


## GROUP TAB LOCATOR

 Introduction	
0 Lubrication & Maintenance	
2 Suspension	
3 Differential & Driveline	
5 Brakes	
7 Cooling	
8A Audio	
8B Chime/Buzzer	
8E Electronic Control Modules	
8F Engine Systems	
8G Heated Systems	
8H Horn	
8I Ignition Control	
8J Instrument Cluster	
8L Lamps	
8M Message Systems	
8N Power Systems	
8O Restraints	
8P Speed Control	
8Q Vehicle Theft Security	
8R Wipers/Washers	
8W Wiring	
9 Engine	
11 Exhaust System	
13 Frame & Bumpers	
14 Fuel System	
19 Steering	
21 Transmission/Transaxle	
22 Tires/Wheels	
23 Body	
24 Heating & Air Conditioning	
25 Emissions Control Systems	
30 New Vehicle Preparation	
Component and System Index	
<b>Service Manual Comment Forms</b>	<b>(Rear of Manual)</b>

# INTRODUCTION

## TABLE OF CONTENTS

	page		page
<b>BODY CODE PLATE</b>		<b>TORQUE REFERENCES</b>	
DESCRIPTION.....	1	DESCRIPTION.....	9
<b>FASTENER IDENTIFICATION</b>		<b>VECI LABEL</b>	
DESCRIPTION.....	3	DESCRIPTION.....	10
<b>FASTENER USAGE</b>		OPERATION.....	10
DESCRIPTION.....	6	<b>VEHICLE IDENTIFICATION NUMBER</b>	
<b>INTERNATIONAL VEHICLE CONTROL &amp; DISPLAY SYMBOLS</b>		DESCRIPTION.....	10
DESCRIPTION.....	6	<b>VEHICLE SAFETY CERTIFICATION LABEL</b>	
<b>METRIC SYSTEM</b>		DESCRIPTION.....	12
DESCRIPTION.....	6	<b>EQUIPMENT IDENTIFICATION PLATE</b>	
		DESCRIPTION.....	12

## BODY CODE PLATE

### DESCRIPTION

The Body Code Plate (Fig. 1) is located on the floor pan under the passenger seat or attached to the front face of the radiator closure panel. There are seven lines of information on the body code plate. Lines 5, 6, and 7 are not used to define service information. Information reads from left to right, starting with line 4 in the center of the plate to line 1 at the bottom of the plate.

The last code imprinted on a vehicle code plate will be followed by the imprinted word END. When two vehicle code plates are required, the last available spaces on the first plate will be imprinted with the letters CTD (for continued).

When a second vehicle code plate is necessary, the first four spaces on each row will not be used because of the plate overlap.

### BODY CODE PLATE—LINE 4

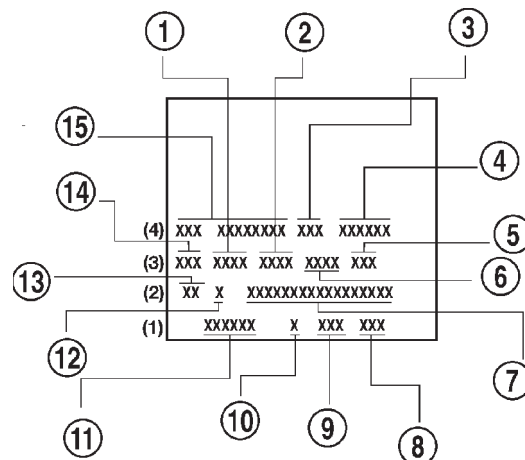
#### DIGITS 1 THROUGH 12

Vehicle Order Number

#### DIGITS 13, 14, AND 15

Transmission Codes

- DGP = 4-speed Automatic (47RE)
- DGT = 4-speed Automatic (46RE)
- DGK = 4-speed Automatic (42RE)
- DDP = 5-speed Manual (NVG-4500)
- DDX = 5-speed Manual (NVG-4500 Heavy Duty)
- DDC = 5-speed Manual (NVG-3500)
- DEE = 6-speed Manual (NVG-5600)



80b6b368

**Fig. 1 Body Code Plate**

- 1 - PRIMARY PAINT
- 2 - SECONDARY PAINT
- 3 - TRANSMISSION CODE
- 4 - VEHICLE MODEL NUMBER
- 5 - ENGINE CODE
- 6 - INTERIOR TRIM CODE
- 7 - VEHICLE IDENTIFICATION NUMBER
- 8 - TAILGATE CODE
- 9 - CARGO BOX CODE
- 10 - TAILGATE TRIM CODE
- 11 - BODY-IN-WHITE SEQUENCE
- 12 - MARKET CODE
- 13 - SPECIES CODE
- 14 - PAINT PROCEDURE
- 15 - VEHICLE ORDER NUMBER

#### DIGITS 16, 17, AND 18

Car Line Shell

- BR1 = 1500 4 X 2
- BE1 = 1500 4 X 2
- BR6 = 1500 4 X 4



## BODY CODE PLATE (Continued)

- BE6 = 1500 4 X 4
- BR2 = 2500 4 X 2
- BE2 = 2500 4 X 2
- BR7 = 2500 4 X 4
- BE7 = 2500 4 X 4
- BR3 = 3500 4 X 2
- BE3 = 3500 4 X 2
- BR8 = 3500 4 X 4
- BE8 = 3500 4 X 4

## DIGIT 19

## Price Class

- L = Ram Truck (All)

## DIGITS 20 AND 21

## Body Type

- 31 = Ram Truck Club Cab (138.7 in. Wheel Base)
- 32 = Ram Truck Club Cab (154.7 in. Wheel Base)
- 33 = Ram Truck Quad Cab (138.7 in. Wheel Base)
- 34 = Ram Truck Quad Cab (154.7 in. Wheel Base)
- 61 = Ram Truck (118.7 in. Wheel Base)
- 62 = Ram Truck (134.7 in. Wheel Base)
- 63 = Ram Truck Cab Chassis (138.7 in. Wheel

## Base)

- 64 = Ram Truck Cab Chassis (162.7 in. Wheel

## Base)

## BODY CODE PLATE—LINE 3

## DIGITS 1,2, AND 3

## Paint Procedure

- APA = Monotone
- AP9 = Special
- APB = Two-tone (Waterfall)
- APC = Two-tone (Centerband)
- APD = Two-tone (Lower break)

## DIGIT 4

## Open Space

## DIGITS 5 THROUGH 8

## Primary Paint

Refer to Group 23, Body for color codes.

## DIGIT 9

## Open Space

## DIGITS 10 THROUGH 13

## Secondary Paint

## DIGIT 14

## Open Space

## DIGITS 15 THROUGH 18

## Interior Trim Code

## DIGIT 19

## Open Space

## DIGITS 20, 21, AND 22

## Engine Code

- EHC = 3.9 L 6 cyl. MPI Gasoline
- ELF = 5.2 L 8 cyl. MPI Gasoline
- ELN = 5.2 L 8 cyl. (CNG)
- EML = 5.9 L 8 cyl. MPI Gasoline
- EMM = 5.9 L 8 cyl. MPI Gasoline (Heavy Duty)
- ETC = 5.9 L 6 cyl. Turbo Diesel
- EWA = 8.0 L 10 cyl. MPI Gasoline

## BODY CODE PLATE—LINE 2

## DIGIT 1 Open Space

## DIGITS 2 AND 3 Species Code. (Used for Manufacturing)

## DIGIT 4

## Open Space

## DIGIT 5

## Market Code

- B = International
- C = Canada
- M = Mexico
- U = United States

## DIGIT 6

## Open Space

## DIGITS 7 THROUGH 23

## Vehicle Identification Number (VIN)

Refer to Vehicle Identification Number (VIN) paragraph for proper breakdown of VIN code.

## BODY CODE PLATE—LINE 1

## DIGITS 1 THROUGH 6 Body-in-white assembly sequence.

## DIGIT 7

## Open Space

## DIGIT 8 Tailgate trim code.

## DIGIT 9

## Open Space

## DIGITS 10 THROUGH 12 Cargo box code

- XBS = Sweptline

## DIGIT 13

## Open Space

## BODY CODE PLATE (Continued)

## DIGITS 14 THROUGH 16 Tailgate code

- MWD = Plain Tailgate
- MPB = Tailgate Applique (Black)

## FASTENER IDENTIFICATION

## DESCRIPTION

The SAE bolt strength grades range from grade 2 to grade 8. The higher the grade number, the greater the bolt strength. Identification is determined by the

line marks on the top of each bolt head. The actual bolt strength grade corresponds to the number of line marks plus 2. The most commonly used metric bolt strength classes are 9.8 and 10.9. The metric strength class identification number is imprinted on the head of the bolt. The higher the class number, the greater the bolt strength. Some metric nuts are imprinted with a single-digit strength class on the nut face. Refer to the Fastener Identification and Fastener Strength Charts.

FASTENER IDENTIFICATION (Continued)

**Bolt Markings and Torque - Metric**

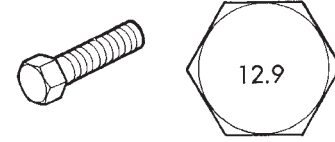
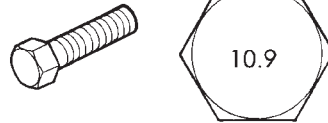
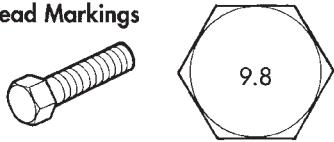
Commercial Steel Class

9.8

10.9

12.9

Bolt Head Markings



Body Size	Torque				Torque				Torque			
	Cast Iron		Aluminum		Cast Iron		Aluminum		Cast Iron		Aluminum	
	Diam. mm	N•m	ft-lb	N•m	ft-lb	N•m	ft-lb	N•m	ft-lb	N•m	ft-lb	N•m
6	9	5	7	4	14	9	11	7	14	9	11	7
7	14	9	11	7	18	14	14	11	23	18	18	14
8	25	18	18	14	32	23	25	18	36	27	28	21
10	40	30	30	25	60	45	45	35	70	50	55	40
12	70	55	55	40	105	75	80	60	125	95	100	75
14	115	85	90	65	160	120	125	95	195	145	150	110
16	180	130	140	100	240	175	190	135	290	210	220	165
18	230	170	180	135	320	240	250	185	400	290	310	230

**Bolt Markings and Torque Values - U.S. Customary**

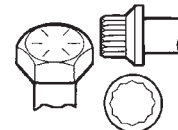
SAE Grade Number

5

8

Bolt Head Markings

These are all SAE Grade 5 (3) line







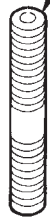


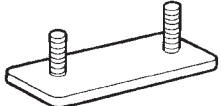


Bolt Torque - Grade 5 Bolt

Bolt Torque - Grade 8 Bolt

Body Size	Cast Iron		Aluminum		Cast Iron		Aluminum	
	N•m	ft-lb	N•m	ft-lb	N•m	ft-lb	N•m	ft-lb
1/4 - 20	9	7	8	6	15	11	12	9
- 28	12	9	9	7	18	13	14	10
5/16 - 18	20	15	16	12	30	22	24	18
- 24	23	17	19	14	33	24	25	19
3/8 - 16	40	30	25	20	55	40	40	30
- 24	40	30	35	25	60	45	45	35
7/16 - 14	60	45	45	35	90	65	65	50
- 20	65	50	55	40	95	70	75	55
1/2 - 13	95	70	75	55	130	95	100	75
- 20	100	75	80	60	150	110	120	90
9/16 - 12	135	100	110	80	190	140	150	110
- 18	150	110	115	85	210	155	170	125
5/8 - 11	180	135	150	110	255	190	205	150
- 18	210	155	160	120	290	215	230	170
3/4 - 10	325	240	255	190	460	340	365	270
- 16	365	270	285	210	515	380	410	300
7/8 - 9	490	360	380	280	745	550	600	440
- 14	530	390	420	310	825	610	660	490
1 - 8	720	530	570	420	1100	820	890	660
- 14	800	590	650	480	1200	890	960	710

## FASTENER IDENTIFICATION (Continued)

## HOW TO DETERMINE BOLT STRENGTH

	Mark	Class		Mark	Class
Hexagon head bolt	 Bolt head No. 4 — 4T 5 — 5T 6 — 6T 7 — 7T 8 — 8T 9 — 9T 10 — 10T 11 — 11T		Stud bolt	 No mark 4T	
	 No mark 4T				
Hexagon flange bolt w/washer hexagon bolt	 No mark 4T		Welded bolt	 Grooved 6T	
Hexagon head bolt	 Two protruding lines 5T				
Hexagon flange bolt w/washer hexagon bolt	 Two protruding lines 6T		 4T		
Hexagon head bolt	 Three protruding lines 7T				
Hexagon head bolt	 Four protruding lines 8T				

95IN-4

## FASTENER USAGE

### DESCRIPTION - FASTENER USAGE

**WARNING: USE OF AN INCORRECT FASTENER MAY RESULT IN COMPONENT DAMAGE OR PERSONAL INJURY.**

Figure art, specifications and torque references in this Service Manual are identified in metric and SAE format.

During any maintenance or repair procedures, it is important to salvage all fasteners (nuts, bolts, etc.) for reassembly. If the fastener is not salvageable, a fastener of equivalent specification must be used.

### DESCRIPTION - THREADED HOLE REPAIR

Most stripped threaded holes can be repaired using a Helicoil®. Follow the manufactures recommendations for application and repair procedures.

## INTERNATIONAL VEHICLE CONTROL & DISPLAY SYMBOLS

### DESCRIPTION - INTERNATIONAL SYMBOLS

























The graphic symbols illustrated in the following International Control and Display Symbols Chart are used to identify various instrument controls. The symbols correspond to the controls and displays that are located on the instrument panel.

## METRIC SYSTEM

### DESCRIPTION - METRIC SYSTEM

The metric system is based on quantities of one, ten, one hundred, one thousand and one million .

The following chart will assist in converting metric units to equivalent English and SAE units, or vice versa.

 1	 2	 3	 4	 5	 6
 7	 8	 9	 10	 11	 12
 13	 14	 15	 16	 17	 18
 19	 20	 21	 22	 23	 24

80be4788

### *International Symbols*

1	High Beam	13	Rear Window Washer
2	Fog Lamps	14	Fuel
3	Headlamp, Parking Lamps, Panel Lamps	15	Engine Coolant Temperature
4	Turn Warning	16	Battery Charging Condition
5	Hazard Warning	17	Engine Oil
6	Windshield Washer	18	Seat Belt
7	Windshield Wiper	19	Brake Failure
8	Windshield Wiper and Washer	20	Parking Brake
9	Windscreen Demisting and Defrosting	21	Front Hood
10	Ventilating Fan	22	Rear hood (Decklid)
11	Rear Window Defogger	23	Horn
12	Rear Window Wiper	24	Lighter

## METRIC SYSTEM (Continued)

## CONVERSION FORMULAS AND EQUIVALENT VALUES

MULTIPLY	BY	TO GET	MULTIPLY	BY	TO GET
in-lbs	x 0.11298	= Newton Meters (N·m)	N·m	x 8.851	= in-lbs
ft-lbs	x 1.3558	= Newton Meters (N·m)	N·m	x 0.7376	= ft-lbs
Inches Hg (60° F)	x 3.377	= Kilopascals (kPa)	kPa	x 0.2961	= Inches Hg
psi	x 6.895	= Kilopascals (kPa)	kPa	x 0.145	= psi
Inches	x 25.4	= Millimeters (mm)	mm	x 0.03937	= Inches
Feet	x 0.3048	= Meters (M)	M	x 3.281	= Feet
Yards	x 0.9144	= Meters	M	x 1.0936	= Yards
mph	x 1.6093	= Kilometers/Hr. (Km/h)	Km/h	x 0.6214	= mph
Feet/Sec	x 0.3048	= Meters/Sec (M/S)	M/S	x 3.281	= Feet/Sec
mph	x 0.4470	= Meters/Sec (M/S)	M/S	x 2.237	= mph
Kilometers/ Hr. (Km/h)	x 0.27778	= Meters/Sec (M/S)	M/S	x 3.600	Kilometers/Hr. (Km/h)

## COMMON METRIC EQUIVALENTS

1 inch = 25 Millimeters	1 Cubic Inch = 16 Cubic Centimeters
1 Foot = 0.3 Meter	1 Cubic Foot = 0.03 Cubic Meter
1 Yard = 0.9 Meter	1 Cubic Yard = 0.8 Cubic Meter
1 Mile = 1.6 Kilometers	

Refer to the Metric Conversion Chart to convert torque values listed in metric Newton- meters (N·m).

Also, use the chart to convert between millimeters (mm) and inches (in.)



## TORQUE REFERENCES

ations Chart for torque references not listed in the individual torque charts.

## DESCRIPTION

Individual Torque Charts appear at the end of many Groups. Refer to the Standard Torque Specifici-

## SPECIFIED TORQUE FOR STANDARD BOLTS

Class	Diameter mm	Pitch mm	Specified torque					
			Hexagon head bolt			Hexagon flange bolt		
			N•m	kgf-cm	ft-lbf	N•m	kgf-cm	ft-lbf
4T	6	1	5	55	48 in.-lbf	6	60	52 in.-lbf
	8	1.25	12.5	130	9	14	145	10
	10	1.25	26	260	19	29	290	21
	12	1.25	47	480	35	53	540	39
	14	1.5	74	760	55	84	850	61
	16	1.5	115	1,150	83	—	—	—
5T	6	1	6.5	65	56 in.-lbf	7.5	75	65 in.-lbf
	8	1.25	15.5	160	12	17.5	175	13
	10	1.25	32	330	24	36	360	26
	12	1.25	59	600	43	65	670	48
	14	1.5	91	930	67	100	1,050	76
	16	1.5	140	1,400	101	—	—	—
6T	6	1	8	80	69 in.-lbf	9	90	78 in.-lbf
	8	1.25	19	195	14	21	210	15
	10	1.25	39	400	29	44	440	32
	12	1.25	71	730	53	80	810	59
	14	1.5	110	1,100	80	125	1,250	90
	16	1.5	170	1,750	127	—	—	—
7T	6	1	10.5	110	8	12	120	9
	8	1.25	25	260	19	28	290	21
	10	1.25	52	530	38	58	590	43
	12	1.25	95	970	70	105	1,050	76
	14	1.5	145	1,500	108	165	1,700	123
	16	1.5	230	2,300	166	—	—	—
8T	8	1.25	29	300	22	33	330	24
	10	1.25	61	620	45	68	690	50
	12	1.25	110	1,100	80	120	1,250	90
9T	8	1.25	34	340	25	37	380	27
	10	1.25	70	710	51	78	790	57
	12	1.25	125	1,300	94	140	1,450	105
10T	8	1.25	38	390	28	42	430	31
	10	1.25	78	800	58	88	890	64
	12	1.25	140	1,450	105	155	1,600	116
11T	8	1.25	42	430	31	47	480	35
	10	1.25	87	890	64	97	990	72
	12	1.25	155	1,600	116	175	1,800	130

## Torque Specifications



## VECI LABEL

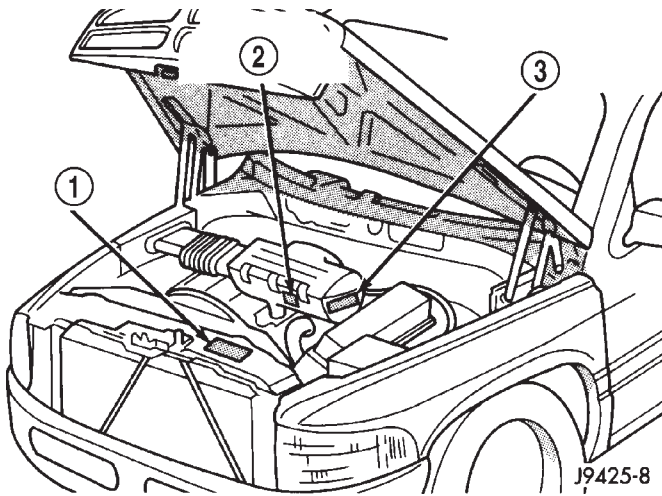
### DESCRIPTION

Vehicles equipped with 3.9L V-6 or 5.2L/5.9L V-8 LDC-gas powered engines have a VECI label.

The label combines both emission control information and vacuum hose routing. This label is located in the engine compartment in front of the radiator (Fig. 2).

The VECI label contains the following:

- Engine family and displacement
- Evaporative family
- Emission control system schematic
- Certification application
- Engine timing specifications (if adjustable)
- Idle speeds (if adjustable)
- Spark plug and gap



**Fig. 2 VECI Label Location**

- 1 - VEHICLE EMISSION CONTROL INFORMATION (VECI) LABEL
- 2 - VECI LABEL (5.9L HDC FOR CANADA ONLY)
- 3 - VECI LABEL (5.9L HDC ONLY) (INCLUDES CANADA)

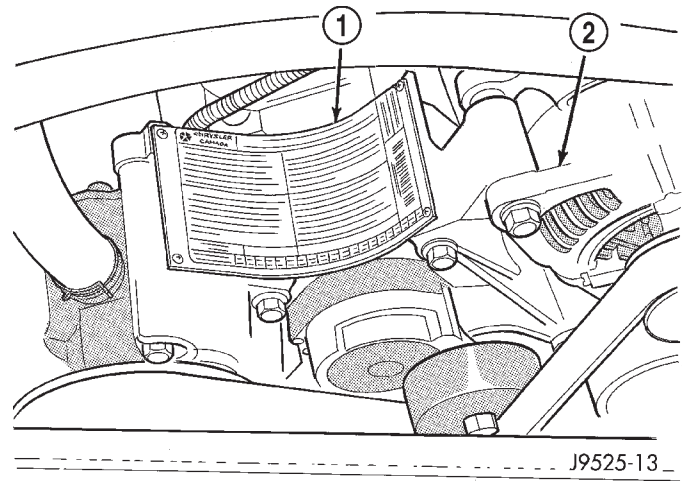
The 5.9L HDC-gas powered engine will have two labels. One of the labels is located in front of the radiator in the engine compartment (Fig. 2) and will contain vacuum hose routing only. The other is attached to the drivers side of the engine air cleaner housing (Fig. 2).

The VECI label for the 5.9L HDC-gas powered engine will contain the following:

- Engine family and displacement
- Evaporative family
- Certification application
- Engine timing specifications (if adjustable)
- Idle speeds (if adjustable)
- Spark plug and gap

The label for the 8.0L V-10 HDC-gas powered engine is also located in the engine compartment. It

is attached to a riveted metal plate located to the right side of the generator (Fig. 3).



**Fig. 3 VECI Label Location—8.0L V-10 Engine**

- 1 - VECI LABEL
- 2 - GENERATOR

### OPERATION

There are unique VECI labels for vehicles built for sale in the country of Canada and for both Light Duty Cycle (LDC) and Heavy Duty Cycle (HDC) engines. Canadian labels are written in both the English and French languages. For all Canadian vehicles, the label is split into two different labels.

The VECI labels are permanently attached and cannot be removed without defacing information and destroying label.

## VEHICLE IDENTIFICATION NUMBER

### DESCRIPTION

#### VIN CODING/LOCATIONS

The Vehicle Identification Number (VIN) plate is located on the lower windshield fence near the left A-pillar (Fig. 4). The VIN contains 17 characters that provide data concerning the vehicle. Refer to the VIN decoding chart to determine the identification of a vehicle.

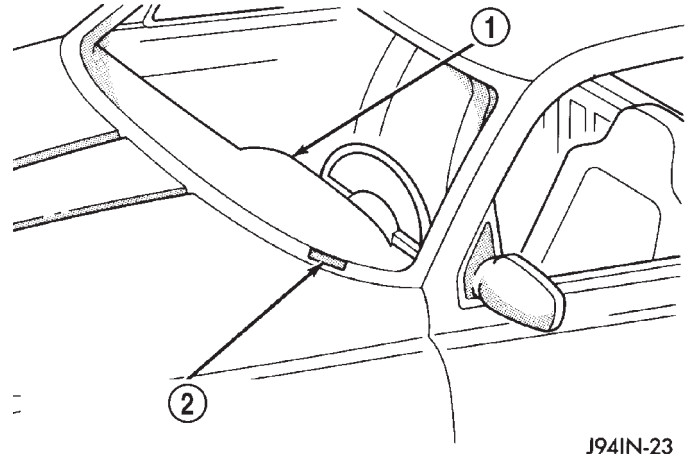
The Vehicle Identification Number is also imprinted on the:

- Body Code Plate.
- Equipment Identification Plate.
- Vehicle Safety Certification Label.
- Frame rail.

To protect the consumer from theft and possible fraud the manufacturer is required to include a Check Digit at the ninth position of the Vehicle Iden-

## VEHICLE IDENTIFICATION NUMBER (Continued)

tification Number. The check digit is used by the manufacturer and government agencies to verify the authenticity of the vehicle and official documentation. The formula to use the check digit is not released to the general public.



J94IN-23

**Fig. 4 Vehicle**

1 - INSTRUMENT PANEL

2 - VEHICLE IDENTIFICATION NUMBER PLATE VIN

POSITION	INTERPRETATION	CODE = DESCRIPTION
1	Country of Origin	1 = United States 3 = Mexico
2	Make	B = Dodge
3	Vehicle Type	6 = Incomplete 7 = Truck
4	Gross Vehicle Weight Rating	H = 6001-7000 J = 7001-8000 K = 8001-9000 L = 9001-10,000 M = 10,001-14,000
5	Vehicle Line	C = Ram Cab Chassis/Ram Pick Up (4x2) F = Ram Cab Chassis/Ram Pick Up (4x4)
6	Series	1 = 1500 2 = 2500 3 = 3500
7	Body Style	2 = Club Cab 3 = Quad Cab 6 = Conventional Cab/Cab Chassis
8	Engine	6 = 5.9L 6 cyl. 24 Valve Diesel 7=5.9 6cyl. 24 Valve Turbo Diesel H/O W = 8.0L 10 cyl. MPI X = 3.9L 6 cyl. MPI Y = 5.2L 8 cyl. MPI Z = 5.9L 8 cyl. MPI-LDC 5 = 5.9L 8cyl. MPI-HDC
9	Check Digit	0 through 9 or X
10	Model Year	1=2001
11	Plant Location	J = St. Louis North S = Dodge City M = Lago Alberto Assembly
12 thru 17	Vehicle Build Sequence	

# VEHICLE SAFETY CERTIFICATION LABEL

## DESCRIPTION

A vehicle safety certification label (Fig. 5) is attached to every Chrysler Corporation vehicle. The label certifies that the vehicle conforms to all applicable Federal Motor Vehicle Safety Standards. The label also lists:

- Month and year of vehicle manufacture.
- Gross Vehicle Weight Rating (GVWR). The gross front and rear axle weight ratings (GAWR's) are based on a minimum rim size and maximum cold tire inflation pressure.
- Vehicle Identification Number (VIN).
- Type of vehicle.
- Type of rear wheels.
- Bar code.
- Month, Day and Hour (MDH) of final assembly.
- Paint and Trim codes.
- Country of origin.

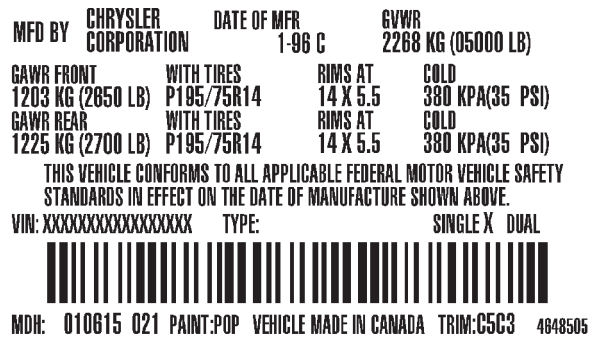
The label is located on the driver-side door shut-face.

## EQUIPMENT IDENTIFICATION PLATE

### DESCRIPTION

The Equipment Identification Plate (Fig. 6) is located at the left, front of the inner hood panel. The plate lists information concerning the vehicle as follows:

- The model.

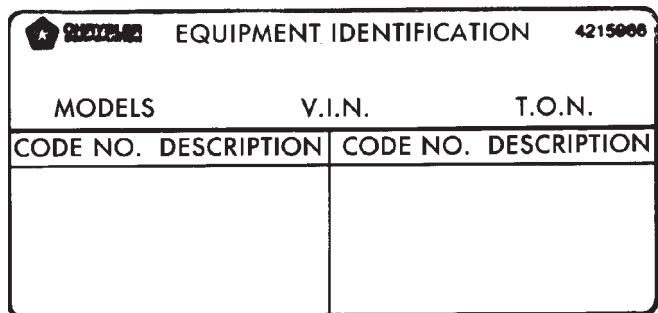


80ab36d€

**Fig. 5 Vehicle Safety Certification Label**

- The wheelbase.
- The VIN (Vehicle Identification Number).
- The T.O.N. (order number).
- The optional and special equipment installed on the vehicle.

Refer to the information listed on the plate when ordering replacement parts.



J901N-37

**Fig. 6 Equipment Identification Plate**

# LUBRICATION & MAINTENANCE

## TABLE OF CONTENTS

	page		page
<b>LUBRICATION &amp; MAINTENANCE</b>		<b>MAINTENANCE SCHEDULES</b>	
DESCRIPTION.....	1	DESCRIPTION.....	7
<b>INTERNATIONAL SYMBOLS</b>		<b>JUMP STARTING</b>	
DESCRIPTION.....	3	STANDARD PROCEDURE.....	27
<b>PARTS &amp; LUBRICANT RECOMMENDATION</b>		<b>HOISTING</b>	
STANDARD PROCEDURE.....	3	STANDARD PROCEDURE.....	28
<b>FLUID TYPES</b>		<b>TOWING</b>	
DESCRIPTION.....	3	STANDARD PROCEDURE.....	29
OPERATION.....	5		
<b>FLUID CAPACITIES</b>			
SPECIFICATIONS.....	6		

## LUBRICATION & MAINTENANCE

### DESCRIPTION - FUEL REQUIREMENTS - GAS ENGINES

Your engine is designed to meet all emissions regulations and provide excellent fuel economy and performance when using high quality unleaded gasoline having an octane rating of 87. The use of premium gasoline is not recommended. The use of premium gasoline will provide no benefit over high quality regular gasoline, and in some circumstances may result in poorer performance.

Light spark knock at low engine speeds is not harmful to your engine. However, continued heavy spark knock at high speeds can cause damage and immediate service is required. Engine damage resulting from operation with a heavy spark knock may not be covered by the new vehicle warranty.

Poor quality gasoline can cause problems such as hard starting, stalling and hesitations. If you experience these symptoms, try another brand of gasoline before considering service for the vehicle.

Over 40 auto manufacturers world-wide have issued and endorsed consistent gasoline specifications (the Worldwide Fuel Charter, WWFC) to define fuel properties necessary to deliver enhanced emissions, performance and durability for your vehicle. We recommend the use of gasolines that meet the WWFC specifications if they are available.

### REFORMULATED GASOLINE

Many areas of the country require the use of cleaner burning gasoline referred to as "reformulated" gasoline. Reformulated gasoline contain oxygenates, and are specifically blended to reduce vehicle emissions and improve air quality.

We strongly supports the use of reformulated gasoline. Properly blended reformulated gasoline will provide excellent performance and durability for the engine and fuel system components.

### GASOLINE/OXYGENATE BLENDS

Some fuel suppliers blend unleaded gasoline with oxygenates such as 10% ethanol, MTBE, and ETBE. Oxygenates are required in some areas of the country during the winter months to reduce carbon monoxide emissions. Fuels blended with these oxygenates may be used in your vehicle.

**CAUTION: DO NOT use gasoline containing METHANOL. Gasoline containing methanol may damage critical fuel system components.**

### MMT IN GASOLINE

MMT is a manganese-containing metallic additive that is blended into some gasoline to increase octane. Gasoline blended with MMT provide no performance advantage beyond gasoline of the same octane number without MMT. Gasoline blended with MMT reduce spark plug life and reduce emission system performance in some vehicles. We recommend that gasolines free of MMT be used in your vehicle. The MMT content of gasoline may not be indicated on the gasoline pump; therefore, you should ask your gasoline retailer whether or not his/her gasoline contains MMT.

## LUBRICATION &amp; MAINTENANCE (Continued)

It is even more important to look for gasoline without MMT in Canada because MMT can be used at levels higher than allowed in the United States. MMT is prohibited in Federal and California reformulated gasoline.

**SULFUR IN GASOLINE**

If you live in the northeast United States, your vehicle may have been designed to meet California low emission standards with Cleaner-Burning California reformulated gasoline with low sulfur. If such fuels are not available in states adopting California emission standards, your vehicles will operate satisfactorily on fuels meeting federal specifications, but emission control system performance may be adversely affected. Gasoline sold outside of California is permitted to have higher sulfur levels which may affect the performance of the vehicle's catalytic converter. This may cause the Malfunction Indicator Lamp (MIL), Check Engine or Service Engine Soon light to illuminate. We recommend that you try a different brand of unleaded gasoline having lower sulfur to determine if the problem is fuel related prior to returning your vehicle to an authorized dealer for service.

**CAUTION: If the Malfunction Indicator Lamp (MIL), Check Engine or Service Engine Soon light is flashing, immediate service is required; see on-board diagnostics system section.**

**MATERIALS ADDED TO FUEL**

All gasoline sold in the United States and Canada are required to contain effective detergent additives. Use of additional detergents or other additives is not needed under normal conditions.

**FUEL SYSTEM CAUTIONS**

**CAUTION: Follow these guidelines to maintain your vehicle's performance:**

- The use of leaded gas is prohibited by Federal law. Using leaded gasoline can impair engine performance, damage the emission control system, and could result in loss of warranty coverage.
- An out-of-tune engine, or certain fuel or ignition malfunctions, can cause the catalytic converter to overheat. If you notice a pungent burning odor or some light smoke, your engine may be out of tune or malfunctioning and may require immediate service. Contact your dealer for service assistance.

- When pulling a heavy load or driving a fully loaded vehicle when the humidity is low and the temperature is high, use a premium unleaded fuel to help prevent spark knock. If spark knock persists, lighten the load, or engine piston damage may result.

- The use of fuel additives which are now being sold as octane enhancers is not recommended. Most of these products contain high concentrations of methanol. Fuel system damage or vehicle performance problems resulting from the use of such fuels or additives is not the responsibility of Daimler-Chrysler Corporation and may not be covered under the new vehicle warranty.

**NOTE: Intentional tampering with emissions control systems can result in civil penalties being assessed against you.**

**DESCRIPTION - FUEL REQUIREMENTS - DIESEL ENGINE****DESCRIPTION**

**WARNING: Do not use alcohol or gasoline as a fuel blending agent. They can be unstable under certain conditions and hazardous or explosive when mixed with diesel fuel.**

Use good quality diesel fuel from a reputable supplier in your Dodge truck. For most year-round service, number 2 diesel fuel meeting ASTM specification D-975 will provide good performance. If the vehicle is exposed to extreme cold (below 0°F/-18°C), or is required to operate at colder-than-normal conditions for prolonged periods, use climatized No. 2 diesel fuel or dilute the No. 2 diesel fuel with 50% No. 1 diesel fuel. This will provide better protection from fuel gelling or wax-plugging of the fuel filters.








Diesel fuel is seldom completely free of water. To prevent fuel system trouble, including fuel line freezing in winter, drain the accumulated water from the fuel/water separator using the fuel/water separator drain provided. If you buy good-quality fuel and follow the cold-weather advice above, fuel conditioners should not be required in your vehicle. If available in your area, a high cetane "premium" diesel fuel may offer improved cold starting and warm-up performance.



## INTERNATIONAL SYMBOLS

### DESCRIPTION

DaimlerChrysler Corporation uses international symbols to identify engine compartment lubricant and fluid inspection and fill locations (Fig. 1).

 <b>CHRYSLER CORPORATION</b>			
	ENGINE OIL		BRAKE FLUID
	AUTOMATIC TRANSMISSION FLUID		POWER STEERING FLUID
	ENGINE COOLANT		WINDSHIELD WASHER FLUID

9500-1

Fig. 1 International Symbols

## PARTS & LUBRICANT RECOMMENDATION

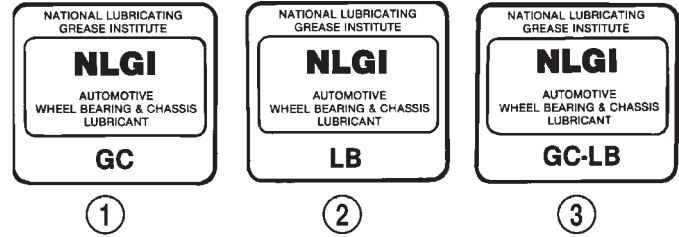
### STANDARD PROCEDURE - CLASSIFICATION OF LUBRICANTS

Only lubricants that are endorsed by the following organization should be used to service a DaimlerChrysler Corporation vehicle.

- Society of Automotive Engineers (SAE)
- American Petroleum Institute (API) (Fig. 4)
- National Lubricating Grease Institute (NLGI) (Fig. 2)

Lubricating grease is rated for quality and usage by the NLGI. All approved products have the NLGI symbol (Fig. 2) on the label. At the bottom NLGI symbol is the usage and quality identification letters. Wheel bearing lubricant is identified by the letter "G". Chassis lubricant is identified by the letter "L". The letter following the usage letter indicates the quality of the lubricant. The following symbols indicate the highest quality.

When service is required, DaimlerChrysler Corporation recommends that only Mopar® brand parts, lubricants and chemicals be used. Mopar provides the best engineered products for servicing DaimlerChrysler Corporation vehicles.



9200-7

Fig. 2 NLGI Symbol

- 1 - WHEEL BEARINGS
- 2 - CHASSIS LUBRICATION
- 3 - CHASSIS AND WHEEL BEARINGS

## FLUID TYPES

### DESCRIPTION - ENGINE OIL

**WARNING: NEW OR USED ENGINE OIL CAN BE IRRITATING TO THE SKIN. AVOID PROLONGED OR REPEATED SKIN CONTACT WITH ENGINE OIL. CONTAMINANTS IN USED ENGINE OIL, CAUSED BY INTERNAL COMBUSTION, CAN BE HAZARDOUS TO YOUR HEALTH. THOROUGHLY WASH EXPOSED SKIN WITH SOAP AND WATER. DO NOT WASH SKIN WITH GASOLINE, DIESEL FUEL, THINNER, OR SOLVENTS, HEALTH PROBLEMS CAN RESULT. DO NOT POLLUTE, DISPOSE OF USED ENGINE OIL PROPERLY. CONTACT YOUR DEALER OR GOVERNMENT AGENCY FOR LOCATION OF COLLECTION CENTER IN YOUR AREA.**

### API SERVICE GRADE CERTIFIED

Use an engine oil that is API Service Grade Certified. MOPAR® provides engine oils that conform to this service grade.

### SAE VISCOSITY

An SAE viscosity grade is used to specify the viscosity of engine oil. Use only engine oils with multiple viscosities such as 5W-30 or 10W-30. These oils are specified with a dual SAE viscosity grade which indicates the cold-to-hot temperature viscosity range. Select an engine oil that is best suited to your particular temperature range and variation (Fig. 3).

FLUID TYPES (Continued)

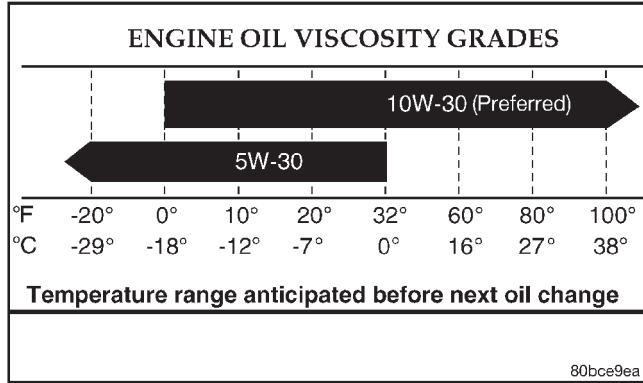


Fig. 3 Temperature/Engine Oil Viscosity - 3.2/3.5L Engine

ENERGY CONSERVING OIL

An Energy Conserving type oil is recommended for gasoline engines. The designation of ENERGY CONSERVING is located on the label of an engine oil container.

CONTAINER IDENTIFICATION

Standard engine oil identification notations have been adopted to aid in the proper selection of engine oil. The identifying notations are located on the label of engine oil plastic bottles and the top of engine oil cans (Fig. 4).



9400-9

Fig. 4 API Symbol

DESCRIPTION—ENGINE OIL

API SERVICE GRADE CERTIFIED

**WARNING: NEW OR USED ENGINE OIL CAN BE IRRITATING TO THE SKIN. AVOID PROLONGED OR REPEATED SKIN CONTACT WITH ENGINE OIL. CONTAMINANTS IN USED ENGINE OIL, CAUSED BY INTERNAL COMBUSTION, CAN BE HAZARDOUS TO YOUR HEALTH. THOROUGHLY WASH EXPOSED SKIN WITH SOAP AND WATER. DO NOT WASH SKIN WITH GASOLINE, DIESEL FUEL, THINNER, OR SOLVENTS, HEALTH PROBLEMS CAN RESULT. DO NOT POLLUTE, DISPOSE OF USED ENGINE OIL PROPERLY. CONTACT YOUR DEALER OR GOVERNMENT AGENCY FOR LOCATION OF COLLECTION CENTER IN YOUR AREA.**

Standard engine-oil identification notations have been adopted to aid in the proper selection of engine oil. The identifying notations are located on the label of engine oil plastic bottles and the top of engine oil cans.

In diesel engines, use an engine oil that conforms to API Service Grade CF-4 or CG-4/SH (Fig. 5). MOPAR® provides an engine oil that conforms to this particular grade.

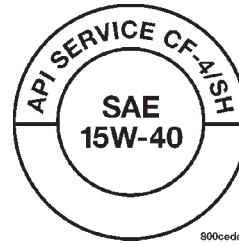


Fig. 5 API Service Grade Certification Label—Diesel Engine Oil

SAE VISCOSITY

An SAE viscosity grade is used to specify the viscosity of engine oil. SAE 15W-40 specifies a multiple viscosity engine oil.

When choosing an engine oil, consider the range of temperatures the vehicle will be operated in before the next oil change. Select an engine oil that is best suited to your area's particular ambient temperature range and variation. For diesel engines, refer to (Fig. 6).

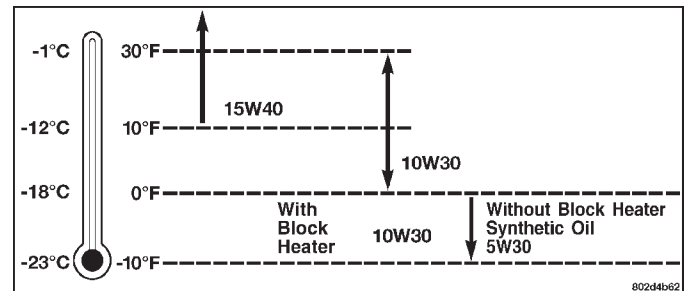


Fig. 6 Engine Oil Viscosity Recommendation—Diesel Engines

## FLUID TYPES (Continued)

**DESCRIPTION**

A multi-purpose, hypoid gear lubricant which conforms to the following specifications should be used. Mopar Hypoid Gear Lubricant conforms to all of these specifications.

SAE ratings also apply to multiple grade gear lubricants. In addition, API classification defines the lubricants usage.

**FRONT AXLE**

- The lubricant should have MIL-L-2105C and API GL 5 quality specifications.
- Lubricant is SAE 75W-140 SYNTHETIC gear lubricant.

**REAR AXLE**

- The lubricant should have MIL-L-2105C and API GL 5 quality specifications.
- Lubricant is a thermally stable SAE 80W-90 gear lubricant.
- Lubricant for axles intended for heavy-duty or trailer tow use is SAE 75W-140 SYNTHETIC gear lubricant.

**NOTE:** Trac-lok™ and Vari-lok™ equipped axles require a friction modifier be added to the lubricant.

**CAUTION:** If axle is submerged in water, lubricant must be replaced immediately to avoid possible premature axle failure.

**DESCRIPTION - TRANSFER CASE FLUID**

Recommended lubricant for the NV231 and NV241 transfer case is Mopar® ATF +4, (MS 9602) Automatic Transmission Fluid.

**DESCRIPTION - AUTOMATIC TRANSMISSION FLUID**

**NOTE:** Refer to the maintenance schedules in this group for the recommended maintenance (fluid/filter change) intervals for this transmission.

**NOTE:** Refer to Service Procedures in this group for fluid level checking procedures.

Mopar® ATF +4, type 9602, Automatic Transmission Fluid is the recommended fluid for DaimlerChrysler automatic transmissions.

**Dexron II fluid IS NOT recommended. Clutch chatter can result from the use of improper fluid.**

Mopar® ATF +4, type 9602, Automatic Transmission Fluid when new is red in color. The ATF is dyed red so it can be identified from other fluids used in the vehicle such as engine oil or antifreeze. The red color is not permanent and is not an indicator of fluid condition. As the vehicle is driven, the ATF will begin to look darker in color and may eventually become brown. **This is normal.** A dark brown/black fluid accompanied with a burnt odor and/or deterioration in shift quality may indicate fluid deterioration or transmission component failure.

**FLUID ADDITIVES**

DaimlerChrysler strongly recommends against the addition of any fluids to the transmission, other than those automatic transmission fluids listed above. Exceptions to this policy are the use of special dyes to aid in detecting fluid leaks.

Various "special" additives and supplements exist that claim to improve shift feel and/or quality. These additives and others also claim to improve converter clutch operation and inhibit overheating, oxidation, varnish, and sludge. These claims have not been supported to the satisfaction of DaimlerChrysler and these additives **must not be used.** The use of transmission "sealers" should also be avoided, since they may adversely affect the integrity of transmission seals.

**OPERATION - AUTOMATIC TRANSMISSION FLUID**

The automatic transmission fluid is selected based upon several qualities. The fluid must provide a high level of protection for the internal components by providing a lubricating film between adjacent metal components. The fluid must also be thermally stable so that it can maintain a consistent viscosity through a large temperature range. If the viscosity stays constant through the temperature range of operation, transmission operation and shift feel will remain consistent. Transmission fluid must also be a good conductor of heat. The fluid must absorb heat from the internal transmission components and transfer that heat to the transmission case.



# FLUID CAPACITIES

## SPECIFICATIONS

### FLUID CAPACITIES

DESCRIPTION	SPECIFICATION
<b>FUEL TANK</b>	
1500 Series with 6.5' Short Box	98 L (26 gal.)*****
2500 Series Club Cab and Quad Cab with 6.5' Short Box	129 L (34 gal.)*****
All 8' Long Box	132 L (35 gal.)*****
All Cab/Chassis Models	132 L (35 gal.)*****
<b>ENGINE OIL WITH FILTER</b>	
3.9L	4.2 L (4.5 qts.)
5.2L	4.7 L (5.0 qts.)
5.9L	4.7 L (5.0 qts.)
8.0L	6.6 L (7.0 qts.)
5.9L DIESEL	10.4 L (11.0 qts.)
<b>COOLING SYSTEM</b>	
3.9L	19 L (20 qts.)****
5.2L	19 L (20 qts.)****
5.9L	19 L (20 qts.)****
8.0L	24.5 L (26.0 qts.)****
5.9L DIESEL	22.7 L (24.0 qts.)****
<b>POWER STEERING</b>	
Power steering fluid capacities are dependent on engine/chassis options as well as steering gear/cooler options. Depending on type and size of internal cooler, length and inside diameter of cooler lines, or use of an auxiliary cooler, these capacities may vary. Refer to 19, Steering for proper fill and bleed procedures.	
<b>AUTOMATIC TRANSMISSION</b>	
Service Fill - 42RE	3.8 L (4.0 qts.)
O-haul - 42RE	9-9.5 L (19-20 pts.)*
Service Fill - 44RE	3.8 L (4.0 qts.)
O-haul - 44RE	9-9.5 L (19-20 pts.)*
Service Fill - 46RE	3.8 L (4.0 qts.)
O-haul - 46RE	9-9.5 L (19-20 pts.)*
Service Fill - 47RE	3.8 L (4.0 qts.)
O-haul - 47RE	14-16 L 29-33 pts.)*

DESCRIPTION	SPECIFICATION
Dry fill capacity Depending on type and size of internal cooler, length and inside diameter of cooler lines, or use of an auxiliary cooler, these figures may vary. Refer to 21, Transmission for proper fluid fill procedure. (Refer to 21 - TRANSMISSION/TRANSAXLE/AUTOMATIC/FLUID - STANDARD PROCEDURE)	
<b>MANUAL TRANSMISSION</b>	
NV3500	2.0 L (4.2 pts.)
NV4500	3.8 L (8.0 pts.)
NV4500 HD	3.8 L (8.0 pts.)
NV5600	4.5 L (9.5 pts.)
<b>TRANSFER CASE</b>	
NV231 HD	1.2 L (2.5 pts.)
NV241	2.18 L (4.61 pts.)
NV241 HD	3.08 L (6.51 pts.)
<b>FRONT AXLE</b>	
Model 216-FBI	2.3 L (4.8 pts.)
Model 248-FBI	4.0L (8.5 pts.)
<b>REAR AXLE</b>	
9-1/4 inch	2.1 L (4.5 pts.)
248-RBI(2WD)	3.0 L (6.3 pts.)
248-RBI(4WD)	3.4L (7.0 pts.)
267-RBI(2WD)	3.3 L (7.0 pts.)
267-RBI (4WD)	3.6L (7.5 pts.)
286-RBI (2WD)	3.2 L (6.8 pts.)
286-RBI (4WD)	4.8 L (10.1 pts.)
<b>REAR AXLE—LIMITED SLIP DIFFERENTIAL</b>	
9-1/4 inch	2.2 L (4.7 pts.) ±
248-RBI (2WD)	3.0 L (6.3 pts.**)
248-RBI (4WD)	3.4 L (7.0 pts.)
267-RBI	3.3 L (7.0 pts.**)
267-RBI (4WD)	3.6 L (7.5 pts.)
286-RBI (2WD)	3.2 L (6.8 pts.**)
286-RBI (4WD)	4.8 L (10.1 pts.***)
** Include 0.05 L (0.25 pts.) friction modifier.	
*** Include 0.19 L (0.4 pts.) friction modifier.	
± Include 0.1 L (0.2 pts.) friction modifier.	
**** Includes 0.9L (1.0 qts.) for coolant reservoir.	
*****Nominal refill capacities are shown. A variation may be observed from vehicle to vehicle due to manufacturing tolerance and refill procedure.	

## MAINTENANCE SCHEDULES

### LIGHT DUTY ENGINE (1500 AND 2500 MODELS EXCEPT 8.0L) MAINTENANCE SCHEDULES

There are two maintenance schedules that show proper service for the vehicle.

First is Schedule "A". It lists all the scheduled maintenance to be performed under "normal" operating conditions.

Second is Schedule "B". It is a schedule for vehicles that are operated under the conditions listed at the beginning of that schedule.

Use the schedule that best describes the driving conditions.

Where time and mileage are listed, follow the interval that occurs first.

#### *At Each Stop For Fuel*

- Check engine oil level and add as required.
- Check windshield washer solvent and add as required.
- Clean windshield and wiper blades as required.

#### *Once A Month*

- Check tire pressure and look for unusual wear or damage.
- Inspect battery and clean and tighten terminals as required.
- Check fluid levels of coolant reservoir, brake master cylinder, power steering, and transmission and add as needed.
- Check all lights and all other electrical items for correct operation.
- Inspect and clean wiper blades. Replace if required.

#### *At Each Oil Change*

- Inspect exhaust system.
- Inspect brake hoses.
- Adjust rear brake shoe to drum clearance.
- Rotate the tires at each oil change interval shown on schedule "A" (7,500 Miles) or every other interval shown on schedule "B" (6,000 Miles).
- Check engine coolant level, hoses, and clamps.
- Lubricate steering linkage.

### EMISSION CONTROL SYSTEM MAINTENANCE

The scheduled emission maintenance listed in **bold type** on the Maintenance Schedules, must be done at the mileage specified to assure the continued proper functioning of the emission control system. These, and all other maintenance services included in this manual, should be done to provide the best vehicle performance and reliability. More frequent maintenance may be needed for vehicles in severe operating

conditions such as dusty areas and very short trip driving.

### FLUID FILL LOCATIONS AND LUBRICATION POINTS

The fluid check/fill locations and lubrication points are located in each applicable group.

#### LIGHT DUTY SCHEDULE "A"

##### *7,500 Miles (12 000 km) or at 6 months*

- Change engine oil.
- Replace engine oil filter.
- Inspect engine coolant level, hoses, and clamps.
- Inspect brake hoses.
- Lubricate the steering linkages.
- Check manual transmission fluid level.
- Inspect exhaust system.

##### *15,000 Miles (24 000 km) or at 12 months*

- Change engine oil.
- Replace engine oil filter.
- Inspect engine coolant level, hoses, and clamps.
- Inspect brake hoses.
- Lubricate the steering linkages.
- Check manual transmission fluid level.
- Inspect exhaust system.

##### *22,500 Miles (36 000 km) or at 18 months*

- Change engine oil.
- Replace engine oil filter.
- Inspect engine coolant level, hoses, and clamps.
- Inspect brake hoses.
- Inspect brake linings.
- Inspect front wheel bearings. Clean and repack, if required (4x2).
- Lubricate the steering linkages.
- Lubricate non permanently sealed ball joints.
- Check manual transmission fluid level.
- Inspect exhaust system.

##### *30,000 Miles (48 000 km) or at 24 months*

- **Replace engine air cleaner element.**
- **Replace spark plugs.**
- Change engine oil.
- Replace engine oil filter.
- Inspect engine coolant level, hoses, and clamps.
- Inspect brake hoses.
- Lubricate the steering linkages.
- Inspect manual transmission fluid level.
- Inspect exhaust system.

##### *37,500 Miles (60 000 km) or at 30 months*

- Change engine oil.
- Replace engine oil filter.
- Inspect engine coolant level, hoses, and clamps.

## MAINTENANCE SCHEDULES (Continued)

- Inspect brake hoses.
- Lubricate the steering linkages.
- Inspect manual transmission fluid level.
- Drain and refill transfer case fluid.
- Inspect exhaust system.

**45,000 Miles (72 000 km) or at 36 months**

- Change engine oil.
- Replace engine oil filter.
- Inspect engine coolant level, hoses, and clamps.
- Inspect brake hoses.
- Inspect brake linings.
- Inspect front wheel bearings. Clean and repack, if required (4x2).
- Lubricate the steering linkages.
- Lubricate non permanently sealed ball joints.
- Check manual transmission fluid level.
- Inspect exhaust system.

**52,500 Miles (84 000 km) or at 42 months**

- Change engine oil.
- Replace engine oil filter.
- Inspect engine coolant level, hoses, and clamps.
- Flush and replace engine coolant.
- Inspect brake hoses.
- Lubricate the steering linkages.
- Inspect manual transmission fluid level.
- Inspect exhaust system.

**60,000 Miles (96 000 km) or at 48 months**

- **Replace engine air cleaner element.**
- **Replace ignition cables.**
- **Check PCV valve and replace as necessary.\***
- **Replace spark plugs.**
- Inspect auto tension drive belt and replace if required.
- Change engine oil.
- Replace engine oil filter.
- Inspect engine coolant level, hoses, and clamps.
- Inspect brake hoses.
- Lubricate the steering linkages.
- Check manual transmission fluid level.
- Inspect exhaust system.

**67,500 Miles (108 000 km) or at 54 months**

- Change engine oil.
- Replace engine oil filter.
- Inspect engine coolant level, hoses, and clamps.
- Inspect brake hoses.
- Inspect brake linings.
- Inspect front wheel bearings. Clean and repack, if required (4x2).
- Lubricate the steering linkages.
- Lubricate non permanently sealed ball joints.
- Check manual transmission fluid level.
- Inspect exhaust system.

**75,000 Miles (120 000 km) or at 60 months**

- Inspect auto tension drive belt and replace if required.\*\*
- Change engine oil.
- Replace engine oil filter.
- Inspect engine coolant level, hoses, and clamps.
- Inspect brake hoses.
- Lubricate the steering linkages.
- Check manual transmission fluid level.
- Drain and refill transfer case fluid.
- Inspect exhaust system.

**82,500 Miles (132 000 km) or at 66 months**

- Change engine oil.
- Replace engine oil filter.
- Inspect engine coolant level, hoses, and clamps.
- Flush and replace engine coolant if it has been 30,000 miles (48 000 km) or 24 months since last change.
- Inspect brake hoses.
- Lubricate the steering linkages.
- Inspect manual transmission fluid level.
- Inspect exhaust system.

**90,000 Miles (144 000 km) or at 72 months**

- **Replace engine air cleaner element.**
- **Check PCV valve and replace as necessary.\***
- **Replace spark plugs.**
- Inspect auto tension drive belt and replace if required.\*\*
- Change engine oil.
- Replace engine oil filter.
- Inspect engine coolant level, hoses, and clamps.
- Inspect brake hoses.
- Inspect brake linings.
- Inspect front wheel bearings. Clean and repack, if required (4x2).
- Lubricate the steering linkages.
- Lubricate non permanently sealed ball joints.
- Check manual transmission fluid level.
- Inspect exhaust system.

**97,500 Miles (156 000 km) or at 78 months**

- Change engine oil.
- Replace engine oil filter.
- Inspect engine coolant level, hoses, and clamps.
- Inspect brake hoses.
- Lubricate the steering linkages.
- Inspect manual transmission fluid level.
- Inspect exhaust system.

**100,000 Miles (160,000 km)**

- Change automatic transmission fluid, filter and adjust bands.

## MAINTENANCE SCHEDULES (Continued)

**105,000 Miles (168 000 km) or at 84 months**

- Inspect auto tension drive belt and replace if required.\*\*
- Change engine oil.
- Replace engine oil filter.
- Inspect engine coolant level, hoses, and clamps.
- Inspect brake hoses.
- Lubricate the steering linkages.
- Check manual transmission fluid level.
- Inspect exhaust system.

**112,500 Miles (180 000 km) or at 90 months**

- Change engine oil.
- Replace engine oil filter.
- Inspect engine coolant level, hoses, and clamps.
- Flush and replace engine coolant if it has been 30,000 miles (48 000 km) or 24 months since last change.
- Inspect brake hoses.
- Inspect brake linings.
- Inspect front wheel bearings. Clean and repack, if required (4x2).
- Lubricate the steering linkages.
- Lubricate non permanently sealed ball joints.
- Check manual transmission fluid level.
- Drain and refill transfer case fluid.
- Inspect exhaust system.

**120,000 Miles (192 000 km) or at 96 months**

- **Replace engine air cleaner element.**
- **Replace ignition cables.**
- **Check PCV valve and replace as necessary.\***
- **Replace spark plugs.**
- Inspect auto tension drive belt and replace if required.\*\*
- Change engine oil.
- Replace engine oil filter.
- Inspect engine coolant level, hoses, and clamps.
- Inspect brake hoses.
- Lubricate the steering linkages.
- Check manual transmission fluid level.
- Inspect exhaust system.

\*This maintenance is recommended by Daimler-Chrysler to the customer but it is not required to maintain warranty on the PCV valve.

\*\*This maintenance is not required if the belt was previously replaced.

**LIGHT DUTY SCHEDULE "B"**

Follow this schedule if the vehicle is usually operated under one or more of the following conditions.

- Frequent short trips of less than 5 miles.
- Frequent driving in dusty conditions.
- Trailer towing.
- Frequent long periods of engine idling.

- More than 50 percent of the driving is at sustained high speeds during hot weather, above 90°F (32°C).

- Frequent stop and go driving.
- Day and night temperatures are below freezing.
- Taxi, police or delivery service (commercial service).
- Off-road or desert operation.

**3,000 Miles (5 000 km)**

- Change engine oil.
- Replace engine oil filter.
- Inspect engine coolant level, hoses, and clamps.
- Inspect brake hoses.
- Lubricate the steering linkages.
- Check manual transmission fluid level.
- Inspect exhaust system.

**6,000 Miles (10 000 km)**

- Change engine oil.
- Replace engine oil filter.
- Inspect engine coolant level, hoses, and clamps.
- Inspect brake hoses.
- Lubricate the steering linkages.
- Check manual transmission fluid level.
- Inspect exhaust system.

**9,000 Miles (14 000 km)**

- Change engine oil.
- Replace engine oil filter.
- Inspect engine coolant level, hoses, and clamps.
- Inspect brake hoses.
- Lubricate the steering linkages.
- Check manual transmission fluid level.
- Inspect exhaust system.

**12,000 Miles (19 000 km)**

- Change engine oil.
- Replace engine oil filter.
- Inspect engine coolant level, hoses, and clamps.
- Inspect brake hoses.
- Inspect brake linings.
- Lubricate the steering linkages.
- Check manual transmission fluid level.
- Change rear axle fluid.
- Change front axle fluid (4x4).
- Inspect exhaust system.

**15,000 Miles (24 000 km)**

- **Inspect engine air cleaner element, replace as necessary.**
- Change engine oil.
- Replace engine oil filter.
- Inspect engine coolant level, hoses, and clamps.
- Inspect brake hoses.
- Lubricate the steering linkages.
- Check manual transmission fluid level.

## MAINTENANCE SCHEDULES (Continued)

- Inspect exhaust system.

**18,000 Miles (29 000 km)**

- Change engine oil.
- Replace engine oil filter.
- Inspect engine coolant level, hoses, and clamps.
- Inspect brake hoses.
- Lubricate the steering linkages.
- Check manual transmission fluid level.
- Inspect exhaust system.

**21,000 Miles (34 000 km)**

- Change engine oil.
- Replace engine oil filter.
- Inspect engine coolant level, hoses, and clamps.
- Inspect brake hoses.
- Lubricate the steering linkages.
- Check manual transmission fluid level.
- Inspect exhaust system.

**24,000 Miles (38 000 km)**

- Change engine oil.
- Replace engine oil filter.
- Inspect engine coolant level, hoses, and clamps.
- Inspect brake hoses.
- Inspect brake linings.
- Lubricate the steering linkages.
- Check manual transmission fluid level.
- Change rear axle fluid.
- Change front axle fluid (4x4).
- Inspect exhaust system.

**27,000 Miles (43 000 km)**

- Change engine oil.
- Replace engine oil filter.
- Inspect engine coolant level, hoses, and clamps.
- Inspect brake hoses.
- Lubricate the steering linkages.
- Check manual transmission fluid level.
- Inspect exhaust system.

**30,000 Miles (48 000 km)**

- **Replace engine air cleaner element.**
- **Inspect PCV valve, replace as necessary.\***
- **Replace spark plugs.**
- Change engine oil.
- Replace engine oil filter.
- Inspect engine coolant level, hoses, and clamps.
- Inspect brake hoses.
- Lubricate the steering linkages.
- Change automatic transmission fluid, filter and adjust the bands.
- Check manual transmission fluid level.
- Inspect exhaust system.

**33,000 Miles (53 000 km)**

- Change engine oil.
- Replace engine oil filter.
- Inspect engine coolant level, hoses, and clamps.
- Inspect brake hoses.
- Lubricate the steering linkages.
- Check manual transmission fluid level.
- Inspect exhaust system.

**36,000 Miles (58 000 km)**

- Change engine oil.
- Replace engine oil filter.
- Inspect engine coolant level, hoses, and clamps.
- Inspect brake hoses.
- Inspect brake linings.
- Lubricate the steering linkages.
- Check manual transmission fluid level.
- Drain and refill transfer case fluid.
- Change rear axle fluid.
- Change front axle fluid (4x4).
- Inspect exhaust system.

**39,000 Miles (62 000 km)**

- Change engine oil.
- Replace engine oil filter.
- Inspect engine coolant level, hoses, and clamps.
- Inspect brake hoses.
- Lubricate the steering linkages.
- Check manual transmission fluid level.
- Inspect exhaust system.

**42,000 Miles (67 000 km)**

- Change engine oil.
- Replace engine oil filter.
- Inspect engine coolant level, hoses, and clamps.
- Inspect brake hoses.
- Lubricate the steering linkages.
- Check manual transmission fluid level.
- Inspect exhaust system.

**45,000 Miles (72 000 km)**

- **Inspect engine air cleaner element, replace as necessary.**
- Change engine oil.
- Replace engine oil filter.
- Inspect engine coolant level, hoses, and clamps.
- Inspect brake hoses.
- Lubricate the steering linkages.
- Check manual transmission fluid level.
- Inspect exhaust system.

**48,000 Miles (77 000 km)**

- Change engine oil.
- Replace engine oil filter.
- Inspect engine coolant level, hoses, and clamps.
- Inspect brake hoses.



## MAINTENANCE SCHEDULES (Continued)

- Inspect brake linings.
- Lubricate the steering linkages.
- Check manual transmission fluid level.
- Change rear axle fluid.
- Change front axle fluid (4x4).
- Inspect exhaust system.

**51,000 Miles (82 000 km)**

- Change engine oil.
- Replace engine oil filter.
- Inspect engine coolant level, hoses, and clamps.
- Flush and replace engine coolant.
- Inspect brake hoses.
- Lubricate the steering linkages.
- Check manual transmission fluid level.
- Inspect exhaust system.

**54,000 Miles (86 000 km)**

- Change engine oil.
- Replace engine oil filter.
- Inspect engine coolant level, hoses, and clamps.
- Inspect brake hoses.
- Lubricate the steering linkages.
- Check manual transmission fluid level.
- Inspect exhaust system.

**57,000 Miles (91 000 km)**

- Change engine oil.
- Replace engine oil filter.
- Inspect engine coolant level, hoses, and clamps.
- Inspect brake hoses.
- Lubricate the steering linkages.
- Check manual transmission fluid level.
- Inspect exhaust system.

**60,000 Miles (96 000 km)**

- **Replace engine air cleaner element.**
- **Replace ignition cables.**
- **Inspect PCV valve and replace as necessary.\***
  - **Replace spark plugs.**
- Inspect auto tension drive belt and replace if required.
- Change engine oil.
- Replace engine oil filter.
- Inspect engine coolant level, hoses, and clamps.
- Inspect brake hoses.
- Inspect brake linings.
- Lubricate the steering linkages.
- Change automatic transmission fluid, filter and adjust the bands.
- Check manual transmission fluid level.
- Change rear axle fluid.
- Change front axle fluid (4x4).
- Inspect exhaust system.

**63,000 Miles (101 000 km)**

- Change engine oil.
- Replace engine oil filter.
- Inspect engine coolant level, hoses, and clamps.
- Inspect brake hoses.
- Lubricate the steering linkages.
- Check manual transmission fluid level.
- Inspect exhaust system.

**66,000 Miles (106 000 km)**

- Change engine oil.
- Replace engine oil filter.
- Inspect engine coolant level, hoses, and clamps.
- Inspect brake hoses.
- Lubricate the steering linkages.
- Check manual transmission fluid level.
- Inspect exhaust system.

**69,000 Miles (110 000 km)**

- Change engine oil.
- Replace engine oil filter.
- Inspect engine coolant level, hoses, and clamps.
- Inspect brake hoses.
- Lubricate the steering linkages.
- Check manual transmission fluid level.
- Inspect exhaust system.

**72,000 Miles (115 000 km)**

- Change engine oil.
- Replace engine oil filter.
- Inspect engine coolant level, hoses, and clamps.
- Inspect brake hoses.
- Inspect brake linings.
- Lubricate the steering linkages.
- Check manual transmission fluid level.
- Drain and refill transfer case fluid.
- Change rear axle fluid.
- Change front axle fluid (4x4).
- Inspect exhaust system.

**75,000 Miles (120 000 km)**

- **Inspect engine air cleaner element, replace as necessary.**
  - Inspect auto tension drive belt and replace if required.\*\*
- Change engine oil.
- Replace engine oil filter.
- Inspect engine coolant level, hoses, and clamps.
- Inspect brake hoses.
- Lubricate the steering linkages.
- Check manual transmission fluid level.
- Inspect exhaust system.

**78,000 Miles (125 000 km)**

- Change engine oil.
- Replace engine oil filter.
- Inspect engine coolant level, hoses, and clamps.

## MAINTENANCE SCHEDULES (Continued)

- Inspect brake hoses.
- Lubricate the steering linkages.
- Check manual transmission fluid level.
- Inspect exhaust system.

**81,000 Miles (130 000 km)**

- Change engine oil.
- Replace engine oil filter.
- Inspect engine coolant level, hoses, and clamps.
- Flush and replace engine coolant.
- Inspect brake hoses.
- Lubricate the steering linkages.
- Check manual transmission fluid level.
- Inspect exhaust system.

**84,000 Miles (134 000 km)**

- Change engine oil.
- Replace engine oil filter.
- Inspect engine coolant level, hoses, and clamps.
- Inspect brake hoses.
- Inspect brake linings.
- Lubricate the steering linkages.
- Check manual transmission fluid level.
- Change rear axle fluid.
- Change front axle fluid (4x4).
- Inspect exhaust system.

**87,000 Miles (139 000 km)**

- Change engine oil.
- Replace engine oil filter.
- Inspect engine coolant level, hoses, and clamps.
- Inspect brake hoses.
- Lubricate the steering linkages.
- Check manual transmission fluid level.
- Inspect exhaust system.

**90,000 Miles (144 000 km)**

- **Replace engine air cleaner element.**
- **Inspect PCV valve, replace as necessary.\***
- **Replace spark plugs.**
- Inspect auto tension drive belt and replace if required.\*\*
- Change engine oil.
- Replace engine oil filter.
- Inspect engine coolant level, hoses, and clamps.
- Inspect brake hoses.
- Lubricate the steering linkages.
- Change automatic transmission fluid, filter and adjust the bands.
- Check manual transmission fluid level.
- Inspect exhaust system.

**93,000 Miles (149 000 km)**

- Change engine oil.
- Replace engine oil filter.
- Inspect engine coolant level, hoses, and clamps.
- Inspect brake hoses.

- Lubricate the steering linkages.
- Check manual transmission fluid level.
- Inspect exhaust system.

**96,000 Miles (154 000 km)**

- Change engine oil.
- Replace engine oil filter.
- Inspect engine coolant level, hoses, and clamps.
- Inspect brake hoses.
- Inspect brake linings.
- Lubricate the steering linkages.
- Check manual transmission fluid level.
- Change rear axle fluid.
- Change front axle fluid (4x4).
- Inspect exhaust system.

**99,000 Miles (158 000 km)**

- Change engine oil.
- Replace engine oil filter.
- Inspect engine coolant level, hoses, and clamps.
- Inspect brake hoses.
- Lubricate the steering linkages.
- Check manual transmission fluid level.
- Inspect exhaust system.

**102,000 Miles (163 000 km)**

- Change engine oil.
- Replace engine oil filter.
- Inspect engine coolant level, hoses, and clamps.
- Inspect brake hoses.
- Lubricate the steering linkages.
- Check manual transmission fluid level.
- Inspect exhaust system.

**105,000 Miles (168 000 km)**

- **Inspect engine air cleaner element, replace as necessary.**
- Inspect auto tension drive belt and replace if required.\*\*
- Change engine oil.
- Replace engine oil filter.
- Inspect engine coolant level, hoses, and clamps.
- Inspect brake hoses.
- Lubricate the steering linkages.
- Check manual transmission fluid level.
- Inspect exhaust system.

**108,000 Miles (173 000 km)**

- Change engine oil.
- Replace engine oil filter.
- Inspect engine coolant level, hoses, and clamps.
- Inspect brake hoses.
- Inspect brake linings.
- Lubricate the steering linkages.
- Check manual transmission fluid level.
- Drain and refill transfer case fluid.
- Change rear axle fluid.

## MAINTENANCE SCHEDULES (Continued)

- Change front axle fluid (4x4).
- Inspect exhaust system.

**111,000 Miles (178 000 km)**

- Change engine oil.
- Replace engine oil filter.
- Inspect engine coolant level, hoses, and clamps.
- Flush and replace engine coolant.
- Inspect brake hoses.
- Lubricate the steering linkages.
- Check manual transmission fluid level.
- Inspect exhaust system.

**114,000 Miles (182 000 km)**

- Change engine oil.
- Replace engine oil filter.
- Inspect engine coolant level, hoses, and clamps.
- Inspect brake hoses.
- Lubricate the steering linkages.
- Check manual transmission fluid level.
- Inspect exhaust system.

**117,000 Miles (187 000 km)**

- Change engine oil.
- Replace engine oil filter.
- Inspect engine coolant level, hoses, and clamps.
- Inspect brake hoses.
- Lubricate the steering linkages.
- Check manual transmission fluid level.
- Inspect exhaust system.

**120,000 Miles (192 000 km)**

- **Replace engine air cleaner element.**
- **Replace ignition cables.**
- **Inspect PCV valve and replace as necessary.\***
- **Replace spark plugs.**
- Inspect auto tension drive belt and replace if required.\*\*
- Change engine oil.
- Replace engine oil filter.
- Inspect engine coolant level, hoses, and clamps.
- Inspect brake hoses.
- Inspect brake linings.
- Lubricate the steering linkages.
- Change automatic transmission fluid, filter and adjust the bands.
- Check manual transmission fluid level.
- Change rear axle fluid.
- Change front axle fluid (4x4).
- Inspect exhaust system.

\*This maintenance is recommended by Daimler-Chrysler to the customer but it is not required to maintain warranty on the PCV valve.

\*\*This maintenance is not required if the belt was previously replaced.

Inspection and service should also be performed anytime a malfunction is observed or suspected.

## DESCRIPTION - MEDIUM DUTY TRUCK MAINTENANCE SCHEDULE (8.0L 2500 & 3500 MODELS — CALIFORNIA ONLY)

There are two maintenance schedules that show proper service based on the conditions that the vehicle is subjected to. Use the schedule that best describes these conditions.

Schedule "A", lists all the scheduled maintenance to be performed under normal operating conditions for Medium Duty vehicles.

Schedule "B", lists maintenance recommended for Medium Duty vehicles operated under the conditions listed at the beginning of that schedule.

• Where the time and mileage are listed, follow the interval that occurs first.

**At Each Stop For Fuel**

- Check engine oil level and add as required.
- Check windshield washer solvent and add as required.
- Clean windshield and wiper blades as required.

**Once A Month**

- Check tire pressure and look for unusual wear or damage.
- Inspect battery and clean and tighten terminals as required.
- Check fluid levels of coolant reservoir, brake master cylinder, power steering, and transmission and add as needed.
- Check all lights and all other electrical items for correct operation.
- Inspect and clean wiper blades. Replace if required.

**At Each Oil Change**

- Inspect exhaust system.
- Inspect brake hoses.
- Adjust rear brakes.
- Rotate the tires at each oil change interval shown on schedule "A" (6,000 Miles) or every other interval shown on schedule "B" (6,000 Miles)
- Check engine coolant level, hoses and clamps.
- Lubricate steering linkage.

**EMISSION CONTROL SYSTEM MAINTENANCE**

The scheduled emission maintenance listed in **bold type** on the Maintenance Schedules, must be done at the mileage specified to assure the continued proper functioning of the emission control system. These, and all other maintenance services included in this manual, should be done to provide the best vehicle performance and reliability. More frequent maintenance may be needed for vehicles in severe operating conditions such as dusty areas and very short trip driving.



## MAINTENANCE SCHEDULES (Continued)

## FLUID FILL LOCATIONS AND LUBRICATION POINTS

The fluid fill/check locations and lubrication points are located in each applicable group.

## MEDIUM DUTY SCHEDULE "A"

**6,000 Miles (10 000 km) or at 6 months**

- Replace engine oil and filter.

**12,000 Miles (19 000 km) or at 12 months**

- Replace engine oil and filter.

**18,000 Miles (29 000 km) or at 18 months**

- Replace engine oil and filter.
- Inspect brake linings.
- Inspect front wheel bearings. Clean and repack, if required (4x2).

**24,000 Miles (38 000 km) or at 24 months**

- Replace engine oil and filter.
  - Drain and refill automatic transmission fluid.
- Replace filter and adjust bands.

**30,000 Miles (48 000 km) or at 30 months**

- Replace engine oil and filter.
- **Replace engine air cleaner element.**
- **Replace spark plugs.**

**36,000 Miles (58 000 km) or at 36 months**

- Replace engine oil and filter.
- Drain and refill transfer case fluid.
- Inspect brake linings
- Flush and replace engine coolant at 36 months, regardless of mileage.
- Inspect front wheel bearings. Clean and repack, if required (4x2).

**42,000 Miles (67 000 km) or at 42 months**

- Replace engine oil and filter.

**48,000 Miles (77 000 km) or at 48 months**

- Replace engine oil and filter.
  - Drain and refill automatic transmission fluid.
- Replace filter and adjust bands.
- Flush and replace engine coolant if not done at 36 months.

**54,000 Miles (86 000 km) or at 54 months**

- Replace engine oil and filter.
- Inspect brake linings.
- Inspect front wheel bearings. Clean and repack, if required (4x2).

**60,000 Miles (96 000 km) or at 60 months**

- Replace engine oil and filter.
- **Replace engine air cleaner element.**
- **Replace ignition cables.**
- **Replace spark plugs.**
- Flush and replace engine coolant if it has been 30,000 miles (48 000 km) or 24 months since last change.

**66,000 Miles (106 000 km) or at 66 months**

- Replace engine oil and filter.

**72,000 Miles (115 000 km) or at 72 months**

- Replace engine oil and filter.
  - Drain and refill automatic transmission fluid.
- Replace filter and adjust bands.
- Drain and refill transfer case fluid.
  - Inspect front wheel bearings. Clean and repack, if required (4x2).
  - Inspect brake linings.

**78,000 Miles (125 000 km) or at 78 months**

- Replace engine oil and filter.
- Flush and replace engine coolant if it has been 30,000 miles (48 000 km) or 24 months since last change.

**84,000 Miles (134 000 km) or at 84 months**

- Replace engine oil and filter.
- Flush and replace engine coolant if it has been 30,000 miles (48 000 km) or 24 months since last change.

**90,000 Miles (144 000 km) or at 90 months**

- Replace engine oil and filter.
- **Replace engine air cleaner element.**
- **Replace spark plugs.**
- Inspect brake linings.
- Inspect front wheel bearings. Clean and repack, if required (4x2).

**96,000 Miles (154 000 km) or at 96 months**

- Replace engine oil and filter.
  - Drain and refill automatic transmission fluid.
- Replace filter and adjust bands.

**102,000 Miles (163 000 km) or at 104 months**

- Replace engine oil and filter.

**108,000 Miles (173 000 km) or at 110 months**

- Replace engine oil and filter.
- Drain and refill transfer case fluid.
- Inspect brake linings.
- Flush and replace engine coolant if it has been 30,000 miles (48 000 km) or 24 months since last change.

## MAINTENANCE SCHEDULES (Continued)

- Inspect front wheel bearings. Clean and repack, if required (4x2).

**114,000 Miles (183 000 km) or at 116 months**

- Replace engine oil and filter.

**120,000 Miles (192 000 km) or at 124 months**

- Replace engine oil and filter.
- **Replace engine air cleaner element.**
- **Replace ignition cables.**
- **Replace spark plugs.**
- Drain and refill automatic transmission fluid. Replace filter and adjust bands.

**MEDIUM DUTY SCHEDULE "B"**

Follow this schedule if the vehicle usually operates under one or more of the following conditions.

- Frequent short trips less than 5 miles (8 km).
- Frequent driving in dusty conditions
- Frequent trailer towing
- Extensive idling
- More than 50% of the driving is at sustained high speeds during hot weather, above 90° F (32° C)

**3,000 Miles (5 000 km)**

- Replace engine oil and filter.

**6,000 Miles (10 000 km)**

- Replace engine oil and filter.

**9,000 Miles (14 000 km)**

- Replace engine oil and filter.

**12,000 Miles (19 000 km)**

- Replace engine oil and filter.
- Drain and refill automatic transmission fluid. Replace filter and adjust bands.‡
- Change rear axle fluid.
- Change front axle fluid (4x4).
- Inspect brake linings.

**15,000 Miles (24 000 km)**

- Replace engine oil and filter.
- **Inspect engine air cleaner element, replace as necessary.**

**18,000 Miles (29 000 km)**

- Replace engine oil and filter.

**21,000 Miles (29 000 km)**

- Replace engine oil and filter.

**24,000 Miles (38 000 km)**

- Replace engine oil and filter.
- Drain and refill automatic transmission fluid. Replace filter and adjust bands.

- Inspect front wheel bearings. Clean and repack, if required (4x2).

- Change rear axle fluid.
- Change front axle fluid (4x4).
- Inspect brake linings.

**27,000 Miles (43 000 km)**

- Replace engine oil and filter.

**30,000 Miles (48 000 km)**

- Replace engine oil and filter.
- **Replace engine air cleaner element.**
- **Replace spark plugs.**

**33,000 Miles (53 000 km)**

- Replace engine oil and filter.

**36,000 Miles (58 000 km)**

- Replace engine oil and filter.
- Drain and refill automatic transmission fluid. Replace filter and adjust bands.‡
- Drain and refill transfer case fluid.
- Change rear axle fluid.
- Change front axle fluid (4x4).
- Inspect brake linings.
- Inspect front wheel bearings. Clean and repack, if required (4x2).

**39,000 Miles (62 000 km)**

- Replace engine oil and filter.

**42,000 Miles (67 000 km)**

- Replace engine oil and filter.

**45,000 Miles (72 000 km)**

- Replace engine oil and filter.
- **Inspect engine air cleaner element, replace as necessary.**

**48,000 Miles (77 000 km)**

- Replace engine oil and filter.
- Drain and refill automatic transmission fluid. Replace filter and adjust bands.
- Change rear axle fluid.
- Change front axle fluid (4x4).
- Inspect brake linings.
- Flush and replace engine coolant.

**51,000 Miles (82 000 km)**

- Replace engine oil and filter.

**54,000 Miles (86 000 km)**

- Replace engine oil and filter.
- Inspect front wheel bearings. Clean and repack, if required (4x2).

## MAINTENANCE SCHEDULES (Continued)

**57,000 Miles (91 000 km)**

- Replace engine oil and filter.

**60,000 Miles (96 000 km)**

- Replace engine oil and filter.
- **Replace engine air cleaner element.**
- **Replace ignition cables.**
- **Replace spark plugs.**
- Drain and refill automatic transmission fluid.

Replace filter and adjust bands.‡

- Change rear axle fluid.
- Change front axle fluid (4x4).
- Inspect brake linings.

**63,000 Miles (101 000 km)**

- Replace engine oil and filter.

**66,000 Miles (106 000 km)**

- Replace engine oil and filter.

**69,000 Miles (110 000 km)**

- Replace engine oil and filter.

**72,000 Miles (115 000 km)**

- Replace engine oil and filter.
- Drain and refill automatic transmission fluid.

Replace filter and adjust bands.

- Drain and refill transfer case fluid.
- Inspect front wheel bearings. Clean and repack, if required (4x2).
- Change rear axle fluid.
- Change front axle fluid (4x4).
- Inspect brake linings.

**75,000 Miles (120 000 km)**

- Replace engine oil and filter.
- **Inspect engine air cleaner element, replace as necessary.**

**78,000 Miles (125 000 km)**

- Replace engine oil and filter.
- Flush and replace engine coolant.

**81,000 Miles (130 000 km)**

- Replace engine oil and filter.

**84,000 Miles (134 000 km)**

- Replace engine oil and filter.
- Drain and refill automatic transmission fluid.

Replace filter and adjust bands.‡

- Change rear axle fluid.
- Change front axle fluid (4x4).
- Inspect brake linings.

**87,000 Miles (139 000 km)**

- Replace engine oil and filter.

**90,000 Miles (144 000 km)**

- Replace engine oil and filter.
- **Replace engine air cleaner element.**
- **Replace spark plugs.**
- Inspect front wheel bearings. Clean and repack, if required (4x2).

**93,000 Miles (149 000 km)**

- Replace engine oil and filter.

**96,000 Miles (154 000 km)**

- Replace engine oil and filter.
  - Drain and refill automatic transmission fluid.
- Replace filter and adjust bands.
- Change rear axle fluid.
  - Change front axle fluid (4x4).
  - Inspect brake linings.

**99,000 Miles (156 000 km)**

- Replace engine oil and filter.

**102,000 Miles (163 000 km)**

- Replace engine oil and filter.

**105,000 Miles (168 000 km)**

- Replace engine oil and filter.
- **Inspect engine air cleaner element, replace as necessary.**

**108,000 Miles (173 000 km)**

- Replace engine oil and filter.
  - Drain and refill automatic transmission fluid.
- Replace filter and adjust bands.‡
- Drain and refill transfer case fluid.
  - Change rear axle fluid.
  - Change front axle fluid (4x4).
  - Inspect brake linings.
  - Flush and replace engine coolant.

**111,000 Miles (178 000 km)**

- Replace engine oil and filter.

**114,000 Miles (183 000 km)**

- Replace engine oil and filter.

**117,000 Miles (187 000 km)**

- Replace engine oil and filter.

**120,000 Miles (192 000 km)**

- Replace engine oil and filter.
  - **Replace engine air cleaner element.**
  - **Replace ignition cables.**
  - **Replace spark plugs.**
  - Drain and refill automatic transmission fluid.
- Replace filter and adjust bands.
- Change rear axle fluid.
  - Change front axle fluid (4x4).

## MAINTENANCE SCHEDULES (Continued)

- Inspect brake linings.

‡Off-the-highway operation, trailer towing snow plowing, prolonged operation with heavy loading, especially in hot weather require the more frequent transmission service indicated with an ‡ in Schedule "B". Perform these services if the vehicle is usually operated under these conditions.

Inspection and service should also be performed anytime a malfunction is observed or suspected.

### DESCRIPTION - HEAVY DUTY ENGINE (FEDERAL ONLY – 2500 8.0L HD AND 3500 5.9L& 8.0L MODELS) MAINTENANCE SCHEDULES

There are two maintenance schedules that show proper service based on the conditions that the vehicle is subjected to. Use the schedule that best describes these conditions.

Schedule "A", lists all the scheduled maintenance to be performed under normal operating conditions for Heavy Duty vehicles.

Schedule "B", lists maintenance recommended for Heavy Duty vehicles operated under the conditions listed at the beginning of that schedule.

- Where time and mileage are listed, follow the interval that occurs first.

#### **At Each Stop For Fuel**

- Check engine oil level, add as required.
- Check windshield washer solvent and add if required.
- Clean windshield and wiper blades as required.

#### **Once A Month**

- Check tire pressure and look for unusual wear or damage.
- Inspect battery and clean and tighten terminals as required.
- Check fluid levels of coolant reservoir, power steering and transmission and add as needed.
- Check all lights and all other electrical items for correct operation.
- Inspect and clean wiper blades. Replace if required.

#### **At Each Oil Change**

- Inspect exhaust system.
- Inspect brake hoses.
- Adjust rear brakes.
- Rotate the tires at each oil change interval shown on schedule "A" (6,000 Miles) or every other interval shown on schedule "B" (6,000 Miles).
- Check engine coolant level, hoses, and clamps.
- Lubricate steering linkage.

### EMISSION CONTROL SYSTEM MAINTENANCE

The scheduled emission maintenance listed in **bold type** on the Maintenance Schedules, must be done at the mileage specified to assure the continued proper functioning of the emission control system. These, and all other maintenance services included in this manual, should be done to provide the best vehicle performance and reliability. More frequent maintenance may be needed for vehicles in severe operating conditions such as dusty areas and very short trip driving.

### FLUID FILL LOCATIONS AND LUBRICATION POINTS

The fluid fill/check locations and lubrication points are located in each applicable group.

#### HEAVY DUTY SCHEDULE "A"

##### **6,000 miles (10 000 km) or at 6 months**

- Change engine oil.
- Replace engine oil filter.

##### **12,000 Miles (19 000 km) or at 12 months**

- Change engine oil.
- Replace engine oil filter.
- **Inspect engine air cleaner element, replace as necessary (8.0L only).**

##### **18,000 Miles (29 000 km) or at 18 months**

- Change engine oil.
- Replace engine oil filter.
- Inspect brake linings
- Inspect front wheel bearings. Clean and repack, if required (4x4).

##### **24,000 Miles (38 000 km) or at 24 months**

- Change engine oil.
- Replace engine oil filter.
- **Replace engine air cleaner element and air pump filter.**
- Clean and lubricate crankcase inlet air filter (5.9L).
- Drain and refill automatic transmission fluid. Replace filter and adjust bands.
- Inspect front wheel bearings. Clean and repack, if required (4x2).

##### **30,000 Miles (48 000 km) or at 30 months**

- Change engine oil.
- Replace engine oil filter.
- **Replace spark plugs.**

##### **36,000 Miles (58 000 km) or at 36 months**

- Change engine oil.
- Replace engine oil filter.

## MAINTENANCE SCHEDULES (Continued)

- Drain and refill transfer case fluid.
- Inspect brake linings.
- Flush and replace engine coolant at 36 months, regardless of mileage.
  - Inspect front wheel bearings. Clean and repack, if required (4x4).
  - **Inspect engine air cleaner element, replace as necessary (8.0L only).**

**42,000 Miles (67 000 km) or at 42 months**

- Change engine oil.
- Replace engine oil filter.

**48,000 Miles (77 000 km) or at 48 months**

- Change engine oil.
- Replace engine oil filter.
- **Replace engine air cleaner element and air pump filter.**
  - Drain and refill automatic transmission fluid. Replace filter and adjust bands.
  - Clean and lubricate crankcase inlet air filter (5.9L).
  - Inspect front wheel bearings. Clean and repack, if required (4x2).
  - Flush and replace engine coolant if not done at 36 months.

**54,000 Miles (86 000 km) or at 54 months**

- Change engine oil.
- Replace engine oil filter.
- Inspect brake linings.
- Inspect front wheel bearings. Clean and repack, if required (4x4).

**60,000 Miles (96 000 km) or at 60 months**

- Change engine oil.
- Replace engine oil filter.
- **Replace ignition cables.**
- **Replace PCV valve (5.9L).\***
- **Replace distributor cap and rotor (5.9L only).**
  - **Replace spark plugs.**
  - Flush and replace engine coolant if it has been 30,000 miles (48 000 km) or 24 months since last change.
  - **Inspect engine air cleaner element, replace as necessary (8.0L only).**

**66,000 Miles (106 000 km) or at 66 months**

- Change engine oil.
- Replace engine oil filter.

**72,000 Miles (115 000 km) or at 72 months**

- Change engine oil.
- Replace engine oil filter.
- **Replace engine air cleaner element and air pump filter.**

- Drain and refill automatic transmission fluid. Replace filter and adjust bands.

- Drain and refill transfer case fluid.
- Clean and lubricate crankcase inlet air filter (5.9L).
- Inspect front wheel bearings. Clean and repack, if required (all).
- Inspect brake linings.

**78,000 Miles (125 000 km) or at 78 months**

- Change engine oil.
- Replace engine oil filter.
- Flush and replace engine coolant if it has been 30,000 miles (48 000 km) or 24 months since last change.

**82,500 Miles (132 000 km) or at 82 months**

- Replace oxygen sensor (5.9L only).\*

**84,000 Miles (134 000 km) or at 84 months**

- Change engine oil.
- Replace engine oil filter.
- Flush and replace engine coolant if it has been 30,000 miles (48 000 km) or 24 months since last change.
  - **Inspect engine air cleaner element, replace as necessary (8.0L only).**

**90,000 Miles (144 000 km) or at 90 months**

- Change engine oil.
- Replace engine oil filter.
- Replace spark plugs.
- Inspect brake linings.
- Inspect front wheel bearings. Clean and repack, if required (4x4).

**96,000 Miles (154 000 km) or at 96 months**

- Change engine oil.
- Replace engine oil filter.
- **Replace engine air cleaner element and air pump filter.**
  - Drain and refill automatic transmission fluid. Replace filter and adjust bands.
  - Clean and lubricate crankcase inlet air filter (5.9L).
  - Inspect front wheel bearings. Clean and repack, if required (4x2).

**102,000 Miles (163 000 km) or at 102 months**

- Change engine oil.
- Replace engine oil filter.

**108,000 Miles (173 000 km) or at 108 months**

- Change engine oil.
- Replace engine oil filter.
- Drain and refill transfer case fluid.
- Inspect brake linings.



## MAINTENANCE SCHEDULES (Continued)

- Flush and replace engine coolant if it has been 30,000 miles (48 000 km) or 24 months since last change.

- Inspect front wheel bearings. Clean and repack, if required (4x4).

- **Inspect engine air cleaner element, replace as necessary (8.0L only).**

\*Requires Service Reminder Indicator Light. If so equipped, these parts are to be replaced at the indicated mileage or when the service reminder indicator light remains on continuously with the key in the "ON" position, whichever occurs first.

**HEAVY DUTY SCHEDULE "B"**

Follow this schedule if the vehicle is usually operated under one or more of the following conditions.

- Frequent short trips driving less than 5 miles (8km)
- Frequent driving in dusty conditions
- Frequent trailer towing
- Extensive idling
- More than 50% of the driving is at sustained high speeds during hot weather, above 90°F (32°C)

**3,000 Miles (5 000 km)**

- Change engine oil.
- Replace engine oil filter.
- Lubricate tie rod ends every 3,000 miles (5 000 km).

**6,000 Miles (10 000 km)**

- Change engine oil.
- Replace engine oil filter.
- Lubricate tie rod ends every 3,000 miles (5 000 km).
- Inspect front wheel bearings (4x4).

**9,000 Miles (14 000 km)**

- Change engine oil.
- Replace engine oil filter.
- Lubricate tie rod ends every 3,000 miles (5 000 km).
- Inspect front wheel bearings (4x2).

**12,000 Miles (19 000 km)**

- Change engine oil.
- Replace engine oil filter.
- **Inspect engine air cleaner element and air pump filter, replace as necessary.**
- Drain and refill automatic transmission fluid. Replace filter and adjust bands.‡
- Change rear axle fluid.
- Change front axle fluid (4x4).
- Inspect brake linings.
- Lubricate tie rod ends every 3,000 miles (5 000 km).
- Inspect front wheel bearings (4x4).

**15,000 Miles (24 000 km)**

- Change engine oil.
- Replace engine oil filter.
- Lubricate tie rod ends every 3,000 miles (5 000 km).

**18,000 Miles (29 000 km)**

- Change engine oil.
- Replace engine oil filter.
- Lubricate tie rod ends every 3,000 miles (5 000 km).
- Inspect front wheel bearings (4x4).
- Inspect front wheel bearings (4x2).
- Drain and refill transfer case fluid every 18,000 miles (4x4).

**21,000 Miles (34 000 km)**

- Change engine oil.
- Replace engine oil filter.
- Lubricate tie rod ends every 3,000 miles (5 000 km).

**24,000 Miles (38 000 km)**

- Change engine oil
- Replace engine oil filter.
- **Replace engine air cleaner element and air pump filter.**
- Drain and refill automatic transmission fluid. Replace filter and adjust bands.
- Change rear axle fluid.
- Change front axle fluid (4x4).
- Clean and lubricate crankcase inlet air filter (5.9L).
- Inspect front wheel bearings. Clean and repack, if required (4x2).
- Inspect brake linings.
- Lubricate tie rod ends every 3,000 miles (5 000 km).
- Inspect front wheel bearings (4x4).

**27,000 Miles (43 000 km)**

- Change engine oil.
- Replace engine oil filter.
- Lubricate tie rod ends every 3,000 miles (5 000 km).
- Inspect front wheel bearings (4x2).

**30,000 Miles (48 000 km)**

- Change engine oil.
- Replace engine oil filter.
- Lubricate tie rod ends every 3,000 miles (5 000 km).
- **Inspect PCV valve, replace as necessary (5.9L).**
- **Replace spark plugs.**
- Inspect front wheel bearings (4x4).



## MAINTENANCE SCHEDULES (Continued)

**33,000 Miles (53 000 km)**

- Change engine oil.
- Replace engine oil filter.
- Lubricate tie rod ends every 3,000 miles (5 000 km).

**36,000 Miles (58 000 km)**

- Change engine oil.
- Replace engine oil filter.
- **Inspect engine air cleaner element and air pump filter, replace as necessary.**

• Drain and refill automatic transmission fluid.

Replace filter and adjust bands.‡

- Drain and refill transfer case (4x4).
- Change rear axle fluid.
- Change front axle fluid (4x4).
- Inspect brake linings.
- Lubricate tie rod ends every 3,000 miles (5 000 km).
- Inspect front wheel bearings (4x4).
- Inspect front wheel bearings (4x2).

**39,000 Miles (62 000 km)**

- Change engine oil.
- Replace engine oil filter.
- Lubricate tie rod ends every 3,000 miles (5 000 km).

**42,000 Miles (67 000 km)**

- Change engine oil.
- Replace engine oil filter.
- Lubricate tie rod ends every 3,000 miles (5 000 km).
- Inspect front wheel bearings (4x4).

**45,000 Miles (72 000 km)**

- Change engine oil.
- Replace engine oil filter.
- Lubricate tie rod ends every 3,000 miles (5 000 km).
- Inspect front wheel bearings (4x2).
- Flush and replace engine coolant (36 months).

**48,000 Miles (77 000 km)**

- Change engine oil.
- Replace engine oil filter.
- **Replace engine air cleaner element and air pump filter.**

• Drain and refill automatic transmission fluid.

Replace filter and adjust bands.

- Change rear axle fluid.
- Change front axle fluid (4x4).
- Clean and lubricate crankcase inlet air filter (5.9L).
- Inspect front wheel bearings. Clean and repack, if required (4x2).

- Inspect brake linings.
- Flush and replace engine coolant.
- Lubricate tie rod ends every 3,000 miles (5 000 km).
- Inspect front wheel bearings (4x4).
- Drain and refill transfer case fluid every 18,000 miles (4x4).

**51,000 Miles (82 000 km)**

- Change engine oil.
- Replace engine oil filter.
- Lubricate tie rod ends every 3,000 miles (5 000 km).

**54,000 Miles (86 000 km)**

- Change engine oil.
- Replace engine oil filter.
- Lubricate tie rod ends every 3,000 miles (5 000 km).
- Inspect front wheel bearings (4x4).
- Inspect front wheel bearings (4x2).
- Drain and refill transfer case (4x4).

**57,000 Miles (91 000 km)**

- Change engine oil.
- Replace engine oil filter.
- Lubricate tie rod ends every 3,000 miles (5 000 km).

**60,000 Miles (96 000 km)**

- Change engine oil.
- Replace engine oil filter.
- **Inspect engine air cleaner element and air pump filter, replace as necessary.**
- **Replace PCV valve (5.9L).\***
- **Replace distributor cap and rotor (5.9L).**
- **Replace ignition cables.**
- **Replace spark plugs.**
- Clean EGR passages (5.9L if so equipped).\*
- Replace EGR valve (5.9L if so equipped).\*
- Drain and refill automatic transmission fluid.

Replace filter and adjust bands.‡

- Change rear axle fluid.
- Change front axle fluid (4x4).
- Inspect brake linings.
- Lubricate tie rod ends every 3,000 miles (5 000 km).
- Inspect front wheel bearings (4x4).

**63,000 Miles (101 000 km)**

- Change engine oil.
- Replace engine oil filter.
- Lubricate tie rod ends every 3,000 miles (5 000 km).
- Inspect front wheel bearings (4x2).

## MAINTENANCE SCHEDULES (Continued)

**66,000 Miles (106 000 km)**

- Change engine oil.
- Replace engine oil filter.
- Lubricate tie rod ends every 3,000 miles (5 000 km).
- Inspect front wheel bearings (4x4).

**69,000 Miles (110 000 km)**

- Change engine oil.
- Replace engine oil filter.
- Lubricate tie rod ends every 3,000 miles (5 000 km).

**72, 000 Miles (115 000 km)**

- Change engine oil.
- Replace engine oil filter.
- **Replace engine air cleaner element and air pump filter.**
- Clean and lubricate crankcase inlet air filter (5.9L).
- Drain and refill automatic transmission fluid. Replace filter and adjust bands.
- Drain and refill transfer case fluid (4x4).
- Change rear axle fluid.
- Change front axle fluid (4x4).
- Inspect front wheel bearings. Clean and repack, if required (4x2).
- Inspect brake linings.
- Lubricate tie rod ends every 3,000 miles (5 000 km).
- Inspect front wheel bearings (4x4).
- Inspect front wheel bearings (4x2).

**75,000 Miles (120 000 km)**

- Change engine oil.
- Replace engine oil filter.
- Lubricate tie rod ends every 3,000 miles (5 000 km).

**78,000 Miles (125 000 km)**

- Change engine oil.
- Replace engine oil filter.
- Flush and replace engine coolant if it has been 30,000 miles (48 000 km) since last change.
- Lubricate tie rod ends every 3,000 miles (5 000 km).
- Inspect front wheel bearings (4x4).

**81,000 Miles (130 000 km)**

- Change engine oil.
- Replace engine oil filter.
- Lubricate tie rod ends every 3,000 miles (5 000 km).
- Inspect front wheel bearings (4x2).

**82,500 Miles (132 000 km)**

- Replace oxygen sensor (5.9L only).\*

**84,000 Miles (134 000 km)**

- Change engine oil.
- Replace engine oil filter.
- **Inspect engine air cleaner element and air pump filter, replace as necessary.**
- Drain and refill automatic transmission fluid. Replace filter and adjust bands.‡
- Change rear axle fluid.
- Change front axle fluid (4x4).
- Inspect brake linings.
- Lubricate tie rod ends every 3,000 miles (5 000 km).
- Inspect front wheel bearings (4x4).

**87,000 Miles (139 000 km)**

- Change engine oil.
- Replace engine oil filter.
- Lubricate tie rod ends every 3,000 miles (5 000 km).

**90,000 Miles (144 000 km)**

- Change engine oil.
- Replace engine oil filter.
- Lubricate tie rod ends every 3,000 miles (5 000 km).
- **Inspect PCV valve, replace as necessary (5.9L).**
- **Replace spark plugs.**
- Inspect front wheel bearings (4x4).
- Inspect front wheel bearings (4x2).
- Drain and refill transfer case fluid (4x4).

**93,000 Miles (149 000 km)**

- Change engine oil.
- Replace engine oil filter.
- Lubricate tie rod ends every 3,000 miles (5 000 km).

**96,000 Miles (154 000 km)**

- Change engine oil.
- Replace engine oil filter.
- **Replace engine air cleaner element and air pump filter.**
- Drain and refill automatic transmission fluid. Replace filter and adjust bands.
- Change rear axle fluid.
- Change front axle fluid (4x4).
- Clean and lubricate crankcase inlet air filter (5.9L).
- Inspect front wheel bearings. Clean and repack, if required (4x2).
- Inspect brake linings.
- Lubricate tie rod ends every 3,000 miles (5 000 km).
- Inspect front wheel bearings (4x4).

## MAINTENANCE SCHEDULES (Continued)

**99,000 Miles (156 000 km)**

- Change engine oil.
- Replace engine oil filter.
- Lubricate tie rod ends every 3,000 miles (5 000 km).
- Inspect front wheel bearings (4x2).

**102,000 Miles (163 000 km)**

- Change engine oil.
- Replace engine oil filter.
- Lubricate tie rod ends every 3,000 miles (5 000 km).
- Inspect front wheel bearings (4x4).

**105,000 Miles (168 000 km)**

- Change engine oil.
- Replace engine oil filter.
- Lubricate tie rod ends every 3,000 miles (5 000 km).

**108,000 Miles (173 000 km)**

- Change engine oil.
- Replace engine oil filter.
- **Inspect engine air cleaner element and air pump filter, replace as necessary.**
- Drain and refill automatic transmission fluid. Replace filter and adjust bands.‡
- Drain and refill transfer case fluid (4x4).
- Change rear axle fluid.
- Change front axle fluid (4x4).
- Inspect brake linings.
- Flush and replace engine coolant if it has been 30,000 miles (48 000 km) since last change.
- Lubricate tie rod ends every 3,000 miles (5 000 km).
- Inspect front wheel bearings (4x4).
- Inspect front wheel bearings (4x2).

\*Requires Service Reminder Indicator Light. If so equipped, these parts are to be replaced at the indicated mileage or when the service reminder indicator light remains on continuously with the key in the "ON" position, whichever occurs first.

‡Off-the-highway operation, trailer towing, snow plowing, prolonged operation with heavy loading, especially in hot weather require the more frequent transmission service indicated with a ‡ in Schedule "B". Perform these services if you usually operate your Ram Truck under these conditions.

Inspection and service should also be performed anytime a malfunction is observed or suspected.

## DESCRIPTION - MAINTENANCE SCHEDULES — 24-VALVE CUMMINS TURBO DIESEL

There are two maintenance schedules that show proper service for the vehicle.

First is Schedule "A." It lists all the scheduled maintenance to be performed under "normal" operating conditions.

Second is Schedule "B." It is a schedule for vehicles that are operated under the conditions listed at the beginning of that schedule.

Use the schedule that best describes the driving conditions.

Where time and mileage are listed, follow the interval that occurs first.

**At Each Stop For Fuel**

- Check engine oil level and add as required.
- Check windshield washer solvent and add if required.
- Clean windshield and wiper blades as required.
- Drain water from fuel filter.

**Once A Month**

- Check tire pressure and look for unusual wear or damage.
- Inspect battery and clean and tighten terminals as required.
- Check fluid levels of coolant reservoir, brake master cylinder, power steering, and transmission. Add fluid as required.
- Check all lights and all other electrical items for correct operation.
- **Check Filter Minder™. Replace air cleaner element if necessary.**
- Inspect and clean wiper blades. Replace if required.

**At Each Oil Change**

- Inspect exhaust system.
- Inspect brake hoses.
- Adjust rear brakes.
- Rotate the tires at each oil change interval shown at 7, 5000 miles (12 000 km) on schedule "A" or every other interval shown at 7,500 miles (12 000 km) on schedule "B".
- Check engine coolant level, hoses, and clamps.
- Lubricate steering linkage.
- Drain crankcase breather canister (if equipped).

**EMISSION CONTROL SYSTEM MAINTENANCE**

The scheduled emission maintenance listed in **bold type** on the Maintenance Schedules, must be done at the mileage specified to assure the continued proper functioning of the emission control system. These, and all other maintenance services included in this manual, should be done to provide the best vehicle performance and reliability. More frequent maintenance may be needed for vehicles in severe operating conditions such as dusty areas and very short trip driving.

## MAINTENANCE SCHEDULES (Continued)

**FLUID FILL LOCATIONS AND LUBRICATION POINTS**

The fluid fill/check locations and lubrication points are located in each applicable group.

**SCHEDULE "A"****7,500 Miles (12 000 km) or at 6 months**

- Change engine oil and filter.
- Drain crankcase breather canister (if equipped).

**15,000 Miles (24 000 km) or at 12 months**

- Change engine oil and filter.
- Drain crankcase breather canister (if equipped).
- Inspect water pump weep hole for blockage.
- Replace fuel filter and clean water in fuel sensor.

sensor.

**22,500 Miles (36 000 km) or at 18 months**

- Change engine oil and filter.
- Drain crankcase breather canister (if equipped).
- Inspect drive belts, replace as necessary.
- Inspect brake linings.

**30,000 Miles (48 000 km) or at 24 months**

- Change engine oil and filter.
- Drain crankcase breather canister (if equipped).
- Inspect fan hub.
- Inspect damper.
- Inspect water pump weep hole for blockage.
- Replace fuel filter and clean water in fuel sensor.

sensor.

• Drain and refill automatic transmission fluid. Replace filter and adjust bands.

- Inspect front wheel bearings. Clean and repack, if required (4x2).
- Flush and replace engine coolant if not done at 36 months.

**37,500 Miles (60 000 km) or at 30 months**

- Change engine oil and filter.
- Drain crankcase breather canister (if equipped).

**45,000 Miles (72 000 km) or at 36 months**

- Change engine oil and filter.
- Drain crankcase breather canister (if equipped).
- Inspect drive belts, replace as necessary.
- Inspect water pump weep hole for blockage.
- Replace fuel filter and clean water in fuel sensor.

sensor.

- Drain and refill transfer case fluid.
- Inspect brake linings.
- Flush and replace engine coolant if not done at 24 months

24 months

**52,500 Miles (84 000 km) or at 42 months**

- Change engine oil and filter.
- Drain crankcase breather canister (if equipped).

**60,000 Miles (96 000 km) or at 48 months**

- Change engine oil and filter.
- Drain crankcase breather canister (if equipped).
- Drain and refill automatic transmission fluid.

Replace filter and adjust bands.

- Inspect fan hub.
- Inspect damper.
- Inspect front wheel bearings. Clean and repack, if required (4x2).
- Inspect water pump weep hole for blockage.
- Replace fuel filter and clean water in fuel sensor.

sensor.

**67,500 Miles (108 000 km) or at 54 months**

- Change engine oil and filter.
- Drain crankcase breather canister (if equipped).
- Inspect drive belts, replace as necessary.
- Inspect brake linings.

**75,000 Miles (120 000 km) or at 60 months**

- Change engine oil and filter.
- Drain crankcase breather canister (if equipped).
- Inspect water pump weep hole for blockage.
- Replace fuel filter and clean water in fuel sensor.

• Flush and replace engine coolant if it has been 30,000 miles (48 000 km) or 24 months since last change.

**82,500 Miles (132 000 km) or at 66 months**

- Change engine oil and filter.
- Drain crankcase breather canister (if equipped).

**90,000 Miles (144 000 km) or at 72 months**

- Change engine oil and filter.
- Drain crankcase breather canister (if equipped).
- Inspect drive belt, replace as required.
- Drain and refill automatic transmission fluid.

Replace filter and adjust bands.

- Drain and refill transfer case fluid.
- Inspect fan hub.
- Inspect damper.
- Inspect water pump weep hole for blockage.
- Replace fuel filter and clean water in fuel sensor.

sensor.

• Inspect front wheel bearings. Clean and repack, if required (4x2).

- Inspect brake linings.

**97,500 Miles (156 000 km) or at 78 months**

- Change engine oil and filter.
- Drain crankcase breather canister (if equipped).



## MAINTENANCE SCHEDULES (Continued)

- Flush and replace engine coolant if it has been 30,000 miles (48 000 km) or 24 months since last change.

**105,000 Miles (168 000 km) or at 84 months**

- Change engine oil and filter.
- Drain crankcase breather canister (if equipped).
- Inspect water pump weep hole for blockage.
- Replace fuel filter and clean water in fuel sensor.
- Flush and replace engine coolant if it has been 30,000 miles (48 000 km) or 24 months since last change.

**112,500 Miles (181 000 km) or at 90 months**

- Change engine oil and filter.
- Drain crankcase breather canister (if equipped).
- Inspect drive belts, replace if necessary.
- Inspect brake linings.

**120,000 Miles (193 000 km) or at 96 months**

- Change engine oil and filter.
- Drain crankcase breather canister (if equipped).
- Drain and refill automatic transmission fluid. Replace filter and adjust bands.
- Inspect fan hub.
- Inspect damper.
- Inspect front wheel bearings. Clean and repack, if required (4x2).
- Inspect water pump weep hole for blockage.
- Replace fuel filter and clean water in fuel sensor.

**127,500 Miles (205 000 km) or at 102 months**

- Change engine oil and filter.
- Drain crankcase breather canister (if equipped).

**135,000 Miles (217 000 km) or at 108 months**

- Change engine oil and filter.
- Drain crankcase breather canister (if equipped).
- Inspect drive belts, replace as necessary.
- Inspect water pump weep hole for blockage.
- Replace fuel filter and clean water in fuel sensor.
- Drain and refill transfer case fluid.
- Inspect brake linings.
- Flush and replace engine coolant if it has been 30,000 miles (48 000 km) or 24 months since last change.

**142,500 Miles (229 000 km) or at 114 months**

- Change engine oil and filter.
- Drain crankcase breather canister (if equipped).
- Drain and refill automatic transmission fluid. Replace filter and adjust bands.
- Inspect fan hub.
- Inspect damper.

- Inspect front wheel bearings. Clean and repack, if required (4x2).
- Inspect water pump weep hole for blockage.

**150,000 Miles (241 000 km) or at 150 months**

- Change engine oil and filter.
- Drain crankcase breather canister (if equipped).
- Adjust valve lash clearance.
- Replace fuel filter and clean water in fuel sensor.

**SCHEDULE "B"**

Follow this schedule if you usually operate your vehicle under one or more of the following conditions.

- Frequent short driving less than 5 miles (8 km);
- Frequent driving in dusty conditions;
- Frequent trailer towing;
- Extensive idling;
- More than 50% of your driving is at sustained high speeds during hot weather, above 90°F (32°C).

**3,750 Miles (6 000 km)**

- Change engine oil and filter.
- Drain crankcase breather canister (if equipped).

**7,500 Miles (12 000 km)**

- Change engine oil and filter.
- Drain crankcase breather canister (if equipped).
- Replace fuel filter and clean water in fuel sensor.

**11,250 Miles (18 000 km)**

- Change engine oil and filter.
- Drain crankcase breather canister (if equipped).

**15,000 Miles (24 000 km)**

- Change engine oil and filter.
- Drain crankcase breather canister (if equipped).
- Inspect water pump weep hole for blockage.
- Replace fuel filter and clean water in fuel sensor.

• Drain and refill automatic transmission fluid. Replace filter and adjust bands.

- Change rear axle fluid.
- Change front axle fluid (4x4).
- Inspect brake linings.

**18,750 Miles (30 000 km)**

- Change engine oil and filter.
- Drain crankcase breather canister (if equipped).

**22,500 Miles (36 000 km)**

- Change engine oil and filter.
- Drain crankcase breather canister (if equipped).
- Inspect drive belts, replace as necessary.
- Replace fuel filter and clean water in fuel sensor.



## MAINTENANCE SCHEDULES (Continued)

**26,250 Miles (42 000 km)**

- Change engine oil and filter.
- Drain crankcase breather canister (if equipped).

**30,000 Miles (48 000 km)**

- Change engine oil and filter.
- Drain crankcase breather canister (if equipped).
- Inspect fan hub.
- Inspect damper.
- Inspect water pump weep hole for blockage.
- Replace fuel filter and clean water in fuel sensor.
- Drain and refill automatic transmission fluid.

Replace filter and adjust bands.

- Change rear axle fluid.
- Change front axle fluid (4x4).
- Inspect front wheel bearings. Clean and repack, if required (4x2).
- Inspect brake linings.

**33,700 Miles (54 000 km)**

- Change engine oil and filter.
- Drain crankcase breather canister (if equipped).

**37,500 Miles (60 000 km)**

- Change engine oil and filter.
- Drain crankcase breather canister (if equipped).
- Replace fuel filter and clean water in fuel sensor.

**41,250 Miles (66 000 km)**

- Change engine oil and filter.
- Drain crankcase breather canister (if equipped).

**45,000 Miles (72 000 km)**

- Change engine oil and filter.
- Drain crankcase breather canister (if equipped).
- Inspect drive belts, replace as necessary.
- Inspect water pump weep hole for blockage.
- Replace fuel filter and clean water in fuel sensor.
- Drain and refill automatic transmission fluid.

Replace filter and adjust bands.

- Drain and refill transfer case fluid.
- Change rear axle fluid.
- Change front axle fluid (4x4).
- Inspect brake linings.

**48,750 Miles (78,000 km)**

- Change engine oil and filter.
- Drain crankcase breather canister (if equipped).

**52,500 Miles (84 000 km)**

- Change engine oil and filter.
- Drain crankcase breather canister (if equipped).
- Replace fuel filter and clean water in fuel sensor.

**56,250 Miles (90 000 km)**

- Change engine oil and filter.
- Drain crankcase breather canister (if equipped).

**60,000 Miles (96 000 km)**

- Change engine oil and filter.
- Drain crankcase breather canister (if equipped).
- Inspect fan hub.
- Inspect damper.
- Inspect water pump weep hole for blockage.
- Replace fuel filter and clean water in fuel sensor.
- Drain and refill automatic transmission fluid.

Replace filter and adjust bands.

- Change rear axle fluid.
- Change front axle fluid (4x4).
- Inspect front wheel bearings. Clean and repack if required (4x2).
- Inspect brake linings.
- Flush and replace engine coolant.

**63,750 Miles (102 000 km)**

- Change engine oil and filter.
- Drain crankcase breather canister (if equipped).

**67,500 Miles (108 000 km)**

- Change engine oil and filter.
- Drain crankcase breather canister (if equipped).
- Inspect drive belts, replace as necessary.
- Replace fuel filter and clean water in fuel sensor.

**71,250 Miles (114 000 km)**

- Change engine oil and filter.
- Drain crankcase breather canister (if equipped).

**75,000 Miles (120 000 km)**

- Change engine oil and filter.
- Drain crankcase breather canister (if equipped).
- Inspect water pump weep hole for blockage.
- Replace fuel filter and clean water in fuel sensor.
- Drain and refill automatic transmission fluid.

Replace filter and adjust bands.

- Change rear axle fluid.
- Change front axle fluid (4x4).
- Inspect brake linings.

**78,750 Miles (126 000 km)**

- Change engine oil and filter.
- Drain crankcase breather canister (if equipped).

**82,500 Miles (132 000 km)**

- Change engine oil and filter.
- Drain crankcase breather canister (if equipped).
- Replace fuel filter and clean water in fuel sensor.

## MAINTENANCE SCHEDULES (Continued)

**86,250 Miles (138 000 km)**

- Change engine oil and filter.
- Drain crankcase breather canister (if equipped).

**90,000 Miles (144 000 km)**

- Change engine oil and filter.
- Drain crankcase breather canister (if equipped).
- Inspect drive belts, replace as necessary.
- Inspect fan hub.
- Inspect damper.
- Inspect water pump weep hole for blockage.
- Replace fuel filter and clean water in fuel sensor.
- Drain and refill automatic transmission fluid.

Replace filter and adjust bands.

- Drain and refill transfer case fluid.
- Change rear axle fluid.
- Change front axle fluid (4x4).
- Inspect front wheel bearings. Clean and repack if required (4x2).
- Inspect brake linings.

**93,750 Miles (150 000 km)**

- Change engine oil and filter.
- Drain crankcase breather canister (if equipped).

**97,500 Miles (156 000 km)**

- Change engine oil and filter.
- Drain crankcase breather canister (if equipped).
- Flush and replace engine coolant.
- Replace fuel filter and clean water in fuel sensor.
- Adjust rear brakes.

**101,250 Miles (162 000 km)**

- Change engine oil and filter.
- Drain crankcase breather canister (if equipped).

**105,000 Miles (168 000 km)**

- Change engine oil and filter.
- Drain crankcase breather canister (if equipped).
- Inspect water pump weep hole for blockage.
- Replace fuel filter and clean water in fuel sensor.

Drain and refill automatic transmission fluid.

Replace filter and adjust bands.

- Change rear axle fluid.
- Change front axle fluid (4x4).
- Inspect brake linings.

**108,750 Miles (174 000 km)**

- Change engine oil and filter.
- Drain crankcase breather canister (if equipped).

**112,500 Miles (180 000 km)**

- Change engine oil and filter.
- Drain crankcase breather canister (if equipped).
- Inspect drive belts, replace as necessary.

- Replace fuel filter and clean water in fuel sensor.

**116,250 Miles (186 000 km)**

- Change engine oil and filter.
- Drain crankcase breather canister (if equipped).

**120,000 Miles (192 000 km)**

- Change engine oil and filter.
- Drain crankcase breather canister (if equipped).
- Inspect fan hub.
- Inspect damper.
- Inspect water pump weep hole for blockage.
- Replace fuel filter and clean water in fuel sensor.

Drain and refill automatic transmission fluid.

Replace filter and adjust bands.

- Change rear axle fluid.
- Change front axle fluid (4x4).
- Inspect front wheel bearings. Clean and repack if required (4x2).
- Inspect brake linings.

**123,750 Miles (198 000 km)**

- Change engine oil and filter.
- Drain crankcase breather canister (if equipped).

**127,500 Miles (204 000 km)**

- Change engine oil and filter.
- Drain crankcase breather canister (if equipped).
- Replace fuel filter and clean water in fuel sensor.

**131,250 Miles (210 000 km)**

- Change engine oil and filter.
- Drain crankcase breather canister (if equipped).

**135,000 Miles (216 000 km)**

- Change engine oil and filter.
- Drain crankcase breather canister (if equipped).
- Clean inside of engine air cleaner element housing.

- Inspect drive belts, replace as necessary.
- Inspect water pump weep hole for blockage.
- Replace fuel filter and clean water in fuel sensor.

Adjust valve lash clearance

Drain and refill automatic transmission fluid.

Replace filter and adjust bands.

- Drain and refill transfer case fluid.
- Change rear axle fluid.
- Change front axle fluid (4x4).
- Inspect brake linings.
- Flush and replace engine coolant.
- Adjust rear brakes

Inspection and service should also be performed anytime a malfunction is observed or suspected.

## JUMP STARTING

### STANDARD PROCEDURE

**WARNING: REVIEW ALL SAFETY PRECAUTIONS AND WARNINGS IN GROUP 8A, BATTERY/STARTING/CHARGING SYSTEMS DIAGNOSTICS. DO NOT JUMP START A FROZEN BATTERY, PERSONAL INJURY CAN RESULT. DO NOT JUMP START WHEN MAINTENANCE FREE BATTERY INDICATOR DOT IS YELLOW OR BRIGHT COLOR. DO NOT JUMP START A VEHICLE WHEN THE BATTERY FLUID IS BELOW THE TOP OF LEAD PLATES. DO NOT ALLOW JUMPER CABLE CLAMPS TO TOUCH EACH OTHER WHEN CONNECTED TO A BOOSTER SOURCE. DO NOT USE OPEN FLAME NEAR BATTERY. REMOVE METALLIC JEWELRY WORN ON HANDS OR WRISTS TO AVOID INJURY BY ACCIDENTAL ARCING OF BATTERY CURRENT. WHEN USING A HIGH OUTPUT BOOSTING DEVICE, DO NOT ALLOW BATTERY VOLTAGE TO EXCEED 16 VOLTS. REFER TO INSTRUCTIONS PROVIDED WITH DEVICE BEING USED.**

**CAUTION:** When using another vehicle as a booster, do not allow vehicles to touch. Electrical systems can be damaged on either vehicle.

#### TO JUMP START A DISABLED VEHICLE:

(1) Raise hood on disabled vehicle and visually inspect engine compartment for:

- Battery cable clamp condition, clean if necessary.
- Frozen battery.
- Yellow or bright color test indicator, if equipped.
- Low battery fluid level.
- Generator drive belt condition and tension.
- Fuel fumes or leakage, correct if necessary.

**CAUTION:** If the cause of starting problem on disabled vehicle is severe, damage to booster vehicle charging system can result.

(2) When using another vehicle as a booster source, park the booster vehicle within cable reach. Turn off all accessories, set the parking brake, place the automatic transmission in PARK or the manual transmission in NEUTRAL and turn the ignition OFF.

(3) On disabled vehicle, place gear selector in park or neutral and set park brake. Turn off all accessories.

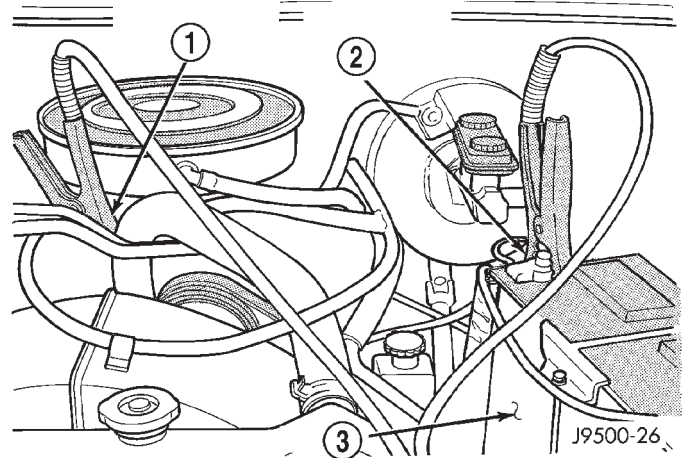
(4) Connect jumper cables to booster battery. RED clamp to positive terminal (+). BLACK clamp to negative terminal (-). DO NOT allow clamps at opposite end of cables to touch, electrical arc will result. Review all warnings in this procedure.

(5) On disabled vehicle, connect RED jumper cable clamp to positive (+) terminal. Connect BLACK jumper cable clamp to engine ground as close to the ground cable attaching point as possible (Fig. 7) and (Fig. 8).

(6) Start the engine in the vehicle which has the booster battery, let the engine idle a few minutes, then start the engine in the vehicle with the discharged battery.

**CAUTION:** Do not crank starter motor on disabled vehicle for more than 15 seconds, starter will overheat and could fail.

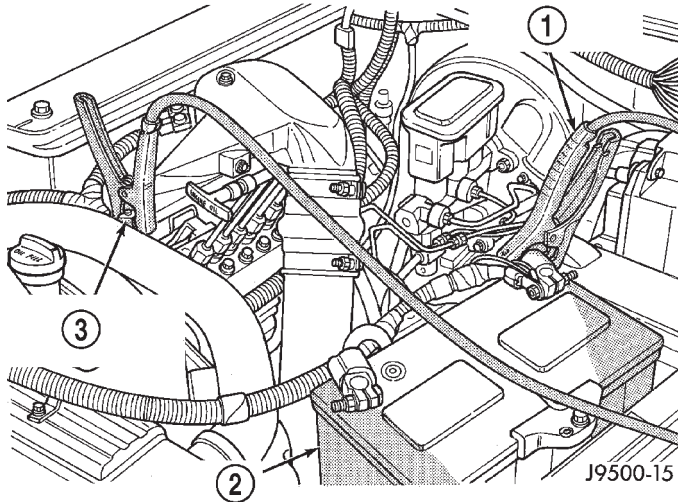
(7) Allow battery in disabled vehicle to charge to at least 12.4 volts (75% charge) before attempting to start engine. If engine does not start within 15 seconds, stop cranking engine and allow starter to cool (15 min.), before cranking again.



**Fig. 7 Jumper Cable Clamp Connections—Gas Engine**

- 1 - NEGATIVE OR GROUND CABLE CONNECTION
- 2 - POSITIVE CABLE CONNECTION
- 3 - BATTERY

## JUMP STARTING (Continued)



**Fig. 8 Jumper Cable Clamp Connections—Diesel Engine**

- 1 - POSITIVE CABLE CONNECTION
- 2 - BATTERY
- 3 - NEGATIVE OR GROUND CABLE CONNECTION

## DISCONNECT CABLE CLAMPS AS FOLLOWS:

- Disconnect BLACK cable clamp from engine ground on disabled vehicle.
- When using a Booster vehicle, disconnect BLACK cable clamp from battery negative terminal. Disconnect RED cable clamp from battery positive terminal.
- Disconnect RED cable clamp from battery positive terminal on disabled vehicle.

## HOISTING

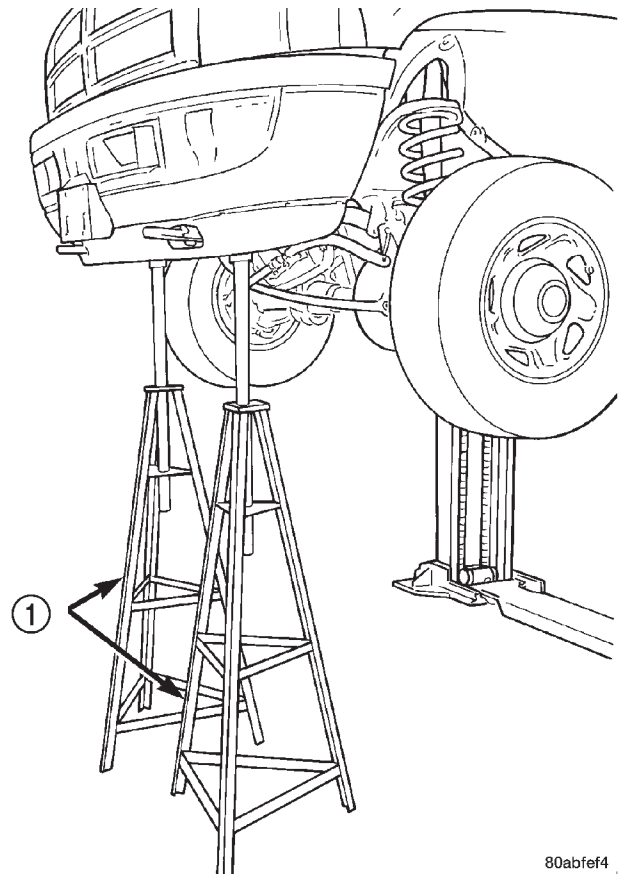
## STANDARD PROCEDURE

Refer to the Owner's Manual for emergency vehicle lifting procedures.

**WARNING: THE HOISTING AND JACK LIFTING POINTS PROVIDED ARE FOR A COMPLETE VEHICLE. WHEN A CHASSIS OR DRIVETRAIN COMPONENT IS REMOVED FROM A VEHICLE, THE CENTER OF GRAVITY IS ALTERED MAKING SOME HOISTING CONDITIONS UNSTABLE. PROPERLY SUPPORT (Fig. 9) OR SECURE VEHICLE TO HOISTING DEVICE WHEN THESE CONDITIONS EXIST.**

## FLOOR JACK

When properly positioned, a floor jack can be used to lift a vehicle (Fig. 10). Support the vehicle in the raised position with jack stands at the front and rear ends of the frame rails (Fig. 9).



**Fig. 9 Safety Stands**

- 1 - SAFETY STANDS

**CAUTION: Do not lift vehicle with a floor jack positioned under:**

- An axle tube.
- A body side sill.
- A steering linkage component.
- A drive shaft.
- The engine or transmission oil pan.
- The fuel tank.
- A front suspension arm.

**NOTE: Use the correct frame rail lifting locations only (Fig. 11).**

## HOIST

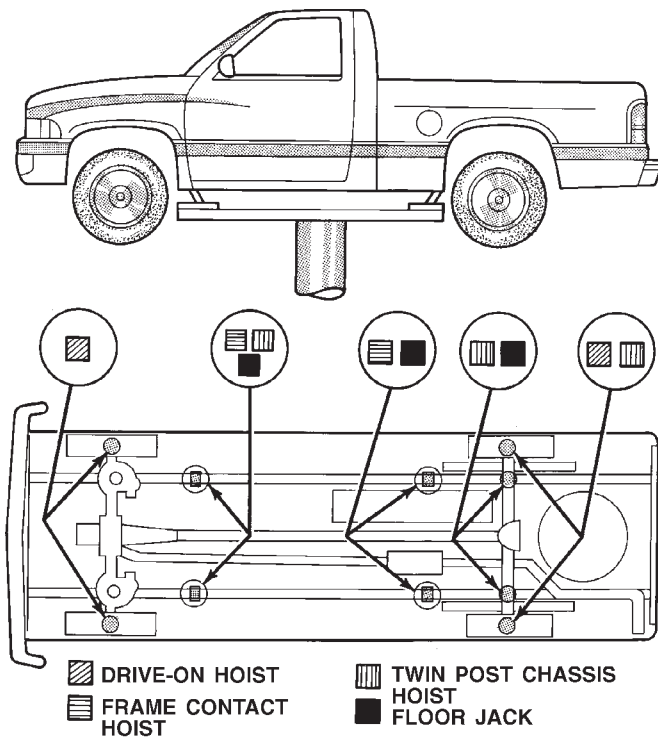
A vehicle can be lifted with:

- A single-post, frame-contact hoist.
- A twin-post, chassis hoist.
- A ramp-type, drive-on hoist.



## HOISTING (Continued)

**NOTE:** When a frame-contact type hoist is used, verify that the lifting pads are positioned properly (Fig. 10). The forward lifting pads should be positioned a minimum of 5 inches forward of the cross-member bolt access holes (Fig. 11).



J9500-5

Fig. 10 Vehicle Lifting Locations

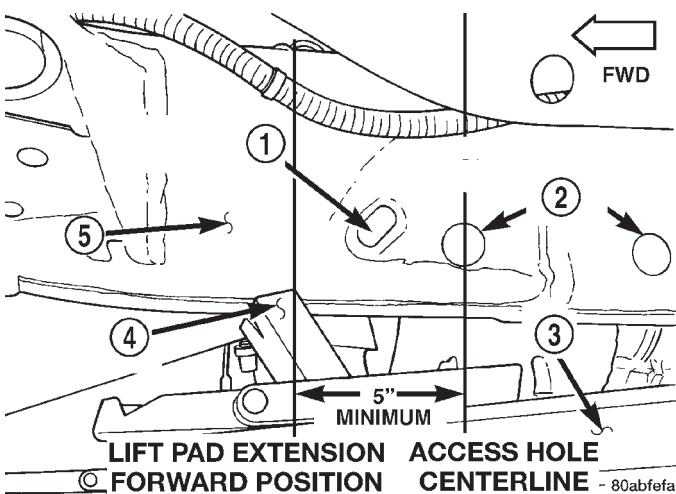


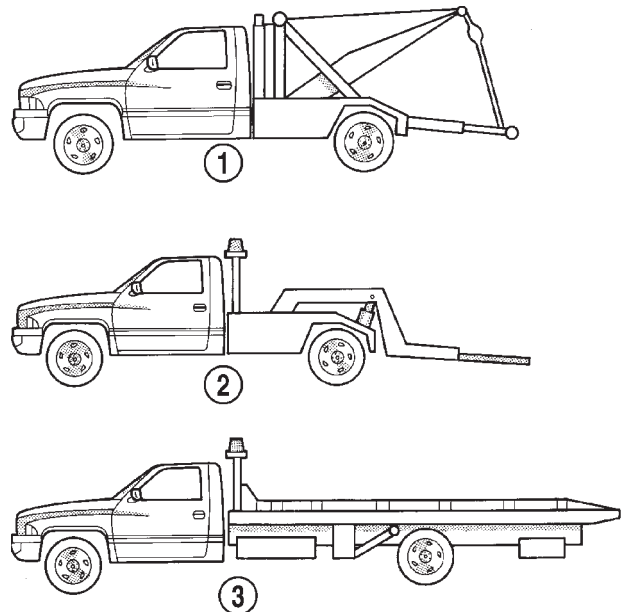
Fig. 11 Front Lift Pad Location

- 1 - SHIPPING TIE DOWN SLOT
- 2 - CROSSMEMBER BOLT ACCESS HOLE
- 3 - LIFTARM
- 4 - LIFT PAD EXTENSION
- 5 - FRAME RAIL

## TOWING

## STANDARD PROCEDURE

A vehicle equipped with SAE approved sling-type towing equipment can be used to tow all vehicles. When towing a 4WD vehicle using a wheel-lift towing device, use tow dollies under the opposite end of the vehicle. A vehicle with flat-bed device can also be used to transport a disabled vehicle (Fig. 12).



J9500-6

Fig. 12 Tow Vehicles With Approved Equipment

- 1 - SLING TYPE
- 2 - WHEEL LIFT
- 3 - FLAT BED

A wooden crossbeam may be required for proper connection when using the sling-type, front-end towing method.

## SAFETY PRECAUTIONS

**CAUTION:** The following safety precautions must be observed when towing a vehicle:

- Secure loose and protruding parts.
- Always use a safety chain system that is independent of the lifting and towing equipment.
- Do not allow towing equipment to contact the disabled vehicle's fuel tank.
- Do not allow anyone under the disabled vehicle while it is lifted by the towing device.
- Do not allow passengers to ride in a vehicle being towed.
- Always observe state and local laws regarding towing regulations.



## TOWING (Continued)

- Do not tow a vehicle in a manner that could jeopardize the safety of the operator, pedestrians or other motorists.
- Do not attach tow chains, T-hooks, J-hooks, or a tow sling to a bumper, steering linkage, drive shafts or a non-reinforced frame hole.
- Do not tow a heavily loaded vehicle. Damage to the cab, cargo box or frame may result. Use a flatbed device to transport a loaded vehicle.

## GROUND CLEARANCE

**CAUTION:** If vehicle is towed with wheels removed, install lug nuts to retain brake drums or rotors.

A towed vehicle should be raised until lifted wheels are a minimum 100 mm (4 in) from the ground. Be sure there is adequate ground clearance at the opposite end of the vehicle, especially when towing over rough terrain or steep rises in the road. If necessary, remove the wheels from the lifted end of the vehicle and lower the vehicle closer to the ground, to increase the ground clearance at the opposite end of the vehicle. Install lug nuts on wheel attaching studs to retain brake drums or rotors.

## RAMP ANGLE

If a vehicle with flat-bed towing equipment is used, the approach ramp angle should not exceed 15 degrees.

## TOWING WHEN KEYS ARE NOT AVAILABLE

When the vehicle is locked and keys are not available, use a flat bed hauler. A Wheel-lift or Sling-type device can be used on 4WD vehicles provided **all the wheels are lifted off the ground using tow dollies.**

## FOUR-WHEEL-DRIVE VEHICLE TOWING

Chrysler Corporation recommends that a vehicle be transported on a flat-bed device. A Wheel-lift or Sling-type device can be used provided **all the wheels are lifted off the ground using tow dollies.**

**WARNING:** WHEN TOWING A DISABLED VEHICLE AND THE DRIVE WHEELS ARE SECURED IN A WHEEL LIFT OR TOW DOLLIES, ENSURE THE TRANSMISSION IS IN THE PARK POSITION (AUTOMATIC TRANSMISSION) OR A FORWARD DRIVE GEAR (MANUAL TRANSMISSION).

**CAUTION:** Many vehicles are equipped with air dams, spoilers, and/or ground effect panels. To avoid component damage, a wheel-lift towing vehicle or a flat-bed hauling vehicle is recommended.

# SUSPENSION

## TABLE OF CONTENTS

	page		page
WHEEL ALIGNMENT .....	1	FRONT - 4WD .....	14
FRONT - 2WD .....	7	REAR .....	26

## WHEEL ALIGNMENT

### TABLE OF CONTENTS

	page		page
WHEEL ALIGNMENT		ALIGNMENT INDEPENDENT FRONT	
DESCRIPTION .....	1	SUSPENSION .....	2
OPERATION .....	2	CASTER CORRECTION MEASUREMENT .....	3
DIAGNOSIS AND TESTING .....	2	ALIGNMENT LINK/COIL SUSPENSION .....	5
PRE-ALIGNMENT .....	2	SPECIFICATIONS .....	6
STANDARD PROCEDURE .....	2		

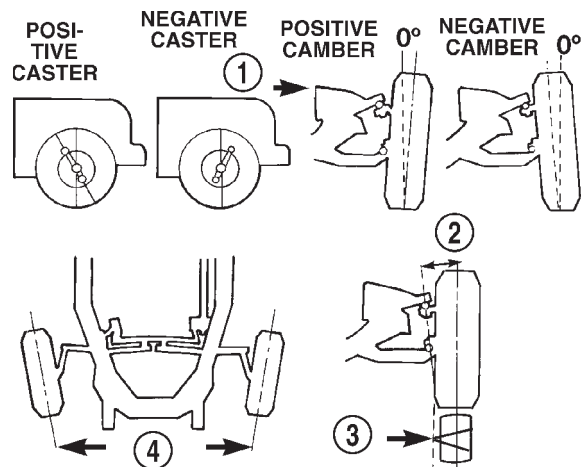
## WHEEL ALIGNMENT

### DESCRIPTION

Wheel alignment is the positioning of the wheels in relation to the vehicle. This is accomplished through suspension and steering linkage adjustments. An alignment is essential for efficient steering, good directional stability and to minimize tire wear. The most important measurements of an alignment are caster, camber and toe position (Fig. 1) and (Fig. 2).

**CAUTION:** Do not attempt to modify any suspension or steering components by heating and bending.

**NOTE:** Periodic lubrication of the front suspension/steering system components may be required. Rubber bushings must never be lubricated. Refer to *Lubrication And Maintenance* for the recommended maintenance schedule.

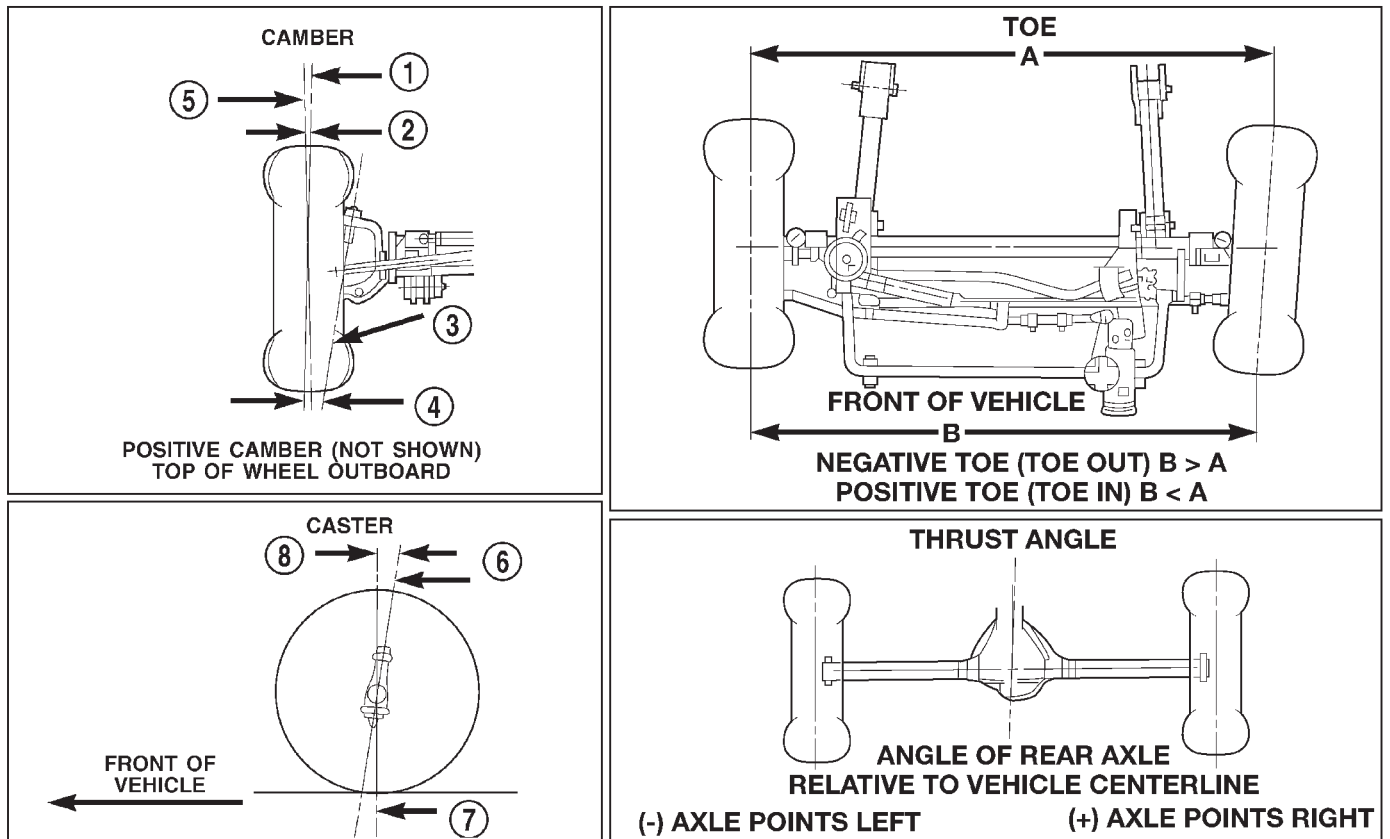


80b0d70b

**Fig. 1 Alignment Angles - Independent Front Suspension**

- 1 - FRONT OF VEHICLE
- 2 - STEERING AXIS INCLINATION
- 3 - PIVOT POINT
- 4 - TOE-IN

## WHEEL ALIGNMENT (Continued)



80b34eaf

Fig. 2 Alignment Angles - Link/Coil

- 1 - WHEEL CENTERLINE
- 2 - NEGATIVE CAMBER ANGLE
- 3 - PIVOT CENTERLINE
- 4 - SCRUB RADIUS
- 5 - TRUE VERTICAL

- 6 - KING PIN
- 7 - VERTICAL
- 8 - POSITIVE CASTER

## OPERATION

• **CASTER** is the forward or rearward tilt of the steering knuckle from vertical. Tilting the top of the knuckle rearward provides positive caster. Tilting the top of the knuckle forward provides negative caster. Caster is a directional stability angle which enables the front wheels to return to a straight ahead position after turns.

• **CAMBER** is the inward or outward tilt of the wheel relative to the center of the vehicle. Tilting the top of the wheel inward provides negative camber. Tilting the top of the wheel outward provides positive camber. Incorrect camber will cause wear on the inside or outside edge of the tire.

• **WHEEL TOE POSITION** is the difference between the leading inside edges and trailing inside edges of the front tires. Incorrect wheel toe position is the most common cause of unstable steering and uneven tire wear. The wheel toe position is the **final** front wheel alignment adjustment.

## DIAGNOSIS AND TESTING - PRE-ALIGNMENT

Before starting wheel alignment, the following inspection and necessary corrections must be completed. Refer to Suspension and Steering System Diagnosis Chart for additional information.

- (1) Inspect tires for size and tread wear.
- (2) Set tire air pressure.
- (3) Inspect front wheel bearings for wear.
- (4) Inspect front wheels for excessive radial or lateral runout and balance.
- (5) Inspect ball studs, linkage pivot points and steering gear for looseness, roughness or binding.
- (6) Inspect suspension components for wear and noise.
- (7) Road test the vehicle.

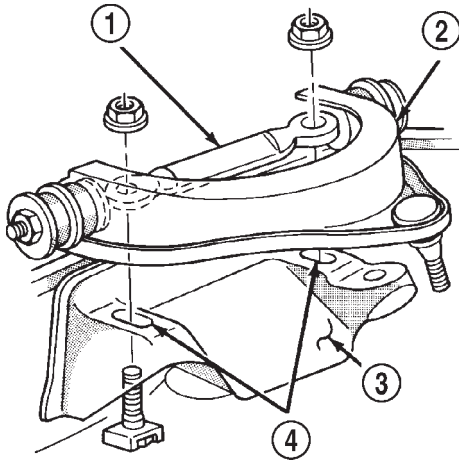
## STANDARD PROCEDURES - ALIGNMENT I.F.S.

Before each alignment reading the vehicle should be jounced (rear first, then front). Grasp each bumper at the center and jounce the vehicle up and

## WHEEL ALIGNMENT (Continued)

down several times. Always release the bumper in the down position. **Set the front end alignment to specifications while the vehicle is in its NORMALLY LOADED CONDITION.**

Camber and caster angle adjustments involve changing the position of the upper suspension arm pivot bar (Fig. 3). Refer to the Alignment Specification Chart for the correct setting.



J9402-55

**Fig. 3 Caster Camber Adjustment Location**

- 1 - PIVOT BAR
- 2 - UPPER SUSPENSION ARM
- 3 - SUSPENSION ARM FRAME MOUNT
- 4 - ADJUSTMENT SLOTS

**CASTER:** Move the rear position of the pivot bar in or out. This will change the caster angle significantly and camber angle only slightly. To retain camber move the forward pivot very slightly in the opposite direction.

**NOTE:** For example, to increase a positive caster angle, move the rear position of the pivot bar inward (toward the engine). Move the front of pivot bar outward (away from the engine) slightly until the original camber angle is obtained.

**CAMBER:** Move the forward position of the pivot bar in or out. This will change the camber angle significantly and caster angle only slightly. The camber angle should be adjusted as close as possible to the **preferred service specification**. After adjustment is made tighten pivot bar nuts to specifications.

**TOE POSITION:** The wheel toe position adjustment should be the final adjustment.

(1) Start the engine and turn wheels both ways before straightening the wheels. Center and secure the steering wheel and turn off engine.

(2) Loosen the tie rod adjustment sleeve clamp bolts/nuts.

**NOTE:** Each front wheel should be adjusted for one-half of the total toe position specification. This will ensure the steering wheel will be centered when the wheels are positioned straight-ahead.

(3) Adjust the wheel toe position by turning the tie rod adjustment sleeves as necessary.

## STANDARD PROCEDURES - CASTER CORRECTION MEASUREMENT

**NOTE:** To determine the correct caster alignment angle for Cab-Chassis vehicles the following procedure must be performed.

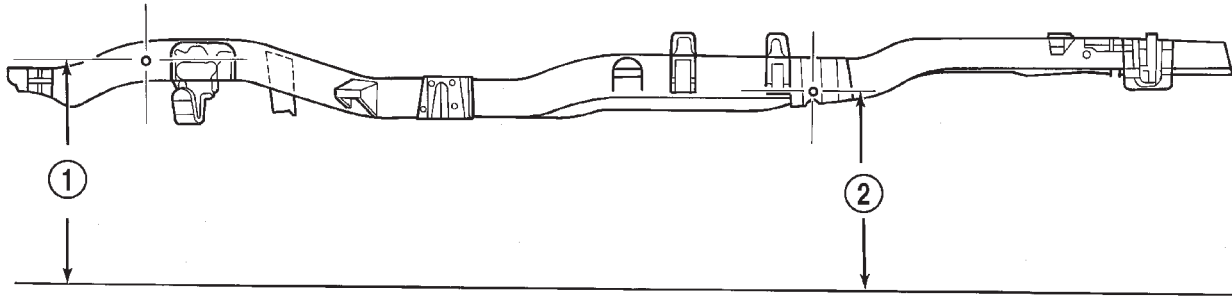
**NOTE:** 4x2 11000 GVW has a solid front axle and uses a 4x4 frame.

(1) Take a height measurement to the center of the front gauge hole in the frame. Take another measurement to the center of the rear spring hanger bolt (Fig. 4). Take these measurements on both sides of the vehicle.

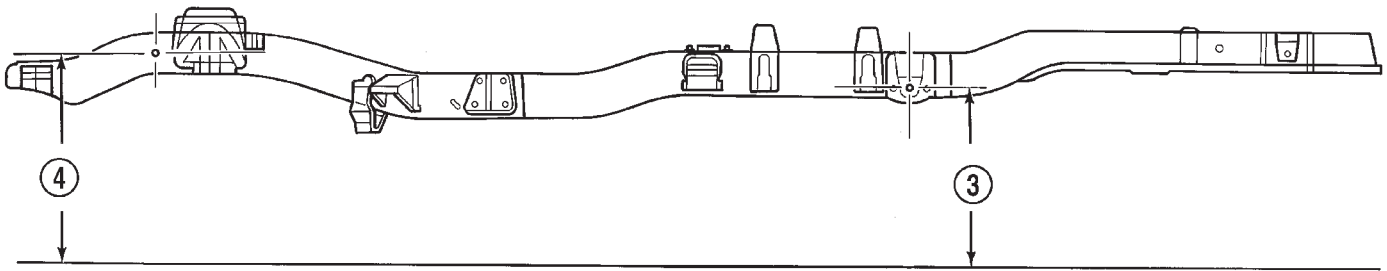
(2) Subtract the front measurement from the rear measurement and use the average between the right and left side. Use this number (caster correlation valve) with the Corrected Caster Chart to obtain the preferred caster angle.

WHEEL ALIGNMENT (Continued)

4x2



4x4



J9502-14

**Fig. 4 Chassis Measurement**

1 - GAUGE HOLE  
2 - HANGER BOLT

3 - HANGER BOLT  
4 - GAUGE HOLE



## WHEEL ALIGNMENT (Continued)

## CORRECTED CASTER CHART-CAB CHASSIS

Caster Correlation Value (inches)	4x2 8800 lb. GVW 134.7 in. wheel base	4x4 8800 lb. GVW 4x2 & 4x4 11000 lb. GVW 134.7 & 138.7 in. wheel base	4x2 & 4x4 11000 lb. GVW 162.7 in. wheel base
	Caster $\pm$ 1 deg.	Caster $\pm$ 1 deg.	Caster $\pm$ 1 deg.
-5.00	4.27°	3.77°	3.81°
-4.75	4.39°	3.89°	3.91°
-4.50	4.51°	4.01°	4.01°
-4.25	4.64°	4.14°	4.11°
-4.00	4.76°	4.26°	4.21°
-3.75	4.88°	4.38°	4.31°
-3.50	5.00°	4.50°	4.41°
-3.25	5.12°	4.62°	4.51°
-3.00	5.25°	4.75°	4.61°
-2.75	5.37°	4.87°	4.71°
-2.50	5.49°	4.99°	4.81°
-2.25	5.61°	5.11°	4.91°
-2.00	5.74°	5.24°	5.01°
-1.75	5.86°	5.36°	5.11°
-1.50	5.98°	5.48°	5.21°
-1.25	6.10°	5.60°	5.31°
-1.00	6.23°	5.73°	5.41°
-0.75	6.33°	5.83°	5.51°
-0.50	6.47°	5.97°	5.61°
-0.25	6.59°	6.09°	5.71°
0.00	6.71°	6.21°	5.81°

## STANDARD PROCEDURES - ALIGNMENT LINK/COIL SUSPENSION

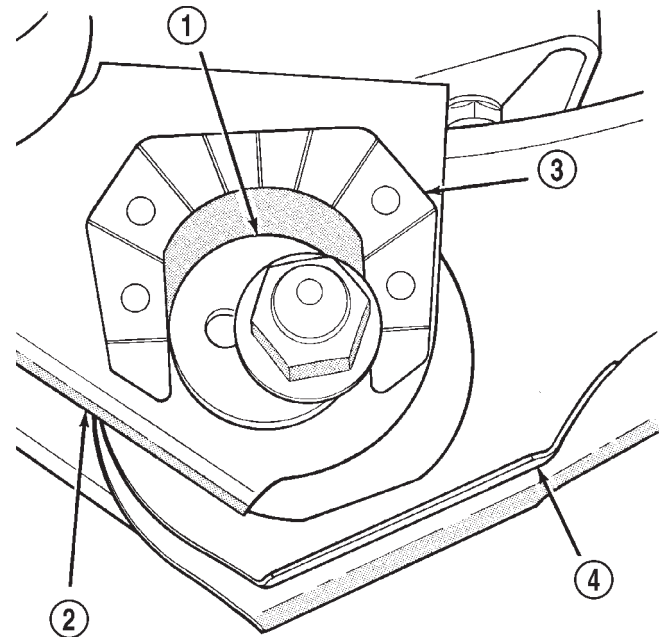
Before each alignment reading the vehicle should be jounced (rear first, then front). Grasp each bumper at the center and jounce the vehicle up and down several times. Always release the bumper in the down position. **Set the front end alignment to specifications while the vehicle is in its NORMALLY LOADED CONDITION.**

**CAMBER:** The wheel camber angle is preset and is not adjustable.

**CASTER:** Check the caster of the front axle for correct angle. Be sure the axle is not bent or twisted.

Road test the vehicle and make left and right turn. Observe the steering wheel return-to-center position. Low caster will cause poor steering wheel returnability.

Caster can be adjusted by rotating the cams on the lower suspension arm (Fig. 5). (Refer to 2 - SUSPENSION/WHEEL ALIGNMENT - STANDARD PROCEDURE).



J9302-59

Fig. 5 Adjustment Cam

- 1 - ADJUSTMENT CAM
- 2 - AXLE BRACKET
- 3 - BRACKET REINFORCEMENT
- 4 - LOWER SUSPENSION ARM

**TOE POSITION:** The wheel toe position adjustment should be the final adjustment.

(1) Start the engine and turn wheels both ways before straightening the wheels. Center and Secure the steering wheel and turn off engine.

(2) Loosen the adjustment sleeve clamp bolts.

(3) Adjust the right wheel toe position with the drag link. Turn the sleeve until the right wheel is at the correct TOE-IN position. Position clamp bolts to their original position and tighten to specifications. **Make sure the toe setting does not change during clamp tightening.**

(4) Adjust left wheel toe position with tie rod at left knuckle. Turn the sleeve until the left wheel is at the correct TOE-IN position. Position clamp bolts to their original position and tighten to specifications. **Make sure the toe setting does not change during clamp tightening.**

(5) Verify the right toe setting.

## WHEEL ALIGNMENT (Continued)

## SPECIFICATIONS

## ALIGNMENT

**NOTE: \*4 x 2 11,000 GVW has a solid front axle with link/coil suspension system.**

DESCRIPTION			SPECIFICATION	
4 x 2 & 4 x 4	GROSS VEHICLE WEIGHT lbs.	WHEEL BASE inches	PREFERRED CASTER $\pm 1.00^\circ$	PREFERRED CAMBER $\pm 0.50^\circ$
4 x 2	6,400	118.7	3.66°	0.50°
4 x 2	6,400	134.7	3.89°	0.50°
4 x 2	6,400	138.7	3.99°	0.50°
4 x 2	6,400	154.7	4.17°	0.50°
4 x 2	8,800	134.7	3.53°	0.50°
4 x 2	8,800	138.7	3.59°	0.50°
4 x 2	8,800	154.7	3.78°	0.50°
4 x 2	10,500	134.7	3.33°	0.50°
4 x 2	10,500	154.7	3.58°	0.50°
4 x 4	6,400	118.7	2.86°	Not Set
4 x 4	6,400	134.7	3.04°	Not Set
4 x 4	6,600	138.7	3.19°	Not Set
4 x 4	6,600	154.7	3.37°	Not Set
4 x 4	8,800	134.7	2.68°	Not Set
4 x 4	8,800	138.7	2.74°	Not Set
4 x 4	8,800	154.7	2.88°	Not Set
4 x 4	10,500	134.7	2.48°	Not Set
4 x 4	10,500	154.7	2.63°	Not Set
CAB-CHASSIS VEHICLES				
4 x 2 / 4 x 4	8,800	134.7	Caster Correction Measurement	Not Set
*4 x 2 / 4 x 4	11,000	138.7		Not Set
*4 x 2 / 4 x 4	11,000	162.7		Not Set
Preferred Total Toe-In $0.10^\circ (\pm 0.10^\circ)$ Preferred Cross Caster $0^\circ (\pm 0.5^\circ)$ Preferred Cross Camber $0^\circ (\pm 0.5^\circ)$ Thrust Angle $0^\circ (\pm 0.4^\circ)$				

## FRONT - 2WD

## TABLE OF CONTENTS

	page		page
<b>FRONT - 2WD</b>		<b>OPERATION</b> . . . . .	11
DESCRIPTION . . . . .	7	<b>DIAGNOSIS AND TESTING</b> . . . . .	11
SPECIFICATIONS . . . . .	8	<b>SHOCK</b> . . . . .	11
SPECIAL TOOLS . . . . .	9	<b>REMOVAL</b> . . . . .	11
<b>HUB / BEARING</b>		<b>INSTALLATION</b> . . . . .	11
<b>REMOVAL</b> . . . . .	9	<b>SPRING</b>	
<b>INSTALLATION</b> . . . . .	9	DESCRIPTION . . . . .	11
<b>JOUNCE BUMPER</b>		OPERATION . . . . .	11
DESCRIPTION . . . . .	9	REMOVAL . . . . .	11
OPERATION . . . . .	9	INSTALLATION . . . . .	12
<b>KNUCKLE</b>		<b>STABILIZER BAR</b>	
DESCRIPTION . . . . .	9	DESCRIPTION . . . . .	12
OPERATION . . . . .	10	OPERATION . . . . .	12
REMOVAL . . . . .	10	REMOVAL . . . . .	12
INSTALLATION . . . . .	10	INSTALLATION . . . . .	12
<b>LOWER BALL JOINT</b>		<b>UPPER BALL JOINT</b>	
DIAGNOSIS AND TESTING . . . . .	10	DIAGNOSIS AND TESTING . . . . .	12
LOWER BALL JOINT . . . . .	10	UPPER BALL JOINT . . . . .	12
<b>LOWER CONTROL ARM</b>		<b>UPPER CONTROL ARM</b>	
REMOVAL . . . . .	10	REMOVAL . . . . .	13
INSTALLATION . . . . .	10	INSTALLATION . . . . .	13
<b>SHOCK</b>			
DESCRIPTION . . . . .	11		

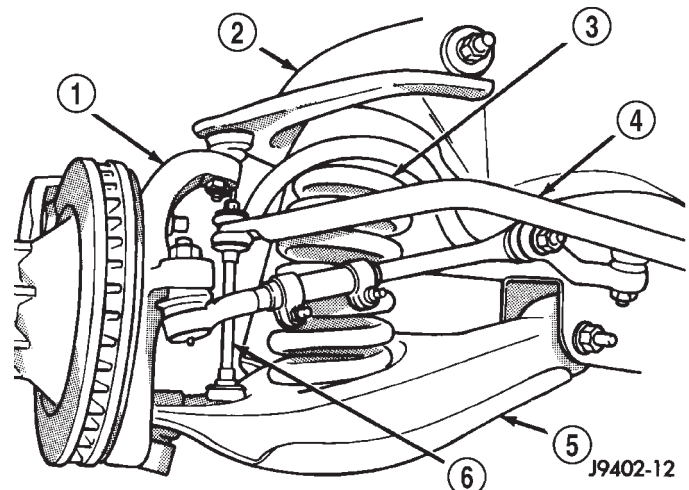
## FRONT - 2WD

## DESCRIPTION

The independent front suspension (IFS) is comprised of (Fig. 1) and (Fig. 2):

- Shock absorbers
- Coil springs
- Upper and lower suspension arms
- Stabilizer bar
- Steering Knuckles
- Hub/Bearing
- Ball Joints
- Jounce Bumpers

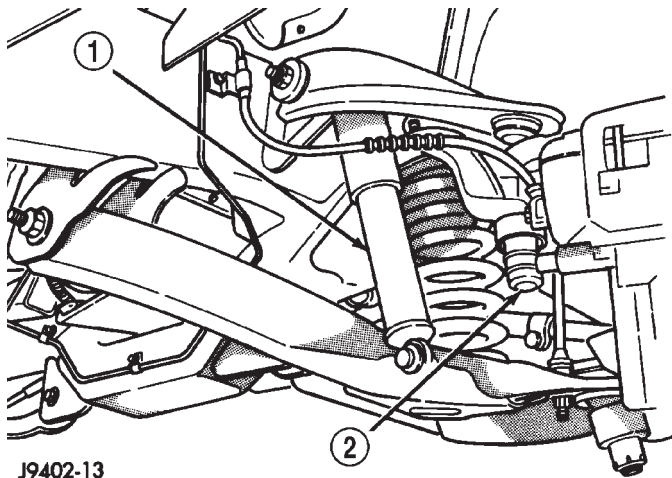
**CAUTION:** Components attached with a nut and cotter pin must be torqued to specification. Then if the slot in the nut does not line up with the cotter pin hole, tighten nut until it is aligned. Never loosen the nut to align the cotter pin hole.



**Fig. 1 Independent Front Suspension**

- 1 - KNUCKLE
- 2 - SUSPENSION ARM
- 3 - COIL SPRING
- 4 - STABILIZER BAR
- 5 - SUSPENSION ARM
- 6 - LINK

## FRONT - 2WD (Continued)



J9402-13

**Fig. 2 Independent Front Suspension**

- 1 - SHOCK  
2 - JOUNCE BUMPER

tightened with the vehicle at normal ride height. It is important to have the springs supporting the weight of the vehicle when the fasteners are torqued. If springs are not at their normal ride position, vehicle ride comfort could be affected and premature bushing wear may occur.

**DESCRIPTION**

The upper suspension arm bolts on frame brackets through the arm pivot shaft. The frame brackets have slotted holes which allow the arms to be adjusted for caster and camber. Pivot shaft bushings are not replaceable.

The lower suspension arms bolt to the lower frame brackets and pivot through bushings, these bushings are not replaceable.

The suspension arms have lube for life riveted ball studs.

**CAUTION:** Suspension components with rubber/urethane bushings (except stabilizer bar) should be

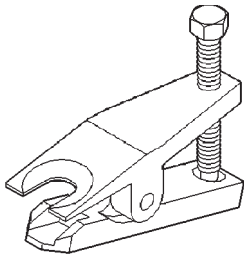
**SPECIFICATIONS****TORQUE CHART***TORQUE SPECIFICATIONS*

DESCRIPTION	N-m	Ft. Lbs.	In. Lbs.
Shock Absorber Upper Nut	54	40	—
Shock Absorber Lower Bolt	142	105	—
Lower Suspension Arm Frame Nuts	169	125	—
Lower Suspension Arm LD Ball Joint Nut	129	95	—
Lower Suspension Arm HD Ball Joint Nut	149	110	—
Upper Suspension Arm Pivot Bar Nuts	169	125	—
Upper Suspension Arm Ball Joint Nut	81	60	—
Stabilizer Bar Clamp Bolt	54	40	—
Stabilizer Bar Link Nuts	37	27	—
Hub Bearing LD 1500 Nut	251	185	—
Hub Bearing HD 2500/3500 Nut	380	280	—

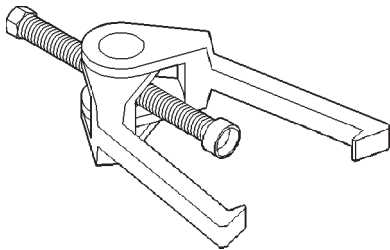
FRONT - 2WD (Continued)

## SPECIAL TOOLS

## INDEPENDENT FRONT SUSPENSION



8011d89c

**Remover, Tie Rod End MB-990635****Puller Tie Rod C-3894-A**

## HUB / BEARING

## REMOVAL

- (1) Raise and support the vehicle.
- (2) Remove the wheel and tire assembly.
- (3) Remove the caliper adapter bolts from the steering knuckle and remove caliper adapter assembly (Refer to 5 - BRAKES/HYDRAULIC/MECHANICAL/DISC BRAKE CALIPERS - REMOVAL).

**NOTE:** Do not allow brake hose to support caliper adapter assembly.

- (4) Remove the rotor from the hub/bearing wheel studs.
- (5) Remove the hub/bearing nut (Fig. 3) and slide the hub/bearing off the spindle.

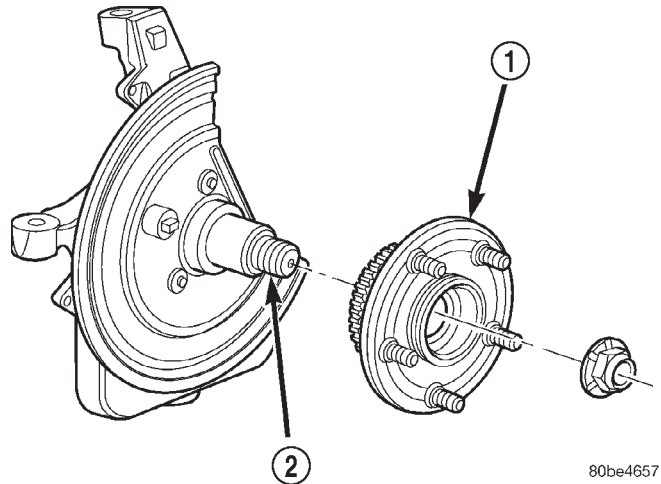
**CAUTION:** The hub/bearing nut can not be re-used.

## INSTALLATION

(1) On models with all-wheel antilock system (ABS), check condition of tone wheel on hub/bearing. If teeth on wheel are damaged, hub/bearing assembly will have to be replaced (tone wheel is not serviced separately).

- (2) Slide the hub/bearing onto the spindle.
- (3) Install the **new** hub/bearing nut and tighten to:

- LD 1500: 251N·m (185 ft. lbs.)
- HD 2500/3500: 380 N·m (280 ft lbs.)



80be4657

**Fig. 3 Caliper Adapter Assembly**

- 1 - HUB/BEARING
- 2 - SPINDLE

- (4) Install the rotor onto hub/bearing wheel studs.
- (5) Install the caliper adapter assembly (Refer to 5 - BRAKES/HYDRAULIC/MECHANICAL/DISC BRAKE CALIPERS - INSTALLATION), and tighten adapter bolts to:

- LD 1500: 176 N·m (130 ft lbs.)
- HD 2500/3500: 285 N·m (210 ft lbs.)

- (6) Install the wheel and tire assembly and lower the vehicle, (Refer to 22 - TIRES/WHEELS/WHEELS - STANDARD PROCEDURE).

- (7) Apply brakes several times to seat brake shoes. Be sure to obtain firm pedal before moving vehicle.

## JOUNCE BUMPER

## DESCRIPTION

The jounce bumpers are mounted under the coil spring bracket.

## OPERATION

The jounce bumpers are used to limit suspension travel in compression.

## KNUCKLE

## DESCRIPTION

The knuckles are a single casting with legs machined for the upper and lower ball joints. The knuckles also has machined mounting locations for the front brake calipers adapters and hub bearing assembly.



## KNUCKLE (Continued)

### OPERATION

The steering knuckles pivot between the upper and lower ball joints. The steering linkage is attached to the knuckles controls vehicle steering.

### REMOVAL

- (1) Raise and support the vehicle.
- (2) Remove the wheel and tire assembly.
- (3) Remove the brake caliper and rotor, (Refer to 5 - BRAKES/HYDRAULIC/MECHANICAL/DISC BRAKE CALIPERS - REMOVAL).
- (4) Remove the cotter pin and nut from the tie-rod end. Remove the tie rod end from the knuckle with Puller C-3894-A.
- (5) Remove the cotter pins and nuts from the upper and lower ball joints. Separate upper ball joint from knuckle with remover MD-990635. Separate lower ball joint with remover C-4150A and remove knuckle.

### INSTALLATION

- (1) Position the knuckle on the ball joints and install the ball joint nuts.
- (2) Tighten the upper ball joint nut to 81 N·m (60 ft. lbs.) and install cotter pin.
- (3) Tighten the lower ball joint nut to:
  - LD: 129 N·m (95 ft. lbs.)
  - HD: 149 N·m (110 ft. lbs.)
- (3) Install the cotter pin.
- (4) Install the tie rod end on the steering knuckle and tighten the nut to 108 N·m (80 ft. lbs.). Install cotter pin.
- (5) Install the brake rotor and caliper, (Refer to 5 - BRAKES/HYDRAULIC/MECHANICAL/DISC BRAKE CALIPERS - INSTALLATION).
- (6) Install wheel and tire assembly (Refer to 22 - TIRES/WHEELS/WHEELS - STANDARD PROCEDURE).
- (7) Remove support and lower vehicle.

## LOWER BALL JOINT

### DIAGNOSIS AND TESTING - LOWER BALL JOINT

- (1) Raise the front of the vehicle. Place safety floor stands under both lower suspension arms as far outboard as possible. Lower the vehicle to allow the stands to support some or all of the vehicle weight.

**NOTE: The upper suspension arms must not be in maximum rebound position.**

- (2) Remove the tire and wheel assembly.
- (3) Mount a dial indicator solidly under the lower suspension arm.

- (4) Position indicator plunger against the bottom of the steering knuckle lower ball joint boss.

**NOTE: The dial Indicator plunger must be perpendicular to the machined surface of the steering knuckle lower ball joint boss.**

- (5) Position a pry bar over the top of the upper suspension arm and under the pivot bar of the upper suspension arm. Pry down on the upper suspension arm and then zero the dial indicator.
- (6) Reposition the pry bar under the upper suspension arm and on top of the frame rail. Pry up on the upper suspension arm and record the dial indicator reading.
- (7) If the travel exceeds 0.8 mm (0.030 in.) replace the suspension arm.

## LOWER CONTROL ARM

### REMOVAL

- (1) Raise and support the vehicle.
- (2) Remove the tire and wheel assembly.
- (3) Remove the brake caliper assembly and rotor, (Refer to 5 - BRAKES/HYDRAULIC/MECHANICAL/ROTORS - REMOVAL).
- (4) Remove the cotter pin and nut from the tie rod. Remove the tie rod end from the steering knuckle with Puller C-3894-A.
- (5) Remove the stabilizer bar link from lower suspension arm.
- (6) Support the lower suspension arm outboard end with jack. Place a jack under the arm in the front of the shock mount.
- (7) Remove the cotter pin and nut from the lower ball joint. Separate the ball joint with Remover C-4150A.
- (8) Remove the lower shock bolt from the suspension arm.
- (9) Lower the jack and suspension arm until spring tension is relieved. Remove spring and rubber isolator (Fig. 5).
- (10) Remove bolts mounting suspension arm to crossmember and remove arm.

### INSTALLATION

- (1) Position the suspension arm on the crossmember and install the bolts and nuts snug.
- (2) Install the rubber isolator on top of the spring. Position the spring into upper spring seat.
- (3) Raise the lower suspension arm with a jack and position the spring into the lower suspension arm mount.
- (4) Install the lower shock bolt and tighten to 142 N·m (105 ft. lbs.).

## LOWER CONTROL ARM (Continued)

(5) Install the steering knuckle on the lower ball joint. Install the lower ball joint nut and tighten to:

- LD: 129 N·m (95 ft. lbs.)
- HD: 136 N·m (110 ft. lbs.)

(5) Install the lower ball joint cotter pin.

(6) Install the stabilizer bar link on the lower suspension arm. Install the grommet, retainer and nut and tighten to 37 N·m (27 ft. lbs.).

(7) Install the tie rod end on the steering knuckle and tighten nut to 108 N·m (80 ft. lbs.). Install cotter pin.

(8) Install the brake rotor and caliper assembly, (Refer to 5 - BRAKES/HYDRAULIC/MECHANICAL/ROTORS - INSTALLATION).

(9) Install the tire and wheel assembly, (Refer to 22 - TIRES/WHEELS/WHEELS - STANDARD PROCEDURE).

(10) Remove the support and lower the vehicle.

(11) Tighten the suspension arm crossmember nuts to 169 N·m (125 ft. lbs.).

## SHOCK

### DESCRIPTION

The top of the shocks mounts on frame brackets using grommets. The bottom of the shock is bolted to the lower suspension arms.

### OPERATION

The shock absorbers dampen jounce and rebound of the vehicle over various road conditions.

### DIAGNOSIS AND TESTING - SHOCK

A knocking or rattling noise from a shock absorber may be caused by movement between mounting bushings and metal brackets or attaching components. These noises can usually be stopped by tightening the attaching nuts. If the noise persists, inspect for damaged and worn bushings, and attaching components. Repair as necessary if any of these conditions exist.

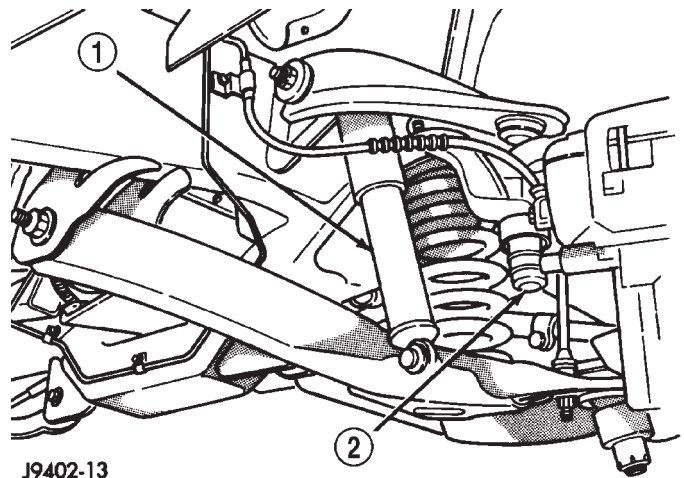
A squeaking noise from the shock absorber may be caused by the hydraulic valving and may be intermittent. This condition is not repairable and the shock absorber must be replaced.

The shock absorbers are not refillable or adjustable. If a malfunction occurs, the shock absorber must be replaced. To test a shock absorber, hold it in an upright position and force the piston in and out of the cylinder four or five times. The action throughout each stroke should be smooth and even.

The shock absorber bushings do not require any type of lubrication. Do not attempt to stop bushing noise by lubricating them. Grease and mineral oil-base lubricants will deteriorate the bushing.

## REMOVAL

- (1) Raise and support vehicle.
- (2) Remove shock upper nut and remove retainer and grommet.
- (3) Remove lower mounting bolt from suspension arm and remove shock (Fig. 4).



**Fig. 4 Shock**

- 1 - SHOCK  
2 - JOUNCE BUMPER

## INSTALLATION

- (1) Extend shock fully, install retainer and grommet on top of shock absorber. Check grommets and retainer for wear.
- (2) Guide shock up through upper suspension arm bracket. Install top grommet, retainer and nut. Tighten nut to 54 N·m (40 ft. lbs.).
- (3) Align bottom end of shock into lower suspension arm and install mounting bolt. Tighten bolt to 142 N·m (105 ft. lbs.).
- (4) Remove support and lower vehicle.

## SPRING

### DESCRIPTION

The springs mount between the lower suspension arms and the front cross member spring seats. A rubber isolator seats on top off the spring to help prevent noise.

### OPERATION

The coil springs control ride quality and maintain proper ride height.

## REMOVAL

- (1) Raise and support the vehicle.
- (2) Remove the tire and wheel assembly.

## SPRING (Continued)

(3) Remove the brake caliper assembly and rotor, (Refer to 5 - BRAKES/HYDRAULIC/MECHANICAL/ROTORS - REMOVAL).

(4) Remove the cotter pin and nut from the tie rod. Remove the tie rod end from the steering knuckle with Puller C-3894-A.

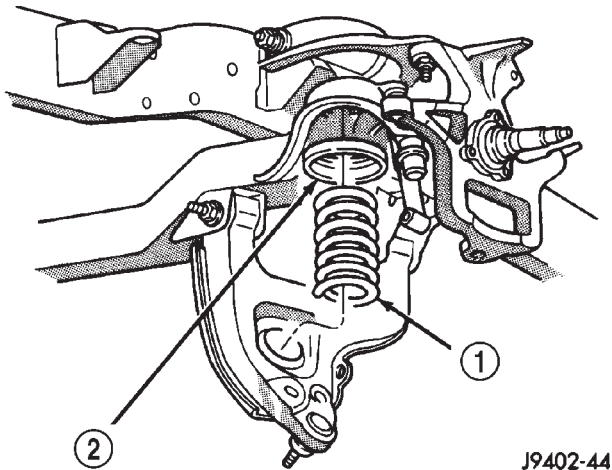
(5) Remove the stabilizer bar link from the lower suspension arm.

(6) Support the lower suspension arm outboard end with a jack. Place a jack under the arm in front of the shock mount.

(7) Remove the cotter pin and nut from the lower ball joint. Separate the ball joint with Remover C-4150A.

(8) Remove the lower shock bolt from the suspension arm.

(9) Lower the jack and suspension arm until spring tension is relieved. Remove spring and rubber isolator (Fig. 5).



J9402-44

**Fig. 5 Coil Spring**

- 1 - COIL SPRING  
2 - RUBBER ISOLATER

## INSTALLATION

(1) Install the rubber isolator on top of the spring. Position the spring into the upper spring seat.

(2) Raise the lower suspension arm with a jack and position the spring into the lower suspension arm mount.

(3) Install the lower shock bolt and tighten to 142 N·m (105 ft. lbs.).

(4) Install the steering knuckle on the lower ball joint. Install the lower ball joint nut and tighten to:

- LD: 129 N·m (95 ft. lbs.)
- HD: 136 N·m (110 ft. lbs.)

(4) Install the lower ball joint cotter pin.

(5) Install the stabilizer bar link on the lower suspension arm. Install the grommet, retainer and nut and tighten to 37 N·m (27 ft. lbs.).

(6) Install the tie rod end on the steering knuckle and tighten nut to 108 N·m (80 ft. lbs.). Install cotter pin.

(7) Install the brake rotor and caliper assembly, (Refer to 5 - BRAKES/HYDRAULIC/MECHANICAL/ROTORS - INSTALLATION).

(8) Install the tire and wheel assembly, (Refer to 22 - TIRES/WHEELS/WHEELS - STANDARD PROCEDURE).

(9) Remove the support and lower the vehicle.

## STABILIZER BAR

### DESCRIPTION

The bar extends across the front underside of the chassis and mounts on the frame rails. Links connected the bar to the lower suspension arms. Stabilizer bar mounts are isolated by rubber bushings. Links are isolated with rubber grommets.

### OPERATION

The stabilizer bar is used to minimize vehicle front sway during turns. The spring steel bar helps to control the vehicle body in relationship to the suspension.

### REMOVAL

- (1) Raise and support the vehicle.
- (2) Remove the link nuts, retainers and grommets from lower suspension arm and stabilizer bar (Fig. 6).
- (3) Remove the stabilizer bar clamps from the frame rails. Remove the stabilizer bar.

### INSTALLATION

(1) Position the stabilizer bar on the frame rail and install the clamps and bolts. Ensure the bar is centered with equal spacing on both sides. Tighten the bolts to 54 N·m (40 ft. lbs.).

(2) Install links on stabilizer bar and lower suspension arm. Install grommets, retainers and nuts. Tighten nuts to 37 N·m (27 ft. lbs.).

(3) Remove the supports and lower the vehicle.

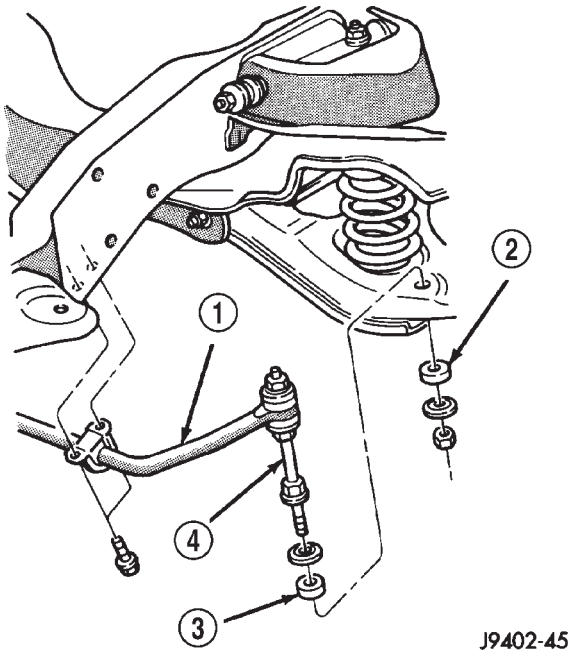
## UPPER BALL JOINT

### DIAGNOSIS AND TESTING - UPPER BALL JOINT

(1) Position a floor jack under the lower suspension arm. Raise the wheel and allow the tire to lightly contact the floor (vehicle weight relieved from the tire).

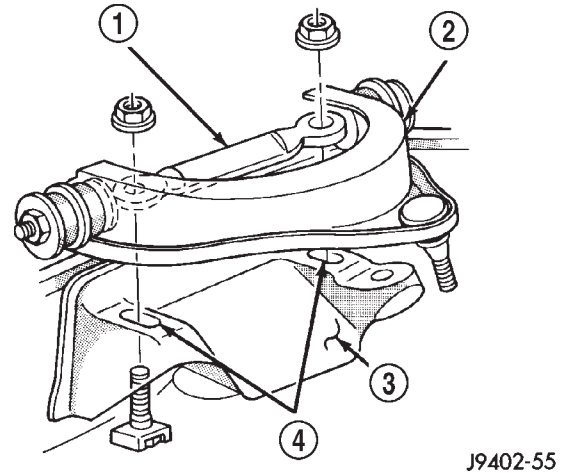
(2) Mount a dial indicator solidly on the upper suspension arm.

## UPPER BALL JOINT (Continued)

**Fig. 6 STABILIZER BAR**

- 1 - STABILIZER BAR
- 2 - GROMMET
- 3 - GROMMET
- 4 - LINK

- (4) Remove upper ball joint cotter pin and nut.
- (5) Separate ball joint from knuckle with remover MB-990635.
- (6) Remove pivot bar bolts from upper suspension arm bracket and remove arm from vehicle (Fig. 7).

**Fig. 7 Upper Suspension Arm**

- 1 - PIVOT BAR
- 2 - UPPER SUSPENSION ARM
- 3 - SUSPENSION ARM FRAME MOUNT
- 4 - ADJUSTMENT SLOTS

(3) Position the indicator plunger against the upper ball stud boss of the steering knuckle.

(4) Grasp the top of the tire and apply force in and out. Look for movement at the ball joint between the upper suspension arm and steering knuckle.

(5) If lateral movement is greater than 0.8 mm (0.030 in.), replace the suspension arm.

## UPPER CONTROL ARM

## REMOVAL

- (1) Raise and support vehicle.
- (2) Remove tire and wheel assembly.
- (3) Support lower suspension arm at outboard end with jack stand.

## INSTALLATION

(1) Position the upper suspension arm on the bracket and install the pivot bar bolts. Tighten to 169 N·m (125 ft. lbs.).

(2) Install the ball joint in the knuckle. Install the nut and tighten to 81 N·m (60 ft. lbs.) and replace the cotter pin.

(3) Remove the jack from the lower suspension arm.

(4) Install the tire and wheel assembly, (Refer to 22 - TIRES/WHEELS/WHEELS - STANDARD PROCEDURE).

(5) Remove the support and lower the vehicle.

(6) Align the front suspension, (Refer to 2 - SUSPENSION/WHEEL ALIGNMENT - STANDARD PROCEDURE).

## FRONT - 4WD

## TABLE OF CONTENTS

	page		page
<b>FRONT - 4WD</b>		<b>OPERATION</b> . . . . .	22
DESCRIPTION . . . . .	14	<b>REMOVAL</b> . . . . .	22
SPECIFICATIONS . . . . .	15	<b>INSTALLATION</b> . . . . .	22
SPECIAL TOOLS . . . . .	16	<b>STABILIZER BAR</b>	
<b>HUB / BEARING</b>		DESCRIPTION . . . . .	22
REMOVAL . . . . .	16	OPERATION . . . . .	22
INSTALLATION . . . . .	18	REMOVAL . . . . .	22
<b>KNUCKLE</b>		INSTALLATION . . . . .	23
DESCRIPTION . . . . .	20	<b>TRACK BAR</b>	
OPERATION . . . . .	20	DESCRIPTION . . . . .	23
REMOVAL . . . . .	20	OPERATION . . . . .	23
INSTALLATION . . . . .	20	DIAGNOSIS AND TESTING . . . . .	23
<b>LOWER CONTROL ARM</b>		TRACK BAR . . . . .	23
REMOVAL . . . . .	20	REMOVAL . . . . .	23
INSTALLATION . . . . .	20	INSTALLATION . . . . .	23
<b>SHOCK</b>		<b>UPPER CONTROL ARM</b>	
DESCRIPTION . . . . .	21	REMOVAL . . . . .	23
OPERATION . . . . .	21	INSTALLATION . . . . .	24
DIAGNOSIS AND TESTING . . . . .	21	<b>LOWER BALL JOINT</b>	
SHOCK . . . . .	21	REMOVAL . . . . .	24
REMOVAL . . . . .	21	INSTALLATION . . . . .	25
INSTALLATION . . . . .	21	<b>UPPER BALL JOINT</b>	
<b>SPRING</b>		REMOVAL . . . . .	25
DESCRIPTION . . . . .	22	INSTALLATION . . . . .	25

## FRONT - 4WD

## DESCRIPTION

The link/coil suspension allows each wheel to adapt to different road surfaces. The suspension is comprised of (Fig. 1) :

- Shock absorbers
- Coil springs
- Upper and lower suspension arms
- Stabilizer bar
- Track bar
- Steering Knuckles
- Hub/Bearing
- Ball Joints
- Jounce Bumpers

**CAUTION:** Components attached with a nut and cotter pin must be torqued to specification. Then if the slot in the nut does not line up with the cotter pin hole, tighten nut until it is aligned. Never loosen the nut to align the cotter pin hole.

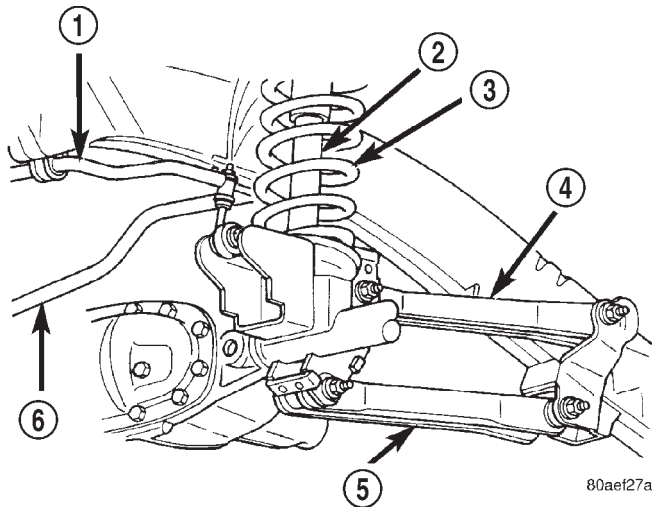
**CAUTION:** Suspension components with rubber bushings (except stabilizer bar) should be tightened with the vehicle at normal height. It is important to have the springs supporting the weight of the vehicle when the fasteners are torqued. If springs are not at their normal ride position, vehicle ride comfort could be affected and premature bushing wear may occur.

## DESCRIPTION

The upper and lower suspension arms use bushings to isolate road noise. The suspension arms are bolted to the frame and axle through the rubber bushings. The lower suspension arm uses cam bolts at the axle to allow for caster and pinion angle adjustment.



## FRONT - 4WD (Continued)



80aef27a

**Fig. 1 Link/Coil Suspension**

- 1 - STABILIZER BAR
- 2 - SHOCK ABSORBER
- 3 - COIL SPRING
- 4 - UPPER SUSPENSION ARM
- 5 - LOWER SUSPENSION ARM
- 6 - TRACK BAR

## SPECIFICATIONS

## TORQUE CHART

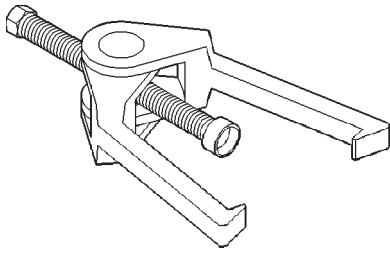
## TORQUE SPECIFICATIONS

DESCRIPTION	N-m	Ft. Lbs.	In. Lbs.
Shock Absorber Upper Nut	47	35	—
Shock Absorber Lower Bolt	135	100	—
Shock Absorber Bracket	75	55	—
Suspension Arm Lower Axle Nut	190	140	—
Suspension Arm Lower Frame Nut	190	140	—
Suspension Arm Upper Axle Nut	163	120	—
Suspension Arm Upper Frame Nut	163	120	—
Stabilizer Bar Clamp Bolt	54	40	—
Stabilizer Bar Link Upper Nut	37	27	—
Stabilizer Bar Link Lower Nut	47	35	—
Track Bar Ball Stud Nut	95	70	—
Track Bar Axle Bracket Bolt	176	130	—
Hub/Bearing Nut	245	180	—
Hub/Bearing Bolts	166	122	—

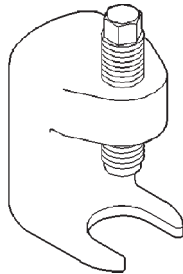
FRONT - 4WD (Continued)

SPECIAL TOOLS

LINK/COIL SUSPENSION



Puller C-3894-A



Remover, Wheel Stud C-4150A

HUB / BEARING

REMOVAL - 2500/3500

- (1) Raise and support the vehicle.
- (2) Remove the wheel and tire assembly.
- (3) Remove the hub extension mounting nuts and remove the extension from the rotor if equipped (Fig. 2).

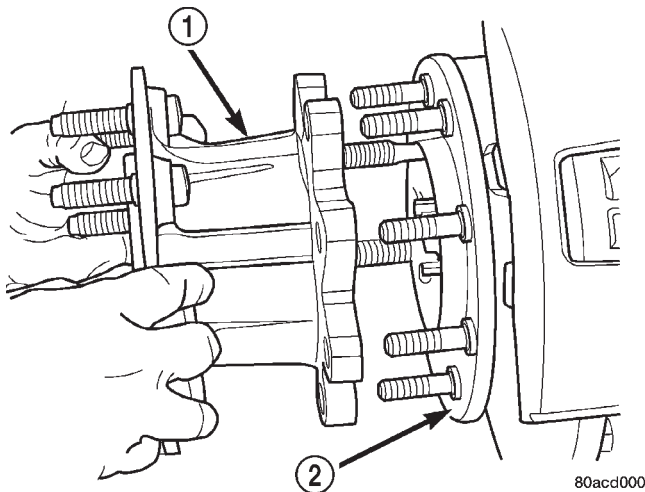


Fig. 2 Hub Extension

- 1 - HUB EXTENSION
- 2 - HUB

- (4) Remove the brake caliper, (Refer to 5 - BRAKES/HYDRAULIC/MECHANICAL/DISC BRAKE CALIPERS - REMOVAL).

- (5) Remove the cotter pin and the hub nut from the axle shaft (Fig. 3).

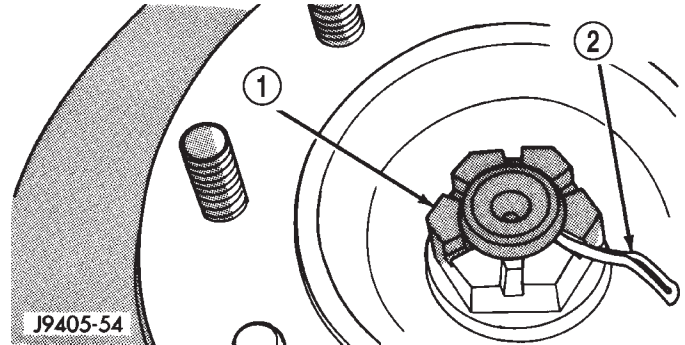


Fig. 3 Hub Nut Cotter Pin

- 1 - HUB NUT
- 2 - COTTER PIN

- (6) Disconnect the ABS wheel speed sensor wire from under the hood. Remove the sensor wire from the frame and steering knuckle if equipped.

- (7) Back off the hub/bearing mounting bolts 1/4 inch each (Fig. 4). Then tap the bolts with a hammer to loosen the hub/bearing from the steering knuckle.

- (8) Remove the hub/bearing mounting bolts and remove the hub/bearing.

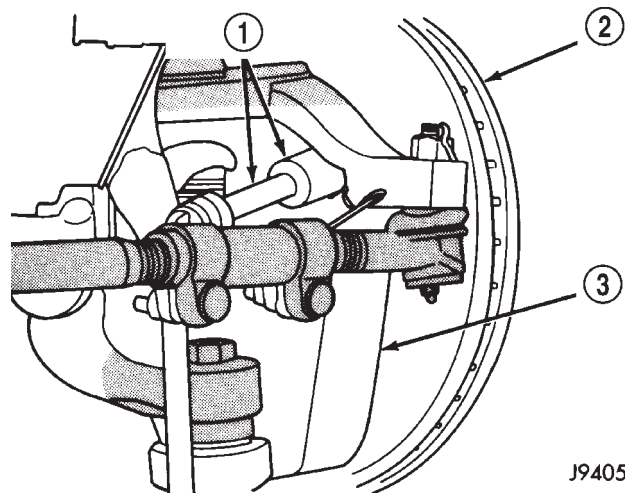


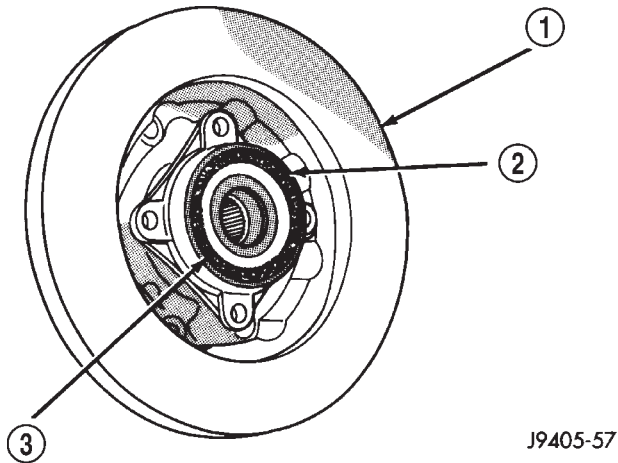
Fig. 4 Hub/Bearing Mounting Bolts

- 1 - SOCKET AND EXTENSION
- 2 - ROTOR AND HUB
- 3 - STEERING KNUCKLE

- (9) Remove the rotor assembly (Fig. 5), brake shield and spacer from the steering knuckle.

- (10) Press out the wheel studs/hub extension studs and separate the rotor from the hub (Fig. 6).

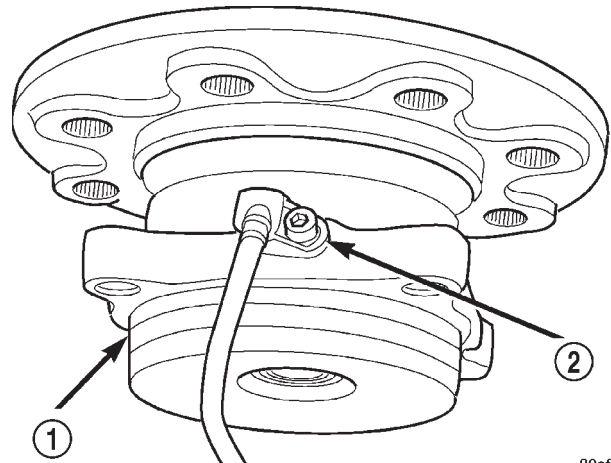
## HUB / BEARING (Continued)



J9405-57

**Fig. 5 Rotor Hub/Bearing Assembly**

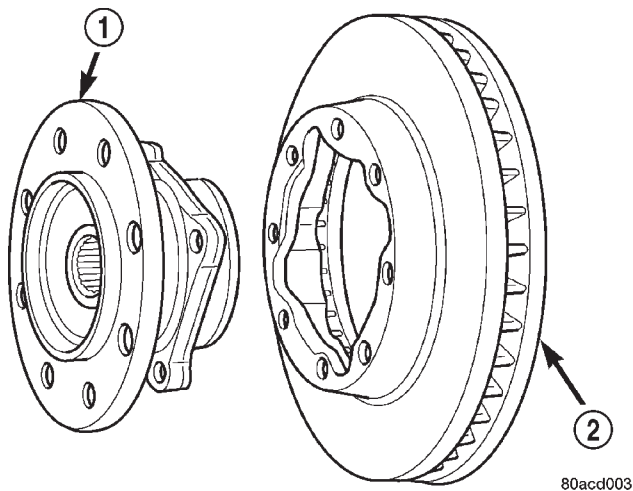
- 1 - ROTOR AND HUB
- 2 - UNIT BEARING ASSEMBLY
- 3 - SEAL



80aff572

**Fig. 7 Wheel Speed Sensor**

- 1 - HUB BEARING
- 2 - WHEEL SPEED SENSOR



80acd003

**Fig. 6 Rotor And Hub/Bearing**

- 1 - HUB BEARING
- 2 - ROTOR

(11) Remove the wheel speed sensor (Fig. 7) from the hub bearing if equipped.

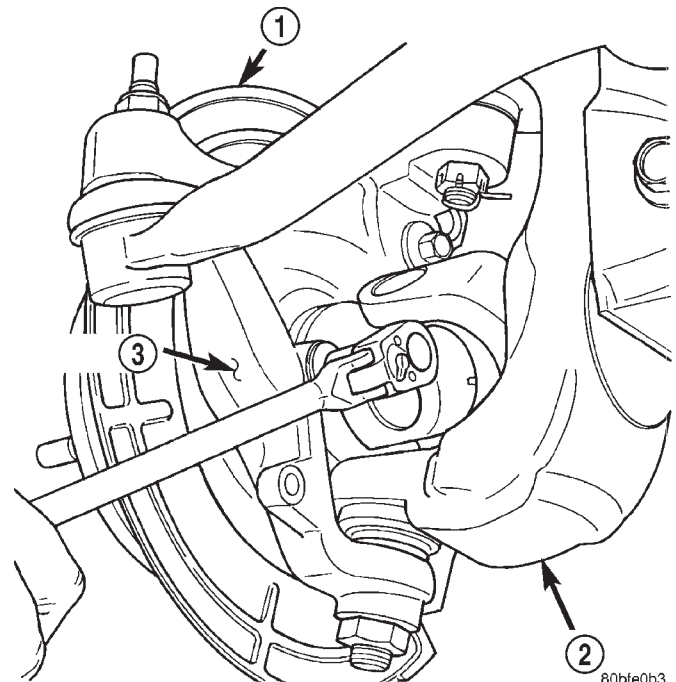
**REMOVAL - 1500**

- (1) Raise and support the vehicle.
- (2) Remove the wheel and tire assembly.
- (3) Remove the cotter pin and axle hub nut.
- (4) Remove the brake caliper with adapter and rotor, (Refer to 5 - BRAKES/HYDRAULIC/MECHANICAL/DISC BRAKE CALIPERS - REMOVAL).
- (5) Remove the ABS sensor if equipped, (Refer to 5 - BRAKES/ELECTRICAL/FRONT WHEEL SPEED SENSOR - REMOVAL).

(6) Back off the hub/bearing mounting bolts 1/4 inch each (Fig. 8). Then tap the bolts with a hammer to loosen the hub/bearing from the steering knuckle.

(7) Remove the hub/bearing mounting bolts and remove the hub/bearing.

(8) Remove the brake shield from the steering knuckle.



80bfe0b3

**Fig. 8 Hub/Bearing Mounting Bolts**

- 1 - BRAKE SHIELD
- 2 - AXLE YOKE
- 3 - KNUCKLE

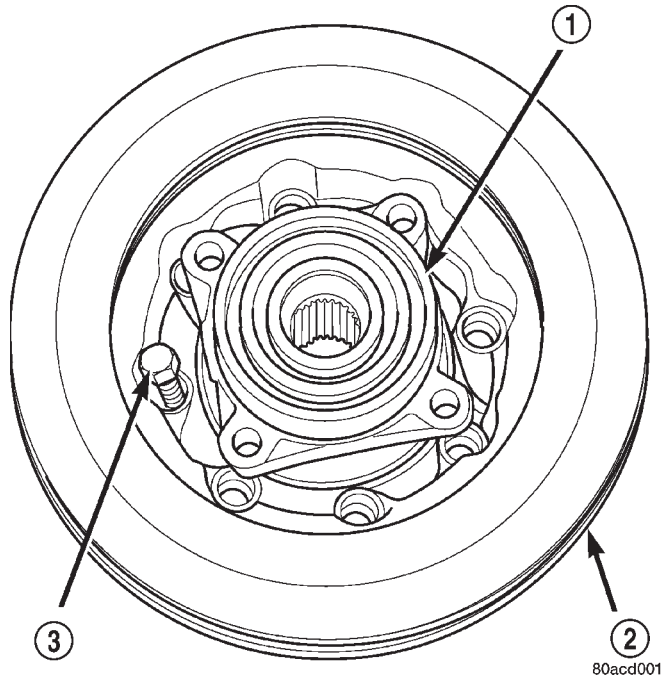
## HUB / BEARING (Continued)

**INSTALLATION - 2500/3500**

(1) Install the wheel speed sensor in the hub bearing if equipped.

(2) Position the rotor on the hub/bearing.

(3) Press the wheel studs/hub extension studs through the back side of the rotor and through the hub bearing flange (Fig. 9).



**Fig. 9 Rotor, Hub/Bearing And Stud**

- 1 - HUB BEARING
- 2 - ROTOR
- 3 - STUD

(4) Apply a liberal quantity of anti-seize compound to the splines of the front drive shaft.

(5) Insert the two rearmost, top and bottom rotor hub bolts in the steering knuckle. Insert the bolts through the back side of the knuckle so they extend out the front face as shown.

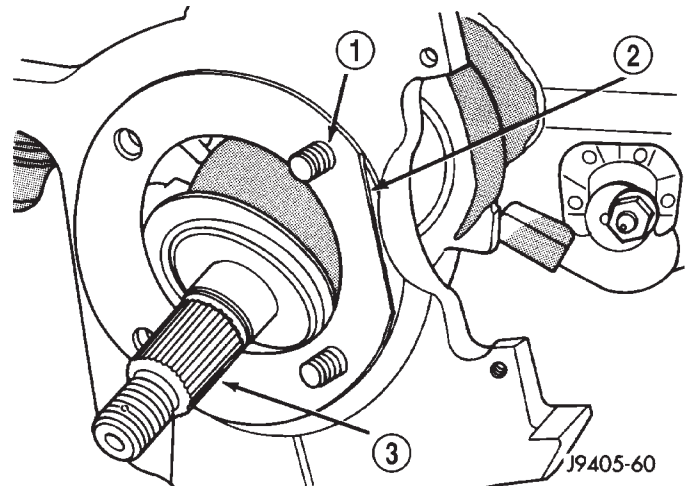
(6) Position the hub spacer (Fig. 10) and brake shield (Fig. 11) on bolts just installed in knuckle.

**NOTE:** If the vehicle is equipped with a wheel speed sensor the brake shield must be positioned on the hub bearing (Fig. 12).

(7) Align the rotor hub with the drive shaft and start the shaft into the rotor hub splines.

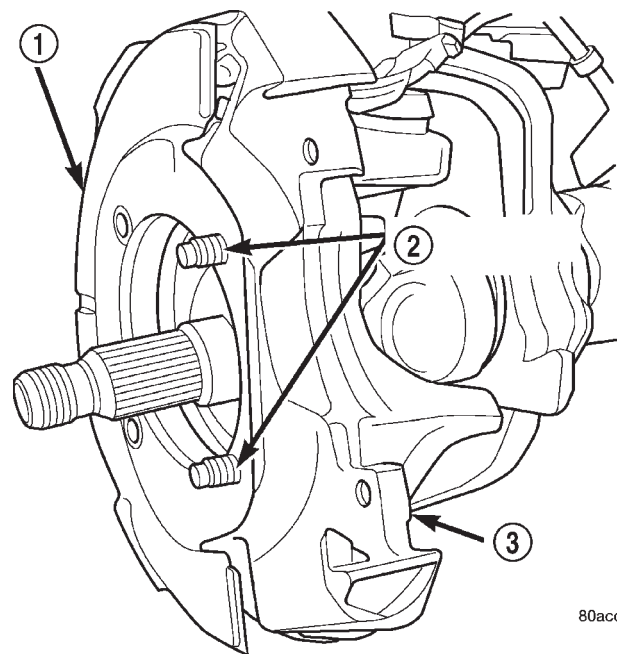
**NOTE:** Position wheel speed sensor wire at the top of the knuckle if equipped.

(8) Align the bolt holes in the hub bearing flange with the bolts installed in the knuckle. Then thread



**Fig. 10 Hub Spacer**

- 1 - ROTOR HUB BOLTS
- 2 - HUB SPACER (POSITION FLAT TO REAR)
- 3 - APPLY ANTI-SEIZE COMPOUND TO SPLINES



**Fig. 11 Brake Shield**

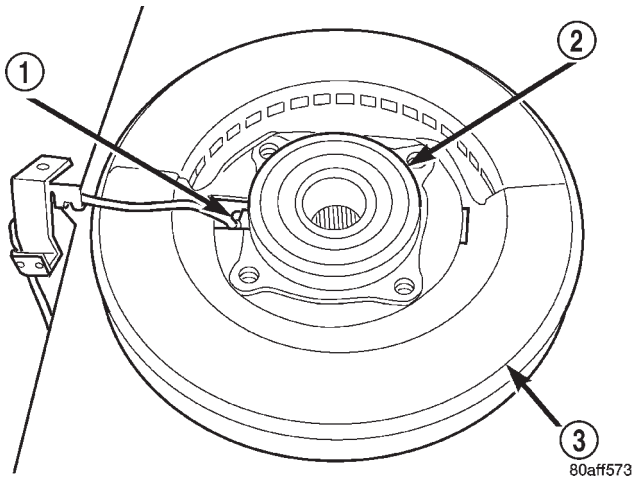
- 1 - BRAKE SHIELD
- 2 - HUB BEARING BOLTS
- 3 - STEERING KNUCKLE

the bolts into the bearing flange far enough to hold the assembly in place.

(9) Install the remaining bolts. Tighten the hub/bearing bolts to 166 N·m (122 ft. lbs.).

(10) Install the washer and hub nut and tighten to 245 N·m (180 ft. lbs.).

## HUB / BEARING (Continued)



**Fig. 12 Brake Shield With Wheel Speed Sensor**

- 1 - WHEEL SPEED SENSOR
- 2 - HUB BEARING
- 3 - SHIELD

(11) Install a new cotter pin in the hub nut. Tighten the nut as needed to align the cotter pin hole in the shaft with the opening in nut.

(12) Install the brake caliper, (Refer to 5 - BRAKES/HYDRAULIC/MECHANICAL/DISC BRAKE CALIPERS - INSTALLATION).

(13) Install the sensor wire to the steering knuckle and frame and if equipped. Connect the wheel speed sensor wire under the hood.

(14) Install the wheel and tire assemblies, (Refer to 22 - TIRES/WHEELS/WHEELS - STANDARD PROCEDURE).

(15) Remove the support and lower the vehicle.

(16) Apply the brakes several times to seat the brake shoes and caliper piston. Do not move the vehicle until a firm brake pedal is obtained.

### INSTALLATION - 1500

(1) Apply a liberal quantity of anti-seize compound to splines of the front drive shaft.

(2) Insert the bolts (Fig. 13) through back side of the steering knuckle.

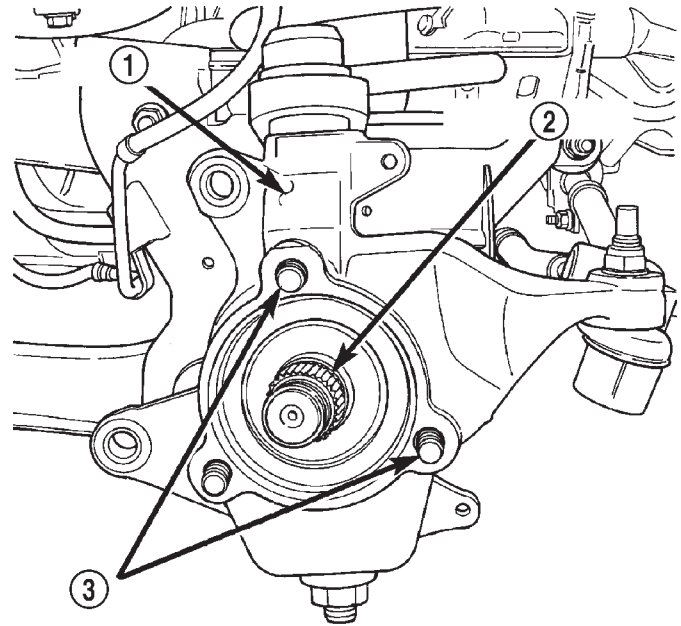
(3) Position the brake shield (Fig. 14) on bolts just installed in the knuckle.

(4) Align the hub with the drive shaft and start the shaft into the hub splines.

(5) Align the bolt holes in the hub bearing flange with bolts installed in the knuckle. Then thread bolts into the bearing flange.

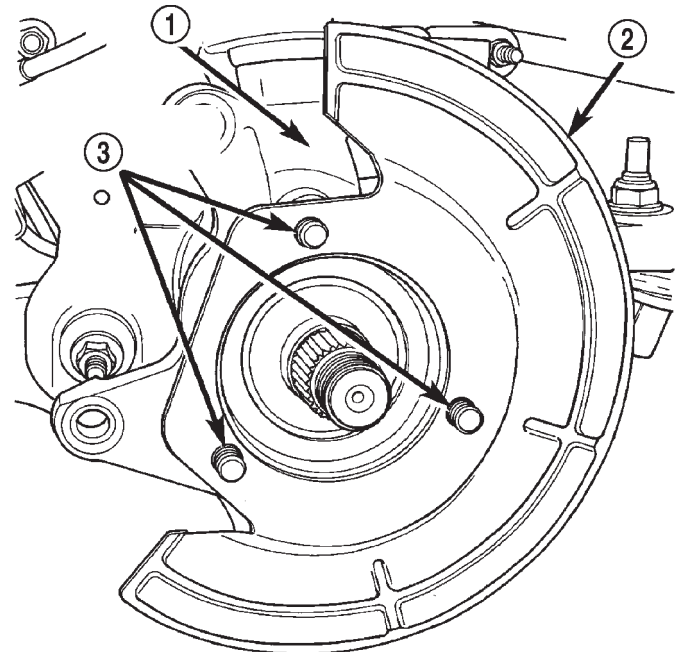
(6) Tighten the hub bearing bolts to 166 N·m (122 ft. lbs.).

(7) Install the washer and axle hub nut and tighten to 245 N·m (180 ft. lbs.).



**Fig. 13 Hub Bearing Mounting Bolts**

- 1 - KNUCKLE
- 2 - AXLE SPLINE
- 3 - HUB BEARING BOLTS



**Fig. 14 Brake Shield**

- 1 - KNUCKLE
- 2 - BRAKE SHIELD
- 3 - HUB BEARING BOLTS

80bfe0b4

80bfe0b5



## HUB / BEARING (Continued)

(8) Install a new cotter pin in hub nut. Tighten the nut as needed to align cotter pin hole in shaft with the opening in the nut.

(9) Install the rotor, brake caliper with adapter, (Refer to 5 - BRAKES/HYDRAULIC/MECHANICAL/DISC BRAKE CALIPERS - INSTALLATION).

(10) Install the ABS wheel speed sensor if equipped, (Refer to 5 - BRAKES/ELECTRICAL/FRONT WHEEL SPEED SENSOR - INSTALLATION).

(11) Install the wheel and tire assemblies, (Refer to 22 - TIRES/WHEELS/WHEELS - STANDARD PROCEDURE).

(12) Remove the support and lower the vehicle.

(13) Apply the brakes several times to seat the brake shoes and the caliper piston. Do not move the vehicle until a firm brake pedal is obtained.

## KNUCKLE

### DESCRIPTION

The knuckles are a single casting with legs machined for the upper and lower ball joints. The knuckles also has machined mounting locations for the front brake calipers adapters and hub bearing assembly.

### OPERATION

The steering knuckles pivots between the upper and lower ball joints. The steering linkage is attached to the knuckles controls vehicle steering.

### REMOVAL

- (1) Remove hub bearing and axle shaft.
- (2) Remove tie-rod or drag link end from the steering knuckle arm.
- (3) Remove the ABS sensor wire and bracket from knuckle.
- (4) Remove the cotter pin from the upper ball stud nut. Remove the upper and lower ball stud nuts.
- (5) Strike the steering knuckle with a brass hammer to loosen. Remove knuckle from axle tube yokes.

### REMOVAL

- (1) Remove hub bearing and axle shaft.
- (2) Remove tie-rod or drag link end from the steering knuckle arm.
- (3) Remove the ABS sensor wire and bracket from knuckle. Refer to Brakes, for proper procedures.
- (4) Remove the cotter pin from the upper ball stud nut. Remove the upper and lower ball stud nuts.
- (5) Strike the steering knuckle with a brass hammer to loosen.
- (6) Remove knuckle from axle tube yokes.

### INSTALLATION

- (1) Position the steering knuckle on the ball studs.
- (2) Install and tighten lower ball stud nut to 108 N·m (80 ft. lbs.) torque. Advance nut to next slot to line up hole and install new cotter pin.
- (3) Install and tighten upper ball stud nut to 101 N·m (75 ft. lbs.) torque. Advance nut to next slot to line up hole and install new cotter pin.
- (4) Install the hub bearing and axle shaft.
- (5) Install tie-rod or drag link end onto the steering knuckle arm.
- (6) Install the ABS sensor wire and bracket to the knuckle. Refer to Brakes, for proper procedures.

### INSTALLATION

- (1) Position the steering knuckle on the ball studs.
- (2) Install and tighten lower ball stud nut to 47 N·m (35 ft. lbs.) torque. Do not install cotter pin at this time.
- (3) Install and tighten upper ball stud nut to 94 N·m (70 ft. lbs.) torque. Advance nut to next slot to line up hole and install new cotter pin.
- (4) Retorque lower ball stud nut to 190–217 N·m (140–160 ft. lbs.) torque. Advance nut to next slot to line up hole and install new cotter pin.
- (5) Install the hub bearing and axle shaft.
- (6) Install tie-rod or drag link end onto the steering knuckle arm.
- (7) Install the ABS sensor wire and bracket to the knuckle. Refer to Brakes, for proper procedure.

## LOWER CONTROL ARM

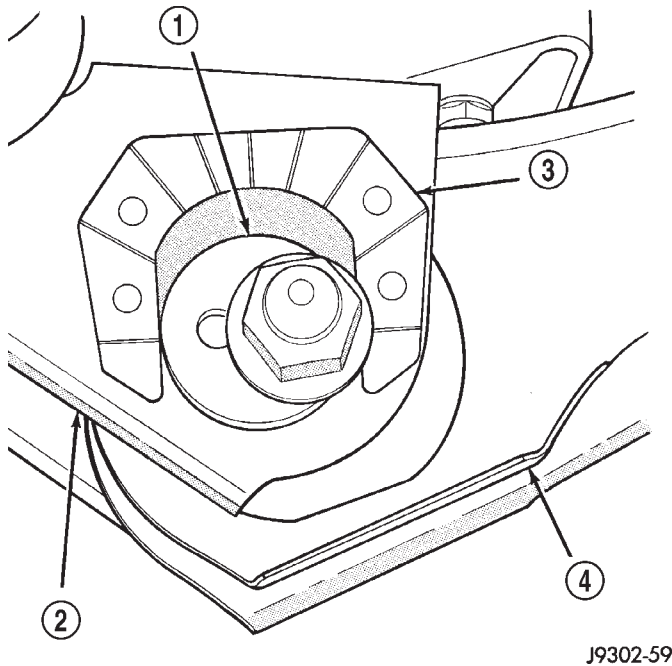
### REMOVAL

- (1) Raise and support the vehicle.
- (2) Paint or scribe alignment marks on the cam adjusters and suspension arm for installation reference (Fig. 15).
- (3) Remove the lower suspension arm nut, cam and cam bolt from the axle.
- (4) Remove the nut and bolt from the frame rail bracket and remove the lower suspension arm (Fig. 22).

### INSTALLATION

- (1) Position the lower suspension arm at the axle bracket and frame rail bracket.
- (2) Install the rear bolt and finger tighten the nut.
- (3) Install the cam bolt, cam and nut in the axle and align the reference marks.
- (4) Remove support and lower the vehicle.
- (5) Tighten cam nut at the axle bracket to 190 N·m (140 ft. lbs.). Tighten rear nut at the frame bracket to 190 N·m (140 ft. lbs.).

## LOWER CONTROL ARM (Continued)



**Fig. 15 Cam Adjuster**

- 1 - ADJUSTMENT CAM
- 2 - AXLE BRACKET
- 3 - BRACKET REINFORCEMENT
- 4 - LOWER SUSPENSION ARM

## SHOCK

## DESCRIPTION

The shocks are mounted inside the springs and attached at the top to brackets with grommets. These brackets are bolted on the frame with three studs on a ring. The shock is mounted at the bottom of the axle below the spring seat.

## OPERATION

The shock absorbers dampen the jounce and rebound of the vehicle over various road conditions.

## DIAGNOSIS AND TESTING - SHOCK

A knocking or rattling noise from a shock absorber may be caused by movement between mounting bushings and metal brackets or attaching components. These noises can usually be stopped by tightening the attaching nuts. If the noise persists, inspect for damaged and worn bushings, and attaching components. Repair as necessary if any of these conditions exist.

A squeaking noise from the shock absorber may be caused by the hydraulic valving and may be intermittent. This condition is not repairable and the shock absorber must be replaced.

The shock absorbers are not refillable or adjustable. If a malfunction occurs, the shock absorber

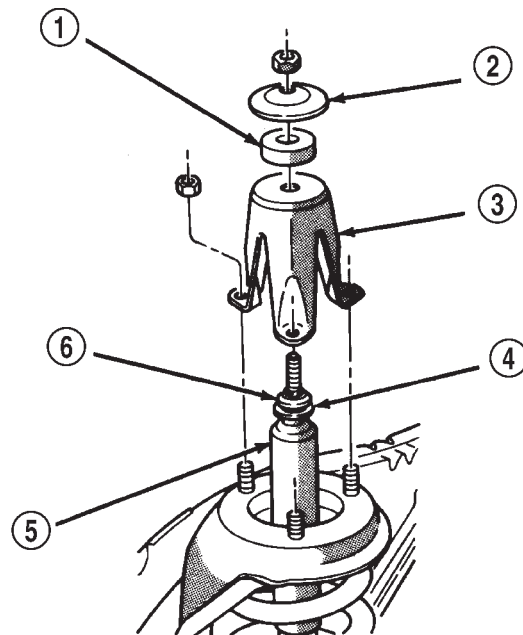
must be replaced. To test a shock absorber, hold it in an upright position and force the piston in and out of the cylinder four or five times. The action throughout each stroke should be smooth and even.

The shock absorber bushings do not require any type of lubrication. Do not attempt to stop bushing noise by lubricating them. Grease and mineral oil-base lubricants will deteriorate the bushing.

## REMOVAL

(1) Remove the nut, retainer and grommet from the upper stud in the engine compartment.

(2) Remove three nuts from the upper shock bracket (Fig. 16) .



J9402-46

**Fig. 16 Shock Absorber and Bracket**

- 1 - GROMMET
- 2 - RETAINER
- 3 - BRACKET
- 4 - RETAINER
- 5 - SHOCK
- 6 - GROMMET

(3) Remove the lower bolt from the axle bracket (Fig. 17) . Remove the shock absorber from engine compartment.

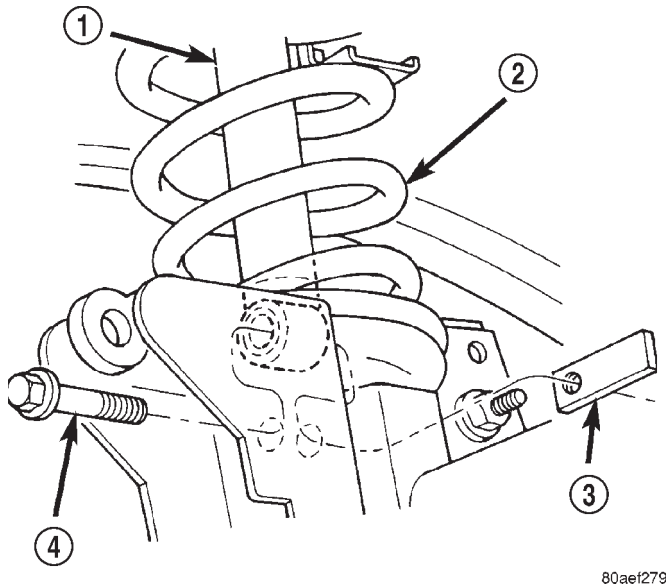
## INSTALLATION

(1) Position the lower retainer and grommet on the upper stud. Insert the shock absorber through the spring from engine compartment.

(2) Install the lower bolt and tighten to 135 N·m (100 ft. lbs.).

(3) Install the upper shock bracket and three nuts. Tighten nuts to 75 N·m (55 ft. lbs.).

## SHOCK (Continued)



**Fig. 17 Shock Absorber Axle Mount**

- 1 - SHOCK  
 2 - SPRING  
 3 - FLAG NUT  
 4 - SHOCK BOLT

80aef279

(4) Install upper grommet and retainer. Install upper shock nut and tighten to 47 N·m (35 ft. lbs).

## SPRING

### DESCRIPTION

The springs use a rubber isolators between the frame bracket and spring. The isolators help prevent road noise. The bottom of the spring sits on a seat mounted to the axle.

### OPERATION

The coil springs control ride quality and maintain proper ride height.

### REMOVAL

- (1) Raise and support the vehicle. Position a hydraulic jack under the axle to support it.
- (2) Paint or scribe alignment marks on lower suspension arm cam adjusters and axle bracket for installation reference.
- (3) Remove the upper suspension arm and loosen lower suspension arm bolts.
- (4) Mark and disconnect the front propeller shaft from the axle 4x4 models.
- (5) Disconnect the track bar from the frame rail bracket.
- (6) Disconnect the drag link from pitman arm.
- (7) Disconnect the stabilizer bar link and shock absorber from the axle.

(8) Lower the axle until the spring is free from the upper mount. Remove the coil spring.

### INSTALLATION

- (1) Position the coil spring on the axle pad.
- (2) Raise the axle into position until the spring seats in the upper mount.
- (3) Connect the stabilizer bar links and shock absorbers to the axle bracket. Connect the track bar to the frame rail bracket.
- (4) Install the upper suspension arm.
- (5) Install the front propeller shaft to the axle 4x4 model.
- (6) Install drag link to pitman arm and tighten nut to specifications. Install new cotter pin.
- (7) Remove the supports and lower the vehicle.
- (8) Tighten the following suspension components to specifications:
  - Link to stabilizer bar nut.
  - Lower shock bolt.
  - Track bar bolt at axle shaft tube bracket.
  - Upper suspension arm nut at axle bracket.
  - Upper suspension nut at frame bracket.
  - Align lower suspension arm reference marks and tighten cam nut.
  - Lower suspension nut at frame bracket.

## STABILIZER BAR

### DESCRIPTION

The stabilizer bar extends across the front underside of the chassis and connects to the frame rails. Links are connected from the bar to the axle brackets. Stabilizer bar mounts are isolated by teflon lined rubber bushings.

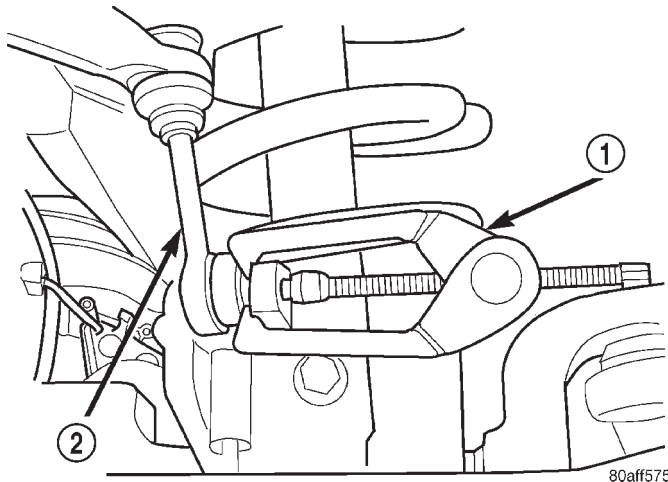
### OPERATION

The stabilizer bar is used to minimize vehicle front sway during turns. The spring steel bar helps to control the vehicle body in relationship to the suspension.

### REMOVAL

- (1) Raise and support the vehicle.
- (2) Hold the stabilizer link shafts with a wrench and remove the link nuts at the stabilizer bar.
- (3) Remove the retainers and grommets from the stabilizer bar links.
- (4) Remove the stabilizer bar link nuts from the axle brackets.
- (5) Remove the links from the axle brackets with Puller C-3894-A (Fig. 18).
- (6) Remove the stabilizer bar clamps from the frame rails and remove the stabilizer bar.

## STABILIZER BAR (Continued)

**Fig. 18 Stabilizer Link**

- 1 - PULLER  
2 - LINK

**INSTALLATION**

- (1) Position the stabilizer bar on the frame rail and install the clamps and bolts. Ensure the bar is centered with equal spacing on both sides.
- (2) Tighten the clamp bolts to 54 N·m (40 ft. lbs.).
- (3) Install links to the axle bracket and tighten nut to 47 N·m (35 ft. lbs.).
- (4) Install links, retainers, grommets and nuts to the stabilizer bar. Hold the link shaft with a wrench and tighten the nuts to 37 N·m (27 ft. lbs.).
- (5) Remove the supports and lower the vehicle.

**TRACK BAR****DESCRIPTION**

The bar is attached to a frame rail bracket with a ball stud and is isolated with a bushing at the axle bracket.

**OPERATION**

The track bar is used to control front axle side-to-side movement.

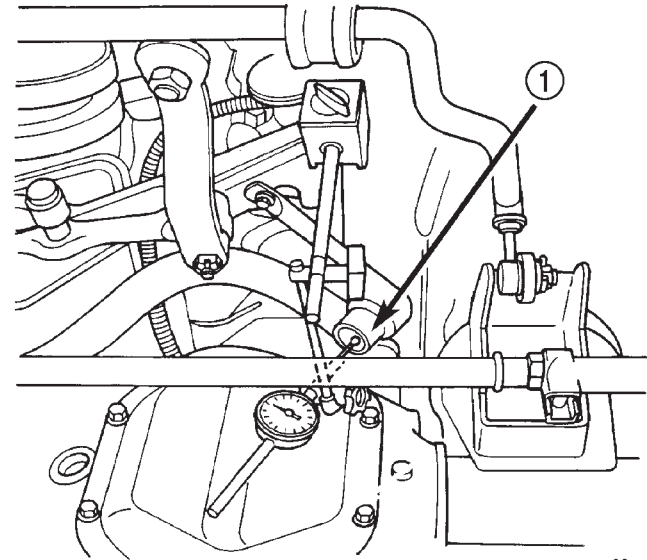
**DIAGNOSIS AND TESTING - TRACK BAR**

- (1) Turn the front wheel 90° to the left of center.
- (2) Mount a dial indicator to the left frame rail in front of the track bar ball joint (Fig. 19).
- (3) Position the dial indicator plunger on the ball joint end cap next to the grease fitting and zero the indicator.

**NOTE:** Dial indicator plunger must be perpendicular to the ball joint end cap.

- (4) Turn the front wheel 180° to the right and record the dial indicator reading. Repeat this step three times and record all readings.

- (5) If any of the readings exceed 2.03 mm (0.080 in) replace the track bar.

**Fig. 19 Dial Indicator Location**

- 1 - TRACK BAR BALL JOINT

**REMOVAL**

- (1) Raise and support the vehicle.
- (2) Remove the cotter pin and nut from the ball stud end at the frame rail bracket (Fig. 20).
- (3) Remove ball stud from bracket with Puller C-4150A (Fig. 21).
- (4) Remove the bolt and flag nut from the axle bracket and remove the track bar (Fig. 20).

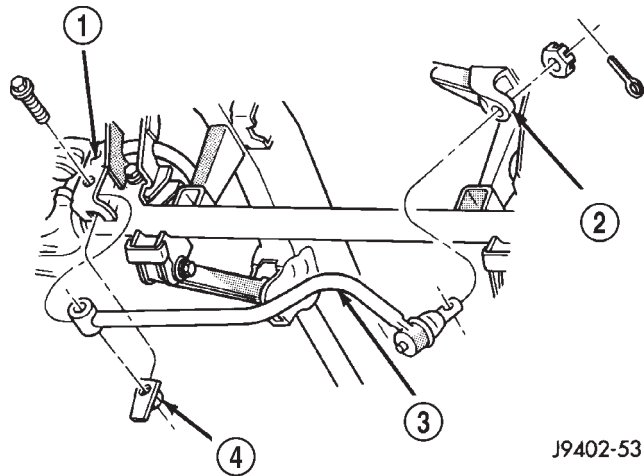
**INSTALLATION**

- (1) Install the track bar at axle bracket. Loosely install the retaining bolt and flag nut.
- (2) Pry the axle assembly over to install the track bar at the frame rail bracket.
- (3) Install the retaining nut on the stud. Tighten the ball stud nut to 95 N·m (70 ft. lbs.). Install a new cotter pin.
- (4) Remove the supports and lower the vehicle.
- (5) Tighten the bolt at the axle bracket to 176 N·m (130 ft. lbs.).

**UPPER CONTROL ARM****REMOVAL**

- (1) Raise and support the vehicle.
- (2) Remove the upper suspension arm nut and bolt at the axle bracket (Fig. 22).

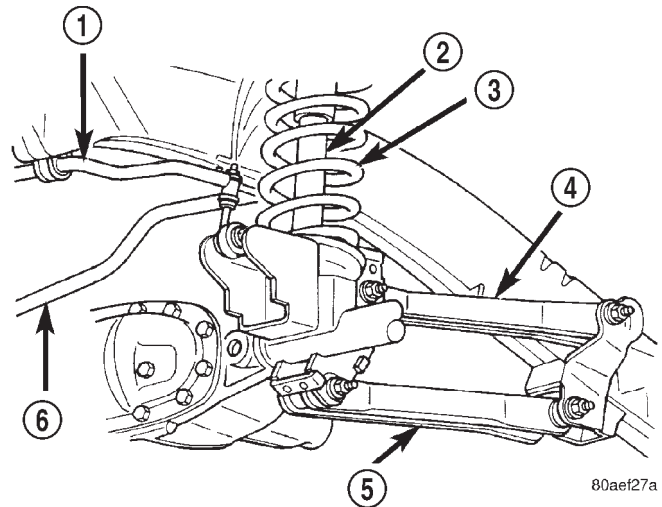
## UPPER CONTROL ARM (Continued)



J9402-53

**Fig. 20 Track Bar**

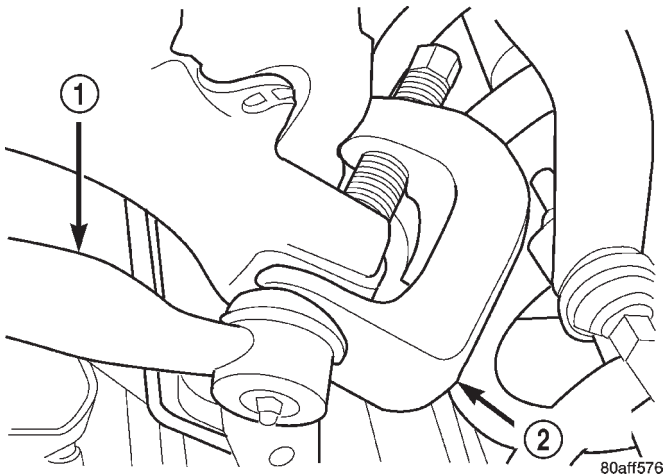
- 1 - AXLE BRACKET
- 2 - FRAME BRACKET
- 3 - TRACK BAR
- 4 - FLAG NUT



80aef27a

**Fig. 22 Upper and Lower Suspension Arm**

- 1 - STABILIZER BAR
- 2 - SHOCK ABSORBER
- 3 - COIL SPRING
- 4 - UPPER SUSPENSION ARM
- 5 - LOWER SUSPENSION ARM
- 6 - TRACK BAR



80aff576

**Fig. 21 Track Bar Puller**

- 1 - TRACK BAR
- 2 - PULLER

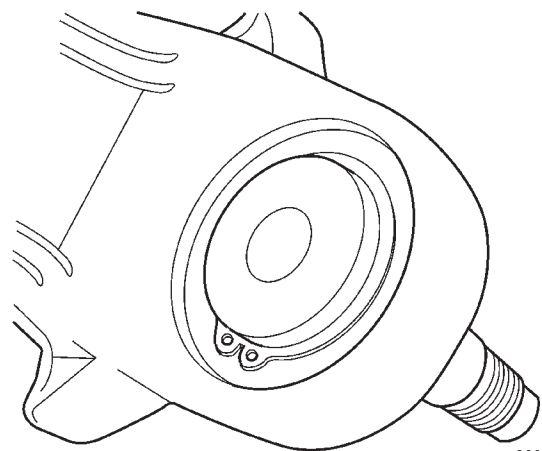
(3) Remove the nut and bolt at the frame rail and remove the upper suspension arm.

**INSTALLATION**

- (1) Position the upper suspension arm at the axle and frame rail.
- (2) Install the bolts and finger tighten the nuts.
- (3) Remove the supports and lower the vehicle.
- (4) Tighten nut at the axle bracket to 163 N·m (120 ft. lbs.). Tighten nut at frame bracket to 163 N·m (120 ft. lbs.).

**LOWER BALL JOINT****REMOVAL -**

- (1) Remove lower snap ring from the lower ball joint (Fig. 23).



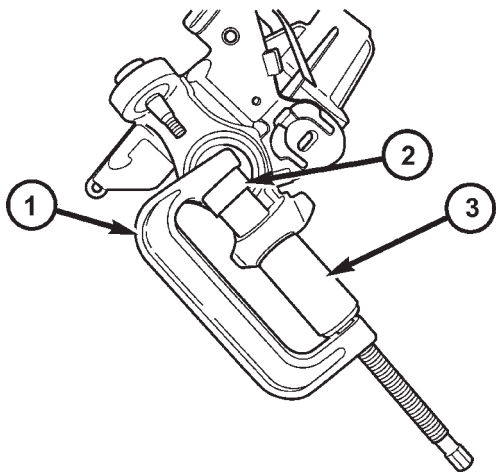
809eae65

**Fig. 23 Lower Snap Ring**



## LOWER BALL JOINT (Continued)

(2) Position tools as shown to remove lower ball stud (Fig. 24).



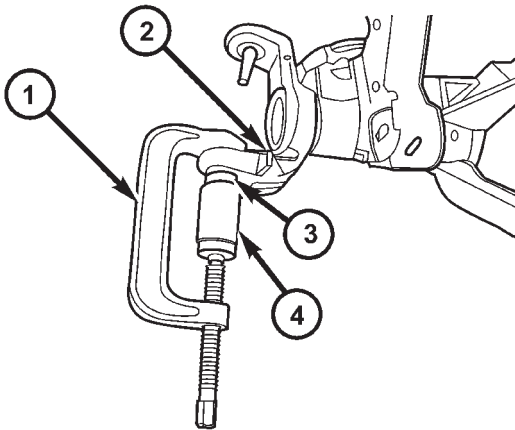
809e9ea4

**Fig. 24 Lower Ball Joint Removal**

- 1 - SPECIAL TOOL C4212-F
- 2 - SPECIAL TOOL 8445-3
- 3 - SPECIAL TOOL 8445-1

## INSTALLATION

(1) Position tools as shown to install lower ball stud (Fig. 25).



809e9f77

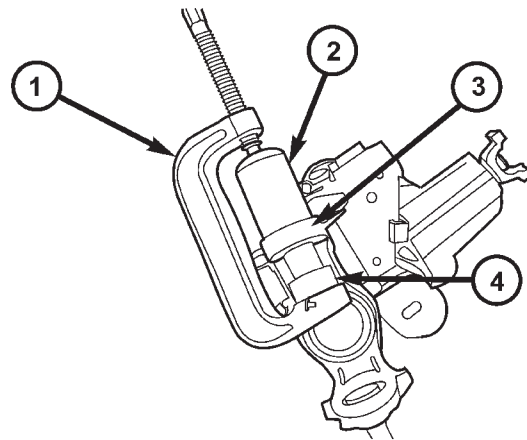
**Fig. 25 Lower Ball Joint Install**

- 1 - SPECIAL TOOL C4212-F
- 2 - SPECIAL TOOL 8445-2
- 3 - BALL JOINT
- 4 - KNUCKLE

## UPPER BALL JOINT

## REMOVAL -

(1) Position tools as shown to remove upper ball stud (Fig. 26).



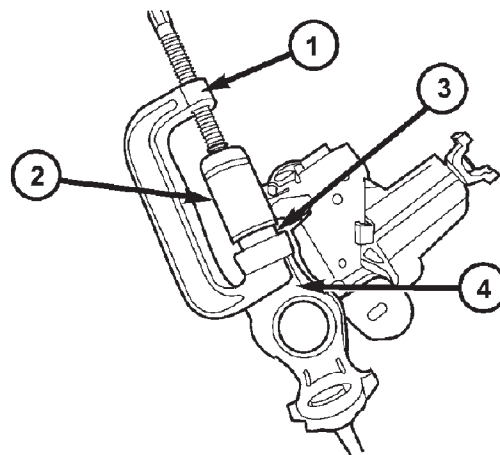
809ea05d

**Fig. 26 Upper Ball Joint Removal**

- 1 - SPECIAL TOOL C4212-F
- 2 - SPECIAL TOOL 6761
- 3 - KNUCKLE
- 4 - SPECIAL TOOL 8445-3

## INSTALLATION

(1) Position tools as shown to install upper ball stud (Fig. 27).



809ea080

**Fig. 27 Upper Ball Joint Installation**

- 1 - SPECIAL TOOL C4212-F
- 2 - SPECIAL TOOL 8445-2
- 3 - BALL JOINT
- 4 - KNUCKLE

# REAR

## TABLE OF CONTENTS

	page		page
<b>REAR</b>		<b>OPERATION</b> .....	28
DESCRIPTION.....	26	REMOVAL.....	28
DIAGNOSIS AND TESTING.....	26	INSTALLATION.....	28
SPRING AND SHOCK.....	26	<b>SPRING</b>	
SPECIFICATIONS.....	27	DESCRIPTION.....	28
SPECIAL TOOLS.....	28	OPERATION.....	28
<b>BUSHINGS</b>		REMOVAL.....	28
REMOVAL.....	28	INSTALLATION.....	29
INSTALLATION.....	28	<b>STABILIZER BAR</b>	
<b>JOUNCE BUMPER</b>		DESCRIPTION.....	30
DESCRIPTION.....	28	OPERATION.....	30
OPERATION.....	28	REMOVAL.....	30
<b>SHOCK</b>		INSTALLATION.....	30
DESCRIPTION.....	28		

## REAR

### DESCRIPTION

The rear suspension is comprised of:

- Shock Absorbers
- Jounce Bumpers
- Stabilizer Bar (optional)
- Leaf Springs
- Drive Axle

**CAUTION:** A vehicle should always be loaded so the vehicle weight center-line is located immediately forward of the rear axle. Correct vehicle loading provides proper front tire-to-road contact. This results in maximum vehicle handling stability and safety. Incorrect vehicle weight distribution can cause excessive tire tread wear, spring fatigue or failure, and erratic steering.

**CAUTION:** Suspension components with rubber/urethane bushings (except stabilizer bar) should be tightened with the vehicle at normal ride height. It is important to have the springs supporting the weight of the vehicle when the fasteners are torqued. If springs are not at their normal ride position, vehicle ride comfort could be affected and premature bushing wear may occur.

### DIAGNOSIS AND TESTING - SPRING AND SHOCK

A knocking or rattling noise from a shock absorber may be caused by movement between mounting bushings and metal brackets or attaching components. These noises can usually be stopped by tightening the attaching nuts. If the noise persists, inspect for damaged and worn bushings, and attaching components. Repair as necessary if any of these conditions exist.

A squeaking noise from the shock absorber may be caused by the hydraulic valving and may be intermittent. This condition is not repairable and the shock absorber must be replaced.

The shock absorbers are not refillable or adjustable. If a malfunction occurs, the shock absorber must be replaced. To test a shock absorber, hold it in an upright position and force the piston in and out of the cylinder four or five times. The action throughout each stroke should be smooth and even.

The spring eye and shock absorber bushings do not require any type of lubrication. Do not attempt to stop spring bushing noise by lubricating them. Grease and mineral oil-base lubricants will deteriorate the bushing rubber.

If the vehicle is used for severe, off-road operation, the springs should be examined periodically. Check for broken and shifted leaves, loose and missing clips, and broken center bolts. Refer to Spring and Shock Absorber Diagnosis chart for additional information.

REAR (Continued)

*SPRING AND SHOCK ABSORBER*

<b>CONDITION</b>	<b>POSSIBLE CAUSES</b>	<b>CORRECTION</b>
SPRING SAGS	1. Broken leaf. 2. Spring fatigue.	1. Replace spring. 2. Replace spring.
SPRING NOISE	1. Loose spring clamp bolts. 2. Worn bushings. 3. Worn or missing spring tip inserts.	1. Tighten to specification. 2. Replace bushings. 3. Replace spring tip inserts.
SHOCK NOISE	1. Loose mounting fastener. 2. Worn bushings. 3. Leaking shock.	1. Tighten to specification. 2. Replace shock. 3. Replace shock.

## SPECIFICATIONS

## TORQUE CHART

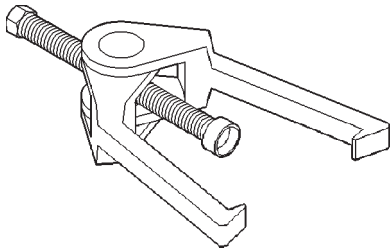
*TORQUE SPECIFICATIONS*

<b>DESCRIPTION</b>	<b>N-m</b>	<b>Ft. Lbs.</b>	<b>In. Lbs.</b>
Shock Absorber Lower Nut	136	100	—
Shock Absorber Upper Nut	136	100	—
Spring Clamp Nuts 6,010-10,500 GVW	149	110	—
Spring Clamp Nuts 11,000 GVW Cab-Chassis	163	120	—
Spring Front and Rear Eye and Shackle Bolt/Nut 6,010-6,400 GVW	163	120	—
Spring Front and Rear Eye and Shackle Bolt/Nut 8,800-11,000 GVW	176	130	—
Stabilizer Bar Retainer Nuts	54	40	—
Stabilizer Bar Link Ball Stud Nut	68	50	—
Stabilizer Bar Link Upper Nut	68	50	—
Stabilizer Bar Frame Bracket Nuts	54	40	—
Jounce Bumper Bolts	61	45	—

REAR (Continued)

## SPECIAL TOOLS

## SUSPENSION-REAR



Puller C-3894-A

## BUSHINGS

## REMOVAL

- (1) Remove the spring from the vehicle.
- (2) Position the spring eye in a press.
- (3) Press the bushing out with an appropriate size driver.

## INSTALLATION

- (1) Press new bushing into the spring eye with an appropriate size driver. The bushing should be centered in the spring eye.
- (2) Install the spring on the vehicle.

## JOUNCE BUMPER

## DESCRIPTION

The jounce bumpers are bolted to the frame rail above the axle.

## OPERATION

The jounce bumpers are used to limit the spring and axle travel.

## SHOCK

## DESCRIPTION

The top of the shock absorbers are bolted to the body crossmember. The bottom of the shocks are bolted to the axle bracket.

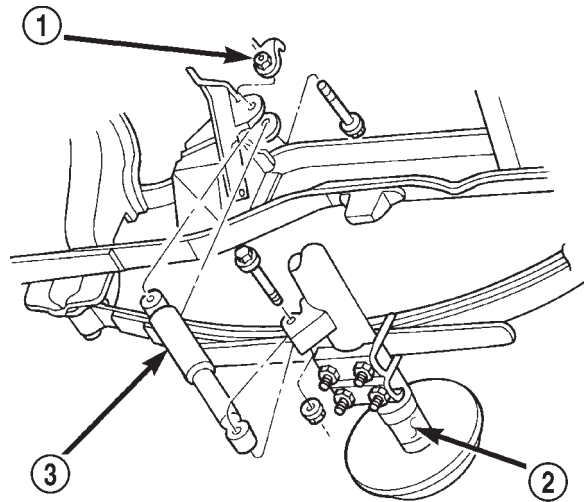
## OPERATION

The shocks dampen the jounce and rebound as the vehicle travels over various road conditions.

## REMOVAL

- (1) Raise vehicle and support axle.
- (2) Remove the bolt and flag nut from the frame crossmember bracket (Fig. 1) .
- (3) Remove the bolt and nut from the axle bracket.

- (4) Remove the rear shock absorber from the vehicle.



80add399

Fig. 1 Shock Absorber

- 1 - FLAG NUT  
2 - AXLE  
3 - SHOCK

## INSTALLATION

- (1) Position the shock absorber in the brackets.
- (2) Install the bolts through the brackets and the shock. Install the flag nut on the top bolt and nut on lower bolt.
- (3) Tighten the upper and lower bolt/nuts Tighten to 136 N.m (100 ft. lbs.)
- (4) Remove the support and lower the vehicle.

## SPRING

## DESCRIPTION

The rear suspension system uses a multi-leaf springs and a solid drive axle. The forward end of the springs are mounted to the body rail hangers through rubber bushings. The rearward end of the springs are attached to the body by the use of shackles. The spring and shackles use rubber bushings.

## OPERATION

The springs control ride quality and maintain vehicle ride height. The shackles allow the springs to change their length as the vehicle moves over various road conditions.

## REMOVAL

- (1) Raise the vehicle and support the axle to remove all weight from the springs.

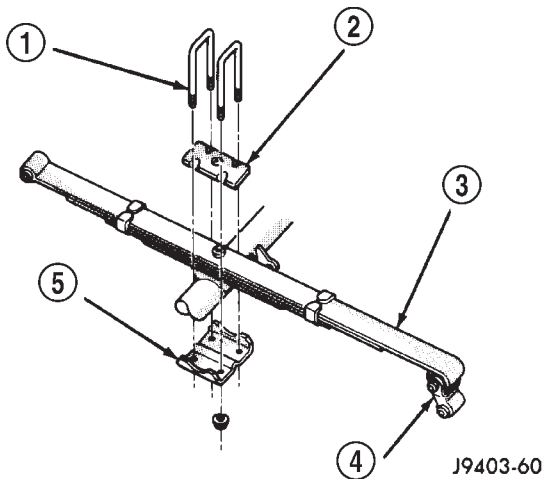
## SPRING (Continued)

(2) Remove the nuts and spring clamp bolts that attach the spring to the axle (Fig. 2) and (Fig. 3) and (Fig. 4).

(3) Remove the nuts and bolts from the spring front and rear shackle eyes. **Note: To remove front eye bolt on left side spring fuel tank must be removed, (Refer to 14 - FUEL SYSTEM/FUEL DELIVERY/FUEL TANK - REMOVAL).**

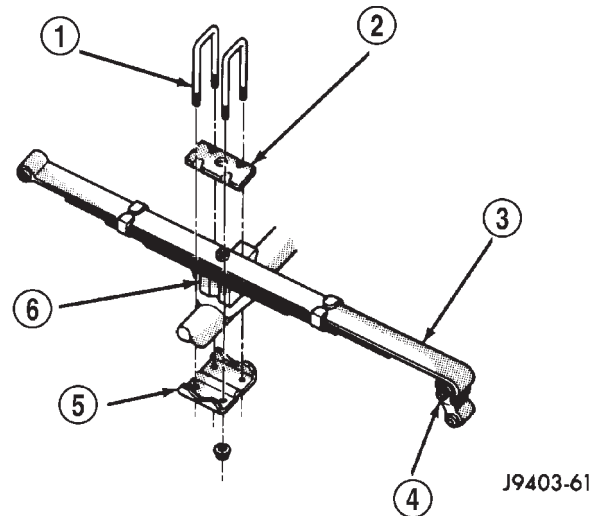
(4) Remove the spring from the vehicle.

(5) Remove the shackle from the spring.



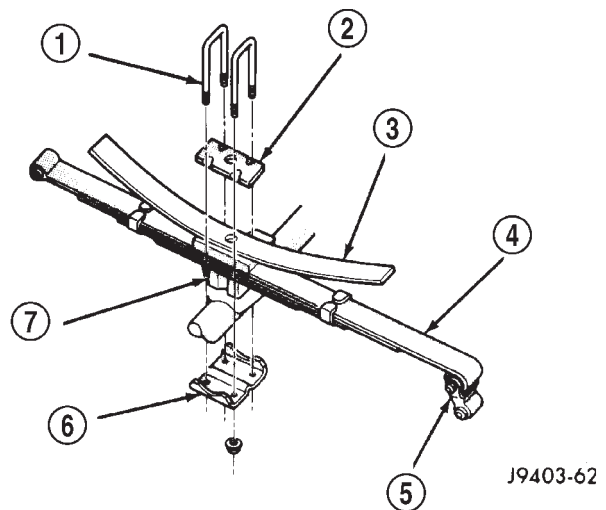
**Fig. 2 Rear Spring - 4x2**

- 1 - SPRING CLAMP BOLTS
- 2 - SPRING SEAT
- 3 - SPRING
- 4 - SHACKLE
- 5 - SPRING PLATE



**Fig. 3 Rear Spring - 4x4**

- 1 - SPRING CLAMP BOLT
- 2 - SPRING SEAT
- 3 - SPRING
- 4 - SHACKLE
- 5 - SPRING PLATE
- 6 - SPACER



**Fig. 4 Rear Spring - Cab-Chassis 11000 GVW**

- 1 - SPRING CLAMP BOLT
- 2 - SPRING SEAT
- 3 - AUXILIARY SPRING
- 4 - SPRING
- 5 - SHACKLE
- 6 - SPRING PLATE
- 7 - SPACER

## INSTALLATION

(1) Install shackle on rear spring eye and install bolt and nut.

(2) Position spring on axle shaft tube so spring center bolt is inserted into the locating hole in the axle tube spring pad or spacer.

(3) Align spring front eye with bolt hole in the front bracket. Install the eye pivot bolt and nut.

(4) Align shackle eye with bolt hole in rear bracket. Install bolt and nut.

(5) Tighten the spring front and rear eye pivot bolt snug do not torque.

(6) Install spring clamp bolts and the retaining nuts.

(7) Align the auxiliary spring with the primary spring if equipped. Tighten the nuts until they force the plate flush against the axle tube.

(8) Remove the supports and lower the vehicle so that the weight is being supported by the tires.

(9) Tighten the spring clamp retaining nuts to specifications

(10) Tighten spring front and rear eye pivot bolt nuts and shackle eye to specifications.



## STABILIZER BAR

### DESCRIPTION

The stabilizer bar extends across the underside of the vehicle and is bolted to the axle. Links at the end of the bar are bolted to the frame.

### OPERATION

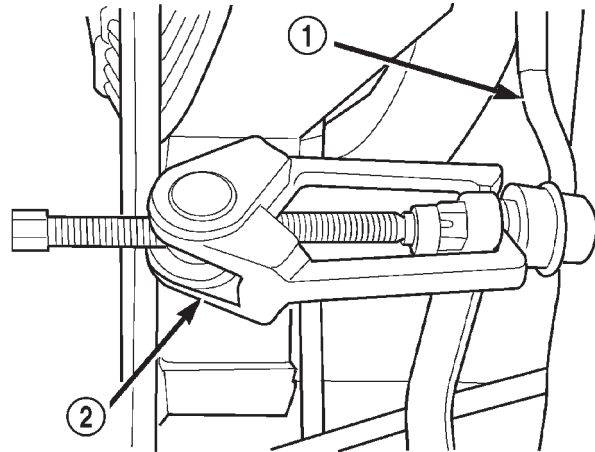
The stabilizer bar is used to minimize vehicle body roll. The spring steel bar helps to control the vehicle body in relationship to the suspension.

### REMOVAL

- (1) Raise and support vehicle.
- (2) Remove nuts from the links at the stabilizer bar and separate the links with Puller C-3894-A (Fig. 5) .
- (3) Remove stabilizer bar retainer nuts and retainers (Fig. 6) .
- (4) Remove stabilizer bar and replace worn, cracked or distorted bushings.
- (5) Remove links upper mounting nuts and bolts and remove links.

### INSTALLATION

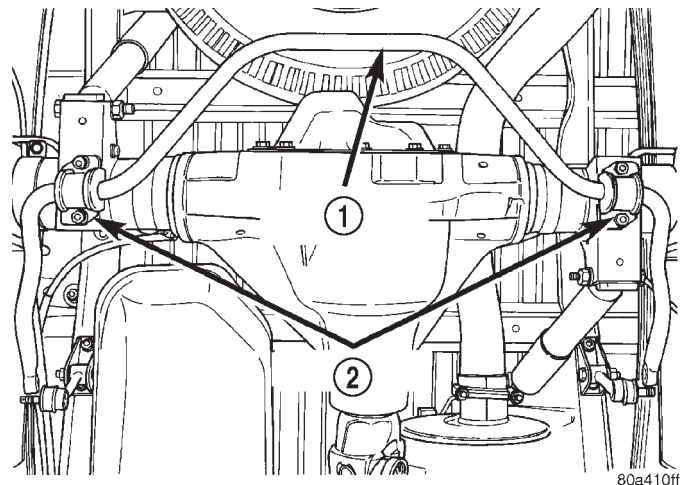
- (1) Install link into frame brackets and install mounting nuts and bolts.
- (2) Install the stabilizer bar and center it with equal spacing on both sides. Install stabilizer bar retainers and tighten nuts to 54 N·m (40 ft. lbs.).
- (3) Install stabilizer link ball studs into the bar and tighten nuts to 68 N·m (50 ft. lbs.).
- (4) Remove support and lower vehicle.
- (5) Tighten upper link mounting nuts to 68 N·m (50 ft. lbs.).



80aff577

**Fig. 5 Stabilizer Link**

- 1 - LINK
- 2 - PULLER



80a410ff

**Fig. 6 Stabilizer Bar Mounting Bolts And**

- 1 - STABILIZER BAR
- 2 - RETAINERS

# DIFFERENTIAL & DRIVELINE

## TABLE OF CONTENTS

	page		page
PROPELLER SHAFT .....	1	REAR AXLE - 248RBI .....	109
FRONT AXLE - 216FBI .....	12	REAR AXLE - 267RBI .....	140
FRONT AXLE - 248FBI .....	45	REAR AXLE - 286RBI .....	169
REAR AXLE - 9 1/4 .....	77		

## PROPELLER SHAFT

### TABLE OF CONTENTS

	page		page
<b>PROPELLER SHAFT</b>		<b>PROPELLER SHAFT - REAR</b>	
DESCRIPTION .....	1	REMOVAL .....	9
OPERATION .....	1	INSTALLATION .....	9
DIAGNOSIS AND TESTING .....	3	<b>CENTER BEARING</b>	
PROPELLER SHAFT .....	3	DESCRIPTION .....	10
STANDARD PROCEDURE .....	5	OPERATION .....	10
SPECIFICATIONS .....	8	REMOVAL .....	10
SPECIAL TOOLS .....	8	INSTALLATION .....	10
<b>PROPELLER SHAFT - FRONT</b>		ADJUSTMENTS .....	10
REMOVAL .....	8	<b>SINGLE CARDAN UNIVERSAL JOINTS</b>	
INSTALLATION .....	8	DISASSEMBLY .....	11

## PROPELLER SHAFT

### DESCRIPTION

A propeller shaft (Fig. 1), (Fig. 2), (Fig. 3), and (Fig. 4) is a shaft which connects the transmission/transfer case to the axle differential. This is the link through which the engine power is transmitted to the axle.

The propeller shaft is designed and built with the yoke lugs in line with each other which is called zero phasing. This design produces the smoothest running condition, an out-of-phase shaft can cause a vibration.

Tubular propeller shafts are balanced by the manufacturer with weights spot welded to the tube.

Use the exact replacement parts when installing the propeller shafts. The use of the correct replacement parts helps to ensure safe operation. All fasteners must be torqued to the specified values for safe operation.

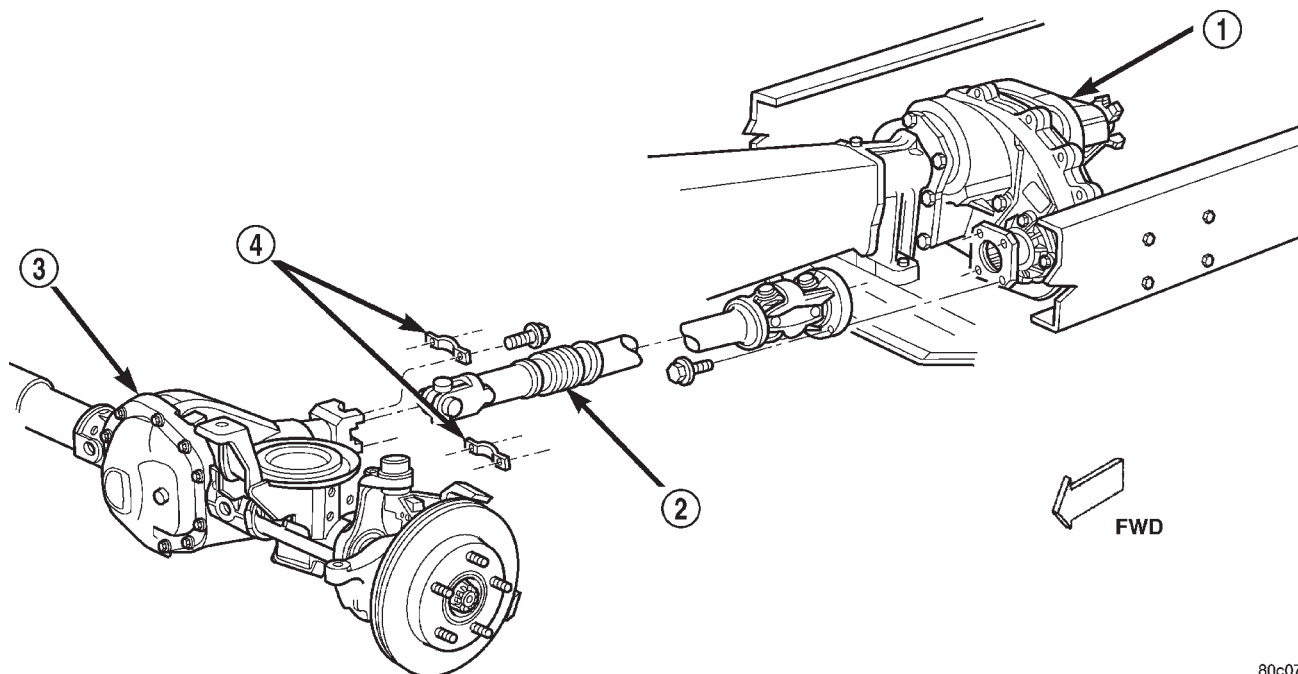
Also make alignment reference marks (Fig. 5) on the propeller shaft yoke and axle, or transmission, yoke prior to servicing. This helps to eliminate possible vibration.

**CAUTION: Do not allow the propeller shaft to drop or hang from any propeller shaft joint during removal. Attach the propeller shaft to the vehicle underside with wire to prevent damage to the joints.**

### OPERATION

The propeller shaft must operate through constantly changing relative angles between the transmission and axle. It must also be capable of changing length while transmitting torque. The axle rides suspended by springs in a floating motion. The propeller shaft must be able to change operating angles when going over various road surfaces. This is accomplished through universal joints, which permit the propeller shaft to operate at different angles. The slip joints (or yokes) permit contraction or expansion.

PROPELLER SHAFT (Continued)

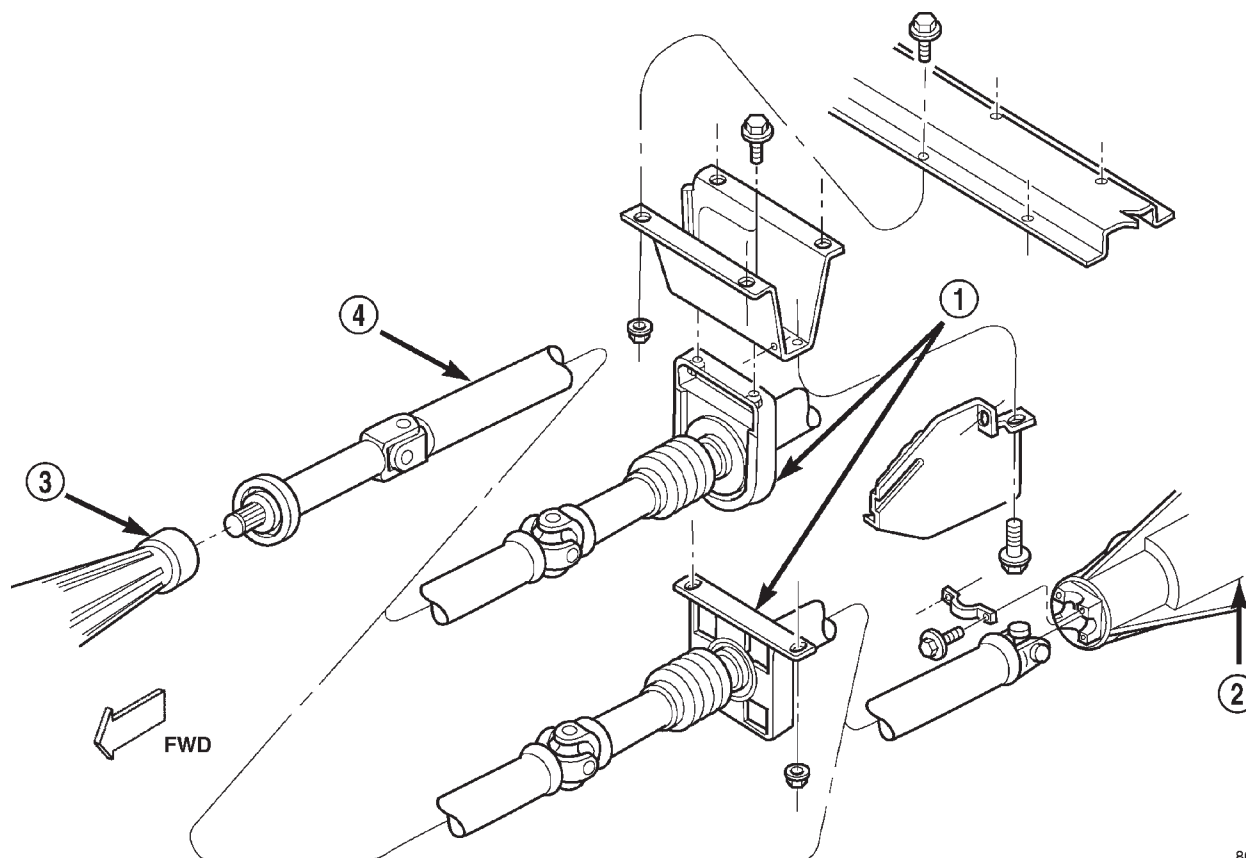


**Fig. 1 Front Propeller Shaft**

80c07125

- 1 - TRANSFER CASE
- 2 - FRONT PROPELLER SHAFT

- 3 - FRONT AXLE
- 4 - UNIVERSAL JOINT CLAMP



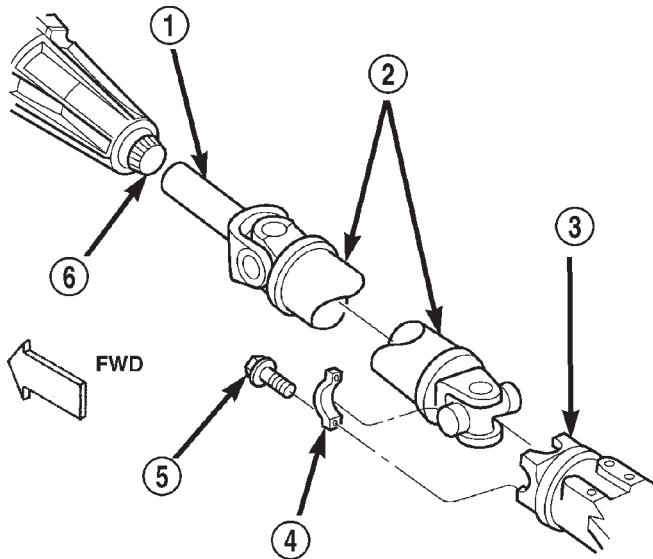
**Fig. 2 Rear Propeller Shaft with Center Bearing**

80c07126

- 1 - CENTER BEARING
- 2 - REAR AXLE

- 3 - TRANSMISSION TRANSFER
- 4 - REAR PROPELLER SHAFT

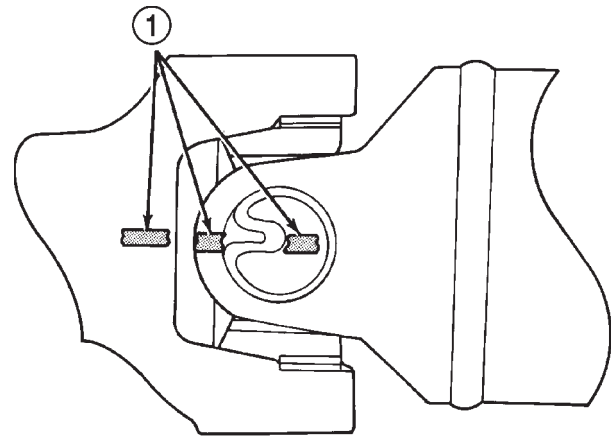
## PROPELLER SHAFT (Continued)



80c07128

**Fig. 3 Rear Propeller Shaft - Dana Axles**

- 1 - SLIDING YOKE
- 2 - PROPELLER SHAFT
- 3 - PINION YOKE
- 4 - CLAMP
- 5 - SCREW
- 6 - OUTPUT SHAFT



J9316-2

**Fig. 5 Propeller Shaft And Yoke**

1 - REFERENCE MARKS

**Before undercoating a vehicle, the propeller shaft and the U-joints should be covered to prevent an out-of-balance condition and driveline vibration.**

**CAUTION:** Use original equipment replacement parts for attaching the propeller shafts. The specified torque must always be applied when tightening the fasteners.

## DIAGNOSIS AND TESTING - PROPELLER SHAFT

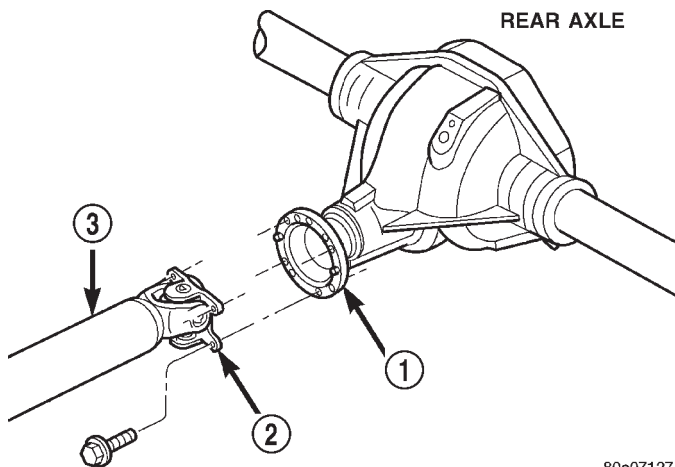
### VIBRATION

Tires that are out-of-round, or wheels that are unbalanced, will cause a low frequency vibration. (Refer to 22 - TIRES/WHEELS - DIAGNOSIS AND TESTING)

Brake drums that are unbalanced will cause a harsh, low frequency vibration. (Refer to 5 - BRAKES - DIAGNOSIS AND TESTING)

Driveline vibration can also result from loose or damaged engine mounts.

Propeller shaft vibration increases as the vehicle speed is increased. A vibration that occurs within a specific speed range is not usually caused by a propeller shaft being unbalanced. Defective universal joints, or an incorrect propeller shaft angle, are usually the cause of such a vibration.



80c07127

**Fig. 4 Rear Propeller Shaft - Corporate Axles**

- 1 - COMPANION FLANGE
- 2 - COMPANION YOKE
- 3 - REAR PROPELLER SHAFT

## PROPELLER SHAFT (Continued)

## DRIVELINE VIBRATION

Drive Condition	Possible Cause	Correction
Propeller Shaft Noise	1) Undercoating or other foreign material on shaft. 2) Loose U-joint clamp screws. 3) Loose or bent U-joint yoke or excessive runout. 4) Incorrect driveline angularity. 5) Rear spring center bolt not in seat. 6) Worn U-joint bearings. 7) Propeller shaft damaged or out of balance. 8) Broken rear spring. 9) Excessive runout or unbalanced condition. 10) Excessive drive pinion gear shaft runout. 11) Excessive axle yoke deflection. 12) Excessive transfer case runout.	1) Clean exterior of shaft and wash with solvent. 2) Install new clamps and screws and tighten to proper torque. 3) Install new yoke. 4) Measure and correct driveline angles. 5) Loosen spring u-bolts and seat center bolt. 6) Install new U-joint. 7) Install new propeller shaft. 8) Install new rear spring. 9) Re-index propeller shaft, test, and evaluate. 10) Re-index propeller shaft and evaluate. 11) Inspect and replace yoke if necessary. 12) Inspect and repair as necessary.
Universal Joint Noise	1) Loose U-joint clamp screws. 2) Lack of lubrication.	1) Install new clamps and screws and tighten to proper torque. 2) Replace as U-joints as necessary.

## BALANCE

**NOTE: Removing and re-indexing the propeller shaft 180° relative to the yoke may eliminate some vibrations.**

If propeller shaft is suspected of being unbalanced, it can be verified with the following procedure:

- (1) Raise the vehicle.
- (2) Clean all the foreign material from the propeller shaft and the universal joints.
- (3) Inspect the propeller shaft for missing balance weights, broken welds, and bent areas. **If the propeller shaft is bent, it must be replaced.**
- (4) Inspect the universal joints to ensure that they are not worn, are properly installed, and are correctly aligned with the shaft.
- (5) Check the universal joint clamp screws torque.
- (6) Remove the wheels and tires. Install the wheel lug nuts to retain the brake drums or rotors.
- (7) Mark and number the shaft six inches from the yoke end at four positions 90° apart.

(8) Run and accelerate the vehicle until vibration occurs. Note the intensity and speed the vibration occurred. Stop the engine.

(9) Install a screw clamp at position 1 (Fig. 6).

(10) Start the engine and re-check for vibration. If there is little or no change in vibration, move the clamp to one of the other three positions. Repeat the vibration test.

(11) If there is no difference in vibration at the other positions, the source of the vibration may not be propeller shaft.

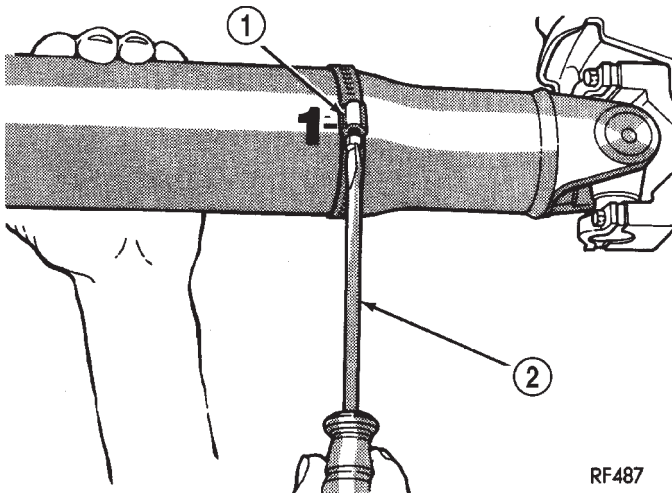
(12) If the vibration decreased, install a second clamp (Fig. 7) and repeat the test.

(13) If the additional clamp causes an additional vibration, separate the clamps (1/2 inch above and below the mark). Repeat the vibration test (Fig. 8).

(14) Increase distance between the clamp screws and repeat the test until the amount of vibration is at the lowest level. Bend the slack end of the clamps so the screws will not loosen.

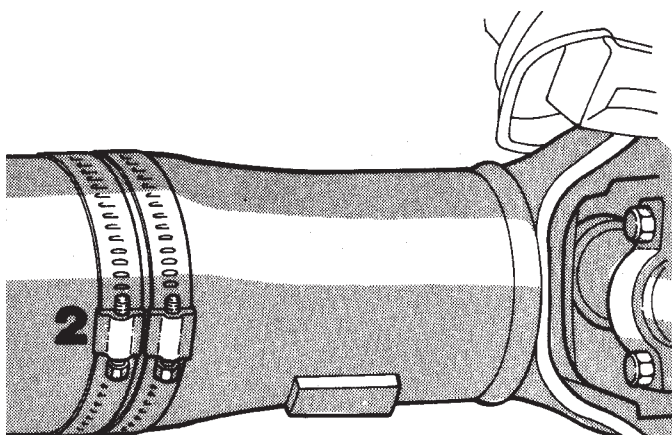


## PROPELLER SHAFT (Continued)

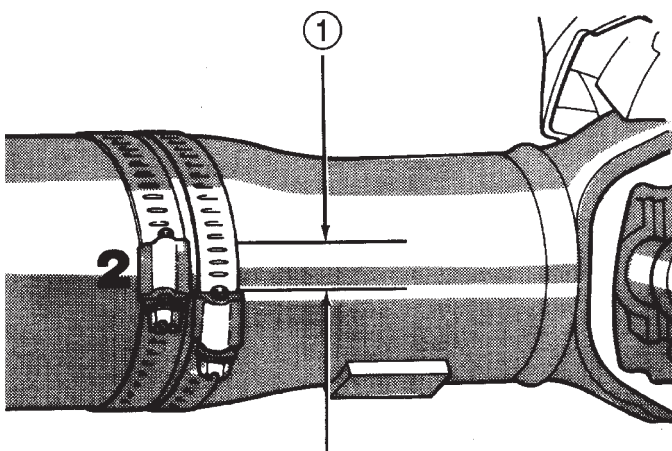


**Fig. 6 Clamp Screw At Position 1**

- 1 - CLAMP  
2 - SCREWDRIVER



**Fig. 7 Two Clamp Screws At The Same Position**



**Fig. 8 Clamp Screws Separated**

1 - 1/2 INCH

- (15) If the vibration remains unacceptable, apply the same steps to the front end of the propeller shaft.  
(16) Install the wheel and tires. Lower the vehicle.

### RUNOUT

- (1) Remove dirt, rust, paint and undercoating from the propeller shaft surface where the dial indicator will contact the shaft.  
(2) The dial indicator must be installed perpendicular to the shaft surface.  
(3) Measure runout at the center and ends of the shaft sufficiently far away from weld areas to ensure that the effects of the weld process will not enter into the measurements.  
(4) Refer to Runout Specifications chart.  
(5) If the propeller shaft runout is out of specification, remove the propeller shaft, index the shaft 180°, and re-install the propeller shaft. Measure shaft runout again.  
(6) If the propeller shaft runout is now within specifications, mark the shaft and yokes for proper orientation.  
(7) If the propeller shaft runout is not within specifications, verify that the runout of the transmission/transfer case and axle are within specifications. Correct as necessary and re-measure propeller shaft runout.  
(8) Replace the propeller shaft if the runout still exceeds the limits.

### RUNOUT SPECIFICATIONS

Front of Shaft	0.020 in. (0.50 mm)
Center of Shaft	0.025 in. (0.63 mm)
Rear of Shaft	0.020 in. (0.50 mm)

#### note:

Measure front/rear runout approximately 3 inches (76 mm) from the weld seam at each end of the shaft tube for tube lengths over 30 inches. For tube lengths under 30 inches, the maximum allowed runout is 0.020 in. (0.50 mm) for the full length of the tube.

### STANDARD PROCEDURES

To accurately check driveline alignment, raise and support the vehicle at the axles as level as possible. Allow the wheels and propeller shaft to turn.

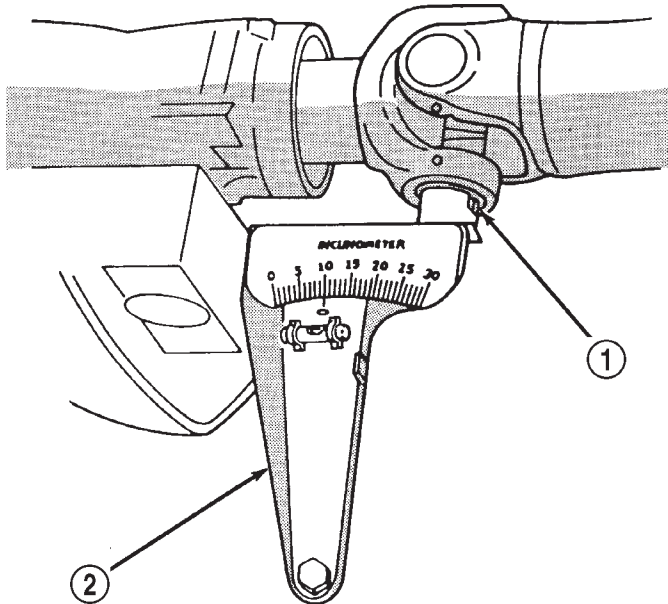
- (1) Remove any external bearing snap rings, if equipped, from universal joint so protractor base sits flat.  
(2) Rotate the shaft until transmission/transfer case output yoke bearing is facing downward.

**NOTE:** Always make measurements from front to rear and from the same side of the vehicle.

## PROPELLER SHAFT (Continued)

(3) Place Inclinator 7663 (J-23498A) on yoke bearing (A) parallel to the shaft (Fig. 9). Center bubble in sight glass and record measurement.

**This measurement will give you the transmission or Output Yoke Angle (A).**



J9216-13

**Fig. 9 Front (Output) Angle Measurement (A)**

- 1 - SLIP YOKE BEARING CAP  
2 - SPECIAL TOOL 7663 (J-23498A)

(4) Rotate propeller shaft 90 degrees and place Inclinator on yoke bearing parallel to the shaft (Fig. 10). Center bubble in sight glass and record measurement. This measurement can also be taken at the rear end of the shaft.

**This measurement will give you the Propeller Shaft Angle (C).**

(5) Subtract smaller figure from larger (C minus A) to obtain Transmission Output Operating Angle.

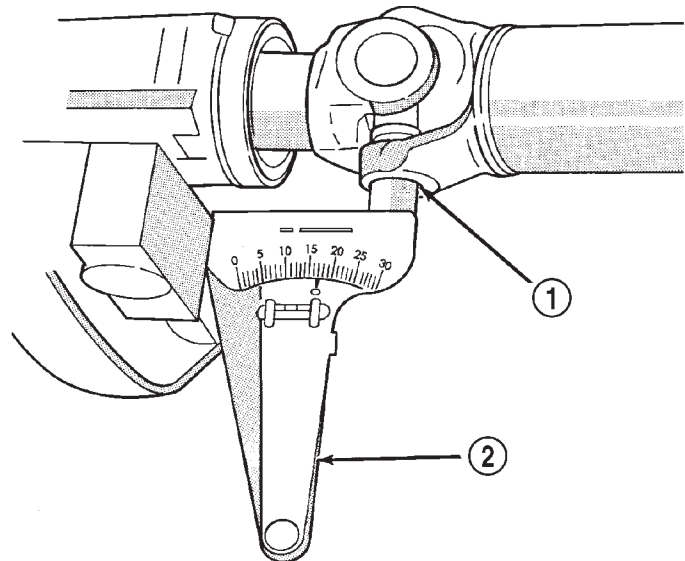
(6) Rotate propeller shaft 90 degrees and place Inclinator on pinion yoke bearing parallel to the shaft (Fig. 11). Center bubble in sight glass and record measurement.

**This measurement will give you the pinion shaft or Input Yoke Angle (B).**

(7) Subtract smaller figure from larger (C minus B) to obtain axle Input Operating Angle.

Refer to rules given below and the example in (Fig. 12) for additional information.

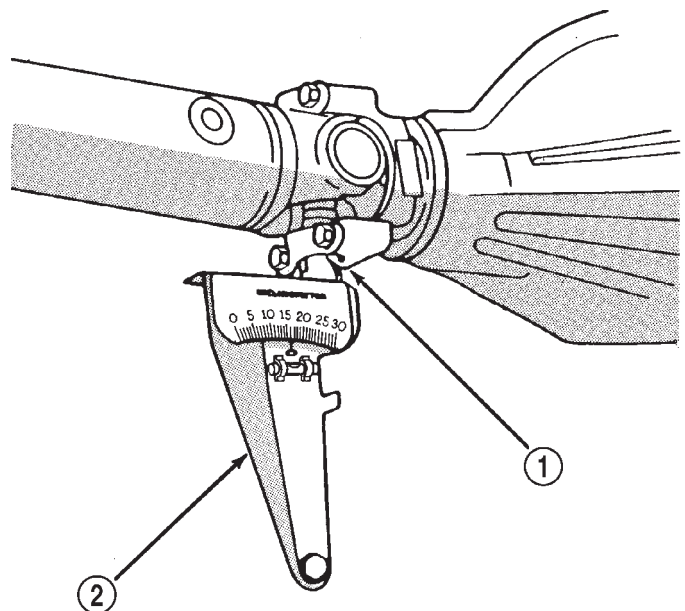
- Good cancellation of U-joint operating angles (within 1°).
- Operating angles less than 3°.
- At least 1/2 of one degree continuous operating (propeller shaft) angle.



J9216-9

**Fig. 10 Propeller Shaft Angle Measurement (C)**

- 1 - SHAFT YOKE BEARING CAP  
2 - SPECIAL TOOL 7663 (J23498-A)



J9216-12

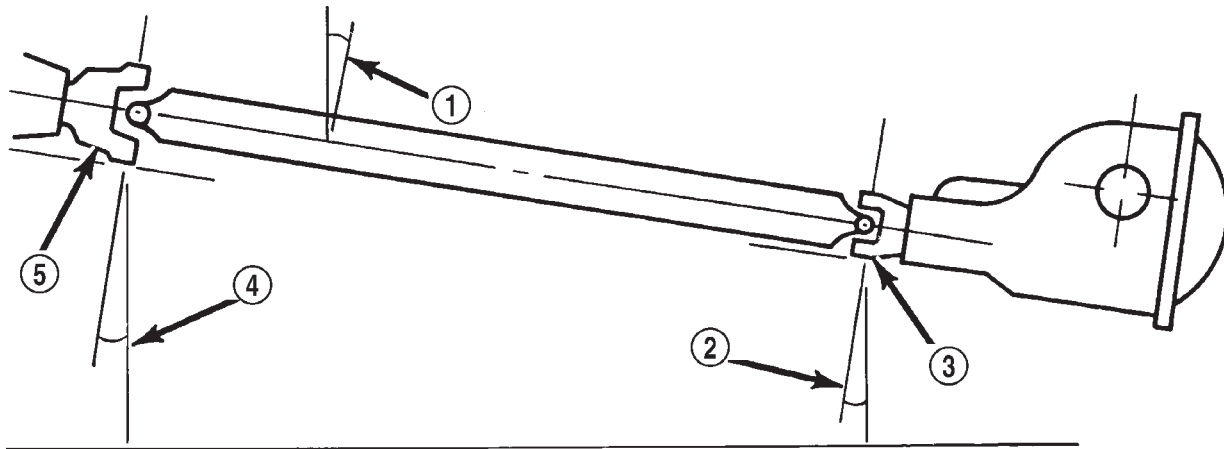
**Fig. 11 Rear (Input) Angle Measurement (B)**

- 1 - PINION YOKE BEARING CAP  
2 - SPECIAL TOOL 7663 (J-23498A)

## TWO-PIECE PROPELLER SHAFT

The procedure to measure the propeller shaft angles involved with a two-piece (Fig. 13) propeller shaft is the same as those for a one-piece propeller shaft.

PROPELLER SHAFT (Continued)



Horizontal Level

(A) Output Yoke = 3.0° or 4.9°  
 (C) Prop. Shaft = 4.9° or -3.0°

(B) Axle Input Yoke = 3.2° or 4.9°  
 (C) Prop. Shaft = 4.9° or -3.2°

Transmission Output Operating Angle 1.9°

Axle Input Operating Angle 1.7°

Trans. Output Operating Angle 1.9°  
 Axle Input Operating Angle -1.7°

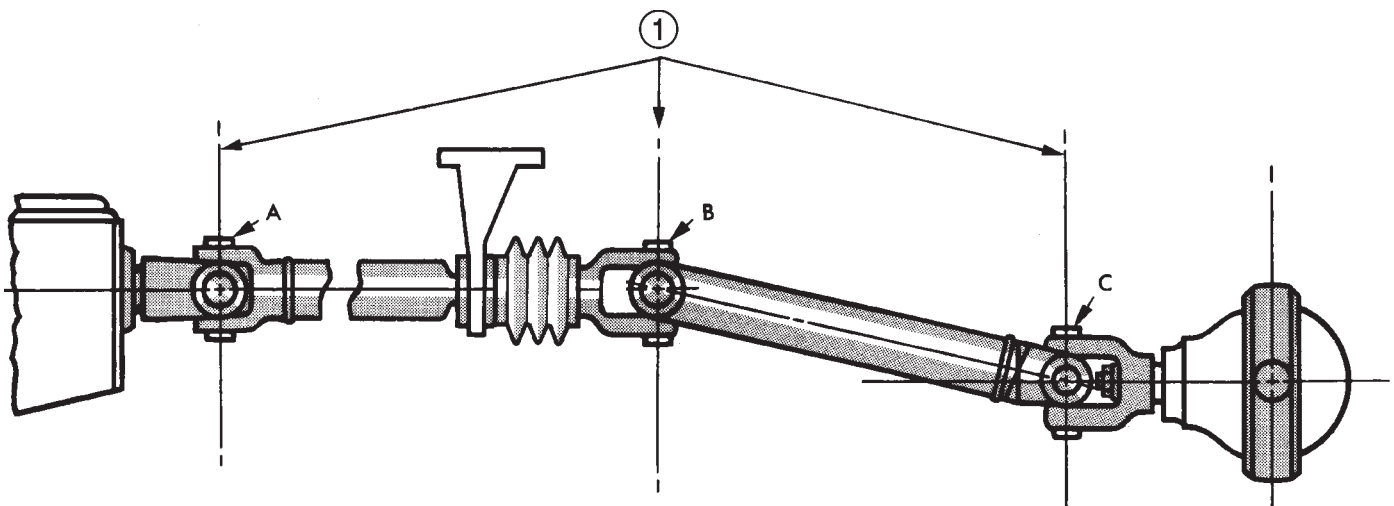
Amount of U-Joint Cancellation 0.2°

J9316-3

**Fig. 12 Universal Joint Angle Example**

- 1 - 4.9° Angle (C)
- 2 - 3.2° Angle (B)
- 3 - Input Yoke

- 4 - 3.0° Angle (A)
- 5 - Output Yoke



J9016-26

**Fig. 13 Universal Joint Angle Two-Piece Shaft**

1 - YOKES MUST BE IN SAME PLANE

## PROPELLER SHAFT (Continued)

## SPECIFICATIONS

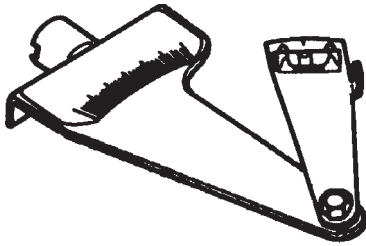
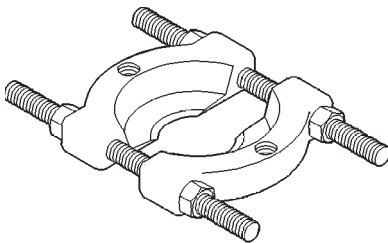
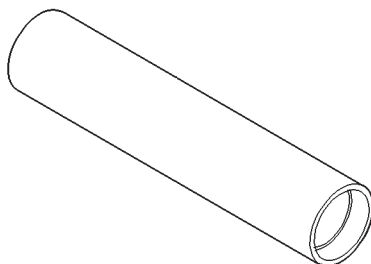
## PROPELLER SHAFT

## TORQUE SPECIFICATIONS

DESCRIPTION	N·m	Ft. Lbs.	In. Lbs.
Center Bearing Bolts	68	50	-
Front Shaft Flange Yoke	88	65	-
Front Shaft Axle Yoke	19	14	-
Rear Shaft 9 1/4 Axle	108	80	-
Rear Shaft Dana Axle	29	22	-

## SPECIAL TOOLS

## PROPELLER SHAFT

**Inclinometer - 7663****Bearing Splitter - 1130****Installer, Bearing - 6052**

## PROPELLER SHAFT - FRONT

## REMOVAL

(1) Shift the transmission and transfer case to their neutral positions. Raise and support vehicle. Remove skid plate, if equipped.

(2) Using a suitable marker, mark a line across the companion flange at the transfer case and propeller shaft flange yoke for installation reference.

(3) Mark a line across the propeller shaft yoke and the pinion shaft yoke for installation reference.

(4) Remove the universal joint strap bolts at the pinion shaft yoke (Fig. 14).

(5) Remove the bolts holding the propeller shaft to the transfer case companion flange.

(6) Remove the propeller shaft.

## INSTALLATION

(1) Position front propeller shaft under vehicle with rear universal joint over the transfer case companion flange.

(2) Place front universal joint into the axle pinion yoke.

(3) Align the mark on the flange yoke to the mark on the transfer case companion flange.

(4) Loosely install bolts to hold universal joint to transfer case companion flange.

(5) Align mark on front universal joint to the mark on the axle pinion yoke.

(6) Install bolts to hold front universal joint to axle pinion yoke. Tighten bolts to 19 N·m (14 ft. lbs.).

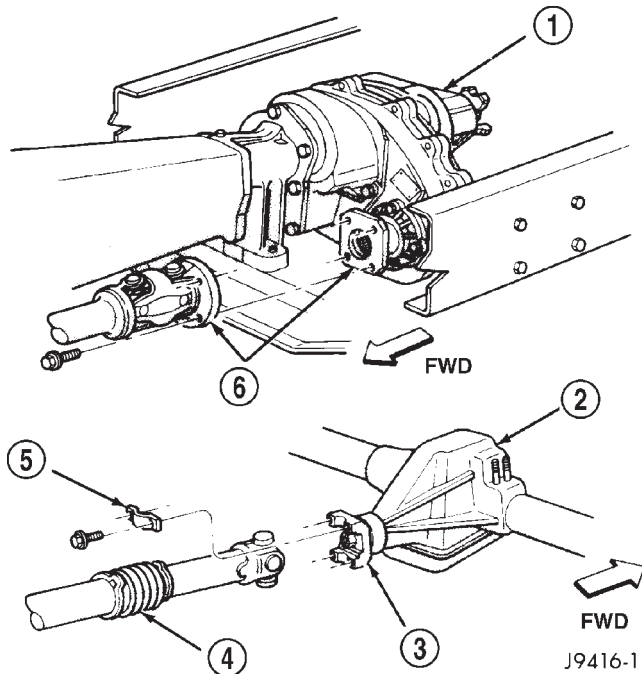
(7) Tighten bolts to hold universal joint to transfer case companion flange to 88 N·m (65 ft. lbs.).

(8) Install skid plate, if equipped.

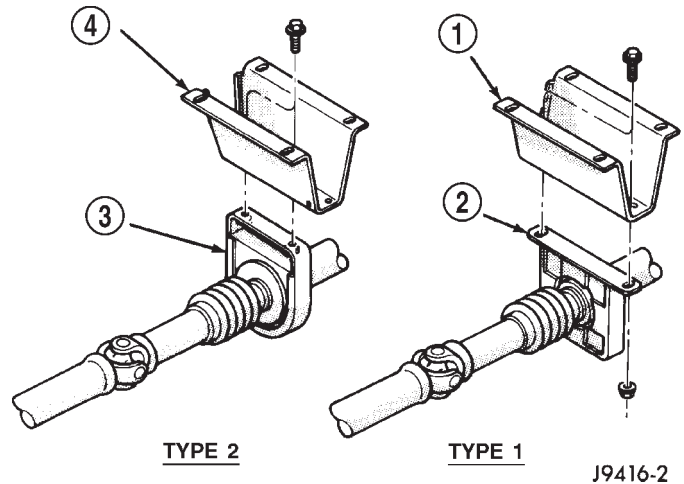
(9) Lower vehicle and road test to verify repair.



## PROPELLER SHAFT - FRONT (Continued)

**Fig. 14 Front Propeller Shaft**

- 1 - TRANSFER CASE
- 2 - FRONT AXLE
- 3 - AXLE YOKE
- 4 - SLIP YOKE BOOT
- 5 - STRAP
- 6 - FLANGE YOKE/COMPANION FLANGE

**Fig. 15 Center Bearing**

- 1 - SUPPORT BRACKET
- 2 - CENTER BEARING ASSEMBLY
- 3 - CENTER BEARING ASSEMBLY
- 4 - SUPPORT BRACKET

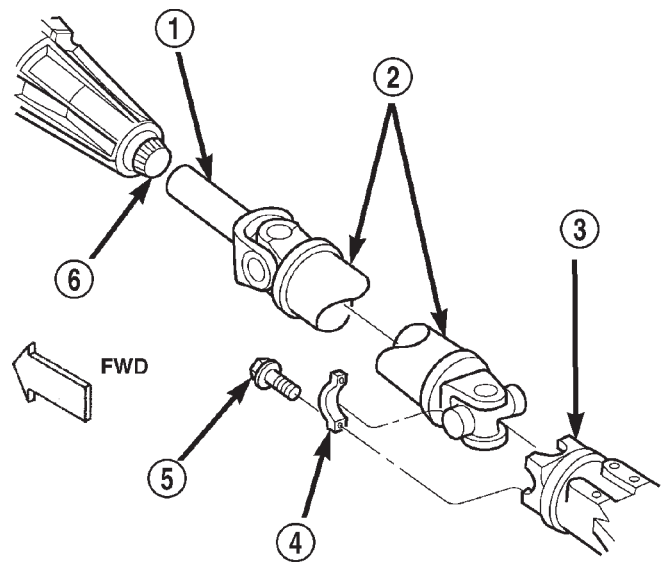
## PROPELLER SHAFT - REAR

**REMOVAL**

- (1) Raise and support vehicle on safety stands.
- (2) Shift the transmission to the Neutral position.
- (3) Using a suitable marker, mark a line across the axle pinion yoke, or companion flange, and the propeller shaft, or flange yoke for installation reference.
- (4) Using a suitable marker, mark the outline of the center bearing on the frame crossmember for installation reference, if equipped.
- (5) Remove bolts that attach the center bearing to the support bracket (Fig. 15), if equipped.
- (6) Remove the bolts holding the universal joint clamps to the pinion yoke (Fig. 16), for Dana axles.
- (7) Remove the bolts holding the flange yoke to the companion flange (Fig. 17), for Corporate axles.
- (8) Slide the slip yoke off of the transmission, or transfer case, output shaft and remove the propeller shaft (Fig. 16).

**INSTALLATION**

- (1) Slide the slip yoke onto the transmission, or transfer case, output shaft.

**Fig. 16 Rear Propeller Shaft—Dana Axles**

- 1 - SLIDING YOKE
- 2 - PROPELLER SHAFT
- 3 - PINION YOKE
- 4 - CLAMP
- 5 - SCREW
- 6 - OUTPUT SHAFT

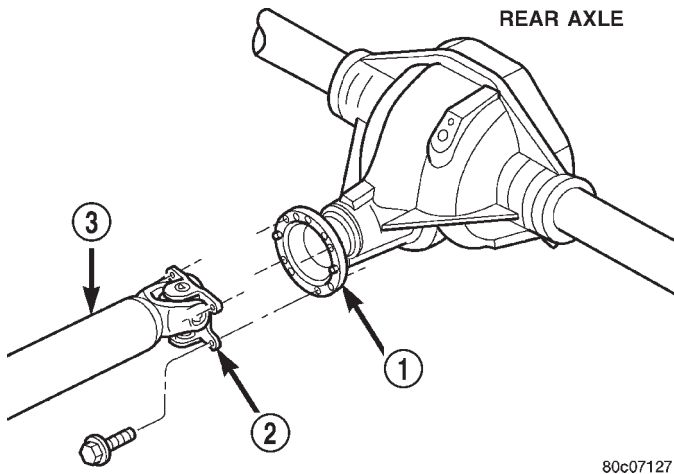
- (2) Align the reference marks made on the propeller shaft yoke/flange yoke and pinion yoke/companion flange.

- (3) Align and install the center bearing to the support bracket, if necessary.

- (4) Install the bolts and tighten to 68 N·m (50 ft. lbs.).



## PROPELLER SHAFT - REAR (Continued)



**Fig. 17 Rear Propeller Shaft—Corporate Axles**

- 1 - COMPANION FLANGE
- 2 - FLANGE YOKE
- 3 - REAR PROPELLER SHAFT

(5) Position universal joint into pinion yoke for Dana axles and tighten strap bolts to 29 N·m (22 ft. lbs.).

(6) Position companion yoke onto the companion flange for Corporate axles and tighten the bolts to 108 N·m (80 ft. lbs.).

(7) Lower the vehicle.

## CENTER BEARING

### DESCRIPTION

The two-piece propeller shaft uses a center bearing to support the shafts. Two types of center bearings are used. Type 1 is used with the 9 1/4 axle. Type 2 is used with the Dana axles (Fig. 18). Both types are mounted in the same location.

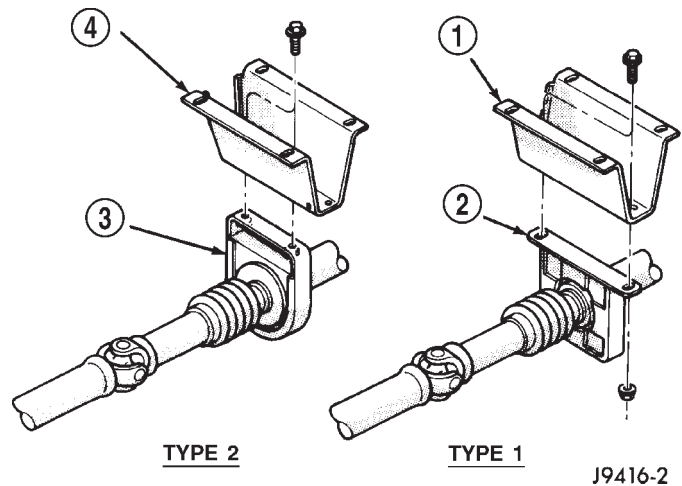
### OPERATION

The propeller shaft center bearing serves to divide the required propeller shaft length into two smaller shafts, which has several inherent advantages. Having two short propeller shafts instead of one long shaft decreases the chance of unwanted noise and vibrations. The shorter shafts are easier to balance and serve to increase ground clearance while maintaining acceptable driveline angles.

### REMOVAL

Two types of center bearings are used. The two types are not interchangeable. Be sure to install the same type as the vehicle was built with.

- (1) Remove rear propeller shaft.
- (2) Remove slip joint boot clamp and separate the two half-shafts.



**Fig. 18 Center Bearing**

- 1 - SUPPORT BRACKET
- 2 - CENTER BEARING ASSEMBLY
- 3 - CENTER BEARING ASSEMBLY
- 4 - SUPPORT BRACKET

(3) Use hammer and punch to tap slinger away from shaft to provide room for bearing splitter.

(4) Position Bearing Splitter Tool 1130 between slinger and shaft.

**CAUTION: Do not damage shaft spline during removal of center bearing.**

(5) Set shaft in press and press bearing off the shaft.

### INSTALLATION

Two types of center bearings are used. The two types are not interchangeable. Be sure to install the same type as the vehicle was built with.

- (1) Install new slinger on shaft and drive into position with appropriate installer tool.
- (2) Install new center bearing on shaft with Bearing Installer Tool 6052. Drive on shaft with hammer until bearing is seated.
- (3) Clean shaft splines and apply a coat of multi-purpose grease.
- (4) Align master splines and slide front and rear half-shafts together. Reposition slip yoke boot and install new clamp.
- (5) Install propeller shaft in vehicle.

### CENTER BEARING ADJUSTMENT

Launch shudder is a vibration that occurs at first acceleration from a stop. Shudder vibration usually peaks at the engines highest torque output. Shudder is a symptom associated with vehicles using a two-piece propeller shaft. To decrease shudder, lower the center bearing in 1/8 inch increments. Use shim stock or fabricated plates. Plate stock must be used

## CENTER BEARING (Continued)

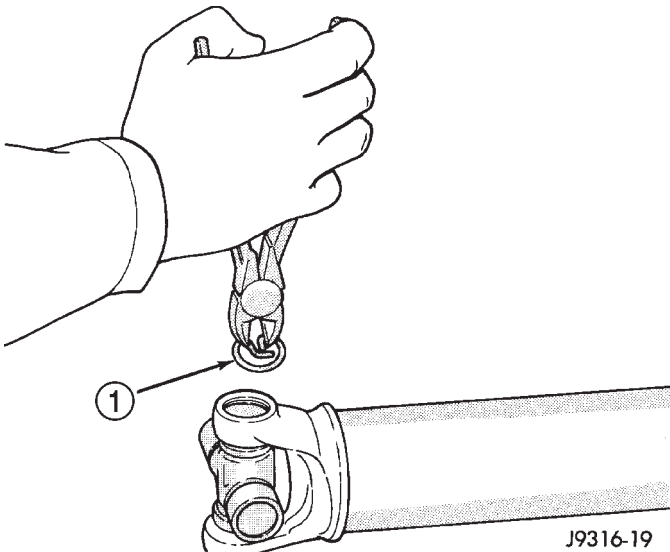
to maintain compression of the rubber insulator around the bearing. Do not use washers. Replace the original bolts with the appropriate increased length bolts.

## SINGLE CARDAN UNIVERSAL JOINTS

## DISASSEMBLY

Individual components of cardan universal joints are not serviceable. If worn or leaking, they must be replaced as an assembly.

- (1) Remove the propeller shaft.
- (2) Using a soft drift, tap the outside of the bearing cap assembly to loosen snap ring.
- (3) Remove snap rings from both sides of yoke (Fig. 19).



**Fig. 19 Remove Snap Ring**

1 - SNAP RING

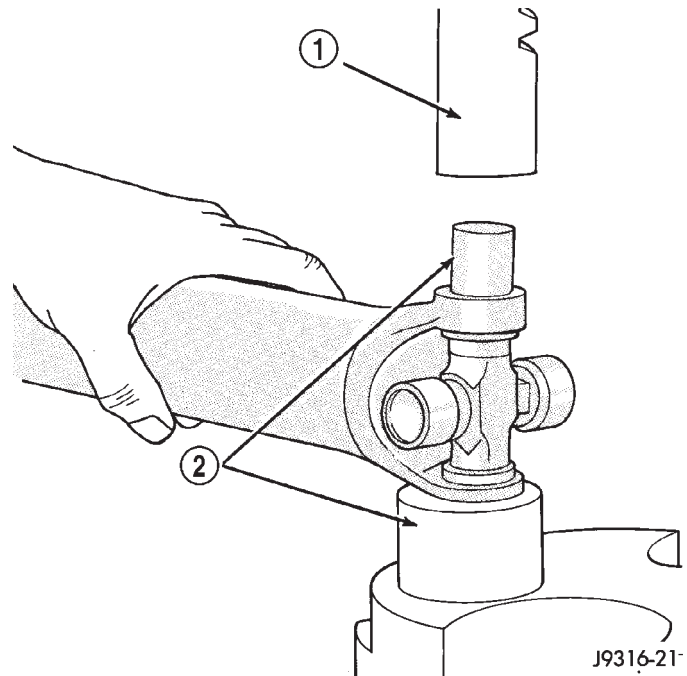
(4) Set the yoke in an arbor press or vise with a socket whose inside diameter is large enough to receive the bearing cap positioned beneath the yoke.

(5) Position the yoke with the grease fitting, if equipped, pointing up.

(6) Place a socket with an outside diameter smaller than the upper bearing cap on the upper bearing cap and press the cap through the yoke to release the lower bearing cap (Fig. 20).

(7) If the bearing cap will not pull out of the yoke by hand after pressing, tap the yoke ear near the bearing cap to dislodge the cap.

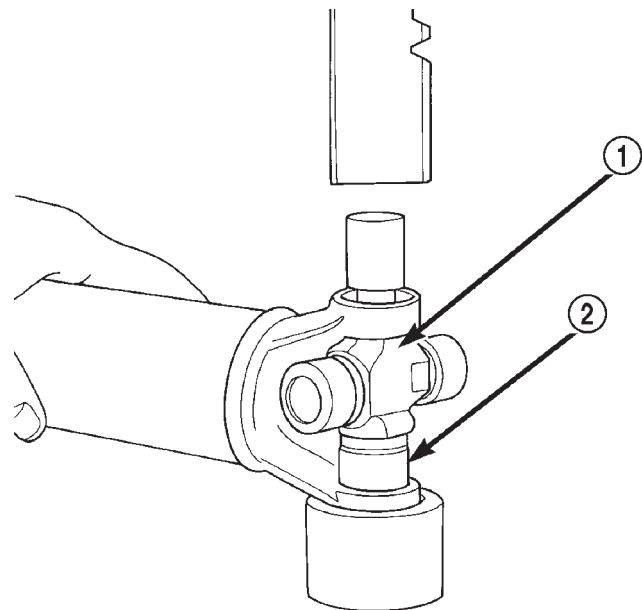
(8) To remove the opposite bearing cap, turn the yoke over and straighten the cross in the open hole. Then, carefully press the end of the cross until the remaining bearing cap can be removed (Fig. 21).



**Fig. 20 Press Out Bearing**

1 - PRESS  
2 - SOCKET

**CAUTION:** If the cross or bearing cap are not straight during installation, the bearing cap will score the walls of the yoke bore and damage can occur.



**Fig. 21 Press Out Remaining Bearing**

1 - CROSS  
2 - BEARING CAP

80a9539c

## FRONT AXLE - 216FBI

## TABLE OF CONTENTS

	page		page
<b>FRONT AXLE - 216FBI</b>		VACUUM MOTOR . . . . .	31
DESCRIPTION . . . . .	12	REMOVAL . . . . .	33
OPERATION . . . . .	12	DISASSEMBLY . . . . .	33
DIAGNOSIS AND TESTING . . . . .	13	ASSEMBLY . . . . .	33
AXLE . . . . .	13	INSTALLATION . . . . .	33
REMOVAL . . . . .	16	<b>SINGLE CARDAN UNIVERSAL JOINTS</b>	
INSTALLATION . . . . .	17	REMOVAL . . . . .	33
ADJUSTMENTS . . . . .	17	INSTALLATION . . . . .	34
SPECIFICATIONS . . . . .	25	<b>PINION SEAL</b>	
SPECIAL TOOLS . . . . .	25	REMOVAL . . . . .	34
<b>AXLE SHAFTS</b>		INSTALLATION . . . . .	34
REMOVAL . . . . .	28	<b>DIFFERENTIAL</b>	
INSTALLATION . . . . .	28	REMOVAL . . . . .	36
<b>AXLE SHAFTS - INTERMEDIATE</b>		DISASSEMBLY . . . . .	36
REMOVAL . . . . .	28	ASSEMBLY . . . . .	37
INSTALLATION . . . . .	28	INSTALLATION . . . . .	37
<b>AXLE SHAFT SEALS</b>		<b>DIFFERENTIAL CASE BEARINGS</b>	
REMOVAL . . . . .	29	REMOVAL . . . . .	39
INSTALLATION . . . . .	29	INSTALLATION . . . . .	39
<b>AXLE VACUUM MOTOR</b>		<b>PINION GEAR/RING GEAR</b>	
DESCRIPTION . . . . .	29	REMOVAL . . . . .	40
OPERATION . . . . .	30	INSTALLATION . . . . .	42
DIAGNOSIS AND TESTING . . . . .	31		

## FRONT AXLE - 216FBI

## DESCRIPTION

The housing for the 216 Front Beam-design Iron (FBI) axles consists of an iron center casting with tubes on each side. The tubes are pressed into and welded to the differential housing.

The integral type housing, hypoid gear design has the centerline of the pinion set below the centerline of the ring gear.

The axle has a vent used to relieve internal pressure caused by lubricant vaporization and internal expansion.

The axles are equipped with semi-floating axle shafts, meaning that loads are supported by the hub bearings. The axle shafts are retained by nuts at the hub bearings. The hub bearings are bolted to the steering knuckle at the outboard end of the axle tube yoke. The hub bearings are serviced as an assembly.

The axles are equipped with ABS brake sensors. The sensors are attached to the knuckle assemblies and the tone rings are pressed onto the axle shaft. **Use care when removing axle shafts as NOT to damage the tone wheel or the sensor.**

The stamped steel cover provides a means for inspection and servicing the differential.

The 216 axle have the assembly part number and gear ratio listed on a tag. The tag is attached to the housing cover by one of the cover bolts. Build date identification codes are stamped on the cover side of a axle tube.

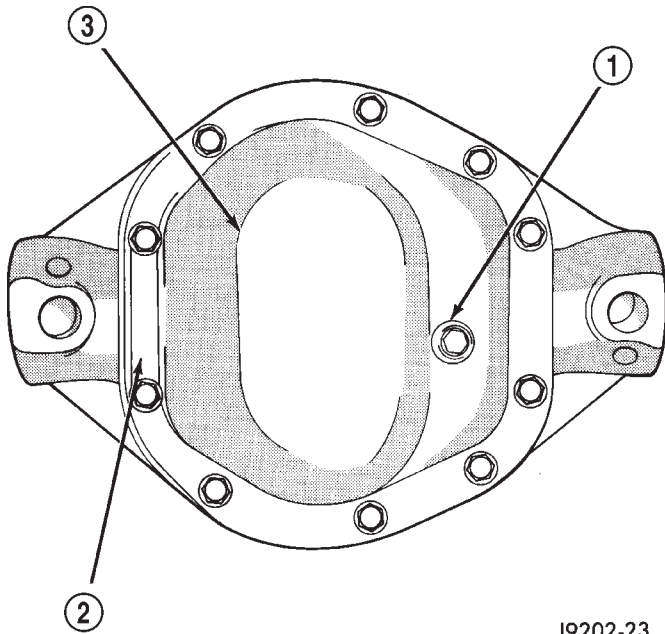
The differential case is a one-piece design. The differential pinion mate shaft is retained with a roll pin. Differential bearing preload and ring gear backlash is adjusted by the use of shims. The shims are located between the differential bearing cones and case. Pinion bearing preload is set and maintained by the use of a collapsible spacer.

The axle differential covers can be used for identification of the axle (Fig. 1). A tag is also attached to the cover.

## OPERATION

The axle receives power from the transfer case through the front propeller shaft. The front propeller shaft is connected to the pinion gear which rotates the differential through the gear mesh with the ring gear bolted to the differential case. The engine power is transmitted to the axle shafts through the pinion

## FRONT AXLE - 216FBI (Continued)



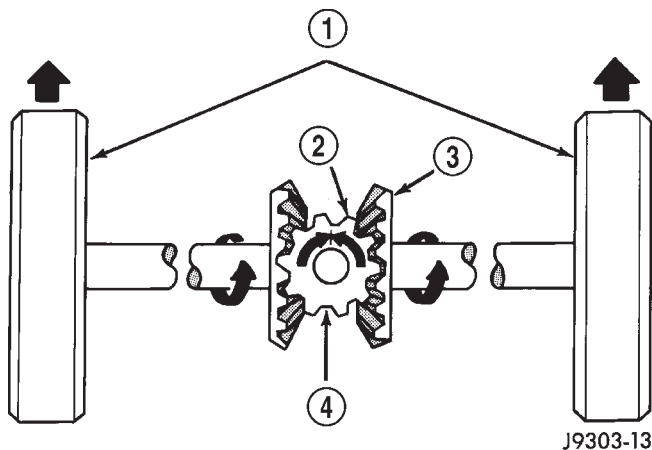
J9202-23

**Fig. 1 216 FBI Differential Cover**

- 1 - FILL PLUG
- 2 - IDENTIFICATION TAG
- 3 - DIFFERENTIAL COVER

mate and side gears. The side gears are splined to the axle shafts.

During straight-ahead driving, the differential pinion gears do not rotate on the pinion mate shaft. This occurs because input torque applied to the gears is divided and distributed equally between the two side gears. As a result, the pinion gears revolve with the pinion mate shaft but do not rotate around it (Fig. 2).

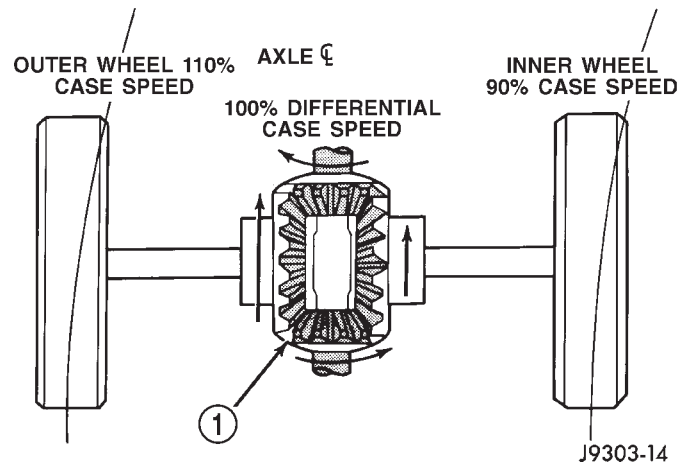


J9303-13

**Fig. 2 Differential Operation-Straight Ahead Driving**

- 1 - IN STRAIGHT AHEAD DRIVING EACH WHEEL ROTATES AT 100% OF CASE SPEED
- 2 - PINION GEAR
- 3 - SIDE GEAR
- 4 - PINION GEARS ROTATE WITH CASE

When turning corners, the outside wheel must travel a greater distance than the inside wheel to complete a turn. The difference must be compensated for to prevent the tires from scuffing and skidding through turns. To accomplish this, the differential allows the axle shafts to turn at unequal speeds (Fig. 3). In this instance, the input torque applied to the pinion gears is not divided equally. The pinion gears now rotate around the pinion mate shaft in opposite directions. This allows the side gear and axle shaft attached to the outside wheel to rotate at a faster speed.



J9303-14

**Fig. 3 Differential Operation-On Turns**

- 1 - PINION GEARS ROTATE ON PINION SHAFT

**DIAGNOSIS AND TESTING - AXLE****GEAR NOISE**

Axle gear noise can be caused by insufficient lubricant, incorrect backlash, tooth contact, worn/damaged gears or the carrier housing not having the proper offset and squareness.

Gear noise usually happens at a specific speed range. The noise can also occur during a specific type of driving condition. These conditions are acceleration, deceleration, coast, or constant load.

When road testing, first warm-up the axle fluid by driving the vehicle at least 5 miles and then accelerate the vehicle to the speed range where the noise is the greatest. Shift out-of-gear and coast through the peak-noise range. If the noise stops or changes greatly:

- Check for insufficient lubricant.
- Incorrect ring gear backlash.
- Gear damage.

Differential side gears and pinions can be checked by turning the vehicle. They usually do not cause noise during straight-ahead driving when the gears are unloaded. The side gears are loaded during vehi-

## FRONT AXLE - 216FBI (Continued)

cle turns. A worn pinion mate shaft can also cause a snapping or a knocking noise.

**BEARING NOISE**

The axle shaft, differential and pinion bearings can all produce noise when worn or damaged. Bearing noise can be either a whining, or a growling sound.

Pinion bearings have a constant-pitch noise. This noise changes only with vehicle speed. Pinion bearing noise will be higher pitched because it rotates at a faster rate. Drive the vehicle and load the differential. If bearing noise occurs, the rear pinion bearing is the source of the noise. If the bearing noise is heard during a coast, the front pinion bearing is the source.

Worn or damaged differential bearings usually produce a low pitch noise. Differential bearing noise is similar to pinion bearing noise. The pitch of differential bearing noise is also constant and varies only with vehicle speed.

Axle shaft bearings produce noise and vibration when worn or damaged. The noise generally changes when the bearings are loaded. Road test the vehicle. Turn the vehicle sharply to the left and to the right. This will load the bearings and change the noise level. Where axle bearing damage is slight, the noise is usually not noticeable at speeds above 30 mph.

**LOW SPEED KNOCK**

Low speed knock is generally caused by a worn U-joint or by worn side-gear thrust washers. A worn pinion shaft bore will also cause low speed knock.

**VIBRATION**

Vibration at the rear of the vehicle is usually caused by:

- Damaged drive shaft.

- Missing drive shaft balance weight(s).
- Worn or out of balance wheels.
- Loose wheel lug nuts.
- Worn U-joint(s).
- Loose/broken springs.
- Damaged axle shaft bearing(s).
- Loose pinion gear nut.
- Excessive pinion yoke run out.
- Bent axle shaft(s).

Check for loose or damaged front end components or engine/transmission mounts. These components can contribute to what appears to be a rear end vibration. Do not overlook engine accessories, brackets and drive belts.

All driveline components should be examined before starting any repair.

(Refer to 22 - TIRES/WHEELS - DIAGNOSIS AND TESTING)

**DRIVELINE SNAP**

A snap or clunk noise when the vehicle is shifted into gear (or the clutch engaged) can be caused by:

- High engine idle speed.
- Transmission shift operation.
- Loose engine/transmission/transfer case mounts.
- Worn U-joints.
- Loose spring mounts.
- Loose pinion gear nut and yoke.
- Excessive ring gear backlash.
- Excessive side gear to case clearance.

The source of a snap or a clunk noise can be determined with the assistance of a helper. Raise the vehicle on a hoist with the wheels free to rotate. Instruct the helper to shift the transmission into gear. Listen for the noise, a mechanics stethoscope is helpful in isolating the source of a noise.



## FRONT AXLE - 216FBI (Continued)

## DIAGNOSTIC CHART

Condition	Possible Causes	Correction
Wheel Noise	<ol style="list-style-type: none"> <li>1. Wheel loose.</li> <li>2. Faulty, brinelled wheel bearing.</li> </ol>	<ol style="list-style-type: none"> <li>1. Tighten loose nuts.</li> <li>2. Replace bearing.</li> </ol>
Axle Shaft Noise	<ol style="list-style-type: none"> <li>1. Misaligned axle tube.</li> <li>2. Bent or sprung axle shaft.</li> <li>3. End-play in pinion bearings.</li> <li>4. Excessive gear backlash between the ring gear and pinion.</li> <li>5. Improper adjustment of pinion gear bearings.</li> <li>6. Loose pinion yoke nut.</li> <li>7. Scuffed gear tooth contact surfaces.</li> </ol>	<ol style="list-style-type: none"> <li>1. Inspect axle tube alignment. Correct as necessary.</li> <li>2. Inspect and correct as necessary.</li> <li>3. Refer to pinion pre-load information and correct as necessary.</li> <li>4. Check adjustment of the ring gear and pinion backlash. Correct as necessary.</li> <li>5. Adjust the pinion bearings pre-load.</li> <li>6. Tighten the pinion yoke nut.</li> <li>7. Inspect and replace as necessary.</li> </ol>
Axle Shaft Broke	<ol style="list-style-type: none"> <li>1. Misaligned axle tube.</li> <li>2. Vehicle overloaded.</li> <li>3. Erratic clutch operation.</li> <li>4. Grabbing clutch.</li> </ol>	<ol style="list-style-type: none"> <li>1. Replace the broken shaft after correcting tube mis-alignment.</li> <li>2. Replace broken shaft and avoid excessive weight on vehicle.</li> <li>3. Replace broken shaft and avoid or correct erratic clutch operation.</li> <li>4. Replace broken shaft and inspect and repair clutch as necessary.</li> </ol>
Differential Cracked	<ol style="list-style-type: none"> <li>1. Improper adjustment of the differential bearings.</li> <li>2. Excessive ring gear backlash.</li> <li>3. Vehicle overloaded.</li> <li>4. Erratic clutch operation.</li> </ol>	<ol style="list-style-type: none"> <li>1. Replace case and inspect gears and bearings for further damage. Set differential bearing pre-load properly.</li> <li>2. Replace case and inspect gears and bearings for further damage. Set ring gear backlash properly.</li> <li>3. Replace case and inspect gears and bearings for further damage. Avoid excessive vehicle weight.</li> <li>4. Replace case and inspect gears and bearings for further damage. Avoid erratic use of clutch.</li> </ol>
Differential Gears Scored	<ol style="list-style-type: none"> <li>1. Insufficient lubrication.</li> <li>2. Improper grade of lubricant.</li> <li>3. Excessive spinning of one wheel/tire.</li> </ol>	<ol style="list-style-type: none"> <li>1. Replace scored gears. Fill differential with the correct fluid type and quantity.</li> <li>2. Replace scored gears. Fill differential with the correct fluid type and quantity.</li> <li>3. Replace scored gears. Inspect all gears, pinion bores, and shaft for damage. Service as necessary.</li> </ol>

## FRONT AXLE - 216FBI (Continued)

Condition	Possible Causes	Correction
Loss Of Lubricant	<ol style="list-style-type: none"> <li>1. Lubricant level too high.</li> <li>2. Worn axle shaft seals.</li> <li>3. Cracked differential housing.</li> <li>4. Worn pinion seal.</li> <li>5. Worn/scored yoke.</li> <li>6. Axle cover not properly sealed.</li> </ol>	<ol style="list-style-type: none"> <li>1. Drain lubricant to the correct level.</li> <li>2. Replace seals.</li> <li>3. Repair as necessary.</li> <li>4. Replace seal.</li> <li>5. Replace yoke and seal.</li> <li>6. Remove, clean, and re-seal cover.</li> </ol>
Axle Overheating	<ol style="list-style-type: none"> <li>1. Lubricant level low.</li> <li>2. Improper grade of lubricant.</li> <li>3. Bearing pre-loads too high.</li> <li>4. Insufficient ring gear backlash.</li> </ol>	<ol style="list-style-type: none"> <li>1. Fill differential to correct level.</li> <li>2. Fill differential with the correct fluid type and quantity.</li> <li>3. Re-adjust bearing pre-loads.</li> <li>4. Re-adjust ring gear backlash.</li> </ol>
Gear Teeth Broke	<ol style="list-style-type: none"> <li>1. Overloading.</li> <li>2. Erratic clutch operation.</li> <li>3. Ice-spotted pavement.</li> <li>4. Improper adjustments.</li> </ol>	<ol style="list-style-type: none"> <li>1. Replace gears. Examine other gears and bearings for possible damage.</li> <li>2. Replace gears and examine the remaining parts for damage. Avoid erratic clutch operation.</li> <li>3. Replace gears and examine remaining parts for damage.</li> <li>4. Replace gears and examine remaining parts for damage. Ensure ring gear backlash is correct.</li> </ol>
Axle Noise	<ol style="list-style-type: none"> <li>1. Insufficient lubricant.</li> <li>2. Improper ring gear and pinion adjustment.</li> <li>3. Unmatched ring gear and pinion.</li> <li>4. Worn teeth on ring gear and/or pinion.</li> <li>5. Loose pinion bearings.</li> <li>6. Loose differential bearings.</li> <li>7. Mis-aligned or sprung ring gear.</li> <li>8. Loose differential bearing cap bolts.</li> <li>9. Housing not machined properly.</li> </ol>	<ol style="list-style-type: none"> <li>1. Fill differential with the correct fluid type and quantity.</li> <li>2. Check ring gear and pinion contact pattern.</li> <li>3. Replace gears with a matched ring gear and pinion.</li> <li>4. Replace ring gear and pinion.</li> <li>5. Adjust pinion bearing pre-load.</li> <li>6. Adjust differential bearing pre-load.</li> <li>7. Measure ring gear run-out. Replace components as necessary.</li> <li>8. Inspect differential components and replace as necessary. Ensure that the bearing caps are torqued to the proper specification.</li> <li>9. Replace housing.</li> </ol>

**REMOVAL**

- (1) Raise and support the vehicle.
- (2) Remove the wheels and tires.
- (3) Remove the brake calipers and rotors. Refer to Group 5, Brakes, for proper procedures.

- (4) Remove ABS wheel speed sensors, if equipped. Refer to Group 5, Brakes, for proper procedures.
- (5) Disconnect the axle vent hose.
- (6) Disconnect vacuum hose and electrical connector at disconnect housing.
- (7) Remove the front propeller shaft.

## FRONT AXLE - 216FBI (Continued)

(8) Disconnect the stabilizer bar links at the axle brackets.

(9) Disconnect the shock absorbers from axle brackets.

(10) Disconnect the track bar from the axle bracket.

(11) Disconnect the tie rod and drag link from the steering knuckles.

(12) Position the axle with a suitable lifting device under the axle assembly.

(13) Secure axle to lifting device.

(14) Mark suspension alignment cams for installation reference.

(15) Disconnect the upper and lower suspension arms from the axle bracket.

(16) Lower the axle. The coil springs will drop with the axle.

(17) Remove the coil springs from the axle bracket.

## INSTALLATION

**CAUTION:** Suspension components with rubber bushings should be tightened with the weight of the vehicle on the suspension, at normal height. If springs are not at their normal ride position, vehicle ride comfort could be affected and premature bushing wear may occur. Rubber bushings must never be lubricated.

(1) Support the axle on a suitable lifting device.

(2) Secure axle to lifting device.

(3) Position the axle under the vehicle.

(4) Install the springs, retainer clip and bolts.

(5) Raise the axle and align it with the spring pads.

(6) Position the upper and lower suspension arms in the axle brackets. Install bolts, nuts and align the suspension alignment cams to the reference marks. Do not tighten at this time.

(7) Connect the track bar to the axle bracket and install the bolt. Do not tighten at this time.

(8) Install the shock absorber and tighten bolts to 121 N·m (89 ft. lbs.) torque.

(9) Install the stabilizer bar link to the axle bracket. Tighten the nut to 37 N·m (27 ft. lbs.) torque.

(10) Install the drag link and tie rod to the steering knuckles and tighten the nuts to 88 N·m (65 ft. lbs.) torque.

(11) Install the ABS wheel speed sensors, if equipped. Refer to group 5, Brakes, for proper procedures.

(12) Install the brake calipers and rotors. Refer to Group 5, Brakes, for proper procedures.

(13) Connect the vent hose to the tube fitting.

(14) Connect vacuum hose and electrical connector to disconnect housing.

(15) Install front propeller shaft.

(16) Check and add differential lubricant, if necessary. Refer to Lubricant Specifications in this section for lubricant requirements.

(17) Install the wheel and tire assemblies.

(18) Remove the supports and lower the vehicle.

(19) Tighten the upper suspension arm nuts at axle to 121 N·m (89 ft. lbs.) torque. Tighten the upper suspension arm nuts at frame to 84 N·m (62 ft. lbs.) torque.

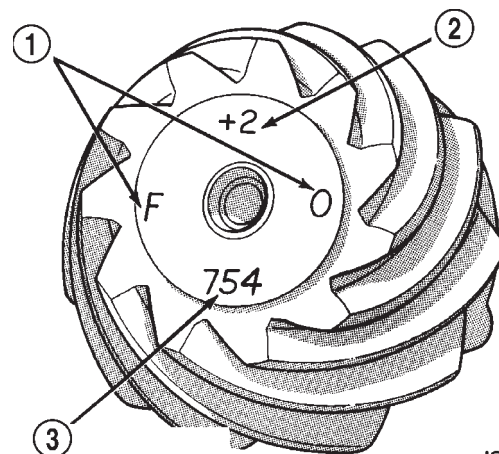
(20) Tighten the lower suspension arm nuts at axle to 84 N·m (62 ft. lbs.) torque. Tighten the lower suspension arm nuts at frame to 119 N·m (88 ft. lbs.) torque.

(21) Tighten the track bar bolt at the axle bracket to 176 N·m (130 ft. lbs.) torque.

(22) Check the front wheel alignment.

## ADJUSTMENTS

Ring and pinion gears are supplied as matched sets only. The identifying numbers for the ring and pinion gear are etched into the face of each gear (Fig. 4). A plus (+) number, minus (-) number or zero (0) is etched into the face of the pinion gear. This number is the amount (in thousandths of an inch) the depth varies from the standard depth setting of a pinion etched with a (0). The standard setting from the center line of the ring gear to the back face of the pinion is 109.5 mm (4.312 in.). The standard depth provides the best gear tooth contact pattern. Refer to Backlash and Contact Pattern in this section for additional information.



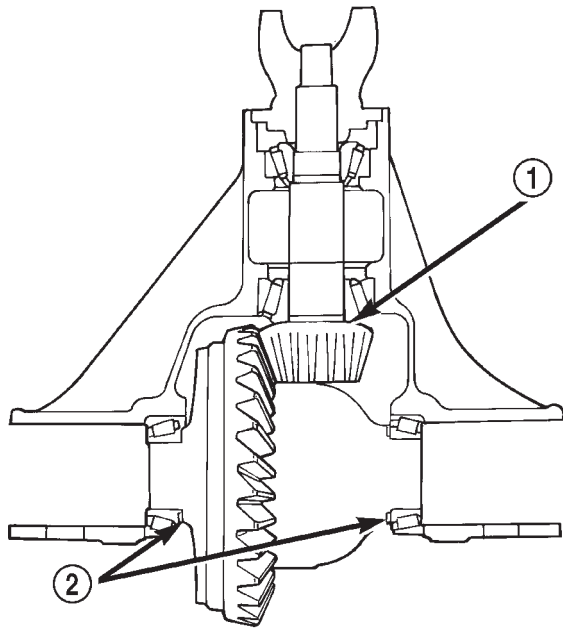
J9003-100

**Fig. 4 Pinion Gear ID Numbers**

- 1 - PRODUCTION NUMBERS
- 2 - PINION GEAR DEPTH VARIANCE
- 3 - GEAR MATCHING NUMBER

Compensation for pinion depth variance is achieved with a select shim/oil baffle. The shims are placed between the rear pinion bearing and the pinion gear head (Fig. 5).

## FRONT AXLE - 216FBI (Continued)



80c07134

**Fig. 5 Adjustment Shim Locations**

- 1 - PINION GEAR DEPTH SHIM/OIL BAFFLE  
2 - DIFFERENTIAL BEARING SHIM

If a new gear set is being installed, note the depth variance etched into both the original and replacement pinion. Add or subtract this number from the thickness of the original depth shim/oil slinger to compensate for the difference in the depth variances. Refer to the Depth Variance chart.

Note where Old and New Pinion Marking columns intersect. Intersecting figure represents plus or minus the amount needed.

Note the etched number on the face of the pinion gear head (-1, -2, 0, +1, +2, etc.). The numbers represent thousands of an inch deviation from the standard. If the number is negative, add that value to the required thickness of the depth shims. If the number is positive, subtract that value from the thickness of the depth shim. If the number is 0 no change is necessary.

**PINION GEAR DEPTH VARIANCE**

Original Pinion Gear Depth Variance	Replacement Pinion Gear Depth Variance								
	-4	-3	-2	-1	0	+1	+2	+3	+4
+4	+0.008	+0.007	+0.006	+0.005	+0.004	+0.003	+0.002	+0.001	0
+3	+0.007	+0.006	+0.005	+0.004	+0.003	+0.002	+0.001	0	-0.001
+2	+0.006	+0.005	+0.004	+0.003	+0.002	+0.001	0	-0.001	-0.002
+1	+0.005	+0.004	+0.003	+0.002	+0.001	0	-0.001	-0.002	-0.003
0	+0.004	+0.003	+0.002	+0.001	0	-0.001	-0.002	-0.003	-0.004
-1	+0.003	+0.002	+0.001	0	-0.001	-0.002	-0.003	-0.004	-0.005
-2	+0.002	+0.001	0	-0.001	-0.002	-0.003	-0.004	-0.005	-0.006
-3	+0.001	0	-0.001	-0.002	-0.003	-0.004	-0.005	-0.006	-0.007
-4	0	-0.001	-0.002	-0.003	-0.004	-0.005	-0.006	-0.007	-0.008

**PINION DEPTH MEASUREMENT AND ADJUSTMENT**

Measurements are taken with pinion bearing cups and pinion bearings installed in the housing. Take measurements with Pinion Gauge Set and Dial Indicator C-3339 (Fig. 6).

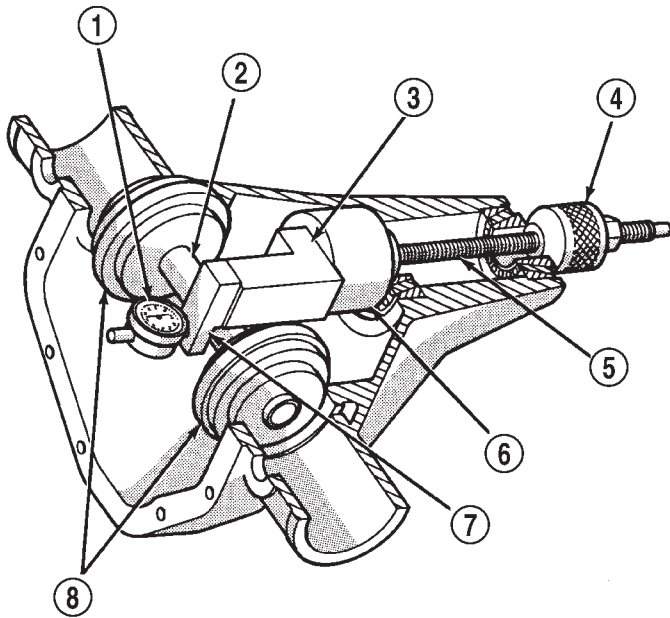
(1) Assemble Pinion Height Block 6739, Pinion Block 6734 and rear pinion bearing onto Screw 6741 (Fig. 6).

(2) Insert assembled height gauge components, rear bearing and screw into the housing through pinion bearing cups (Fig. 7).

(3) Install front pinion bearing and Cone-nut 6740 hand tight (Fig. 6).

(4) Place Arbor Disc 6732 on Arbor D-115-3 in position in the housing side bearing cradles (Fig. 8).

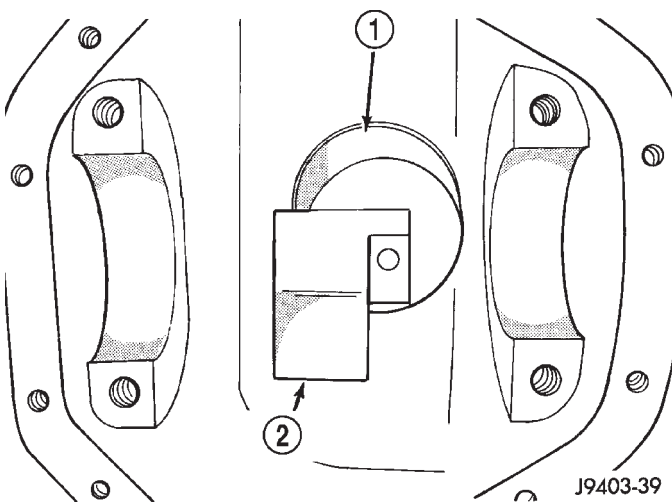
## FRONT AXLE - 216FBI (Continued)



J9403-45

**Fig. 6 Pinion Gear Depth Gauge Tools**

- 1 - DIAL INDICATOR
- 2 - ARBOR
- 3 - PINION HEIGHT BLOCK
- 4 - CONE
- 5 - SCREW
- 6 - PINION BLOCK
- 7 - SCOOTER BLOCK
- 8 - ARBOR DISC



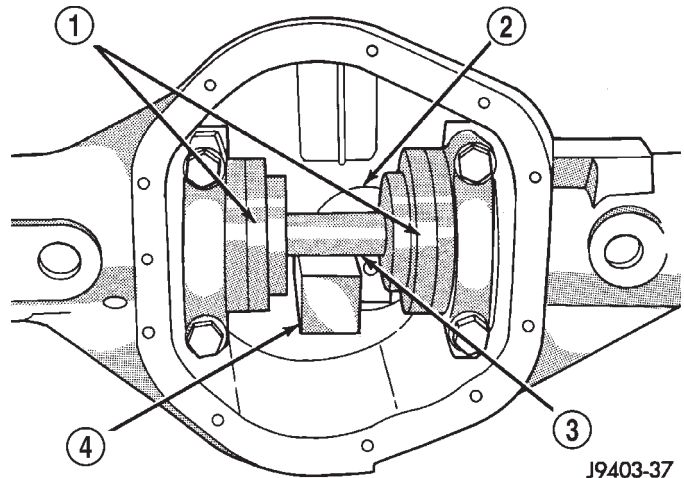
J9403-39

**Fig. 7 Pinion Height Block**

- 1 - PINION BLOCK
- 2 - PINION HEIGHT BLOCK

**NOTE:** Arbor Discs 6732 has different step diameters to fit other axles. Choose proper step for axle being serviced.

(5) Install differential bearing caps on arbor discs and snug the bearing cap bolts. Then cross tighten cap bolts to 108 N·m (80 ft. lbs.).



J9403-37

**Fig. 8 Gauge Tools In Housing**

- 1 - ARBOR DISC
- 2 - PINION BLOCK
- 3 - ARBOR
- 4 - PINION HEIGHT BLOCK

(6) Assemble Dial Indicator C-3339 into Scooter Block D-115-2 and secure set screw.

(7) Place Scooter Block/Dial Indicator in position in the housing so dial probe and scooter block are flush against the rearward surface of the pinion height block (Fig. 6). Hold scooter block in place and zero the dial indicator face to the pointer. Tighten dial indicator face lock screw.

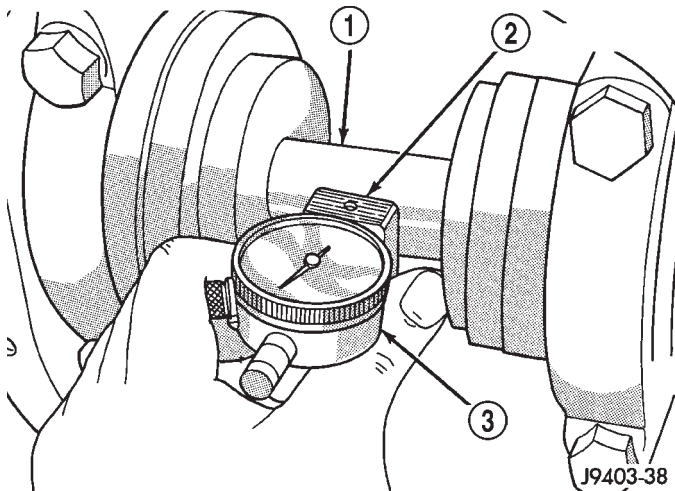
(8) With scooter block still in position against the pinion height block, slowly slide the dial indicator probe over the edge of the pinion height block.

(9) Slide the dial indicator probe across the gap between the pinion height block and the arbor bar with the scooter block against the pinion height block (Fig. 9). When the dial probe contacts the arbor bar, the dial pointer will turn clockwise. Bring dial pointer back to zero against the arbor bar, do not turn dial face. Continue moving the dial probe to the crest of the arbor bar and record the highest reading. If the dial indicator can not achieve the zero reading, the rear bearing cup or the pinion depth gauge set is not installed correctly.

(10) Select a shim/oil baffle equal to the dial indicator reading plus the pinion depth variance number etched in the face of the pinion (Fig. 4). For example, if the depth variance is -2, add +0.002 in. to the dial indicator reading.



## FRONT AXLE - 216FBI (Continued)

**Fig. 9 Pinion Gear Depth Measurement**

- 1 - ARBOR
- 2 - SCOOTER BLOCK
- 3 - DIAL INDICATOR

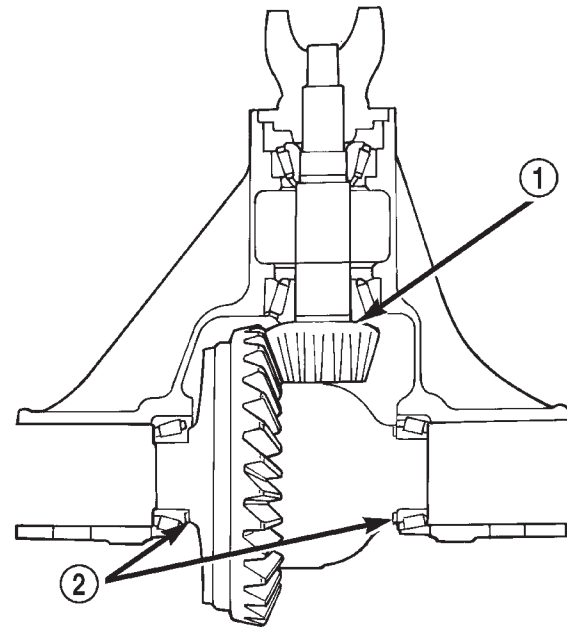
**DIFFERENTIAL SIDE BEARING PRELOAD AND GEAR BACKLASH**

Differential side bearing preload and gear backlash is achieved by selective shims positioned behind the differential side bearing cones. The proper shim thickness can be determined using slip-fit Dummy Bearings D-345 in place of the differential side bearings and a Dial Indicator C-3339. Before proceeding with the differential bearing preload and gear backlash measurements, measure the pinion gear depth and prepare the pinion for installation. Establishing proper pinion gear depth is essential to establishing gear backlash and tooth contact patterns. After the overall shim thickness to take up differential side play is measured, the pinion is installed, and the gear backlash shim thickness is measured. The overall shim thickness is the total of the dial indicator reading and the preload specification added together. The gear backlash measurement determines the thickness of the shim used on the ring gear side of the differential case. Subtract the gear backlash shim thickness from the total overall shim thickness and select that amount for the pinion gear side of the differential (Fig. 10). Differential shim measurements are performed with spreader W-129-B removed.

**SHIM SELECTION**

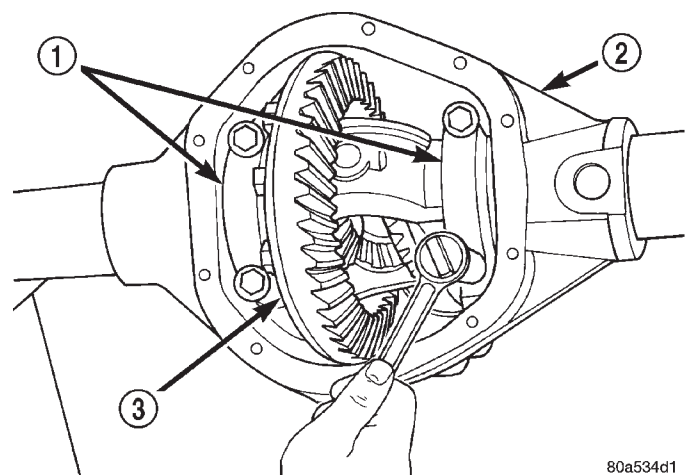
**NOTE:** It is difficult to salvage the differential side bearings during the removal procedure. Install replacement bearings if necessary.

(1) Remove differential side bearings from differential case.

**Fig. 10 Adjustment Shim Locations**

- 1 - PINION GEAR DEPTH SHIM/OIL BAFFLE
- 2 - DIFFERENTIAL BEARING SHIM

- (2) Remove factory installed shims from differential case.
- (3) Install ring gear on differential case and tighten bolts to specification.
- (4) Install dummy side bearings D-345 on differential case.
- (5) Install differential case in the housing.
- (6) Install the marked bearing caps in their correct positions and snug the bolts (Fig. 11).

**Fig. 11 Bearing Cap Bolts**

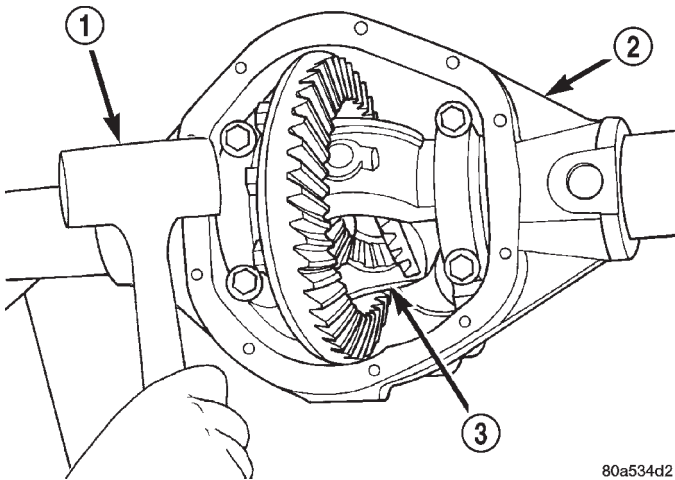
- 1 - BEARING CAP
- 2 - DIFFERENTIAL HOUSING
- 3 - DIFFERENTIAL CASE

80c07134

80a534d1

## FRONT AXLE - 216FBI (Continued)

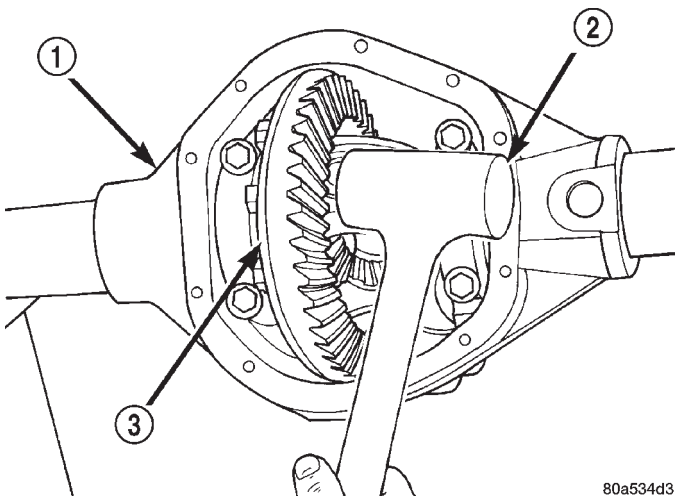
(7) Using a dead-blow hammer, seat the differential dummy bearings to each side of the housing (Fig. 12) and (Fig. 13).



80a534d2

**Fig. 12 Seat Pinion Gear Side Dummy Bearing**

- 1 - DEAD-BLOW HAMMER
- 2 - DIFFERENTIAL HOUSING
- 3 - DIFFERENTIAL CASE



80a534d3

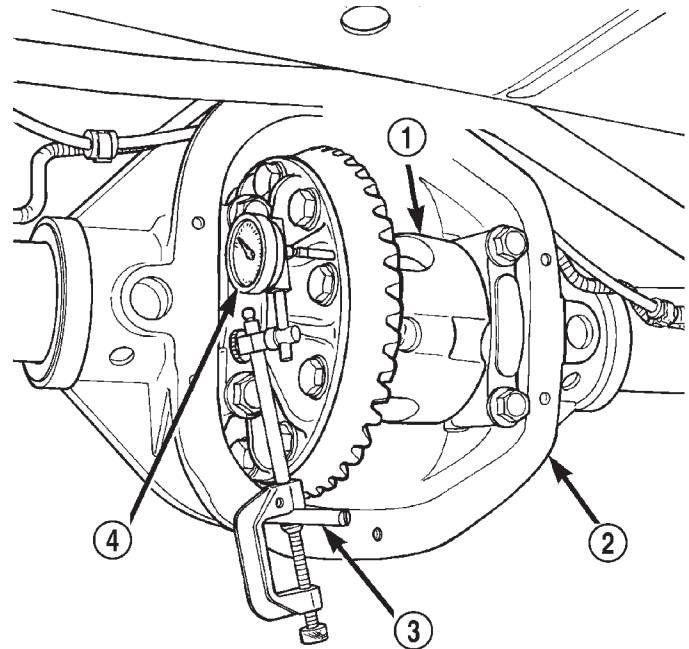
**Fig. 13 Seat Ring Gear Side Differential Dummy Bearing**

- 1 - DIFFERENTIAL HOUSING
- 2 - DEAD-BLOW HAMMER
- 3 - DIFFERENTIAL CASE

(8) Thread Pilot Stud C-3288-B into rear cover bolt hole below ring gear (Fig. 14).

(9) Attach the Dial Indicator C-3339 to pilot stud. Position the dial indicator plunger on a flat surface between the ring gear bolt heads (Fig. 14).

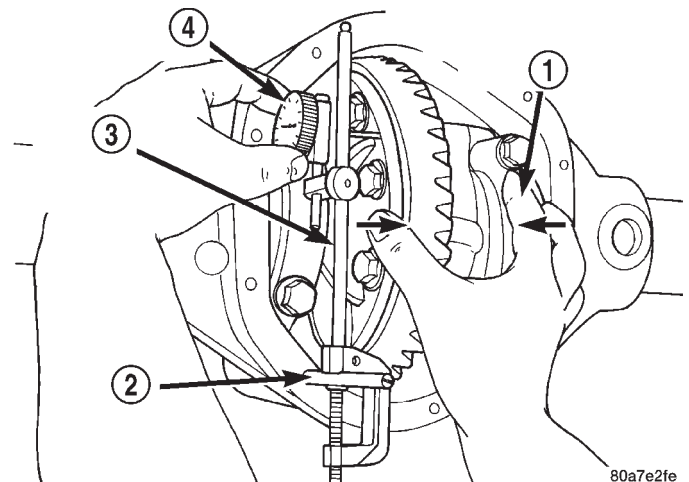
(10) Push and hold differential case to pinion gear side of the housing and zero dial indicator (Fig. 15).



80a7e2cf

**Fig. 14 Differential Side Play Measurement**

- 1 - DIFFERENTIAL CASE
- 2 - DIFFERENTIAL HOUSING
- 3 - PILOT STUD
- 4 - DIAL INDICATOR



80a7e2fe

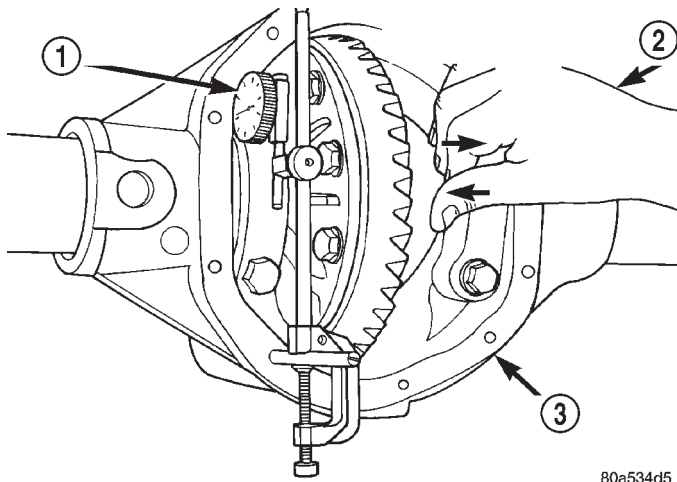
**Fig. 15 Dial Indicator Location**

- 1 - DIFFERENTIAL CASE TO PINION GEAR SIDE
- 2 - PILOT STUD
- 3 - DIAL INDICATOR ARM
- 4 - DIAL INDICATOR FACE

(11) Push and hold differential case to ring gear side of the housing and record the dial indicator reading (Fig. 16).

(12) Add 0.38 mm (0.015 in.) to the zero end play total. This total represents the thickness of shims

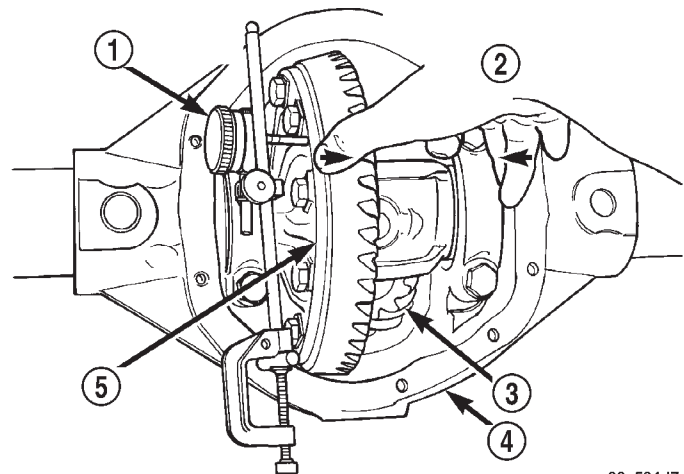
## FRONT AXLE - 216FBI (Continued)



80a534d5

**Fig. 16 Differential Case To Ring Gear Side**

- 1 - DIAL INDICATOR
- 2 - DIFFERENTIAL CASE TO RING GEAR SIDE
- 3 - DIFFERENTIAL HOUSING



80a534d7

**Fig. 17 Differential Case To Pinion Gear Side**

- 1 - DIAL INDICATOR FACE
- 2 - DIFFERENTIAL CASE TO PINION GEAR SIDE
- 3 - PINION GEAR
- 4 - DIFFERENTIAL HOUSING
- 5 - DIFFERENTIAL CASE

needed to preload the new bearings when the differential is installed.

(13) Rotate dial indicator out of the way on the pilot stud.

(14) Remove differential case and dummy bearings from the housing.

(15) Install the pinion gear in the housing. Install the pinion yoke and establish the correct pinion rotating torque.

(16) Install differential case and dummy bearings D-345 in the housing (without shims), install bearing caps and tighten bolts snug.

(17) Seat ring gear side dummy bearing (Fig. 13).

(18) Position the dial indicator plunger on a flat surface between the ring gear bolt heads (Fig. 14).

(19) Push and hold differential case toward pinion gear and zero the dial indicator (Fig. 17).

(20) Push and hold differential case to ring gear side of the housing and record dial indicator reading (Fig. 18).

(21) This is the shim thickness needed on the ring gear side of the differential case for proper backlash.

(22) Subtract the backlash shim thickness from the total preload shim thickness. The remainder is the shim thickness required on the pinion side of the housing.

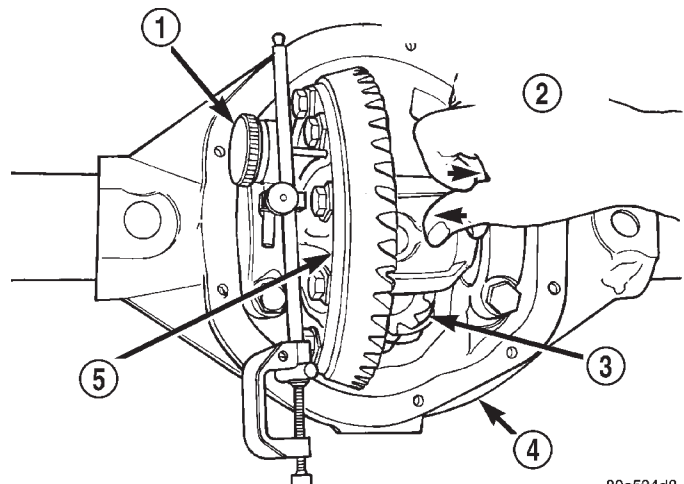
(23) Rotate dial indicator out of the way on pilot stud.

(24) Remove differential case and dummy bearings from the housing.

(25) Install the selected side bearing shims onto the differential case hubs.

(26) Install side bearings on differential case hubs with Install D-156 and Handle C-4171.

(27) Install bearing cups on differential.



80a534d8

**Fig. 18 Differential Case To Ring Gear Side**

- 1 - DIAL INDICATOR
- 2 - DIFFERENTIAL CASE TO RING GEAR SIDE
- 3 - PINION GEAR
- 4 - DIFFERENTIAL HOUSING
- 5 - DIFFERENTIAL CASE

(28) Install Spreader W-129-B and some items from Adapter Set 6987 on the housing and spread open enough to receive differential case.

**CAUTION: Do not spread housing over 0.50 mm (0.020 in.). The housing can be damaged if over-spread.**

(29) Install differential case into the housing.

(30) Remove spreader from the housing.

## FRONT AXLE - 216FBI (Continued)

(31) Rotate the differential case several times to seat the side bearings.

(32) Position the indicator plunger against a ring gear tooth (Fig. 19).

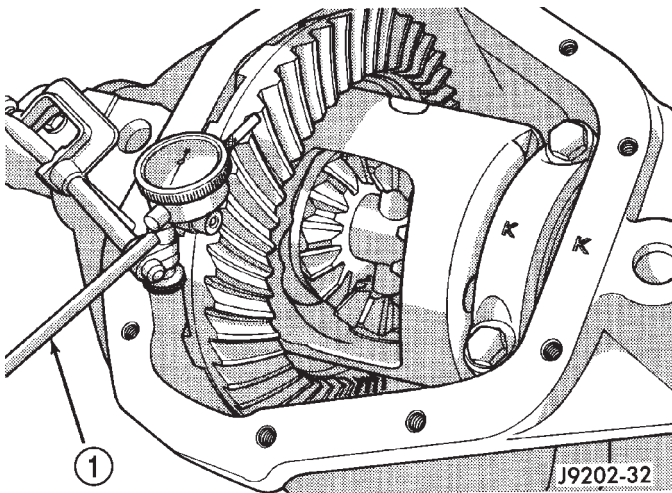
(33) Push and hold ring gear upward while not allowing the pinion gear to rotate.

(34) Zero dial indicator face to pointer.

(35) Push and hold ring gear downward while not allowing the pinion gear to rotate. Dial indicator reading should be between 0.12 mm (0.005 in.) and 0.20 mm (0.008 in.). If backlash is not within specifications transfer the necessary amount of shim thickness from one side of the housing to the other (Fig. 20).

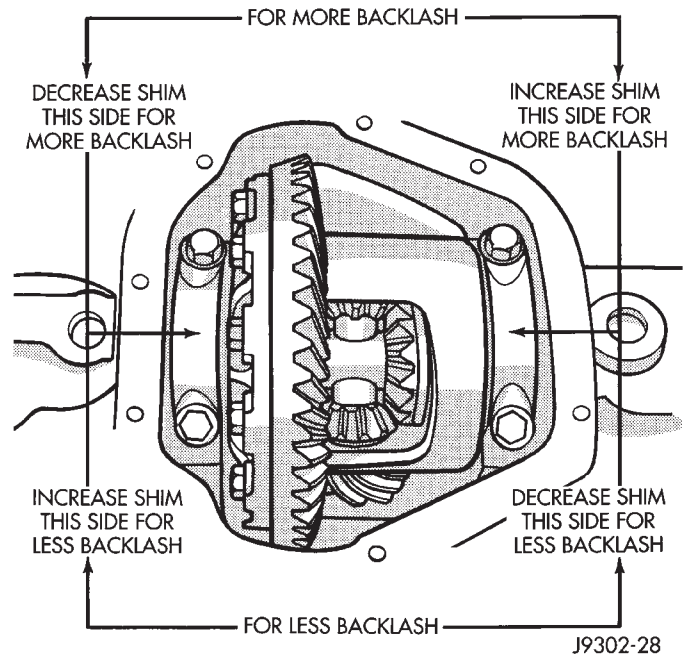
(36) Verify differential case and ring gear runout by measuring ring to pinion gear backlash at eight locations around the ring gear. Readings should not vary more than 0.05 mm (0.002 in.). If readings vary more than specified, the ring gear or the differential case is defective.

After the proper backlash is achieved, perform Gear Contact Pattern Analysis procedure.



**Fig. 19 Ring Gear Backlash Measurement**

1 - DIAL INDICATOR



**Fig. 20 Backlash Shim**

### GEAR CONTACT PATTERN

The ring and pinion gear contact patterns will show if the pinion depth is correct. It will also show if the ring gear backlash has been adjusted correctly. The backlash can be adjusted within specifications to achieve desired tooth contact patterns.

(1) Apply a thin coat of hydrated ferric oxide or equivalent to the drive and coast side of the ring gear teeth.

(2) Wrap, twist and hold a shop towel around the pinion yoke to increase the turning resistance of the pinion. This will provide a more distinct contact pattern.

(3) With a boxed end wrench on the ring gear bolt, rotate the differential case one complete revolution in both directions while a load is being applied from shop towel.

The areas on the ring gear teeth with the greatest degree of contact against the pinion teeth will squeegee the compound to the areas with the least amount of contact. Note and compare patterns on the ring gear teeth to Gear Tooth Contact Patterns chart (Fig. 21) and adjust pinion depth and gear backlash as necessary.



FRONT AXLE - 216FBI (Continued)

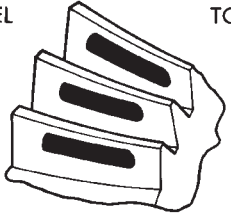
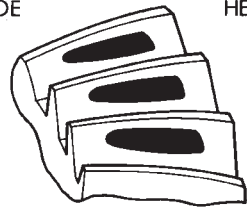
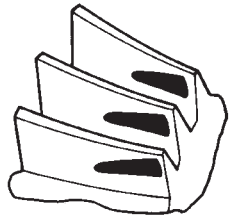
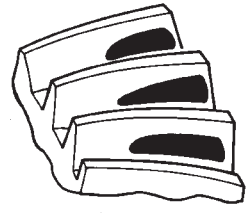
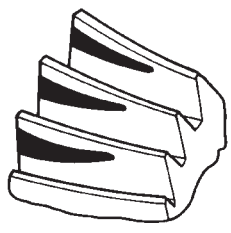
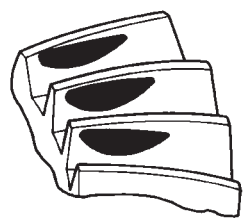
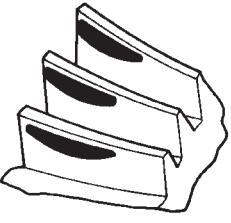
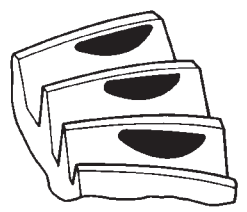
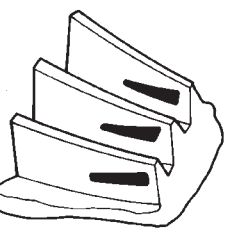
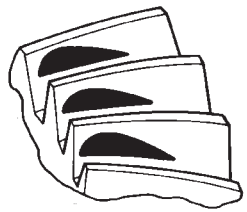
<p>DRIVE SIDE OF RING GEAR TEETH</p> <p>HEEL TOE</p> 	<p>COAST SIDE OF RING GEAR TEETH</p> <p>TOE HEEL</p> 	<p>DESIRABLE CONTACT PATTERN. PATTERN SHOULD BE CENTERED ON THE DRIVE SIDE OF TOOTH. PATTERN SHOULD BE CENTERED ON THE COAST SIDE OF TOOTH, BUT MAY BE SLIGHTLY TOWARD THE TOE. THERE SHOULD ALWAYS BE SOME CLEARANCE BETWEEN CONTACT PATTERN AND TOP OF THE TOOTH.</p>
		<p>RING GEAR BACKLASH CORRECT. <b>THINNER</b> PINION GEAR DEPTH SHIM REQUIRED.</p>
		<p>RING GEAR BACKLASH CORRECT. <b>THICKER</b> PINION GEAR DEPTH SHIM REQUIRED.</p>
		<p>PINION GEAR DEPTH SHIM CORRECT. <b>DECREASE</b> RING GEAR BACKLASH.</p>
		<p>PINION GEAR DEPTH SHIM CORRECT. <b>INCREASE</b> RING GEAR BACKLASH.</p>

Fig. 21 Gear Tooth Contact Patterns



FRONT AXLE - 216FBI (Continued)

SPECIFICATIONS

FRONT AXLE - 216FBI

AXLE SPECIFICATIONS

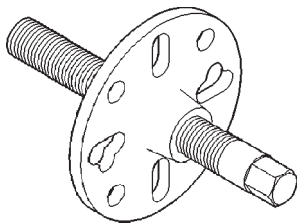
DESCRIPTION	SPECIFICATION
Axle Ratio	3.55, 3.92, 4.10
Ring Gear Diameter	216 mm (8.50 in.)
Ring Gear Backlash	0.12-0.20 mm (0.005-0.008 in.)
Pinion Gear Standard Depth	109.5 mm (4.312 in.)
Pinion Bearing Preload - Original Bearing	1-2 N·m (10-20 in. lbs.)
Pinion Bearing Preload - New Bearing	2-4 N·m (15-35 in. lbs.)

TORQUE SPECIFICATIONS

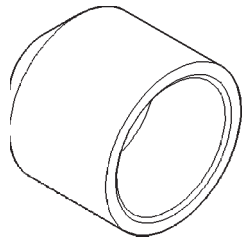
DESCRIPTION	N·m	Ft. Lbs.	In. Lbs.
Plug Fill Hole	34	25	-
Differential Cover Bolts	41	30	-
Bearing Cap Bolts	108	80	-
Pinion Nut	258-393	190-290	-
Ring Gear Bolts	108	80	-
Shift Motor Bolts	11	8	-
Axle Nut	237	175	-
Wheel Bearing Bolts	170	125	-

SPECIAL TOOLS

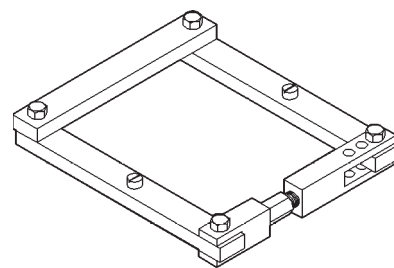
FRONT AXLES



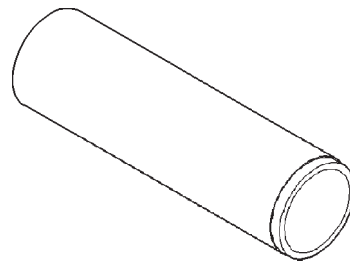
**REMOVER - C-452**



**INSTALLER - 8108**

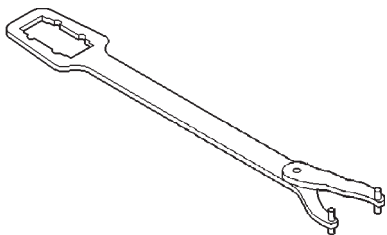


**SPREADER - W-129-B**

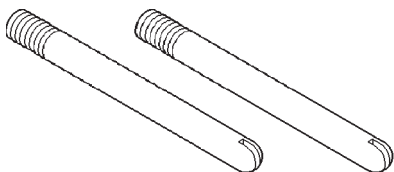


**INSTALLER - C-3095-A**

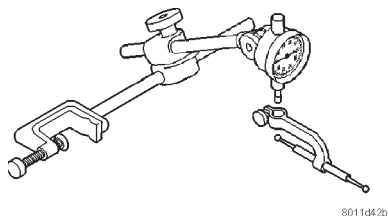
FRONT AXLE - 216FBI (Continued)



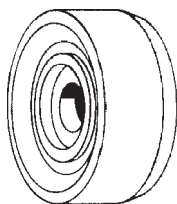
**FLANGE WRENCH - C-3281**



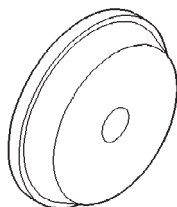
**PILOTS - C-3288-B**



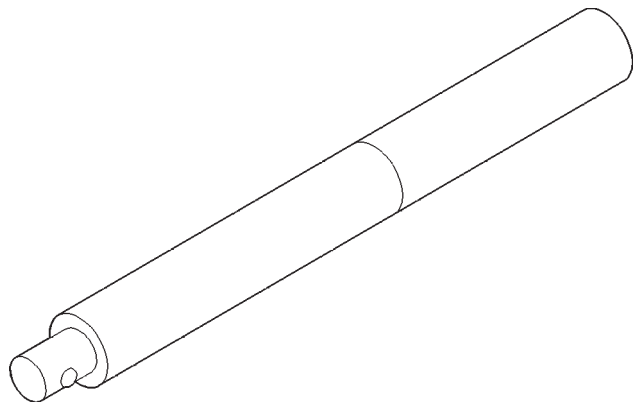
**DIAL INDICATOR - C-3339**



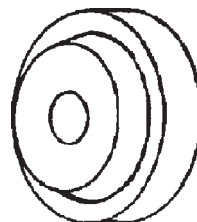
**INSTALLER, BEARING - C-3716-A**



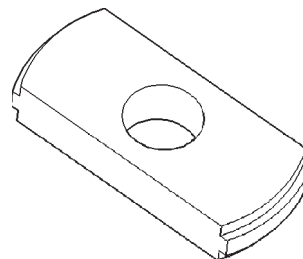
**INSTALLER, CUP - D-146**



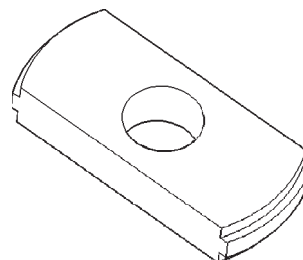
**HANDLE, DRIVE - C-4171**



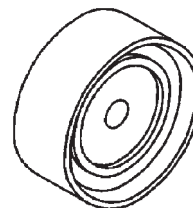
**INSTALLER, CUP - D-144**



**REMOVER, CUP - D-147**

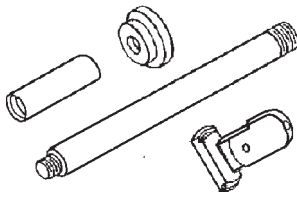


**REMOVER, CUP - D-149**

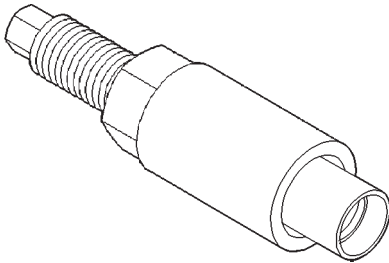


**INSTALLER, BEARING - D-156**

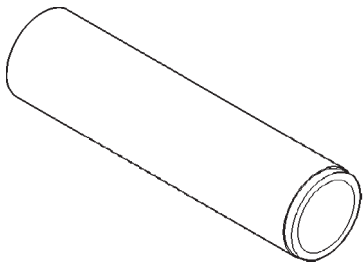
FRONT AXLE - 216FBI (Continued)



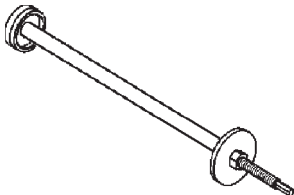
**REMOVER/INSTALLER BEARING D-354**



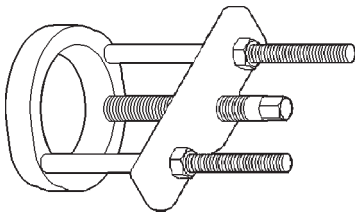
**INSTALLER, YOKE - W-162-D**



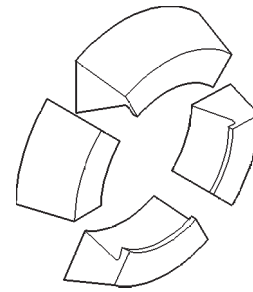
**INSTALLER, BEARING - W-262**



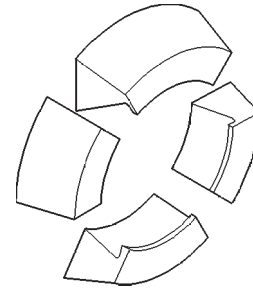
**INSTALLER, SEAL - 5041**



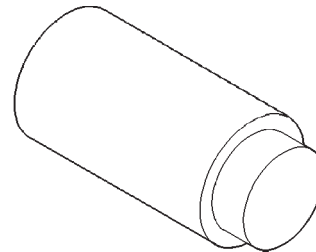
**PULLER/PRESS - C-293-PA**



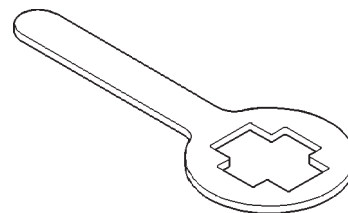
**BLOCK, ADAPTERS - C-293-40**



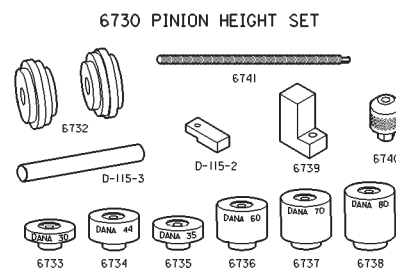
**BLOCK, ADAPTER - C-293-18**



**ADAPTER PLUG - C-293-3**



**HOLDER YOKE - 6719A**



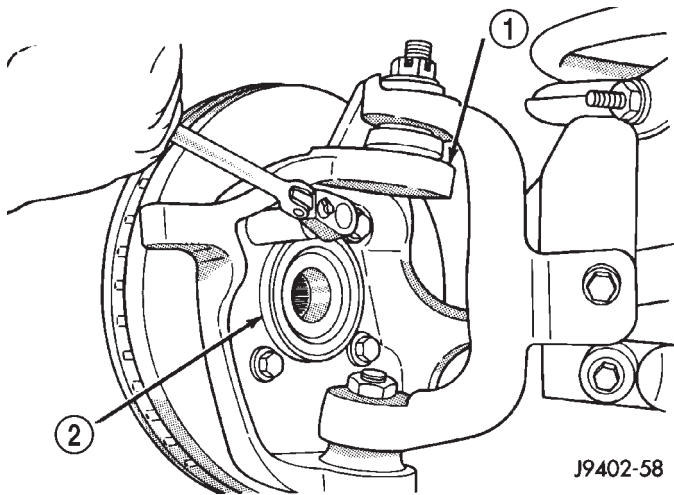
**6730 PINION HEIGHT SET**

**PINION DEPTH SET - 6730**

## AXLE SHAFTS

### REMOVAL

- (1) Raise and support the vehicle.
- (2) Remove wheel and tire assembly.
- (3) Remove brake caliper and rotor. Refer to Brakes for procedures.
- (4) Remove ABS wheel speed sensor if equipped. Refer to Brakes for procedures.
- (5) Remove the cotter pin and axle hub nut.
- (6) Remove hub bearing bolts (Fig. 22) and remove hub bearing from the steering knuckle.



**Fig. 22 Hub and Knuckle**

- 1 - KNUCKLE  
2 - HUB BEARING

- (7) Remove brake dust shield from knuckle.
- (8) Remove axle shaft from the housing. Avoid damaging the axle shaft oil seal.

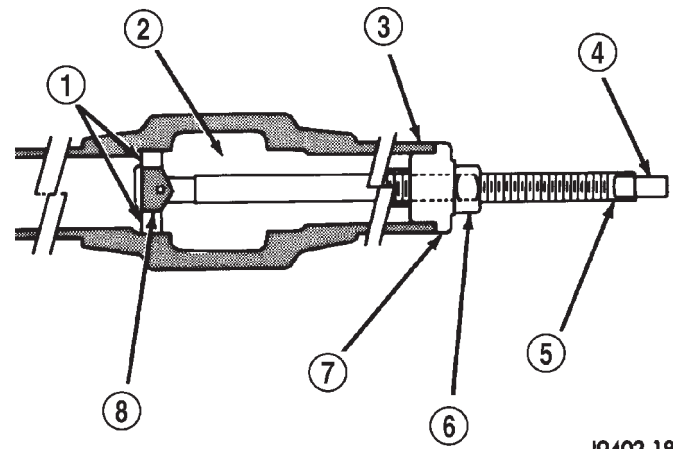
### INSTALLATION

- (1) Clean axle shaft and apply a thin film of Mopar Wheel Bearing Grease to the shaft splines, seal contact surface, hub bore.
- (2) Install axle shaft into the housing and differential side gears. Avoid damaging axle shaft oil seals in the differential.
- (3) Install dust shield and hub bearing on knuckle.
- (4) Install hub bearing bolts and tighten to 170 N·m (125 ft. lbs.).
- (5) Install axle washer and nut, tighten nut to 237 N·m (175 ft. lbs.). Align nut to next cotter pin hole and install new cotter pin.
- (6) Install ABS wheel speed sensor, brake rotor and caliper. Refer to Brakes for proper procedures.
- (7) Install wheel and tire assembly.
- (8) Remove support and lower the vehicle.

## AXLE SHAFTS - INTERMEDIATE

### REMOVAL

- (1) Remove vacuum shift motor housing.
- (2) Remove outer axle shaft.
- (3) Remove inner axle shaft seal from shift motor housing with a long drift or punch. Be careful not to damage housing.
- (4) Remove intermediate axle shaft and shift collar.
- (5) Remove intermediate axle shaft bearing (Fig. 23).



**Fig. 23 Bearing Removal**

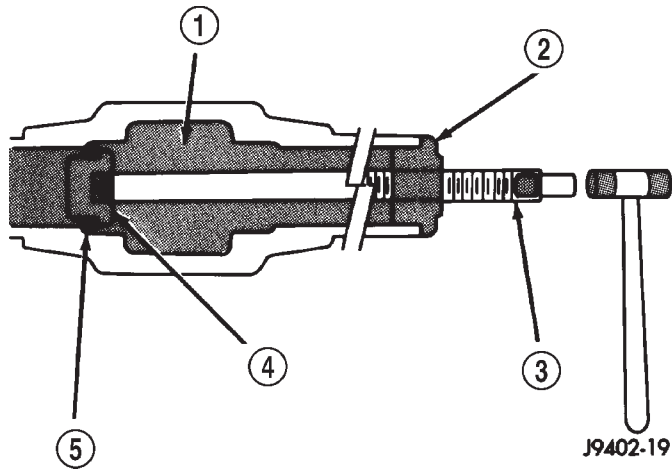
- 1 - BEARING  
2 - SHIFT MOTOR HOUSING OPENING  
3 - AXLE TUBE  
4 - LOCATION FOR OPEN-END WRENCH  
5 - SPECIAL TOOL 5041-2  
6 - NUT  
7 - SPECIAL TOOL 5041-3  
8 - SPECIAL TOOL D-354-2

### INSTALLATION

- (1) Position bearing on the installation tool and seat the bearing (Fig. 24) in the housing bore.
- (2) Clean the inside perimeter of the axle shaft tube with fine crocus cloth.
- (3) Apply a light film of oil to the inside lip of the new axle shaft seal.
- (4) Install the inner axle seal (Fig. 25).
- (5) Install shift collar in the axle housing.
- (6) Lubricate the splined end of the intermediate axle shaft with multi-purpose lubricant.
- (7) Insert the intermediate axle shaft into the differential side gear.

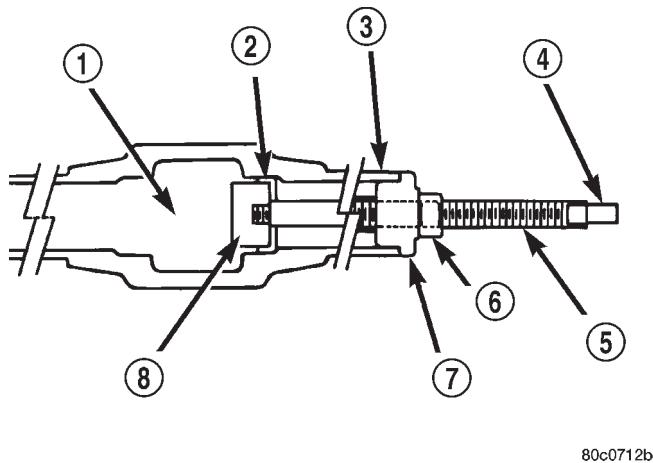
**CAUTION:** Apply all-purpose lubricant to the axle shaft splines to prevent damage to the seal during axle shaft installation.

AXLE SHAFTS - INTERMEDIATE (Continued)



**Fig. 24 Bearing Installer**

- 1 - SHIFT MOTOR HOUSING OPENING
- 2 - SPECIAL TOOL 5041-3
- 3 - SPECIAL TOOL 5041-2
- 4 - SPECIAL TOOL D-354-3
- 5 - BEARING



**Fig. 25 Seal Installer**

- 1 - SHIFT MOTOR HOUSING OPENING
- 2 - SEAL
- 3 - AXLE TUBE
- 4 - LOCATION FOR OPEN-END WRENCH
- 5 - SPECIAL TOOL 5041-2
- 6 - NUT
- 7 - SPECIAL TOOL 5041-3
- 8 - SPECIAL TOOL 8409

- (8) Insert axle shaft into the tube and engage splined end of the shaft with the shift collar.
- (9) Install vacuum shift motor housing.

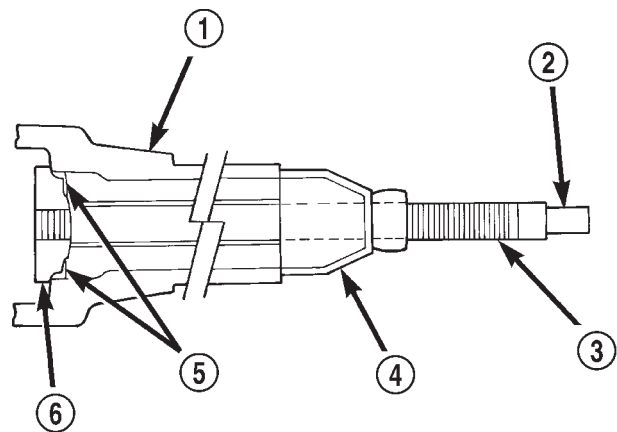
AXLE SHAFT SEALS

REMOVAL

- (1) Remove hub bearings and axle shafts.
- (2) Remove axle shaft seal from the differential housing with a long drift or punch. **Be careful not to damage housing.**
- (3) Clean the inside perimeter of the differential housing with fine crocus cloth.

INSTALLATION

- (1) Apply a light film of oil to the inside lip of the new axle shaft seal.
- (2) Install inner axle seal (Fig. 26).



**Fig. 26 Seal Installer**

- 1 - DIFFERENTIAL HOUSING
- 2 - POSITION FOR OPEN-END WRENCH
- 3 - SPECIAL TOOL 5041-2
- 4 - SPECIAL TOOL C-3716-A
- 5 - SEAL
- 6 - SPECIAL TOOL 8409

- (3) Install axle shafts and hub bearings.

AXLE VACUUM MOTOR

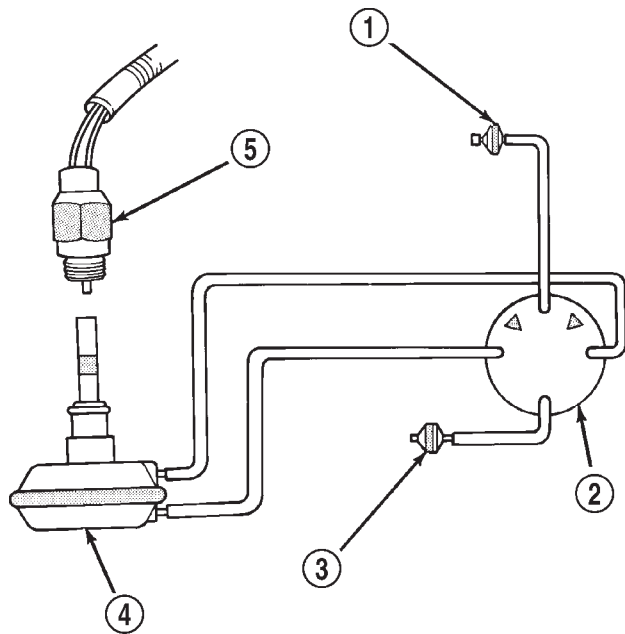
DESCRIPTION

The disconnect axle control system consists of:

- Shift motor.
- Indicator switch.
- Vacuum switch.
- Vacuum harness (Fig. 27).



## AXLE VACUUM MOTOR (Continued)



J9202-55

**Fig. 27 Vacuum Control System**

- 1 - CHECK VALVE
- 2 - CONTROL SWITCH ON TRANSFER CASE
- 3 - AIR VENT FILTER
- 4 - AXLE SHIFT MOTOR
- 5 - INDICATOR SWITCH

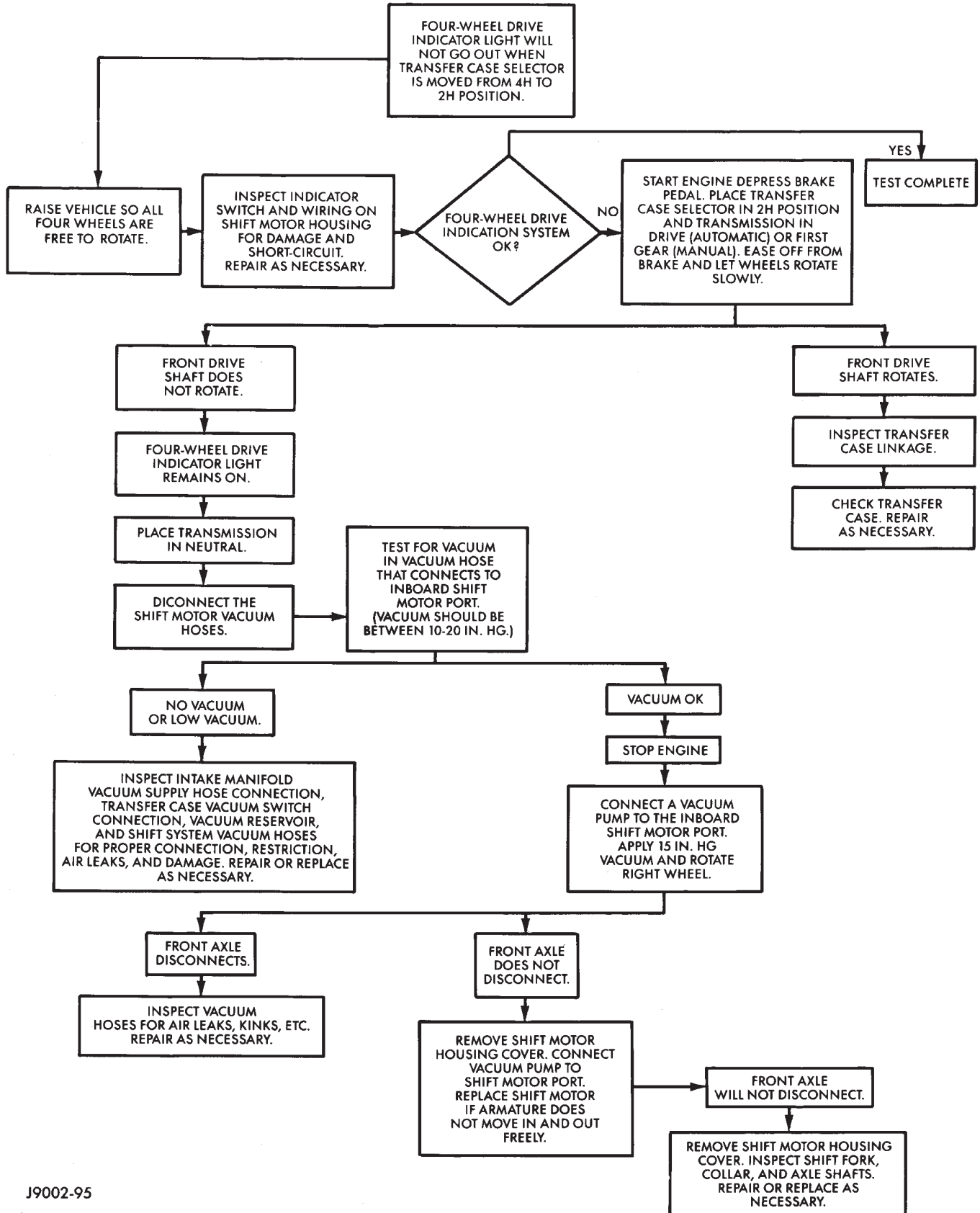
**OPERATION**

The shift motor receives a vacuum signal from the switch mounted on the transfer case when the vehicle operator wants to switch from two wheel drive mode to four wheel drive mode, or vice versa. When this signal is received, the shift motor begins to move the shift fork and collar within the axle housing. In the four wheel drive mode, the shift collar connects the axle intermediate shaft to the axle shaft to supply engine power to both front wheels. In two wheel drive mode, the shift collar is disengaged from the intermediate shaft and the intermediate shaft is allowed to free-spin. When the two shafts are disengaged, the load on the engine is reduced, thereby providing better fuel economy and road handling.

AXLE VACUUM MOTOR (Continued)

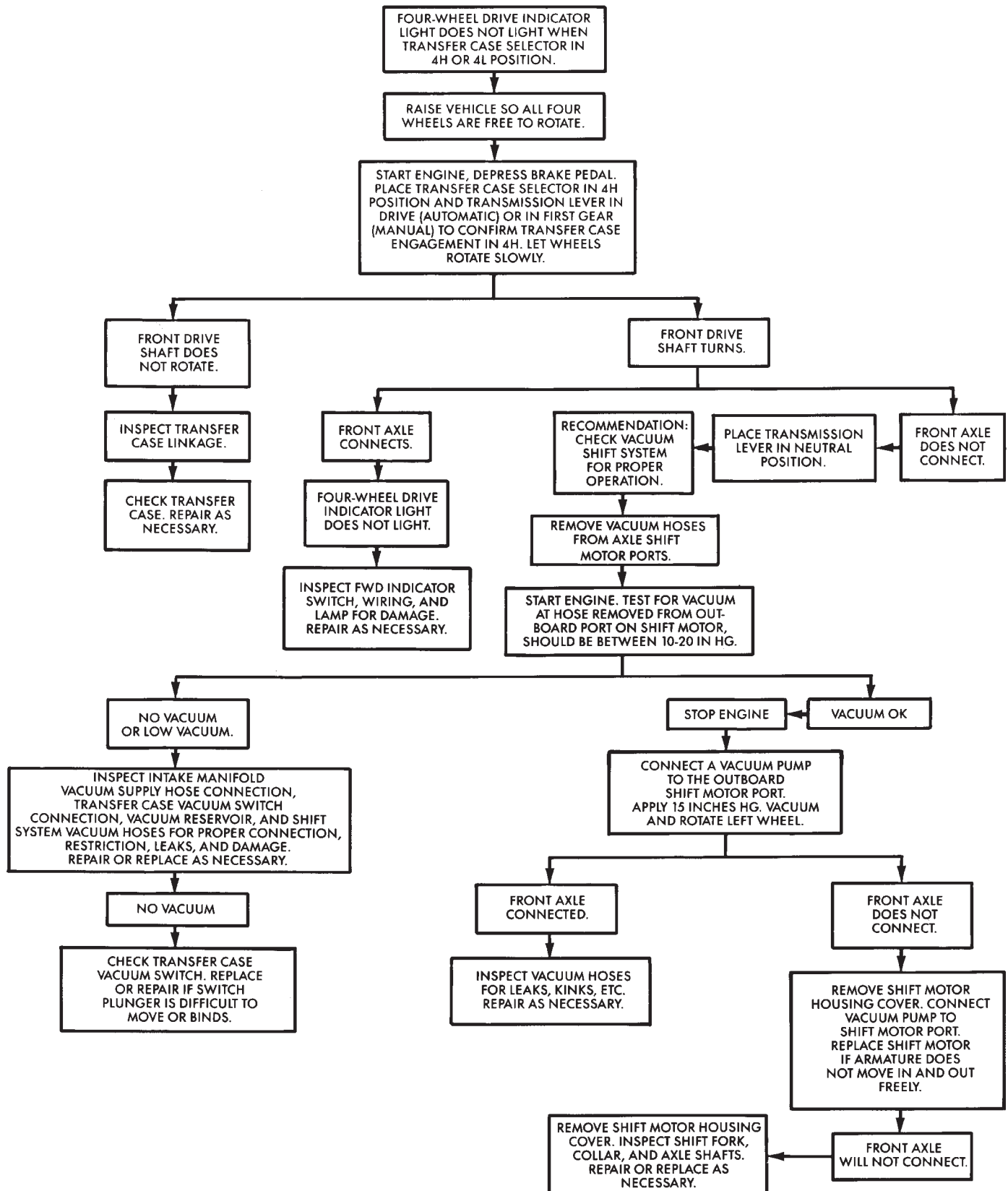
DIAGNOSIS AND TESTING - VACUUM MOTOR

AXLE VACUUM SHIFT MOTOR  
TWO-WHEEL DRIVE OPERATION DIAGNOSIS



AXLE VACUUM MOTOR (Continued)

**AXLE VACUUM SHIFT MOTOR (CONT'D)  
FOUR-WHEEL DRIVE OPERATION DIAGNOSIS**



## AXLE VACUUM MOTOR (Continued)

## REMOVAL

- (1) Disconnect the vacuum and wiring connector from the shift housing.
- (2) Remove indicator switch.
- (3) Remove shift motor housing cover, gasket and shield from the housing (Fig. 28).

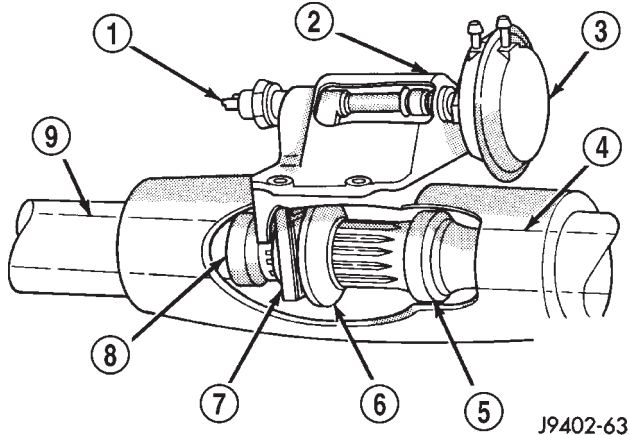


Fig. 28 Shift Motor Housing

- 1 - INDICATOR LAMP SWITCH
- 2 - DISCONNECT HOUSING
- 3 - VACUUM SHIFT MOTOR
- 4 - AXLE SHAFT
- 5 - SEAL
- 6 - SHIFT COLLAR
- 7 - SHIFT FORK
- 8 - BEARING
- 9 - INTERMEDIATE AXLE SHAFT

## DISASSEMBLY

- (1) Remove E-clips from the shift motor housing and shaft. Remove shift motor and shift fork from the housing (Fig. 29).
- (2) Remove O-ring seal from the shift motor shaft.
- (3) Clean and inspect all components. Replace any component that is excessively worn or damaged.

## ASSEMBLY

- (1) Install a new O-ring seal on the shift motor shaft.
- (2) Insert shift motor shaft through the hole in the housing and shift fork. The shift fork offset should be toward the differential.
- (3) Install E-clips on the shift motor shaft and housing.

## INSTALLATION

- (1) Install shift motor housing gasket and cover. Ensure shift fork is correctly guided into the shift collar groove.
- (2) Install shift motor housing shield and tighten the bolts to 11 N·m (96 in. lbs.).

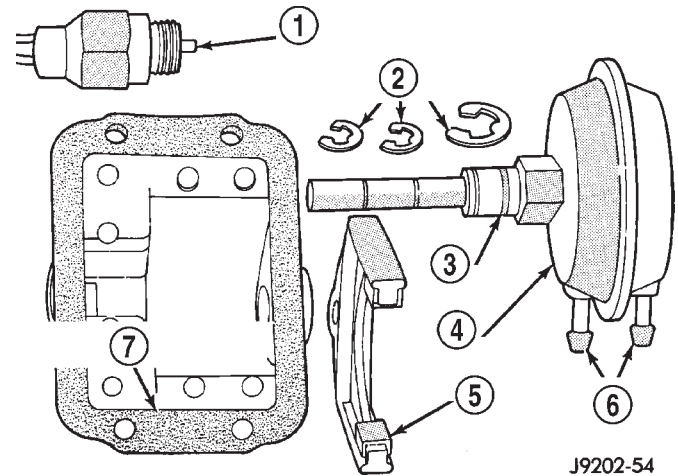


Fig. 29 Shift Motor Components

- 1 - INDICATOR SWITCH
- 2 - E-CLIP
- 3 - O-RING
- 4 - SHIFT MOTOR
- 5 - SHIFT FORK
- 6 - VACUUM PORTS
- 7 - DISCONNECT HOUSING AND GASKET

(3) Add 148 ml (5 ounces) of API grade GL 5 hypoid gear lubricant to the shift motor housing. Add lubricant through indicator switch mounting hole.

(4) Install indicator switch, electrical connector and vacuum harness.

## SINGLE CARDAN UNIVERSAL JOINTS

## REMOVAL

Single cardan U-joint components are not serviceable. If defective they must be replaced as a unit.

**CAUTION: Clamp only the narrow forged portion of the yoke in the vise. To avoid distorting the yoke, do not over tighten the vise jaws.**

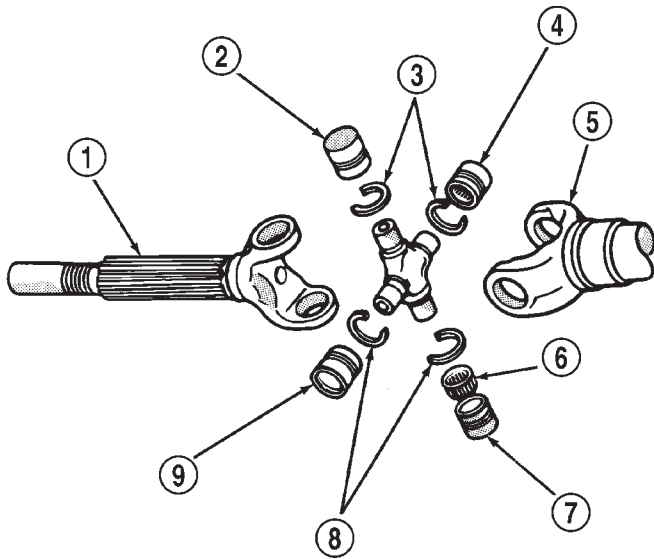
- (1) Remove axle shaft.
- (2) Remove the bearing cap retaining snap rings (Fig. 30).

**NOTE: Saturate bearing caps with penetrating oil prior to removal.**

(3) Locate a socket with an inside diameter is larger than the bearing cap. Place the socket (receiver) against the yoke and around the perimeter of the bearing cap to be removed.

(4) Locate a socket with an outside diameter is smaller than the bearing cap. Place the socket (driver) against the opposite bearing cap.

## SINGLE CARDAN UNIVERSAL JOINTS (Continued)



J8902-15

**Fig. 30 Axle Shaft U-Joint**

- 1 - SHAFT YOKE
- 2 - BEARING CAP
- 3 - SNAP RINGS
- 4 - BEARING CAP
- 5 - SPINDLE YOKE
- 6 - BEARING
- 7 - BEARING CAP
- 8 - SNAP RINGS
- 9 - BEARING CAP

(5) Position yoke with the sockets in a vise (Fig. 31).

(6) Tighten the vise jaws to force the bearing cap into the larger socket (receiver).

(7) Release the vise jaws. Remove the sockets and bearing cap that was partially forced out of the yoke.

(8) Repeat the above procedure for the remaining bearing cap and remove spider from the propeller shaft yoke.

**INSTALLATION**

(1) Pack the bearing caps 1/3 full of wheel bearing lubricant. Apply extreme pressure (EP), lithium-base lubricant to aid in installation.

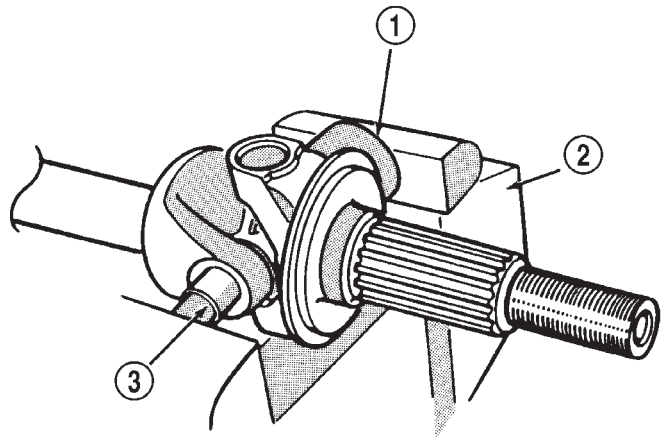
(2) Position the spider in the yoke. Insert the seals and bearings. Tap the bearing caps into the yoke bores far enough to hold the spider in position.

(3) Place the socket (driver) against one bearing cap. Position the yoke with the socket in a vise.

(4) Tighten the vise to force the bearing caps into the yoke. Force the caps enough to install the retaining clips.

(5) Install the bearing cap retaining clips.

(6) Install axle shaft.



J8902-16

**Fig. 31 Yoke Bearing Cap**

- 1 - LARGE-DIAMETER SOCKET WRENCH
- 2 - VISE
- 3 - SMALL-DIAMETER SOCKET WRENCH

**PINION SEAL****REMOVAL**

(1) Raise and support the vehicle.

(2) Remove wheel and tire assemblies.

(3) Remove brake calipers and rotors, Refer to Brakes for procedure.

(4) Mark the propeller shaft and pinion yoke for installation reference.

(5) Remove propeller shaft from the yoke.

(6) Rotate pinion gear three or four times and verify it rotates smoothly.

(7) Record rotating torque of the pinion gear with an inch pound torque wrench for installation reference.

(8) Remove pinion yoke nut and washer with Remover C-452 and Flange Wrench C-3281 (Fig. 32).

(9) Remove pinion shaft seal with a pry tool or slide hammer mounted screw.

**INSTALLATION**

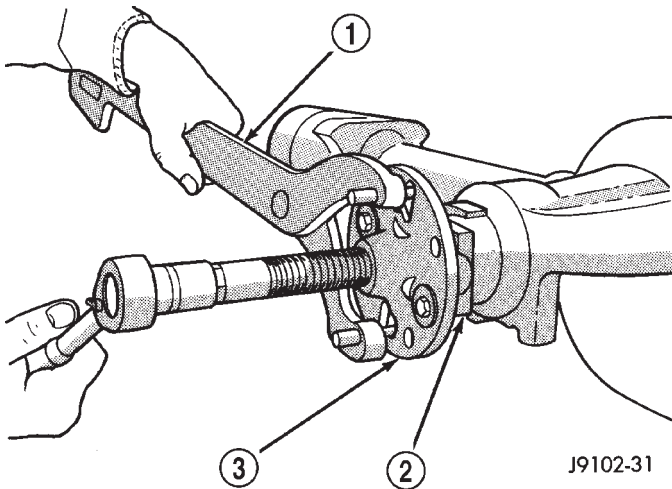
(1) Apply a light coating of gear lubricant on the lip of pinion seal. Install seal with an appropriate installer (Fig. 33).

(2) Install yoke on the pinion gear with Installer W-162-D (Fig. 34).

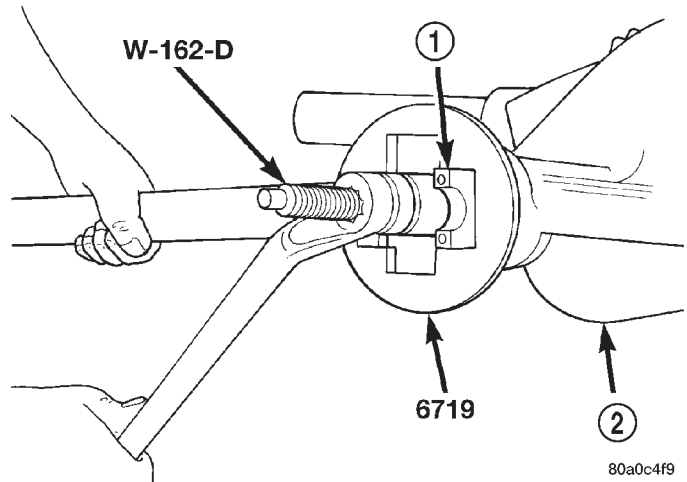
**CAUTION:** Do not exceed the minimum tightening torque when installing the pinion yoke retaining nut. Damage to collapsible spacer or bearings may result.



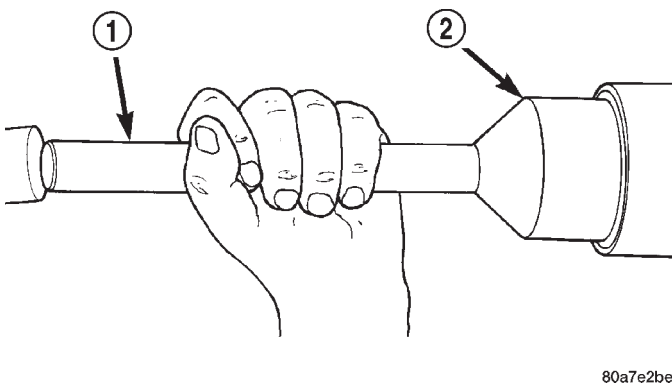
## PINION SEAL (Continued)

**Fig. 32 Pinion Yoke**

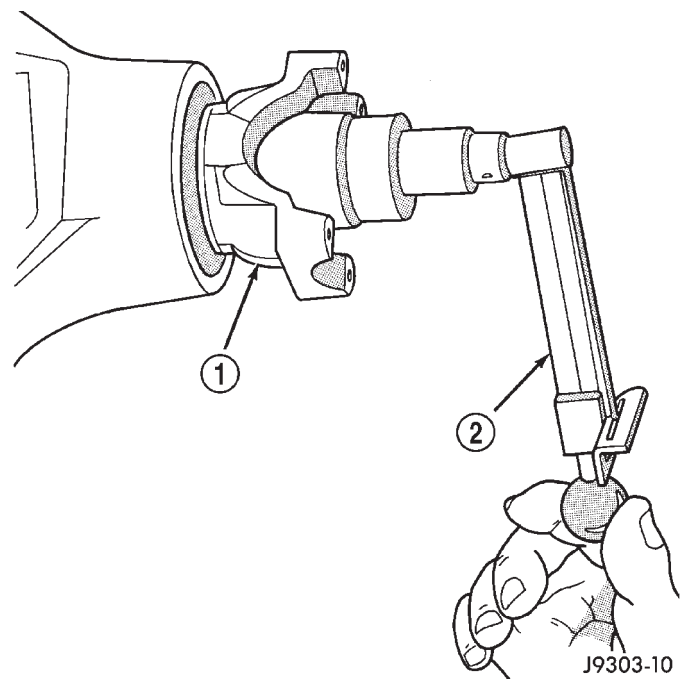
- 1 - YOKE HOLDER
- 2 - YOKE
- 3 - YOKE PULLER

**Fig. 34 Pinion Yoke Installer**

- 1 - PINION FLANGE
- 2 - DIFFERENTIAL HOUSING

**Fig. 33 Pinion Seal Installer**

- 1 - HANDLE
- 2 - INSTALLER

**Fig. 35 Pinion Rotation Torque**

- 1 - PINION YOKE
- 2 - INCH POUND TORQUE WRENCH

(3) Install a **new** nut on the pinion gear. Tighten the nut only enough to remove the shaft end play.

(4) Rotate the pinion shaft using a inch pound torque wrench. Rotating torque should be equal to the reading recorded during removal, plus an additional 0.56 N·m (5 in. lbs.) (Fig. 35).

(5) If the rotating torque is too low, use Holder 6719A to hold the pinion yoke (Fig. 36) and tighten the pinion shaft nut in 6.8 N·m (5 ft. lbs.) until proper rotating torque is achieved.

(6) Installation propeller shaft with reference marks aligned.

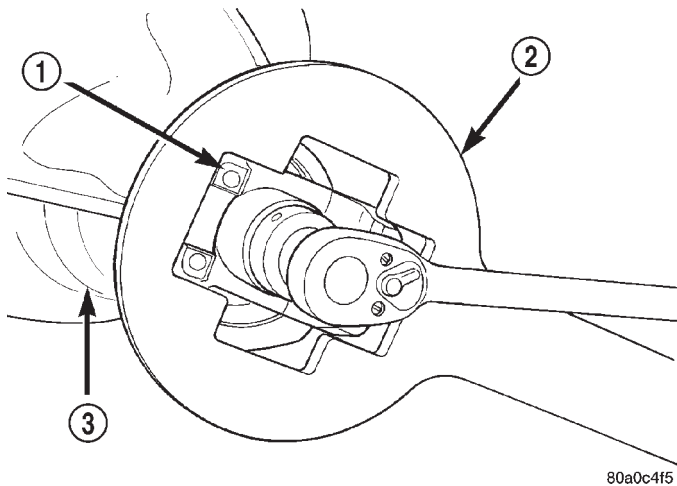
(7) Check and add gear lubricant to axle if necessary.

(8) Install brake rotors and calipers, refer to Brakes for procedure.

(9) Install wheel and tire assemblies.

(10) Lower the vehicle.

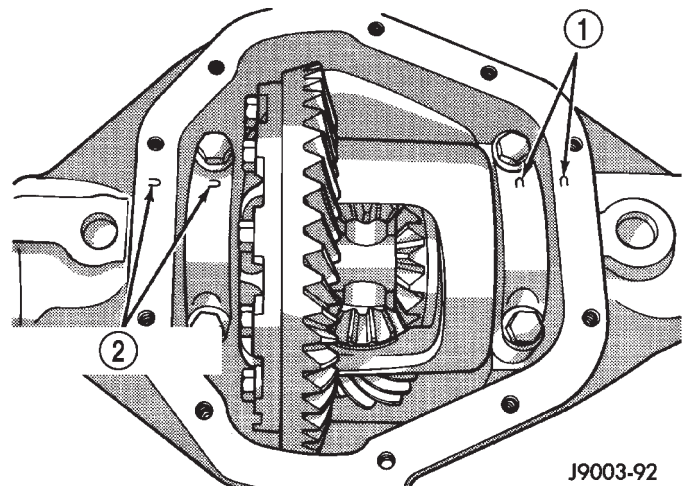
## PINION SEAL (Continued)



80a0c4f5

**Fig. 36 Pinion Shaft Nut**

- 1 - PINION FLANGE
- 2 - HOLDING TOOL 6719
- 3 - AXLE HOUSING



J9003-92

**Fig. 37 Bearing Cap Reference**

- 1 - REFERENCE LETTERS
- 2 - REFERENCE LETTERS

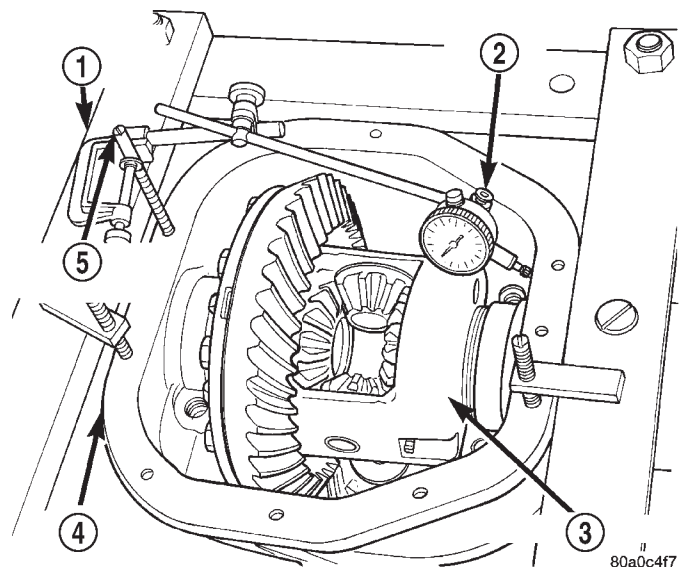
## DIFFERENTIAL

## REMOVAL

- (1) Raise and support vehicle.
- (2) Remove lubricant fill hole plug from the differential housing cover.
- (3) Remove differential housing cover and drain the lubricant from the housing.
- (4) Clean the housing cavity with a flushing oil, light engine oil or lint free cloth. **Do not use water, steam, kerosene or gasoline for cleaning.**
- (5) Remove hub bearings and axle shafts.
- (6) Note the installation reference letters stamped on the bearing caps and housing machined sealing surface (Fig. 37).
- (7) Remove the differential bearing caps.
- (8) Position Spreader W-129-B with the tool dowel pins seated in the locating holes (Fig. 38).
- (9) Install the hold down clamps and tighten the spreader turnbuckle finger-tight.
- (10) Install Pilot Stud C-3288-B to the left side of the differential housing and attach dial indicator to the pilot stud. Load the indicator plunger against the opposite side of the housing (Fig. 38) and zero the dial indicator.
- (11) Spread the housing enough to remove the case from the housing. Measure the distance with the dial indicator (Fig. 38).

**CAUTION:** Do not spread over 0.50 mm (0.020 in). If the housing is over-spread it could be distorted or damaged.

- (12) Remove the dial indicator.



80a0c4f7

**Fig. 38 Spread Differential Housing**

- 1 - HOUSING SPREADER W-129B
- 2 - DIAL INDICATOR C-3339
- 3 - DIFFERENTIAL
- 4 - AXLE HOUSING
- 5 - GUIDE PIN C-3288-B

- (13) Pry the differential case loose from the housing. To prevent damage, pivot on housing with the end of the pry bar against spreader (Fig. 39).

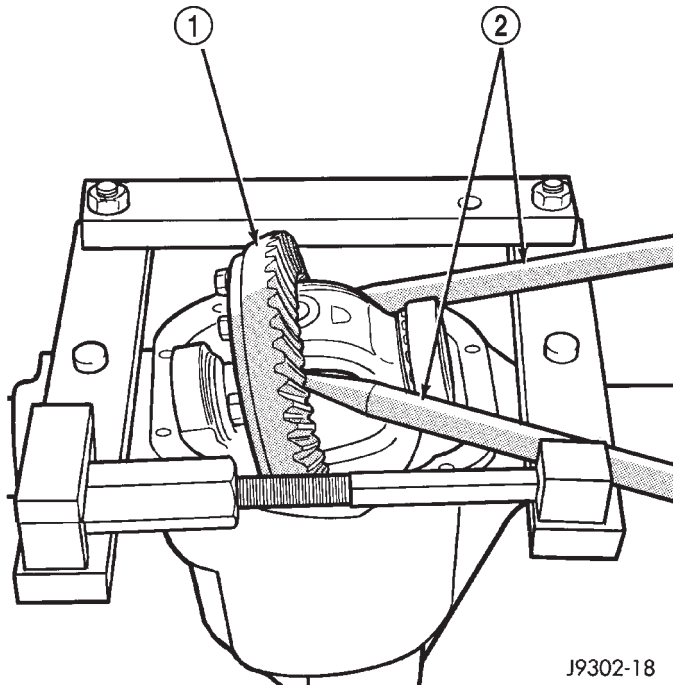
- (14) Remove the case from housing.

- (15) Remove and tag bearing cups to indicate their original location.

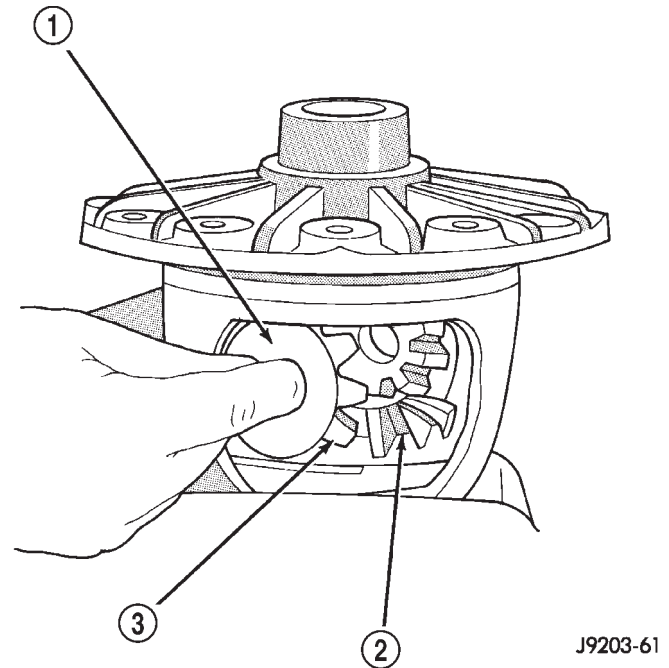
## DISASSEMBLY

- (1) Remove roll-pin holding mate shaft in housing.
- (2) Remove pinion gear mate shaft (Fig. 40).

## DIFFERENTIAL (Continued)

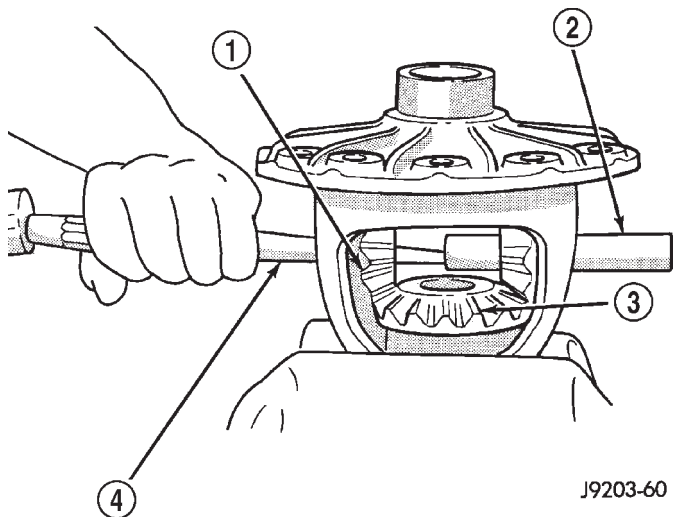
**Fig. 39 Differential Removal**

- 1 - DIFFERENTIAL
- 2 - PRY BAR

**Fig. 41 Pinion Mate/Side Gear**

- 1 - THRUST WASHER
- 2 - SIDE GEAR
- 3 - PINION MATE GEAR

(3) Rotate the differential side gears and remove the pinion mate gears and thrust washers (Fig. 41).

**Fig. 40 Pinion Mate Shaft**

- 1 - PINION MATE GEAR
- 2 - PINION MATE SHAFT
- 3 - SIDE GEAR
- 4 - DRIFT

(4) Remove the differential side gears and thrust washers.

**ASSEMBLY**

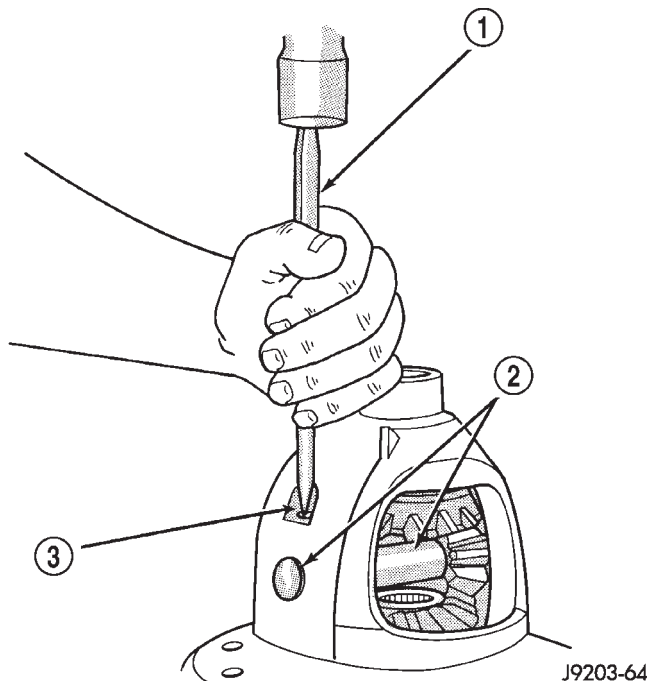
- (1) Install the differential side gears and thrust washers.
- (2) Install the pinion mate gears and thrust washers.
- (3) Install the pinion gear mate shaft.
- (4) Align the hole in the pinion gear mate shaft with the hole in the differential case.
- (5) Install and seat the pinion mate shaft roll-pin in the differential case and mate shaft with a punch and hammer (Fig. 42). Peen the edge of the roll-pin hole in the differential case slightly in two places, 180° apart.
- (6) Lubricate all differential components with hypoid gear lubricant.

**INSTALLATION**

**NOTE:** If replacement differential bearings or differential case are being installed, differential side bearing shim requirements may change. Refer to **Adjustments (Differential Bearing Preload and Gear Backlash)** procedures to determine proper shim selection.

- (1) Position Spreader W-129-B with the tool dowel pins seated in the locating holes. Install the hold down clamps and tighten the tool turnbuckle finger-tight.

## DIFFERENTIAL (Continued)



**Fig. 42 Pinion Mate Shaft Roll-Pin**

- 1 - PUNCH
- 2 - PINION MATE SHAFT
- 3 - MATE SHAFT LOCKPIN

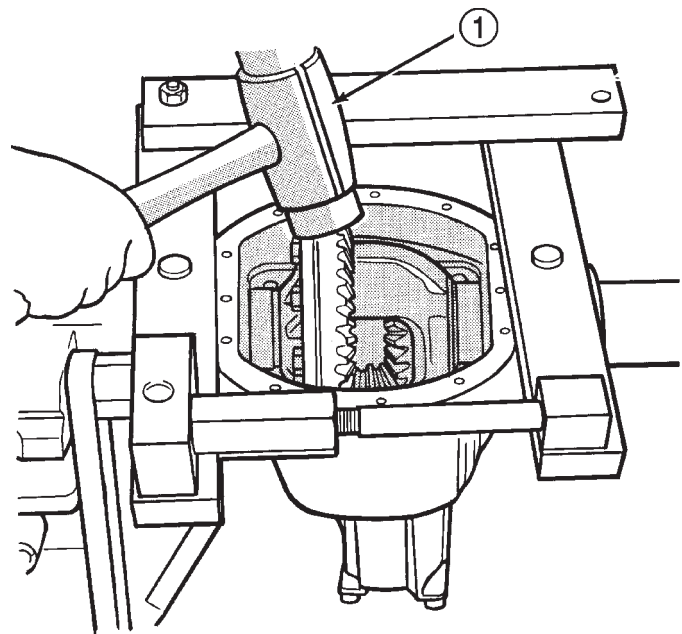
(2) Install a Pilot Stud C-3288-B at the left side of the differential housing and attach dial indicator to the pilot stud. Load the indicator plunger against the opposite side of the housing and zero the dial indicator.

(3) Spread the housing enough to install the case in the housing. Measure the distance with the dial indicator.

**CAUTION:** Do not spread over 0.50 mm (0.020 in). If the housing is over-spread, it could be distorted or damaged.

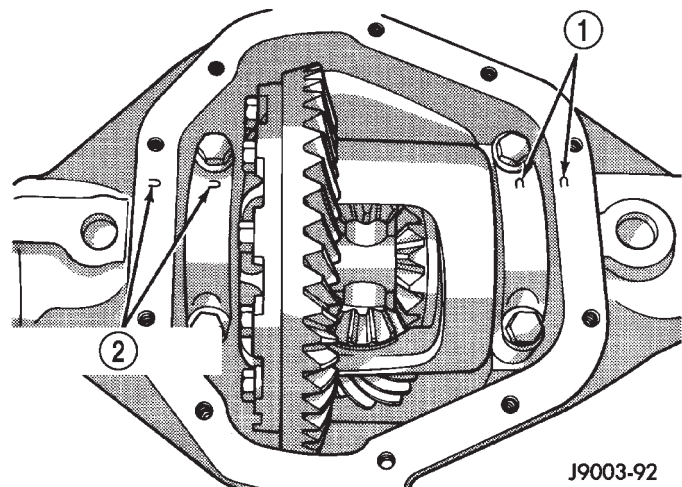
- (4) Remove the dial indicator.
- (5) Install differential into the housing. Tap the differential case with a rawhide/rubber hammer to ensure the bearings are seated in housing (Fig. 43).
- (6) Remove the spreader.
- (7) Install bearing caps in their original locations (Fig. 44) and tighten bearing cap bolts to 109 N·m (80 ft. lbs.).
- (8) Install axle shafts.
- (9) Install the hub bearings.
- (10) Apply a bead of Mopar Silicone Rubber Sealant or equivalent to the housing cover (Fig. 45).

**Install the housing cover within 5 minutes after applying the sealant.**



**Fig. 43 Differential Case**

- 1 - RAWHIDE HAMMER



**Fig. 44 Bearing Cap Reference**

- 1 - REFERENCE LETTERS
- 2 - REFERENCE LETTERS

(11) Install the cover and any identification tag. Tighten the cover bolts in a criss-cross pattern to 47 N·m (35 ft. lbs.).

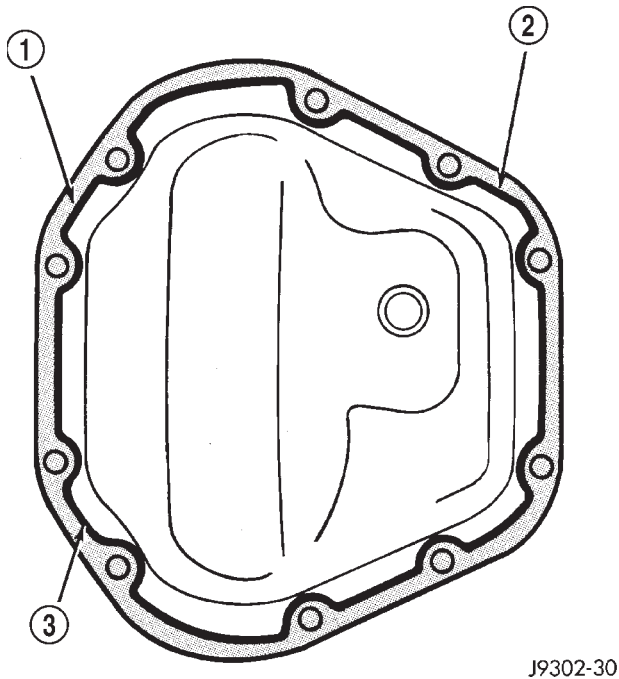
(12) Refill the differential with Mopar Hypoid Gear Lubricant or equivalent to bottom of the fill plug hole. Refer to the Lubricant Specifications for correct quantity and type.

(13) Install the fill hole plug and tighten to 34 N·m (25 ft. lbs.).

(14) Remove support and lower vehicle.



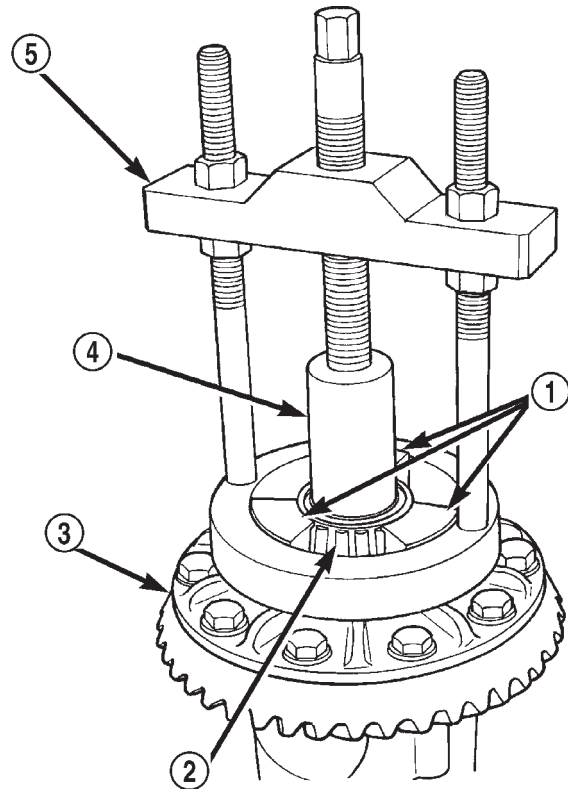
## DIFFERENTIAL (Continued)



J9302-30

**Fig. 45 Differential Cover**

- 1 - SEALANT SURFACE
- 2 - SEALANT
- 3 - SEALANT THICKNESS



80a9b32t

**Fig. 46 Differential Bearing Puller**

- 1 - ADAPTERS
- 2 - BEARING
- 3 - DIFFERENTIAL
- 4 - PLUG
- 5 - PULLER

DIFFERENTIAL CASE  
BEARINGS**REMOVAL**

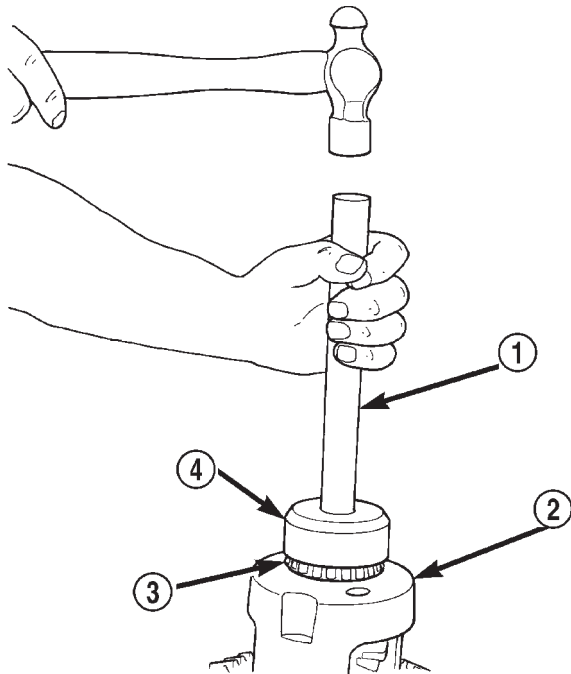
- (1) Remove differential case from axle housing.
- (2) Remove differential bearings from the case with Puller/Press C-293-PA, Adapters C-293-18 and Plug C-293-3 (Fig. 46).
- (3) Remove differential preload shims from differential case hubs and tag shims to indicate location.

**INSTALLATION**

- (1) Install differential preload shims on differential case in their original locations.
- (2) Install differential bearings with Installer D-156 with Handle C-4171 (Fig. 47).
- (3) Install differential into the housing.

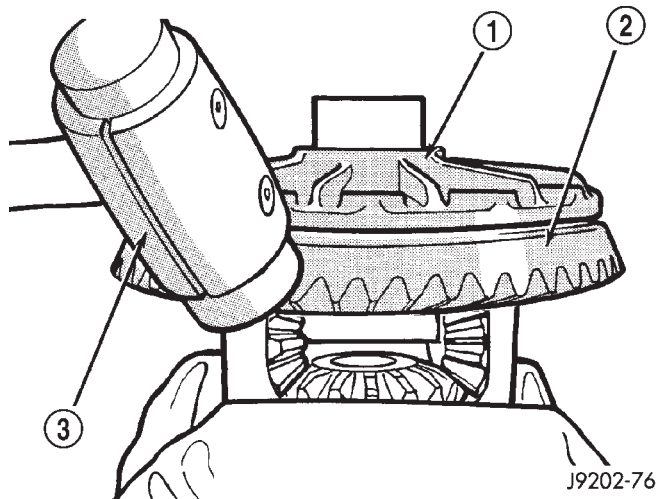


## DIFFERENTIAL CASE BEARINGS (Continued)

**Fig. 47 Differential Bearing Installer**

- 1 - HANDLE
- 2 - DIFFERENTIAL
- 3 - BEARING
- 4 - INSTALLER

80a9b32c

**Fig. 48 Ring Gear**

- 1 - CASE
- 2 - RING GEAR
- 3 - HAMMER

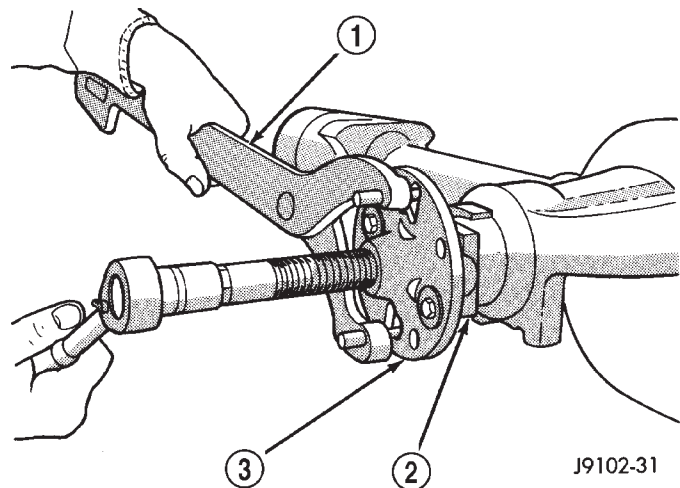
J9202-76

## PINION GEAR/RING GEAR

## REMOVAL

**NOTE:** The ring and pinion gears are serviced as a matched set. Never replace one gear without replacing the other gear.

- (1) Raise and support the vehicle.
- (2) Mark pinion yoke and propeller shaft for installation reference.
- (3) Disconnect propeller shaft from pinion yoke and tie propeller shaft to underbody.
- (4) Remove differential from the housing.
- (5) Secure differential case in a vise with soft metal jaw.
- (6) Remove ring gear bolts from the differential case.
- (7) Drive ring gear off the differential case with a rawhide hammer (Fig. 48).
- (8) Hold yoke with Holder 6719A and remove pinion nut and washer.
- (9) Remove pinion yoke from the pinion shaft with Puller C-452 and Flange Wrench C-3281 (Fig. 49).
- (10) Remove pinion gear from housing (Fig. 50).
- (11) Remove pinion seal with a pry bar or slide hammer mounted screw.

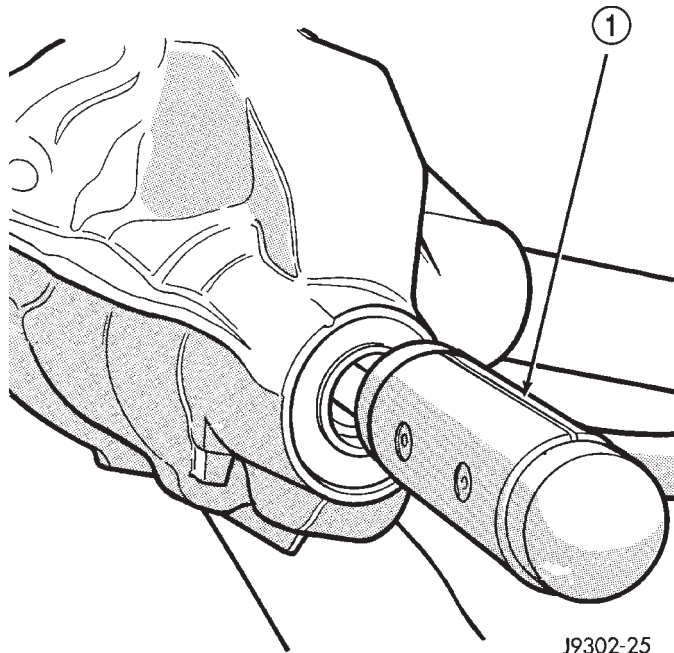
**Fig. 49 Pinion Yoke**

- 1 - YOKE HOLDER
- 2 - YOKE
- 3 - YOKE PULLER

J9102-31

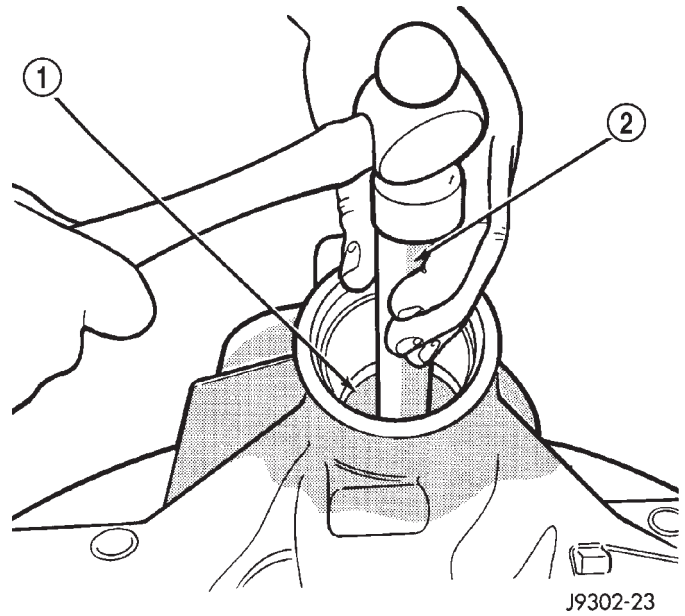
- (12) Remove front pinion bearing and oil slinger.
- (13) Remove front pinion bearing cup with Remover D-147 and Handle C-4171 (Fig. 51).
- (14) Remove rear bearing cup (Fig. 52) with Remover D-149 and Handle C-4171.
- (15) Remove collapsible preload spacer from pinion shaft (Fig. 53).
- (16) Remove rear pinion bearing with Puller C-293-PA and Adapters C-293-40 (Fig. 54).
- (17) Remove pinion depth shims from pinion shaft and record thickness.

PINION GEAR/RING GEAR (Continued)



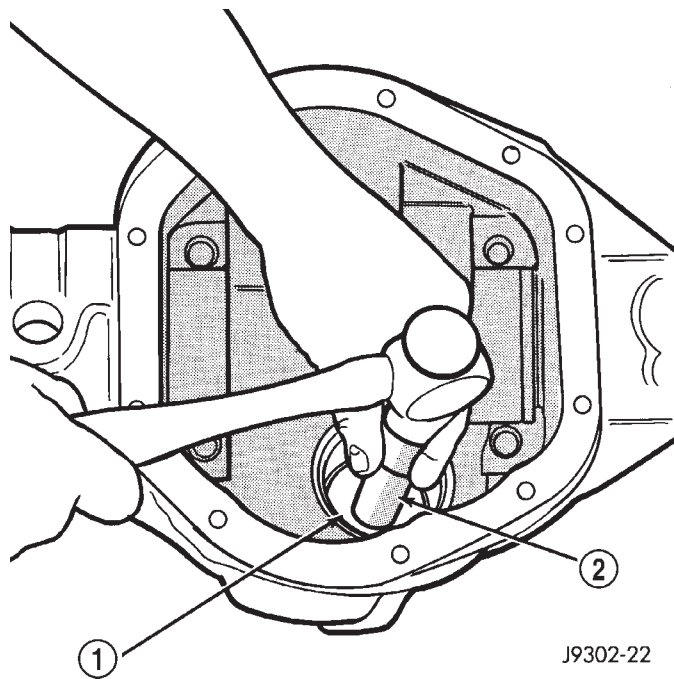
**Fig. 50 Pinion Gear**

- 1 - RAWHIDE HAMMER



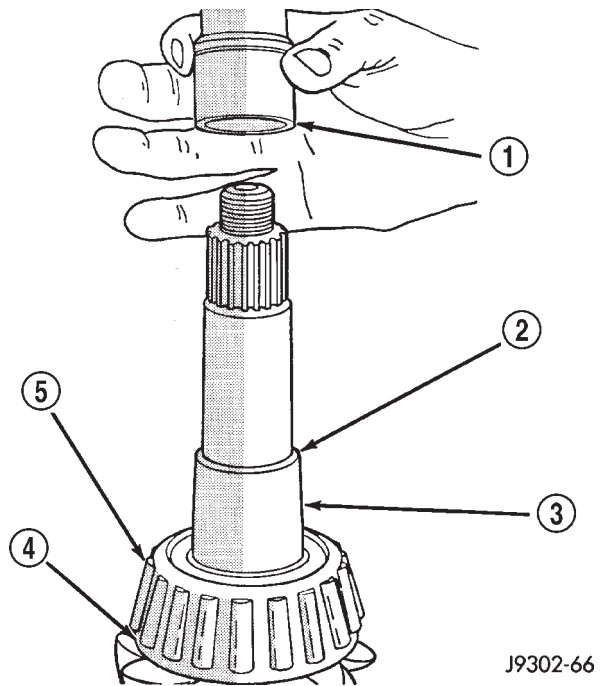
**Fig. 52 Rear Pinion Bearing Cup**

- 1 - DRIVER
- 2 - HANDLE



**Fig. 51 Front Pinion Bearing Cup**

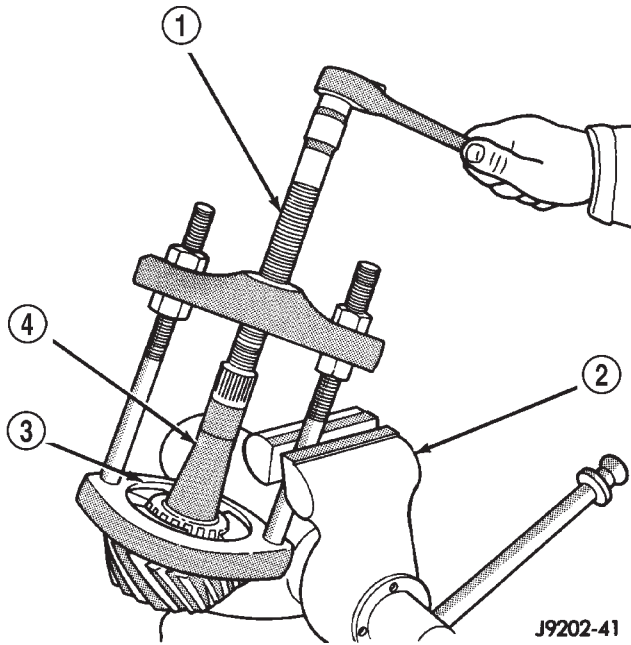
- 1 - REMOVER
- 2 - HANDLE



**Fig. 53 Collapsible Spacer**

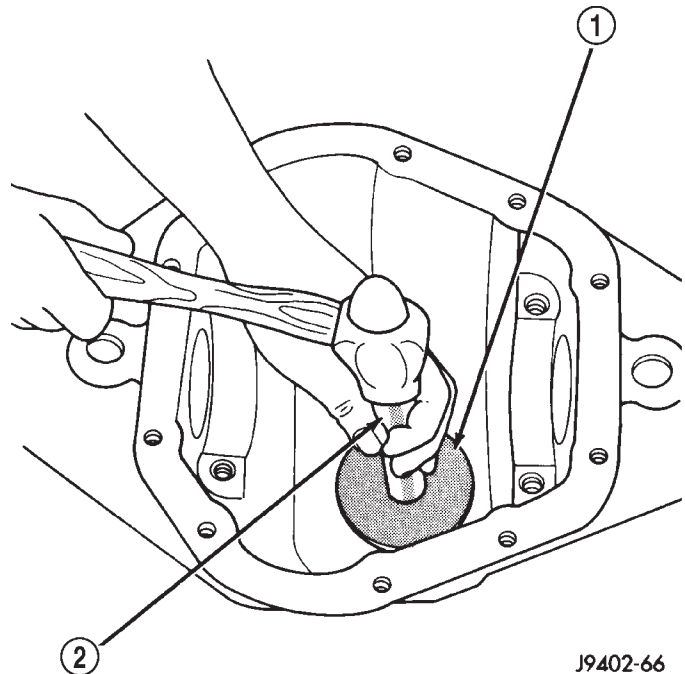
- 1 - COLLAPSIBLE SPACER
- 2 - SHOULDER
- 3 - PINION GEAR
- 4 - OIL SLINGER
- 5 - REAR BEARING

## PINION GEAR/RING GEAR (Continued)



**Fig. 54 Rear Pinion Bearing**

- 1 - PULLER
- 2 - VISE
- 3 - ADAPTERS
- 4 - PINION SHAFT



**Fig. 55 Rear Pinion Bearing Cup**

- 1 - INSTALLER
- 2 - HANDLE

## INSTALLATION

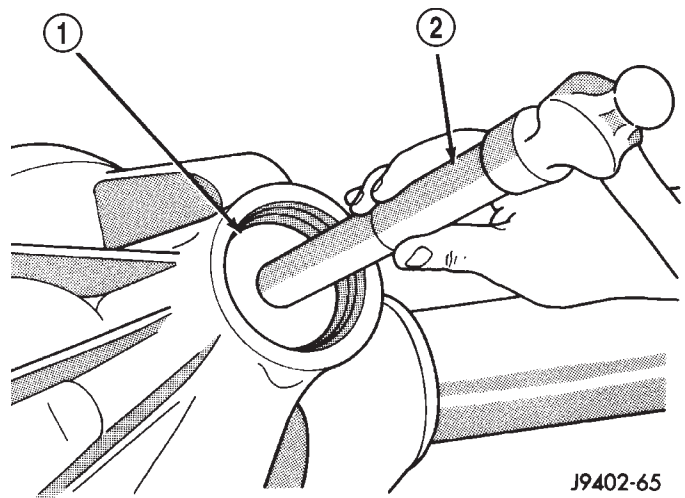
**NOTE:** Pinion depth shims are placed between the rear pinion bearing cone and pinion gear to achieve proper ring and pinion gear mesh. If ring and pinion gears are reused, the original pinion depth shim can be used. Refer to Adjustments (Pinion Gear Depth) to select the proper shim thickness if ring and pinion gears are replaced.

(1) Apply Mopar Door Ease stick lubricant to outside surface of bearing cups.

(2) Install rear pinion bearing cup with Installer D-146 and Handle C-4171 (Fig. 55) and verify cup is seated.

(3) Install front pinion bearing cup with Installer D-144 and Handle C-4171 (Fig. 56) and verify cup is seated.

(4) Install pinion front bearing, oil slinger. Apply a light coating of gear lubricant on the lip of pinion seal.

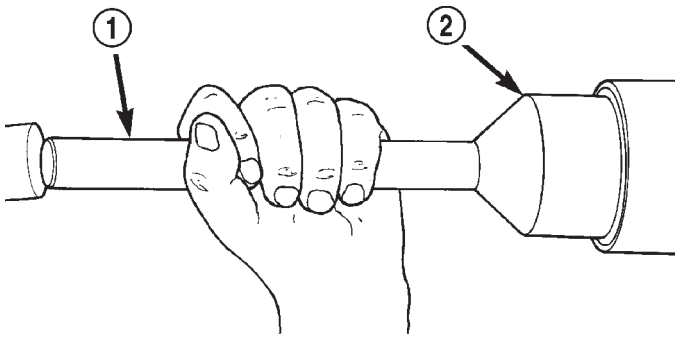


**Fig. 56 Front Pinion Bearing Cup**

- 1 - INSTALLER
- 2 - HANDLE

## PINION GEAR/RING GEAR (Continued)

(5) Install pinion seal with an appropriate installer (Fig. 57).



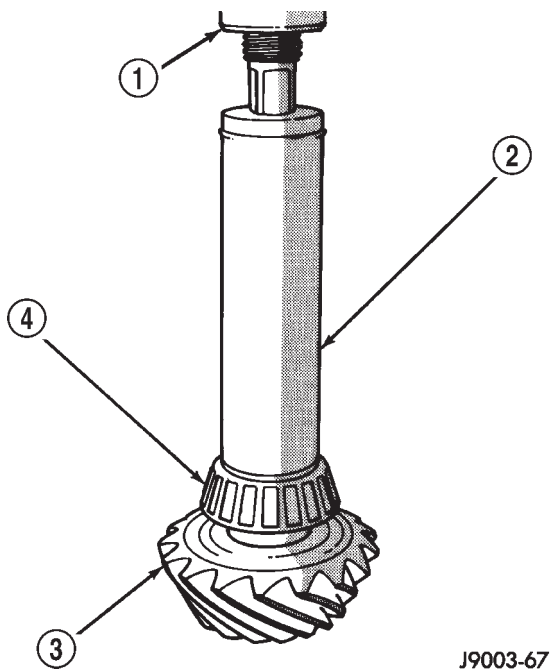
80a7e2be

**Fig. 57 Pinion Seal Installer**

- 1 - HANDLE  
2 - INSTALLER

(6) Install proper thickness depth shim on the pinion gear.

(7) Install rear bearing and oil slinger, if equipped on pinion gear with Installer W-262 (Fig. 58).



J9003-67

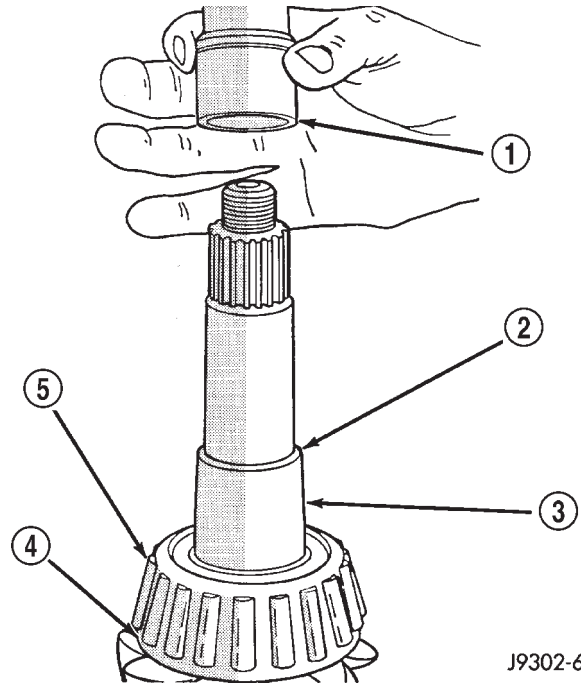
**Fig. 58 Rear Pinion Bearing**

- 1 - PRESS  
2 - INSTALLER  
3 - PINION GEAR  
4 - PINION BEARING

(8) Install a new collapsible preload spacer on pinion shaft (Fig. 59).

(9) Install pinion gear in housing.

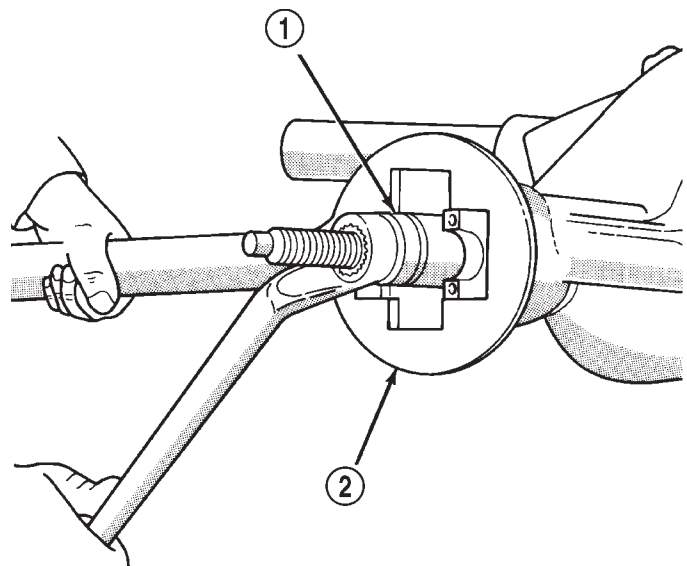
(10) Install yoke with Installer W-162-D and Yoke Holder 6719A (Fig. 60).



J9302-66

**Fig. 59 Collapsible Preload Spacer**

- 1 - COLLAPSIBLE SPACER  
2 - SHOULDER  
3 - PINION GEAR  
4 - OIL SLINGER  
5 - REAR PINION BEARING



J9402-61

**Fig. 60 Pinion Yoke Installer**

- 1 - INSTALLER  
2 - YOKE HOLDER

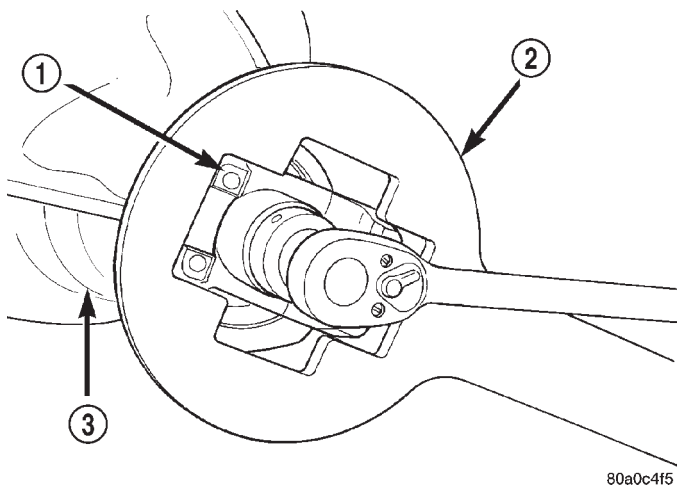


## PINION GEAR/RING GEAR (Continued)

(11) Install yoke washer and a **new** nut on the pinion gear. Tighten the nut to 258 N·m (190 ft. lbs.) minimum. **Do not over-tighten.** Maximum torque is 393 N·m (290 ft. lbs.).

**CAUTION:** Never loosen pinion gear nut to decrease pinion gear bearing preload torque and never exceed specified preload torque. If preload torque is exceeded a new collapsible spacer must be installed.

(12) Use Yoke Holder 6719A to hold the yoke (Fig. 61) and tighten the nut in 6.8 N·m (5 ft. lbs.) until the rotating torque is achieved. Measure the preload torque frequently to avoid over-tightening the nut.



**Fig. 61 Tightening Pinion Nut**

- 1 - PINION FLANGE
- 2 - YOKE HOLDING
- 3 - DIFFERENTIAL HOUSING

(13) Check bearing preload torque with an inch pound torque wrench (Fig. 62). The torque necessary to rotate the pinion gear should be:

- Original Bearings: 1 to 3 N·m (10 to 20 in. lbs.).
- New Bearings: 2 to 5 N·m (15 to 35 in. lbs.).

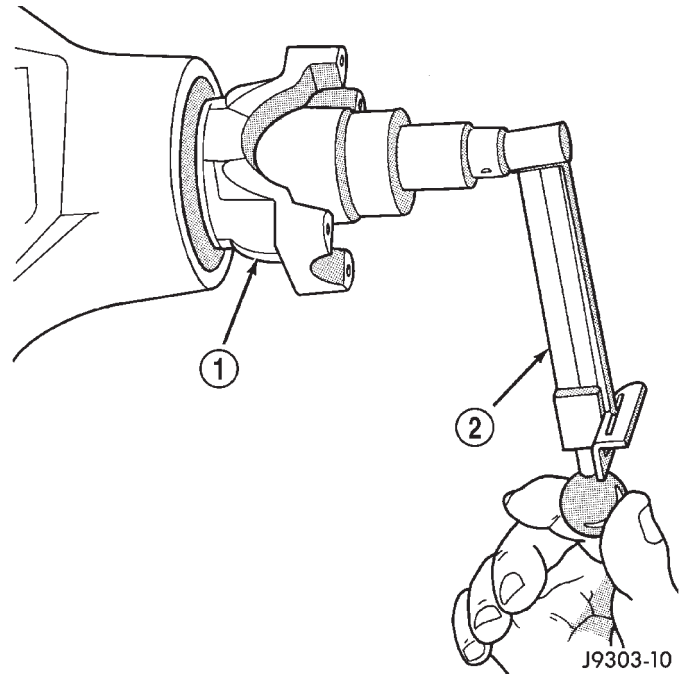
(14) Invert differential case in a vise and start two ring gear bolts. This will provide case-to-ring gear bolt hole alignment.

(15) Install **new** ring gear bolts and alternately tighten to 108 N·m (80 ft. lbs.). (Fig. 63).

**CAUTION:** Do not reuse the bolts that held the ring gear to the differential case. The bolts can fracture causing extensive damage.

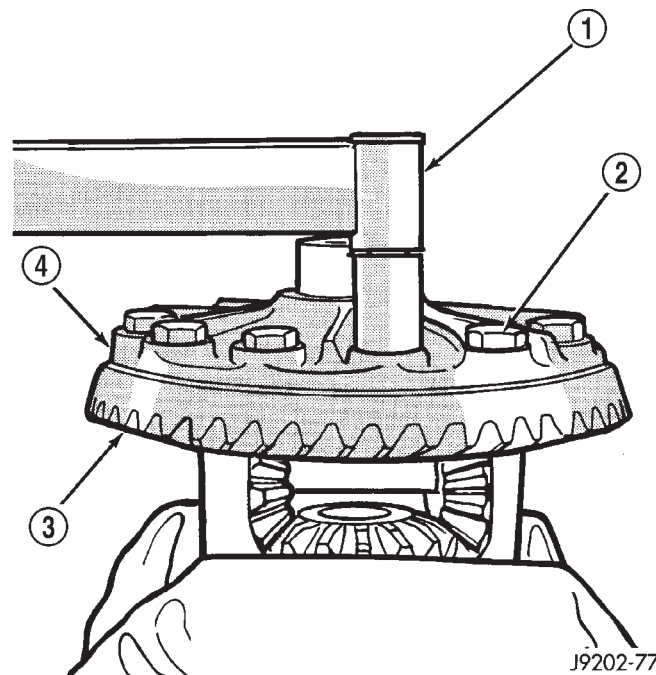
(16) Install differential in axle housing and verify gear mesh and contact pattern. Refer to Adjustments (Gear Contact Pattern).

(17) Install differential cover and fill with lubricant.



**Fig. 62 Pinion Rotating Torque**

- 1 - PINION YOKE
- 2 - INCH POUND TORQUE WRENCH



**Fig. 63 Ring Gear Bolt**

- 1 - TORQUE WRENCH
- 2 - RING GEAR BOLT
- 3 - RING GEAR
- 4 - CASE

(18) Install propeller shaft with reference marks aligned.

(19) Remove support and lower vehicle.



## FRONT AXLE - 248FBI

## TABLE OF CONTENTS

	page		page
<b>FRONT AXLE - 248FBI</b>		VACUUM MOTOR.....	63
DESCRIPTION.....	45	REMOVAL.....	65
OPERATION.....	45	DISASSEMBLY.....	65
DIAGNOSIS AND TESTING.....	46	ASSEMBLY.....	65
AXLE.....	46	INSTALLATION.....	65
REMOVAL.....	50	<b>SINGLE CARDAN UNIVERSAL JOINTS</b>	
INSTALLATION.....	50	REMOVAL.....	65
ADJUSTMENTS.....	50	INSTALLATION.....	66
SPECIFICATIONS.....	58	<b>PINION SEAL</b>	
SPECIAL TOOLS.....	58	REMOVAL.....	66
<b>AXLE SHAFTS</b>		INSTALLATION.....	66
REMOVAL.....	60	<b>DIFFERENTIAL</b>	
INSTALLATION.....	60	REMOVAL.....	68
<b>AXLE SHAFTS - INTERMEDIATE</b>		DISASSEMBLY.....	68
REMOVAL.....	60	ASSEMBLY.....	69
INSTALLATION.....	61	INSTALLATION.....	69
<b>AXLE SHAFT SEALS</b>		<b>DIFFERENTIAL CASE BEARINGS</b>	
REMOVAL.....	61	REMOVAL.....	71
INSTALLATION.....	61	INSTALLATION.....	71
<b>AXLE VACUUM MOTOR</b>		<b>PINION GEAR/RING GEAR</b>	
DESCRIPTION.....	62	REMOVAL.....	72
OPERATION.....	62	INSTALLATION.....	74
DIAGNOSIS AND TESTING.....	63		

## FRONT AXLE - 248FBI

## DESCRIPTION

The housing for the 248 Front Beam-design Iron (FBI) axle consists of an iron center casting with tubes on each side. The tubes are pressed into and welded to the differential housing.

The integral type housing, hypoid gear design has the centerline of the pinion set below the centerline of the ring gear.

The axle has a vent used to relieve internal pressure caused by lubricant vaporization and internal expansion.

The axles are equipped with semi-floating axle shafts, meaning that loads are supported by the hub bearings. The axle shafts are retained by nuts at the hub bearings. The hub bearings are bolted to the steering knuckle at the outboard end of the axle tube yoke. The hub bearings are serviced as an assembly.

The axles are equipped with ABS brake sensors. The sensors are attached to the knuckle assemblies and the tone rings are pressed onto the axle shaft. **Use care when removing axle shafts as NOT to damage the tone wheel or the sensor.**

The stamped steel cover provides a means for inspection and servicing the differential.

The 248 FBI axle have the assembly part number and gear ratio listed on a tag. The tag is attached to the housing cover by one of the cover bolts. Build date identification codes are stamped on the cover side of a axle tube.

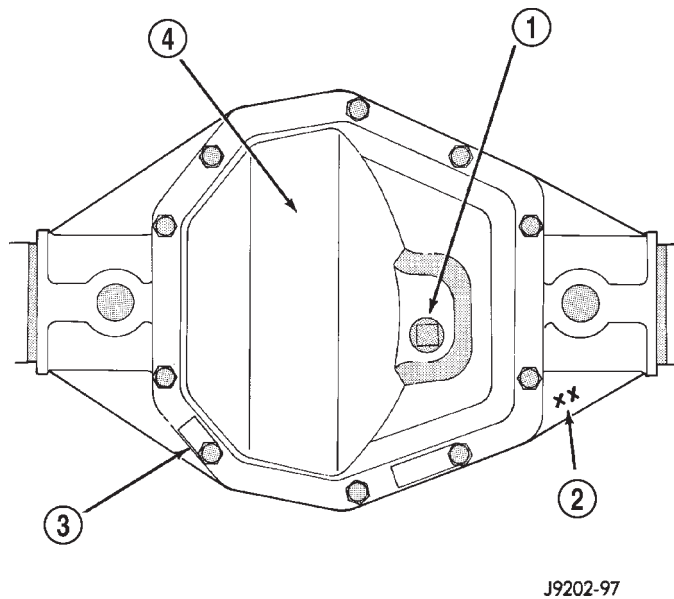
The differential case is a one-piece design. The differential pinion mate shaft is retained with a roll pin. Differential bearing preload and ring gear backlash is adjusted by the use of shims. The shims are located between the differential bearing cones and case. Pinion bearing preload is set and maintained by the use of a collapsible spacer.

The axle differential covers can be used for identification of the axle (Fig. 1). A tag is also attached to the cover.

## OPERATION

The axle receives power from the transfer case through the front propeller shaft. The front propeller shaft is connected to the pinion gear which rotates the differential through the gear mesh with the ring gear bolted to the differential case. The engine power is transmitted to the axle shafts through the pinion

FRONT AXLE - 248FBI (Continued)

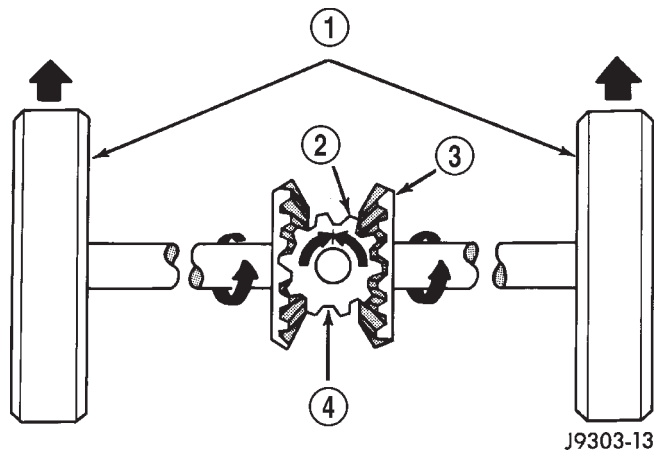


**Fig. 1 248 FBI Differential Cover**

- 1 - FILL PLUG
- 2 - MODEL NUMBER
- 3 - RATIO TAG
- 4 - DIFFERENTIAL COVER

mate and side gears. The side gears are splined to the axle shafts.

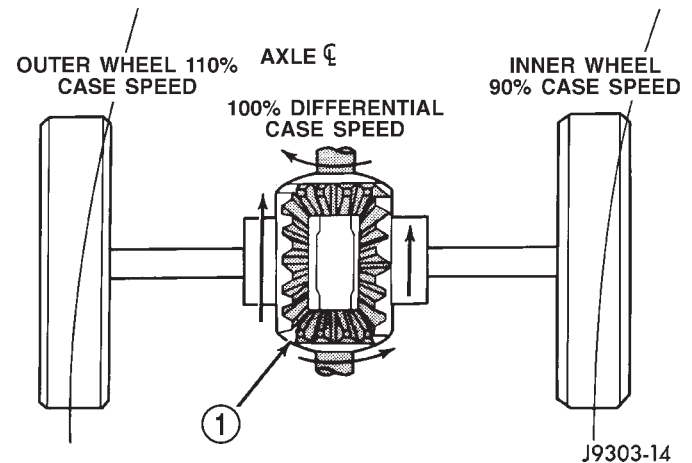
During straight-ahead driving, the differential pinion gears do not rotate on the pinion mate shaft. This occurs because input torque applied to the gears is divided and distributed equally between the two side gears. As a result, the pinion gears revolve with the pinion mate shaft but do not rotate around it (Fig. 2).



**Fig. 2 Differential Operation-Straight Ahead Driving**

- 1 - IN STRAIGHT AHEAD DRIVING EACH WHEEL ROTATES AT 100% OF CASE SPEED
- 2 - PINION GEAR
- 3 - SIDE GEAR
- 4 - PINION GEARS ROTATE WITH CASE

When turning corners, the outside wheel must travel a greater distance than the inside wheel to complete a turn. The difference must be compensated for to prevent the tires from scuffing and skidding through turns. To accomplish this, the differential allows the axle shafts to turn at unequal speeds (Fig. 3). In this instance, the input torque applied to the pinion gears is not divided equally. The pinion gears now rotate around the pinion mate shaft in opposite directions. This allows the side gear and axle shaft attached to the outside wheel to rotate at a faster speed.



**Fig. 3 Differential Operation-On Turns**

- 1 - PINION GEARS ROTATE ON PINION SHAFT

**DIAGNOSIS AND TESTING - AXLE**

**GEAR NOISE**

Axle gear noise can be caused by insufficient lubricant, incorrect backlash, tooth contact, worn/damaged gears or the carrier housing not having the proper offset and squareness.

Gear noise usually happens at a specific speed range. The noise can also occur during a specific type of driving condition. These conditions are acceleration, deceleration, coast, or constant load.

When road testing, first warm-up the axle fluid by driving the vehicle at least 5 miles and then accelerate the vehicle to the speed range where the noise is the greatest. Shift out-of-gear and coast through the peak-noise range. If the noise stops or changes greatly:

- Check for insufficient lubricant.
- Incorrect ring gear backlash.
- Gear damage.

Differential side gears and pinions can be checked by turning the vehicle. They usually do not cause noise during straight-ahead driving when the gears are unloaded. The side gears are loaded during vehi-

## FRONT AXLE - 248FBI (Continued)

cle turns. A worn pinion mate shaft can also cause a snapping or a knocking noise.

**BEARING NOISE**

The axle shaft, differential and pinion bearings can all produce noise when worn or damaged. Bearing noise can be either a whining, or a growling sound.

Pinion bearings have a constant-pitch noise. This noise changes only with vehicle speed. Pinion bearing noise will be higher pitched because it rotates at a faster rate. Drive the vehicle and load the differential. If bearing noise occurs, the rear pinion bearing is the source of the noise. If the bearing noise is heard during a coast, the front pinion bearing is the source.

Worn or damaged differential bearings usually produce a low pitch noise. Differential bearing noise is similar to pinion bearing noise. The pitch of differential bearing noise is also constant and varies only with vehicle speed.

Axle shaft bearings produce noise and vibration when worn or damaged. The noise generally changes when the bearings are loaded. Road test the vehicle. Turn the vehicle sharply to the left and to the right. This will load the bearings and change the noise level. Where axle bearing damage is slight, the noise is usually not noticeable at speeds above 30 mph.

**LOW SPEED KNOCK**

Low speed knock is generally caused by a worn U-joint or by worn side-gear thrust washers. A worn pinion shaft bore will also cause low speed knock.

**VIBRATION**

Vibration at the rear of the vehicle is usually caused by:

- Damaged drive shaft.

- Missing drive shaft balance weight(s).
- Worn or out of balance wheels.
- Loose wheel lug nuts.
- Worn U-joint(s).
- Loose/broken springs.
- Damaged axle shaft bearing(s).
- Loose pinion gear nut.
- Excessive pinion yoke run out.
- Bent axle shaft(s).

Check for loose or damaged front end components or engine/transmission mounts. These components can contribute to what appears to be a rear end vibration. Do not overlook engine accessories, brackets and drive belts.

All driveline components should be examined before starting any repair.

(Refer to 22 - TIRES/WHEELS - DIAGNOSIS AND TESTING)

**DRIVELINE SNAP**

A snap or clunk noise when the vehicle is shifted into gear (or the clutch engaged) can be caused by:

- High engine idle speed.
- Transmission shift operation.
- Loose engine/transmission/transfer case mounts.
- Worn U-joints.
- Loose spring mounts.
- Loose pinion gear nut and yoke.
- Excessive ring gear backlash.
- Excessive side gear to case clearance.

The source of a snap or a clunk noise can be determined with the assistance of a helper. Raise the vehicle on a hoist with the wheels free to rotate. Instruct the helper to shift the transmission into gear. Listen for the noise, a mechanics stethoscope is helpful in isolating the source of a noise.

## FRONT AXLE - 248FBI (Continued)

## DIAGNOSTIC CHART

Condition	Possible Causes	Correction
Wheel Noise	<ol style="list-style-type: none"> <li>1. Wheel loose.</li> <li>2. Faulty, brinelled wheel bearing.</li> </ol>	<ol style="list-style-type: none"> <li>1. Tighten loose nuts.</li> <li>2. Replace bearing.</li> </ol>
Axle Shaft Noise	<ol style="list-style-type: none"> <li>1. Misaligned axle tube.</li> <li>2. Bent or sprung axle shaft.</li> <li>3. End-play in pinion bearings.</li> <li>4. Excessive gear backlash between the ring gear and pinion.</li> <li>5. Improper adjustment of pinion gear bearings.</li> <li>6. Loose pinion yoke nut.</li> <li>7. Scuffed gear tooth contact surfaces.</li> </ol>	<ol style="list-style-type: none"> <li>1. Inspect axle tube alignment. Correct as necessary.</li> <li>2. Inspect and correct as necessary.</li> <li>3. Refer to pinion pre-load information and correct as necessary.</li> <li>4. Check adjustment of the ring gear and pinion backlash. Correct as necessary.</li> <li>5. Adjust the pinion bearings pre-load.</li> <li>6. Tighten the pinion yoke nut.</li> <li>7. Inspect and replace as necessary.</li> </ol>
Axle Shaft Broke	<ol style="list-style-type: none"> <li>1. Misaligned axle tube.</li> <li>2. Vehicle overloaded.</li> <li>3. Erratic clutch operation.</li> <li>4. Grabbing clutch.</li> </ol>	<ol style="list-style-type: none"> <li>1. Replace the broken shaft after correcting tube mis-alignment.</li> <li>2. Replace broken shaft and avoid excessive weight on vehicle.</li> <li>3. Replace broken shaft and avoid or correct erratic clutch operation.</li> <li>4. Replace broken shaft and inspect and repair clutch as necessary.</li> </ol>
Differential Cracked	<ol style="list-style-type: none"> <li>1. Improper adjustment of the differential bearings.</li> <li>2. Excessive ring gear backlash.</li> <li>3. Vehicle overloaded.</li> <li>4. Erratic clutch operation.</li> </ol>	<ol style="list-style-type: none"> <li>1. Replace case and inspect gears and bearings for further damage. Set differential bearing pre-load properly.</li> <li>2. Replace case and inspect gears and bearings for further damage. Set ring gear backlash properly.</li> <li>3. Replace case and inspect gears and bearings for further damage. Avoid excessive vehicle weight.</li> <li>4. Replace case and inspect gears and bearings for further damage. Avoid erratic use of clutch.</li> </ol>
Differential Gears Scored	<ol style="list-style-type: none"> <li>1. Insufficient lubrication.</li> <li>2. Improper grade of lubricant.</li> <li>3. Excessive spinning of one wheel/tire.</li> </ol>	<ol style="list-style-type: none"> <li>1. Replace scored gears. Fill differential with the correct fluid type and quantity.</li> <li>2. Replace scored gears. Fill differential with the correct fluid type and quantity.</li> <li>3. Replace scored gears. Inspect all gears, pinion bores, and shaft for damage. Service as necessary.</li> </ol>

## FRONT AXLE - 248FBI (Continued)

Condition	Possible Causes	Correction
Loss Of Lubricant	<ol style="list-style-type: none"> <li>1. Lubricant level too high.</li> <li>2. Worn axle shaft seals.</li> <li>3. Cracked differential housing.</li> <li>4. Worn pinion seal.</li> <li>5. Worn/scored yoke.</li> <li>6. Axle cover not properly sealed.</li> </ol>	<ol style="list-style-type: none"> <li>1. Drain lubricant to the correct level.</li> <li>2. Replace seals.</li> <li>3. Repair as necessary.</li> <li>4. Replace seal.</li> <li>5. Replace yoke and seal.</li> <li>6. Remove, clean, and re-seal cover.</li> </ol>
Axle Overheating	<ol style="list-style-type: none"> <li>1. Lubricant level low.</li> <li>2. Improper grade of lubricant.</li> <li>3. Bearing pre-loads too high.</li> <li>4. Insufficient ring gear backlash.</li> </ol>	<ol style="list-style-type: none"> <li>1. Fill differential to correct level.</li> <li>2. Fill differential with the correct fluid type and quantity.</li> <li>3. Re-adjust bearing pre-loads.</li> <li>4. Re-adjust ring gear backlash.</li> </ol>
Gear Teeth Broke	<ol style="list-style-type: none"> <li>1. Overloading.</li> <li>2. Erratic clutch operation.</li> <li>3. Ice-spotted pavement.</li> <li>4. Improper adjustments.</li> </ol>	<ol style="list-style-type: none"> <li>1. Replace gears. Examine other gears and bearings for possible damage.</li> <li>2. Replace gears and examine the remaining parts for damage. Avoid erratic clutch operation.</li> <li>3. Replace gears and examine remaining parts for damage.</li> <li>4. Replace gears and examine remaining parts for damage. Ensure ring gear backlash is correct.</li> </ol>
Axle Noise	<ol style="list-style-type: none"> <li>1. Insufficient lubricant.</li> <li>2. Improper ring gear and pinion adjustment.</li> <li>3. Unmatched ring gear and pinion.</li> <li>4. Worn teeth on ring gear and/or pinion.</li> <li>5. Loose pinion bearings.</li> <li>6. Loose differential bearings.</li> <li>7. Mis-aligned or sprung ring gear.</li> <li>8. Loose differential bearing cap bolts.</li> <li>9. Housing not machined properly.</li> </ol>	<ol style="list-style-type: none"> <li>1. Fill differential with the correct fluid type and quantity.</li> <li>2. Check ring gear and pinion contact pattern.</li> <li>3. Replace gears with a matched ring gear and pinion.</li> <li>4. Replace ring gear and pinion.</li> <li>5. Adjust pinion bearing pre-load.</li> <li>6. Adjust differential bearing pre-load.</li> <li>7. Measure ring gear run-out. Replace components as necessary.</li> <li>8. Inspect differential components and replace as necessary. Ensure that the bearing caps are torqued to the proper specification.</li> <li>9. Replace housing.</li> </ol>



## FRONT AXLE - 248FBI (Continued)

**REMOVAL**

- (1) Raise and support the vehicle.
- (2) Remove the wheels and tires.
- (3) Remove the brake calipers and rotors. Refer to Group 5, Brakes, for proper procedures.
- (4) Remove ABS wheel speed sensors, if equipped. Refer to Group 5, Brakes, for proper procedures.
- (5) Disconnect the axle vent hose.
- (6) Disconnect vacuum hose and electrical connector at disconnect housing.
- (7) Remove the front propeller shaft.
- (8) Disconnect the stabilizer bar links at the axle brackets.
- (9) Disconnect the shock absorbers from axle brackets.
- (10) Disconnect the track bar from the axle bracket.
- (11) Disconnect the tie rod and drag link from the steering knuckles.
- (12) Position the axle with a suitable lifting device under the axle assembly.
- (13) Secure axle to lifting device.
- (14) Mark suspension alignment cams for installation reference.
- (15) Disconnect the upper and lower suspension arms from the axle bracket.
- (16) Lower the axle. The coil springs will drop with the axle.
- (17) Remove the coil springs from the axle bracket.

**INSTALLATION**

**CAUTION:** Suspension components with rubber bushings should be tightened with the weight of the vehicle on the suspension, at normal height. If springs are not at their normal ride position, vehicle ride comfort could be affected and premature bushing wear may occur. Rubber bushings must never be lubricated.

- (1) Support the axle on a suitable lifting device.
- (2) Secure axle to lifting device.
- (3) Position the axle under the vehicle.
- (4) Install the springs, retainer clip and bolts.
- (5) Raise the axle and align it with the spring pads.
- (6) Position the upper and lower suspension arms in the axle brackets. Install bolts, nuts and align the suspension alignment cams to the reference marks. Do not tighten at this time.
- (7) Connect the track bar to the axle bracket and install the bolt. Do not tighten at this time.
- (8) Install the shock absorber and tighten bolts to 121 N·m (89 ft. lbs.) torque.

(9) Install the stabilizer bar link to the axle bracket. Tighten the nut to 37 N·m (27 ft. lbs.) torque.

(10) Install the drag link and tie rod to the steering knuckles and tighten the nuts to 88 N·m (65 ft. lbs.) torque.

(11) Install the ABS wheel speed sensors, if equipped. Refer to group 5, Brakes, for proper procedures.

(12) Install the brake calipers and rotors. Refer to Group 5, Brakes, for proper procedures.

(13) Connect the vent hose to the tube fitting.

(14) Connect vacuum hose and electrical connector to disconnect housing.

(15) Install front propeller shaft.

(16) Check and add differential lubricant, if necessary. Refer to Lubricant Specifications in this section for lubricant requirements.

(17) Install the wheel and tire assemblies.

(18) Remove the supports and lower the vehicle.

(19) Tighten the upper suspension arm nuts at axle to 121 N·m (89 ft. lbs.) torque. Tighten the upper suspension arm nuts at frame to 84 N·m (62 ft. lbs.) torque.

(20) Tighten the lower suspension arm nuts at axle to 84 N·m (62 ft. lbs.) torque. Tighten the lower suspension arm nuts at frame to 119 N·m (88 ft. lbs.) torque.

(21) Tighten the track bar bolt at the axle bracket to 176 N·m (130 ft. lbs.) torque.

(22) Check the front wheel alignment.

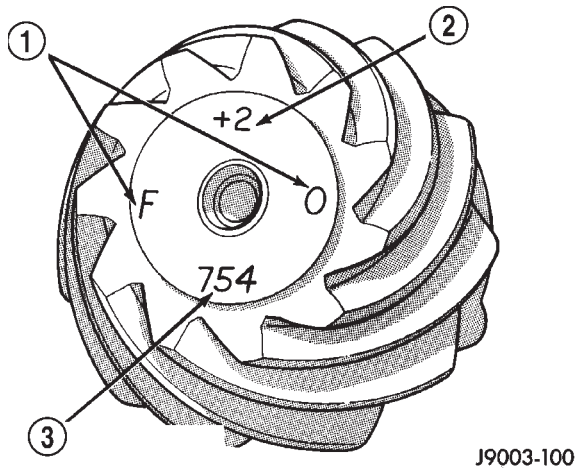
**ADJUSTMENTS**

Ring and pinion gears are supplied as matched sets only. The identifying numbers for the ring and pinion gear are etched into the face of each gear (Fig. 4). A plus (+) number, minus (-) number or zero (0) is etched into the face of the pinion gear. This number is the amount (in thousandths of an inch) the depth varies from the standard depth setting of a pinion etched with a (0). The standard setting from the center line of the ring gear to the back face of the pinion is 127 mm (5.00 in.). The standard depth provides the best gear tooth contact pattern. Refer to Backlash and Contact Pattern in this section for additional information.

Compensation for pinion depth variance is achieved with a select shim/oil baffle. The shims are placed between the rear pinion bearing and the pinion gear head (Fig. 5).

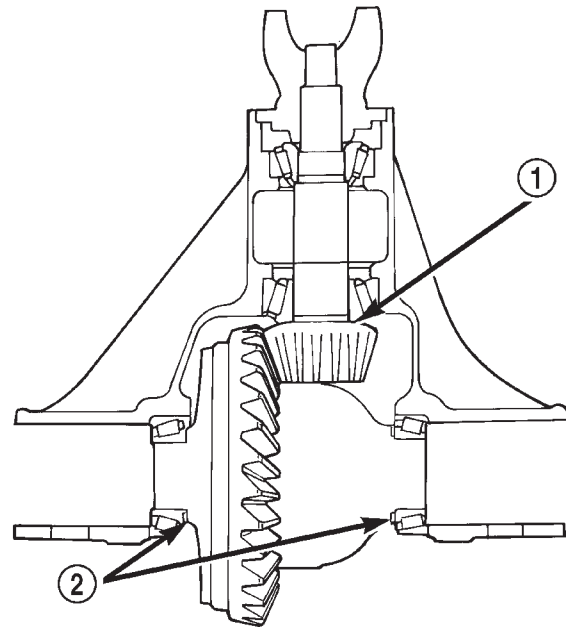
If a new gear set is being installed, note the depth variance etched into both the original and replacement pinion. Add or subtract this number from the thickness of the original depth shim/oil slinger to compensate for the difference in the depth variances. Refer to the Depth Variance chart.

## FRONT AXLE - 248FBI (Continued)



**Fig. 4 Pinion Gear ID Numbers**

- 1 - PRODUCTION NUMBERS
- 2 - PINION GEAR DEPTH VARIANCE
- 3 - GEAR MATCHING NUMBER



**Fig. 5 Adjustment Shim Locations**

- 1 - PINION GEAR DEPTH SHIM/OIL BAFFLE
- 2 - DIFFERENTIAL BEARING SHIM

80c07134

Note where Old and New Pinion Marking columns intersect. Intersecting figure represents plus or minus the amount needed.

Note the etched number on the face of the pinion gear head (-1, -2, 0, +1, +2, etc.). The numbers represent thousands of an inch deviation from the standard. If the number is negative, add that value to the required thickness of the depth shims. If the number

is positive, subtract that value from the thickness of the depth shim. If the number is 0 no change is necessary.

#### PINION GEAR DEPTH VARIANCE

Original Pinion Gear Depth Variance	Replacement Pinion Gear Depth Variance								
	-4	-3	-2	-1	0	+1	+2	+3	+4
+4	+0.008	+0.007	+0.006	+0.005	+0.004	+0.003	+0.002	+0.001	0
+3	+0.007	+0.006	+0.005	+0.004	+0.003	+0.002	+0.001	0	-0.001
+2	+0.006	+0.005	+0.004	+0.003	+0.002	+0.001	0	-0.001	-0.002
+1	+0.005	+0.004	+0.003	+0.002	+0.001	0	-0.001	-0.002	-0.003
0	+0.004	+0.003	+0.002	+0.001	0	-0.001	-0.002	-0.003	-0.004
-1	+0.003	+0.002	+0.001	0	-0.001	-0.002	-0.003	-0.004	-0.005
-2	+0.002	+0.001	0	-0.001	-0.002	-0.003	-0.004	-0.005	-0.006
-3	+0.001	0	-0.001	-0.002	-0.003	-0.004	-0.005	-0.006	-0.007
-4	0	-0.001	-0.002	-0.003	-0.004	-0.005	-0.006	-0.007	-0.008

#### PINION DEPTH MEASUREMENT AND ADJUSTMENT

Measurements are taken with pinion bearing cups and pinion bearings installed in the housing. Take measurements with Pinion Gauge Set and Dial Indicator C-3339 (Fig. 6).

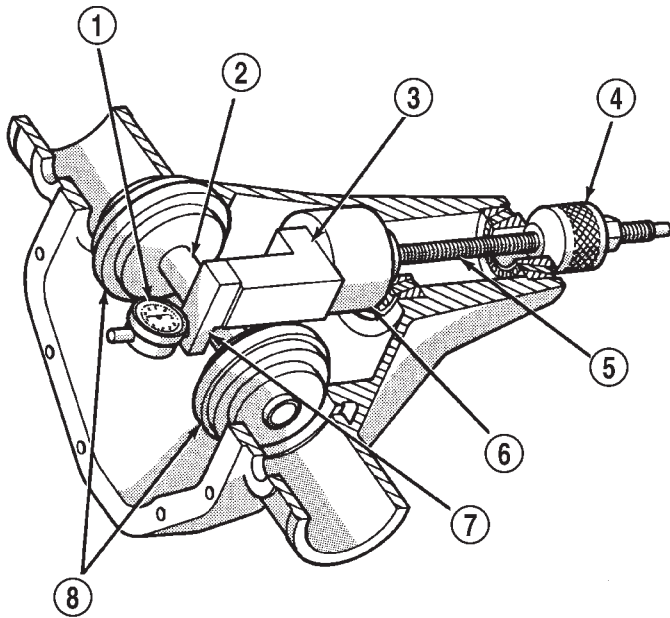
(1) Assemble Pinion Height Block 6739, Pinion Block 6736 and rear pinion bearing onto Screw 6741 (Fig. 6).

(2) Insert assembled height gauge components, rear bearing and screw into the housing through pinion bearing cups (Fig. 7).

(3) Install front pinion bearing and Cone-nut 6740 hand tight (Fig. 6).

(4) Place Arbor Disc 6732 on Arbor D-115-3 in position in the housing side bearing cradles (Fig. 8).

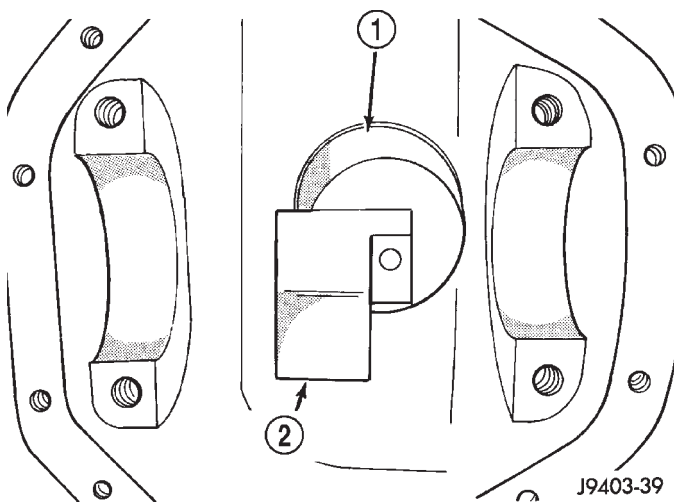
## FRONT AXLE - 248FBI (Continued)



J9403-45

**Fig. 6 Pinion Gear Depth Gauge Tools**

- 1 - DIAL INDICATOR
- 2 - ARBOR
- 3 - PINION HEIGHT BLOCK
- 4 - CONE
- 5 - SCREW
- 6 - PINION BLOCK
- 7 - SCOOTER BLOCK
- 8 - ARBOR DISC



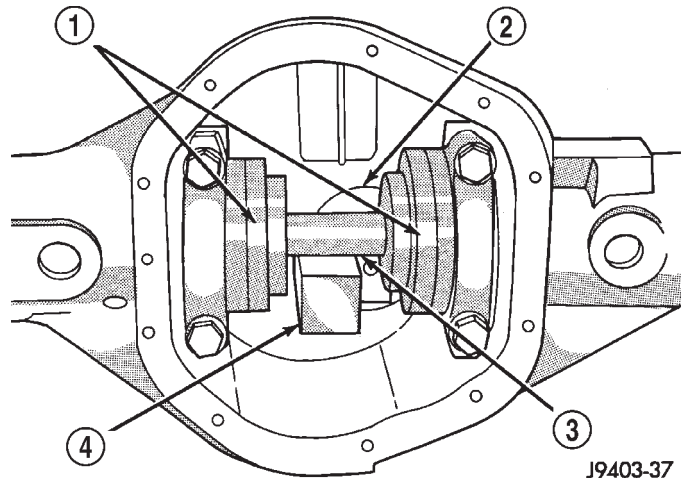
J9403-39

**Fig. 7 Pinion Height Block**

- 1 - PINION BLOCK
- 2 - PINION HEIGHT BLOCK

**NOTE:** Arbor Discs 6732 has different step diameters to fit other axles. Choose proper step for axle being serviced.

(5) Install differential bearing caps on arbor discs and snug the bearing cap bolts. Then cross tighten cap bolts to 108 N·m (80 ft. lbs.).



J9403-37

**Fig. 8 Gauge Tools In Housing**

- 1 - ARBOR DISC
- 2 - PINION BLOCK
- 3 - ARBOR
- 4 - PINION HEIGHT BLOCK

(6) Assemble Dial Indicator C-3339 into Scooter Block D-115-2 and secure set screw.

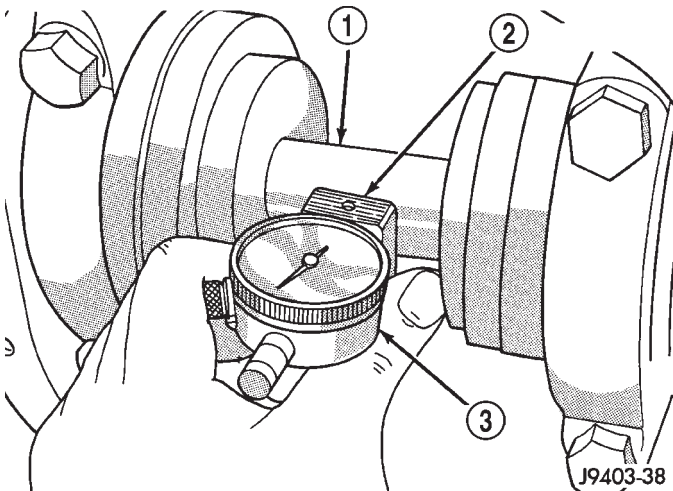
(7) Place Scooter Block/Dial Indicator in position in the housing so dial probe and scooter block are flush against the rearward surface of the pinion height block (Fig. 6). Hold scooter block in place and zero the dial indicator face to the pointer. Tighten dial indicator face lock screw.

(8) With scooter block still in position against the pinion height block, slowly slide the dial indicator probe over the edge of the pinion height block.

(9) Slide the dial indicator probe across the gap between the pinion height block and the arbor bar with the scooter block against the pinion height block (Fig. 9). When the dial probe contacts the arbor bar, the dial pointer will turn clockwise. Bring dial pointer back to zero against the arbor bar, do not turn dial face. Continue moving the dial probe to the crest of the arbor bar and record the highest reading. If the dial indicator can not achieve the zero reading, the rear bearing cup or the pinion depth gauge set is not installed correctly.

(10) Select a shim/oil baffle equal to the dial indicator reading plus the pinion depth variance number etched in the face of the pinion (Fig. 4). For example, if the depth variance is -2, add +0.002 in. to the dial indicator reading.

## FRONT AXLE - 248FBI (Continued)

**Fig. 9 Pinion Gear Depth Measurement**

- 1 - ARBOR
- 2 - SCOOTER BLOCK
- 3 - DIAL INDICATOR

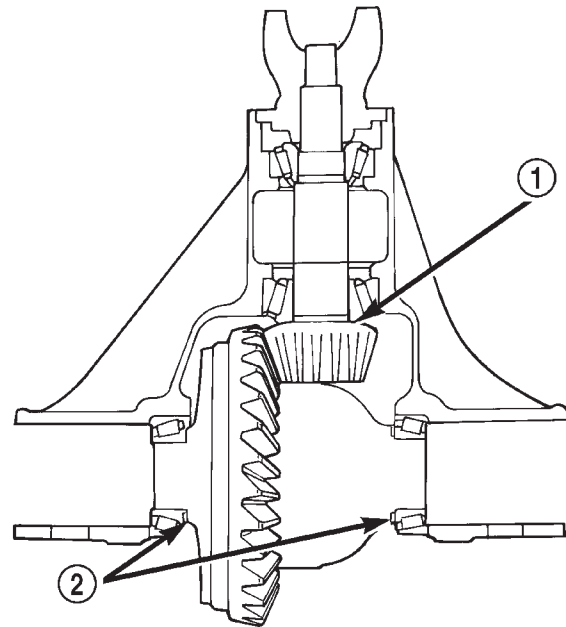
**DIFFERENTIAL SIDE BEARING PRELOAD AND GEAR BACKLASH**

Differential side bearing preload and gear backlash is achieved by selective shims positioned behind the differential side bearing cones. The proper shim thickness can be determined using slip-fit Dummy Bearings D-343 in place of the differential side bearings and a Dial Indicator C-3339. Before proceeding with the differential bearing preload and gear backlash measurements, measure the pinion gear depth and prepare the pinion for installation. Establishing proper pinion gear depth is essential to establishing gear backlash and tooth contact patterns. After the overall shim thickness to take up differential side play is measured, the pinion is installed, and the gear backlash shim thickness is measured. The overall shim thickness is the total of the dial indicator reading and the preload specification added together. The gear backlash measurement determines the thickness of the shim used on the ring gear side of the differential case. Subtract the gear backlash shim thickness from the total overall shim thickness and select that amount for the pinion gear side of the differential (Fig. 10). Differential shim measurements are performed with spreader W-129-B removed.

**SHIM SELECTION**

**NOTE:** It is difficult to salvage the differential side bearings during the removal procedure. Install replacement bearings if necessary.

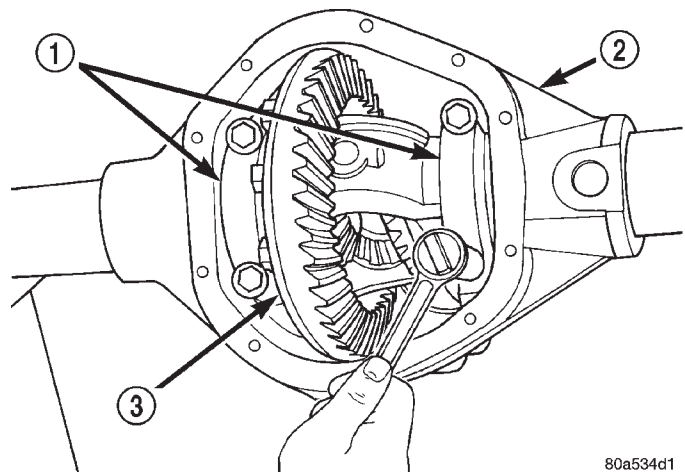
(1) Remove differential side bearings from differential case.

**Fig. 10 Adjustment Shim Locations**

- 1 - PINION GEAR DEPTH SHIM/OIL BAFFLE
- 2 - DIFFERENTIAL BEARING SHIM

80c07134

- (2) Remove factory installed shims from differential case.
- (3) Install ring gear on differential case and tighten bolts to specification.
- (4) Install dummy side bearings D-343 on differential case.
- (5) Install differential case in the housing.
- (6) Install the marked bearing caps in their correct positions and snug the bolts (Fig. 11).



80a534d1

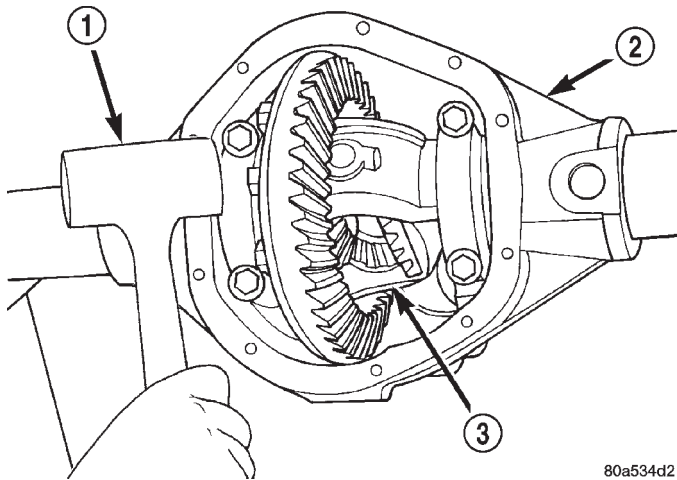
**Fig. 11 Bearing Cap Bolts**

- 1 - BEARING CAP
- 2 - DIFFERENTIAL HOUSING
- 3 - DIFFERENTIAL CASE



## FRONT AXLE - 248FBI (Continued)

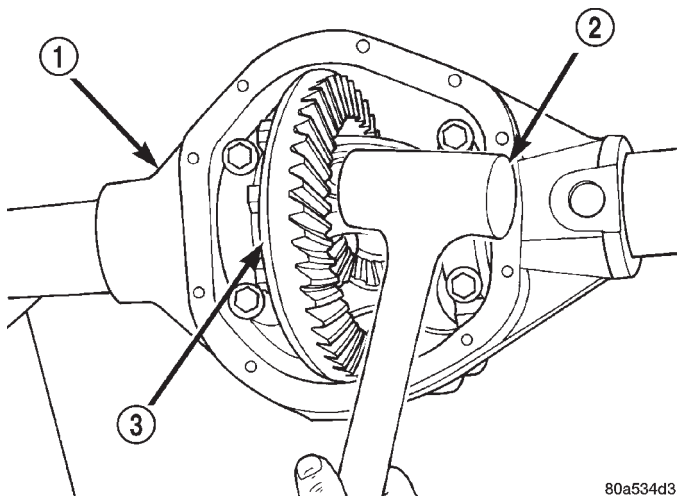
(7) Using a dead-blow hammer, seat the differential dummy bearings to each side of the housing (Fig. 12) and (Fig. 13).



80a534d2

**Fig. 12 Seat Pinion Gear Side Dummy Bearing**

- 1 - DEAD-BLOW HAMMER
- 2 - DIFFERENTIAL HOUSING
- 3 - DIFFERENTIAL CASE



80a534d3

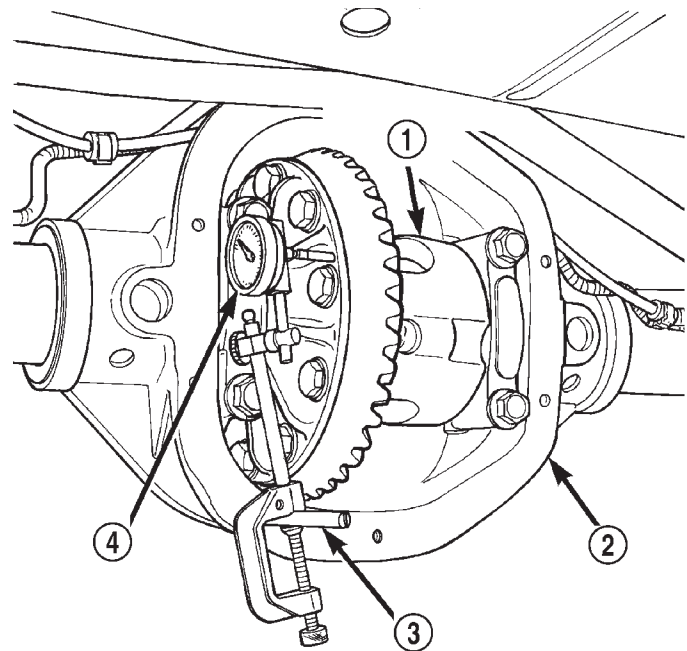
**Fig. 13 Seat Ring Gear Side Differential Dummy Bearing**

- 1 - DIFFERENTIAL HOUSING
- 2 - DEAD-BLOW HAMMER
- 3 - DIFFERENTIAL CASE

(8) Thread Pilot Stud C-3288-B into rear cover bolt hole below ring gear (Fig. 14).

(9) Attach the Dial Indicator C-3339 to pilot stud. Position the dial indicator plunger on a flat surface between the ring gear bolt heads (Fig. 14).

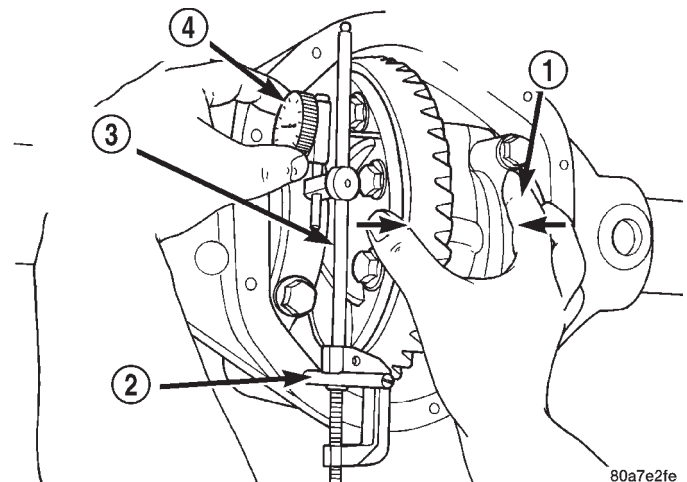
(10) Push and hold differential case to pinion gear side of the housing and zero dial indicator (Fig. 15).



80a7e2cf

**Fig. 14 Differential Side Play Measurement**

- 1 - DIFFERENTIAL CASE
- 2 - DIFFERENTIAL HOUSING
- 3 - PILOT STUD
- 4 - DIAL INDICATOR



80a7e2fe

**Fig. 15 Dial Indicator Location**

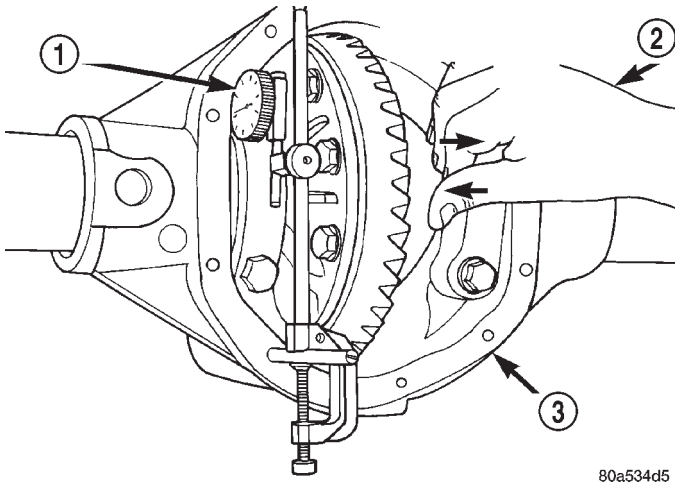
- 1 - DIFFERENTIAL CASE TO PINION GEAR SIDE
- 2 - PILOT STUD
- 3 - DIAL INDICATOR ARM
- 4 - DIAL INDICATOR FACE

(11) Push and hold differential case to ring gear side of the housing and record the dial indicator reading (Fig. 16).

(12) Add 0.38 mm (0.015 in.) to the zero end play total. This total represents the thickness of shims



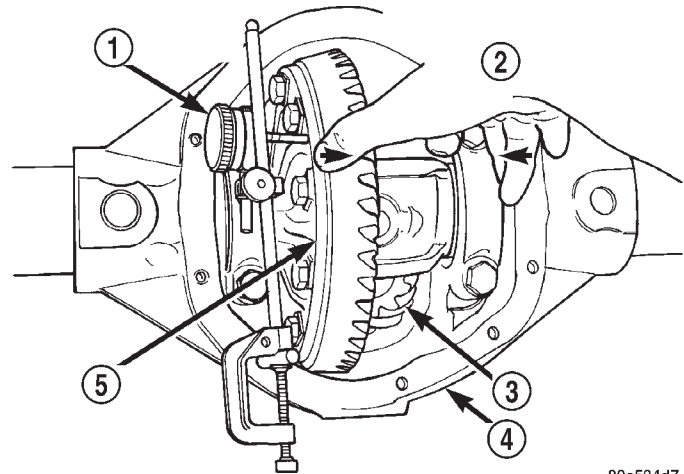
## FRONT AXLE - 248FBI (Continued)



80a534d5

**Fig. 16 Differential Case To Ring Gear Side**

- 1 - DIAL INDICATOR
- 2 - DIFFERENTIAL CASE TO RING GEAR SIDE
- 3 - DIFFERENTIAL HOUSING



80a534d7

**Fig. 17 Differential Case To Pinion Gear Side**

- 1 - DIAL INDICATOR FACE
- 2 - DIFFERENTIAL CASE TO PINION GEAR SIDE
- 3 - PINION GEAR
- 4 - DIFFERENTIAL HOUSING
- 5 - DIFFERENTIAL CASE

needed to preload the new bearings when the differential is installed.

(13) Rotate dial indicator out of the way on the pilot stud.

(14) Remove differential case and dummy bearings from the housing.

(15) Install the pinion gear in the housing. Install the pinion yoke and establish the correct pinion rotating torque.

(16) Install differential case and dummy bearings D-343 in the housing (without shims), install bearing caps and tighten bolts snug.

(17) Seat ring gear side dummy bearing (Fig. 13).

(18) Position the dial indicator plunger on a flat surface between the ring gear bolt heads (Fig. 14).

(19) Push and hold differential case toward pinion gear and zero the dial indicator (Fig. 17).

(20) Push and hold differential case to ring gear side of the housing and record dial indicator reading (Fig. 18).

(21) This is the shim thickness needed on the ring gear side of the differential case for proper backlash.

(22) Subtract the backlash shim thickness from the total preload shim thickness. The remainder is the shim thickness required on the pinion side of the housing.

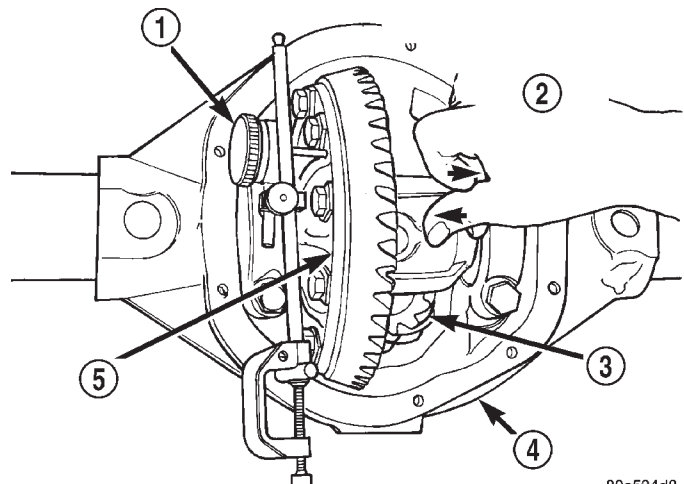
(23) Rotate dial indicator out of the way on pilot stud.

(24) Remove differential case and dummy bearings from the housing.

(25) Install the selected side bearing shims onto the differential case hubs.

(26) Install side bearings on differential case hubs with Install C-4487-1 and Handle C-4171.

(27) Install bearing cups on differential.



80a534d8

**Fig. 18 Differential Case To Ring Gear Side**

- 1 - DIAL INDICATOR
- 2 - DIFFERENTIAL CASE TO RING GEAR SIDE
- 3 - PINION GEAR
- 4 - DIFFERENTIAL HOUSING
- 5 - DIFFERENTIAL CASE

(28) Install Spreader W-129-B and some items from Adapter Set 6987 on the housing and spread open enough to receive differential case.

**CAUTION: Do not spread housing over 0.50 mm (0.020 in.). The housing can be damaged if over-spread.**

(29) Install differential case into the housing.

(30) Remove spreader from the housing.

## FRONT AXLE - 248FBI (Continued)

(31) Rotate the differential case several times to seat the side bearings.

(32) Position the indicator plunger against a ring gear tooth (Fig. 19).

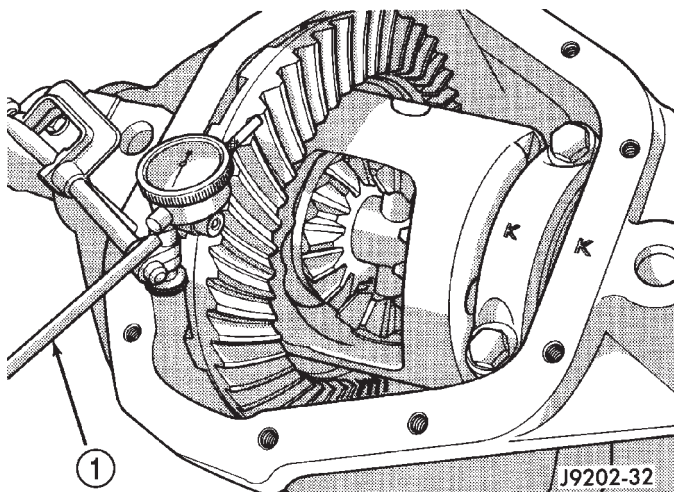
(33) Push and hold ring gear upward while not allowing the pinion gear to rotate.

(34) Zero dial indicator face to pointer.

(35) Push and hold ring gear downward while not allowing the pinion gear to rotate. Dial indicator reading should be between 0.12 mm (0.005 in.) and 0.20 mm (0.008 in.). If backlash is not within specifications transfer the necessary amount of shim thickness from one side of the housing to the other (Fig. 20).

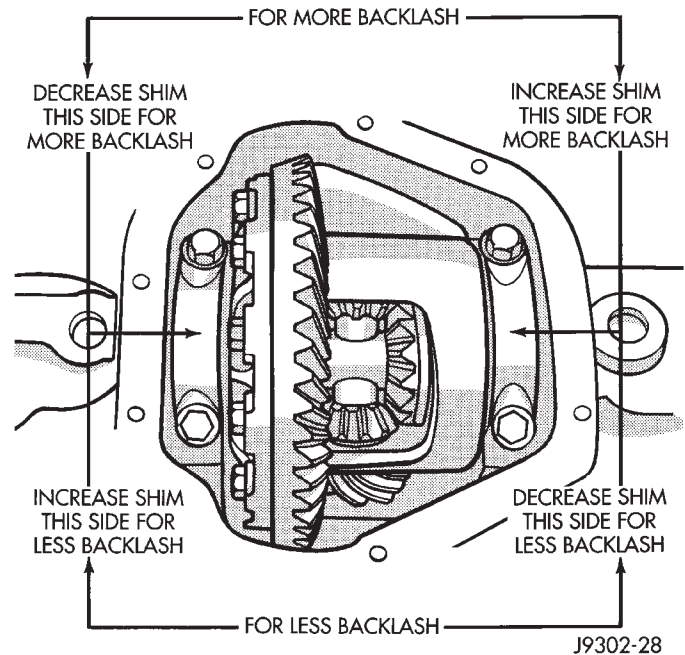
(36) Verify differential case and ring gear runout by measuring ring to pinion gear backlash at eight locations around the ring gear. Readings should not vary more than 0.05 mm (0.002 in.). If readings vary more than specified, the ring gear or the differential case is defective.

After the proper backlash is achieved, perform Gear Contact Pattern Analysis procedure.



**Fig. 19 Ring Gear Backlash Measurement**

1 - DIAL INDICATOR



**Fig. 20 Backlash Shim**

### GEAR CONTACT PATTERN

The ring and pinion gear contact patterns will show if the pinion depth is correct. It will also show if the ring gear backlash has been adjusted correctly. The backlash can be adjusted within specifications to achieve desired tooth contact patterns.

(1) Apply a thin coat of hydrated ferric oxide or equivalent to the drive and coast side of the ring gear teeth.

(2) Wrap, twist and hold a shop towel around the pinion yoke to increase the turning resistance of the pinion. This will provide a more distinct contact pattern.

(3) With a boxed end wrench on the ring gear bolt, rotate the differential case one complete revolution in both directions while a load is being applied from shop towel.

The areas on the ring gear teeth with the greatest degree of contact against the pinion teeth will squeeze the compound to the areas with the least amount of contact. Note and compare patterns on the ring gear teeth to Gear Tooth Contact Patterns chart (Fig. 21) and adjust pinion depth and gear backlash as necessary.

FRONT AXLE - 248FBI (Continued)

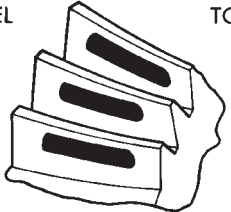
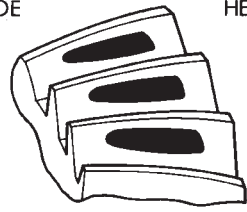

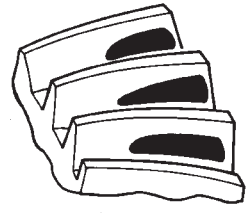
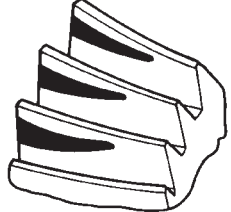
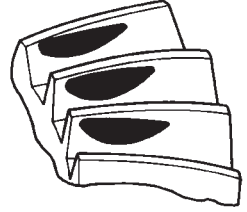
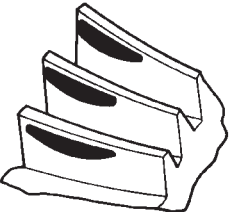
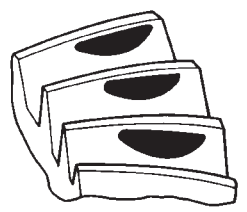
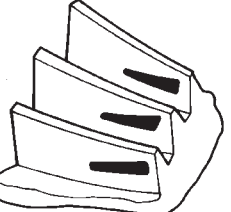
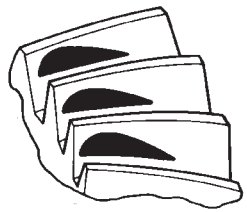
<p>DRIVE SIDE OF RING GEAR TEETH</p> <p>HEEL TOE</p> 	<p>COAST SIDE OF RING GEAR TEETH</p> <p>TOE HEEL</p> 	<p>DESIRABLE CONTACT PATTERN. PATTERN SHOULD BE CENTERED ON THE DRIVE SIDE OF TOOTH. PATTERN SHOULD BE CENTERED ON THE COAST SIDE OF TOOTH, BUT MAY BE SLIGHTLY TOWARD THE TOE. THERE SHOULD ALWAYS BE SOME CLEARANCE BETWEEN CONTACT PATTERN AND TOP OF THE TOOTH.</p>
		<p>RING GEAR BACKLASH CORRECT. <b>THINNER</b> PINION GEAR DEPTH SHIM REQUIRED.</p>
		<p>RING GEAR BACKLASH CORRECT. <b>THICKER</b> PINION GEAR DEPTH SHIM REQUIRED.</p>
		<p>PINION GEAR DEPTH SHIM CORRECT. <b>DECREASE</b> RING GEAR BACKLASH.</p>
		<p>PINION GEAR DEPTH SHIM CORRECT. <b>INCREASE</b> RING GEAR BACKLASH.</p>

Fig. 21 Gear Tooth Contact Patterns

FRONT AXLE - 248FBI (Continued)

SPECIFICATIONS

FRONT AXLE - 248FBI

AXLE SPECIFICATIONS

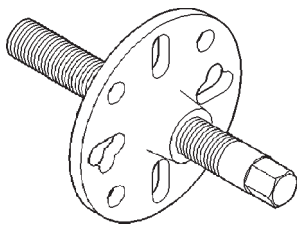
DESCRIPTION	SPECIFICATION
Axle Ratio	3.55, 4.10
Ring Gear Diameter	248 mm (9.75 in.)
Ring Gear Backlash	0.12-0.20 mm (0.005-0.008 in.)
Pinion Gear Standard Depth	127 mm (5.000 in.)
Pinion Bearing Preload - Original Bearing	1-2 N·m (10-20 in. lbs.)
Pinion Bearing Preload - New Bearing	1.7-4 N·m (15-35 in. lbs.)

TORQUE SPECIFICATIONS

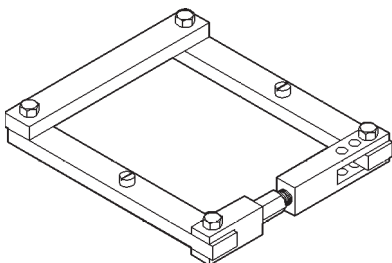
DESCRIPTION	N·m	Ft. Lbs.	In. Lbs.
Fill Hole Plug	34	25	-
Differential Cover Bolts	41	30	-
Bearing Cap Bolts	108	80	-
Ring Gear Bolts	176	130	-
Pinion Nut	292-678	215-496	-
Axle Nut	237	175	-
Shift Motor Bolts	11	8	96

SPECIAL TOOLS

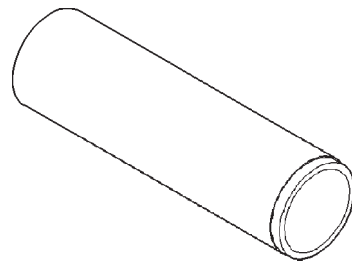
FRONT AXLE



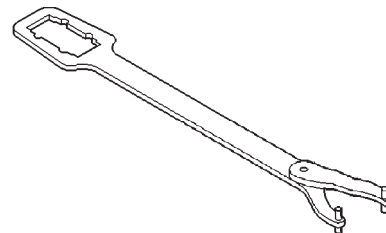
**REMOVER - C-452**



**SPREADER - W-129-B**

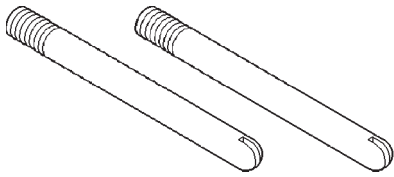


**INSTALLER, BEARING - C-3095-A**

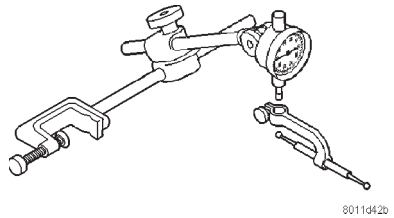


**WRENCH, FLANGE - C-3281**

FRONT AXLE - 248FBI (Continued)

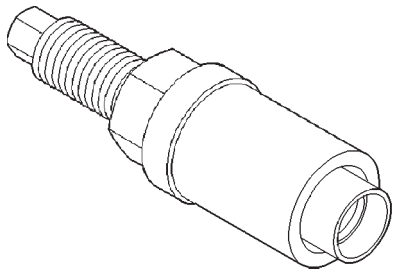


**PILOTS, STUDS - C-3288-B**

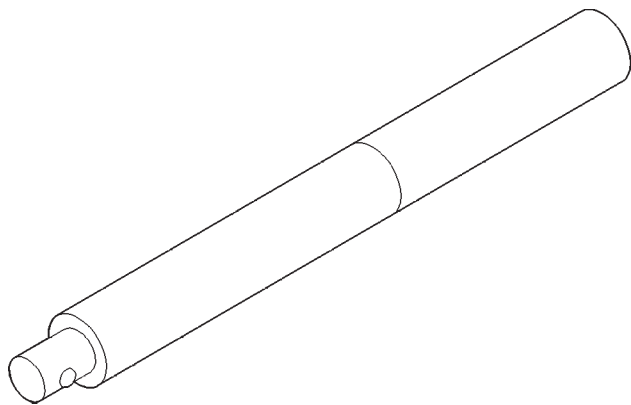


8011d42b

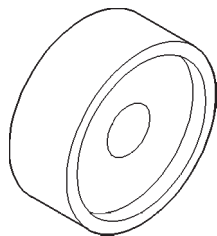
**DIAL INDICATOR, SET - C-3339**



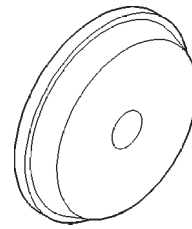
**INSTALLER, FLANGE - C-3718**



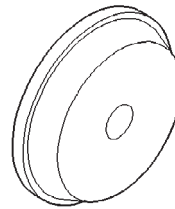
**HANDLE, DRIVE - C-4171**



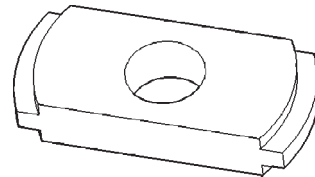
**INSTALLER, BEARING - C-4190**



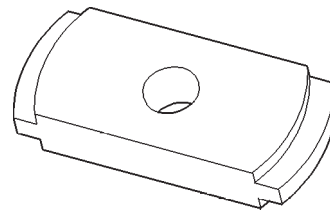
**INSTALLER, CUP - C-111**



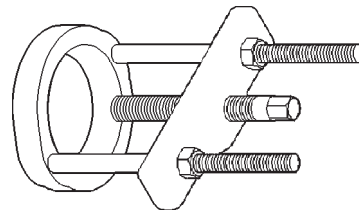
**INSTALLER, CUP - C-146**



**REMOVER, CUP - D-158**



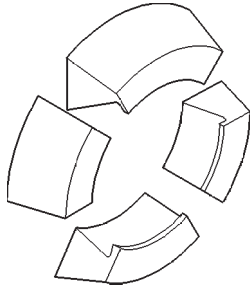
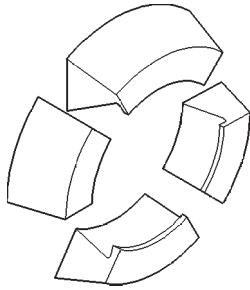
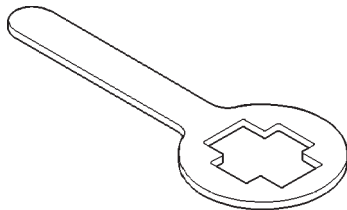
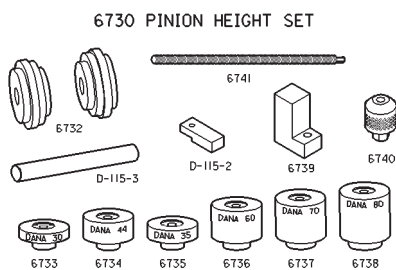
**REMOVER, CUP - D-162**



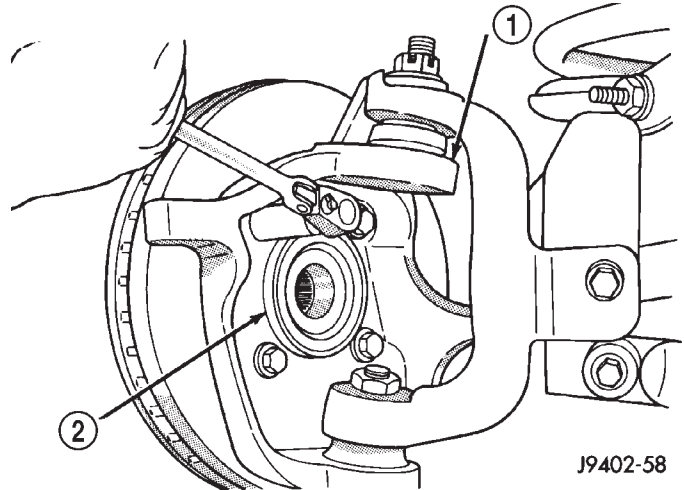
**PULLER/PRESS - C-293-PA**



## FRONT AXLE - 248FBI (Continued)

**BLOCK, ADAPTER – C-239-37****BLOCK, ADAPTER – C-239-62****HOLDER, YOKE - 6719A****PINION DEPTH, SET – 6730****AXLE SHAFTS****REMOVAL**

- (1) Raise and support the vehicle.
- (2) Remove wheel and tire assembly.
- (3) Remove brake caliper and rotor. Refer to Brakes for procedures.
- (4) Remove ABS wheel speed sensor if equipped. Refer to Brakes for procedures.
- (5) Remove the cotter pin and axle hub nut.
- (6) Remove hub bearing bolts (Fig. 22) and remove hub bearing from the steering knuckle.
- (7) Remove brake dust shield from knuckle.

**Fig. 22 Hub and Knuckle**

- 1 - KNUCKLE
- 2 - HUB BEARING

- (8) Remove axle shaft from the housing. Avoid damaging the axle shaft oil seal.

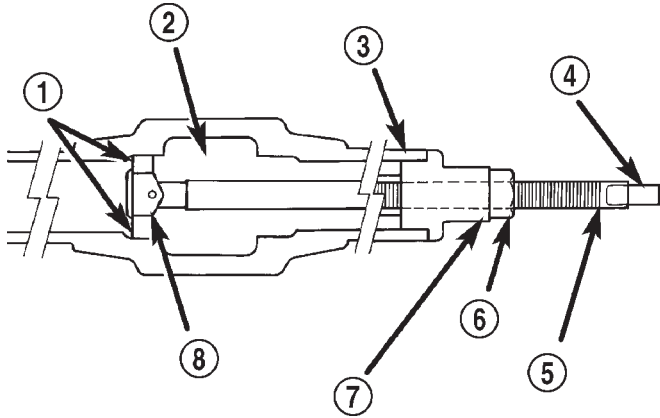
**INSTALLATION**

- (1) Clean axle shaft and apply a thin film of Mopar Wheel Bearing Grease to the shaft splines, seal contact surface, hub bore.
- (2) Install axle shaft into the housing and differential side gears. Avoid damaging axle shaft oil seals in the differential.
- (3) Install dust shield and hub bearing on knuckle.
- (4) Install hub bearing bolts and tighten to 170 N·m (125 ft. lbs.).
- (5) Install axle washer and nut, tighten nut to 237 N·m (175 ft. lbs.). Align nut to next cotter pin hole and install new cotter pin.
- (6) Install ABS wheel speed sensor, brake rotor and caliper. Refer to Brakes for proper procedures.
- (7) Install wheel and tire assembly.
- (8) Remove support and lower the vehicle.

**AXLE SHAFTS - INTERMEDIATE****REMOVAL - INTERMEDIATE AXLE**

- (1) Remove the vacuum shift motor housing.
- (2) Remove the outer axle shaft.
- (3) Remove the inner axle shaft seal from the shift motor housing with a long drift or punch. Be careful not to damage housing.
- (4) Remove intermediate axle shaft and shift collar.
- (5) Remove the intermediate axle shaft bushing (Fig. 23).

AXLE SHAFTS - INTERMEDIATE (Continued)

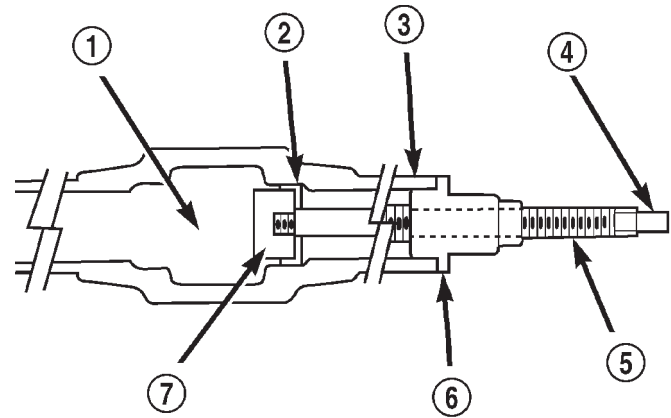


80c07137

**Fig. 23 Bushing Removal**

- 1 - BUSHING
- 2 - SHIFT MOTOR HOUSING OPENING
- 3 - AXLE TUBE
- 4 - LOCATION FOR OPEN-END WRENCH
- 5 - SPECIAL TOOL 5041-2
- 6 - NUT
- 7 - SPECIAL TOOL 8417
- 8 - SPECIAL TOOL 8415

(4) Install the inner axle seal (Fig. 25).



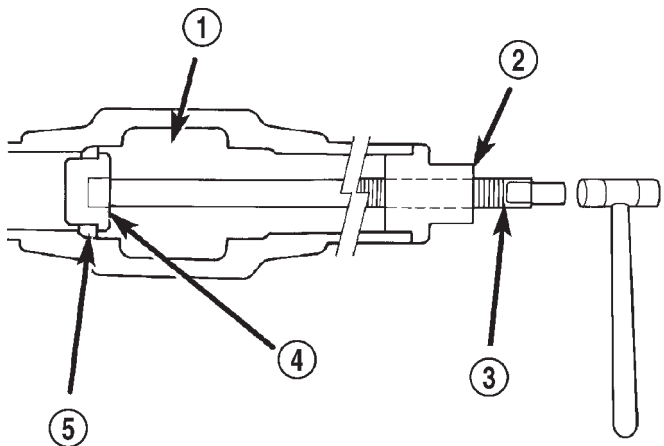
80c0712c

**Fig. 25 Seal Installation**

- 1 - SHIFT MOTOR HOUSING OPENING
- 2 - SEAL
- 3 - AXLE TUBE
- 4 - LOCATION FOR OPEN-END WRENCH
- 5 - SPECIAL TOOL 5041-2
- 6 - SPECIAL TOOL 8417
- 7 - SPECIAL TOOL 8411

**INSTALLATION - INTERMEDIATE AXLE**

(1) Position the bushing on installation tool and seat the bushing (Fig. 24) in the housing bore.



80c07136

**Fig. 24 Bushing Installation**

- 1 - SHIFT MOTOR HOUSING OPENING
- 2 - SPECIAL TOOL 5417
- 3 - SPECIAL TOOL 5041-2
- 4 - SPECIAL TOOL 8416
- 5 - BUSHING

(2) Clean the inside perimeter of the axle shaft tube with fine crocus cloth.

(3) Apply a light film of oil to the inside lip of the new axle shaft seal.

- (5) Install the shift collar in the axle housing.
- (6) Lubricate the splined end of the intermediate axle shaft with multi-purpose lubricant.
- (7) Insert the intermediate axle shaft into the differential side gear.

**CAUTION:** Apply all-purpose lubricant to the axle shaft splines to prevent damage to the seal during axle shaft installation.

(8) Insert the axle shaft into the tube. Engage the splined end of the shaft with the shift collar.

(9) Install the vacuum shift motor housing.

**AXLE SHAFT SEALS**

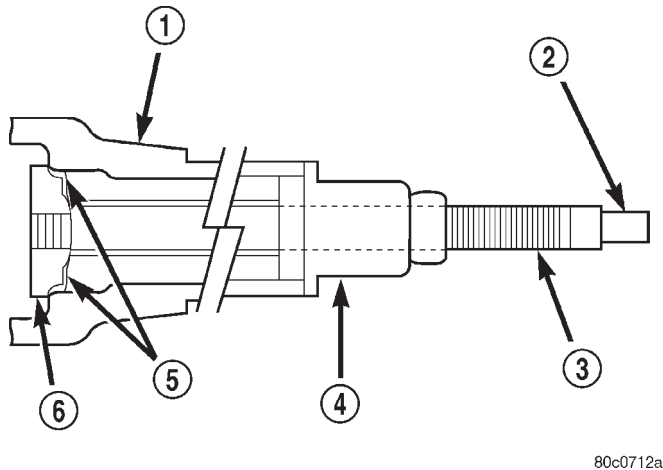
**REMOVAL**

- (1) Remove hub bearings and axle shafts.
- (2) Remove axle shaft seal from the differential housing with a long drift or punch. **Be careful not to damage housing.**
- (3) Clean the inside perimeter of the differential housing with fine crocus cloth.

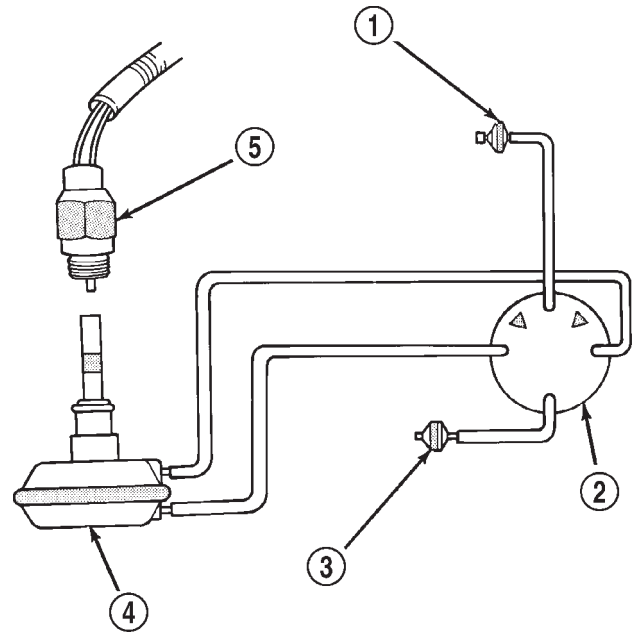
**INSTALLATION**

- (1) Apply a light film of oil to the inside lip of the new axle shaft seal.
- (2) Install the inner axle seal (Fig. 26).
- (3) Install axles and hub bearings.

## AXLE SHAFT SEALS (Continued)

**Fig. 26 Seal Installation**

- 1 - DIFFERENTIAL HOUSING
- 2 - POSITION FOR OPEN-END WRENCH
- 3 - SPECIAL TOOL 5041-2
- 4 - SPECIAL TOOL 8417
- 5 - SEAL
- 6 - SPECIAL TOOL 8411

**Fig. 27 Vacuum Control System**

- 1 - CHECK VALVE
- 2 - CONTROL SWITCH ON TRANSFER CASE
- 3 - AIR VENT FILTER
- 4 - AXLE SHIFT MOTOR
- 5 - INDICATOR SWITCH

## AXLE VACUUM MOTOR

## DESCRIPTION

The disconnect axle control system consists of:

- Shift motor.
- Indicator switch.
- Vacuum switch.
- Vacuum harness (Fig. 27).

## OPERATION

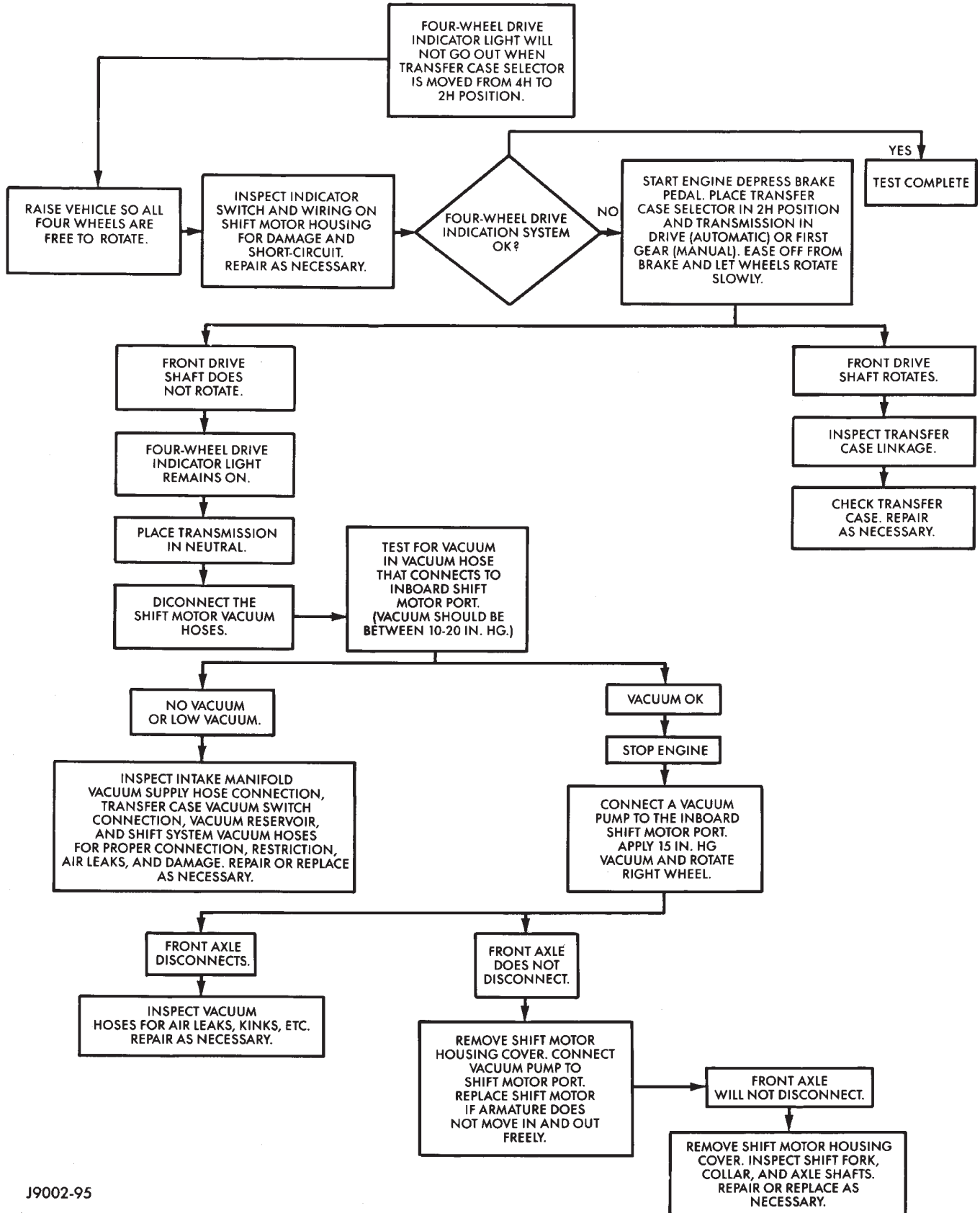
The shift motor receives a vacuum signal from the switch mounted on the transfer case when the vehicle operator wants to switch from two wheel drive mode to four wheel drive mode, or vice versa. When

this signal is received, the shift motor begins to move the shift fork and collar within the axle housing. In the four wheel drive mode, the shift collar connects the axle intermediate shaft to the axle shaft to supply engine power to both front wheels. In two wheel drive mode, the shift collar is disengaged from the intermediate shaft and the intermediate shaft is allowed to free-spin. When the two shafts are disengaged, the load on the engine is reduced, thereby providing better fuel economy and road handling.

AXLE VACUUM MOTOR (Continued)

DIAGNOSIS AND TESTING - VACUUM MOTOR

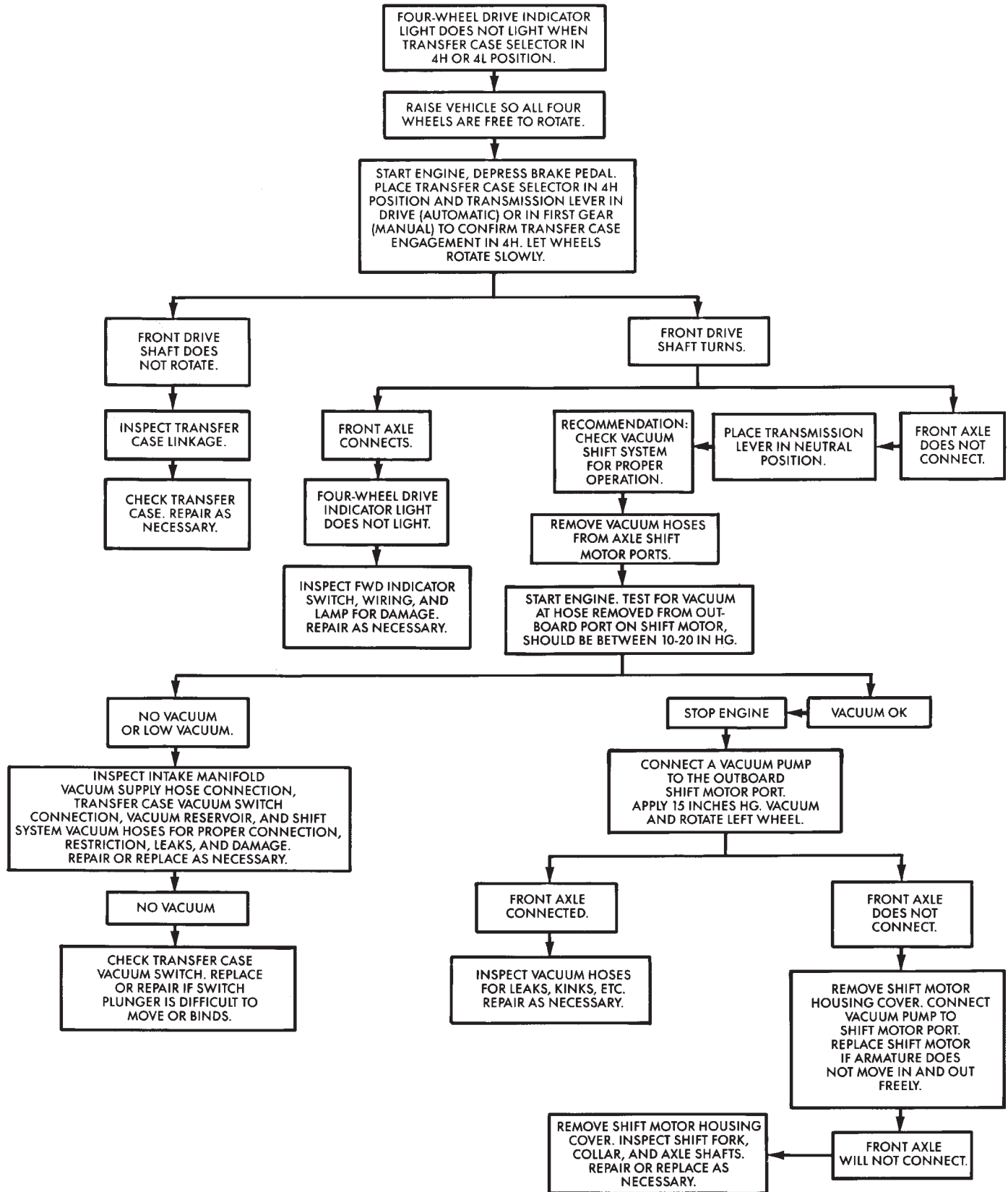
AXLE VACUUM SHIFT MOTOR  
TWO-WHEEL DRIVE OPERATION DIAGNOSIS



AXLE VACUUM MOTOR (Continued)

AXLE VACUUM SHIFT MOTOR (CONT'D)

**FOUR-WHEEL DRIVE OPERATION DIAGNOSIS**





## AXLE VACUUM MOTOR (Continued)

## REMOVAL

- (1) Disconnect the vacuum and wiring connector from the shift housing.
- (2) Remove indicator switch.
- (3) Remove shift motor housing cover, gasket and shield from the housing (Fig. 28).

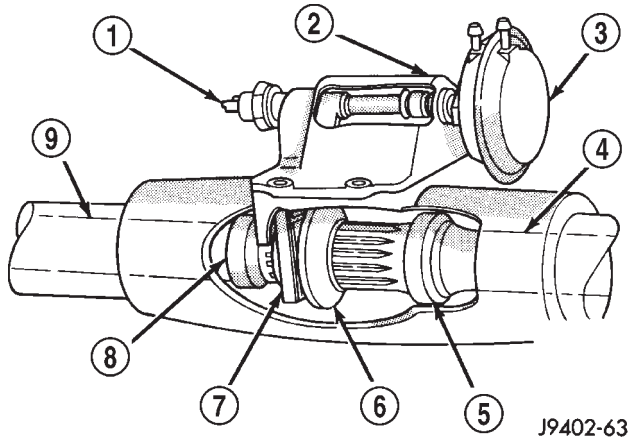


Fig. 28 Shift Motor Housing

- 1 - INDICATOR LAMP SWITCH
- 2 - DISCONNECT HOUSING
- 3 - VACUUM SHIFT MOTOR
- 4 - AXLE SHAFT
- 5 - SEAL
- 6 - SHIFT COLLAR
- 7 - SHIFT FORK
- 8 - BEARING
- 9 - INTERMEDIATE AXLE SHAFT

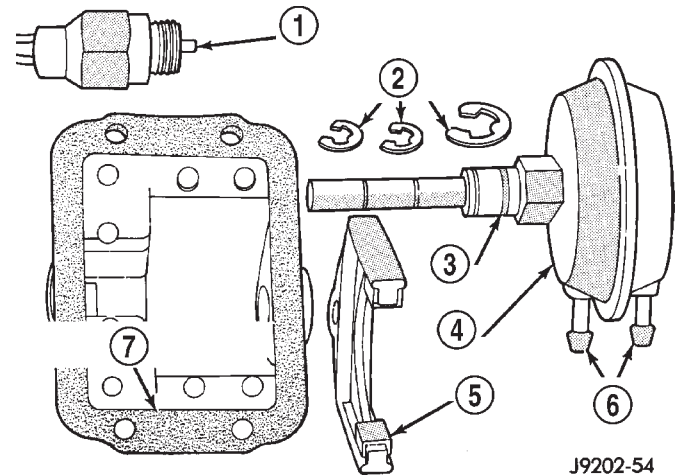


Fig. 29 Shift Motor Components

- 1 - INDICATOR SWITCH
- 2 - E-CLIP
- 3 - O-RING
- 4 - SHIFT MOTOR
- 5 - SHIFT FORK
- 6 - VACUUM PORTS
- 7 - DISCONNECT HOUSING AND GASKET

(3) Add 148 ml (5 ounces) of API grade GL 5 hypoid gear lubricant to the shift motor housing. Add lubricant through indicator switch mounting hole.

(4) Install indicator switch, electrical connector and vacuum harness.

## DISASSEMBLY

- (1) Remove E-clips from the shift motor housing and shaft. Remove shift motor and shift fork from the housing (Fig. 29).
- (2) Remove O-ring seal from the shift motor shaft.
- (3) Clean and inspect all components. Replace any component that is excessively worn or damaged.

## ASSEMBLY

- (1) Install a new O-ring seal on the shift motor shaft.
- (2) Insert shift motor shaft through the hole in the housing and shift fork. The shift fork offset should be toward the differential.
- (3) Install E-clips on the shift motor shaft and housing.

## INSTALLATION

- (1) Install shift motor housing gasket and cover. Ensure shift fork is correctly guided into the shift collar groove.
- (2) Install shift motor housing shield and tighten the bolts to 11 N·m (96 in. lbs.).

## SINGLE CARDAN UNIVERSAL JOINTS

## REMOVAL

Single cardan U-joint components are not serviceable. If defective they must be replaced as a unit.

**CAUTION:** Clamp only the narrow forged portion of the yoke in the vise. To avoid distorting the yoke, do not over tighten the vise jaws.

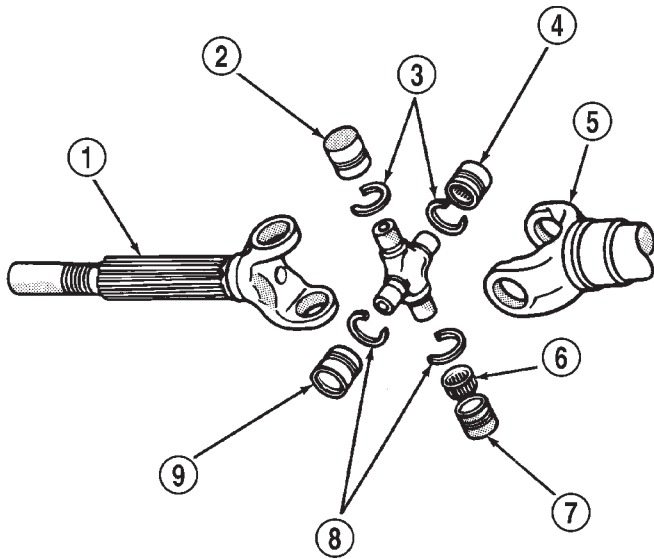
- (1) Remove axle shaft.
- (2) Remove the bearing cap retaining snap rings (Fig. 30).

**NOTE:** Saturate the bearing caps with penetrating oil prior to removal.

(3) Locate a socket with an inside diameter is larger than the bearing cap. Place the socket (receiver) against the yoke and around the perimeter of the bearing cap to be removed.

(4) Locate a socket with an outside diameter is smaller than the bearing cap. Place the socket (driver) against the opposite bearing cap.

## SINGLE CARDAN UNIVERSAL JOINTS (Continued)



J8902-15

**Fig. 30 Axle Shaft Outer U—Joint**

- 1 - SHAFT YOKE
- 2 - BEARING CAP
- 3 - SNAP RINGS
- 4 - BEARING CAP
- 5 - SPINDLE YOKE
- 6 - BEARING
- 7 - BEARING CAP
- 8 - SNAP RINGS
- 9 - BEARING CAP

(5) Position the yoke with the sockets in a vise (Fig. 31).

(6) Tighten the vise jaws to force the bearing cap into the larger socket (receiver).

(7) Release the vise jaws. Remove the sockets and bearing cap that was partially forced out of the yoke.

(8) Repeat the above procedure for the remaining bearing cap and remove spider from the propeller shaft yoke.

**INSTALLATION**

(1) Pack the bearing caps 1/3 full of wheel bearing lubricant. Apply extreme pressure (EP), lithium-base lubricant to aid in installation.

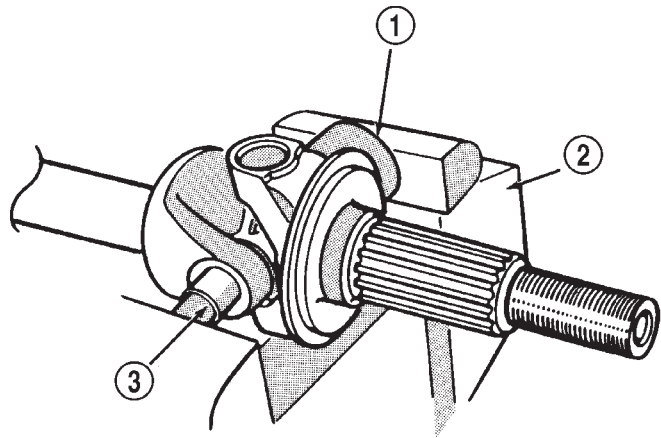
(2) Position the spider in the yoke. Insert the seals and bearings. Tap the bearing caps into the yoke bores far enough to hold the spider in position.

(3) Place the socket (driver) against one bearing cap. Position the yoke with the socket in a vise.

(4) Tighten the vise to force the bearing caps into the yoke. Force the caps enough to install the retaining clips.

(5) Install the bearing cap retaining clips.

(6) Install axle shaft.



J8902-16

**Fig. 31 Yoke Bearing Cap**

- 1 - LARGE-DIAMETER SOCKET WRENCH
- 2 - VISE
- 3 - SMALL-DIAMETER SOCKET WRENCH

**PINION SEAL****REMOVAL**

(1) Raise and support the vehicle.

(2) Remove wheel and tire assemblies.

(3) Remove brake calipers and rotors

(4) Mark the propeller shaft and pinion yoke for installation reference.

(5) Remove the propeller shaft from the yoke.

(6) Rotate the pinion gear three or four times.

(7) Measure the amount of torque necessary to rotate the pinion gear with a (in. lbs.) dial-type torque wrench. Record the torque reading for installation reference.

(8) Remove the pinion yoke nut and washer. Use Remover C-452 and Wrench C-3281 to remove the pinion yoke (Fig. 32).

(9) Use suitable pry tool or slide hammer mounted screw to remove the pinion shaft seal.

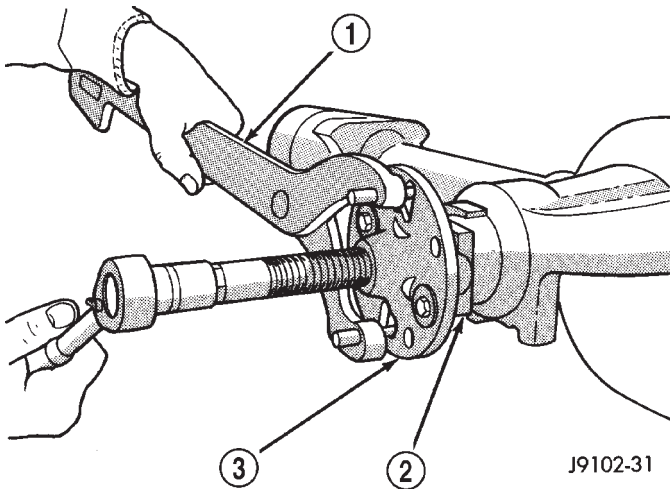
**INSTALLATION**

(1) Apply a light coating of gear lubricant on the lip of pinion seal. Install seal with an appropriate installer (Fig. 33).

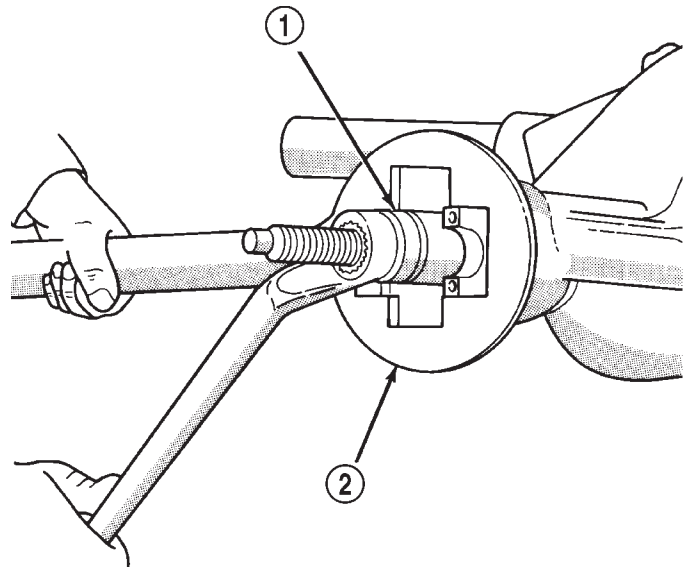
(2) Install yoke on the pinion gear with Installer C-3718 and Holder 6719 (Fig. 34).

**CAUTION:** Do not exceed the minimum tightening torque when installing the pinion yoke retaining nut. Damage to collapsible spacer or bearings may result.

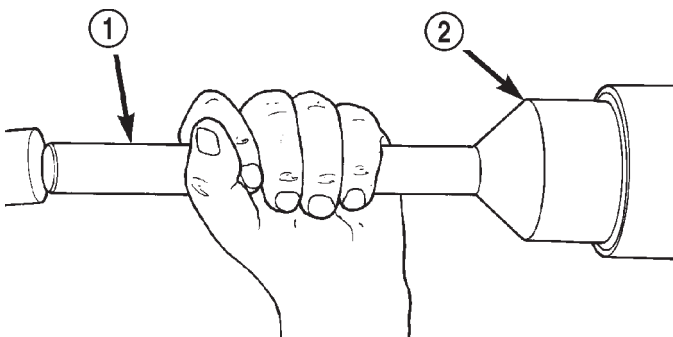
## PINION SEAL (Continued)

**Fig. 32 Pinion**

- 1 - YOKE HOLDER  
2 - YOKE  
3 - YOKE PULLER

**Fig. 34 Install Pinion Yoke**

- 1 - YOKE INSTALLER  
2 - YOKE HOLDER

**Fig. 33 Pinion Seal Installation**

- 1 - SPECIAL TOOL C—4171  
2 - SPECIAL TOOL C—8108

(3) Install a new nut on the pinion gear. Tighten the nut only enough to remove the shaft end play.

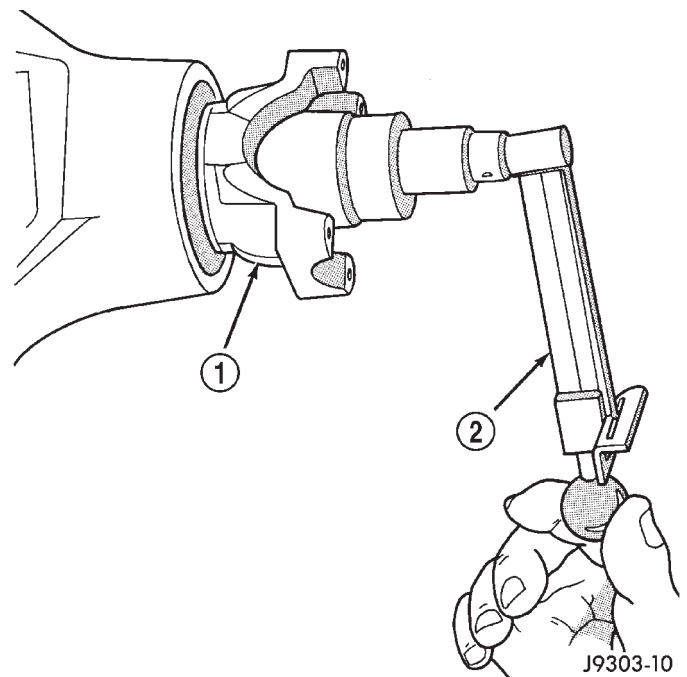
(4) Rotate the pinion shaft using an inch pound torque wrench. Rotating torque should be equal to the reading recorded during removal, plus an additional 0.56 N·m (5 in. lbs.) (Fig. 35).

(5) If the rotating torque is too low, use Holder 6719 to hold the pinion yoke (Fig. 36), and tighten the pinion shaft nut in 6.8 N·m (5 ft. lbs.) until proper rotating torque is achieved.

(6) Align the installation reference marks and attach the propeller shaft to the yoke.

(7) Check and add lubricant to axle, if necessary. Refer to Lubricant Specifications in this section for lubricant requirements.

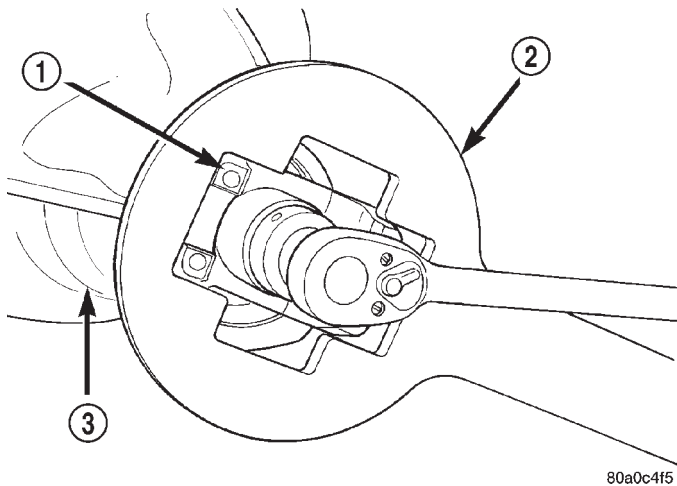
(8) Install brake rotors and calipers.

**Fig. 35 Check Pinion Rotation**

- 1 - PINION YOKE  
2 - INCH POUND TORQUE WRENCH

- (9) Install wheel and tire assemblies.  
(10) Lower the vehicle.

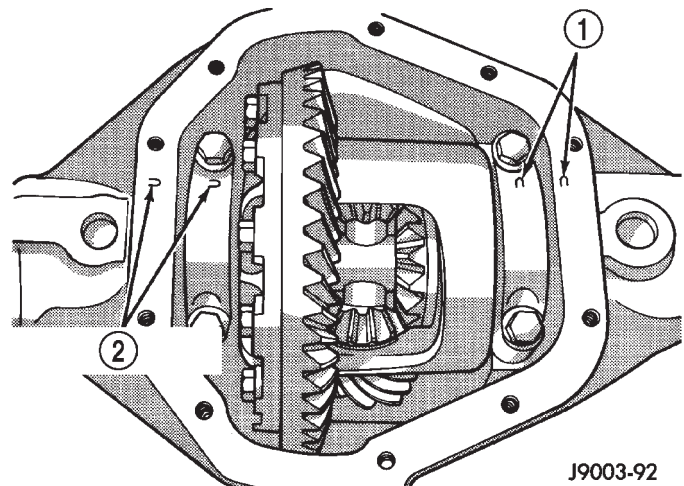
## PINION SEAL (Continued)



80a0c4f5

**Fig. 36 Tightening Pinion Shaft Nut**

- 1 - PINION FLANGE
- 2 - HOLDING TOOL 6719
- 3 - AXLE HOUSING



J9003-92

**Fig. 37 Bearing Cap Reference**

- 1 - REFERENCE LETTERS
- 2 - REFERENCE LETTERS

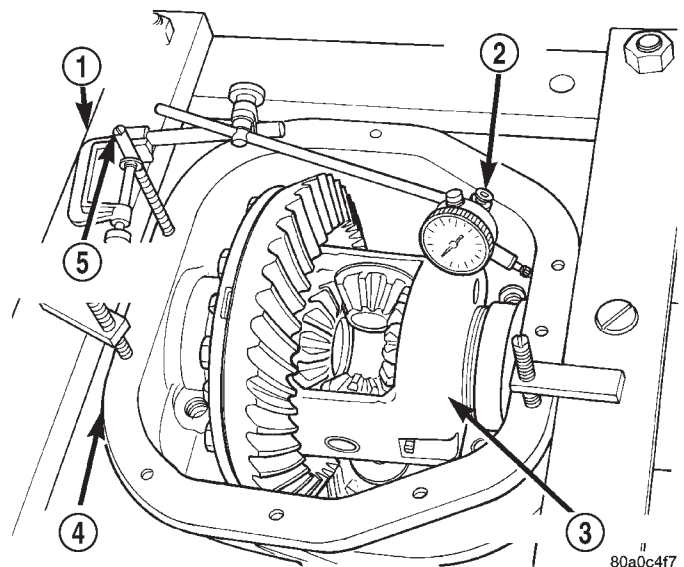
## DIFFERENTIAL

## REMOVAL

- (1) Raise and support vehicle.
- (2) Remove lubricant fill hole plug from the differential housing cover.
- (3) Remove differential housing cover and drain the lubricant from the housing.
- (4) Clean the housing cavity with a flushing oil, light engine oil or lint free cloth. **Do not use water, steam, kerosene or gasoline for cleaning.**
- (5) Remove hub bearings and axle shafts.
- (6) Note the installation reference letters stamped on the bearing caps and housing machined sealing surface (Fig. 37).
- (7) Remove the differential bearing caps.
- (8) Position Spreader W-129-B with the tool dowel pins seated in the locating holes (Fig. 38).
- (9) Install the hold down clamps and tighten the spreader turnbuckle finger-tight.
- (10) Install Pilot Stud C-3288-B to the left side of the differential housing and attach dial indicator to the pilot stud. Load the indicator plunger against the opposite side of the housing (Fig. 38) and zero the dial indicator.
- (11) Spread the housing enough to remove the case from the housing. Measure the distance with the dial indicator (Fig. 38).

**CAUTION:** Do not spread over 0.50 mm (0.020 in). If the housing is over-spread it could be distorted or damaged.

- (12) Remove the dial indicator.



80a0c4f7

**Fig. 38 Spread Differential Housing**

- 1 - HOUSING SPREADER W-129B
- 2 - DIAL INDICATOR C-3339
- 3 - DIFFERENTIAL
- 4 - AXLE HOUSING
- 5 - GUIDE PIN C-3288-B

- (13) Pry the differential case loose from the housing. To prevent damage, pivot on housing with the end of the pry bar against spreader (Fig. 39).

- (14) Remove the case from housing.

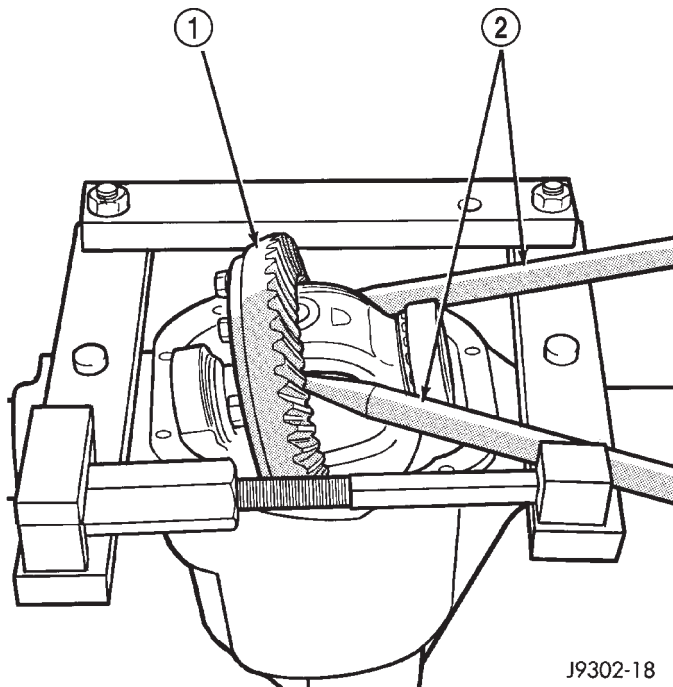
- (15) Remove and tag bearing cups to indicate their original location.

## DISASSEMBLY

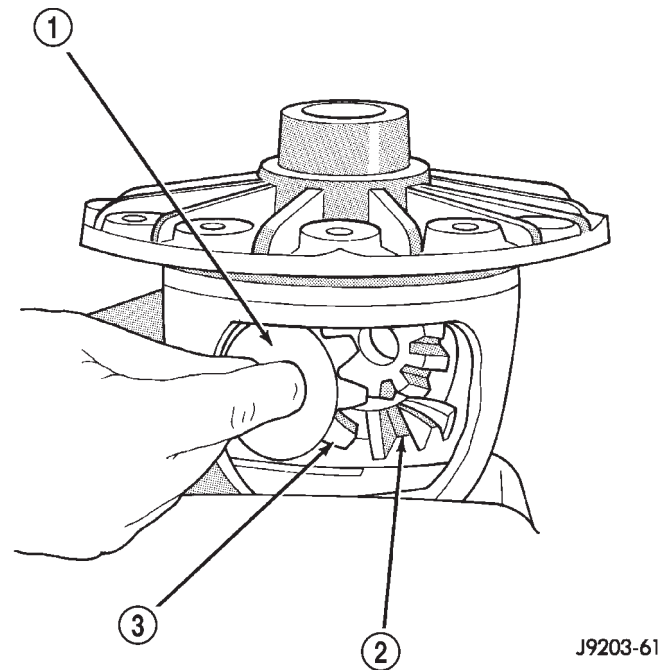
- (1) Remove roll-pin holding mate shaft in housing.
- (2) Remove pinion gear mate shaft (Fig. 40).



## DIFFERENTIAL (Continued)

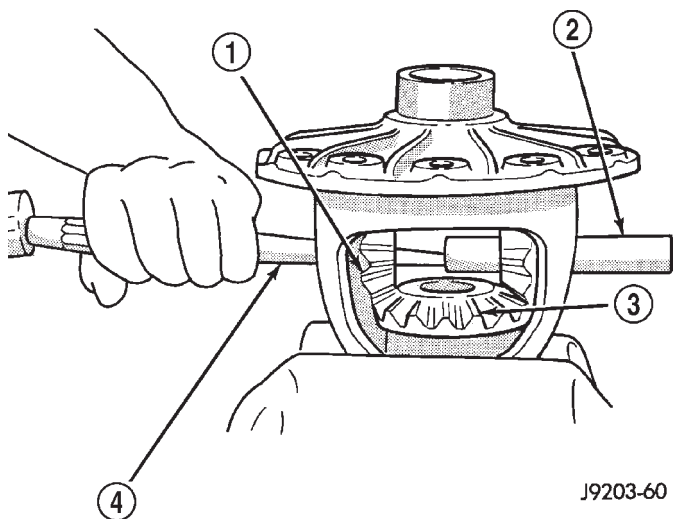
**Fig. 39 Differential Removal**

- 1 - DIFFERENTIAL
- 2 - PRY BAR

**Fig. 41 Pinion Mate/Side Gear**

- 1 - THRUST WASHER
- 2 - SIDE GEAR
- 3 - PINION MATE GEAR

(3) Rotate the differential side gears and remove the pinion mate gears and thrust washers (Fig. 41).

**Fig. 40 Pinion Mate Shaft**

- 1 - PINION MATE GEAR
- 2 - PINION MATE SHAFT
- 3 - SIDE GEAR
- 4 - DRIFT

(4) Remove the differential side gears and thrust washers.

**ASSEMBLY**

- (1) Install the differential side gears and thrust washers.
- (2) Install the pinion mate gears and thrust washers.
- (3) Install the pinion gear mate shaft.
- (4) Align the hole in the pinion gear mate shaft with the hole in the differential case.
- (5) Install and seat the pinion mate shaft roll-pin in the differential case and mate shaft with a punch and hammer (Fig. 42). Peen the edge of the roll-pin hole in the differential case slightly in two places, 180° apart.
- (6) Lubricate all differential components with hypoid gear lubricant.

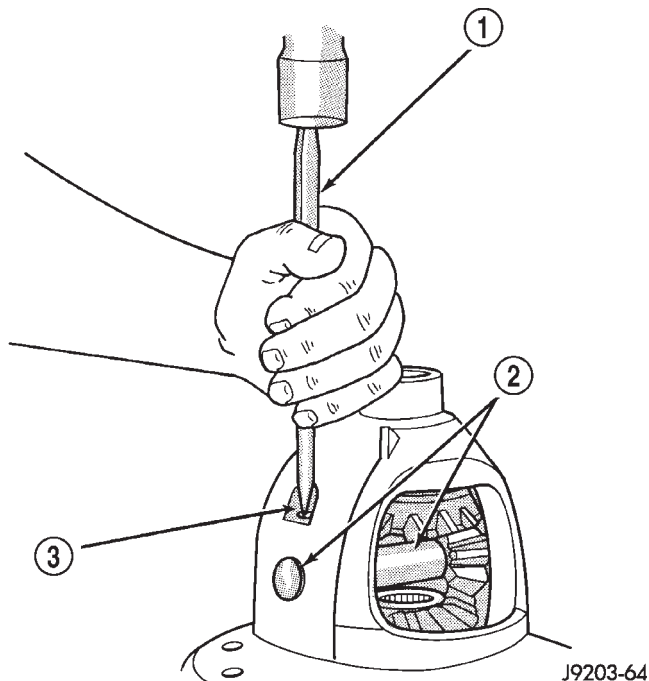
**INSTALLATION**

**NOTE:** If replacement differential bearings or differential case are being installed, differential side bearing shim requirements may change. Refer to **Adjustments (Differential Bearing Preload and Gear Backlash)** procedures to determine proper shim selection.

- (1) Position Spreader W-129-B with the tool dowel pins seated in the locating holes. Install the hold down clamps and tighten the tool turnbuckle finger-tight.



## DIFFERENTIAL (Continued)

**Fig. 42 Pinion Mate Shaft Roll-Pin**

- 1 - PUNCH
- 2 - PINION MATE SHAFT
- 3 - MATE SHAFT LOCKPIN

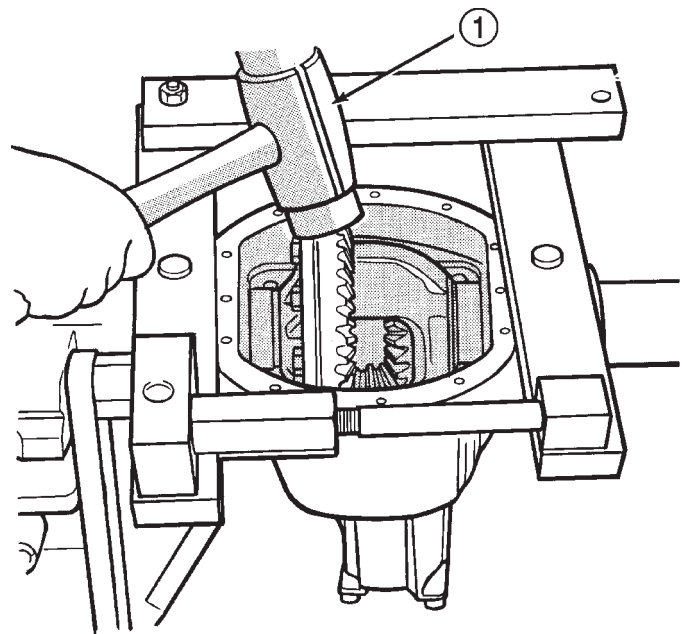
(2) Install a Pilot Stud C-3288-B at the left side of the differential housing and attach dial indicator to the pilot stud. Load the indicator plunger against the opposite side of the housing and zero the dial indicator.

(3) Spread the housing enough to install the case in the housing. Measure the distance with the dial indicator.

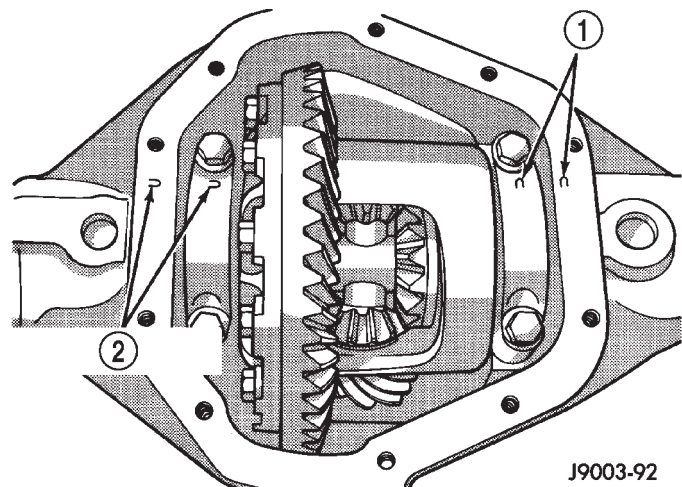
**CAUTION:** Do not spread over 0.50 mm (0.020 in). If the housing is over-spread, it could be distorted or damaged.

- (4) Remove the dial indicator.
- (5) Install differential into the housing. Tap the differential case with a rawhide/rubber hammer to ensure the bearings are seated in housing (Fig. 43).
- (6) Remove the spreader.
- (7) Install bearing caps in their original locations (Fig. 44) and tighten bearing cap bolts to 109 N·m (80 ft. lbs.).
- (8) Install axle shafts.
- (9) Install the hub bearings.
- (10) Apply a bead of Mopar Silicone Rubber Sealant or equivalent to the housing cover (Fig. 45).

**Install the housing cover within 5 minutes after applying the sealant.**

**Fig. 43 Differential Case**

- 1 - RAWHIDE HAMMER

**Fig. 44 Bearing Cap Reference**

- 1 - REFERENCE LETTERS
- 2 - REFERENCE LETTERS

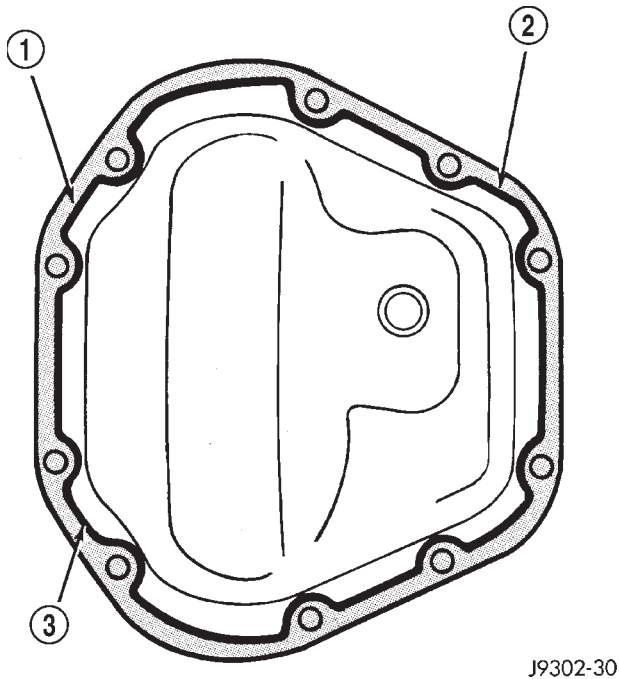
(11) Install the cover and any identification tag. Tighten the cover bolts in a criss-cross pattern to 47 N·m (35 ft. lbs.).

(12) Refill the differential with Mopar Hypoid Gear Lubricant or equivalent to bottom of the fill plug hole. Refer to the Lubricant Specifications for correct quantity and type.

(13) Install the fill hole plug and tighten to 34 N·m (25 ft. lbs.).

(14) Remove support and lower vehicle.

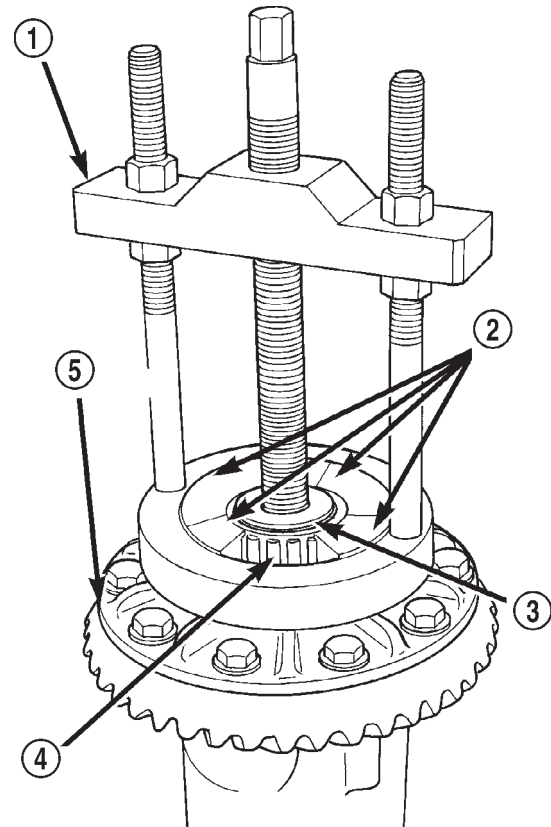
## DIFFERENTIAL (Continued)



J9302-30

**Fig. 45 Differential Cover**

- 1 - SEALANT SURFACE
- 2 - SEALANT
- 3 - SEALANT THICKNESS



80a9834a

**Fig. 46 Differential Bearing Removal**

- 1 - SPECIAL TOOL C-293-PA
- 2 - SPECIAL TOOL C-293-62
- 3 - SPECIAL TOOL C-4487-1
- 4 - BEARING
- 5 - DIFFERENTIAL

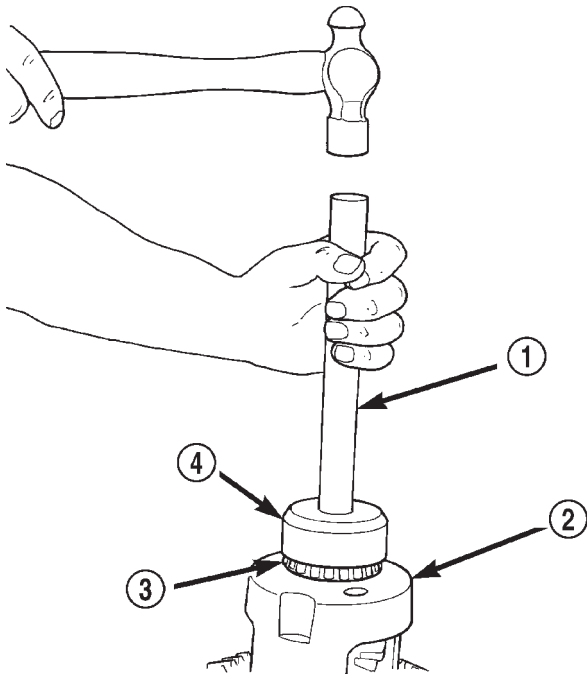
DIFFERENTIAL CASE  
BEARINGS**REMOVAL**

- (1) Remove differential case from axle housing.
- (2) Remove the bearings from the differential case with Puller/Press C-293-PA, Adapters C-293-62, and Step Plate C-4487-1 (Fig. 46).

**INSTALLATION**

- (1) Using tool C-4190 with handle C-4171, install differential side bearings (Fig. 47).
- (2) Install differential case in axle housing.

## DIFFERENTIAL CASE BEARINGS (Continued)

**Fig. 47 Install Differential Side Bearings**

- 1 - HANDLE C-4171
- 2 - DIFFERENTIAL CASE
- 3 - BEARING
- 4 - TOOL C-4190

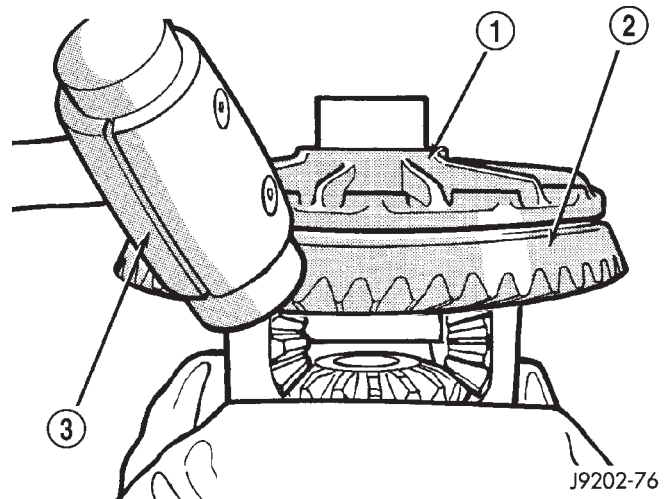
80a9834b

## PINION GEAR/RING GEAR

## REMOVAL

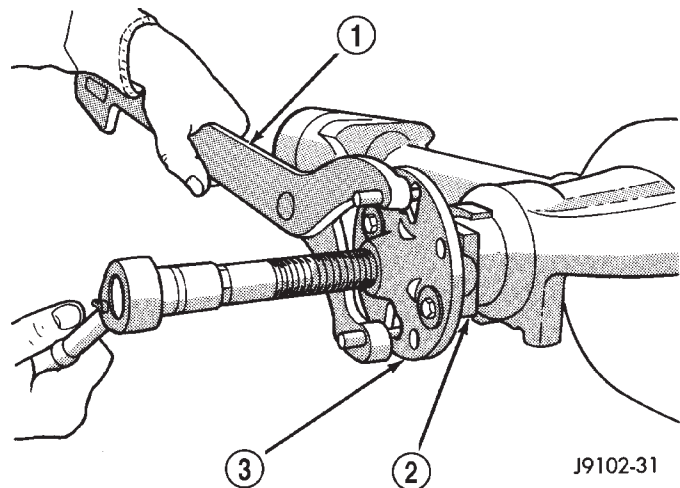
**NOTE:** The ring and pinion gears are service in a matched set. Do not replace the ring gear without replacing the pinion gear.

- (1) Raise and support the vehicle.
- (2) Remove differential from housing.
- (3) Place differential case in a vise with soft metal jaw.
- (4) Remove ring gear bolts from differential case.
- (5) Drive ring gear from differential case with a soft hammer (Fig. 48).
- (6) Mark the pinion yoke and propeller shaft for installation alignment.
- (7) Remove propeller shaft from pinion yoke and tie propeller shaft to underbody.
- (8) Hold pinion yoke with Holder 6719A and remove pinion yoke nut and washer.
- (9) Remove pinion yoke with Puller C-452 and Flange Wrench C-3281 (Fig. 49).
- (10) Remove pinion gear from housing (Fig. 50).
- (11) Remove pinion seal with a pry bar or screw mounted slide hammer.

**Fig. 48 Ring Gear**

- 1 - CASE
- 2 - RING GEAR
- 3 - HAMMER

J9202-76

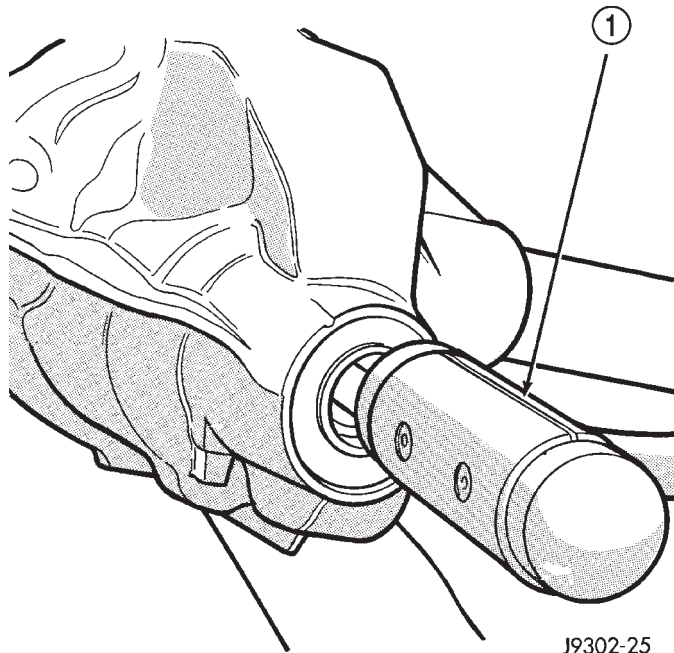
**Fig. 49 Pinion Yoke**

- 1 - YOKE HOLDER
- 2 - YOKE
- 3 - YOKE PULLER

J9102-31

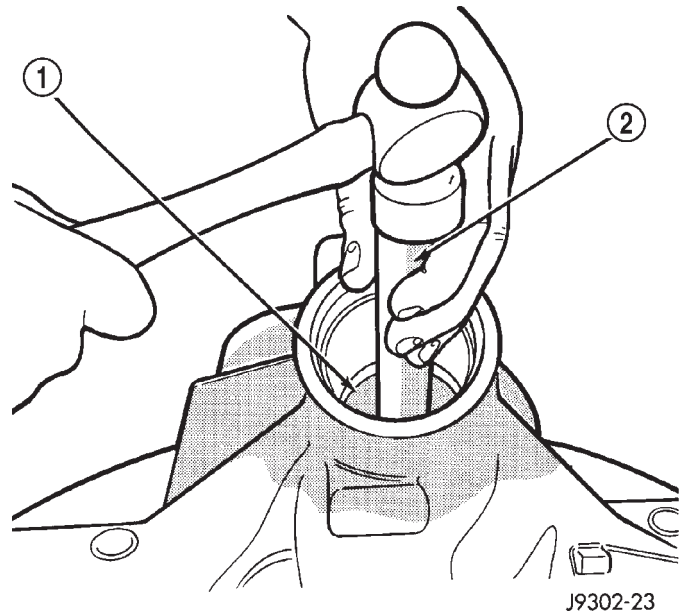
- (12) Remove oil slinger and front pinion bearing.
- (13) Remove front pinion bearing cup with Driver D-158 and Handle C-4171 (Fig. 51).
- (14) Remove rear bearing cup with remover D-162 and Handle C-4171 (Fig. 52).
- (15) Remove collapsible preload spacer (Fig. 53).
- (16) Remove rear pinion bearing from pinion with Puller C-293-PA and Adapters C-293-37 (Fig. 54).
- (17) Remove pinion depth shims from the pinion shaft and record thickness.

PINION GEAR/RING GEAR (Continued)



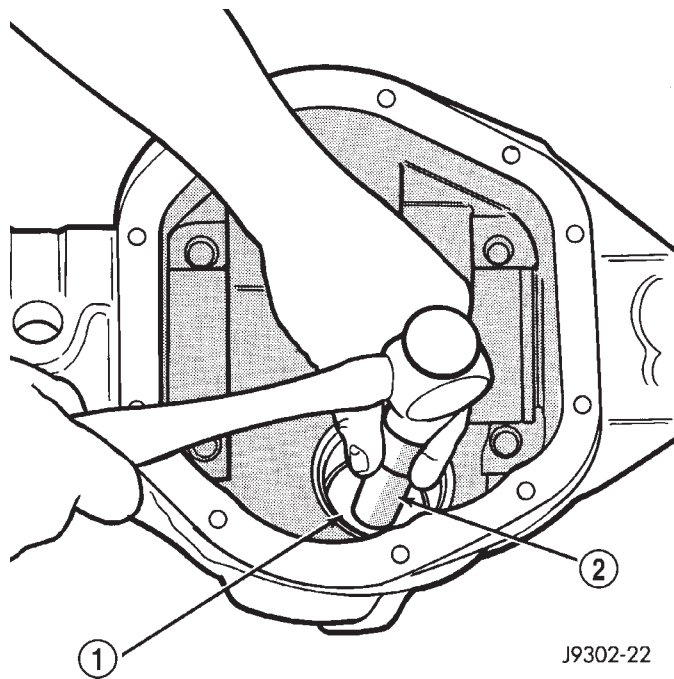
**Fig. 50 Remove Pinion**

- 1 - RAWHIDE HAMMER



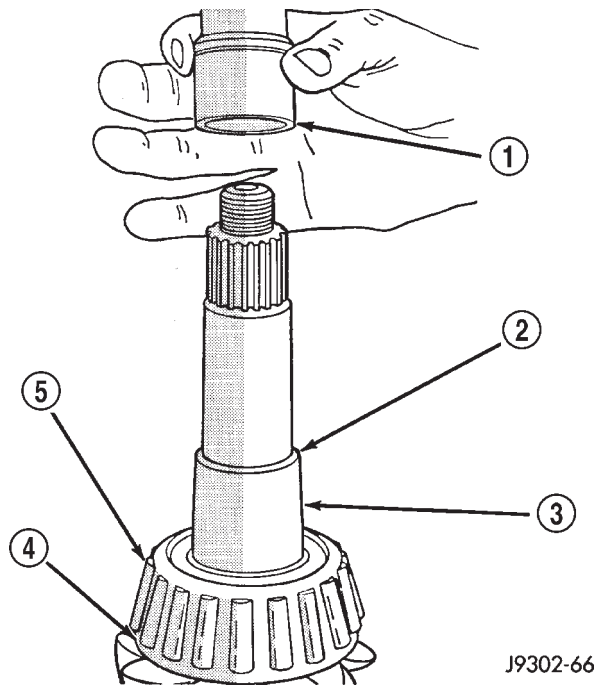
**Fig. 52 Rear Pinion Bearing Cup**

- 1 - DRIVER
- 2 - HANDLE



**Fig. 51 Front Pinion Bearing Cup**

- 1 - REMOVER
- 2 - HANDLE

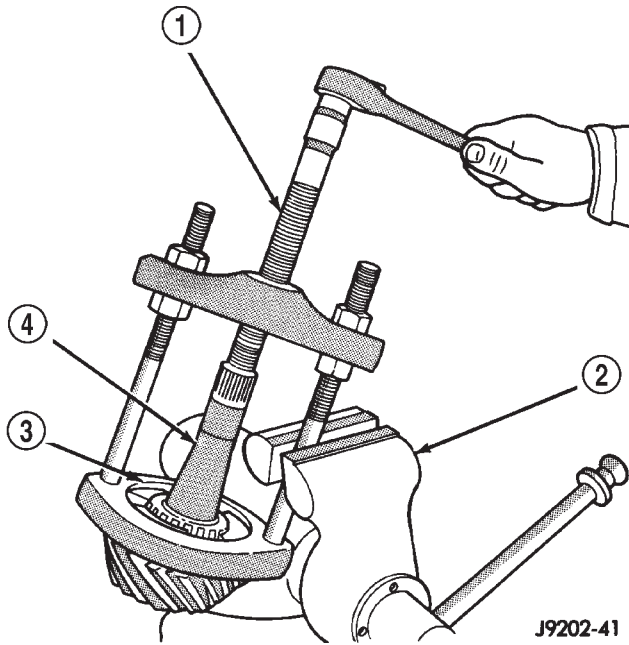


**Fig. 53 Collapsible Spacer**

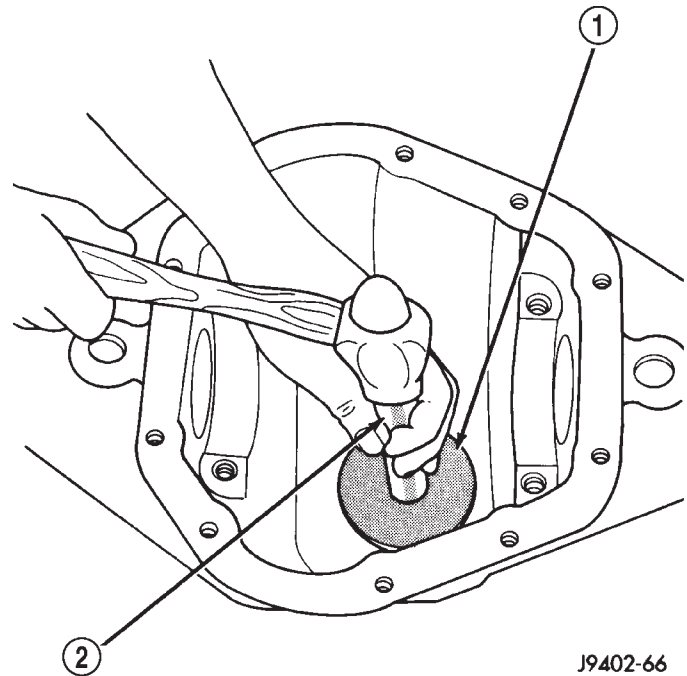
- 1 - COLLAPSIBLE SPACER
- 2 - SHOULDER
- 3 - PINION GEAR
- 4 - OIL SLINGER
- 5 - REAR BEARING



## PINION GEAR/RING GEAR (Continued)

**Fig. 54 Rear Bearing**

- 1 - PULLER
- 2 - VISE
- 3 - ADAPTERS
- 4 - PINION SHAFT

**Fig. 55 Rear Pinion Bearing Cup**

- 1 - INSTALLER
- 2 - HANDLE

**INSTALLATION**

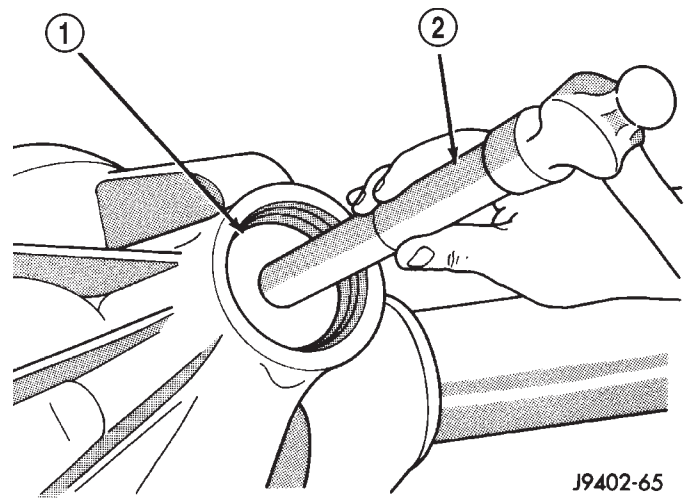
**NOTE:** Pinion depth shims are placed between the rear pinion bearing cone and pinion gear to achieve proper ring and pinion gear mesh. If ring and pinion gears are reused, the original pinion depth shim can be used. Refer to Adjustments (Pinion Gear Depth) to select the proper shim thickness if ring and pinion gears are replaced.

(1) Apply Mopar Door Ease stick lubricant to outside surface of bearing cups.

(2) Install rear pinion bearing cup with Installer D-111 and Handle C-4171 (Fig. 55) and verify cup is seated.

(3) Install front pinion bearing cup with Installer D-146 and Handle C-4171 (Fig. 56) and verify cup is seated.

(4) Install pinion front bearing, oil slinger. Apply a light coating of gear lubricant on the lip of pinion seal.

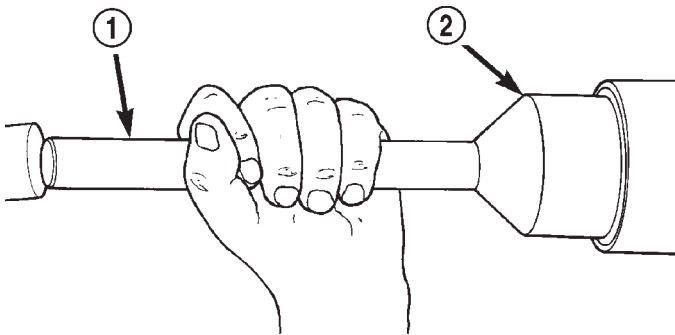
**Fig. 56 Front Pinion Bearing Cup**

- 1 - INSTALLER
- 2 - HANDLE



## PINION GEAR/RING GEAR (Continued)

(5) Install pinion seal with an appropriate installer (Fig. 57).



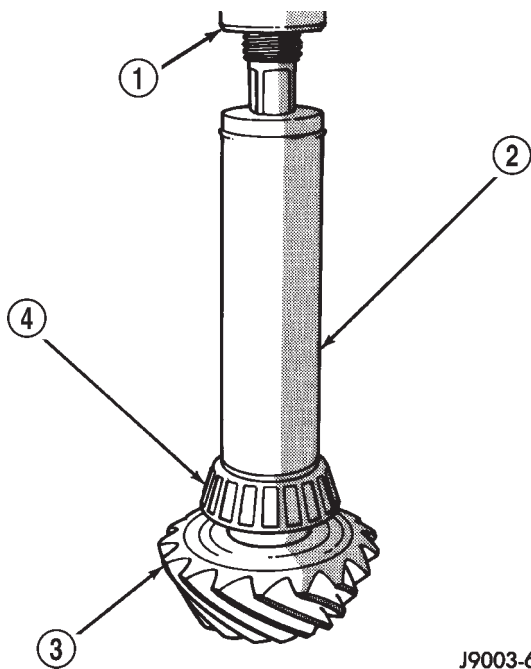
80a7e2be

**Fig. 57 Pinion Seal Installer**

- 1 - HANDLE  
2 - INSTALLER

(6) Install proper thickness depth shim on the pinion gear.

(7) Install rear bearing and oil slinger, if equipped on pinion gear with Installer C-3095-A (Fig. 58).



J9003-67

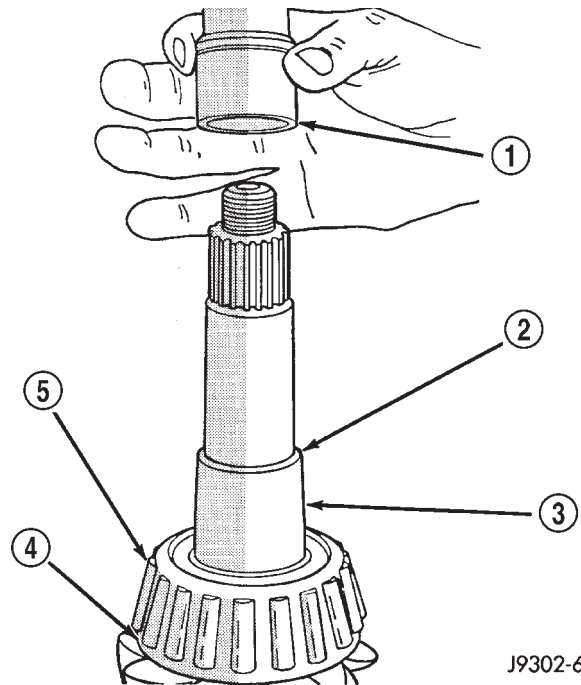
**Fig. 58 Rear Pinion Bearing**

- 1 - PRESS  
2 - INSTALLER  
3 - PINION GEAR  
4 - PINION REAR BEARING

(8) Install a new collapsible preload spacer on pinion shaft (Fig. 59).

(9) Install pinion gear in housing.

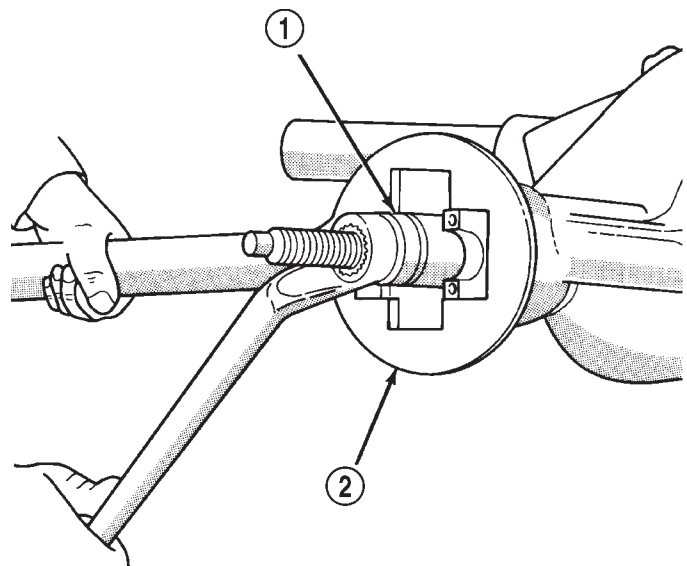
(10) Install yoke with Installer C-3718 and Yoke Holder 6719A (Fig. 60).



J9302-66

**Fig. 59 Collapsible Preload Spacer**

- 1 - COLLAPSIBLE SPACER  
2 - SHOULDER  
3 - PINION GEAR  
4 - OIL SLINGER  
5 - REAR PINION BEARING



J9402-61

**Fig. 60 Pinion Yoke Installer**

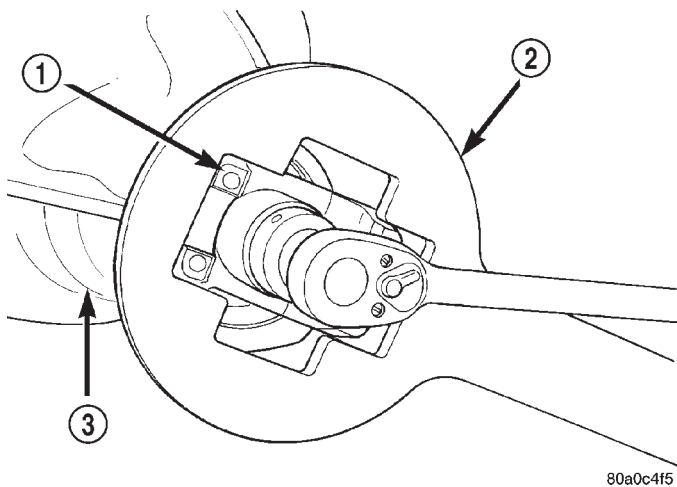
- 1 - INSTALLER  
2 - YOKE HOLDER

## PINION GEAR/RING GEAR (Continued)

(11) Install yoke washer and a **new** nut on the pinion gear. Tighten the nut to 291 N·m (215 ft. lbs.) minimum. **Do not over-tighten.** Maximum torque is 380 N·m (280 ft. lbs.).

**CAUTION:** Never loosen pinion gear nut to decrease pinion gear bearing preload torque and never exceed specified preload torque. If preload torque is exceeded a new collapsible spacer must be installed.

(12) Use Yoke Holder 6719A to hold the yoke (Fig. 61) and tighten the nut in 6.8 N·m (5 ft. lbs.) until the rotating torque is achieved. Measure the preload torque frequently to avoid over-tightening the nut.



**Fig. 61 Tightening Pinion Nut**

- 1 - PINION FLANGE
- 2 - YOKE HOLDING
- 3 - DIFFERENTIAL HOUSING

(13) Check bearing preload torque with an inch pound torque wrench (Fig. 62). The torque necessary to rotate the pinion gear should be:

- Original Bearings: 1 to 2 N·m (10 to 20 in. lbs.).
- New Bearings: 1.7 to 4 N·m (15 to 35 in. lbs.).

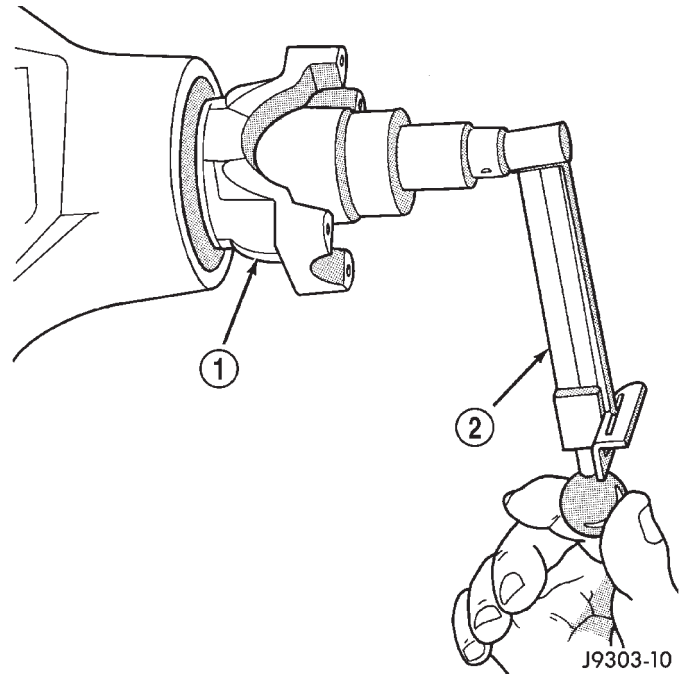
(14) Invert differential case in a vise and start two ring gear bolts. This will provide case-to-ring gear bolt hole alignment.

(15) Install **new** ring gear bolts and alternately tighten to 176 N·m (130 ft. lbs.). (Fig. 63).

**CAUTION:** Do not reuse the bolts that held the ring gear to the differential case. The bolts can fracture causing extensive damage.

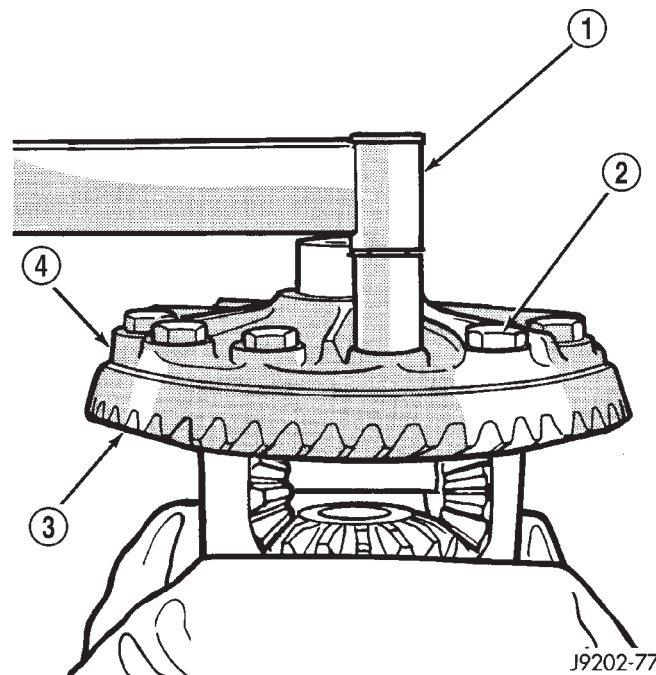
(16) Install differential in axle housing and verify gear mesh and contact pattern. Refer to Adjustments (Gear Contact Pattern).

(17) Install differential cover and fill with lubricant.



**Fig. 62 Pinion Rotating Torque**

- 1 - PINION YOKE
- 2 - TORQUE WRENCH



**Fig. 63 Ring Gear Bolt**

- 1 - TORQUE WRENCH
- 2 - RING GEAR BOLT
- 3 - RING GEAR
- 4 - CASE

(18) Install propeller shaft with reference marks aligned.

(19) Remove support and lower vehicle.

## REAR AXLE - 9 1/4

### TABLE OF CONTENTS

	page		page
<b>REAR AXLE - 9 1/4</b>		<b>PINION SEAL</b>	
DESCRIPTION . . . . .	77	REMOVAL . . . . .	95
OPERATION . . . . .	77	INSTALLATION . . . . .	95
DIAGNOSIS AND TESTING . . . . .	80	<b>DIFFERENTIAL</b>	
AXLE . . . . .	80	REMOVAL . . . . .	96
REMOVAL . . . . .	83	DISASSEMBLY . . . . .	97
INSTALLATION . . . . .	84	ASSEMBLY . . . . .	98
ADJUSTMENTS . . . . .	84	INSTALLATION . . . . .	98
SPECIFICATIONS . . . . .	90	<b>DIFFERENTIAL - TRAC-LOK</b>	
SPECIAL TOOLS . . . . .	90	DIAGNOSIS AND TESTING . . . . .	98
<b>AXLE SHAFTS</b>		TRAC-LOK . . . . .	98
REMOVAL . . . . .	93	DISASSEMBLY . . . . .	99
INSTALLATION . . . . .	93	ASSEMBLY . . . . .	101
<b>AXLE SHAFT SEALS</b>		<b>DIFFERENTIAL CASE BEARINGS</b>	
REMOVAL . . . . .	94	REMOVAL . . . . .	103
INSTALLATION . . . . .	94	INSTALLATION . . . . .	103
<b>AXLE BEARINGS</b>		<b>PINION GEAR/RING GEAR/TONE RING</b>	
REMOVAL . . . . .	94	REMOVAL . . . . .	103
INSTALLATION . . . . .	95	INSTALLATION . . . . .	105

## REAR AXLE - 9 1/4

### DESCRIPTION

The 9 1/4 Inch axle housings consist of a cast iron center section with axle tubes extending from either side. The tubes are pressed into and welded to the differential housing to form a one-piece axle housing (Fig. 1).

The axles have a vent hose to relieve internal pressure caused by lubricant vaporization and internal expansion.

The axles are equipped with semi-floating axle shafts, meaning vehicle loads are supported by the axle shaft and bearings. The axle shafts are retained by C-locks in the differential side gears.

The removable, stamped steel cover provides a means for inspection and service without removing the complete axle from the vehicle.

The axle has a date tag and a gear ratio tag. The tags are attached to the differential housing by a cover bolt.

The rear wheel anti-lock (RWAL) brake speed sensor is attached to the top, forward exterior of the differential housing. A seal is located between the sensor and the wire harness connector. The seal must be in place when the wire connector is connected to the sensor. The RWAL brake exciter ring is press-fit-

ted onto the differential case against the ring gear flange.

The differential case is a one-piece design. The differential pinion shaft is retained with a screw. Differential bearing preload and ring gear backlash are set and maintained by threaded adjusters at the outside of the differential housing. Pinion bearing preload is set and maintained by the use of a collapsible spacer.

Axles equipped with a Trac-Lok<sup>™</sup> differential are optional. A differential has a one-piece differential case, and the same internal components as a standard differential, plus two clutch disc packs.

### AXLE IDENTIFICATION

The axle differential cover can be used for identification of the axle (Fig. 2). A ratio tag is attached to the top of the differential cover.

### OPERATION

The axle receives power from the transmission/transfer case through the rear propeller shaft. The rear propeller shaft is connected to the drive pinion which rotates the differential through the gear mesh with the ring gear bolted to the differential case. The engine power is transmitted to the axle shafts through the differential pinions and side gears. The side gears are splined to the axle shafts.

REAR AXLE - 9 1/4 (Continued)

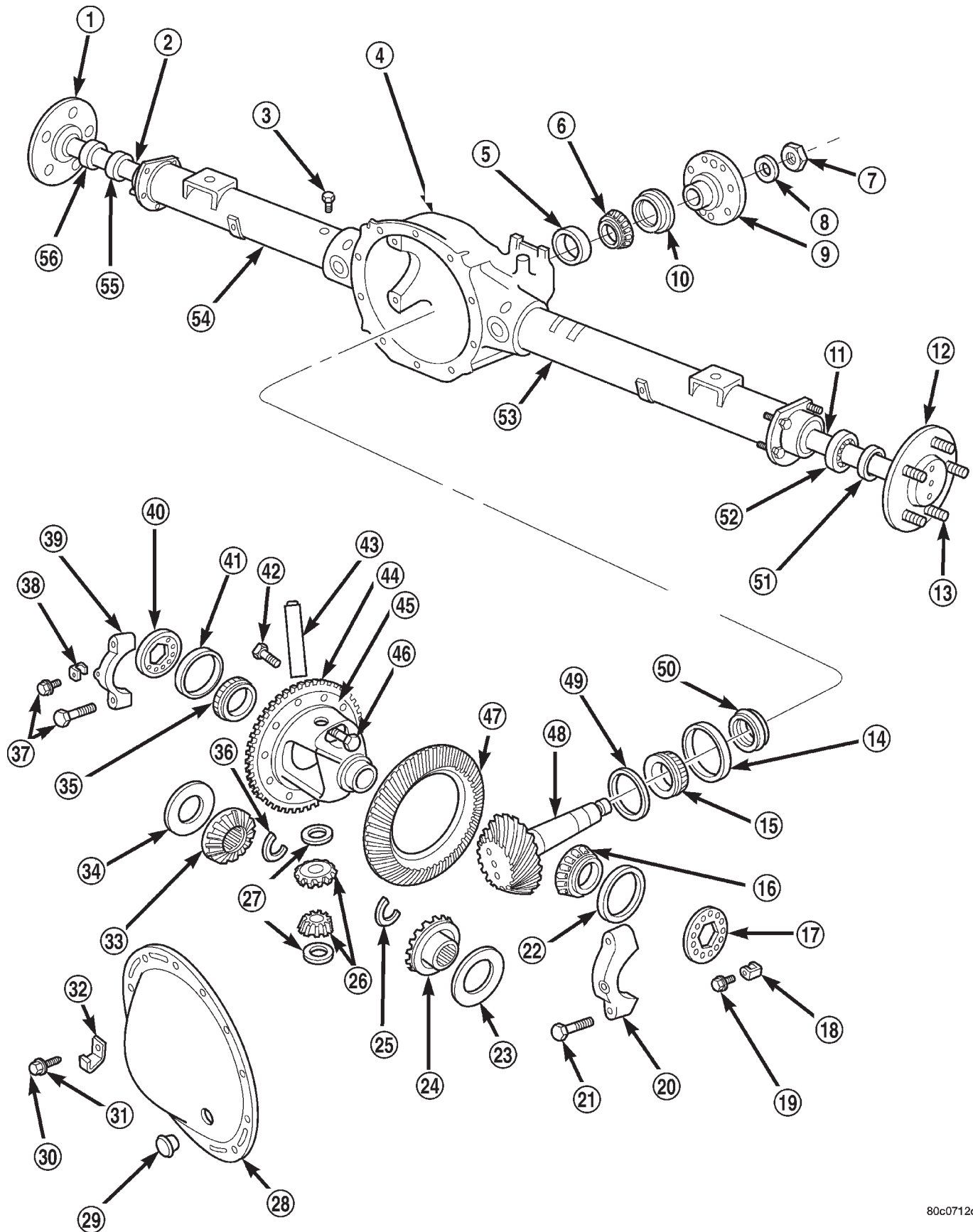
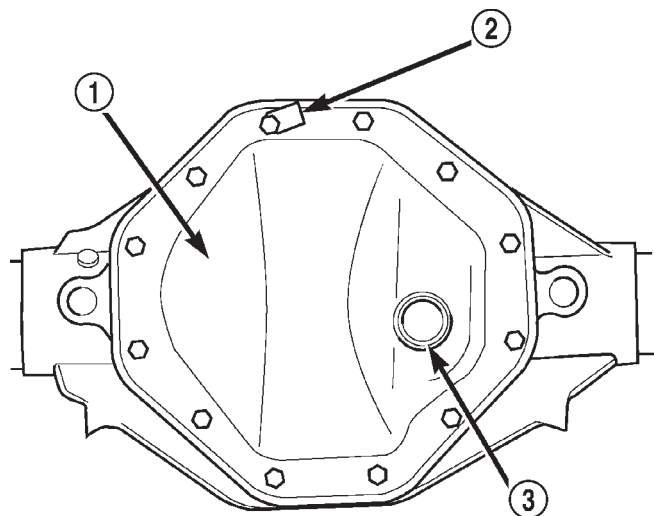


Fig. 1 9 1/4 Axle

## REAR AXLE - 9 1/4 (Continued)

- |                               |   |
|-------------------------------|---|
| 1 - HUB                       | 30 - COVER BOLT                         |
| 2 - AXLE SHAFT                | 31 - WASHER                             |
| 3 - VENT FITTING              | 32 - CLIP                               |
| 4 - DIFFERENTIAL HOUSING      | 33 - SIDE GEAR                          |
| 5 - CUP                       | 34 - THRUST WASHER                      |
| 6 - PINION FRONT BEARING CONE | 35 - DIFFERENTIAL BEARING CONE          |
| 7 - NUT                       | 36 - C-LOCK                             |
| 8 - WASHER                    | 37 - BOLT                               |
| 9 - COMPANION FLANGE          | 38 - LOCK                               |
| 10 - SEAL                     | 39 - BEARING CUP                        |
| 11 - AXLE SHAFT               | 40 - ADJUSTER                           |
| 12 - HUB                      | 41 - BEARING CUP                        |
| 13 - STUD                     | 42 - BOLT                               |
| 14 - BEARING CUP              | 43 - PINION MATE SHAFT                  |
| 15 - PINION REAR BEARING CONE | 44 - EXCITER RING                       |
| 16 - DIFFERENTIAL BEARING     | 45 - DIFFERENTIAL CASE                  |
| 17 - ADJUSTER                 | 46 - RING GEAR BOLT                     |
| 18 - LOCK                     | 47 - RING GEAR                          |
| 19 - BOLT                     | 48 - PINION                             |
| 20 - BEARING CAP              | 49 - PINION GEAR DEPTH SHIM             |
| 21 - CAP BOLT                 | 50 - BEARING PRELOAD COLLAPSIBLE SPACER |
| 22 - BEARING CUP              | 51 - SEAL                               |
| 23 - THRUST WASHER            | 52 - AXLE SHAFT BEARING                 |
| 24 - SIDE GEAR                | 53 - AXLE SHAFT TUBE                    |
| 25 - C-LOCK                   | 54 - AXLE TUBE                          |
| 26 - DIFFERENTIAL POSITIONS   | 55 - AXLE SHAFT BEARING                 |
| 27 - THRUST WASHER            | 56 - SEAL                               |
| 28 - COVER                    |   |
| 29 - PLUG                     |   |



80c0712e

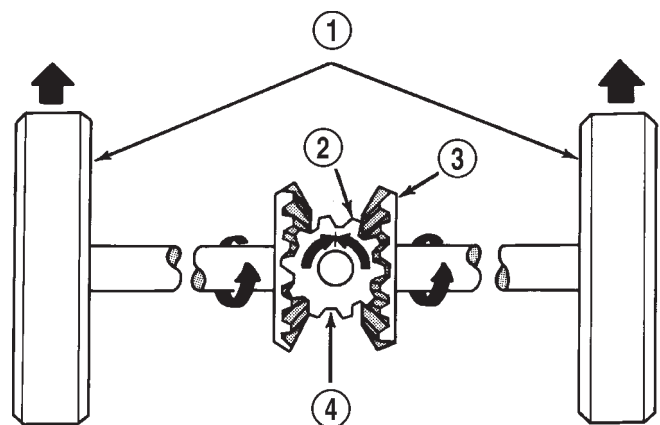
**Fig. 2 Differential Cover 9 1/4 Inch Axle**

- 1 - DIFFERENTIAL COVER
- 2 - RATIO TAG
- 3 - PUSH-IN FILL PLUG

**STANDARD DIFFERENTIAL**

During straight-ahead driving, the differential pinion gears do not rotate on the pinion shaft. This

occurs because input torque applied to the gears is divided and distributed equally between the two side gears. As a result, the differential pinion gears revolve with the pinion shaft but do not rotate around it (Fig. 3).



J9303-13

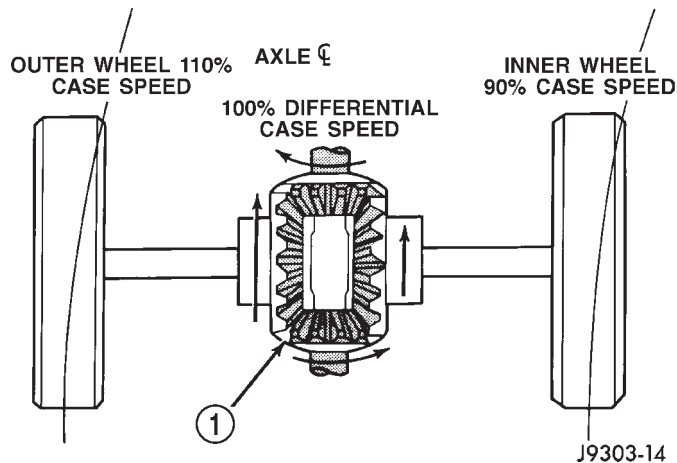
**Fig. 3 Differential Operation - Straight Ahead Driving**

- 1 - IN STRAIGHT AHEAD DRIVING EACH WHEEL ROTATES AT 100% OF CASE SPEED
- 2 - DIFFERENTIAL PINION GEAR
- 3 - SIDE GEAR
- 4 - DIFFERENTIAL PINIONS ROTATE WITH CASE



## REAR AXLE - 9 1/4 (Continued)

When turning corners, the outside wheel must travel a greater distance than the inside wheel to complete a turn. The difference must be compensated for to prevent the tires from scuffing and skidding through turns. To accomplish this, the differential allows the axle shafts to turn at unequal speeds (Fig. 4). In this instance, the input torque applied to the differential pinions is not divided equally. The differential pinions now rotate around the pinion shaft in opposite directions. This allows the side gears and axle shaft attached to the outside wheel to rotate at a faster speed.



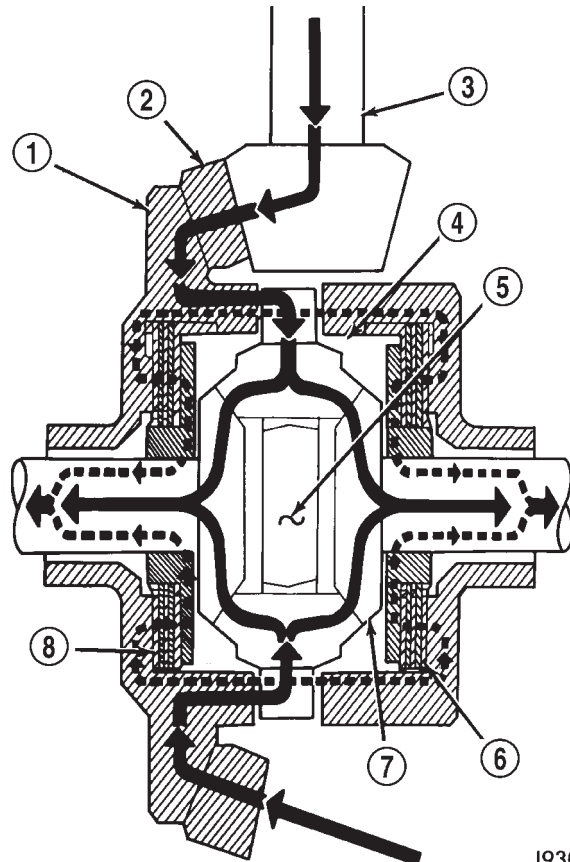
**Fig. 4 Differential Operation - On Turns**

1 - DIFFERENTIAL PINIONS ROTATE ON PINION SHAFT

### TRAC-LOK™ DIFFERENTIAL

The Trac-lok™ clutches are engaged by two concurrent forces. The first being the preload force exerted through Belleville spring washers within the clutch packs. The second is the separating forces generated by the side gears as torque is applied through the ring gear (Fig. 5).

The Trac-lok™ design provides the differential action needed for turning corners and for driving straight ahead during periods of unequal traction. When one wheel loses traction, the clutch packs transfer additional torque to the wheel having the most traction. Trac-lok™ differentials resist wheel spin on bumpy roads and provide more pulling power when one wheel loses traction. Pulling power is provided continuously until both wheels lose traction. If both wheels slip due to unequal traction, Trac-lok™ operation is normal. In extreme cases of differences of traction, the wheel with the least traction may spin.



**Fig. 5 Trac-lok™ Limited Slip Differential**

- 1 - CASE
- 2 - RING GEAR
- 3 - DRIVE PINION
- 4 - DIFFERENTIAL PINION
- 5 - PINION SHAFT
- 6 - CLUTCH PACK
- 7 - SIDE GEAR
- 8 - CLUTCH PACK

### DIAGNOSIS AND TESTING - AXLE

#### GEAR NOISE

Axle gear noise can be caused by insufficient lubricant, incorrect backlash, incorrect pinion depth, tooth contact, worn/damaged gears, or the carrier housing not having the proper offset and squareness.

Gear noise usually happens at a specific speed range. The noise can also occur during a specific type of driving condition. These conditions are acceleration, deceleration, coast, or constant load.

## REAR AXLE - 9 1/4 (Continued)

When road testing, first warm-up the axle fluid by driving the vehicle at least 5 miles and then accelerate the vehicle to the speed range where the noise is the greatest. Shift out-of-gear and coast through the peak-noise range. If the noise stops or changes greatly:

- Check for insufficient lubricant.
- Incorrect ring gear backlash.
- Gear damage.

Differential side gears and pinions can be checked by turning the vehicle. They usually do not cause noise during straight-ahead driving when the gears are unloaded. The side gears are loaded during vehicle turns. A worn pinion shaft can also cause a snapping or a knocking noise.

**BEARING NOISE**

The axle shaft, differential and pinion bearings can all produce noise when worn or damaged. Bearing noise can be either a whining, or a growling sound.

Pinion bearings have a constant-pitch noise. This noise changes only with vehicle speed. Pinion bearing noise will be higher pitched because it rotates at a faster rate. Drive the vehicle and load the differential. If bearing noise occurs, the rear pinion bearing is the source of the noise. If the bearing noise is heard during a coast, the front pinion bearing is the source.

Worn or damaged differential bearings usually produce a low pitch noise. Differential bearing noise is similar to pinion bearing noise. The pitch of differential bearing noise is also constant and varies only with vehicle speed.

Axle shaft bearings produce noise and vibration when worn or damaged. The noise generally changes when the bearings are loaded. Road test the vehicle. Turn the vehicle sharply to the left and to the right. This will load the bearings and change the noise level. Where axle bearing damage is slight, the noise is usually not noticeable at speeds above 30 mph.

**LOW SPEED KNOCK**

Low speed knock is generally caused by a worn U-joint or by worn side-gear thrust washers. A worn pinion shaft bore will also cause low speed knock.

**VIBRATION**

Vibration at the rear of the vehicle is usually caused by a:

- Damaged drive shaft.
- Missing drive shaft balance weight(s).
- Worn or out-of-balance wheels.
- Loose wheel lug nuts.
- Worn U-joint(s).
- Loose/broken springs.
- Damaged axle shaft bearing(s).
- Loose pinion gear nut.
- Excessive pinion yoke run out.
- Bent axle shaft(s).

Check for loose or damaged front-end components or engine/transmission mounts. These components can contribute to what appears to be a rearend vibration. Do not overlook engine accessories, brackets and drive belts.

All driveline components should be examined before starting any repair.

(Refer to 22 - TIRES/WHEELS - DIAGNOSIS AND TESTING)

**DRIVELINE SNAP**

A snap or clunk noise when the vehicle is shifted into gear (or the clutch engaged), can be caused by:

- High engine idle speed.
- Transmission shift operation.
- Loose engine/transmission/transfer case mounts.
- Worn U-joints.
- Loose spring mounts.
- Loose pinion gear nut and yoke.
- Excessive ring gear backlash.
- Excessive side gear to case clearance.

The source of a snap or a clunk noise can be determined with the assistance of a helper. Raise the vehicle on a hoist with the wheels free to rotate. Instruct the helper to shift the transmission into gear. Listen for the noise, a mechanics stethoscope is helpful in isolating the source of a noise.

## REAR AXLE - 9 1/4 (Continued)

## DIAGNOSTIC CHART

Condition	Possible Causes	Correction
Wheel Noise	<ol style="list-style-type: none"> <li>1. Wheel loose.</li> <li>2. Faulty, brinelled wheel bearing.</li> </ol>	<ol style="list-style-type: none"> <li>1. Tighten loose nuts.</li> <li>2. Replace bearing.</li> </ol>
Axle Shaft Noise	<ol style="list-style-type: none"> <li>1. Misaligned axle tube.</li> <li>2. Bent or sprung axle shaft.</li> </ol>	<ol style="list-style-type: none"> <li>1. Inspect axle tube alignment. Correct as necessary.</li> <li>2. Inspect and correct as necessary.</li> </ol>
Axle Shaft Broke	<ol style="list-style-type: none"> <li>1. Misaligned axle tube.</li> <li>2. Vehicle overloaded.</li> <li>3. Erratic clutch operation.</li> <li>4. Grabbing clutch.</li> </ol>	<ol style="list-style-type: none"> <li>1. Replace the broken shaft after correcting tube mis-alignment.</li> <li>2. Replace broken shaft and avoid excessive weight on vehicle.</li> <li>3. Replace broken shaft and avoid or correct erratic clutch operation.</li> <li>4. Replace broken shaft and inspect and repair clutch as necessary.</li> </ol>
Differential Cracked	<ol style="list-style-type: none"> <li>1. Improper adjustment of the differential bearings.</li> <li>2. Excessive ring gear backlash.</li> <li>3. Vehicle overloaded.</li> <li>4. Erratic clutch operation.</li> </ol>	<ol style="list-style-type: none"> <li>1. Replace case and inspect gears and bearings for further damage. Set differential bearing pre-load properly.</li> <li>2. Replace case and inspect gears and bearings for further damage. Set ring gear backlash properly.</li> <li>3. Replace case and inspect gears and bearings for further damage. Avoid excessive vehicle weight.</li> <li>4. Replace case and inspect gears and bearings for further damage. Avoid erratic use of clutch.</li> </ol>
Differential Gears Scored	<ol style="list-style-type: none"> <li>1. Insufficient lubrication.</li> <li>2. Improper grade of lubricant.</li> <li>3. Excessive spinning of one wheel/tire.</li> </ol>	<ol style="list-style-type: none"> <li>1. Replace scored gears. Fill differential with the correct fluid type and quantity.</li> <li>2. Replace scored gears. Fill differential with the correct fluid type and quantity.</li> <li>3. Replace scored gears. Inspect all gears, pinion bores, and shaft for damage. Service as necessary.</li> </ol>
Loss Of Lubricant	<ol style="list-style-type: none"> <li>1. Lubricant level too high.</li> <li>2. Worn axle shaft seals.</li> <li>3. Cracked differential housing.</li> <li>4. Worn pinion seal.</li> <li>5. Worn/scored yoke.</li> <li>6. Axle cover not properly sealed.</li> </ol>	<ol style="list-style-type: none"> <li>1. Drain lubricant to the correct level.</li> <li>2. Replace seals.</li> <li>3. Repair as necessary.</li> <li>4. Replace seal.</li> <li>5. Replace yoke and seal.</li> <li>6. Remove, clean, and re-seal cover.</li> </ol>

## REAR AXLE - 9 1/4 (Continued)

Condition	Possible Causes	Correction
Axle Overheating	<ol style="list-style-type: none"> <li>1. Lubricant level low.</li> <li>2. Improper grade of lubricant.</li> <li>3. Bearing pre-loads too high.</li> <li>4. Insufficient ring gear backlash.</li> </ol>	<ol style="list-style-type: none"> <li>1. Fill differential to correct level.</li> <li>2. Fill differential with the correct fluid type and quantity.</li> <li>3. Re-adjust bearing pre-loads.</li> <li>4. Re-adjust ring gear backlash.</li> </ol>
Gear Teeth Broke	<ol style="list-style-type: none"> <li>1. Overloading.</li> <li>2. Erratic clutch operation.</li> <li>3. Ice-spotted pavement.</li> <li>4. Improper adjustments.</li> </ol>	<ol style="list-style-type: none"> <li>1. Replace gears. Examine other gears and bearings for possible damage.</li> <li>2. Replace gears and examine the remaining parts for damage. Avoid erratic clutch operation.</li> <li>3. Replace gears and examine remaining parts for damage.</li> <li>4. Replace gears and examine remaining parts for damage. Ensure ring gear backlash is correct.</li> </ol>
Axle Noise	<ol style="list-style-type: none"> <li>1. Insufficient lubricant.</li> <li>2. Improper ring gear and pinion adjustment.</li> <li>3. Unmatched ring gear and pinion.</li> <li>4. Worn teeth on ring gear and/or pinion.</li> <li>5. Loose pinion bearings.</li> <li>6. Loose differential bearings.</li> <li>7. Mis-aligned or sprung ring gear.</li> <li>8. Loose differential bearing cap bolts.</li> <li>9. Housing not machined properly.</li> </ol>	<ol style="list-style-type: none"> <li>1. Fill differential with the correct fluid type and quantity.</li> <li>2. Check ring gear and pinion contact pattern. Adjust backlash or pinion depth.</li> <li>3. Replace gears with a matched ring gear and pinion.</li> <li>4. Replace ring gear and pinion.</li> <li>5. Adjust pinion bearing pre-load.</li> <li>6. Adjust differential bearing pre-load.</li> <li>7. Measure ring gear run-out. Replace components as necessary.</li> <li>8. Inspect differential components and replace as necessary. Ensure that the bearing caps are torqued to the proper specification.</li> <li>9. Replace housing.</li> </ol>

**REMOVAL**

- (1) Raise and support the vehicle.
- (2) Position a suitable lifting device under the axle.
- (3) Secure axle to device.
- (4) Remove the wheels and tires.
- (5) Secure brake drums to the axle shaft.
- (6) Remove the RWAL sensor from the differential housing, if necessary. Refer to 5 Brakes for procedures.
- (7) Disconnect the brake hose at the axle junction block. Do not disconnect the brake hydraulic lines at the wheel cylinders. Refer to 5 Brakes for procedures.

- (8) Disconnect the parking brake cables and cable brackets.
- (9) Disconnect the vent hose from the axle shaft tube.
- (10) Mark the propeller shaft and companion flange for installation alignment reference.
- (11) Remove propeller shaft.
- (12) Disconnect shock absorbers from axle.
- (13) Remove the spring clamps and spring brackets. Refer to 2 Suspension for procedures.
- (14) Separate the axle from the vehicle.

## REAR AXLE - 9 1/4 (Continued)

**INSTALLATION**

(1) Raise the axle with lifting device and align to the leaf spring centering bolts.

(2) Install the spring clamps and spring brackets. Refer to 2 Suspension for procedures.

(3) Install shock absorbers and tighten nuts to 82 N·m (60 ft. lbs.).

(4) Install the RWAL sensor to the differential housing, if necessary. Refer to 5 Brakes for procedures.

(5) Connect the parking brake cables and cable brackets.

(6) Install the brake drums. Refer to 5 Brakes for procedures.

(7) Connect the brake hose to the axle junction block. Refer to 5 Brakes for procedures.

(8) Install axle vent hose.

(9) Align propeller shaft and pinion companion flange reference marks. Install the companion flange bolts. Tighten to 108 N·m (80 ft. lbs.).

(10) Install the wheels and tires.

(11) Add gear lubricant, if necessary. Refer to Specifications for lubricant requirements.

(12) Remove lifting device from axle and lower the vehicle.

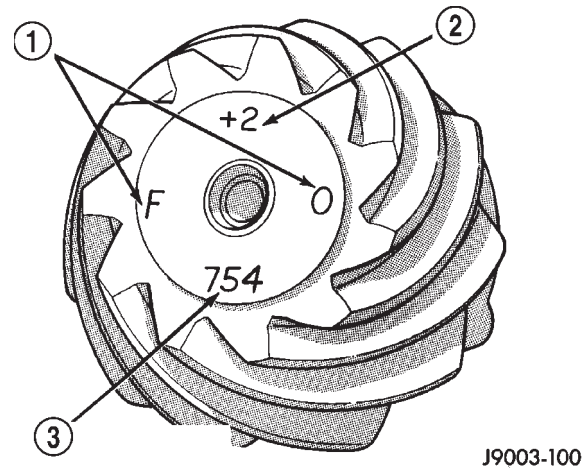
**ADJUSTMENTS**

Ring gear and pinion are supplied as matched sets only. The identifying numbers for the ring gear and pinion are painted onto the pinion gear head (Fig. 6) and the side of the ring gear. A plus (+) number, minus (-) number or zero (0) along with the gear set sequence number (01 to 99) is on each gear. This first number is the amount (in thousandths of an inch) the depth varies from the standard depth setting of a pinion marked with a (0). The next two numbers are the sequence number of the gear set. The standard depth provides the best teeth contact pattern. Refer to Backlash and Contact Pattern for additional information.

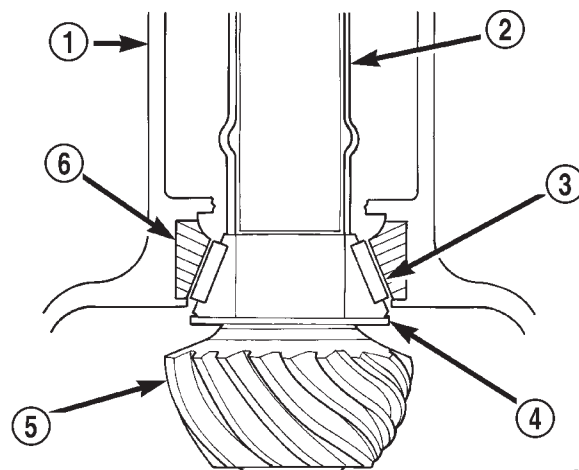
Compensation for pinion depth variance is achieved with select shims. The shims are placed behind the rear pinion bearing. (Fig. 7).

If a new gear set is being installed, note the depth variance painted onto both the original and replacement pinion. Add or subtract the thickness of the original depth shims to compensate for the difference in the depth variances. Refer to the Depth Variance chart.

Note where Old and New Pinion Marking columns intersect. Intersecting figure represents plus or minus the amount needed.

**Fig. 6 Pinion ID Number**

- 1 - PRODUCTION NUMBER
- 2 - PINION GEAR DEPTH VARIANCE
- 3 - GEAR MATCHING NUMBER

**Fig. 7 Adjustment Shim Locations**

- 1 - AXLE HOUSING
- 2 - COLLAPSIBLE SPACER
- 3 - PINION BEARING
- 4 - PINION DEPTH SHIM
- 5 - DRIVE PINION GEAR
- 6 - BEARING CUP

Note the painted number on the shaft of the drive pinion (-1, -2, 0, +1, +2, etc.). The numbers represent thousandths of an inch deviation from the standard. If the number is negative, add that value to the required thickness of the depth shims. If the number is positive, subtract that value from the thickness of the depth shim. If the number is 0 no change is necessary.



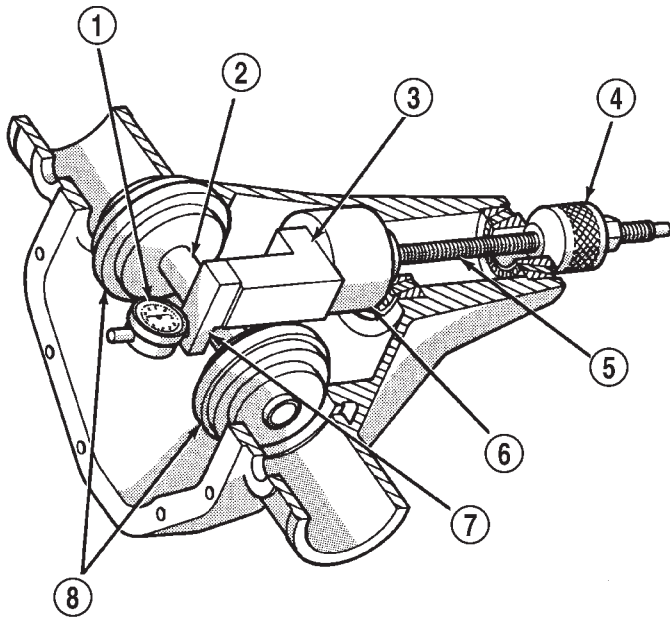
## REAR AXLE - 9 1/4 (Continued)

## PINION GEAR DEPTH VARIANCE

Original Pinion Gear Depth Variance	Replacement Pinion Gear Depth Variance								
	-4	-3	-2	-1	0	+1	+2	+3	+4
+4	+0.008	+0.007	+0.006	+0.005	+0.004	+0.003	+0.002	+0.001	0
+3	+0.007	+0.006	+0.005	+0.004	+0.003	+0.002	+0.001	0	-0.001
+2	+0.006	+0.005	+0.004	+0.003	+0.002	+0.001	0	-0.001	-0.002
+1	+0.005	+0.004	+0.003	+0.002	+0.001	0	-0.001	-0.002	-0.003
0	+0.004	+0.003	+0.002	+0.001	0	-0.001	-0.002	-0.003	-0.004
-1	+0.003	+0.002	+0.001	0	-0.001	-0.002	-0.003	-0.004	-0.005
-2	+0.002	+0.001	0	-0.001	-0.002	-0.003	-0.004	-0.005	-0.006
-3	+0.001	0	-0.001	-0.002	-0.003	-0.004	-0.005	-0.006	-0.007
-4	0	-0.001	-0.002	-0.003	-0.004	-0.005	-0.006	-0.007	-0.008

## PINION DEPTH MEASUREMENT

Measurements are taken with pinion bearing cups and pinion bearings installed in the housing. Take measurements with Pinion Gauge Set and Dial Indicator C-3339 (Fig. 8).



J9403-45

Fig. 8 Pinion Depth Gauge Tools

- 1 - DIAL INDICATOR
- 2 - ARBOR
- 3 - PINION HEIGHT BLOCK
- 4 - CONE
- 5 - SCREW
- 6 - PINION BLOCK
- 7 - SCOOTER BLOCK
- 8 - ARBOR DISC

(1) Assemble Pinion Height Block 6739, Pinion Block 8542 and rear pinion bearing onto Screw 6741 (Fig. 8).

(2) Insert assembled height gauge components, rear bearing, and screw into the housing through pinion bearing cups (Fig. 9).

(3) Install front pinion bearing and Cone-Nut 6740 hand tight (Fig. 8).

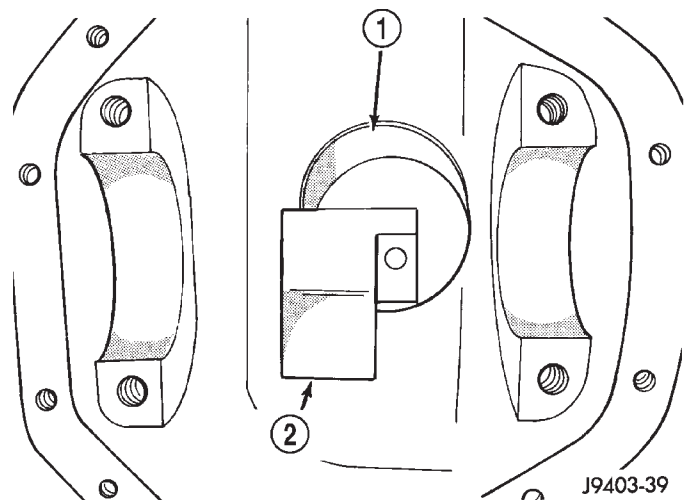


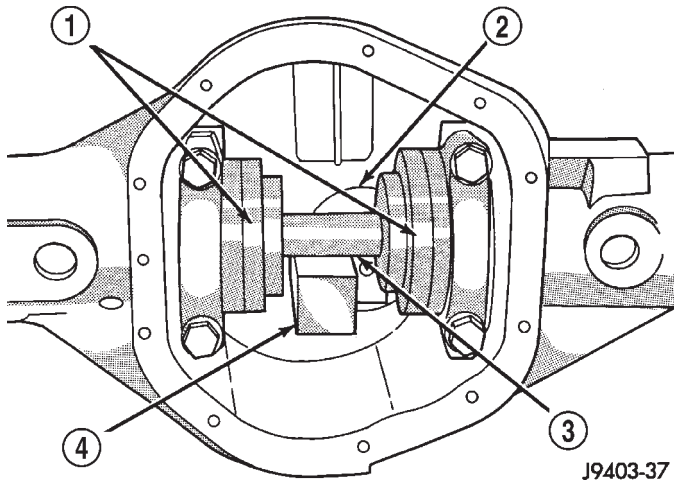
Fig. 9 Pinion Height Block

- 1 - PINION BLOCK
- 2 - PINION HEIGHT BLOCK

(4) Place Arbor Disc 8541 on Arbor D-115-3 in position in the housing side bearing cradles (Fig. 10). Install differential bearing caps on arbor discs and tighten cap bolts to 41 N·m (30 ft. lbs.).

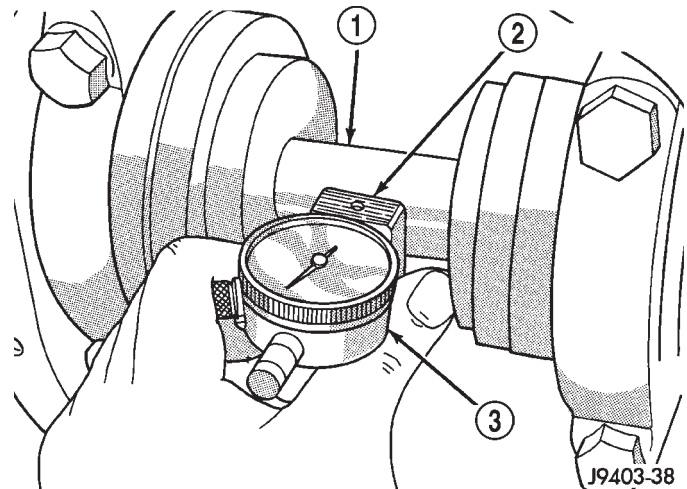
**NOTE:** Arbor Discs 8541 has different step diameters to fit other axles. Choose proper step for axle being serviced.

## REAR AXLE - 9 1/4 (Continued)



**Fig. 10 Pinion Depth Tools**

- 1 - ARBOR DISC
- 2 - PINION BLOCK
- 3 - ARBOR
- 4 - PINION HEIGHT BLOCK



**Fig. 11 Pinion Gear Depth Measurement**

- 1 - ARBOR
- 2 - SCOOTER BLOCK
- 3 - DIAL INDICATOR

(5) Assemble Dial Indicator C-3339 into Scooter Block D-115-2 and secure set screw.

(6) Place Scooter Block/Dial Indicator in position in axle housing so dial probe and scooter block are flush against the rearward surface of the pinion height block (Fig. 8). Hold scooter block in place and zero the dial indicator. Tighten dial indicator face lock screw.

(7) Slowly slide the dial indicator probe over the edge of the pinion height block.

(8) Slide the dial indicator probe across the gap between the pinion height block and the arbor bar with the scooter block against the pinion height block (Fig. 11). When the dial probe contacts the arbor bar, the dial pointer will turn clockwise. Continue moving the dial probe to the crest of the arbor bar and record the highest reading. If the dial indicator can not achieve the zero reading, the rear bearing cup or the pinion depth gauge set is not installed correctly.

(9) Select a shim equal to the dial indicator reading plus the drive pinion gear depth variance number marked on the shaft of the pinion. For example, if the depth variance is  $-2$ , add  $+0.002$  in. to the dial indicator reading.

### DIFFERENTIAL BEARING PRELOAD AND GEAR BACKLASH

The following must be considered when adjusting bearing preload and gear backlash:

- The maximum ring gear backlash variation is 0.003 inch (0.076 mm).
- Mark the gears so the same teeth are meshed during all backlash measurements.

- Maintain the torque while adjusting the bearing preload and ring gear backlash.

- Excessive adjuster torque will introduce a high bearing load and cause premature bearing failure. Insufficient adjuster torque can result in excessive differential case free-play and ring gear noise.

- Insufficient adjuster torque will not support the ring gear correctly and can cause excessive differential case free-play and ring gear noise.

**NOTE:** The differential bearing cups will not always immediately follow the threaded adjusters as they are moved during adjustment. To ensure accurate bearing cup responses to the adjustments:

- Maintain the gear teeth engaged (meshed) as marked.

- The bearings must be seated by rapidly rotating the drive pinion gear a half turn back and forth.

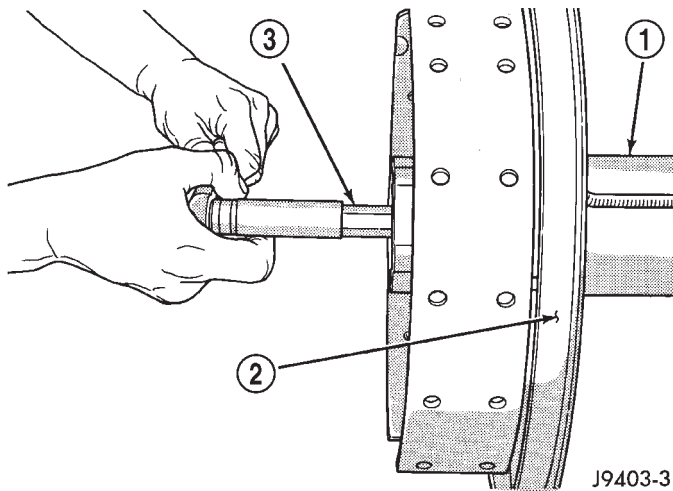
- Do this five to ten times each time the threaded adjusters are adjusted.

(1) Use Wrench C-4164 to adjust each threaded adjuster inward until the differential bearing free-play is eliminated (Fig. 12). Allow some ring gear backlash (approximately 0.25 mm / 0.01 inch) between the ring and pinion gear. Seat the bearing cups with the procedure described above.

(2) Install dial indicator and position the plunger against the drive side of a ring gear tooth (Fig. 13). Measure the backlash at 4 positions (90 degrees apart) around the ring gear. Locate and mark the area of minimum backlash.

(3) Rotate the ring gear to the position of the least backlash. Mark the gear so that all future backlash

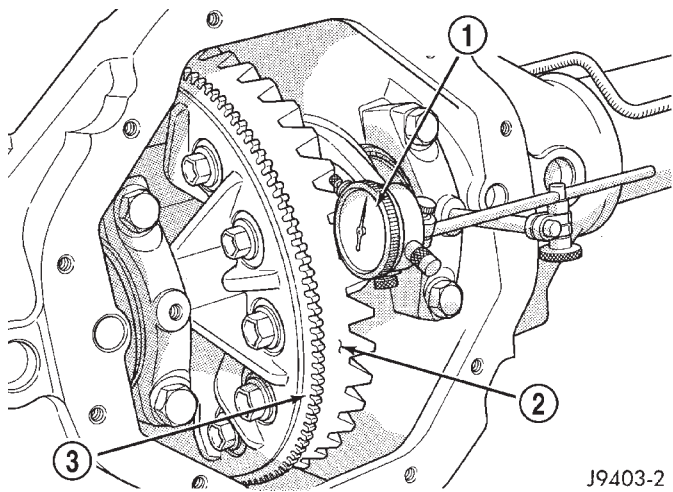
## REAR AXLE - 9 1/4 (Continued)



**Fig. 12 Threaded Adjuster Tool**

- 1 - AXLE TUBE
- 2 - BACKING PLATE
- 3 - THREAD ADJUSTER WRENCH

measurements will be taken with the same gear teeth meshed.



**Fig. 13 Ring Gear Backlash**

- 1 - DIAL INDICATOR
- 2 - RING GEAR
- 3 - EXCITER RING

(4) Loosen the right-side, tighten the left-side threaded adjuster. Obtain backlash of 0.003 to 0.004 inch (0.076 to 0.102 mm) with each adjuster tightened to 14 N·m (10 ft. lbs.). Seat the bearing cups with the procedure described above.

(5) Tighten the differential bearing cap bolts 136 N·m (100 ft. lbs.).

(6) Tighten the right-side threaded adjuster to 102 N·m (75 ft. lbs.). Seat the bearing cups with the procedure described above. Continue to tighten the

right-side adjuster and seat bearing cups until the torque remains constant at 102 N·m (75 ft. lbs.)

(7) Measure the ring gear backlash. The range of backlash is 0.13 to 0.203 mm (0.005 to 0.008 inch).

(8) Continue increasing the torque at the right-side threaded adjuster until the specified backlash is obtained.

**NOTE:** The left-side threaded adjuster torque should have approximately 102 N·m (75 ft. lbs.). If the torque is considerably less, the complete adjustment procedure must be repeated.

(9) Tighten the left-side threaded adjuster until 102 N·m (75 ft. lbs.) torque is indicated. Seat the bearing rollers with the procedure described above. Do this until the torque remains constant.

(10) Install the threaded adjuster locks and tighten the lock screws to 10 N·m (90 in. lbs.).

After the proper backlash is achieved, perform the Gear Contact procedure.

### GEAR CONTACT PATTERN

The ring gear and pinion teeth contact patterns will show if the pinion depth is correct in the housing. It will also show if the ring gear backlash has been adjusted correctly. The backlash can be adjusted within specifications to achieve desired tooth contact patterns.

(1) Apply a thin coat of hydrated ferric oxide or equivalent to the drive and coast side of the ring gear teeth.

(2) Wrap, twist, and hold a shop towel around the pinion yoke to increase the turning resistance of the pinion. This will provide a more distinct contact pattern.

(3) With a boxed end wrench on a ring gear bolt, rotate the differential case one complete revolution in both directions while a load is being applied from shop towel.

The areas on the ring gear teeth with the greatest degree of contact against the pinion teeth will squeegee the compound to the areas with the least amount of contact. Note and compare patterns on the ring gear teeth to Gear Tooth Contact Patterns chart (Fig. 14) and adjust pinion depth and gear backlash as necessary.

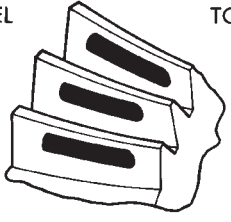
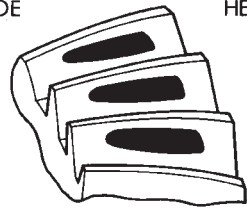
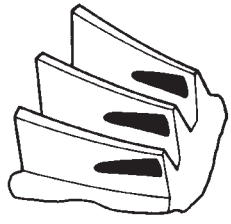
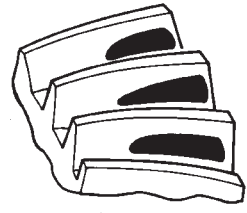
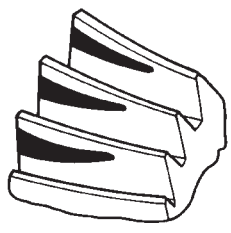
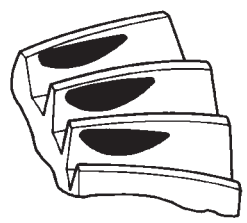
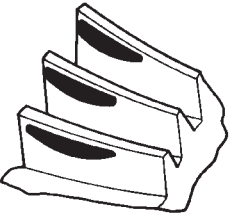
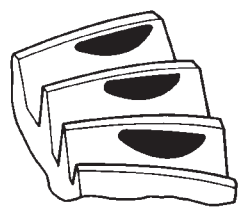
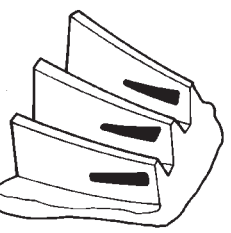
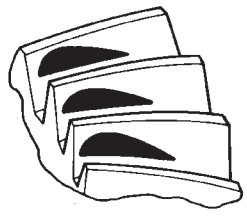
### SIDE GEAR CLEARANCE

When measuring side gear clearance, check each gear independently. If it necessary to replace a side gear, replace both gears as a matched set.

(1) Install the axle shafts and C-locks and pinion shaft.

(2) Measure each side gear clearance. Insert a matched pair of feeler gauge blades between the gear

REAR AXLE - 9 1/4 (Continued)

<p>DRIVE SIDE OF RING GEAR TEETH</p> <p>HEEL TOE</p> 	<p>COAST SIDE OF RING GEAR TEETH</p> <p>TOE HEEL</p> 	<p>DESIRABLE CONTACT PATTERN. PATTERN SHOULD BE CENTERED ON THE DRIVE SIDE OF TOOTH. PATTERN SHOULD BE CENTERED ON THE COAST SIDE OF TOOTH, BUT MAY BE SLIGHTLY TOWARD THE TOE. THERE SHOULD ALWAYS BE SOME CLEARANCE BETWEEN CONTACT PATTERN AND TOP OF THE TOOTH.</p>
		<p>RING GEAR BACKLASH CORRECT. <b>THINNER</b> PINION GEAR DEPTH SHIM REQUIRED.</p>
		<p>RING GEAR BACKLASH CORRECT. <b>THICKER</b> PINION GEAR DEPTH SHIM REQUIRED.</p>
		<p>PINION GEAR DEPTH SHIM CORRECT. <b>DECREASE</b> RING GEAR BACKLASH.</p>
		<p>PINION GEAR DEPTH SHIM CORRECT. <b>INCREASE</b> RING GEAR BACKLASH.</p>

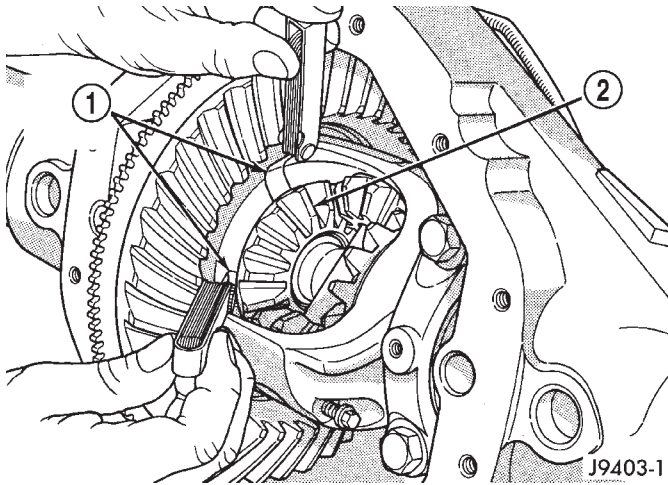
J9003-24

Fig. 14 Gear Tooth Contact Patterns



## REAR AXLE - 9 1/4 (Continued)

and differential housing on opposite sides of the hub (Fig. 15).



**Fig. 15 Side Gear Clearance**

- 1 - FEELER GAUGE  
2 - SIDE GEAR

(3) If side gear clearances is no more than 0.005 inch. Determine if the axle shaft is contacting the pinion shaft. **Do not remove the feeler gauges, inspect the axle shaft with the feeler gauge inserted behind the side gear.** If the end of the axle shaft is not contacting the pinion shaft, the side gear clearance is acceptable.

(4) If clearance is more than 0.005 inch (axle shaft not contacting pinion shaft), record the side gear clearance. Remove the thrust washer and measure

its thickness with a micrometer. Add the washer thickness to the recorded side gear clearance. The sum of gear clearance and washer thickness will determine required thickness of replacement thrust washer (Fig. 16). In some cases, the end of the axle

SIDE GEAR CLEARANCE	0.007
THRUST WASHER THICKNESS	+ 0.033
TOTAL	0.040
	→ 0.040
REPLACEMENT WASHER THICKNESS	- 0.037
NEW SIDE GEAR CLEARANCE	0.003
	J9203-31

**Fig. 16 Side Gear Calculations**

shaft will move and contact the pinion shaft when the feeler gauge is inserted. The C-lock is preventing the side gear from sliding on the axle shaft.

(5) If there is no side gear clearance, remove the C-lock from the axle shaft. Use a micrometer to measure the thrust washer thickness. Record the thickness and re-install the thrust washer. Assemble the differential case without the C-lock installed and re-measure the side gear clearance.

(6) Compare both clearance measurements. If the difference is less than 0.012 inch (0.305 mm), add clearance recorded when the C-lock was installed to thrust washer thickness measured. The sum will determine the required thickness of the replacement thrust washer.

(7) If clearance is 0.012 inch (0.305 mm) or greater, both side gears must be replaced (matched set) and the clearance measurements repeated.

(8) If clearance (above) continues to be 0.012 inch (0.305 mm) or greater, the case must be replaced.



REAR AXLE - 9 1/4 (Continued)

SPECIFICATIONS

REAR AXLE - 9 1/4

AXLE SPECIFICATIONS

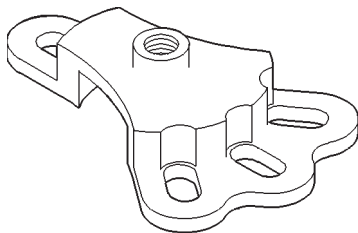
DESCRIPTION	SPECIFICATION
Axle Ratio	3.21, 3.55, 3.92
Differential Case Flange Runout	0.076 mm (0.003 in.)
Differential Case Clearance	0.12 mm (0.005 in.)
Ring Gear Diameter	235 mm (9.25 in.)
Ring Gear Backlash	0.13-0.20 mm (0.005-0.008 in.)
Ring Gear Runout	0.12 mm (0.005 in.)
Pinion Bearing Preload - Original Bearings	1-2 N·m (10-20 in. lbs.)
Pinion Bearing Preload - New Bearings	1.7-4 N·m (15-35 in. lbs.)

TORQUE SPECIFICATIONS

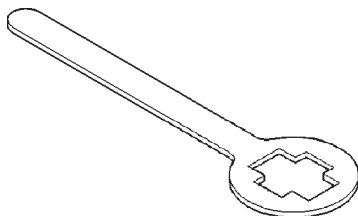
DESCRIPTION	N·m	Ft. Lbs.	In. Lbs.
Differential Cover Bolts	41	30	-
Bearing Cap Bolts	136	100	-
Ring Gear Bolts	157	115	-
Pinion Nut Minimum	285	210	-
Adjuster Lock Screw	11	8	96
Backing Plate Nuts	54	40	-

SPECIAL TOOLS

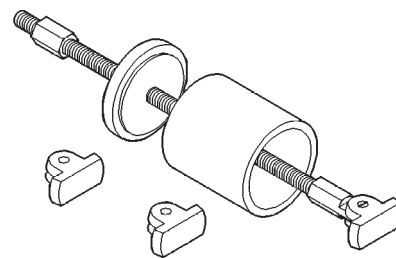
REAR AXLE - 9 1/4



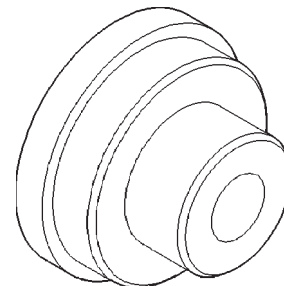
**Puller 6790**



**Holder Yoke 6719A**

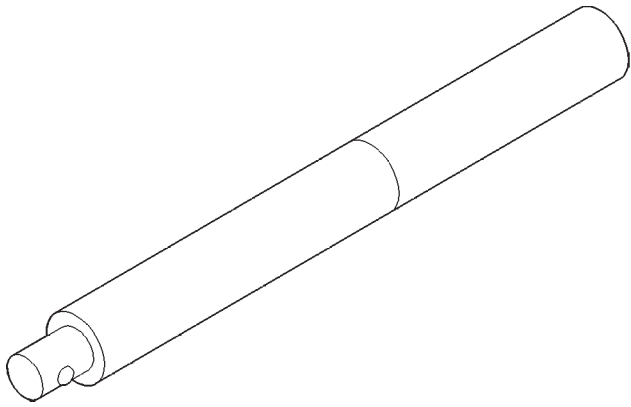


**Remover, Bearing 6310**

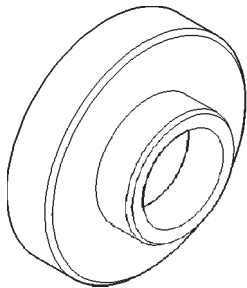


**Installer C-4198**

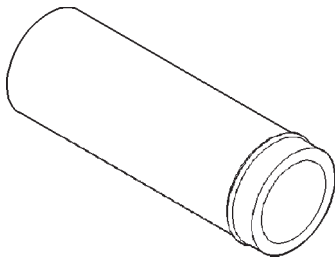
REAR AXLE - 9 1/4 (Continued)



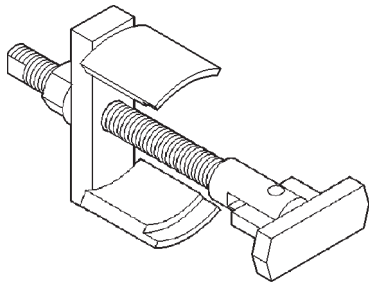
**Handle C-4171**



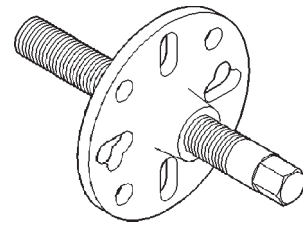
**Installer—C-4076-B**



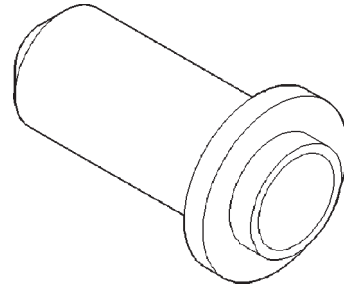
**Handle C-4735-1**



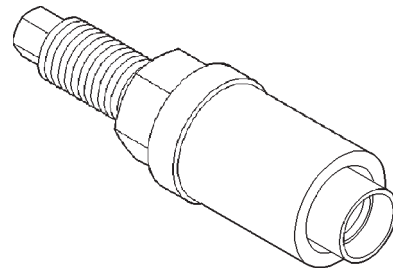
**Remover C-4828**



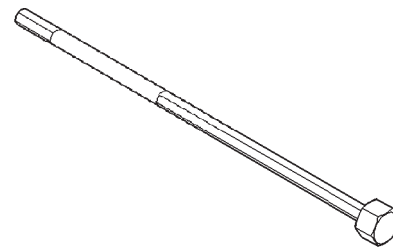
**Puller C-452**



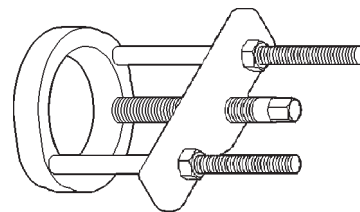
**Installer C-3860-A**



**Installer C-3718**

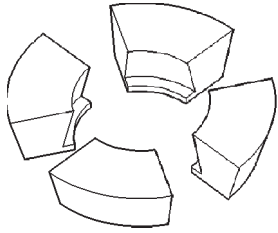


**Wrench C-4164**

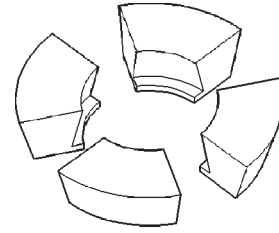


**Puller/Press C-293-PA**

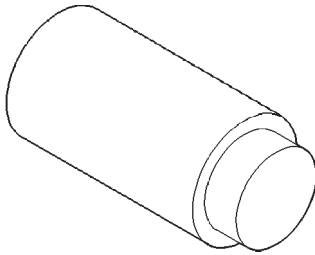
REAR AXLE - 9 1/4 (Continued)



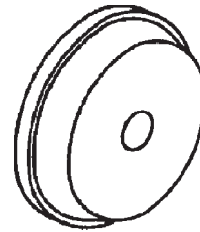
**Adapters C-293-47**



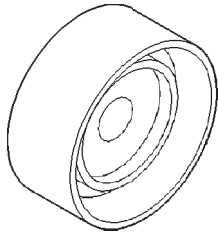
**Adapters C-293-37**



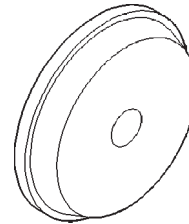
**Plug C-293-3**



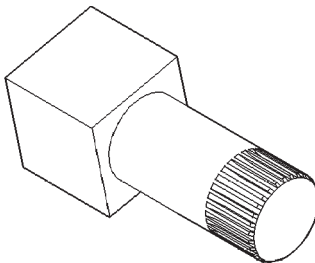
**Installer C-4310**



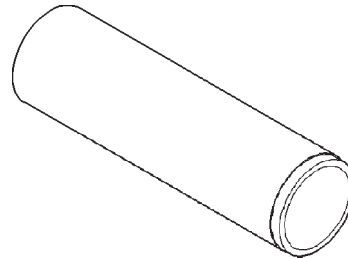
**Installer C-4213**



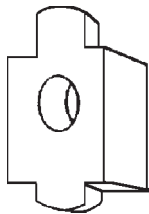
**Installer D-129**



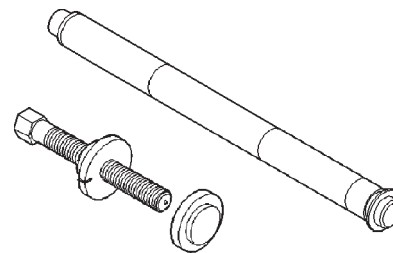
**Fixture 8136**



**Installer C-3095**

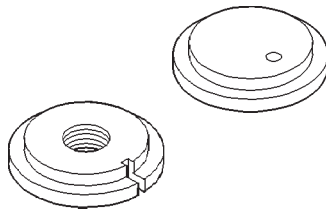
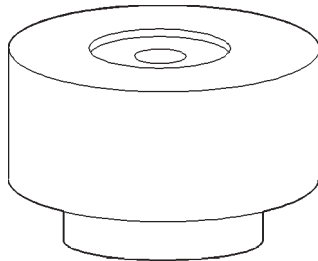
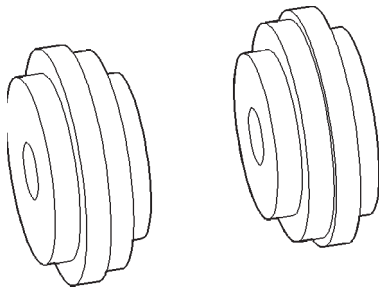


**Remover C-4309**

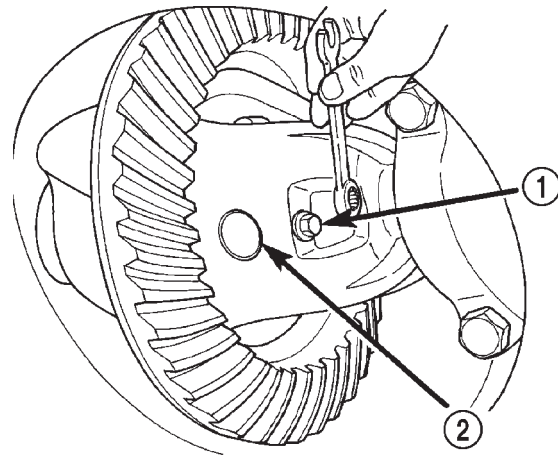


**Trac-lok Tools C-4487**

## REAR AXLE - 9 1/4 (Continued)

**Trac-lok Tools 8139****Height Block 8542****Arbor Discs 8541****AXLE SHAFTS****REMOVAL**

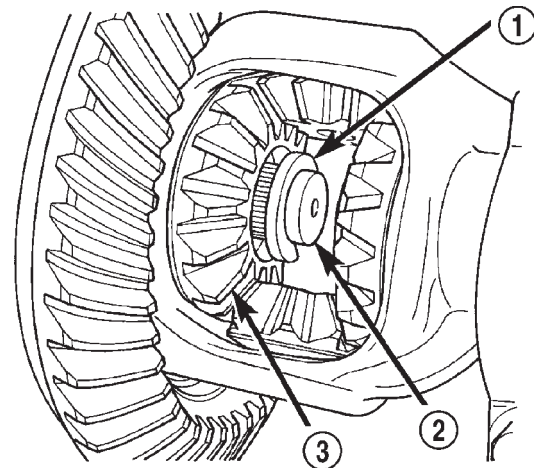
- (1) Place the transmission in NEUTRAL and raise and support vehicle.
- (2) Remove wheel and tire assembly.
- (3) Remove brake drum (Refer to 5 - BRAKES/HYDRAULIC/MECHANICAL/DRUM - REMOVAL) ..
- (4) Clean all foreign material from housing cover area.
- (5) Remove the housing cover and drain lubricant.
- (6) Rotate differential case to access the pinion shaft lock screw. Remove lock screw and pinion shaft from differential case (Fig. 17).
- (7) Push axle shaft inward then remove axle shaft C-lock (Fig. 18).
- (8) Remove axle shaft being carefull not to damage shaft bearing and seal.
- (9) Inspect axle shaft seal for leakage or damage.
- (10) Inspect axle shaft bearing contact surface for signs of brinelling, galling and pitting.



80be4604

**Fig. 17 Pinion Shaft Lock Screw**

- 1 - LOCK SCREW
- 2 - PINION MATE SHAFT



80be4603

**Fig. 18 Axle Shaft C-Lock**

- 1 - C-LOCK
- 2 - AXLE SHAFT
- 3 - SIDE GEAR

**INSTALLATION**

- (1) Lubricate bearing bore and seal lip with gear lubricant. Insert axle shaft through seal, bearing and engage it into side gear splines.

**NOTE: Use care to prevent shaft splines from damaging axle shaft seal lip.**

- (2) Insert C-lock in end of axle shaft. Push axle shaft outward to seat C-lock in side gear.
- (3) Insert pinion shaft into differential case and through thrust washers and differential pinions.
- (4) Align hole in shaft with hole in the differential case and install lock screw with Loctite® on the threads. Tighten lock screw to 11 N·m (8 ft. lbs.).

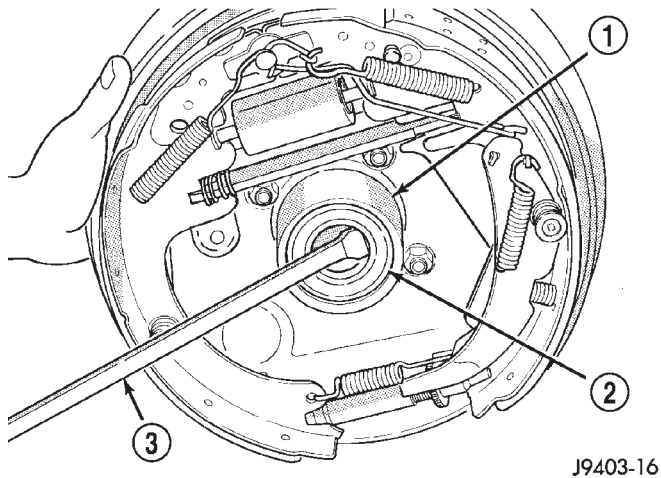
## AXLE SHAFTS (Continued)

- (5) Install cover and fill with gear lubricant.
- (6) Install brake drum (Refer to 5 - BRAKES/HYDRAULIC/MECHANICAL/DRUM - INSTALLATION).
- (7) Install wheel and tire assemblies.
- (8) Remove support and lower vehicle.

## AXLE SHAFT SEALS

## REMOVAL

- (1) Remove axle shaft.
- (2) Remove axle shaft seal from the end of the axle tube with a small pry bar (Fig. 19).



J9403-16

Fig. 19 Axle Seal

- 1 - AXLE TUBE
- 2 - AXLE SEAL
- 3 - PRY BAR

## INSTALLATION

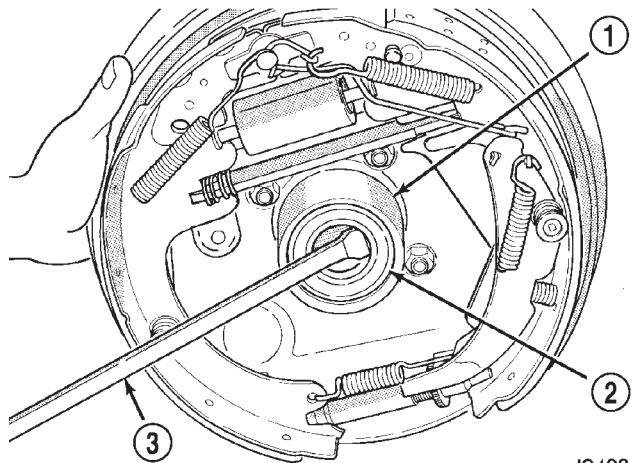
- (1) Wipe the axle tube bore clean. Remove any old sealer or burrs from the tube.
- (2) Install a **new** axle seal with Installer C-4076-B and Handle C-4735-1. When the tool contacts the axle tube, the seal is installed to the correct depth.
- (3) Coat the lip of the seal with axle lubricant for protection prior to installing the axle shaft.
- (4) Install the axle shaft.

## AXLE BEARINGS

## REMOVAL

- (1) Remove axle shaft.
- (2) Remove axle shaft seal from the end of the axle tube with a small pry bar (Fig. 20).

**NOTE:** The seal and bearing can be removed at the same time with the bearing removal tool.

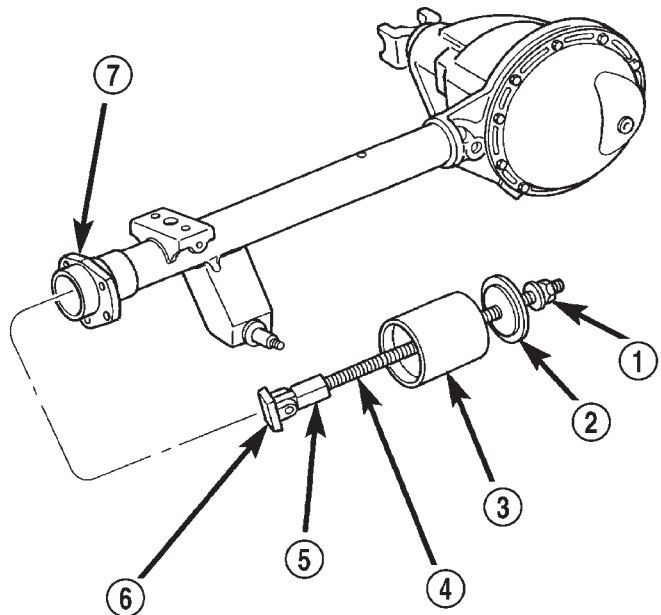


J9403-16

Fig. 20 Axle Seal

- 1 - AXLE TUBE
- 2 - AXLE SEAL
- 3 - PRY BAR

- (3) Remove the axle shaft bearing from the axle tube with Bearing Removal 6310 and Adapter 6310-9 (Fig. 21).



80be460E

Fig. 21 Axle Shaft Bearing

- 1 - NUT
- 2 - GUIDE PLATE
- 3 - GUIDE
- 4 - THREADED ROD
- 5 - ADAPTER
- 6 - FOOT
- 7 - AXLE TUBE



## AXLE BEARINGS (Continued)

## INSTALLATION

(1) Wipe the axle tube bore clean. Remove any old sealer or burrs from the tube.

(2) Install the axle shaft bearing with Installer C-4198 and Handle C-4171. Ensure that the bearing part number is against the installer. Verify that the bearing is installed straight and the tool fully contacts the axle tube when seating the bearing.

(3) Install a **new** axle seal with Installer C-4076-B and Handle C-4735-1. When the tool contacts the axle tube, the seal is installed to the correct depth.

(4) Coat the lip of the seal with axle lubricant for protection prior to installing the axle shaft.

(5) Install the axle shaft.

## PINION SEAL

## REMOVAL

(1) Raise and support the vehicle.

(2) Mark the universal joint, companion flange and pinion shaft for installation reference.

(3) Remove the propeller shaft from the companion flange. Secure the propeller shaft in an upright position to prevent damage to the rear universal joint.

(4) Remove the wheel and tire assemblies.

(5) Remove the brake drums to prevent any drag. The drag may cause a false bearing preload torque measurement.

(6) Rotate the companion flange three or four times.

(7) Measure the amount of torque necessary to rotate the pinion with an inch pound torque wrench. Record the torque reading for installation reference.

(8) Install socket head bolts into two of the threaded holes in the companion flange, 180° apart.

(9) Position Holder 6719A against the companion flange and install a hex head bolt and washer into one of the remaining threaded holes. Tighten the bolts so the holder is held to the flange.

(10) Hold the flange with holder and remove the pinion nut and washer.

(11) Remove the companion flange with Remover C-452 (Fig. 22).

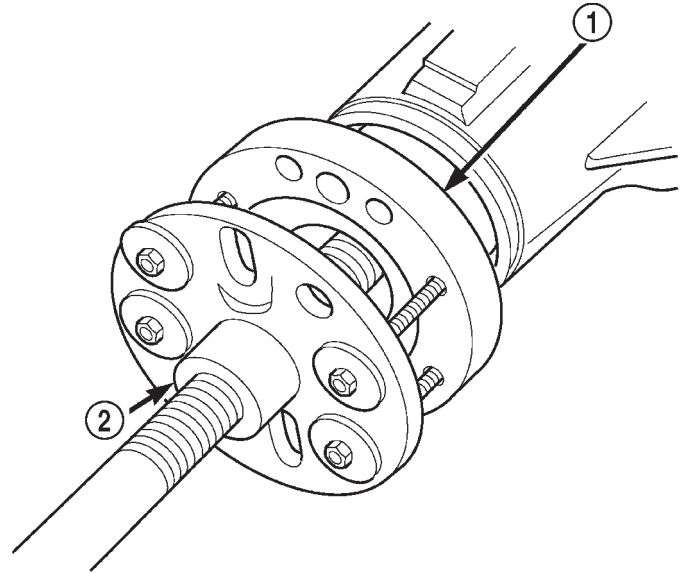
(12) Remove pinion seal with a pry tool or slide-hammer mounted screw.

## INSTALLATION

**NOTE:** The outer perimeter of the seal is pre-coated with a special sealant. An additional application of sealant is not required.

(1) Apply a light coating of gear lubricant on the lip of pinion seal.

(2) Install **new** pinion seal with Installer C-3860-A and Handle C-4171.



80c07130

**Fig. 22 Companion Flange Remover**

- 1 - COMPANION FLANGE  
2 - PULLER TOOL

**NOTE:** The seal is correctly installed when the seal flange contacts the face of the differential housing.

(3) Position the companion flange on the end of the shaft with the reference marks aligned.

(4) Install socket head bolts into two of the threaded holes in the companion flange, 180° apart.

(5) Position Holder 6719A against the companion flange and install a hex head bolt and washer into one of the remaining threaded holes. Tighten the bolts so the holder is held to the flange.

(6) Seat companion flange on pinion shaft with Installer C-3718 and Holder 6719.

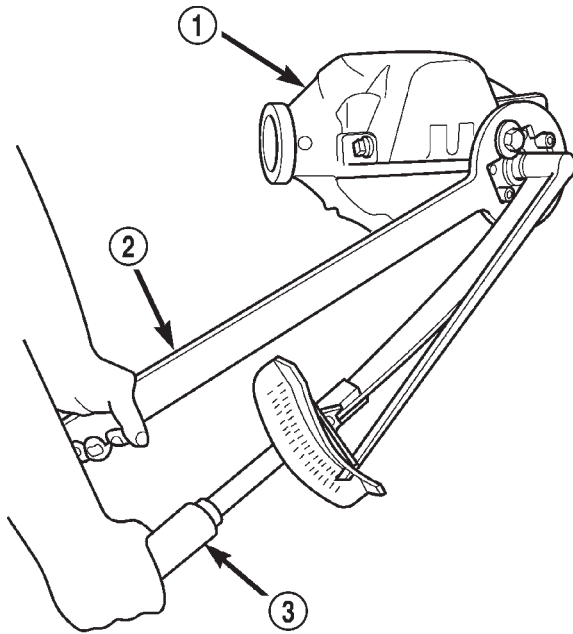
(7) Remove the installer and install the pinion washer and a **new** pinion nut. The convex side of the washer must face outward.

**CAUTION:** Do not exceed the minimum tightening torque when installing the companion flange retaining nut at this point. Damage to collapsible spacer or bearings may result.

(8) Hold companion flange with Holder 6719 and tighten the pinion nut to 285 N·m (210 ft. lbs.) (Fig. 23). Rotate pinion several revolutions to ensure the bearing rollers are seated.

(9) Rotate the pinion using an (in. lbs.) torque wrench. Rotating torque should be equal to the reading recorded during removal, plus an additional 0.56 N·m (5 in. lbs.) (Fig. 24).

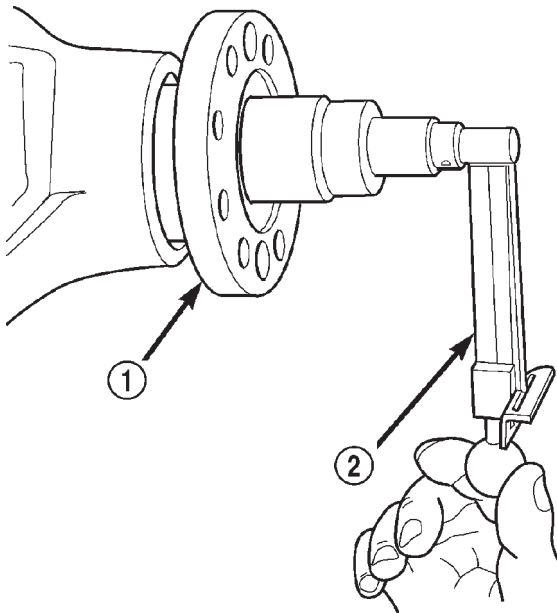
## PINION SEAL (Continued)



80c07131

**Fig. 23 Pinion Nut**

- 1 - DIFFERENTIAL HOUSING  
2 - COMPANION FLANGE HOLDER  
3 - TORQUE WRENCH



80c07132

**Fig. 24 Pinion Rotation Torque**

- 1 - COMPANION FLANGE  
2 - INCH POUND TORQUE WRENCH

**CAUTION:** Never loosen pinion nut to decrease pinion bearing rotating torque and never exceed specified preload torque. If rotating torque is exceeded, a new collapsible spacer must be installed.

(10) If the rotating torque is low, use Holder 6719 to hold the companion flange (Fig. 23) and tighten the pinion nut in 6.8 N·m (5 ft. lbs.) increments until proper rotating torque is achieved.

**NOTE:** The bearing rotating torque should be constant during a complete revolution of the pinion. If the rotating torque varies, this indicates a binding condition.

(11) The seal replacement is unacceptable if the final pinion nut torque is less than 285 N·m (210 ft. lbs.).

(12) Install the propeller shaft with the installation reference marks aligned.

(13) Tighten the companion flange bolts to 108 N·m (80 ft. lbs.).

(14) Install the brake drums.

(15) Install wheel and tire assemblies and lower the vehicle.

(16) Check the differential housing lubricant level.

## DIFFERENTIAL

### REMOVAL

- (1) Raise and support the vehicle.
- (2) Remove lubricant fill hole plug from the differential housing cover.
- (3) Remove differential housing cover and drain the lubricant from the housing.
- (4) Clean the housing cavity with a flushing oil, light engine oil or lint free cloth. **Do not use water, steam, kerosene or gasoline for cleaning.**
- (5) Remove the axle shafts.
- (6) Remove RWAL/ABS sensor from housing.

**NOTE:** Side play resulting from bearing races being loose on case hubs requires replacement of the differential case.

(7) Mark the differential housing and differential bearing caps for installation reference (Fig. 25).

(8) Remove bearing threaded adjuster lock from each bearing cap. Loosen the bolts, but do not remove the bearing caps.

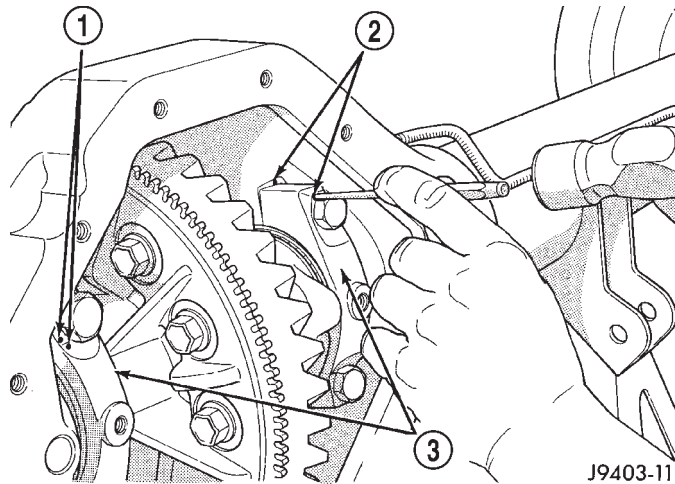
(9) Loosen the threaded adjusters with Wrench C-4164 (Fig. 26).

(10) Hold the differential case while removing bearing caps and adjusters.

(11) Remove the differential case.

**NOTE:** Each differential bearing cup and threaded adjuster must be kept with their respective bearing.

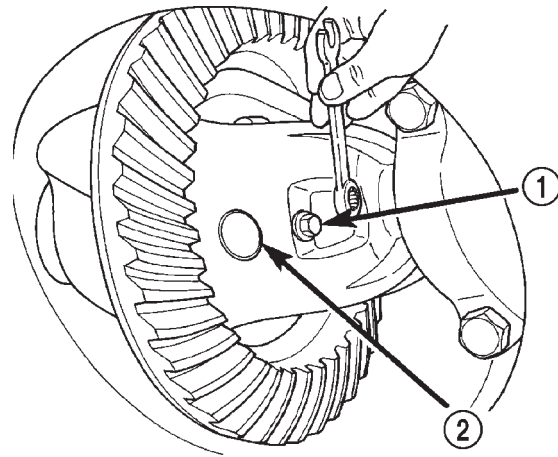
## DIFFERENTIAL (Continued)



J9403-11

**Fig. 25 Reference Mark**

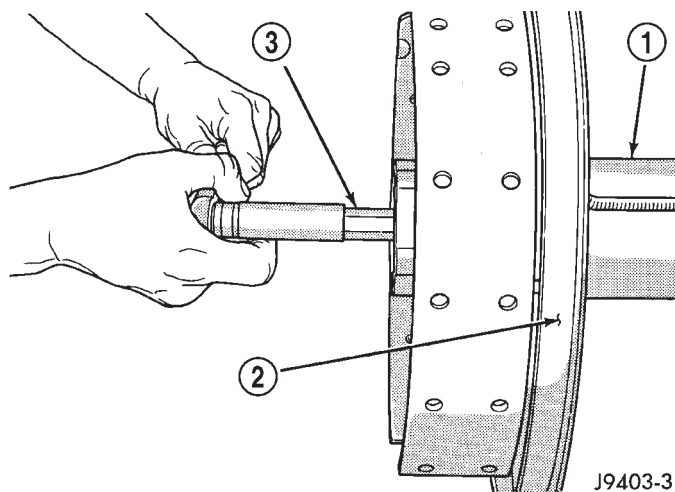
- 1 - REFERENCE MARKS
- 2 - REFERENCE MARK
- 3 - BEARING CAPS



80be4604

**Fig. 27 Pinion Shaft Lock Screw**

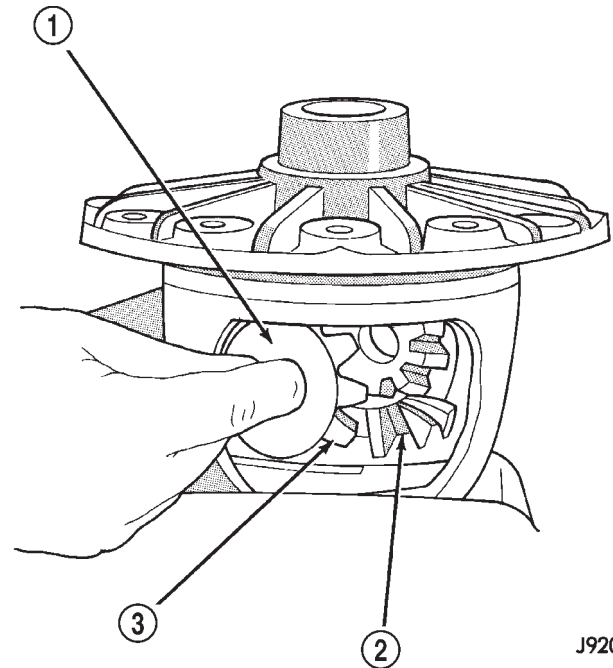
- 1 - LOCK SCREW
- 2 - PINION SHAFT



J9403-3

**Fig. 26 Threaded Adjuster**

- 1 - AXLE TUBE
- 2 - BACKING PLATE
- 3 - TOOL C-4164



J9203-61

**Fig. 28 Differential**

- 1 - THRUST WASHER
- 2 - SIDE GEAR
- 3 - DIFFERENTIAL PINIONS

**DISASSEMBLY**

- (1) Remove pinion shaft lock screw (Fig. 27).
- (2) Remove pinion shaft.
- (3) Rotate differential side gears and remove the differential pinions and thrust washers (Fig. 28).

- (4) Remove the differential side gears and thrust washers.

## DIFFERENTIAL (Continued)

## ASSEMBLY

- (1) Install differential side gears and thrust washers.
- (2) Install differential pinion and thrust washers.
- (3) Install the pinion shaft.
- (4) Align the hole in the pinion shaft with the hole in the differential case and install the pinion shaft lock screw.
- (5) Lubricate all differential components with hypoid gear lubricant.

## INSTALLATION

- (1) Apply a coating of hypoid gear lubricant to the differential bearings, bearing cups, and threaded adjusters. A dab of grease can be used to keep the adjusters in position. Carefully position the assembled differential case in the housing.
- (2) Observe the reference marks and install the differential bearing caps at their original locations (Fig. 29).

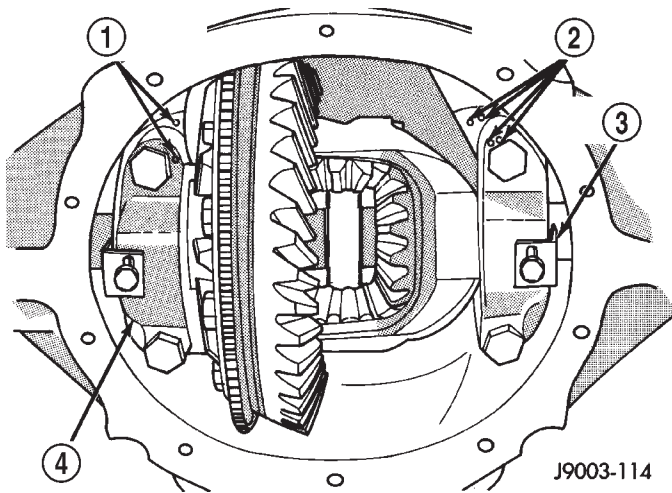


Fig. 29 Bearing Caps &amp; Bolts

- 1 - REFERENCE MARKS
- 2 - REFERENCE MARKS
- 3 - ADJUSTER LOCK
- 4 - BEARING CAP

(3) Install bearing cap bolts and tighten the upper bolts to 14 N·m (10 ft. lbs.). Tighten the lower bolts finger-tight until the bolt head is seated.

(4) Perform the differential bearing preload and adjustment procedure.

**NOTE:** Be sure that all bearing cap bolts are tightened to their final torque of 136 N·m (100 ft.lbs.) before proceeding.

- (5) Install the axle shafts.
- (6) Apply a bead of Mopar Silicone Rubber Sealant or equivalent to the housing cover (Fig. 30).

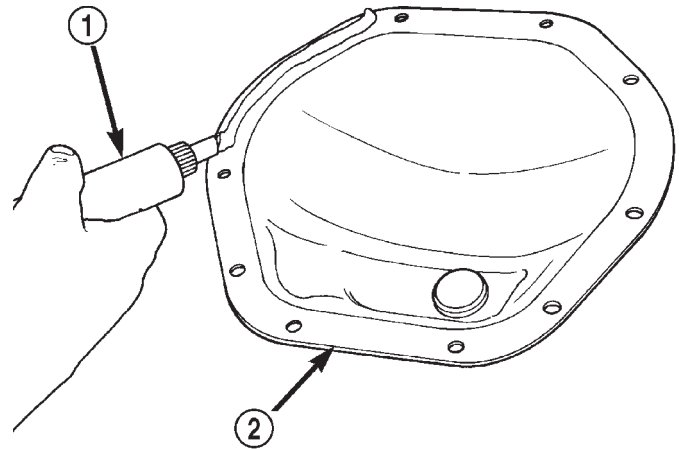


Fig. 30 Differential Cover

- 1 - SEALANT
- 2 - DIFFERENTIAL COVER

**Install the housing cover within 5 minutes after applying the sealant.**

(7) Install the cover and any identification tag. Tighten the cover bolts to 41 N·m (30 ft. lbs.) torque.

(8) Fill differential with lubricant to bottom of the fill plug hole. Refer to the Lubricant Specifications for the quantity and type.

(9) Install the fill hole plug and lower the vehicle.

(10) Trac-lok™ differential equipped vehicles should be road tested by making 10 to 12 slow figure-eight turns. This maneuver will pump the lubricant through the clutch discs to eliminate a possible chatter noise complaint.

## DIFFERENTIAL - TRAC-LOK

## DIAGNOSIS AND TESTING - TRAC-LOK™

The most common problem is a chatter noise when turning corners. Before removing a Trac-lok™ unit for repair, drain, flush and refill the axle with the specified lubricant. A container of Mopar Trac-lok™ Lubricant (friction modifier) should be added after repair service or during a lubricant change.

After changing the lubricant, drive the vehicle and make 10 to 12 slow, figure-eight turns. This maneuver will pump lubricant through the clutches. This will correct the condition in most instances. If the chatter persists, clutch damage could have occurred.

## DIFFERENTIAL TEST

The differential can be tested without removing the differential case by measuring rotating torque. Make sure brakes are not dragging during this measurement.

(1) Place blocks in front and rear of both front wheels.



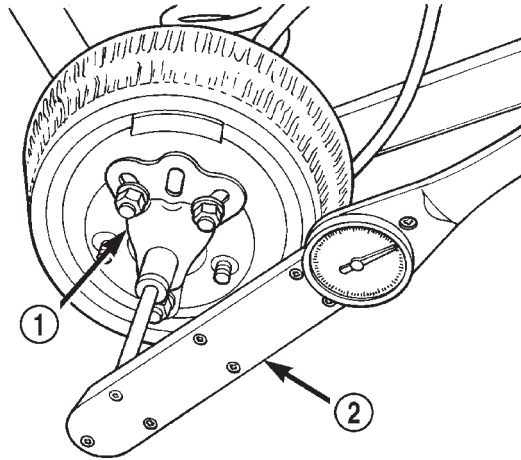
## DIFFERENTIAL - TRAC-LOK (Continued)

(2) Raise one rear wheel until it is completely off the ground.

(3) Engine off, transmission in neutral, and parking brake off.

(4) Remove wheel and bolt Special Tool 6790 or equivalent tool to studs.

(5) Use torque wrench on special tool to rotate wheel and read rotating torque (Fig. 31).



80a4d327

**Fig. 31 Trac-lok™ Test - Typical**

- 1 - SPECIAL TOOL 6790 WITH BOLT IN CENTER HOLE  
2 - TORQUE WRENCH

(6) If rotating torque is less than 22 N·m (30 ft. lbs.) or more than 271 N·m (200 ft. lbs.) on either wheel the unit should be serviced.

## DISASSEMBLY

(1) Clamp side gear Holding Fixture 6965 in a vise and position the differential case on the Holding Fixture (Fig. 32).

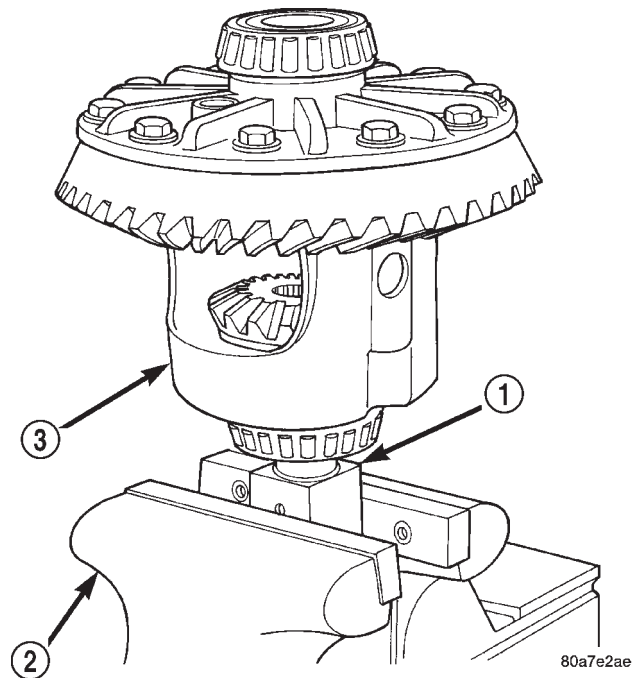
(2) Remove ring gear if the ring gear is to be replaced. The Trac-lok™ differential can be serviced with the ring gear installed.

(3) Remove pinion shaft roll pin.

(4) Remove pinion shaft with a drift and hammer (Fig. 33).

(5) Install and lubricate Step Plate C-6960-3 (Fig. 34).

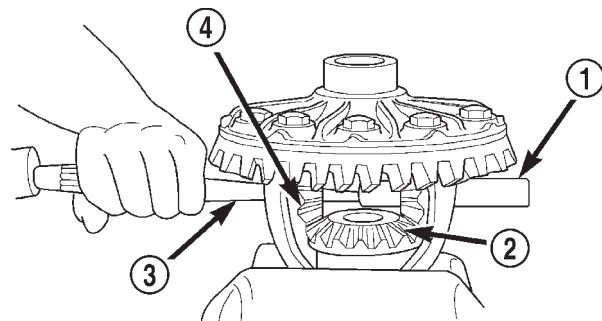
(6) Assemble Threaded Adapter C-6960-1 into top side gear. Thread Forcing Screw C-6960-4 into adapter until it becomes centered in adapter plate.



80a7e2ae

**Fig. 32 Differential Case Holding Fixture**

- 1 - HOLDING FIXTURE  
2 - VISE  
3 - DIFFERENTIAL



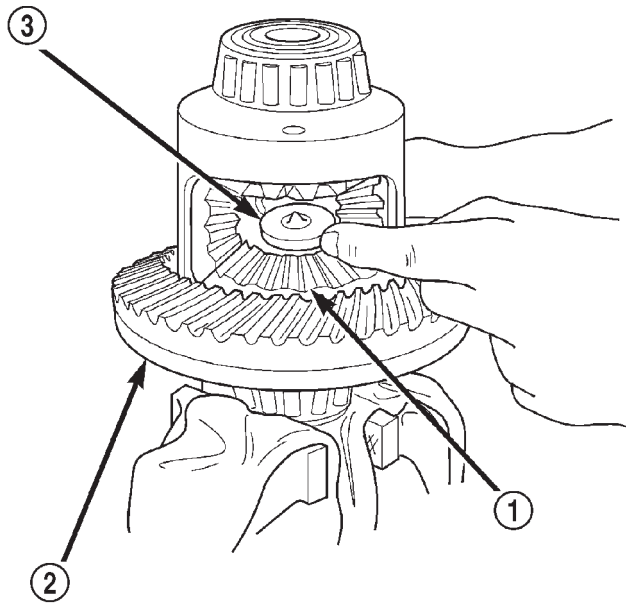
80a773e1

**Fig. 33 Pinion Shaft**

- 1 - PINION MATE SHAFT  
2 - SIDE GEAR  
3 - DRIFT  
4 - PINION MATE GEAR



## DIFFERENTIAL - TRAC-LOK (Continued)



80a83886

**Fig. 34 Step Plate**

- 1 - LOWER SIDE GEAR
- 2 - DIFFERENTIAL CASE
- 3 - STEP PLATE

(7) Position a small screw driver in slot of Threaded Adapter Disc C-6960-3 (Fig. 35) to prevent adapter from turning.

(8) Install Forcing Screw C-6960-4 and tighten screw to 122 N-m (90 ft. lbs.) maximum to compress Belleville springs in clutch packs (Fig. 36).

(9) With a feeler gauge remove thrust washers from behind the differential pinion gears (Fig. 37).

(10) Insert Turning Bar C-6960-2 into the pinion shaft hole in the case (Fig. 38).

(11) Loosen the Forcing Screw in small increments until the clutch pack tension is relieved and the differential case can be turned using Turning Bar.

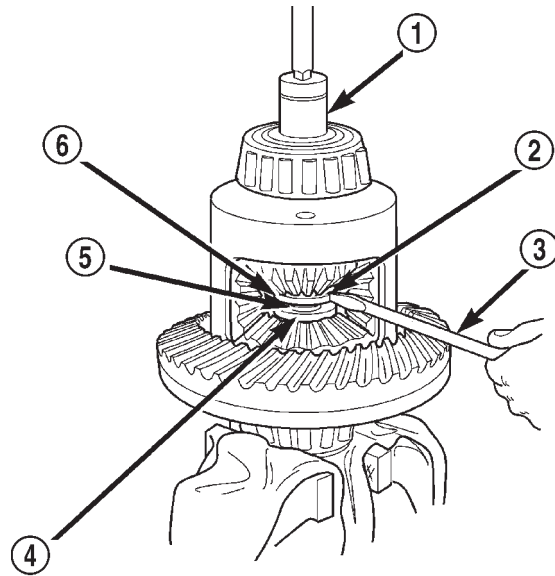
(12) Rotate differential case until the pinion gears can be removed.

(13) Remove pinion gears from differential case.

(14) Remove Forcing Screw, Step Plate and Threaded Adapter.

(15) Remove top side gear, clutch pack retainer and clutch pack. Keep plates in correct order during removal (Fig. 39).

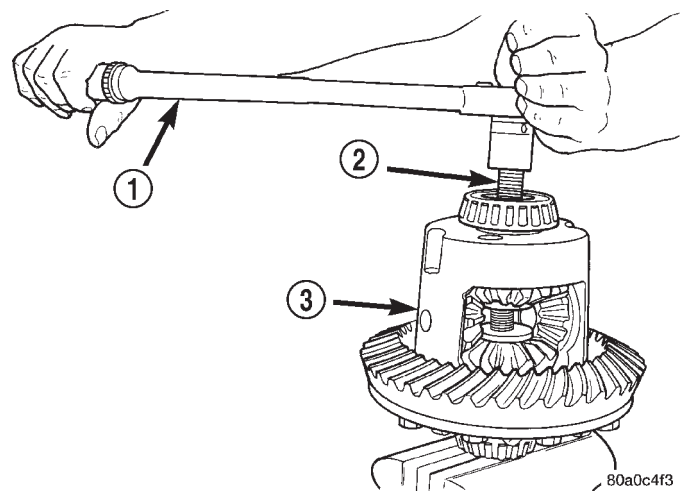
(16) Remove differential case from the Holding Fixture. Remove side gear, clutch pack retainer and clutch pack. Keep plates in correct order during removal.



80a8387f

**Fig. 35 Threaded Adapter Disc**

- 1 - SOCKET
- 2 - SLOT IN ADAPTER
- 3 - SCREWDRIVER
- 4 - DISC
- 5 - FORCING SCREW
- 6 - THREADED ADAPTER DISC

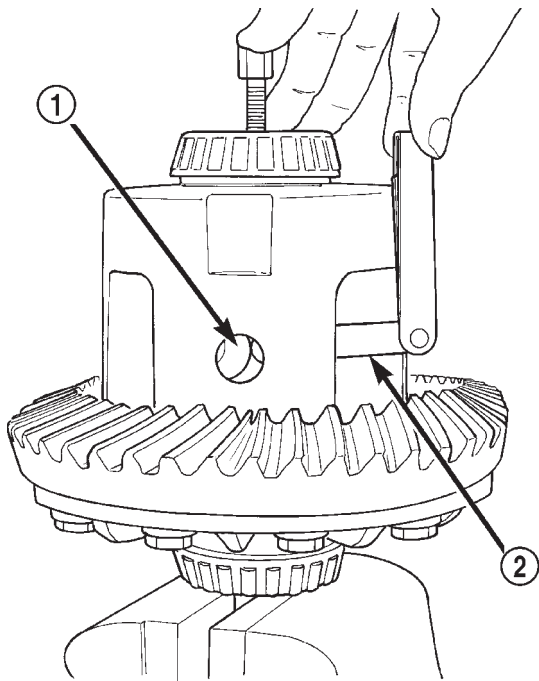


80a0c4f3

**Fig. 36 Compress Belleville Spring**

- 1 - TORQUE WRENCH
- 2 - TOOL ASSEMBLED
- 3 - DIFFERENTIAL CASE

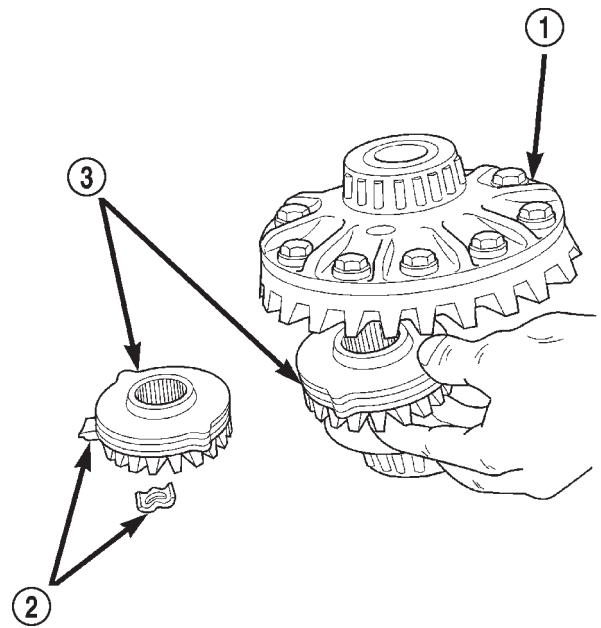
## DIFFERENTIAL - TRAC-LOK (Continued)



80a77406

**Fig. 37 Pinion Gear Thrust Washer**

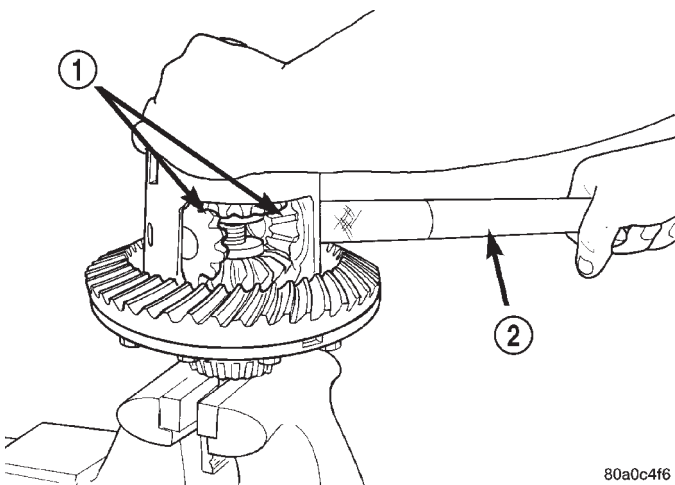
- 1 - THRUST WASHER
- 2 - FEELER GAUGE



80a98382

**Fig. 39 Side Gear & Clutch Pack**

- 1 - DIFFERENTIAL CASE
- 2 - RETAINER
- 3 - SIDE GEAR AND CLUTCH DISC PACK



80a0c4f6

**Fig. 38 Pinion Gear**

- 1 - PINION GEARS
- 2 - TOOL

**ASSEMBLY**

Clean all components in cleaning solvent. Dry components with compressed air. Inspect clutch pack plates for wear, scoring or damage. Replace both clutch packs if any one component in either pack is damaged. Inspect side gears and pinions. Replace any gear that is worn, cracked, chipped or damaged. Inspect differential case and pinion shaft. Replace if worn or damaged.

Lubricate each component with gear lubricant before assembly.

(1) Assemble the clutch discs into packs and secure disc packs with retaining clips (Fig. 40).

**NOTE: New Plates and discs with fiber coating (no grooves or lines) must be presoaked in Friction Modifier before assembly. Soak plates and discs for a minimum of 20 minutes.**

(2) Position assembled clutch disc packs on the side gear hubs.

(3) Install clutch pack and side gear in the ring gear side of the differential case (Fig. 41). **Be sure clutch pack retaining clips remain in position and are seated in the case pockets.**

(4) Position the differential case on the Holding Fixture 6965.

(5) Install lubricated Step Plate C-6960-3 in lower side gear (Fig. 42).

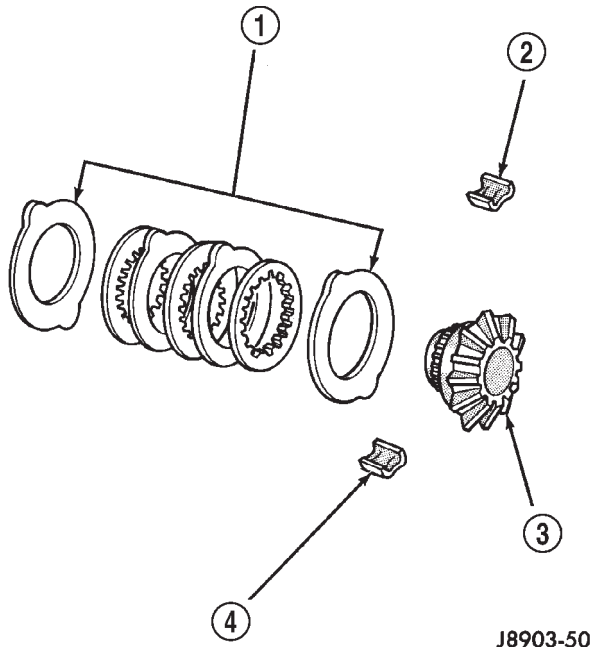
(6) Install the upper side gear and clutch disc pack (Fig. 42).

(7) Hold assembly in position. Insert Threaded Adapter C-6960-1 into top side gear.

(8) Install Forcing Screw C-6960-4 and tighten screw to slightly compress clutch disc.

(9) Place differential pinion gears in position in side gears and verify that the pinion shaft hole is aligned.

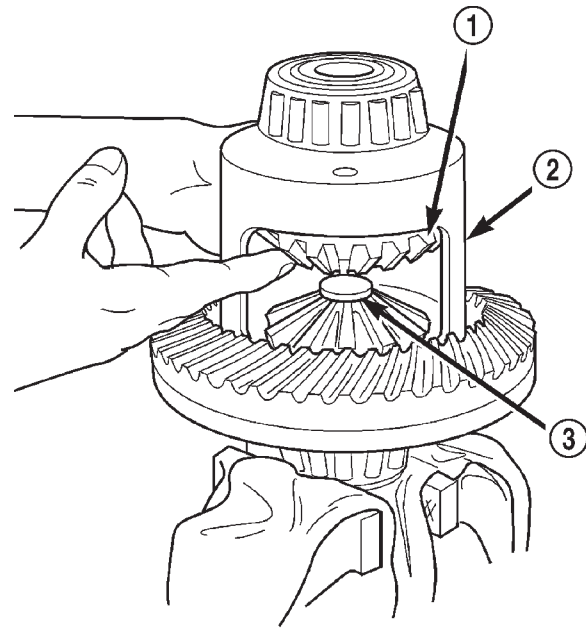
## DIFFERENTIAL - TRAC-LOK (Continued)



J8903-50

**Fig. 40 Clutch Disc Pack**

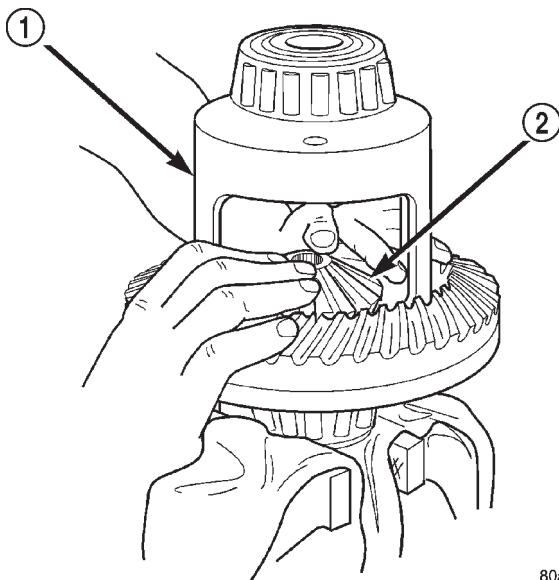
- 1 - CLUTCH PACK
- 2 - RETAINER
- 3 - SIDE GEAR
- 4 - RETAINER



80a83887

**Fig. 42 Clutch Pack and Upper Side Gear**

- 1 - SIDE GEAR AND CLUTCH PACK
- 2 - DIFFERENTIAL CASE
- 3 - STEP PLATE - C-6960-3



80a7739c

**Fig. 41 Clutch Pack and Side Gear**

- 1 - DIFFERENTIAL CASE
- 2 - LOWER SIDE GEAR AND CLUTCH DISC PACK

(10) Rotate case with Turning Bar C-6960-2 until the pinion shaft holes in pinion gears align with holes in case. It may be necessary to slightly tighten the forcing screw in order to install the pinion gears.

(11) Tighten forcing screw to 122 N·m (90 ft. lbs.) maximum to compress the Belleville springs.

(12) Lubricate and install thrust washers behind pinion gears and align washers with a small screw driver. Insert pinion shaft into each pinion gear to verify alignment.

(13) Remove Forcing Screw, Step Plate and Threaded Adapter.

(14) Install pinion shaft and align holes in shaft and case.

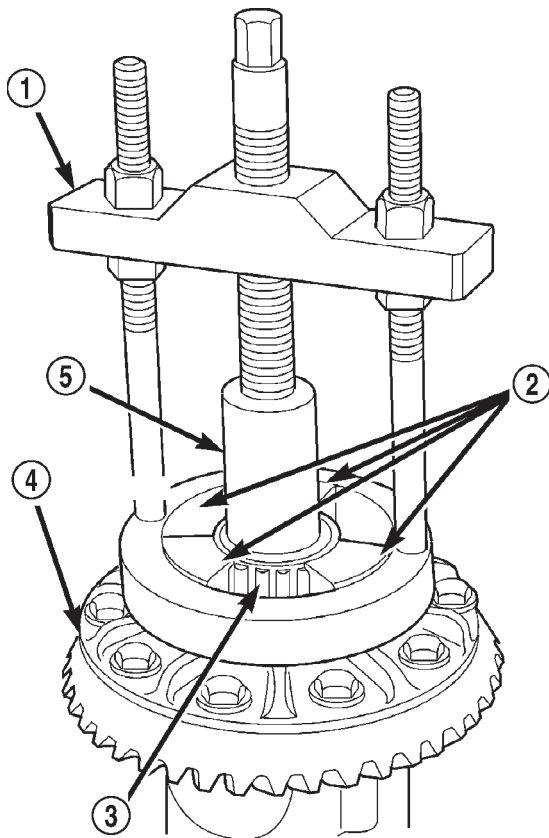
(15) Install and seat pinion shaft roll pin in differential case. Peen the edge of the roll pin hole in the case slightly in two places 180° apart.

(16) Lubricate all differential components with hypoid gear lubricant.

## DIFFERENTIAL CASE BEARINGS

### REMOVAL

- (1) Remove differential case from axle housing.
- (2) Remove bearings from the differential case with Puller C-293-PA, Adapters C-293-47 and Plug SP-293-3 (Fig. 43).

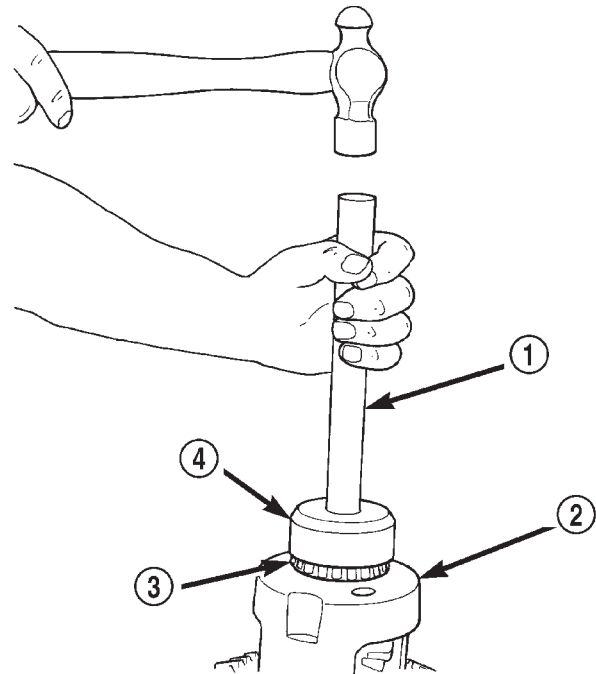


**Fig. 43 Differential Bearing**

- 1 - SPECIAL TOOL C-293-PA
- 2 - SPECIAL TOOL C-293-48
- 3 - BEARING
- 4 - DIFFERENTIAL
- 5 - SPECIAL TOOL SP-3289

### INSTALLATION

- (1) Install differential side bearings with Installer C-4213 and Handle C-4171 (Fig. 44).
- (2) Install differential case in axle housing.



**Fig. 44 Differential Side Bearings**

- 1 - HANDLE
- 2 - DIFFERENTIAL
- 3 - BEARING
- 4 - BEARING INSTALLER

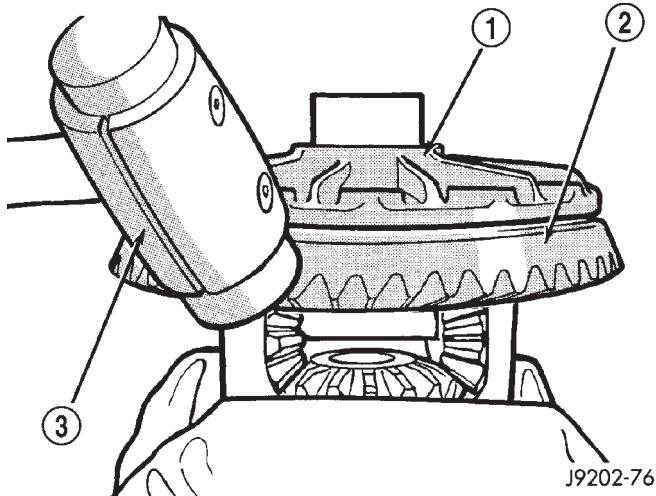
## PINION GEAR/RING GEAR/TONE RING

### REMOVAL

**NOTE:** The ring gear and pinion are serviced in a matched set. Never replace one gear without replacing the other.

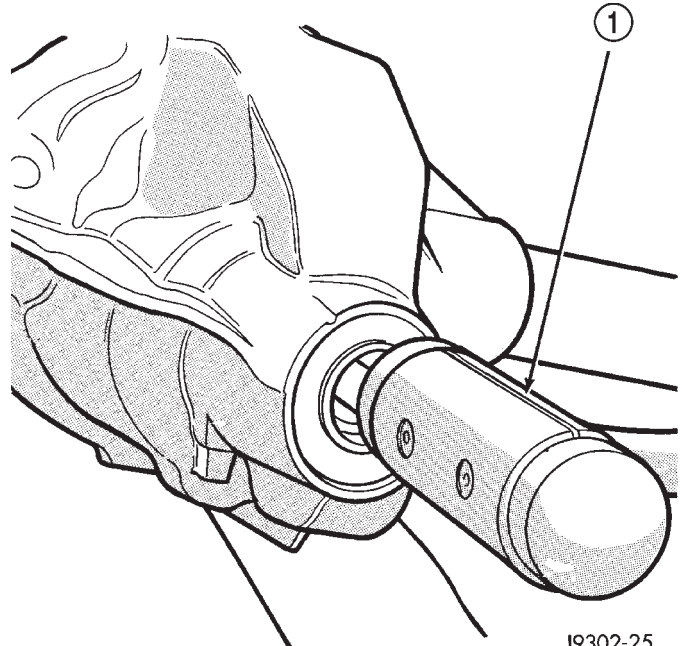
- (1) Raise and support vehicle.
- (2) Remove wheel and tire assemblies.
- (3) Mark companion flange and propeller shaft for installation reference.
- (4) Disconnect propeller shaft from the companion flange and tie propeller shaft to underbody.
- (5) Remove axle shafts.
- (6) Remove differential from the differential housing.
- (7) Place differential case in a vise with soft metal jaw protectors. (Fig. 45).
- (8) Remove ring gear bolts from the differential case.
- (9) Drive ring gear off the differential case with a rawhide hammer (Fig. 45).

PINION GEAR/RING GEAR/TONE RING (Continued)



**Fig. 45 Ring Gear**

- 1 - CASE
- 2 - RING GEAR
- 3 - RAWHIDE HAMMER



**Fig. 47 Pinion Gear**

- 1 - RAWHIDE HAMMER

(10) Install bolts into two of the threaded holes in the companion flange 180° apart.

(11) Position Holder 6719 against the companion flange and install a bolt and washer into one of the remaining threaded holes. Tighten the bolts so the Holder 6719 is held to the flange.

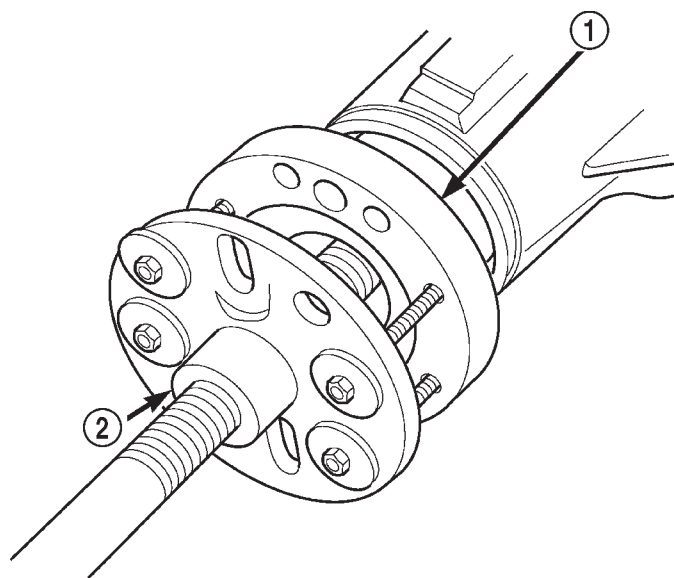
(12) Use Holder 6719 to hold companion flange and remove the companion flange nut and washer.

(13) Remove the companion flange from the pinion with Remover C-452 (Fig. 46).

(15) Remove pinion seal with a pry tool or slide-hammer mounted screw.

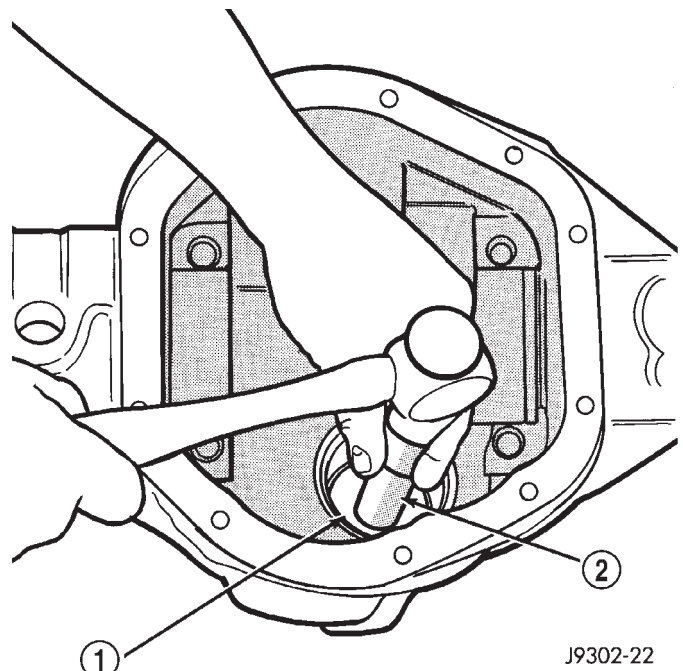
(16) Remove oil slinger if equipped and front pinion bearing.

(17) Remove front pinion bearing cup with Remover C-4345 and Handle C-4171 (Fig. 48).



**Fig. 46 Companion Flange**

- 1 - COMPANION FLANGE
- 2 - REMOVER



**Fig. 48 Front Pinion Bearing Cup**

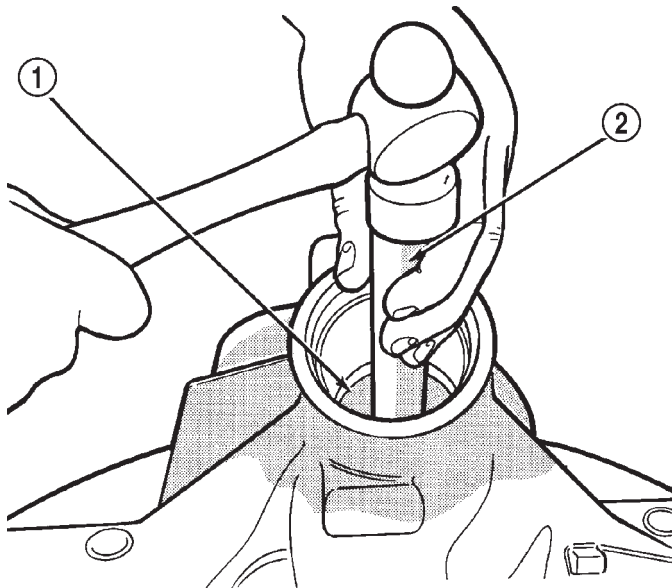
- 1 - REMOVER
- 2 - HANDLE

(14) Remove the pinion from housing (Fig. 47).



## PINION GEAR/RING GEAR/TONE RING (Continued)

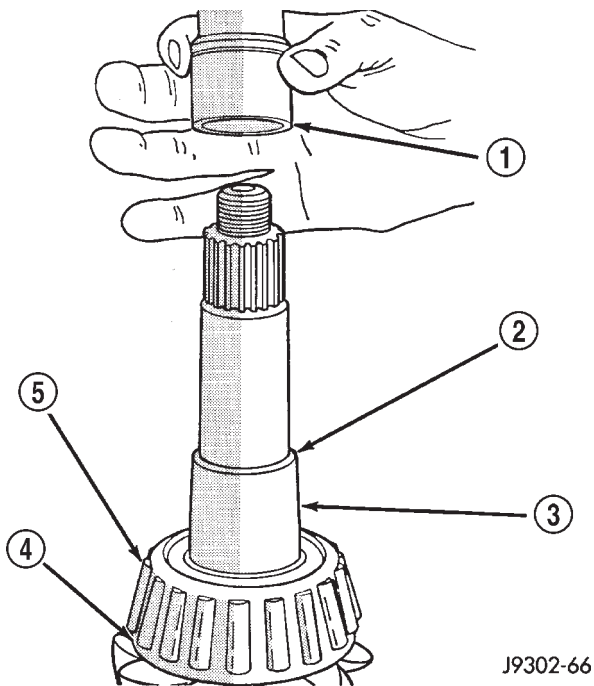
(18) Remove the rear bearing cup from housing (Fig. 49) with Remover C-4307 and Handle C-4171.



**Fig. 49 Rear Pinion Bearing Cup**

- 1 - DRIVER  
2 - HANDLE

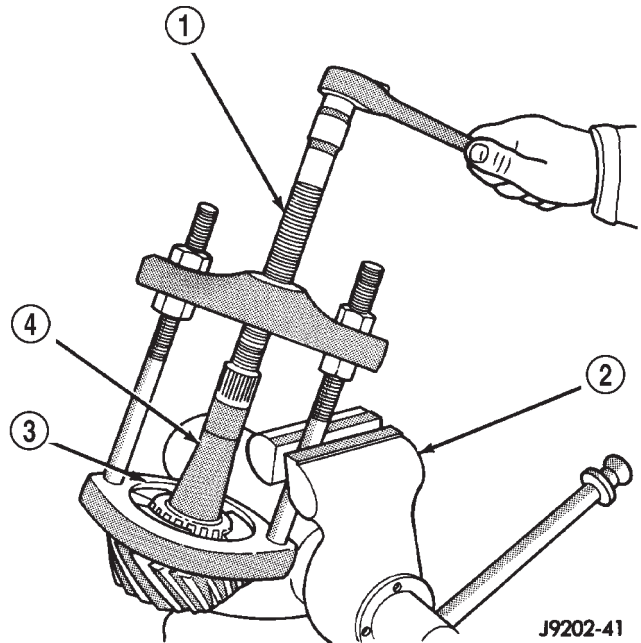
(19) Remove the collapsible preload spacer (Fig. 50).



**Fig. 50 Collapsible Spacer**

- 1 - COLLAPSIBLE SPACER  
2 - SHOULDER  
3 - PINION GEAR  
4 - DEPTH SHIM  
5 - REAR BEARING

(20) Remove rear bearing from the pinion (Fig. 51) with Puller/Press C-293-PA and Adapters C-293-47.



**Fig. 51 Rear Pinion Bearing**

- 1 - PULLER  
2 - VISE  
3 - ADAPTERS  
4 - PINION SHAFT

(21) Remove depth shims from the pinion shaft and record shim thickness.

## INSTALLATION

**NOTE:** The ring gear and pinion are serviced in a matched set. Do not replace the pinion without replacing the ring gear. If ring and pinion gears or bearings are replaced, Refer to Adjustments for Pinion Gear Depth Setting.

(1) Apply Mopar Door Ease or stick lubricant to outside surface of bearing cup.

(2) Install rear pinion bearing cup (Fig. 52) with Installer C-4308 and Driver Handle C-4171 and verify cup is seated.

(3) Apply Mopar Door Ease or stick lubricant to outside surface of bearing cup.

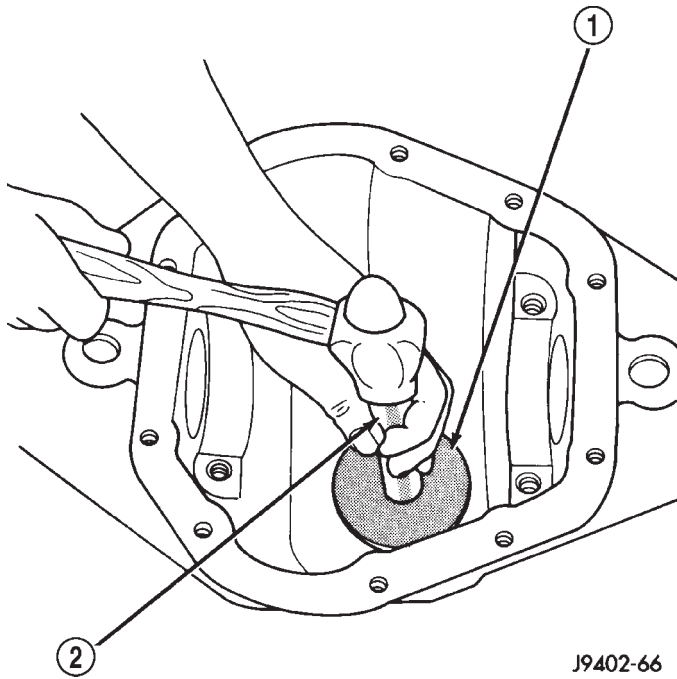
(4) Install front pinion bearing cup (Fig. 53) with Installer D-130 and Handle C-4171 and verify cup is seated.

(5) Install front pinion bearing.

(6) Apply a light coating of gear lubricant on the lip of pinion seal. Install seal with Installer C-4076-B and Handle C-4735-1 (Fig. 54).

(7) Place the proper thickness depth shim on the pinion shaft.

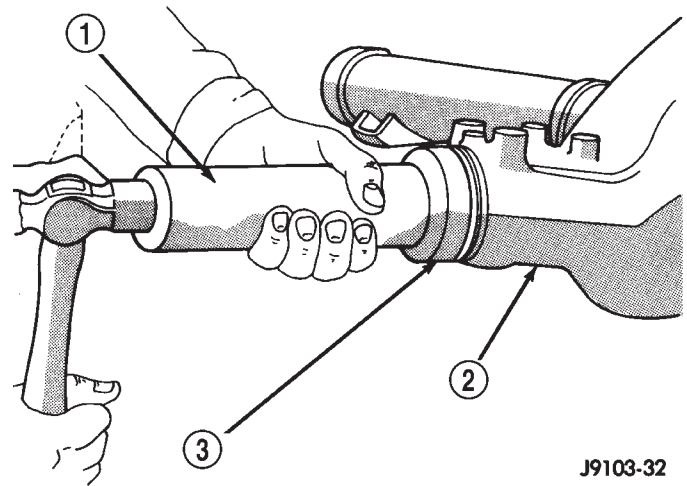
PINION GEAR/RING GEAR/TONE RING (Continued)



J9402-66

**Fig. 52 Rear Pinion Bearing Cup**

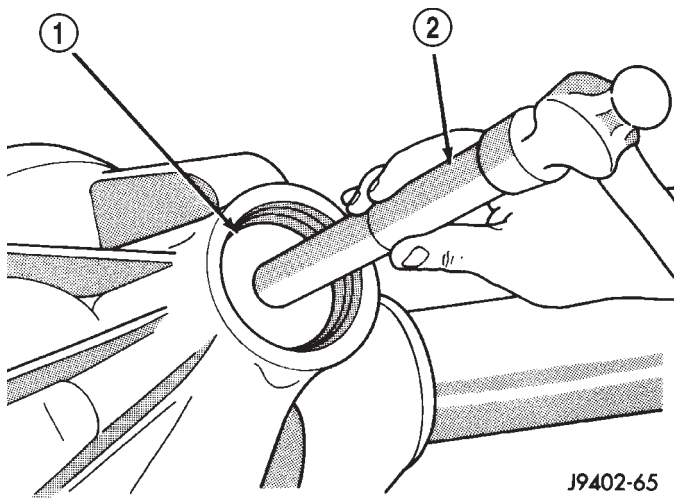
- 1 - INSTALLER
- 2 - HANDLE



J9103-32

**Fig. 54 Pinion Seal**

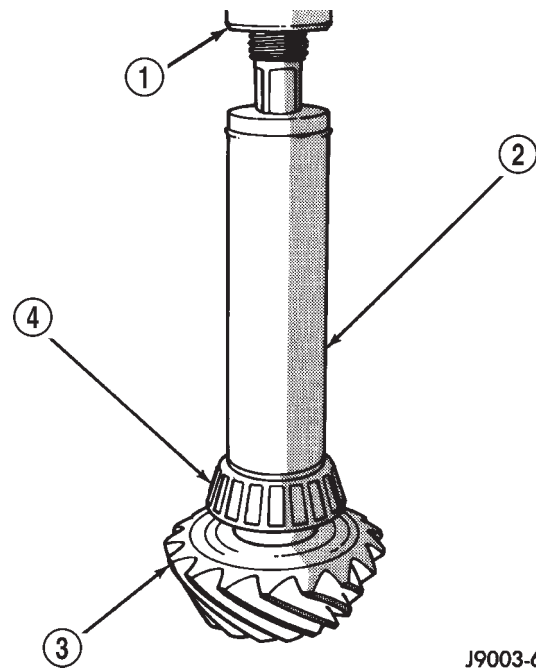
- 1 - HANDLE
- 2 - DIFFERENTIAL HOUSING
- 3 - INSTALLER



J9402-65

**Fig. 53 Front Pinion Bearing Cup**

- 1 - INSTALLER
- 2 - HANDLE



J9003-67

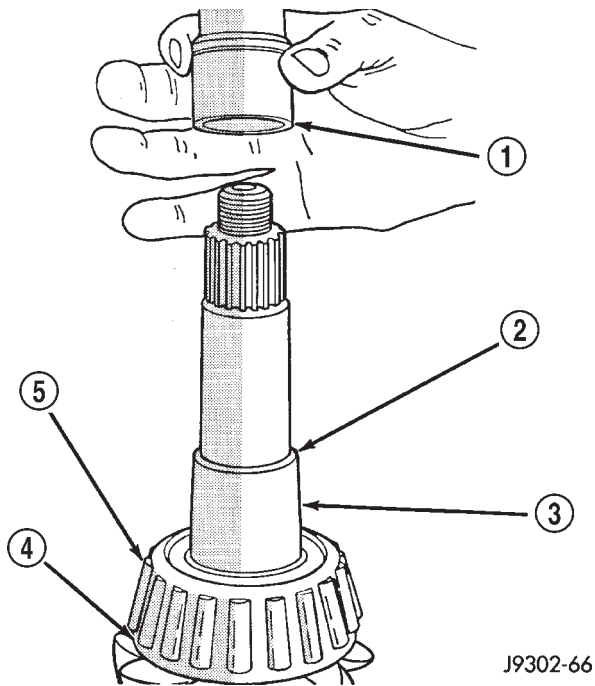
**Fig. 55 Rear Pinion Bearing**

- 1 - PRESS
- 2 - INSTALLER
- 3 - PINION GEAR
- 4 - REAR PINION BEARING

(8) Install the rear bearing on the pinion (Fig. 55) with Installer 6448 and a press.

## PINION GEAR/RING GEAR/TONE RING (Continued)

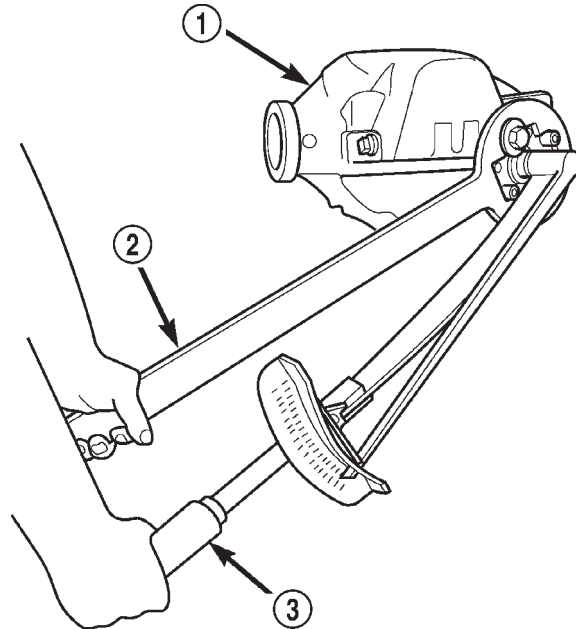
(9) Install a **new** collapsible preload spacer on pinion shaft and install the pinion into the housing (Fig. 56).



**Fig. 56 Collapsible Preload Spacer**

- 1 - COLLAPSIBLE SPACER
- 2 - SHOULDER
- 3 - PINION GEAR
- 4 - DEPTH SHIM
- 5 - REAR BEARING

**CAUTION: Never loosen pinion nut to decrease pinion bearing rotating torque and never exceed specified preload torque. If preload torque or rotating torque is exceeded a new collapsible spacer must be installed.**



**Fig. 57 Pinion Nut**

- 1 - DIFFERENTIAL HOUSING
- 2 - HOLDER
- 3 - TORQUE WRENCH

(10) Install companion flange with Installer C-3718 and Holder 6719.

(11) Install bolts into two of the threaded holes in the companion flange 180° apart.

(12) Position Holder 6719 against the companion flange and install a bolt and washer into one of the remaining threaded holes. Tighten the bolts so the Holder 6719 is held to the flange.

(13) Install the companion flange washer and a new nut on the pinion and tighten the pinion nut until there is zero bearing end-play.

(14) Tighten the nut to 285 N·m (210 ft. lbs.) (Fig. 57).

(15) Slowly tighten the nut in 6.8 N·m (5 ft. lbs.) increments until the desired rotating torque is achieved. Measure the rotating torque frequently to avoid over crushing the collapsible spacer (Fig. 58).

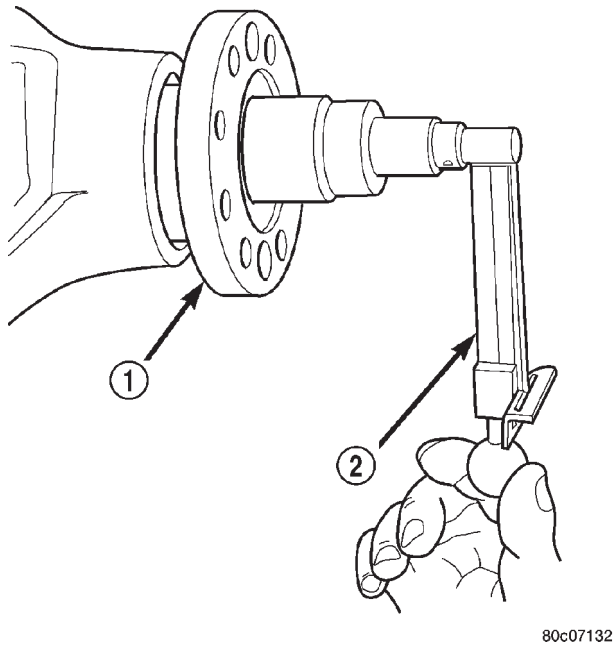
(16) Check bearing rotating torque with an inch pound torque wrench (Fig. 58). The torque necessary to rotate the pinion should be:

- Original Bearings: 1 to 3 N·m (10 to 20 in. lbs.).
- New Bearings: 2 to 5 N·m (15 to 35 in. lbs.).

(17) Position exciter ring on differential case.

(18) Using a brass drift, slowly and evenly tap the exciter ring into position.

## PINION GEAR/RING GEAR/TONE RING (Continued)

**Fig. 58 Pinion**

- 1 - COMPANION FLANGE  
2 - TORQUE WRENCH

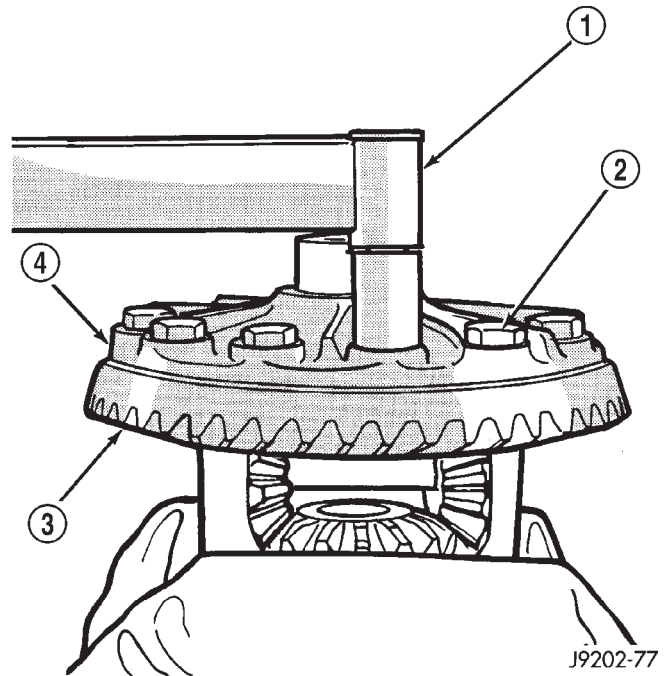
(19) Position ring gear on the differential case and start two ring gear bolts. This will provide case-to-ring gear bolt hole alignment.

(20) Invert the differential case in the vise.

(21) Install **new** ring gear bolts and alternately tighten to 156 N·m (115 ft. lbs.) (Fig. 59).

**CAUTION:** Do not reuse the bolts that held the ring gear to the differential case. The bolts can fracture causing extensive damage.

(22) Install differential in axle housing and verify gear mesh and contact pattern.

**Fig. 59 Ring Gear Bolts**

- 1 - TORQUE WRENCH  
2 - RING GEAR BOLTS  
3 - RING GEAR  
4 - DIFFERENTIAL CASE

(23) Install axle shafts.

(24) Install wheel and tire assemblies.

(25) Install differential cover and fill with gear lubricant.

(26) Install propeller shaft with reference marks aligned.

(27) Remove support and lower vehicle.

## REAR AXLE - 248RBI

## TABLE OF CONTENTS

	page		page
<b>REAR AXLE - 248RBI</b>		<b>INSTALLATION</b> .....	125
DESCRIPTION.....	109	<b>DIFFERENTIAL</b>	
OPERATION.....	109	REMOVAL.....	127
DIAGNOSIS AND TESTING.....	111	DISASSEMBLY.....	128
AXLE.....	111	ASSEMBLY.....	128
REMOVAL.....	113	INSTALLATION.....	129
INSTALLATION.....	114	<b>DIFFERENTIAL - TRAC-LOK</b>	
ADJUSTMENTS.....	114	DIAGNOSIS AND TESTING.....	130
SPECIFICATIONS.....	122	TRAC-LOK.....	130
SPECIAL TOOLS.....	122	DISASSEMBLY.....	130
<b>AXLE SHAFTS</b>		ASSEMBLY.....	132
REMOVAL.....	125	<b>DIFFERENTIAL CASE BEARINGS</b>	
INSTALLATION.....	125	REMOVAL.....	134
<b>AXLE BEARINGS</b>		INSTALLATION.....	134
REMOVAL.....	125	<b>PINION GEAR/RING GEAR/TONE RING</b>	
INSTALLATION.....	125	REMOVAL.....	135
<b>PINION SEAL</b>		INSTALLATION.....	137
REMOVAL.....	125		

## REAR AXLE - 248RBI

## DESCRIPTION

The Rear Beam-design Iron (RBI) axle housings consist of an iron center casting (differential housing) with axle shaft tubes extending from either side. The tubes are pressed in to form a one-piece axle housing.

The integral type housing, hypoid gear design has the centerline of the pinion set below the centerline of the ring gear.

The axles are equipped with full-floating axle shafts, meaning that loads are supported by the axle housing tubes. The full-float axle shafts are retained by bolts attached to the hub. The hub rides on two bearings at the outboard end of the axle tube. The axle shafts can be removed without disturbing or removing the wheel bearings. The wheel bearings are opposed tapered roller bearings and are contained in the hub assembly.

The removable, stamped steel cover provides a means for inspection and service without removing the complete axle from the vehicle. A small, stamped metal axle gear ratio identification tag is attached to the housing cover via one of the cover bolts. This tag also identifies the number of ring and pinion teeth.

The rear wheel anti-lock (RWAL) brake speed sensor is attached to the top, forward exterior of the differential housing. A seal is located between the sensor and the wire harness connector. The seal must

be in place when the wire connector is connected to the sensor. The RWAL brake exciter ring is press-fitted onto the differential case against the ring gear flange.

The differential case for the standard differentials and the Trac-lok<sup>™</sup> differential are a one-piece design. The differential pinion mate shaft is retained with a roll pin. Differential bearing preload and ring gear backlash are adjusted by the use of shims located between the differential bearing cones and case. Pinion bearing preload is set and maintained by the use of a solid shims.

## OPERATION

## STANDARD DIFFERENTIAL

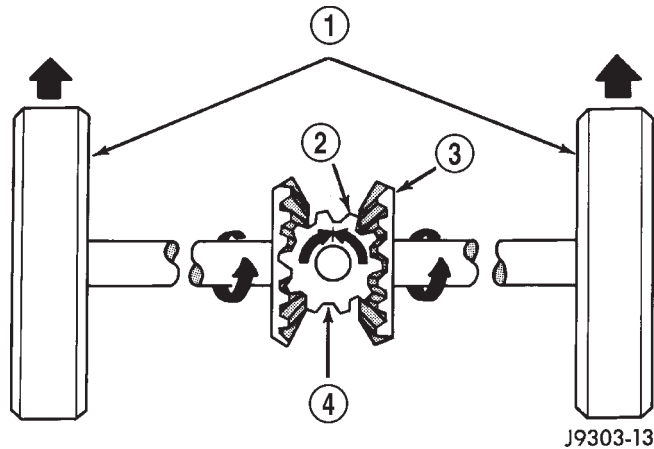
The axle receives power from the transmission/transfer case through the rear propeller shaft. The rear propeller shaft is connected to the pinion gear which rotates the differential through the gear mesh with the ring gear bolted to the differential case. The engine power is transmitted to the axle shafts through the pinion mate and side gears. The side gears are splined to the axle shafts.

During straight-ahead driving, the differential pinion gears do not rotate on the pinion mate shaft. This occurs because input torque applied to the gears is divided and distributed equally between the two side



REAR AXLE - 248RBI (Continued)

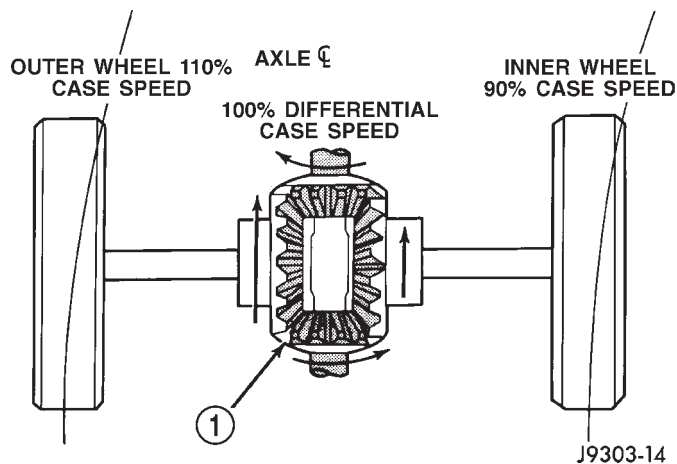
gears. As a result, the pinion gears revolve with the pinion mate shaft but do not rotate around it (Fig. 1).



**Fig. 1 Differential Operation - Straight Ahead Driving**

- 1 - IN STRAIGHT AHEAD DRIVING EACH WHEEL ROTATES AT 100% OF CASE SPEED
- 2 - PINION GEAR
- 3 - SIDE GEAR
- 4 - PINION GEARS ROTATE WITH CASE

When turning corners, the outside wheel must travel a greater distance than the inside wheel to complete a turn. The difference must be compensated for to prevent the tires from scuffing and skidding through turns. To accomplish this, the differential allows the axle shafts to turn at unequal speeds (Fig. 2). In this instance, the input torque applied to the pinion gears is not divided equally. The pinion gears now rotate around the pinion mate shaft in opposite directions. This allows the side gear and axle shaft attached to the outside wheel to rotate at a faster speed.

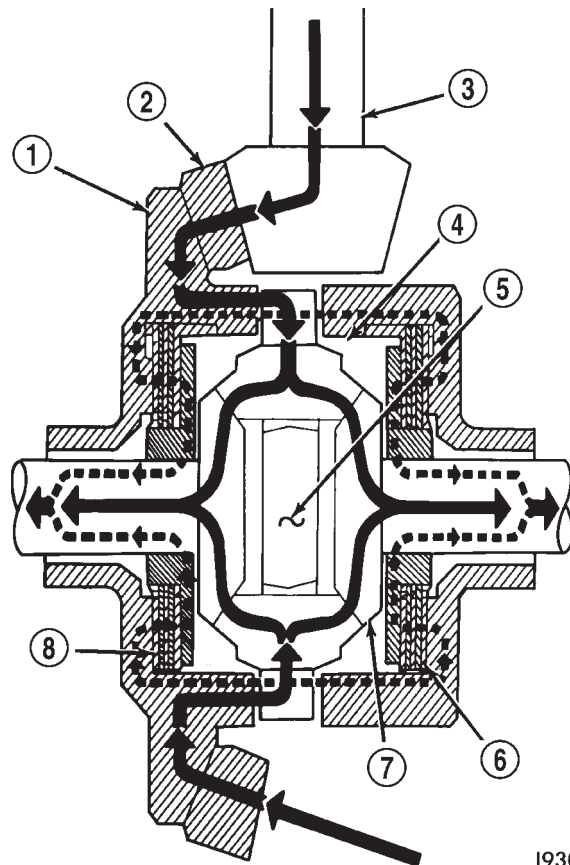


**Fig. 2 Differential Operation - On Turns**

- 1 - PINION GEARS ROTATE ON PINION SHAFT

**TRAC-LOK™ DIFFERENTIAL**

The Trac-lok™ clutches are engaged by two concurrent forces. The first being the preload force exerted through Belleville spring washers within the clutch packs. The second is the separating forces generated by the side gears as torque is applied through the ring gear (Fig. 3).



**Fig. 3 Trac-lok™ Limited Slip Differential**

- 1 - CASE
- 2 - RING GEAR
- 3 - DRIVE PINION
- 4 - PINION GEAR
- 5 - MATE SHAFT
- 6 - CLUTCH PACK
- 7 - SIDE GEAR
- 8 - CLUTCH PACK

The Trac-lok™ design provides the differential action needed for turning corners and for driving straight ahead during periods of unequal traction. When one wheel loses traction, the clutch packs transfer additional torque to the wheel having the most traction. Trac-lok™ differentials resist wheel spin on bumpy roads and provide more pulling power when one wheel loses traction. Pulling power is provided continuously until both wheels lose traction. If both wheels slip due to unequal traction, Trac-lok™ operation is normal. In extreme cases of differences

## REAR AXLE - 248RBI (Continued)

of traction, the wheel with the least traction may spin.

**DIAGNOSIS AND TESTING - AXLE****GEAR NOISE**

Axle gear noise can be caused by insufficient lubricant, incorrect backlash, incorrect pinion depth, tooth contact, worn/damaged gears, or the carrier housing not having the proper offset and squareness.

Gear noise usually happens at a specific speed range. The noise can also occur during a specific type of driving condition. These conditions are acceleration, deceleration, coast, or constant load.

When road testing, first warm-up the axle fluid by driving the vehicle at least 5 miles and then accelerate the vehicle to the speed range where the noise is the greatest. Shift out-of-gear and coast through the peak-noise range. If the noise stops or changes greatly:

- Check for insufficient lubricant.
- Incorrect ring gear backlash.
- Gear damage.

Differential side gears and pinions can be checked by turning the vehicle. They usually do not cause noise during straight-ahead driving when the gears are unloaded. The side gears are loaded during vehicle turns. A worn pinion shaft can also cause a snapping or a knocking noise.

**BEARING NOISE**

The axle shaft, differential and pinion bearings can all produce noise when worn or damaged. Bearing noise can be either a whining, or a growling sound.

Pinion bearings have a constant-pitch noise. This noise changes only with vehicle speed. Pinion bearing noise will be higher pitched because it rotates at a faster rate. Drive the vehicle and load the differential. If bearing noise occurs, the rear pinion bearing is the source of the noise. If the bearing noise is heard during a coast, the front pinion bearing is the source.

Worn or damaged differential bearings usually produce a low pitch noise. Differential bearing noise is similar to pinion bearing noise. The pitch of differential bearing noise is also constant and varies only with vehicle speed.

Axle shaft bearings produce noise and vibration when worn or damaged. The noise generally changes when the bearings are loaded. Road test the vehicle.

Turn the vehicle sharply to the left and to the right. This will load the bearings and change the noise level. Where axle bearing damage is slight, the noise is usually not noticeable at speeds above 30 mph.

**LOW SPEED KNOCK**

Low speed knock is generally caused by a worn U-joint or by worn side-gear thrust washers. A worn pinion shaft bore will also cause low speed knock.

**VIBRATION**

Vibration at the rear of the vehicle is usually caused by a:

- Damaged drive shaft.
- Missing drive shaft balance weight(s).
- Worn or out-of-balance wheels.
- Loose wheel lug nuts.
- Worn U-joint(s).
- Loose/broken springs.
- Damaged axle shaft bearing(s).
- Loose pinion gear nut.
- Excessive pinion yoke run out.
- Bent axle shaft(s).

Check for loose or damaged front-end components or engine/transmission mounts. These components can contribute to what appears to be a rearend vibration. Do not overlook engine accessories, brackets and drive belts.

All driveline components should be examined before starting any repair.

(Refer to 22 - TIRES/WHEELS - DIAGNOSIS AND TESTING)

**DRIVELINE SNAP**

A snap or clunk noise when the vehicle is shifted into gear (or the clutch engaged), can be caused by:

- High engine idle speed.
- Transmission shift operation.
- Loose engine/transmission/transfer case mounts.
- Worn U-joints.
- Loose spring mounts.
- Loose pinion gear nut and yoke.
- Excessive ring gear backlash.
- Excessive side gear to case clearance.

The source of a snap or a clunk noise can be determined with the assistance of a helper. Raise the vehicle on a hoist with the wheels free to rotate. Instruct the helper to shift the transmission into gear. Listen for the noise, a mechanics stethoscope is helpful in isolating the source of a noise.

## REAR AXLE - 248RBI (Continued)

## DIAGNOSTIC CHART

Condition	Possible Causes	Correction
Wheel Noise	<ol style="list-style-type: none"> <li>1. Wheel loose.</li> <li>2. Faulty, brinelled wheel bearing.</li> </ol>	<ol style="list-style-type: none"> <li>1. Tighten loose nuts.</li> <li>2. Replace bearing.</li> </ol>
Axle Shaft Noise	<ol style="list-style-type: none"> <li>1. Misaligned axle tube.</li> <li>2. Bent or sprung axle shaft.</li> </ol>	<ol style="list-style-type: none"> <li>1. Inspect axle tube alignment. Correct as necessary.</li> <li>2. Inspect and correct as necessary.</li> </ol>
Axle Shaft Broke	<ol style="list-style-type: none"> <li>1. Misaligned axle tube.</li> <li>2. Vehicle overloaded.</li> <li>3. Erratic clutch operation.</li> <li>4. Grabbing clutch.</li> </ol>	<ol style="list-style-type: none"> <li>1. Replace the broken shaft after correcting tube mis-alignment.</li> <li>2. Replace broken shaft and avoid excessive weight on vehicle.</li> <li>3. Replace broken shaft and avoid or correct erratic clutch operation.</li> <li>4. Replace broken shaft and inspect and repair clutch as necessary.</li> </ol>
Differential Cracked	<ol style="list-style-type: none"> <li>1. Improper adjustment of the differential bearings.</li> <li>2. Excessive ring gear backlash.</li> <li>3. Vehicle overloaded.</li> <li>4. Erratic clutch operation.</li> </ol>	<ol style="list-style-type: none"> <li>1. Replace case and inspect gears and bearings for further damage. Set differential bearing pre-load properly.</li> <li>2. Replace case and inspect gears and bearings for further damage. Set ring gear backlash properly.</li> <li>3. Replace case and inspect gears and bearings for further damage. Avoid excessive vehicle weight.</li> <li>4. Replace case and inspect gears and bearings for further damage. Avoid erratic use of clutch.</li> </ol>
Differential Gears Scored	<ol style="list-style-type: none"> <li>1. Insufficient lubrication.</li> <li>2. Improper grade of lubricant.</li> <li>3. Excessive spinning of one wheel/tire.</li> </ol>	<ol style="list-style-type: none"> <li>1. Replace scored gears. Fill differential with the correct fluid type and quantity.</li> <li>2. Replace scored gears. Fill differential with the correct fluid type and quantity.</li> <li>3. Replace scored gears. Inspect all gears, pinion bores, and shaft for damage. Service as necessary.</li> </ol>
Loss Of Lubricant	<ol style="list-style-type: none"> <li>1. Lubricant level too high.</li> <li>2. Worn axle shaft seals.</li> <li>3. Cracked differential housing.</li> <li>4. Worn pinion seal.</li> <li>5. Worn/scored yoke.</li> <li>6. Axle cover not properly sealed.</li> </ol>	<ol style="list-style-type: none"> <li>1. Drain lubricant to the correct level.</li> <li>2. Replace seals.</li> <li>3. Repair as necessary.</li> <li>4. Replace seal.</li> <li>5. Replace yoke and seal.</li> <li>6. Remove, clean, and re-seal cover.</li> </ol>

## REAR AXLE - 248RBI (Continued)

Condition	Possible Causes	Correction
Axle Overheating	<ol style="list-style-type: none"> <li>1. Lubricant level low.</li> <li>2. Improper grade of lubricant.</li> <li>3. Bearing pre-loads too high.</li> <li>4. Insufficient ring gear backlash.</li> </ol>	<ol style="list-style-type: none"> <li>1. Fill differential to correct level.</li> <li>2. Fill differential with the correct fluid type and quantity.</li> <li>3. Re-adjust bearing pre-loads.</li> <li>4. Re-adjust ring gear backlash.</li> </ol>
Gear Teeth Broke	<ol style="list-style-type: none"> <li>1. Overloading.</li> <li>2. Erratic clutch operation.</li> <li>3. Ice-spotted pavement.</li> <li>4. Improper adjustments.</li> </ol>	<ol style="list-style-type: none"> <li>1. Replace gears. Examine other gears and bearings for possible damage.</li> <li>2. Replace gears and examine the remaining parts for damage. Avoid erratic clutch operation.</li> <li>3. Replace gears and examine remaining parts for damage.</li> <li>4. Replace gears and examine remaining parts for damage. Ensure ring gear backlash is correct.</li> </ol>
Axle Noise	<ol style="list-style-type: none"> <li>1. Insufficient lubricant.</li> <li>2. Improper ring gear and pinion adjustment.</li> <li>3. Unmatched ring gear and pinion.</li> <li>4. Worn teeth on ring gear and/or pinion.</li> <li>5. Loose pinion bearings.</li> <li>6. Loose differential bearings.</li> <li>7. Mis-aligned or sprung ring gear.</li> <li>8. Loose differential bearing cap bolts.</li> <li>9. Housing not machined properly.</li> </ol>	<ol style="list-style-type: none"> <li>1. Fill differential with the correct fluid type and quantity.</li> <li>2. Check ring gear and pinion contact pattern. Adjust backlash or pinion depth.</li> <li>3. Replace gears with a matched ring gear and pinion.</li> <li>4. Replace ring gear and pinion.</li> <li>5. Adjust pinion bearing pre-load.</li> <li>6. Adjust differential bearing pre-load.</li> <li>7. Measure ring gear run-out. Replace components as necessary.</li> <li>8. Inspect differential components and replace as necessary. Ensure that the bearing caps are torqued to the proper specification.</li> <li>9. Replace housing.</li> </ol>

**REMOVAL**

- (1) Raise and support the vehicle.
- (2) Position a suitable lifting device under the axle.
- (3) Secure axle to device.
- (4) Remove the wheels and tires.
- (5) Secure brake drums to the axle shaft.
- (6) Remove RWAL sensor from the differential housing, if necessary. Refer to 5 Brakes for procedures.
- (7) Disconnect the brake hose at the axle junction block. Do not disconnect the brake hydraulic lines at the wheel cylinders. Refer to 5 Brakes for procedures.

- (8) Disconnect the parking brake cables and cable brackets.
- (9) Disconnect the vent hose from the axle shaft tube.
- (10) Mark propeller shaft and yoke for installation alignment reference.
- (11) Remove propeller shaft.
- (12) Disconnect shock absorbers from axle.
- (13) Remove spring clamps and spring brackets. Refer to 2 Suspension for procedures.
- (14) Separate axle from the vehicle.

## REAR AXLE - 248RBI (Continued)

**INSTALLATION**

- (1) Raise axle with lifting device and align to the leaf spring centering bolts.
- (2) Install spring clamps and spring brackets. Refer to 2 Suspension for procedures.
- (3) Install shock absorbers and tighten nuts to 82 N·m (60 ft. lbs.).
- (4) Install RWAL sensor to the differential housing, if necessary. Refer to 5 Brakes for procedures.
- (5) Install parking brake cables, cable brackets and brake drums. Refer to 5 Brakes for procedures.
- (6) Connect brake hose to axle junction block. Refer to 5 Brakes for procedures.
- (7) Install axle vent hose.
- (8) Align propeller shaft and pinion yoke reference marks. Install universal joint straps and bolts. Tighten to 19 N·m (14 ft. lbs.).
- (9) Install the wheels and tires.
- (10) Add gear lubricant, if necessary. Refer to Lubricant Specifications for lubricant requirements.
- (11) Remove lifting device from axle and lower the vehicle.

**ADJUSTMENTS**

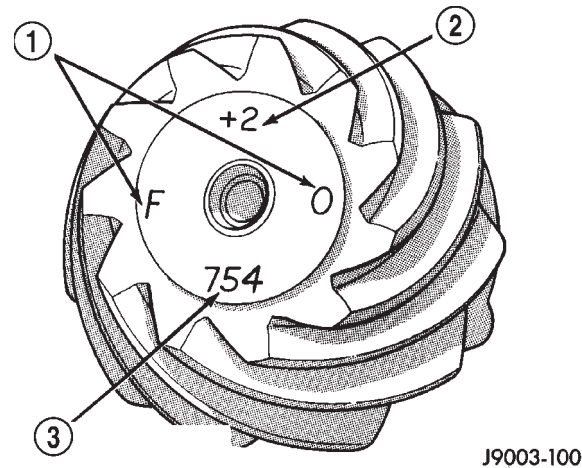
Ring and pinion gears are supplied as matched sets only. The identifying numbers for the ring and pinion gear are etched into the face of each gear (Fig. 4). A plus (+) number, minus (-) number or zero (0) is etched into the face of the pinion gear. This number is the amount (in thousandths of an inch) the depth varies from the standard depth setting of a pinion etched with a (0). The standard setting from the center line of the ring gear to the back face of the pinion is 127 mm (5.00 in.). The standard depth provides the best gear tooth contact pattern. Refer to Backlash and Contact Pattern in this section for additional information.

Compensation for pinion depth variance is achieved with a select shim/oil baffle. The shims are placed between the rear pinion bearing and the pinion gear head (Fig. 5).

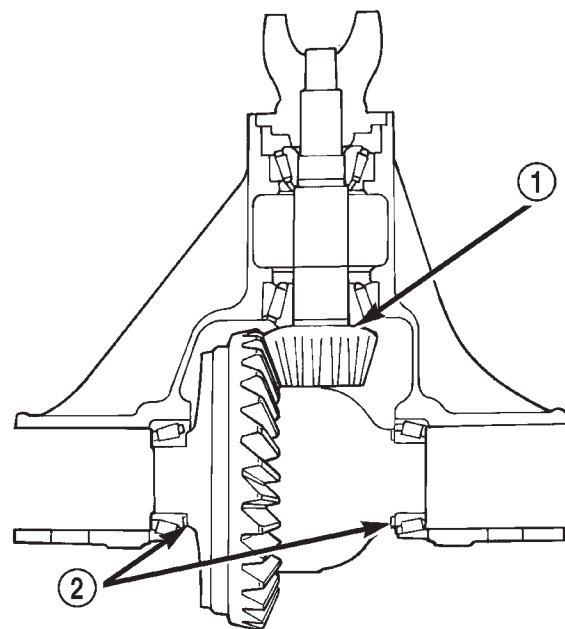
If a new gear set is being installed, note the depth variance etched into both the original and replacement pinion. Add or subtract this number from the thickness of the original depth shim/oil slinger to compensate for the difference in the depth variances. Refer to the Depth Variance chart.

Note where Old and New Pinion Marking columns intersect. Intersecting figure represents plus or minus the amount needed.

Note the etched number on the face of the pinion gear head (-1, -2, 0, +1, +2, etc.). The numbers represent thousands of an inch deviation from the stan-

**Fig. 4 Pinion Gear ID Numbers**

- 1 - PRODUCTION NUMBERS
- 2 - PINION GEAR DEPTH VARIANCE
- 3 - GEAR MATCHING NUMBER

**Fig. 5 Adjustment Shim Locations**

- 1 - PINION GEAR DEPTH SHIM/OIL BAFFLE
- 2 - DIFFERENTIAL BEARING SHIM

dard. If the number is negative, add that value to the required thickness of the depth shims. If the number is positive, subtract that value from the thickness of the depth shim. If the number is 0 no change is necessary.



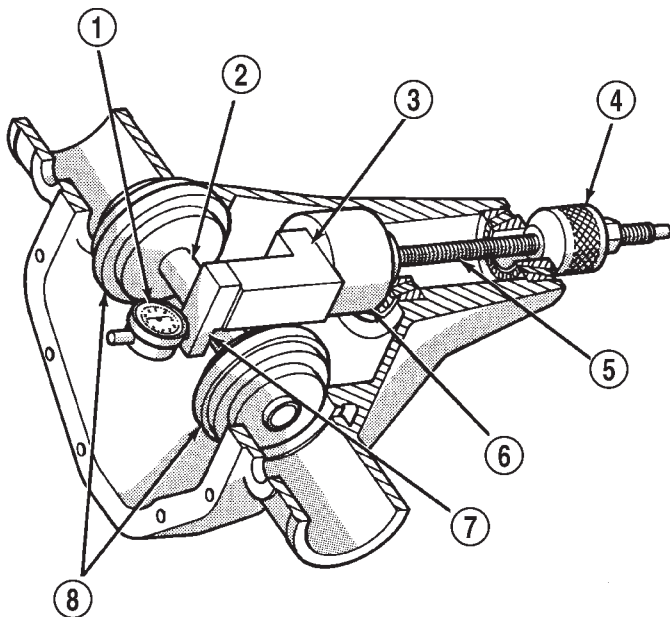
## REAR AXLE - 248RBI (Continued)

## PINION GEAR DEPTH VARIANCE

Original Pinion Gear Depth Variance	Replacement Pinion Gear Depth Variance								
	-4	-3	-2	-1	0	+1	+2	+3	+4
+4	+0.008	+0.007	+0.006	+0.005	+0.004	+0.003	+0.002	+0.001	0
+3	+0.007	+0.006	+0.005	+0.004	+0.003	+0.002	+0.001	0	-0.001
+2	+0.006	+0.005	+0.004	+0.003	+0.002	+0.001	0	-0.001	-0.002
+1	+0.005	+0.004	+0.003	+0.002	+0.001	0	-0.001	-0.002	-0.003
0	+0.004	+0.003	+0.002	+0.001	0	-0.001	-0.002	-0.003	-0.004
-1	+0.003	+0.002	+0.001	0	-0.001	-0.002	-0.003	-0.004	-0.005
-2	+0.002	+0.001	0	-0.001	-0.002	-0.003	-0.004	-0.005	-0.006
-3	+0.001	0	-0.001	-0.002	-0.003	-0.004	-0.005	-0.006	-0.007
-4	0	-0.001	-0.002	-0.003	-0.004	-0.005	-0.006	-0.007	-0.008

## PINION DEPTH MEASUREMENT AND ADJUSTMENT

Measurements are taken with pinion bearing cups and pinion bearings installed in the housing. Take measurements with Pinion Gauge Set and Dial Indicator C-3339 (Fig. 6).



J9403-45

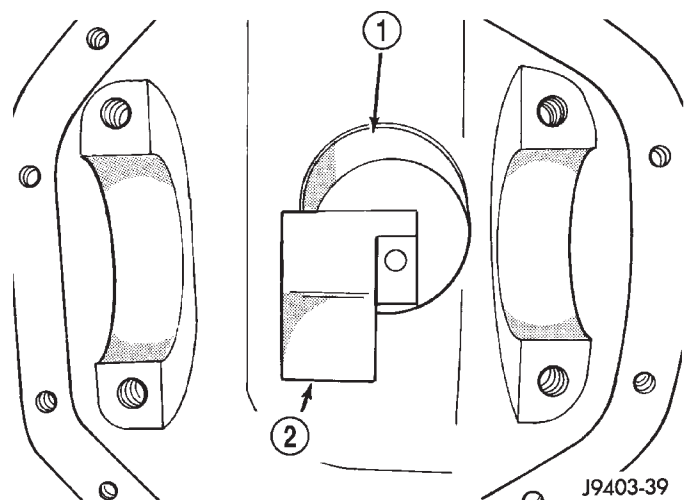
Fig. 6 Pinion Gear Depth Gauge Tools

- 1 - DIAL INDICATOR
- 2 - ARBOR
- 3 - PINION HEIGHT BLOCK
- 4 - CONE
- 5 - SCREW
- 6 - PINION BLOCK
- 7 - SCOOTER BLOCK
- 8 - ARBOR DISC

(1) Assemble Pinion Height Block 6739, Pinion Block 6736 and rear pinion bearing onto Screw 6741 (Fig. 6).

(2) Insert assembled height gauge components, rear bearing and screw into the housing through pinion bearing cups (Fig. 7).

(3) Install front pinion bearing and Cone-nut 6740 hand tight (Fig. 6).



J9403-39

Fig. 7 Pinion Height Block

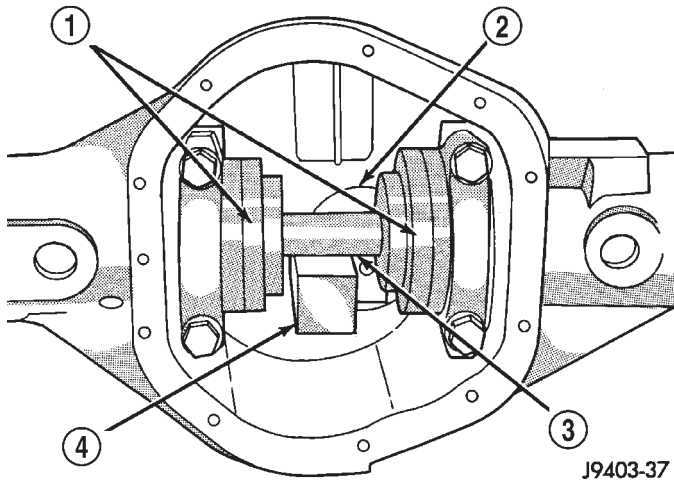
- 1 - PINION BLOCK
- 2 - PINION HEIGHT BLOCK

(4) Place Arbor Disc 6732 on Arbor D-115-3 in position in the housing side bearing cradles (Fig. 8).

**NOTE:** Arbor Discs 6732 has different step diameters to fit other axles. Choose proper step for axle being serviced.

## REAR AXLE - 248RBI (Continued)

(5) Install differential bearing caps on arbor discs and snug the bearing cap bolts. Then cross tighten cap bolts to 108 N·m (80 ft. lbs.).



**Fig. 8 Gauge Tools In Housing**

- 1 - ARBOR DISC
- 2 - PINION BLOCK
- 3 - ARBOR
- 4 - PINION HEIGHT BLOCK

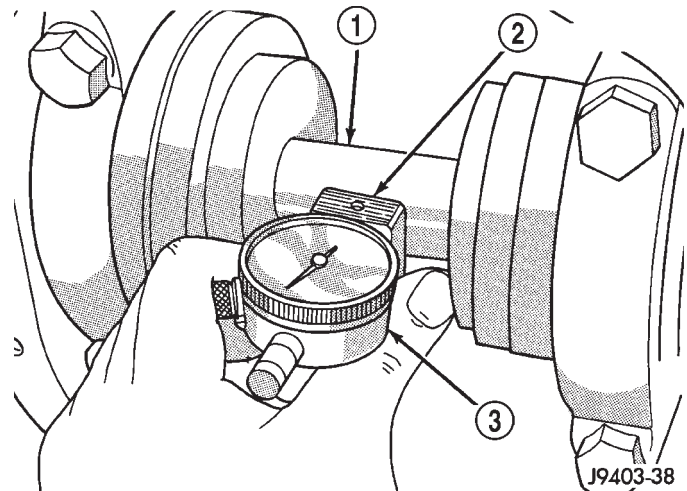
(6) Assemble Dial Indicator C-3339 into Scooter Block D-115-2 and secure set screw.

(7) Place Scooter Block/Dial Indicator in position in the housing so dial probe and scooter block are flush against the rearward surface of the pinion height block (Fig. 6). Hold scooter block in place and zero the dial indicator face to the pointer. Tighten dial indicator face lock screw.

(8) With scooter block still in position against the pinion height block, slowly slide the dial indicator probe over the edge of the pinion height block.

(9) Slide the dial indicator probe across the gap between the pinion height block and the arbor bar with the scooter block against the pinion height block (Fig. 9). When the dial probe contacts the arbor bar, the dial pointer will turn clockwise. Bring dial pointer back to zero against the arbor bar, do not turn dial face. Continue moving the dial probe to the crest of the arbor bar and record the highest reading. If the dial indicator can not achieve the zero reading, the rear bearing cup or the pinion depth gauge set is not installed correctly.

(10) Select a shim/oil baffle equal to the dial indicator reading plus the pinion depth variance number etched in the face of the pinion (Fig. 4). For example, if the depth variance is -2, add +0.002 in. to the dial indicator reading.



**Fig. 9 Pinion Gear Depth Measurement**

- 1 - ARBOR
- 2 - SCOOTER BLOCK
- 3 - DIAL INDICATOR

## DIFFERENTIAL SIDE BEARING PRELOAD AND GEAR BACKLASH

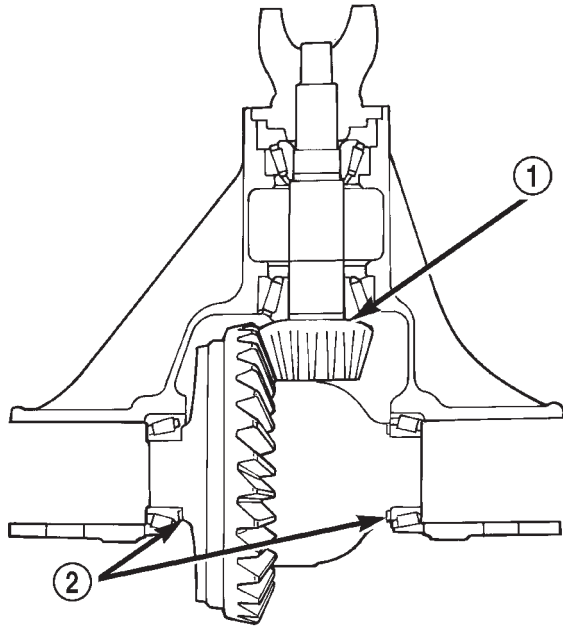
Differential side bearing preload and gear backlash is achieved by selective shims positioned behind the differential side bearing cones. The proper shim thickness can be determined using slip-fit Dummy Bearings D-343 in place of the differential side bearings and a Dial Indicator C-3339. Before proceeding with the differential bearing preload and gear backlash measurements, measure the pinion gear depth and prepare the pinion for installation. Establishing proper pinion gear depth is essential to establishing gear backlash and tooth contact patterns. After the overall shim thickness to take up differential side play is measured, the pinion is installed, and the gear backlash shim thickness is measured. The overall shim thickness is the total of the dial indicator reading and the preload specification added together. The gear backlash measurement determines the thickness of the shim used on the ring gear side of the differential case. Subtract the gear backlash shim thickness from the total overall shim thickness and select that amount for the pinion gear side of the differential (Fig. 10). Differential shim measurements are performed with spreader W-129-B removed.

## SHIM SELECTION

**NOTE:** It is difficult to salvage the differential side bearings during the removal procedure. Install replacement bearings if necessary.

(1) Remove differential side bearings from differential case.

## REAR AXLE - 248RBI (Continued)



80c07134

**Fig. 10 Adjustment Shim Locations**

- 1 - PINION GEAR DEPTH SHIM/OIL BAFFLE
- 2 - DIFFERENTIAL BEARING SHIM

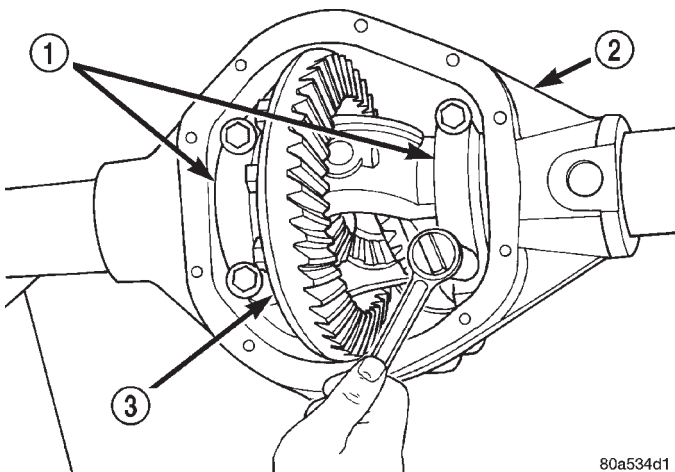
(2) Remove factory installed shims from differential case.

(3) Install ring gear on differential case and tighten bolts to specification.

(4) Install dummy side bearings D-343 on differential case.

(5) Install differential case in the housing.

(6) Install the marked bearing caps in their correct positions and snug the bolts (Fig. 11).

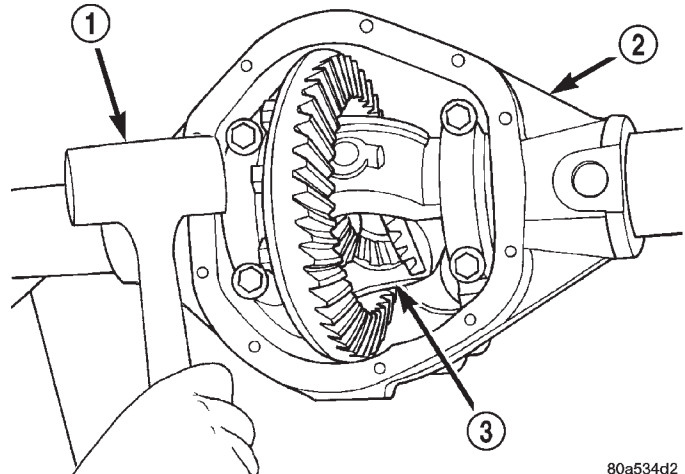


80a534d1

**Fig. 11 Bearing Cap Bolts**

- 1 - BEARING CAP
- 2 - DIFFERENTIAL HOUSING
- 3 - DIFFERENTIAL CASE

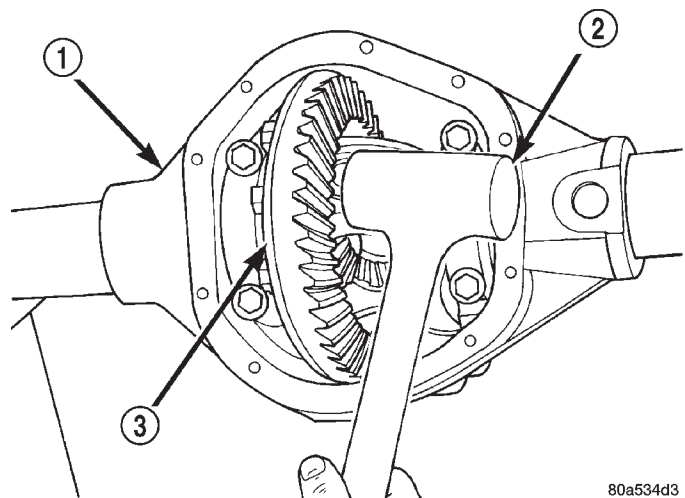
(7) Using a dead-blow hammer, seat the differential dummy bearings to each side of the housing (Fig. 12) and (Fig. 13).



80a534d2

**Fig. 12 Seat Pinion Gear Side Dummy Bearing**

- 1 - DEAD-BLOW HAMMER
- 2 - DIFFERENTIAL HOUSING
- 3 - DIFFERENTIAL CASE



80a534d3

**Fig. 13 Seat Ring Gear Side Differential Dummy Bearing**

- 1 - DIFFERENTIAL HOUSING
- 2 - DEAD-BLOW HAMMER
- 3 - DIFFERENTIAL CASE

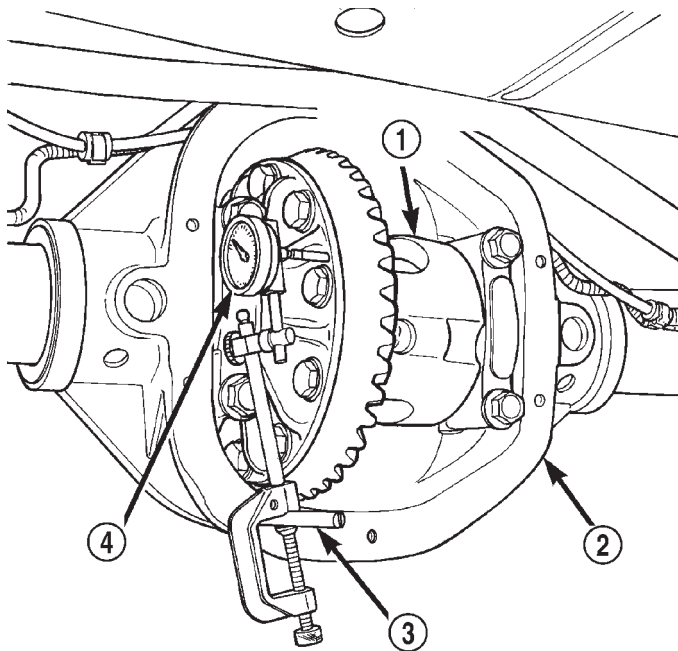
(8) Thread Pilot Stud C-3288-B into rear cover bolt hole below ring gear (Fig. 14).

(9) Attach the Dial Indicator C-3339 to pilot stud. Position the dial indicator plunger on a flat surface between the ring gear bolt heads (Fig. 14).

(10) Push and hold differential case to pinion gear side of the housing and zero dial indicator (Fig. 15).

(11) Push and hold differential case to ring gear side of the housing and record the dial indicator reading (Fig. 16).

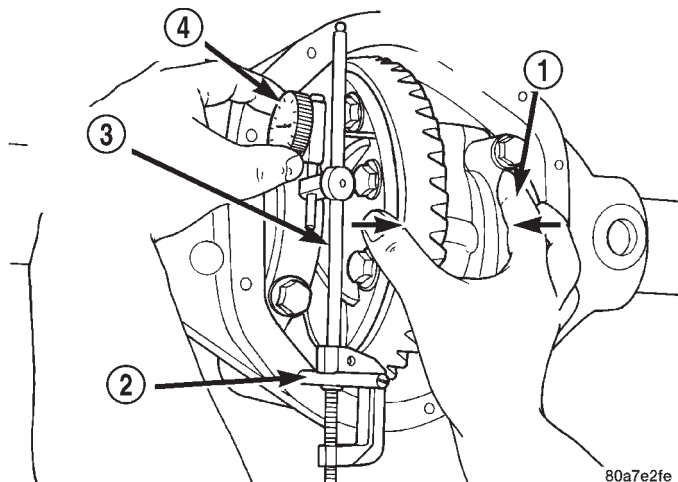
REAR AXLE - 248RBI (Continued)



80a7e2cf

**Fig. 14 Differential Side Play Measurement**

- 1 - DIFFERENTIAL CASE
- 2 - DIFFERENTIAL HOUSING
- 3 - PILOT STUD
- 4 - DIAL INDICATOR



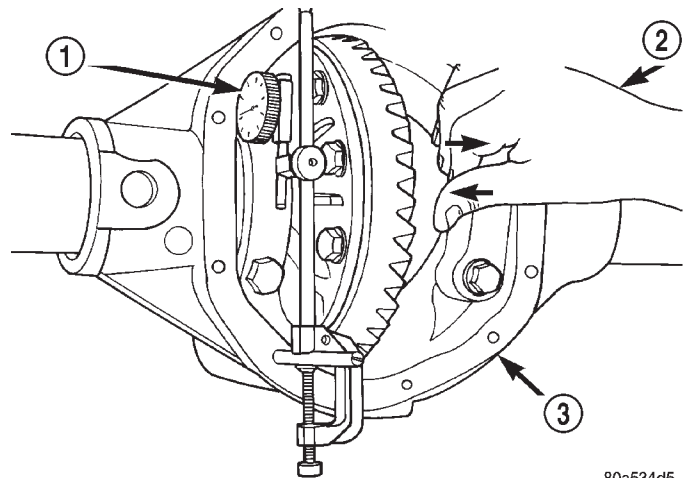
80a7e2fe

**Fig. 15 Dial Indicator Location**

- 1 - DIFFERENTIAL CASE TO PINION GEAR SIDE
- 2 - PILOT STUD
- 3 - DIAL INDICATOR ARM
- 4 - DIAL INDICATOR FACE

(12) Add 0.38 mm (0.015 in.) to the zero end play total. This total represents the thickness of shims needed to preload the new bearings when the differential is installed.

(13) Rotate dial indicator out of the way on the pilot stud.



80a534d5

**Fig. 16 Differential Case To Ring Gear Side**

- 1 - DIAL INDICATOR
- 2 - DIFFERENTIAL CASE TO RING GEAR SIDE
- 3 - DIFFERENTIAL HOUSING

(14) Remove differential case and dummy bearings from the housing.

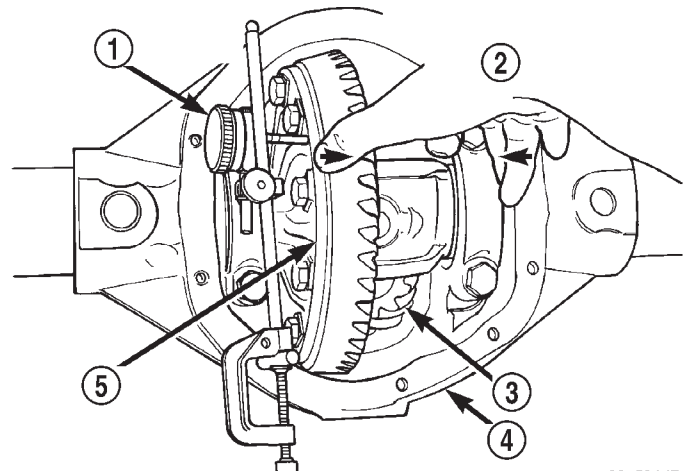
(15) Install the pinion gear in the housing. Install the pinion yoke and establish the correct pinion rotating torque.

(16) Install differential case and dummy bearings D-343 in the housing (without shims), install bearing caps and tighten bolts snug.

(17) Seat ring gear side dummy bearing (Fig. 13).

(18) Position the dial indicator plunger on a flat surface between the ring gear bolt heads (Fig. 14).

(19) Push and hold differential case toward pinion gear and zero the dial indicator (Fig. 17).



80a534d7

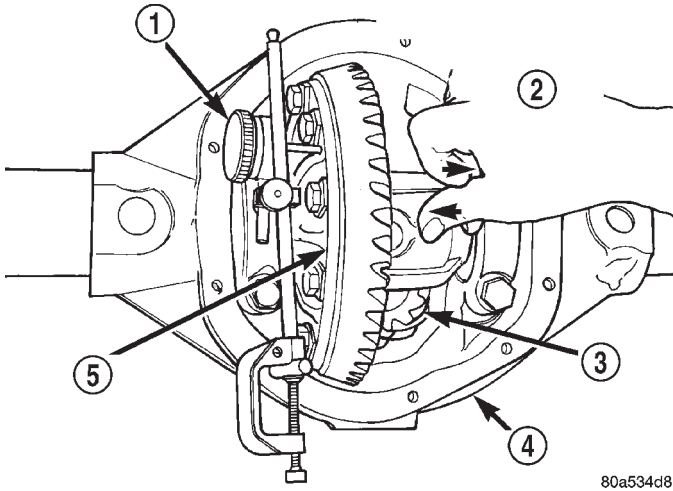
**Fig. 17 Differential Case To Pinion Gear Side**

- 1 - DIAL INDICATOR FACE
- 2 - DIFFERENTIAL CASE TO PINION GEAR SIDE
- 3 - PINION GEAR
- 4 - DIFFERENTIAL HOUSING
- 5 - DIFFERENTIAL CASE



## REAR AXLE - 248RBI (Continued)

(20) Push and hold differential case to ring gear side of the housing and record dial indicator reading (Fig. 18).



**Fig. 18 Differential Case To Ring Gear Side**

- 1 - DIAL INDICATOR
- 2 - DIFFERENTIAL CASE TO RING GEAR SIDE
- 3 - PINION GEAR
- 4 - DIFFERENTIAL HOUSING
- 5 - DIFFERENTIAL CASE

(21) This is the shim thickness needed on the ring gear side of the differential case for proper backlash.

(22) Subtract the backlash shim thickness from the total preload shim thickness. The remainder is the shim thickness required on the pinion side of the housing.

(23) Rotate dial indicator out of the way on pilot stud.

(24) Remove differential case and dummy bearings from the housing.

(25) Install the selected side bearing shims onto the differential case hubs.

(26) Install side bearings on differential case hubs with Install C-4487-1 and Handle C-4171.

(27) Install bearing cups on differential.

(28) Install Spreader W-129-B and some items from Adapter Set 6987 on the housing and spread open enough to receive differential case.

**CAUTION:** Do not spread housing over 0.50 mm (0.020 in.). The housing can be damaged if over-spread.

(29) Install differential case into the housing.

(30) Remove spreader from the housing.

(31) Rotate the differential case several times to seat the side bearings.

(32) Position the indicator plunger against a ring gear tooth (Fig. 19).

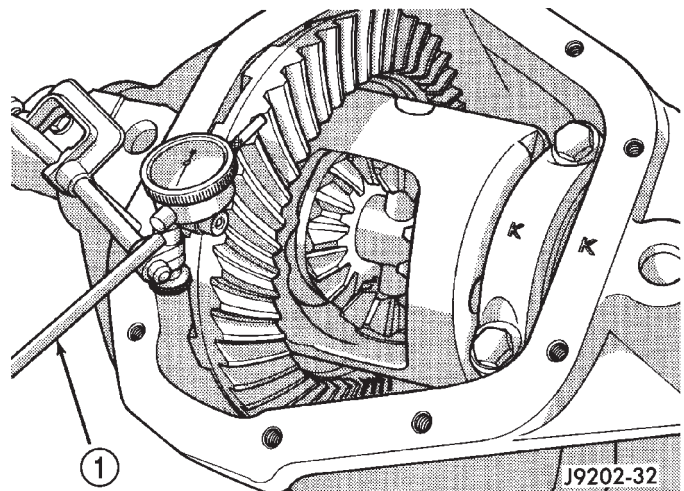
(33) Push and hold ring gear upward while not allowing the pinion gear to rotate.

(34) Zero dial indicator face to pointer.

(35) Push and hold ring gear downward while not allowing the pinion gear to rotate. Dial indicator reading should be between 0.12 mm (0.005 in.) and 0.20 mm (0.008 in.). If backlash is not within specifications transfer the necessary amount of shim thickness from one side of the housing to the other (Fig. 20).

(36) Verify differential case and ring gear runout by measuring ring to pinion gear backlash at eight locations around the ring gear. Readings should not vary more than 0.05 mm (0.002 in.). If readings vary more than specified, the ring gear or the differential case is defective.

After the proper backlash is achieved, perform Gear Contact Pattern Analysis procedure.

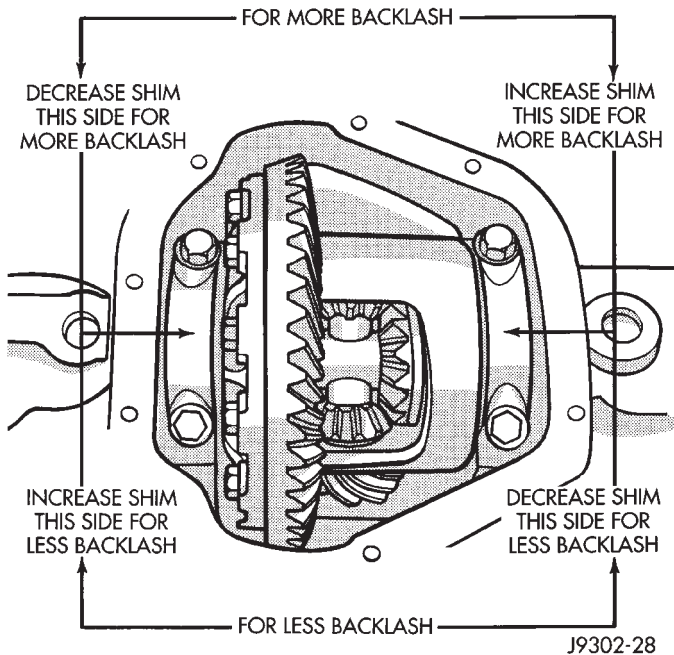


**Fig. 19 Ring Gear Backlash Measurement**

- 1 - DIAL INDICATOR



## REAR AXLE - 248RBI (Continued)



**Fig. 20 Backlash Shim**

### GEAR CONTACT PATTERN

The ring and pinion gear contact patterns will show if the pinion depth is correct. It will also show if the ring gear backlash has been adjusted correctly. The backlash can be adjusted within specifications to achieve desired tooth contact patterns.

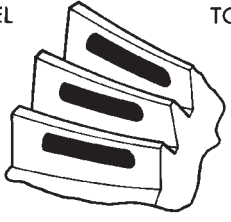
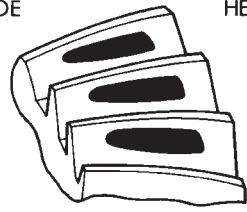
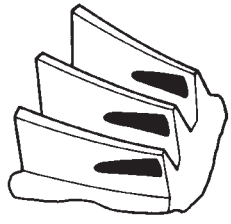
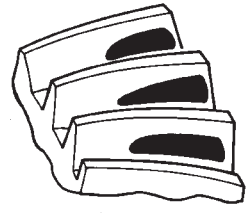
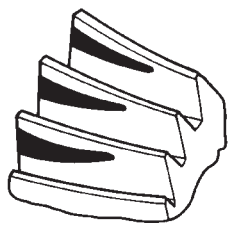
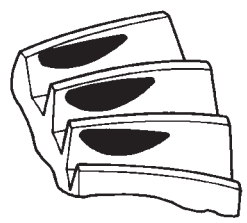
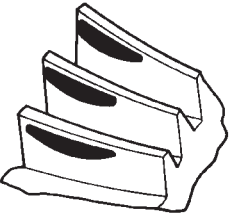
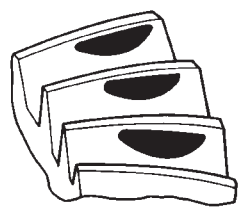
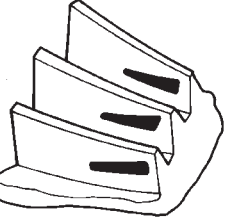
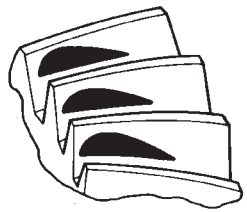
(1) Apply a thin coat of hydrated ferric oxide or equivalent to the drive and coast side of the ring gear teeth.

(2) Wrap, twist and hold a shop towel around the pinion yoke to increase the turning resistance of the pinion. This will provide a more distinct contact pattern.

(3) With a boxed end wrench on the ring gear bolt, rotate the differential case one complete revolution in both directions while a load is being applied from shop towel.

The areas on the ring gear teeth with the greatest degree of contact against the pinion teeth will squeeze the compound to the areas with the least amount of contact. Note and compare patterns on the ring gear teeth to Gear Tooth Contact Patterns chart (Fig. 21) and adjust pinion depth and gear backlash as necessary.

## REAR AXLE - 248RBI (Continued)

<p>DRIVE SIDE OF RING GEAR TEETH</p> <p>HEEL                      TOE</p> 	<p>COAST SIDE OF RING GEAR TEETH</p> <p>TOE                      HEEL</p> 	<p>DESIRABLE CONTACT PATTERN. PATTERN SHOULD BE CENTERED ON THE DRIVE SIDE OF TOOTH. PATTERN SHOULD BE CENTERED ON THE COAST SIDE OF TOOTH, BUT MAY BE SLIGHTLY TOWARD THE TOE. THERE SHOULD ALWAYS BE SOME CLEARANCE BETWEEN CONTACT PATTERN AND TOP OF THE TOOTH.</p>
		<p>RING GEAR BACKLASH CORRECT. <b>THINNER</b> PINION GEAR DEPTH SHIM REQUIRED.</p>
		<p>RING GEAR BACKLASH CORRECT. <b>THICKER</b> PINION GEAR DEPTH SHIM REQUIRED.</p>
		<p>PINION GEAR DEPTH SHIM CORRECT. <b>DECREASE</b> RING GEAR BACKLASH.</p>
		<p>PINION GEAR DEPTH SHIM CORRECT. <b>INCREASE</b> RING GEAR BACKLASH.</p>

J9003-24

Fig. 21 Gear Tooth Contact Patterns

REAR AXLE - 248RBI (Continued)

## SPECIFICATIONS

## REAR AXLE - 248RBI

## AXLE SPECIFICATIONS

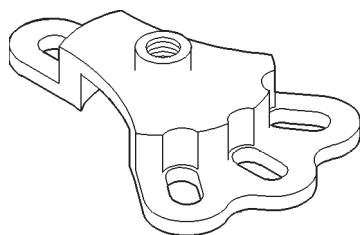
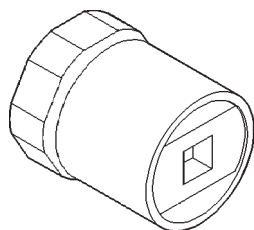
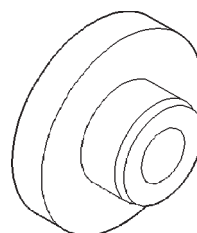
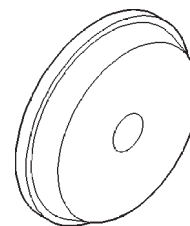
DESCRIPTION	SPECIFICATION
Axle Ratio	3.55, 4.10
Ring Gear Diameter	248 mm (9.75 in.)
Ring Gear Backlash	0.12-0.20 mm (0.005-0.008 in.)
Pinion Gear Standard Depth	127.0 mm (5.000 in.)
Pinion Bearing Preload - Original Bearings	1-2 N-m (10-20 in. lbs.)
Pinion Bearing Preload - New Bearings	2.3-5.1 N-m (20-45 in. lbs.)

## TORQUE SPECIFICATIONS

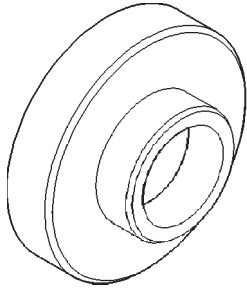
DESCRIPTION	N-m	Ft. Lbs.	In. Lbs.
Fill Hole Plug	34	25	-
Differential Cover Bolts	41	30	-
Bearing Cap Bolts	108	80	-
Ring Gear Bolt	176	130	-
Pinion Nut	292-447	215-330	-
Axle Shaft Bolts	122-136	90-100	-
Hub Bearing Nut	163-190	120-140	-

## SPECIAL TOOLS

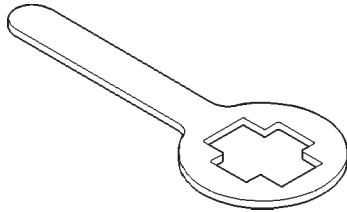
## REAR AXLE - 248RBI

**Puller 6790****Wrench DD-1241-JD****Installer 5064****Installer D-111**

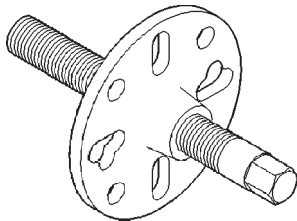
REAR AXLE - 248RBI (Continued)



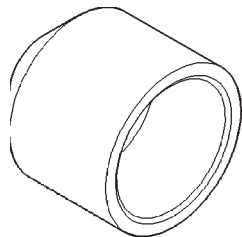
**Installer 8149**



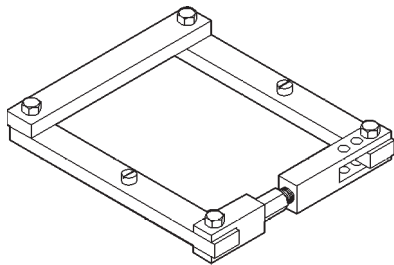
**Holder 6719A**



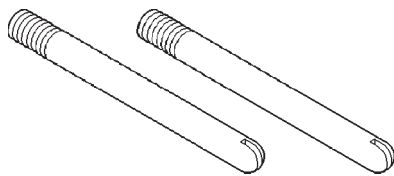
**Puller C-452**



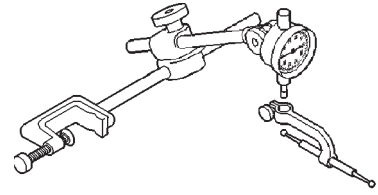
**Installer 8108**



**Spreader W-129-B**

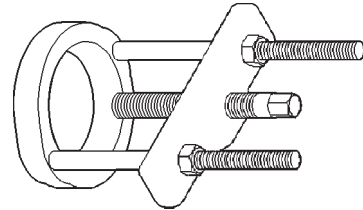


**Pilot Studs C-3288-B**

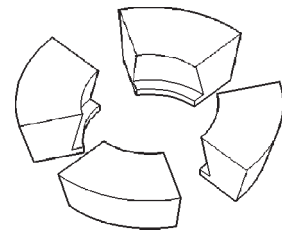


8011d42b

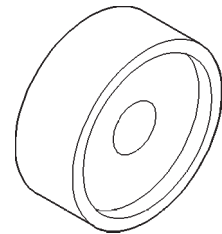
**Dial Indicator C-3339**



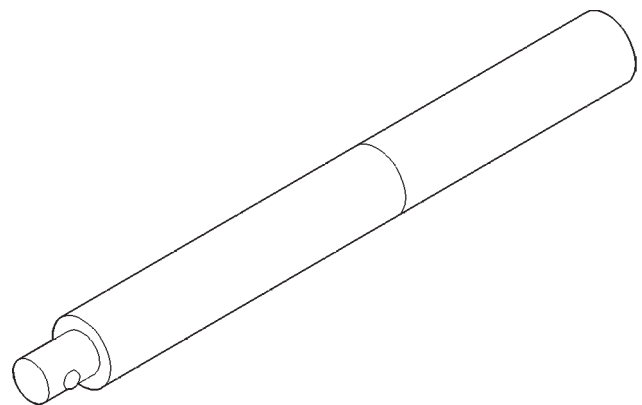
**Puller/Press C-293-PA**



**Adapters C-293-37**

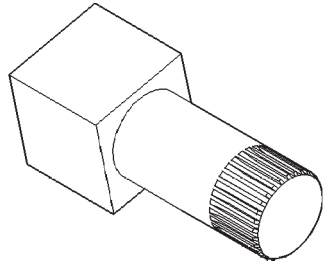


**Installer C-4190**

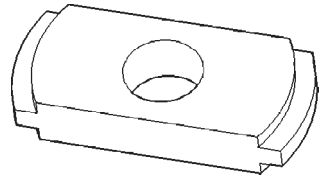


**Handle C-4171**

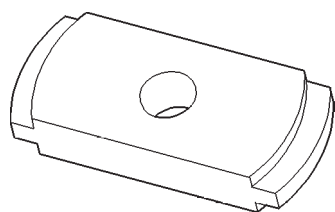
REAR AXLE - 248RBI (Continued)



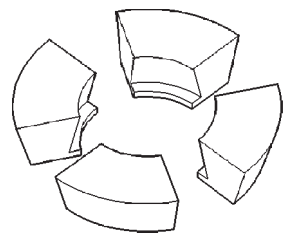
**Fixture 6963-A**



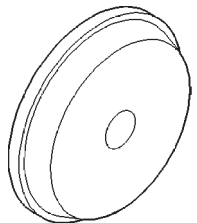
**Remover D-158**



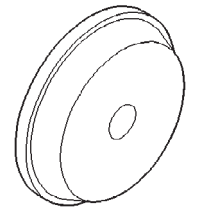
**Remover D-162**



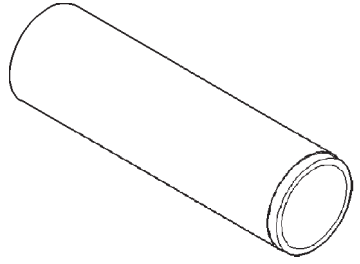
**Adapters C-293-37**



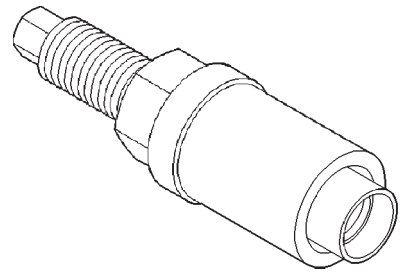
**Installer D-111**



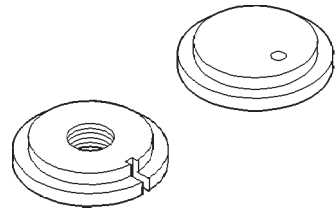
**Installer D-146**



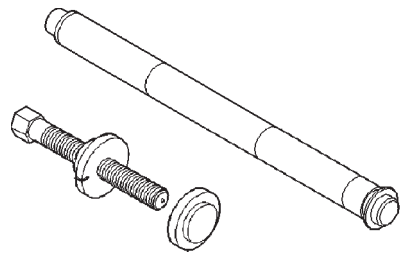
**Installer C-3095-A**



**Installer C-3718**

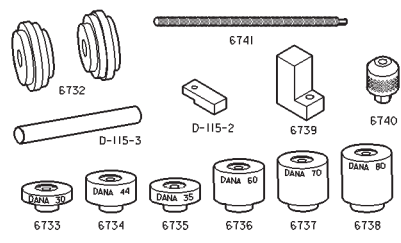


**Trac-lok Tools 8139**



**Trac-lok Tools C-4487**

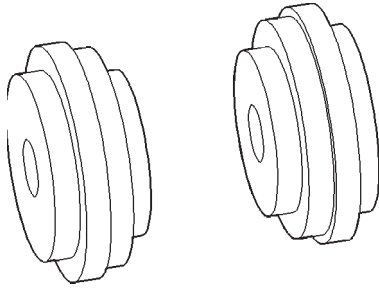
6730 PINION HEIGHT SET



**Gauge Set 6730**



## REAR AXLE - 248RBI (Continued)

**Arbor Discs 6732****AXLE SHAFTS****REMOVAL**

- (1) Remove the axle shaft flange bolts.
- (2) Slide the axle shaft out from the axle tube.

**INSTALLATION**

- (1) Clean the gasket contact surface area on the flange with an appropriate solvent. Install a new flange gasket and slide the axle shaft into the tube.
- (2) Install the bolts and tighten to 129 N·m (95 ft. lbs.).

**AXLE BEARINGS****REMOVAL**

- (1) Remove wheel and tire assembly.
- (2) Remove brake drum.
- (3) Remove the axle shaft.
- (4) Remove the lock wedge and adjustment nut. Use Socket DD-1241-JD to remove the adjustment nut.
- (5) Remove the hub assembly. The outer axle bearing will slide out as the hub is being removed.
- (6) Remove inner grease seal and discard. Use Installer 5064 and Handle C-4171 to drive grease seal and inner axle bearing from the hub.
- (7) Remove the bearing cups from the hub bore. Use a brass drift, or an appropriate removal tool, to tap out the cups.

**INSTALLATION**

- (1) Thoroughly clean both axle bearings and interior of the hub with an appropriate cleaning solvent.
- (2) Install bearing cups with Installer 8151 and Handle C-4171.
- (3) **Pack inner and outer bearings with Mopar wheel bearing grease or equivalent.**
- (4) Apply grease to inner and outer bearing cup surfaces.
- (5) Install inner axle bearing in the hub.
- (6) Install **new** grease seal in hub with Installer 8149 and Handle C-4171.

(7) Inspect bearing and seal contact surfaces on the axle tube for burrs/roughness. Remove all the rough contact surfaces from the axle tube.

(8) Carefully slide the hub onto the axle.

**CAUTION: Do not let grease seal contact axle tube threads during installation.**

- (9) Install outer axle bearing.
- (10) Install hub bearing adjustment nut with Socket DD-1241-JD.
- (11) Tighten adjustment nut to 163-190 N·m (120-140 ft. lbs.) while rotating the wheel. Then loosen adjustment nut 1/8 to 1/3 of-a-turn to provide 0.025-0.250mm (0.001-0.009 in.) wheel bearing end play.
- (12) Tap locking wedge into the spindle keyway and adjustment nut.

**NOTE: Located locking wedge in a new position in the adjustment nut.**

- (13) Install axle shaft and brake drum.
- (14) Install the wheel and tire assembly.

**PINION SEAL****REMOVAL**

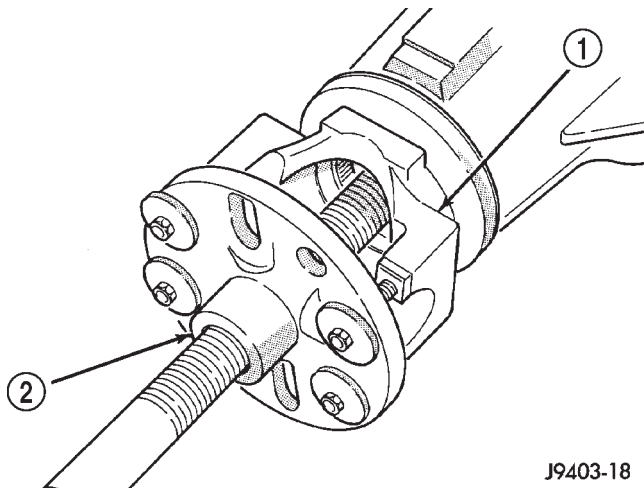
- (1) Raise and support the vehicle.
- (2) Scribe a mark on the universal joint, pinion yoke, and pinion shaft for reference.
- (3) Disconnect the propeller shaft from the pinion yoke. Secure the propeller shaft in an upright position to prevent damage to the rear universal joint.
- (4) Remove the wheel and tire assemblies.
- (5) Remove the brake drums to prevent any drag. The drag may cause a false bearing preload torque measurement.
- (6) Rotate the pinion yoke three or four times.
- (7) Measure the amount of torque necessary to rotate the pinion gear with a (in. lbs.) dial-type torque wrench. Record the torque reading for installation reference.
- (8) Hold the yoke with Wrench 6719. Remove the pinion shaft nut and washer.
- (9) Remove the yoke with Remover C-452 (Fig. 22).
- (10) Remove the pinion shaft seal with suitable pry tool or slide-hammer mounted screw.

**INSTALLATION**

**NOTE: The outer perimeter of the seal is pre-coated with a special sealant. An additional application of sealant is not required.**

- (1) Apply a light coating of gear lubricant on the lip of pinion seal.

## PINION SEAL (Continued)

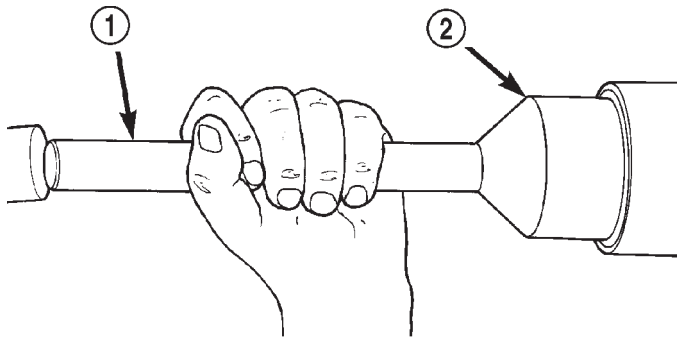


J9403-18

**Fig. 22 Yoke Removal**

- 1 - PINION YOKE  
2 - REMOVER C452

(2) Install new pinion seal with an appropriate installer (Fig. 23).



80a98349

**Fig. 23 Pinion Seal Installation**

- 1 - SPECIAL TOOL C—4171  
2 - SPECIAL TOOL C—8108

**NOTE:** The seal is correctly installed when the seal flange contacts the face of the differential housing flange.

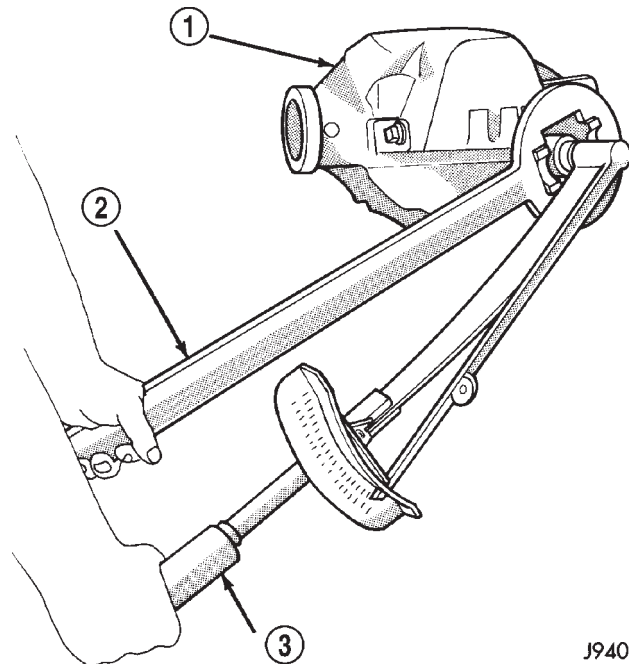
(3) Position the pinion yoke on the end of the shaft with the reference marks aligned.

(4) Seat yoke on pinion shaft with Installer C-3718 and Yoke Holder 6719.

(5) Remove the tools and install the pinion yoke washer and nut.

**CAUTION:** Do not exceed the minimum tightening torque when installing the pinion yoke retaining nut at this point. Damage to collapsible spacer, if equipped, or bearings may result.

(6) Hold pinion yoke with Yoke Holder 6719 and tighten shaft nut to 291.5 N·m (215 ft. lbs.) (Fig. 24). Rotate pinion shaft several revolutions to ensure the bearing rollers are seated.



J9402-62

**Fig. 24 Tightening Pinion Shaft Nut**

- 1 - DIFFERENTIAL HOUSING  
2 - YOKE HOLDER  
3 - TORQUE WRENCH

(7) Rotate the pinion shaft using a (in. lbs.) torque wrench. Rotating resistance torque should be equal to the reading recorded during removal, plus an additional 0.56 N·m (5 in. lbs.) (Fig. 25).

**CAUTION:** Never loosen pinion gear nut to decrease pinion gear bearing rotating torque and never exceed specified preload torque. If preload torque is exceeded a new pinion nut and collapsible spacer, if equipped, must be installed. The torque sequence will then have to be repeated.

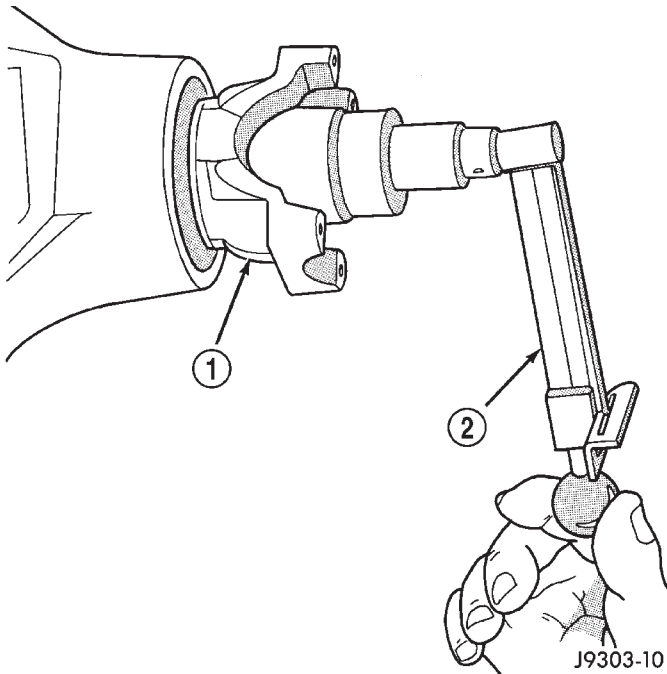
(8) If the rotating torque is low, use Yoke Holder 6719 to hold the pinion yoke (Fig. 24) and tighten the pinion shaft nut in 6.8 N·m (5 ft. lbs.) increments until proper rotating torque is achieved.

**NOTE:** The bearing rotating torque should be constant during a complete revolution of the pinion. If the rotating torque varies, this indicates a binding condition.

(9) Install the propeller shaft with the installation reference marks aligned.

(10) Tighten the universal joint yoke clamp screws to 19 N·m (14 ft. lbs.).

## PINION SEAL (Continued)

**Fig. 25 Check Pinion Rotation Torque**

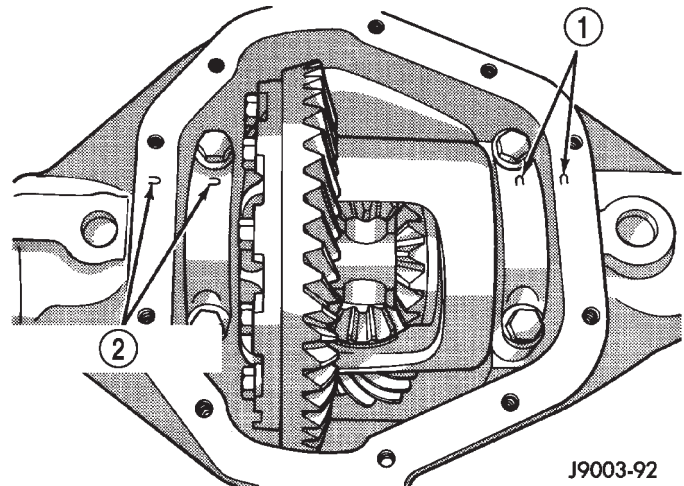
- 1 - PINION YOKE  
2 - INCH POUND TORQUE WRENCH

- (11) Install the brake drums.  
(12) Add gear lubricant to the differential housing, if necessary. Refer to the Lubricant Specifications for gear lubricant requirements.  
(13) Install wheel and tire assemblies and lower the vehicle.

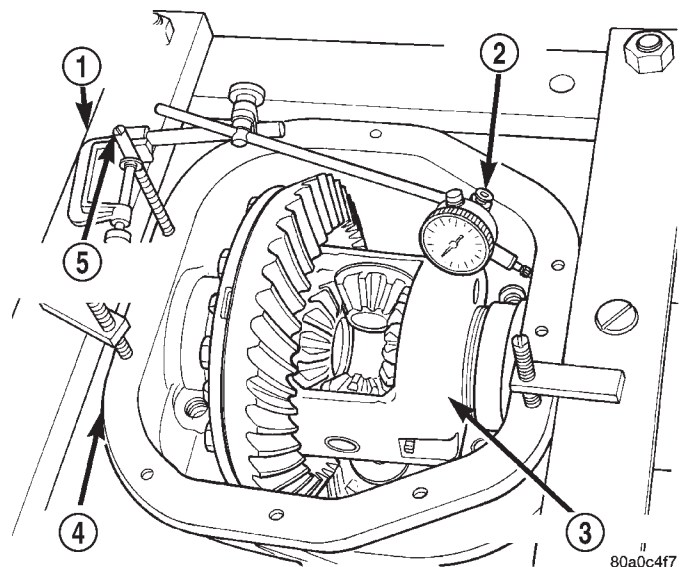
## DIFFERENTIAL

## REMOVAL

- (1) Raise and support the vehicle.  
(2) Remove the lubricant fill hole plug from the differential housing cover.  
(3) Remove differential housing cover and drain the lubricant from the housing.  
(4) Clean the housing cavity with a flushing oil, light engine oil or lint free cloth. **Do not use water, steam, kerosene or gasoline for cleaning.**  
(5) Remove axle shafts.  
(6) Note the orientation of the installation reference letters stamped on the bearing caps and housing machined sealing surface (Fig. 26).  
(7) Remove the differential bearing caps.  
(8) Position Spreader W-129-B with the tool dowel pins seated in the locating holes (Fig. 27).  
(9) Install the hold down clamps and tighten the tool turnbuckle finger-tight.  
(10) Install a Pilot Stud C-3288-B at the left side of the differential housing. Attach dial indicator to

**Fig. 26 Bearing Cap Identification**

- 1 - REFERENCE LETTERS  
2 - REFERENCE LETTERS

**Fig. 27 Spread Differential Housing**

- 1 - SPREADER  
2 - DIAL INDICATOR  
3 - DIFFERENTIAL  
4 - DIFFERENTIAL HOUSING  
5 - PILOT STUD

housing pilot stud. Load the indicator plunger against the opposite side of the housing (Fig. 27) and zero the indicator.

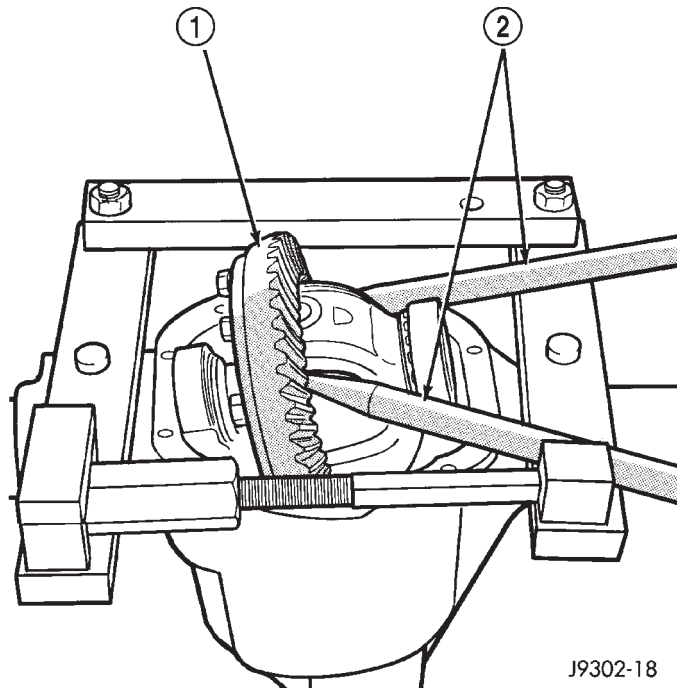
(11) Spread the housing enough to remove the case from the housing. Measure the distance with the dial indicator (Fig. 27).

**CAUTION:** Do not spread over 0.50 mm (0.020 in). If the housing is over-spread, it could be distorted or damaged.

## DIFFERENTIAL (Continued)

(12) Remove the dial indicator.

(13) Pry the differential case loose from the housing. To prevent damage, pivot on housing with the end of the pry bar against spreader (Fig. 28).



**Fig. 28 Differential Removal**

- 1 - DIFFERENTIAL
- 2 - PRY BAR

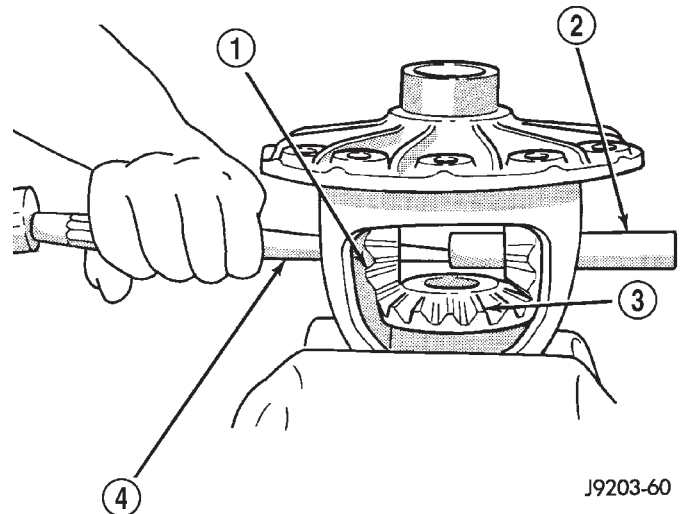
(14) Remove the case from housing. Tag bearing cups to indicate their location.

## DISASSEMBLY

- (1) Remove roll-pin holding mate shaft in housing.
- (2) Remove pinion gear mate shaft (Fig. 29).
- (3) Rotate the differential side gears and remove the pinion mate gears and thrust washers (Fig. 30).
- (4) Remove the differential side gears and thrust washers.

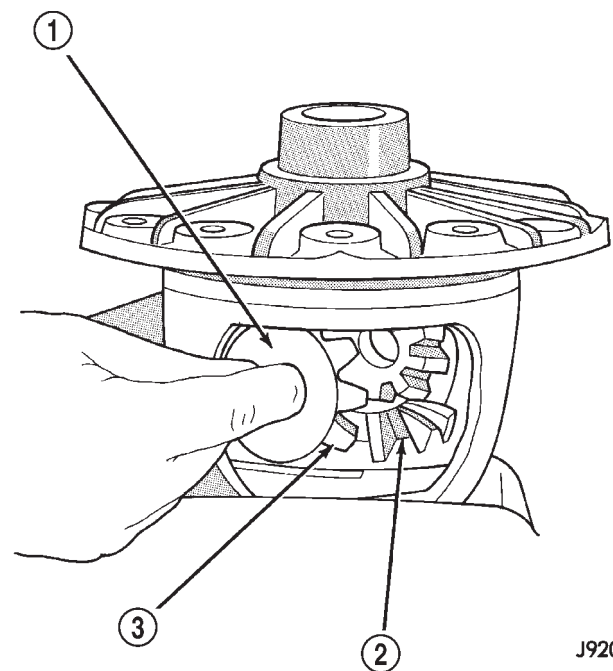
## ASSEMBLY

- (1) Install the differential side gears and thrust washers.
- (2) Install the pinion mate gears and thrust washers.
- (3) Install the pinion gear mate shaft.
- (4) Align the hole in the pinion gear mate shaft with the hole in the differential case.
- (5) Install and seat the pinion mate shaft roll-pin in the differential case and mate shaft with a punch and hammer (Fig. 31). Peen the edge of the roll-pin hole in the differential case slightly in two places, 180° apart.



**Fig. 29 Pinion Mate Shaft**

- 1 - PINION MATE GEAR
- 2 - PINION MATE SHAFT
- 3 - SIDE GEAR
- 4 - DRIFT



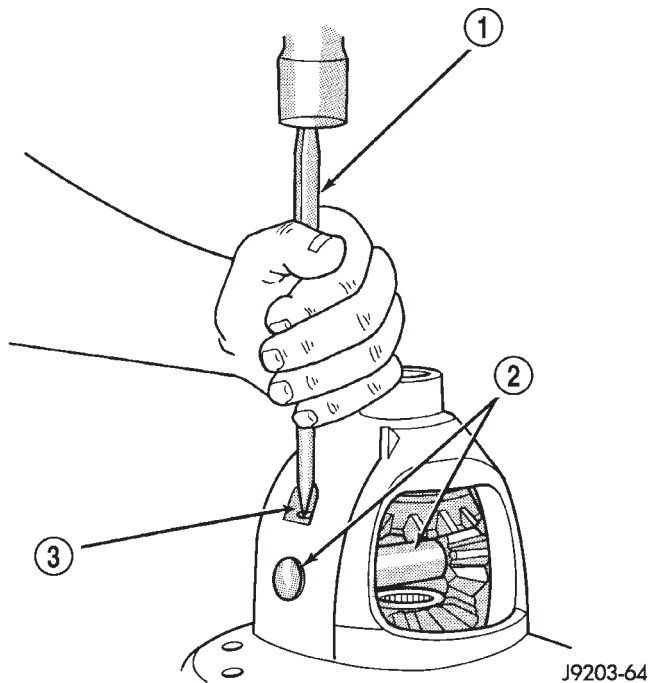
**Fig. 30 Pinion Mate/Side Gear**

- 1 - THRUST WASHER
- 2 - SIDE GEAR
- 3 - PINION MATE GEAR

(6) Lubricate all differential components with hypoid gear lubricant.



## DIFFERENTIAL (Continued)



**Fig. 31 Pinion Mate Shaft Roll-Pin**

- 1 - PUNCH
- 2 - PINION MATE SHAFT
- 3 - MATE SHAFT LOCKPIN

## INSTALLATION

**NOTE:** If replacement differential bearings or differential case are being installed, differential side bearing shim requirements may change. Refer to **Adjustments (Differential Bearing Preload and Gear Backlash)** procedures to determine proper shim selection.

(1) Position Spreader W-129-B with the tool dowel pins seated in the locating holes. Install the hold down clamps and tighten the tool turnbuckle finger-tight.

(2) Install a Pilot Stud C-3288-B at the left side of the differential housing and attach dial indicator to the pilot stud. Load the indicator plunger against the opposite side of the housing and zero the dial indicator.

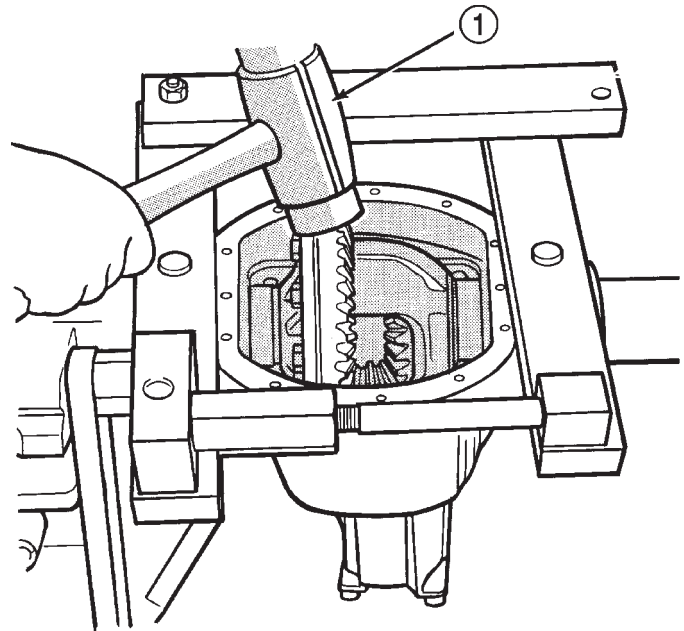
(3) Spread the housing enough to install the case in the housing. Measure the distance with the dial indicator.

**CAUTION:** Do not spread over 0.50 mm (0.020 in). If the housing is over-spread, it could be distorted or damaged.

(4) Remove the dial indicator.

(5) Install differential into the housing. Tap the differential case with a rawhide/rubber hammer to ensure the bearings are seated in housing (Fig. 32).

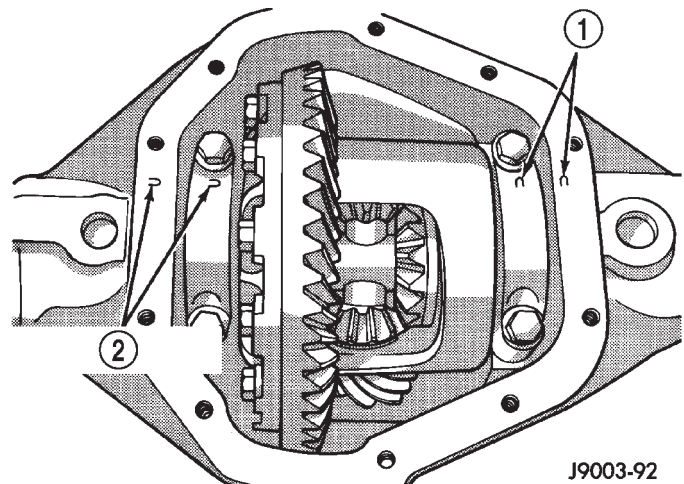
(6) Remove the spreader.



**Fig. 32 Differential Case**

- 1 - RAWHIDE HAMMER

(7) Install bearing caps in their original locations (Fig. 33) and tighten bearing cap bolts to 109 N·m (80 ft. lbs.).



**Fig. 33 Bearing Cap Reference**

- 1 - REFERENCE LETTERS
- 2 - REFERENCE LETTERS

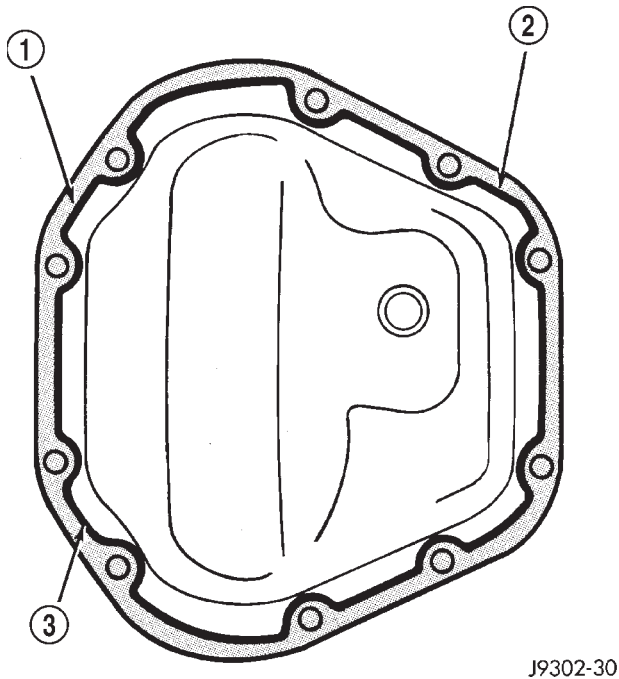
(8) Install axle shafts.

(9) Install the hub bearings.



## DIFFERENTIAL (Continued)

(10) Apply a bead of Mopar Silicone Rubber Sealant or equivalent to the housing cover (Fig. 34).



**Fig. 34 Differential Cover**

- 1 - SEALANT SURFACE  
2 - SEALANT  
3 - SEALANT THICKNESS

**Install the housing cover within 5 minutes after applying the sealant.**

(11) Install the cover and any identification tag. Tighten the cover bolts in a criss-cross pattern to 47 N·m (35 ft. lbs.).

(12) Refill the differential with Mopar Hypoid Gear Lubricant or equivalent to bottom of the fill plug hole. Refer to the Lubricant Specifications for correct quantity and type.

(13) Install the fill hole plug and tighten to 34 N·m (25 ft. lbs.).

(14) Remove support and lower vehicle.

## DIFFERENTIAL - TRAC-LOK

## DIAGNOSIS AND TESTING - TRAC-LOK™

The most common problem is a chatter noise when turning corners. Before removing a Trac-lok™ unit for repair, drain, flush and refill the axle with the specified lubricant. A container of Mopar Trac-lok™ Lubricant (friction modifier) should be added after repair service or during a lubricant change.

After changing the lubricant, drive the vehicle and make 10 to 12 slow, figure-eight turns. This maneuver will pump lubricant through the clutches. This

will correct the condition in most instances. If the chatter persists, clutch damage could have occurred.

## DIFFERENTIAL TEST

The differential can be tested without removing the differential case by measuring rotating torque. Make sure brakes are not dragging during this measurement.

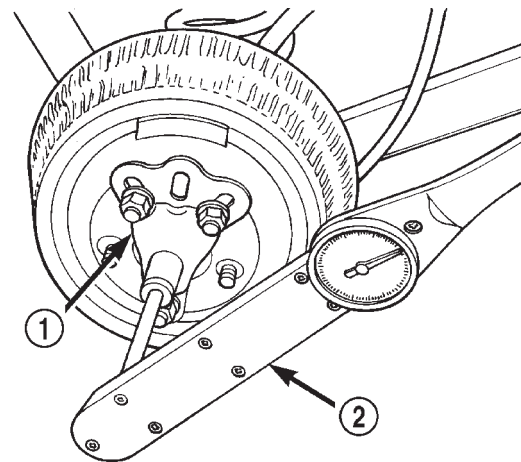
(1) Place blocks in front and rear of both front wheels.

(2) Raise one rear wheel until it is completely off the ground.

(3) Engine off, transmission in neutral, and parking brake off.

(4) Remove wheel and bolt Special Tool 6790 or equivalent tool to studs.

(5) Use torque wrench on special tool to rotate wheel and read rotating torque (Fig. 35).



**Fig. 35 Trac-lok™ Test - Typical**

- 1 - SPECIAL TOOL 6790 WITH BOLT IN CENTER HOLE  
2 - TORQUE WRENCH

(6) If rotating torque is less than 22 N·m (30 ft. lbs.) or more than 271 N·m (200 ft. lbs.) on either wheel the unit should be serviced.

## DISASSEMBLY

(1) Clamp side gear Holding Fixture 6965 in a vise and position the differential case on the Holding Fixture (Fig. 36).

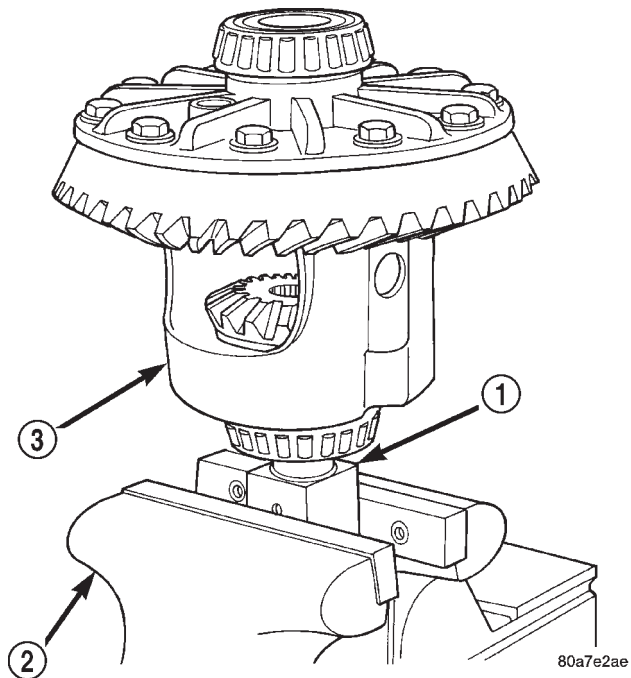
(2) Remove ring gear if the ring gear is to be replaced. The Trac-lok™ differential can be serviced with the ring gear installed.

(3) Remove pinion shaft roll pin.

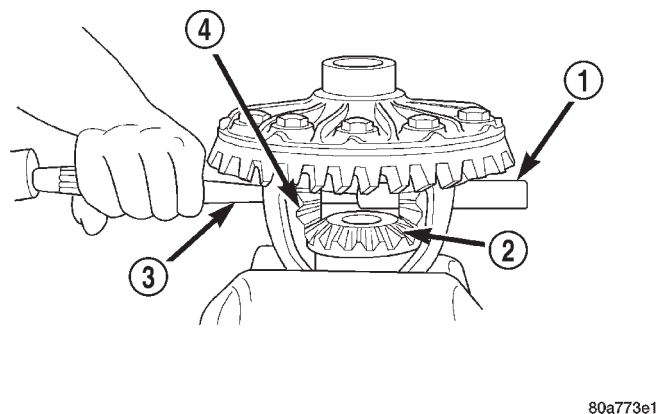
(4) Remove pinion shaft with a drift and hammer (Fig. 37).

(5) Install and lubricate Step Plate C-6960-3 (Fig. 38).

## DIFFERENTIAL - TRAC-LOK (Continued)

**Fig. 36 Differential Case Holding Fixture**

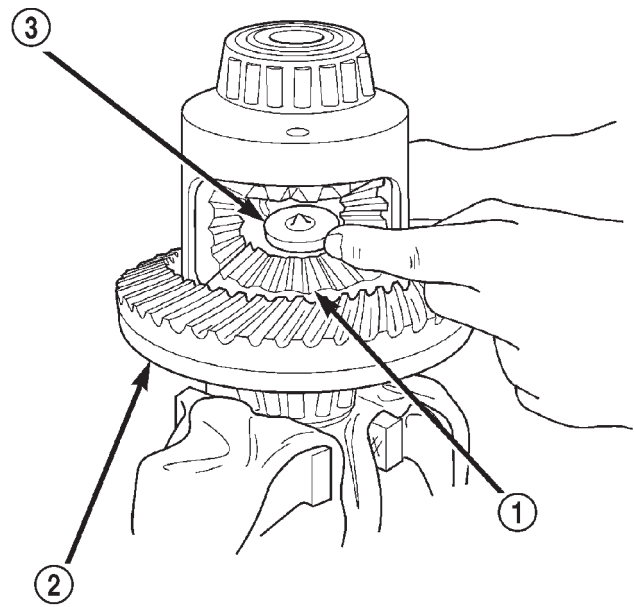
- 1 - HOLDING FIXTURE
- 2 - VISE
- 3 - DIFFERENTIAL

**Fig. 37 Pinion Shaft**

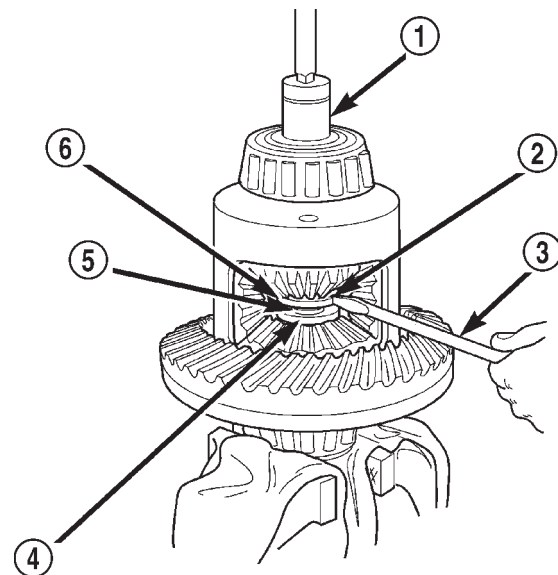
- 1 - PINION MATE SHAFT
- 2 - SIDE GEAR
- 3 - DRIFT
- 4 - PINION MATE GEAR

(6) Assemble Threaded Adapter C-6960-1 into top side gear. Thread Forcing Screw C-6960-4 into adapter until it becomes centered in adapter plate.

(7) Position a small screw driver in slot of Threaded Adapter Disc C-6960-3 (Fig. 39) to prevent adapter from turning.

**Fig. 38 Step Plate**

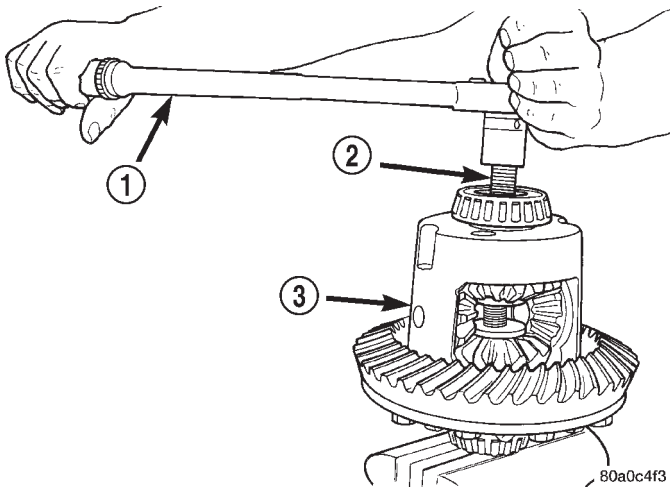
- 1 - LOWER SIDE GEAR
- 2 - DIFFERENTIAL CASE
- 3 - STEP PLATE

**Fig. 39 Threaded Adapter Disc**

- 1 - SOCKET
- 2 - SLOT IN ADAPTER
- 3 - SCREWDRIVER
- 4 - DISC
- 5 - FORCING SCREW
- 6 - THREADED ADAPTER DISC

## DIFFERENTIAL - TRAC-LOK (Continued)

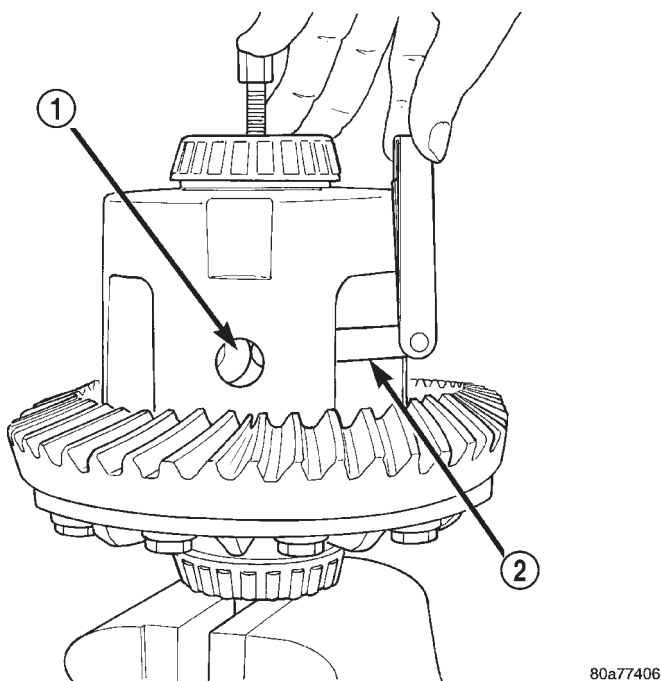
(8) Install Forcing Screw C-6960-4 and tighten screw to 122 N-m (90 ft. lbs.) maximum to compress Belleville springs in clutch packs (Fig. 40).



**Fig. 40 Compress Belleville Spring**

- 1 - TORQUE WRENCH  
2 - TOOL ASSEMBLED  
3 - DIFFERENTIAL CASE

(9) With a feeler gauge remove thrust washers from behind the differential pinion gears (Fig. 41).



**Fig. 41 Pinion Gear Thrust Washer**

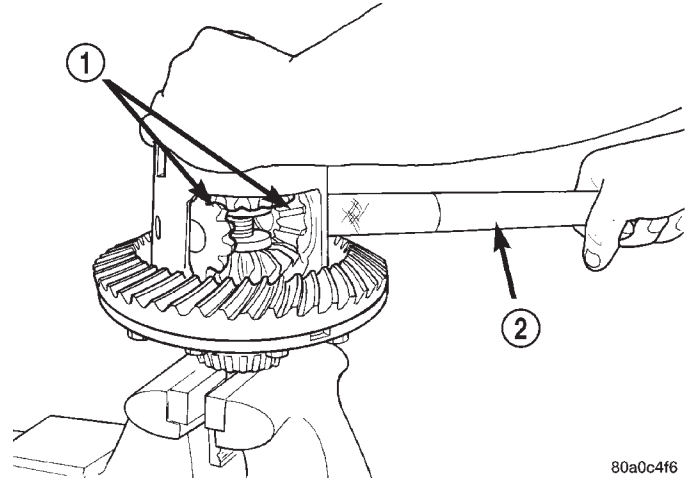
- 1 - THRUST WASHER  
2 - FEELER GAUGE

(10) Insert Turning Bar C-6960-2 into the pinion shaft hole in the case (Fig. 42).

(11) Loosen the Forcing Screw in small increments until the clutch pack tension is relieved and the differential case can be turned using Turning Bar.

(12) Rotate differential case until the pinion gears can be removed.

(13) Remove pinion gears from differential case.



**Fig. 42 Pinion Gear**

- 1 - PINION GEARS  
2 - TOOL

(14) Remove Forcing Screw, Step Plate and Threaded Adapter.

(15) Remove top side gear, clutch pack retainer and clutch pack. Keep plates in correct order during removal (Fig. 43).

(16) Remove differential case from the Holding Fixture. Remove side gear, clutch pack retainer and clutch pack. Keep plates in correct order during removal.

## ASSEMBLY

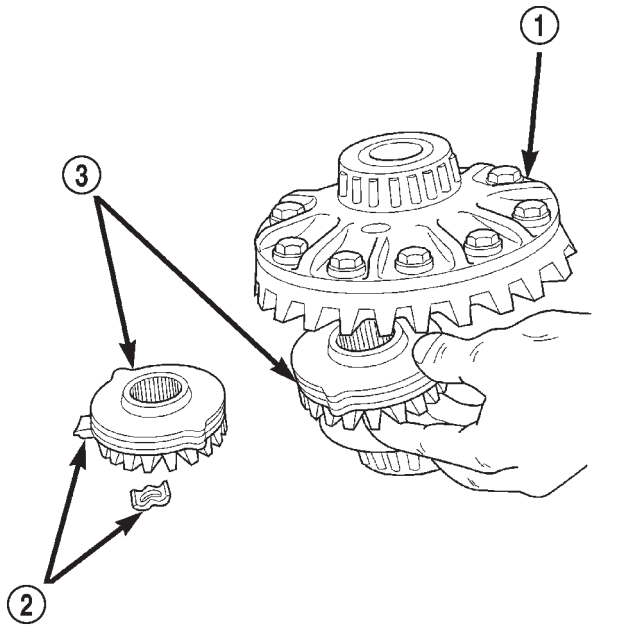
Clean all components in cleaning solvent. Dry components with compressed air. Inspect clutch pack plates for wear, scoring or damage. Replace both clutch packs if any one component in either pack is damaged. Inspect side gears and pinions. Replace any gear that is worn, cracked, chipped or damaged. Inspect differential case and pinion shaft. Replace if worn or damaged.

Lubricate each component with gear lubricant before assembly.

(1) Assemble the clutch discs into packs and secure disc packs with retaining clips (Fig. 44).

**NOTE:** New Plates and discs with fiber coating (no grooves or lines) must be presoaked in Friction Modifier before assembly. Soak plates and discs for a minimum of 20 minutes.

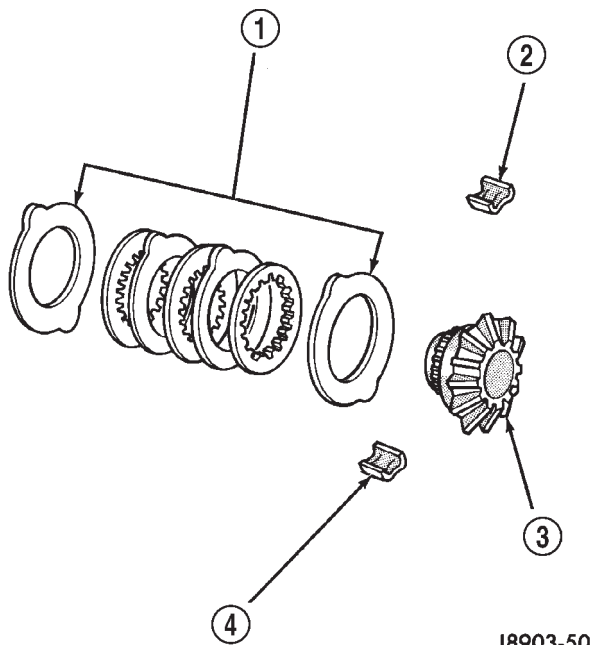
## DIFFERENTIAL - TRAC-LOK (Continued)



80a98382

**Fig. 43 Side Gear & Clutch Pack**

- 1 - DIFFERENTIAL CASE
- 2 - RETAINER
- 3 - SIDE GEAR AND CLUTCH DISC PACK



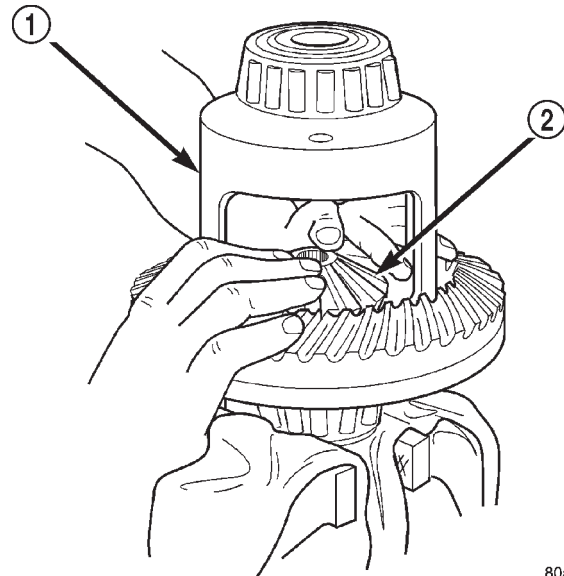
J8903-50

**Fig. 44 Clutch Disc Pack**

- 1 - CLUTCH PACK
- 2 - RETAINER
- 3 - SIDE GEAR
- 4 - RETAINER

(2) Position assembled clutch disc packs on the side gear hubs.

(3) Install clutch pack and side gear in the ring gear side of the differential case (Fig. 45). **Be sure clutch pack retaining clips remain in position and are seated in the case pockets.**



80a7739c

**Fig. 45 Clutch Pack and Side Gear**

- 1 - DIFFERENTIAL CASE
- 2 - LOWER SIDE GEAR AND CLUTCH DISC PACK

(4) Position the differential case on the Holding Fixture 6965.

(5) Install lubricated Step Plate C-6960-3 in lower side gear (Fig. 46).

(6) Install the upper side gear and clutch disc pack (Fig. 46).

(7) Hold assembly in position. Insert Threaded Adapter C-6960-1 into top side gear.

(8) Install Forcing Screw C-6960-4 and tighten screw to slightly compress clutch disc.

(9) Place differential pinion gears in position in side gears and verify that the pinion shaft hole is aligned.

(10) Rotate case with Turning Bar C-6960-2 until the pinion shaft holes in pinion gears align with holes in case. It may be necessary to slightly tighten the forcing screw in order to install the pinion gears.

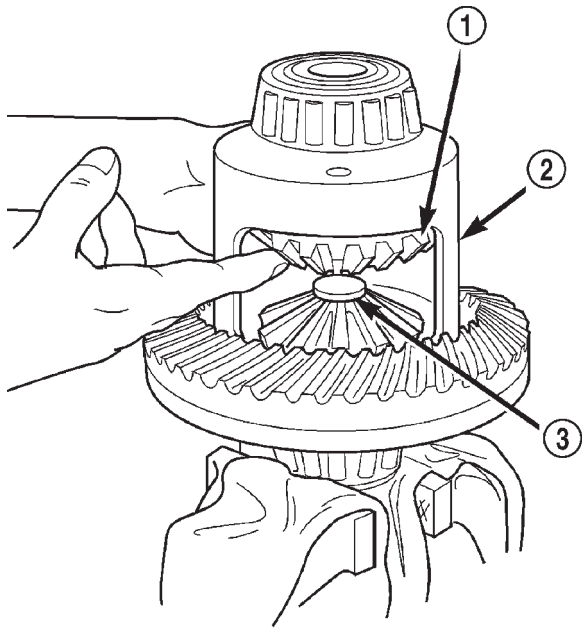
(11) Tighten forcing screw to 122 N·m (90 ft. lbs.) maximum to compress the Belleville springs.

(12) Lubricate and install thrust washers behind pinion gears and align washers with a small screw driver. Insert pinion shaft into each pinion gear to verify alignment.

(13) Remove Forcing Screw, Step Plate and Threaded Adapter.

(14) Install pinion shaft and align holes in shaft and case.

## DIFFERENTIAL - TRAC-LOK (Continued)



80a83887

**Fig. 46 Clutch Pack and Upper Side Gear**

- 1 - SIDE GEAR AND CLUTCH PACK
- 2 - DIFFERENTIAL CASE
- 3 - STEP PLATE - C-6960-3

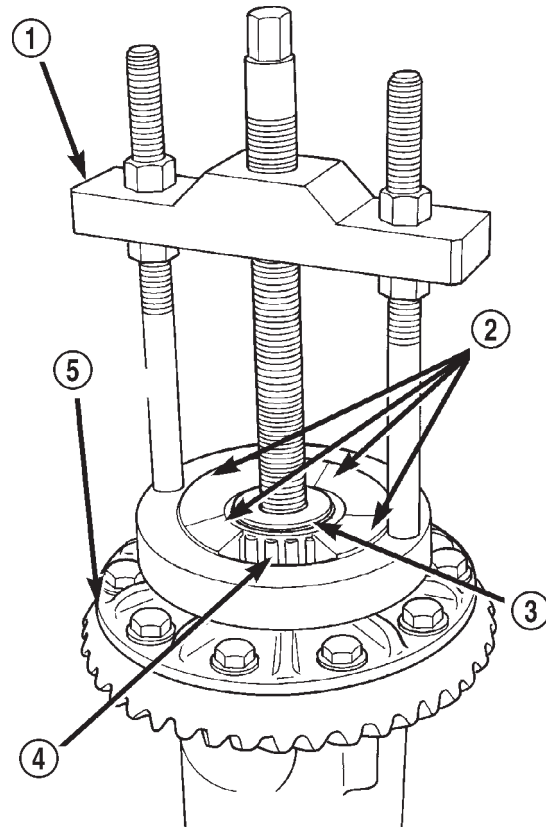
(15) Install and seat pinion shaft roll pin in differential case. Peen the edge of the roll pin hole in the case slightly in two places 180° apart.

(16) Lubricate all differential components with hypoid gear lubricant.

## DIFFERENTIAL CASE BEARINGS

### REMOVAL

- (1) Remove differential case from axle housing.
- (2) Remove bearings from the differential case with Puller/Press C-293-PA, Adapters C-293-62 and Step Plate 8139-2 (Fig. 47).



80a9834a

**Fig. 47 Differential Bearing**

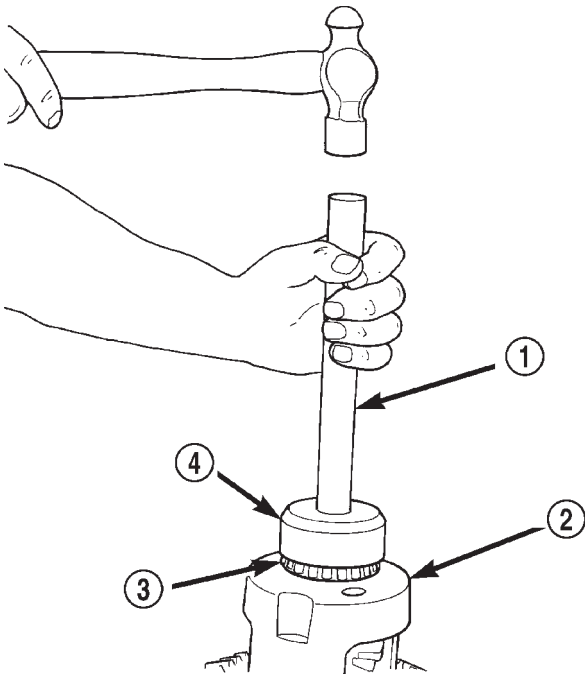
- 1 - SPECIAL TOOL C-293-PA
- 2 - SPECIAL TOOL C-293-62
- 3 - SPECIAL TOOL C-4487-1
- 4 - BEARING
- 5 - DIFFERENTIAL

### INSTALLATION

- (1) Using tool C-4190 with handle C-4171, install differential side bearings (Fig. 48).
- (2) Install differential case in axle housing.



## DIFFERENTIAL CASE BEARINGS (Continued)



80a9834b

**Fig. 48 Install Differential Side Bearings**

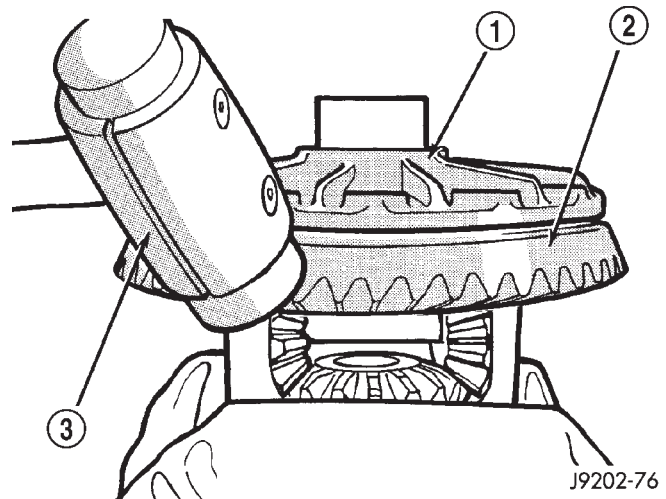
- 1 - HANDLE C-4171
- 2 - DIFFERENTIAL CASE
- 3 - BEARING
- 4 - TOOL C-4190

PINION GEAR/RING GEAR/  
TONE RING

## REMOVAL

**NOTE:** The ring and pinion gears are service in a matched set. Do not replace the ring gear without replacing the pinion gear.

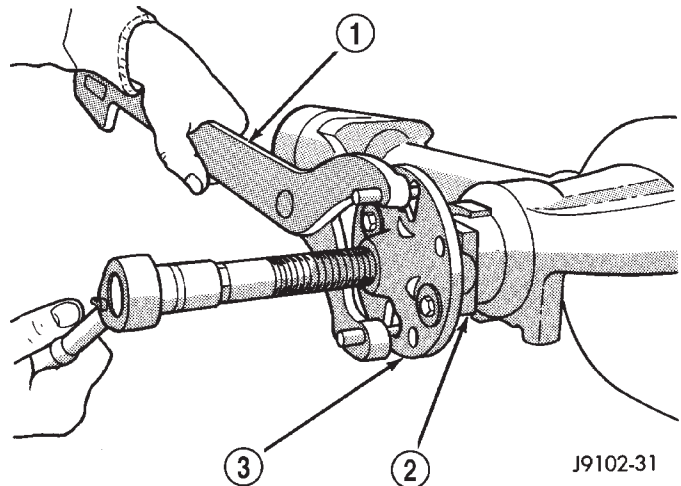
- (1) Remove differential from axle housing.
- (2) Place differential case in a suitable vise with soft metal jaw protectors. (Fig. 49)
- (3) Remove bolts holding ring gear to differential case.
- (4) Using a soft hammer, drive ring gear from differential case (Fig. 49).
- (5) Use a brass drift and slowly tap the exciter ring from the differential case.
- (6) Mark pinion yoke and propeller shaft for installation alignment.
- (7) Disconnect propeller shaft from pinion yoke. Using suitable wire, tie propeller shaft to underbody.
- (8) Using Yoke Holder 6719 to hold yoke, remove the pinion yoke nut and washer.
- (9) Using Remover C-452 and Wrench C-3281, remove the pinion yoke from pinion shaft (Fig. 50).



J9202-76

**Fig. 49 Ring Gear Removal**

- 1 - CASE
- 2 - RING GEAR
- 3 - RAWHIDE HAMMER



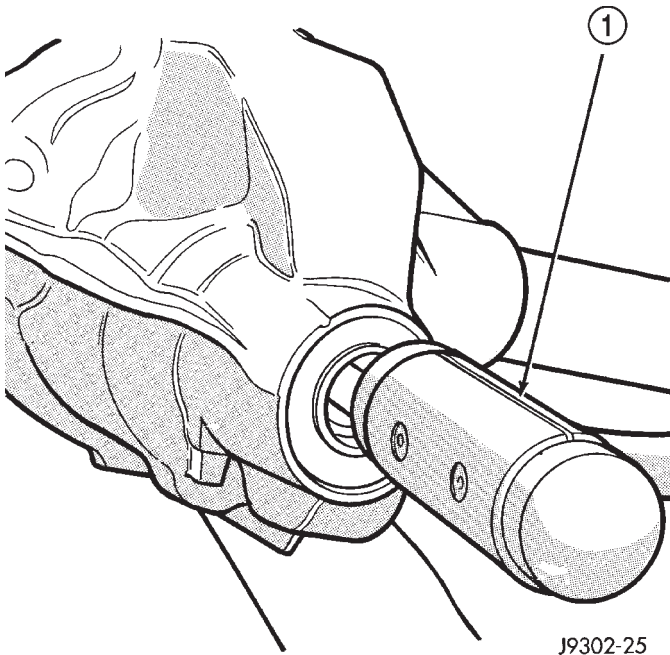
J9102-31

**Fig. 50 Pinion Yoke Removal**

- 1 - SPECIAL TOOL C-3281
- 2 - YOKE
- 3 - SPECIAL TOOL C-452

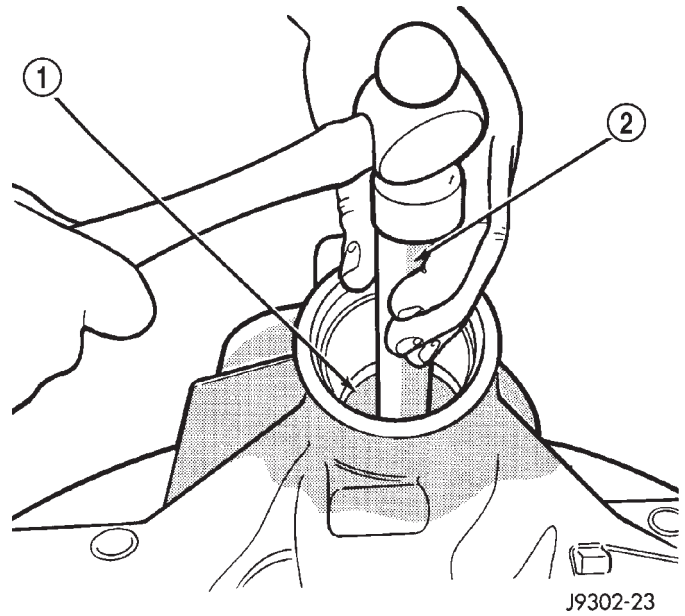
- (10) Remove the pinion gear from housing (Fig. 51). Catch the pinion with your hand to prevent it from falling and being damaged.
- (11) Remove the pinion seal with a slide hammer or suitable pry bar.
- (12) Remove oil slinger, if equipped, and the front pinion bearing.
- (13) Remove the front pinion bearing cup with Remover D-158 and Handle C-4171 (Fig. 52).
- (14) Remove the rear bearing cup from housing (Fig. 53). Use Remover D-162 and Handle C-4171.
- (15) Remove the collapsible preload spacer (Fig. 54) from pinion gears.

PINION GEAR/RING GEAR/TONE RING (Continued)



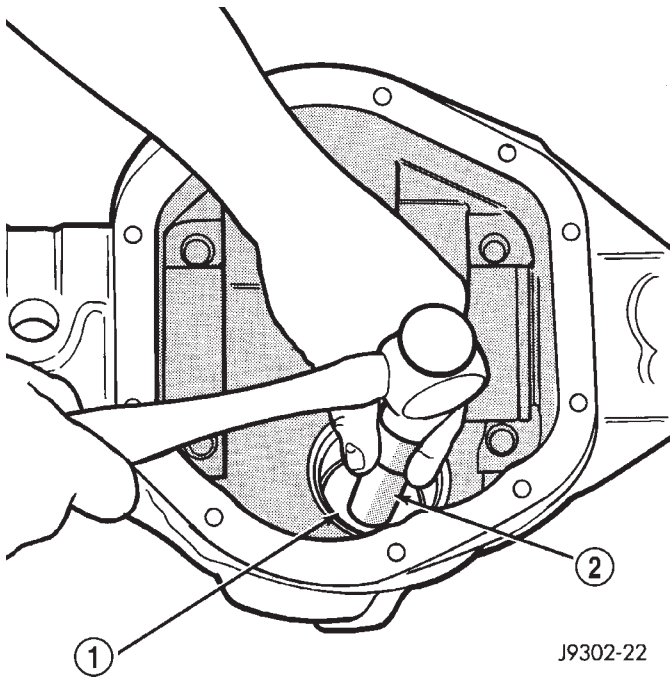
**Fig. 51 Remove Pinion Gear**

- 1 - RAWHIDE HAMMER



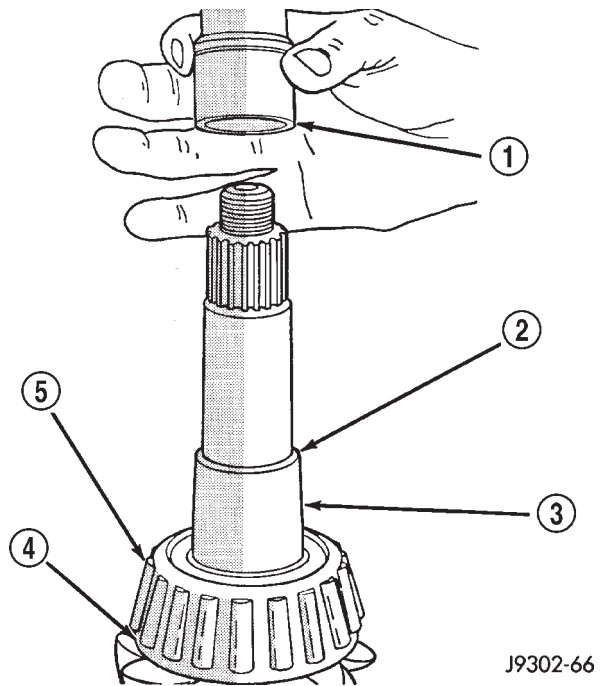
**Fig. 53 Rear Bearing Cup Removal**

- 1 - DRIVER  
2 - HANDLE



**Fig. 52 Front Bearing Cup Removal**

- 1 - REMOVER  
2 - HANDLE



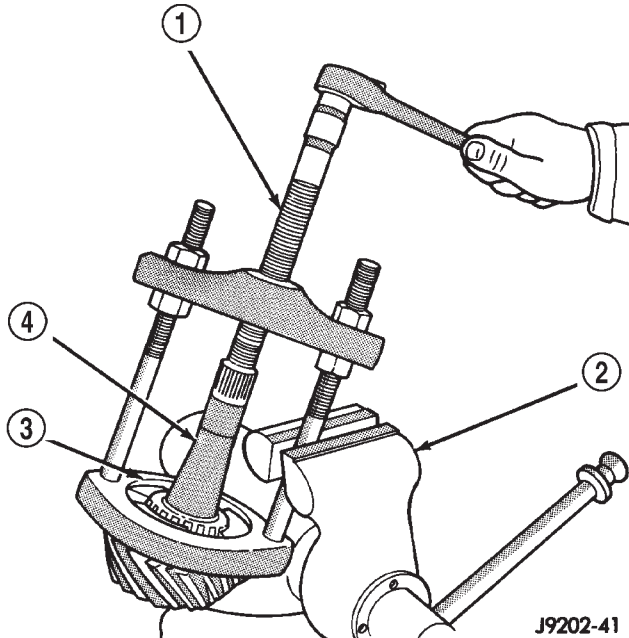
**Fig. 54 Collapsible Spacer**

- 1 - COLLAPSIBLE SPACER  
2 - SHOULDER  
3 - PINION GEAR  
4 - OIL SLINGER  
5 - REAR BEARING

## PINION GEAR/RING GEAR/TONE RING (Continued)

(16) Remove the rear bearing from the pinion with Puller/Press C-293-PA and Adapters C-293-37 (Fig. 55).

**Place 4 adapter blocks so they do not damage the bearing cage.**



**Fig. 55 Inner Bearing Removal**

- 1 - SPECIAL TOOL C-293-PA
- 2 - VISE
- 3 - ADAPTERS
- 4 - DRIVE PINION GEAR SHAFT

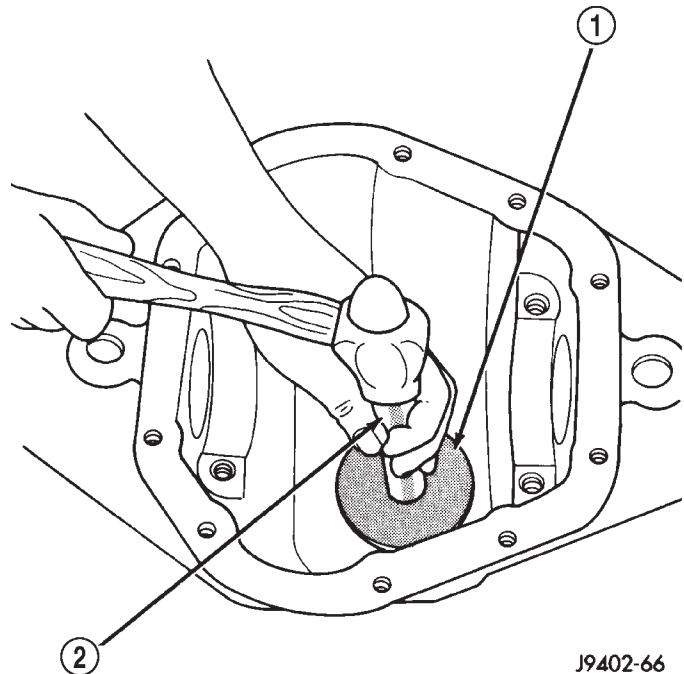
(17) Remove the pinion depth shims from the pinion gear shaft. Record the total thickness of the depth shims.

## INSTALLATION

(1) Apply Mopar® Door Ease stick lubricant to outside surface of bearing cup. Install the pinion rear bearing cup with Installer D-111 and Handle C-4171 (Fig. 56). Ensure cup is correctly seated.

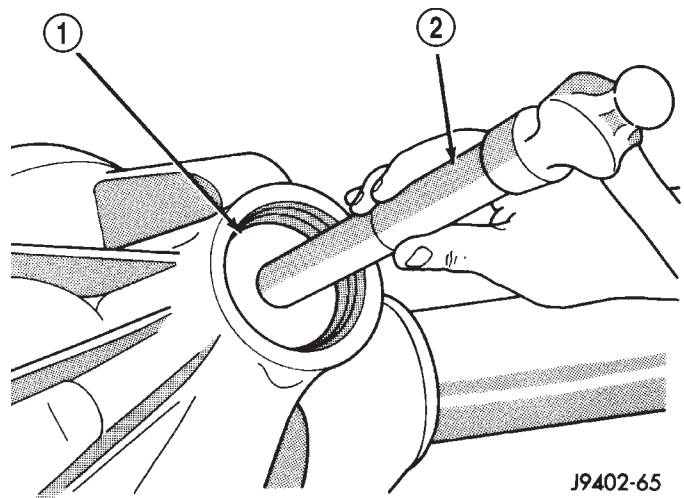
(2) Apply Mopar® Door Ease stick lubricant to outside surface of bearing cup. Install the pinion front bearing cup with Installer D-146 and Handle C-4171 (Fig. 57).

(3) Install pinion front bearing and oil slinger, if equipped. Apply a light coating of gear lubricant on the lip of pinion seal.



**Fig. 56 Pinion Rear Bearing Cup**

- 1 - INSTALLER
- 2 - HANDLE

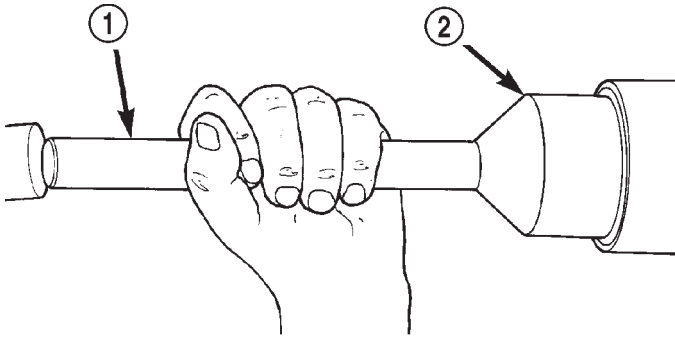


**Fig. 57 Pinion Front Bearing Cup**

- 1 - INSTALLER
- 2 - HANDLE

## PINION GEAR/RING GEAR/TONE RING (Continued)

(4) Install new pinion seal with an appropriate installer (Fig. 58).



80a98349

**Fig. 58 Pinion Seal**

- 1 - SPECIAL TOOL C—4171  
2 - SPECIAL TOOL C—8108

**NOTE:** Pinion depth shims are placed between the rear pinion bearing cone and pinion gear to achieve proper ring and pinion gear mesh. If the ring and pinion gears are reused, the pinion depth shim should not require replacement. Refer to **Adjustments (Pinion Gear Depth)** to select the proper thickness shim before installing rear pinion bearing cone.

(5) Place the proper thickness pinion depth shim on the pinion gear.

(6) Install the rear bearing and oil slinger, if equipped, on the pinion gear with Installer C-3095-A (Fig. 59).

(7) Install a new collapsible preload spacer on pinion shaft (Fig. 60).

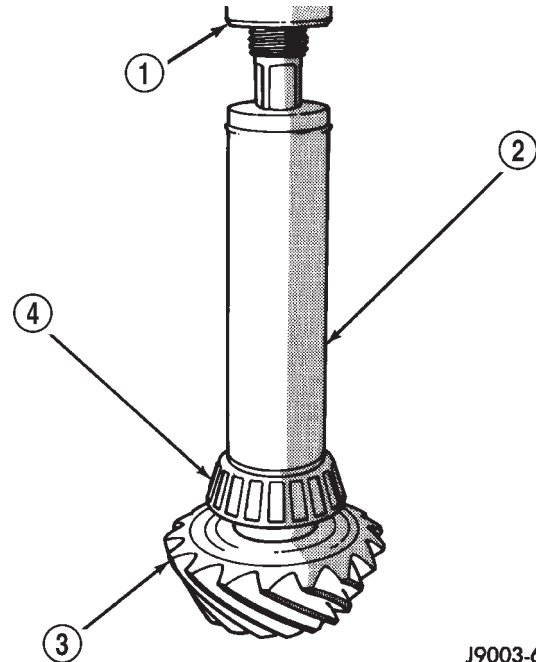
(8) Install pinion gear in housing.

(9) Install yoke with Installer C-3718 and Yoke Holder 6719 (Fig. 61).

(10) Install the yoke washer and a new nut on the pinion gear. Tighten the nut to 292 N·m (215 ft. lbs.) minimum. **Do not over-tighten.** Maximum torque is 447 N·m (330 ft. lbs.).

**CAUTION:** Never loosen pinion gear nut to decrease pinion gear bearing preload torque and never exceed specified preload torque. If preload torque is exceeded a new pinion nut and collapsible spacer, if equipped, must be installed. The torque sequence will have to be repeated.

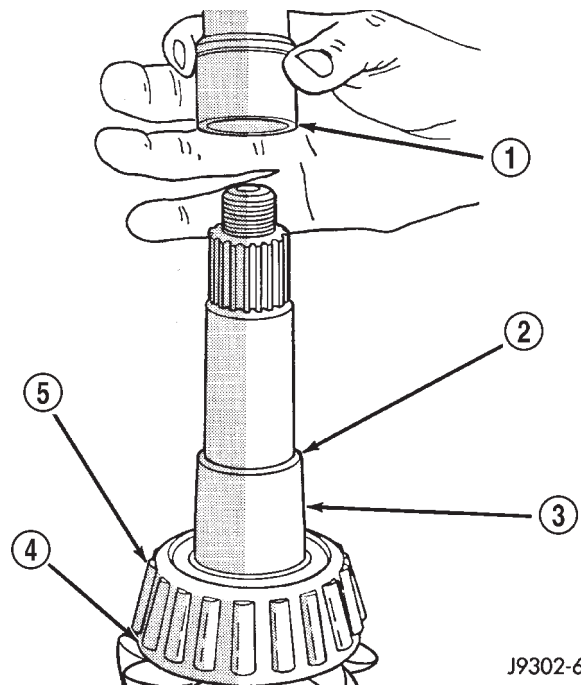
(11) Tighten pinion nut with Yoke Holder 6719, and a torque wrench set at 447 N·m (330 ft. lbs.). Crush collapsible spacer until bearing end play is taken up. Slowly tighten the nut in 6.8 N·m (5 ft. lbs.) increments until the rotating torque is achieved.



J9003-67

**Fig. 59 Rear Pinion Bearing**

- 1 - PRESS  
2 - INSTALLATION TOOL  
3 - DRIVE PINION GEAR  
4 - DRIVE PINION GEAR SHAFT REAR BEARING



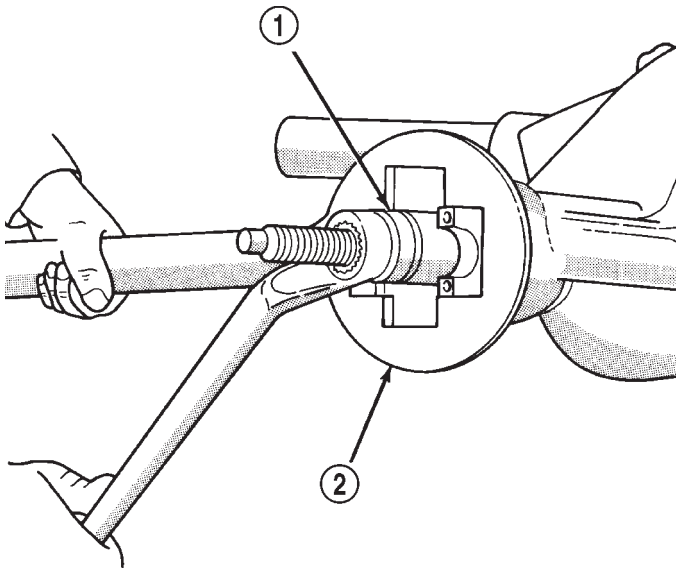
J9302-66

**Fig. 60 Collapsible Preload**

- 1 - COLLAPSIBLE SPACER  
2 - SHOULDER  
3 - PINION GEAR  
4 - OIL SLINGER  
5 - REAR BEARING



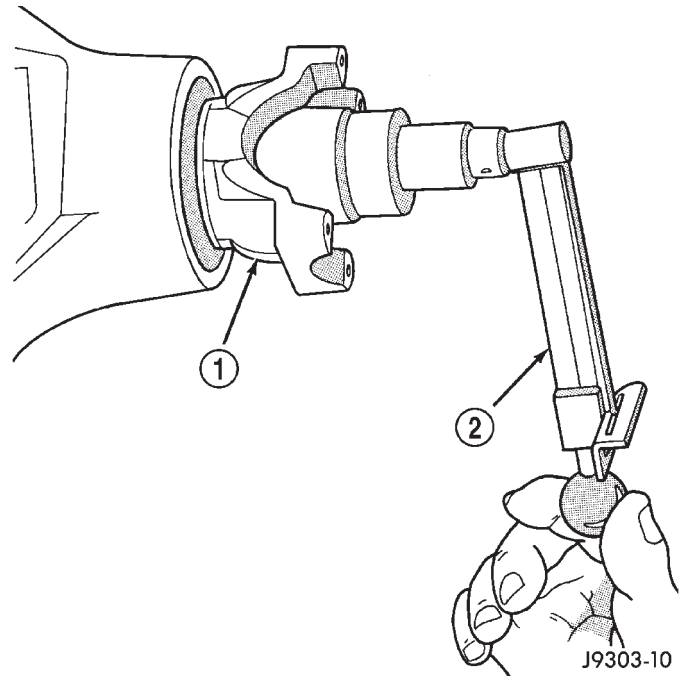
## PINION GEAR/RING GEAR/TONE RING (Continued)



J9402-61

**Fig. 61 Pinion Yoke**

- 1 - YOKE INSTALLER  
2 - YOKE HOLDER



J9303-10

**Fig. 62 Check Pinion Gear Rotation Torque**

- 1 - PINION YOKE  
2 - INCH POUND TORQUE WRENCH

Measure the rotating torque frequently to avoid over crushing the collapsible spacer (Fig. 62).

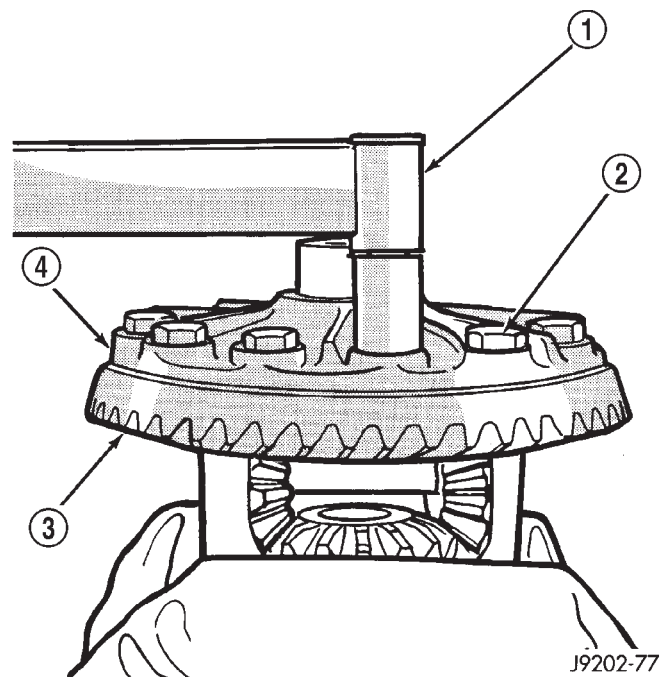
(12) Check bearing rotating torque with an inch pound torque wrench (Fig. 62). Pinion rotating torque should be:

- Original Bearings - 1 to 3 N·m (10 to 20 in. lbs.).
- New Bearings - 2.3 to 5.1 N·m (20 to 45 in. lbs.).

(13) Align previously made marks on yoke and propeller shaft and install propeller shaft.

**CAUTION:** Do not reuse ring gear bolts, the bolts can fracture causing extensive damage.

- (14) Invert the differential case.  
 (15) Position exciter ring on differential case.  
 (16) Using a brass drift, slowly and evenly tap the exciter ring into position.  
 (17) Invert the differential case and start two ring gear bolts. This will provide case-to-ring gear bolt hole alignment.  
 (18) Invert the differential case in the vise.  
 (19) Install new ring gear bolts and alternately tighten to 176 N·m (130 ft. lbs.) (Fig. 63).  
 (20) Install differential in axle housing and verify gear mesh and contact pattern.  
 (21) Install differential into the housing.



J9202-77

**Fig. 63 Ring Gear Bolt**

- 1 - TORQUE WRENCH  
2 - RING GEAR BOLT  
3 - RING GEAR  
4 - CASE



## REAR AXLE - 267RBI

## TABLE OF CONTENTS

	page		page
<b>REAR AXLE - 267RBI</b>		<b>INSTALLATION</b> .....	157
DESCRIPTION.....	140	<b>DIFFERENTIAL</b>	
OPERATION.....	140	REMOVAL.....	158
DIAGNOSIS AND TESTING.....	142	DISASSEMBLY.....	158
AXLE.....	142	ASSEMBLY.....	159
REMOVAL.....	144	INSTALLATION.....	159
INSTALLATION.....	145	<b>DIFFERENTIAL - POWR-LOK</b>	
ADJUSTMENTS.....	145	DIAGNOSIS AND TESTING.....	161
SPECIFICATIONS.....	153	POWR - LOK.....	161
SPECIAL TOOLS.....	153	DISASSEMBLY.....	161
<b>AXLE SHAFTS</b>		ASSEMBLY.....	163
REMOVAL.....	156	<b>DIFFERENTIAL CASE BEARINGS</b>	
INSTALLATION.....	156	REMOVAL.....	164
<b>AXLE BEARINGS</b>		INSTALLATION.....	164
REMOVAL.....	156	<b>PINION GEAR/RING GEAR/TONE RING</b>	
INSTALLATION.....	156	REMOVAL.....	165
<b>PINION SEAL</b>		INSTALLATION.....	166
REMOVAL.....	156		

## REAR AXLE - 267RBI

## DESCRIPTION

The Rear Beam-design Iron (RBI) axle housings consist of an iron center casting (differential housing) with axle shaft tubes extending from either side. The tubes are pressed in to form a one-piece axle housing.

The integral type housing, hypoid gear design has the centerline of the pinion set below the centerline of the ring gear.

The axles are equipped with full-floating axle shafts, meaning that loads are supported by the axle housing tubes. The full-float axle shafts are retained by bolts attached to the hub. The hub rides on two bearings at the outboard end of the axle tube. The axle shafts can be removed without disturbing or removing the wheel bearings. The wheel bearings are opposed tapered roller bearings and are contained in the hub assembly.

The removable, stamped steel cover provides a means for inspection and service without removing the complete axle from the vehicle. A small, stamped metal axle gear ratio identification tag is attached to the housing cover via one of the cover bolts. This tag also identifies the number of ring and pinion teeth.

The rear wheel anti-lock (RWAL) brake speed sensor is attached to the top, forward exterior of the differential housing. A seal is located between the sensor and the wire harness connector. The seal must

be in place when the wire connector is connected to the sensor. The RWAL brake exciter ring is press-fitted onto the differential case against the ring gear flange.

The differential case for the standard differential is a one-piece design. The differential pinion mate shaft is retained with a roll pin. Differential bearing preload and ring gear backlash are adjusted by the use of shims located between the differential bearing cones and case. Pinion bearing preload is set and maintained by the use of a solid shims.

Axles equipped with a Powr-Lok™ differential are optional. A Powr-lok™ differential has a two-piece differential case. A Powr-lok™ differential contains four pinion gears and a two-piece pinion mate cross shaft to provide increased torque to the non-slipping wheel through a ramping motion in addition to the standard Trac-lok™ components.

## OPERATION

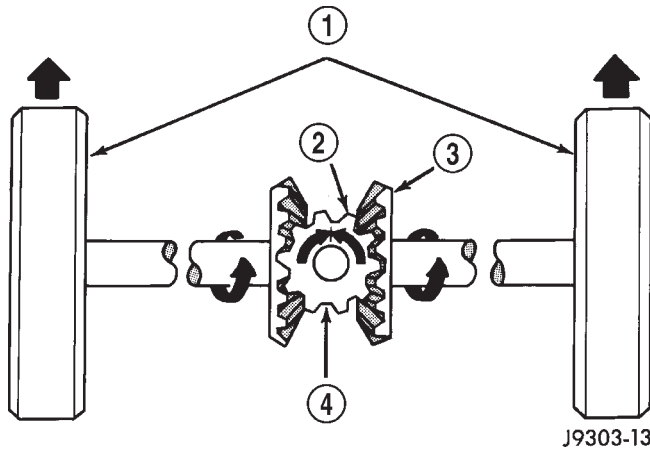
## STANDARD DIFFERENTIAL

The axle receives power from the transmission/transfer case through the rear propeller shaft. The rear propeller shaft is connected to the pinion gear which rotates the differential through the gear mesh with the ring gear bolted to the differential case. The engine power is transmitted to the axle shafts

## REAR AXLE - 267RBI (Continued)

through the pinion mate and side gears. The side gears are splined to the axle shafts.

During straight-ahead driving, the differential pinion gears do not rotate on the pinion mate shaft. This occurs because input torque applied to the gears is divided and distributed equally between the two side gears. As a result, the pinion gears revolve with the pinion mate shaft but do not rotate around it (Fig. 1).



**Fig. 1 Differential Operation - Straight Ahead Driving**

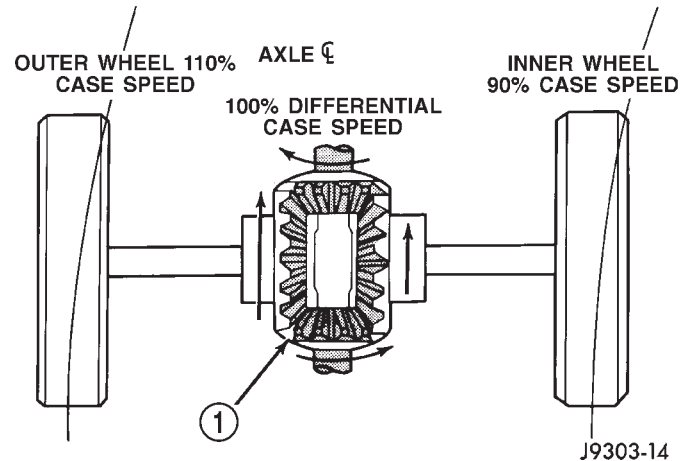
- 1 - IN STRAIGHT AHEAD DRIVING EACH WHEEL ROTATES AT 100% OF CASE SPEED
- 2 - PINION GEAR
- 3 - SIDE GEAR
- 4 - PINION GEARS ROTATE WITH CASE

When turning corners, the outside wheel must travel a greater distance than the inside wheel to complete a turn. The difference must be compensated for to prevent the tires from scuffing and skidding through turns. To accomplish this, the differential allows the axle shafts to turn at unequal speeds (Fig. 2). In this instance, the input torque applied to the pinion gears is not divided equally. The pinion gears now rotate around the pinion mate shaft in opposite directions. This allows the side gear and axle shaft attached to the outside wheel to rotate at a faster speed.

### POWR-LOK™ DIFFERENTIAL

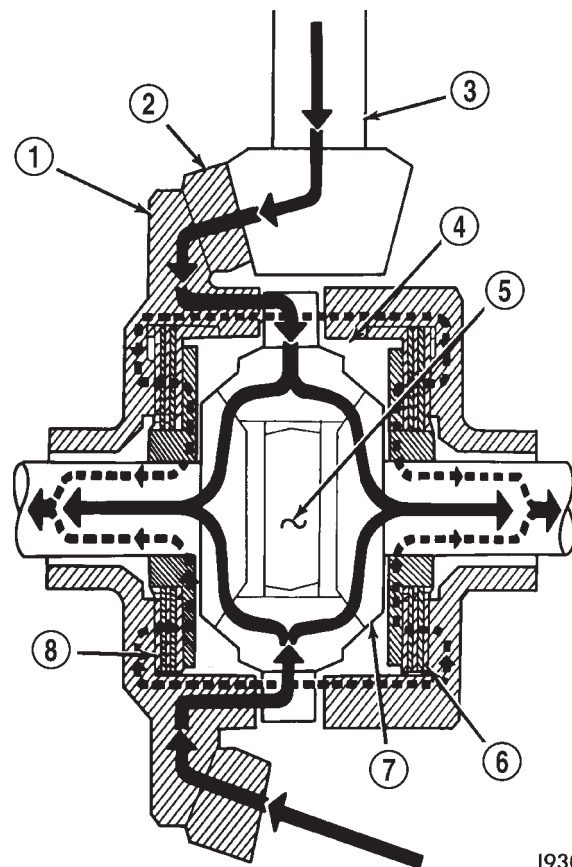
The Powr-lok™ clutches are engaged by two concurrent forces. The first being the preload force exerted through Belleville spring washers within the clutch packs. The second is the separating forces generated by the side gears as torque is applied through the ring gear (Fig. 3).

The Powr-lok™ designs provide the differential action needed for turning corners and for driving straight ahead during periods of unequal traction. When one wheel loses traction, the clutch packs transfer additional torque to the wheel having the most traction. The Powr-lok™ differential addition-



**Fig. 2 Differential Operation - On Turns**

- 1 - PINION GEARS ROTATE ON PINION SHAFT



**Fig. 3 Powr-lok™ Limited Slip Differential**

- 1 - CASE
- 2 - RING GEAR
- 3 - DRIVE PINION
- 4 - PINION GEAR
- 5 - MATE SHAFT
- 6 - CLUTCH PACK
- 7 - SIDE GEAR
- 8 - CLUTCH PACK

## REAR AXLE - 267RBI (Continued)

ally utilizes a ramping action supplied by the cross shafts to increase the force applied to the clutch packs to increase the torque supplied to the non-slipping wheel. Powr-lok<sup>™</sup> differentials resist wheel spin on bumpy roads and provide more pulling power when one wheel loses traction. Pulling power is provided continuously until both wheels lose traction. If both wheels slip due to unequal traction, operation is normal. In extreme cases of differences of traction, the wheel with the least traction may spin.

**DIAGNOSIS AND TESTING - AXLE****GEAR NOISE**

Axle gear noise can be caused by insufficient lubricant, incorrect backlash, incorrect pinion depth, tooth contact, worn/damaged gears, or the carrier housing not having the proper offset and squareness.

Gear noise usually happens at a specific speed range. The noise can also occur during a specific type of driving condition. These conditions are acceleration, deceleration, coast, or constant load.

When road testing, first warm-up the axle fluid by driving the vehicle at least 5 miles and then accelerate the vehicle to the speed range where the noise is the greatest. Shift out-of-gear and coast through the peak-noise range. If the noise stops or changes greatly:

- Check for insufficient lubricant.
- Incorrect ring gear backlash.
- Gear damage.

Differential side gears and pinions can be checked by turning the vehicle. They usually do not cause noise during straight-ahead driving when the gears are unloaded. The side gears are loaded during vehicle turns. A worn pinion shaft can also cause a snapping or a knocking noise.

**BEARING NOISE**

The axle shaft, differential and pinion bearings can all produce noise when worn or damaged. Bearing noise can be either a whining, or a growling sound.

Pinion bearings have a constant-pitch noise. This noise changes only with vehicle speed. Pinion bearing noise will be higher pitched because it rotates at a faster rate. Drive the vehicle and load the differential. If bearing noise occurs, the rear pinion bearing is the source of the noise. If the bearing noise is heard during a coast, the front pinion bearing is the source.

Worn or damaged differential bearings usually produce a low pitch noise. Differential bearing noise is similar to pinion bearing noise. The pitch of differential bearing noise is also constant and varies only with vehicle speed.

Axle shaft bearings produce noise and vibration when worn or damaged. The noise generally changes when the bearings are loaded. Road test the vehicle. Turn the vehicle sharply to the left and to the right. This will load the bearings and change the noise level. Where axle bearing damage is slight, the noise is usually not noticeable at speeds above 30 mph.

**LOW SPEED KNOCK**

Low speed knock is generally caused by a worn U-joint or by worn side-gear thrust washers. A worn pinion shaft bore will also cause low speed knock.

**VIBRATION**

Vibration at the rear of the vehicle is usually caused by a:

- Damaged drive shaft.
- Missing drive shaft balance weight(s).
- Worn or out-of-balance wheels.
- Loose wheel lug nuts.
- Worn U-joint(s).
- Loose/broken springs.
- Damaged axle shaft bearing(s).
- Loose pinion gear nut.
- Excessive pinion yoke run out.
- Bent axle shaft(s).

Check for loose or damaged front-end components or engine/transmission mounts. These components can contribute to what appears to be a rear-end vibration. Do not overlook engine accessories, brackets and drive belts.

All driveline components should be examined before starting any repair.

(Refer to 22 - TIRES/WHEELS - DIAGNOSIS AND TESTING)

**DRIVELINE SNAP**

A snap or clunk noise when the vehicle is shifted into gear (or the clutch engaged), can be caused by:

- High engine idle speed.
- Transmission shift operation.
- Loose engine/transmission/transfer case mounts.
- Worn U-joints.
- Loose spring mounts.
- Loose pinion gear nut and yoke.
- Excessive ring gear backlash.
- Excessive side gear to case clearance.

The source of a snap or a clunk noise can be determined with the assistance of a helper. Raise the vehicle on a hoist with the wheels free to rotate. Instruct the helper to shift the transmission into gear. Listen for the noise, a mechanics stethoscope is helpful in isolating the source of a noise.

## REAR AXLE - 267RBI (Continued)

## DIAGNOSTIC CHART

Condition	Possible Causes	Correction
Wheel Noise	<ol style="list-style-type: none"> <li>1. Wheel loose.</li> <li>2. Faulty, brinelled wheel bearing.</li> </ol>	<ol style="list-style-type: none"> <li>1. Tighten loose nuts.</li> <li>2. Replace bearing.</li> </ol>
Axle Shaft Noise	<ol style="list-style-type: none"> <li>1. Misaligned axle tube.</li> <li>2. Bent or sprung axle shaft.</li> </ol>	<ol style="list-style-type: none"> <li>1. Inspect axle tube alignment. Correct as necessary.</li> <li>2. Inspect and correct as necessary.</li> </ol>
Axle Shaft Broke	<ol style="list-style-type: none"> <li>1. Misaligned axle tube.</li> <li>2. Vehicle overloaded.</li> <li>3. Erratic clutch operation.</li> <li>4. Grabbing clutch.</li> </ol>	<ol style="list-style-type: none"> <li>1. Replace the broken shaft after correcting tube mis-alignment.</li> <li>2. Replace broken shaft and avoid excessive weight on vehicle.</li> <li>3. Replace broken shaft and avoid or correct erratic clutch operation.</li> <li>4. Replace broken shaft and inspect and repair clutch as necessary.</li> </ol>
Differential Cracked	<ol style="list-style-type: none"> <li>1. Improper adjustment of the differential bearings.</li> <li>2. Excessive ring gear backlash.</li> <li>3. Vehicle overloaded.</li> <li>4. Erratic clutch operation.</li> </ol>	<ol style="list-style-type: none"> <li>1. Replace case and inspect gears and bearings for further damage. Set differential bearing pre-load properly.</li> <li>2. Replace case and inspect gears and bearings for further damage. Set ring gear backlash properly.</li> <li>3. Replace case and inspect gears and bearings for further damage. Avoid excessive vehicle weight.</li> <li>4. Replace case and inspect gears and bearings for further damage. Avoid erratic use of clutch.</li> </ol>
Differential Gears Scored	<ol style="list-style-type: none"> <li>1. Insufficient lubrication.</li> <li>2. Improper grade of lubricant.</li> <li>3. Excessive spinning of one wheel/tire.</li> </ol>	<ol style="list-style-type: none"> <li>1. Replace scored gears. Fill differential with the correct fluid type and quantity.</li> <li>2. Replace scored gears. Fill differential with the correct fluid type and quantity.</li> <li>3. Replace scored gears. Inspect all gears, pinion bores, and shaft for damage. Service as necessary.</li> </ol>
Loss Of Lubricant	<ol style="list-style-type: none"> <li>1. Lubricant level too high.</li> <li>2. Worn axle shaft seals.</li> <li>3. Cracked differential housing.</li> <li>4. Worn pinion seal.</li> <li>5. Worn/scored yoke.</li> <li>6. Axle cover not properly sealed.</li> </ol>	<ol style="list-style-type: none"> <li>1. Drain lubricant to the correct level.</li> <li>2. Replace seals.</li> <li>3. Repair as necessary.</li> <li>4. Replace seal.</li> <li>5. Replace yoke and seal.</li> <li>6. Remove, clean, and re-seal cover.</li> </ol>

## REAR AXLE - 267RBI (Continued)

Condition	Possible Causes	Correction
Axle Overheating	<ol style="list-style-type: none"> <li>1. Lubricant level low.</li> <li>2. Improper grade of lubricant.</li> <li>3. Bearing pre-loads too high.</li> <li>4. Insufficient ring gear backlash.</li> </ol>	<ol style="list-style-type: none"> <li>1. Fill differential to correct level.</li> <li>2. Fill differential with the correct fluid type and quantity.</li> <li>3. Re-adjust bearing pre-loads.</li> <li>4. Re-adjust ring gear backlash.</li> </ol>
Gear Teeth Broke	<ol style="list-style-type: none"> <li>1. Overloading.</li> <li>2. Erratic clutch operation.</li> <li>3. Ice-spotted pavement.</li> <li>4. Improper adjustments.</li> </ol>	<ol style="list-style-type: none"> <li>1. Replace gears. Examine other gears and bearings for possible damage.</li> <li>2. Replace gears and examine the remaining parts for damage. Avoid erratic clutch operation.</li> <li>3. Replace gears and examine remaining parts for damage.</li> <li>4. Replace gears and examine remaining parts for damage. Ensure ring gear backlash is correct.</li> </ol>
Axle Noise	<ol style="list-style-type: none"> <li>1. Insufficient lubricant.</li> <li>2. Improper ring gear and pinion adjustment.</li> <li>3. Unmatched ring gear and pinion.</li> <li>4. Worn teeth on ring gear and/or pinion.</li> <li>5. Loose pinion bearings.</li> <li>6. Loose differential bearings.</li> <li>7. Mis-aligned or sprung ring gear.</li> <li>8. Loose differential bearing cap bolts.</li> <li>9. Housing not machined properly.</li> </ol>	<ol style="list-style-type: none"> <li>1. Fill differential with the correct fluid type and quantity.</li> <li>2. Check ring gear and pinion contact pattern. Adjust backlash or pinion depth.</li> <li>3. Replace gears with a matched ring gear and pinion.</li> <li>4. Replace ring gear and pinion.</li> <li>5. Adjust pinion bearing pre-load.</li> <li>6. Adjust differential bearing pre-load.</li> <li>7. Measure ring gear run-out. Replace components as necessary.</li> <li>8. Inspect differential components and replace as necessary. Ensure that the bearing caps are torqued to the proper specification.</li> <li>9. Replace housing.</li> </ol>

**REMOVAL**

- (1) Raise and support the vehicle.
- (2) Position a suitable lifting device under the axle.
- (3) Secure axle to device.
- (4) Remove the wheels and tires.
- (5) Secure brake drums to the axle shaft.
- (6) Remove RWAL sensor from the differential housing, if necessary. Refer to 5 Brakes for procedures.
- (7) Disconnect the brake hose at the axle junction block. Do not disconnect the brake hydraulic lines at the wheel cylinders. Refer to 5 Brakes for procedures.

(8) Disconnect the parking brake cables and cable brackets.

(9) Disconnect the vent hose from the axle shaft tube.

(10) Mark propeller shaft and yoke for installation alignment reference.

(11) Remove propeller shaft.

(12) Disconnect shock absorbers from axle.

(13) Remove spring clamps and spring brackets. Refer to 2 Suspension for procedures.

(14) Separate axle from the vehicle.



## REAR AXLE - 267RBI (Continued)

**INSTALLATION**

- (1) Raise axle with lifting device and align to the leaf spring centering bolts.
- (2) Install spring clamps and spring brackets. Refer to 2 Suspension for procedures.
- (3) Install shock absorbers and tighten nuts to 82 N·m (60 ft. lbs.).
- (4) Install RWAL sensor to the differential housing, if necessary. Refer to 5 Brakes for procedures.
- (5) Install parking brake cables, cable brackets and brake drums. Refer to 5 Brakes for procedures.
- (6) Connect brake hose to axle junction block. Refer to 5 Brakes for procedures.
- (7) Install axle vent hose.
- (8) Align propeller shaft and pinion yoke reference marks. Install universal joint straps and bolts. Tighten to 19 N·m (14 ft. lbs.).
- (9) Install the wheels and tires.
- (10) Add gear lubricant, if necessary. Refer to Lubricant Specifications for lubricant requirements.
- (11) Remove lifting device from axle and lower the vehicle.

**ADJUSTMENTS**

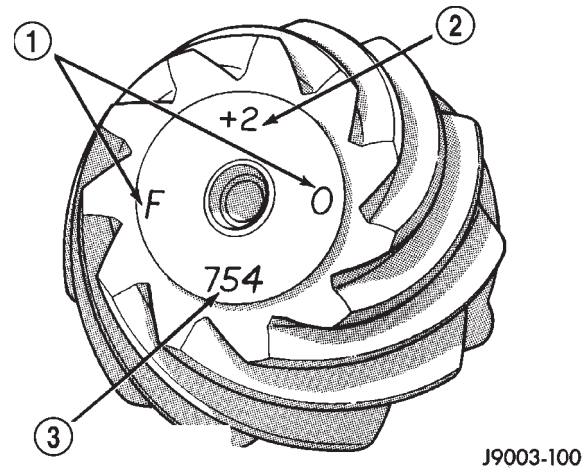
Ring and pinion gears are supplied as matched sets only. The identifying numbers for the ring and pinion gear are etched into the face of each gear (Fig. 4). A plus (+) number, minus (-) number or zero (0) is etched into the face of the pinion gear. This number is the amount (in thousandths of an inch) the depth varies from the standard depth setting of a pinion etched with a (0). The standard setting from the center line of the ring gear to the back face of the pinion is 136.53 mm (5.375 in.). The standard depth provides the best gear tooth contact pattern. Refer to Backlash and Contact Pattern in this section for additional information.

Compensation for pinion depth variance is achieved with a select shim/oil baffle. The shims are placed between the rear pinion bearing and the pinion gear head (Fig. 5).

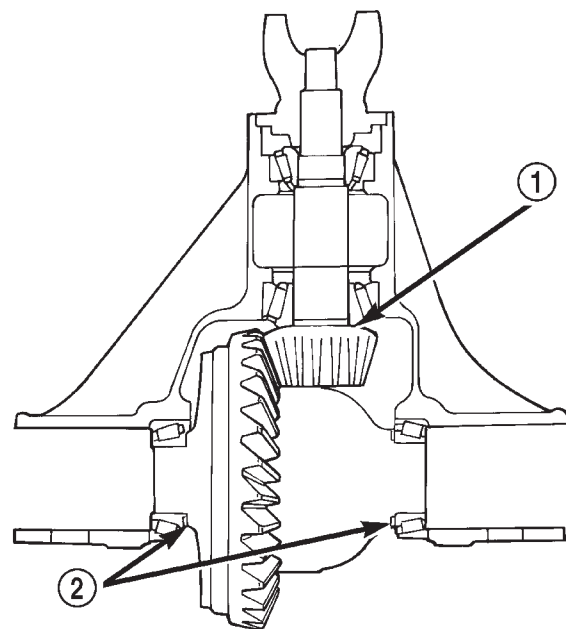
If a new gear set is being installed, note the depth variance etched into both the original and replacement pinion. Add or subtract this number from the thickness of the original depth shim/oil slinger to compensate for the difference in the depth variances. Refer to the Depth Variance chart.

Note where Old and New Pinion Marking columns intersect. Intersecting figure represents plus or minus the amount needed.

Note the etched number on the face of the pinion gear head (-1, -2, 0, +1, +2, etc.). The numbers represent thousands of an inch deviation from the stan-

**Fig. 4 Pinion Gear ID Numbers**

- 1 - PRODUCTION NUMBERS
- 2 - PINION GEAR DEPTH VARIANCE
- 3 - GEAR MATCHING NUMBER

**Fig. 5 Adjustment Shim Locations**

- 1 - PINION GEAR DEPTH SHIM/OIL BAFFLE
- 2 - DIFFERENTIAL BEARING SHIM

dard. If the number is negative, add that value to the required thickness of the depth shims. If the number is positive, subtract that value from the thickness of the depth shim. If the number is 0 no change is necessary.

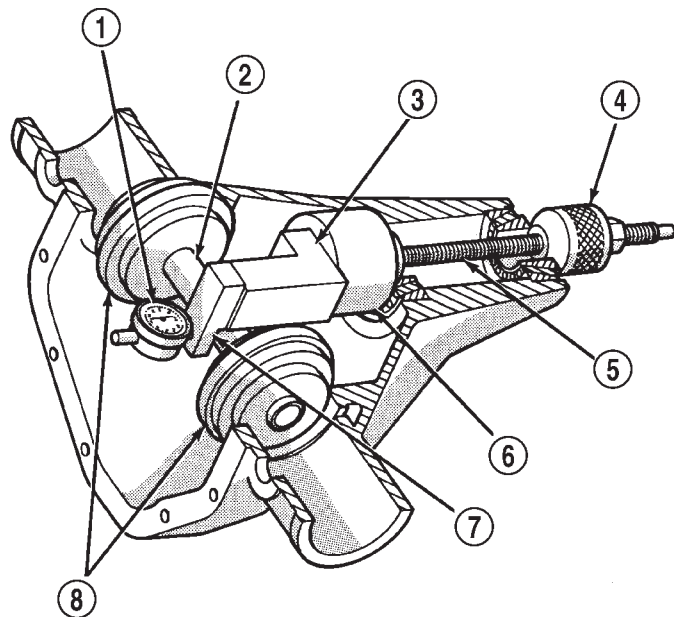
REAR AXLE - 267RBI (Continued)

PINION GEAR DEPTH VARIANCE

Original Pinion Gear Depth Variance	Replacement Pinion Gear Depth Variance								
	-4	-3	-2	-1	0	+1	+2	+3	+4
+4	+0.008	+0.007	+0.006	+0.005	+0.004	+0.003	+0.002	+0.001	0
+3	+0.007	+0.006	+0.005	+0.004	+0.003	+0.002	+0.001	0	-0.001
+2	+0.006	+0.005	+0.004	+0.003	+0.002	+0.001	0	-0.001	-0.002
+1	+0.005	+0.004	+0.003	+0.002	+0.001	0	-0.001	-0.002	-0.003
0	+0.004	+0.003	+0.002	+0.001	0	-0.001	-0.002	-0.003	-0.004
-1	+0.003	+0.002	+0.001	0	-0.001	-0.002	-0.003	-0.004	-0.005
-2	+0.002	+0.001	0	-0.001	-0.002	-0.003	-0.004	-0.005	-0.006
-3	+0.001	0	-0.001	-0.002	-0.003	-0.004	-0.005	-0.006	-0.007
-4	0	-0.001	-0.002	-0.003	-0.004	-0.005	-0.006	-0.007	-0.008

PINION DEPTH MEASUREMENT AND ADJUSTMENT

Measurements are taken with pinion bearing cups and pinion bearings installed in the housing. Take measurements with Pinion Gauge Set and Dial Indicator C-3339 (Fig. 6).



J9403-45

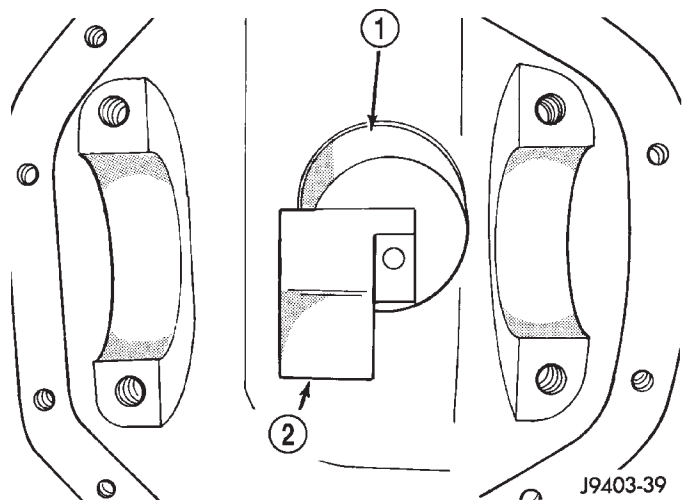
Fig. 6 Pinion Gear Depth Gauge Tools

- 1 - DIAL INDICATOR
- 2 - ARBOR
- 3 - PINION HEIGHT BLOCK
- 4 - CONE
- 5 - SCREW
- 6 - PINION BLOCK
- 7 - SCOOTER BLOCK
- 8 - ARBOR DISC

(1) Assemble Pinion Height Block 6739, Pinion Block 6737 and rear pinion bearing onto Screw 6741 (Fig. 6).

(2) Insert assembled height gauge components, rear bearing and screw into the housing through pinion bearing cups (Fig. 7).

(3) Install front pinion bearing and Cone-nut 6740 hand tight (Fig. 6).



J9403-39

Fig. 7 Pinion Height Block

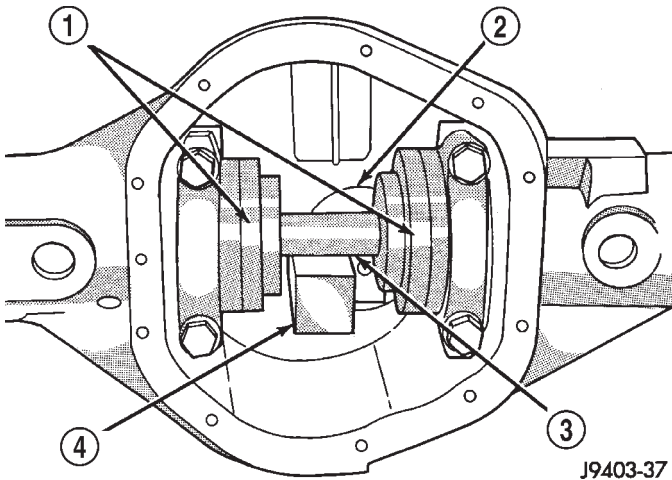
- 1 - PINION BLOCK
- 2 - PINION HEIGHT BLOCK

(4) Place Arbor Disc 6732 on Arbor D-115-3 in position in the housing side bearing cradles (Fig. 8).

**NOTE:** Arbor Discs 6732 has different step diameters to fit other axles. Choose proper step for axle being serviced.

## REAR AXLE - 267RBI (Continued)

(5) Install differential bearing caps on arbor discs and snug the bearing cap bolts. Then cross tighten cap bolts to 108 N·m (80 ft. lbs.).



**Fig. 8 Gauge Tools In Housing**

- 1 - ARBOR DISC
- 2 - PINION BLOCK
- 3 - ARBOR
- 4 - PINION HEIGHT BLOCK

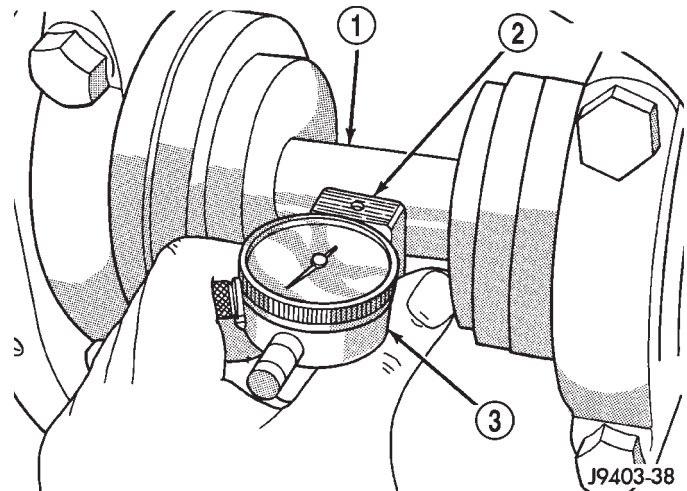
(6) Assemble Dial Indicator C-3339 into Scooter Block D-115-2 and secure set screw.

(7) Place Scooter Block/Dial Indicator in position in the housing so dial probe and scooter block are flush against the rearward surface of the pinion height block (Fig. 6). Hold scooter block in place and zero the dial indicator face to the pointer. Tighten dial indicator face lock screw.

(8) With scooter block still in position against the pinion height block, slowly slide the dial indicator probe over the edge of the pinion height block.

(9) Slide the dial indicator probe across the gap between the pinion height block and the arbor bar with the scooter block against the pinion height block (Fig. 9). When the dial probe contacts the arbor bar, the dial pointer will turn clockwise. Bring dial pointer back to zero against the arbor bar, do not turn dial face. Continue moving the dial probe to the crest of the arbor bar and record the highest reading. If the dial indicator can not achieve the zero reading, the rear bearing cup or the pinion depth gauge set is not installed correctly.

(10) Select a shim/oil baffle equal to the dial indicator reading plus the pinion depth variance number etched in the face of the pinion (Fig. 4). For example, if the depth variance is -2, add +0.002 in. to the dial indicator reading.



**Fig. 9 Pinion Gear Depth Measurement**

- 1 - ARBOR
- 2 - SCOOTER BLOCK
- 3 - DIAL INDICATOR

## DIFFERENTIAL SIDE BEARING PRELOAD AND GEAR BACKLASH

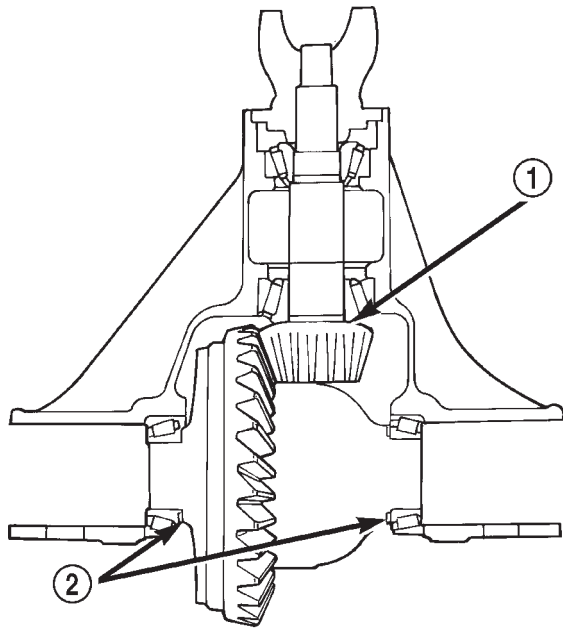
Differential side bearing preload and gear backlash is achieved by selective shims positioned behind the differential side bearing cones. The proper shim thickness can be determined using slip-fit Dummy Bearings D-343 in place of the differential side bearings and a Dial Indicator C-3339. Before proceeding with the differential bearing preload and gear backlash measurements, measure the pinion gear depth and prepare the pinion for installation. Establishing proper pinion gear depth is essential to establishing gear backlash and tooth contact patterns. After the overall shim thickness to take up differential side play is measured, the pinion is installed, and the gear backlash shim thickness is measured. The overall shim thickness is the total of the dial indicator reading and the preload specification added together. The gear backlash measurement determines the thickness of the shim used on the ring gear side of the differential case. Subtract the gear backlash shim thickness from the total overall shim thickness and select that amount for the pinion gear side of the differential (Fig. 10). Differential shim measurements are performed with spreader W-129-B removed.

## SHIM SELECTION

**NOTE:** It is difficult to salvage the differential side bearings during the removal procedure. Install replacement bearings if necessary.

(1) Remove differential side bearings from differential case.

## REAR AXLE - 267RBI (Continued)



80c07134

**Fig. 10 Adjustment Shim Locations**

- 1 - PINION GEAR DEPTH SHIM/OIL BAFFLE
- 2 - DIFFERENTIAL BEARING SHIM

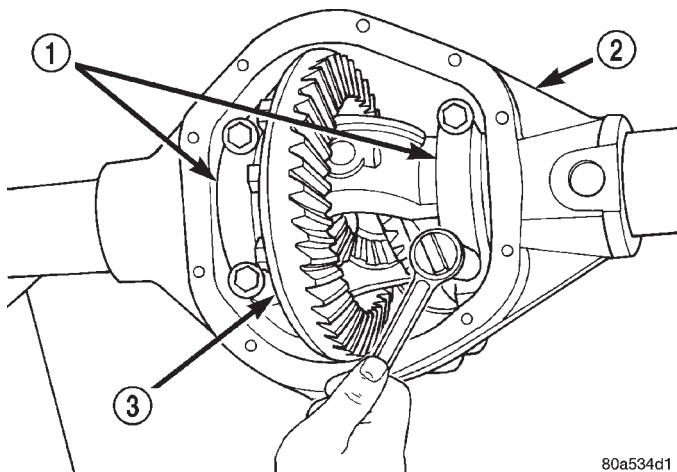
(2) Remove factory installed shims from differential case.

(3) Install ring gear on differential case and tighten bolts to specification.

(4) Install dummy side bearings D-343 on differential case.

(5) Install differential case in the housing.

(6) Install the marked bearing caps in their correct positions and snug the bolts (Fig. 11).

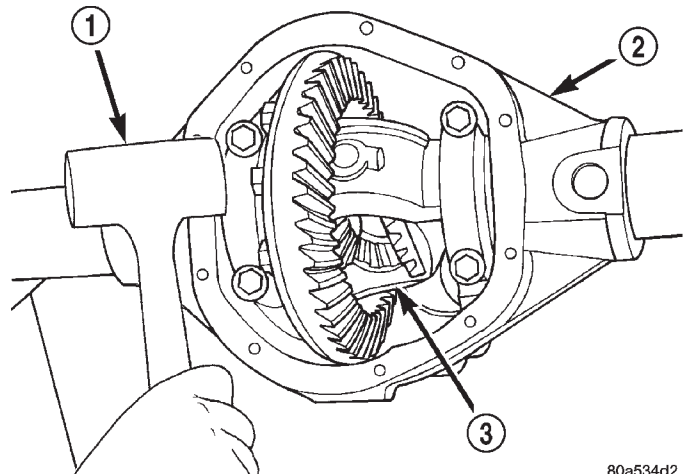


80a534d1

**Fig. 11 Bearing Cap Bolts**

- 1 - BEARING CAP
- 2 - DIFFERENTIAL HOUSING
- 3 - DIFFERENTIAL CASE

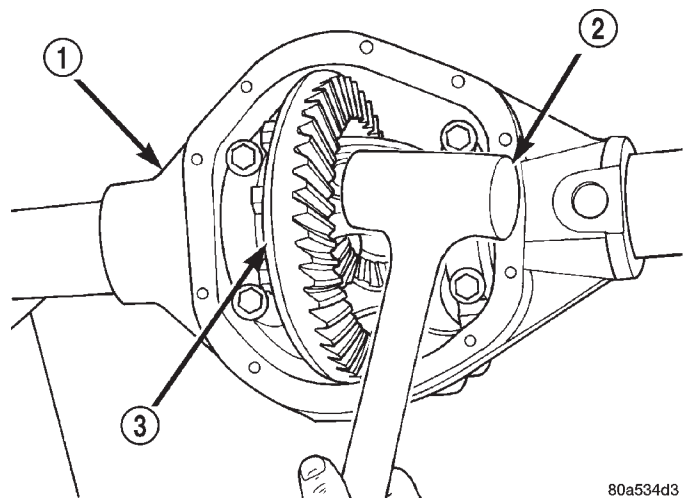
(7) Using a dead-blow hammer, seat the differential dummy bearings to each side of the housing (Fig. 12) and (Fig. 13).



80a534d2

**Fig. 12 Seat Pinion Gear Side Dummy Bearing**

- 1 - DEAD-BLOW HAMMER
- 2 - DIFFERENTIAL HOUSING
- 3 - DIFFERENTIAL CASE



80a534d3

**Fig. 13 Seat Ring Gear Side Differential Dummy Bearing**

- 1 - DIFFERENTIAL HOUSING
- 2 - DEAD-BLOW HAMMER
- 3 - DIFFERENTIAL CASE

(8) Thread Pilot Stud C-3288-B into rear cover bolt hole below ring gear (Fig. 14).

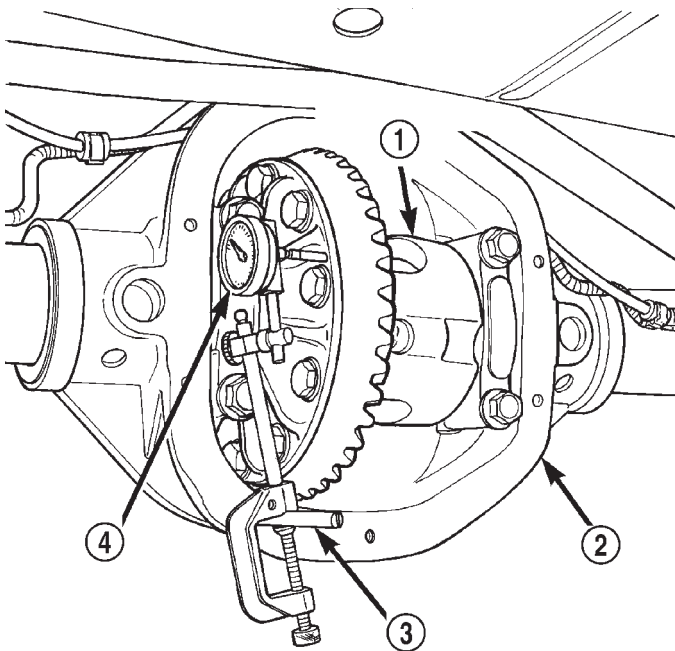
(9) Attach the Dial Indicator C-3339 to pilot stud. Position the dial indicator plunger on a flat surface between the ring gear bolt heads (Fig. 14).

(10) Push and hold differential case to pinion gear side of the housing and zero dial indicator (Fig. 15).

(11) Push and hold differential case to ring gear side of the housing and record the dial indicator reading (Fig. 16).



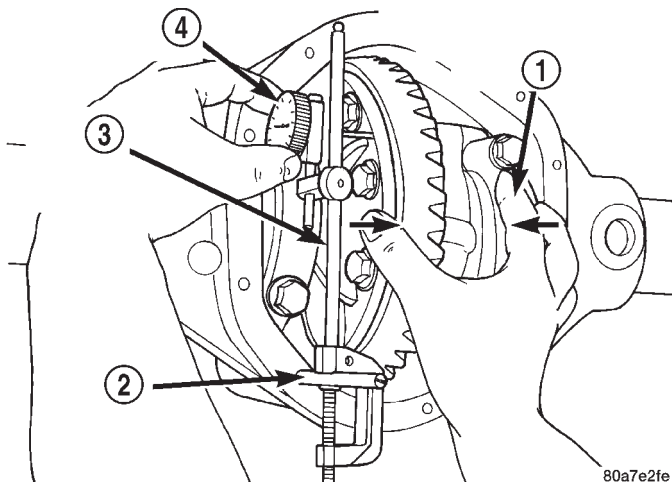
## REAR AXLE - 267RBI (Continued)



80a7e2cf

**Fig. 14 Differential Side Play Measurement**

- 1 - DIFFERENTIAL CASE
- 2 - DIFFERENTIAL HOUSING
- 3 - PILOT STUD
- 4 - DIAL INDICATOR



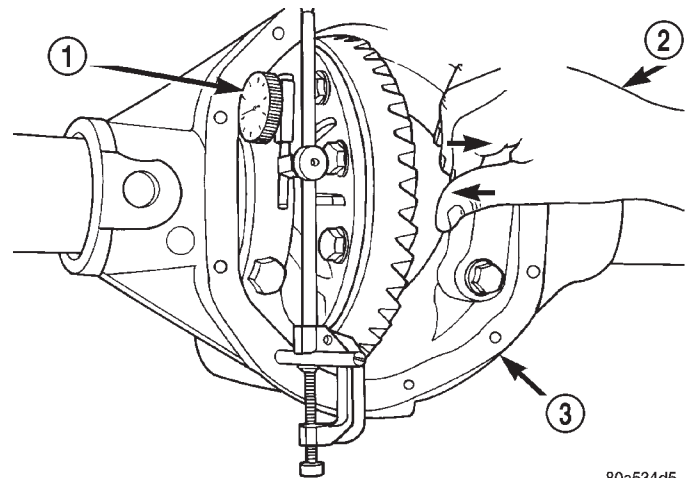
80a7e2fe

**Fig. 15 Dial Indicator Location**

- 1 - DIFFERENTIAL CASE TO PINION GEAR SIDE
- 2 - PILOT STUD
- 3 - DIAL INDICATOR ARM
- 4 - DIAL INDICATOR FACE

(12) Add 0.38 mm (0.015 in.) to the zero end play total. This total represents the thickness of shims needed to preload the new bearings when the differential is installed.

(13) Rotate dial indicator out of the way on the pilot stud.



80a534d5

**Fig. 16 Differential Case To Ring Gear Side**

- 1 - DIAL INDICATOR
- 2 - DIFFERENTIAL CASE TO RING GEAR SIDE
- 3 - DIFFERENTIAL HOUSING

(14) Remove differential case and dummy bearings from the housing.

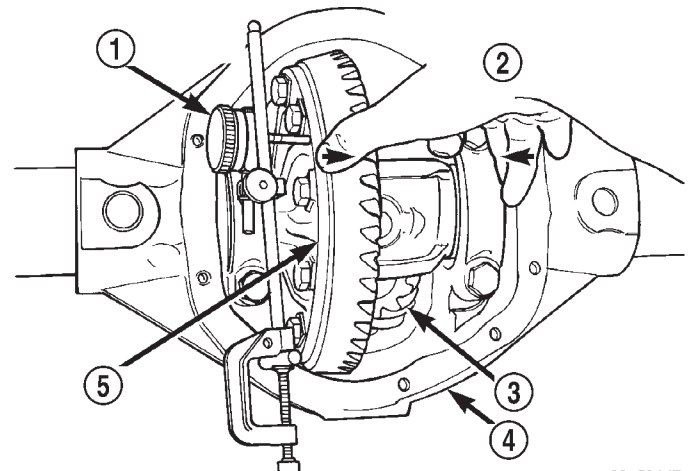
(15) Install the pinion gear in the housing. Install the pinion yoke and establish the correct pinion rotating torque.

(16) Install differential case and dummy bearings D-343 in the housing (without shims), install bearing caps and tighten bolts snug.

(17) Seat ring gear side dummy bearing (Fig. 13).

(18) Position the dial indicator plunger on a flat surface between the ring gear bolt heads (Fig. 14).

(19) Push and hold differential case toward pinion gear and zero the dial indicator (Fig. 17).



80a534d7

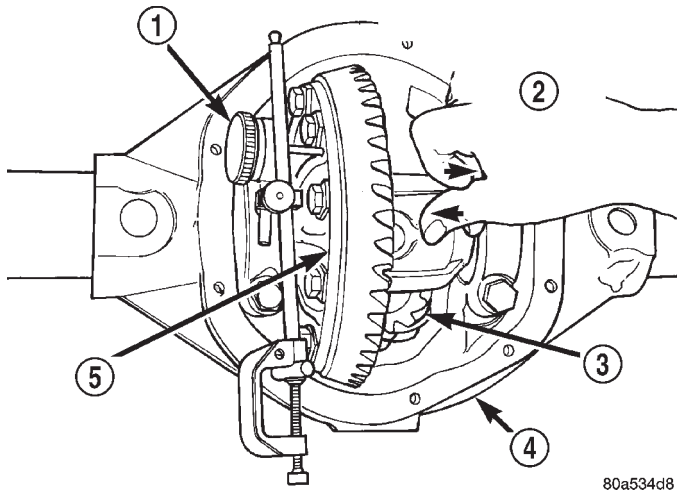
**Fig. 17 Differential Case To Pinion Gear Side**

- 1 - DIAL INDICATOR FACE
- 2 - DIFFERENTIAL CASE TO PINION GEAR SIDE
- 3 - PINION GEAR
- 4 - DIFFERENTIAL HOUSING
- 5 - DIFFERENTIAL CASE



## REAR AXLE - 267RBI (Continued)

(20) Push and hold differential case to ring gear side of the housing and record dial indicator reading (Fig. 18).



80a534d8

**Fig. 18 Differential Case To Ring Gear Side**

- 1 - DIAL INDICATOR
- 2 - DIFFERENTIAL CASE TO RING GEAR SIDE
- 3 - PINION GEAR
- 4 - DIFFERENTIAL HOUSING
- 5 - DIFFERENTIAL CASE

(21) This is the shim thickness needed on the ring gear side of the differential case for proper backlash.

(22) Subtract the backlash shim thickness from the total preload shim thickness. The remainder is the shim thickness required on the pinion side of the housing.

(23) Rotate dial indicator out of the way on pilot stud.

(24) Remove differential case and dummy bearings from the housing.

(25) Install the selected side bearing shims onto the differential case hubs.

(26) Install side bearings on differential case hubs with Install C-4487-1 and Handle C-4171.

(27) Install bearing cups on differential.

(28) Install Spreader W-129-B and some items from Adapter Set 6987 on the housing and spread open enough to receive differential case.

**CAUTION:** Do not spread housing over 0.50 mm (0.020 in.). The housing can be damaged if over-spread.

(29) Install differential case into the housing.

(30) Remove spreader from the housing.

(31) Rotate the differential case several times to seat the side bearings.

(32) Position the indicator plunger against a ring gear tooth (Fig. 19).

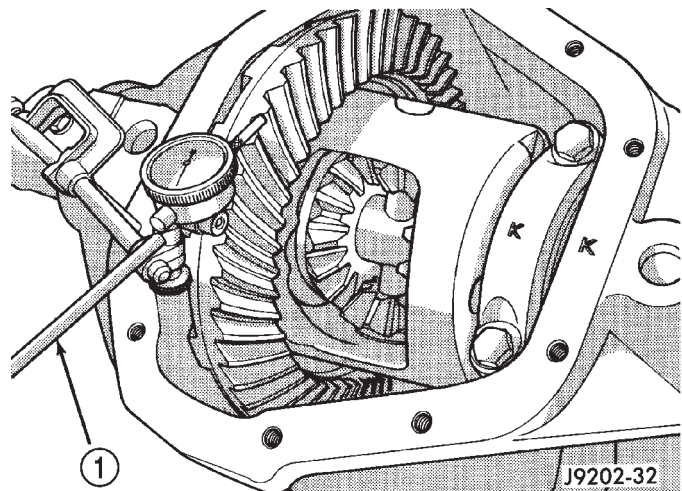
(33) Push and hold ring gear upward while not allowing the pinion gear to rotate.

(34) Zero dial indicator face to pointer.

(35) Push and hold ring gear downward while not allowing the pinion gear to rotate. Dial indicator reading should be between 0.12 mm (0.005 in.) and 0.20 mm (0.008 in.). If backlash is not within specifications transfer the necessary amount of shim thickness from one side of the housing to the other (Fig. 20).

(36) Verify differential case and ring gear runout by measuring ring to pinion gear backlash at eight locations around the ring gear. Readings should not vary more than 0.05 mm (0.002 in.). If readings vary more than specified, the ring gear or the differential case is defective.

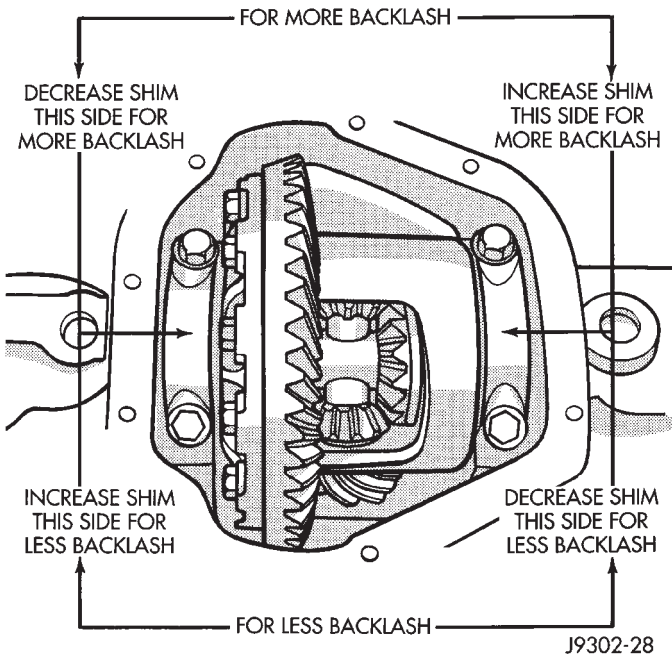
After the proper backlash is achieved, perform Gear Contact Pattern Analysis procedure.



**Fig. 19 Ring Gear Backlash Measurement**

- 1 - DIAL INDICATOR

## REAR AXLE - 267RBI (Continued)



**Fig. 20 Backlash Shim**

### GEAR CONTACT PATTERN

The ring and pinion gear contact patterns will show if the pinion depth is correct. It will also show if the ring gear backlash has been adjusted correctly. The backlash can be adjusted within specifications to achieve desired tooth contact patterns.

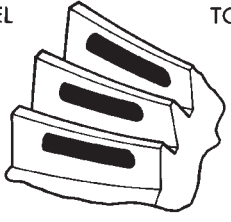
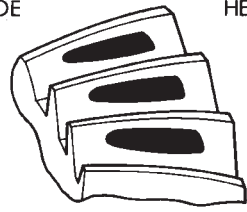
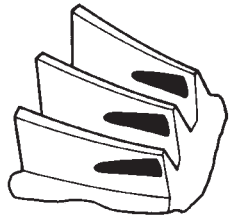
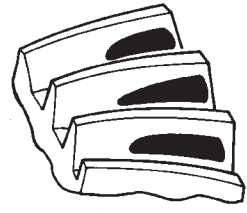
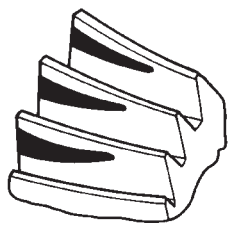
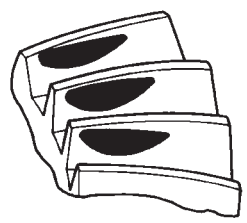
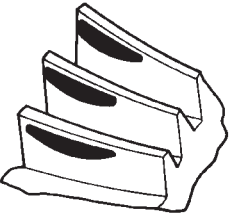
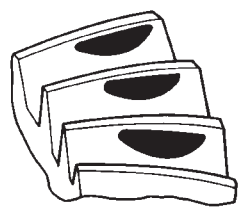
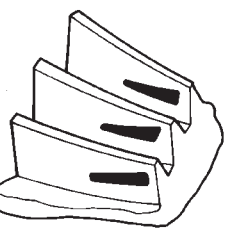
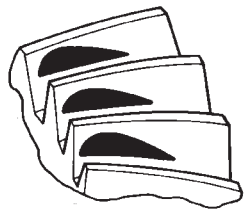
(1) Apply a thin coat of hydrated ferric oxide or equivalent to the drive and coast side of the ring gear teeth.

(2) Wrap, twist and hold a shop towel around the pinion yoke to increase the turning resistance of the pinion. This will provide a more distinct contact pattern.

(3) With a boxed end wrench on the ring gear bolt, rotate the differential case one complete revolution in both directions while a load is being applied from shop towel.

The areas on the ring gear teeth with the greatest degree of contact against the pinion teeth will squeeze the compound to the areas with the least amount of contact. Note and compare patterns on the ring gear teeth to Gear Tooth Contact Patterns chart (Fig. 21) and adjust pinion depth and gear backlash as necessary.

REAR AXLE - 267RBI (Continued)

<p>DRIVE SIDE OF RING GEAR TEETH</p> <p>HEEL TOE</p> 	<p>COAST SIDE OF RING GEAR TEETH</p> <p>TOE HEEL</p> 	<p>DESIRABLE CONTACT PATTERN. PATTERN SHOULD BE CENTERED ON THE DRIVE SIDE OF TOOTH. PATTERN SHOULD BE CENTERED ON THE COAST SIDE OF TOOTH, BUT MAY BE SLIGHTLY TOWARD THE TOE. THERE SHOULD ALWAYS BE SOME CLEARANCE BETWEEN CONTACT PATTERN AND TOP OF THE TOOTH.</p>
		<p>RING GEAR BACKLASH CORRECT. <b>THINNER</b> PINION GEAR DEPTH SHIM REQUIRED.</p>
		<p>RING GEAR BACKLASH CORRECT. <b>THICKER</b> PINION GEAR DEPTH SHIM REQUIRED.</p>
		<p>PINION GEAR DEPTH SHIM CORRECT. <b>DECREASE</b> RING GEAR BACKLASH.</p>
		<p>PINION GEAR DEPTH SHIM CORRECT. <b>INCREASE</b> RING GEAR BACKLASH.</p>

J9003-24

Fig. 21 Gear Tooth Contact Patterns

## REAR AXLE - 267RBI (Continued)

## SPECIFICATIONS

## REAR AXLE - 267RBI

## AXLE SPECIFICATIONS

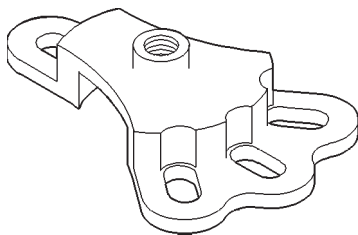
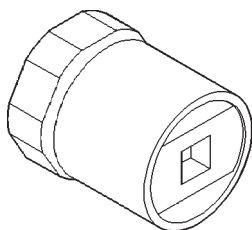
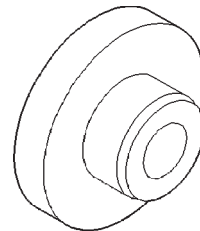
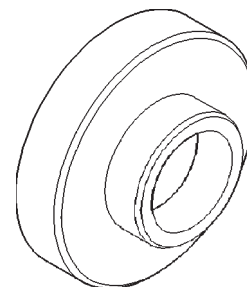
DESCRIPTION	SPECIFICATION
Axle Ratio	3.55, 4.10
Ring Gear Diameter	267 mm (10.50 in.)
Ring Gear Backlash	0.12-0.20 mm (0.005-0.008 in.)
Pinion Gear Standard. Depth	136.53 mm (5.375 in.)
Pinion Bearing Preload - Original Bearings	1-2 N-m (10-20 in. lbs.)
Pinion Bearing Preload - New Bearings	2.3-5.1 N-m (20-45 in. lbs.)

## TORQUE SPECIFICATIONS

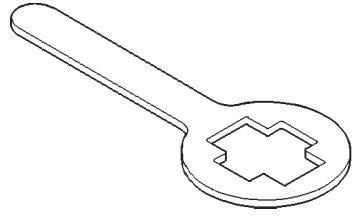
DESCRIPTION	N-m	Ft. Lbs.	In. Lbs.
Fill Hole Plug	34	25	-
Differential Cover Bolts	47	35	-
Bearing Cap Bolts	108	80	-
Ring Gear Bolt	176	130	-
Pinion Nut	298-380	220-280	-
Axle Shaft Bolts	129	95	-
Hub Bearing Nut	163-190	120-140	-

## SPECIAL TOOLS

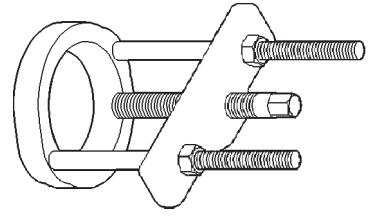
## REAR AXLE - 267RBI

**Puller 6790****Wrench DD-1241-JD****Installer 5064****Installer 8149**

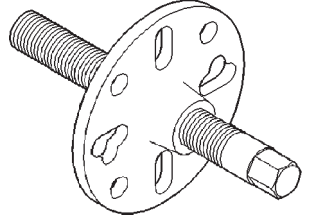
REAR AXLE - 267RBI (Continued)



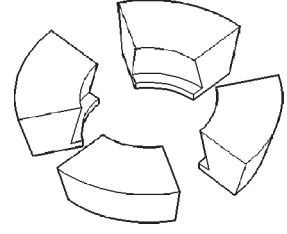
**Holder 6719A**



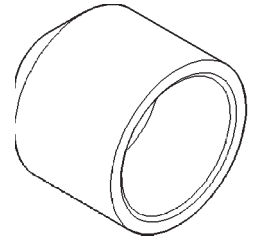
**Puller/Press C-293-PA**



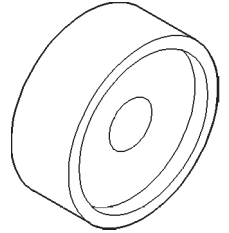
**Puller C-452**



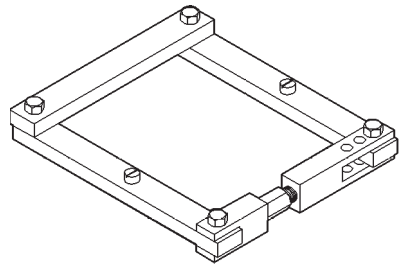
**Adapters C-293-62**



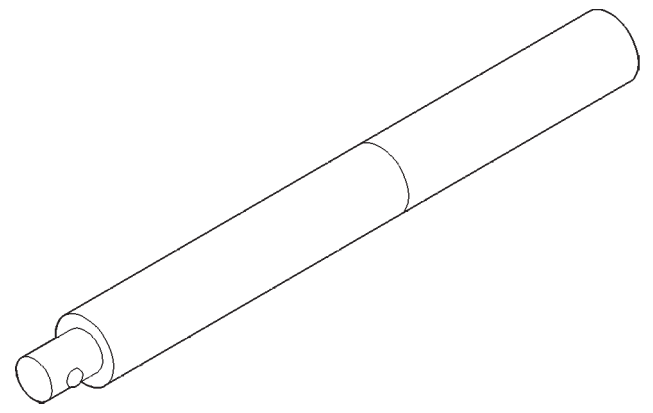
**Installer 8108**



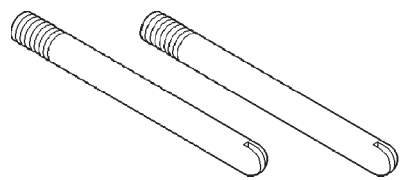
**Installer C-4190**



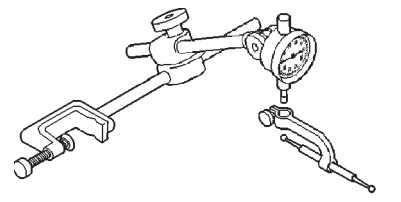
**Spreader W-129-B**



**Handle C-4171**

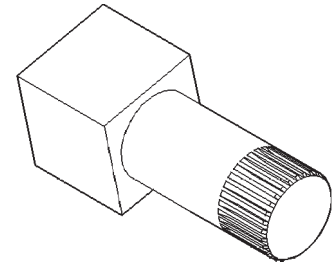


**Pilot Studs C-3288-B**



**Dial Indicator C-3339**

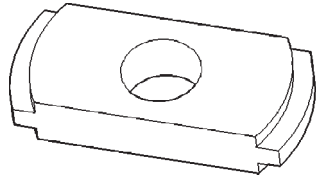
8011d42b



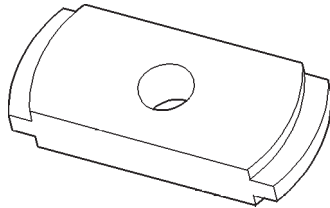
**Fixture 6963-A**



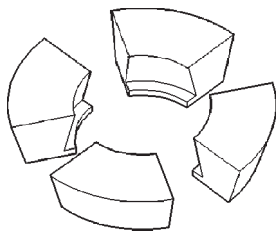
REAR AXLE - 267RBI (Continued)



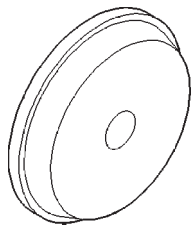
**Remover D-158**



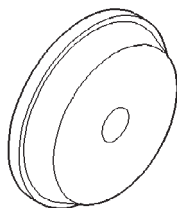
**Remover D-162**



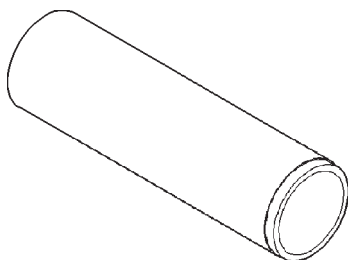
**Adapters C-293-62**



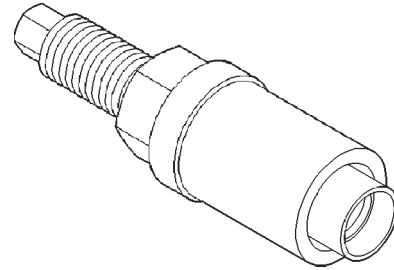
**Installer D-111**



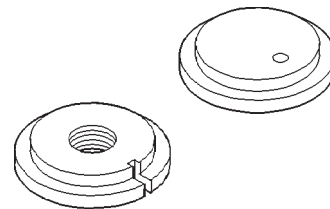
**Installer D-146**



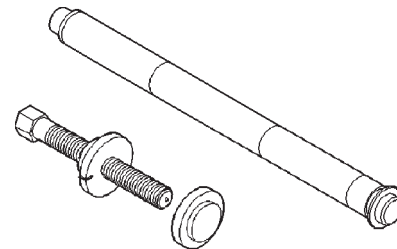
**Installer C-3095-A**



**Installer C-3718**

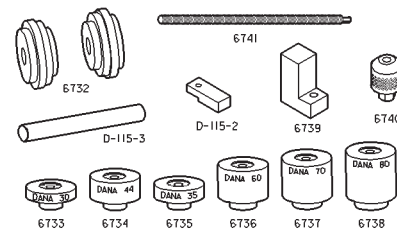


**Trac-lok Tools 8139**

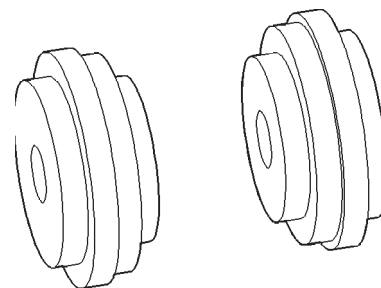


**Trac-lok Tools C-4487**

**6730 PINION HEIGHT SET**



**Gauge Set 6730**



**Arbor Discs 6732**

## AXLE SHAFTS

### REMOVAL

- (1) Remove the axle shaft flange bolts.
- (2) Slide the axle shaft out from the axle tube.

### INSTALLATION

- (1) Clean the gasket contact surface area on the flange with an appropriate solvent. Install a new flange gasket and slide the axle shaft into the tube.
- (2) Install the bolts and tighten to 129 N·m (95 ft. lbs.).

## AXLE BEARINGS

### REMOVAL

- (1) Remove wheel and tire assembly.
- (2) Remove brake drum.
- (3) Remove the axle shaft.
- (4) Remove the lock wedge and adjustment nut. Use Socket DD-1241-JD to remove the adjustment nut.
- (5) Remove the hub assembly. The outer axle bearing will slide out as the hub is being removed.
- (6) Remove inner grease seal and discard. Use Installer 5064 and Handle C-4171 to drive grease seal and inner axle bearing from the hub.
- (7) Remove the bearing cups from the hub bore. Use a brass drift, or an appropriate removal tool, to tap out the cups.

### INSTALLATION

- (1) Thoroughly clean both axle bearings and interior of the hub with an appropriate cleaning solvent.
- (2) Install bearing cups with Installer 8151 and Handle C-4171.
- (3) **Pack inner and outer bearings with Mopar wheel bearing grease or equivalent.**
- (4) Apply grease to inner and outer bearing cup surfaces.
- (5) Install inner axle bearing in the hub.
- (6) Install **new** grease seal in hub with Installer 8149 and Handle C-4171.
- (7) Inspect bearing and seal contact surfaces on the axle tube for burrs/roughness. Remove all the rough contact surfaces from the axle tube.
- (8) Carefully slide the hub onto the axle.

**CAUTION:** Do not let grease seal contact axle tube threads during installtion.

- (9) Install outer axle bearing.
- (10) Install hub bearing adjustment nut with Socket DD-1241-JD.

- (11) Tighten adjustment nut to 163-190 N·m (120-140 ft. lbs.) while rotating the wheel. Then loosen adjustment nut 1/8 to 1/3 of-a-turn to provide 0.025-0.250mm (0.001-0.009 in.) wheel bearing end play.

- (12) Tap locking wedge into the spindle keyway and adjustment nut.

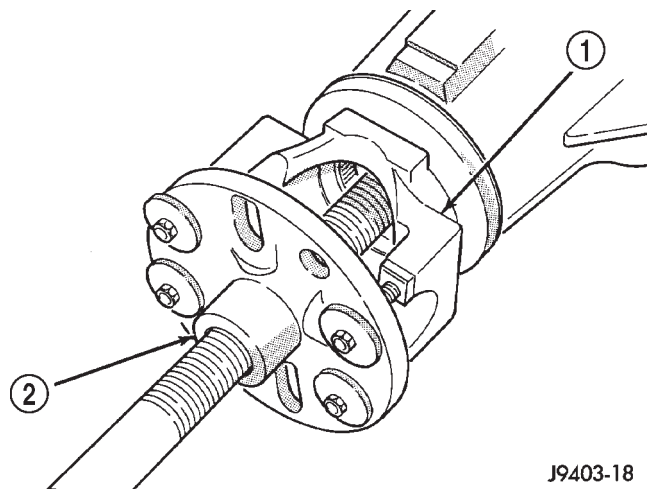
**NOTE:** Located locking wedge in a new position in the adjustment nut.

- (13) Install axle shaft and brake drum.
- (14) Install the wheel and tire assembly.

## PINION SEAL

### REMOVAL

- (1) Raise and support the vehicle.
- (2) Scribe a mark on the universal joint, pinion yoke, and pinion shaft for reference.
- (3) Disconnect the propeller shaft from the pinion yoke. Secure the propeller shaft in an upright position to prevent damage to the rear universal joint.
- (4) Remove the wheel and tire assemblies.
- (5) Remove the brake drums to prevent any drag. The drag may cause a false bearing preload torque measurement.
- (6) Rotate the pinion yoke three or four times.
- (7) Measure the amount of torque necessary to rotate the pinion gear with a (in. lbs.) dial-type torque wrench. Record the torque reading for installation reference.
- (8) Hold the yoke with Wrench 6719. Remove the pinion shaft nut and washer.
- (9) Remove the yoke with Remover C-452 (Fig. 22).



J9403-18

**Fig. 22 Yoke Removal**

- 1 - PINION YOKE
- 2 - REMOVER C452

## PINION SEAL (Continued)

(10) Remove the pinion shaft seal with suitable pry tool or slide-hammer mounted screw.

**INSTALLATION**

(1) Clean the seal contact surface in the housing bore.

(2) Examine the splines on the pinion shaft for burrs or wear. Remove any burrs and clean the shaft.

**NOTE: The outer perimeter of the seal is pre-coated with a special sealant. An additional application of sealant is not required.**

(3) Apply a light coating of gear lubricant on the lip of pinion seal.

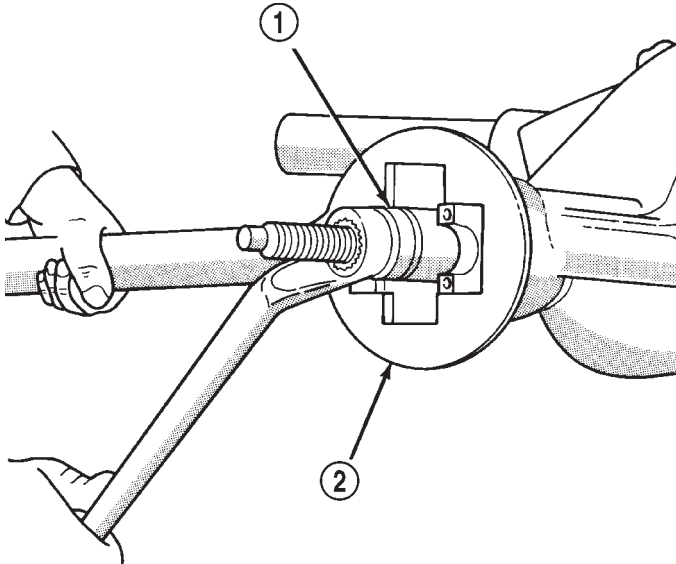
(4) Install the new pinion shaft seal with an appropriate installer.

(5) Position the pinion yoke on the end of the shaft with the reference marks aligned.

(6) Seat yoke on pinion shaft with Installer D-191 and Yoke Holder 6719 (Fig. 23).

(7) Remove the tools and install the pinion yoke washer and nut.

(8) Hold pinion yoke with Yoke Holder 6719 and tighten shaft nut to 289-380 N·m (220-280 ft. lbs.) (Fig. 24). Rotate pinion shaft several revolutions to ensure the bearing rollers are seated.

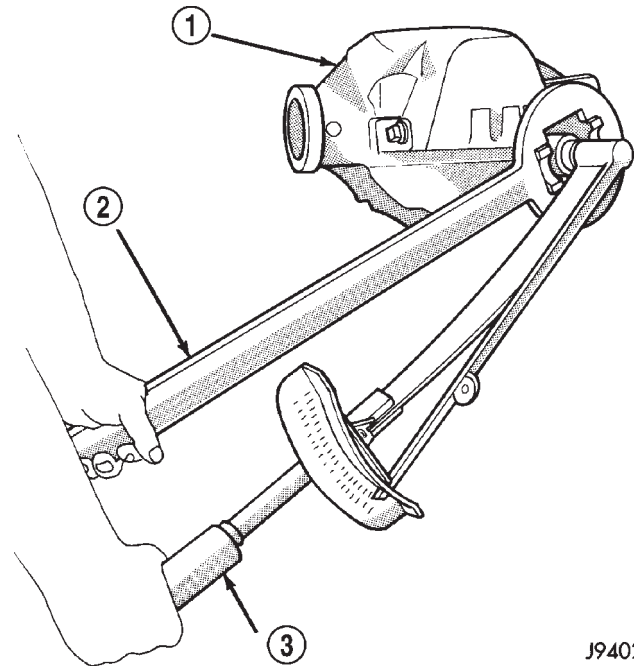


J9402-61

**Fig. 23 Yoke Installation**

- 1 - YOKE INSTALLER
- 2 - YOKE HOLDER

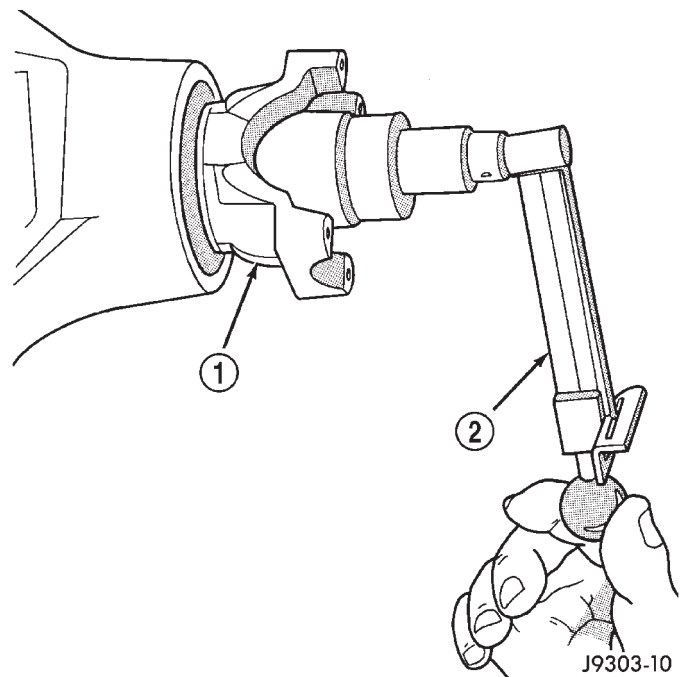
(9) Rotate the pinion shaft using an inch pound torque wrench. Rotating resistance torque should be equal to the reading recorded, plus a small amount for the drag the new seal will have (Fig. 25).



J9402-62

**Fig. 24 Tightening Pinion Shaft Nut**

- 1 - DIFFERENTIAL HOUSING
- 2 - YOKE HOLDER
- 3 - TORQUE WRENCH



J9303-10

**Fig. 25 Check Pinion Rotation Torque**

- 1 - PINION YOKE
- 2 - INCH POUND TORQUE WRENCH

## PINION SEAL (Continued)

**NOTE:** The bearing rotating torque should be constant during a complete revolution of the pinion. If the rotating torque varies, this indicates a binding condition.

(10) Install the propeller shaft with the installation reference marks aligned.

(11) Tighten the universal joint yoke clamp screws to 19 N·m (14 ft. lbs.).

(12) Install the brake drums.

(13) Add gear lubricant to the differential housing, if necessary. Refer to the Lubricant Specifications for gear lubricant requirements.

(14) Install wheel and tire assemblies and lower the vehicle.

## DIFFERENTIAL

## REMOVAL

(1) Raise and support the vehicle.

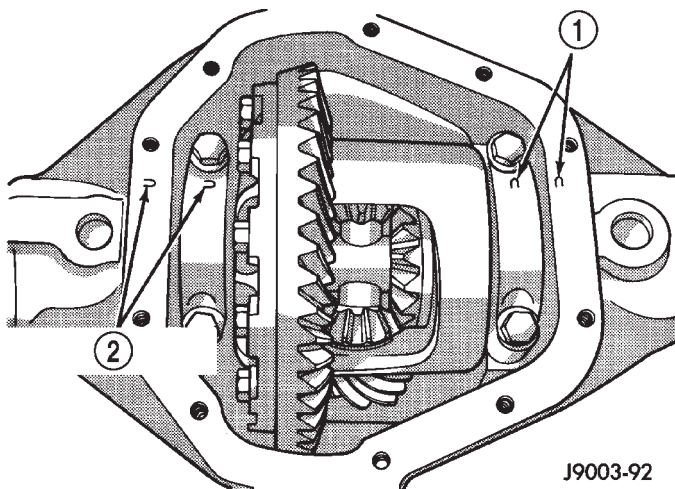
(2) Remove the lubricant fill hole plug from the differential housing cover.

(3) Remove differential housing cover and drain the lubricant from the housing.

(4) Clean the housing cavity with a flushing oil, light engine oil or lint free cloth. **Do not use water, steam, kerosene or gasoline for cleaning.**

(5) Remove axle shafts.

(6) Note the orientation of the installation reference letters stamped on the bearing caps and housing machined sealing surface (Fig. 26).



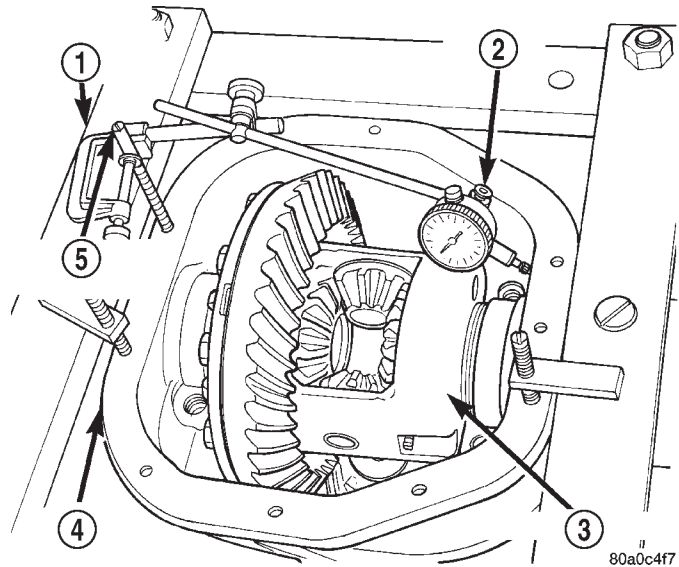
**Fig. 26 Bearing Cap Identification**

- 1 - REFERENCE LETTERS  
2 - REFERENCE LETTERS

(7) Remove the differential bearing caps.

(8) Position Spreader W-129-B with the tool dowel pins seated in the locating holes (Fig. 27).

(9) Install the hold down clamps and tighten the tool turnbuckle finger-tight.



**Fig. 27 Spread Differential Housing**

- 1 - SPREADER  
2 - DIAL INDICATOR  
3 - DIFFERENTIAL  
4 - DIFFERENTIAL HOUSING  
5 - PILOT STUD

(10) Install a Pilot Stud C-3288-B at the left side of the differential housing. Attach dial indicator to housing pilot stud. Load the indicator plunger against the opposite side of the housing (Fig. 27) and zero the indicator.

(11) Spread the housing enough to remove the case from the housing. Measure the distance with the dial indicator (Fig. 27).

**CAUTION:** Do not spread over 0.50 mm (0.020 in). If the housing is over-spread, it could be distorted or damaged.

(12) Remove the dial indicator.

(13) Pry the differential case loose from the housing. To prevent damage, pivot on housing with the end of the pry bar against spreader (Fig. 28).

(14) Remove the case from housing. Tag bearing cups to indicate their location.

## DISASSEMBLY

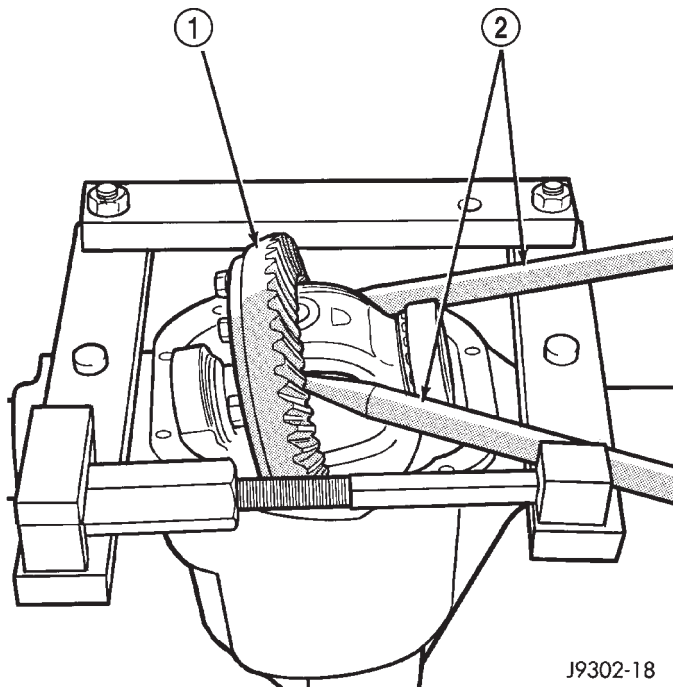
(1) Remove roll-pin holding mate shaft in housing.

(2) Remove pinion gear mate shaft (Fig. 29).

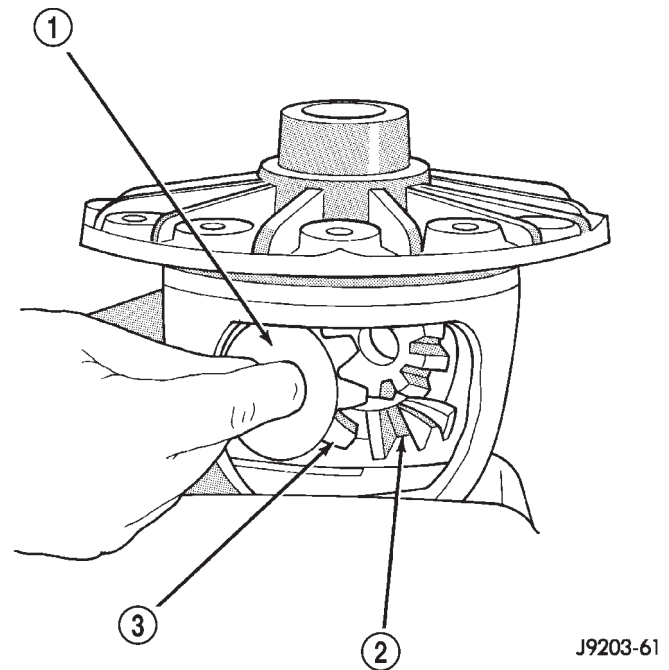
(3) Rotate the differential side gears and remove the pinion mate gears and thrust washers (Fig. 30).

(4) Remove the differential side gears and thrust washers.

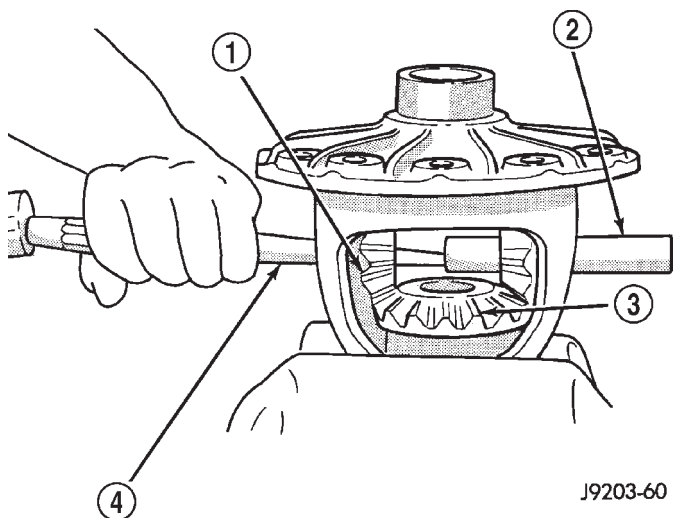
## DIFFERENTIAL (Continued)

**Fig. 28 Differential Removal**

- 1 - DIFFERENTIAL
- 2 - PRY BAR

**Fig. 30 Pinion Mate/Side Gear**

- 1 - THRUST WASHER
- 2 - SIDE GEAR
- 3 - PINION MATE GEAR

**Fig. 29 Pinion Mate Shaft**

- 1 - PINION MATE GEAR
- 2 - PINION MATE SHAFT
- 3 - SIDE GEAR
- 4 - DRIFT

**ASSEMBLY**

- (1) Install the differential side gears and thrust washers.
- (2) Install the pinion mate gears and thrust washers.
- (3) Install the pinion gear mate shaft.

(4) Align the hole in the pinion gear mate shaft with the hole in the differential case.

(5) Install and seat the pinion mate shaft roll-pin in the differential case and mate shaft with a punch and hammer (Fig. 31). Peen the edge of the roll-pin hole in the differential case slightly in two places, 180° apart.

(6) Lubricate all differential components with hypoid gear lubricant.

**INSTALLATION**

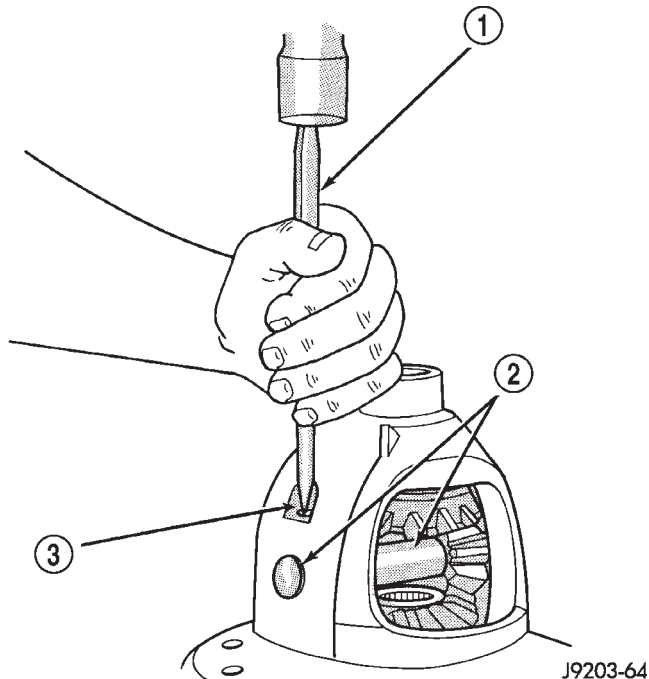
**NOTE:** If replacement differential bearings or differential case are being installed, differential side bearing shim requirements may change. Refer to Adjustments (Differential Bearing Preload and Gear Backlash) procedures to determine proper shim selection.

(1) Position Spreader W-129-B with the tool dowel pins seated in the locating holes. Install the hold down clamps and tighten the tool turnbuckle finger-tight.

(2) Install a Pilot Stud C-3288-B at the left side of the differential housing and attach dial indicator to the pilot stud. Load the indicator plunger against the opposite side of the housing and zero the dial indicator.



## DIFFERENTIAL (Continued)



**Fig. 31 Pinion Mate Shaft Roll-Pin**

- 1 - PUNCH
- 2 - PINION MATE SHAFT
- 3 - MATE SHAFT LOCKPIN

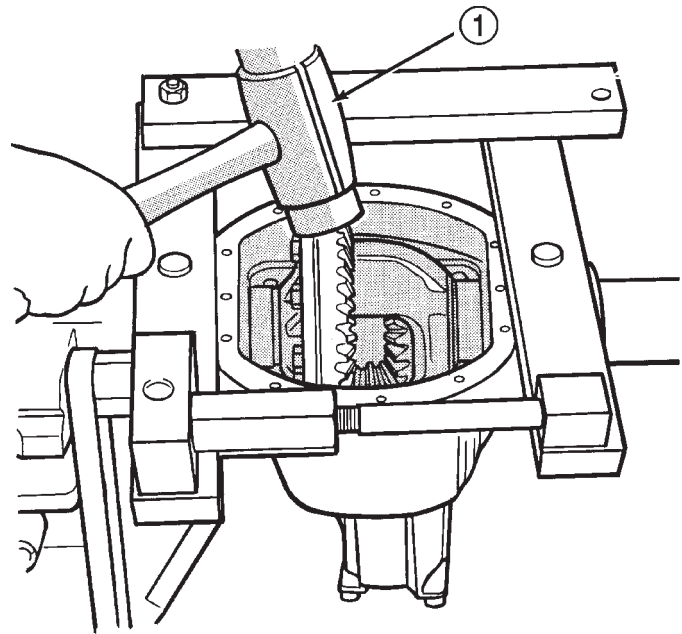
(3) Spread the housing enough to install the case in the housing. Measure the distance with the dial indicator.

**CAUTION:** Do not spread over 0.50 mm (0.020 in). If the housing is over-spread, it could be distorted or damaged.

- (4) Remove the dial indicator.
- (5) Install differential into the housing. Tap the differential case with a rawhide/rubber hammer to ensure the bearings are seated in housing (Fig. 32).
- (6) Remove the spreader.
- (7) Install bearing caps in their original locations (Fig. 33) and tighten bearing cap bolts to 109 N·m (80 ft. lbs.).
- (8) Install axle shafts.
- (9) Install the hub bearings.
- (10) Apply a bead of Mopar Silicone Rubber Sealant or equivalent to the housing cover (Fig. 34).

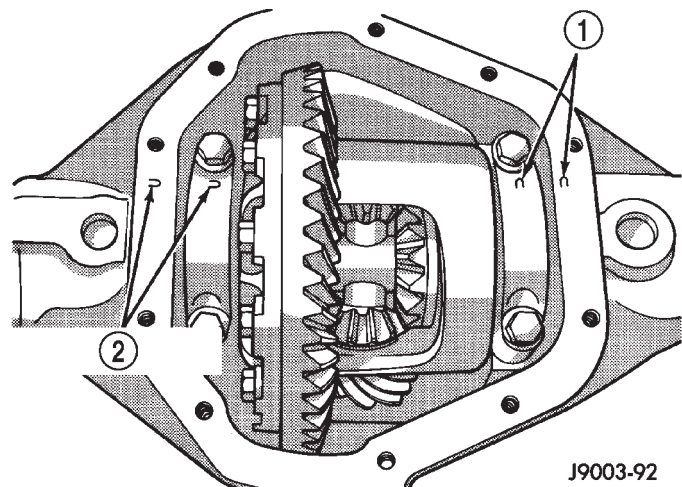
**Install the housing cover within 5 minutes after applying the sealant.**

(11) Install the cover and any identification tag. Tighten the cover bolts in a criss-cross pattern to 47 N·m (35 ft. lbs.).



**Fig. 32 Differential Case**

- 1 - RAWHIDE HAMMER



**Fig. 33 Bearing Cap Reference**

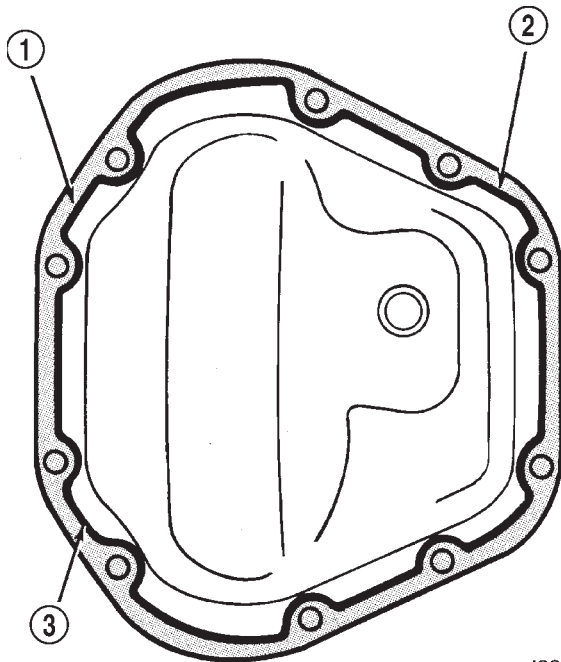
- 1 - REFERENCE LETTERS
- 2 - REFERENCE LETTERS

(12) Refill the differential with Mopar Hypoid Gear Lubricant or equivalent to bottom of the fill plug hole. Refer to the Lubricant Specifications for correct quantity and type.

(13) Install the fill hole plug and tighten to 34 N·m (25 ft. lbs.).

(14) Remove support and lower vehicle.

## DIFFERENTIAL (Continued)



J9302-30

**Fig. 34 Differential Cover**

- 1 - SEALANT SURFACE
- 2 - SEALANT
- 3 - SEALANT THICKNESS

## DIFFERENTIAL - POWR-LOK

## DIAGNOSIS AND TESTING - POWR-LOK™ TEST

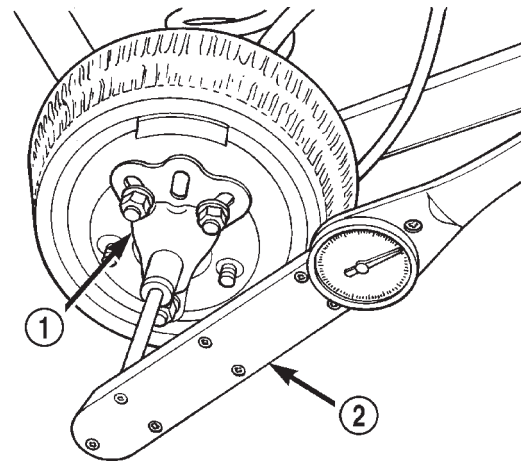
**WARNING: WHEN SERVICING VEHICLES WITH A POWER-LOK™ DIFFERENTIAL DO NOT USE THE ENGINE TO TURN THE AXLE AND WHEELS. BOTH REAR WHEELS MUST BE RAISED AND THE VEHICLE SUPPORTED. A POWER-LOK™ AXLE CAN EXERT ENOUGH FORCE IF ONE WHEEL IS IN CONTACT WITH A SURFACE TO CAUSE THE VEHICLE TO MOVE.**

The differential can be tested without removing the differential case by measuring rotating torque. Make sure brakes are not dragging during this measurement.

- (1) Place blocks in front and rear of both front wheels.
- (2) Raise one rear wheel until it is completely off the ground.
- (3) Engine off, transmission in neutral, and parking brake off.

(4) Remove wheel and bolt Special Tool 6790 to studs.

(5) Use torque wrench on special tool to rotate wheel and read rotating torque (Fig. 35).



80a4d327

**Fig. 35 Powr-lok™ Test - Typical**

- 1 - SPECIAL TOOL 6790 WITH BOLT IN CENTER HOLE
- 2 - TORQUE WRENCH

(6) If rotating torque is less than 22 N·m (30 ft. lbs.) or more than 271 N·m (200 ft. lbs.) on either wheel the unit should be serviced.

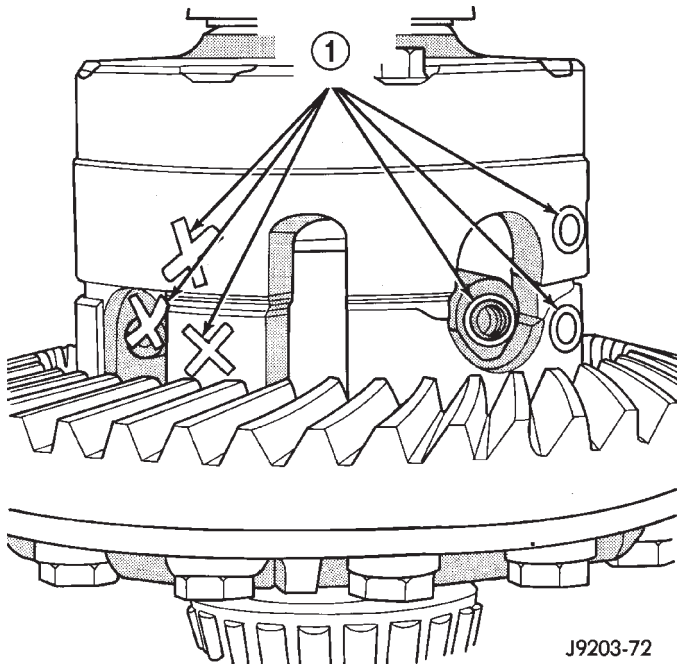
## DISASSEMBLY

The Powr-Lok™ differential has a two-piece cross shaft and uses 2 disc and 3 plates for each clutch pack. One plate and one disc in each clutch pack is dished.

**NOTE: Pay close attention to the clutch pack arrangement during this procedure. Note the direction of the concave and convex side of the plates and discs.**

- (1) Mark the ring gear half and cover half for installation reference (Fig. 36).
- (2) Remove the case attaching bolts and remove the button cover half (Fig. 37).
- (3) Remove top clutch pack (Fig. 38).
- (4) Remove top side gear clutch ring.
- (5) Remove top side gear.
- (6) Remove pinion mate gears and cross shafts.
- (7) Remove the same parts listed above from the ring gear flange half of the case. Keep these parts with the flange cover half for correct installation in their original positions.

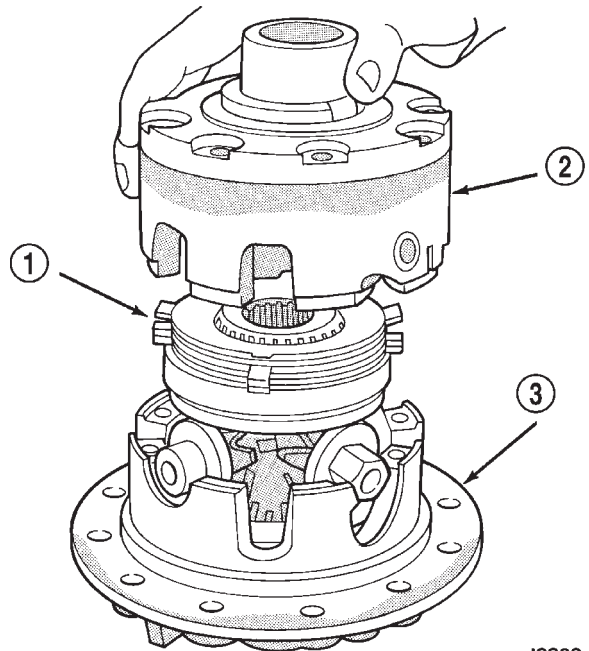
DIFFERENTIAL - POWR-LOK (Continued)



J9203-72

**Fig. 36 Case Marked**

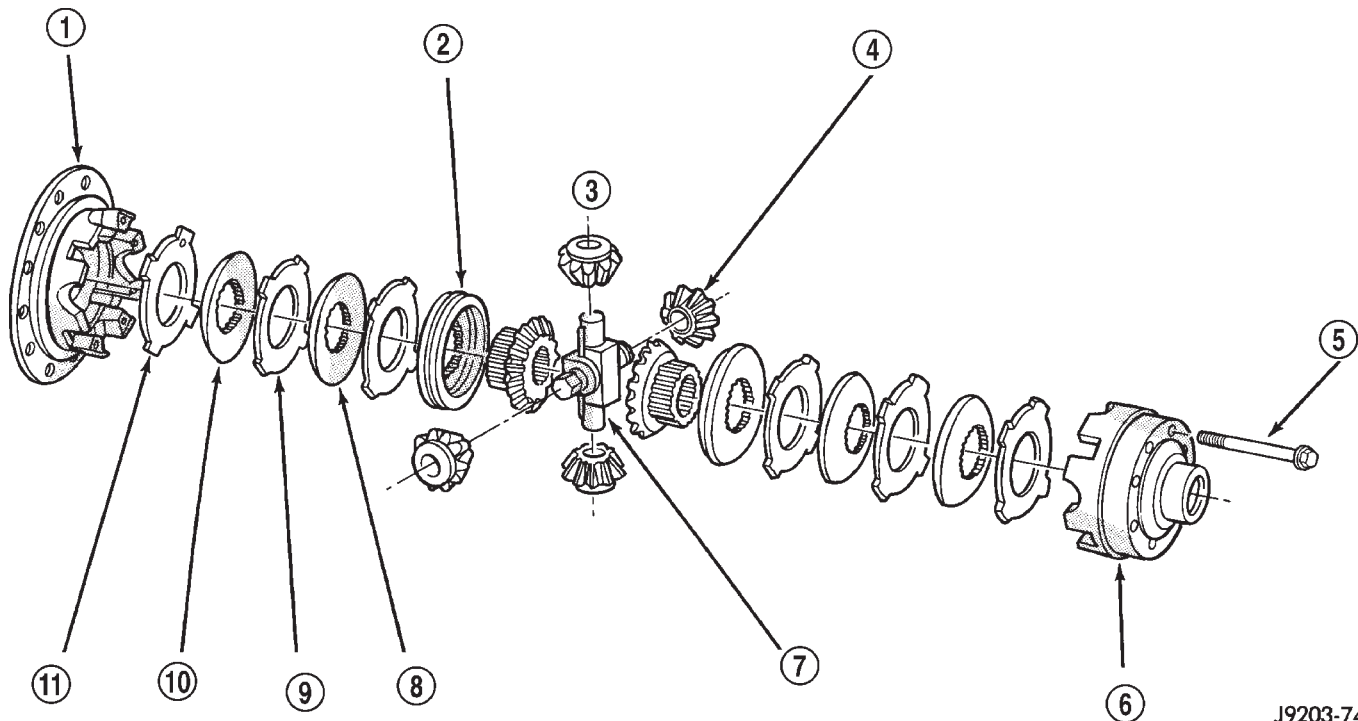
1 - REFERENCE MARKS



J9203-73

**Fig. 37 Cover Half Removal**

1 - CLUTCH PLATES  
2 - BUTTON HALF  
3 - FLANGE HALF



J9203-74

**Fig. 38 Powr-Lok™ Components**

1 - FLANGE HALF	7 - PINION MATE CROSS SHAFT
2 - CLUTCH RING	8 - DISHED DISC
3 - SIDE GEAR	9 - PLATE
4 - PINION MATE GEAR	10 - DISHED DISC
5 - SCREW	11 - PLATE
6 - BUTTON HALF	

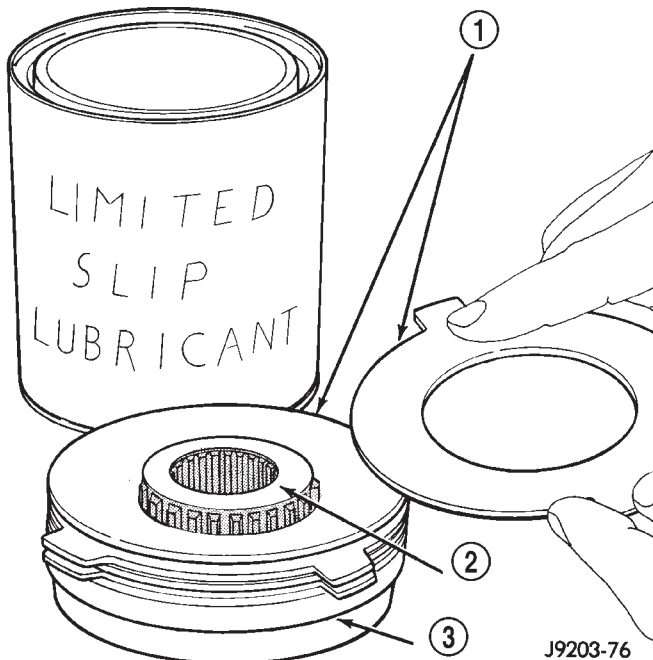
## DIFFERENTIAL - POWR-LOK (Continued)

## ASSEMBLY

The Powr-Lok™ differential has a two-piece cross shaft and uses 2 disc and 3 plates for each clutch pack. One plate and one disc in each clutch pack is dished.

**NOTE:** The clutch discs are replaceable as complete sets only. If one clutch disc pack is damaged, both packs must be replaced.

(1) Saturate the clutch plates with Mopar® Hypoid Gear Lubricant or Additive (Fig. 39). Assemble clutch packs into the side gear plate in exactly the same position as removed (Fig. 38).



**Fig. 39 Clutch Pack Pre-lubrication**

- 1 - CLUTCH PLATES
- 2 - SIDE GEAR
- 3 - CLUTCH RING

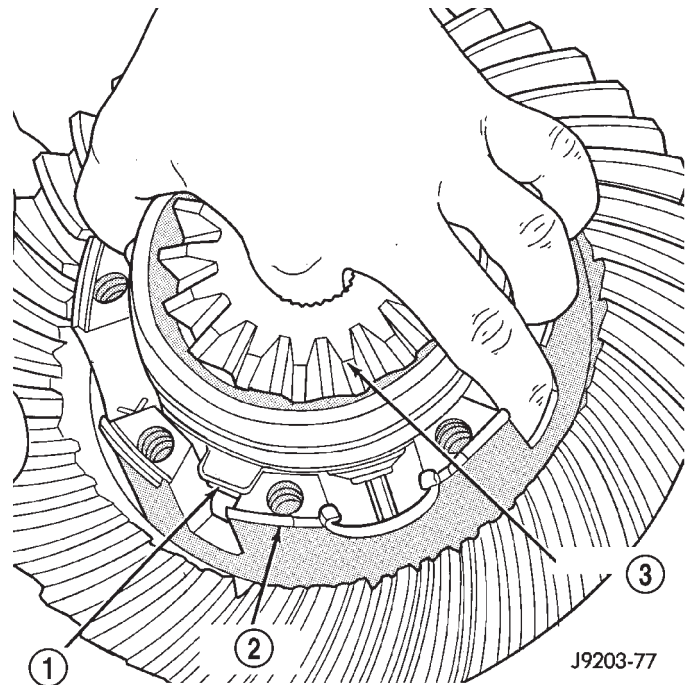
(2) Line up the plate ears and install the assembled pack into the flange half (Fig. 40). Ensure that the clutch plate lugs enter the slots in the case. Also ensure that the clutch pack bottoms out on the case.

(3) Install pinion mate shafts and pinion mate gears (Fig. 41). **Make sure shafts are correctly installed according to the alignment marks.**

(4) Lubricate and install the other side gear and clutch pack (Fig. 40).

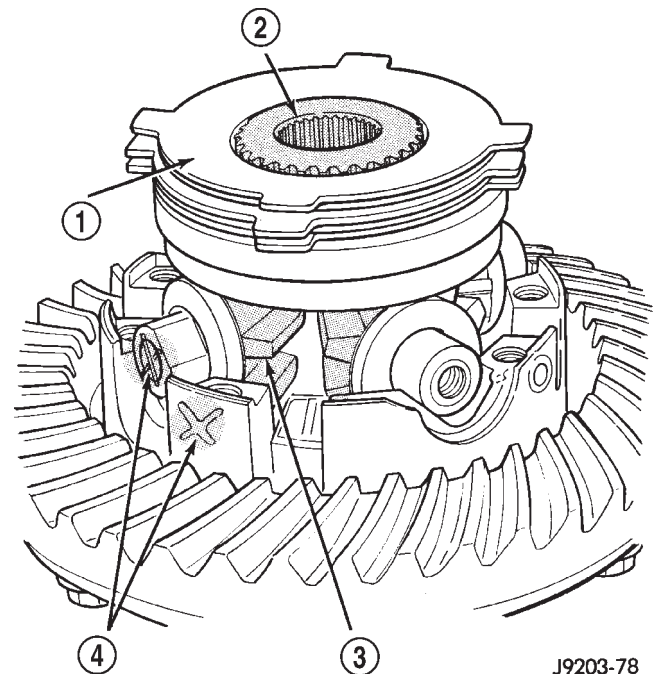
(5) Correctly align and assemble button half to flange half. Install case body screws finger tight.

(6) Tighten body screws alternately and evenly. Tighten screws to 89-94 N·m (65-70 ft. lbs.) torque (Fig. 42).



**Fig. 40 Clutch Pack Installation**

- 1 - LUGS
- 2 - FLANGE HALF
- 3 - SIDE GEAR



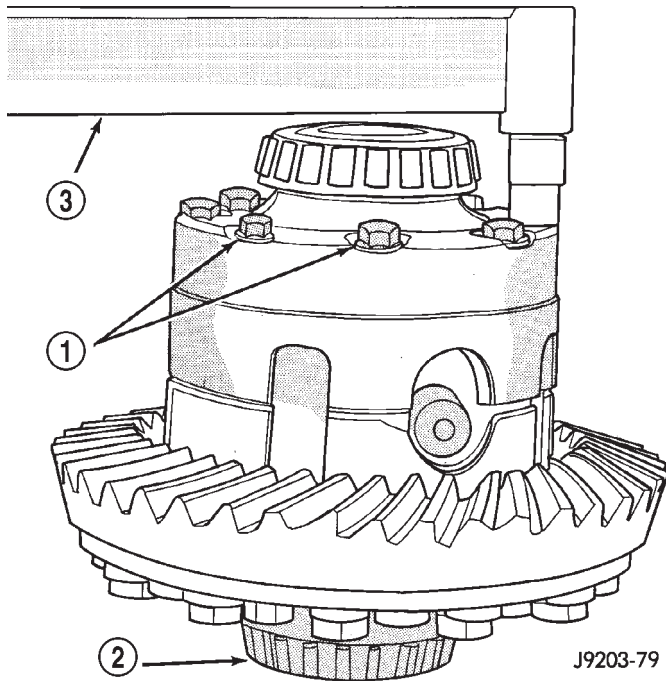
**Fig. 41 Clutch Pack**

- 1 - CLUTCH PACK
- 2 - SIDE GEAR
- 3 - PINION GEARS AND MATE SHAFT
- 4 - ALIGNMENT MARKS



## DIFFERENTIAL - POWR-LOK (Continued)

If bolt heads have 7 radial lines or the number 180 stamped on the head, tighten these bolts to 122-136 N·m (90-100 ft. lbs.) torque.



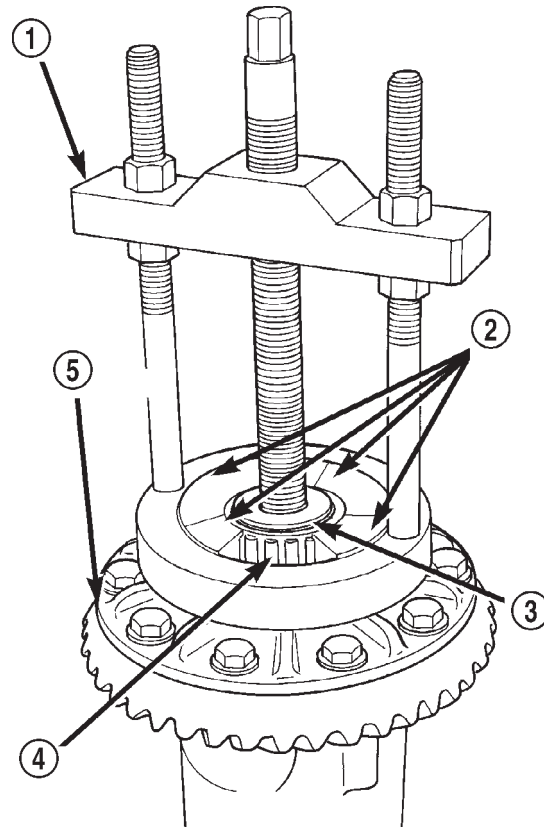
**Fig. 42 Case Half Installation**

- 1 - FIXTURE
- 2 - CASE BOLTS
- 3 - TORQUE WRENCH

## DIFFERENTIAL CASE BEARINGS

### REMOVAL

- (1) Remove differential case from axle housing.
- (2) Remove bearings from the differential case with Puller/Press C-293-PA, Adapters C-293-62 and Step Plate 8139-2 (Fig. 43).



**Fig. 43 Differential Bearing**

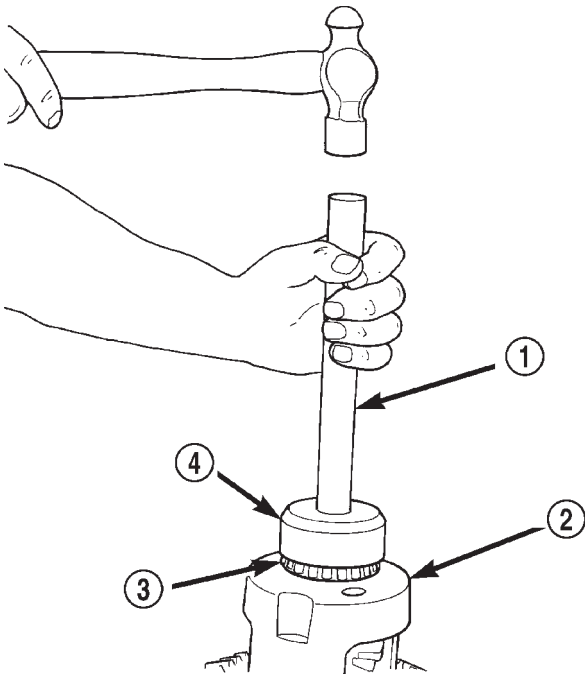
- 1 - SPECIAL TOOL C-293-PA
- 2 - SPECIAL TOOL C-293-62
- 3 - SPECIAL TOOL C-4487-1
- 4 - BEARING
- 5 - DIFFERENTIAL

### INSTALLATION

- (1) Using tool C-4190 with handle C-4171, install differential side bearings (Fig. 44).
- (2) Install differential case in axle housing.

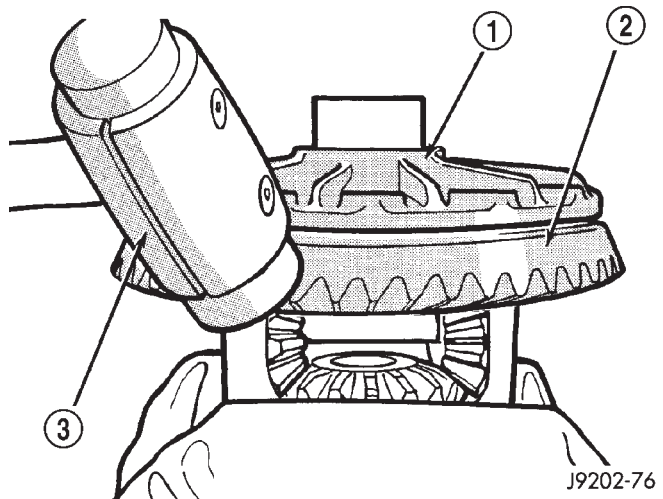


## DIFFERENTIAL CASE BEARINGS (Continued)

**Fig. 44 Install Differential Side Bearings**

- 1 - HANDLE C-4171
- 2 - DIFFERENTIAL CASE
- 3 - BEARING
- 4 - TOOL C-4190

80a9834b

**Fig. 45 Ring Gear Removal**

- 1 - DIFFERENTIAL CASE
- 2 - RING GEAR
- 3 - HAMMER

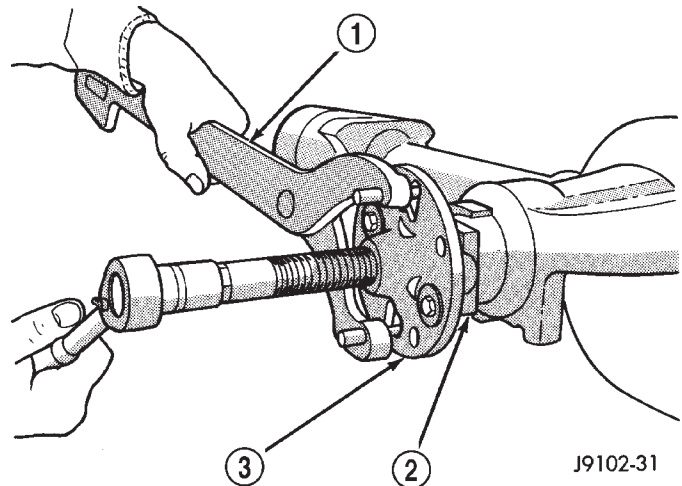
J9202-76

PINION GEAR/RING GEAR/  
TONE RING

## REMOVAL

**NOTE:** The ring and pinion gears are service in a matched set. Do not replace the ring gear without replacing the matched pinion gear.

- (1) Remove differential from axle housing.
- (2) Place differential case in a vise with soft metal jaw protectors. (Fig. 45)
- (3) Remove bolts holding ring gear to differential case.
- (4) Drive ring gear from differential case with a soft hammer (Fig. 45).
- (5) Use a brass drift and slowly tap the exciter ring from the differential case.
- (6) Mark pinion yoke and propeller shaft for installation alignment.
- (7) Disconnect propeller shaft from pinion yoke. Tie propeller shaft to underbody.
- (8) Using Yoke Holder 6719 to hold yoke, remove pinion yoke nut and washer.
- (9) Remove pinion yoke from pinion with Remover C-452 and Wrench C-3281, shaft (Fig. 46).
- (10) Remove pinion gear from housing (Fig. 47).

**Fig. 46 Pinion Yoke Removal**

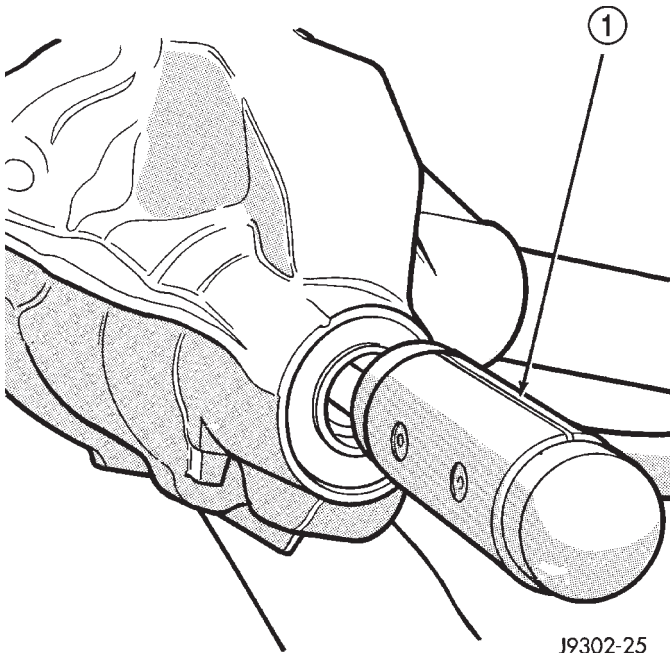
- 1 - WRENCH
- 2 - YOKE
- 3 - REMOVER

J9102-31

- (11) Remove pinion seal with a slide hammer or pry bar.
- (12) Remove oil slinger, if equipped, and the front pinion bearing.
- (13) Remove front pinion bearing cup with Remover D-158 and Handle C-4171 (Fig. 48).
- (14) Remove rear bearing cup with Remover D-162 and Handle C-4171 (Fig. 49).
- (15) Remove rear bearing from the pinion with Puller/Press C-293-PA and Adapters C-293-37 (Fig. 50).

**Place 4 adapter blocks so they do not damage the bearing cage.**

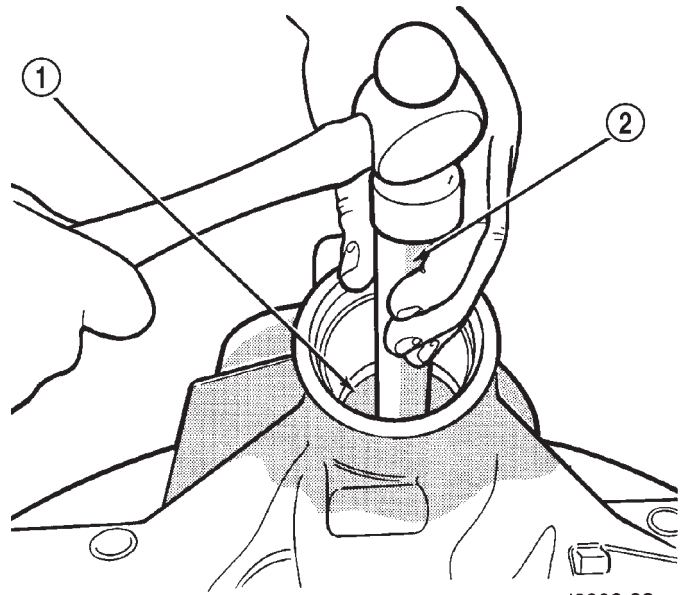
PINION GEAR/RING GEAR/TONE RING (Continued)



J9302-25

**Fig. 47 Remove Pinion Gear**

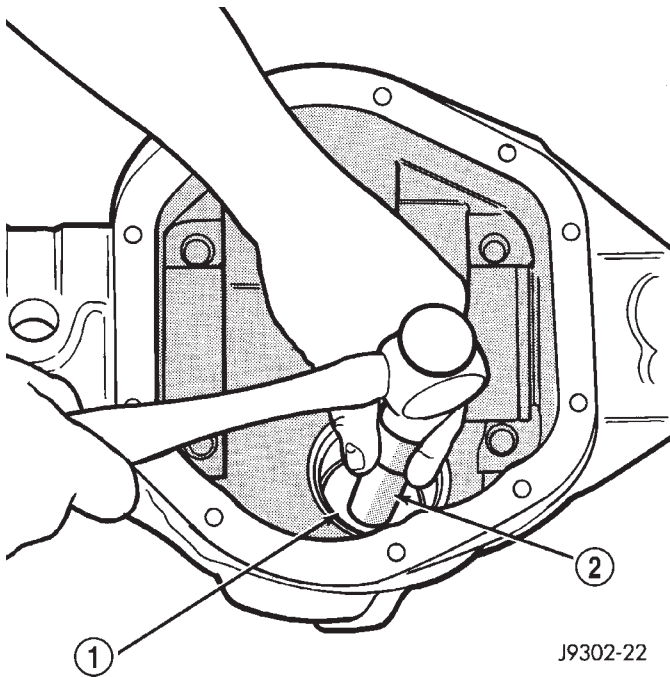
- 1 - RAWHIDE HAMMER



J9302-23

**Fig. 49 Rear Bearing Cup Removal**

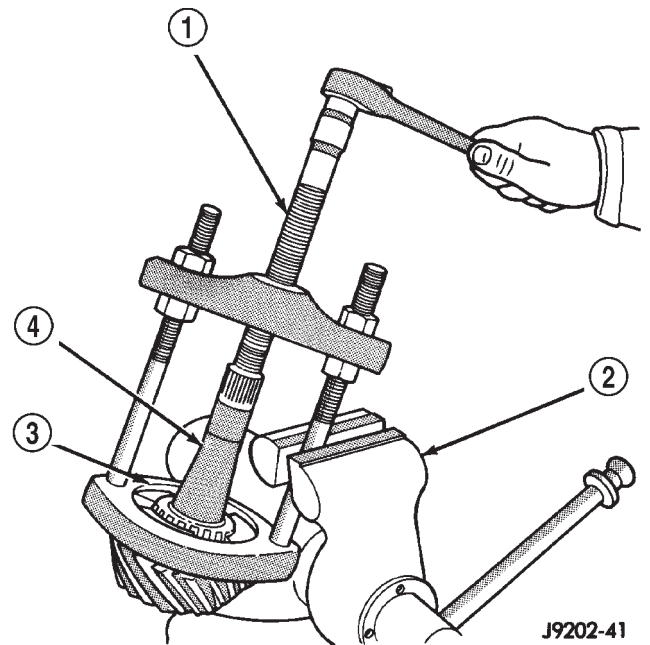
- 1 - REMOVER  
2 - HANDLE



J9302-22

**Fig. 48 Front Bearing Cup Removal**

- 1 - REMOVER  
2 - HANDLE



J9202-41

**Fig. 50 Rear Pinion Bearing Removal**

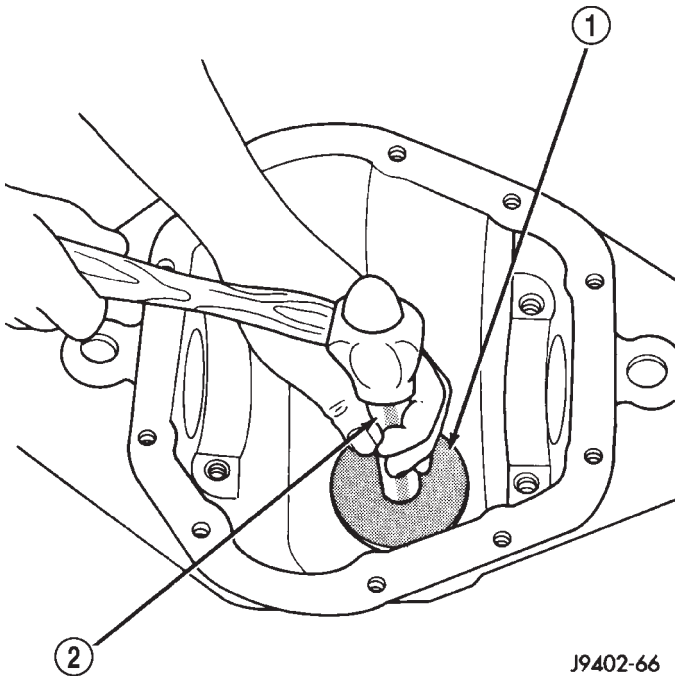
- 1 - PULLER  
2 - VISE  
3 - PINION SHAFT  
4 - ADAPTER BLOCKS

(16) Remove the pinion depth shims from the pinion gear shaft. Record the total thickness of the depth shims.

**INSTALLATION**

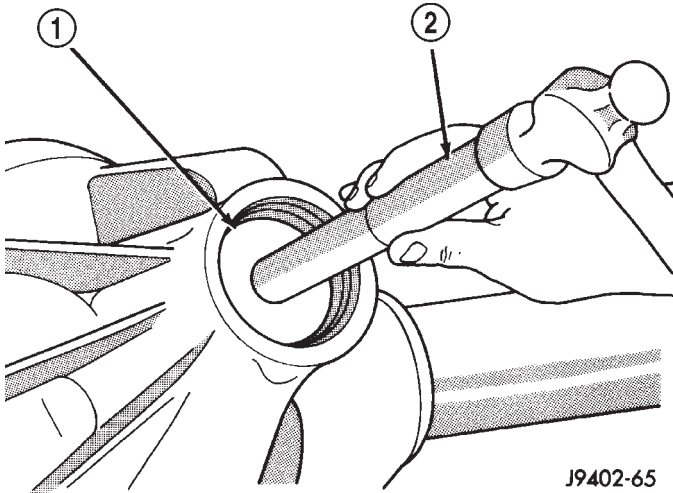
(1) Apply Mopar Door Ease stick lubricant to outside surface of bearing cup. Install the pinion rear bearing cup with Installer C-111 and Handle C-4171 (Fig. 51) and verify cup is seated.

## PINION GEAR/RING GEAR/TONE RING (Continued)

**Fig. 51 Pinion Rear Bearing Cup**

- 1 - INSTALLER  
2 - HANDLE

(2) Apply Mopar Door Ease stick lubricant to outside surface of bearing cup. Install the pinion front bearing cup with Installer D-146 and Handle C-4171 (Fig. 52) and verify cup is seated.

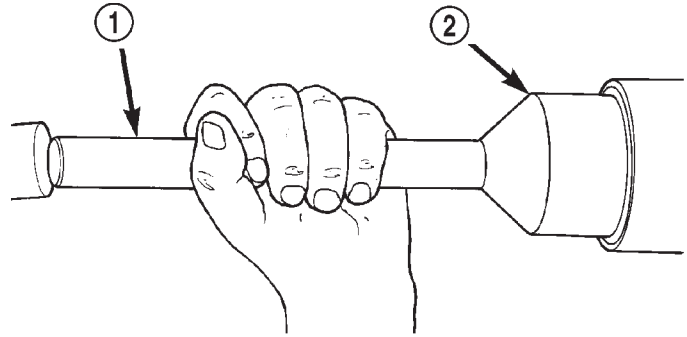
**Fig. 52 Pinion Front Bearing Cup**

- 1 - INSTALLER  
2 - HANDLE

(3) Install pinion front bearing and oil slinger, if equipped. Apply a light coating of gear lubricant on the lip of pinion gear.

(4) Install a new pinion seal with an appropriate installer (Fig. 53).

**NOTE:** Pinion depth shims are placed between the rear pinion bearing cone and pinion gear to achieve proper ring and pinion gear mesh. If ring and pinion gears are reused, the pinion depth shim should not require replacement. If the ring and pinion gears are replaced refer to Adjustments (Pinion Gear Depth ) to select the proper thickness shim.

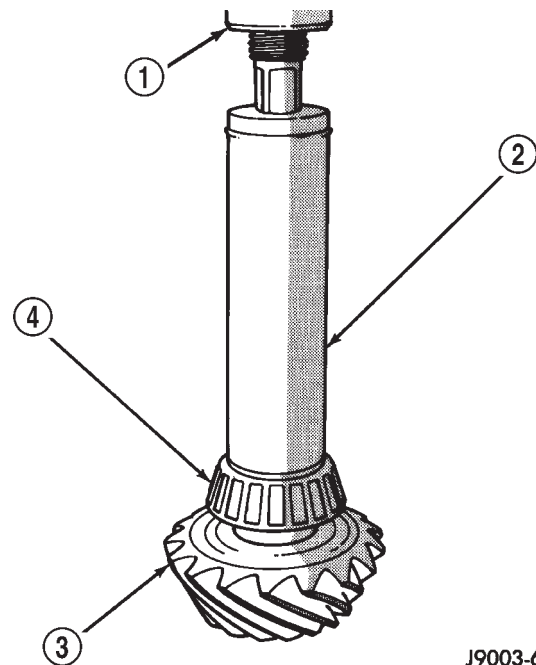
**Fig. 53 Pinion Seal**

80a98349

- 1 - HANDLE  
2 - INSTALLER

(5) Place the proper thickness pinion depth shim on the pinion gear.

(6) Install rear pinion bearing and oil slinger, if equipped on the pinion gear with Installer C-3095-A and a press (Fig. 54).

**Fig. 54 Rear Pinion Bearing**

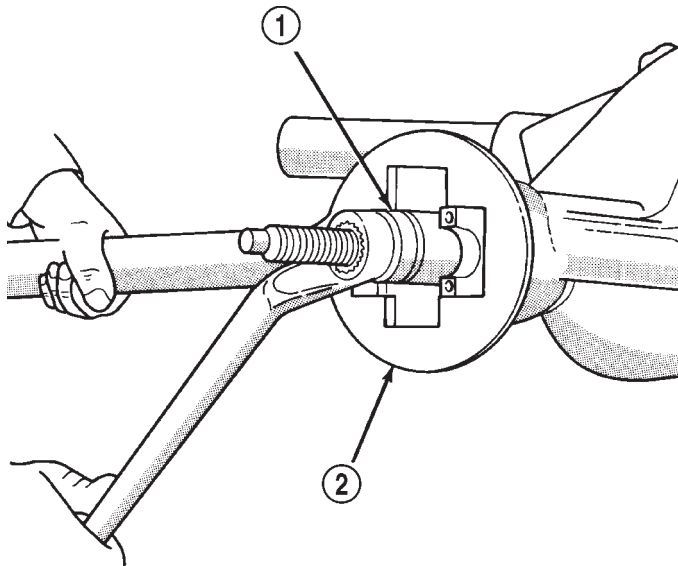
J9003-67

- 1 - PRESS  
2 - INSTALLER  
3 - PINION GEAR  
4 - PINION BEARING

## PINION GEAR/RING GEAR/TONE RING (Continued)

(7) Install original solid shims on pinion gears.

(8) Install yoke with Installer C-3718 and Yoke Holder 6719 (Fig. 55).



**Fig. 55 Pinion Yoke**

J9402-61

- 1 - INSTALLER  
2 - HOLDER

(9) Install the yoke washer and **new** nut on the pinion gear. Tighten the nut to 298-380 N·m (220-280 ft. lbs.).

(10) Check bearing rotating torque with an inch pound torque wrench (Fig. 56). Pinion rotating torque should be:

- Original Bearings: 1 to 3 N·m (10 to 20 in. lbs.).
- New Bearings: 2.3 to 5.1 N·m (20 to 45 in. lbs.).

(11) If rotating torque is less than the desired rotating torque, remove the pinion yoke and decrease the thickness of the solid shim pack if greater increase shim pack. Changing the shim pack thickness by 0.025 mm (0.001 in.) will change the rotating torque approximately 0.9 N·m (8 in. lbs.).

(12) Invert the differential case.

(13) Position exciter ring on differential case.

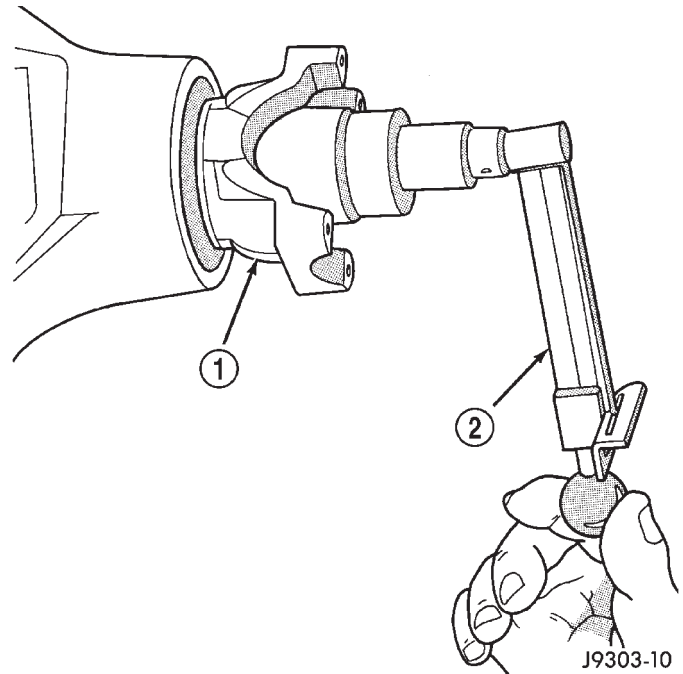
(14) Using a brass drift, slowly and evenly tap the exciter ring into position.

(15) Invert the differential case and start two ring gear bolts. This will provide case-to-ring gear bolt hole alignment.

(16) Invert the differential case in the vise.

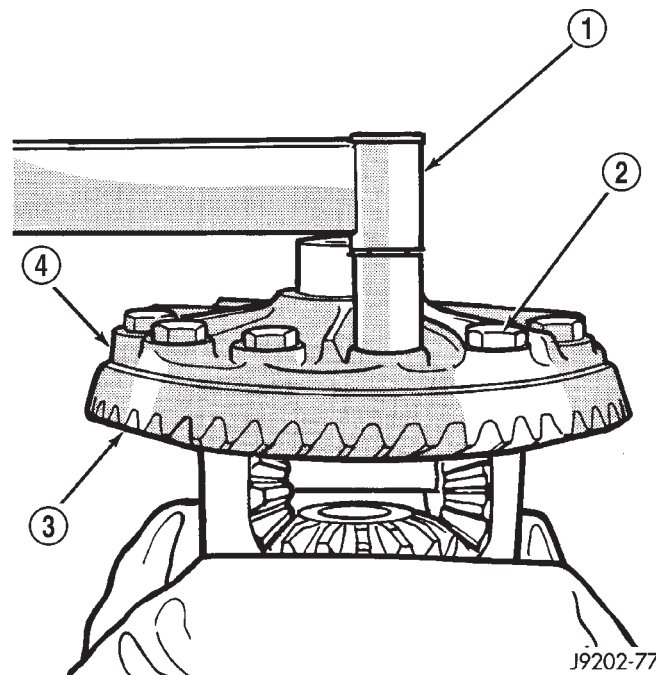
(17) Install new ring gear bolts and alternately tighten to 176 N·m (130 ft. lbs.) (Fig. 57).

**CAUTION:** Do not reuse ring gear bolts, the bolts can fracture causing extensive damage.



**Fig. 56 Pinion Gear Rotation Torque**

- 1 - PINION YOKE  
2 - TORQUE WRENCH



**Fig. 57 Ring Gear Bolt**

- 1 - TORQUE WRENCH  
2 - RING GEAR BOLT  
3 - RING GEAR  
4 - CASE

(18) Install differential in housing and verify gear mesh and contact pattern.

(19) Install propeller shaft with reference marks aligned.



## REAR AXLE - 286RBI

### TABLE OF CONTENTS

	page		page
<b>REAR AXLE - 286RBI</b>		<b>INSTALLATION</b> .....	185
DESCRIPTION.....	169	<b>DIFFERENTIAL</b>	
OPERATION.....	169	REMOVAL.....	187
DIAGNOSIS AND TESTING.....	171	DISASSEMBLY.....	188
AXLE.....	171	ASSEMBLY.....	188
REMOVAL.....	173	INSTALLATION.....	188
INSTALLATION.....	174	<b>DIFFERENTIAL - TRAC-LOK</b>	
ADJUSTMENTS.....	174	DIAGNOSIS AND TESTING.....	190
SPECIFICATIONS.....	182	TRAC-LOK.....	190
SPECIAL TOOLS.....	182	DISASSEMBLY.....	190
<b>AXLE SHAFTS</b>		ASSEMBLY.....	190
REMOVAL.....	185	<b>DIFFERENTIAL CASE BEARINGS</b>	
INSTALLATION.....	185	REMOVAL.....	192
<b>AXLE BEARINGS</b>		INSTALLATION.....	192
REMOVAL.....	185	<b>PINION GEAR/RING GEAR/TONE RING</b>	
INSTALLATION.....	185	REMOVAL.....	193
<b>PINION SEAL</b>		INSTALLATION.....	195
REMOVAL.....	185		

## REAR AXLE - 286RBI

### DESCRIPTION

The 286 Rear Beam-design Iron (RBI) axle housings consist of an iron center casting (differential housing) with axle shaft tubes extending from either side. The tubes are pressed in to form a one-piece axle housing.

The integral type housing, hypoid gear design has the centerline of the pinion set below the centerline of the ring gear.

The axles are equipped with full-floating axle shafts, meaning that loads are supported by the axle housing tubes. The full-float axle shafts are retained by bolts attached to the hub. The hub rides on two bearings at the outboard end of the axle tube. The axle shafts can be removed without disturbing or removing the wheel bearings. The wheel bearings are opposed tapered roller bearings and are contained in the hub assembly.

The removable, stamped steel cover provides a means for inspection and service without removing the complete axle from the vehicle. A small, stamped metal axle gear ratio identification tag is attached to the housing cover via one of the cover bolts. This tag also identifies the number of ring and pinion teeth.

The rear wheel anti-lock (RWAL) brake speed sensor is attached to the top, forward exterior of the differential housing. A seal is located between the

sensor and the wire harness connector. The seal must be in place when the wire connector is connected to the sensor. The RWAL brake exciter ring is press-fitted onto the differential case against the ring gear flange.

The differential case for the standard differential is a one-piece design. The differential pinion mate shaft is retained with a roll pin. Differential bearing preload and ring gear backlash are adjusted by the use of shims located between the differential bearing cones and case. Pinion bearing preload is set and maintained by the use of solid shims.

Axles equipped with a Trac-Lok™ differential are optional for the 286 RBI axle. A Trac-Lok™ differential contains two clutch packs, four pinion gears, and a one-piece pinion mate cross shaft to provide increased torque to the non-slipping wheel in addition to the standard differential components. A Trac-Lok™ differential for the 286 RBI axle has a two-piece differential case.

### OPERATION

#### STANDARD DIFFERENTIAL

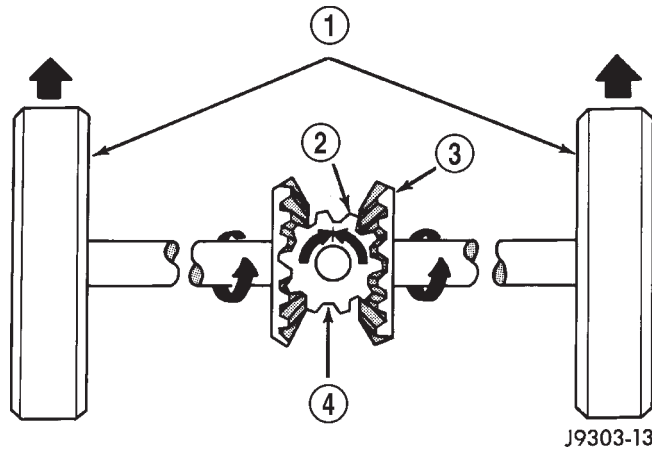
The axle receives power from the transmission/transfer case through the rear propeller shaft. The rear propeller shaft is connected to the pinion gear which rotates the differential through the gear mesh with the ring gear bolted to the differential case. The engine power is transmitted to the axle shafts



REAR AXLE - 286RBI (Continued)

through the pinion mate and side gears. The side gears are splined to the axle shafts.

During straight-ahead driving, the differential pinion gears do not rotate on the pinion mate shaft. This occurs because input torque applied to the gears is divided and distributed equally between the two side gears. As a result, the pinion gears revolve with the pinion mate shaft but do not rotate around it (Fig. 1).



**Fig. 1 Differential Operation - Straight Ahead Driving**

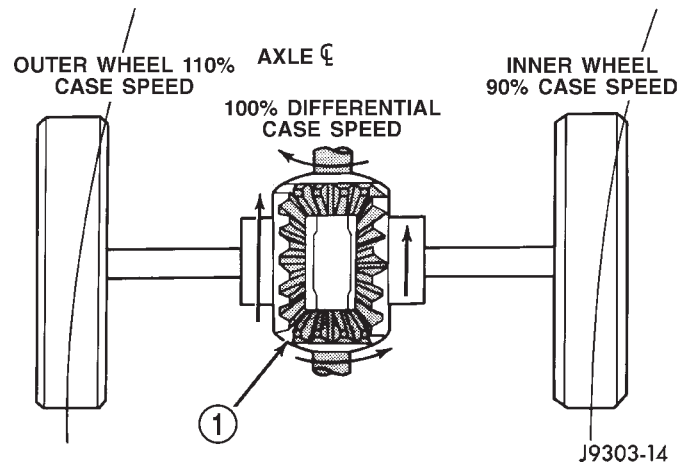
- 1 - IN STRAIGHT AHEAD DRIVING EACH WHEEL ROTATES AT 100% OF CASE SPEED
- 2 - PINION GEAR
- 3 - SIDE GEAR
- 4 - PINION GEARS ROTATE WITH CASE

When turning corners, the outside wheel must travel a greater distance than the inside wheel to complete a turn. The difference must be compensated for to prevent the tires from scuffing and skidding through turns. To accomplish this, the differential allows the axle shafts to turn at unequal speeds (Fig. 2). In this instance, the input torque applied to the pinion gears is not divided equally. The pinion gears now rotate around the pinion mate shaft in opposite directions. This allows the side gear and axle shaft attached to the outside wheel to rotate at a faster speed.

**TRAC-LOK™ DIFFERENTIAL**

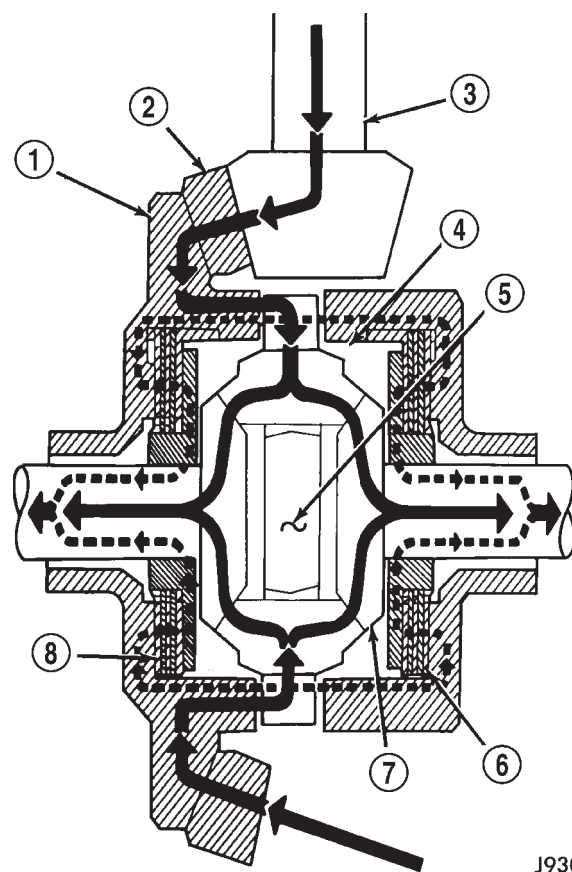
The Trac-lok™ clutches are engaged by two concurrent forces. The first being the preload force exerted through Belleville spring washers within the clutch packs. The second is the separating forces generated by the side gears as torque is applied through the ring gear (Fig. 3).

The Trac-lok™ design provides the differential action needed for turning corners and for driving straight ahead during periods of unequal traction. When one wheel loses traction, the clutch packs transfer additional torque to the wheel having the most traction. Trac-lok™ differentials resist wheel spin



**Fig. 2 Differential Operation - On Turns**

- 1 - PINION GEARS ROTATE ON PINION SHAFT



**Fig. 3 Trac-lok™ Limited Slip Differential**

- 1 - CASE
- 2 - RING GEAR
- 3 - DRIVE PINION
- 4 - PINION GEAR
- 5 - MATE SHAFT
- 6 - CLUTCH PACK
- 7 - SIDE GEAR
- 8 - CLUTCH PACK

## REAR AXLE - 286RBI (Continued)

on bumpy roads and provide more pulling power when one wheel loses traction. Pulling power is provided continuously until both wheels lose traction. If both wheels slip due to unequal traction, Trac-lok<sup>™</sup> operation is normal. In extreme cases of differences of traction, the wheel with the least traction may spin.

**DIAGNOSIS AND TESTING - AXLE****GEAR NOISE**

Axle gear noise can be caused by insufficient lubricant, incorrect backlash, incorrect pinion depth, tooth contact, worn/damaged gears, or the carrier housing not having the proper offset and squareness.

Gear noise usually happens at a specific speed range. The noise can also occur during a specific type of driving condition. These conditions are acceleration, deceleration, coast, or constant load.

When road testing, first warm-up the axle fluid by driving the vehicle at least 5 miles and then accelerate the vehicle to the speed range where the noise is the greatest. Shift out-of-gear and coast through the peak-noise range. If the noise stops or changes greatly:

- Check for insufficient lubricant.
- Incorrect ring gear backlash.
- Gear damage.

Differential side gears and pinions can be checked by turning the vehicle. They usually do not cause noise during straight-ahead driving when the gears are unloaded. The side gears are loaded during vehicle turns. A worn pinion shaft can also cause a snapping or a knocking noise.

**BEARING NOISE**

The axle shaft, differential and pinion bearings can all produce noise when worn or damaged. Bearing noise can be either a whining, or a growling sound.

Pinion bearings have a constant-pitch noise. This noise changes only with vehicle speed. Pinion bearing noise will be higher pitched because it rotates at a faster rate. Drive the vehicle and load the differential. If bearing noise occurs, the rear pinion bearing is the source of the noise. If the bearing noise is heard during a coast, the front pinion bearing is the source.

Worn or damaged differential bearings usually produce a low pitch noise. Differential bearing noise is similar to pinion bearing noise. The pitch of differential bearing noise is also constant and varies only with vehicle speed.

Axle shaft bearings produce noise and vibration when worn or damaged. The noise generally changes

when the bearings are loaded. Road test the vehicle. Turn the vehicle sharply to the left and to the right. This will load the bearings and change the noise level. Where axle bearing damage is slight, the noise is usually not noticeable at speeds above 30 mph.

**LOW SPEED KNOCK**

Low speed knock is generally caused by a worn U-joint or by worn side-gear thrust washers. A worn pinion shaft bore will also cause low speed knock.

**VIBRATION**

Vibration at the rear of the vehicle is usually caused by a:

- Damaged drive shaft.
- Missing drive shaft balance weight(s).
- Worn or out-of-balance wheels.
- Loose wheel lug nuts.
- Worn U-joint(s).
- Loose/broken springs.
- Damaged axle shaft bearing(s).
- Loose pinion gear nut.
- Excessive pinion yoke run out.
- Bent axle shaft(s).

Check for loose or damaged front-end components or engine/transmission mounts. These components can contribute to what appears to be a rear-end vibration. Do not overlook engine accessories, brackets and drive belts.

All driveline components should be examined before starting any repair.

(Refer to 22 - TIRES/WHEELS - DIAGNOSIS AND TESTING)

**DRIVELINE SNAP**

A snap or clunk noise when the vehicle is shifted into gear (or the clutch engaged), can be caused by:

- High engine idle speed.
- Transmission shift operation.
- Loose engine/transmission/transfer case mounts.
- Worn U-joints.
- Loose spring mounts.
- Loose pinion gear nut and yoke.
- Excessive ring gear backlash.
- Excessive side gear to case clearance.

The source of a snap or a clunk noise can be determined with the assistance of a helper. Raise the vehicle on a hoist with the wheels free to rotate. Instruct the helper to shift the transmission into gear. Listen for the noise, a mechanics stethoscope is helpful in isolating the source of a noise.

## REAR AXLE - 286RBI (Continued)

## DIAGNOSTIC CHART

Condition	Possible Causes	Correction
Wheel Noise	<ol style="list-style-type: none"> <li>1. Wheel loose.</li> <li>2. Faulty, brinelled wheel bearing.</li> </ol>	<ol style="list-style-type: none"> <li>1. Tighten loose nuts.</li> <li>2. Replace bearing.</li> </ol>
Axle Shaft Noise	<ol style="list-style-type: none"> <li>1. Misaligned axle tube.</li> <li>2. Bent or sprung axle shaft.</li> </ol>	<ol style="list-style-type: none"> <li>1. Inspect axle tube alignment. Correct as necessary.</li> <li>2. Inspect and correct as necessary.</li> </ol>
Axle Shaft Broke	<ol style="list-style-type: none"> <li>1. Misaligned axle tube.</li> <li>2. Vehicle overloaded.</li> <li>3. Erratic clutch operation.</li> <li>4. Grabbing clutch.</li> </ol>	<ol style="list-style-type: none"> <li>1. Replace the broken shaft after correcting tube mis-alignment.</li> <li>2. Replace broken shaft and avoid excessive weight on vehicle.</li> <li>3. Replace broken shaft and avoid or correct erratic clutch operation.</li> <li>4. Replace broken shaft and inspect and repair clutch as necessary.</li> </ol>
Differential Cracked	<ol style="list-style-type: none"> <li>1. Improper adjustment of the differential bearings.</li> <li>2. Excessive ring gear backlash.</li> <li>3. Vehicle overloaded.</li> <li>4. Erratic clutch operation.</li> </ol>	<ol style="list-style-type: none"> <li>1. Replace case and inspect gears and bearings for further damage. Set differential bearing pre-load properly.</li> <li>2. Replace case and inspect gears and bearings for further damage. Set ring gear backlash properly.</li> <li>3. Replace case and inspect gears and bearings for further damage. Avoid excessive vehicle weight.</li> <li>4. Replace case and inspect gears and bearings for further damage. Avoid erratic use of clutch.</li> </ol>
Differential Gears Scored	<ol style="list-style-type: none"> <li>1. Insufficient lubrication.</li> <li>2. Improper grade of lubricant.</li> <li>3. Excessive spinning of one wheel/tire.</li> </ol>	<ol style="list-style-type: none"> <li>1. Replace scored gears. Fill differential with the correct fluid type and quantity.</li> <li>2. Replace scored gears. Fill differential with the correct fluid type and quantity.</li> <li>3. Replace scored gears. Inspect all gears, pinion bores, and shaft for damage. Service as necessary.</li> </ol>
Loss Of Lubricant	<ol style="list-style-type: none"> <li>1. Lubricant level too high.</li> <li>2. Worn axle shaft seals.</li> <li>3. Cracked differential housing.</li> <li>4. Worn pinion seal.</li> <li>5. Worn/scored yoke.</li> <li>6. Axle cover not properly sealed.</li> </ol>	<ol style="list-style-type: none"> <li>1. Drain lubricant to the correct level.</li> <li>2. Replace seals.</li> <li>3. Repair as necessary.</li> <li>4. Replace seal.</li> <li>5. Replace yoke and seal.</li> <li>6. Remove, clean, and re-seal cover.</li> </ol>

## REAR AXLE - 286RBI (Continued)

Condition	Possible Causes	Correction
Axle Overheating	<ol style="list-style-type: none"> <li>1. Lubricant level low.</li> <li>2. Improper grade of lubricant.</li> <li>3. Bearing pre-loads too high.</li> <li>4. Insufficient ring gear backlash.</li> </ol>	<ol style="list-style-type: none"> <li>1. Fill differential to correct level.</li> <li>2. Fill differential with the correct fluid type and quantity.</li> <li>3. Re-adjust bearing pre-loads.</li> <li>4. Re-adjust ring gear backlash.</li> </ol>
Gear Teeth Broke	<ol style="list-style-type: none"> <li>1. Overloading.</li> <li>2. Erratic clutch operation.</li> <li>3. Ice-spotted pavement.</li> <li>4. Improper adjustments.</li> </ol>	<ol style="list-style-type: none"> <li>1. Replace gears. Examine other gears and bearings for possible damage.</li> <li>2. Replace gears and examine the remaining parts for damage. Avoid erratic clutch operation.</li> <li>3. Replace gears and examine remaining parts for damage.</li> <li>4. Replace gears and examine remaining parts for damage. Ensure ring gear backlash is correct.</li> </ol>
Axle Noise	<ol style="list-style-type: none"> <li>1. Insufficient lubricant.</li> <li>2. Improper ring gear and pinion adjustment.</li> <li>3. Unmatched ring gear and pinion.</li> <li>4. Worn teeth on ring gear and/or pinion.</li> <li>5. Loose pinion bearings.</li> <li>6. Loose differential bearings.</li> <li>7. Mis-aligned or sprung ring gear.</li> <li>8. Loose differential bearing cap bolts.</li> <li>9. Housing not machined properly.</li> </ol>	<ol style="list-style-type: none"> <li>1. Fill differential with the correct fluid type and quantity.</li> <li>2. Check ring gear and pinion contact pattern. Adjust backlash or pinion depth.</li> <li>3. Replace gears with a matched ring gear and pinion.</li> <li>4. Replace ring gear and pinion.</li> <li>5. Adjust pinion bearing pre-load.</li> <li>6. Adjust differential bearing pre-load.</li> <li>7. Measure ring gear run-out. Replace components as necessary.</li> <li>8. Inspect differential components and replace as necessary. Ensure that the bearing caps are torqued to the proper specification.</li> <li>9. Replace housing.</li> </ol>

**REMOVAL**

- (1) Raise and support the vehicle.
- (2) Position a suitable lifting device under the axle.
- (3) Secure axle to device.
- (4) Remove the wheels and tires.
- (5) Secure brake drums to the axle shaft.
- (6) Remove the RWAL sensor from the differential housing, if necessary. Refer to 5 Brakes for procedures.
- (7) Disconnect the brake hose at the axle junction block. Do not disconnect the brake hydraulic lines at the wheel cylinders. Refer to 5 Brakes for procedures.

- (8) Disconnect the parking brake cables and cable brackets.
- (9) Disconnect the vent hose from the axle shaft tube.
- (10) Mark the propeller shaft and companion flange for installation alignment reference.
- (11) Remove propeller shaft.
- (12) Disconnect shock absorbers from axle.
- (13) Remove the spring clamps and spring brackets. Refer to 2 Suspension for procedures.
- (14) Separate the axle from the vehicle.

## REAR AXLE - 286RBI (Continued)

**INSTALLATION**

(1) Raise the axle with lifting device and align to the leaf spring centering bolts.

(2) Install the spring clamps and spring brackets. Refer to 2 Suspension for procedures.

(3) Install shock absorbers and tighten nuts to 82 N·m (60 ft. lbs.).

(4) Install the RWAL sensor to the differential housing, if necessary. Refer to 5 Brakes for procedures.

(5) Connect the parking brake cables and cable brackets.

(6) Install the brake drums. Refer to 5 Brakes for procedures.

(7) Connect the brake hose to the axle junction block. Refer to 5 Brakes for procedures.

(8) Install axle vent hose.

(9) Align propeller shaft and pinion companion flange reference marks. Install the companion flange bolts. Tighten to 108 N·m (80 ft. lbs.).

(10) Install the wheels and tires.

(11) Add gear lubricant, if necessary. Refer to Specifications for lubricant requirements.

(12) Remove lifting device from axle and lower the vehicle.

**ADJUSTMENTS**

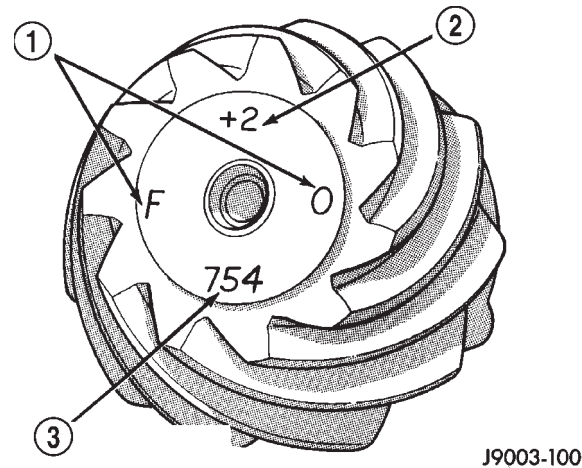
Ring and pinion gears are supplied as matched sets only. The identifying numbers for the ring and pinion gear are etched into the face of each gear (Fig. 4). A plus (+) number, minus (-) number or zero (0) is etched into the face of the pinion gear. This number is the amount (in thousandths of an inch) the depth varies from the standard depth setting of a pinion etched with a (0). The standard setting from the center line of the ring gear to the back face of the pinion is 147.625 mm (5.812 in.). The standard depth provides the best teeth contact pattern. Refer to Backlash and Contact Pattern Analysis Paragraph in this section for additional information.

Compensation for pinion depth variance is achieved with select shims. The shims are placed under the inner pinion bearing cone (Fig. 5).

If a new gear set is being installed, note the depth variance etched into both the original and replacement pinion gear. Add or subtract the thickness of the original depth shims to compensate for the difference in the depth variances. Refer to the Depth Variance charts.

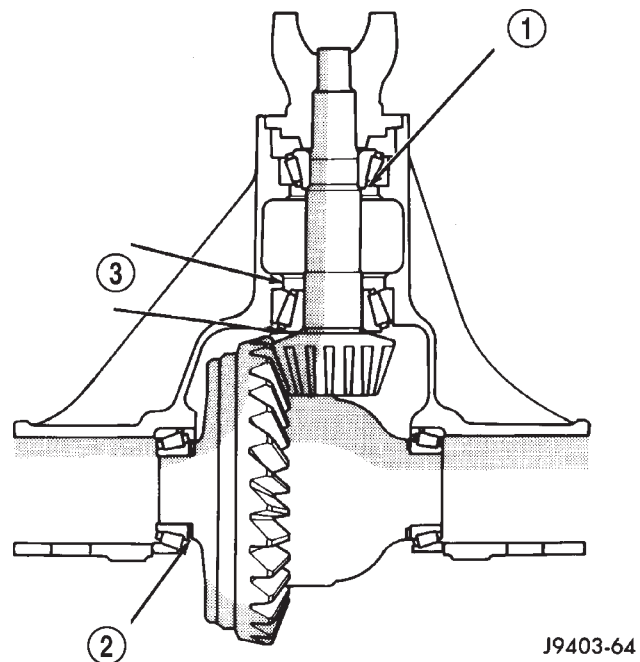
Note where Old and New Pinion Marking columns intersect. Intersecting figure represents plus or minus amount needed.

Note the etched number on the face of the drive pinion gear (-1, -2, 0, +1, +2, etc.). The numbers represent thousands of an inch deviation from the stan-



**Fig. 4 Pinion Gear ID Numbers**

- 1 - PRODUCTION NUMBERS
- 2 - PINION GEAR DEPTH VARIANCE
- 3 - GEAR MATCHING NUMBER



**Fig. 5 Adjustment Shim Locations**

- 1 - PINION BEARING PRELOAD SHIM
- 2 - DIFFERENTIAL BEARING SHIM
- 3 - PINION GEAR DEPTH SHIM

dard. If the number is negative, add that value to the required thickness of the depth shim(s). If the number is positive, subtract that value from the thickness of the depth shim(s). If the number is 0 no change is necessary. Refer to the Pinion Gear Depth Variance Chart.



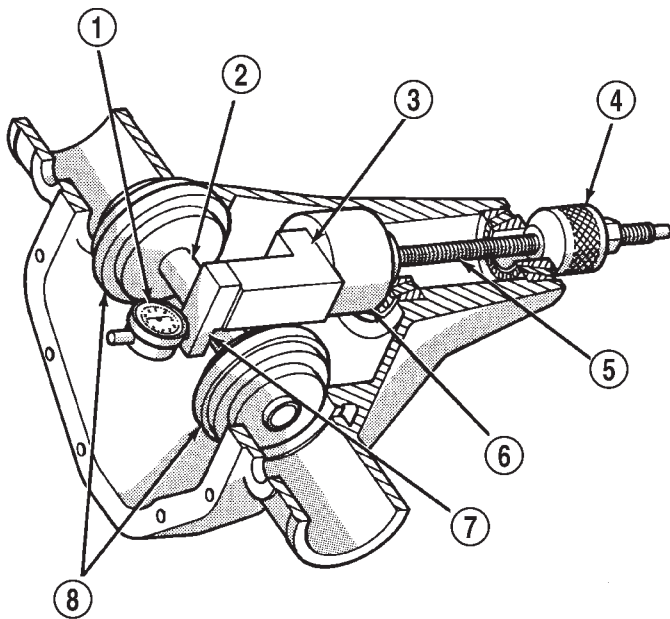
## REAR AXLE - 286RBI (Continued)

## PINION GEAR DEPTH VARIANCE

Original Pinion Gear Depth Variance	Replacement Pinion Gear Depth Variance								
	-4	-3	-2	-1	0	+1	+2	+3	+4
+4	+0.008	+0.007	+0.006	+0.005	+0.004	+0.003	+0.002	+0.001	0
+3	+0.007	+0.006	+0.005	+0.004	+0.003	+0.002	+0.001	0	-0.001
+2	+0.006	+0.005	+0.004	+0.003	+0.002	+0.001	0	-0.001	-0.002
+1	+0.005	+0.004	+0.003	+0.002	+0.001	0	-0.001	-0.002	-0.003
0	+0.004	+0.003	+0.002	+0.001	0	-0.001	-0.002	-0.003	-0.004
-1	+0.003	+0.002	+0.001	0	-0.001	-0.002	-0.003	-0.004	-0.005
-2	+0.002	+0.001	0	-0.001	-0.002	-0.003	-0.004	-0.005	-0.006
-3	+0.001	0	-0.001	-0.002	-0.003	-0.004	-0.005	-0.006	-0.007
-4	0	-0.001	-0.002	-0.003	-0.004	-0.005	-0.006	-0.007	-0.008

## PINION DEPTH MEASUREMENT AND ADJUSTMENT

Measurements are taken with pinion cups and pinion bearings installed in housing. Take measurements with a Pinion Gauge Set 6730 and Dial Indicator C-3339 (Fig. 6).



J9403-45

Fig. 6 Pinion Gear Depth Gauge

- 1 - DIAL INDICATOR
- 2 - ARBOR
- 3 - PINION HEIGHT BLOCK
- 4 - CONE
- 5 - SCREW
- 6 - PINION BLOCK
- 7 - SCOOTER BLOCK
- 8 - ARBOR DISC

(1) Assemble Pinion Height Block 6739, Pinion Block 6738 and rear pinion bearing onto Screw 6741 (Fig. 6).

(2) Insert assembled height gauge components, rear bearing and screw into the housing through pinion bearing cups (Fig. 7).

(3) Install front pinion bearing and Cone 6740 hand tight (Fig. 6).

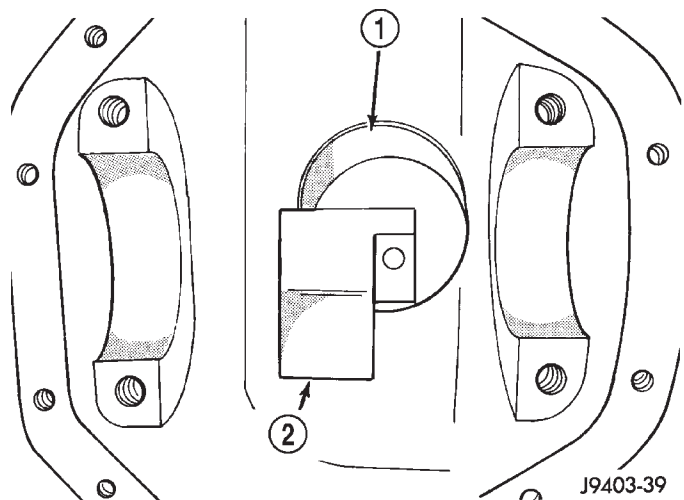


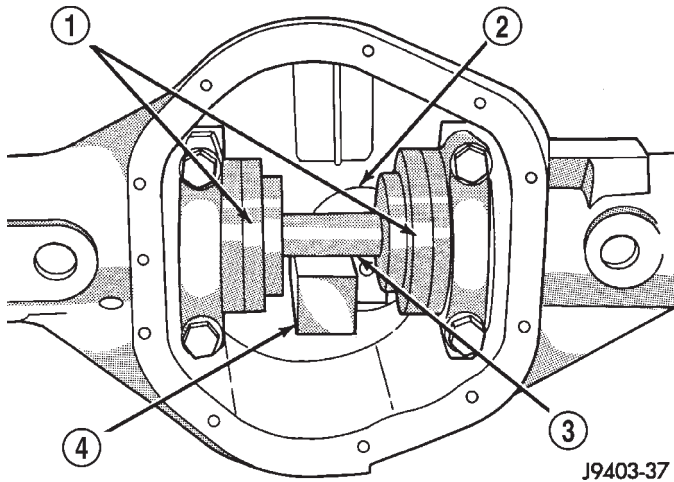
Fig. 7 Pinion Height Block

- 1 - PINION BLOCK
- 2 - PINION HEIGHT BLOCK

(4) Place Arbor Disc 6732 on Arbor D-115-3 in position in the housing side bearing cradles (Fig. 8). Install differential bearing caps on Arbor Discs and snug the bearing cap bolts. Then tighten cap bolts in a criss-cross pattern to 108 N·m (80 ft. lbs.).

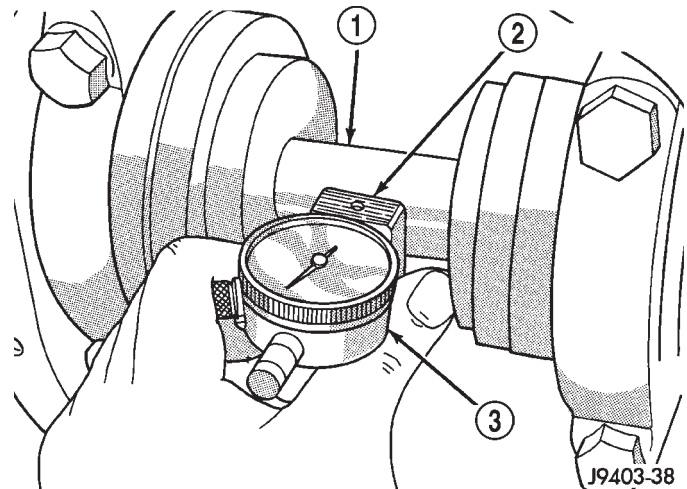
**NOTE:** Arbor Discs 6732 have different step diameters to fit other axle sizes. Pick correct size step for axle being serviced.

## REAR AXLE - 286RBI (Continued)



**Fig. 8 Gauge Tools In Housing**

- 1 - ARBOR DISC
- 2 - PINION BLOCK
- 3 - ARBOR
- 4 - PINION HEIGHT BLOCK



**Fig. 9 Pinion Gear Depth Measurement**

- 1 - ARBOR
- 2 - SCOOTER BLOCK
- 3 - DIAL INDICATOR

(5) Assemble Dial Indicator C-3339 into Scooter Block D-115-2 and secure set screw.

(6) Place Scooter Block/Dial Indicator in position in the housing so dial probe and scooter block are flush against the surface of the pinion height block. Hold scooter block in place and zero the dial indicator face to the pointer. Tighten dial indicator face lock screw.

(7) With scooter block still in position against the pinion height block, slowly slide the dial indicator probe over the edge of the pinion height block. Observe how many revolutions counterclockwise the dial pointer travels (approximately 0.125 in.) to the out-stop of the dial indicator.

(8) Slide the dial indicator probe across the gap between the pinion height block and the arbor bar with the scooter block against the pinion height block (Fig. 9). When the dial probe contacts the arbor bar, the dial pointer will turn clockwise. Bring dial pointer back to zero against the arbor bar, do not turn dial face. Continue moving the dial probe to the crest of the arbor bar and record the highest reading. If the dial indicator can not achieve the zero reading, the rear bearing cup or the pinion depth gauge set is not installed correctly.

(9) Select a shim equal to the dial indicator reading plus the drive pinion gear depth variance number etched in the face of the pinion gear (Fig. 4) using the opposite sign on the variance number. For example, if the depth variance is -2, add +0.002 in. to the dial indicator reading.

(10) Remove the pinion depth gauge components from the axle housing

## DIFFERENTIAL BEARING PRELOAD AND GEAR BACKLASH

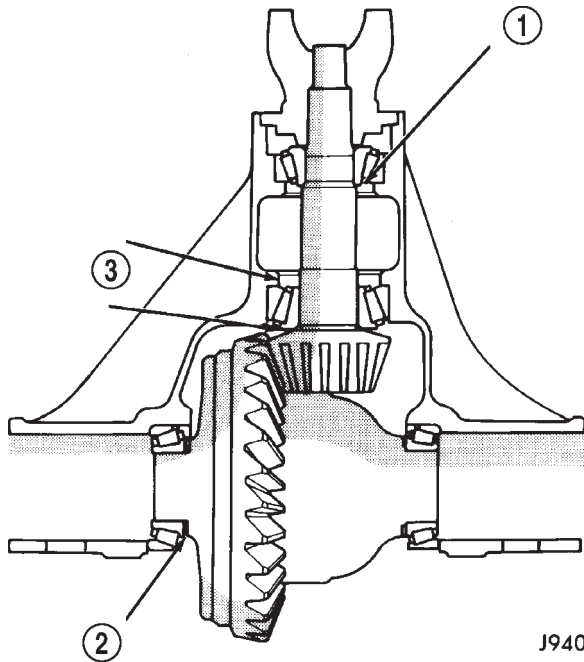
Differential side bearing preload and gear backlash is achieved by selective shims positioned behind the differential side bearing cones. The proper shim thickness can be determined using slip-fit dummy bearings D-346 in place of the differential side bearings and a dial indicator C-3339. Before proceeding with the differential bearing preload and gear backlash measurements, measure the pinion gear depth and prepare the pinion gear for installation. Establishing proper pinion gear depth is essential to establishing gear backlash and tooth contact patterns. After the overall shim thickness to take up differential side play is measured, the pinion gear is installed, and the gear backlash shim thickness is measured. The overall shim thickness is the total of the dial indicator reading and the preload specification added together. The gear backlash measurement determines the thickness of the shim used on the ring gear side of the differential case. Subtract the gear backlash shim thickness from the total overall shim thickness and select that amount for the pinion gear side of the differential (Fig. 10). Differential shim measurements are performed with axle spreader W-129-B removed.

## SHIM SELECTION

**NOTE:** It is difficult to salvage the differential side bearings during the removal procedure. Install replacement bearings if necessary.

(1) Remove differential side bearings from differential case.

## REAR AXLE - 286RBI (Continued)



J9403-64

**Fig. 10 Adjustment Shim Locations**

- 1 - PINION BEARING PRELOAD SHIM
- 2 - DIFFERENTIAL BEARING SHIM
- 3 - PINION GEAR DEPTH SHIM

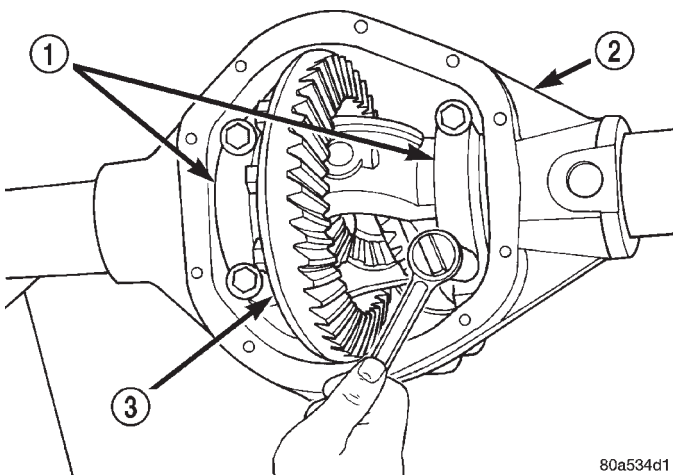
(2) Remove factory installed shims from differential case.

(3) Install ring gear on differential case and tighten bolts to specification, if necessary.

(4) Install dummy side bearings D-346 on differential case.

(5) Install differential case in the housing.

(6) Install the marked bearing caps in their correct positions. Install and snug the bolts (Fig. 11).

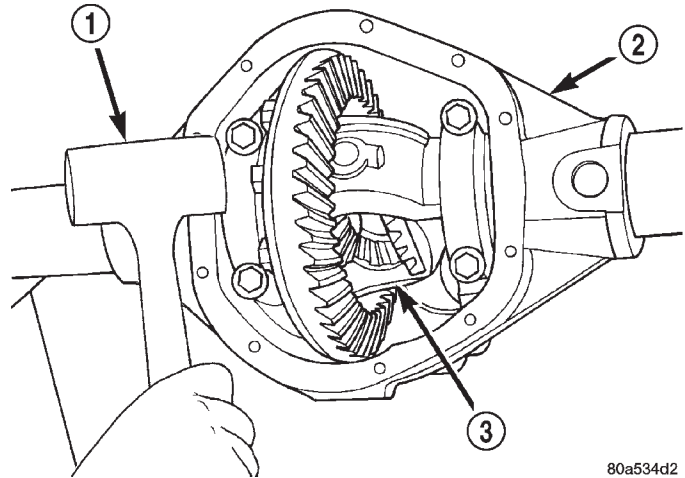


80a534d1

**Fig. 11 Bearing Cap Bolts**

- 1 - BEARING CAP
- 2 - DIFFERENTIAL HOUSING
- 3 - DIFFERENTIAL CASE

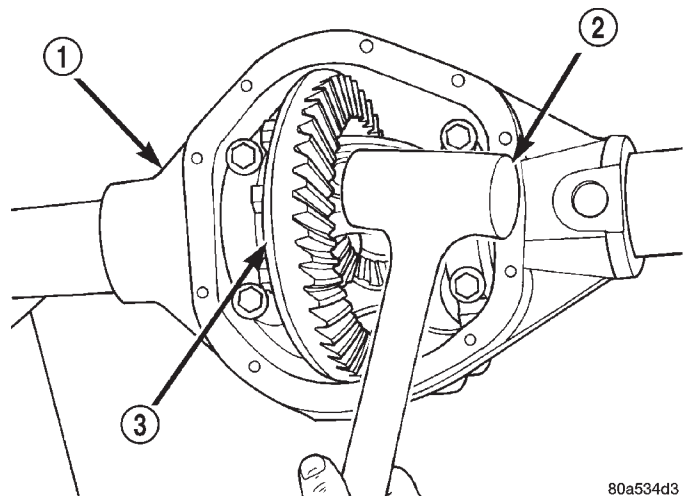
(7) Using a dead-blow hammer, seat the differential dummy bearings to each side of the housing (Fig. 12) and (Fig. 13).



80a534d2

**Fig. 12 Seat Pinion Gear Side Dummy Bearing**

- 1 - DEAD-BLOW HAMMER
- 2 - DIFFERENTIAL HOUSING
- 3 - DIFFERENTIAL CASE



80a534d3

**Fig. 13 Seat Ring Gear Side Dummy Bearing**

- 1 - DIFFERENTIAL HOUSING
- 2 - DEAD-BLOW HAMMER
- 3 - DIFFERENTIAL CASE

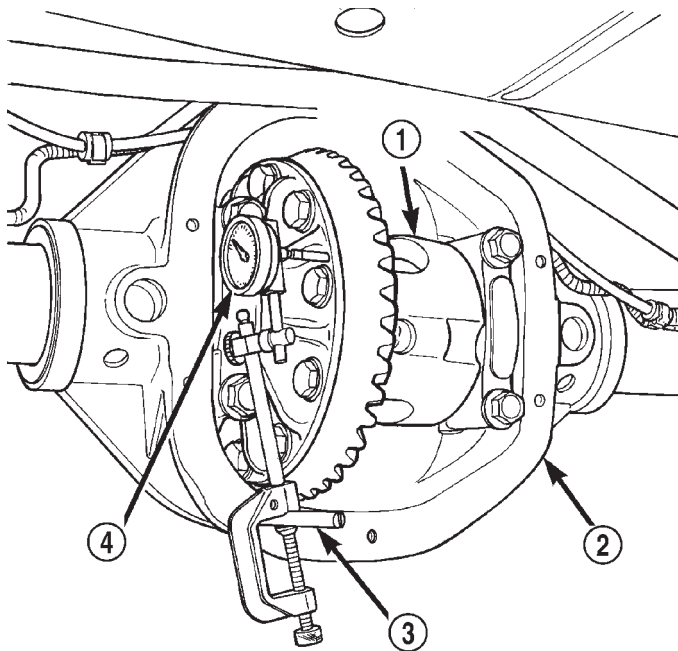
(8) Thread Pilot Stud C-3288-B into rear cover bolt hole below ring gear (Fig. 14).

(9) Attach a dial indicator C-3339 to pilot stud. Position the dial indicator plunger on a flat surface between the ring gear bolt heads (Fig. 14).

(10) Push and hold differential case to pinion gear side of the housing and zero dial indicator (Fig. 15).

(11) Push and hold differential case to ring gear side of the housing and record dial indicator reading (Fig. 16).

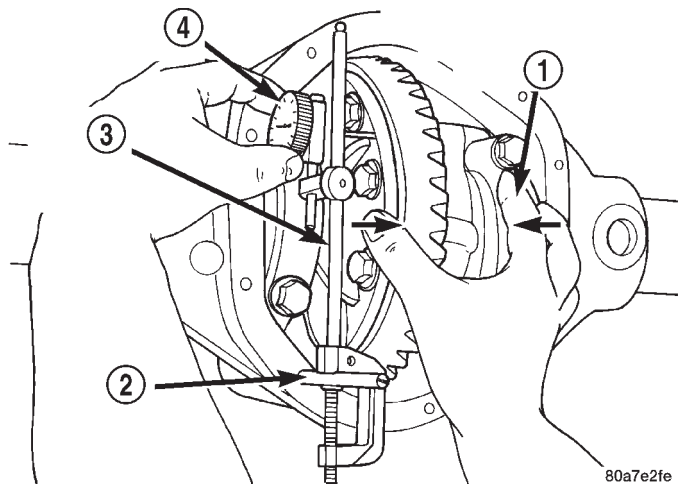
REAR AXLE - 286RBI (Continued)



80a7e2cf

**Fig. 14 Differential Side play Measurement**

- 1 - DIFFERENTIAL CASE
- 2 - DIFFERENTIAL HOUSING
- 3 - PILOT STUD
- 4 - DIAL INDICATOR



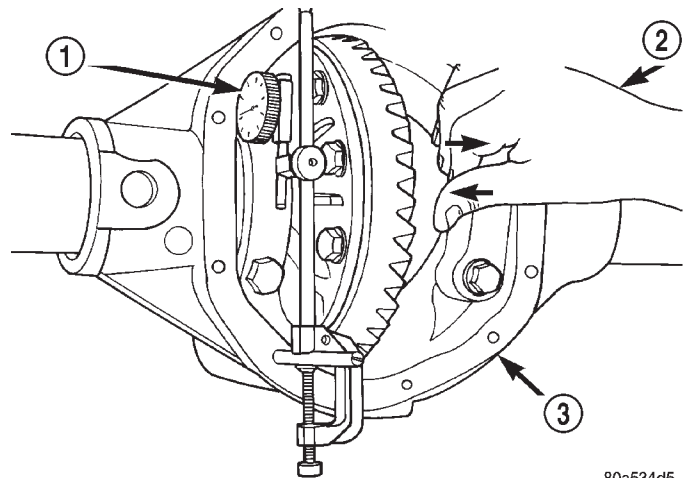
80a7e2fe

**Fig. 15 Differential Case and Dial Indicator**

- 1 - DIFFERENTIAL CASE TO PINION GEAR SIDE
- 2 - PILOT STUD
- 3 - DIAL INDICATOR EXTENSION
- 4 - DIAL INDICATOR FACE

(12) Add 0.254mm (0.010 in.) to the zero end play total. This total represents the thickness of shims to preload the new bearings when the differential is installed.

(13) Rotate dial indicator out of the way on the pilot stud.



80a534d5

**Fig. 16 Differential Case and Dial Indicator**

- 1 - DIAL INDICATOR
- 2 - DIFFERENTIAL CASE TO RING GEAR SIDE
- 3 - DIFFERENTIAL HOUSING

(14) Remove differential case and dummy bearings from the housing.

(15) Install the pinion gear in axle housing. Install the pinion yoke, or flange, and establish the correct pinion rotating torque.

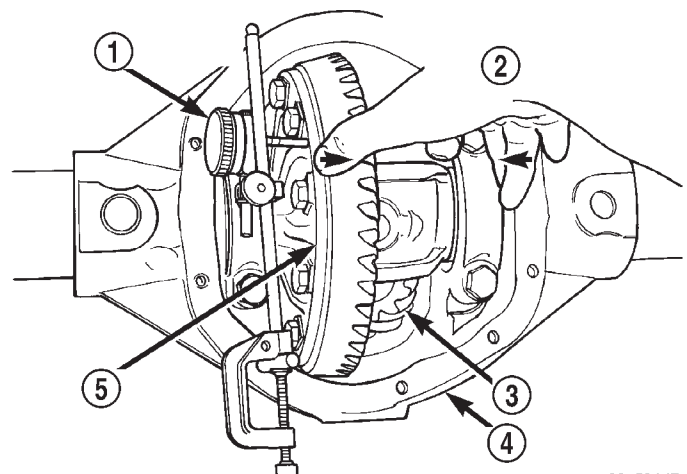
(16) Install differential case and Dummy Bearings D-346 in the housing (without shims), install bearing caps and tighten bolts snug .

(17) Seat ring gear side dummy bearing (Fig. 12).

(18) Position the dial indicator plunger on a flat surface between the ring gear bolt heads. (Fig. 14).

(19) Push and hold differential case toward pinion gear (Fig. 17).

(20) Zero dial indicator face to pointer (Fig. 17).



80a534d7

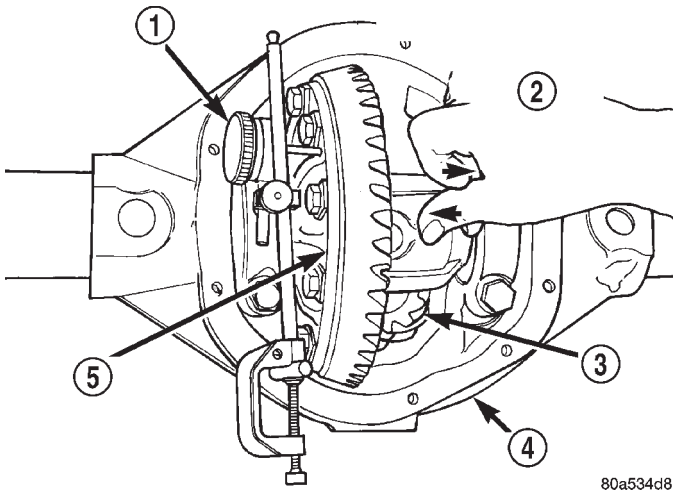
**Fig. 17 Differential Case and Dial Indicator**

- 1 - DIAL INDICATOR FACE
- 2 - DIFFERENTIAL CASE TO PINION GEAR SIDE
- 3 - PINION GEAR
- 4 - DIFFERENTIAL HOUSING
- 5 - DIFFERENTIAL CASE



## REAR AXLE - 286RBI (Continued)

(21) Push and hold differential case to ring gear side of the housing and record dial indicator reading (Fig. 18).



**Fig. 18 Differential Case and Dial Indicator**

- 1 - DIAL INDICATOR
- 2 - DIFFERENTIAL CASE TO RING GEAR SIDE
- 3 - PINION GEAR
- 4 - DIFFERENTIAL HOUSING
- 5 - DIFFERENTIAL CASE

(22) This is the thickness shim required on the ring gear side of the differential case to achieve proper backlash.

(23) Subtract the backlash shim thickness from the total preload shim thickness. The remainder is the shim thickness required on the pinion side of the housing.

(24) Rotate dial indicator out of the way on pilot stud.

(25) Remove differential case and dummy bearings from the housing.

(26) Install side bearing shims on differential case hubs.

(27) Install side bearings and cups on differential case.

(28) Install spreader W-129-B on the housing and spread housing enough to install differential case.

**CAUTION:** Do not spread over 0.50 mm (0.020 in.). If the housing is over-spread, it could be distorted or damaged.

(29) Install differential case in the housing.

(30) Remove spreader from the housing.

(31) Rotate the differential case several times to seat the side bearings.

(32) Position the indicator plunger against a ring gear tooth (Fig. 19).

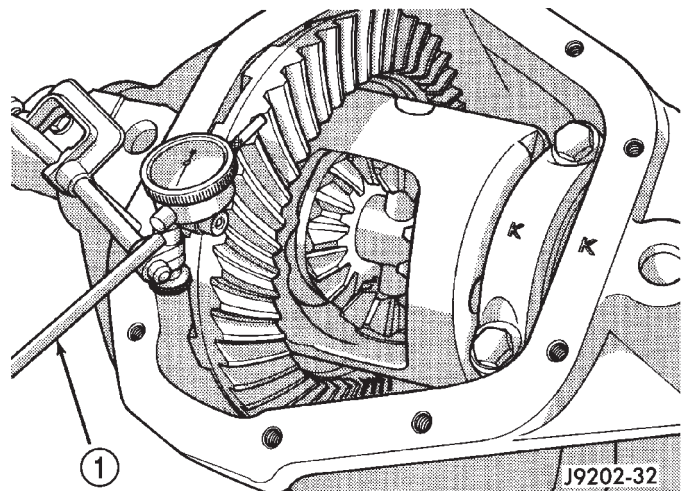
(33) Push and hold ring gear upward while not allowing the pinion gear to rotate.

(34) Zero dial indicator face to pointer.

(35) Push and hold ring gear downward while not allowing the pinion gear to rotate. Dial indicator reading should be between 0.12 mm (0.005 in.) and 0.20 mm (0.008 in.). If backlash is not within specifications transfer the necessary amount of shim thickness from one side of the axle housing to the other (Fig. 20).

(36) Verify differential case and ring gear runout by measuring ring to pinion gear backlash at several locations around the ring gear. Readings should not vary more than 0.05 mm (0.002 in.). If readings vary more than specified, the ring gear or the differential case is defective.

After the proper backlash is achieved, perform Gear Contact Pattern Analysis procedure.

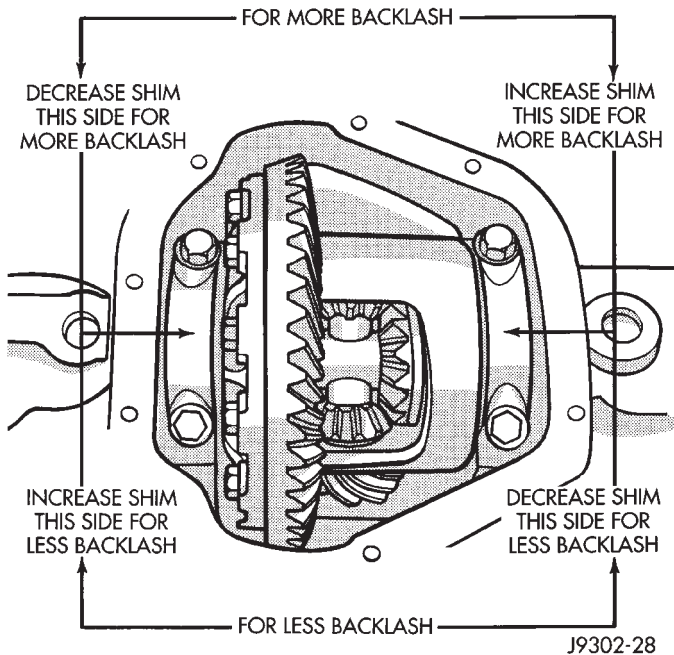


**Fig. 19 Ring Gear Backlash Measurement**

- 1 - DIAL INDICATOR



## REAR AXLE - 286RBI (Continued)



**Fig. 20 Backlash Shim Adjustment**

### GEAR CONTACT PATTERN ANALYSIS

The ring gear and pinion teeth contact patterns will show if the pinion depth is correct in the axle housing. It will also show if the ring gear backlash has been adjusted correctly. The backlash can be adjusted within specifications to achieve desired tooth contact patterns.

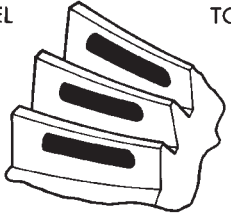
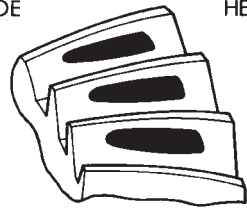
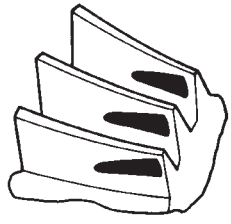
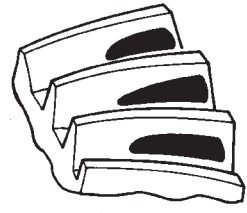
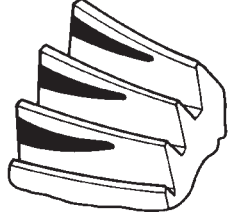
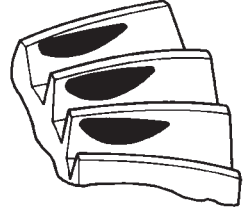
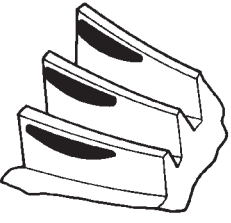
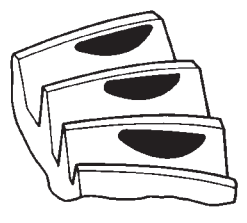
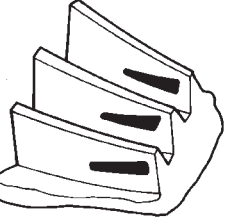
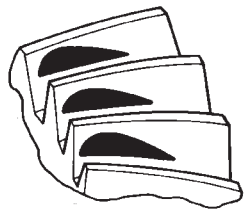
(1) Apply a thin coat of hydrated ferric oxide, or equivalent, to the drive and coast side of the ring gear teeth.

(2) Wrap, twist, and hold a shop towel around the pinion yoke to increase the turning resistance of the pinion. This will provide a more distinct contact pattern.

(3) Using a boxed end wrench on a ring gear bolt, Rotate the differential case one complete revolution in both directions while a load is being applied from shop towel.

The areas on the ring gear teeth with the greatest degree of contact against the pinion teeth will squeeze the compound to the areas with the least amount of contact. Note and compare patterns on the ring gear teeth to Gear Tooth Contact Patterns chart (Fig. 21) and adjust pinion depth and gear backlash as necessary.

## REAR AXLE - 286RBI (Continued)

<p>DRIVE SIDE OF RING GEAR TEETH</p> <p>HEEL                      TOE</p> 	<p>COAST SIDE OF RING GEAR TEETH</p> <p>TOE                      HEEL</p> 	<p>DESIRABLE CONTACT PATTERN. PATTERN SHOULD BE CENTERED ON THE DRIVE SIDE OF TOOTH. PATTERN SHOULD BE CENTERED ON THE COAST SIDE OF TOOTH, BUT MAY BE SLIGHTLY TOWARD THE TOE. THERE SHOULD ALWAYS BE SOME CLEARANCE BETWEEN CONTACT PATTERN AND TOP OF THE TOOTH.</p>
		<p>RING GEAR BACKLASH CORRECT. <b>THINNER</b> PINION GEAR DEPTH SHIM REQUIRED.</p>
		<p>RING GEAR BACKLASH CORRECT. <b>THICKER</b> PINION GEAR DEPTH SHIM REQUIRED.</p>
		<p>PINION GEAR DEPTH SHIM CORRECT. <b>DECREASE</b> RING GEAR BACKLASH.</p>
		<p>PINION GEAR DEPTH SHIM CORRECT. <b>INCREASE</b> RING GEAR BACKLASH.</p>

J9003-24

Fig. 21 Gear Tooth Contact Pattern

REAR AXLE - 286RBI (Continued)

## SPECIFICATIONS

## REAR AXLE - 286RBI

## AXLE SPECIFICATIONS

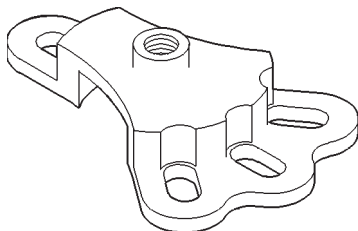
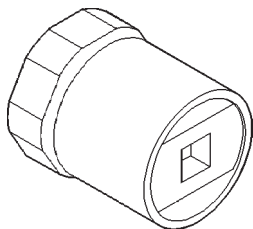
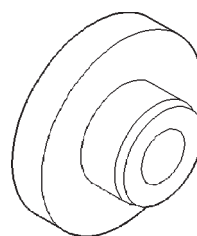
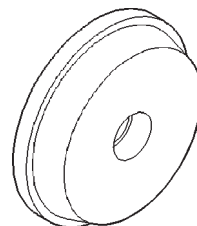
DESCRIPTION	SPECIFICATION
Axle Ratio	3.55, 4.10
Ring Gear Diameter	286 mm (11.25 in.)
Ring Gear Backlash	0.12-0.20 mm (0.005-0.008 in.)
Pinion Gear Standard Depth	147.625 mm (5.812 in.)
Pinion Bearing Preload - Original Bearings	1-2 N-m (10-20 in. lbs.)
Pinion Bearing Preload - New Bearings	2.8-5.1 N-m (25-45 in. lbs.)

## TORQUE SPECIFICATIONS

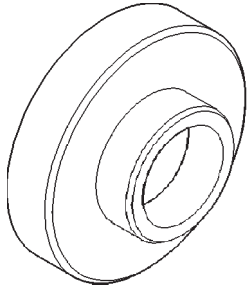
DESCRIPTION	N-m	Ft. Lbs.	In. Lbs.
Fill Hole Plug	34	25	-
Differential Cover Bolts	47	35	-
Bearing Cap Bolts	108	80	-
Ring Gear Bolt	298	220	-
Pinion Nut	597-678	440-500	-
Axle Shaft Bolts	128	95	-
Hub Bearing Nut	163-190	120-140	-
Trac-Loc <sup>™</sup> Case Bolts	122-136	90-100	-

## SPECIAL TOOLS

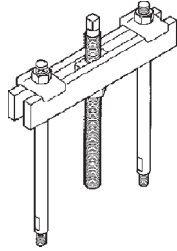
## REAR AXLE - 286 RBI

**Puller, Hub 6790****Wrench DD-1241-JD****Installer 5064****Installer C-4308**

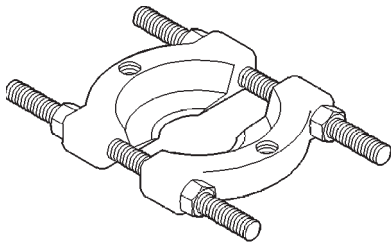
REAR AXLE - 286RBI (Continued)



**Installer, Seal 8152**

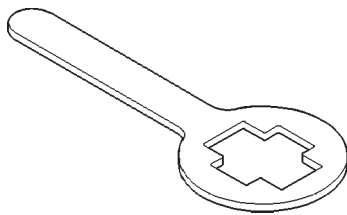


**Bridge 938**

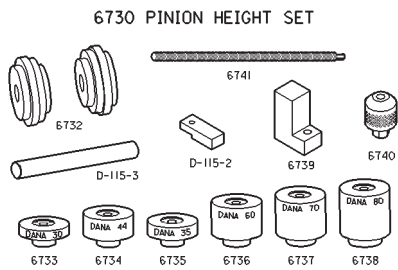


113C-801098c3

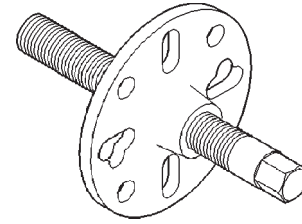
**Splitter, Bearing 1130**



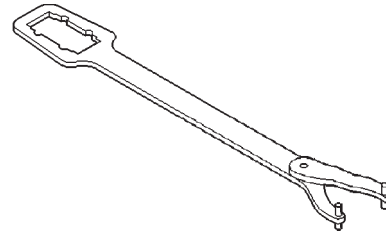
**Holder, Yoke 6719**



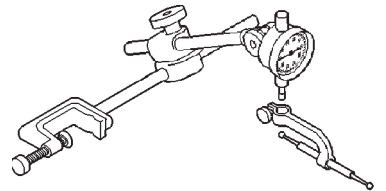
**Gauge, Pinion Depth Setting 6730**



**Puller C-452**

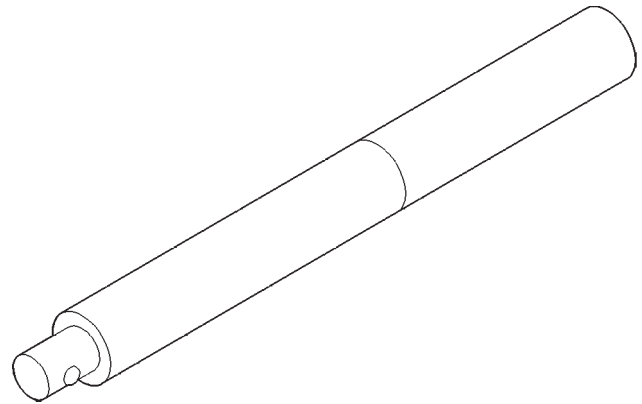


**Wrench C-3281**

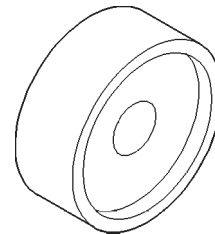


8011d42b

**Dial Indicator Set C-3339**

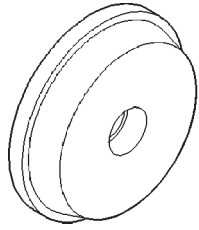


**Handle C-4171**

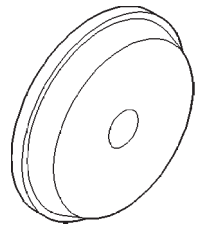


**Installer C-4190**

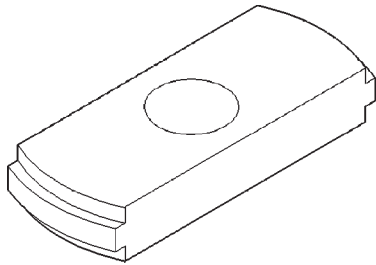
REAR AXLE - 286RBI (Continued)



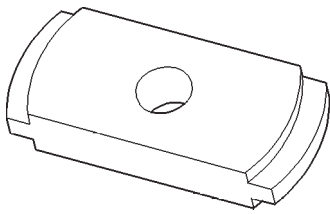
**Installer C-4308**



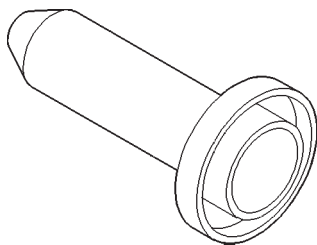
**Installer C-4204**



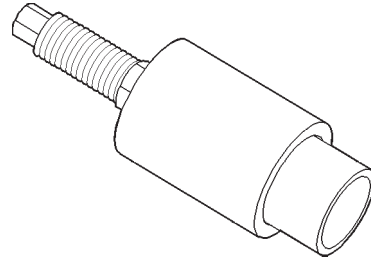
**Remover C-4307**



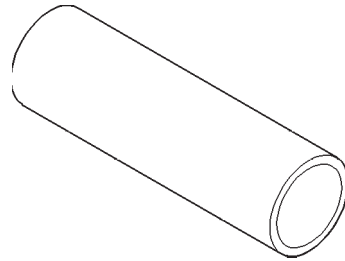
**Remover D-159**



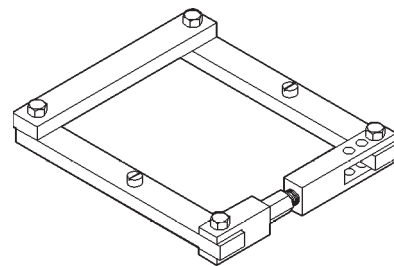
**Installer D-187-B**



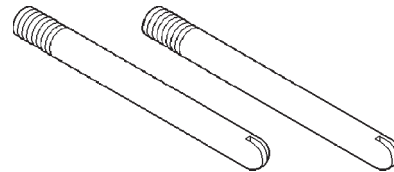
**Installer D-191**



**Installer D-389**



**Spreader W-129-B**



**Pilot Studs C-3288-B**



## AXLE SHAFTS

### REMOVAL

- (1) Remove the axle shaft flange bolts.
- (2) Slide the axle shaft out from the axle tube.

### INSTALLATION

- (1) Clean the gasket contact surface area on the flange with an appropriate solvent. Install a new flange gasket and slide the axle shaft into the tube.
- (2) Install the bolts and tighten to 129 N·m (95 ft. lbs.).

## AXLE BEARINGS

### REMOVAL

- (1) Remove wheel and tire assembly.
- (2) Remove brake drum.
- (3) Remove the axle shaft.
- (4) Remove the lock wedge and adjustment nut. Use Socket DD-1241-JD to remove the adjustment nut.
- (5) Remove the hub assembly. The outer axle bearing will slide out as the hub is being removed.
- (6) Remove inner grease seal and discard. Use Installer 5064 and Handle C-4171 to drive grease seal and inner axle bearing from the hub.
- (7) Remove the bearing cups from the hub bore. Use a brass drift, or an appropriate removal tool, to tap out the cups.

### INSTALLATION

- (1) Thoroughly clean both axle bearings and interior of the hub with an appropriate cleaning solvent.
- (2) Install the bearing cups. Use Installer 8153 and Handle C-4171 to install the bearing cups.
- (3) Apply lubricant to surface area of the bearing cup.
- (4) Install the inner axle bearing in the hub.
- (5) Install a new bearing grease seal. Use Installer 8152 and Handle C-4171 to install the grease seal.
- (6) Inspect the bearing and seal contact surfaces on the axle tube spindle for burrs and/or roughness. Remove all the rough contact surfaces from the axle spindle. Apply a coating of multi-purpose NLGI, grade 2, EP-type lubricant to the axle.

**CAUTION:** Use care to prevent the bearing grease seal from contacting the axle tube spindle threads during installation. Otherwise, the seal could be damaged.

- (7) Carefully slide the hub onto the axle.
- (8) Install the outer axle bearing.

(9) Install the hub bearing adjustment nut. Use Socket DD-1241-JD to install the adjustment nut.

(10) Tighten the adjustment nut to 163-190 N·m (120-140 ft. lbs.) while rotating the wheel.

(11) Loosen the adjustment nut 1/8 of-a-turn to provide 0.001-inch to 0.010-inch wheel bearing end play.

(12) Tap the locking wedge into the spindle keyway and adjustment nut. Try to ensure that the locking wedge is installed into a new position in the adjustment nut.

(13) Install the axle shaft.

(14) Install the brake drum.

(15) Install the wheel and tire assembly.

## PINION SEAL

### REMOVAL

- (1) Raise and support the vehicle.
- (2) Scribe a mark on the universal joint, pinion yoke, and pinion shaft for reference.
- (3) Disconnect the propeller shaft from the pinion yoke. Secure the propeller shaft in an upright position to prevent damage to the rear universal joint.
- (4) Remove the wheel and tire assemblies.
- (5) Remove the brake drums to prevent any drag. The drag may cause a false bearing preload torque measurement.
- (6) Rotate the pinion yoke three or four times.
- (7) Measure the amount of torque necessary to rotate the pinion gear with a (in. lbs.) dial-type torque wrench. Record the torque reading for installation reference.
- (8) Hold the yoke with Wrench 6719. Remove the pinion shaft nut and washer.
- (9) Remove the yoke with Remover C-452 (Fig. 22).
- (10) Remove the pinion shaft seal with suitable pry tool or slide-hammer mounted screw.

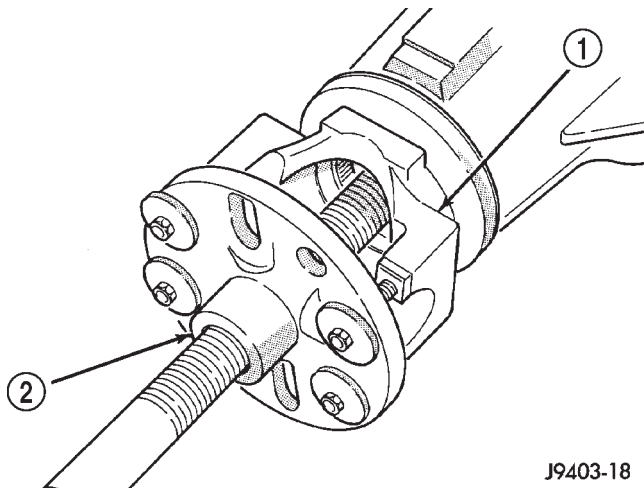
### INSTALLATION

- (1) Clean the seal contact surface in the housing bore.
- (2) Examine the splines on the pinion shaft for burrs or wear. Remove any burrs and clean the shaft.
- (3) Inspect pinion yoke for cracks, worn splines and worn seal contact surface. Replace yoke if necessary.

**NOTE:** The outer perimeter of the seal is pre-coated with a special sealant. An additional application of sealant is not required.

- (4) Apply a light coating of gear lubricant on the lip of pinion seal.
- (5) Install new pinion shaft seal with an appropriate Installer.

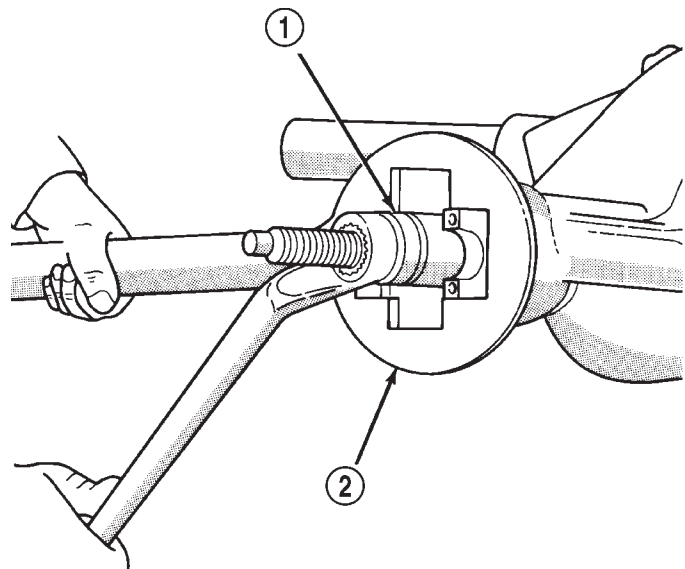
## PINION SEAL (Continued)



J9403-18

**Fig. 22 Yoke Removal**

- 1 - PINION YOKE  
2 - REMOVER C452



J9402-61

**Fig. 23 Yoke Installation**

- 1 - YOKE INSTALLER  
2 - YOKE HOLDER

**NOTE:** The seal is correctly installed when the seal flange contacts the face of the differential housing flange.

(6) Position pinion yoke on the end of the shaft with the reference marks aligned.

(7) Seat yoke on pinion shaft with Installer D-191 and Yoke Holder 6719 (Fig. 23).

(8) Remove the tools and install the pinion yoke washer and nut.

(9) Hold pinion yoke with Yoke Holder 6719 and tighten shaft nut to 597 N·m (440 ft. lbs.) (Fig. 24). Rotate pinion shaft several revolutions to ensure the bearing rollers are seated.

(10) Rotate the pinion shaft using an inch pound torque wrench. Rotating resistance torque should be equal to the reading recorded, plus a small amount for the drag the new seal will have (Fig. 25).

**NOTE:** The bearing rotating torque should be constant during a complete revolution of the pinion. If the rotating torque varies, this indicates a binding condition.

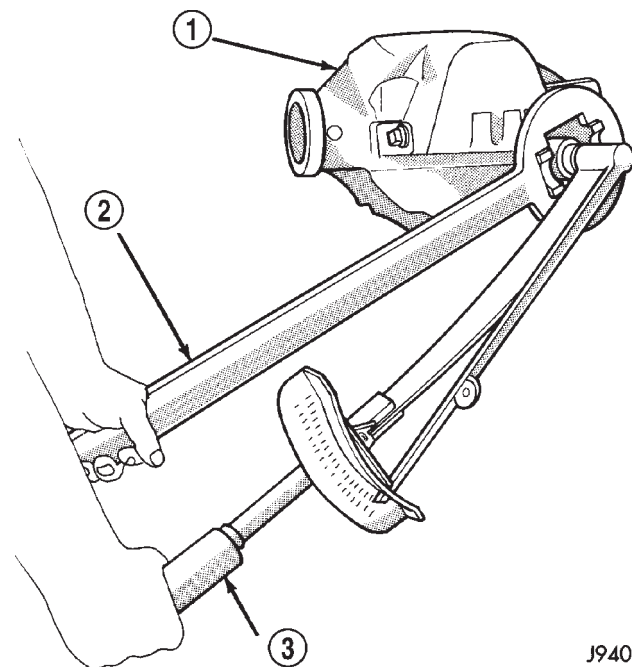
(11) Install the propeller shaft with the installation reference marks aligned.

(12) Tighten the universal joint yoke clamp screws to 19 N·m (14 ft. lbs.).

(13) Install the brake drums.

(14) Add gear lubricant to the differential housing, if necessary. Refer to the Lubricant Specifications for gear lubricant requirements.

(15) Install wheel and tire assemblies and lower the vehicle.

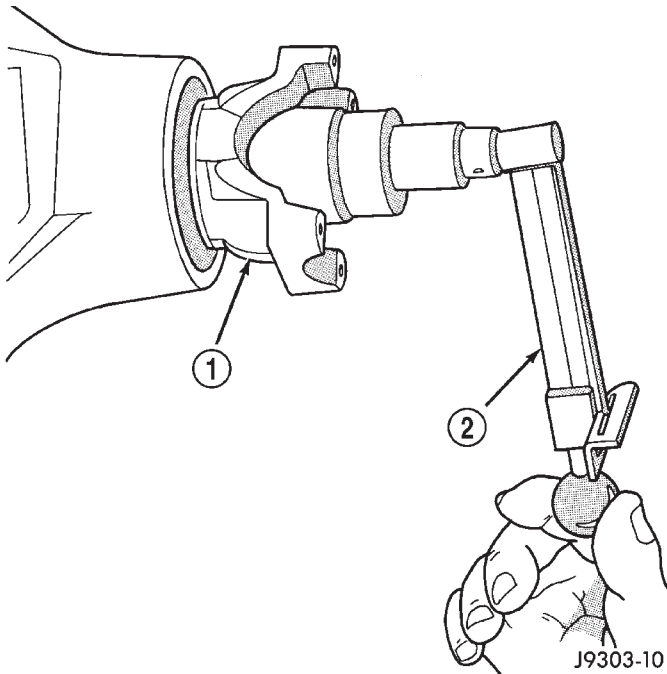


J9402-62

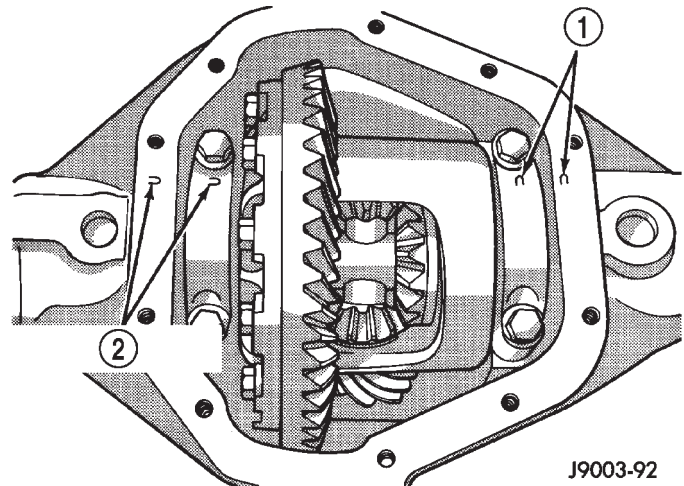
**Fig. 24 Tightening Pinion Shaft Nut**

- 1 - DIFFERENTIAL HOUSING  
2 - YOKE HOLDER  
3 - TORQUE WRENCH

## PINION SEAL (Continued)

**Fig. 25 Check Pinion Rotation Torque**

- 1 - PINION YOKE  
2 - INCH POUND TORQUE WRENCH

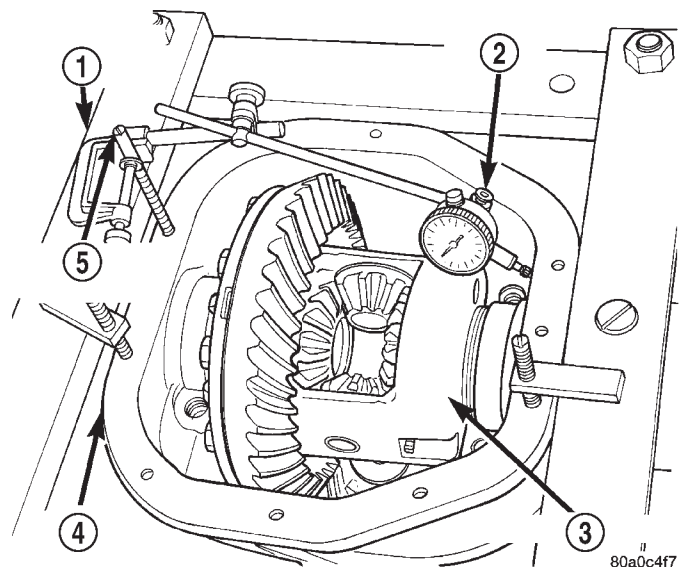
**Fig. 26 Bearing Cap Identification**

- 1 - REFERENCE LETTERS  
2 - REFERENCE LETTERS

## DIFFERENTIAL

## REMOVAL

- (1) Raise and support the vehicle.
- (2) Remove the lubricant fill hole plug from the differential housing cover.
- (3) Remove differential housing cover and drain the lubricant from the housing.
- (4) Clean the housing cavity with a flushing oil, light engine oil or lint free cloth. **Do not use water, steam, kerosene or gasoline for cleaning.**
- (5) Remove axle shafts.
- (6) Note the orientation of the installation reference letters stamped on the bearing caps and housing machined sealing surface (Fig. 26).
- (7) Remove the differential bearing caps.
- (8) Position Spreader W-129-B with the tool dowel pins seated in the locating holes (Fig. 27).
- (9) Install the hold down clamps and tighten the tool turnbuckle finger-tight.
- (10) Install a Pilot Stud C-3288-B at the left side of the differential housing. Attach dial indicator to housing pilot stud. Load the indicator plunger against the opposite side of the housing (Fig. 27) and zero the indicator.
- (11) Spread the housing enough to remove the case from the housing. Measure the distance with the dial indicator (Fig. 27).

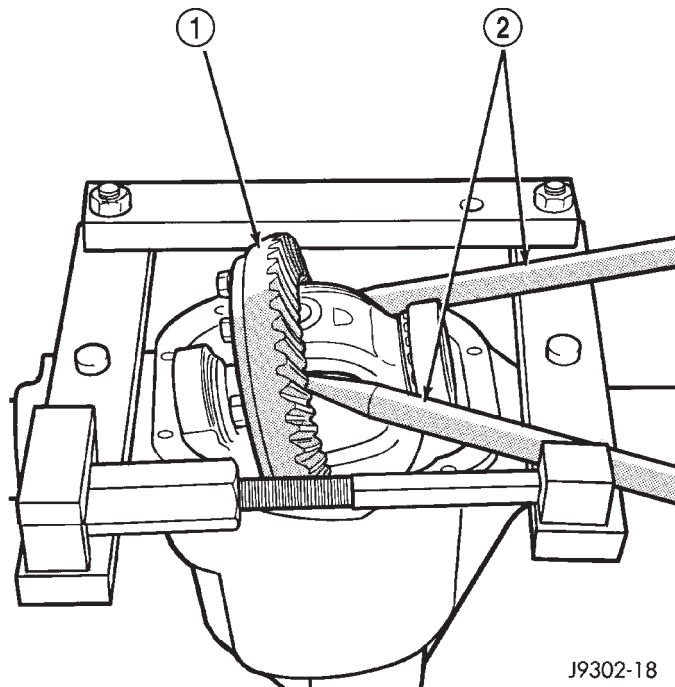
**Fig. 27 Spread Differential Housing**

- 1 - SPREADER  
2 - DIAL INDICATOR  
3 - DIFFERENTIAL  
4 - DIFFERENTIAL HOUSING  
5 - PILOT STUD

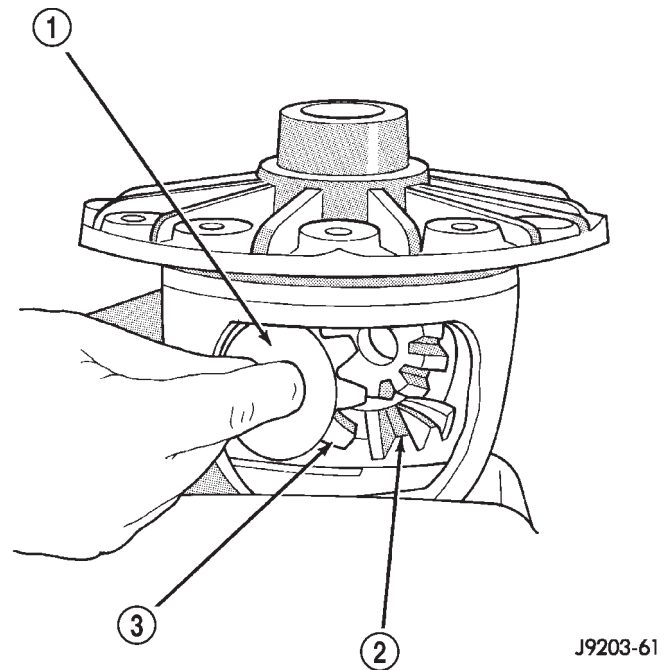
**CAUTION:** Do not spread over 0.50 mm (0.020 in). If the housing is over-spread, it could be distorted or damaged.

- (12) Remove the dial indicator.
- (13) Pry the differential case loose from the housing. To prevent damage, pivot on housing with the end of the pry bar against spreader (Fig. 28).
- (14) Remove the case from housing. Tag bearing cups to indicate their location.

## DIFFERENTIAL (Continued)

**Fig. 28 Differential Removal**

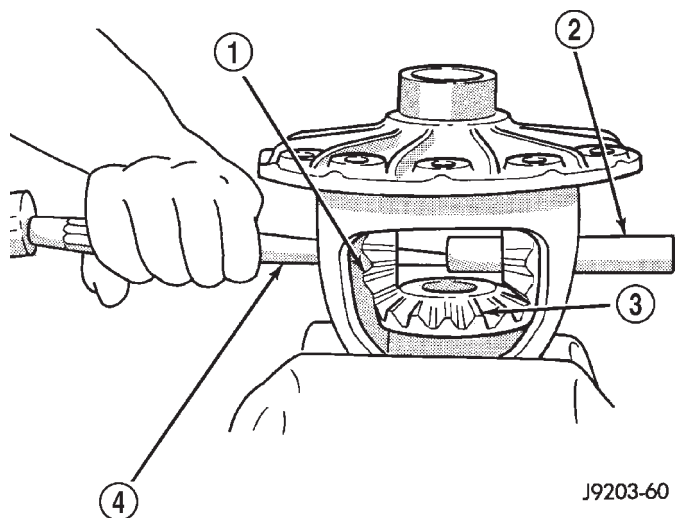
- 1 - DIFFERENTIAL
- 2 - PRY BAR

**Fig. 30 Pinion Mate/Side Gear**

- 1 - THRUST WASHER
- 2 - SIDE GEAR
- 3 - PINION MATE GEAR

**DISASSEMBLY**

- (1) Remove roll-pin holding mate shaft in housing.
- (2) Remove pinion gear mate shaft (Fig. 29).
- (3) Rotate the differential side gears and remove the pinion mate gears and thrust washers (Fig. 30).

**Fig. 29 Pinion Mate Shaft**

- 1 - PINION MATE GEAR
- 2 - PINION MATE SHAFT
- 3 - SIDE GEAR
- 4 - DRIFT

- (4) Remove the differential side gears and thrust washers.

**ASSEMBLY**

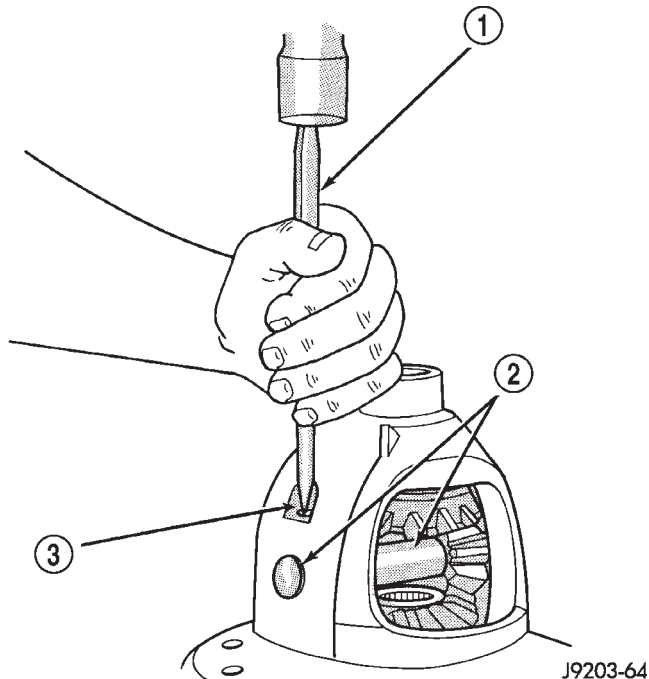
- (1) Install the differential side gears and thrust washers.
- (2) Install the pinion mate gears and thrust washers.
- (3) Install the pinion gear mate shaft.
- (4) Align the hole in the pinion gear mate shaft with the hole in the differential case.
- (5) Install and seat the pinion mate shaft roll-pin in the differential case and mate shaft with a punch and hammer (Fig. 31). Peen the edge of the roll-pin hole in the differential case slightly in two places, 180° apart.
- (6) Lubricate all differential components with hypoid gear lubricant.

**INSTALLATION**

**NOTE:** If replacement differential bearings or differential case are being installed, differential side bearing shim requirements may change. Refer to **Adjustments (Differential Bearing Preload and Gear Backlash)** procedures to determine proper shim selection.



## DIFFERENTIAL (Continued)



**Fig. 31 Pinion Mate Shaft Roll-Pin**

- 1 - PUNCH
- 2 - PINION MATE SHAFT
- 3 - MATE SHAFT LOCKPIN

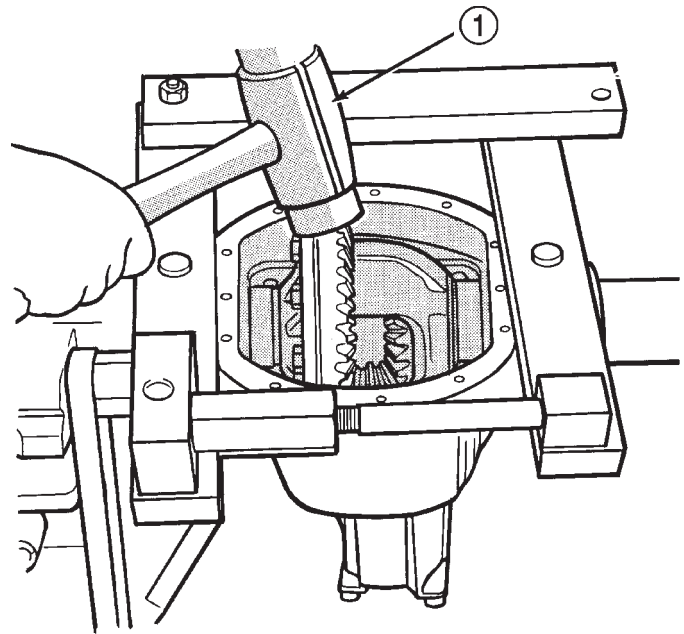
(1) Position Spreader W-129-B with the tool dowel pins seated in the locating holes. Install the hold down clamps and tighten the tool turnbuckle finger-tight.

(2) Install a Pilot Stud C-3288-B at the left side of the differential housing and attach dial indicator to the pilot stud. Load the indicator plunger against the opposite side of the housing and zero the dial indicator.

(3) Spread the housing enough to install the case in the housing. Measure the distance with the dial indicator.

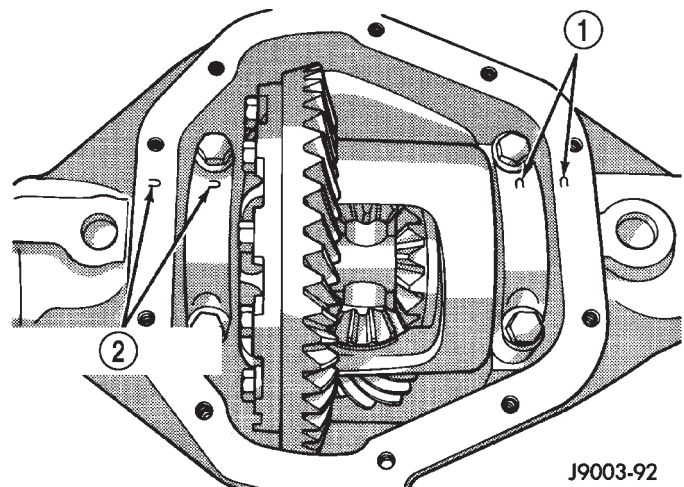
**CAUTION: Do not spread over 0.50 mm (0.020 in). If the housing is over-spread, it could be distorted or damaged.**

- (4) Remove the dial indicator.
- (5) Install differential into the housing. Tap the differential case with a rawhide/rubber hammer to ensure the bearings are seated in housing (Fig. 32).
- (6) Remove the spreader.
- (7) Install bearing caps in their original locations (Fig. 33) and tighten bearing cap bolts to 109 N·m (80 ft. lbs.).
- (8) Install axle shafts.
- (9) Install the hub bearings.
- (10) Apply a bead of Mopar Silicone Rubber Sealant or equivalent to the housing cover (Fig. 34).



**Fig. 32 Differential Case**

- 1 - RAWHIDE HAMMER



**Fig. 33 Bearing Cap Reference**

- 1 - REFERENCE LETTERS
- 2 - REFERENCE LETTERS

**Install the housing cover within 5 minutes after applying the sealant.**

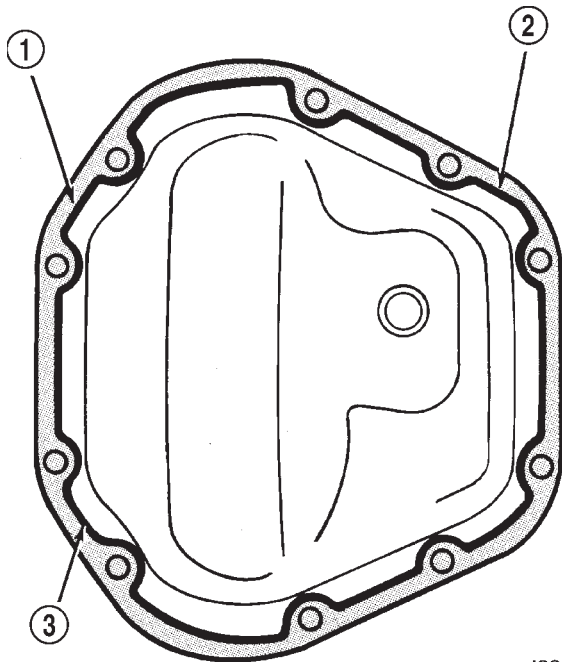
(11) Install the cover and any identification tag. Tighten the cover bolts in a criss-cross pattern to 47 N·m (35 ft. lbs.).

(12) Refill the differential with Mopar Hypoid Gear Lubricant or equivalent to bottom of the fill plug hole. Refer to the Lubricant Specifications for correct quantity and type.

(13) Install the fill hole plug and tighten to 34 N·m (25 ft. lbs.).



## DIFFERENTIAL (Continued)



J9302-30

**Fig. 34 Differential Cover**

- 1 - SEALANT SURFACE
- 2 - SEALANT
- 3 - SEALANT THICKNESS

(14) Remove support and lower vehicle.

## DIFFERENTIAL - TRAC-LOK

## DIAGNOSIS AND TESTING - TRAC-LOK™

The most common problem is a chatter noise when turning corners. Before removing a Trac-lok™ unit for repair, drain, flush and refill the axle with the specified lubricant. A container of Mopar Trac-lok™ Lubricant (friction modifier) should be added after repair service or during a lubricant change.

After changing the lubricant, drive the vehicle and make 10 to 12 slow, figure-eight turns. This maneuver will pump lubricant through the clutches. This will correct the condition in most instances. If the chatter persists, clutch damage could have occurred.

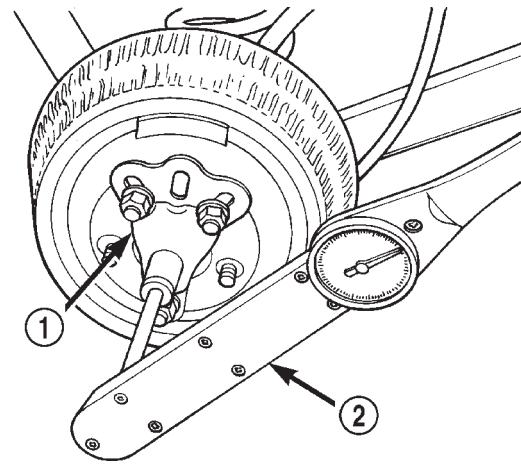
## DIFFERENTIAL TEST

The differential can be tested without removing the differential case by measuring rotating torque. Make sure brakes are not dragging during this measurement.

- (1) Place blocks in front and rear of both front wheels.
- (2) Raise one rear wheel until it is completely off the ground.
- (3) Engine off, transmission in neutral, and parking brake off.

(4) Remove wheel and bolt Special Tool 6790 or equivalent tool to studs.

(5) Use torque wrench on special tool to rotate wheel and read rotating torque (Fig. 35).



80a4d327

**Fig. 35 Trac-lok™ Test - Typical**

(6) If rotating torque is less than 22 N·m (30 ft. lbs.) or more than 271 N·m (200 ft. lbs.) on either wheel the unit should be serviced.

## DISASSEMBLY

The Trac-Lok™ differential on this axle has a one-piece cross shaft and uses one dished disc, regular 5 disc and 7 plates.

**NOTE: Pay attention to the clutch pack arrangement during disassembly. Note the direction of the concave and convex side of the plates and discs.**

- (1) Mark the ring gear half and cover half for installation reference (Fig. 36).
- (2) Remove case attaching bolts and remove the button cover half (Fig. 37).
- (3) Remove top clutch pack.
- (4) Remove top side gear clutch ring.
- (5) Remove top side gear.
- (6) Remove pinion mate gears and cross shaft.
- (7) Remove the same parts listed above from the ring gear flange half of the case. Keep these parts with the flange cover half for installation in their original positions.

## ASSEMBLY

The Trac-Lok™ differential for this axle has a one-piece cross shaft and uses one dished disc, 5 regular disc and 7 plates for each clutch pack.

**NOTE: The clutch discs are replaceable as complete sets only. If one clutch disc pack is damaged, both packs must be replaced.**

## DIFFERENTIAL - TRAC-LOK (Continued)

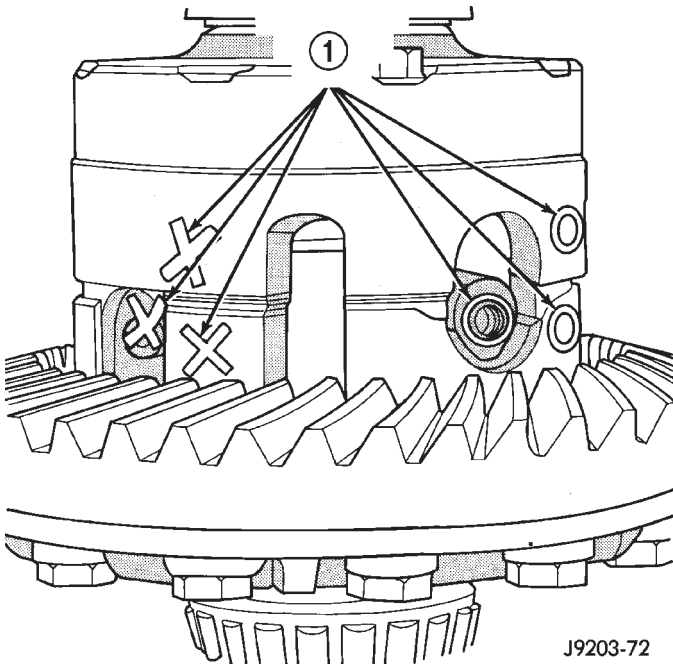


Fig. 36 Case Marked

1 - REFERENCE MARKS

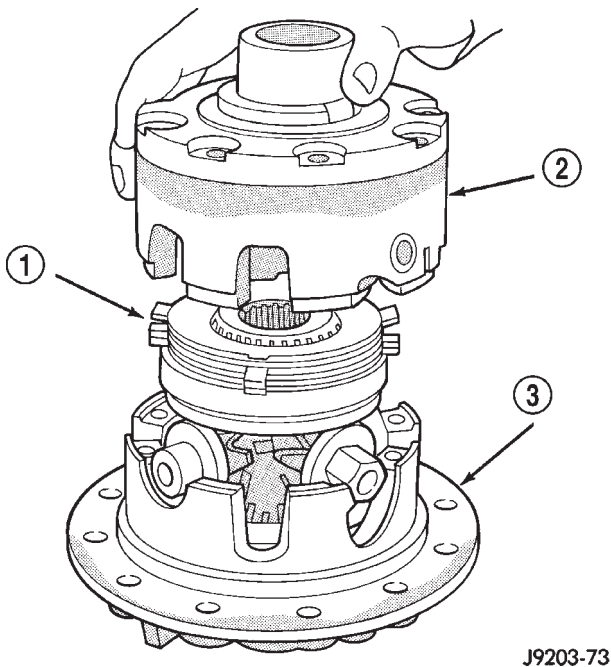


Fig. 37 Cover Half Removal

1 - CLUTCH PLATES  
 2 - BUTTON HALF  
 3 - FLANGE HALF

Lubricate each component with gear lube before assembly and installation.

(1) Saturate the clutch plates with Mopar Hypoid Gear Lubricant or Additive.

(2) Assemble the discs and plates on the side gear (Fig. 38) in the following order.

- (a) Install dished disc on side gear.
- (b) Install one disc on side gear.
- (c) Install one plate on side gear.
- (d) Install one disc on side gear.
- (e) Install one plate on side gear.
- (f) Install three discs on side gear.
- (g) Install five plates on side gear.

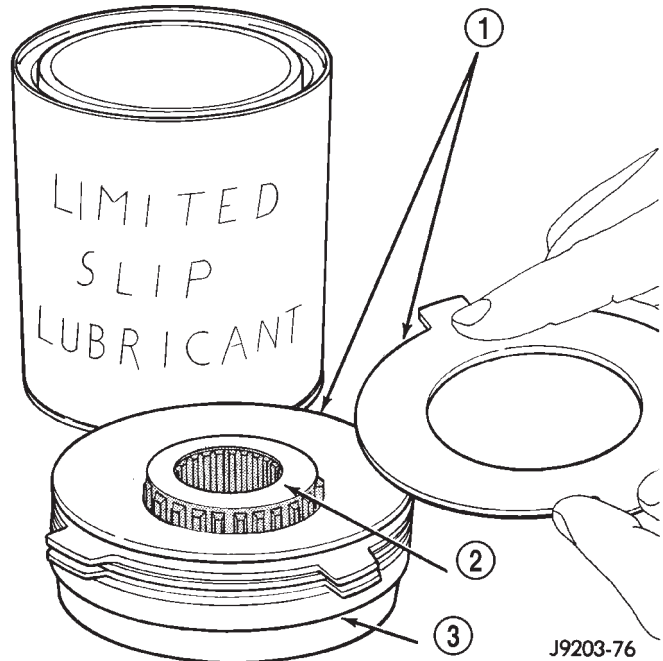


Fig. 38 Clutch Pack Assembly

1 - CLUTCH PLATES  
 2 - SIDE GEAR  
 3 - CLUTCH RING

(3) Line up the plate ears and install the assembled pack into the flange half (Fig. 39). Verify clutch plate lugs enter the slots in the case and clutch pack bottoms out in the case.

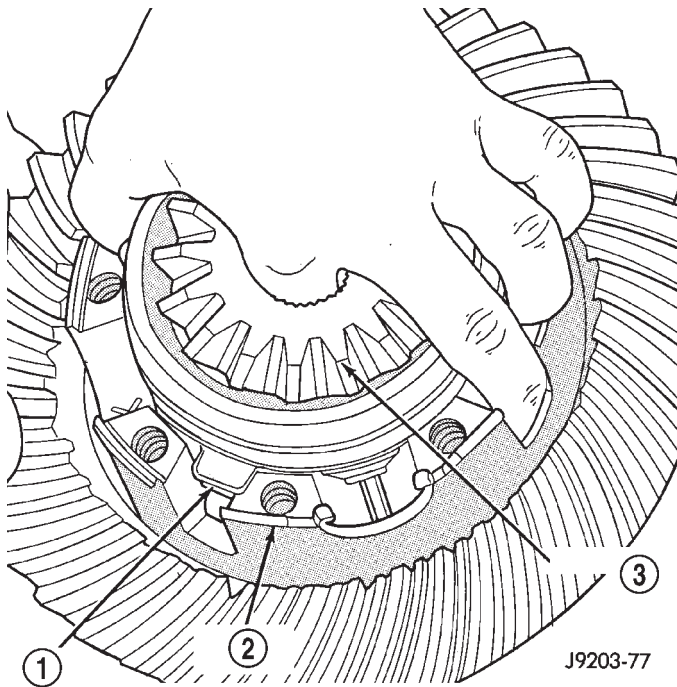
(4) Install pinion mate shafts and pinion mate gears (Fig. 40). **Verify shafts are correctly installed according to the alignment marks.**

(5) Lubricate and install the other side gear and clutch pack (Fig. 39).

(6) Correctly align and assemble button half to flange half. Install case body screws finger tight.

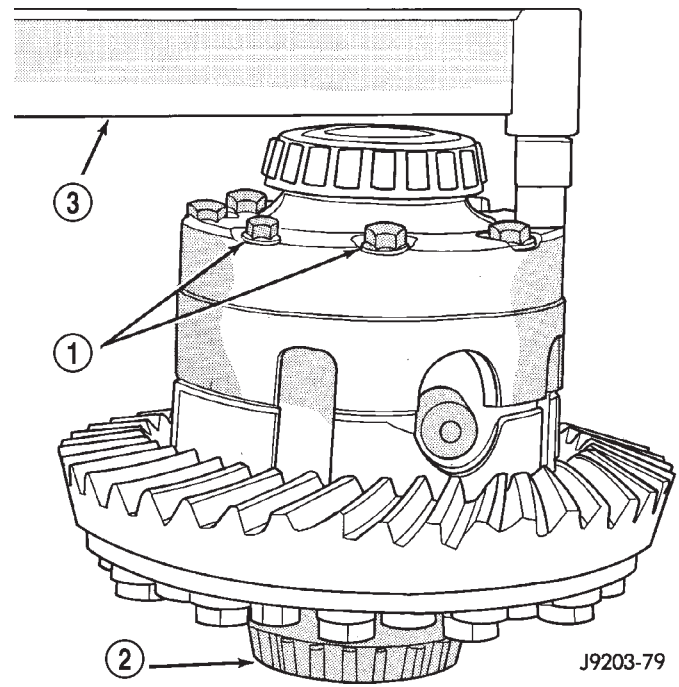
(7) Tighten body screws alternately and evenly. Tighten screws to 122-136 N·m (90-100 ft. lbs.) (Fig. 41).

DIFFERENTIAL - TRAC-LOK (Continued)



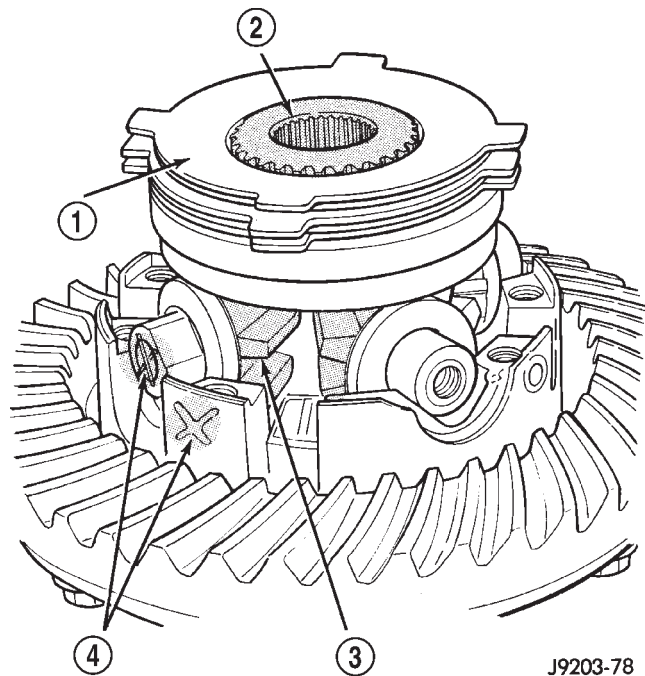
**Fig. 39 Clutch Pack**

- 1 - LUGS
- 2 - FLANGE HALF
- 3 - SIDE GEAR



**Fig. 41 Case Halfs**

- 1 - FIXTURE
- 2 - CASE BOLTS
- 3 - TORQUE WRENCH



**Fig. 40 Clutch Pack**

- 1 - CLUTCH PACK
- 2 - SIDE GEAR
- 3 - PINION GEARS AND MATE SHAFT
- 4 - ALIGNMENT MARKS

## DIFFERENTIAL CASE BEARINGS

### REMOVAL

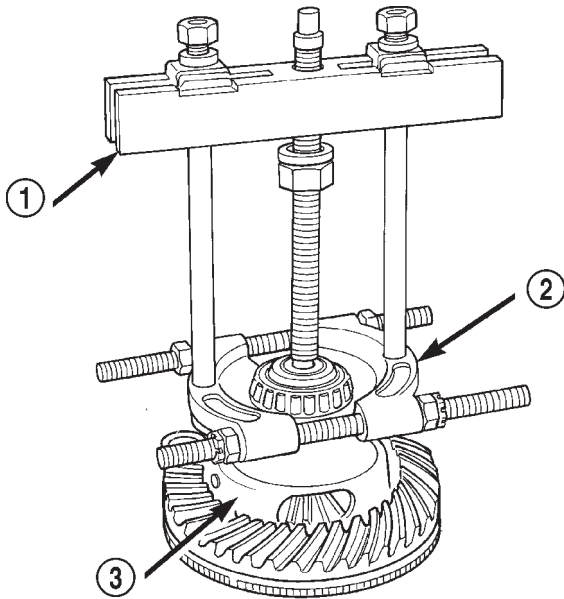
- (1) Remove differential case from axle housing.
- (2) Remove the bearings from the differential case with Press 938 and Bearing Splitter 1130 (Fig. 42).

### INSTALLATION

If ring and pinion gears have been replaced, verify differential side bearing preload and gear mesh backlash.

- (1) Using tool C-4190 with handle C-4171, install differential side bearings (Fig. 43).
- (2) Install differential in axle housing.

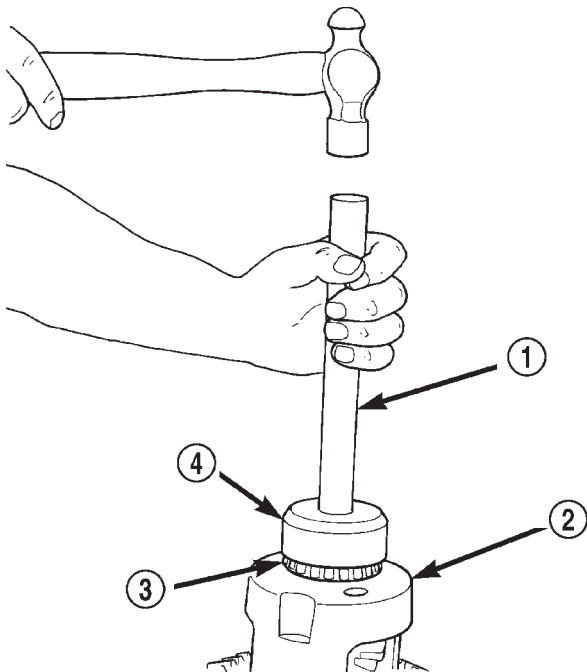
## DIFFERENTIAL CASE BEARINGS (Continued)



80a0c4fc

**Fig. 42 Differential Bearing Removal**

- 1 - BRIDGE 938
- 2 - TOOL 1130
- 3 - DIFFERENTIAL



80a9834b

**Fig. 43 Install Differential Side Bearings**

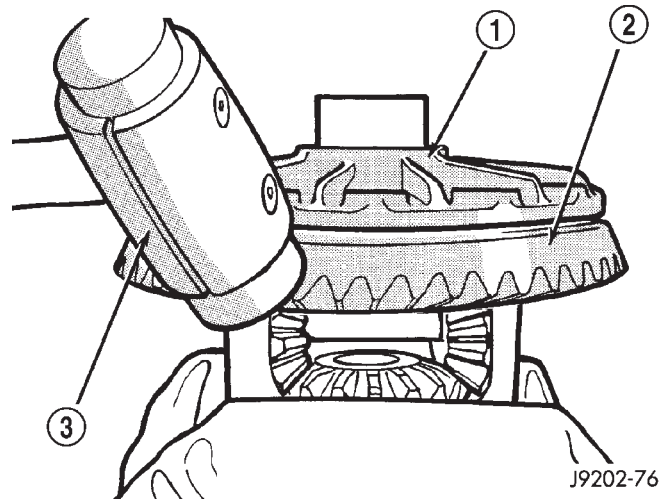
- 1 - HANDLE C-4171
- 2 - DIFFERENTIAL CASE
- 3 - BEARING
- 4 - TOOL C-4190

PINION GEAR/RING GEAR/  
TONE RING

## REMOVAL

**NOTE:** The ring and pinion gears are service in a matched set. Do not replace the ring gear without replacing the matched pinion gear.

- (1) Remove differential from axle housing.
- (2) Place differential case in a vise with soft metal jaw protectors. (Fig. 44)
- (3) Remove bolts holding ring gear to differential case.
- (4) Drive ring gear from differential case with a soft hammer (Fig. 44).



J9202-76

**Fig. 44 Ring Gear Removal**

- 1 - DIFFERENTIAL CASE
- 2 - RING GEAR
- 3 - HAMMER

(5) Use a brass drift and slowly tap the exciter ring from the differential case.

(6) Mark pinion yoke and propeller shaft for installation alignment.

(7) Disconnect propeller shaft from pinion yoke. Tie propeller shaft to underbody.

(8) Using Yoke Holder 6719 to hold yoke, remove pinion yoke nut and washer.

(9) Remove pinion yoke from pinion with Remover C-452 and Wrench C-3281, shaft (Fig. 45).

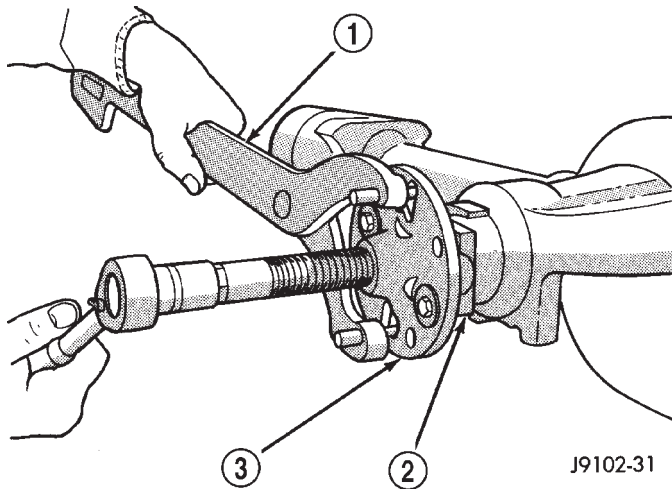
(10) Remove pinion gear from housing (Fig. 46).

(11) Remove pinion seal with a slide hammer or pry bar.

(12) Remove oil slinger, if equipped, and the front pinion bearing.



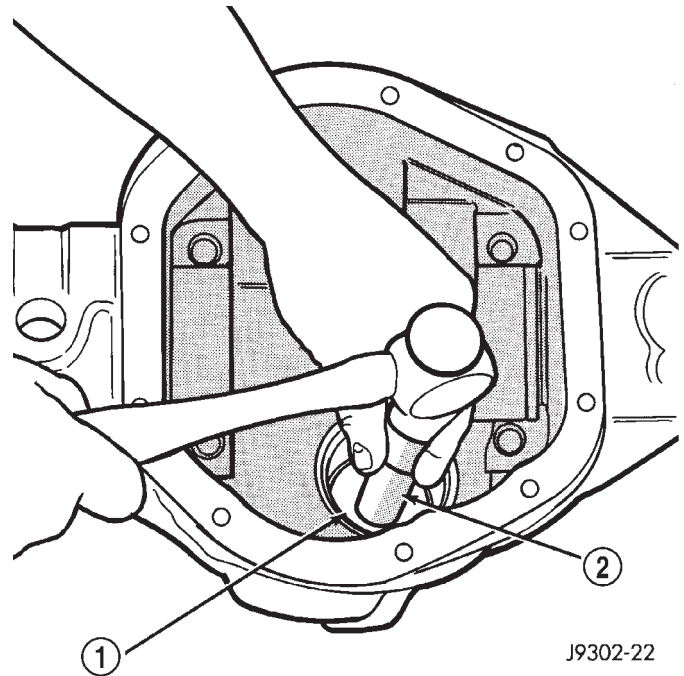
## PINION GEAR/RING GEAR/TONE RING (Continued)



J9102-31

**Fig. 45 Pinion Yoke Removal**

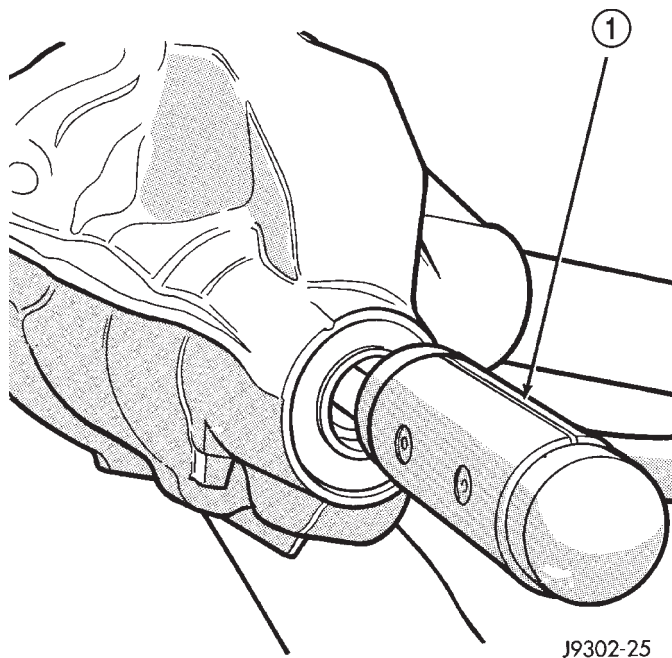
- 1 - WRENCH
- 2 - YOKE
- 3 - REMOVER



J9302-22

**Fig. 47 Front Bearing Cup Removal**

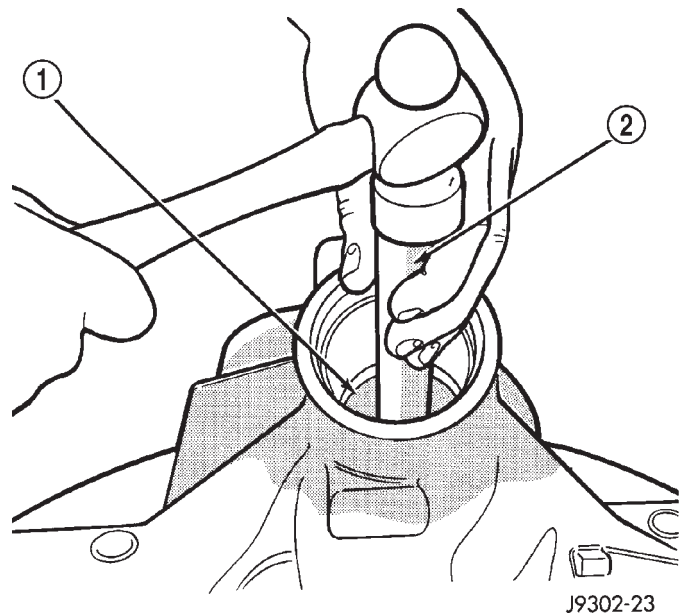
- 1 - REMOVER
- 2 - HANDLE



J9302-25

**Fig. 46 Remove Pinion Gear**

- 1 - RAWHIDE HAMMER



J9302-23

**Fig. 48 Rear Bearing Cup Removal**

- 1 - REMOVER
- 2 - HANDLE

(13) Remove front pinion bearing cup with Remover C-4307 and Handle C-4171 (Fig. 47).

(14) Remove rear bearing cup with Remover D-159 and Handle C-4171 (Fig. 48).

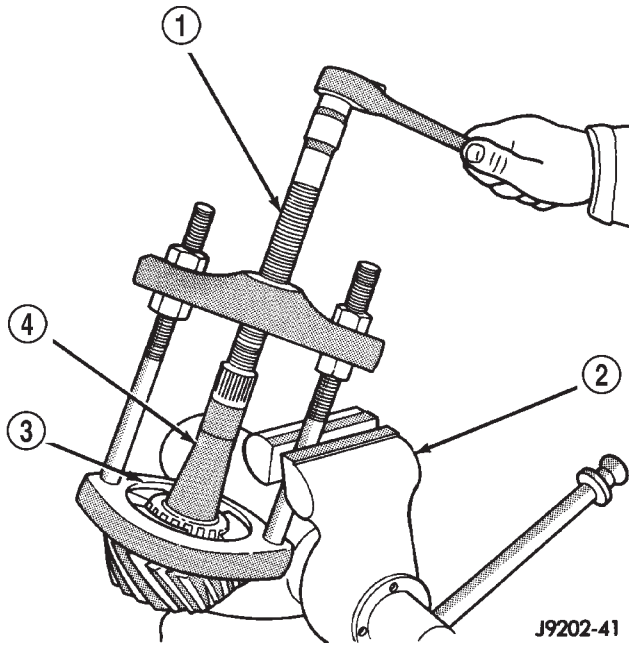
(15) Remove rear bearing from the pinion with Puller/Press C-293-PA and Adapters DD-914-95 (Fig. 49).

**Place 4 adapter blocks so they do not damage the bearing cage.**

(16) Remove the pinion depth shims from the pinion gear shaft. Record the total thickness of the depth shims.

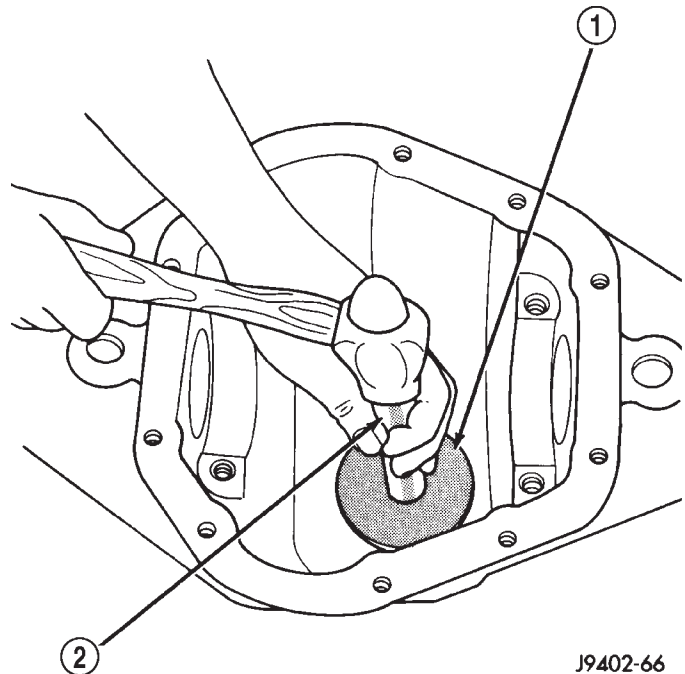


## PINION GEAR/RING GEAR/TONE RING (Continued)



**Fig. 49 Rear Pinion Bearing Removal**

- 1 - PULLER
- 2 - VISE
- 3 - PINION SHAFT
- 4 - ADAPTER BLOCKS



**Fig. 50 Pinion Rear Bearing Cup**

- 1 - INSTALLER
- 2 - HANDLE

## INSTALLATION

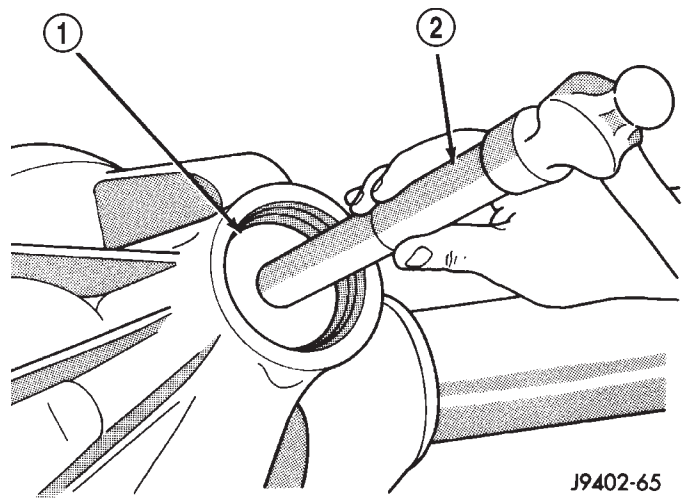
(1) Apply Mopar Door Ease stick lubricant to outside surface of bearing cup. Install the pinion rear bearing cup with Installer C-4204 and Handle C-4171 (Fig. 50) and verify cup is seated.

(2) Apply Mopar Door Ease stick lubricant to outside surface of bearing cup. Install the pinion front bearing cup with Installer C-4308 and Handle C-4171 (Fig. 51) and verify cup is seated.

(3) Install pinion front bearing and oil slinger, if equipped. Apply a light coating of gear lubricant on the lip of pinion seal.

(4) Install new pinion seal with an appropriate installer 8108 (Fig. 52).

**NOTE:** Pinion depth shims are placed between the rear pinion bearing cone and pinion gear to achieve proper ring and pinion gear mesh. If ring and pinion gears are reused, the pinion depth shim should not require replacement or adjustment. If the ring and pinion gears are replaced refer to Adjustments to select the proper thickness shim.

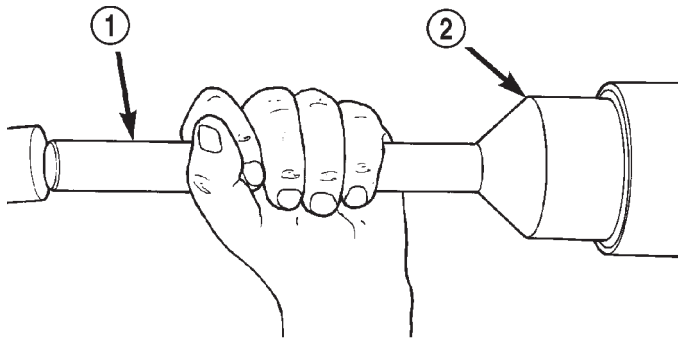


**Fig. 51 Pinion Front Bearing Cup**

- 1 - INSTALLER
- 2 - HANDLE

(5) Place the proper thickness pinion depth shim on the pinion gear.

## PINION GEAR/RING GEAR/TONE RING (Continued)

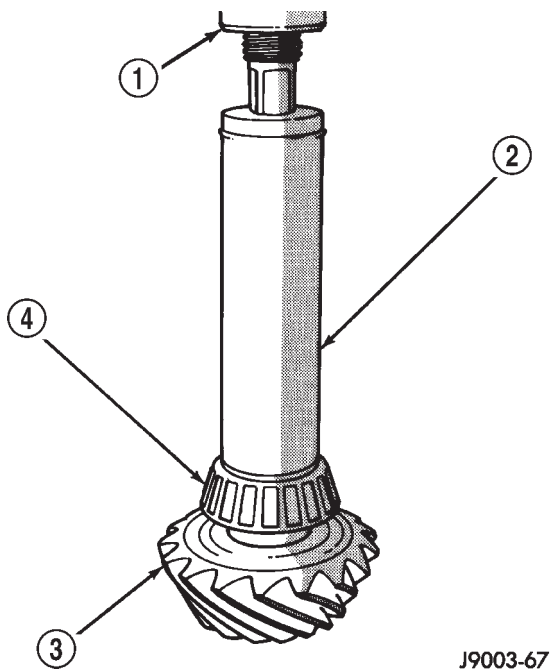


80a98349

**Fig. 52 Pinion Seal**

- 1 - HANDLE  
2 - INSTALLER

(6) Install rear bearing and oil slinger, if equipped, on the pinion gear with Installer D-389 and a press (Fig. 53).

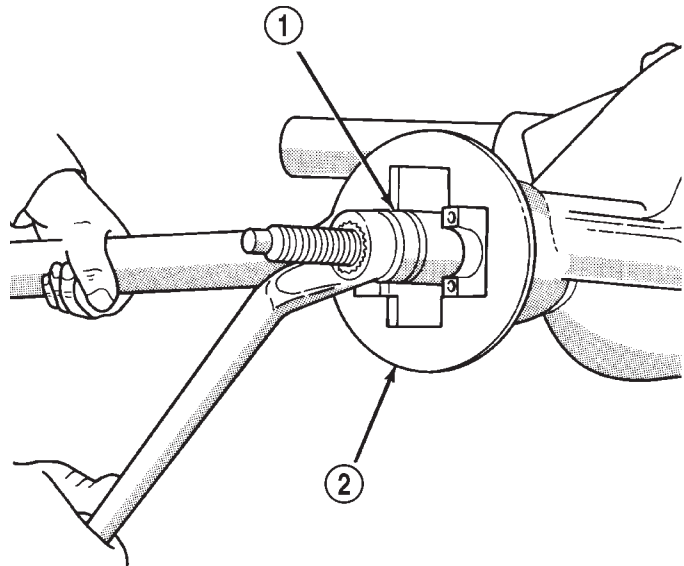


J9003-67

**Fig. 53 Rear Pinion Bearing**

- 1 - PRESS  
2 - INSTALLER  
3 - PINION GEAR  
4 - PINION BEARING

(7) Install original solid shims on pinion gears.  
(8) Install yoke with Installer C-3718 and Yoke Holder 6719 (Fig. 54).



J9402-61

**Fig. 54 Pinion Yoke**

- 1 - INSTALLER  
2 - HOLDER

(9) Install the yoke washer and **new** nut on the pinion gear. Tighten the nut to 637 N·m (470 ft. lbs.).

(10) Check bearing rotating torque with an inch pound torque wrench (Fig. 55). Pinion rotating torque should be:

- Original Bearings: 1 to 3 N·m (10 to 20 in. lbs.).
- New Bearings: 2.8 to 5.1 N·m (25 to 45 in. lbs.).

(11) If rotating torque is less than the desired rotating torque, remove the pinion yoke and decrease the thickness of the solid shim pack if greater increase shim pack. Changing the shim pack thickness by 0.025 mm (0.001 in.) will change the rotating torque approximately 0.9 N·m (8 in. lbs.).

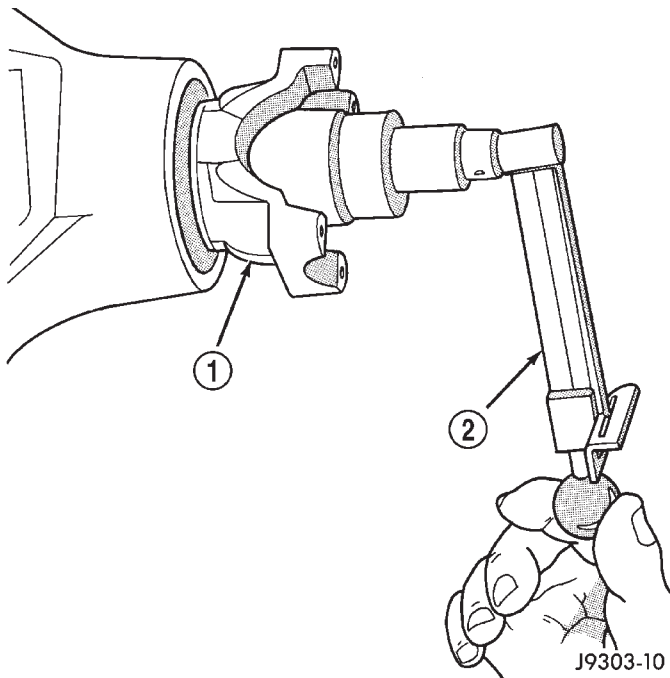
(12) Invert the differential case.

(13) Position exciter ring on differential case.

(14) Using a brass drift, slowly and evenly tap the exciter ring into position.

(15) Invert the differential case and start two ring gear bolts. This will provide case-to-ring gear bolt hole alignment.

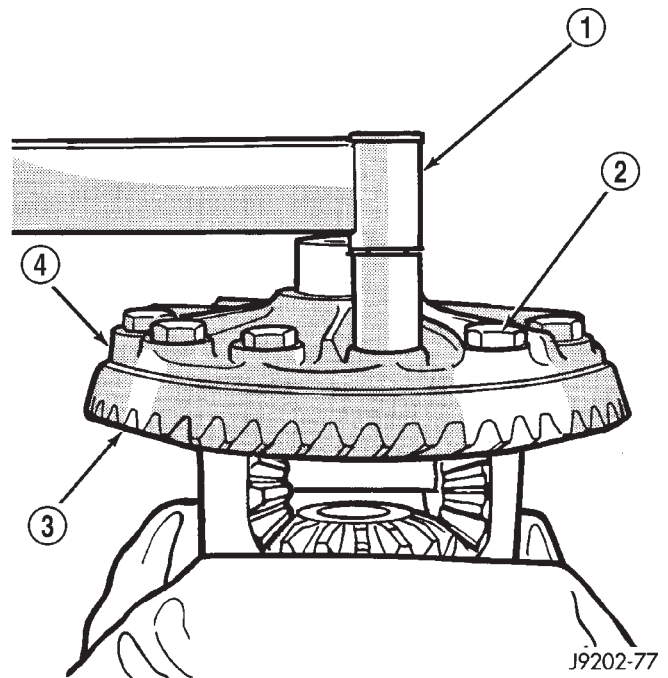
## PINION GEAR/RING GEAR/TONE RING (Continued)

**Fig. 55 Pinion Gear Rotation Torque**

- 1 - PINION YOKE  
2 - TORQUE WRENCH

(16) Invert the differential case in the vise.  
(17) Install new ring gear bolts and alternately tighten to 298 N·m (220 ft. lbs.) (Fig. 56).

**CAUTION: Do not reuse ring gear bolts, the bolts can fracture causing extensive damage.**

**Fig. 56 Ring Gear Bolt**

- 1 - TORQUE WRENCH  
2 - RING GEAR BOLT  
3 - RING GEAR  
4 - CASE

(18) Install differential in housing and verify gear mesh and contact pattern.

(19) Install propeller shaft with reference marks aligned.



# BRAKES

## TABLE OF CONTENTS

	page		page
<b>BRAKES - BASE</b>		<b>INSTALLATION</b> . . . . .	20
SPECIFICATIONS . . . . .	2	<b>ROTORS</b>	
SPECIAL TOOLS . . . . .	4	DIAGNOSIS AND TESTING . . . . .	20
<b>HYDRAULIC/MECHANICAL</b>		DISC BRAKE ROTOR . . . . .	20
DESCRIPTION . . . . .	4	REMOVAL . . . . .	21
WARNING . . . . .	5	INSTALLATION . . . . .	22
DIAGNOSIS AND TESTING . . . . .	5	<b>BRAKE PADS/SHOES</b>	
BASE BRAKE SYSTEM . . . . .	5	REMOVAL . . . . .	23
STANDARD PROCEDURE . . . . .	7	INSTALLATION . . . . .	26
MANUAL BLEEDING . . . . .	7	<b>MASTER CYLINDER</b>	
PRESSURE BLEEDING . . . . .	8	DESCRIPTION . . . . .	29
<b>BRAKE LINES</b>		OPERATION . . . . .	29
STANDARD PROCEDURE . . . . .	8	DIAGNOSIS AND TESTING . . . . .	29
DOUBLE INVERTED FLARING . . . . .	8	MASTER CYLINDER/POWER BOOSTER . . . . .	29
ISO FLARING . . . . .	8	STANDARD PROCEDURE . . . . .	30
<b>COMBINATION VALVE</b>		MASTER CYLINDER BLEEDING . . . . .	30
DESCRIPTION . . . . .	9	REMOVAL . . . . .	30
OPERATION . . . . .	9	INSTALLATION . . . . .	30
DIAGNOSIS AND TESTING . . . . .	9	<b>WHEEL CYLINDERS</b>	
COMBINATION VALVE . . . . .	9	REMOVAL . . . . .	31
REMOVAL . . . . .	10	DISASSEMBLY . . . . .	31
INSTALLATION . . . . .	10	CLEANING . . . . .	31
<b>DISC BRAKE CALIPERS</b>		INSPECTION . . . . .	31
REMOVAL . . . . .	10	ASSEMBLY . . . . .	31
DISASSEMBLY . . . . .	11	INSTALLATION . . . . .	32
CLEANING . . . . .	12	<b>SUPPORT PLATE</b>	
INSPECTION . . . . .	12	REMOVAL . . . . .	32
ASSEMBLY . . . . .	12	INSTALLATION . . . . .	32
INSTALLATION . . . . .	13	<b>DRUM</b>	
<b>FLUID</b>		DESCRIPTION . . . . .	32
DIAGNOSIS AND TESTING . . . . .	14	OPERATION . . . . .	32
BRAKE FLUID CONTAMINATION . . . . .	14	DIAGNOSIS AND TESTING . . . . .	33
STANDARD PROCEDURE . . . . .	14	BRAKE DRUM . . . . .	33
BRAKE FLUID LEVEL . . . . .	14	STANDARD PROCEDURE . . . . .	33
SPECIFICATIONS . . . . .	15	BRAKE DRUM MACHINING . . . . .	33
<b>FLUID RESERVOIR</b>		CLEANING . . . . .	33
REMOVAL . . . . .	15	INSPECTION . . . . .	33
INSTALLATION . . . . .	15	ADJUSTMENTS . . . . .	34
<b>PEDAL</b>		<b>PARKING BRAKE</b>	
DESCRIPTION . . . . .	16	DESCRIPTION . . . . .	35
OPERATION . . . . .	16	OPERATION . . . . .	36
REMOVAL . . . . .	16	<b>PEDAL</b>	
INSTALLATION . . . . .	17	REMOVAL . . . . .	36
<b>POWER BRAKE BOOSTER</b>		INSTALLATION . . . . .	36
DIAGNOSIS AND TESTING . . . . .	17	<b>CABLES</b>	
HYDRAULIC BOOSTER . . . . .	17	REMOVAL . . . . .	37
STANDARD PROCEDURE . . . . .	19	INSTALLATION . . . . .	38
POWER BRAKE BOOSTER . . . . .	19	<b>CABLE TENSIONER</b>	
REMOVAL . . . . .	19	ADJUSTMENTS . . . . .	40



**RELEASE**

REMOVAL .....	40
INSTALLATION.....	41

**SHOES**

REMOVAL .....	41
INSTALLATION.....	42

**BRAKES - BASE****SPECIFICATIONS****BASE BRAKE***SPECIFICATIONS*

DESCRIPTION	SPECIFICATION
Front/Rear Disc Brake Caliper Type	Dual Piston Sliding
Front Disc Brake Caliper Piston Diameter LD	54 mm (2.00 in.)
Front Disc Brake Caliper Piston Diameter HD	56 mm (2.00 in.)
Front Disc Brake Rotor 1500 4x2	304x30 mm (11.96x1.18 in.)
Front Disc Brake Rotor 1500 4x4	307.5x30 mm (12.10x1.18 in.)
Front Disc Brake Rotor 2500/3500	326.5x36 mm (12.5x1.5 in.)
Front/Rear Disc Brake Rotor Max. Runout	0.127 mm (0.005 in.)
Front/Rear Disc Brake Rotor Max. Thickness Variation	0.025 mm (0.001 in.)
Minimum Front Rotor Thickness 1500	28.39 mm (1.117 in.)
Minimum Front Rotor Thickness 2500/3500	33.90 mm (1.334 in.)
Minimum Rear Rotor Thickness 2500/3500	28.39 mm (1.117 in.)

DESCRIPTION	SPECIFICATION
Drum Brake Size 1500	279x57 mm (11x2.25 in.)
Drum Brake Size 2500/3500	308x89 mm (12.125x3.5 in.)
Drum Brake Max. Runout 1500	0.18 mm (0.007 in.)
Drum Brake Max. Thickness Variation 1500	0.076 mm (0.003 in.)
Rear Disc Brake Caliper 2500	2x45 mm (1.77 in)
Rear Disc Brake Caliper 3500	2x51 mm (2.00 in)
Rear Disc Brake Rotor 2500/3500	323.5x30 mm (1.18 in)
Wheel Cylinder Bore Size 1500	25.4 mm (1.00 in.)
Wheel Cylinder Bore Size 2500/3500	25.4 mm (1.00 in.)
Brake Booster Type 1500/2500 Gasoline Engines	Vacuum Dual Diaphragm
Brake Booster Type All 3500/2500 Diesel Engines Only	Hydraulic

## BRAKES - BASE (Continued)

## TORQUE CHART

## TORQUE SPECIFICATIONS

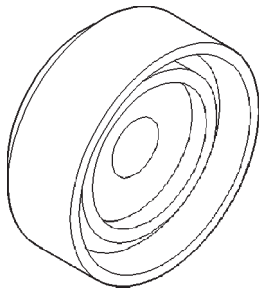
DESCRIPTION	N-m	Ft. Lbs.	In. Lbs.
Booster Mounting Nuts	28	21	250
Booster Mounting Nuts to the Dashpanel	33	24	300
Diesel Hydraulic Booster Mounting Bolts	28	21	250
Diesel Hydraulic Booster Booster Lines	28	21	250
Diesel Hydraulic Booster Booster Hoses	31	23	275
Master Cylinder Mounting Nuts	23	17	200
Master Cylinder Brake Lines	21	16	190
Combination Valve Mounting Bolt	23	17	210
Combination Valve Brake Lines	21	16	190
Proportioning Valve Mounting Nuts	34	25	300
Proportioning Valve Brake Hose	31	23	276
Proportioning Valve Brake Lines	21	16	190
Front Caliper Mounting Bolts	33	24	—
Front Caliper LD Adapter Bolts	176	130	—
Front Caliper HD Adapter Bolts	285	210	—
Rear Caliper Slide Pins	33	24	300
Rotor to Hub Rear Bolt	128	95	—
All Caliper Banjo Bolts	40	30	360
Wheel Cylinder Mounting Bolts	20	15	180
Wheel Cylinder Brake Line	13	10	115
Support Plate Mounting Bolts	58	43	—

BRAKES - BASE (Continued)

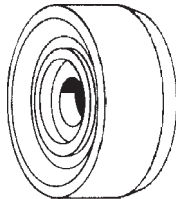
DESCRIPTION	N-m	Ft. Lbs.	In. Lbs.
Park Brake Pedal Assembly Mounting Bolts/Nuts	28	21	250
Hub/Bearing LD 4x2 Spindle Nut	251	185	—
Hub/Bearing HD 4x2 Spindle Nut	380	280	—
Hub/Bearing 4x4 Hub/Bearing Bolts	170	125	—

SPECIAL TOOLS

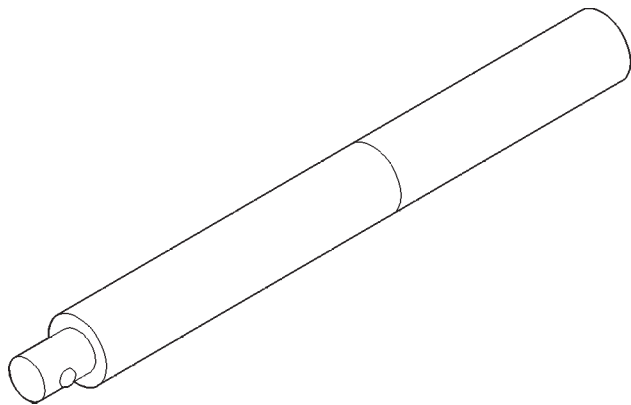
BASE BRAKES



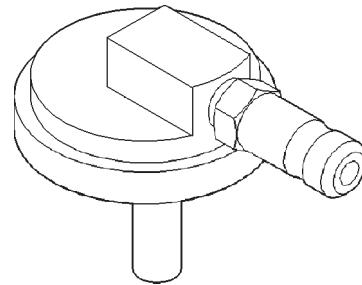
*Installer, Brake Caliper Dust Boot C-4340*



*Installer, Brake Caliper Dust Boot C-3716-A*



*Handle C-4171*



*Cap, Master Cylinder Pressure Bleed 6921*

HYDRAULIC/MECHANICAL

DESCRIPTION

This vehicle is equipped with front disc brakes and rear drum brakes also certain vehicles have four wheel disc brakes. The front and rear disc brakes consist of dual piston calipers and ventilated rotors. The rear brakes are dual brake shoe, internal expanding units with cast brake drums. The parking brake mechanism is cable operated and connected to the rear brake trailing shoes. Power brake assist is standard equipment. A vacuum operated power brake booster is used on gas engine vehicles. A hydraulic booster is used on diesel engine vehicles.

Two antilock brake systems are used on this vehicle. A rear wheel antilock (RWAL) brake system and all-wheel antilock brake system (ABS). The RWAL and ABS systems are designed to retard wheel lockup while braking. Retarding wheel lockup is accomplished by modulating fluid pressure to the wheel brake units. Both systems are monitored by a microprocessor which controls the operation of the systems.

## HYDRAULIC/MECHANICAL (Continued)

## WARNING

**WARNING: DUST AND DIRT ACCUMULATING ON BRAKE PARTS DURING NORMAL USE MAY CONTAIN ASBESTOS FIBERS FROM PRODUCTION OR AFTERMARKET LININGS. BREATHING EXCESSIVE CONCENTRATIONS OF ASBESTOS FIBERS CAN CAUSE SERIOUS BODILY HARM. EXERCISE CARE WHEN SERVICING BRAKE PARTS. DO NOT CLEAN BRAKE PARTS WITH COMPRESSED AIR OR BY DRY BRUSHING. USE A VACUUM CLEANER SPECIFICALLY DESIGNED FOR THE REMOVAL OF ASBESTOS FIBERS FROM BRAKE COMPONENTS. IF A SUITABLE VACUUM CLEANER IS NOT AVAILABLE, CLEANING SHOULD BE DONE WITH A WATER DAMPENED CLOTH. DO NOT SAND, OR GRIND BRAKE LINING UNLESS EQUIPMENT USED IS DESIGNED TO CONTAIN THE DUST RESIDUE. DISPOSE OF ALL RESIDUE CONTAINING ASBESTOS FIBERS IN SEALED BAGS OR CONTAINERS TO MINIMIZE EXPOSURE TO YOURSELF AND OTHERS. FOLLOW PRACTICES PRESCRIBED BY THE OCCUPATIONAL SAFETY AND HEALTH ADMINISTRATION AND THE ENVIRONMENTAL PROTECTION AGENCY FOR THE HANDLING, PROCESSING, AND DISPOSITION OF DUST OR DEBRIS THAT MAY CONTAIN ASBESTOS FIBERS.**

**CAUTION:** Never use gasoline, kerosene, alcohol, motor oil, transmission fluid, or any fluid containing mineral oil to clean the system components. These fluids damage rubber cups and seals. Use only fresh brake fluid or Mopar brake cleaner to clean or flush brake system components. These are the only cleaning materials recommended. If system contamination is suspected, check the fluid for dirt, discoloration, or separation into distinct layers. Also check the reservoir cap seal for distortion. Drain and flush the system with new brake fluid if contamination is suspected.

**CAUTION:** Use Mopar brake fluid, or an equivalent quality fluid meeting SAE/DOT standards J1703 and DOT 3. Brake fluid must be clean and free of contaminants. Use fresh fluid from sealed containers only to ensure proper antilock component operation.

**CAUTION:** Use Mopar multi-mileage or high temperature grease to lubricate caliper slide surfaces, drum brake pivot pins, and shoe contact points on the backing plates. Use multi-mileage grease or GE 661 or Dow 111 silicone grease on caliper slide pins to ensure proper operation.

## DIAGNOSIS AND TESTING - BASE BRAKE SYSTEM

Base brake components consist of the brake shoes, calipers, wheel cylinders, brake drums, rotors, brake lines, master cylinder, booster, and parking brake components.

Brake diagnosis involves determining if the problem is related to a mechanical, hydraulic, or vacuum operated component.

The first diagnosis step is the preliminary check.

## PRELIMINARY BRAKE CHECK

(1) Check condition of tires and wheels. Damaged wheels and worn, damaged, or underinflated tires can cause pull, shudder, vibration, and a condition similar to grab.

(2) If complaint was based on noise when braking, check suspension components. Jounce front and rear of vehicle and listen for noise that might be caused by loose, worn or damaged suspension or steering components.

(3) Inspect brake fluid level and condition. Note that the brake reservoir fluid level will decrease in proportion to normal lining wear. **Also note that brake fluid tends to darken over time. This is normal and should not be mistaken for contamination.**

(a) If fluid level is abnormally low, look for evidence of leaks at calipers, wheel cylinders, brake lines, and master cylinder.

(b) If fluid appears contaminated, drain out a sample to examine. System will have to be flushed if fluid is separated into layers, or contains a substance other than brake fluid. The system seals and cups will also have to be replaced after flushing. Use clean brake fluid to flush the system.

(4) Check parking brake operation. Verify free movement and full release of cables and pedal. Also note if vehicle was being operated with parking brake partially applied.

(5) Check brake pedal operation. Verify that pedal does not bind and has adequate free play. If pedal lacks free play, check pedal and power booster for being loose or for bind condition. Do not road test until condition is corrected.

(6) Check booster vacuum check valve and hose.

(7) If components checked appear OK, road test the vehicle.

## ROAD TESTING

(1) If complaint involved low brake pedal, pump pedal and note if it comes back up to normal height.

(2) Check brake pedal response with transmission in Neutral and engine running. Pedal should remain firm under constant foot pressure.

## HYDRAULIC/MECHANICAL (Continued)

(3) During road test, make normal and firm brake stops in 25-40 mph range. Note faulty brake operation such as low pedal, hard pedal, fade, pedal pulsation, pull, grab, drag, noise, etc.

(4) Attempt to stop the vehicle with the parking brake only and note grab, drag, noise, etc.

**PEDAL FALLS AWAY**

A brake pedal that falls away under steady foot pressure is generally the result of a system leak. The leak point could be at a brake line, fitting, hose, or caliper/wheel cylinder. If leakage is severe, fluid will be evident at or around the leaking component.

Internal leakage (seal by-pass) in the master cylinder caused by worn or damaged piston cups, may also be the problem cause.

An internal leak in the ABS or RWAL system may also be the problem with no physical evidence.

**LOW PEDAL**

If a low pedal is experienced, pump the pedal several times. If the pedal comes back up, worn linings, rotors, drums, or rear brakes out of adjustment are the most likely causes. The proper course of action is to inspect and replace all worn component and make the proper adjustments.

**SPONGY PEDAL**

A spongy pedal is most often caused by air in the system. However, thin brake drums or substandard brake lines and hoses can also cause a spongy pedal. The proper course of action is to bleed the system, and replace thin drums and substandard quality brake hoses if suspected.

**HARD PEDAL OR HIGH PEDAL EFFORT**

A hard pedal or high pedal effort may be due to lining that is water soaked, contaminated, glazed, or badly worn. The power booster or check valve could also be faulty.

**PEDAL PULSATION**

Pedal pulsation is caused by components that are loose, or beyond tolerance limits.

The primary cause of pulsation are disc brake rotors with excessive lateral runout or thickness variation, or out of round brake drums. Other causes are loose wheel bearings or calipers and worn or damaged tires.

**NOTE:** Some pedal pulsation may be felt during ABS/EBD activation.

**BRAKE DRAG**

Brake drag occurs when the lining is in constant contact with the rotor or drum. Drag can occur at one wheel, all wheels, fronts only, or rears only.

Drag is a product of incomplete brake shoe release. Drag can be minor or severe enough to overheat the linings, rotors and drums.

Minor drag will usually cause slight surface charring of the lining. It can also generate hard spots in rotors and drums from the overheat-cool down process. In most cases, the rotors, drums, wheels and tires are quite warm to the touch after the vehicle is stopped.

Severe drag can char the brake lining all the way through. It can also distort and score rotors and drums to the point of replacement. The wheels, tires and brake components will be extremely hot. In severe cases, the lining may generate smoke as it chars from overheating.

Common causes of brake drag are:

- Seized or improperly adjusted parking brake cables
- Loose/worn wheel bearing
- Seized caliper or wheel cylinder piston
- Caliper binding on damaged or missing anti-rattle clips or bushings
- Loose caliper mounting
- Drum brake shoes binding on worn/damaged support plates
- Mis-assembled components
- Long booster output rod

If brake drag occurs at all wheels, the problem may be related to a blocked master cylinder return port, or faulty power booster (binds-does not release).

**BRAKE FADE**

Brake fade is usually a product of overheating caused by brake drag. However, brake overheating and resulting fade can also be caused by riding the brake pedal, making repeated high deceleration stops in a short time span, or constant braking on steep mountain roads. Refer to the Brake Drag information in this section for causes.

**BRAKE PULL**

Front brake pull condition could result from:

- Contaminated lining in one caliper
- Seized caliper piston
- Binding caliper
- Loose caliper
- Damaged anti-rattle clips
- Improper brake shoes
- Damaged rotor

A worn, damaged wheel bearing or suspension component are further causes of pull. A damaged



## HYDRAULIC/MECHANICAL (Continued)

front tire (bruised, ply separation) can also cause pull.

A common and frequently misdiagnosed pull condition is where direction of pull changes after a few stops. The cause is a combination of brake drag followed by fade at one of the brake units.

As the dragging brake overheats, efficiency is so reduced that fade occurs. Since the opposite brake unit is still functioning normally, its braking effect is magnified. This causes pull to switch direction in favor of the normally functioning brake unit.

An additional point when diagnosing a change in pull condition concerns brake cool down. Remember that pull will return to the original direction, if the dragging brake unit is allowed to cool down (and is not seriously damaged).

## REAR BRAKE GRAB OR PULL

Rear grab or pull is usually caused by improperly adjusted or seized parking brake cables, contaminated lining, bent or binding shoes and support plates, or improperly assembled components. This is particularly true when only one rear wheel is involved. However, when both rear wheels are affected, the master cylinder or proportioning valve could be at fault.

## BRAKES DO NOT HOLD AFTER DRIVING THROUGH DEEP WATER PUDDLES

This condition is generally caused by water soaked lining. If the lining is only wet, it can be dried by driving with the brakes very lightly applied for a mile or two. However, if the lining is both soaked and dirt contaminated, cleaning and/or replacement will be necessary.

## BRAKE LINING CONTAMINATION

Brake lining contamination is mostly a product of leaking calipers or wheel cylinders, worn seals, driving through deep water puddles, or lining that has become covered with grease and grit during repair. Contaminated lining should be replaced to avoid further brake problems.

## WHEEL AND TIRE PROBLEMS

Some conditions attributed to brake components may actually be caused by a wheel or tire problem.

A damaged wheel can cause shudder, vibration and pull. A worn or damaged tire can also cause pull.

Severely worn tires with very little tread left can produce a grab-like condition as the tire loses and recovers traction. Flat-spotted tires can cause vibration and generate shudder during brake operation. A tire with internal damage such as a severe bruise, cut, or ply separation can cause pull and vibration.

## BRAKE NOISES

Some brake noise is common with rear drum brakes and on some disc brakes during the first few stops after a vehicle has been parked overnight or stored. This is primarily due to the formation of trace corrosion (light rust) on metal surfaces. This light corrosion is typically cleared from the metal surfaces after a few brake applications causing the noise to subside.

## BRAKE SQUEAK/SQUEAL

Brake squeak or squeal may be due to linings that are wet or contaminated with brake fluid, grease, or oil. Glazed linings and rotors with hard spots can also contribute to squeak. Dirt and foreign material embedded in the brake lining will also cause squeak/squeal.

A very loud squeak or squeal is frequently a sign of severely worn brake lining. If the lining has worn through to the brake shoes in spots, metal-to-metal contact occurs. If the condition is allowed to continue, rotors and drums can become so scored that replacement is necessary.

## BRAKE CHATTER

Brake chatter is usually caused by loose or worn components, or glazed/burnt lining. Rotors with hard spots can also contribute to chatter. Additional causes of chatter are out-of-tolerance rotors, brake lining not securely attached to the shoes, loose wheel bearings and contaminated brake lining.

## THUMP/CLUNK NOISE

Thumping or clunk noises during braking are frequently **not** caused by brake components. In many cases, such noises are caused by loose or damaged steering, suspension, or engine components. However, calipers that bind on the slide surfaces can generate a thump or clunk noise. In addition, worn out, improperly adjusted, or improperly assembled rear brake shoes can also produce a thump noise.

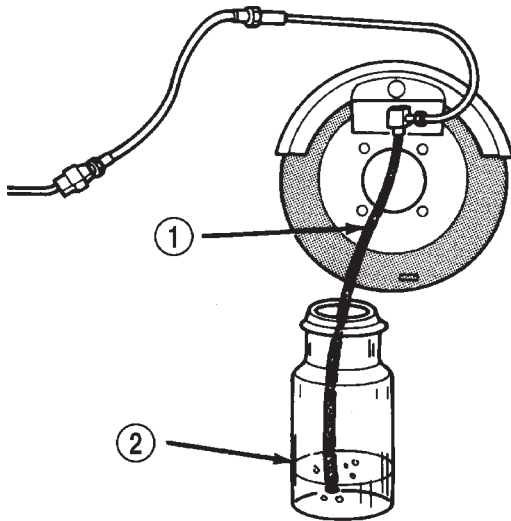
## STANDARD PROCEDURE - MANUAL BLEEDING

Use Mopar brake fluid, or an equivalent quality fluid meeting SAE J1703-F and DOT 3 standards only. Use fresh, clean fluid from a sealed container at all times.

- (1) Remove reservoir filler caps and fill reservoir.
- (2) If calipers, or wheel cylinders were overhauled, open all caliper and wheel cylinder bleed screws. Then close each bleed screw as fluid starts to drip from it. Top off master cylinder reservoir once more before proceeding.
- (3) Attach one end of bleed hose to bleed screw and insert opposite end in glass container partially

## HYDRAULIC/MECHANICAL (Continued)

filled with brake fluid (Fig. 1). Be sure end of bleed hose is immersed in fluid.



J8905-18

**Fig. 1 Bleed Hose Setup**

- 1 - BLEED HOSE  
2 - FLUID CONTAINER PARTIALLY FILLED WITH FLUID

(4) Open up bleeder, then have a helper press down the brake pedal. Once the pedal is down close the bleeder. Repeat bleeding until fluid stream is clear and free of bubbles. Then move to the next wheel.

### STANDARD PROCEDURE - PRESSURE BLEEDING

Use Mopar brake fluid, or an equivalent quality fluid meeting SAE J1703-F and DOT 3 standards only. Use fresh, clean fluid from a sealed container at all times.

If pressure bleeding equipment will be used, the front brake metering valve will have to be held open to bleed the front brakes. The valve stem is located in the forward end or top of the combination valve. The stem must either be pressed inward, or held outward slightly. A spring clip tool or helper is needed to hold the valve stem in position.

Follow the manufacturers instructions carefully when using pressure equipment. Do not exceed the tank manufacturers pressure recommendations. Generally, a tank pressure of 15-20 psi is sufficient for bleeding.

Fill the bleeder tank with recommended fluid and purge air from the tank lines before bleeding.

Do not pressure bleed without a proper master cylinder adapter. The wrong adapter can lead to leakage, or drawing air back into the system. Use

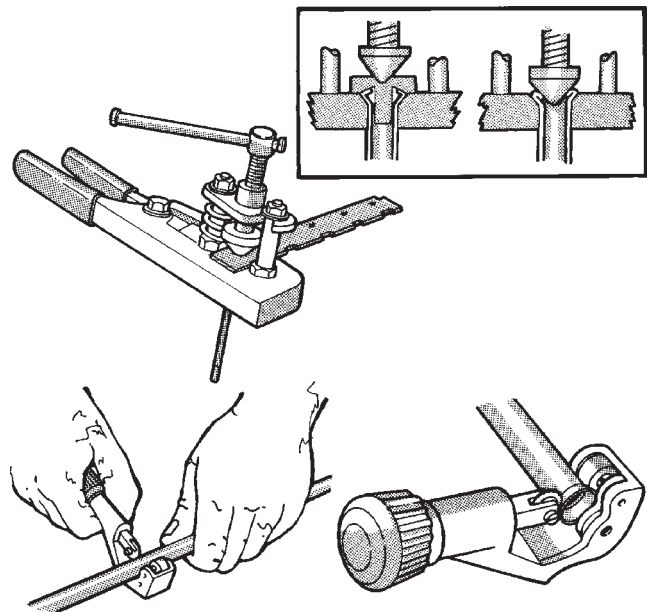
adapter provided with the equipment or Adapter 6921.

## BRAKE LINES

### STANDARD PROCEDURE - DOUBLE INVERTED FLARING

A preformed metal brake tube is recommended and preferred for all repairs. However, double-wall steel tube can be used for emergency repair when factory replacement parts are not readily available.

- (1) Cut off damaged tube with Tubing Cutter.
- (2) Ream cut edges of tubing to ensure proper flare.
- (3) Install replacement tube nut on the tube.
- (4) Insert tube in flaring tool.
- (5) Place gauge form over the end of the tube.
- (6) Push tubing through flaring tool jaws until tube contacts recessed notch in gauge that matches tube diameter.
- (7) Tighten the tool bar on the tube
- (8) Insert plug on gauge in the tube. Then swing compression disc over gauge and center tapered flaring screw in recess of compression disc (Fig. 2).
- (9) Tighten tool handle until plug gauge is squarely seated on jaws of flaring tool. This will start the inverted flare.
- (10) Remove the plug gauge and complete the inverted flare.



RH222

**Fig. 2 Inverted Flare Tools**

### STANDARD PROCEDURE - ISO FLARING

A preformed metal brake tube is recommended and preferred for all repairs. However, double-wall steel

## BRAKE LINES (Continued)

tube can be used for emergency repair when factory replacement parts are not readily available.

To make a ISO flare use an ISO flaring tool kit.

- (1) Cut off damaged tube with Tubing Cutter.
- (2) Remove any burrs from the inside of the tube.
- (3) Install tube nut on the tube.
- (4) Position the tube in the flaring tool flush with the top of the tool bar (Fig. 3). Then tighten the tool bar on the tube.
- (5) Install the correct size adaptor on the flaring tool yoke screw.
- (6) Lubricate the adaptor.
- (7) Align the adaptor and yoke screw over the tube (Fig. 3).
- (8) Turn the yoke screw in until the adaptor is squarely seated on the tool bar.

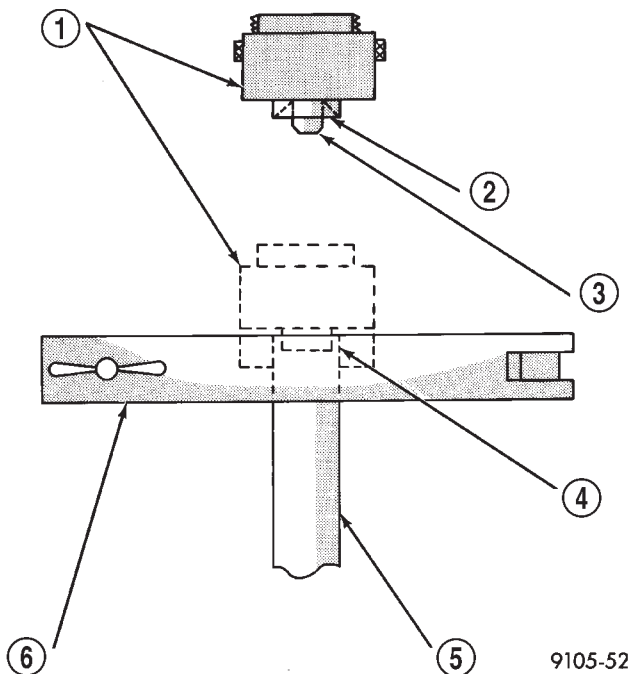


Fig. 3 ISO Flaring

- 1 - ADAPTER
- 2 - LUBRICATE HERE
- 3 - PILOT
- 4 - FLUSH WITH BAR
- 5 - TUBING
- 6 - BAR ASSEMBLY

## COMBINATION VALVE

## DESCRIPTION

The combination valve contains a pressure differential valve and switch, metering valve and a rear brake proportioning valve on 1500 and early 2500/3500 models with rear drum brakes. The combination valve/rear brake proportioning valve are not repairable and must be replaced as an assembly.

The pressure differential switch is connected to the brake warning lamp.

The metering valve on the 1500 and early 2500/3500 models with rear drum brakes is used to balance brake action between the front disc and rear drum brakes.

The proportioning valve on the 1500 and early 2500/3500 models with rear drum brakes is used to balance front-rear brake action at high decelerations.

## OPERATION

## PRESSURE DIFFERENTIAL SWITCH

The switch is triggered by movement of the switch valve. The purpose of the switch is to monitor fluid pressure in the separate front/rear brake hydraulic circuits.

A decrease or loss of fluid pressure in either hydraulic circuit will cause the switch valve to shuttle forward or rearward in response to the pressure differential. Movement of the switch valve will push the switch plunger upward. This closes the switch internal contacts completing the electrical circuit to the warning lamp. The switch valve may remain in an actuated position until repair restores system pressures to normal levels.

## METERING VALVE (1500 Model)(and early 2500/3500 models with rear drum brakes)

The valve holds-off the initial pressure to the front disc brakes until the rear brake shoes retracting springs are overcome. The valve is designed to maintain front brake fluid pressure at 241-517 kPa (35-75 psi) until the hold-off limit of 310-689 kPa (100 psi) is reached. At this point, the metering valve opens completely permitting full fluid apply pressure to the front disc brakes. This reduces front brake lining wear during low deceleration stops.

## PROPORTIONING VALVE (1500 Model)(and early 2500/3500 models with rear drum brakes)

The valve allows normal fluid flow during moderate braking. The valve only controls fluid flow during high decelerations brake stops, when a percentage of rear weight is transferred to the front wheels.

## DIAGNOSIS AND TESTING - COMBINATION VALVE

## Pressure Differential Switch

- (1) Have helper sit in drivers seat to apply brake pedal and observe red brake warning light.
- (2) Raise vehicle on hoist.
- (3) Connect bleed hose to a rear wheel cylinder and immerse hose end in container partially filled with brake fluid.

## COMBINATION VALVE (Continued)

(4) Have helper press and hold brake pedal to floor and observe warning light.

(a) If warning light illuminates, switch is operating correctly.

(b) If light fails to illuminate, check circuit fuse, bulb, and wiring. The parking brake switch can be used to aid in identifying whether or not the brake light bulb and fuse is functional. Repair or replace parts as necessary and test differential pressure switch operation again.

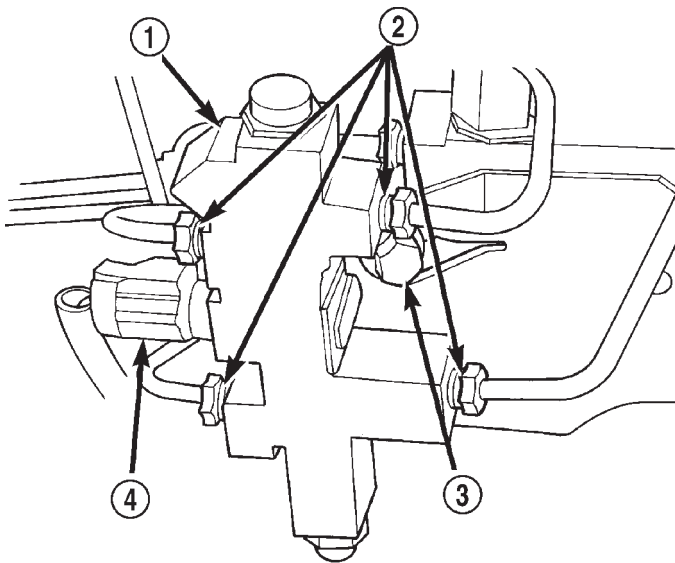
(5) If warning light still does not illuminate, switch is faulty. Replace combination valve assembly, bleed brake system and verify proper switch and valve operation.

## REMOVAL

(1) Remove pressure differential switch wire connector (Fig. 4) from the valve.

(2) Remove the brake lines from the valve.

(3) Remove the valve mounting bolt and remove the valve from the bracket.



80aff541

Fig. 4 Pressure

- 1 - COMBINATION VALVE
- 2 - BRAKE LINES
- 3 - MOUNTING BOLT
- 4 - PRESSURE DIFFERENTIAL SWITCH

## INSTALLATION

(1) Position the valve on the bracket and install the mounting bolt. Tighten the mounting bolt to 23 N·m (210 in. lbs.).

(2) Install the brake lines into the valve and tighten to 19-23 N·m (170-200 in. lbs.).

(3) Connect the pressure differential switch wire connector.

(4) Bleed base brake system, (Refer to 5 - BRAKES/HYDRAULIC/MECHANICAL - STANDARD PROCEDURE).

## DISC BRAKE CALIPERS

## REMOVAL - REAR

(1) Raise and support the vehicle.

(2) Remove the tire and wheel assembly.

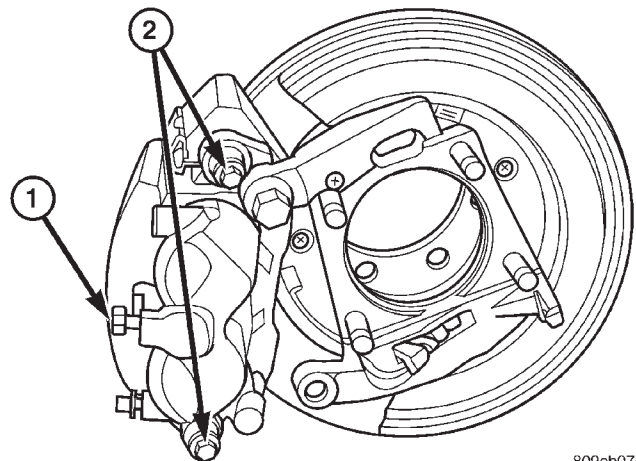
(3) Compress the disc brake caliper using tool #C4212F.

(4) Remove the caliper pin bolts.

(5) Remove the banjo bolt and discard the copper washer.

**CAUTION: Never allow the disc brake caliper to hang from the brake hose. Damage to the brake hose with result. Provide a suitable support to hang the caliper securely.**

(6) Remove the rear disc brake caliper (Fig. 5).



809eb07a

Fig. 5 REAR CALIPER

- 1 - Banjo Bolt
- 2 - Caliper Pin Bolts

## REMOVAL - FRONT

(1) Raise and support vehicle.

(2) Remove front wheel and tire assembly.

(3) Remove caliper brake hose bolt, washers and hose (Fig. 6).

(4) Remove caliper mounting bolts.

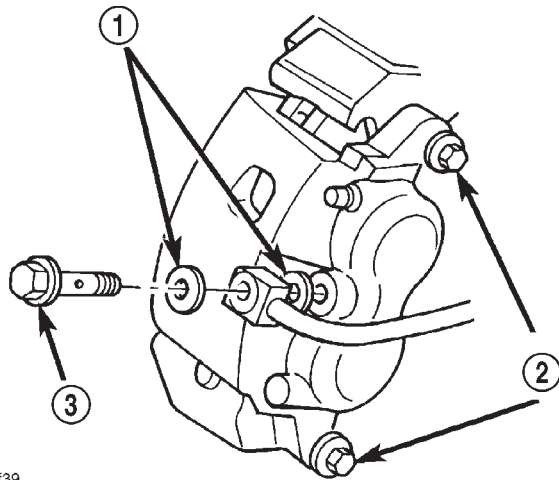
(5) Tilt the top of the caliper up and remove it from the adapter.

(6) Remove anti-rattle springs.

**NOTE: Upper and lower anti-rattle springs are not interchangeable.**



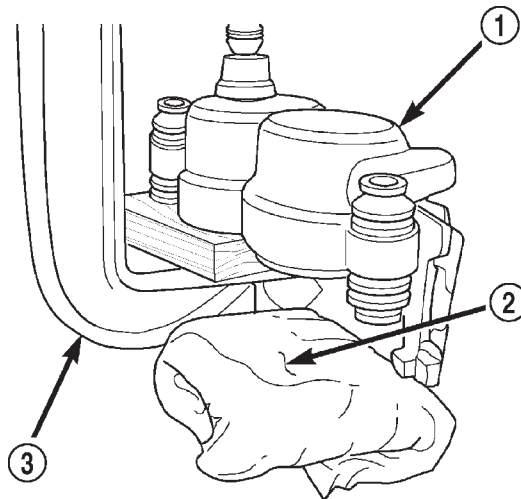
## DISC BRAKE CALIPERS (Continued)



80b31f39

**Fig. 6 Caliper**

- 1 - WASHERS
- 2 - MOUNTING BOLTS
- 3 - HOSE BOLT



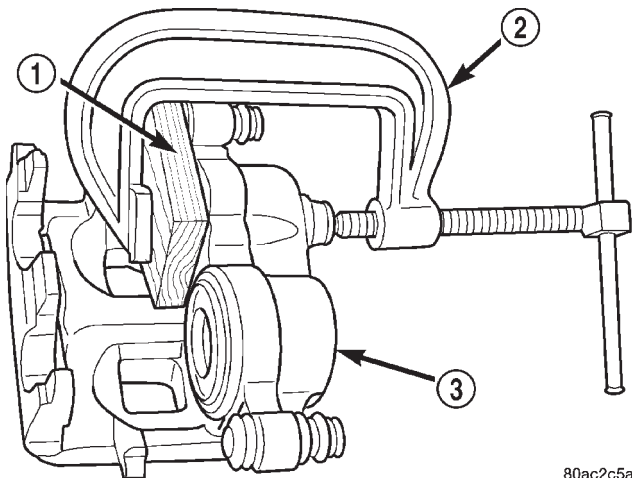
80ac2c5b

**Fig. 8 Protect Caliper Piston**

- 1 - CALIPER
- 2 - PADDED BLOCK OF WOOD
- 3 - C-CLAMP

**DISASSEMBLY**

- (1) Drain the brake fluid from caliper.
- (2) C-clamp a block of wood over one piston (Fig. 7).



80ac2c5a

**Fig. 7 C-Clamp One Piston**

- 1 - BLOCK OF WOOD
- 2 - C-CLAMP
- 3 - CALIPER

(3) Take another piece of wood and pad it with one-inch thickness of shop towels. Place this piece in the outboard shoe side of the caliper in front of the other piston. This will cushion and protect caliper piston during removal (Fig. 8).

(4) To remove the caliper piston direct **short bursts of low pressure air** with a blow gun through the caliper brake hose port. Use only enough air pressure to ease the piston out.

**CAUTION:** Do not blow the piston out of the bore with sustained air pressure. This could result in a cracked piston.

**WARNING:** NEVER ATTEMPT TO CATCH THE PISTON AS IT LEAVES THE BORE. THIS COULD RESULT IN PERSONAL INJURY.

(5) Remove the C-clamp and block of wood from the caliper and clamp it over the dust boot of the first piston removed. This will seal the empty piston bore.

(6) Move the padded piece of wood in front of the other piston.

(7) Remove the second piston using the same procedure with **short bursts of low pressure air**.

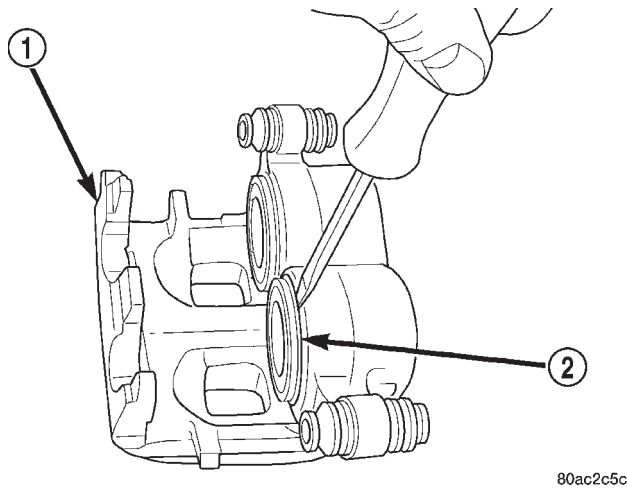
(8) Remove piston dust boots with a suitable pry tool (Fig. 9).

(9) Remove piston seals from caliper (Fig. 10).

**CAUTION:** Do not scratch piston bore while removing the seals.



## DISC BRAKE CALIPERS (Continued)



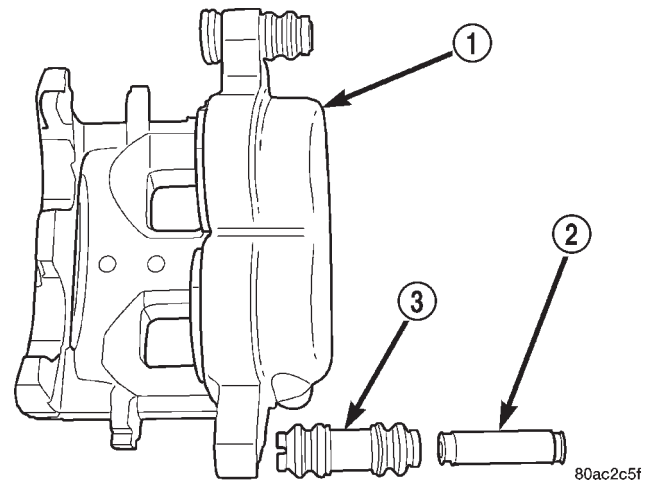
80ac2c5c

**Fig. 9 Piston Dust Boot Removal**

- 1 - CALIPER
- 2 - DUST BOOT

(10) Push caliper mounting bolt bushings out of the boot seals and remove the boot seals from the caliper (Fig. 11).

(11) Remove caliper bleed screw.



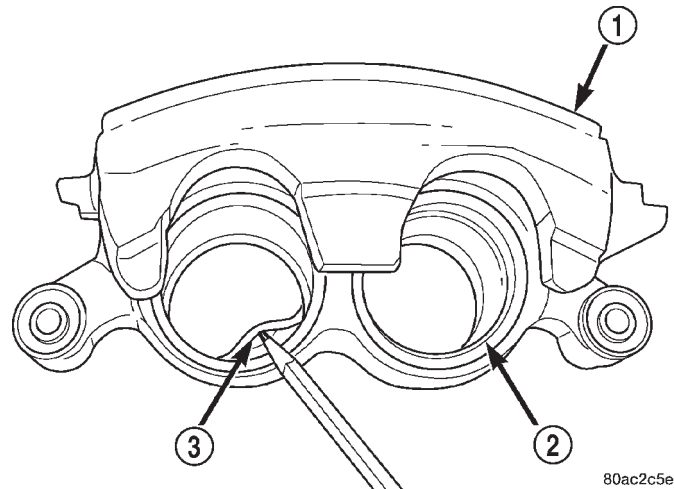
80ac2c5f

**Fig. 11 Bushings And Boot Seals**

- 1 - CALIPER
- 2 - BUSHING
- 3 - BOOT SEAL

(10) Push caliper mounting bolt bushings out of the boot seals and remove the boot seals from the caliper (Fig. 11).

(11) Remove caliper bleed screw.



80ac2c5e

**Fig. 10 Piston Seal**

- 1 - CALIPER
- 2 - PISTON BORE
- 3 - PISTON SEAL

**CLEANING**

Clean the caliper components with clean brake fluid or brake clean only. Wipe the caliper and piston dry with lint free towels or use low pressure compressed air.

**CAUTION:** Do not use gasoline, kerosene, thinner, or similar solvents. These products may leave a residue that could damage the piston and seal.

**INSPECTION**

The piston is made from a phenolic resin (plastic material) and should be smooth and clean.

The piston must be replaced if cracked or scored. Do not attempt to restore a scored piston surface by sanding or polishing.

**CAUTION:** If the caliper piston is replaced, install the same type of piston in the caliper. Never interchange phenolic resin and steel caliper pistons. The pistons, seals, seal grooves, caliper bore and piston tolerances are different.

The bore can be **lightly** polished with a brake hone to remove very minor surface imperfections (Fig. 12). The caliper should be replaced if the bore is severely corroded, rusted, scored, or if polishing would increase bore diameter more than 0.025 mm (0.001 inch).

**ASSEMBLY**

**CAUTION:** Dirt, oil, and solvents can damage caliper seals. Insure assembly area is clean and dry.

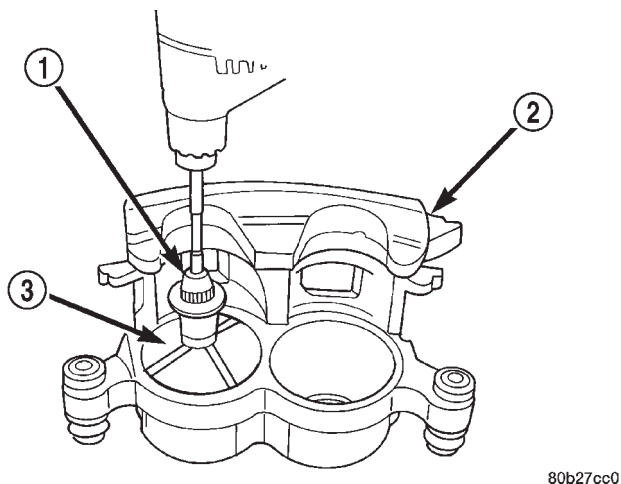
(1) Lubricate caliper pistons, piston seals and piston bores with clean, fresh brake fluid.

(2) Install new piston seals into caliper bores (Fig. 13).

**NOTE:** Verify seal is fully seated and not twisted.

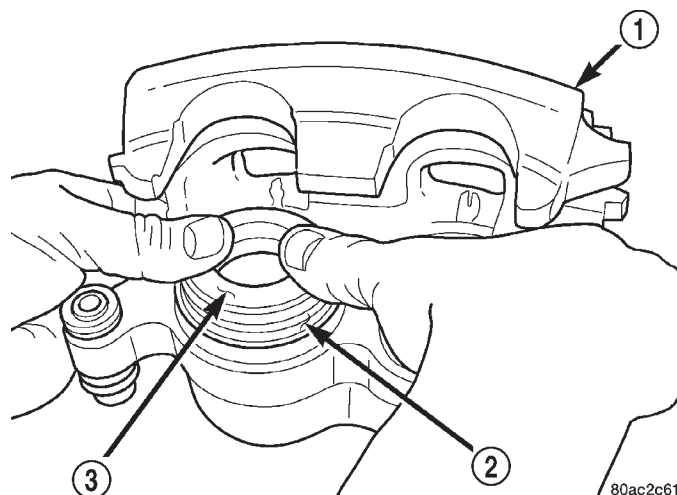
(3) Lightly lubricate lip of new boot with silicone grease. Install boot on piston and work boot lip into the groove at the top of piston.

## DISC BRAKE CALIPERS (Continued)



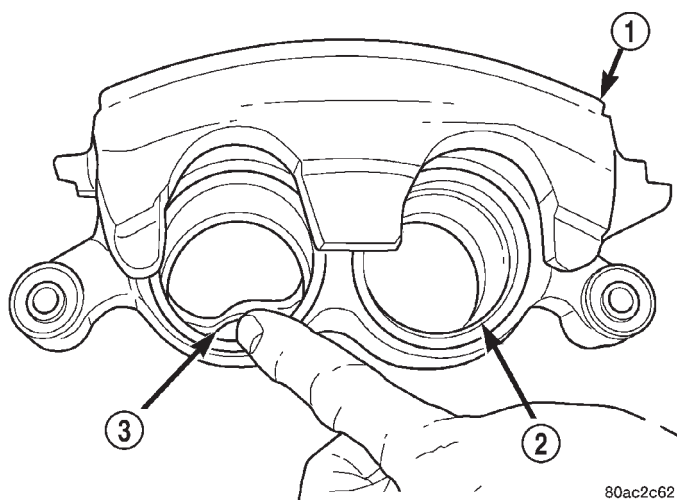
**Fig. 12 Polishing Piston Bore**

- 1 - HONE  
2 - CALIPER  
3 - PISTON BORE



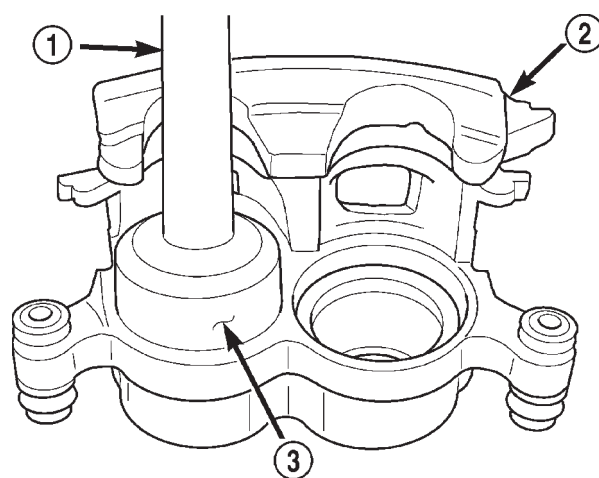
**Fig. 14 Caliper Piston Installation**

- 1 - CALIPER  
2 - DUST BOOT  
3 - PISTON



**Fig. 13 Piston Seal**

- 1 - CALIPER  
2 - PISTON BORE  
3 - PISTON SEAL



**Fig. 15 Seating Dust Boot**

- 1 - HANDLE  
2 - CALIPER  
3 - DUST BOOT INSTALLER

(4) Stretch boot rearward to straighten boot folds, then move boot forward until folds snap into place.

(5) Install piston into caliper bore and press piston down to the bottom of the caliper bore by hand or with hammer handle (Fig. 14).

(6) Seat dust boot in caliper (Fig. 15) with Handle C-4171 and Installer:

- HD 56 mm caliper: Installer C-4340
- LD 54 mm caliper: Installer C-3716-A

(7) Install the second piston and dust boot.

(8) Lubricate caliper mounting bolt bushings, boot seals and bores with Mopar brake grease or Dow Corning® 807 grease only.

**CAUTION:** Use of alternative grease may cause damage to the boots seals.

(9) Install the boot seals into the caliper seal bores and center the seals in the bores.

(10) Install mounting bolt bushings into the boot seals and insure seal lip is engaged into the bushing grooves at either end of the bushing.

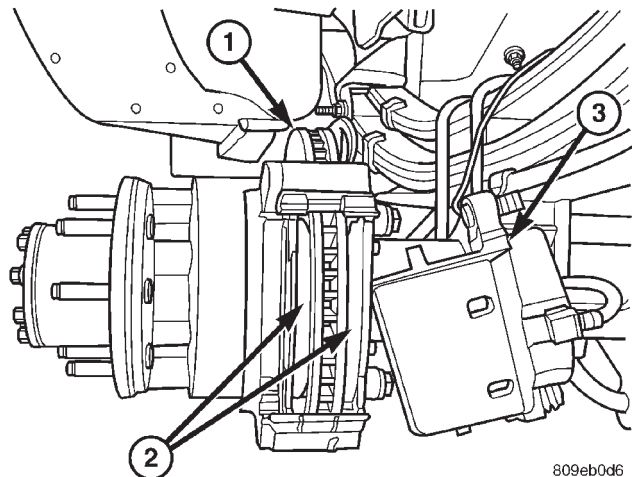
(11) Install caliper bleed screw.

## INSTALLATION - REAR

**NOTE:** Install a new copper washers on the banjo bolt when installing

## DISC BRAKE CALIPERS (Continued)

- (1) Install the rear disc brake caliper (Fig. 16).
- (2) Install the banjo bolt with new copper washers to the caliper .tighten to 38 N·m (28 ft. lbs.)
- (3) Install the caliper pin bolts. tighten to 33 N·m (25 ft. lbs.)



**Fig. 16 REAR CALIPER INSTALL**

- 1 - Rotor  
2 - Brake Shoes  
3 - Disc Brake Caliper

(4) Bleed the base brake system, (Refer to 5 - BRAKES/HYDRAULIC/MECHANICAL - STANDARD PROCEDURE).

(5) Install the tire and wheel assembly, (Refer to 22 - TIRES/WHEELS/WHEELS - STANDARD PROCEDURE).

(6) Lower the vehicle.

### INSTALLATION - FRONT

(1) Clean the caliper mounting adapter and the anti-rattle springs and grease with Mopar brake grease or Dow Corning® 807 grease only.

(2) Install the anti-rattle springs.

(3) Tilt the bottom of the caliper over the rotor and under the adapter. Then push the top of the caliper down onto the adapter.

(4) Install the caliper mounting bolts and tighten to 33 N·m (24 ft. lbs.).

(5) Install the brake hose to caliper with **new seal washers** and tighten fitting bolt to 24 N·m (18 ft. lbs.).

**CAUTION:** Verify brake hose is not twisted or kinked before tightening fitting bolt.

(6) Bleed the base brake system, (Refer to 5 - BRAKES/HYDRAULIC/MECHANICAL - STANDARD PROCEDURE).

(7) Install the wheel and tire assemblies, (Refer to 22 - TIRES/WHEELS/WHEELS - STANDARD PROCEDURE).

(8) Remove the supports and lower the vehicle.

(9) Verify a firm pedal before moving the vehicle.

## FLUID

### DIAGNOSIS AND TESTING - BRAKE FLUID CONTAMINATION

Indications of fluid contamination are swollen or deteriorated rubber parts.

Swollen rubber parts indicate the presence of petroleum in the brake fluid.

To test for contamination, put a small amount of drained brake fluid in clear glass jar. If fluid separates into layers, there is mineral oil or other fluid contamination of the brake fluid.

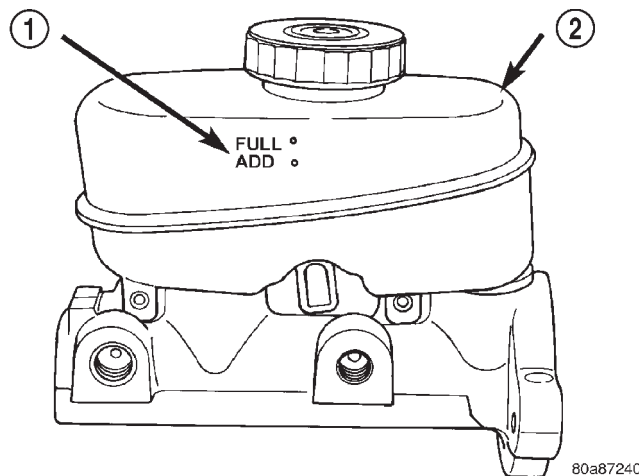
If brake fluid is contaminated, drain and thoroughly flush system. Replace master cylinder, proportioning valve, caliper seals, wheel cylinder seals, Antilock Brakes hydraulic unit and all hydraulic fluid hoses.

### STANDARD PROCEDURE - BRAKE FLUID LEVEL

Always clean the master cylinder reservoir and caps before checking fluid level. If not cleaned, dirt could enter the fluid.

The fluid fill level is indicated on the side of the master cylinder reservoir (Fig. 17).

The correct fluid level is to the FULL indicator on the side of the reservoir. If necessary, add fluid to the proper level.



**Fig. 17 Master Cylinder Fluid Level - Typical**

- 1 - INDICATOR  
2 - RESERVOIR

## FLUID (Continued)

## SPECIFICATIONS

## BRAKE FLUID

The brake fluid used in this vehicle must conform to DOT 3 specifications and SAE J1703 standards. No other type of brake fluid is recommended or approved for usage in the vehicle brake system. Use only Mopar brake fluid or an equivalent from a tightly sealed container.

**CAUTION:** Never use reclaimed brake fluid or fluid from an container which has been left open. An open container of brake fluid will absorb moisture from the air and contaminate the fluid.

**CAUTION:** Never use any type of a petroleum-based fluid in the brake hydraulic system. Use of such type fluids will result in seal damage of the vehicle brake hydraulic system causing a failure of the vehicle brake system. Petroleum based fluids would be items such as engine oil, transmission fluid, power steering fluid, etc.

## FLUID RESERVOIR

## REMOVAL

(1) Remove reservoir cap and empty fluid into drain container.

(2) Clamp cylinder body in vise with brass protective jaws.

(3) Remove pins that retain reservoir to master cylinder. Use hammer and pin punch to remove pins (Fig. 18).

(4) Loosen reservoir from grommets with pry tool (Fig. 19).

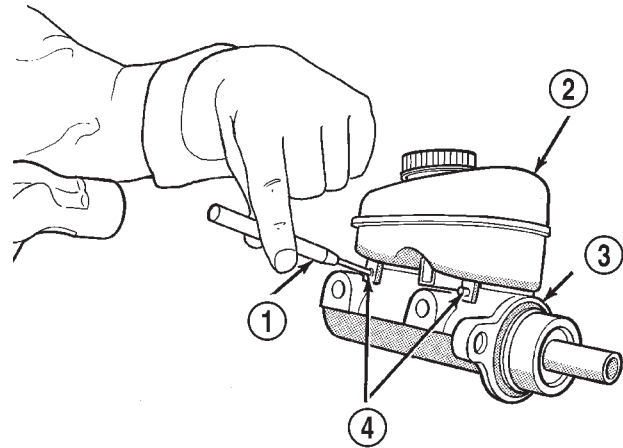
(5) Remove reservoir by rocking it to one side and pulling free of grommets (Fig. 20).

(6) Remove old grommets from cylinder body (Fig. 21).

## INSTALLATION

**CAUTION:** Do not use any type of tool to install the grommets. Tools may cut, or tear the grommets creating a leak problem after installation. Install the grommets using finger pressure only.

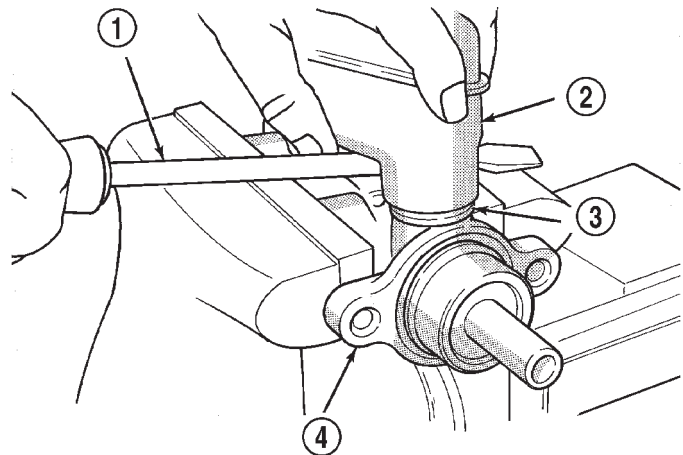
(1) Lubricate new grommets with clean brake fluid and Install new grommets in cylinder body (Fig. 22). Use finger pressure to install and seat grommets.



J9505-77

**Fig. 18 Reservoir Retaining Pins**

- 1 - PIN PUNCH
- 2 - RESERVOIR
- 3 - BODY
- 4 - ROLL PINS



J9505-47

**Fig. 19 Loosening Reservoir**

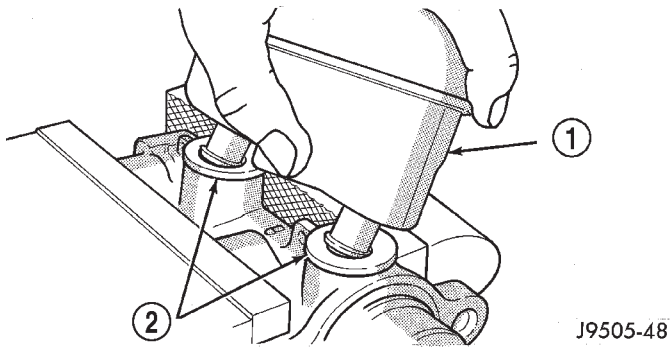
- 1 - PRY TOOL
- 2 - RESERVOIR
- 3 - GROMMET
- 4 - MASTER CYLINDER BODY

(2) Start reservoir in grommets. Then rock reservoir back and forth while pressing downward to seat it in grommets.

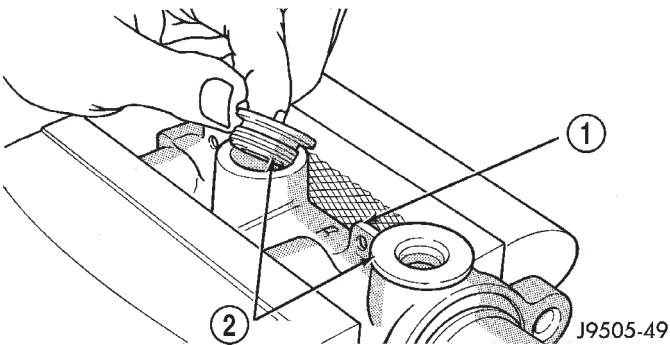
(3) Install pins that retain reservoir to cylinder body.

(4) Fill and bleed master cylinder on bench before installation in vehicle.

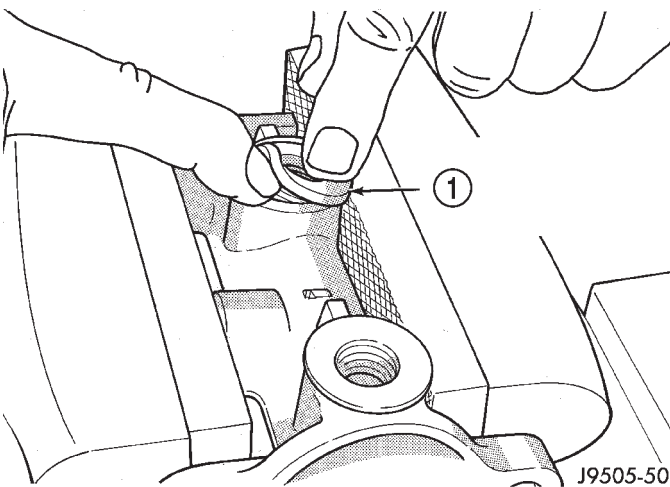
## FLUID RESERVOIR (Continued)

**Fig. 20 Reservoir Removal**

- 1 - RESERVOIR  
2 - GROMMETS

**Fig. 21 Grommet Removal**

- 1 - MASTER CYLINDER BODY  
2 - GROMMETS

**Fig. 22 Grommet Installation**

- 1 - WORK NEW GROMMETS INTO PLACE USING FINGER PRESSURE ONLY

## PEDAL

## DESCRIPTION

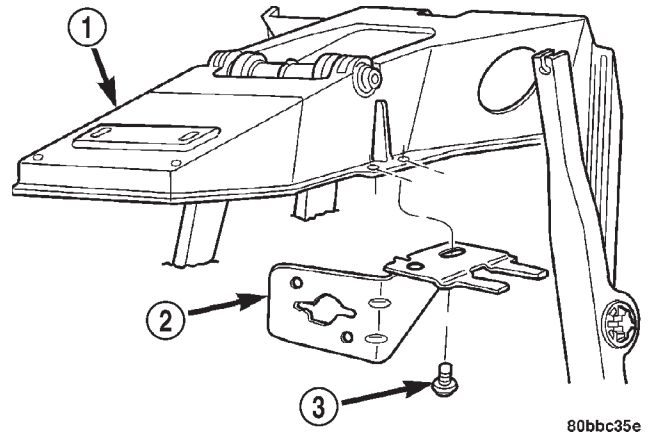
The brake booster is operated by a suspended type brake pedal. The pedal pivots on a shaft located in a mounting bracket attached to the dash panel. The pedal shaft is supported by bushings in the pedal and mounting bracket. The brake pedal is attached to the booster push rod.

## OPERATION

When the pedal is depressed, the primary booster push rod is depressed which move the booster secondary rod. The booster secondary rod depress the master cylinder piston.

## REMOVAL

- (1) Remove knee bolster, (Refer to 23 - BODY/INSTRUMENT PANEL/STEERING COLUMN OPENING COVER - REMOVAL).
- (2) Remove brake lamp switch, (Refer to 8 - ELECTRICAL/LAMPS/LIGHTING - EXTERIOR/BRAKE LAMP SWITCH - REMOVAL).
- (3) Remove switches from tabs on brake lamp switch bracket.
- (4) Remove brake lamp switch bracket bolts and remove bracket (Fig. 23).

**Fig. 23 Brake Lamp Switch Bracket**

- 1 - PEDAL BRACKET  
2 - BRAKELIGHT SWITCH BRACKET  
3 - BRACKET SCREWS (2)

- (5) Remove clip and washer attaching booster push rod and slide push rod off pedal.

- (6) Remove E-clip from passenger side of pedal shaft (Fig. 24). Use flat blade screwdriver to pry clip out of shaft groove.

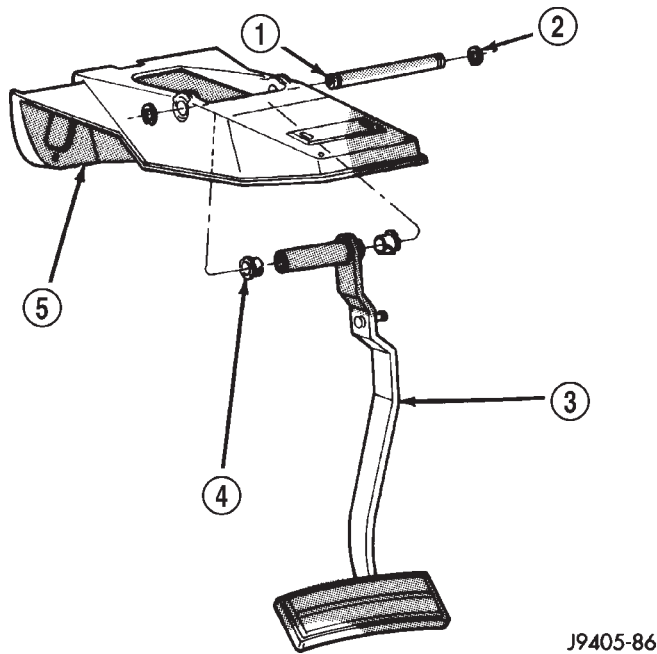
- (7) Push shaft toward driver side of bracket just enough to expose opposite E-clip. Then remove E-clip with flat blade screwdriver.



## PEDAL (Continued)

(8) Push pedal shaft back and out of passenger side of bracket (Fig. 24).

(9) Remove pedal shaft, brake pedal, wave washer and bushings from vehicle.



J9405-86

**Fig. 24 Brake Pedal Mounting (With Automatic Transmission)**

- 1 - PEDAL SHAFT
- 2 - SHAFT RETAINING E-CLIPS (2)
- 3 - BRAKE PEDAL
- 4 - PEDAL BUSHING (2)
- 5 - PEDAL MOUNTING BRACKET

## INSTALLATION

(1) Replace bracket and pedal bushings if necessary. Lubricate shaft bores in bracket and pedal before installing bushings with Mopar Multi-mileage silicone grease.

(2) Apply liberal quantity of Mopar multi-mileage grease to pedal shaft and to pedal and bracket bushings.

(3) Position brake pedal in mounting bracket.

(4) Slide pedal shaft into bracket and through pedal from passenger side.

(5) Push pedal shaft out driver side of mounting bracket just enough to allow installation of retaining E-clip.

(6) Install the wave washer between the bracket and the pedal bushing on the passenger side.

(7) Push pedal shaft back toward passenger side of bracket and install remaining E-clip on pedal shaft.

(8) Install booster push rod on brake pedal. Secure push rod to pedal with washer and retaining clip.

(9) Install brake lamp switch bracket and switch, (Refer to 8 - ELECTRICAL/LAMPS/LIGHTING -

EXTERIOR/BRAKE LAMP SWITCH - INSTALLATION).

(10) Install knee bolster, (Refer to 23 - BODY/INSTRUMENT PANEL/STEERING COLUMN OPENING COVER - INSTALLATION).

## POWER BRAKE BOOSTER

### DIAGNOSIS AND TESTING - HYDRAULIC BOOSTER

The hydraulic booster uses hydraulic pressure from the power steering pump. Before diagnosing a booster problem, first verify the power steering pump is operating properly. Perform the following checks.

- Check the power steering fluid level.
- Check the brake fluid level.
- Check all power steering hoses and lines for leaks and restrictions.
- Check power steering pump pressure.

### NOISES

The hydraulic booster unit will produce certain characteristic booster noises. The noises may occur when the brake pedal is used in a manner not associated with normal braking or driving habits.

#### HISSING

A hissing noise may be noticed when above normal brake pedal pressure is applied, 40 lbs. or above. The noise will be more noticeable if the vehicle is not moving. The noise will increase with the brake pedal pressure and an increase of system operating temperature.

#### CLUNK-CHATTER-CLICKING

A clunk-chatter-clicking may be noticed when the brake pedal is released quickly, after above normal brake pedal pressure is applied 50-100 lbs..

### BOOSTER FUNCTION TEST

With the engine off depress the brake pedal several times to discharge the accumulator. Then depress the brake pedal using 40 lbs. of force and start the engine. The brake pedal should fall and then push back against your foot. This indicates the booster is operating properly.

### ACCUMULATOR LEAKDOWN

(1) Start the engine, apply the brakes and turn the steering wheel from lock to lock. This will ensure the accumulator is charged. Turn off the engine and let the vehicle sit for one hour. After one hour there should be at least two power assisted brake application with the engine off. If the system does not retain a charge the booster must be replaced.

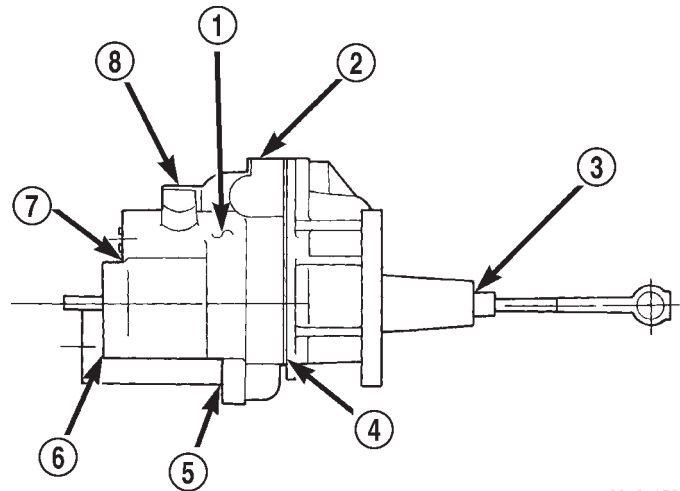
POWER BRAKE BOOSTER (Continued)

(2) With the engine off depress the brake pedal several times to discharge the accumulator. Grasp the accumulator and see if it wobbles or turns. If it does the accumulator has lost a gas charge and the booster must be replaced.

**SEAL LEAKAGE**

If the booster leaks from any of the seals the booster assembly must be replaced (Fig. 25).

- **INPUT ROD SEAL:** Fluid leakage from rear end of the booster.
- **PISTON SEAL:** Fluid leakage from vent at front of booster.
- **HOUSING SEAL:** Fluid leakage between housing and housing cover.
- **SPOOL VALVE SEAL:** Fluid leakage near spool plug.
- **RETURN PORT FITTING SEAL:** Fluid leakage from port fitting.



80a6a150

**Fig. 25 Hydraulic Booster Seals**

- 1 - PUMP
- 2 - GEAR
- 3 - INPUT SEAL
- 4 - HOUSING SEAL
- 5 - ACCUMULATOR SEAL
- 6 - PISTON SEAL
- 7 - SPOOL PLUG SEAL
- 8 - RETURN

HYDRAULIC BOOSTER DIAGNOSIS CHART

CONDITION	POSSIBLE CAUSES	CORRECTION
Slow Brake Pedal Return	1. Excessive seal friction in booster. 2. Faulty spool valve action. 3. Restriction in booster return hose. 4. Damaged input rod.	1. Replace booster. 2. Replace booster. 3. Replace hose. 4. Replace booster.
Excessive Brake Pedal Effort.	1. Internal or external seal leakage. 2. Faulty steering pump.	1. Replace booster. 2. Replace pump.
Brakes Self Apply	1. Dump valve faulty. 2. Contamination in hydraulic system. 3. Restriction in booster return hose.	1. Replace booster. 2. Flush hydraulic system and replace booster. 3. Replace hose.
Booster Chatter, Pedal Vibration	1. Slipping pump belt. 2. Low pump fluid level.	1. Replace power steering belt. 2. Fill pump and check for leaks.
Grabbing Brakes	1. Low pump flow. 2. Faulty spool valve action.	1. Test and repair/replace pump. 2. Replace booster.

## POWER BRAKE BOOSTER (Continued)

**STANDARD PROCEDURE - BLEEDING**

The hydraulic booster is generally self-bleeding, this procedure will normally bleed the air from the booster. Normal driving and operation of the unit will remove any remaining trapped air.

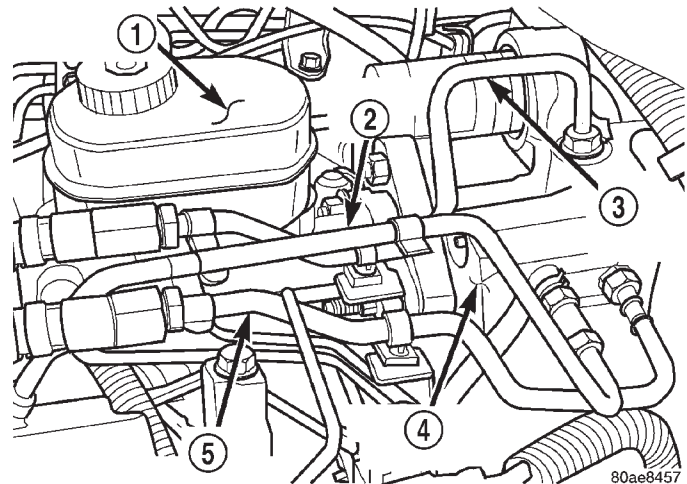
- (1) Fill power steering pump reservoir.
- (2) Disconnect fuel shutdown relay and crank the engine for several seconds, Refer to Fuel System for relay location and WARNING.
- (3) Check fluid level and add if necessary.
- (4) Connect fuel shutdown relay and start the engine.
- (5) Turn the steering wheel slowly from lock to lock twice.
- (6) Stop the engine and discharge the accumulator by depressing the brake pedal 5 times.
- (7) Start the engine and turn the steering wheel slowly from lock to lock twice.
- (8) Turn off the engine and check fluid level and add if necessary.

**NOTE:** If fluid foaming occurs, wait for foam to dissipate and repeat steps 7 and 8.

**REMOVAL**

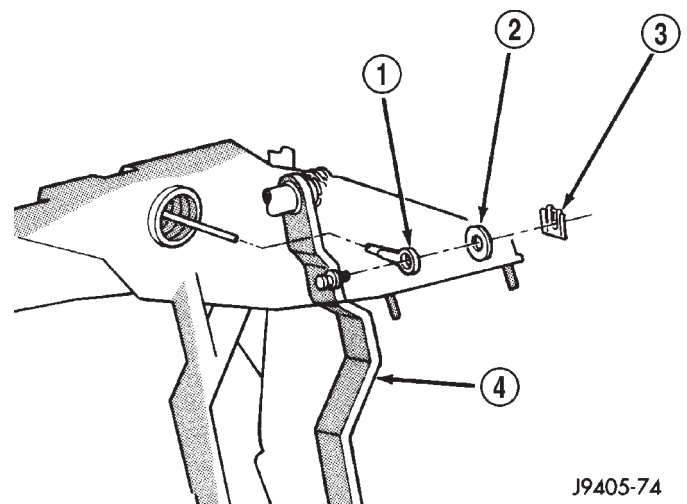
**NOTE:** If the booster is being replaced because the power steering fluid is contaminated, flush the power steering system before replacing the booster.

- (1) With engine off depress the brake pedal 5 times to discharge the accumulator.
- (2) Remove brake lines from master cylinder.
- (3) Remove mounting nuts from the master cylinder.
- (4) Remove the bracket from the hydraulic booster lines and master cylinder mounting studs.
- (5) Remove the master cylinder.
- (6) Remove the return hose and the two pressure lines from the hydraulic booster (Fig. 26).
- (7) Remove the booster push rod clip, washer and rod remove from the brake pedal. (Fig. 27).
- (8) Remove the mounting nuts from the hydraulic booster and remove the booster (Fig. 28).



**Fig. 26 Master Cylinder And Booster**

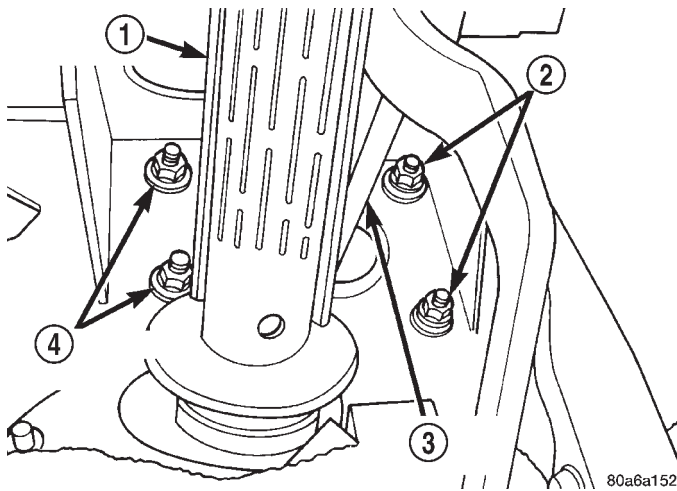
- 1 - MASTER CYLINDER
- 2 - RETURN LINE
- 3 - LINE FROM PUMP
- 4 - HYDRAULIC BOOSTER
- 5 - LINE TO GEAR



**Fig. 27 Booster Push Rod**

- 1 - BOOSTER PUSH ROD
- 2 - WASHER
- 3 - CLIP
- 4 - PEDAL

## POWER BRAKE BOOSTER (Continued)



**Fig. 28 Booster Mounting**

- 1 - STEERING COLUMN  
 2 - MOUNTING NUTS  
 3 - BOOSTER PEDAL ROD  
 4 - MOUNTING NUTS

## INSTALLATION

- (1) Install the hydraulic booster and tighten the mounting nuts to 28 N·m (21 ft. lbs.).
- (2) Install the booster push rod, washer and clip onto the brake pedal.
- (3) Install the master cylinder on the mounting studs, and tighten the mounting nuts to 23 N·m (17 ft. lbs.).
- (4) Install the brake lines to the master cylinder and tighten to 19-200 N·m (170-200 in. lbs.).
- (5) Install the hydraulic booster line bracket onto the master cylinder mounting studs.
- (6) Install the master cylinder mounting nuts and tighten to 23 N·m (17 ft. lbs.).
- (7) Install the hydraulic booster pressure lines to the bracket and booster.
- (8) Tighten the pressure lines to 28 N·m (21 ft. lbs.).

**NOTE:** Inspect o-rings on the pressure line fittings to insure they are in good condition before installation. Replace o-rings if necessary.

- (9) Install the return hose to the booster.
- (10) Bleed base brake system, (Refer to 5 - BRAKES/HYDRAULIC/MECHANICAL - STANDARD PROCEDURE).
- (11) Fill the power steering pump with fluid, (Refer to 19 - STEERING/PUMP - STANDARD PROCEDURE).

**CAUTION:** Use only MOPAR power steering fluid or equivalent. Do not use automatic transmission fluid and do not overfill.

- (12) Bleed the hydraulic booster.

## ROTORS

### DIAGNOSIS AND TESTING—DISC BRAKE ROTOR

The rotor braking surfaces should not be refinished unless necessary.

Light surface rust and scale can be removed with a lathe equipped with dual sanding discs. The rotor surfaces can be restored by machining with a disc brake lathe if surface scoring and wear are light.

Replace the rotor for the following conditions:

- Severely Scored
- Tapered
- Hard Spots
- Cracked
- Below Minimum Thickness

### ROTOR MINIMUM THICKNESS

Measure rotor thickness at the center of the brake shoe contact surface. Replace the rotor if below minimum thickness, or if machining would reduce thickness below the allowable minimum.

Rotor minimum thickness is usually specified on the rotor hub. The specification is either stamped or cast into the hub surface.

### ROTOR RUNOUT

Check rotor lateral runout with dial indicator C-3339 (Fig. 29). Excessive lateral runout will cause brake pedal pulsation and rapid, uneven wear of the brake shoes. Position the dial indicator plunger approximately 25.4 mm (1 in.) inward from the rotor edge.

**NOTE:** Be sure wheel bearing has zero end play before checking rotor runout.

Maximum allowable rotor runout is 0.127 mm (0.005 in.).

### ROTOR THICKNESS VARIATION

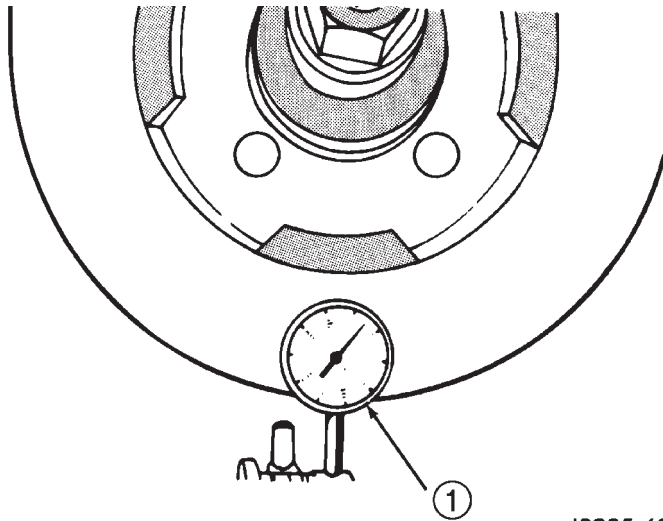
Variations in rotor thickness will cause pedal pulsation, noise and shudder.

Measure rotor thickness at 6 to 12 points around the rotor face (Fig. 30).

Position the micrometer approximately 25.4 mm (1 in.) from the rotor outer circumference for each measurement.

Thickness should not vary by more than 0.025 mm (0.001 in.) from point-to-point on the rotor. Machine or replace the rotor if necessary.

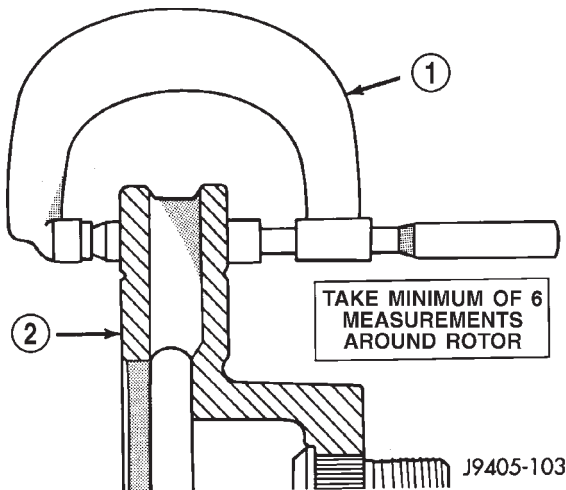
## ROTORS (Continued)



J8905-68

**Fig. 29 Checking Rotor Runout And Thickness Variation**

1 - DIAL INDICATOR



J9405-103

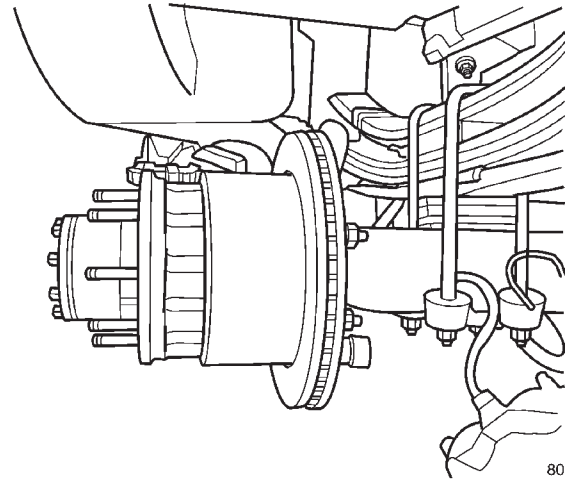
**Fig. 30 Measuring Rotor Thickness**

1 - MICROMETER  
2 - ROTOR

## REMOVAL - REAR - 2500/3500

- (1) Raise and support the vehicle
- (2) Remove the tire and wheel assembly.
- (3) Remove the disc brake caliper, (Refer to 5 - BRAKES/HYDRAULIC/MECHANICAL/DISC BRAKE CALIPERS - REMOVAL).
- (4) Remove the caliper adapter bolts.
- (5) Remove the rear axle shaft from the housing on dual rear wheels, (Refer to 3 - DIFFERENTIAL & DRIVELINE/REAR AXLE - 286RBI/AXLE SHAFTS - REMOVAL).

- (6) Remove the hub and rotor assembly (C3500 only) (Fig. 31).



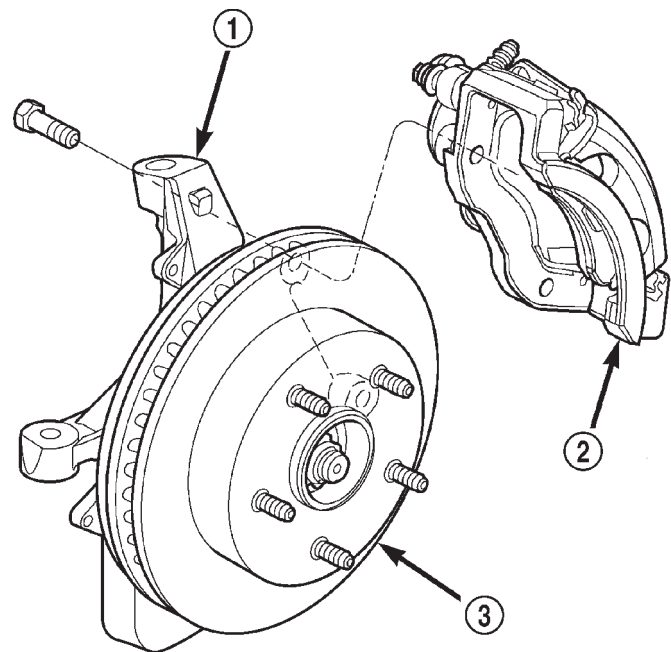
809eb17c

**Fig. 31 ROTOR / HUB REMOVAL**

## REMOVAL - 1500/2500 FRONT

- (1) Raise and support the vehicle.
- (2) Remove the wheel and tire assembly.
- (3) Remove the caliper from the steering knuckle, (Refer to 5 - BRAKES/HYDRAULIC/MECHANICAL/DISC BRAKE CALIPERS - REMOVAL) and remove caliper adapter assembly (Fig. 32).

**NOTE: Do not allow brake hose to support caliper adapter assembly.**



80be4656

**Fig. 32 Caliper Adapter Assembly**

1 - KNUCKLE  
2 - CALIPER  
3 - ROTOR



## ROTORS (Continued)

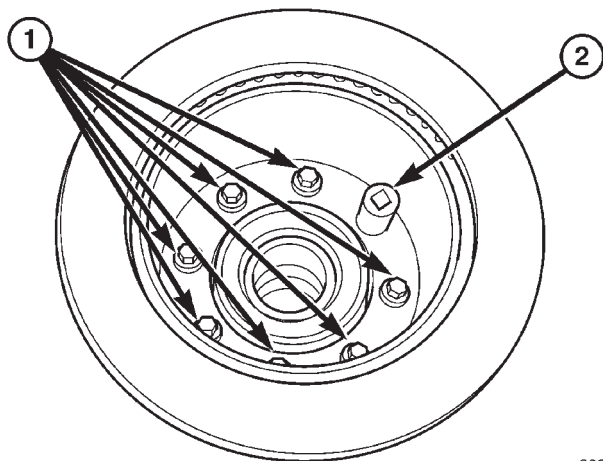
(4) Remove the rotor from the hub/bearing wheel studs.

**REMOVAL - 3500 FRONT**

- (1) Raise and support the vehicle.
- (2) Remove the wheel and tire assembly.
- (3) Remove the hub extension mounting nuts and remove the extension from the rotor if equipped.
- (4) Remove the brake caliper adapter assembly. (Refer to 5 - BRAKES/HYDRAULIC/MECHANICAL/DISC BRAKE CALIPERS - REMOVAL).
- (5) Remove the rotor assembly.

**INSTALLATION - REAR - 2500/3500**

(1) Install the hub to the rotor. Tighten the bolts to 128 N·m (95 ft. lbs.) (Fig. 33).

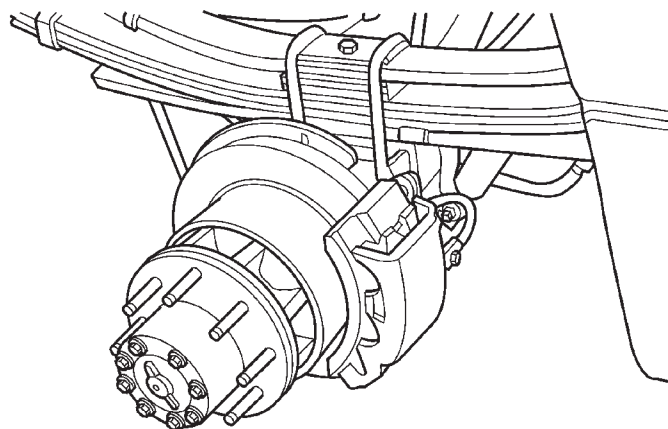


809eb125

**Fig. 33 ROTOR TO HUB**

- 1 - Hub Bolts  
2 - Socket

- (2) Install the hub and rotor assembly.
- (3) Install the rear axle shaft to the housing with dual wheels, (Refer to 3 - DIFFERENTIAL & DRIVE/ELINE/REAR AXLE - 286RBI/AXLE SHAFTS - INSTALLATION).
- (4) Install the caliper adapter bolts.
- (5) Install the disc brake caliper, (Refer to 5 - BRAKES/HYDRAULIC/MECHANICAL/DISC BRAKE CALIPERS - INSTALLATION). (Fig. 34).
- (6) Install the tire and wheel assembly, (Refer to 22 - TIRES/WHEELS/WHEELS - STANDARD PROCEDURE).
- (7) Lower the vehicle.



809eb11d

**Fig. 34 ROTOR INSTALLED****INSTALLATION - 1500/2500 FRONT**

(1) On models with all-wheel antilock system (ABS), check condition of tone wheel on hub/bearing. If teeth on wheel are damaged, hub/bearing assembly will have to be replaced (tone wheel is not serviced separately).

- (2) Install rotor onto the hub/bearing wheel studs.
- (3) Install the caliper adapter assembly, (Refer to 5 - BRAKES/HYDRAULIC/MECHANICAL/DISC BRAKE CALIPERS - INSTALLATION) and tighten adapter bolts to:

- LD 1500: 176 N·m (130 ft lbs.)
- HD 2500: 285 N·m (210 ft lbs.)

(4) Install the wheel and tire assembly, (Refer to 22 - TIRES/WHEELS/WHEELS - STANDARD PROCEDURE) and lower vehicle.

(5) Apply brakes several times to seat brake shoes. Be sure to obtain firm pedal before moving vehicle.

**INSTALLATION - 3500 FRONT**

(1) Position the rotor on the hub/bearing.

(2) Install the brake caliper adapter assembly (Refer to 5 - BRAKES/HYDRAULIC/MECHANICAL/DISC BRAKE CALIPERS - INSTALLATION) and tighten adapter bolts to 285 N·m (210 ft. lbs).

(3) Install the wheel and tire assemblies, (Refer to 22 - TIRES/WHEELS/WHEELS - STANDARD PROCEDURE).

- (4) Remove the support and lower the vehicle.
- (5) Apply brakes several times to seat brake shoes and caliper piston. Do not move vehicle until firm brake pedal is obtained.

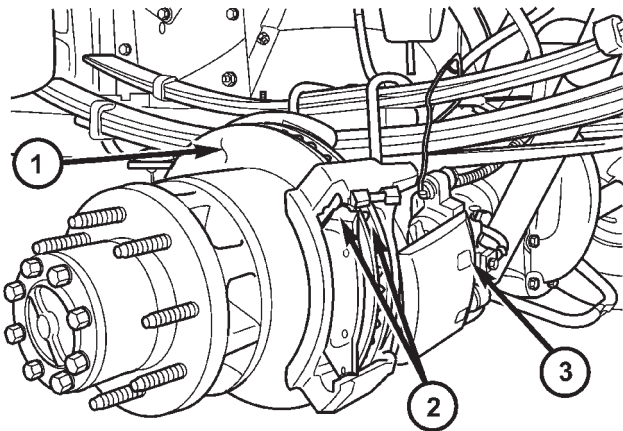
## BRAKE PADS/SHOES

### REMOVAL - REAR

- (1) Raise and support the vehicle.
- (2) Remove the rear wheel and tire assemblies.
- (3) Compress the caliper.
- (4) Remove caliper mounting bolts

**NOTE: Do not allow brake hose to support caliper assembly.**

(5) Remove the caliper, (Refer to 5 - BRAKES/HYDRAULIC/MECHANICAL/DISC BRAKE CALIPERS - REMOVAL) and then tilt the top up and off the caliper adapter (Fig. 35).



809eb894

**Fig. 35 ROTOR / PADS/ CALIPER**

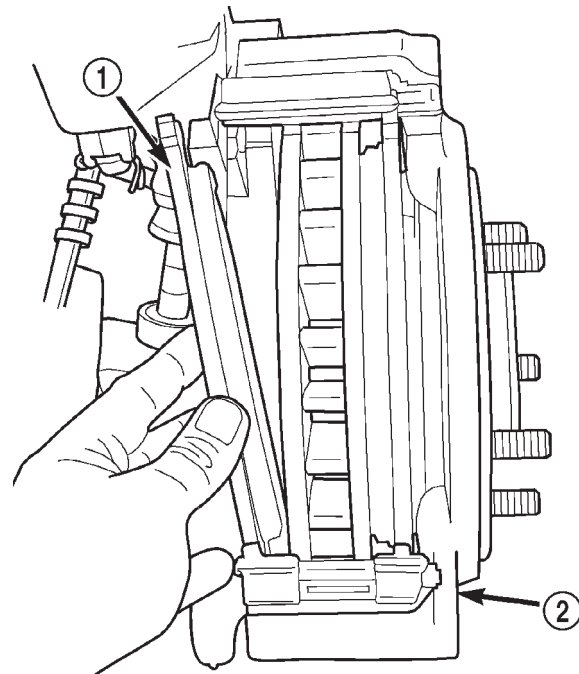
- 1 - Rotor
- 2 - Brake Shoes
- 3 - Disc Brake Caliper

(6) Remove inboard brake shoe from the caliper adapter (Fig. 36).

(7) Remove outboard brake shoe from caliper adapter (Fig. 37).

(8) Remove the anti-rattle springs from the caliper adapter (Fig. 38) and (Fig. 39).

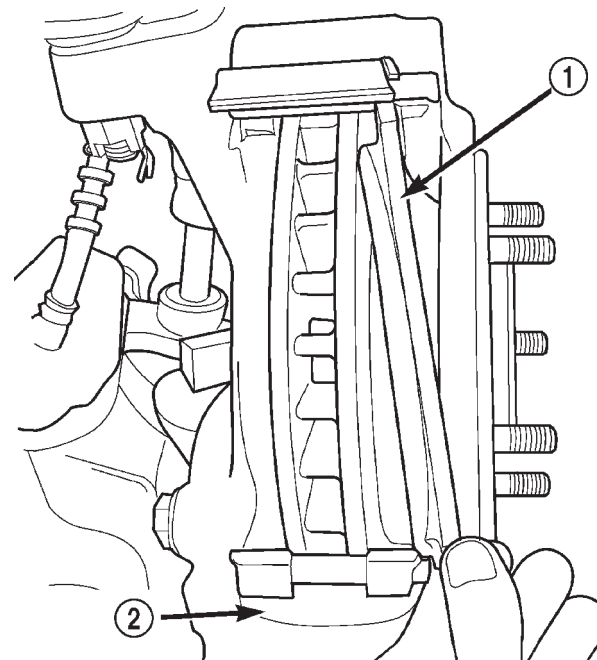
**NOTE: Anti-rattle springs are not interchangeable.**



80be4652

**Fig. 36 Inboard Brake Shoe**

- 1 - INBOARD SHOE
- 2 - CALIPER ADAPTER



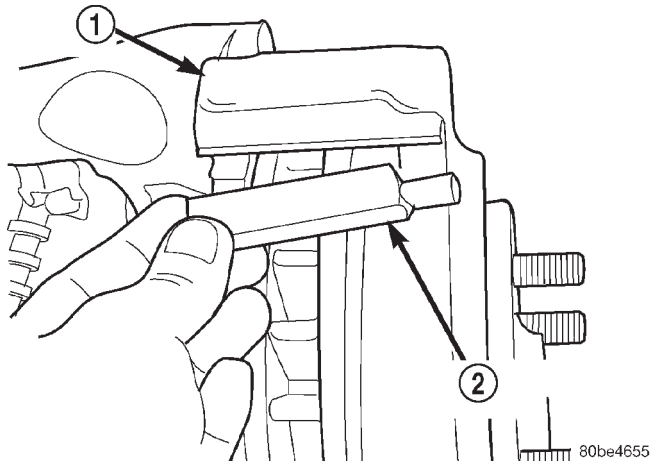
80be4653

**Fig. 37 Outboard Brake Shoe**

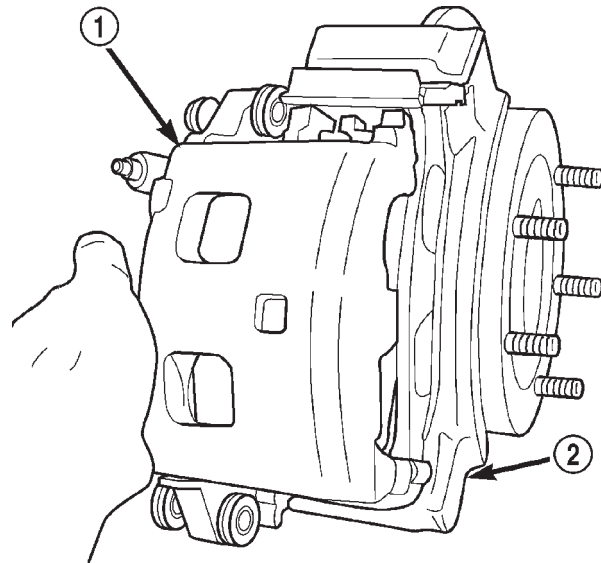
- 1 - OUTBOARD SHOE
- 2 - CALIPER ADAPTER

## BRAKE PADS/SHOES (Continued)

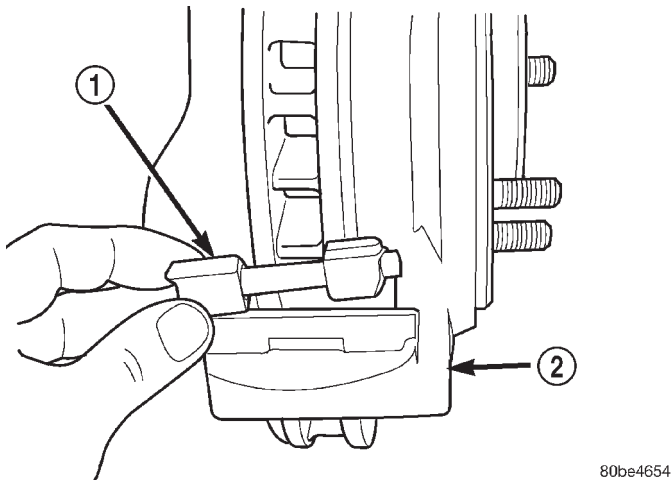
## REMOVAL - FRONT

**Fig. 38 Top Anti-Rattle Spring**

- 1 - CALIPER ADAPTER  
2 - ANTI-RATTLE SPRING

**Fig. 40 Caliper**

- 1 - CALIPER  
2 - CALIPER ADAPTER

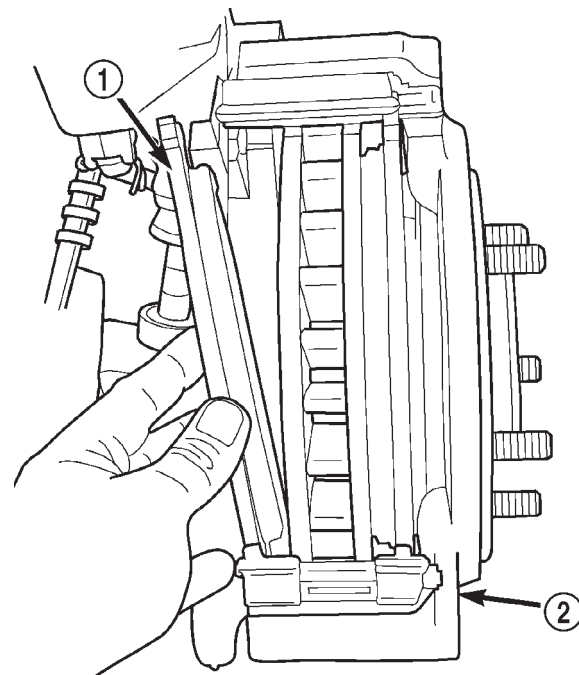
**Fig. 39 Bottom Anti-Rattle Spring**

- 1 - ANTI-RATTLE SPRING  
2 - CALIPER ADAPTER

- (1) Raise and support vehicle.
- (2) Remove front wheel and tire assemblies.
- (3) Compress caliper.
- (4) Remove caliper, (Refer to 5 - BRAKES/HYDRAULIC/MECHANICAL/DISC BRAKE CALIPERS - REMOVAL).
- (5) Remove caliper by tilting the top up and off the caliper adapter (Fig. 40).

**NOTE: Do not allow brake hose to support caliper assembly.**

- (6) Remove inboard brake shoe from the caliper adapter (Fig. 41).

**Fig. 41 Inboard Brake Shoe**

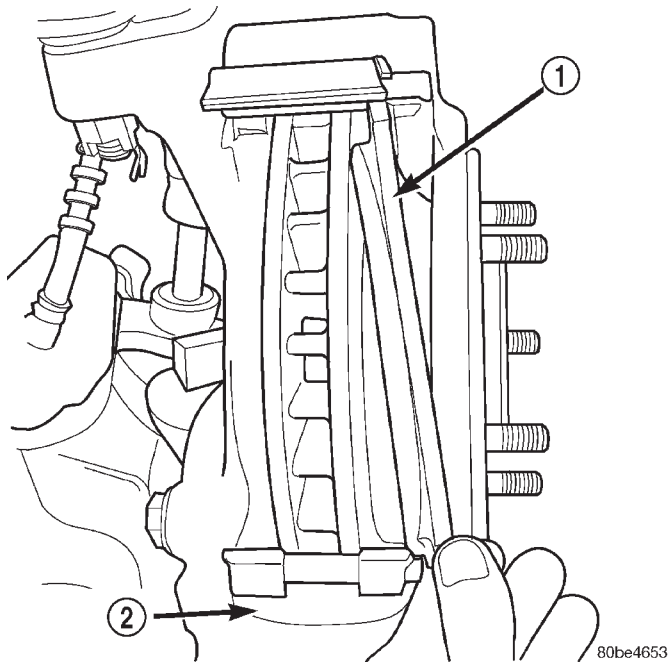
- 1 - INBOARD SHOE  
2 - CALIPER ADAPTER

- (7) Remove outboard brake shoe from caliper adapter (Fig. 42).

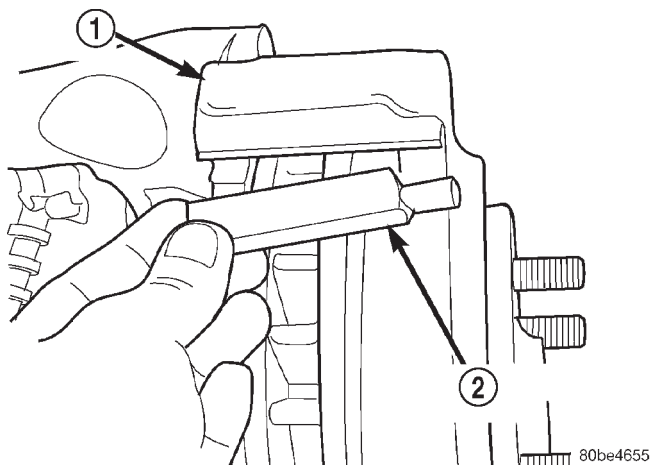
- (8) Remove the anti-rattle springs from the caliper adapter (Fig. 43) and (Fig. 44).

**NOTE: Anti-rattle springs are not interchangeable.**

## BRAKE PADS/SHOES (Continued)

**Fig. 42 Outboard Brake Shoe**

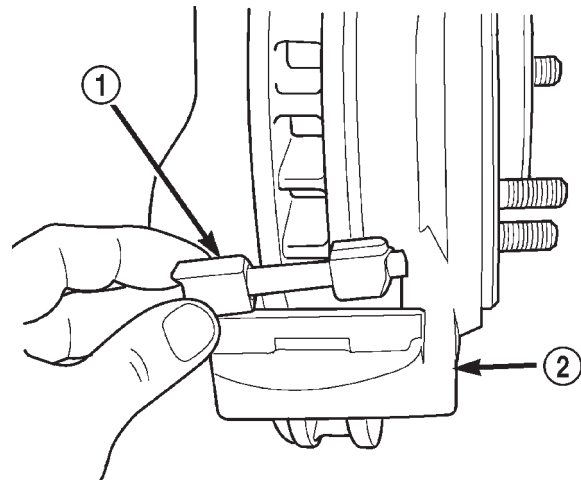
- 1 - OUTBOARD SHOE
- 2 - CALIPER ADAPTER

**Fig. 43 Top Anti-Rattle Spring**

- 1 - CALIPER ADAPTER
- 2 - ANTI-RATTLE SPRING

**REMOVAL - REAR BRAKE SHOES-11 inch**

- (1) Raise and support vehicle.
- (2) Remove wheel and tire assembly.
- (3) Remove clip nuts securing brake drum to wheel studs.
- (4) Remove drum. If drum is difficult to remove, remove rear plug from access hole in support plate. Back-off self adjusting by inserting a thin screwdriver into access hole and push lever away from adjuster screw star wheel. Then insert an adjuster

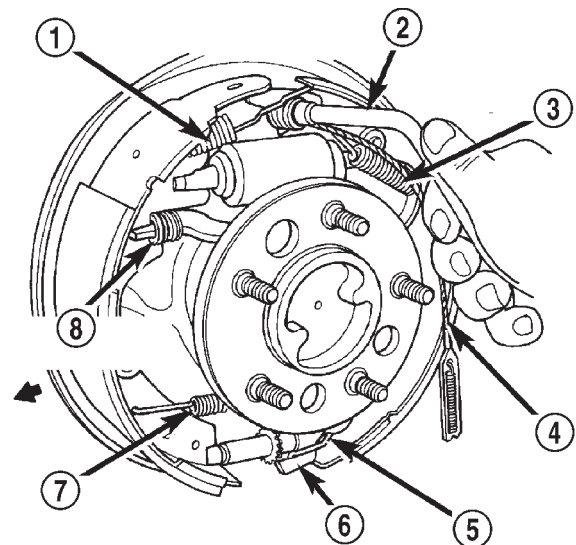
**Fig. 44 Bottom Anti-Rattle Spring**

- 1 - ANTI-RATTLE SPRING
- 2 - CALIPER ADAPTER

tool into brake adjusting hole rotate adjuster star wheel to retract brake shoes.

(5) Vacuum brake components to remove brake lining dust.

(6) Remove shoe return springs with brake spring plier tool (Fig. 45).

**Fig. 45 Shoe Return Springs**

- 1 - SHOE RETURN SPRING
- 2 - SPECIAL TOOL (REMOVING AND INSTALLING)
- 3 - SHOE RETURN SPRING
- 4 - ADJUSTER CABLE
- 5 - LEVER SPRING
- 6 - ADJUSTER LEVER
- 7 - SHOE TO SHOE SPRING
- 8 - ANTI-RATTLE SPRING

## BRAKE PADS/SHOES (Continued)

(7) Remove adjuster cable. Slide cable eye off anchor pin. Then unhook and remove cable from adjuster lever.

(8) Remove cable guide from secondary shoe and anchor plate from anchor pin.

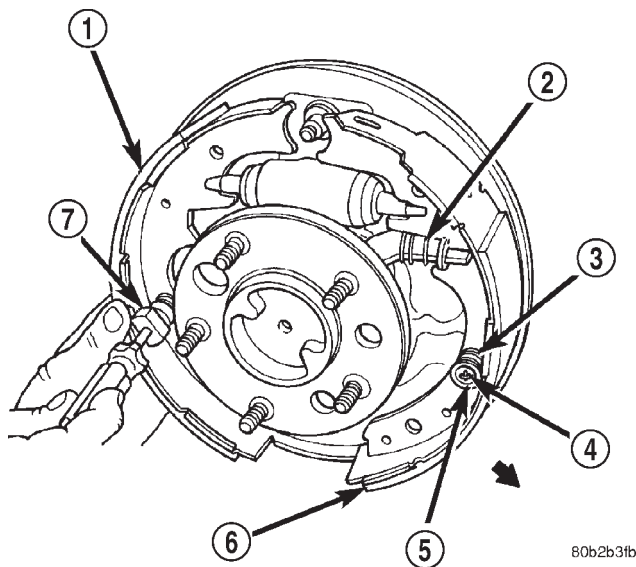
(9) Remove adjuster lever. Disengage lever from spring by sliding lever forward to clear pivot and work lever out from under spring.

(10) Remove adjuster lever spring from pivot.

(11) Disengage and remove shoe to shoe spring from brake shoes.

(12) Disengage and remove adjuster screw assembly from brake shoes.

(13) Remove brake shoe retainers, springs (Fig. 46).



**Fig. 46 Shoe Retainers, Springs and Pins**

- 1 - SECONDARY SHOE AND LINING
- 2 - STRUT AND SPRING
- 3 - SPRING
- 4 - PIN
- 5 - RETAINER
- 6 - PRIMARY SHOE AND LINING
- 7 - TOOL C-4070

(14) Remove secondary brake shoe from support plate.

(15) Remove strut and spring (Fig. 46).

(16) Remove parking brake lever retaining clip from the secondary shoe and remove the lever.

(17) Remove primary shoe from support plate.

(18) Disengage parking brake lever from parking brake cable.

(19) Remove parking brake cable guide spring.

### REMOVAL - 12 1/8 INCH

(1) Raise and support vehicle.

(2) Remove wheel and tire assembly.

(3) Remove clip nuts securing brake drum to wheel studs.

(4) Remove brake drum.

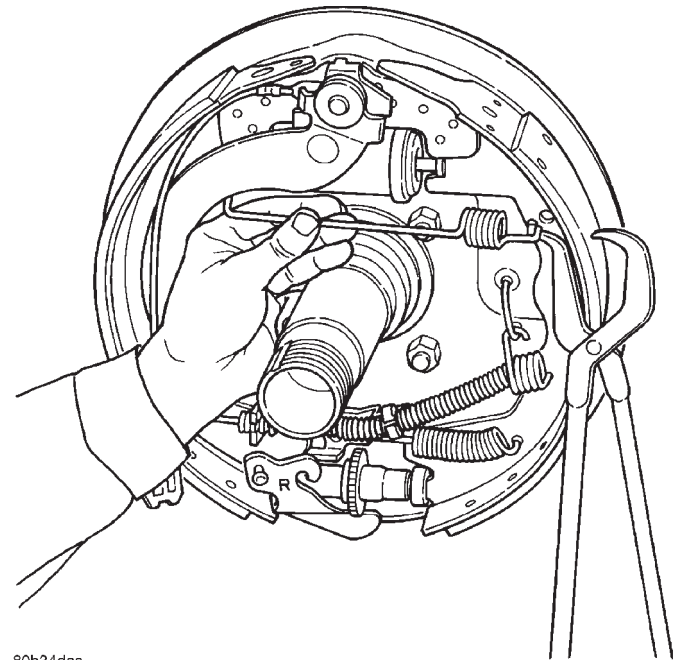
(5) Vacuum brake components to remove brake lining dust.

(6) Unhook adjusting lever return spring from lever.

(7) Remove lever and return spring from lever pivot pin.

(8) Unhook adjuster lever from adjuster cable assembly.

(9) Remove shoe-to-shoe upper spring (Fig. 47).



**Fig. 47 Upper Spring**

(10) Remove shoe hold-down springs (Fig. 48).

(11) Disconnect parking brake cable from parking brake lever.

(12) Remove shoe-to-shoe lower spring and adjuster assembly.

(13) Remove brake shoes (Fig. 49).

### INSTALLATION - REAR

(1) Clean caliper mounting adapter and anti-rattle springs.

(2) Lubricate anti-rattle springs with Mopar brake grease.

(3) Install anti-rattle springs.

**NOTE: Anti-rattle springs are not interchangeable.**

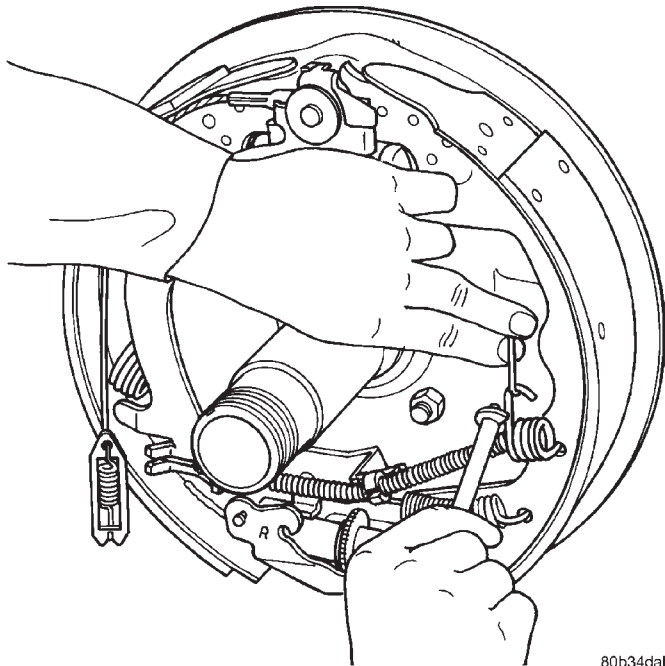
(4) Install inboard brake shoe in adapter.

(5) Install outboard brake shoe in adapter.

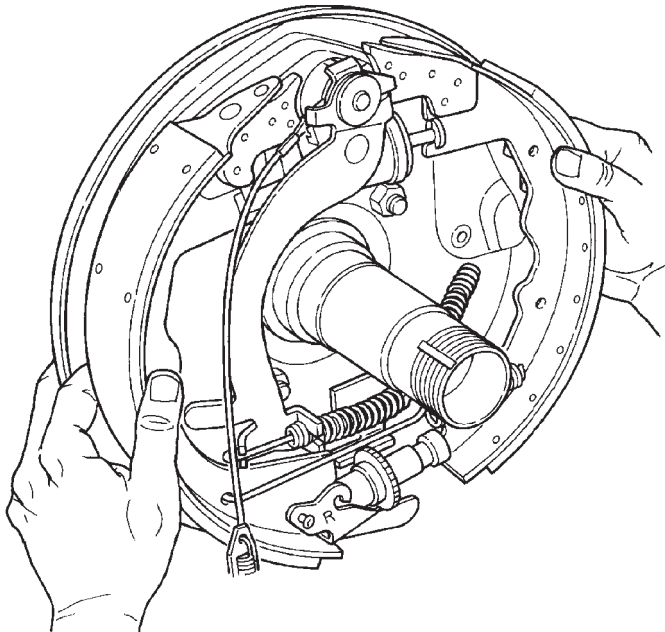
(6) Tilt the bottom of the caliper over rotor and under adapter. Then push the top of the caliper down onto the adapter.



## BRAKE PADS/SHOES (Continued)



80b34dab

**Fig. 48 Shoe Hold-Down Springs**

80b34dac

**Fig. 49 Brake Shoe Removal**

(7) Install caliper, (Refer to 5 - BRAKES/HYDRAULIC/MECHANICAL/DISC BRAKE CALIPERS - INSTALLATION) (Refer to 5 - BRAKES/HYDRAULIC/MECHANICAL/DISC BRAKE CALIPERS - INSTALLATION).

(8) Install wheel and tire assemblies and lower vehicle, (Refer to 22 - TIRES/WHEELS/WHEELS - STANDARD PROCEDURE).

(9) Apply brakes several times to seat caliper pistons and brake shoes and obtain firm pedal.

(10) Top off master cylinder fluid level.

**INSTALLATION - FRONT**

(1) Bottom pistons in caliper bore with C-clamp. Place an old brake shoe between a C-clamp and caliper piston.

(2) Clean caliper mounting adapter and anti-rattle springs.

(3) Lubricate anti-rattle springs with Mopar brake grease.

(4) Install anti-rattle springs.

**NOTE: Anti-rattle springs are not interchangeable.**

(5) Install inboard brake shoe in adapter.

(6) Install outboard brake shoe in adapter.

(7) Tilt the bottom of the caliper over rotor and under adapter. Then push the top of the caliper down onto the adapter.

(8) Install caliper, (Refer to 5 - BRAKES/HYDRAULIC/MECHANICAL/DISC BRAKE CALIPERS - INSTALLATION).

(9) Install wheel and tire assemblies and lower vehicle, (Refer to 22 - TIRES/WHEELS/WHEELS - STANDARD PROCEDURE).

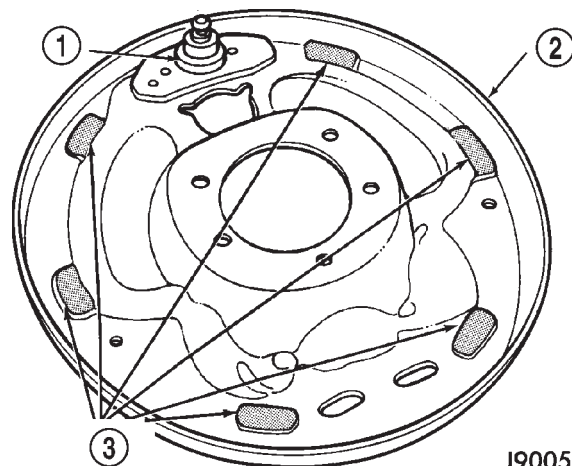
(10) Apply brakes several times to seat caliper pistons and brake shoes and obtain firm pedal.

(11) Top off master cylinder fluid level.

**INSTALLATION - REAR BRAKE SHOES-11 inch**

(1) Clean and inspect individual brake components, (Refer to 5 - BRAKES/HYDRAULIC/MECHANICAL/DRUM - CLEANING).

(2) Lubricate anchor pin and brake shoe contact pads on support plate with high temperature grease or Lubriplate (Fig. 50).



J9005-14

**Fig. 50 Shoe Contact Surfaces**

1 - ANCHOR PIN

2 - SUPPORT PLATE

3 - SHOE CONTACT SURFACES

## BRAKE PADS/SHOES (Continued)

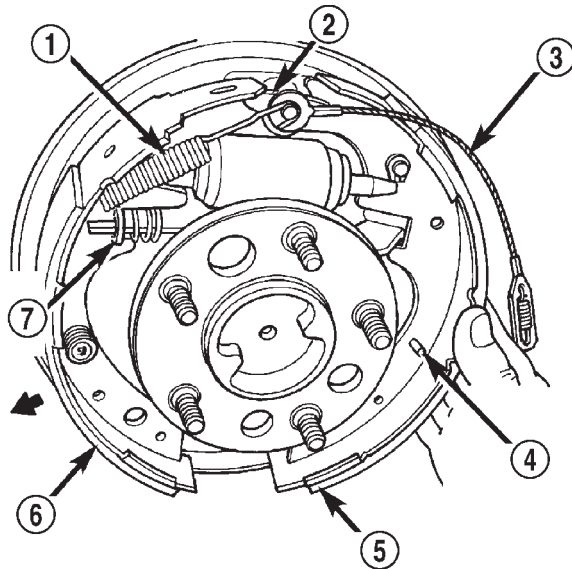
(3) Lubricate adjuster screw socket, nut, button and screw thread surfaces with grease or Lubriplate.

(4) Install parking brake lever to the secondary shoe and install retaining clip.

(5) Install primary shoe on support plate. Secure shoe with new spring retainers and pin.

(6) Install spring on parking brake strut and engage strut in primary.

(7) Install secondary shoe on support plate (Fig. 51). Insert strut in shoe and guide shoe onto anchor pin. Temporarily secure shoe with retaining pin.



30b2b3f9

**Fig. 51 Brake Shoe Installation**

- 1 - SHOE RETURN SPRING
- 2 - ANCHOR PLATE
- 3 - ADJUSTER CABLE
- 4 - SHOE RETAINING PIN
- 5 - SECONDARY SHOE AND LINING
- 6 - PRIMARY SHOE AND LINING
- 7 - STRUT AND SPRING

(8) Install anchor plate and adjuster cable eyelet on support plate anchor pin.

(9) Install cable guide in secondary shoe and position cable in guide.

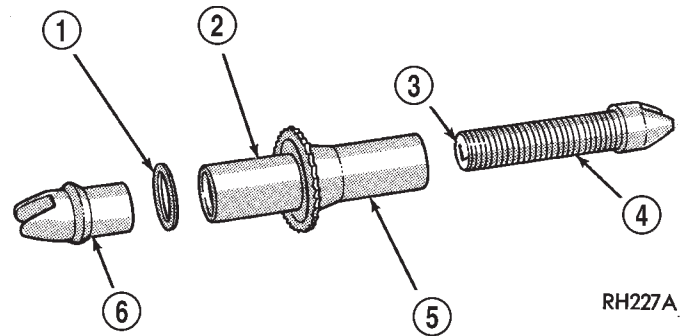
(10) Assemble adjuster screw (Fig. 52). Then install and adjuster screw between the brake shoes.

**CAUTION:** Be sure the adjuster screws are installed on the correct brake unit. The adjuster screws are marked L (left) and R (right) for identification.

(11) Install adjuster lever and spring and connect adjuster cable to lever.

(12) Install secondary shoe retainers and spring.

(13) Install shoe to shoe spring to secondary shoe, then to primary shoe.



RH227A

**Fig. 52 Adjuster Screw**

- 1 - WASHER
- 2 - SOCKET
- 3 - STAMPED LETTER  
L-LEFT BRAKE  
R-RIGHT BRAKE
- 4 - SCREW THREADS
- 5 - NUT
- 6 - BUTTON

(14) Verify adjuster operation. Pull adjuster cable upward, cable should lift lever and rotate star wheel. Be sure adjuster lever properly engages star wheel teeth.

(15) Install the parking brake cable into guide spring and insert cable into the backing plate.

(16) Adjust brake shoes to drum with brake gauge.

(17) Install wheel and tire assembly, (Refer to 22 - TIRES/WHEELS/WHEELS - STANDARD PROCEDURE).

(18) Remove support and lower the vehicle.

## INSTALLATION - 12 1/8 INCH

**NOTE:** Pivot screw and adjusting nut have left hand threads on left side brake and right hand threads on right side brake. Verify that adjusting nuts are installed on correct side of vehicle.

(1) Coat contact pads on support plate with Mopar high temperature grease, multi-mileage grease, or equivalent.

(2) Assemble adjuster, lower spring and both brake shoes. Then position the assembled components on the support plate.

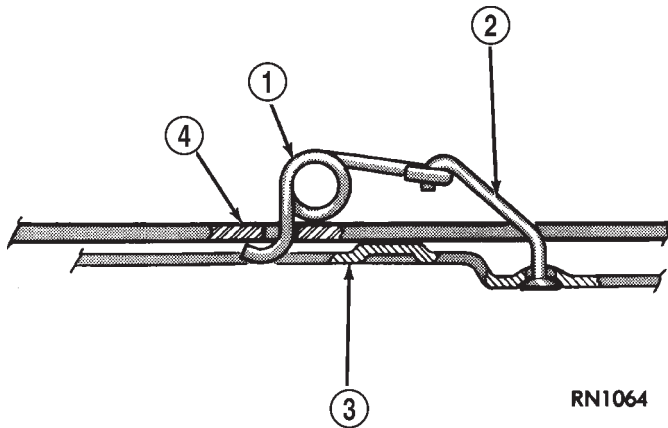
**NOTE:** Primary shoe is installed toward the front of the vehicle and secondary toward the rear of the vehicle.

(3) Install brake shoe hold-down springs and pins. Be sure hold-down pins are seated in support plate and springs are connected (Fig. 53).

(4) Insert parking brake cable through parking brake cable guide spring to parking brake lever. Be sure cable end is properly secured in lever.

(5) Install upper spring.

## BRAKE PADS/SHOES (Continued)



**Fig. 53 Hold-Down Spring And Pin Attachment**

- 1 - SHOE HOLD DOWN SPRING
- 2 - HOLD DOWN PIN
- 3 - BACKING PLATE
- 4 - BRAKE SHOE WEB

- (6) Position adjuster lever return spring on pivot.
- (7) Install adjuster lever.
- (8) Attach adjuster cable to adjuster lever. Be sure cable is properly routed.
- (9) Adjust brake shoes to drum with brake gauge.

## MASTER CYLINDER

### DESCRIPTION

A two-piece master cylinder is used on all models. The cylinder body containing the primary and secondary pistons is made of aluminum. The removable fluid reservoir is made of nylon reinforced with glass fiber. The reservoir stores reserve brake fluid for the hydraulic brake circuits. The reservoir is the only serviceable component.

The fluid compartments of the nylon reservoir are interconnected to permit fluid level equalization. However, the equalization feature does not affect circuit separation in the event of a front or rear brake malfunction. The reservoir compartments will retain enough fluid to operate the functioning hydraulic circuit.

Care must be exercised when removing/installing the master cylinder connecting lines. The threads in the cylinder fluid ports can be damaged if care is not exercised. Start all brake line fittings by hand to avoid cross threading.

The cylinder reservoir can be replaced when necessary. However, the aluminum body section of the master cylinder is not a repairable component.

**NOTE:** If diagnosis indicates that an internal malfunction has occurred, the aluminum body section must be replaced as an assembly.

### OPERATION

The master cylinder bore contains a primary and secondary piston. The primary piston supplies hydraulic pressure to the front brakes. The secondary piston supplies hydraulic pressure to the rear brakes.

### DIAGNOSIS AND TESTING - MASTER CYLINDER/POWER BOOSTER

- (1) Start engine and check booster vacuum hose connections. A hissing noise indicates vacuum leak. Correct any vacuum leak before proceeding.
- (2) Stop engine and shift transmission into Neutral.
- (3) Pump brake pedal until all vacuum reserve in booster is depleted.
- (4) Press and hold brake pedal under light foot pressure. The pedal should hold firm, if the pedal falls away master cylinder is faulty (internal leakage).
- (5) Start engine and note pedal action. It should fall away slightly under light foot pressure then hold firm. If no pedal action is discernible, power booster, vacuum supply, or vacuum check valve is faulty. Proceed to the POWER BOOSTER VACUUM TEST.
- (6) If the POWER BOOSTER VACUUM TEST passes, rebuild booster vacuum reserve as follows: Release brake pedal. Increase engine speed to 1500 rpm, close the throttle and immediately turn off ignition to stop engine.
- (7) Wait a minimum of 90 seconds and try brake action again. Booster should provide two or more vacuum assisted pedal applications. If vacuum assist is not provided, booster is faulty.

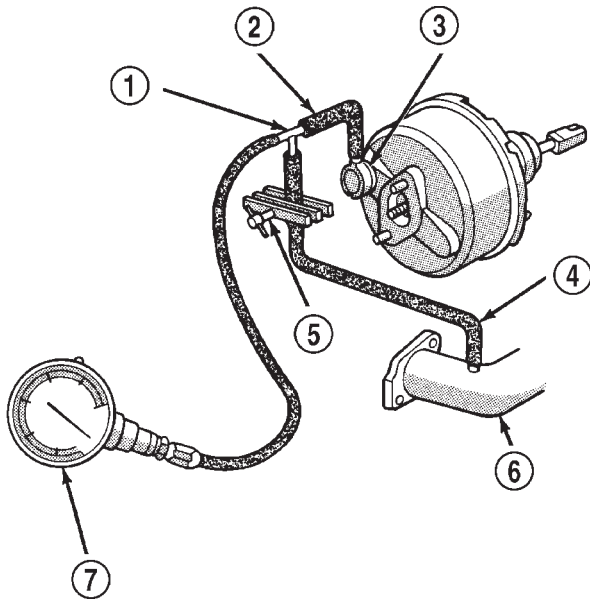
### POWER BOOSTER VACUUM TEST

- (1) Connect vacuum gauge to booster check valve with short length of hose and T-fitting (Fig. 54).
- (2) Start and run engine at curb idle speed for one minute.
- (3) Observe the vacuum supply. If vacuum supply is not adequate, repair vacuum supply.
- (4) Clamp hose shut between vacuum source and check valve.
- (5) Stop engine and observe vacuum gauge.
- (6) If vacuum drops more than one inch HG (33 millibars) within 15 seconds, booster diaphragm or check valve is faulty.

### POWER BOOSTER CHECK VALVE TEST

- (1) Disconnect vacuum hose from check valve.
- (2) Remove check valve and valve seal from booster.
- (3) Use a hand operated vacuum pump for test.
- (4) Apply 15-20 inches vacuum at large end of check valve (Fig. 55).

## MASTER CYLINDER (Continued)

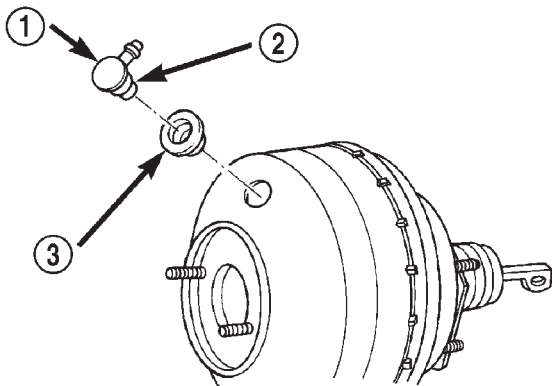


J9005-81

**Fig. 54 Typical Booster Vacuum Test Connections**

- 1 - TEE FITTING
- 2 - SHORT CONNECTING HOSE
- 3 - CHECK VALVE
- 4 - CHECK VALVE HOSE
- 5 - CLAMP TOOL
- 6 - INTAKE MANIFOLD
- 7 - VACUUM GAUGE

(5) Vacuum should hold steady. If gauge on pump indicates vacuum loss, check valve is faulty and should be replaced.



8031e866

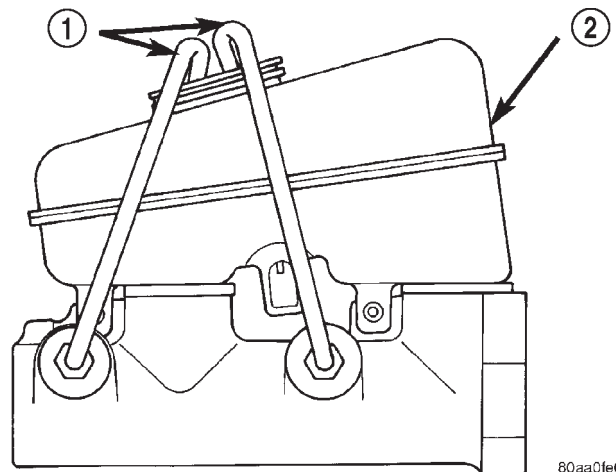
**Fig. 55 Vacuum Check Valve And Seal**

- 1 - BOOSTER CHECK VALVE
- 2 - APPLY TEST VACUUM HERE
- 3 - VALVE SEAL

**STANDARD PROCEDURE—MASTER CYLINDER BLEEDING**

A new master cylinder should be bled before installation on the vehicle. Required bleeding tools include bleed tubes and a wood dowel to stroke the pistons. Bleed tubes can be fabricated from brake line.

- (1) Mount master cylinder in vise.
- (2) Attach bleed tubes to cylinder outlet ports. Then position each tube end into reservoir (Fig. 56).
- (3) Fill reservoir with fresh brake fluid.
- (4) Press cylinder pistons inward with wood dowel. Then release pistons and allow them to return under spring pressure. Continue bleeding operations until air bubbles are no longer visible in fluid.



80aa0fe0

**Fig. 56 Master Cylinder Bleeding—Typical**

- 1 - BLEEDING TUBES
- 2 - RESERVOIR

**REMOVAL**

- (1) Pump the brake pedal several times to deplete booster vacuum reserve.
- (2) Remove brake lines from the master cylinder (Fig. 57).
- (3) Remove mounting nuts from the master cylinder (Fig. 57).
- (4) Remove the master cylinder.

**INSTALLATION**

**NOTE:** If master cylinder is replaced, bleed cylinder before installation.

- (1) Install master cylinder on the booster mounting studs.
- (2) Install mounting nuts and tighten to 23 N·m (17 ft. lbs.).
- (3) Install brake lines and tighten to 19-23 N·m (170-200 in. lbs.).



## MASTER CYLINDER (Continued)

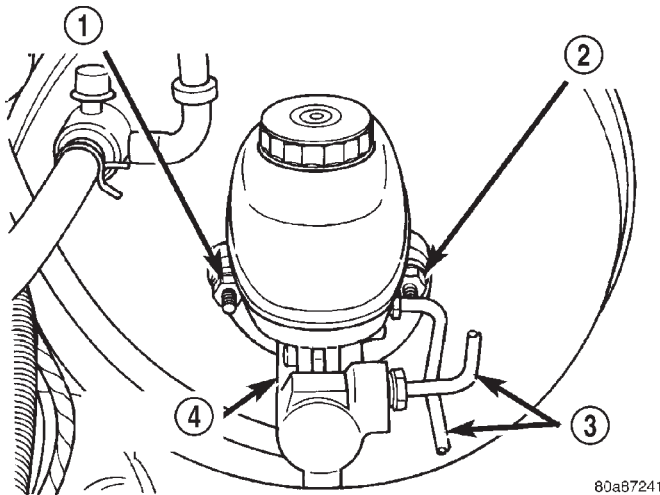


Fig. 57 Master Cylinder

- 1 - MOUNTING NUT
- 2 - MOUNTING NUT
- 3 - BRAKE LINES
- 4 - MASTER CYLINDER

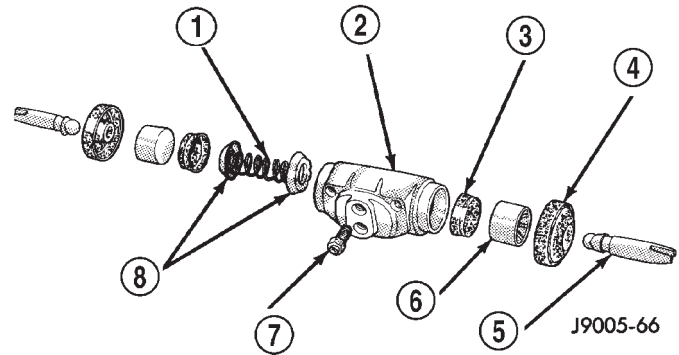


Fig. 58 Wheel Cylinder Components-Typical

- 1 - SPRING
- 2 - CYLINDER
- 3 - PISTON CLIP
- 4 - BOOT
- 5 - PUSH ROD
- 6 - PISTON
- 7 - BLEED SCREW
- 8 - CUP EXPANDERS

(4) Bleed base brake system, (Refer to 5 - BRAKES/HYDRAULIC/MECHANICAL - STANDARD PROCEDURE)

## WHEEL CYLINDERS

## REMOVAL

- (1) Raise vehicle and remove tire and wheel assembly.
- (2) Remove brake drum.
- (3) Lift adjuster lever away from adjuster screw. Then turn screw star wheel until screw is fully retracted.
- (4) Remove brake shoe return springs, adjuster spring and adjuster screw. Move upper ends of brake shoes apart to provide removal clearance for wheel cylinder links.
- (5) Disconnect brake line from wheel cylinder.
- (6) Remove wheel cylinder attaching screws and remove cylinder from support plate

## DISASSEMBLY

- (1) Remove push rods and boots (Fig. 58).
- (2) Press pistons, cups and spring and expander out of cylinder bore.
- (3) Remove bleed screw.

## CLEANING

Clean the cylinder and pistons with clean brake fluid or brake cleaner only. Do not use any other cleaning agents.

Dry the cylinder and pistons with compressed air. Do not use rags or shop towels to dry the cylinder

components. Lint from cloth material will adhere to the cylinder bores and pistons.

## INSPECTION

Inspect the cylinder bore. Light discoloration and dark stains in the bore are normal and will not impair cylinder operation.

The cylinder bore can be lightly polished but only with crocus cloth. Replace the cylinder if the bore is scored, pitted or heavily corroded. Honing the bore to restore the surface is not recommended.

Inspect the cylinder pistons. The piston surfaces should be smooth and free of scratches, scoring and corrosion. Replace the pistons if worn, scored, or corroded. Do attempt to restore the surface by sanding or polishing.

Discard the old piston cups and the spring and expander. These parts are not reusable. The original dust boots may be reused but only if they are in good condition.

## ASSEMBLY

(1) Lubricate wheel cylinder bore, pistons, piston cups and spring and expander with clean brake fluid.

(2) Install first piston in cylinder bore. Then install first cup in bore and against piston. **Be sure lip of piston cup is facing inward (toward spring and expander) and flat side is against piston.**

(3) Install spring and expander followed by remaining piston cup and piston.

(4) Install boots on each end of cylinder and insert push rods in boots.

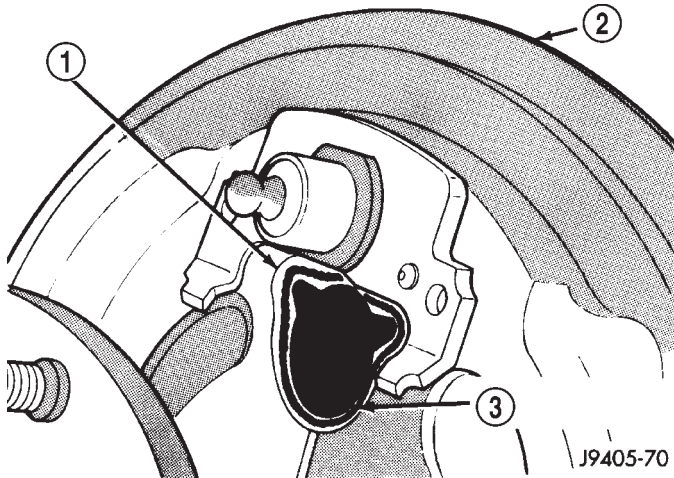
(5) Install cylinder bleed screw.



## WHEEL CYLINDERS (Continued)

## INSTALLATION

(1) Apply thin coat of silicone sealer to wheel cylinder mounting surface of support plate (Fig. 59). Sealer prevents road splash from entering brake drum past cylinder.



**Fig. 59 Wheel Cylinder Mounting Surface**

- 1 - CYLINDER MOUNTING SURFACE  
2 - SUPPORT PLATE  
3 - APPLY THIN SEALER COAT HERE

(2) Start brake line in cylinder inlet by hand. Do not tighten fitting at this time.

(3) Mount wheel cylinder on support plate and install cylinder attaching screws. Tighten screws to 20 N·m (15 ft. lbs.).

(4) Tighten brake line fitting to 13 N·m (115 in. lbs.).

(5) Install brake shoe components.

(6) Adjust brake shoes to drum using brake gauge.

(7) Install brake drum.

(8) Bleed base brake system, (Refer to 5 - BRAKES/HYDRAULIC/MECHANICAL - STANDARD PROCEDURE).

(9) Install wheel and tire assemblies, (Refer to 22 - TIRES/WHEELS/WHEELS - STANDARD PROCEDURE) and lower vehicle.

## SUPPORT PLATE

## REMOVAL

(1) Remove wheel and tire assemblies.

(2) Remove brake drums

(3) Remove axle shaft, (Refer to 3 - DIFFERENTIAL & DRIVELINE/REAR AXLE - 9 1/4/AXLE SHAFTS - REMOVAL).

(4) Remove brake shoes and hardware for access to parking brake cable.

(5) Remove parking brake cable from support plate.

(6) Disconnect brake line at wheel cylinder and remove cylinder.

(7) Remove bolts attaching support plate to axle and remove support plate.

## INSTALLATION

(1) Apply thin bead of silicone sealer around axle mounting surface of support plate.

(2) Install support plate on axle flange. Tighten attaching bolts to 47-68 N·m (35-50 ft. lbs.).

(3) Apply thin bead of silicone sealer around wheel cylinder mounting surface. Install wheel cylinder on new support plate.

(4) Install parking brake cable in support plate.

(5) Install brake shoes and hardware.

(6) Install axle shaft, (Refer to 3 - DIFFERENTIAL & DRIVELINE/REAR AXLE - 9 1/4/AXLE SHAFTS - INSTALLATION).

(7) Adjust brake shoes to drum with brake gauge.

(8) Install brake drums.

(9) Fill and bleed brake system, (Refer to 5 - BRAKES/HYDRAULIC/MECHANICAL - STANDARD PROCEDURE).

(10) Install wheel and tire assemblies, (Refer to 22 - TIRES/WHEELS/WHEELS - STANDARD PROCEDURE) and lower vehicle.

## DRUM

## DESCRIPTION

All 1500 models and early year production 2500/3500 are equipped with rear drum brake assemblies. They are two-shoe, duo-servo units with an automatic adjuster mechanism.

Drum brake assemblies used:

- 1500 models: 11 x 2.25 in.
- 2500/3500 models: 12 1/8 x 3.5 in.

The drum brakes are a semi-floating, self-energizing, servo action design. The brake shoes are not fixed on the support plate. This type of brake allows the shoes to pivot and move vertically to a certain extent.

## OPERATION

In operation, fluid apply pressure causes the wheel cylinder pistons to move outward. This movement is transferred directly to the brake shoes by the cylinder connecting links. The resulting brake shoe expansion brings the lining material into contact with the rotating brake drum.

Two forces affect the brake shoes once they contact the drum. The first force being hydraulic pressure exerted through the wheel cylinder pistons. And the second force is the friction generated turning torque of the rotating drum.

## DRUM (Continued)

The drum forces both brake shoes to move in the same direction of rotation. Servo action begins with the primary brake shoe which begins to wedge (or wrap) itself against the rotating drum surface. This force is transmitted equally to the secondary brake shoe through the adjuster screw and anchor pin. The net result is that each shoe helps the other exert extra force against the drum. It is servo action that creates the wedging (or wrap) effect which produces increased force on the drum braking surface.

All drum brake assemblies are equipped with a self adjusting mechanism. The components forming the mechanism consist of the: adjuster screw, adjuster lever, actuating lever (11 inch brake), lever return spring and the adjuster lever spring. The adjuster lever on the 12 inch brake, is also equipped with a lever and tension spring.

The adjuster mechanism performs two important functions. First, is in maintaining proper brake shoe operating clearance. And second, is to maintain brake pedal height. The mechanism does so, by adjusting the shoes in small increments to compensate for lining wear. The adjustment process is continuous throughout the useful life of the brake lining.

The adjuster components are all connected to the secondary brake shoes. Actual adjustment only occurs during reverse brake stops. Secondary brake shoe movement (during reverse stops), is what activates the adjuster components.

In operation, secondary shoe movement causes the adjuster lever spring to exert pull on the lever. This pivots the lever away from the adjuster screw teeth. When the stop is completed and the brakes released, the adjuster lever pivots back to a normal position. It is during this return movement of the lever when adjustment occurs. At this point, the lever comes back into contact with the adjuster screw teeth as it moves upward. The lever will then rotate the adjuster screw one or two teeth as needed for adjustment.

**NOTE: The adjustment process requires a complete stop to actually occur. Rolling stops will NOT activate the adjuster components. In addition, the adjuster screws are left and right hand parts and must NOT be interchanged.**

### DIAGNOSIS AND TESTING - BRAKE DRUM

The maximum allowable diameter of the drum braking surface is indicated on the drum outer edge. Generally, a drum can be machined to a maximum of 1.52 mm (0.060 in.) oversize. Always replace the drum if machining would cause drum diameter to exceed the size limit indicated on the drum.

### BRAKE DRUM RUNOUT

Measure drum diameter and runout with an accurate gauge. The most accurate method of measurement involves mounting the drum in a brake lathe and checking variation and runout with a dial indicator.

Variations in drum diameter should not exceed 0.069 mm (0.0028 in.). Drum runout should not exceed 0.18 mm (0.007 in.) out of round. Machine the drum if runout or variation exceed these values. Replace the drum if machining causes the drum to exceed the maximum allowable diameter.

### STANDARD PROCEDURE - BRAKE DRUM MACHINING

The brake drums can be machined on a drum lathe when necessary. Initial machining cuts should be limited to 0.12 - 0.20 mm (0.005 - 0.008 in.) at a time as heavier feed rates can produce taper and surface variation. Final finish cuts of 0.025 to 0.038 mm (0.001 to 0.0015 in.) are recommended and will generally provide the best surface finish.

Be sure the drum is securely mounted in the lathe before machining operations. A damper strap should always be used around the drum to reduce vibration and avoid chatter marks.

The maximum allowable diameter of the drum braking surface is stamped or cast into the drum outer edge.

**CAUTION: Replace the drum if machining will cause the drum to exceed the maximum allowable diameter.**

### CLEANING

Clean the individual brake components, including the support plate and wheel cylinder exterior, with a water dampened cloth or with brake cleaner. Do not use any other cleaning agents. Remove light rust and scale from the brake shoe contact pads on the support plate with fine sandpaper.

### INSPECTION

As a general rule, riveted brake shoes should be replaced when worn to within 0.78 mm (1/32 in.) of the rivet heads. Bonded lining should be replaced when worn to a thickness of 1.6 mm (1/16 in.).

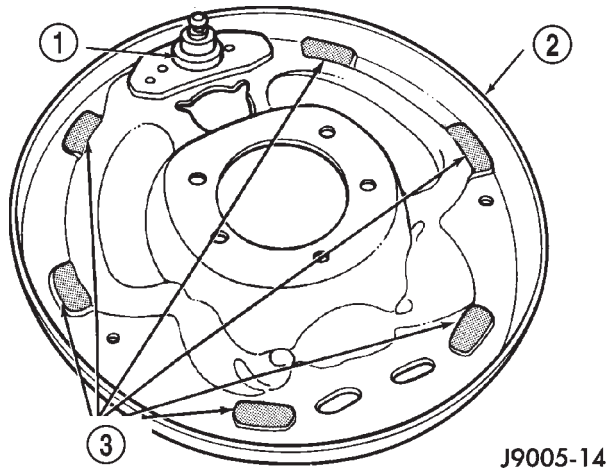
Examine the lining contact pattern to determine if the shoes are bent or the drum is tapered. The lining should exhibit contact across its entire width. Shoes exhibiting contact only on one side should be replaced and the drum checked for runout or taper.

Inspect the adjuster screw assembly. Replace the assembly if the star wheel or threads are damaged, or the components are severely rusted or corroded.

## DRUM (Continued)

Discard the brake springs and retainer components if worn, distorted or collapsed. Also replace the springs if a brake drag condition had occurred. Overheating will distort and weaken the springs.

Inspect the brake shoe contact pads on the support plate, replace the support plate if any of the pads are worn or rusted through. Also replace the plate if it is bent or distorted (Fig. 60).



**Fig. 60 Shoe Contact Surfaces**

- 1 - ANCHOR PIN
- 2 - SUPPORT PLATE
- 3 - SHOE CONTACT SURFACES

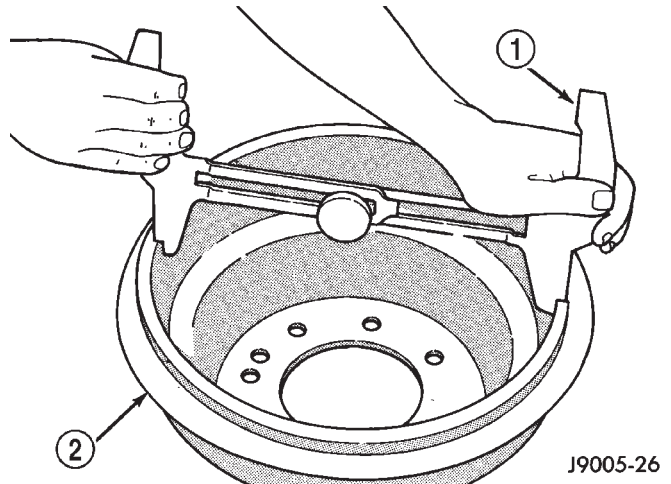
### ADJUSTMENT - REAR BRAKE DRUM

The rear drum brakes are equipped with a self-adjusting mechanism. Under normal circumstances, the only time adjustment is required is when the shoes are replaced, removed for access to other parts, or when one or both drums are replaced.

Adjustment can be made with a standard brake gauge or with adjusting tool. Adjustment is performed with the complete brake assembly installed on the backing plate.

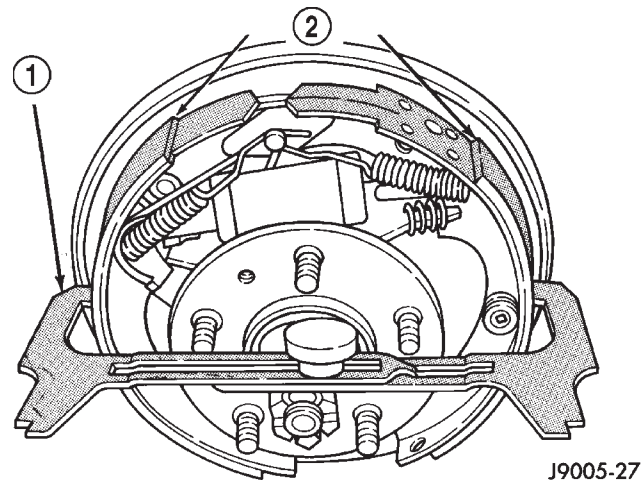
#### ADJUSTMENT WITH BRAKE GAUGE

- (1) Be sure parking brakes are fully released.
- (2) Raise rear of vehicle and remove wheels and brake drums.
- (3) Verify that left and right automatic adjuster levers and cables are properly connected.
- (4) Insert brake gauge in drum. Expand gauge until gauge inner legs contact drum braking surface. Then lock gauge in position (Fig. 61).
- (5) Reverse gauge and install it on brake shoes. Position gauge legs at shoe centers as shown (Fig. 62). If gauge does not fit (too loose/too tight), adjust shoes.
- (6) Pull shoe adjuster lever away from adjuster screw star wheel.



**Fig. 61 Adjusting Gauge On Drum**

- 1 - BRAKE GAUGE
- 2 - BRAKE DRUM



**Fig. 62 Adjusting Gauge On Brake Shoes**

- 1 - BRAKE GAUGE
- 2 - BRAKE SHOES

(7) Turn adjuster screw star wheel (by hand) to expand or retract brake shoes. Continue adjustment until gauge outside legs are light drag-fit on shoes.

(8) Install brake drums and wheels and lower vehicle.

(9) Drive vehicle and make one forward stop followed by one reverse stop. Repeat procedure 8-10 times to operate automatic adjusters and equalize adjustment.

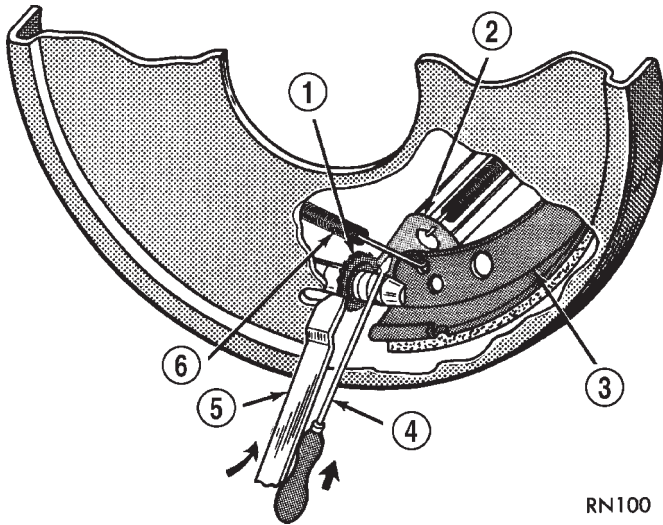
**NOTE: Bring vehicle to complete standstill at each stop. Incomplete, rolling stops will not activate automatic adjusters.**



## DRUM (Continued)

## ADJUSTMENT WITH ADJUSTING TOOL

- (1) Be sure parking brake lever is fully released.
- (2) Raise vehicle so rear wheels can be rotated freely.
- (3) Remove plug from each access hole in brake support plates.
- (4) Loosen parking brake cable adjustment nut until there is slack in front cable.
- (5) Insert adjusting tool through support plate access hole and engage tool in teeth of adjusting screw star wheel (Fig. 63).



RN100

Fig. 63 Brake Adjustment

- 1 - STAR WHEEL
- 2 - LEVER
- 3 - BRAKE SHOE WEB
- 4 - SCREWDRIVER
- 5 - ADJUSTING TOOL
- 6 - ADJUSTER SPRING

(6) Rotate adjuster screw star wheel (move tool handle upward) until slight drag can be felt when wheel is rotated.

(7) Push and hold adjuster lever away from star wheel with thin screwdriver.

(8) Back off adjuster screw star wheel until brake drag is eliminated.

(9) Repeat adjustment at opposite wheel. Be sure adjustment is equal at both wheels.

(10) Install support plate access hole plugs.

(11) Adjust parking brake cable and lower vehicle.

(12) Drive vehicle and make one forward stop followed by one reverse stop. Repeat procedure 8-10 times to operate automatic adjusters and equalize adjustment.

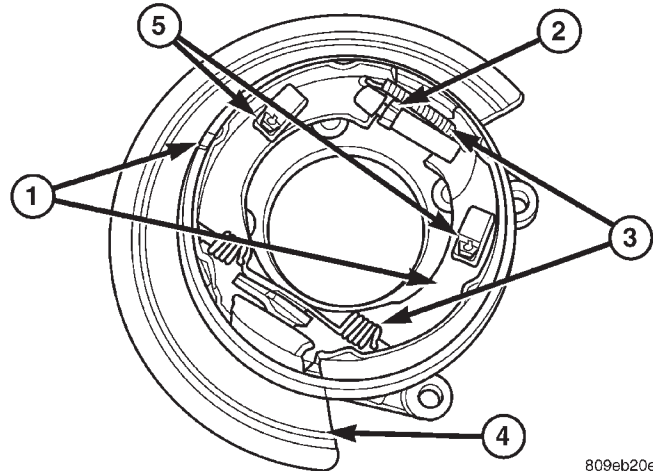
**NOTE:** Bring vehicle to complete standstill at each stop. Incomplete, rolling stops will not activate automatic adjusters.

## PARKING BRAKE

## DESCRIPTION - 2500/3500 WITH REAR DISC BRAKES

The parking brakes are operated by a system of cables and levers attached to a primary and secondary shoe positioned within the drum section of the rotor.

The drum-in-hat design utilizes an independent set of shoes to park the vehicle (Fig. 64).



809eb20e

Fig. 64 SHOES REMOVAL

- 1 - Park Brake Shoes
- 2 - Adjuster
- 3 - Return Springs
- 4 - Splash Shield
- 5 - Hold Downs

## DESCRIPTION - (1500 Models)(Early 2500/3500 models with rear drum brakes)

The parking brakes are operated by a system of cables and levers attached to the rear brake shoes.

The rear drum brake shoes serve as the parking brakes. The shoes make contact with the brake drum surface by a cable and lever mechanism attached to the secondary brake shoe.

The front parking brake cable is connected to the parking brake pedal and to an intermediate cable. The intermediate cable connects the front cable to the rear cables.

The parking brake pedal assembly is mounted on the driver side cowl panel. The front cable is directly attached to the assembly. The pedal assembly contains a spring loaded, torsion-type mechanism that will hold the cable in the applied position and allow the pedal to return. A rod used to release the torsion mechanism and return the pedal to normal position.

## PARKING BRAKE (Continued)

**OPERATION - 2500/3500 WITH REAR DISC BRAKES**

To apply the parking brake the pedal is depressed. This creates tension in the cable which pulls forward on the park brake lever. The lever pushes the park brake shoes outward and into contact with the drum section of the rotor. The contact of shoe to rotor parks the vehicle.

A torsion locking mechanism is used to hold the pedal in an applied position. Parking brake release is accomplished by the hand release.

A parking brake switch is mounted on the parking brake lever and is actuated by movement of the lever. The switch, which is in circuit with the red warning light in the dash, will illuminate the warning light whenever the parking brake is applied.

Parking brake adjustment is controlled by a cable tensioner mechanism. The cable tensioner, once adjusted at the factory, should not need further adjustment under normal circumstances. Adjustment may be required if a new tensioner, or cables are installed, or disconnected.

**OPERATION - (1500 models) (Early 2500/3500 models with rear drum brakes)**

To apply the parking brakes, the pedal is depressed. This pulls the rear brake shoe actuating levers forward. As the actuating lever is pulled forward, the parking brake strut or cam, exerts a linear force against the primary brake shoe. This action presses the primary shoe into contact with the drum. Once the primary shoe contacts the drum, force is exerted through the strut/cam. This force is transferred through the strut/cam to the secondary brake shoe causing it to pivot into the drum as well.

A torsion locking mechanism is used to hold the pedal in an applied position. Parking brake release is accomplished by the hand release.

A parking brake switch is mounted on the parking brake lever and is actuated by movement of the lever. The switch, which is in circuit with the red warning light in the dash, will illuminate the warning light whenever the parking brake is applied.

Parking brake adjustment is controlled by a cable tensioner mechanism. The cable tensioner, once adjusted at the factory, should not need further adjustment under normal circumstances. Adjustment may be required if a new tensioner, or cables are installed, or disconnected.

**PEDAL****REMOVAL**

- (1) Release the parking brake.
- (2) Raise the vehicle.

(3) Loosen the cable tensioner nut at the equalizer to create slack in the front cable.

(4) Lower the vehicle.

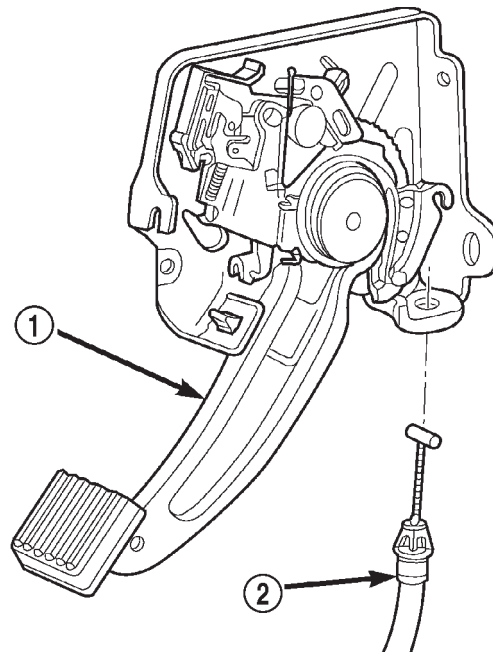
(5) Remove the knee bolster, (Refer to 23 - BODY/ INSTRUMENT PANEL/STEERING COLUMN OPENING COVER - REMOVAL).

(6) Disconnect the brake lamp wire from the switch on the pedal assembly.

(7) Roll the carpet back, loosen the front cable grommet from the floorpan and the cable retainer.

(8) Disengage the cable end connector (Fig. 65) from the arm on the pedal assembly.

(9) Remove the bolts/nuts from the pedal assembly and remove the assembly.



**Fig. 65 Parking Brake Pedal Assembly**

- 1 - PARK BRAKE PEDAL
- 2 - FRONT CABLE

**INSTALLATION**

(1) Position the replacement pedal assembly on the dash and cowl.

(2) Install the bolts/nuts and tighten to 28 N·m (21 ft. lbs.).

(3) Connect the front cable to the arm on the pedal assembly.

(4) Tighten the front cable grommet to the floorpan and the cable retainer, roll the carpet back.

(5) Connect the wires to the brake lamp switch.

(6) Install the knee bolster, (Refer to 23 - BODY/ INSTRUMENT PANEL/STEERING COLUMN OPENING COVER - INSTALLATION).

(7) Raise the vehicle.

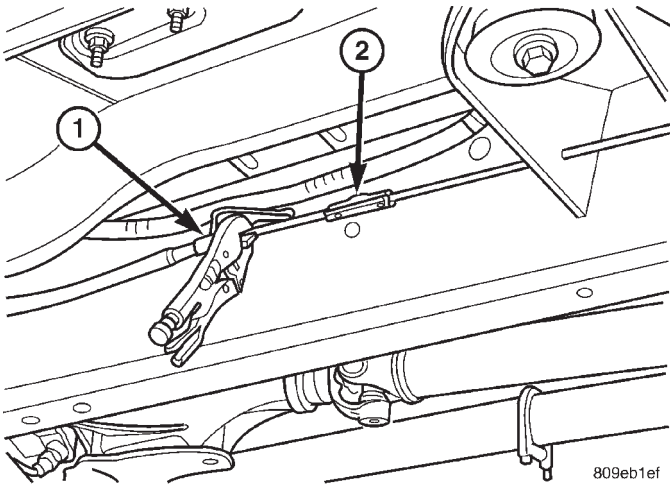
(8) Adjust the parking brake cable tensioner.



## CABLES

### REMOVAL - REAR PARK BRAKE CABLE - 2500/3500 WITH REAR DISC BRAKES

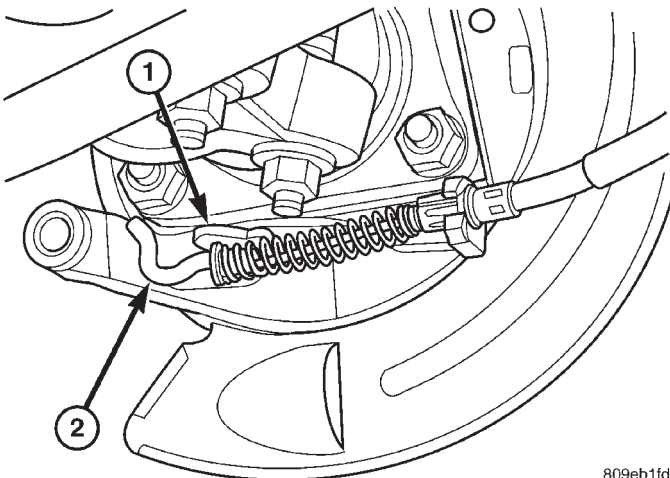
- (1) Raise and support the vehicle.
- (2) Lockout the parking brake cable (Fig. 66).



**Fig. 66 LOCK OUT PARKING CABLE**

- 1 - LOCKING PLIERS  
2 - PARKING BRAKE CABLE

- (3) Loosen cable adjuster nut.
- (4) Remove the rear park brake cable from the intermediate park brake cable.
- (5) Compress tabs on cable end fitting on the rear park brake cable to the frame mount bracket. Then pull the cable through the bracket.
- (6) Disengage the park brake cable from behind the rotor assembly. (Fig. 67).



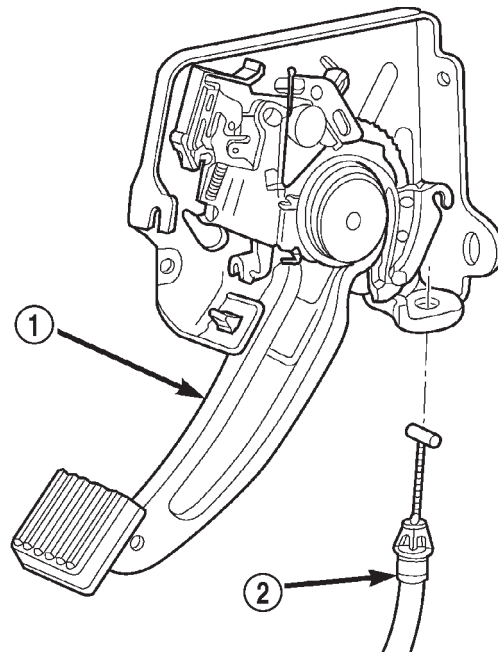
**Fig. 67 DISENGAGEMENT OF CABLE**

- 1 - LEVER  
2 - CABLE END

- (7) Compress cable tabs on each cable end fitting at the brake cable support plate.
- (8) Remove the cables from the brake cable support plates.

### REMOVAL - FRONT PARKING BRAKE CABLE

- (1) Raise and support vehicle.
- (2) Loosen adjusting nut to create slack in front cable.
- (3) Remove the front cable from the cable connector.
- (4) Compress cable end fitting at underbody bracket and remove the cable from the bracket.
- (5) Lower vehicle.
- (6) Push ball end of cable out of pedal clevis with small screwdriver.
- (7) Compress cable end fitting at the pedal bracket and remove the cable (Fig. 68).



**Fig. 68 Parking Brake Pedal**

- 1 - PARK BRAKE PEDAL  
2 - FRONT CABLE

- (8) Remove the left cowl trim and sill plate.
- (9) Pull up the carpet and remove the cable from the body clip.
- (10) Pull up on the cable and remove the cable with the body grommet.

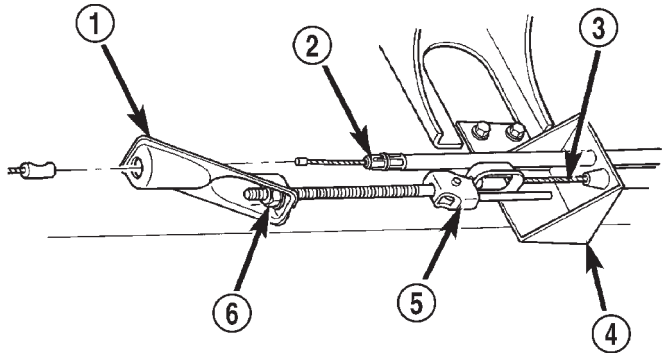
### REMOVAL - REAR PARK BRAKE CABLES - 1500 SERIES

- (1) Release parking brakes.
- (2) Raise and support vehicle.
- (3) Loosen cable adjuster nut.

## CABLES (Continued)

(4) Remove the rear cables from the cable connectors.

(5) Compress tabs on cable end fitting on the right rear cable (Fig. 69) at the equalizer. Then pull the cable through the bracket.



80be465f

**Fig. 69 Cables And Tensioner**

- 1 - EQUALIZER
- 2 - RIGHT CABLE
- 3 - LEFT CABLE
- 4 - CABLE BRACKET
- 5 - TENSIONER
- 6 - TENSIONER NUT

(6) Compress tabs on cable end fitting on the left rear cable at the frame bracket and pull both cables through the frame bracket.

(7) Pull the right rear cable through the brake hose bracket and remove the cable retainers from the axle.

(8) Remove rear wheels and brake drums (1500 series only).

(9) Disconnect each cable from the park brake lever.

(10) Remove the parking brake cable guide spring.

(11) Compress cable tabs on each cable end fitting at the brake support plate.

(12) Remove the cables from the brake support plates.

### REMOVAL - REAR PARK BRAKE CABLES 2500/3500 SERIES WITH DRUM BRAKES

- (1) Release parking brakes.
- (2) Raise and support vehicle.
- (3) Loosen cable adjuster nut.
- (4) Remove the rear cables from the cable tensioner bracket (Fig. 70).
- (5) Remove the right rear cable O-ring. Then pull the cable through the bracket.
- (6) Compress tabs on them left cable end fitting. Then pull the cable through the frame bracket.

(7) Pull the right rear cable through the brake hose bracket and remove the cable retainers from the axle.

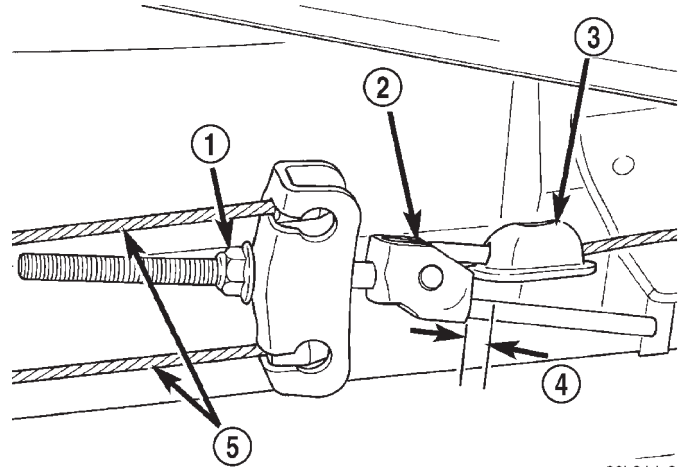
(8) Remove rear wheels and brake drums.

(9) Disconnect each cable from the park brake lever.

(10) Remove cable guide spring.

(11) Compress cable tabs on each cable end fitting at the brake support plate.

(12) Remove the cables from the brake support plates.



80b34da9

**Fig. 70 Cables And**

- 1 - ADJUSTER NUT
- 2 - TENSIONER
- 3 - CABLE CONNECTOR
- 4 - 6.35MM  
(1/4 IN.)
- 5 - REAR CABLES

### INSTALLATION - REAR PARK BRAKE CABLE - 2500/3500 WITH REAR DISC BRAKES

(1) Push each cable end through the brake cable support plate hole until the cable end fitting tabs lock into place.

**NOTE: Pull on the cable to ensure it is locked into place.**

- (2) Push the cable through the frame bracket.
- (3) Lock the left cable end fitting tabs into the frame bracket hole.
- (4) Install the rear cables into the tensioner rod behind the rear of the brake assembly.
- (5) Install the cable to the intermediate cable connector.
- (6) Release and remove the lock out device.
- (7) Perform the park brake adjustment procedure, (Refer to 5 - BRAKES/PARKING BRAKE/CABLE TENSIONER - ADJUSTMENTS).
- (8) Remove the supports and lower the vehicle.

## CABLES (Continued)

**INSTALLATION - FRONT PARKING BRAKE CABLE**

- (1) From inside the vehicle, insert the cable end fitting into the hole in the pedal assembly.
- (2) Seat the cable retainer in the pedal assembly.
- (3) Engage the cable ball end in clevis on the pedal assembly.
- (4) Route the cable along the top of the wheel well and clip in place.
- (5) Route the cable through the floorpan and install the body grommet.
- (6) Place the carpet down and install the left cowl trim and sill plate.
- (7) Raise and support the vehicle.
- (8) Route the cable through the underbody bracket and seat the cable housing retainer in the bracket.
- (9) Connect the cable to the cable connector.
- (10) Perform the park brake adjustment procedure, (Refer to 5 - BRAKES/PARKING BRAKE/CABLE TENSIONER - ADJUSTMENTS).
- (11) Lower the vehicle.

**INSTALLATION - REAR PARK BRAKE CABLES - 1500 SERIES**

- (1) Install the parking brake cable guide spring.
- (2) Install the brake drums.
- (3) Pull back on the cable. Then push the cable through the brake support plate hole to engage the cable in the park brake lever.

**NOTE: Pull on the cable end to ensure it is attached to the park brake lever.**

- (4) Push each cable end through the brake support plate hole until the cable end fitting tabs lock into place.

**NOTE: Pull on the cable to ensure it is locked into place.**

- (5) Install the right cable retainers on the axle. Route the right cable through the hole in the brake hose bracket.
- (6) Push both cables through the frame bracket.

**NOTE: The right cable must be installed in the top hole of the bracket.**

- (7) Lock the left cable end fitting tabs into the frame bracket lower hole.

- (8) Install the right rear cable into the tensioner cable bracket and lock the cable end fitting tabs into place.

- (9) Install the cables onto the cable connectors.

- (10) Install the wheel and tire assemblies, (Refer to 22 - TIRES/WHEELS/WHEELS - STANDARD PROCEDURE).

- (11) Perform the park brake adjustment procedure, (Refer to 5 - BRAKES/PARKING BRAKE/CABLE TENSIONER - ADJUSTMENTS).

- (12) Remove the supports and lower the vehicle.

**INSTALLATION - REAR PARK BRAKE CABLE 2500/3500 SERIES WITH DRUM BRAKES**

- (1) Install cable guide spring.
- (2) Install the brake drums.
- (3) Pull back on the cable. Then push the cable through the brake support plate hole to engage the cable in the park brake lever.

**NOTE: Pull on the cable end to ensure it is attached to the park brake lever.**

- (4) Push each cable housing through the brake support plate hole until the cable end fitting tabs lock into place.

**NOTE: Pull on the cable housing to ensure it is locked into place.**

- (5) Install the right cable retainers on the axle. The push the right cable through the hole in the brake hose bracket.

- (6) Push both cables through the frame bracket. Push the left cable until the cable end fitting tabs lock into place. Install the O-ring on the right cable.

**NOTE: The right cable must be installed in the top hole of the bracket and left cable in the bottom hole.**

- (7) Install the cables onto the cable tensioner bracket and install the cables into the cable connectors.

- (8) Install the wheel and tire assemblies.

- (9) Perform park brake adjustment procedure.

- (10) Remove supports and lower vehicle.

## CABLE TENSIONER

### ADJUSTMENT

**NOTE:** Tensioner adjustment is only necessary when the tensioner, or a cable has been replaced or disconnected for service. When adjustment is necessary, perform adjustment only as described in the following procedure. This is necessary to avoid faulty park brake operation.

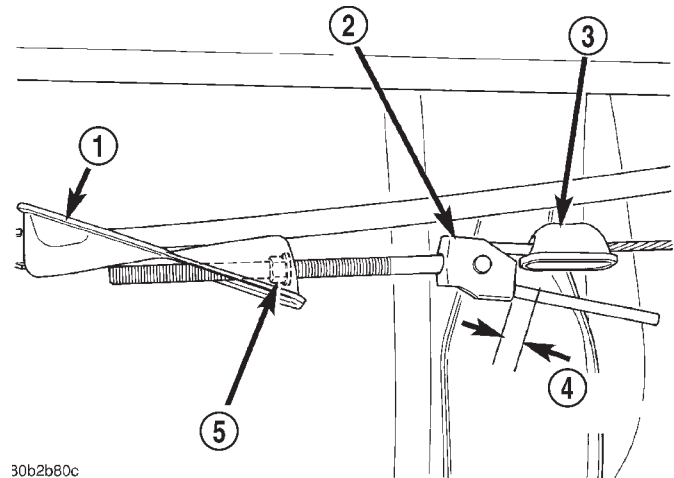
- (1) Raise the vehicle.
- (2) Back off the cable tensioner adjusting nut to create slack in the cables.
- (3) Remove the rear wheel/tire assemblies. Then remove the brake drums.
- (4) Verify the brakes are in good condition and operating properly.
- (5) Verify the park brake cables operate freely and are not binding, or seized.
- (6) Check the rear brake shoe adjustment with standard brake gauge.
- (7) Install the drums and verify that the drums rotate freely without drag.
- (8) Install the wheel/tire assemblies, (Refer to 22 - TIRES/WHEELS/WHEELS - STANDARD PROCEDURE).
- (9) Lower the vehicle enough for access to the park brake foot pedal. Then fully apply the park brakes.

**NOTE:** Leave park brakes applied until adjustment is complete.

- (10) Raise the vehicle again.
- (11) Mark the tensioner rod 6.35 mm (1/4 in.) from edge of the tensioner (Fig. 71).
- (12) Tighten the adjusting nut on the tensioner rod until the mark is no longer visible.

**CAUTION:** Do not loosen, or tighten the tensioner adjusting nut for any reason after completing adjustment.

- (13) Lower the vehicle until the rear wheels are 15-20 cm (6-8 in.) off the shop floor.
- (14) Release the park brake foot pedal and verify that rear wheels rotate freely without drag. Then lower the vehicle.



**Fig. 71 Adjustment Mark**

- 1 - TENSIONER CABLE BRACKET
- 2 - TENSIONER
- 3 - CABLE CONNECTOR
- 4 - 6.35mm (1/4 IN.)
- 5 - ADJUSTER NUT

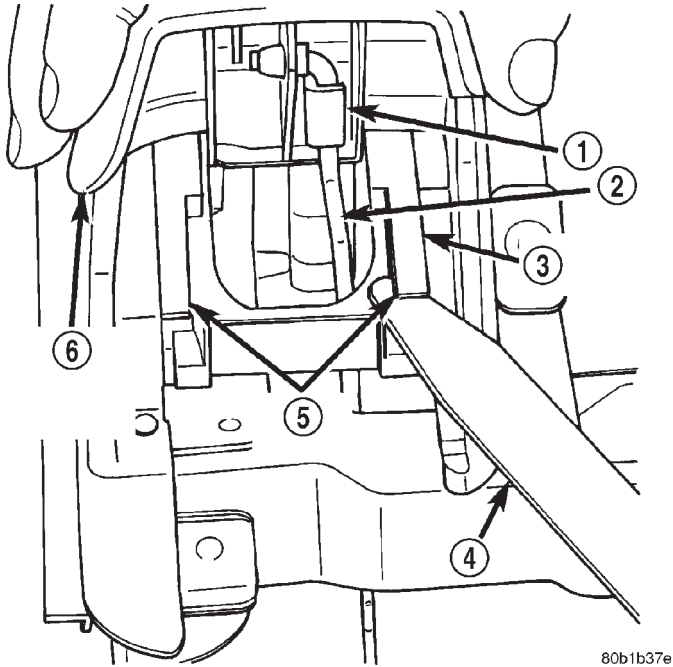
## RELEASE

### REMOVAL

- (1) Disconnect and isolate the battery negative cable.
- (2) Reach under the driver side outboard end of the instrument panel to access and unsnap the plastic retainer clip that secures the park brake release linkage rod to the park brake mechanism on the left cowl side inner panel.
- (3) Disengage the park brake release linkage rod end from the park brake mechanism.
- (4) Lift the park brake release handle to access and unsnap the plastic retainer clip that secures the park brake release linkage rod to the lever on the back of the park brake release handle.
- (5) Lower the park brake release handle and reach under the driver side outboard end of the instrument panel to disengage the park brake release linkage rod end from the lever on the back of the park brake release handle.
- (6) Lift the park brake release handle to access the handle mounting bracket.

## RELEASE (Continued)

(7) Using a trim stick or another suitable wide flat-bladed tool, gently pry each of the park brake release handle mounting bracket latch tabs away from the retaining notches in the instrument panel receptacle (Fig. 72).



80b1b37e

**Fig. 72 Park Brake Release Handle Remove/Install**

- 1 - CLIP
- 2 - ROD
- 3 - MOUNTING BRACKET
- 4 - TRIM STICK
- 5 - LATCH TABS
- 6 - PARK BRAKE RELEASE HANDLE

(8) With both of the park brake release handle mounting bracket latches released, slide the handle and bracket assembly down and out of the instrument panel receptacle.

## INSTALLATION

(1) Position the park brake release handle to the instrument panel.

(2) Slide the handle and bracket assembly up into the instrument panel receptacle until both of the park brake release handle mounting bracket latches are engaged with the notches in the instrument panel receptacle.

(3) Lower the park brake release handle and reach under the driver side outboard end of the instrument panel to engage the park brake release linkage rod end with the lever on the back of the park brake release handle.

(4) Lift the park brake release handle to access and snap the plastic retainer clip that secures the park brake release linkage rod to the lever on the back of the park brake release handle over the linkage rod.

(5) Reach under the driver side outboard end of the instrument panel to access and engage the park brake release linkage rod end to the park brake mechanism.

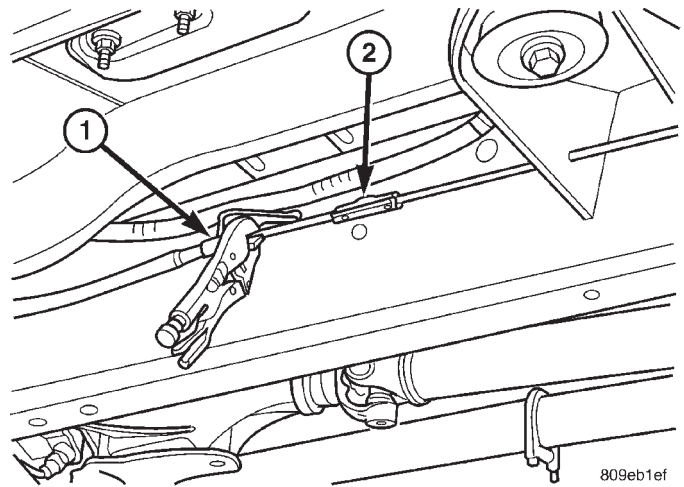
(6) Snap the plastic retainer clip that secures the park brake release linkage rod to the park brake mechanism on the left cowl side inner panel over the linkage rod.

(7) Reconnect the battery negative cable.

## SHOES

## REMOVAL - REAR DRUM IN HAT PARK BRAKE SHOES - 2500/3500

- (1) Raise and support the vehicle.
- (2) Remove the tire and wheel assembly.
- (3) Remove the disc brake caliper, (Refer to 5 - BRAKES/HYDRAULIC/MECHANICAL/DISC BRAKE CALIPERS - REMOVAL)
- (4) Remove the disc brake rotor, (Refer to 5 - BRAKES/HYDRAULIC/MECHANICAL/ROTORS - REMOVAL)
- (5) Lockout the parking brake cable (Fig. 73).



809eb1ef

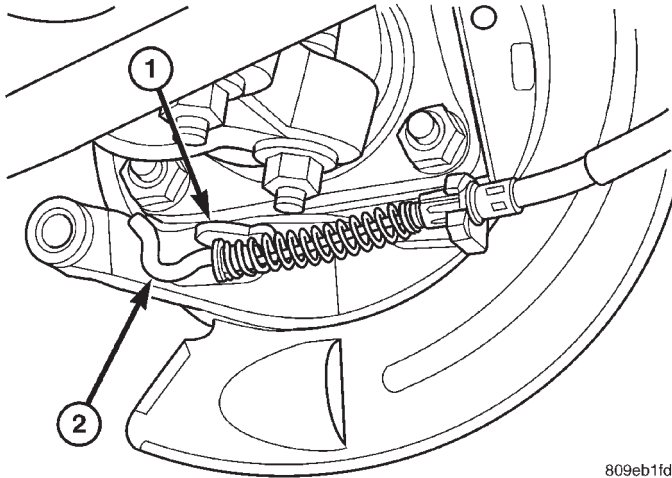
**Fig. 73 LOCK OUT PARKING CABLE**

- 1 - LOCKING PLIERS
- 2 - PARKING BRAKE CABLE



## SHOES (Continued)

(6) Disengage the park brake cable from behind the rotor assembly to allow easier disassembly of the park brake shoes (Fig. 74).



809eb1fd

**Fig. 74 DISENGAGEMENT OF CABLE**

- 1 - LEVER
- 2 - CABLE END

(7) Disassemble the rear park brake shoes (Fig. 75).

### INSTALLATION - REAR DRUM IN HAT PARK BRAKE SHOES - 2500/3500

(1) Reassemble the rear park brake shoes (Fig. 76).

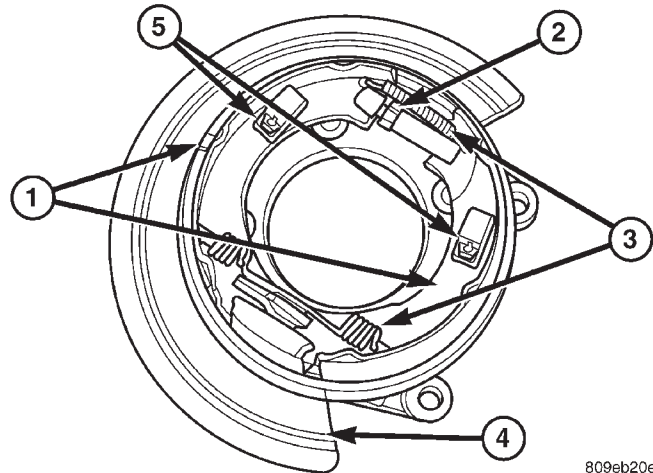
(2) Release the parking brake cable.

(3) Install the disc brake rotor, (Refer to 5 - BRAKES/HYDRAULIC/MECHANICAL/ROTORS - INSTALLATION).

(4) Install the disc brake caliper, (Refer to 5 - BRAKES/HYDRAULIC/MECHANICAL/DISC BRAKE CALIPERS - INSTALLATION).

(5) Install the tire and wheel assembly, (Refer to 22 - TIRES/WHEELS/WHEELS - STANDARD PROCEDURE).

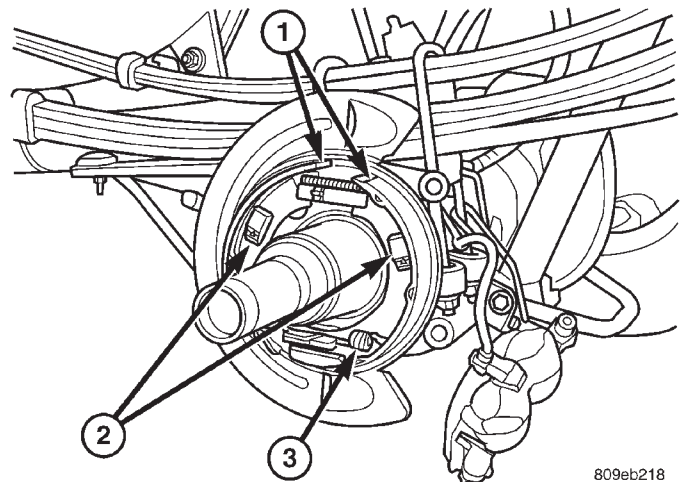
(6) Lower the vehicle.



809eb20e

**Fig. 75 SHOES REMOVAL**

- 1 - PARK BRAKE SHOES
- 2 - ADJUSTER
- 3 - RETURN SPRINGS
- 4 - SPLASH SHIELD
- 5 - HOLD DOWNS



809eb218

**Fig. 76 SHOE ASSEMBLY**

- 1 - Park Brake Shoes
- 2 - Hold Downs
- 3 - Return Springs

# CLUTCH

## TABLE OF CONTENTS

	page		page
<b>CLUTCH</b>		<b>OPERATION</b> .....	16
DESCRIPTION.....	1	<b>FLYWHEEL</b>	
OPERATION.....	1	DESCRIPTION.....	16
WARNING.....	2	OPERATION.....	16
DIAGNOSIS AND TESTING.....	2	DIAGNOSIS AND TESTING.....	17
CLUTCH.....	2	FLYWHEEL.....	17
SPECIFICATIONS.....	7	DISASSEMBLY.....	17
<b>CLUTCH DISC</b>		ASSEMBLY.....	17
DESCRIPTION.....	7	<b>PILOT BEARING</b>	
OPERATION.....	8	DESCRIPTION.....	17
REMOVAL.....	8	OPERATION.....	18
INSTALLATION.....	9	REMOVAL.....	18
<b>CLUTCH HOUSING</b>		INSTALLATION.....	18
DIAGNOSIS AND TESTING.....	11	<b>CLUTCH PEDAL</b>	
CLUTCH HOUSING.....	11	REMOVAL.....	18
REMOVAL.....	13	INSTALLATION.....	19
INSTALLATION.....	13	<b>LINKAGE</b>	
<b>CLUTCH RELEASE BEARING</b>		DESCRIPTION.....	19
DESCRIPTION.....	14	OPERATION.....	20
OPERATION.....	14	REMOVAL.....	20
REMOVAL.....	15	INSTALLATION.....	20
INSTALLATION.....	15	<b>CLUTCH PEDAL POSITION SWITCH</b>	
<b>PRESSURE PLATE</b>		DESCRIPTION.....	22
DESCRIPTION.....	15	OPERATION.....	22

## CLUTCH

### DESCRIPTION

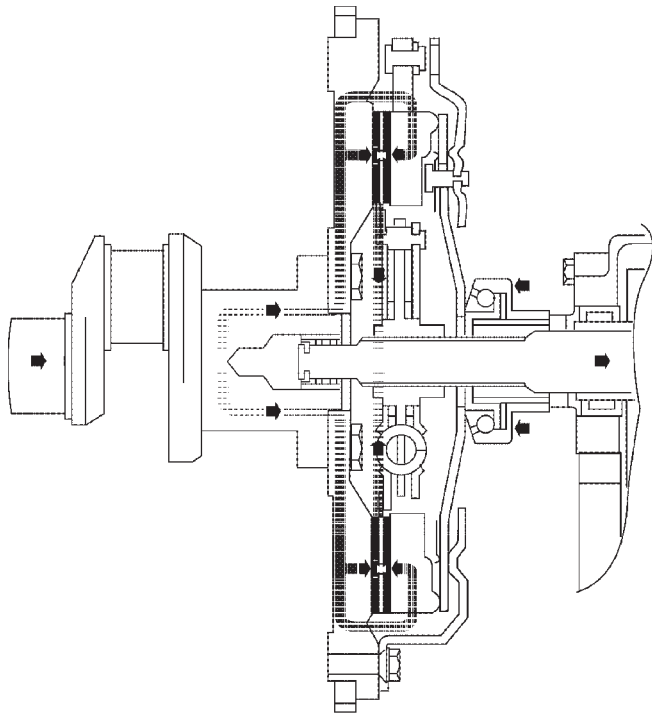
The clutch mechanism consists of a flywheel, a single, dry-type disc, and a diaphragm style clutch cover (Fig. 1). A hydraulic linkage is used to operate the clutch release bearing and fork. The flywheel is bolted to the rear flange of the crankshaft. The clutch pressure plate is bolted to the flywheel with the clutch disc located between these two components. The clutch system provides the mechanical, but still easily detachable, link between the engine and the transmission. The system is designed to ensure that the full torque output of the engine is transferred to the transmission while isolating the transmission from the engine firing pulses to minimize concerns such as gear rattle.

### OPERATION

Leverage, clamping force, and friction are what make the clutch work. The disc serves as the friction element and a diaphragm spring and pressure plate provide the clamping force. The clutch pedal, hydraulic linkage, release lever and bearing provide the leverage.

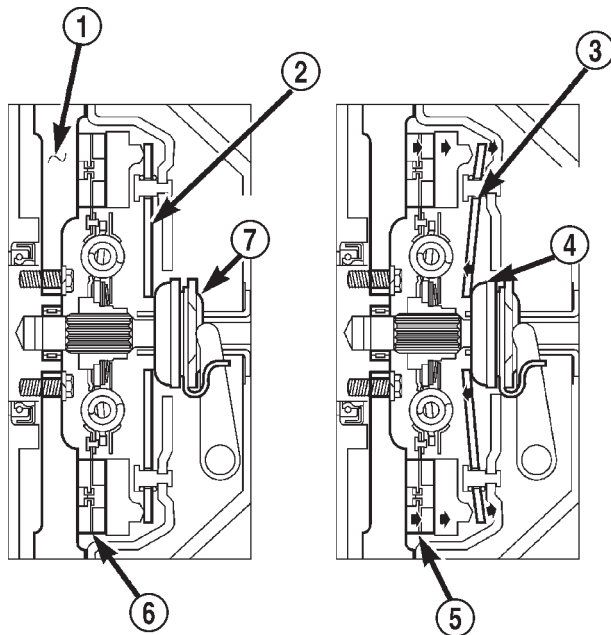
The clutch master cylinder push rod is connected to the clutch pedal. When the clutch pedal is depressed, the slave cylinder is operated by the clutch master cylinder mounted on the dash panel. The release fork is actuated by the hydraulic slave cylinder mounted on the transmission housing. The release bearing is operated by a release fork pivoting on a ball stud mounted in the transmission housing. The release bearing then depresses the pressure plate spring fingers, thereby releasing pressure on the clutch disc and allowing the engine crankshaft to spin independently of the transmission input shaft (Fig. 2).

## CLUTCH (Continued)



80be45e9

**Fig. 1 Engine Powerflow**



80be45ea

**Fig. 2 Clutch Operation**

- 1 - FLYWHEEL
- 2 - PRESSURE PLATE FINGERS
- 3 - PIVOT POINT
- 4 - RELEASE BEARING PUSHED IN
- 5 - CLUTCH DISC ENGAGED
- 6 - CLUTCH DISC ENGAGED
- 7 - RELEASE BEARING

## WARNING

**WARNING:: EXERCISE CARE WHEN SERVICING CLUTCH COMPONENTS. FACTORY INSTALLED CLUTCH DISCS DO NOT CONTAIN ASBESTOS FIBERS. DUST AND DIRT ON CLUTCH PARTS MAY CONTAIN ASBESTOS FIBERS FROM AFTERMARKET COMPONENTS. BREATHING EXCESSIVE CONCENTRATIONS OF THESE FIBERS CAN CAUSE SERIOUS BODILY HARM. WEAR A RESPIRATOR DURING SERVICE AND NEVER CLEAN CLUTCH COMPONENTS WITH COMPRESSED AIR OR WITH A DRY BRUSH. EITHER CLEAN THE COMPONENTS WITH A WATER DAMPENED RAGS OR USE A VACUUM CLEANER SPECIFICALLY DESIGNED FOR REMOVING ASBESTOS FIBERS AND DUST. DO NOT CREATE DUST BY SANDING A CLUTCH DISC. REPLACE THE DISC IF THE FRICTION MATERIAL IS DAMAGED OR CONTAMINATED. DISPOSE OF ALL DUST AND DIRT CONTAINING ASBESTOS FIBERS IN SEALED BAGS OR CONTAINERS. THIS WILL HELP MINIMIZE EXPOSURE TO YOURSELF AND TO OTHERS. FOLLOW ALL RECOMMENDED SAFETY PRACTICES PRESCRIBED BY THE OCCUPATIONAL SAFETY AND HEALTH ADMINISTRATION (OSHA) AND THE ENVIRONMENTAL SAFETY AGENCY (EPA), FOR THE HANDLING AND DISPOSAL OF PRODUCTS CONTAINING ASBESTOS.**

## DIAGNOSTIC AND TESTING - CLUTCH

A road test and component inspection (Fig. 3) is recommended to determine a clutch problem.

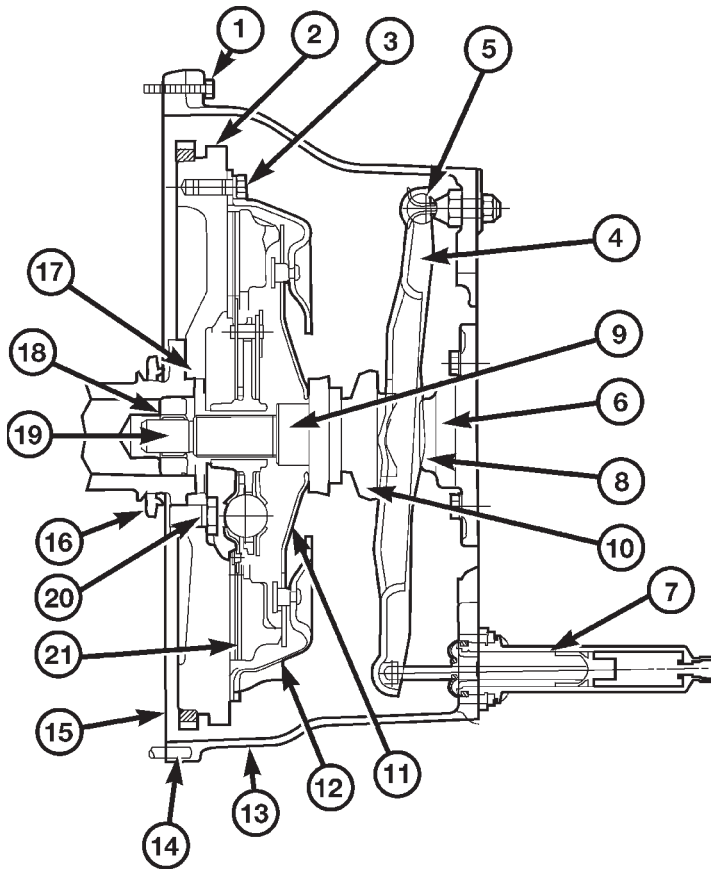
During a road test, drive the vehicle at normal speeds. Shift the transmission through all gear ranges and observe clutch action. If the clutch chatters, grabs, slips or does not release properly, remove and inspect the clutch components. If the problem is noise or hard shifting, further diagnosis may be needed as the transmission or another driveline component may be at fault.

## CLUTCH CONTAMINATION

Fluid contamination is a frequent cause of clutch malfunctions. Oil, water or clutch fluid on the clutch disc and pressure plate surfaces will cause chatter, slip and grab.

During inspection, note if any components are contaminated with oil, hydraulic fluid or water/road splash.

## CLUTCH (Continued)



- 1 Check clutch housing bolts. Tighten if loose. Be sure housing is fully seated on engine block.
- 2 Check flywheel. Scuff sand face to remove glaze. Clean surface with wax and grease remover. Replace flywheel if severely scored, worn or cracked. Secure flywheel with new bolts (if removed). Do not reuse old bolts. Use Mopar Lock N'Seal on bolts.
- 3 Tighten clutch cover bolts 2-3 threads at a time, alternately and evenly (in a star pattern) to specified torque. Failure to do so could warp the cover.
- 4 Check release fork. Replace fork if bent or worn. Make sure pivot and bearing contact surfaces are lubricated.
- 5 Check release fork pivot (in housing). Be sure pivot is secure and ball end is lubricated.
- 6 Transmission input shaft bearing will cause noise, chatter, or improper release if damaged. Check condition before installing transmission.
- 7 Check slave cylinder. Replace it if leaking. Be sure cylinder is properly secured in housing and cylinder piston is seated in release fork.
- 8 Check input shaft seal if clutch cover and disc were oil covered. Replace seal if worn, or cut.
- 9 Inspect release bearing slide surface of trans. front bearing retainer. Surface should be smooth, free of nicks, scores. Replace retainer if necessary. Lubricate slide surface before installing release bearing.
- 10 Do not replace release bearing unless actually faulty. Replace bearing only if seized, noisy, or damaged.
- 11 Check clutch cover diaphragm spring and release fingers. Replace cover if spring or fingers are bent, warped, broken, cracked. Do not tamper with factory spring setting as clutch problems will result.
- 12 Check condition of clutch cover. Replace clutch cover if plate surface is deeply scored, warped, worn, or cracked. Be sure cover is correct size and properly aligned on disc and flywheel.
- 13 Inspect clutch housing. Be sure bolts are tight. Replace housing if damaged.
- 14 Verify that housing alignment dowels are in position before installing housing.
- 15 Clean engine block surface before installing clutch housing. Dirt, grime can produce misalignment.
- 16 Check rear main seal if clutch disc and cover were oil covered. Replace seal if necessary.
- 17 Check crankshaft flange (if flywheel is removed). Be sure flange is clean and flywheel bolt threads are in good condition.
- 18 Check pilot bearing. Replace bearing if damaged. Lube with Mopar high temp. bearing grease before installation.
- 19 Check transmission input shaft. Disc must slide freely on shaft splines. Lightly grease splines before installation. Replace shaft if splines or pilot bearing hub are damaged.
- 20 Check flywheel bolt torque. If bolts are loose, replace them. Use Mopar Lock N'Seal to secure new bolts.
- 21 Check clutch disc facing. Replace disc if facing is charred, scored, flaking off, or worn. Also check runout of new disc. Runout should not exceed 0.5 mm (0.02 in.).

**Fig. 3 Clutch Components And Inspection**

## CLUTCH (Continued)

Oil contamination indicates a leak at either the rear main seal or transmission input shaft. Oil leakage produces a residue of oil on the housing interior and on the clutch cover and flywheel. Heat buildup caused by slippage between the cover, disc and flywheel, can sometimes bake the oil residue onto the components. The glaze-like residue ranges in color from amber to black.

Road splash contamination means dirt/water is entering the clutch housing due to loose bolts, housing cracks or through hydraulic line openings. Driving through deep water puddles can force water/road splash into the housing through such openings.

Clutch fluid leaks are usually from damaged slave cylinder push rod seals.

### IMPROPER RELEASE OR CLUTCH ENGAGEMENT

Clutch release or engagement problems are caused by wear or damage to one or more clutch components. A visual inspection of the release components will usually reveal the problem part.

Release problems can result in hard shifting and noise. Items to look for are: leaks at the clutch cylinders and interconnecting line; loose slave cylinder bolts; worn/loose release fork and pivot stud; damaged release bearing; and a worn clutch disc, or pressure plate.

Normal condensation in vehicles that are stored or out of service for long periods of time can generate enough corrosion to make the disc stick to the flywheel, or pressure plate. If this condition is experienced, correction only requires that the disc be loosened manually through the inspection plate opening.

Engagement problems usually result in slip, chatter/shudder, and noisy operation. The primary causes are clutch disc contamination; clutch disc wear; misalignment, or distortion; flywheel damage; or a combination of the foregoing. A visual inspection is required to determine the part actually causing the problem.

### CLUTCH MISALIGNMENT

Clutch components must be in proper alignment with the crankshaft and transmission input shaft. Misalignment caused by excessive runout or warpage of any clutch component will cause grab, chatter and improper clutch release.

### CLUTCH COVER AND DISC RUNOUT

Check the clutch disc before installation. Axial (face) runout of a **new** disc should not exceed 0.50 mm (0.020 in.). Measure runout about 6 mm (1/4 in.) from the outer edge of the disc facing. Obtain another disc if runout is excessive.

Check condition of the clutch before installation. A warped cover or diaphragm spring will cause grab and incomplete release or engagement. Be careful when handling the cover and disc. Impact can distort the cover, diaphragm spring, release fingers and the hub of the clutch disc.

Use an alignment tool when positioning the disc on the flywheel. The tool prevents accidental misalignment which could result in cover distortion and disc damage.

A frequent cause of clutch cover distortion (and consequent misalignment) is improper bolt tightening.

### CLUTCH FLYWHEEL RUNOUT

Check flywheel runout whenever misalignment is suspected. Flywheel runout should not exceed 0.08 mm (0.003 in.). Measure runout at the outer edge of the flywheel face with a dial indicator. Mount the indicator on the rear face of the engine block.

Common causes of runout are:

- heat warpage
- improper machining
- incorrect bolt tightening
- improper seating on crankshaft flange shoulder
- foreign material on crankshaft flange

Flywheel machining is not recommended. The flywheel clutch surface is machined to a unique contour and machining will negate this feature. However, minor flywheel scoring can be cleaned up by hand with 180 grit emery, or with surface grinding equipment. Remove only enough material to reduce scoring (approximately 0.001 - 0.003 in.). Heavy stock removal is **not recommended**. Replace the flywheel if scoring is severe and deeper than 0.076 mm (0.003 in.). Excessive stock removal can result in flywheel cracking or warpage after installation; it can also weaken the flywheel and interfere with proper clutch release.

Clean the crankshaft flange before mounting the flywheel. Dirt and grease on the flange surface may cock the flywheel causing excessive runout. Use new bolts when remounting a flywheel and secure the bolts with Mopar® Lock And Seal. Tighten flywheel bolts to specified torque only. Overtightening can distort the flywheel hub causing runout.

### DIAGNOSIS CHART

The clutch inspection chart (Fig. 3) outlines items to be checked before and during clutch installation. Use the chart as a check list to help avoid overlooking potential problem sources during service operations.

The diagnosis charts describe common clutch problems, causes and correction. Fault conditions are listed at the top of each chart. Conditions, causes and corrective action are outlined in the indicated columns.

The charts are provided as a convenient reference when diagnosing faulty clutch operation.



## CLUTCH (Continued)

## DIAGNOSIS CHART

CONDITION	POSSIBLE CAUSES	CORRECTION
Disc facing worn out	<ol style="list-style-type: none"> <li>1. Normal wear.</li> <li>2. Driver frequently rides (slips) the clutch. Results in rapid overheating and wear.</li> <li>3. Insufficient clutch cover diaphragm spring tension.</li> </ol>	<ol style="list-style-type: none"> <li>1. Replace cover and disc.</li> <li>2. Replace cover and disc.</li> <li>3. Replace cover and disc.</li> </ol>
Clutch disc facing contaminated with oil, grease, or clutch fluid.	<ol style="list-style-type: none"> <li>1. Leak at rear main engine seal or transmission input shaft seal.</li> <li>2. Excessive amount of grease applied to the input shaft splines.</li> <li>3. Road splash, water entering housing.</li> <li>4. Slave cylinder leaking.</li> </ol>	<ol style="list-style-type: none"> <li>1. Replace appropriate seal.</li> <li>2. Remove grease and apply the correct amount of grease.</li> <li>3. Replace clutch disc. Clean clutch cover and reuse if in good condition.</li> <li>4. Replace hydraulic clutch linkage.</li> </ol>
Clutch is running partially disengaged.	<ol style="list-style-type: none"> <li>1. Release bearing sticking or binding and does not return to the normal running position.</li> </ol>	<ol style="list-style-type: none"> <li>1. Verify failure. Replace the release bearing and transmission front bearing retainer as necessary.</li> </ol>
Flywheel below minimum thickness specification.	<ol style="list-style-type: none"> <li>1. Improper flywheel machining. Flywheel has excessive taper or excessive material removal.</li> </ol>	<ol style="list-style-type: none"> <li>1. Replace flywheel.</li> </ol>
Clutch disc, cover and/or diaphragm spring warped or distorted.	<ol style="list-style-type: none"> <li>1. Rough handling. Impact bent cover, spring, or disc.</li> <li>2. Improper bolt tightening procedure.</li> </ol>	<ol style="list-style-type: none"> <li>1. Replace disc or cover as necessary.</li> <li>2. Tighten clutch cover using proper procedure.</li> </ol>
Facing on flywheel side of disc torn, gouged, or worn.	<ol style="list-style-type: none"> <li>1. Flywheel surface scored or nicked.</li> <li>2. Clutch disc sticking or binding on transmission input shaft.</li> </ol>	<ol style="list-style-type: none"> <li>2. Correct surface condition if possible. Replace flywheel and disc as necessary.</li> <li>2. Inspect components and correct/replace as necessary.</li> </ol>
Clutch disc facing burnt. Flywheel and cover pressure plate surfaces heavily glazed.	<ol style="list-style-type: none"> <li>1. Frequent operation under high loads or hard acceleration conditions.</li> <li>2. Driver frequently rides (slips) clutch. Results in rapid wear and overheating of disc and cover.</li> </ol>	<ol style="list-style-type: none"> <li>1. Correct condition of flywheel and pressure plate surface. Replace clutch cover and disc. Alert driver to problem cause.</li> <li>2. Correct condition of flywheel and pressure plate surface. Replace clutch cover and disc. Alert driver to problem cause.</li> </ol>

## CLUTCH (Continued)

CONDITION	POSSIBLE CAUSES	CORRECTION
Clutch disc binds on input shaft splines.	<ol style="list-style-type: none"> <li>1. Clutch disc hub splines damaged during installation.</li> <li>2. Input shaft splines rough, damaged, or corroded.</li> </ol>	<ol style="list-style-type: none"> <li>1. Clean, smooth, and lubricate hub splines if possible. Replace disc if necessary.</li> <li>2. Clean, smooth, and lubricate shaft splines if possible. Replace input shaft if necessary.</li> </ol>
Clutch disc rusted to flywheel and/or pressure plate.	<ol style="list-style-type: none"> <li>1. Clutch not used for and extended period of time (e.g. long term vehicle storage).</li> </ol>	<ol style="list-style-type: none"> <li>1. Sand rusted surfaces with 180 grit sanding paper. Replace clutch cover and flywheel if necessary.</li> </ol>
Pilot bearing seized, loose, or rollers are worn.	<ol style="list-style-type: none"> <li>1. Bearing cocked during installation.</li> <li>2. Bearing defective.</li> <li>3. Bearing not lubricated.</li> <li>4. Clutch misalignment.</li> </ol>	<ol style="list-style-type: none"> <li>1. Install and lubricate a new bearing.</li> <li>2. Install and lubricate a new bearing.</li> <li>3. Install and lubricate a new bearing.</li> <li>4. Inspect clutch and correct as necessary. Install and lubricate a new bearing.</li> </ol>
Clutch will not disengage properly.	<ol style="list-style-type: none"> <li>1. Low clutch fluid level.</li> <li>2. Clutch cover loose.</li> <li>3. Clutch disc bent or distorted.</li> <li>4. Clutch cover diaphragm spring bent or warped.</li> <li>5. Clutch disc installed backwards.</li> <li>6. Release fork bent or fork pivot loose or damaged.</li> <li>7. Clutch master or slave cylinder failure.</li> </ol>	<ol style="list-style-type: none"> <li>1. Replace hydraulic linkage assembly.</li> <li>2. Follow proper bolt tightening procedure.</li> <li>3. Replace clutch disc.</li> <li>4. Replace clutch cover.</li> <li>5. Remove and install clutch disc correctly.</li> <li>6. Replace fork or pivot as necessary.</li> <li>7. Replace hydraulic linkage assembly.</li> </ol>
Clutch pedal squeak.	<ol style="list-style-type: none"> <li>1. Pivot pin loose.</li> <li>2. Master cylinder bushing not lubricated.</li> <li>3. Pedal bushings worn out or cracked.</li> </ol>	<ol style="list-style-type: none"> <li>1. Tighten pivot pin if possible. Replace clutch pedal if necessary.</li> <li>2. Lubricate master cylinder bushing.</li> <li>3. Replace and lubricate bushings.</li> </ol>
Clutch master or slave cylinder plunger dragging and/or binding	<ol style="list-style-type: none"> <li>1. Master or slave cylinder components worn or corroded.</li> </ol>	<ol style="list-style-type: none"> <li>1. Replace clutch hydraulic linkage assembly.</li> </ol>
Release bearing is noisy.	<ol style="list-style-type: none"> <li>1. Release bearing defective or damaged.</li> </ol>	<ol style="list-style-type: none"> <li>1. Replace release bearing.</li> </ol>

## CLUTCH (Continued)

CONDITION	POSSIBLE CAUSES	CORRECTION
Contact surface of release bearing damaged.	<ol style="list-style-type: none"> <li>1. Clutch cover incorrect or release fingers bent or distorted.</li> <li>2. Release bearing defective or damaged.</li> <li>3. Release bearing misaligned.</li> </ol>	<ol style="list-style-type: none"> <li>1. Replace clutch cover and release bearing.</li> <li>2. Replace the release bearing.</li> <li>3. Check and correct runout of clutch components. Check front bearing sleeve for damage/alignment. Repair as necessary.</li> </ol>
Partial engagement of clutch disc. One side of disc is worn and the other side is glazed and lightly worn.	<ol style="list-style-type: none"> <li>1. Clutch pressure plate position incorrect.</li> <li>2. Clutch cover, spring, or release fingers bent or distorted.</li> <li>3. Clutch disc damaged or distorted.</li> <li>4. Clutch misalignment.</li> </ol>	<ol style="list-style-type: none"> <li>1. Replace clutch disc and cover.</li> <li>2. Replace clutch disc and cover.</li> <li>2. Replace clutch disc.</li> <li>4. Check alignment and runout of flywheel, disc, pressure plate, and/or clutch housing. Correct as necessary.</li> </ol>

## SPECIFICATIONS

## SPECIFICATIONS - CLUTCH

## TORQUE SPECIFICATIONS

DESCRIPTION	N-m	Ft. Lbs.	In. Lbs.
Nut, slave cylinder	19-26	14-19	170-230
Bolt, clutch cover-5/16 in.	23	17	-
Bolt, clutch cover-3/8 in.	41	30	-
Pivot, release bearing	23	17	-
Screw, fluid reservoir	5	-	40

## CLUTCH DISC

## DESCRIPTION

The clutch disc friction material is riveted to the disc hub. The hub bore is splined for installation on the transmission input shaft. The clutch disc has cushion springs in the disc hub to dampen disc vibrations during application and release of the clutch.

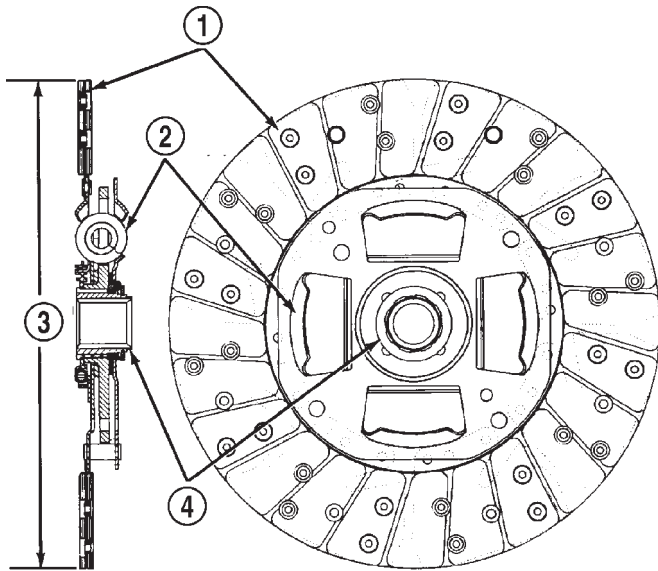
Various size and design of clutches are used for the different engine transmission combinations. The currently used clutches and applications are listed below.

A 281 mm (11 in.) diameter clutch disc is used with a 3.9L, 5.2L, or 5.9L gas engines (Fig. 4) and (Fig. 5).

A 312.5 mm (12.3 in.) diameter clutch disc is used with diesel and V10 engines and (Fig. 6).

All the discs have damper springs in the hub. The 281 mm discs have four springs, the 312.5 mm diesel/V10 disc has nine springs. The damper springs provide smoother torque transfer and disc engagement.

## CLUTCH DISC (Continued)

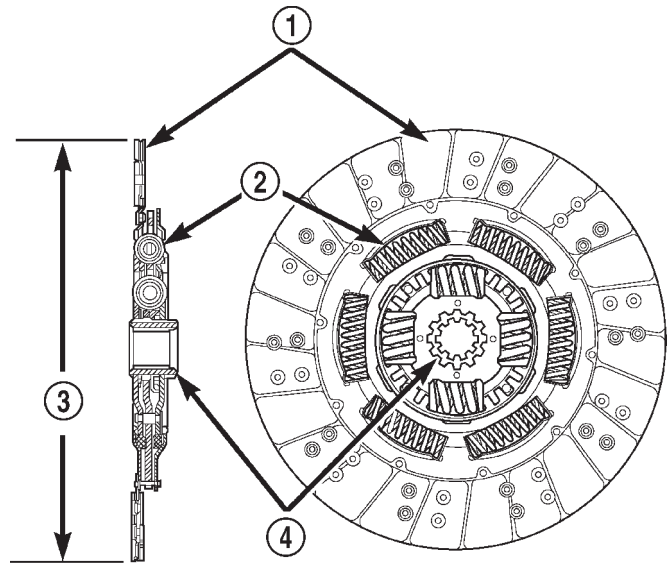


V6

J9406-7

**Fig. 4 Clutch Disc-V6 Engine**

- 1 - FACING MATERIAL
- 2 - DAMPER SPRINGS (4)
- 3 - 281 mm (11 in.)
- 4 - HUB

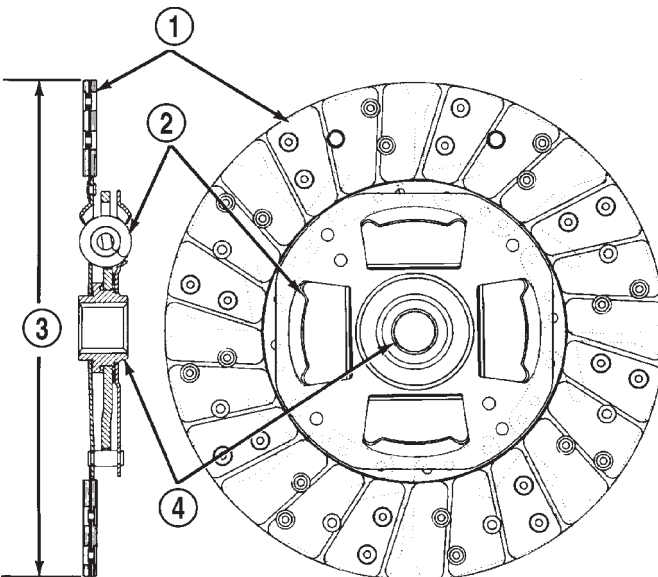


DIESEL

80ba7973

**Fig. 6 Clutch Disc-V10/Diesel Engines**

- 1 - FACING MATERIAL
- 2 - DAMPER SPRINGS (9)
- 3 - 312.5 mm (12.3 IN)
- 4 - HUB



V8

J9406-8

**Fig. 5 Clutch Disc-V8 Engine**

- 1 - FACING MATERIAL
- 2 - DAMPER SPRINGS (4)
- 3 - 281 mm (11 in.)
- 4 - HUB

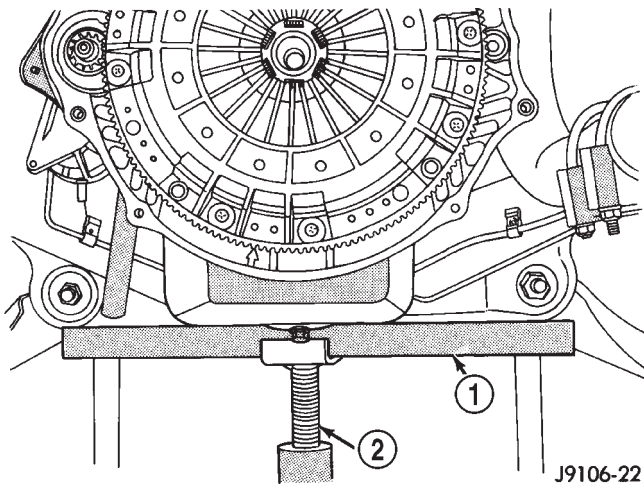
**OPERATION**

The clutch disc is held onto the surface of the flywheel by the force exerted by the pressure plate's diaphragm spring. The friction material of the clutch disc then transfers the engine torque from the flywheel and pressure plate to the input shaft of the transmission.

**REMOVAL**

- (1) Raise and support vehicle.
- (2) Support engine with wood block and adjustable jack stand (Fig. 7). Supporting engine is necessary to avoid undue strain on engine mounts.
- (3) Remove transmission and transfer case, if equipped. Refer to Group 21, Transmission and Transfer Case, for proper procedures.
- (4) If clutch cover will be reused, mark position of cover on flywheel with paint or scribe (Fig. 8).
- (5) Insert clutch alignment tool in clutch disc and into pilot bushing. Tool will hold disc in place when cover bolts are removed.
- (6) If clutch cover will be reused, loosen cover bolts evenly, only few threads at a time, and in a diagonal pattern (Fig. 9). This relieves cover spring tension evenly to avoid warping.
- (7) Remove cover bolts completely and remove cover, disc and alignment tool.

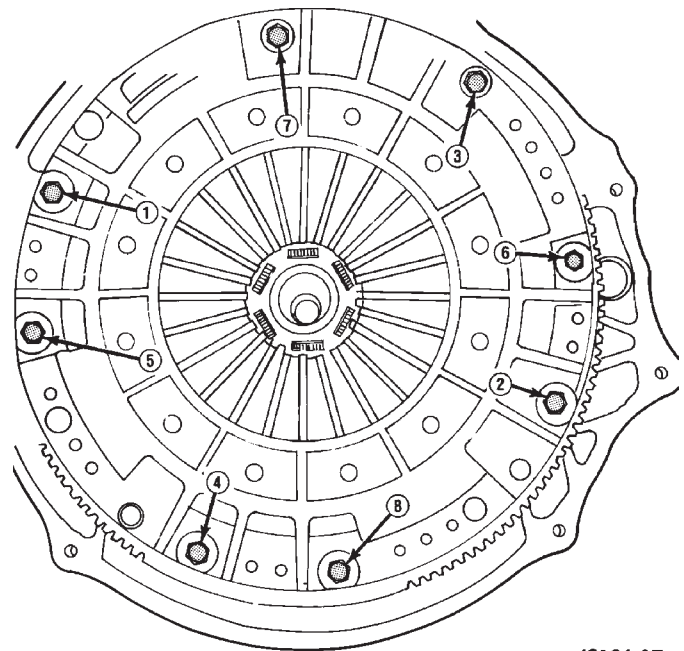
## CLUTCH DISC (Continued)



J9106-22

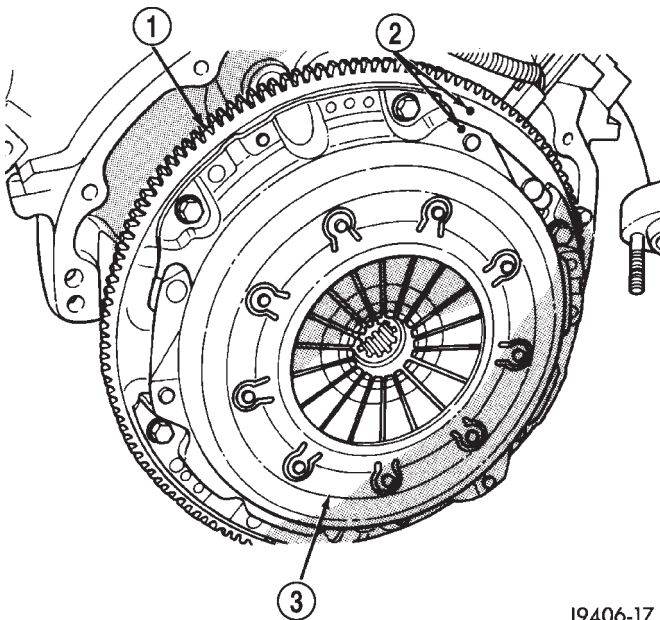
**Fig. 7 Supporting Engine With Jack Stand And Wood Block—Diesel Model Shown**

- 1 - WOOD BLOCK  
2 - ADJUSTABLE JACK STAND



J9106-17

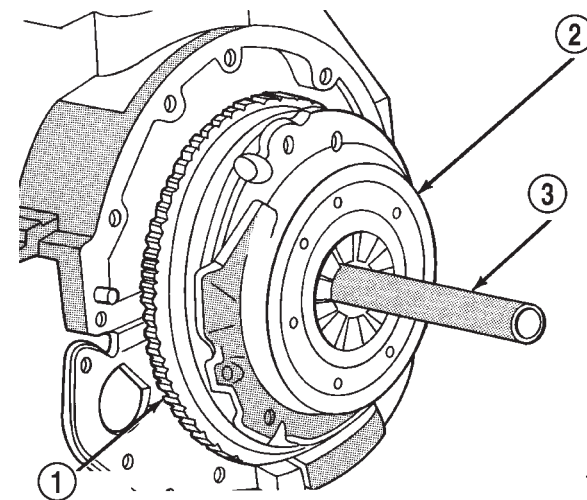
**Fig. 9 Clutch Cover Bolt Loosening/Tightening Pattern**



J9406-17

**Fig. 8 Marking Clutch Cover Position**

- 1 - FLYWHEEL  
2 - ALIGNMENT MARKS (SCRIBE OR PAINT)  
3 - CLUTCH COVER



J9106-18

**Fig. 10 Clutch Disc And Cover Alignment/Installation**

- 1 - FLYWHEEL  
2 - CLUTCH COVER AND DISC  
3 - CLUTCH DISC ALIGNMENT TOOL

## INSTALLATION

(1) Check runout and free operation of new clutch disc.

(2) Insert clutch alignment tool in clutch disc hub.

(3) Verify that disc hub is positioned correctly. The raised side of hub is installed away from the flywheel.

(4) Insert alignment tool in pilot bearing and position disc on flywheel surface (Fig. 10).

(5) Position clutch cover over disc and onto flywheel (Fig. 10).

(6) Align and hold clutch cover in position and install cover bolts finger tight.

(7) Tighten cover bolts evenly and a few threads at a time. Cover bolts must be tightened evenly and to specified torque to avoid distorting cover.

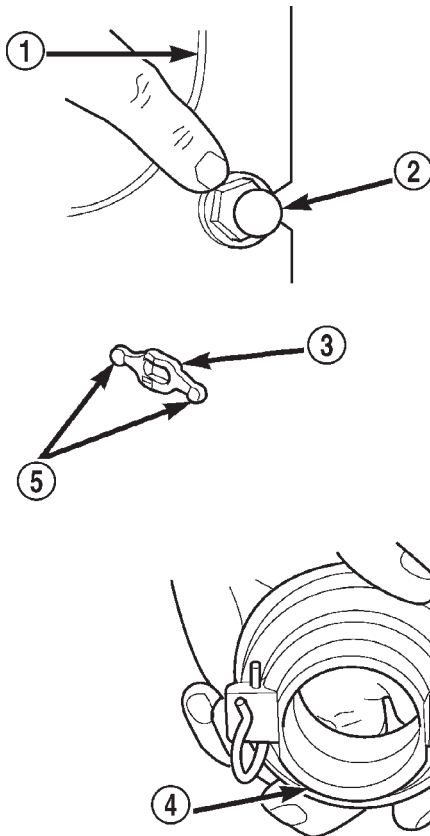
(8) Tighten clutch cover bolts to following:

- 5/16 in. diameter bolts to 23 N·m (17 ft. lbs.).
- 3/8 in. diameter bolts to 41 N·m (30 ft. lbs.).



## CLUTCH DISC (Continued)

(9) Remove release lever and release bearing from clutch housing. Apply Mopar® high temperature bearing grease to bore of release bearing, release lever contact surfaces and release lever pivot stud (Fig. 11).

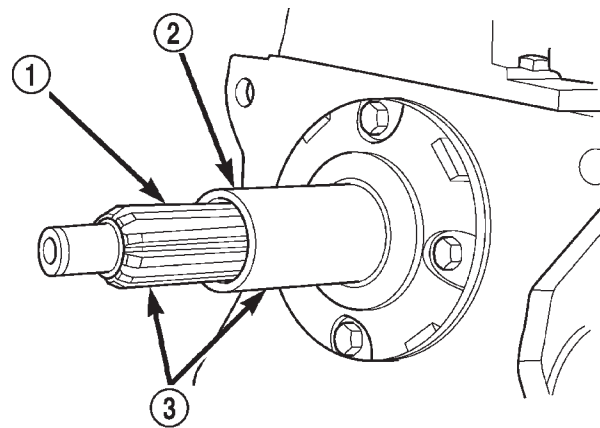


80c07109

**Fig. 11 Clutch Release Component Lubrication Points**

- 1 - CLUTCH HOUSING
- 2 - COAT RELEASE FORK PIVOT BALL STUD WITH HIGH TEMP. GREASE
- 3 - RELEASE FORK
- 4 - APPLY LIGHT COAT HIGH TEMP. GREASE TO RELEASE BEARING BORE
- 5 - LUBE POINTS (HIGH TEMP. GREASE)

(10) Apply light coat of Mopar® high temperature bearing grease to splines of transmission input shaft (or drive gear) and to release bearing slide surface of the transmission front bearing retainer (Fig. 12). Do not over lubricate shaft splines. This can result in grease contamination of disc.

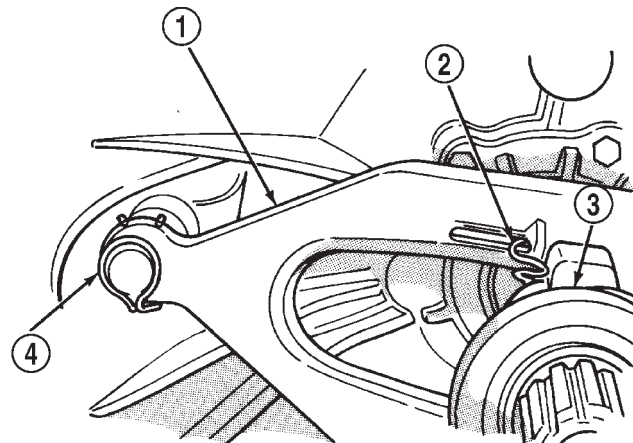


80c0710b

**Fig. 12 Input Shaft Lubrication Points**

- 1 - INPUT SHAFT
- 2 - BEARING RETAINER
- 3 - APPLY LIGHT COAT OF HI-TEMP GREASE TO THESE SURFACES BEFORE INSTALLATION

(11) Install release lever and bearing in clutch housing. Be sure spring clips that retain fork on pivot ball and release bearing on fork are properly installed (Fig. 13). Also verify that the release lever is installed properly. When the release lever is installed correctly, the lever part number will be toward the bottom of the transmission and right side up. There is also a stamped "I" in the lever which goes to the pivot ball side of the transmission.



J9406-18

**Fig. 13 Release Fork And Bearing Spring Clip Position**

- 1 - FORK
- 2 - SPRING CLIP
- 3 - BEARING
- 4 - SPRING CLIP

(12) Install transmission. Refer to Group 21, Transmission and Transfer Case, for proper procedures.

(13) Check fluid level in clutch master cylinder.

## CLUTCH HOUSING

### DIAGNOSIS AND TESTING - CLUTCH HOUSING

Clutch housing alignment is important to proper clutch operation. The housing maintains alignment between the crankshaft and transmission input shaft. Misalignment can cause clutch noise, hard shifting, incomplete release and chatter. It can also result in premature wear of the pilot bearing, cover release fingers and clutch disc. In severe cases, misalignment can also cause premature wear of the transmission input shaft and front bearing.

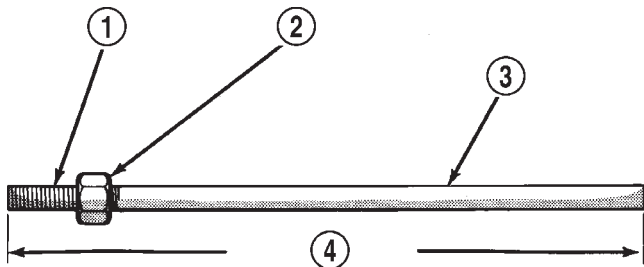
Housing misalignment is generally caused by incorrect seating on the engine or transmission, loose housing bolts, missing alignment dowels, or housing damage. Infrequently, misalignment may also be caused by housing mounting surfaces that are not completely parallel. Misalignment can be corrected with shims.

### CHECKING RUNOUT

**Only the NV4500 clutch housing can be checked using the following bore and face runout procedures. The NV3500 and NV5600 clutch housings are an integral part of the transmission and can only be checked off the vehicle.**

#### MEASURING CLUTCH HOUSING BORE RUNOUT

- (1) Remove the clutch housing and strut.
- (2) Remove the clutch cover and disc.
- (3) Replace one of the flywheel bolts with an appropriate size threaded rod that is 10 in. (25.4 cm) long (Fig. 14). The rod will be used to mount the dial indicator.



J9006-25

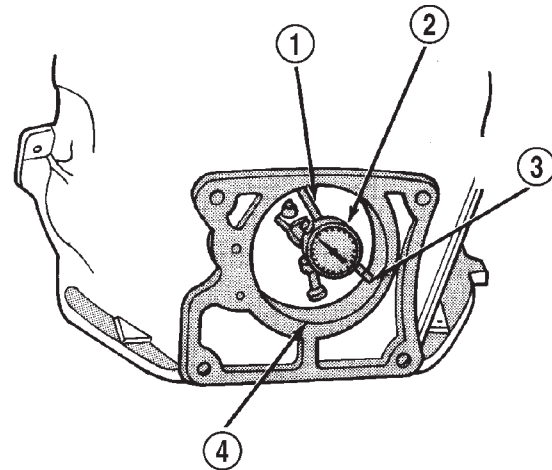
**Fig. 14 Dial Indicator Mounting Stud Or Rod**

- 1 - 7/16 - 20 THREAD
- 2 - NUT
- 3 - STUD OR THREADED ROD
- 4 - 10 INCHES LONG

- (4) Remove the release fork from the clutch housing.

- (5) Reinstall the clutch housing. Tighten the housing bolts nearest the alignment dowels first.

- (6) Mount the dial indicator on the threaded rod and position the indicator plunger on the surface of the clutch housing bore (Fig. 15).



J9006-26

**Fig. 15 Checking Clutch Housing Bore Runout**

- 1 - MOUNTING STUD OR ROD
- 2 - DIAL INDICATOR
- 3 - INDICATOR PLUNGER
- 4 - CLUTCH HOUSING BORE

- (7) Rotate the crankshaft until the indicator plunger is at the top center of the housing bore. Zero the indicator at this point.

- (8) Rotate the crankshaft and record the indicator readings at eight points (45° apart) around the bore (Fig. 15). Repeat the measurement at least twice for accuracy.

- (9) Subtract each reading from the one 180° opposite to determine magnitude and direction of runout. Refer to (Fig. 16) and following example.

Bore runout example:

$$0.000 - (-0.007) = 0.007 \text{ in.}$$

$$+0.002 - (-0.010) = 0.012 \text{ in.}$$

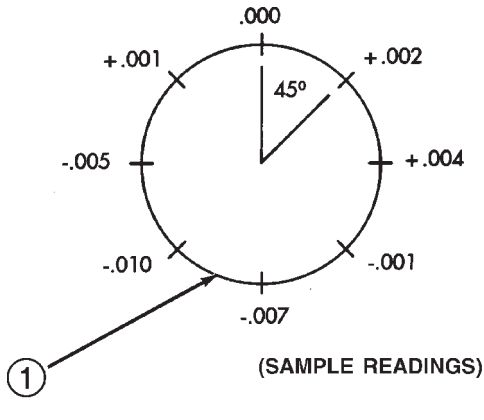
$$+0.004 - (-0.005) = 0.009 \text{ in.}$$

$$-0.001 - (+0.001) = -0.002 \text{ in. (= 0.002 inch)}$$

In the above example, the largest difference is 0.012 in. and is called the total indicator reading (TIR). This means that the housing bore is offset from the crankshaft centerline by 0.006 in. (which is 1/2 of 0.012 in.).

CLUTCH HOUSING (Continued)

On gas engines, the acceptable maximum TIR for housing bore runout is 0.010 inch. If measured TIR is more than 0.010 in. (as in the example), bore runout will have to be corrected with offset dowels. Offset dowels are available in 0.007, 0.014 and 0.021 in. sizes for this purpose (Fig. 16). Refer to Correcting Housing Bore Runout for dowel installation.



J9006-27

**Fig. 16 Housing Bore Measurement Points And Sample Readings**

1 - CLUTCH HOUSING BORE CIRCLE

On diesel engines, the acceptable maximum TIR for housing bore runout is 0.015 inch. However, unlike gas engines, offset dowels are not available to correct runout on diesel engines. **If bore runout exceeds the stated maximum on a diesel engine, it may be necessary to replace either the clutch housing, or transmission adapter plate.**

Correcting Clutch Housing Bore Runout - Engine Only

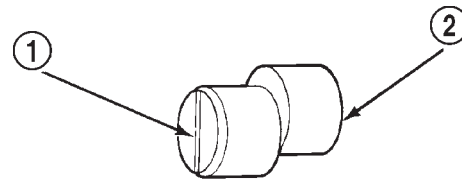
On gas engine vehicles, clutch housing bore runout can be corrected with offset dowels.

The dial indicator reads positive when the plunger moves inward (toward indicator) and negative when it moves outward (away from indicator). As a result, the lowest or most negative reading determines the direction of housing bore offset (runout).

In the sample readings shown (Fig. 17) and in Step 7 above, the bore is offset toward the 0.010 inch reading. To correct this, remove the housing and original dowels. Then install the new offset dowels in the direction needed to center the bore with the crankshaft centerline.

In the example, TIR was 0.012 inch. The dowels needed for correction would have an offset of 0.007 in. (Fig. 17).

Install the dowels with the slotted side facing out so they can be turned with a screwdriver. Then install the housing, remount the dial indicator and check bore runout again. Rotate the dowels until the TIR is less than 0.010 in. if necessary.



TIR VALUE	OFFSET DOWEL REQUIRED
0.011 - 0.021 inch	0.007 inch
0.022 - 0.035 inch	0.014 inch
0.036 - 0.052 inch	0.021 inch

DOWEL SELECTION

J9206-7

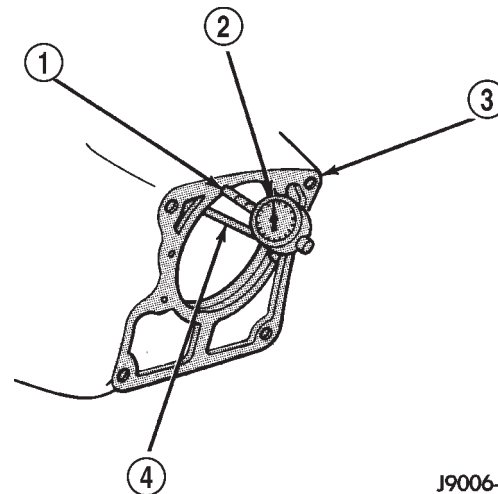
**Fig. 17 Housing Bore Alignment Dowel Selection**

- 1 - SLOT SHOWS DIRECTION OF OFFSET
- 2 - OFFSET DOWEL

If a TIR of 0.053 in., or greater is encountered, it will be necessary to replace the clutch housing.

Measuring Clutch Housing Face Runout

(1) Reposition the dial indicator plunger on the housing face (Fig. 18). Place the indicator plunger at the rim of the housing bore as shown.



J9006-29

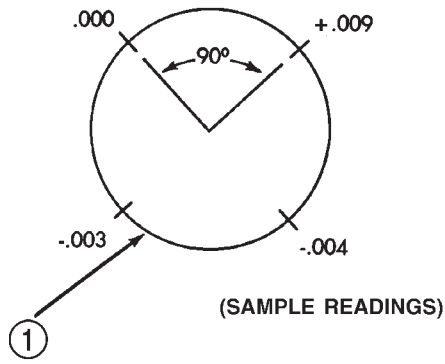
**Fig. 18 Measuring Clutch Housing Face Runout**

- 1 - INDICATOR PLUNGER
- 2 - DIAL INDICATOR
- 3 - CLUTCH HOUSING FACE
- 4 - INDICATOR MOUNTING STUD OR ROD

(2) Rotate the crankshaft until the indicator plunger is at the 10 O'clock position on the bore. Then zero the dial indicator.

(3) Measure and record face runout at four points 90° apart around the housing face (Fig. 19) . Perform the measurement at least twice for accuracy.

## CLUTCH HOUSING (Continued)



J9006-30

**Fig. 19 Housing Face Measurement Points And Sample Readings**

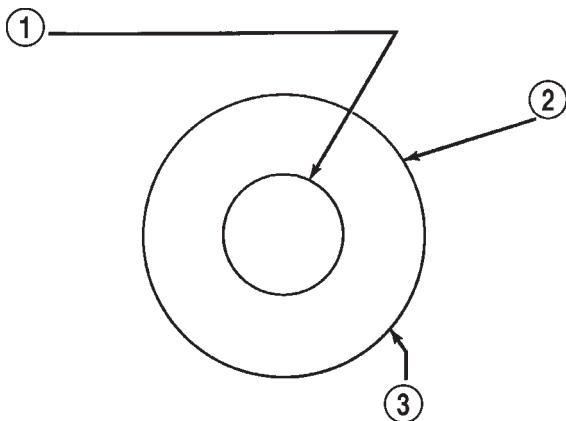
1 - CLUTCH HOUSING FACE CIRCLE (AT RIM OF BORE)

(4) Subtract the lowest reading from the highest to determine total runout. As an example, refer to the sample readings shown (Fig. 21). If the low reading was **minus** 0.004 in. and the highest reading was **plus** 0.009 in., total runout is actually 0.013 inch.

(5) Total allowable face runout is 0.010 inch. If runout exceeds this figure, runout will have to be corrected. Refer to Correcting Clutch Housing Face Runout.

### CORRECTING CLUTCH HOUSING FACE RUNOUT

Housing face runout, on gas or diesel engines, can be corrected by installing shims between the clutch housing and transmission (Fig. 20). The shims can be made from shim stock or similar materials of the required thickness.



J9006-31

**Fig. 20 Housing Face Alignment Shims**

- 1 - CUT/DRILL BOLT HOLE TO SIZE  
 2 - SHIM STOCK  
 3 - MAKE SHIM 1—INCH DIAMETER

As an example, assume that face runout is the same as shown in (Fig. 21) and in Step 4. In this case, three shims will be needed. Shim thicknesses should be

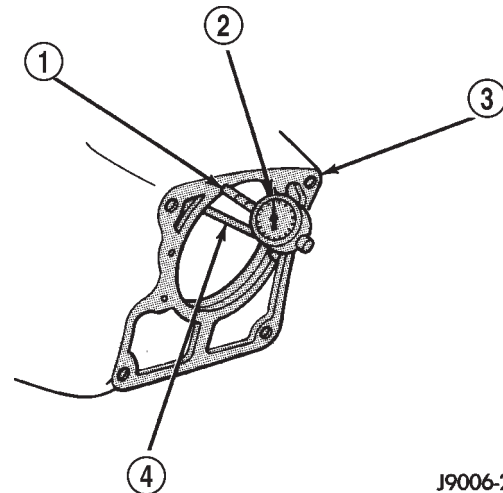
0.009 in. (at the 0.000 corner), 0.012 in. (at the -0.003 corner) and 0.013 in. (at the -0.004 corner).

After installing the clutch assembly and housing, tighten the housing bolts nearest the alignment dowels first.

Clutch housing preferred bolt torques are:

- 41 N·m (30 ft. lbs.) for 3/8 in. diameter bolts
- 68 N·m (50 ft. lbs.) for 7/16 in. diameter bolts
- 47 N·m (35 ft. lbs.) for V10 and diesel clutch housing bolts

During final transmission installation, install the shims between the clutch housing and transmission at the appropriate bolt locations.



J9006-29

**Fig. 21 Measuring Clutch Housing Face Runout**

- 1 - INDICATOR PLUNGER  
 2 - DIAL INDICATOR  
 3 - CLUTCH HOUSING FACE  
 4 - INDICATOR MOUNTING STUD OR ROD

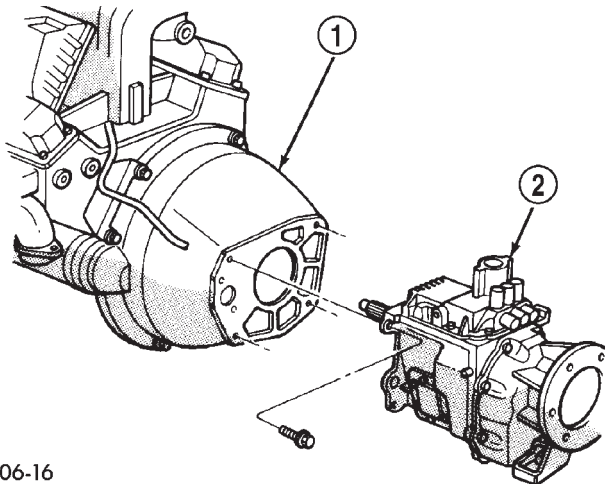
### REMOVAL

- (1) Raise and support vehicle.
- (2) Remove transmission and transfer case, if equipped. Refer to 21 Transmission and Transfer Case for proper procedures.
- (3) Remove the starter from the clutch housing.
- (4) Remove the clutch housing dust shield from the clutch housing.
- (5) Remove clutch housing bolts and remove housing from engine (Fig. 22) and (Fig. 23).

### INSTALLATION

- (1) Clean housing mounting surface of engine block with wax and grease remover.
- (2) Verify that clutch housing alignment dowels are in good condition and properly seated.
- (3) Transfer slave cylinder, release fork and boot, fork pivot stud, and wire/hose brackets to new housing.

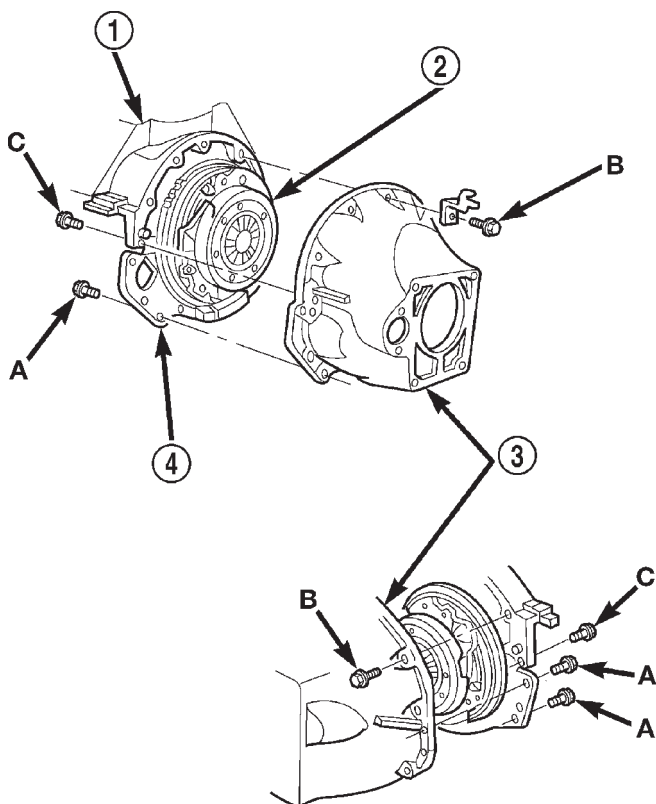
## CLUTCH HOUSING (Continued)



J9406-16

**Fig. 22 Transmission/Clutch Housing - NV4500**

- 1 - CLUTCH HOUSING  
2 - NV4500 TRANSMISSION



80c0710c

**Fig. 23 Clutch Housing Installation - NV4500**

- 1 - ENGINE BLOCK  
2 - CLUTCH DISC AND COVER  
3 - CLUTCH HOUSING  
4 - DUST COVER

(4) Lubricate release fork and pivot contact surfaces with Mopar® High Temperature wheel bearing grease before installation.

(5) Align and install clutch housing on transmission (Fig. 23). Tighten housing bolts closest to alignment dowels first and to the following torque values:

- 1/4in. diameter "A" bolts are torqued to 4.5 N-m (40 in.lb.).
- 3/8in. diameter "A" bolts are torqued to 47.5 N-m (35 ft.lb.).
- 7/16in. diameter "A" bolts are torqued to 68 N-m (50 ft.lb.).
- "B" bolts for 5.2L/5.9L applications are torqued to 41 N-m (30 ft.lb.).
- "B" bolts for 5.9L TD/8.0L applications are torqued to 47.5 N-m (35 ft.lb.).
- "C" bolts for 5.2/5.9L applications are torqued to 68 N-m (50 ft.lb.).
- "C" bolts for 5.9L TD applications are torqued to 47.5 N-m (35 ft.lb.).
- "C" bolts for 8.0L applications are torqued to 74.5 N-m (55 ft.lb.).

(6) Install transmission-to-engine strut after installing clutch housing. Tighten bolt attaching strut to clutch housing first and engine bolt last.

(7) Install the starter to the clutch housing.

(8) Install the clutch housing dust shield to the clutch housing. Tighten the bolts to

(9) Install transmission and transfer case, if equipped. Refer to 21Transmission and Transfer Case for proper procedures.

## CLUTCH RELEASE BEARING

### DESCRIPTION

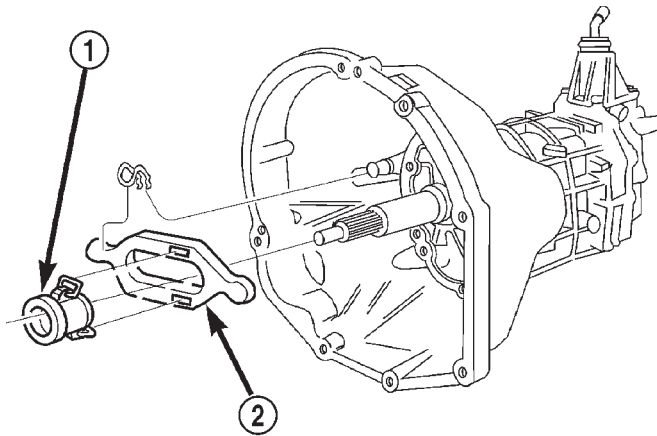
A conventional release bearing (Fig. 24) is used to engage and disengage the clutch pressure plate assembly. The clutch release bearing is mounted on the transmission front bearing retainer. The bearing is attached to the release fork, which moves the bearing into contact with the clutch cover diaphragm spring.

### OPERATION

The release bearing is operated by a release fork in the clutch housing. Slave cylinder force causes the release lever to move the release bearing into contact with the diaphragm spring. As additional force is applied, the bearing presses the diaphragm spring fingers inward on the fulcrums. This action moves the pressure plate rearward relieving clamp force on the disc. Releasing pedal pressure removes clutch hydraulic pressure. The release bearing then moves away from the diaphragm spring which allows the pressure plate to exert clamping force on the clutch disc.



## CLUTCH RELEASE BEARING (Continued)



80be45ed

**Fig. 24 Clutch Release Bearing**

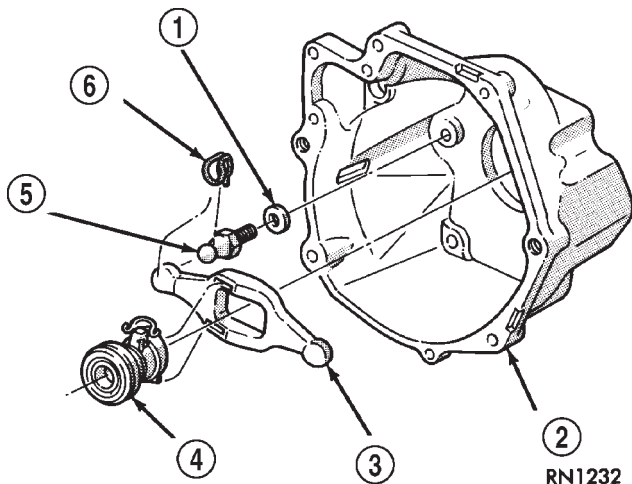
- 1 - RELEASE BEARING  
2 - RELEASE FORK

**REMOVAL**

(1) Remove transmission and transfer case, if equipped. Refer to Group 21, Transmission and Transfer Case, for proper procedures.

(2) Remove clutch housing, for NV4500 equipped vehicles.

(3) Disconnect release bearing from release fork and remove bearing (Fig. 25).



RN1232

**Fig. 25 Clutch Release Components**

- 1 - CONED WASHER  
2 - CLUTCH HOUSING  
3 - RELEASE FORK  
4 - RELEASE BEARING AND SLEEVE  
5 - PIVOT 23 N-m (200 IN. LBS.)  
6 - SPRING

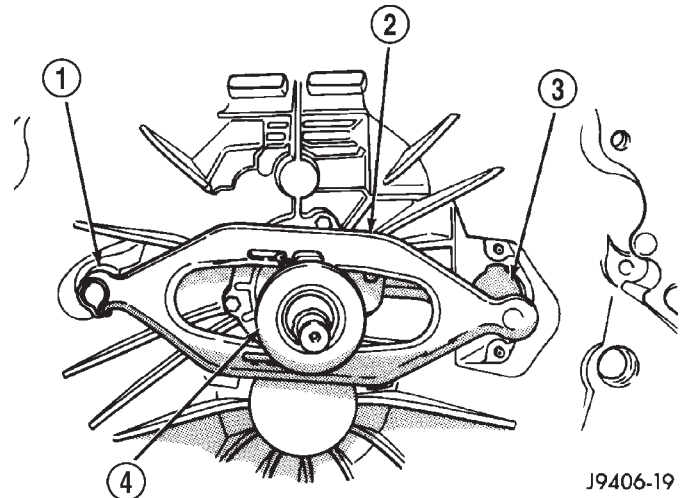
**INSTALLATION**

(1) Inspect bearing slide surface on transmission front bearing retainer. Replace retainer if slide surface is scored, worn, or cracked.

(2) Inspect release lever and pivot stud. Be sure stud is secure and in good condition. Be sure fork is not distorted or worn. Replace fork spring clips if bent or damaged.

(3) Lubricate input shaft splines, bearing retainer slide surface, lever pivot ball stud, and release lever pivot surface with Mopar® high temperature bearing grease.

(4) Install release fork and release bearing (Fig. 26). Be sure fork and bearing are properly secured by spring clips. Also be sure that the release fork is installed properly. The rear side of the release lever has one end with a raised area. This raised area goes toward the slave cylinder side of the transmission.



J9406-19

**Fig. 26 Clutch Release Fork And**

- 1 - PIVOT BALL  
2 - FORK  
3 - SLAVE CYLINDER OPENING  
4 - BEARING

(5) Install clutch housing, if removed.

(6) Install transmission and transfer case, if equipped. Refer to Group 21, Transmission and Transfer Case, for proper procedures.

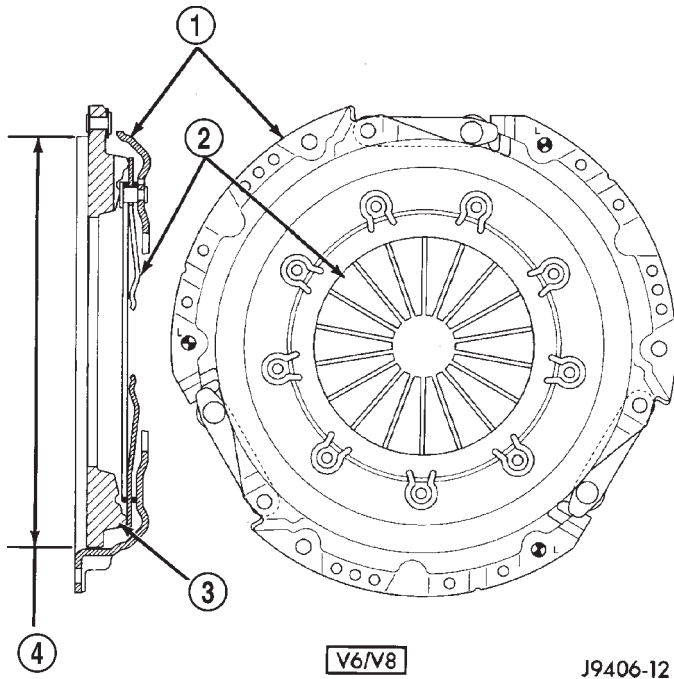
**PRESSURE PLATE****DESCRIPTION**

The clutch pressure plate assembly is a diaphragm type with a one-piece spring and multiple release fingers. The pressure plate release fingers are preset during manufacture and are not adjustable. The assembly also contains the cover, pressure plate, and fulcrum components.

Various sizes and designs of clutch covers are used for the different engine and transmission combinations. The currently used clutch covers and applications are listed below.

## PRESSURE PLATE (Continued)

Two clutch covers are used for all applications. The 281 mm cover (Fig. 27) is used for 3.9L, 5.2L and 5.9L gas engine applications.



**Fig. 27 Pressure Plate - V6/V8 Gas Engine**

- 1 - COVER
- 2 - RELEASE FINGERS
- 3 - PRESSURE PLATE
- 4 - 281 mm (11 in.)

The 312.5 mm cover (Fig. 28) is used for 5.9L diesel and 8.0L gas engine applications.

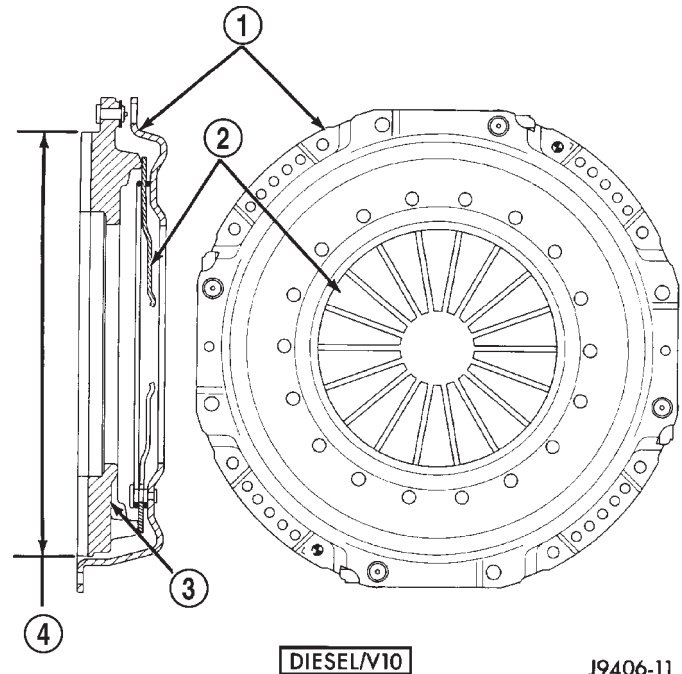
## OPERATION

The clutch pressure plate assembly clamps the clutch disc against the flywheel. When the release bearing is depressed by the shift fork, the pressure exerted on the clutch disc by the pressure plate spring is decreased. As additional force is applied, the bearing presses the diaphragm spring fingers inward on the fulcrums. This action moves the pressure plate rearward relieving clamp force on the disc. The clutch disc is disengaged and freewheeling at this point.

## FLYWHEEL

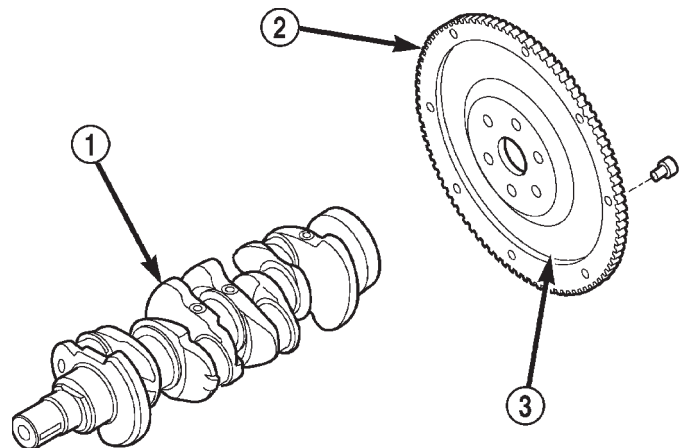
## DESCRIPTION

The flywheel (Fig. 29) is a heavy plate bolted to the rear of the crankshaft. The flywheel incorporates the ring gear around the outer circumference to mesh with the starter to permit engine cranking. The rear face of the flywheel serves as the driving member to the clutch disc.



**Fig. 28 Pressure Plate - V10/Diesel Engine**

- 1 - COVER
- 2 - RELEASE FINGERS
- 3 - PRESSURE PLATE
- 4 - 312.5 mm (12.3 in.)



**Fig. 29 Flywheel**

- 1 - CRANKSHAFT
- 2 - RING GEAR
- 3 - FLYWHEEL

## OPERATION

The flywheel serves to dampen the engine firing pulses. The heavy weight of the flywheel relative to the rotating mass of the engine components serves to stabilize the flow of power to the remainder of the drivetrain. The crankshaft has the tendency to attempt to speed up and slow down in response to the cylinder firing pulses. The flywheel dampens these impulses by absorbing energy when the crank-

## FLYWHEEL (Continued)

shaft speeds and releasing the energy back into the system when the crankshaft slows down.

**DIAGNOSIS AND TESTING - FLYWHEEL**

Check flywheel runout whenever misalignment is suspected. Flywheel runout should not exceed 0.08 mm (0.003 in.). Measure runout at the outer edge of the flywheel face with a dial indicator. Mount the indicator on a stud installed in place of one of the flywheel bolts.

Common causes of runout are:

- heat warpage
- improper machining
- incorrect bolt tightening
- improper seating on crankshaft flange shoulder
- foreign material on crankshaft flange

Flywheel machining is not recommended. The flywheel clutch surface is machined to a unique contour and machining will negate this feature. However, minor flywheel scoring can be cleaned up by hand with 180 grit emery, or with surface grinding equipment. Remove only enough material to reduce scoring (approximately 0.001 - 0.003 in.). Heavy stock removal is **not recommended**. Replace the flywheel if scoring is severe and deeper than 0.076 mm (0.003 in.). Excessive stock removal can result in flywheel cracking or warpage after installation; it can also weaken the flywheel and interfere with proper clutch release.

Clean the crankshaft flange before mounting the flywheel. Dirt and grease on the flange surface may cock the flywheel causing excessive runout. Use new bolts when remounting a flywheel and secure the bolts with Mopar® Lock And Seal. Tighten flywheel bolts to specified torque only. Overtightening can distort the flywheel hub causing runout.

**DISASSEMBLY**

**NOTE:** If the teeth are worn or damaged, the flywheel should be replaced as an assembly. This is the recommended and preferred method of repair. In cases where a new flywheel is not readily available, (V10/Diesel Engine only) a replacement ring gear can be installed. The following procedure must be observed to avoid damaging the flywheel and replacement gear.

**WARNING: WEAR PROTECTIVE GOGGLES OR SAFETY GLASSES WHILE CUTTING RING GEAR.**

- (1) Mark position of the old gear for alignment reference on the flywheel. Use a scribe for this purpose.
- (2) Remove the old gear by cutting most of the way through it (at one point) with an abrasive cut-off wheel. Then complete removal with a cold chisel or punch.

**ASSEMBLY**

**NOTE:** The ring gear is a shrink fit on the flywheel. This means the gear must be expanded by heating in order to install it. The method of heating and expanding the gear is extremely important. Every surface of the gear must be heated at the same time to produce uniform expansion. An oven or similar enclosed heating device must be used. Temperature required for uniform expansion is approximately 375° F.

**CAUTION:** Do not use an oxy/acetylene torch to remove the old gear, or to heat and expand a new gear. The high temperature of the torch flame can cause localized heating that will damage the flywheel. In addition, using the torch to heat a replacement gear will cause uneven heating and expansion. The torch flame can also anneal the gear teeth resulting in rapid wear and damage after installation.

**WARNING: WEAR PROTECTIVE GOGGLES OR SAFETY GLASSES AND HEAT RESISTENT GLOVES WHEN HANDLING A HEATED RING GEAR.**

- (1) The heated gear must be installed evenly to avoid misalignment or distortion.
- (2) Position and install the heated ring gear on the flywheel with a shop press and a suitable press plates.
- (3) Place flywheel on work bench and let it cool in normal shop air. Allow the ring gear to cool down completely before installation it on the engine.

**CAUTION:** Do not use water or compressed air to cool the flywheel. The rapid cooling produced by water or compressed air will distort or crack the new gear.

**PILOT BEARING****DESCRIPTION**

Vehicles equipped with a manual transmission utilize a pilot bearing. This bearing is located in the back of the engine crankshaft. Depending on the type of engine or application, the pilot bearing can be a solid soft metallic bushing or a fully caged needle bearing. The pilot bearing's main functions are to support the transmission input shaft, maintain proper alignment of the clutch assembly and allow the transmission main shaft to rotate at a different speed than the engine mounted crankshaft.

## PILOT BEARING (Continued)

## OPERATION

The pilot bearing supports the transmission input shaft, maintains proper clutch assembly alignment and allows the transmission input shaft to rotate at a different speed (RPM) than the engine mounted crankshaft.

When the clutch pedal is depressed (with vehicle in drive mode) the clutch disc slows and stops therefore, the transmission input shaft slows and stops as well. The pilot bearing allows the engine crankshaft to continue to rotate even though the transmission input shaft is stationary.

## REMOVAL

(1) Remove transmission, transfer case, if equipped, and clutch housing. Refer to Group 21, Transmission and Transfer Case, for proper procedures.

(2) Remove clutch cover and disc.

(3) Using a suitable blind hole puller, remove pilot bearing.

## INSTALLATION

(1) Clean bearing bore with solvent and wipe dry with shop towel.

(2) Install new bearing with clutch alignment tool (Fig. 30). Keep bearing straight during installation. Do not allow bearing to become cocked. Tap bearing into place until flush with edge of bearing bore. Do not recess bearing.

(3) Install clutch cover and disc.

(4) Install clutch housing, transmission and transfer case, if equipped. Refer to Group 21, Transmission and Transfer Case, for proper procedures.

## CLUTCH PEDAL

## REMOVAL

(1) Remove retaining clips that secure the brake and clutch pedals to the push rods (Fig. 31).

(2) Remove the brake and clutch master cylinder pushrods from the pedals.

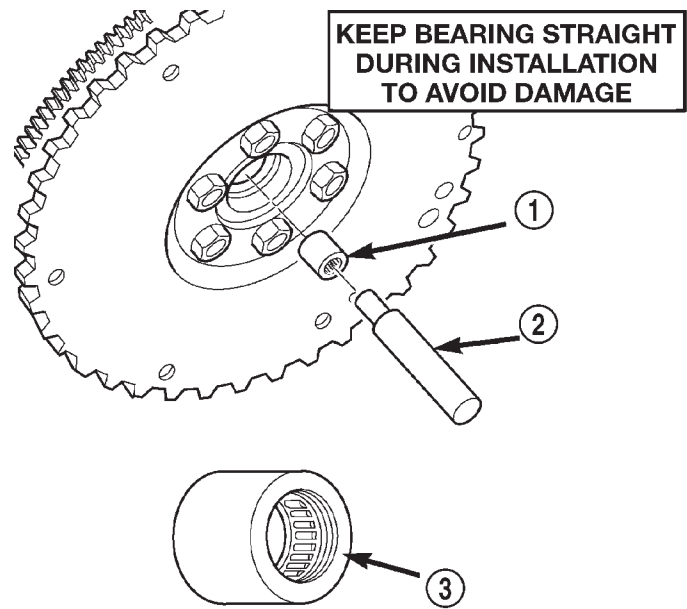
(3) Remove knee bolster (Fig. 32) for access to pedal pivot shaft.

(4) Remove brake lamp switch.

(5) Remove retainer from passenger side of pedal pivot shaft (Fig. 33).

(6) Push pedal pivot shaft toward driver side of support only enough to remove clutch pedal. It is not necessary to remove shaft from pedal support entirely.

(7) Remove clutch pedal.



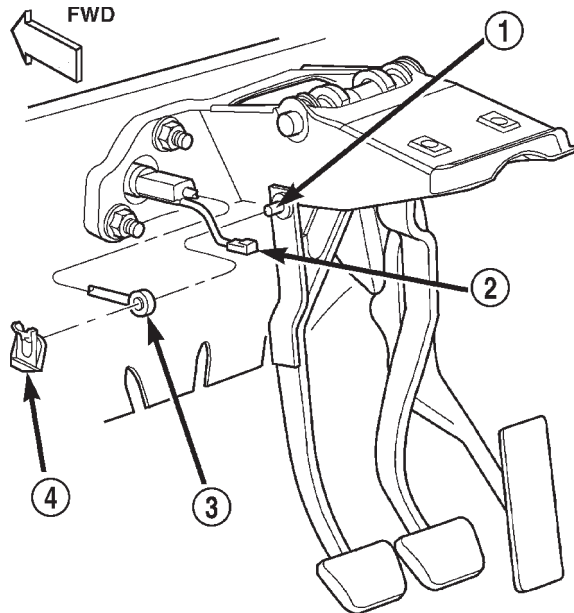
80c0710d

**Fig. 30 Typical Method Of Installing Pilot Bearing**

1 - PILOT BEARING

2 - ALIGNMENT TOOL

3 - LETTER SIDE MUST FACE TRANSMISSION



80c07122

**Fig. 31 Clutch Cylinder Push Rod Attachment**

1 - PIN

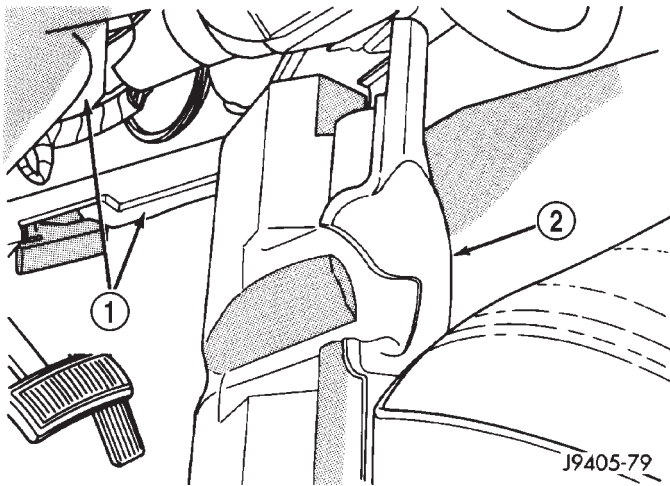
2 - CLUTCH INTERLOCK WIRE

3 - PUSH ROD

4 - CLIP

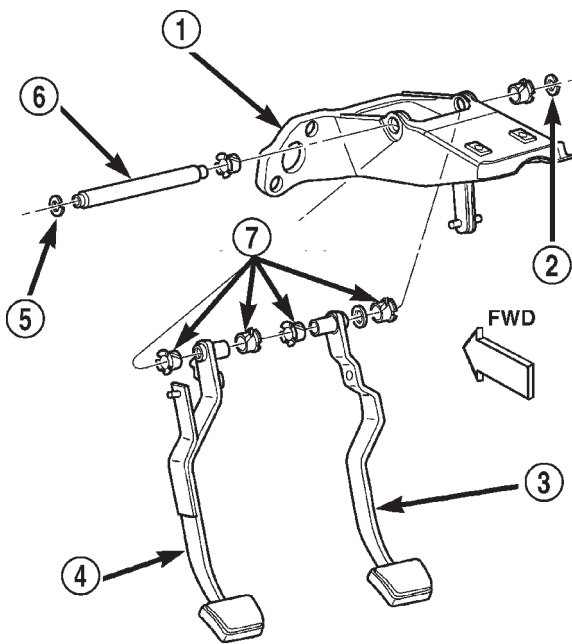


## CLUTCH PEDAL (Continued)



**Fig. 32 Knee Bolster Removal—Typical**

- 1 - INSTRUMENT PANEL FLANGES  
2 - KNEE BOLSTER



**Fig. 33 Clutch/Brake Pedal Mounting**

- 1 - PEDAL SUPPORT  
2 - SHAFT RETAINER  
3 - BRAKE PEDAL  
4 - CLUTCH PEDAL  
5 - SHAFT RETAINER  
6 - PEDAL PIVOT SHAFT  
7 - BUSHINGS

## INSTALLATION

(1) Inspect bushings in clutch and brake pedals (Fig. 33). Replace bushings if worn, cracked, or distorted.

(2) Lubricate pedal shaft, pedal shaft bore (Fig. 33) and all bushings with Mopar® Multi Mileage, or high temperature bearing grease.

(3) Position clutch pedal in support. Align pedal with pivot shaft and slide shaft through pedal bushings. Then repeat process for brake pedal.

(4) Slide pedal shaft through support and install shaft retainer.

(5) Secure push rods to clutch and brake pedals.

(6) Install brake lamp switch in bracket.

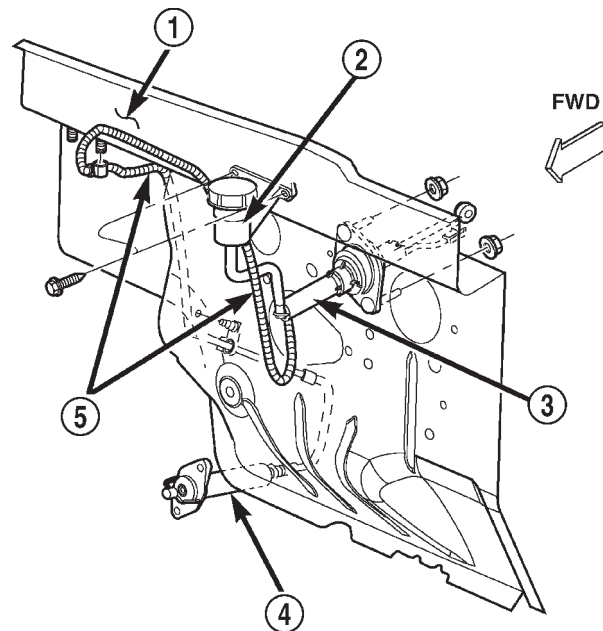
(7) Install knee bolster.

## LINKAGE

## DESCRIPTION

The hydraulic linkage consists of a clutch master cylinder, reservoir, a clutch slave cylinder and an interconnecting fluid line 9 (Fig 34).

The clutch master cylinder push rod is connected to the clutch pedal. The slave cylinder push rod is connected to the clutch release fork. The master cylinder is mounted on the driver side of the dash panel adjacent to the brake master cylinder and booster assembly.



**Fig. 34 Clutch**

- 1 - DASH PANEL  
2 - CYLINDER RESERVOIR  
3 - CLUTCH MASTER CYLINDER  
4 - SLAVE CYLINDER  
5 - CLUTCH HYDRAULIC LINE

The hydraulic linkage is serviced as an assembly only. The individual components that form the linkage assembly cannot be overhauled or serviced separately.



## LINKAGE (Continued)

The clutch fluid reservoir, master cylinder, slave cylinder and fluid lines are pre-filled with fluid at the factory during assembly operations.

The hydraulic system should not require additional fluid under normal circumstances. **The reservoir fluid level will actually increase as normal clutch wear occurs. Avoid overfilling, or removing fluid from the reservoir.**

Clutch fluid level is checked at the master cylinder reservoir. An indicator ring is provided on the outside of the reservoir. With the cap and diaphragm removed, fluid level should not be above indicator ring.

To avoid contaminating the hydraulic fluid during inspection, wipe reservoir and cover clean before removing the cap.

## OPERATION

The clutch linkage uses hydraulic pressure to operate the clutch. Depressing the clutch pedal develops fluid pressure in the clutch master cylinder. This pressure is transmitted to the slave cylinder through a connecting line. In turn, the slave cylinder operates the clutch release lever.

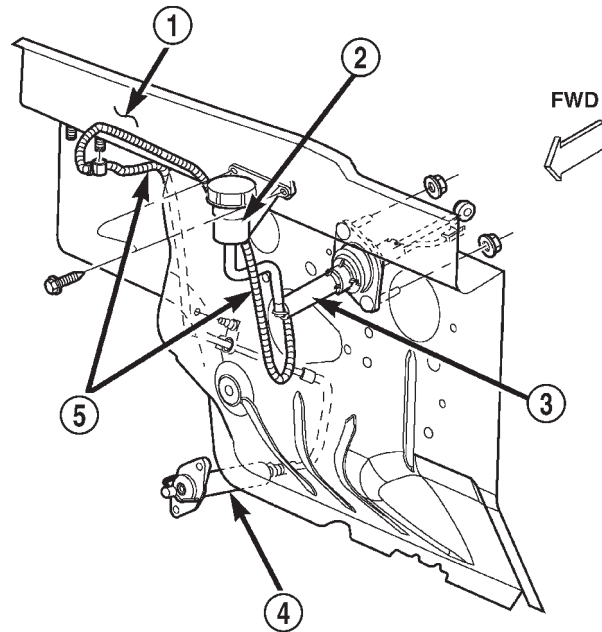
The slave cylinder has an integral spring which preloads the release bearing against the clutch diaphragm fingers to maintain zero free-play.

Slave cylinder force causes the release lever to move the release bearing into contact with the diaphragm spring. As additional force is applied, the bearing presses the diaphragm spring fingers inward on the fulcrums. This action moves the pressure plate rearward relieving clamp force on the disc.

## REMOVAL

The factory installed hydraulic linkage has a quick disconnect at the slave cylinder. This fitting should not be disconnected or tampered with. The hydraulic linkage is serviced as an assembly only, but it comes as two pieces to ease installation. Once the clutch hydraulic line is connected to the slave cylinder, it should not be disconnected. The individual components that form the linkage assembly cannot be overhauled or serviced separately.

- (1) Raise and support vehicle.
- (2) Remove nuts attaching slave cylinder to studs on clutch housing (Fig. 35).
- (3) Remove slave cylinder from clutch housing.
- (4) Remove the plastic clip securing the hydraulic line to the dash panel from the lower dash panel flange.
- (5) Remove the plastic clip securing the hydraulic line to the dash panel from the upper dash panel stud.
- (6) Lower vehicle.
- (7) Disconnect clutch pedal interlock switch wires.



80c0710f

**Fig. 35 Clutch Hydraulic Linkage**

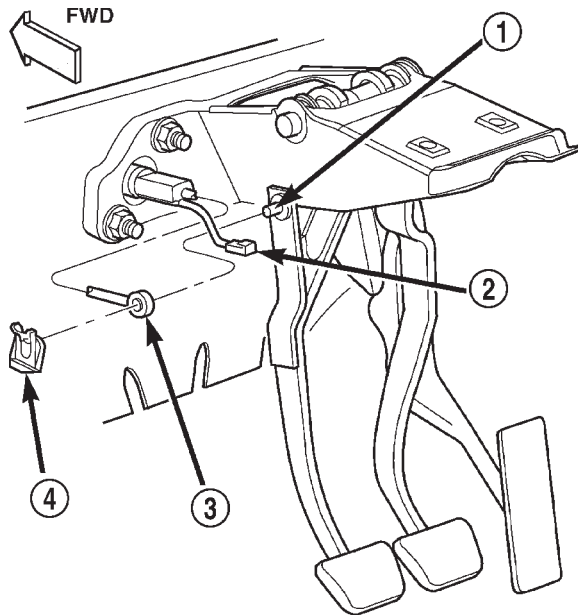
- 1 - DASH PANEL
- 2 - CYLINDER RESERVOIR
- 3 - CLUTCH MASTER CYLINDER
- 4 - SLAVE CYLINDER
- 5 - CLUTCH HYDRAULIC LINE

- (8) Remove retaining clip (Fig. 36).
- (9) Slide clutch master cylinder push rod off pedal pin.
- (10) Inspect condition of bushing in the clutch master cylinder pushrod (Fig. 36). Replace the clutch hydraulic linkage if bushing is worn or damaged.
- (11) Verify that cap on clutch master cylinder reservoir is tight. This will avoid spillage during removal.
- (12) Remove the nuts holding the clutch master cylinder to the dash panel.
- (13) Remove screws that attach clutch fluid reservoir to dash panel.
- (14) Remove the clutch master cylinder from the dash panel.
- (15) Remove clutch cylinders, reservoir and connecting lines from vehicle.

## INSTALLATION

The factory installed hydraulic linkage has a quick disconnect at the slave cylinder. This fitting should not be disconnected or tampered with. The hydraulic linkage is serviced as an assembly only, but it comes as two pieces to ease installation. Once the clutch hydraulic line is connected to the slave cylinder, it

## LINKAGE (Continued)



80c07122

**Fig. 36 Clutch Cylinder Push Rod Attachment**

- 1 - PIN
- 2 - CLUTCH INTERLOCK WIRE
- 3 - PUSH ROD
- 4 - CLIP

should not be disconnected. The individual components that form the linkage assembly cannot be overhauled or serviced separately.

(1) Tighten cap on clutch fluid reservoir to avoid spillage during installation.

(2) Position cylinders, connecting lines and reservoir in vehicle engine compartment. Locate the clutch hydraulic line against the dash panel and behind all engine hoses and wiring.

(3) Insert clutch master cylinder in dash panel. Install and tighten the nuts to hold the clutch master cylinder to the dash panel.

(4) Apply a light coating of grease to the inside and outside diameter of the master cylinder bushing.

(5) Install clutch master cylinder push rod on clutch pedal pin. Secure rod with retaining clip.

(6) Connect clutch pedal position (interlock) switch wires.

(7) Position clutch fluid reservoir on dash panel and install reservoir screws. Tighten screws to 5 N·m (40 in. lbs.) torque.

(8) Install the plastic clip securing the hydraulic line to the dash panel into the lower dash panel flange.

(9) Install the plastic clip securing the hydraulic line to the dash panel onto the upper dash panel stud.

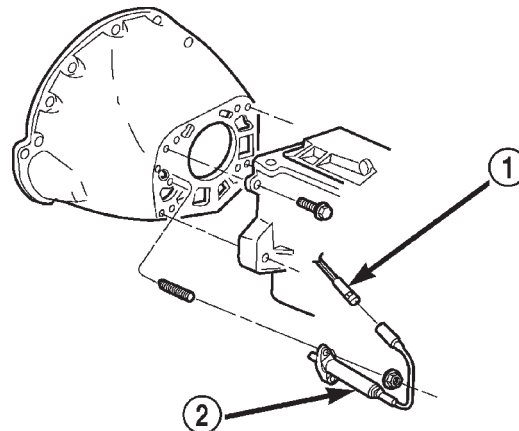
(10) Raise vehicle.

(11) Install slave cylinder. Be sure cap at end of cylinder rod is seated in release lever. Check this before installing cylinder attaching nuts.

**NOTE:** If new linkage is being installed, do not remove the plastic shipping strap from slave cylinder push rod. The shipping strap will break on its own upon the first clutch application.

(12) Install and tighten slave cylinder attaching nuts to 23 N·m (200 in. lbs.) torque.

(13) If a new clutch linkage is being installed, connect the clutch hydraulic line (Fig. 37) to the clutch slave cylinder.



80c07123

**Fig. 37 Clutch Slave Cylinder**

- 1 - CLUTCH HYDRAULIC LINE
- 2 - CLUTCH SLAVE CYLINDER

(14) Lower vehicle.

(15) Operate linkage several times to verify proper operation.

## CLUTCH PEDAL POSITION SWITCH

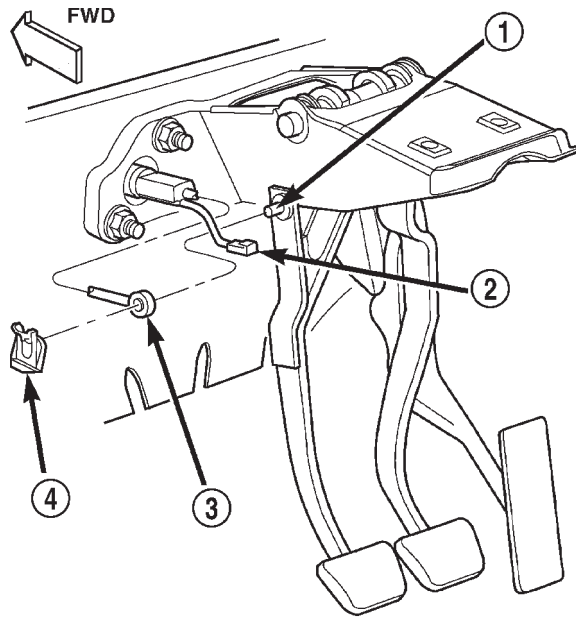
### DESCRIPTION

A clutch pedal position (interlock) switch is in the starter relay circuit and is mounted on the clutch master cylinder push rod (Fig. 38). The switch is actuated by clutch pedal movement.

### OPERATION

The switch, which is in circuit with the starter solenoid, requires that the clutch pedal be fully depressed in order to start the engine. Switch circuitry and operation is provided in section 8W of Group 8.

The position switch is an integral part of the clutch master cylinder push rod and is not serviced separately.



80c07122

**Fig. 38 Clutch Pedal Position (Interlock) Switch**

- 1 - PIN
- 2 - CLUTCH INTERLOCK WIRE
- 3 - PUSH ROD
- 4 - CLIP

# COOLING

## TABLE OF CONTENTS

	page		page
<b>COOLING</b>		REFILLING COOLING SYSTEM - 3.9L/5.2L/ 5.9L/8.0L ENGINES . . . . .	15
DESCRIPTION . . . . .	1	REFILLING COOLING SYSTEM - 5.9L DIESEL ENGINE . . . . .	15
OPERATION . . . . .	2	ADDING ADDITIONAL COOLANT . . . . .	16
DIAGNOSIS AND TESTING . . . . .	4	COOLANT LEVEL CHECK . . . . .	16
PRELIMINARY CHECKS . . . . .	4	COOLING SYSTEM CLEANING/REVERSE FLUSHING . . . . .	16
ON-BOARD DIAGNOSTICS (OBD) . . . . .	4	COOLANT SELECTION-ADDITIVES . . . . .	17
COOLING SYSTEM LEAKS . . . . .	5	SPECIFICATIONS . . . . .	17
COOLING SYSTEM GAS ENGINE . . . . .	7	SPECIAL TOOLS . . . . .	18
COOLING SYSTEM DIESEL ENGINE . . . . .	12	<b>ACCESSORY DRIVE</b> . . . . .	19
STANDARD PROCEDURE . . . . .	15	<b>ENGINE</b> . . . . .	39
DRAINING COOLING SYSTEM - 3.9L/5.2L/ 5.9L/8.0L ENGINES . . . . .	15	<b>TRANSMISSION</b> . . . . .	79
DRAINING COOLING SYSTEM - 5.9L DIESEL ENGINE . . . . .	15		

## COOLING

### DESCRIPTION—COOLING SYSTEM FLOW - 3.9L/5.2L/5.9L ENGINE

The cooling system regulates engine operating temperature. It allows the engine to reach normal operating temperature as quickly as possible. It also maintains normal operating temperature and prevents overheating.

The cooling system also provides a means of heating the passenger compartment and cooling the automatic transmission fluid (if equipped). The cooling system is pressurized and uses a centrifugal water pump to circulate coolant throughout the system.

An optional factory installed maximum duty cooling package is available on most models. This package will provide additional cooling capacity for

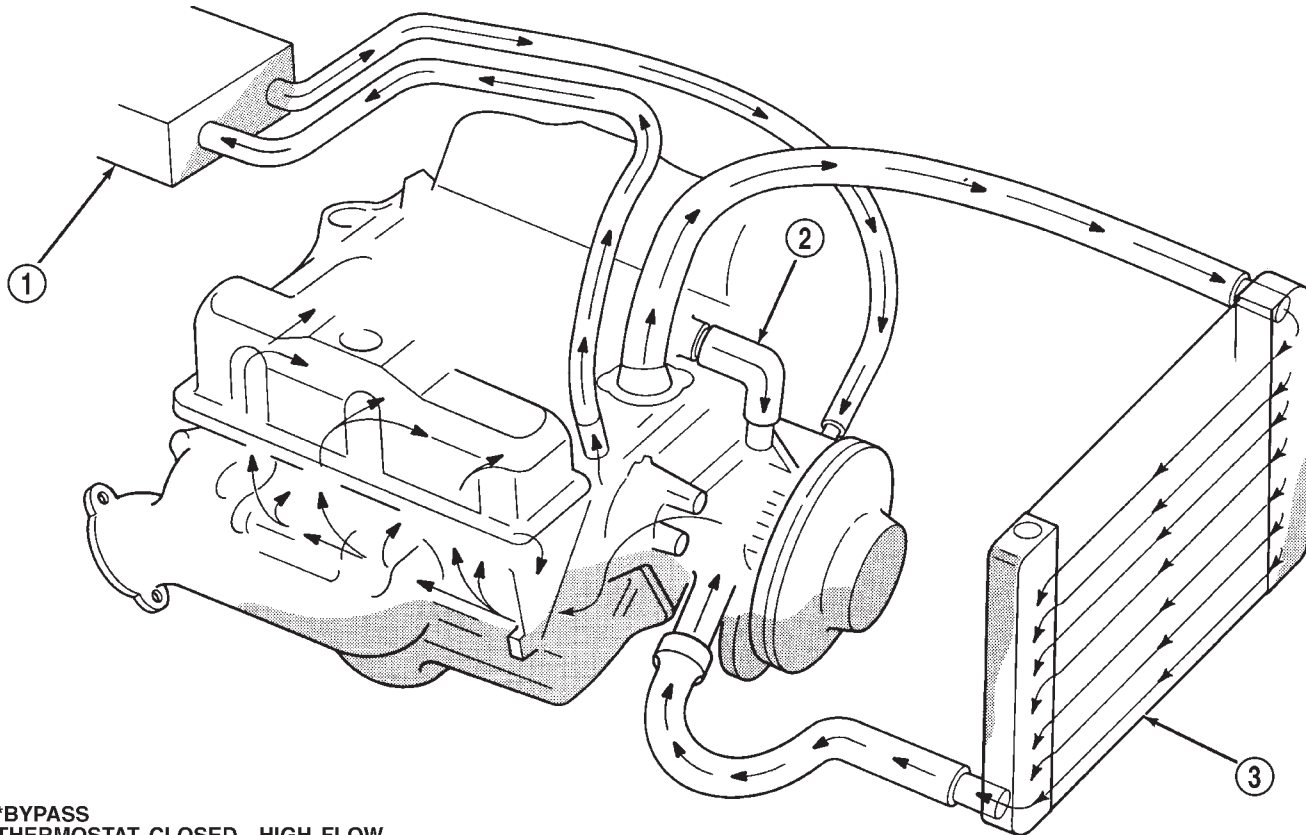
vehicles used under extreme conditions such as trailer towing in high ambient temperatures (Fig. 1).

### DESCRIPTION—COOLING SYSTEM FLOW - 5.9L DIESEL

The diesel engine cooling system consists of (Fig. 2):

- Cross-flow radiator
- Belt driven water pump
- Belt driven mechanical cooling fan
- Thermal viscous fan drive
- Fan shroud
- Radiator pressure cap
- Vertically mounted thermostat
- Coolant reserve/recovery system
- Transmission oil cooler
- Coolant

COOLING (Continued)



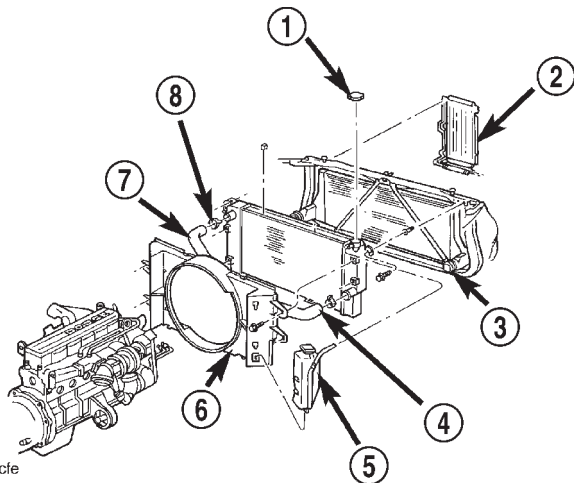
\*BYPASS  
THERMOSTAT CLOSED—HIGH FLOW  
THERMOSTAT OPEN—LOW FLOW

J9407-1

**Fig. 1 Engine Cooling System Flow**

- 1 - HEATER
- 2 - BYPASS\*

- 3 - CROSSFLOW RADIATOR



80bdbcf

**Fig. 2 Cooling System Components 5.9L Diesel Engine**

- 1 - RADIATOR CAP
- 2 - AUXILIARY TRANSMISSION OIL COOLER
- 3 - CHARGE AIR COOLER
- 4 - RADIATOR LOWER HOSE
- 5 - OVERFLOW/RESERVOIR BOTTLE
- 6 - FAN SHROUD
- 7 - RADIATOR UPPER HOSE
- 8 - CONSTANT TENSION CLAMP

Coolant flow circuits for the 5.9L diesel engine are shown in (Fig. 3).

**DESCRIPTION—HOSE CLAMPS**

The cooling system utilizes both worm drive and spring type hose clamps. If a spring type clamp replacement is necessary, replace with the original Mopar® equipment spring type clamp.

**CAUTION:** A number or letter is stamped into the tongue of constant tension clamps. If replacement is necessary, use only a original equipment clamp with matching number or letter (Fig. 4).

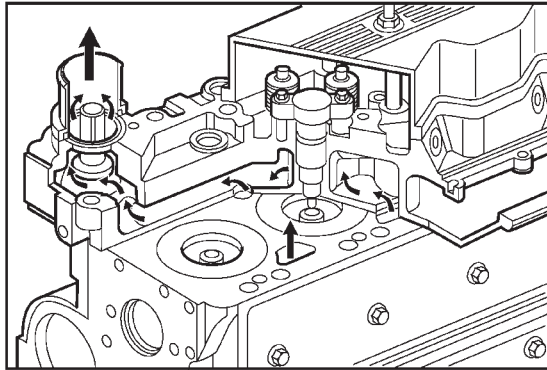
**OPERATION—HOSE CLAMPS**

The worm type hose clamp uses a specified torque value to maintain proper tension on a hose connection.

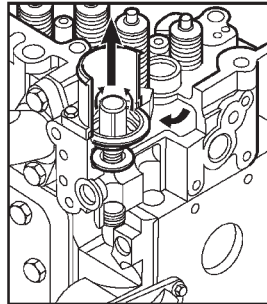
The spring type hose clamp applies constant tension on a hose connection. To remove a spring type hose clamp, only use constant tension clamp pliers designed to compress the hose clamp.



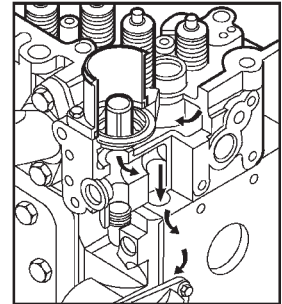
COOLING (Continued)



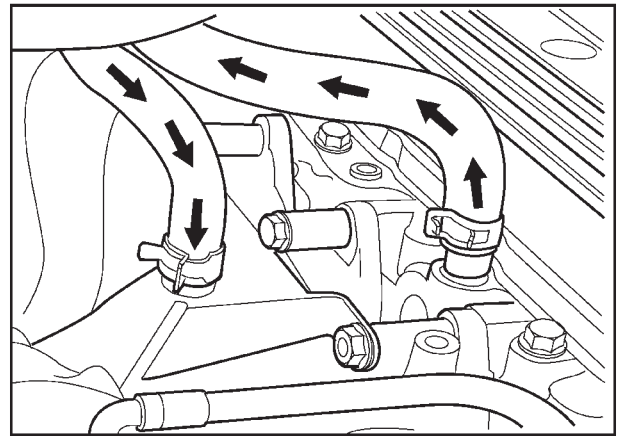
**COOLANT FLOW THROUGH CYLINDER HEAD**



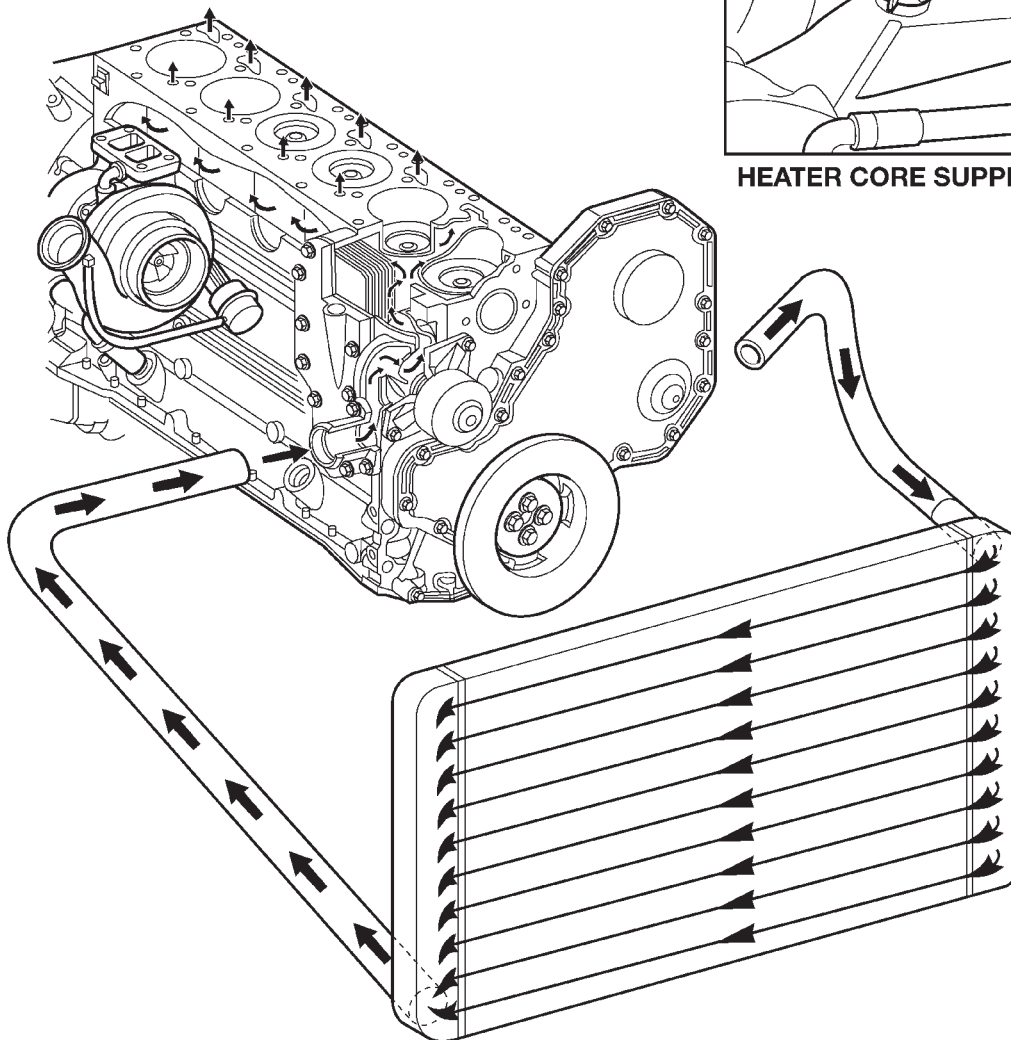
**THERMOSTAT OPEN  
BYPASS CLOSED**



**THERMOSTAT CLOSED  
BYPASS OPEN**

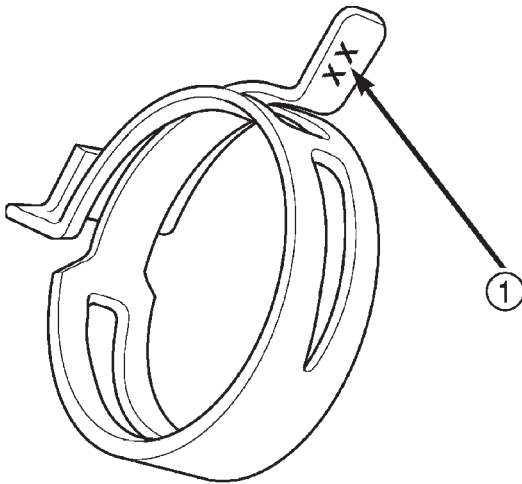


**HEATER CORE SUPPLY AND RETURN HOSES**



**Fig. 3 Cooling System Circulation—Diesel Engine**

## COOLING (Continued)



80b76ee

**Fig. 4 Spring Clamp Size Location**

1 - SPRING CLAMP SIZE LOCATION

## OPERATION—COOLING SYSTEM

The cooling system regulates engine operating temperature. It allows the engine to reach normal operating temperature as quickly as possible. It also maintains normal operating temperature and prevents overheating.

The cooling system also provides a means of heating the passenger compartment and cooling the automatic transmission fluid (if equipped). The cooling system is pressurized and uses a centrifugal water pump to circulate coolant throughout the system.

An optional factory installed maximum duty cooling package is available on most models. This package will provide additional cooling capacity for vehicles used under extreme conditions such as trailer towing in high ambient temperatures.

## DIAGNOSIS AND TESTING - PRELIMINARY CHECKS

### ENGINE COOLING SYSTEM OVERHEATING

Establish what driving conditions caused the complaint. Abnormal loads on the cooling system such as the following may be the cause:

- PROLONGED IDLE
- VERY HIGH AMBIENT TEMPERATURE
- SLIGHT TAIL WIND AT IDLE
- SLOW TRAFFIC
- TRAFFIC JAMS
- HIGH SPEED OR STEEP GRADES

Driving techniques that avoid overheating are:

- Idle with A/C off when temperature gauge is at end of normal range.

- Increasing engine speed for more air flow is recommended.

### TRAILER TOWING:

Consult Trailer Towing section of owners manual. Do not exceed limits.

### AIR CONDITIONING; ADD-ON OR AFTER MARKET:

A maximum cooling package should have been ordered with vehicle if add-on or after market A/C is installed. If not, maximum cooling system components should be installed for model involved per manufacturer's specifications.

### RECENT SERVICE OR ACCIDENT REPAIR:

Determine if any recent service has been performed on vehicle that may effect cooling system. This may be:

- Engine adjustments (incorrect timing)
- Slipping engine accessory drive belt(s)
- Brakes (possibly dragging)
- Changed parts. Incorrect water pump or pump rotating in wrong direction due to belt not correctly routed
- Reconditioned radiator or cooling system refill- ing (possibly under filled or air trapped in system).

**NOTE:** If investigation reveals none of the previous items as a cause for an engine overheating complaint, (Refer to 7 - COOLING - DIAGNOSIS AND TESTING)

## DIAGNOSIS AND TESTING—ON-BOARD DIAGNOSTICS (OBD)

### COOLING SYSTEM RELATED DIAGNOSTICS

The powertrain control module (PCM) has been programmed to monitor certain cooling system components:

- If the engine has remained cool for too long a period, such as with a stuck open thermostat, a Diagnostic Trouble Code (DTC) can be set.
- If an open or shorted condition has developed in the relay circuit controlling the electric radiator fan, a Diagnostic Trouble Code (DTC) can be set.

If the problem is sensed in a monitored circuit often enough to indicated an actual problem, a DTC is stored. The DTC will be stored in the PCM memory for eventual display to the service technician. (Refer to 25 - EMISSIONS CONTROL - DESCRIPTION).

## COOLING (Continued)

**ACCESSING DIAGNOSTIC TROUBLE CODES**

To read DTC's and to obtain cooling system data, (Refer to 25 - EMISSIONS CONTROL - DESCRIPTION).

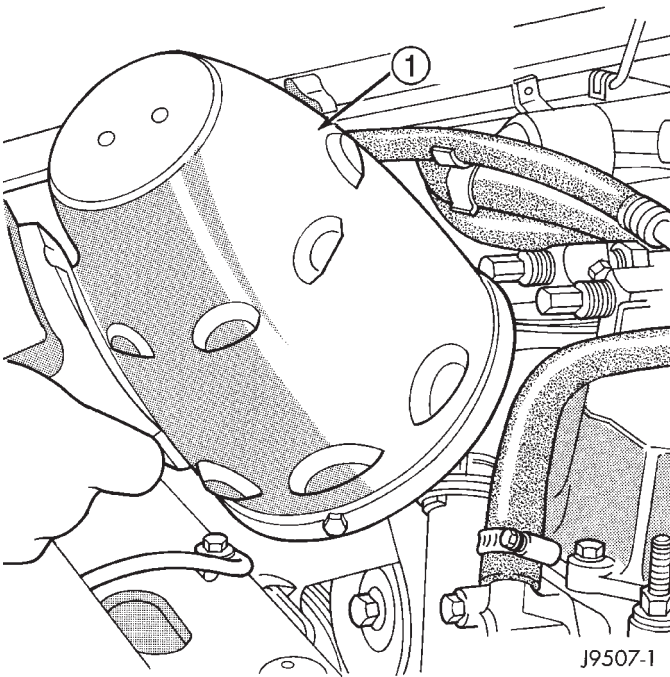
**ERASING TROUBLE CODES**

After the problem has been repaired, use the DRB scan tool to erase a DTC. Refer to the appropriate Powertrain Diagnostic Procedures service information for operation of the DRB scan tool.

**DIAGNOSIS AND TESTING—COOLING SYSTEM LEAKS****ULTRAVIOLET LIGHT METHOD**

A leak detection additive is available through the parts department that can be added to cooling system. The additive is highly visible under ultraviolet light (black light). Pour one ounce of additive into cooling system. Place heater control unit in HEAT position. Start and operate engine until radiator upper hose is warm to touch. Aim the commercially available black light tool at components to be checked. If leaks are present, black light will cause additive to glow a bright green color.

The black light can be used in conjunction with a pressure tester to determine if any external leaks exist (Fig. 5).



**Fig. 5 Leak Detection Using Black Light—Typical**

1 - TYPICAL BLACK LIGHT TOOL

**PRESSURE TESTER METHOD**

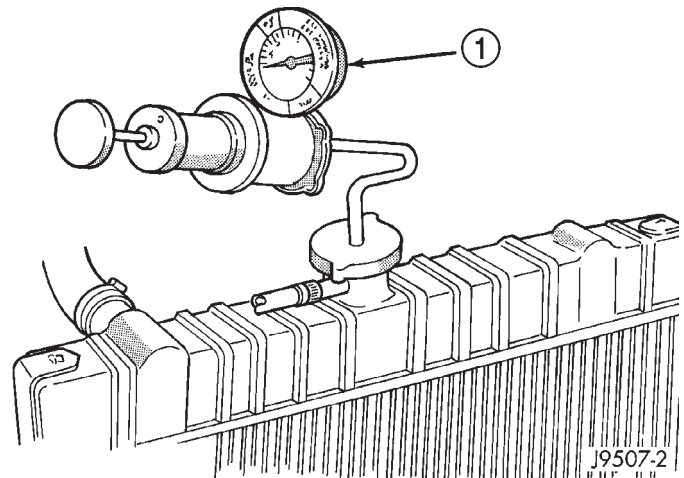
The engine should be at normal operating temperature. Recheck the system cold if cause of coolant loss is not located during the warm engine examination.

**WARNING: HOT, PRESSURIZED COOLANT CAN CAUSE INJURY BY SCALDING.**

Carefully remove radiator pressure cap from filler neck and check coolant level. Push down on cap to disengage it from stop tabs. Wipe inside of filler neck and examine lower inside sealing seat for nicks, cracks, paint, dirt and solder residue. Inspect radiator-to-reserve/overflow tank hose for internal obstructions. Insert a wire through the hose to be sure it is not obstructed.

Inspect cams on outside of filler neck. If cams are damaged, seating of pressure cap valve and tester seal will be affected.

Attach pressure tester (7700 or an equivalent) to radiator filler neck (Fig. 6).



**Fig. 6 Pressure Testing Cooling System—Typical**

1 - TYPICAL COOLING SYSTEM PRESSURE TESTER

Operate tester pump to apply 103.4 kPa (15 psi) pressure to system. If hoses enlarge excessively or bulges while testing, replace as necessary. Observe gauge pointer and determine condition of cooling system according to following criteria:

**Holds Steady:** If pointer remains steady for two minutes, serious coolant leaks are not present in system. However, there could be an internal leak that does not appear with normal system test pressure. If it is certain that coolant is being lost and leaks cannot be detected, inspect for interior leakage or perform Internal Leakage Test.

**Drops Slowly:** Indicates a small leak or seepage is occurring. Examine all connections for seepage or slight leakage with a flashlight. Inspect radiator,

## COOLING (Continued)

hoses, gasket edges and heater. Seal small leak holes with a Sealer Lubricant (or equivalent). Repair leak holes and inspect system again with pressure applied.

**Drops Quickly:** Indicates that serious leakage is occurring. Examine system for external leakage. If leaks are not visible, inspect for internal leakage. Large radiator leak holes should be repaired by a reputable radiator repair shop.

**INTERNAL LEAKAGE INSPECTION**

Remove engine oil pan drain plug and drain a small amount of engine oil. If coolant is present in the pan, it will drain first because it is heavier than oil. An alternative method is to operate engine for a short period to churn the oil. After this is done, remove engine dipstick and inspect for water globules. Also inspect transmission dipstick for water globules and transmission fluid cooler for leakage.

**WARNING: WITH RADIATOR PRESSURE TESTER TOOL INSTALLED ON RADIATOR, DO NOT ALLOW PRESSURE TO EXCEED 110 KPA (20 PSI). PRESSURE WILL BUILD UP QUICKLY IF A COMBUSTION LEAK IS PRESENT. TO RELEASE PRESSURE, ROCK TESTER FROM SIDE TO SIDE. WHEN REMOVING TESTER, DO NOT TURN TESTER MORE THAN 1/2 TURN IF SYSTEM IS UNDER PRESSURE.**

Operate engine without pressure cap on radiator until thermostat opens. Attach a Pressure Tester to filler neck. If pressure builds up quickly it indicates a combustion leak exists. This is usually the result of a cylinder head gasket leak or crack in engine. Repair as necessary.

If there is not an immediate pressure increase, pump the Pressure Tester. Do this until indicated pressure is within system range of 110 kPa (16 psi). Fluctuation of gauge pointer indicates compression or combustion leakage into cooling system.

Because the vehicle is equipped with a catalytic converter, **do not** remove spark plug cables or short out cylinders to isolate compression leak.

If the needle on dial of pressure tester does not fluctuate, race engine a few times to check for an abnormal amount of coolant or steam. This would be emitting from exhaust pipe. Coolant or steam from exhaust pipe may indicate a faulty cylinder head gasket, cracked engine cylinder block or cylinder head.

A convenient check for exhaust gas leakage into cooling system is provided by a commercially available Block Leak Check tool. Follow manufacturers instructions when using this product.

**COMBUSTION LEAKAGE TEST—WITHOUT PRESSURE TESTER**

DO NOT WASTE reusable coolant. If solution is clean, drain coolant into a clean container for reuse.

**WARNING: DO NOT REMOVE CYLINDER BLOCK DRAIN PLUGS OR LOOSEN RADIATOR DRAIN-COCK WITH SYSTEM HOT AND UNDER PRESSURE. SERIOUS BURNS FROM COOLANT CAN OCCUR.**

Drain sufficient coolant to allow thermostat removal. (Refer to 7 - COOLING/ENGINE/ENGINE COOLANT THERMOSTAT - REMOVAL). Remove accessory drive belt (Refer to 7 - COOLING/ACCESSORY DRIVE/DRIVE BELTS - REMOVAL).

Add coolant to radiator to bring level to within 6.3 mm (1/4 in) of top of thermostat housing.

**CAUTION: Avoid overheating. Do not operate engine for an excessive period of time. Open drain-cock immediately after test to eliminate boil over.**

Start engine and accelerate rapidly three times, to approximately 3000 rpm while observing coolant. If internal engine combustion gases are leaking into cooling system, bubbles will appear in coolant. If bubbles do not appear, internal combustion gas leakage is not present.



COOLING (Continued)

**DIAGNOSIS AND TESTING - COOLING SYSTEM  
GAS ENGINE***COOLING SYSTEM DIAGNOSIS—GASOLINE ENGINE*

<b>CONDITION</b>	<b>POSSIBLE CAUSES</b>	<b>CORRECTION</b>
TEMPERATURE GAUGE READS LOW	<ol style="list-style-type: none"> <li>1. Has a Diagnostic Trouble Code (DTC) been set indicating a stuck open thermostat?</li> <li>2. Is the temperature sending unit connected?</li> <li>3. Is the temperature gauge operating OK?</li> <li>4. Coolant level low in cold ambient temperatures accompanied with poor heater performance.</li> <li>5. Improper operation of internal heater doors or heater controls.</li> </ol>	<ol style="list-style-type: none"> <li>1. (Refer to 25 - EMISSIONS CONTROL - DESCRIPTION) for On-Board Diagnostics and DTC information. Replace thermostat if necessary.</li> <li>2. Check the temperature sensor connector. (Refer to 8 - ELECTRICAL/ INSTRUMENT CLUSTER - SCHEMATIC - ELECTRICAL) Repair connector if necessary.</li> <li>3. Check gauge operation. (Refer to 8 - ELECTRICAL/INSTRUMENT CLUSTER/ ENGINE TEMPERATURE GAUGE - DESCRIPTION) . Repair as necessary.</li> <li>4. Check coolant level in the coolant reserve/overflow tank and the radiator. Inspect system for leaks. Repair leaks as necessary. Refer to the Coolant section of the manual text for WARNINGS and CAUTIONS associated with removing the radiator cap.</li> <li>5. Inspect heater and repair as necessary. (Refer to 24 - HEATING &amp; AIR CONDITIONING - DIAGNOSIS AND TESTING) for procedures.</li> </ol>
TEMPERATURE GAUGE READS HIGH OR THE COOLANT WARNING LAMP ILLUMINATES. COOLANT MAY OR MAY NOT BE LOST OR LEAKING FROM THE COOLING SYSTEM	<ol style="list-style-type: none"> <li>1. Trailer is being towed, a steep hill is being climbed, vehicle is operated in slow moving traffic, or engine is being idled with very high ambient (outside) temperatures and the air conditioning is on. Higher altitudes could aggravate these conditions.</li> <li>2. Is the temperature gauge reading correctly?</li> <li>3. Is the temperature warning illuminating unnecessarily?</li> <li>4. Coolant low in coolant reserve/overflow tank and radiator?</li> </ol>	<ol style="list-style-type: none"> <li>1. This may be a temporary condition and repair is not necessary. Turn off the air conditioning and attempt to drive the vehicle without any of the previous conditions. Observe the temperature gauge. The gauge should return to the normal range. If the gauge does not return to the normal range, determine the cause for overheating and repair. Refer to Possible Causes (2-20).</li> <li>2. Check gauge. (Refer to 8 - ELECTRICAL/INSTRUMENT CLUSTER - SCHEMATIC - ELECTRICAL) . Repair as necessary.</li> <li>3. (Refer to 8 - ELECTRICAL/ INSTRUMENT CLUSTER - SCHEMATIC - ELECTRICAL).</li> <li>4. Check for coolant leaks and repair as necessary. (Refer to 7 - COOLING - DIAGNOSIS AND TESTING).</li> </ol>



## COOLING (Continued)

CONDITION	POSSIBLE CAUSES	CORRECTION
	<p>5. Pressure cap not installed tightly. If cap is loose, boiling point of coolant will be lowered. Also refer to the following Step 6.</p> <p>6. Poor seals at the radiator cap.</p> <p>7. Coolant level low in radiator but not in coolant reserve/overflow tank. This means the radiator is not drawing coolant from the coolant reserve/overflow tank as the engine cools</p> <p>8. Incorrect coolant concentration</p> <p>9. Coolant not flowing through system</p> <p>10. Radiator or A/C condenser fins are dirty or clogged.</p> <p>11. Radiator core is corroded or plugged.</p> <p>12. Aftermarket A/C installed without proper radiator.</p> <p>13. Fuel or ignition system problems.</p> <p>14. Dragging brakes.</p> <p>15. Bug screen or cardboard is being used, reducing airflow.</p>	<p>5. Tighten cap</p> <p>6. (a) Check condition of cap and cap seals. Refer to Radiator Cap. Replace cap if necessary. (b) Check condition of radiator filler neck. If neck is bent or damaged, replace radiator.</p> <p>7. (a) Check condition of radiator cap and cap seals. Refer to Radiator Cap in this Group. Replace cap if necessary. (b) Check condition of radiator filler neck. If neck is bent or damaged, replace radiator. (c) Check condition of the hose from the radiator to the coolant tank. It should fit tight at both ends without any kinks or tears. Replace hose if necessary. (d) Check coolant reserve/overflow tank and tanks hoses for blockage. Repair as necessary.</p> <p>8. Check coolant. (Refer to LUBRICATION &amp; MAINTENANCE/FLUID TYPES - DESCRIPTION).</p> <p>9. Check for coolant flow at radiator filler neck with some coolant removed, engine warm and thermostat open. Coolant should be observed flowing through radiator. If flow is not observed, determine area of obstruction and repair as necessary.</p> <p>10. Remove insects and debris. (Refer to 7 - COOLING - STANDARD PROCEDURE).</p> <p>11. Have radiator re-cored or replaced.</p> <p>12. Install proper radiator.</p> <p>13. Refer to 14 - Fuel System or 8 - Electrical for diagnosis and testing procedures.</p> <p>14. Check and correct as necessary. (Refer to 5 - BRAKES - DIAGNOSIS AND TESTING) for correct procedures.</p> <p>15. Remove bug screen or cardboard.</p>

## COOLING (Continued)

CONDITION	POSSIBLE CAUSES	CORRECTION
	<p>16. Thermostat partially or completely shut.</p> <p>17. Viscous fan drive not operating properly.</p> <p>18. Cylinder head gasket leaking.</p> <p>19. Heater core leaking.</p>	<p>16. Check thermostat operation and replace as necessary. (Refer to 7 - COOLING/ENGINE/ENGINE COOLANT THERMOSTAT - REMOVAL) .</p> <p>17. Check fan drive operation and replace as necessary. (Refer to 7 - COOLING/ENGINE/FAN DRIVE VISCOUS CLUTCH - REMOVAL) .</p> <p>18. Check for cylinder head gasket leaks. (Refer to 7 - COOLING - DIAGNOSIS AND TESTING).</p> <p>19. Check heater core for leaks. (Refer to 24 - HEATING &amp; AIR CONDITIONING/ PLUMBING - DIAGNOSIS AND TESTING). Repair as necessary.</p>
<p>TEMPERATURE GAUGE READING IS INCONSISTENT (FLUCTUATES, CYCLES OR IS ERRATIC)</p>	<p>1. During cold weather operation, with the heater blower in the high position, the gauge reading may drop slightly.</p> <p>2. Temperature gauge or engine mounted gauge sensor defective or shorted. Also, corroded or loose wiring in this circuit.</p> <p>3. Gauge reading rises when vehicle is brought to a stop after heavy use (engine still running)</p> <p>4. Gauge reading high after re-starting a warmed up (hot) engine.</p> <p>5. Coolant level low in radiator (air will build up in the cooling system causing the thermostat to open late).</p> <p>6. Cylinder head gasket leaking allowing exhaust gas to enter cooling system causing a thermostat to open late.</p> <p>7. Water pump impeller loose on shaft.</p> <p>8. Loose accessory drive belt. (water pump slipping)</p> <p>9. Air leak on the suction side of the water pump allows air to build up in cooling system causing thermostat to open late.</p>	<p>1. A normal condition. No correction is necessary.</p> <p>2. Check operation of gauge and repair if necessary. (Refer to 8 - ELECTRICAL/ INSTRUMENT CLUSTER - DIAGNOSIS AND TESTING).</p> <p>3. A normal condition. No correction is necessary. Gauge should return to normal range after vehicle is driven.</p> <p>4. A normal condition. No correction is necessary. The gauge should return to normal range after a few minutes of engine operation.</p> <p>5. Check and correct coolant leaks. (Refer to 7 - COOLING - DIAGNOSIS AND TESTING).</p> <p>6. (a) Check for cylinder head gasket leaks. (Refer to 7 - COOLING - DIAGNOSIS AND TESTING).</p> <p>(b) Check for coolant in the engine oil. Inspect for white steam emitting from the exhaust system. Repair as necessary.</p> <p>7. Check water pump and replace as necessary. (Refer to 7 - COOLING/ ENGINE/WATER PUMP - REMOVAL).</p> <p>8. (Refer to 7 - COOLING/ACCESSORY DRIVE/DRIVE BELTS - DIAGNOSIS AND TESTING). Check and correct as necessary.</p> <p>9. Locate leak and repair as necessary.</p>

## COOLING (Continued)

CONDITION	POSSIBLE CAUSES	CORRECTION
PRESSURE CAP IS BLOWING OFF STEAM AND/OR COOLANT TO COOLANT TANK. TEMPERATURE GAUGE READING MAY BE ABOVE NORMAL BUT NOT HIGH. COOLANT LEVEL MAY BE HIGH IN COOLANT RESERVE/OVERFLOW TANK	1. Pressure relief valve in radiator cap is defective.	1. Check condition of radiator cap and cap seals. (Refer to 7 - COOLING/ ENGINE/RADIATOR PRESSURE CAP - DIAGNOSIS AND TESTING). Replace cap as necessary.
COOLANT LOSS TO THE GROUND WITHOUT PRESSURE CAP BLOWOFF. GAUGE READING HIGH OR HOT	1. Coolant leaks in radiator, cooling system hoses, water pump or engine.	1. Pressure test and repair as necessary. (Refer to 7 - COOLING - DIAGNOSIS AND TESTING).
DETONATION OR PRE-IGNITION (NOT CAUSED BY IGNITION SYSTEM). GAUGE MAY OR MAY NOT BE READING HIGH	1. Engine overheating. 2. Freeze point of coolant not correct. Mixture is too rich or too lean.	1. Check reason for overheating and repair as necessary. 2. Check coolant concentration. (Refer to LUBRICATION & MAINTENANCE/FLUID TYPES - DESCRIPTION).
HOSE OR HOSES COLLAPSE WHILE ENGINE IS RUNNING	1. Vacuum created in cooling system on engine cool-down is not being relieved through coolant reserve/overflow system.	1. (a) Radiator cap relief valve stuck. (Refer to 7 - COOLING/ENGINE/ RADIATOR PRESSURE CAP - DIAGNOSIS AND TESTING). Replace if necessary (b) Hose between coolant reserve/ overflow tank and radiator is kinked. Repair as necessary. (c) Vent at coolant reserve/overflow tank is plugged. Clean vent and repair as necessary. (d) Reserve/overflow tank is internally blocked or plugged. Check for blockage and repair as necessary.

## COOLING (Continued)

CONDITION	POSSIBLE CAUSES	CORRECTION
NOISY VISCOUS FAN/DRIVE	<ol style="list-style-type: none"> <li>1. Fan blades loose.</li> <li>2. Fan blades striking a surrounding object.</li> <li>3. Air obstructions at radiator or air conditioning condenser.</li> <li>4. Thermal viscous fan drive has defective bearing.</li> <li>5. A certain amount of fan noise may be evident on models equipped with a thermal viscous fan drive. Some of this noise is normal.</li> </ol>	<ol style="list-style-type: none"> <li>1. Replace fan blade assembly. (Refer to 7 - COOLING/ENGINE/RADIATOR FAN - REMOVAL)</li> <li>2. Locate point of fan blade contact and repair as necessary.</li> <li>3. Remove obstructions and/or clean debris or insects from radiator or A/C condenser.</li> <li>4. Replace fan drive. Bearing is not serviceable. (Refer to 7 - COOLING/ENGINE/FAN DRIVE VISCOUS CLUTCH - REMOVAL).</li> <li>5. (Refer to 7 - COOLING/ENGINE/FAN DRIVE VISCOUS CLUTCH - DESCRIPTION) for an explanation of normal fan noise.</li> </ol>
INADEQUATE HEATER PERFORMANCE. THERMOSTAT FAILED IN OPEN POSITION	<ol style="list-style-type: none"> <li>1. Has a Diagnostic trouble Code (DTC) been set?</li> <li>2. Coolant level low</li> <li>3. Obstructions in heater hose/fittings</li> <li>4. Heater hose kinked</li> <li>5. Water pump is not pumping water to/through the heater core. When the engine is fully warmed up, both heater hoses should be hot to the touch. If only one of the hoses is hot, the water pump may not be operating correctly or the heater core may be plugged. Accessory drive belt may be slipping causing poor water pump operation.</li> </ol>	<ol style="list-style-type: none"> <li>1. (Refer to 25 - EMISSIONS CONTROL - DESCRIPTION) for correct procedures and replace thermostat if necessary</li> <li>2. (Refer to 7 - COOLING - DIAGNOSIS AND TESTING).</li> <li>3. Remove heater hoses at both ends and check for obstructions</li> <li>4. Locate kinked area and repair as necessary</li> <li>5. (Refer to 7 - COOLING/ENGINE/WATER PUMP - REMOVAL). If a slipping belt is detected, (Refer to 7 - COOLING/ACCESSORY DRIVE/DRIVE BELTS - DIAGNOSIS AND TESTING). If heater core obstruction is detected, (Refer to 24 - HEATING &amp; AIR CONDITIONING/PLUMBING/HEATER CORE - REMOVAL).</li> </ol>
STEAM IS COMING FROM THE FRONT OF VEHICLE NEAR THE GRILL AREA WHEN WEATHER IS WET, ENGINE IS WARMED UP AND RUNNING, AND VEHICLE IS STATIONARY. TEMPERATURE GAUGE IS IN NORMAL RANGE	<ol style="list-style-type: none"> <li>1. During wet weather, moisture (snow, ice or rain condensation) on the radiator will evaporate when the thermostat opens. This opening allows heated water into the radiator. When the moisture contacts the hot radiator, steam may be emitted. This usually occurs in cold weather with no fan or airflow to blow it away.</li> </ol>	<ol style="list-style-type: none"> <li>1. Occasional steam emitting from this area is normal. No repair is necessary.</li> </ol>

## COOLING (Continued)

CONDITION	POSSIBLE CAUSES	CORRECTION
COOLANT COLOR	1. Coolant color is not necessarily an indication of adequate corrosion or temperature protection. Do not rely on coolant color for determining condition of coolant.	1. (Refer to LUBRICATION & MAINTENANCE/FLUID TYPES - DESCRIPTION). Adjust coolant mixture as necessary.
COOLANT LEVEL CHANGES IN COOLANT RESERVE/OVERFLOW TANK. TEMPERATURE GAUGE IS IN NORMAL RANGE	1. Level changes are to be expected as coolant volume fluctuates with engine temperature. If the level in the tank was between the FULL and ADD marks at normal operating temperature, the level should return to within that range after operation at elevated temperatures.	1. A normal condition. No repair is necessary.

## DIAGNOSIS AND TESTING - COOLING SYSTEM DIESEL ENGINE

### COOLING SYSTEM DIAGNOSIS—DIESEL ENGINE

CONDITION	POSSIBLE CAUSES	CORRECTION
TEMPERATURE GAUGE READS LOW	<ol style="list-style-type: none"> <li>1. Vehicle is equipped with a heavy duty cooling system.</li> <li>2. Temperature gauge not connected</li> <li>3. Temperature gauge connected but not operating.</li> <li>4. Coolant level low.</li> </ol>	<ol style="list-style-type: none"> <li>1. None. System operating normally.</li> <li>2. Connect gauge.</li> <li>3. Check gauge. Refer (Refer to 8 - ELECTRICAL/INSTRUMENT CLUSTER - DIAGNOSIS AND TESTING)</li> <li>4. Fill cooling system. (Refer to 7 - COOLING - STANDARD PROCEDURE)</li> </ol>
TEMPERATURE GAUGE READS HIGH. COOLANT MAY OR MAY NOT BE LEAKING FROM SYSTEM	<ol style="list-style-type: none"> <li>1. Vehicle overloaded, high ambient (outside) temperatures with A/C turned on, stop and go driving or prolonged operation at idle speeds.</li> <li>2. Temperature gauge not functioning correctly.</li> <li>3. Air trapped in cooling</li> <li>4. Radiator cap faulty.</li> <li>5. Plugged A/C or radiator cooling fins.</li> </ol>	<ol style="list-style-type: none"> <li>1. Temporary condition, repair not required. Notify customer of vehicle operation instructions located in Owners Manual.</li> <li>2. Check gauge. (Refer to 8 - ELECTRICAL/INSTRUMENT CLUSTER - DIAGNOSIS AND TESTING)</li> <li>3. Drain cooling system (Refer to 7 - COOLING - STANDARD PROCEDURE) and refill (Refer to 7 - COOLING - STANDARD PROCEDURE)</li> <li>4. Replace radiator cap.</li> <li>5. Clean all debris away from A/C and radiator cooling fins.</li> </ol>



## COOLING (Continued)

CONDITION	POSSIBLE CAUSES	CORRECTION
	<ul style="list-style-type: none"> <li>6. Coolant mixture incorrect.</li> <li>7. Thermostat stuck shut.</li> <li>8. Bug screen or winter front being used.</li> <li>9. Viscous fan drive not operating properly.</li> <li>10. Cylinder head gasket leaking.</li> <li>11. Heater core leaking.</li> <li>12. cooling system hoses leaking.</li> <li>13. Brakes dragging.</li> </ul>	<ul style="list-style-type: none"> <li>6. Drain cooling system (Refer to 7 - COOLING - STANDARD PROCEDURE) refill with correct mixture (Refer to 7 - COOLING - STANDARD PROCEDURE).</li> <li>7. Replace thermostat.</li> <li>8. Remove bug screen or winter front.</li> <li>9. Check viscous fan (Refer to 7 - COOLING/ENGINE/FAN DRIVE VISCOUS CLUTCH - DIAGNOSIS AND TESTING)</li> <li>10. Check for leaking head gaskets (Refer to 7 - COOLING - DIAGNOSIS AND TESTING).</li> <li>11. Replace heater core.</li> <li>12. Tighten clamps or Replace hoses.</li> <li>13. Check brakes. (Refer to 5 - BRAKES/HYDRAULIC/ MECHANICAL - DIAGNOSIS AND TESTING)</li> </ul>
TEMPERATURE GAUGE READING INCONSISTENT ( ERRATIC, CYCLES OR FLUCTUATES)	<ul style="list-style-type: none"> <li>1. Heavy duty cooling system, extream cold ambient (outside) temperature or heater blower motor in high position.</li> <li>2. Temperature gauge or gauge sensor defective.</li> <li>3. Temporary heavy usage or load.</li> <li>4. Air traped in cooling system.</li> <li>5. Water pump</li> <li>6. Air leak on suction side of water pump.</li> </ul>	<ul style="list-style-type: none"> <li>1. None. System operating normaly.</li> <li>2. Check gauge. (Refer to 8 - ELECTRICAL/INSTRUMENT CLUSTER - DIAGNOSIS AND TESTING)</li> <li>3. None. Normal condition.</li> <li>4. Fill cooling system (Refer to 7 - COOLING - STANDARD PROCEDURE).</li> <li>5. Replace water pump.</li> <li>6. Check for leak. (Refer to 7 - COOLING - DIAGNOSIS AND TESTING)</li> </ul>
RADIATOR CAP LEAKING STEAM AND /OR COOLANT INTO RESERVOIR BOTTLE. (TEMPERATURE GAUGE MAY READ HIGH)	<ul style="list-style-type: none"> <li>1. Radiator cap defective.</li> <li>2. Radiator neck surface damaged.</li> </ul>	<ul style="list-style-type: none"> <li>1. Replace radiator cap.</li> <li>2. Replace radiator.</li> </ul>

## COOLING (Continued)

CONDITION	POSSIBLE CAUSES	CORRECTION
HOSE OR HOSES COLLAPSE WHEN ENGINE IS COOLING.	1. Vacuum created in cooling system on engine cool-down is not being relieved through coolant reservoir/overflow system.	1. Replace radiator cap, check vent hose between radiator and reservoir bottle for blockage also check reservoir bottle vent for blockage.
NOISY FAN	1. Fan blade(s) loose, damaged. 2. Thermal viscous fan drive. 3. Fan blades striking surrounding objects. 4. Thermal viscous fan drive bearing.  5. Obstructed air flow through radiator.	1. Replace fan blade assembly. 2. None. Normal condition. 3. Locate contact point and repair as necessary. 4. Replace viscous fan drive assembly.  5. Remove obstruction.
INADEQUATE AIR CONDITIONER PERFORMANCE (COOLING SYSTEM SUSPECTED)	1. Radiator and/or A/C condenser air flow obstructed. 2. Thermal viscous fan drive not working.  3. Air seals around radiator damaged or missing.	1. Remove obstruction and/or clean.  2. Check fan drive. (Refer to 7 - COOLING/ENGINE/FAN DRIVE VISCOUS CLUTCH - DIAGNOSIS AND TESTING) 3. Inspect air seals, repair or replace as necessary.
INADEQUATE HEATER PERFORMANCE. GAUGE MAY OR MAY NOT READ LOW.	1. Heavy duty cooling system, and cooler ambient temperatures. 2. Obstruction in heater hoses.  3. Water pump damaged.	1. None. Normal condition. 2. Remove hoses, remove obstruction. 3. Replace water pump.
HEAT ODOR	1. Damaged or missing drive line heat shields. 2. Thermal viscous fan drive damaged.	1. Repair or replace damaged or missing heat shields. 2. Check thermal viscous fan drive. (Refer to 7 - COOLING/ENGINE/FAN DRIVE VISCOUS CLUTCH - DIAGNOSIS AND TESTING)

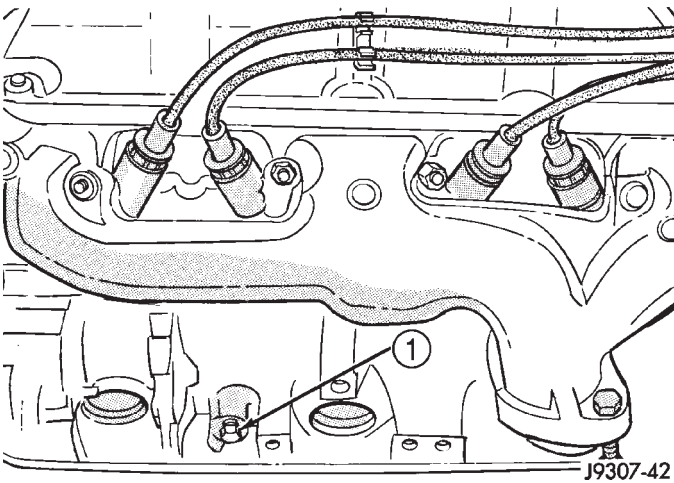
## COOLING (Continued)

**STANDARD PROCEDURE—DRAINING COOLING SYSTEM 3.9L/5.2L/5.9L/8.0L ENGINES**

**WARNING: DO NOT REMOVE CYLINDER BLOCK DRAIN PLUGS OR LOOSEN RADIATOR DRAIN-COCK WITH SYSTEM HOT AND UNDER PRESSURE. SERIOUS BURNS FROM COOLANT CAN OCCUR.**

DO NOT WASTE reusable coolant. If solution is clean, drain coolant into a clean container for reuse.

- (1) Remove radiator pressure cap.
- (2) Loosen radiator petcock.
- (3) Remove cylinder block drain plugs. Refer to (Fig. 7).



**Fig. 7 Cylinder Block Drain Plug—3.9L/5.2L/5.9L**

1 - BLOCK DRAIN PLUG *Engines*

**STANDARD PROCEDURE—DRAINING COOLING SYSTEM 5.9L DIESEL ENGINE**

**WARNING: DO NOT REMOVE THE CYLINDER BLOCK DRAIN PLUGS OR LOOSEN THE RADIATOR DRAIN PLUG WITH SYSTEM HOT AND UNDER PRESSURE. SERIOUS BURNS FROM COOLANT CAN OCCUR.**

DO NOT WASTE reusable coolant. If the solution is clean, drain the coolant into a clean container for reuse.

- (1) Start the engine and place the heater control temperature selector in the Full-On position. Vacuum is needed to actuate the heater controls.
- (2) Turn the ignition off.
- (3) Do not remove radiator cap when draining coolant from reserve/overflow tank. Open radiator drain plug and when tank is empty, remove radiator cap. If the coolant reserve/overflow tank does not drain, (Refer to 7 - COOLING - DIAGNOSIS AND TEST-

ING). The coolant need not be removed from tank unless the system is being refilled with fresh mixture.

- (4) Remove radiator pressure cap.

**STANDARD PROCEDURE—REFILLING COOLING SYSTEM 3.9L/5.2L/5.9L/8.0L ENGINES**

**WARNING: DO NOT REMOVE CYLINDER BLOCK DRAIN PLUGS OR LOOSEN RADIATOR DRAIN-COCK WITH SYSTEM HOT AND UNDER PRESSURE. SERIOUS BURNS FROM COOLANT CAN OCCUR.**

DO NOT WASTE reusable coolant. If solution is clean, drain coolant into a clean container for reuse.

Clean cooling system prior to refilling. (Refer to 7 - COOLING - STANDARD PROCEDURE).

- (1) Install cylinder block drain plugs. Coat the threads with Mopar® Thread Sealant with Teflon.
- (2) Close radiator petcock.
- (3) Fill cooling system with a 50/50 mixture of water and antifreeze.
- (4) Fill coolant reserve/overflow tank to FULL mark on indicator stick.
- (5) Start and operate engine until thermostat opens (upper radiator hose warm to touch).
- (6) If necessary, add a 50/50 water and antifreeze mixture to the coolant reserve/overflow tank. This is done to maintain coolant level between the FULL and ADD marks. The level in the reserve/overflow tank may drop below the ADD mark after three or four warm-up and cool-down cycles.

**STANDARD PROCEDURE—REFILLING COOLING SYSTEM 5.9L DIESEL ENGINE**

Clean cooling system prior to refilling (Refer to 7 - COOLING - STANDARD PROCEDURE).

- (1) Close radiator drain plug.

**CAUTION: Due to the use of the one-way check valve, the engine must not be operating when refilling the cooling system.**

**NOTE: The diesel engine is equipped with a one-way check valve (jiggle pin). The check valve is used as a servicing feature and will vent air when the system is being filled. Water pressure (or flow) will hold the valve closed.**

- (2) Fill the cooling system with a 50/50 mixture of water and antifreeze.

## COOLING (Continued)

(3) Fill coolant reserve/overflow tank to the FULL mark.

(4) Start and operate engine until thermostat opens. Upper radiator hose should be warm to touch.

(5) If necessary, add 50/50 water and antifreeze mixture to the coolant reserve/overflow tank to maintain coolant level. This level should be between the ADD and FULL marks. The level in the reserve/overflow tank may drop below the ADD mark after three or four warm-up and cool-down cycles.

### STANDARD PROCEDURE—ADDING ADDITIONAL COOLANT

**Do not remove radiator cap to add coolant to system.** When adding coolant to maintain correct level, do so at coolant reserve/overflow tank. Use a 50/50 mixture of ethylene glycol antifreeze containing Alugard 340-2 <sup>™</sup> and low mineral content water. Remove radiator cap only for testing or when refilling system after service. Removing cap unnecessarily can cause loss of coolant and allow air to enter system, which produces corrosion.

### STANDARD PROCEDURE—COOLANT LEVEL CHECK

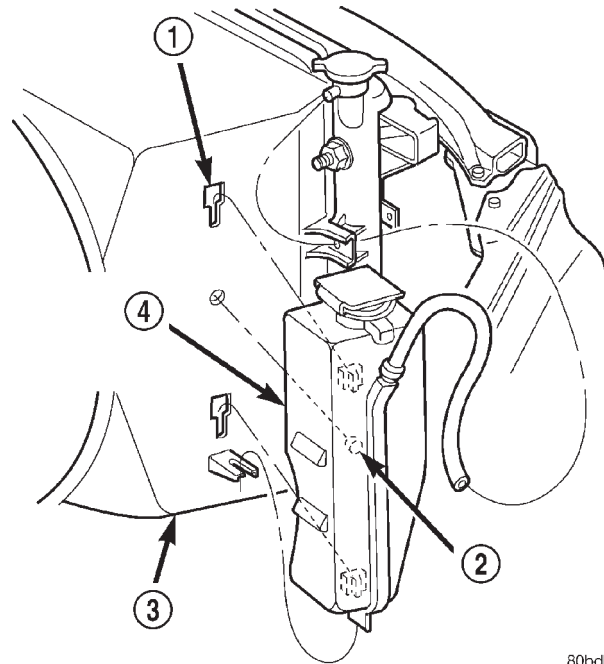
**NOTE: Do not remove radiator cap for routine coolant level inspections. The coolant level can be checked at coolant recovery bottle .**

The coolant reserve/overflow system provides a quick method for determining coolant level without removing radiator pressure cap. With engine not running, open the coolant recovery bottle cap and remove coolant level indicator dipstick to observe coolant level in coolant recovery bottle. The coolant level should be between ADD and FULL marks. If the coolant level is at or below the ADD mark, fill the recovery bottle with a 50/50 mixture of antifreeze and water **ONE QUART AT A TIME**. Repeat this procedure until the coolant level is at the FULL mark (Fig. 8).

### STANDARD PROCEDURE—COOLING SYSTEM CLEANING/REVERSE FLUSHING

#### CLEANING

Drain cooling system and refill with water. Run engine with radiator cap installed until upper radiator hose is hot. Stop engine and drain water from system. If water is dirty, fill system with water, run engine and drain system. Repeat until water drains clean.



80bcbd0a

**Fig. 8 COOLANT RESERVE/OVERFLOW TANK—ALL EXCEPT 8.0L V-10 ENGINE**

- 1 - T-SLOTS
- 2 - ALIGNMENT PIN
- 3 - FAN SHROUD
- 4 - COOLANT RESERVE/OVERFLOW TANK

### REVERSE FLUSHING

Reverse flushing of cooling system is the forcing of water through the cooling system. This is done using air pressure in the opposite direction of normal coolant flow. It is usually only necessary with very dirty systems with evidence of partial plugging.

#### REVERSE FLUSHING RADIATOR

Disconnect radiator hoses from radiator inlet and outlet. Attach a section of radiator hose to radiator bottom outlet fitting and insert flushing gun. Connect a water supply hose and air supply hose to flushing gun.

**CAUTION: Internal radiator pressure must not exceed 138 kPa (20 psi) as damage to radiator may result.**

Allow radiator to fill with water. When radiator is filled, apply air in short blasts. Allow radiator to refill between blasts. Continue this reverse flushing until clean water flows out through rear of radiator cooling tube passages. Have radiator cleaned more extensively by a radiator repair shop.

## COOLING (Continued)

## REVERSE FLUSHING ENGINE

Drain cooling system. Remove thermostat housing and thermostat. Install thermostat housing. Disconnect radiator upper hose from radiator and attach flushing gun to hose. Disconnect radiator lower hose from water pump and attach a lead-away hose to water pump inlet fitting.

**CAUTION: On vehicles equipped with a heater water control valve, be sure heater control valve is closed (heat off). This will prevent coolant flow with scale and other deposits from entering heater core.**

Connect water supply hose and air supply hose to flushing gun. Allow engine to fill with water. When engine is filled, apply air in short blasts, allowing system to fill between air blasts. Continue until clean water flows through the lead away hose.

Remove lead away hose, flushing gun, water supply hose and air supply hose. Remove thermostat housing and install thermostat. Install thermostat housing with a replacement gasket. Refer to Thermostat Replacement. Connect radiator hoses. Refill cooling system with correct antifreeze/water mixture. Refer to Refilling the Cooling System.

## CHEMICAL CLEANING

In some instances, use a radiator cleaner (Mopar Radiator Kleen or equivalent) before flushing. This will soften scale and other deposits and aid flushing operation.

**CAUTION: Follow manufacturers instructions when using these products.**

## STANDARD PROCEDURE—COOLANT SELECTION-ADDITIVES

The presence of aluminum components in the cooling system requires strict corrosion protection. Maintain coolant at specified level with a mixture of ethylene glycol based antifreeze and water. If coolant becomes contaminated or loses color, drain and flush cooling system and fill with correctly mixed solution.

**CAUTION: Do not use coolant additives that are claimed to improve engine cooling.**

## SPECIFICATIONS

## TORQUE

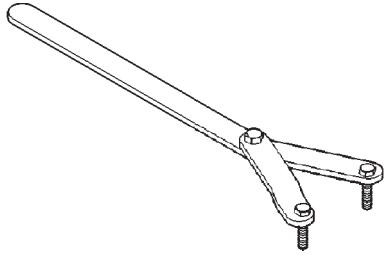
DESCRIPTION	N·m	Ft.	In.
		Lbs.	Lbs
Belt Tensioner Pulley 3.9/5.2/5.9L Engines—Bolt	61	45	—
Belt Tensioner Pulley 8.0L Engine— Bolt	88	65	—
Belt Tensioner to Mounting Bracket— Bolt 3.9L/5.2L/5.9L Engines	67	50	—
Belt Tensioner to Mounting Bracket— Bolt 8.0L Engine	41	30	—
Block Heater—Screw Gas Engines	2	—	17
Block Heater—Hex Diesel Engine	43	32	—
Fan Shroud to Radiator Mounting— Bolts	6	—	50
Heater Hose Fitting at Water Pump—(8.0L)	16	—	142
Idler Pulley Mounting—Bolts Gas Engines	61	45	—
Radiator Mounting—Bolts	11	—	95
Thermal Viscous Fan to Hub—(Diesel)	57	42	—
Thermostat Housing—Bolts 3.9/5.2/5.9L	23	—	200
Thermostat Housing—Bolts 8.0L	25	—	220
Thermostat Housing—Bolts Diesel	24	—	212
Water Pump Mounting—Bolts Gas Engines	40	30	—
Water Pump Mounting—Bolts Diesel	24	—	212



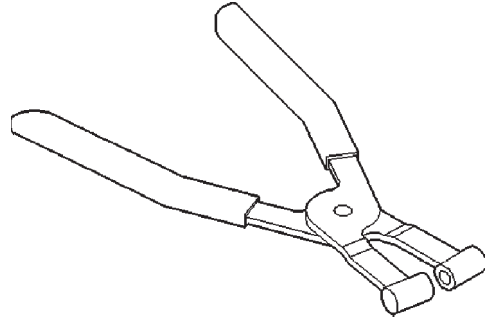
COOLING (Continued)

SPECIAL TOOLS

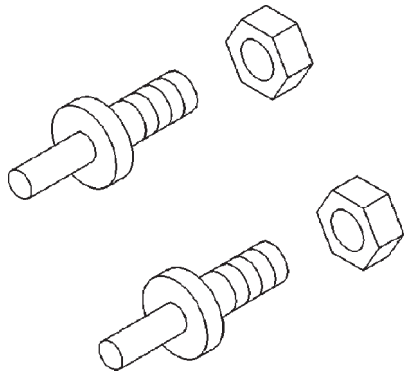
COOLING



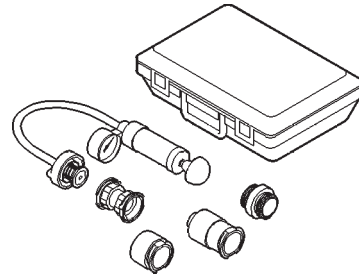
**Spanner Wrench 6958**



**Pliers 6094**



**Adapter Pins 8346**



**Pressure Tester 7700-A**

## ACCESSORY DRIVE

### TABLE OF CONTENTS

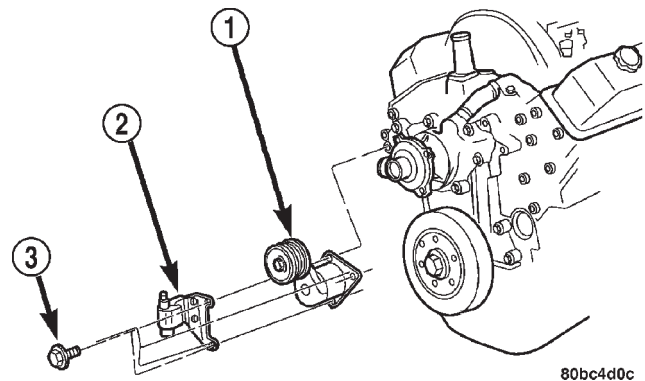
	page		page
<b>BELT TENSIONERS - 3.9L/5.2L/5.9L</b>		<b>INSTALLATION</b> .....	27
DESCRIPTION.....	19	<b>DRIVE BELTS - 8.0L</b>	
OPERATION.....	19	DIAGNOSIS AND TESTING.....	27
REMOVAL.....	20	ACCESSORY DRIVE BELT.....	27
INSTALLATION.....	20	REMOVAL.....	30
<b>BELT TENSIONERS - 8.0L</b>		INSTALLATION.....	30
DESCRIPTION.....	20	<b>DRIVE BELTS - 5.9L DIESEL</b>	
OPERATION.....	20	DIAGNOSIS AND TESTING.....	31
REMOVAL.....	21	ACCESSORY DRIVE BELT.....	31
INSTALLATION.....	22	REMOVAL.....	33
<b>BELT TENSIONERS - 5.9L DIESEL</b>		INSTALLATION.....	34
DESCRIPTION.....	23	<b>VACUUM PUMP - 5.9L DIESEL</b>	
OPERATION.....	23	DESCRIPTION.....	34
REMOVAL.....	23	OPERATION.....	35
INSTALLATION.....	23	DIAGNOSIS AND TESTING.....	35
<b>DRIVE BELTS - 3.9L/5.2L/5.9L</b>		VACUUM PUMP OUTPUT.....	35
DIAGNOSIS AND TESTING.....	24	REMOVAL.....	35
ACCESSORY DRIVE BELT.....	24	INSTALLATION.....	37
REMOVAL.....	26		

## BELT TENSIONERS - 3.9L/5.2L/ 5.9L

### DESCRIPTION

Correct drive belt tension is required to ensure optimum performance of the belt driven engine accessories. If specified tension is not maintained, belt slippage may cause; engine overheating, lack of power steering assist, loss of air conditioning capacity, reduced generator output rate, and greatly reduced belt life.

It is not necessary to adjust belt tension on the 3.9L/5.2L or 5.9L engines. These engines are equipped with an automatic belt tensioner (Fig. 1). The tensioner maintains correct belt tension at all times. Due to use of this belt tensioner, do not attempt to use a belt tension gauge on 3.9L/5.2L or 5.9L engines.



**Fig. 1 Automatic Belt Tensioner—5.2L and 5.9L Engines**

- 1 - AUTOMATIC TENSIONER
- 2 - COIL AND BRACKET
- 3 - SCREW AND WASHER

### OPERATION

The automatic belt tensioner maintains belt tension by using internal spring pressure, a pivoting arm and pulley to press against the drive belt.

## BELT TENSIONERS - 3.9L/5.2L/5.9L (Continued)

## REMOVAL

**WARNING: BECAUSE OF HIGH SPRING PRESSURE, DO NOT ATTEMPT TO DISASSEMBLE AUTOMATIC TENSIONER. UNIT IS SERVICED AS AN ASSEMBLY (EXCEPT FOR PULLEY).**

(1) Remove accessory drive belt. (Refer to 7 - COOLING/ACCESSORY DRIVE/DRIVE BELTS - REMOVAL).

(2) Disconnect wiring and secondary cable from ignition coil.

(3) Remove ignition coil from coil mounting bracket (two bolts). Do not remove coil mounting bracket from cylinder head.

(4) Remove tensioner assembly from mounting bracket (one nut) (Fig. 2).

(5) Remove pulley bolt. Remove pulley from tensioner.

## INSTALLATION

(1) Install pulley and pulley bolt to tensioner. Tighten bolt to 61 N·m (45 ft. lbs.) torque.

(2) Install tensioner assembly to mounting bracket. An indexing tab is located on back of tensioner. Align this tab to slot in mounting bracket. Tighten nut to 67 N·m (50 ft. lbs.) torque.

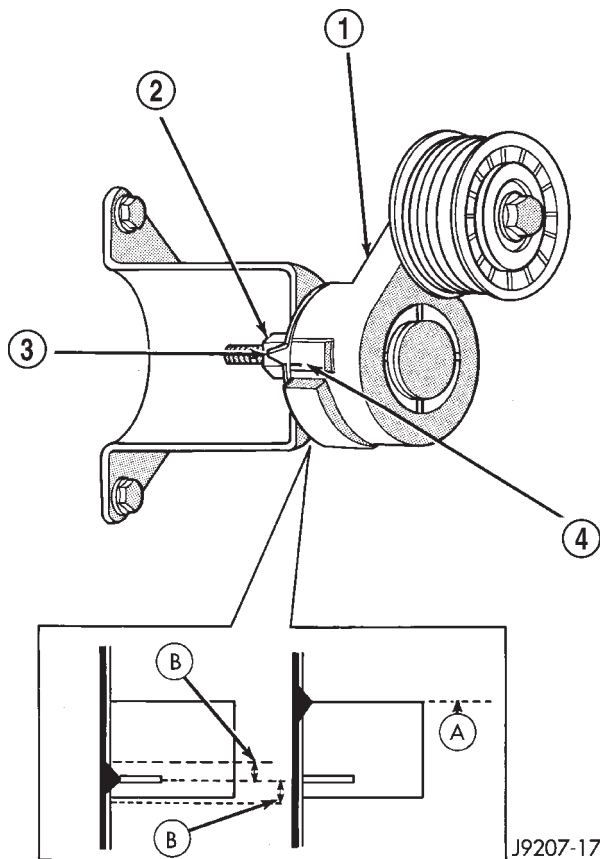
(3) Connect all wiring to ignition coil.

**CAUTION: To prevent damage to coil case, coil mounting bolts must be torqued.**

(4) Install coil to coil bracket. If nuts and bolts are used to secure coil to coil bracket, tighten to 11 N·m (100 in. lbs.) torque. If coil mounting bracket has been tapped for coil mounting bolts, tighten bolts to 5 N·m (50 in. lbs.) torque.

(5) Install drive belt. (Refer to 7 - COOLING/ACCESSORY DRIVE/DRIVE BELTS - INSTALLATION).

(6) Check belt indexing marks (Fig. 2).



**Fig. 2 Tensioner Indexing Marks and Mounting Nut**

- 1 - TENSIONER ASSEMBLY
- 2 - TENSIONER MOUNTING NUT
- 3 - INDEXING ARROW
- 4 - INDEXING MARK

## BELT TENSIONERS - 8.0L

## DESCRIPTION

**CAUTION: Do not attempt to check belt tension with a belt tension gauge on vehicles equipped with an automatic belt tensioner.**

Drive belts on 8.0L engines are equipped with a spring loaded automatic belt tensioner (Fig. 3). This belt tensioner will be used with all belt configurations, such as with or without power steering or air conditioning.

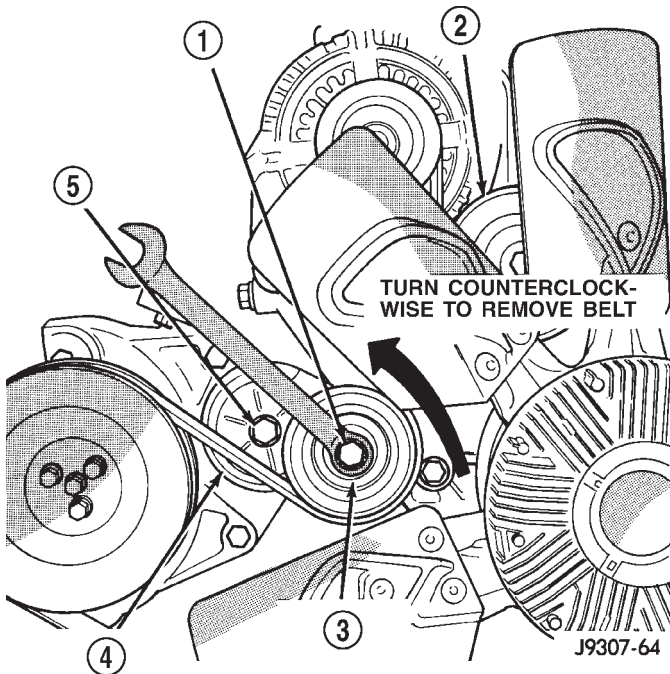
The tensioner is equipped with an indexing arrow (Fig. 4) on back of tensioner and an indexing mark on tensioner housing.

## OPERATION

**WARNING: THE AUTOMATIC BELT TENSIONER ASSEMBLY IS SPRING LOADED. DO NOT ATTEMPT TO DISASSEMBLE THE TENSIONER ASSEMBLY.**

The automatic belt tensioner maintains correct belt tension using a coiled spring within the tensioner housing. The spring applies pressure to the tensioner arm pressing the arm into the belt, tensioning the belt.

## BELT TENSIONERS - 8.0L (Continued)



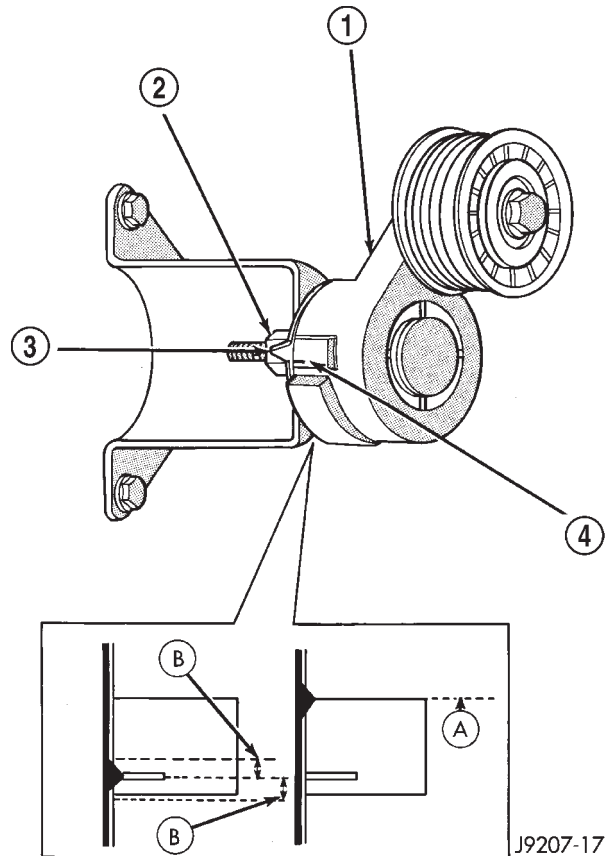
**Fig. 3 Belt Tensioner—8.0L V-10 Engines**

- 1 - PULLEY BOLT
- 2 - IDLER PULLEY
- 3 - TENSIONER PULLEY
- 4 - TENSIONER
- 5 - TENSIONER MOUNTING BOLT

If a new belt is being installed, the arrow must be within approximately 3 mm (1/8 in.) of indexing mark (point B-) (Fig. 5). Belt is considered new if it has been used 15 minutes or less. If this specification cannot be met, check for:

- The wrong belt being installed (incorrect length/width)
- Worn bearings on an engine accessory (A/C compressor, power steering pump, water pump, idler pulley or generator)
- A pulley on an engine accessory being loose
- Misalignment of an engine accessory
- Belt incorrectly routed.

A used belt should be replaced if tensioner indexing arrow has moved to point-A (Fig. 5). Tensioner travel stops at point-A.



**Fig. 4 Indexing Marks—8.0L Engines Typical**

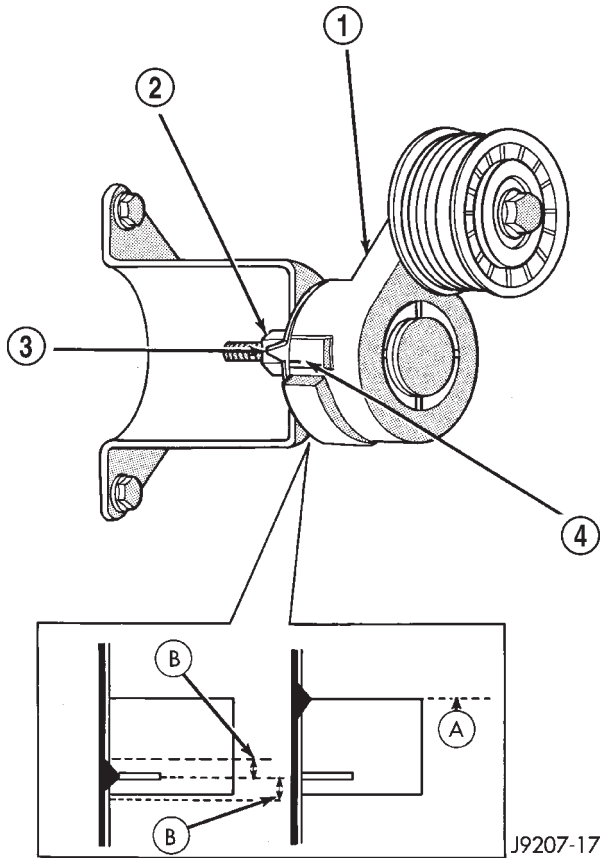
- 1 - TENSIONER ASSEMBLY
- 2 - TENSIONER MOUNTING NUT
- 3 - INDEXING ARROW
- 4 - INDEXING MARK

## REMOVAL

**WARNING: BECAUSE OF HIGH SPRING PRESSURE, DO NOT ATTEMPT TO DISASSEMBLE AUTOMATIC TENSIONER. UNIT IS SERVICED AS AN ASSEMBLY (EXCEPT FOR PULLEY).**

**CAUTION: If the pulley is to be removed from the tensioner, its mounting bolt has left-hand threads.**

## BELT TENSIONERS - 8.0L (Continued)



**Fig. 5 Indexing Marks—8.0L Engines Typical**

- 1 - TENSIONER ASSEMBLY
- 2 - TENSIONER MOUNTING NUT
- 3 - INDEXING ARROW
- 4 - INDEXING MARK

(1) Remove accessory drive belt (Refer to 7 - COOLING/ACCESSORY DRIVE/DRIVE BELTS - REMOVAL).

(2) Remove tensioner mounting bolt (Fig. 6) and remove tensioner.

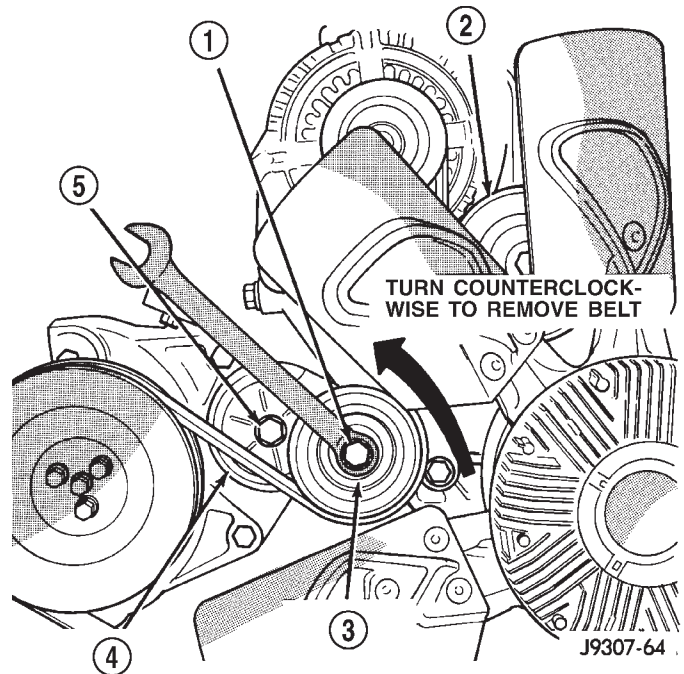
## INSTALLATION

**CAUTION:** If the pulley is to be removed from the tensioner, its mounting bolt has left-hand threads.

(1) Install pulley and pulley bolt to tensioner. Tighten bolt to 88 N·m (65 ft. lbs.) torque.

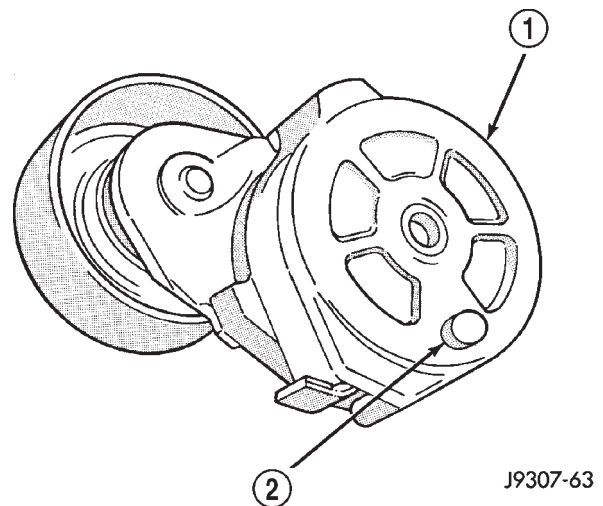
(2) Install tensioner assembly to mounting bracket. A dowel pin is located on back of tensioner (Fig. 7). Align this to dowel hole (Fig. 8) in tensioner mounting bracket. Tighten bolt to 41 N·m (30 ft. lbs.) torque.

(3) Install drive belt (Refer to 7 - COOLING/ACCESSORY DRIVE/DRIVE BELTS - INSTALLATION).



**Fig. 6 Belt Tensioner**

- 1 - PULLEY BOLT
- 2 - IDLER PULLEY
- 3 - TENSIONER PULLEY
- 4 - TENSIONER
- 5 - TENSIONER MOUNTING BOLT

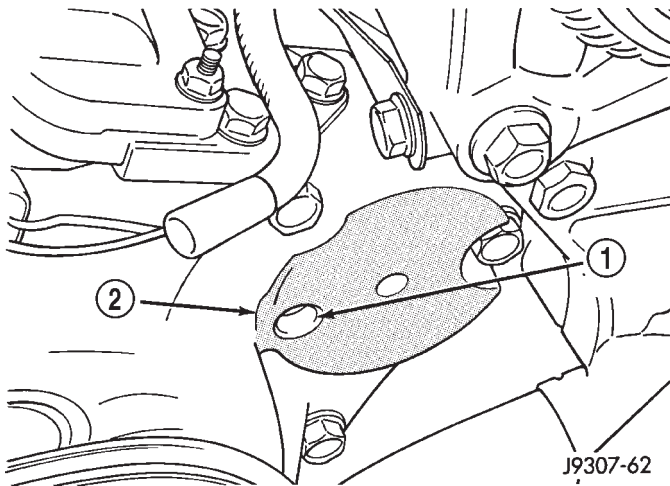


**Fig. 7 Tensioner Dowel Pin**

- 1 - BELT TENSIONER
- 2 - DOWEL PIN



## BELT TENSIONERS - 8.0L (Continued)



**Fig. 8 Tensioner Dowel Hole**

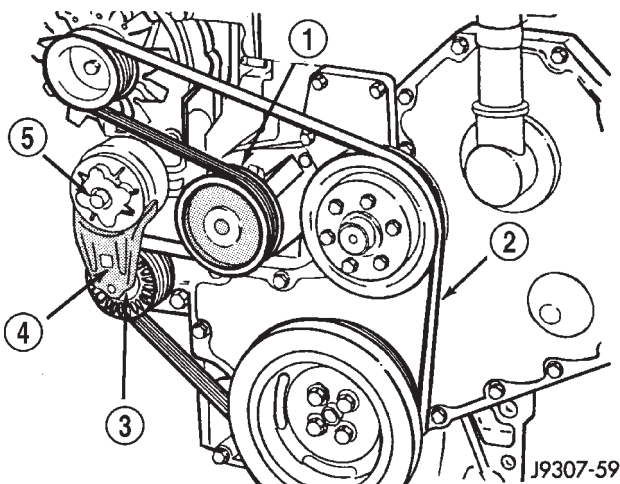
- 1 - DOWEL PIN HOLE  
2 - TENSIONER MOUNTING BRACKET

## BELT TENSIONERS - 5.9L DIESEL

## DESCRIPTION

Drive belts on all engines are equipped with a spring loaded automatic belt tensioner (Fig. 9). This tensioner maintains constant belt tension at all times and requires no maintenance or adjustment.

**CAUTION:** Do not attempt to check belt tension with a belt tension gauge on vehicles equipped with an automatic belt tensioner.



**Fig. 9 Belt**

- 1 - WATER PUMP  
2 - ACCESSORY DRIVE BELT  
3 - AUTOMATIC BELT TENSIONER  
4 - 3/8" SQUARE BOLT  
5 - MOUNT. BOLT

## OPERATION

**WARNING: THE AUTOMATIC BELT TENSIONER ASSEMBLY IS SPRING LOADED. DO NOT ATTEMPT TO DISASSEMBLE THE TENSIONER ASSEMBLY.**

The automatic belt tensioner maintains correct belt tension using a coiled spring within the tensioner housing. The spring applies pressure to the tensioner arm pressing the arm into the belt, tensioning the belt.

If a new belt is being installed, the arrow must be within approximately 3 mm (1/8 in.) of indexing mark. Belt is considered new if it has been used 15 minutes or less. If this specification cannot be met, check for:

- The wrong belt being installed (incorrect length/width)
- Worn bearings on an engine accessory (A/C compressor, power steering pump, water pump, idler pulley or generator)
- A pulley on an engine accessory being loose
- Misalignment of an engine accessory
- Belt incorrectly routed.

## REMOVAL

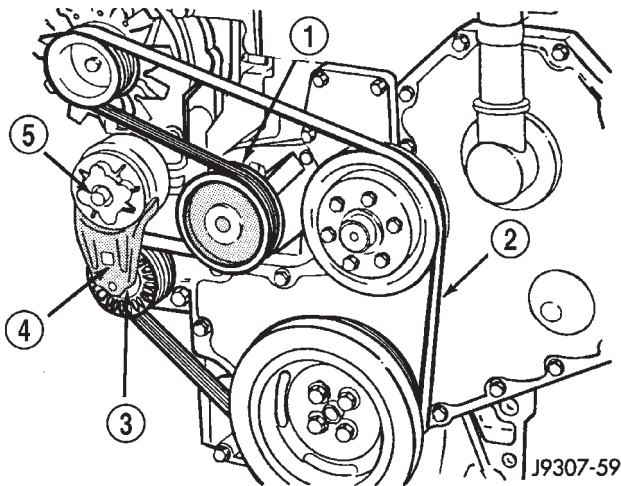
**WARNING: BECAUSE OF HIGH SPRING PRESSURE, DO NOT ATTEMPT TO DISASSEMBLE AUTOMATIC TENSIONER. UNIT IS SERVICED AS AN ASSEMBLY.**

- (1) Remove accessory drive belt (Refer to 7 - COOLING/ACCESSORY DRIVE/DRIVE BELTS - REMOVAL).
- (2) Remove tensioner mounting bolt (Fig. 10) and remove tensioner.

## INSTALLATION

- (1) Install tensioner assembly to mounting bracket. A dowel is located on back of tensioner. Align this dowel to hole in tensioner mounting bracket. Tighten bolt to 41 N·m (30 ft. lbs.) torque.
- (2) Install drive belt (Refer to 7 - COOLING/ACCESSORY DRIVE/DRIVE BELTS - INSTALLATION).

## BELT TENSIONERS - 5.9L DIESEL (Continued)



**Fig. 10 Automatic Belt Tensioner Diesel Engine—  
Typical**

- 1 - WATER PUMP
- 2 - ACCESSORY DRIVE BELT
- 3 - AUTOMATIC BELT TENSIONER
- 4 - 3/8" SQUARE BOLT
- 5 - MOUNT. BOLT

## DRIVE BELTS - 3.9L/5.2L/5.9L

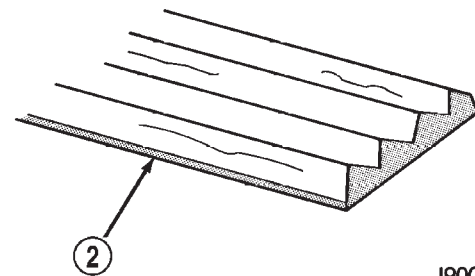
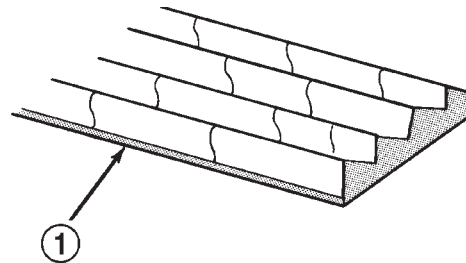
## DIAGNOSIS AND TESTING—ACCESSORY DRIVE BELT

## VISUAL DIAGNOSIS

When diagnosing serpentine accessory drive belts, small cracks that run across the ribbed surface of the belt from rib to rib (Fig. 11), are considered normal. These are not a reason to replace the belt. However, cracks running along a rib (not across) are **not** normal. Any belt with cracks running along a rib must

be replaced (Fig. 11). Also replace the belt if it has excessive wear, frayed cords or severe glazing.

Refer to ACCESSORY DRIVE BELT DIAGNOSIS CHART for further belt diagnosis.



J9007-44

**Fig. 11 Belt Wear Patterns**

- 1 - NORMAL CRACKS BELT OK
- 2 - NOT NORMAL CRACKS REPLACE BELT

## NOISE DIAGNOSIS

Noises generated by the accessory drive belt are most noticeable at idle. Before replacing a belt to resolve a noise condition, inspect all of the accessory drive pulleys for alignment, glazing, or excessive end play.

## DRIVE BELTS - 3.9L/5.2L/5.9L (Continued)

## ACCESSORY DRIVE BELT DIAGNOSIS CHART

CONDITION	POSSIBLE CAUSES	CORRECTION
RIB CHUNKING (One or more ribs has separated from belt body)	<ol style="list-style-type: none"> <li>1. Foreign objects imbedded in pulley grooves.</li> <li>2. Installation damage</li> </ol>	<ol style="list-style-type: none"> <li>1. Remove foreign objects from pulley grooves. Replace belt.</li> <li>2. Replace belt</li> </ol>
RIB OR BELT WEAR	<ol style="list-style-type: none"> <li>1. Pulley misaligned</li> <li>2. Abrasive environment</li> <li>3. Rusted pulley(s)</li> <li>4. Sharp or jagged pulley groove tips</li> <li>5. Belt rubber deteriorated</li> </ol>	<ol style="list-style-type: none"> <li>1. Align pulley(s)</li> <li>2. Clean pulley(s). Replace belt if necessary</li> <li>3. Clean rust from pulley(s)</li> <li>4. Replace pulley. Inspect belt.</li> <li>5. Replace belt</li> </ol>
BELT SLIPS	<ol style="list-style-type: none"> <li>1. Belt slipping because of insufficient tension</li> <li>2. Belt or pulley exposed to substance that has reduced friction (belt dressing, oil, ethylene glycol)</li> <li>3. Driven component bearing failure (seizure)</li> <li>4. Belt glazed or hardened from heat and excessive slippage</li> </ol>	<ol style="list-style-type: none"> <li>1. Inspect/Replace tensioner if necessary</li> <li>2. Replace belt and clean pulleys</li> <li>3. Replace faulty component or bearing</li> <li>4. Replace belt.</li> </ol>
LONGITUDINAL BELT CRACKING	<ol style="list-style-type: none"> <li>1. Belt has mistracked from pulley groove</li> <li>2. Pulley groove tip has worn away rubber to tensile member</li> </ol>	<ol style="list-style-type: none"> <li>1. Replace belt</li> <li>2. Replace belt</li> </ol>
"GROOVE JUMPING" (Belt does not maintain correct position on pulley)	<ol style="list-style-type: none"> <li>1. Incorrect belt tension</li> <li>2. Pulley(s) not within design tolerance</li> <li>3. Foreign object(s) in grooves</li> <li>4. Pulley misalignment</li> <li>5. Belt cordline is broken</li> </ol>	<ol style="list-style-type: none"> <li>1. Inspect/Replace tensioner if necessary</li> <li>2. Replace pulley(s)</li> <li>3. Remove foreign objects from grooves</li> <li>4. Align component</li> <li>5. Replace belt</li> </ol>
BELT BROKEN (Note: Identify and correct problem before new belt is installed)	<ol style="list-style-type: none"> <li>1. Incorrect belt tension</li> <li>2. Tensile member damaged during belt installation</li> <li>3. Severe misalignment</li> <li>4. Bracket, pulley, or bearing failure</li> </ol>	<ol style="list-style-type: none"> <li>1. Replace Inspect/Replace tensioner if necessary</li> <li>2. Replace belt</li> <li>3. Align pulley(s)</li> <li>4. Replace defective component and belt</li> </ol>

## DRIVE BELTS - 3.9L/5.2L/5.9L (Continued)

CONDITION	POSSIBLE CAUSES	CORRECTION
NOISE (Objectionable squeal, squeak, or rumble is heard or felt while drive belt is in operation)	<ol style="list-style-type: none"> <li>1. Incorrect belt tension</li> <li>2. Bearing noise</li> <li>3. Belt misalignment</li> <li>4. Belt to pulley mismatch</li> <li>5. Driven component induced vibration</li> </ol>	<ol style="list-style-type: none"> <li>1. Inspect/Replace tensioner if necessary</li> <li>2. Locate and repair</li> <li>3. Align belt/pulley(s)</li> <li>4. Install correct belt</li> <li>5. Locate defective driven component and repair</li> </ol>
TENSION SHEETING FABRIC FAILURE (Woven fabric on outside, circumference of belt has cracked or separated from body of belt)	<ol style="list-style-type: none"> <li>1. Tension sheeting contacting stationary object</li> <li>2. Excessive heat causing woven fabric to age</li> <li>3. Tension sheeting splice has fractured</li> </ol>	<ol style="list-style-type: none"> <li>1. Correct rubbing condition</li> <li>2. Replace belt</li> <li>3. Replace belt</li> </ol>
CORD EDGE FAILURE (Tensile member exposed at edges of belt or separated from belt body)	<ol style="list-style-type: none"> <li>1. Incorrect belt tension</li> <li>2. Belt contacting stationary object</li> <li>3. Pulley(s) out of tolerance</li> <li>4. Insufficient adhesion between tensile member and rubber matrix</li> </ol>	<ol style="list-style-type: none"> <li>1. Inspect/Replace tensioner if necessary</li> <li>2. Replace belt</li> <li>3. Replace pulley</li> <li>4. Replace belt</li> </ol>

## REMOVAL

**NOTE:** The belt routing schematics are published from the latest information available at the time of publication. If anything differs between these schematics and the Belt Routing Label, use the schematics on Belt Routing Label. This label is located in the engine compartment.

**CAUTION:** Do not attempt to check belt tension with a belt tension gauge on vehicles equipped with an automatic belt tensioner. Refer to Automatic Belt Tensioner in this group.

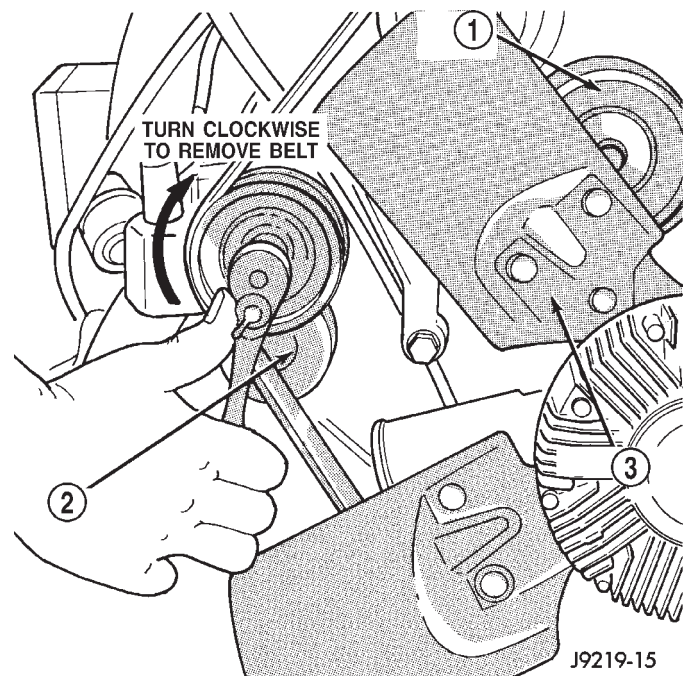
Drive belts on these engines are equipped with a spring loaded automatic belt tensioner (Fig. 12). This belt tensioner will be used on all belt configurations, such as with or without power steering or air conditioning. For more information, (Refer to 7 - COOLING/ACCESSORY DRIVE/BELT TENSIONERS - DESCRIPTION).

(1) Attach a socket/wrench to pulley mounting bolt of automatic tensioner (Fig. 12).

(2) Rotate tensioner assembly clockwise (as viewed from front) until tension has been relieved from belt.

(3) Remove belt from idler pulley first.

(4) Remove belt from vehicle.



**Fig. 12 Belt Tensioner—5.2L/5.9L Gas Engines**

- 1 - IDLER PULLEY
- 2 - TENSIONER
- 3 - FAN BLADE

## DRIVE BELTS - 3.9L/5.2L/5.9L (Continued)

## INSTALLATION

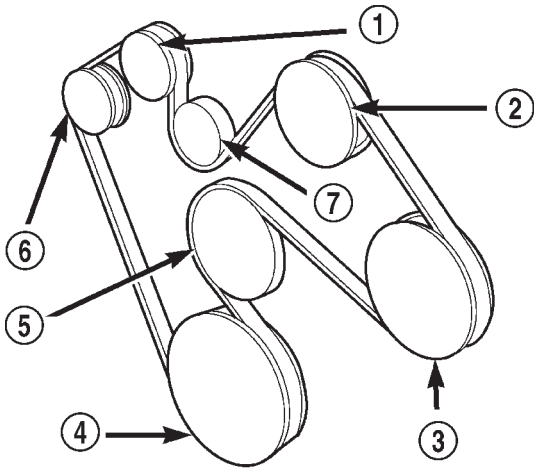
**CAUTION:** When installing the accessory drive belt, the belt must be routed correctly. If not, engine may overheat due to water pump rotating in wrong direction. Refer to (Fig. 13) (Fig. 14) for correct engine belt routing. The correct belt with correct length must be used.

(1) Position drive belt over all pulleys **except** idler pulley. This pulley is located between generator and A/C compressor.

(2) Attach a socket/wrench to pulley mounting bolt of automatic tensioner (Fig. 12).

(3) Rotate socket/wrench clockwise. Place belt over idler pulley. Let tensioner rotate back into place. Remove wrench. Be sure belt is properly seated on all pulleys.

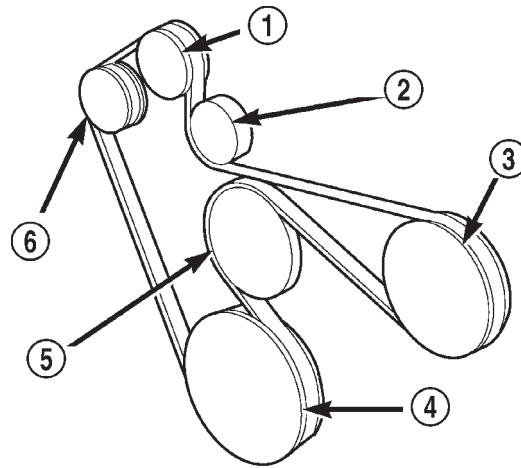
(4) Check belt indexing marks. .



80bcdbd04

**Fig. 13 Belt Routing—5.2L/5.9L Engines with A/C**

- 1 - GENERATOR PULLEY
- 2 - A/C PULLEY
- 3 - POWER STEERING PULLEY
- 4 - CRANKSHAFT PULLEY
- 5 - WATER PUMP PULLEY
- 6 - TENSIONER PULLEY
- 7 - IDLER PULLEY



80bcdbd05

**Fig. 14 Belt Routing—5.2L/5.9L Engines Without A/C**

- 1 - GENERATOR PULLEY
- 2 - IDLER PULLEY
- 3 - POWER STEERING PULLEY
- 4 - CRANKSHAFT PULLEY
- 5 - WATER PUMP PULLEY
- 6 - TENSIONER PULLEY

## DRIVE BELTS - 8.0L

## DIAGNOSIS AND TESTING—ACCESSORY DRIVE BELT

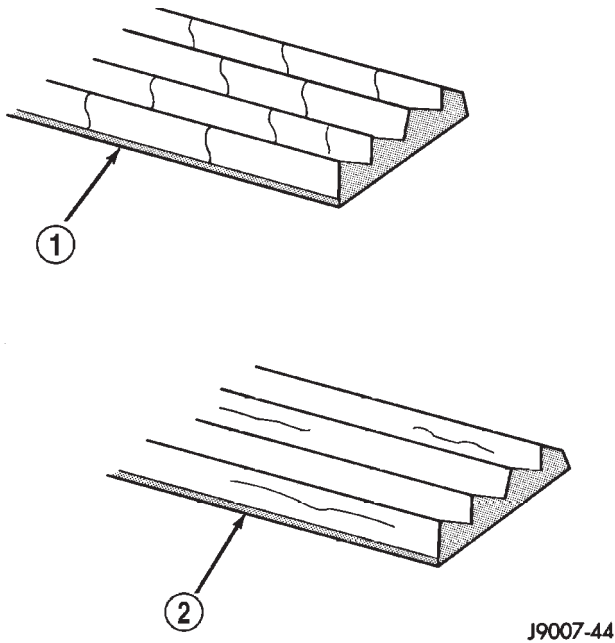
## VISUAL DIAGNOSIS

When diagnosing serpentine accessory drive belts, small cracks that run across the ribbed surface of the belt from rib to rib (Fig. 15), are considered normal. These are not a reason to replace the belt. However, cracks running along a rib (not across) are **not** normal. Any belt with cracks running along a rib must be replaced (Fig. 15). Also replace the belt if it has excessive wear, frayed cords or severe glazing.

Refer to ACCESSORY DRIVE BELT DIAGNOSIS CHART for further belt diagnosis.



DRIVE BELTS - 8.0L (Continued)



J9007-44

**Fig. 15 Belt Wear Patterns**

- 1 - NORMAL CRACKS BELT OK
- 2 - NOT NORMAL CRACKS REPLACE BELT

**NOISE DIAGNOSIS**

Noises generated by the accessory drive belt are most noticeable at idle. Before replacing a belt to resolve a noise condition, inspect all of the accessory drive pulleys for alignment, glazing, or excessive end play.

*ACCESSORY DRIVE BELT DIAGNOSIS CHART*

CONDITION	POSSIBLE CAUSES	CORRECTION
RIB CHUNKING (One or more ribs has separated from belt body)	<ol style="list-style-type: none"> <li>1. Foreign objects imbedded in pulley grooves.</li> <li>2. Installation damage</li> </ol>	<ol style="list-style-type: none"> <li>1. Remove foreign objects from pulley grooves. Replace belt.</li> <li>2. Replace belt</li> </ol>
RIB OR BELT WEAR	<ol style="list-style-type: none"> <li>1. Pulley misaligned</li> <li>2. Abrasive environment</li> <li>3. Rusted pulley(s)</li> <li>4. Sharp or jagged pulley groove tips</li> <li>5. Belt rubber deteriorated</li> </ol>	<ol style="list-style-type: none"> <li>1. Align pulley(s)</li> <li>2. Clean pulley(s). Replace belt if necessary</li> <li>3. Clean rust from pulley(s)</li> <li>4. Replace pulley. Inspect belt.</li> <li>5. Replace belt</li> </ol>
BELT SLIPS	<ol style="list-style-type: none"> <li>1. Belt slipping because of insufficient tension</li> <li>2. Belt or pulley exposed to substance that has reduced friction (belt dressing, oil, ethylene glycol)</li> <li>3. Driven component bearing failure (seizure)</li> <li>4. Belt glazed or hardened from heat and excessive slippage</li> </ol>	<ol style="list-style-type: none"> <li>1. Inspect/Replace tensioner if necessary</li> <li>2. Replace belt and clean pulleys</li> <li>3. Replace faulty component or bearing</li> <li>4. Replace belt.</li> </ol>

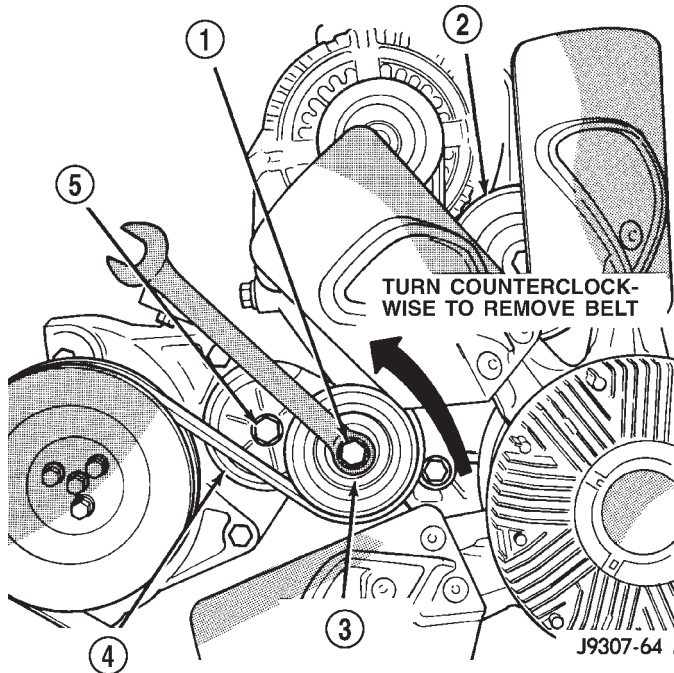
## DRIVE BELTS - 8.0L (Continued)

CONDITION	POSSIBLE CAUSES	CORRECTION
LONGITUDAL BELT CRACKING	<ol style="list-style-type: none"> <li>1. Belt has mistracked from pulley groove</li> <li>2. Pulley groove tip has worn away rubber to tensile member</li> </ol>	<ol style="list-style-type: none"> <li>1. Replace belt</li> <li>2. Replace belt</li> </ol>
"GROOVE JUMPING" (Belt does not maintain correct position on pulley)	<ol style="list-style-type: none"> <li>1. Incorrect belt tension</li> <li>2. Pulley(s) not within design tolerance</li> <li>3. Foreign object(s) in grooves</li> <li>4. Pulley misalignment</li> <li>5. Belt cordline is broken</li> </ol>	<ol style="list-style-type: none"> <li>1. Inspect/Replace tensioner if necessary</li> <li>2. Replace pulley(s)</li> <li>3. Remove foreign objects from grooves</li> <li>4. Align component</li> <li>5. Replace belt</li> </ol>
BELT BROKEN (Note: Identify and correct problem before new belt is installed)	<ol style="list-style-type: none"> <li>1. Incorrect belt tension</li> <li>2. Tensile member damaged during belt installation</li> <li>3. Severe misalignment</li> <li>4. Bracket, pulley, or bearing failure</li> </ol>	<ol style="list-style-type: none"> <li>1. Replace Inspect/Replace tensioner if necessary</li> <li>2. Replace belt</li> <li>3. Align pulley(s)</li> <li>4. Replace defective component and belt</li> </ol>
NOISE (Objectional squeal, spueak, or rumble is heard or felt while drive belt is in operation)	<ol style="list-style-type: none"> <li>1. Incorrect belt tension</li> <li>2. Bearing noise</li> <li>3. Belt misalignment</li> <li>4. Belt to pulley mismatch</li> <li>5. Driven component induced vibration</li> </ol>	<ol style="list-style-type: none"> <li>1. Inspect/Replace tensioner if necessary</li> <li>2. Locate and repair</li> <li>3. Align belt/pulley(s)</li> <li>4. Install correct belt</li> <li>5. Locate defective driven component and repair</li> </ol>
TENSION SHEETING FABRIC FAILURE (Woven fabric on outside, circumference of belt has cracked or separated from body of belt)	<ol style="list-style-type: none"> <li>1. Tension sheeting contacting stationary object</li> <li>2. Excessive heat causing woven fabric to age</li> <li>3. Tension sheeting splice has fractured</li> </ol>	<ol style="list-style-type: none"> <li>1. Correct rubbing condition</li> <li>2. Replace belt</li> <li>3. Replace belt</li> </ol>
CORD EDGE FAILURE (Tensile member exposed at edges of belt or separated from belt body)	<ol style="list-style-type: none"> <li>1. Incorrect belt tension</li> <li>2. Belt contacting stationary object</li> <li>3. Pulley(s) out of tolerance</li> <li>4. Insufficient adhesion between tensile member and rubber matrix</li> </ol>	<ol style="list-style-type: none"> <li>1. Inspect/Replace tensioner if necessary</li> <li>2. Replace belt</li> <li>3. Replace pulley</li> <li>4. Replace belt</li> </ol>

## DRIVE BELTS - 8.0L (Continued)

## REMOVAL

Drive belts are equipped with a spring loaded automatic belt tensioner (Fig. 16). This belt tensioner will be used on all belt configurations, such as with or without power steering or air conditioning. For more information, refer to Automatic Belt Tensioner, proceeding in this group.



**Fig. 16 Belt Tensioner**

- 1 - PULLEY BOLT
- 2 - IDLER PULLEY
- 3 - TENSIONER PULLEY
- 4 - TENSIONER
- 5 - TENSIONER MOUNTING BOLT

(1) Attach a socket/wrench to pulley mounting bolt of automatic tensioner (Fig. 16). The threads on the pulley mounting bolt are left-hand.

(2) Relax the tension from the belt by rotating the tensioner counterclockwise (as viewed from front) (Fig. 16). When all belt tension has been relaxed, remove belt from tensioner pulley first and other pulleys last.

## INSTALLATION

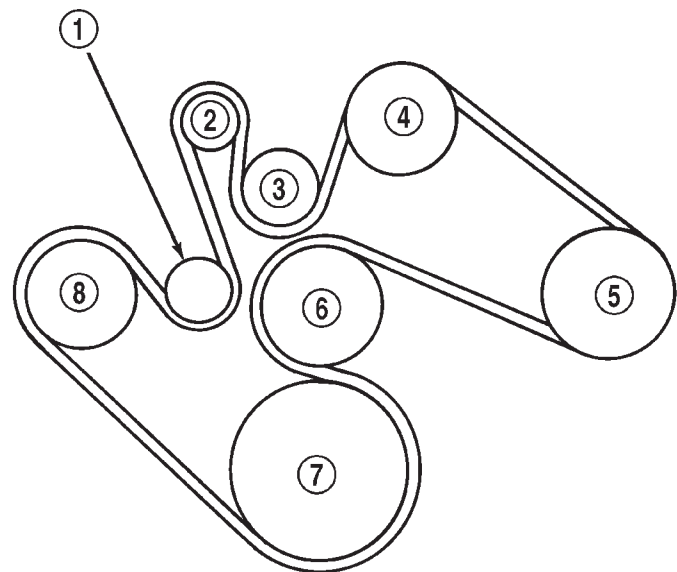
**CAUTION:** When installing the accessory drive belt, the belt must be routed correctly. If not, engine may overheat due to water pump rotating in wrong direction. Refer to (Fig. 17) (Fig. 18) for correct engine belt routing. The correct belt with correct length must be used.

**CAUTION:** If the pulley is to be removed from the tensioner, its mounting bolt has left-hand threads.

(1) Position drive belt over all pulleys **except** tensioner pulley.

(2) Attach a socket/wrench to pulley mounting bolt of automatic tensioner (Fig. 16).

(3) Rotate socket/wrench counterclockwise. Install belt over tensioner pulley. Let tensioner rotate back into place. Remove wrench. Be sure belt is properly seated on all pulleys.

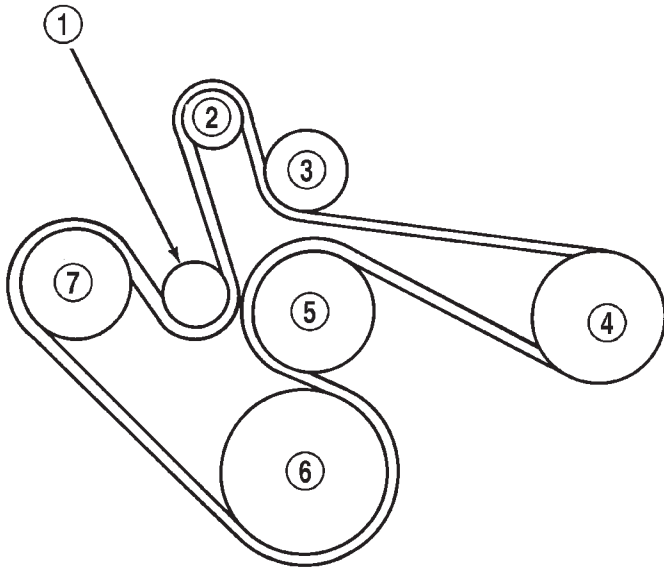


**Fig. 17 Belt Routing—With A/C**

J9307-55

- 1 - AUTOMATIC TENSIONER
- 2 - GENERATOR PULLEY
- 3 - IDLER PULLEY
- 4 - A/C COMPRESSOR PUMP PULLEY
- 5 - POWER STEERING PUMP PULLEY
- 6 - WATER PUMP AND FAN PULLEY
- 7 - CRANKSHAFT PULLEY
- 8 - AIR PUMP (A.I.R.) PULLEY

## DRIVE BELTS - 8.0L (Continued)



**Fig. 18 Belt Routing—Without A/C** J9307-56

- 1 - AUTOMATIC TENSIONER
- 2 - GENERATOR PULLEY
- 3 - IDLER PULLEY
- 4 - POWER STEERING PUMP PULLEY
- 5 - WATER PUMP AND FAN PULLEY
- 6 - CRANKSHAFT PULLEY
- 7 - AIR PUMP (A.I.R.) PULLEY

## DRIVE BELTS - 5.9L DIESEL

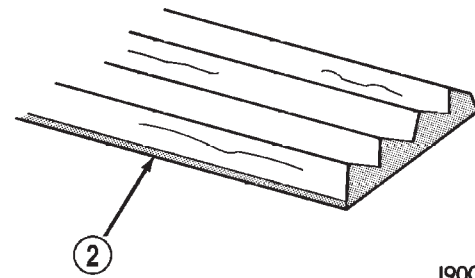
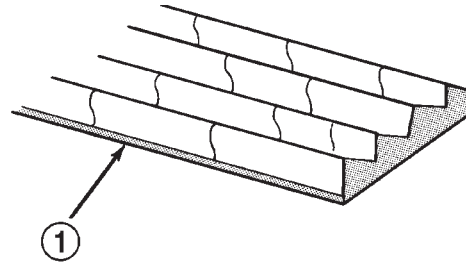
## DIAGNOSIS AND TESTING—ACCESSORY DRIVE BELT

## VISUAL DIAGNOSIS

When diagnosing serpentine accessory drive belts, small cracks that run across the ribbed surface of the belt from rib to rib (Fig. 19), are considered normal.

These are not a reason to replace the belt. However, cracks running along a rib (not across) are **not** normal. Any belt with cracks running along a rib must be replaced (Fig. 19). Also replace the belt if it has excessive wear, frayed cords or severe glazing.

Refer to ACCESSORY DRIVE BELT DIAGNOSIS CHART for further belt diagnosis.



**Fig. 19 Belt Wear Patterns** J9007-44

- 1 - NORMAL CRACKS BELT OK
- 2 - NOT NORMAL CRACKS REPLACE BELT

## NOISE DIAGNOSIS

Noises generated by the accessory drive belt are most noticeable at idle. Before replacing a belt to resolve a noise condition, inspect all of the accessory drive pulleys for alignment, glazing, or excessive end play.

## DRIVE BELTS - 5.9L DIESEL (Continued)

## ACCESSORY DRIVE BELT DIAGNOSIS CHART

CONDITION	POSSIBLE CAUSES	CORRECTION
RIB CHUNKING (One or more ribs has separated from belt body)	<ol style="list-style-type: none"> <li>1. Foreign objects imbedded in pulley grooves.</li> <li>2. Installation damage</li> </ol>	<ol style="list-style-type: none"> <li>1. Remove foreign objects from pulley grooves. Replace belt.</li> <li>2. Replace belt</li> </ol>
RIB OR BELT WEAR	<ol style="list-style-type: none"> <li>1. Pulley misaligned</li> <li>2. Abrasive environment</li> <li>3. Rusted pulley(s)</li> <li>4. Sharp or jagged pulley groove tips</li> <li>5. Belt rubber deteriorated</li> </ol>	<ol style="list-style-type: none"> <li>1. Align pulley(s)</li> <li>2. Clean pulley(s). Replace belt if necessary</li> <li>3. Clean rust from pulley(s)</li> <li>4. Replace pulley. Inspect belt.</li> <li>5. Replace belt</li> </ol>
BELT SLIPS	<ol style="list-style-type: none"> <li>1. Belt slipping because of insufficient tension</li> <li>2. Belt or pulley exposed to substance that has reduced friction (belt dressing, oil, ethylene glycol)</li> <li>3. Driven component bearing failure (seizure)</li> <li>4. Belt glazed or hardened from heat and excessive slippage</li> </ol>	<ol style="list-style-type: none"> <li>1. Inspect/Replace tensioner if necessary</li> <li>2. Replace belt and clean pulleys</li> <li>3. Replace faulty component or bearing</li> <li>4. Replace belt.</li> </ol>
LONGITUDINAL BELT CRACKING	<ol style="list-style-type: none"> <li>1. Belt has mistracked from pulley groove</li> <li>2. Pulley groove tip has worn away rubber to tensile member</li> </ol>	<ol style="list-style-type: none"> <li>1. Replace belt</li> <li>2. Replace belt</li> </ol>
"GROOVE JUMPING" (Belt does not maintain correct position on pulley)	<ol style="list-style-type: none"> <li>1. Incorrect belt tension</li> <li>2. Pulley(s) not within design tolerance</li> <li>3. Foreign object(s) in grooves</li> <li>4. Pulley misalignment</li> <li>5. Belt cordline is broken</li> </ol>	<ol style="list-style-type: none"> <li>1. Inspect/Replace tensioner if necessary</li> <li>2. Replace pulley(s)</li> <li>3. Remove foreign objects from grooves</li> <li>4. Align component</li> <li>5. Replace belt</li> </ol>
BELT BROKEN (Note: Identify and correct problem before new belt is installed)	<ol style="list-style-type: none"> <li>1. Incorrect belt tension</li> <li>2. Tensile member damaged during belt installation</li> <li>3. Severe misalignment</li> <li>4. Bracket, pulley, or bearing failure</li> </ol>	<ol style="list-style-type: none"> <li>1. Replace Inspect/Replace tensioner if necessary</li> <li>2. Replace belt</li> <li>3. Align pulley(s)</li> <li>4. Replace defective component and belt</li> </ol>



## DRIVE BELTS - 5.9L DIESEL (Continued)

CONDITION	POSSIBLE CAUSES	CORRECTION
NOISE (Objectional squeal, spueak, or rumble is heard or felt while drive belt is in operation)	<ol style="list-style-type: none"> <li>1. Incorrect belt tension</li> <li>2. Bearing noise</li> <li>3. Belt misalignment</li> <li>4. Belt to pulley mismatch</li> <li>5. Driven component induced vibration</li> </ol>	<ol style="list-style-type: none"> <li>1. Inspect/Replace tensioner if necessary</li> <li>2. Locate and repair</li> <li>3. Align belt/pulley(s)</li> <li>4. Install correct belt</li> <li>5. Locate defective driven component and repair</li> </ol>
TENSION SHEETING FABRIC FAILURE (Woven fabric on outside, circumference of belt has cracked or separated from body of belt)	<ol style="list-style-type: none"> <li>1. Tension sheeting contacting stationary object</li> <li>2. Excessive heat causing woven fabric to age</li> <li>3. Tension sheeting splice has fractured</li> </ol>	<ol style="list-style-type: none"> <li>1. Correct rubbing condition</li> <li>2. Replace belt</li> <li>3. Replace belt</li> </ol>
CORD EDGE FAILURE (Tensile member exposed at edges of belt or separated from belt body)	<ol style="list-style-type: none"> <li>1. Incorrect belt tension</li> <li>2. Belt contacting stationary object</li> <li>3. Pulley(s) out of tolerance</li> <li>4. Insufficient adhesion between tensile member and rubber matrix</li> </ol>	<ol style="list-style-type: none"> <li>1. Inspect/Replace tensioner if necessary</li> <li>2. Replace belt</li> <li>3. Replace pulley</li> <li>4. Replace belt</li> </ol>

## REMOVAL

**CAUTION:** Do not attempt to check belt tension with a belt tension gauge on vehicles equipped with an automatic belt tensioner. Refer to Automatic Belt Tensioner in this group.

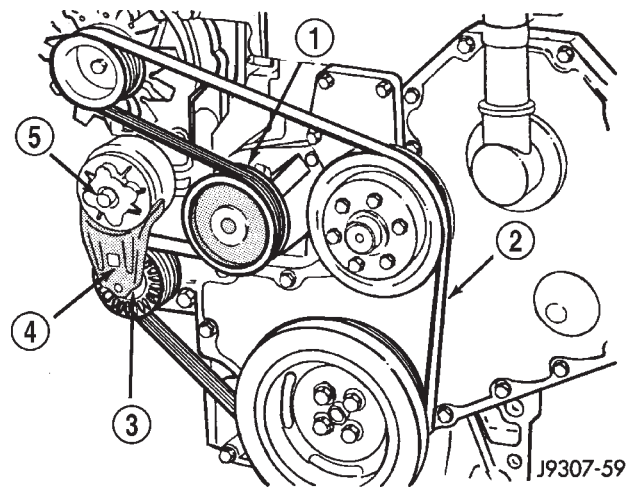
**NOTE:** The belt routing schematics are published from the latest information available at the time of publication. If anything differs between these schematics and the Belt Routing Label, use the schematics on Belt Routing Label. This label is located in the engine compartment.

Drive belts on diesel engines are equipped with a spring loaded automatic belt tensioner (Fig. 20). (Fig. 20) displays the tensioner for vehicles without air conditioning.

This belt tensioner will be used on all belt configurations, such as with or without air conditioning. For more information, (Refer to 7 - COOLING/ACCESSORY DRIVE/BELT TENSIONERS - DESCRIPTION).

(1) A 3/8 inch square hole is provided in the automatic belt tensioner (Fig. 20). Attach a 3/8 inch drive-long handle ratchet to this hole.

(2) Rotate ratchet and tensioner assembly counter-clockwise (as viewed from front) until tension has been relieved from belt.



**Fig. 20 Belt Tensioner—5.9L Diesel—Typical (non-A/C shown)**

- 1 - WATER PUMP
- 2 - ACCESSORY DRIVE BELT
- 3 - AUTOMATIC BELT TENSIONER
- 4 - 3/8" SQUARE BOLT
- 5 - MOUNT. BOLT

- (3) Remove belt from water pump pulley first.
- (4) Remove belt from vehicle.

## DRIVE BELTS - 5.9L DIESEL (Continued)

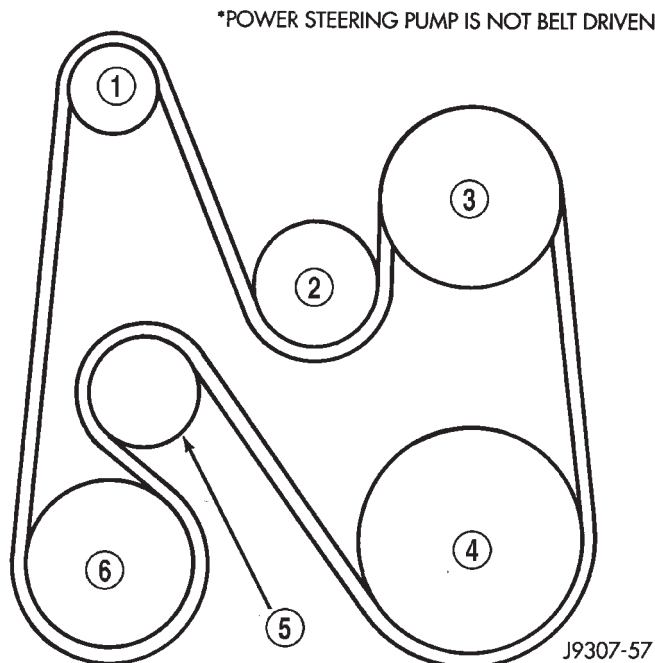
## INSTALLATION

**CAUTION:** When installing the accessory drive belt, the belt must be routed correctly. If not, engine may overheat due to water pump rotating in wrong direction. Refer to (Fig. 21) (Fig. 22) for correct engine belt routing. The correct belt with correct length must be used.

(1) Position drive belt over all pulleys **except** water pump pulley.

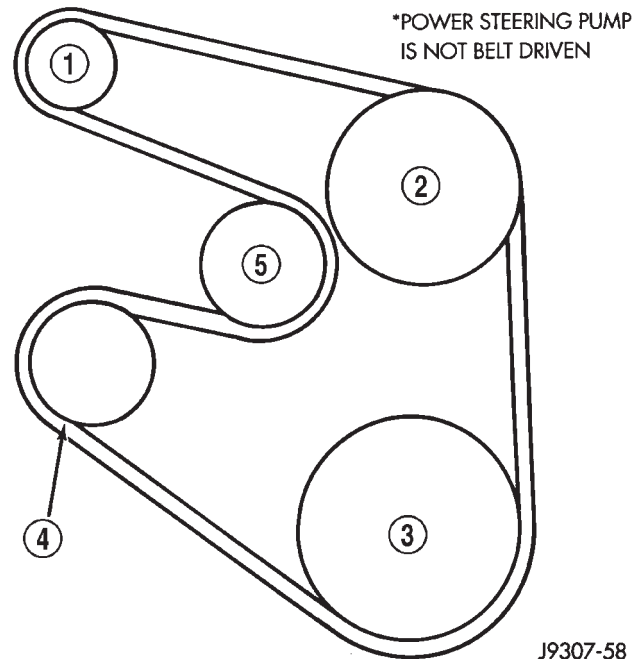
(2) Attach a 3/8 inch ratchet to tensioner.

(3) Rotate ratchet and belt tensioner counterclockwise. Place belt over water pump pulley. Let tensioner rotate back into place. Remove ratchet. Be sure belt is properly seated on all pulleys.



**Fig. 21 Belt Routing—5.9L Diesel Engine—With A/C**

- 1 - GENERATOR PULLEY
- 2 - WATER PUMP PULLEY
- 3 - FAN PULLEY
- 4 - CRANKSHAFT PULLEY
- 5 - AUTOMATIC TENSIONER
- 6 - A/C COMPRESSOR PUMP PULLEY



**Fig. 22 Belt Routing—5.9L Diesel Engine—Without A/C**

- 1 - GENERATOR PULLEY
- 2 - FAN PULLEY
- 3 - CRANKSHAFT PULLEY
- 4 - AUTOMATIC TENSIONER
- 5 - WATER PUMP PULLEY

## VACUUM PUMP - 5.9L DIESEL

## DESCRIPTION

The vacuum pump and the power steering pump are combined into a single assembly on diesel engine models (Fig. 23). Both pumps are operated by a drive gear attached to the vacuum pump shaft. The shaft gear is driven by the camshaft gear.

The vacuum pump is a constant displacement, vane-type pump. Vacuum is generated by four vanes mounted in the pump rotor. The rotor is located in the pump housing and is pressed onto the pump shaft.

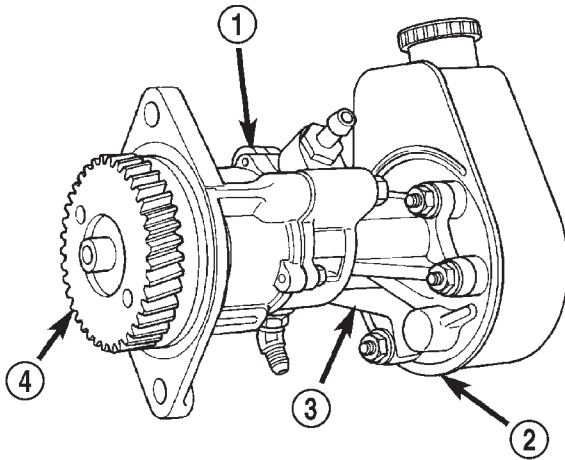
The vacuum and steering pumps are operated by a single drive gear pressed onto the vacuum pump shaft. The drive gear is operated by the engine camshaft gear.

The vacuum and power steering pump shafts are connected by a coupling. Each pump shaft has an adapter with drive lugs that engage in the coupling.

The vacuum pump rotating components are lubricated by engine oil. Lubricating oil is supplied to the pump through an oil line at the underside of the pump housing.

## VACUUM PUMP - 5.9L DIESEL (Continued)

The complete assembly must be removed in order to service either pump. However, the power steering pump can be removed and serviced separately when necessary.



80a611d3

**Fig. 23 Diesel Vacuum & Power Steering Pump Assembly**

- 1 - VACUUM PUMP
- 2 - POWER STEERING PUMP
- 3 - PUMP ADAPTER
- 4 - DRIVE GEAR

The vacuum pump is not a serviceable component. If diagnosis indicates a pump malfunction, the pump must be replaced as an assembly. Do not disassemble or attempt to repair the pump.

The combined vacuum and steering pump assembly must be removed for access to either pump. However, the vacuum pump can be removed without having to disassemble the power steering pump.

If the power steering pump requires service, simply remove the assembly and separate the two pumps. Refer to the pump removal and installation procedures in this section.

## OPERATION

Vacuum pump output is transmitted to the HEVAC, speed control, systems through a supply hose. The hose is connected to an outlet port on the pump housing and uses an in-line check valve to retain system vacuum when vehicle is not running.

Pump output ranges from a minimum of 8.5 to 25 inches vacuum.

The pump rotor and vanes are rotated by the pump drive gear. The drive gear is operated by the camshaft gear.

## DIAGNOSIS AND TESTING—VACUUM PUMP OUTPUT

The vacuum pump supplies necessary vacuum to components in the following systems:

- HEVAC system
- Speed Control System

A quick check to determine if the vacuum pump is the cause of the problem in any of these systems is to road test the vehicle and verify that all of these systems are functioning properly. If only one of these has a vacuum related failure, then it is likely the vacuum pump is not the cause.

A standard vacuum gauge can be used to check pump output when necessary. Simply disconnect the pump supply hose and connect a vacuum gauge to the outlet port for testing purposes. With the engine running, vacuum output should be a minimum of 25 inches, depending on engine speed.

## DIAGNOSING LOW VACUUM OUTPUT CONDITION

If the vacuum pump is suspected of low vacuum output, check the pump and vacuum harnesses as follows:

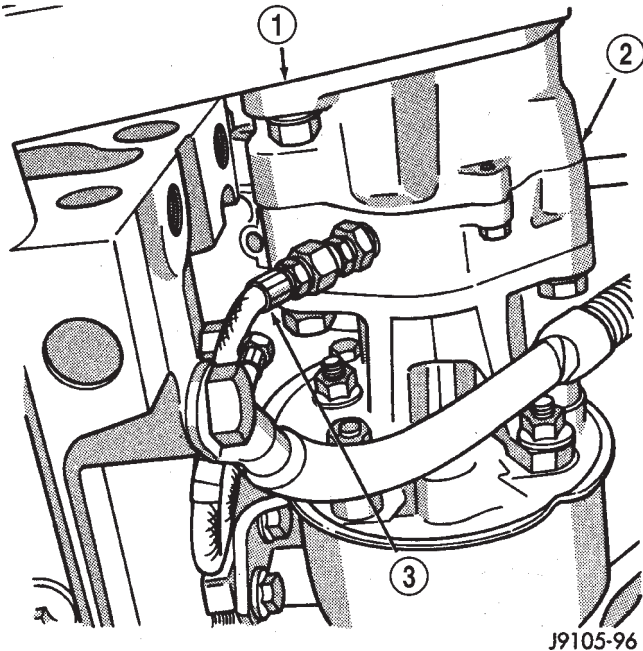
- (1) Visually inspect the vacuum harness for obvious failures (i.e. disconnected, cracks, breaks etc.)
- (2) Disconnect the vacuum supply hose at the vacuum pump check valve. Connect vacuum gauge to this valve and run engine at various throttle openings. Output should be a minimum 25 inches of vacuum. If vacuum is consistently below 25 inches, the vacuum pump should be replaced. If output is within specified limits, the vacuum harness should be suspected as the cause.
- (3) Disconnect and isolate the vacuum supply harness. Cap off open ends and apply roughly 15 inches of vacuum to the harness. If the vacuum gauge does not hold its reading, then there is an open in the harness and it should be repaired or replaced.
- (4) If the vacuum loss is still not detected at this point, then the pump and harness are not the cause of the low vacuum condition. Apply vacuum to the related components of the vacuum supply system (i.e. valves, servos, solenoids, etc.) to find the source of the vacuum loss.

## REMOVAL

- (1) Disconnect battery negative cables.
- (2) Position drain pan under power steering pump.
- (3) Disconnect vacuum and steering pump hoses.
- (4) Disconnect lubricating oil feed line from fitting at underside of vacuum pump (Fig. 24).
- (5) Remove lower bolt that attaches pump assembly to engine block (Fig. 25).

## VACUUM PUMP - 5.9L DIESEL (Continued)

(6) Remove bottom, inboard nut that attaches adapter to steering pump. This nut secures a small bracket to engine block. Nut and bracket must be removed before pump assembly can be removed from block.



**Fig. 24 Vacuum Pump Oil Feed Line**

- 1 - ENGINE BLOCK
- 2 - VACUUM PUMP
- 3 - VACUUM PUMP OIL FEED LINE

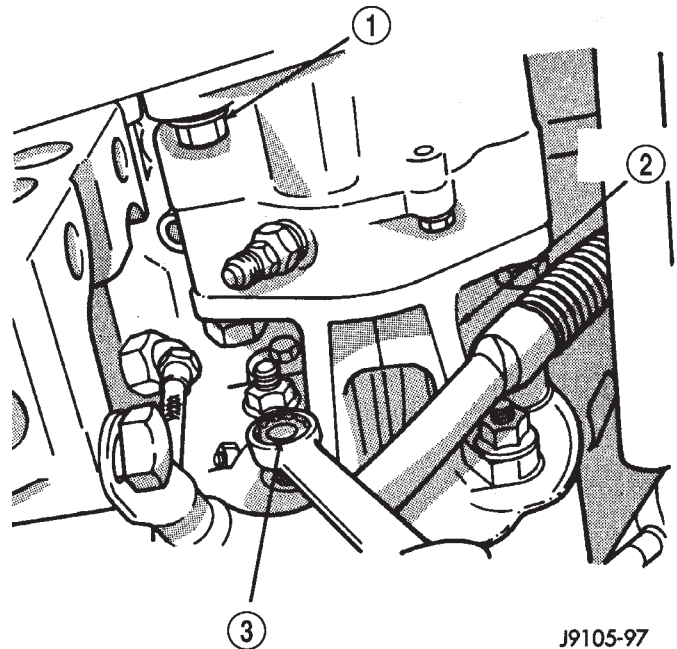
(7) Remove upper bolt that attaches pump assembly to engine block (Fig. 26).

(8) Remove pump assembly from vehicle.

**NOTE:** The vacuum pump and adapter are serviced as an assembly and must not be separated.

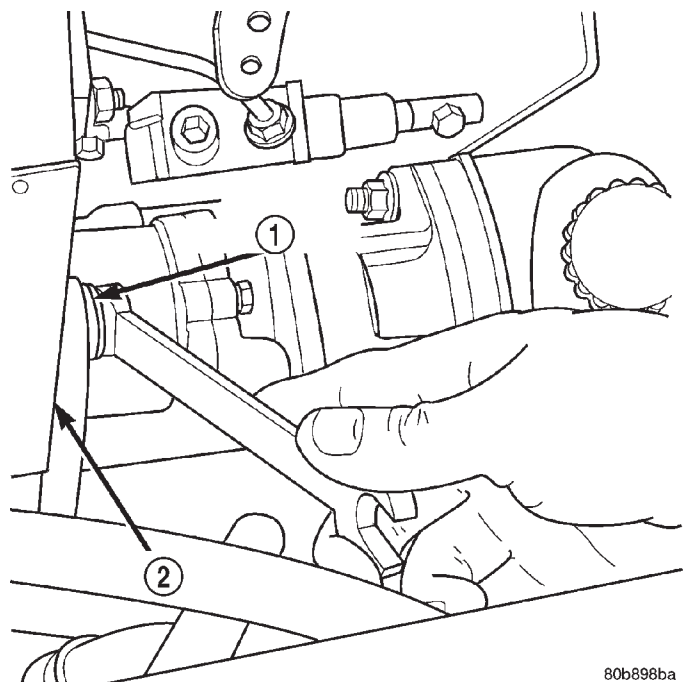
(9) Remove the remaining three power steering pump to adapter mounting nuts (Fig. 27).

(10) Gently, remove the steering pump from the adapter. Use caution not to damage the oil seal in the adapter body (Fig. 28).



**Fig. 25 Vacuum Pump Mounting**

- 1 - PUMP ASSEMBLY LOWER MOUNTING BOLT
- 2 - ADAPTER BRACKET
- 3 - BOTTOM—INBOARD ADAPTER BRACKET NUT

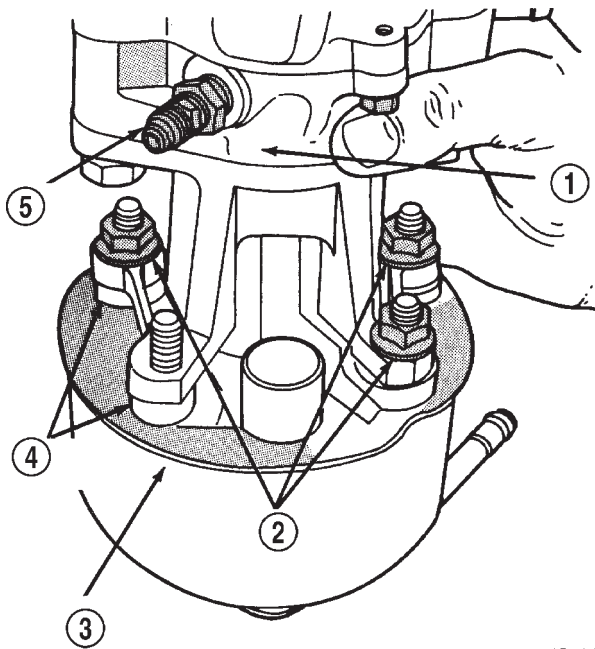


**Fig. 26 Pump Assembly Upper Mounting Bolt**

- 1 - PUMP UPPER BOLT
- 2 - DRIVE COVER



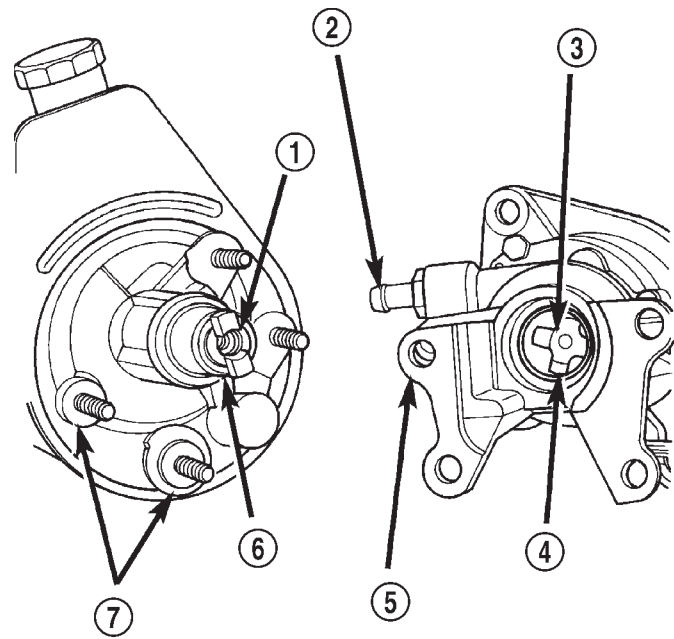
## VACUUM PUMP - 5.9L DIESEL (Continued)



J9119-78

**Fig. 27 Adapter to Power Steering Pump Nuts**

- 1 - VACUUM PUMP
- 2 - ATTACHING NUTS
- 3 - STEERING PUMP
- 4 - PUMP SPACERS
- 5 - OIL FEED FITTING



80a611d1

**Fig. 28 Steering Pump, Vacuum Pump and Adapter**

- 1 - PUMP SHAFT
- 2 - VACUUM FITTING
- 3 - VACUUM PUMP DRIVE
- 4 - OIL SEAL
- 5 - MOUNTING BRACKET
- 6 - DRIVE DOG
- 7 - PUMP SPACERS

## INSTALLATION

**NOTE:** Make sure the two pump spacers are present before assembling power steering pump to adapter.

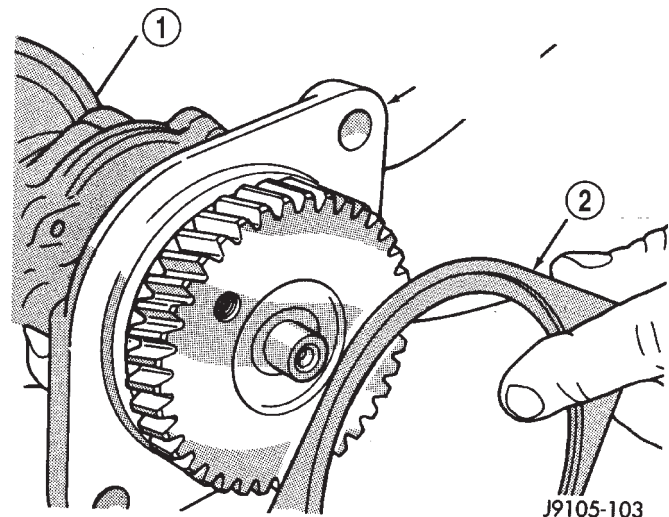
(1) Aline the steering pump drive dog with the slot in the vacuum pump drive assembly, slide the steering pump into place on the adapter. **Use care not to damage the oil seal in the adapter body.**

(2) Install the three steering pump to adapter nuts, do not install the lower inboard mounting nut at this time. Tighten nuts to 24 N·m (18 ft. lbs.).

(3) Position new gasket on vacuum pump mounting flange (Fig. 29). Use Mopar® Perfect Seal, or silicone adhesive/sealer to hold gasket in place.

(4) Insert pump assembly upper attaching bolt in mounting flange and gasket. Use sealer or grease to hold bolt in place if necessary.

(5) Position pump assembly on engine and install upper bolt (Fig. 30). Tighten upper bolt only enough to hold assembly in place at this time.



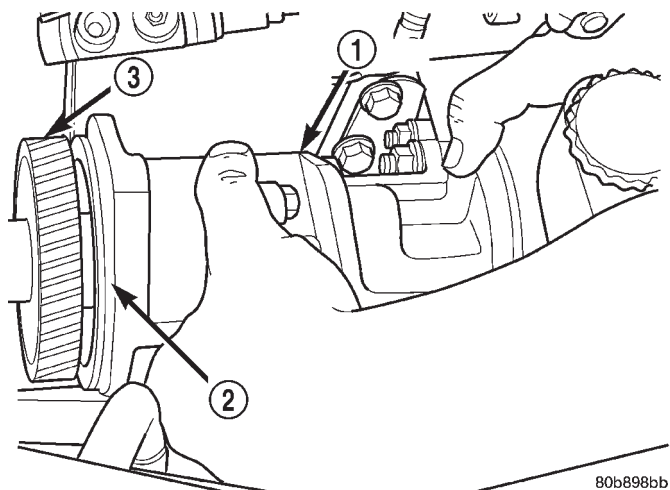
J9105-103

**Fig. 29 Pump Mounting Flange Gasket**

- 1 - PUMP MOUNTING FLANGE
- 2 - PUMP GASKET (APPLY SEALER TO BOTH SIDES)



## VACUUM PUMP - 5.9L DIESEL (Continued)



**Fig. 30 Installing Pump Assembly On Engine**

- 1 - PUMP ASSEMBLY
- 2 - PUMP GASKET
- 3 - DRIVE GEAR

(6) Working from under vehicle, install pump assembly lower attaching bolt. Then tighten upper and lower bolt to 77 N-m (57 ft. lbs.).

(7) Position bracket on steering pump inboard stud. Then install remaining adapter attaching nut on stud. Tighten nut to 24 N-m (18 ft. lbs.).

(8) Connect oil feed line to vacuum pump connector and tighten line fitting.

(9) Connect steering pump pressure and return lines to pump. Tighten pressure line fitting to 30 N-m (22 ft. lbs.).

(10) Connect vacuum hose to vacuum pump.

(11) Connect battery cables, if removed.

(12) Fill power steering pump reservoir and Purge air from steering pump lines (Refer to 19 - STEERING/PUMP - STANDARD PROCEDURE).

## ENGINE

## TABLE OF CONTENTS

	page		page
<b>COOLANT</b>		REMOVAL . . . . .	49
DESCRIPTION . . . . .	40	INSTALLATION . . . . .	50
OPERATION . . . . .	40	<b>ENGINE COOLANT THERMOSTAT - 8.0L</b>	
<b>COOLANT RECOVERY CONTAINER - 3.9L/5.2L/ 5.9L/5.9L DIESEL</b>		DESCRIPTION . . . . .	52
DESCRIPTION . . . . .	41	OPERATION . . . . .	52
OPERATION . . . . .	41	DIAGNOSIS AND TESTING . . . . .	52
REMOVAL . . . . .	41	THERMOSTAT . . . . .	52
INSTALLATION . . . . .	41	REMOVAL . . . . .	52
<b>COOLANT RECOVERY CONTAINER - 8.0L</b>		INSTALLATION . . . . .	53
DESCRIPTION . . . . .	42	<b>ENGINE COOLANT THERMOSTAT - 5.9L DIESEL</b>	
OPERATION . . . . .	42	DESCRIPTION . . . . .	54
<b>RADIATOR FAN - 3.9L/5.2L/5.9L/8.0L</b>		OPERATION . . . . .	54
REMOVAL . . . . .	42	DIAGNOSIS AND TESTING . . . . .	54
CLEANING . . . . .	43	THERMOSTAT . . . . .	54
INSPECTION . . . . .	43	REMOVAL . . . . .	55
INSTALLATION . . . . .	43	INSTALLATION . . . . .	55
<b>RADIATOR FAN - 5.9L DIESEL</b>		<b>FAN DRIVE VISCOUS CLUTCH - 3.9L/5.2L/5.9L/ 8.0L</b>	
REMOVAL . . . . .	44	DESCRIPTION . . . . .	56
CLEANING . . . . .	44	OPERATION . . . . .	56
INSPECTION . . . . .	44	DIAGNOSIS AND TESTING . . . . .	56
INSTALLATION . . . . .	45	VISCOUS FAN DRIVE . . . . .	56
<b>ENGINE BLOCK HEATER - 3.9L/5.2L/5.9L</b>		<b>FAN DRIVE VISCOUS CLUTCH - 5.9L DIESEL</b>	
DESCRIPTION . . . . .	45	DESCRIPTION . . . . .	57
OPERATION . . . . .	45	OPERATION . . . . .	57
REMOVAL . . . . .	45	DIAGNOSIS AND TESTING . . . . .	58
INSTALLATION . . . . .	45	VISCOUS FAN DRIVE . . . . .	58
<b>ENGINE BLOCK HEATER - 8.0L</b>		<b>RADIATOR - 3.9L/5.2L/5.9L</b>	
DESCRIPTION . . . . .	46	DESCRIPTION . . . . .	59
OPERATION . . . . .	46	OPERATION . . . . .	59
REMOVAL . . . . .	46	DIAGNOSIS AND TESTING . . . . .	59
INSTALLATION . . . . .	46	RADIATOR COOLANT FLOW . . . . .	59
<b>ENGINE BLOCK HEATER - 5.9L DIESEL</b>		REMOVAL . . . . .	59
DESCRIPTION . . . . .	47	CLEANING . . . . .	60
OPERATION . . . . .	47	INSPECTION . . . . .	61
REMOVAL . . . . .	47	INSTALLATION . . . . .	61
INSTALLATION . . . . .	47	<b>RADIATOR - 8.0L</b>	
<b>ENGINE COOLANT TEMP SENSOR - 3.9L/5.2L/ 5.9L</b>		DESCRIPTION . . . . .	61
DESCRIPTION . . . . .	48	OPERATION . . . . .	61
OPERATION . . . . .	48	DIAGNOSIS AND TESTING . . . . .	61
REMOVAL . . . . .	48	RADIATOR COOLANT FLOW . . . . .	61
INSTALLATION . . . . .	48	REMOVAL . . . . .	62
<b>ENGINE COOLANT THERMOSTAT - 3.9L/5.2L/ 5.9L</b>		CLEANING . . . . .	62
DESCRIPTION . . . . .	49	INSPECTION . . . . .	62
OPERATION . . . . .	49	INSTALLATION . . . . .	63
DIAGNOSIS AND TESTING . . . . .	49	<b>RADIATOR - 5.9L DIESEL</b>	
THERMOSTAT . . . . .	49	DESCRIPTION . . . . .	63
		OPERATION . . . . .	63

DIAGNOSIS AND TESTING .....	63	INSPECTION .....	69
RADIATOR COOLANT FLOW .....	63	INSTALLATION .....	70
REMOVAL .....	63	<b>WATER PUMP - 8.0L</b>	
CLEANING .....	65	DIAGNOSIS AND TESTING .....	70
INSPECTION .....	65	WATER PUMP .....	70
INSTALLATION .....	65	REMOVAL .....	70
<b>RADIATOR PRESSURE CAP</b>		CLEANING .....	72
DESCRIPTION .....	65	INSPECTION .....	72
OPERATION .....	65	INSTALLATION .....	72
DIAGNOSIS AND TESTING .....	66	<b>WATER PUMP - 5.9L DIESEL</b>	
RADIATOR CAP-TO-FILLER NECK SEAL .....	66	DESCRIPTION .....	73
RADIATOR CAP .....	66	OPERATION .....	73
CLEANING .....	66	DIAGNOSIS AND TESTING .....	73
INSPECTION .....	66	WATER PUMP .....	73
<b>WATER PUMP - 3.9L/5.2L/5.9L</b>		REMOVAL .....	73
DESCRIPTION .....	67	CLEANING .....	73
OPERATION .....	67	INSPECTION .....	73
DIAGNOSIS AND TESTING .....	67	INSTALLATION .....	74
WATER PUMP .....	67	<b>WATER PUMP INLET TUBE - 3.9L/5.2L/5.9L</b>	
REMOVAL .....	67	REMOVAL .....	74
CLEANING .....	69	INSTALLATION .....	77

## COOLANT

### DESCRIPTION

#### ETHYLENE-GLYCOL MIXTURES

**CAUTION:** Richer antifreeze mixtures cannot be measured with normal field equipment and can cause problems associated with 100 percent ethylene-glycol.

The required ethylene-glycol (antifreeze) and water mixture depends upon the climate and vehicle operating conditions. The recommended mixture of 50/50 ethylene-glycol and water will provide protection against freezing to -37 deg. C (-35 deg. F). The antifreeze concentration **must always** be a minimum of 44 percent, year-round in all climates. **If percentage is lower than 44 percent, engine parts may be eroded by cavitation, and cooling system components may be severely damaged by corrosion.** Maximum protection against freezing is provided with a 68 percent antifreeze concentration, which prevents freezing down to -67.7 deg. C (-90 deg. F). A higher percentage will freeze at a warmer temperature. Also, a higher percentage of antifreeze can cause the engine to overheat because the specific heat of antifreeze is lower than that of water.

Use of 100 percent ethylene-glycol will cause formation of additive deposits in the system, as the corrosion inhibitive additives in ethylene-glycol require the presence of water to dissolve. The deposits act as insulation, causing temperatures to rise to as high as 149 deg. C (300 deg. F). This temperature is hot enough to melt plastic and soften solder. The

increased temperature can result in engine detonation. In addition, 100 percent ethylene-glycol freezes at 22 deg. C (-8 deg. F).

#### PROPYLENE-GLYCOL MIXTURES

Its overall effective temperature range is smaller than that of ethylene-glycol. The freeze point of 50/50 propylene-glycol and water is -32 deg. C (-26 deg. F), 5 deg. C higher than ethylene-glycol's freeze point. The boiling point (protection against summer boil-over) of propylene-glycol is 125 deg. C (257 deg. F) at 96.5 kPa (14 psi), compared to 128 deg. C (263 deg. F) for ethylene-glycol. Use of propylene-glycol can result in boil-over or freeze-up on a cooling system designed for ethylene-glycol. Propylene glycol also has poorer heat transfer characteristics than ethylene glycol. This can increase cylinder head temperatures under certain conditions.

Propylene-glycol/ethylene-glycol Mixtures can cause the destabilization of various corrosion inhibitors, causing damage to the various cooling system components. Also, once ethylene-glycol and propylene-glycol based coolants are mixed in the vehicle, conventional methods of determining freeze point will not be accurate. Both the refractive index and specific gravity differ between ethylene glycol and propylene glycol.

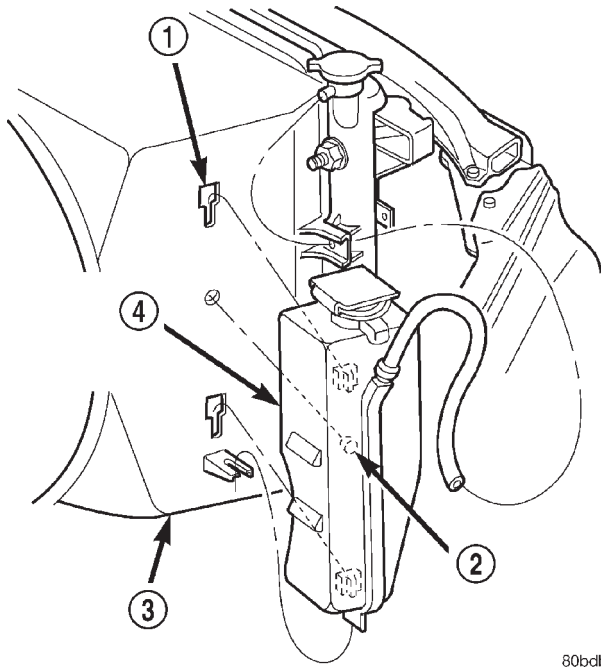
### OPERATION

Coolant flows through the engine block absorbing the heat from the engine, then flows to the radiator where the cooling fins in the radiator transfers the heat from the coolant to the atmosphere. During cold weather the ethylene-glycol coolant prevents water present in the cooling system from freezing within temperatures indicated by mixture ratio of coolant to water.

## COOLANT RECOVERY CONTAINER - 3.9L/5.2L/5.9L/ 5.9L DIESEL

### DESCRIPTION

The coolant reserve/overflow tank is mounted to the side of the fan shroud (Fig. 1), and is made of high temperature plastic.



**Fig. 1 Coolant Reserve/Overflow Tank**

- 1 - T-SLOTS
- 2 - ALIGNMENT PIN
- 3 - FAN SHROUD
- 4 - COOLANT RESERVE/OVERFLOW TANK

### OPERATION

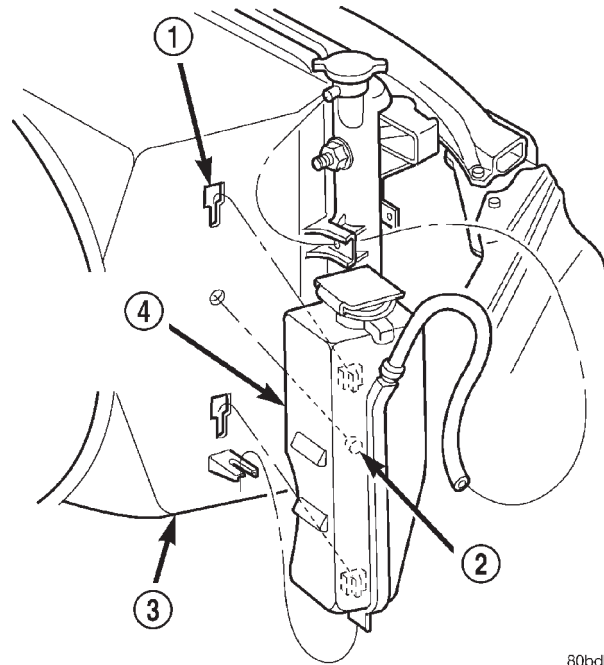
The coolant reserve/overflow system works in conjunction with the radiator pressure cap. It utilizes thermal expansion and contraction of coolant to keep coolant free of trapped air. It provides a volume for expansion and contraction of coolant. It also provides a convenient and safe method for checking coolant level and adjusting level at atmospheric pressure. This is done without removing the radiator pressure

cap. The system also provides some reserve coolant to the radiator to cover minor leaks and evaporation or boiling losses.

As the engine cools, a vacuum is formed in the cooling system of both the radiator and engine. Coolant will then be drawn from the coolant tank and returned to a proper level in the radiator.

### REMOVAL

- (1) Remove overflow hose from radiator.
- (2) Unsnap the coolant reserve/overflow tank from fan shroud. Lift straight up. The fan shroud is equipped with T-shaped slots (Fig. 2) to attach the tank. An alignment pin is located on the side of tank.



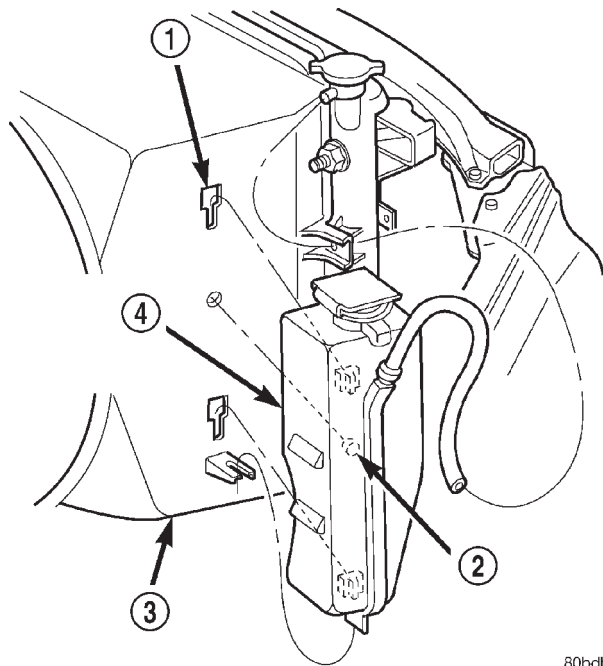
**Fig. 2 COOLANT RESERVE/OVERFLOW TANK—ALL  
EXCEPT 8.0L V-10 ENGINE**

- 1 - T-SLOTS
- 2 - ALIGNMENT PIN
- 3 - FAN SHROUD
- 4 - COOLANT RESERVE/OVERFLOW TANK

### INSTALLATION

- (1) Snap the tank into the two T-slots and the alignment pin on fan shroud (Fig. 3).
- (2) Connect overflow hose to radiator.

## COOLANT RECOVERY CONTAINER - 3.9L/5.2L/5.9L/5.9L DIESEL (Continued)



80bcd0a

**Fig. 3 COOLANT RESERVE/OVERFLOW TANK—ALL EXCEPT 8.0L V-10 ENGINE**

- 1 - T-SLOTS
- 2 - ALIGNMENT PIN
- 3 - FAN SHROUD
- 4 - COOLANT RESERVE/OVERFLOW TANK

## COOLANT RECOVERY CONTAINER - 8.0L

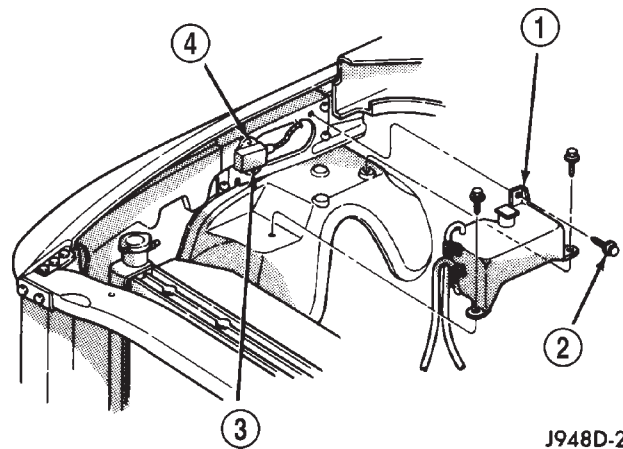
### DESCRIPTION

On the 8.0L V-10 engine the tank is mounted to right inner fender (Fig. 4), and is made of high temperature plastic.

### OPERATION

The coolant reserve/overflow system works in conjunction with the radiator pressure cap. It utilizes thermal expansion and contraction of coolant to keep coolant free of trapped air. It provides a volume for expansion and contraction of coolant. It also provides a convenient and safe method for checking coolant level and adjusting level at atmospheric pressure. This is done without removing the radiator pressure cap. The system also provides some reserve coolant to the radiator to cover minor leaks and evaporation or boiling losses.

As the engine cools, a vacuum is formed in the cooling system of both the radiator and engine. Coolant will then be drawn from the coolant tank and returned to a proper level in the radiator.



J948D-21

**Fig. 4 Coolant Reserve/Overflow Tank—8.0L V-10 Engine**

- 1 - COOLANT RESERVE/OVERFLOW TANK
- 2 - TANK MOUNTING BOLTS (3)
- 3 - ICM MOUNTING BOLTS (2)
- 4 - IGNITION CONTROL MODULE (ICM)

## RADIATOR FAN - 3.9L/5.2L/5.9L/8.0L

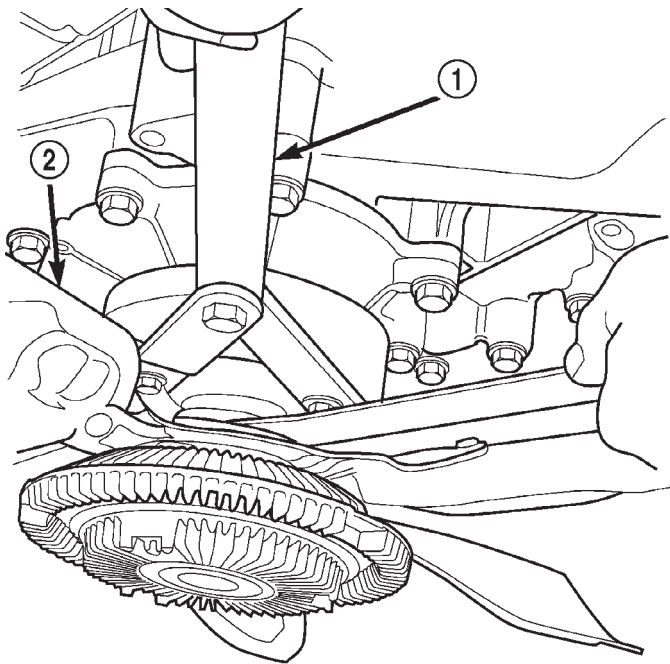
### REMOVAL

**CAUTION:** If the viscous fan drive is replaced because of mechanical damage, the cooling fan blades should also be inspected. Inspect for fatigue cracks, loose blades, or loose rivets that could have resulted from excessive vibration. Replace fan blade assembly if any of these conditions are found. Also inspect water pump bearing and shaft assembly for any related damage due to a viscous fan drive malfunction.

- (1) Disconnect negative battery cable from battery.
- (2) Remove throttle cable at top of fan shroud.
- (3) All Except 8.0L V-10 Engine: Unsnap coolant reserve/overflow tank from fan shroud and lay aside. The tank is held to shroud with T-shaped slots. Do not disconnect hose or drain coolant from tank.
- (4) The thermal viscous fan drive/fan blade assembly is attached (threaded) to water pump hub shaft (Fig. 6). Remove fan blade/viscous fan drive assembly from water pump by turning mounting nut counter-clockwise as viewed from front. Threads on viscous fan drive are **RIGHT-HAND**. A Snap-On 36 MM Fan Wrench (number SP346 from Snap-On Cummins Diesel Tool Set number 2017DSP), Special Tool 6958 Spanner Wrench and Adapter Pins 8346 should be used to prevent pulley from rotating (Fig. 5).
- (5) Do not attempt to remove fan/viscous fan drive assembly from vehicle at this time.



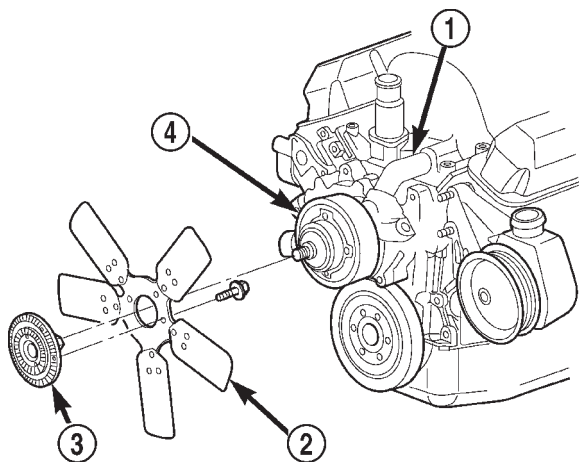
## RADIATOR FAN - 3.9L/5.2L/5.9L/8.0L (Continued)



80b6b293

**Fig. 5 Using Special Tool 6958 Spanner Wrench**

- 1 - SPECIAL TOOL 6958 SPANNER WRENCH WITH ADAPTER PINS 8346  
2 - FAN



80bdbd2c

**Fig. 6 Fan Blade/Viscous Fan Drive—Gas Engines—Typical**

- 1 - WATER PUMP BYPASS HOSE  
2 - FAN BLADE ASSEMBLY  
3 - VISCIOUS FAN DRIVE  
4 - WATER PUMP AND PULLEY

(6) Do not unbolt fan blade assembly (Fig. 6) from viscous fan drive at this time.

(7) Remove four fan shroud-to-radiator mounting bolts.

(8) Remove fan shroud and fan blade/viscous fan drive assembly as a complete unit from vehicle.

(9) After removing fan blade/viscous fan drive assembly, **do not** place viscous fan drive in horizontal position. If stored horizontally, silicone fluid in the viscous fan drive could drain into its bearing assembly and contaminate lubricant.

**CAUTION:** Do not remove water pump pulley-to-water pump bolts. This pulley is under spring tension.

(10) Remove four bolts securing fan blade assembly to viscous fan drive (Fig. 6).

**CAUTION:** Some engines equipped with serpentine drive belts have reverse rotating fans and viscous fan drives. They are marked with the word **REVERSE** to designate their usage. Installation of the wrong fan or viscous fan drive can result in engine overheating.

## CLEANING

Clean the fan blades using a mild soap and water. Do not use an abrasive to clean the blades.

## INSPECTION

**WARNING:** DO NOT ATTEMPT TO BEND OR STRAIGHTEN FAN BLADES IF FAN IS NOT WITHIN SPECIFICATIONS.

**CAUTION:** If fan blade assembly is replaced because of mechanical damage, water pump and viscous fan drive should also be inspected. These components could have been damaged due to excessive vibration.

(1) Remove fan blade assembly from viscous fan drive unit (four bolts).

(2) Lay fan on a flat surface with leading edge facing down. With tip of blade touching flat surface, replace fan if clearance between opposite blade and surface is greater than 2.0 mm (.090 inch). Rocking motion of opposite blades should not exceed 2.0 mm (.090 inch). Test all blades in this manner.

(3) Inspect fan assembly for cracks, bends, loose rivets or broken welds. Replace fan if any damage is found.

## INSTALLATION

(1) Install fan blade assembly to viscous fan drive. Tighten bolts (Fig. 6) to 23 N·m (17 ft. lbs.) torque.

(2) Position fan shroud and fan blade/viscous fan drive assembly to vehicle as a complete unit.

(3) Install fan shroud.

## RADIATOR FAN - 3.9L/5.2L/5.9L/8.0L (Continued)

(4) Install fan blade/viscous fan drive assembly to water pump shaft (Fig. 6).

(5) Except 8.0L V-10 Engine: Install coolant reserve/overflow tank to fan shroud. Snaps into position.

(6) Install throttle cable to fan shroud.

(7) Connect negative battery cable.

**NOTE: Viscous Fan Drive Fluid Pump Out Requirement:** After installing a new viscous fan drive, bring the engine speed up to approximately 2000 rpm and hold for approximately two minutes. This will ensure proper fluid distribution within the drive.

## RADIATOR FAN - 5.9L DIESEL

## REMOVAL

**CAUTION:** If the viscous fan drive is replaced because of mechanical damage, the cooling fan blades should also be inspected. Inspect for fatigue cracks, loose blades, or loose rivets that could have resulted from excessive vibration. Replace fan blade assembly if any of these conditions are found. Also inspect water pump bearing and shaft assembly for any related damage due to a viscous fan drive malfunction.

- (1) Disconnect the battery negative cables.
- (2) Remove the fan shroud mounting bolts. Position fan shroud towards engine.

**CAUTION:** Do not remove the fan pulley bolts. This pulley is under spring tension.

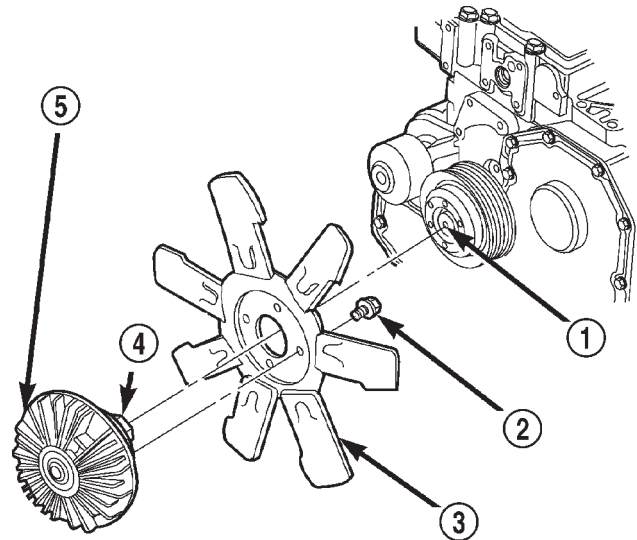
(3) The thermal viscous fan drive/fan blade assembly is attached (threaded) to the fan hub shaft (Fig. 7). Remove the fan blade/fan drive assembly from fan pulley by turning the mounting nut clockwise (as viewed from front). Threads on the viscous fan drive are **LEFT-HAND**. A Snap-On 36 MM Fan Wrench (number SP346 from Snap-On Cummins Diesel Tool Set number 2017DSP) can be used. Place a bar or screwdriver between the fan pulley bolts to prevent pulley from rotating.

(4) Remove the fan shroud and the fan blade/viscous drive as an assembly from vehicle.

(5) Remove fan blade-to-viscous fan drive mounting bolts.

(6) Inspect the fan for cracks, loose rivets, loose or bent fan blades.

**CAUTION:** Some engines equipped with serpentine drive belts have reverse rotating fans and viscous fan drives. They are marked with the word



80b5cc02

**Fig. 7 Fan Blade/Viscous Fan Drive**

- 1 - THREADED SHAFT
- 2 - BOLT (4)
- 3 - FAN BLADE
- 4 - THREADED NUT
- 5 - VISCOUS FAN DRIVE

**REVERSE** to designate their usage. Installation of the wrong fan or viscous fan drive can result in engine overheating.

## CLEANING

Clean the fan blades using a mild soap and water. Do not use an abrasive to clean the blades.

## INSPECTION

**WARNING:** DO NOT ATTEMPT TO BEND OR STRAIGHTEN FAN BLADES IF FAN IS NOT WITHIN SPECIFICATIONS.

**CAUTION:** If fan blade assembly is replaced because of mechanical damage, water pump and viscous fan drive should also be inspected. These components could have been damaged due to excessive vibration.

(1) Remove fan blade assembly from viscous fan drive unit (four bolts).

(2) Lay fan on a flat surface with leading edge facing down. With tip of blade touching flat surface, replace fan if clearance between opposite blade and surface is greater than 2.0 mm (.090 inch). Rocking motion of opposite blades should not exceed 2.0 mm (.090 inch). Test all blades in this manner.

## RADIATOR FAN - 5.9L DIESEL (Continued)

(3) Inspect fan assembly for cracks, bends, loose rivets or broken welds. Replace fan if any damage is found.

## INSTALLATION

(1) Install fan blade assembly to viscous fan drive. Tighten mounting bolts to 23 N·m (17 ft. lbs.) torque.

(2) Position the fan shroud and fan blade/viscous fan drive to the vehicle as an assembly.

(3) Install viscous fan drive assembly on fan hub shaft (Fig. 7). Tighten mounting nut to 57 N·m (42 ft. lbs.) torque.

(4) Install fan shroud bolts into position and tighten the mounting bolts to 6 N·m (50 in. lbs.) torque.

(5) Connect the battery negative cables.

**NOTE: Viscous Fan Drive Fluid Pump Out Requirement:** After installing a new viscous fan drive, bring the engine speed up to approximately 2000 rpm and hold for approximately two minutes. This will ensure proper fluid distribution within the drive.

ENGINE BLOCK HEATER -  
3.9L/5.2L/5.9L

## DESCRIPTION

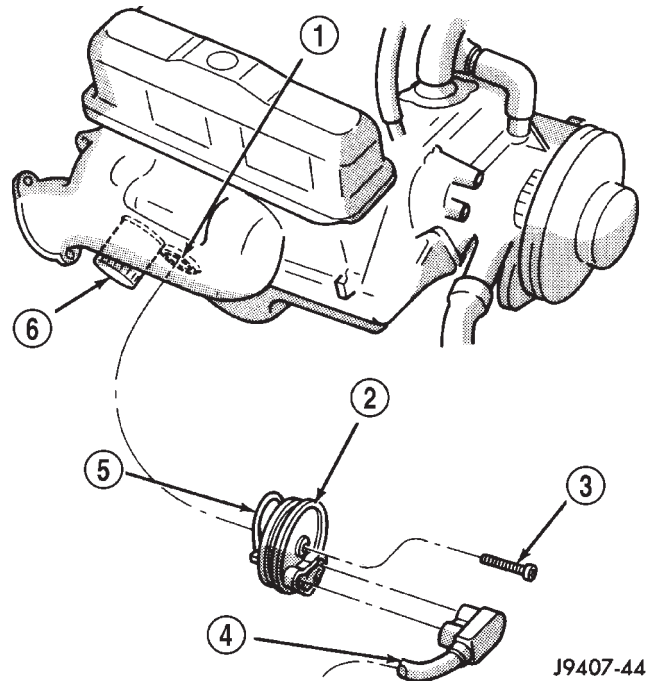
**WARNING: DO NOT OPERATE ENGINE UNLESS BLOCK HEATER CORD HAS BEEN DISCONNECTED FROM POWER SOURCE AND SECURED IN PLACE. THE POWER CORD MUST BE SECURED IN ITS RETAINING CLIPS AND ROUTED AWAY FROM EXHAUST MANIFOLDS AND MOVING PARTS.**

An optional engine block heater is available on all models. The heater is equipped with a power cord. The heater is mounted in a core hole of the engine cylinder block (in place of a freeze plug) with the heating element immersed in engine coolant. The cord is attached to an engine compartment component with tie-straps.

The 3.9L and 5.9L gas powered engine has the block heater located on the right side of engine next to the oil filter (Fig. 8).

## OPERATION

The heater warms the engine coolant providing easier engine starting and faster warm-up in low temperatures. Connecting the power cord to a grounded 110-120 volt AC electrical outlet with a grounded three wire extension cord provides the electricity needed to heat the element..



**Fig. 8 Engine Block Heater**

- 1 - FREEZE PLUG HOLE
- 2 - BLOCK HEATER
- 3 - SCREW
- 4 - POWER CORD (120V AC)
- 5 - HEATING COIL
- 6 - OIL FILTER

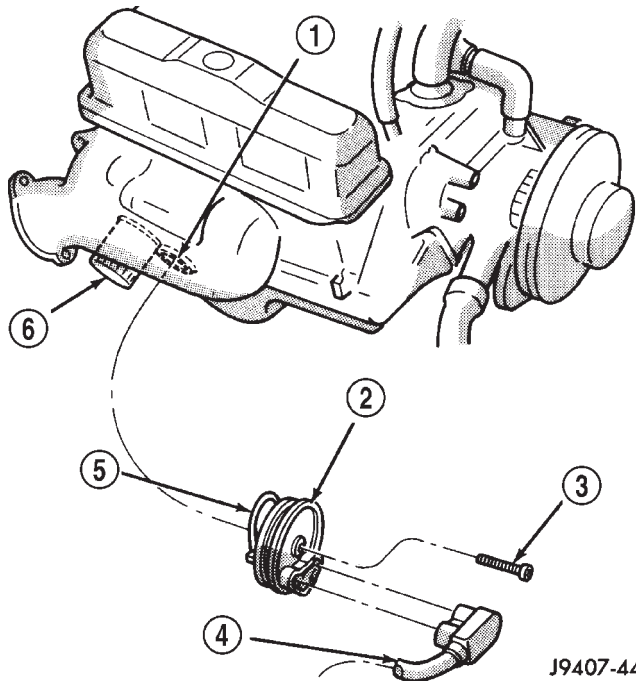
## REMOVAL

- (1) Disconnect battery negative cable.
- (2) Drain coolant (Refer to 7 - COOLING - STANDARD PROCEDURE).
- (3) Remove power cord from heater by unplugging (Fig. 9).
- (4) Loosen (but do not completely remove) the screw at center of block heater (Fig. 9).
- (5) Remove block heater by carefully prying from side-to-side. Note direction of heating element coil (up or down). Element coil must be installed correctly to prevent damage.

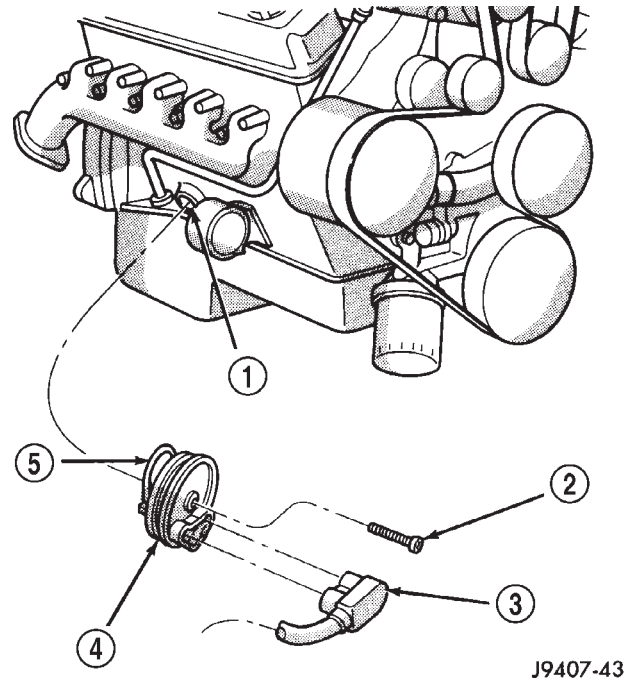
## INSTALLATION

- (1) Clean and inspect the block heater hole.
- (2) Install new O-ring seal(s) to heater in gasoline engines.
- (3) Insert block heater into cylinder block.
- (4) With heater fully seated, tighten center screw to 2 N·m (17 in. lbs.).
- (5) Fill cooling system with recommended coolant. (Refer to 7 - COOLING - STANDARD PROCEDURE).
- (6) Start and warm the engine.
- (7) Check block heater for leaks.

## ENGINE BLOCK HEATER - 3.9L/5.2L/5.9L (Continued)

**Fig. 9 Engine Block Heater**

- 1 - FREEZE PLUG HOLE
- 2 - BLOCK HEATER
- 3 - SCREW
- 4 - POWER CORD (120V AC)
- 5 - HEATING COIL
- 6 - OIL FILTER

**Fig. 10 Engine Block Heater—8.0L V-10 Engine**

- 1 - FREEZE PLUG HOLE
- 2 - SCREW
- 3 - POWER CORD (120V AC)
- 4 - BLOCK HEATER
- 5 - HEATING COIL

## ENGINE BLOCK HEATER - 8.0L

**DESCRIPTION**

An optional engine block heater is available on all models. The heater is equipped with a power cord. The heater is mounted in a core hole of the engine cylinder block (in place of a freeze plug) with the heating element immersed in engine coolant. The cord is attached to an engine compartment component with tie-straps.

The 8.0L V-10 engine has the block heater located on the right side of engine next to the engine oil dipstick tube (Fig. 10).

**WARNING: DO NOT OPERATE ENGINE UNLESS BLOCK HEATER CORD HAS BEEN DISCONNECTED FROM POWER SOURCE AND SECURED IN PLACE. THE POWER CORD MUST BE SECURED IN ITS RETAINING CLIPS AND ROUTED AWAY FROM EXHAUST MANIFOLDS AND MOVING PARTS.**

**OPERATION**

The heater warms the engine coolant providing easier engine starting and faster warm-up in low temperatures. Connecting the power cord to a

grounded 110-120 volt AC electrical outlet with a grounded three wire extension cord provides the electricity needed to heat the element..

**REMOVAL**

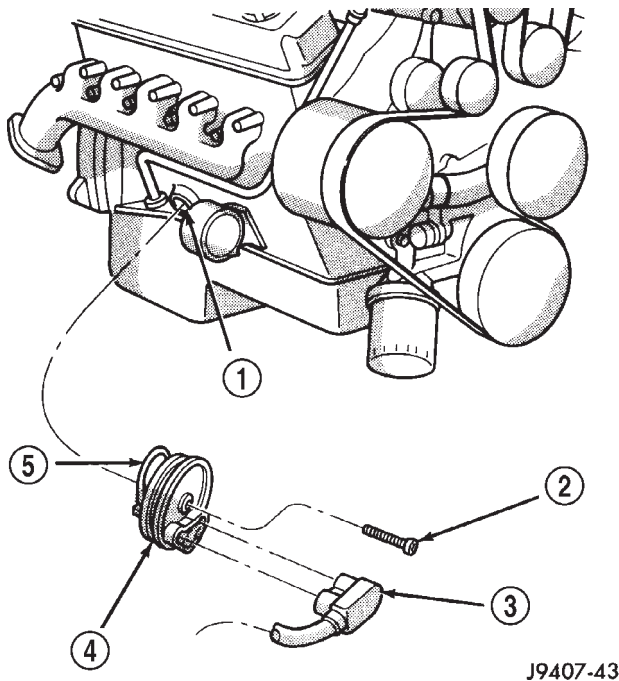
- (1) Disconnect battery negative cable.
- (2) Drain coolant from radiator and cylinder block (Refer to 7 - COOLING - STANDARD PROCEDURE).
- (3) Remove power cord from heater by unplugging (Fig. 11).
- (4) Loosen (but do not completely remove) the screw at center of block heater (Fig. 11).
- (5) Remove block heater by carefully prying from side-to-side. Note direction of heating element coil (up or down). Element coil must be installed correctly to prevent damage.

**INSTALLATION**

- (1) Clean and inspect the block heater hole.
- (2) Install new O-ring seal(s) to heater in gasoline engines.
- (3) Insert block heater into cylinder block.
- (4) With heater fully seated, tighten center screw to 2 N·m (17 in. lbs.).



## ENGINE BLOCK HEATER - 8.0L (Continued)

**Fig. 11 Block Heater—8.0L V-10 Engine**

- 1 - FREEZE PLUG HOLE
- 2 - SCREW
- 3 - POWER CORD (120V AC)
- 4 - BLOCK HEATER
- 5 - HEATING COIL

(5) Fill cooling system with recommended coolant (Refer to 7 - COOLING - STANDARD PROCEDURE).

(6) Start and warm the engine.

(7) Check block heater for leaks.

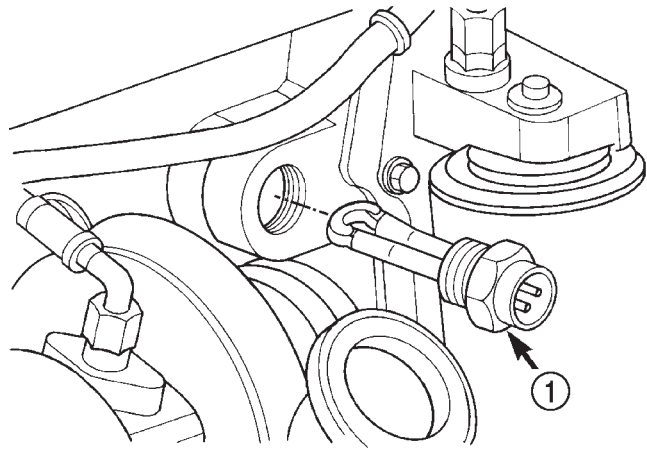
## ENGINE BLOCK HEATER - 5.9L DIESEL

## DESCRIPTION

**WARNING: DO NOT OPERATE ENGINE UNLESS BLOCK HEATER CORD HAS BEEN DISCONNECTED FROM POWER SOURCE AND SECURED IN PLACE. THE POWER CORD MUST BE SECURED IN ITS RETAINING CLIPS AND ROUTED AWAY FROM EXHAUST MANIFOLDS AND MOVING PARTS.**

An optional engine block heater is available on all models. The heater is equipped with a power cord. The heater is mounted in a core hole of the engine cylinder block (in place of a freeze plug) with the heating element immersed in engine coolant. The cord is attached to an engine compartment component with tie-straps.

The 5.9L diesel engine has the block heater located on the right side of the engine below the exhaust manifold next to the oil cooler (Fig. 12).



80b04f16

**Fig. 12 Engine Block Heater—5.9L Diesel Engine**

1 - BLOCK HEATER

## OPERATION

The heater warms the engine coolant providing easier engine starting and faster warm-up in low temperatures. Connecting the power cord to a grounded 110-120 volt AC electrical outlet with a grounded three wire extension cord provides the electricity needed to heat the element.

## REMOVAL

(1) Disconnect the battery negative cables.

(2) Drain coolant from radiator and cylinder block (Refer to 7 - COOLING - STANDARD PROCEDURE).

(3) Unscrew the power cord retaining cap and disconnect cord from heater element.

(4) Using a suitable size socket, loosen and remove the block heater element (Fig. 13).

## INSTALLATION

(1) Clean and inspect the threads in the cylinder block.

(2) Coat heater element threads with Mopar® Thread Sealer with Teflon.

(3) Screw block heater into cylinder block and tighten to 43 N·m (32 ft. lbs.).

(4) Connect block heater cord and tighten retaining cap.

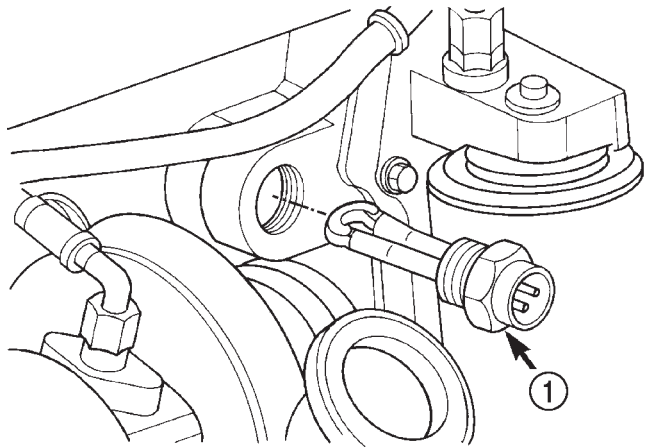
(5) Fill cooling system with recommended coolant (Refer to 7 - COOLING - STANDARD PROCEDURE).

(6) Start and warm the engine.

(7) Check block heater for leaks.



## ENGINE BLOCK HEATER - 5.9L DIESEL (Continued)



80b041f6

**Fig. 13 Block Heater—Diesel Engine**

1 - BLOCK HEATER

ENGINE COOLANT TEMP  
SENSOR - 3.9L/5.2L/5.9L

## DESCRIPTION

The Engine Coolant Temperature (ECT) sensor is used to sense engine coolant temperature. The sensor protrudes into an engine water jacket.

The ECT sensor is a two-wire Negative Thermal Coefficient (NTC) sensor. Meaning, as engine coolant temperature increases, resistance (voltage) in the sensor decreases. As temperature decreases, resistance (voltage) in the sensor increases.

## OPERATION

At key-on, the Powertrain Control Module (PCM) sends out a regulated 5 volt signal to the ECT sensor. The PCM then monitors the signal as it passes through the ECT sensor to the sensor ground (sensor return).

When the engine is cold, the PCM will operate in Open Loop cycle. It will demand slightly richer air-fuel mixtures and higher idle speeds. This is done until normal operating temperatures are reached.

The PCM uses inputs from the ECT sensor for the following calculations:

- for engine coolant temperature gauge operation through CCD or PCI (J1850) communications
- Injector pulse-width
- Spark-advance curves
- ASD relay shut-down times
- Idle Air Control (IAC) motor key-on steps
- Pulse-width prime-shot during cranking
- O<sub>2</sub> sensor closed loop times
- Purge solenoid on/off times
- EGR solenoid on/off times (if equipped)
- Leak Detection Pump operation (if equipped)

- Radiator fan relay on/off times (if equipped)
- Target idle speed

## REMOVAL

**WARNING: HOT, PRESSURIZED COOLANT CAN CAUSE INJURY BY SCALDING. COOLING SYSTEM MUST BE PARTIALLY DRAINED BEFORE REMOVING THE COOLANT TEMPERATURE SENSOR. REFER TO GROUP 7, COOLING.**

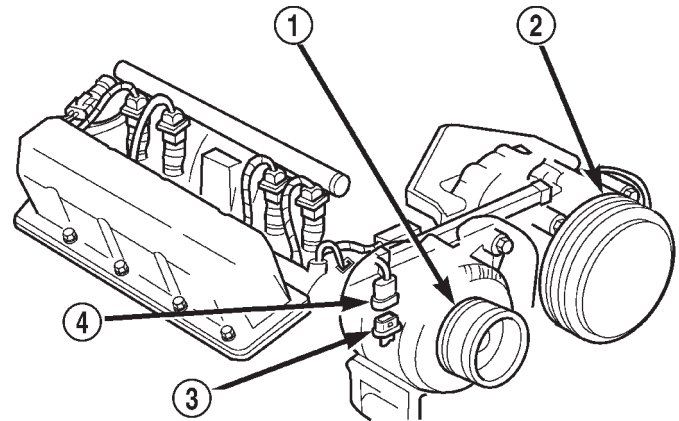
(1) Partially drain cooling system (Refer to 7 - COOLING - STANDARD PROCEDURE).

(2) Remove air cleaner assembly.

(3) Disconnect electrical connector from sensor (Fig. 14).

(4) **Engines with air conditioning:** When removing the connector from sensor, do not pull directly on wiring harness. Fabricate an L-shaped hook tool from a coat hanger (approximately eight inches long). Place the hook part of tool under the connector for removal. The connector is snapped onto the sensor. It is not equipped with a lock type tab.

(5) Remove sensor from intake manifold.



80b1b2f7

**Fig. 14 Engine Coolant Temperature**

1 - GENERATOR

2 - A/C COMPRESSOR

3 - ENGINE COOLANT TEMPERATURE SENSOR

4 - ELEC. CONN.

## INSTALLATION

(1) Install sensor.

(2) Tighten to 6–8 N·m (55–75 in. lbs.) torque.

(3) Connect electrical connector to sensor. The sensor connector is symmetrical (not indexed). It can be installed to the sensor in either direction.

(4) Install air cleaner assembly.

(5) Refill cooling system (Refer to 7 - COOLING - STANDARD PROCEDURE).

## ENGINE COOLANT THERMOSTAT - 3.9L/5.2L/5.9L

### DESCRIPTION

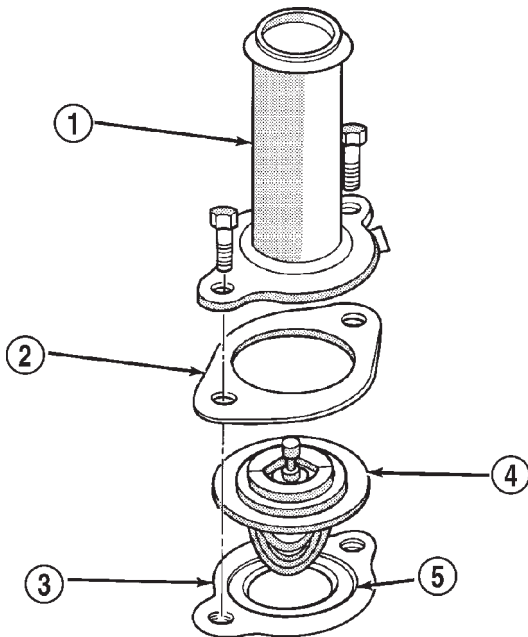
**CAUTION:** Do not operate an engine without a thermostat, except for servicing or testing.

The thermostat on the 3.9L, 5.2L and 5.9L gas powered engines is located beneath the thermostat housing at the front of the intake manifold (Fig. 15).

The thermostat is a wax pellet driven, reverse poppet choke type.

Coolant leakage into the pellet container will cause the thermostat to fail in the open position. Thermostats very rarely stick. Do not attempt to free a thermostat with a prying device.

The same thermostat is used for winter and summer seasons. An engine should not be operated without a thermostat, except for servicing or testing. Operating without a thermostat causes longer engine warmup time, unreliable warmup performance, increased exhaust emissions and crankcase condensation that can result in sludge formation.



J9207-14

**Fig. 15 Thermostat—5.2L and 5.9L Gas Powered Engines**

- 1 - THERMOSTAT HOUSING
- 2 - GASKET
- 3 - INTAKE MANIFOLD
- 4 - THERMOSTAT
- 5 - MACHINED GROOVE

### OPERATION

The wax pellet is located in a sealed container at the spring end of the thermostat. When heated, the pellet expands, overcoming closing spring tension and water pump pressure to force the valve to open.

### DIAGNOSIS AND TESTING—THERMOSTAT

#### ON-BOARD DIAGNOSTICS

All **gasoline powered models** are equipped with On-Board Diagnostics for certain cooling system components. Refer to On-Board Diagnostics (OBD) in the Diagnosis section of this group for additional information. If the powertrain control module (PCM) detects low engine coolant temperature, it will record a Diagnostic Trouble Code (DTC) in the PCM memory. Do not change a thermostat for lack of heat as indicated by the instrument panel gauge or by poor heater performance unless a DTC is present. Refer to the Diagnosis section of this group for other probable causes. For other DTC numbers, (Refer to 25 - EMISSIONS CONTROL - DESCRIPTION).

The DTC can also be accessed through the DRB scan tool. Refer to the appropriate Powertrain Diagnostic Procedures information for diagnostic information and operation of the DRB scan tool.

#### REMOVAL

**WARNING: DO NOT LOOSEN RADIATOR DRAINCOCK WITH SYSTEM HOT AND PRESSURIZED. SERIOUS BURNS FROM COOLANT CAN OCCUR.**

Do not waste reusable coolant. If solution is clean, drain coolant into a clean container for reuse.

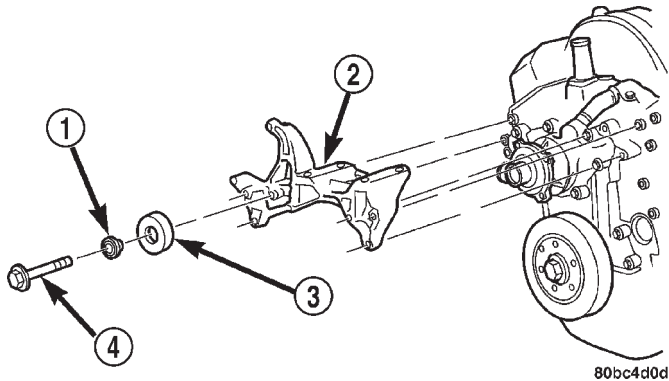
If thermostat is being replaced, be sure that replacement is specified thermostat for vehicle model and engine type.

Factory installed thermostat housings on 3.9L, 5.2L and 5.9L engines are installed on a gasket with an anti-stick coating. This will aid in gasket removal and clean-up.

- (1) Disconnect negative battery cable at battery.
- (2) Drain cooling system until coolant level is below thermostat (Refer to 7 - COOLING - STANDARD PROCEDURE).
- (3) Air Conditioned vehicles: Remove support bracket (generator mounting bracket-to-intake manifold) located near rear of generator (Fig. 16).

**NOTE:** On air conditioning equipped vehicles, the generator must be partially removed.

## ENGINE COOLANT THERMOSTAT - 3.9L/5.2L/5.9L (Continued)



**Fig. 16 Generator Support Bracket—3.9L and 5.9L Engine**

- 1 - IDLER PULLEY BUSHING
- 2 - A/C AND/OR GENERATOR MOUNTING BRACKET
- 3 - IDLER PULLEY
- 4 - SCREW AND WASHER

(4) Remove accessory drive belt (Refer to 7 - COOLING/ACCESSORY DRIVE/DRIVE BELTS - REMOVAL) (Fig. 17).

(5) Remove two generator mounting bolts. Do not remove any wiring at generator. If equipped with 4WD, unplug 4WD indicator lamp wiring harness (located near rear of generator).

(6) Remove generator. Position generator to gain access for thermostat gasket removal.

**WARNING: CONSTANT TENSION HOSE CLAMPS ARE USED ON MOST COOLING SYSTEM HOSES. WHEN REMOVING OR INSTALLING, USE ONLY TOOLS DESIGNED FOR SERVICING THIS TYPE OF CLAMP, SUCH AS SPECIAL CLAMP TOOL (NUMBER 6094). SNAP-ON CLAMP TOOL (NUMBER HPC-20) MAY BE USED FOR LARGER CLAMPS. ALWAYS WEAR SAFETY GLASSES WHEN SERVICING CONSTANT TENSION CLAMPS.**

**CAUTION: A number or letter is stamped into the tongue of constant tension clamps (Fig. 18). If replacement is necessary, use only an original equipment clamp with matching number or letter.**

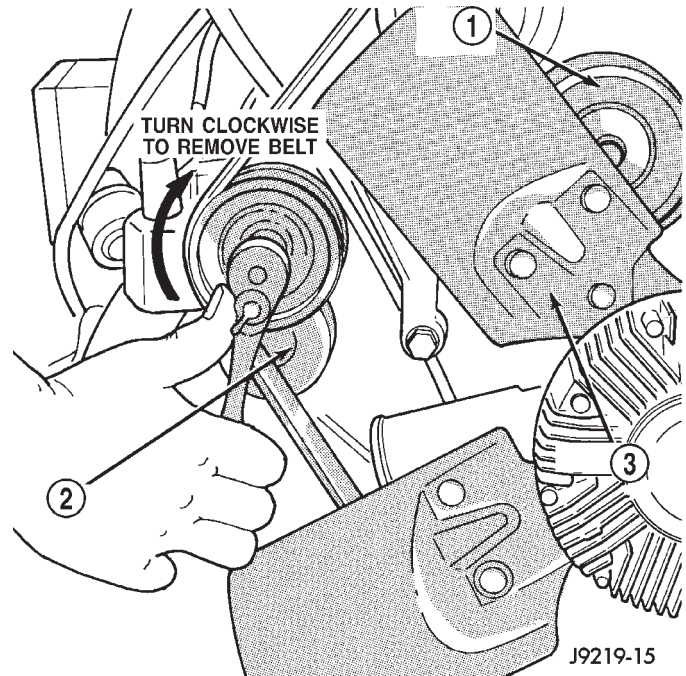
(7) Remove radiator upper hose clamp and upper hose at thermostat housing.

(8) Position wiring harness (behind thermostat housing) to gain access to thermostat housing.

(9) Remove thermostat housing mounting bolts, thermostat housing, gasket and thermostat (Fig. 19). Discard old gasket.

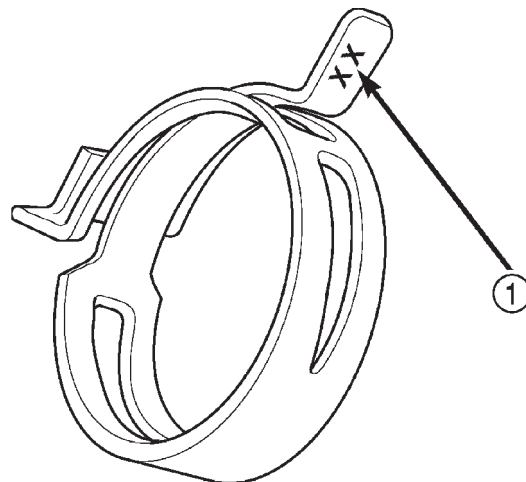
## INSTALLATION

(1) Clean mating areas of intake manifold and thermostat housing.



**Fig. 17 Automatic Belt Tensioner—3.9L and 5.9L Engines**

- 1 - IDLER PULLEY
- 2 - TENSIONER
- 3 - FAN BLADE



80b76ee

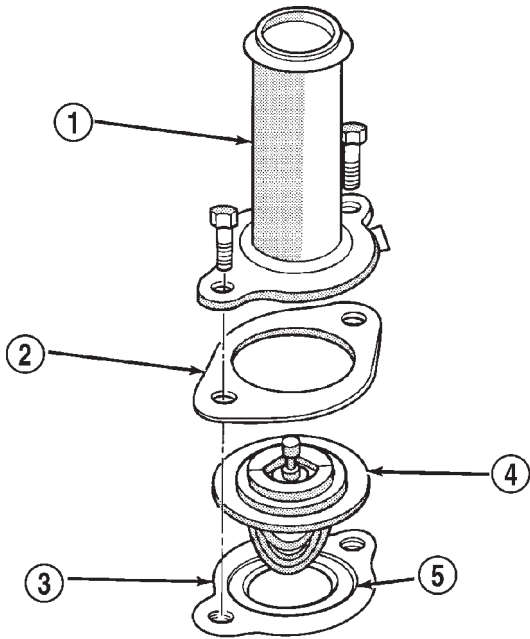
**Fig. 18 SPRING CLAMP SIZE LOCATION**

- 1 - SPRING CLAMP SIZE LOCATION

(2) Install thermostat (spring side down) into recessed machined groove on intake manifold (Fig. 19).

(3) Install gasket on intake manifold and over thermostat (Fig. 19).

## ENGINE COOLANT THERMOSTAT - 3.9L/5.2L/5.9L (Continued)



J9207-14

**Fig. 19 Thermostat—3.9L and 5.9L Engines**

- 1 - THERMOSTAT HOUSING
- 2 - GASKET
- 3 - INTAKE MANIFOLD
- 4 - THERMOSTAT
- 5 - MACHINED GROOVE

(4) Position thermostat housing to intake manifold. Note the word FRONT stamped on housing (Fig. 20). For adequate clearance, this **must** be placed towards front of vehicle. The housing is slightly angled forward after installation to intake manifold.

(5) Install two housing-to-intake manifold bolts. Tighten bolts to 23 N·m (200 in. lbs.) torque.

(6) Install radiator upper hose to thermostat housing.

**CAUTION:** When installing the serpentine accessory drive belt, the belt must be routed correctly. If not, engine may overheat due to water pump rotating in wrong direction. Refer to (Fig. 21) for correct 3.9L, 5.2L and 5.9L engine belt routing. The correct belt with correct length must be used.

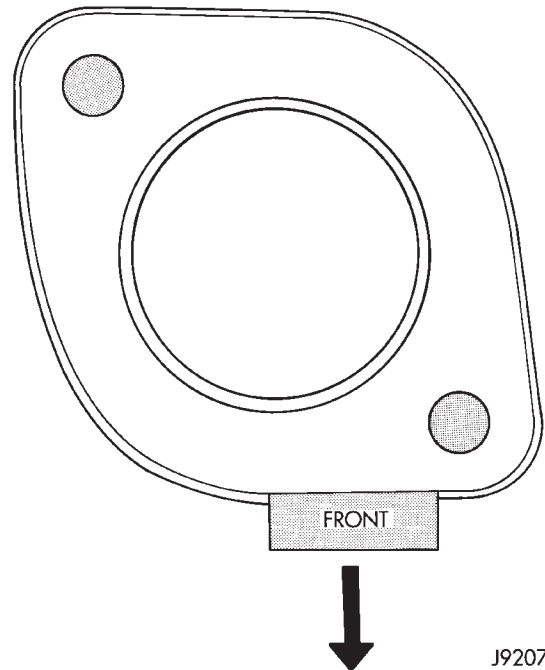
(7) Air Conditioned vehicles; Install generator. Tighten bolts to 41 N·m (30 ft. lbs.).

(8) Install support bracket (generator mounting bracket-to-intake manifold) (Fig. 16). Tighten bolts to 54 N·m (40 ft. lbs.) torque.

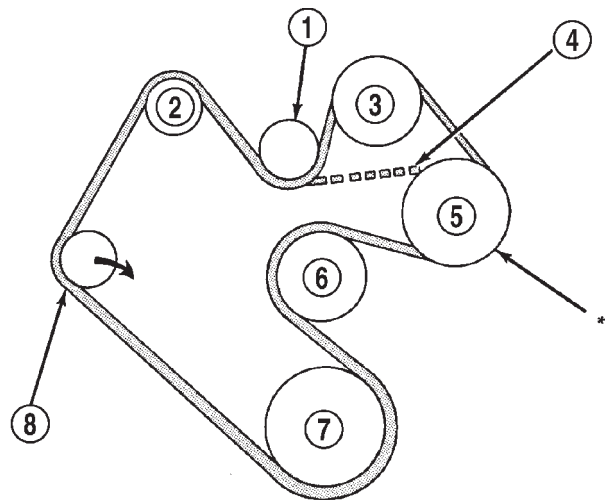
(9) Install accessory drive belt (Fig. 17)(Refer to 7 - COOLING/ACCESSORY DRIVE/DRIVE BELTS - INSTALLATION).

(10) Fill cooling system (Refer to 7 - COOLING - STANDARD PROCEDURE).

(11) Connect battery negative cable.



J9207-13

**Fig. 20 Thermostat Position—5.2L and 5.9L Engines**

\*IF VEHICLE IS NOT EQUIPPED WITH POWER STEERING, THIS WILL BE AN IDLER PULLEY.

J9307-26

**Fig. 21 Belt Routing—5.2L and 5.9L Engines**

- 1 - IDLER PULLEY
- 2 - GENERATOR PULLEY
- 3 - A/C COMPRESSOR PULLEY
- 4 - IF W/OUT A/C
- 5 - POWER STEERING PUMP PULLEY
- 6 - WATER PUMP PULLEY
- 7 - CRANKSHAFT PULLEY
- 8 - AUTOMATIC TENSIONER

(12) Start and warm the engine. Check for leaks.



## ENGINE COOLANT THERMOSTAT - 8.0L

### DESCRIPTION

**CAUTION:** Do not operate an engine without a thermostat, except for servicing or testing.

The thermostat on all gas powered engines is located beneath the thermostat housing at the front of the intake manifold (Fig. 22).

The thermostat is a moveable sleeve type.

Coolant leakage into the pellet container will cause the thermostat to fail in the open position. Thermostats very rarely stick. Do not attempt to free a thermostat with a prying device.

The same thermostat is used for winter and summer seasons. An engine should not be operated without a thermostat, except for servicing or testing. Operating without a thermostat causes longer engine warmup time, unreliable warmup performance, increased exhaust emissions and crankcase condensation that can result in sludge formation.

### OPERATION

The wax pellet is located in a sealed container at the spring end of the thermostat. When heated, the pellet expands, overcoming closing spring tension and water pump pressure to force the valve to open.

### DIAGNOSIS AND TESTING—THERMOSTAT

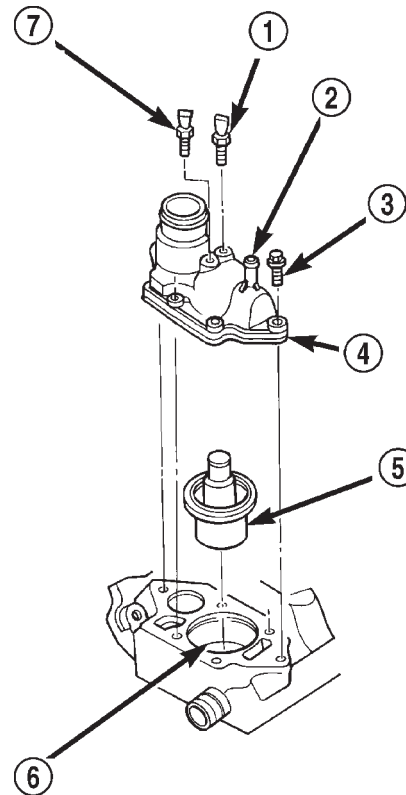
#### ON-BOARD DIAGNOSTICS

All **gasoline powered models** are equipped with On-Board Diagnostics for certain cooling system components. Refer to On-Board Diagnostics (OBD) in the Diagnosis section of this group for additional information. If the powertrain control module (PCM) detects low engine coolant temperature, it will record a Diagnostic Trouble Code (DTC) in the PCM memory. Do not change a thermostat for lack of heat as indicated by the instrument panel gauge or by poor heater performance unless a DTC is present. Refer to the Diagnosis section of this group for other probable causes. For other DTC numbers, (Refer to 25 - EMIS- SIONS CONTROL - DESCRIPTION).

The DTC can also be accessed through the DRB scan tool. Refer to the appropriate Powertrain Diagnostic Procedures information for diagnostic information and operation of the DRB scan tool.

### REMOVAL

**WARNING:** DO NOT LOOSEN THE RADIATOR DRAINCOCK WITH THE SYSTEM HOT AND PRES-



80a82c93

**Fig. 22 Thermostat—8.0L V-10 Engine**

- 1 - COOLANT TEMP. SENSOR (FOR PCM)
- 2 - HEATER SUPPLY FITTING
- 3 - BOLTS (6)
- 4 - HOUSING WITH INTEGRAL SEAL
- 5 - THERMOSTAT
- 6 - RUBBER LIP SEAL
- 7 - TEMP. GAUGE SENDING UNIT

**SURIZED. SERIOUS BURNS FROM THE COOLANT CAN OCCUR.**

Do not waste reusable coolant. If the solution is clean, drain the coolant into a clean container for reuse.

If the thermostat is being replaced, be sure that the replacement is the specified thermostat for the vehicle model and engine type.

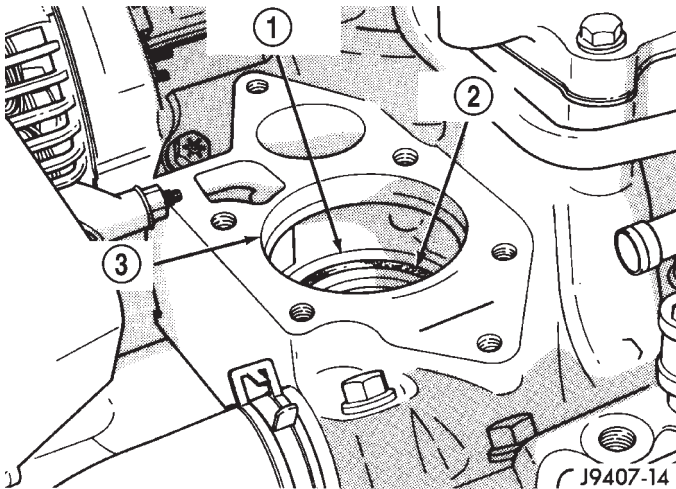
A rubber lip-type seal with a metal shoulder is pressed into the intake manifold beneath the thermostat (Fig. 23).

(1) Disconnect negative battery cable at battery.

(2) Drain cooling system until coolant level is below thermostat (Refer to 7 - COOLING - STANDARD PROCEDURE).



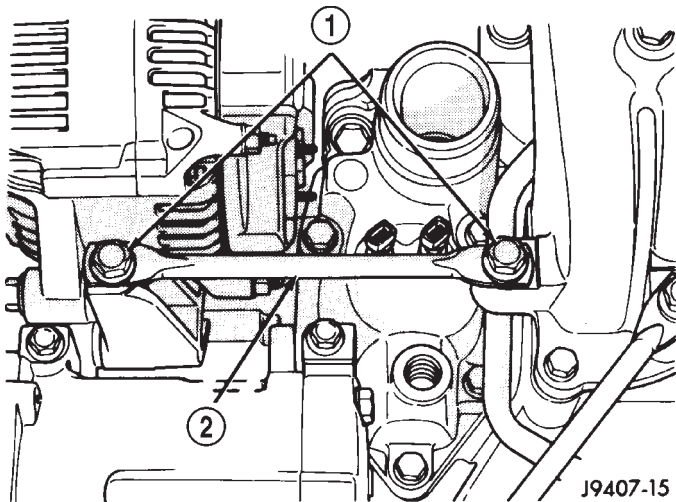
## ENGINE COOLANT THERMOSTAT - 8.0L (Continued)



**Fig. 23 Thermostat Seal—8.0L V-10 Engine**

- 1 - METAL SEAL SHOULDER
- 2 - RUBBER LIP SEAL
- 3 - THERMOSTAT OPENING

(3) Remove the two support rod mounting bolts and remove support rod (intake manifold-to-generator mount) (Fig. 24).



**Fig. 24 Support Rod—8.0L V-10 Engine**

- 1 - BOLTS
- 2 - SUPPORT ROD

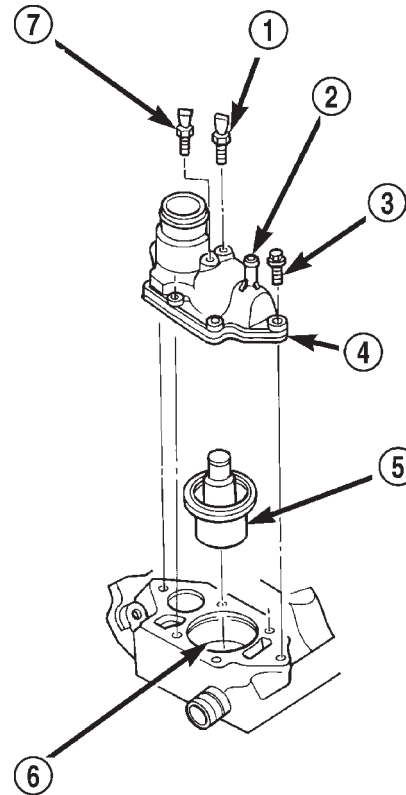
**WARNING: CONSTANT TENSION HOSE CLAMPS ARE USED ON MOST COOLING SYSTEM HOSES. WHEN REMOVING OR INSTALLING, USE ONLY TOOLS DESIGNED FOR SERVICING THIS TYPE OF CLAMP, SUCH AS SPECIAL CLAMP TOOL (NUMBER 6094). SNAP-ON CLAMP TOOL (NUMBER HPC-20) MAY BE USED FOR LARGER CLAMPS. ALWAYS WEAR SAFETY GLASSES WHEN SERVICING CONSTANT TENSION CLAMPS.**

**CAUTION: A number or letter is stamped into the tongue of constant tension clamps. If replacement is necessary, use only an original equipment clamp with a matching number or letter.**

(4) Remove upper radiator hose clamp. Remove upper radiator hose at thermostat housing.

(5) Disconnect the wiring connectors at both of the sensors located on thermostat housing.

(6) Remove six thermostat housing mounting bolts, thermostat housing and thermostat.



**Fig. 25 Thermostat—8.0L V-10 Engine**

- 1 - COOLANT TEMP. SENSOR (FOR PCM)
- 2 - HEATER SUPPLY FITTING
- 3 - BOLTS (6)
- 4 - HOUSING WITH INTEGRAL SEAL
- 5 - THERMOSTAT
- 6 - RUBBER LIP SEAL
- 7 - TEMP. GAUGE SENDING UNIT

## INSTALLATION

(1) Clean mating areas of intake manifold and thermostat housing.

(2) Check the condition (for tears or cracks) of the rubber thermostat seal located in the intake manifold (Fig. 23) (Fig. 25). The thermostat should fit snugly into the rubber seal.

(3) If seal replacement is necessary, coat the outer (metal) portion of the seal with Mopar® Gasket Maker. Install the seal into the manifold using Spe-

## ENGINE COOLANT THERMOSTAT - 8.0L (Continued)

cial Seal Tool number C-3995-A with handle tool number C-4171.

(4) Install thermostat into recessed machined groove on intake manifold (Fig. 25).

(5) Install thermostat housing (Fig. 25).

(6) Install housing-to-intake manifold bolts. Tighten bolts to 25 N·m (220 in. lbs.) torque.

**CAUTION:** Housing bolts should be tightened evenly to prevent damage to housing and to prevent leaks.

(7) Connect the wiring to both sensors.

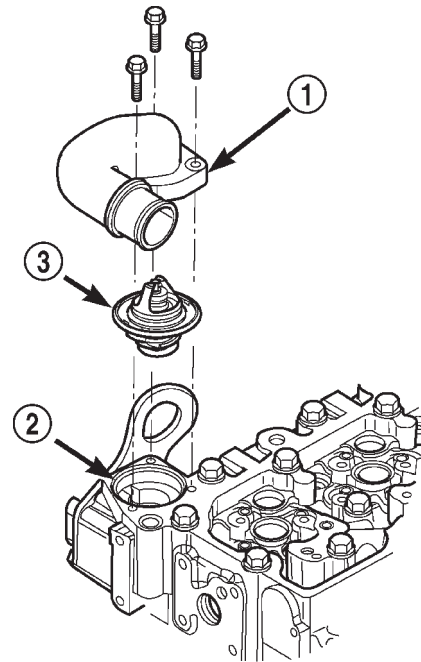
(8) Install the upper radiator hose and hose clamp to thermostat housing.

(9) Install support rod.

(10) Fill cooling system (Refer to 7 - COOLING - STANDARD PROCEDURE).

(11) Connect negative battery cable to battery.

(12) Start and warm engine. Check for leaks.



80b4fb46

**Fig. 26 Thermostat—5.9L Diesel—Typical**

- 1 - WATER OUTLET CONNECTOR
- 2 - THERMOSTAT HOUSING
- 3 - THERMOSTAT

## ENGINE COOLANT THERMOSTAT - 5.9L DIESEL

### DESCRIPTION

**CAUTION:** Do not operate an engine without a thermostat, except for servicing or testing. An engine with the thermostat removed will operate in the radiator bypass mode, causing an overheat condition.

The thermostat of the 5.9L diesel engine is located in the front of the cylinder head, underneath the water outlet connector (Fig. 26).

The same thermostat is used for winter and summer seasons. An engine should not be operated without a thermostat, except for servicing or testing. Operating without a thermostat causes longer engine warmup time, unreliable warmup performance, increased exhaust emissions and crankcase condensation that can result in sludge formation.

### OPERATION

The wax pellet is located in a sealed container at the spring end of the thermostat. When heated, the pellet expands, overcoming closing spring tension and water pump pressure to force the valve to open.

### DIAGNOSIS AND TESTING—THERMOSTAT

The cooling system used with the diesel engine provides the extra coolant capacity and extra cooling protection needed for higher GVWR (Gross Vehicle Weight Rating) and GCWR (Gross Combined Weight Rating) vehicles.

This system capacity will not effect warm up or cold weather operating characteristics if the thermostat is operating properly. This is because coolant will be held in the engine until it reaches the thermostat "set" temperature.

Diesel engines, due to their inherent efficiency are slower to warm up than gasoline powered engines, and will operate at lower temperatures when the vehicle is unloaded. Because of this, lower temperature gauge readings for diesel versus gasoline engines may, at times be normal.

Typically, complaints of low engine coolant temperature are observed as low heater output when combined with cool or cold outside temperatures.

To help promote faster engine warm-up, the electric engine block heater must be used with cool or cold outside temperatures. This will help keep the engine coolant warm when the vehicle is parked. Use the block heater if the outside temperature is below 4°C (40°F). **Do not use the block heater if the outside temperature is above 4°C (40°F).**

A "Cold Weather Cover" is available from the parts department through the Mopar Accessories product line. This accessory cover is designed to block airflow entering the radiator and engine compartment to promote faster engine warm-up. It attaches to the front of the vehicle at the grill opening. **The cover is**

## ENGINE COOLANT THERMOSTAT - 5.9L DIESEL (Continued)

**to be used with cool or cold temperatures only. If used with high outside temperatures, serious engine damage could result.** Refer to the literature supplied with the cover for additional information.

(1) To determine if the thermostat is defective, it must be removed from the vehicle (Refer to 7 - COOLING/ENGINE/ENGINE COOLANT THERMOSTAT - REMOVAL).

(2) After the thermostat has been removed, examine the thermostat and inside of thermostat housing for contaminants. If contaminants are found, the thermostat may already be in a "stuck open" position. Flush the cooling system before replacing thermostat (Refer to 7 - COOLING - STANDARD PROCEDURE).

(3) Place the thermostat into a container filled with water.

(4) Place the container on a hot plate or other suitable heating device.

(5) Place a commercially available radiator thermometer into the water.

(6) Apply heat to the water while observing the thermostat and thermometer.

(7) When the water temperature reaches 83°C (181°F) the thermostat should start to open (valve will start to move). If the valve starts to move before this temperature is reached, it is opening too early. Replace thermostat. The thermostat should be fully open (valve will stop moving) at 95°C (203°F). If the valve is still moving when the water temperature reaches 203°, it is opening too late. Replace thermostat. If the valve refuses to move at any time, replace thermostat.

## REMOVAL

**WARNING: DO NOT LOOSEN THE RADIATOR DRAINCOCK WITH THE SYSTEM HOT AND PRESSURIZED. SERIOUS BURNS FROM THE COOLANT CAN OCCUR.**

Do not waste reusable coolant. If the solution is clean, drain the coolant into a clean container for reuse.

(1) Disconnect the battery negative cables.

(2) Drain cooling system until coolant level is below thermostat (Refer to 7 - COOLING - STANDARD PROCEDURE).

**WARNING: CONSTANT TENSION HOSE CLAMPS ARE USED ON MOST COOLING SYSTEM HOSES. WHEN REMOVING OR INSTALLING, USE ONLY TOOLS DESIGNED FOR SERVICING THIS TYPE OF CLAMP, SUCH AS SPECIAL CLAMP TOOL (NUMBER 6094). SNAP-ON CLAMP TOOL (NUMBER HPC-20) MAY BE USED FOR LARGER CLAMPS. ALWAYS**

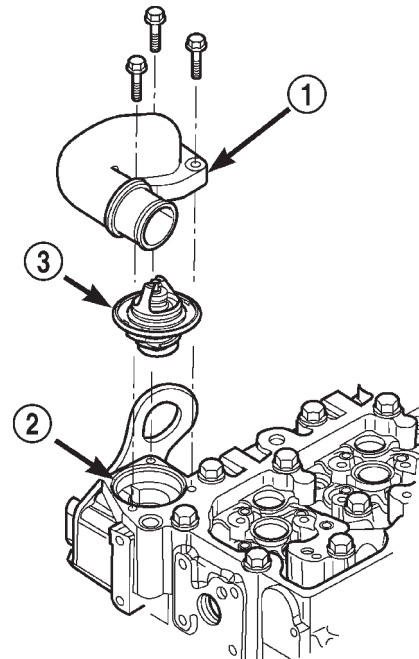
**WEAR SAFETY GLASSES WHEN SERVICING CONSTANT TENSION CLAMPS.**

**CAUTION: A number or letter is stamped into the tongue of constant tension clamps. If replacement is necessary, use only an original equipment clamp with a matching number or letter.**

(3) Remove radiator hose clamp and hose from thermostat housing.

(4) Remove the three (3) water outlet-to-cylinder head bolts and remove the water outlet connector (Fig. 27).

(5) Clean the mating surfaces of the water outlet connector and clean the thermostat seat groove at the top of the thermostat housing (Fig. 27).



80b4fb46

**Fig. 27 Thermostat Removal/Installation**

1 - WATER OUTLET CONNECTOR

2 - THERMOSTAT HOUSING

3 - THERMOSTAT

## INSTALLATION

(1) Install the thermostat into the groove in the top of the thermostat housing (Fig. 27).

(2) Install the water outlet connector and bolts. Tighten the bolts to 24 N·m (18 ft. lbs.) torque.

(3) Install the radiator upper hose and clamp.

(4) Fill the cooling system with coolant (Refer to 7 - COOLING - STANDARD PROCEDURE).

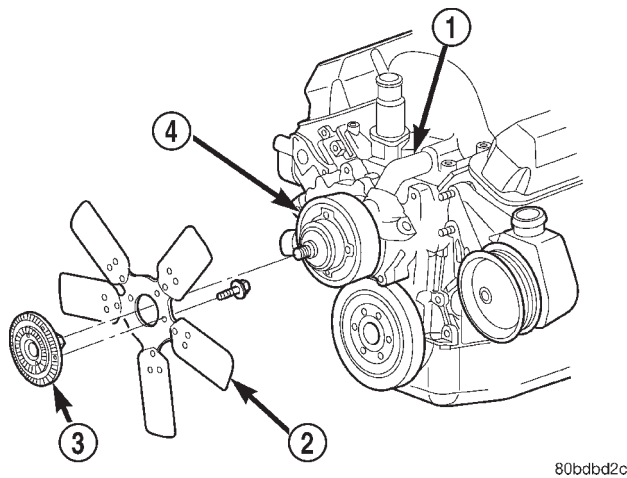
(5) Connect the battery negative cables.

(6) Start the engine and check for coolant leaks. Run engine to check for proper thermostat operation.

## FAN DRIVE VISCOUS CLUTCH - 3.9L/5.2L/5.9L/8.0L

### DESCRIPTION

The thermal viscous fan drive (Fig. 28) is a silicone-fluid-filled coupling used to connect the fan blades to the water pump shaft. The coupling allows the fan to be driven in a normal manner. This is done at low engine speeds while limiting the top speed of the fan to a predetermined maximum level at higher engine speeds.



**Fig. 28 Viscous Fan**

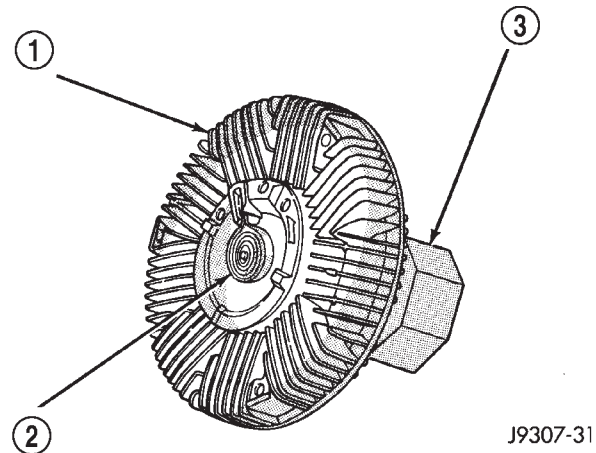
- 1 - WATER PUMP BYPASS HOSE
- 2 - FAN BLADE ASSEMBLY
- 3 - VISCOUS FAN DRIVE
- 4 - WATER PUMP AND PULLEY

### OPERATION

A thermostatic bimetallic spring coil is located on the front face of the viscous fan drive unit (a typical viscous unit is shown in (Fig. 29). This spring coil reacts to the temperature of the radiator discharge air. It engages the viscous fan drive for higher fan speed if the air temperature from the radiator rises above a certain point. Until additional engine cooling is necessary, the fan will remain at a reduced rpm regardless of engine speed.

Only when sufficient heat is present, will the viscous fan drive engage. This is when the air flowing through the radiator core causes a reaction to the bimetallic coil. It then increases fan speed to provide the necessary additional engine cooling.

Once the engine has cooled, the radiator discharge temperature will drop. The bimetallic coil again reacts and the fan speed is reduced to the previous disengaged speed.



J9307-31

**Fig. 29 Viscous Fan Drive—Typical**

- 1 - VISCOUS FAN DRIVE
- 2 - THERMOSTATIC SPRING
- 3 - MOUNTING NUT TO WATER PUMP HUB

### DIAGNOSIS AND TESTING—VISCOUS FAN DRIVE

#### NOISE

**NOTE:** It is normal for fan noise to be louder (roaring) when:

- The underhood temperature is above the engagement point for the viscous drive coupling. This may occur when ambient (outside air temperature) is very high.
- Engine loads and temperatures are high such as when towing a trailer.
- Cool silicone fluid within the fan drive unit is being redistributed back to its normal disengaged (warm) position. This can occur during the first 15 seconds to one minute after engine start-up on a cold engine.

#### LEAKS

Viscous fan drive operation is not affected by small oil stains near the drive bearing. If leakage appears excessive, replace the fan drive unit.

#### VISCOUS DRIVE

If the fan assembly free-wheels without drag (the fan blades will revolve more than five turns when spun by hand), replace the fan drive. This spin test must be performed when the engine is cool.

For the following test, the cooling system must be in good condition. It also will ensure against excessively high coolant temperature.



## FAN DRIVE VISCOUS CLUTCH - 3.9L/5.2L/5.9L/8.0L (Continued)

**WARNING: BE SURE THAT THERE IS ADEQUATE FAN BLADE CLEARANCE BEFORE DRILLING.**

(1) Drill a 3.18-mm (1/8-in) diameter hole in the top center of the fan shroud.

(2) Obtain a dial thermometer with an 8 inch stem (or equivalent). It should have a range of -18°-to-105°C (0°-to-220° F). Insert thermometer through the hole in the shroud. Be sure that there is adequate clearance from the fan blades.

(3) Connect a tachometer and an engine ignition timing light. The timing light is to be used as a strobe light. This step cannot be used on the diesel engine.

(4) Block the air flow through the radiator. Secure a sheet of plastic in front of the radiator (or air conditioner condenser). Use tape at the top to secure the plastic and be sure that the air flow is blocked.

(5) Be sure that the air conditioner (if equipped) is turned off.

**WARNING: USE EXTREME CAUTION WHEN THE ENGINE IS OPERATING. DO NOT STAND IN A DIRECT LINE WITH THE FAN. DO NOT PUT YOUR HANDS NEAR THE PULLEYS, BELTS OR FAN. DO NOT WEAR LOOSE CLOTHING.**

(6) Start the engine and operate at 2400 rpm. Within ten minutes the air temperature (indicated on the dial thermometer) should be up to 88° C (190° F). Fan drive **engagement** should start to occur at/between:

- 3.9L/5.2L/5.9L gas engines — 79° C (175° F)
- 8.0L engine — 88° to 96° C (190° to 205° F)
- 5.9L diesel engine — 71° to 82° C (160° to 179° F)

Engagement is distinguishable by a definite **increase** in fan flow noise (roaring). The timing light also will indicate an increase in the speed of the fan (non-diesel only).

(7) When viscous drive engagement is verified, remove the plastic sheet. Fan drive **disengagement** should start to occur at between 57° to 79° C (135° to 175° F). A definite **decrease** of fan flow noise (roaring) should be noticed. If not, replace the defective viscous fan drive unit.

**CAUTION: Some engines equipped with serpentine drive belts have reverse rotating fans and viscous fan drives. They are marked with the word REVERSE to designate their usage. Installation of the wrong fan or viscous fan drive can result in engine overheating.**

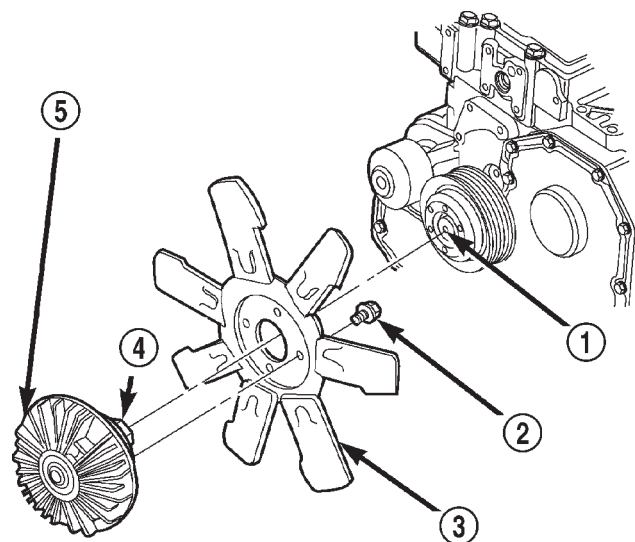
**CAUTION: If the viscous fan drive is replaced because of mechanical damage, the cooling fan blades should also be inspected. Inspect for fatigue**

cracks, loose blades, or loose rivets that could have resulted from excessive vibration. Replace fan blade assembly if any of these conditions are found. Also inspect water pump bearing and shaft assembly for any related damage due to a viscous fan drive malfunction.

## FAN DRIVE VISCOUS CLUTCH - 5.9L DIESEL

## DESCRIPTION

The thermal viscous fan drive (Fig. 30) is a silicone-fluid-filled coupling used to connect the fan blades to the water pump shaft. The coupling allows the fan to be driven in a normal manner. This is done at low engine speeds while limiting the top speed of the fan to a predetermined maximum level at higher engine speeds.



80b5cc02

**Fig. 30 Viscous Fan**

- 1 - THREADED SHAFT
- 2 - BOLT (4)
- 3 - FAN BLADE
- 4 - THREADED NUT
- 5 - VISCOUS FAN DRIVE

## OPERATION

A thermostatic bimetallic spring coil is located on the front face of the viscous fan drive unit (a typical viscous unit is shown in (Fig. 31). This spring coil reacts to the temperature of the radiator discharge air. It engages the viscous fan drive for higher fan speed if the air temperature from the radiator rises above a certain point. Until additional engine cooling is necessary, the fan will remain at a reduced rpm regardless of engine speed.



## FAN DRIVE VISCOUS CLUTCH - 5.9L DIESEL (Continued)

Only when sufficient heat is present, will the viscous fan drive engage. This is when the air flowing through the radiator core causes a reaction to the bimetallic coil. It then increases fan speed to provide the necessary additional engine cooling.

Once the engine has cooled, the radiator discharge temperature will drop. The bimetallic coil again reacts and the fan speed is reduced to the previous disengaged speed.

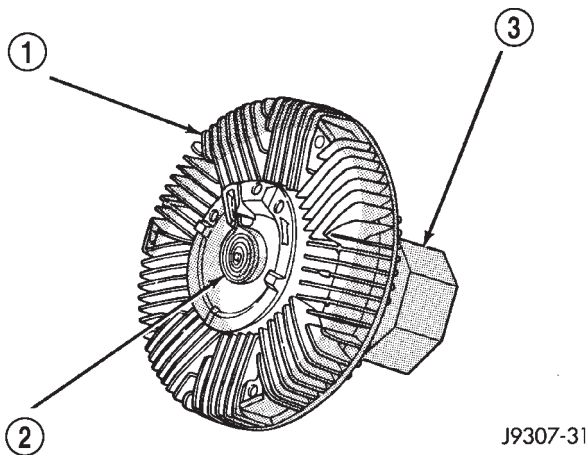


Fig. 31 Viscous Fan Drive—Typical

- 1 - VISCOUS FAN DRIVE  
 2 - THERMOSTATIC SPRING  
 3 - MOUNTING NUT TO WATER PUMP HUB

## DIAGNOSIS AND TESTING—VISCOUS FAN DRIVE

### NOISE

**NOTE:** It is normal for fan noise to be louder (roaring) when:

- The underhood temperature is above the engagement point for the viscous drive coupling. This may occur when ambient (outside air temperature) is very high.
- Engine loads and temperatures are high such as when towing a trailer.
- Cool silicone fluid within the fan drive unit is being redistributed back to its normal disengaged (warm) position. This can occur during the first 15 seconds to one minute after engine start-up on a cold engine.

### LEAKS

Viscous fan drive operation is not affected by small oil stains near the drive bearing. If leakage appears excessive, replace the fan drive unit.

## VISCOUS DRIVE

If the fan assembly free-wheels without drag (the fan blades will revolve more than five turns when spun by hand), replace the fan drive. This spin test must be performed when the engine is cool.

For the following test, the cooling system must be in good condition. It also will ensure against excessively high coolant temperature.

**WARNING: BE SURE THAT THERE IS ADEQUATE FAN BLADE CLEARANCE BEFORE DRILLING.**

(1) Drill a 3.18-mm (1/8-in) diameter hole in the top center of the fan shroud.

(2) Obtain a dial thermometer with an 8 inch stem (or equivalent). It should have a range of -18° to 105°C (0° to 220° F). Insert thermometer through the hole in the shroud. Be sure that there is adequate clearance from the fan blades.

(3) Connect a tachometer and an engine ignition timing light. The timing light is to be used as a strobe light. This step cannot be used on the diesel engine.

(4) Block the air flow through the radiator. Secure a sheet of plastic in front of the radiator (or air conditioner condenser). Use tape at the top to secure the plastic and be sure that the air flow is blocked.

(5) Be sure that the air conditioner (if equipped) is turned off.

**WARNING: USE EXTREME CAUTION WHEN THE ENGINE IS OPERATING. DO NOT STAND IN A DIRECT LINE WITH THE FAN. DO NOT PUT YOUR HANDS NEAR THE PULLEYS, BELTS OR FAN. DO NOT WEAR LOOSE CLOTHING.**

(6) Start the engine and operate at 2400 rpm. Within ten minutes the air temperature (indicated on the dial thermometer) should be up to 88° C (190° F). Fan drive **engagement** should start to occur at/between:

- 3.9L/5.2L/5.9L gas engines — 79° C (175° F)
- 8.0L engine — 88° to 96° C (190° to 205° F)
- 5.9L diesel engine — 71° to 82° C (160° to 179° F)

Engagement is distinguishable by a definite **increase** in fan flow noise (roaring). The timing light also will indicate an increase in the speed of the fan (non-diesel only).

(7) When viscous drive engagement is verified, remove the plastic sheet. Fan drive **disengagement** should start to occur at between 57° to 79° C (135° to 175° F). A definite **decrease** of fan flow noise (roaring) should be noticed. If not, replace the defective viscous fan drive unit.

## FAN DRIVE VISCOUS CLUTCH - 5.9L DIESEL (Continued)

**CAUTION:** Some engines equipped with serpentine drive belts have reverse rotating fans and viscous fan drives. They are marked with the word **REVERSE** to designate their usage. Installation of the wrong fan or viscous fan drive can result in engine overheating.

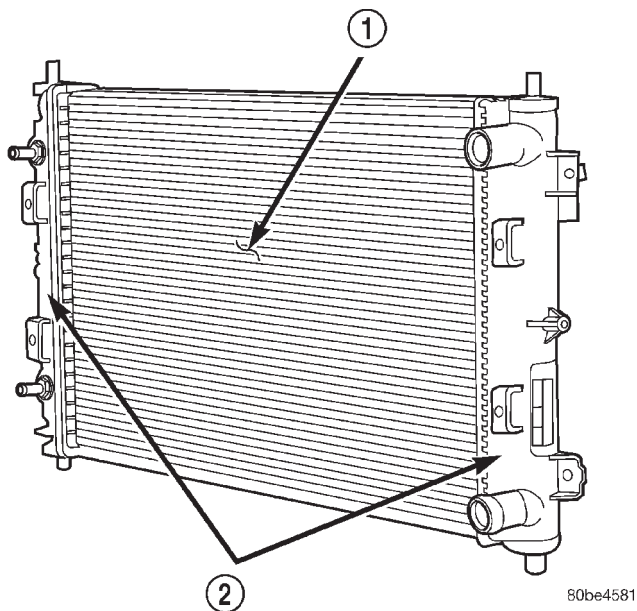
**CAUTION:** If the viscous fan drive is replaced because of mechanical damage, the cooling fan blades should also be inspected. Inspect for fatigue cracks, loose blades, or loose rivets that could have resulted from excessive vibration. Replace fan blade assembly if any of these conditions are found. Also inspect water pump bearing and shaft assembly for any related damage due to a viscous fan drive malfunction.

## RADIATOR - 3.9L/5.2L/5.9L

## DESCRIPTION

The radiator is a aluminum cross-flow design with horizontal tubes through the radiator core and vertical plastic side tanks (Fig. 32).

This radiator contains an internal transmission oil cooler only on the V-10 gas engine and the 5.9L diesel engine combinations.



**Fig. 32 Cross Flow Radiator—Typical**

- 1 - COOLING TUBES
- 2 - TANKS

## OPERATION

The radiator supplies sufficient heat transfer using the cooling fins interlaced between the horizontal tubes in the radiator core to cool the engine.

## DIAGNOSIS AND TESTING—RADIATOR COOLANT FLOW

Use the following procedure to determine if coolant is flowing through the cooling system.

(1) Idle engine until operating temperature is reached. If the upper radiator hose is warm to the touch, the thermostat is opening and coolant is flowing to the radiator.

**WARNING: HOT, PRESSURIZED COOLANT CAN CAUSE INJURY BY SCALDING. USING A RAG TO COVER THE RADIATOR PRESSURE CAP, OPEN RADIATOR CAP SLOWLY TO THE FIRST STOP. THIS WILL ALLOW ANY BUILT-UP PRESSURE TO VENT TO THE RESERVE/OVERFLOW TANK. AFTER PRESSURE BUILD-UP HAS BEEN RELEASED, REMOVE CAP FROM FILLER NECK.**

(2) Drain a small amount of coolant from the radiator until the ends of the radiator tubes are visible through the filler neck. Idle the engine at normal operating temperature. If coolant is flowing past the exposed tubes, the coolant is circulating.

## REMOVAL

(1) Disconnect battery negative cables.

**WARNING: DO NOT REMOVE THE CYLINDER BLOCK DRAIN PLUGS OR LOOSEN THE RADIATOR DRAINCOCK WITH THE SYSTEM HOT AND UNDER PRESSURE. SERIOUS BURNS FROM COOLANT CAN OCCUR.**

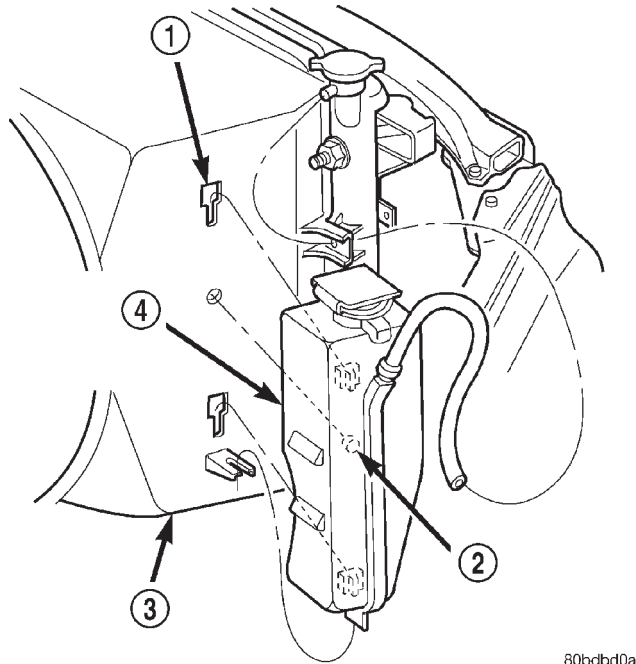
(2) Drain the cooling system (Refer to 7 - COOLING - STANDARD PROCEDURE).

**WARNING: CONSTANT TENSION HOSE CLAMPS ARE USED ON MOST COOLING SYSTEM HOSES. WHEN REMOVING OR INSTALLING, USE ONLY TOOLS DESIGNED FOR SERVICING THIS TYPE OF CLAMP, SUCH AS SPECIAL CLAMP TOOL (NUMBER 6094). SNAP-ON CLAMP TOOL (NUMBER HPC-20) MAY BE USED FOR LARGER CLAMPS. ALWAYS WEAR SAFETY GLASSES WHEN SERVICING CONSTANT TENSION CLAMPS.**

## RADIATOR - 3.9L/5.2L/5.9L (Continued)

**CAUTION:** A number or letter is stamped into the tongue of constant tension clamps. If replacement is necessary, use only an original equipment clamp with a matching number or letter.

- (3) Remove hose clamps and hoses from radiator.
- (4) Remove coolant reserve/overflow tank hose from radiator filler neck nipple.
- (5) Remove the coolant reserve/overflow tank from the fan shroud (pull straight up). The tank slips into T-slots on the fan shroud (Fig. 33).



**Fig. 33 Coolant Recovery Bottle**

- 1 - T-SLOTS
- 2 - ALIGNMENT PIN
- 3 - FAN SHROUD
- 4 - COOLANT RESERVE/OVERFLOW TANK

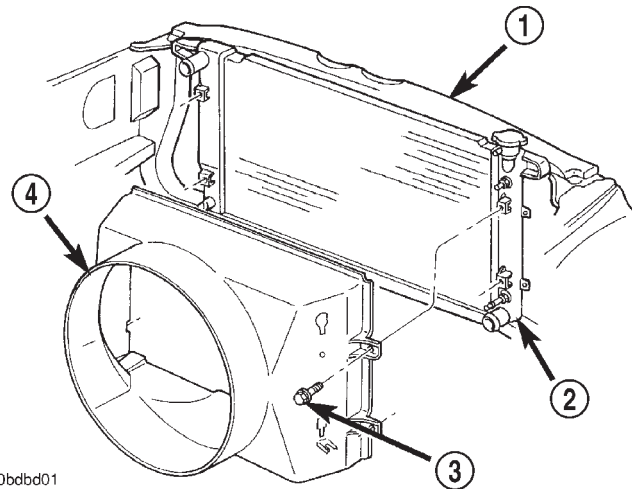
(6) Disconnect electrical connectors at windshield washer reservoir tank and remove tank.

(7) Remove the four fan shroud mounting bolts (Fig. 34). Position shroud rearward over the fan blades towards engine.

(8) Remove the plastic clips retaining the rubber shields to the sides of radiator. Position rubber shields to the side.

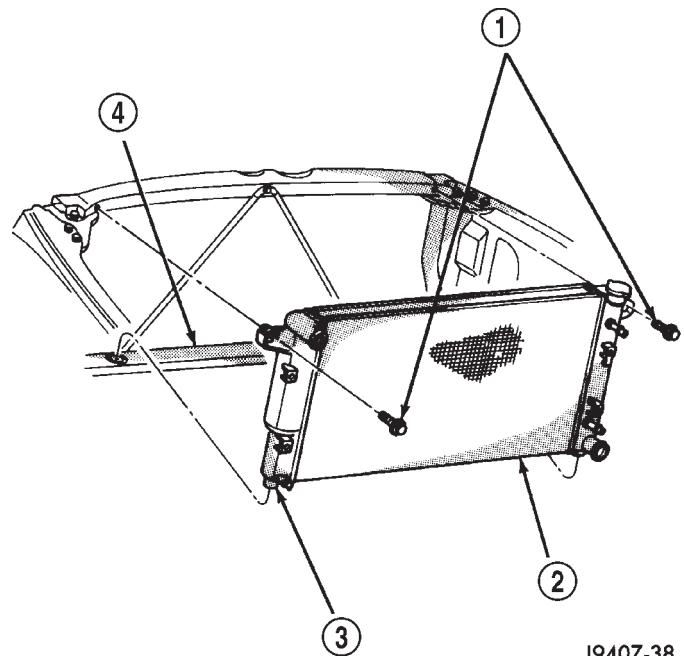
(9) Remove the two radiator upper mounting bolts (Fig. 35).

(10) Lift radiator straight up and out of engine compartment. The bottom of the radiator is equipped with two alignment dowels that fit into holes in the lower radiator support panel (Fig. 35). Rubber biscuits (insulators) are installed to these dowels. Take care not to damage cooling fins or tubes on the radiator and air conditioning condenser when removing.



**Fig. 34 Fan Shroud Mounting—3.9L/5.2L/5.9L Engines**

- 1 - RADIATOR SUPPORT
- 2 - RADIATOR
- 3 - BOLTS (4)
- 4 - FAN SHROUD



**Fig. 35 Typical Radiator Mounting**

- 1 - MOUNTING BOLTS
- 2 - RADIATOR
- 3 - ALIGNMENT DOWELS (2)
- 4 - RADIATOR SUPPORT

## CLEANING

Clean radiator fins are necessary for good heat transfer. The radiator and air conditioning fins should be cleaned when an accumulation of debris has occurred. With the engine cold, apply cold water

## RADIATOR - 3.9L/5.2L/5.9L (Continued)

and compressed air to the back (engine side) of the radiator to flush the radiator and/or A/C condenser of debris.

## INSPECTION

Inspect the radiator side tanks for cracks, broken or missing fittings also inspect the joint where the tanks seam up to the radiator core for signs of leakage and/or deteriorating seals.

Inspect radiator core for corroded, bent or missing cooling fins. Inspect the core for bent or damaged cooling tubes.

## INSTALLATION

(1) Position fan shroud over the fan blades rearward towards engine.

(2) Install rubber insulators to alignment dowels at lower part of radiator.

(3) Lower the radiator into position while guiding the two alignment dowels into lower radiator support. Different alignment holes are provided in the lower radiator support for each engine application.

(4) Install two upper radiator mounting bolts. Tighten bolts to 11 N·m (95 in. lbs.) torque.

(5) Position the rubber shields to the sides of radiator. Install the plastic clips retaining the rubber shields to the sides of radiator.

(6) Connect both radiator hoses and install hose clamps.

(7) Install windshield washer reservoir tank.

(8) Position fan shroud to flanges on sides of radiator. Install fan shroud mounting bolts (Fig. 34). Tighten bolts to 6 N·m (50 in. lbs.) torque.

(9) Install coolant reserve/overflow tank hose to radiator filler neck nipple.

(10) Install coolant reserve/overflow tank to fan shroud (fits into T-slots on shroud).

(11) Install battery negative cables.

(12) Position heater controls to **full heat** position.

(13) Fill cooling system with coolant (Refer to 7 - COOLING - STANDARD PROCEDURE).

(14) Operate engine until it reaches normal temperature. Check cooling system fluid levels.

## RADIATOR - 8.0L

## DESCRIPTION

The radiator is a aluminum cross-flow design with horizontal tubes through the radiator core and vertical plastic side tanks (Fig. 36).

This radiator contains an internal transmission oil cooler only on the V-10 gas engine and the 5.9L diesel engine combinations.

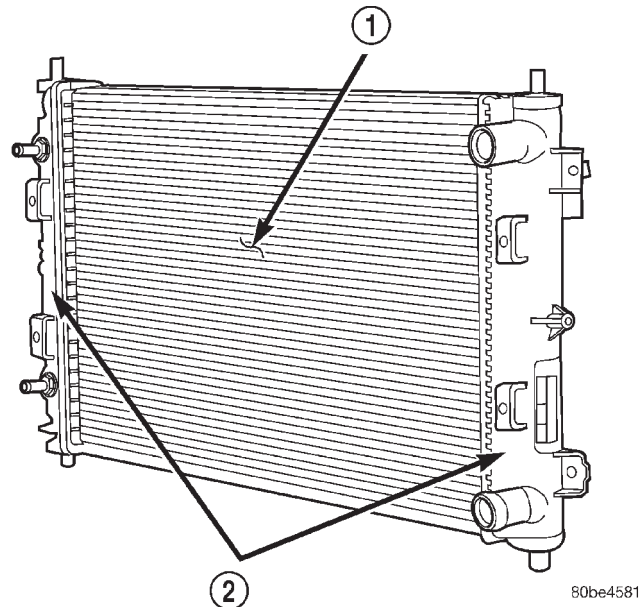


Fig. 36 Cross Flow Radiator—Typical

- 1 - COOLING TUBES  
2 - TANKS

80be4581

## OPERATION

The radiator supplies sufficient heat transfer using the cooling fins interlaced between the horizontal tubes in the radiator core to cool the engine.

## DIAGNOSIS AND TESTING—RADIATOR COOLANT FLOW

Use the following procedure to determine if coolant is flowing through the cooling system.

(1) Idle engine until operating temperature is reached. If the upper radiator hose is warm to the touch, the thermostat is opening and coolant is flowing to the radiator.

**WARNING: HOT, PRESSURIZED COOLANT CAN CAUSE INJURY BY SCALDING. USING A RAG TO COVER THE RADIATOR PRESSURE CAP, OPEN RADIATOR CAP SLOWLY TO THE FIRST STOP. THIS WILL ALLOW ANY BUILT-UP PRESSURE TO VENT TO THE RESERVE/OVERFLOW TANK. AFTER PRESSURE BUILD-UP HAS BEEN RELEASED, REMOVE CAP FROM FILLER NECK.**

(2) Drain a small amount of coolant from the radiator until the ends of the radiator tubes are visible through the filler neck. Idle the engine at normal operating temperature. If coolant is flowing past the exposed tubes, the coolant is circulating.



## RADIATOR - 8.0L (Continued)

## REMOVAL

- (1) Disconnect battery negative cables.

**WARNING: DO NOT REMOVE THE CYLINDER BLOCK DRAIN PLUGS OR LOOSEN THE RADIATOR DRAINCOCK WITH THE SYSTEM HOT AND UNDER PRESSURE. SERIOUS BURNS FROM COOLANT CAN OCCUR.**

- (2) Drain the cooling system (Refer to 7 - COOLING - STANDARD PROCEDURE).

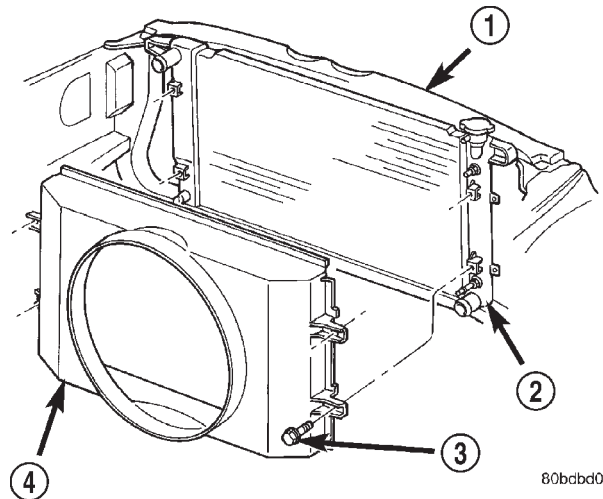
**WARNING: CONSTANT TENSION HOSE CLAMPS ARE USED ON MOST COOLING SYSTEM HOSES. WHEN REMOVING OR INSTALLING, USE ONLY TOOLS DESIGNED FOR SERVICING THIS TYPE OF CLAMP, SUCH AS SPECIAL CLAMP TOOL (NUMBER 6094). SNAP-ON CLAMP TOOL (NUMBER HPC-20) MAY BE USED FOR LARGER CLAMPS. ALWAYS WEAR SAFETY GLASSES WHEN SERVICING CONSTANT TENSION CLAMPS.**

**CAUTION: A number or letter is stamped into the tongue of constant tension clamps. If replacement is necessary, use only an original equipment clamp with a matching number or letter.**

- (3) Remove hose clamps and hoses from radiator.
- (4) Remove coolant reserve/overflow tank hose from radiator filler neck nipple.
- (5) The coolant recovery/reservoir does not require removal. Disconnect the overflow hose from the radiator.
- (6) Disconnect electrical connectors at windshield washer reservoir tank and remove tank.
- (7) Remove the four fan shroud mounting bolts (Fig. 37). Position shroud rearward over the fan blades towards engine.
- (8) Remove the two radiator upper mounting bolts (Fig. 38).
- (9) Lift radiator straight up and out of engine compartment. The bottom of the radiator is equipped with two alignment dowels that fit into holes in the lower radiator support panel (Fig. 38). Rubber biscuits (insulators) are installed to these dowels. Take care not to damage cooling fins or tubes on the radiator and air conditioning condenser when removing.

## CLEANING

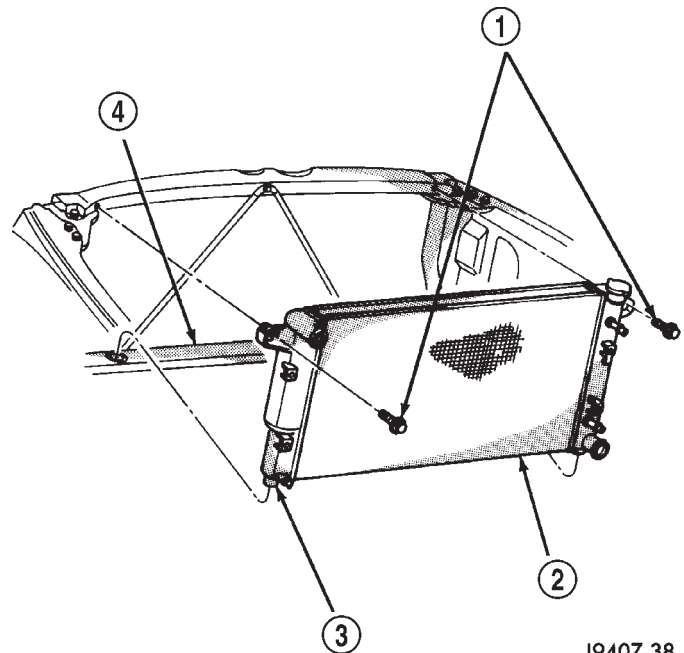
Clean radiator fins are necessary for good heat transfer. The radiator and air conditioning fins should be cleaned when an accumulation of debris has occurred. With the engine cold, apply cold water and compressed air to the back (engine side) of the radiator to flush the radiator and/or A/C condenser of debris.



80bcb02

**Fig. 37 Fan Shroud Mounting—8.0L Engine**

- 1 - RADIATOR SUPPORT
- 2 - RADIATOR
- 3 - BOLTS (4)
- 4 - FAN SHROUD



J9407-38

**Fig. 38 Typical Radiator Mounting**

- 1 - MOUNTING BOLTS
- 2 - RADIATOR
- 3 - ALIGNMENT DOWELS (2)
- 4 - RADIATOR SUPPORT

## INSPECTION

Inspect the radiator side tanks for cracks, broken or missing fittings also inspect the joint where the tanks seam up to the radiator core for signs of leakage and/or deteriorating seals.



## RADIATOR - 8.0L (Continued)

Inspect radiator core for corroded, bent or missing cooling fins. Inspect the core for bent or damaged cooling tubes.

## INSTALLATION

- (1) Position fan shroud over the fan blades rearward towards engine.
- (2) Install rubber insulators to alignment dowels at lower part of radiator.
- (3) Lower the radiator into position while guiding the two alignment dowels into lower radiator support. Different alignment holes are provided in the lower radiator support for each engine application.
- (4) Install two upper radiator mounting bolts. Tighten bolts to 11 N·m (95 in. lbs.) torque.
- (5) Connect both radiator hoses and install hose clamps.
- (6) Install windshield washer reservoir tank.
- (7) Position fan shroud to flanges on sides of radiator. Install fan shroud mounting bolts (Fig. 37). Tighten bolts to 6 N·m (50 in. lbs.) torque.
- (8) Install coolant reserve/overflow tank hose to radiator filler neck nipple.
- (9) Connect the overflow hose to the radiator.
- (10) Install battery negative cables.
- (11) Position heater controls to **full heat** position.
- (12) Fill cooling system with coolant (Refer to 7 - COOLING - STANDARD PROCEDURE).
- (13) Operate engine until it reaches normal temperature. Check cooling system fluid levels.

## RADIATOR - 5.9L DIESEL

## DESCRIPTION

The radiator is a aluminum cross-flow design with horizontal tubes through the radiator core and vertical plastic side tanks (Fig. 39).

This radiator contains an internal transmission oil cooler only on the V-10 gas engine and the 5.9L diesel engine combinations.

## OPERATION

The radiator supplies sufficient heat transfer using the cooling fins interlaced between the horizontal tubes in the radiator core to cool the engine.

## DIAGNOSIS AND TESTING—RADIATOR COOLANT FLOW

Use the following procedure to determine if coolant is flowing through the cooling system.

- (1) Idle engine until operating temperature is reached. If the upper radiator hose is warm to the touch, the thermostat is opening and coolant is flowing to the radiator.

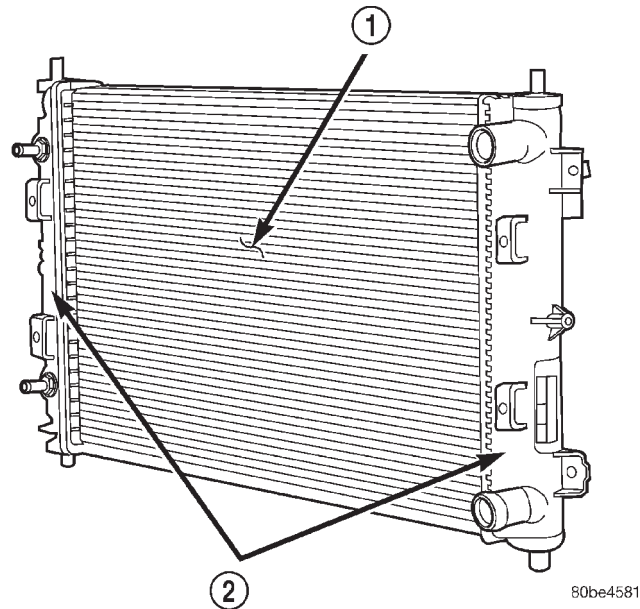


Fig. 39 Cross Flow Radiator—Typical

- 1 - COOLING TUBES  
2 - TANKS

**WARNING: HOT, PRESSURIZED COOLANT CAN CAUSE INJURY BY SCALDING. USING A RAG TO COVER THE RADIATOR PRESSURE CAP, OPEN RADIATOR CAP SLOWLY TO THE FIRST STOP. THIS WILL ALLOW ANY BUILT-UP PRESSURE TO VENT TO THE RESERVE/OVERFLOW TANK. AFTER PRESSURE BUILD-UP HAS BEEN RELEASED, REMOVE CAP FROM FILLER NECK.**

- (2) Drain a small amount of coolant from the radiator until the ends of the radiator tubes are visible through the filler neck. Idle the engine at normal operating temperature. If coolant is flowing past the exposed tubes, the coolant is circulating.

## REMOVAL

- (1) Disconnect both battery negative cables. Remove the nuts retaining the positive cable to the top of radiator. Position positive battery cable to rear of vehicle.

**WARNING: DO NOT REMOVE THE CYLINDER BLOCK DRAIN PLUGS OR LOOSEN THE RADIATOR DRAINCOCK WITH THE SYSTEM HOT AND UNDER PRESSURE. SERIOUS BURNS FROM COOLANT CAN OCCUR.**

- (2) Drain the cooling system (Refer to 7 - COOLING - STANDARD PROCEDURE).

## RADIATOR - 5.9L DIESEL (Continued)

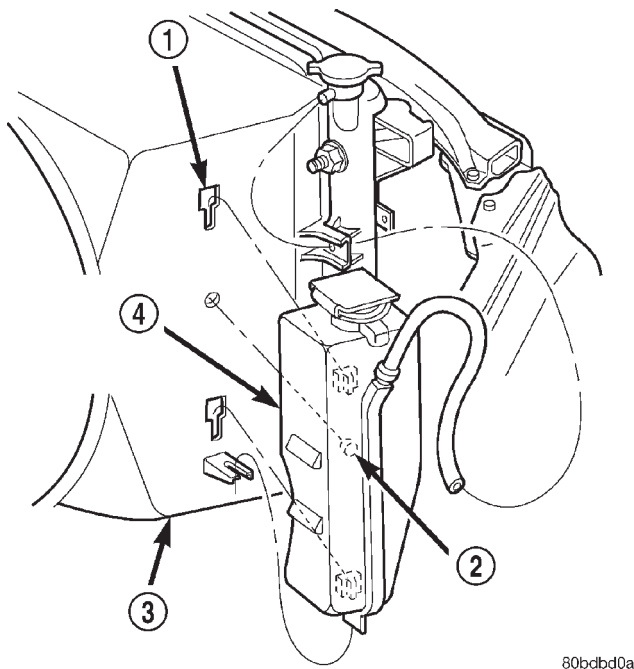
**WARNING: CONSTANT TENSION HOSE CLAMPS ARE USED ON MOST COOLING SYSTEM HOSES. WHEN REMOVING OR INSTALLING, USE ONLY TOOLS DESIGNED FOR SERVICING THIS TYPE OF CLAMP, SUCH AS SPECIAL CLAMP TOOL (NUMBER 6094). SNAP-ON CLAMP TOOL (NUMBER HPC-20) MAY BE USED FOR LARGER CLAMPS. ALWAYS WEAR SAFETY GLASSES WHEN SERVICING CONSTANT TENSION CLAMPS.**

**CAUTION: A number or letter is stamped into the tongue of constant tension clamps. If replacement is necessary, use only an original equipment clamp with a matching number or letter.**

(3) Remove hose clamps and hoses from radiator.

(4) Remove coolant reserve/overflow tank hose from radiator filler neck nipple.

(5) Remove the coolant reserve/overflow tank from the fan shroud (pull straight up). The tank slips into T-slots on the fan shroud (Fig. 40). The coolant recovery/reservoir does not require removal. Disconnect the overflow hose from the radiator.



80bcbbd0a

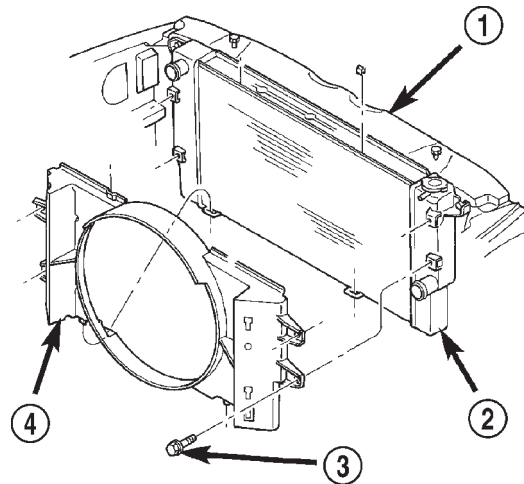
**Fig. 40 Coolant Recovery Bottle—Typical**

- 1 - T-SLOTS
- 2 - ALIGNMENT PIN
- 3 - FAN SHROUD
- 4 - COOLANT RESERVE/OVERFLOW TANK

(6) Disconnect electrical connectors at windshield washer reservoir tank and remove tank.

(7) Remove the two metal clips retaining the upper part of fan shroud to the top of radiator.

(8) Remove the four fan shroud mounting bolts (Fig. 41). Position shroud rearward over the fan blades towards engine.

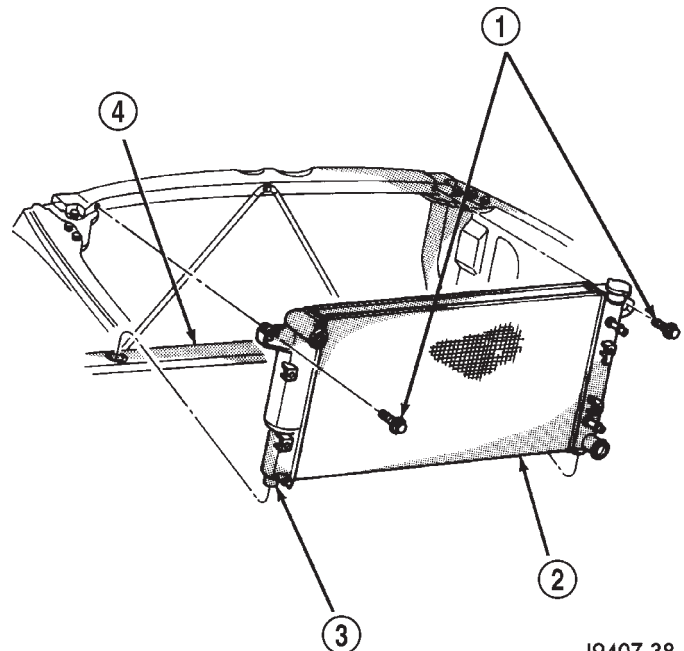


80bcbbd03

**Fig. 41 Fan Shroud Mounting—5.9L Diesel Engine**

- 1 - RADIATOR SUPPORT
- 2 - RADIATOR
- 3 - BOLTS (4)
- 4 - FAN SHROUD

(9) Remove the two radiator upper mounting bolts (Fig. 42).



J9407-38

**Fig. 42 Typical Radiator Mounting**

- 1 - MOUNTING BOLTS
- 2 - RADIATOR
- 3 - ALIGNMENT DOWELS (2)
- 4 - RADIATOR SUPPORT

## RADIATOR - 5.9L DIESEL (Continued)

(10) Lift radiator straight up and out of engine compartment. The bottom of the radiator is equipped with two alignment dowels that fit into holes in the lower radiator support panel (Fig. 42). Rubber biscuits (insulators) are installed to these dowels. Take care not to damage cooling fins or tubes on the radiator and air conditioning condenser when removing.

## CLEANING

Clean radiator fins are necessary for good heat transfer. The radiator and air conditioning fins should be cleaned when an accumulation of debris has occurred. With the engine cold, apply cold water and compressed air to the back (engine side) of the radiator to flush the radiator and/or A/C condenser of debris.

## INSPECTION

Inspect the radiator side tanks for cracks, broken or missing fittings also inspect the joint where the tanks seam up to the radiator core for signs of leakage and/or deteriorating seals.

Inspect radiator core for corroded, bent or missing cooling fins. Inspect the core for bent or damaged cooling tubes.

## INSTALLATION

(1) Position fan shroud over the fan blades rearward towards engine.

(2) Install rubber insulators to alignment dowels at lower part of radiator.

(3) Lower the radiator into position while guiding the two alignment dowels into lower radiator support. Different alignment holes are provided in the lower radiator support for each engine application.

(4) Install two upper radiator mounting bolts. Tighten bolts to 11 N·m (95 in. lbs.) torque.

(5) Connect both radiator hoses and install hose clamps.

(6) Connect transmission cooler lines to radiator tank. Inspect quick connect fittings for debris and install until an audible "click" is heard. Pull apart to verify connection.

(7) Install windshield washer reservoir tank.

(8) Position fan shroud to flanges on sides of radiator. Install fan shroud mounting bolts (Fig. 41). Tighten bolts to 6 N·m (50 in. lbs.) torque.

(9) Install metal clips to top of fan shroud.

(10) Install coolant reserve/overflow tank hose to radiator filler neck nipple.

(11) Install coolant reserve/overflow tank to fan shroud (fits into T-slots on shroud).

(12) Install battery negative cables.

(13) Install positive battery cable to top of radiator. Tighten radiator-to-battery cable mounting nuts.

(14) Position heater controls to **full heat** position.

(15) Fill cooling system with coolant (Refer to 7 - COOLING - STANDARD PROCEDURE).

(16) Operate engine until it reaches normal temperature. Check cooling system and automatic transmission (if equipped) fluid levels.

## RADIATOR PRESSURE CAP

## DESCRIPTION

Radiators are equipped with a pressure cap, which releases pressure at some point within a range of 97-124 kPa (14-18 psi). The pressure relief point (in pounds) is engraved on top of cap.

The cooling system will operate at pressures slightly above atmospheric pressure. This results in a higher coolant boiling point allowing increased radiator cooling capacity.

A rubber gasket seals radiator filler neck to prevent leakage. This is done to keep system under pressure. It also maintains vacuum during coolant cool-down allowing coolant to return from reserve/overflow tank.

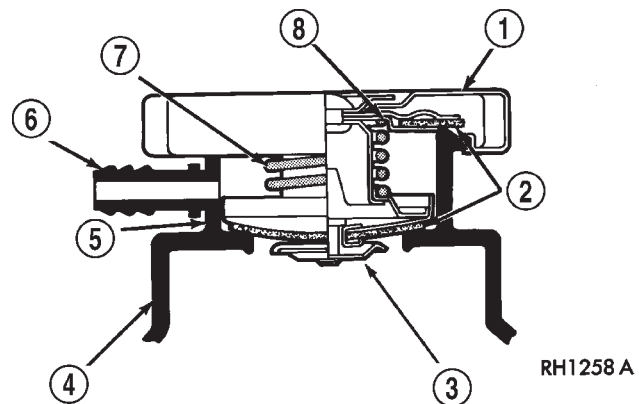


Fig. 43 Radiator Pressure Cap and Filler Neck—  
Typical

- 1 - STAINLESS-STEEL SWIVEL TOP
- 2 - RUBBER SEALS
- 3 - VENT VALVE
- 4 - RADIATOR TANK
- 5 - FILLER NECK
- 6 - OVERFLOW NIPPLE
- 7 - MAIN SPRING
- 8 - GASKET RETAINER

## OPERATION

The cap (Fig. 43) contains a spring-loaded pressure relief valve that opens when system pressure reaches release range of 97-124 kPa (14-18 psi).

A vent valve in the center of cap allows a small coolant flow through cap when coolant is below boiling temperature. The valve is completely closed when boiling point is reached. As the coolant cools, it con-

## RADIATOR PRESSURE CAP (Continued)

tracts and creates a vacuum in the cooling system. This causes the vacuum valve to open and coolant in the reserve/overflow tank to be drawn through its connecting hose into radiator. If the vacuum valve is stuck shut, the radiator hoses will collapse on cool-down. Clean the vent valve (Fig. 43).

## DIAGNOSIS AND TESTING—RADIATOR CAP-TO-FILLER NECK SEAL

The pressure cap upper gasket (seal) pressure relief can be tested by removing overflow hose from radiator filler neck nipple. Attach hose of pressure tester tool 7700 (or equivalent) to nipple. It will be necessary to disconnect hose from its adapter for filler neck. Pump air into radiator. The pressure cap upper gasket should relieve at 69-124 kPa (10-18 psi) and hold pressure at a minimum of 55 kPa (8 psi).

**WARNING: THE WARNING WORDS —DO NOT OPEN HOT— ON RADIATOR PRESSURE CAP, ARE A SAFETY PRECAUTION. WHEN HOT, PRESSURE BUILDS UP IN COOLING SYSTEM. TO PREVENT SCALDING OR INJURY, RADIATOR CAP SHOULD NOT BE REMOVED WHILE SYSTEM IS HOT AND/OR UNDER PRESSURE.**

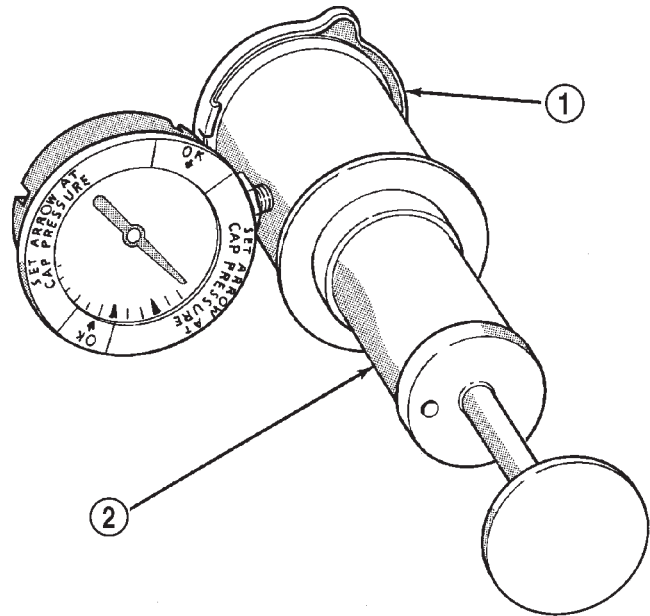
Do not remove radiator cap at any time **except** for the following purposes:

- Check and adjust antifreeze freeze point
- Refill system with new antifreeze
- Conducting service procedures
- Checking for vacuum leaks

**WARNING: IF VEHICLE HAS BEEN RUN RECENTLY, WAIT AT LEAST 15 MINUTES BEFORE REMOVING RADIATOR CAP. WITH A RAG, SQUEEZE RADIATOR UPPER HOSE TO CHECK IF SYSTEM IS UNDER PRESSURE. PLACE A RAG OVER CAP AND WITHOUT PUSHING CAP DOWN, ROTATE IT COUNTER-CLOCKWISE TO FIRST STOP. ALLOW FLUID TO ESCAPE THROUGH THE COOLANT RESERVE/OVERFLOW HOSE INTO RESERVE/OVERFLOW TANK. SQUEEZE RADIATOR UPPER HOSE TO DETERMINE WHEN PRESSURE HAS BEEN RELEASED. WHEN COOLANT AND STEAM STOP BEING PUSHED INTO TANK AND SYSTEM PRESSURE DROPS, REMOVE RADIATOR CAP COMPLETELY.**

## DIAGNOSIS AND TESTING—RADIATOR CAP

Remove cap from radiator. Be sure that sealing surfaces are clean. Moisten rubber gasket with water and install cap on pressure tester 7700 or an equivalent (Fig. 44).



J9507-3

**Fig. 44 Pressure Testing Radiator Cap—Typical Tester**

- 1 - PRESSURE CAP  
2 - TYPICAL COOLING SYSTEM PRESSURE TESTER

**NOTE: Radiator pressure testing tools are very sensitive to small air leaks, which will not cause cooling system problems. A pressure cap that does not have a history of coolant loss should not be replaced just because it leaks slowly when tested with this tool. Add water to tool. Turn tool upside down and recheck pressure cap to confirm that cap needs replacement.**

Operate tester pump to bring pressure to 104 kPa (15 psi) on gauge. If pressure cap fails to hold pressure of at least 97 kPa (14 psi) replace cap.

The pressure cap may test properly while positioned on tool 7700 (or equivalent). It may not hold pressure or vacuum when installed on radiator. If so, inspect radiator filler neck and cap's top gasket for damage. Also inspect for dirt or distortion that may prevent cap from sealing properly.

## CLEANING

Clean radiator pressure cap using a mild soap and water mixture. **DO NOT** use any chemicals stronger than mild soap, damage to the seal can occur .

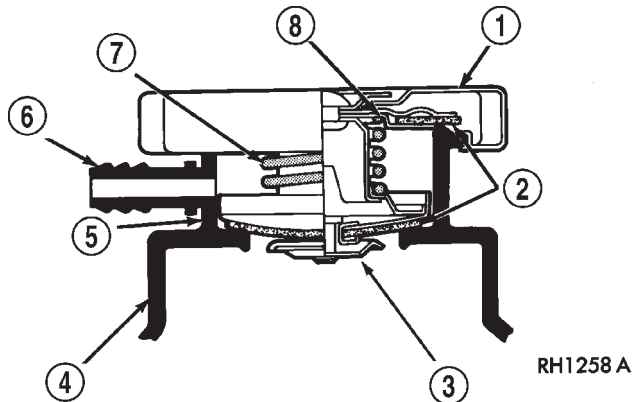
## INSPECTION

Hold cap at eye level, right side up. The vent valve (Fig. 45) at bottom of cap should open. If rubber gas-



## RADIATOR PRESSURE CAP (Continued)

ket has swollen and prevents vent valve from opening, replace cap.



**Fig. 45 Radiator Pressure Cap**

- 1 - STAINLESS-STEEL SWIVEL TOP
- 2 - RUBBER SEALS
- 3 - VENT VALVE
- 4 - RADIATOR TANK
- 5 - FILLER NECK
- 6 - OVERFLOW NIPPLE
- 7 - MAIN SPRING
- 8 - GASKET RETAINER

Hold cap at eye level, upside down. If any light can be seen between vent valve and rubber gasket, replace cap. **Do not use a replacement cap that has a spring to hold vent shut.** A replacement cap must be the type designed for a coolant reserve/overflow system with a completely sealed diaphragm spring and a rubber gasket. This gasket is used to seal to radiator filler neck top surface. Use of proper cap will allow coolant return to radiator.

## WATER PUMP - 3.9L/5.2L/5.9L

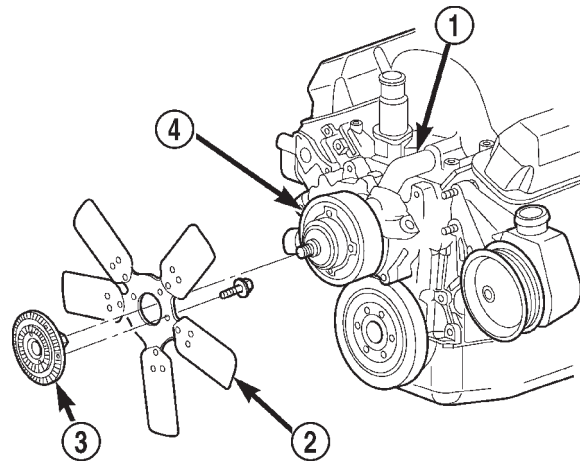
## DESCRIPTION

The water pump is located on the engine front cover, and has an integral pulley attached (Fig. 46).

The water pump impeller is pressed onto the rear of a shaft that rotates in a bearing pressed into the water pump body. The body has a small hole for ventilation. The water pump seals are lubricated by antifreeze in the coolant mixture. Additional lubrication is not necessary.

## OPERATION

A centrifugal water pump circulates coolant through the water jackets, passages, intake manifold, radiator core, cooling system hoses and heater core, this coolant absorbs the heat generated when the engine is running. The pump is driven by the engine crankshaft via a drive belt.



**Fig. 46 Water Pump Location—Typical**

- 1 - WATER PUMP BYPASS HOSE
- 2 - FAN BLADE ASSEMBLY
- 3 - VISCOUS FAN DRIVE
- 4 - WATER PUMP AND PULLEY

## DIAGNOSIS AND TESTING—WATER PUMP

A quick test to determine if pump is working is to check if heater warms properly. A defective water pump will not be able to circulate heated coolant through the long heater hose to the heater core.

## REMOVAL

The water pump on all models can be removed without discharging the air conditioning system (if equipped).

The water pump on all gas powered engines is bolted directly to the engine timing chain case/cover.

On all 3.9L/5.2L/5.9L gas powered engines, a gasket is used as a seal between the water pump and timing chain case/cover.

If water pump is replaced because of bearing/shaft damage or leaking shaft seal, the mechanical cooling fan assembly should also be inspected. Inspect for fatigue cracks, loose blades or loose rivets that could have resulted from excessive vibration. Replace fan if any of these conditions are found. Also check condition of the thermal viscous fan drive (Refer to 7 - COOLING/ENGINE/FAN DRIVE VISCOUS CLUTCH - DIAGNOSIS AND TESTING).

- (1) Disconnect negative cable from battery.
- (2) Drain cooling system (Refer to 7 - COOLING - STANDARD PROCEDURE).

Do not waste reusable coolant. If solution is clean, drain coolant into a clean container for reuse.

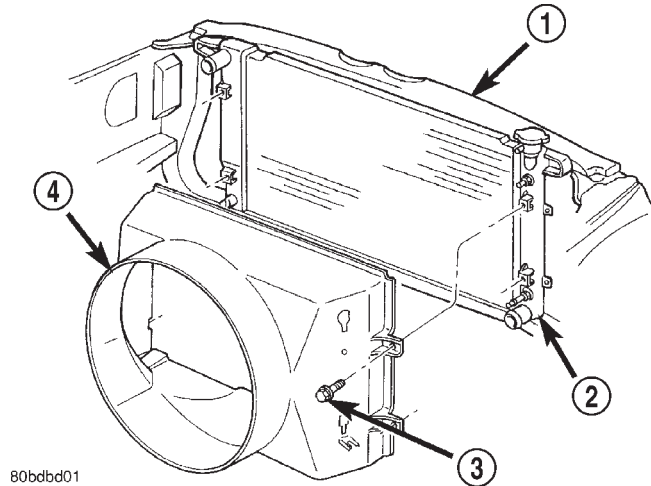
- (3) Remove windshield washer reservoir tank from radiator fan shroud.



## WATER PUMP - 3.9L/5.2L/5.9L (Continued)

(4) Disconnect the coolant reserve/overflow tank-to-radiator hose at the tank.

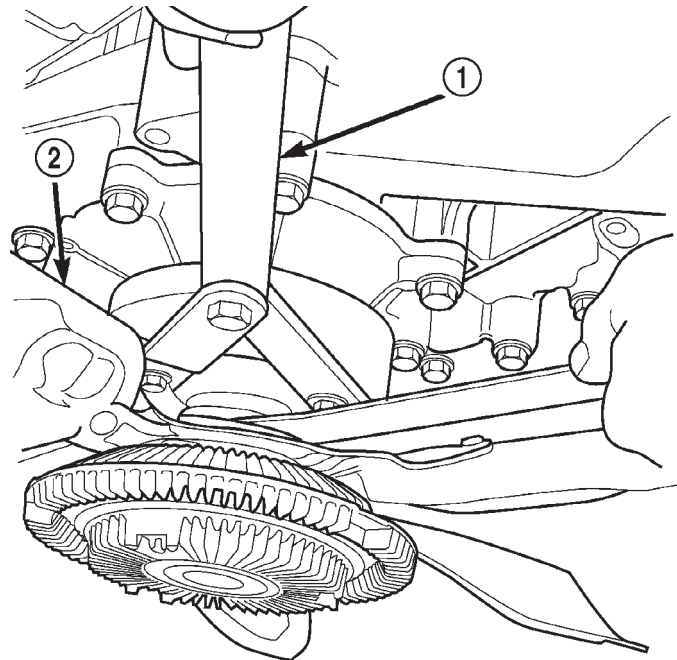
(5) Remove the four fan shroud mounting bolts at the radiator (Fig. 47). Do not attempt to remove shroud from vehicle at this time.



80bdbd01

**Fig. 47 Typical Fan Shroud Mounting**

- 1 - RADIATOR SUPPORT
- 2 - RADIATOR
- 3 - BOLTS (4)
- 4 - FAN SHROUD



80b6b293

**Fig. 48 Using Special Tool 6958 Spanner Wrench and Adapter Pins 8346**

- 1 - SPECIAL TOOL 6958 SPANNER WRENCH WITH ADAPTER PINS 8346
- 2 - FAN

**WARNING: CONSTANT TENSION HOSE CLAMPS ARE USED ON MOST COOLING SYSTEM HOSES. WHEN REMOVING OR INSTALLING, USE ONLY TOOLS DESIGNED FOR SERVICING THIS TYPE OF CLAMP, SUCH AS SPECIAL CLAMP TOOL (NUMBER 6094). SNAP-ON CLAMP TOOL (NUMBER HPC-20) MAY BE USED FOR LARGER CLAMPS. ALWAYS WEAR SAFETY GLASSES WHEN SERVICING CONSTANT TENSION CLAMPS.**

**CAUTION: A number or letter is stamped into the tongue of constant tension clamps. If replacement is necessary, use only an original equipment clamp with a matching number or letter.**

(6) Remove upper radiator hose at radiator.

(7) The thermal viscous fan drive is attached (threaded) to the water pump hub shaft (Fig. 49). Remove the fan/fan drive assembly from water pump by turning the mounting nut counterclockwise (as viewed from front). Threads on the fan drive are **RIGHT-HAND**. A Snap-On 36 MM Fan Wrench (number SP346 from Snap-On Cummins Diesel Tool Set number 2017DSP) can be used with Special Tool 6958 Spanner Wrench and Adapter Pins 8346 (Fig. 48) to prevent the pulley from rotating.

(8) If water pump is being replaced, do not unbolt fan blade assembly (Fig. 49) from the thermal control fan drive.

(9) Remove fan blade/fan drive and fan shroud as an assembly from vehicle.

(10) After removing fan blade/fan drive assembly, **do not** place the thermal viscous fan drive in the horizontal position. If stored horizontally, the silicone fluid in the viscous drive could drain into its bearing assembly and contaminate the bearing lubricant.

(11) Remove accessory drive belt (Refer to 7 - COOLING/ACCESSORY DRIVE/DRIVE BELTS - REMOVAL) (Fig. 50).

(12) Remove the lower radiator hose and heater hose from water pump.

(13) Loosen heater hose coolant return tube mounting bolt (Fig. 51) and remove tube from water pump. Discard the old tube O-ring.

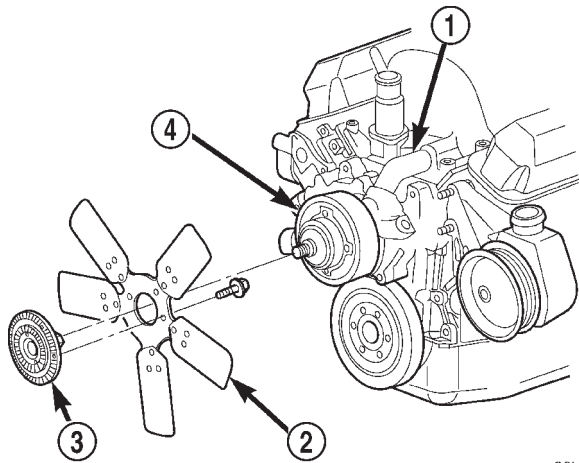
(14) Remove the seven water pump mounting bolts (Fig. 52).

(15) Loosen the clamp at the water pump end of bypass hose (Fig. 49). Slip the bypass hose from the water pump while removing pump from vehicle. Do not remove the clamp from the bypass hose.

(16) Discard old gasket.

**CAUTION: Do not pry the water pump at timing chain case/cover. The machined surfaces may be damaged resulting in leaks.**

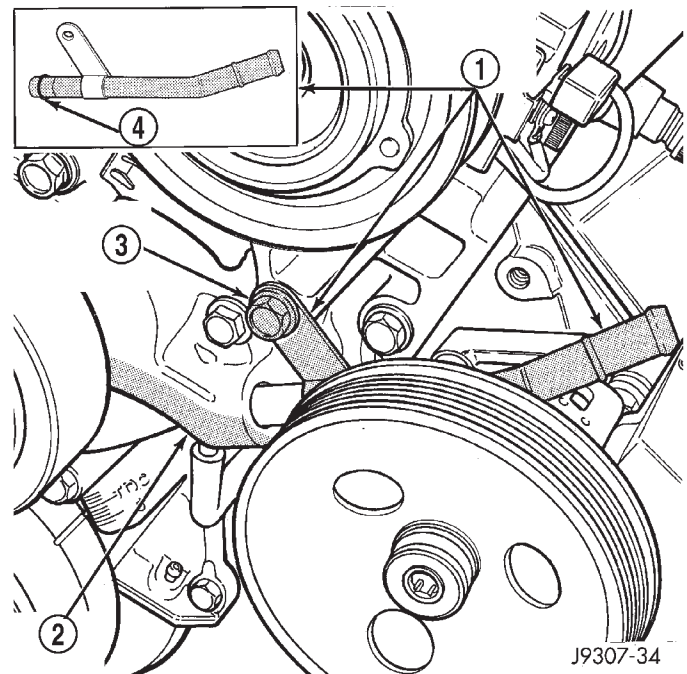
## WATER PUMP - 3.9L/5.2L/5.9L (Continued)



80bdbd2c

**Fig. 49 Fan Blade and Viscous Fan Drive—Typical**

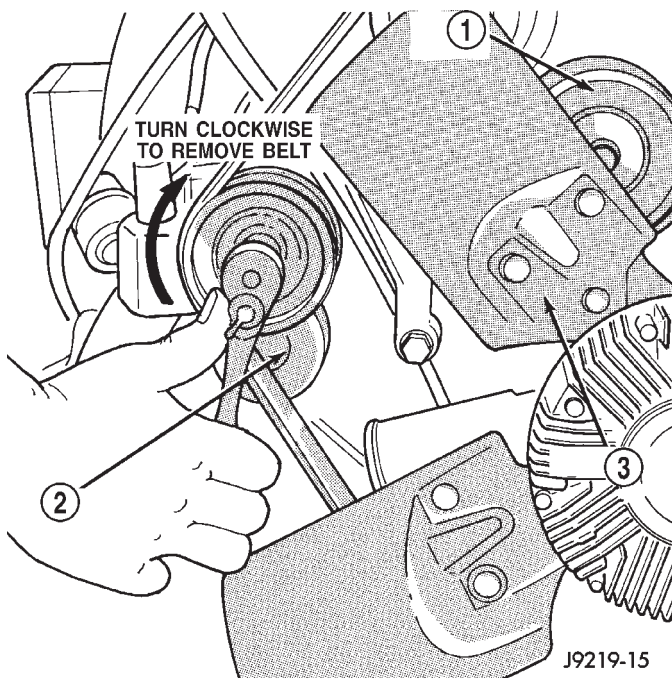
- 1 - WATER PUMP BYPASS HOSE
- 2 - FAN BLADE ASSEMBLY
- 3 - VISCOUS FAN DRIVE
- 4 - WATER PUMP AND PULLEY



J9307-34

**Fig. 51 Coolant Return Tube—3.9L V-6 or 5.2/5.9L V-8 Engines**

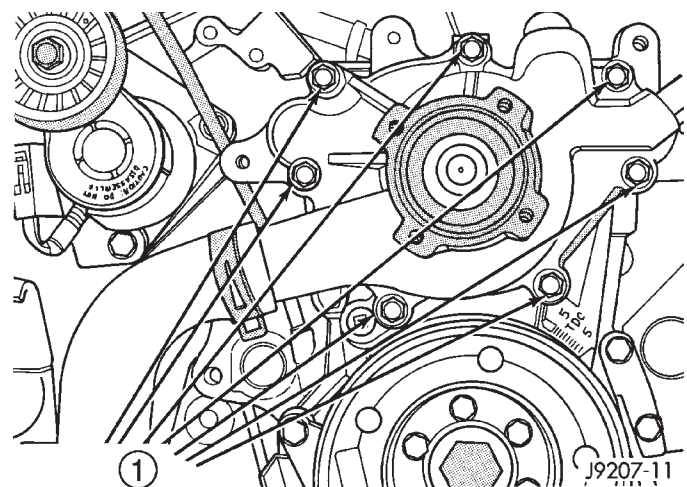
- 1 - COOLANT RETURN TUBE
- 2 - WATER PUMP
- 3 - TUBE MOUNTING BOLT
- 4 - O-RING



J9219-15

**Fig. 50 Belt Tensioner—3.9L V-6 or 5.2/5.9L V-8 Engines**

- 1 - IDLER PULLEY
- 2 - TENSIONER
- 3 - FAN BLADE



J9207-11

**Fig. 52 Water Pump Bolts—3.9L V-6 or 5.2/5.9L V-8 Gas Engines—Typical**

- 1 - WATER PUMP MOUNTING BOLTS

**CLEANING**

Clean gasket mating surfaces as necessary.

**INSPECTION**

Visually inspect the water pump and replace if it has any of the following conditions:

- The body is cracked or damaged
- Water leaks from the shaft seal. This is evident by traces of coolant below the vent hole
- Loose or rough turning bearing. Also inspect thermal fan drive
- Impeller rubbing the pump body

## WATER PUMP - 3.9L/5.2L/5.9L (Continued)

**INSTALLATION**

- (1) Clean gasket mating surfaces.
- (2) Using a new gasket, install water pump to engine as follows: Guide water pump nipple into bypass hose as pump is being installed. Install water pump bolts (Fig. 52). Tighten water pump mounting bolts to 40 N·m (30 ft. lbs.) torque.
- (3) Position bypass hose clamp to bypass hose.
- (4) Spin water pump to be sure that pump impeller does not rub against timing chain case/cover.
- (5) Install a new o-ring to the heater hose coolant return tube (Fig. 51). Coat the new o-ring with anti-freeze before installation.
- (6) Install coolant return tube and its mounting bolt to engine (Fig. 51). Be sure the slot in tube bracket is bottomed to mounting bolt. This will properly position return tube.
- (7) Connect radiator lower hose to water pump.
- (8) Connect heater hose and hose clamp to coolant return tube.
- (9) Install drive belt (Refer to 7 - COOLING/ACCESSORY DRIVE/DRIVE BELTS - INSTALLATION) (Fig. 50).
- (10) Position fan shroud and fan blade/viscous fan drive assembly to vehicle as a complete unit.
- (11) Install fan shroud.
- (12) Install fan blade/viscous fan drive assembly to water pump shaft.
- (13) Fill cooling system (Refer to 7 - COOLING - STANDARD PROCEDURE).
- (14) Connect negative battery cable.
- (15) Start and warm the engine. Check for leaks.

## WATER PUMP - 8.0L

**DIAGNOSIS AND TESTING—WATER PUMP**

A quick test to determine if pump is working is to check if heater warms properly. A defective water pump will not be able to circulate heated coolant through the long heater hose to the heater core.

**REMOVAL**

**NOTE:** The water pump on all models can be removed without discharging the air conditioning system (if equipped).

The water pump on all gas powered engines is bolted directly to the engine timing chain case/cover.

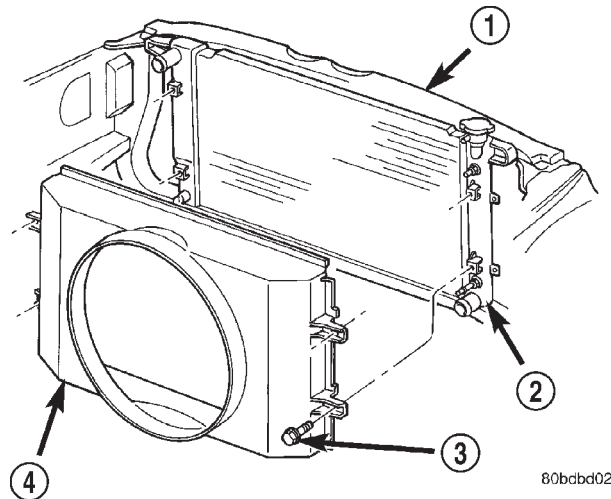
On the 8.0L V-10 engine, a rubber o-ring (instead of a gasket) is used as a seal between the water pump and timing chain case/cover.

If water pump is replaced because of bearing/shaft damage or leaking shaft seal, the mechanical cooling fan assembly should also be inspected. Inspect for fatigue cracks, loose blades or loose rivets that could have resulted from excessive vibration. Replace fan if any of these conditions are found. Also check condition of the thermal viscous fan drive (Refer to 7 - COOLING/ENGINE/FAN DRIVE VISCOUS CLUTCH - DIAGNOSIS AND TESTING).

- (1) Disconnect negative battery cable from battery.
- (2) Drain cooling system (Refer to 7 - COOLING - STANDARD PROCEDURE).

Do not waste reusable coolant. If solution is clean, drain coolant into a clean container for reuse.

- (3) Remove windshield washer reservoir tank from radiator fan shroud.
- (4) Remove the four fan shroud mounting bolts at the radiator (Fig. 53). Do not attempt to remove shroud from vehicle at this time.



80bcbcd02

**Fig. 53 Typical Fan Shroud Mounting**

- 1 - RADIATOR SUPPORT
- 2 - RADIATOR
- 3 - BOLTS (4)
- 4 - FAN SHROUD

**WARNING: CONSTANT TENSION HOSE CLAMPS ARE USED ON MOST COOLING SYSTEM HOSES. WHEN REMOVING OR INSTALLING, USE ONLY TOOLS DESIGNED FOR SERVICING THIS TYPE OF CLAMP, SUCH AS SPECIAL CLAMP TOOL (NUMBER 6094). SNAP-ON CLAMP TOOL (NUMBER HPC-20) MAY BE USED FOR LARGER CLAMPS. ALWAYS WEAR SAFETY GLASSES WHEN SERVICING CONSTANT TENSION CLAMPS.**

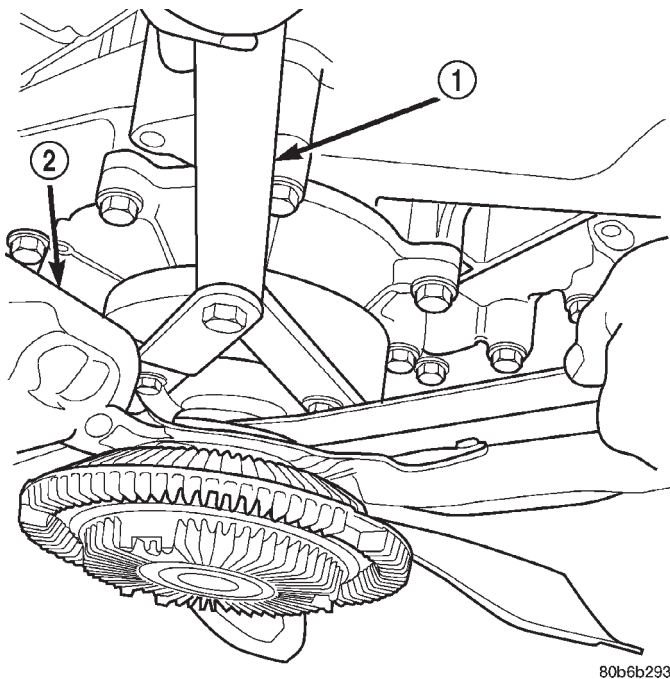


## WATER PUMP - 8.0L (Continued)

**CAUTION:** A number or letter is stamped into the tongue of constant tension clamps. If replacement is necessary, use only an original equipment clamp with a matching number or letter.

(5) Remove radiator upper hose at radiator.

(6) The thermal viscous fan drive is attached (threaded) to the water pump hub shaft (Fig. 55). Remove the fan/fan drive assembly from water pump by turning the mounting nut counterclockwise (as viewed from front). Threads on the fan drive are **RIGHT-HAND**. A Snap-On 36 MM Fan Wrench (number SP346 from Snap-On Cummins Diesel Tool Set number 2017DSP) can be used with Special Tool 6958 Spanner Wrench and Adapter Pins 8346 (Fig. 54) to prevent the pulley from rotating.



80b6b293

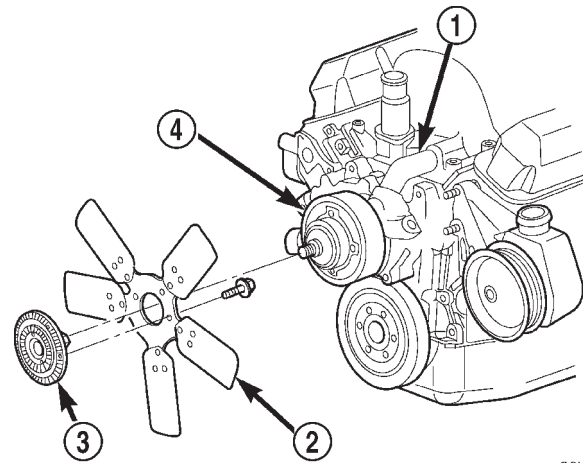
**Fig. 54 Using Special Tool 6958 Spanner Wrench and Adapter Pins 8346**

- 1 - SPECIAL TOOL 6958 SPANNER WRENCH WITH ADAPTER PINS 8346
- 2 - FAN

(7) If water pump is being replaced, do not unbolt fan blade assembly (Fig. 55) from the thermal control fan drive.

(8) Remove fan blade/fan drive and fan shroud as an assembly from vehicle.

After removing fan blade/fan drive assembly, **do not** place the thermal viscous fan drive in the horizontal position. If stored horizontally, the silicone fluid in the viscous drive could drain into its bearing assembly and contaminate the bearing lubricant.

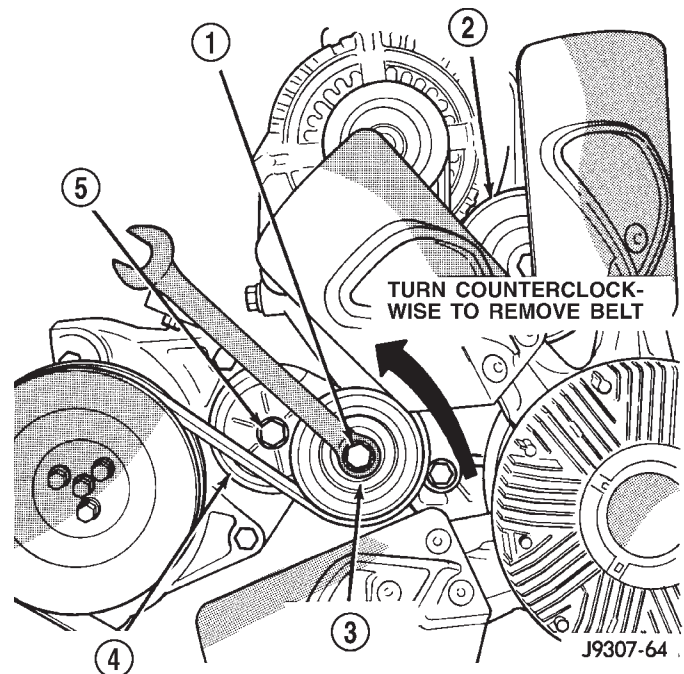


80b6bd2c

**Fig. 55 Fan Blade and Viscous Fan Drive—Typical**

- 1 - WATER PUMP BYPASS HOSE
- 2 - FAN BLADE ASSEMBLY
- 3 - VISCIOUS FAN DRIVE
- 4 - WATER PUMP AND PULLEY

(9) Remove accessory drive belt (Refer to 7 - COOLING/ACCESSORY DRIVE/DRIVE BELTS - REMOVAL) (Fig. 56).



J9307-64

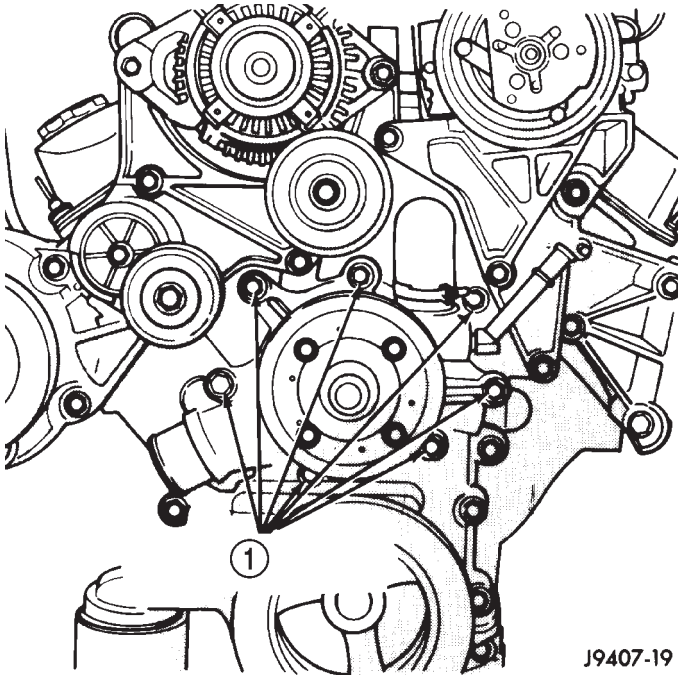
**Fig. 56 Belt Tensioner—8.0L V-10 Engine**

- 1 - PULLEY BOLT
- 2 - IDLER PULLEY
- 3 - TENSIONER PULLEY
- 4 - TENSIONER
- 5 - TENSIONER MOUNTING BOLT

(10) Remove the radiator lower hose at water pump.

## WATER PUMP - 8.0L (Continued)

- (11) Remove heater hose at water pump fitting.  
 (12) Remove the seven water pump mounting bolts (Fig. 57).



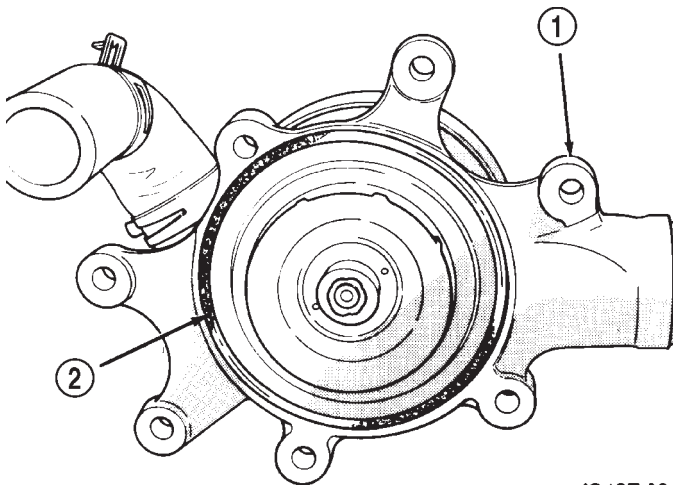
J9407-19

**Fig. 57 Water Pump Bolts—8.0L V-10—Typical**

1 - WATER PUMP MOUNTING BOLTS (7)

- (13) Loosen the clamp at the water pump end of bypass hose. Slip the bypass hose from the water pump while removing pump from vehicle. Do not remove the clamp from the bypass hose.

- (14) Discard the water pump-to-timing chain/case cover o-ring seal (Fig. 58).



J9407-18

**Fig. 58 Water Pump O-Ring Seal—8.0L V-10**

1 - WATER PUMP  
 2 - O-RING SEAL

- (15) Remove the heater hose fitting from water pump if pump replacement is necessary. Note position (direction) of fitting before removal. Fitting must be re-installed to same position.

**CAUTION:** Do not pry the water pump at timing chain case/cover. The machined surfaces may be damaged resulting in leaks.

### CLEANING

Clean gasket mating surfaces as necessary.

### INSPECTION

Visually inspect the water pump and replace if it has any of the following conditions:

- The body is cracked or damaged
- Water leaks from the shaft seal. This is evident by traces of coolant below the vent hole
- Loose or rough turning bearing. Also inspect thermal fan drive
- Impeller rubbing the pump body

### INSTALLATION

- (1) If water pump is being replaced, install the heater hose fitting to the pump. Tighten fitting to 16 N·m (144 in. lbs.) torque. After fitting has been torqued, position fitting as shown in (Fig. 59). When positioning fitting, do not back off (rotate counter-clockwise). Use a sealant on the fitting such as Mopar® Thread Sealant With Teflon. Refer to the directions on the package.

**CAUTION:** This heater hose fitting must be installed to pump before pump is installed to engine.

- (2) Clean the o-ring mating surfaces at rear of water pump and front of timing chain/case cover.

- (3) Apply a small amount of petroleum jelly to o-ring (Fig. 58). This will help retain o-ring to water pump.

- (4) Install water pump to engine as follows: Guide water pump fitting into bypass hose as pump is being installed. Install water pump bolts (Fig. 57). Tighten water pump mounting bolts to 40 N·m (30 ft. lbs.) torque.

- (5) Position bypass hose clamp to bypass hose.

- (6) Spin water pump to be sure that pump impeller does not rub against timing chain case/cover.

- (7) Connect radiator lower hose to water pump.

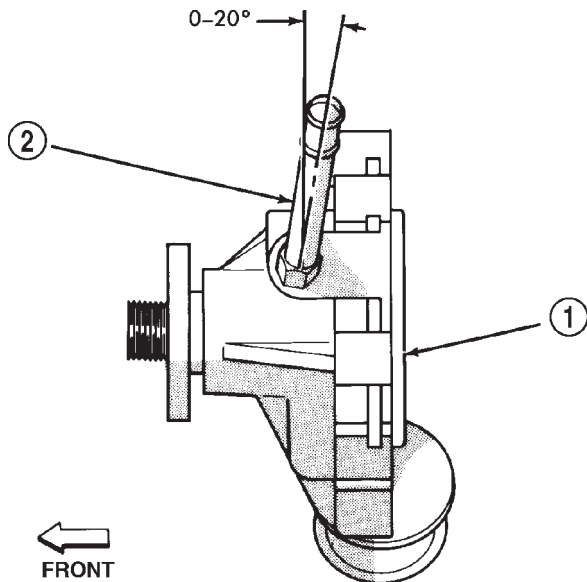
- (8) Connect heater hose and hose clamp to heater hose fitting.

- (9) Install drive belt (Refer to 7 - COOLING/ACCESSORY DRIVE/DRIVE BELTS - INSTALLATION) (Fig. 56).

- (10) Position fan shroud and fan blade/viscous fan drive assembly to vehicle as a complete unit.



## WATER PUMP - 8.0L (Continued)



J9407-17

**Fig. 59 Heater Hose Fitting Position—8.0L V-10**

- 1 - HEATER HOSE FITTING  
2 - WATER PUMP

(11) Install fan shroud to radiator. Tighten bolts to 6 N·m (50 in. lbs.) torque.

(12) Install fan blade/viscous fan drive assembly to water pump shaft.

(13) Fill cooling system (Refer to 7 - COOLING - STANDARD PROCEDURE).

(14) Connect negative battery cable.

(15) Start and warm the engine. Check for leaks.

## WATER PUMP - 5.9L DIESEL

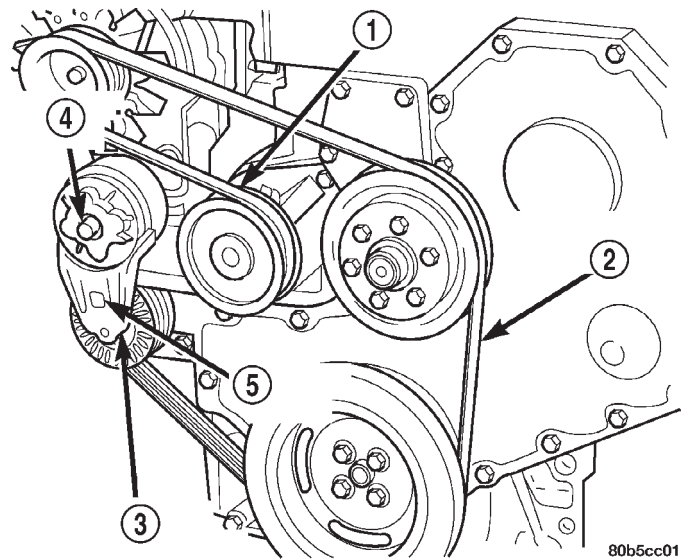
## DESCRIPTION

The water pump is mounted to the engine front cover between the automatic belt tensioner and the fan drive pulley (Fig. 60).

The water pump impeller is pressed onto the rear of a shaft that rotates in a bearing pressed into the water pump body. The body has a small hole for ventilation. The water pump seals are lubricated by antifreeze in the coolant mixture. Additional lubrication is not necessary.

## OPERATION

The diesel engine water pump draws coolant from radiator outlet and circulates it through engine, heater core and back to radiator inlet. The crankshaft pulley drives the water pump with a serpentine drive belt (Fig. 60).



80b5cc01

**Fig. 60 Water Pump—5.9L Diesel—Typical (non-A/C shown)**

- 1 - WATER PUMP  
2 - ACCESSORY DRIVE BELT  
3 - AUTOMATIC BELT TENSIONER  
4 - MOUNT BOLT  
5 - 3/8" SQUARE HOLE

## DIAGNOSIS AND TESTING—WATER PUMP

A quick test to determine if pump is working is to check if heater warms properly. A defective water pump will not be able to circulate heated coolant through the long heater hose to the heater core.

## REMOVAL

(1) Disconnect battery negative cables.

(2) Drain cooling system (Refer to 7 - COOLING - STANDARD PROCEDURE).

(3) Remove the bolt retaining the wiring harness near the top of water pump. Position wire harness to the side.

(4) Remove the accessory drive belt (Refer to 7 - COOLING/ACCESSORY DRIVE/DRIVE BELTS - REMOVAL).

(5) Remove water pump mounting bolts (Fig. 61).

(6) Clean water pump sealing surface on cylinder block.

## CLEANING

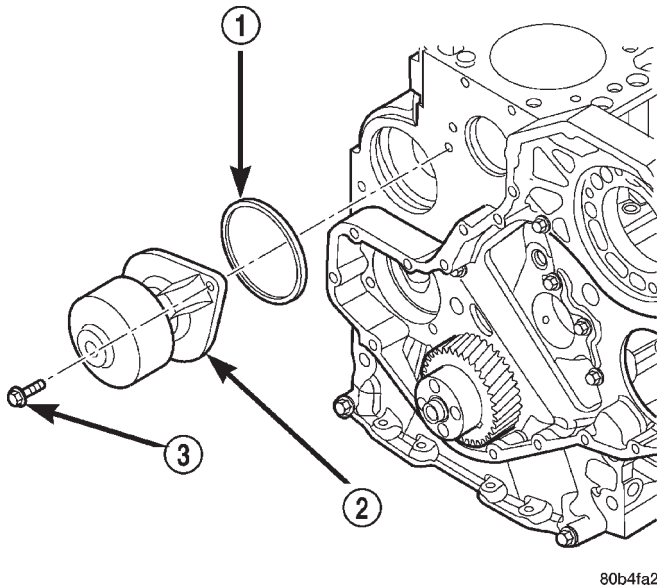
Clean gasket mating surfaces as necessary.

## INSPECTION

Visually inspect the water pump and replace if it has any of the following conditions:

- The body is cracked or damaged

## WATER PUMP - 5.9L DIESEL (Continued)



80b4fa21

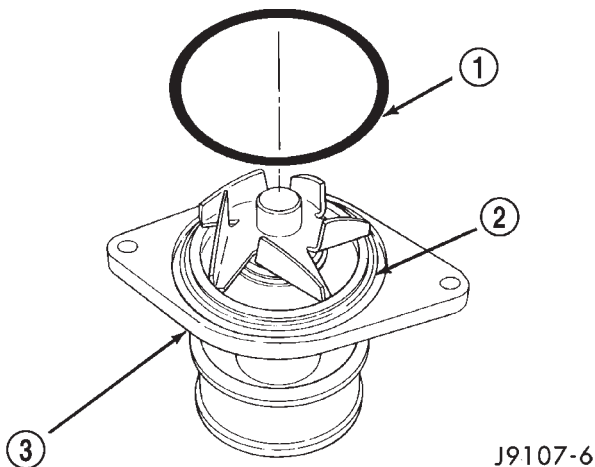
**Fig. 61 Water Pump Removal/Installation**

- 1 - O-RING SEAL (SQUARE)
- 2 - WATER PUMP
- 3 - BOLT (2)

- Water leaks from the shaft seal. This is evident by traces of coolant below the vent hole
- Loose or rough turning bearing. Also inspect thermal fan drive
- Impeller rubbing the pump body

**INSTALLATION**

(1) Install new O-ring seal in groove on water pump (Fig. 62).



J9107-6

**Fig. 62 Pump O-ring Seal**

- 1 - O-RING SEAL
- 2 - GROOVE
- 3 - WATER PUMP

(2) Install water pump. Tighten mounting bolts to 24 N·m (18 ft. lbs.) torque.

(3) Install accessory drive belt. Refer to procedure in this group.

(4) Install the bolt retaining the wiring harness near top of water pump.

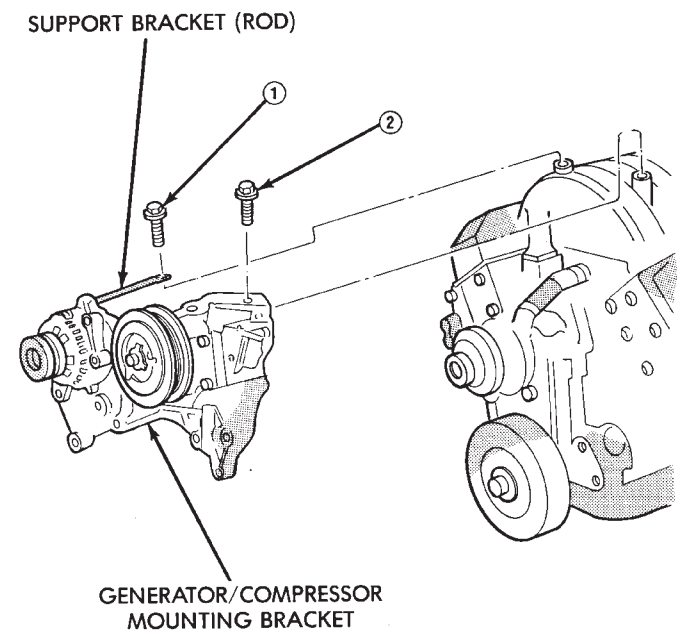
(5) Fill cooling system. Refer to Refilling Cooling System in this section.

(6) Connect both battery cables.

(7) Start and warm the engine. Check for leaks.

**WATER PUMP INLET TUBE - 3.9L/5.2L/5.9L****REMOVAL—WATER PUMP BYPASS HOSE WITH AIR CONDITIONING**

If equipped with A/C, the generator and A/C compressor along with their common mounting bracket (Fig. 63) must be partially removed. Removing the generator or A/C compressor from their mounting bracket is not necessary. Also, discharging the A/C system is not necessary. **Do not** remove any refrigerant lines from A/C compressor.



J9307-66

**Fig. 63 Generator—A/C Compressor Mounting Bracket—Typical**

**WARNING: THE A/C SYSTEM IS UNDER PRESSURE EVEN WITH THE ENGINE OFF. REFER TO REFRIGERANT WARNINGS IN 24 - HEATING AND AIR CONDITIONING.**

(1) Disconnect negative battery cable from battery.

(2) Partially drain cooling system (Refer to 7 - COOLING - STANDARD PROCEDURE).

## WATER PUMP INLET TUBE - 3.9L/5.2L/5.9L (Continued)

(2) Do not waste reusable coolant. If the solution is clean, drain the coolant into a clean container for reuse.

(3) Remove upper radiator hose clamp at radiator. A special clamp tool must be used to remove the constant tension clamps. Remove hose at radiator.

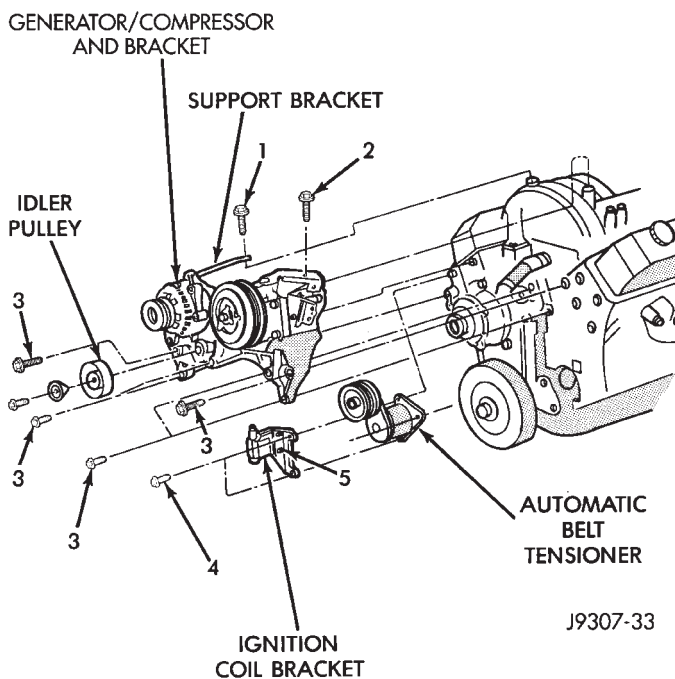
(4) Disconnect throttle cable from clip at radiator fan shroud.

(5) Unplug wiring harness from A/C compressor.

(6) Remove the air cleaner assembly.

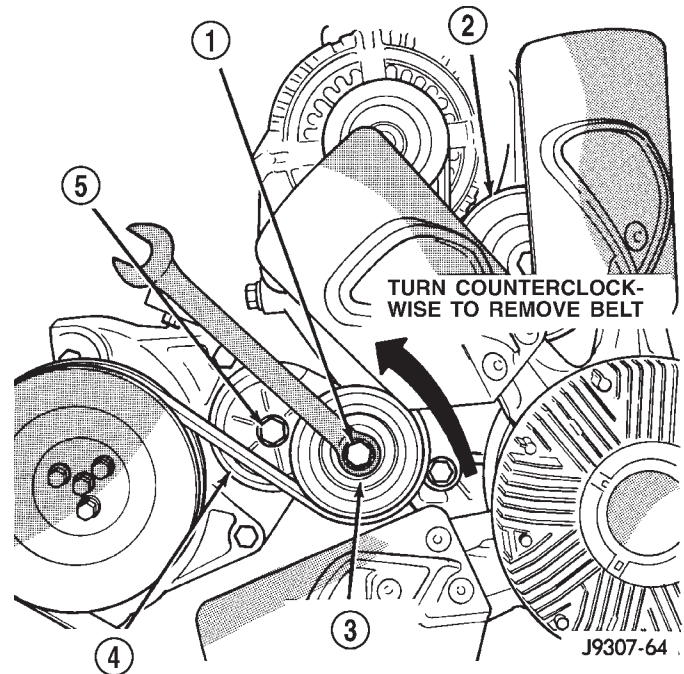
(7) Remove accessory drive belt (Refer to 7 - COOLING/ACCESSORY DRIVE/DRIVE BELTS - REMOVAL).

(8) **3.9L V-6 or 5.2/5.9L V-8 LDC-Gas:** The drive belt idler pulley must be removed to gain access to one of the A/C compressor/generator bracket mounting bolts. Remove the idler pulley bolt and remove idler pulley (Fig. 64).



**Fig. 64 Idler Pulley—3.9L V-6 or 5.2/5.9L V-8 LDC-Gas Engines**

(9) **5.9L HDC-Gas:** The automatic belt tensioner/pulley assembly must be removed to gain access to one of the A/C compressor/generator bracket mounting bolts. Remove the tensioner mounting bolt (Fig. 65) and remove tensioner.



**Fig. 65 Belt Tensioner—5.9L HDC-Gas Engine**

- 1 - PULLEY BOLT
- 2 - IDLER PULLEY
- 3 - TENSIONER PULLEY
- 4 - TENSIONER
- 5 - TENSIONER MOUNTING BOLT

(10) Remove the engine oil dipstick tube mounting bolt at the side of the A/C-generator mounting bracket.

(11) Disconnect throttle body control cables.

(12) Remove heater hose coolant return tube mounting bolt (Fig. 66) (Fig. 67) and remove tube from engine. Discard the old tube O-ring.

(13) Remove bracket-to-intake manifold bolts (number 1 and 2 (Fig. 63).

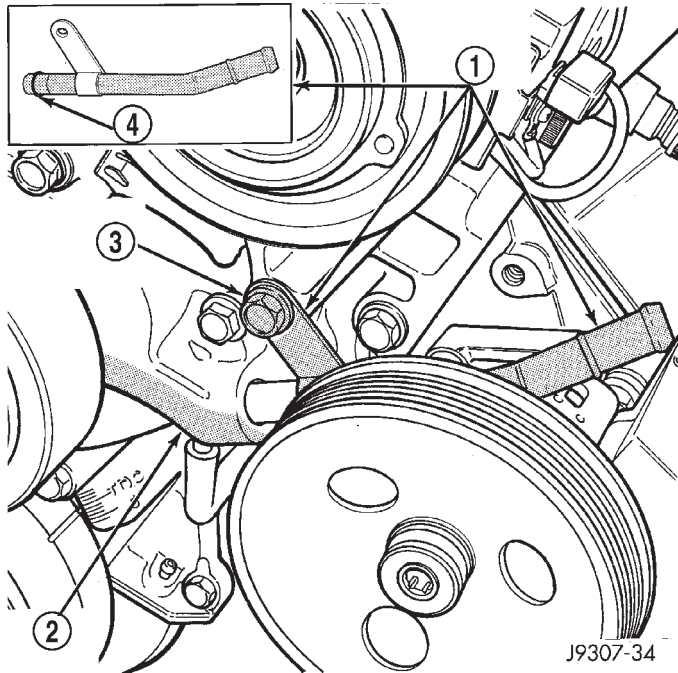
(14) Remove remaining bracket-to-engine bolts (Fig. 68) (Fig. 69).

(15) Lift and position generator and A/C compressor (along with their common mounting bracket) to gain access to bypass hose. A block of wood may be used to hold assembly in position.

(16) Loosen and position both hose clamps to the center of bypass hose. A special clamp tool must be used to remove the constant tension clamps. Remove hose from vehicle.

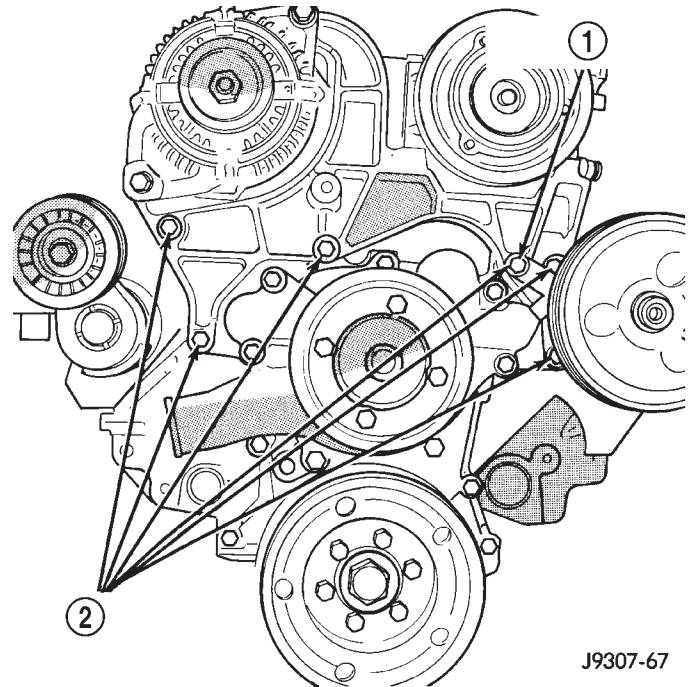


WATER PUMP INLET TUBE - 3.9L/5.2L/5.9L (Continued)



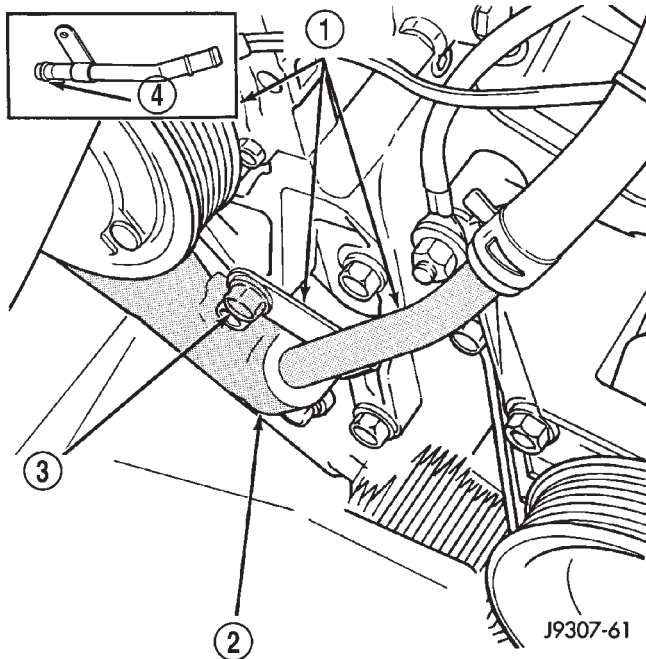
**Fig. 66 Coolant Return**

- 1 - COOLANT RETURN TUBE
- 2 - WATER PUMP
- 3 - TUBE MOUNTING BOLT
- 4 - O-RING



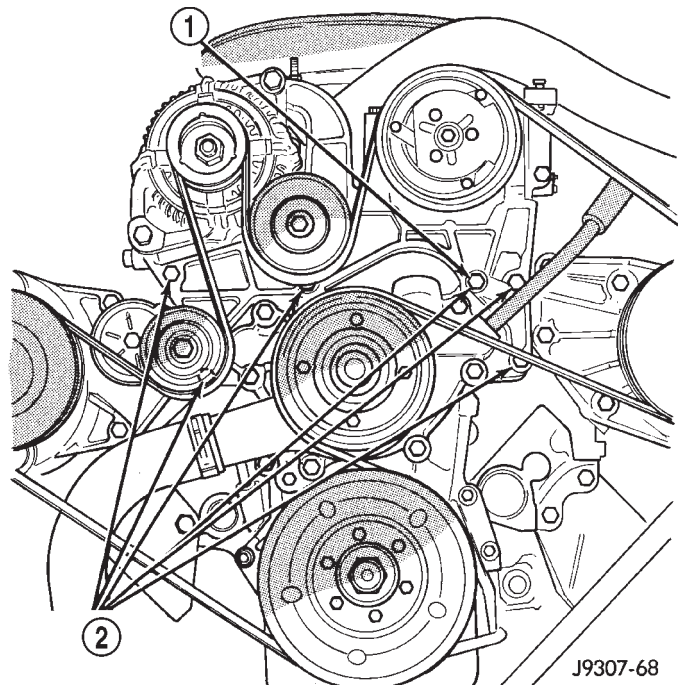
**Fig. 68 Bracket Bolts—3.9L V-6 or 5.2/5.9L V-8 LDC-Gas**

- 1 - COOLANT TUBE MOUNTING BOLT
- 2 - BRACKET MOUNTING BOLTS



**Fig. 67 Coolant Return Tube—5.9L HDC-Gas Engine**

- 1 - COOLANT RETURN TUBE
- 2 - WATER PUMP
- 3 - TUBE MOUNTING BOLT
- 4 - O-RING



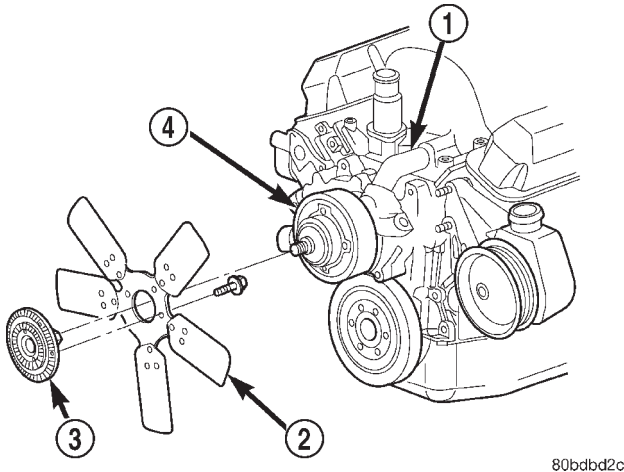
**Fig. 69 Bracket Bolts—5.9L HDC-Gas Engine**

- 1 - COOLANT TUBE MOUNTING BOLT
- 2 - BRACKET MOUNTING BOLTS

## WATER PUMP INLET TUBE - 3.9L/5.2L/5.9L (Continued)

**REMOVAL—WATER PUMP BYPASS HOSE WITHOUT AIR CONDITIONING**

A water pump bypass hose (Fig. 70) is used between the intake manifold and water pump on all gas powered engines. To test for leaks, refer to Testing Cooling System for Leaks in this group.



80bdbd2c

**Fig. 70 Water Pump Bypass Hose—Typical**

- 1 - WATER PUMP BYPASS HOSE
- 2 - FAN BLADE ASSEMBLY
- 3 - VISCOUS FAN DRIVE
- 4 - WATER PUMP AND PULLEY

(1) Partially drain cooling system (Refer to 7 - COOLING - STANDARD PROCEDURE). Do not waste reusable coolant. If the solution is clean, drain the coolant into a clean container for reuse.

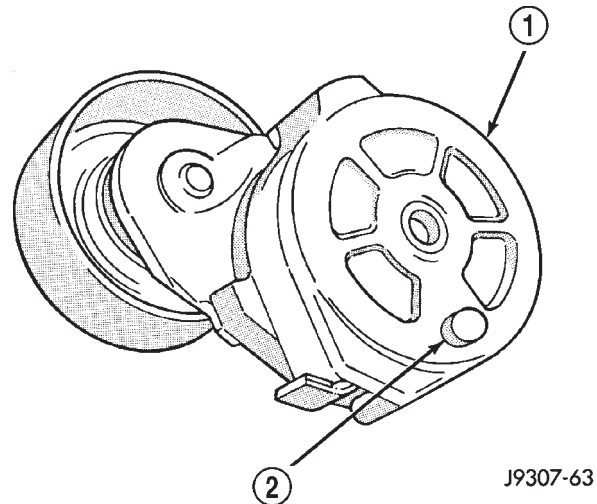
**WARNING: CONSTANT TENSION HOSE CLAMPS ARE USED ON MOST COOLING SYSTEM HOSES. WHEN REMOVING OR INSTALLING, USE ONLY TOOLS DESIGNED FOR SERVICING THIS TYPE OF CLAMP, SUCH AS SPECIAL CLAMP TOOL (NUMBER 6094). SNAP-ON CLAMP TOOL (NUMBER HPC-20) MAY BE USED FOR LARGER CLAMPS. ALWAYS WEAR SAFETY GLASSES WHEN SERVICING CONSTANT TENSION CLAMPS.**

**CAUTION: A number or letter is stamped into the tongue of constant tension clamps. If replacement is necessary, use only an original equipment clamp with a matching number or letter.**

- (2) Loosen both bypass hose clamps and position to the center of hose.
- (3) Remove hose from vehicle.

**INSTALLATION—WATER PUMP BYPASS HOSE WITH AIR CONDITIONING**

- (1) Position bypass hose clamps to the center of hose.
- (2) Install bypass hose to engine.
- (3) Secure both hose clamps.
- (4) Install generator-A/C mounting bracket assembly to engine. Tighten bolt number 1 (Fig. 63) to 41 N·m (30 ft. lbs.) torque. Tighten bolt number 2 (Fig. 63) to 28 N·m (20 ft. lbs.) torque. Tighten bracket mounting bolts (Fig. 68) (Fig. 69) to 40 N·m (30 ft. lbs.) torque.
- (5) Install a new O-ring to the heater hose coolant return tube (Fig. 66) (Fig. 67). Coat the new O-ring with antifreeze before installation.
- (6) Install coolant return tube and its mounting bolt to engine (Fig. 66) (Fig. 67).
- (7) Connect throttle body control cables.
- (8) Install oil dipstick mounting bolt.
- (9) **3.9L V-6 or 5.2/5.9L V-8 LDC-Gas Engines:** Install idler pulley. Tighten bolt to 41 N·m (30 ft. lbs.) torque.
- (10) **5.9L HDC-Gas:** Install automatic belt tensioner assembly to mounting bracket. A dowel pin is located on back of tensioner (Fig. 71). Align this to dowel hole (Fig. 72) in tensioner mounting bracket. Tighten bolt to 41 N·m (30 ft. lbs.) torque.



J9307-63

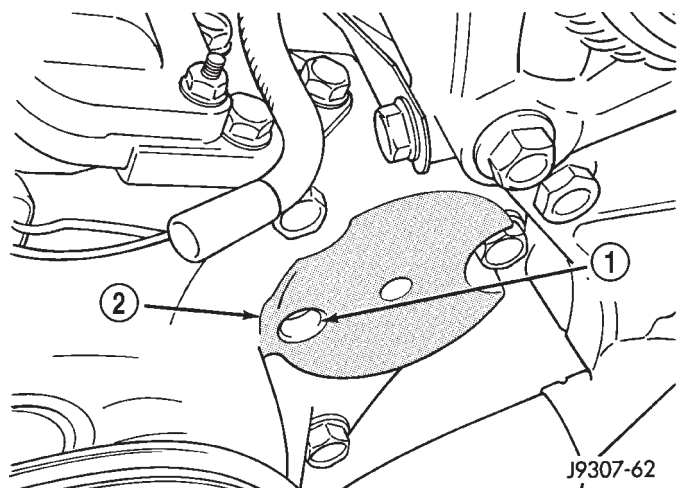
**Fig. 71 Tensioner Dowel Pin—5.9L HDC-Gas Engine**

- 1 - BELT TENSIONER
- 2 - DOWEL PIN

- (11) Install drive belt (Refer to 7 - COOLING/ACCESSORY DRIVE/DRIVE BELTS - INSTALLATION).



## WATER PUMP INLET TUBE - 3.9L/5.2L/5.9L (Continued)



**Fig. 72 Tensioner Mounting**

- 1 - DOWEL PIN HOLE  
2 - TENSIONER MOUNTING BRACKET

- (12) Install air cleaner assembly.
- (13) Install upper radiator hose to radiator.
- (14) Connect throttle cable to clip at radiator fan shroud.
- (15) Connect wiring harness to A/C compressor.
- (16) Fill cooling system (Refer to 7 - COOLING - STANDARD PROCEDURE).
- (17) Start and warm the engine. Check for leaks.

### INSTALLATION—WATER PUMP BYPASS HOSE WITHOUT AIR CONDITIONING

- (1) Position bypass hose clamps to the center of hose.
- (2) Install bypass hose to engine.
- (3) Secure both hose clamps.
- (4) Fill cooling system (Refer to 7 - COOLING - STANDARD PROCEDURE).
- (5) Start and warm the engine. Check for leaks.

**CAUTION:** When installing the serpentine accessory drive belt, the belt must be routed correctly. If not, the engine may overheat due to the water pump rotating in the wrong direction (Refer to 7 - COOLING/ACCESSORY DRIVE/DRIVE BELTS - INSTALLATION). The correct belt with the correct length must be used.

# TRANSMISSION

## TABLE OF CONTENTS

	page		page
<b>TRANS COOLER - 3.9L/5.2L/5.9L</b>		<b>FLUSHING COOLER AND TUBES -</b>	
DESCRIPTION . . . . .	79	WITHOUT RADIATOR IN-TANK	
OPERATION . . . . .	79	TRANSMISSION OIL COOLER . . . . .	83
STANDARD PROCEDURE . . . . .	79	REMOVAL . . . . .	84
FLUSHING COOLERS AND TUBES - WITH		INSTALLATION . . . . .	85
RADIATOR IN-TANK TRANSMISSION OIL		<b>TRANS COOLER - 5.9L DIESEL</b>	
COOLER . . . . .	79	DESCRIPTION . . . . .	85
FLUSHING COOLER AND TUBES -		OPERATION . . . . .	85
WITHOUT RADIATOR IN-TANK		STANDARD PROCEDURE . . . . .	85
TRANSMISSION OIL COOLER . . . . .	80	FLUSHING COOLERS AND TUBES - WITH	
REMOVAL . . . . .	81	RADIATOR IN-TANK TRANSMISSION OIL	
DISASSEMBLY . . . . .	81	COOLER . . . . .	85
ASSEMBLY . . . . .	82	FLUSHING COOLER AND TUBES -	
INSTALLATION . . . . .	82	WITHOUT RADIATOR IN-TANK	
<b>TRANS COOLER - 8.0L</b>		TRANSMISSION OIL COOLER . . . . .	86
DESCRIPTION . . . . .	82	REMOVAL . . . . .	87
OPERATION . . . . .	82	INSTALLATION . . . . .	88
STANDARD PROCEDURE . . . . .	83		
FLUSHING COOLERS AND TUBES - WITH			
RADIATOR IN-TANK TRANSMISSION OIL			
COOLER . . . . .	83		

## TRANS COOLER - 3.9L/5.2L/ 5.9L

### DESCRIPTION

An air-to-oil transmission oil cooler is standard on all engine packages. the cooler is located between the radiator and air conditioning condenser (Fig. 1).

### OPERATION

The transmission oil is routed through the cooler where heat is removed from the transmission oil before returning to the transmission. The cooler has an internal thermostat that controls fluid flow through the cooler. When the transmission fluid is cold ( less than operating temperature) the fluid is routed through the cooler bypass. when the transmission fluid reaches operating temperatures and above,

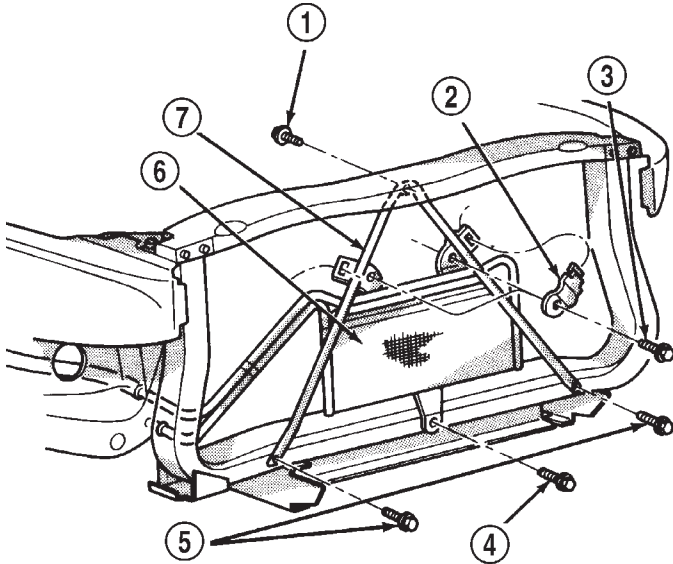
the thermostat closes off the bypass allowing fluid flow through the cooler. The thermostat **MUST** be removed from the cooler before the cooler can be flushed. The thermostat is serviceable.

### STANDARD PROCEDURE - FLUSHING COOLERS AND TUBES - WITH RADIATOR IN-TANK TRANSMISSION OIL COOLER

When a transmission failure has contaminated the fluid, the oil cooler(s) must be flushed. The torque converter must also be replaced. This will insure that metal particles or sludged oil are not later transferred back into the reconditioned (or replaced) transmission.

The only recommended procedure for flushing coolers and lines is to use Tool 6906-B Cooler Flusher.

## TRANS COOLER - 3.9L/5.2L/5.9L (Continued)



J9407-40

**Fig. 1 Automatic Transmission Oil**

- 1 - UPPER RADIATOR SUPPORT BRACKET BOLT
- 2 - MOUNTING STRAPS (2)
- 3 - TRANS. OIL COOLER UPPER MOUNTING BOLTS (2)
- 4 - TRANS. OIL COOLER LOWER MOUNTING BOLT
- 5 - LOWER RADIATOR SUPPORT BRACKET BOLTS (2)
- 6 - TRANSMISSION OIL COOLER
- 7 - RADIATOR SUPPORT BRACKET

**WARNING: WEAR PROTECTIVE EYEWEAR THAT MEETS THE REQUIREMENTS OF OSHA AND ANSI Z87.1-1968. WEAR STANDARD INDUSTRIAL RUBBER GLOVES.**

**KEEP LIGHTED CIGARETTES, SPARKS, FLAMES, AND OTHER IGNITION SOURCES AWAY FROM THE AREA TO PREVENT THE IGNITION OF COMBUSTIBLE LIQUIDS AND GASES. KEEP A CLASS (B) FIRE EXTINGUISHER IN THE AREA WHERE THE FLUSHER WILL BE USED.**

**KEEP THE AREA WELL VENTILATED.**

**DO NOT LET FLUSHING SOLVENT COME IN CONTACT WITH YOUR EYES OR SKIN: IF EYE CONTAMINATION OCCURS, FLUSH EYES WITH WATER FOR 15 TO 20 SECONDS. REMOVE CONTAMINATED CLOTHING AND WASH AFFECTED SKIN WITH SOAP AND WATER. SEEK MEDICAL ATTENTION.**

(1) Remove cover plate filler plug on Tool 6906-B. Fill reservoir 1/2 to 3/4 full of fresh flushing solution. Flushing solvents are petroleum based solutions generally used to clean automatic transmission components. **DO NOT** use solvents containing acids, water, gasoline, or any other corrosive liquids.

(2) Reinstall filler plug on Tool 6906-B.

(3) Verify pump power switch is turned OFF. Connect red alligator clip to positive (+) battery post. Connect black (-) alligator clip to a good ground.

(4) Disconnect the cooler lines at the transmission.

**NOTE: When flushing transmission cooler and lines, ALWAYS reverse flush.**

**NOTE: The converter drainback valve must be removed and an appropriate replacement hose installed to bridge the space between the transmission cooler line and the cooler fitting. Failure to remove the drainback valve will prevent reverse flushing the system. A suitable replacement hose can be found in the adapter kit supplied with the flushing tool.**

(5) Connect the BLUE pressure line to the OUTLET (From) cooler line.

(6) Connect the CLEAR return line to the INLET (To) cooler line

(7) Turn pump ON for two to three minutes to flush cooler(s) and lines.

(8) Turn pump OFF.

(9) Disconnect CLEAR suction line from reservoir at cover plate. Disconnect CLEAR return line at cover plate, and place it in a drain pan.

(10) Turn pump ON for 30 seconds to purge flushing solution from cooler and lines. Turn pump OFF.

(11) Place CLEAR suction line into a one quart container of Mopar® ATF +4, type 9602, Automatic Transmission Fluid.

(12) Turn pump ON until all transmission fluid is removed from the one quart container and lines. This purges any residual cleaning solvent from the transmission cooler and lines. Turn pump OFF.

(13) Disconnect alligator clips from battery. Reconnect flusher lines to cover plate, and remove flushing adapters from cooler lines.

### STANDARD PROCEDURE - FLUSHING COOLER AND TUBES - WITHOUT RADIATOR IN-TANK TRANSMISSION OIL COOLER

When a transmission failure has contaminated the fluid, the oil cooler(s) must be flushed. The torque converter must also be replaced. This will insure that metal particles or sludged oil are not later transferred back into the reconditioned (or replaced) transmission.

(1) Remove cover plate filler plug on Tool 6906B. Fill reservoir 1/2 to 3/4 full of fresh flushing solution. Flushing solvents are petroleum based solutions generally used to clean automatic transmission components. **DO NOT** use solvents containing acids, water, gasoline, or any other corrosive liquids.

## TRANS COOLER - 3.9L/5.2L/5.9L (Continued)

- (2) Reinstall filler plug on Tool 6906B.
- (3) Verify pump power switch is turned OFF. Connect red alligator clip to positive (+) battery post. Connect black (-) alligator clip to a good ground.
- (4) Disconnect the cooler lines at the transmission.

**NOTE: When flushing transmission cooler and lines, ALWAYS reverse flush.**

**NOTE: The converter drainback valve must be removed and an appropriate replacement hose installed to bridge the space between the transmission cooler line and the cooler fitting. Failure to remove the drainback valve will prevent reverse flushing the system. A suitable replacement hose can be found in the adapter kit supplied with the flushing tool.**

- (5) Connect the BLUE pressure line to the OUTLET (From) cooler line.
- (6) Connect the CLEAR return line to the INLET (To) cooler line
- (7) Remove the transmission oil cooler from the vehicle. (Refer to 7 - COOLING/TRANSMISSION/TRANS COOLER - REMOVAL)
- (8) Remove the transmission oil cooler thermostat. (Refer to 7 - COOLING/TRANSMISSION/TRANS COOLER - DISASSEMBLY)
- (9) Re-install the thermostat cover onto the oil cooler and install the snap-ring.
- (10) Re-connect the oil cooler to the transmission cooler lines.
- (11) Turn pump ON for two to three minutes to flush cooler(s) and lines.

**NOTE: This flushes the bypass circuit of the cooler only.**

- (12) Turn pump OFF.
- (13) Remove the thermostat cover from the oil cooler.
- (14) Install Special Tool Cooler Plug 8414 into the transmission oil cooler.
- (15) Re-install the thermostat cover onto the oil cooler and install the snap-ring.
- (16) Turn pump ON for two to three minutes to flush cooler(s) and lines.

**NOTE: This flushes the main oil cooler core passages only.**

- (17) Turn pump OFF.
- (18) Remove the thermostat cover from the oil cooler.
- (19) Remove Special Tool Cooler Plug 8414 from the transmission oil cooler.

(20) Install a new thermostat spring, thermostat, cover, and snap-ring into the transmission oil cooler. (Refer to 7 - COOLING/TRANSMISSION/TRANS COOLER - ASSEMBLY)

(21) Install the transmission oil cooler onto the vehicle. (Refer to 7 - COOLING/TRANSMISSION/TRANS COOLER - INSTALLATION)

(22) Disconnect CLEAR suction line from reservoir at cover plate. Disconnect CLEAR return line at cover plate, and place it in a drain pan.

(23) Turn pump ON for 30 seconds to purge flushing solution from cooler and lines. Turn pump OFF.

(24) Place CLEAR suction line into a one quart container of Mopar® ATF +4, type 9602, Automatic Transmission fluid.

(25) Turn pump ON until all transmission fluid is removed from the one quart container and lines. This purges any residual cleaning solvent from the transmission cooler and lines. Turn pump OFF.

(26) Disconnect alligator clips from battery. Reconnect flusher lines to cover plate, and remove flushing adapters from cooler lines.

## REMOVAL

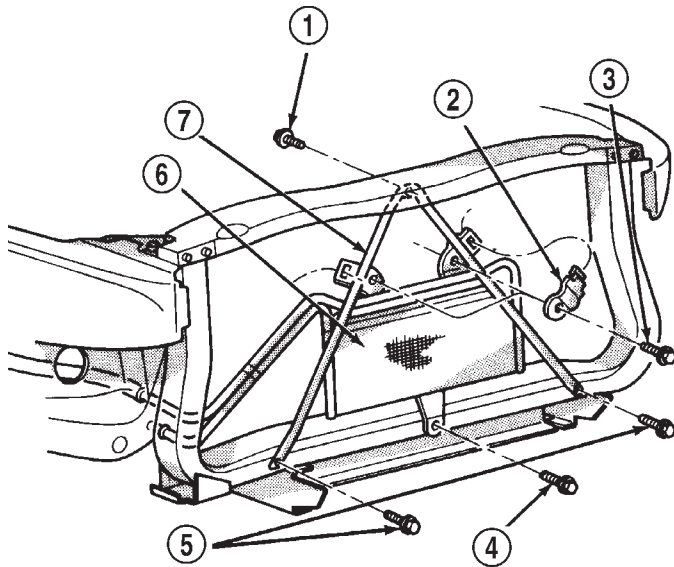
- (1) Disconnect battery negative cable.
- (2) Place a drain pan under the oil cooler lines.
- (3) Disconnect the transmission oil cooler line quick-connect fitting at the cooler outlet using the quick connect release tool 6935. Loosen clamp from inlet connection and slide hose off of nipple. Plug cooler lines to prevent oil leakage.
- (4) Remove the oil cooler lower mounting bolt (oil cooler-to-vehicle body) (Fig. 2).
- (5) Remove three bolts (radiator support bracket-to-body) . Remove this A-shaped support bracket and the transmission oil cooler as an assembly from the vehicle. Take care not to damage the radiator core or A/C condenser fins with the cooling lines when removing.
- (6) Remove oil cooler from A-shaped support bracket by removing two upper mounting strap bolts and mounting straps at support bracket (Fig. 2).
- (7) Remove oil cooler from the A-shaped radiator support bracket.

## DISASSEMBLY

**NOTE: The transmission oil cooler uses an internal thermostat to control transmission oil flow through the cooler. This thermostat is servicable.**

- (1) Remove the transmission oil cooler (Refer to 7 - COOLING/TRANSMISSION/TRANS COOLER - REMOVAL).
- (2) Remove the snap ring retaining the thermostat end plug (Fig. 3).

## TRANS COOLER - 3.9L/5.2L/5.9L (Continued)

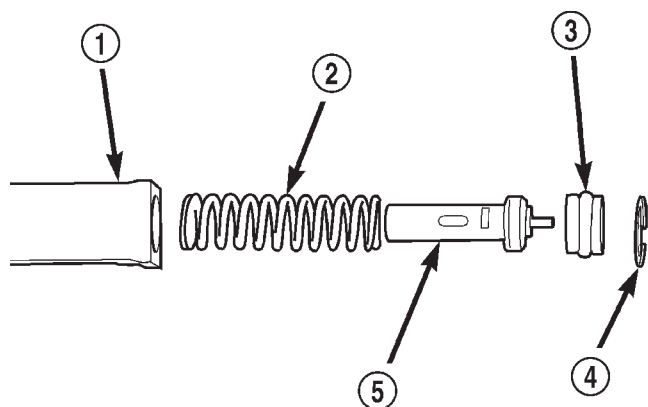


J9407-40

**Fig. 2 Transmission Oil Cooler—3.9/5.2/5.9L Engines**

- 1 - UPPER RADIATOR SUPPORT BRACKET BOLT
- 2 - MOUNTING STRAPS (2)
- 3 - TRANS. OIL COOLER UPPER MOUNTING BOLTS (2)
- 4 - TRANS. OIL COOLER LOWER MOUNTING BOLT
- 5 - LOWER RADIATOR SUPPORT BRACKET BOLTS (2)
- 6 - TRANSMISSION OIL COOLER
- 7 - RADIATOR SUPPORT BRACKET

(3) Remove the end plug, thermostat and spring from transmission oil cooler (Fig. 3).



80c07235

**Fig. 3 Transmission Oil Cooler Thermostat Removal/Installation**

- 1 - THERMOSTAT HOUSING
- 2 - SPRING
- 3 - END PLUG
- 4 - SNAP RING
- 5 - THERMOSTAT

**ASSEMBLY**

- (1) Thoroughly clean the thermostat bore on the transmission oil cooler.
- (2) Install new spring, thermostat, end plug and snap ring.
- (3) Install transmission oil cooler (Refer to 7 - COOLING/TRANSMISSION/TRANS COOLER - INSTALLATION).

**INSTALLATION**

- (1) Install the oil cooler assembly to the A-shaped radiator support bracket using the two upper mounting bolts and mounting straps. Install the bolts but do not tighten at this time.
- (2) Install the radiator support bracket and oil cooler (as an assembly) to the vehicle.
- (3) Install the two lower radiator A-shaped support bracket bolts. Do not tighten bolts at this time.
- (4) Slide and position the oil cooler on the A-shaped bracket until its lower mounting hole lines up with the bolt hole on the vehicle body. Tighten the oil cooler mounting strap bolts to 6 N·m (50 in. lbs.) torque.
- (5) Install the upper radiator A-shaped support bracket bolt. Tighten all three radiator support bracket mounting bolts to 11 N·m (95 in. lbs.) torque.
- (6) Inspect quick connect fitting for debris and install the quick-connect fitting on the cooler outler tube until an audible "click" is heard. Pull apart to verify connection.
- (7) Connect battery negative cable.
- (8) Start the engine and check all fittings for leaks.
- (9) Check the fluid level in the automatic transmission (Refer to 21 - TRANSMISSION/TRAN-SAXLE/AUTOMATIC - 42RE/FLUID - STANDARD PROCEDURE), (Refer to 21 - TRANSMISSION/TRAN-SAXLE/AUTOMATIC - 44RE/FLUID - STANDARD PROCEDURE) or (Refer to 21 - TRANSMISSION/TRAN-SAXLE/AUTOMATIC - 46RE/FLUID - STANDARD PROCEDURE).

**TRANS COOLER - 8.0L****DESCRIPTION**

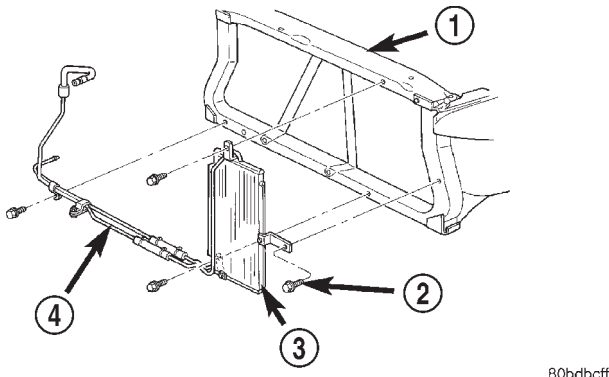
The air-to-oil cooler is located in front of and to the left side of the radiator (Fig. 4). This cooler is supplied as standard equipment on all models equipped with an automatic transmission.

**OPERATION**

The transmission oil is routed through the cooler where the cooler removes heat from the transmission fluid, before returning to the transmission.



## TRANS COOLER - 8.0L (Continued)



80bdbcff

**Fig. 4 Automatic Transmission Oil Cooler—8.0L Engine**

- 1 - RADIATOR SUPPORT
- 2 - OIL COOLER MOUNTING BOLTS
- 3 - TRANSMISSION OIL COOLER
- 4 - TRANSMISSION OIL COOLER LINES

### STANDARD PROCEDURE - FLUSHING COOLERS AND TUBES - WITH RADIATOR IN-TANK TRANSMISSION OIL COOLER

When a transmission failure has contaminated the fluid, the oil cooler(s) must be flushed. The torque converter must also be replaced. This will insure that metal particles or sludged oil are not later transferred back into the reconditioned (or replaced) transmission.

The only recommended procedure for flushing coolers and lines is to use Tool 6906-B Cooler Flusher.

**WARNING: WEAR PROTECTIVE EYEWEAR THAT MEETS THE REQUIREMENTS OF OSHA AND ANSI Z87.1-1968. WEAR STANDARD INDUSTRIAL RUBBER GLOVES.**

**KEEP LIGHTED CIGARETTES, SPARKS, FLAMES, AND OTHER IGNITION SOURCES AWAY FROM THE AREA TO PREVENT THE IGNITION OF COMBUSTIBLE LIQUIDS AND GASES. KEEP A CLASS (B) FIRE EXTINGUISHER IN THE AREA WHERE THE FLUSHER WILL BE USED.**

**KEEP THE AREA WELL VENTILATED.**

**DO NOT LET FLUSHING SOLVENT COME IN CONTACT WITH YOUR EYES OR SKIN: IF EYE CONTAMINATION OCCURS, FLUSH EYES WITH WATER FOR 15 TO 20 SECONDS. REMOVE CONTAMINATED CLOTHING AND WASH AFFECTED SKIN WITH SOAP AND WATER. SEEK MEDICAL ATTENTION.**

(1) Remove cover plate filler plug on Tool 6906-B. Fill reservoir 1/2 to 3/4 full of fresh flushing solution. Flushing solvents are petroleum based solutions generally used to clean automatic transmission components. **DO NOT** use solvents containing acids, water, gasoline, or any other corrosive liquids.

(2) Reinstall filler plug on Tool 6906-B.

(3) Verify pump power switch is turned OFF. Connect red alligator clip to positive (+) battery post. Connect black (-) alligator clip to a good ground.

(4) Disconnect the cooler lines at the transmission.

**NOTE: When flushing transmission cooler and lines, ALWAYS reverse flush.**

**NOTE: The converter drainback valve must be removed and an appropriate replacement hose installed to bridge the space between the transmission cooler line and the cooler fitting. Failure to remove the drainback valve will prevent reverse flushing the system. A suitable replacement hose can be found in the adapter kit supplied with the flushing tool.**

(5) Connect the BLUE pressure line to the OUTLET (From) cooler line.

(6) Connect the CLEAR return line to the INLET (To) cooler line

(7) Turn pump ON for two to three minutes to flush cooler(s) and lines.

(8) Turn pump OFF.

(9) Disconnect CLEAR suction line from reservoir at cover plate. Disconnect CLEAR return line at cover plate, and place it in a drain pan.

(10) Turn pump ON for 30 seconds to purge flushing solution from cooler and lines. Turn pump OFF.

(11) Place CLEAR suction line into a one quart container of Mopar® ATF +4, type 9602, Automatic Transmission Fluid.

(12) Turn pump ON until all transmission fluid is removed from the one quart container and lines. This purges any residual cleaning solvent from the transmission cooler and lines. Turn pump OFF.

(13) Disconnect alligator clips from battery. Reconnect flusher lines to cover plate, and remove flushing adapters from cooler lines.

### STANDARD PROCEDURE - FLUSHING COOLER AND TUBES - WITHOUT RADIATOR IN-TANK TRANSMISSION OIL COOLER

When a transmission failure has contaminated the fluid, the oil cooler(s) must be flushed. The torque converter must also be replaced. This will insure that metal particles or sludged oil are not later transferred back into the reconditioned (or replaced) transmission.

(1) Remove cover plate filler plug on Tool 6906B. Fill reservoir 1/2 to 3/4 full of fresh flushing solution. Flushing solvents are petroleum based solutions gen-

## TRANS COOLER - 8.0L (Continued)

erally used to clean automatic transmission components. **DO NOT** use solvents containing acids, water, gasoline, or any other corrosive liquids.

(2) Reinstall filler plug on Tool 6906B.

(3) Verify pump power switch is turned OFF. Connect red alligator clip to positive (+) battery post. Connect black (-) alligator clip to a good ground.

(4) Disconnect the cooler lines at the transmission.

**NOTE: When flushing transmission cooler and lines, ALWAYS reverse flush.**

**NOTE: The converter drainback valve must be removed and an appropriate replacement hose installed to bridge the space between the transmission cooler line and the cooler fitting. Failure to remove the drainback valve will prevent reverse flushing the system. A suitable replacement hose can be found in the adapter kit supplied with the flushing tool.**

(5) Connect the BLUE pressure line to the OUTLET (From) cooler line.

(6) Connect the CLEAR return line to the INLET (To) cooler line

(7) Remove the transmission oil cooler from the vehicle. (Refer to 7 - COOLING/TRANSMISSION/TRANS COOLER - REMOVAL)

(8) Remove the transmission oil cooler thermostat. (Refer to 7 - COOLING/TRANSMISSION/TRANS COOLER - DISASSEMBLY)

(9) Re-install the thermostat cover onto the oil cooler and install the snap-ring.

(10) Re-connect the oil cooler to the transmission cooler lines.

(11) Turn pump ON for two to three minutes to flush cooler(s) and lines.

**NOTE: This flushes the bypass circuit of the cooler only.**

(12) Turn pump OFF.

(13) Remove the thermostat cover from the oil cooler.

(14) Install Special Tool Cooler Plug 8414 into the transmission oil cooler.

(15) Re-install the thermostat cover onto the oil cooler and install the snap-ring.

(16) Turn pump ON for two to three minutes to flush cooler(s) and lines.

**NOTE: This flushes the main oil cooler core passages only.**

(17) Turn pump OFF.

(18) Remove the thermostat cover from the oil cooler.

(19) Remove Special Tool Cooler Plug 8414 from the transmission oil cooler.

(20) Install a new thermostat spring, thermostat, cover, and snap-ring into the transmission oil cooler. (Refer to 7 - COOLING/TRANSMISSION/TRANS COOLER - ASSEMBLY)

(21) Install the transmission oil cooler onto the vehicle. (Refer to 7 - COOLING/TRANSMISSION/TRANS COOLER - INSTALLATION)

(22) Disconnect CLEAR suction line from reservoir at cover plate. Disconnect CLEAR return line at cover plate, and place it in a drain pan.

(23) Turn pump ON for 30 seconds to purge flushing solution from cooler and lines. Turn pump OFF.

(24) Place CLEAR suction line into a one quart container of Mopar® ATF +4, type 9602, Automatic Transmission fluid.

(25) Turn pump ON until all transmission fluid is removed from the one quart container and lines. This purges any residual cleaning solvent from the transmission cooler and lines. Turn pump OFF.

(26) Disconnect alligator clips from battery. Reconnect flusher lines to cover plate, and remove flushing adapters from cooler lines.

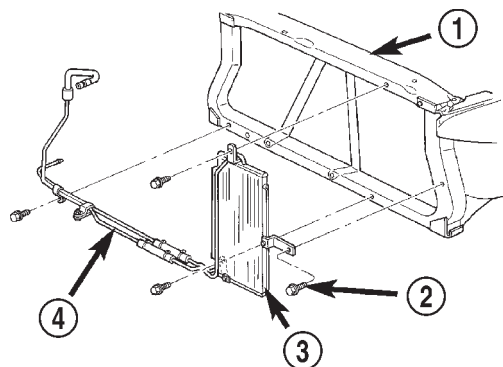
## REMOVAL

(1) Place a drain pan under the oil cooler lines.

(2) Disconnect the two transmission lines from the oil cooler by loosening the two worm gear clamps and pulling the rubber hoses off of the oil cooler tubes (Fig. 5). Plug all oil cooler lines to prevent oil leakage.

(3) Remove three oil cooler-to-radiator support mounting bolts (Fig. 5).

(4) Remove the oil cooler and line assembly from the vehicle.



80bdbcff

**Fig. 5 Transmission Oil Cooler—8.0L Engine**

- 1 - RADIATOR SUPPORT
- 2 - OIL COOLER MOUNTING BOLTS
- 3 - TRANSMISSION OIL COOLER
- 4 - TRANSMISSION OIL COOLER LINES

## TRANS COOLER - 8.0L (Continued)

## INSTALLATION

(1) Install the oil cooler and cooler line assembly to the vehicle.

(2) Install three mounting bolts and tighten to 6 N·m (50 in. lbs.) torque.

(3) Connect the transmission cooling lines to the oil cooler by pushing the rubber hoses onto the oil cooler tubes. Tighten the worm gear clamps to 2 N·m (18 in. lbs.)

(4) Start the engine and check all fittings for leaks.

(5) Check the fluid level in the automatic transmission (Refer to 21 - TRANSMISSION/TRAN-SAXLE/AUTOMATIC - 47RE/FLUID - STANDARD PROCEDURE).

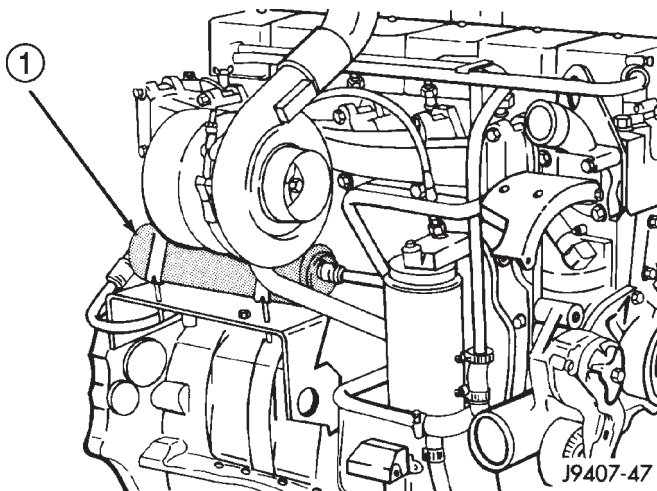
## TRANS COOLER - 5.9L DIESEL

## DESCRIPTION

All diesel models equipped with an automatic transmission are equipped with both a main water-to-oil cooler and a separate air-to-oil cooler. Both coolers are supplied as standard equipment on diesel engine powered models when equipped with an automatic transmission.

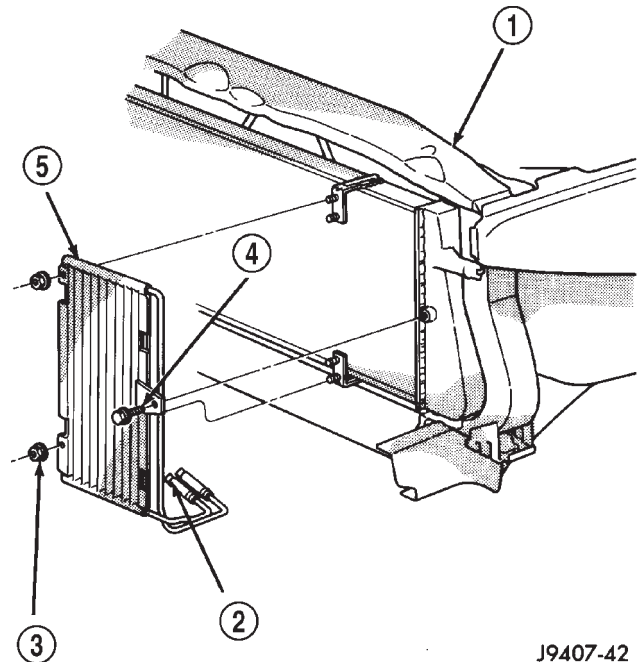
The main water-to-oil transmission oil cooler is mounted to a bracket on the turbocharger side of the engine (Fig. 6).

The air-to-oil cooler is located in front of and to the left side of the radiator (Fig. 7).



**Fig. 6 Transmission Water-To-Oil Cooler—Diesel Engine—Typical**

1 - TRANSMISSION WATER-TO-OIL COOLER



J9407-42

**Fig. 7 Auxiliary Transmission Oil Cooler—Diesel Engine**

- 1 - CHARGE AIR COOLER (INTERCOOLER)
- 2 - QUICK-CONNECT FITTINGS (2)
- 3 - MOUNTING NUTS (2)
- 4 - MOUNTING BOLT
- 5 - TRANSMISSION OIL COOLER

## OPERATION

The transmission oil is routed through the main cooler first, then the auxiliary cooler where additional heat is removed from the transmission oil before returning to the transmission.

## STANDARD PROCEDURE - FLUSHING COOLERS AND TUBES - WITH RADIATOR IN-TANK TRANSMISSION OIL COOLER

When a transmission failure has contaminated the fluid, the oil cooler(s) must be flushed. The torque converter must also be replaced. This will insure that metal particles or sludged oil are not later transferred back into the reconditioned (or replaced) transmission.

The only recommended procedure for flushing coolers and lines is to use Tool 6906-B Cooler Flusher.

## TRANS COOLER - 5.9L DIESEL (Continued)

**WARNING: WEAR PROTECTIVE EYEWEAR THAT MEETS THE REQUIREMENTS OF OSHA AND ANSI Z87.1-1968. WEAR STANDARD INDUSTRIAL RUBBER GLOVES.**

**KEEP LIGHTED CIGARETTES, SPARKS, FLAMES, AND OTHER IGNITION SOURCES AWAY FROM THE AREA TO PREVENT THE IGNITION OF COMBUSTIBLE LIQUIDS AND GASES. KEEP A CLASS (B) FIRE EXTINGUISHER IN THE AREA WHERE THE FLUSHER WILL BE USED.**

**KEEP THE AREA WELL VENTILATED.**

**DO NOT LET FLUSHING SOLVENT COME IN CONTACT WITH YOUR EYES OR SKIN: IF EYE CONTAMINATION OCCURS, FLUSH EYES WITH WATER FOR 15 TO 20 SECONDS. REMOVE CONTAMINATED CLOTHING AND WASH AFFECTED SKIN WITH SOAP AND WATER. SEEK MEDICAL ATTENTION.**

(1) Remove cover plate filler plug on Tool 6906-B. Fill reservoir 1/2 to 3/4 full of fresh flushing solution. Flushing solvents are petroleum based solutions generally used to clean automatic transmission components. **DO NOT** use solvents containing acids, water, gasoline, or any other corrosive liquids.

(2) Reinstall filler plug on Tool 6906-B.

(3) Verify pump power switch is turned OFF. Connect red alligator clip to positive (+) battery post. Connect black (-) alligator clip to a good ground.

(4) Disconnect the cooler lines at the transmission.

**NOTE: When flushing transmission cooler and lines, ALWAYS reverse flush.**

**NOTE: The converter drainback valve must be removed and an appropriate replacement hose installed to bridge the space between the transmission cooler line and the cooler fitting. Failure to remove the drainback valve will prevent reverse flushing the system. A suitable replacement hose can be found in the adapter kit supplied with the flushing tool.**

(5) Connect the BLUE pressure line to the OUTLET (From) cooler line.

(6) Connect the CLEAR return line to the INLET (To) cooler line

(7) Turn pump ON for two to three minutes to flush cooler(s) and lines.

(8) Turn pump OFF.

(9) Disconnect CLEAR suction line from reservoir at cover plate. Disconnect CLEAR return line at cover plate, and place it in a drain pan.

(10) Turn pump ON for 30 seconds to purge flushing solution from cooler and lines. Turn pump OFF.

(11) Place CLEAR suction line into a one quart container of Mopar® ATF +4, type 9602, Automatic Transmission Fluid.

(12) Turn pump ON until all transmission fluid is removed from the one quart container and lines. This purges any residual cleaning solvent from the transmission cooler and lines. Turn pump OFF.

(13) Disconnect alligator clips from battery. Reconnect flusher lines to cover plate, and remove flushing adapters from cooler lines.

### STANDARD PROCEDURE - FLUSHING COOLER AND TUBES - WITHOUT RADIATOR IN-TANK TRANSMISSION OIL COOLER

When a transmission failure has contaminated the fluid, the oil cooler(s) must be flushed. The torque converter must also be replaced. This will insure that metal particles or sludged oil are not later transferred back into the reconditioned (or replaced) transmission.

(1) Remove cover plate filler plug on Tool 6906B. Fill reservoir 1/2 to 3/4 full of fresh flushing solution. Flushing solvents are petroleum based solutions generally used to clean automatic transmission components. **DO NOT** use solvents containing acids, water, gasoline, or any other corrosive liquids.

(2) Reinstall filler plug on Tool 6906B.

(3) Verify pump power switch is turned OFF. Connect red alligator clip to positive (+) battery post. Connect black (-) alligator clip to a good ground.

(4) Disconnect the cooler lines at the transmission.

**NOTE: When flushing transmission cooler and lines, ALWAYS reverse flush.**

**NOTE: The converter drainback valve must be removed and an appropriate replacement hose installed to bridge the space between the transmission cooler line and the cooler fitting. Failure to remove the drainback valve will prevent reverse flushing the system. A suitable replacement hose can be found in the adapter kit supplied with the flushing tool.**

(5) Connect the BLUE pressure line to the OUTLET (From) cooler line.

(6) Connect the CLEAR return line to the INLET (To) cooler line

(7) Remove the transmission oil cooler from the vehicle. (Refer to 7 - COOLING/TRANSMISSION/TRANS COOLER - REMOVAL)

(8) Remove the transmission oil cooler thermostat. (Refer to 7 - COOLING/TRANSMISSION/TRANS COOLER - DISASSEMBLY)



## TRANS COOLER - 5.9L DIESEL (Continued)

(9) Re-install the thermostat cover onto the oil cooler and install the snap-ring.

(10) Re-connect the oil cooler to the transmission cooler lines.

(11) Turn pump ON for two to three minutes to flush cooler(s) and lines.

**NOTE: This flushes the bypass circuit of the cooler only.**

(12) Turn pump OFF.

(13) Remove the thermostat cover from the oil cooler.

(14) Install Special Tool Cooler Plug 8414 into the transmission oil cooler.

(15) Re-install the thermostat cover onto the oil cooler and install the snap-ring.

(16) Turn pump ON for two to three minutes to flush cooler(s) and lines.

**NOTE: This flushes the main oil cooler core passages only.**

(17) Turn pump OFF.

(18) Remove the thermostat cover from the oil cooler.

(19) Remove Special Tool Cooler Plug 8414 from the transmission oil cooler.

(20) Install a new thermostat spring, thermostat, cover, and snap-ring into the transmission oil cooler. (Refer to 7 - COOLING/TRANSMISSION/TRANS COOLER - ASSEMBLY)

(21) Install the transmission oil cooler onto the vehicle. (Refer to 7 - COOLING/TRANSMISSION/TRANS COOLER - INSTALLATION)

(22) Disconnect CLEAR suction line from reservoir at cover plate. Disconnect CLEAR return line at cover plate, and place it in a drain pan.

(23) Turn pump ON for 30 seconds to purge flushing solution from cooler and lines. Turn pump OFF.

(24) Place CLEAR suction line into a one quart container of Mopar® ATF +4, type 9602, Automatic Transmission fluid.

(25) Turn pump ON until all transmission fluid is removed from the one quart container and lines. This purges any residual cleaning solvent from the transmission cooler and lines. Turn pump OFF.

(26) Disconnect alligator clips from battery. Reconnect flusher lines to cover plate, and remove flushing adapters from cooler lines.

## REMOVAL—AIR TO OIL COOLER

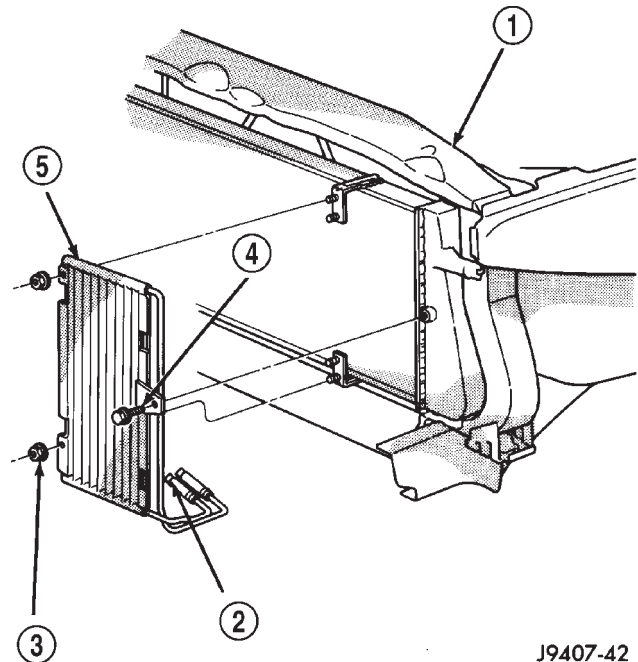
(1) Remove front bumper.

(2) Place a drain pan under the oil cooler.

(3) Raise the vehicle.

(4) Disconnect the oil cooler quick-connect fittings from the transmission lines.

(5) Remove the charge air cooler-to-oil cooler bolt (Fig. 8).



J9407-42

**Fig. 8 Auxiliary Transmission Oil Cooler—Diesel Engine**

- 1 - CHARGE AIR COOLER (INTERCOOLER)
- 2 - QUICK-CONNECT FITTINGS (2)
- 3 - MOUNTING NUTS (2)
- 4 - MOUNTING BOLT
- 5 - TRANSMISSION OIL COOLER

(6) Remove two mounting nuts.

(7) Remove the oil cooler and line assembly towards the front of vehicle. Cooler must be rotated and tilted into position while removing.

## REMOVAL—WATER TO OIL COOLER

**CAUTION: If a leak should occur in the water-to-oil cooler mounted to the side of the engine block, engine coolant may become mixed with transmission fluid. Transmission fluid may also enter engine cooling system. Both cooling system and transmission should be drained and inspected in case of oil cooler leakage.**

(1) Disconnect both battery negative cables.

(2) Remove air cleaner assembly and air cleaner intake hoses.

(3) Drain cooling system (Refer to 7 - COOLING - STANDARD PROCEDURE).

(4) Disconnect coolant lines from cooler.

(5) Disconnect transmission oil lines from cooler. Plug cooler lines to prevent oil leakage.

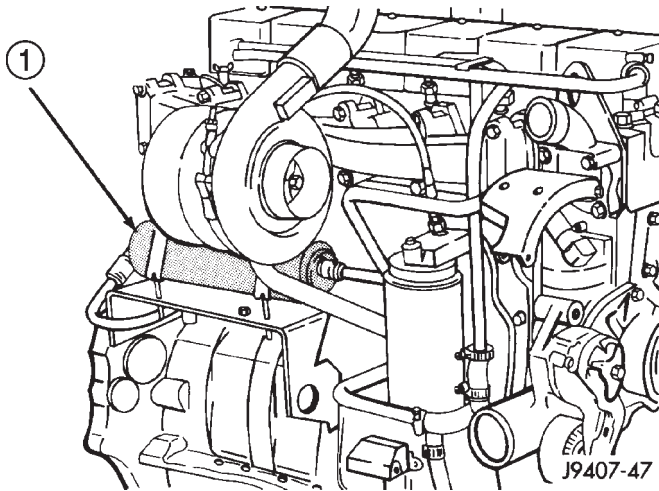
(6) Remove oil cooler mounting straps (Fig. 9).



## TRANS COOLER - 5.9L DIESEL (Continued)

(7) Lift oil cooler off of mounting bracket.

(8) If replacing cooler, make sure to transfer converter drain back valve to new cooler.



**Fig. 9 Transmission Water-To- Oil Cooler—Diesel**

1 - TRANSMISSION WATER-TO-OIL COOLER

**INSTALLATION—AIR TO OIL COOLER**

(1) Carefully position the oil cooler assembly to the vehicle.

(2) Install two nuts and one bolt. Tighten to 11 N·m (95 in. lbs.) torque.

(3) Connect the quick-connect fittings to the transmission cooler lines.

(4) Install front bumper.

(5) Start the engine and check all fittings for leaks.

(6) Check the fluid level in the automatic transmission (Refer to 21 - TRANSMISSION/TRANSAXLE/AUTOMATIC - 47RE/FLUID - STANDARD PROCEDURE).

**INSTALLATION**

(1) Position oil cooler on bracket.

(2) Install mounting straps.

(3) Connect transmission oil lines to cooler.

(4) Connect coolant hoses to cooler.

(5) Connect battery negative cables.

(6) Fill cooling system (Refer to 7 - COOLING - STANDARD PROCEDURE).

(7) Check transmission oil level and fill as necessary (Refer to 21 - TRANSMISSION/TRANSAXLE/AUTOMATIC - 47RE/FLUID - STANDARD PROCEDURE).

(8) Install air cleaner assembly and air cleaner intake hoses.

# AUDIO

## TABLE OF CONTENTS

	page	page
<b>AUDIO</b>		
DESCRIPTION . . . . .	1	
OPERATION . . . . .	2	
DIAGNOSIS AND TESTING . . . . .	2	
AUDIO . . . . .	2	
SPECIAL TOOLS . . . . .	4	
<b>ANTENNA BODY &amp; CABLE</b>		
DESCRIPTION . . . . .	4	
OPERATION . . . . .	4	
DIAGNOSIS AND TESTING . . . . .	5	
ANTENNA . . . . .	5	
REMOVAL . . . . .	6	
INSTALLATION . . . . .	7	
<b>RADIO CHOKE RELAY</b>		
DESCRIPTION . . . . .	8	
OPERATION . . . . .	8	
DIAGNOSIS AND TESTING . . . . .	8	
RADIO CHOKE RELAY . . . . .	8	
REMOVAL . . . . .	9	
INSTALLATION . . . . .	9	
<b>INSTRUMENT PANEL ANTENNA CABLE</b>		
REMOVAL . . . . .	9	
INSTALLATION . . . . .	10	
<b>RADIO</b>		
DESCRIPTION . . . . .	10	
OPERATION . . . . .	10	
DIAGNOSIS AND TESTING . . . . .	10	
RADIO . . . . .	10	
REMOVAL . . . . .	11	
INSTALLATION . . . . .	12	
<b>RADIO NOISE SUPPRESSION COMPONENTS</b>		
DESCRIPTION . . . . .	12	
DIAGNOSIS AND TESTING . . . . .	12	
RADIO NOISE SUPPRESSION COMPONENTS . . . . .	12	
<b>ENGINE-TO-BODY GROUND STRAP</b>		
REMOVAL . . . . .	13	
INSTALLATION . . . . .	13	
<b>CAB-TO- BED GROUND STRAP</b>		
REMOVAL . . . . .	14	
INSTALLATION . . . . .	14	
<b>HEATER CORE GROUND STRAP</b>		
REMOVAL . . . . .	14	
INSTALLATION . . . . .	15	
<b>REMOTE SWITCHES</b>		
DESCRIPTION . . . . .	15	
OPERATION . . . . .	15	
DIAGNOSIS AND TESTING . . . . .	16	
REMOTE SWITCHES . . . . .	16	
REMOVAL . . . . .	16	
INSTALLATION . . . . .	17	
<b>SPEAKER</b>		
DESCRIPTION . . . . .	17	
OPERATION . . . . .	17	
DIAGNOSIS AND TESTING . . . . .	18	
SPEAKER . . . . .	18	
<b>A-PILLAR TWEETER SPEAKER</b>		
REMOVAL . . . . .	19	
INSTALLATION . . . . .	19	
<b>FRONT DOOR SPEAKER</b>		
REMOVAL . . . . .	20	
INSTALLATION . . . . .	20	
<b>REAR CAB SIDE PANEL SPEAKER</b>		
REMOVAL . . . . .	20	
INSTALLATION . . . . .	21	
<b>REAR DOOR SPEAKER</b>		
REMOVAL . . . . .	21	
INSTALLATION . . . . .	21	

## AUDIO

### DESCRIPTION

An audio system is standard factory-installed equipment on this model, unless the vehicle is ordered with an available radio delete option. The standard equipment audio system includes an AM/FM/cassette (RAS sales code) receiver, and speakers in four locations. Several combinations of radio receivers and speaker systems are offered as optional equipment on this model. The audio system uses an ignition switched source of battery current so that the system will only operate when the

ignition switch is in the On or Accessory positions. The audio system includes the following components:

- Antenna
- Clockspring (with remote radio switches only)
- Filter, choke and speaker relay (with premium speaker system only)
- High-line or premium Central Timer Module (CTM) (with remote radio switches)
- Radio noise suppression components
- Radio receiver
- Remote radio switches (optional with RAZ radio receiver only)
- Speakers

## AUDIO (Continued)

Refer to Electrical, Restraints for more information on the clockspring. Refer to Electrical, Body Control/Central Control Module for more information on the Central Timer Module. Refer to the appropriate wiring information. The wiring information includes wiring diagrams, proper wire and connector repair procedures, details of wire harness routing and retention, connector pin-out information and location views for the various wire harness connectors, splices and grounds. Following are general descriptions of the remaining major components in the standard and optional factory-installed audio systems.

**OPERATION**

See the owner's manual in the vehicle glove box for more information on the features, use and operation of each of the available audio systems.

**CENTRAL TIMER MODULE**

The high-line or premium Central Timer Module (CTM) can also control some features of the audio system when the vehicle is equipped with the optional RAZ radio receiver and remote radio switches. A high-line CTM is used on high-line versions of this vehicle. A premium CTM is used on vehicles equipped with the optional heated seats. The CTM combines the functions of a chime/buzzer module, an intermittent wipe module, an illuminated entry module, a remote keyless entry module, and a vehicle theft security system module in a single unit.

The high-line or premium CTM also controls and integrates many of the additional electronic functions and features included on models with this option.

The RAZ radio receiver with a remote radio switch option is one of the features that the CTM controls. The CTM is programmed to send switch status messages over the Chrysler Collision Detection (CCD) data bus to control the volume, seek, and pre-set station advance functions of the RAZ radio receiver. The CTM monitors the status of the remote radio switches located on the steering wheel through a hard wired circuit. The CTM then sends the proper switch status messages to the radio receiver. The electronic circuitry within the radio receiver responds to the switch status messages it receives by adjusting the radio settings as requested.

Refer to Electrical, Body Control/Central Timer Module for more information on the high-line CTM. Refer to Remote Radio Switch in Description and Operation for more information on this component. In addition, radio receivers connected to the CCD data bus have several audio system functions that can be diagnosed using a DRBIII® scan tool. Refer to the proper Diagnostic Procedures manual for more information on DRBIII® testing of the audio systems.

**DIAGNOSIS AND TESTING - AUDIO**

**WARNING: ON VEHICLES EQUIPPED WITH AIRBAGS, REFER TO ELECTRICAL, RESTRAINTS BEFORE ATTEMPTING ANY STEERING WHEEL, STEERING COLUMN, OR INSTRUMENT PANEL COMPONENT DIAGNOSIS OR SERVICE. FAILURE TO TAKE THE PROPER PRECAUTIONS COULD RESULT IN ACCIDENTAL AIRBAG DEPLOYMENT AND POSSIBLE PERSONAL INJURY.**

## AUDIO (Continued)

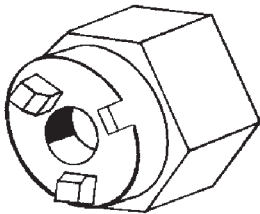
Audio System Diagnosis		
CONDITION	POSSIBLE CAUSE	CORRECTION
NO AUDIO	1. Fuse faulty.	1. Check radio fuses in junction block. Replace faulty fuses, if required.
	2. Radio connector faulty.	2. Check for loose or corroded radio connections. Repair, if required.
	3. Wiring faulty.	3. Check for battery voltage at radio connector. Repair wiring, if required.
	4. Ground faulty.	4. Check for continuity between radio chassis and a known good ground. There should be continuity. Repair ground, if required.
	5. Radio faulty.	5. Refer to Radio in the Diagnosis and Testing section of this group.
	6. Speakers faulty.	6. Refer to Speaker in the Diagnosis and Testing section of this group.
	7. Amplifier faulty (if equipped).	7. Refer to Speaker in the Diagnosis and Testing section of this group.
NO DISPLAY	1. Fuse faulty.	1. Check radio fuses in junction block. Replace faulty fuses, if required.
	2. Radio connector faulty.	2. Check for loose or corroded radio connections. Repair, if required.
	3. Wiring faulty.	3. Check for battery voltage at radio connector. Repair wiring, if required.
	4. Ground faulty.	4. Check for continuity between radio chassis and a known good ground. There should be continuity. Repair ground, if required.
	5. Radio faulty.	5. Refer to Radio in the Diagnosis and Testing section of this group.
CLOCK WILL NOT KEEP SET TIME	1. Fuse faulty.	1. Check ignition-off draw fuse. Replace faulty fuse, if required.
	2. Radio connector faulty.	2. Check for loose or corroded radio connections. Repair, if required.
	3. Wiring faulty.	3. Check for battery voltage at radio connector. Repair wiring, if required.
	4. Ground faulty.	4. Check for continuity between radio chassis and a known good ground. There should be continuity. Repair ground, if required.
	5. Radio faulty.	5. Refer to Radio in the Diagnosis and Testing section of this group.
POOR RADIO RECEPTION	1. Antenna faulty.	1. Refer to Antenna in the Diagnosis and Testing section of this group.
	2. Ground faulty.	2. Check for continuity between radio chassis and a known good ground. There should be continuity. Repair ground, if required.
	3. Radio faulty.	3. Refer to Radio in the Diagnosis and Testing section of this group.
	4. Faulty EMI or RFI noise suppression.	4. Refer to Radio Frequency Interference in the Diagnosis and Testing section of this group.

## AUDIO (Continued)

Audio System Diagnosis		
CONDITION	POSSIBLE CAUSE	CORRECTION
NO/POOR TAPE OPERATION	1. Faulty tape.	1. Insert known good tape and test operation.
	2. Foreign objects behind tape door.	2. Remove foreign objects and test operation.
	3. Dirty cassette tape head.	3. Clean head with Mopar Cassette Head Cleaner.
	4. Faulty tape deck.	4. Exchange or replace radio, if required.
NO COMPACT DISC OPERATION	1. Faulty CD.	1. Insert known good CD and test operation.
	2. Foreign material on CD.	2. Clean CD and test operation.
	3. Condensation on CD or optics.	3. Allow temperature of vehicle interior to stabilize and test operation.
	4. Faulty CD player.	4. Exchange or replace radio, if required.

## SPECIAL TOOLS

## AUDIO SYSTEMS

*Antenna Nut Wrench C-4816*

## ANTENNA BODY &amp; CABLE

## DESCRIPTION

The antenna body and cable are not readily visible in their installed positions in the vehicle. The most visible component of the antenna body and cable are the antenna adapter and the antenna cap nut, which are located on the top of the right front fender panel of the vehicle, near the right end of the cowl plenum. The antenna body and cable are secured below the fender panel by the antenna cap nut through a pre-fabricated and dedicated mounting hole in the top of the right front fender. The primary coaxial antenna cable is then routed beneath the fender sheet metal and through a prefabricated and dedicated cable entry hole in the right cowl side panel into the interior of the vehicle. Inside the vehicle, the primary coaxial cable is connected to a secondary instrument panel antenna coaxial cable with an in-line connector that is located behind the right end of the instrument

panel. The secondary coaxial cable is then routed behind the instrument panel to the back of the radio.

The factory-installed radio antenna body and cable consists of the following components:

- **Antenna adapter** - The antenna adapter is sometimes also referred to as the antenna bezel or escutcheon.
- **Antenna body** - The die cast white metal antenna body is the mating structure between the antenna mast and the primary antenna coaxial cable.
- **Antenna cable** - This vehicle uses a two-piece antenna coaxial cable. The primary antenna cable is integral to the antenna body, and the secondary antenna cable connects the primary cable to the radio.
- **Antenna cap nut** - The antenna cap nut is a special, bright-plated threaded fastener that captures the antenna adapter and retains the antenna body to the fender sheet metal.

The components of the radio antenna body and cable cannot be adjusted or repaired. All factory-installed radios automatically compensate for radio antenna trim. Therefore, no antenna trimmer adjustment is required or possible after replacing the antenna body and cable or the radio. If an antenna body and cable component is damaged or faulty, it must be replaced. Other than the primary antenna cable, which is integral to the antenna body, the individual components of the antenna are available for service replacement.

## OPERATION

The antenna body and cable connects the antenna mast to the radio. The radio antenna is an electromagnetic circuit component used to capture radio frequency signals that are broadcast by local



## ANTENNA BODY & CABLE (Continued)

commercial radio stations in both the Amplitude Modulating (AM) and Frequency Modulating (FM) frequency ranges. These electromagnetic radio frequency signals induce small electrical modulations into the antenna as they move past the mast. The antenna body transfers the weak electromagnetic radio waves induced into the rigid antenna mast into the center conductor of the flexible primary antenna coaxial cable. The braided outer shield of the antenna coaxial cable is grounded through both the antenna body and the radio chassis, effectively shielding the radio waves as they are conducted to the radio. The radio then tunes and amplifies the weak radio signals into stronger electrical signals in order to operate the audio system speakers.

The antenna body includes an integral flange that mates with and grounds the antenna body to the underside of the fender panel sheet metal. Above the fender panel, the antenna body has a short nipple that is externally threaded to accept the antenna cap nut. Inside the nipple is a plastic insulator tube, and inside this insulator is an internally threaded metal receptacle that accepts the adapter stud on the bottom of the antenna mast. The antenna adapter serves as an above fender interface to mount and secure the antenna body to the vehicle. The antenna adapter is a black molded plastic component that provides a functional transition between the top of the fender and the antenna cap nut, while concealing the edges of the antenna mounting hole and protecting the painted finish of the fender from marring as the antenna cap nut is tightened. The adapter is installed over and shrouds the threaded nipple of the antenna body, which is installed from under and protrudes through the top of the mounting hole in the fender. The antenna cap nut is installed on top of the antenna adapter and tightened onto the external threads of the antenna body nipple to effectively secure and ground the antenna body to the fender. Three notches on the outer circumference of the cap nut are engaged by matching projections of an antenna nut wrench (Special Tool C-4816) to facilitate the removal and installation of this special fastener. Proper tightening of the antenna cap nut is critical to ensuring proper grounding of the antenna body to the fender sheet metal, which is necessary for clear radio signal reception.

A short length of coaxial cable serves as the primary antenna cable. The center conductor of the cable is connected to the antenna mast receptacle. The outer wire mesh of the cable is connected to and grounded through the antenna body. One end of the primary antenna cable is securely crimped to the lower end of the antenna body, while the opposite end features a simple push/pull-type male coaxial cable connector that serves as the in-line connector to

the instrument panel (secondary) antenna coaxial cable. The primary coaxial cable includes a grommet that seals the cable to an entry hole in the right cowl side outer panel where the cable passes into the passenger compartment of the vehicle. The secondary antenna cable has a push/pull-type male coaxial cable connector on the radio end, and a push/pull-type female coaxial cable connector on the opposite end, which serves as the in-line connector to the primary antenna cable. In the passenger compartment the primary cable is routed to the lower right side of the instrument panel, where it is connected to the secondary instrument panel antenna cable. The instrument panel antenna cable is routed near the instrument panel wire harness through the instrument panel to the radio and is secured to the instrument panel structural support with small metal push-on retainers. This two-piece antenna cable arrangement allows the instrument panel or the antenna body and cable to be removed or installed without disturbing the radio.

## DIAGNOSIS AND TESTING

### DIAGNOSIS AND TESTING - ANTENNA

**WARNING: ON VEHICLES EQUIPPED WITH AIRBAGS, REFER TO ELECTRICAL, RESTRAINTS BEFORE ATTEMPTING ANY STEERING WHEEL, STEERING COLUMN, OR INSTRUMENT PANEL COMPONENT DIAGNOSIS OR SERVICE. FAILURE TO TAKE THE PROPER PRECAUTIONS COULD RESULT IN ACCIDENTAL AIRBAG DEPLOYMENT AND POSSIBLE PERSONAL INJURY.**

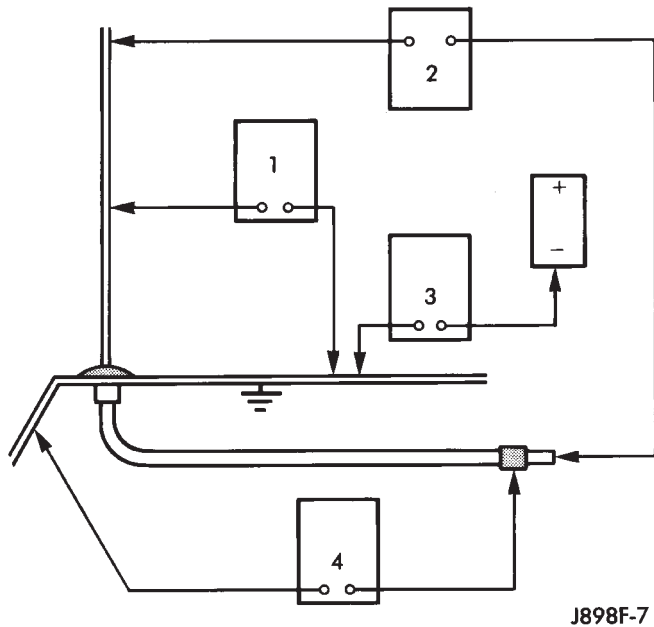
The following four tests are used to diagnose the antenna with an ohmmeter:

- **Test 1** - Mast to ground test
- **Test 2** - Tip-of-mast to tip-of-conductor test
- **Test 3** - Body ground to battery ground test
- **Test 4** - Body ground to coaxial shield test.

The ohmmeter test lead connections for each test are shown in Antenna Tests (Fig. 1).

**NOTE: This model has a two-piece antenna coaxial cable. Tests 2 and 4 must be conducted in two steps to isolate a coaxial cable problem; from the coaxial cable connection under the right end of the instrument panel near the right cowl side inner panel to the antenna base, and then from the coaxial cable connection to the radio receiver chassis connection.**

## ANTENNA BODY &amp; CABLE (Continued)

**Fig. 1 Antenna Tests****TEST 1**

Test 1 determines if the antenna mast is insulated from the base. Proceed as follows:

- (1) Disconnect and isolate the antenna coaxial cable connector from the radio receiver chassis.
- (2) Connect one ohmmeter test lead to the tip of the antenna mast. Connect the other test lead to the antenna base. Check for continuity.
- (3) There should be no continuity. If continuity is found, replace the faulty or damaged antenna base and cable assembly.

**TEST 2**

Test 2 checks the antenna for an open circuit as follows:

- (1) Disconnect the antenna coaxial cable connector from the radio receiver chassis.
- (2) Connect one ohmmeter test lead to the tip of the antenna mast. Connect the other test lead to the center pin of the antenna coaxial cable connector.
- (3) Continuity should exist (the ohmmeter should only register a fraction of an ohm). High or infinite resistance indicates damage to the base and cable assembly. Replace the faulty or damaged antenna base and cable, if required.

**TEST 3**

Test 3 checks the condition of the vehicle body ground connection. This test should be performed with the battery positive cable removed from the battery. Disconnect both battery cables, the negative cable first. Reconnect the battery negative cable and perform the test as follows:

- (1) Connect one ohmmeter test lead to the vehicle fender. Connect the other test lead to the battery negative terminal post.
- (2) The resistance should be less than one ohm.
- (3) If the resistance is more than one ohm, check the braided ground strap(s) connected to the engine and the vehicle body for being loose, corroded, or damaged. Repair the ground strap connections, if required.

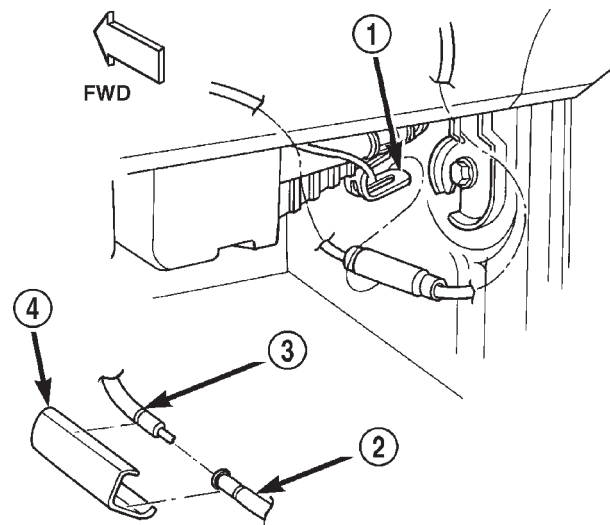
**TEST 4**

Test 4 checks the condition of the ground between the antenna base and the vehicle body as follows:

- (1) Connect one ohmmeter test lead to the vehicle fender. Connect the other test lead to the outer crimp on the antenna coaxial cable connector.
- (2) The resistance should be less than one ohm.
- (3) If the resistance is more than one ohm, clean and/or tighten the antenna base to fender mounting hardware.

**REMOVAL**

- (1) Disconnect and isolate the battery negative cable.
- (2) Reach under the passenger side of the instrument panel near the right cowl side inner panel to disengage the coaxial cable connector from the retainer clip located on the bottom of the heater-A/C housing (Fig. 2).



80b171b2

**Fig. 2 Antenna Coaxial Cable Connector**

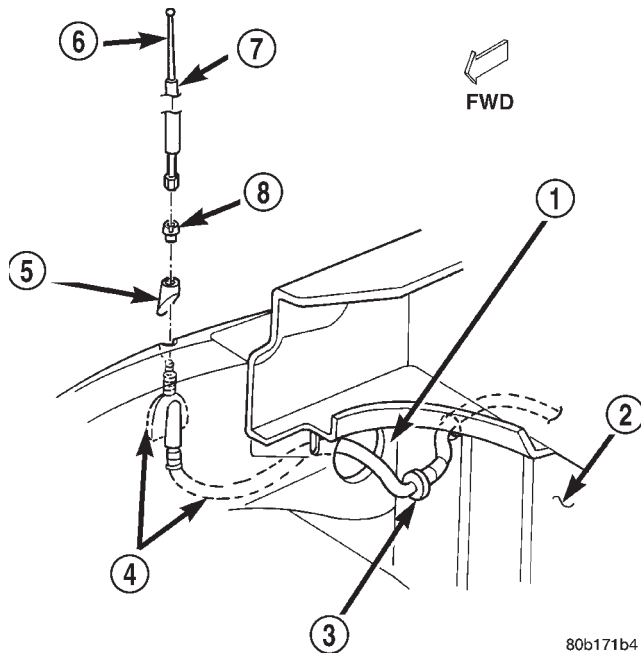
- 1 - RETAINER CLIP
- 2 - TO RADIO
- 3 - TO ANTENNA
- 4 - FOAM TAPE

## ANTENNA BODY &amp; CABLE (Continued)

(3) Remove the foam tape to access the coaxial cable connector. Disconnect the connector by pulling it apart while twisting the metal connector halves. Do not pull on the cable.

(4) Securely tie a suitable length of cord or twine to the antenna half of the coaxial cable connector. This cord will be used to pull or "fish" the cable back into position during installation.

(5) Reach above the Powertrain Control Module (PCM) on the right side of the dash panel in the engine compartment to disengage the antenna coaxial cable grommet from the hole in the dash panel (Fig. 3).



**Fig. 3 Antenna Mounting**

- 1 - COWL SIDE REINFORCEMENT
- 2 - DASH PANEL
- 3 - GROMMET
- 4 - ANTENNA BODY AND CABLE
- 5 - ADAPTER
- 6 - MAST
- 7 - SLEEVE
- 8 - NUT

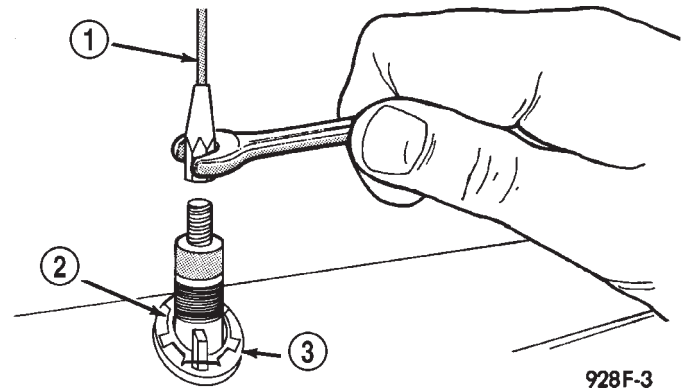
(6) Pull the antenna coaxial cable out of the passenger compartment and into the engine compartment through the hole in the dash panel.

(7) Raise the sleeve on the antenna mast far enough to access and unscrew the antenna mast from the antenna body (Fig. 4).

(8) Remove the antenna cap nut using an antenna nut wrench (Special Tool C-4816) (Fig. 5).

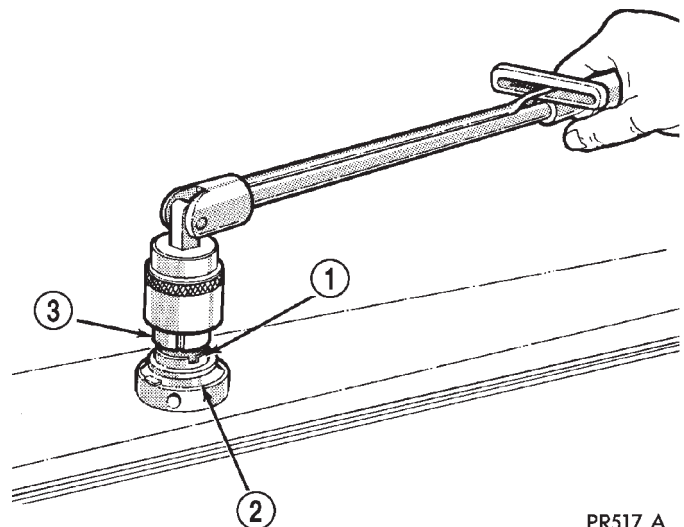
(9) Remove the antenna adapter from the top of the fender.

(10) Lower the antenna body and cable assembly through the top of the fender.



**Fig. 4 Antenna Mast Remove/Install - Typical**

- 1 - ANTENNA MAST
- 2 - CAP NUT
- 3 - ADAPTER



**Fig. 5 Antenna Cap Nut Remove/Install - Typical**

- 1 - CAP NUT
- 2 - ANTENNA ADAPTER
- 3 - TOOL

(11) Pull the antenna body and cable out through the opening between the right cowl side outer panel and the top of the fender, while feeding the antenna coaxial cable out of the engine compartment through the hole in the right cowl side reinforcement.

(12) Untie the cord or twine from the antenna body and cable coaxial cable connector, leaving the cord or twine in the place of the cable through the vehicle.

(13) Remove the antenna body and cable from the vehicle.

## INSTALLATION

(1) Tie the end of the cord or twine that was used during instrument panel antenna cable removal

## ANTENNA BODY & CABLE (Continued)

securely to the connector on the end of the antenna cable being installed into the instrument panel. This cord will be used to pull or "fish" the cable back into position.

(2) Using the cord or twine, pull the antenna cable through the radio receiver opening from under the instrument panel.

(3) Install the radio receiver onto the instrument panel.

(4) Reach through the glove box opening to engage the antenna cable with the retainer clips on the back of the instrument panel.

(5) Install the glove box onto the instrument panel.

(6) Untie the cord or twine from the instrument panel antenna cable connector.

(7) Reach under the passenger side of the instrument panel near the right cowl side inner panel to reconnect the two halves of the radio antenna coaxial cable connector. Wrap the connection with a piece of foam tape.

(8) Engage the coaxial cable connector with the retainer clip located on the bottom of the heater-A/C housing.

(9) Reconnect the battery negative cable.

## RADIO CHOKE RELAY

### DESCRIPTION

Models equipped with the Infinity premium speaker package have a filter, choke, and speaker relay unit. The filter, choke, and speaker relay unit is mounted to the lower instrument panel center brace, inboard of the Central Timer Module (CTM) and directly above the 16-way data link connector. The filter, choke, and speaker relay unit can be accessed for service without instrument panel disassembly or removal.

The filter, choke, and speaker relay unit should be checked if there is no sound output noted from the speakers. The filter, choke, and speaker relay unit cannot be repaired or adjusted and, if faulty or damaged, the unit must be replaced.

### OPERATION

The filter, choke, and speaker relay unit is used to control the supply of fused battery current to the front door speaker-mounted dual amplifiers. The speaker relay is energized by a fused 12 volt output from the radio receiver whenever the radio is turned on. For complete circuit diagrams, refer to the appropriate wiring information. The wiring information includes wiring diagrams, proper wire and connector repair procedures, details of wire harness routing and retention, connector pin-out information and

location views for the various wire harness connectors, splices and grounds.

## DIAGNOSIS AND TESTING - RADIO CHOKE RELAY

The filter, choke and speaker relay is used to switch power to the individual speaker amplifiers used with the Infinity premium speaker package. The choke and relay are serviced only as a unit. If all of the speakers are inoperative the filter, choke and speaker relay unit should be considered suspect. However, before replacement make the following checks of the filter, choke and speaker relay circuits. For complete circuit diagrams, refer to the appropriate wiring information. The wiring information includes wiring diagrams, proper wire and connector repair procedures, details of wire harness routing and retention, connector pin-out information and location views for the various wire harness connectors, splices and grounds.

(1) Check the fused B(+) fuse in the junction block. If OK, go to Step 2. If not OK, replace the faulty fuse.

(2) Check for battery voltage at the fused B(+) fuse in the junction block. If OK, go to Step 3. If not OK, repair the open fused B(+) circuit to the battery as required.

(3) Disconnect the instrument panel wire harness connector from the filter, choke and speaker relay unit. Check for battery voltage at the fused B(+) circuit cavity of the instrument panel wire harness connector for the filter, choke and speaker relay unit. If OK, go to Step 4. If not OK, repair the open fused B(+) circuit to the junction block fuse as required.

(4) Probe the ground circuit cavity of the instrument panel wire harness connector for the filter, choke and speaker relay unit. Check for continuity to a good ground. There should be continuity. If OK, go to Step 5. If not OK, repair the open ground circuit to ground as required.

(5) Turn the ignition switch to the On position and turn the radio on. Check for battery voltage at the radio 12-volt output circuit cavity of the instrument panel wire harness connector for the filter, choke and speaker relay unit. If OK, go to Step 6. If not OK, repair the open radio 12-volt output circuit to the radio as required.

(6) Turn the radio and ignition switches to the Off position. Reconnect the instrument panel wire harness connector to the filter, choke and speaker relay unit. Check for battery voltage at the amplified speaker (+) circuit cavity of the instrument panel wire harness connector for the filter, choke and speaker relay unit. There should be zero volts. Turn the ignition and radio switches to the On position.



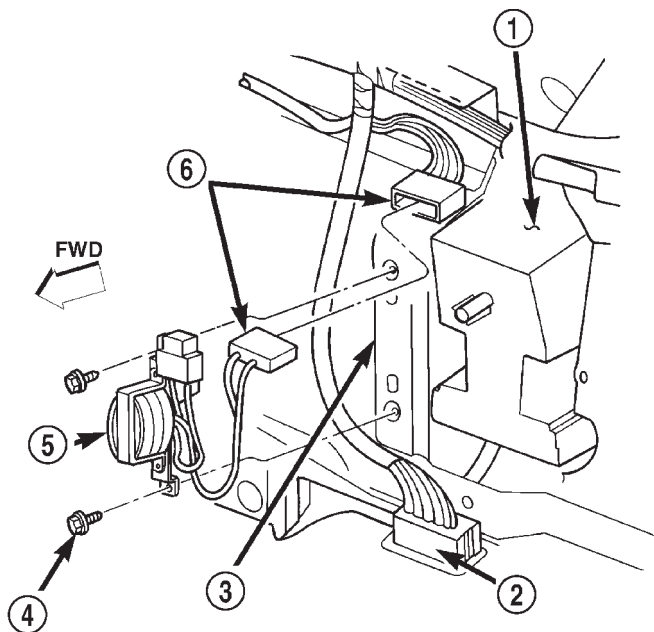
## RADIO CHOKE RELAY (Continued)

There should now be battery voltage. If OK, repair the open amplified speaker (+) circuits to the speaker-mounted amplifiers as required. If not OK, replace the faulty filter, choke and speaker relay unit.

## REMOVAL

(1) Disconnect and isolate the battery negative cable.

(2) Reach under the driver side of the instrument panel near the 16-way data link connector and inboard of the ash receiver to access the filter, choke, and speaker relay (Fig. 6) .



80b171b1

**Fig. 6 Filter, Choke, and Speaker Relay Remove/Install**

- 1 - ASH RECEIVER HOUSING
- 2 - DATA LINK CONNECTOR
- 3 - CENTER BRACE
- 4 - SCREW
- 5 - CHOKE AND RELAY
- 6 - WIRE HARNESS CONNECTORS

(3) Disconnect the instrument panel wire harness connector from the filter, choke and speaker relay wire harness connector.

(4) Remove the two screws that secure the filter, choke, and speaker relay mounting bracket to the instrument panel center brace.

(5) Remove the filter, choke, and speaker relay unit from under the instrument panel.

## INSTALLATION

(1) Position the filter, choke, and speaker relay unit under the instrument panel.

(2) Install and tighten the two screws that secure the filter, choke, and speaker relay mounting bracket to the instrument panel center brace. Tighten the screws to 2.7 N-m (24 in. lbs.).

(3) Reconnect the instrument panel wire harness connector to the filter, choke and speaker relay wire harness connector.

(4) Reconnect the battery negative cable.

## INSTRUMENT PANEL ANTENNA CABLE

## REMOVAL

(1) Disconnect and isolate the battery negative cable.

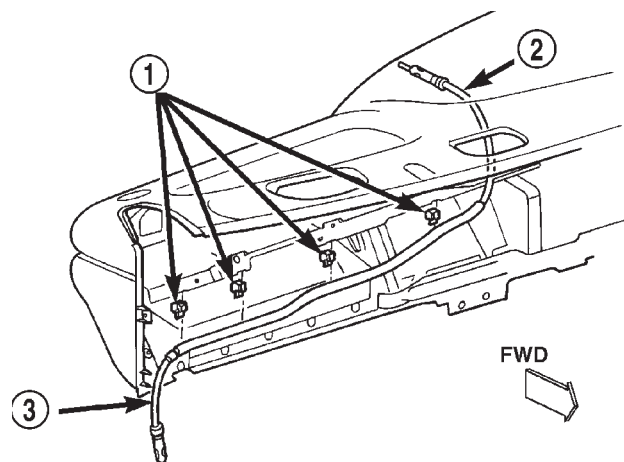
(2) Reach under the passenger side of the instrument panel near the right cowl side inner panel to disengage the coaxial cable connector from the retainer clip located on the bottom of the heater-A/C housing .

(3) Remove the foam tape to access the coaxial cable connector. Disconnect the connector by pulling it apart while twisting the metal connector halves. Do not pull on the cable.

(4) Securely tie a suitable length of cord or twine to the instrument panel half of the antenna coaxial cable connector. This cord will be used to pull or "fish" the cable back into position during installation.

(5) Roll down the glove box from the instrument panel. Refer to Body, Instrument Panel for the procedures.

(6) Reach through the glove box opening to disengage the antenna cable from the retainer clips on the back of the instrument panel (Fig. 7).



80b171b3

**Fig. 7 ANTENNA CABLE ROUTING**

- 1 - RETAINER CLIPS
- 2 - TO RADIO
- 3 - TO ANTENNA



## INSTRUMENT PANEL ANTENNA CABLE (Continued)

(7) Remove the radio receiver from the instrument panel. Refer to Audio, Radio for the procedures.

(8) Pull the antenna cable out through the radio receiver opening in the instrument panel.

(9) Untie the cord or twine from the instrument panel antenna cable connector, leaving the cord or twine in place of the cable in the instrument panel.

(10) Remove the antenna cable from the instrument panel.

**INSTALLATION**

(1) Tie the end of the cord or twine that was used during instrument panel antenna cable removal securely to the connector on the end of the antenna cable being installed into the instrument panel. This cord will be used to pull or "fish" the cable back into position.

(2) Using the cord or twine, pull the antenna cable through the radio receiver opening from under the instrument panel.

(3) Install the radio receiver onto the instrument panel. Refer to Audio, Radio for the procedures.

(4) Reach through the glove box opening to engage the antenna cable with the retainer clips on the back of the instrument panel.

(5) Install the glove box onto the instrument panel. Refer to Body, Instrument Panel for the procedures.

(6) Untie the cord or twine from the instrument panel antenna cable connector.

(7) Reach under the passenger side of the instrument panel near the right cowl side inner panel to reconnect the two halves of the radio antenna coaxial cable connector. Wrap the connection with a piece of foam tape.

(8) Engage the coaxial cable connector with the retainer clip located on the bottom of the heater-A/C housing.

(9) Reconnect the battery negative cable.

**RADIO****DESCRIPTION**

Available factory-installed radio receivers for this model include an AM/FM/cassette (RAS sales code), an AM/FM/cassette/5-band graphic equalizer with CD changer control feature (RBN sales code), an AM/FM/CD/3-band graphic equalizer (RBR sales code), or an AM/FM/CD/cassette/3-band graphic equalizer (RAZ sales code). The factory-installed RAZ sales code radio receivers can also communicate on the Chrysler Collision Detection (CCD) data bus network through a separate two-way wire harness connector. All factory-installed receivers are stereo Electronically Tuned Radios (ETR) and include an electronic digital clock function.

These radio receivers can only be serviced by an authorized radio repair station. See the latest Warranty Policies and Procedures manual for a current listing of authorized radio repair stations.

All vehicles are equipped with an Ignition-Off Draw (IOD) fuse that is removed when the vehicle is shipped from the factory. This fuse feeds various accessories that require battery current when the ignition switch is in the Off position, including the clock. The IOD fuse is removed to prevent battery discharge during vehicle storage.

When removing or installing the IOD fuse, it is important that the ignition switch be in the Off position. Failure to place the ignition switch in the Off position can cause the radio display to become scrambled when the IOD fuse is removed and replaced. Removing and replacing the IOD fuse again, with the ignition switch in the Off position, will correct the scrambled display condition.

The IOD fuse should be checked if the radio or clock displays are inoperative. The IOD fuse is located in the junction block. Refer to the fuse layout label on the back of the instrument panel fuse access panel for IOD fuse identification and location.

**OPERATION**

The radio receiver operates on fused battery current that is available only when the ignition switch is in the On or Accessory positions. The electronic digital clock function of the radio operates on fused battery current supplied through the IOD fuse, regardless of the ignition switch position.

For more information on the features, setting procedures, and control functions for each of the available factory-installed radio receivers, see the owner's manual in the vehicle glove box. For complete circuit diagrams, refer to the appropriate wiring information. The wiring information includes wiring diagrams, proper wire and connector repair procedures, details of wire harness routing and retention, connector pin-out information and location views for the various wire harness connectors, splices and grounds.

**DIAGNOSIS AND TESTING****DIAGNOSIS AND TESTING - RADIO**

If the vehicle is equipped with the optional remote radio switches located on the steering wheel and the problem being diagnosed is related to one of the symptoms listed below, be certain to check the remote radio switches and circuits. Refer to Audio, Remote Radio Switch prior to attempting radio diagnosis or repair.

- Stations changing with no remote radio switch input

## RADIO (Continued)

- Radio memory presets not working properly
- Volume changes with no remote radio switch input
- Remote radio switch buttons taking on other functions
- CD player skipping tracks
- Remote radio switch inoperative.

For complete circuit diagrams, refer to the appropriate wiring information. The wiring information includes wiring diagrams, proper wire and connector repair procedures, details of wire harness routing and retention, connector pin-out information and location views for the various wire harness connectors, splices and grounds.

**WARNING: ON VEHICLES EQUIPPED WITH AIRBAGS, REFER TO ELECTRICAL, RESTRAINTS BEFORE ATTEMPTING ANY STEERING WHEEL, STEERING COLUMN, OR INSTRUMENT PANEL COMPONENT DIAGNOSIS OR SERVICE. FAILURE TO TAKE THE PROPER PRECAUTIONS COULD RESULT IN ACCIDENTAL AIRBAG DEPLOYMENT AND POSSIBLE PERSONAL INJURY.**

**CAUTION: The speaker output of the radio receiver is a "floating ground" system. Do not allow any speaker lead to short to ground, as damage to the radio receiver may result.**

(1) Check the fused B(+) fuse in the junction block. If OK, go to Step 2. If not OK, repair the shorted circuit or component as required and replace the faulty fuse.

(2) Check for battery voltage at the fused B(+) fuse in the junction block. If OK, go to Step 3. If not OK, repair the open fused B(+) circuit to the Power Distribution Center (PDC) as required.

(3) Check the fused ignition switch output (acc/run) fuse in the junction block. If OK, go to Step 4. If not OK, repair the shorted circuit or component as required and replace the faulty fuse(s).

(4) Turn the ignition switch to the On position. Check for battery voltage at the fused ignition switch output (acc/run) fuse in the junction block. If OK, go to Step 5. If not OK, repair the open fused ignition switch output (acc/run) circuit to the ignition switch as required.

(5) Turn the ignition switch to the Off position. Disconnect and isolate the battery negative cable. Remove the radio receiver from the instrument panel, but do not disconnect the wire harness connectors. Check for continuity between the radio receiver chassis and a good ground. There should be continuity. If OK, go to Step 6. If not OK, repair the open ground circuit to ground as required.

(6) Connect the battery negative cable. Turn the ignition switch to the On position. Check for battery voltage at the fused ignition switch output (acc/run) circuit cavity of the left (gray) radio wire harness connector. If OK, go to Step 7. If not OK, repair the open fused ignition switch output (acc/run) circuit to the junction block fuse as required.

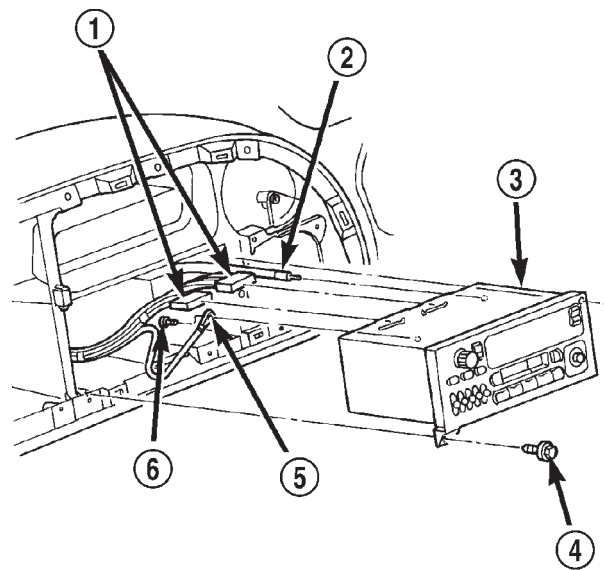
(7) Turn the ignition switch to the Off position. Check for battery voltage at the fused B(+) circuit cavity of the left (gray) radio wire harness connector. If OK, replace the faulty radio receiver. If not OK, repair the open fused B(+) circuit to the junction block fuse as required.

## REMOVAL

(1) Disconnect and isolate the battery negative cable.

(2) Remove the cluster bezel from the instrument panel.

(3) Remove the two screws that secure the radio receiver to the instrument panel (Fig. 8).



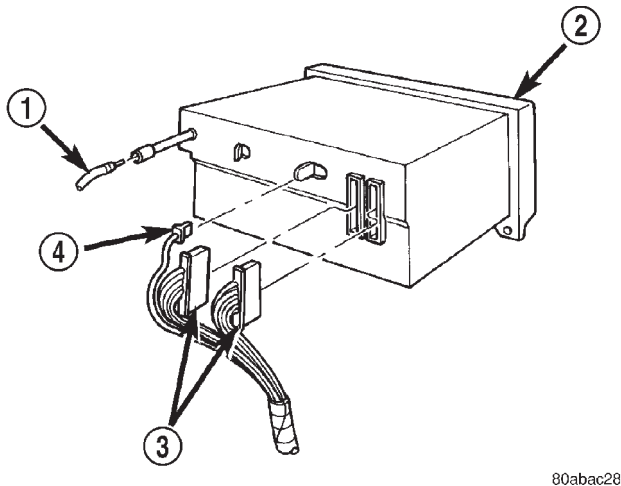
80b171b0

**Fig. 8 Radio Receiver Remove/Install**

- 1 - WIRE HARNESS CONNECTORS
- 2 - ANTENNA COAXIAL CABLE
- 3 - RADIO
- 4 - SCREW
- 5 - GROUND WIRE
- 6 - SCREW

(4) Pull the radio receiver out from the instrument panel far enough to access the instrument panel wire harness connectors and the antenna coaxial cable connector (Fig. 9).

## RADIO (Continued)



80abac28

**Fig. 9 Radio Receiver Connections - Typical**

- 1 - ANTENNA CABLE  
 2 - RADIO  
 3 - INSTRUMENT PANEL WIRING  
 4 - GROUND WIRE

(5) Disconnect the instrument panel wire harness connectors and the antenna coaxial cable connector from the receptacles on the rear of the radio receiver.

(6) If so equipped, remove the screw that secures the ground wire to the back of the radio receiver chassis.

(7) Remove the radio receiver from the instrument panel.

## INSTALLATION

(1) Position the radio receiver to the instrument panel.

(2) If so equipped, install and tighten the screw that secures the ground wire to the back of the radio receiver chassis. Tighten the screw to 7 N·m (65 in. lbs.).

(3) Reconnect the instrument panel wire harness connectors and the antenna coaxial cable connector to the receptacles on the rear of the radio receiver.

(4) Position the radio receiver into the mounting hole in the instrument panel.

(5) Install and tighten the two screws that secure the radio receiver to the instrument panel. Tighten the screws to 5 N·m (45 in. lbs.).

(6) Install the cluster bezel onto the instrument panel.

(7) Reconnect the battery negative cable.

## RADIO NOISE SUPPRESSION COMPONENTS

### DESCRIPTION

Radio Frequency Interference (RFI) and Electro-Magnetic Interference (EMI) noise suppression is accomplished primarily through circuitry internal to the radio receivers. These internal suppression devices are only serviced as part of the radio receiver.

External suppression devices that are used on this vehicle to control RFI or EMI noise include the following:

- Radio antenna base ground
- Radio receiver chassis ground wire or strap
- Engine-to-body ground straps
- Cab-to-bed ground strap
- Heater core ground strap
- Resistor-type spark plugs
- Radio suppression-type secondary ignition wiring.

For more information on the spark plugs and secondary ignition components, refer to Electrical, Ignition Control.

## DIAGNOSIS AND TESTING

### DIAGNOSIS AND TESTING - RADIO NOISE SUPPRESSION COMPONENTS

**WARNING: ON VEHICLES EQUIPPED WITH AIRBAGS, REFER TO ELECTRICAL, RESTRAINTS BEFORE ATTEMPTING ANY STEERING WHEEL, STEERING COLUMN, OR INSTRUMENT PANEL COMPONENT DIAGNOSIS OR SERVICE. FAILURE TO TAKE THE PROPER PRECAUTIONS COULD RESULT IN ACCIDENTAL AIRBAG DEPLOYMENT AND POSSIBLE PERSONAL INJURY.**

For complete circuit diagrams, refer to the appropriate wiring information. The wiring information includes wiring diagrams, proper wire and connector repair procedures, details of wire harness routing and retention, connector pin-out information and location views for the various wire harness connectors, splices and grounds. Inspect the ground paths and connections at the following locations:

- Blower motor
- Cab-to-bed ground strap
- Electric fuel pump
- Engine-to-body ground straps
- Generator
- Ignition module
- Heater core ground strap
- Radio antenna base ground
- Radio receiver chassis ground wire or strap

## RADIO NOISE SUPPRESSION COMPONENTS (Continued)

- Wiper motor.

If the source of RFI or EMI noise is identified as a component on the vehicle (i.e., generator, blower motor, etc.), the ground path for that component should be checked. If excessive resistance is found in any ground circuit, clean, tighten, or repair the ground circuits or connections to ground as required before considering any component replacement.

For service and inspection of secondary ignition components, refer to Electrical, Ignition Control. Inspect the following secondary ignition system components:

- Distributor cap and rotor
- Ignition coil
- Spark plugs
- Spark plug wire routing and condition.

Reroute the spark plug wires or replace the faulty components as required.

If the source of the RFI or EMI noise is identified as two-way mobile radio or telephone equipment, check the equipment installation for the following:

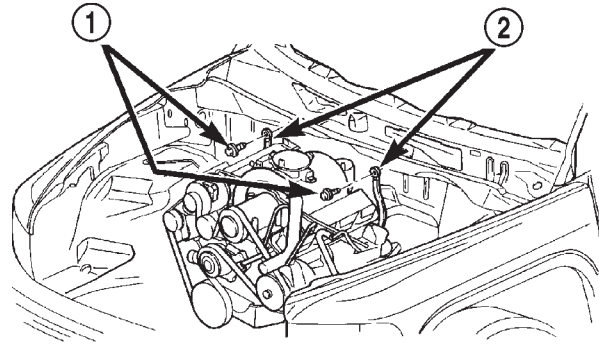
- Power connections should be made directly to the battery, and fused as closely to the battery as possible.
- The antenna should be mounted on the roof or toward the rear of the vehicle. Remember that magnetic antenna mounts on the roof panel can adversely affect the operation of an overhead console compass, if the vehicle is so equipped.
- The antenna cable should be fully shielded coaxial cable, should be as short as is practical, and should be routed away from the factory-installed vehicle wire harnesses whenever possible.
- The antenna and cable must be carefully matched to ensure a low Standing Wave Ratio (SWR).

Fleet vehicles are available with an extra-cost RFI-suppressed Powertrain Control Module (PCM). This unit reduces interference generated by the PCM on some radio frequencies used in two-way radio communications. However, this unit will not resolve complaints of RFI in the commercial AM or FM radio frequency ranges.

## ENGINE-TO-BODY GROUND STRAP

### REMOVAL

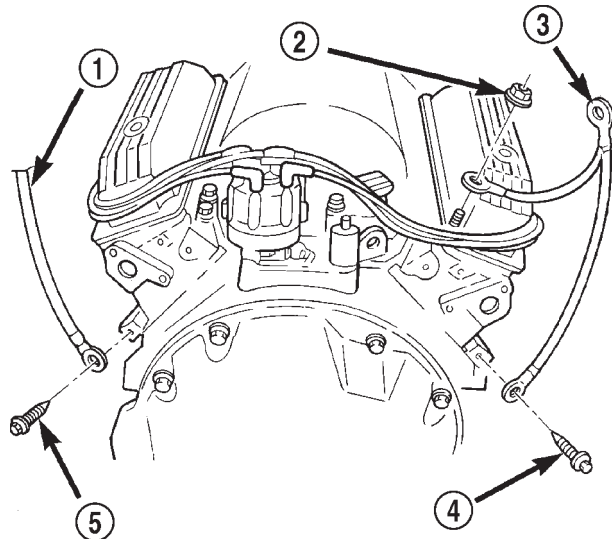
- (1) Remove the screw that secures the engine-to-body ground strap eyelet to the dash panel (Fig. 10).
- (2) Remove the screw that secures the engine-to-body ground strap eyelet to the back of the engine cylinder head (Fig. 11) or (Fig. 12).
- (3) For the right side only on vehicles equipped with a 3.9L, 5.2L or 5.9L engine, remove the nut that



80b9a510

**Fig. 10 Engine-To-Body Ground**

- 1 - SCREWS (2)
- 2 - GROUND STRAPS



80b9a511

**Fig. 11 Engine-To-Body Ground Strap Remove/Install - V6 & V8 Engine**

- 1 - GROUND STRAP
- 2 - NUT
- 3 - GROUND STRAP
- 4 - SCREW
- 5 - SCREW

secures the engine-to-body ground strap eyelet to the right rear valve cover stud.

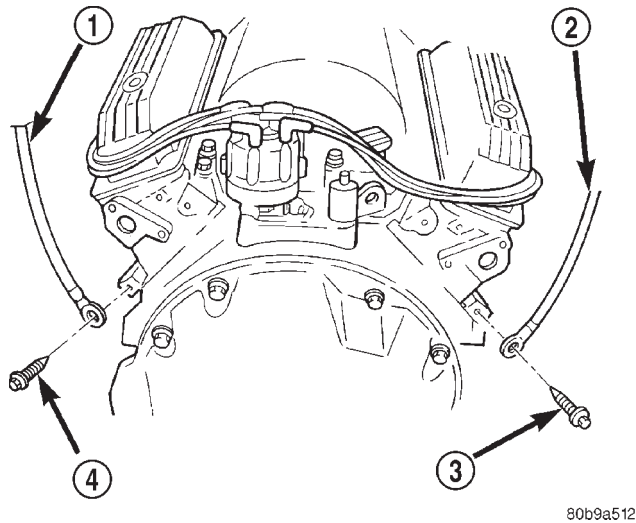
(4) Remove the engine-to-body ground strap from the engine compartment.

### INSTALLATION

- (1) Position the engine-to-body ground strap to the back of the engine cylinder head.
- (2) Install and tighten the screw that secures the engine-to-body ground strap eyelet to the back of the engine cylinder head. Tighten the screw to 3.9 N·m (35 in. lbs.).



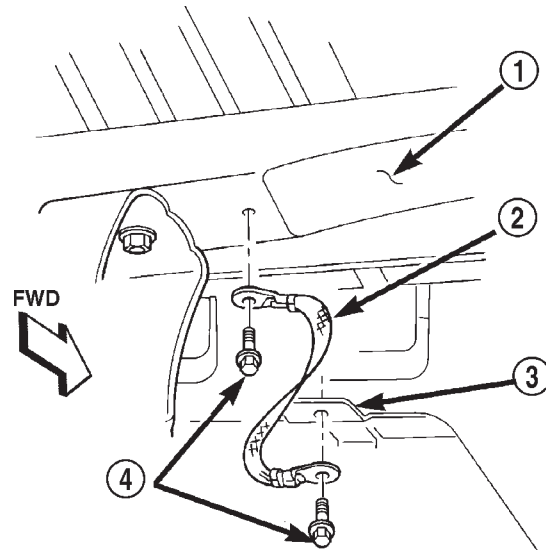
## ENGINE-TO-BODY GROUND STRAP (Continued)



80b9a512

**Fig. 12 Engine-To-Body Ground Strap Remove/Install - V10 Engine**

- 1 - GROUND STRAP
- 2 - GROUND STRAP
- 3 - SCREW
- 4 - SCREW



80b9a50e

**Fig. 13 Cab-To-Bed Ground Strap Remove/Install**

- 1 - BED CROSSMEMBER
- 2 - GROUND STRAP
- 3 - CAB FLOOR PANEL
- 4 - SCREWS

(3) For the right side only on vehicles equipped with a 3.9L, 5.2L or 5.9L engine, position the engine-to-body ground strap eyelet over the right rear valve cover stud.

(4) For the right side only on vehicles equipped with a 3.9L, 5.2L or 5.9L engine, install and tighten the nut that secures the engine-to-body ground strap eyelet to the right rear valve cover stud. Tighten the nut to 3.9 N·m (35 in. lbs.).

(5) Position the engine-to-body ground strap to the dash panel.

(6) Install and tighten the screw that secures the engine-to-body ground strap eyelet to the dash panel. Tighten the screw to 3.9 N·m (35 in. lbs.).

## CAB-TO- BED GROUND STRAP

### REMOVAL

- (1) Raise and support the vehicle.
- (2) Remove the screw that secures the cab-to-bed ground strap eyelet to the front crossmember of the cargo bed (Fig. 13).
- (3) Remove the screw that secures the cab-to-bed ground strap eyelet to the cab floor panel.
- (4) Remove the cab-to-bed ground strap from the vehicle.

### INSTALLATION

- (1) Position the cab-to-bed ground strap to the cab floor panel.

(2) Install and tighten the screw that secures the cab-to-bed ground strap eyelet to the cab floor panel. Tighten the screw to 3.9 N·m (35 in. lbs.).

(3) Position the cab-to-bed ground strap to the front crossmember of the cargo bed.

(4) Install and tighten the screw that secures the cab-to-bed ground strap eyelet to the front crossmember of the cargo bed. Tighten the screw to 3.9 N·m (35 in. lbs.).

(5) Lower the vehicle.

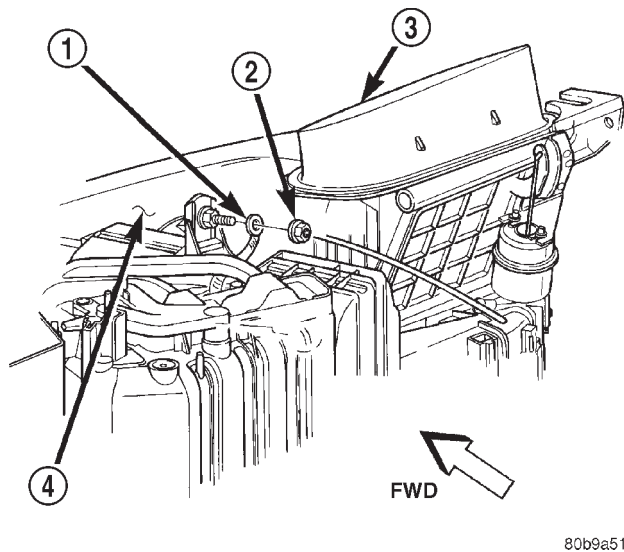
## HEATER CORE GROUND STRAP

### REMOVAL

- (1) Disconnect and isolate the battery negative cable.
- (2) Remove the glove box from the instrument panel. Refer to Body, Instrument Panel for the procedures.
- (3) Reach through the instrument panel glove box opening to access and remove the nut that secures the heater core ground strap eyelet to the stud on the dash panel (Fig. 14).
- (4) Remove the heater core ground strap eyelet from the stud on the dash panel.
- (5) Remove the screw that secures the heater core ground strap eyelet and the heater core tube retaining strap to the top of the heater-A/C housing.



## HEATER CORE GROUND STRAP (Continued)



80b9a513

**Fig. 14 Heater Core Ground Strap Remove/Install**

- 1 - GROUND STRAP
- 2 - NUT
- 3 - HEATER-A/C HOUSING
- 4 - DASH PANEL

(6) Remove the heater core ground strap from the top of the heater-A/C housing.

**INSTALLATION**

(1) Position the heater core ground strap and the heater core tube retaining strap to the top of the heater-A/C housing.

(2) Install and tighten the screw that secures the heater core ground strap eyelet and the heater core tube retaining strap to the top of the heater-A/C housing. Tighten the screw to 2.2 N·m (20 in. lbs.).

(3) Position the heater core ground strap eyelet over the stud on the dash panel.

(4) Install and tighten the nut that secures the heater core ground strap eyelet to the stud on the dash panel. Tighten the nut to 3.9 N·m (35 in. lbs.).

(5) Install the glove box onto the instrument panel. Refer to Body, Instrument Panel for the procedures.

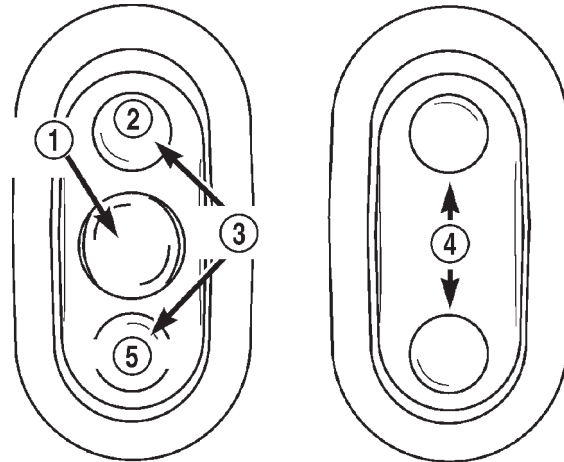
(6) Reconnect the battery negative cable.

**REMOTE SWITCHES****DESCRIPTION**

A remote radio switch option is available on models equipped with the AM/FM/CD/cassette/3-band graphic equalizer (RAZ sales code) radio receiver and the high-line Central Timer Module (CTM). Refer to Electrical, Body Control/Central Timer Module for more information on this component.

Two rocker-type switches (Fig. 15) are mounted in the sides of the rear (instrument panel side) steering

wheel trim cover. The switch on the left side is the seek switch and has seek up, seek down, and preset station advance functions. The switch on the right side is the volume control switch and has volume up, and volume down functions. The two switches are retained in mounting holes located on each side of the rear steering wheel trim cover by four latches that are integral to the switches.



80b0d6f0

**Fig. 15 Remote Radio Switches**

- 1 - PRESET SEEK
- 2 - UP
- 3 - SEEK
- 4 - VOLUME
- 5 - DOWN

The remote radio switches share a common steering wheel wire harness with the vehicle speed control switches. The steering wheel wire harness is connected to the instrument panel wire harness through the clockspring. Refer to Electrical, Clockspring for more information on this component.

**OPERATION**

The remote radio switches are resistor multiplexed units that are hard wired to the high-line or premium CTM through the clockspring. The CTM monitors the status of the remote radio switches and sends the proper switch status messages on the Chrysler Collision Detection (CCD) data bus network to the radio receiver. The electronic circuitry within the radio is programmed to respond to these remote radio switch status messages by adjusting the radio settings as requested.

For diagnosis of the CTM or the CCD data bus, the use of a DRBIII® scan tool and the proper Diagnostic Procedures manual are recommended. For more information on the features and control functions for each of the remote radio switches, see the owner's

## REMOTE SWITCHES (Continued)

manual in the vehicle glove box. For complete circuit diagrams, refer to the appropriate wiring information. The wiring information includes wiring diagrams, proper wire and connector repair procedures, details of wire harness routing and retention, connector pin-out information and location views for the various wire harness connectors, splices and grounds.

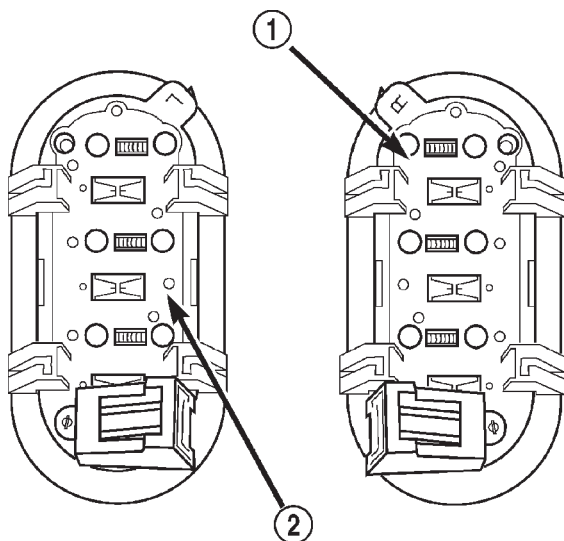
## DIAGNOSIS AND TESTING

## DIAGNOSIS AND TESTING - REMOTE SWITCHES

For complete circuit diagrams, refer to the appropriate wiring information. The wiring information includes wiring diagrams, proper wire and connector repair procedures, details of wire harness routing and retention, connector pin-out information and location views for the various wire harness connectors, splices and grounds.

**WARNING: ON VEHICLES EQUIPPED WITH AIRBAGS, REFER TO ELECTRICAL, RESTRAINTS BEFORE ATTEMPTING ANY STEERING WHEEL, STEERING COLUMN, OR INSTRUMENT PANEL COMPONENT DIAGNOSIS OR SERVICE. FAILURE TO TAKE THE PROPER PRECAUTIONS COULD RESULT IN ACCIDENTAL AIRBAG DEPLOYMENT AND POSSIBLE PERSONAL INJURY.**

(1) Remove the remote radio switch(es) (Fig. 16) from the steering wheel.



80b0d6f1

**Fig. 16 Remote Radio Switches**

- 1 - WHITE REAR SWITCH  
2 - BLACK REAR SWITCH

(2) Use an ohmmeter to check the switch resistances as shown in the Remote Radio Switch Test chart. If the remote radio switch resistances check OK, go to Step 3. If not OK, replace the faulty switch.

REMOTE RADIO SWITCH TEST		
SWITCH	SWITCH POSITION	RESISTANCE
Right (White)	Volume Up	7320 Ohms
Right (White)	Volume Down	1210 Ohms
Left (Black)	Seek Up	4530 Ohms
Left (Black)	Seek Down	2050 Ohms
Left (Black)	Pre-Set Station Advance	10 Ohms

(3) Check for continuity between the ground circuit cavity of the remote radio switch wire harness connector and a good ground. There should be continuity. If OK, go to Step 4. If not OK, repair the open ground circuit to ground as required.

(4) Disconnect the 18-way wire harness connector from the Central Timer Module (CTM). Check for continuity between the radio control mux circuit cavity of the remote radio switch wire harness connector and a good ground. There should be no continuity. If OK, go to Step 5. If not OK, repair the shorted radio control mux circuit as required.

(5) Check for continuity between the radio control mux circuit cavities of the remote radio switch wire harness connector and the 18-way CTM wire harness connector. There should be continuity. If OK, refer to the proper Diagnostic Procedures manual to test the CTM and the Chrysler Collision Detection (CCD) data bus. If not OK, repair the open radio control mux circuit as required.

## REMOVAL

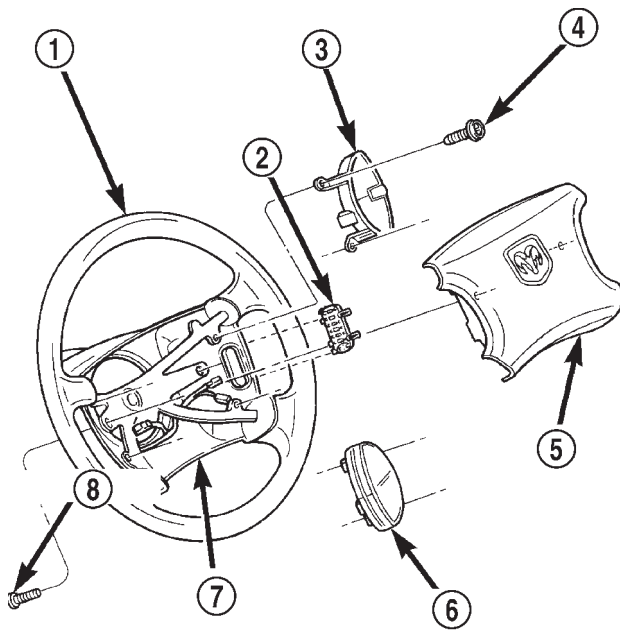
(1) Disconnect and isolate the battery negative cable.

(2) Remove the driver side airbag module from the steering wheel. Refer to Electrical, Restraints for the procedures.

(3) Remove the speed control switch located on the same side of the steering wheel as the remote radio switch that is being serviced. Refer to Electrical, Speed Control for the procedures.

(4) Disconnect the steering wheel wire harness connector from the connector receptacle of the remote radio switch (Fig. 17).

## REMOTE SWITCHES (Continued)



80b9a4f0

**Fig. 17 Remote Radio Switches Remove/Install**

- 1 - STEERING WHEEL
- 2 - REMOTE RADIO SWITCH
- 3 - SPEED CONTROL SWITCH
- 4 - SCREW (2)
- 5 - DRIVER SIDE AIRBAG MODULE
- 6 - SPEED CONTROL SWITCH
- 7 - REAR TRIM COVER
- 8 - SCREW (2)

(5) Disengage the four remote radio switch latches that secure the switch to the inside of the mounting hole in the steering wheel rear trim cover .

(6) From the outside of the steering wheel rear trim cover, remove the remote radio switch from the trim cover mounting hole.

**INSTALLATION**

(1) Position the remote radio switch to the mounting hole on the outside of the steering wheel rear trim cover. Be certain that the connector receptacle is oriented toward the bottom of the switch and pointed toward the center of the steering wheel.

(2) Press firmly and evenly on the remote radio switch until each of the switch latches is fully engaged in the mounting hole of the steering wheel rear trim cover.

(3) Reconnect the steering wheel wire harness connector to the connector receptacle of the remote radio switch.

(4) Install the speed control switch onto the steering wheel. Refer to Electrical, Speed Control for the procedures.

(5) Install the driver side airbag module onto the steering wheel. Refer to Electrical, Restraints for the procedures.

(6) Reconnect the battery negative cable.

**SPEAKER****DESCRIPTION****STANDARD**

The standard equipment speaker system includes speakers in four locations. One full-range 15.2 by 22.9 centimeter (6.0 by 9.0 inch) speaker is located in each front door. There is also one full-range 13.3 centimeter (5.25 inch) diameter speaker located in each rear cab side panel for the standard cab and the club cab models, or in each rear door of the quad cab models.

**PREMIUM**

The optional premium speaker system features Infinity model speakers in six locations. Each of the standard front door speakers are replaced with Infinity model speakers that include integral dual 30 watt amplifiers. Each of the standard rear speakers is also replaced by an Infinity model speaker. The premium speaker system also includes an additional Infinity tweeter mounted in the A-pillar garnish molding. The total available power of the premium speaker system is about 120 watts.

**OPERATION****STANDARD**

Each of the four full-range speakers used in the standard speaker system is driven by the amplifier that is integral to the factory-installed radio receiver. For complete circuit diagrams, refer to the appropriate wiring information. The wiring information includes wiring diagrams, proper wire and connector repair procedures, details of wire harness routing and retention, connector pin-out information and location views for the various wire harness connectors, splices and grounds.

## SPEAKER (Continued)

**PREMIUM**

The Infinity speakers used in the premium speaker system are driven by dual amplifiers that are integral to each of the front door speakers. One of these dual amplifiers drives the front door speaker and the A-pillar mounted tweeter for that side of the vehicle, while the other amplifier drives the rear speaker for that side of the vehicle. For complete circuit diagrams, to refer to the appropriate wiring information. The wiring information includes wiring diagrams, proper wire and connector repair procedures, details of wire harness routing and retention, connector pin-out information and location views for the various wire harness connectors, splices and grounds.

**DIAGNOSIS AND TESTING - SPEAKER**

For complete circuit diagrams, refer to the appropriate wiring information. The wiring information includes wiring diagrams, proper wire and connector repair procedures, details of wire harness routing and retention, connector pin-out information and location views for the various wire harness connectors, splices and grounds.

**WARNING: ON VEHICLES EQUIPPED WITH AIRBAGS, REFER TO ELECTRICAL, RESTRAINTS BEFORE ATTEMPTING ANY STEERING WHEEL, STEERING COLUMN, OR INSTRUMENT PANEL COMPONENT DIAGNOSIS OR SERVICE. FAILURE TO TAKE THE PROPER PRECAUTIONS COULD RESULT IN ACCIDENTAL AIRBAG DEPLOYMENT AND POSSIBLE PERSONAL INJURY.**

**CAUTION: The speaker output of the radio receiver is a "floating ground" system. Do not allow any speaker lead to short to ground, as damage to the radio receiver may result.**

(1) Turn the ignition switch to the On position. Turn the radio receiver on. Adjust the balance and fader controls to check the performance of each individual speaker. Note the speaker locations that are not performing correctly. If only an Infinity A-pillar or an Infinity rear speaker is inoperative, go to Step 8. If any other speaker is inoperative, go to Step 2.

**NOTE: If the vehicle is equipped with the Infinity premium speaker package and all of the speakers are inoperative, refer to Filter, Choke, and Speaker Relay in the Diagnosis and Testing section of this group.**

(2) Turn the radio receiver off. Turn the ignition switch to the Off position. Disconnect and isolate the battery negative cable. Remove the radio receiver from the instrument panel. Check both the feed (+)

circuit and return (-) circuit cavities for the inoperative speaker location(s) in the radio receiver wire harness connectors for continuity to ground. In each case, there should be no continuity. If OK, go to Step 3. If not OK, repair the shorted speaker feed (+) and/or return (-) circuit(s) to the speaker as required.

(3) If the inoperative speaker is an Infinity-amplified speaker, go to Step 5. If the vehicle is equipped with the standard speaker system, check the resistance between the speaker feed (+) circuit and return (-) circuit cavities of the radio receiver wire harness connectors for the inoperative speaker location(s). The meter should read between 2.5 and 4 ohms (speaker resistance). If OK, go to Step 4. If not OK, go to Step 5.

(4) Install a known good radio receiver. Connect the battery negative cable. Turn the ignition switch to the On position. Turn on the radio receiver and test the speaker operation. If OK, replace the faulty radio receiver. If not OK, turn the radio receiver off, turn the ignition switch to the Off position, disconnect and isolate the battery negative cable, remove the test radio receiver, and go to Step 5.

(5) Disconnect the wire harness connector at the inoperative standard speaker system speaker or at the Infinity-amplified front door-mounted speaker. Check for continuity between the speaker feed (+) circuit cavities of the radio receiver wire harness connector and the speaker wire harness connector for the inoperative speaker location. Repeat the check between the speaker return (-) circuit cavities of the radio receiver wire harness connector and the speaker wire harness connector for the inoperative speaker location. In each case, there should be continuity. If OK with an Infinity-amplified front door-mounted speaker, go to Step 6. If OK with the standard speaker system, replace the faulty speaker. If not OK, repair the open speaker feed (+) and/or return (-) circuit(s) as required.

(6) Check for continuity between the ground circuit cavity in the body half of the wire harness connector for the Infinity-amplified front door-mounted speaker on the same side of the vehicle as the inoperative speaker and a good ground. There should be continuity. If OK, go to Step 7. If not OK, repair the open ground circuit to ground as required.

(7) Install the radio receiver. Connect the battery negative cable. Turn the ignition switch to the On position. Turn the radio receiver on. Check for battery voltage at the radio choke output circuit cavity of the wire harness connector for the Infinity-amplified front door-mounted speaker on the same side of the vehicle as the inoperative speaker. If OK, go to Step 8. If not OK, repair the open radio choke output circuit to the filter, choke, and speaker relay as required.



## SPEAKER (Continued)

(8) Turn the radio receiver off. Turn the ignition switch to the Off position. Disconnect and isolate the battery negative cable. Disconnect the wire harness connector for the Infinity-amplified front door-mounted speaker on the same side of the vehicle as the inoperative speaker. Check both the amplified feed (+) circuit and amplified return (-) circuit cavities for the inoperative speaker location in the body half of the front door speaker wire harness connector for continuity to ground. In each case, there should be no continuity. If OK, go to Step 9. If not OK, repair the shorted amplified feed (+) and/or amplified return (-) circuit(s) as required.

(9) Disconnect the wire harness connector at the inoperative speaker. Check for continuity between the amplified feed (+) circuit cavities in the body half of the wire harness connector for the Infinity-amplified front door-mounted speaker on the same side of the vehicle as the inoperative speaker and the inoperative speaker wire harness connector. Repeat the check between the amplified return (-) circuit cavities in the body half of the wire harness connector for the Infinity-amplified front door-mounted speaker on the same side of the vehicle as the inoperative speaker and the inoperative speaker wire harness connector. In each case, there should be continuity. If OK, go to Step 10. If not OK, repair the open amplified feed (+) and/or amplified return (-) circuit(s) as required.

(10) Check the resistance between the amplified feed (+) circuit and amplified return (-) circuit cavities for the inoperative speaker in the body half of the wire harness connector for the Infinity-amplified front door-mounted speaker on the same side of the vehicle as the inoperative speaker. The meter should read between 2.5 and 4 ohms (speaker resistance). If OK, replace the faulty front door-mounted Infinity speaker and amplifier unit. If not OK, replace the faulty A-pillar or rear-mounted Infinity speaker.

## A-PILLAR TWEETER SPEAKER

### REMOVAL

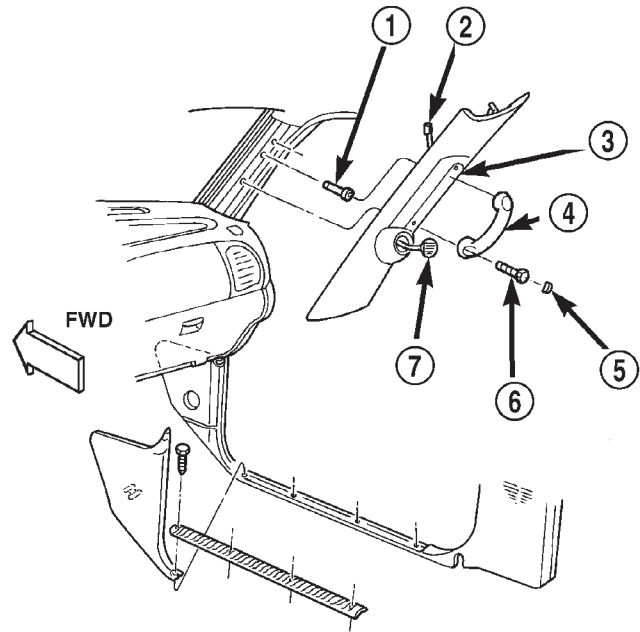
The A-pillar-mounted tweeters are used only with the optional Infinity premium speaker package.

(1) Disconnect and isolate the battery negative cable.

(2) If the vehicle is so equipped, remove the grab handle from the A-pillar. Refer to Body, Interior for the procedures.

(3) Disengage the trim from the A-pillar. Refer to Body, Interior for the procedures.

(4) Pull the trim away from the A-pillar far enough to access the tweeter wire harness connector (Fig. 18).



80b1b308

**Fig. 18 A-Pillar Tweeter Remove/Install**

- 1 - NUT
- 2 - WIRE HARNESS CONNECTOR
- 3 - MOULDING
- 4 - HANDLE
- 5 - PLUG
- 6 - SCREW
- 7 - TWEETER

(5) Disconnect the body wire harness connector from the A-pillar tweeter wire harness connector.

(6) Remove the trim and tweeter from the A-pillar as a unit.

(7) Disengage the tweeter wire harness retainers from the heat stakes on the back of the A-pillar trim.

(8) Disengage the tweeter from the A-pillar trim by pushing out on the tweeter firmly and evenly from the inside of the trim until it unsnaps from the mounting hole.

(9) Remove the tweeter from the mounting hole in the A-pillar trim.

### INSTALLATION

(1) Position the tweeter into the mounting hole in the A-pillar trim.

(2) Install the tweeter onto the A-pillar trim by pushing in on the tweeter firmly and evenly from the outside of the trim until it snaps into the mounting hole.

(3) Use a suitable tape or adhesive to secure the tweeter wire harness to the inside of the A-pillar trim.

(4) Position the trim and tweeter to the A-pillar as a unit.



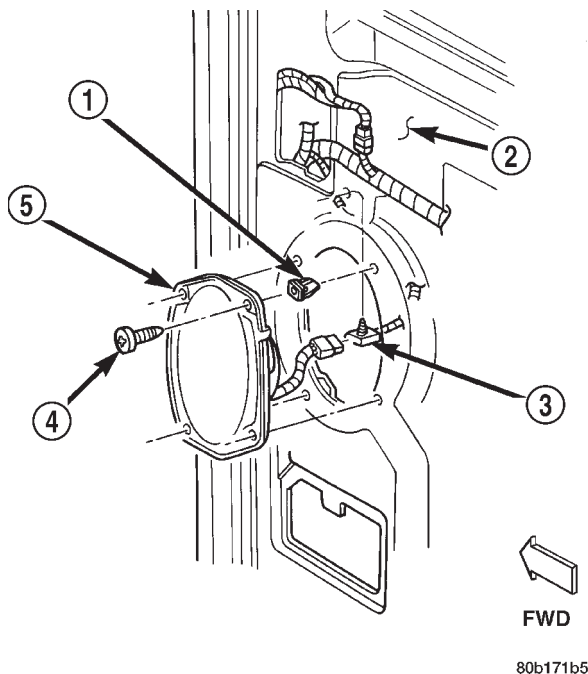
## A-PILLAR TWEETER SPEAKER (Continued)

- (5) Reconnect the body wire harness connector to the A-pillar tweeter wire harness connector.
- (6) Engage the trim onto the A-pillar. Refer to Body, Interior for the procedures.
- (7) If the vehicle is so equipped, install the grab handle onto the A-pillar. Refer to Body, Interior for the procedures.
- (8) Reconnect the battery negative cable.

## FRONT DOOR SPEAKER

## REMOVAL

- (1) Disconnect and isolate the battery negative cable.
- (2) Remove the trim panel from the front door. Refer to Body, Door Front for the procedures.
- (3) Remove the four screws that secure the speaker to the front door inner panel (Fig. 19).



**Fig. 19 Front Door Speaker Remove/Install**

- 1 - CLIP
- 2 - FRONT DOOR INNER PANEL
- 3 - WIRE HARNESS CONNECTOR
- 4 - SCREW
- 5 - SPEAKER

- (4) Pull the speaker away from the mounting hole in the front door inner panel far enough to access the speaker wire harness connector.
- (5) Disconnect the speaker wire harness connector from the front door wire harness connector.
- (6) Remove the speaker from the front door inner panel.

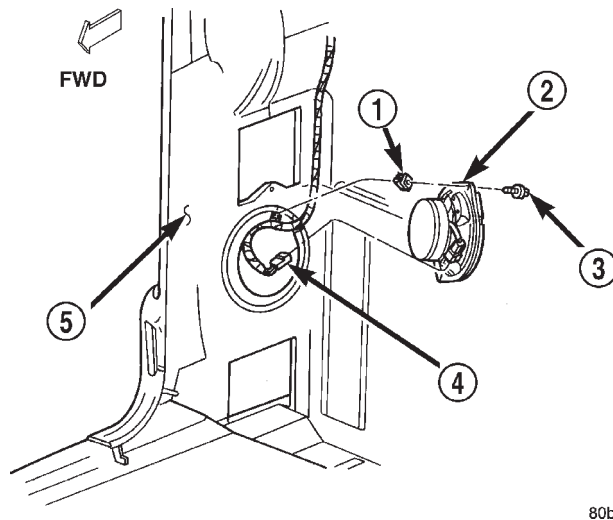
## INSTALLATION

- (1) Position the speaker to the front door inner panel.
- (2) Reconnect the speaker wire harness connector to the front door wire harness connector.
- (3) Position the speaker into the mounting hole in the front door inner panel.
- (4) Install and tighten the four screws that secure the speaker to the front door inner panel. Tighten the screws to 4 N·m (35 in. lbs.).
- (5) Install the trim panel onto the front door. Refer to Body, Door Front for the procedures.
- (6) Reconnect the battery negative cable.

## REAR CAB SIDE PANEL SPEAKER

## REMOVAL

- (1) Disconnect and isolate the battery negative cable.
- (2) Remove the trim from the rear cab side panel. Refer to Body, Interior for the procedures.
- (3) Remove the two screws that secure the speaker to the cab side inner panel (Fig. 20) or (Fig. 21).

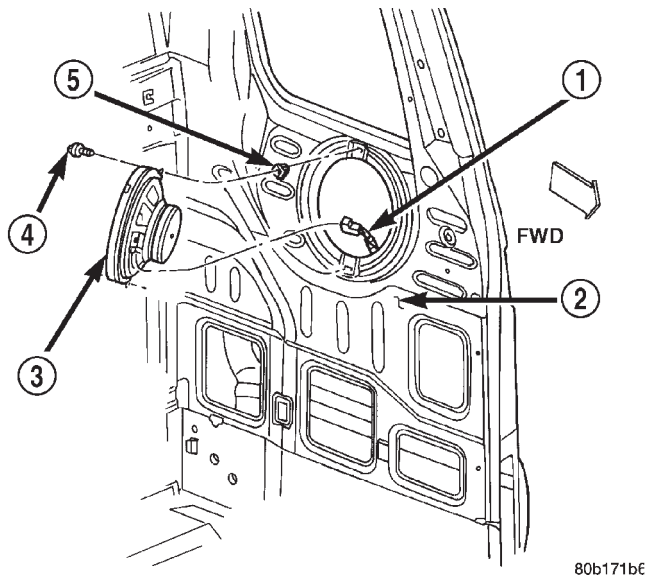


**Fig. 20 Rear Speaker Remove/Install - Standard Cab**

- 1 - CLIP
- 2 - SPEAKER
- 3 - SCREW
- 4 - WIRE HARNESS CONNECTOR
- 5 - CAB SIDE INNER PANEL

- (4) Pull the speaker away from the mounting hole in the cab side inner panel far enough to access the body wire harness connector.
- (5) Disconnect the body wire harness connector from the speaker connector receptacle.

## REAR CAB SIDE PANEL SPEAKER (Continued)

**Fig. 21 Rear Speaker Remove/Install - Club Cab**

- 1 - WIRE HARNESS CONNECTOR
- 2 - CAB SIDE INNER PANEL
- 3 - SPEAKER
- 4 - SCREW
- 5 - CLIP

(6) Remove the speaker from the cab side inner panel.

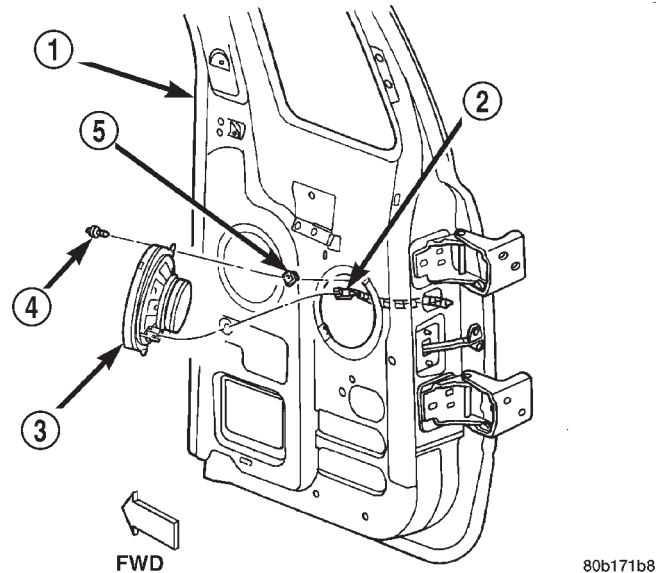
**INSTALLATION**

- (1) Position the speaker to the cab side inner panel.
- (2) Reconnect the body wire harness connector to the speaker connector receptacle.
- (3) Position the speaker into the mounting hole in the cab side inner panel.
- (4) Install and tighten the two screws that secure the speaker to the cab side inner panel. Tighten the screws to 4 N·m (35 in. lbs.).
- (5) Install the trim onto the rear cab side panel. Refer to Body, Interior for the procedures.
- (6) Reconnect the battery negative cable.

**REAR DOOR SPEAKER****REMOVAL**

- (1) Disconnect and isolate the battery negative cable.
- (2) Remove the trim panel from the rear door.

(3) Remove the two screws that secure the speaker to the rear door inner panel (Fig. 22).

**Fig. 22 Rear Door Speaker Remove/Install - Quad Cab**

- 1 - REAR DOOR INNER PANEL
- 2 - WIRE HARNESS CONNECTOR
- 3 - SPEAKER
- 4 - SCREW
- 5 - CLIP

(4) Pull the speaker away from the mounting hole in the rear door inner panel far enough to access the door wire harness connector.

- (5) Disconnect the door wire harness connector from the speaker connector receptacle.
- (6) Remove the speaker from the rear door inner panel.

**INSTALLATION**

- (1) Position the speaker to the rear door inner panel.
- (2) Reconnect the door wire harness connector to the speaker connector receptacle.
- (3) Position the speaker into the mounting hole in the rear door inner panel.
- (4) Install and tighten the two screws that secure the speaker to the rear door inner panel. Tighten the screws to 4 N·m (35 in. lbs.).
- (5) Install the trim panel onto the rear door.
- (6) Reconnect the battery negative cable.



# CHIME/BUZZER

## TABLE OF CONTENTS

	page		page
<b>CHIME WARNING SYSTEM</b>		<b>DIAGNOSIS AND TESTING</b> . . . . .	2
DESCRIPTION . . . . .	1	CHIME WARNING SYSTEM . . . . .	2
OPERATION . . . . .	1		

## CHIME WARNING SYSTEM

### DESCRIPTION

A chime warning system is standard factory-installed equipment on this model. The chime warning system uses a single chime tone generator that is integral to the Central Timer Module (CTM) to provide an audible indication of various vehicle conditions that may require the attention of the vehicle operator. The chime warning system includes the following major components, which are described in further detail elsewhere in this service manual:

- **Central Timer Module** - The Central Timer Module (CTM) is located under the driver side end of the instrument panel, inboard of the instrument panel steering column opening. The CTM contains an integral chime tone generator to provide all of the proper chime warning system features based upon the monitored inputs.

- **Door Ajar Switch** - A door ajar switch is integral to the driver side front door latch. This switch provides an input to the chime warning system indicating whether the driver side front door is open or closed.

- **Headlamp Switch** - The headlamp switch is located on the instrument panel outboard of the steering column. The headlamp switch provides an input to the chime warning system indicating when the exterior lamps are turned On or Off.

- **Ignition Switch** - A key-in ignition switch is integral to the ignition switch. The key-in ignition switch provides an input to the chime warning system indicating whether a key is present in the ignition lock cylinder.

- **Seat Belt Switch** - A seat belt switch is integral to the driver side front seat belt retractor unit. The seat belt switch provides an input to the chime warning system indicating whether the driver side front seat belt is fastened.

Hard wired circuitry connects many of the chime warning system components to each other through the electrical system of the vehicle. These hard wired circuits are integral to several wire harnesses, which are routed throughout the vehicle and retained by

many different methods. These circuits may be connected to each other, to the vehicle electrical system and to the chime warning system components through the use of a combination of soldered splices, splice block connectors, and many different types of wire harness terminal connectors and insulators. Refer to the appropriate wiring information. The wiring information includes wiring diagrams, proper wire and connector repair procedures, further details on wire harness routing and retention, as well as pin-out and location views for the various wire harness connectors, splices and grounds.

The CTM chime warning system circuitry and the integral chime tone generator cannot be adjusted or repaired. If the CTM or the chime tone generator are damaged or faulty, the CTM unit must be replaced.

### OPERATION

The chime warning system is designed to provide an audible output as an indication of various conditions that may require the attention or awareness of the vehicle operator. The chime warning system components operate on battery current received through a fused B(+) fuse in the Junction Block (JB) on a non-switched fused B(+) circuit so that the system may operate regardless of the ignition switch position.

The chime warning system provides an audible indication to the vehicle operator under the following conditions:

- **Fasten Seat Belt Warning** - The Central Timer Module (CTM) chime tone generator will generate repetitive chime tones at a slow rate to announce that a hard wired input from the seat belt switch to the Electro-Mechanical Instrument Cluster (EMIC) indicates that the driver side front seat belt is not fastened with the ignition switch in the On position. Unless the driver side front seat belt is fastened, the chimes will continue to sound for a duration of about seven seconds each time the ignition switch is turned to the On position or until the driver side front seat belt is fastened, whichever occurs first. This chime tone is based upon a hard wired chime request input to the CTM from the EMIC, but is not related to the operation of the EMIC "Seatbelt" indicator.

## CHIME WARNING SYSTEM (Continued)

- **Head/Park Lights-On Warning** - The CTM chime tone generator will generate repetitive chime tones at a fast rate to announce that hard wired inputs from the driver door ajar switch, headlamp switch, and ignition switch indicate that the exterior lamps are turned On with the driver side front door opened and the ignition switch in the Off position. The chimes will continue to sound until the exterior lamps are turned Off, the driver side front door is closed, or the ignition switch is turned to the On position, whichever occurs first.

- **Key-In-Ignition Warning** - The BCM chime tone generator will generate repetitive chime tones at a fast rate to announce that hard wired inputs from the driver door ajar switch, headlamp switch, and ignition switch indicate that the key is in the ignition lock cylinder with the driver side front door opened and the ignition switch in the Off position. The chimes will continue to sound until the key is removed from the ignition lock cylinder, the driver side front door is closed, or the ignition switch is turned to the On position, whichever occurs first.

- **Warning Chime Support** - The CTM chime tone generator will generate repetitive chime tones at a slow rate to announce that a hard wired chime request input has been received from the EMIC. These chime tones provide an audible alert to the vehicle operator that supplements certain visual indications displayed by the EMIC. Supplemented indications include the following:

- The “Airbag” indicator is illuminated. The chimes will continue to sound for a duration of about four seconds each time the indicator is illuminated or until the ignition switch is turned to the Off position, whichever occurs first.

- The “Check Gages” indicator is illuminated. The chimes will continue to sound for a duration of about two seconds each time the indicator is illuminated or until the ignition switch is turned to the Off position, whichever occurs first.

- The “Low Fuel” indicator is illuminated. The chimes will continue to sound for a duration of about two seconds each time the indicator is illuminated or until the ignition switch is turned to the Off position, whichever occurs first.

- The “Low Wash” indicator is illuminated. The chimes will continue to sound for a duration of about two seconds each time the indicator is illuminated or until the ignition switch is turned to the Off position, whichever occurs first.

- The “Trans Temp” indicator is illuminated (automatic transmission only). The chimes will continue to sound for a duration of about two seconds each time the indicator is illuminated or until the ignition switch is turned to the Off position, whichever occurs first.

- The vehicle is over a programmed speed value (Middle East Gulf Coast Country (GCC) only). The CTM chime tone generator will generate repetitive chime tones at a slow rate to announce that the vehicle speed exceeds a programmed value. The chimes will continue to sound until the vehicle speed is below the programmed value.

- The “Water-In-Fuel” indicator is illuminated (diesel engine only). The chimes will continue to sound for a duration of about two seconds each time the indicator is illuminated or until the ignition switch is turned to the Off position, whichever occurs first.

The CTM provides chime service for all available features in the chime warning system. The CTM relies upon hard wired inputs from the driver door ajar switch, the EMIC, the headlamp switch, and the key-in ignition switch (ignition switch) to provide chime service for all of the chime warning system features. Upon receiving the proper inputs, the CTM activates the integral chime tone generator to provide the audible chime tone to the vehicle operator. The chime tone generator in the CTM is capable of producing repeated chime tones at two different rates, slow or fast. The slow chime rate is about fifty chime tones per minute, while the fast chime rate is about 180 chime tones per minute. The internal programming of the CTM and the EMIC determines the priority of each chime tone request input that is received, as well as the rate and duration of each chime tone that is to be generated.

The hard wired chime warning system inputs to the CTM and the EMIC, as well as other hard wired circuits for this system may be diagnosed and tested using conventional diagnostic tools and procedures. See the owner's manual in the vehicle glove box for more information on the features provided by the chime warning system.

## DIAGNOSIS AND TESTING - CHIME WARNING SYSTEM

Refer to the appropriate wiring information. The wiring information includes wiring diagrams, proper wire and connector repair procedures, further details on wire harness routing and retention, as well as pin-out and location views for the various wire harness connectors, splices and grounds. The hard wired chime warning system inputs to the Central Timer Module (CTM) and the Electro-Mechanical Instrument Cluster (EMIC), as well as other hard wired circuits for this system may be diagnosed and tested using conventional diagnostic tools and procedures.



## CHIME WARNING SYSTEM (Continued)

**WARNING: ON VEHICLES EQUIPPED WITH AIRBAGS, DISABLE THE AIRBAG SYSTEM BEFORE ATTEMPTING ANY STEERING WHEEL, STEERING COLUMN, OR INSTRUMENT PANEL COMPONENT DIAGNOSIS OR SERVICE. DISCONNECT AND ISOLATE THE BATTERY NEGATIVE (GROUND) CABLE, THEN WAIT TWO MINUTES FOR THE AIRBAG SYSTEM**

**TO DISCHARGE BEFORE PERFORMING FURTHER DIAGNOSIS OR SERVICE. THIS IS THE ONLY SURE WAY TO DISABLE THE AIRBAG SYSTEM. FAILURE TO TAKE THE PROPER PRECAUTIONS COULD RESULT IN ACCIDENTAL AIRBAG DEPLOYMENT AND POSSIBLE PERSONAL INJURY.**

CHIME WARNING SYSTEM DIAGNOSIS		
CONDITION	POSSIBLE CAUSES	CORRECTION
SEAT BELT WARNING CHIME WITH SEAT BELT BUCKLED	<ol style="list-style-type: none"> <li>1. Seat belt switch sense circuit shorted.</li> <li>2. Faulty seat belt switch.</li> </ol>	<ol style="list-style-type: none"> <li>1. Disconnect the body wire harness connector for the seat belt switch and the instrument panel wire harness connector (Connector C2) for the EMIC. Check for continuity between the seat belt switch sense circuit cavity and a good ground. There should be no continuity. Repair the seat belt switch sense circuit, if required.</li> <li>2. Check for continuity between the ground circuit cavity and the seat belt switch sense circuit cavity of the seat belt switch connector receptacle. There should be no continuity with the seat belt buckled. Replace the faulty seat belt, if required.</li> </ol>
NO SEAT BELT WARNING CHIME WITH SEAT BELT UNBUCKLED, BUT OTHER CHIME FEATURES OK	<ol style="list-style-type: none"> <li>1. Seat belt switch ground circuit open.</li> <li>2. Seat belt switch sense circuit open.</li> <li>3. Faulty seat belt switch.</li> </ol>	<ol style="list-style-type: none"> <li>1. Disconnect the body wire harness connector for the seat belt switch. Check for continuity between the ground circuit cavity of the connector for the seat belt switch and a good ground. There should be continuity. If not OK, repair the open ground circuit to ground as required.</li> <li>2. With the body wire harness connector for the seat belt switch and the instrument panel wire harness connector (Connector C2) for the EMIC disconnected, there should be continuity between the seat belt switch sense circuit cavities of the two connectors. Repair the seat belt switch sense circuit, if required.</li> <li>3. Check for continuity between the ground circuit cavity and the seat belt switch sense circuit cavity of the seat belt switch connector receptacle. There should be continuity with the seat belt unbuckled. Replace the faulty seat belt, if required.</li> </ol>

## CHIME WARNING SYSTEM (Continued)

CHIME WARNING SYSTEM DIAGNOSIS		
CONDITION	POSSIBLE CAUSES	CORRECTION
NO KEY-IN IGNITION WARNING CHIME, BUT OTHER CHIME FEATURES OK	<ol style="list-style-type: none"> <li>1. Driver door ajar switch sense circuit open.</li> <li>2. Key-in ignition switch sense circuit open.</li> <li>3. Faulty ignition switch.</li> </ol>	<ol style="list-style-type: none"> <li>1. Check for continuity between the driver door ajar switch sense circuit cavities of the connector for the driver side front door ajar switch and the instrument panel wire harness connector (Connector C2) for the ignition switch. Repair the driver door ajar switch sense circuit, if required.</li> <li>2. Check for continuity between the key-in ignition switch sense circuit cavities of the instrument panel wire harness connector (Connector C2) for the ignition switch and the instrument panel wire harness connector for the CTM. Repair the key-in ignition switch sense circuit, if required.</li> <li>3. Check for continuity between the two terminals in the ignition switch C2 connector receptacle. There should be continuity with a key in the ignition lock cylinder. Replace the faulty ignition switch, if required.</li> </ol>
NO HEADLAMPS-ON WARNING CHIME, BUT OTHER CHIME FEATURES OK	<ol style="list-style-type: none"> <li>1. Driver door ajar switch sense circuit open.</li> <li>2. Key-in ignition switch sense circuit open.</li> <li>3. Faulty headlamp switch.</li> </ol>	<ol style="list-style-type: none"> <li>1. Check for continuity between the driver door ajar switch sense circuit cavities of the connector for the driver side front door ajar switch and the instrument panel wire harness connector (Connector C1) for the headlamp switch. Repair the driver door ajar switch sense circuit, if required.</li> <li>2. Check for continuity between the key-in ignition switch sense circuit cavities of the instrument panel wire harness connector (Connector C1) for the headlamp switch and the instrument panel wire harness connector for the CTM. Repair the key-in ignition switch sense circuit, if required.</li> <li>3. Check for continuity between the driver door ajar switch sense terminal and the key-in ignition switch sense terminal in the headlamp switch C1 connector receptacle. There should be continuity with the headlamp switch in the On position. Replace the faulty headlamp switch, if required.</li> </ol>
CONTINUOUS CHIME WITH HEADLAMP SWITCH IN OFF POSITION AND KEY REMOVED FROM IGNITION LOCK CYLINDER	<ol style="list-style-type: none"> <li>1. Key-in ignition switch sense circuit shorted.</li> <li>2. Faulty CTM.</li> </ol>	<ol style="list-style-type: none"> <li>1. With the instrument panel wire harness connector (Connector C1) for the headlamp switch, the instrument panel wire harness connector (Connector C2) for the ignition switch, and the instrument panel wire harness connector for the CTM all disconnected, there should be no continuity between the key-in ignition switch sense circuit and a good ground. Repair the key-in ignition switch sense circuit, if required.</li> <li>2. Replace the faulty CTM, if required.</li> </ol>

## CHIME WARNING SYSTEM (Continued)

CHIME WARNING SYSTEM DIAGNOSIS		
CONDITION	POSSIBLE CAUSES	CORRECTION
NO CHIMES AND OTHER CTM FEATURES ERRATIC OR DISABLED	<ol style="list-style-type: none"> <li>1. CTM ground circuit(s) open.</li> <li>2. CTM fused B(+) circuit open.</li> <li>3. CTM fused ignition switch output (start-run) circuit open.</li> <li>4. Faulty CTM.</li> </ol>	<ol style="list-style-type: none"> <li>1. Check for continuity between the ground circuit cavities of the instrument panel wire harness connector(s) for the CTM and a good ground. Repair the ground circuit(s), if required.</li> <li>2. Check for battery voltage at the fused B(+) circuit cavity of the instrument panel wire harness connector for the CTM. Repair the fused B(+) circuit, if required.</li> <li>3. With the ignition switch in the On position, check for battery voltage at the fused ignition switch output circuit cavity of the instrument panel wire harness connector for the CTM. Repair the fused ignition switch output circuit, if required.</li> <li>4. Replace the faulty CTM, if required.</li> </ol>
NO WARNING CHIME SUPPORT FEATURES FOR EMIC, BUT HARD WIRED CHIMES OK	<ol style="list-style-type: none"> <li>1. Tone request signal circuit open.</li> <li>2. Tone request signal circuit shorted.</li> <li>3. Faulty CTM.</li> <li>4. Faulty EMIC.</li> </ol>	<ol style="list-style-type: none"> <li>1. Check for continuity between the tone request signal circuit cavities of the instrument panel wire harness connectors for the EMIC and the CTM. Repair the open tone request signal circuit, if required.</li> <li>2. With the instrument panel wire harness connectors for the EMIC and the CTM both disconnected, there should be no continuity between the tone request signal circuit and a good ground. Repair the shorted tone request signal circuit, if required.</li> <li>3. Replace the faulty CTM, if required.</li> <li>4. Replace the faulty EMIC, if required.</li> </ol>
NO CHIMES, BUT ALL OTHER CTM FEATURES OK	<ol style="list-style-type: none"> <li>1. Faulty CTM.</li> </ol>	<ol style="list-style-type: none"> <li>1. Replace the faulty CTM, if required.</li> </ol>



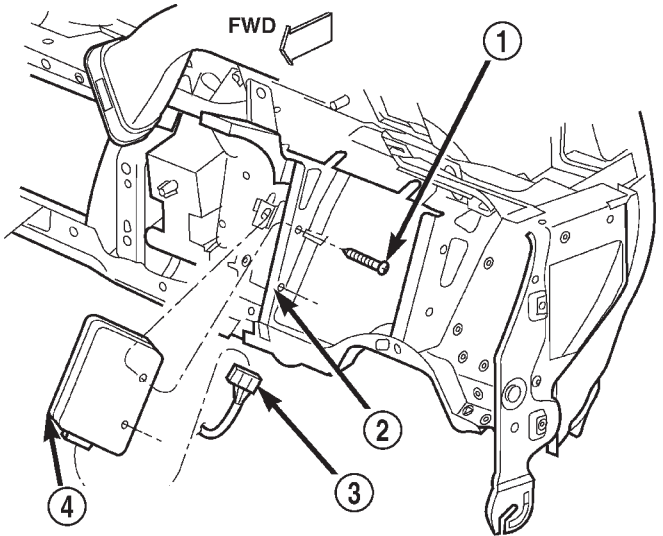
# ELECTRONIC CONTROL MODULES

## TABLE OF CONTENTS

	page		page
<b>BODY CONTROL/CENTRAL TIMER MODULE</b>		<b>REMOVAL</b> .....	12
DESCRIPTION .....	1	<b>INSTALLATION</b> .....	12
OPERATION .....	3	<b>DATA LINK CONNECTOR</b>	
DIAGNOSIS AND TESTING .....	4	DESCRIPTION .....	12
CENTRAL TIMER MODULE .....	4	OPERATION .....	12
REMOVAL .....	5	<b>ENGINE CONTROL MODULE</b>	
INSTALLATION .....	6	DESCRIPTION .....	13
<b>COMMUNICATION</b>		OPERATION .....	13
DESCRIPTION .....	6	REMOVAL .....	14
OPERATION .....	7	INSTALLATION .....	14
DIAGNOSIS AND TESTING .....	11	<b>POWERTRAIN CONTROL MODULE</b>	
CCD DATA BUS .....	11	DESCRIPTION .....	14
<b>CONTROLLER ANTILOCK BRAKE</b>		OPERATION .....	17
DESCRIPTION .....	11	REMOVAL .....	19
OPERATION .....	11	INSTALLATION .....	20

## BODY CONTROL/CENTRAL TIMER MODULE

### DESCRIPTION

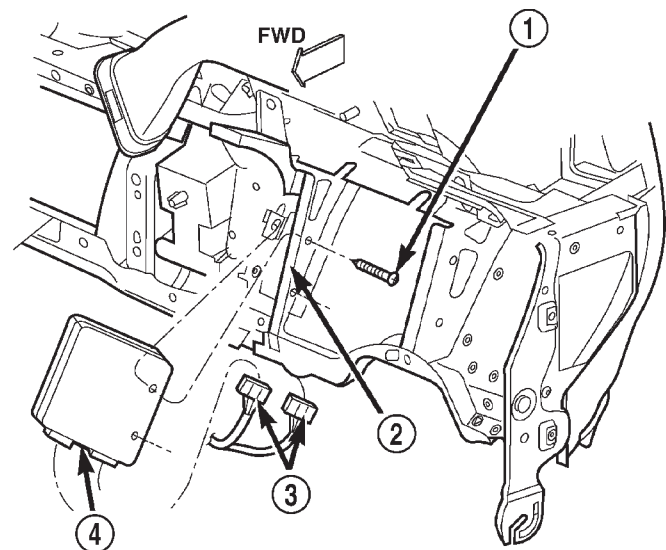


80b1713a

**Fig. 1 Central Timer Module (Base)**

- 1 - SCREWS
- 2 - BRACKET
- 3 - WIRE HARNESS CONNECTOR
- 4 - CENTRAL TIMER MODULE (BASE)

Three versions of the Central Timer Module (CTM) are available on this vehicle, a base version (Fig. 1),



80b1713b

**Fig. 2 Central Timer Module (High-Line/Premium)**

- 1 - SCREWS
- 2 - BRACKET
- 3 - WIRE HARNESS CONNECTORS
- 4 - CENTRAL TIMER MODULE (HIGH-LINE/PREMIUM)

a high-line version (Fig. 2), and a premium version. Whichever version of the CTM the vehicle is equipped with, it is concealed under the driver side end of the instrument panel inboard of the instrument panel steering column opening, where it is secured with two screws to a stamped steel bracket that is integral to the instrument panel armature. The CTM is enclosed in a molded plastic housing with one (base) or two (high-line/premium) integral



## BODY CONTROL/CENTRAL TIMER MODULE (Continued)

external connector receptacles that connect it to the vehicle electrical system through one (base) or two (high-line/premium) take outs with connectors from the instrument panel wire harness.

The base version of the CTM is used on base models of this vehicle. It is also sometimes referred to as the Integrated Electronic Module (IEM). The base version of the CTM combines the functions of a chime module and an intermittent wipe module in a single unit. The high-line version of the CTM is used on high-line vehicles. The high-line CTM provides all of the functions of the base version of the CTM, but also is used to control and integrate many additional electronic functions and features included on high-line models. The premium version of the CTM is the same as the high-line version, but is used only on models equipped with the heated seat option.

The high-line and premium versions of the CTM utilize integrated circuitry and information carried on the Chrysler Collision Detection (CCD) data bus network along with many hard wired inputs to monitor many sensor and switch inputs throughout the vehicle. In response to those inputs, the internal circuitry and programming of the CTM allow it to control and integrate many electronic functions and features of the vehicle through both hard wired outputs and the transmission of electronic message outputs to other electronic modules in the vehicle over the CCD data bus.

The features that the CTM supports or controls include the following:

- **Automatic Door Lock** - The high-line/premium CTM provides an optional automatic door lock feature (also known as rolling door locks). This is a programmable feature.

- **Central Locking** - The high-line/premium CTM provides an optional central locking/unlocking feature.

- **Chimes** - All versions of the CTM provide chime service through an integral chime tone generator.

- **Courtesy Lamps** - The high-line/premium CTM provides courtesy lamp control with timed load shedding.

- **Door Lock Inhibit** - The high-line/premium CTM provides a door lock inhibit feature.

- **Enhanced Accident Response** - The high-line/premium CTM provides an optional enhanced accident response feature. This is a programmable feature.

- **Heated Seats** - The premium CTM controls the optional heated seat system by controlling the operation of the heated seat relay.

- **Illuminated Entry** - The high-line/premium CTM provides a timed illuminated entry feature.

- **Intermittent Wipe Control** - All versions of the CTM provide control of the intermittent wipe delay, and wipe-after-wash features.

- **Panic Mode** - The high-line/premium CTM provides support for the optional RKE system panic mode features.

- **Power Lock Control** - The high-line/premium CTM provides the optional power lock system features, including support for the automatic door lock and door lock inhibit modes.

- **Programmable Features** - The high-line/premium CTM provides support for certain programmable features.

- **Remote Keyless Entry** - The high-line/premium CTM provides the optional Remote Keyless Entry (RKE) system features, including support for the RKE Lock (with optional horn chirp), Unlock, Panic, and illuminated entry modes, as well as the ability to be programmed to recognize up to four RKE transmitters. The RKE horn chirp is a programmable feature.

- **Remote Radio Switch Interface** - The high-line/premium CTM monitors and transmits the status of the optional remote radio switches.

- **Speed Sensitive Intermittent Wipe Control** - The high-line/premium CTM provides the speed sensitive intermittent wipe feature.

- **Vehicle Theft Alarm** - The high-line/premium CTM provides control of the optional Vehicle Theft Alarm features, including support for the central locking/unlocking mode.

Hard wired circuitry connects the CTM to the electrical system of the vehicle. These hard wired circuits are integral to several wire harnesses, which are routed throughout the vehicle and retained by many different methods. These circuits may be connected to each other, to the vehicle electrical system and to the CTM through the use of a combination of soldered splices, splice block connectors, and many different types of wire harness terminal connectors and insulators. Refer to the appropriate wiring information. The wiring information includes wiring diagrams, proper wire and connector repair procedures, further details on wire harness routing and retention, as well as pin-out and location views for the various wire harness connectors, splices and grounds.

All versions of the CTM for this model are serviced only as a complete unit. Many of the electronic features in the vehicle controlled or supported by the high-line or premium versions of the CTM are programmable using the DRBIII® scan tool. In addition, the high-line/premium CTM software is Flash compatible, which means it can be reprogrammed using Flash reprogramming procedures. However, if any of the CTM hardware components are damaged or faulty, the entire CTM unit must be replaced. The

## BODY CONTROL/CENTRAL TIMER MODULE (Continued)

base version of the CTM and the hard wired inputs or outputs of all CTM versions can be diagnosed using conventional diagnostic tools and methods; however, for diagnosis of the high-line or premium versions of the CTM or the CCD data bus, the use of a DRBIII® scan tool is required. Refer to the appropriate diagnostic information.

## OPERATION

The Central Timer Module (CTM) is designed to control and integrate many of the electronic features and functions of the vehicle. The base version of the CTM monitors only hard wired inputs and responds with the proper hard wired outputs. The microprocessor-based high-line/premium version of the CTM monitors many hard wired switch and sensor inputs as well as those resources it shares with other electronic modules in the vehicle through its communication over the Chrysler Collision Detection (CCD) data bus network. The internal programming and all of these inputs allow the high-line/premium CTM microprocessor to determine the tasks it needs to perform and their priorities, as well as both the standard and optional features that it should provide. The high-line/premium CTM programming then performs those tasks and provides those features through both CCD data bus communication with other electronic modules and through hard wired outputs to a number of circuits, relays, and actuators. These outputs allow the high-line/premium CTM the ability to control numerous accessory systems in the vehicle.

All versions of the CTM operate on battery current received through fuses in the Junction Block (JB) on a non-switched fused B(+) circuit, a fused ignition switch output (st-run) circuit (base version only), and a fused ignition switch output (run-acc) circuit (high-line/premium version only). This arrangement allows the CTM to provide some features regardless of the ignition switch position, while other features will operate only with the ignition switch in the Accessory, On, and/or Start positions. All versions of the CTM are grounded through their connector and take out of the instrument panel wire harness. The high-line/premium CTM has another ground received through a second connector and take out of the instrument panel wire harness. The first ground circuit receives ground through a take out with an eyelet terminal connector of the instrument panel wire harness that is secured by a nut to a ground stud located on the left instrument panel end bracket, while the second ground circuit (high-line/premium version only) receives ground through a take out with an eyelet terminal connector of the instrument panel wire harness that is secured by a nut to a ground stud located on the back of the instrument panel

armature above the inboard side of the instrument panel steering column opening.

The high-line/premium CTM monitors its own internal circuitry as well as many of its input and output circuits, and will store a Diagnostic Trouble Code (DTC) in electronic memory for any failure it detects. These DTCs can be retrieved and diagnosed using a DRBIII® scan tool. Refer to the appropriate diagnostic information.

## HARD WIRED INPUTS

The hard wired inputs to the CTM include the following:

- CCD bus- - high-line/premium version only
- CCD bus+ - high-line/premium version only
- Cylinder lock switch mux - high-line premium version only
- Driver door ajar switch sense
- Fused B(+)
- Fused ignition switch output (run-acc) - high-line/premium version only
- Fused ignition switch output (st-run) - base version only
- Ground (one circuit - base version, two circuits - high-line/premium version)
- Key-in ignition switch sense
- Passenger door ajar switch sense - high-line/premium version only
- Power door lock motor B(+) lock - high-line/premium version only
- Power door lock motor B(+) unlock - high-line/premium version only
- Radio control mux - high-line/premium version only
- Tone request signal
- Washer switch sense
- Wiper park switch sense
- Wiper switch mode sense
- Wiper switch mode signal

## HARD WIRED OUTPUTS

The hard wired outputs of the CTM include the following:

- CCD bus- - high-line/premium version only
- CCD bus+ - high-line/premium version only
- Courtesy lamp switch output - high-line/premium version only
- Door lock driver - high-line/premium version only
- Door unlock driver - high-line/premium version only
- Headlamp relay control - high-line/premium version only
- Heated seat relay control - premium version only

## BODY CONTROL/CENTRAL TIMER MODULE (Continued)

- Horn relay control - high-line/premium version only
- VTSS indicator driver - high-line/premium version only
- Wiper motor relay control

## MESSAGING

The high-line/premium CTM uses the following messages received from other electronic modules over the CCD data bus:

- Airbag Deploy (ACM)
- Charging System Failure (PCM)
- Engine RPM (PCM)
- System Voltage (PCM)
- Vehicle Speed (PCM)
- Voltage Fault (PCM)

The high-line/premium CTM provides the following messages to other electronic modules over the CCD data bus:

- Engine Enable (PCM)
- Radio Seek Up (Radio)
- Radio Seek Down (Radio)
- Radio Volume Up (Radio)
- Radio Volume Down (Radio)
- Preset Scan (Radio)

## DIAGNOSIS AND TESTING - CENTRAL TIMER MODULE

The hard wired inputs to and outputs from the Central Timer Module (CTM) may be diagnosed and tested using conventional diagnostic tools and methods. Refer to the appropriate wiring information. The wiring information includes wiring diagrams, proper wire and connector repair procedures, further details on wire harness routing and retention, as well as pin-out and location views for the various wire harness connectors, splices and grounds.

However, conventional diagnostic methods may not prove conclusive in the diagnosis of the high-line/premium CTM. In order to obtain conclusive testing of the high-line/premium CTM, the Chrysler Collision Detection (CCD) data bus network and all of the electronic modules that provide inputs to or receive outputs from the CTM must also be checked. The most reliable, efficient, and accurate means to diagnose the high-line/premium CTM, the CCD data bus network, and the electronic modules that provide inputs to or receive outputs from the high-line/premium CTM requires the use of a DRBIII® scan tool and the appropriate diagnostic information. The DRBIII® scan tool can provide confirmation that the CCD data bus network is functional, that all of the electronic modules are sending and receiving the proper messages over the CCD data bus, and that the CTM is receiving the proper hard wired inputs and respond-

ing with the proper hard wired outputs needed to perform its many functions.

**WARNING: ON VEHICLES EQUIPPED WITH AIRBAGS, DISABLE THE AIRBAG SYSTEM BEFORE ATTEMPTING ANY STEERING WHEEL, STEERING COLUMN, OR INSTRUMENT PANEL COMPONENT DIAGNOSIS OR SERVICE. DISCONNECT AND ISOLATE THE BATTERY NEGATIVE (GROUND) CABLE, THEN WAIT TWO MINUTES FOR THE AIRBAG SYSTEM CAPACITOR TO DISCHARGE BEFORE PERFORMING FURTHER DIAGNOSIS OR SERVICE. THIS IS THE ONLY SURE WAY TO DISABLE THE AIRBAG SYSTEM. FAILURE TO TAKE THE PROPER PRECAUTIONS COULD RESULT IN ACCIDENTAL AIRBAG DEPLOYMENT AND POSSIBLE PERSONAL INJURY.**

**NOTE: The following tests may not prove conclusive in the diagnosis of the high-line or premium versions of the Central Timer Module (CTM). The most reliable, efficient, and accurate means to diagnose the high-line or premium CTM requires the use of a DRBIII® scan tool and the appropriate diagnostic information.**

(1) Check the fused B(+) fuse (Fuse 13 - 10 ampere) in the Junction Block (JB). If OK, go to Step 2. If not OK, repair the shorted circuit or component as required and replace the faulty fuse.

(2) Check for battery voltage at the fused B(+) fuse (Fuse 13 - 10 ampere) in the JB. If OK, go to Step 3. If not OK, repair the open fused B(+) circuit between the JB and the Power Distribution Center (PDC) as required.

(3) For a base version CTM, check the fused ignition switch output (st-run) fuse (Fuse 11 - 10 ampere) in the JB. For a high-line/premium version CTM, check the fused ignition switch output (run-acc) fuse (Fuse 6 - 25 ampere) in the JB. If OK, go to Step 4. If not OK, repair the shorted circuit or component as required and replace the faulty fuse.

(4) Turn the ignition switch to the On position. For a base version CTM, check for battery voltage at the fused ignition switch output (st-run) fuse (Fuse 11 - 10 ampere) in the JB. For a high-line/premium version CTM, check for battery voltage at the fused ignition switch output (run-acc) fuse (Fuse 6 - 25 ampere) in the JB. If OK, go to Step 5. If not OK, repair the shorted circuit or component as required and replace the faulty fuse.

(5) Turn the ignition switch to the Off position. Disconnect and isolate the battery negative cable. Remove the CTM from its mounting bracket to access the CTM wire harness connector(s). Disconnect the instrument panel wire harness connector(s) for the

## BODY CONTROL/CENTRAL TIMER MODULE (Continued)

CTM from the CTM connector receptacle(s). Check the wire harness connectors and the CTM receptacles for loose, corroded, or damaged terminals and pins. If OK, go to Step 6. If not OK, repair as required.

(6) Check for continuity between the ground circuit cavity of the instrument panel wire harness connector (Connector C1) for the CTM and a good ground. For the high-line/premium version of the CTM only, repeat the check between the ground circuit cavity of the instrument panel wire harness connector (Connector C2) for the CTM and a good ground. In each case, there should be continuity. If OK, go to Step 7. If not OK, repair the open ground circuit(s) to ground as required.

(7) Reconnect the battery negative cable. Check for battery voltage at the fused B(+) circuit cavity of the instrument panel wire harness connector (Connector C1) for the CTM. If OK, go to Step 8. If not OK, repair the open fused B(+) circuit between the CTM and the JB as required.

(8) Turn the ignition switch to the On position. Check for battery voltage at the fused ignition switch output (st-run) circuit cavity (base version) or fused ignition switch output (run-acc) circuit cavity (high-line/premium version) of the instrument panel wire harness connector (Connector C1) for the CTM. If OK with a base version CTM, replace the faulty CTM. If OK with a high-line/premium version CTM, use a DRBIII® scan tool and the appropriate diagnostic information to perform further diagnosis of the CTM. If not OK, repair the open fused ignition switch output circuit between the CTM and the JB.

## REMOVAL

**WARNING: ON VEHICLES EQUIPPED WITH AIRBAGS, DISABLE THE AIRBAG SYSTEM BEFORE ATTEMPTING ANY STEERING WHEEL, STEERING COLUMN, OR INSTRUMENT PANEL COMPONENT DIAGNOSIS OR SERVICE. DISCONNECT AND ISOLATE THE BATTERY NEGATIVE (GROUND) CABLE, THEN WAIT TWO MINUTES FOR THE AIRBAG SYSTEM CAPACITOR TO DISCHARGE BEFORE PERFORMING FURTHER DIAGNOSIS OR SERVICE. THIS IS THE ONLY SURE WAY TO DISABLE THE AIRBAG SYSTEM. FAILURE TO TAKE THE PROPER PRECAUTIONS COULD RESULT IN ACCIDENTAL AIRBAG DEPLOYMENT AND POSSIBLE PERSONAL INJURY.**

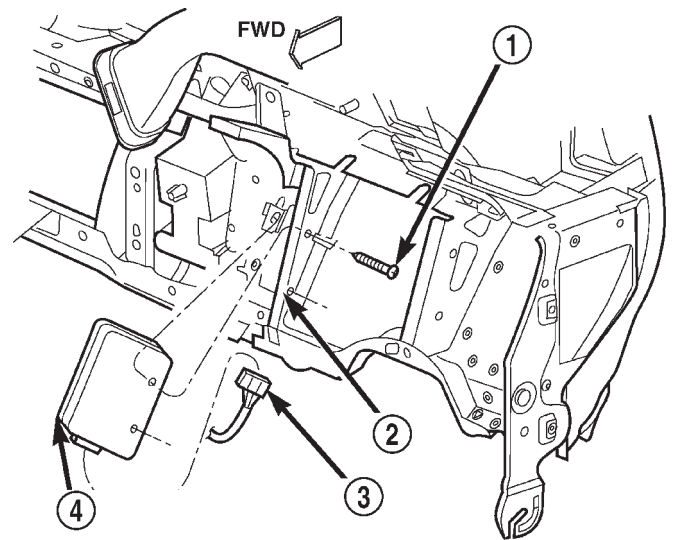
**NOTE:** Before replacing a high-line/premium version Central Timer Module (CTM), use a DRBIII® scan tool to retrieve the current settings for the CTM programmable features. Refer to the appropriate diagnostic information. These settings should be duplicated in the replacement high-line/premium

**CTM using the DRBIII® scan tool before returning the vehicle to service.**

(1) Disconnect and isolate the battery negative cable.

(2) Remove the steering column opening cover from the instrument panel. (Refer to 23 - BODY/INSTRUMENT PANEL/STEERING COLUMN OPENING COVER - REMOVAL).

(3) Remove the two screws that secure the Central Timer Module (CTM) to the bracket on the inboard side of the instrument panel steering column opening (Fig. 3) or (Fig. 4).



80b1713a

**Fig. 3 Central Timer Module (Base) Remove/Install**

- 1 - SCREWS
- 2 - BRACKET
- 3 - WIRE HARNESS CONNECTOR
- 4 - CENTRAL TIMER MODULE (BASE)

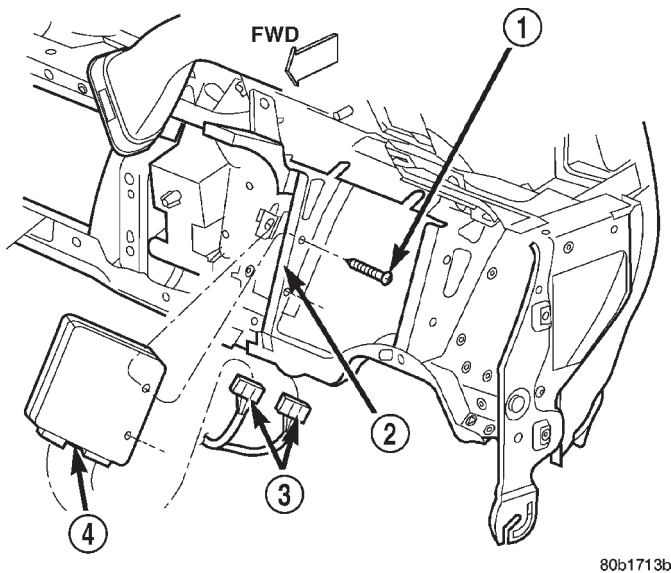
(4) Pull the CTM into the instrument panel steering column opening far enough to access the instrument panel wire harness connector(s).

(5) Disconnect the instrument panel wire harness connector(s) (one connector for the base version CTM, two connectors for the high-line/premium version) from the CTM connector receptacle(s).

(6) Remove the CTM from the instrument panel.



## BODY CONTROL/CENTRAL TIMER MODULE (Continued)



**Fig. 4 Central Timer Module (High-Line/Premium)  
Remove/Install**

- 1 - SCREWS
- 2 - BRACKET
- 3 - WIRE HARNESS CONNECTORS
- 4 - CENTRAL TIMER MODULE (HIGH-LINE/PREMIUM)

## INSTALLATION

**WARNING: ON VEHICLES EQUIPPED WITH AIRBAGS, DISABLE THE AIRBAG SYSTEM BEFORE ATTEMPTING ANY STEERING WHEEL, STEERING COLUMN, OR INSTRUMENT PANEL COMPONENT DIAGNOSIS OR SERVICE. DISCONNECT AND ISOLATE THE BATTERY NEGATIVE (GROUND) CABLE, THEN WAIT TWO MINUTES FOR THE AIRBAG SYSTEM CAPACITOR TO DISCHARGE BEFORE PERFORMING FURTHER DIAGNOSIS OR SERVICE. THIS IS THE ONLY SURE WAY TO DISABLE THE AIRBAG SYSTEM. FAILURE TO TAKE THE PROPER PRECAUTIONS COULD RESULT IN ACCIDENTAL AIRBAG DEPLOYMENT AND POSSIBLE PERSONAL INJURY.**

**NOTE:** Before replacing a high-line/premium version Central Timer Module (CTM), use a DRBIII® scan tool to retrieve the current settings for the CTM programmable features. Refer to the appropriate diagnostic information. These settings should be duplicated in the replacement high-line/premium CTM using the DRBIII® scan tool before returning the vehicle to service.

(1) Position the CTM to the inboard side of the instrument panel steering column opening.

(2) Reconnect the instrument panel wire harness connector(s) for the CTM (one connector for the base version CTM, two connectors for the high-line/premium version) to the CTM connector receptacle(s) (Fig. 3) or (Fig. 4).

(3) Position the CTM to the bracket on the inboard side of the instrument panel steering column opening.

(4) Install and tighten the two screws that secure the CTM to the bracket on the inboard side of instrument panel steering column opening. Tighten the screws to 1.6 N·m (15 in. lbs.).

(5) Reinstall the steering column opening cover onto the instrument panel. (Refer to 23 - BODY/INSTRUMENT PANEL/STEERING COLUMN OPENING COVER - INSTALLATION).

(6) Reconnect the battery negative cable.

## COMMUNICATION

### DESCRIPTION - CCD DATA BUS

The Chrysler Collision Detection (also referred to as CCD or C<sup>2</sup>D ) data bus system is a multiplex system used for vehicle communications on many Chrysler Corporation vehicles. Within the context of the CCD system, the term “collision” refers to the system’s ability to avoid collisions of the electronic data that enters the data bus from various electronic control modules at approximately the same time.

Multiplexing is a system that enables the transmission of several messages over a single channel or circuit. Many Chrysler vehicles use this principle for communication between the various microprocessor-based electronic control modules.

Many of the electronic control modules in a vehicle require information from the same sensing device. In the past, if information from one sensing device was required by several controllers, a wire from each controller needed to be connected in parallel to that sensor. In addition, each controller utilizing analog sensors required an Analog/Digital (A/D) converter in order to “read” these sensor inputs. Multiplexing reduces wire harness complexity, sensor current loads and controller hardware because each sensing device is connected to only one controller, which reads and distributes the sensor information to the other controllers over the data bus. Also, because each controller on the data bus can access the controller sensor inputs to every other controller on the data bus, more function and feature capabilities are possible.



## COMMUNICATION (Continued)

In addition to reducing wire harness complexity, component sensor current loads and controller hardware, multiplexing offers a diagnostic advantage. A multiplex system allows the information flowing between controllers to be monitored using a diagnostic scan tool. The Chrysler system allows an electronic control module to broadcast message data out onto the bus where all other electronic control modules can "hear" the messages that are being sent. When a module hears a message on the data bus that it requires, it relays that message to its microprocessor. Each module ignores the messages on the data bus that are being sent to other electronic control modules.

With a diagnostic scan tool connected into the CCD circuit, a technician is able to observe many of the electronic control module function and message outputs while; at the same time, controlling many of the sensor message inputs. The CCD data bus, along with the use of a diagnostic scan tool and a logic-based approach to test procedures, as found in the Diagnostic Procedures manuals, allows the trained automotive technician to more easily, accurately and efficiently diagnose the many complex and integrated electronic functions and features found on today's vehicles.

## OPERATION - CCD DATA BUS

The CCD data bus system was designed to run at a 7812.5 baud rate (or 7812.5 bits per second). In order to successfully transmit and receive binary messages over the CCD data bus, the system requires the following:

- Bus (+) and Bus (-) Circuits
- CCD Chips in Each Electronic Control Module
- Bus Bias and Termination
- Bus Messaging
- Bus Message Coding

Following are additional details of each of the above system requirements.

## BUS (+) AND BUS (-) CIRCUITS

The two wires (sometimes referred to as the "twisted pair") that comprise the CCD data bus are the D1 circuit [Bus (+)], and the D2 circuit [Bus (-)]. The "D" in D1 and D2 identify these as diagnostic circuits. Transmission and receipt of binary messages on the CCD data bus is accomplished by cycling the voltage differential between the Bus (+) and Bus (-) circuits.

The two data bus wires are twisted together in order to shield the wires from the effects of any Electro-Magnetic Interference (EMI) from switched voltage sources. An induced EMI voltage can be generated in any wire by a nearby switched voltage or switched ground circuit. By twisting the data bus wires together, the induced voltage spike (either up or down) affects both wires equally. Since both wires are affected equally, a voltage differential still exists between the Bus (+) and Bus (-) circuits, and the data bus messages can still be broadcast or received. The correct specification for data bus wire twisting is one turn for every 44.45 millimeters (1  $\frac{3}{4}$  inches) of wire.

## CCD CHIPS

In order for an electronic control module to communicate on the CCD data bus, it must have a CCD chip (Fig. 5). The CCD chip contains a differential transmitter/receiver (or transceiver), which is used to send and receive messages. Each module is wired in parallel to the data bus through its CCD chip.

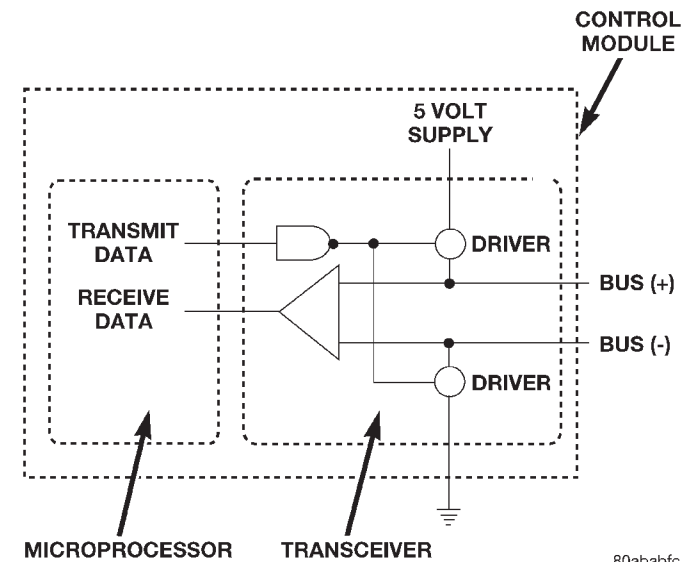


Fig. 5 CCD Chip

The differential transceiver sends messages by using two current drivers: one current source driver, and one current sink driver. The current drivers are matched and allow 0.006 ampere to flow through the data bus circuits. When the transceiver drivers are turned On, the Bus (+) voltage increases slightly, and the Bus (-) voltage decreases slightly. By cycling the drivers On and Off, the CCD chip causes the voltage on the data bus circuit to fluctuate to reflect the message.

## COMMUNICATION (Continued)

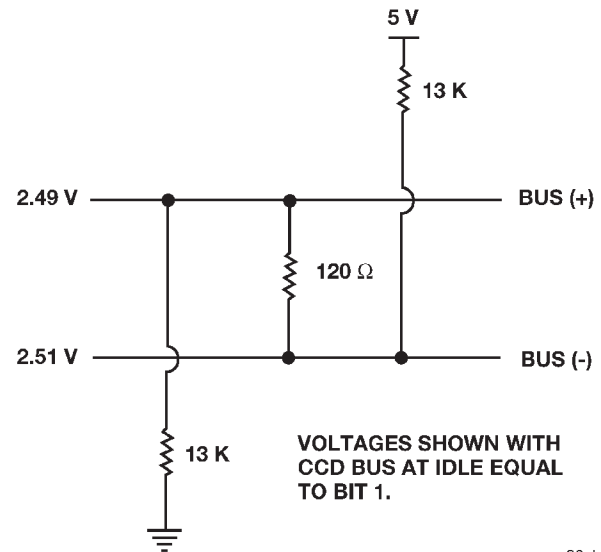
Once a message is broadcast over the CCD data bus, all electronic control modules on the data bus have the ability to receive it through their CCD chip. Reception of CCD messages is also carried out by the transceiver in the CCD chip. The transceiver monitors the voltage on the data bus for any fluctuations. When data bus voltage fluctuations are detected, they are interpreted by the transceiver as binary messages and sent to the electronic control module's microprocessor.

**BUS BIAS AND TERMINATION**

The voltage network used by the CCD data bus to transmit messages requires both bias and termination. At least one electronic control module on the data bus must provide a voltage source for the CCD data bus network known as bus bias, and there must be at least one bus termination point for the data bus circuit to be complete. However, while bias and termination are both required for data bus operation, they both do not have to be within the same electronic control module. The CCD data bus is biased to approximately 2.5 volts. With each of the electronic control modules wired in parallel to the data bus, all modules utilize the same bus bias. Therefore, based upon vehicle options, the data bus can accommodate two or twenty electronic control modules without affecting bus voltage.

The power supplied to the data bus is known as bus biasing. Bus bias is provided through a series circuit. To properly bias the data bus circuits, a 5 volt supply is provided through a 13 kilohm resistor to the Bus (-) circuit (Fig. 6). Voltage from the Bus (-) circuit flows through a 120 ohm termination resistor to the Bus (+) circuit. The Bus (+) circuit is grounded through another 13 kilohm resistor. While at least one termination resistor is required for the system to operate, most Chrysler systems use two. The second termination resistor serves as a backup (Fig. 7). The termination resistor provides a path for the bus bias voltage. Without a termination point, voltage biasing would not occur. Voltage would go to 5 volts on one bus wire and 0 volts on the other bus wire.

The voltage drop through the termination resistor creates 2.51 volts on Bus (-), and 2.49 volts on Bus (+). The voltage difference between the two circuits is 0.02 volts. When the data bus voltage differential is a steady 0.02 volts, the CCD system is considered "idle." When no input is received from any module and the ignition switch is in the Off position for a pre-programmed length of time, the bus data becomes inactive or enters the "sleep mode." Electronic control modules that provide bus bias can be programmed to "wake up" the data bus and become



80ababf9

**Fig. 6 Bus Biasing**

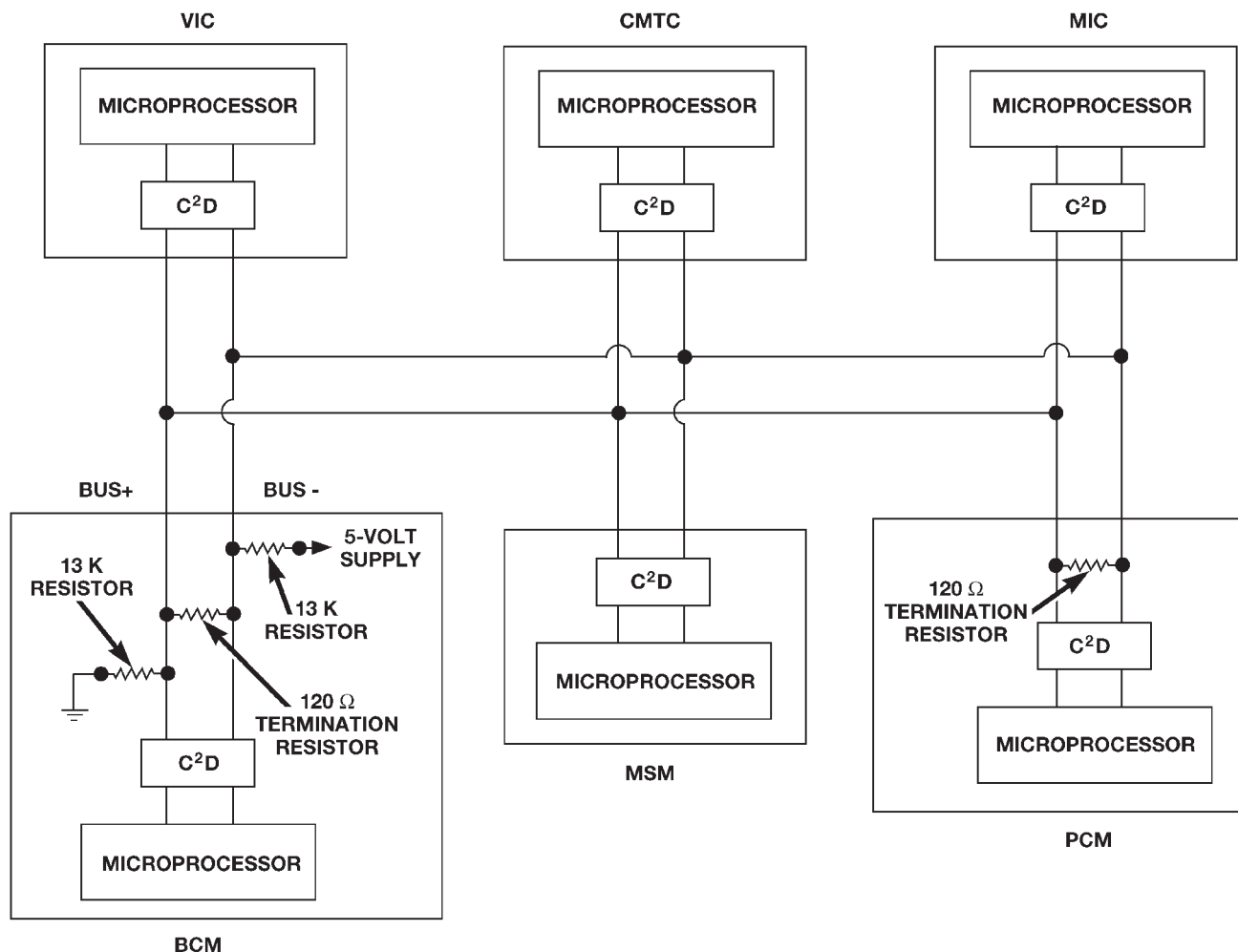
active upon receiving any predetermined input or when the ignition switch is turned to the On position.

**BUS MESSAGING**

The electronic control modules used in the CCD data bus system contain microprocessors. Digital signals are the means by which microprocessors operate internally and communicate messages to other microprocessors. Digital signals are limited to two states, voltage high or voltage low, corresponding to either a one or a zero. Unlike conventional binary code, the CCD data bus systems translate a small voltage difference as a one (1), and a larger voltage difference as a zero (0). The use of the 0 and 1 is referred to as binary coding. Each binary number is called a bit, and eight bits make up a byte. For example: 01011101 represents a message. The controllers in the multiplex system are able to send thousands of these bytes strung together to communicate a variety of messages. Through the use of binary data transmission, all electronic control modules on the data bus can communicate with each other.

The microprocessors in the CCD data bus system translate the binary messages into Hexadecimal Code (or Hex Code). Hex code is the means by which microprocessors communicate and interpret messages. When fault codes are received by the DRBIII® scan tool, they are translated into text for display on the DRBIII® screen. Although not displayed by the DRBIII® for Body Systems, hex codes are shown by the DRBIII® for Engine System faults.

## COMMUNICATION (Continued)



80a9f127

**Fig. 7 Bus Termination**

When the microprocessor signals the transceiver in the CCD chip to broadcast a message, the transceiver turns the current drivers On and Off, which cycles the voltage on the CCD data bus circuits to correspond to the message. At idle, the CCD system recognizes the 0.02 voltge differential as a binary bit 1. When the current drivers are actuated, the voltage differential from idle must increase by 0.02 volt for the CCD system to recognize a binary bit 0 (Fig. 8). The nominal voltage differential for a 0 bit is 0.100 volts. However, data bus voltage differentials can range anywhere between 0.02 and 0.120 volt.

**BUS MESSAGE CODING**

The first part of a data bus message has an Identification (ID) byte. The ID byte contains message priority, message identification, message content and message length information. All messages sent over the data bus are coded for both priority and identification.

**PRIORITY**

Messages can be broadcast almost simultaneously by modules over the CCD data bus. Therefore, all messages are defined and ranked by a predetermined priority. When two CCD chips start a message at exactly the same time, non-destructive arbitration occurs between the two CCD chips. Arbitration will occur based upon the priority code, to determine which message takes priority on the data bus and to prevent data collision. If a CCD chip senses a message of higher priority being transmitted, it stops transmitting its message. The higher priority message is then transmitted in its entirety without interruption. The other CCD chips on the data bus do not allow any other messages to be broadcast.

To determine the winner in an arbitration, all messages start with an ID byte which contains the predetermined priority code. In the digital broadcast, zero is the dominant bit. All ID bytes start with a zero. This is the start of the message. With zeros being the dominant bit, messages starting with more

COMMUNICATION (Continued)

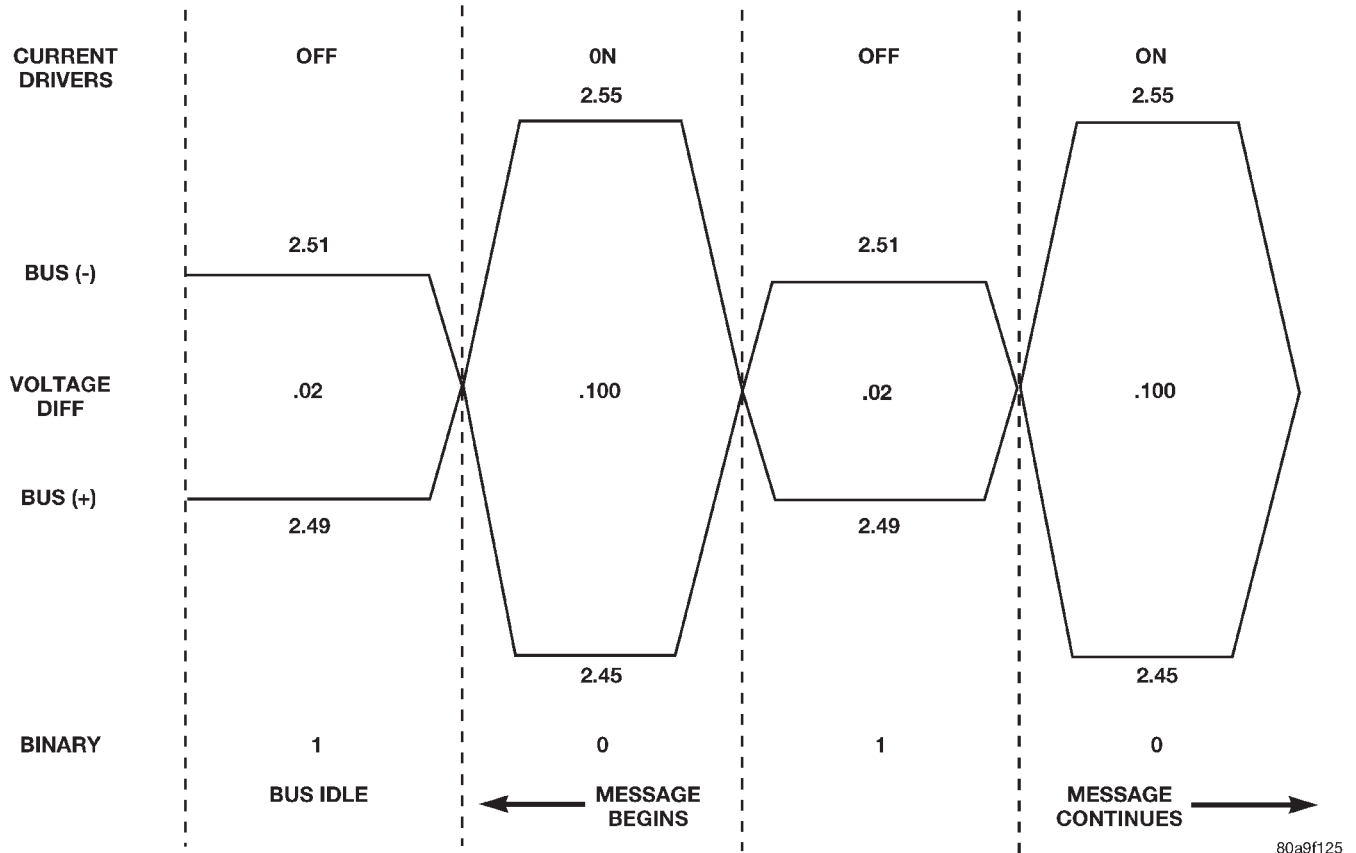
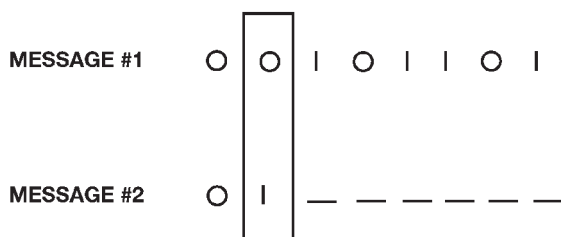


Fig. 8 Voltage Cycling to Correspond to Message

zeros have a higher priority. For example: of the two messages below, Message #2 loses arbitration at the second bit, where Message #1 has a zero and Message #2 has a one (Fig. 9). After the message is broadcast, an idle period occurs while all microprocessors can queue, if necessary, and attempt to broadcast their messages again.

- Message #1 = 00010110
- Message #2 = 01010101



MESSAGE #2 LOSES ARBITRATION AT SECOND BIT AND THE CCD CHIP STOPS TRANSMITTING THE MESSAGE.

80ababf8

Fig. 9 Message Arbitration

MESSAGE IDENTIFICATION

Because messages are broadcast over the data bus, all modules can receive them, yet not all modules need all messages. In order to enhance microprocessor speed, unneeded messages are filtered out. The ID byte, along with showing message priority, also identifies the data, content and length. The electronic control module, through its CCD chip transceiver, monitors the ID code of the messages. If the message is not for that particular module, the message is simply ignored. Once the module recognizes a message that it requires, the rest of the message is monitored and processed.

TRANSMISSION VERIFICATION

Once a CCD chip transmits a message over the CCD data bus, the message is received by the transmitting module at the same time through the CCD chip differential transceiver. The module knows the message was broadcast correctly when it receives its own message back. If the message received does not match the message transmitted, the message is said to be corrupt.

Corruption occurs when the message is incorrectly transmitted on the data bus. Corruption can also occur from interference, wiring problems, or other data bus problems. In the case of a corrupt message,

## COMMUNICATION (Continued)

the module attempts to have the CCD chip re-send the message.

## DIAGNOSIS AND TESTING - CCD DATA BUS

## CCD BUS FAILURE

The CCD data bus can be monitored using the DRBIII® scan tool. However, it is possible for the data bus to pass all tests since the voltage parameters will be in "range" and false signals are being sent. There are essentially 12 "hard failures" that can occur with the CCD data bus:

- Bus Shorted to Battery
- Bus Shorted to 5 Volts
- Bus Shorted to Ground
- Bus (+) Shorted to Bus (-)
- Bus (-) and Bus (+) Open
- Bus (+) Open
- Bus (-) Open
- No Bus Bias
- Bus Bias Level Too High
- Bus Bias Level Too Low
- No Bus Termination
- Not Receiving Bus Messages Correctly

Refer to the appropriate diagnostic procedures for details on how to diagnose these faults using a DRBIII® scan tool.

## BUS FAILURE VISUAL SYMPTOM DIAGNOSIS

The following visible symptoms or customer complaints, alone or in combination, may indicate a CCD data bus failure:

- Airbag Indicator Lamp and Malfunction Indicator Lamp (MIL) Illuminated
- Instrument Cluster Gauges (All) Inoperative
- No Compass Mini-Trip Computer (CMTC) Operation

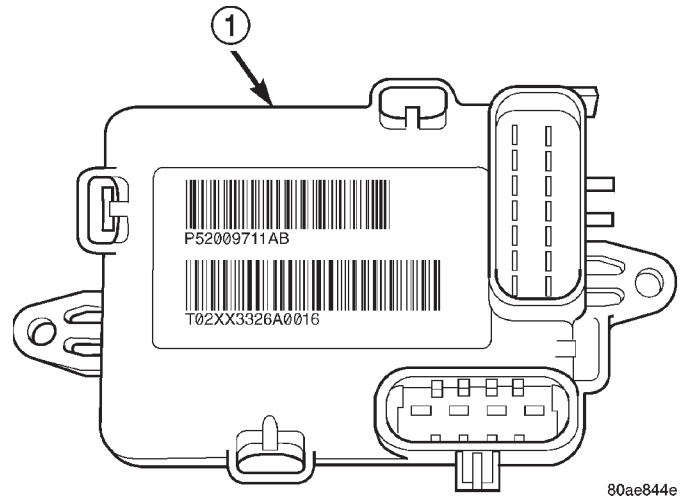
## CONTROLLER ANTILOCK BRAKE

## DESCRIPTION

The Controller Antilock Brakes (CAB) is a micro-processor which handles testing, monitoring and controlling the ABS brake system operation (Fig. 10). The CAB functions are:

- Perform self-test diagnostics.
- Monitor the RWAL brake system for proper operation.
- Control the RWAL valve solenoids.

**NOTE:** If the CAB needs to be replaced, the rear axle type and tire revolutions per mile must be programmed into the new CAB. For axle type refer to Group 3 Differential and Driveline. For tire revolu-



**Fig. 10 RWAL CAB**

1 - RWAL CAB

tions per mile, (Refer to 22 - TIRES/WHEELS/TIRES - SPECIFICATIONS) . To program the CAB refer to the Chassis Diagnostic Manual.

## OPERATION

## SYSTEM SELF-TEST

When the ignition switch is turned-on the micro-processor RAM and ROM are tested. If an error occurs during the test, a DTC will be set into the RAM memory. However it is possible the DTC will not be stored in memory if the error has occurred in the RAM module where the DTC's are stored. Also it is possible a DTC may not be stored if the error has occurred in the ROM which signals the RAM to store the DTC.

## CAB INPUTS

The CAB continuously monitors the speed of the differential ring gear by monitoring signals generated by the rear wheel speed sensor. The CAB determines a wheel locking tendency when it recognizes the ring gear is decelerating too rapidly. The CAB monitors the following inputs to determine when a wheel locking tendency may exist:

- Rear Wheel Speed Sensor
- Brake Lamp Switch
- Brake Warning Lamp Switch
- Reset Switch
- 4WD Switch (If equipped)

## CAB OUTPUTS

The CAB controls the following outputs for antilock braking and brake warning information:

- RWAL Valve

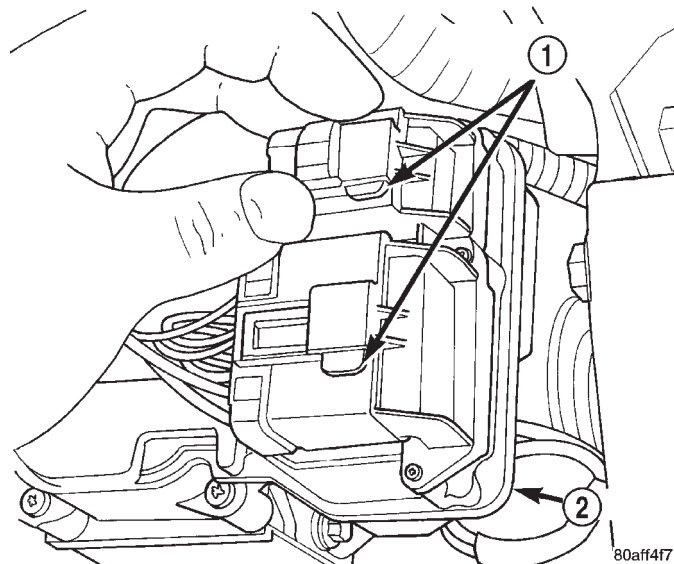


## CONTROLLER ANTILOCK BRAKE (Continued)

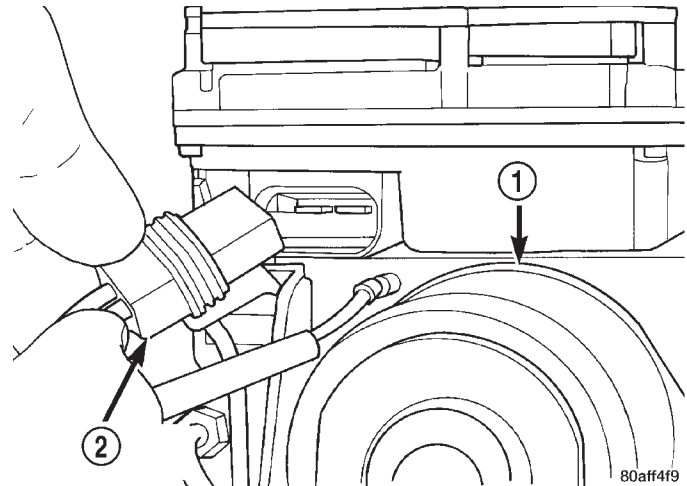
- ABS Warning Lamp
- Brake Warning Lamp

**REMOVAL**

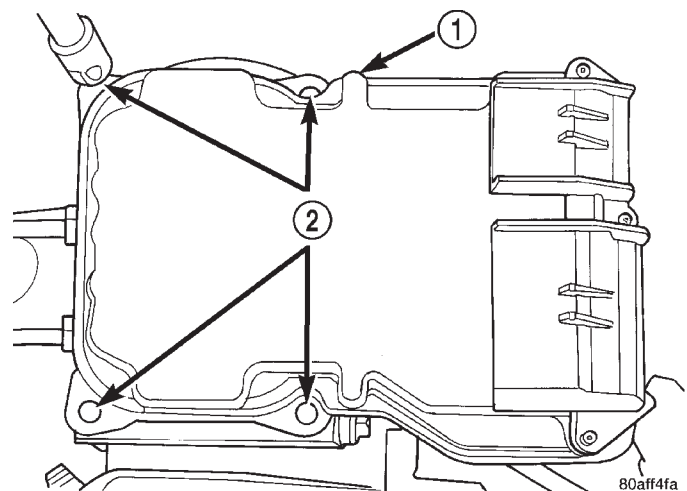
- (1) Disconnect battery negative cable.
- (2) Push the harness connector locks to release the locks, (Fig. 11) then remove the connectors from the CAB.
- (3) Disconnect the pump motor connector (Fig. 12)
- (4) Remove screws attaching CAB to the HCU (Fig. 13).
- (5) Remove the CAB.

**Fig. 11 Harness Connector Locks**

- 1 - CONNECTOR LOCK
- 2 - CAB

**Fig. 12 Pump**

- 1 - PUMP MOTOR
- 2 - PUMP CONNECTOR

**Fig. 13 Controller Mounting Screws**

- 1 - CAB
- 2 - MOUNTING LOCATIONS

**INSTALLATION**

- (1) Place the CAB onto the HCU.

**NOTE:** Insure the CAB seal is in position before installation.

- (2) Install the mounting screws and tighten to 4-4.7 N·m (36-42 in. lbs.).
- (3) Connect the pump motor harness.
- (4) Connect the harnesses to the CAB and lock the connectors.
- (5) Connect battery.

**DATA LINK CONNECTOR****DESCRIPTION - DATA LINK CONNECTOR**

The data link connector is located at the lower edge of the instrument panel near the steering column.

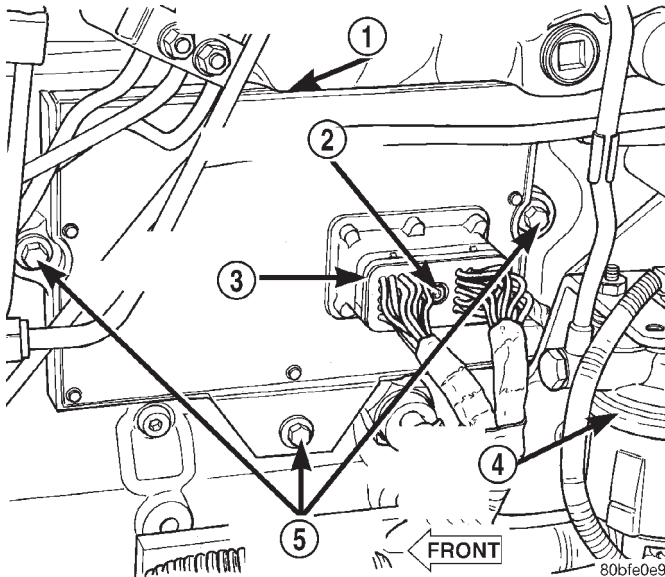
**OPERATION - DATA LINK CONNECTOR**

The 16-way data link connector (diagnostic scan tool connector) links the Diagnostic Readout Box (DRB) scan tool or the Mopar Diagnostic System (MDS) with the Powertrain Control Module (PCM).

## ENGINE CONTROL MODULE

### DESCRIPTION - ECM

The ECM is bolted to the left side of the engine behind the fuel filter (Fig. 14). It is a separate component and can be serviced. The FPCM is internal to the fuel injection pump (Fig. 15) and cannot be serviced.



**Fig. 14 Engine Control Module (ECM) Location**

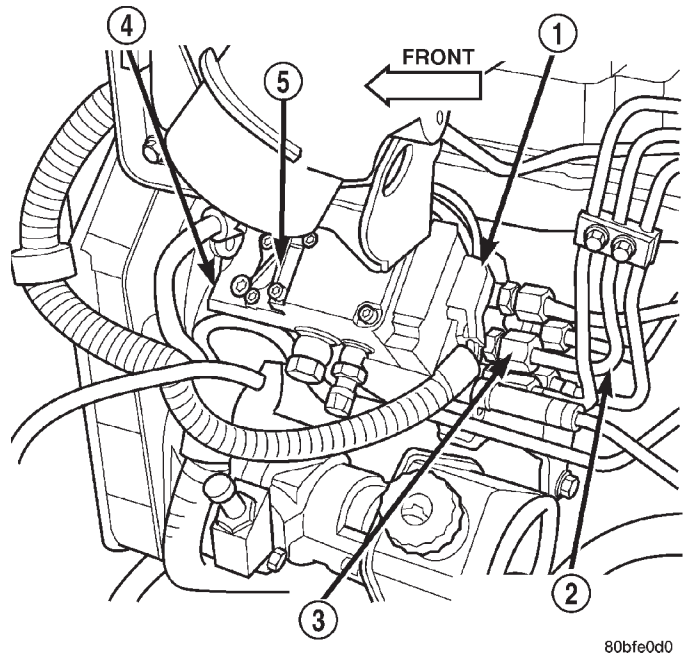
- 1 - ENGINE CONTROL MODULE (ECM)
- 2 - HEX HEADED BOLT
- 3 - 50-WAY CONNECTOR
- 4 - FUEL TRANSFER PUMP
- 5 - MOUNTING BOLTS (3)

### OPERATION - ECM

The main functions of the Engine Control Module (ECM) and Fuel Injection Pump Control Module (FPCM) are to electrically control the fuel system. The Powertrain Control Module (PCM) **does not control** the fuel system.

The ECM can adapt its programming to meet changing operating conditions. **If the ECM has been replaced, flashed or re-calibrated, the ECM must learn the Accelerator Pedal Position Sensor (APPS) idle voltage. Failure to learn this voltage may result in unnecessary diagnostic trouble codes. Refer to ECM Removal/Installation for learning procedures.**

The ECM receives input signals from various switches and sensors. Based on these inputs, the ECM regulates various engine and vehicle operations through different system components. These components are referred to as **ECM Outputs**. The sensors and switches that provide inputs to the ECM are considered **ECM Inputs**.



80bfe0d0

**Fig. 15 Fuel Injection Pump Control Module (FPCM) Location**

- 1 - FPCM ELECTRICAL CONNECTOR
- 2 - HIGH-PRESSURE FUEL LINES
- 3 - FITTINGS
- 4 - FUEL INJECTION PUMP
- 5 - FPCM

### NOTE: ECM Inputs:

- Accelerator Pedal Position Sensor (APPS) Volts
- APPS Idle Validation Switches #1 and #2
- Battery voltage
- Camshaft Position Sensor (CMP)
- CCD bus (+) circuits
- CCD bus (-) circuits
- Crankshaft Position Sensor (CKP)
- Data link connection for DRB scan tool
- (FPCM) Fuel Injection Pump Control Module
- Engine Coolant Temperature (ECT) sensor
- Ground circuits
- Intake manifold Air Temperature (IAT) sensor
- Manifold Air Pressure Sensor (Boost Pressure Sensor)
- Oil pressure sensor
- PCM
- Power Take Off (PTO)
- Power ground
- Sensor return
- Signal ground
- Water-In-Fuel (WIF) sensor

## ENGINE CONTROL MODULE (Continued)

**NOTE: ECM Outputs:**

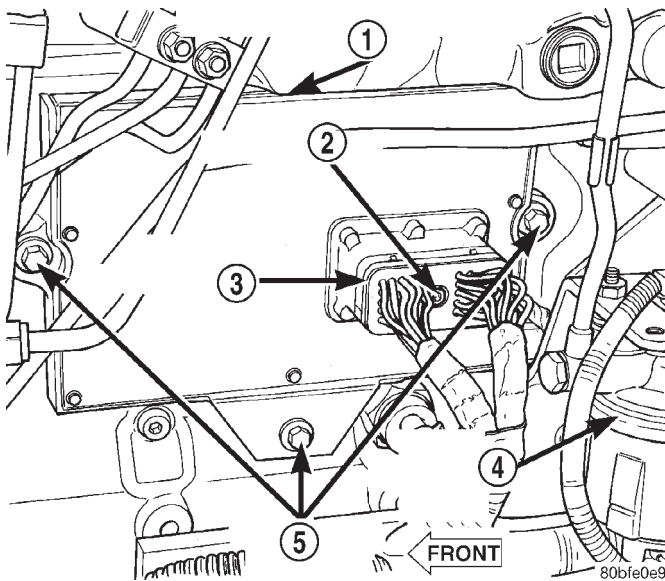
After inputs are received by the ECM, certain sensors, switches and components are controlled or regulated by the ECM. These are considered **ECM**

**Outputs.** These outputs are for:

- CCD bus (+) circuits
- CCD bus (-) circuits
- CKP and APPS outputs to the PCM
- Data link connection for DRB scan tool
- Five volt sensor supply
- Fuel injection pump
- Fuel injection pump relay
- (FPCM) Fuel Pump Control Module
- Fuel transfer (lift) pump
- Intake manifold air heater relays #1 and #2 control circuits
- Malfunction indicator lamp (Check engine lamp)
- Oil pressure gauge/warning lamp
- PCM
- Wait-to-start warning lamp
- Water-In-Fuel (WIF) warning lamp

**REMOVAL**

The ECM is bolted to the engine block behind the fuel filter (Fig. 16).



**Fig. 16 Engine Control Module (ECM) Location and Mounting**

- 1 - ENGINE CONTROL MODULE (ECM)
- 2 - HEX HEADED BOLT
- 3 - 50-WAY CONNECTOR
- 4 - FUEL TRANSFER PUMP
- 5 - MOUNTING BOLTS (3)

(1) Record any Diagnostic Trouble Codes (DTC's) found in the PCM or ECM.

To avoid possible voltage spike damage to either the Powertrain Control Module (PCM) or ECM, ignition key must be off, and negative battery cables must be disconnected before unplugging ECM connectors.

(2) Disconnect both negative battery cables at both batteries.

(3) Remove 50-way electrical connector bolt at ECM (Fig. 16). Note: Connector bolt is female 4mm hex head. To remove bolt, use a ball-hex bit or ball-hex screwdriver such as Snap-On® 4mm SDABM4 (5/32" may also be used). As bolt is being removed, very carefully remove connector from ECM.

(4) Remove three ECM mounting bolts and remove ECM from vehicle.

**INSTALLATION**

Do not apply paint to back of ECM. Poor ground will result.

(1) Clean ECM mounting points at engine block.

(2) Position ECM to engine block and install 3 mounting bolts. Tighten bolts to 24 N·m (18 ft. lbs.).

(3) Check pin connectors in ECM and 50-way connector for corrosion or damage. Repair as necessary.

(4) Clean pins in 50-way electrical connector with a quick-dry electrical contact cleaner.

(5) Very carefully install 50-way connector to ECM. Tighten connector hex bolt.

(6) Install battery cables.

(7) **Turn key to ON position. Without starting engine, slowly press throttle pedal to floor and then slowly release. This step must be done (one time) to ensure accelerator pedal position sensor calibration has been learned by ECM. If not done, possible DTC's may be set.**

(8) Use DRB scan tool to erase any stored companion DTC's from PCM.

**POWERTRAIN CONTROL MODULE****DESCRIPTION - PCM**

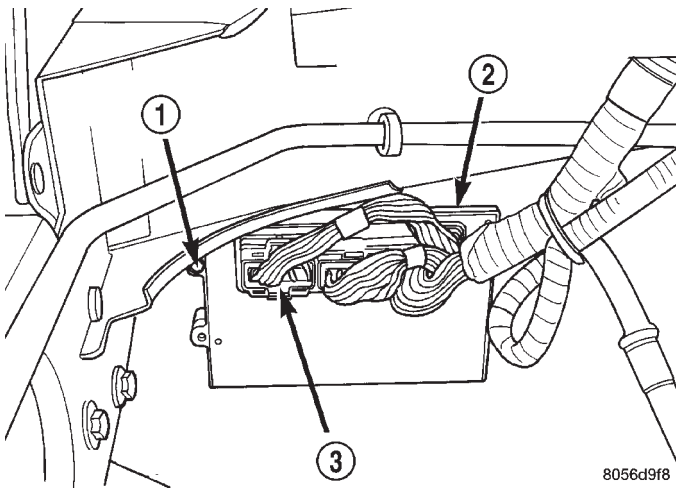
The Powertrain Control Module (PCM) is located in the engine compartment (Fig. 17). The PCM is referred to as JTEC.

**DESCRIPTION - MODES OF OPERATION**

As input signals to the Powertrain Control Module (PCM) change, the PCM adjusts its response to the output devices. For example, the PCM must calculate different injector pulse width and ignition timing for idle than it does for wide open throttle (WOT).

The PCM will operate in two different modes: **Open Loop and Closed Loop.**

## POWERTRAIN CONTROL MODULE (Continued)



**Fig. 17 PCM Location**

- 1 - PCM MOUNTING BOLTS (3)  
 2 - POWERTRAIN CONTROL MODULE (PCM)  
 3 - (3) 32-WAY CONNECTORS

During Open Loop modes, the PCM receives input signals and responds only according to preset PCM programming. Input from the oxygen (O<sub>2</sub>S) sensors is not monitored during Open Loop modes.

During Closed Loop modes, the PCM will monitor the oxygen (O<sub>2</sub>S) sensors input. This input indicates to the PCM whether or not the calculated injector pulse width results in the ideal air-fuel ratio. This ratio is 14.7 parts air-to-1 part fuel. By monitoring the exhaust oxygen content through the O<sub>2</sub>S sensor, the PCM can fine tune the injector pulse width. This is done to achieve optimum fuel economy combined with low emission engine performance.

The fuel injection system has the following modes of operation:

- Ignition switch ON
- Engine start-up (crank)
- Engine warm-up
- Idle
- Cruise
- Acceleration
- Deceleration
- Wide open throttle (WOT)
- Ignition switch OFF

The ignition switch On, engine start-up (crank), engine warm-up, acceleration, deceleration and wide open throttle modes are Open Loop modes. The idle and cruise modes, (with the engine at operating temperature) are Closed Loop modes.

#### IGNITION SWITCH (KEY-ON) MODE

This is an Open Loop mode. When the fuel system is activated by the ignition switch, the following actions occur:

- The PCM pre-positions the idle air control (IAC) motor.
- The PCM determines atmospheric air pressure from the MAP sensor input to determine basic fuel strategy.
- The PCM monitors the engine coolant temperature sensor input. The PCM modifies fuel strategy based on this input.
- Intake manifold air temperature sensor input is monitored.
- Throttle position sensor (TPS) is monitored.
- The auto shutdown (ASD) relay is energized by the PCM for approximately three seconds.
- The fuel pump is energized through the fuel pump relay by the PCM. The fuel pump will operate for approximately three seconds unless the engine is operating or the starter motor is engaged.
- The O<sub>2</sub>S sensor heater element is energized via the ASD relay. The O<sub>2</sub>S sensor input is not used by the PCM to calibrate air-fuel ratio during this mode of operation.

#### ENGINE START-UP MODE

This is an Open Loop mode. The following actions occur when the starter motor is engaged.

The PCM receives inputs from:

- Battery voltage
- Engine coolant temperature sensor
- Crankshaft position sensor
- Intake manifold air temperature sensor
- Manifold absolute pressure (MAP) sensor
- Throttle position sensor (TPS)
- Starter motor relay
- Camshaft position sensor signal

The PCM monitors the crankshaft position sensor. If the PCM does not receive a crankshaft position sensor signal within 3 seconds of cranking the engine, it will shut down the fuel injection system.

The fuel pump is activated by the PCM through the fuel pump relay.

Voltage is applied to the fuel injectors with the ASD relay via the PCM. The PCM will then control the injection sequence and injector pulse width by turning the ground circuit to each individual injector on and off.

The PCM determines the proper ignition timing according to input received from the crankshaft position sensor.

#### ENGINE WARM-UP MODE

This is an Open Loop mode. During engine warm-up, the PCM receives inputs from:

- Battery voltage
- Crankshaft position sensor
- Engine coolant temperature sensor
- Intake manifold air temperature sensor



## POWERTRAIN CONTROL MODULE (Continued)

- Manifold absolute pressure (MAP) sensor
- Throttle position sensor (TPS)
- Camshaft position sensor signal (in the distributor)
- Park/neutral switch (gear indicator signal—auto. trans. only)

- Air conditioning select signal (if equipped)
- Air conditioning request signal (if equipped)

Based on these inputs the following occurs:

• Voltage is applied to the fuel injectors with the ASD relay via the PCM. The PCM will then control the injection sequence and injector pulse width by turning the ground circuit to each individual injector on and off.

• The PCM adjusts engine idle speed through the idle air control (IAC) motor and adjusts ignition timing.

• The PCM operates the A/C compressor clutch through the clutch relay. This is done if A/C has been selected by the vehicle operator and requested by the A/C thermostat.

• When engine has reached operating temperature, the PCM will begin monitoring O<sub>2</sub>S sensor input. The system will then leave the warm-up mode and go into closed loop operation.

## IDLE MODE

When the engine is at operating temperature, this is a Closed Loop mode. At idle speed, the PCM receives inputs from:

- Air conditioning select signal (if equipped)
- Air conditioning request signal (if equipped)
- Battery voltage
- Crankshaft position sensor
- Engine coolant temperature sensor
- Intake manifold air temperature sensor
- Manifold absolute pressure (MAP) sensor
- Throttle position sensor (TPS)
- Camshaft position sensor signal (in the distributor)
- Battery voltage
- Park/neutral switch (gear indicator signal—auto. trans. only)

- Oxygen sensors

Based on these inputs, the following occurs:

• Voltage is applied to the fuel injectors with the ASD relay via the PCM. The PCM will then control injection sequence and injector pulse width by turning the ground circuit to each individual injector on and off.

• The PCM monitors the O<sub>2</sub>S sensor input and adjusts air-fuel ratio by varying injector pulse width. It also adjusts engine idle speed through the idle air control (IAC) motor.

• The PCM adjusts ignition timing by increasing and decreasing spark advance.

• The PCM operates the A/C compressor clutch through the clutch relay. This happens if A/C has been selected by the vehicle operator and requested by the A/C thermostat.

## CRUISE MODE

When the engine is at operating temperature, this is a Closed Loop mode. At cruising speed, the PCM receives inputs from:

- Air conditioning select signal (if equipped)
- Air conditioning request signal (if equipped)
- Battery voltage
- Engine coolant temperature sensor
- Crankshaft position sensor
- Intake manifold air temperature sensor
- Manifold absolute pressure (MAP) sensor
- Throttle position sensor (TPS)
- Camshaft position sensor signal (in the distributor)

• Park/neutral switch (gear indicator signal—auto. trans. only)

- Oxygen (O<sub>2</sub>S) sensors

Based on these inputs, the following occurs:

• Voltage is applied to the fuel injectors with the ASD relay via the PCM. The PCM will then adjust the injector pulse width by turning the ground circuit to each individual injector on and off.

• The PCM monitors the O<sub>2</sub>S sensor input and adjusts air-fuel ratio. It also adjusts engine idle speed through the idle air control (IAC) motor.

• The PCM adjusts ignition timing by turning the ground path to the coil on and off.

• The PCM operates the A/C compressor clutch through the clutch relay. This happens if A/C has been selected by the vehicle operator and requested by the A/C thermostat.

## ACCELERATION MODE

This is an Open Loop mode. The PCM recognizes an abrupt increase in throttle position or MAP pressure as a demand for increased engine output and vehicle acceleration. The PCM increases injector pulse width in response to increased throttle opening.

## DECELERATION MODE

When the engine is at operating temperature, this is an Open Loop mode. During hard deceleration, the PCM receives the following inputs.

- Air conditioning select signal (if equipped)
- Air conditioning request signal (if equipped)
- Battery voltage
- Engine coolant temperature sensor
- Crankshaft position sensor
- Intake manifold air temperature sensor
- Manifold absolute pressure (MAP) sensor
- Throttle position sensor (TPS)



## POWERTRAIN CONTROL MODULE (Continued)

- Camshaft position sensor signal (in the distributor)
- Park/neutral switch (gear indicator signal—auto. trans. only)
- Vehicle speed sensor

If the vehicle is under hard deceleration with the proper rpm and closed throttle conditions, the PCM will ignore the oxygen sensor input signal. The PCM will enter a fuel cut-off strategy in which it will not supply a ground to the injectors. If a hard deceleration does not exist, the PCM will determine the proper injector pulse width and continue injection.

Based on the above inputs, the PCM will adjust engine idle speed through the idle air control (IAC) motor.

The PCM adjusts ignition timing by turning the ground path to the coil on and off.

**WIDE OPEN THROTTLE MODE**

This is an Open Loop mode. During wide open throttle operation, the PCM receives the following inputs.

- Battery voltage
- Crankshaft position sensor
- Engine coolant temperature sensor
- Intake manifold air temperature sensor
- Manifold absolute pressure (MAP) sensor
- Throttle position sensor (TPS)
- Camshaft position sensor signal (in the distributor)

During wide open throttle conditions, the following occurs:

- Voltage is applied to the fuel injectors with the ASD relay via the PCM. The PCM will then control the injection sequence and injector pulse width by turning the ground circuit to each individual injector on and off. The PCM ignores the oxygen sensor input signal and provides a predetermined amount of additional fuel. This is done by adjusting injector pulse width.
- The PCM adjusts ignition timing by turning the ground path to the coil on and off.

**IGNITION SWITCH OFF MODE**

When ignition switch is turned to OFF position, the PCM stops operating the injectors, ignition coil, ASD relay and fuel pump relay.

**DESCRIPTION - 5 VOLT SUPPLIES**

Two different Powertrain Control Module (PCM) five volt supply circuits are used; primary and secondary.

**DESCRIPTION - IGNITION CIRCUIT SENSE**

This circuit ties the ignition switch to the Powertrain Control Module (PCM).

**DESCRIPTION - POWER GROUNDS**

The Powertrain Control Module (PCM) has 2 main grounds. Both of these grounds are referred to as power grounds. All of the high-current, noisy, electrical devices are connected to these grounds as well as all of the sensor returns. The sensor return comes into the sensor return circuit, passes through noise suppression, and is then connected to the power ground.

The power ground is used to control ground circuits for the following PCM loads:

- Generator field winding
- Fuel injectors
- Ignition coil(s)
- Certain relays/solenoids
- Certain sensors

**DESCRIPTION - SENSOR RETURN**

The Sensor Return circuits are internal to the Powertrain Control Module (PCM).

Sensor Return provides a low-noise ground reference for all engine control system sensors. Refer to Power Grounds for more information.

**DESCRIPTION - SIGNAL GROUND**

Signal ground provides a low noise ground to the data link connector.

**OPERATION - PCM - GAS ENGINES**

The PCM operates the fuel system. The PCM is a pre-programmed, triple microprocessor digital computer. It regulates ignition timing, air-fuel ratio, emission control devices, charging system, certain transmission features, speed control, air conditioning compressor clutch engagement and idle speed. The PCM can adapt its programming to meet changing operating conditions.

The PCM receives input signals from various switches and sensors. Based on these inputs, the PCM regulates various engine and vehicle operations through different system components. These components are referred to as Powertrain Control Module (PCM) Outputs. The sensors and switches that provide inputs to the PCM are considered Powertrain Control Module (PCM) Inputs.

The PCM adjusts ignition timing based upon inputs it receives from sensors that react to: engine rpm, manifold absolute pressure, engine coolant temperature, throttle position, transmission gear selection (automatic transmission), vehicle speed and the brake switch.

The PCM adjusts idle speed based on inputs it receives from sensors that react to: throttle position, vehicle speed, transmission gear selection, engine coolant temperature and from inputs it receives from the air conditioning clutch switch and brake switch.

## POWERTRAIN CONTROL MODULE (Continued)

Based on inputs that it receives, the PCM adjusts ignition coil dwell. The PCM also adjusts the generator charge rate through control of the generator field and provides speed control operation.

**NOTE: PCM Inputs:**

- A/C request (if equipped with factory A/C)
- A/C select (if equipped with factory A/C)
- Auto shutdown (ASD) sense
- Battery temperature
- Battery voltage
- Brake switch
- CCD bus (+) circuits
- CCD bus (-) circuits
- Camshaft position sensor signal
- Crankshaft position sensor
- Data link connection for DRB scan tool
- Engine coolant temperature sensor
- Fuel level
- Generator (battery voltage) output
- Ignition circuit sense (ignition switch in on/off/crank/run position)
  - Intake manifold air temperature sensor
  - Leak detection pump (switch) sense (if equipped)
  - Manifold absolute pressure (MAP) sensor
  - Oil pressure
  - Output shaft speed sensor
  - Overdrive/override switch
  - Oxygen sensors
  - Park/neutral switch (auto. trans. only)
  - Power ground
  - Sensor return
  - Signal ground
  - Speed control multiplexed single wire input
  - Throttle position sensor
  - Transmission governor pressure sensor
  - Transmission temperature sensor
  - Vehicle speed inputs from ABS or RWAL system

**NOTE: PCM Outputs:**

- A/C clutch relay
- Auto shutdown (ASD) relay
- CCD bus (+/-) circuits for: speedometer, voltmeter, fuel gauge, oil pressure gauge/lamp, engine temp. gauge and speed control warn. lamp
- Data link connection for DRB scan tool
- EGR valve control solenoid (if equipped)
- EVAP canister purge solenoid
- Five volt sensor supply (primary)
- Five volt sensor supply (secondary)
- Fuel injectors
- Fuel pump relay
- Generator field driver (-)
- Generator field driver (+)
- Generator lamp (if equipped)

- Idle air control (IAC) motor
- Ignition coil
- Leak detection pump (if equipped)
- Malfunction indicator lamp (Check engine lamp). Driven through CCD circuits.
  - Overdrive indicator lamp (if equipped)
  - Service Reminder Indicator (SRI) Lamp (MAINT REQ'D lamp). Driven through CCD circuits.
    - Speed control vacuum solenoid
    - Speed control vent solenoid
    - Tachometer (if equipped). Driven through CCD circuits.
      - Transmission convertor clutch circuit
      - Transmission 3-4 shift solenoid
      - Transmission relay
      - Transmission temperature lamp (if equipped)
      - Transmission variable force solenoid

**OPERATION - DIESEL**

Two different control modules are used: The Powertrain Control Module (PCM), and the Engine Control Module (ECM). The ECM **controls** the fuel system. The PCM **does not control** the fuel system.

The PCM's main function is to control: the vehicle charging system, speed control system, transmission, air conditioning system and certain bussed messages.

The PCM can adapt its programming to meet changing operating conditions.

The PCM receives input signals from various switches and sensors. Based on these inputs, the PCM regulates various engine and vehicle operations through different system components. These components are referred to as **PCM Outputs**. The sensors and switches that provide inputs to the PCM are considered **PCM Inputs**.

**NOTE: PCM Inputs:**

- A/C request (if equipped with factory A/C)
- A/C select (if equipped with factory A/C)
- Accelerator Pedal Position Sensor (APPS) output from ECM
  - Auto shutdown (ASD) relay sense
  - Battery temperature sensor
  - Battery voltage
  - Brake switch
  - CCD bus (+) circuits
  - CCD bus (-) circuits
  - Crankshaft Position Sensor (CKP) output from ECM
    - Data link connection for DRB scan tool
    - Fuel level sensor
    - Generator (battery voltage) output
    - Ignition sense
    - Output shaft speed sensor
    - Overdrive/override switch
    - Park/neutral switch (auto. trans. only)

## POWERTRAIN CONTROL MODULE (Continued)

- Power ground
- Sensor return
- Signal ground
- Speed control resume switch
- Speed control set switch
- Speed control on/off switch
- Transmission governor pressure sensor
- Transmission temperature sensor
- Vehicle speed inputs from ABS or RWAL system

**NOTE: PCM Outputs:**

After inputs are received by the PCM, certain sensors, switches and components are controlled or regulated by the PCM. These are considered **PCM**

**Outputs.** These outputs are for:

- A/C clutch relay and A/C clutch
- Auto shutdown (ASD) relay
- CCD bus (+/-) circuits for: speedometer, voltmeter, fuel gauge, oil pressure gauge/lamp, engine temp. gauge and speed control warn. lamp
- Data link connection for DRB scan tool
- Five volt sensor supply
- Generator field driver (-)
- Generator field driver (+)
- Generator lamp (if equipped)
- Malfunction indicator lamp (Check engine lamp)
- Overdrive warning lamp (if equipped)
- Speed control vacuum solenoid
- Speed control vent solenoid
- Tachometer (if equipped)
- Transmission convertor clutch circuit
- Transmission 3-4 shift solenoid
- Transmission relay
- Transmission temperature lamp (if equipped)
- Transmission variable force solenoid (governor sol.)

**OPERATION - 5 VOLT SUPPLIES**

Primary 5-volt supply:

- supplies the required 5 volt power source to the Crankshaft Position (CKP) sensor.
- supplies the required 5 volt power source to the Camshaft Position (CMP) sensor.
- supplies a reference voltage for the Manifold Absolute Pressure (MAP) sensor.
- supplies a reference voltage for the Throttle Position Sensor (TPS) sensor.

Secondary 5-volt supply:

- supplies the required 5 volt power source to the oil pressure sensor.
- supplies the required 5 volt power source for the Vehicle Speed Sensor (VSS) (if equipped).
- supplies the 5 volt power source to the transmission pressure sensor (if equipped with an RE automatic transmission).

**OPERATION - IGNITION CIRCUIT SENSE**

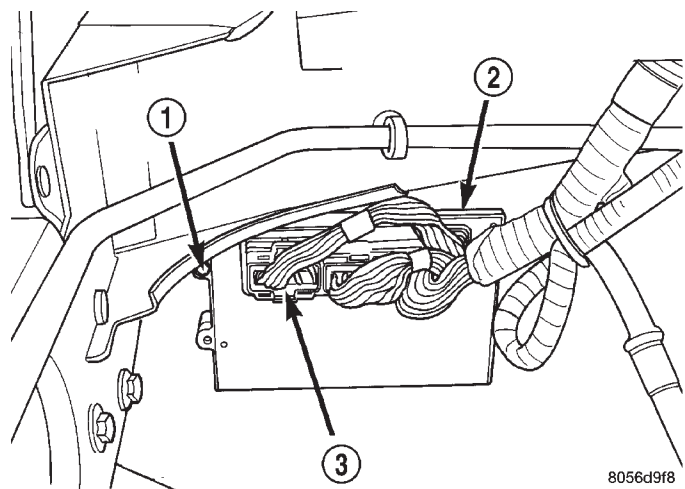
The ignition circuit sense input tells the PCM the ignition switch has energized the ignition circuit.

Battery voltage is also supplied to the PCM through the ignition switch when the ignition is in the RUN or START position. This is referred to as the "ignition sense" circuit and is used to "wake up" the PCM. Voltage on the ignition input can be as low as 6 volts and the PCM will still function. Voltage is supplied to this circuit to power the PCM's 8-volt regulator and to allow the PCM to perform fuel, ignition and emissions control functions.

**REMOVAL**

**USE THE DRB SCAN TOOL TO REPROGRAM THE NEW POWERTRAIN CONTROL MODULE (PCM) WITH THE VEHICLES ORIGINAL IDENTIFICATION NUMBER (VIN) AND THE VEHICLES ORIGINAL MILEAGE. IF THIS STEP IS NOT DONE, A DIAGNOSTIC TROUBLE CODE (DTC) MAY BE SET.**

The PCM is located in the engine compartment (Fig. 18).



**Fig. 18 PCM Location and Mounting**

- 1 - PCM MOUNTING BOLTS (3)
- 2 - POWERTRAIN CONTROL MODULE (PCM)
- 3 - (3) 32-WAY CONNECTORS

To avoid possible voltage spike damage to the PCM, ignition key must be off, and negative battery cable must be disconnected before unplugging PCM connectors.

- (1) Disconnect negative battery cable(s) at battery(s).
- (2) Remove cover over electrical connectors. Cover snaps onto PCM.
- (3) Carefully unplug the three 32-way connectors from PCM.

## POWERTRAIN CONTROL MODULE (Continued)

(4) Remove three PCM mounting bolts and remove PCM from vehicle.

**INSTALLATION**

**USE THE DRB SCAN TOOL TO REPROGRAM THE NEW POWERTRAIN CONTROL MODULE (PCM) WITH THE VEHICLES ORIGINAL IDENTIFICATION NUMBER (VIN) AND THE VEHICLES ORIGINAL MILEAGE. IF THIS STEP IS NOT DONE, A DIAGNOSTIC TROUBLE CODE (DTC) MAY BE SET.**

- (1) Install PCM and mounting bolts to vehicle.
- (2) Tighten bolts to 4 N·m (35 in. lbs.).

(3) Check pin connectors in the PCM and the three 32-way connectors for corrosion or damage. Repair as necessary.

- (4) Install three 32-way connectors.
- (5) Install cover over electrical connectors. Cover snaps onto PCM.
- (6) Install battery cable(s).
- (7) Use the DRB scan tool to reprogram new PCM with vehicles original Identification Number (VIN) and original vehicle mileage. If this step is not done, a Diagnostic Trouble Code (DTC) may be set.

# ENGINE SYSTEMS

## TABLE OF CONTENTS

	page		page
BATTERY SYSTEM .....	1	STARTING .....	32
CHARGING .....	27		

# BATTERY SYSTEM

## TABLE OF CONTENTS

	page		page
<b>BATTERY SYSTEM</b>		IGNITION-OFF DRAW TEST .....	15
DESCRIPTION .....	1	REMOVAL .....	17
OPERATION .....	2	INSTALLATION .....	17
DIAGNOSIS AND TESTING .....	2	<b>BATTERY HOLDDOWN</b>	
BATTERY SYSTEM .....	2	DESCRIPTION .....	18
CLEANING .....	5	OPERATION .....	18
INSPECTION .....	5	REMOVAL .....	18
SPECIFICATIONS .....	6	INSTALLATION .....	18
<b>BATTERY</b>		<b>BATTERY CABLE</b>	
DESCRIPTION .....	6	DESCRIPTION .....	19
OPERATION .....	7	OPERATION .....	20
DIAGNOSIS AND TESTING .....	7	DIAGNOSIS AND TESTING .....	20
BATTERY .....	7	BATTERY CABLES .....	20
STANDARD PROCEDURE .....	8	REMOVAL .....	23
CHECKING BATTERY ELECTROLYTE		INSTALLATION .....	23
LEVEL .....	8	<b>BATTERY TRAY</b>	
BATTERY CHARGING .....	9	DESCRIPTION .....	24
BUILT-IN INDICATOR TEST .....	11	OPERATION .....	25
HYDROMETER TEST .....	12	REMOVAL .....	25
OPEN-CIRCUIT VOLTAGE TEST .....	13	INSTALLATION .....	25
LOAD TEST .....	14		

## BATTERY SYSTEM

### DESCRIPTION

A single 12-volt battery system is standard factory-installed equipment on gasoline engine equipped models. Models equipped with a diesel engine utilize two 12-volt batteries connected in parallel. All of the components of the battery system are located within the engine compartment of the vehicle. The service information for the battery system in this vehicle covers the following related components, which are covered in further detail elsewhere in this service manual:

- **Battery** - The storage battery provides a reliable means of storing a renewable source of electrical energy within the vehicle.

- **Battery Cable** - The battery cables connect the battery terminal posts to the vehicle electrical system.

- **Battery Holddown** - The battery holddown hardware secures the battery in the battery tray in the engine compartment.

- **Battery Tray** - The battery tray provides a secure mounting location in the vehicle for the battery and an anchor point for the battery holddown hardware.



## BATTERY SYSTEM (Continued)

For battery system maintenance schedules and jump starting procedures, see the owner's manual in the vehicle glove box. Optionally, refer to Lubrication and Maintenance for the recommended battery maintenance schedules and for the proper battery jump starting procedures. While battery charging can be considered a maintenance procedure, the battery charging procedures and related information are located in the standard procedures section of this service manual. This was done because the battery must be fully-charged before any battery system diagnosis or testing procedures can be performed. Refer to Standard procedures for the proper battery charging procedures.

**OPERATION**

The battery system is designed to provide a safe, efficient, reliable and mobile means of producing, delivering and storing electrical energy. This electrical energy is required to operate the engine starting system, as well as to operate many of the other vehicle accessory systems for limited durations while the engine and/or the charging system are not operating. The battery system is also designed to provide a reserve of electrical energy to supplement the charging system for short durations while the engine is running and the electrical current demands of the vehicle exceed the output of the charging system. In addition to producing, delivering, and storing electrical energy for the vehicle, the battery system serves as a capacitor and voltage stabilizer for the vehicle electrical system. It absorbs most abnormal or transient voltages caused by the switching of any of the electrical components or circuits in the vehicle.

**DIAGNOSIS AND TESTING - BATTERY SYSTEM**

The battery, starting, and charging systems in the vehicle operate with one another and must be tested as a single complete system. In order for the engine to start and the battery to charge properly, all of the components that are used in these systems must perform within specifications. It is important that the battery, starting, and charging systems be thoroughly tested and inspected any time a battery needs to be charged or replaced. The cause of abnormal battery discharge, overcharging or early battery failure must be diagnosed and corrected before a battery is replaced and before a vehicle is returned to service. The service information for these systems has been separated within this service manual to make it easier to locate the specific information you are seeking. However, when attempting to diagnose any of these systems, it is important that you keep their interdependency in mind.

The diagnostic procedures used for the battery, starting, and charging systems include the most basic conventional diagnostic methods, to the more sophisticated On-Board Diagnostics (OBD) built into the Powertrain Control Module (PCM). Use of an induction-type milliamperimeter, a volt/ohmmeter, a battery charger, a carbon pile rheostat (load tester) and a 12-volt test lamp may be required. All OBD-sensed systems are monitored by the PCM. Each monitored circuit is assigned a Diagnostic Trouble Code (DTC). The PCM will store a DTC in electronic memory for any failure it detects. Refer to Charging System for the proper charging system on-board diagnostic test procedures.

## BATTERY SYSTEM (Continued)

BATTERY SYSTEM DIAGNOSIS		
CONDITION	POSSIBLE CAUSES	CORRECTION
THE BATTERY SEEMS WEAK OR DEAD WHEN ATTEMPTING TO START THE ENGINE.	<ol style="list-style-type: none"> <li>1. The battery has an incorrect size or rating for this vehicle.</li> <li>2. The battery is physically damaged.</li> <li>3. The battery terminal connections are loose or corroded.</li> <li>4. The battery is discharged.</li> <li>5. The electrical system ignition-off draw is excessive.</li> <li>6. The battery is faulty.</li> <li>7. The starting system is faulty.</li> <li>8. The charging system is faulty.</li> </ol>	<ol style="list-style-type: none"> <li>1. Refer to Battery Specifications for the proper size and rating. Replace an incorrect battery, as required.</li> <li>2. Inspect the battery for loose terminal posts or a cracked and leaking case. Replace the damaged battery, as required.</li> <li>3. Refer to Battery Cable for the proper cable diagnosis and testing procedures. Clean and tighten the battery terminal connections, as required.</li> <li>4. Determine the battery state-of-charge. Refer to Standard Procedures for the proper test procedures. Charge the faulty battery, as required.</li> <li>5. Refer to Standard Procedures for the proper test procedures. Repair the faulty electrical system, as required.</li> <li>6. Determine the battery cranking capacity. Refer to Standard Procedures for the test procedures. Replace the faulty battery, as required.</li> <li>7. Determine if the starting system is performing to specifications. Refer to Starting System for the proper starting system diagnosis and testing procedures. Repair the faulty starting system, as required.</li> <li>8. Determine if the charging system is performing to specifications. Refer to Charging System for the proper charging system diagnosis and testing procedures. Repair the faulty charging system, as required.</li> </ol>

## BATTERY SYSTEM (Continued)

BATTERY SYSTEM DIAGNOSIS		
CONDITION	POSSIBLE CAUSES	CORRECTION
THE BATTERY STATE OF CHARGE CANNOT BE MAINTAINED.	<ol style="list-style-type: none"> <li>1. The battery has an incorrect size or rating for this vehicle.</li> <li>2. The battery terminal connections are loose or corroded.</li> <li>3. The generator drive belt is slipping.</li> <li>4. The electrical system ignition-off draw is excessive.</li> <li>5. The battery is faulty.</li> <li>6. The starting system is faulty.</li> <li>7. The charging system is faulty.</li> <li>8. Electrical loads exceed the output of the charging system.</li> <li>9. Slow driving or prolonged idling with high-amperage draw systems in use.</li> </ol>	<ol style="list-style-type: none"> <li>1. Refer to Battery Specifications for the proper specifications. Replace an incorrect battery, as required.</li> <li>2. Refer to Battery Cable for the proper cable diagnosis and testing procedures. Clean and tighten the battery terminal connections, as required.</li> <li>3. Refer to Cooling System for the proper accessory drive belt diagnosis and testing procedures. Replace or adjust the faulty generator drive belt, as required.</li> <li>4. Refer to Standard Procedures for the proper test procedures. Repair the faulty electrical system, as required.</li> <li>5. Determine the battery cranking capacity. Refer to Standard Procedures for the proper test procedures. Replace the faulty battery, as required.</li> <li>6. Determine if the starting system is performing to specifications. Refer to Starting System for the proper starting system diagnosis and testing procedures. Repair the faulty starting system, as required.</li> <li>7. Determine if the charging system is performing to specifications. Refer to Charging System for the proper charging system diagnosis and testing procedures. Repair the faulty charging system, as required.</li> <li>8. Inspect the vehicle for aftermarket electrical equipment which might cause excessive electrical loads.</li> <li>9. Advise the vehicle operator, as required.</li> </ol>
THE BATTERY WILL NOT ACCEPT A CHARGE.	<ol style="list-style-type: none"> <li>1. The battery is faulty.</li> </ol>	<ol style="list-style-type: none"> <li>1. Refer to Standard Procedures for the proper battery charging procedures. Charge or replace the faulty battery, as required.</li> </ol>

**ABNORMAL BATTERY DISCHARGING**

Any of the following conditions can result in abnormal battery discharging:

- Corroded or loose battery posts and terminal clamps.
- A loose or worn generator drive belt.
- Electrical loads that exceed the output of the charging system. This can be due to equipment installed after manufacture, or repeated short trip use.

- Slow driving speeds (heavy traffic conditions) or prolonged idling, with high-amperage draw systems in use.

- A faulty circuit or component causing excessive ignition-off draw.
- A faulty or incorrect charging system component. Refer to Charging System for the proper charging system diagnosis and testing procedures.

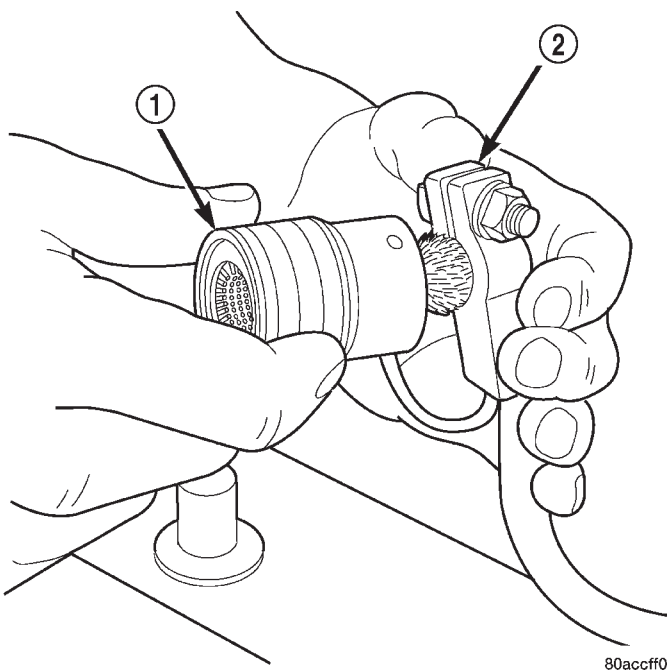
## BATTERY SYSTEM (Continued)

- A faulty or incorrect starting system component. Refer to Starting System for the proper starting system diagnosis and testing procedures.
- A faulty or incorrect battery. Refer to Standard Procedures for the proper battery diagnosis and testing procedures. Refer to Battery System Specifications for the proper specifications.

## CLEANING

The following information details the recommended cleaning procedures for the battery and related components. In addition to the maintenance schedules found in this service manual and the owner's manual, it is recommended that these procedures be performed any time the battery or related components must be removed for vehicle service.

(1) Clean the battery cable terminal clamps of all corrosion. Remove any corrosion using a wire brush or a post and terminal cleaning tool, and a sodium bicarbonate (baking soda) and warm water cleaning solution (Fig. 1).



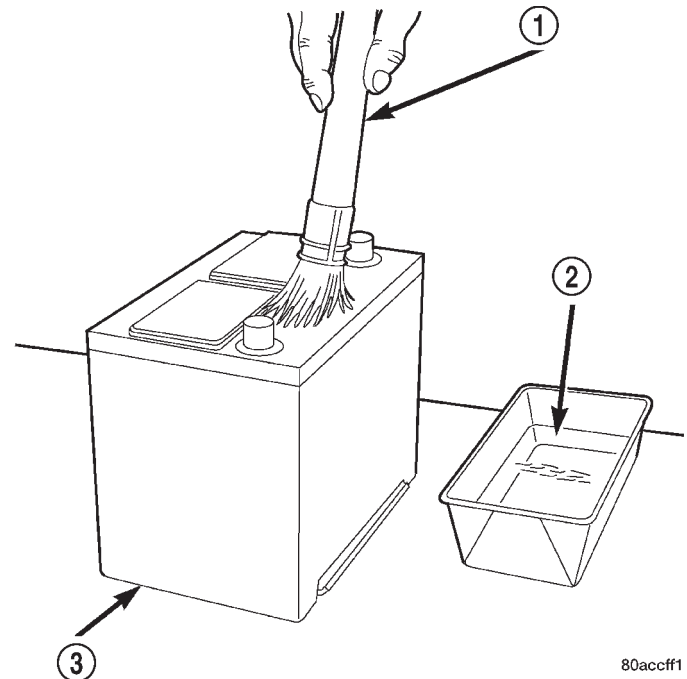
**Fig. 1 Clean Battery Cable Terminal Clamp - Typical**

- 1 - TERMINAL BRUSH  
2 - BATTERY CABLE

(2) Clean the battery tray and battery holddown hardware of all corrosion. Remove any corrosion using a wire brush and a sodium bicarbonate (baking soda) and warm water cleaning solution. Paint any exposed bare metal.

(3) If the removed battery is to be reinstalled, clean the outside of the battery case and the top cover with a sodium bicarbonate (baking soda) and warm water cleaning solution using a stiff bristle

parts cleaning brush to remove any acid film (Fig. 2). Rinse the battery with clean water. Ensure that the cleaning solution does not enter the battery cells through the vent holes. If the battery is being replaced, refer to Battery Specifications for the factory-installed battery specifications. Confirm that the replacement battery is the correct size and has the correct ratings for the vehicle.



**Fig. 2 Clean Battery - Typical**

- 1 - CLEANING BRUSH  
2 - WARM WATER AND BAKING SODA SOLUTION  
3 - BATTERY

(4) Clean the battery thermal guard with a sodium bicarbonate (baking soda) and warm water cleaning solution using a stiff bristle parts cleaning brush to remove any acid film.

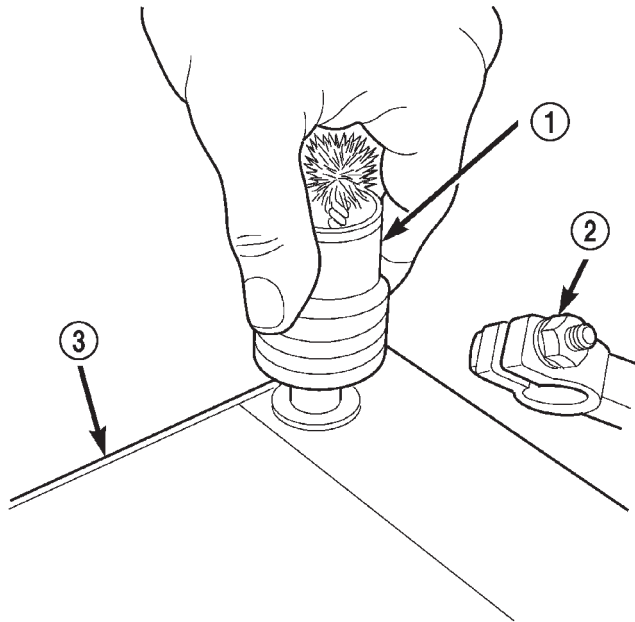
(5) Clean any corrosion from the battery terminal posts with a wire brush or a post and terminal cleaner, and a sodium bicarbonate (baking soda) and warm water cleaning solution (Fig. 3).

## INSPECTION

The following information details the recommended inspection procedures for the battery and related components. In addition to the maintenance schedules found in this service manual and the owner's manual, it is recommended that these procedures be performed any time the battery or related components must be removed for vehicle service.

(1) Inspect the battery cable terminal clamps for damage. Replace any battery cable that has a damaged or deformed terminal clamp.

## BATTERY SYSTEM (Continued)



80accff2

**Fig. 3 Clean Battery Terminal Post - Typical**

- 1 - TERMINAL BRUSH
- 2 - BATTERY CABLE
- 3 - BATTERY

## SPECIFICATIONS

## BATTERY

Battery Classifications and Ratings					
Part Number	BCI Group Size Classification	Cold Cranking Amperage	Reserve Capacity	Ampere-Hours	Load Test Amperage
56028375AA	27	600	120 Minutes	66	300
56028376AA	27	750	150 Minutes	75	375

## BATTERY

## DESCRIPTION

A large capacity, low-maintenance storage battery (Fig. 4) is standard factory-installed equipment on this model. Refer to Battery Specifications for the proper specifications of the factory-installed batteries available on this model. Male post type terminals made of a soft lead material protrude from the top of the molded plastic battery case to provide the means for connecting the battery to the vehicle electrical system. The battery positive terminal post is physically larger in diameter than the negative terminal

(2) Inspect the battery tray and battery holddown hardware for damage. Replace any damaged parts.

(3) Slide the thermal guard off of the battery case, if equipped. Inspect the battery case for cracks or other damage that could result in electrolyte leaks. Also, check the battery terminal posts for looseness. Batteries with damaged cases or loose terminal posts must be replaced.

(4) Inspect the battery thermal guard for tears, cracks, deformation or other damage. Replace any battery thermal guard that has been damaged.

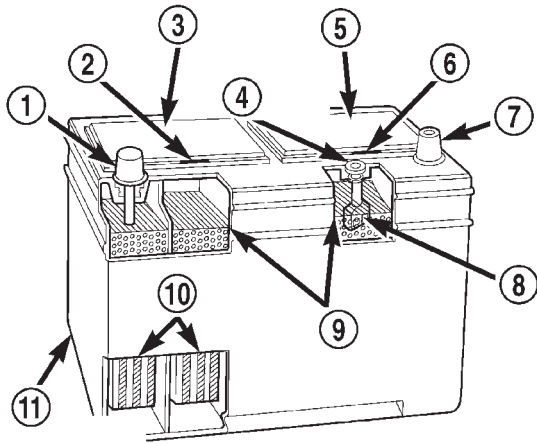
(5) Inspect the battery built-in test indicator sight glass for an indication of the battery condition. If the battery is discharged, charge as required. Refer to Standard Procedures for the proper battery built-in indicator test procedures. Also refer to Standard Procedures for the proper battery charging procedures.

post to ensure proper battery connection. The letters **POS** and **NEG** are also molded into the top of the battery case adjacent to their respective positive and negative terminal posts for identification confirmation. Refer to Battery Cables for more information on the battery cables that connect the battery to the vehicle electrical system.

The battery is made up of six individual cells that are connected in series. Each cell contains positively charged plate groups that are connected with lead straps to the positive terminal post, and negatively charged plate groups that are connected with lead straps to the negative terminal post. Each plate consists of a stiff mesh framework or grid coated with



## BATTERY (Continued)



80accfel

**Fig. 4 Low-Maintenance Battery - Typical**

- 1 - POSITIVE POST
- 2 - VENT
- 3 - CELL CAP
- 4 - TEST INDICATOR
- 5 - CELL CAP
- 6 - VENT
- 7 - NEGATIVE POST
- 8 - GREEN BALL
- 9 - ELECTROLYTE LEVEL
- 10 - PLATE GROUPS
- 11 - LOW-MAINTENANCE BATTERY

lead dioxide (positive plate) or sponge lead (negative plate). Insulators or plate separators made of a non-conductive material are inserted between the positive and negative plates to prevent them from contacting or shorting against one another. These dissimilar metal plates are submerged in a sulfuric acid and water solution called an electrolyte.

The factory-installed battery has a built-in test indicator (hydrometer). The color visible in the sight glass of the indicator will reveal the battery condition. Refer to Standard Procedures for the proper built-in indicator test procedures. **The factory-installed low-maintenance battery has non-removable battery cell caps.** Water cannot be added to this battery. The battery is not sealed and has vent holes in the cell caps. The chemical composition of the metal coated plates within the low-maintenance battery reduces battery gassing and water loss, at normal charge and discharge rates. Therefore, the battery should not require additional water in normal service. Rapid loss of electrolyte can be caused by an overcharging condition. Be certain to diagnose the charging system before returning the vehicle to service. Refer to Charging System for the proper charging system diagnosis and testing procedures.

## OPERATION

The battery is designed to store electrical energy in a chemical form. When an electrical load is applied to the terminals of the battery, an electrochemical reaction occurs. This reaction causes the battery to discharge electrical current from its terminals. As the battery discharges, a gradual chemical change takes place within each cell. The sulfuric acid in the electrolyte combines with the plate materials, causing both plates to slowly change to lead sulfate. At the same time, oxygen from the positive plate material combines with hydrogen from the sulfuric acid, causing the electrolyte to become mainly water. The chemical changes within the battery are caused by the movement of excess or free electrons between the positive and negative plate groups. This movement of electrons produces a flow of electrical current through the load device attached to the battery terminals.

As the plate materials become more similar chemically, and the electrolyte becomes less acid, the voltage potential of each cell is reduced. However, by charging the battery with a voltage higher than that of the battery itself, the battery discharging process is reversed. Charging the battery gradually changes the sulfated lead plates back into sponge lead and lead dioxide, and the water back into sulfuric acid. This action restores the difference in the electron charges deposited on the plates, and the voltage potential of the battery cells. For a battery to remain useful, it must be able to produce high-amperage current over an extended period. A battery must also be able to accept a charge, so that its voltage potential may be restored.

The battery is vented to release excess hydrogen gas that is created when the battery is being charged or discharged. However, even with these vents, hydrogen gas can collect in or around the battery. If hydrogen gas is exposed to flame or sparks, it may ignite. If the electrolyte level is low, the battery may arc internally and explode. If the battery is equipped with removable cell caps, add distilled water whenever the electrolyte level is below the top of the plates. If the battery cell caps cannot be removed, the battery must be replaced if the electrolyte level becomes low.

## DIAGNOSIS AND TESTING - BATTERY

The battery must be completely charged and the top, posts and terminal clamps should be properly cleaned and inspected before diagnostic procedures are performed. Refer to Battery System Cleaning for the proper cleaning procedures, and Battery System Inspection for the proper battery inspection procedures. Refer to Standard Procedures for the proper battery charging procedures.

## BATTERY (Continued)

**WARNING: IF THE BATTERY SHOWS SIGNS OF FREEZING, LEAKING OR LOOSE POSTS, DO NOT TEST, ASSIST-BOOST, OR CHARGE. THE BATTERY MAY ARC INTERNALLY AND EXPLODE. PERSONAL INJURY AND/OR VEHICLE DAMAGE MAY RESULT.**

**WARNING: EXPLOSIVE HYDROGEN GAS FORMS IN AND AROUND THE BATTERY. DO NOT SMOKE, USE FLAME, OR CREATE SPARKS NEAR THE BATTERY. PERSONAL INJURY AND/OR VEHICLE DAMAGE MAY RESULT.**

**WARNING: THE BATTERY CONTAINS SULFURIC ACID, WHICH IS POISONOUS AND CAUSTIC. AVOID CONTACT WITH THE SKIN, EYES, OR CLOTHING. IN THE EVENT OF CONTACT, FLUSH WITH WATER AND CALL A PHYSICIAN IMMEDIATELY. KEEP OUT OF THE REACH OF CHILDREN.**

**WARNING: IF THE BATTERY IS EQUIPPED WITH REMOVABLE CELL CAPS, BE CERTAIN THAT EACH OF THE CELL CAPS ARE IN PLACE AND TIGHT BEFORE THE BATTERY IS RETURNED TO SERVICE. PERSONAL INJURY AND/OR VEHICLE DAMAGE MAY RESULT FROM LOOSE OR MISSING CELL CAPS.**

The condition of a battery is determined by two criteria:

- **State-Of-Charge** - This can be determined by checking the specific gravity of the battery electrolyte (built-in indicator test or hydrometer test), or by checking the battery voltage (open-circuit voltage test).

- **Cranking Capacity** - This can be determined by performing a battery load test, which measures the ability of the battery to supply high-amperage current.

First, determine the battery state-of-charge. This can be done in one of three ways. If the battery has a built-in test indicator, perform the built-in indicator test to determine the state-of-charge. If the battery has no built-in test indicator but does have removable cell caps, perform the hydrometer test to determine the state-of-charge. If the battery cell caps are not removable, or a hydrometer is not available, perform the open-circuit voltage test to determine the state-of-charge.

Second, determine the battery cranking capacity by performing a load test. The battery must be charged before proceeding with a load test if:

- The battery built-in test indicator has a black or dark color visible.
- The temperature corrected specific gravity of the battery electrolyte is less than 1.235.

- The battery open-circuit voltage is less than 12.4 volts.

A battery that will not accept a charge is faulty, and must be replaced. Further testing is not required. A fully-charged battery must be load tested to determine its cranking capacity. A battery that is fully-charged, but does not pass the load test, is faulty and must be replaced.

**NOTE: Completely discharged batteries may take several hours to accept a charge. Refer to Standard Procedures for the proper battery charging procedures.**

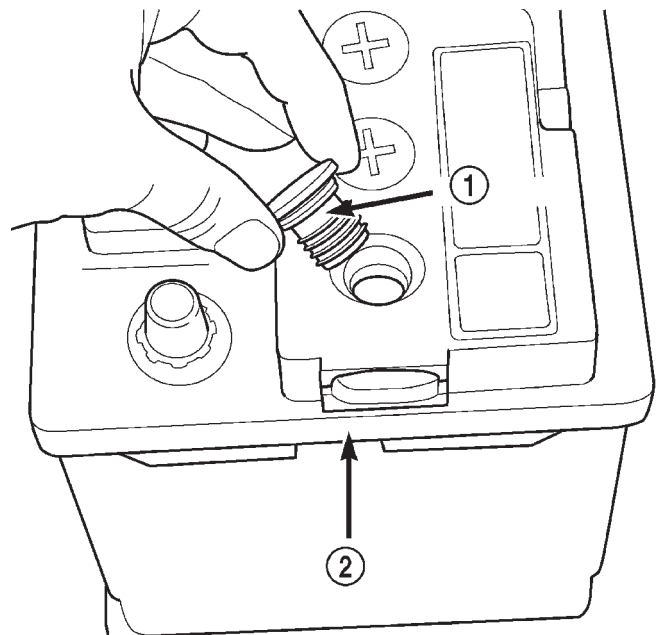
A battery is fully-charged when:

- All battery cells are gassing freely during charging.
- A green color is visible in the sight glass of the battery built-in test indicator.
- Three corrected specific gravity tests, taken at one-hour intervals, indicate no increase in the specific gravity of the battery electrolyte.
- Open-circuit voltage of the battery is 12.4 volts or greater.

### STANDARD PROCEDURE - CHECKING BATTERY ELECTROLYTE LEVEL

The following procedure can be used to check the electrolyte level in the battery.

- (1) Remove the battery caps (Fig. 5).



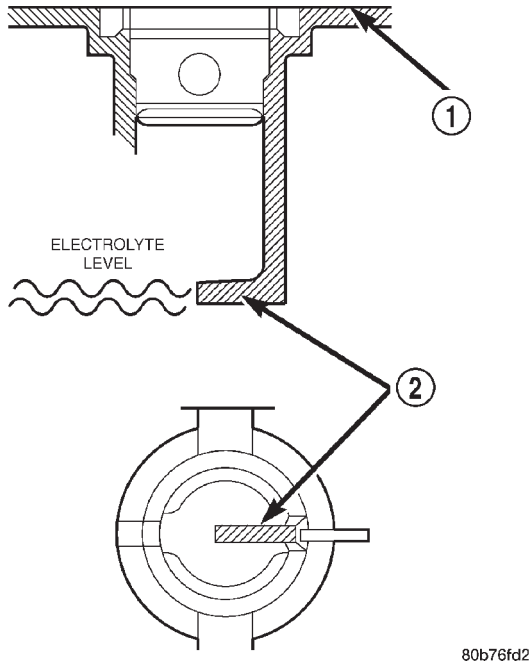
80b76fd0

**Fig. 5 Battery Caps - Export Battery**

- 1 - BATTERY CAP
- 2 - BATTERY

## BATTERY (Continued)

(2) Look through the battery cap holes to determine the level of the electrolyte in the battery (Fig. 6). The electrolyte should be approximately 1 centimeter above the battery plates or until the hook inside the battery cap holes is covered.



**Fig. 6 Hook Inside Battery Cap Holes - Export Battery**

- 1 - BATTERY SURFACE COVER  
2 - HOOK

(3) Add only distilled water until the electrolyte level is approx. one centimeter above the plates.

## STANDARD PROCEDURE - BATTERY CHARGING

Battery charging is the means by which the battery can be restored to its full voltage potential. A battery is fully-charged when:

- All of the battery cells are gassing freely during battery charging.
- A green color is visible in the sight glass of the battery built-in test indicator.
- Three hydrometer tests, taken at one-hour intervals, indicate no increase in the temperature-corrected specific gravity of the battery electrolyte.
- Open-circuit voltage of the battery is 12.65 volts or above.

**WARNING: NEVER EXCEED TWENTY AMPERES WHEN CHARGING A COLD (-1° C [30° F] OR LOWER) BATTERY. THE BATTERY MAY ARC INTERNALLY AND EXPLODE. PERSONAL INJURY AND/OR VEHICLE DAMAGE MAY RESULT.**

**WARNING: IF THE BATTERY SHOWS SIGNS OF FREEZING, LEAKING OR LOOSE POSTS, DO NOT TEST, ASSIST-BOOST, OR CHARGE. THE BATTERY MAY ARC INTERNALLY AND EXPLODE. PERSONAL INJURY AND/OR VEHICLE DAMAGE MAY RESULT.**

**WARNING: EXPLOSIVE HYDROGEN GAS FORMS IN AND AROUND THE BATTERY. DO NOT SMOKE, USE FLAME, OR CREATE SPARKS NEAR THE BATTERY. PERSONAL INJURY AND/OR VEHICLE DAMAGE MAY RESULT.**

**WARNING: THE BATTERY CONTAINS SULFURIC ACID, WHICH IS POISONOUS AND CAUSTIC. AVOID CONTACT WITH THE SKIN, EYES, OR CLOTHING. IN THE EVENT OF CONTACT, FLUSH WITH WATER AND CALL A PHYSICIAN IMMEDIATELY. KEEP OUT OF THE REACH OF CHILDREN.**

**WARNING: IF THE BATTERY IS EQUIPPED WITH REMOVABLE CELL CAPS, BE CERTAIN THAT EACH OF THE CELL CAPS IS IN PLACE AND TIGHT BEFORE THE BATTERY IS RETURNED TO SERVICE. PERSONAL INJURY AND/OR VEHICLE DAMAGE MAY RESULT FROM LOOSE OR MISSING CELL CAPS.**

**CAUTION: Always disconnect and isolate the battery negative cable before charging a battery. Do not exceed sixteen volts while charging a battery. Damage to the vehicle electrical system components may result.**

**CAUTION: Battery electrolyte will bubble inside the battery case during normal battery charging. Electrolyte boiling or being discharged from the battery vents indicates a battery overcharging condition. Immediately reduce the charging rate or turn off the charger to evaluate the battery condition. Damage to the battery may result from overcharging.**

**CAUTION: The battery should not be hot to the touch. If the battery feels hot to the touch, turn off the charger and let the battery cool before continuing the charging operation. Damage to the battery may result.**

## BATTERY (Continued)

**NOTE:** Models equipped with the diesel engine option are equipped with two 12-volt batteries, connected in parallel (positive-to-positive and negative-to-negative). In order to ensure proper charging of each battery, these batteries **MUST** be disconnected from each other, as well as from the vehicle electrical system, while being charged.

Some battery chargers are equipped with polarity-sensing circuitry. This circuitry protects the battery charger and the battery from being damaged if they are improperly connected. If the battery state-of-charge is too low for the polarity-sensing circuitry to detect, the battery charger will not operate. This makes it appear that the battery will not accept charging current. See the instructions provided by the manufacturer of the battery charger for details on how to bypass the polarity-sensing circuitry.

After the battery has been charged to 12.4 volts or greater, perform a load test to determine the battery cranking capacity. Refer to Standard Procedures for the proper battery load test procedures. If the battery will endure a load test, return the battery to service. If the battery will not endure a load test, it is faulty and must be replaced.

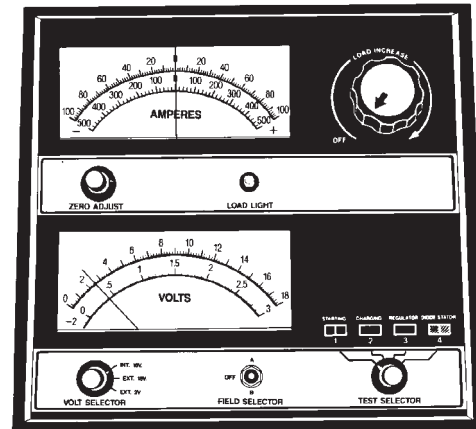
Clean and inspect the battery hold downs, tray, terminals, posts, and top before completing battery service. Refer to Battery System Cleaning for the proper battery system cleaning procedures, and Battery System Inspection for the proper battery system inspection procedures.

### CHARGING A COMPLETELY DISCHARGED BATTERY

The following procedure should be used to recharge a completely discharged battery. Unless this procedure is properly followed, a good battery may be needlessly replaced.

(1) Measure the voltage at the battery posts with a voltmeter, accurate to 1/10 (0.10) volt (Fig. 7). If the reading is below ten volts, the battery charging current will be low. It could take some time before the battery accepts a current greater than a few milliamperes. Such low current may not be detectable on the ammeters built into many battery chargers.

(2) Disconnect and isolate the battery negative cable. Connect the battery charger leads. Some battery chargers are equipped with polarity-sensing circuitry. This circuitry protects the battery charger and the battery from being damaged if they are improperly connected. If the battery state-of-charge is too low for the polarity-sensing circuitry to detect, the battery charger will not operate. This makes it appear that the battery will not accept charging current. See the instructions provided by the manufac-



898A-12

**Fig. 7 Voltmeter - Typical**

turer of the battery charger for details on how to bypass the polarity-sensing circuitry.

(3) Battery chargers vary in the amount of voltage and current they provide. The amount of time required for a battery to accept measurable charging current at various voltages is shown in the Charge Rate Table. If the charging current is still not measurable at the end of the charging time, the battery is faulty and must be replaced. If the charging current is measurable during the charging time, the battery may be good and the charging should be completed in the normal manner.

CHARGE RATE TABLE	
Voltage	Hours
16.0 volts maximum	up to 4 hours
14.0 to 15.9 volts	up to 8 hours
13.9 volts or less	up to 16 hours

### CHARGING TIME REQUIRED

The time required to charge a battery will vary, depending upon the following factors:

- **Battery Capacity** - A completely discharged heavy-duty battery requires twice the charging time of a small capacity battery.

- **Temperature** - A longer time will be needed to charge a battery at -18° C (0° F) than at 27° C (80° F). When a fast battery charger is connected to a cold battery, the current accepted by the battery will be very low at first. As the battery warms, it will accept a higher charging current rate (amperage).

- **Charger Capacity** - A battery charger that supplies only five amperes will require a longer charging time. A battery charger that supplies twenty amperes or more will require a shorter charging time.

- **State-Of-Charge** - A completely discharged battery requires more charging time than a partially discharged battery. Electrolyte is nearly pure water



## BATTERY (Continued)

in a completely discharged battery. At first, the charging current (amperage) will be low. As the battery charges, the specific gravity of the electrolyte will gradually rise.

The Battery Charging Time Table gives an indication of the time required to charge a typical battery at room temperature based upon the battery state-of-charge and the charger capacity.

BATTERY CHARGING TIME TABLE			
Charging Amperage	5 Amps	10 Amps	20 Amps
Open Circuit Voltage	Hours Charging @ 21° C (70° F)		
12.25 to 12.49	6 hours	3 hours	1.5 hours
12.00 to 12.24	10 hours	5 hours	2.5 hours
10.00 to 11.99	14 hours	7 hours	3.5 hours
Below 10.00	18 hours	9 hours	4.5 hours

## STANDARD PROCEDURE - BUILT-IN INDICATOR TEST

An indicator (hydrometer) built into the top of the battery case provides visual information for battery testing (Fig. 8). Like a hydrometer, the built-in indicator measures the specific gravity of the battery electrolyte. The specific gravity of the electrolyte reveals the battery state-of-charge; however, it will not reveal the cranking capacity of the battery. A load test must be performed to determine the battery cranking capacity. Refer to Standard Procedures for the proper battery load test procedures.

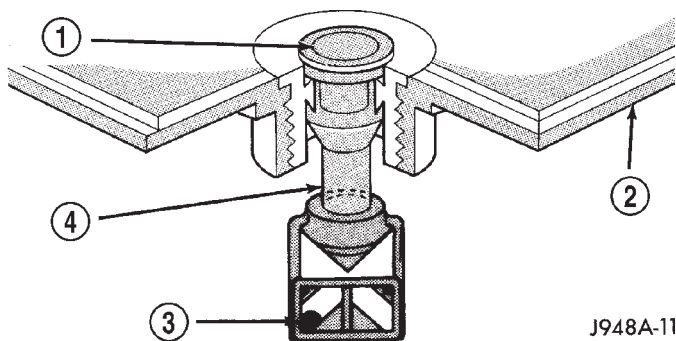


Fig. 8 Built-In Indicator

- 1 - SIGHT GLASS
- 2 - BATTERY TOP
- 3 - GREEN BALL
- 4 - PLASTIC ROD

**WARNING: IF THE BATTERY SHOWS SIGNS OF FREEZING, LEAKING OR LOOSE POSTS, DO NOT TEST, ASSIST-BOOST, OR CHARGE. THE BATTERY MAY ARC INTERNALLY AND EXPLODE. PERSONAL INJURY AND/OR VEHICLE DAMAGE MAY RESULT.**

**WARNING: EXPLOSIVE HYDROGEN GAS FORMS IN AND AROUND THE BATTERY. DO NOT SMOKE, USE FLAME, OR CREATE SPARKS NEAR THE BATTERY. PERSONAL INJURY AND/OR VEHICLE DAMAGE MAY RESULT.**

**WARNING: THE BATTERY CONTAINS SULFURIC ACID, WHICH IS POISONOUS AND CAUSTIC. AVOID CONTACT WITH THE SKIN, EYES, OR CLOTHING. IN THE EVENT OF CONTACT, FLUSH WITH WATER AND CALL A PHYSICIAN IMMEDIATELY. KEEP OUT OF THE REACH OF CHILDREN.**

**WARNING: IF THE BATTERY IS EQUIPPED WITH REMOVABLE CELL CAPS, BE CERTAIN THAT EACH OF THE CELL CAPS IS IN PLACE AND TIGHT BEFORE THE BATTERY IS RETURNED TO SERVICE. PERSONAL INJURY AND/OR VEHICLE DAMAGE MAY RESULT FROM LOOSE OR MISSING CELL CAPS.**

Before testing, visually inspect the battery for any damage (a cracked case or cover, loose posts, etc.) that would cause the battery to be faulty. In order to obtain correct indications from the built-in indicator, it is important that the battery be level and have a clean sight glass. Additional light may be required to view the indicator. **Do not use open flame as a source of additional light.**

To read the built-in indicator, look into the sight glass and note the color of the indication (Fig. 9). The battery condition that each color indicates is described in the following list:

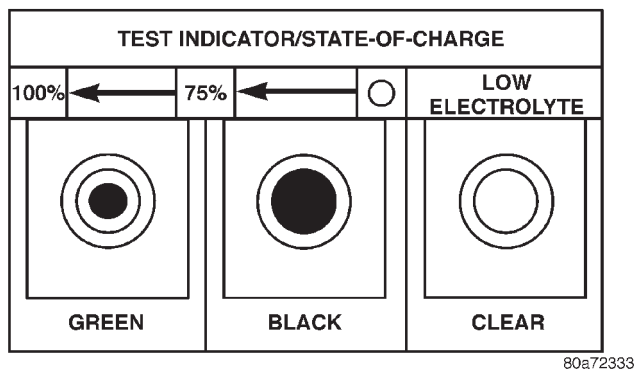
- **Green** - Indicates 75% to 100% battery state-of-charge. The battery is adequately charged for further testing or return to service. If the starter will not crank for a minimum of fifteen seconds with a fully-charged battery, the battery must be load tested. Refer to Standard Procedures for the proper battery load test procedures.

- **Black or Dark** - Indicates 0% to 75% battery state-of-charge. The battery is inadequately charged and must be charged until a green indication is visible in the sight glass (12.4 volts or more), before the battery is tested further or returned to service. Refer to Standard Procedures for the proper battery charging procedures. Also refer to Diagnosis and Testing for more information on the possible causes of the discharged battery condition.



## BATTERY (Continued)

• **Clear or Bright** - Indicates a low battery electrolyte level. The electrolyte level in the battery is below the built-in indicator. A maintenance-free battery with non-removable cell caps must be replaced if the electrolyte level is low. Water must be added to a low-maintenance battery with removable cell caps before it is charged. Refer to Standard Procedures for the proper battery filling procedures. A low electrolyte level may be caused by an overcharging condition. Refer to Charging System for the proper charging system diagnosis and testing procedures.



80a72333

**Fig. 9 Built-In Indicator Sight Glass Chart**

### STANDARD PROCEDURE - HYDROMETER TEST

The hydrometer test reveals the battery state-of-charge by measuring the specific gravity of the electrolyte. **This test cannot be performed on maintenance-free batteries with non-removable cell caps.** If the battery has non-removable cell caps, refer to Diagnosis and Testing for alternate methods of determining the battery state-of-charge.

Specific gravity is a comparison of the density of the battery electrolyte to the density of pure water. Pure water has a specific gravity of 1.000, and sulfuric acid has a specific gravity of 1.835. Sulfuric acid makes up approximately 35% of the battery electrolyte by weight, or 24% by volume. In a fully-charged battery the electrolyte will have a temperature-corrected specific gravity of 1.260 to 1.290. However, a specific gravity of 1.235 or above is satisfactory for the battery to be load tested and/or returned to service.

**WARNING: IF THE BATTERY SHOWS SIGNS OF FREEZING, LEAKING OR LOOSE POSTS, DO NOT TEST, ASSIST-BOOST, OR CHARGE. THE BATTERY MAY ARC INTERNALLY AND EXPLODE. PERSONAL INJURY AND/OR VEHICLE DAMAGE MAY RESULT.**

**WARNING: EXPLOSIVE HYDROGEN GAS FORMS IN AND AROUND THE BATTERY. DO NOT SMOKE, USE FLAME, OR CREATE SPARKS NEAR THE BATTERY. PERSONAL INJURY AND/OR VEHICLE DAMAGE MAY RESULT.**

**WARNING: THE BATTERY CONTAINS SULFURIC ACID, WHICH IS POISONOUS AND CAUSTIC. AVOID CONTACT WITH THE SKIN, EYES, OR CLOTHING. IN THE EVENT OF CONTACT, FLUSH WITH WATER AND CALL A PHYSICIAN IMMEDIATELY. KEEP OUT OF THE REACH OF CHILDREN.**

**WARNING: IF THE BATTERY IS EQUIPPED WITH REMOVABLE CELL CAPS, BE CERTAIN THAT EACH OF THE CELL CAPS IS IN PLACE AND TIGHT BEFORE THE BATTERY IS RETURNED TO SERVICE. PERSONAL INJURY AND/OR VEHICLE DAMAGE MAY RESULT FROM LOOSE OR MISSING CELL CAPS.**

Before testing, visually inspect the battery for any damage (a cracked case or cover, loose posts, etc.) that would cause the battery to be faulty. Then remove the battery cell caps and check the electrolyte level. Add distilled water if the electrolyte level is below the top of the battery plates. Refer to Battery System Cleaning for the proper battery inspection procedures.

See the instructions provided by the manufacturer of the hydrometer for recommendations on the correct use of the hydrometer that you are using. Remove only enough electrolyte from the battery cell so that the float is off the bottom of the hydrometer barrel with pressure on the bulb released. To read the hydrometer correctly, hold it with the top surface of the electrolyte at eye level (Fig. 10).

**CAUTION: Exercise care when inserting the tip of the hydrometer into a battery cell to avoid damaging the plate separators. Damaged plate separators can cause early battery failure.**

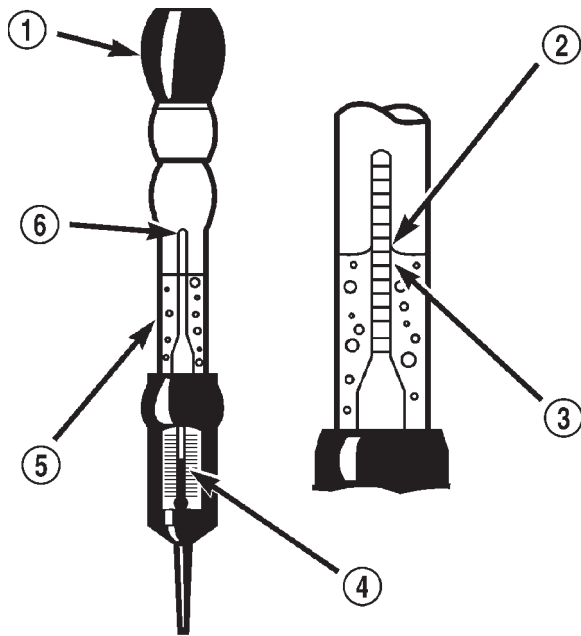
Hydrometer floats are generally calibrated to indicate the specific gravity correctly only at 26.7° C (80° F). When testing the specific gravity at any other temperature, a correction factor is required. The correction factor is approximately a specific gravity value of 0.004, which may also be identified as four points of specific gravity. For each 5.5° C above 26.7° C (10° F above 80° F), add four points. For each 5.5° C below 26.7° C (10° F below 80° F), subtract four points. Always correct the specific gravity for temperature variation.

**EXAMPLE:** A battery is tested at -12.2° C (10° F) and has a specific gravity of 1.240. Determine the actual specific gravity as follows:

(1) Determine the number of degrees above or below 26.7° C (80° F):  $26.6^{\circ}\text{C} - -12.2^{\circ}\text{C} = 38.8^{\circ}\text{C}$  ( $80^{\circ}\text{F} - 10^{\circ}\text{F} = 70^{\circ}\text{F}$ )

(2) Divide the result from Step 1 by 5.5° C (10° F):  $38.8^{\circ}\text{C} \div 5.5^{\circ}\text{C} = 7$  ( $70^{\circ}\text{F} \div 10^{\circ}\text{F} = 7$ )

## BATTERY (Continued)



80a483b9

**Fig. 10 Hydrometer - Typical**

- 1 - BULB
- 2 - SURFACE COHESION
- 3 - SPECIFIC GRAVITY READING
- 4 - TEMPERATURE READING
- 5 - HYDROMETER BARREL
- 6 - FLOAT

(3) Multiply the result from Step 2 by the temperature correction factor (0.004):  $7 \times 0.004 = 0.028$

(4) The temperature at testing was below 26.7° C (80° F); therefore, the temperature correction factor is subtracted:  $1.240 - 0.028 = 1.212$

(5) The corrected specific gravity of the battery cell in this example is 1.212.

Test the specific gravity of the electrolyte in each battery cell. If the specific gravity of all cells is above 1.235, but the variation between cells is more than fifty points (0.050), the battery should be replaced. If the specific gravity of one or more cells is less than 1.235, charge the battery at a rate of approximately five amperes. Continue charging the battery until three consecutive specific gravity tests, taken at one-hour intervals, are constant. If the cell specific gravity variation is more than fifty points (0.050) at the end of the charge period, replace the battery.

When the specific gravity of all cells is above 1.235, and the cell variation is less than fifty points (0.050), the battery may be load tested to determine its cranking capacity. Refer to Standard Procedures for the proper battery load test procedures.

### STANDARD PROCEDURE - OPEN-CIRCUIT VOLTAGE TEST

A battery open-circuit voltage (no load) test will show the approximate state-of-charge of a battery. This test can be used in place of the hydrometer test when a hydrometer is not available, or for maintenance-free batteries with non-removable cell caps.

**WARNING: IF THE BATTERY SHOWS SIGNS OF FREEZING, LEAKING OR LOOSE POSTS, DO NOT TEST, ASSIST-BOOST, OR CHARGE. THE BATTERY MAY ARC INTERNALLY AND EXPLODE. PERSONAL INJURY AND/OR VEHICLE DAMAGE MAY RESULT.**

**WARNING: EXPLOSIVE HYDROGEN GAS FORMS IN AND AROUND THE BATTERY. DO NOT SMOKE, USE FLAME, OR CREATE SPARKS NEAR THE BATTERY. PERSONAL INJURY AND/OR VEHICLE DAMAGE MAY RESULT.**

**WARNING: THE BATTERY CONTAINS SULFURIC ACID, WHICH IS POISONOUS AND CAUSTIC. AVOID CONTACT WITH THE SKIN, EYES, OR CLOTHING. IN THE EVENT OF CONTACT, FLUSH WITH WATER AND CALL A PHYSICIAN IMMEDIATELY. KEEP OUT OF THE REACH OF CHILDREN.**

**WARNING: IF THE BATTERY IS EQUIPPED WITH REMOVABLE CELL CAPS, BE CERTAIN THAT EACH OF THE CELL CAPS IS IN PLACE AND TIGHT BEFORE THE BATTERY IS RETURNED TO SERVICE. PERSONAL INJURY AND/OR VEHICLE DAMAGE MAY RESULT FROM LOOSE OR MISSING CELL CAPS.**

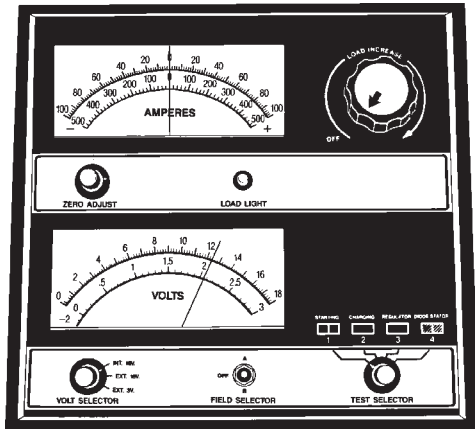
Before proceeding with this test, completely charge the battery. Refer to Standard Procedures for the proper battery charging procedures.

(1) Before measuring the open-circuit voltage, the surface charge must be removed from the battery. Turn on the headlamps for fifteen seconds, then allow up to five minutes for the battery voltage to stabilize.

(2) Disconnect and isolate both battery cables, negative cable first.

(3) Using a voltmeter connected to the battery posts (see the instructions provided by the manufacturer of the voltmeter), measure the open-circuit voltage (Fig. 11).

## BATTERY (Continued)



898A-7

**Fig. 11 Testing Open-Circuit Voltage - Typical**

See the Open-Circuit Voltage Table. This voltage reading will indicate the battery state-of-charge, but will not reveal its cranking capacity. If a battery has an open-circuit voltage reading of 12.4 volts or greater, it may be load tested to reveal its cranking capacity. Refer to Standard Procedures for the proper battery load test procedures.

OPEN CIRCUIT VOLTAGE TABLE	
Open Circuit Voltage	Charge Percentage
11.7 volts or less	0%
12.0 volts	25%
12.2 volts	50%
12.4 volts	75%
12.6 volts or more	100%

### STANDARD PROCEDURE - LOAD TEST

A battery load test will verify the battery cranking capacity. The test is based on the Cold Cranking Amperage (CCA) rating of the battery. To determine the battery CCA rating, see the label affixed to the battery case or refer to Battery Specifications for the proper factory-installed specifications.

**WARNING: IF THE BATTERY SHOWS SIGNS OF FREEZING, LEAKING OR LOOSE POSTS, DO NOT TEST, ASSIST-BOOST, OR CHARGE. THE BATTERY MAY ARC INTERNALLY AND EXPLODE. PERSONAL INJURY AND/OR VEHICLE DAMAGE MAY RESULT.**

**WARNING: EXPLOSIVE HYDROGEN GAS FORMS IN AND AROUND THE BATTERY. DO NOT SMOKE, USE FLAME, OR CREATE SPARKS NEAR THE BATTERY. PERSONAL INJURY AND/OR VEHICLE DAMAGE MAY RESULT.**

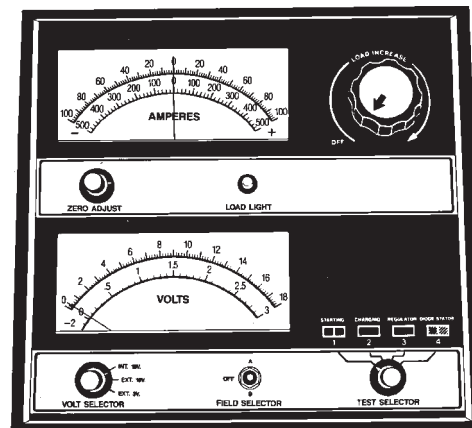
**WARNING: THE BATTERY CONTAINS SULFURIC ACID, WHICH IS POISONOUS AND CAUSTIC. AVOID CONTACT WITH THE SKIN, EYES, OR CLOTHING. IN THE EVENT OF CONTACT, FLUSH WITH WATER AND CALL A PHYSICIAN IMMEDIATELY. KEEP OUT OF THE REACH OF CHILDREN.**

**WARNING: IF THE BATTERY IS EQUIPPED WITH REMOVABLE CELL CAPS, BE CERTAIN THAT EACH OF THE CELL CAPS IS IN PLACE AND TIGHT BEFORE THE BATTERY IS RETURNED TO SERVICE. PERSONAL INJURY AND/OR VEHICLE DAMAGE MAY RESULT FROM LOOSE OR MISSING CELL CAPS.**

Before proceeding with this test, completely charge the battery. Refer to Standard Procedures for the proper battery charging procedures.

(1) Disconnect and isolate both battery cables, negative cable first. The battery top and posts should be clean. Refer to Battery System Cleaning for the proper cleaning procedures.

(2) Connect a suitable volt-ammeter-load tester (Fig. 12) to the battery posts (Fig. 13). See the instructions provided by the manufacturer of the tester you are using. Check the open-circuit voltage (no load) of the battery. Refer to Standard Procedures for the proper battery open-circuit voltage test procedures. The battery open-circuit voltage must be 12.4 volts or greater.



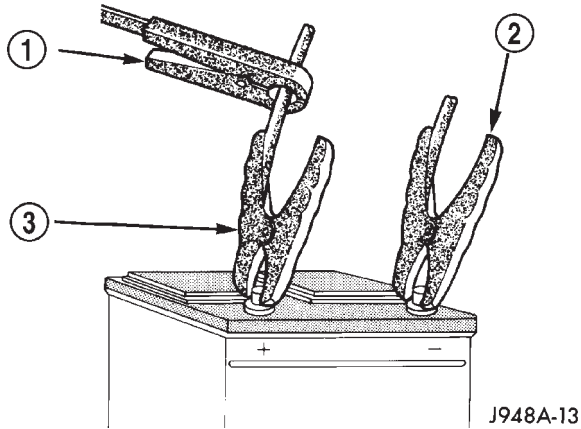
898A-8

**Fig. 12 Volt-Ammeter-Load Tester - Typical**

(3) Rotate the load control knob (carbon pile rheostat) to apply a 300 ampere load to the battery for fifteen seconds, then return the control knob to the Off position (Fig. 14). This will remove the surface charge from the battery.

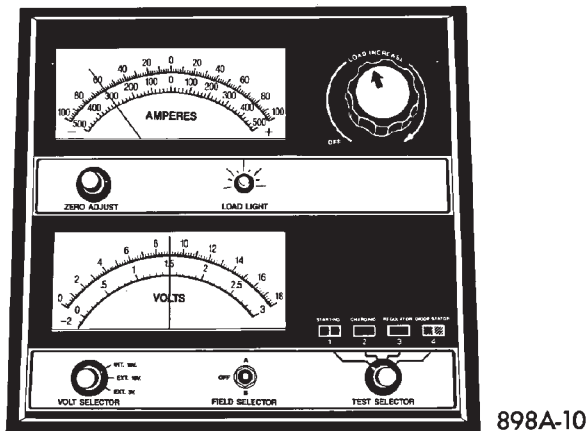
(4) Allow the battery to stabilize to open-circuit voltage. It may take up to five minutes for the battery voltage to stabilize.

## BATTERY (Continued)



**Fig. 13 Volt-Ammeter-Load**

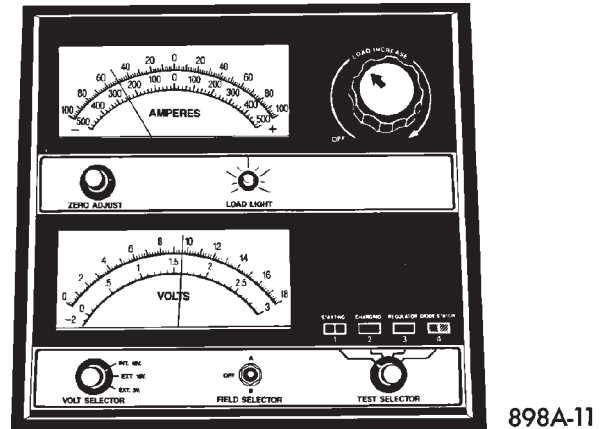
- 1 - INDUCTION AMMETER CLAMP
- 2 - NEGATIVE CLAMP
- 3 - POSITIVE CLAMP



**Fig. 14 Remove Surface Charge from Battery**

(5) Rotate the load control knob to maintain a load equal to 50% of the CCA rating of the battery (Fig. 15). After fifteen seconds, record the loaded voltage reading, then return the load control knob to the Off position.

(6) The voltage drop will vary with the battery temperature at the time of the load test. The battery temperature can be estimated by using the ambient temperature during the past several hours. If the battery has been charged, boosted, or loaded a few minutes prior to the test, the battery will be somewhat warmer. See the Load Test Temperature Table for the proper loaded voltage reading.



**Fig. 15 Load 50% CCA Rating - Note Voltage - Typical**

LOAD TEST TEMPERATURE TABLE		
Minimum Voltage	Temperature	
	°F	°C
9.6 volts	70° and above	21° and above
9.5 volts	60°	16°
9.4 volts	50°	10°
9.3 volts	40°	4°
9.1 volts	30°	-1°
8.9 volts	20°	-7°
8.7 volts	10°	-12°
8.5 volts	0°	-18°

(7) If the voltmeter reading falls below 9.6 volts, at a minimum battery temperature of 21° C (70° F), the battery is faulty and must be replaced.

### STANDARD PROCEDURE - IGNITION-OFF DRAW TEST

The term Ignition-Off Draw (IOD) identifies a normal condition where power is being drained from the battery with the ignition switch in the Off position. A normal vehicle electrical system will draw from five to thirty-five milliamperes (0.005 to 0.035 ampere) with the ignition switch in the Off position, and all non-ignition controlled circuits in proper working order. Up to thirty-five milliamperes are needed to enable the memory functions for the Powertrain Control Module (PCM), digital clock, electronically tuned radio, and other modules which may vary with the vehicle equipment.

## BATTERY (Continued)

A vehicle that has not been operated for approximately twenty days, may discharge the battery to an inadequate level. When a vehicle will not be used for twenty days or more (stored), remove the IOD fuse from the Power Distribution Center (PDC). This will reduce battery discharging.

Excessive IOD can be caused by:

- Electrical items left on.
- Faulty or improperly adjusted switches.
- Faulty or shorted electronic modules and components.
- An internally shorted generator.
- Intermittent shorts in the wiring.

If the IOD is over thirty-five milliamperes, the problem must be found and corrected before replacing a battery. In most cases, the battery can be charged and returned to service after the excessive IOD condition has been corrected.

(1) Verify that all electrical accessories are off. Turn off all lamps, remove the ignition key, and close all doors. If the vehicle is equipped with an illuminated entry system or an electronically tuned radio, allow the electronic timer function of these systems to automatically shut off (time out). This may take up to three minutes. See the Electronic Module Ignition-Off Draw Table for more information.

ELECTRONIC MODULE IGNITION-OFF DRAW (IOD) TABLE			
Module	Time Out? (If Yes, Interval And Wake-Up Input)	IOD	IOD After Time Out
Radio	No	1 to 3 milliamperes	N/A
Audio Power Amplifier	No	up to 1 milliampere	N/A
Central Timer Module (CTM)	No	4.75 milliamperes (max.)	N/A
Powertrain Control Module (PCM)	No	0.95 milliampere	N/A
ElectroMechanical Instrument Cluster (EMIC)	No	0.44 milliampere	N/A
Combination Flasher	No	0.08 milliampere	N/A

(2) Determine that the underhood lamp is operating properly, then disconnect the lamp wire harness connector or remove the lamp bulb.

(3) Disconnect the battery negative cable.

(4) Set an electronic digital multi-meter to its highest amperage scale. Connect the multi-meter between the disconnected battery negative cable terminal clamp and the battery negative terminal post. Make sure that the doors remain closed so that the illuminated entry system is not activated. The multi-meter amperage reading may remain high for up to three minutes, or may not give any reading at all while set in the highest amperage scale, depending upon the electrical equipment in the vehicle. The multi-meter leads must be securely clamped to the battery negative cable terminal clamp and the battery negative terminal post. If continuity between the battery negative terminal post and the negative cable terminal clamp is lost during any part of the IOD test, the electronic timer function will be activated and all of the tests will have to be repeated.

(5) After about three minutes, the high-amperage IOD reading on the multi-meter should become very low or nonexistent, depending upon the electrical equipment in the vehicle. If the amperage reading remains high, remove and replace each fuse or circuit breaker in the Power Distribution Center (PDC) and then in the Junction Block (JB), one at a time until the amperage reading becomes very low, or nonexistent. Refer to the appropriate wiring information in this service manual for complete PDC and JB fuse, circuit breaker, and circuit identification. This will isolate each circuit and identify the circuit that is the source of the high-amperage IOD. If the amperage reading remains high after removing and replacing each fuse and circuit breaker, disconnect the wire harness from the generator. If the amperage reading now becomes very low or nonexistent, refer to Charging System for the proper charging system diagnosis and testing procedures. After the high-amperage IOD has been corrected, switch the multi-meter to progressively lower amperage scales and, if necessary, repeat the fuse and circuit breaker remove-and-re-



## BATTERY (Continued)

place process to identify and correct all sources of excessive IOD. It is now safe to select the lowest milliamperage scale of the multi-meter to check the low-amperage IOD.

**CAUTION:** Do not open any doors, or turn on any electrical accessories with the lowest milliamperage scale selected, or the multi-meter may be damaged.

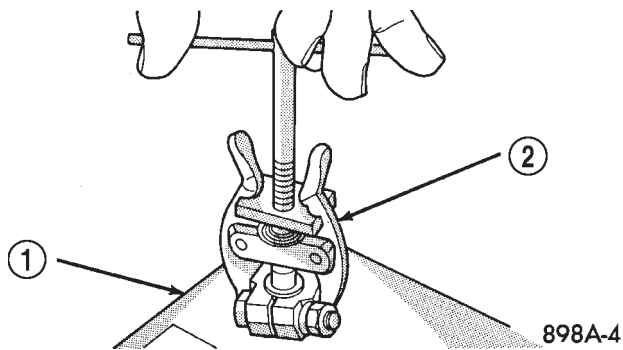
(6) Observe the multi-meter reading. The low-amperage IOD should not exceed thirty-five milliamperes (0.035 ampere). If the current draw exceeds thirty-five milliamperes, isolate each circuit using the fuse and circuit breaker remove-and-replace process in Step 5. The multi-meter reading will drop to within the acceptable limit when the source of the excessive current draw is disconnected. Repair this circuit as required; whether a wiring short, incorrect switch adjustment, or a component failure is at fault.

## REMOVAL

(1) Turn the ignition switch to the Off position. Be certain that all electrical accessories are turned off.

(2) Loosen the battery negative cable terminal clamp pinch-bolt hex nut.

(3) Disconnect the battery negative cable terminal clamp from the battery negative terminal post. If necessary, use a battery terminal puller to remove the terminal clamp from the battery post (Fig. 16).



**Fig. 16 Remove Battery Cable Terminal Clamp - Typical**

- 1 - BATTERY  
2 - BATTERY TERMINAL PULLER

(4) Loosen the battery positive cable terminal clamp pinch-bolt hex nut.

(5) Disconnect the battery positive cable terminal clamp from the battery positive terminal post. If necessary, use a battery terminal puller to remove the terminal clamp from the battery post.

(6) Remove the battery hold downs from the battery. Refer to **Battery Hold Downs** in this group for the location of the proper battery hold down removal procedures.

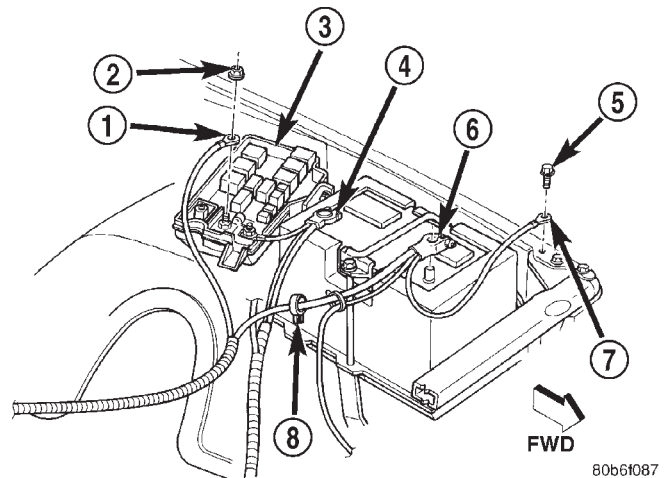
**WARNING:** WEAR A SUITABLE PAIR OF RUBBER GLOVES (NOT THE HOUSEHOLD TYPE) WHEN REMOVING A BATTERY BY HAND. SAFETY GLASSES SHOULD ALSO BE WORN. IF THE BATTERY IS CRACKED OR LEAKING, THE ELECTROLYTE CAN BURN THE SKIN AND EYES.

(7) Remove the battery from the battery tray.

## INSTALLATION

(1) Clean and inspect the battery. Refer to **Battery System** in this group for the location of the proper battery system cleaning and inspection procedures.

(2) Position the battery onto the battery tray. Ensure that the battery positive and negative terminal posts are correctly positioned. The battery cable terminal clamps must reach the correct battery terminal post without stretching the cables (Fig. 17).



**Fig. 17 Battery Cables - Typical**

- 1 - EYELET  
2 - NUT  
3 - POWER DISTRIBUTION CENTER  
4 - POSITIVE CABLE  
5 - SCREW  
6 - NEGATIVE CABLE  
7 - EYELET  
8 - CLIP

(3) Reinstall the battery hold downs onto the battery. Refer to **Battery Hold Downs** in this group for the location of the proper battery hold down installation procedures.

**CAUTION:** Be certain that the battery cable terminal clamps are connected to the correct battery terminal posts. Reversed battery polarity may damage electrical components of the vehicle.

## BATTERY (Continued)

(4) Clean the battery cable terminal clamps and the battery terminal posts. Refer to **Battery System** in this group for the location of the proper battery system cleaning and inspection procedures.

(5) Reconnect the battery positive cable terminal clamp to the battery positive terminal post. Tighten the terminal clamp pinch-bolt hex nut to 4 N·m (35 in. lbs.).

(6) Reconnect the battery negative cable terminal clamp to the battery negative terminal post. Tighten the terminal clamp pinch-bolt hex nut to 4 N·m (35 in. lbs.).

(7) Apply a thin coating of petroleum jelly or chassis grease to the exposed surfaces of the battery cable terminal clamps and the battery terminal posts.

## BATTERY HOLDDOWN

## DESCRIPTION

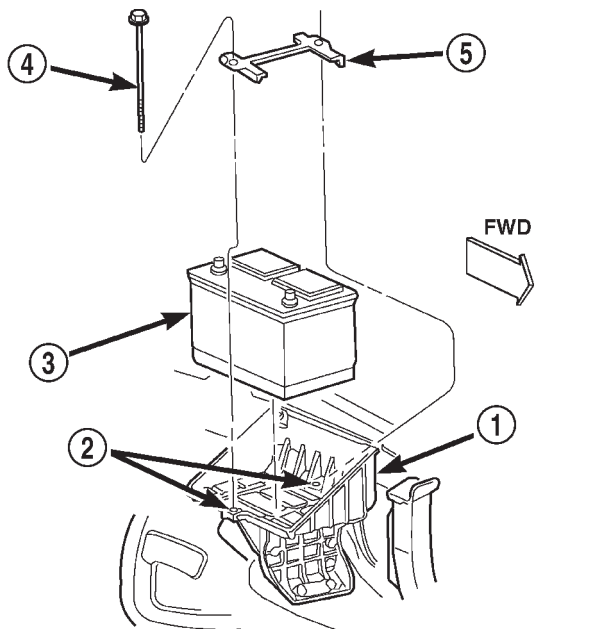


Fig. 18 Battery Hold Downs - Typical

- 1 - BATTERY TRAY
- 2 - U-NUT (2)
- 3 - BATTERY
- 4 - BOLT (2)
- 5 - STRAP

The battery hold down hardware (Fig. 18) includes two bolts, two U-nuts and a hold down strap. The battery hold down bracket consists of a formed steel rod with a stamped steel angle bracket welded to each end. The hold down bracket assembly is then plastic-coated for corrosion protection. Models equipped with the optional diesel engine have a second battery installed in a second battery tray on the right side of the engine compartment. The hold down hardware for the right

side battery is mirror image of the hold down hardware used for the left side battery.

When installing a battery into the battery tray, be certain that the hold down hardware is properly installed and that the fasteners are tightened to the proper specifications. Improper hold down fastener tightness, whether too loose or too tight, can result in damage to the battery, the vehicle or both. Refer to **Battery Hold Downs** in this group for the location of the proper battery hold down installation procedures, including the proper hold down fastener tightness specifications.

## OPERATION

The battery holddown secures the battery in the battery tray. This holddown is designed to prevent battery movement during the most extreme vehicle operation conditions. Periodic removal and lubrication of the battery holddown hardware is recommended to prevent hardware seizure at a later date.

**NOTE:** Never operate a vehicle without a battery holddown device properly installed. Damage to the vehicle, components and battery could result.

## REMOVAL

All of the battery hold down hardware except for the outboard U-nut can be serviced without removal of the battery or the battery tray. The battery tray must be removed from the vehicle to service the outboard U-nut. If the outboard U-nut requires service replacement, refer to **Battery Tray** in the index of this service manual for the location of the proper battery tray removal and installation procedures.

(1) Turn the ignition switch to the Off position. Be certain that all electrical accessories are turned off.

(2) Loosen the battery negative cable terminal clamp pinch-bolt hex nut.

(3) Disconnect the battery negative cable terminal clamp from the battery negative terminal post. If necessary, use a battery terminal puller to remove the terminal clamp from the battery post.

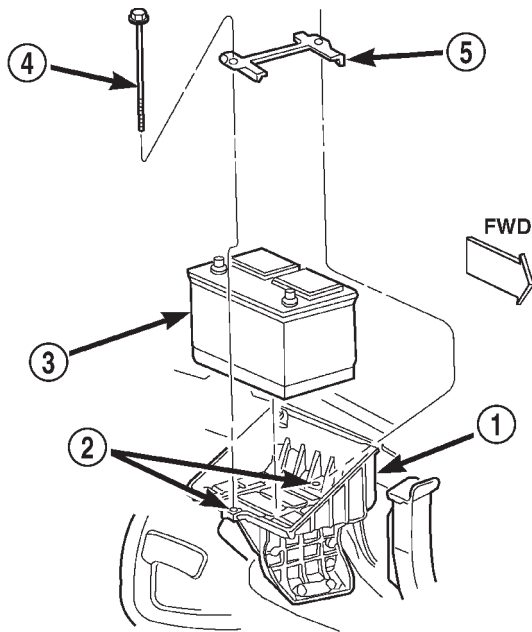
(4) Remove the two battery hold down bolts from the battery hold down strap (Fig. 19).

(5) Remove the battery hold down strap from the top of the battery case.

## INSTALLATION

All of the battery hold down hardware except for the outboard U-nut can be serviced without removal of the battery or the battery tray. The battery tray must be removed from the vehicle to service the outboard U-nut. If the outboard U-nut requires service replacement, refer to **Battery Tray** in the index of this service manual for the location of the proper battery tray removal and installation procedures.

## BATTERY HOLDDOWN (Continued)



80be466c

**Fig. 19 Left Battery Hold Downs Remove/Install - Typical for Right Battery**

- 1 - BATTERY TRAY
- 2 - U-NUT (2)
- 3 - BATTERY
- 4 - BOLT (2)
- 5 - STRAP

(1) Clean and inspect the battery hold down hardware. Refer to **Battery** in the index of this service manual for the location of the proper battery hold down hardware cleaning and inspection procedures.

(2) Position the battery hold down strap across the top of the battery case.

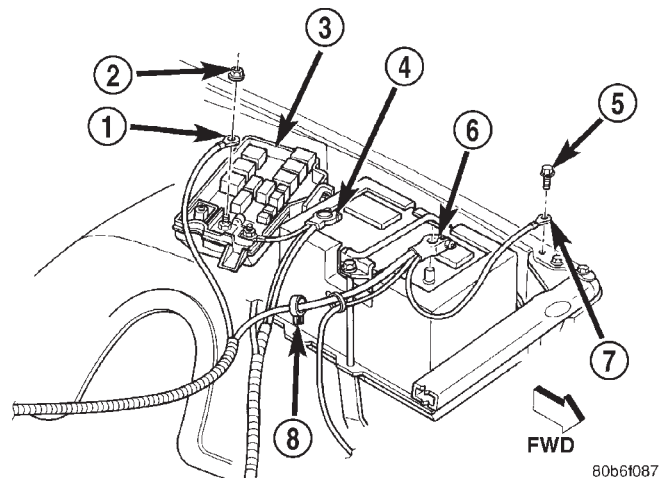
(3) Install and tighten the two battery hold down bolts through the holes on each end of the hold down strap and into the U-nuts on each side of the battery tray. Tighten the bolts to 4 N·m (35 in. lbs.).

(4) Reconnect the battery negative cable terminal clamp to the battery negative terminal post. Tighten the terminal clamp pinch-bolt hex nut to 4 N·m (35 in. lbs.).

## BATTERY CABLE

### DESCRIPTION

The battery cables (Fig. 20) are large gauge, stranded copper wires sheathed within a heavy plastic or synthetic rubber insulating jacket. The wire used in the battery cables combines excellent flexibility and reliability with high electrical current carrying capacity. Refer to **Wiring Diagrams** in the index of this service manual for the location of the proper battery cable wire gauge information.



80b6f087

**Fig. 20 Battery Cables - Typical**

- 1 - EYELET
- 2 - NUT
- 3 - POWER DISTRIBUTION CENTER
- 4 - POSITIVE CABLE
- 5 - SCREW
- 6 - NEGATIVE CABLE
- 7 - EYELET
- 8 - CLIP

The battery cables cannot be repaired and, if damaged or faulty they must be replaced. Both the battery positive and negative cables are available for service replacement only as a unit with the battery positive cable wire harness or the battery negative cable wire harness, which may include portions of the wiring circuits for the generator and other components on some models. Refer to **Wiring Diagrams** in the index of this service manual for the location of more information on the various wiring circuits included in the battery cable wire harnesses for the vehicle being serviced.

### GASOLINE ENGINE

Gasoline engine models feature a stamped brass clamping type female battery terminal crimped onto one end of the battery cable wire and then solder-dipped. A square headed pinch-bolt and hex nut are installed at the open end of the female battery terminal clamp. The battery positive cable also includes a red molded rubber protective cover for the female battery terminal clamp. Large eyelet type terminals are crimped onto the opposite end of the battery cable wire and then solder-dipped. The battery positive cable wires have a red insulating jacket to provide visual identification and feature a larger female battery terminal clamp to allow connection to the larger battery positive terminal post. The battery negative cable wires have a black insulating jacket and a smaller female battery terminal clamp.

## BATTERY CABLE (Continued)

**DIESEL ENGINE**

Diesel engine models feature a clamping type female battery terminal made of soft lead die cast onto one end of the battery cable wire. A square headed pinch-bolt and hex nut are installed at the open end of the female battery terminal clamp. The pinch-bolt on the left side battery positive cable female terminal clamp also has a stud extending from the head of the bolt. Large eyelet type terminals are crimped onto the opposite end of the battery cable wire and then solder-dipped. The battery positive cable wires have a red insulating jacket to provide visual identification and feature a larger female battery terminal clamp to allow connection to the larger battery positive terminal post. The battery negative cable wires have a black insulating jacket and a smaller female battery terminal clamp.

**OPERATION**

The battery cables connect the battery terminal posts to the vehicle electrical system. These cables also provide a return path for electrical current generated by the charging system for restoring the voltage potential of the battery. The female battery terminal clamps on the ends of the battery cable wires provide a strong and reliable connection of the battery cable to the battery terminal posts. The terminal pinch bolts allow the female terminal clamps to be tightened around the male terminal posts on the top of the battery. The eyelet terminals secured to the ends of the battery cable wires opposite the female battery terminal clamps provide secure and reliable connection of the battery to the vehicle electrical system.

**GASOLINE ENGINE**

The battery positive cable terminal clamp is crimped onto the ends of two wires. One wire has an eyelet terminal that connects the battery positive cable to the B(+) terminal stud of the Power Distribution Center (PDC), and the other wire has an eyelet terminal that connects the battery positive cable to the B(+) terminal stud of the engine starter motor solenoid. The battery negative cable terminal clamp is also crimped onto the ends of two wires. One wire has an eyelet terminal that connects the battery negative cable to the vehicle powertrain through a stud on the front of the left engine cylinder head. The other wire has an eyelet terminal that connects the battery negative cable to the vehicle body through a ground screw on the left front fender inner shield, just ahead of the battery. An additional ground wire with two eyelet terminals is used to provide ground to the vehicle frame. One eyelet terminal of this ground wire is installed under the head of the battery negative cable terminal clamp pinch-bolt, and

the other eyelet terminal is secured with a ground screw to the outer surface of the left frame rail, below the battery.

**DIESEL ENGINE**

The left battery positive cable terminal clamp is die cast onto the ends of two wires. One wire has an eyelet terminal that connects the left battery positive cable to the B(+) terminal stud of the Power Distribution Center (PDC), and the other wire has an eyelet terminal that connects the left battery positive cable to the B(+) terminal stud of the engine starter motor solenoid. The right battery positive cable terminal clamp is die cast onto the end of a single wire. The eyelet terminal on the other end of the right battery positive cable is connected to the stud on the pinch-bolt of the left battery positive cable terminal clamp. This stud also provides a connection point for the eyelet terminals from the fuel heater relay and intake air heater relay jumper harness take outs. All of these eyelet terminals are secured to the left battery positive cable terminal clamp pinch-bolt stud with a single hex nut.

The left battery negative cable terminal clamp is die cast onto the ends of two wires. One wire has an eyelet terminal that connects the left battery negative cable to the vehicle powertrain through a ground screw on the left side of the engine block, below the power steering and vacuum pumps. The other wire has an eyelet terminal that connects the left battery negative cable to the vehicle body through a ground screw on the left front fender inner shield, just ahead of the left battery. An additional ground wire with two eyelet terminals is used to provide ground to the vehicle frame. One eyelet terminal of this ground wire is installed under the nut of the left battery negative cable terminal clamp pinch-bolt, and the other eyelet terminal is secured with a ground screw to the outer surface of the left frame rail, below the left battery. The right battery negative cable terminal is also die cast onto the ends of two wires. One wire has an eyelet terminal that connects the right battery negative cable to the vehicle powertrain through a ground screw on the right side of the engine block, just forward of the right engine mount. The other wire has an eyelet terminal that connects the right battery negative cable to the vehicle body through a ground screw on the right front fender inner shield, just behind the right battery.

**DIAGNOSIS & TESTING - BATTERY CABLES**

A voltage drop test will determine if there is excessive resistance in the battery cable terminal connections or the battery cables. If excessive resistance is found in the battery cable connections, the connection point should be disassembled, cleaned of all cor-



## BATTERY CABLE (Continued)

rosion or foreign material, then reassembled. Following reassembly, check the voltage drop for the battery cable connection and the battery cable again to confirm repair.

When performing the voltage drop test, it is important to remember that the voltage drop is giving an indication of the resistance between the two points at which the voltmeter probes are attached. **EXAMPLE:** When testing the resistance of the battery positive cable, touch the voltmeter leads to the battery positive cable terminal clamp and to the battery positive cable eyelet terminal at the starter solenoid B(+) terminal stud. If you probe the battery positive terminal post and the battery positive cable eyelet terminal at the starter solenoid B(+) terminal stud, you are reading the combined voltage drop in the battery positive cable terminal clamp-to-terminal post connection and the battery positive cable.

## VOLTAGE DROP TEST

**WARNING: IF THE BATTERY SHOWS SIGNS OF FREEZING, LEAKING, LOOSE POSTS, OR LOW ELECTROLYTE LEVEL, DO NOT TEST, ASSIST-BOOST, OR CHARGE. THE BATTERY MAY ARC INTERNALLY AND EXPLODE. PERSONAL INJURY AND/OR VEHICLE DAMAGE MAY RESULT.**

**WARNING: EXPLOSIVE HYDROGEN GAS FORMS IN AND AROUND THE BATTERY. DO NOT SMOKE, USE FLAME, OR CREATE SPARKS NEAR THE BATTERY. PERSONAL INJURY AND/OR VEHICLE DAMAGE MAY RESULT.**

**WARNING: THE BATTERY CONTAINS SULFURIC ACID, WHICH IS POISONOUS AND CAUSTIC. AVOID CONTACT WITH THE SKIN, EYES, OR CLOTHING. IN THE EVENT OF CONTACT, FLUSH WITH WATER AND CALL A PHYSICIAN IMMEDIATELY. KEEP OUT OF THE REACH OF CHILDREN.**

**WARNING: IF THE BATTERY IS EQUIPPED WITH REMOVABLE CELL CAPS, BE CERTAIN THAT EACH OF THE CELL CAPS IS IN PLACE AND TIGHT BEFORE THE BATTERY IS RETURNED TO SERVICE. PERSONAL INJURY AND/OR VEHICLE DAMAGE MAY RESULT FROM LOOSE OR MISSING CELL CAPS.**

**WARNING: MODELS EQUIPPED WITH THE DIESEL ENGINE OPTION ALSO HAVE AN AUTOMATIC SHUTDOWN (ASD) RELAY LOCATED IN THE POWER DISTRIBUTION CENTER (PDC), IN THE ENGINE COMPARTMENT. HOWEVER, REMOVAL OF**

**THE ASD RELAY MAY NOT PREVENT THE DIESEL ENGINE FROM STARTING. BE CERTAIN TO ALSO DISCONNECT THE FUEL SHUTDOWN SOLENOID WIRE HARNESS CONNECTOR ON MODELS WITH A DIESEL ENGINE. FAILURE TO DO SO MAY RESULT IN PERSONAL INJURY.**

The following operation will require a voltmeter accurate to 1/10 (0.10) volt. Before performing this test, be certain that the following procedures are accomplished:

- The battery is fully-charged and load tested. Refer to **Battery Charging** in the index of this service manual for the location of the proper battery charging procedures. Refer to **Battery** in the index of this service manual for the location of the battery diagnosis and testing procedures, including the proper battery load test procedures.

- Fully engage the parking brake.
- If the vehicle is equipped with an automatic transmission, place the gearshift selector lever in the Park position. If the vehicle is equipped with a manual transmission, place the gearshift selector lever in the Neutral position and block the clutch pedal in the fully depressed position.

- Verify that all lamps and accessories are turned off.

- To prevent a gasoline engine from starting, remove the Automatic ShutDown (ASD) relay. The ASD relay is located in the Power Distribution Center (PDC), in the engine compartment. See the fuse and relay layout label affixed to the underside of the PDC cover for ASD relay identification and location. To prevent a diesel engine from starting, disconnect the fuel shutdown solenoid wire harness connector (Fig. 21).

(1) Connect the positive lead of the voltmeter to the battery negative terminal post. Connect the negative lead of the voltmeter to the battery negative cable terminal clamp (Fig. 22). Rotate and hold the ignition switch in the Start position. Observe the voltmeter. If voltage is detected, correct the poor connection between the battery negative cable terminal clamp and the battery negative terminal post.

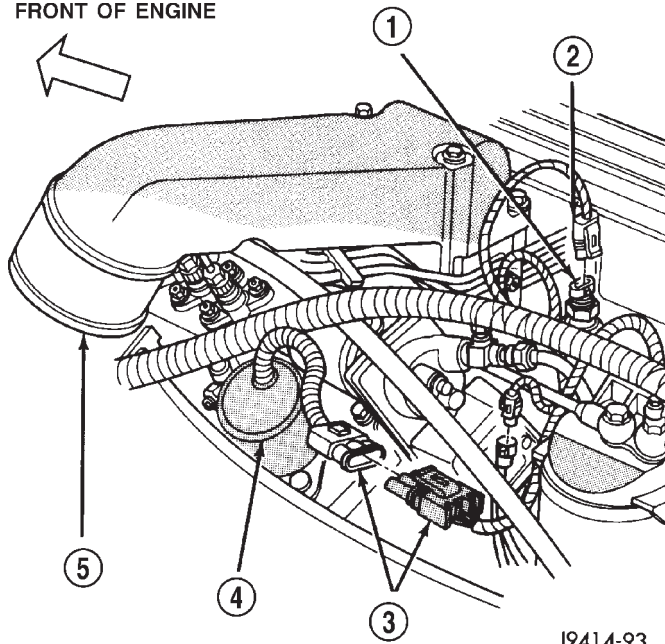
**NOTE: If the vehicle is equipped with a dual battery system, Step 1 must be performed twice, once for each battery.**

(2) Connect the positive lead of the voltmeter to the battery positive terminal post. Connect the negative lead of the voltmeter to the battery positive cable terminal clamp (Fig. 23). Rotate and hold the ignition switch in the Start position. Observe the voltmeter. If voltage is detected, correct the poor connection between the battery positive cable terminal clamp and the battery positive terminal post.



BATTERY CABLE (Continued)

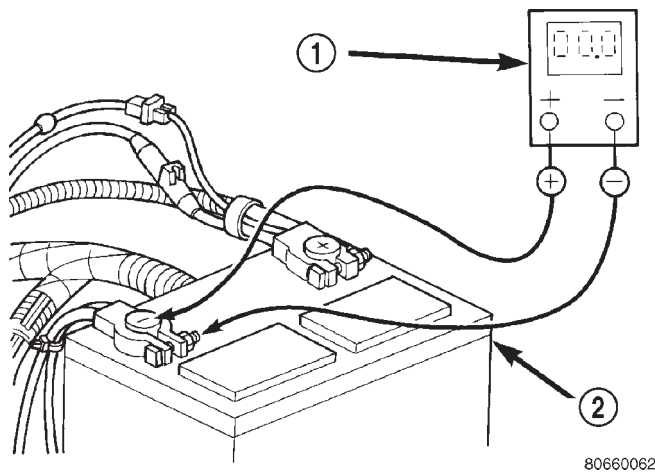
FRONT OF ENGINE



J9414-93

**Fig. 21 Fuel Shutdown Solenoid Connector - Diesel Engine**

- 1 - AIR TEMPERATURE SENSOR
- 2 - SENSOR ELECTRICAL CONNECTOR
- 3 - SOLENOID ELECTRICAL CONNECTOR
- 4 - FUEL SHUTDOWN SOLENOID
- 5 - INTAKE MANIFOLD (UPPER HALF)

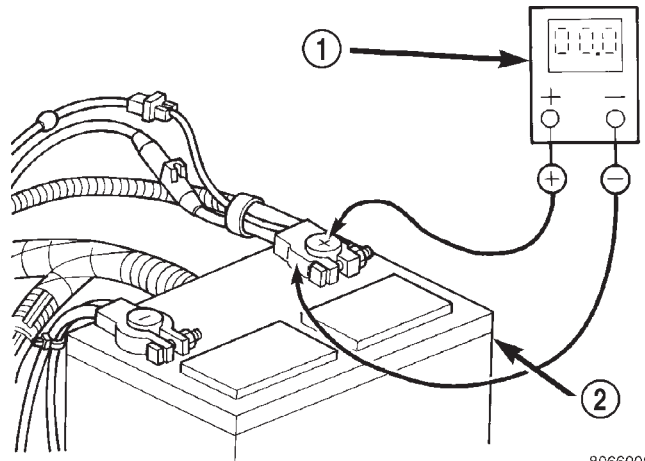


80660062

**Fig. 22 Test Battery Negative Connection Resistance - Typical**

- 1 - VOLTMETER
- 2 - BATTERY

**NOTE:** If the vehicle is equipped with a dual battery system, Step 2 must be performed twice, once for each battery.



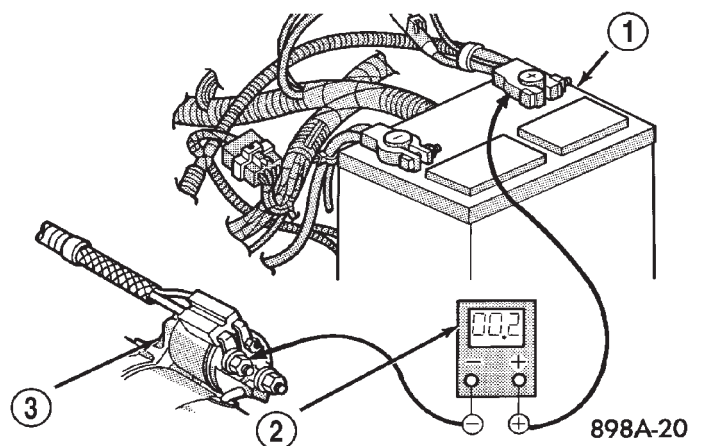
80660061

**Fig. 23 Test Battery Positive Connection Resistance - Typical**

- 1 - VOLTMETER
- 2 - BATTERY

(3) Connect the voltmeter to measure between the battery positive cable terminal clamp and the starter solenoid B(+) terminal stud (Fig. 24). Rotate and hold the ignition switch in the Start position. Observe the voltmeter. If the reading is above 0.2 volt, clean and tighten the battery positive cable eyelet terminal connection at the starter solenoid B(+) terminal stud. Repeat the test. If the reading is still above 0.2 volt, replace the faulty battery positive cable.

**NOTE:** If the vehicle is equipped with a dual battery system, Step 3 must be performed on the driver side battery only.



898A-20

**Fig. 24 Test Battery Positive Cable Resistance - Typical**

- 1 - BATTERY
- 2 - VOLTMETER
- 3 - STARTER MOTOR

## BATTERY CABLE (Continued)

(4) Connect the voltmeter to measure between the battery negative cable terminal clamp and a good clean ground on the engine block (Fig. 25). Rotate and hold the ignition switch in the Start position. Observe the voltmeter. If the reading is above 0.2 volt, clean and tighten the battery negative cable eyelet terminal connection to the engine block. Repeat the test. If the reading is still above 0.2 volt, replace the faulty battery negative cable.

**NOTE:** If the vehicle is equipped with a dual battery system, Step 4 must be performed twice, once for each battery.

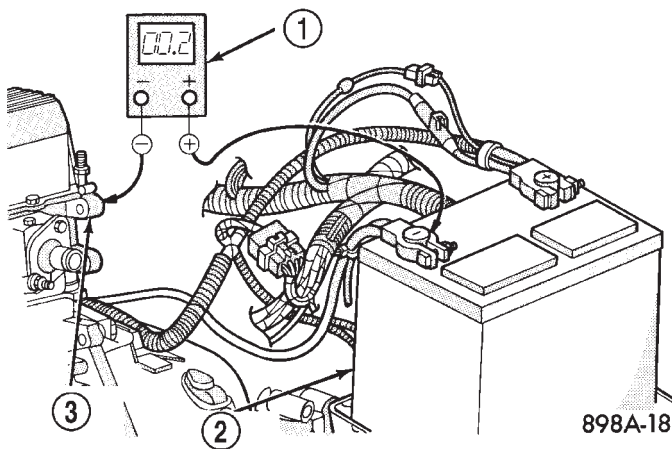


Fig. 25 Test Ground Circuit

- 1 - VOLTMETER
- 2 - BATTERY
- 3 - ENGINE GROUND

## POSITIVE CABLE REMOVAL - GASOLINE

Both the battery negative cable and the battery positive cable are serviced in the battery wire harness. If either battery cable is damaged or faulty, the battery wire harness assembly must be replaced.

- (1) Remove the positive battery cable from the battery.
- (2) Remove the cover from the PDC.
- (3) Remove the positive battery cable from the PDC.
- (4) Disconnect the starter motor signal wire harness connector, located on the PDC housing.
- (5) Disengage wire harness assembly pushpin retainers.
- (6) From under the vehicle, disengage wire harness assembly pushpin retainers.
- (7) Remove the positive battery cable from the starter motor B+ terminal stud.
- (8) Remove the starter motor trigger wire from the starter motor.
- (9) Remove the positive cable wire harness assembly from the vehicle.

## NEGATIVE CABLE REMOVAL - GASOLINE

Both the battery negative cable and the battery positive cable are serviced in the battery wire harness. If either battery cable is damaged or faulty, the battery wire harness unit must be replaced.

- (1) Turn the ignition switch to the Off position. Be certain that all electrical accessories are turned off.
- (2) Loosen the battery negative cable terminal clamp pinch-bolt hex nut.
- (3) Disconnect the battery negative cable terminal clamp from the battery negative terminal post. If necessary, use a battery terminal puller to remove the terminal clamp from the battery post.
- (4) Remove the negative cable jumper from the left side of the radiator closure panel.
- (5) Remove the negative cable jumper from the left side of the frame assembly.
- (6) Remove the PDC cover and remove the generator output wire from the PDC.
- (7) Following the wire, remove the pushpin retainers holding the wire assembly in place.
- (8) Remove the negative cable eyelet from the power steering pump pivot bolt.
- (9) Remove the generator output wire from the generator.
- (10) Remove the negative battery cable assembly, by fishing out from under the compressor mounting bracket, if equipped.

## POSITIVE CABLE INSTALLATION - GASOLINE

- (1) Position the battery wire harness into the engine compartment.
- (2) Install the positive battery cable on the battery.
- (3) Install the positive battery cable on the PDC.
- (4) Install the cover on the PDC.
- (5) Connect the starter motor signal wire harness connector, located on the PDC housing.
- (6) Install wire harness assembly pushpin retainers in their original position.
- (7) From under the vehicle, install wire harness assembly pushpin retainers.
- (8) Install and tighten the nut that secures the battery positive cable eyelet terminal to the B(+) terminal stud on the starter solenoid. Tighten the nut to 10 N·m (90 in. lbs.).
- (9) Connect the starter motor trigger wire on the starter motor.
- (10) Reconnect the battery positive cable terminal clamp to the battery positive terminal post. Tighten the terminal clamp pinch-bolt hex nut to 4 N·m (35 in. lbs.).
- (11) Apply a thin coating of petroleum jelly or chassis grease to the exposed surfaces of the battery cable terminal clamps and the battery terminal posts.

## BATTERY CABLE (Continued)

## NEGATIVE CABLE INSTALLATION - GASOLINE

(1) Position the battery wire harness into the engine compartment and under the compressor mounting bracket, if equipped.

(2) Install and tighten the nut that secures the battery negative cable ground eyelet terminal to the stud on the power steering pump pivot bolt.

(3) Install the generator output cable eyelet terminal onto the generator output terminal stud.

(4) Install and tighten the nut that secures the generator output cable eyelet terminal to the generator output terminal stud. Tighten the nut to 8.4 N·m (75 in. lbs.).

(5) Position the cover for the generator output terminal stud housing onto the back of the generator and snap it into place.

(6) Secure wire assembly in place with pushpin retainers in their original positions.

(7) Install and tighten the screw that secures the battery negative cable eyelet terminal to the radiator closure panel, near the battery. Tighten the screw to 40 in. lbs.

(8) Install and tighten the screw that secures the battery negative cable eyelet terminal to the left front side of the frame assembly. Tighten the screw to 80 in. lbs.

(9) Install and tighten the nut that secures the battery positive cable eyelet terminal and the generator output cable eyelet terminal to the PDC B(+) terminal stud. Tighten the nut to 80 in. lbs.

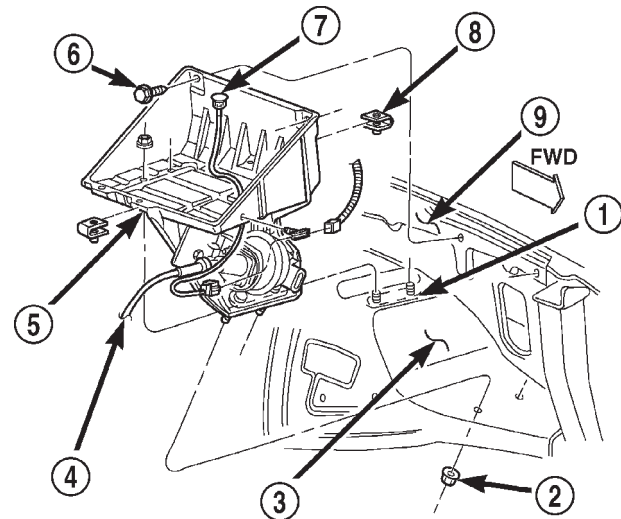
(10) Reconnect the battery negative cable terminal clamp to the battery negative terminal post. Tighten the terminal clamp pinch-bolt hex nut to 35 in. lbs.

(11) Apply a thin coating of petroleum jelly or chassis grease to the exposed surfaces of the battery cable terminal clamps and the battery terminal posts.

## BATTERY TRAY

## DESCRIPTION

The battery is mounted in a molded plastic tray (Fig. 26) with an integral support located in the left front corner of the engine compartment. A U-nut held in a molded formation on each side of the battery tray provides anchor points for the battery hold down bolts. The battery tray is secured on the outboard side to the inner fender shield by two hex screws with washers, and from underneath the integral battery tray support is secured to the left front wheelhouse inner panel by two stud plates. Each stud plate has two studs and is secured by two nuts with washers. The stud plate that secures the front of the battery tray support to the wheelhouse inner



80be466e

**Fig. 26 Battery Tray - Typical**

- 1 - STUD PLATE (2)
- 2 - NUT AND WASHER (4)
- 3 - FRONT WHEELHOUSE INNER PANEL
- 4 - SPEED CONTROL SERVO
- 5 - TRAY
- 6 - SCREW AND WASHER (2)
- 7 - BATTERY TEMPERATURE SENSOR
- 8 - U-NUT (2)
- 9 - FENDER INNER SHIELD

panel is installed through the wheelhouse panel from the top. The stud plate that secures the rear of the battery tray support to the wheelhouse inner panel is installed through the wheelhouse panel from the bottom.

A hole in the bottom of the battery tray is fitted with a battery temperature sensor. Refer to **Battery Temperature Sensor** in the index of this service manual for the location of more information on the battery temperature sensor. Models that are equipped with an optional vehicle speed control system have the speed control servo secured to the integral battery tray support. Refer to **Speed Control Servo** in the index of this service manual for the location of more information on the speed control servo and its mounting.

Models that are equipped with the diesel engine option have a second battery tray located in the right front corner of the engine compartment. This second battery tray and its mounting are mirror image of the standard equipment left battery tray. However, the right battery tray and support have no provisions for a battery temperature sensor or a speed control servo mounting bracket.

## BATTERY TRAY (Continued)

## OPERATION

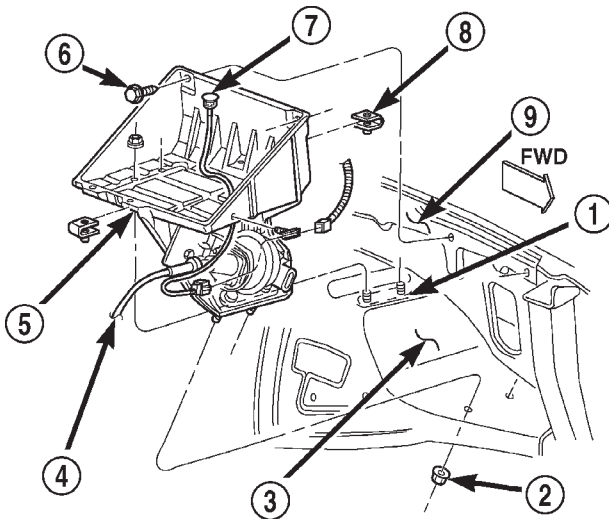
The battery tray provides a secure mounting location and supports the battery. On some vehicles, the battery tray also provides the anchor point/s for the battery holddown hardware. The battery tray and the battery holddown hardware combine to secure and stabilize the battery in the engine compartment, which prevents battery movement during vehicle operation. Unrestrained battery movement during vehicle operation could result in damage to the vehicle, the battery, or both.

## REMOVAL

(1) Remove the battery from the battery tray. Refer to **Battery** in this group for the location of the proper battery removal procedure.

(2) If the left battery tray is being removed, remove the battery temperature sensor from the left battery tray. Refer to **Battery Temperature Sensor** in the index of this service manual for the location of the proper battery temperature sensor removal procedures.

(3) Remove the two screws with washers that secure the outboard side of the battery tray to the inner fender shield (Fig. 27).



80be466e

**Fig. 27 Left Battery Tray Remove/Install - Typical for Right Battery Tray**

- 1 - STUD PLATE (2)
- 2 - NUT AND WASHER (4)
- 3 - FRONT WHEELHOUSE INNER PANEL
- 4 - SPEED CONTROL SERVO
- 5 - TRAY
- 6 - SCREW AND WASHER (2)
- 7 - BATTERY TEMPERATURE SENSOR
- 8 - U-NUT (2)
- 9 - FENDER INNER SHIELD

(4) From the engine compartment, remove the two nuts with washers that secure the rear of the battery tray support to the two studs that extend through the top of the front wheelhouse inner panel.

(5) From inside the front fender wheelhouse, remove the two nuts with washers that secure the front of the battery tray support to the two studs that extend through the underside of the front wheelhouse inner panel.

(6) From inside the front fender wheelhouse, remove the stud plate that secures the rear of the battery tray support from the underside of the front wheelhouse inner panel.

(7) From the engine compartment, remove the battery tray and the stud plate that secures the front of the battery tray support from the front wheelhouse inner panel as a unit.

(8) If the vehicle is equipped with the optional vehicle speed control package, the speed control servo must be removed from the left battery tray support to complete battery tray removal. Refer to **Speed Control Servo** in the index of this service manual for the location of the proper speed control servo removal procedures.

## INSTALLATION

(1) Clean and inspect the battery tray. Refer to **Battery System** in this group for the location of the proper battery tray cleaning and inspection procedures.

(2) If the vehicle is equipped with the optional vehicle speed control package, the speed control servo must be installed onto the left battery tray support to complete battery tray installation. Refer to **Speed Control Servo** in the index of this service manual for the location of the proper speed control servo installation procedures.

(3) Install the stud plate onto the front of the battery tray support.

(4) From the engine compartment, position the battery tray and the stud plate that secures the front of the battery tray support onto the front wheelhouse inner panel as a unit.

(5) From inside the front fender wheelhouse, loosely install the two nuts with washers that secure the front of the battery tray support to the two studs that extend through the underside of the front wheelhouse inner panel.

(6) From inside the front fender wheelhouse, position the stud plate that secures the rear of the battery tray support onto the underside of the front wheelhouse inner panel.

(7) From the engine compartment, loosely install the two nuts with washers that secure the rear of the battery tray support to the two studs that extend through the top of the front wheelhouse inner panel.



## BATTERY TRAY (Continued)

(8) Install and tighten the two screws with washers that secure the outboard side of the battery tray to the inner fender shield. Tighten the screws to 15.8 N·m (140 in. lbs.).

(9) Final tighten the four nuts with washers that secure the battery tray support to the stud plates on the front wheelhouse inner panel. Tighten the nuts to 15.8 N·m (140 in. lbs.).

(10) If the left battery tray is being installed, install the battery temperature sensor onto the left battery tray. Refer to **Battery Temperature Sensor** in the index of this service manual for the location of the proper battery temperature sensor installation procedures.

(11) Install the battery onto the battery tray. Refer to **Battery** in this group for the location of the proper battery installation procedures.



# CHARGING

## TABLE OF CONTENTS

	page		page
<b>CHARGING</b>		<b>INSTALLATION</b> .....	29
DESCRIPTION.....	27	<b>GENERATOR</b>	
OPERATION.....	27	DESCRIPTION.....	29
DIAGNOSIS AND TESTING.....	27	OPERATION.....	29
CHARGING SYSTEM.....	27	REMOVAL.....	30
SPECIFICATIONS.....	28	INSTALLATION.....	30
<b>BATTERY TEMPERATURE SENSOR</b>		<b>VOLTAGE REGULATOR</b>	
DESCRIPTION.....	29	DESCRIPTION.....	31
OPERATION.....	29	OPERATION.....	31
REMOVAL.....	29		

## CHARGING

### DESCRIPTION

The charging system consists of:

- Generator
- Electronic Voltage Regulator (EVR) circuitry within the Powertrain Control Module (PCM)
- Ignition switch (refer to Ignition System for information)
- Battery (refer to 8, Battery for information)
- Battery temperature sensor
- Check Gauges Lamp (if equipped)
- Voltmeter (refer to 8, Instrument Panel and Gauges for information)
- Wiring harness and connections (refer to 8, Wiring Diagrams for information)

### OPERATION

The charging system is turned on and off with the ignition switch. The system is on when the engine is running and the ASD relay is energized. When the ASD relay is on, voltage is supplied to the ASD relay sense circuit at the PCM. This voltage is connected through the PCM and supplied to one of the generator field terminals (Gen. Source +) at the back of the generator.

The amount of direct current produced by the generator is controlled by the EVR (field control) circuitry contained within the PCM. This circuitry is connected in series with the second rotor field terminal and ground.

A battery temperature sensor, located in the battery tray housing, is used to sense battery temperature. This temperature data, along with data from monitored line voltage, is used by the PCM to vary the battery charging rate. This is done by cycling the ground path to control the strength of the rotor mag-

netic field. The PCM then compensates and regulates generator current output accordingly.

All vehicles are equipped with On-Board Diagnostics (OBD). All OBD-sensed systems, including EVR (field control) circuitry, are monitored by the PCM. Each monitored circuit is assigned a Diagnostic Trouble Code (DTC). The PCM will store a DTC in electronic memory for certain failures it detects. Refer to On-Board Diagnostics in 25, Emission Control System for more DTC information and a list of codes.

The Check Gauges Lamp (if equipped) monitors: **charging system voltage**, engine coolant temperature and engine oil pressure. If an extreme condition is indicated, the lamp will be illuminated. This is done as reminder to check the three gauges. The signal to activate the lamp is sent via the CCD bus circuits. The lamp is located on the instrument panel. Refer to 8, Instrument Panel and Gauges for additional information.

## DIAGNOSIS AND TESTING - CHARGING SYSTEM

The following procedures may be used to diagnose the charging system if:

- the check gauges lamp (if equipped) is illuminated with the engine running
- the voltmeter (if equipped) does not register properly
- an undercharged or overcharged battery condition occurs.

Remember that an undercharged battery is often caused by:

- accessories being left on with the engine not running
- a faulty or improperly adjusted switch that allows a lamp to stay on. Refer to Ignition-Off Draw Test in 8, Battery for more information.

## CHARGING (Continued)

**INSPECTION**

The Powertrain Control Module (PCM) monitors critical input and output circuits of the charging system, making sure they are operational. A Diagnostic Trouble Code (DTC) is assigned to each input and output circuit monitored by the On-Board Diagnostic (OBD) system. Some charging system circuits are checked continuously, and some are checked only under certain conditions.

Refer to Diagnostic Trouble Codes in; Powertrain Control Module; Electronic Control Modules for more DTC information. This will include a complete list of DTC's including DTC's for the charging system.

To perform a complete test of the charging system, refer to the appropriate Powertrain Diagnostic Procedures service manual and the DRB® scan tool. Perform the following inspections before attaching the scan tool.

(1) Inspect the battery condition. Refer to 8, Battery for procedures.

(2) Inspect condition of battery cable terminals, battery posts, connections at engine block, starter solenoid and relay. They should be clean and tight. Repair as required.

(3) Inspect all fuses in both the fuseblock and Power Distribution Center (PDC) for tightness in receptacles. They should be properly installed and tight. Repair or replace as required.

(4) Inspect generator mounting bolts for tightness. Replace or tighten bolts if required. Refer to the Generator Removal/Installation section of this group for torque specifications.

(5) Inspect generator drive belt condition and tension. Tighten or replace belt as required. Refer to Belt Tension Specifications in 7, Cooling System.

(6) Inspect automatic belt tensioner (if equipped). Refer to 7, Cooling System for information.

(7) Inspect generator electrical connections at generator field, battery output, and ground terminal (if equipped). Also check generator ground wire connection at engine (if equipped). They should all be clean and tight. Repair as required.

**SPECIFICATIONS****GENERATOR RATINGS**

TYPE	PART NUMBER	RATED SAE AMPS	ENGINES	MINIMUM TEST AMPS
DENSO	56028920AB	136	3.9L/5.2L/5.9L GAS	100
DENSO	56029913AA	117	3.9L/5.2L/5.9L GAS	90
BOSCH	56028237AB	117	3.9L/5.2L/5.9L GAS	90
BOSCH	56028238AB	136	3.9L/5.2L/5.9L GAS	100
DENSO	56027221AD	136	5.9L DIESEL	120
BOSCH	56028239AB	136	5.9L DIESEL	120
BOSCH	56028560AA	136	8.0L	100
DENSO	56028920AC	136	8.0L	100

**SPECIFICATIONS - TORQUE - GENERATOR/CHARGING SYSTEM**

DESCRIPTION	N-m	Ft. Lbs.	In. Lbs.
Generator Mounting Bolts—Gas Engine	41	30	
Generator Upper Mounting Bolt—Diesel Engine	54	40	
Generator Pivot Bolt/Nut—Diesel Engine	54	40	
Generator Mounting Bracket-to-Engine Bolt—Diesel Engine	24	18	
Generator B+ Cable Eyelet Nut	12	9	108

## BATTERY TEMPERATURE SENSOR

### DESCRIPTION

The Battery Temperature Sensor (BTS) is attached to the battery tray located under the battery.

### OPERATION

The BTS is used to determine the battery temperature and control battery charging rate. This temperature data, along with data from monitored line voltage, is used by the PCM to vary the battery charging rate. System voltage will be higher at colder temperatures and is gradually reduced at warmer temperatures.

The PCM sends 5 volts to the sensor and is grounded through the sensor return line. As temperature increases, resistance in the sensor decreases and the detection voltage at the PCM increases.

The BTS is also used for OBD II diagnostics. Certain faults and OBD II monitors are either enabled or disabled, depending upon BTS input (for example, disable purge and enable Leak Detection Pump (LDP) and O<sub>2</sub> sensor heater tests). Most OBD II monitors are disabled below 20°F.

### REMOVAL

The battery temperature sensor is located under the vehicle battery (Fig. 1) and is attached (snapped into) a mounting hole on battery tray. On models equipped with a diesel engine (dual batteries), only one sensor is used. The sensor is located under the battery on drivers side of vehicle.

(1) Remove battery. Refer to 8, Battery for procedures.

(2) Disconnect sensor pigtail harness from engine wire harness.

(3) Pry sensor straight up from battery tray mounting hole.

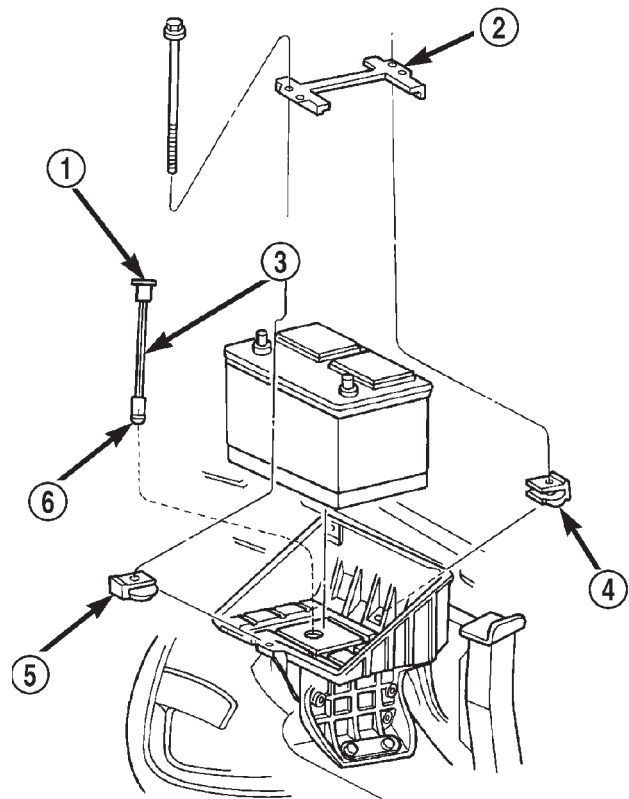
### INSTALLATION

The battery temperature sensor is located under the vehicle battery (Fig. 1) and is attached (snapped into) a mounting hole on battery tray. On models equipped with a diesel engine (dual batteries), only one sensor is used. The sensor is located under the battery on drivers side of vehicle.

(1) Feed pigtail harness through mounting hole in top of battery tray and press sensor into top of tray (snaps in).

(2) Connect pigtail harness.

(3) Install battery. Refer to 8A, Battery for procedures.



8056d9f6

**Fig. 1 Battery Temperature Sensor Location**

- 1 - BATT. TEMP. SENSOR
- 2 - BATTERY HOLD DOWN STRAP
- 3 - PIGTAIL HARNESS
- 4 - U-NUT
- 5 - U-NUT
- 6 - ELEC. CONNEX.

## GENERATOR

### DESCRIPTION

The generator is belt-driven by the engine using a serpentine type drive belt. It is serviced only as a complete assembly. If the generator fails for any reason, the entire assembly must be replaced.

### OPERATION

As the energized rotor begins to rotate within the generator, the spinning magnetic field induces a current into the windings of the stator coil. Once the generator begins producing sufficient current, it also provides the current needed to energize the rotor.

The Y type stator winding connections deliver the induced alternating current to 3 positive and 3 negative diodes for rectification. From the diodes, rectified direct current is delivered to the vehicle electrical system through the generator battery terminal.

## GENERATOR (Continued)

Although the generators appear the same externally, different generators with different output ratings are used on this vehicle. Be certain that the replacement generator has the same output rating and part number as the original unit. Refer to Generator Ratings in the Specifications section at the back of this group for amperage ratings and part numbers.

Noise emitting from the generator may be caused by: worn, loose or defective bearings; a loose or defective drive pulley; incorrect, worn, damaged or misadjusted fan drive belt; loose mounting bolts; a misaligned drive pulley or a defective stator or diode.

## REMOVAL

**WARNING: DISCONNECT NEGATIVE CABLE FROM BATTERY BEFORE REMOVING BATTERY OUTPUT WIRE (B+ WIRE) FROM GENERATOR. FAILURE TO DO SO CAN RESULT IN INJURY OR DAMAGE TO ELECTRICAL SYSTEM.**

(1) Disconnect negative battery cable at battery. Diesel Engines: Disconnect both negative battery cables at both batteries.

(2) Remove generator drive belt. Refer to 7, Cooling System for procedure.

(3) Gasoline Engines: Remove generator pivot and mounting bolts/nut (Fig. 2) or (Fig. 3).

(4) Diesel Engines: Loosen (but do not remove) generator mounting bracket-to-engine bolt (Fig. 4).

(5) All Engines: Remove upper generator mounting bolt and lower mounting bolt/nut.

(6) Remove B+ terminal mounting nut at rear of generator (Fig. 5) or (Fig. 6). Disconnect terminal from generator.

(7) Disconnect field wire connector at rear of generator by pushing on connector tab.

(8) Remove generator from vehicle.

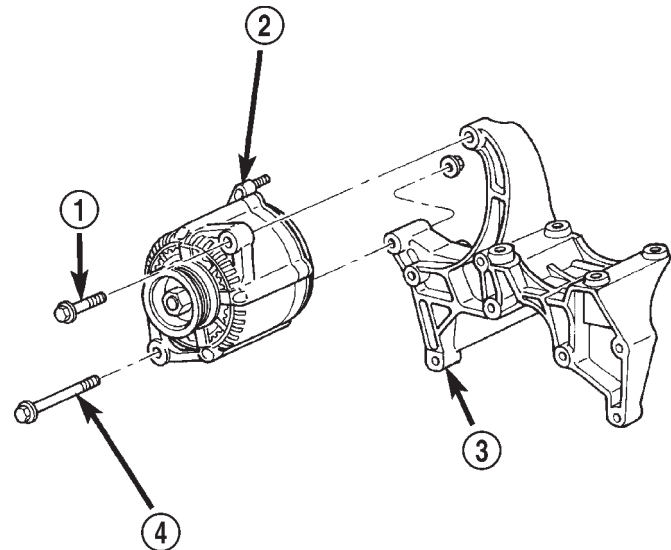
## INSTALLATION

(1) Position generator to engine and snap field wire connector into rear of generator.

(2) Install B+ terminal eyelet to generator stud. Tighten mounting nut to 12 N·m (108 in. lbs.) torque.

(3) Install generator mounting fasteners and tighten as follows:

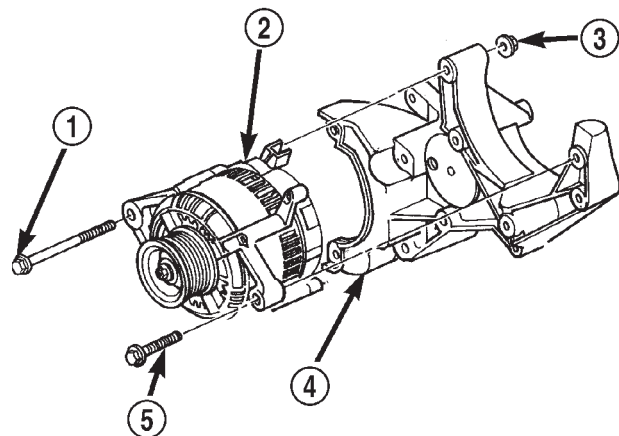
- Generator mounting bolt—All gas powered engines—41 N·m (30 ft. lbs.) torque.
- Generator pivot bolt/nut—All gas powered engines—41 N·m (30 ft. lbs.) torque.
- Generator mounting bolt—Diesel powered engines—54 N·m (40 ft. lbs.) torque.
- Generator pivot bolt/nut—Diesel powered engines—54 N·m (40 ft. lbs.) torque.



80a592b3

**Fig. 2 Remove/Install Generator—3.9L/5.2L/5.9L Engines**

- 1 - MOUNTING BOLT
- 2 - GENERATOR
- 3 - MOUNTING BRACKET
- 4 - MOUNTING BOLT/NUT



80a592b0

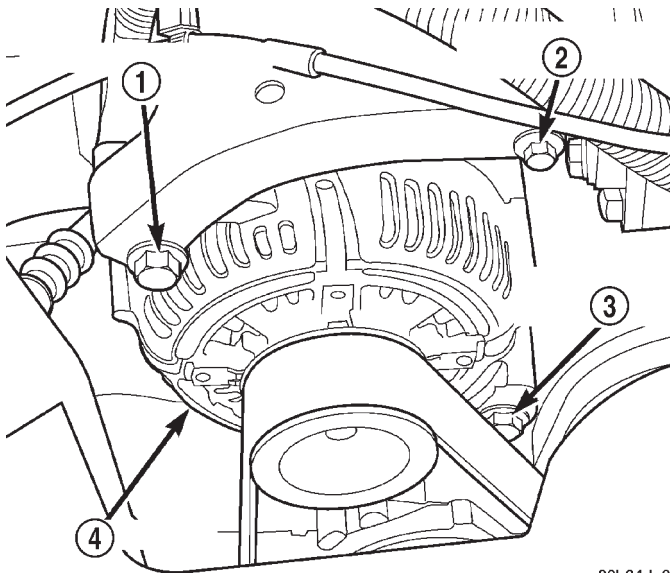
**Fig. 3 Remove/Install Generator—8.0L Engine**

- 1 - MOUNTING BOLT
- 2 - GENERATOR
- 3 - NUT
- 4 - MOUNTING BRACKET
- 5 - MOUNTING BOLT

**CAUTION: Never force a belt over a pulley rim using a screwdriver. The synthetic fiber of the belt can be damaged.**



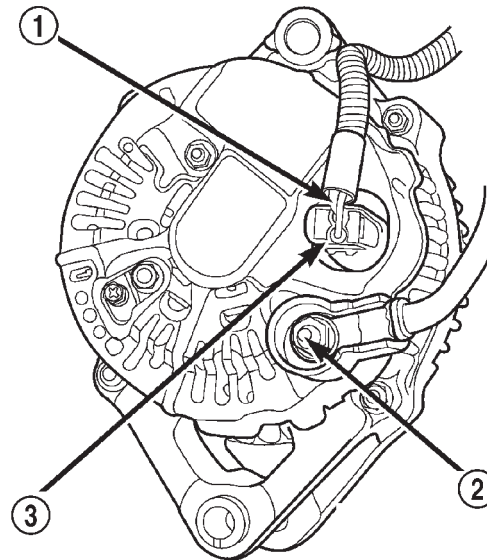
## GENERATOR (Continued)



80b34de2

**Fig. 4 Remove/Install Generator—Diesel Engine**

- 1 - UPPER MOUNTING BOLT
- 2 - BRACKET-TO-ENGINE BOLT
- 3 - LOWER MOUNTING BOLT/NUT
- 4 - GENERATOR

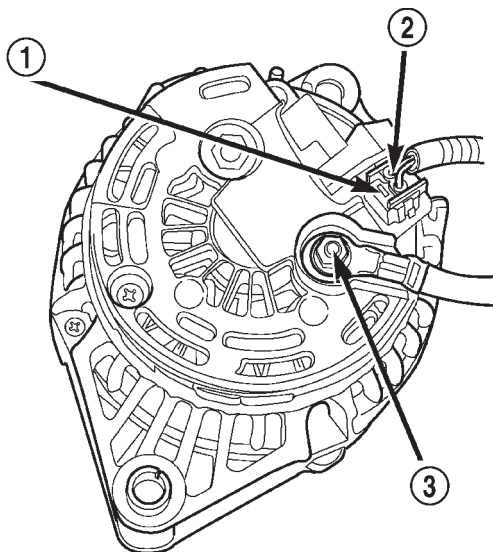


80b6f031

**Fig. 6 Generator Connectors—Typical Denso**

- 1 - FIELD WIRES
- 2 - B+ (OUTPUT TERMINAL)
- 3 - FIELD WIRE CONNECTOR

- (5) Install negative battery cable(s) to battery(s).



80b6f030

**Fig. 5 Generator Connectors—Typical Bosch**

- 1 - FIELD WIRE CONNECTOR
- 2 - FIELD WIRES
- 3 - B+ (OUTPUT TERMINAL)

**CAUTION:** When installing a serpentine accessory drive belt, the belt **MUST** be routed correctly. The water pump will be rotating in the wrong direction if the belt is installed incorrectly, causing the engine to overheat. Refer to belt routing label in engine compartment, or refer to Belt Schematics in Group 7, Cooling System.

- (4) Install generator drive belt. Refer to 7, Cooling System for procedure.

## VOLTAGE REGULATOR

### DESCRIPTION

The Electronic Voltage Regulator (EVR) is not a separate component. It is actually a voltage regulating circuit located within the Powertrain Control Module (PCM). The EVR is not serviced separately. If replacement is necessary, the PCM must be replaced.

### OPERATION

The amount of direct current produced by the generator is controlled by EVR circuitry contained within the PCM. This circuitry is connected in series with the generator's second rotor field terminal and its ground.

Voltage is regulated by cycling the ground path to control the strength of the rotor magnetic field. The EVR circuitry monitors system line voltage (B+) and battery temperature (refer to Battery Temperature Sensor for more information). It then determines a target charging voltage. If sensed battery voltage is 0.5 volts or lower than the target voltage, the PCM grounds the field winding until sensed battery voltage is 0.5 volts above target voltage. A circuit in the PCM cycles the ground side of the generator field up to 100 times per second (100Hz), but has the capability to ground the field control wire 100% of the time (full field) to achieve the target voltage. If the charging rate cannot be monitored (limp-in), a duty cycle of 25% is used by the PCM in order to have some generator output. Also refer to Charging System Operation for additional information.



# STARTING

## TABLE OF CONTENTS

	page		page
<b>STARTING</b>		<b>STARTER MOTOR</b> . . . . .	39
DESCRIPTION . . . . .	32	REMOVAL . . . . .	40
OPERATION . . . . .	32	INSTALLATION . . . . .	41
DIAGNOSIS AND TESTING . . . . .	33	<b>ENGINE STARTER MOTOR RELAY</b>	
STARTING SYSTEM . . . . .	33	DESCRIPTION . . . . .	42
SPECIFICATIONS . . . . .	38	OPERATION . . . . .	42
<b>ENGINE STARTER MOTOR</b>		DIAGNOSIS AND TESTING . . . . .	42
DESCRIPTION . . . . .	39	STARTER RELAY . . . . .	42
OPERATION . . . . .	39	REMOVAL . . . . .	43
DIAGNOSIS AND TESTING . . . . .	39	INSTALLATION . . . . .	43

## STARTING

### DESCRIPTION

The starting system consists of:

- Starter relay
- Starter motor (including an integral starter solenoid)

Other components to be considered as part of starting system are:

- Battery
- Battery cables
- Ignition switch and key lock cylinder
- Clutch pedal position switch (manual transmission)
- Park/neutral position switch (automatic transmission)
- Wire harnesses and connections.

The Battery, Starting, and Charging systems operate in conjunction with one another, and must be tested as a complete system. For correct operation of starting/charging systems, all components used in these 3 systems must perform within specifications. When attempting to diagnose any of these systems, it is important that you keep their interdependency in mind.

The diagnostic procedures used in each of these groups include the most basic conventional diagnostic methods, to the more sophisticated On-Board Diagnostics (OBD) built into the Powertrain Control Module (PCM). Use of an induction-type milliamperemeter, volt/ohmmeter, battery charger, carbon pile rheostat (load tester), and 12-volt test lamp may be required.

Certain starting system components are monitored by the PCM and may produce a Diagnostic Trouble Code (DTC). Refer to Diagnostic Trouble Codes for additional information and a list of codes.

### OPERATION

The starting system components form two separate circuits. A high-amperage feed circuit that feeds the starter motor between 150 and 350 amperes (700 amperes - diesel engine), and a low-amperage control circuit that operates on less than 20 amperes. The high-amperage feed circuit components include the battery, the battery cables, the contact disc portion of the starter solenoid, and the starter motor. The low-amperage control circuit components include the ignition switch, the clutch pedal position switch (manual transmission), the park/neutral position switch (automatic transmission), the starter relay, the electromagnetic windings of the starter solenoid, and the connecting wire harness components.

If the vehicle is equipped with a manual transmission, it has a clutch pedal position switch installed in series between the ignition switch and the coil battery terminal of the starter relay. This normally open switch prevents the starter relay from being energized when the ignition switch is turned to the momentary Start position, unless the clutch pedal is depressed. This feature prevents starter motor operation while the clutch disc and the flywheel are engaged. The starter relay coil ground terminal is always grounded on vehicles with a manual transmission.

If the vehicle is equipped with an automatic transmission, battery voltage is supplied through the low-amperage control circuit to the coil battery terminal of the starter relay when the ignition switch is turned to the momentary Start position. The park/neutral position switch is installed in series between the starter relay coil ground terminal and ground. This normally open switch prevents the starter relay from being energized and the starter motor from operating unless the automatic transmission gear selector is in the Neutral or Park positions.

## STARTING (Continued)

When the starter relay coil is energized, the normally open relay contacts close. The relay contacts connect the relay common feed terminal to the relay normally open terminal. The closed relay contacts energize the starter solenoid coil windings.

The energized solenoid pull-in coil pulls in the solenoid plunger. The solenoid plunger pulls the shift lever in the starter motor. This engages the starter overrunning clutch and pinion gear with the starter ring gear on the manual transmission flywheel or on the automatic transmission torque converter or torque converter drive plate.

As the solenoid plunger reaches the end of its travel, the solenoid contact disc completes the high-amperage starter feed circuit and energizes the solenoid plunger hold-in coil. Current now flows between the solenoid battery terminal and the starter motor, energizing the starter.

Once the engine starts, the overrunning clutch protects the starter motor from damage by allowing the starter pinion gear to spin faster than the pinion

shaft. When the driver releases the ignition switch to the On position, the starter relay coil is de-energized. This causes the relay contacts to open. When the relay contacts open, the starter solenoid plunger hold-in coil is de-energized.

When the solenoid plunger hold-in coil is de-energized, the solenoid plunger return spring returns the plunger to its relaxed position. This causes the contact disc to open the starter feed circuit, and the shift lever to disengage the overrunning clutch and pinion gear from the starter ring gear.

## DIAGNOSIS AND TESTING - STARTING SYSTEM

The battery, starting, and charging systems operate in conjunction with one another, and must be tested as a complete system. For correct starting/charging system operation, all of the components involved in these 3 systems must perform within specifications.

Starting System Diagnosis		
CONDITION	POSSIBLE CAUSE	CORRECTION
STARTER FAILS TO OPERATE.	1. Battery discharged or faulty.	1. Refer to Battery. Charge or replace battery, if required.
	2. Starting circuit wiring faulty.	2. Refer to 8, Wiring Diagrams. Test and repair starter feed and/or control circuits, if required.
	3. Starter relay faulty.	3. Refer to Starter Relay in the Diagnosis and Testing section of this group. Replace starter relay, if required.
	4. Ignition switch faulty.	4. Refer to Ignition Switch and Key Lock Cylinder. Replace ignition switch, if required.
	5. Clutch pedal position switch faulty.	5. Refer to Clutch Pedal Position Switch.
	6. Park/Neutral position switch faulty or misadjusted.	6. Refer to Park/Neutral Position Switch. Replace park/neutral position switch, if required.
	7. Starter solenoid faulty.	7. Refer to Starter Motor. Replace starter motor assembly, if required.
	8. Starter motor faulty.	8. If all other starting system components and circuits test OK, replace starter motor.
STARTER ENGAGES, FAILS TO TURN ENGINE.	1. Battery discharged or faulty.	1. Refer to Battery. Charge or replace battery, if required.
	2. Starting circuit wiring faulty.	2. Refer to 8, Wiring Diagrams. Test and repair starter feed and/or control circuits, if required.
	3. Starter motor faulty.	3. If all other starting system components and circuits test OK, replace starter motor assembly.
	4. Engine seized.	4. Refer to Engine Diagnosis in the Diagnosis and Testing section of 9, Engine.

## STARTING (Continued)

Starting System Diagnosis		
CONDITION	POSSIBLE CAUSE	CORRECTION
STARTER ENGAGES, SPINS OUT BEFORE ENGINE STARTS.	1. Starter ring gear faulty.	1. Refer to Starter Motor in Removal and Installation. Remove starter motor to inspect starter ring gear. Replace starter ring gear, if required.
	2. Starter motor faulty.	2. If all other starting system components and circuits test OK, replace the starter motor assembly.
STARTER DOES NOT DISENGAGE.	1. Starter motor improperly installed.	1. Refer to Starter Motor in the Removal and Installation section of this group. Tighten the starter mounting hardware to the correct tightness specifications.
	2. Starter relay faulty.	2. Refer to Starter Relay in the Diagnosis and Testing section of this group. Replace starter relay, if required.
	3. Ignition switch faulty.	3. Refer to Ignition Switch and Key Lock Cylinder. Replace ignition switch, if required.
	4. Starter motor faulty.	4. If all other starting system components and circuits test OK, replace starter motor.

## INSPECTION

For complete starter wiring circuit diagrams, refer to 8, Wiring Diagrams. Before removing any unit from starting system for repair or diagnosis, perform the following inspections:

**WARNING: ON VEHICLES EQUIPPED WITH AIRBAGS, REFER TO 8, PASSIVE RESTRAINT SYSTEMS, BEFORE ATTEMPTING ANY STEERING WHEEL, STEERING COLUMN, OR INSTRUMENT PANEL COMPONENT DIAGNOSIS OR SERVICE. FAILURE TO TAKE THE PROPER PRECAUTIONS COULD RESULT IN ACCIDENTAL AIRBAG DEPLOYMENT AND POSSIBLE PERSONAL INJURY.**

- **Battery** - Visually inspect battery for indications of physical damage and loose or corroded cable connections. Determine the state-of-charge and cranking capacity of battery. Charge or replace battery, if required. Refer to **Battery** in 8, Battery. **Note: If equipped with diesel engine, a dual battery system is used, and both batteries must be inspected.**

- **Ignition Switch** - Visually inspect ignition switch for indications of physical damage and loose or corroded wire harness connections. Refer to **Ignition Switch and Key Lock Cylinder**.

- **Clutch Pedal Position Switch** - If equipped with manual transmission, visually inspect clutch pedal position switch for indications of physical damage and loose or corroded wire harness connections. Refer to **Clutch Pedal Position Switch** in 6, Clutch.

- **Park/Neutral Position Switch** - If equipped with automatic transmission, visually inspect park/neutral position switch for indications of physical damage and loose or corroded wire harness connections.

Refer to **Park/Neutral Position Switch** in 21, Transmission.

- **Starter Relay** - Visually inspect starter relay for indications of physical damage and loose or corroded wire harness connections.

- **Starter Motor** - Visually inspect starter motor for indications of physical damage and loose or corroded wire harness connections.

- **Starter Solenoid** - Visually inspect starter solenoid for indications of physical damage and loose or corroded wire harness connections.

- **Wiring** - Visually inspect wire harnesses for damage. Repair or replace any faulty wiring, as required. Refer to 8, Wiring Diagrams.

## TESTING

## COLD CRANKING TEST

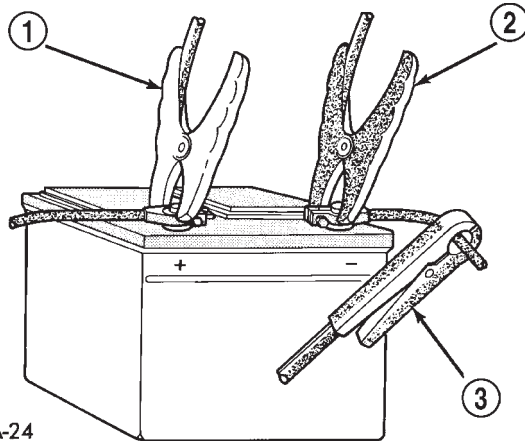
For complete starter wiring circuit diagrams, refer to 8, Wiring Diagrams. The battery must be fully-charged and load-tested before proceeding. Refer to **Battery** in 8, Battery.

(1) Connect volt-ampere tester to battery terminals (Fig. 1). See instructions provided by manufacturer of volt-ampere tester being used. **Note: If equipped with dual battery system (diesel), tester should be connected to driver side battery only. Also, tester current reading must be taken from battery positive cable lead that connects to starter motor.**

(2) Fully engage parking brake.

(3) If equipped with manual transmission, place gearshift selector lever in Neutral position and block clutch pedal in fully depressed position. If equipped with automatic transmission, place gearshift selector lever in Park position.

## STARTING (Continued)



948A-24

**Fig. 1 Volts-Amps Tester Connections - Typical**

- 1 - POSITIVE CLAMP  
 2 - NEGATIVE CLAMP  
 3 - INDUCTION AMMETER CLAMP

(4) Verify that all lamps and accessories are turned off.

(5) To prevent a gasoline engine from starting, remove Automatic ShutDown (ASD) relay. To prevent a diesel engine from starting, remove Fuel Pump Relay. These relays are located in Power Distribution Center (PDC). Refer to label on PDC cover for relay location.

**WARNING: IF EQUIPPED WITH DIESEL ENGINE, ATTEMPT TO START ENGINE A FEW TIMES BEFORE PROCEEDING WITH FOLLOWING STEP.**

(6) Rotate and hold ignition switch in Start position. Note cranking voltage and current (amperage) draw readings shown on volt-ampere tester.

(a) If voltage reads below 9.6 volts, refer to **Starter Motor** in Diagnosis and Testing. If starter motor is OK, refer to **Engine Diagnosis** in 9, Engine for further testing of engine. If starter motor is not OK, replace faulty starter motor.

(b) If voltage reads above 9.6 volts and current (amperage) draw reads below specifications, refer to **Feed Circuit Test** in this section.

(c) If voltage reads 12.5 volts or greater and starter motor does not turn, refer to **Control Circuit Testing** in this section.

(d) If voltage reads 12.5 volts or greater and starter motor turns very slowly, refer to **Feed Circuit Test** in this section.

**NOTE: A cold engine will increase starter current (amperage) draw reading, and reduce battery voltage reading.**

### FEED CIRCUIT TEST

The starter feed circuit test (voltage drop method) will determine if there is excessive resistance in high-amperage feed circuit. For complete starter wiring circuit diagrams, refer 8, Wiring Diagrams.

When performing these tests, it is important to remember that voltage drop is giving an indication of resistance between two points at which voltmeter probes are attached.

**Example:** When testing resistance of battery positive cable, touch voltmeter leads to battery positive cable clamp and cable connector at starter solenoid. If you probe battery positive terminal post and cable connector at starter solenoid, you are reading combined voltage drop in battery positive cable clamp-to-terminal post connection and battery positive cable.

The following operation will require a voltmeter accurate to 1/10 (0.10) volt. Before performing tests, be certain that following procedures are accomplished:

- Battery is fully-charged and load-tested. Refer to **Battery** in 8, Battery.
- Fully engage parking brake.
- If equipped with manual transmission, place gearshift selector lever in Neutral position and block clutch pedal in fully depressed position. If equipped with automatic transmission, place gearshift selector lever in Park position.
- Verify that all lamps and accessories are turned off.
- To prevent a gasoline engine from starting, remove Automatic ShutDown (ASD) relay. To prevent a diesel engine from starting, remove Fuel Pump Relay. These relays are located in Power Distribution Center (PDC). Refer to label on PDC cover for relay location.

(1) Connect positive lead of voltmeter to battery negative terminal post. Connect negative lead of voltmeter to battery negative cable clamp (Fig. 2). Rotate and hold ignition switch in Start position. Observe voltmeter. If voltage is detected, correct poor contact between cable clamp and terminal post. **Note: If equipped with a dual battery system (diesel), procedure must be performed twice, once for each battery.**

(2) Connect positive lead of voltmeter to battery positive terminal post. Connect negative lead of voltmeter to battery positive cable clamp (Fig. 3). Rotate and hold ignition switch in Start position. Observe voltmeter. If voltage is detected, correct poor contact between cable clamp and terminal post. **Note: If equipped with a dual battery system (diesel), this procedure must be performed twice, once for each battery.**



STARTING (Continued)

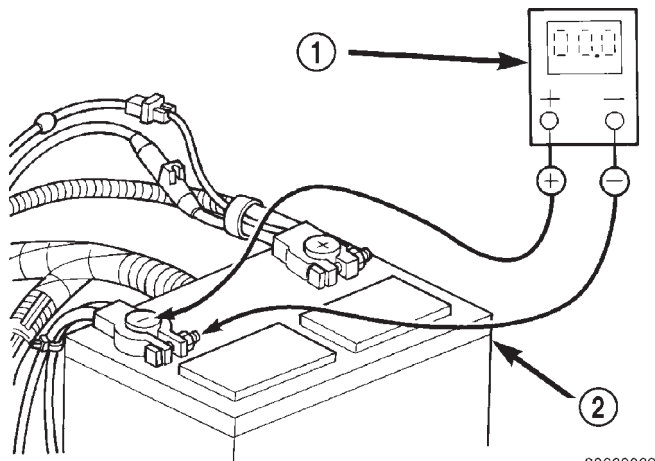


Fig. 2 Test

80660062

- 1 - VOLTMETER
- 2 - BATTERY

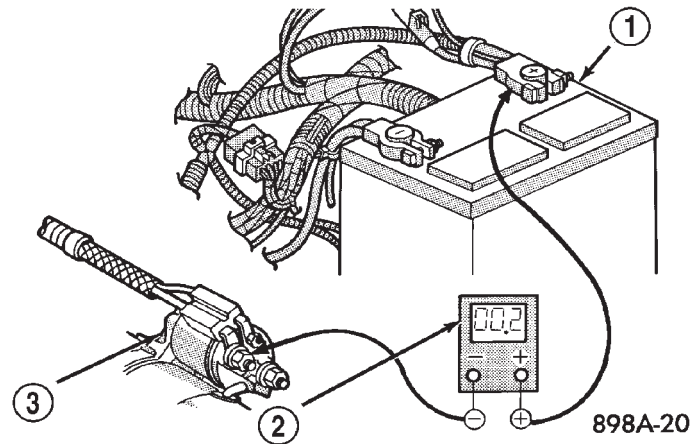


Fig. 4 Test Battery Positive Cable

- 1 - BATTERY
- 2 - VOLTMETER
- 3 - STARTER MOTOR

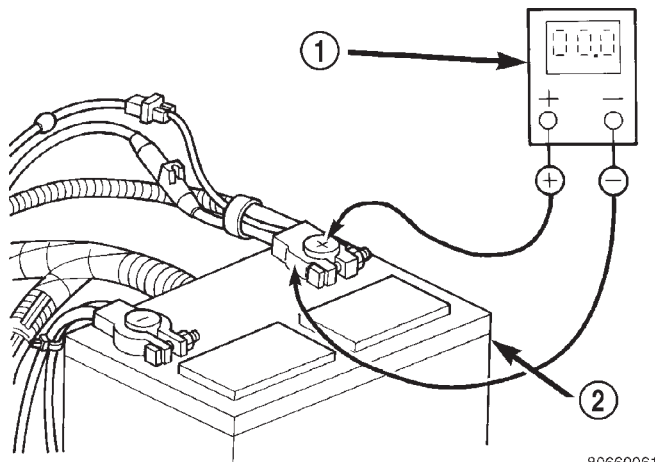


Fig. 3 Test Battery Positive Connection Resistance - Typical

80660061

- 1 - VOLTMETER
- 2 - BATTERY

(3) Connect voltmeter to measure between battery positive terminal post and starter solenoid battery terminal stud (Fig. 4). Rotate and hold ignition switch in Start position. Observe voltmeter. If reading is above 0.2 volt, clean and tighten battery cable connection at solenoid. Repeat test. If reading is still above 0.2 volt, replace faulty battery positive cable. **Note: If equipped with a dual battery system (diesel), this procedure must be performed on driver side battery only.**

(4) Connect voltmeter to measure between battery negative terminal post and a good clean ground on engine block (Fig. 5). Rotate and hold ignition switch in Start position. Observe voltmeter. If reading is above 0.2 volt, clean and tighten battery negative cable attachment on engine block. Repeat test. If reading is still above 0.2 volt, replace faulty battery negative cable. **Note: If equipped with dual battery system (diesel), this procedure must be performed twice, once for each battery.**

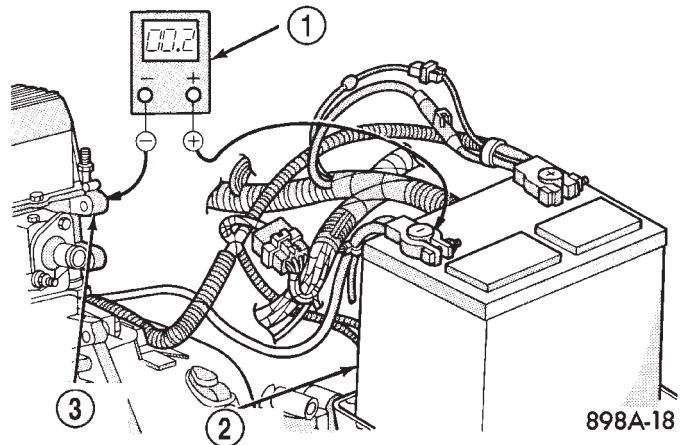


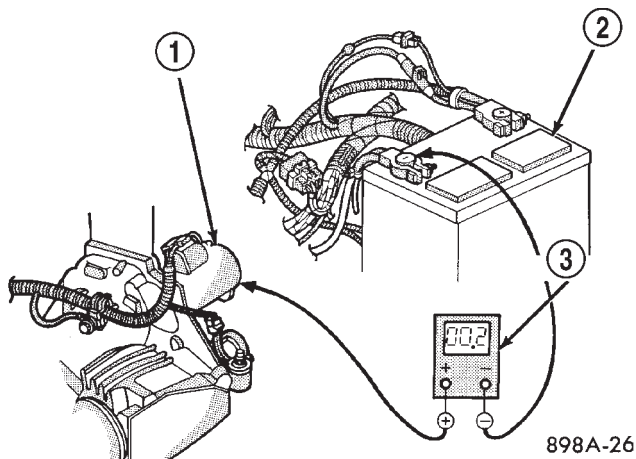
Fig. 5 Test Ground Circuit Resistance - Typical

- 1 - VOLTMETER
- 2 - BATTERY
- 3 - ENGINE GROUND



## STARTING (Continued)

(5) Connect positive lead of voltmeter to starter housing. Connect negative lead of voltmeter to battery negative terminal post (Fig. 6). Rotate and hold ignition switch in Start position. Observe voltmeter. If reading is above 0.2 volt, correct poor starter to engine block ground contact. **Note: If equipped with a dual battery system (diesel), this procedure must be performed on driver side battery only.**



**Fig. 6 Test Starter Ground - Typical**

- 1 - STARTER MOTOR
- 2 - BATTERY
- 3 - VOLTMETER

(6) If equipped with dual battery system (diesel), connect positive lead of voltmeter to driver side battery positive cable clamp. Connect negative lead of voltmeter to passenger side battery positive terminal post. Rotate and hold ignition switch in Start position. Observe voltmeter. If reading is above 0.2 volt, clean and tighten passenger side battery positive cable eyelet connection at driver side battery positive cable clamp bolt. Repeat test. If reading is still above 0.2 volt, replace faulty passenger side battery positive cable.

If resistance tests detect no feed circuit problems, refer to **Starter Motor** in the Diagnosis and Testing.

## CONTROL CIRCUIT TESTING

The starter control circuit components should be tested in the order in which they are listed, as follows:

- **Starter Relay** - Refer to **Starter Relay** Diagnosis and Testing.
- **Starter Solenoid** - Refer to **Starter Motor** Diagnosis and Testing.
- **Ignition Switch** - Refer to **Ignition Switch and Key Lock Cylinder**
- **Clutch Pedal Position Switch** - If equipped with manual transmission, refer to **Clutch Pedal Position Switch** in 6, Clutch.
- **Park/Neutral Position Switch** - If equipped with automatic transmission, refer to **Park/Neutral Position Switch** in 21, Transmission.
- **Wire harnesses and connections** - Refer to 8, Wiring Diagrams.

STARTING (Continued)

## SPECIFICATIONS

## STARTING SYSTEM

Starter Motor and Solenoid			
Manufacturer	Nippon Denso	Nippon Denso	Nippon Denso
Part Number	56027702AB	56027703AB	4741012
Engine Application	3.9L, 5.2L, 5.9L (Gasoline)	8.0L (Gasoline)	5.9L (Diesel)
Power Rating	1.4 Kilowatt 1.9 Horsepower	1.4 Kilowatt 1.9 Horsepower	2.7 Kilowatt 3.6 Horsepower
Voltage	12 Volts	12 Volts	12 Volts
Pinion Teeth	10	11	13
Number of Fields	4	4	4
Number of Poles	4	4	4
Number of Brushes	4	4	4
Drive Type	Reduction Gear Train	Reduction Gear Train	Conventional Gear Train
Free Running Test Voltage	11 Volts	11 Volts	11 Volts
Free Running Test Amperage Draw	73 Amperes	73 Amperes	200 Amperes
Free Running Test Minimum Speed	3601 rpm	3601 rpm	3000 rpm
Solenoid Closing Maximum Voltage Required	7.5 Volts	7.5 Volts	8.0 Volts
* Cranking Amperage Draw Test	125 - 250 Amperes	125 - 250 Amperes	450 - 700 Amperes
* Test at operating temperature. Cold engine, tight (new) engine, or heavy oil will increase starter amperage draw.			

## SPECIFICATIONS - TORQUE - STARTING SYSTEM

DESCRIPTION	N-m	Ft. Lbs.	In. Lbs.
Battery Cable Eyelet Nut at Solenoid (large nut – gas engines)	25	19	221
Battery Cable Eyelet Nut at Solenoid (large nut – diesel engine)	14		120
Starter Solenoid Nut (small nut – diesel engine)	6		55
Starter Mounting Bolts – Gas Engines	68	50	
Starter Mounting Nut – Gas Engines	68	50	
Starter Mounting Bolts – Diesel	43	32	

## ENGINE STARTER MOTOR

### DESCRIPTION

The starter motors used for the 5.9L diesel engine and the 8.0L gasoline engine available in this model are not interchangeable with each other, or with the starter motors used for the other available engines. The starter motors used for the 3.9L, 5.2L and the 5.9L gasoline engines available in this model are interchangeable.

The starter motor for the 5.9L diesel engine is mounted with three screws to the flywheel housing on the left side of the engine. The starter motor for the 8.0L gasoline engine is mounted with two screws to the flange on the left rear corner of the engine block, while the starter motors for all of the other engines are mounted with one screw, a stud and a nut to the manual transmission clutch housing or automatic transmission torque converter housing and are located on the left side of the engine.

Each of these starter motors incorporates several of the same features to create a reliable, efficient, compact, lightweight and powerful unit. The electric motors of all of these starters have four brushes contacting the motor commutator, and feature four electromagnetic field coils wound around four pole shoes. The 3.9L, 5.2L, 5.9L and 8.0L gasoline engine starter motors are rated at 1.4 kilowatts (about 1.9 horsepower) output at 12 volts, while the 5.9L diesel engine starter motor is rated at 2.7 kilowatts (about 3.6 horsepower) output at 12 volts.

All of these starter motors are serviced only as a unit with their starter solenoids, and cannot be repaired. If either component is faulty or damaged, the entire starter motor and starter solenoid unit must be replaced.

### OPERATION

These starter motors are equipped with a gear reduction (intermediate transmission) system. The gear reduction system consists of a gear that is integral to the output end of the electric motor armature shaft that is in continual engagement with a larger gear that is splined to the input end of the starter pinion gear shaft. This feature makes it possible to reduce the dimensions of the starter. At the same time, it allows higher armature rotational speed and delivers increased torque through the starter pinion gear to the starter ring gear.

The starter motors for all engines are activated by an integral heavy duty starter solenoid switch mounted to the overrunning clutch housing. This electromechanical switch connects and disconnects the feed of battery voltage to the starter motor, also engaging and disengaging the starter pinion gear with the starter ring gear.

All starter motors use an overrunning clutch and starter pinion gear unit to engage and drive a starter ring gear that is integral to the flywheel (manual transmission), torque converter or torque converter drive plate (automatic transmission) mounted on the rear crankshaft flange.

### DIAGNOSIS AND TESTING - STARTER MOTOR

Correct starter motor operation can be confirmed by performing the following free running bench test. This test can only be performed with starter motor removed from vehicle. Refer to Starter Specifications for starter motor specifications.

(1) Remove starter motor from vehicle. Refer to **Starter Motor** Removal and Installation.

(2) Mount starter motor securely in a soft-jawed bench vise. The vise jaws should be clamped on mounting flange of starter motor. Never clamp on starter motor by field frame.

(3) Connect suitable volt-ampere tester and 12-volt battery to starter motor in series, and set ammeter to 100 ampere scale (250 ampere scale for diesel engine starters). See instructions provided by manufacturer of volt-ampere tester being used.

(4) Install jumper wire from solenoid terminal to solenoid battery terminal. The starter motor should operate. If starter motor fails to operate, replace faulty starter motor assembly.

(5) Adjust carbon pile load of tester to obtain free running test voltage. Refer to Specifications for the starter motor free running test voltage specifications.

(6) Note reading on ammeter and compare this reading to free running test maximum amperage draw. Refer to Specifications for starter motor free running test maximum amperage draw specifications.

(7) If ammeter reading exceeds maximum amperage draw specification, replace faulty starter motor assembly.

### STARTER MOTOR SOLENOID

This test can only be performed with starter motor removed from vehicle.

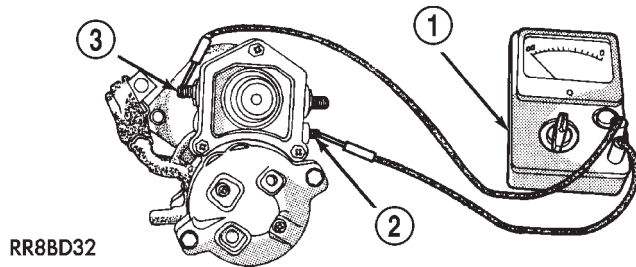
(1) Remove starter motor. Refer to **Starter Motor** Removal and Installation.

(2) Disconnect wire from solenoid field coil terminal.

(3) Check for continuity between solenoid terminal and solenoid field coil terminal with continuity tester (Fig. 7). There should be continuity. If OK, go to Step 4. If not OK, replace faulty starter motor assembly.

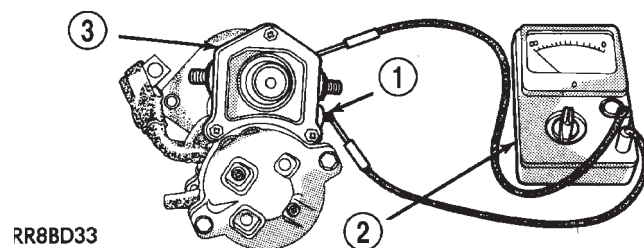
(4) Check for continuity between solenoid terminal and solenoid case (Fig. 8). There should be continuity. If not OK, replace faulty starter motor assembly.

## ENGINE STARTER MOTOR (Continued)



**Fig. 7 Continuity Test Between Solenoid Terminal and Field Coil Terminal - Typical**

- 1 - OHMMETER  
2 - SOLENOID TERMINAL  
3 - FIELD COIL TERMINAL



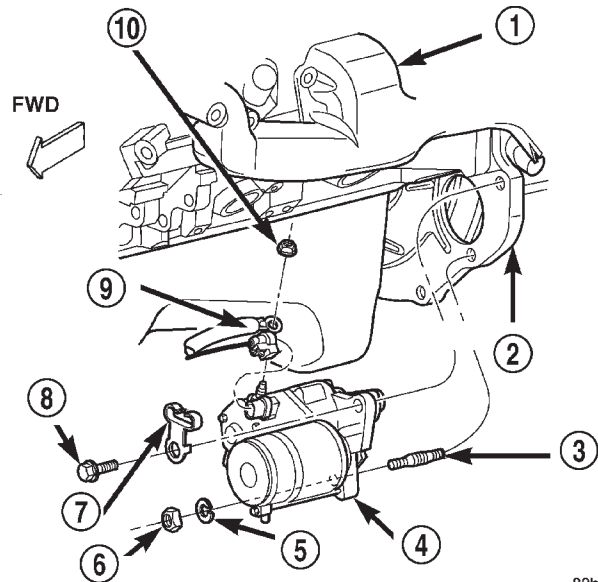
**Fig. 8 Continuity Test Between Solenoid Terminal and Solenoid Case - Typical**

- 1 - SOLENOID TERMINAL  
2 - OHMMETER  
3 - SOLENOID

## REMOVAL

## 3.9L/5.2L/5.9L GASOLINE ENGINE

- (1) Disconnect and isolate negative battery cable.
- (2) Raise and support vehicle.
- (3) Remove nut and lock washer securing starter motor to mounting stud (Fig. 9).
- (4) While supporting starter motor, remove upper mounting bolt from starter motor.
- (5) If equipped with automatic transmission, slide cooler tube bracket forward on tubes far enough for starter motor mounting flange to be removed from lower mounting stud.
- (6) Move starter motor towards front of vehicle far enough for nose of starter pinion housing to clear housing. Always support starter motor during this process, do not let starter motor hang from wire harness.
- (7) Tilt nose downwards and lower starter motor far enough to access and remove nut that secures battery positive cable wire harness connector eyelet to solenoid battery terminal stud. Do not let starter motor hang from wire harness.



80b6f019

**Fig. 9 Starter Motor Remove/Install - 3.9L/5.2L/5.9L Gasoline Engine**

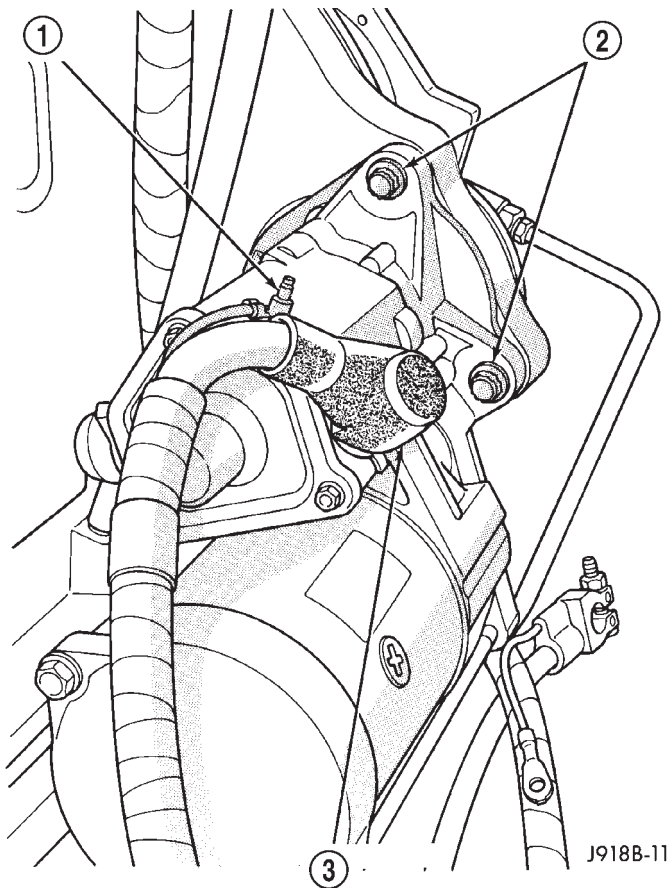
- 1 - ENGINE  
2 - STARTER MOUNTING FLANGE  
3 - STUD  
4 - STARTER MOTOR  
5 - LOCK WASHER  
6 - NUT  
7 - BRACKET  
8 - BOLT  
9 - POSITIVE BATTERY CABLE WIRE HARNESS  
10 - POSITIVE BATTERY CABLE WIRE HARNESS NUT

- (8) Remove battery positive cable wire harness connector eyelet from solenoid battery terminal stud.
- (9) Disconnect battery positive cable wire harness connector from solenoid terminal connector receptacle.
- (10) Remove starter motor.

## 5.9L DIESEL ENGINE

- (1) Disconnect and isolate negative cables of both batteries.
- (2) Raise and support vehicle.
- (3) Pull back protective rubber boot from solenoid battery terminal far enough to access and remove nut securing battery positive cable wire harness connector eyelet to solenoid battery terminal stud (Fig. 10).
- (4) Remove nut securing battery positive cable wire harness solenoid connector eyelet to solenoid terminal stud.
- (5) Remove battery positive cable wire harness connector eyelets from solenoid terminal studs.

## ENGINE STARTER MOTOR (Continued)



**Fig. 10 Starter Motor Wire Harness Remove/Install - 5.9L Diesel Engine**

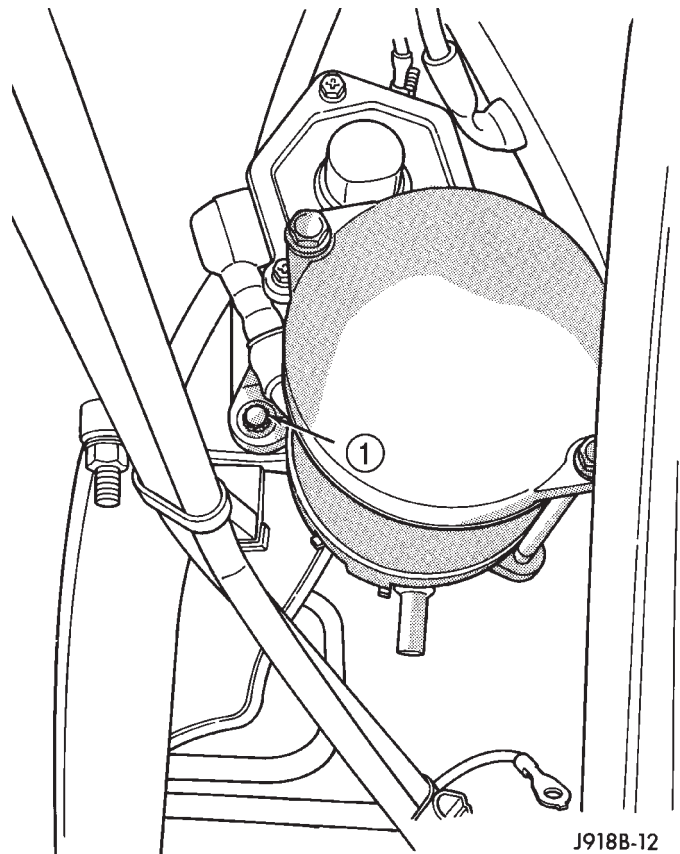
- 1 - SOLENOID WIRE
- 2 - MOUNTING BOLTS (3)
- 3 - BATTERY TERMINAL

(6) While supporting starter motor, remove three bolts securing starter motor to flywheel housing (Fig. 10) and (Fig. 11).

(7) Remove starter motor from engine (certain diesel engines have an aluminum spacer mounted between the starter and the starter mounting flange. Note position and orientation of spacer before removal).

#### 8.0L GASOLINE ENGINE

- (1) Disconnect and isolate negative battery cable.
- (2) Raise and support vehicle.
- (3) Remove nut securing battery positive cable wire harness connector eyelet to solenoid battery terminal stud (Fig. 12).
- (4) Remove battery positive cable connector eyelet from solenoid battery terminal stud.
- (5) Disconnect battery positive cable wire harness connector from solenoid terminal connector receptacle.



**Fig. 11 Starter Motor Remove/Install - 5.9L Diesel Engine**

- 1 - MOUNTING BOLT

(6) Support starter motor and remove two bolts securing starter motor to engine.

(7) Remove starter motor from engine.

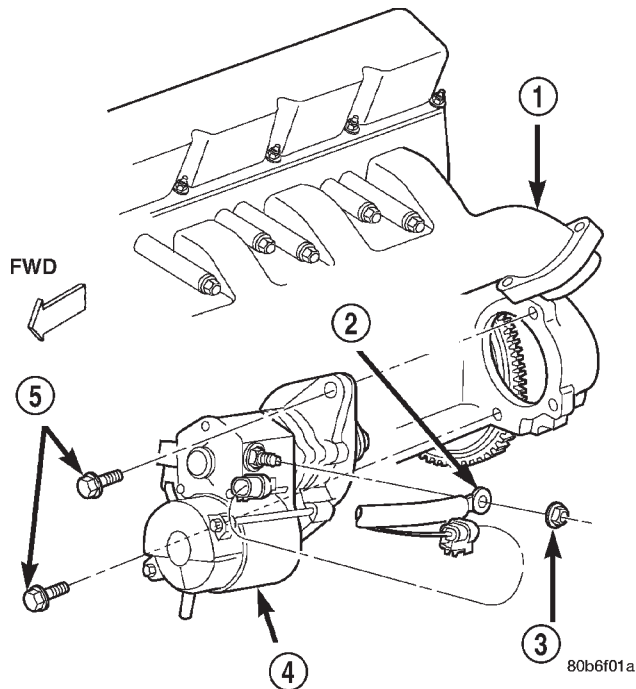
## INSTALLATION

#### 3.9L/5.2L/5.9L GASOLINE ENGINE

- (1) Connect wiring harness to starter motor and tighten eyelet nut to 25 N·m (221 in. lbs.). Do not allow starter motor to hang from wire harness.
- (2) Position starter motor to starter mounting flange.
- (3) If equipped with automatic transmission, slide cooler tube bracket into position.
- (4) Loosely install upper bolt.
- (5) Position lock washer and loosely install lower nut.
- (6) Tighten upper bolt to 67.8 N·m (50 ft. lbs.).
- (7) Tighten lower nut to 67.8 N·m (50 ft. lbs.).
- (8) Lower vehicle.
- (9) Connect battery cable.



## ENGINE STARTER MOTOR (Continued)



**Fig. 12 Starter Motor Remove/Install - 8.0L Gasoline Engine**

- 1 - ENGINE
- 2 - BATTERY POSITIVE CABLE WIRE HARNESS
- 3 - NUT
- 4 - STARTER MOTOR
- 5 - SCREW AND WASHER (2)

## 5.9L DIESEL ENGINE

- (1) If equipped, position aluminum spacer to rear of starter.
- (2) Position starter motor to engine.
- (3) Support starter and loosely install three mounting bolts.
- (4) Tighten 3 bolts to 43.4 N·m (32 ft. lbs.).
- (5) Position wiring eyelets to starter studs and install nuts. Tighten small nut to 6.2 N·m (55 in. lbs.). Tighten large nut to 13.6 N·m (120 in. lbs.).
- (6) Install protective rubber boot over stud.
- (7) Lower vehicle.
- (8) Connect battery cables to both batteries.

## 8.0L GASOLINE ENGINE

- (1) Support starter motor and loosely install two bolts securing starter motor to engine.
- (2) Tighten 2 bolts to 67.8 N·m (50 ft. lbs.).
- (3) Connect solenoid wire to solenoid terminal.
- (4) Position battery cable eyelet to starter stud. Install nut and tighten to 13.6 N·m (120 in. lbs.).
- (5) Lower vehicle.
- (6) Connect battery cable.

## ENGINE STARTER MOTOR RELAY

## DESCRIPTION

The starter relay is an electromechanical device that switches battery current to the pull-in coil of the starter solenoid when ignition switch is turned to Start position. The starter relay is located in the Power Distribution Center (PDC) in the engine compartment. See PDC cover for relay identification and location.

The starter relay is a International Standards Organization (ISO) relay. Relays conforming to ISO specifications have common physical dimensions, current capacities, terminal patterns, and terminal functions.

The starter relay cannot be repaired or adjusted and, if faulty or damaged, it must be replaced.

## OPERATION

The ISO relay consists of an electromagnetic coil, a resistor or diode, and three (two fixed and one movable) electrical contacts. The movable (common feed) relay contact is held against one of the fixed contacts (normally closed) by spring pressure. When electromagnetic coil is energized, it draws the movable contact away from normally closed fixed contact, and holds it against the other (normally open) fixed contact.

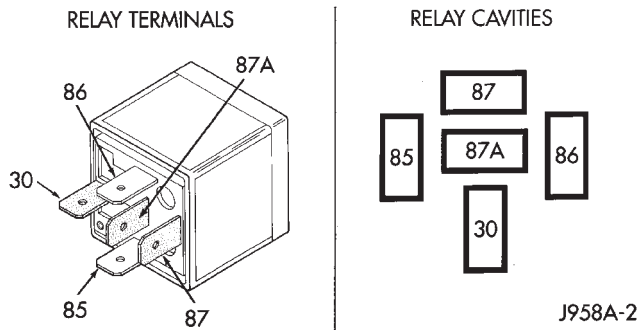
When electromagnetic coil is de-energized, spring pressure returns movable contact to normally closed position. The resistor or diode is connected in parallel with electromagnetic coil within relay, and helps to dissipate voltage spikes produced when coil is de-energized.

## DIAGNOSIS AND TESTING - STARTER RELAY

The starter relay (Fig. 13) is located in Power Distribution Center (PDC). Refer to PDC cover for relay identification and location. For complete starter relay wiring circuit diagrams, refer to 8, Wiring Diagrams.

- (1) Remove starter relay from PDC.
- (2) A relay in de-energized position should have continuity between terminals 87A and 30, and no continuity between terminals 87 and 30. If OK, go to Step 3. If not OK, replace faulty relay.
- (3) Resistance between terminals 85 and 86 (electromagnet) should be  $75 \pm 5$  ohms. If OK, go to Step 4. If not OK, replace faulty relay.
- (4) Connect 12V battery to terminals 85 and 86. There should now be continuity between terminals 30 and 87, and no continuity between terminals 87A and 30. If OK, perform Relay Circuit Test that follows. If not OK, replace faulty relay.

## ENGINE STARTER MOTOR RELAY (Continued)

**Fig. 13 Starter Relay**

TERMINAL LEGEND	
NUMBER	IDENTIFICATION
30	COMMON FEED
85	COIL GROUND
86	COIL BATTERY
87	NORMALLY OPEN
87A	NORMALLY CLOSED

## RELAY CIRCUIT TEST

(1) The relay common feed terminal cavity (30) is connected to battery voltage and should be hot at all times. If OK, go to Step 2. If not OK, repair open circuit to fuse in PDC as required.

(2) The relay normally closed terminal (87A) is connected to terminal 30 in the de-energized position, but is not used for this application. Go to Step 3.

(3) The relay normally open terminal (87) is connected to common feed terminal (30) in the energized position. This terminal supplies battery voltage to starter solenoid field coils. There should be continuity between cavity for relay terminal 87 and starter solenoid terminal at all times. If OK, go to Step 4. If not OK, repair open circuit to starter solenoid as required.

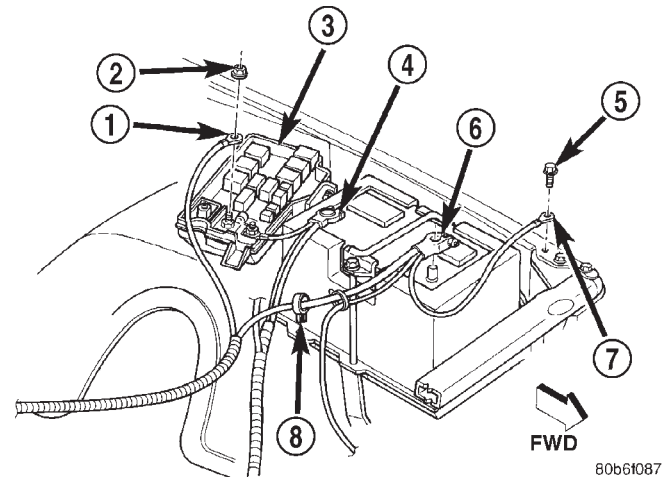
(4) The coil battery terminal (86) is connected to electromagnet in relay. It is energized when ignition switch is held in Start position. On vehicles with manual transmission, clutch pedal must be fully depressed for this test. Check for battery voltage at cavity for relay terminal 86 with ignition switch in Start position, and no voltage when ignition switch is released to On position. If OK, go to Step 5. If not OK with automatic transmission, check for open or short circuit to ignition switch and repair, if required. If circuit to ignition switch is OK, refer to **Ignition Switch and Key Lock Cylinder**. If not OK with a manual transmission, check circuit between relay and clutch pedal position switch for open or a short. If circuit is OK, refer to **Clutch Pedal Position Switch** in 6, Clutch.

(5) The coil ground terminal (85) is connected to the electromagnet in the relay. On vehicles with manual transmission, it is grounded at all times. On vehicles with automatic transmission, it is grounded through park/neutral position switch only when gearshift selector lever is in Park or Neutral positions. Check for continuity to ground at cavity for relay terminal 85. If not OK with manual transmission, repair circuit to ground as required. If not OK with automatic transmission, check for pen or short circuit to park/neutral position switch and repair, if required. If circuit to park/neutral position switch is OK, refer to **Park/Neutral Position Switch** in 21, Transmission.

## REMOVAL

(1) Disconnect and isolate negative battery cable (both negative cables if diesel).

(2) Remove cover from Power Distribution Center (PDC) (Fig. 14).

**Fig. 14 Power Distribution Center**

- 1 - EYELET
- 2 - NUT
- 3 - POWER DISTRIBUTION CENTER
- 4 - POSITIVE CABLE
- 5 - SCREW
- 6 - NEGATIVE CABLE
- 7 - EYELET
- 8 - CLIP

(3) Refer to PDC cover for relay identification and location.

(4) Remove starter relay from PDC.

## INSTALLATION

(1) Position starter relay in proper receptacle in PDC.

(2) Align starter relay terminals with terminal cavities in PDC receptacle.

(3) Push down firmly on starter relay until terminals are fully seated in terminal cavities in PDC receptacle.

(4) Install PDC cover.

(5) Reconnect negative battery cable(s).



# HEATED SYSTEMS

## TABLE OF CONTENTS

	page	page	
HEATED MIRRORS .....	1	HEATED SEAT SYSTEM .....	5

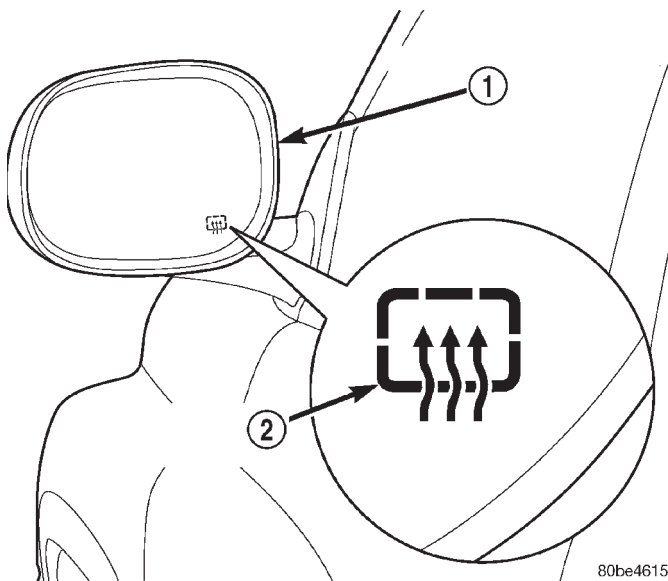
## HEATED MIRRORS

### TABLE OF CONTENTS

	page	page	
<b>HEATED MIRRORS</b>		<b>DIAGNOSIS AND TESTING</b> .....	3
DESCRIPTION .....	1	HEATED MIRROR SWITCH .....	3
OPERATION .....	2	<b>HEATED MIRROR GRID</b>	
DIAGNOSIS AND TESTING .....	2	DESCRIPTION .....	4
HEATED MIRROR SYSTEM .....	2	OPERATION .....	4
<b>MIRROR SWITCH</b>		DIAGNOSIS AND TESTING .....	0
DESCRIPTION .....	3	HEATED MIRROR GRID .....	4
OPERATION .....	3		

## HEATED MIRRORS

### DESCRIPTION - HEATED MIRROR SYSTEM



**Fig. 1 HEATED MIRROR**

- 1 - POWER HEATED OUTSIDE REAR VIEW MIRROR  
2 - REAR WINDOW DEFOGGER ICON

Electrically heated outside rear view mirrors are an additional factory-installed option on models that are equipped with factory-installed dual power mirrors. Vehicles with this option can be visually identified by the International Control and Display Symbol icon for rear window defogger, which appears on the lower inboard corner of each outside mirror glass (Fig. 1); or, by the heated mirror switch that is located in the lower left corner of the a/c heater control unit face plate. The heated mirror system helps the vehicle operator maintain outside rear view mirror visibility during inclement operating conditions by keeping both outside mirror glasses clear of ice, snow, or fog. The heated mirror system for this vehicle includes the following major components:

- The heated mirror switch, including the heated mirror system solid state electronic control logic and timer circuitry, the heated mirror relay and the heated mirror system indicator lamp. All of these components are integral to the a/c heater control unit on the instrument panel.
- The two outside mirror heating grids, which are integral to the power outside mirror units.

Following are general descriptions of the major components in the heated mirror system. See the owner's manual in the vehicle glove box for more information on the features, use and operation of the heated mirror system.

## HEATED MIRRORS (Continued)

**OPERATION - HEATED MIRROR SYSTEM**

The solid state electronic control logic and timer circuitry for the heated mirror system receives battery current from a fuse in the Junction Block (JB) only when the ignition switch is in the On or Start positions. After the heated mirror system is turned On, the electronic control logic and timer circuitry will automatically turn the system off after a programmed time interval of about fifteen minutes. After the initial time interval has expired, if the heated mirror switch is depressed and released a second time during the same ignition cycle, the electronic control logic and timer circuitry will automatically turn the heated mirror system off after a programmed time interval of about five minutes. The heated mirror system will be shut off automatically if the ignition switch is turned to the Off or Accessory positions. After the heated mirror system is turned On, it can also be turned off manually by depressing and releasing the heated mirror switch a second time.

When the heated mirror system is turned On, the heated mirror system control logic and timer circuitry energizes the heated mirror system indicator lamp and the heated mirror relay. When energized, the heated mirror relay supplies fused ignition switch output (run/start) current from a fuse in the JB to the outside mirror heating grids located behind the mirror glass of each of the outside rear view mirrors. When energized, each of the outside mirror heating grids produces enough heat to warm the glass of the outside rear view mirrors.

**DIAGNOSIS AND TESTING - HEATED MIRROR SYSTEM**

If only one of the outside mirror heating grids is inoperative, perform continuity checks on the circuits and heater grid for that mirror only. If both outside mirror heating grids are inoperative, proceed with the heated mirror system diagnosis as follows. (Refer to Appropriate Wiring Information).

**WARNING: ON VEHICLES EQUIPPED WITH AIRBAGS, DISABLE THE AIRBAG SYSTEM BEFORE ATTEMPTING ANY STEERING WHEEL, STEERING COLUMN, OR INSTRUMENT PANEL COMPONENT DIAGNOSIS OR SERVICE. DISCONNECT AND ISOLATE THE BATTERY NEGATIVE (GROUND) CABLE, THEN WAIT TWO MINUTES FOR THE AIRBAG SYSTEM CAPACITOR TO DISCHARGE BEFORE PERFORMING FURTHER DIAGNOSIS OR SERVICE. THIS IS THE ONLY SURE WAY TO DISABLE THE AIRBAG SYSTEM. FAILURE TO TAKE THE PROPER PRECAUTIONS COULD RESULT IN ACCIDENTAL AIRBAG DEPLOYMENT AND POSSIBLE PERSONAL INJURY.**

The operation of the heated mirror system can be confirmed in one of the following manners:

- Turn the ignition switch to the On position. While monitoring the instrument panel voltmeter, momentarily depress and release the heated mirror switch. When the heated mirror system is turned On, a distinct voltmeter needle deflection should be noted.

- Turn the ignition switch to the On position. Momentarily depress and release the heated mirror switch to turn the heated mirror system On. The heated mirror operation can be checked by feeling the outside rear view mirror glass. A distinct difference in temperature between the unheated and heated mirror glass can be detected within three to four minutes of system operation.

The above checks will confirm system operation. Illumination of the heated mirror system indicator lamp means that there is electrical current available at the heated mirror relay, but does not confirm that the electrical current is reaching the outside mirror heating grids.

If the heated mirror system does not operate, the problem should be isolated in the following manner:

- (1) Confirm that the ignition switch is in the On position.

- (2) Check the fuses in the Power Distribution Center (PDC) and in the Junction Block (JB). The fuses must be tight in their receptacles and all electrical connections must be secure.

When the above steps have been completed and both outside mirror heating grids are still inoperative, one or more of the following is faulty:

- Heated mirror switch, electronic control logic and timer circuitry, and heated mirror relay.

- Heated mirror wire harness circuits or connectors.

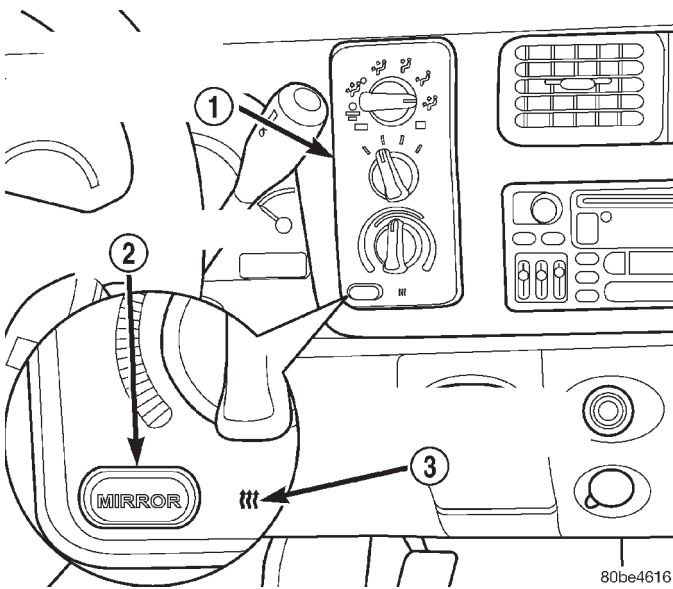
- Outside mirror heating grid (both mirror grids would have to be faulty).

If turning On the heated mirror system produces a severe voltmeter deflection or fuse failures, check for a shorted circuit between the output of the heated mirror relay and the outside mirror heating grids.



## MIRROR SWITCH

### DESCRIPTION



**Fig. 2 HEATED MIRROR SWITCH**

- 1 - A/C HEATER CONTROL
- 2 - HEATED MIRROR SWITCH
- 3 - HEATED MIRROR SYSTEM INDICATOR LAMP

The heated mirror switch, the heated mirror system indicator lamp, the heated mirror system solid state electronic control logic and timer circuitry and the heated mirror relay are all integral to the a/c heater control, which is located between the instrument cluster and the radio near the center of the instrument cluster bezel on the instrument panel. The heated mirror switch and the heated mirror system indicator lamp are visible in the lower left corner of the a/c heater control face plate (Fig. 2).

The heated mirror switch, the heated mirror system indicator lamp, the heated mirror system solid state electronic control logic and timer circuitry and the heated mirror relay cannot be repaired. If any of these components is damaged or faulty, the entire a/c heater control must be replaced. (Refer to 24 - HEATING & AIR CONDITIONING/CONTROLS/A/C HEATER CONTROL - REMOVAL)

### OPERATION

The momentary-type heated mirror switch provides a hard-wired battery current signal to the heated mirror system electronic control logic circuitry each time it is depressed. In response to the heated mirror switch input, the electronic control logic and timer circuitry energizes or de-energizes the amber heated mirror system indicator lamp next to the heated mirror switch to indicate that the heated mirror system

is turned On or Off. The electronic control logic and timer circuitry also energizes or de-energizes the heated mirror relay, which controls the feed of electrical current to the outside mirror heating grids.

The heated mirror system electronic control logic and timer circuitry is programmed to turn the heated mirror system Off automatically after about fifteen minutes of operation. If the heated mirror system is turned On a second time following an initial time-out event during the same ignition switch cycle, the heated mirror system electronic control logic and timer circuit is programmed to turn the system Off automatically after about five minutes. When the electronic control logic and timer circuit detects that a programmed time interval has elapsed, it will automatically de-energize the heated mirror system indicator lamp and the heated mirror relay. The heated mirror system will also be turned Off if the heated mirror switch is depressed while the system is turned On, or if the ignition switch is turned to the Off or Accessory positions.

### DIAGNOSIS AND TESTING - HEATED MIRROR SWITCH

The heated mirror switch, the solid state electronic heated mirror system control logic and timer circuitry, the heated mirror system indicator lamp and the heated mirror relay are all integral to the a/c heater control. For circuit descriptions and diagrams (Refer to Appropriate Wiring Information).

**WARNING: ON VEHICLES EQUIPPED WITH AIRBAGS, DISABLE THE AIRBAG SYSTEM BEFORE ATTEMPTING ANY STEERING WHEEL, STEERING COLUMN, OR INSTRUMENT PANEL COMPONENT DIAGNOSIS OR SERVICE. DISCONNECT AND ISOLATE THE BATTERY NEGATIVE (GROUND) CABLE, THEN WAIT TWO MINUTES FOR THE AIRBAG SYSTEM CAPACITOR TO DISCHARGE BEFORE PERFORMING FURTHER DIAGNOSIS OR SERVICE. THIS IS THE ONLY SURE WAY TO DISABLE THE AIRBAG SYSTEM. FAILURE TO TAKE THE PROPER PRECAUTIONS COULD RESULT IN ACCIDENTAL AIRBAG DEPLOYMENT AND POSSIBLE PERSONAL INJURY.**

(1) Check the fused ignition switch output (run/start) fuse in the Junction Block (JB). If OK, go to Step 2. If not OK, repair the shorted circuit or component as required and replace the faulty fuse.

(2) Turn the ignition switch to the On position. Check for battery voltage at the fused ignition switch output (run/start) fuse in the JB. If OK, go to Step 3. If not OK, repair the open circuit to the ignition switch as required.

## MIRROR SWITCH (Continued)

(3) Disconnect and isolate the battery negative cable. Disconnect the 3-way instrument panel wire harness connector for the heated mirror switch from the heated mirror switch connector receptacle on the back of the a/c heater control. Check for continuity between the ground circuit cavity of the wire harness connector and a good ground. There should be continuity. If OK, go to Step 4. If not OK, repair the open ground circuit to ground as required.

(4) Reconnect the battery negative cable. Turn the ignition switch to the On position. Check for battery voltage at the fused ignition switch output (run/start) circuit cavity of the 3-way instrument panel wire harness connector for the heated mirror switch. If OK, go to Step 5. If not OK, repair the open fused ignition switch output (run/start) circuit to the fuse in the JB as required.

(5) Turn the ignition switch to the Off position. Disconnect and isolate the battery negative cable. Reconnect the 3-way instrument panel wire harness connector for the heated mirror switch to the heated mirror switch connector receptacle on the back of the a/c heater control. Reconnect the battery negative cable. Turn the ignition switch to the On position. Depress and release the heated mirror switch. The amber heated mirror system indicator lamp next to the heated mirror switch button should light. If OK, go to Step 6. If not OK, replace the faulty a/c heater control.

(6) Back probe the fused heated mirror relay output circuit cavity of the 3-way instrument panel wire harness connector for the heated mirror switch on the back of the a/c heater control and check for voltage (battery voltage less the resistance in both outside mirror heating grids). If OK, (Refer to 8 - ELECTRICAL/HEATED MIRRORS/HEATED MIRROR GRID - DIAGNOSIS AND TESTING).

## HEATED MIRROR GRID

### DESCRIPTION

Vehicles equipped with the optional heated mirror system have an electrically operated heating grid located behind the mirror glass of each power operated outside rear view mirror. The outside mirror heating grid consists of two thin laminations of plastic that approximate the outer dimensions and shape of the mirror glass. A single length of resistor wire weaves in a back and forth pattern between, and is held in place by the two thin laminations of plastic. The two ends of the resistor wire terminate near the inboard edge of the grid, where they are soldered to the ground feed and battery current feed wires contained in the power mirror wire harness. The heating grid is then sandwiched between the back of the

molded plastic mirror glass case and the mirror glass, where it remains in direct contact with the back of the mirror glass at all times.

The outside mirror heating grids cannot be repaired and, if faulty or damaged, the entire outside power mirror unit must be replaced. Refer to Power Mirrors for the service procedures.

### OPERATION

One end of the outside mirror heating grid resistor wire is connected to a ground feed at all times through a body ground screw located inside the left rear corner of the truck cab. Battery current is directed to the other end of the outside mirror heating grid resistor wire by the energized heated mirror relay when the heated mirror switch is in the On position. As electrical current passes through the heating grid, the resistance of the wire in the heating grid converts some of that electrical current into heat. The heat produced by the heating grid is then conducted through the back of the mirror glass to help keep the glass clear of ice, snow or fog.

### DIAGNOSIS AND TESTING - HEATED MIRROR GRID

For circuit descriptions and diagrams (Refer to Appropriate Wiring Information).

(1) Disconnect and isolate the battery negative cable. Disconnect the door wire harness connector from the power mirror wire harness connector at the power mirror with the inoperative heating grid. Check for continuity between the ground circuit cavity in the door wire harness connector for the power mirror and a good ground. If OK, go to Step 2. If not OK, repair the open ground circuit to ground as required.

(2) Reconnect the battery negative cable. Turn the ignition switch to the On position. Turn on the heated mirror system. Check for voltage (battery voltage less the resistance in the outside mirror heating grid that is still connected) at the fused heated mirror relay output circuit cavity in the door wire harness connector for the power mirror. If OK, go to Step 3. If not OK, repair the open fused heated mirror relay output circuit to the heater and air conditioner control unit as required.

(3) Check the outside mirror heating grid by testing for continuity between the ground circuit and the fused heated mirror relay output circuit cavities in the power mirror wire harness connector. There should be continuity. If not OK, replace the faulty power mirror. If OK, check the resistance through the outside mirror heating grid. The correct resistance should be from 10 to 16 ohms when measured at an ambient temperature of 21° C (70° F). If not OK, replace the faulty power mirror.

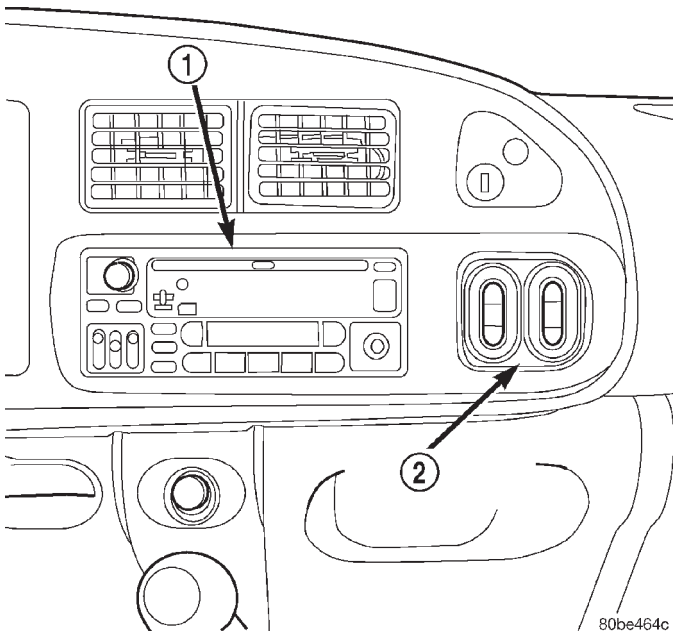
# HEATED SEAT SYSTEM

## TABLE OF CONTENTS

	page	page
<b>HEATED SEAT SYSTEM</b>		
DESCRIPTION .....	5	
OPERATION .....	6	
DIAGNOSIS AND TESTING .....	6	
HEATED SEAT SYSTEM .....	6	
<b>DRIVER SEAT HEATER SWITCH</b>		
DESCRIPTION .....	7	
OPERATION .....	7	
DIAGNOSIS AND TESTING .....	8	
HEATED SEAT SWITCH .....	8	
REMOVAL .....	9	
INSTALLATION .....	9	
<b>HEATED SEAT ELEMENT</b>		
DESCRIPTION .....	10	
OPERATION .....	10	
DIAGNOSIS AND TESTING .....	11	
		HEATED SEAT ELEMENT & SENSOR ..... 11
<b>HEATED SEAT RELAY</b>		
DESCRIPTION .....	11	
OPERATION .....	12	
DIAGNOSIS AND TESTING .....	12	
HEATED SEAT RELAY .....	12	
REMOVAL .....	13	
INSTALLATION .....	13	
<b>PASSENGER SEAT HEATER SWITCH</b>		
DESCRIPTION .....	13	
OPERATION .....	14	
DIAGNOSIS AND TESTING .....	14	
HEATED SEAT SWITCH .....	14	
REMOVAL .....	15	
INSTALLATION .....	16	

## HEATED SEAT SYSTEM

### DESCRIPTION



**Fig. 1 Heated Seat System Switches**

- 1 - RADIO RECEIVER  
2 - HEATED SEAT SWITCHES

Individually controlled electrically heated front seats are available factory-installed optional equipment on the Ram quad cab models that are also equipped with the optional SLT Plus (leather) trim

package. Vehicles with this option can be visually identified by the two separate heated seat switches mounted in a bezel located in the lower right corner of the instrument cluster bezel, next to the radio receiver (Fig. 1). The heated seat system allows the front seat driver and passenger to select from two different levels of supplemental electrical seat heating, or no seat heating to suit their individual comfort requirements. The heated seat system for this vehicle includes the following major components:

- The heated seat switches, including two heated seat Light-Emitting Diode (LED) indicator lamps and an incandescent back lighting bulb for each switch.
- The heated seat module, also referred to as the Seat Heat Interface Module (SHIM), which contains the solid state electronic control and diagnostic logic circuitry for the heated seat system. Refer to the Electronic Control Modules section of the service manual for heated seat module information.
- The heated seat elements and sensors, which are integral to the individual front seat cushion and front seat back trim covers.
- The heated seat relay, which controls the availability of battery current to the heated seat module or SHIM.

Following are general descriptions of the major components in the heated seat system. See the owner's manual in the vehicle glove box for more information on the features, use and operation of the heated seat system. Refer to **Power Seat** in the index of this service manual for the location of complete heated seat system wiring diagrams.

## HEATED SEAT SYSTEM (Continued)

## OPERATION

The heated seat module receives fused battery current through the energized heated seat relay in the Junction Block (JB) only when the engine is running. The heated seat switches receive battery current through a fused ignition switch output (run) circuit only when the ignition switch is in the On position. The heated seat module shares a common ground circuit with each of the heated seat elements. The heated seat elements will only operate when the surface temperature of the seat cushion cover at the heated seat sensors is below the designed temperature set points of the system.

The heated seat module will automatically turn off the heated seat elements if it detects a short in the heated seat element circuit or a heated seat sensor value that is out of range. The heated seat system will also be turned off automatically whenever the ignition switch is turned to any position except On or if the engine quits running. If the ignition switch is turned to the Off position or if the engine quits running while a heated seat is turned ON, the heated seat will remain Off after the engine is restarted until a heated seat switch is depressed again.

The heated seat module monitors inputs from the heated seat sensors and the heated seat switches. In response to these inputs the heated seat module uses its internal programming to control outputs to the heated seat elements in both front seats and to control the heated seat LED indicator lamps located in both of the heated seat switches. The heated seat module is also programmed to provide a self-diagnostic capability. When the module detects certain failures within the heated seat system, it will provide a visual indication of the failure by flashing the indicator lamps in the heated seat switches.

## DIAGNOSIS &amp; TESTING - HEATED SEAT SYSTEM

## SELF-DIAGNOSIS

The heated seat system is capable of performing some self-diagnostics. The following table depicts the various failure modes which will be reported to the vehicle operator or technician by flashing the individual heated seat switch Light Emitting Diode (LED) indicator lamps. See the Heated Seat System Self-Diagnosis table for the diagnostic routines. The driver side heated seat switch indicator lamps will flash if a failure occurs in the driver side heated seat, and the passenger side heated seat switch indicator lamps will flash for a passenger side heated seat failure. If a monitored heated seat system failure occurs, the switch indicator lamps will flash at a pulse rate of about one-half second on, followed by about one-half second off for a duration of about one minute after

the switch for the faulty heated seat is depressed in either the Low or High direction. This process will repeat every time the faulty heated seat switch is actuated until the problem has been corrected.

Heated Seat System Self-Diagnosis		
Monitored Failure	Switch High Indicator Lamp	Switch Low Indicator Lamp
Heated Seat Element Shorted	Flashing	Flashing
Heated Seat Element Open	Flashing	Off
Heated Seat Sensor Value Out of Range	Off	Flashing

## TESTING

Refer to **Power Seat** in the index of this service manual for the location of complete heated seat system wiring diagrams. Before testing the individual components in the heated seat system, perform the following preliminary checks:

**WARNING: ON VEHICLES EQUIPPED WITH AIRBAGS, DISABLE THE AIRBAG SYSTEM BEFORE ATTEMPTING ANY STEERING WHEEL, STEERING COLUMN, OR INSTRUMENT PANEL COMPONENT DIAGNOSIS OR SERVICE. DISCONNECT AND ISOLATE THE BATTERY NEGATIVE (GROUND) CABLE, THEN WAIT TWO MINUTES FOR THE AIRBAG SYSTEM CAPACITOR TO DISCHARGE BEFORE PERFORMING FURTHER DIAGNOSIS OR SERVICE. THIS IS THE ONLY SURE WAY TO DISABLE THE AIRBAG SYSTEM. FAILURE TO TAKE THE PROPER PRECAUTIONS COULD RESULT IN ACCIDENTAL AIRBAG DEPLOYMENT AND POSSIBLE PERSONAL INJURY.**

- If the heated seat switch back lighting and the cluster illumination lamps do not illuminate with the headlamps or park lamps turned On, refer to **Instrument Cluster** in the index of this service manual for the location of the proper cluster illumination lamps diagnosis and testing procedures. If the heated seat switch back lighting does not illuminate, but the cluster illumination lamps do illuminate with the headlamps or park lamps turned On, refer to **Heated Seat Switch** in this section for the location of the proper heated seat switch diagnosis and testing procedure.

- If a single indicator lamp for one heated seat switch does not operate and the heated seat elements do heat, refer to **Heated Seat Switch** in this section for the location of the proper heated seat switch diagnosis and testing procedure.



## HEATED SEAT SYSTEM (Continued)

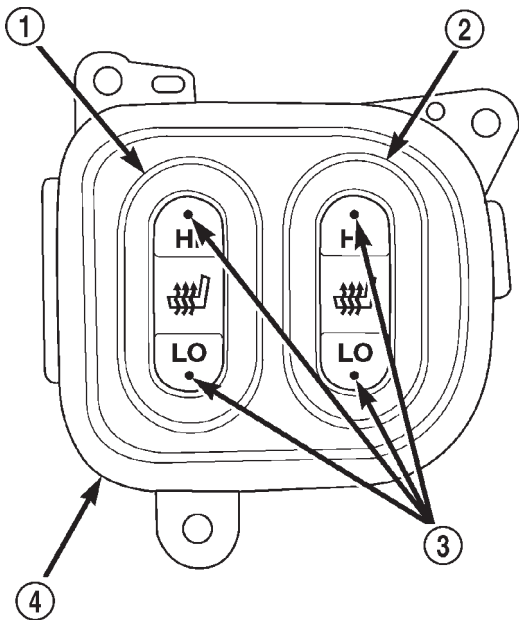
- If both indicator lamps for a heated seat switch operate, but the heated seat elements do not heat, refer to **Heated Seat Module** in Electronic Control Modules for the location of the proper heated seat module diagnosis and testing procedures. Also refer to the Body Diagnostic Manual for additional diagnosis and testing procedures.

- If none of the indicator lamps for both heated seat switches will operate and the heated seat elements for both seats do not heat, refer to **Heated Seat Relay** in this section for the location of the proper heated seat relay diagnosis and testing procedures.

- If the an indicator lamp on either heated seat switch remains illuminated after the heated seat has been turned Off, refer to **Heated Seat Module** in Electronic Control Modules for the location of the proper heated seat module diagnosis and testing procedures. Also refer to the Body Diagnostic Manual for additional diagnosis and testing procedures.

## DRIVER SEAT HEATER SWITCH

### DESCRIPTION



80be464d

**Fig. 2 Heated Seat Switches**

- 1 - DRIVER SIDE SWITCH
- 2 - PASSENGER SIDE SWITCH
- 3 - INDICATOR LAMPS
- 4 - HEATED SEAT SWITCH BEZEL

cubby bin located in the lower right corner of the instrument cluster bezel next to the radio receiver. The two switches are snapped into the mounting holes of the heated seat switch bezel, and the heated seat switch bezel is secured with three screws to the instrument panel. The mounts for the heated seat switch bezel are concealed behind the instrument cluster bezel. The two heated seat switches are identical in appearance and construction, except for the location of a keyway in the single connector receptacle on the back of each switch. The instrument panel wire harness connectors for the heated seat switches are keyed to match the connector receptacles on the switches so that the two heated seat switches can only be connected to the proper heated seat.

The momentary, bidirectional rocker-type heated seat switch provides a resistor-multiplexed signal to the heated seat module. Each switch has a center neutral position and momentary Low and High positions so that both the driver and the front seat passenger can select a preferred seat heating mode. Each heated seat switch has two Light-Emitting Diode (LED) indicator lamps, which indicate the selected mode (Low or High) of the seat heater for each seat and to provide diagnostic feedback for the heated seat system. Each switch also has an incandescent bulb, which provides panel lamps dimmer controlled back lighting of the switch nomenclature when the headlamps or park lamps are turned on.

The two LED indicator lamps and the incandescent bulb in each heated seat switch cannot be repaired. If the indicator lamps or back lighting bulb are faulty or damaged, the individual heated seat switch unit must be replaced.

### OPERATION

The heated seat switches receive battery current through a fused ignition switch output (run) circuit when the ignition switch is in the On position. Depressing the heated seat switch rocker to its momentary High or Low position provides a hard-wired resistor multiplexed voltage request signal to the heated seat module to power the heated seat element of the selected seat and maintain the requested temperature setting. If the heated seat switch is depressed to a different position (Low or High) than the currently selected state, the heated seat module will change states to support the new selection. If a heated seat switch is depressed a second time to the same position as the currently selected state, the heated seat module interprets the second input as a request to turn the seat heater off. The heated seat module will then turn the heated seat elements for that seat off.

The heated seat switches used on vehicles with this option are both mounted in a heated seat switch bezel (Fig. 2), which replaces the standard equipment



## DRIVER SEAT HEATER SWITCH (Continued)

The indicator lamps in the heated seat switches receive battery current through a fused ignition switch output (run) circuit when the ignition switch is in the On position. The ground side of each indicator lamp is controlled by a separate (high or low/driver or passenger) indicator lamp driver circuit by the heated seat module. The heated seat module control of the switch indicator lamps also allows the module to provide diagnostic feedback to the vehicle operator to indicate monitored heated seat system faults by flashing the indicator lamps on and off. One side of the incandescent back lighting bulb in each heated seat switch is connected to ground at all times. The other side of the incandescent bulb is connected to the fused panel lamps dimmer switch signal circuit. These bulbs are energized when the park lamps or headlamps are turned on, and their illumination intensity is controlled by the panel lamps dimmer switch.

## DIAGNOSIS & TESTING - HEATED SEAT SWITCH

Refer to **Wiring Diagrams** for the location of complete heated seat system wiring diagrams.

**WARNING: ON VEHICLES EQUIPPED WITH AIRBAGS, DISABLE THE AIRBAG SYSTEM BEFORE ATTEMPTING ANY STEERING WHEEL, STEERING COLUMN, OR INSTRUMENT PANEL COMPONENT DIAGNOSIS OR SERVICE. DISCONNECT AND ISOLATE THE BATTERY NEGATIVE (GROUND) CABLE, THEN WAIT TWO MINUTES FOR THE AIRBAG SYSTEM CAPACITOR TO DISCHARGE BEFORE PERFORMING FURTHER DIAGNOSIS OR SERVICE. THIS IS THE ONLY SURE WAY TO DISABLE THE AIRBAG SYSTEM. FAILURE TO TAKE THE PROPER PRECAUTIONS COULD RESULT IN ACCIDENTAL AIRBAG DEPLOYMENT AND POSSIBLE PERSONAL INJURY.**

(1) If the problem being diagnosed involves inoperative heated seat switch back lighting and the cluster illumination lamps operate, go to Step 2. If the problem being diagnosed involves inoperative heated seat switch back lighting and the cluster illumination lamps are also inoperative, refer to **Instrument Cluster** in the index of this service manual for the proper cluster illumination lamps diagnosis and testing procedures. If the problem being diagnosed involves inoperative heated seat switch indicator lamps and the heated seat elements do not heat, refer to Step 4. If the problem being diagnosed involves inoperative heated seat switch indicator lamps and the heated seat elements do heat, go to Step 8. If the problem being diagnosed involves a heated seat switch indicator lamp that remains illu-

minated after the heated seat has been turned Off, refer to **Heated Seat Module** in Electronic Control Modules for the location of the proper heated seat module diagnosis and testing procedures. Also refer to the Body Diagnostic Manual for additional diagnosis and testing procedures.

(2) Disconnect and isolate the battery negative cable. Remove the heated seat switch and bezel unit from the instrument panel. Disconnect the instrument panel wire harness connector from the connector receptacle on the back of the heated seat switch to be tested. Check for continuity between the ground circuit cavity of the instrument panel wire harness connector for the heated seat switch and a good ground. There should be continuity. If OK, go to Step 3. If not OK, repair the open ground circuit to ground as required.

(3) Reconnect the battery negative cable. Turn the park lamps on with the headlamp switch. Rotate the panel lamps dimmer thumbwheel on the headlamp switch upward to just before the interior lamps detent. Check for battery voltage at the fused panel lamps dimmer switch signal circuit cavity of the instrument panel wire harness connector for the heated seat switch. If OK, replace the faulty heated seat switch. If not OK, repair the open fused panel lamps dimmer switch signal circuit to the fuse in the Junction Block (JB) as required.

(4) Check the fused ignition switch output (run) fuse in the Junction Block (JB). If OK, go to Step 5. If not OK, repair the shorted circuit or component as required and replace the faulty fuse.

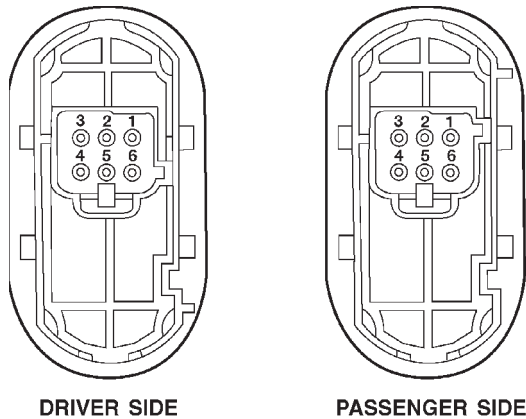
(5) Turn the ignition switch to the On position. Check for battery voltage at the fused ignition switch output (run) fuse in the JB. If OK, go to Step 6. If not OK, repair the open fused ignition switch output (run) circuit to the ignition switch as required.

(6) Disconnect and isolate the battery negative cable. Remove the heated seat switch and bezel unit from the instrument panel. Disconnect the instrument panel wire harness connector from the connector receptacle on the back of the heated seat switch to be tested. Reconnect the battery negative cable. Turn the ignition switch to the On position. Check for battery voltage at the fused ignition switch output (run) circuit cavity of the instrument panel wire harness connector for the heated seat switch. If OK, go to Step 7. If not OK, repair the open fused ignition switch output (run) circuit to the JB fuse as required.

(7) Check the continuity and resistance values of the heated seat switch in the Neutral, Low and High positions as shown in the Heated Seat Switch Continuity chart (Fig. 3). If OK, refer to **Heated Seat Module** in Electronic Control Modules for the location of the proper heated seat module diagnosis and testing procedures. Also refer to the Body Diagnostic

## DRIVER SEAT HEATER SWITCH (Continued)

Manual for additional diagnosis and testing procedures. If not OK, replace the faulty heated seat switch.



80be464b

**Fig. 3 Heated Seat Switch**

Heated Seat Switch Continuity		
Switch Position	Continuity Between	Resistance
Neutral	4 & 6	2.2 Kilohms
Low	4 & 6	510 Ohms
High	4 & 6	33 Ohms

(8) Replace the inoperative heated seat switch with a known good unit and test the operation of the switch indicator lamps. If OK, discard the faulty heated seat switch. If not OK, refer to **Heated Seat Module** in Electronic Control Modules for the location of the proper heated seat module diagnosis and testing procedures. Also refer to the Body Diagnostic Manual for additional diagnosis and testing procedures.

## REMOVAL

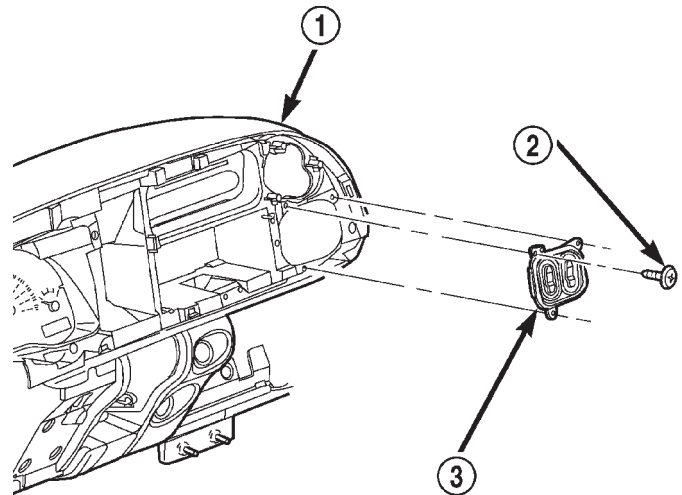
Both heated seat switches and the heated seat switch bezel are available individually for service replacement.

(1) Disconnect and isolate the battery negative cable.

(2) Remove the cluster bezel from the instrument panel. Refer to **Cluster Bezel** in the index of this service manual for the location of the proper cluster bezel removal procedures.

(3) Remove the three screws that secure the heated seat switch bezel to the instrument panel (Fig. 4).

(4) Pull the heated seat switch bezel out from the instrument panel far enough to access and disconnect the two instrument panel wire harness connectors from the connector receptacles on the backs of the heated seat switches.



80be464e

**Fig. 4 Heated Seat Switch and Bezel Remove/Install**

1 - INSTRUMENT PANEL

2 - SCREW (3)

3 - HEATED SEAT SWITCHES AND BEZEL UNIT

(5) Remove the heated seat switch bezel and both switches from the instrument panel as a unit.

(6) From the back of the heated seat switch bezel, gently push the heated seat switch out through the front of the bezel.

## INSTALLATION

Both heated seat switches and the heated seat switch bezel are available individually for service replacement.

**NOTE:** When installing the heated seat switches, be certain they are installed in the proper mounting holes of the heated seat switch bezel. Note that the driver side and passenger side switches are identical in appearance except for the keyway in the connector receptacle on the backs of the switches. The driver side switch has the keyway located near the bottom of the connector receptacle and should be installed in the left mounting hole of the heated seat switch bezel. The passenger side switch has the keyway located near the top of the connector receptacle and should be installed in the right mounting hole of the heated seat switch bezel.

(1) From the front of the heated seat switch bezel, align the back of the heated seat switch with the proper mounting hole in the heated seat switch bezel and gently push the switch into the bezel until it snaps into place.

(2) Position the heated seat switch bezel and both switches to the instrument panel as a unit.

## DRIVER SEAT HEATER SWITCH (Continued)

(3) Reconnect the two instrument panel wire harness connectors to the connector receptacles on the backs of the heated seat switches.

(4) Position the heated seat switch bezel and both switches in the instrument panel mounting hole as a unit.

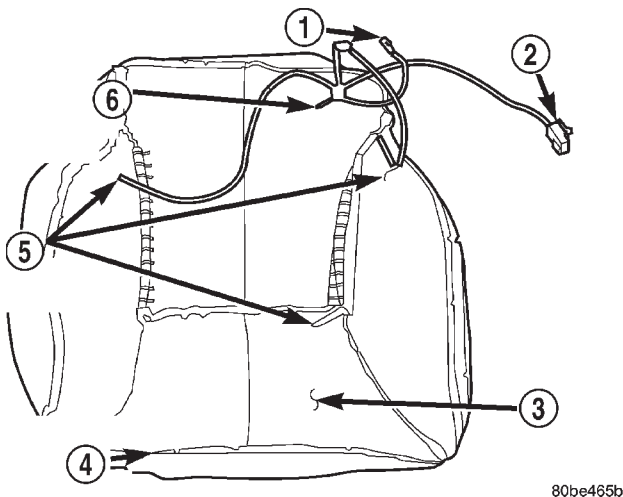
(5) Install and tighten the three screws that secure the heated seat switch bezel to the instrument panel. Tighten the screws to 2.2 N-m (20 in. lbs.).

(6) Install the cluster bezel onto the instrument panel. Refer to **Cluster Bezel** in the index of this service manual for the location of the proper cluster bezel installation procedures.

(7) Reconnect the battery negative cable.

## HEATED SEAT ELEMENT

## DESCRIPTION



80be465b

**Fig. 5 Heated Seat Cushion Trim Cover**

- 1 - TO SEAT BACK COVER
- 2 - TO SEAT WIRE HARNESS
- 3 - FOAM PADDING
- 4 - HEATED SEAT CUSHION TRIM COVER
- 5 - TO ELEMENT GRIDS
- 6 - TO ELEMENT GRIDS AND SENSOR

Vehicles equipped with the optional heated seat system have two sets of electrically operated heating element grids located in each outboard seating position of the front seat, one set for the seat cushion and the other set for the seat back. Each of the heated seat element grids consists of a single length of resistor wire that is routed in a zigzag pattern and captured between the leather trim cover and the foam rubber backing on the underside of its respective seat cushion trim cover and seat back trim cover assembly. Short pigtail wires with connectors (Fig. 5) are soldered to each end of each resistor wire element grid, which connect all of the element grids for

each seating position to each other in series with the heated seat module through the seat wire harness.

One temperature sensor is used for each outboard seating position of the front seat, and it is located in the center insert area of the seat cushion cover. The heated seat sensors and their pigtail wires are also captured between the leather trim cover and the foam rubber backing on the underside of their respective seat cushion trim cover assemblies. The heated seat sensors are Negative Thermal Coefficient (NTC) thermistors. The sensors for both front seats receive a voltage feed from a single output of the heated seat module, but the module receives individual sensor inputs from the driver side and passenger side sensors.

The heated seat elements and sensors cannot be repaired. If damaged or faulty, the front seat cushion trim cover or front seat back trim cover assembly must be replaced. Refer to **Front Seat Cushion Cover - Quad Cab** or **Front Seat Back Cover - Quad Cab** in the index of this service manual for the location of the proper front seat trim cover removal and installation procedures.

## OPERATION

One end of the heated seat element resistor wire is connected to a ground feed at all times through a splice in the heated seat module ground circuit. Battery current is directed to the other end of the heated seat element resistor wire by the energized N-channel Field Effect Transistor (N-FET) located within the heated seat module. The heated seat module will energize the N-FET only when the heated seat switch is in the Low or High position and the heated seat sensor indicates that the seat cushion surface temperature is below the selected (Low or High) temperature set point. As electrical current passes through the heating element grid, the resistance of the wire used in the element disperses some of that electrical current in the form of heat. The heat produced by the heated seat element grid then radiates through the underside of the seat cushion and seat back trim covers, warming the seat cover and its occupant.

The resistance of the heated seat sensor increases and decreases as the surface temperature of the seat cushion cover changes. The heated seat module supplies each sensor with a voltage feed, then detects the sensor resistance by monitoring the voltage of the separate sensor return circuits. The heated seat module compares the heated seat sensor resistance (seat cushion surface temperature) with the heated seat switch resistance (Low or High set point) to determine when the heated seat element grids need to be cycled on or off in order to maintain the selected temperature set point.

## HEATED SEAT ELEMENT (Continued)

**DIAGNOSIS & TESTING - HEATED SEAT ELEMENT AND SENSOR**

The heated seat module will self-diagnose shorted or open heated seat element circuits and the sensor circuits. Refer to **Heated Seat System** in this section for the location of the proper heated seat system diagnosis and testing procedures. To manually check the heated seat element and sensor circuits, proceed as follows. The wire harness connectors for the seat cushion heated seat element and sensor and for the seat back heated seat element are located under the seat, near the rear edge of the seat cushion frame. Refer to **Wiring Diagrams** for the location of complete heated seat system wiring diagrams.

**HEATED SEAT ELEMENT**

(1) Disconnect and isolate the battery negative cable. Disconnect the 4-way heated seat wire harness connector. Check for continuity between the two heated seat element circuit cavities in the seat cushion trim cover half of the 4-way heated seat wire harness connector. There should be continuity. If OK, go to Step 2. If not OK, go to Step 3.

(2) Check for continuity between one of the heated seat element circuit cavities in the seat cushion trim cover half of the 4-way heated seat wire harness connector and the seat cushion frame. There should be no continuity. If OK, go to Step 5. If not OK, go to Step 4.

(3) Disconnect the 2-way heated seat wire harness connector between the seat cushion trim cover and the seat back trim cover. Check for continuity between the heated seat element circuit cavity and the ground circuit cavity in the seat back trim cover half of the 2-way heated seat wire harness connector. There should be continuity. If OK, go to Step 5. If not OK, replace the faulty seat back trim cover unit.

(4) Check for continuity between the heated seat element circuit cavity in the seat back trim cover half of the 2-way heated seat wire harness connector and the seat back frame. There should be no continuity. If OK, go to Step 5. If not OK, replace the faulty seat back trim cover unit.

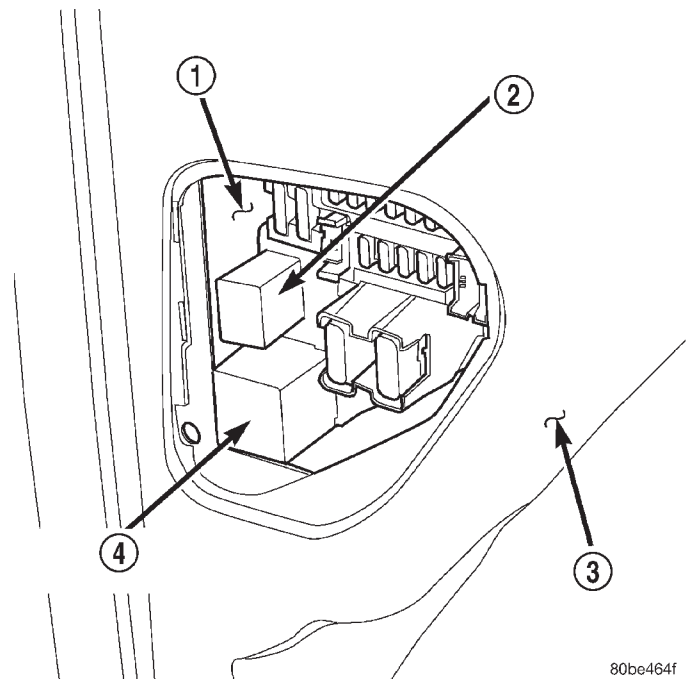
(5) Test the seat wire harness between the heated seat module connector and the 4-way heated seat wire harness connectors for shorted or open circuits. If OK, replace the faulty seat cushion trim cover unit. If not OK, repair the shorted or open seat wire harness as required.

**HEATED SEAT SENSOR**

(1) Disconnect and isolate the battery negative cable. Disconnect the 4-way heated seat wire harness connector. Using an ohmmeter, check the resistance between the heated seat sensor input circuit cavity and the heated seat sensor feed circuit cavity in the

seat cushion cover half of the 4-way heated seat wire harness connector. The heated seat sensor resistance should be between 1 kilohm and 200 kilohms. If OK, go to Step 2. If not OK, replace the faulty seat cushion trim cover unit.

(2) Test the seat wire harness between the heated seat module connector and the 4-way heated seat wire harness connector for shorted or open circuits. If OK, refer to **Heated Seat Module** in Electronic Control Modules for the location of the proper heated seat module diagnosis and testing procedures. Also refer to the Body Diagnostic Manual for additional diagnosis and testing procedures. If not OK, repair the shorted or open heated seat wire harness as required.

**HEATED SEAT RELAY****DESCRIPTION****Fig. 6 Heated Seat Relay**

- 1 - JUNCTION BLOCK
- 2 - HEATED SEAT RELAY
- 3 - INSTRUMENT PANEL
- 4 - COMBINATION FLASHER

The heated seat relay is an electromechanical device that switches battery current to the heated seat module when the relay control coil is energized. The heated seat relay is located in the Junction Block (JB), on the left end of the instrument panel in the passenger compartment (Fig. 6). The heated seat relay is a International Standards Organization (ISO) micro-relay. Relays conforming to the ISO spec-



## HEATED SEAT RELAY (Continued)

ifications have common physical dimensions, current capacities, terminal patterns, and terminal functions. The ISO micro-relay terminal functions are the same as a conventional ISO relay. However, the ISO micro-relay terminal pattern (or footprint) is different, the current capacity is lower, and the physical dimensions are smaller than those of the conventional ISO relay.

The heated seat relay cannot be repaired or adjusted and, if faulty or damaged, it must be replaced.

## OPERATION

The ISO relay consists of an electromagnetic coil, a resistor or diode, and three (two fixed and one movable) electrical contacts. The movable (common feed) relay contact is held against one of the fixed contacts (normally closed) by spring pressure. When the electromagnetic coil is energized, it draws the movable contact away from the normally closed fixed contact, and holds it against the other (normally open) fixed contact. When the electromagnetic coil is de-energized, spring pressure returns the movable contact to the normally closed position. The resistor or diode is connected in parallel with the electromagnetic coil in the relay, and helps to dissipate voltage spikes that are produced when the coil is de-energized.

The heated seat relay is controlled by the premium version of the Central Timer Module (CTM), which controls the ground feed to the coil ground terminal of the relay to energize and de-energize the electromagnetic coil of the relay. The CTM monitors engine operation through messages it receives from the Powertrain Control Module (PCM) over the Chrysler Collision Detection (CCD) data bus network. The CTM is programmed to energize the relay only when the engine is running, and to de-energize the relay when the engine is not running. Refer to **Central Timer Module** in the index of this service manual for the location of more information on the premium CTM.

## DIAGNOSIS &amp; TESTING - HEATED SEAT RELAY

The heated seat relay (Fig. 7) is located in the Junction Block (JB) on the left end of the instrument panel in the passenger compartment of the vehicle. Refer to **Wiring Diagrams** for the location of complete heated seat system wiring diagrams.

**WARNING: ON VEHICLES EQUIPPED WITH AIRBAGS, DISABLE THE AIRBAG SYSTEM BEFORE ATTEMPTING ANY STEERING WHEEL, STEERING COLUMN, OR INSTRUMENT PANEL COMPONENT DIAGNOSIS OR SERVICE. DISCONNECT AND ISOLATE THE BATTERY NEGATIVE (GROUND) CABLE, THEN WAIT TWO MINUTES FOR THE AIRBAG SYSTEM CAPACITOR TO DISCHARGE BEFORE PER-**

**FORMING FURTHER DIAGNOSIS OR SERVICE. THIS IS THE ONLY SURE WAY TO DISABLE THE AIRBAG SYSTEM. FAILURE TO TAKE THE PROPER PRECAUTIONS COULD RESULT IN ACCIDENTAL AIRBAG DEPLOYMENT AND POSSIBLE PERSONAL INJURY.**

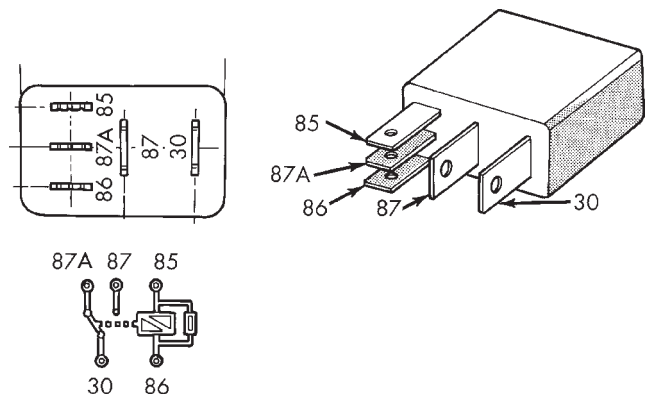
## RELAY TEST

(1) Remove the heated seat relay from the JB. Refer to **Heated Seat Relay** in this section for the location of the proper heated seat relay removal procedures.

(2) A relay in the de-energized position should have continuity between terminals 87A and 30, and no continuity between terminals 87 and 30. If OK, go to Step 3. If not OK, replace the faulty relay.

(3) Resistance between terminals 85 and 86 (electromagnet) should be  $75 \pm 5$  ohms. If OK, go to Step 4. If not OK, replace the faulty relay.

(4) Connect a battery to terminals 85 and 86. There should now be continuity between terminals 30 and 87, and no continuity between terminals 87A and 30. If OK, perform the Relay Circuit Test that follows. If not OK, replace the faulty relay.



**Fig. 7 Heated Seat Relay**

TERMINAL LEGEND	
NUMBER	IDENTIFICATION
30	COMMON FEED
85	COIL GROUND
86	COIL BATTERY
87	NORMALLY OPEN
87A	NORMALLY CLOSED

## RELAY CIRCUIT TEST

(1) The relay common feed terminal cavity (30) is connected to battery voltage and should be hot at all times. If OK, go to Step 2. If not OK, repair the open circuit to the fused B(+) fuse in the Power Distribution Center (PDC) as required.

(2) The relay normally closed terminal (87A) is connected to terminal 30 in the de-energized position, but is not used for this application. Go to Step 3.



## HEATED SEAT RELAY (Continued)

(3) The relay normally open terminal (87) is connected to the common feed terminal (30) in the energized position. This terminal supplies battery voltage to the heated seat module. There should be continuity between the cavity for relay terminal 87 and the B(+) to heated seat module circuit cavity of the heated seat module wire harness connector at all times. If OK, go to Step 4. If not OK, repair the open B(+) to heated seat module circuit to the heated seat module as required.

(4) The coil battery terminal (86) is connected to the electromagnet in the relay. It is connected to battery voltage and should be hot at all times. Check for battery voltage at the cavity for relay terminal 86. If OK, go to Step 5. If not OK, repair the open circuit to the fused B(+) fuse in the PDC as required.

(5) The coil ground terminal (85) is connected to the electromagnet in the relay. It is grounded by the premium version of the Central Timer Module (CTM) in response to an engine speed message received over the Chrysler Collision Detection (CCD) data bus from the Powertrain Control Module (PCM) when the engine is running. Check for continuity between the cavity for relay terminal 85 and the heated seat relay control circuit cavity of the CTM wire harness connector. There should be continuity at all times. If OK, use a DRBIII® scan tool and the proper diagnostic procedures manual to test the operation of the CTM and CCD data bus. If not OK, repair the open heated seat relay control circuit as required.

## REMOVAL

(1) Disconnect and isolate the battery negative cable.

(2) Remove the fuse access panel by inserting a finger in the finger recess molded into the panel and then pulling the panel sharply away from the left outboard end of the instrument panel.

(3) The heated seat relay is located on the forward side of the Junction Block (JB), just above the combination flasher (Fig. 8).

(4) Grasp the heated seat relay firmly and pull it straight out from the JB.

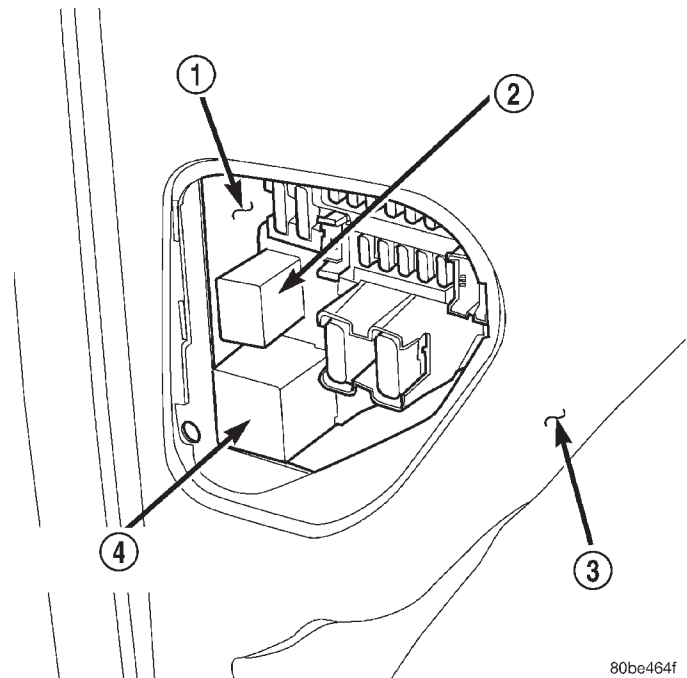
## INSTALLATION

(1) Position the heated seat relay in the proper receptacle in the JB.

(2) Align the heated seat relay terminals with the terminal cavities in the JB receptacle.

(3) Push in firmly on the heated seat relay until the terminals are fully seated in the terminal cavities in the JB receptacle.

(4) Insert the tabs on the forward edge of the fuse access panel in the notches on the forward edge of the instrument panel fuse access panel opening.



80be464f

Fig. 8 Heated Seat

- 1 - JUNCTION BLOCK
- 2 - HEATED SEAT RELAY
- 3 - INSTRUMENT PANEL
- 4 - COMBINATION FLASHER

(5) Press the rear edge of the fuse access panel in toward the instrument panel until the panel snaps back into place.

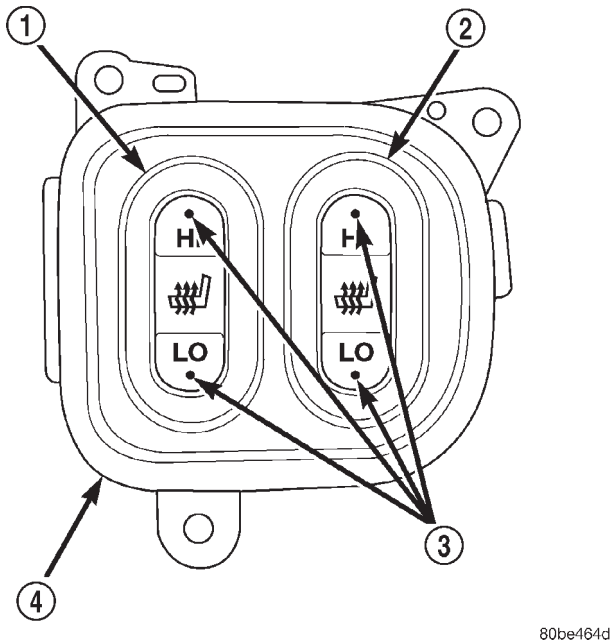
(6) Reconnect the battery negative cable.

## PASSENGER SEAT HEATER SWITCH

## DESCRIPTION

The heated seat switches used on vehicles with this option are both mounted in a heated seat switch bezel (Fig. 9), which replaces the standard equipment cubby bin located in the lower right corner of the instrument cluster bezel next to the radio receiver. The two switches are snapped into the mounting holes of the heated seat switch bezel, and the heated seat switch bezel is secured with three screws to the instrument panel. The mounts for the heated seat switch bezel are concealed behind the instrument cluster bezel. The two heated seat switches are identical in appearance and construction, except for the location of a keyway in the single connector receptacle on the back of each switch. The instrument panel wire harness connectors for the heated seat switches are keyed to match the connector receptacles on the switches so that the two heated seat switches can only be connected to the proper heated seat.

## PASSENGER SEAT HEATER SWITCH (Continued)



**Fig. 9 Heated Seat Switches**

- 1 - DRIVER SIDE SWITCH
- 2 - PASSENGER SIDE SWITCH
- 3 - INDICATOR LAMPS
- 4 - HEATED SEAT SWITCH BEZEL

The momentary, bidirectional rocker-type heated seat switch provides a resistor-multiplexed signal to the heated seat module. Each switch has a center neutral position and momentary Low and High positions so that both the driver and the front seat passenger can select a preferred seat heating mode. Each heated seat switch has two Light-Emitting Diode (LED) indicator lamps, which indicate the selected mode (Low or High) of the seat heater for each seat and to provide diagnostic feedback for the heated seat system. Each switch also has an incandescent bulb, which provides panel lamps dimmer controlled back lighting of the switch nomenclature when the headlamps or park lamps are turned on.

The two LED indicator lamps and the incandescent bulb in each heated seat switch cannot be repaired. If the indicator lamps or back lighting bulb are faulty or damaged, the individual heated seat switch unit must be replaced.

## OPERATION

The heated seat switches receive battery current through a fused ignition switch output (run) circuit when the ignition switch is in the On position. Depressing the heated seat switch rocker to its momentary High or Low position provides a hard-wired resistor multiplexed voltage request signal to the heated seat module to power the heated seat element of the selected seat and maintain the requested

temperature setting. If the heated seat switch is depressed to a different position (Low or High) than the currently selected state, the heated seat module will change states to support the new selection. If a heated seat switch is depressed a second time to the same position as the currently selected state, the heated seat module interprets the second input as a request to turn the seat heater off. The heated seat module will then turn the heated seat elements for that seat off.

The indicator lamps in the heated seat switches receive battery current through a fused ignition switch output (run) circuit when the ignition switch is in the On position. The ground side of each indicator lamp is controlled by a separate (high or low/driver or passenger) indicator lamp driver circuit by the heated seat module. The heated seat module control of the switch indicator lamps also allows the module to provide diagnostic feedback to the vehicle operator to indicate monitored heated seat system faults by flashing the indicator lamps on and off. One side of the incandescent back lighting bulb in each heated seat switch is connected to ground at all times. The other side of the incandescent bulb is connected to the fused panel lamps dimmer switch signal circuit. These bulbs are energized when the park lamps or headlamps are turned on, and their illumination intensity is controlled by the panel lamps dimmer switch.

## DIAGNOSIS & TESTING - HEATED SEAT SWITCH

Refer to **Wiring Diagrams** for the location of complete heated seat system wiring diagrams.

**WARNING: ON VEHICLES EQUIPPED WITH AIRBAGS, DISABLE THE AIRBAG SYSTEM BEFORE ATTEMPTING ANY STEERING WHEEL, STEERING COLUMN, OR INSTRUMENT PANEL COMPONENT DIAGNOSIS OR SERVICE. DISCONNECT AND ISOLATE THE BATTERY NEGATIVE (GROUND) CABLE, THEN WAIT TWO MINUTES FOR THE AIRBAG SYSTEM CAPACITOR TO DISCHARGE BEFORE PERFORMING FURTHER DIAGNOSIS OR SERVICE. THIS IS THE ONLY SURE WAY TO DISABLE THE AIRBAG SYSTEM. FAILURE TO TAKE THE PROPER PRECAUTIONS COULD RESULT IN ACCIDENTAL AIRBAG DEPLOYMENT AND POSSIBLE PERSONAL INJURY.**

(1) If the problem being diagnosed involves inoperative heated seat switch back lighting and the cluster illumination lamps operate, go to Step 2. If the problem being diagnosed involves inoperative heated seat switch back lighting and the cluster illumination lamps are also inoperative, refer to **Instrument**

## PASSENGER SEAT HEATER SWITCH (Continued)

**Cluster** in the index of this service manual for the proper cluster illumination lamps diagnosis and testing procedures. If the problem being diagnosed involves inoperative heated seat switch indicator lamps and the heated seat elements do not heat, refer to Step 4. If the problem being diagnosed involves inoperative heated seat switch indicator lamps and the heated seat elements do heat, go to Step 8. If the problem being diagnosed involves a heated seat switch indicator lamp that remains illuminated after the heated seat has been turned Off, refer to **Heated Seat Module** in Electronic Control Modules for the location of the proper heated seat module diagnosis and testing procedures. Also refer to the Body Diagnostic Manual for additional diagnosis and testing procedures.

(2) Disconnect and isolate the battery negative cable. Remove the heated seat switch and bezel unit from the instrument panel. Disconnect the instrument panel wire harness connector from the connector receptacle on the back of the heated seat switch to be tested. Check for continuity between the ground circuit cavity of the instrument panel wire harness connector for the heated seat switch and a good ground. There should be continuity. If OK, go to Step 3. If not OK, repair the open ground circuit to ground as required.

(3) Reconnect the battery negative cable. Turn the park lamps on with the headlamp switch. Rotate the panel lamps dimmer thumbwheel on the headlamp switch upward to just before the interior lamps detent. Check for battery voltage at the fused panel lamps dimmer switch signal circuit cavity of the instrument panel wire harness connector for the heated seat switch. If OK, replace the faulty heated seat switch. If not OK, repair the open fused panel lamps dimmer switch signal circuit to the fuse in the Junction Block (JB) as required.

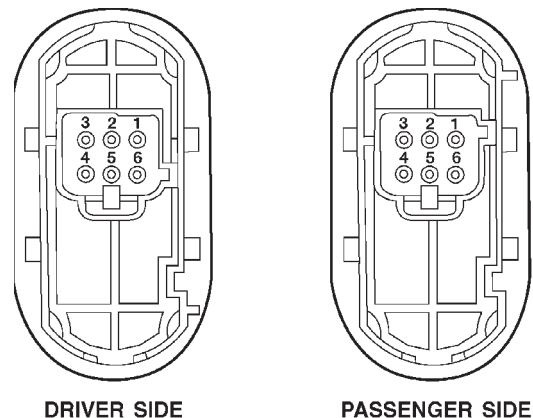
(4) Check the fused ignition switch output (run) fuse in the Junction Block (JB). If OK, go to Step 5. If not OK, repair the shorted circuit or component as required and replace the faulty fuse.

(5) Turn the ignition switch to the On position. Check for battery voltage at the fused ignition switch output (run) fuse in the JB. If OK, go to Step 6. If not OK, repair the open fused ignition switch output (run) circuit to the ignition switch as required.

(6) Disconnect and isolate the battery negative cable. Remove the heated seat switch and bezel unit from the instrument panel. Disconnect the instrument panel wire harness connector from the connector receptacle on the back of the heated seat switch to be tested. Reconnect the battery negative cable. Turn the ignition switch to the On position. Check for battery voltage at the fused ignition switch output (run) circuit cavity of the instrument panel wire

harness connector for the heated seat switch. If OK, go to Step 7. If not OK, repair the open fused ignition switch output (run) circuit to the JB fuse as required.

(7) Check the continuity and resistance values of the heated seat switch in the Neutral, Low and High positions as shown in the Heated Seat Switch Continuity chart (Fig. 10). If OK, refer to **Heated Seat Module** in Electronic Control Modules for the location of the proper heated seat module diagnosis and testing procedures. Also refer to the Body Diagnostic Manual for additional diagnosis and testing procedures. If not OK, replace the faulty heated seat switch.



80be464b

Fig. 10 Heated Seat Switch

Heated Seat Switch Continuity		
Switch Position	Continuity Between	Resistance
Neutral	4 & 6	2.2 Kilohms
Low	4 & 6	510 Ohms
High	4 & 6	33 Ohms

(8) Replace the inoperative heated seat switch with a known good unit and test the operation of the switch indicator lamps. If OK, discard the faulty heated seat switch. If not OK, refer to **Heated Seat Module** in Electronic Control Modules for the location of the proper heated seat module diagnosis and testing procedures. Also refer to the Body Diagnostic Manual for additional diagnosis and testing procedures.

## REMOVAL

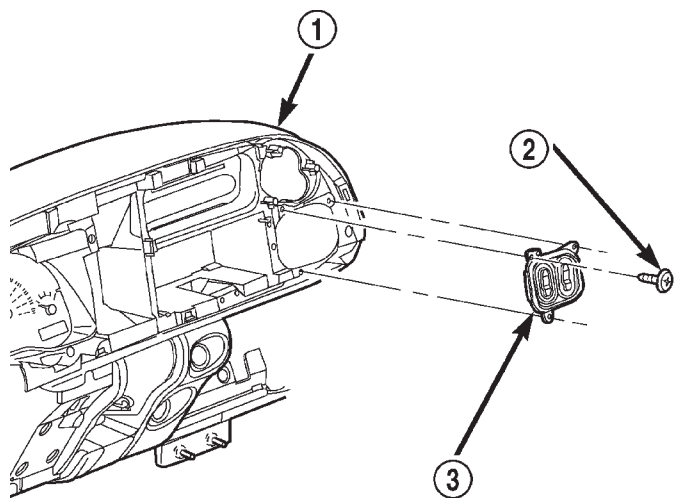
Both heated seat switches and the heated seat switch bezel are available individually for service replacement.

(1) Disconnect and isolate the battery negative cable.

## PASSENGER SEAT HEATER SWITCH (Continued)

(2) Remove the cluster bezel from the instrument panel. Refer to **Cluster Bezel** in the index of this service manual for the location of the proper cluster bezel removal procedures.

(3) Remove the three screws that secure the heated seat switch bezel to the instrument panel (Fig. 11).



80be464e

**Fig. 11 Heated Seat Switch and Bezel Remove/Install**

- 1 - INSTRUMENT PANEL
- 2 - SCREW (3)
- 3 - HEATED SEAT SWITCHES AND BEZEL UNIT

(4) Pull the heated seat switch bezel out from the instrument panel far enough to access and disconnect the two instrument panel wire harness connectors from the connector receptacles on the backs of the heated seat switches.

(5) Remove the heated seat switch bezel and both switches from the instrument panel as a unit.

(6) From the back of the heated seat switch bezel, gently push the heated seat switch out through the front of the bezel.

**INSTALLATION**

Both heated seat switches and the heated seat switch bezel are available individually for service replacement.

**NOTE:** When installing the heated seat switches, be certain they are installed in the proper mounting holes of the heated seat switch bezel. Note that the driver side and passenger side switches are identical in appearance except for the keyway in the connector receptacle on the backs of the switches. The driver side switch has the keyway located near the bottom of the connector receptacle and should be installed in the left mounting hole of the heated seat switch bezel. The passenger side switch has the keyway located near the top of the connector receptacle and should be installed in the right mounting hole of the heated seat switch bezel.

(1) From the front of the heated seat switch bezel, align the back of the heated seat switch with the proper mounting hole in the heated seat switch bezel and gently push the switch into the bezel until it snaps into place.

(2) Position the heated seat switch bezel and both switches to the instrument panel as a unit.

(3) Reconnect the two instrument panel wire harness connectors to the connector receptacles on the backs of the heated seat switches.

(4) Position the heated seat switch bezel and both switches in the instrument panel mounting hole as a unit.

(5) Install and tighten the three screws that secure the heated seat switch bezel to the instrument panel. Tighten the screws to 2.2 N·m (20 in. lbs.).

(6) Install the cluster bezel onto the instrument panel. Refer to **Cluster Bezel** in the index of this service manual for the location of the proper cluster bezel installation procedures.

(7) Reconnect the battery negative cable.



# HORN

## TABLE OF CONTENTS

	page		page
<b>HORN</b>		<b>OPERATION</b> .....	3
DESCRIPTION .....	1	<b>DIAGNOSIS AND TESTING</b> .....	3
OPERATION .....	1	HORN RELAY .....	3
<b>HORN</b>		REMOVAL .....	4
DESCRIPTION .....	2	INSTALLATION .....	4
OPERATION .....	2	<b>HORN SWITCH</b>	
DIAGNOSIS AND TESTING .....	2	DESCRIPTION .....	4
HORN .....	2	OPERATION .....	5
REMOVAL .....	2	DIAGNOSIS AND TESTING .....	5
INSTALLATION .....	3	HORN SWITCH .....	5
<b>HORN RELAY</b>		REMOVAL .....	5
DESCRIPTION .....	3		

## HORN

### DESCRIPTION

An electric horn system is standard factory-installed equipment on this model. Two horn systems are offered on this model. The standard equipment horn system features a single low-note electromagnetic horn unit, while the optional dual horn system features one low-note horn unit and one high-note horn unit. Both horn systems use a non-switched source of battery current so that the system will remain functional, regardless of the ignition switch position. The horn system includes the following components:

- Clockspring
- High-line or premium Central Timer Module (CTM)
- Horn(s)
- Horn relay
- Horn switch

(Refer to 8 - ELECTRICAL/RESTRAINTS/CLOCK-SPRING - DESCRIPTION) for more information on this component. (Refer to 8 - ELECTRICAL/ELECTRONIC CONTROL MODULES/BODY CONTROL/CENTRAL TIMER MODUL - DESCRIPTION) for more information on this component. Refer to the appropriate wiring information. The wiring information includes wiring diagrams, proper wire and connector repair procedures, details of wire harness routing and retention, connector pin-out information and location views for the various wire harness connectors, splices and grounds. Following are general descriptions of the remaining major components in the horn system.

### OPERATION

Each horn system is activated by a horn switch concealed beneath the driver side airbag module trim cover in the center of the steering wheel. Depressing the center of the driver side airbag module trim cover closes the horn switch. Closing the horn switch activates the horn relay. The activated horn relay then switches the battery current needed to energize the horn(s).

Refer to the owner's manual in the vehicle glove box for more information on the features, use and operation of the horn system.

### CENTRAL TIMER MODULE

The high-line or premium Central Timer Module (CTM) can also operate the horn system. A high-line CTM is used on high-line versions of this vehicle. A premium CTM is used on vehicles equipped with the optional heated seats. The CTM combines the functions of a chime/buzzer module, an intermittent wipe module, an illuminated entry module, a remote keyless entry module, and a vehicle theft security system module in a single unit.

The high-line or premium CTM also controls and integrates many of the additional electronic functions and features included on models with this option. The horn relay is one of the hard wired outputs of the CTM. The high-line or premium CTM is programmed to energize or de-energize the horn relay in response to certain inputs from the Vehicle Theft Security System (VTSS) and/or the Remote Keyless Entry (RKE) system.

(Refer to 8 - ELECTRICAL/ELECTRONIC CONTROL MODULES/BODY CONTROL/CENTRAL TIMER MODUL - DESCRIPTION) for more informa-



## HORN (Continued)

tion on the high-line or premium CTM. (Refer to 8 - ELECTRICAL/VEHICLE THEFT SECURITY - GENERAL INFORMATION) for more information on the VTSS. (Refer to 8 - ELECTRICAL/POWER LOCKS - GENERAL INFORMATION) for more information on the RKE system.

## HORN

## DESCRIPTION

The standard single, low-note, electromagnetic diaphragm-type horn is secured with a bracket to the right front fender wheel house extension in the engine compartment. The high-note horn for the optional dual-note horn system is connected in parallel with and secured with a bracket just forward of the low-note horn. Each horn is grounded through its wire harness connector and circuit to a ground splice joint connector, and receives battery feed through the closed contacts of the horn relay.

The horns cannot be repaired or adjusted and, if faulty or damaged, they must be individually replaced.

## OPERATION

Within the two halves of the molded plastic horn housing are a flexible diaphragm, a plunger, an electromagnetic coil and a set of contact points. The diaphragm is secured in suspension around its perimeter by the mating surfaces of the horn housing. The plunger is secured to the center of the diaphragm and extends into the center of the electromagnet. The contact points control the current flow through the electromagnet.

When the horn is energized, electrical current flows through the closed contact points to the electromagnet. The resulting electromagnetic field draws the plunger and diaphragm toward it until that movement mechanically opens the contact points. When the contact points open, the electromagnetic field collapses allowing the plunger and diaphragm to return to their relaxed positions and closing the contact points again. This cycle continues repeating at a very rapid rate producing the vibration and movement of air that creates the sound that is directed through the horn outlet.

## DIAGNOSIS AND TESTING

## DIAGNOSIS AND TESTING - HORN

For complete circuit diagrams, refer to the appropriate wiring information. The wiring information includes wiring diagrams, proper wire and connector repair procedures, details of wire harness routing and retention, connector pin-out information and

location views for the various wire harness connectors, splices and grounds.

(1) Disconnect the wire harness connector(s) from the horn connector receptacle(s). Measure the resistance between the ground circuit cavity of the horn(s) wire harness connector(s) and a good ground. There should be no measurable resistance. If OK, go to Step 2. If not OK, repair the open ground circuit to ground as required.

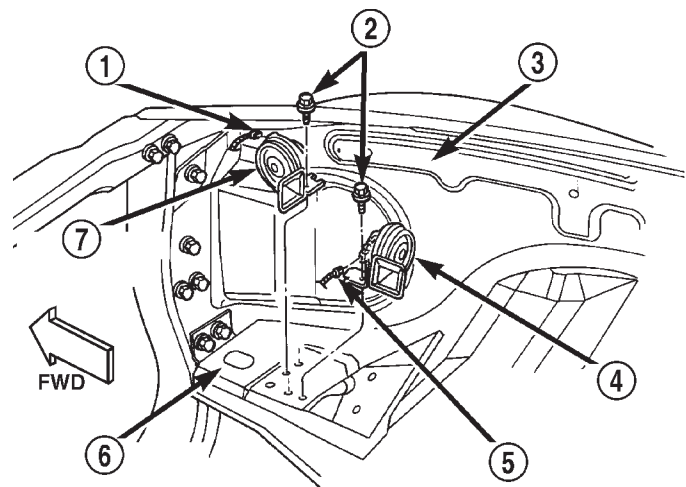
(2) Check for battery voltage at the horn relay output circuit cavity of the horn(s) wire harness connector(s). There should be zero volts. If OK, go to Step 3. If not OK, repair the shorted horn relay output circuit or replace the faulty horn relay as required.

(3) Depress the horn switch. There should now be battery voltage at the horn relay output circuit cavity of the horn(s) wire harness connector(s). If OK, replace the faulty horn(s). If not OK, repair the open horn relay output circuit to the horn relay as required.

## REMOVAL

(1) Disconnect and isolate the battery negative cable.

(2) Disconnect the wire harness connector(s) from the horn connector receptacle(s) (Fig. 1).



80b171ba

**Fig. 1 Horns Remove/Install**

- 1 - WIRE HARNESS CONNECTOR
- 2 - SCREWS
- 3 - INNER FENDER
- 4 - LOW NOTE HORN
- 5 - WIRE HARNESS CONNECTOR
- 6 - WHEELHOUSE EXTENSION
- 7 - HIGH NOTE HORN

(3) Remove the screw that secures the horn and mounting bracket unit(s) to the right fender wheel house front extension.

(4) Remove the horn and mounting bracket unit(s) from the right fender wheel house front extension.

## HORN (Continued)

**INSTALLATION**

- (1) Position the horn and mounting bracket unit(s) onto the right fender wheel house front extension.
- (2) Install and tighten the screw that secures the horn and mounting bracket unit(s) to the right fender wheel house front extension. Tighten the screw to 11 N·m (95 in. lbs.).
- (3) Reconnect the wire harness connector(s) to the horn connector receptacle(s).
- (4) Reconnect the battery negative cable.

**HORN RELAY****DESCRIPTION**

The horn relay is a electromechanical device that switches battery current to the horn when the horn switch grounds the relay coil. The horn relay is located in the Power Distribution Center (PDC) in the engine compartment. If a problem is encountered with a continuously sounding horn, it can usually be quickly resolved by removing the horn relay from the PDC until further diagnosis is completed. See the fuse and relay layout label affixed to the inside surface of the PDC cover for horn relay identification and location.

The horn relay is a International Standards Organization (ISO) micro-relay. Relays conforming to the ISO specifications have common physical dimensions, current capacities, terminal patterns, and terminal functions. The ISO micro-relay terminal functions are the same as a conventional ISO relay. However, the ISO micro-relay terminal pattern (or footprint) is different, the current capacity is lower, and the physical dimensions are smaller than those of the conventional ISO relay.

The horn relay cannot be repaired or adjusted and, if faulty or damaged, it must be replaced.

**OPERATION**

The ISO relay consists of an electromagnetic coil, a resistor or diode, and three (two fixed and one movable) electrical contacts. The movable (common feed) relay contact is held against one of the fixed contacts (normally closed) by spring pressure. When the electromagnetic coil is energized, it draws the movable contact away from the normally closed fixed contact, and holds it against the other (normally open) fixed contact.

When the electromagnetic coil is de-energized, spring pressure returns the movable contact to the normally closed position. The resistor or diode is connected in parallel with the electromagnetic coil in the relay, and helps to dissipate voltage spikes that are produced when the coil is de-energized.

**DIAGNOSIS AND TESTING****DIAGNOSIS AND TESTING - HORN RELAY**

The horn relay (Fig. 2) is located in the Power Distribution Center (PDC) behind the battery on the driver side of the engine compartment. If a problem is encountered with a continuously sounding horn, it can usually be quickly resolved by removing the horn relay from the PDC until further diagnosis is completed. See the fuse and relay layout label affixed to the inside surface of the PDC cover for horn relay identification and location. For complete circuit diagrams, refer to the appropriate wiring information. The wiring information includes wiring diagrams, proper wire and connector repair procedures, details of wire harness routing and retention, connector pin-out information and location views for the various wire harness connectors, splices and grounds.

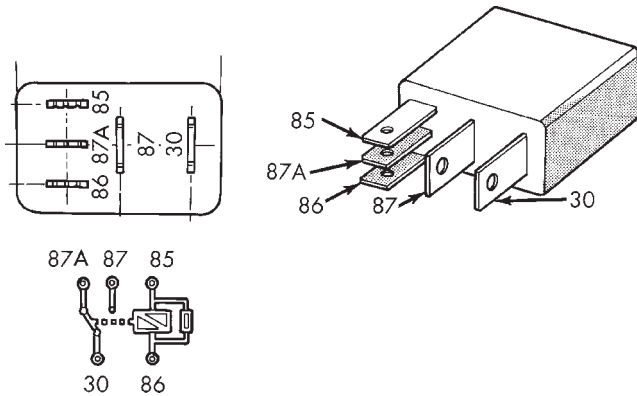
**WARNING: ON VEHICLES EQUIPPED WITH AIRBAGS, REFER TO ELECTRICAL, RESTRAINTS BEFORE ATTEMPTING ANY STEERING WHEEL, STEERING COLUMN, OR INSTRUMENT PANEL COMPONENT DIAGNOSIS OR SERVICE. FAILURE TO TAKE THE PROPER PRECAUTIONS COULD RESULT IN ACCIDENTAL AIRBAG DEPLOYMENT AND POSSIBLE PERSONAL INJURY.**

- (1) Remove the horn relay from the PDC. (Refer to 8 - ELECTRICAL/HORN/HORN RELAY - REMOVAL) for the procedures.
- (2) A relay in the de-energized position should have continuity between terminals 87A and 30, and no continuity between terminals 87 and 30. If OK, go to Step 3. If not OK, replace the faulty relay.
- (3) Resistance between terminals 85 and 86 (electromagnet) should be  $75 \pm 5$  ohms. If OK, go to Step 4. If not OK, replace the faulty relay.
- (4) Connect a battery to terminals 85 and 86. There should now be continuity between terminals 30 and 87, and no continuity between terminals 87A and 30. If OK, perform the Relay Circuit Test that follows. If not OK, replace the faulty relay.

**RELAY CIRCUIT TEST**

- (1) The relay common feed terminal cavity (30) is connected to battery voltage and should be hot at all times. If OK, go to Step 2. If not OK, repair the open circuit to the fuse in the PDC as required.
- (2) The relay normally closed terminal (87A) is connected to terminal 30 in the de-energized position, but is not used for this application. Go to Step 3.

## HORN RELAY (Continued)

**Fig. 2 Horn Relay**

## TERMINAL LEGEND

NUMBER	IDENTIFICATION
30	COMMON FEED
85	COIL GROUND
86	COIL BATTERY
87	NORMALLY OPEN
87A	NORMALLY CLOSED

(3) The relay normally open terminal (87) is connected to the common feed terminal (30) in the energized position. This terminal supplies battery voltage to the horn(s). There should be continuity between the cavity for relay terminal 87 and the horn relay output circuit cavity of each horn wire harness connector at all times. If OK, go to Step 4. If not OK, repair the open circuit to the horn(s) as required.

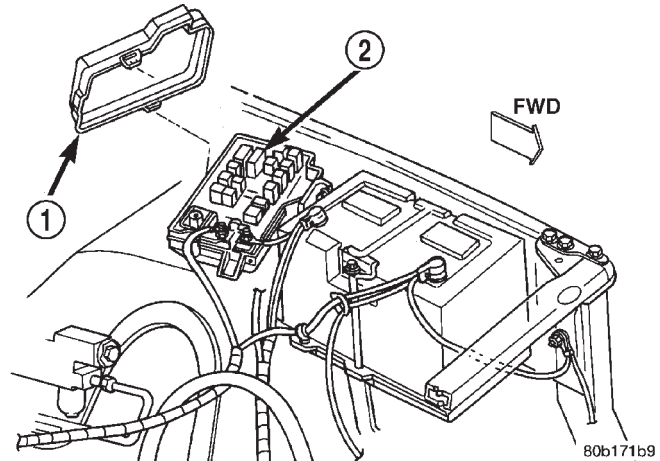
(4) The coil battery terminal (86) is connected to the electromagnet in the relay. It is connected to battery voltage and should be hot at all times. Check for battery voltage at the cavity for relay terminal 86. If OK, go to Step 5. If not OK, repair the open circuit to the fuse in the PDC as required.

(5) The coil ground terminal (85) is connected to the electromagnet in the relay. It is grounded through the horn switch when the horn switch is depressed. On vehicles equipped with the Vehicle Theft Security System (VTSS), the horn relay coil ground terminal can also be grounded by the Central Timer Module (CTM) in response to certain inputs related to the VTSS or Remote Keyless Entry (RKE) system. Check for continuity to ground at the cavity for relay terminal 85. There should be continuity with the horn switch depressed, and no continuity with the horn switch released. If not OK, (Refer to 8 - ELECTRICAL/HORN/HORN SWITCH - DIAGNOSIS AND TESTING).

**REMOVAL**

(1) Disconnect and isolate the battery negative cable.

(2) Remove the cover from the Power Distribution Center (PDC) (Fig. 3) .

**Fig. 3 Power Distribution Center**

- 1 - COVER  
2 - POWER DISTRIBUTION CENTER

(3) See the fuse and relay layout label affixed to the underside of the PDC cover for horn relay identification and location.

(4) Remove the horn relay from the PDC.

**INSTALLATION**

(1) See the fuse and relay layout label affixed to the underside of the PDC cover for the proper horn relay location.

(2) Position the horn relay in the proper receptacle in the PDC.

(3) Align the horn relay terminals with the terminal cavities in the PDC receptacle.

(4) Push down firmly on the horn relay until the terminals are fully seated in the terminal cavities in the PDC receptacle.

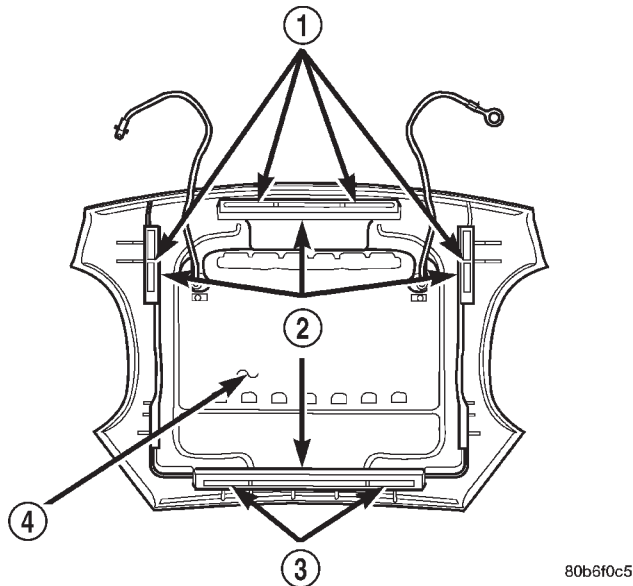
(5) Install the cover onto the PDC.

(6) Reconnect the battery negative cable.

**HORN SWITCH****DESCRIPTION**

A center-blow, normally open, resistive membrane-type horn switch is secured with heat stakes to the back side of the driver side airbag module trim cover in the center of the steering wheel (Fig. 4) . The switch consists of two plastic membranes, one that is flat and one that is slightly convex. These two membranes are secured to each other around the perimeter. Inside the switch, the centers of the facing surfaces of these membranes each has a grid made with an electrically conductive material applied to it. One of the grids is connected to a circuit that provides it with continuity to ground at all times. The grid of the other membrane is connected to the horn relay control circuit.

## HORN SWITCH (Continued)



80b6f0c5

**Fig. 4 Driver Side Airbag Module Trim Cover and Horn Switch**

- 1 - RETAINER SLOTS
- 2 - LOCKING BLOCKS
- 3 - RETAINER SLOTS
- 4 - HORN SWITCH

The steering wheel and steering column must be properly grounded in order for the horn switch to function properly. The horn switch is only serviced as a part of the driver side airbag module trim cover. If the horn switch is damaged or faulty, or if the driver side airbag is deployed, the driver side airbag module trim cover and horn switch must be replaced as a unit.

## OPERATION

When the center area of the driver side airbag trim cover is depressed, the electrically conductive grids on the facing surfaces of the horn switch membranes contact each other, closing the switch circuit. The completed horn switch circuit provides a ground for the control coil side of the horn relay, which activates the relay. When the horn switch is released, the resistive tension of the convex membrane separates the two electrically conductive grids and opens the switch circuit.

## DIAGNOSIS AND TESTING

### DIAGNOSIS AND TESTING - HORN SWITCH

For complete circuit diagrams, refer to the appropriate wiring information. The wiring information includes wiring diagrams, proper wire and connector repair procedures, details of wire harness routing and retention, connector pin-out information and

location views for the various wire harness connectors, splices and grounds.

**WARNING: ON VEHICLES EQUIPPED WITH AIRBAGS, REFER TO ELECTRICAL, RESTRAINTS BEFORE ATTEMPTING ANY STEERING WHEEL, STEERING COLUMN, OR INSTRUMENT PANEL COMPONENT DIAGNOSIS OR SERVICE. FAILURE TO TAKE THE PROPER PRECAUTIONS COULD RESULT IN ACCIDENTAL AIRBAG DEPLOYMENT AND POSSIBLE PERSONAL INJURY.**

(1) Disconnect and isolate the battery negative cable. Remove the steering column opening cover from the instrument panel.

(2) Check for continuity between the metal steering column jacket and a good ground. There should be continuity. If OK, go to Step 3. If not OK, (Refer to 19 - STEERING/COLUMN - INSTALLATION) for proper installation of the steering column.

(3) Remove the driver side airbag module from the steering wheel. Disconnect the horn switch wire harness connectors from the driver side airbag module.

(4) Remove the horn relay from the Power Distribution Center (PDC). Check for continuity between the steering column half of the horn switch feed wire harness connector and a good ground. There should be no continuity. If OK, go to Step 5. If not OK, repair the shorted horn relay control circuit to the horn relay in the PDC as required.

(5) Check for continuity between the steering column half of the horn switch feed wire harness connector and the horn relay control circuit cavity for the horn relay in the PDC. There should be continuity. If OK, go to Step 6. If not OK, repair the open horn relay control circuit to the horn relay in the PDC as required.

(6) Check for continuity between the horn switch feed wire and the horn switch ground wire on the driver side airbag module. There should be no continuity. If OK, go to Step 7. If not OK, replace the faulty horn switch.

(7) Depress the center of the driver side airbag module trim cover and check for continuity between the horn switch feed wire and the horn switch ground wire on the driver side airbag module. There should now be continuity. If not OK, replace the faulty horn switch.

## REMOVAL

If the horn switch is damaged or faulty, or if the driver side airbag is deployed, the driver side airbag module trim cover and horn switch must be replaced as a unit. (Refer to 8 - ELECTRICAL/RESTRAINTS/DRIVER AIRBAG - REMOVAL).





# IGNITION CONTROL

## TABLE OF CONTENTS

	page	page
<b>IGNITION CONTROL</b>		
DESCRIPTION . . . . .	1	
OPERATION . . . . .	1	
SPECIFICATIONS . . . . .	2	
<b>AUTOMATIC SHUT DOWN RELAY</b>		
DESCRIPTION . . . . .	3	
OPERATION . . . . .	3	
DIAGNOSIS AND TESTING . . . . .	3	
ASD AND FUEL PUMP RELAYS . . . . .	3	
REMOVAL . . . . .	4	
INSTALLATION . . . . .	5	
<b>CAMSHAFT POSITION SENSOR</b>		
DESCRIPTION . . . . .	5	
OPERATION . . . . .	5	
REMOVAL . . . . .	7	
INSTALLATION . . . . .	8	
<b>DISTRIBUTOR</b>		
DESCRIPTION . . . . .	10	
OPERATION . . . . .	11	
REMOVAL . . . . .	11	
INSTALLATION . . . . .	11	
<b>DISTRIBUTOR CAP</b>		
DIAGNOSIS AND TESTING . . . . .	12	
DISTRIBUTOR CAP . . . . .	12	
<b>DISTRIBUTOR ROTOR</b>		
DIAGNOSIS AND TESTING . . . . .	13	
DISTRIBUTOR ROTOR . . . . .	13	
<b>IGNITION COIL</b>		
DESCRIPTION . . . . .	13	
OPERATION . . . . .	14	
REMOVAL . . . . .	14	
INSTALLATION . . . . .	15	
<b>SPARK PLUG</b>		
DESCRIPTION . . . . .	16	
OPERATION . . . . .	16	
DIAGNOSIS AND TESTING . . . . .	16	
SPARK PLUG CONDITIONS . . . . .	16	
REMOVAL . . . . .	18	
CLEANING . . . . .	19	
INSTALLATION . . . . .	19	
<b>SPARK PLUG CABLE</b>		
DESCRIPTION . . . . .	19	
OPERATION . . . . .	19	
DIAGNOSIS AND TESTING . . . . .	19	
SPARK PLUG CABLES . . . . .	19	
REMOVAL . . . . .	20	
INSTALLATION . . . . .	20	

## IGNITION CONTROL

### DESCRIPTION - 8.0L V-10

The ignition system used on the 8.0L V-10 engine does not use a conventional mechanical distributor. The system will be referred to as a distributor-less ignition system.

### DESCRIPTION - V-6/V-8

The ignition systems used on the 3.9L V-6, the 5.2L V-8 and the 5.9L V-8 are basically identical.

### OPERATION - 8.0L V-10

The ignition coils are individually fired, but each coil is a dual output. Refer to Ignition Coil for additional information.

The ignition system is controlled by the Powertrain Control Module (PCM) on all engines.

The ignition system consists of:

- Spark Plugs
- Ignition Coil packs containing individual coils

- Secondary Ignition Cables
- Powertrain Control Module (PCM)
- Also to be considered part of the ignition system are certain inputs from the Crankshaft Position, Camshaft Position, Throttle Position and MAP Sensors

### OPERATION - V-6/V-8

The ignition system is controlled by the Powertrain Control Module (PCM) on all engines.

The ignition system consists of:

- Spark Plugs
- Ignition Coil
- Secondary Ignition Cables
- Distributor (contains rotor and camshaft position sensor)
  - Powertrain Control Module (PCM)
  - Also to be considered part of the ignition system are certain inputs from the Crankshaft Position, Camshaft Position, Throttle Position and MAP Sensors

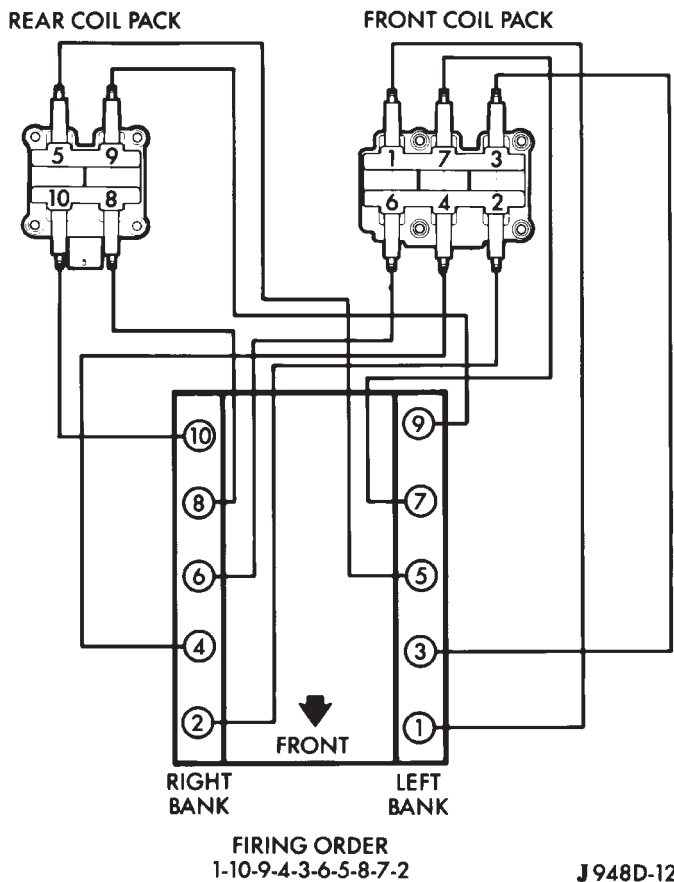
IGNITION CONTROL (Continued)

SPECIFICATIONS

SPECIFICATIONS - TORQUE - IGNITION

DESCRIPTION	N-m	Ft. Lbs.	In. Lbs.
Camshaft Position Sensor—8.0L Engine	6		50
Crankshaft Position Sensor—All Engines	8		70
Distributor Hold Down Bolt	23	17	
Ignition Coil Mounting—3.9L/5.2L/5.9L Engines—if tapped bolts are used	5		50
Ignition Coil Mounting—3.9L/5.2L/5.9L Engines—if nuts/bolts are used	11		100
Ignition Coil Mounting—8.0L Engine	10		90
Spark Plugs (all engines)	41		30

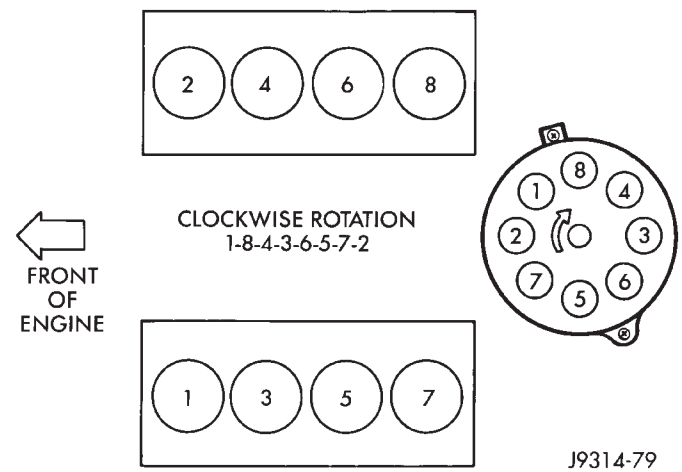
SPARK PLUG CABLE ORDER—8.0L V-10 ENGINE



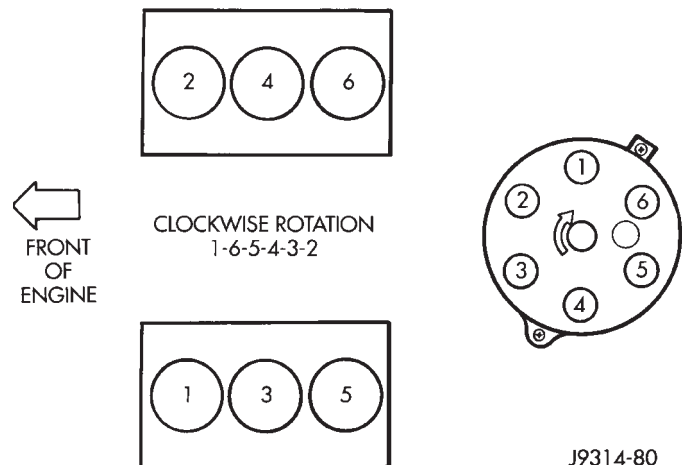
Spark Plug Cable Order—8.0L V-10 Engine

J948D-12

ENGINE FIRING ORDER—5.2L/5.9L V-8 ENGINES



ENGINE FIRING ORDER—3.9L V-6 ENGINE



## IGNITION CONTROL (Continued)

## SPARK PLUG CABLE RESISTANCE

MINIMUM	MAXIMUM
250 Ohms Per Inch	1000 Ohms Per Inch
3000 Ohms Per Foot	12,000 Ohms Per Foot

## SPARK PLUGS

ENGINE	PLUG TYPE	ELECTRODE GAP
3.9L V-6	RC12LC4	1.01 mm (.040 in.)
5.2L/5.9L V-8	RC12LC4	1.01 mm (.040 in.)
8.0L V-10	QC9MC4	1.14 mm (.045 in.)

## IGNITION COIL RESISTANCE—3.9L/5.2L/5.9L ENGINES

COIL MANUFACTURER	PRIMARY RESISTANCE 21-27°C (70-80°F)	SECONDARY RESISTANCE 21-27°C (70-80°F)
Diamond	0.97 - 1.18 Ohms	11,300 - 15,300 Ohms
Toyodenso	0.95 - 1.20 Ohms	11,300 - 13,300 Ohms

IGNITION COIL RESISTANCE—8.0L V-10  
ENGINE

Primary Resistance: 0.53-0.65 Ohms. Test across the primary connector. Refer to text for test procedures.

Secondary Resistance: 10.9-14.7K Ohms. Test across the individual coil towers. Refer to text for test procedures.

## IGNITION TIMING

Ignition timing is not adjustable on any engine.

AUTOMATIC SHUT DOWN  
RELAY

## DESCRIPTION - PCM OUTPUT

The 5-pin, 12-volt, Automatic Shutdown (ASD) relay is located in the Power Distribution Center (PDC). Refer to label on PDC cover for relay location.

## OPERATION - PCM OUTPUT

The ASD relay supplies battery voltage (12+ volts) to the fuel injectors and ignition coil(s). With certain emissions packages it also supplies 12-volts to the oxygen sensor heating elements.

The ground circuit for the coil within the ASD relay is controlled by the Powertrain Control Module (PCM). The PCM operates the ASD relay by switching its ground circuit on and off.

The ASD relay will be shut-down, meaning the 12-volt power supply to the ASD relay will be de-activated by the PCM if:

- the ignition key is left in the ON position. This is if the engine has not been running for approximately 1.8 seconds.
- there is a crankshaft position sensor signal to the PCM that is lower than pre-determined values.

## OPERATION - ASD SENSE - PCM INPUT

A 12 volt signal at this input indicates to the PCM that the ASD has been activated. The relay is used to connect the oxygen sensor heater element, ignition coil and fuel injectors to 12 volt + power supply.

This input is used only to sense that the ASD relay is energized. If the Powertrain Control Module (PCM) does not see 12 volts at this input when the ASD should be activated, it will set a Diagnostic Trouble Code (DTC).

DIAGNOSIS AND TESTING - ASD AND FUEL  
PUMP RELAYS

**The following description of operation and tests apply only to the Automatic Shutdown (ASD) and fuel pump relays.** The terminals on the bottom of each relay are numbered. Two different types of relays may be used, (Fig. 1) or (Fig. 2).

- Terminal number 30 is connected to battery voltage. For both the ASD and fuel pump relays, terminal 30 is connected to battery voltage at all times.

## AUTOMATIC SHUT DOWN RELAY (Continued)

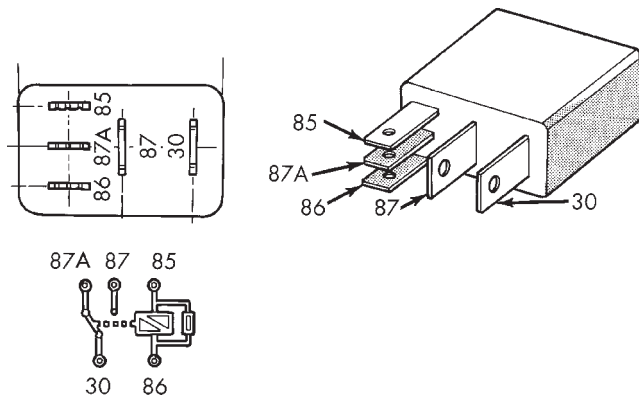


Fig. 1 ASD and Fuel Pump Relay Terminals—Type 1

TERMINAL LEGEND	
NUMBER	IDENTIFICATION
30	COMMON FEED
85	COIL GROUND
86	COIL BATTERY
87	NORMALLY OPEN
87A	NORMALLY CLOSED

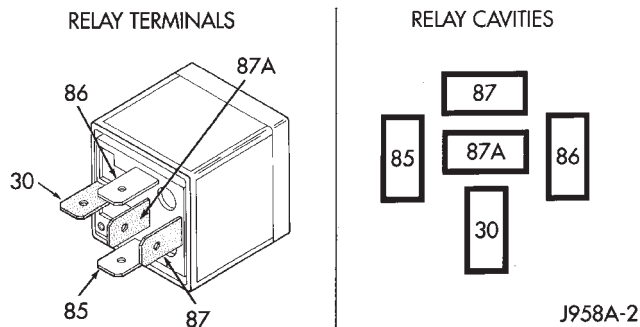


Fig. 2 ASD and Fuel Pump Relay Terminals—Type 2

TERMINAL LEGEND	
NUMBER	IDENTIFICATION
30	COMMON FEED
85	COIL GROUND
86	COIL BATTERY
87	NORMALLY OPEN
87A	NORMALLY CLOSED

- The PCM grounds the coil side of the relay through terminal number 85.
- Terminal number 86 supplies voltage to the coil side of the relay.
- When the PCM de-energizes the ASD and fuel pump relays, terminal number 87A connects to terminal 30. This is the Off position. In the off position, voltage is not supplied to the rest of the circuit. Terminal 87A is the center terminal on the relay.

• When the PCM energizes the ASD and fuel pump relays, terminal 87 connects to terminal 30. This is the On position. Terminal 87 supplies voltage to the rest of the circuit.

The following procedure applies to the ASD and fuel pump relays.

- (1) Remove relay from connector before testing.
- (2) With the relay removed from the vehicle, use an ohmmeter to check the resistance between terminals 85 and 86. The resistance should be 75 ohms +/- 5 ohms.
- (3) Connect the ohmmeter between terminals 30 and 87A. The ohmmeter should show continuity between terminals 30 and 87A.
- (4) Connect the ohmmeter between terminals 87 and 30. The ohmmeter should not show continuity at this time.
- (5) Connect one end of a jumper wire (16 gauge or smaller) to relay terminal 85. Connect the other end of the jumper wire to the ground side of a 12 volt power source.
- (6) Connect one end of another jumper wire (16 gauge or smaller) to the power side of the 12 volt power source. **Do not attach the other end of the jumper wire to the relay at this time.**

**WARNING: DO NOT ALLOW OHMMETER TO CONTACT TERMINALS 85 OR 86 DURING THIS TEST. DAMAGE TO OHMMETER MAY RESULT.**

- (7) Attach the other end of the jumper wire to relay terminal 86. This activates the relay. The ohmmeter should now show continuity between relay terminals 87 and 30. The ohmmeter should not show continuity between relay terminals 87A and 30.

(8) Disconnect jumper wires.

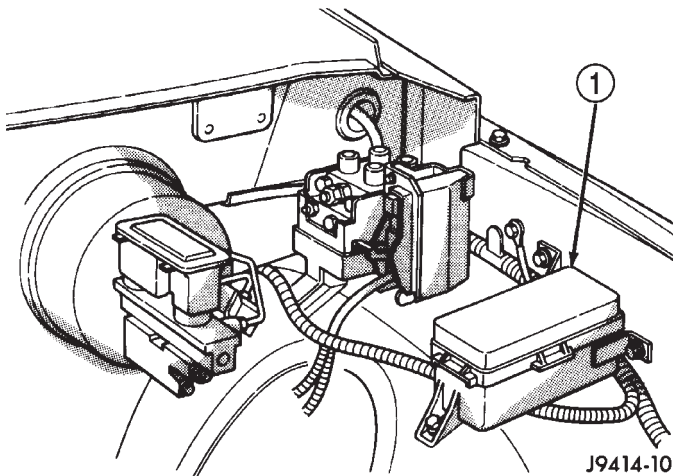
- (9) Replace the relay if it did not pass the continuity and resistance tests. If the relay passed the tests, it operates properly. Check the remainder of the ASD and fuel pump relay circuits. Refer to 8, Wiring Diagrams.

## REMOVAL

The ASD relay is located in the Power Distribution Center (PDC) (Fig. 3). Refer to label on PDC cover for relay location.

- (1) Remove PDC cover.
- (2) Remove relay from PDC.
- (3) Check condition of relay terminals and PDC connector terminals for damage or corrosion. Repair if necessary before installing relay.
- (4) Check for pin height (pin height should be the same for all terminals within the PDC connector). Repair if necessary before installing relay.

## AUTOMATIC SHUT DOWN RELAY (Continued)



**Fig. 3 Power Distribution Center (PDC)**

1 - POWER DISTRIBUTION CENTER (PDC)

### INSTALLATION

The ASD relay is located in the Power Distribution Center (PDC) (Fig. 3). Refer to label on PDC cover for relay location.

- (1) Install relay to PDC.
- (2) Install cover to PDC.

## CAMSHAFT POSITION SENSOR

### DESCRIPTION - DIESEL

The three-wire Camshaft Position Sensor (CMP) is located below the fuel injection pump (Fig. 4). It is attached to the back of the timing gear cover housing.

### DESCRIPTION - 3.9L/5.2L/5.9L

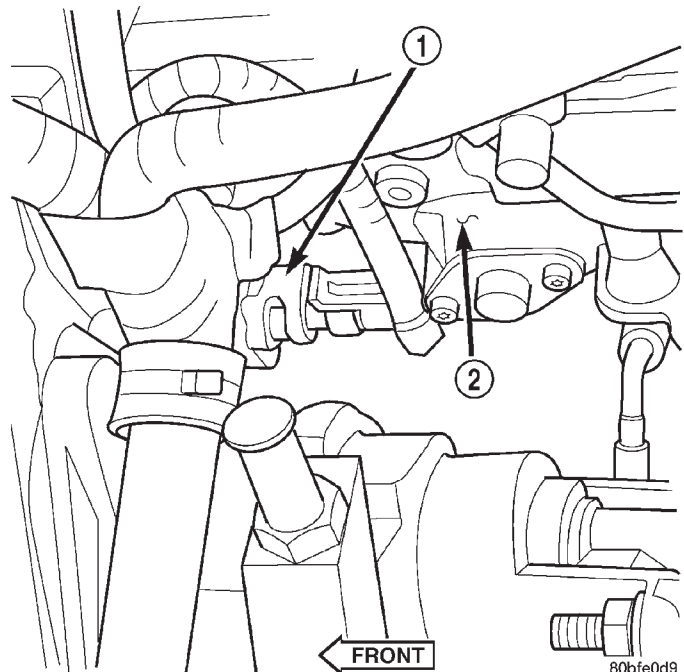
The Camshaft Position (CMP) sensor is located in the distributor.

### DESCRIPTION - 8.0L

The Camshaft Position (CMP) sensor is located on the timing chain case/cover on the left-front side of the engine (Fig. 5).

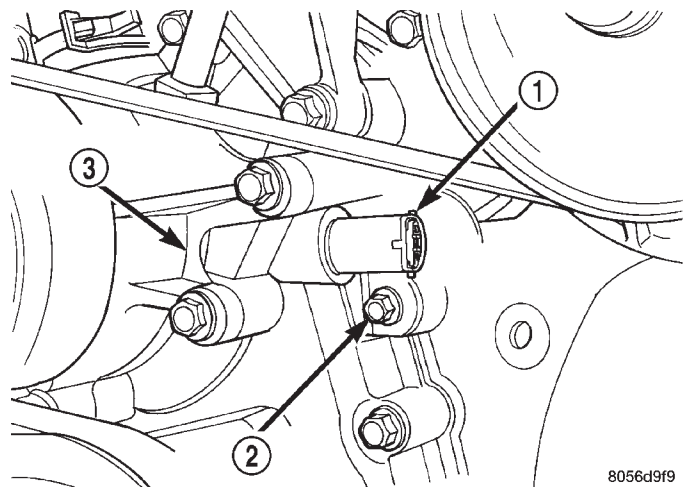
### OPERATION - DIESEL

The Camshaft Position Sensor (CMP) performs multiple functions. One function is to detect engine speed (rpm). Another function is to relate crankshaft position and Top Dead Center (TDC) of the number 1 cylinder. Because the CMP is now used to relate crankshaft position, **the Crankshaft Position Sensor (CKP) is no longer used.**



**Fig. 4 Camshaft Position Sensor (CMP) Location**

1 - CAMSHAFT POSITION SENSOR (CMP)  
2 - BOTTOM OF FUEL INJECTION PUMP



**Fig. 5 CMP Sensor Location—8.0L V-10 Engine**

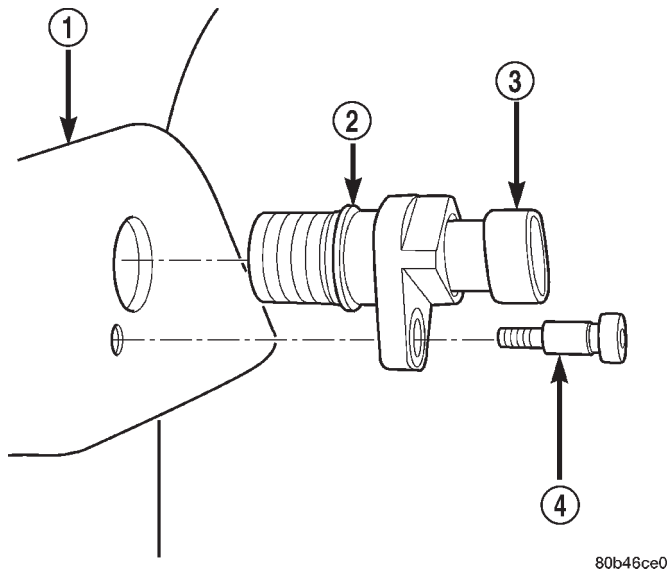
1 - CAMSHAFT POSITION SENSOR  
2 - MOUNTING BOLT  
3 - TIMING CHAIN CASE/COVER

The CMP (Fig. 6) contains a hall effect device called a sync signal generator to generate a sync signal.

The CMP uses three wires (circuits) for operation. One wire supplies a 5-volt signal from the Engine Control Module (ECM). Another wire supplies a sensor ground. The third wire supplies a signal back to the ECM relating engine speed and crankshaft position.

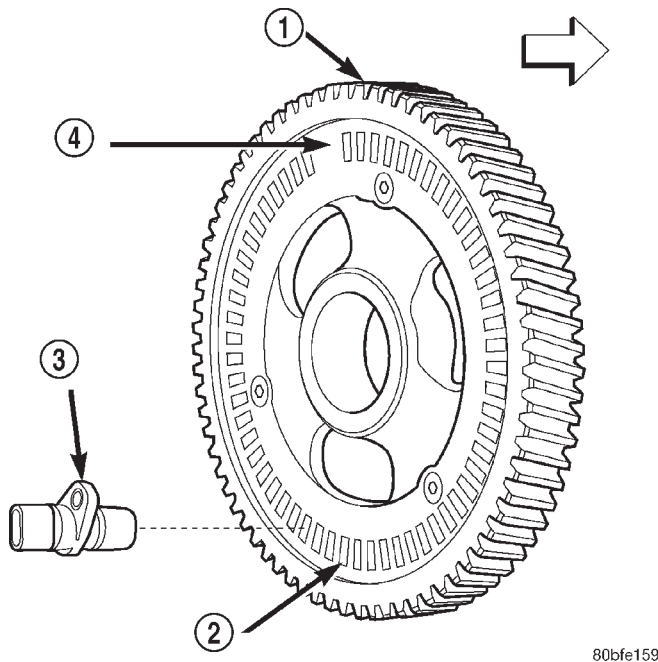


## CAMSHAFT POSITION SENSOR (Continued)



**Fig. 6 Camshaft Position Sensor (CMP)**

- 1 - GEAR HOUSING
- 2 - O-RING
- 3 - CMP SENSOR
- 4 - CMP HEX HEAD BOLT



**Fig. 7 Notches at Rear Of Camshaft Drive Gear**

- 1 - CAMSHAFT DRIVE GEAR
- 2 - NOTCHES
- 3 - CAMSHAFT POSITION SENSOR (CKP)
- 4 - NO NOTCH

The sensor detects machined notches on the rear face of the camshaft drive gear (Fig. 7) to sense engine speed.

The CMP also detects an area on the camshaft drive gear that has no notch (Fig. 7). When the sensor passes this area, it tells the Engine Control Module (ECM) that Top Dead Center (TDC) of the number 1 cylinder is occurring. The ECM will then adjust fuel timing accordingly.

As the tip of the sensor passes the notches, the interruption of magnetic field causes voltage changes from 5 volts to 0 volts.

### OPERATION - 3.9L/5.2L/5.9L

The sensor contains a hall effect device called a sync signal generator to generate a fuel sync signal. This sync signal generator detects a rotating pulse ring (shutter) on the distributor shaft. The pulse ring rotates 180 degrees through the sync signal generator. Its signal is used in conjunction with the Crankshaft Position (CKP) sensor to differentiate between fuel injection and spark events. It is also used to synchronize the fuel injectors with their respective cylinders.

When the leading edge of the pulse ring (shutter) enters the sync signal generator, the following occurs: The interruption of magnetic field causes the voltage to switch high resulting in a sync signal of approximately 5 volts.

When the trailing edge of the pulse ring (shutter) leaves the sync signal generator, the following occurs: The change of the magnetic field causes the sync signal voltage to switch low to 0 volts.

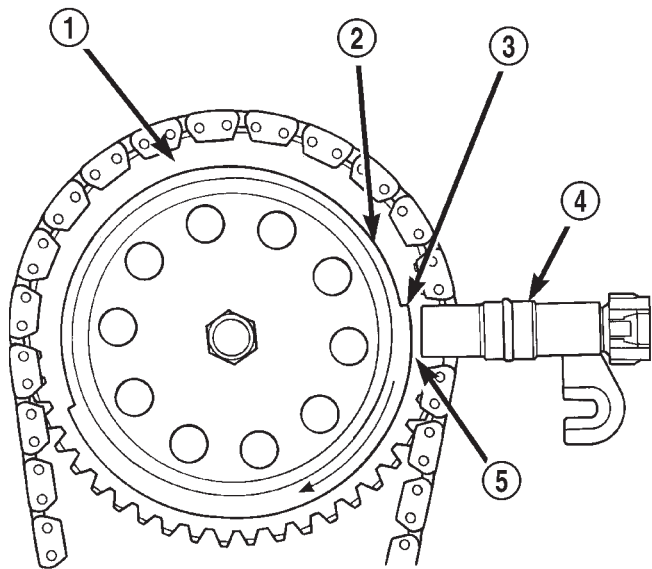
### OPERATION - 8.0L

The CMP sensor is used in conjunction with the crankshaft position sensor to differentiate between fuel injection and spark events. It is also used to synchronize the fuel injectors with their respective cylinders. The sensor generates electrical pulses. These pulses (signals) are sent to the Powertrain Control Module (PCM). The PCM will then determine crankshaft position from both the camshaft position sensor and crankshaft position sensor.

A low and high area are machined into the camshaft drive gear (Fig. 8). The sensor is positioned in the timing gear cover so that a small air gap (Fig. 8) exists between the face of sensor and the high machined area of cam gear.

When the cam gear is rotating, the sensor will detect the machined low area. Input voltage from the sensor to the PCM will then switch from a low (approximately 0.3 volts) to a high (approximately 5 volts). When the sensor detects the high machined area, the input voltage switches back low to approximately 0.3 volts.

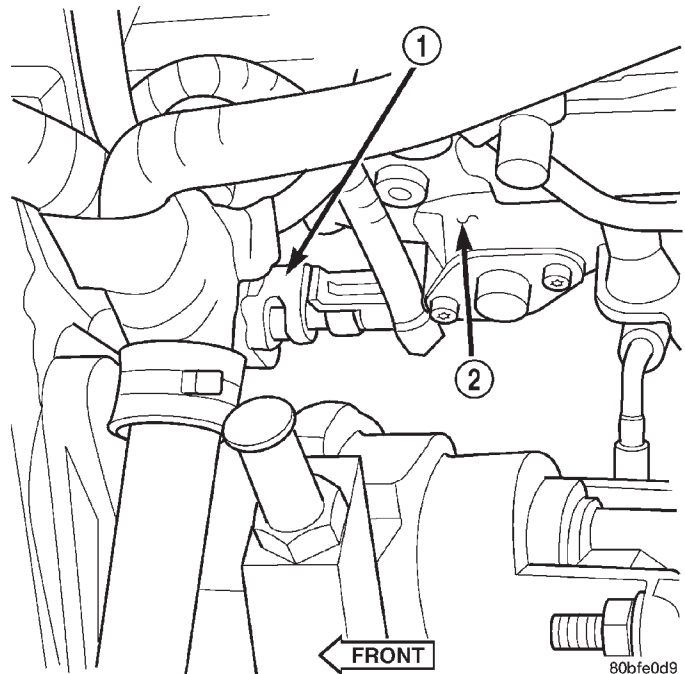
## CAMSHAFT POSITION SENSOR (Continued)



80570e18

**Fig. 8 CMP Sensor Operation—8.0L V-10 Engine**

- 1 - CAM DRIVE GEAR
- 2 - LOW MACHINED AREA
- 3 - HIGH MACHINED AREA
- 4 - CAMSHAFT POSITION SENSOR
- 5 - AIR GAP



80bfe0d9

**Fig. 9 CMP Location - Diesel**

- 1 - CAMSHAFT POSITION SENSOR (CMP)
- 2 - BOTTOM OF FUEL INJECTION PUMP

**REMOVAL - DIESEL**

The camshaft position sensor (CMP) is located below the fuel injection pump (Fig. 9). It is attached to the back of the timing gear cover housing.

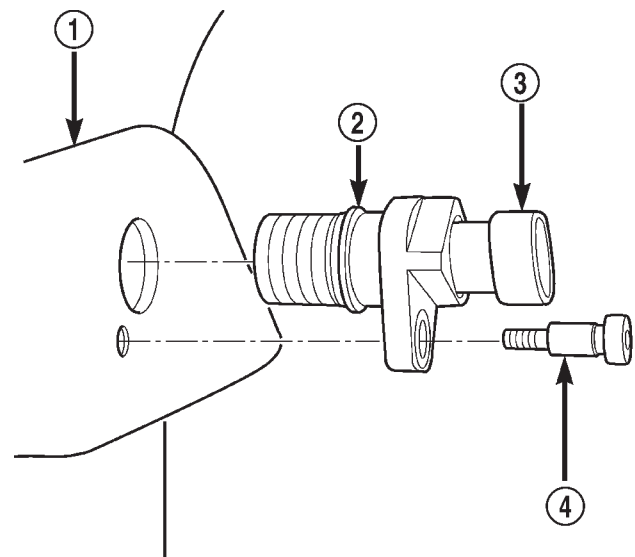
- (1) Disconnect both negative cables from both batteries.
- (2) Clean area around CMP.
- (3) Disconnect electrical at CMP (Fig. 9).
- (4) Remove CMP mounting bolt. Bolt head is female-hex (Fig. 10).
- (5) Remove CMP from engine by twisting and pulling straight back.
- (6) Discard CMP o-ring (Fig. 10).

**REMOVAL - 3.9L/5.2L/5.9L**

The camshaft position sensor is located in the distributor (Fig. 11).

Distributor removal is not necessary to remove camshaft position sensor.

- (1) Remove air cleaner assembly.
- (2) Disconnect negative cable from battery.
- (3) Remove distributor cap from distributor (two screws).
- (4) Disconnect camshaft position sensor wiring harness from main engine wiring harness.
- (5) Remove distributor rotor from distributor shaft.



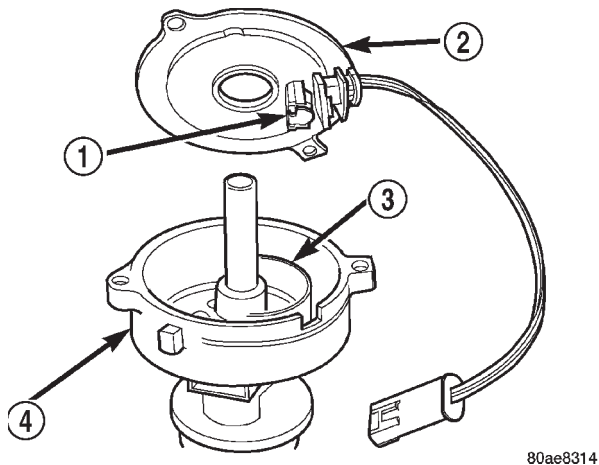
80b46ce0

**Fig. 10 CMP R/I - Diesel**

- 1 - GEAR HOUSING
- 2 - O-RING
- 3 - CMP SENSOR
- 4 - CMP HEX HEAD BOLT

- (6) Lift the camshaft position sensor assembly from the distributor housing (Fig. 11).

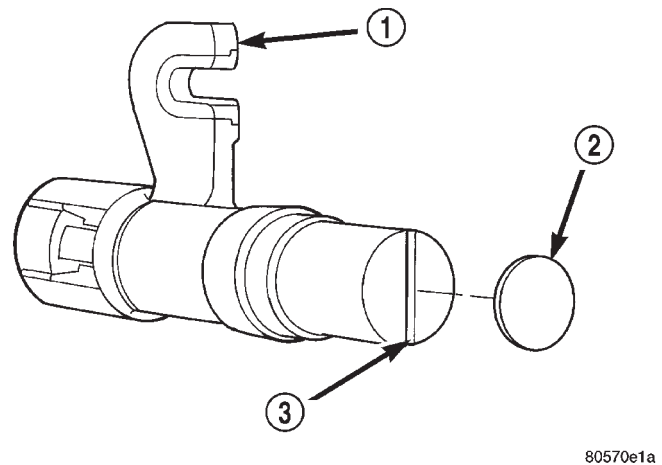
## CAMSHAFT POSITION SENSOR (Continued)



80ae8314

**Fig. 11 Camshaft Position Sensor—Typical**

- 1 - SYNC SIGNAL GENERATOR
- 2 - CAMSHAFT POSITION SENSOR
- 3 - PULSE RING
- 4 - DISTRIBUTOR ASSEMBLY



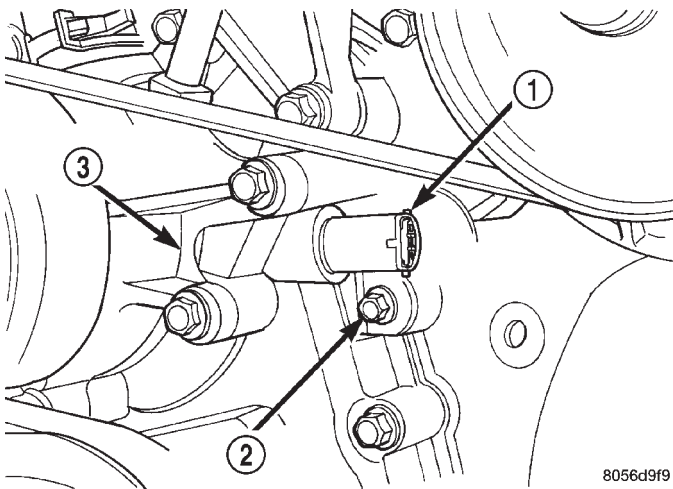
80570e1a

**Fig. 13 Sensor Depth Positioning Rib—8.0L V-10 Engine**

- 1 - CAMSHAFT POSITION SENSOR
- 2 - PAPER SPACER
- 3 - RIB MATERIAL (FOR SENSOR DEPTH POSITIONING)

## REMOVAL - 8.0L

The camshaft position sensor is located on the timing chain case/cover on the left-front side of the engine (Fig. 12).



8056d9f9

**Fig. 12 CMP Location - 8.0L**

- 1 - CAMSHAFT POSITION SENSOR
- 2 - MOUNTING BOLT
- 3 - TIMING CHAIN CASE/COVER

A thin plastic rib is molded into the face of the sensor (Fig. 13) to position the depth of sensor to the upper cam gear (sprocket). This rib can be found on both the new replacement sensors and sensors that were originally installed to the engine. The first time the engine has been operated, part of this rib may be sheared (ground) off. Depending on parts tolerances, some of the rib material may still be observed after removal.

Refer to either of the following procedures; Replacing Old Sensor With Original, or Replacing With New Sensor:

### REPLACING OLD SENSOR WITH ORIGINAL

If the original camshaft position sensor is to be removed and installed, such as when servicing the timing chain, timing gears or timing chain cover, use this procedure.

- (1) Disconnect the sensor harness connector from the sensor.
- (2) Remove the sensor mounting bolt (Fig. 12).
- (3) Carefully pry the sensor from the timing chain case/cover in a rocking action with two small screwdrivers.
- (4) Remove the sensor from vehicle.
- (5) Check condition of sensor o-ring (Fig. 14).

### REPLACING WITH NEW SENSOR

If a new replacement camshaft position sensor is to be installed, use this procedure.

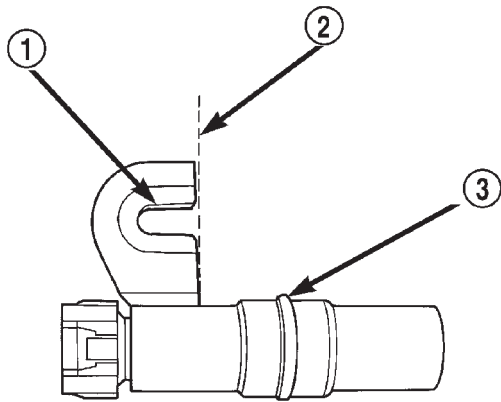
- (1) Disconnect the sensor wiring harness connector from sensor.
- (2) Remove the sensor mounting bolt (Fig. 12).
- (3) Carefully pry the sensor from the timing chain case/cover in a rocking action with two small screwdrivers.
- (4) Remove the sensor from vehicle.

## INSTALLATION - DIESEL

The camshaft position sensor (CMP) is located below the fuel injection pump (Fig. 9). It is attached to the back of the timing gear cover housing.

- (1) Install new o-ring to CMP. Apply clean engine oil to o-ring.

## CAMSHAFT POSITION SENSOR (Continued)



80570e19

**Fig. 14 Camshaft Sensor O-Ring—8.0L**

- 1 - SLOTTED MOUNTING HOLE  
 2 - SCRIBE LINE  
 3 - CAMSHAFT POSITION SENSOR O-RING

- (2) Clean area around CMP mounting hole.  
 (3) To prevent tearing o-ring, install CMP into gear housing using a twisting action.  
 (4) Install mounting bolt and tighten to 20 Nm (15 ft. lbs.) torque.  
 (5) Install electrical connector to CMP.  
 (6) Connect both negative cables to both batteries.

**INSTALLATION - 3.9L/5.2L/5.9L**

The camshaft position sensor is located in the distributor (Fig. 11).

- (1) Install camshaft position sensor to distributor. Align sensor into notch on distributor housing.  
 (2) Connect wiring harness.  
 (3) Install rotor.  
 (4) Install distributor cap. Tighten mounting screws.  
 (5) Install air cleaner assembly.

**INSTALLATION - 8.0L****If Replacing Old Sensor With Original**

The camshaft position sensor is located on the timing chain case/cover on the left-front side of the engine (Fig. 12).

When installing a used camshaft position sensor, the sensor depth must be adjusted to prevent contact with the camshaft gear (sprocket).

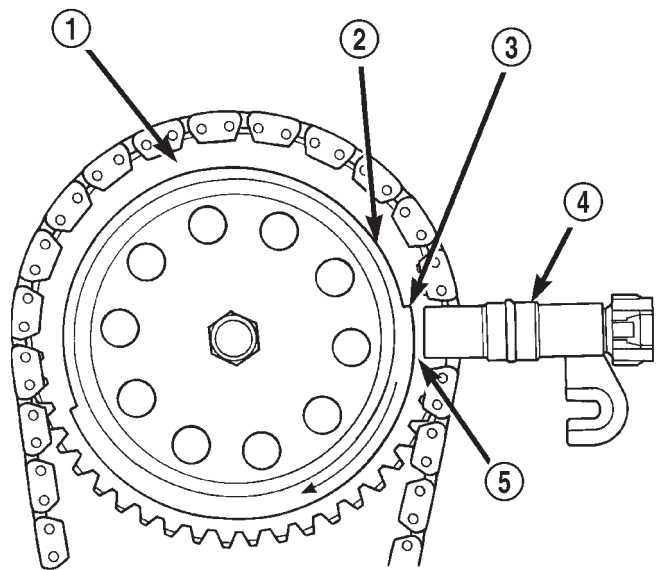
- (1) Observe the face of the sensor. If any of the original rib material remains (Fig. 13), it must be cut down flush to the face of the sensor with a razor knife. Remove only enough of the rib material until the face of the sensor is flat. Do not remove more material than necessary as damage to sensor may result. Due to a high magnetic field and possible electrical damage to the sensor, never use an electric grinder to remove material from sensor.

- (2) From the parts department, obtain a peel-and-stick paper spacer (Fig. 13). These special paper spacers are of a certain thickness and are to be used as a tool to set sensor depth.

- (3) Clean the face of sensor and apply paper spacer (Fig. 13).

- (4) Apply a small amount of engine oil to the sensor o-ring (Fig. 14).

A low and high area are machined into the camshaft drive gear (Fig. 15). The sensor is positioned in the timing gear cover so that a small air gap (Fig. 15) exists between the face of sensor and the high machined area of cam gear.



80570e18

**Fig. 15 Sensor Operation—8.0L V-10 Engine**

- 1 - CAM DRIVE GEAR  
 2 - LOW MACHINED AREA  
 3 - HIGH MACHINED AREA  
 4 - CAMSHAFT POSITION SENSOR  
 5 - AIR GAP

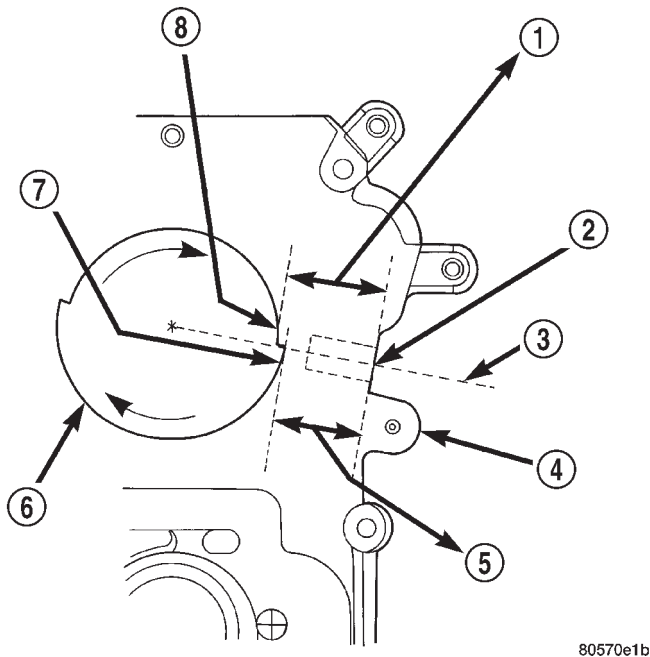
Before the sensor is installed, the cam gear may have to be rotated. This is to allow the high machined area on the gear to be directly in front of the sensor mounting hole opening on the timing gear cover.

**Do not install sensor with gear positioned at low area (Fig. 16) or (Fig. 15). When the engine is started, the sensor will be broken.**

- (5) Using a 1/2 in. wide metal ruler, measure the distance from the cam gear to the face of the sensor mounting hole opening on the timing gear cover (Fig. 16).

- (6) If the dimension is approximately 1.818 inches, it is OK to install sensor. Proceed to step Step 9.

## CAMSHAFT POSITION SENSOR (Continued)



80570e1b

**Fig. 16 Sensor Depth Dimensions**

- 1 - 2.018" **DO NOT INSTALL SENSOR**
- 2 - SENSOR MOUNTING HOLE OPENING
- 3 - SENSOR CENTER LINE
- 4 - TIMING CHAIN COVER
- 5 - 1.818" **OK TO INSTALL SENSOR**
- 6 - CAM DRIVE GEAR
- 7 - HIGH MACHINED AREA
- 8 - LOW MACHINED AREA

(7) If the dimension is approximately 2.018 inches, the cam gear will have to be rotated.

(8) Attach a socket to the vibration damper mounting bolt and rotate engine until the 1.818 inch dimension is attained.

(9) Install the sensor into the timing case/cover with a slight rocking action until the paper spacer contacts the camshaft gear. Do not install the sensor mounting bolt. Do not twist the sensor into position as damage to the o-ring or tearing of the paper spacer may result.

(10) Scratch a scribe line into the timing chain case/cover to indicate depth of sensor (Fig. 14).

(11) Remove the sensor from timing chain case/cover.

(12) Remove the paper spacer from the sensor. This step must be followed to prevent the paper spacer from getting into the engine lubrication system.

(13) Again, apply a small amount of engine oil to sensor o-ring.

(14) Again, install the sensor into the timing case/cover with a slight rocking action until the sensor is aligned to scribe line.

(15) Install sensor mounting bolt and tighten to 6 N·m (50 in. lbs.) torque.

(16) Connect engine wiring harness to sensor.

**Replacing With a New Sensor**

(1) Apply a small amount of engine oil to the sensor o-ring (Fig. 14).

A low and high area are machined into the camshaft drive gear (Fig. 15). The sensor is positioned in the timing gear cover so that a small air gap (Fig. 15) exists between the face of sensor and the high machined area of cam gear.

Before the sensor is installed, the cam gear may have to be rotated. This is to allow the high machined area on the gear to be directly in front of the sensor mounting hole opening on the timing gear cover.

**Do not install sensor with gear positioned at low area (Fig. 16) or (Fig. 15). When the engine is started, the sensor will be broken.**

(2) Using a 1/2 in. wide metal ruler, measure the distance from the cam gear to the face of the sensor mounting hole opening on the timing gear cover (Fig. 16).

(3) If the dimension is approximately 1.818 inches, it is OK to install sensor. Proceed to step Step 9.

(4) If the dimension is approximately 2.018 inches, the cam gear will have to be rotated.

(5) Attach a socket to the vibration damper mounting bolt and rotate engine until the 1.818 inch dimension is attained.

(6) Install the sensor into the timing case/cover with a slight rocking action. Do not twist the sensor into position as damage to the o-ring may result. Push the sensor all the way into the cover until the rib material on the sensor (Fig. 13) contacts the camshaft gear.

(7) Install the mounting bolt and tighten to 6 N·m (50 in. lbs.) torque.

(8) Connect sensor wiring harness to engine harness.

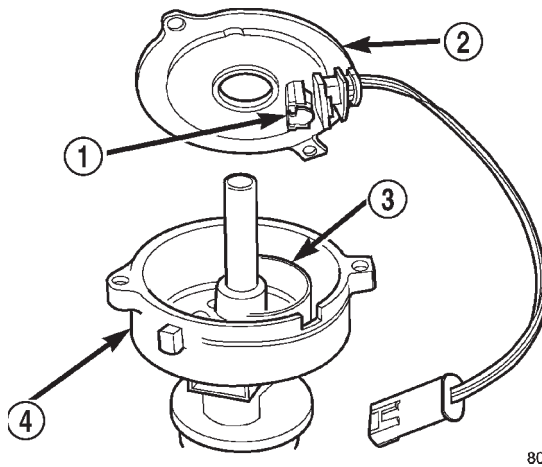
When the engine is started, the rib material will be sheared off the face of sensor. This will automatically set sensor air gap.

**DISTRIBUTOR****DESCRIPTION**

All 3.9L/5.2L/5.9L engines are equipped with a camshaft driven mechanical distributor (Fig. 17) containing a shaft driven distributor rotor. All distributors are equipped with an internal camshaft position (fuel sync) sensor (Fig. 17).



## DISTRIBUTOR (Continued)



80ae8314

**Fig. 17 Distributor and Camshaft Position Sensor**

- 1 - SYNC SIGNAL GENERATOR
- 2 - CAMSHAFT POSITION SENSOR
- 3 - PULSE RING
- 4 - DISTRIBUTOR ASSEMBLY

## OPERATION

The camshaft position sensor provides fuel injection synchronization and cylinder identification.

The distributor does not have built in centrifugal or vacuum assisted advance. Base ignition timing and all timing advance is controlled by the Powertrain Control Module (PCM). Because ignition timing is controlled by the PCM, **base ignition timing is not adjustable.**

The distributor is held to the engine in the conventional method using a holddown clamp and bolt. **Although the distributor can be rotated, it will have no effect on ignition timing.**

All distributors contain an internal oil seal that prevents oil from entering the distributor housing. The seal is not serviceable.

## REMOVAL

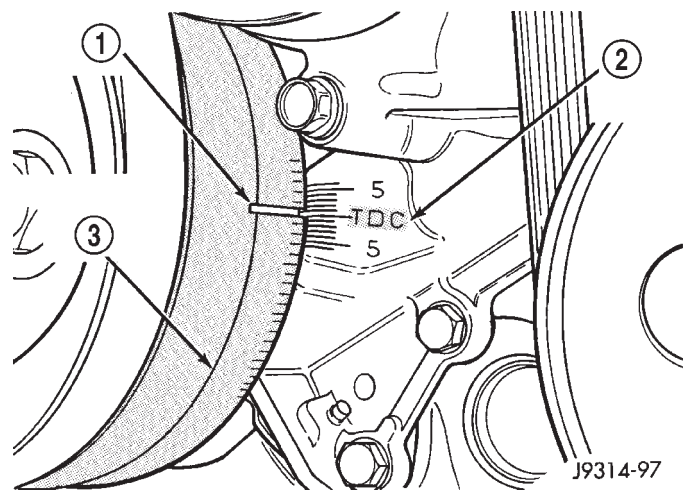
**CAUTION:** Base ignition timing is not adjustable on any engine. Distributors do not have built in centrifugal or vacuum assisted advance. Base ignition timing and timing advance are controlled by the Powertrain Control Module (PCM). Because a conventional timing light can not be used to adjust distributor position after installation, note position of distributor before removal.

- (1) Remove air cleaner assembly.
- (2) Disconnect negative cable from battery.
- (3) Remove distributor cap from distributor (two screws).
- (4) Mark the position of distributor housing in relationship to engine or dash panel. This is done to aid in installation.

(5) Before distributor is removed, the number one cylinder must be brought to the Top Dead Center (TDC) firing position.

(6) Attach a socket to the Crankshaft Vibration Damper mounting bolt.

(7) Slowly rotate engine clockwise, as viewed from front, until indicating mark on crankshaft vibration damper is aligned to 0 degree (TDC) mark on timing chain cover (Fig. 18).



J9314-97

**Fig. 18 Damper-To-Cover Alignment Marks—Typical**

- 1 - ALIGNMENT MARK
- 2 - TIMING CHAIN COVER MARKS
- 3 - CRANKSHAFT VIBRATION DAMPER

(8) The distributor rotor should now be aligned to the CYL. NO. 1 alignment mark (stamped) into the camshaft position sensor (Fig. 19). If not, rotate the crankshaft through another complete 360 degree turn. Note the position of the number one cylinder spark plug cable (on the cap) in relation to rotor. Rotor should now be aligned to this position.

(9) Disconnect camshaft position sensor wiring harness from main engine wiring harness.

(10) Remove distributor rotor from distributor shaft.

(11) Remove distributor holddown clamp bolt and clamp (Fig. 20). Remove distributor from vehicle.

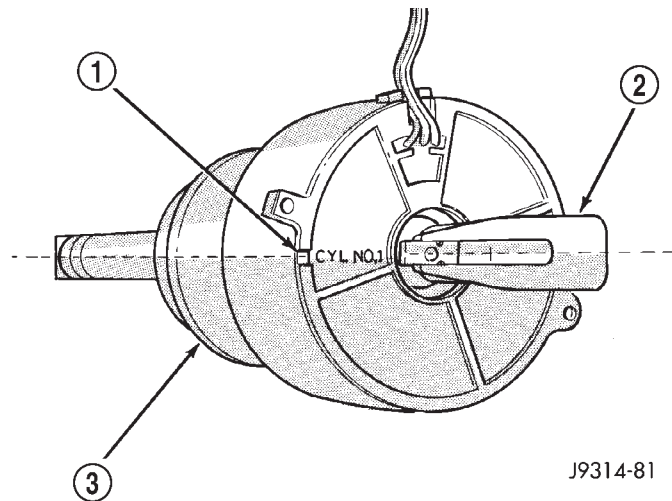
**CAUTION:** Do not crank engine with distributor removed. Distributor/crankshaft relationship will be lost.

## INSTALLATION

If engine has been cranked while distributor is removed, establish the relationship between distributor shaft and number one piston position as follows:

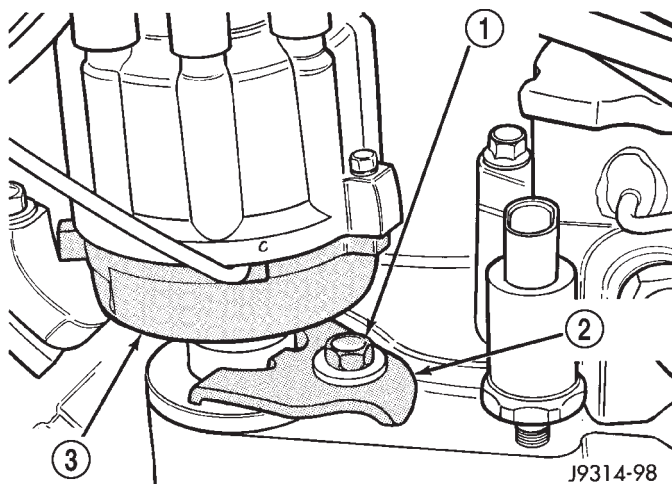
Rotate crankshaft in a clockwise direction, as viewed from front, until number one cylinder piston is at top of compression stroke (compression should be felt on finger with number one spark plug

## DISTRIBUTOR (Continued)



**Fig. 19 Rotor Alignment Mark**

- 1 - CAMSHAFT POSITION SENSOR ALIGNMENT MARK
- 2 - ROTOR
- 3 - DISTRIBUTOR



**Fig. 20 Distributor Holddown Clamp**

- 1 - CLAMP BOLT
- 2 - HOLDDOWN CLAMP
- 3 - DISTRIBUTOR HOUSING

removed). Then continue to slowly rotate engine clockwise until indicating mark (Fig. 18) is aligned to 0 degree (TDC) mark on timing chain cover.

(1) Clean top of cylinder block for a good seal between distributor base and block.

(2) Lightly oil the rubber o-ring seal on the distributor housing.

(3) Install rotor to distributor shaft.

(4) Position distributor into engine to its original position. Engage tongue of distributor shaft with slot in distributor oil pump drive gear. Position rotor to the number one spark plug cable position.

(5) Install distributor holddown clamp and clamp bolt. Do not tighten bolt at this time.

(6) Rotate the distributor housing until rotor is aligned to CYL. NO. 1 alignment mark on the camshaft position sensor (Fig. 19).

(7) Tighten clamp holddown bolt (Fig. 20) to 22.5 N-m (200 in. lbs.) torque.

(8) Connect camshaft position sensor wiring harness to main engine harness.

(9) Install distributor cap. Tighten mounting screws.

(10) Refer to the following, Checking Distributor Position.

#### Checking Distributor Position

To verify correct distributor rotational position, the DRB scan tool must be used.

**WARNING: WHEN PERFORMING THE FOLLOWING TEST, THE ENGINE WILL BE RUNNING. BE CAREFUL NOT TO STAND IN LINE WITH THE FAN BLADES OR FAN BELT. DO NOT WEAR LOOSE CLOTHING.**

(1) Connect DRB scan tool to data link connector. The data link connector is located in passenger compartment, below and to left of steering column.

(2) Gain access to SET SYNC screen on DRB.

(3) Follow directions on DRB screen and start engine. Bring to operating temperature (engine must be in "closed loop" mode).

(4) With engine running at **idle speed**, the words IN RANGE should appear on screen along with 0°. This indicates correct distributor position.

(5) If a plus (+) or a minus (-) is displayed next to degree number, and/or the degree displayed is not zero, loosen but do not remove distributor holddown clamp bolt. Rotate distributor until IN RANGE appears on screen. Continue to rotate distributor until achieving as close to 0° as possible. After adjustment, tighten clamp bolt to 22.5 N-m (200 in. lbs.) torque.

The degree scale on SET SYNC screen of DRB is referring to fuel synchronization only. **It is not referring to ignition timing.** Because of this, do not attempt to adjust ignition timing using this method. Rotating distributor will have no effect on ignition timing. All ignition timing values are controlled by powertrain control module (PCM).

After testing, install air cleaner assembly.

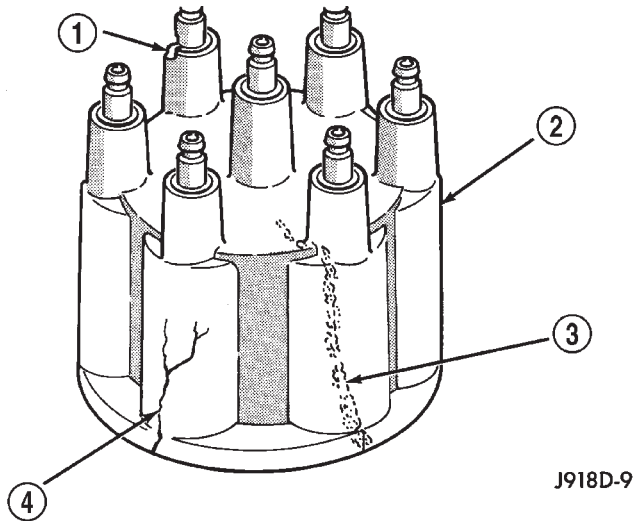
## DISTRIBUTOR CAP

### DIAGNOSIS AND TESTING - DISTRIBUTOR CAP

Remove the distributor cap and wipe it clean with a dry lint free cloth. Visually inspect the cap for cracks, carbon paths, broken towers or damaged

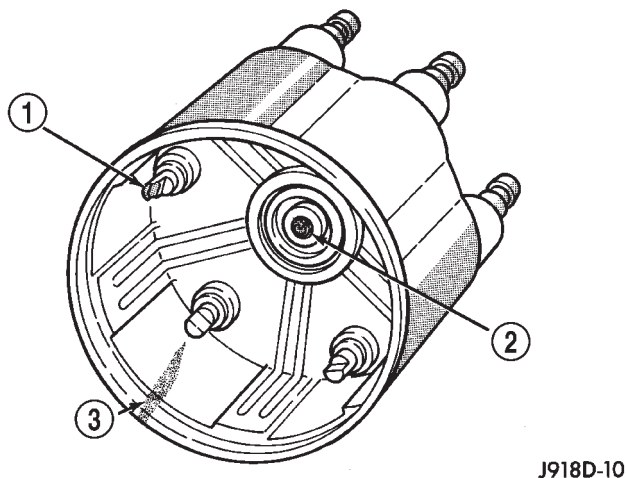
## DISTRIBUTOR CAP (Continued)

rotor button (Fig. 21) or (Fig. 22). Also check for white deposits on the inside (caused by condensation entering the cap through cracks). Replace any cap that displays charred or eroded terminals. The machined surface of a terminal end (faces toward rotor) will indicate some evidence of erosion from normal operation. Examine the terminal ends for evidence of mechanical interference with the rotor tip.



**Fig. 21 Cap Inspection—External—Typical**

- 1 - BROKEN TOWER
- 2 - DISTRIBUTOR CAP
- 3 - CARBON PATH
- 4 - CRACK



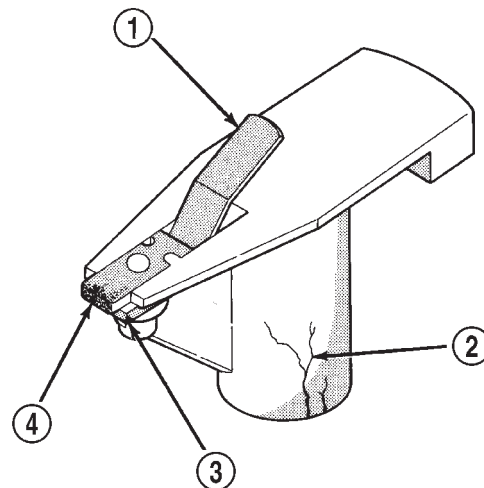
**Fig. 22 Cap Inspection—Internal—Typical**

- 1 - CHARRED OR ERODED TERMINALS
- 2 - WORN OR DAMAGED ROTOR BUTTON
- 3 - CARBON PATH

## DISTRIBUTOR ROTOR

## DIAGNOSIS AND TESTING - DISTRIBUTOR ROTOR

Visually inspect the rotor (Fig. 23) for cracks, evidence of corrosion or the effects of arcing on the metal tip. Also check for evidence of mechanical interference with the cap. Some charring is normal on the end of the metal tip. The silicone-dielectric-varnish-compound applied to the rotor tip for radio interference noise suppression, will appear charred. This is normal. **Do not remove the charred compound.** Test the spring for insufficient tension. Replace a rotor that displays any of these adverse conditions.



**Fig. 23 Rotor Inspection—Typical**

- 1 - INSUFFICIENT SPRING TENSION
- 2 - CRACKS
- 3 - EVIDENCE OF PHYSICAL CONTACT WITH CAP
- 4 - ROTOR TIP CORRODED

## IGNITION COIL

## DESCRIPTION - 3.9L/5.2L/5.9L

A single ignition coil is used. The coil is not oil filled. The coil windings are embedded in an epoxy compound. This provides heat and vibration resistance that allows the coil to be mounted on the engine.

## DESCRIPTION - 8.0L

Two separate coil packs containing a total of five independent coils are attached to a common mounting bracket. They are located above the right engine valve cover (Fig. 24). The coil packs are not oil filled. The front coil pack contains three independent epoxy

## IGNITION COIL (Continued)

filled coils. The rear coil pack contains two independent epoxy filled coils.

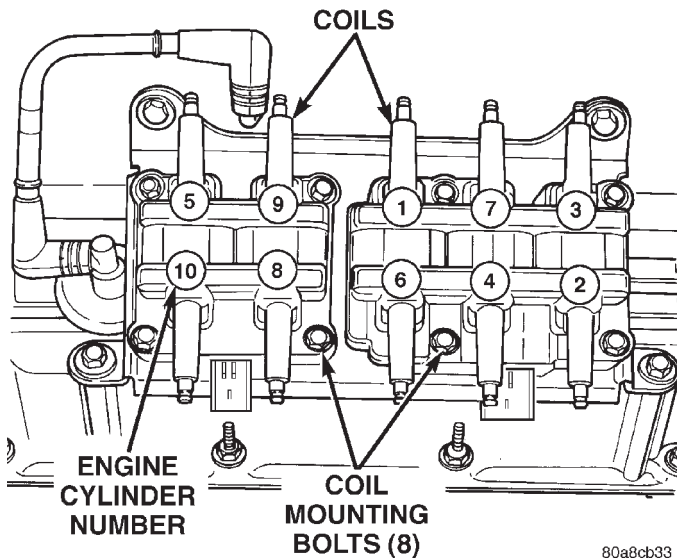


Fig. 24 Ignition Coil Packs—8.0L V-10 Engine

## OPERATION - 3.9L/5.2L/5.9L

The Powertrain Control Module (PCM) opens and closes the ignition coil ground circuit for ignition coil operation.

Battery voltage is supplied to the ignition coil positive terminal from the ASD relay. If the PCM does not see a signal from the crankshaft and camshaft sensors (indicating the ignition key is ON but the engine is not running), it will shut down the ASD circuit.

**Base ignition timing is not adjustable on any engine.** By controlling the coil ground circuit, the PCM is able to set the base timing and adjust the ignition timing advance. This is done to meet changing engine operating conditions.

## OPERATION - 8.0L

When one of the 5 independent coils discharges, it fires two paired cylinders at the same time (one cylinder on compression stroke and the other cylinder on exhaust stroke).

Coil firing is paired together on cylinders:

- Number 5 and 10
- Number 9 and 8
- Number 1 and 6
- Number 7 and 4
- Number 3 and 2

The ignition system is controlled by the Powertrain Control Module (PCM) on all engines.

Battery voltage is supplied to all of the ignition coils positive terminals from the ASD relay. If the PCM does not see a signal from the crankshaft and camshaft sensors (indicating the ignition key is ON

but the engine is not running), it will shut down the ASD circuit.

**Base ignition timing is not adjustable on the 8.0L V-10 engine.** By controlling the coil ground circuit, the PCM is able to set the base timing and adjust the ignition timing advance. This is done to meet changing engine operating conditions.

The PCM adjusts ignition timing based on inputs it receives from:

- The engine coolant temperature sensor
- The crankshaft position sensor (engine speed)
- The manifold absolute pressure (MAP) sensor
- The throttle position sensor
- Transmission gear selection

## REMOVAL - 3.9L/5.2L/5.9L

The ignition coil is an epoxy filled type. If the coil is replaced, it must be replaced with the same type.

3.9L V-6 or 5.2/5.9L V-8 LDC-Gas Engines: The coil is mounted to a bracket that is bolted to the front of the right engine cylinder head (Fig. 25). This bracket is mounted on top of the automatic belt tensioner bracket using common bolts.

5.9L V-8 HDC-Gas Engine: The coil is mounted to a bracket that is bolted to the air injection pump (AIR pump) mounting bracket (Fig. 26).

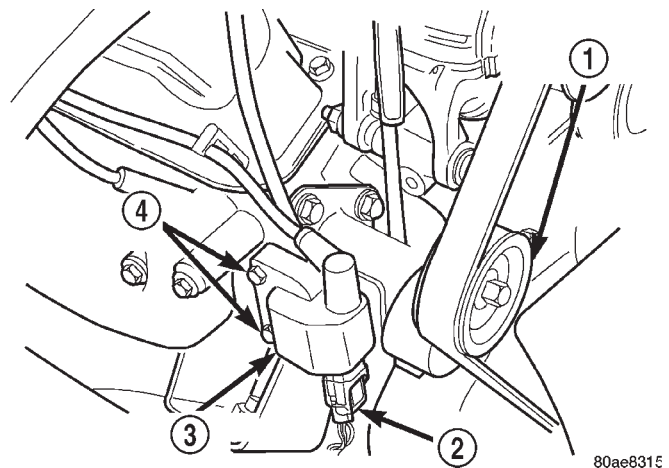


Fig. 25 Ignition Coil—3.9L V-6 or 5.2/5.9L V-8 LDC-Gas Engines

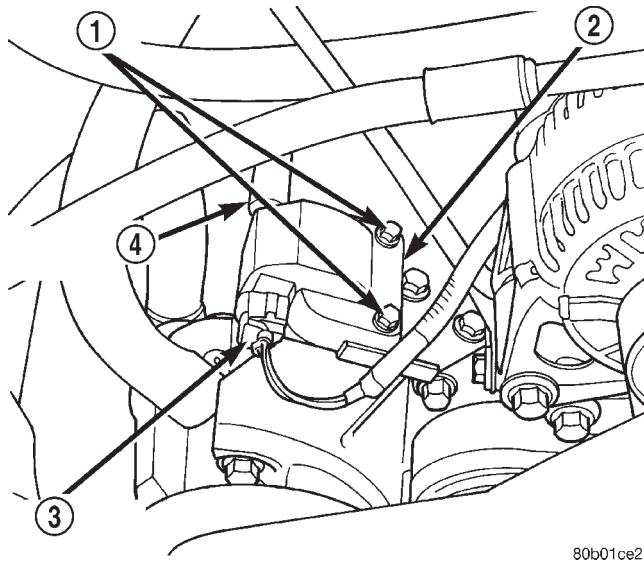
- 1 - ACCESSORY DRIVE BELT TENSIONER
- 2 - COIL CONNECTOR
- 3 - IGNITION COIL
- 4 - COIL MOUNTING BOLTS

(1) Disconnect the primary wiring from the ignition coil.

(2) Disconnect the secondary spark plug cable from the ignition coil.



## IGNITION COIL (Continued)



80b01ce2

**Fig. 26 Ignition Coil—5.9L V-8 HDC-Gas Engine**

- 1 - COIL MOUNTING BOLTS
- 2 - IGNITION COIL
- 3 - COIL ELEC. CONNECTOR
- 4 - SECONDARY CABLE

**WARNING: 3.9L V-6 OR 5.2/5.9L V-8 LDC-GAS ENGINES: DO NOT REMOVE THE COIL MOUNTING BRACKET-TO-CYLINDER HEAD MOUNTING BOLTS. THE COIL MOUNTING BRACKET IS UNDER ACCESSORY DRIVE BELT TENSION. IF THIS BRACKET IS TO BE REMOVED FOR ANY REASON, ALL BELT TENSION MUST FIRST BE RELIEVED. REFER TO THE BELT SECTION OF GROUP 7, COOLING SYSTEM.**

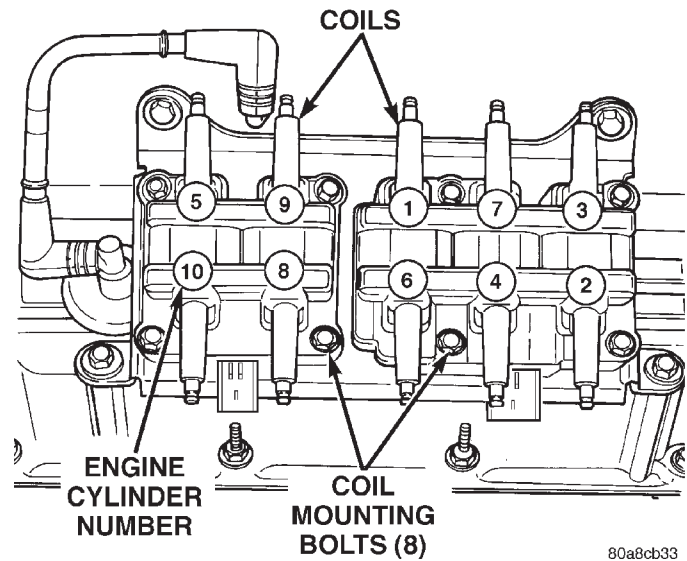
(3) Remove ignition coil from coil mounting bracket (two bolts).

### REMOVAL - 8.0L

Two separate coil packs containing a total of five independent coils are attached to a common mounting bracket located above the right engine valve cover (Fig. 27). The front and rear coil packs can be serviced separately.

(1) Remove the secondary spark plug cables from the coil packs. Note position of cables before removal.

(2) Disconnect the primary wiring harness connectors at coil packs.



80a8cb33

**Fig. 27 Ignition Coil Packs—8.0L V-10 Engine**

(3) Remove the four (4) coil pack-to-coil mounting bracket bolts for the coil pack being serviced (Fig. 27).

(4) Remove coil(s) from mounting bracket.

### INSTALLATION - 3.9L/5.2L/5.9L

The ignition coil is an epoxy filled type. If the coil is replaced, it must be replaced with the same type.

(1) Install the ignition coil to coil bracket. If nuts and bolts are used to secure coil to coil bracket, tighten to 11 N·m (100 in. lbs.) torque. If the coil mounting bracket has been tapped for coil mounting bolts, tighten bolts to 5 N·m (50 in. lbs.) torque.

(2) Connect all wiring to ignition coil.

### INSTALLATION - 8.0L

(1) Position coil packs to mounting bracket (primary wiring connectors face downward).

(2) Install coil pack mounting bolts. Tighten bolts to 10 N·m (90 in. lbs.) torque.

(3) Install coil pack-to-engine mounting bracket (if necessary).

(4) Connect primary wiring connectors to coil packs (four wire connector to front coil pack and three wire connector to rear coil pack).

(5) Connect secondary spark plug cables to coil packs. Refer to (Fig. 28) for correct cable order.



## IGNITION COIL (Continued)

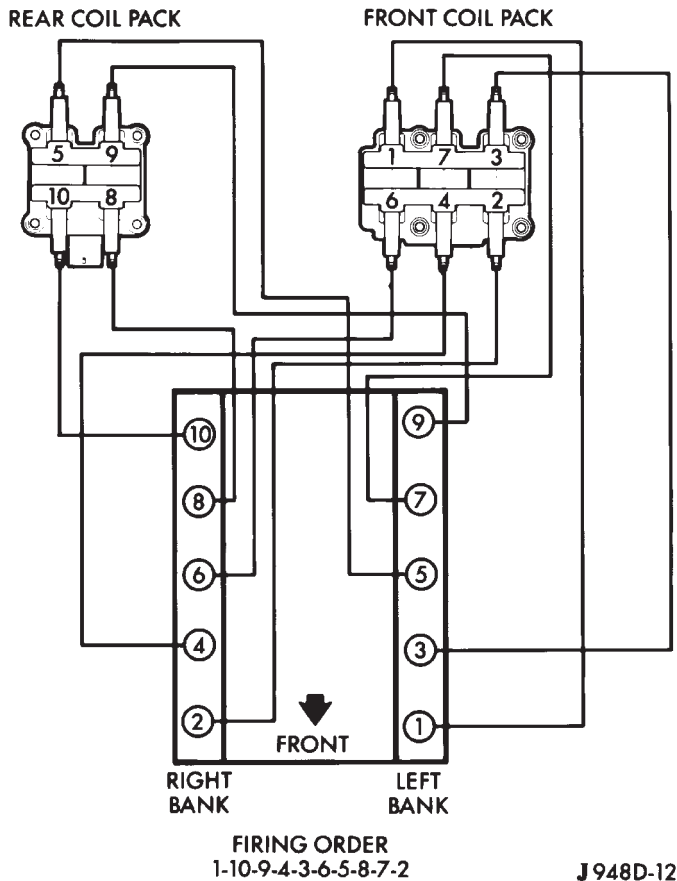


Fig. 28 Spark Plug Cable Order—8.0L V-10 Engine

## SPARK PLUG

## DESCRIPTION

The 3.9L V-6 and 5.2L/5.9L V-8 engines use resistor type spark plugs. The 8.0L V-10 engine uses inductive type spark plugs.

Spark plug resistance values range from 6,000 to 20,000 ohms (when checked with at least a 1000 volt spark plug tester). **Do not use an ohmmeter to check the resistance values of the spark plugs. Inaccurate readings will result.**

## OPERATION

To prevent possible pre-ignition and/or mechanical engine damage, the correct type/heat range/number spark plug must be used.

Always use the recommended torque when tightening spark plugs. Incorrect torque can distort the spark plug and change plug gap. It can also pull the plug threads and do possible damage to both the spark plug and the cylinder head.

Remove the spark plugs and examine them for burned electrodes and fouled, cracked or broken porcelain insulators. Keep plugs arranged in the order in which they were removed from the engine. A sin-

gle plug displaying an abnormal condition indicates that a problem exists in the corresponding cylinder. Replace spark plugs at the intervals recommended in Group O, Lubrication and Maintenance

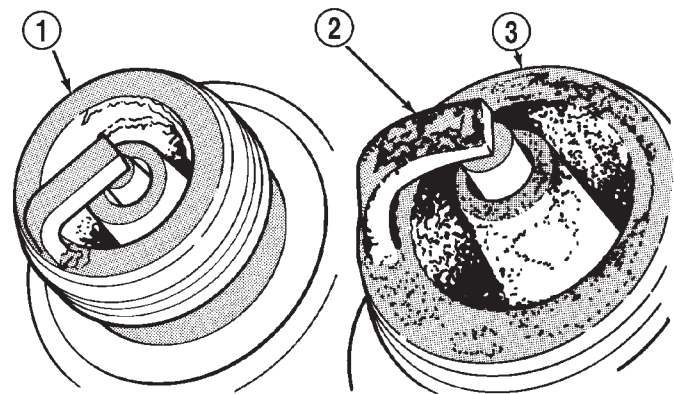
Spark plugs that have low mileage may be cleaned and reused if not otherwise defective, carbon or oil fouled. Also refer to Spark Plug Conditions.

**CAUTION:** Never use a motorized wire wheel brush to clean the spark plugs. Metallic deposits will remain on the spark plug insulator and will cause plug misfire.

## DIAGNOSIS AND TESTING - SPARK PLUG CONDITIONS

## NORMAL OPERATING

The few deposits present on the spark plug will probably be light tan or slightly gray in color. This is evident with most grades of commercial gasoline (Fig. 29). There will not be evidence of electrode burning. Gap growth will not average more than approximately 0.025 mm (.001 in) per 3200 km (2000 miles) of operation. Spark plugs that have normal wear can usually be cleaned, have the electrodes filed, have the gap set and then be installed.



J908D-15

Fig. 29 Normal Operation and Cold (Carbon) Fouling

- 1 - NORMAL
- 2 - DRY BLACK DEPOSITS
- 3 - COLD (CARBON) FOULING

Some fuel refiners in several areas of the United States have introduced a manganese additive (MMT) for unleaded fuel. During combustion, fuel with MMT causes the entire tip of the spark plug to be coated with a rust colored deposit. This rust color can be misdiagnosed as being caused by coolant in the combustion chamber. Spark plug performance may be affected by MMT deposits.

## SPARK PLUG (Continued)

**COLD FOULING/CARBON FOULING**

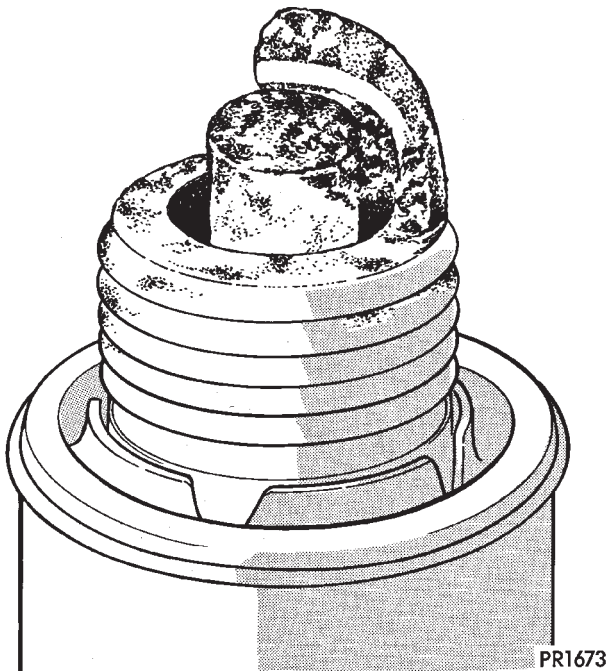
Cold fouling is sometimes referred to as carbon fouling. The deposits that cause cold fouling are basically carbon (Fig. 29). A dry, black deposit on one or two plugs in a set may be caused by sticking valves or defective spark plug cables. Cold (carbon) fouling of the entire set of spark plugs may be caused by a clogged air cleaner element or repeated short operating times (short trips).

**WET FOULING OR GAS FOULING**

A spark plug coated with excessive wet fuel or oil is wet fouled. In older engines, worn piston rings, leaking valve guide seals or excessive cylinder wear can cause wet fouling. In new or recently overhauled engines, wet fouling may occur before break-in (normal oil control) is achieved. This condition can usually be resolved by cleaning and reinstalling the fouled plugs.

**OIL OR ASH ENCRUSTED**

If one or more spark plugs are oil or oil ash encrusted (Fig. 30), evaluate engine condition for the cause of oil entry into that particular combustion chamber.

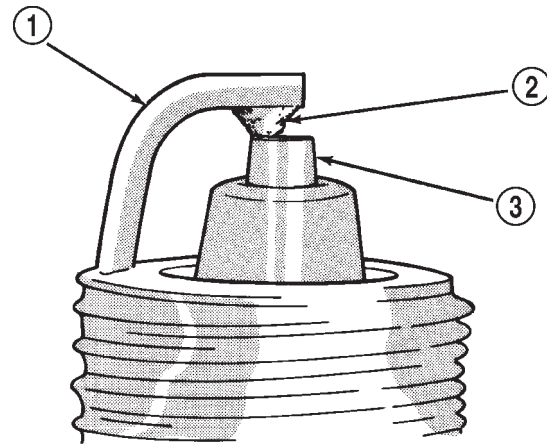


**Fig. 30 Oil or Ash Encrusted**

**ELECTRODE GAP BRIDGING**

Electrode gap bridging may be traced to loose deposits in the combustion chamber. These deposits accumulate on the spark plugs during continuous stop-and-go driving. When the engine is suddenly subjected to a high torque load, deposits partially liquefy and bridge the gap between electrodes (Fig. 31).

This short circuits the electrodes. Spark plugs with electrode gap bridging can be cleaned using standard procedures.



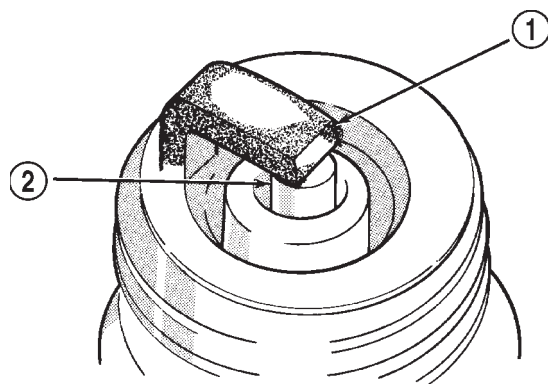
J908D-11

**Fig. 31 Electrode Gap Bridging**

- 1 - GROUND ELECTRODE
- 2 - DEPOSITS
- 3 - CENTER ELECTRODE

**SCAVENGER DEPOSITS**

Fuel scavenger deposits may be either white or yellow (Fig. 32). They may appear to be harmful, but this is a normal condition caused by chemical additives in certain fuels. These additives are designed to change the chemical nature of deposits and decrease spark plug misfire tendencies. Notice that accumulation on the ground electrode and shell area may be heavy, but the deposits are easily removed. Spark plugs with scavenger deposits can be considered normal in condition and can be cleaned using standard procedures.



J908D-12

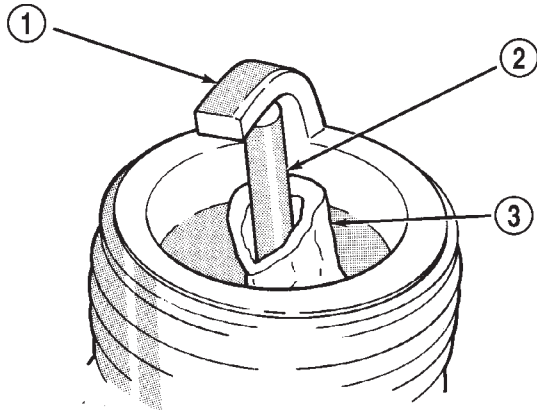
**Fig. 32 Scavenger Deposits**

- 1 - GROUND ELECTRODE COVERED WITH WHITE OR YELLOW DEPOSITS
- 2 - CENTER ELECTRODE

## SPARK PLUG (Continued)

**CHIPPED ELECTRODE INSULATOR**

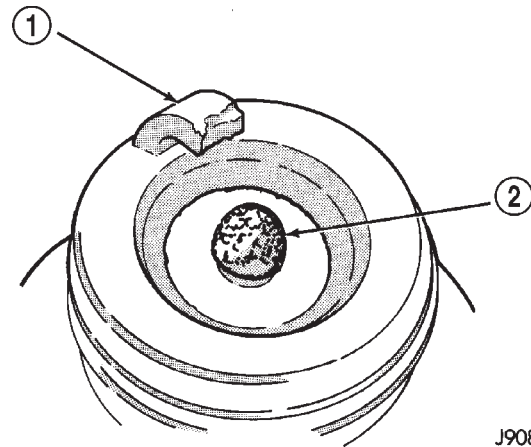
A chipped electrode insulator usually results from bending the center electrode while adjusting the spark plug electrode gap. Under certain conditions, severe detonation can also separate the insulator from the center electrode (Fig. 33). Spark plugs with this condition must be replaced.



J908D-13

**Fig. 33 Chipped Electrode Insulator**

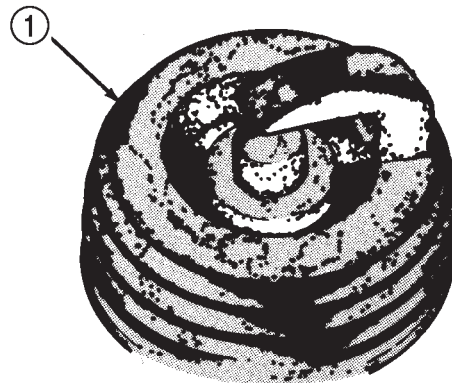
- 1 - GROUND ELECTRODE
- 2 - CENTER ELECTRODE
- 3 - CHIPPED INSULATOR



J908D-14

**Fig. 34 Preignition Damage**

- 1 - GROUND ELECTRODE STARTING TO DISSOLVE
- 2 - CENTER ELECTRODE DISSOLVED



J908D-16

**Fig. 35 Spark Plug Overheating**

- 1 - BLISTERED WHITE OR GRAY COLORED INSULATOR

**PREIGNITION DAMAGE**

Preignition damage is usually caused by excessive combustion chamber temperature. The center electrode dissolves first and the ground electrode dissolves somewhat later (Fig. 34). Insulators appear relatively deposit free. Determine if the spark plug has the correct heat range rating for the engine. Determine if ignition timing is over advanced or if other operating conditions are causing engine overheating. (The heat range rating refers to the operating temperature of a particular type spark plug. Spark plugs are designed to operate within specific temperature ranges. This depends upon the thickness and length of the center electrodes porcelain insulator.)

**SPARK PLUG OVERHEATING**

Overheating is indicated by a white or gray center electrode insulator that also appears blistered (Fig. 35). The increase in electrode gap will be considerably in excess of 0.001 inch per 2000 miles of operation. This suggests that a plug with a cooler heat range rating should be used. Over advanced ignition timing, detonation and cooling system malfunctions can also cause spark plug overheating.

**REMOVAL**

On 3.9L/5.2L/5.9L engines, spark plug cable heat shields are pressed into the cylinder head to surround each cable boot and spark plug (Fig. 36).

(1) Always remove spark plug or ignition coil cables by grasping at the cable boot (Fig. 38). Turn the cable boot 1/2 turn and pull straight back in a steady motion. Never pull directly on the cable. Internal damage to cable will result.

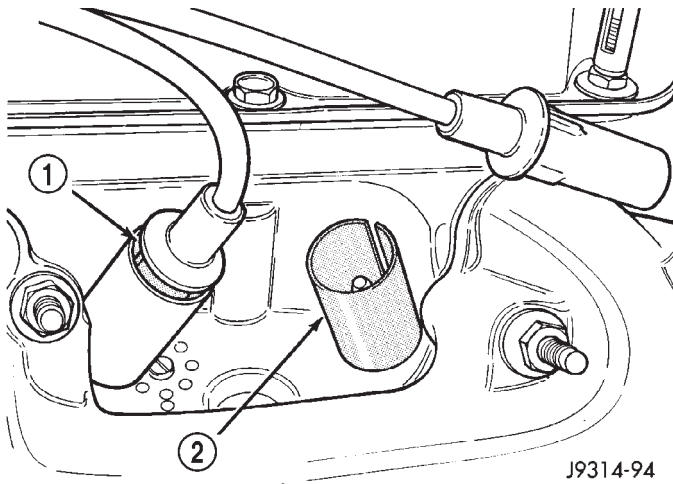
(2) Prior to removing the spark plug, spray compressed air around the spark plug hole and the area around the spark plug. This will help prevent foreign material from entering the combustion chamber.

(3) Remove the spark plug using a quality socket with a rubber or foam insert.

(4) Inspect the spark plug condition. Refer to Spark Plug Condition in the Diagnostics and Testing section of this group.



## SPARK PLUG (Continued)



**Fig. 36 Heat Shields—3.9L/5.2L/5.9L Engines**

1 - AIR GAP

2 - SPARK PLUG BOOT HEAT SHIELD

## CLEANING

The plugs may be cleaned using commercially available spark plug cleaning equipment. After cleaning, file center electrode flat with a small point file or jewelers file before adjusting gap.

**CAUTION:** Never use a motorized wire wheel brush to clean spark plugs. Metallic deposits will remain on spark plug insulator and will cause plug misfire.

## INSTALLATION

Special care should be taken when installing spark plugs into the cylinder head spark plug wells. Be sure the plugs do not drop into the plug wells as electrodes can be damaged.

Always tighten spark plugs to the specified torque. Over tightening can cause distortion resulting in a change in the spark plug gap or a cracked porcelain insulator.

When replacing the spark plug and ignition coil cables, route the cables correctly and secure them in the appropriate retainers. Failure to route the cables properly can cause the radio to reproduce ignition noise. It could cause cross ignition of the spark plugs or short circuit the cables to ground.

- (1) Start the spark plug into the cylinder head by hand to avoid cross threading.
- (2) Tighten spark plugs to 35-41 N·m (26-30 ft. lbs.) torque.
- (3) Install spark plug cables over spark plugs.

## SPARK PLUG CABLE

### DESCRIPTION

Spark plug cables are sometimes referred to as secondary ignition wires.

### OPERATION

The spark plug cables transfer electrical current from the ignition coil(s) and/or distributor, to individual spark plugs at each cylinder. The resistive spark plug cables are of nonmetallic construction. The cables provide suppression of radio frequency emissions from the ignition system.

### DIAGNOSIS AND TESTING - SPARK PLUG CABLES

Cable routing is important on certain engines. To prevent possible ignition crossfire, be sure the cables are clipped into the plastic routing looms. Try to prevent any one cable from contacting another. Before removing cables, note their original location and routing. Never allow one cable to be twisted around another.

Check the spark plug cable connections for good contact at the coil(s), distributor cap towers, and spark plugs. Terminals should be fully seated. The insulators should be in good condition and should fit tightly on the coil, distributor and spark plugs. Spark plug cables with insulators that are cracked or torn must be replaced.

Clean high voltage ignition cables with a cloth moistened with a non-flammable solvent. Wipe the cables dry. Check for brittle or cracked insulation.

On 3.9L/5.2L/5.9L engines, spark plug cable heat shields are pressed into the cylinder head to surround each spark plug cable boot and spark plug (Fig. 37). These shields protect the spark plug boots from damage (due to intense engine heat generated by the exhaust manifolds) and should not be removed. After the spark plug cable has been installed, the lip of the cable boot should have a small air gap to the top of the heat shield (Fig. 37).

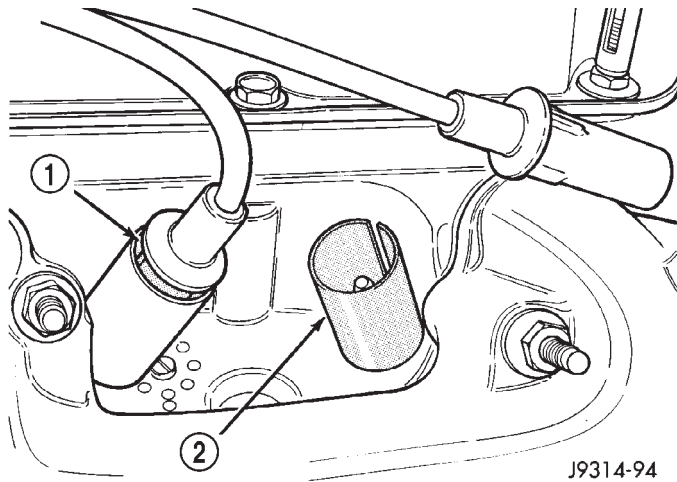
### TESTING

When testing secondary cables for damage with an oscilloscope, follow the instructions of the equipment manufacturer.

If an oscilloscope is not available, spark plug cables may be tested as follows:

**CAUTION:** Do not leave any one spark plug cable disconnected for longer than necessary during testing. This may cause possible heat damage to the catalytic converter. Total test time must not exceed ten minutes.

## SPARK PLUG CABLE (Continued)



**Fig. 37 Heat Shields—3.9L/5.2L/5.9L Engines**

- 1 - AIR GAP  
2 - SPARK PLUG BOOT HEAT SHIELD

With the engine running, remove spark plug cable from spark plug (one at a time) and hold next to a good engine ground. If the cable and spark plug are in good condition, the engine rpm should drop and the engine will run poorly. If engine rpm does not drop, the cable and/or spark plug may not be operating properly and should be replaced. Also check engine cylinder compression.

With the engine not running, connect one end of a test probe to a good ground. Start the engine and run the other end of the test probe along the entire length of all spark plug cables. If cables are cracked or punctured, there will be a noticeable spark jump from the damaged area to the test probe. The cable running from the ignition coil to the distributor cap can be checked in the same manner. Cracked, damaged or faulty cables should be replaced with resistance type cable. This can be identified by the words ELECTRONIC SUPPRESSION printed on the cable jacket.

Use an ohmmeter to test for open circuits, excessive resistance or loose terminals. If equipped, remove the distributor cap from the distributor. **Do not remove cables from cap.** Remove cable from spark plug. Connect ohmmeter to spark plug terminal end of cable and to corresponding electrode in distributor cap. Resistance should be 250 to 1000 Ohms per inch of cable. If not, remove cable from distributor cap tower and connect ohmmeter to the terminal ends of cable. If resistance is not within specifications as found in the SPARK PLUG CABLE RESISTANCE chart, replace the cable. Test all spark plug cables in this manner.

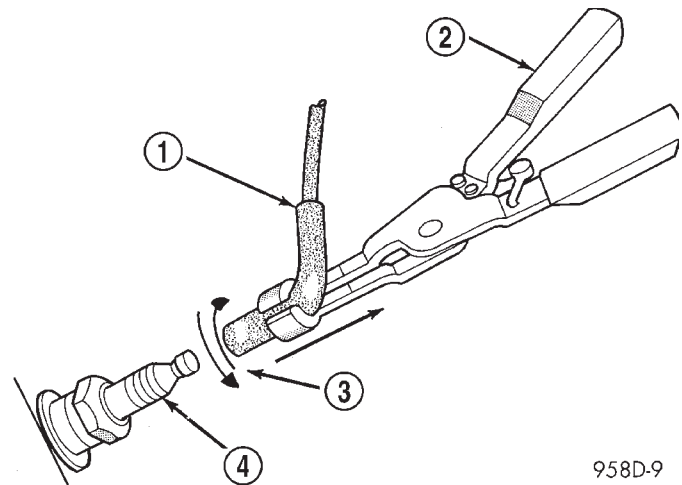
## SPARK PLUG CABLE RESISTANCE

MINIMUM	MAXIMUM
250 Ohms Per Inch	1000 Ohms Per Inch
3000 Ohms Per Foot	12,000 Ohms Per Foot

To test ignition coil-to-distributor cap cable, do not remove the cable from the cap. Connect ohmmeter to rotor button (center contact) of distributor cap and terminal at ignition coil end of cable. If resistance is not within specifications as found in the Spark Plug Cable Resistance chart, remove the cable from the distributor cap. Connect the ohmmeter to the terminal ends of the cable. If resistance is not within specifications as found in the Spark Plug Cable Resistance chart, replace the cable. Inspect the ignition coil tower for cracks, burns or corrosion.

## REMOVAL

**CAUTION:** When disconnecting a high voltage cable from a spark plug or from the distributor cap, twist the rubber boot slightly (1/2 turn) to break it loose (Fig. 38). Grasp the boot (not the cable) and pull it off with a steady, even force.



**Fig. 38 Cable Removal**

- 1 - SPARK PLUG CABLE AND BOOT  
2 - SPARK PLUG BOOT PULLER  
3 - TWIST AND PULL  
4 - SPARK PLUG

958D-9

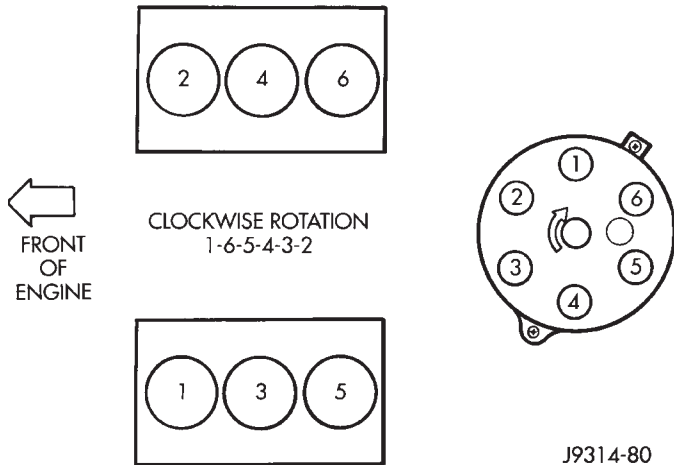
## INSTALLATION

Install cables into the proper engine cylinder firing order (Fig. 39), (Fig. 40) or (Fig. 41).

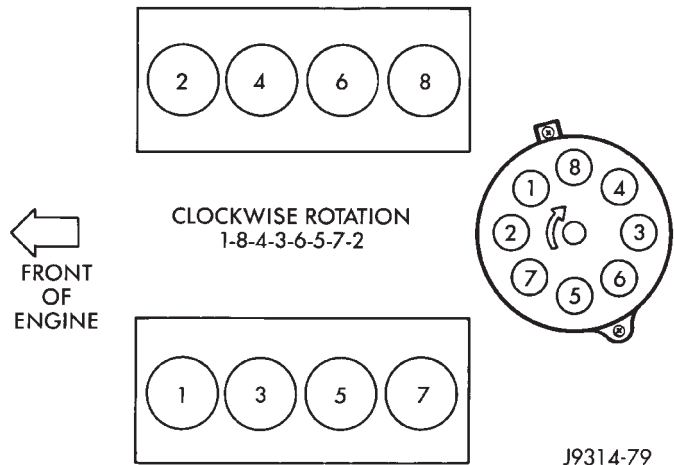
When replacing the spark plug and coil cables, route the cables correctly and secure in the proper retainers. Failure to route the cables properly can cause the radio to reproduce ignition noise. It could also cause cross ignition of the plugs or short circuit the cables to ground.



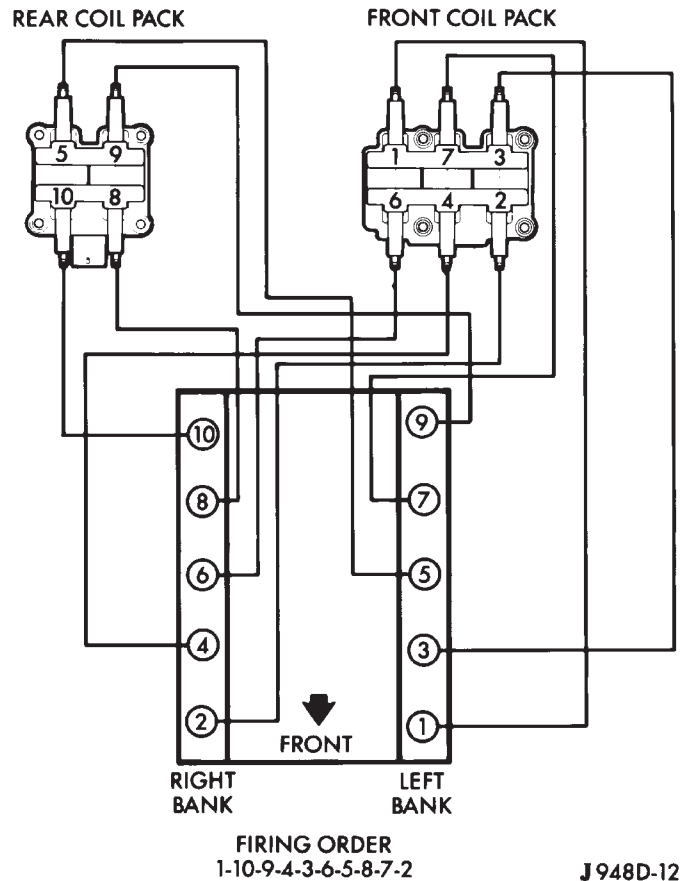
SPARK PLUG CABLE (Continued)



**Fig. 39 Engine Firing Order—3.9L V-6 Engine**



**Fig. 40 Engine Firing Order—5.2L/5.9L V-8 Engines**



**Fig. 41 Spark Plug Cable Order—8.0L V-10 Engine**

When installing new cables, make sure a positive connection is made. A snap should be felt when a good connection is made between the plug cable and the distributor cap tower.



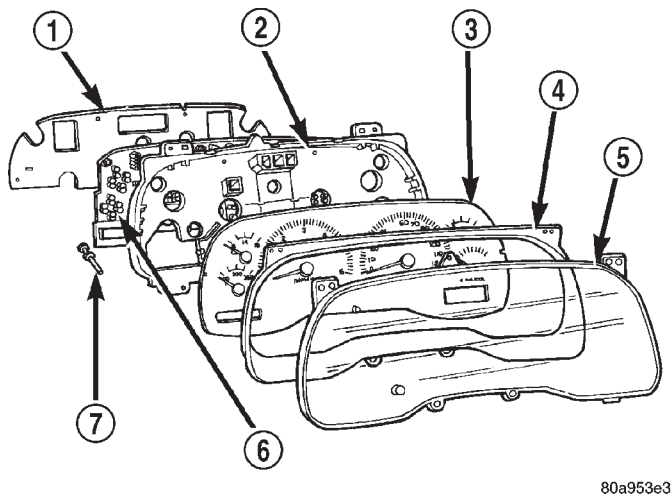
# INSTRUMENT CLUSTER

## TABLE OF CONTENTS

	page		page
<b>INSTRUMENT CLUSTER</b>		<b>OIL PRESSURE GAUGE</b>	
DESCRIPTION . . . . .	2	DESCRIPTION . . . . .	25
OPERATION . . . . .	3	OPERATION . . . . .	26
DIAGNOSIS AND TESTING . . . . .	6	<b>OVERDRIVE OFF INDICATOR</b>	
INSTRUMENT CLUSTER . . . . .	6	DESCRIPTION . . . . .	27
REMOVAL . . . . .	10	OPERATION . . . . .	27
DISASSEMBLY . . . . .	11	<b>SEATBELT INDICATOR</b>	
ASSEMBLY . . . . .	13	DESCRIPTION . . . . .	27
INSTALLATION . . . . .	14	OPERATION . . . . .	27
<b>ABS INDICATOR</b>		<b>SERVICE REMINDER INDICATOR</b>	
DESCRIPTION . . . . .	14	DESCRIPTION . . . . .	28
OPERATION . . . . .	14	OPERATION . . . . .	28
<b>AIRBAG INDICATOR</b>		<b>SHIFT INDICATOR (TRANSFER CASE)</b>	
DESCRIPTION . . . . .	15	DESCRIPTION . . . . .	29
OPERATION . . . . .	15	OPERATION . . . . .	29
<b>BRAKE/PARK BRAKE INDICATOR</b>		DIAGNOSIS AND TESTING . . . . .	29
DESCRIPTION . . . . .	16	FOUR-WHEEL DRIVE INDICATOR . . . . .	29
OPERATION . . . . .	16	<b>SPEEDOMETER</b>	
DIAGNOSIS AND TESTING . . . . .	16	DESCRIPTION . . . . .	30
BRAKE INDICATOR . . . . .	16	OPERATION . . . . .	30
<b>CHECK GAUGES INDICATOR</b>		<b>TACHOMETER</b>	
DESCRIPTION . . . . .	17	DESCRIPTION . . . . .	30
OPERATION . . . . .	17	OPERATION . . . . .	31
<b>CRUISE INDICATOR</b>		<b>TRANSMISSION OVERTEMP INDICATOR</b>	
DESCRIPTION . . . . .	18	DESCRIPTION . . . . .	31
OPERATION . . . . .	18	OPERATION . . . . .	31
<b>ENGINE TEMPERATURE GAUGE</b>		<b>TURN SIGNAL INDICATORS</b>	
DESCRIPTION . . . . .	19	DESCRIPTION . . . . .	32
OPERATION . . . . .	19	OPERATION . . . . .	32
<b>FUEL GAUGE</b>		DIAGNOSIS AND TESTING . . . . .	32
DESCRIPTION . . . . .	20	TURN SIGNAL INDICATORS . . . . .	32
OPERATION . . . . .	20	<b>UPSHIFT INDICATOR</b>	
<b>GEAR SELECTOR INDICATOR</b>		DESCRIPTION . . . . .	33
DESCRIPTION . . . . .	21	OPERATION . . . . .	33
OPERATION . . . . .	21	<b>VOLTAGE GAUGE</b>	
<b>HIGH BEAM INDICATOR</b>		DESCRIPTION . . . . .	33
DESCRIPTION . . . . .	21	OPERATION . . . . .	34
OPERATION . . . . .	22	<b>WAIT-TO-START INDICATOR</b>	
DIAGNOSIS AND TESTING . . . . .	22	DESCRIPTION . . . . .	34
HIGH BEAM INDICATOR . . . . .	22	OPERATION . . . . .	35
<b>LOW FUEL INDICATOR</b>		<b>WASHER FLUID INDICATOR</b>	
DESCRIPTION . . . . .	23	DESCRIPTION . . . . .	35
OPERATION . . . . .	23	OPERATION . . . . .	35
<b>MALFUNCTION INDICATOR LAMP (MIL)</b>		DIAGNOSIS AND TESTING . . . . .	36
DESCRIPTION . . . . .	24	WASHER FLUID INDICATOR . . . . .	36
OPERATION . . . . .	24	<b>WATER-IN-FUEL INDICATOR</b>	
<b>ODOMETER</b>		DESCRIPTION . . . . .	36
DESCRIPTION . . . . .	24	OPERATION . . . . .	37
OPERATION . . . . .	25		

## INSTRUMENT CLUSTER

## DESCRIPTION



80a953e3

**Fig. 1 Instrument Cluster Components**

- 1 - COVER
- 2 - HOUSING
- 3 - OVERLAY AND GAUGES
- 4 - HOOD
- 5 - LENS
- 6 - CIRCUIT BOARD
- 7 - ODOMETER SWITCH BUTTON

The instrument cluster for this model is an ElectroMechanical Instrument Cluster (EMIC) module that is located in the instrument panel above the steering column opening, directly in front of the driver (Fig. 1). The EMIC gauges and indicators are protected by an integral clear plastic cluster lens, and are visible through a dedicated opening in the cluster bezel on the instrument panel. Just behind the cluster lens is the cluster hood. The cluster hood serves as a visor and shields the face of the cluster from ambient light and reflections to reduce glare. Behind the cluster hood is the cluster overlay and gauges. The overlay is a multi-layered unit. The dark, visible surface of the outer layer of the overlay is marked with all of the gauge identification and graduations, but this layer is also translucent. The darkness of this outer layer prevents the cluster from appearing cluttered or busy by concealing the cluster indicators that are not illuminated, while the translucence of this layer allows those indicators and icons that are illuminated to be readily visible. The underlying layer of the overlay is opaque and allows light from the various indicators and illumination lamps behind it to be visible through the outer layer of the overlay only through predetermined cutouts. On the lower edge of the cluster lens just left of center, the odometer/trip odometer switch knob protrudes

through a dedicated hole in the lens. The remainder of the EMIC, including the mounts and the electrical connections, are concealed behind the cluster bezel. The molded plastic EMIC housing has four integral mounting tabs, two each on the upper and lower edges of the housing. The EMIC is secured to the molded plastic instrument panel cluster carrier with four screws. All electrical connections to the EMIC are made at the back of the cluster housing through two take outs of the instrument panel wire harness, each equipped with a self-docking connector.

A single EMIC module is offered on this model. This module utilizes integrated circuitry and information carried on the Chrysler Collision Detection (CCD) data bus network for control of all gauges and many of the indicators. (Refer to 8 - ELECTRICAL/ELECTRONIC CONTROL MODULES/COMMUNICATION - DESCRIPTION). The EMIC also uses several hard wired inputs in order to perform its many functions. In addition to instrumentation and indicators, the EMIC has hardware and/or software to support the following functions:

- **Chime Warning Requests** - The EMIC sends chime tone requests over a hard wired circuit to the Central Timer Module (CTM) when it monitors certain conditions or inputs. The CTM replaces the chime or buzzer module and performs the functions necessary to provide audible alerts that are synchronized with the visual alerts provided by the EMIC. (Refer to 8 - ELECTRICAL/CHIME/BUZZER - DESCRIPTION).

- **Vacuum Fluorescent Display (VFD) Dimming Service** - The EMIC performs the functions necessary to eliminate the need for a separate VFD dimming module by providing control and synchronization of the illumination intensity of all vacuum fluorescent displays in the vehicle, as well as a parade mode.

The EMIC module incorporates a blue-green digital VFD for displaying odometer and trip odometer information, as well as the amber cruise-on indicator display function. Some variations of the EMIC are necessary to support optional equipment and regulatory requirements. The EMIC includes the following analog gauges:

- **Coolant Temperature Gauge**
- **Fuel Gauge**
- **Oil Pressure Gauge**
- **Speedometer**
- **Tachometer**
- **Voltage Gauge**

The EMIC also includes provisions for the following indicators:

- **Airbag Indicator**
- **Antilock Brake System (ABS) Indicator**
- **Brake Indicator**

## INSTRUMENT CLUSTER (Continued)

- **Check Gauges Indicator**
- **Cruise Indicator (Odometer VFD)**
- **Four-Wheel Drive Indicator**
- **High Beam Indicator**
- **Low Fuel Indicator**
- **Washer Fluid Indicator**
- **Malfunction Indicator Lamp (MIL)**
- **Overdrive-Off Indicator**
- **Seatbelt Indicator**
- **Service Reminder Indicator (SRI)**
- **Transmission Overtemp Indicator**
- **Turn Signal (Right and Left) Indicators**
- **Upshift Indicator**
- **Wait-To-Start Indicator (Diesel Only)**
- **Water-In-Fuel Indicator (Diesel Only)**

Some of these indicators are either programmable or automatically configured when the EMIC is connected to the vehicle electrical system. This feature allows those indicators to be activated or deactivated for compatibility with certain optional equipment. The EMIC also includes a provision for mounting the automatic transmission gear selector indicator in the lower right corner of the cluster. The spring-loaded, cable driven, mechanical gear selector indicator gives an indication of the transmission gear that has been selected with the automatic transmission gear selector lever. The gear selector indicator pointer is easily visible through an opening provided in the front of the cluster overlay, and is also lighted by the cluster illumination lamps for visibility at night. Models equipped with a manual transmission have a block-out plate installed in place of the gear selector indicator.

Cluster illumination is accomplished by adjustable incandescent back lighting, which illuminates the gauges for visibility when the exterior lighting is turned on. The EMIC high beam indicator, turn signal indicators, and wait-to-start indicator are also illuminated by dedicated incandescent bulbs. The remaining indicators in the EMIC are each illuminated by a dedicated Light Emitting Diode (LED) that is soldered onto the electronic circuit board. Each of the incandescent bulbs is secured by an integral bulb holder to the electronic circuit board from the back of the cluster housing.

Hard wired circuitry connects the EMIC to the electrical system of the vehicle. These hard wired circuits are integral to several wire harnesses, which are routed throughout the vehicle and retained by many different methods. These circuits may be connected to each other, to the vehicle electrical system and to the EMIC through the use of a combination of soldered splices, splice block connectors, and many different types of wire harness terminal connectors and insulators. Refer to the appropriate wiring information. The wiring information includes wiring dia-

grams, proper wire and connector repair procedures, further details on wire harness routing and retention, as well as pin-out and location views for the various wire harness connectors, splices and grounds.

The EMIC modules for this model are serviced only as complete units. The EMIC module cannot be adjusted or repaired. If a gauge, an LED indicator, the VFD, the electronic circuit board, the circuit board hardware, the cluster overlay, or the EMIC housing are damaged or faulty, the entire EMIC module must be replaced. The cluster lens and hood unit, the rear cluster housing cover, the automatic transmission gear selector indicator, and the incandescent lamp bulbs with holders are available for individual service replacement.

## OPERATION

The ElectroMechanical Instrument Cluster (EMIC) is designed to allow the vehicle operator to monitor the conditions of many of the vehicle components and operating systems. The gauges and indicators in the EMIC provide valuable information about the various standard and optional powertrains, fuel and emissions systems, cooling systems, lighting systems, safety systems and many other convenience items. The EMIC is installed in the instrument panel so that all of these monitors can be easily viewed by the vehicle operator when driving, while still allowing relative ease of access for service. The microprocessor-based EMIC hardware and software uses various inputs to control the gauges and indicators visible on the face of the cluster. Some of these inputs are hard wired, but most are in the form of electronic messages that are transmitted by other electronic modules over the Chrysler Collision Detection (CCD) data bus network. (Refer to 8 - ELECTRICAL/ELECTRONIC CONTROL MODULES/COMMUNICATION - OPERATION).

The EMIC microprocessor smooths the input data using algorithms to provide gauge readings that are accurate, stable and responsive to operating conditions. These algorithms are designed to provide gauge readings during normal operation that are consistent with customer expectations. However, when abnormal conditions exist, such as low/high battery voltage, low oil pressure, or high coolant temperature, the algorithm drives the gauge pointer to an extreme position and the microprocessor turns on the Check Gauges indicator to provide a distinct visual indication of a problem to the vehicle operator. The instrument cluster circuitry may also generate a hard wired chime tone request to the Central Timer Module (CTM) when it monitors certain conditions or inputs, in order to provide the vehicle operator with an audible alert.



## INSTRUMENT CLUSTER (Continued)

The EMIC circuitry operates on battery current received through a fused B(+) fuse in the Junction Block (JB) on a non-switched fused B(+) circuit, and on battery current received through a fused ignition switch output (st-run) fuse in the JB on a fused ignition switch output (st-run) circuit. This arrangement allows the EMIC to provide some features regardless of the ignition switch position, while other features will operate only with the ignition switch in the Start or On positions. The EMIC circuitry is grounded through two separate ground circuits located in one of the two instrument cluster connectors and take outs of the instrument panel wire harness. One ground circuit receives ground through a take out with an eyelet terminal connector of the instrument panel wire harness that is secured by a nut to a ground stud located on the left instrument panel end bracket, while the other ground circuit receives ground through a take out with an eyelet terminal connector of the instrument panel wire harness that is secured by a nut to a ground stud located on the back of the instrument panel armature above the inboard side of the instrument panel steering column opening.

The EMIC also has a self-diagnostic actuator test capability, which will test each of the CCD bus message-controlled functions of the cluster by lighting the appropriate indicators and positioning the gauge needles at several predetermined locations on the gauge faces in a prescribed sequence. (Refer to 8 - ELECTRICAL/INSTRUMENT CLUSTER - DIAGNOSIS AND TESTING). See the owner's manual in the vehicle glove box for more information on the features, use and operation of the EMIC.

#### GAUGES

All gauges receive battery current through the EMIC circuitry when the ignition switch is in the On or Start positions. With the ignition switch in the Off position battery current is not supplied to any gauges, and the EMIC circuitry is programmed to move all of the gauge needles back to the low end of their respective scales. Therefore, the gauges do not accurately indicate any vehicle condition unless the ignition switch is in the On or Start positions. All of the EMIC gauges, except the odometer, are air core magnetic units. Two fixed electromagnetic coils are located within each gauge. These coils are wrapped at right angles to each other around a movable permanent magnet. The movable magnet is suspended within the coils on one end of a pivot shaft, while the gauge needle is attached to the other end of the shaft. One of the coils has a fixed current flowing through it to maintain a constant magnetic field

strength. Current flow through the second coil changes, which causes changes in its magnetic field strength. The current flowing through the second coil is changed by the EMIC circuitry in response to messages received over the CCD data bus. The gauge needle moves as the movable permanent magnet aligns itself to the changing magnetic fields created around it by the electromagnets.

The gauges are diagnosed using the EMIC self-diagnostic actuator test. (Refer to 8 - ELECTRICAL/INSTRUMENT CLUSTER - DIAGNOSIS AND TESTING). Proper testing of the CCD data bus and the data bus message inputs to the EMIC that control each gauge require the use of a DRBIII® scan tool. Refer to the appropriate diagnostic information. Specific operation details for each gauge may be found elsewhere in this service manual.

#### VACUUM-FLUORESCENT DISPLAY

The Vacuum-Fluorescent Display (VFD) module is soldered to the EMIC circuit board. The display is active with the ignition switch in the On or Start positions, and inactive when the ignition switch is in any other position. The VFD has several display capabilities including odometer, trip odometer, and an amber "CRUISE" indication whenever the optional speed control system is turned On. The cruise indicator function of the VFD is automatically enabled or disabled by the EMIC circuitry based upon whether the vehicle is equipped with the speed control option. An odometer/trip odometer switch on the EMIC circuit board is used to control several of the display modes. This switch is actuated manually by depressing the odometer/trip odometer switch knob that extends through the lower edge of the cluster lens, just right of center. Actuating this switch momentarily with the ignition switch in the On position will toggle the VFD between the odometer and trip odometer modes. The word "TRIP" will also appear in blue-green text when the VFD trip odometer mode is active. Depressing the switch button for about two seconds while the VFD is in the trip odometer mode will reset the trip odometer value to zero. Holding this switch depressed while turning the ignition switch from the Off position to the On position will activate the EMIC self-diagnostic actuator test. The EMIC will automatically flash the odometer or trip odometer information on and off if there is a loss of CCD data bus communication. The VFD will also display various information used in several diagnostic procedures. Refer to the appropriate diagnostic information for additional details on this VFD function.

## INSTRUMENT CLUSTER (Continued)

The VFD is diagnosed using the EMIC self-diagnostic actuator test. (Refer to 8 - ELECTRICAL/INSTRUMENT CLUSTER - DIAGNOSIS AND TESTING). Proper testing of the CCD data bus and the data bus message inputs to the EMIC that control some of the VFD functions requires the use of a DRBIII® scan tool. Refer to the appropriate diagnostic information. Specific operation details for the odometer and trip odometer functions of the VFD may be found elsewhere in this service manual.

## INDICATORS

Indicators are located in various positions within the EMIC and are all connected to the EMIC circuit board. The four-wheel drive indicator, high beam indicator, washer fluid indicator, turn signal indicators, and wait-to-start indicator are hard wired. The brake indicator is controlled by CCD data bus messages from the Controller Anti-lock Brake (CAB) and the hard wired park brake switch input to the EMIC. The seatbelt indicator is controlled by the EMIC programming, CCD data bus messages from the Airbag Control Module (ACM), and the hard wired seat belt switch input to the EMIC. The Malfunction Indicator Lamp (MIL) is normally controlled by CCD data bus messages from the Powertrain Control Module (PCM); however, if the EMIC loses CCD data bus communications, the EMIC circuitry will automatically turn the MIL on, and flash the odometer VFD on and off repeatedly until CCD data bus communication is restored. The EMIC uses CCD data bus messages from the Powertrain Control Module (PCM), the diesel engine only Engine Control Module (ECM), the ACM, and the CAB to control all of the remaining indicators. Different indicators are controlled by different strategies; some receive fused ignition switch output from the EMIC circuitry cluster and have a switched ground, while others are grounded through the EMIC circuitry and have a switched battery feed.

In addition, certain indicators in this instrument cluster are programmable or configurable. This feature allows the programmable indicators to be activated or deactivated with a DRBIII® scan tool, while the configurable indicators will be automatically enabled or disabled by the EMIC circuitry for compatibility with certain optional equipment. The only programmable indicator for this model is the upshift indicator. The cruise indicator, four-wheel drive indicator, overdrive-off indicator, service reminder indicator, and the transmission overtemp indicator are automatically configured, either electronically or mechanically.

The hard wired indicators are diagnosed using conventional diagnostic methods. The EMIC and CCD bus message controlled indicator lamps are diagnosed using the EMIC self-diagnostic actuator test. (Refer to 8 - ELECTRICAL/INSTRUMENT CLUSTER - DIAGNOSIS AND TESTING). Proper testing of the CCD data bus and the data bus message inputs to the EMIC that control each indicator lamp require the use of a DRBIII® scan tool. Refer to the appropriate diagnostic information. Specific operation details for each indicator may be found elsewhere in this service manual.

## CLUSTER ILLUMINATION

The EMIC has several illumination lamps that are illuminated when the exterior lighting is turned on with the headlamp switch. The illumination brightness of these lamps is adjusted by the panel lamps dimmer rheostat when the headlamp switch thumbwheel is rotated (down to dim, up to brighten). The illumination lamps receive battery current through the panel lamps dimmer rheostat and a fuse in the JB on a fused panel lamps dimmer switch signal circuit. The illumination lamps are grounded at all times.

In addition, an analog/digital (A/D) converter in the EMIC converts the analog panel lamps dimmer rheostat input from the headlamp switch to a digital dimming level signal for controlling the lighting level of the VFD. The EMIC also broadcasts this digital dimming information as a message over the CCD data bus for use by the Compass Mini-Trip Computer (CMTC) in synchronizing the lighting level of its VFD with that of the EMIC. The headlamp switch thumbwheel also has a Parade position to provide a parade mode. The EMIC monitors the request for this mode through a hard wired day brightness sense circuit input from the headlamp switch. In this mode, the EMIC will override the selected panel dimmer switch signal and send a message over the CCD data bus to illuminate all vacuum fluorescent displays at full brightness for easier visibility when driving in daylight with the exterior lighting turned on. The parade mode has no effect on the incandescent bulb illumination intensity.

The hard wired cluster illumination lamps are diagnosed using conventional diagnostic methods. Proper testing of the VFD dimming level and the CCD data bus dimming level message functions requires the use of a DRBIII® scan tool. Refer to the appropriate diagnostic information.

## INSTRUMENT CLUSTER (Continued)

## CHIME WARNING REQUESTS

The EMIC is programmed to request chime service from the Central Timer Module (CTM) when certain indicator lamps are illuminated. When the programmed conditions are met, the EMIC generates a chime request signal and sends it over a hard wired tone request circuit to the CTM. Upon receiving the proper chime request, the CTM activates an integral chime tone generator to provide the audible chime tone to the vehicle operator. (Refer to 8 - ELECTRICAL/CHIME/BUZZER - OPERATION). Proper testing of the CTM and the EMIC chime requests requires the use of a DRBIII® scan tool. Refer to the appropriate diagnostic information.

## DIAGNOSIS AND TESTING - INSTRUMENT CLUSTER

If all of the instrument cluster gauges and/or indicators are inoperative, refer to PRELIMINARY DIAGNOSIS . If an individual gauge or Chrysler Collision Detection (CCD) data bus message-controlled indicator is inoperative, refer to ACTUATOR TEST . If an individual hard wired indicator is inoperative, refer to the diagnosis and testing information for that specific indicator. If the instrument cluster chime warning request function is inoperative, refer to CHIME WARNING REQUEST DIAGNOSIS . If the instrument cluster illumination lighting is inoperative, refer to CLUSTER ILLUMINATION DIAGNOSIS . If the instrument cluster Vacuum-Fluorescent Display (VFD) dimmer service is inoperative, use a DRBIII® scan tool to diagnose the problem. Refer to the appropriate diagnostic procedures. Refer to the appropriate wiring information. The wiring information includes wiring diagrams, proper wire and connector repair procedures, details of wire harness routing and retention, connector pin-out information and location views for the various wire harness connectors, splices and grounds.

**NOTE:** Certain indicators in this instrument cluster are programmable. This feature allows those indicators to be activated or deactivated with a DRBIII® scan tool for compatibility with certain optional equipment. If the problem being diagnosed involves improper illumination of the upshift indicator, use a DRBIII® scan tool to be certain that the instrument cluster has been programmed with the proper vehicle equipment option settings.

## PRELIMINARY DIAGNOSIS

**WARNING: ON VEHICLES EQUIPPED WITH AIRBAGS, DISABLE THE AIRBAG SYSTEM BEFORE ATTEMPTING ANY STEERING WHEEL, STEERING COLUMN, OR INSTRUMENT PANEL COMPONENT DIAGNOSIS OR SERVICE. DISCONNECT AND ISOLATE THE BATTERY NEGATIVE (GROUND) CABLE, THEN WAIT TWO MINUTES FOR THE AIRBAG SYSTEM CAPACITOR TO DISCHARGE BEFORE PERFORMING FURTHER DIAGNOSIS OR SERVICE. THIS IS THE ONLY SURE WAY TO DISABLE THE AIRBAG SYSTEM. FAILURE TO TAKE THE PROPER PRECAUTIONS COULD RESULT IN ACCIDENTAL AIRBAG DEPLOYMENT AND POSSIBLE PERSONAL INJURY.**

(1) If the indicators operate, but none of the gauges operate, go to Step 2. If all of the gauges and the CCD data bus message-controlled indicators are inoperative, go to Step 5.

(2) Check the fused B(+) fuse (Fuse 14 - 10 ampere) in the Junction Block (JB). If OK, go to Step 3. If not OK, repair the shorted circuit or component as required and replace the faulty fuse.

(3) Check for battery voltage at the fused B(+) fuse (Fuse 14 - 10 ampere) in the JB. If OK, go to Step 4. If not OK, repair the open fused B(+) circuit between the JB and the Power Distribution Center (PDC) as required.

(4) Disconnect and isolate the battery negative cable. Remove the instrument cluster. Connect the battery negative cable. Check for battery voltage at the fused B(+) circuit cavity of the instrument panel wire harness connector (Connector C1) for the instrument cluster. If OK, refer to ACTUATOR TEST . If not OK, repair the open fused B(+) circuit between the instrument cluster and the JB as required.

(5) Check the fused ignition switch output (st-run) fuse (Fuse 17 - 10 ampere) in the JB. If OK, go to Step 6. If not OK, repair the shorted circuit or component as required and replace the faulty fuse.

(6) Turn the ignition switch to the On position. Check for battery voltage at the fused ignition switch output (st-run) fuse (Fuse 17 - 10 ampere) in the JB. If OK, go to Step 7. If not OK, repair the open fused ignition switch output (st-run) circuit between the instrument cluster and the JB as required.

## INSTRUMENT CLUSTER (Continued)

(7) Turn the ignition switch to the Off position. Disconnect and isolate the battery negative cable. Reinstall the instrument cluster. Reconnect the battery negative cable. Turn the ignition switch to the On position. Set the park brake. The brake indicator in the instrument cluster should light. If OK, go to Step 8. If not OK, go to Step 9.

(8) Turn the ignition switch to the Off position. Turn on the park lamps and adjust the panel lamps dimmer thumbwheel in the headlamp switch to the full bright position. The cluster illumination lamps should light. If OK, go to Step 10. If not OK, repair the open ground circuit (Z3) between the instrument cluster and ground (G201) as required.

(9) Turn the ignition switch to the Off position. Disconnect and isolate the battery negative cable. Remove the instrument cluster. Connect the battery negative cable. Turn the ignition switch to the On position. Check for battery voltage at the fused ignition switch output (st-run) circuit cavity of the instrument panel wire harness connector (Connector C1). If OK, refer to ACTUATOR TEST . If not OK, repair the open fused ignition switch output (st-run) circuit between the instrument cluster and the JB as required.

(10) Disconnect and isolate the battery negative cable. Remove the instrument cluster. Check for continuity between the ground circuit (Z2) cavity of the instrument panel wire harness connector (Connector C1) and a good ground. There should be continuity. If OK, refer to ACTUATOR TEST . If not OK, repair the open ground circuit to ground (G200) as required.

## ACTUATOR TEST

**WARNING: ON VEHICLES EQUIPPED WITH AIRBAGS, DISABLE THE AIRBAG SYSTEM BEFORE ATTEMPTING ANY STEERING WHEEL, STEERING COLUMN, OR INSTRUMENT PANEL COMPONENT DIAGNOSIS OR SERVICE. DISCONNECT AND ISOLATE THE BATTERY NEGATIVE (GROUND) CABLE, THEN WAIT TWO MINUTES FOR THE AIRBAG SYSTEM CAPACITOR TO DISCHARGE BEFORE PERFORMING FURTHER DIAGNOSIS OR SERVICE. THIS IS THE ONLY SURE WAY TO DISABLE THE AIRBAG SYSTEM. FAILURE TO TAKE THE PROPER PRE-**

**CAUTIONS COULD RESULT IN ACCIDENTAL AIRBAG DEPLOYMENT AND POSSIBLE PERSONAL INJURY.**

The instrument cluster actuator test will put the instrument cluster into its self-diagnostic mode. In this mode the instrument cluster can perform a self-diagnostic test that will confirm that the instrument cluster circuitry, the gauges, and the CCD data bus message-controlled indicators are capable of operating as designed. During the actuator test the instrument cluster circuitry position each of the gauge needles at various calibration points, illuminate each of the segments in the Vacuum-Fluorescent Display (VFD), and turn all of the CCD data bus message-controlled indicators on and off.

Successful completion of the actuator test will confirm that the instrument cluster is operational. However, there may still be a problem with the CCD data bus, the Powertrain Control Module (PCM), the Engine Control Module (ECM), the Airbag Control Module (ACM), the Controller Anti-lock Brake (CAB), or the inputs to one of these electronic control modules. Use a DRBIII® scan tool to diagnose these components. Refer to the appropriate diagnostic information.

(1) Begin the test with the ignition switch in the Off position.

(2) Depress the odometer/trip odometer switch button.

(3) While still holding the odometer/trip odometer switch button depressed, turn the ignition switch to the On position, but do not start the engine.

(4) Keep the odometer/trip odometer switch button depressed for about ten seconds, until **CHEC** appears in the odometer display, then release the odometer/trip odometer switch button.

(5) A series of three-digit numeric failure messages may appear in the odometer display, depending upon the failure mode. If a failure message appears, refer to the Instrument Cluster Failure Message chart for the description and proper correction. If no failure message appears, the actuator test will proceed as described in Step 6.



## INSTRUMENT CLUSTER (Continued)

INSTRUMENT CLUSTER FAILURE MESSAGE		
Message	Description	Correction
110	A failure has been identified in the cluster CPU, RAM, or EEPROM.	1. Replace the faulty cluster.
900	The CCD data bus is not operational.	1. Check the CCD data bus connections at the cluster. 2. Check the cluster fuses. 3. Check the CCD data bus bias. 4. Check the CCD data bus voltage. 5. Check the CCD data bus terminations.
920	The cluster is not receiving a vehicle speed message from the PCM.	1. Check the PCM software level and reflash if required. 2. Use a DRBIII® scan tool to verify that the vehicle speed message is being sent by the PCM.
921	The cluster is not receiving a distance pulse message from the PCM.	1. Check the PCM software level and reflash if required. 2. Use a DRBIII® scan tool to verify that the distance pulse message is being sent by the PCM.
940	The cluster is not receiving an airbag lamp-on message from the ACM.	1. Check the CCD data bus connections at the ACM. 2. Check the ACM fuse.
950	The cluster is not receiving an ABS lamp-on message from the CAB.	1. Check the CCD data bus connections at the CAB. 2. Check the CAB fuse.
999	An error has been discovered.	1. Record the failure message. 2. Depress the trip odometer reset button to continue the Self-Diagnostic Test.

(6) The instrument cluster will begin the Vacuum Fluorescent Display (VFD) walking segment test. This test will require the operator to visually inspect each VFD segment as it is displayed to determine a pass or fail condition. First, all of the segments will be illuminated at once; then, each individual segment of the VFD will be illuminated in sequence. If any segment in the display fails to illuminate, repeat the test to confirm the failure. If the failure is confirmed, replace the faulty instrument cluster. Following completion of the VFD walking segment test, the actuator test will proceed as described in Step 7.

(7) The instrument cluster will perform a bulb check of each indicator that the instrument cluster circuitry controls. If the wait-to-start indicator does not illuminate during this test, the instrument cluster should be removed. However, check that the incandescent bulb is not faulty and that the bulb holder is properly installed on the instrument cluster electronic circuit board before considering instrument cluster replacement. If the bulb and bulb holder check OK, replace the faulty instrument cluster. Each of the remaining instrument cluster circuitry

controlled indicators except the cruise indicator are illuminated by a Light Emitting Diode (LED). If an LED or the cruise indicator in the VFD, fails to illuminate during this test, the instrument cluster must be replaced. Following the bulb check test, the actuator test will proceed as described in Step 8.

(8) The instrument cluster will perform a gauge actuator test. In this test the instrument cluster circuitry positions each of the gauge needles at three different calibration points, then returns the gauge needles to their relaxed positions. If an individual gauge does not respond properly, or does not respond at all during the gauge actuator test, the instrument cluster should be removed. However, check that the gauge terminal pins are properly inserted through the spring-clip terminal pin receptacles on the instrument cluster electronic circuit board before considering instrument cluster replacement. If the gauge terminal connections are OK, replace the faulty instrument cluster.

(9) The actuator test is now completed. The instrument cluster will automatically exit the self-diagnostic mode and return to normal operation at the



## INSTRUMENT CLUSTER (Continued)

completion of the test, if the ignition switch is turned to the Off position during the test, or if a vehicle speed message indicating that the vehicle is moving is received from the PCM on the CCD data bus during the test.

(10) Go back to Step 1 to repeat the test, if required.

**CHIME WARNING REQUEST DIAGNOSIS**

Before performing this test, complete the testing of the seat belt switch and the Central Timer Module (CTM). (Refer to 8 - ELECTRICAL/RESTRAINTS/SEAT BELT SWITCH - DIAGNOSIS AND TESTING) and (Refer to 8 - ELECTRICAL/ELECTRONIC CONTROL MODULES/BODY CONTROL/CENTRAL TIMER MODULE - DIAGNOSIS AND TESTING). The diagnosis found here consists of confirming the viability of the hard wired tone request circuit between the instrument cluster and the Central Timer Module (CTM). For diagnosis of the CCD data bus and the data bus message inputs that cause the instrument cluster to issue a request for chime service, a DRBIII® scan tool is required. Refer to the appropriate diagnostic information.

**WARNING: ON VEHICLES EQUIPPED WITH AIRBAGS, DISABLE THE AIRBAG SYSTEM BEFORE ATTEMPTING ANY STEERING WHEEL, STEERING COLUMN, OR INSTRUMENT PANEL COMPONENT DIAGNOSIS OR SERVICE. DISCONNECT AND ISOLATE THE BATTERY NEGATIVE (GROUND) CABLE, THEN WAIT TWO MINUTES FOR THE AIRBAG SYSTEM CAPACITOR TO DISCHARGE BEFORE PERFORMING FURTHER DIAGNOSIS OR SERVICE. THIS IS THE ONLY SURE WAY TO DISABLE THE AIRBAG SYSTEM. FAILURE TO TAKE THE PROPER PRECAUTIONS COULD RESULT IN ACCIDENTAL AIRBAG DEPLOYMENT AND POSSIBLE PERSONAL INJURY.**

(1) Disconnect and isolate the battery negative cable. Remove the instrument cluster from the instrument panel. Move the CTM away from its mounting bracket far enough to access the instrument panel wire harness connector(s) for the CTM. Disconnect the instrument panel wire harness connector (Connector C1) from the CTM connector receptacle.

(2) Check for continuity between the tone request circuit cavity of the instrument panel wire harness connector (Connector C2) for the instrument cluster and a good ground. There should be no continuity. If OK, go to Step 3. If not OK, repair the shorted tone request circuit between the instrument cluster and the CTM as required.

(3) Check for continuity between the tone request circuit cavities of the instrument panel wire harness

connector (Connector C2) for the instrument cluster and the instrument panel wire harness connector (Connector C1) for the CTM. There should be continuity. If OK, replace the faulty instrument cluster. If not OK, repair the open tone request circuit between the instrument cluster and the CTM as required.

**CLUSTER ILLUMINATION DIAGNOSIS**

The diagnosis found here addresses an inoperative instrument cluster illumination lamp condition. If the problem being diagnosed is a single inoperative illumination lamp, be certain that the bulb and bulb holder unit are properly installed in the instrument cluster electronic circuit board. If no installation problems are found replace the faulty bulb and bulb holder unit. If all of the cluster illumination lamps are inoperative and the problem being diagnosed includes inoperative exterior lighting controlled by the headlamp switch, that system needs to be repaired first. (Refer to 8 - ELECTRICAL/LAMPS/LIGHTING - EXTERIOR/HEADLAMP - DIAGNOSIS AND TESTING). If no exterior lighting system problems are found, the following procedure will help locate a short or open in the cluster illumination lamp circuit. If the problem being diagnosed involves a lack of dimming control for the odometer/trip odometer Vacuum Fluorescent Display (VFD), but all of the other cluster illumination lamps can be dimmed, test and repair the day brightness circuit between the instrument cluster and the headlamp switch as required. Refer to the appropriate wiring information. The wiring information includes wiring diagrams, proper wire and connector repair procedures, details of wire harness routing and retention, connector pin-out information and location views for the various wire harness connectors, splices and grounds.

**WARNING: ON VEHICLES EQUIPPED WITH AIRBAGS, DISABLE THE AIRBAG SYSTEM BEFORE ATTEMPTING ANY STEERING WHEEL, STEERING COLUMN, OR INSTRUMENT PANEL COMPONENT DIAGNOSIS OR SERVICE. DISCONNECT AND ISOLATE THE BATTERY NEGATIVE (GROUND) CABLE, THEN WAIT TWO MINUTES FOR THE AIRBAG SYSTEM CAPACITOR TO DISCHARGE BEFORE PERFORMING FURTHER DIAGNOSIS OR SERVICE. THIS IS THE ONLY SURE WAY TO DISABLE THE AIRBAG SYSTEM. FAILURE TO TAKE THE PROPER PRECAUTIONS COULD RESULT IN ACCIDENTAL AIRBAG DEPLOYMENT AND POSSIBLE PERSONAL INJURY.**

(1) Check the instrument panel dimmer fuse (Fuse 5 - 5 ampere) in the Junction Block (JB). If OK, go to Step 2. If not OK, repair the shorted circuit or component as required and replace the faulty fuse.

## INSTRUMENT CLUSTER (Continued)

(2) Turn the exterior lamps On with the headlamp switch. Rotate the headlamp switch panel lamps dimmer thumbwheel upward to just before the interior lamps detent. Check for battery voltage at the panel lamps dimmer fuse (Fuse 5 - 5 ampere) in the JB. Rotate the panel lamps dimmer thumbwheel downward while observing the test voltmeter. The reading should go from battery voltage to zero volts. If OK, go to Step 3. If not OK, repair the open panel lamps dimmer switch signal circuit between the headlamp switch and the JB as required.

(3) Turn the exterior lamps Off. Disconnect and isolate the battery negative cable. Remove the instrument cluster. Remove the instrument panel dimmer fuse (Fuse 5 - 5 ampere) from the JB. Probe the fused panel lamps dimmer switch signal cavity of the instrument panel wire harness connector (Connector C2) for the instrument cluster. Check for continuity to a good ground. There should be no continuity. If OK, go to Step 4. If not OK, repair the shorted fused panel lamps dimmer switch signal circuit between the instrument cluster and the JB as required.

(4) Reinstall the instrument panel dimmer fuse (Fuse 5 - 5 ampere) in the JB. Reconnect the battery negative cable. Turn the exterior lamps On with the headlamp switch. Rotate the headlamp switch panel lamps dimmer thumbwheel upward to just before the interior lamps detent. Check for battery voltage at the fused panel lamps dimmer switch signal circuit cavity of the instrument panel wire harness connector (Connector C2) for the instrument cluster. If OK, replace the faulty bulb and bulb holder units. If not OK, repair the open fused panel lamps dimmer switch signal circuit between the instrument cluster and the JB as required.

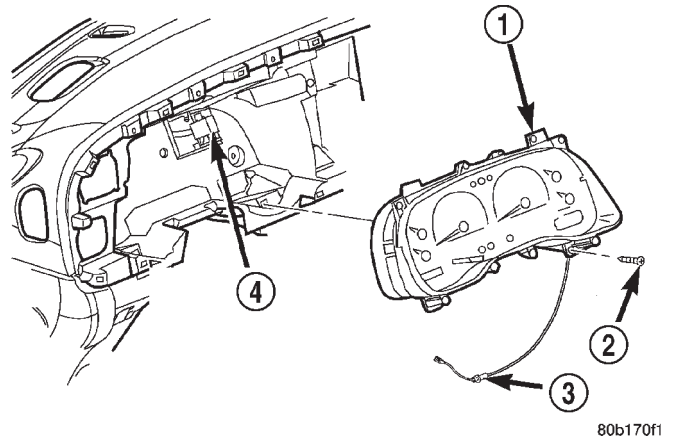
## REMOVAL

**WARNING: ON VEHICLES EQUIPPED WITH AIRBAGS, DISABLE THE AIRBAG SYSTEM BEFORE ATTEMPTING ANY STEERING WHEEL, STEERING COLUMN, OR INSTRUMENT PANEL COMPONENT DIAGNOSIS OR SERVICE. DISCONNECT AND ISOLATE THE BATTERY NEGATIVE (GROUND) CABLE, THEN WAIT TWO MINUTES FOR THE AIRBAG SYSTEM CAPACITOR TO DISCHARGE BEFORE PERFORMING FURTHER DIAGNOSIS OR SERVICE. THIS IS THE ONLY SURE WAY TO DISABLE THE AIRBAG SYSTEM. FAILURE TO TAKE THE PROPER PRECAUTIONS COULD RESULT IN ACCIDENTAL AIRBAG DEPLOYMENT AND POSSIBLE PERSONAL INJURY.**

(1) Disconnect and isolate the battery negative cable.

(2) Remove the cluster bezel from the instrument panel. (Refer to 23 - BODY/INSTRUMENT PANEL/CLUSTER BEZEL - REMOVAL).

(3) Remove the four screws that secure the instrument cluster to the instrument panel (Fig. 2).



80b170f1

**Fig. 2 Instrument Cluster Remove/Install**

- 1 - INSTRUMENT CLUSTER
- 2 - SCREW
- 3 - PRNDL CABLE
- 4 - SELF-DOCKING WIRE HARNESS CONNECTOR

(4) If the vehicle is equipped with an automatic transmission, place the automatic transmission gear selector lever in the Park position.

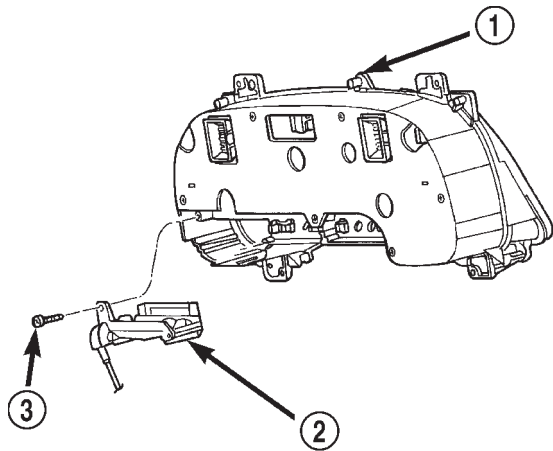
(5) Pull the instrument cluster rearward far enough to disengage the two self-docking instrument panel wire harness connectors from the cluster connector receptacles.

(6) If the vehicle is equipped with an automatic transmission, pull the instrument cluster rearward far enough to access and remove the two screws that secure the gear selector indicator to the back of the instrument cluster housing (Fig. 3).

(7) If the vehicle is equipped with an automatic transmission, disengage the gear selector indicator from the back of the instrument cluster housing.

(8) Remove the instrument cluster from the instrument panel.

## INSTRUMENT CLUSTER (Continued)



80a92a7f

**Fig. 3 Gear Selector Indicator Remove/Install**

- 1 - INSTRUMENT CLUSTER
- 2 - GEAR SELECTOR INDICATOR
- 3 - SCREW

**DISASSEMBLY**

Some of the components for the instrument cluster used in this vehicle are serviced individually. The serviced components include: the automatic transmission gear selector indicator, the incandescent instrument cluster indicator lamp and illumination lamp bulbs (including the integral bulb holders), the cluster lens and hood unit, and the cluster housing rear cover. The remaining components are serviced only as a part of the cluster housing unit, which includes: the cluster housing, the electronic circuit board unit, the cluster overlay, the gauges, and the odometer/trip odometer reset switch button. Following are the procedures for disassembling the serviced components from the instrument cluster unit.

**WARNING: ON VEHICLES EQUIPPED WITH AIRBAGS, DISABLE THE AIRBAG SYSTEM BEFORE ATTEMPTING ANY STEERING WHEEL, STEERING COLUMN, OR INSTRUMENT PANEL COMPONENT DIAGNOSIS OR SERVICE. DISCONNECT AND ISOLATE THE BATTERY NEGATIVE (GROUND) CABLE, THEN WAIT TWO MINUTES FOR THE AIRBAG SYSTEM CAPACITOR TO DISCHARGE BEFORE PERFORMING FURTHER DIAGNOSIS OR SERVICE. THIS IS THE ONLY SURE WAY TO DISABLE THE AIRBAG SYSTEM. FAILURE TO TAKE THE PROPER PRECAUTIONS COULD RESULT IN ACCIDENTAL AIRBAG DEPLOYMENT AND POSSIBLE PERSONAL INJURY.**

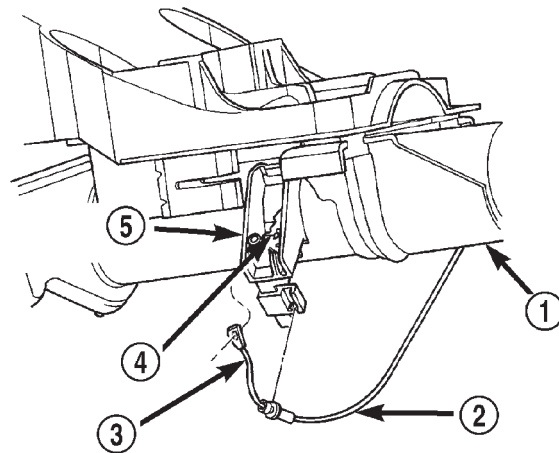
**GEAR SELECTOR INDICATOR**

(1) Disconnect and isolate the battery negative cable.

(2) Remove the instrument cluster from the instrument panel. (Refer to 8 - ELECTRICAL/INSTRUMENT CLUSTER - REMOVAL).

(3) Remove the steering column opening cover from the instrument panel. (Refer to 23 - BODY/INSTRUMENT PANEL/STEERING COLUMN OPENING COVER - REMOVAL).

(4) Reach through the instrument panel steering column opening to access and disengage the loop end of the gear selector indicator cable from the PRNDL driver lever on the left side of the steering column (Fig. 4).



80a92a8a

**Fig. 4 Gear Selector Indicator Cable Remove/Install**

- 1 - STEERING COLUMN
- 2 - CABLE
- 3 - LOOP END
- 4 - LEVER
- 5 - ADJUSTER AND BRACKET

(5) Squeeze the sides of the plastic adjuster and bracket unit to disengage the tabs that secure it to the sides of the steering column window.

(6) Remove the gear selector indicator mechanism and cable unit through the instrument panel cluster opening.

**CLUSTER BULB**

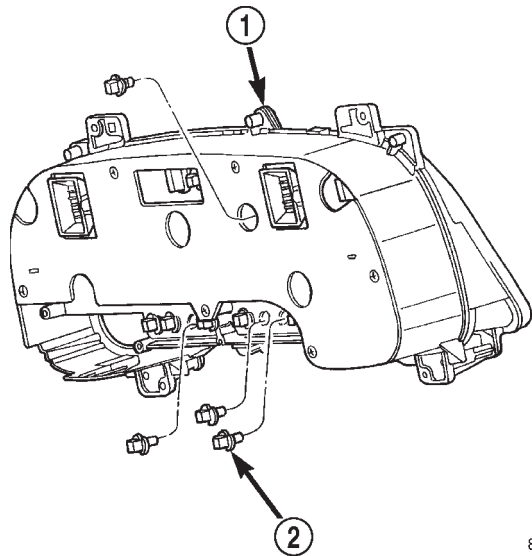
This procedure applies to each of the incandescent cluster illumination lamp or indicator lamp bulb and bulb holder units. However, the illumination lamps and the indicator lamps use different bulb and bulb holder unit sizes. They must never be interchanged.

(1) Disconnect and isolate the battery negative cable.

(2) Remove the instrument cluster from the instrument panel. (Refer to 8 - ELECTRICAL/INSTRUMENT CLUSTER - REMOVAL).

## INSTRUMENT CLUSTER (Continued)

(3) Turn the bulb holder counterclockwise about sixty degrees on the cluster electronic circuit board (Fig. 5).



80a92a79

**Fig. 5 Cluster Bulb Remove/Install**

- 1 - INSTRUMENT CLUSTER
- 2 - BULB AND HOLDER

(4) Pull the bulb and bulb holder unit straight back to remove it from the bulb mounting hole in the cluster electronic circuit board.

## CLUSTER LENS AND HOOD

(1) Disconnect and isolate the battery negative cable.

(2) Remove the instrument cluster from the instrument panel. (Refer to 8 - ELECTRICAL/INSTRUMENT CLUSTER - REMOVAL).

(3) Remove the seven screws that secure the lens and hood unit to the cluster housing (Fig. 6).

(4) Gently pull the lens and hood unit away from the cluster housing.

**CAUTION:** Do not touch the face of the gauge overlay or the back of the cluster lens with your finger. It will leave a permanent finger print.

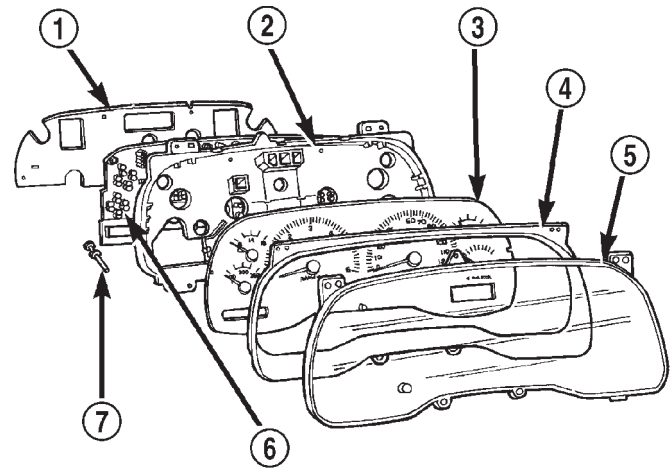
## CLUSTER HOUSING REAR COVER

(1) Disconnect and isolate the battery negative cable.

(2) Remove the instrument cluster from the instrument panel. (Refer to 8 - ELECTRICAL/INSTRUMENT CLUSTER - REMOVAL).

(3) Remove the six screws that secure the rear cover to the back of the cluster housing (Fig. 7).

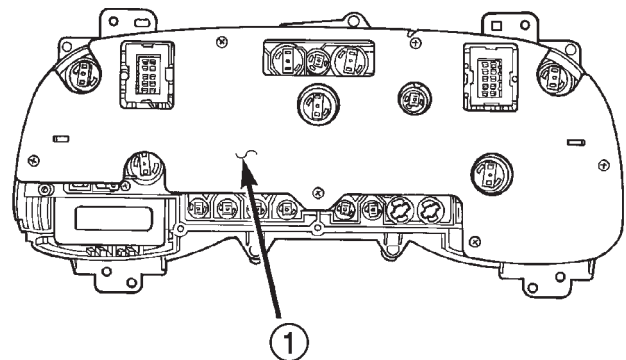
(4) Remove the rear cover from the back of the cluster housing.



80a953e3

**Fig. 6 Instrument Cluster Components**

- 1 - COVER
- 2 - HOUSING
- 3 - OVERLAY AND GAUGES
- 4 - HOOD
- 5 - LENS
- 6 - CIRCUIT BOARD
- 7 - ODOMETER SWITCH BUTTON



80a953e8

**Fig. 7 Cluster Housing Rear Cover Remove/Install**

- 1 - REAR CLUSTER HOUSING COVER

## CLUSTER HOUSING

(1) Disconnect and isolate the battery negative cable.

(2) Remove the instrument cluster from the instrument panel. (Refer to 8 - ELECTRICAL/INSTRUMENT CLUSTER - REMOVAL).

(3) Remove the lens and hood unit from the cluster housing. Refer to CLUSTER LENS AND HOOD .

(4) Remove the rear cover from the cluster housing. Refer to CLUSTER HOUSING REAR COVER .



## INSTRUMENT CLUSTER (Continued)

**ASSEMBLY**

**WARNING: ON VEHICLES EQUIPPED WITH AIRBAGS, DISABLE THE AIRBAG SYSTEM BEFORE ATTEMPTING ANY STEERING WHEEL, STEERING COLUMN, OR INSTRUMENT PANEL COMPONENT DIAGNOSIS OR SERVICE. DISCONNECT AND ISOLATE THE BATTERY NEGATIVE (GROUND) CABLE, THEN WAIT TWO MINUTES FOR THE AIRBAG SYSTEM CAPACITOR TO DISCHARGE BEFORE PERFORMING FURTHER DIAGNOSIS OR SERVICE. THIS IS THE ONLY SURE WAY TO DISABLE THE AIRBAG SYSTEM. FAILURE TO TAKE THE PROPER PRECAUTIONS COULD RESULT IN ACCIDENTAL AIRBAG DEPLOYMENT AND POSSIBLE PERSONAL INJURY.**

**GEAR SELECTOR INDICATOR**

(1) Position the gear selector indicator mechanism and cable unit into the instrument panel cluster opening.

(2) Route the cable through the instrument panel and under the steering column to the PRNDL driver lever on the left side of the steering column.

(3) Squeeze the sides of the plastic adjuster and bracket unit and engage the tabs that secure it with the sides of the steering column window.

(4) Engage the loop end of the gear selector indicator cable onto the PRNDL driver lever on the left side of the steering column (Fig. 4).

(5) Reinstall the instrument cluster onto the instrument panel. (Refer to 8 - ELECTRICAL/INSTRUMENT CLUSTER - INSTALLATION).

(6) Confirm proper operation of the gear selector indicator. Calibrate the indicator, if required. (Refer to 19 - STEERING/COLUMN - INSTALLATION).

(7) Reinstall the steering column opening cover onto the instrument panel. (Refer to 23 - BODY/INSTRUMENT PANEL/STEERING COLUMN OPENING COVER - INSTALLATION).

(8) Reconnect the battery negative cable.

**CLUSTER BULB**

This procedure applies to each of the incandescent cluster illumination lamp or indicator lamp bulb and bulb holder units. However, the illumination lamps and the indicator lamps use different bulb and bulb holder unit sizes. They must never be interchanged.

**CAUTION: Be certain that any bulb and bulb holder unit removed from the cluster electronic circuit board is reinstalled in the correct position. Always use the correct bulb size and type for replacement. An incorrect bulb size or type may overheat and cause damage to the instrument cluster, the electronic circuit board and/or the gauges.**

(1) Insert the bulb and bulb holder unit straight into the correct bulb mounting hole in the cluster electronic circuit board (Fig. 5).

(2) With the bulb holder fully seated against the cluster electronic circuit board, turn the bulb holder clockwise about sixty degrees to lock it into place.

(3) Reinstall the instrument cluster onto the instrument panel. (Refer to 8 - ELECTRICAL/INSTRUMENT CLUSTER - INSTALLATION).

(4) Reconnect the battery negative cable.

**CLUSTER LENS AND HOOD**

**CAUTION: Do not touch the face of the gauge overlay or the back of the cluster lens with your finger. It will leave a permanent finger print.**

(1) Align the cluster lens and hood unit with the cluster housing. Be certain that the odometer/trip odometer switch button is installed through the clearance hole in the lens (Fig. 6).

(2) Install and tighten the seven screws that secure the lens and hood unit to the cluster housing. Tighten the screws to 2.2 N-m (20 in. lbs.).

(3) Reinstall the instrument cluster onto the instrument panel. (Refer to 8 - ELECTRICAL/INSTRUMENT CLUSTER - INSTALLATION).

(4) Reconnect the battery negative cable.

**CLUSTER HOUSING REAR COVER**

(1) Position the rear cover onto the back of the cluster housing (Fig. 7).

(2) Install and tighten the six screws that secure the rear cover to the back of the cluster housing. Tighten the screws to 2.2 N-m (20 in. lbs.).

(3) Reinstall the instrument cluster onto the instrument panel. (Refer to 8 - ELECTRICAL/INSTRUMENT CLUSTER - INSTALLATION).

(4) Reconnect the battery negative cable.

**CLUSTER HOUSING**

(1) Assemble the rear cover onto the cluster housing. Refer to CLUSTER HOUSING REAR COVER .

(2) Assemble the lens and hood unit onto the cluster housing. Refer to CLUSTER LENS AND HOOD .

(3) Reinstall the instrument cluster onto the instrument panel. (Refer to 8 - ELECTRICAL/INSTRUMENT CLUSTER - INSTALLATION).

(4) Reconnect the battery negative cable.



## INSTRUMENT CLUSTER (Continued)

## INSTALLATION

**WARNING: ON VEHICLES EQUIPPED WITH AIRBAGS, DISABLE THE AIRBAG SYSTEM BEFORE ATTEMPTING ANY STEERING WHEEL, STEERING COLUMN, OR INSTRUMENT PANEL COMPONENT DIAGNOSIS OR SERVICE. DISCONNECT AND ISOLATE THE BATTERY NEGATIVE (GROUND) CABLE, THEN WAIT TWO MINUTES FOR THE AIRBAG SYSTEM CAPACITOR TO DISCHARGE BEFORE PERFORMING FURTHER DIAGNOSIS OR SERVICE. THIS IS THE ONLY SURE WAY TO DISABLE THE AIRBAG SYSTEM. FAILURE TO TAKE THE PROPER PRECAUTIONS COULD RESULT IN ACCIDENTAL AIRBAG DEPLOYMENT AND POSSIBLE PERSONAL INJURY.**

(1) Position the instrument cluster to the instrument panel.

(2) If the vehicle is equipped with an automatic transmission, position the gear selector indicator onto the back of the cluster housing (Fig. 3).

(3) If the vehicle is equipped with an automatic transmission, install and tighten the two screws that secure the gear selector indicator mechanism to the back of the cluster housing. Tighten the screws to 2.2 N·m (20 in. lbs.).

(4) Align the instrument cluster with the cluster opening in the instrument panel and push the cluster firmly and evenly into place. The instrument panel wire harness has two self-docking connectors that will be automatically aligned with, and connected to the instrument cluster connector receptacles when the cluster is properly installed in the instrument panel.

(5) Install and tighten the four screws that secure the instrument cluster to the instrument panel (Fig. 2). Tighten the screws to 2.2 N·m (20 in. lbs.).

(6) Reinstall the cluster bezel onto the instrument panel. (Refer to 23 - BODY/INSTRUMENT PANEL/CLUSTER BEZEL - INSTALLATION).

(7) If the vehicle is equipped with an automatic transmission, confirm proper operation of the gear selector indicator. Calibrate the indicator, if required. (Refer to 19 - STEERING/COLUMN - INSTALLATION).

(8) Reconnect the battery negative cable.

**NOTE:** Some of the indicators in this instrument cluster are either programmable (upshift indicator) or automatically configured (cruise, overdrive-off, and transmission overtemp indicators) when the cluster is connected to the vehicle electrical system. This feature allows those indicator lamps to be enabled or disabled for compatibility with certain optional equipment. If a new instrument cluster is being installed, use a DRBIII® scan tool to program

the instrument cluster with the proper vehicle equipment option setting to enable and/or disable the upshift indicator lamp. Refer to the appropriate diagnostic information.

## ABS INDICATOR

## DESCRIPTION

An Antilock Brake System (ABS) indicator is standard equipment on all instrument clusters. This indicator serves both the standard equipment Rear Wheel Anti-Lock (RWAL) and optional equipment 4-Wheel Anti-Lock (4WAL) brake systems. The ABS indicator is located near the lower edge of the instrument cluster overlay, to the left of center. The ABS indicator consists of a stencilled cutout of the International Control and Display Symbol icon for "Failure of Anti-lock Braking System" in the opaque layer of the instrument cluster overlay. The dark outer layer of the overlay prevents the indicator from being clearly visible when it is not illuminated. An amber lens behind the cutout in the opaque layer of the overlay causes the icon to appear in amber through the translucent outer layer of the overlay when it is illuminated from behind by a Light Emitting Diode (LED) soldered onto the instrument cluster electronic circuit board. The ABS indicator is serviced as a unit with the instrument cluster.

## OPERATION

The ABS indicator gives an indication to the vehicle operator when the ABS system is faulty or inoperative. This indicator is controlled by a transistor on the instrument cluster circuit board based upon cluster programming and electronic messages received by the cluster from the Controller Antilock Brake (CAB) over the Chrysler Collision Detection (CCD) data bus. The ABS indicator Light Emitting Diode (LED) receives battery current on the instrument cluster electronic circuit board through the fused ignition switch output (st-run) circuit whenever the ignition switch is in the On or Start positions; therefore, the LED will always be off when the ignition switch is in any position except On or Start. The LED only illuminates when it is provided a path to ground by the instrument cluster transistor. The instrument cluster will turn on the ABS indicator for the following reasons:

- **Bulb Test** - Each time the ignition switch is turned to the On position the ABS indicator is illuminated by the cluster for about two seconds as a bulb test.

- **ABS Lamp-On Message** - Each time the cluster receives a lamp-on message from the CAB, the

## ABS INDICATOR (Continued)

ABS indicator will be illuminated. The indicator remains illuminated until the cluster receives a lamp-off message from the CAB, or until the ignition switch is turned to the Off position, whichever occurs first.

- **Communication Error** - If the cluster receives no lamp-on or lamp-off messages from the CAB for six consecutive seconds, the ABS indicator is illuminated. The indicator remains illuminated until the cluster receives a valid message from the CAB, or until the ignition switch is turned to the Off position, whichever occurs first.

- **Actuator Test** - Each time the instrument cluster is put through the actuator test, the ABS indicator will be turned on during the bulb check portion of the test to confirm the functionality of the LED and the cluster control circuitry.

- **ABS Diagnostic Test** - The ABS indicator is blinked on and off by lamp-on and lamp-off messages from the CAB during the performance of the ABS diagnostic tests.

The CAB continually monitors the ABS circuits and sensors to decide whether the system is in good operating condition. The CAB then sends the proper lamp-on or lamp-off messages to the instrument cluster. If the CAB sends a lamp-on message after the bulb test, it indicates that the CAB has detected a system malfunction and/or that the ABS system has become inoperative. The CAB will store a Diagnostic Trouble Code (DTC) for any malfunction it detects. Each time the ABS indicator fails to light due to an open or short in the cluster ABS indicator circuit, the cluster sends a message notifying the CAB of the condition, and the CAB will store a DTC. For proper diagnosis of the antilock brake system, the CAB, the CCD data bus, or the message inputs to the instrument cluster that control the ABS indicator, a DRBIII® scan tool is required. Refer to the appropriate diagnostic information.

## AIRBAG INDICATOR

### DESCRIPTION

An airbag indicator is standard equipment on all instrument clusters. However, on vehicles not equipped with airbags, this indicator is electronically disabled. The airbag indicator is located near the lower edge of the instrument cluster overlay, to the right of center. The airbag indicator consists of a stenciled cutout of the word "AIRBAG" in the opaque layer of the instrument cluster overlay. The dark outer layer of the overlay prevents the indicator from being clearly visible when it is not illuminated. A red lens behind the cutout in the opaque layer of the overlay causes the "AIRBAG" text to appear in red

through the translucent outer layer of the overlay when it is illuminated from behind by a Light Emitting Diode (LED) soldered onto the instrument cluster electronic circuit board. The airbag indicator is serviced as a unit with the instrument cluster.

### OPERATION

The airbag indicator gives an indication to the vehicle operator when the airbag system is faulty or inoperative. The airbag indicator is controlled by a transistor on the instrument cluster circuit board based upon cluster programming and electronic messages received by the cluster from the Airbag Control Module (ACM) over the Chrysler Collision Detection (CCD) data bus. The airbag indicator Light Emitting Diode (LED) receives battery current on the instrument cluster electronic circuit board through the fused ignition switch output (st-run) circuit whenever the ignition switch is in the On or Start positions; therefore, the indicator will always be off when the ignition switch is in any position except On or Start. The LED only illuminates when it is provided a path to ground by the instrument cluster transistor. The instrument cluster will turn on the airbag indicator for the following reasons:

- **Bulb Test** - Each time the ignition switch is turned to the On position the airbag indicator is illuminated for about seven seconds. The first two seconds is the cluster bulb test function, and the remainder is the ACM bulb test function.

- **ACM Lamp-On Message** - Each time the cluster receives a lamp-on message from the ACM, the airbag indicator will be illuminated. The indicator remains illuminated for about twelve seconds or until the cluster receives a lamp-off message from the ACM, whichever is longer.

- **Communication Error** - If the cluster receives no airbag messages for three consecutive seconds, the airbag indicator is illuminated. The indicator remains illuminated for about twelve seconds or until the cluster receives a single lamp-off message from the ACM, whichever is longer.

- **Actuator Test** - Each time the cluster is put through the actuator test, the airbag indicator will be turned on during the bulb check portion of the test to confirm the functionality of the LED and the cluster control circuitry.

The ACM continually monitors the airbag system circuits and sensors to decide whether the system is in good operating condition. The ACM then sends the proper lamp-on or lamp-off messages to the instrument cluster. If the ACM sends a lamp-on message after the bulb test, it indicates that the ACM has detected a system malfunction and/or that the airbags may not deploy when required, or may deploy when not required. The ACM will store a Diagnostic

## AIRBAG INDICATOR (Continued)

Trouble Code (DTC) for any malfunction it detects. Each time the airbag indicator fails to illuminate due to an open or short in the cluster airbag indicator circuit, the cluster sends a message notifying the ACM of the condition, the ACM will store a DTC, and the cluster begins blinking the seat belt indicator. (Refer to 8 - ELECTRICAL/INSTRUMENT CLUSTER/SEATBELT INDICATOR - OPERATION). For proper diagnosis of the airbag system, the ACM, the CCD data bus, or the message inputs to the instrument cluster that control the airbag indicator, a DRBIII® scan tool is required. Refer to the appropriate diagnostic information.

## BRAKE/PARK BRAKE INDICATOR

## DESCRIPTION

A brake indicator is standard equipment on all instrument clusters. The brake indicator is located near the lower edge of the instrument cluster overlay, to the right of center. The brake indicator consists of a stenciled cutout of the word "BRAKE" in the opaque layer of the instrument cluster overlay. The dark outer layer of the overlay prevents the indicator from being clearly visible when it is not illuminated. A red lens behind the cutout in the opaque layer of the overlay causes the "BRAKE" text to appear in red through the translucent outer layer of the overlay when it is illuminated from behind by a Light Emitting Diode (LED) soldered onto the instrument cluster electronic circuit board. The brake indicator is serviced as a unit with the instrument cluster.

## OPERATION

The brake indicator gives an indication to the vehicle operator when the parking brake is applied, or when there are certain brake hydraulic system malfunctions. This indicator is controlled by a transistor on the instrument cluster circuit board based upon a hard wired input to the instrument cluster, cluster programming, and electronic messages received by the cluster from the Controller Antilock Brake (CAB) over the Chrysler Collision Detection (CCD) data bus. The brake indicator Light Emitting Diode (LED) receives battery current on the instrument cluster electronic circuit board through the fused ignition switch output (st-run) circuit whenever the ignition switch is in the On or Start positions; therefore, the LED will always be off when the ignition switch is in any position except On or Start. The LED only illuminates when it is provided a path to ground by the instrument cluster transistor. The instrument cluster will turn on the brake indicator for the following reasons:

- **Bulb Test** - Each time the ignition switch is turned to the On position the brake indicator is illuminated by the instrument cluster for about four seconds as a bulb test.

- **Park Brake-On** - If the park brake is applied or not fully released with the ignition switch in the On position, the brake indicator is illuminated solid. The brake indicator will blink on and off repeatedly when the park brake is applied or not fully released and the ignition switch is in the On position if a vehicle with an automatic transmission is not in Park or Neutral, or if the engine is running on vehicles with a manual transmission.

- **Brake Lamp-On Message** - Each time the cluster receives a lamp-on message from the CAB, the brake indicator will be illuminated. The indicator remains illuminated until the cluster receives a lamp-off message from the CAB, or until the ignition switch is turned to the Off position, whichever occurs first.

- **Actuator Test** - Each time the instrument cluster is put through the actuator test, the brake indicator will be turned on during the bulb check portion of the test to confirm the functionality of the LED and the cluster control circuitry.

The park brake switch on the park brake pedal mechanism provides a hard wired ground input to the instrument cluster circuitry through the park brake switch sense circuit whenever the park brake is applied or not fully released. The CAB continually monitors the brake pressure switch on the brake combination valve to determine if the pressures in the two halves of the split brake hydraulic system are unequal. The CAB then sends the proper lamp-on or lamp-off messages to the instrument cluster. If the CAB sends a lamp-on message after the bulb test, it indicates that the CAB has detected a brake hydraulic system malfunction and/or that the ABS system has become inoperative. The CAB will store a Diagnostic Trouble Code (DTC) for any malfunction it detects. The park brake switch input to the instrument cluster can be diagnosed using conventional diagnostic tools and methods. For proper diagnosis of the antilock brake system, the CAB, the CCD data bus, or the message inputs to the instrument cluster that control the brake indicator, a DRBIII® scan tool is required. Refer to the appropriate diagnostic information.

## DIAGNOSIS AND TESTING - BRAKE INDICATOR

The diagnosis found here addresses an inoperative brake indicator condition. If the brake indicator comes on or stays on with the ignition switch in the On position and the park brake released, or comes on while driving, the brake system must be diagnosed and repaired prior to performing the following tests.



## BRAKE/PARK BRAKE INDICATOR (Continued)

(Refer to 5 - BRAKES - DIAGNOSIS AND TESTING). If no brake system problem is found, the following procedure will help locate a faulty park brake switch or park brake switch sense circuit. Refer to the appropriate wiring information. The wiring information includes wiring diagrams, proper wire and connector repair procedures, details of wire harness routing and retention, connector pin-out information and location views for the various wire harness connectors, splices and grounds.

**WARNING: ON VEHICLES EQUIPPED WITH AIRBAGS, DISABLE THE AIRBAG SYSTEM BEFORE ATTEMPTING ANY STEERING WHEEL, STEERING COLUMN, OR INSTRUMENT PANEL COMPONENT DIAGNOSIS OR SERVICE. DISCONNECT AND ISOLATE THE BATTERY NEGATIVE (GROUND) CABLE, THEN WAIT TWO MINUTES FOR THE AIRBAG SYSTEM CAPACITOR TO DISCHARGE BEFORE PERFORMING FURTHER DIAGNOSIS OR SERVICE. THIS IS THE ONLY SURE WAY TO DISABLE THE AIRBAG SYSTEM. FAILURE TO TAKE THE PROPER PRECAUTIONS COULD RESULT IN ACCIDENTAL AIRBAG DEPLOYMENT AND POSSIBLE PERSONAL INJURY.**

(1) Disconnect and isolate the battery negative cable. Disconnect the instrument panel wire harness connector for the park brake switch from the switch terminal. With the park brake released, check for continuity between the park brake switch terminal and a good ground. There should be no continuity. If OK, go to Step 2. If not OK, adjust or replace the faulty park brake switch.

(2) Remove the instrument cluster from the instrument panel. With the park brake switch still disconnected, check for continuity between the park brake switch sense circuit cavity of the instrument panel wire harness connector for the park brake switch and a good ground. There should be no continuity. If OK, go to Step 3. If not OK, repair the shorted park brake switch sense circuit between the park brake switch and the instrument cluster as required.

(3) Check for continuity between the park brake switch sense circuit cavities of the instrument panel wire harness connector for the park brake switch and the instrument panel wire harness connector (Connector C1) for the instrument cluster. There should be continuity. If OK, proceed with diagnosis of the instrument cluster. (Refer to 8 - ELECTRICAL/INSTRUMENT CLUSTER - DIAGNOSIS AND TESTING). If not OK, repair the open park brake switch sense circuit between the park brake switch and the instrument cluster as required.

## CHECK GAUGES INDICATOR

## DESCRIPTION

A check gauges indicator is standard equipment on all instrument clusters. The check gauges indicator is located on the lower edge of the instrument cluster overlay, to the right of center. The check gauges indicator consists of a stenciled cutout of the words "CHECK GAGES" in the opaque layer of the instrument cluster overlay. The dark outer layer of the overlay prevents the indicator from being clearly visible when the it is not illuminated. A red lens behind the cutout in the opaque layer of the overlay causes the "CHECK GAGES" text to appear in red through the translucent outer layer of the overlay when the indicator is illuminated from behind by a Light Emitting Diode (LED) soldered onto the instrument cluster electronic circuit board. The check gauges indicator is serviced as a unit with the instrument cluster.

## OPERATION

The check gauges indicator gives an indication to the vehicle operator when certain instrument cluster gauge readings reflect a condition requiring immediate attention. This indicator is controlled by a transistor on the instrument cluster circuit board based upon the cluster programming and electronic messages received by the cluster from the Powertrain Control Module (PCM) over the Chrysler Collision Detection (CCD) data bus. The check gauges indicator Light Emitting Diode (LED) receives battery current on the instrument cluster electronic circuit board through the fused ignition switch output (st-run) circuit whenever the ignition switch is in the On or Start positions; therefore, the LED will always be off when the ignition switch is in any position except On or Start. The LED only illuminates when it is provided a path to ground by the instrument cluster transistor. The instrument cluster will turn on the check gauges indicator for the following reasons:

- **Bulb Test** - Each time the ignition switch is turned to the On position the check gauges indicator is illuminated for about two seconds as a bulb test.

- **Engine Temperature High Message** - Each time the cluster receives a message from the PCM indicating the engine coolant temperature of a gasoline engine is about 122° C (253° F) or higher, or a diesel engine is about 112° C (233° F) or higher, the check gauges indicator will be illuminated. The indicator remains illuminated until the cluster receives a message from the PCM indicating that the temperature of a gasoline engine is about 119° C (246° F) or lower, a diesel engine is about 109° C (226° F) or lower, or until the ignition switch is turned to the Off position, whichever occurs first.

## CHECK GAUGES INDICATOR (Continued)

- **Engine Oil Pressure Low Message** - Each time the cluster receives a message from the PCM indicating the engine oil pressure of a gasoline engine is about 3.45 kPa (0.5 psi) or lower, or a diesel engine is about 51.71 kPa (7.5 psi) or lower, the check gauges indicator will be illuminated. The indicator remains illuminated until the cluster receives a message from the PCM indicating that the engine oil pressure of a gasoline engine is above 3.45 kPa (0.5 psi), a diesel engine is above 51.71 kPa (7.5 psi), or until the ignition switch is turned to the Off position, whichever occurs first. The cluster will only turn the indicator on in response to an engine oil pressure low message if the engine speed is greater than zero.

- **System Voltage Low Message** - Each time the cluster receives a message from the PCM indicating the electrical system voltage is less than 11.5 volts, the check gauges indicator will be illuminated. The indicator remains illuminated until the cluster receives a message from the PCM indicating the electrical system voltage is greater than 12.0 volts (but less than 16.6 volts), or until the ignition switch is turned to the Off position, whichever occurs first.

- **System Voltage High Message** - Each time the cluster receives a message from the PCM indicating the electrical system voltage is greater than 16.6 volts, the check gauges indicator will be illuminated. The indicator remains illuminated until the cluster receives a message from the PCM indicating the electrical system voltage is less than 16.1 volts (but greater than 11.5 volts), or until the ignition switch is turned to the Off position, whichever occurs first.

- **Actuator Test** - Each time the cluster is put through the actuator test, the indicator will be turned on during the bulb check portion of the test to confirm the functionality of the LED and the cluster control circuitry.

The PCM continually monitors the engine temperature, oil pressure, and electrical system voltage, then sends the proper messages to the instrument cluster. For further diagnosis of the check gauges indicator or the instrument cluster circuitry that controls the LED, (Refer to 8 - ELECTRICAL/INSTRUMENT CLUSTER - DIAGNOSIS AND TESTING). For proper diagnosis of the PCM, the CCD data bus, or the message inputs to the instrument cluster that control the check gauges indicator, a DRBIII® scan tool is required. Refer to the appropriate diagnostic information.

## CRUISE INDICATOR

### DESCRIPTION

A cruise indicator is standard equipment on all instrument clusters. However, on vehicles not

equipped with the optional speed control system, this indicator is electronically disabled. The cruise indicator consists of the word "CRUISE", which appears in the lower portion of the odometer/trip odometer Vacuum-Fluorescent Display (VFD). The VFD is part of the cluster electronic circuit board, and is visible through a cutout located in the lower left corner of the cluster overlay. The dark lens of the VFD prevents the indicator from being clearly visible when it is not illuminated. The word "CRUISE" appears in an amber color and at the same lighting level as the odometer/trip odometer information when it is illuminated by the instrument cluster electronic circuit board. The cruise indicator lamp is serviced as a unit with the VFD in the instrument cluster.

### OPERATION

The cruise indicator gives an indication to the vehicle operator when the speed control system is turned On, regardless of whether the speed control is engaged. This indicator is controlled by the instrument cluster circuit board based upon the cluster programming and electronic messages received by the cluster from the Powertrain Control Module (PCM) over the Chrysler Collision Detection (CCD) data bus. The cruise indicator receives battery current on the instrument cluster electronic circuit board through the fused ignition switch output (st-run) circuit whenever the ignition switch is in the On or Start positions; therefore, the indicator will always be off when the ignition switch is in any position except On or Start. The indicator only illuminates when it is switched to ground by the instrument cluster circuitry. The instrument cluster will turn on the cruise indicator for the following reasons:

- **Bulb Test** - Each time the ignition switch is turned to the On position the cruise indicator is illuminated for about two seconds as a bulb test.

- **Cruise Lamp-On Message** - Each time the cluster receives a cruise lamp-on message from the PCM indicating the speed control system has been turned On, the cruise indicator is illuminated. The indicator remains illuminated until the cluster receives a cruise lamp-off message from the PCM or until the ignition switch is turned to the Off position, whichever occurs first.

- **Actuator Test** - Each time the cluster is put through the actuator test, the cruise indicator will be turned on during the VFD portion of the test to confirm the functionality of the VFD, and again during the bulb check portion of the test to confirm the functionality of the cluster control circuitry.

The PCM continually monitors the speed control switches to determine the proper outputs to the speed control servo. The PCM then sends the proper cruise indicator lamp-on and lamp-off messages to



## CRUISE INDICATOR (Continued)

the instrument cluster. For further diagnosis of the cruise indicator or the instrument cluster circuitry that controls the indicator, (Refer to 8 - ELECTRICAL/INSTRUMENT CLUSTER - DIAGNOSIS AND TESTING). For proper diagnosis of the speed control system, the PCM, the CCD data bus, or the message inputs to the instrument cluster that control the cruise indicator, a DRBIII® scan tool is required. Refer to the appropriate diagnostic information.

## ENGINE TEMPERATURE GAUGE

### DESCRIPTION

An engine coolant temperature gauge is standard equipment on all instrument clusters. The engine coolant temperature gauge is located in the lower left quadrant of the instrument cluster, below the voltage gauge. The engine coolant temperature gauge consists of a movable gauge needle or pointer controlled by the instrument cluster circuitry and a fixed 90 degree scale on the cluster overlay that reads left-to-right from 54° C (130° F) to 127° C (260° F) for gasoline engines, or from 60° C (140° F) to 116° C (240° F) for diesel engines. An International Control and Display Symbol icon for "Engine Coolant Temperature" is located on the cluster overlay, directly below the lowest graduation of the gauge scale. The engine coolant temperature gauge graphics are white against a black field except for a single red graduation at the high end of the gauge scale, making them clearly visible within the instrument cluster in daylight. When illuminated from behind by the panel lamps dimmer controlled cluster illumination lighting with the exterior lamps turned On, the white graphics appear blue-green and the red graphics appear red. The orange gauge needle is internally illuminated. Gauge illumination is provided by replaceable incandescent bulb and bulb holder units located on the instrument cluster electronic circuit board. The engine coolant temperature gauge is serviced as a unit with the instrument cluster.

### OPERATION

The engine coolant temperature gauge gives an indication to the vehicle operator of the engine coolant temperature. This gauge is controlled by the instrument cluster circuit board based upon the cluster programming and electronic messages received by the cluster from the Powertrain Control Module (PCM) over the Chrysler Collision Detection (CCD) data bus. The engine coolant temperature gauge is an air core magnetic unit that receives battery current on the instrument cluster electronic circuit board through the fused ignition switch output (st-

run) circuit whenever the ignition switch is in the On or Start positions. The cluster is programmed to move the gauge needle back to the low end of the scale after the ignition switch is turned to the Off position. The instrument cluster circuitry controls the gauge needle position and provides the following features:

- **Engine Temperature Message** - Each time the cluster receives a message from the PCM indicating the engine coolant temperature is between the low end of normal [about 57° C (130° F) for gasoline engines, or 60° C (140° F) for diesel engines] and the high end of normal [about 129° C (264° F) for gasoline engines, or 116° C (240° F) for diesel engines], the gauge needle is moved to the actual temperature position on the gauge scale.

- **Engine Temperature Low Message** - Each time the cluster receives a message from the PCM indicating the engine coolant temperature is below the low end of normal [about 57° C (130° F) for gasoline engines, or 60° C (140° F) for diesel engines], the gauge needle is held at the lowest increment [57° C (130° F) for gasoline engines, or 60° C (140° F) for diesel engines] at the far left end of the gauge scale. The gauge needle remains at the far left end of the scale until the cluster receives a message from the PCM indicating that the engine temperature is above about 57° C (130° F) for gasoline engines, or 60° C (140° F) for diesel engines, or until the ignition switch is turned to the Off position, whichever occurs first.

- **Engine Temperature High Message** - Each time the cluster receives a message from the PCM indicating the engine coolant temperature is above about 122° C (253° F) for gasoline engines, or 112° C (233° F) for diesel engines, the gauge needle is moved to the appropriate position on the gauge scale, the check gauges indicator is illuminated, and a single chime tone is sounded. The check gauges indicator remains illuminated until the cluster receives a message from the PCM indicating that the engine temperature is below about 119° C (246° F) for gasoline engines, or 109° C (226° F) for diesel engines, or until the ignition switch is turned to the Off position, whichever occurs first. The chime tone feature will only repeat during the same ignition cycle if the check gauges indicator is cycled off and then on again by the appropriate engine temperature messages from the PCM.

- **Message Failure** - If the cluster fails to receive an engine temperature message, it will hold the gauge needle at the last indication until a new message is received, or until the ignition switch is turned to the Off position, whichever occurs first.

- **Actuator Test** - Each time the cluster is put through the actuator test, the gauge needle will be

## ENGINE TEMPERATURE GAUGE (Continued)

swept to several calibration points on the gauge scale in a prescribed sequence in order to confirm the functionality of the gauge and the cluster control circuitry.

The PCM continually monitors the engine coolant temperature sensor to determine the engine operating temperature. The PCM then sends the proper engine coolant temperature messages to the instrument cluster. For further diagnosis of the engine coolant temperature gauge or the instrument cluster circuitry that controls the gauge, (Refer to 8 - ELECTRICAL/INSTRUMENT CLUSTER - DIAGNOSIS AND TESTING). If the instrument cluster turns on the check gauges indicator due to a high engine temperature gauge reading, it may indicate that the engine or the engine cooling system requires service. For proper diagnosis of the engine coolant temperature sensor, the PCM, the CCD data bus, or the message inputs to the instrument cluster that control the engine coolant temperature gauge, a DRBIII® scan tool is required. Refer to the appropriate diagnostic information.

## FUEL GAUGE

### DESCRIPTION

A fuel gauge is standard equipment on all instrument clusters. The fuel gauge is located in the lower right quadrant of the instrument cluster, below the oil pressure gauge. The fuel gauge consists of a movable gauge needle or pointer controlled by the instrument cluster circuitry and a fixed 90 degree scale on the cluster overlay that reads left-to-right from E (or Empty) to F (or Full). An International Control and Display Symbol icon for "Fuel" is located on the cluster overlay, directly below the highest graduation of the gauge scale. The text "FUEL DOOR" and an arrowhead pointed to the left side of the vehicle is imprinted on the cluster overlay directly below the fuel gauge to provide the driver with a reminder as to the location of the fuel filler access. The fuel gauge graphics are white against a black field except for a single red graduation at the low end of the gauge scale, making them clearly visible within the instrument cluster in daylight. When illuminated from behind by the panel lamps dimmer controlled cluster illumination lighting with the exterior lamps turned On, the white graphics appear blue-green and the red graphics appear red. The orange gauge needle is internally illuminated. Gauge illumination is provided by replaceable incandescent bulb and bulb holder units located on the instrument cluster electronic circuit board. The fuel gauge is serviced as a unit with the instrument cluster.

### OPERATION

The fuel gauge gives an indication to the vehicle operator of the level of fuel in the fuel tank. This gauge is controlled by the instrument cluster circuit board based upon the cluster programming and electronic messages received by the cluster from the Powertrain Control Module (PCM) over the Chrysler Collision Detection (CCD) data bus. The fuel gauge is an air core magnetic unit that receives battery current on the instrument cluster electronic circuit board through the fused ignition switch output (st-run) circuit whenever the ignition switch is in the On or Start positions. The cluster is programmed to move the gauge needle back to the low end of the scale after the ignition switch is turned to the Off position. The instrument cluster circuitry controls the gauge needle position and provides the following features:

- **Percent Tank Full Message** - Each time the cluster receives a message from the PCM indicating the percent tank full, the cluster programming applies an algorithm to calculate the proper gauge needle position, then moves the gauge needle to the proper position on the gauge scale. The algorithm is used to dampen gauge needle movement against the negative effect that fuel sloshing within the fuel tank can have on accurate inputs from the fuel tank sending unit to the PCM.

- **Less Than 12.5 Percent Tank Full Message** - Each time the cluster receives messages from the PCM indicating the percent tank full is 12.5 (one-eighth) or less for 10 consecutive seconds and the vehicle speed is zero, or for 60 consecutive seconds and the vehicle speed is greater than zero, the gauge needle is moved to the proper position on the gauge scale, the low fuel indicator is illuminated, and a single chime tone is sounded. The low fuel indicator remains illuminated until the cluster receives messages from the PCM indicating that the percent tank full is greater than 12.5 (one-eighth) for 10 consecutive seconds and the vehicle speed is zero, or for 60 consecutive seconds and the vehicle speed is greater than zero, or until the ignition switch is turned to the Off position, whichever occurs first. The chime tone feature will only repeat during the same ignition cycle if the low fuel indicator is cycled off and then on again by the appropriate percent tank full messages from the PCM.

- **Less Than Empty Percent Tank Full Message** - Each time the cluster receives a message from the PCM indicating the percent tank full is less than empty, the gauge needle is moved to the far left (low) end of the gauge scale and the low fuel indicator is illuminated immediately. This message would indicate that the fuel tank sender input to the PCM is a short circuit.

## FUEL GAUGE (Continued)

- **More Than Full Percent Tank Full Message**

- Each time the cluster receives a message from the PCM indicating the percent tank full is more than full, the gauge needle is moved to the far left (low) end of the gauge scale and the low fuel indicator is illuminated immediately. This message would indicate that the fuel tank sender input to the PCM is an open circuit.

- **Message Failure** - If the cluster fails to receive a percent tank full message, it will hold the gauge needle at the last indication until a new message is received, or until the ignition switch is turned to the Off position, whichever occurs first.

- **Actuator Test** - Each time the cluster is put through the actuator test, the gauge needle will be swept to several calibration points on the gauge scale in a prescribed sequence in order to confirm the functionality of the gauge and the cluster control circuitry.

The PCM continually monitors the fuel tank sending unit, then sends the proper messages to the instrument cluster. For further diagnosis of the fuel gauge or the instrument cluster circuitry that controls the gauge, (Refer to 8 - ELECTRICAL/INSTRUMENT CLUSTER - DIAGNOSIS AND TESTING). For proper diagnosis of the fuel tank sending unit, the PCM, the CCD data bus, or the message inputs to the instrument cluster that control the fuel gauge, a DRBIII® scan tool is required. Refer to the appropriate diagnostic information.

## GEAR SELECTOR INDICATOR

### DESCRIPTION

A mechanical automatic transmission gear selector indicator is standard factory-installed equipment on this model, when it is also equipped with an optional automatic transmission. The gear selector indicator consists of a molded black plastic housing with integral mounting tabs that is secured to the back of the instrument cluster housing with two screws. A face plate on the indicator housing is visible through a rectangular cutout in the lower right corner of the instrument cluster overlay, just below the fuel gauge. Vehicles with a manual transmission have a block-off plate mounted to the back of the instrument cluster behind this cutout in the overlay, in place of the gear selector indicator. Near the top of this face plate the following characters are imprinted from left to right: "P," "R," "N," "D," "2," and "1." Respectively, these characters represent the park, reverse, neutral, drive, second gear, and first gear positions of the transmission gear selector lever on the steering column. Directly below each character on the face plate

is a small, rectangular window, and behind these windows is a single, movable red pointer.

The gear selector indicator graphics are white against a black field except for the single red pointer, making them clearly visible within the instrument cluster in daylight. When illuminated from behind by the panel lamps dimmer controlled cluster illumination lighting with the exterior lamps turned On, the white graphics appear blue-green, while the red pointer still appears red. Indicator illumination is provided by replaceable incandescent bulb and bulb holder units located on the instrument cluster electronic circuit board. The gear selector indicator is available for service replacement separate from the instrument cluster. The instrument cluster must be removed from the instrument panel for service access to the gear selector indicator. (Refer to 8 - ELECTRICAL/INSTRUMENT CLUSTER - REMOVAL).

### OPERATION

The mechanical gear selector indicator gives an indication of the transmission gear that has been selected with the automatic transmission gear selector lever. A red pointer appears in a window below the character in the indicator representing the transmission gear that has been selected. The small, spring-loaded pointer moves on a track through a trolley-like mechanism within the indicator housing. A short length of small diameter stranded cable is attached to one side of the pointer trolley and is encased in a tubular plastic housing that exits the right side of the indicator. The cable is routed through the instrument panel and under the steering column to the left side of the column. The looped end of the cable is hooked over the end of the PRNDL driver lever on the steering column gearshift mechanism, and the cable housing is secured in a molded plastic adjuster and bracket on the column housing. When the gear selector lever is moved the PRNDL driver lever moves, which moves the pointer through the mechanical actuator cable. The cable adjuster and bracket unit mounted on the steering column housing provides a mechanical means of calibrating the gear selector indicator mechanism. (Refer to 19 - STEERING/COLUMN - INSTALLATION).

## HIGH BEAM INDICATOR

### DESCRIPTION

A high beam indicator is standard equipment on all instrument clusters. The high beam indicator is located near the upper edge of the instrument cluster overlay, between the tachometer and the speedometer. The high beam indicator consists of a stenciled cutout of the International Control and Display Sym-



## HIGH BEAM INDICATOR (Continued)

bol icon for "High Beam" in the opaque layer of the instrument cluster overlay. The dark outer layer of the overlay prevents the indicator from being clearly visible when it is not illuminated. A blue lens behind the cutout in the opaque layer of the overlay causes the icon to appear in blue through the translucent outer layer of the overlay when it is illuminated from behind by a replaceable incandescent bulb and bulb holder unit located on the instrument cluster electronic circuit board. The high beam indicator is serviced as a unit with the instrument cluster.

**OPERATION**

The high beam indicator gives an indication to the vehicle operator when the headlamp high beams are illuminated. This indicator is hard wired on the instrument cluster electronic circuit board, and is controlled by a headlamp beam select switch input to the cluster. The headlamp high beam indicator bulb receives battery current on the instrument cluster electronic circuit board through a fused B(+) circuit at all times; therefore, the indicator remains operational regardless of the ignition switch position. The headlamp beam select switch is integral to the multi-function switch on the left side of the steering column, and is connected in series between ground and the headlamp high beam indicator. The indicator bulb only illuminates when it is provided with a path to ground through the high beam indicator driver circuit by the headlamp beam select switch. (Refer to 8 - ELECTRICAL/LAMPS/LIGHTING - EXTERIOR/MULTI-FUNCTION SWITCH - OPERATION). The high beam indicator can be diagnosed using conventional diagnostic tools and methods.

**DIAGNOSIS AND TESTING - HIGH BEAM INDICATOR**

The diagnosis found here addresses an inoperative headlamp high beam indicator condition. If the problem being diagnosed is related to inoperative headlamp high beams, be certain to repair the headlamp system before attempting to diagnose or repair the high beam indicator. If no headlamp system problems are found, the following procedure will help locate a short or open in the high beam indicator circuit. Refer to the appropriate wiring information. The wiring information includes wiring diagrams, proper wire and connector repair procedures, details of wire harness routing and retention, connector pin-out information and location views for the various wire harness connectors, splices and grounds.

**WARNING: ON VEHICLES EQUIPPED WITH AIRBAGS, DISABLE THE AIRBAG SYSTEM BEFORE ATTEMPTING ANY STEERING WHEEL, STEERING COLUMN, OR INSTRUMENT PANEL COMPONENT**

**DIAGNOSIS OR SERVICE. DISCONNECT AND ISOLATE THE BATTERY NEGATIVE (GROUND) CABLE, THEN WAIT TWO MINUTES FOR THE AIRBAG SYSTEM CAPACITOR TO DISCHARGE BEFORE PERFORMING FURTHER DIAGNOSIS OR SERVICE. THIS IS THE ONLY SURE WAY TO DISABLE THE AIRBAG SYSTEM. FAILURE TO TAKE THE PROPER PRECAUTIONS COULD RESULT IN ACCIDENTAL AIRBAG DEPLOYMENT AND POSSIBLE PERSONAL INJURY.**

**INDICATOR DOES NOT ILLUMINATE WITH HIGH BEAMS SELECTED**

(1) Check the fused B(+) fuse (Fuse 14 - 10 ampere) in the Junction Block (JB). If OK, go to Step 2. If not OK, repair the shorted circuit or component as required and replace the faulty fuse.

(2) Check for battery voltage at the fused B(+) fuse (Fuse 14 - 10 ampere) in the JB. If OK, go to Step 3. If not OK, repair the open fused B(+) circuit between the JB and the Power Distribution Center (PDC) as required.

(3) Be certain that the headlamp high beams are selected with the headlamp beam select switch by turning the headlamp switch to the On position, pulling the multi-function switch stalk toward the steering wheel, then inspecting the headlamps at the front of the vehicle. Once the headlamp high beams are selected, turn the headlamp switch to the Off position.

(4) Disconnect and isolate the battery negative cable. Remove the instrument cluster from the instrument panel. Reconnect the battery negative cable. Check for battery voltage at the fused B(+) circuit cavity of the instrument panel wire harness connector (Connector C1) for the instrument cluster. If OK, go to . If not OK, repair the open fused B(+) circuit between the instrument cluster and the JB as required.

(5) Disconnect and isolate the battery negative cable. Check for continuity between the high beam indicator driver circuit cavity of the instrument panel wire harness connector (Connector C2) for the instrument cluster and a good ground. There should be continuity. If OK, replace the faulty headlamp high beam indicator bulb and bulb holder unit. If not OK, repair the open high beam indicator driver circuit between the instrument cluster and the headlamp beam select (multi-function) switch as required.

**INDICATOR STAYS ILLUMINATED WITH HIGH BEAMS NOT SELECTED**

(1) Be certain that the headlamp low beams are selected with the headlamp beam select switch by turning the headlamp switch to the On position, pulling the multi-function switch stalk toward the steer-

## HIGH BEAM INDICATOR (Continued)

ing wheel, then inspecting the headlamps at the front of the vehicle. Once the headlamp low beams are selected, turn the headlamp switch to the Off position.

(2) Disconnect and isolate the battery negative cable. Remove the instrument cluster from the instrument panel. Check for continuity between the high beam indicator driver circuit cavity of the instrument panel wire harness connector (Connector C2) for the instrument cluster and a good ground. There should be no continuity. If OK, replace the faulty instrument cluster. If not OK, repair the shorted high beam indicator driver circuit between the instrument cluster and the headlamp beam select (multi-function) switch as required.

## LOW FUEL INDICATOR

### DESCRIPTION

A low fuel indicator is standard equipment on all instrument clusters. The low fuel indicator is located near the lower edge of the instrument cluster overlay, to the right of center. The low fuel indicator consists of a stenciled cutout of the International Control and Display Symbol icon for "Fuel" in the opaque layer of the instrument cluster overlay. The dark outer layer of the overlay prevents the indicator from being clearly visible when it is not illuminated. An amber lens behind the cutout in the opaque layer of the overlay causes the icon to appear in amber through the translucent outer layer of the overlay when the indicator is illuminated from behind by a Light Emitting Diode (LED) soldered onto the instrument cluster electronic circuit board. The low fuel indicator lamp is serviced as a unit with the instrument cluster.

### OPERATION

The low fuel indicator gives an indication to the vehicle operator when the level of fuel in the fuel tank becomes low. This indicator is controlled by a transistor on the instrument cluster circuit board based upon cluster programming and electronic messages received by the cluster from the Powertrain Control Module (PCM) over the Chrysler Collision Detection (CCD) data bus. The low fuel indicator Light Emitting Diode (LED) receives battery current on the instrument cluster electronic circuit board through the fused ignition switch output (st-run) circuit whenever the ignition switch is in the On or Start positions; therefore, the LED will always be off when the ignition switch is in any position except On or Start. The LED only illuminates when it is provided a path to ground by the instrument cluster

transistor. The instrument cluster will turn on the low fuel indicator for the following reasons:

- **Bulb Test** - Each time the ignition switch is turned to the On position the indicator is illuminated for about two seconds as a bulb test.

- **Less Than 12.5 Percent Tank Full Message** - Each time the cluster receives messages from the PCM indicating the percent tank full is 12.5 (one-eighth) or less for 10 consecutive seconds and the vehicle speed is zero, or for 60 consecutive seconds and the vehicle speed is greater than zero, the low fuel indicator is illuminated and a single chime tone is sounded. The low fuel indicator remains illuminated until the cluster receives messages from the PCM indicating that the percent tank full is greater than 12.5 (one-eighth) for 10 consecutive seconds and the vehicle speed is zero, or for 60 consecutive seconds and the vehicle speed is greater than zero, or until the ignition switch is turned to the Off position, whichever occurs first. The chime tone feature will only repeat during the same ignition cycle if the low fuel indicator is cycled off and then on again by the appropriate percent tank full messages from the PCM.

- **Less Than Empty Percent Tank Full Message** - Each time the cluster receives a message from the PCM indicating the percent tank full is less than empty, the low fuel indicator is illuminated immediately. This message would indicate that the fuel tank sender input to the PCM is a short circuit.

- **More Than Full Percent Tank Full Message** - Each time the cluster receives a message from the PCM indicating the percent tank full is more than full, the low fuel indicator is illuminated immediately. This message would indicate that the fuel tank sender input to the PCM is an open circuit.

- **Actuator Test** - Each time the cluster is put through the actuator test, the indicator will be turned on during the bulb check portion of the test to confirm the functionality of the LED and the cluster control circuitry.

The PCM continually monitors the fuel tank sending unit, then sends the proper messages to the instrument cluster. For further diagnosis of the low fuel indicator or the instrument cluster circuitry that controls the LED, (Refer to 8 - ELECTRICAL/INSTRUMENT CLUSTER - DIAGNOSIS AND TESTING). For proper diagnosis of the fuel tank sending unit, the PCM, the CCD data bus, or the message inputs to the instrument cluster that control the low fuel indicator, a DRBIII® scan tool is required. Refer to the appropriate diagnostic information.



## MALFUNCTION INDICATOR LAMP (MIL)

### DESCRIPTION

A Malfunction Indicator Lamp (MIL) is standard equipment on all instrument clusters. The MIL is located near the lower edge of the instrument cluster overlay, to the left of center. The MIL consists of a stencilled cutout of the International Control and Display Symbol icon for "Engine" in the opaque layer of the instrument cluster overlay. The dark outer layer of the overlay prevents the indicator from being clearly visible when it is not illuminated. An amber lens behind the cutout in the opaque layer of the overlay causes the icon to appear in amber through the translucent outer layer of the overlay when the indicator is illuminated from behind by a Light Emitting Diode (LED) soldered onto the instrument cluster electronic circuit board. The MIL is serviced as a unit with the instrument cluster.

### OPERATION

The Malfunction Indicator Lamp (MIL) gives an indication to the vehicle operator when the Powertrain Control Module (PCM) has recorded a Diagnostic Trouble Code (DTC) for an On-Board Diagnostics II (OBDII) emissions-related circuit or component malfunction. In addition, on models with a diesel engine an Engine Control Module (ECM) supplements the PCM, and can also record an OBDII DTC. The MIL is controlled by a transistor on the instrument cluster circuit board based upon cluster programming and electronic messages received by the cluster from the PCM or ECM over the Chrysler Collision Detection (CCD) data bus. The MIL Light Emitting Diode (LED) receives battery current on the instrument cluster electronic circuit board through the fused ignition switch output (st-run) circuit whenever the ignition switch is in the On or Start positions; therefore, the LED will always be off when the ignition switch is in any position except On or Start. The LED only illuminates when it is provided a path to ground by the instrument cluster transistor. The instrument cluster will turn on the MIL for the following reasons:

- **Bulb Test** - Each time the ignition switch is turned to the On position the indicator is illuminated for about seven seconds as a bulb test.
- **PCM Lamp-On Message** - Each time the cluster receives a lamp-on message from the PCM or ECM, the indicator will be illuminated. The indicator can be flashed on and off, or illuminated solid, as dictated by the PCM/ECM message. For some DTC's, if a problem does not recur, the PCM or ECM will send a lamp-off message automatically. Other DTC's may

require that a fault be repaired and the PCM or ECM be reset before a lamp-off message will be sent. For more information on the PCM, the ECM, and the DTC set and reset parameters, (Refer to 25 - EMISSIONS CONTROL - OPERATION).

- **Communication Error** - If the cluster receives no lamp-on message from the PCM or ECM for twenty seconds, the MIL is illuminated by the instrument cluster to indicate a loss of bus communication. The indicator remains controlled and illuminated by the cluster until a valid lamp-on message is received from the PCM or ECM.

- **Actuator Test** - Each time the cluster is put through the actuator test, the indicator will be turned on during the bulb check portion of the test to confirm the functionality of the LED and the cluster control circuitry.

The PCM/ECM continually monitor the fuel and emissions system circuits and sensors to decide whether the system is in good operating condition. The PCM/ECM then sends the proper lamp-on or lamp-off messages to the instrument cluster. For further diagnosis of the MIL or the instrument cluster circuitry that controls the LED, (Refer to 8 - ELECTRICAL/INSTRUMENT CLUSTER - DIAGNOSIS AND TESTING). If the instrument cluster turns on the MIL after the bulb test, it may indicate that a malfunction has occurred and that the fuel and emissions systems may require service. For proper diagnosis of the fuel and emissions systems, the PCM, the ECM, the CCD data bus, or the message inputs to the instrument cluster that control the MIL, a DRBIII® scan tool is required. Refer to the appropriate diagnostic information.

## ODOMETER

### DESCRIPTION

An odometer and trip odometer are standard equipment in all instrument clusters. The odometer and trip odometer information are displayed in a common electronic Vacuum-Fluorescent Display (VFD), which is visible through a small window cut-out located in the left lower quadrant of the cluster overlay. However, the odometer and trip odometer information are not displayed simultaneously. The trip odometer reset switch on the instrument cluster circuit board toggles the display between odometer and trip odometer modes by depressing the odometer/trip odometer switch knob that extends through the lower edge of the cluster lens, just right of the tachometer. Both the odometer and the trip odometer information is stored in the instrument cluster memory.

## ODOMETER (Continued)

The odometer can display values up to 499,999 kilometers (499,999 miles). The odometer latches at these values, and will not roll over to zero. The trip odometer can display values up to 999.9 kilometers (999.9 miles) before it rolls over to zero. The odometer display does not have a decimal point and will not show values less than a full unit (kilometer or mile), the trip odometer display does have a decimal point and will show tenths of a unit (kilometer or mile). The unit of measure (kilometers or miles) for the odometer and trip odometer display is not shown in the VFD. The unit of measure for the instrument cluster odometer/trip odometer is selected at the time that it is manufactured, and cannot be changed. During daylight hours (exterior lamps Off) the VFD is illuminated at full brightness for clear visibility. At night (exterior lamps are On) the VFD lighting level is adjusted with the other cluster illumination lamps using the panel lamps dimmer thumbwheel on the headlamp switch. However, a "Parade" mode position of the panel lamps dimmer thumbwheel allows the VFD to be illuminated at full brightness while the exterior lamps are turned On during daylight hours. The VFD, the trip odometer switch, and the trip odometer switch button are serviced as a unit with the instrument cluster.

## OPERATION

The odometer and trip odometer give an indication to the vehicle operator of the distance the vehicle has traveled. This gauge is controlled by the instrument cluster circuit board based upon the cluster programming and electronic messages received by the cluster from the Powertrain Control Module (PCM) over the Chrysler Collision Detection (CCD) data bus. The odometer and trip odometer information is displayed by the instrument cluster Vacuum Fluorescent Display (VFD), and the VFD will not display odometer or trip odometer information after the ignition switch is turned to the Off position. The instrument cluster circuitry controls the VFD and provides the following features:

- **Odometer/Trip Odometer Display Toggling** - Actuating the trip odometer reset switch momentarily with the ignition switch in the On position will toggle the VFD between the odometer and trip odometer display. Each time the ignition switch is turned to the On position the VFD will automatically return to the mode (odometer or trip odometer) last displayed when the ignition switch was turned to the Off position.

- **Trip Odometer Reset** - When the trip odometer reset switch is pressed and held for longer than about two seconds, the trip odometer will be reset to 000.0 kilometers (miles). The VFD must be display-

ing the trip odometer information in order for the trip odometer information to be reset.

- **Message Failure** - If the cluster fails to receive a distance message during normal operation, it will flash the odometer/trip odometer distance information on and off repeatedly until a distance message is received, or until the ignition switch is turned to the Off position, whichever occurs first. If the cluster does not receive a distance message within one second after the ignition switch is turned to the On position, it will display the last distance message stored in the cluster memory. If the cluster is unable to display distance information due to an error internal to the cluster, the VFD display will be blank.

- **Actuator Test** - Each time the cluster is put through the actuator test, the VFD will display all of its characters at once, then step through each character segment individually during the VFD portion of the test to confirm the functionality of the VFD and the cluster control circuitry.

The PCM continually monitors the vehicle speed sensor, then sends the proper distance messages to the instrument cluster. For further diagnosis of the odometer/trip odometer or the instrument cluster circuitry that controls these functions, (Refer to 8 - ELECTRICAL/INSTRUMENT CLUSTER - DIAGNOSIS AND TESTING). For proper diagnosis of the vehicle speed sensor, the PCM, the CCD data bus, or the message inputs to the instrument cluster that control the odometer/trip odometer, a DRBIII® scan tool is required. Refer to the appropriate diagnostic information.

## OIL PRESSURE GAUGE

## DESCRIPTION

An oil pressure gauge is standard equipment on all instrument clusters. The oil pressure gauge is located in the upper right quadrant of the instrument cluster, above the fuel gauge. The oil pressure gauge consists of a movable gauge needle or pointer controlled by the instrument cluster circuitry and a fixed 90 degree scale on the cluster overlay that reads left-to-right either from 0 kPa (0 psi) to 758 kPa (110 psi). An International Control and Display Symbol icon for "Engine Oil" is located on the cluster overlay, directly below the highest graduation of the gauge scale. The oil pressure gauge graphics are white against a black field except for a single red graduation at the low end of the gauge scale, making them clearly visible within the instrument cluster in daylight. When illuminated from behind by the panel lamps dimmer controlled cluster illumination lighting with the exterior lamps turned On, the white graphics appear blue-green and the red graphics appear red. The

## OIL PRESSURE GAUGE (Continued)

orange gauge needle is internally illuminated. Gauge illumination is provided by replaceable incandescent bulb and bulb holder units located on the instrument cluster electronic circuit board. The oil pressure gauge is serviced as a unit with the instrument cluster.

## OPERATION

The oil pressure gauge gives an indication to the vehicle operator of the engine oil pressure. This gauge is controlled by the instrument cluster circuit board based upon the cluster programming and electronic messages received by the cluster from the Powertrain Control Module (PCM) over the Chrysler Collision Detection (CCD) data bus. The oil pressure gauge is an air core magnetic unit that receives battery current on the instrument cluster electronic circuit board through the fused ignition switch output (st-run) circuit whenever the ignition switch is in the On or Start positions. The cluster is programmed to move the gauge needle back to the low end of the scale after the ignition switch is turned to the Off position. The instrument cluster circuitry controls the gauge needle position and provides the following features:

- **Engine Oil Pressure Message** - The instrument cluster circuitry restricts the oil pressure gauge needle operation in order to provide readings that are consistent with customer expectations. Each time the cluster receives a message from the PCM indicating the engine oil pressure is between about 6.9 kPa (1 psi) and 137.9 kPa (20 psi) for gasoline engines, or 55 kPa (8 psi) and 58.6 kPa (8.5 psi) for diesel engines, the cluster holds the gauge needle at a point about 11 degrees above the low end of normal increment on the gauge scale. Each time the cluster receives a message from the PCM indicating the engine oil pressure is between about 517.1 kPa (75 psi) and 755 kPa (109.5 psi) for gasoline engines, or 551.6 kPa (80 psi) and 755 kPa (109.5 psi) for diesel engines, the cluster holds the gauge needle at a point about 7.4 degrees below the high end of normal increment on the gauge scale. When the cluster receives messages from the PCM indicating the engine oil pressure is between about 137.9 kPa (20 psi) and 517.1 kPa (75 psi) for gasoline engines, or 58.6 kPa (8.5 psi) and 551.6 kPa (80 psi) for diesel engines, the gauge needle is moved to the actual pressure position on the gauge scale.

- **Engine Oil Pressure Low Message** - Each time the cluster receives a message from the PCM indicating the engine oil pressure is below about 6.9 kPa (1 psi) for gasoline engines, or 55 kPa (8 psi) for diesel engines, the gauge needle is moved to the 0 kPa (0 psi) graduation at the far left (low) end of the gauge scale, the check gauges indicator is illumi-

nated, and a single chime tone is generated. The gauge needle remains at the low end of the scale and the check gauges indicator remains illuminated until the cluster receives a message from the PCM indicating that the engine oil pressure is above about 6.9 kPa (1 psi) for gasoline engines, or 55 kPa (8 psi) for diesel engines, or until the ignition switch is turned to the Off position, whichever occurs first. The cluster will only turn the check gauges indicator lamp on in response to an engine oil pressure low message if the engine speed message is greater than zero.

- **Engine Oil Pressure High Message** - Each time the cluster receives a message from the PCM indicating the engine oil pressure is above about 755 kPa (109.5 psi) for gasoline or diesel engines, the gauge needle is moved to the 758.4 kPa (110 psi) graduation at the far right (high) end of the gauge scale. The gauge needle remains at the high end of the scale until the cluster receives a message from the PCM indicating that the engine oil pressure is below about 755 kPa (109.5 psi) for gasoline or diesel engines, or until the ignition switch is turned to the Off position, whichever occurs first.

- **Message Failure** - If the cluster fails to receive an engine oil pressure message, it will hold the gauge needle at the last indication until a new message is received, or until the ignition switch is turned to the Off position, whichever occurs first.

- **Actuator Test** - Each time the cluster is put through the actuator test, the gauge needle will be swept to several calibration points on the gauge scale in a prescribed sequence in order to confirm the functionality of the gauge and the cluster control circuitry.

The PCM continually monitors the engine oil pressure sensor to determine the engine oil pressure. The PCM then sends the proper engine oil pressure messages to the instrument cluster. For further diagnosis of the oil pressure gauge or the instrument cluster circuitry that controls the gauge, (Refer to 8 - ELECTRICAL/INSTRUMENT CLUSTER - DIAGNOSIS AND TESTING). If the instrument cluster turns on the check gauges indicator due to a low oil pressure gauge reading, it may indicate that the engine or the engine oiling system requires service. For proper diagnosis of the engine oil pressure sensor, the PCM, the CCD data bus, or the message inputs to the instrument cluster that control the oil pressure gauge, a DRBIII® scan tool is required. Refer to the appropriate diagnostic information.



## OVERDRIVE OFF INDICATOR

### DESCRIPTION

An overdrive off indicator is standard equipment on all instrument clusters. However, on vehicles not equipped with the optional overdrive automatic transmission, this indicator is electronically disabled. The overdrive off indicator is located near the lower edge of the instrument cluster overlay, to the right of center. The overdrive off indicator consists of a stencilled cutout of the words "O/D OFF" in the opaque layer of the instrument cluster overlay. The dark outer layer of the overlay prevents the indicator from being clearly visible when it is not illuminated. An amber lens behind the cutout in the opaque layer of the overlay causes the "O/D OFF" text to appear in amber through the translucent outer layer of the overlay when the indicator is illuminated from behind by a Light Emitting Diode (LED) soldered onto the instrument cluster electronic circuit board. The overdrive off indicator is serviced as a unit with the instrument cluster.

### OPERATION

The overdrive off indicator gives an indication to the vehicle operator when the Off position of the overdrive off switch has been selected, disabling the electronically controlled overdrive feature of the automatic transmission. This indicator is controlled by a transistor on the instrument cluster circuit board based upon the cluster programming and electronic messages received by the cluster from the Powertrain Control Module (PCM) over the Chrysler Collision Detection (CCD) data bus. The overdrive off indicator Light Emitting Diode (LED) receives battery current on the instrument cluster electronic circuit board through the fused ignition switch output (st-run) circuit whenever the ignition switch is in the On or Start positions; therefore, the LED will always be off when the ignition switch is in any position except On or Start. The LED only illuminates when it is provided a path to ground by the instrument cluster transistor. The instrument cluster will turn on the overdrive off indicator for the following reasons:

- **Bulb Test** - Each time the ignition switch is turned to the On position the overdrive off indicator is illuminated for about two seconds as a bulb test.
- **Overdrive Off Lamp-On Message** - Each time the cluster receives an overdrive off lamp-on message from the PCM indicating that the Off position of the overdrive off switch has been selected, the overdrive off indicator will be illuminated. The indicator remains illuminated until the cluster receives an overdrive off lamp-off message from the PCM, or until the ignition switch is turned to the Off position, whichever occurs first.

- **Actuator Test** - Each time the cluster is put through the actuator test, the indicator will be turned on during the bulb check portion of the test to confirm the functionality of the LED and the cluster control circuitry.

The PCM continually monitors the overdrive off switch to determine the proper outputs to the automatic transmission, then sends the proper messages to the instrument cluster. For further diagnosis of the overdrive off indicator or the instrument cluster circuitry that controls the LED, (Refer to 8 - ELECTRICAL/INSTRUMENT CLUSTER - DIAGNOSIS AND TESTING). For proper diagnosis of the overdrive control system, the PCM, the CCD data bus, or the message inputs to the instrument cluster that control the overdrive off indicator, a DRBIII® scan tool is required. Refer to the appropriate diagnostic information.

## SEATBELT INDICATOR

### DESCRIPTION

A seatbelt indicator is standard equipment on all instrument clusters. The seatbelt indicator is located near the lower edge of the instrument cluster overlay, to the right of center. The seatbelt indicator consists of a stencilled cutout of the International Control and Display Symbol icon for "Seat Belt" in the opaque layer of the instrument cluster overlay. The dark outer layer of the overlay prevents the indicator from being clearly visible when it is not illuminated. A red lens behind the cutout in the opaque layer of the overlay causes the icon to appear in red through the translucent outer layer of the overlay when the indicator is illuminated from behind by a Light Emitting Diode (LED) soldered onto the instrument cluster electronic circuit board. The seatbelt indicator is serviced as a unit with the instrument cluster.

### OPERATION

The seatbelt indicator gives an indication to the vehicle operator of the status of the driver side front seatbelt buckle. This indicator is controlled by a transistor on the instrument cluster circuit board based upon the cluster programming, and a hard wired input from the seatbelt switch in the driver side front seatbelt through the seat belt switch sense circuit. The seatbelt indicator Light Emitting Diode (LED) receives battery current on the instrument cluster electronic circuit board through the fused ignition switch output (st-run) circuit whenever the ignition switch is in the On or Start positions; therefore, the lamp will always be off when the ignition switch is in any position except On or Start. The LED only illuminates when it is switched to ground by the instrument cluster transistor. The instrument cluster will

## SEATBELT INDICATOR (Continued)

turn on the seatbelt indicator for the following reasons:

- **Seatbelt Reminder Function** - Each time the cluster receives a battery current input on the fused ignition switch output (st-run) circuit, the indicator will be illuminated as a seatbelt reminder for about seven seconds, or until the ignition switch is turned to the Off position, whichever occurs first. This reminder function will occur regardless of the status of the seatbelt switch input to the cluster.

- **Driver Side Front Seatbelt Not Buckled** - Following the seatbelt reminder function, each time the cluster receives a ground input on the seat belt switch sense circuit (seatbelt switch closed - seatbelt unbuckled) with the ignition switch in the Start or On positions, the indicator will be illuminated. The seatbelt indicator remains illuminated until the seat belt switch sense input to the cluster is an open circuit (seatbelt switch opened - seatbelt buckled), or until the ignition switch is turned to the Off position, whichever occurs first.

- **Actuator Test** - Each time the cluster is put through the actuator test, the indicator will be turned on during the bulb check portion of the test to confirm the functionality of the LED and the cluster control circuitry.

The seatbelt switch input to the instrument cluster circuitry can be diagnosed using conventional diagnostic tools and methods. For further diagnosis of the seatbelt indicator or the instrument cluster circuitry that controls the LED, (Refer to 8 - ELECTRICAL/INSTRUMENT CLUSTER - DIAGNOSIS AND TESTING).

## SERVICE REMINDER INDICATOR

### DESCRIPTION

A Service Reminder Indicator (SRI) is standard equipment on all instrument clusters. However, on vehicles not equipped with certain optional heavy duty emission cycle gasoline engines, this indicator is electronically disabled. The SRI is located near the lower edge of the instrument cluster overlay, to the left of center. The SRI consists of a stencilled cutout of the words "MAINT REQD" in the opaque layer of the instrument cluster overlay. The dark outer layer of the overlay prevents the indicator from being clearly visible when it is not illuminated. An amber lens behind the cutout in the opaque layer of the overlay causes the "MAINT REQD" text to appear in amber through the translucent outer layer of the overlay when the indicator is illuminated from behind by a Light Emitting Diode (LED) soldered onto the instrument cluster electronic circuit board.

The SRI is serviced as a unit with the instrument cluster.

### OPERATION

The Service Reminder Indicator (SRI) gives an indication to the vehicle operator when engine emissions maintenance procedures should be performed. This indicator is controlled by a transistor on the instrument cluster circuit board based upon the cluster programming and electronic messages received by the cluster from the Powertrain Control Module (PCM) over the Chrysler Collision Detection (CCD) data bus. The SRI Light Emitting Diode (LED) receives battery current on the instrument cluster electronic circuit board through the fused ignition switch output (st-run) circuit whenever the ignition switch is in the On or Start positions; therefore, the LED will always be off when the ignition switch is in any position except On or Start. The LED only illuminates when it is provided a path to ground by the instrument cluster transistor. The instrument cluster will turn on the SRI for the following reasons:

- **Bulb Test** - Each time the ignition switch is turned to the On position the SRI is illuminated for about two seconds as a bulb test.

- **Service Required Lamp-On Message** - Each time the cluster receives a service required lamp-on message from the PCM indicating that an emissions maintenance interval has been reached, the SRI will be illuminated. The indicator remains illuminated until the cluster receives a service required lamp-off message from the PCM, or until the ignition switch is turned to the Off position, whichever occurs first.

- **Actuator Test** - Each time the cluster is put through the actuator test, the SRI will be turned on during the bulb check portion of the test to confirm the functionality of the LED and the cluster control circuitry.

The PCM continually monitors the vehicle speed sensor to determine the distance the vehicle has been driven, then sends the proper messages to the instrument cluster. Once the SRI has been illuminated and the required emissions maintenance procedures have been completed, the PCM must be reset using a DRBIII® scan tool before it will send the proper service required lamp-off message to the instrument cluster. Refer to the appropriate diagnostic information. For further diagnosis of the SRI or the instrument cluster circuitry that controls the LED, (Refer to 8 - ELECTRICAL/INSTRUMENT CLUSTER - DIAGNOSIS AND TESTING). For proper diagnosis of the PCM, the CCD data bus, or the message inputs to the instrument cluster that control the SRI, a DRBIII® scan tool is required. Refer to the appropriate diagnostic information.



## SHIFT INDICATOR (TRANSFER CASE)

### DESCRIPTION

A four-wheel drive indicator is standard equipment on all instrument clusters. However, on vehicles not equipped with the optional four-wheel drive system, this indicator is mechanically disabled. The four-wheel drive indicator is located near the lower edge of the instrument cluster overlay, to the right of center. The four-wheel drive indicator consists of a stencilled cutout of the text "4WD" in the opaque layer of the instrument cluster overlay. The dark outer layer of the overlay prevents the indicator from being clearly visible when it is not illuminated. An amber lens behind the cutout in the opaque layer of the overlay causes the "4WD" text to appear in amber through the translucent outer layer of the overlay when the indicator is illuminated from behind by a Light Emitting Diode (LED) soldered onto the instrument cluster electronic circuit board. The four-wheel drive indicator is serviced as a unit with the instrument cluster.

### OPERATION

The four-wheel drive indicator lamp gives an indication to the vehicle operator that a four-wheel drive operating mode is engaged. The indicator will be illuminated when either high range (4H) or low range (4L) have been selected with the transfer case shift lever. This indicator is controlled by a transistor on the instrument cluster circuit board based upon the cluster programming, and a hard wired input from the four-wheel drive switch on the front axle disconnect housing. The four-wheel drive indicator Light Emitting Diode (LED) receives battery current on the instrument cluster electronic circuit board through the fused ignition switch output (st-run) circuit whenever the ignition switch is in the On or Start positions; therefore, the lamp will always be off when the ignition switch is in any position except On or Start. The LED only illuminates when it is switched to ground by the instrument cluster transistor.

The four-wheel drive switch is connected in series between ground and the four-wheel drive switch sense input to the instrument cluster. For further information on the transfer case and the transfer case operating ranges, (Refer to 21 - TRANSMISSION/TRANSAXLE/TRANSFER CASE - OPERATION. For further information on the front axle disconnect mechanism, (Refer to 3 - DIFFERENTIAL & DRIVELINE/FRONT AXLE/AXLE VACUUM MOTOR - OPERATION). The four-wheel drive switch input to the instrument cluster circuitry can be diag-

nosed using conventional diagnostic tools and methods.

### DIAGNOSIS AND TESTING - FOUR-WHEEL DRIVE INDICATOR

The diagnosis found here addresses an inoperative four-wheel drive indicator condition. If the problem being diagnosed is related to indicator accuracy, be certain to confirm that the problem is with the indicator and not with a damaged or inoperative front axle disconnect mechanism. (Refer to 3 - DIFFERENTIAL & DRIVELINE/FRONT AXLE/AXLE VACUUM MOTOR - DIAGNOSIS AND TESTING). If no front axle disconnect problem is found, the following procedure will help locate a short or open in the four-wheel drive switch input to the instrument cluster. Refer to the appropriate wiring information. The wiring information includes wiring diagrams, proper wire and connector repair procedures, details of wire harness routing and retention, connector pin-out information and location views for the various wire harness connectors, splices and grounds.

**WARNING: ON VEHICLES EQUIPPED WITH AIRBAGS, DISABLE THE AIRBAG SYSTEM BEFORE ATTEMPTING ANY STEERING WHEEL, STEERING COLUMN, OR INSTRUMENT PANEL COMPONENT DIAGNOSIS OR SERVICE. DISCONNECT AND ISOLATE THE BATTERY NEGATIVE (GROUND) CABLE, THEN WAIT TWO MINUTES FOR THE AIRBAG SYSTEM CAPACITOR TO DISCHARGE BEFORE PERFORMING FURTHER DIAGNOSIS OR SERVICE. THIS IS THE ONLY SURE WAY TO DISABLE THE AIRBAG SYSTEM. FAILURE TO TAKE THE PROPER PRECAUTIONS COULD RESULT IN ACCIDENTAL AIRBAG DEPLOYMENT AND POSSIBLE PERSONAL INJURY.**

#### INDICATOR DOES NOT ILLUMINATE WITH FOUR-WHEEL DRIVE MODE SELECTED

(1) Disconnect and isolate the battery negative cable. Disconnect the engine wire harness connector for the four-wheel drive switch from the switch connector receptacle. Check for continuity between the ground circuit cavity of the engine wire harness connector for the four-wheel drive switch and a good ground. There should be continuity. If OK, go to Step 2. If not OK, repair the open ground circuit to ground (G100) as required.

(2) Reconnect the battery negative cable. Turn the ignition switch to the On position. Install a jumper wire between the 4WD switch sense circuit cavity of the engine wire harness connector for the four-wheel drive switch and a good ground. The four-wheel drive indicator should light. If OK, replace the faulty four-wheel drive switch. If not OK, go to Step 3.

## SHIFT INDICATOR (TRANSFER CASE) (Continued)

(3) Turn the ignition switch to the Off position. Disconnect and isolate the battery negative cable. Remove the instrument cluster from the instrument panel. Check for continuity between the 4WD switch sense circuit cavities of the instrument panel wire harness connector (Connector C2) for the instrument cluster and the engine wire harness connector for the four-wheel drive switch. There should be continuity. If OK, replace the faulty instrument cluster. If not OK, repair the open 4WD switch sense circuit between the instrument cluster and the four-wheel drive switch as required.

## INDICATOR STAYS ILLUMINATED WITH FOUR-WHEEL DRIVE MODE NOT SELECTED

(1) Disconnect and isolate the battery negative cable. Disconnect the engine wire harness connector for the four-wheel drive switch from the switch connector receptacle. Check for continuity between the ground circuit terminal and the 4WD switch sense circuit terminal in the four-wheel drive switch connector receptacle. There should be no continuity. If OK, repair the shorted 4WD switch sense circuit between the four-wheel drive switch and the instrument cluster as required. If not OK, replace the faulty four-wheel drive switch.

## SPEEDOMETER

## DESCRIPTION

A speedometer is standard equipment on all instrument clusters. The speedometer is located just to the right of the tachometer near the center of the instrument cluster. The speedometer consists of a movable gauge needle or pointer controlled by the instrument cluster circuitry and a fixed 210 degree primary scale on the gauge dial face that reads left-to-right either from 0 to 120 mph, or from 0 to 200 km/h, depending upon the market for which the vehicle is manufactured. Each version also has a secondary inner scale on the gauge dial face that provides the equivalent opposite units from the primary scale. Text appearing on the cluster overlay just below the hub of the speedometer needle abbreviates the unit of measure for the primary scale in all upper case letters (i.e.: MPH or KM/H), followed by the unit of measure for the secondary scale in all lower case letters (i.e.: mph or km/h). The speedometer graphics are white (primary scale) and red (secondary scale) against a black field, making them clearly visible within the instrument cluster in daylight. When illuminated from behind by the panel lamps dimmer controlled cluster illumination lighting with the exterior lamps turned On, the white graphics appear blue-green, while the red graphics still appear red. The orange gauge needle is internally illuminated. Gauge illumination is

provided by replaceable incandescent bulb and bulb holder units located on the instrument cluster electronic circuit board. The speedometer is serviced as a unit with the instrument cluster.

## OPERATION

The speedometer gives an indication to the vehicle operator of the vehicle road speed. This gauge is controlled by the instrument cluster circuit board based upon the cluster programming and electronic messages received by the cluster from the Powertrain Control Module (PCM) over the Chrysler Collision Detection (CCD) data bus. The speedometer is an air core magnetic unit that receives battery current on the instrument cluster electronic circuit board through the fused ignition switch output (st-run) circuit whenever the ignition switch is in the On or Start positions. The cluster is programmed to move the gauge needle back to the low end of the scale after the ignition switch is turned to the Off position. The instrument cluster circuitry controls the gauge needle position and provides the following features:

- **Message Failure** - If the cluster fails to receive a speedometer message, it will hold the gauge needle at the last indication for about four seconds, or until the ignition switch is turned to the Off position, whichever occurs first. If a new speedometer message is not received after about four seconds, the gauge needle will return to the far left (low) end of the scale.

- **Actuator Test** - Each time the cluster is put through the actuator test, the gauge needle will be swept to several calibration points on the gauge scale in a prescribed sequence in order to confirm the functionality of the gauge and the cluster control circuitry.

The PCM continually monitors the vehicle speed sensor to determine the vehicle road speed, then sends the proper vehicle speed messages to the instrument cluster. For further diagnosis of the speedometer or the instrument cluster circuitry that controls the gauge, (Refer to 8 - ELECTRICAL/INSTRUMENT CLUSTER - DIAGNOSIS AND TESTING). For proper diagnosis of the vehicle speed sensor, the PCM, the CCD data bus, or the message inputs to the instrument cluster that control the speedometer, a DRBIII® scan tool is required. Refer to the appropriate diagnostic information.

## TACHOMETER

## DESCRIPTION

A tachometer is standard equipment on all instrument clusters. The tachometer is located just to the left of the speedometer near the center of the instru-

## TACHOMETER (Continued)

ment cluster. The tachometer consists of a movable gauge needle or pointer controlled by the instrument cluster circuitry and a fixed 210 degree scale on the gauge dial face that reads left-to-right either from 0 to 6 for gasoline engines, or from 0 to 4 for diesel engines. The text "RPM X 1000" imprinted on the cluster overlay directly below the hub of the tachometer needle identifies that each number on the tachometer scale is to be multiplied times 1000 rpm. The gauge scale of the gasoline engine tachometer is red lined at 5000 rpm, while the diesel engine tachometer is red lined at 3375 rpm. The diesel engine tachometer also includes text that specifies "DIESEL FUEL ONLY" located just above the hub of the tachometer needle. The tachometer graphics are white and red against a black field, making them clearly visible within the instrument cluster in daylight. When illuminated from behind by the panel lamps dimmer controlled cluster illumination lighting with the exterior lamps turned On, the white graphics appear blue-green, while the red graphics still appear red. The orange gauge needle is internally illuminated. Gauge illumination is provided by replaceable incandescent bulb and bulb holder units located on the instrument cluster electronic circuit board. The tachometer is serviced as a unit with the instrument cluster.

## OPERATION

The tachometer gives an indication to the vehicle operator of the engine speed. This gauge is controlled by the instrument cluster circuit board based upon the cluster programming and electronic messages received by the cluster from the Powertrain Control Module (PCM) over the Chrysler Collision Detection (CCD) data bus. The tachometer is an air core magnetic unit that receives battery current on the instrument cluster electronic circuit board through the fused ignition switch output (st-run) circuit whenever the ignition switch is in the On or Start positions. The cluster is programmed to move the gauge needle back to the low end of the scale after the ignition switch is turned to the Off position. The instrument cluster circuitry controls the gauge needle position and provides the following features:

- **Message Failure** - If the cluster fails to receive an engine speed message, it will hold the gauge needle at the last indication for about four seconds, or until the ignition switch is turned to the Off position, whichever occurs first. If a new engine speed message is not received after about four seconds, the gauge needle will return to the far left (low) end of the scale.

- **Actuator Test** - Each time the cluster is put through the actuator test, the gauge needle will be swept to several calibration points on the gauge scale

in a prescribed sequence in order to confirm the functionality of the gauge and the cluster control circuitry.

The PCM continually monitors the crankshaft position sensor to determine the engine speed, then sends the proper engine speed messages to the instrument cluster. For further diagnosis of the tachometer or the instrument cluster circuitry that controls the gauge, (Refer to 8 - ELECTRICAL/INSTRUMENT CLUSTER - DIAGNOSIS AND TESTING). For proper diagnosis of the crankshaft position sensor, the PCM, the CCD data bus, or the message inputs to the instrument cluster that control the tachometer, a DRBIII® scan tool is required. Refer to the appropriate diagnostic information.

## TRANSMISSION OVERTEMP INDICATOR

## DESCRIPTION

A transmission over-temperature indicator lamp is standard equipment on all instrument clusters. However, on vehicles not equipped with the optional automatic transmission, this indicator is electronically disabled. The transmission over-temperature indicator is located near the lower edge of the instrument cluster overlay, to the left of center. The transmission over-temperature indicator consists of a stencilled cutout of the words "TRANS TEMP" in the opaque layer of the instrument cluster overlay. The dark outer layer of the overlay prevents the indicator from being clearly visible when it is not illuminated. A red lens behind the cutout in the opaque layer of the overlay causes the "TRANS TEMP" text to appear in red through the translucent outer layer of the overlay when the indicator is illuminated from behind by a Light Emitting Diode (LED) soldered onto the instrument cluster electronic circuit board. The transmission over-temperature indicator is serviced as a unit with the instrument cluster.

## OPERATION

The transmission over-temperature indicator gives an indication to the vehicle operator when the transmission fluid temperature is excessive, which may lead to accelerated transmission component wear or failure. This indicator is controlled by a transistor on the instrument cluster circuit board based upon the cluster programming and electronic messages received by the cluster from the Powertrain Control Module (PCM) over the Chrysler Collision Detection (CCD) data bus. The transmission over-temperature indicator Light Emitting Diode (LED) receives battery current on the instrument cluster electronic circuit board through the fused ignition switch output



## TRANSMISSION OVERTEMP INDICATOR (Continued)

(st-run) circuit whenever the ignition switch is in the On or Start positions; therefore, the LED will always be off when the ignition switch is in any position except On or Start. The LED bulb only illuminates when it is provided a path to ground by the instrument cluster transistor. The instrument cluster will turn on the transmission over-temperature indicator for the following reasons:

- **Bulb Test** - Each time the ignition switch is turned to the On position the transmission over-temperature indicator is illuminated for about two seconds as a bulb test.

- **Trans Over-Temp Lamp-On Message** - Each time the cluster receives a trans over-temp lamp-on message from the PCM indicating that the transmission fluid temperature is 135° C (275° F) or higher, the indicator will be illuminated and a single chime tone is sounded. The lamp remains illuminated until the cluster receives a trans over-temp lamp-off message from the PCM, or until the ignition switch is turned to the Off position, whichever occurs first. The chime tone feature will only repeat during the same ignition cycle if the transmission over-temperature indicator is cycled off and then on again by the appropriate trans over-temp messages from the PCM.

- **Actuator Test** - Each time the cluster is put through the actuator test, the indicator will be turned on during the bulb check portion of the test to confirm the functionality of the LED and the cluster control circuitry.

The PCM continually monitors the transmission temperature sensor to determine the transmission operating condition, then sends the proper messages to the instrument cluster. If the instrument cluster turns on the transmission over-temperature indicator due to a high transmission oil temperature condition, it may indicate that the transmission and/or the transmission cooling system are being overloaded or that they require service. For further diagnosis of the transmission over-temperature indicator or the instrument cluster circuitry that controls the LED, (Refer to 8 - ELECTRICAL/INSTRUMENT CLUSTER - DIAGNOSIS AND TESTING). For proper diagnosis of the transmission temperature sensor, the PCM, the CCD data bus, or the message inputs to the instrument cluster that control the transmission over-temperature indicator, a DRBIII® scan tool is required. Refer to the appropriate diagnostic information.

## TURN SIGNAL INDICATORS

### DESCRIPTION

Two turn signal indicators are standard equipment on all instrument clusters. The turn signal indicators

are located near the upper edge of the instrument cluster overlay, between the speedometer and the tachometer. Each turn signal indicator consists of a stenciled cutout of the International Control and Display Symbol icon for "Turn Warning" in the opaque layer of the instrument cluster overlay. The dark outer layer of the overlay prevents these icons from being clearly visible when their lamps are not illuminated. The icons appear in green through the translucent outer layer of the overlay when the indicator is illuminated from behind by a replaceable incandescent bulb and bulb holder unit located on the instrument cluster electronic circuit board. The turn signal indicators are serviced as a unit with the instrument cluster.

### OPERATION

The turn signal indicators give an indication to the vehicle operator that the turn signal (left or right indicator flashing) or hazard warning (both left and right indicators flashing) have been selected. These indicators are controlled by two individual hard wired inputs to the instrument cluster electronic circuit board. The turn signal indicator bulbs are grounded on the instrument cluster electronic circuit board at all times. The turn signal indicator bulbs only illuminate when they are provided with battery current by the turn signal and hazard warning switch circuitry of the left multi-function switch on the steering column through separate left and right turn signal inputs to the instrument cluster; therefore, these indicators can be illuminated, regardless of the ignition switch position.

The turn signal indicators are connected in series between ground and the output of the turn signal and hazard warning switch circuitry, but in parallel with the other turn signal circuits. This arrangement allows the turn signal indicators to remain functional regardless of the condition of the other circuits in the turn signal and hazard warning system. For more information on the turn signal and hazard warning system, (Refer to 8 - ELECTRICAL/LAMPS/LIGHTING - EXTERIOR - OPERATION - TURN SIGNAL & HAZARD WARNING SYSTEM). The turn signal indicators can be diagnosed using conventional diagnostic tools and methods.

### DIAGNOSIS AND TESTING - TURN SIGNAL INDICATORS

The diagnosis found here addresses an inoperative turn signal indicator lamp condition. If the problem being diagnosed is related to inoperative turn signals or hazard warning lamps, be certain to repair the turn signal and hazard warning system before attempting to diagnose or repair the turn signal indicators. If no turn signal or hazard warning system

## TURN SIGNAL INDICATORS (Continued)

problems are found, the following procedure will help locate a short or open in the left or right turn signal indicator circuit. Refer to the appropriate wiring information. The wiring information includes wiring diagrams, proper wire and connector repair procedures, details of wire harness routing and retention, connector pin-out information and location views for the various wire harness connectors, splices and grounds.

(1) Disconnect and isolate the battery negative cable. Remove the instrument cluster.

(2) Connect the battery negative cable. Activate the hazard warning system by moving the hazard warning switch button to the On position. Check for battery voltage at the inoperative (right or left) turn signal circuit cavity of the instrument panel wire harness connector (Connector C2) for the instrument cluster. There should be a switching (on and off) battery voltage signal. If OK, replace the faulty turn signal indicator bulb. If not OK, repair the open (right or left) turn signal circuit to the left multi-function switch as required.

## UPSHIFT INDICATOR

### DESCRIPTION

An upshift indicator is standard equipment on all instrument clusters. However, on vehicles not equipped with a manual transmission, this indicator is disabled. The upshift indicator is located near the fuel gauge in the instrument cluster overlay, to the left of center. The upshift indicator consists of an upward pointed arrow icon that is a stenciled cutout in the opaque layer of the instrument cluster overlay. The dark outer layer of the overlay prevents the indicator from being clearly visible when it is not illuminated. An amber lens behind the cutout in the opaque layer of the overlay causes the icon to appear in amber through the translucent outer layer of the overlay when the indicator is illuminated from behind by a replaceable incandescent bulb and bulb holder unit located on the instrument cluster electronic circuit board. The upshift indicator is serviced as a unit with the instrument cluster.

### OPERATION

The upshift indicator gives an indication to the vehicle operator when the transmission should be shifted to the next highest gear in order to achieve the best fuel economy. This indicator is controlled by a transistor on the instrument cluster circuit board based upon the cluster programming and electronic messages received by the cluster from the Powertrain Control Module (PCM) over the Chrysler Collision Detection (CCD) data bus. The upshift indicator bulb

receives battery current on the instrument cluster electronic circuit board through the fused ignition switch output (st-run) circuit whenever the ignition switch is in the On or Start positions; therefore, the lamp will always be off when the ignition switch is in any position except On or Start. The bulb only illuminates when it is provided a path to ground by the instrument cluster transistor. On models not equipped with a manual transmission, the incandescent bulb and bulb holder unit are not installed at the factory when the vehicle is built. The instrument cluster will turn on the upshift indicator for the following reasons:

- **Upshift Lamp-On Message** - Each time the cluster receives an upshift lamp-on message from the PCM indicating the engine speed and load conditions are right for a transmission upshift to occur, the upshift indicator is illuminated. The indicator remains illuminated until the cluster receives an upshift lamp-off message from the PCM or until the ignition switch is turned to the Off position, whichever occurs first. The PCM will normally send an upshift lamp-off message three to five seconds after a lamp-on message, if an upshift is not performed. The indicator will then remain off until the vehicle stops accelerating and is brought back into the range of indicator operation, or until the transmission is shifted into another gear.

- **Actuator Test** - Each time the cluster is put through the actuator test, the indicator will be turned on during the bulb check portion of the test to confirm the functionality of the indicator and the cluster control circuitry.

The PCM continually monitors the engine speed and load conditions to determine the proper fuel and ignition requirements. The PCM then sends the proper messages to the instrument cluster. If the upshift indicator fails to light during normal vehicle operation, replace the bulb with a known good unit. For further diagnosis of the upshift indicator or the instrument cluster circuitry that controls the indicator, (Refer to 8 - ELECTRICAL/INSTRUMENT CLUSTER - DIAGNOSIS AND TESTING). For proper diagnosis of the PCM, the CCD data bus, or the message inputs to the instrument cluster that control the upshift indicator, a DRBIII® scan tool is required. Refer to the appropriate diagnostic information.

## VOLTAGE GAUGE

### DESCRIPTION

A voltage gauge is standard equipment on all instrument clusters. The voltage gauge is located in the upper left quadrant of the instrument cluster,



## VOLTAGE GAUGE (Continued)

above the temperature gauge. The voltage gauge consists of a movable gauge needle or pointer controlled by the instrument cluster circuitry and a fixed 90 degree scale on the cluster overlay that reads left-to-right from 8 volts to 18 volts. An International Control and Display Symbol icon for "Battery Charging Condition" is located directly below the lowest graduation of the gauge scale. The voltage gauge graphics are white against a black field except for a single red graduation at each end of the gauge scale, making them clearly visible within the instrument cluster in daylight. When illuminated from behind by the panel lamps dimmer controlled cluster illumination lighting with the exterior lamps turned On, the white graphics appear blue-green and the red graphics appear red. The orange gauge needle is internally illuminated. Gauge illumination is provided by replaceable incandescent bulb and bulb holder units located on the instrument cluster electronic circuit board. The voltage gauge is serviced as a unit with the instrument cluster.

## OPERATION

The voltage gauge gives an indication to the vehicle operator of the electrical system voltage. This gauge is controlled by the instrument cluster circuit board based upon the cluster programming and electronic messages received by the cluster from the Powertrain Control Module (PCM) over the Chrysler Collision Detection (CCD) data bus. The voltage gauge is an air core magnetic unit that receives battery current on the instrument cluster electronic circuit board through the fused ignition switch output (st-run) circuit whenever the ignition switch is in the On or Start positions. The cluster is programmed to move the gauge needle back to the low end of the scale after the ignition switch is turned to the Off position. The instrument cluster circuitry controls the gauge needle position and provides the following features:

- **Charge Fail Message** - Each time the cluster receives a message from the PCM indicating a charge fail condition (system voltage is 10.8 volts or lower), the gauge needle is moved to the 8 volt graduation on the gauge scale and the check gauges indicator is illuminated. The gauge needle remains on the 8 volt graduation and the check gauges indicator remains illuminated until the cluster receives a message from the PCM indicating there is no charge fail condition (system voltage is 10.9 volts or higher, but lower than 16.7 volts), or until the ignition switch is turned to the Off position, whichever occurs first. On models equipped with the optional diesel engine, the instrument cluster is programmed to support the voltmeter gauge needle above the low end of normal graduation and suppress the check gauges indicator operation

until ten seconds after the engine intake manifold air heater has completed its cycle.

- **Voltage High Message** - Each time the cluster receives a message from the PCM indicating a voltage high condition (system voltage is 16.7 volts or higher), the gauge needle is moved to the 18 volt graduation on the gauge scale and the check gauges indicator is illuminated. The gauge needle remains on the 18 volt graduation and the check gauges indicator remains illuminated until the cluster receives a message from the PCM indicating there is no voltage high condition (system voltage is 16.6 volts or lower, but higher than 10.9 volts), or until the ignition switch is turned to the Off position, whichever occurs first.

- **Message Failure** - If the cluster fails to receive a system voltage message, it will hold the gauge needle at the last indication until a new message is received, or until the ignition switch is turned to the Off position, whichever occurs first.

- **Actuator Test** - Each time the cluster is put through the actuator test, the gauge needle will be swept to several calibration points on the gauge scale in a prescribed sequence in order to confirm the functionality of the gauge and the cluster control circuitry.

The PCM continually monitors the system voltage to control the generator output. The PCM then sends the proper system voltage messages to the instrument cluster. For further diagnosis of the voltage gauge or the instrument cluster circuitry that controls the gauge, (Refer to 8 - ELECTRICAL/INSTRUMENT CLUSTER - DIAGNOSIS AND TESTING). If the instrument cluster turns on the check gauges indicator due to a charge fail or voltage high condition, it may indicate that the charging system requires service. For proper diagnosis of the charging system, the CCD data bus, or the message inputs to the instrument cluster that control the voltage gauge, a DRBIII® scan tool is required. Refer to the appropriate diagnostic information.

## WAIT-TO-START INDICATOR

### DESCRIPTION

A wait-to-start indicator is standard equipment on all instrument clusters, but is only functional in vehicles equipped with an optional diesel engine. The wait-to-start indicator is located near the lower edge of the instrument cluster overlay, to the right of center. The wait-to-start indicator consists of a stenciled cutout of the text "WAIT TO START" in the opaque layer of the cluster overlay. The dark outer layer of the overlay prevents the indicator from being clearly visible when it is not illuminated. A red lens located

## WAIT-TO-START INDICATOR (Continued)

behind the cutout causes the "WAIT TO START" text to appear in red through the translucent outer layer of the overlay when the indicator is illuminated from behind by a Light Emitting Diode (LED) that is soldered onto the instrument cluster electronic circuit board. The wait-to-start indicator is serviced as a unit with the instrument cluster.

### OPERATION

The wait-to-start indicator gives an indication to the vehicle operator when the diesel engine intake air heater is energized in its preheat operating mode. This indicator is controlled by a hard wired input to the instrument cluster from the Engine Control Module (ECM). The wait-to-start indicator Light Emitting Diode (LED) receives battery current on the instrument cluster electronic circuit board through the fused ignition switch output (st-run) circuit whenever the ignition switch is in the On or Start positions; therefore, the lamp will always be off when the ignition switch is in any position except On or Start. The indicator LED only illuminates when it is switched to ground by the input from the ECM. The ECM will turn on the wait-to-start indicator by pulling the wait-to-start indicator driver circuit to ground each time the ignition switch is turned to the On or Start positions. The indicator then remains illuminated until the ECM detects that the air within the intake manifold is the proper temperature to ensure reliable and efficient engine starting, until the ECM detects that the engine is running, or until the ignition switch is turned to the Off position, whichever occurs first.

The ECM continually monitors the intake manifold air temperature sensor, the Manifold Absolute Pressure (MAP) sensor, and many other vehicle conditions to determine when the wait-to-start indicator should be illuminated. For proper diagnosis of the wait-to-start indicator, the ECM, or the inputs the ECM uses to control the wait-to-start indicator operation, a DRBIII® scan tool is required. Refer to the appropriate diagnostic information.

## WASHER FLUID INDICATOR

### DESCRIPTION

A washer fluid indicator is standard equipment on all instrument clusters. The washer fluid indicator is located near the lower edge of the instrument cluster overlay, to the right of center. The washer fluid indicator consists of a stenciled cutout of the words "LOW WASHER" in the opaque layer of the instrument cluster overlay. The dark outer layer of the overlay prevents the indicator from being clearly visible when it is not illuminated. An amber lens behind

the cutout in the opaque layer of the overlay causes the "LOW WASHER" text to appear in amber through the translucent outer layer of the overlay when it is illuminated from behind by a Light Emitting Diode (LED) soldered onto the instrument cluster electronic circuit board. The washer fluid indicator is serviced as a unit with the instrument cluster.

### OPERATION

The washer fluid indicator gives an indication to the vehicle operator when the fluid level in the washer fluid reservoir is low. This indicator is controlled by a transistor on the instrument cluster electronic circuit board based upon cluster programming and a hard wired washer fluid level switch input to the cluster. The washer fluid indicator Light Emitting Diode (LED) receives battery current on the instrument cluster electronic circuit board through the fused ignition switch output (st-run) circuit whenever the ignition switch is in the On or Start positions; therefore, the indicator will always be off when the ignition switch is in any position except On or Start. The LED only illuminates when it is provided a path to ground by the instrument cluster transistor. The instrument cluster will turn on the washer fluid indicator for the following reasons:

- **Bulb Test** - Each time the ignition switch is turned to the On position the indicator is illuminated for about two seconds as a bulb test.

- **Washer Fluid Level Switch Input** - Immediately after the bulb test, if the cluster senses ground on the washer fluid switch sense circuit for more than about thirty seconds, it turns on the washer fluid indicator. Any time after the bulb test, the cluster must sense ground on the washer fluid switch sense circuit for more than about sixty seconds before it turns on the indicator. Once illuminated, the indicator will remain illuminated until the ignition switch is cycled and the cluster senses an open circuit on the low washer fluid sense input. This strategy is intended to reduce the effect that fluid sloshing within the washer reservoir can have on reliable indicator operation.

- **Actuator Test** - Each time the cluster is put through the actuator test, the indicator will be turned on during the bulb check portion of the test to confirm the functionality of the LED and the cluster control circuitry.

The washer fluid level switch is connected in series between ground and the washer fluid switch sense input to the instrument cluster. For more information on the washer fluid level switch, (Refer to 8 - ELECTRICAL/WIPERS/WASHERS/WASHER FLUID LEVEL SWITCH - OPERATION). For further diagnosis of the washer fluid indicator or the instrument

## WASHER FLUID INDICATOR (Continued)

cluster circuitry that controls the indicator, (Refer to 8 - ELECTRICAL/INSTRUMENT CLUSTER - DIAGNOSIS AND TESTING). The washer fluid level switch input to the cluster can be diagnosed using conventional diagnostic tools and methods.

**DIAGNOSIS AND TESTING - WASHER FLUID INDICATOR**

The diagnosis found here addresses an inoperative washer fluid indicator condition. If the problem being diagnosed is related to indicator accuracy, be certain to confirm that the problem is with the indicator or washer fluid level switch input and not with a damaged or empty washer fluid reservoir, or inoperative instrument cluster indicator control circuitry. Inspect the washer fluid reservoir for proper fluid level and signs of damage or distortion that could affect washer fluid level switch performance and perform the instrument cluster actuator test before you proceed with the following diagnosis. If no washer fluid reservoir or instrument cluster control circuitry problem is found, the following procedure will help to locate a short or open in the washer fluid switch sense circuit. Refer to the appropriate wiring information. The wiring information includes wiring diagrams, proper wire and connector repair procedures, details of wire harness routing and retention, connector pin-out information and location views for the various wire harness connectors, splices and grounds.

**WARNING: ON VEHICLES EQUIPPED WITH AIRBAGS, DISABLE THE AIRBAG SYSTEM BEFORE ATTEMPTING ANY STEERING WHEEL, STEERING COLUMN, OR INSTRUMENT PANEL COMPONENT DIAGNOSIS OR SERVICE. DISCONNECT AND ISOLATE THE BATTERY NEGATIVE (GROUND) CABLE, THEN WAIT TWO MINUTES FOR THE AIRBAG SYSTEM CAPACITOR TO DISCHARGE BEFORE PERFORMING FURTHER DIAGNOSIS OR SERVICE. THIS IS THE ONLY SURE WAY TO DISABLE THE AIRBAG SYSTEM. FAILURE TO TAKE THE PROPER PRECAUTIONS COULD RESULT IN ACCIDENTAL AIRBAG DEPLOYMENT AND POSSIBLE PERSONAL INJURY.**

**INDICATOR DOES NOT ILLUMINATE WITH WASHER RESERVOIR EMPTY**

(1) Disconnect and isolate the battery negative cable. Disconnect the headlamp and dash wire harness connector for the washer fluid level switch from the washer fluid level switch connector receptacle. Check for continuity between the ground circuit cavity of the headlamp and dash wire harness connector for the washer fluid level switch and a good ground. There should be continuity. If OK, go to Step 2. If not

OK, repair the open ground circuit to ground (G100) as required.

(2) Remove the instrument cluster from the instrument panel. Check for continuity between the washer fluid switch sense circuit cavities of the headlamp and dash wire harness connector for the washer fluid level switch and the instrument panel wire harness connector (Connector C2) for the instrument cluster. If OK, replace the faulty washer fluid level switch. If not OK, repair the open washer fluid switch sense circuit between the washer fluid level switch and the instrument cluster as required.

**INDICATOR STAYS ILLUMINATED WITH WASHER RESERVOIR FULL**

(1) Disconnect and isolate the battery negative cable. Disconnect the headlamp and dash wire harness connector for the washer fluid level switch from the washer fluid level switch connector receptacle. Check for continuity between the ground circuit terminal and the washer fluid switch sense terminal in the washer fluid level switch connector receptacle. There should be no continuity. If OK, go to Step 2. If not OK, replace the faulty washer fluid level switch.

(2) Remove the instrument cluster from the instrument panel. Check for continuity between the washer fluid switch sense circuit cavity of the headlamp and dash wire harness connector for the washer fluid level switch and a good ground. There should be no continuity. If not OK, repair the shorted washer fluid switch sense circuit between the washer fluid level switch and the instrument cluster as required.

**WATER-IN-FUEL INDICATOR****DESCRIPTION**

A water-in-fuel indicator is standard equipment on all instrument clusters, but is only functional in vehicles equipped with an optional diesel engine. The water-in-fuel indicator is located near the lower edge of the instrument cluster overlay, to the left of center. The water-in-fuel indicator consists of a stencilled cutout of the text "WATER IN FUEL" in the opaque layer of the instrument cluster overlay. The dark outer layer of the overlay prevents the indicator from being clearly visible when it is not illuminated. A red lens located behind the cutout causes the "WATER IN FUEL" text to appear in red through the translucent outer layer of the overlay when the indicator is illuminated from behind by a Light Emitting Diode (LED) soldered onto the instrument cluster electronic circuit board. The water-in-fuel indicator is serviced as a unit with the instrument cluster.

## WATER-IN-FUEL INDICATOR (Continued)

**OPERATION**

The water-in-fuel indicator gives an indication to the vehicle operator when the water accumulated in the diesel engine fuel filter/separator filter bowl requires draining. This indicator is controlled by a transistor on the instrument cluster circuit board based upon cluster programming and electronic messages received by the cluster from the Engine Control Module (ECM) over the Chrysler Collision Detection (CCD) data bus. The water-in-fuel indicator Light Emitting Diode (LED) receives battery current on the instrument cluster electronic circuit board through the fused ignition switch output (st-run) circuit whenever the ignition switch is in the On or Start positions; therefore, the indicator will always be off when the ignition switch is in any position except On or Start. The LED only illuminates when it is switched to ground by the instrument cluster transistor. The instrument cluster will turn on the water-in-fuel indicator for the following reasons:

- **Bulb Test** - Each time the ignition switch is turned to the On position the indicator is illuminated for about two seconds as a bulb test.
- **Water-In-Fuel Lamp-On Message** - Each time the cluster receives a water-in-fuel lamp-on message

from the ECM, the indicator will be illuminated. The indicator remains illuminated until the cluster receives a water-in-fuel lamp-off message from the ECM or until the ignition switch is turned to the Off position, whichever occurs first.

- **Actuator Test** - Each time the cluster is put through the actuator test, the indicator will be turned on during the bulb check portion of the test to confirm the functionality of the LED and the cluster control circuitry.

The ECM continually monitors the water-in-fuel sensor, then sends the proper messages to the instrument cluster. For further diagnosis of the water-in-fuel indicator or the instrument cluster circuitry that controls the indicator, (Refer to 8 - ELECTRICAL/INSTRUMENT CLUSTER - DIAGNOSIS AND TESTING). For proper diagnosis of the water-in-fuel sensor, the ECM, the CCD data bus, or the message inputs to the instrument cluster that control the water-in-fuel indicator, a DRBIII® scan tool is required. Refer to the appropriate diagnostic information.





# LAMPS

## TABLE OF CONTENTS

	page	page
LAMPS/LIGHTING - EXTERIOR .....	1	LAMPS/LIGHTING - INTERIOR..... 33

## LAMPS/LIGHTING - EXTERIOR

### TABLE OF CONTENTS

	page	page
<b>LAMPS/LIGHTING - EXTERIOR</b>		
DESCRIPTION.....	2	REMOVAL..... 11
OPERATION .....	2	INSTALLATION..... 11
DIAGNOSIS AND TESTING .....	3	<b>FOG LAMP UNIT</b>
TURN SIGNAL & HAZARD WARNING		REMOVAL..... 11
SYSTEM.....	3	INSTALLATION..... 12
SPECIFICATIONS .....	4	ADJUSTMENTS..... 12
SPECIAL TOOLS .....	4	<b>HEADLAMP</b>
<b>BRAKE LAMP SWITCH</b>		DESCRIPTION..... 13
DESCRIPTION.....	4	OPERATION..... 13
OPERATION .....	4	DIAGNOSIS AND TESTING .....
DIAGNOSIS AND TESTING .....	5	HEADLAMP..... 13
BRAKE LAMP SWITCH .....	5	REMOVAL..... 16
REMOVAL.....	5	INSTALLATION..... 16
INSTALLATION.....	5	<b>HEADLAMP RELAY</b>
<b>CENTER HIGH MOUNTED STOP LAMP</b>		DESCRIPTION..... 16
REMOVAL.....	6	OPERATION..... 17
INSTALLATION.....	6	DIAGNOSIS AND TESTING .....
<b>CENTER HIGH MOUNTED STOP LAMP UNIT</b>		HEADLAMP RELAY..... 17
REMOVAL.....	6	REMOVAL..... 18
INSTALLATION.....	6	INSTALLATION..... 18
<b>CLEARANCE LAMP</b>		<b>HEADLAMP SWITCH</b>
REMOVAL.....	6	DESCRIPTION..... 18
INSTALLATION.....	6	OPERATION..... 18
<b>COMBINATION FLASHER</b>		DIAGNOSIS AND TESTING .....
DESCRIPTION.....	7	HEADLAMP SWITCH..... 18
OPERATION .....	7	REMOVAL..... 19
REMOVAL.....	8	INSTALLATION..... 20
INSTALLATION.....	8	<b>HEADLAMP UNIT</b>
<b>DAYTIME RUNNING LAMP MODULE</b>		REMOVAL..... 20
DESCRIPTION.....	9	INSTALLATION..... 20
OPERATION .....	9	ADJUSTMENTS..... 21
REMOVAL.....	9	<b>LICENSE PLATE LAMP</b>
INSTALLATION.....	9	REMOVAL..... 22
<b>FOG LAMP</b>		INSTALLATION..... 22
DIAGNOSIS AND TESTING .....	9	<b>LICENSE PLATE LAMP UNIT</b>
FOG LAMP.....	9	REMOVAL..... 22
		INSTALLATION..... 22

<b>MARKER LAMP</b>	
REMOVAL . . . . .	22
INSTALLATION . . . . .	23
<b>MULTI-FUNCTION SWITCH</b>	
DESCRIPTION . . . . .	23
OPERATION . . . . .	24
DIAGNOSIS AND TESTING . . . . .	25
MULTI-FUNCTION SWITCH . . . . .	25
REMOVAL . . . . .	27
INSTALLATION . . . . .	28
<b>OUTBOARD IDENTIFICATION LAMP</b>	
REMOVAL . . . . .	28
INSTALLATION . . . . .	29
<b>PARK/TURN SIGNAL LAMP</b>	
REMOVAL . . . . .	29
INSTALLATION . . . . .	29
<b>PARK/TURN SIGNAL LAMP UNIT</b>	
REMOVAL . . . . .	29
INSTALLATION . . . . .	29
<b>TAIL LAMP</b>	
DESCRIPTION . . . . .	29
OPERATION . . . . .	29
REMOVAL . . . . .	29
INSTALLATION . . . . .	30
<b>TAIL LAMP UNIT</b>	
REMOVAL . . . . .	30
INSTALLATION . . . . .	30
<b>TURN SIGNAL CANCEL CAM</b>	
DESCRIPTION . . . . .	30
OPERATION . . . . .	31
<b>UNDERHOOD LAMP</b>	
REMOVAL . . . . .	31
INSTALLATION . . . . .	32
<b>UNDERHOOD LAMP UNIT</b>	
REMOVAL . . . . .	32
INSTALLATION . . . . .	32

## LAMPS/LIGHTING - EXTERIOR

### DESCRIPTION - TURN SIGNAL & HAZARD WARNING SYSTEM

A turn signal and hazard warning system is standard factory-installed safety equipment on this model. The turn signal and hazard warning system includes the following major components, which are described in further detail elsewhere in this service information:

- **Combination Flasher** - The electronic combination flasher is installed in the Junction Block (JB), which is located behind the fuse access panel on the left outboard end of the instrument panel.

- **Hazard Warning Switch** - The hazard warning switch is integral to the multi-function switch on the left side of the steering column. The hazard warning switch button protrudes from a dedicated opening in the shroud on the top of the steering column, just below the steering wheel.

- **Turn Signal Cancel Cam** - The turn signal cancel cam is integral to the clockspring, which is located beneath the steering column shrouds at the top of the steering column, just below the steering wheel.

- **Turn Signal Indicators** - The two turn signal indicators, one right and one left, are integral to the ElectroMechanical Instrument Cluster (EMIC) located in the instrument panel.

- **Turn Signal Lamps** - The front turn signal lamps are integral to the lower front outboard ends of the headlamp modules, located just outboard of the two sides of the radiator grille opening. The rear turn signal lamps are integral to the taillamp modules located on either side of the vehicle. For pickup models the taillamp modules are secured to the rear of the quarter panels at each side of the tailgate opening. For cab and chassis models the taillamp

modules are secured by a stamped steel bracket on the outboard side of each frame rail near the rear of the vehicle.

- **Turn Signal Switch** - The turn signal switch is integral to the multi-function switch on the left side of the steering column. The multi-function switch control stalk that actuates the turn signal switch protrudes from a dedicated opening in the steering column shrouds on the left side of the column, just below the steering wheel.

Hard wired circuitry connects the turn signal and hazard warning system components to each other through the electrical system of the vehicle. These hard wired circuits are integral to several wire harnesses, which are routed throughout the vehicle and retained by many different methods. These circuits may be connected to each other, to the vehicle electrical system and to the turn signal and hazard warning system components through the use of a combination of soldered splices, splice block connectors and many different types of wire harness terminal connectors and insulators. Refer to the appropriate wiring information. The wiring information includes wiring diagrams, proper wire and connector repair procedures, details of wire harness routing and retention, connector pin-out information and location views for the various wire harness connectors, splices and grounds.

### OPERATION - TURN SIGNAL & HAZARD WARNING SYSTEM

The turn signal system operates on battery current received on a fused ignition switch output (run-acc) circuit so that the turn signals will only operate with the ignition switch in the On or Accessory positions. The hazard warning system operates on non-switched battery current received on a fused B(+) circuit so that the hazard warning remains operational

## LAMPS/LIGHTING - EXTERIOR (Continued)

regardless of the ignition switch position. When the turn signal (multi-function) switch control stalk is moved up (right turn) or down (left turn), the turn signal system is activated. When the turn signal system is activated, the circuitry of the turn signal switch and the combination flasher will cause the selected (right or left) turn signal indicator, front park/turn signal lamp, and rear tail/stop/turn signal lamp to flash on and off. With the hazard warning (multi-function) switch in the On position, the hazard warning system is activated. When the hazard warning system is activated, the circuitry of the hazard warning switch and the combination flasher will cause both the right side and the left side turn signal indicators, front park/turn signal lamps, and rear tail/stop/turn signal lamps to flash on and off.

Refer to the owner's manual in the vehicle glove box for more information on the features, use and operation of the turn signal and hazard warning system.

## DIAGNOSIS AND TESTING - TURN SIGNAL & HAZARD WARNING SYSTEM

When diagnosing the turn signal and hazard warning circuits, remember that high generator output can burn out bulbs rapidly and repeatedly. If this is a problem on the vehicle being diagnosed, be certain to diagnose and repair the charging system as required. If the problem being diagnosed is related to a failure of the turn signals to automatically cancel following completion of a turn, inspect the multi-function switch for a faulty or damaged cancel actuator and inspect the turn signal cancel cam on the clockspring for damaged lobes or improper installation. Refer to the appropriate wiring information. The wiring information includes wiring diagrams, proper wire and connector repair procedures, details of wire harness routing and retention, connector pin-out information and location views for the various wire harness connectors, splices and grounds.

**WARNING: ON VEHICLES EQUIPPED WITH AIRBAGS, DISABLE THE AIRBAG SYSTEM BEFORE ATTEMPTING ANY STEERING WHEEL, STEERING COLUMN, OR INSTRUMENT PANEL COMPONENT DIAGNOSIS OR SERVICE. DISCONNECT AND ISOLATE THE BATTERY NEGATIVE (GROUND) CABLE, THEN WAIT TWO MINUTES FOR THE AIRBAG SYSTEM CAPACITOR TO DISCHARGE BEFORE PERFORMING FURTHER DIAGNOSIS OR SERVICE. THIS IS THE ONLY SURE WAY TO DISABLE THE AIRBAG SYSTEM. FAILURE TO TAKE THE PROPER PRECAUTIONS COULD RESULT IN ACCIDENTAL AIRBAG DEPLOYMENT AND POSSIBLE PERSONAL INJURY.**

(1) Turn the ignition switch to the On position. Actuate the turn signal switch or the hazard warning switch. Observe the turn signal indicator lamp(s) in the instrument cluster. If the flash rate is very high, check for a turn signal bulb that is not lit or is very dimly lit. Repair the circuits to that lamp or replace the faulty bulb, as required. If the turn signal indicator(s) fail to light, go to Step 2.

(2) Turn the ignition switch to the Off position. Check the fused ignition switch output (run-acc) fuse (Fuse 10 - 10 ampere) in the Junction Block (JB) and the fused B(+) fuse (Fuse 4 - 20 ampere) in the Power Distribution Center (PDC). If OK, go to Step 3. If not OK, repair the shorted circuit or component as required and replace the faulty fuse(s).

(3) Check for battery voltage at the fused B(+) fuse (Fuse 4 - 20 ampere) in the PDC. If OK, go to Step 4. If not OK, repair the open fused B(+) circuit between the PDC and the battery as required.

(4) Turn the ignition switch to the On position. Check for battery voltage at the fused ignition switch output (run-acc) fuse (Fuse 10 - 10 ampere) in the JB. If OK, go to Step 5. If not OK, repair the open fused ignition switch output (run-acc) circuit between the JB and the ignition switch as required.

(5) Turn the ignition switch to the Off position. Disconnect and isolate the battery negative cable. Remove the combination flasher from the JB and replace it with a known good unit. Reconnect the battery negative cable. Test the operation of the turn signal and hazard warning systems. If OK, discard the faulty combination flasher. If not OK, remove the test flasher and go to Step 6.

(6) Turn the ignition switch to the On position. Check for battery voltage at the fused ignition switch output (run-acc) circuit cavity in the JB receptacle for the combination flasher. If OK, go to Step 7. If not OK, repair the open fused ignition switch output (run-acc) circuit between the combination flasher and the fused ignition switch output (run-acc) fuse (Fuse 10 - 10 ampere) in the JB as required.

(7) Turn the ignition switch to the Off position. Check for battery voltage at the fused B(+) circuit cavity of the JB receptacle for the combination flasher. If OK, go to Step 8. If not OK, repair the open fused B(+) circuit between the combination flasher and the fused B(+) fuse (Fuse 4 - 20 ampere) in the PDC as required.

(8) Disconnect and isolate the battery negative cable. Check for continuity between the ground circuit cavity of the JB receptacle for the combination flasher and a good ground. There should be continuity. If OK, go to Step 9. If not OK, repair the open ground circuit to ground (G201) as required.

## LAMPS/LIGHTING - EXTERIOR (Continued)

(9) Disconnect the instrument panel wire harness connector for the multi-function switch from the switch connector receptacle. Check for continuity between the hazard flasher signal circuit cavities in the JB receptacle for the combination flasher and the instrument panel wire harness connector for the multi-function switch. There should be continuity. If OK, go to Step 10. If not OK, repair the open hazard flasher signal circuit between the JB and the multi-function switch as required.

(10) Check for continuity between the flasher output circuit cavities of the JB receptacle for the combination flasher and in the instrument panel wire harness connector for the multi-function switch. There should be continuity. If OK, test the multi-function switch. (Refer to 8 - ELECTRICAL/LAMPS/LIGHTING - EXTERIOR/MULTI-FUNCTION SWITCH - DIAGNOSIS AND TESTING). If not OK, repair the open flasher output circuit between the JB and the multi-function switch as required.

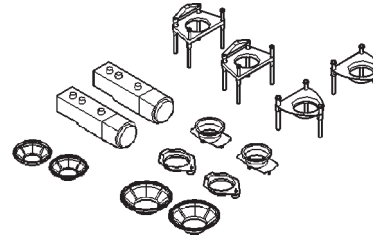
## SPECIFICATIONS

## EXTERIOR LAMPS

LAMP	BULB
Back-up	3157
Cargo	921
Center High Mounted Stop	921
Clearance Roof Mounted	168
Fog Lamps	896
Headlamp - SLT	9004LL
Headlamp - Sport Low Beam	9007
Headlamp - Sport High Beam	9004LL
License Plate w/o Bumper	1155
License Plate -Step Bumper	168
Park/Turn Signal	3157NA
Snow Plow Control	161
Tail/Brake/Turn Signal	3157
Tail/Brake/Cab - Chassis	1157
Underhood	105

## SPECIAL TOOLS

## HEADLAMP ALIGNMENT



*Headlamp Aiming Kit C-4466-A*

## BRAKE LAMP SWITCH

## DESCRIPTION

The plunger type brake lamp switch is mounted on a bracket attached to the brake pedal support under the instrument panel.

**CAUTION:** The switch can only be adjusted during initial installation. If the switch is not adjusted properly a new switch must be installed.

## OPERATION

The brake lamp switch is used for the brake lamp, speed control brake sensor circuits and electronic brake distribution (EBD). The brake lamp circuit is open until the plunger is depressed. The speed control and brake sensor circuits are closed until the plunger is depressed.

When the brake light switch is activated, the Powertrain Control Module (PCM) receives an input indicating that the brakes are being applied. After receiving this input, the PCM maintains idle speed to a scheduled rpm through control of the Idle Air Control (IAC) motor. The brake switch input is also used to disable vent and vacuum solenoid output signals to the speed control servo.

Vehicles equipped with the speed control option use a dual function brake lamp switch. The PCM monitors the state of the dual function brake lamp switch. Refer to the Brake section for more information on brake lamp switch service and adjustment procedures.

The brake switch is equipped with three sets of contacts, one normally open and the other two normally closed (brakes disengaged). The PCM sends a 12 volt signal to one of the normally closed contacts in the brake switch, which is returned to the PCM as a brake switch state signal. With the contacts closed, the 12 volt signal is pulled to ground causing the signal to go low. The low voltage signal, monitored by the PCM, indicates that the brakes are not applied. When the brakes are applied, the contacts open,



## BRAKE LAMP SWITCH (Continued)

causing the PCM's output brake signal to go high, disengaging the speed control, cutting off PCM power to the speed control solenoids.

The second set of normally closed contacts supplies 12 volts from the PCM any time speed control is turned on. Through the brake switch, current is routed to the speed control servo solenoids. The speed control solenoids (vacuum, vent and dump) are provided this current any time the speed control is ON and the brakes are disengaged.

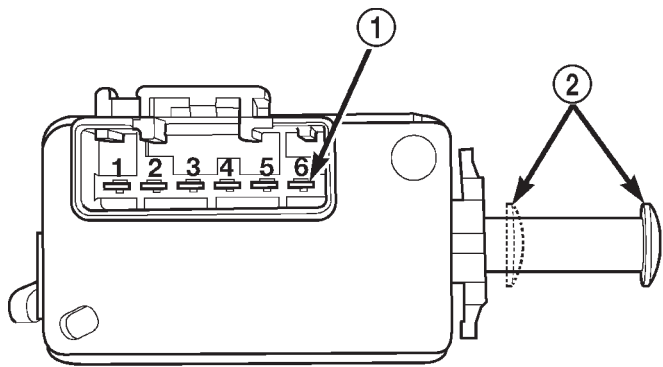
When the driver applies the brakes, the contacts open and current is interrupted to the solenoids. The normally open contacts are fed battery voltage. When the brakes are applied, battery voltage is supplied to the brake lamps.

## DIAGNOSIS AND TESTING - BRAKE LAMP SWITCH

The brake lamp switch can be tested with an ohmmeter. The ohmmeter is used to check continuity between the pin terminals (Fig. 1).

## SWITCH CIRCUIT IDENTIFICATION

- Terminals 1 and 2: brake lamp circuit
- Terminals 3 and 4: RWAL/ABS module and Powertrain Control Module (PCM) circuit
- Terminals 5 and 6: speed control circuit



80bce8e6

**Fig. 1 Brake Lamp Switch Terminal Identification**

- 1 - TERMINAL PINS  
2 - PLUNGER TEST POSITIONS

## SWITCH CONTINUITY TEST

**NOTE:** Disconnect switch harness before testing switch continuity.

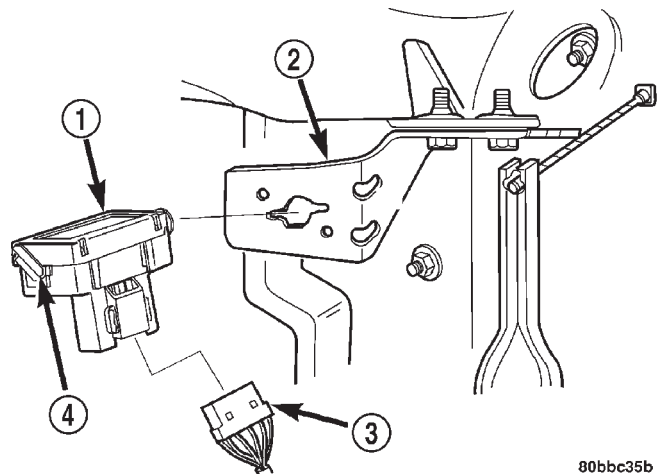
With switch plunger extended, attach test leads to pins 1 and 2. Replace switch if meter indicates no continuity.

With switch plunger retracted, attach test leads to pins 3 and 4. Replace switch if meter indicates no continuity.

With switch plunger retracted, attach test leads to pins 5 and 6. Replace switch if meter indicates no continuity.

## REMOVAL

- (1) Remove knee bolster for access to brake lamp switch and pedal.
- (2) Disconnect switch harness (Fig. 2).
- (3) Press and hold brake pedal in applied position.
- (4) Rotate switch counterclockwise about 30° to align switch lock tabs with notch in bracket.
- (5) Pull switch rearward out of mounting bracket and release brake pedal.



80bbc35b

**Fig. 2 Brake Lamp Switch & Harness Connector**

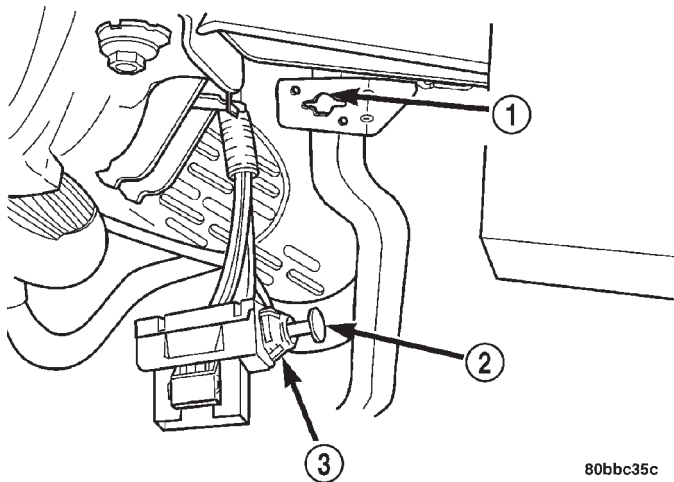
- 1 - BRAKE LIGHT SWITCH  
2 - SWITCH BRACKET  
3 - HARNESS CONNECTOR  
4 - SWITCH LEVER

## INSTALLATION

- (1) Connect harness wires to **new** switch.
- (2) Press and hold brake pedal down.
- (3) Install switch. Align tabs on switch with notches in switch bracket (Fig. 3). Then insert switch in bracket and turn it clockwise approximately 30° to lock it in place.
- (4) Release brake pedal. Then move the release lever on the switch to engage the switch plunger. The switch is now adjusted and can not be adjusted again.
- (5) Install the knee bolster.



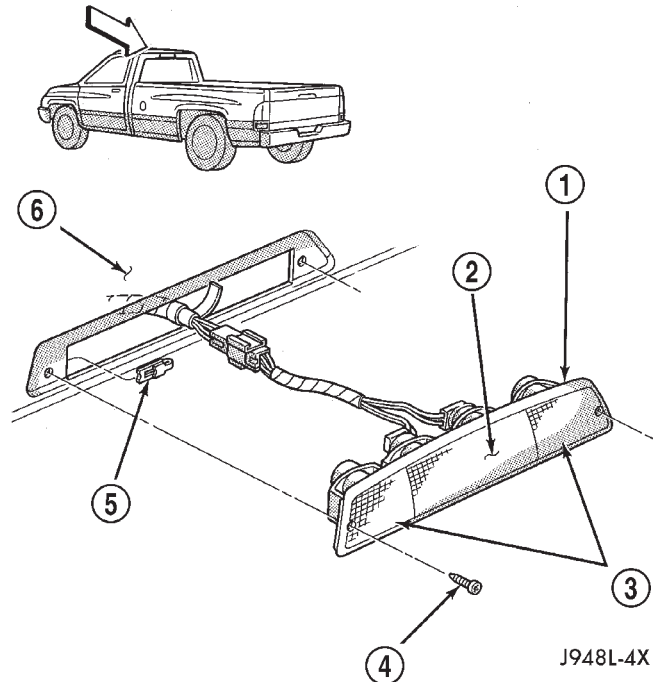
## BRAKE LAMP SWITCH (Continued)



80bbc35c

**Fig. 3 Brake Lamp Switch**

- 1 - TAB NOTCH (IN BRACKET)
- 2 - SWITCH PLUNGER
- 3 - SWITCH TAB



J948L-4X

**Fig. 4 Center High Mounted Stop Lamp**

- 1 - CHMSL CARGO LAMP HOUSING
- 2 - CHMSL
- 3 - CARGO LAMPS
- 4 - SCREW
- 5 - CLIP
- 6 - CAB

## CENTER HIGH MOUNTED STOP LAMP

**REMOVAL**

- (1) Disconnect and isolate the battery negative cable.
- (2) Remove the CHMSL from the roof panel.
- (3) Rotate sockets 1/4 turn clockwise and remove from lamp. (The two center bulbs light the stoplamp and the outside bulbs light the cargo lamp, if equipped.)
- (4) Pull bulb from socket.

**INSTALLATION**

- (1) Push bulb into socket.
- (2) Position socket in lamp and rotate socket 1/4 turn counterclockwise.
- (3) Install the CHMSL.
- (4) Connect the battery negative cable.

## CENTER HIGH MOUNTED STOP LAMP UNIT

**REMOVAL**

- (1) Disconnect and isolate the battery negative cable.
- (2) Remove screws holding CHMSL to roof panel (Fig. 4).
- (3) Separate CHMSL from roof.
- (4) Disengage wire connector from body wire harness.
- (5) Separate CHMSL from vehicle.

**INSTALLATION**

- (1) Position lamp at cab roof and connect wire connector.
- (2) Install screws holding CHMSL to roof panel. Tighten securely.
- (3) Connect the battery negative cable.

## CLEARANCE LAMP

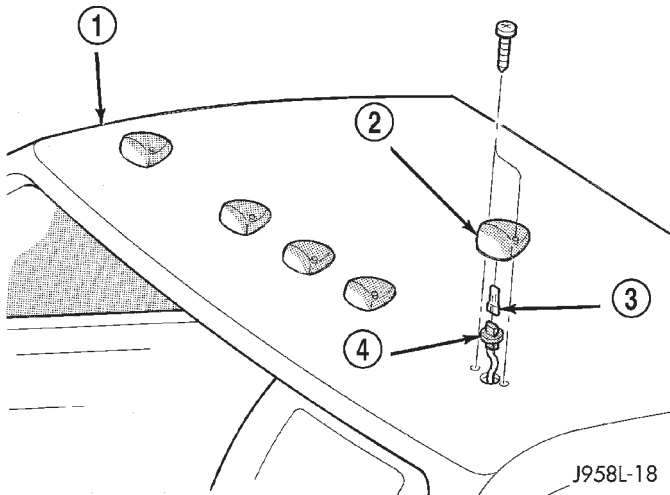
**REMOVAL**

- (1) Disconnect and isolate the battery negative cable.
- (2) Remove screws holding clearance lamp lens to roof panel (Fig. 5).
- (3) Rotate socket 1/4 turn counterclockwise and separate socket from lamp.

**INSTALLATION**

- (1) Install socket in lamp and rotate socket 1/4 turn clockwise.
- (2) Position clearance lamp on roof.
- (3) Install screws holding clearance lamp lens to roof panel. Tighten to 1 N-m (13 in. lbs.).
- (4) Connect the battery negative cable.

## CLEARANCE LAMP (Continued)



**Fig. 5 Roof Clearance Lamps**

- 1 - ROOF
- 2 - LAMP LENS
- 3 - BULB
- 4 - SOCKET

## COMBINATION FLASHER

## DESCRIPTION

The combination flasher is located in the Junction Block (JB) behind the fuse access panel on the left outboard end of the instrument panel. The combination flasher is a smart relay that functions as both the turn signal system and the hazard warning system flasher. The combination flasher contains active electronic Integrated Circuitry (IC) elements. This flasher is designed to handle the current flow requirements of the factory-installed lighting. If supplemental lighting is added to the turn signal lamp circuits, such as when towing a trailer with lights, the combination flasher will automatically try to compensate to keep the flash rate the same.

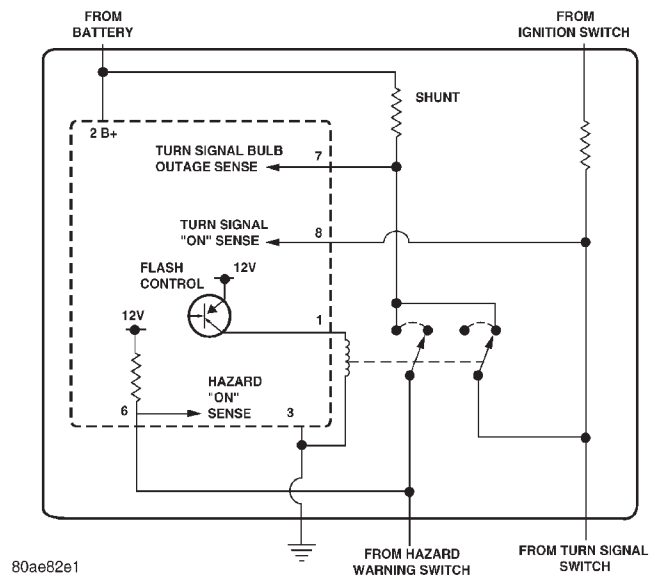
The combination flasher has five blade-type terminals that connect it to the vehicle electrical system through five matching cavities in the receptacle of the JB. While the combination flasher has a International Standards Organization (ISO)-type relay terminal configuration or footprint, the internal circuitry is much different. The combination flasher does not use standard ISO-relay inputs or provide ISO-relay type outputs or functions. The combination flasher should never be substituted for an ISO-relay or replaced with an ISO-relay, or else component and vehicle damage may occur.

The combination flasher cannot be repaired or adjusted and, if faulty or damaged, it must be replaced.

## OPERATION

The combination flasher has five blade-type terminals intended for the following inputs and outputs: fused B(+), fused ignition switch output, ground, turn signal circuit, and hazard warning circuit. Constant battery voltage and ground are supplied to the flasher so that it can perform the hazard warning function, and ignition switched battery voltage is supplied for the turn signal function.

The Integrated Circuitry (IC) within the combination flasher (Fig. 6) contains the logic that controls the flasher operation and the flash rate. Pin 6 of the IC receives a sense voltage from the hazard warning circuit of the multi-function switch. When the hazard warning switch is turned on, the "hazard on sense" voltage will become low due to the circuit being grounded through the turn signal bulbs. This low voltage sense signals the IC to energize the flash control Positive-Negative-Positive (PNP) transistor at a pre-calibrated flash rate or frequency. Each time the PNP transistor energizes the hazard warning circuit, the pin 6 "hazard on sense" voltage will become high and the IC signals the PNP transistor to de-energize the circuit. This cycling will continue until the hazard warning switch is turned off.



**Fig. 6 Combination Flasher - Typical**

Likewise, pin 8 of the IC receives a sense voltage from the turn signal circuits of the multi-function switch. When the left or right turn signal switch is turned on, the "turn signal on sense" voltage will become low due to the circuit being grounded through the turn signal bulbs. This low voltage sense signals the IC to energize the flash control PNP transistor at a pre-calibrated flash rate or frequency. Each time the PNP transistor energizes the turn signal circuit, the pin 8 "turn signal on sense" voltage

## COMBINATION FLASHER (Continued)

will become high and the IC signals the PNP transistor to de-energize the circuit. This cycling will continue until the right or left turn signal switch is turned off.

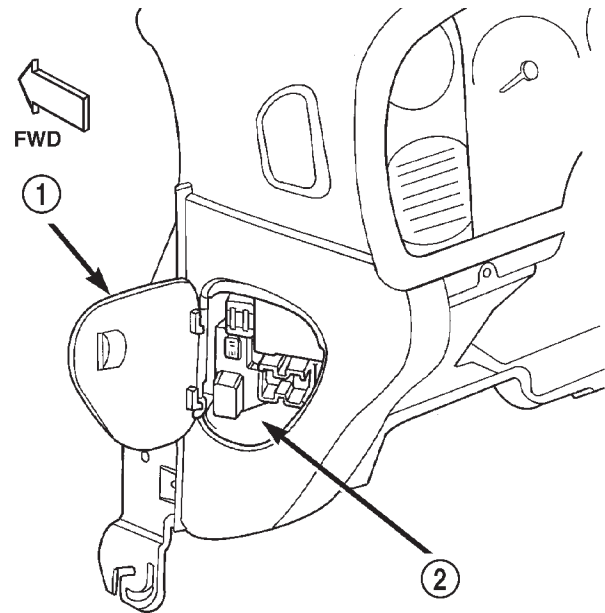
A special design feature of the combination flasher allows it to "sense" that a turn signal circuit or bulb is not operating, and provide the driver an indication of the condition by flashing the remaining bulbs in the affected circuit at a higher rate (120 flashes-per-minute or higher). Conventional flashers either continue flashing at their typical rate (heavy-duty type), or discontinue flashing the affected circuit entirely (standard-duty type). During turn signal operation, the combination flasher IC compares normal battery voltage input on pin 2 with the shunt resistor voltage input on pin 7. If the IC "senses" that the voltage difference between pin 2 and pin 7 is different than the pre-calibrated value of the IC, it will increase the rate at which it signals the PNP transistor to energize the pin 1 output. Thus, the inoperative half (left or right side) of the turn signal circuit will flash faster.

Because of the active electronic elements within the combination flasher, it cannot be tested with conventional automotive electrical test equipment. If the combination flasher is believed to be faulty, test the turn signal system and hazard warning system. Then replace the combination flasher with a known good unit to confirm system operation. (Refer to 8 - ELECTRICAL/LAMPS/LIGHTING - EXTERIOR/TURN SIGNAL & HAZARD WARNING SYSTEM - DIAGNOSIS AND TESTING).

## REMOVAL

**WARNING: ON VEHICLES EQUIPPED WITH AIRBAGS, DISABLE THE AIRBAG SYSTEM BEFORE ATTEMPTING ANY STEERING WHEEL, STEERING COLUMN, OR INSTRUMENT PANEL COMPONENT DIAGNOSIS OR SERVICE. DISCONNECT AND ISOLATE THE BATTERY NEGATIVE (GROUND) CABLE, THEN WAIT TWO MINUTES FOR THE AIRBAG SYSTEM CAPACITOR TO DISCHARGE BEFORE PERFORMING FURTHER DIAGNOSIS OR SERVICE. THIS IS THE ONLY SURE WAY TO DISABLE THE AIRBAG SYSTEM. FAILURE TO TAKE THE PROPER PRECAUTIONS COULD RESULT IN ACCIDENTAL AIRBAG DEPLOYMENT AND POSSIBLE PERSONAL INJURY.**

- (1) Disconnect and isolate the battery negative cable.
- (2) Remove the fuse access panel by unsnapping it from the left outboard end of the instrument panel.
- (3) Remove the combination flasher from the Junction Block (JB) (Fig. 7).



80b171c0

**Fig. 7 Junction Block**

- 1 - JUNCTION BLOCK
- 2 - FUSE ACCESS PANEL

## INSTALLATION

**WARNING: ON VEHICLES EQUIPPED WITH AIRBAGS, DISABLE THE AIRBAG SYSTEM BEFORE ATTEMPTING ANY STEERING WHEEL, STEERING COLUMN, OR INSTRUMENT PANEL COMPONENT DIAGNOSIS OR SERVICE. DISCONNECT AND ISOLATE THE BATTERY NEGATIVE (GROUND) CABLE, THEN WAIT TWO MINUTES FOR THE AIRBAG SYSTEM CAPACITOR TO DISCHARGE BEFORE PERFORMING FURTHER DIAGNOSIS OR SERVICE. THIS IS THE ONLY SURE WAY TO DISABLE THE AIRBAG SYSTEM. FAILURE TO TAKE THE PROPER PRECAUTIONS COULD RESULT IN ACCIDENTAL AIRBAG DEPLOYMENT AND POSSIBLE PERSONAL INJURY.**

- (1) Position the combination flasher in the proper receptacle of the Junction Block (JB).
- (2) Align the terminals of the combination flasher with the terminal cavities in the JB receptacle for the flasher.
- (3) Push in firmly and evenly on the combination flasher until the terminals are fully seated in the terminal cavities of the JB receptacle for the flasher.
- (4) Reinstall the fuse access panel by snapping it onto the left outboard end of the instrument panel.
- (5) Reconnect the battery negative cable.

## DAYTIME RUNNING LAMP MODULE

### DESCRIPTION

The Daytime Running Lights (Headlamps) System is installed on vehicles manufactured for sale in Canada only. A separate module, mounted on the cowl, controls the DRL.

### OPERATION

The headlamps are illuminated when the ignition switch is turned to the ON position. The DRL module receives a vehicle-moving signal from the vehicle speed sensor. This provides a constant **head-lamps-on** condition as long as the vehicle is moving. The lamps are illuminated at less than 50 percent of normal intensity.

### REMOVAL

- (1) Disconnect and isolate the battery negative cable.
- (2) Disengage wire connector from DRLM (Fig. 8).
- (3) Remove screws attaching DRLM to left front inner fender panel.
- (4) Separate DRLM from fender.

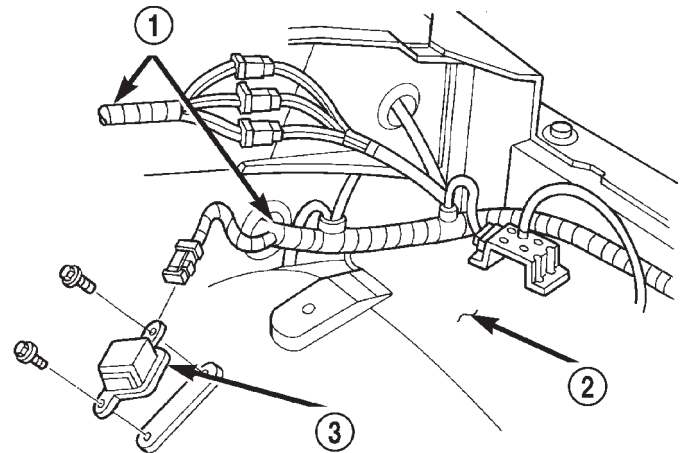
### INSTALLATION

- (1) Position DRLM on fender.

## FOG LAMP

### DIAGNOSIS AND TESTING - FOG LAMP

CONDITION	POSSIBLE CAUSES	CORRECTION
FOG LAMPS ARE DIM WITH ENGINE IDLING OR IGNITION TURNED OFF.	<ol style="list-style-type: none"> <li>1. Loose or corroded battery cables.</li> <li>2. Loose or worn generator drive belt.</li> <li>3. Charging system output too low.</li> <li>4. Battery has insufficient charge.</li> <li>5. Battery is sulfated or shorted.</li> <li>6. Poor lighting circuit Z33-ground.</li> </ol>	<ol style="list-style-type: none"> <li>1. Clean and secure battery cable clamps and posts.</li> <li>2. Adjust or replace generator drive belt.</li> <li>3. Test and repair charging system.</li> <li>4. Test battery state-of-charge.</li> <li>5. Load test battery.</li> <li>6. Test for voltage drop across Z33-ground locations.</li> </ol>
FOG LAMP BULBS BURN OUT FREQUENTLY	<ol style="list-style-type: none"> <li>1. Charging system output too high.</li> <li>2. Loose or corroded terminals or splices in circuit.</li> </ol>	<ol style="list-style-type: none"> <li>1. Test and repair charging system.</li> <li>2. Inspect and repair all connectors and splices.</li> </ol>



80b04f2a

**Fig. 8 Daytime Running Lamp Module (DRLM)**

- 1 - HEADLAMP AND DASH WIRING HARNESS
- 2 - LEFT FENDER SIDE SHIELD
- 3 - DAYTIME RUNNING LAMP MODULE

- (2) Install screws attaching DRLM to left front inner fender panel.
- (3) Engage wire connector to DRLM.
- (4) Connect the battery negative cable.

## FOG LAMP (Continued)

CONDITION	POSSIBLE CAUSES	CORRECTION
FOG LAMPS ARE DIM WITH ENGINE RUNNING ABOVE IDLE	<ol style="list-style-type: none"> <li>1. Charging system output too low.</li> <li>2. Poor lighting circuit Z33-ground.</li> <li>3. High resistance in fog lamp circuit.</li> </ol>	<ol style="list-style-type: none"> <li>1. Test and repair charging system.</li> <li>2. Test for voltage drop across Z33-ground locations.</li> <li>3. Test amperage draw of fog lamp circuit.</li> </ol>
FOG LAMPS FLASH RANDOMLY	<ol style="list-style-type: none"> <li>1. Poor lighting circuit Z33-ground.</li> <li>2. High resistance in fog lamp circuit.</li> <li>3. Faulty fog lamp switch.</li> <li>4. Loose or corroded terminals or splices in circuit.</li> </ol>	<ol style="list-style-type: none"> <li>1. Test for voltage drop across Z33-ground locations.</li> <li>2. Test amperage draw of fog lamp circuit.</li> <li>3. Replace fog lamp switch.</li> <li>4. Inspect and repair all connectors and splices.</li> </ol>
FOG LAMPS DO NOT ILLUMINATE	<ol style="list-style-type: none"> <li>1. Blown fuse for fog lamp.</li> <li>2. No Z33-ground at fog lamps.</li> <li>3. Faulty fog lamp switch.</li> <li>4. Broken connector terminal or wire splice in fog lamp circuit.</li> <li>5. Defective or burned out bulb.</li> </ol>	<ol style="list-style-type: none"> <li>1. Trace short and replace fuse.</li> <li>2. Repair circuit ground.</li> <li>3. Replace fog lamp switch.</li> <li>4. Repair connector terminal or wire splice.</li> <li>5. Replace bulb.</li> </ol>
FOG LAMPS ARE INOPERATIVE AND FOG LAMP INDICATOR LIGHT ALWAYS STAYS ON.	<ol style="list-style-type: none"> <li>1. Fog lamp/DRL* feed shorted to ground.</li> </ol>	<ol style="list-style-type: none"> <li>1. Check wiring circuit from fog lamp/DRL* fuse to fog lamp. Trace short circuit in wiring and repair.</li> </ol>
FOG LAMPS ARE INOPERATIVE AND FOG LAMP INDICATOR LIGHT IS ILLUMINATED.	<ol style="list-style-type: none"> <li>1. Fog lamp/DRL* fuse defective.</li> <li>2. Open circuit from fog lamp fuse to fog lamp.</li> </ol>	<ol style="list-style-type: none"> <li>1. Trace short circuit and replace fuse.</li> <li>2. Check wiring circuit from fog lamp/DRL* fuse to fog lamp. Trace open circuit in wiring and repair.</li> </ol>
PARK LAMPS ARE INOPERATIVE. FOG LAMP INDICATOR IS ON WHEN ALL SWITCHES ARE OFF AND FUNCTIONS OPPOSITE TO FOG LAMPS.	<ol style="list-style-type: none"> <li>1. Park lamp feed is shorted.</li> </ol>	<ol style="list-style-type: none"> <li>1. Check wiring circuit from park lamp fuse to headlamp switch. Trace short circuit in wiring and repair.</li> </ol>
PARK LAMPS ARE INOPERATIVE. FOG LAMP INDICATOR FUNCTIONS OPPOSITE TO FOG LAMPS.	<ol style="list-style-type: none"> <li>1. Park lamp fuse is defective.</li> <li>2. Open circuit from park lamp fuse to headlamp switch.</li> </ol>	<ol style="list-style-type: none"> <li>1. Trace short circuit and replace fuse.</li> <li>2. Check wiring circuit from park lamp fuse to headlamp switch. Trace open circuit in wiring and repair.</li> </ol>

\*Canada vehicles use Daytime Running Lamps (DRL).



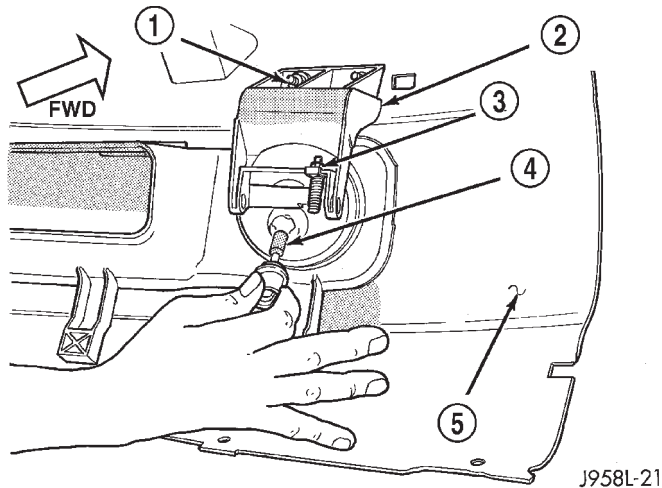
FOG LAMP (Continued)

Additional fog lamp diagnostic procedures listed are for vehicles equipped with quad headlamps and the DRL option.

CONDITION	POSSIBLE CAUSES	CORRECTION
FOG LAMPS ARE INOPERATIVE AND FOG LAMP INDICATOR STAYS ALWAYS ON.	1 Fog lamp/DRL* feed shorted to ground.	1. Check wiring circuit from fog lamp/DRL* fuse to fog lamp.Trace short circuit in wiring and repair.
FOG LAMP INDICATOR COMES ON WITH OUT ILLUMINATING THE FOG LAMPS	1. Fog lamp/DRL* fuse defective.	1. Trace short circuit and replace fuse.
FOG LAMPS INOPERATIVE WITH IGNITION OFF.	Open circuit from fog lamp fuse to fog lamp.	1. Check wiring circuit from fog lamp/DRL* fuse to fog lamp. Trace open circuit in wiring and repair.

**REMOVAL**

- (1) Disconnect and isolate the battery negative cable.
- (2) Disengage fog lamp harness connector.
- (3) Rotate bulb assembly counterclockwise and pull from lamp to separate (Fig. 9).



**Fig. 9 Fog Lamp**

- 1 - NUT
- 2 - FOG LAMP ASSEMBLY
- 3 - UP/DOWN ADJUSTER
- 4 - BULB
- 5 - BUMPER

**INSTALLATION**

**CAUTION:** Do not touch the bulb glass with fingers or other oily surfaces. Reduced bulb life will result.

- (1) Position bulb assembly in lamp and rotate clockwise.
- (2) Connect fog lamp harness connector.
- (3) Connect the battery negative cable.

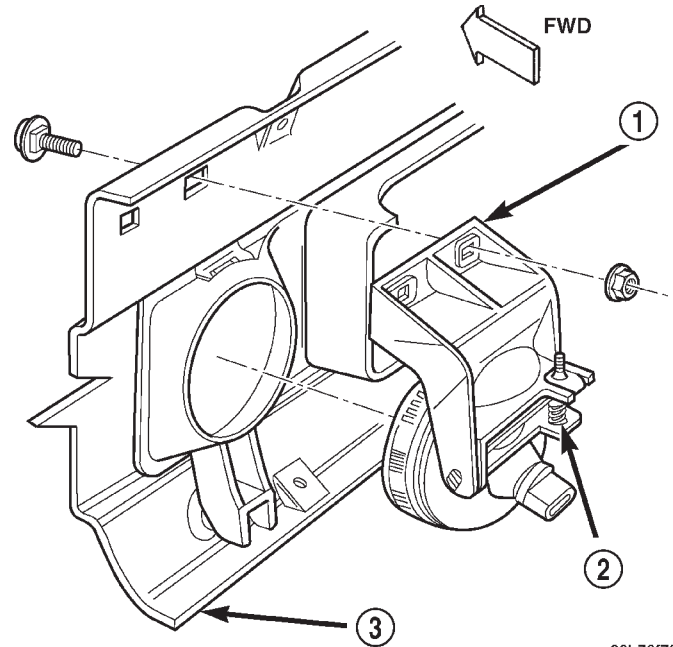
**FOG LAMP UNIT**

**REMOVAL**

**SLT**

The fog lamps are serviced from the rearward side of the front bumper.

- (1) Disconnect and isolate the battery negative cable.
- (2) Disengage fog lamp harness connector.
- (3) Remove fog lamp to bumper attaching nuts (Fig. 10).
- (4) Separate fog lamp from bumper.



**Fig. 10 Fog Lamp**

- 1 - FOG LAMP
- 2 - BEAM ADJUSTER
- 3 - BUMPER

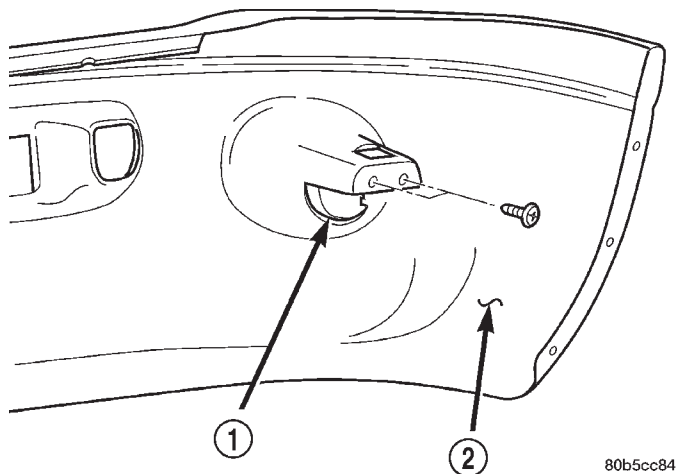
80b76f79

## FOG LAMP UNIT (Continued)

**SPORT**

The fog lamps are serviced from the rearward side of the front bumper.

- (1) Disconnect and isolate the battery negative cable.
- (2) Disengage fog lamp harness connector.
- (3) Remove fog lamp to bumper attaching nuts (Fig. 11).
- (4) Separate fog lamp from bumper.



**Fig. 11 Fog Lamp**

- 1 - FOG LAMP
- 2 - BEAM ADJUSTER
- 3 - BUMPER

**INSTALLATION****SLT**

- (1) Position fog lamp in bumper.
- (2) Install fog lamp to bumper attaching nuts.
- (3) Connect fog lamp harness connector.
- (4) Check for proper operation and beam alignment.
- (5) Connect the battery negative cable.

**SPORT**

- (1) Position fog lamp in fascia.
- (2) Install screws attaching fog lamp to fascia.
- (3) Connect wire connector to fog lamp.
- (4) Check for proper operation and beam alignment.
- (5) Connect the battery negative cable.

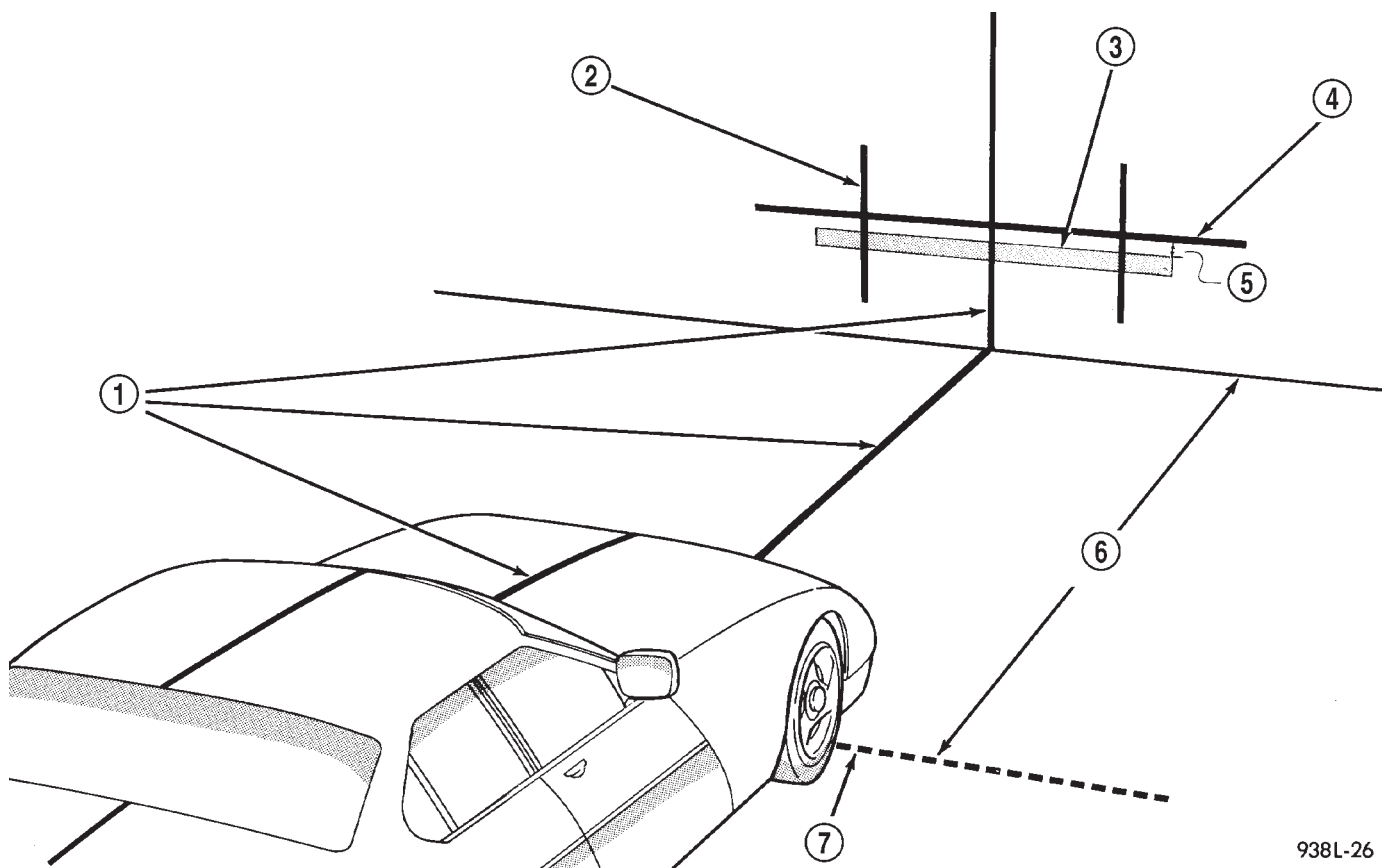
**ADJUSTMENTS**

Prepare an alignment screen. (Refer to 8 - ELECTRICAL/LAMPS/LIGHTING - EXTERIOR/HEAD-LAMP UNIT - ADJUSTMENTS)

A properly aligned fog lamp will project a pattern on the alignment screen 100 mm (4 in.) below the fog lamp centerline and straight ahead (Fig. 12).

To adjust fog lamp aim, rotate adjustment screw on the rear of fog lamp to achieve the specified height.

## FOG LAMP UNIT (Continued)



938L-26

**Fig. 12 Fog Lamp Alignment**

1 - VEHICLE CENTERLINE

2 - CENTER OF VEHICLE TO CENTER OF FOG LAMP LENS

3 - HIGH-INTENSITY AREA

4 - FLOOR TO CENTER OF FOG LAMP LENS

5 - 100 mm (4 in.)

6 - 7.62 METERS (25 FEET)

7 - FRONT OF FOG LAMP

## HEADLAMP

### DESCRIPTION

Headlamps on the Ram Pick-Up are modular in design. The turn/park lamp module is incorporated into the headlamp module. The module contains two bulbs; a dual filament headlamp bulb, and a dual filament turn/park bulb. The Sport headlamp module has two separate bulbs for the headlamp illumination.

### OPERATION

Headlamps and parking lamps are controlled by the headlamp switch. The multifunction switch mounted on the steering column controls the high beam function, and the turn signal function.

## DIAGNOSIS AND TESTING - HEADLAMP

A good ground is necessary for proper lighting operation. Grounding is provided by the lamp socket when it comes in contact with the metal body, or through a separate ground wire.

Always begin any diagnosis by testing all of the fuses and circuit breakers in the system. For complete circuit diagrams, refer to the appropriate wiring information. The wiring information includes wiring diagrams, proper wire and connector repair procedures, details of wire harness routing and retention, connector pin-out information and location views for the various wire harness connectors, splices and grounds.

## HEADLAMP (Continued)

CONDITION	POSSIBLE CAUSES	CORRECTION
HEADLAMPS ARE DIM WITH ENGINE IDLING OR IGNITION TURNED OFF	<ol style="list-style-type: none"> <li>1. Loose or corroded battery cables.</li> <li>2. Loose or worn generator drive belt.</li> <li>3. Charging system output too low.</li> <li>4. Battery has insufficient charge.</li> <li>5. Battery is sulfated or shorted.</li> <li>6. Poor lighting circuit Z3-ground.</li> <li>7. Both headlamp bulbs defective.</li> </ol>	<ol style="list-style-type: none"> <li>1. Clean and secure battery cable clamps and posts.</li> <li>2. Adjust or replace generator drive belt.</li> <li>3. Test and repair charging system.</li> <li>4. Test battery state-of -charge.</li> <li>5. Load test battery.</li> <li>6. Test for voltage drop across Z3-ground locations.</li> <li>7. Replace both headlamp bulbs.</li> </ol>
HEADLAMP BULBS BURN OUT FREQUENTLY	<ol style="list-style-type: none"> <li>1. Charging system output too high.</li> <li>2. Loose or corroded terminals or splices in circuit.</li> </ol>	<ol style="list-style-type: none"> <li>1. Test and repair charging system.</li> <li>2. Inspect and repair all connectors and splices.</li> </ol>
HEADLAMPS ARE DIM WITH ENGINE RUNNING ABOVE IDLE*	<ol style="list-style-type: none"> <li>1. Charging system output too low.</li> <li>2. Poor lighting circuit Z3-ground.</li> <li>3. High resistance in headlamp circuit.</li> <li>4. Both headlamp bulbs defective.</li> </ol>	<ol style="list-style-type: none"> <li>1. Test and repair charging system.</li> <li>2. Test for voltage drop across Z3-ground locations.</li> <li>3. Test amperage draw of headlamp circuit.</li> <li>4. Replace both headlamp bulbs.</li> </ol>
HEADLAMPS FLASH RANDOMLY	<ol style="list-style-type: none"> <li>1. Poor lighting circuit Z3-ground.</li> <li>2. High resistance in headlamp circuit.</li> <li>3. Faulty headlamps switch circuit breaker.</li> <li>4. Loose or corroded terminals or splices in circuit.</li> </ol>	<ol style="list-style-type: none"> <li>1. Test for voltage drop across Z3-ground locations.</li> <li>2. Test amperage draw of headlamp circuit. Should not exceed 30 amps.</li> <li>3. Replace headlamp switch.</li> <li>4. Inspect and repair all connectors and splices.</li> </ol>
HEADLAMPS (HIGH & LOW) DO NOT ILLUMINATE	<ol style="list-style-type: none"> <li>1. No voltage at either headlamp.</li> <li>2. No ground for high and low beam circuit.</li> <li>3. Headlamp bulb(s) defective.</li> <li>4. Faulty headlamp switch.</li> <li>5. Faulty headlamp dimmer (Multifunction) switch.</li> </ol>	<ol style="list-style-type: none"> <li>1. Voltage should always be present. Trace short circuit and replace BOTH headlamp fuses. Check wiring circuit from Right headlamp fuse to headlamp. (Repeat for Left side)</li> <li>2. Ground should always be present according to switch position. Check ground at headlamp switch. Check wiring circuit from headlamp switch to Multifunction switch. Check headlamp switch and Multifunction switch continuity. Repair circuit ground.</li> <li>3. Replace bulb(s).</li> <li>4. Replace headlamp switch.</li> <li>5. Replace Multifunction switch.</li> </ol>

## HEADLAMP (Continued)

CONDITION	POSSIBLE CAUSES	CORRECTION
	6. Broken connector terminal or wire splice in headlamp circuit.	6. Repair connector terminal or wire splice.
HEADLAMPS (LOW BEAM) DO NOT ILLUMINATE.	1. No ground for low beam circuit.	1. Ground should be present according to Multifunction switch position. Check wiring circuit from Multifunction switch to headlamp . Trace open circuit in wiring and repair. Check Multifunction Switch for continuity.
HEADLAMPS (HIGH BEAM) DO NOT ILLUMINATE.	1. No ground for high beam circuit.	1. Ground should be present according to Multifunction switch position. Check wiring circuit from Multifunction switch to headlamp . Trace open circuit in wiring and repair. Check Multifunction Switch for continuity.
HEADLAMPS (LOW BEAM) ALWAYS ILLUMINATE AND CAN NOT BE SHUT OFF.	1. Low beam circuit from bulb to Multifunction switch is shorted to ground.	1. Ground should be present according to Multifunction switch position. Check wiring circuit from Multifunction switch to headlamp . Trace short circuit in wiring and repair.
HEADLAMPS (HIGH BEAM) ALWAYS ILLUMINATE AND CAN NOT BE SHUT OFF.	1. High beam circuit from bulb to Multifunction switch is shorted to ground.	1. Ground should be present according to Multifunction switch position. Check wiring circuit from Multifunction switch to headlamp . Trace short circuit in wiring and repair.
QUAD LAMPS DO NOT ILLUMINATE AND HIGH BEAMS ILLUMINATE.	1. No voltage at either headlamp.  2. No ground for Quad beam circuit.  3. If voltage and ground are present, bulb(s) is defective.	1. Voltage should always be present. Check Quad lamp fuse. Check wiring circuit from Quad lamp fuse to Quad lamp. Repeat for left side 2. Ground should be present according to Multifunction switch position. Check ground at quad lamp relay. Check for battery voltage at quad lamp relay. Check quad lamp relay. Check relay control circuit (relay coil to high beam). 3. Replace bulb(s).
HEADLAMP SWITCH OFF HEADLAMPS AND HIGHBEAM INDICATOR REMAIN ON AND ARE DIM.	1. Headlamp switch feed circuit shorted to ground.	1. Check wiring circuit from right headlamp fuse to headlamp. Repeat for left side. Trace short circuit in wiring and repair.
HEADLAMP SWITCH ON (LOW BEAMS ON), ONE LOW BEAM ON AND BOTH HIGH BEAMS DIM.	1. Headlamp feed circuit shorted to ground.	1. Check wiring circuit from right headlamp fuse to headlamp. Repeat for left side. Trace short circuit in wiring and repair.



HEADLAMP (Continued)

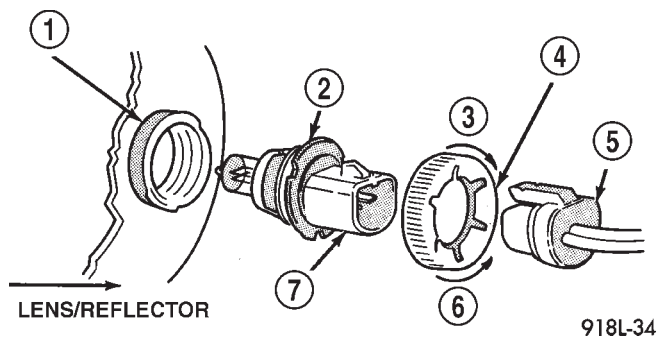
CONDITION	POSSIBLE CAUSES	CORRECTION
HEADLAMP SWITCH ON (HIGH BEAMS ON), ONE HIGH BEAM ON AND BOTH LOW BEAMS DIM.	1. Headlamp feed circuit shorted to ground.	1. Check wiring circuit from right headlamp fuse to headlamp. Repeat for left side. Trace short circuit in wiring and repair.
HEADLAMP SWITCH ON, ONE HEADLAMP FILAMENT WILL BE AT FULL INTENSITY AND ALL OTHER FILAMENTS ARE ON AND DIM.	1. Blown headlamp fuse.  2. Open circuit from headlamp fuse to headlamp.	1. Trace short circuit and replace fuse.  2. Repair open headlamp circuit.
1. HEADLAMPS STAY ON WITH KEY OUT (DRLM EQUIPPED VEHICLES).	1. Failed DRLM	1. Replace DRLM.

\*Canada vehicles must have lamps ON.

**REMOVAL**

On the driver side, the battery and battery tray must be removed to service the headlamp bulb.

- (1) Disconnect and isolate the battery negative cable.
- (2) Remove the battery tray (Refer to 8 - ELECTRICAL/BATTERY SYSTEM/TRAY - REMOVAL).
- (3) Disengage wire connector from headlamp bulb(s).
- (4) Remove retaining ring holding bulb(s) to headlamp (Fig. 13).
- (5) Pull bulb(s) from headlamp.



**Fig. 13 Headlamp Bulb**

- 1 - BULB SOCKET
- 2 - BULB ASSEMBLY
- 3 - LOCK
- 4 - BULB RETAINING RING
- 5 - ELECTRICAL CONNECTOR
- 6 - UNLOCK
- 7 - PLASTIC BASE

**INSTALLATION**

**CAUTION: Do not touch the bulb glass with fingers or other oily surfaces. Reduced bulb life will result.**

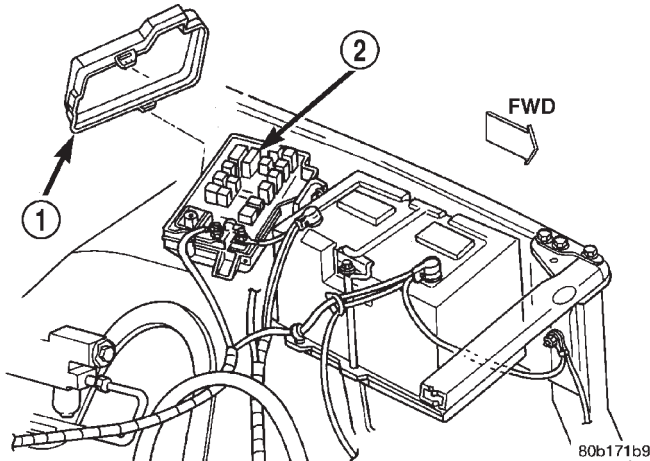
- (1) Position bulb(s) in headlamp.
- (2) Install retaining ring holding bulb(s) to headlamp.
- (3) Connect wire connector to headlamp bulb(s).
- (4) Install battery tray, if removed (Refer to 8 - ELECTRICAL/BATTERY SYSTEM/TRAY - INSTALLATION).
- (5) Connect battery negative cable.

**HEADLAMP RELAY**

**DESCRIPTION**

The headlamp (or security) relay is located in the Power Distribution Center (PDC) near the battery in the engine compartment (Fig. 14). See the fuse and relay layout label affixed to the inside surface of the PDC cover for headlamp relay identification and location. The headlamp relay is a conventional International Standards Organization (ISO) micro relay. Relays conforming to the ISO specifications have common physical dimensions, current capacities, terminal patterns, and terminal functions. The relay is contained within a small, rectangular, molded plastic housing. The relay is connected to all of the required inputs and outputs through its PDC receptacle by five male spade-type terminals that extend from the bottom of the relay base. The ISO designation for each terminal is molded into the base adjacent to the

## HEADLAMP RELAY (Continued)



**Fig. 14 Power Distribution Center**

- 1 - COVER  
2 - POWER DISTRIBUTION CENTER

terminal. The ISO terminal designations are as follows:

- **30 (Common Feed)** - This terminal is connected to the movable contact point of the relay.
- **85 (Coil Ground)** - This terminal is connected to the ground feed side of the relay control coil.
- **86 (Coil Battery)** - This terminal is connected to the battery feed side of the relay control coil.
- **87 (Normally Open)** - This terminal is connected to the normally open fixed contact point of the relay.
- **87A (Normally Closed)** - This terminal is connected to the normally closed fixed contact point of the relay.

The headlamp relay cannot be adjusted or repaired. If the relay is damaged or faulty, it must be replaced.

## OPERATION

The headlamp (or security) relay is an electromechanical switch that uses a low current input from the high-line or premium Central Timer Module (CTM) to control a high current output to the headlamps. The movable common feed contact point is held against the fixed normally closed contact point by spring pressure. When the relay coil is energized, an electromagnetic field is produced by the coil windings. This electromagnetic field draws the movable relay contact point away from the fixed normally closed contact point, and holds it against the fixed normally open contact point. When the relay coil is de-energized, spring pressure returns the movable contact point back against the fixed normally closed contact point. A resistor or diode is connected in parallel with the relay coil in the relay, and helps to dissipate voltage spikes and electromagnetic

interference that can be generated as the electromagnetic field of the relay coil collapses.

The headlamp relay terminals are connected to the vehicle electrical system through a connector receptacle in the Power Distribution Center (PDC). The inputs and outputs of the headlamp relay include:

- The common feed terminal (30) is connected to ground at all times through a take out and eyelet terminal connector of the right headlamp and dash wire harness that is secured by a ground screw to the left fender inner shield near the PDC in the engine compartment.
- The coil ground terminal (85) is connected to the Central Timer Module (CTM) through the security relay control circuit. The CTM energizes the headlamp relay control coil by internally pulling this circuit to ground.
- The coil battery terminal (86) is connected to battery current at all times through a fused B(+) circuit that is internal to the PDC.
- The normally open terminal (87) is connected to the headlamps at all times through the beam select switch low beam output circuit. This circuit provides a path to ground for the headlamps through the common feed terminal when the headlamp relay control coil is energized by the CTM.
- The normally closed terminal (87A) is not connected to any circuit in this application, but is grounded through the common feed terminal when the headlamp relay control coil is de-energized.

The headlamp relay can be diagnosed using conventional diagnostic tools and methods.

## DIAGNOSIS AND TESTING - HEADLAMP RELAY

The headlamp (or security) relay (Fig. 15) is located in the Power Distribution Center (PDC) near the battery in the engine compartment. See the fuse and relay layout label affixed to the inside surface of the PDC cover for headlamp relay identification and location. Refer to the appropriate wiring information. The wiring information includes wiring diagrams, proper wire and connector repair procedures, details of wire harness routing and retention, connector pin-out information and location views for the various wire harness connectors, splices and grounds.

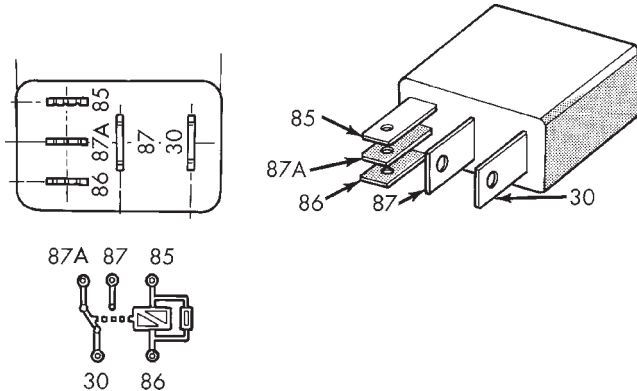
(1) Remove the headlamp relay from the PDC. (Refer to 8 - ELECTRICAL/LAMPS/LIGHTING - EXTERIOR/HEADLAMP RELAY - REMOVAL).

(2) A relay in the de-energized position should have continuity between terminals 87A and 30, and no continuity between terminals 87 and 30. If OK, go to Step 3. If not OK, replace the faulty relay.

(3) Resistance between terminals 85 and 86 (electromagnet) should be  $75 \pm 5$  ohms. If OK, go to Step 4. If not OK, replace the faulty relay.

## HEADLAMP RELAY (Continued)

(4) Connect a battery to terminals 85 and 86. There should now be continuity between terminals 30 and 87, and no continuity between terminals 87A and 30. If OK, test the relay input and output circuits. If not OK, replace the faulty relay.

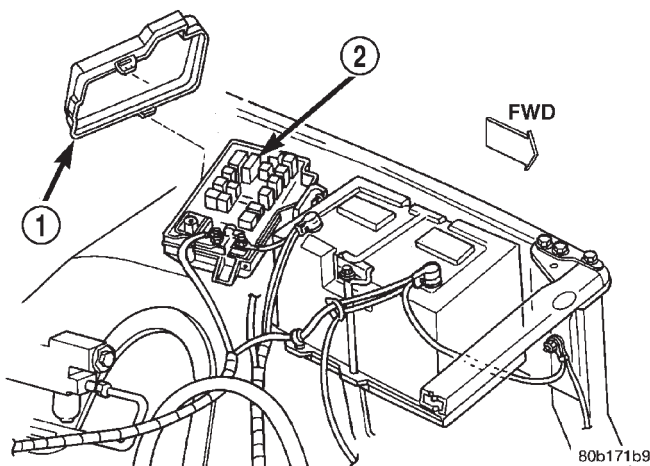


**Fig. 15 Headlamp Relay**

- 30 - COMMON FEED
- 85 - COIL GROUND
- 86 - COIL BATTERY
- 87 - NORMALLY OPEN
- 87A - NORMALLY CLOSED

## REMOVAL

- (1) Disconnect and isolate the battery negative cable.
- (2) Unlatch and remove the cover from the Power Distribution Center (PDC) (Fig. 16).



**Fig. 16 Power Distribution Center**

- 1 - COVER
- 2 - POWER DISTRIBUTION CENTER

(3) See the fuse and relay layout label affixed to the underside of the PDC cover for headlamp (or security) relay identification and location.

(4) Remove the headlamp relay by grasping it firmly and pulling it straight out from the receptacle in the PDC.

## INSTALLATION

- (1) See the fuse and relay layout label affixed to the underside of the PDC cover for the proper headlamp (or security) relay location.
- (2) Position the headlamp relay in the proper receptacle in the PDC.
- (3) Align the headlamp relay terminals with the terminal cavities in the PDC receptacle.
- (4) Push firmly and evenly on the top of the headlamp relay until the terminals are fully seated in the terminal cavities in the PDC receptacle.
- (5) Reinstall and latch the cover onto the PDC.
- (6) Connect the battery negative cable.

## HEADLAMP SWITCH

## DESCRIPTION

The headlamp switch module is located on the instrument panel. The headlamp switch controls the parking lamps, and the headlamps. A separate switch in the module controls the interior lamps and instrument cluster illumination. This switch also contains a rheostat for controlling the illumination level of the cluster lamps.

## OPERATION

The headlamp switch has an off position, a parking lamp position, and a headlamp on position. High beams are controlled by the multifunction switch on the steering column. The headlamp switch cannot be repaired. It must be replaced.

## DIAGNOSIS AND TESTING - HEADLAMP SWITCH

For circuit descriptions and diagrams, refer to the appropriate wiring information. The wiring information includes wiring diagrams, proper wire and connector repair procedures, details of wire harness routing and retention, connector pin-out information and location views for the various wire harness connectors, splices and grounds.

**WARNING: ON VEHICLES EQUIPPED WITH AIRBAGS, REFER TO ELECTRICAL, RESTRAINTS BEFORE ATTEMPTING ANY STEERING WHEEL, STEERING COLUMN, OR INSTRUMENT PANEL COMPONENT DIAGNOSIS OR SERVICE. FAILURE TO TAKE THE PROPER PRECAUTIONS COULD RESULT IN ACCIDENTAL AIRBAG DEPLOYMENT AND POSSIBLE PERSONAL INJURY.**

## HEADLAMP SWITCH (Continued)

(1) Disconnect and isolate the battery negative cable. Remove the headlamp switch from the instrument panel. (Refer to 8 - ELECTRICAL/LAMPS/LIGHTING - EXTERIOR/HEADLAMP SWITCH - REMOVAL) for the procedures. Unplug the headlamp switch wire harness connectors. Check for continuity between the left door jamb switch sense circuit cavity of the headlamp switch wire harness connector and a good ground. There should be continuity with the driver door open, and no continuity with the driver door closed. If OK, go to Step 2. If not OK, repair the circuit to the driver door jamb switch as required.

(2) Remove the Central Timer Module (CTM) from its mounting bracket to access the CTM wire harness connectors. (Refer to 8 - ELECTRICAL/ELECTRONIC CONTROL MODULES/BODY CONTROL/CENTRAL TIMER MODUL - REMOVAL) for the procedures. Unplug the 14-way CTM wire harness connector. Remove the key from the ignition lock cylinder. Check for continuity between the key-in ignition switch sense circuit cavity of the 14-way CTM wire harness connector and a good ground. There should be no continuity. If OK, go to Step 3. If not OK, repair the short circuit as required.

(3) Check for continuity between the key-in ignition switch sense circuit cavities of the 14-way CTM wire harness connector and the headlamp switch wire harness connector. There should be continuity. If OK, go to Step 4. If not OK, repair the open circuit as required.

(4) Check for continuity between the left front door jamb switch sense circuit terminal and the key-in ignition switch sense circuit terminal of the headlamp switch. There should be no continuity with the switch in the Off position, and continuity with the switch in the park or head lamps On position. If OK, (Refer to 8 - ELECTRICAL/ELECTRONIC CONTROL MODULES/BODY CONTROL/CENTRAL TIMER MODUL - DIAGNOSIS AND TESTING) If not OK, replace the faulty headlamp switch.

## REMOVAL

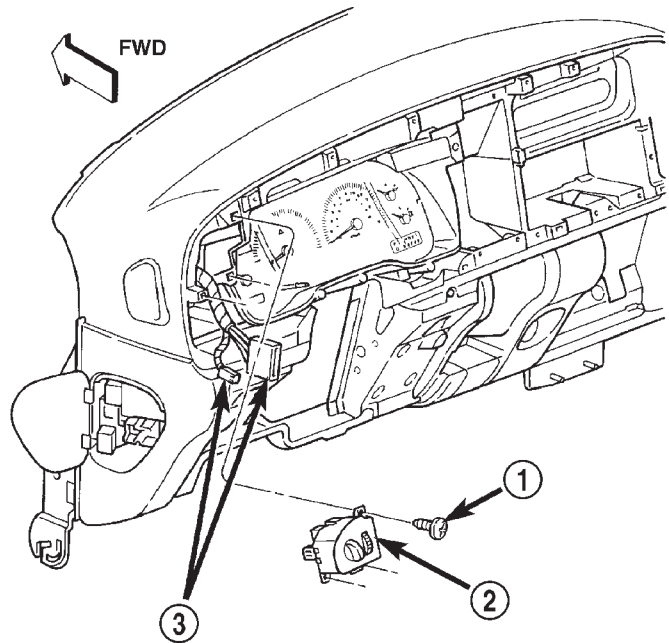
**WARNING: ON VEHICLES EQUIPPED WITH AIRBAGS, DISABLE THE AIRBAG SYSTEM BEFORE ATTEMPTING ANY STEERING WHEEL, STEERING COLUMN, OR INSTRUMENT PANEL COMPONENT DIAGNOSIS OR SERVICE. DISCONNECT AND ISOLATE THE BATTERY NEGATIVE (GROUND) CABLE, THEN WAIT TWO MINUTES FOR THE AIRBAG SYSTEM CAPACITOR TO DISCHARGE BEFORE PERFORMING FURTHER DIAGNOSIS OR SERVICE. THIS IS THE ONLY SURE WAY TO DISABLE THE AIRBAG SYSTEM. FAILURE TO TAKE THE PROPER PRECAUTIONS COULD RESULT IN ACCIDENTAL AIR-**

**BAG DEPLOYMENT AND POSSIBLE PERSONAL INJURY.**

(1) Disconnect and isolate the battery negative cable.

(2) Remove the cluster bezel from the instrument panel. (Refer to 23 - BODY/INSTRUMENT PANEL/CLUSTER BEZEL - REMOVAL).

(3) Remove the three screws that secure the headlamp switch to the instrument panel (Fig. 17).



80689841

**Fig. 17 Headlamp Switch Removal**

- 1 - SCREWS (3)
- 2 - HEADLAMP SWITCH
- 3 - INSTRUMENT PANEL WIRE HARNESS CONNECTORS

(4) Pull the headlamp switch away from the instrument panel far enough to access the instrument panel wire harness connectors.

(5) Disconnect the two instrument panel wire harness connectors for the headlamp switch from the connector receptacles on the back of the switch.

(6) Remove the headlamp switch from the instrument panel.



## HEADLAMP SWITCH (Continued)

## INSTALLATION

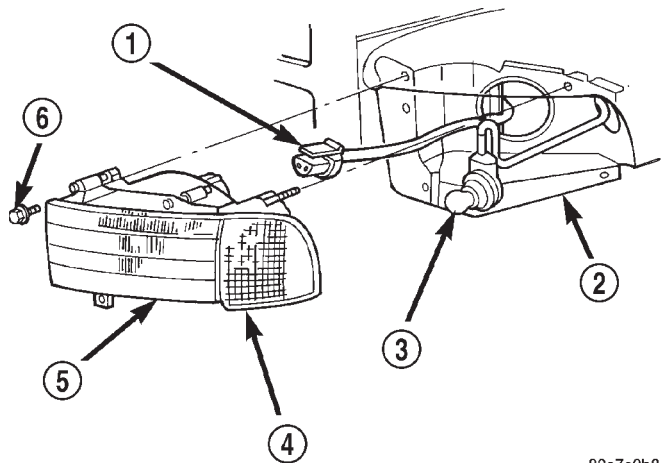
**WARNING: ON VEHICLES EQUIPPED WITH AIRBAGS, DISABLE THE AIRBAG SYSTEM BEFORE ATTEMPTING ANY STEERING WHEEL, STEERING COLUMN, OR INSTRUMENT PANEL COMPONENT DIAGNOSIS OR SERVICE. DISCONNECT AND ISOLATE THE BATTERY NEGATIVE (GROUND) CABLE, THEN WAIT TWO MINUTES FOR THE AIRBAG SYSTEM CAPACITOR TO DISCHARGE BEFORE PERFORMING FURTHER DIAGNOSIS OR SERVICE. THIS IS THE ONLY SURE WAY TO DISABLE THE AIRBAG SYSTEM. FAILURE TO TAKE THE PROPER PRECAUTIONS COULD RESULT IN ACCIDENTAL AIRBAG DEPLOYMENT AND POSSIBLE PERSONAL INJURY.**

- (1) Position the headlamp switch to the instrument panel.
- (2) Reconnect the two instrument panel wire harness connectors for the headlamp switch to the connector receptacles on the back of the switch.
- (3) Position the headlamp switch into the instrument panel.
- (4) Install and tighten the three screws that secure the headlamp switch to the instrument panel. Tighten the screws to 2.2 N-m (20 in. lbs.).
- (5) Reinstall the cluster bezel onto the instrument panel. (Refer to 23 - BODY/INSTRUMENT PANEL/CLUSTER BEZEL - INSTALLATION).
- (6) Connect the battery negative cable.

## HEADLAMP UNIT

## REMOVAL

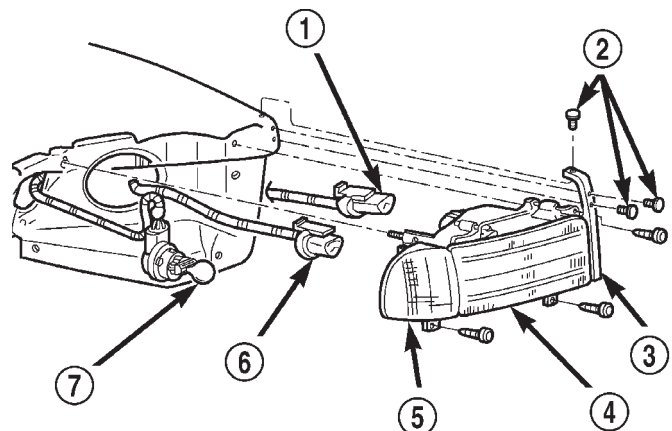
- (1) Disconnect and isolate the battery negative cable.
- (2) Remove push-in fastener attaching seal to radiator closure panel.
- (3) Remove park and turn signal lamp.
- (4) Remove screws attaching top of headlamp module to radiator closure panel (Fig. 18).
- (5) From behind front bumper, remove screws attaching bottom of headlamp module to radiator closure panel.
- (6) From behind the bumper, loosen the bumper mounting nuts to allow the bumper to lower for clearance. This is only necessary on the side to be removed.
- (7) Separate headlamp module from radiator closure panel.
- (8) Disengage wire connector from headlamp bulb(s) (Fig. 19).
- (9) Separate headlamp module from vehicle.



80a7e2b8

Fig. 18 Headlamp

- 1 - HEADLAMP SOCKET
- 2 - CARRIER BRACKET
- 3 - TURN AND PARK LAMP BULB
- 4 - TURN AND PARK LAMP HOUSING
- 5 - HEADLAMP HOUSING
- 6 - SCREW



80b5cb8f

Fig. 19 Headlamp-Sport

- 1 - HIGH BEAM BULB SOCKET
- 2 - PUSH-IN FASTENER
- 3 - SEAL
- 4 - HEADLAMP MODULE
- 5 - TURN/PARK LAMP MODULE
- 6 - LOW BEAM BULB SOCKET
- 7 - TURN/PARK LAMP BULB

## INSTALLATION

- (1) If removed, install headlamp bulb(s).
- (2) Connect headlamp bulb wire connector(s).
- (3) Position headlamp in radiator closure panel.
- (4) From behind front bumper, install the screws attaching bottom of headlamp module to radiator closure panel.



## HEADLAMP UNIT (Continued)

- (5) From behind the bumper, tighten the bumper mounting nuts.
- (6) Install the screws attaching top of headlamp module to radiator closure panel.
- (7) Install park and turn signal lamp.
- (8) Install push-in fastener attaching seal to radiator closure panel.
- (9) Connect the battery negative cable.

## ADJUSTMENTS

## LAMP ALIGNMENT SCREEN PREPARATION

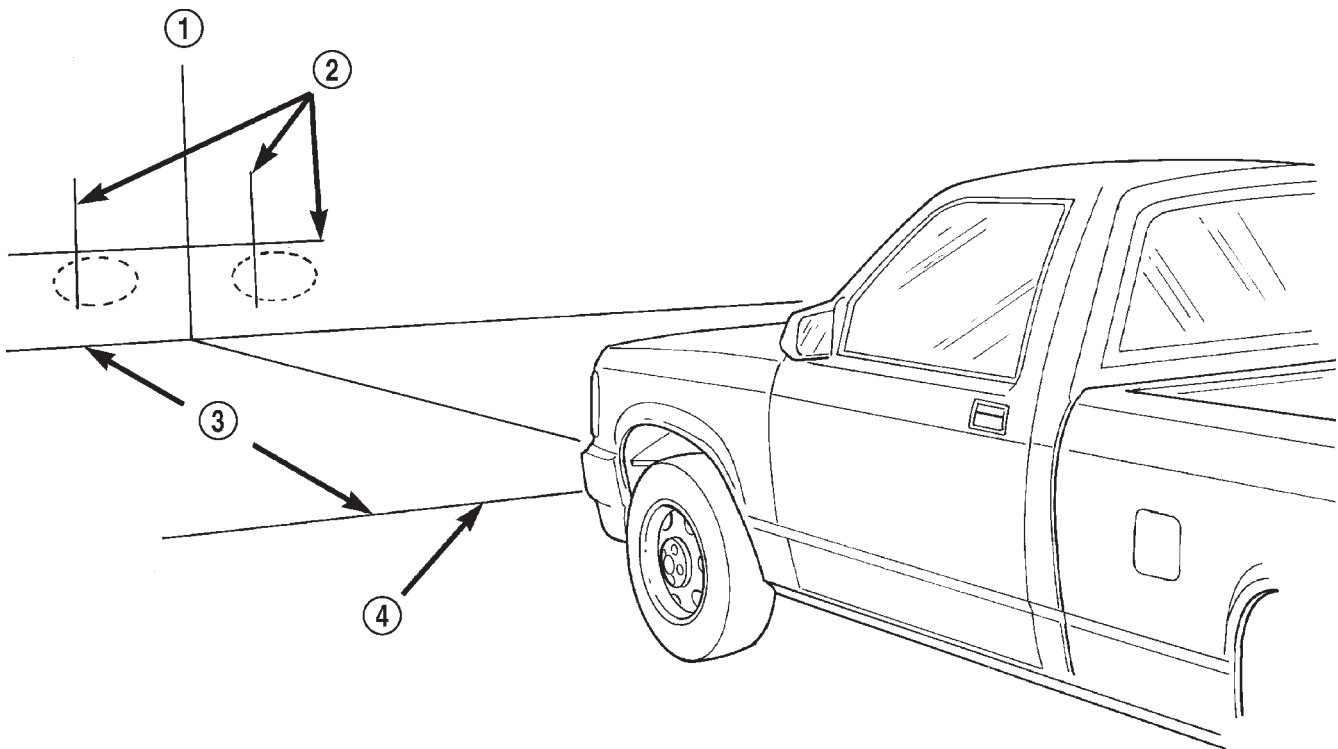
- (1) Position vehicle on a level surface perpendicular to a flat wall 7.62 meters (25 ft) away from front of headlamp lens (Fig. 20).
- (2) If necessary, tape a line on the floor 7.62 meters (25 ft) away from and parallel to the wall.
- (3) Up 1.27 meters (5 feet) from the floor, tape a line on the wall at the centerline of the vehicle. Sight along the centerline of the vehicle (from rear of vehicle forward) to verify accuracy of the line placement.
- (4) Rock vehicle side-to-side three times to allow suspension to stabilize.
- (5) Jounce front suspension three times by pushing downward on front bumper and releasing.

- (6) Measure the distance from the center of headlamp lens to the floor. Transfer measurement to the alignment screen (with tape). Use this line for up/down adjustment reference.

- (7) Measure distance from the centerline of the vehicle to the center of each headlamp being aligned. Transfer measurements to screen (with tape) to each side of vehicle centerline. Use these lines for left/right adjustment reference.

## VEHICLE PREPARATION FOR HEADLAMP ALIGNMENT

- (1) Verify headlamp dimmer switch and high beam indicator operation.
- (2) Verify headlamps are set for low beam operation.
- (3) Correct defective components that could hinder proper headlamp alignment.
- (4) Verify proper tire inflation.
- (5) Clean headlamp lenses.
- (6) Verify that luggage area is not heavily loaded.
- (7) Fuel tank should be FULL. Add 2.94 kg (6.5 lbs.) of weight over the fuel tank for each estimated gallon of missing fuel.



8020cdbf

**Fig. 20 Lamp Alignment Screen—Typical**

1 - CENTER OF VEHICLE  
2 - CENTER OF HEADLAMP

3 - 7.62 METERS (25 FT.)  
4 - FRONT OF HEADLAMP

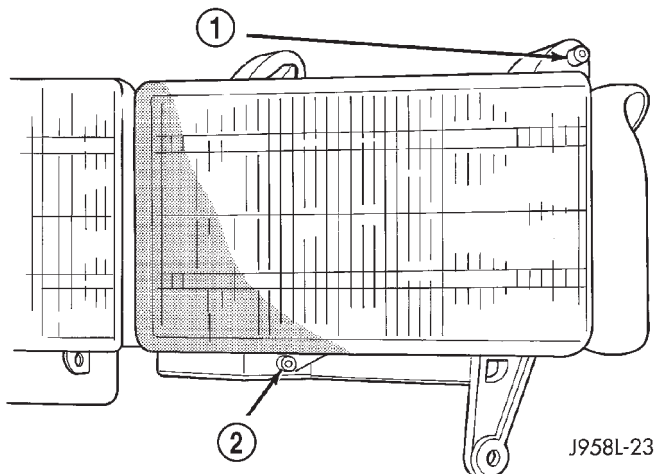
## HEADLAMP UNIT (Continued)

## HEADLAMP ADJUSTMENT

Headlamps can be aligned using the screen method provided or alignment tool C-4466-A or equivalent can be used. refer to the instructions provided with the tool for proper procedures.

A properly aimed low beam headlamp will project top edge of high intensity pattern on screen from 50 mm (2 in.) above to 50 mm (2 in.) below headlamp centerline. The side-to-side outboard edge of high intensity pattern should be from 50 mm (2 in.) left to 50 mm (2 in.) right of headlamp centerline. (Fig. 20) **The preferred headlamp alignment is 1" down for the up/down adjustment and 0 for the left/right adjustment.** The high beam pattern should be correct when the low beams are aligned properly.

To adjust headlamp aim, rotate alignment screws (Fig. 21) to achieve the specified high intensity pattern.



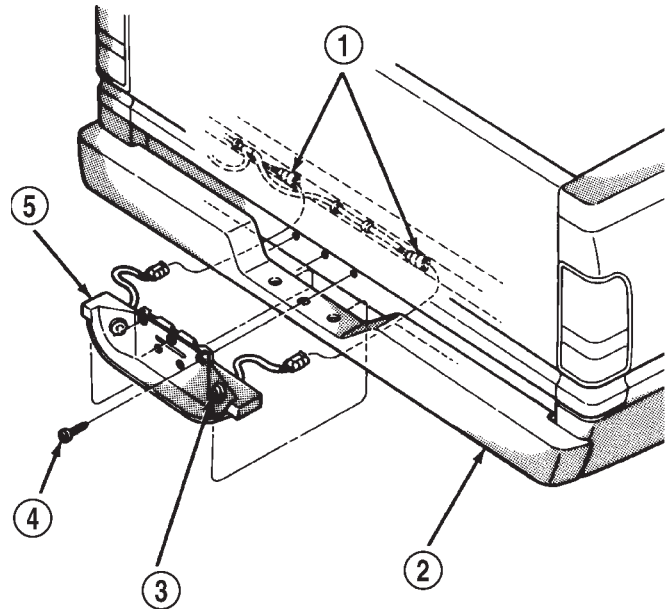
**Fig. 21 Aero Headlamp Alignment**

- 1 - LEFT AND RIGHT ADJUSTMENT SCREW
- 2 - UP AND DOWN ADJUSTMENT SCREW

## LICENSE PLATE LAMP UNIT

## REMOVAL

- (1) Disconnect and isolate the battery negative cable.
- (2) Remove screws attaching license plate panel to cargo box.
- (3) Disengage license plate lamp wire connector from body wire harness (Fig. 22).
- (4) Separate license plate lamp from vehicle.



**Fig. 22 License Plate Lamp Panel**

- 1 - LIGHTING HARNESS
- 2 - BUMPER
- 3 - LICENSE PLATE LAMP
- 4 - SCREW
- 5 - LAMP PANEL

## LICENSE PLATE LAMP

## REMOVAL

- (1) Disconnect and isolate the battery negative cable.
- (2) Remove license plate lamp lens.
- (3) Pull bulb from license plate lamp.

## INSTALLATION

- (1) Install bulb in license plate lamp.
- (2) Install license plate lamp lens.
- (3) Connect the battery negative cable.

## INSTALLATION

- (1) Position license plate lamp in vehicle.
- (2) Engage license plate lamp wire connector to body wire harness.
- (3) Install screws attaching license plate panel to cargo box.
- (4) Connect the battery negative cable.

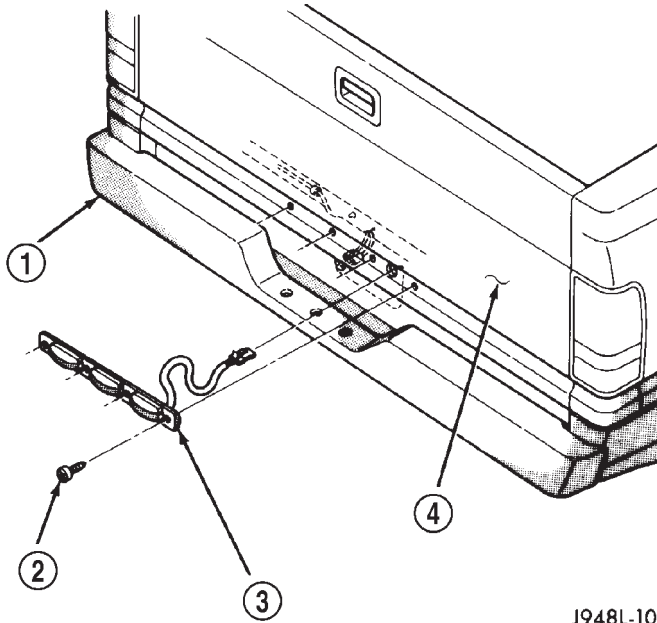
## MARKER LAMP

## REMOVAL

Individual lamps may be replaced by removing the lamp from the light bar. Using a flat blade screwdriver, carefully pry lamp to disengage clips attaching ID lamp to retainer.

## MARKER LAMP (Continued)

- (1) Disconnect and isolate the battery negative cable.
- (2) Remove four screws attaching rear ID lamps to tailgate (Fig. 23).
- (3) Separate ID lamps from tailgate.
- (4) Disengage ID lamp wire connector from body wire harness.
- (5) Separate ID lamp from vehicle.



J948L-10

Fig. 23 Rear Identification Lamps

- 1 - BUMPER
- 2 - SCREW
- 3 - TAILGATE MARKER LAMPS
- 4 - TAILGATE

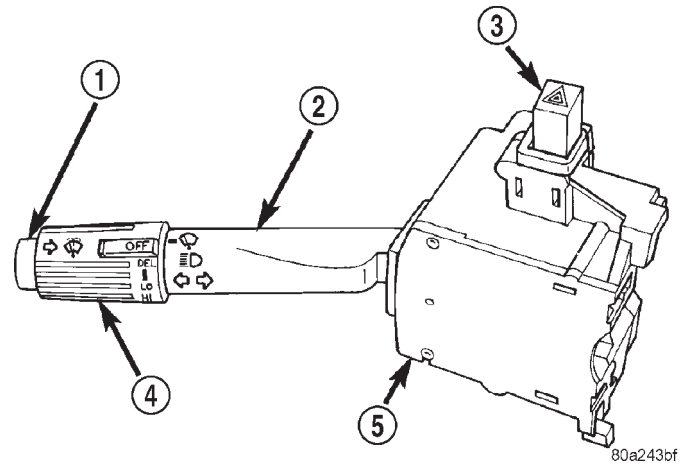
## INSTALLATION

- (1) Position ID lamp on vehicle.
- (2) Engage ID lamp wire connector to body wire harness.
- (3) Install screws attaching rear ID lamps to tailgate.
- (4) Connect the battery negative cable.

## MULTI-FUNCTION SWITCH

## DESCRIPTION

The multi-function switch is secured with two screws to the left side of the upper steering column housing at the top of the steering column, just below the steering wheel (Fig. 24). The only visible parts of the multi-function switch are the control stalk that extends through a dedicated opening in the left side of the upper steering column shrouds, and the hazard warning switch push button that protrudes through an opening in the upper steering column



80a243bf

Fig. 24 Multi-Function Switch

- 1 - WINDSHIELD WASHER BUTTON
- 2 - CONTROL STALK
- 3 - HAZARD WARNING BUTTON
- 4 - WINDSHIELD WIPER CONTROL
- 5 - MULTI-FUNCTION SWITCH

shroud on the top of the steering column. The remainder of the switch, its mounting provisions, and its electrical connections are all concealed beneath the steering column shrouds. The multi-function switch control stalk has both nomenclature and International Control and Display Symbol graphics applied to it, which identify its many functions. An International Control and Display Symbol icon for "Hazard Warning" is applied to the top of the hazard warning switch push button.

The switch housing and its controls are constructed of molded black plastic. A single connector receptacle with up to twenty-four terminals is located on the back of the switch housing and connects the switch to the vehicle electrical system through a take out and connector of the instrument panel wire harness. The connector receptacle also has a threaded receptacle for a screw, which secures the wire harness connector to the switch connector receptacle.

The multi-function switch supports the following functions and features:

- **Continuous Wipe Modes** - The control knob of the multi-function switch provides two continuous wipe switch positions, low speed or high speed.
- **Hazard Warning Control** - The internal circuitry and hardware of the multi-function switch provide detent switching for activation and deactivation of the hazard warning system.
- **Headlamp Beam Selection** - The internal circuitry and hardware of the multi-function switch provide detent switching for selection of the headlamp high or low beams.
- **Headlamp Optical Horn** - The internal circuitry and hardware of the multi-function switch

## MULTI-FUNCTION SWITCH (Continued)

includes momentary switching of the headlamp high beam circuits to provide an optical horn feature (sometimes referred to as flash-to-pass), which allows the vehicle operator to momentarily flash the headlamp high beams as an optical signalling device.

- **Intermittent Wipe Mode** - The control knob of the multi-function switch provides an intermittent wipe mode with multiple delay interval positions.

- **Turn Signal Control** - The internal circuitry and hardware of the multi-function switch provide both momentary non-detent switching and detent switching with automatic cancellation for both the left and right turn signals.

- **Washer Mode** - A button on the end of the control stalk of the multi-function switch provides washer system operation when the button is depressed towards the steering column.

The multi-function switch cannot be adjusted or repaired. If any function of the switch is faulty, or if the switch is damaged, the entire switch unit must be replaced.

## OPERATION

The multi-function switch uses conventionally switched outputs and a variable resistor to control the many functions and features it provides using hard wired circuitry. The switch is grounded at all times through a single wire take out with an eyelet terminal connector of the instrument panel wire harness that is secured by a nut to a ground stud located on the instrument panel armature, just above and to the left of the glove box opening. When the ignition switch is in the Accessory or On positions, battery current from a fuse in the Junction Block (JB) is provided through a fused ignition switch output (run-acc) circuit. Following are descriptions of the how the multi-function switch operates to control the many functions and features it provides:

- **Continuous Wipe Modes** - When the control knob of the multi-function switch is rotated to the High or Low positions, the circuitry within the switch provides a battery current output directly to the high or low speed brush of the wiper motor. When the control knob is in the Off position, the circuitry within the switch connects the output of the wiper motor park switch to the low speed brush of the wiper motor.

- **Hazard Warning Control** - The hazard warning push button is pushed down to unlatch the switch and activate the hazard warning system, and pushed down again to latch the switch and turn the system off. When the hazard warning switch is latched (hazard warning off), the push button will be in a lowered position on the top of the steering column shroud; and, when the hazard warning switch is unlatched (hazard warning on), the push button will

be in a raised position. The multi-function switch hazard warning circuitry simultaneously provides a signal to the hazard warning sense of the combination flasher to activate or deactivate the flasher output, and directs the output of the flasher to the hazard warning lamps.

- **Headlamp Beam Selection** - The multi-function switch control stalk is pulled towards the steering wheel past a detent, then released to actuate the headlamp beam selection switch. Each time the control stalk is actuated in this manner, the opposite headlamp mode from what is currently selected will be activated. The internal circuitry of the headlamp beam selection switch directs the output of the headlamp switch through hard wired circuitry to activate the selected headlamp beam.

- **Headlamp Optical Horn** - The left multi-function switch control stalk is pulled towards the steering wheel to just before a detent, to momentarily activate the headlamp high beams. The high beams will remain illuminated until the control stalk is released. The internal circuitry of the headlamp beam selection switch provides a momentary ground path to the headlamp high beams.

- **Intermittent Wipe Mode** - When the multi-function switch control knob is rotated to the Delay position, the circuitry within the switch connects the output of the wiper motor relay to the low speed brush of the wiper motor and provides a battery current signal to the Central Timer Module (CTM). If the Delay mode is selected, the control knob can then be rotated to multiple minor detent positions, which actuates a variable resistor within the switch and provides a hard wired output to the CTM that signals the desired delay interval for the intermittent wiper feature.

- **Turn Signal Control** - The multi-function switch control stalk actuates the turn signal switch. When the control stalk is moved in the upward direction, the right turn signal circuitry is activated; and, when the control stalk is moved in the downward direction, the left turn signal circuitry is activated. The multi-function switch turn signal circuitry simultaneously provides a signal to the turn signal sense of the combination flasher to activate or deactivate the flasher output, and directs the output of the flasher to the proper turn signal lamps. The turn signal switch has a detent position in each direction that provides turn signals with automatic cancellation, and an intermediate, momentary position in each direction that provides turn signals only until the left multi-function switch control stalk is released. When the control stalk is moved to a turn signal switch detent position, the cancel actuator extends toward the center of the steering column. A turn signal cancel cam that is integral to the clock-

## MULTI-FUNCTION SWITCH (Continued)

spring mechanism rotates with the steering wheel and the cam lobes contact the cancel actuator when it is extended from the multi-function switch. When the steering wheel is rotated during a turning maneuver, one of the two turn signal cancel cam lobes will contact the turn signal cancel actuator. The cancel actuator latches against the cancel cam rotation in the direction opposite that which is signaled. In other words, if the left turn signal detent is selected, the lobes of the cancel cam will ratchet past the cancel actuator when the steering wheel is rotated to the left, but will unlatch the cancel actuator as the steering wheel rotates to the right and returns to center, which will cancel the turn signal event and release the control stalk from the detent so it returns to the neutral Off position.

- **Washer Mode** - Pushing the button on the end of the multi-function switch control knob towards the steering column provides a battery current output through the momentary single pole, single throw washer switch circuitry to operate the washer pump/motor and provides a signal to the CTM. If the wipers are not operating when the washer switch is actuated, the CTM will operate the wiper motor for as long as the washer switch is depressed plus about three additional wipe cycles. If the wipers are operating in the intermittent mode when the washer switch is actuated, the CTM will operate the wiper motor at a fixed low speed for as long as the washer switch is depressed plus about three additional wipe cycles before the wipers return to the selected intermittent wipe interval.

**DIAGNOSIS AND TESTING - MULTI-FUNCTION SWITCH**

Refer to the appropriate wiring information. The wiring information includes wiring diagrams, proper wire and connector repair procedures, details of wire harness routing and retention, connector pin-out information and location views for the various wire harness connectors, splices and grounds.

**WARNING: ON VEHICLES EQUIPPED WITH AIRBAGS, DISABLE THE AIRBAG SYSTEM BEFORE ATTEMPTING ANY STEERING WHEEL, STEERING COLUMN, OR INSTRUMENT PANEL COMPONENT DIAGNOSIS OR SERVICE. DISCONNECT AND ISOLATE THE BATTERY NEGATIVE (GROUND) CABLE, THEN WAIT TWO MINUTES FOR THE AIRBAG SYSTEM CAPACITOR TO DISCHARGE BEFORE PERFORMING FURTHER DIAGNOSIS OR SERVICE. THIS IS THE ONLY SURE WAY TO DISABLE THE AIRBAG SYSTEM. FAILURE TO TAKE THE PROPER PRECAUTIONS COULD RESULT IN ACCIDENTAL AIRBAG DEPLOYMENT AND POSSIBLE PERSONAL INJURY.**

- (1) Disconnect and isolate the battery negative cable. Disconnect the instrument panel wire harness connector from the multi-function switch connector receptacle.

- (2) Using an ohmmeter, perform the continuity and resistance tests at the terminals in the multi-function switch connector receptacle as shown in the Multi-Function Switch Tests chart (Fig. 25).



MULTI-FUNCTION SWITCH (Continued)

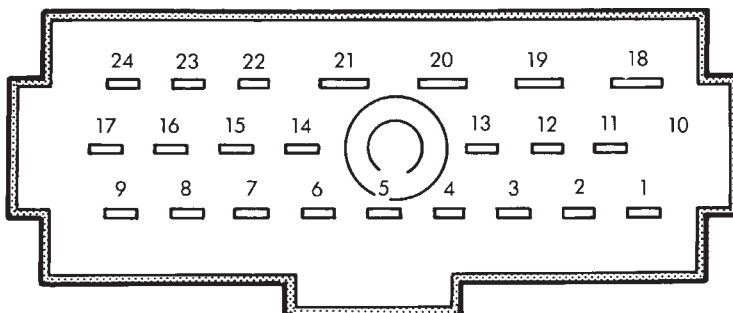


Fig. 25 Multi-Function Switch Tests

908J-4

MULTI-FUNCTION SWITCH TESTS		
SWITCH POSITIONS		CONTINUITY BETWEEN
TURN SIGNAL	HAZARD WARNING	
Neutral	Off	Pins 12, 14, & 15
Left	Off	Pins 15, 16, & 17
Left	Off	Pins 12 & 14
Left	Off	*Pins 22 & 23
Right	Off	Pins 11, 12, & 17
Right	Off	Pins 14 & 15
Right	Off	*Pins 23 & 24
Neutral	On	Pins 11, 12, 13, 15, & 16
* with optional corner lamps		
WIPER & WASHER SWITCH POSITIONS		CONTINUITY BETWEEN
Off		Pins 6 & 7
**Delay		Pins 1, 2, & 4, Pins 8 & 9
Low		Pins 4 & 6
High		Pins 4 & 5
Wash		Pins 3 & 4
**Resistance between Pins 1 & 2 at Maximum delay position is between 270 and 330 kilohms, and at Minimum delay position is zero ohms.		
HEADLAMP BEAM SELECTION SWITCH POSITIONS		CONTINUITY BETWEEN
Low Beams		Pins 18 & 19
High Beams		Pins 19 & 20
Flash		Pins 19, 20, & 21

## MULTI-FUNCTION SWITCH (Continued)

(3) If the multi-function switch fails any of the continuity or resistance tests, replace the faulty switch unit as required.

## REMOVAL

**WARNING: ON VEHICLES EQUIPPED WITH AIRBAGS, DISABLE THE AIRBAG SYSTEM BEFORE ATTEMPTING ANY STEERING WHEEL, STEERING COLUMN, OR INSTRUMENT PANEL COMPONENT DIAGNOSIS OR SERVICE. DISCONNECT AND ISOLATE THE BATTERY NEGATIVE (GROUND) CABLE, THEN WAIT TWO MINUTES FOR THE AIRBAG SYSTEM CAPACITOR TO DISCHARGE BEFORE PERFORMING FURTHER DIAGNOSIS OR SERVICE. THIS IS THE ONLY SURE WAY TO DISABLE THE AIRBAG SYSTEM. FAILURE TO TAKE THE PROPER PRECAUTIONS COULD RESULT IN ACCIDENTAL AIRBAG DEPLOYMENT AND POSSIBLE PERSONAL INJURY.**

(1) Disconnect and isolate the battery negative cable.

(2) If the vehicle is so equipped, unscrew the lever from the tilt steering column adjuster mechanism located on the left side of the column just below the multi-function switch control stalk. Turn the lever counterclockwise to unscrew it from the adjuster.

(3) From below the steering column, remove the two outboard screws that secure the upper shroud to the lower outer shroud (Fig. 26).

(4) Press carefully inward on each side of the outer shrouds to release the snap features and remove the upper outer shroud from the lower outer shroud.

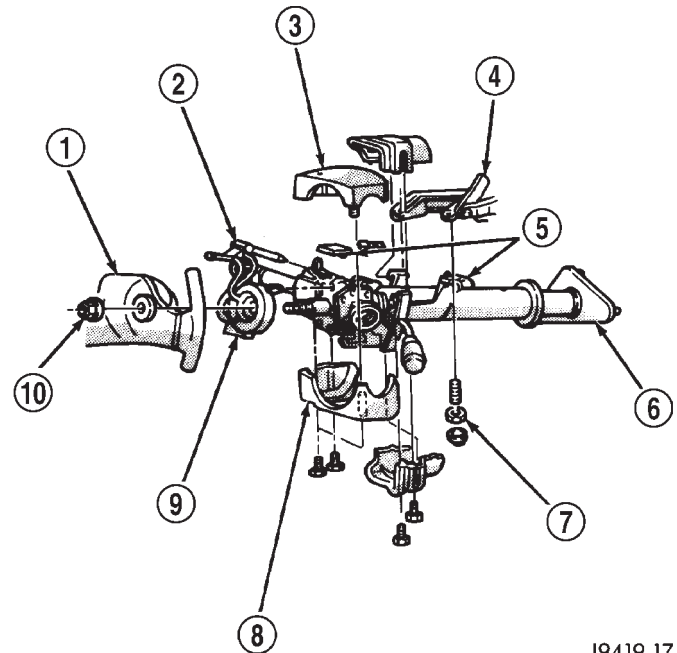
(5) From below the steering column, remove the one center screw that secures the lower outer shroud to the steering column housing.

(6) Remove the lower outer shroud from the steering column.

(7) From below the steering column, remove the two screws that secure the lower inner shroud to the steering column housing and the upper inner shroud.

(8) Press carefully inward on the gearshift lever side of the inner shrouds to release the snap features and remove the lower inner shroud from the steering column.

(9) Carefully lift the upper inner shroud upward far enough to access the multi-function switch mounting screws.



J9419-17

**Fig. 26 Steering Column Shrouds Remove/Install - Typical**

- 1 - STEERING WHEEL
- 2 - TILT LEVER
- 3 - UPPER SHROUD
- 4 - PANEL BRACKET
- 5 - SPACER
- 6 - TOE PLATE
- 7 - NUT
- 8 - LOWER SHROUD
- 9 - CLOCK SPRING
- 10 - NUT

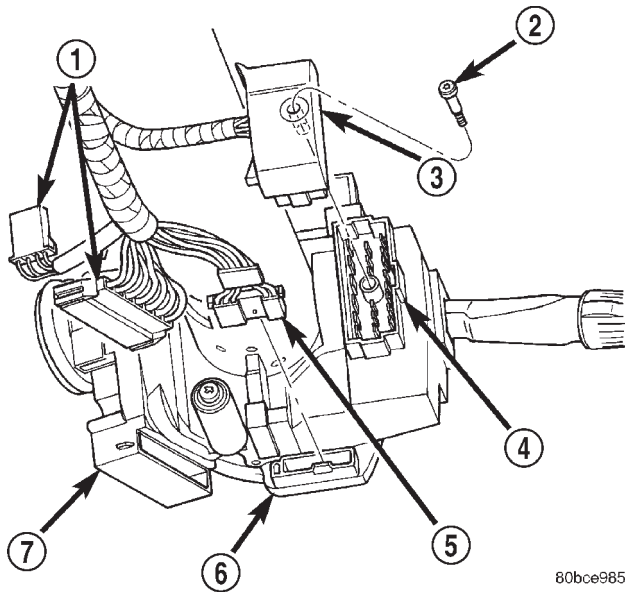
(10) Remove the two tamper proof screws (a Snap On tamper proof Torx bit TTXR20B2 or equivalent is required) that secure the multi-function switch to the steering column housing.

(11) Gently pull the multi-function switch away from the steering column far enough to access and remove the screw that secures the instrument panel wire harness connector for the multi-function switch to the switch connector receptacle (Fig. 27).

(12) Disconnect the instrument panel wire harness connector from the multi-function switch connector receptacle.

(13) Remove the multi-function switch from the steering column.

## MULTI-FUNCTION SWITCH (Continued)



**Fig. 27 Multi-Function Switch Connector**

- 1 - WIRE HARNESS CONNECTORS
- 2 - SCREW
- 3 - WIRE HARNESS CONNECTOR
- 4 - MULTI-FUNCTION SWITCH CONNECTOR RECEPTACLE
- 5 - WIRE HARNESS CONNECTOR
- 6 - CLOCKSPRING
- 7 - IGNITION SWITCH

## INSTALLATION

**WARNING: ON VEHICLES EQUIPPED WITH AIRBAGS, DISABLE THE AIRBAG SYSTEM BEFORE ATTEMPTING ANY STEERING WHEEL, STEERING COLUMN, OR INSTRUMENT PANEL COMPONENT DIAGNOSIS OR SERVICE. DISCONNECT AND ISOLATE THE BATTERY NEGATIVE (GROUND) CABLE, THEN WAIT TWO MINUTES FOR THE AIRBAG SYSTEM CAPACITOR TO DISCHARGE BEFORE PERFORMING FURTHER DIAGNOSIS OR SERVICE. THIS IS THE ONLY SURE WAY TO DISABLE THE AIRBAG SYSTEM. FAILURE TO TAKE THE PROPER PRECAUTIONS COULD RESULT IN ACCIDENTAL AIRBAG DEPLOYMENT AND POSSIBLE PERSONAL INJURY.**

- (1) Position the multi-function switch next to the steering column.
- (2) Reconnect the instrument panel wire harness connector for the multi-function switch to the switch connector receptacle (Fig. 27).
- (3) Install and tighten the screw that secures the instrument panel wire harness connector for the multi-function switch to the switch connector receptacle. Tighten the screw to 2 N·m (18 in. lbs.).
- (4) Position the multi-function switch onto the steering column.

(5) Carefully lift the upper inner shroud upward far enough to access the multi-function switch mounting screws.

(6) Install and tighten the two tamper proof screws (a Snap On tamper proof Torx bit TTXR20B2 or equivalent is required) that secure the multi-function switch to the steering column housing. Tighten the screws to 2 N·m (18 in. lbs.).

(7) Position the lower inner shroud onto the steering column (Fig. 26). Be certain to insert the gearshift lever hider strip into the channel located on the inside surface of the shroud.

(8) Align the locking tabs on the gearshift lever side of the upper inner shroud with the receptacles on the lower inner shroud and apply hand pressure to snap them together.

(9) From below the steering column, install and tighten the two screws that secure the lower inner shroud to the steering column housing and the upper inner shroud. Tighten the screws to 2 N·m (18 in. lbs.).

(10) Position the lower outer shroud onto the steering column.

(11) From below the steering column, install and tighten the one center screw that secures the lower outer shroud to the steering column housing. Tighten the screw to 2 N·m (18 in. lbs.).

(12) Align the locking tabs on the upper outer shroud with the receptacles on the lower outer shroud and apply hand pressure to snap them together.

(13) From below the steering column, install and tighten the two outboard screws that secure the lower outer shroud to the upper outer shroud. Tighten the screws to 2 N·m (18 in. lbs.).

(14) If the vehicle is so equipped, reinstall the lever into the tilt steering column adjuster on the left side of the column. Turn the lever clockwise to screw it into the adjuster.

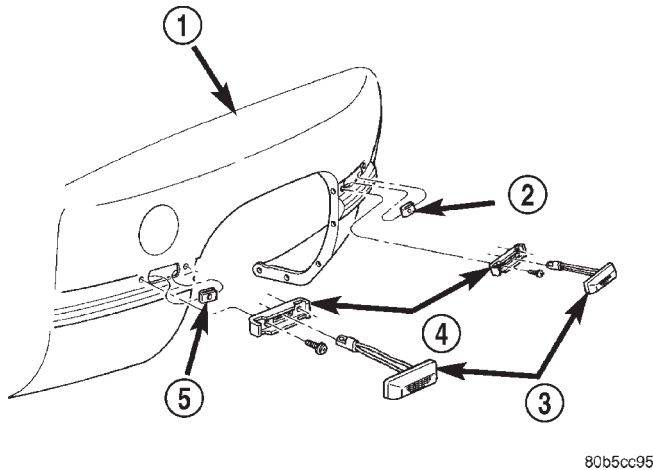
(15) Reconnect the battery negative cable.

## OUTBOARD IDENTIFICATION LAMP

### REMOVAL

- (1) Disconnect and isolate the battery negative cable.
- (2) Using a flat blade screw driver, carefully pry lamp to disengage clips attaching ID lamp to retainer (Fig. 28).
- (3) Separate ID lamp from retainer.
- (4) Disengage lamp bulb socket from lamp.
- (5) Remove screws attaching lamp retainer to rear fender.
- (6) Separate retainer from rear fender.

## OUTBOARD IDENTIFICATION LAMP (Continued)



**Fig. 28 Side Identification Lamps**

- 1 - FENDER
- 2 - U-NUT
- 3 - IDENTIFICATION LAMP
- 4 - RETAINER
- 5 - U-NUT

### INSTALLATION

- (1) Position retainer on rear fender.
- (2) Install screws attaching lamp retainer to rear fender.
- (3) Engage lamp bulb socket to lamp.
- (4) Position and press ID lamp in retainer.
- (5) Connect the battery negative cable.

## PARK/TURN SIGNAL LAMP

### REMOVAL

- (1) Disconnect and isolate the battery negative cable.
- (2) Remove park and turn signal lamp.
- (3) Rotate bulb socket 1/4 turn counterclockwise and pull turn signal lamp socket from back of lamp.
- (4) Pull park and turn signal lamp bulb from socket.

### INSTALLATION

- (1) Install park and turn signal lamp bulb in socket.
- (2) Install park and turn signal lamp socket into back of lamp.
- (3) Install park/turn signal lamp.
- (4) Connect the battery negative cable.

## PARK/TURN SIGNAL LAMP UNIT

### REMOVAL

- (1) Disconnect and isolate the battery negative cable.
- (2) Remove screw attaching the park lamp to headlamp module.
- (3) Grasp lamp and pull forward to disengage clip attaching park/turn lamp to headlamp module.
- (4) Separate park lamp headlamp module.
- (5) Rotate park/turn signal socket 1/4 turn counter-clockwise and remove from back of lamp.
- (6) Remove side marker socket from back of lamp.
- (7) Separate park/turn signal lamp from vehicle.

### INSTALLATION

- (1) Install side marker socket from back of lamp.
- (2) Install park/turn signal socket in back of lamp.
- (3) Install park/turn signal lamp in vehicle.
- (4) Install screw attaching the park lamp to headlamp module.
- (5) Connect the battery negative cable.

## TAIL LAMP

### DESCRIPTION

There are two types of tail lamp modules used on the Ram Truck. One type is integrated into the pick-up bed, The other is a bracket mounted module used on the Ram Truck Cab and Chassis. The Cab and Chassis module is made up of a housing, lens, and two bulbs. This type of module has license plate illumination built into the lens. The integrated pick up module contains a housing, lens, and two bulbs. A dual filament bulb is used for tail, stop, and turn signal operations. A separate bulb is used for back-up illumination.

### OPERATION

Tail lamp functions are controlled by the headlamp switch. Turn signal operations are controlled by the multifunction switch. Stop lamp functions are controlled by the stoplamp switch. The back-up lamps are controlled by the back-up lamp switch on the transmission.

### REMOVAL

#### CHASSIS CAB

- (1) Disconnect and isolate the battery negative cable.
- (2) Remove screws holding tail lamp lens to lamp body.

## TAIL LAMP (Continued)

- (3) Separate lens from lamp.
- (4) Grasp bulb, push in slightly and rotate 1/2 turn counter-clockwise.

## PICKUP

- (1) Disconnect and isolate the battery negative cable.
- (2) Remove screws from tail lamp.
- (3) Grasp lamp, firmly pull lamp rearward to disengage retaining studs.
- (4) Remove socket from tail lamp.
- (5) Separate tail lamp from cargo box.
- (6) Pull bulb from socket.

## INSTALLATION

## CHASSIS CAB

- (1) Install bulb in socket.
- (2) Install lamp lens.
- (3) Connect the battery negative cable.

## PICKUP

- (1) Install bulb in socket.
- (2) Install socket in tail lamp.
- (3) Position tail lamp in cargo box, engage retaining studs and install screws.
- (4) Connect the battery negative cable.

## TAIL LAMP UNIT

## REMOVAL

## CAB CHASSIS

- (1) Disconnect and isolate the battery negative cable.
- (2) Remove nuts attaching tail lamp to mounting bracket (Fig. 29).
- (3) Disengage tail lamp wire connector from body wire harness.
- (4) Separate tail lamp from vehicle.

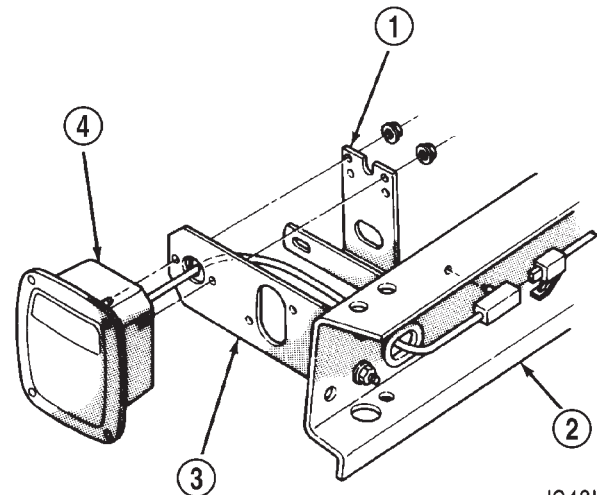
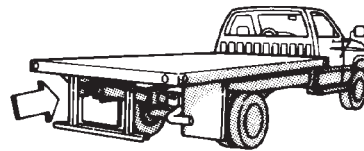
## PICKUP

- (1) Disconnect and isolate the battery negative cable.
- (2) Remove screws from tail lamp (Fig. 30).
- (3) Grasp lamp, firmly pull lamp rearward to disengage retaining studs.
- (4) Remove socket from tail lamp.
- (5) Separate tail lamp from cargo box.
- (6) Pull bulb from socket.

## INSTALLATION

## CAB CHASSIS

- (1) Position tail lamp on vehicle.



J948L-9

**Fig. 29 Tail, Brake, Turn Signal and Back-up Lamps—Cab Chassis**

- 1 - LICENCE PLATE BRACKET
- 2 - FRAME
- 3 - TAILLAMP MOUNTING BRACKET
- 4 - TAILLAMP-BRAKE LAMP-BACKUP LAMP HOUSING

(2) Engage tail lamp wire connector to body wire harness.

(3) Install nuts attaching tail lamp to mounting bracket.

(4) Connect the battery negative cable.

## PICKUP

- (1) Install bulb in socket.
- (2) Install socket in tail lamp.
- (3) Position tail lamp in cargo box, engage retaining studs and install screws.
- (4) Connect the battery negative cable.

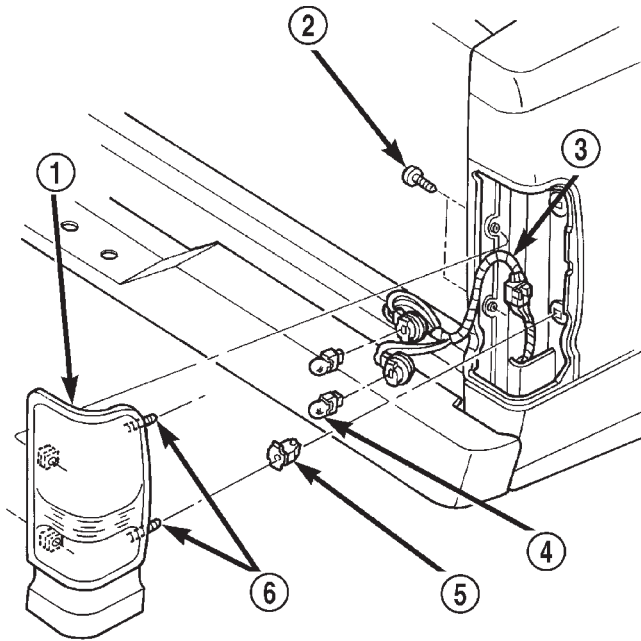
## TURN SIGNAL CANCEL CAM

## DESCRIPTION

The turn signal cancel cam is concealed within the steering column below the steering wheel. The turn signal cancel cam consists of two lobes that are integral to the lower surface of the clockspring rotor. The clockspring mechanism provides turn signal cancellation as well as a constant electrical connection between the horn switch, driver airbag, speed control switches, and remote radio switches on the steering wheel and the instrument panel wire harness on the steering column. The housing of the clockspring is secured to the steering column and remains station-



## TURN SIGNAL CANCEL CAM (Continued)



80b04f1a

**Fig. 30 Tail, Brake, Turn Signal and Back-up Lamp Bulb**

- 1 - TAIL LAMP
- 2 - SCREW
- 3 - LIGHTING HARNESS
- 4 - BULB
- 5 - RETAINING CLIP
- 6 - RETAINING STUDS

ary. The rotor of the clockspring, including the turn signal cancel cam lobes rotate with the steering wheel.

The turn signal cancel cam is serviced as a unit with the clockspring and cannot be repaired. If faulty or damaged, the entire clockspring unit must be replaced. (Refer to 8 - ELECTRICAL/RESTRAINTS/CLOCKSPRING - REMOVAL).

## OPERATION

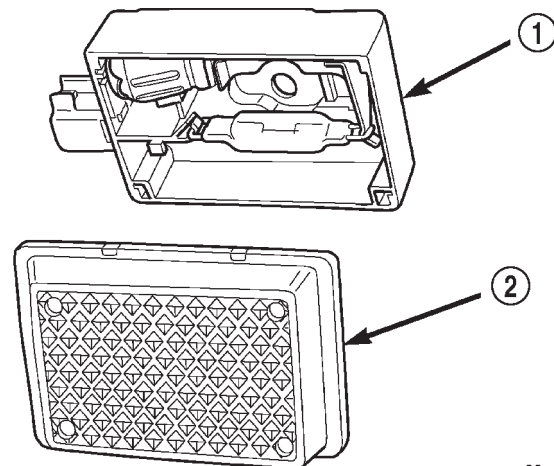
The turn signal cancel cam has two lobes molded into the lower surface of the clockspring rotor. When the turn signals are activated by moving the multi-function switch control stalk to a detent position, a turn signal cancel actuator is extended from the inside surface of the multi-function switch housing toward the center of the steering column and the

turn signal cancel cam. When the steering wheel is rotated during a turning maneuver, one of the two turn signal cancel cam lobes will contact the turn signal cancel actuator. The cancel actuator latches against the cancel cam rotation in the direction opposite that which is signaled. In other words, if the left turn signal detent is selected, the lobes of the cancel cam will ratchet past the cancel actuator when the steering wheel is rotated to the left, but will unlatch the cancel actuator as the steering wheel rotates to the right and returns to center, which will cancel the turn signal event and release the control stalk from the detent so it returns to the neutral Off position.

## UNDERHOOD LAMP

## REMOVAL

- (1) Disconnect and isolate the battery negative cable.
- (2) Insert a small flat blade in the access slot between the lamp base and lamp lens.
- (3) Pry the lamp lens upward and remove the lamp lens (Fig. 31).
- (4) Depress the bulb terminal inward (Fig. 32) to release the bulb.

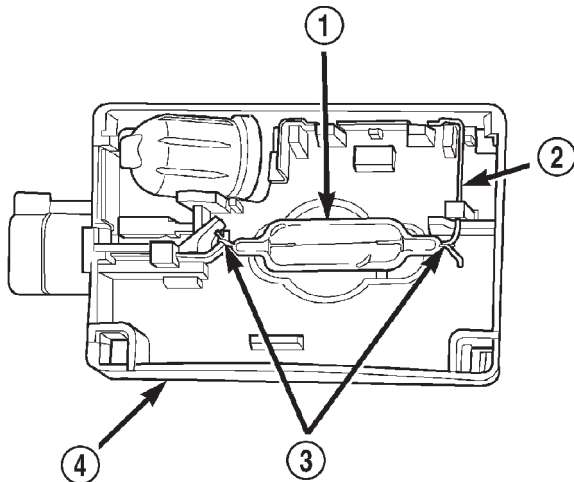


80ad847e

**Fig. 31 Underhood Lamp Lens**

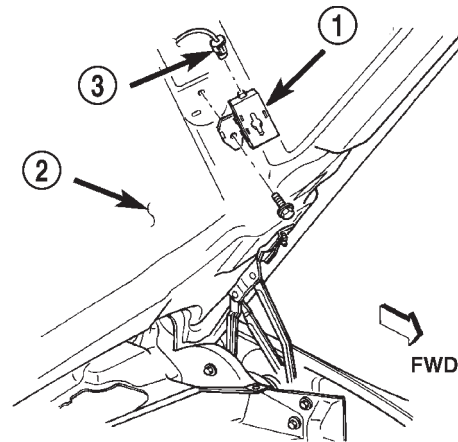
- 1 - LAMP
- 2 - LAMP LENS

## UNDERHOOD LAMP (Continued)

**Fig. 32 Underhood Lamp Bulb**

- 1 - BULB
- 2 - DEPRESS TERMINAL INWARD
- 3 - BULB WIRE LOOP
- 4 - LAMP BASE

80add414



80b5cc96

**Fig. 33 Underhood Lamp**

- 1 - UNDER HOOD LAMP
- 2 - HOOD
- 3 - CONNECTOR

**INSTALLATION**

- (1) Engage the replacement bulb wire loop to the terminal closest to the lamp base wire connector.
- (2) Depress the opposite terminal inward and engage the remaining bulb wire loop.
- (3) Position the lamp lens on the lamp base and press into place.
- (4) Connect the battery negative cable.

**UNDERHOOD LAMP UNIT****REMOVAL**

- (1) Disconnect and isolate the battery negative cable.
- (2) Disconnect the wire harness connector from the lamp.
- (3) Remove lamp lens.
- (4) Remove bulb.
- (5) Remove screw attaching underhood lamp to the inner hood panel (Fig. 33).
- (6) Separate underhood lamp from vehicle.

**INSTALLATION**

- (1) Install bulb.
- (2) Install lamp lens.
- (3) Position the underhood lamp on the hood inner panel.
- (4) Install the attaching screw through the lamp and into the hood panel. Tighten the screw securely.
- (5) Fold lamp housing over and firmly press onto base to snap into place.
- (6) Connect the wire harness connector to the lamp.
- (7) Connect the battery negative cable.

## LAMPS/LIGHTING - INTERIOR

### TABLE OF CONTENTS

	page		page
<b>LAMPS/LIGHTING - INTERIOR</b>		<b>GLOVE BOX LAMP AND SWITCH</b>	
SPECIFICATIONS .....	33	REMOVAL .....	35
<b>DOME LAMP</b>		INSTALLATION .....	35
REMOVAL .....	33	<b>READING LAMP</b>	
INSTALLATION .....	33	DESCRIPTION .....	36
<b>DOOR AJAR SWITCH</b>		OPERATION .....	36
DESCRIPTION .....	34	REMOVAL .....	36
DIAGNOSIS AND TESTING .....	34	INSTALLATION .....	36
DOOR AJAR SWITCH .....	34	<b>VANITY LAMP</b>	
REMOVAL .....	35	REMOVAL .....	37
INSTALLATION .....	35	INSTALLATION .....	37

## LAMPS/LIGHTING - INTERIOR

### SPECIFICATIONS

#### INTERIOR LAMPS

LAMP	BULB
A/C HEATER CONTROL	158
ASH RECEIVER	161
CIGAR LIGHTER	161
HEADLAMP SWITCH	158
HEATER CONTROL	158
INSTRUMENT CLUSTER	PC194
RADIO	ASC
AIRBAG HIGH LINE	PC194
AIRBAG LOW LINE	PC74
ANTI-LOCK BRAKE	PC74
BATTERY VOLTAGE	PC194
BRAKE WARNING	PC194
CHECK ENGINE	PC74
ENGINE OIL PRESSURE	PC74
FOUR WHEEL DRIVE	PC194
HIGH BEAM	PC194
LOW FUEL	PC194
LOW WASHER FLUID	PC74
MAINTENANCE REQUIRED	PC74
MESSAGE CENTER	PC194
SEAT BELT	PC74

LAMP	BULB
TURN SIGNAL	PC194
UPSHIFT	PC74
DOME	1004
GLOVE COMPARTMENT	1891
VANITY MIRROR LAMP	P/N 6501966

## DOME LAMP

### REMOVAL

(1) Using a small flat blade, pry the left side (driver's side) of the dome lamp lens downward from dome lamp.

(2) Allow the lens to hang down (Fig. 1) , this will disengage the right side of the lamp (passenger's side) from the headliner.

(3) Pull the right side of the lamp down and slide the lamp to the right (Fig. 2) .

(4) Separate the lamp from the headliner.

(5) Disengage dome lamp wire connector from body wire harness.

(6) Separate dome lamp from vehicle.

### INSTALLATION

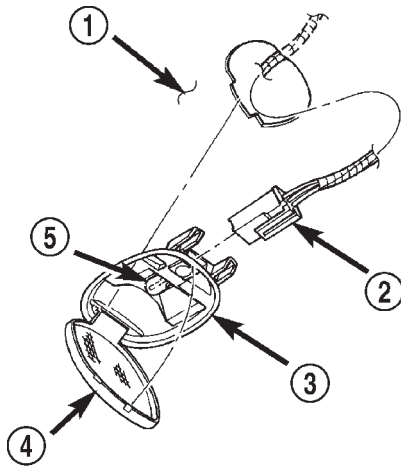
(1) Position dome lamp at headliner.

(2) Connect dome lamp wire connector to body wire harness.

(3) Position the left side of the lamp in the headliner opening and slide lamp to the left.

(4) Push the right side of the lamp in the headliner opening and push the lamp lens up into the lamp to secure.

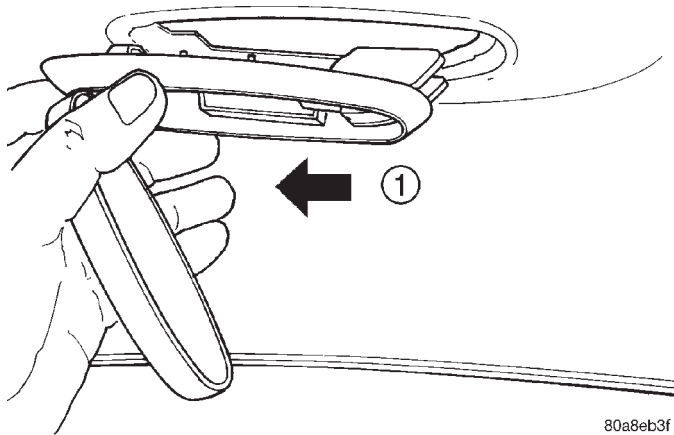
## DOME LAMP (Continued)



80b5cc97

**Fig. 1 Dome Lamp Lens**

- 1 - HEADLINER
- 2 - CONNECTOR
- 3 - DOME LAMP
- 4 - LENS
- 5 - BULB



80a8eb3f

**Fig. 2 Dome Lamp**

- 1 - SLIDE LAMP

tion includes wiring diagrams, proper wire and connector repair procedures, details of wire harness routing and retention, connector pin-out information and location views for the various wire harness connectors, splices and grounds.

**WARNING: ON VEHICLES EQUIPPED WITH AIRBAGS, REFER TO ELECTRICAL, RESTRAINTS BEFORE ATTEMPTING ANY STEERING WHEEL, STEERING COLUMN, OR INSTRUMENT PANEL COMPONENT DIAGNOSIS OR SERVICE. FAILURE TO TAKE THE PROPER PRECAUTIONS COULD RESULT IN ACCIDENTAL AIRBAG DEPLOYMENT AND POSSIBLE PERSONAL INJURY.**

(1) Rotate the headlamp switch knob counterclockwise to ensure that the dome lamps are not switched off. Open the driver door and note whether the interior lamps light. They should light. If OK, (Refer to 8 - ELECTRICAL/LAMPS/LIGHTING - EXTERIOR/HEADLAMP SWITCH - DIAGNOSIS AND TESTING). If not OK, go to Step 2.

(2) Disconnect and isolate the battery negative cable. Unplug the driver door ajar switch from its wire harness connector. Check for continuity between the ground circuit cavity of the driver door ajar switch wire harness connector and a good ground. There should be continuity. If OK, go to Step 3. If not OK, repair the circuit to ground as required.

(3) Check for continuity between the door ajar switch ground circuit terminal and each of the other two terminals of the driver door ajar switch. There should be continuity with the switch plunger released, and no continuity with the switch plunger depressed. If OK, go to Step 4. If not OK, replace the faulty switch.

(4) Remove the Central Timer Module (CTM) from its mounting bracket to access the CTM wire harness connectors (Refer to 8 - ELECTRICAL/ELECTRONIC CONTROL MODULES/BODY CONTROL/CENTRAL TIMER MODUL - REMOVAL). Unplug the 14-way CTM wire harness connector. Check for continuity between the driver door switch sense circuit cavity of the 14-way CTM wire harness connector and a good ground. There should be no continuity. If OK, go to Step 5. If not OK, repair the short circuit as required.

(5) Check for continuity between the driver door switch sense circuit cavities of the 14-way CTM wire harness connector and the driver door ajar switch wire harness connector. There should be continuity. If OK, (Refer to 8 - ELECTRICAL/LAMPS/LIGHTING - EXTERIOR/HEADLAMP SWITCH - DIAGNOSIS AND TESTING) If not OK, repair the open circuit as required.

## DOOR AJAR SWITCH

### DESCRIPTION

The door ajar switches are mounted to the door hinge pillars. The switches close a path to ground for the Central Timer Module (CTM) when a door is opened, and open the ground path when a door is closed.

The door ajar switches cannot be repaired and, if faulty or damaged, they must be replaced.

### DIAGNOSIS AND TESTING - DOOR AJAR SWITCH

For circuit descriptions and diagrams, refer to the appropriate wiring information. The wiring informa-

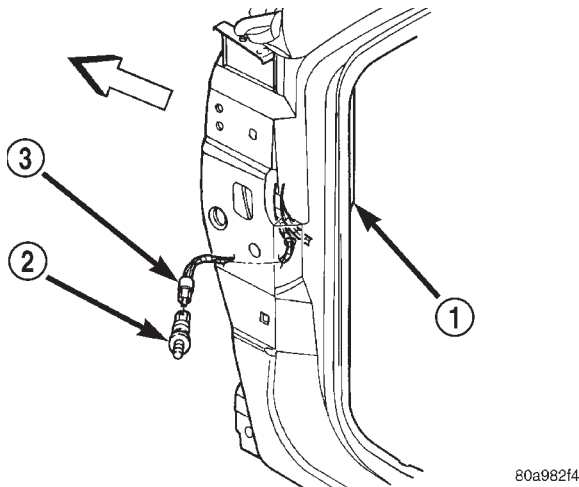
## DOOR AJAR SWITCH (Continued)

## REMOVAL

(1) Disconnect and isolate the battery negative cable.

(2) Grasp the body of the door ajar switch with a pair of pliers and move the switch gently back-and-forth while pulling it out of the door hinge pillar mounting hole.

(3) Pull the door ajar switch out from the pillar far enough to access the wire harness connector (Fig. 3).



**Fig. 3 DOOR AJAR SWITCH REMOVE/INSTALL**

- 1 - DOOR HINGE PILLAR
- 2 - DOOR AJAR SWITCH
- 3 - CONNECTOR

(4) Unplug the door ajar switch from the wire harness connector.

## INSTALLATION

(1) Install the door ajar switch to the wire harness connector.

(2) Push the door ajar switch into the pillar.

(3) Connect the battery negative cable.

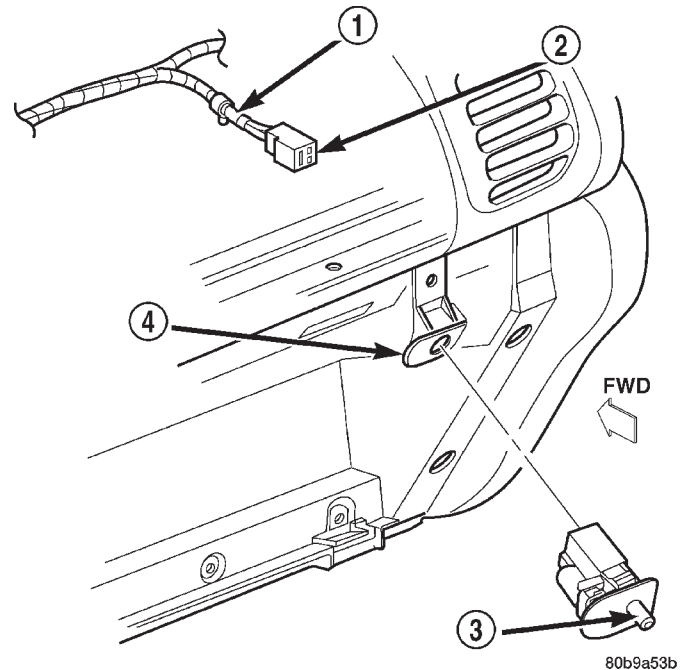
## GLOVE BOX LAMP AND SWITCH

## REMOVAL

(1) Disconnect and isolate the battery negative cable.

(2) Remove the glove box from the instrument panel. (Refer to 23 - BODY/INSTRUMENT PANEL/GLOVE BOX - REMOVAL) for the procedures.

(3) Reach through the glove box opening and behind the glove box lamp and switch mounting bracket to access the instrument panel wire harness connector on the glove box lamp and switch (Fig. 4).



**Fig. 4 Glove Box Lamp and Switch Remove/Install**

- 1 - RETAINER
- 2 - WIRE HARNESS CONNECTOR
- 3 - GLOVE BOX LAMP AND SWITCH
- 4 - MOUNTING BRACKET

(4) Disconnect the instrument panel wire harness connector from the connector receptacle on the back of the glove box lamp and switch unit.

(5) Reach through the glove box opening and behind the glove box lamp and switch mounting bracket to depress the retaining tabs on the top and bottom of the glove box lamp and switch housing.

(6) While holding the retaining tabs depressed, push the glove box lamp and switch unit out through the hole in the mounting bracket on the instrument panel glove box opening upper reinforcement.

(7) Remove the glove box lamp and switch unit from the instrument panel.

## INSTALLATION

(1) Reach through the glove box opening and behind the glove box lamp and switch mounting bracket to feed the instrument panel wire harness connectors out through the hole in the glove box lamp and switch housing mounting bracket.

(2) Position the glove box lamp and switch unit to the instrument panel.

(3) Reconnect the instrument panel wire harness connector to the connector receptacle on the back of the glove box lamp and switch unit.

(4) Push the glove box lamp and switch unit into the hole in the mounting bracket on the instrument panel glove box opening upper reinforcement.



## GLOVE BOX LAMP AND SWITCH (Continued)

- (5) Install the glove box onto the instrument panel. (Refer to 23 - BODY/INSTRUMENT PANEL/GLOVE BOX - INSTALLATION) for the procedures.
- (6) Close the glove box.
- (7) Reconnect the battery negative cable.

## READING LAMP

## DESCRIPTION

The overhead console in this vehicle is equipped with two individual reading and courtesy lamps. The lamp lenses are the only visible components of these lamps. The reading and courtesy lamp lenses are mounted in the overhead console housing between the garage door opener storage bin and the sunglasses storage bin. Each lamp has its own switch, bulb, reflector and lens; but both lamps share a common lamp housing within the overhead console.

The overhead console reading and courtesy lamps operate on battery current that is provided at all times, regardless of the ignition switch position. The ground feed for the lamps is switched through the integral reading and courtesy lamp switches or through the door jamb switches. Each lamp is designed and aimed to provide illumination that will be directed only to that side of the vehicle on which the lamp is located.

The reading and courtesy lamp lenses, bulbs and the lamp housing and reflector unit are available for service replacement. The reading and courtesy lamp switches, bulb holders and wiring are only available as part of the overhead console wire harness. If either of the lamp switches or bulb holders is faulty or damaged, the entire overhead console wire harness assembly must be replaced.

For service of the reading and courtesy lamp bulbs, refer to the appropriate wiring information. The wiring information includes wiring diagrams, proper wire and connector repair procedures, details of wire harness routing and retention, connector pin-out information and location views for the various wire harness connectors, splices and grounds.

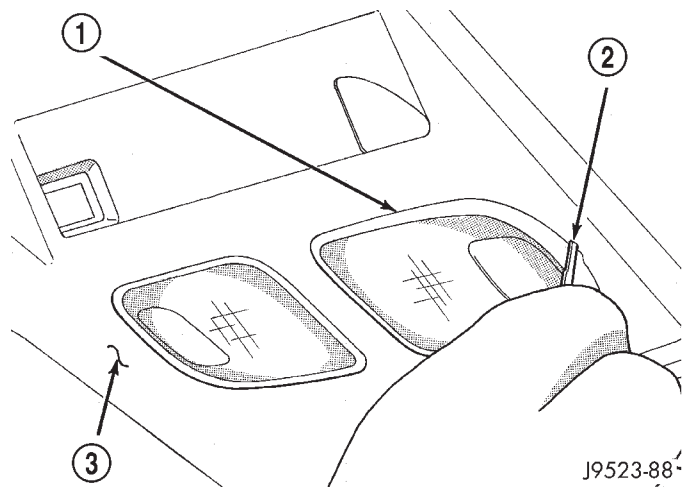
## OPERATION

All reading and courtesy lamps located in the overhead console are activated by the door jamb switches. When all of the doors are closed, these lamps can be individually activated by depressing the corresponding lens. When any door is open, depressing the lamp lenses to activate the lamp switches will not turn the lamps off.

See the owner's manual in the vehicle glove box for more information on the use and operation of the overhead console reading and courtesy lamps.

## REMOVAL

- (1) Disconnect and isolate the battery negative cable.
- (2) Insert a long, narrow, flat-bladed tool between the curved (outboard) edge of the reading and courtesy lamp lens and the overhead console housing (Fig. 5).
- (3) Gently pry inward and downward against the lens until the latch tab in the center of the outboard edge of the reading and courtesy lamp lens is disengaged from the overhead console housing.
- (4) Pull firmly on the lens toward the outboard side of the vehicle to disengage the two pivot tabs on the inboard edge of the reading and courtesy lamp lens are disengaged from the overhead console housing.
- (5) Remove the reading and courtesy lamp lens from the overhead console housing.



**Fig. 5 Overhead Console Reading Lamp Bulb Removal**

- 1 - LENS
- 2 - FLAT BLADE
- 3 - CONSOLE

## INSTALLATION

- (1) Position the reading and courtesy lamp lens onto the overhead console housing.
- (2) Align the two pivot tabs on the inboard edge of the reading and courtesy lamp lens with the two pivot holes in the overhead console housing.
- (3) Push firmly on the lens toward the inboard side of the vehicle to insert the two pivot tabs on the inboard edge of the reading and courtesy lamp lens into the two pivot holes in the overhead console housing.
- (4) Pivot the lens back up into position and press upward firmly until the latch tab in the center of the outboard edge of the reading and courtesy lamp lens snaps back into the overhead console housing.

READING LAMP (Continued)

- (5) Reconnect the battery negative cable.
- (4) Remove bulb from lamp terminals.

VANITY LAMP

**REMOVAL**

- (1) Insert a flat blade into the slot at front of lens.
- (2) Rotate blade until lens pops out of lamp.
- (3) Remove lens from housing.

**INSTALLATION**

- (1) Install bulb into lamp terminals.
- (2) Place one side of lens into housing.
- (3) Insure dim control is in place, and snap lens into housing.



# MESSAGE SYSTEMS

## TABLE OF CONTENTS

	page		page
<b>OVERHEAD CONSOLE</b>		<b>OPERATION</b> .....	9
DESCRIPTION .....	1	DIAGNOSIS AND TESTING .....	10
STANDARD PROCEDURE .....	4	COMPASS MINI-TRIP COMPUTER .....	10
COMPASS CALIBRATION .....	4	REMOVAL .....	11
COMPASS VARIATION ADJUSTMENT .....	4	INSTALLATION .....	11
COMPASS DEMAGNETIZING .....	5	<b>AMBIENT TEMP SENSOR</b>	
REMOVAL .....	6	DESCRIPTION .....	11
DISASSEMBLY .....	7	OPERATION .....	11
ASSEMBLY .....	7	DIAGNOSIS AND TESTING .....	12
INSTALLATION .....	8	AMBIENT TEMPERATURE SENSOR .....	12
SPECIAL TOOLS .....	8	REMOVAL .....	12
<b>COMPASS/MINI-TRIP COMPUTER</b>		INSTALLATION .....	13
DESCRIPTION .....	8		

## OVERHEAD CONSOLE

### DESCRIPTION

Two different overhead console units are available factory-installed options on this model, base or premium. The base overhead console unit features a garage door opener storage bin, a sunglasses storage bin and two reading and courtesy lamps. The premium overhead console has all of the features of the base unit, but adds a compass mini-trip computer. See the owner's manual in the vehicle glove box for more information on the features, use and operation of all of the overhead console components and systems. Refer to **Overhead Console** in the Contents of Wiring Diagrams for complete circuit diagrams.

The premium overhead console (Fig. 1) includes two front-mounted reading and courtesy lamps, a garage door opener storage bin, and a sunglasses storage bin. The premium overhead console includes a compass mini-trip computer. The base overhead console uses the same overhead console housing, but has a computer cover plug installed in place of the compass mini-trip computer display module lens and push buttons.

The rear of the overhead console is secured to two rear mounting holes in the inner roof panel by two plastic hook formations that are integral to the overhead console housing. The front of the overhead console is secured to the two front mounting holes of the inner roof panel by two plastic latches that are integral to the overhead console housing. A single electrical connection joins the overhead console wire

harness to the roof wire harness for both the base and premium overhead console units.

Following are general descriptions of the major components used in the overhead console. See the owner's manual in the vehicle glove box for more information on the use and operation of the various overhead console features.

### GARAGE DOOR OPENER STORAGE BIN

A compartment near the front of the overhead console is designed to hold most garage door opener remote control transmitters. The transmitter is mounted within the compartment with an adhesive-backed hook and loop fastener patch and, when the compartment is closed, a push button in the center of the compartment door is depressed to actuate the transmitter.

A transmitter mounting kit including the adhesive-backed hook and loop fastener material is available for service. The garage door opener storage bin door and the push button with three assorted length adapter pegs are also available for service replacement.

The garage door opener storage compartment door is opened by pressing the integral latch towards the front of the vehicle. When the compartment door is opened, the push button unit is removed from the compartment by squeezing the latch tabs and pulling the unit downward. With the push button removed, the garage door opener can be installed in the compartment using the adhesive-backed hook and loop fastener material provided.

OVERHEAD CONSOLE (Continued)

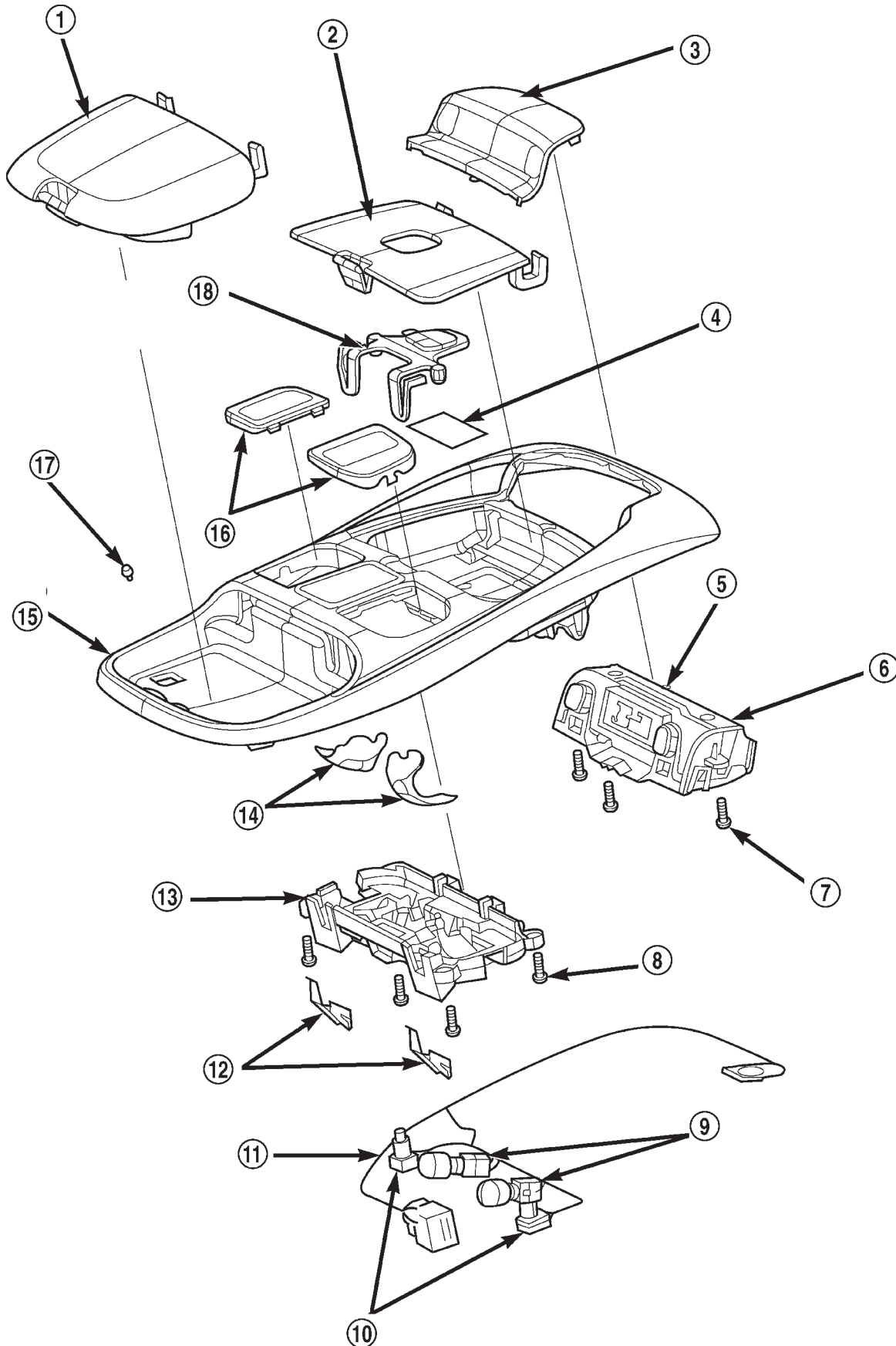


Fig. 1 Overhead Console



## OVERHEAD CONSOLE (Continued)

- |   |  |
|---|--|
| 1 - SUNGLASSES STORAGE BIN              | 11 - WIRE HARNESS                      |
| 2 - GARAGE DOOR OPENER STORAGE BIN DOOR | 12 - SPRINGS (2)                       |
| 3 - COMPUTER LENS OR COVER PLUG         | 13 - READING AND COURTESY LAMP HOUSING |
| 4 - HOOK AND LOOP FASTENER              | 14 - REFLECTORS                        |
| 5 - SECURITY INDICATOR LAMP             | 15 - OVERHEAD CONSOLE HOUSING          |
| 6 - COMPASS MINI-TRIP COMPUTER MODULE   | 16 - LENSES                            |
| 7 - SCREW (3)                           | 17 - BUMPER                            |
| 8 - SCREW (4)                           | 18 - GARAGE DOOR OPENER PUSH BUTTON    |
| 9 - BULB HOLDERS                        |  |
| 10 - SWITCHES                           |  |

With the transmitter mounted in the storage bin, adapter pegs located on the garage door opener push button unit are selected and mounted on one of two posts on the back side of the push button. The combination of the adapter peg length and the push button post location must be suitable to depress the button of the transmitter when the push button in the center of the garage door opener storage bin door is depressed. When the proper combination has been selected, the push button is reinstalled in the compartment and the compartment door is closed.

### SUNGLASS STORAGE BIN

A sunglasses storage bin is included in the overhead console. The storage bin is located near the rear of the overhead console and is held in the closed position by a latch that is integral to the storage bin door. The interior of the bin is lined with a foam rubber padding material to protect the sunglasses from being scratched. Dampening springs that are located on the back of the overhead console reading and courtesy lamp housing contact the hinges of the sunglasses storage bin for a smooth opening action.

The sunglasses storage bin and door unit is available for service replacement. The hinge dampening springs are serviced as a unit with the overhead console reading and courtesy lamp housing.

The sunglasses storage bin is opened by pressing the latch on the rear edge of the door towards the front of the vehicle, then pulling the bin downward to the open position. The integral latch on the sunglasses bin door will automatically engage when the bin is closed. See the owner's manual in the vehicle glove box for more information on the use and operation of the sunglasses storage bin.

### COMPASS

While in the compass/temperature mode, the compass will display the direction in which the vehicle is pointed using the eight major compass headings (Examples: north is N, northeast is NE), along with the outside ambient temperature. When the compass unit is placed in the compass/compass in degrees

mode, the compass will display the direction the vehicle is heading using the eight major compass headings and in degrees (0 to 359 degrees). North is 0 degrees, East is 90 degrees, South is 180 degrees and West is 270 degrees. It will not display the headings in minutes or seconds.

The self-calibrating compass unit requires no adjusting in normal use. The compass unit will compensate for magnetism the body of the vehicle may acquire during normal use. However, avoid placing anything magnetic directly on the roof of the vehicle. Magnetic mounts for an antenna, a repair order hat, or a funeral procession flag can exceed the compensating ability of the compass unit if placed on the roof panel. If the vehicle roof should become magnetized, the demagnetizing and calibration procedures found in this group may be required to restore proper compass operation.

### THERMOMETER

The thermometer displays the outside ambient temperature in whole degrees. The temperature display can be changed from Fahrenheit to Celsius using the U.S./Metric push button. The displayed temperature is not an instant reading of conditions, but an average temperature. It may take the thermometer display several minutes to respond to a major temperature change, such as driving out of a heated garage into winter temperatures.

When the ignition switch is turned to the Off position, the last displayed temperature reading stays in the thermometer unit memory. When the ignition switch is turned to the On position again, the thermometer will display the memory temperature if the engine coolant temperature is above about 43° C (109° F). If the engine coolant temperature is below about 43° C (109° F), the thermometer will display the actual temperature sensed by the ambient temperature sensor. The thermometer temperature display update interval varies with the vehicle speed; therefore, if the temperature reading seems inaccurate, drive the vehicle for at least three minutes

## OVERHEAD CONSOLE (Continued)

while maintaining a speed of 48 kilometers-per-hour (30 miles-per-hour) or higher.

The thermometer function is supported by an ambient temperature sensor. The sensor is mounted outside the passenger compartment near the front and center of the vehicle, and is hard wired to the module. The ambient temperature sensor is available as a separate service item.

### STANDARD PROCEDURE - COMPASS CALIBRATION

**CAUTION: Do not place any external magnets, such as magnetic roof mount antennas, in the vicinity of the compass. Do not use magnetic tools when servicing the overhead console.**

The electronic compass unit features a self-calibrating design, which simplifies the calibration procedure. This feature automatically updates the compass calibration while the vehicle is being driven. This allows the compass unit to compensate for small changes in the residual magnetism that the vehicle may acquire during normal use. If the compass readings appear to be erratic or out of calibration, perform the following calibration procedure. Also, new service replacement compass mini-trip computer modules must have their compass calibrated using this procedure. Do not attempt to calibrate the compass near large metal objects such as other vehicles, large buildings, or bridges; or, near overhead or underground power lines.

(1) Start the engine. If the compass/temperature data is not currently being displayed, momentarily depress and release the Step push button to step through the display options until you have reached the compass/temperature display.

(2) Depress both the U.S./Metric and the Step push buttons at the same time for more than six seconds, until "CAL" appears in the display, then release both push buttons. The "CAL" in the display indicates that the compass is in the calibration mode.

(3) Drive the vehicle on a level surface, at least fifty feet away from large metal objects and power lines, in all four compass directions, such as driving around a city block several times or driving in two to three complete circles at a slow to medium speed.

(4) When the calibration is successfully completed, "CAL" will disappear from the display and normal compass mini-trip computer operation will resume.

**NOTE: If the "CAL" message remains in the display, either there is excessive magnetism near the compass, or the unit is faulty. Repeat the calibration procedure at least one more time.**

**NOTE: If the wrong direction is still indicated in the compass display, the area selected for calibration may be too close to a strong magnetic field. Repeat the calibration procedure in another location.**

### STANDARD PROCEDURE - COMPASS VARIATION ADJUSTMENT

Compass variance, also known as magnetic declination, is the difference in angle between magnetic north and true geographic north. In some geographic locations, the difference between magnetic and geographic north is great enough to cause the compass to give false readings. If this problem occurs, the compass variance must be set. There are two methods that can be used to enter this information into the compass mini-trip computer module. They are the zone method and the direct method.

#### ZONE METHOD

(1) Using the Variance Settings map, find your geographic location and note the zone number (Fig. 2).

(2) Turn the ignition switch to the On position. If the compass/temperature data is not currently being displayed, momentarily depress and release the Step push button to step through the display options until you have reached the compass/temperature display.

(3) Depress both the U.S./Metric and the Step push buttons at the same time and hold them down for more than 100 milliseconds, but not more than one second. The compass mini-trip computer will enter the variation adjustment mode and "VAR" along with the current variance zone will appear in the display.

(4) Momentarily depress and release the Step push button to step through the zone numbers, until the zone number for your geographic location appears in the display.

(5) After five seconds, the displayed zone will automatically be set in the compass mini-trip computer module memory and normal operation will resume.

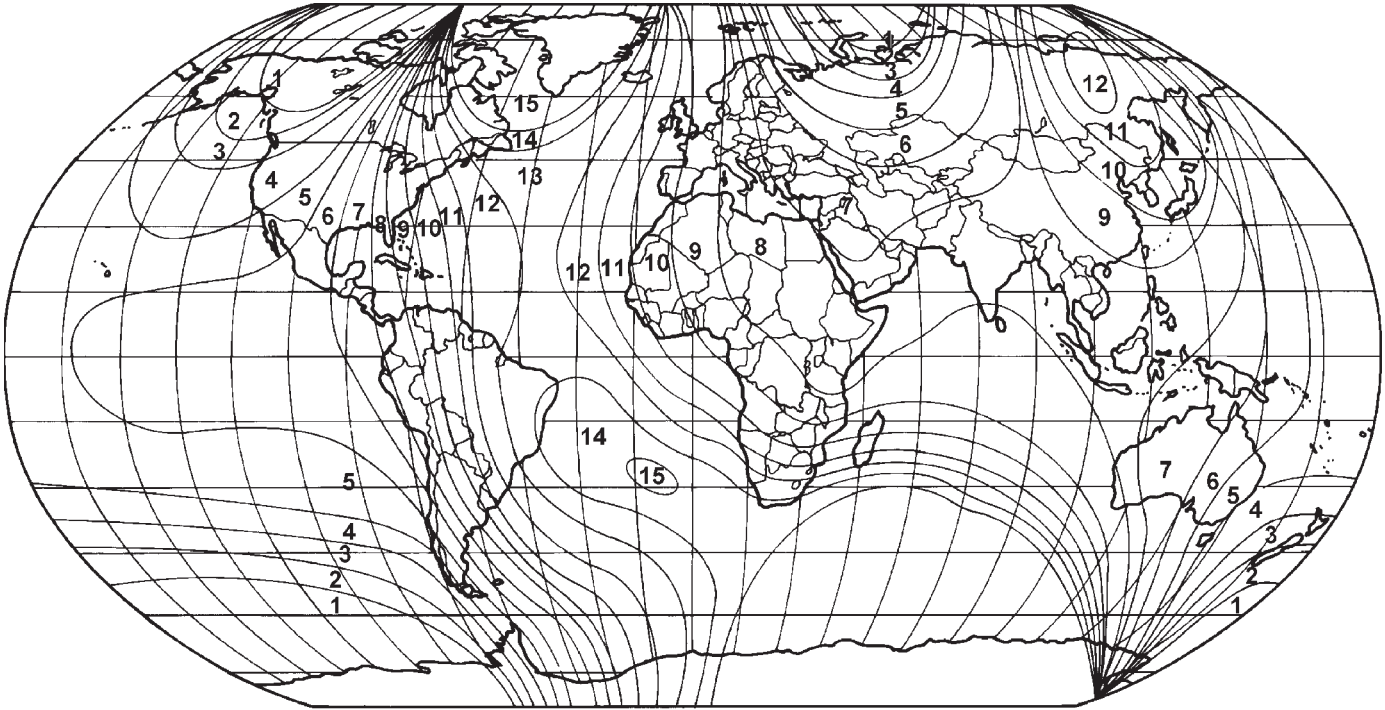
(6) Confirm that the correct directions are now indicated by the compass.

#### DIRECT METHOD

(1) Turn the vehicle so it is headed in either the north or south direction. The vehicle must be headed within 45 degrees of north or south for this procedure to work. The vehicle may be moving or stationary.

(2) Turn the ignition switch to the On position. If the compass/temperature data is not currently being displayed, momentarily depress and release the Step push button to step through the display options until you have reached the compass/temperature display.

## OVERHEAD CONSOLE (Continued)



80a13863

**Fig. 2 Variance Settings**

(3) Depress both the U.S./Metric and the Step push buttons at the same time and hold them down for more than 100 milliseconds, but not more than one second. The compass mini-trip computer will enter the variation adjustment mode and "VAR" along with the current variance zone will appear in the display.

(4) Within the next five seconds, momentarily depress and release the U.S./Metric push button. The variance zone will automatically be set in the compass mini-trip computer module memory and normal operation will resume.

(5) If the "VAR" in the display flashes twice before the compass mini-trip computer module resumes normal operation, the new variance zone setting was not accepted. Reorient the vehicle so it is headed within 45 degrees of north or south and repeat this procedure.

## STANDARD PROCEDURE - COMPASS DEMAGNETIZING

A degaussing tool (Special Tool 6029) is used to demagnetize, or degauss, the overhead console forward mounting screw and the roof panel above the overhead console. Equivalent units must be rated as continuous duty for 110/115 volts and 60 Hz. They must also have a field strength of over 350 gauss at 7 millimeters (0.25 inch) beyond the tip of the probe.

To demagnetize the roof panel and the overhead console forward mounting screw, proceed as follows:

(1) Be certain that the ignition switch is in the Off position, before you begin the demagnetizing procedure.

(2) Connect the degaussing tool to an electrical outlet, while keeping the tool at least 61 centimeters (2 feet) away from the compass unit.

(3) Slowly approach the head of the overhead console forward mounting screw with the degaussing tool connected.

(4) Contact the head of the screw with the plastic coated tip of the degaussing tool for about two seconds.

(5) With the degaussing tool still energized, slowly back it away from the screw. When the tip of the tool is at least 61 centimeters (2 feet) from the screw head, disconnect the tool.

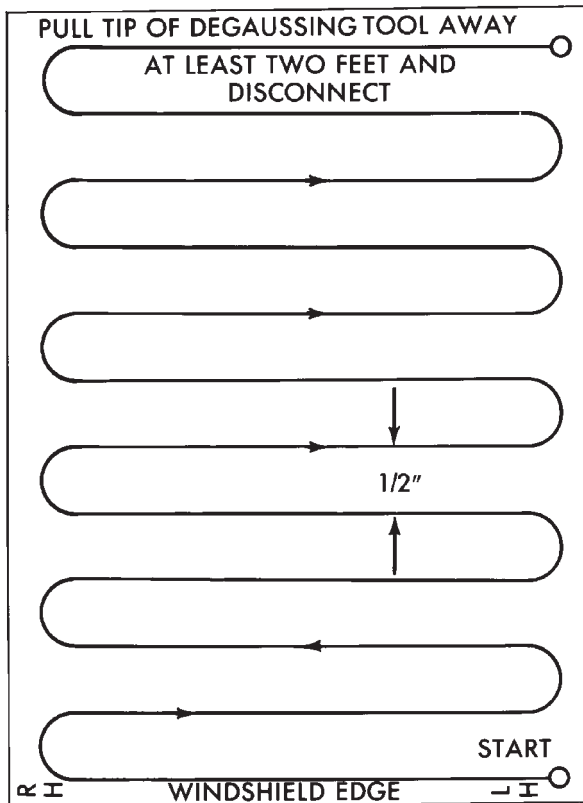
(6) Place a piece of paper approximately 22 by 28 centimeters (8.5 by 11 inches), oriented on the vehicle lengthwise from front to rear, on the center line of the roof at the windshield header (Fig. 3). The purpose of the paper is to protect the roof panel from scratches, and to define the area to be demagnetized.

(7) Connect the degaussing tool to an electrical outlet, while keeping the tool at least 61 centimeters (2 feet) away from the compass unit.

(8) Slowly approach the center line of the roof panel at the windshield header, with the degaussing tool connected.

(9) Contact the roof panel with the plastic coated tip of the degaussing tool. Be sure that the template

## OVERHEAD CONSOLE (Continued)



J908E-27

**Fig. 3 Roof Demagnetizing Pattern**

is in place to avoid scratching the roof panel. Using a slow, back-and-forth sweeping motion, and allowing 13 millimeters (0.50 inch) between passes, move the tool at least 11 centimeters (4 inches) to each side of the roof center line, and 28 centimeters (11 inches) back from the windshield header.

(10) With the degaussing tool still energized, slowly back it away from the roof panel. When the tip of the tool is at least 61 centimeters (2 feet) from the roof panel, disconnect the tool.

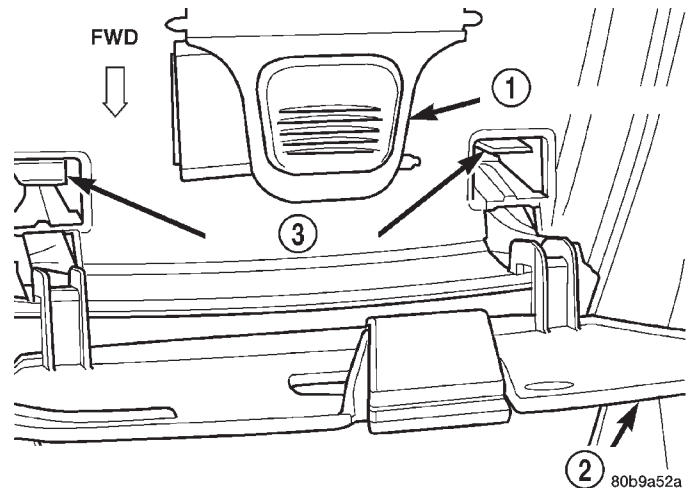
(11) Calibrate the compass and adjust the compass variance. Refer to **Compass Variation Adjustment** and **Compass Calibration** in the Standard Procedures section of this group for the procedures.

**REMOVAL**

(1) Disconnect and isolate the battery negative cable.

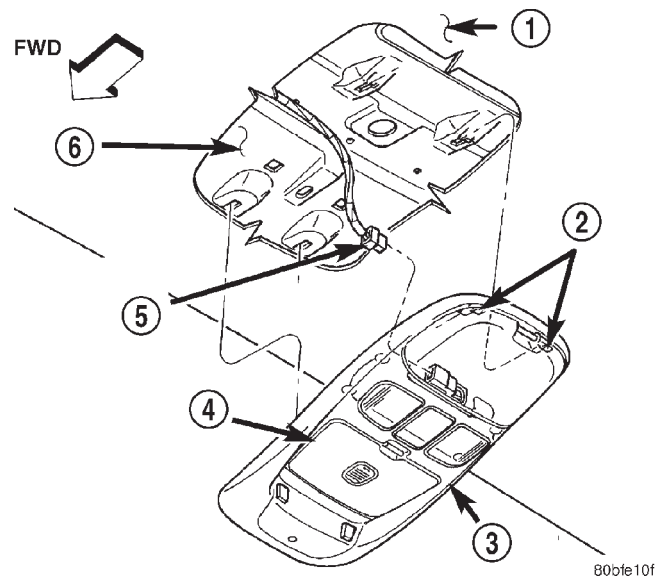
(2) Open the garage door opener storage bin door and locate the two overhead console latch tabs near the front of the bin (Fig. 4).

(3) While pulling gently downward on the front of the overhead console, push the latch tabs forward until each latch is disengaged from its receptacle in the inner roof panel.

**Fig. 4 Overhead Console Latch Tabs**

- 1 - PUSH BUTTON
- 2 - GARAGE DOOR OPENER STORAGE BIN DOOR
- 3 - LATCH TABS

(4) Slide the overhead console rearward far enough to disengage the two mounting hooks on the rear of the housing from the mounting holes in the inner roof panel (Fig. 5).

**Fig. 5 Overhead Console Remove/Install**

- 1 - HEADLINER
- 2 - MOUNTING HOOKS
- 3 - OVERHEAD CONSOLE
- 4 - GARAGE DOOR OPENER STORAGE BIN DOOR
- 5 - WIRE HARNESS CONNECTOR
- 6 - INNER ROOF PANEL

(5) Lower the overhead console from the headliner far enough to access the wire harness connector.

(6) Disconnect the roof wire harness connector from the overhead console wire harness connector.



## OVERHEAD CONSOLE (Continued)

- (7) Remove the overhead console from the vehicle.

## OVERHEAD CONSOLE DISASSEMBLY

## GARAGE DOOR OPENER STORAGE BIN REMOVAL

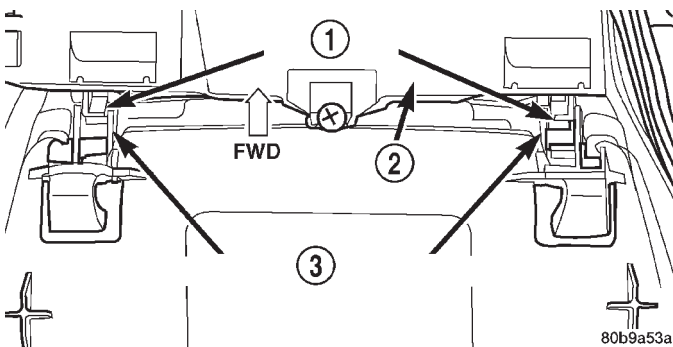
(1) Disconnect and isolate the battery negative cable.

(2) Remove the overhead console from the headliner. Refer to **Overhead Console** in the Removal and Installation section of this group for the procedures.

(3) If the vehicle is so equipped, remove the three screws that secure the compass mini-trip computer module to the back side of the overhead console housing. Move the module aside as needed for access to the pivot latches that are integral to the overhead console housing for the garage door opener storage bin door pivot pins.

(4) Open the garage door opener storage bin door.

(5) From the back side of the of the overhead console housing, gently pry one of the pivot latches (Fig. 6) forward while pulling the garage door opener storage bin door pivot arm rearward until the pivot pin is disengaged from the latch. Repeat this step to disengage the second pivot pin from its pivot latch.



**Fig. 6 Garage Door Opener Storage Bin Door Pivot Latches**

- 1 - PIVOT LATCHES
- 2 - COMPASS MINI-TRIP COMPUTER MODULE
- 3 - GARAGE DOOR OPENER STORAGE BIN DOOR PIVOT ARMS

(6) From the face side of the overhead console housing, remove the garage door opener storage bin door from the storage bin.

## SUNGLASS STORAGE BIN REMOVAL

(1) Remove the overhead console from the headliner. Refer to **Overhead Console** in the Removal and Installation section of this group for the procedures.

(2) Remove the four screws that secure the reading and courtesy lamp housing to the back side of the overhead console housing. Move the lamp housing

aside as needed for access to the pivot latches that are integral to the overhead console housing for the sunglasses storage bin pivot pins.

(3) Open the sunglasses storage bin.

(4) From the back side of the of the overhead console housing, gently pry one of the pivot latches forward while pulling the sunglasses storage bin pivot arm rearward until the pivot pin is disengaged from the latch. Repeat this step to disengage the second pivot pin from its pivot latch.

(5) From the face side of the overhead console housing, remove the sunglasses storage bin from the overhead console.

## COMPASS MINI-TRIP LENS REMOVAL

Overhead consoles equipped with the optional compass mini-trip computer have a lens installed in the front of the overhead console housing through which the Vacuum-Fluorescent Display can be viewed. If the overhead console is not equipped with the compass mini-trip computer option, a plastic cover plug is installed in the front of the overhead console housing in place of the lens.

(1) Remove the overhead console from the headliner. Refer to **Overhead Console** in the Removal and Installation section of this group for the procedures.

(2) If the vehicle is so equipped, remove the compass mini-trip computer module from the overhead console. Refer to **Compass Mini-Trip Computer** in the Removal and Installation section of this group for the procedures.

(3) From the back side of the overhead console, push downward firmly and evenly on the rear of the trip computer lens to disengage the rear mounting boss, or the snap features of the cover plug from the overhead console housing.

(4) From the face of the overhead console, pull the trip computer lens or the cover plug rearward far enough to disengage the four forward mounting tabs from the overhead console housing.

(5) Remove the trip computer lens or the cover plug from the overhead console housing.

## OVERHEAD CONSOLE ASSEMBLY

## GARAGE DOOR OPENER STORAGE BIN

(1) From the face side of the overhead console housing, position the garage door opener storage bin door pivot arms through the openings in the front of the storage bin.

(2) From the back side of the of the overhead console housing, align one of the pivot pins of the garage door opener storage bin door with the pivot latch integral to the overhead console housing. Press the pivot arm forward until the pivot pin is engaged in



## OVERHEAD CONSOLE (Continued)

the latch. Repeat this step to engage the second pivot pin with its pivot latch.

(3) Close the garage door opener storage bin door.

(4) If the vehicle is so equipped, position the compass mini-trip computer module to the back side of the overhead console housing. Install and tighten the three screws that secure the module to the housing. Tighten the screws to 2.2 N-m (20 in. lbs.).

(5) Install the overhead console onto the headliner. Refer to **Overhead Console** in the Removal and Installation section of this group for the procedures.

## SUNGLASS STORAGE BIN

(1) From the face side of the overhead console housing, position the sunglasses storage bin pivot arms through the openings in the front of the storage bin housing in the overhead console.

(2) From the back side of the of the overhead console housing, align one of the pivot pins of the sunglasses storage bin with the pivot latch integral to the overhead console housing. Press the pivot arm forward until the pivot pin is engaged in the latch. Repeat this step to engage the second pivot pin with its pivot latch.

(3) Close the sunglasses storage bin.

(4) Position the reading and courtesy lamp housing to the back side of the overhead console housing. Install and tighten the four screws that secure the lamp housing to the back of the overhead console housing. Tighten the screws to 2.2 N-m (20 in. lbs.).

(5) Install the overhead console onto the headliner. Refer to **Overhead Console** in the Removal and Installation section of this group for the procedures.

## MINI-TRIP COMPUTER LENS

Overhead consoles equipped with the optional compass mini-trip computer have a lens installed in the front of the overhead console housing through which the Vacuum-Fluorescent Display can be viewed. If the overhead console is not equipped with the compass mini-trip computer option, a plastic cover plug is installed in the front of the overhead console housing in place of the lens.

(1) Remove the trip computer lens or the cover plug onto the overhead console housing.

(2) From the face of the overhead console, push the trip computer lens or the cover plug forward far enough to engage the four forward mounting tabs in the overhead console unit.

(3) From the face of the overhead console, align the rear mounting boss of the trip computer lens or the alignment pin of the cover plug with the receptacle in the overhead console housing.

(4) Press firmly and evenly on the rear edge of the trip computer lens or the cover plug until the rear mounting boss is fully seated in the receptacle, or the

snap features of the cover plug are fully engaged in the overhead console housing.

(5) If the vehicle is so equipped, install the compass mini-trip computer module onto the overhead console. Refer to **Compass Mini-Trip Computer** in the Removal and Installation section of this group for the procedures.

(6) Install the overhead console onto the headliner. Refer to **Overhead Console** in the Removal and Installation section of this group for the procedures.

## INSTALLATION

(1) Position the overhead console near the mounting location on the headliner in the vehicle.

(2) Reconnect the roof wire harness connector to the overhead console wire harness connector.

(3) Engage the two mounting hooks on the rear of the overhead console housing in the mounting holes in the inner roof panel.

(4) Slide the overhead console forward far enough to align the two latches on the front of the housing with their receptacles in the inner roof panel.

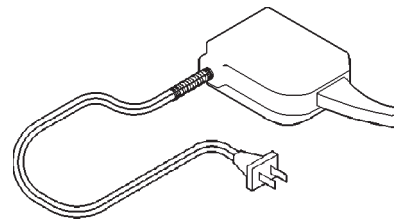
(5) Push upward firmly and evenly on the front of the overhead console until each of the two latches is fully engaged in its receptacle in the inner roof panel.

(6) Close the garage door opener storage bin door.

(7) Reconnect the battery negative cable.

## SPECIAL TOOLS

## OVERHEAD CONSOLE SYSTEMS



*Degaussing Tool 6029*

COMPASS/MINI-TRIP  
COMPUTER

## DESCRIPTION

The compass mini-trip computer is located in the premium overhead console on models equipped with this option. Two compass mini-trip computer units are available. One unit is used on vehicles not equipped with the Vehicle Theft Security System (VTSS) option, and the other is used on vehicles with the VTSS option. Both compass mini-trip computer units include the electronic control module, a Vacuum-Fluorescent Display (VFD), a compass flux-gate unit and two push button function switches.

## COMPASS/MINI-TRIP COMPUTER (Continued)

Compass mini-trip computer units for vehicles equipped with the VTSS include a red Light-Emitting Diode (LED) on their electronic circuit board. This LED protrudes through the bottom of the lens on the front of the overhead console unit, and serves as the security indicator lamp. Refer to **Security Indicator Lamp** in Vehicle Theft/Security Systems for more information on this feature.

The compass mini-trip computer module contains a central processing unit and interfaces with other electronic modules in the vehicle on the Chrysler Collision Detection (CCD) data bus network. The CCD data bus network allows the sharing of sensor information. This helps to reduce wire harness complexity, reduce internal controller hardware, and reduce component sensor current loads. At the same time, this system provides increased reliability, enhanced diagnostics, and allows the addition of many new feature capabilities.

The compass mini-trip computer provides several electronic functions and features. Some of the functions and features that the compass mini-trip computer module supports and/or controls, include the following display options:

- **Compass and temperature** - provides the outside temperature and one of eight compass readings to indicate the direction the vehicle is facing.
- **Compass and compass in degrees** - provides one of eight compass readings to indicate the direction the vehicle is facing and provides the compass direction in degrees.
- **Trip odometer (ODO)** - shows the distance travelled since the last trip computer reset.
- **Average fuel economy (AVG ECO)** - shows the average fuel economy since the last trip computer reset.
- **Instant fuel economy (ECO)** - shows the present fuel economy based upon the current vehicle distance and fuel used information.
- **Distance to empty (DTE)** - shows the estimated distance that can be travelled with the fuel remaining in the fuel tank. This estimated distance is computed using the average miles-per-gallon from the last 30 gallons of fuel used.
- **Elapsed time (ET)** - shows the accumulated ignition-on time since the last trip computer reset.
- **Blank screen** - the compass mini-trip VFD is turned off.

The ambient temperature sensor is hard wired to the compass mini-trip computer module. Data input for all other compass mini-trip computer functions, including VFD dimming level, is received through CCD data bus messages. The compass mini-trip computer uses its internal programming and all of these inputs to calculate and display the requested data. If the data displayed is incorrect, perform the self-diag-

nostic tests as described in this group. If these tests prove inconclusive, the use of a DRBIII® scan tool and the proper Diagnostic Procedures manual are recommended for further testing of the compass mini-trip computer module and the CCD data bus.

The compass mini-trip computer module cannot be repaired, and is available for service only as a unit. If faulty or damaged, the complete module must be replaced.

## OPERATION

The compass mini-trip computer only operates with the ignition switch in the On position. When the ignition switch is turned to the On position, all of the segments in the compass mini-trip computer VFD will be turned on for one second, then the display will return to the last function being displayed before the ignition was turned to the Off position. With the ignition switch in the On position, momentarily depressing and releasing the Step push button switch will cause the compass-mini-trip computer to change its mode of operation, and momentarily depressing and releasing the U.S./Metric push button will cause the unit to toggle between U.S. and Metric measurements. While in either compass mode, depressing the U.S./Metric push button for more than ten seconds will toggle the display between the compass/temperature and the compass/compass in degrees modes.

This compass mini-trip computer features several functions that can be reset. If both the Step and U.S./Metric push buttons are depressed at the same time with the ignition switch in the On position, the trip computer information that can be reset is reset. Depressing and releasing the Step and U.S./Metric push buttons at the same time for more than 100 milliseconds, but not more than one second while in any display mode (except the compass/temperature mode) will cause a local reset. A local reset affects only the function currently displayed. See the Reset Chart below for more information on this feature. Performing a local reset while in the compass/temperature mode enters the module into the compass variance setting mode.

Depressing and releasing the Step and U.S./Metric push buttons at the same time for more than two seconds while in any display mode (except the compass/temperature mode) will cause a global reset. A global reset changes all of the trip computer functions that can be reset.

For more information on the features and control functions of the compass mini-trip computer, see the owner's manual in the vehicle glove box.

## COMPASS/MINI-TRIP COMPUTER (Continued)

**DIAGNOSIS & TESTING - COMPASS MINI-TRIP COMPUTER**

If the problem with the compass mini-trip computer module is an inoperative security indicator lamp, refer to **Security Indicator Lamp** in Vehicle Theft/Security Systems. If the problem with the compass mini-trip computer module is an "OC" or "SC" in the compass/thermometer display, refer to **Ambient Temperature Sensor** in the Diagnosis and Testing section of this group. If the problem with the compass mini-trip computer module is an inaccurate or scrambled display, refer to **Self-Diagnostic Test** in the Diagnosis and Testing section of this group. If the problem with the compass mini-trip computer module is incorrect Vacuum Fluorescent Display (VFD) dimming levels, use a DRB® scan tool and the proper Diagnostic Procedures manual to test for the correct dimming message inputs being received from the instrument cluster over the Chrysler Collision Detection (CCD) data bus. If the problem is a no-display condition, use the following procedures. For complete circuit diagrams, refer to **Overhead Console** in the Contents of Wiring Diagrams.

(1) Check the fused B(+) fuse in the junction block. If OK, go to Step 2. If not OK, repair the shorted circuit or component as required and replace the faulty fuse.

(2) Check for battery voltage at the fused B(+) fuse in the junction block. If OK, go to Step 3. If not OK, repair the open fused B(+) circuit to the battery as required.

(3) Check the fused ignition switch output (run/start) fuse in the junction block. If OK, go to Step 4. If not OK, repair the shorted circuit or component as required and replace the faulty fuse.

(4) Turn the ignition switch to the On position. Check for battery voltage at the fused ignition switch output (run/start) fuse in the junction block. If OK, go to Step 5. If not OK, repair the open fused ignition switch output (run/start) circuit to the ignition switch as required.

(5) Turn the ignition switch to the Off position. Disconnect and isolate the battery negative cable. Remove the overhead console. Check for continuity between the ground circuit cavities of the roof wire harness connector for the overhead console and a good ground. There should be continuity. If OK, go to Step 6. If not OK, repair the open ground circuit to ground as required.

(6) Connect the battery negative cable. Check for battery voltage at the fused B(+) circuit cavity of the roof wire harness connector for the overhead console. If OK, go to Step 7. If not OK, repair the open fused B(+) circuit to the junction block fuse as required.

(7) Turn the ignition switch to the On position. Check for battery voltage at the fused ignition switch output (run/start) circuit cavity of the roof wire harness connector for the overhead console. If OK, refer to **Self-Diagnostic Test** in the Diagnosis and Testing section of this group for further diagnosis of the compass mini-trip computer module and the CCD data bus. If not OK, repair the open fused ignition switch output (run/start) circuit to the junction block fuse as required.

**SELF-DIAGNOSTIC TEST**

A self-diagnostic test is used to determine that the compass mini-trip computer module is operating properly electrically. Initiate the self-diagnostic test as follows:

(1) With the ignition switch in the Off position, simultaneously depress and hold the Step button and the U.S./Metric button.

(2) Turn the ignition switch to the On position.

(3) Continue to hold both buttons depressed until the compass mini-trip computer module enters the display segment test. In this test, all of the Vacuum Fluorescent Display (VFD) segments are lighted while the compass mini-trip computer module performs the following checks:

- Microprocessor RAM read/write test
- Non-volatile memory read/write test
- Microprocessor ROM verification test
- CCD communications test.

(4) Following completion of these tests, the compass mini-trip computer will display one of three messages: "PASS," "FAIL," or "CCd." Respond to the respective test results as follows:

- If the "PASS" message is displayed, but compass mini-trip computer operation is still improper, the use of a DRB scan tool and the proper Diagnostic Procedures manual are required for further diagnosis.

- If the "FAIL" message is displayed, the compass mini-trip computer module is faulty and must be replaced.

- If the "CCd" message is displayed, the use of a DRB® scan tool and the proper Diagnostic Procedures manual are required for further diagnosis.

- If any VFD segment should fail to light during the display segment test, the compass mini-trip computer module is faulty and must be replaced.

(5) If all tests are passed, or if the ignition switch is turned to the Off position, the compass mini-trip computer module will automatically return to normal operation.

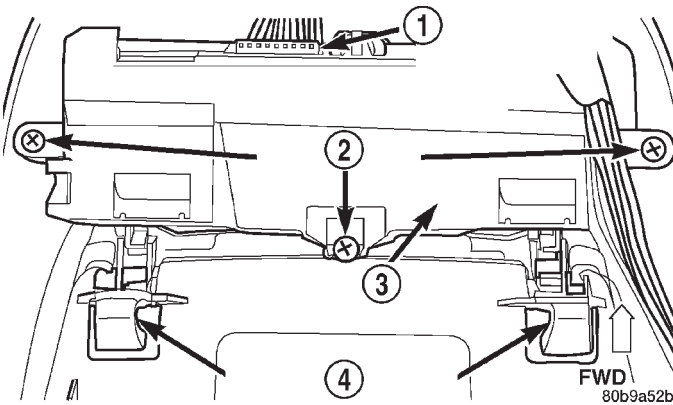
## COMPASS/MINI-TRIP COMPUTER (Continued)

**NOTE:** If the compass functions, but accuracy is suspect, it may be necessary to perform a variation adjustment. This procedure allows the compass unit to accommodate variations in the earth's magnetic field strength, based on geographic location. Refer to **Compass Variation Adjustment** in the **Service Procedures** section of this group.

**NOTE:** If the compass reading has blanked out, and only "CAL" appears in the display, demagnetizing may be necessary to remove excessive residual magnetic fields from the vehicle. Refer to **Compass Demagnetizing** in the **Service Procedures** section of this group.

## REMOVAL

- (1) Disconnect and isolate the battery negative cable.
- (2) Remove the overhead console from the headliner. Refer to **Overhead Console** in the **Removal and Installation** section of this group for the procedures.
- (3) Remove the three screws that secure the compass mini-trip computer module to the overhead console housing (Fig. 7).



**Fig. 7 Compass Mini-Trip Computer**

- 1 - WIRE HARNESS CONNECTOR
- 2 - SCREWS (3)
- 3 - COMPASS MINI-TRIP COMPUTER MODULE
- 4 - FRONT LATCHES

(4) Pull the compass mini-trip computer module away from the overhead console far enough to access the wire harness connector.

(5) Disconnect the overhead console wire harness connector from the compass mini-trip computer module connector receptacle.

(6) Remove the compass mini-trip computer module from the overhead console housing.

## INSTALLATION

(1) Position the compass mini-trip computer module onto the overhead console housing.

(2) Reconnect the overhead console wire harness connector to the compass mini-trip computer module connector receptacle.

(3) Install and tighten the three screws that secure the compass mini-trip computer module to the overhead console housing. Tighten the screws to 2.2 N·m (20 in. lbs.).

(4) Install the overhead console onto the headliner. Refer to **Overhead Console** in the **Removal and Installation** section of this group for the procedures.

(5) Reconnect the battery negative cable.

**NOTE:** If a new compass mini-trip computer has been installed, the compass will have to be calibrated and the variance set. Refer to **Compass Variation Adjustment and Compass Calibration** in the **Service Procedures** section of this group for the procedures.

## AMBIENT TEMP SENSOR

## DESCRIPTION

Ambient air temperature is monitored by the compass mini-trip computer module through the ambient temperature sensor. The ambient temperature sensor is a variable resistor mounted to a bracket that is secured with a screw to the underside of the hood panel near the hood latch striker in the engine compartment.

For complete circuit diagrams, refer to **Overhead Console** in the **Contents of Wiring Diagrams**. The ambient temperature sensor cannot be adjusted or repaired and, if faulty or damaged, it must be replaced.

## OPERATION

The ambient temperature sensor is a variable resistor that operates on a five-volt reference signal sent to it by the compass mini-trip computer module. The resistance in the sensor changes as temperature changes, changing the return circuit voltage to the compass mini-trip computer module. Based upon the resistance in the sensor, the compass mini-trip computer module senses a specific voltage on the return circuit, which it is programmed to correspond to a specific temperature.



## AMBIENT TEMP SENSOR (Continued)

**DIAGNOSIS & TESTING - AMBIENT TEMPERATURE SENSOR**

The thermometer function is supported by the ambient temperature sensor, a wiring circuit, and a portion of the compass mini-trip computer module. If any portion of the ambient temperature sensor circuit fails, the compass/thermometer display function will self-diagnose the circuit. If 55° C (131° F) appears in the display, the sensor is being exposed to temperatures above 55° C (131° F), or the sensor circuit is shorted. If -40° C (-40° F) appears in the display, the sensor is being exposed to temperatures below -40° C (-40° F), or the sensor circuit is open.

The ambient temperature sensor circuit can also be diagnosed using the following Sensor Test, and Sensor Circuit Test. If the temperature sensor and circuit are confirmed to be OK, but the temperature display is inoperative or incorrect, refer to **Compass Mini-Trip Computer** in the Diagnosis and Testing section of this group. For complete circuit diagrams, refer to **Overhead Console** in the Contents of Wiring Diagrams.

**SENSOR TEST**

(1) Turn the ignition switch to the Off position. Disconnect and isolate the battery negative cable. Disconnect the ambient temperature sensor wire harness connector.

(2) Measure the resistance of the ambient temperature sensor. At -40° C (-40° F), the sensor resistance is 336 kilohms. At 55° C (131° F), the sensor resistance is 2.488 kilohms. The sensor resistance should read between these two values. If OK, refer to **Sensor Circuit Test** in the Diagnosis and Testing section of this group. If not OK, replace the faulty ambient temperature sensor.

**SENSOR CIRCUIT TEST**

(1) Turn the ignition switch to the Off position. Disconnect and isolate the battery negative cable. Disconnect the ambient temperature sensor wire harness connector and the overhead console wire harness connector.

(2) Connect a jumper wire between the two terminals in the body half of the ambient temperature sensor wire harness connector.

(3) Check for continuity between the sensor return circuit and the ambient temperature sensor signal circuit cavities of the roof wire harness overhead console connector. There should be continuity. If OK, go to Step 4. If not OK, repair the open sensor return circuit or ambient temperature sensor signal circuit to the ambient temperature sensor as required.

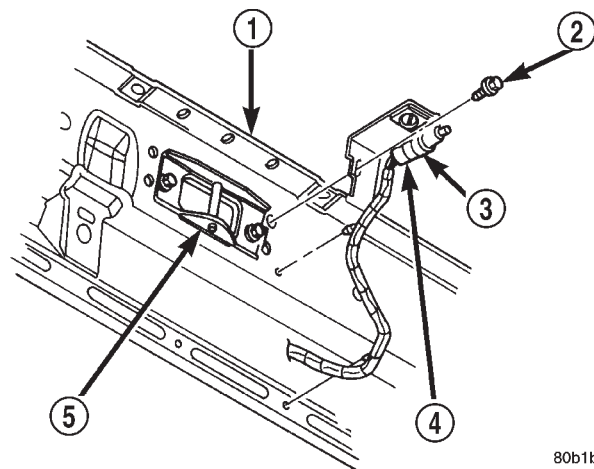
(4) Remove the jumper wire from the body half of the ambient temperature sensor wire harness connector. Check for continuity between the sensor return circuit cavity of the roof wire harness overhead console connector and a good ground. There should be no continuity. If OK, go to Step 5. If not OK, repair the shorted sensor return circuit as required.

(5) Check for continuity between the ambient temperature sensor signal circuit cavity of the roof wire harness overhead console connector and a good ground. There should be no continuity. If OK, refer to **Compass Mini-Trip Computer** in the Diagnosis and Testing section of this group. If not OK, repair the shorted ambient temperature sensor signal circuit as required.

**REMOVAL**

(1) Disconnect and isolate the battery negative cable.

(2) Locate the ambient temperature sensor, on the underside of the hood near the hood latch striker (Fig. 8).



80b1b31E

**Fig. 8 Ambient Temperature Sensor Remove/Install**

- 1 - HOOD
- 2 - SCREW
- 3 - SENSOR AND BRACKET
- 4 - WIRE HARNESS CONNECTOR
- 5 - HOOD LATCH STRIKER

(3) Disconnect the wire harness connector from the ambient temperature sensor connector receptacle.

(4) Remove the one screw that secures the ambient temperature sensor bracket to the inner hood reinforcement.

(5) Remove the ambient temperature sensor from the inner hood reinforcement.



AMBIENT TEMP SENSOR (Continued)

**INSTALLATION**

(1) Position the ambient temperature sensor onto the inner hood reinforcement.

(2) Install and tighten the one screw that secures the ambient temperature sensor bracket to the inner hood reinforcement. Tighten the screw to 5.6 N·m (50 in. lbs.).

(3) Reconnect the wire harness connector to the ambient temperature sensor connector receptacle.

(4) Reconnect the battery negative cable.



## POWER SYSTEMS

### TABLE OF CONTENTS

	page		page
POWER LOCKS .....	1	POWER SEAT SYSTEM.....	15
POWER MIRRORS .....	10	POWER WINDOWS.....	23

## POWER LOCKS

### TABLE OF CONTENTS

	page		page
<b>POWER LOCKS</b>		OPERATION .....	6
DESCRIPTION .....	1	DIAGNOSIS AND TESTING .....	7
OPERATION .....	3	POWER LOCK MOTOR .....	7
DIAGNOSIS AND TESTING .....	4	<b>REMOTE KEYLESS ENTRY TRANSMITTER</b>	
POWER LOCK SYSTEM.....	4	DESCRIPTION.....	7
POWER LOCK & REMOTE KEYLESS		OPERATION .....	7
ENTRY SYSTEM .....	4	DIAGNOSIS AND TESTING .....	7
<b>DOOR CYLINDER LOCK SWITCH</b>		REMOTE KEYLESS ENTRY TRANSMITTER.....	7
DESCRIPTION.....	5	STANDARD PROCEDURE.....	8
OPERATION .....	5	RKE TRANSMITTER PROGRAMMING .....	8
DIAGNOSIS AND TESTING .....	5	RKE TRANSMITTER BATTERIES.....	8
DOOR CYLINDER LOCK SWITCH .....	5	<b>POWER LOCK SWITCH</b>	
REMOVAL .....	6	DESCRIPTION.....	8
INSTALLATION.....	6	OPERATION .....	8
<b>POWER LOCK MOTOR</b>		DIAGNOSIS AND TESTING .....	8
DESCRIPTION.....	6	POWER LOCK SWITCH.....	8

## POWER LOCKS

### DESCRIPTION - POWER LOCK SYSTEM

Two different power lock systems are offered as optional factory-installed equipment on this model. Both power lock systems are offered only on models that are also equipped with power windows. On models without the optional Remote Keyless Entry (RKE) system, a base version of the Central Timer Module (CTM) is used. In this version of the power lock system, the power lock switches provide the only control over the operation of the power lock motors. On models with the optional RKE system, a high-line or premium version of the CTM is used to provide many electronic features and conveniences that are not possible with the base version CTM. In this power lock system, the power lock motors are controlled by the microprocessor-based high-line or premium version of

the CTM based upon the CTM programming and electronic message inputs received from other electronic modules in the vehicle over the Chrysler Collision Detection (CCD) data bus network, Radio Frequency (RF) inputs received from the RKE transmitters, as well as many hard wired inputs.

Both versions of the power lock system include the following major components, which are described in further detail elsewhere in this service manual:

- **Power Lock Motors** - A reversible electric motor integral to the door latch of each front door locks or unlocks the front door latch when provided with the appropriate electrical inputs.

- **Power Lock Switches** - A power lock switch integral to the power window/lock switch unit located near the forward end of the arm rest on each front door trim panel allows the power door lock system to be operated by either the driver or the front seat passenger.

## POWER LOCKS (Continued)

On those models equipped with the optional RKE system, the power lock system also includes the following components, which are described in further detail elsewhere in this service manual:

- **Central Timer Module** - The high-line or premium Central Timer Module (CTM) is located under the driver side end of the instrument panel, inboard of the instrument panel steering column opening. The high-line or premium CTM contains a microprocessor and software that allow it to provide the many electronic functions and features not available with base version of the power lock system.

- **Door Cylinder Lock Switches** - A resistor-multiplexed switch located on the back of each front door lock cylinder allows the power door lock system to be operated using a key inserted in either the driver or passenger front door lock cylinder.

Some of the additional features of the power lock system found in vehicles with the RKE system option include:

- **Automatic Door Lock** - The high-line/premium CTM provides an optional automatic door lock feature (also known as rolling door locks). This is a programmable feature.

- **Central Locking** - The high-line/premium CTM provides an optional central locking/unlocking feature.

- **Door Lock Inhibit** - The high-line/premium CTM provides a door lock inhibit feature.

- **Enhanced Accident Response** - The high-line/premium CTM provides an optional enhanced accident response feature. This is a programmable feature.

Hard wired circuitry connects the power lock system components to the electrical system of the vehicle. These hard wired circuits are integral to several wire harnesses, which are routed throughout the vehicle and retained by many different methods. These circuits may be connected to each other, to the vehicle electrical system and to the power lock system components through the use of a combination of soldered splices, splice block connectors, and many different types of wire harness terminal connectors and insulators. Refer to the appropriate wiring information. The wiring information includes wiring diagrams, proper wire and connector repair procedures, further details on wire harness routing and retention, as well as pin-out and location views for the various wire harness connectors, splices and grounds.

Many of the electronic features in the vehicle controlled or supported by the high-line or premium versions of the CTM are programmable using the DRBIII® scan tool. In addition, the high-line/premium CTM software is Flash compatible, which means it can be reprogrammed using Flash reprogramming procedures. However, if any of the CTM

hardware components are damaged or faulty, the entire CTM unit must be replaced. The power lock system components and the hard wired inputs or outputs of the CTM can be diagnosed using conventional diagnostic tools and methods; however, for diagnosis of the high-line or premium versions of the CTM or the CCD data bus, the use of a DRBIII® scan tool is required. Refer to the appropriate diagnostic information.

## DESCRIPTION - REMOTE KEYLESS ENTRY SYSTEM

A Remote Keyless Entry (RKE) system is an available option on this model. The Remote Keyless Entry (RKE) system is a Radio Frequency (RF) system that allows the remote operation of the power lock system and, if the vehicle is so equipped, the Vehicle Theft Security System (VTSS). (Refer to 8 - ELECTRICAL/VEHICLE THEFT SECURITY - DESCRIPTION). The RKE system includes the following major components, which are described in further detail elsewhere in this service manual:

- **Central Timer Module** - The high-line or premium Central Timer Module (CTM) is located under the driver side end of the instrument panel, inboard of the instrument panel steering column opening. The high-line or premium CTM contains a microprocessor, an RF receiver, and the software that allow it to provide the many electronic functions and features of the RKE system.

- **Keyless Entry Transmitter** - The keyless entry transmitter is a small, battery-powered, RF transmitter that is contained within a molded plastic case that is designed to also serve as a convenient key fob.

Some additional features of the RKE system include:

- **Horn Chirp** - This feature provides a short, sharp chirp of the vehicle horn to give an audible confirmation that a valid Lock signal has been received from the RKE transmitter. This feature can be enabled or disabled and, if enabled, one of two optional horn chirp durations (twenty or forty milliseconds) can also be selected.

- **Illuminated Entry** - This feature turns on the courtesy lamps in the vehicle for a timed interval (about thirty seconds) each time a valid Unlock signal has been received from the RKE transmitter.

- **Panic Mode** - This feature allows the vehicle operator to cause the vehicle horn to pulse, the headlights to flash, and the courtesy lamps to illuminate for about three minutes by depressing a Panic button on the RKE transmitter. Pressing the Panic button a second time will cancel the Panic mode. A vehicle speed of about 24 kilometers-per-hour (15 miles-per-hour) will also cancel the panic mode.

## POWER LOCKS (Continued)

**OPERATION - POWER LOCK SYSTEM**

All versions of the power lock system allow both doors to be locked or unlocked electrically by operating the power lock switch on either front door trim panel. On vehicles that are also equipped with the optional Remote Keyless Entry (RKE) system, both doors may also be locked or unlocked using a key in either front door lock cylinder, or by using the RKE transmitter. On vehicles with the RKE system, if certain features have been electronically enabled, the locks may also be operated automatically by the high-line or premium Central Timer Module (CTM) based upon various other inputs. Those features and their inputs are:

- **Automatic Door Lock** - If enabled, the high-line/premium CTM will automatically lock the doors when it receives a message from the Powertrain Control Module (PCM) indicating that the vehicle speed is about 24 kilometers-per-hour (15 miles-per-hour) or greater. The CTM also monitors the door ajar switches, and will not activate the automatic door lock feature until both doors have been closed for at least five seconds. If this feature is enabled and a door is opened after the vehicle is moving, the CTM will also lock the doors five seconds after both doors are closed.

- **Central Locking** - Vehicles equipped with a high-line/premium CTM also have a resistor-multi-plexed door cylinder lock switch mounted to the back of the door lock cylinder within each front door. The CTM continually monitors the input from these switches to provide the central locking/unlocking feature. The CTM will automatically lock or unlock both front doors when either front door is locked or unlocked using a key.

- **Door Lock Inhibit** - The high-line/premium CTM receives inputs from the key-in ignition switch, the headlamp switch, and the door ajar switches. The logic within the CTM allows it to monitor these inputs to provide a door lock inhibit feature. The door lock inhibit feature prevents the power lock system from being energized with a power lock switch input if the driver door is open with the headlamps on or the key still in the ignition switch. However, the locks can still be operated with the manual door lock button or with a key in the door lock cylinder, and the power locks will still operate using the RKE transmitter while the driver door is open with the headlamps on or a key in the ignition.

- **Enhanced Accident Response** - If enabled, the high-line/premium CTM provides an enhanced accident response feature. This feature uses electronic message inputs received by the CTM from the Airbag Control Module (ACM) to determine when an airbag has been deployed. The CTM also monitors the state of the power lock system and the vehicle

speed messages from the PCM in order to provide this feature. If the airbag has been deployed and the vehicle has stopped moving, the CTM will automatically unlock the doors, prevent the doors from being locked, and turn on the courtesy lamps inside the vehicle. Of course, these responses are dependent upon a functional battery and electrical circuitry following the impact.

All versions of the power lock system operate on battery current received through a fused B(+) circuit from a fuse in the Junction Block (JB) so that the system remains functional, regardless of the ignition switch position. Also, in both versions of the power lock system, each power lock switch receives battery current independent of the other. In vehicles with the base version of the power lock system, the driver side power lock switch receives ground through the body wire harness. A single wire take out of the body wire harness with an eyelet terminal connector is secured by a ground screw to the lower left B-pillar (regular cab, extended cab) or lower left quarter inner panel (quad cab). The passenger side power lock switch receives ground through the driver side power lock switch in the base version of the power lock system. The base version power lock switches direct the appropriate battery current and ground feeds to the power lock motors. In the power lock system for vehicles with the RKE system, the power lock switches direct a battery current Lock or Unlock request signal to the high-line or premium CTM, and the CTM energizes internal relays to direct the appropriate battery current and ground feeds to the power lock motors.

**OPERATION - REMOTE KEYLESS ENTRY SYSTEM**

On vehicles with the Remote Keyless Entry (RKE) system, the power locks can be operated remotely using the RKE transmitter. If the vehicle is so equipped, the RKE transmitter also arms and disarms the factory-installed Vehicle Theft Security System (VTSS). Three small, recessed buttons on the outside of the transmitter case labelled Lock, Unlock, and Panic allow the user to choose the function that is desired. The RKE transmitter then sends the appropriate Radio Frequency (RF) signal. An RF receiver that is integral to the high-line or premium version of the Central Timer Module (CTM) receives the transmitted signal, then uses its internal electronic programming to determine whether the received signal is valid and what function has been requested. If the signal is valid, the CTM provides the programmed features.

Besides operating the power lock system and arming or disarming the VTSS, the RKE system also controls the following features:



## POWER LOCKS (Continued)

- **Horn Chirp** - If this feature is enabled, the CTM provides a horn chirp by internally pulling the control coil of the horn relay to ground through a hard wired circuit output.

- **Illuminated Entry** - The CTM provides illuminated entry by internally controlling the current flow to the courtesy lamps in the vehicle through a hard wired output circuit.

- **Panic Mode** - The CTM provides the horn pulse and headlight flash by internally pulling the control coils of the horn relay and headlamp relay to ground through hard wired circuit outputs. The CTM controls the current flow to the courtesy lamps in the vehicle through a hard wired output circuit. The CTM also monitors the vehicle speed through electronic messages it receives from the Powertrain Control Module (PCM) over the Chrysler Collision Detection (CCD) data bus network.

The RKE system operates on battery current received through a fused B(+) circuit from a fuse in the Junction Block (JB) so that the system remains functional, regardless of the ignition switch position. The RKE system can retain the vehicle access codes of up to four RKE transmitters. The transmitter codes are retained in RKE system memory, even if the battery is disconnected. If a transmitter is faulty or is lost, new transmitter vehicle access codes can be programmed into the system using a DRBIII® scan tool. Refer to the appropriate diagnostic information. Many of the electronic features in the vehicle controlled or supported by the high-line or premium versions of the CTM are programmable using the DRBIII® scan tool. In addition, the high-line/premium CTM software is Flash compatible, which means it can be reprogrammed using Flash reprogramming procedures. However, if any of the CTM hardware components are damaged or faulty, the entire CTM unit must be replaced. The hard wired inputs or outputs of the CTM can be diagnosed using conventional diagnostic tools and methods; however, for diagnosis of the high-line or premium versions of the CTM or the CCD data bus, the use of a DRBIII® scan tool is required. Refer to the appropriate diagnostic information.

## DIAGNOSIS AND TESTING - POWER LOCK SYSTEM

The following tests provide a preliminary diagnosis for the power lock system used **only** on vehicles equipped with a base version of the Central Timer Module (CTM). These tests **do not** apply to the diagnosis of the power lock system used on vehicles equipped with the optional Remote Keyless Entry (RKE) system, which includes a high-line or premium CTM. (Refer to 8 - ELECTRICAL/POWER LOCKS - DIAGNOSIS AND TESTING - POWER LOCK & REMOTE KEYLESS ENTRY SYSTEM). Refer to the

appropriate wiring information. The wiring information includes wiring diagrams, proper wire and connector repair procedures, details of wire harness routing and retention, connector pin-out information and location views for the various wire harness connectors, splices and grounds.

### PRELIMINARY TESTS

To begin this test, note the system operation while you actuate both the Lock and Unlock functions with the power lock switches. Then, proceed as follows:

- If the entire power lock system fails to function with both of the power lock switches, check the fused B(+) fuse in the Junction Block (JB). If the fuse is OK, check the ground circuit between the driver side power lock switch and ground (G301). If the ground circuit is OK, proceed to the diagnosis of the power lock motors. (Refer to 8 - ELECTRICAL/POWER LOCKS/POWER LOCK MOTOR - DIAGNOSIS AND TESTING).

- If the entire power lock system fails to function with only one of the power lock switches, proceed to diagnosis of the power lock switches. (Refer to 8 - ELECTRICAL/POWER LOCKS/POWER LOCK SWITCH - DIAGNOSIS AND TESTING).

- If only one power lock motor fails to operate with both power lock switches, proceed to diagnosis of the power lock motor. (Refer to 8 - ELECTRICAL/POWER LOCKS/POWER LOCK MOTOR - DIAGNOSIS AND TESTING).

## DIAGNOSIS AND TESTING - POWER LOCK & REMOTE KEYLESS ENTRY SYSTEM

The following tests include a preliminary diagnosis for the power lock system used **only** on vehicles equipped with the optional Remote Keyless Entry (RKE) system, which includes a high-line or premium Central Timer Module (CTM). These tests **do not** apply to the diagnosis of the power lock system on vehicles equipped with a base version of the CTM. (Refer to 8 - ELECTRICAL/POWER LOCKS - DIAGNOSIS AND TESTING - POWER LOCK SYSTEM).

These tests will help to diagnose the hard wired components and circuits of the power lock system. However, these tests may not prove conclusive in the diagnosis of this system. In order to obtain conclusive testing of the power lock and RKE system, the Chrysler Collision Detection (CCD) data bus network and all of the electronic modules that provide inputs to, or receive outputs from the power lock and RKE system components must be checked.

The most reliable, efficient, and accurate means to diagnose the power lock and RKE system requires the use of a DRBIII® scan tool. The DRBIII® scan tool can provide confirmation that the CCD data bus is functional, that all of the electronic modules are sending

## POWER LOCKS (Continued)

and receiving the proper messages on the CCD data bus, that the CTM is receiving the proper hard wired inputs, and that the power lock motors are being sent the proper hard wired outputs by the CTM.

Refer to the appropriate wiring information. The wiring information includes wiring diagrams, proper wire and connector repair procedures, details of wire harness routing and retention, connector pin-out information and location views for the various wire harness connectors, splices and grounds.

**PRELIMINARY TESTS**

To begin this test, note the system operation while you actuate both the Lock and Unlock functions with the power lock switches, the door cylinder lock switches, and the RKE transmitter. Then, proceed as follows:

- If the entire power lock system fails to function with the power lock switches, the door cylinder lock switches, or the RKE transmitter, check the fused B(+) fuse in the Junction Block (JB). If the fuse is OK, proceed to the diagnosis of the power lock motors. (Refer to 8 - ELECTRICAL/POWER LOCKS/POWER LOCK MOTOR - DIAGNOSIS AND TESTING).

- If the power lock system functions with both power lock switches, and both door cylinder lock switches, but not with the RKE transmitter, proceed to the diagnosis of the transmitter. (Refer to 8 - ELECTRICAL/POWER LOCKS/REMOTE KEYLESS ENTRY TRANSMITTER - DIAGNOSIS AND TESTING).

- If the entire power lock system functions with the RKE transmitter, and both door cylinder lock switches, but not with one or both of the power lock switches, proceed to diagnosis of the power lock switches. (Refer to 8 - ELECTRICAL/POWER LOCKS/POWER LOCK SWITCH - DIAGNOSIS AND TESTING).

- If the entire power lock system functions with the RKE transmitter, and both power lock switches, but not with one or both of the door cylinder lock switches, proceed to diagnosis of the door cylinder lock switches. (Refer to 8 - ELECTRICAL/POWER LOCKS/DOOR CYLINDER LOCK SWITCH - DIAGNOSIS AND TESTING).

- If one power lock motor fails to operate with both of the power lock switches, both of the door cylinder lock switches and/or the RKE transmitter, proceed to diagnosis of the power lock motor. (Refer to 8 - ELECTRICAL/POWER LOCKS/POWER LOCK MOTOR - DIAGNOSIS AND TESTING).

If the problem being diagnosed is related to one or more of the electronic features (automatic locks, door lock inhibit, enhanced accident response, illuminated entry, panic mode, or RKE horn chirp), further diagnosis should be performed using a DRBIII® scan tool. Refer to the appropriate diagnostic information.

**DOOR CYLINDER LOCK SWITCH****DESCRIPTION**

A door cylinder lock switch is snapped onto the back of the key lock cylinder inside each front door of vehicles equipped with a high-line or premium Central Timer Module (CTM). The door cylinder lock switch is a resistor multiplexed momentary switch that is hard wired in series between a body ground and the CTM through the front door wire harness. The door cylinder lock switches are driven by the key lock cylinders and contain three internal resistors. One resistor is used for the neutral switch position, one for the Lock position, and one for the Unlock position.

The door cylinder lock switches cannot be adjusted or repaired and, if faulty or damaged, they must be replaced.

**OPERATION**

The door cylinder lock switches are actuated by the key lock cylinder when the key is inserted in the lock cylinder and turned to the lock or unlock positions. The door cylinder lock switch closes a path to ground through one of three internal resistors for the Central Timer Module (CTM) when the front door key lock cylinder is in the Lock, Unlock, or Neutral positions. The CTM reads the switch status through an internal pull-up, then uses this information as an input for both power lock system and Vehicle Theft Security System (VTSS) operation.

The door cylinder lock switches and circuits can be diagnosed using conventional diagnostic tools and methods.

**DIAGNOSIS & TESTING - DOOR CYLINDER LOCK SWITCH**

Refer to the appropriate wiring information. The wiring information includes wiring diagrams, proper wire and connector repair procedures, details of wire harness routing and retention, connector pin-out information and location views for the various wire harness connectors, splices and grounds.

- (1) Disconnect the door cylinder lock switch pigtail wire connector from the door wire harness connector.

- (2) Using an ohmmeter, perform the switch resistance checks between the two cavities of the door cylinder lock switch pigtail wire connector. Actuate the switch by rotating the key in the door lock cylinder to test for the proper resistance values in each of the three switch positions, as shown in the Door Cylinder Lock Switch chart.

## DOOR CYLINDER LOCK SWITCH (Continued)

DOOR CYLINDER LOCK SWITCH		
Switch Position		Resistance
Driver Side	Passenger Side	
Neutral	Neutral	12 Kilohms
Lock (Clockwise)	Lock (Counter Clockwise)	644 Ohms
Unlock (Counter Clockwise)	Unlock (Clockwise)	1565 Ohms

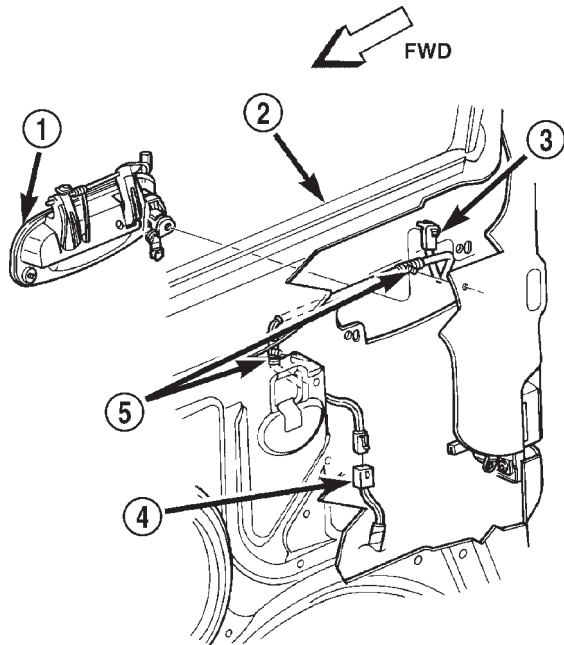
(3) If a door cylinder lock switch fails any of the resistance tests, replace the faulty switch as required.

**REMOVAL**

(1) Disconnect and isolate the battery negative cable.

(2) Remove the door outside latch handle mounting hardware and linkage from the inside of the door. (Refer to 23 - BODY/DOOR - FRONT/EXTERIOR HANDLE - REMOVAL).

(3) From the outside of the door, pull the door outside latch handle out from the door far enough to access the door cylinder lock switch (Fig. 1).



**Fig. 1 Door Cylinder Lock Switch**

- 1 - DOOR OUTSIDE LATCH HANDLE
- 2 - DOOR
- 3 - DOOR CYLINDER LOCK SWITCH
- 4 - CONNECTOR
- 5 - RETAINERS

(4) Disengage the door cylinder lock switch from the back of the lock cylinder.

(5) Disconnect the door cylinder lock switch pigtail wire connector from the door wire harness connector.

(6) Disengage the retainers that secure the door cylinder lock switch pigtail wire harness to the inner door panel.

(7) Remove the door cylinder lock switch from the door.

**INSTALLATION**

(1) Position the door cylinder lock switch into the door (Fig. 1).

(2) Engage the retainers that secure the door cylinder lock switch pigtail wire harness to the inner door panel.

(3) Reconnect the door cylinder lock switch pigtail wire connector to the door wire harness connector.

(4) Reinstall the door cylinder lock switch onto the back of the lock cylinder.

(5) Reinstall the door outside latch handle mounting hardware and linkage on the inside of the door. (Refer to 23 - BODY/DOOR - FRONT/EXTERIOR HANDLE - INSTALLATION).

(6) Reconnect the battery negative cable.

**POWER LOCK MOTOR****DESCRIPTION**

Models equipped with the optional power lock system have a power operated door locking mechanism located within each front door. The lock mechanisms are actuated by a reversible electric power lock motor that is integral to the door latch unit within each front door. A single short pigtail wire with a molded plastic connector insulator connects the door lock motor to the vehicle electrical system through a take out and connector of each front door wire harness.

The power lock motors cannot be adjusted or repaired and, if faulty or damaged, the entire door latch unit must be replaced.

**OPERATION**

On models with a base version of the Central Timer Module (CTM), the power lock motor is controlled by the battery and ground feeds from the power lock switches. On models with the high-line or premium versions of the CTM, the power lock motor is controlled by the battery and ground feeds from the power lock and unlock relays, which are integral and internal to the high-line and premium versions of the CTM. A positive and negative battery connection to the two motor terminals will cause the power lock motor plunger to move in one direction. Reversing the current through these same two connections will cause the power lock motor plunger to move in the opposite direction.

The power lock motors and circuits can be tested using conventional diagnostic tools and methods.



## POWER LOCK MOTOR (Continued)

**DIAGNOSIS AND TESTING - POWER LOCK MOTOR**

On models with a base version of the Central Timer Module (CTM), confirm proper power lock switch operation before you proceed with this diagnosis. On models with a high-line or premium version of the CTM, confirm proper power lock switch, power lock switch output circuit, and CTM operation before you proceed with this diagnosis. Remember, the power lock switch controls the output to the power lock motors on models with a base CTM, while the CTM controls the output to the power lock motors on models with a high-line or premium CTM. Refer to the appropriate wiring information. The wiring information includes wiring diagrams, proper wire and connector repair procedures, details of wire harness routing and retention, connector pin-out information and location views for the various wire harness connectors, splices and grounds.

(1) Check each power lock motor for correct operation while moving the power lock switch to both the Lock and Unlock positions. If both of the power lock motors are inoperative, go to Step 2. If one power lock motor is inoperative, go to Step 3.

(2) If both of the power lock motors are inoperative, the problem may be caused by one shorted motor. Disconnecting a shorted power lock motor from the power lock circuit will allow the good power lock motors to operate. Disconnect the wire harness connector from each power lock motor, one at a time, and recheck both the lock and unlock functions by operating the power lock switch. If both power lock motors are still inoperative after the above test, check for a short or open circuit between the power lock motors and either the power lock switch (base CTM) or the CTM (high-line or premium CTM). If disconnecting one power lock motor causes the other motor to become functional, go to Step 3 to test the disconnected motor.

(3) Once it is determined which power lock motor is inoperative, that motor can be tested as follows. Disconnect the door wire harness connector from the inoperative power lock motor. Apply 12 volts to the lock and unlock driver circuit cavities of the power lock motor pigtail wire connector to check its operation in one direction. Reverse the polarity to check the motor operation in the opposite direction. If OK, repair the shorted or open circuits between the power lock motor and the power lock switch (base CTM) or the CTM (high-line or premium CTM) as required. If not OK, replace the faulty power lock motor.

**REMOTE KEYLESS ENTRY TRANSMITTER****DESCRIPTION**

The Remote Keyless Entry (RKE) system Radio Frequency (RF) transmitter is equipped with three buttons, labeled Lock, Unlock, and Panic. It is also equipped with a key ring and is designed to serve as a key fob. The operating range of the transmitter radio signal is up to 7 meters (23 feet) from the RKE receiver. The RKE receiver is integral to the high-line or premium Central Timer Module (CTM) in this vehicle.

Each RKE transmitter has a different vehicle access code, which must be programmed into the memory of the RKE receiver in the vehicle in order to operate the RKE system. The RKE receiver can retain the access codes for up to four transmitters in its memory. (Refer to 8 - ELECTRICAL/POWER LOCKS/REMOTE KEYLESS ENTRY TRANSMITTER - STANDARD PROCEDURE - RKE TRANSMITTER PROGRAMMING).

The RKE transmitter operates on two Duracell DL2016, Panasonic CR2016 (or equivalent) batteries. Typical battery life is from one to two years. The RKE transmitter cannot be repaired and, if faulty or damaged, it must be replaced.

**OPERATION**

See the owner's manual in the vehicle glove box for more information on the features, use and operation of the Remote Keyless Entry (RKE) transmitters.

**DIAGNOSIS AND TESTING - REMOTE KEYLESS ENTRY TRANSMITTER**

(1) Replace the Remote Keyless Entry (RKE) transmitter batteries. (Refer to 8 - ELECTRICAL/POWER LOCKS/REMOTE KEYLESS ENTRY TRANSMITTER - STANDARD PROCEDURE - RKE TRANSMITTER BATTERIES). Test each of the RKE transmitter functions. If OK, discard the faulty batteries. If not OK, go to Step 2.

(2) Program the suspect RKE transmitter and another known good transmitter into the RKE receiver. (Refer to 8 - ELECTRICAL/POWER LOCKS/REMOTE KEYLESS ENTRY TRANSMITTER - STANDARD PROCEDURE - RKE TRANSMITTER PROGRAMMING).

(3) Test the RKE system operation with both transmitters. If both transmitters fail to operate the power lock system, a DRBIII® scan tool is required for further diagnosis of the RKE system. Refer to the appropriate diagnostic information. If the known good RKE transmitter operates the power locks and

## REMOTE KEYLESS ENTRY TRANSMITTER (Continued)

the suspect transmitter does not, replace the faulty RKE transmitter.

**NOTE: Be certain to perform the RKE Transmitter Programming procedure again following this test. This procedure will erase the access code of the test transmitter from the RKE receiver.**

### STANDARD PROCEDURE - RKE TRANSMITTER PROGRAMMING

To program the Remote Keyless Entry (RKE) transmitter access codes into the RKE receiver in the high-line or premium Central Timer Module (CTM) requires the use of a DRBIII® scan tool. Refer to the appropriate diagnostic information.

### STANDARD PROCEDURE - RKE TRANSMITTER BATTERIES

The Remote Keyless Entry (RKE) transmitter case snaps open and shut for battery access. To replace the RKE transmitter batteries:

- (1) Using a trim stick or a thin coin, gently pry at the notch in the center seam of the RKE transmitter case halves located near the key ring until the two halves unsnap.
- (2) Lift the back half of the transmitter case off of the RKE transmitter.
- (3) Remove the two batteries from the RKE transmitter.
- (4) Replace the two batteries with new Duracell DL2016, or their equivalent. Be certain that the batteries are installed with their polarity correctly oriented.
- (5) Align the two RKE transmitter case halves with each other, and squeeze them firmly and evenly together using hand pressure until they snap back into place.

## POWER LOCK SWITCH

### DESCRIPTION

The power lock system can be controlled by a two-way momentary switch integral to the power window and lock switch and bezel unit on the trim panel of each front door. Each power lock switch is illuminated by a Light-Emitting Diode (LED) that is integral to the switch paddle. The LED of each switch is illuminated whenever the ignition switch is in the On position.

The power lock switches and their LEDs cannot be adjusted or repaired and, if faulty or damaged, the entire power window and lock switch and bezel unit must be replaced.

### OPERATION

On models with a base version of the Central Timer Module (CTM), the power lock switches are hard-wired to the power lock motors. The power lock switch provides the correct battery and ground feeds to the power lock motors to lock or unlock the door latches.

On models with a high-line or premium version of the CTM, the power lock switch controls battery current signals to the lock and unlock sense inputs of the CTM. The CTM then relays the correct battery and ground feeds to the power lock motors to lock or unlock the door latches.

### DIAGNOSIS AND TESTING - POWER LOCK SWITCH

The Light-Emitting Diode (LED) illumination lamps for all of the power window and lock switch and bezel unit switch paddles receive battery current through the power window circuit breaker in the Junction Block (JB). If all of the LEDs are inoperative in either or both power window and lock switch and bezel units, be certain to diagnose the power window system before replacing the switch unit. (Refer to 8 - ELECTRICAL/POWER WINDOWS - DIAGNOSIS AND TESTING). If only one LED in a power window and lock switch and bezel unit is inoperative, replace the faulty switch and bezel unit. Refer to the appropriate wiring information. The wiring information includes wiring diagrams, proper wire and connector repair procedures, details of wire harness routing and retention, connector pin-out information and location views for the various wire harness connectors, splices and grounds.

(1) Check the fused B(+) fuse (Fuse 13 - 10 ampere) in the Junction Block (JB). If OK, go to Step 2. If not OK, repair the shorted circuit or component as required and replace the faulty fuse.

(2) Check for battery voltage at the fused B(+) fuse (Fuse 13 - 10 ampere) in the JB. If OK, go to Step 3. If not OK, repair the open fused B(+) circuit between the JB and the Power Distribution Center (PDC) as required.

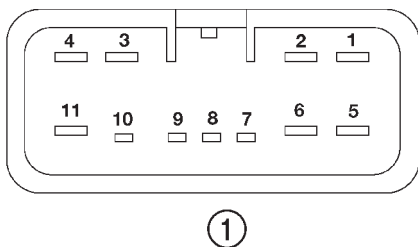
(3) Disconnect and isolate the battery negative cable. Remove the power window and lock switch and bezel unit from the door trim panel. Disconnect the door wire harness connector for the power window and lock switch unit from the switch connector receptacle.

(4) Reconnect the battery negative cable. Check for battery voltage at the fused B(+) circuit cavity of the door wire harness connector for the power window and lock switch unit. If OK, go to Step 5. If not OK, repair the open fused B(+) circuit between the power window and lock switch unit and the JB as required.



POWER LOCK SWITCH (Continued)

(5) Test the power lock switch continuity. See the Power Lock Switch Continuity charts to determine if the continuity is correct in the Neutral, Lock, and Unlock switch positions (Fig. 2) or (Fig. 3). If OK, repair the door lock switch output (lock and/or unlock) circuit(s) between the power window and lock switch unit and the power lock motors (base Central Timer Module [CTM]) or the CTM (high-line or premium CTM) as required. If not OK, replace the faulty power window and lock switch and bezel unit.

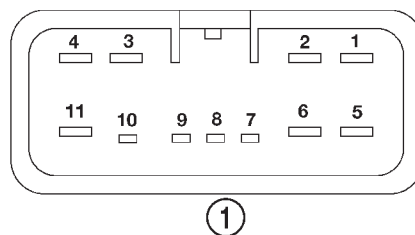


80b099e7

**Fig. 2 Power Lock Switch Continuity - Driver Side**

1 - VIEW OF SWITCH CONNECTOR RECEPTACLE

DRIVER SIDE LOCK SWITCH	
SWITCH POSITION	CONTINUITY BETWEEN
NEUTRAL	7 & 9, 8 & 9
LOCK	7 & 9, 8 & 10
UNLOCK	7 & 10, 8 & 9
LAMP	3 & 5



80b099e8

**Fig. 3 Power Lock Switch Continuity - Passenger Side**

1 - VIEW OF SWITCH CONNECTOR RECEPTACLE

PASSENGER SIDE LOCK SWITCH	
SWITCH POSITION	CONTINUITY BETWEEN
NEUTRAL	6 & 7, 9 & 10
LOCK	5 & 7, 9 & 10
UNLOCK	5 & 9, 6 & 7
LAMP	8 & 11

# POWER MIRRORS

## TABLE OF CONTENTS

	page		page
<b>POWER MIRRORS</b>		<b>OPERATION</b> .....	12
DESCRIPTION.....	10	<b>REMOVAL</b> .....	12
OPERATION.....	10	<b>INSTALLATION</b> .....	13
<b>AUTOMATIC DAY / NIGHT MIRROR</b>		<b>SIDEVIEW MIRROR</b>	
DESCRIPTION.....	10	DESCRIPTION.....	13
OPERATION.....	11	OPERATION.....	13
DIAGNOSIS AND TESTING.....	11	DIAGNOSIS AND TESTING.....	13
AUTOMATIC DAY/NIGHT MIRROR.....	11	SIDEVIEW MIRROR.....	13
REMOVAL.....	12	REMOVAL.....	14
INSTALLATION.....	12		
<b>POWER MIRROR SWITCH</b>			
DESCRIPTION.....	12		

## POWER MIRRORS

### DESCRIPTION

#### AUTOMATIC DAY / NIGHT MIRROR

The automatic day/night mirror system is able to automatically change the reflectance of the inside rear view mirror in order to reduce the glare of headlamps approaching the vehicle from the rear. The automatic day/night rear view mirror receives battery current through a fuse in the junction block only when the ignition switch is in the On position.

#### OUTSIDE REAR VIEW MIRROR

The heated mirror option includes an electric heating grid behind the mirror glass in each outside mirror, which can clear the mirror glass of ice, snow, or fog. The heating grid receives fused battery current through the heated mirror relay in the heater and air conditioner control only when the ignition switch is in the On position, and the heated mirror system is turned on. (Refer to 8 - ELECTRICAL/HEATED MIRRORS - DESCRIPTION) for more information.

Refer to the owner's manual in the vehicle glove box for more information on the features, use and operation of the power mirror system.

### OPERATION

#### AUTOMATIC DAY / NIGHT MIRROR

A switch located on the bottom of the automatic day/night mirror housing allows the vehicle operator to select whether the automatic dimming feature is operational. When the automatic day/night mirror is

turned on, the mirror switch is lighted by an integral Light-Emitting Diode (LED). The mirror will automatically disable its self-dimming feature whenever the vehicle is being driven in reverse.

Refer to the owner's manual in the vehicle glove box for more information on the features, use and operation of the automatic day/night mirror system.

#### OUTSIDE REAR VIEW MIRROR

The heated mirror option includes an electric heating grid behind the mirror glass in each outside mirror, which can clear the mirror glass of ice, snow, or fog. The heating grid receives fused battery current through the heated mirror relay in the heater and air conditioner control only when the ignition switch is in the On position, and the heated mirror system is turned on. (Refer to 8 - ELECTRICAL/HEATED MIRRORS - OPERATION) for more information.

Refer to the owner's manual in the vehicle glove box for more information on the features, use and operation of the power mirror system.

## AUTOMATIC DAY / NIGHT MIRROR

### DESCRIPTION

The automatic day/night mirror uses a thin layer of electrochromic material between two pieces of conductive glass to make up the face of the mirror. When the mirror switch is in the On position, two photocell sensors are used by the mirror circuitry to monitor external light levels and adjust the reflectance of the mirror.

## AUTOMATIC DAY / NIGHT MIRROR (Continued)

## OPERATION

The ambient photocell sensor is located on the forward-facing (windshield side) of the rear view mirror housing, and detects the ambient light levels outside of the vehicle. The headlamp photocell sensor is located inside the rear view mirror housing behind the mirror glass and faces rearward, to detect the level of the light being received at the rear window side of the mirror. When the circuitry of the automatic day/night mirror detects that the difference between the two light levels is too great (the light level received at the rear of the mirror is much higher than that at the front of the mirror), it begins to darken the mirror.

The automatic day/night mirror circuitry also monitors the transmission using an input from the backup lamp circuit. The mirror circuitry is programmed to automatically disable its self-dimming feature whenever it senses that the transmission backup lamp circuit is energized.

The automatic day/night mirror is a completely self-contained unit and cannot be repaired. If faulty or damaged, the entire mirror assembly must be replaced.

## DIAGNOSIS AND TESTING - AUTOMATIC DAY/NIGHT MIRROR

For circuit descriptions and diagrams, refer to the appropriate wiring information. The wiring information includes wiring diagrams, proper wire and connector repair procedures, details of wire harness routing and retention, connector pin-out information and location views for the various wire harness connectors, splices and grounds.

(1) Check the fuse in the junction block. If OK, go to Step 2. If not OK, repair the shorted circuit or component as required replace the faulty fuse.

(2) Turn the ignition switch to the On position. Check for battery voltage at the fuse in the junction block. If OK, go to Step 3. If not OK, repair the open circuit to the ignition switch as required.

(3) Turn the ignition switch to the Off position. Disconnect and isolate the battery negative cable. Unplug the wire harness connector from the automatic day/night mirror (Fig. 1). Connect the battery negative cable. Turn the ignition switch to the On position. Check for battery voltage at the fused ignition switch output (run/start) circuit cavity of the automatic day/night mirror wire harness connector. If OK, go to Step 4. If not OK, repair the open circuit to the junction block as required.

(4) Turn the ignition switch to the Off position. Disconnect and isolate the battery negative cable. Check for continuity between the ground circuit cavity of the automatic day/night mirror wire harness connector and a good ground. There should be conti-

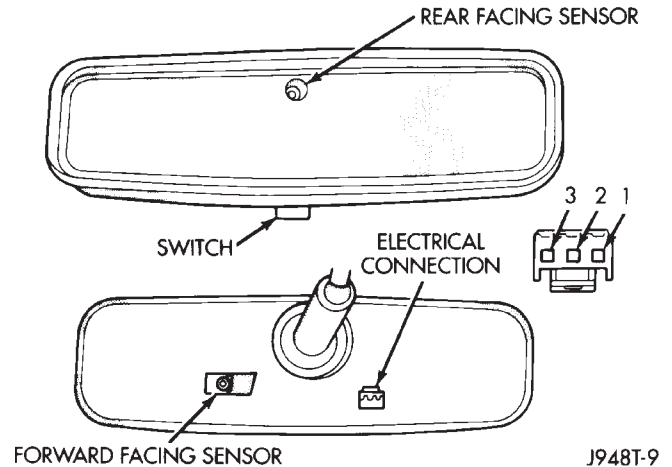


Fig. 1 Automatic Day/Night Mirror

nity. If OK, go to Step 5. If not OK, repair the circuit to ground as required.

(5) Connect the battery negative cable. Turn the ignition switch to the On position. Set the parking brake. Place the transmission gear selector lever in the Reverse position. Check for battery voltage at the backup lamp switch output circuit cavity of the automatic day/night mirror wire harness connector. If OK, go to Step 6. If not OK, repair the open circuit as required.

(6) Turn the ignition switch to the Off position. Disconnect the battery negative cable. Plug in the automatic day/night mirror wire harness connector. Connect the battery negative cable. Turn the ignition switch to the On position. Place the transmission gear selector lever in the Neutral position. Place the mirror switch in the On (LED in the mirror switch is lighted) position. Cover the forward facing ambient photocell sensor to keep out any ambient light.

**NOTE: The ambient photocell sensor must be covered completely, so that no light reaches the sensor. Use a finger pressed tightly against the sensor, or cover the sensor completely with electrical tape.**

(7) Shine a light into the rearward facing headlamp photocell sensor. The mirror glass should darken. If OK, go to Step 8. If not OK, replace the faulty automatic day/night mirror unit.

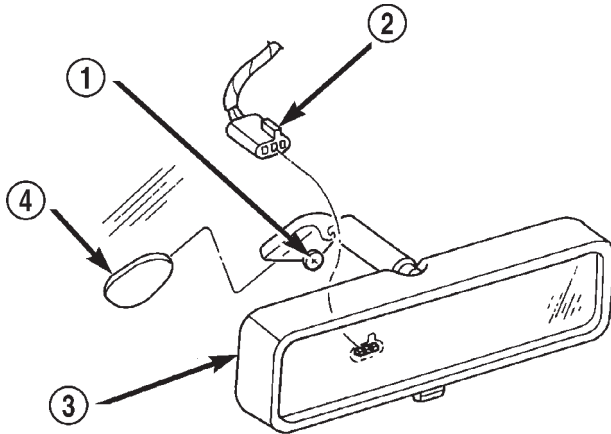
(8) With the mirror glass darkened, place the transmission gear selector lever in the Reverse position. The mirror should return to its normal reflectance. If not OK, replace the faulty automatic day/night mirror unit.

## AUTOMATIC DAY / NIGHT MIRROR (Continued)

**REMOVAL**

(1) Disconnect and isolate the battery negative cable.

(2) Unplug the wire harness connector from the automatic day/night mirror (Fig. 2).



80b1b318

**Fig. 2 AUTOMATIC DAY/NIGHT MIRROR REMOVE**

- 1 - SCREW
- 2 - WIRE HARNESS CONNECTOR
- 3 - AUTOMATIC DAY/NIGHT MIRROR
- 4 - SUPPORT BUTTON

(3) Remove the set screw that secures the automatic day/night mirror to the windshield support button.

(4) Push the automatic day/night mirror upwards far enough for the mounting bracket to clear the support button and remove the mirror from the windshield.

**INSTALLATION**

- (1) Install the mirror to the support button.
- (2) Tighten the set screw.
- (3) Reconnect the harness connector to the mirror.
- (4) Reconnect the negative battery cable.

**POWER MIRROR SWITCH****DESCRIPTION**

Both the right and left power outside mirrors are controlled by a single multi-function switch unit located on and mounted to the upper flag area of the driver side door trim panel.

**OPERATION**

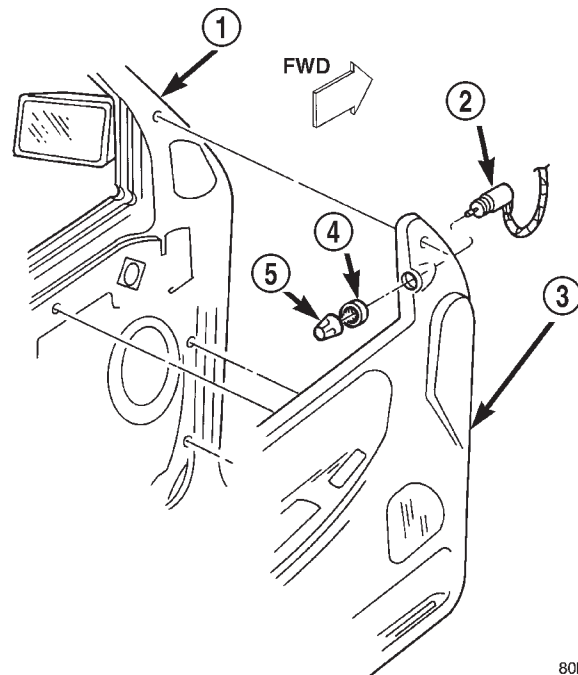
The switch knob is rotated clockwise (right mirror control), or counterclockwise (left mirror control) to select the mirror to be adjusted. The switch knob is then moved in a joystick fashion to control movement of the selected mirror up, down, right, or left.

The power mirror switch cannot be repaired and, if faulty or damaged, it must be replaced. The power mirror switch knob is available for service replacement.

**REMOVAL**

(1) Disconnect and isolate the battery negative cable.

(2) Pull the control knob rearward to remove it from the power mirror switch stem (Fig. 3).



80b1b301

**Fig. 3 POWER MIRROR SWITCH REMOVE/INSTALL**

- 1 - DOOR
- 2 - SWITCH
- 3 - DOOR TRIM PANEL
- 4 - KNOB
- 5 - NUT

## POWER MIRROR SWITCH (Continued)

(3) Remove the nut that secures the power mirror switch to the driver side front door trim panel.

(4) Remove the trim panel from the inside of the driver side front door. (Refer to 23 - BODY/DOOR - FRONT/TRIM PANEL - REMOVAL) for the procedures.

(5) Pull the trim panel away from the inner door far enough to access the power mirror switch wire harness connector.

(6) Unplug the power mirror switch wire harness connector.

(7) Remove the power mirror switch from the back of the door trim panel.

## INSTALLATION

(1) Insert the power mirror switch to the back of the door trim panel.

(2) Connect the power mirror switch to the harness connector.

(3) Install the trim panel to the inside of the driver side door. (Refer to 23 - BODY/DOOR - FRONT/TRIM PANEL - INSTALLATION).

(4) Install the nut that secures the power mirror switch to the driver side front door.

(5) Push the control knob on to the power mirror switch.

(6) Connect the battery negative cable.

## SIDEVIEW MIRROR

### DESCRIPTION

Each power mirror head contains two electric motors, two drive mechanisms, and the mirror glass. One motor and drive controls mirror up-and-down movement, and the other controls right-and-left movement.

## OPERATION

The power mirrors in vehicles equipped with the available heated mirror system option also include an electric heating grid located behind the mirror glass. This heating grid is energized by the heated mirror relay in the heater and air conditioner control only when the ignition switch is in the On position, and the heated mirror system is turned on. (Refer to 8 - ELECTRICAL/HEATED MIRRORS - DESCRIPTION) for more information.

The power mirror assembly cannot be repaired. If any component of the power mirror unit is faulty or damaged, the entire assembly must be replaced.

## DIAGNOSIS AND TESTING - SIDEVIEW MIRROR

For circuit descriptions and diagrams, refer to the appropriate wiring information. The wiring information includes wiring diagrams, proper wire and connector repair procedures, details of wire harness routing and retention, connector pin-out information and location views for the various wire harness connectors, splices and grounds.

(1) Check the fuses in the Power Distribution Center (PDC) and the junction block. If OK, go to Step 2. If not OK, repair the shorted circuit or component as required and replace the faulty fuse(s).

(2) Check for battery voltage at the fuse in the junction block. If OK, go to Step 3. If not OK, repair the open circuit to the PDC as required.

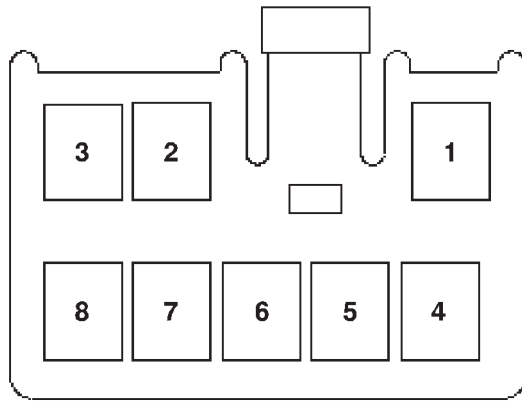
(3) Disconnect and isolate the battery negative cable. Remove the driver side door trim panel and unplug the wire harness connector from the power mirror switch. Connect the battery negative cable. Check for battery voltage at the fused B(+) circuit cavity in the door wire harness half of the power mirror switch wire harness connector. If OK, go to Step 4. If not OK, repair the open circuit to the junction block as required.



SIDEVIEW MIRROR (Continued)

(4) Disconnect and isolate the battery negative cable. Check for continuity between the ground circuit cavity in the door wire harness half of the power mirror switch wire harness connector and a good ground. There should be continuity. If OK, go to Step 5. If not OK, repair the circuit to ground as required.

(5) Check the power mirror switch continuity as shown in (Fig. 4). If OK, go to Step 6. If not OK, replace the faulty switch.

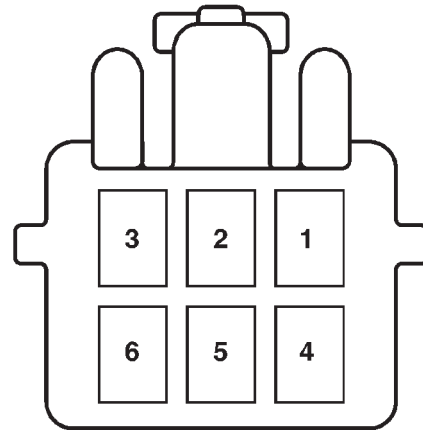


80b3f4c1

**Fig. 4 Power Mirror Switch Continuity**

MIRROR SELECTOR KNOB IN "L" POSITION	
<b>MOVE LEVER</b>	<b>CONTINUITY BETWEEN</b>
UP	Pins 3 and 8, 1 and 7, 4 and 7
RIGHT	Pins 3 and 7, 2 and 8, 5 and 8
DOWN	Pins 3 and 7, 1 and 8, 4 and 8
LEFT	Pins 3 and 8, 2 and 7, 5 and 7
MIRROR SELECTOR KNOB IN "R" POSITION	
<b>MOVE LEVER</b>	<b>CONTINUITY BETWEEN</b>
UP	Pins 6 and 8, 1 and 7, 4 and 7
RIGHT	Pins 6 and 7, 2 and 8, 4 and 8
DOWN	Pins 6 and 7, 1 and 8, 4 and 8
LEFT	Pins 6 and 8, 2 and 7, 5 and 7

(6) Unplug the wire harness connector at the inoperative power mirror. Use two jumper wires, one connected to a 12-volt battery feed, and the other connected to a good body ground. See the Power Mirror Test chart for the correct jumper wire connections to the power mirror half of the power mirror wire harness connector (Fig. 5). If the power mirror(s) do not respond as indicated in the chart, replace the faulty power mirror assembly. If the power mirror(s) do respond as indicated in the chart, repair the circuits between the power mirror and the power mirror switch for a short or open as required.



80b3f585

**Fig. 5 Power Mirror Test**

12 Volts	Ground	Left or Right Mirror MIRROR MOVEMENT
Pin 3	Pin 1	UP
Pin 1	Pin 3	DOWN
Pin 2	Pin 1	LEFT
Pin 1	Pin 2	RIGHT

**REMOVAL**

For removal procedures (Refer to 23 - BODY/EXTERIOR/SIDE VIEW MIRROR - REMOVAL) .

# POWER SEAT SYSTEM

## TABLE OF CONTENTS

	page		page
<b>POWER SEAT SYSTEM</b>		<b>POWER LUMBAR ADJUSTER</b> . . . . .	18
DESCRIPTION . . . . .	15	<b>PASSENGER POWER SEAT SWITCH</b>	
OPERATION . . . . .	15	DESCRIPTION . . . . .	19
DIAGNOSIS AND TESTING . . . . .	15	OPERATION . . . . .	19
POWER SEAT SYSTEM . . . . .	15	DIAGNOSIS AND TESTING . . . . .	19
<b>DRIVER POWER SEAT SWITCH</b>		PASSENGER POWER SEAT SWITCH . . . . .	19
DESCRIPTION . . . . .	16	REMOVAL . . . . .	20
OPERATION . . . . .	16	INSTALLATION . . . . .	20
DIAGNOSIS AND TESTING . . . . .	16	<b>RECLINER MOTOR</b>	
DRIVER POWER SEAT SWITCH . . . . .	16	DESCRIPTION . . . . .	20
REMOVAL . . . . .	17	OPERATION . . . . .	21
INSTALLATION . . . . .	17	DIAGNOSIS AND TESTING . . . . .	21
<b>LUMBAR CONTROL SWITCH</b>		POWER SEAT RECLINER . . . . .	21
DESCRIPTION . . . . .	17	<b>POWER SEAT TRACK</b>	
OPERATION . . . . .	18	DESCRIPTION . . . . .	21
REMOVAL . . . . .	18	OPERATION . . . . .	21
<b>LUMBAR MOTOR</b>		DIAGNOSIS AND TESTING . . . . .	21
DESCRIPTION . . . . .	18	POWER SEAT TRACK . . . . .	21
OPERATION . . . . .	18	REMOVAL . . . . .	22
DIAGNOSIS AND TESTING . . . . .	18	INSTALLATION . . . . .	22

## POWER SEAT SYSTEM

### DESCRIPTION

The power seat system option allows the driver (or passenger on SLT Plus with power seats) to electrically adjust the seat position for optimum control and comfort using the power seat switches located on the outboard seat cushion side shield. The power seat system allows the seating position to be adjusted forward, rearward, front up, front down, rear up, or rear down. The power seat system receives battery current through a fuse in the Power Distribution Center and a circuit breaker in the junction block, regardless of the ignition switch position.

Extended cab (club cab and quad cab) models equipped with the power seat option also feature a power operated lumbar support in the seat back. The power lumbar support allows the user to inflate or deflate a bladder located in the lower seat back to achieve optimum comfort and support in the lower lumbar region of the spinal column. The power lumbar support shares the battery feed circuit of the power seat system.

The power seat system includes the power seat adjuster and motors unit, the power lumbar support bladder and electric pump (extended cab only), the power seat switch, and the circuit breaker. Following

are general descriptions of the major components in the power seat system. Refer to the owner's manual in the vehicle glove box for more information on the features, use and operation of the power seat system.

### OPERATION

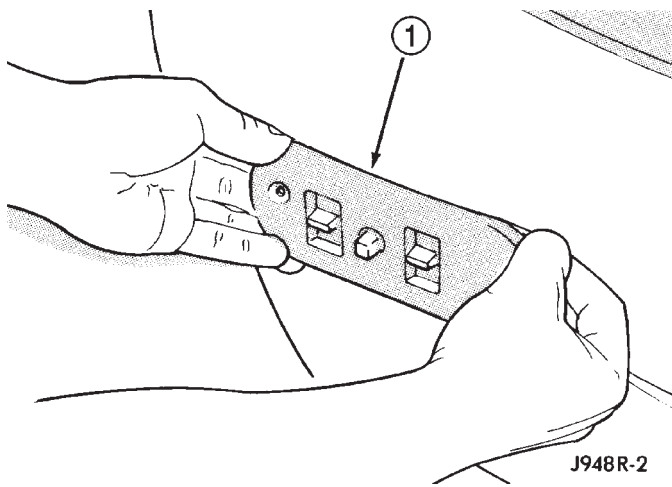
The power seat system allows the driver and/or front passenger seating positions to be adjusted electrically and independently using the separate power seat switches found on the outboard seat cushion side shield of each front seat. See the owner's manual in the vehicle glove box for more information on the features, use and operation of the power seat system.

### DIAGNOSIS & TESTING - POWER SEAT SYSTEM

Before any testing of the power seat system is attempted, the battery should be fully-charged and all wire harness connections and pins cleaned and tightened to ensure proper continuity and grounds. For circuit descriptions and diagrams, refer to Wiring Diagrams.

With the dome lamp on, apply the power seat switch in the direction of the failure. If the dome lamp dims, the seat may be jamming. Check under and behind the seat for binding or obstructions. If the dome lamp does not dim, proceed with testing of the individual components and circuits.

## DRIVER POWER SEAT SWITCH DESCRIPTION



**Fig. 1 Seat Switches and Bezel - Standard Cab**

1 - Seat Switch

The power seat in standard cab models can be adjusted in six different ways using the power seat switches (Fig. 1). The power seat switch for extended cab models (club cab and quad cab) has an additional switch knob for adjusting the power lumbar support. The switch is located on the lower outboard side of the seat cushion on the seat cushion side shield on all models. Refer to the owner's manual in the vehicle glove box for more information on the power seat switch functions and the seat adjusting procedures.

The individual switches in the power seat switch module cannot be repaired. If one switch is damaged or faulty, the entire power seat switch module must be replaced.

## OPERATION

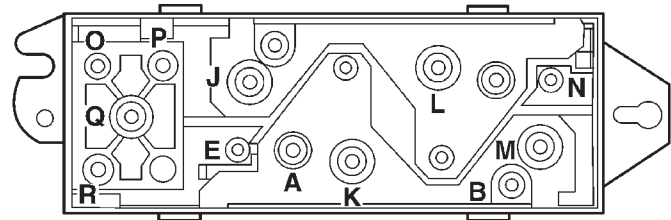
When a power switch control knob or knobs are actuated, a battery feed and a ground path are applied through the switch contacts to the power seat track or recliner adjuster motor. The selected adjuster motor operates to move the seat track or recliner through its drive unit in the selected direction until the switch is released, or until the travel limit of the adjuster is reached. When the switch is moved in the opposite direction, the battery feed and ground path to the motor are reversed through the switch contacts. This causes the adjuster motor to run in the opposite direction.

No power seat switch should be held applied in any direction after the adjuster has reached its travel limit. The power seat adjuster motors each contain a self-resetting circuit breaker to protect them from overload. However, consecutive or frequent resetting of the circuit breaker must not be allowed to continue, or the motor may be damaged.

## DIAGNOSIS & TESTING - DRIVER POWER SEAT SWITCH

For circuit descriptions and diagrams, refer to Wiring Diagrams.

- (1) Disconnect and isolate the battery negative cable.
- (2) Remove the power seat switch from the power seat.
- (3) Use an ohmmeter to test the continuity of the power seat switches in each position. See the Power Seat Switch Continuity chart (Fig. 2) . If OK, see Power Seat Adjuster and Motors or Power Lumbar Adjuster and Motor in the Diagnosis and Testing section of this group. If not OK, replace the faulty power seat switch unit.



8087ce02

**Fig. 2 Testing Driver Power Seat Switch**

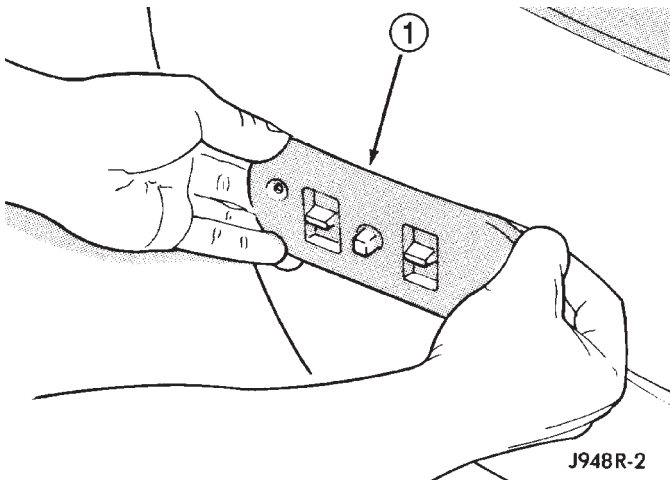
DRIVER POWER SEAT SWITCH TEST TABLE	
DRIVER SWITCH POSITION	CONTINUITY BETWEEN
OFF	B-N, B-J, B-M B-E, B-L, B-K
VERTICAL UP	A-E, A-M, B-N, B-E
VERTICAL DOWN	A-J, A-N, B-M, B-E
HORIZONTAL FORWARD	A-L, B-K
HORIZONTAL REARWARD	A-K, B-L
FRONT TILT UP	A-M, B-N
FRONT TILT DOWN	A-N, B-M
REAR TILT UP	A-E, B-J
REAR TILT DOWN	A-J, B-E
LUMBAR OFF	O-P, O-R, P-R
LUMBAR UP (INFLATE)	O-P, Q-R
LUMBAR DOWN (DEFLATE)	O-R, P-Q

## DRIVER POWER SEAT SWITCH (Continued)

**REMOVAL**

(1) Disconnect and isolate the battery negative cable.

(2) If equipped with a 6-way power seat, remove the two screws that secure the power seat switch and bezel unit to the seat cushion frame (Fig. 3).

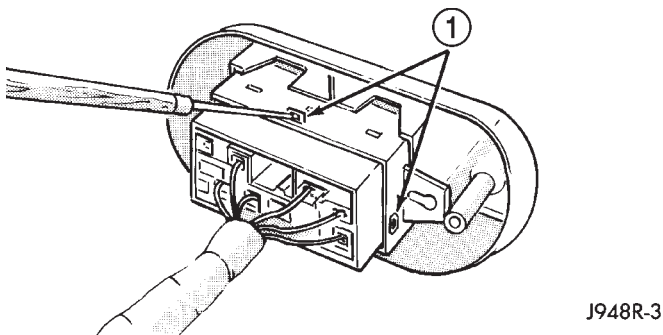


**Fig. 3 Seat Switches and Bezel - Standard Cab**

1 - Seat Switch

(3) If equipped with a 8-way power seat, remove the seat cushion side shield from the seat. Refer to Body for the procedure.

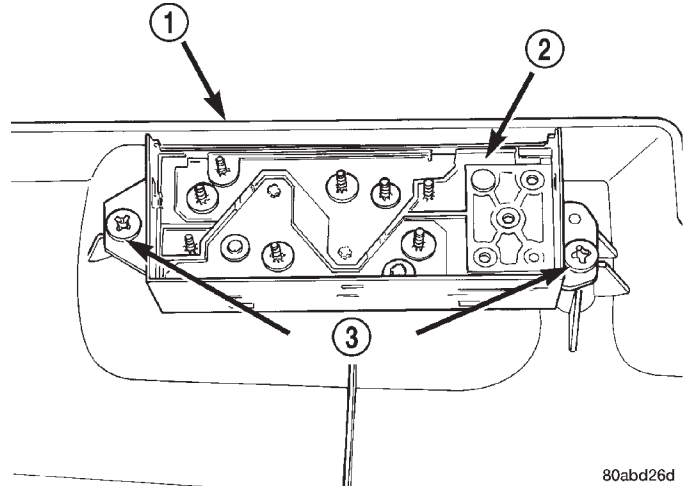
(4) Pull the switch bezel or side shield unit out from the seat far enough to access the switch wire harness connector. Gently pry the locking tabs of the switch away from the wire harness connector and carefully unplug the connector from the power seat switch module (Fig. 4).



**Fig. 4 Power Seat Switch Connector Remove - Standard Cab**

1 - Release Tabs (3)

(5) Remove the screws that secure the power seat switch (Fig. 5).



**Fig. 5 Power Seat Switch Remove/Install - Extended Cab**

1 - Seat Cushion Side Shield

2 - Power Seat Switch

3 - Retaining Screws

**INSTALLATION**

(1) Position the power seat switch on the seat cushion side shield and connect the electrical connector.

(2) Install the screws that secure the power seat switch to seat cushion side shield.

(3) Install the seat cushion side shield on the seat. Refer to Body for the procedure.

(4) If equipped, install the recliner lever on the recliner mechanism release shaft.

(5) If equipped, install the screw that secures the recliner lever to the recliner mechanism release shaft on the outboard side of the front seat.

(6) Connect the battery negative cable.

**LUMBAR CONTROL SWITCH****DESCRIPTION**

The 8-way power seat option includes an electrically operated lumbar support mechanism. A single two-way momentary power lumbar switch is integral with the power seat switches. The power lumbar switch is secured to the back of the seat cushion side shield with screws, and the switch paddle protrudes through a hole to the outside of the shield. The switch paddle is located in a shallow depression molded into the outer surface of the seat cushion side shield that helps to shroud it from unintentional actuation when entering or leaving the vehicle.

The power lumbar switches cannot be adjusted or repaired and, if faulty or damaged, the seat switch assembly must be replaced.

## LUMBAR CONTROL SWITCH (Continued)

## OPERATION

When the power lumbar switch paddle is actuated, a battery feed and a ground path are applied through the switch contacts to the power lumbar adjuster motor. The motor operates to move the lumbar adjuster through its drive unit in the selected direction until the switch is released, or until the travel limit of the adjuster is reached. When the switch is moved in the opposite direction, the battery feed and ground path to the motor are reversed through the switch contacts. This causes the motor to run in the opposite direction.

The power lumbar switch should not be held applied in either direction after the adjuster has reached its travel limit. The power lumbar adjuster motor contains a self-resetting circuit breaker to protect it from overload. However, consecutive or frequent resetting of the circuit breaker must not be allowed to continue, or the motor may be damaged.

## REMOVAL

The power lumbar switch is integral with the other power seat switches. Refer to the appropriate driver or passenger power front seat switch removal and/or installation procedure.

## LUMBAR MOTOR

## DESCRIPTION

The 8-way power seat option includes an electrically operated lumbar support mechanism. The only visible evidence of this option is the separate power lumbar switch control paddle that is located on the outboard seat cushion side shield, next to the other power seat switch control knobs. The power lumbar adjuster and motor are concealed beneath the seat back trim cover and padding, where they are secured to a molded plastic back panel and to the seat back frame.

The power lumbar adjuster cannot be repaired, and is serviced only as a unit with the seat back frame. If the power lumbar adjuster or the seat back frame are damaged or faulty, the entire seat back frame unit must be replaced. Refer to **Bucket Seat Back** in Body for the seat back frame service procedures.

## OPERATION

The power lumbar adjuster mechanism includes a reversible electric motor that is secured to the inboard side of the seat back panel and is connected to a worm-drive gearbox. The motor and gearbox operate the lumbar adjuster mechanism in the center of the seat back by extending and retracting a cable that actuates a lever. The action of this lever compresses or relaxes a grid of flexible slats. The more

this grid is compressed, the more the slats bow outward against the center of the seat back padding, providing additional lumbar support.

## DIAGNOSIS &amp; TESTING - POWER LUMBAR ADJUSTER

Actuate the power lumbar switch to move the power lumbar adjuster in each direction. The power lumbar adjuster should move in both directions. It should be noted that the power lumbar adjuster normally operates very quietly and exhibits little visible movement. If the power lumbar adjuster fails to operate in only one direction, move the adjuster a short distance in the opposite direction and test again to be certain that the adjuster is not at its travel limit. If the power lumbar adjuster still fails to operate in only one direction, refer to **Power Lumbar Switch** in the Diagnosis and Testing section of this group. If the power lumbar adjuster fails to operate in either direction, perform the following tests. For complete circuit diagrams, refer to **Power Seat** in Wiring Diagrams.

(1) Check the power seat circuit breaker in the junction block. If OK, go to Step 2. If not OK, replace the faulty power seat circuit breaker.

(2) Check for battery voltage at the power seat circuit breaker in the junction block. If OK, go to Step 3. If not OK, repair the open fused B(+) circuit to the fuse in the Power Distribution Center as required.

(3) Remove the outboard seat cushion side shield from the seat. Disconnect the seat wire harness connector from the power lumbar switch connector receptacle. Check for battery voltage at the fused B(+) circuit cavity of the power seat wire harness connector for the power lumbar switch. If OK, go to Step 4. If not OK, repair the open fused B(+) circuit to the power seat circuit breaker in the junction block as required.

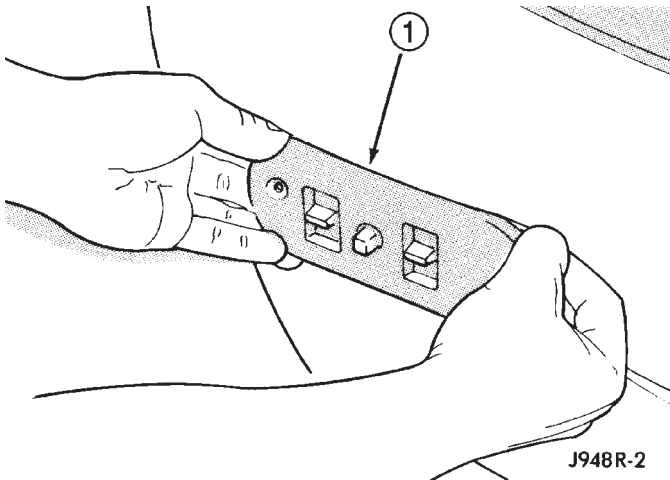
(4) Check for continuity between the ground circuit cavity of the power seat wire harness connector for the power lumbar switch and a good ground. There should be continuity. If OK, go to Step 5. If not OK, repair the open ground circuit to ground as required.

(5) Test the power lumbar switch. Refer to **Power Lumbar Switch** in the Diagnosis and Testing section of this group. If the switch tests OK, test the circuits of the power seat wire harness between the power lumbar adjuster motor and the power lumbar switch for shorts or opens. If the circuits check OK, replace the faulty seat back frame assembly. If the circuits are not OK, repair the power seat wire harness as required.



## PASSENGER POWER SEAT SWITCH

### DESCRIPTION



**Fig. 6 Seat Switches and Bezel - Standard Cab**

1 - Seat Switch

The power seat in standard cab models can be adjusted in six different ways using the power seat switches (Fig. 6). The power seat switch for extended cab models (club cab and quad cab) has an additional switch knob for adjusting the power lumbar support. The switch is located on the lower outboard side of the seat cushion on the seat cushion side shield on all models. Refer to the owner's manual in the vehicle glove box for more information on the power seat switch functions and the seat adjusting procedures.

The individual switches in the power seat switch module cannot be repaired. If one switch is damaged or faulty, the entire power seat switch module must be replaced.

### OPERATION

When a power switch control knob or knobs are actuated, a battery feed and a ground path are applied through the switch contacts to the power seat track or recliner adjuster motor. The selected adjuster motor operates to move the seat track or recliner through its drive unit in the selected direction until the switch is released, or until the travel limit of the adjuster is reached. When the switch is moved in the opposite direction, the battery feed and ground path to the motor are reversed through the switch contacts. This causes the adjuster motor to run in the opposite direction.

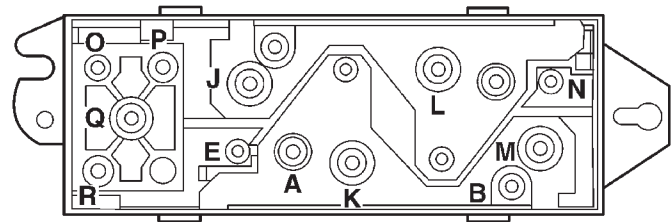
No power seat switch should be held applied in any direction after the adjuster has reached its travel limit. The power seat adjuster motors each contain a self-resetting circuit breaker to protect them from overload. However, consecutive or frequent resetting

of the circuit breaker must not be allowed to continue, or the motor may be damaged.

### DIAGNOSIS & TESTING - PASSENGER POWER SEAT SWITCH

For circuit descriptions and diagrams, refer to Wiring Diagrams.

- (1) Disconnect and isolate the battery negative cable.
- (2) Remove the power seat switch from the power seat.
- (3) Use an ohmmeter to test the continuity of the power seat switches in each position. See the Power Seat Switch Continuity chart below (Fig. 7) . If OK, see Power Seat Adjuster and Motors or Power Lumbar Adjuster and Motor in the Diagnosis and Testing section of this group. If not OK, replace the faulty power seat switch unit.



8087ce02

**Fig. 7 Testing Passenger Power Seat Switch**

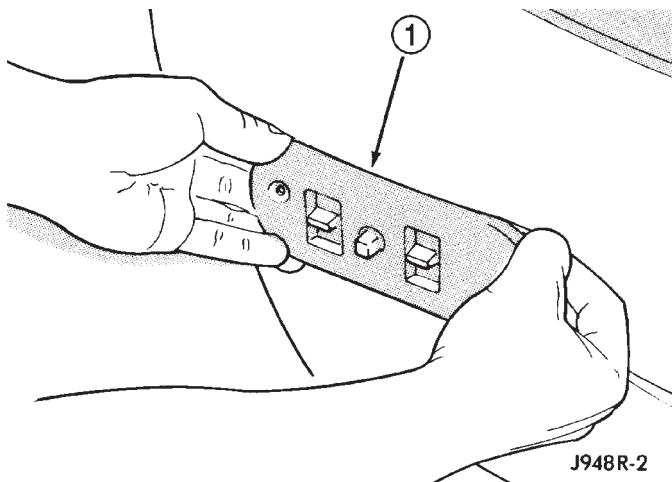
PASSENGER POWER SEAT SWITCH TEST TABLE	
PASSENGER SWITCH POSITION	CONTINUITY BETWEEN
OFF	B-N, B-J, B-M, B-E, B-L, B-K
VERTICAL DOWN	A-E, A-M, B-N, B-E
VERTICAL UP	A-J, A-N, B-M, B-E
HORIZONTAL FORWARD	A-L, B-K
HORIZONTAL REARWARD	A-K, B-L
FRONT TILT DOWN	A-M, B-N
FRONT TILT UP	A-N, B-M
REAR TILT DOWN	A-E, B-J
REAR TILT UP	A-J, B-E
LUMBAR OFF	O-P, O-R, P-R
LUMBAR DOWN (DEFLATE)	O-P, Q-R
LUMBAR UP (INFLATE)	O-R, P-Q

## PASSENGER POWER SEAT SWITCH (Continued)

**REMOVAL**

(1) Disconnect and isolate the battery negative cable.

(2) If equipped with a 6-way power seat, remove the two screws that secure the power seat switch and bezel unit to the seat cushion frame (Fig. 8).

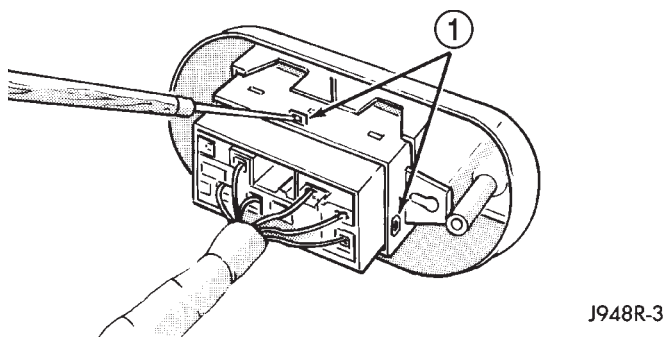


**Fig. 8 Seat Switches and Bezel - Standard Cab**

1 - Seat Switch

(3) If equipped with a 8-way power seat, remove the seat cushion side shield from the seat. Refer to Body for the procedure.

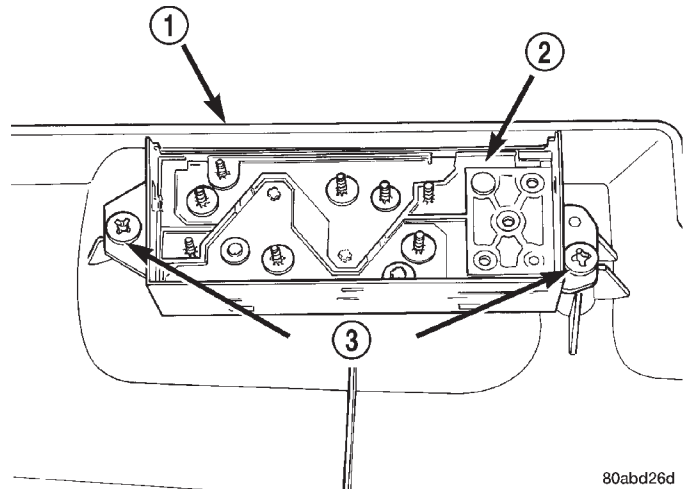
(4) Pull the switch bezel or side shield unit out from the seat far enough to access the switch wire harness connector. Gently pry the locking tabs of the switch away from the wire harness connector and carefully unplug the connector from the power seat switch module (Fig. 9).



**Fig. 9 Power Seat Switch Connector Remove - Standard Cab**

1 - Release Tabs (3)

(5) Remove the screws that secure the power seat switch (Fig. 10).



**Fig. 10 Power Seat Switch Remove/Install - Extended Cab**

1 - Seat Cushion Side Shield  
2 - Power Seat Switch  
3 - Retaining Screws

**INSTALLATION**

(1) Position the power seat switch on the seat cushion side shield and connect the electrical connector.

(2) Install the screws that secure the power seat switch to seat cushion side shield.

(3) Install the seat cushion side shield on the seat. Refer to Body for the procedure.

(4) If equipped, install the recliner lever on the recliner mechanism release shaft.

(5) If equipped, install the screw that secures the recliner lever to the recliner mechanism release shaft on the outboard side of the front seat.

(6) Connect the battery negative cable.

**RECLINER MOTOR****DESCRIPTION**

The 8-way power seat option includes an electrically operated seat back recliner mechanism. The only visible evidence of this option is the power seat recliner switch control knob that is located on the outboard seat cushion side shield, just behind the other power seat switch control knob. The power seat recliner switch is integral to the 8-way power seat switch.

The power seat recliner unit is mounted in the place of a seat hinge on the outboard side of the seat. The upper hinge plate of the power seat recliner mechanism is secured with two screws to the seat back frame and is concealed beneath the seat back trim cover and padding. The lower hinge plate and

## RECLINER MOTOR (Continued)

the motor and drive unit of the power seat recliner mechanism is secured with two screws to the seat cushion frame, and is concealed by the outboard seat cushion side shield.

The power seat recliner cannot be repaired. If the unit is faulty or damaged, it must be replaced. Refer to **Bucket Seat Recliner** in Body for the service procedure.

## OPERATION

The power seat recliner includes a reversible electric motor that is secured to the lower hinge plate of the recliner unit. The motor is connected to a gearbox that moves the upper hinge plate of the power seat recliner through a screw-type drive unit.

## DIAGNOSIS & TESTING - POWER SEAT RECLINER

Following are tests that will help to diagnose the hard wired components and circuits of the power seat system. Actuate the power seat recliner switch to move the power seat recliner adjuster in each direction. The power seat recliner adjuster should move in both directions. If the power seat recliner adjuster fails to operate in only one direction, move the adjuster a short distance in the opposite direction and test again to be certain that the adjuster is not at its travel limit. If the power seat recliner adjuster still fails to operate in only one direction, refer to **Power Seat Switch** in the Diagnosis and Testing section of this group. If the power recliner adjuster fails to operate in either direction, perform the following tests. For complete circuit diagrams, refer to **Power Seat** in Wiring Diagrams.

(1) Check the power seat circuit breaker in the junction block. If OK, go to Step 2. If not OK, replace the faulty power seat circuit breaker.

(2) Check for battery voltage at the power seat circuit breaker in the junction block. If OK, go to Step 3. If not OK, repair the open fused B(+) circuit to the fuse in the Power Distribution Center as required.

(3) Remove the outboard seat cushion side shield from the seat. Disconnect the seat wire harness connector from the power seat switch connector receptacle. Check for battery voltage at the fused B(+) circuit cavity of the power seat wire harness connector for the power seat switch. If OK, go to Step 4. If not OK, repair the open fused B(+) circuit to the power seat circuit breaker in the junction block as required.

(4) Check for continuity between the ground circuit cavity of the power seat wire harness connector for the power seat switch and a good ground. There should be continuity. If OK, go to Step 5. If not OK, repair the open ground circuit to ground as required.

(5) Test the power seat switch. Refer to **Power Seat Switch** in the Diagnosis and Testing section of this group. If the switch tests OK, test the circuits of the power seat wire harness between the power seat recliner adjuster motor and the power seat switch for shorts or opens. If the circuits check OK, replace the faulty power seat recliner unit. If the circuits are not OK, repair the power seat wire harness as required.

## POWER SEAT TRACK

### DESCRIPTION

There are three reversible motors that operate the power seat adjuster. The motors are connected to worm-drive gearboxes that move the seat adjuster through a combination of screw-type drive units.

The front and rear of a seat are operated by different motors. They can be raised or lowered independently of each other. When the center seat switch is pushed in the Up or Down direction, both the front and rear motors operate in unison. On standard cab models the entire seat is moved up or down, on extended cab models (club cab and quad cab) the seat cushion moves independently of the seat back in the up or down directions. The forward-rearward motor is operated by pushing the center seat switch in the Forward or Rearward direction, which moves the entire seat in the selected direction on all models.

Each motor contains a self-resetting circuit breaker to protect it from overload. Consecutive or frequent resetting of the circuit breakers must not be allowed to continue, or the motors may be damaged. Make the necessary repairs.

The power seat adjuster and motors cannot be repaired, and are serviced only as a complete unit. If any component in this unit is faulty or damaged, the entire power seat adjuster and motors assembly must be replaced.

### OPERATION

When a power seat switch is actuated, a battery feed and a ground path are applied through the switch contacts to the motor(s). The motor(s) and drive unit(s) operate to move the seat in the selected direction until the switch is released, or until the travel limit of the power seat adjuster is reached. When the switch is moved in the opposite direction, the battery feed and ground path to the motor(s) are reversed through the switch contacts. This causes the motor to run in the opposite direction.

## DIAGNOSIS & TESTING - POWER SEAT TRACK

For circuit descriptions and diagrams, refer to Wiring Diagrams.

## POWER SEAT TRACK (Continued)

Operate the power seat switch to move all three seat motors in each direction. The seat should move in each of the selected directions. If the power seat adjuster fails to operate in only one direction, move the adjuster a short distance in the opposite direction and test again to be certain that the adjuster is not at its travel limit. If the power seat adjuster still fails to operate in only one direction, see Power Seat Switch in the Diagnosis and Testing section of this group. If the power seat adjuster fails to operate in more than one direction, proceed as follows:

(1) Test the fuse in the power distribution center as described in this group. If OK, go to Step 2. If not OK, replace the faulty fuse.

(2) Remove the power seat switch from the seat. Check for battery voltage at the fused B(+) circuit cavity of the power seat switch wire harness connector. If OK, go to Step 3. If not OK, repair the open circuit to the power distribution center as required.

(3) Check for continuity between the ground circuit cavity of the power seat switch wire harness connector and a good ground. There should be continuity. If OK, go to Step 4. If not OK, repair the open circuit to ground as required.

(4) Test the power seat switch as described in this group. If the switch tests OK, check the wire harness for the inoperative power seat motor(s) between the power seat switch and the motor for shorts or opens. If the circuits check OK, replace the faulty power seat adjuster and motors assembly. If the circuits are not OK, repair the wire harness as required.

**REMOVAL**

(1) Disconnect and isolate the battery negative cable.

(2) Remove the seat, power seat track from the vehicle as a unit. Refer to Body for the procedure.

(3) Unplug the power seat wire harness connectors at each of the three power seat motors.

(4) Release the power seat wire harness retainers from the seat track.

(5) Remove the fasteners that secure the center seat cushion section to the brackets on the power seat track.

(6) Remove the screws that secure the power seat track assembly to the seat cushion frame.

(7) Remove the power seat track assembly from the seat cushion frame.

**INSTALLATION**

(1) Position the power seat track assembly on the seat cushion frame.

(2) Install the fasteners that secure the center seat cushion section to the brackets on the power seat adjuster.

(3) Install the screws that secure the power seat track assembly to the seat cushion frame.

(4) Connect the power seat wire harness connectors at each of the three power seat motors.

(5) Install the power seat wire harness retainers on the seat track assembly.

(6) Install the seat, power seat track as a unit. Refer to Body for the procedure.

(7) Connect the battery negative cable.



# POWER WINDOWS

## TABLE OF CONTENTS

	page		page
<b>POWER WINDOWS</b>		<b>POWER WINDOW SWITCH</b> . . . . .	24
DESCRIPTION . . . . .	23	REMOVAL . . . . .	25
OPERATION . . . . .	23	INSTALLATION . . . . .	26
DIAGNOSIS AND TESTING . . . . .	23	<b>WINDOW MOTOR</b>	
POWER WINDOWS . . . . .	23	DESCRIPTION . . . . .	26
<b>POWER WINDOW SWITCH</b>		DIAGNOSIS AND TESTING . . . . .	26
DESCRIPTION . . . . .	24	WINDOW MOTOR . . . . .	26
OPERATION . . . . .	24	REMOVAL . . . . .	26
DIAGNOSIS AND TESTING . . . . .	24		

## POWER WINDOWS

### DESCRIPTION

Power windows are available as factory-installed optional equipment on this model. The power lock system is included on vehicles equipped with the power window option.

### OPERATION

The power window system allows each of the front door windows to be raised and lowered electrically by actuating a switch on the trim panel of each respective door. Additionally, the master switch on the driver side door trim panel allows the driver to raise or lower the passenger side front door window. The power window system receives battery feed through a circuit breaker in the junction block, only when the ignition switch is in the On position.

The power window system includes the power window switches on each front door trim panel, the circuit breaker in the junction block, and the power window motors inside each front door. This group covers diagnosis and service of only the electrical components in the power window system. For service of mechanical components, such as the regulator, lift plate, window tracks, or glass refer to Group 23 - Body.

Refer to the owner's manual in the vehicle glove box for more information on the features, use and operation of the power window system.

### DIAGNOSIS AND TESTING - POWER WINDOWS

For circuit descriptions and diagrams, refer to the appropriate wiring information. The wiring information includes wiring diagrams, proper wire and connector repair procedures, details of wire harness routing and retention, connector pin-out information

and location views for the various wire harness connectors, splices and grounds.

### ALL WINDOWS INOPERATIVE

(1) Check the circuit breaker in the junction block. If OK, go to Step 2. If not OK, replace the faulty circuit breaker.

(2) Disconnect and isolate the battery negative cable. Remove the power window and lock switch and bezel unit from the driver side front door trim panel. Unplug the wire harness connector from the switch and bezel unit.

(3) Check for continuity between the ground circuit cavity of the switch and bezel unit wire harness connector and a good ground. If OK, (Refer to 8 - ELECTRICAL/POWER WINDOWS/POWER WINDOW SWITCH - DIAGNOSIS AND TESTING). If not OK, repair the circuit to ground as required.

### ONE WINDOW INOPERATIVE

The window glass must be free to slide up and down for the power window motor to function properly. If the glass is not free to move up and down, the motor will overload and trip the integral circuit breaker. To determine if the glass is free, disconnect the regulator plate from the glass. Then slide the window up and down by hand.

There is an alternate method to check if the glass is free. Position the glass between the up and down stops. Then, shake the glass in the door. Check that the glass can be moved slightly from side to side, front to rear, and up and down. Then check that the glass is not bound tight in the tracks. If the glass is free, proceed with the diagnosis that follows. If the glass is not free, (Refer to 23 - BODY/DOOR - FRONT/DOOR GLASS - REMOVAL).

(1) Disconnect and isolate the battery negative cable. Remove the power window and lock switch and bezel unit from the door trim panel on the side of the



## POWER WINDOWS (Continued)

vehicle with the inoperative window. Unplug the wire harness connector from the switch and bezel unit.

(2) Connect the battery negative cable. Turn the ignition switch to the On position. Check for battery voltage at the fused ignition switch output (run) circuit cavity in the body half of the switch and bezel unit wire harness connector. If OK, and the inoperative power window is on the driver side, go to Step 4. If OK, and the inoperative power window is on the passenger side, go to Step 3. If not OK, repair the open circuit to the junction block as required.

(3) Disconnect and isolate the battery negative cable. Check for continuity between each of the two master window switch right up/down control circuit cavities in the body half of the passenger side switch and bezel unit wire harness connector and a good ground. In each case, there should be continuity. If OK, go to Step 4. If not OK, repair the open circuit to the driver side switch and bezel unit as required.

(4) Test the power window switch continuity. (Refer to 8 - ELECTRICAL/POWER WINDOWS/POWER WINDOW SWITCH - DIAGNOSIS AND TESTING). If OK, go to Step 5. If not OK, replace the faulty power window and lock switch and bezel unit.

(5) Refer to the appropriate wiring information. The wiring information includes wiring diagrams, proper wire and connector repair procedures, details of wire harness routing and retention, connector pin-out information and location views for the various wire harness connectors, splices and grounds. Check the continuity in each circuit between the inoperative power window and lock switch and bezel unit wire harness connector cavities and the corresponding power window motor wire harness connector cavities. If OK, (Refer to 8 - ELECTRICAL/POWER WINDOWS/WINDOW MOTOR - DIAGNOSIS AND TESTING). If not OK, repair the open circuit(s) as required.

**NOTE:** The passenger side power window switch receives the ground feed for operating the passenger side power window motor through the driver side power window switch and wire harness connector.

## POWER WINDOW SWITCH

### DESCRIPTION

The power windows are controlled by two-way switches integral to the power window and lock switch and bezel unit on the trim panel of each front door. A second power window switch in the driver side switch and bezel unit allows the driver to control the passenger side window. A Light-Emitting Diode

(LED) in the paddle of each switch is illuminated whenever the ignition switch is in the On position.

### OPERATION

The power window switch for the driver side front door has an Auto label on it. This switch has a second detent position beyond the normal Down position that provides an automatic one-touch window down feature. This feature is controlled by an electronic circuit and a relay that are integral to the driver side front door power window and lock switch unit.

The power window switches control the battery and ground feeds to the power window motors. The passenger side power window switch receives a ground feed through the driver side power window switch for operating the passenger side power window motor.

The power window and lock switch and bezel unit cannot be repaired and, if faulty or damaged, the entire switch and bezel unit must be replaced.

### DIAGNOSIS AND TESTING - POWER WINDOW SWITCH

The auto down feature of the driver side power window switch is controlled by an electronic circuit within the switch unit. The auto down circuitry is activated when the driver side power window switch is moved to the second detent in the Down direction. The outputs from the auto down circuitry are carried through the same switch pins that provide the normal down function. The auto down circuit cannot be tested. If the driver side power window switch continuity tests are passed, but the auto down feature is inoperative, replace the faulty driver side power window switch unit.

The Light-Emitting Diode (LED) illumination lamps for all of the power window and lock switch and bezel unit switch paddles receive battery current through the power window circuit breaker in the junction block. If all of the LEDs are inoperative in either or both power window and lock switch and bezel units and the power windows are inoperative, perform the diagnosis for Power Window System in this group. If the power windows operate, but any or all of the LEDs are inoperative, the power window and lock switch and bezel unit with the inoperative LED(s) is faulty and must be replaced. For circuit descriptions and diagrams, refer to the appropriate wiring information. The wiring information includes wiring diagrams, proper wire and connector repair procedures, details of wire harness routing and retention, connector pin-out information and location views for the various wire harness connectors, splices and grounds.

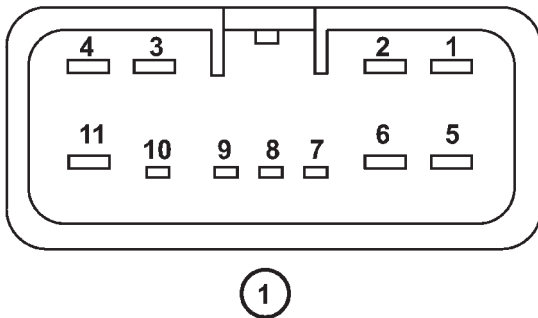
## POWER WINDOW SWITCH (Continued)

(1) Check the circuit breaker in the junction block. If OK, go to Step 2. If not OK, replace the faulty circuit breaker.

(2) Turn the ignition switch to the On position. Check for battery voltage at the circuit breaker in the junction block. If OK, turn the ignition switch to the Off position and go to Step 3. If not OK, repair the circuit to the ignition switch as required.

(3) Disconnect and isolate the battery negative cable. Remove the power window and lock switch and bezel unit from the door trim panel. Unplug the wire harness connector from the switch and bezel unit.

(4) Test the power window switch continuity. See the Power Window Switch Continuity charts to determine if the continuity is correct in the Neutral, Up and Down switch positions (Fig. 1) or (Fig. 2). If OK, (Refer to 8 - ELECTRICAL/POWER WINDOWS/WINDOW MOTOR - DIAGNOSIS AND TESTING) If not OK, replace the faulty switch.



80a2a5ba

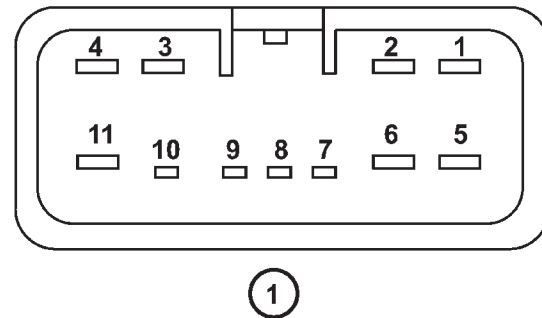
**Fig. 1 Power Window Switch Continuity — Driver Side**

DRIVER SIDE WINDOW SWITCH	
SWITCH POSITION	CONTINUITY BETWEEN
NEUTRAL	1 & 4, 2 & 3, 3&4, 3 & 6
LEFT UP	3 & 4, 5 & 6
RIGHT UP	1 & 5, 2 & 3
LEFT DOWN	3 & 6, 4 & 5
RIGHT DOWN	1 & 3, 2 & 5
LAMP	3 & 5

## REMOVAL

(1) Disconnect and isolate the battery negative cable.

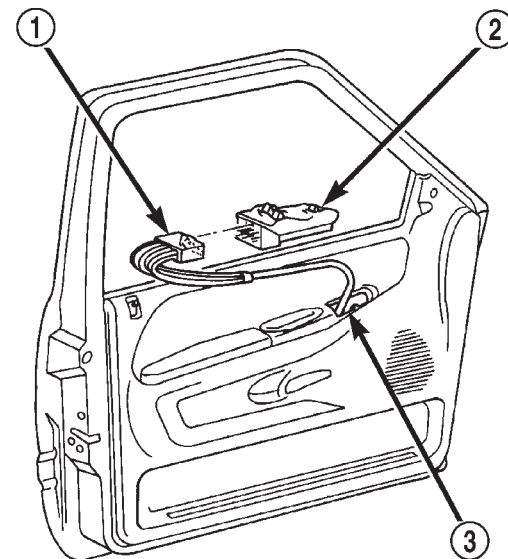
(2) Using a wide flat-bladed tool such as a trim stick, gently pry the upper edge of the switch bezel at the front and the rear to release the retainer clips that secure the switch bezel to the door trim panel opening (Fig. 3).



80a2a611

**Fig. 2 Power Window Switch Continuity - Passenger Side**

PASSENGER SIDE WINDOW SWITCH	
SWITCH POSITION	CONTINUITY BETWEEN
NEUTRAL	1 & 4, 2 & 3
UP	2 & 3, 4 & 11
DOWN	1 & 4, 3 & 11
LAMP	8 & 11



80b1b30e

**Fig. 3 Power Window and Lock Switch and Bezel Unit Remove/Install**

- 1 - ELECTRICAL CONNECTOR  
2 - POWER WINDOW/LOCK SWITCH PANEL  
3 - WIRE HARNESS

(3) Pull the switch and bezel unit away from the door trim panel opening far enough to access and unplug the wire harness connector.

(4) Remove the power window and lock switch and bezel unit from the door trim panel.

## POWER WINDOW SWITCH (Continued)

**INSTALLATION**

- (1) Connect the power window switch to the harness connector.
- (2) Insert the rear of the switch and bezel unit into the opening.
- (3) Push down on the front of the switch until the retaining tabs snap into place.
- (4) Reconnect the battery negative cable.

**WINDOW MOTOR****DESCRIPTION**

A permanent magnet reversible motor moves the window regulator through an integral gearbox mechanism. A positive and negative battery connection to the two motor terminals will cause the motor to rotate in one direction. Reversing the current through these same two connections will cause the motor to rotate in the opposite direction.

In addition, each power window motor is equipped with an integral self-resetting circuit breaker to protect the motor from overloads. The power window motor and gearbox assembly cannot be repaired and, if faulty or damaged, the entire power window regulator assembly must be replaced.

**DIAGNOSIS AND TESTING - WINDOW MOTOR**

For circuit descriptions and diagrams, refer to the appropriate wiring information. The wiring information includes wiring diagrams, proper wire and connector repair procedures, details of wire harness routing and retention, connector pin-out information and location views for the various wire harness connectors, splices and grounds. Before you proceed with

this diagnosis, confirm proper switch operation. (Refer to 8 - ELECTRICAL/POWER WINDOWS/POWER WINDOW SWITCH - DIAGNOSIS AND TESTING).

(1) Disconnect and isolate the battery negative cable. Remove the trim panel from the door with the inoperative power window.

(2) Unplug the power window motor wire harness connector. Apply 12 volts across the motor terminals to check its operation in one direction. Reverse the connections across the motor terminals to check the operation in the other direction. Remember, if the window is in the full up or full down position, the motor will not operate in that direction by design. If OK, repair the circuits from the power window motor to the power window switch as required. If not OK, replace the faulty motor.

(3) If the motor operates in both directions, check the operation of the window glass and lift mechanism through its complete up and down travel. There should be no binding or sticking of the window glass or lift mechanism through the entire travel range. If not OK, (Refer to 23 - BODY/DOOR - FRONT/WINDOW REGULATOR - REMOVAL).

**REMOVAL**

The power window motor and mechanism is integral to the power window regulator unit. If the power window motor or mechanism is faulty or damaged, the entire power window regulator unit must be replaced. (Refer to 23 - BODY/DOOR - FRONT/WINDOW REGULATOR - REMOVAL) for the window regulator service procedures.

# RESTRAINTS

## TABLE OF CONTENTS

	page		page
<b>RESTRAINTS</b>		<b>FRONT SEAT BELT &amp; RETRACTOR</b>	
DESCRIPTION . . . . .	1	REMOVAL . . . . .	18
OPERATION . . . . .	2	INSTALLATION . . . . .	19
WARNING . . . . .	3	<b>FRONT SEAT BELT BUCKLE</b>	
DIAGNOSIS AND TESTING . . . . .	4	REMOVAL . . . . .	20
AIRBAG SYSTEM . . . . .	4	INSTALLATION . . . . .	20
STANDARD PROCEDURE . . . . .	4	<b>PASSENGER AIRBAG</b>	
HANDLING NON-DEPLOYED AIRBAGS . . . . .	4	DESCRIPTION . . . . .	21
SERVICE AFTER AN AIRBAG		OPERATION . . . . .	21
DEPLOYMENT . . . . .	4	REMOVAL . . . . .	21
VERIFICATION TEST . . . . .	5	INSTALLATION . . . . .	23
SPECIAL TOOLS . . . . .	6	<b>PASSENGER AIRBAG ON/OFF SWITCH</b>	
<b>AIRBAG CONTROL MODULE</b>		DESCRIPTION . . . . .	23
DESCRIPTION . . . . .	6	OPERATION . . . . .	24
OPERATION . . . . .	6	REMOVAL . . . . .	24
REMOVAL . . . . .	7	INSTALLATION . . . . .	25
INSTALLATION . . . . .	8	<b>REAR SEAT BELT &amp; RETRACTOR</b>	
<b>CHILD TETHER</b>		REMOVAL . . . . .	26
REMOVAL . . . . .	9	INSTALLATION . . . . .	26
INSTALLATION . . . . .	9	<b>REAR SEAT BELT BUCKLE</b>	
<b>CLOCKSPRING</b>		REMOVAL . . . . .	27
DESCRIPTION . . . . .	10	INSTALLATION . . . . .	27
OPERATION . . . . .	10	<b>SEAT BELT SWITCH</b>	
STANDARD PROCEDURE . . . . .	11	DESCRIPTION . . . . .	28
CLOCKSPRING CENTERING . . . . .	11	OPERATION . . . . .	28
REMOVAL . . . . .	11	DIAGNOSIS AND TESTING . . . . .	28
INSTALLATION . . . . .	13	SEAT BELT SWITCH . . . . .	28
<b>DRIVER AIRBAG</b>		<b>SEAT BELT TURNING LOOP ADJUSTER</b>	
DESCRIPTION . . . . .	14	REMOVAL . . . . .	29
OPERATION . . . . .	14	INSTALLATION . . . . .	29
REMOVAL . . . . .	14	<b>TURNING LOOP HEIGHT ADJUSTER KNOB</b>	
DISASSEMBLY . . . . .	15	REMOVAL . . . . .	30
ASSEMBLY . . . . .	17	INSTALLATION . . . . .	30
INSTALLATION . . . . .	18		

## RESTRAINTS

### DESCRIPTION

A dual front airbag system is standard factory-installed safety equipment on this model. The airbag system is a passive, inflatable, Supplemental Restraint System (SRS) and vehicles with this equipment can be readily identified by the "SRS - AIRBAG" logo molded into the driver airbag trim cover in the center of the steering wheel and also into the passenger airbag door on the instrument panel above the glove box (Fig. 1). Vehicles with the airbag system can also be identified by the airbag indicator,

which will illuminate in the instrument cluster for about seven seconds as a bulb test each time the ignition switch is turned to the On position.

The dual front airbag system consists of the following major components, which are described in further detail elsewhere in this service manual:

- **Airbag Control Module** - The Airbag Control Module (ACM) is located on a mount on the floor panel transmission tunnel, below the center of the instrument panel.

- **Airbag Indicator** - The airbag indicator is integral to the ElectroMechanical Instrument Cluster (EMIC), which is located on the instrument panel in front of the driver.

## RESTRAINTS (Continued)



8098029e

*Fig. 1 SRS Logo*

- **Clockspring** - The clockspring is located near the top of the steering column, directly beneath the steering wheel.
- **Driver Airbag** - The driver airbag is located in the center of the steering wheel, beneath the driver airbag trim cover.
- **Driver Knee Blocker** - The driver knee blocker is a molded plastic structural unit secured to the back side of and integral to the instrument panel steering column opening cover.
- **Passenger Airbag** - The passenger airbag is located on the instrument panel, beneath the passenger airbag door on the instrument panel above the glove box on the passenger side of the vehicle.
- **Passenger Airbag On/Off Switch** - The passenger airbag on/off switch is located in a dedicated opening in the upper right corner of the instrument panel cluster bezel, to the right of the center panel outlets of the climate control system.
- **Passenger Knee Blocker** - The passenger knee blocker is a structural reinforcement that is integral to and concealed within the glove box door.

The ACM and the EMIC each contain a central processing unit and programming that allow them to communicate with each other using the Chrysler Collision Detection (CCD) data bus network. This method of communication is used for control of the airbag indicator on all models. (Refer to 8 - ELECTRICAL/ELECTRONIC CONTROL MODULES/COMMUNICATION - DESCRIPTION).

Hard wired circuitry connects the airbag system components to each other through the electrical system of the vehicle. These hard wired circuits are integral to several wire harnesses, which are routed throughout the vehicle and retained by many different methods. These circuits may be connected to each other, to the vehicle electrical system, and to the airbag system components through the use of a combination of soldered splices, splice block connectors,

and many different types of wire harness terminal connectors and insulators. Refer to the appropriate wiring information. The wiring information includes wiring diagrams, proper wire and connector repair procedures, further details on wire harness routing and retention, as well as pin-out and location views for the various wire harness connectors, splices and grounds.

**OPERATION**

The airbag system is referred to as a supplemental restraint system because it was designed and is intended to enhance the protection for the front seat occupants of the vehicle **only** when used in conjunction with the seat belts. It is referred to as a passive system because the vehicle occupants are not required to do anything to make it work. The primary passenger restraints in this or any other vehicle are the standard equipment factory-installed seat belts. Seat belts are referred to as an active restraint because the vehicle occupants are required to physically fasten and properly adjust these restraints in order to benefit from them. The vehicle occupants must be wearing their seat belts in order to obtain the maximum safety benefit from the factory-installed airbag system.

The airbag system electrical circuits are continuously monitored and controlled by a microprocessor and software contained within the Airbag Control Module (ACM). An airbag indicator in the ElectroMechanical Instrument Cluster (EMIC) lights for about seven seconds as a bulb test each time the ignition switch is turned to the On or Start positions. Following the bulb test, the airbag indicator is turned on or off by the ACM to indicate the status of the airbag system. If the airbag indicator comes on at any time other than during the bulb test, it indicates that there is a problem in the airbag system electrical circuits. Such a problem may cause the airbags not to deploy when required, or to deploy when not required.

The clockspring on the top of the steering column allows a continuous electrical circuit to be maintained between the stationary steering column and the driver airbag inflator, which rotates with the steering wheel. The passenger airbag on/off switch allows the passenger side airbag to be disabled when circumstances necessitate that a child, or an adult with certain medical conditions be placed in the front passenger seating position. Refer to the owner's manual in the vehicle glove box for specific recommendations concerning the specific circumstances where the passenger airbag on/off switch should be used to disable the passenger airbag.



## RESTRAINTS (Continued)

Deployment of the airbags depends upon the angle and severity of the impact. The airbag system is designed to deploy upon a frontal impact within a thirty degree angle from either side of the vehicle center line. Deployment is not based upon vehicle speed; rather, deployment is based upon the rate of deceleration as measured by the forces of gravity (G force) upon the airbag system impact sensor, which is integral to the ACM. When a frontal impact is severe enough, the microprocessor in the ACM signals the inflator units of both airbag modules to deploy the airbags. During a frontal vehicle impact, the knee blockers work in concert with properly fastened and adjusted seat belts to restrain both the driver and the front seat passenger in the proper position for an airbag deployment. The knee blockers also absorb and distribute the crash energy from the driver and the front seat passenger to the structure of the instrument panel.

Typically, the driver and front seat passenger recall more about the events preceding and following a collision than they have of the airbag deployment itself. This is because the airbag deployment and deflation occur so rapidly. In a typical 48 kilometer-per-hour (30 mile-per-hour) barrier impact, from the moment of impact until both airbags are fully inflated takes about 40 milliseconds. Within one to two seconds from the moment of impact, both airbags are almost entirely deflated. The times cited for these events are approximations, which apply only to a barrier impact at the given speed. Actual times will vary somewhat, depending upon the vehicle speed, impact angle, severity of the impact, and the type of collision.

When the ACM monitors a problem in any of the airbag system circuits or components, it stores a fault code or Diagnostic Trouble Code (DTC) in its memory circuit and sends an electronic message to the EMIC to turn on the airbag indicator. Proper testing of the airbag system components, the Chrysler Collision Detection (CCD) data bus, the data bus message inputs to and outputs from the EMIC or the ACM, as well as the retrieval or erasure of a DTC from the ACM requires the use of a DRBIII® scan tool. Refer to the appropriate diagnostic information.

See the owner's manual in the vehicle glove box for more information on the features, use and operation of all of the factory-installed passenger restraints, including the airbag system.

**WARNING**

**WARNING: THE AIRBAG SYSTEM IS A SENSITIVE, COMPLEX ELECTROMECHANICAL UNIT. BEFORE ATTEMPTING TO DIAGNOSE OR SERVICE ANY AIRBAG SYSTEM OR RELATED STEERING WHEEL,**

**STEERING COLUMN, OR INSTRUMENT PANEL COMPONENTS YOU MUST FIRST DISCONNECT AND ISOLATE THE BATTERY NEGATIVE (GROUND) CABLE. THEN WAIT TWO MINUTES FOR THE SYSTEM CAPACITOR TO DISCHARGE BEFORE FURTHER SYSTEM SERVICE. THIS IS THE ONLY SURE WAY TO DISABLE THE AIRBAG SYSTEM. FAILURE TO DO THIS COULD RESULT IN ACCIDENTAL AIRBAG DEPLOYMENT AND POSSIBLE PERSONAL INJURY.**

**WARNING: THE DRIVER AIRBAG INFLATOR UNIT CONTAINS SODIUM AZIDE AND POTASSIUM NITRATE. THESE MATERIALS ARE POISONOUS AND EXTREMELY FLAMMABLE. CONTACT WITH ACID, WATER, OR HEAVY METALS MAY PRODUCE HARMFUL AND IRRITATING GASES (SODIUM HYDROXIDE IS FORMED IN THE PRESENCE OF MOISTURE) OR COMBUSTIBLE COMPOUNDS. THE PASSENGER AIRBAG UNIT CONTAINS ARGON GAS PRESSURIZED TO OVER 2500 PSI. DO NOT ATTEMPT TO DISMANTLE AN AIRBAG UNIT OR TAMPER WITH ITS INFLATOR. DO NOT PUNCTURE, INCINERATE, OR BRING INTO CONTACT WITH ELECTRICITY. DO NOT STORE AT TEMPERATURES EXCEEDING 93° C (200° F).**

**WARNING: REPLACE AIRBAG SYSTEM COMPONENTS ONLY WITH PARTS SPECIFIED IN THE DAIMLERCHRYSLER MOPAR PARTS CATALOG. SUBSTITUTE PARTS MAY APPEAR INTERCHANGEABLE, BUT INTERNAL DIFFERENCES MAY RESULT IN INFERIOR OCCUPANT PROTECTION.**

**WARNING: THE FASTENERS, SCREWS, AND BOLTS ORIGINALLY USED FOR THE AIRBAG SYSTEM COMPONENTS HAVE SPECIAL COATINGS AND ARE SPECIFICALLY DESIGNED FOR THE AIRBAG SYSTEM. THEY MUST NEVER BE REPLACED WITH ANY SUBSTITUTES. ANY TIME A NEW FASTENER IS NEEDED, REPLACE IT WITH THE CORRECT FASTENERS PROVIDED IN THE SERVICE PACKAGE OR SPECIFIED IN THE DAIMLERCHRYSLER MOPAR PARTS CATALOG.**

**WARNING: WHEN A STEERING COLUMN HAS AN AIRBAG UNIT ATTACHED, NEVER PLACE THE COLUMN ON THE FLOOR OR ANY OTHER SURFACE WITH THE STEERING WHEEL OR AIRBAG UNIT FACE DOWN.**

## RESTRAINTS (Continued)

**DIAGNOSIS AND TESTING - AIRBAG SYSTEM**

Proper diagnosis and testing of the airbag system components, the PCI data bus, the data bus message inputs to and outputs from the ElectroMechanical Instrument Cluster (EMIC) or the Airbag Control Module (ACM), as well as the retrieval or erasure of a Diagnostic Trouble Code (DTC) from the ACM requires the use of a DRBIII® scan tool. Refer to the appropriate diagnostic information.

**WARNING: ON VEHICLES EQUIPPED WITH AIRBAGS, DISABLE THE AIRBAG SYSTEM BEFORE ATTEMPTING ANY STEERING WHEEL, STEERING COLUMN, OR INSTRUMENT PANEL COMPONENT DIAGNOSIS OR SERVICE. DISCONNECT AND ISOLATE THE BATTERY NEGATIVE (GROUND) CABLE, THEN WAIT TWO MINUTES FOR THE AIRBAG SYSTEM CAPACITOR TO DISCHARGE BEFORE PERFORMING FURTHER DIAGNOSIS OR SERVICE. THIS IS THE ONLY SURE WAY TO DISABLE THE AIRBAG SYSTEM. FAILURE TO TAKE THE PROPER PRECAUTIONS COULD RESULT IN ACCIDENTAL AIRBAG DEPLOYMENT AND POSSIBLE PERSONAL INJURY.**

**STANDARD PROCEDURE - HANDLING NON-DEPLOYED AIRBAGS**

At no time should any source of electricity be permitted near the inflator on the back of a non-deployed airbag. When carrying a non-deployed airbag, the trim cover or airbag cushion side of the unit should be pointed away from the body to minimize injury in the event of an accidental deployment. If the airbag unit is placed on a bench or any other surface, the trim cover or airbag cushion side of the unit should be face up to minimize movement in the event of an accidental deployment. In addition, the airbag system should be disarmed whenever any steering wheel, steering column, or instrument panel components require diagnosis or service. Failure to observe this warning could result in accidental airbag deployment and possible personal injury.

All damaged or faulty and non-deployed driver or passenger airbags which are replaced on vehicles are to be returned. If an airbag unit is faulty or damaged and non-deployed, refer to the parts return list in the current DaimlerChrysler Corporation Warranty Policies and Procedures manual for the proper handling and disposal procedures.

**AIRBAG STORAGE**

An airbag must be stored in its original, special container until it is used for service. Also, it must be stored in a clean, dry environment; away from sources of extreme heat, sparks, and high electrical

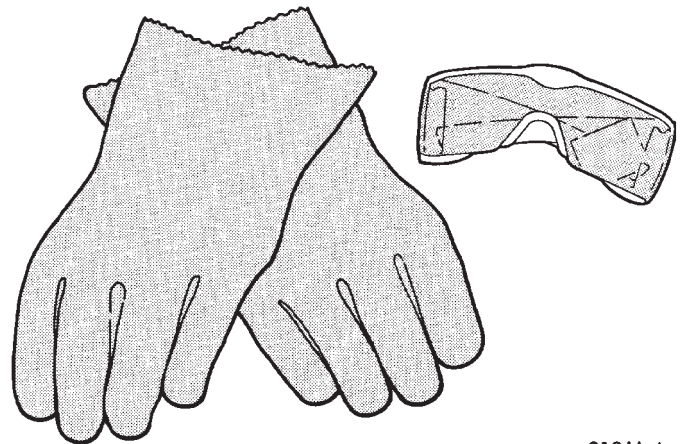
energy. Always place or store any airbag on a surface with its trim cover or airbag cushion side facing up, to minimize movement in case of an accidental deployment.

**STANDARD PROCEDURE - SERVICE AFTER AN AIRBAG DEPLOYMENT**

Any vehicle which is to be returned to use following an airbag deployment, must have both airbags, the driver airbag trim cover, the clockspring, and the steering column assembly replaced. These components are not intended for reuse and will be damaged or weakened as a result of an airbag deployment, which may or may not be obvious during a visual inspection. Other vehicle components should be closely inspected, but are to be replaced only as required by the extent of the visible damage incurred.

**CLEANUP PROCEDURE**

Following an airbag deployment, the vehicle interior will contain a powdery residue. This residue consists primarily of harmless particulate by-products of the small pyrotechnic charge used to initiate the propellant used to deploy the airbags. However, this residue may also contain traces of sodium hydroxide powder, a chemical by-product of the propellant material that is used to generate the nitrogen gas that inflates the airbag. Since sodium hydroxide powder can irritate the skin, eyes, nose, or throat, be sure to wear safety glasses, rubber gloves, and a long-sleeved shirt during cleanup (Fig. 2).



918M-4

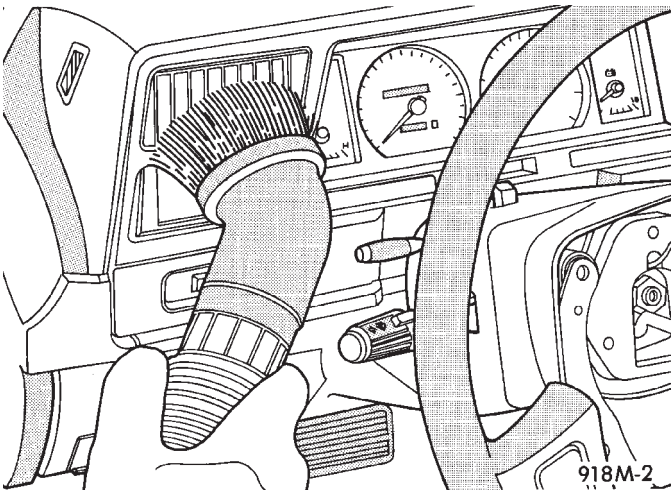
**Fig. 2 Wear Safety Glasses and Rubber Gloves - Typical**

## RESTRAINTS (Continued)

**WARNING: IF YOU EXPERIENCE SKIN IRRITATION DURING CLEANUP, RUN COOL WATER OVER THE AFFECTED AREA. ALSO, IF YOU EXPERIENCE IRRITATION OF THE NOSE OR THROAT, EXIT THE VEHICLE FOR FRESH AIR UNTIL THE IRRITATION CEASES. IF IRRITATION CONTINUES, SEE A PHYSICIAN.**

Begin the cleanup by removing both airbags from the vehicle. Refer to the appropriate service removal procedures. Place the deployed airbags in your vehicular scrap pile.

Next, use a vacuum cleaner to remove any residual powder from the vehicle interior. Clean from outside the vehicle and work your way inside, so that you avoid kneeling or sitting on a non-cleaned area. Be certain to vacuum the heater and air conditioning outlets as well (Fig. 3). Run the heater and air conditioner blower on the lowest speed setting and vacuum any powder expelled from the outlets. You may need to vacuum the interior of the vehicle a second time to recover all of the powder.



**Fig. 3 Vacuum Heater and A/C Outlets - Typical**

## STANDARD PROCEDURE - VERIFICATION TEST

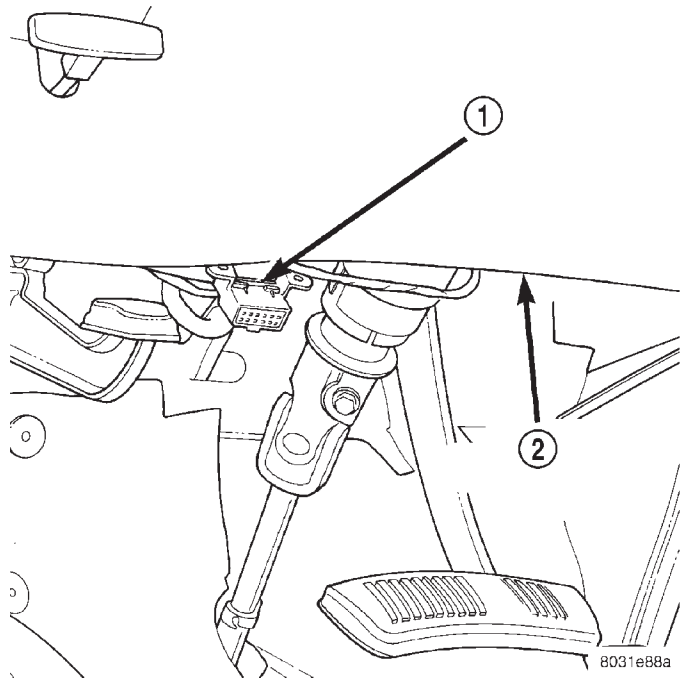
The following procedure should be performed using a DRBIII® scan tool to verify proper airbag system operation following the service or replacement of any airbag system component.

**WARNING: ON VEHICLES EQUIPPED WITH AIRBAGS, DISABLE THE AIRBAG SYSTEM BEFORE ATTEMPTING ANY STEERING WHEEL, STEERING COLUMN, OR INSTRUMENT PANEL COMPONENT DIAGNOSIS OR SERVICE. DISCONNECT AND ISOLATE THE BATTERY NEGATIVE (GROUND) CABLE, THEN WAIT TWO MINUTES FOR THE AIRBAG SYSTEM CAPACITOR TO DISCHARGE BEFORE PERFORMING FURTHER DIAGNOSIS OR SERVICE. THIS IS THE ONLY SURE WAY TO DISABLE THE AIRBAG**

**SYSTEM. FAILURE TO TAKE THE PROPER PRECAUTIONS COULD RESULT IN ACCIDENTAL AIRBAG DEPLOYMENT AND POSSIBLE PERSONAL INJURY.**

(1) During the following test, the battery negative cable remains disconnected and isolated, as it was during the airbag component removal and installation procedures.

(2) Be certain that the DRBIII® scan tool contains the latest version of the proper DRBIII® software. Connect the DRBIII® to the 16-way Data Link Connector (DLC). The DLC is located on the driver side lower edge of the instrument panel, outboard of the steering column (Fig. 4).



**Fig. 4 16-Way Data Link Connector - Typical**

- 1 - 16-WAY DATA LINK CONNECTOR
- 2 - BOTTOM OF INSTRUMENT PANEL

(3) Turn the ignition switch to the On position and exit the vehicle with the DRBIII®.

(4) Check to be certain that nobody is in the vehicle, then reconnect the battery negative cable.

(5) Using the DRBIII®, read and record the active (current) Diagnostic Trouble Code (DTC) data.

(6) Next, use the DRBIII® to read and record any stored (historical) DTC data.

(7) If any DTC is found in Step 5 or Step 6, refer to the appropriate diagnostic information.

(8) Use the DRBIII® to erase the stored DTC data. If any problems remain, the stored DTC data will not erase. Refer to the appropriate diagnostic information to diagnose any stored DTC that will not erase. If the stored DTC information is successfully erased, go to Step 9.

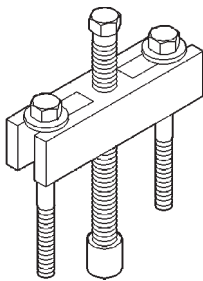


## RESTRAINTS (Continued)

(9) Turn the ignition switch to the Off position for about fifteen seconds, and then back to the On position. Observe the airbag indicator in the instrument cluster. It should light for six to eight seconds, and then go out. This indicates that the airbag system is functioning normally and that the repairs are complete. If the airbag indicator fails to light, or lights and stays on, there is still an active airbag system fault or malfunction. Refer to the appropriate diagnostic information to diagnose the problem.

## SPECIAL TOOLS

## SPECIAL TOOLS - AIRBAG SYSTEM



*Puller C-3428-B*

## AIRBAG CONTROL MODULE

## DESCRIPTION

The Airbag Control Module (ACM) is concealed underneath the plastic ACM trim cover (automatic transmission) or center console (manual transmission), directly below the instrument panel in the passenger compartment of the vehicle. The ACM is secured with screws to a mounting bracket located under the instrument panel center support bracket on the floor panel transmission tunnel. The ACM contains an electronic microprocessor, an electronic impact sensor, an electromechanical safing sensor, and an energy storage capacitor. The ACM is connected to the vehicle electrical system through a take out and connector of the instrument panel wire harness.

The ACM cannot be repaired or adjusted and, if damaged or faulty, it must be replaced.

## OPERATION

The microprocessor in the ACM contains the airbag system logic circuits, and it monitors and controls all of the airbag system components. The ACM also uses On-Board Diagnostics (OBD) and can communicate with other electronic modules in the vehicle as well as with the DRBIII® scan tool using the Chrysler Collision Detection (CCD) data bus network. This method of communication is used for control of the airbag indicator in the ElectroMechanical Instrument

Cluster (EMIC) and for airbag system diagnosis and testing through the 16-way data link connector located on the lower left edge of the instrument panel. (Refer to 8 - ELECTRICAL/ELECTRONIC CONTROL MODULES/COMMUNICATION - OPERATION). The ACM microprocessor continuously monitors all of the airbag system electrical circuits to determine the system readiness. If the ACM detects a monitored system fault, it sets an active Diagnostic Trouble Code (DTC) and sends messages to the EMIC over the CCD data bus to turn on the airbag indicator. (Refer to 8 - ELECTRICAL/INSTRUMENT CLUSTER/AIRBAG INDICATOR - OPERATION). If the airbag system fault is still present when the ignition switch is turned to the Off position, the DTC is stored in memory by the ACM. However, if a fault does not recur for a number of ignition cycles, the ACM will automatically erase the stored DTC.

The ACM receives battery current through two circuits, on a fused ignition switch output (run) circuit through a fuse in the Junction Block (JB), and on a fused ignition switch output (start-run) circuit through a second fuse in the JB. The ACM is grounded through a ground circuit and take out of the instrument panel wire harness. This take out has a single eyelet terminal connector secured by a nut to a ground stud located on the forward extension of the left front fender wheel housing in the engine compartment. Therefore, the ACM is operational whenever the ignition switch is in the Start or On positions. The ACM also contains an energy-storage capacitor. When the ignition switch is in the Start or On positions, this capacitor is continually being charged with enough electrical energy to deploy the airbags for up to one second following a battery disconnect or failure. The purpose of the capacitor is to provide backup airbag system protection in case there is a loss of battery current supply to the ACM during an impact. The capacitor is only serviced as a unit with the ACM.

Two sensors are contained within the ACM, an electronic impact sensor and a safing sensor. The electronic impact sensor is an accelerometer that senses the rate of vehicle deceleration, which provides verification of the direction and severity of an impact. A pre-programmed decision algorithm in the ACM microprocessor determines when the deceleration rate as signaled by the impact sensor indicates an impact that is severe enough to require airbag system protection. When the programmed conditions are met, the ACM sends an electrical signal to deploy the airbags. The safing sensor is an electromechanical sensor within the ACM that is connected in series between the ACM microprocessor airbag deployment circuit and the airbags. The safing sensor is a normally open switch that is used to verify or confirm

## AIRBAG CONTROL MODULE (Continued)

the need for an airbag deployment by detecting impact energy of a lesser magnitude than that of the electronic impact sensor, and must be closed in order for the airbags to deploy. The impact sensor and safing sensor are calibrated for the specific vehicle, and are only serviced as a unit with the ACM.

## REMOVAL

**WARNING: DISABLE THE AIRBAG SYSTEM BEFORE ATTEMPTING ANY STEERING WHEEL, STEERING COLUMN, OR INSTRUMENT PANEL COMPONENT DIAGNOSIS OR SERVICE. DISCONNECT AND ISOLATE THE BATTERY NEGATIVE (GROUND) CABLE, THEN WAIT TWO MINUTES FOR THE AIRBAG SYSTEM CAPACITOR TO DISCHARGE BEFORE PERFORMING FURTHER DIAGNOSIS OR SERVICE. THIS IS THE ONLY SURE WAY TO DISABLE THE AIRBAG SYSTEM. FAILURE TO TAKE THE PROPER PRECAUTIONS COULD RESULT IN ACCIDENTAL AIRBAG DEPLOYMENT AND POSSIBLE PERSONAL INJURY.**

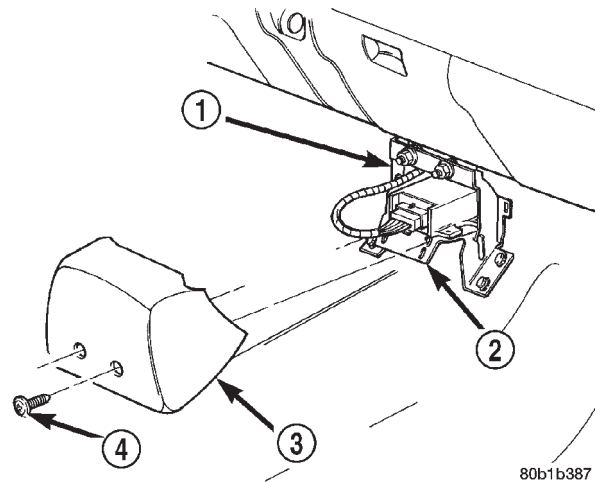
**WARNING: THE AIRBAG CONTROL MODULE CONTAINS THE IMPACT SENSOR, WHICH ENABLES THE SYSTEM TO DEPLOY THE AIRBAGS. NEVER STRIKE OR KICK THE AIRBAG CONTROL MODULE, AS IT CAN DAMAGE THE IMPACT SENSOR OR AFFECT ITS CALIBRATION. IF AN AIRBAG CONTROL MODULE IS ACCIDENTALLY DROPPED DURING SERVICE, THE MODULE MUST BE SCRAPPED AND REPLACED WITH A NEW UNIT. FAILURE TO OBSERVE THIS WARNING COULD RESULT IN ACCIDENTAL, INCOMPLETE, OR IMPROPER AIRBAG DEPLOYMENT AND POSSIBLE OCCUPANT INJURIES.**

(1) Disconnect and isolate the battery negative cable. If either of the airbags has not been deployed, wait two minutes for the system capacitor to discharge before further service.

(2) If the vehicle is equipped with a manual transmission, remove the center floor console from the floor panel transmission tunnel. (Refer to 23 - BODY/INTERIOR/CENTER CONSOLE - REMOVAL).

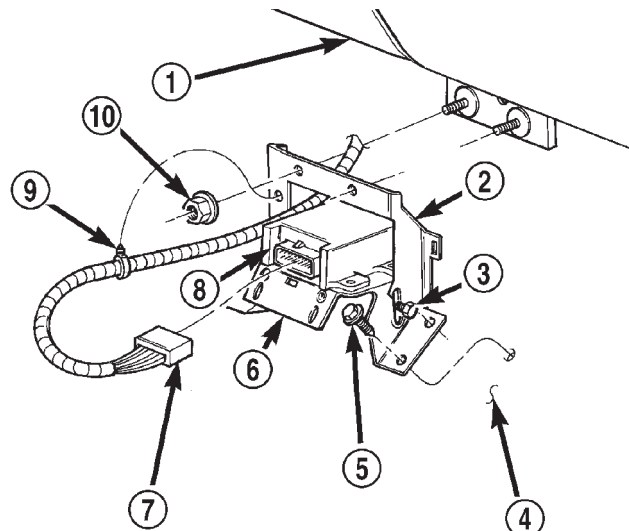
(3) If the vehicle is equipped with an automatic transmission, remove the two screws that secure the trim cover to the Airbag Control Module (ACM) mounting bracket on the floor panel transmission tunnel and remove the trim cover (Fig. 5).

(4) Loosen the screw that secures each side of the instrument panel center support bracket to the ACM mounting bracket (Fig. 6). Do not remove these screws.



**Fig. 5 Airbag Control Module Trim Cover Remove/Install**

- 1 - INSTRUMENT PANEL CENTER SUPPORT BRACKET
- 2 - ACM MOUNTING BRACKET
- 3 - TRIM COVER
- 4 - SCREW (2)



**Fig. 6 Airbag Control Module Remove/Install**

- 1 - INSTRUMENT PANEL
- 2 - CENTER SUPPORT BRACKET
- 3 - SCREW (2)
- 4 - FLOOR PANEL
- 5 - SCREW (4)
- 6 - ACM MOUNTING BRACKET
- 7 - CONNECTOR
- 8 - AIRBAG CONTROL MODULE
- 9 - RETAINER
- 10 - NUT (2)

(5) Remove the two nuts that secure the instrument panel center support bracket to the studs on the lower instrument panel structural support.



## AIRBAG CONTROL MODULE (Continued)

(6) Disengage the retainer on the instrument panel wire harness take out to the ACM from the retainer hole in the left side of the instrument panel center support bracket.

(7) Pull the top of the instrument panel center support bracket rearward and down from the instrument panel studs. Fold it down over the top of the ACM until it is laying flat on the floor panel transmission tunnel.

(8) Disconnect the instrument panel wire harness connector for the ACM from the ACM connector receptacle. To disconnect this connector:

(a) Slide the red Connector Position Assurance (CPA) lock on the top of the connector toward the side of the vehicle.

(b) Depress the connector latch tab and pull the connector straight away from the ACM connector receptacle.

**NOTE: Always remove and replace the ACM and its mounting bracket as a unit. Replacement modules include a replacement mounting bracket. Do not transfer the ACM to another mounting bracket.**

(9) Remove the four screws that secure the ACM mounting bracket to the floor panel transmission tunnel.

(10) Remove the ACM, the mounting bracket, and the instrument panel center support bracket from the floor panel transmission tunnel as a unit.

## INSTALLATION

**WARNING: DISABLE THE AIRBAG SYSTEM BEFORE ATTEMPTING ANY STEERING WHEEL, STEERING COLUMN, OR INSTRUMENT PANEL COMPONENT DIAGNOSIS OR SERVICE. DISCONNECT AND ISOLATE THE BATTERY NEGATIVE (GROUND) CABLE, THEN WAIT TWO MINUTES FOR THE AIRBAG SYSTEM CAPACITOR TO DISCHARGE BEFORE PERFORMING FURTHER DIAGNOSIS OR SERVICE. THIS IS THE ONLY SURE WAY TO DISABLE THE AIRBAG SYSTEM. FAILURE TO TAKE THE PROPER PRECAUTIONS COULD RESULT IN ACCIDENTAL AIRBAG DEPLOYMENT AND POSSIBLE PERSONAL INJURY.**

**WARNING: THE AIRBAG CONTROL MODULE CONTAINS THE IMPACT SENSOR, WHICH ENABLES THE SYSTEM TO DEPLOY THE AIRBAGS. NEVER STRIKE OR KICK THE AIRBAG CONTROL MODULE, AS IT CAN DAMAGE THE IMPACT SENSOR OR AFFECT ITS CALIBRATION. IF AN AIRBAG CONTROL MODULE IS ACCIDENTALLY DROPPED DURING SERVICE, THE MODULE MUST BE SCRAPPED AND REPLACED WITH A NEW UNIT. FAILURE TO**

**OBSERVE THIS WARNING COULD RESULT IN ACCIDENTAL, INCOMPLETE, OR IMPROPER AIRBAG DEPLOYMENT AND POSSIBLE OCCUPANT INJURIES.**

(1) Carefully position the Airbag Control Module (ACM), the mounting bracket, and the instrument panel center support bracket onto the floor panel transmission tunnel as a unit (Fig. 6). When the ACM is correctly positioned, the arrow on the ACM label will be pointed forward in the vehicle.

(2) Install and tighten the four screws that secure the ACM mounting bracket to the floor panel transmission tunnel. Tighten the screws to 14 N·m (125 in. lbs.).

(3) With the instrument panel center support bracket still folded down flat on the floor panel transmission tunnel, reconnect the instrument panel wire harness connector for the ACM to the ACM connector receptacle. Be certain that the connector latch and the red Connector Position Assurance (CPA) lock are fully engaged.

(4) Fold the top of the instrument panel center support bracket up over the top of the ACM and forward over the studs on the lower instrument panel structural support.

(5) Install and tighten the nuts that secure the instrument panel center support bracket to the studs on the lower instrument panel structural support. Tighten the nuts to 14 N·m (125 in. lbs.).

(6) Engage the retainer on the instrument panel wire harness take out for the ACM in the retainer hole on the left side of the instrument panel center support bracket.

(7) Tighten the screws that secure each side of the instrument panel center support bracket to the ACM mounting bracket. Tighten the screws 14 N·m (125 in. lbs.).

(8) If the vehicle is equipped with an automatic transmission, position the ACM trim cover to the ACM mounting bracket on the floor panel transmission tunnel (Fig. 5).

(9) If the vehicle is equipped with an automatic transmission, install and tighten the two screws that secure the ACM trim cover to the ACM mounting bracket. Tighten the screws to 2.2 N·m (20 in. lbs.).

(10) If the vehicle is equipped with a manual transmission, reinstall the center floor console onto the floor panel transmission tunnel. (Refer to 23 - BODY/INTERIOR/CENTER CONSOLE - INSTALLATION).

(11) Do not reconnect the battery negative cable at this time. The airbag system verification test procedure should be performed following service of any airbag system component. (Refer to 8 - ELECTRICAL/RESTRAINTS - STANDARD PROCEDURE - VERIFICATION TEST).

## CHILD TETHER

### REMOVAL

Standard cab models have two child tether anchors secured near the top of the cab back panel. Club cab and quad cab models have three child tethers secured near the top of the cab back panel.

**WARNING: DURING AND FOLLOWING ANY SEAT BELT SERVICE, CAREFULLY INSPECT ALL SEAT BELTS, BUCKLES, MOUNTING HARDWARE, AND RETRACTORS FOR PROPER INSTALLATION, OPERATION, OR DAMAGE. REPLACE ANY BELT THAT IS CUT, FRAYED, OR TORN. STRAIGHTEN ANY BELT THAT IS TWISTED. TIGHTEN ANY LOOSE FASTENERS. REPLACE ANY BELT THAT HAS A DAMAGED OR INOPERATIVE BUCKLE OR RETRACTOR. REPLACE ANY BELT THAT HAS A BENT OR DAMAGED LATCH PLATE OR ANCHOR PLATE. NEVER ATTEMPT TO REPAIR A SEAT BELT COMPONENT. ALWAYS REPLACE DAMAGED OR FAULTY SEAT BELT COMPONENTS WITH THE CORRECT, NEW AND UNUSED REPLACEMENT PARTS LISTED IN THE MOPAR PARTS CATALOG.**

(1) Remove the trim from the inside of the cab back panel. (Refer to 23 - BODY/INTERIOR/REAR CLOSURE PANEL TRIM - REMOVAL).

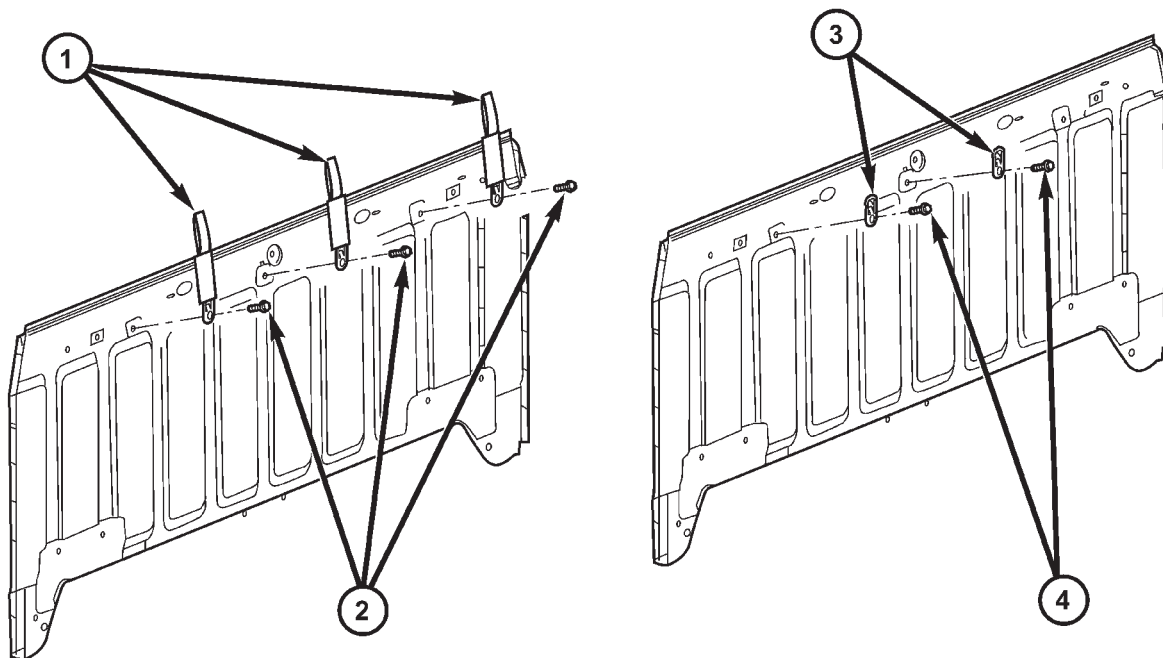
(2) Remove the screw that secures the child tether anchor (standard cab) or child tether (club/quad cab) to the cab back panel (Fig. 7).

(3) Remove the child tether anchor (standard cab) or child tether (club/quad cab) from the cab back panel.

### INSTALLATION

Standard cab models have two child tether anchors secured near the top of the cab back panel. Club cab and quad cab models have three child tethers secured near the top of the cab back panel.

**WARNING: DURING AND FOLLOWING ANY SEAT BELT SERVICE, CAREFULLY INSPECT ALL SEAT BELTS, BUCKLES, MOUNTING HARDWARE, AND RETRACTORS FOR PROPER INSTALLATION, OPERATION, OR DAMAGE. REPLACE ANY BELT THAT IS CUT, FRAYED, OR TORN. STRAIGHTEN ANY BELT THAT IS TWISTED. TIGHTEN ANY LOOSE FASTENERS. REPLACE ANY BELT THAT HAS A DAMAGED OR INOPERATIVE BUCKLE OR RETRACTOR. REPLACE ANY BELT THAT HAS A BENT OR DAMAGED LATCH PLATE OR ANCHOR PLATE. NEVER ATTEMPT TO REPAIR A SEAT BELT COMPONENT. ALWAYS REPLACE DAMAGED OR FAULTY SEAT BELT COMPONENTS WITH THE CORRECT, NEW AND UNUSED REPLACEMENT PARTS LISTED IN THE MOPAR PARTS CATALOG.**



80b5c963

**Fig. 7 Child Tether Anchor**

1 - CHILD TETHER (CLUB/QUAD CAB) (3)  
2 - SCREW (3)

3 - CHILD TETHER ANCHOR (STANDARD CAB) (2)  
4 - SCREW (2)

## CHILD TETHER (Continued)

(1) Position the child tether anchor (standard cab) or child tether (club/quad cab) onto the cab back panel (Fig. 7).

(2) Install and tighten the screw that secures the child tether anchor (standard cab) or child tether (club/quad cab) onto the cab back panel. Tighten the screw to 13.5 N·m (120 in. lbs.).

(3) Reinstall the trim onto the inside of the cab back panel. (Refer to 23 - BODY/INTERIOR/REAR CLOSURE PANEL TRIM - INSTALLATION).

## CLOCKSPRING

### DESCRIPTION

The clockspring assembly is secured with two integral plastic latches onto the steering column lock housing near the top of the steering column, behind the steering wheel. The clockspring consists of a flat, round molded plastic case with a stubby tail that hangs below the steering column and contains a connector receptacle and a long pigtail wire with connector that face toward the instrument panel. Within the plastic housing is a spool-like molded plastic rotor with a large exposed hub. The upper surface of the rotor hub has a large center hole, two large flats, two auto-locking tabs, and three short pigtail wires with connectors that face toward the steering wheel. The lower surface of the rotor hub has two integral turn signal cancelling cam lobes. Within the plastic case and wound around the rotor spool is a long ribbon-like tape that consists of several thin copper wire leads sandwiched between two thin plastic membranes. The outer end of the tape terminates at the connector receptacle and pigtail wire that face the instrument panel, while the inner end of the tape terminates at the pigtail wires on the hub of the clockspring rotor that face the steering wheel.

Service replacement clocksprings are shipped pre-centered and with a piece of tape covering the engaged auto-locking tabs. The auto-locking tabs secure the centered clockspring rotor to the clockspring case during shipment, but these tabs are automatically disengaged once the clockspring is installed on the steering column. (Refer to 8 - ELECTRICAL/RESTRAINTS/CLOCKSPRING - STANDARD PROCEDURE - CLOCKSPRING CENTERING).

The clockspring cannot be repaired. If the clockspring is faulty, damaged, or if the driver airbag has been deployed, the clockspring must be replaced.

### OPERATION

The clockspring is a mechanical electrical circuit component that is used to provide continuous electrical continuity between the fixed instrument panel wire harness and the electrical components mounted

on or in the rotating steering wheel. On this model the rotating electrical components include the driver airbag, the horn switch, the speed control switches, and the remote radio switches if the vehicle is so equipped. The clockspring case is positioned and secured to the upper steering column lock housing by two integral plastic latches. The connector receptacle on the tail of the fixed clockspring housing connect the clockspring to the vehicle electrical system through a take out with connector from the instrument panel wire harness. The lower clockspring pigtail on the tail of the clockspring housing connect the clockspring driver airbag circuits to a separate take out and connector of the instrument panel wire harness located near the lower instrument panel reinforcement, below the steering column. The clockspring rotor is movable and is keyed to the hub of the steering wheel by two large flats that are molded into the rotor hub. The two lobes on the lower surface of the clockspring rotor hub contact a turn signal cancel actuator of the multi-function switch to provide automatic turn signal cancellation. The pigtail wires on the upper surface of the clockspring connect the clockspring to the horn switch, the two speed control switches, and the remote radio switches on vehicles that are so equipped.

Like the clockspring in a timepiece, the clockspring tape has travel limits and can be damaged by being wound too tightly during full stop-to-stop steering wheel rotation. To prevent this from occurring, the clockspring must be centered when it is installed on the steering column. Centering the clockspring indexes the clockspring spool to the movable steering components so that the tape can operate within its designed travel limits. However, if the clockspring is removed from the steering column or if the steering shaft is disconnected from the steering gear, the clockspring spool can change position relative to the movable steering components and must be re-centered following completion of the service or the tape may be damaged. Service replacement clocksprings are shipped pre-centered and with the auto-locking tabs engaged. A piece of tape covers the auto-locking tabs to discourage tampering. These auto-locking tabs should not be disengaged until the clockspring has been installed on the steering column. If this shipping tape is removed or damaged, or if the auto-locking tabs are disengaged before the clockspring is installed on a steering column, the clockspring centering procedure must be performed. (Refer to 8 - ELECTRICAL/RESTRAINTS/CLOCKSPRING - STANDARD PROCEDURE - CLOCKSPRING CENTERING).

## CLOCKSPRING (Continued)

**STANDARD PROCEDURE - CLOCKSPRING CENTERING**

The clockspring is designed to wind and unwind when the steering wheel is rotated, but is only designed to rotate the same number of turns (about five complete rotations) as the steering wheel can be turned from stop to stop. Centering the clockspring indexes the clockspring tape to other steering components so that it can operate within its designed travel limits. The rotor of a centered clockspring can be rotated two and one-half turns in either direction from the centered position, without damaging the clockspring tape.

However, if the clockspring is removed for service or if the steering column is disconnected from the steering gear, the clockspring tape can change position relative to the other steering components. The clockspring must then be re-centered following completion of such service or the clockspring tape may be damaged. Service replacement clocksprings are shipped pre-centered and with the auto-locking tabs engaged (raised). These auto-locking tabs should not be disengaged until the clockspring has been installed on the steering column. If the auto-locking tabs are disengaged before the clockspring is installed on a steering column, the clockspring centering procedure must be performed.

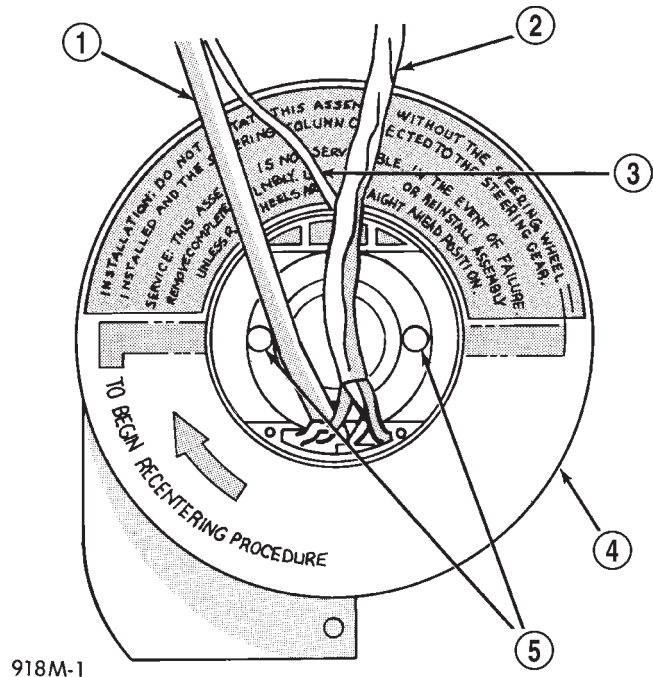
**WARNING: DISABLE THE AIRBAG SYSTEM BEFORE ATTEMPTING ANY STEERING WHEEL, STEERING COLUMN, OR INSTRUMENT PANEL COMPONENT DIAGNOSIS OR SERVICE. DISCONNECT AND ISOLATE THE BATTERY NEGATIVE (GROUND) CABLE, THEN WAIT TWO MINUTES FOR THE AIRBAG SYSTEM CAPACITOR TO DISCHARGE BEFORE PERFORMING FURTHER DIAGNOSIS OR SERVICE. THIS IS THE ONLY SURE WAY TO DISABLE THE AIRBAG SYSTEM. FAILURE TO TAKE THE PROPER PRECAUTIONS COULD RESULT IN ACCIDENTAL AIRBAG DEPLOYMENT AND POSSIBLE PERSONAL INJURY.**

**NOTE: Before starting this procedure, be certain to turn the steering wheel until the front wheels are in the straight-ahead position.**

(1) Place the front wheels in the straight-ahead position.

(2) Remove the clockspring from the steering column. (Refer to 8 - ELECTRICAL/RESTRAINTS/CLOCKSPRING - REMOVAL).

(3) Depress the two plastic clockspring auto-locking tabs (Fig. 8).



**Fig. 8 Clockspring Auto-Locking Tabs**

- 1 - AIRBAG MODULE WIRE
- 2 - SPEED CONTROL WIRING
- 3 - HORN WIRE
- 4 - CLOCKSPRING ASSEMBLY
- 5 - AUTO-LOCKING TABS

(4) Keeping the auto-locking tabs depressed, rotate the clockspring rotor clockwise to the end of its travel. **Do not apply excessive torque.**

(5) From the end of the clockwise travel, rotate the rotor about two and one-half turns counterclockwise, then release the auto-locking tabs. The clockspring pigtail wire for the horn switch should end up at the top, and the pigtail wires for the airbag, optional speed control switches, and optional remote radio switches at the bottom. The clockspring is now centered.

(6) The front wheels should still be in the straight-ahead position. Reinstall the clockspring onto the steering column. (Refer to 8 - ELECTRICAL/RESTRAINTS/CLOCKSPRING - INSTALLATION).

**REMOVAL**

The clockspring cannot be repaired. It must be replaced if faulty or damaged, or if the driver airbag has been deployed.



## CLOCKSPRING (Continued)

**WARNING: DISABLE THE AIRBAG SYSTEM BEFORE ATTEMPTING ANY STEERING WHEEL, STEERING COLUMN, OR INSTRUMENT PANEL COMPONENT DIAGNOSIS OR SERVICE. DISCONNECT AND ISOLATE THE BATTERY NEGATIVE (GROUND) CABLE, THEN WAIT TWO MINUTES FOR THE AIRBAG SYSTEM CAPACITOR TO DISCHARGE BEFORE PERFORMING FURTHER DIAGNOSIS OR SERVICE. THIS IS THE ONLY SURE WAY TO DISABLE THE AIRBAG SYSTEM. FAILURE TO TAKE THE PROPER PRECAUTIONS COULD RESULT IN ACCIDENTAL AIRBAG DEPLOYMENT AND POSSIBLE PERSONAL INJURY.**

**NOTE:** Before starting this procedure, be certain to turn the steering wheel until the front wheels are in the straight-ahead position.

(1) Place the front wheels in the straight-ahead position.

(2) Remove the driver airbag from the steering wheel. (Refer to 8 - ELECTRICAL/RESTRAINTS/DRIVER AIRBAG - REMOVAL).

(3) If the vehicle is so equipped, disconnect the clockspring pigtail wire connectors from the speed control switches and the remote radio switches located within the hub cavity of the steering wheel.

(4) Remove the nut that secures the steering wheel armature to the steering column upper shaft, which is located within the hub cavity of the steering wheel.

(5) Pull the steering wheel off of the steering column upper shaft spline using a steering wheel puller (Special Tool C-3428-B).

(6) Remove the steering column opening cover from the instrument panel. (Refer to 23 - BODY/INSTRUMENT PANEL/STEERING COLUMN OPENING COVER - REMOVAL).

(7) If the vehicle is so equipped, unscrew the lever from the tilt steering column adjuster mechanism located on the left side of the column just below the multi-function switch control stalk. Turn the lever counterclockwise to unscrew it from the adjuster.

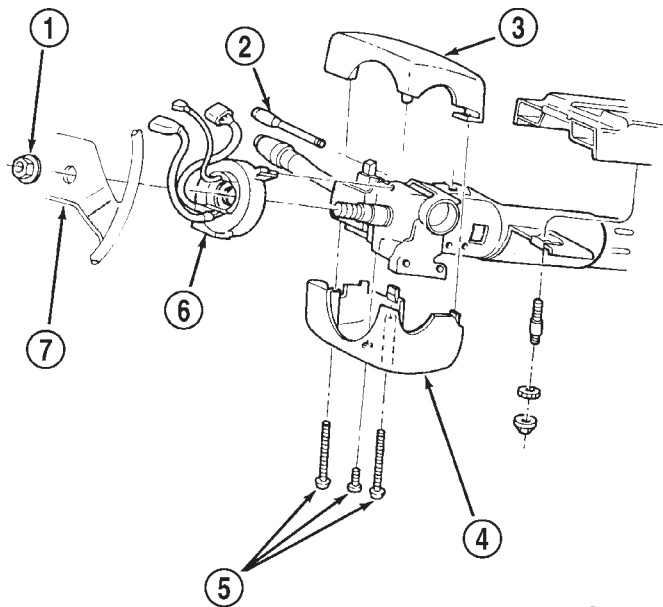
(8) From below the steering column, remove the two outboard screws that secure the upper shroud to the lower outer shroud (Fig. 9).

(9) Press carefully inward on each side of the outer shrouds to release the snap features and remove the upper outer shroud from the lower outer shroud.

(10) From below the steering column, remove the one center screw that secures the lower outer shroud to the steering column housing.

(11) Remove the lower outer shroud from the steering column.

(12) From below the steering column, remove the two screws that secure the lower inner shroud to the steering column housing and the upper inner shroud.



J938J-5

**Fig. 9 Steering Column Shrouds Remove/Install - Typical**

- 1 - NUT
- 2 - TILT LEVER
- 3 - UPPER SHROUD
- 4 - LOWER SHROUD
- 5 - SCREWS
- 6 - CLOCK SPRING
- 7 - STEERING WHEEL

(13) Press carefully inward on the gearshift lever side of the inner shrouds to release the snap features and remove the lower inner shroud from the steering column.

(14) Disconnect the instrument panel wire harness connector for the clockspring from the lower clockspring connector receptacle.

(15) Disconnect the lower clockspring pigtail wire connector from the instrument panel wire harness, located on the instrument panel lower reinforcement below the steering column.

(16) Carefully disengage the plastic latches of the clockspring assembly from the steering column lock housing and remove the clockspring from the column. The clockspring cannot be repaired. It must be replaced if faulty or damaged, or if the driver airbag has been deployed.

(17) If the removed clockspring is to be reused, secure the clockspring rotor to the clockspring case to maintain clockspring centering until it is reinstalled on the steering column. If clockspring centering is not maintained, the clockspring must be centered again before it is reinstalled. (Refer to 8 - ELECTRICAL/RESTRAINTS/CLOCKSPRING - STANDARD PROCEDURE - CLOCKSPRING CENTERING).



## CLOCKSPRING (Continued)

**INSTALLATION**

The clockspring cannot be repaired. It must be replaced if faulty or damaged, or if the driver airbag has been deployed.

If the clockspring is not properly centered in relation to the steering wheel, steering shaft and steering gear, it may be damaged. (Refer to 8 - ELECTRICAL/RESTRAINTS/CLOCKSPRING - STANDARD PROCEDURE - CLOCKSPRING CENTERING). Service replacement clocksprings are shipped pre-centered and with a piece of tape covering the engaged clockspring auto-locking tabs. This tape should not be removed until the clockspring has been installed on the steering column. If the tape is removed before the clockspring is installed on a steering column, the clockspring centering procedure must be performed.

**WARNING: DISABLE THE AIRBAG SYSTEM BEFORE ATTEMPTING ANY STEERING WHEEL, STEERING COLUMN, OR INSTRUMENT PANEL COMPONENT DIAGNOSIS OR SERVICE. DISCONNECT AND ISOLATE THE BATTERY NEGATIVE (GROUND) CABLE, THEN WAIT TWO MINUTES FOR THE AIRBAG SYSTEM CAPACITOR TO DISCHARGE BEFORE PERFORMING FURTHER DIAGNOSIS OR SERVICE. THIS IS THE ONLY SURE WAY TO DISABLE THE AIRBAG SYSTEM. FAILURE TO TAKE THE PROPER PRECAUTIONS COULD RESULT IN ACCIDENTAL AIRBAG DEPLOYMENT AND POSSIBLE PERSONAL INJURY.**

**NOTE: Before starting this procedure, be certain that the front wheels are still in the straight-ahead position.**

(1) Carefully slide the centered clockspring down over the steering column upper shaft until the clockspring latches engage the steering column lock housing (Fig. 9).

(2) Reconnect the lower clockspring pigtail wire connector to the instrument panel wire harness connector located near the instrument panel lower reinforcement, below the steering column. Be certain that the pigtail wire locator clips are properly seated on the outside of the wiring trough and that the connector latches are fully engaged.

(3) Reconnect the instrument panel wire harness connector for the clockspring to the lower clockspring connector receptacle.

(4) Position the lower inner shroud onto the steering column. Be certain to insert the gearshift lever hider strip into the channel located on the inside surface of the shroud.

(5) Align the locking tabs on the gearshift lever side of the upper inner shroud with the receptacles

on the lower inner shroud and apply hand pressure to snap them together.

(6) From below the steering column, install and tighten the two screws that secure the lower inner shroud to the steering column housing and the upper inner shroud. Tighten the screws to 2 N·m (18 in. lbs.).

(7) Position the lower outer shroud onto the steering column. Be certain that the lower clockspring pigtail wire is routed inside the shrouds.

(8) From below the steering column, install and tighten the one center screw that secures the lower outer shroud to the steering column housing. Tighten the screw to 2 N·m (18 in. lbs.).

(9) Align the locking tabs on the upper outer shroud with the receptacles on the lower outer shroud and apply hand pressure to snap them together.

(10) From below the steering column, install and tighten the two outboard screws that secure the lower outer shroud to the upper outer shroud. Tighten the screws to 2 N·m (18 in. lbs.).

(11) If the vehicle is so equipped, reinstall the lever into the tilt steering column adjuster on the left side of the column. Turn the lever clockwise to screw it into the adjuster.

(12) Reinstall the steering column opening cover onto the instrument panel. (Refer to 23 - BODY/INSTRUMENT PANEL/STEERING COLUMN OPENING COVER - INSTALLATION).

(13) Reinstall the steering wheel onto the steering column upper shaft. Be certain to index the flats on the hub of the steering wheel with the formations on the inside of the clockspring hub. Pull the upper clockspring pigtail wires through the upper and lower holes between the steering wheel back trim cover and the steering wheel armature.

(14) Install and tighten the steering wheel mounting nut. Tighten the nut to 61 N·m (45 ft. lbs.). Be certain not to pinch the pigtail wires between the steering wheel and the nut.

(15) If the vehicle is so equipped, reconnect the upper clockspring pigtail wire connectors to the speed control switches and/or the remote radio switches. Be certain that the upper clockspring pigtail wires are routed between the steering wheel back trim cover and the steering wheel armature.

(16) Reinstall the driver airbag onto the steering wheel. (Refer to 8 - ELECTRICAL/RESTRAINTS/DRIVER AIRBAG - INSTALLATION).

## DRIVER AIRBAG

### DESCRIPTION

The driver airbag protective trim cover is the most visible part of the driver airbag. The airbag used in this model is a Next Generation-type that complies with revised federal airbag standards to deploy with less force than those used in some prior models. The driver airbag is located in the center of the steering wheel, where it is secured with two screws to the steering wheel armature. Concealed beneath the driver airbag trim cover are the horn switch, the folded airbag cushion, the airbag retainer or housing, the airbag inflator, and the retainers that secure the trim cover to the airbag housing. The resistive membrane-type horn switch is secured with heat stakes to the inside surface of the airbag trim cover, between the trim cover and the folded airbag cushion. The airbag inflator is a conventional pyrotechnic-type unit that is secured with nuts to four studs on the back of the stamped metal airbag housing.

The driver airbag trim cover has locking blocks molded into the back side of it that engage a lip formed around the perimeter of the airbag housing. Two stamped metal retainers then fit over the inflator mounting studs on the back of the airbag housing and tabs on the retainer are engaged in slots on the inside of the trim cover, securely locking the cover into place. One horn switch pigtail wire has an eyelet terminal connector that is captured on the upper left inflator mounting stud between the inflator and the upper trim cover retainer. The connector insulator of the other horn switch pigtail wire is routed between the upper right inflator mounting stud and the inflator, where it is captured by a small plastic that is pushed onto the stud. The driver airbag cannot be repaired, and must be replaced if deployed or in any way damaged. The driver airbag trim cover and horn switch are available as a unit, and may be disassembled from the driver airbag for service replacement.

### OPERATION

The driver airbag is deployed by an electrical signal generated by the Airbag Control Module (ACM) through the driver airbag line 1 and line 2 (or squib) circuits. When the ACM sends the proper electrical signal to the airbag inflator, the electrical energy generates enough heat to initiate a small pyrotechnic charge which, in turn, ignites chemical pellets within the inflator. Once ignited, these chemical pellets burn rapidly and produce a large quantity of nitrogen gas. The inflator is sealed to the back of the airbag housing and a diffuser in the inflator directs all of the nitrogen gas into the airbag cushion, causing the cushion to inflate. As the cushion inflates, the driver airbag trim cover will split at predetermined break-

out lines, then fold back out of the way along with the horn switch. Following an airbag deployment, the airbag cushion quickly deflates by venting the nitrogen gas towards the instrument panel through the porous fabric material used on the steering wheel side of the airbag cushion.

Some of the chemicals used to create the nitrogen gas are considered hazardous in their solid state, before they are burned, but they are securely sealed within the airbag inflator. However, the nitrogen gas that is produced when the chemicals are burned is harmless. A small amount of residue from the burned chemicals may cause some temporary discomfort if it contacts the skin, eyes, or breathing passages. If skin or eye irritation is noticed, rinse the affected area with plenty of cool, clean water. If breathing passages are irritated, move to another area where there is plenty of clean, fresh air to breathe. If the irritation is not alleviated by these actions, contact a physician.

### REMOVAL

The following procedure is for replacement of a faulty or damaged driver airbag. If the driver airbag has been deployed, the clockspring and the steering column assembly must also be replaced. (Refer to 8 - ELECTRICAL/RESTRAINTS/CLOCKSPRING - REMOVAL) (Refer to 19 - STEERING/COLUMN - REMOVAL).

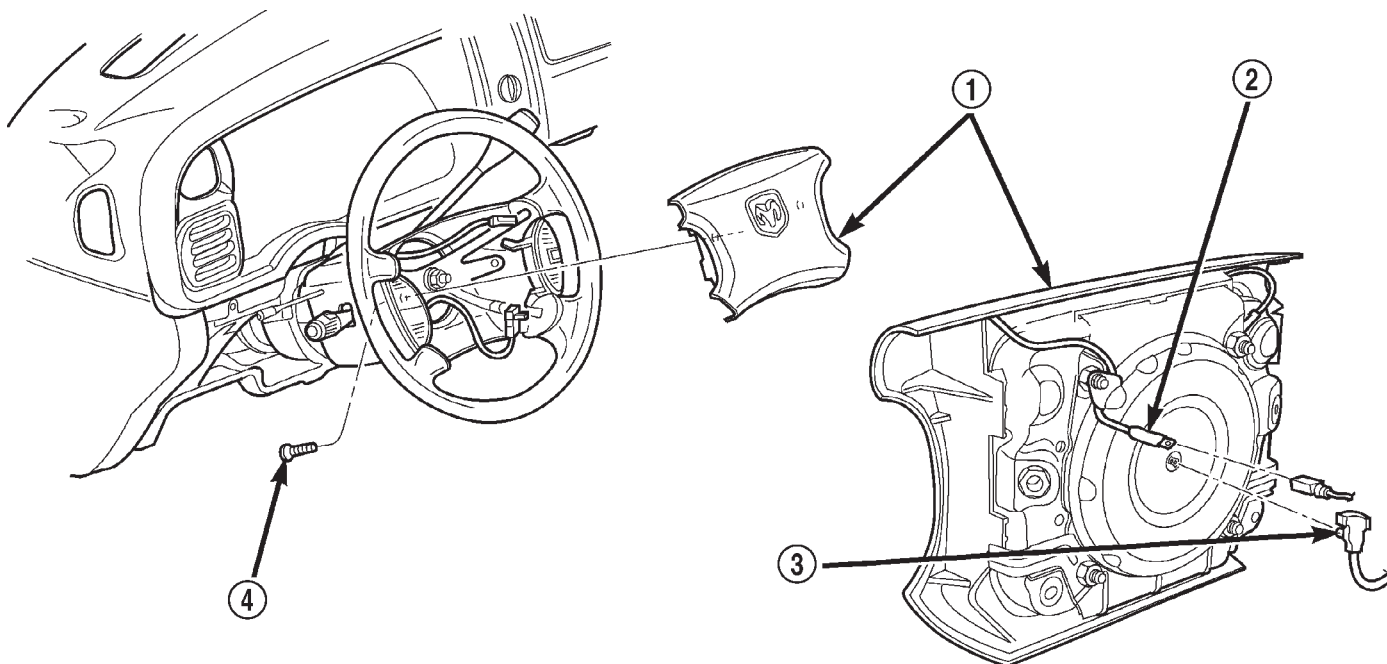
**WARNING: DISABLE THE AIRBAG SYSTEM BEFORE ATTEMPTING ANY STEERING WHEEL, STEERING COLUMN, OR INSTRUMENT PANEL COMPONENT DIAGNOSIS OR SERVICE. DISCONNECT AND ISOLATE THE BATTERY NEGATIVE (GROUND) CABLE, THEN WAIT TWO MINUTES FOR THE AIRBAG SYSTEM CAPACITOR TO DISCHARGE BEFORE PERFORMING FURTHER DIAGNOSIS OR SERVICE. THIS IS THE ONLY SURE WAY TO DISABLE THE AIRBAG SYSTEM. FAILURE TO TAKE THE PROPER PRECAUTIONS COULD RESULT IN ACCIDENTAL AIRBAG DEPLOYMENT AND POSSIBLE PERSONAL INJURY.**

**WARNING: WHEN REMOVING A DEPLOYED AIRBAG, RUBBER GLOVES, EYE PROTECTION, AND A LONG-SLEEVED SHIRT SHOULD BE WORN. THERE MAY BE DEPOSITS ON THE AIRBAG CUSHION AND OTHER INTERIOR SURFACES. IN LARGE DOSES, THESE DEPOSITS MAY CAUSE IRRITATION TO THE SKIN AND EYES.**

(1) Disconnect and isolate the battery negative cable. If either of the airbags has not been deployed, wait two minutes for the system capacitor to discharge before further service.

(2) From the underside of the steering wheel, remove the two screws that secure the driver airbag to the steering wheel armature (Fig. 10).

## DRIVER AIRBAG (Continued)



80be47d5

**Fig. 10 Driver Airbag Remove/Install**

1 - DRIVER AIRBAG

2 - HORN SWITCH FEED PIGTAIL WIRE CONNECTOR

3 - CLOCKSRING PIGTAIL WIRE CONNECTOR

4 - SCREW (2)

(3) Pull the driver airbag away from the steering wheel far enough to access the two wire harness connectors at the back of the airbag.

(4) Disconnect the clockspring horn switch pigtail wire connector from the horn switch feed pigtail wire connector, which is located at the back of the driver airbag.

**CAUTION:** Do not pull on the clockspring pigtail wire to disengage the connector from the driver airbag inflator connector receptacle.

(5) The clockspring driver airbag pigtail wire connector is a tight snap-fit into the airbag inflator connector receptacle, which is located at the back of the driver airbag. Firmly grasp and pull or gently pry on the clockspring driver airbag wire harness connector to disconnect it from the airbag inflator connector receptacle.

(6) Remove the driver airbag from the steering wheel.

(7) If the driver airbag has been deployed, the clockspring and the steering column must be replaced. (Refer to 8 - ELECTRICAL/RESTRAINTS/CLOCKSRING - REMOVAL) (Refer to 19 - STEERING/COLUMN - REMOVAL).

## DISASSEMBLY

The horn switch is integral to the driver airbag trim cover. If either component is faulty or damaged, the entire driver airbag trim cover and horn switch unit must be replaced.

**WARNING: DISABLE THE AIRBAG SYSTEM BEFORE ATTEMPTING ANY STEERING WHEEL, STEERING COLUMN, OR INSTRUMENT PANEL COMPONENT DIAGNOSIS OR SERVICE. DISCONNECT AND ISOLATE THE BATTERY NEGATIVE (GROUND) CABLE, THEN WAIT TWO MINUTES FOR THE AIRBAG SYSTEM CAPACITOR TO DISCHARGE BEFORE PERFORMING FURTHER DIAGNOSIS OR SERVICE. THIS IS THE ONLY SURE WAY TO DISABLE THE AIRBAG SYSTEM. FAILURE TO TAKE THE PROPER PRECAUTIONS COULD RESULT IN ACCIDENTAL AIRBAG DEPLOYMENT AND POSSIBLE PERSONAL INJURY.**

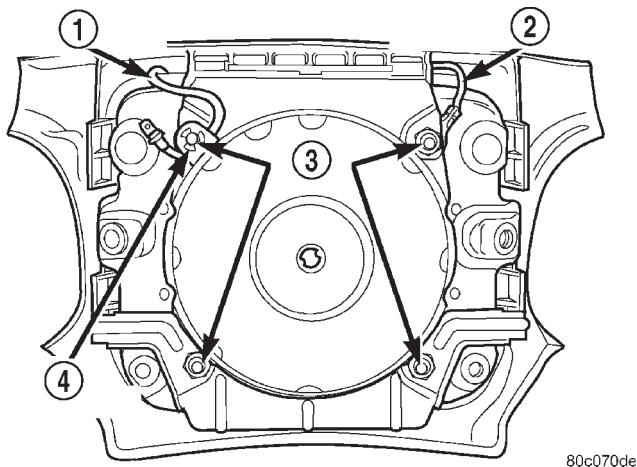
## DRIVER AIRBAG (Continued)

**WARNING: THE HORN SWITCH IS INTEGRAL TO THE DRIVER AIRBAG UNIT. SERVICE OF THIS UNIT SHOULD BE PERFORMED ONLY BY DAIMLER-CHRYSLER-TRAINED AND AUTHORIZED DEALER SERVICE TECHNICIANS. FAILURE TO TAKE THE PROPER PRECAUTIONS OR TO FOLLOW THE PROPER PROCEDURES COULD RESULT IN ACCIDENTAL, INCOMPLETE, OR IMPROPER AIRBAG DEPLOYMENT AND POSSIBLE OCCUPANT INJURIES.**

(1) Disconnect and isolate the battery negative cable. If either of the airbags has not been deployed, wait two minutes for the system capacitor to discharge before further service.

(2) Remove the driver airbag from the steering wheel. (Refer to 8 - ELECTRICAL/RESTRAINTS/DRIVER AIRBAG - REMOVAL).

(3) Remove the plastic wire retainer that captures the horn switch feed pigtail wire between the upper left inflator stud and the inflator on the back of the driver airbag housing (Fig. 11).



80c070de

**Fig. 11 Driver Airbag Trim Cover Retainer Nuts Remove/Install**

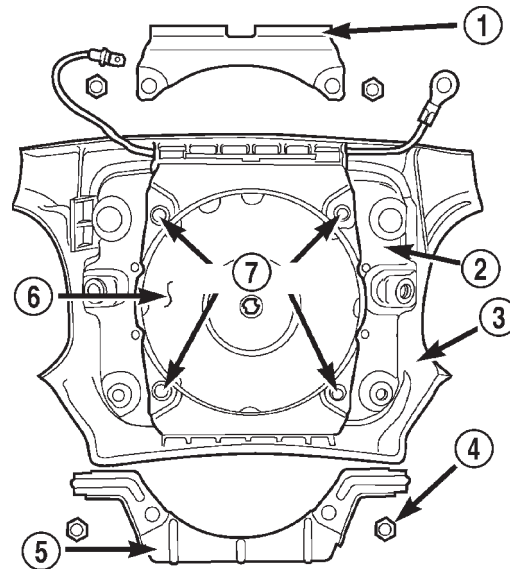
- 1 - HORN SWITCH FEED PIGTAIL WIRE
- 2 - HORN SWITCH GROUND PIGTAIL WIRE
- 3 - NUTS
- 4 - WIRE RETAINER

(4) Remove the four nuts that secure the upper and lower trim cover retainers to the studs on the back of the driver airbag housing

(5) Remove the upper and lower trim cover retainers from the airbag housing studs (Fig. 12).

(6) Remove the horn switch ground pigtail wire eyelet terminal from the upper right airbag housing stud.

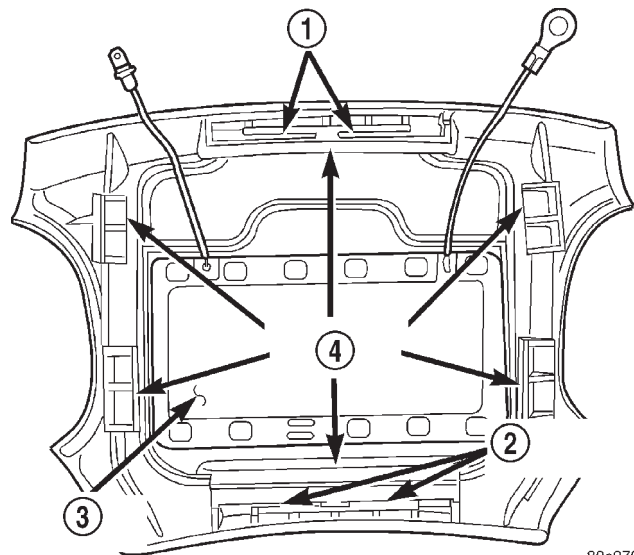
(7) Disengage the six trim cover locking blocks from the lip around the outside edge of the driver airbag housing and remove the housing from the cover (Fig. 13).



80c070dc

**Fig. 12 Driver Airbag Trim Cover Retainers**

- 1 - UPPER RETAINER
- 2 - AIRBAG HOUSING
- 3 - TRIM COVER
- 4 - NUT (4)
- 5 - LOWER RETAINER
- 6 - INFLATOR
- 7 - STUDS



80c070da

**Fig. 13 Driver Airbag Trim Cover Remove/Install**

- 1 - RETAINER SLOTS
- 2 - RETAINER SLOTS
- 3 - HORN SWITCH
- 4 - LOCKING BLOCKS



## DRIVER AIRBAG (Continued)

**ASSEMBLY**

The horn switch is integral to the driver airbag trim cover. If either component is faulty or damaged, the entire driver airbag trim cover and horn switch unit must be replaced.

**WARNING: DISABLE THE AIRBAG SYSTEM BEFORE ATTEMPTING ANY STEERING WHEEL, STEERING COLUMN, OR INSTRUMENT PANEL COMPONENT DIAGNOSIS OR SERVICE. DISCONNECT AND ISOLATE THE BATTERY NEGATIVE (GROUND) CABLE, THEN WAIT TWO MINUTES FOR THE AIRBAG SYSTEM CAPACITOR TO DISCHARGE BEFORE PERFORMING FURTHER DIAGNOSIS OR SERVICE. THIS IS THE ONLY SURE WAY TO DISABLE THE AIRBAG SYSTEM. FAILURE TO TAKE THE PROPER PRECAUTIONS COULD RESULT IN ACCIDENTAL AIRBAG DEPLOYMENT AND POSSIBLE PERSONAL INJURY.**

**WARNING: THE HORN SWITCH IS INTEGRAL TO THE DRIVER AIRBAG UNIT. SERVICE OF THIS UNIT SHOULD BE PERFORMED ONLY BY DAIMLER-CHRYSLER-TRAINED AND AUTHORIZED DEALER SERVICE TECHNICIANS. FAILURE TO TAKE THE PROPER PRECAUTIONS OR TO FOLLOW THE PROPER PROCEDURES COULD RESULT IN ACCIDENTAL, INCOMPLETE, OR IMPROPER AIRBAG DEPLOYMENT AND POSSIBLE OCCUPANT INJURIES.**

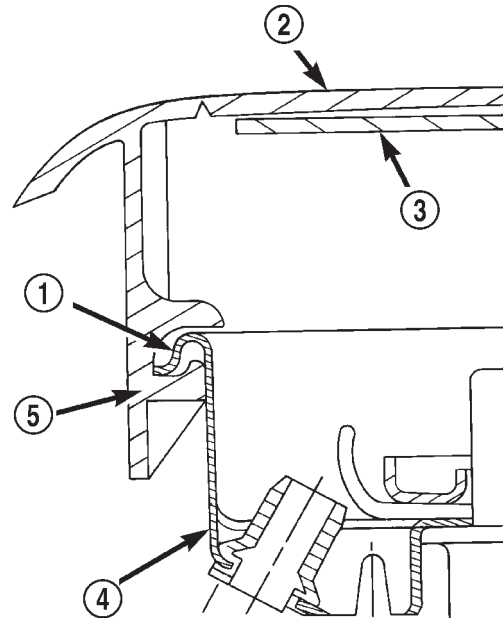
**WARNING: USE EXTREME CARE TO PREVENT ANY FOREIGN MATERIAL FROM ENTERING THE DRIVER AIRBAG, OR BECOMING ENTRAPPED BETWEEN THE DRIVER AIRBAG CUSHION AND THE DRIVER AIRBAG TRIM COVER. FAILURE TO OBSERVE THIS WARNING COULD RESULT IN OCCUPANT INJURIES UPON AIRBAG DEPLOYMENT.**

**WARNING: THE DRIVER AIRBAG TRIM COVER MUST NEVER BE PAINTED. REPLACEMENT TRIM COVERS ARE SERVICED IN THE ORIGINAL COLORS. PAINT MAY CHANGE THE WAY IN WHICH THE MATERIAL OF THE TRIM COVER RESPONDS TO AN AIRBAG DEPLOYMENT. FAILURE TO OBSERVE THIS WARNING COULD RESULT IN OCCUPANT INJURIES UPON AIRBAG DEPLOYMENT.**

(1) Carefully position the driver airbag in the trim cover. Be certain that the horn switch feed and ground pigtail wires are not pinched between the airbag housing and the trim cover locking blocks.

(2) Engage the upper and lower trim cover locking blocks with the lip of the driver airbag housing, then

engage the locking blocks on each side of the trim cover with the lip of the housing. Be certain that each of the locking blocks is fully engaged on the lip of the airbag housing (Fig. 14).



80a0f19f

**Fig. 14 Driver Airbag Trim Cover Locking Blocks Engaged**

- 1 - LIP
- 2 - TRIM COVER
- 3 - HORN SWITCH
- 4 - AIRBAG HOUSING
- 5 - LOCKING BLOCK

(3) Reinstall the horn switch ground pigtail wire eyelet terminal over the left upper airbag housing stud.

(4) Reinstall the upper and lower airbag trim cover retainers over the airbag housing studs. Be certain that the tabs on the retainers are engaged in the retainer slots of the trim cover locking blocks (Fig. 13).

(5) Install and tighten the nuts that secure the trim cover retainers to the airbag housing studs. Tighten the nuts to 10 N·m (90 in. lbs.).

(6) Route the horn switch feed pigtail wire between the inflator housing and the right upper airbag housing stud.

(7) Reinstall the plastic wire retainer onto the right upper airbag housing stud to capture horn switch feed pigtail wire.

(8) Reinstall the driver airbag onto the steering wheel. (Refer to 8 - ELECTRICAL/RESTRAINTS/DRIVER AIRBAG - INSTALLATION).



## DRIVER AIRBAG (Continued)

**INSTALLATION**

The following procedure is for replacement of a faulty or damaged driver airbag. If the driver airbag has been deployed, the clockspring and the steering column assembly must also be replaced. (Refer to 8 - ELECTRICAL/RESTRAINTS/CLOCKSPRING - REMOVAL) and (Refer to 19 - STEERING/COLUMN - REMOVAL).

**WARNING: DISABLE THE AIRBAG SYSTEM BEFORE ATTEMPTING ANY STEERING WHEEL, STEERING COLUMN, OR INSTRUMENT PANEL COMPONENT DIAGNOSIS OR SERVICE. DISCONNECT AND ISOLATE THE BATTERY NEGATIVE (GROUND) CABLE, THEN WAIT TWO MINUTES FOR THE AIRBAG SYSTEM CAPACITOR TO DISCHARGE BEFORE PERFORMING FURTHER DIAGNOSIS OR SERVICE. THIS IS THE ONLY SURE WAY TO DISABLE THE AIRBAG SYSTEM. FAILURE TO TAKE THE PROPER PRECAUTIONS COULD RESULT IN ACCIDENTAL AIRBAG DEPLOYMENT AND POSSIBLE PERSONAL INJURY.**

**WARNING: USE EXTREME CARE TO PREVENT ANY FOREIGN MATERIAL FROM ENTERING THE DRIVER AIRBAG, OR BECOMING ENTRAPPED BETWEEN THE DRIVER AIRBAG CUSHION AND THE DRIVER AIRBAG TRIM COVER. FAILURE TO OBSERVE THIS WARNING COULD RESULT IN OCCUPANT INJURIES UPON AIRBAG DEPLOYMENT.**

**WARNING: THE DRIVER AIRBAG TRIM COVER MUST NEVER BE PAINTED. REPLACEMENT TRIM COVERS ARE SERVICED IN THE ORIGINAL COLORS. PAINT MAY CHANGE THE WAY IN WHICH THE MATERIAL OF THE TRIM COVER RESPONDS TO AN AIRBAG DEPLOYMENT. FAILURE TO OBSERVE THIS WARNING COULD RESULT IN OCCUPANT INJURIES UPON AIRBAG DEPLOYMENT.**

(1) Assemble the driver airbag trim cover onto the airbag housing. (Refer to 8 - ELECTRICAL/RESTRAINTS/DRIVER AIRBAG - ASSEMBLY).

(2) When installing the driver airbag, reconnect the clockspring driver airbag pigtail wire harness connector to the airbag inflator connector receptacle by pressing straight in on the connector (Fig. 10). You can be certain that the connector is fully engaged by listening carefully for a distinct, audible click as the connector snaps into place.

(3) Reconnect the clockspring horn switch pigtail wire harness connector to the horn switch feed pigtail wire connector, which is located on the back of the driver airbag.

(4) Carefully position the driver airbag in the steering wheel. Be certain that the clockspring pigtail wires in the steering wheel hub area are not pinched between the driver airbag and the steering wheel.

(5) From the underside of the steering wheel, install and tighten the two screws that secure the driver airbag to the steering wheel armature. Tighten the screws to 10.2 N-m (90 in. lbs.).

(6) Do not reconnect the battery negative cable at this time. The airbag system verification test procedure should be performed following service of any airbag system component. (Refer to 8 - ELECTRICAL/RESTRAINTS - STANDARD PROCEDURE - VERIFICATION TEST).

**FRONT SEAT BELT & RETRACTOR****REMOVAL - STANDARD CAB**

**WARNING: DURING AND FOLLOWING ANY SEAT BELT SERVICE, CAREFULLY INSPECT ALL SEAT BELTS, BUCKLES, MOUNTING HARDWARE, AND RETRACTORS FOR PROPER INSTALLATION, OPERATION, OR DAMAGE. REPLACE ANY BELT THAT IS CUT, FRAYED, OR TORN. STRAIGHTEN ANY BELT THAT IS TWISTED. TIGHTEN ANY LOOSE FASTENERS. REPLACE ANY BELT THAT HAS A DAMAGED OR INOPERATIVE BUCKLE OR RETRACTOR. REPLACE ANY BELT THAT HAS A BENT OR DAMAGED LATCH PLATE OR ANCHOR PLATE. NEVER ATTEMPT TO REPAIR A SEAT BELT COMPONENT. ALWAYS REPLACE DAMAGED OR FAULTY SEAT BELT COMPONENTS WITH THE CORRECT, NEW AND UNUSED REPLACEMENT PARTS LISTED IN THE MOPAR PARTS CATALOG.**

(1) Move the front seats to their most forward position for easiest access to the front shoulder belt lower seat belt anchor plate, the retractor, and the B-pillar.

(2) Remove the screw that secures the lower seat belt anchor plate to the floor panel near the base of the B-pillar.

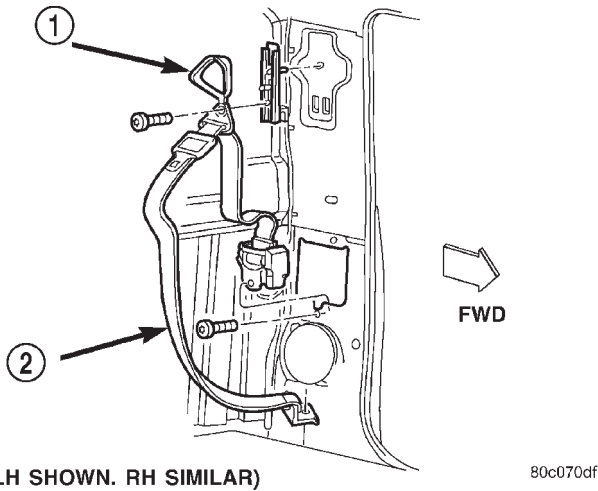
(3) Unsnap and lift the front shoulder belt turning loop cover to access the screw that secures the turning loop to the height adjuster (Fig. 15).

(4) Remove the screw that secures the shoulder belt turning loop to the height adjuster.

(5) Remove the shoulder belt turning loop from the height adjuster.

(6) Remove the trim from the B-pillar. (Refer to 23 - BODY/INTERIOR/B-PILLAR TRIM - REMOVAL).

## FRONT SEAT BELT &amp; RETRACTOR (Continued)



**Fig. 15 Front Shoulder Belt - Standard Cab**

- 1 - TURNING LOOP COVER  
2 - SHOULDER BELT ASSEMBLY

(7) Disengage the front seat shoulder belt turning loop and lower seat belt anchor plate from the B-pillar trim.

(8) Remove the screw that secures the retractor to the B-pillar.

(9) Remove the front shoulder belt and retractor from the B-pillar.

### REMOVAL - CLUB/QUAD CAB

The front seat shoulder belt and retractor are integral to the driver and passenger front seat backs on club cab and quad cab models.

**WARNING: DURING AND FOLLOWING ANY SEAT BELT SERVICE, CAREFULLY INSPECT ALL SEAT BELTS, BUCKLES, MOUNTING HARDWARE, AND RETRACTORS FOR PROPER INSTALLATION, OPERATION, OR DAMAGE. REPLACE ANY BELT THAT IS CUT, FRAYED, OR TORN. STRAIGHTEN ANY BELT THAT IS TWISTED. TIGHTEN ANY LOOSE FASTENERS. REPLACE ANY BELT THAT HAS A DAMAGED OR INOPERATIVE BUCKLE OR RETRACTOR. REPLACE ANY BELT THAT HAS A BENT OR DAMAGED LATCH PLATE OR ANCHOR PLATE. NEVER ATTEMPT TO REPAIR A SEAT BELT COMPONENT. ALWAYS REPLACE DAMAGED OR FAULTY SEAT BELT COMPONENTS WITH THE CORRECT, NEW AND UNUSED REPLACEMENT PARTS LISTED IN THE MOPAR PARTS CATALOG.**

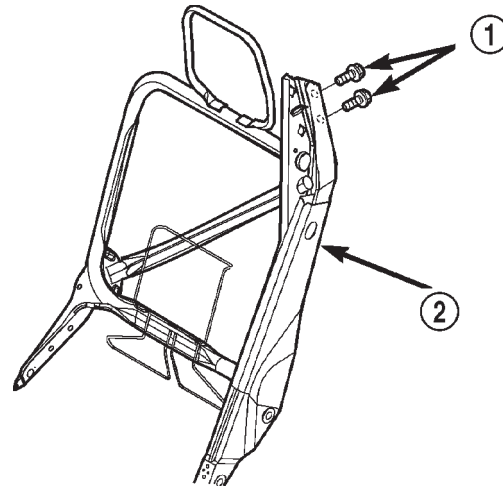
(1) Remove the trim cover from the front seat back frame. (Refer to 23 - BODY/SEATS/SEAT BACK COVER - REMOVAL).

(2) Remove the screws that secure the retractor cover to the seat back frame.

(3) Remove the retractor cover from the seat back frame.

(4) Remove the two screws that secure the seat belt retractor to the seat back frame (Fig. 16).

(5) Remove the front shoulder belt and retractor from the seat back frame.



**Fig. 16 Seat Belt Retractor**

- 1 - RETRACTOR SCREWS  
2 - SEAT BACK FRAME

### INSTALLATION - STANDARD CAB

**WARNING: DURING AND FOLLOWING ANY SEAT BELT SERVICE, CAREFULLY INSPECT ALL SEAT BELTS, BUCKLES, MOUNTING HARDWARE, AND RETRACTORS FOR PROPER INSTALLATION, OPERATION, OR DAMAGE. REPLACE ANY BELT THAT IS CUT, FRAYED, OR TORN. STRAIGHTEN ANY BELT THAT IS TWISTED. TIGHTEN ANY LOOSE FASTENERS. REPLACE ANY BELT THAT HAS A DAMAGED OR INOPERATIVE BUCKLE OR RETRACTOR. REPLACE ANY BELT THAT HAS A BENT OR DAMAGED LATCH PLATE OR ANCHOR PLATE. NEVER ATTEMPT TO REPAIR A SEAT BELT COMPONENT. ALWAYS REPLACE DAMAGED OR FAULTY SEAT BELT COMPONENTS WITH THE CORRECT, NEW AND UNUSED REPLACEMENT PARTS LISTED IN THE MOPAR PARTS CATALOG.**

(1) Position the retractor onto the B-pillar (Fig. 15).

(2) Install and tighten the screw that secures the retractor to the B-pillar. Tighten the screw to 40 N·m (29 ft. lbs.).

(3) Engage the front seat shoulder belt turning loop and lower seat belt anchor plate with the B-pillar trim.

## FRONT SEAT BELT &amp; RETRACTOR (Continued)

(4) Reinstall the trim onto the B-pillar. (Refer to 23 - BODY/INTERIOR/B-PILLAR TRIM - INSTALLATION).

(5) Position the shoulder belt turning loop onto the height adjuster.

(6) Install and tighten the screw that secures the shoulder belt turning loop to the height adjuster. Tighten the screw to 30 N·m (22 ft. lbs.).

(7) Fold and snap the cover over the front shoulder belt turning loop to conceal the screw that secures the turning loop to the height adjuster.

(8) Install and tighten the screw that secures the lower seat belt anchor plate to the floor panel near the base of the B-pillar. Tighten the screw to 40 N·m (29 ft. lbs.).

**INSTALLATION - CLUB/QUAD CAB**

The front seat shoulder belt and retractor are integral to the driver and passenger front seat backs on club cab and quad cab models.

**WARNING: DURING AND FOLLOWING ANY SEAT BELT SERVICE, CAREFULLY INSPECT ALL SEAT BELTS, BUCKLES, MOUNTING HARDWARE, AND RETRACTORS FOR PROPER INSTALLATION, OPERATION, OR DAMAGE. REPLACE ANY BELT THAT IS CUT, FRAYED, OR TORN. STRAIGHTEN ANY BELT THAT IS TWISTED. TIGHTEN ANY LOOSE FASTENERS. REPLACE ANY BELT THAT HAS A DAMAGED OR INOPERATIVE BUCKLE OR RETRACTOR. REPLACE ANY BELT THAT HAS A BENT OR DAMAGED LATCH PLATE OR ANCHOR PLATE. NEVER ATTEMPT TO REPAIR A SEAT BELT COMPONENT. ALWAYS REPLACE DAMAGED OR FAULTY SEAT BELT COMPONENTS WITH THE CORRECT, NEW AND UNUSED REPLACEMENT PARTS LISTED IN THE MOPAR PARTS CATALOG.**

(1) Position the front shoulder belt and retractor onto the seat back frame.

(2) Install and tighten the two screws that secure the seat belt retractor to the seat back frame (Fig. 16). Tighten the screws to 16 N·m (12 ft. lbs.).

(3) Position the retractor cover onto the seat back frame.

(4) Install and tighten the screws that secure the retractor cover to the seat back frame. Tighten the screws to 2 N·m (17 in. lbs.).

(5) Reinstall the trim cover onto the front seat back frame. (Refer to 23 - BODY/SEATS/SEAT BACK COVER - INSTALLATION).

**FRONT SEAT BELT BUCKLE****REMOVAL**

**WARNING: DURING AND FOLLOWING ANY SEAT BELT SERVICE, CAREFULLY INSPECT ALL SEAT BELTS, BUCKLES, MOUNTING HARDWARE, AND RETRACTORS FOR PROPER INSTALLATION, OPERATION, OR DAMAGE. REPLACE ANY BELT THAT IS CUT, FRAYED, OR TORN. STRAIGHTEN ANY BELT THAT IS TWISTED. TIGHTEN ANY LOOSE FASTENERS. REPLACE ANY BELT THAT HAS A DAMAGED OR INOPERATIVE BUCKLE OR RETRACTOR. REPLACE ANY BELT THAT HAS A BENT OR DAMAGED LATCH PLATE OR ANCHOR PLATE. NEVER ATTEMPT TO REPAIR A SEAT BELT COMPONENT. ALWAYS REPLACE DAMAGED OR FAULTY SEAT BELT COMPONENTS WITH THE CORRECT, NEW AND UNUSED REPLACEMENT PARTS LISTED IN THE MOPAR PARTS CATALOG.**

(1) Move the front seat to its most forward position for easiest access to the front seat belt buckle anchors.

(2) Tilt both front seat backs forward far enough to access the seat belt buckle anchor screws.

(3) On the driver's side only, disconnect the body wire harness connector for the seat belt switch from the seat belt switch pigtail wire connector on the seat belt buckle.

(4) Remove the screw that secures the seat belt buckle to the anchor on the seat cushion frame.

(5) Remove the front seat belt buckle from the seat cushion frame.

**INSTALLATION**

**WARNING: DURING AND FOLLOWING ANY SEAT BELT SERVICE, CAREFULLY INSPECT ALL SEAT BELTS, BUCKLES, MOUNTING HARDWARE, AND RETRACTORS FOR PROPER INSTALLATION, OPERATION, OR DAMAGE. REPLACE ANY BELT THAT IS CUT, FRAYED, OR TORN. STRAIGHTEN ANY BELT THAT IS TWISTED. TIGHTEN ANY LOOSE FASTENERS. REPLACE ANY BELT THAT HAS A DAMAGED OR INOPERATIVE BUCKLE OR RETRACTOR. REPLACE ANY BELT THAT HAS A BENT OR DAMAGED LATCH PLATE OR ANCHOR PLATE. NEVER ATTEMPT TO REPAIR A SEAT BELT COMPONENT. ALWAYS REPLACE DAMAGED OR FAULTY SEAT BELT COMPONENTS WITH THE CORRECT, NEW AND UNUSED REPLACEMENT PARTS LISTED IN THE MOPAR PARTS CATALOG.**

(1) Position the front seat belt buckle onto the seat cushion frame.

## FRONT SEAT BELT BUCKLE (Continued)

(2) On the driver's side only, reconnect the body wire harness connector for the seat belt switch to the seat belt switch pigtail wire connector on the seat belt buckle.

(3) Install and tighten the screw that secures the seat belt buckle to the anchor on the seat cushion frame. Tighten the screw to 40 N·m (29 ft. lbs.).

## PASSENGER AIRBAG

## DESCRIPTION

The rearward facing surface of the passenger airbag door above the glove box is the most visible part of the passenger airbag. The airbag used in this model is a Next Generation-type that complies with revised federal airbag standards to deploy with less force than those used in some prior models. The passenger airbag is located in the instrument panel in front of the front seat passenger seating position, where it is secured to the instrument panel. Concealed beneath the passenger airbag door are the folded airbag cushion, the airbag retainer or housing, and the airbag inflator. The airbag inflator is a hybrid-type unit that is secured to and sealed within the stamped steel airbag housing along with the folded airbag cushion. The airbag housing stamping also includes the two mounting brackets, one front and one rear. The front bracket is secured beneath the instrument panel top cover with screws to the instrument panel structural support. The rear bracket is secured with screws to the upper glove box opening reinforcement. A yellow connector on the end of a short, two-wire pigtail harness connects the passenger airbag inflator to the vehicle electrical system.

The molded plastic passenger airbag door has predetermined breakout lines concealed beneath its decorative cover. The lower edge of the passenger airbag door is secured to the airbag housing, and includes the two passenger side panel outlets. The sides and upper edges are secured to the instrument panel top cover with five molded tabs that are each fit with a small metal retainer. The five retainers are snapped into five slotted receptacles located around the sides and top of the airbag door opening in the instrument panel top cover. Following a passenger airbag deployment, the passenger airbag and airbag door unit must be replaced. The passenger airbag cannot be repaired, and must be replaced if faulty or in any way damaged. The passenger airbag door is serviced only as a unit with the passenger airbag, and includes the two passenger side heating and air conditioning panel outlet housings and barrels.

## OPERATION

The passenger airbag is deployed by an electrical signal generated by the Airbag Control Module (ACM) through the passenger airbag line 1 and line 2 (or squib) circuits. The hybrid-type inflator assembly includes a small canister of highly compressed argon gas. When the ACM sends the proper electrical signal to the airbag inflator, the electrical energy generates enough heat to ignite chemical pellets within the inflator. Once ignited, these chemical pellets burn rapidly and produce the pressure necessary to rupture a containment disk in the argon gas canister. The inflator and argon gas canister are sealed to the airbag cushion so that all of the released argon gas is directed into the airbag cushion, causing the cushion to inflate. As the cushion inflates, the passenger airbag door will split at the breakout lines and the door will pivot out of the way. Following an airbag deployment, the airbag cushion quickly deflates by venting the argon gas through the porous fabric material used on each end panel of the airbag cushion.

Some of the chemicals used to create the pressure to burst the argon gas containment disk are considered hazardous in their solid state, before they are burned, but they are securely sealed within the airbag inflator. However, the gas that is produced when the chemicals are burned is harmless. A small amount of residue from the burned chemicals may cause some temporary discomfort if it contacts the skin, eyes, or breathing passages. If skin or eye irritation is noticed, rinse the affected area with plenty of cool, clean water. If breathing passages are irritated, move to another area where there is plenty of clean, fresh air to breathe. If the irritation is not alleviated by these actions, contact a physician immediately.

## REMOVAL

**WARNING: DISABLE THE AIRBAG SYSTEM BEFORE ATTEMPTING ANY STEERING WHEEL, STEERING COLUMN, OR INSTRUMENT PANEL COMPONENT DIAGNOSIS OR SERVICE. DISCONNECT AND ISOLATE THE BATTERY NEGATIVE (GROUND) CABLE, THEN WAIT TWO MINUTES FOR THE AIRBAG SYSTEM CAPACITOR TO DISCHARGE BEFORE PERFORMING FURTHER DIAGNOSIS OR SERVICE. THIS IS THE ONLY SURE WAY TO DISABLE THE AIRBAG SYSTEM. FAILURE TO TAKE THE PROPER PRECAUTIONS COULD RESULT IN ACCIDENTAL AIRBAG DEPLOYMENT AND POSSIBLE PERSONAL INJURY.**



## PASSENGER AIRBAG (Continued)

**WARNING: WHEN REMOVING A DEPLOYED AIRBAG, RUBBER GLOVES, EYE PROTECTION, AND A LONG-SLEEVED SHIRT SHOULD BE WORN. THERE MAY BE DEPOSITS ON THE AIRBAG UNIT AND OTHER INTERIOR SURFACES. IN LARGE DOSES, THESE DEPOSITS MAY CAUSE IRRITATION TO THE SKIN AND EYES.**

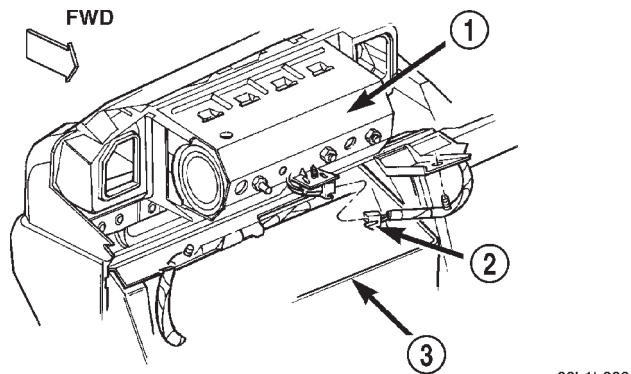
(1) Disconnect and isolate the battery negative cable. If either of the airbags has not been deployed, wait two minutes for the system capacitor to discharge before further service.

(2) Remove the glove box from the instrument panel. (Refer to 23 - BODY/INSTRUMENT PANEL/GLOVE BOX - REMOVAL).

(3) Remove the glove box opening upper trim from the instrument panel. (Refer to 23 - BODY/INSTRUMENT PANEL/GLOVE BOX OPENING UPPER TRIM - REMOVAL).

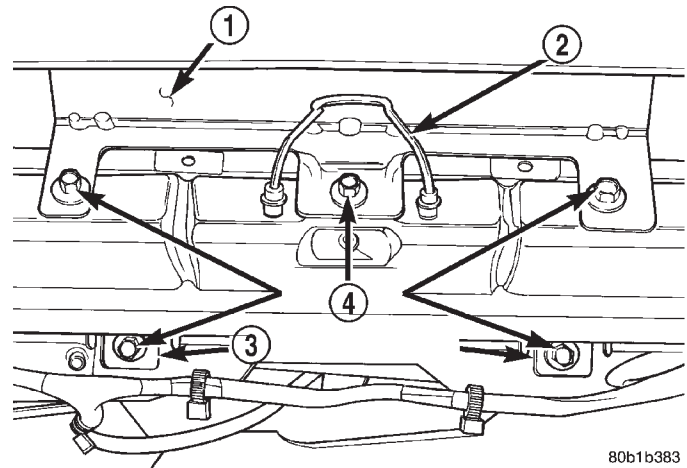
(4) Remove the four screws that secure the two plastic support brackets for the passenger airbag door panel outlet housing to the glove box opening upper reinforcement.

(5) Reach through and above the glove box opening to access and disconnect the passenger airbag pigtail wire connector from the instrument panel wire harness (Fig. 17).



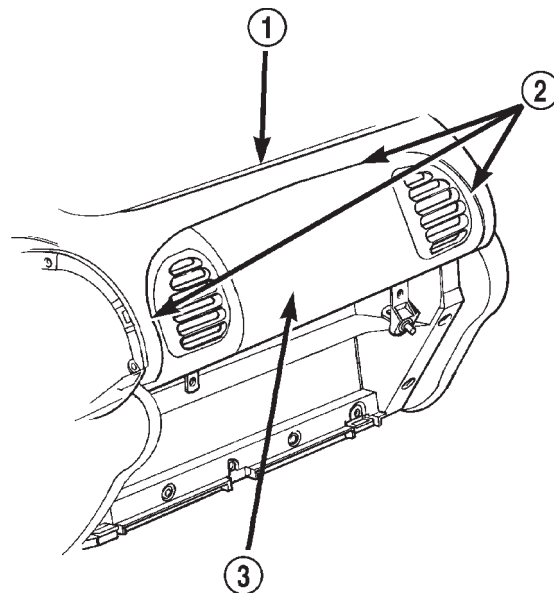
**Fig. 17 Passenger Airbag Connector**

- 1 - PASSENGER AIRBAG
- 2 - WIRE HARNESS CONNECTOR
- 3 - GLOVE BOX OPENING



**Fig. 18 Passenger Airbag Remove/Install**

- 1 - PASSENGER AIRBAG REAR BRACKET
- 2 - GLOVE BOX LATCH STRIKER
- 3 - FRONT BRACKET
- 4 - SCREWS



**Fig. 19 Passenger Airbag Door Disengage**

- 1 - INSTRUMENT PANEL TOP COVER
- 2 - PRY HERE
- 3 - PASSENGER AIRBAG DOOR

(6) Remove the two screws that secure the passenger airbag front bracket to the instrument panel structural support (Fig. 18).

(7) Remove the three screws that secure the passenger airbag rear bracket to the glove box opening upper reinforcement.

(8) Using a trim stick or another suitable wide flat-bladed tool and starting at the lower left edge, gently pry the passenger airbag door away from the instrument panel far enough to disengage the five molded tabs and snap retainers securing it to the receptacles in the instrument panel top cover (Fig. 19).

(9) Remove the passenger airbag, the airbag door, and the panel outlet housing and barrel assemblies from the instrument panel as a unit.



## PASSENGER AIRBAG (Continued)

## INSTALLATION

**WARNING: DISABLE THE AIRBAG SYSTEM BEFORE ATTEMPTING ANY STEERING WHEEL, STEERING COLUMN, OR INSTRUMENT PANEL COMPONENT DIAGNOSIS OR SERVICE. DISCONNECT AND ISOLATE THE BATTERY NEGATIVE (GROUND) CABLE, THEN WAIT TWO MINUTES FOR THE AIRBAG SYSTEM CAPACITOR TO DISCHARGE BEFORE PERFORMING FURTHER DIAGNOSIS OR SERVICE. THIS IS THE ONLY SURE WAY TO DISABLE THE AIRBAG SYSTEM. FAILURE TO TAKE THE PROPER PRECAUTIONS COULD RESULT IN ACCIDENTAL AIRBAG DEPLOYMENT AND POSSIBLE PERSONAL INJURY.**

**WARNING: WHEN REMOVING A DEPLOYED AIRBAG, RUBBER GLOVES, EYE PROTECTION, AND A LONG-SLEEVED SHIRT SHOULD BE WORN. THERE MAY BE DEPOSITS ON THE AIRBAG UNIT AND OTHER INTERIOR SURFACES. IN LARGE DOSES, THESE DEPOSITS MAY CAUSE IRRITATION TO THE SKIN AND EYES.**

**WARNING: USE EXTREME CARE TO PREVENT ANY FOREIGN MATERIAL FROM ENTERING THE PASSENGER AIRBAG, OR BECOMING ENTRAPPED BETWEEN THE PASSENGER AIRBAG CUSHION AND THE PASSENGER AIRBAG DOOR. FAILURE TO OBSERVE THIS WARNING COULD RESULT IN OCCUPANT INJURIES UPON AIRBAG DEPLOYMENT.**

**WARNING: THE PASSENGER AIRBAG DOOR MUST NEVER BE PAINTED. REPLACEMENT PASSENGER AIRBAG DOORS ARE SERVICED IN THE ORIGINAL COLORS. PAINT MAY CHANGE THE WAY IN WHICH THE MATERIAL OF THE AIRBAG DOOR RESPONDS TO AN AIRBAG DEPLOYMENT. FAILURE TO OBSERVE THIS WARNING COULD RESULT IN OCCUPANT INJURIES UPON AIRBAG DEPLOYMENT.**

(1) Carefully inspect the five receptacle slots around the top and sides of the passenger airbag door opening of the instrument panel top cover. Remove any of the small metal airbag door snap retainers that did not remain on the molded airbag door tabs during the removal procedure.

(2) If the removed passenger airbag module is being reinstalled, install the metal snap retainers recovered in Step 1 onto the proper airbag door tabs. Each of the five molded airbag door tabs must have a snap retainer on it before it is installed in the instru-

ment panel. New replacement passenger airbags come with new airbag door snap retainers installed.

(3) Carefully position the passenger airbag onto the instrument panel.

(4) Align the five tabs and retainers on the upper edge and sides of the passenger airbag door with the receptacles in the instrument panel top cover.

(5) Using hand pressure, press firmly on the passenger airbag door over each of the tab and retainer locations until each of them is fully engaged in its receptacle. Be certain that each of the metal snap retainers is in position on the airbag door tabs.

(6) Install and tighten the five screws that secure the passenger airbag front and rear mounting brackets to the instrument panel (Fig. 18). Tighten the screws to 9 N·m (80 in. lbs.).

(7) Install and tighten the four screws that secure the two plastic support brackets of the passenger airbag door panel outlet housing to the glove box opening upper reinforcement. Tighten the screws to 2.2 N·m (20 in. lbs.).

(8) Reach through and above the glove box opening to access and reconnect the passenger airbag pigtail wire connector to the instrument panel wire harness connector (Fig. 17). Be certain that the passenger airbag pigtail wire connector is fully engaged with and latched to the instrument panel wire harness connector.

(9) Reinstall the glove box opening upper trim onto the instrument panel. (Refer to 23 - BODY/INSTRUMENT PANEL/GLOVE BOX OPENING UPPER TRIM - INSTALLATION).

(10) Reinstall the glove box onto the instrument panel. (Refer to 23 - BODY/INSTRUMENT PANEL/GLOVE BOX - INSTALLATION).

(11) Do not reconnect the battery negative cable at this time. The airbag system verification test procedure should be performed following service of any airbag system component. (Refer to 8 - ELECTRICAL/RESTRAINTS - STANDARD PROCEDURE - VERIFICATION TEST).

## PASSENGER AIRBAG ON/OFF SWITCH

### DESCRIPTION

The passenger airbag on-off switch is standard equipment on this model when it is not equipped with a full size rear seat. This switch is a single pole, single throw switch with a single integral red Light-Emitting Diode (LED), and a non-coded key cylinder-type actuator. The switch is located in the upper right corner of instrument panel cluster bezel, near the center of instrument panel to make the Off indicator visible to all front seat occupants. When the

## PASSENGER AIRBAG ON/OFF SWITCH (Continued)

switch is in its installed position, the only components visible through the dedicated opening of the cluster bezel are the switch face plate and nomenclature, the key cylinder actuator, and a small round lens with the text "Off" imprinted on it. The "On" position of the switch is designated by text imprinted upon the face plate of the switch, but is not illuminated. The remainder of the switch is concealed behind the switch face plate and the instrument panel cluster bezel.

The passenger airbag on-off switch housing is constructed of molded plastic and has three integral mounting tabs. These mounting tabs are used to secure the switch to the back of the molded plastic switch face plate with three small screws. The molded plastic face plate also has three integral mounting tabs that are used to secure the switch and face plate unit to the instrument panel carrier with three additional screws. Two short pigtail wires with molded plastic connector insulators exit the back of the switch housing and connect the switch to the vehicle electrical system through two dedicated take outs of the instrument panel wire harness. The harness take outs are equipped with molded plastic connector insulators that are keyed and latched to ensure proper and secure switch electrical connections. The passenger airbag on/off switch cannot be adjusted or repaired and, if faulty or damaged, the switch must be replaced.

## OPERATION

The passenger airbag on-off switch allows the customer to turn the passenger airbag function On or Off to accommodate certain uses of the right front seating position where airbag protection may not be desired. See the owner's manual in the vehicle glove box for specific recommendations on when to enable or disable the passenger airbag. The Off indicator of the switch will be illuminated whenever the switch is turned to the Off position. The ignition key is the only key or object that should ever be inserted into the switch. The on-off switch requires only a partial key insertion to fully depress a spring-loaded locking plunger. The spring-loaded locking plunger prevents the user from leaving the key in the switch. The key will be automatically ejected when force is not applied. To actuate the passenger side airbag on/off switch, insert the ignition key into the switch key actuator far enough to fully depress the plunger and rotate to the desired switch position. When the switch key actuator is rotated to its clockwise stop (the key actuator slot will be aligned with the Off indicator lamp), the Off indicator is illuminated and the passenger airbag is disabled. When the switch is rotated to its counterclockwise stop (the key actuator slot will be in a vertical position), the Off indicator

will be extinguished and the passenger airbag is enabled.

The passenger airbag switch is connected in series between the Airbag Control Module (ACM) and the passenger airbag inflator unit. When the switch is in the On position, the switch connects the ACM directly to the passenger airbag inflator. When the switch is in the Off position it interrupts the inflator circuits, but replaces the normal resistance in these circuits with an internal resistor. Thus, the ACM is unable to distinguish the mode of the switch and still sends an electrical signal as though it were deploying the passenger airbag when it detects a sufficient impact. However, the switch position should not be changed while the ignition switch is in the On position, as the ACM may detect a fault, record a Diagnostic Trouble Code (DTC), and illuminate the Airbag indicator in response to a momentary open it senses in the passenger airbag inflator circuits as the on/off switch changes states.

## REMOVAL

**WARNING: DISABLE THE AIRBAG SYSTEM BEFORE ATTEMPTING ANY STEERING WHEEL, STEERING COLUMN, OR INSTRUMENT PANEL COMPONENT DIAGNOSIS OR SERVICE. DISCONNECT AND ISOLATE THE BATTERY NEGATIVE (GROUND) CABLE, THEN WAIT TWO MINUTES FOR THE AIRBAG SYSTEM CAPACITOR TO DISCHARGE BEFORE PERFORMING FURTHER DIAGNOSIS OR SERVICE. THIS IS THE ONLY SURE WAY TO DISABLE THE AIRBAG SYSTEM. FAILURE TO TAKE THE PROPER PRECAUTIONS COULD RESULT IN ACCIDENTAL AIRBAG DEPLOYMENT AND POSSIBLE PERSONAL INJURY.**

(1) Disconnect and isolate the battery negative cable. If either of the airbags has not been deployed, wait two minutes for the system capacitor to discharge before further service.

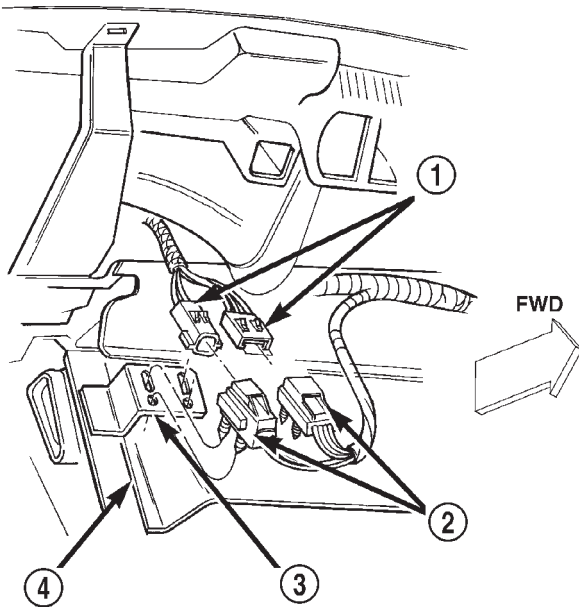
(2) Remove the cluster bezel from the instrument panel. (Refer to 23 - BODY/INSTRUMENT PANEL/CLUSTER BEZEL - REMOVAL).

(3) Remove the glove box from the instrument panel. (Refer to 23 - BODY/INSTRUMENT PANEL/GLOVE BOX - REMOVAL).

(4) Reach through the glove box opening to access and disconnect the two passenger airbag on/off switch pigtail wire harness connectors from the instrument panel wire harness connectors. These connectors are retained on a bracket located on the inboard glove box opening reinforcement (Fig. 20).

(5) Remove the three screws that secure the passenger airbag on/off switch face plate to the instrument panel (Fig. 21).

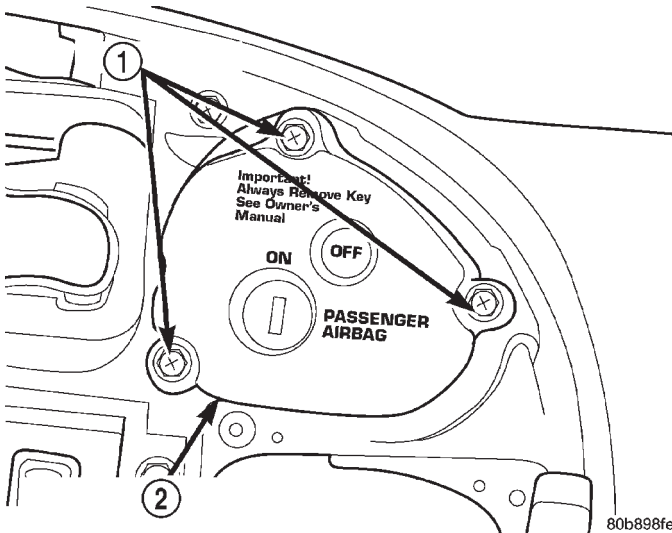
## PASSENGER AIRBAG ON/OFF SWITCH (Continued)



80b6f0c6

**Fig. 20 Passenger Airbag On/Off Switch Connectors**

- 1 - PASSENGER AIRBAG ON/OFF SWITCH PIGTAIL WIRE CONNECTORS
- 2 - INSTRUMENT PANEL WIRE HARNESS CONNECTORS
- 3 - BRACKET
- 4 - REINFORCEMENT



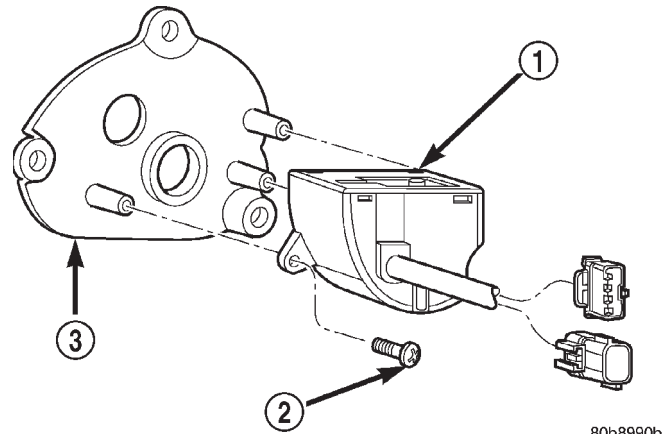
80b898fe

**Fig. 21 Passenger Airbag On/Off Switch Remove/Install**

- 1 - SCREWS (3)
- 2 - PASSENGER AIRBAG ON/OFF SWITCH FACE PLATE

(6) Remove the passenger airbag on/off switch and face plate from the instrument panel as a unit.

(7) Remove the three screws that secure the passenger airbag on/off switch to the back of the switch face plate (Fig. 22).



80b8990b

**Fig. 22 Passenger Airbag On/Off Switch Face Plate Remove/Install**

- 1 - PASSENGER SIDE AIRBAG ON/OFF SWITCH
- 2 - SCREW (3)
- 3 - FACE PLATE

(8) Remove the passenger airbag on/off switch from the face plate.

**INSTALLATION**

**WARNING: DISABLE THE AIRBAG SYSTEM BEFORE ATTEMPTING ANY STEERING WHEEL, STEERING COLUMN, OR INSTRUMENT PANEL COMPONENT DIAGNOSIS OR SERVICE. DISCONNECT AND ISOLATE THE BATTERY NEGATIVE (GROUND) CABLE, THEN WAIT TWO MINUTES FOR THE AIRBAG SYSTEM CAPACITOR TO DISCHARGE BEFORE PERFORMING FURTHER DIAGNOSIS OR SERVICE. THIS IS THE ONLY SURE WAY TO DISABLE THE AIRBAG SYSTEM. FAILURE TO TAKE THE PROPER PRECAUTIONS COULD RESULT IN ACCIDENTAL AIRBAG DEPLOYMENT AND POSSIBLE PERSONAL INJURY.**

(1) Position the passenger airbag on/off switch to the back of the face plate (Fig. 22).

(2) Install and tighten the three screws that secure the passenger airbag on/off switch to the face plate. Tighten the screws to 2.2 N·m (20 in. lbs.).

(3) Route the passenger airbag on/off switch pigtail wires through the switch opening of the instrument panel.

(4) Reach through the glove box opening to access and reconnect the two passenger airbag on/off switch pigtail wire connectors to the instrument panel wire harness connectors. These connectors are retained on a bracket located on the inboard glove box opening reinforcement (Fig. 20). Be certain that both connectors are fully engaged and latched.

## PASSENGER AIRBAG ON/OFF SWITCH (Continued)

(5) Position the passenger airbag on/off switch and face plate unit to the opening in the instrument panel (Fig. 21).

(6) Install and tighten the three screws that secure the passenger airbag on/off switch face plate to the instrument panel. Tighten the screws to 2.2 N-m (20 in. lbs.).

(7) Reinstall the glove box onto the instrument panel. (Refer to 23 - BODY/INSTRUMENT PANEL/GLOVE BOX - INSTALLATION).

(8) Reinstall the cluster bezel onto the instrument panel. (Refer to 23 - BODY/INSTRUMENT PANEL/CLUSTER BEZEL - INSTALLATION).

(9) Do not reconnect the battery negative cable at this time. The airbag system verification test procedure should be performed following service of any airbag system component. (Refer to 8 - ELECTRICAL/RESTRAINTS - STANDARD PROCEDURE - VERIFICATION TEST).

## REAR SEAT BELT & RETRACTOR

### REMOVAL

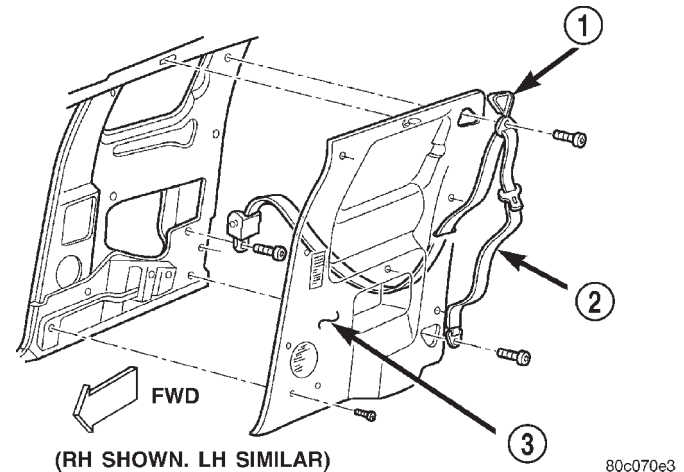
**WARNING: DURING AND FOLLOWING ANY SEAT BELT SERVICE, CAREFULLY INSPECT ALL SEAT BELTS, BUCKLES, MOUNTING HARDWARE, AND RETRACTORS FOR PROPER INSTALLATION, OPERATION, OR DAMAGE. REPLACE ANY BELT THAT IS CUT, FRAYED, OR TORN. STRAIGHTEN ANY BELT THAT IS TWISTED. TIGHTEN ANY LOOSE FASTENERS. REPLACE ANY BELT THAT HAS A DAMAGED OR INOPERATIVE BUCKLE OR RETRACTOR. REPLACE ANY BELT THAT HAS A BENT OR DAMAGED LATCH PLATE OR ANCHOR PLATE. NEVER ATTEMPT TO REPAIR A SEAT BELT COMPONENT. ALWAYS REPLACE DAMAGED OR FAULTY SEAT BELT COMPONENTS WITH THE CORRECT, NEW AND UNUSED REPLACEMENT PARTS LISTED IN THE MOPAR PARTS CATALOG.**

(1) Remove the rear seat from the passenger compartment. (Refer to 23 - BODY/SEATS/REAR SEAT - REMOVAL).

(2) Remove the trim cover from the door sill. (Refer to 23 - BODY/INTERIOR/DOOR SILL TRIM - REMOVAL).

(3) Remove the screw that secures the lower seat belt anchor plate to the quarter inner panel near the base of the C-pillar (Fig. 23).

(4) Unsnap and lift the rear shoulder belt turning loop cover to access the screw that secures the turning loop to the quarter inner panel near the top of the C-pillar.



**Fig. 23 Rear Seat Belt & Retractor - Typical**

- 1 - TURNING LOOP
- 2 - REAR SEAT BELT AND RETRACTOR
- 3 - QUARTER TRIM PANEL

(5) Remove the screw that secures the shoulder belt turning loop to the quarter inner panel.

(6) Remove the trim from the quarter inner panel. (Refer to 23 - BODY/INTERIOR/QUARTER TRIM PANEL - REMOVAL).

(7) Disengage the rear seat shoulder belt turning loop and lower seat belt anchor plate from the quarter trim panel.

(8) Remove the screw that secures the retractor to the quarter inner panel near the C-pillar.

(9) Remove the rear shoulder belt and retractor from the quarter inner panel.

### INSTALLATION

**WARNING: DURING AND FOLLOWING ANY SEAT BELT SERVICE, CAREFULLY INSPECT ALL SEAT BELTS, BUCKLES, MOUNTING HARDWARE, AND RETRACTORS FOR PROPER INSTALLATION, OPERATION, OR DAMAGE. REPLACE ANY BELT THAT IS CUT, FRAYED, OR TORN. STRAIGHTEN ANY BELT THAT IS TWISTED. TIGHTEN ANY LOOSE FASTENERS. REPLACE ANY BELT THAT HAS A DAMAGED OR INOPERATIVE BUCKLE OR RETRACTOR. REPLACE ANY BELT THAT HAS A BENT OR DAMAGED LATCH PLATE OR ANCHOR PLATE. NEVER ATTEMPT TO REPAIR A SEAT BELT COMPONENT. ALWAYS REPLACE DAMAGED OR FAULTY SEAT BELT COMPONENTS WITH THE CORRECT, NEW AND UNUSED REPLACEMENT PARTS LISTED IN THE MOPAR PARTS CATALOG.**

(1) Position the rear shoulder belt retractor onto the quarter inner panel (Fig. 23).



## REAR SEAT BELT &amp; RETRACTOR (Continued)

(2) Install and tighten the screw that secures the retractor to the quarter inner panel. Tighten the screw to 40 N-m (29 ft. lbs.).

(3) Engage the rear seat shoulder belt turning loop and lower seat belt anchor plate with the quarter trim panel.

(4) Reinstall the trim onto the quarter inner panel. (Refer to 23 - BODY/INTERIOR/QUARTER TRIM PANEL - INSTALLATION).

(5) Position the shoulder belt turning loop onto the quarter inner panel near the top of the C-pillar.

(6) Install and tighten the screw that secures the shoulder belt turning loop to the quarter inner panel. Tighten the screw to 40 N-m (29 ft. lbs.).

(7) Fold and snap the cover over the rear shoulder belt turning loop to conceal the screw that secures the turning loop to the quarter inner panel.

(8) Position the lower seat belt anchor plate onto the quarter inner panel near the base of the C-pillar.

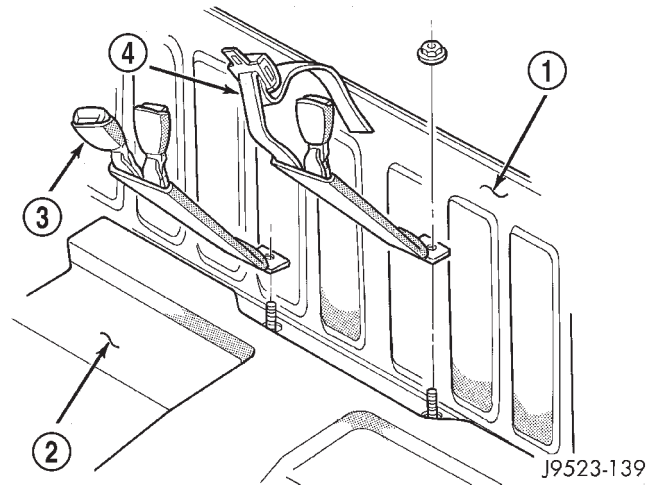
(9) Install and tighten the screw that secures the lower seat belt anchor plate to the quarter inner panel near the base of the C-pillar. Tighten the screw to 40 N-m (29 ft. lbs.).

(10) Reinstall the trim cover onto the door sill. (Refer to 23 - BODY/INTERIOR/DOOR SILL TRIM - INSTALLATION).

(11) Reinstall the rear seat into the passenger compartment. (Refer to 23 - BODY/SEATS/REAR SEAT - INSTALLATION).

(2) Fold the rear seat unit up and back against the cab back panel (stowed position) for access to the rear seat belt buckle anchors.

(3) Reach through the opening between the rear seat back and the floor panel to access and remove the nut that secures the rear seat belt buckle/buckle unit (right side) or lap belt/buckle unit (left side) anchor plate to the stud on the rear floor panel (Fig. 24).



**Fig. 24 Rear Seat Belt Buckle Remove/Install**

- 1 - CAB BACK PANEL
- 2 - REAR FLOOR PANEL
- 3 - REAR SEAT BUCKLE/BUCKLE UNIT
- 4 - REAR SEAT LAP BELT/BUCKLE UNIT

## REAR SEAT BELT BUCKLE

## REMOVAL

**WARNING: DURING AND FOLLOWING ANY SEAT BELT SERVICE, CAREFULLY INSPECT ALL SEAT BELTS, BUCKLES, MOUNTING HARDWARE, AND RETRACTORS FOR PROPER INSTALLATION, OPERATION, OR DAMAGE. REPLACE ANY BELT THAT IS CUT, FRAYED, OR TORN. STRAIGHTEN ANY BELT THAT IS TWISTED. TIGHTEN ANY LOOSE FASTENERS. REPLACE ANY BELT THAT HAS A DAMAGED OR INOPERATIVE BUCKLE OR RETRACTOR. REPLACE ANY BELT THAT HAS A BENT OR DAMAGED LATCH PLATE OR ANCHOR PLATE. NEVER ATTEMPT TO REPAIR A SEAT BELT COMPONENT. ALWAYS REPLACE DAMAGED OR FAULTY SEAT BELT COMPONENTS WITH THE CORRECT, NEW AND UNUSED REPLACEMENT PARTS LISTED IN THE MOPAR PARTS CATALOG.**

(1) Disengage the rear seat latch by pulling the release handle on the underside of the rear seat cushion.

(4) Remove the rear seat belt buckle/buckle unit (right side) or lap belt/buckle unit (left side) from the rear floor panel.

## INSTALLATION

**WARNING: DURING AND FOLLOWING ANY SEAT BELT SERVICE, CAREFULLY INSPECT ALL SEAT BELTS, BUCKLES, MOUNTING HARDWARE, AND RETRACTORS FOR PROPER INSTALLATION, OPERATION, OR DAMAGE. REPLACE ANY BELT THAT IS CUT, FRAYED, OR TORN. STRAIGHTEN ANY BELT THAT IS TWISTED. TIGHTEN ANY LOOSE FASTENERS. REPLACE ANY BELT THAT HAS A DAMAGED OR INOPERATIVE BUCKLE OR RETRACTOR. REPLACE ANY BELT THAT HAS A BENT OR DAMAGED LATCH PLATE OR ANCHOR PLATE. NEVER ATTEMPT TO REPAIR A SEAT BELT COMPONENT. ALWAYS REPLACE DAMAGED OR FAULTY SEAT BELT COMPONENTS WITH THE CORRECT, NEW AND UNUSED REPLACEMENT PARTS LISTED IN THE MOPAR PARTS CATALOG.**



## REAR SEAT BELT BUCKLE (Continued)

(1) Reach through the opening between the rear seat back and the floor panel to position the rear seat belt buckle/buckle unit (right side) or lap belt/buckle unit (left side) onto the stud on the rear floor panel (Fig. 24).

(2) Install and tighten the nut that secures the rear seat belt buckle/buckle unit (right side) or lap belt/buckle unit (left side) anchor plate to the stud on the rear floor panel. Tighten the nut to 40 N·m (29 ft. lbs.).

(3) Route the lap belt and buckles between the rear seat back and rear seat cushion.

(4) Disengage the rear seat from its stowed position by pulling the release handle on the underside of the rear seat cushion.

(5) Fold the rear seat cushion down toward the rear floor panel until the unit is latched in its open position.

## SEAT BELT SWITCH

### DESCRIPTION

The seat belt switch is a small, normally closed, single pole, single throw, leaf contact, momentary switch. Only one seat belt switch is installed in the vehicle, and it is integral to the buckle of the driver seat belt buckle-half, located near the inboard side of the driver side front seating position. The seat belt switch is connected to the vehicle electrical system through a two-wire pigtail wire and connector on the seat belt buckle-half, which is connected to a wire harness connector and take out of the body wire harness.

The seat belt switch cannot be adjusted or repaired and, if faulty or damaged, the entire driver seat belt buckle-half unit must be replaced.

### OPERATION

The seat belt switch is designed to control a path to ground for the seat belt switch sense input of the Electro-Mechanical Instrument Cluster (EMIC). When the driver side seat belt tip-half is inserted in the seat belt buckle, the switch opens the path to ground; and, when the driver side seat belt tip-half is removed from the seat belt buckle, the switch closes the ground path. The switch is actuated by the latch mechanism within the seat belt buckle. The EMIC monitors the driver seat belt switch status, then controls the seatbelt indicator and sends hard wired chime requests to the Central Timer Module (CTM) based upon that input.

The seat belt switch receives ground through its pigtail wire connection to the body wire harness from another take out of the body wire harness. An eyelet terminal connector on that ground take out is secured under a nut to a ground stud on the left lower B-pillar (standard cab models) or the left lower cowl side inner panel (club cab and quad cab models). The seat belt switch is connected in series between ground and the seat belt switch sense input of the EMIC.

### DIAGNOSIS AND TESTING - SEAT BELT SWITCH

Refer to the appropriate wiring information. The wiring information includes wiring diagrams, proper wire and connector repair procedures, details of wire harness routing and retention, connector pin-out information and location views for the various wire harness connectors, splices and grounds.

**WARNING: ON VEHICLES EQUIPPED WITH AIRBAGS, DISABLE THE AIRBAG SYSTEM BEFORE ATTEMPTING ANY STEERING WHEEL, STEERING COLUMN, OR INSTRUMENT PANEL COMPONENT DIAGNOSIS OR SERVICE. DISCONNECT AND ISOLATE THE BATTERY NEGATIVE (GROUND) CABLE, THEN WAIT TWO MINUTES FOR THE AIRBAG SYSTEM CAPACITOR TO DISCHARGE BEFORE PERFORMING FURTHER DIAGNOSIS OR SERVICE. THIS IS THE ONLY SURE WAY TO DISABLE THE AIRBAG SYSTEM. FAILURE TO TAKE THE PROPER PRECAUTIONS COULD RESULT IN ACCIDENTAL AIRBAG DEPLOYMENT AND POSSIBLE PERSONAL INJURY.**

(1) Disconnect and isolate the battery negative cable. Disconnect the body wire harness connector for the seat belt switch from the seat belt switch pigtail wire connector located near the floor panel under the driver side front seat cushion. Check for continuity between the seat belt switch sense circuit and the ground circuit cavities in the seat belt switch pigtail wire connector. There should be continuity with the driver side seat belt tip-half and buckle-half unfastened, and no continuity with tip-half and buckle-half fastened. If OK, go to Step 2. If not OK, replace the faulty driver side seat belt buckle-half unit.

(2) Check for continuity between the ground circuit cavity in the body wire harness connector for the seat belt switch and a good ground. There should be continuity. If OK, go to Step 3. If not OK, repair the open ground circuit to ground (G301 - standard cab, or G300 - club/quad cab) as required.

## SEAT BELT SWITCH (Continued)

(3) Remove the instrument cluster from the instrument panel. Check for continuity between the seat belt switch sense circuit cavity in the instrument panel wire harness connector (Connector C2) for the instrument cluster and a good ground. There should be no continuity. If OK, go to Step 4. If not OK, repair the shorted seat belt switch sense circuit between the seat belt switch and the instrument cluster as required.

(4) Check for continuity between the seat belt switch sense circuit cavities in the body wire harness connector for the seat belt switch and the instrument panel wire harness connector (Connector C2) for the instrument cluster. There should be continuity. If OK, proceed to the diagnosis for the instrument cluster. (Refer to 8 - ELECTRICAL/INSTRUMENT CLUSTER - DIAGNOSIS AND TESTING). If not OK, repair the open seat belt switch sense circuit between the seat belt switch and the instrument cluster as required.

SEAT BELT TURNING LOOP  
ADJUSTER

## REMOVAL

**WARNING: DURING AND FOLLOWING ANY SEAT BELT SERVICE, CAREFULLY INSPECT ALL SEAT BELTS, BUCKLES, MOUNTING HARDWARE, AND RETRACTORS FOR PROPER INSTALLATION, OPERATION, OR DAMAGE. REPLACE ANY BELT THAT IS CUT, FRAYED, OR TORN. STRAIGHTEN ANY BELT THAT IS TWISTED. TIGHTEN ANY LOOSE FASTENERS. REPLACE ANY BELT THAT HAS A DAMAGED OR INOPERATIVE BUCKLE OR RETRACTOR. REPLACE ANY BELT THAT HAS A BENT OR DAMAGED LATCH PLATE OR ANCHOR PLATE. NEVER ATTEMPT TO REPAIR A SEAT BELT COMPONENT. ALWAYS REPLACE DAMAGED OR FAULTY SEAT BELT COMPONENTS WITH THE CORRECT, NEW AND UNUSED REPLACEMENT PARTS LISTED IN THE MOPAR PARTS CATALOG.**

(1) Remove the knob from the lever of the seat belt turning loop adjuster. (Refer to 8 - ELECTRICAL/RESTRAINTS/TURNING LOOP HEIGHT ADJUSTER KNOB - REMOVAL).

(2) Remove the screw that secures the shoulder belt turning loop to the height adjuster.

(3) Remove the trim from the B-pillar. (Refer to 23 - BODY/INTERIOR/B-PILLAR TRIM - REMOVAL).

(4) Remove the screw that secures the upper end of the height adjuster to the B-pillar.

(5) Pull the upper end of the height adjuster away from the B-pillar far enough to disengage the hooks on the lower end of the adjuster from the slots in the pillar.

(6) Remove the adjuster from the B-pillar.

## INSTALLATION

**WARNING: DURING AND FOLLOWING ANY SEAT BELT SERVICE, CAREFULLY INSPECT ALL SEAT BELTS, BUCKLES, MOUNTING HARDWARE, AND RETRACTORS FOR PROPER INSTALLATION, OPERATION, OR DAMAGE. REPLACE ANY BELT THAT IS CUT, FRAYED, OR TORN. STRAIGHTEN ANY BELT THAT IS TWISTED. TIGHTEN ANY LOOSE FASTENERS. REPLACE ANY BELT THAT HAS A DAMAGED OR INOPERATIVE BUCKLE OR RETRACTOR. REPLACE ANY BELT THAT HAS A BENT OR DAMAGED LATCH PLATE OR ANCHOR PLATE. NEVER ATTEMPT TO REPAIR A SEAT BELT COMPONENT. ALWAYS REPLACE DAMAGED OR FAULTY SEAT BELT COMPONENTS WITH THE CORRECT, NEW AND UNUSED REPLACEMENT PARTS LISTED IN THE MOPAR PARTS CATALOG.**

(1) Position the height adjuster to the B-pillar with the hook formations oriented toward the lower end of the adjuster.

(2) Engage the hooks on the lower end of the adjuster into the slots in the B-pillar.

(3) Tilt the upper end of the height adjuster up into position against the B-pillar.

(4) Install and tighten the screw that secures the upper end of the height adjuster to the B-pillar. Tighten the screw to 41 N·m (30 ft. lbs.).

(5) Reinstall the trim onto the B-pillar. (Refer to 23 - BODY/INTERIOR/B-PILLAR TRIM - INSTALLATION).

(6) Install and tighten the anchor screw that secures the seat belt turning loop to the adjuster. Tighten the screw to 30 N·m (22 ft. lbs.).

(7) Reinstall the knob onto the lever of the seat belt turning loop adjuster. (Refer to 8 - ELECTRICAL/RESTRAINTS/TURNING LOOP HEIGHT ADJUSTER KNOB - INSTALLATION).

## TURNING LOOP HEIGHT ADJUSTER KNOB

### REMOVAL

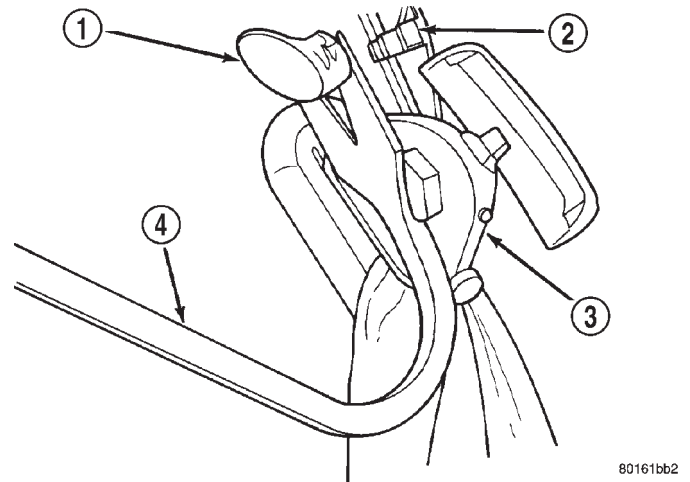
**WARNING: DURING AND FOLLOWING ANY SEAT BELT SERVICE, CAREFULLY INSPECT ALL SEAT BELTS, BUCKLES, MOUNTING HARDWARE, AND RETRACTORS FOR PROPER INSTALLATION, OPERATION, OR DAMAGE. REPLACE ANY BELT THAT IS CUT, FRAYED, OR TORN. STRAIGHTEN ANY BELT THAT IS TWISTED. TIGHTEN ANY LOOSE FASTENERS. REPLACE ANY BELT THAT HAS A DAMAGED OR INOPERATIVE BUCKLE OR RETRACTOR. REPLACE ANY BELT THAT HAS A BENT OR DAMAGED LATCH PLATE OR ANCHOR PLATE. NEVER ATTEMPT TO REPAIR A SEAT BELT COMPONENT. ALWAYS REPLACE DAMAGED OR FAULTY SEAT BELT COMPONENTS WITH THE CORRECT, NEW AND UNUSED REPLACEMENT PARTS LISTED IN THE MOPAR PARTS CATALOG.**

(1) Unsnap and lift the seat belt turning loop cover to expose the anchor screw that secures the turning loop to the height adjuster.

(2) Using the head of the turning loop anchor screw as a fulcrum, carefully pry the knob from the height adjuster lever with a suitable trim tool (Fig. 25).

### INSTALLATION

**WARNING: DURING AND FOLLOWING ANY SEAT BELT SERVICE, CAREFULLY INSPECT ALL SEAT BELTS, BUCKLES, MOUNTING HARDWARE, AND RETRACTORS FOR PROPER INSTALLATION, OPERATION, OR DAMAGE. REPLACE ANY BELT THAT IS CUT, FRAYED, OR TORN. STRAIGHTEN ANY BELT THAT IS TWISTED. TIGHTEN ANY LOOSE FASTENERS. REPLACE ANY BELT THAT HAS A DAMAGED OR INOPERATIVE BUCKLE OR RETRACTOR. REPLACE ANY BELT THAT HAS A BENT OR DAMAGED LATCH PLATE OR ANCHOR PLATE. NEVER ATTEMPT TO REPAIR A SEAT BELT COMPONENT. ALWAYS REPLACE DAMAGED OR FAULTY SEAT BELT COMPONENTS WITH THE CORRECT, NEW AND UNUSED REPLACEMENT PARTS LISTED IN THE MOPAR PARTS CATALOG.**



80161bb2

**Fig. 25 Turning Loop Height Adjuster Knob Removal - Typical**

- 1 - KNOB
- 2 - ADJUSTER LEVER
- 3 - SEAT BELT TURNING LOOP
- 4 - TRIM TOOL (SNAP-ON A179A)

(1) Fold and snap the seat belt turning loop cover back into place over the anchor screw that secures the turning loop to the adjuster.

(2) Position the height adjuster knob to the seat belt turning loop height adjuster lever.

(3) Using hand pressure, push the knob firmly and evenly onto the lever until it is fully engaged.

# SPEED CONTROL

## TABLE OF CONTENTS

	page		page
<b>SPEED CONTROL</b>		<b>OPERATION</b> . . . . .	5
DESCRIPTION . . . . .	1	REMOVAL . . . . .	6
OPERATION . . . . .	2	INSTALLATION . . . . .	10
DIAGNOSIS AND TESTING . . . . .	2	<b>SWITCH</b>	
VACUUM SUPPLY . . . . .	2	DESCRIPTION . . . . .	12
ROAD TEST . . . . .	3	OPERATION . . . . .	12
SPECIFICATIONS . . . . .	4	REMOVAL . . . . .	13
<b>CABLE</b>		INSTALLATION . . . . .	13
DESCRIPTION . . . . .	4	<b>VACUUM RESERVOIR</b>	
OPERATION . . . . .	4	DESCRIPTION . . . . .	13
REMOVAL . . . . .	4	REMOVAL . . . . .	13
INSTALLATION . . . . .	4	INSTALLATION . . . . .	14
<b>SPEED CONTROL SERVO</b>			
DESCRIPTION . . . . .	5		

## SPEED CONTROL

### DESCRIPTION - SPEED CONTROL SYSTEM

Gas Engines and/or Diesel With Automatic Trans.

The speed control system is operated by the use of a cable and a vacuum controlled servo. Electronic control of the speed control system is integrated into the Powertrain Control Module (PCM). The controls consist of two steering wheel mounted switches. The switches are labeled: ON/OFF, RES/ACCEL, SET, COAST, and CANCEL.

The system is designed to operate at speeds above 30 mph (50 km/h).

**WARNING: THE USE OF SPEED CONTROL IS NOT RECOMMENDED WHEN DRIVING CONDITIONS DO NOT PERMIT MAINTAINING A CONSTANT SPEED, SUCH AS IN HEAVY TRAFFIC OR ON ROADS THAT ARE WINDING, ICY, SNOW COVERED, OR SLIPPERY.**

Diesel With Manual Trans.

The speed control system is fully electronically controlled by the Engine Control Module (ECM). **A cable and a vacuum controlled servo are not used if the vehicle is equipped with a manual transmission and a diesel engine. This is a servo-less system.** The controls consist of two steering wheel mounted switches. The switches are labeled: ON/OFF, RES/ACCEL, SET, COAST, and CANCEL.

The system is designed to operate at speeds above 30 mph (50 km/h).

**WARNING: THE USE OF SPEED CONTROL IS NOT RECOMMENDED WHEN DRIVING CONDITIONS DO NOT PERMIT MAINTAINING A CONSTANT SPEED, SUCH AS IN HEAVY TRAFFIC OR ON ROADS THAT ARE WINDING, ICY, SNOW COVERED, OR SLIPPERY.**

### DESCRIPTION - VEHICLE SPEED INPUT

Gas Engines and/or Diesel With Automatic Trans.

The Vehicle Speed Sensor (VSS) is no longer used for any Dodge Truck.

Vehicle speed and distance covered are measured by the Rear Wheel Speed Sensor. The sensor is mounted to the rear axle. A signal is sent from this sensor to the Controller Antilock Brake (CAB) computer. A signal is then sent from the CAB to the Powertrain Control Module (PCM) to determine vehicle speed and distance covered. The PCM will then determine strategies for speed control system operation.

Diesel With Manual Trans.

The Vehicle Speed Sensor (VSS) is no longer used for any Dodge Truck.

Vehicle speed and distance covered are measured by the Rear Wheel Speed Sensor. The sensor is mounted to the rear axle. A signal is sent from this sensor to the Controller Antilock Brake (CAB) computer. A signal is then sent from the CAB to the Engine Control Module (ECM) to determine vehicle speed and distance covered. The ECM will then determine strategies for speed control system operation.



## SPEED CONTROL (Continued)

## OPERATION - SPEED CONTROL SYSTEM

## Gas Engines and/or Diesel With Automatic Trans.

When speed control is selected by depressing the ON switch, the PCM allows a set speed to be stored in PCM RAM for speed control. To store a set speed, depress the SET switch while the vehicle is moving at a speed between 35 and 85 mph. In order for the speed control to engage, the brakes cannot be applied, nor can the gear selector be indicating the transmission is in Park or Neutral. The speed control can be disengaged manually by:

- Stepping on the brake pedal
- Depressing the OFF switch
- Depressing the CANCEL switch.
- Depressing the clutch pedal (if equipped)

**NOTE: Depressing the OFF switch or turning off the ignition switch will erase the set speed stored in the PCM.**

For added safety, the speed control system is programmed to disengage for any of the following conditions:

- An indication of Park or Neutral
- A rapid increase of rpm (indication that the clutch has been disengaged)
- Excessive engine rpm (indicates that the transmission may be in a low gear)
- The speed signal increases at a rate of 10 mph per second (indicates that the coefficient of friction between the road surface and tires is extremely low)
- The speed signal decreases at a rate of 10 mph per second (indicates that the vehicle may have decelerated at an extremely high rate)

Once the speed control has been disengaged, depressing the RES/ACCEL switch (when speed is greater than 30 mph) restores the vehicle to the target speed that was stored in the PCM.

While the speed control is engaged, the driver can increase the vehicle speed by depressing the RES/ACCEL switch. The new target speed is stored in the PCM when the RES/ACCEL is released. The PCM also has a "tap-up" feature in which vehicle speed increases at a rate of approximately 2 mph for each momentary switch activation of the RES/ACCEL switch.

A "tap down" feature is used to decelerate without disengaging the speed control system. To decelerate from an existing recorded target speed, momentarily depress the COAST switch. For each switch activation, speed will be lowered approximately 1 mph.

## Diesel With Manual Trans.

When speed control is selected by depressing the ON switch, the Engine Control Module (ECM) allows a set speed to be stored in ECM RAM for speed con-

trol. To store a set speed, depress the SET switch while the vehicle is moving at a speed between 35 and 85 mph. In order for the speed control to engage, the brakes cannot be applied. The speed control can be disengaged manually by:

- Stepping on the brake pedal
- Depressing the OFF switch
- Depressing the CANCEL switch.
- Depressing the clutch pedal

**NOTE: Depressing the OFF switch or turning off the ignition switch will erase the set speed stored in the ECM.**

For added safety, the speed control system is programmed to disengage for any of the following conditions:

- A rapid increase of rpm (indication that the clutch has been disengaged)
- Excessive engine rpm (indicates that the transmission may be in a low gear)
- The speed signal increases at a rate of 10 mph per second (indicates that the coefficient of friction between the road surface and tires is extremely low)
- The speed signal decreases at a rate of 10 mph per second (indicates that the vehicle may have decelerated at an extremely high rate)

Once the speed control has been disengaged, depressing the RES/ACCEL switch (when speed is greater than 30 mph) restores the vehicle to the target speed that was stored in the ECM.

While the speed control is engaged, the driver can increase the vehicle speed by depressing the RES/ACCEL switch. The new target speed is stored in the ECM when the RES/ACCEL is released. The ECM also has a "tap-up" feature in which vehicle speed increases at a rate of approximately 2 mph for each momentary switch activation of the RES/ACCEL switch.

A "tap down" feature is used to decelerate without disengaging the speed control system. To decelerate from an existing recorded target speed, momentarily depress the COAST switch. For each switch activation, speed will be lowered approximately 1 mph.

## DIAGNOSIS AND TESTING - VACUUM SUPPLY

## Gas Powered Engines

On gasoline powered engines: actual engine vacuum, a vacuum reservoir, a one-way check valve and vacuum lines are used to supply vacuum to the speed control servo.

- (1) Disconnect vacuum hose at speed control servo and install a vacuum gauge into the disconnected hose.
- (2) Start engine and observe gauge at idle. Vacuum gauge should read at least ten inches of mercury.



## SPEED CONTROL (Continued)

(3) If vacuum is less than ten inches of mercury, determine source of leak. Check vacuum line to engine for leaks. Also check actual engine intake manifold vacuum. If manifold vacuum does not meet this requirement, check for poor engine performance and repair as necessary.

(4) If vacuum line to engine is not leaking, check for leak at vacuum reservoir. To locate and gain access to reservoir, refer to Vacuum Reservoir Removal/Installation in this group. Disconnect vacuum line at reservoir and connect a hand-operated vacuum pump to reservoir fitting. Apply vacuum. Reservoir vacuum should not bleed off. If vacuum is being lost, replace reservoir.

(5) Verify operation of one-way check valve and check it for leaks.

(a) Locate one-way check valve. The valve is located in vacuum line between vacuum reservoir and engine vacuum source. Disconnect vacuum hoses (lines) at each end of valve.

(b) Connect a hand-operated vacuum pump to reservoir end of check valve. Apply vacuum. Vacuum should not bleed off. If vacuum is being lost, replace one-way check valve.

(c) Connect a hand-operated vacuum pump to vacuum source end of check valve. Apply vacuum. Vacuum should flow through valve. If vacuum is not flowing, replace one-way check valve. Seal the fitting at opposite end of valve with a finger and apply vacuum. If vacuum will not hold, diaphragm within check valve has ruptured. Replace valve.

**Diesel Engines With Automatic Trans.**

On diesel powered engines equipped with an automatic transmission: an engine driven vacuum pump, a one-way check valve and vacuum lines are used to supply vacuum to the speed control servo. A vacuum reservoir is not used.

(1) Disconnect vacuum hose at speed control servo and install a vacuum gauge into the disconnected hose.

(2) Start engine and observe gauge at idle. For vacuum testing and vacuum specifications, refer to Vacuum Pump Output—Diesel Engine in 9, Engines.

(3) If vacuum pump output is OK, determine other source of leak. Check all vacuum lines to: speed control servo, engine vacuum pump and heating/air conditioning system for leaks.

(4) Verify operation of one-way check valve and check it for leaks.

(a) Locate one-way check valve. The valve is located in vacuum line between speed control servo and engine vacuum pump. Disconnect vacuum hoses (lines) at each end of valve.

(b) Connect a hand-operated vacuum pump to reservoir end of check valve. Apply vacuum. Vacuum should not bleed off. If vacuum is being lost, replace one-way check valve.

(c) Connect a hand-operated vacuum pump to vacuum source end of check valve. Apply vacuum. Vacuum should flow through valve. If vacuum is not flowing, replace one-way check valve. Seal the fitting at opposite end of valve with a finger and apply vacuum. If vacuum will not hold, diaphragm within check valve has ruptured. Replace valve.

**Diesel Engine With Manual Trans.**

Vacuum is not used for any part of the speed control system if equipped with a diesel engine and a manual transmission.

**DIAGNOSIS AND TESTING - ROAD TEST**

Perform a vehicle road test to verify reports of speed control system malfunction. The road test should include attention to the speedometer.

If a road test verifies a system problem and the speedometer operates properly, check for:

- A Diagnostic Trouble Code (DTC). If a DTC exists, conduct tests per the Powertrain Diagnostic Procedures service manual.
- A misadjusted brake (stop) lamp switch. This could also cause an intermittent problem.
- Loose, damaged or corroded electrical connections at the servo. Corrosion should be removed from electrical terminals and a light coating of Mopar MultiPurpose Grease, or equivalent, applied.
- Leaking vacuum reservoir.
- Loose or leaking vacuum hoses or connections.
- Defective one-way vacuum check valve.
- Secure attachment of both ends of the speed control servo cable.
- Smooth operation of throttle linkage and throttle body air valve.
- Failed speed control servo. Do the servo vacuum test.

**CAUTION:** When test probing for voltage or continuity at electrical connectors, care must be taken not to damage connector, terminals or seals. If these components are damaged, intermittent or complete system failure may occur.

## SPEED CONTROL (Continued)

## SPECIFICATIONS

## TORQUE - SPEED CONTROL SYSTEM

DESCRIPTION	N-m	Ft. Lbs.	In. Lbs.
Servo Mounting Bracket Nuts	8.5		75
Switch Module Mounting Screws	3		26
Vacuum Reservoir Mounting Screws	2.2		20

## CABLE

## DESCRIPTION

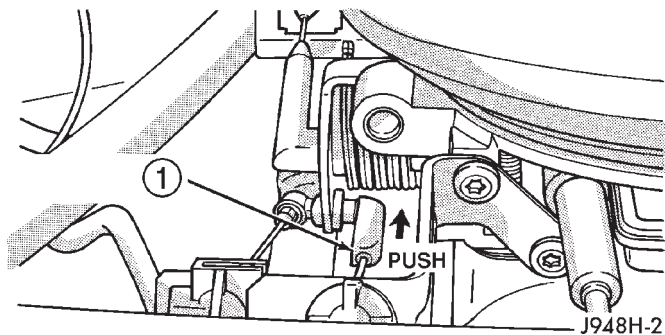
The speed control servo cable is connected between the speed control vacuum servo diaphragm and the throttle body control linkage.

## OPERATION

This cable causes the throttle control linkage to open or close the throttle valve in response to movement of the vacuum servo diaphragm.

## REMOVAL - GAS ENGINES

- (1) Disconnect negative battery cable at battery.
- (2) Remove air cleaner (all except 8.0L V-10 engine).
- (3) Using finger pressure only, remove speed control cable connector at bellcrank by pushing connector off the bellcrank pin (Fig. 1) or (Fig. 2). **DO NOT** try to pull connector off perpendicular to the bellcrank pin. Connector will be broken.



**Fig. 1 Servo Cable at Throttle Body—V-6/V-8 Engine**

1 - VEHICLE SPEED CONTROL CABLE

(4) Squeeze 2 tabs on sides of speed control cable at throttle body mounting bracket (locking plate) and push out of bracket.

(5) Remove servo cable from servo. Refer to Speed Control Servo Removal/Installation in this group.

## REMOVAL - DIESEL WITH AUTO. TRANS.

- (1) Disconnect both negative battery cables at both batteries.
- (2) Remove cable/lever/linkage cover. Refer to Speed Control Servo Removal/Installation.
- (3) Remove (disconnect) servo cable from servo. Refer to Speed Control Servo Removal/Installation.
- (4) Using finger pressure only, disconnect end of servo cable from throttle lever pin by pulling forward on connector while holding lever rearward (Fig. 3). **DO NOT try to pull connector off perpendicular to lever pin. Connector will be broken.**
- (5) Squeeze 2 pinch tabs (Fig. 3) on sides of speed control cable at mounting bracket and push cable rearward out of bracket.
- (6) Remove cable from vehicle.

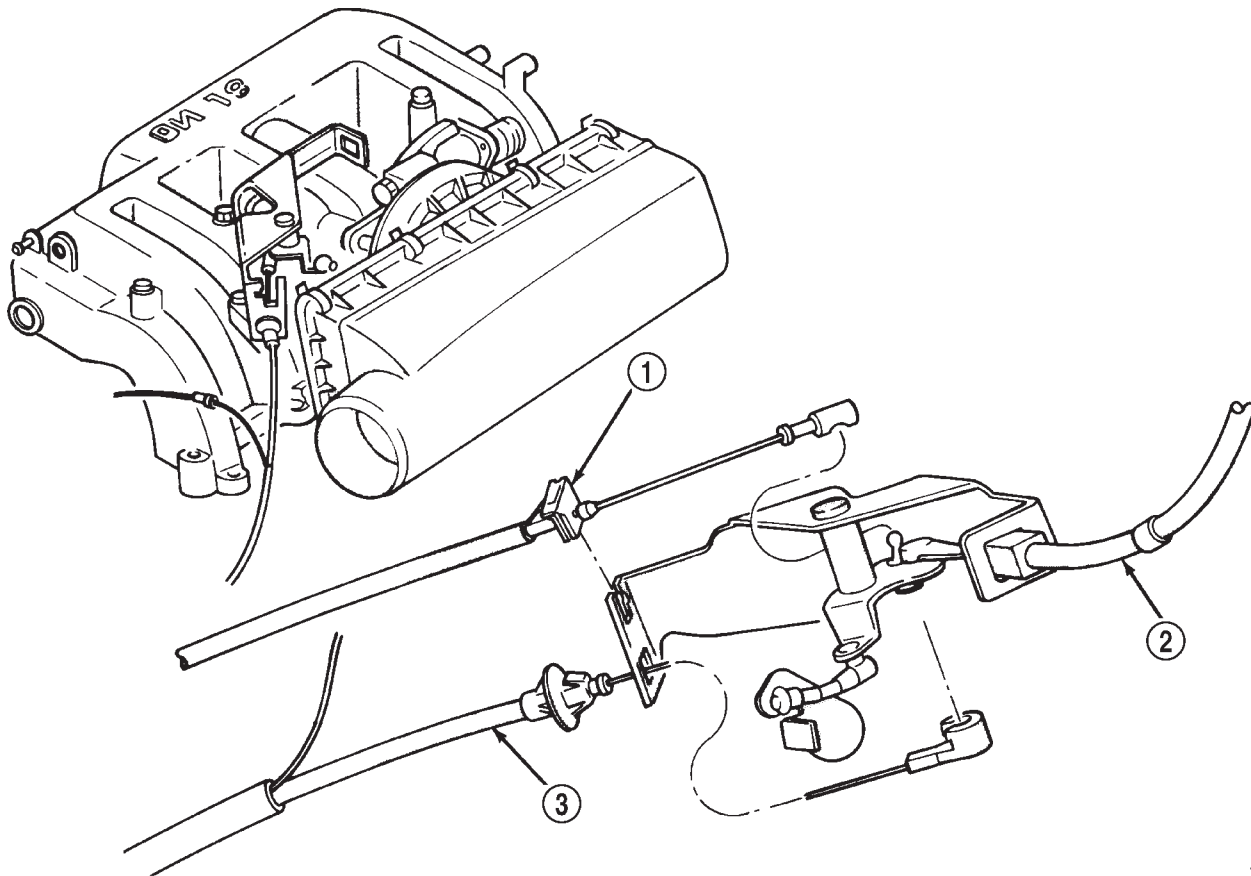
## INSTALLATION - GAS ENGINES

- (1) Install end of cable to speed control servo. Refer to Speed Control Servo Removal/Installation.
- (2) Install cable into throttle body mounting bracket (injection pump bracket on diesel engine). Cable snaps into bracket.
- (3) Install speed control cable connector at throttle body bellcrank pin (injection pump bellcrank pin on diesel engine). Connector snaps onto pin.
- (4) Connect negative battery cable to battery.
- (5) Before starting engine, operate accelerator pedal to check for any binding.

## INSTALLATION - DIESEL WITH AUTO. TRANS.

- (1) Install (connect) end of speed control servo cable to speed control servo. Refer to Speed Control Servo Removal/Installation.
- (2) Install cable through mounting hole on mounting bracket. Cable snaps into bracket.
- (3) Connect servo cable to throttle lever by pushing cable connector rearward onto lever pin while holding lever forward.
- (4) Connect negative battery cables to both batteries.

## CABLE (Continued)



J948H-10

**Fig. 2 Servo Cable at Throttle Body—V-10 Engine**

- 1 - THROTTLE CABLE
- 2 - THROTTLE VALVE CABLE
- 3 - SPEED CONTROL SERVO CABLE

(5) Before starting engine, operate accelerator pedal to check for any binding.

(6) Install cable/lever cover.

## SPEED CONTROL SERVO

### DESCRIPTION

**A speed control servo is not used if equipped with both a diesel engine and a manual transmission.**

The servo unit consists of a solenoid valve body, and a vacuum chamber. The solenoid valve body contains three solenoids:

- Vacuum
- Vent
- Dump

The vacuum chamber contains a diaphragm with a cable attached to control the throttle linkage.

### OPERATION

**A speed control servo is not used if equipped with both a diesel engine and a manual transmission.**

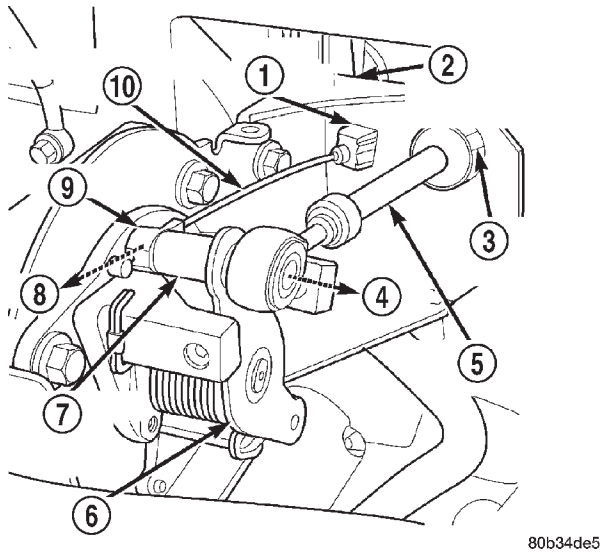
The Powertrain Control Module (PCM) controls the solenoid valve body. The solenoid valve body controls the application and release of vacuum to the diaphragm of the vacuum servo. The servo unit cannot be repaired and is serviced only as a complete assembly.

Power is supplied to the servo's by the PCM through the brake switch. The PCM controls the ground path for the vacuum and vent solenoids.

The dump solenoid is energized anytime it receives power. If power to the dump solenoid is interrupted, the solenoid dumps vacuum in the servo. This provides a safety backup to the vent and vacuum solenoids.

The vacuum and vent solenoids must be grounded at the PCM to operate. When the PCM grounds the vacuum servo solenoid, the solenoid allows vacuum

## SPEED CONTROL SERVO (Continued)



**Fig. 3 Servo Cable at Throttle Lever**

- 1 - PINCH (2) TABS
- 2 - CABLE MOUNTING BRACKET
- 3 - PINCH TABS (2)
- 4 - OFF
- 5 - THROTTLE CABLE
- 6 - THROTTLE LEVER
- 7 - THROTTLE LEVER PIN
- 8 - OFF
- 9 - CONNECTOR
- 10 - SPEED CONTROL CABLE

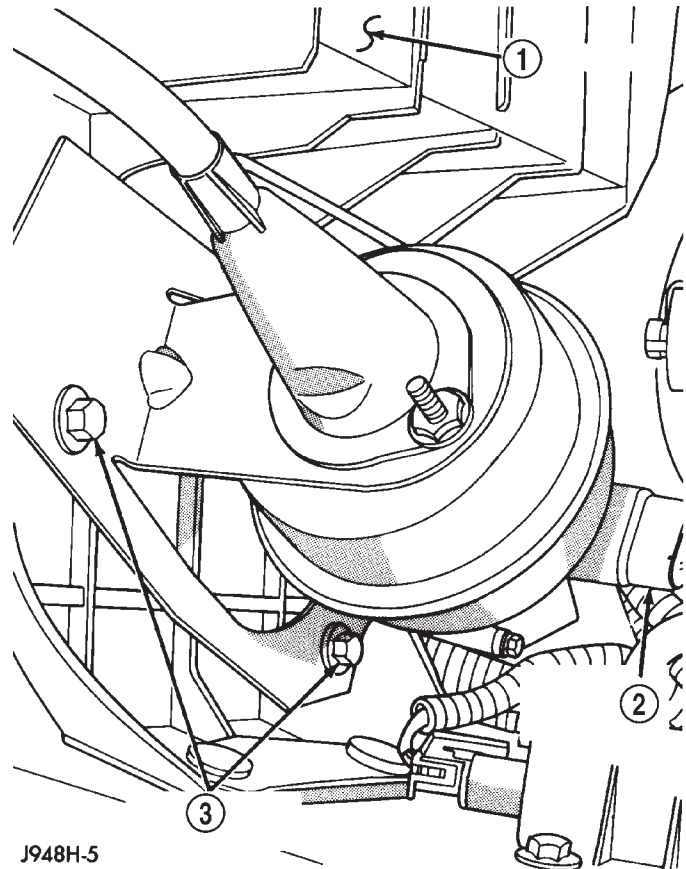
to enter the servo and pull open the throttle plate using the cable. When the PCM breaks the ground, the solenoid closes and no more vacuum is allowed to enter the servo. The PCM also operates the vent solenoid via ground. The vent solenoid opens and closes a passage to bleed or hold vacuum in the servo as required.

The PCM duty cycles the vacuum and vent solenoids to maintain the set speed, or to accelerate and decelerate the vehicle. To increase throttle opening, the PCM grounds the vacuum and vent solenoids. To decrease throttle opening, the PCM removes the grounds from the vacuum and vent solenoids. When the brake is released, if vehicle speed exceeds 30 mph to resume, 35 mph to set, and the RES/ACCEL switch has been depressed, ground for the vent and vacuum circuits is restored.

## REMOVAL

### V-6/V-8 ENGINES

- (1) Disconnect negative battery cable at battery.
- (2) Disconnect electrical connector at servo (Fig. 4).
- (3) Disconnect vacuum hose at servo.
- (4) Disconnect servo cable at throttle body. Refer to Servo Cable Removal/Installation in this group.



**Fig. 4 Servo Location—Removal/Installation**

- 1 - BATTERY TRAY
- 2 - SERVO ELECTRICAL CONNECTOR
- 3 - SERVO BRACKET SCREWS (3)

(5) Remove three bolts retaining servo/servo mounting bracket to side of battery tray (Fig. 5).

(6) Position servo assembly to gain access to 2 servo mounting nuts (Fig. 5) or (Fig. 6).

(7) Remove 2 mounting nuts holding servo cable sleeve to bracket (Fig. 6).

(8) Pull speed control cable sleeve and servo away from servo mounting bracket to expose cable retaining clip (Fig. 6) and remove clip. Note: The servo mounting bracket displayed in (Fig. 6) is a typical bracket and may/may not be applicable to this model vehicle.

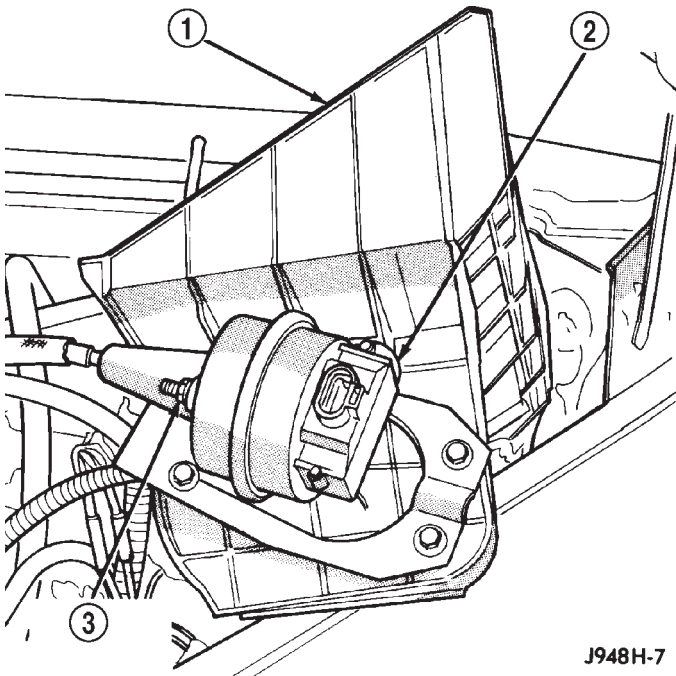
(9) Remove servo from mounting bracket. While removing, note orientation of servo to bracket.

### 8.0L V-10 ENGINE

- (1) Disconnect negative battery cable at battery.
- (2) Disconnect positive battery cable at battery.
- (3) Remove 2 bolts and battery holddown (Fig. 7).
- (4) If equipped, pull up on battery heat shield to remove it (Fig. 8).
- (5) Remove battery from vehicle.



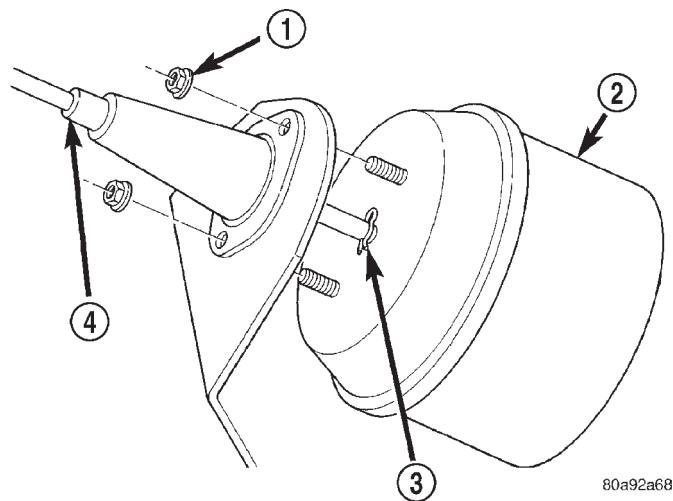
## SPEED CONTROL SERVO (Continued)



J948H-7

**Fig. 5 Servo Mounting at Battery Tray**

- 1 - BATTERY TRAY
- 2 - SPEED CONTROL SERVO
- 3 - SERVO MOUNTING NUTS (2)



80a92a68

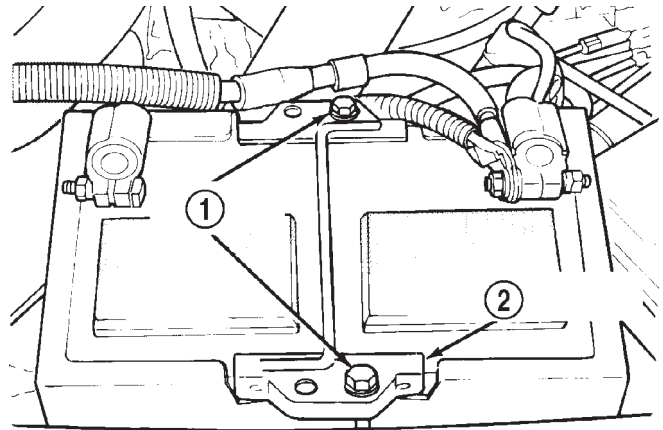
**Fig. 6 Servo Cable Clip Remove/Install—Typical**

- 1 - SERVO MOUNTING NUTS (2)
- 2 - SERVO
- 3 - CABLE RETAINING CLIP
- 4 - SERVO CABLE AND SLEEVE

(6) From under left front wheel opening, remove 2 forward battery tray nuts (Fig. 9).

(7) Remove 2 nuts and 2 bolts holding battery tray to vehicle (Fig. 10).

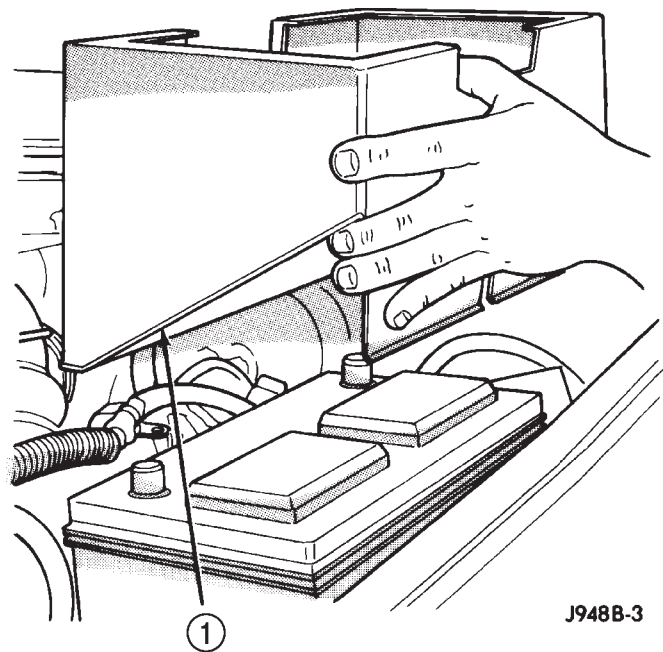
(8) Disconnect servo cable at throttle body. Refer to Servo Cable Removal/Installation in this group.



J948B-2

**Fig. 7 Battery Holddown**

- 1 - REMOVE 2 BOLTS
- 2 - BATTERY HOLDDOWN STRAP



J948B-3

**Fig. 8 Battery Heat Shield**

- 1 - BATTERY HEAT SHIELD

(9) Position battery tray up far enough for access to speed control servo electrical connector and vacuum line.

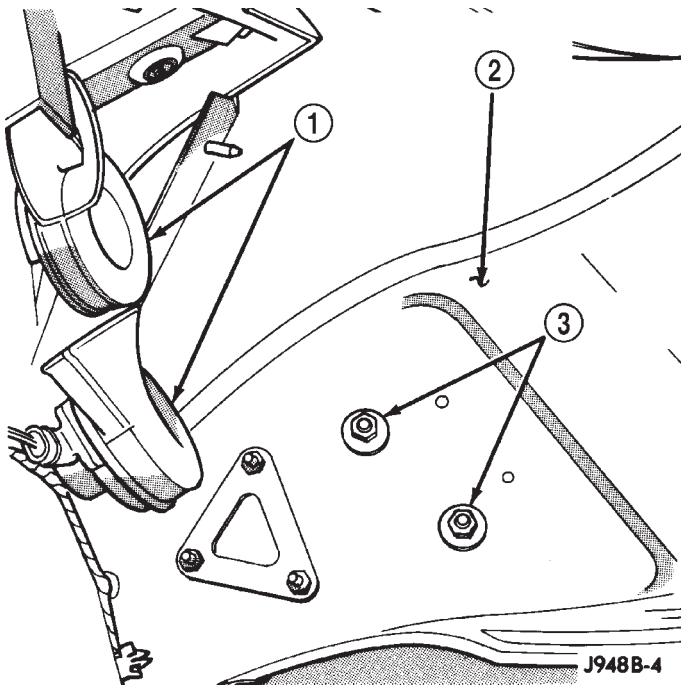
(10) Disconnect electrical connector and vacuum line at servo.

(11) Position battery tray with attached servo assembly to gain access to 2 servo mounting nuts (Fig. 5) or (Fig. 6).

(12) Remove 2 mounting nuts holding servo cable sleeve to bracket (Fig. 6).

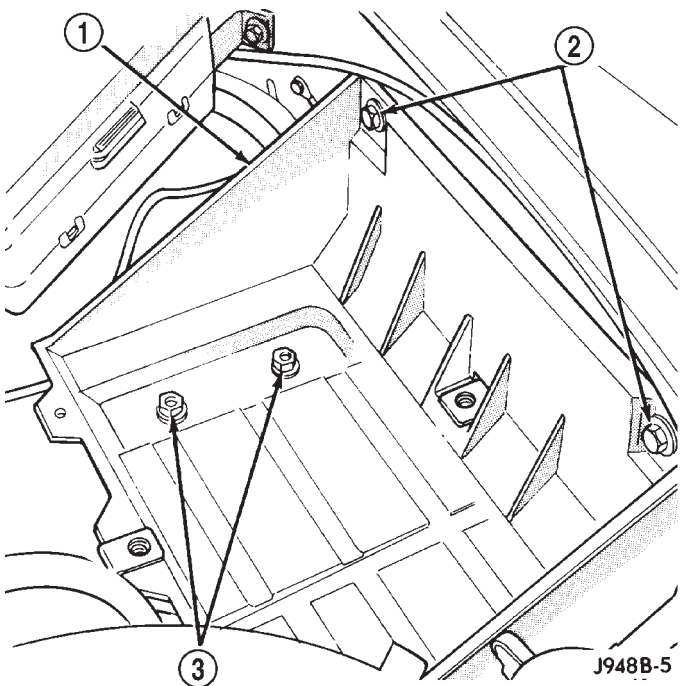


## SPEED CONTROL SERVO (Continued)



**Fig. 9 Forward Battery Tray Nuts**

- 1 - HORNS
- 2 - UNDERSIDE OF LEFT FRONT WHEEL OPENING
- 3 - BATTERY TRAY NUTS



**Fig. 10 Battery Tray Mounting**

- 1 - BATTERY TRAY
- 2 - REMOVE 2 BOLTS
- 3 - REMOVE 2 NUTS

(13) Pull speed control cable sleeve and servo away from servo mounting bracket to expose cable retaining clip (Fig. 6) and remove clip. Note: The servo mounting bracket displayed in (Fig. 6) is a typical bracket and may/may not be applicable to this model vehicle.

(14) Remove servo from mounting bracket. While removing, note orientation of servo to bracket.

### REMOVAL - DIESEL WITH AUTO. TRANS.

(1) Disconnect both negative battery cables at both batteries.

(2) Disconnect positive battery cable at battery (drivers side battery).

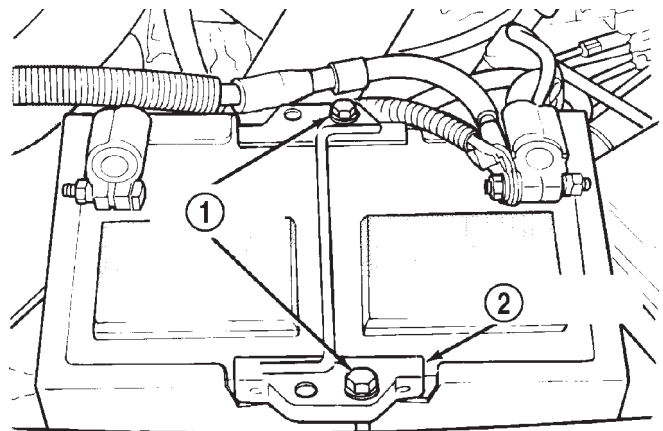
(3) Remove battery holddown bolts (Fig. 11).

(4) If equipped, pull up on battery heat shield to remove it (Fig. 12).

(5) Remove battery from vehicle.

(6) From under vehicle, and in front of left front wheelhouse, remove 2 lower battery tray nuts (Fig. 13).

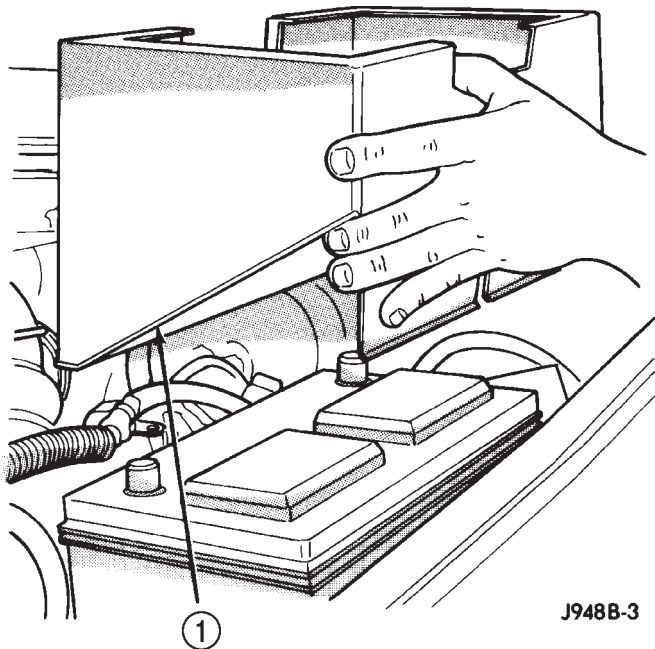
(7) Remove 2 nuts and 2 bolts holding battery tray to vehicle (Fig. 14).



**Fig. 11 Battery Holddown Bolts**

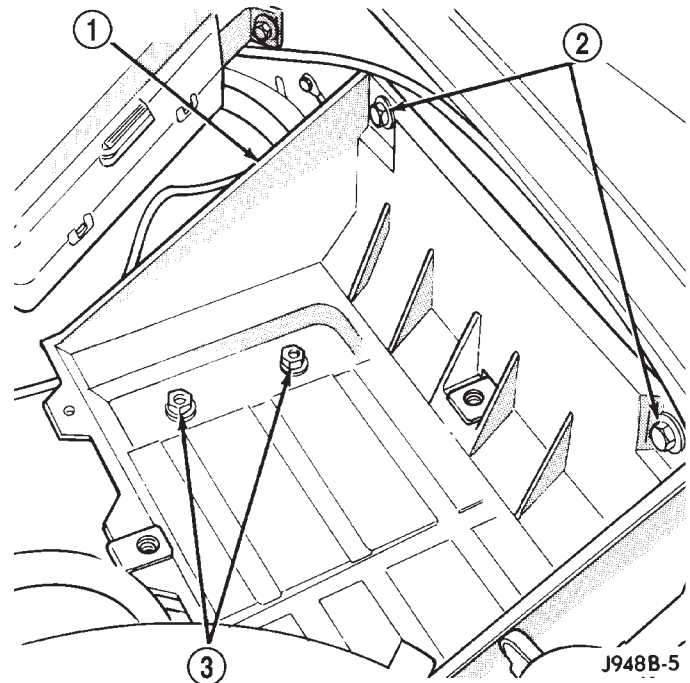
- 1 - REMOVE 2 BOLTS
- 2 - BATTERY HOLDDOWN STRAP

## SPEED CONTROL SERVO (Continued)



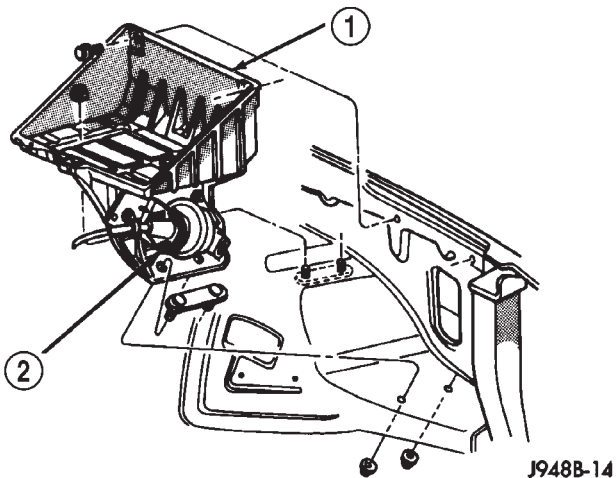
**Fig. 12 Battery Heat Shield**

1 - BATTERY HEAT SHIELD



**Fig. 14 Battery Tray Upper Mounting Bolts/Nuts**

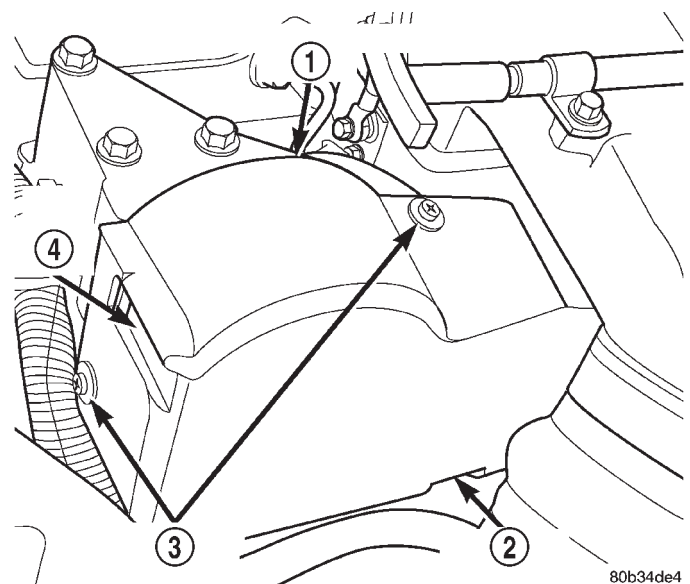
1 - BATTERY TRAY  
2 - REMOVE 2 BOLTS  
3 - REMOVE 2 NUTS



**Fig. 13 Battery Tray Lower Mounting Nuts**

1 - BATTERY TRAY  
2 - SPEED CONTROL SERVO

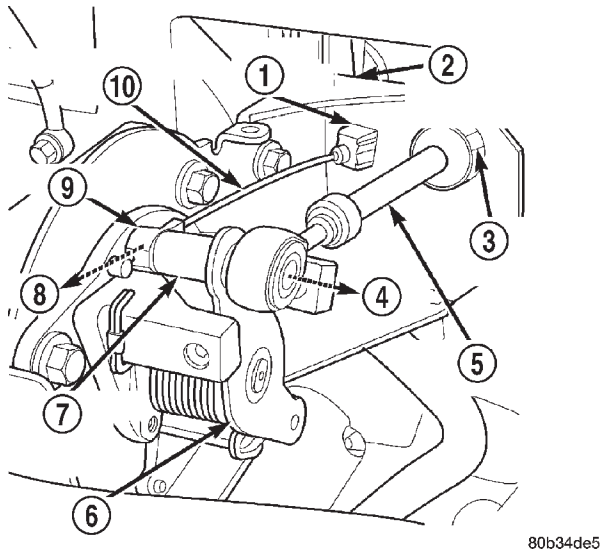
(8) Remove cable cover (Fig. 15). Cable cover is attached with 2 Phillips screws, 2 plastic retention clips and 2 push tabs (Fig. 15). Remove 2 Phillips screws and carefully pry out 2 retention clips. After clip removal, push rearward on front tab, and upward on lower tab for cover removal.



**Fig. 15 Cable/Lever/Throttle Linkage Cover**

1 - CABLE/LEVER/LINKAGE COVER  
2 - PUSH UP LOWER TAB  
3 - SCREWS/CLIPS (2)  
4 - TAB PUSH HERE

## SPEED CONTROL SERVO (Continued)



**Fig. 16 Servo Cable at Throttle Lever**

- 1 - PINCH (2) TABS
- 2 - CABLE MOUNTING BRACKET
- 3 - PINCH TABS (2)
- 4 - OFF
- 5 - THROTTLE CABLE
- 6 - THROTTLE LEVER
- 7 - THROTTLE LEVER PIN
- 8 - OFF
- 9 - CONNECTOR
- 10 - SPEED CONTROL CABLE

(9) Using finger pressure only, disconnect end of servo cable from throttle lever pin by pulling forward on connector while holding lever rearward (Fig. 16). **DO NOT try to pull connector off perpendicular to lever pin. Connector will be broken.**

(10) Position battery tray up far enough for access to speed control servo electrical connector and vacuum line.

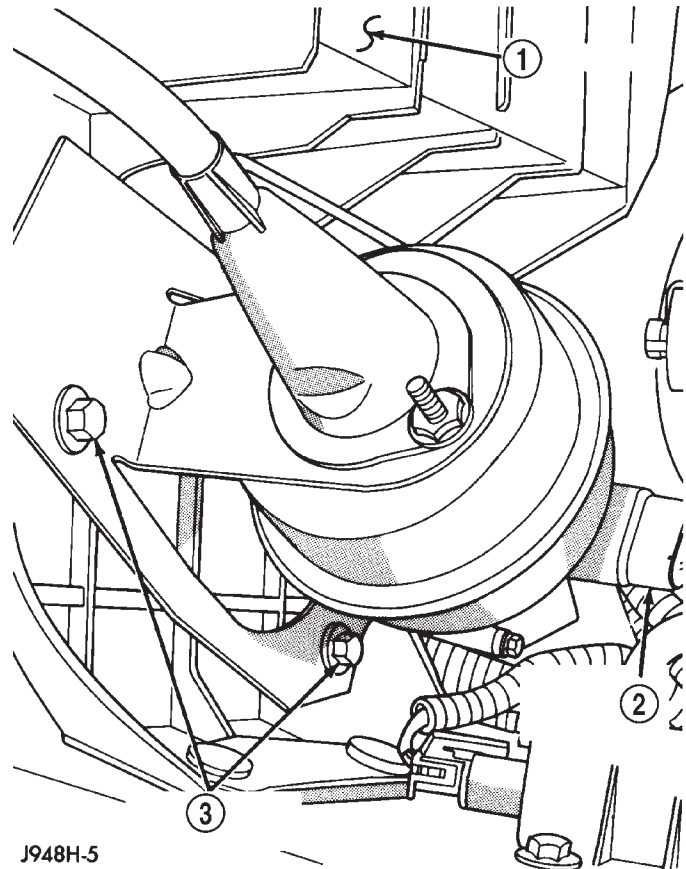
(11) Disconnect electrical connector and vacuum line at servo.

(12) Position battery tray with attached servo assembly to gain access to 2 servo mounting nuts (Fig. 18) or (Fig. 19).

(13) Remove 2 mounting nuts holding servo cable sleeve to bracket (Fig. 19).

(14) Pull speed control cable sleeve and servo away from servo mounting bracket to expose cable retaining clip (Fig. 19) and remove clip. Note: The servo mounting bracket displayed in (Fig. 19) is a typical bracket and may/may not be applicable to this model vehicle.

(15) Remove servo from mounting bracket. While removing, note orientation of servo to bracket.



**Fig. 17 Servo Location—Removal/Installation**

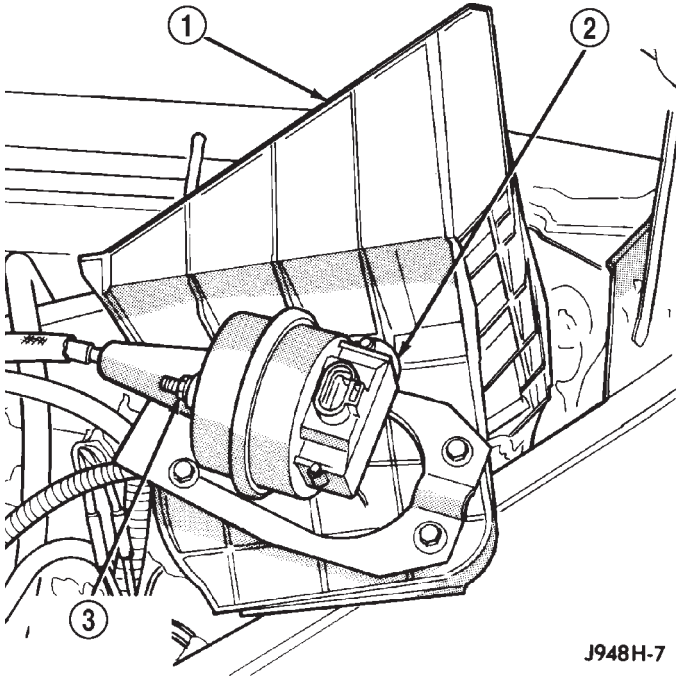
- 1 - BATTERY TRAY
- 2 - SERVO ELECTRICAL CONNECTOR
- 3 - SERVO BRACKET SCREWS (3)

## INSTALLATION

### V-6/V-8 ENGINES

- (1) Position servo to mounting bracket.
- (2) Align hole in cable connector with hole in servo pin. Install cable-to-servo retaining clip.
- (3) Insert servo studs through holes in servo mounting bracket.
- (4) Insert servo studs through holes in servo cable sleeve.
- (5) Install servo mounting nuts and tighten to 8.5 N·m (75 in. lbs.) torque.
- (6) Connect vacuum line to servo.
- (7) Connect electrical connector to servo terminals.
- (8) Install three bolts retaining servo/servo mounting bracket to battery tray.
- (9) Connect servo cable to throttle body. Refer to Servo Cable Removal/Installation in this group.
- (10) Connect negative battery cable to battery.
- (11) Before starting engine, operate accelerator pedal to check for any binding.

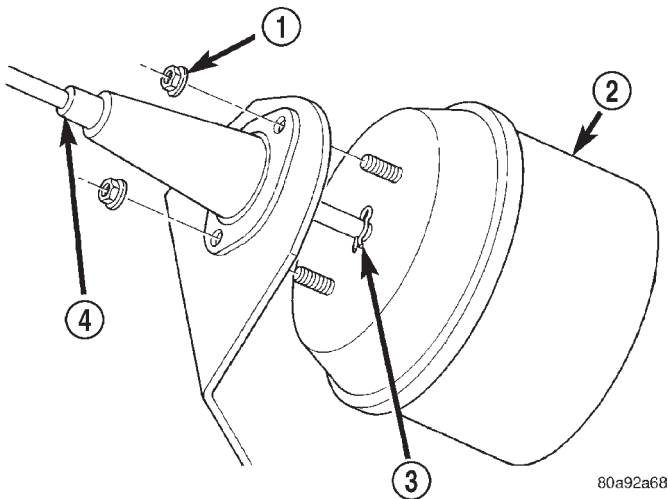
## SPEED CONTROL SERVO (Continued)



J948H-7

**Fig. 18 Servo Mounting at Battery Tray**

- 1 - BATTERY TRAY
- 2 - SPEED CONTROL SERVO
- 3 - SERVO MOUNTING NUTS (2)



80a92a68

**Fig. 19 Servo Cable Clip Remove/Install—Typical**

- 1 - SERVO MOUNTING NUTS (2)
- 2 - SERVO
- 3 - CABLE RETAINING CLIP
- 4 - SERVO CABLE AND SLEEVE

**8.0L V-10 ENGINE**

- (1) Position servo to mounting bracket.
- (2) Align hole in cable connector with hole in servo pin. Install cable-to-servo retaining clip.
- (3) Insert servo studs through holes in servo mounting bracket.
- (4) Insert servo studs through holes in servo cable sleeve.
- (5) Install servo mounting nuts and tighten to 8.5 N·m (75 in. lbs.) torque.
- (6) Connect vacuum line to servo.
- (7) Connect electrical connector to servo terminals.
- (8) Connect servo cable to throttle body. Refer to Servo Cable Removal/Installation in this group.
- (9) Install battery tray. Tighten all battery tray mounting hardware to 16 N·m (140 in. lbs.) torque.
- (10) Position battery into battery tray.
- (11) If equipped, install battery heat shield.
- (12) Install battery holddown clamp. Tighten bolt to 4 N·m (35 in. lbs.) torque.
- (13) Connect positive battery cable to battery.
- (14) Connect negative battery cable to battery.
- (15) Before starting engine, operate accelerator pedal to check for any binding.

**INSTALLATION - DIESEL WITH AUTO. TRANS.**

- (1) Position servo to mounting bracket.
- (2) Align hole in cable connector with hole in servo pin. Install cable-to-servo retaining clip.
- (3) Insert servo studs through holes in servo mounting bracket.
- (4) Insert servo studs through holes in servo cable sleeve.
- (5) Install servo mounting nuts and tighten to 8.5 N·m (75 in. lbs.) torque.
- (6) Connect vacuum line to servo.
- (7) Connect electrical connector to servo terminals.
- (8) Connect servo cable to throttle lever by pushing cable connector rearward onto lever pin while holding lever forward.
- (9) Install battery tray. Tighten all battery tray mounting hardware to 16 N·m (140 in. lbs.) torque.
- (10) Position battery into battery tray.
- (11) If equipped, install battery heat shield.
- (12) Install battery holddown clamp. Tighten bolt to 4 N·m (35 in. lbs.) torque.
- (13) Connect positive battery cable to battery.
- (14) Connect negative battery cables to both batteries.
- (15) Before starting engine, operate accelerator pedal to check for any binding.
- (16) Install cable/lever cover.



## SWITCH

### DESCRIPTION

#### Gas Engines and Diesel With Auto. Trans.

There are two separate switch pods that operate the speed control system. The steering-wheel-mounted switches use multiplexed circuits to provide inputs to the Powertrain Control Module (PCM) for ON, OFF, RESUME, ACCELERATE, SET, DECEL and CANCEL modes. Refer to the owner's manual for more information on speed control switch functions and setting procedures.

The individual switches cannot be repaired. If one switch fails, the entire switch module must be replaced.

#### Diesel With Manual Trans.

There are two separate switch pods that operate the speed control system. The steering-wheel-mounted switches use multiplexed circuits to provide inputs to the Engine Control Module (ECM) for ON, OFF, RESUME, ACCELERATE, SET, DECEL and CANCEL modes. Refer to the owner's manual for more information on speed control switch functions and setting procedures.

The individual switches cannot be repaired. If one switch fails, the entire switch module must be replaced.

### OPERATION

#### Gas Engines and Diesel With Auto. Trans.

When speed control is selected by depressing the ON, OFF switch, the Powertrain Control Module (PCM) allows a set speed to be stored in its RAM for speed control. To store a set speed, depress the SET switch while the vehicle is moving at a speed between approximately 35 and 85 mph. In order for the speed control to engage, the brakes cannot be applied, nor can the gear selector be indicating the transmission is in Park or Neutral. The speed control can be disengaged manually by:

- Stepping on the brake pedal
- Depressing the OFF switch
- Depressing the CANCEL switch. The speed control can be disengaged also by any of the following conditions:
  - An indication of Park or Neutral
  - The vehicle speed signal increases at a rate of 10 mph per second (indicates that the co-efficient of friction between the road surface and tires is extremely low)
  - Depressing the clutch pedal.
  - Excessive engine rpm (indicates that the transmission may be in a low gear)

- The vehicle speed signal decreases at a rate of 10 mph per second (indicates that the vehicle may have decelerated at an extremely high rate)

- If the actual speed is not within 20 mph of the set speed The previous disengagement conditions are programmed for added safety.

Once the speed control has been disengaged, depressing the ACCEL switch restores the vehicle to the target speed that was stored in the PCM's RAM.

**NOTE: Depressing the OFF switch will erase the set speed stored in the PCM's RAM.**

If, while the speed control is engaged, the driver wishes to increase vehicle speed, the PCM is programmed for an acceleration feature. With the ACCEL switch held closed, the vehicle accelerates slowly to the desired speed. The new target speed is stored in the PCM's RAM when the ACCEL switch is released. The PCM also has a "tap-up" feature in which vehicle speed increases at a rate of approximately 2 mph for each momentary switch activation of the ACCEL switch.

The PCM also provides a means to decelerate without disengaging speed control. To decelerate from an existing recorded target speed, depress and hold the COAST switch until the desired speed is reached. Then release the switch. The ON, OFF switch operates two components: the PCM's ON, OFF input, and the battery voltage to the brake switch, which powers the speed control servo.

#### Diesel With Manual Trans.

When speed control is selected by depressing the ON, OFF switch, the Engine Control Module (ECM) allows a set speed to be stored in its RAM for speed control. To store a set speed, depress the SET switch while the vehicle is moving at a speed between approximately 35 and 85 mph. In order for the speed control to engage, the brakes cannot be applied. The speed control can be disengaged manually by:

- Stepping on the brake pedal
- Depressing the OFF switch
- Depressing the CANCEL switch. The speed control can be disengaged also by any of the following conditions:
  - The vehicle speed signal increases at a rate of 10 mph per second (indicates that the co-efficient of friction between the road surface and tires is extremely low)
  - Depressing the clutch pedal.
  - Excessive engine rpm (indicates that the transmission may be in a low gear)
  - The vehicle speed signal decreases at a rate of 10 mph per second (indicates that the vehicle may have decelerated at an extremely high rate)



## SWITCH (Continued)

- If the actual speed is not within 20 mph of the set speed, the previous disengagement conditions are programmed for added safety.

Once the speed control has been disengaged, depressing the ACCEL switch restores the vehicle to the target speed that was stored in the ECM's RAM.

**NOTE: Depressing the OFF switch will erase the set speed stored in the ECM's RAM.**

If, while the speed control is engaged, the driver wishes to increase vehicle speed, the ECM is programmed for an acceleration feature. With the ACCEL switch held closed, the vehicle accelerates slowly to the desired speed. The new target speed is stored in the ECM's RAM when the ACCEL switch is released. The ECM also has a "tap-up" feature in which vehicle speed increases at a rate of approximately 2 mph for each momentary switch activation of the ACCEL switch.

The ECM also provides a means to decelerate without disengaging speed control. To decelerate from an existing recorded target speed, depress and hold the COAST switch until the desired speed is reached. Then release the switch. The ON, OFF switch operates two components: the ECM's ON, OFF input, and the battery voltage to the brake switch, which powers the speed control servo.

## REMOVAL

**WARNING: BEFORE BEGINNING ANY AIRBAG SYSTEM COMPONENT REMOVAL OR INSTALLATION, REMOVE AND ISOLATE THE NEGATIVE (-) CABLE(S) FROM THE BATTERY. THIS IS THE ONLY SURE WAY TO DISABLE THE AIRBAG SYSTEM. THEN WAIT TWO MINUTES FOR SYSTEM CAPACITOR TO DISCHARGE BEFORE FURTHER SYSTEM SERVICE. FAILURE TO DO THIS COULD RESULT IN ACCIDENTAL AIRBAG DEPLOYMENT AND POSSIBLE INJURY.**

(1) Disconnect and isolate negative battery cable(s).

(2) Remove airbag module. Refer to 8, Restraint Systems for procedures.

(3) Remove switch-to-steering wheel mounting screws (Fig. 20).

(4) Remove switch.

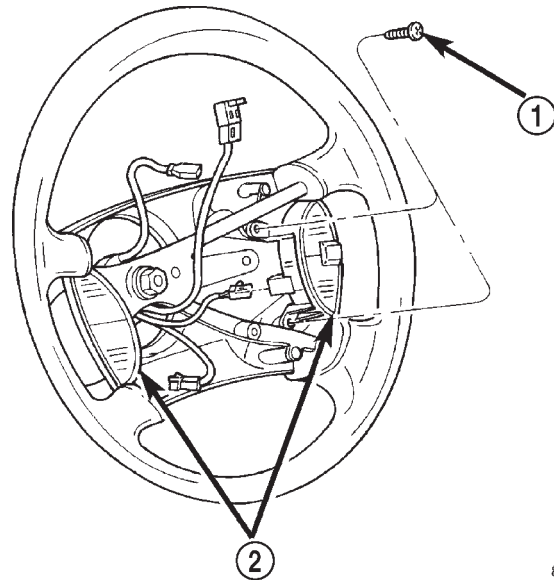
(5) Remove electrical connector at switch.

## INSTALLATION

(1) Install electrical connector to switch.

(2) Install switch and mounting screws.

(3) Tighten screws to 3 N·m (26 in. lbs. +/- 2 in. lbs.) torque.



80a6f161

**Fig. 20 Speed Control Switches**

1 - MOUNTING SCREWS (2)

2 - SPEED CONTROL SWITCHES (2)

(4) Install airbag module. Refer to 8, Restraint Systems for procedures.

(5) Connect negative battery cable(s).

## VACUUM RESERVOIR

## DESCRIPTION

**Gasoline Powered Engines :** A vacuum reservoir is used to supply the vacuum needed to maintain proper speed control operation when engine vacuum drops, such as in climbing a grade while driving. A one-way check valve is used in the vacuum line between the reservoir and the vacuum source. This check valve is used to trap engine vacuum in the reservoir. On certain vehicle applications, this reservoir is shared with the heating/air-conditioning system. The vacuum reservoir cannot be repaired and must be replaced if faulty.

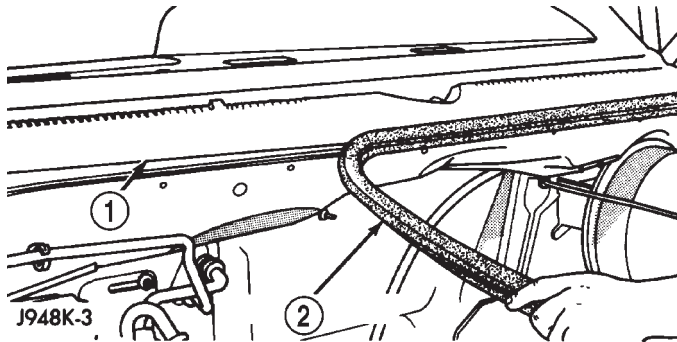
**Diesel Powered Engines With Auto. Trans. :** A vacuum reservoir is not used if equipped with a diesel powered engine. Instead, an engine driven pump (vacuum pump) is used to supply vacuum for speed control operation. This vacuum pump is used with the diesel engine only if it is equipped with an automatic transmission. Refer to Vacuum Pump in 9, Engines for information.

## REMOVAL

The vacuum reservoir is located under the plastic cowl plenum cover at lower base of windshield. The vacuum reservoir is not used if equipped with a diesel engine.

## VACUUM RESERVOIR (Continued)

- (1) Disconnect and isolate battery negative cable.
- (2) Remove both windshield wiper arm/blade assemblies. Refer to 8, Wiper and Washer Systems.
- (3) Remove rubber weather-strip at front edge of cowl grille (Fig. 21).

**Fig. 21 Cowl Grille Panel Weather-strip**

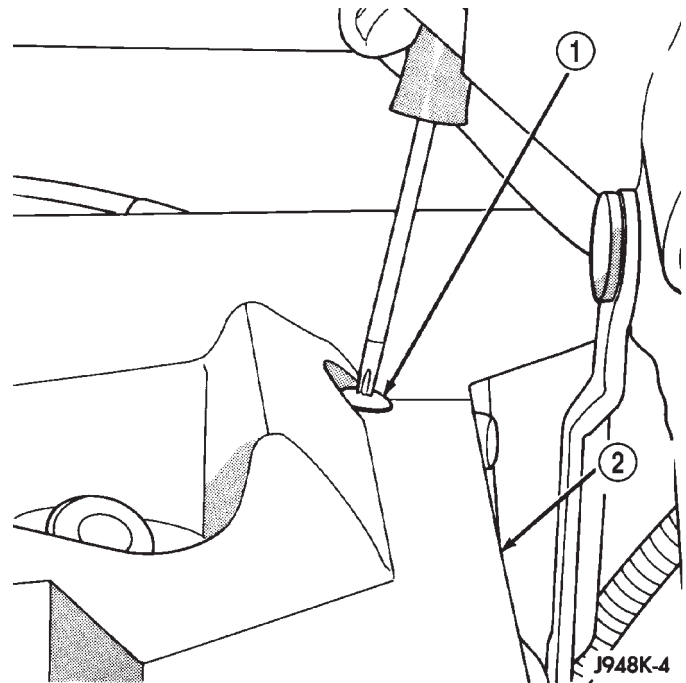
- 1 - COWL GRILLE  
2 - WEATHERSTRIP

- (4) Release cowl grille plastic anchor screws (Fig. 22).
- (5) Lift cowl plenum cover/grille panel from vehicle far enough to access vacuum reservoir.
- (6) Disconnect vacuum supply line from vacuum reservoir (Fig. 23).
- (7) Remove 2 vacuum reservoir mounting screws.
- (8) Remove vacuum reservoir from vehicle.

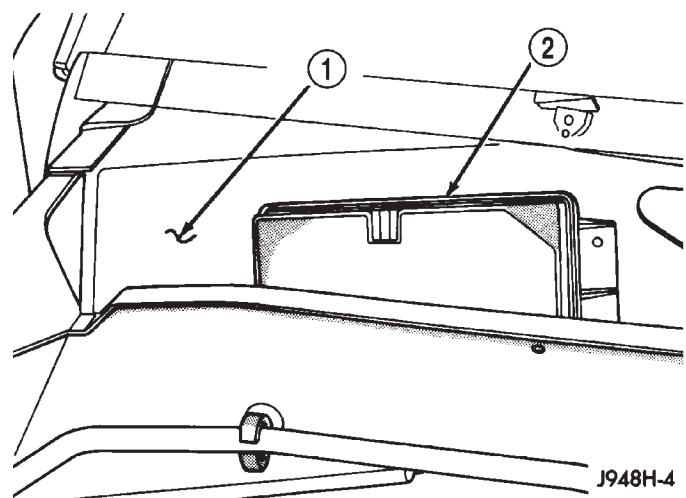
**INSTALLATION**

The vacuum reservoir is located under the plastic cowl plenum cover at lower base of windshield. The vacuum reservoir is not used if equipped with a diesel engine.

- (1) Install vacuum reservoir and two mounting screws. Tighten screws to 2.2 N·m (20 in. lbs.) torque.
- (2) Connect vacuum supply hose to vacuum reservoir.
- (3) Position cowl plenum cover/grille panel to vehicle.
- (4) Install and tighten cowl cover fasteners to vehicle body.
- (5) Install rubber weather-strip at front edge of cowl grille.
- (6) Install windshield wiper arms. Refer to 8, Wiper and Washer Systems.

**Fig. 22 Plastic Anchor Screws Remove/Install**

- 1 - PLASTIC SCREW ANCHOR  
2 - COWL GRILLE

**Fig. 23 Vacuum Reservoir Remove/Install**

- 1 - COWL PLENUM  
2 - VACUUM RESERVOIR

- (7) Connect negative battery to cable.

# VEHICLE THEFT SECURITY

## TABLE OF CONTENTS

	page		page
<b>VEHICLE THEFT SECURITY</b>		<b>VTSS INDICATOR</b>	
DESCRIPTION.....	1	DESCRIPTION.....	3
OPERATION .....	2	OPERATION .....	3
DIAGNOSIS AND TESTING .....	3	DIAGNOSIS AND TESTING .....	3
VEHICLE THEFT SECURITY SYSTEM.....	3	VTSS INDICATOR .....	3

## VEHICLE THEFT SECURITY

### DESCRIPTION

The Vehicle Theft Security System (VTSS) is an available factory-installed option on this model when it is also equipped with the high-line or premium Central Timer Module (CTM). The VTSS is designed to provide perimeter protection against unauthorized use or tampering by monitoring the vehicle doors and the ignition system. If unauthorized vehicle use or tampering is detected, the system responds by pulsing the horn, flashing the headlamps, and preventing the engine from operating.

The VTSS includes the following major components, which are described in further detail elsewhere in this service manual:

- **Central Timer Module** - The high-line or premium Central Timer Module (CTM) is located under the driver side end of the instrument panel, inboard of the instrument panel steering column opening. The high-line or premium CTM contains a microprocessor and software that allow it to provide many electronic functions and features not available with base version of the CTM, including the VTSS. The CTM provides all of the proper VTSS features and outputs based upon the monitored inputs. The CTM circuitry monitors hard wired switch inputs, as well as message inputs received from other vehicle electronic modules over the Chrysler Collision Detection (CCD) data bus network. (Refer to 8 - ELECTRICAL/ELECTRONIC CONTROL MODULES/BODY CONTROL/CENTRAL TIMER MODULE - DESCRIPTION).

- **Door Ajar Switch** - A door ajar switch is located on the hinge pillar of each front door in the vehicle. These switches provide an input to the VTSS indicating whether the door is opened or closed. (Refer to 8 - ELECTRICAL/LAMPS/LIGHTING - INTERIOR/DOOR AJAR SWITCH - DESCRIPTION).

- **Door Cylinder Lock Switch** - A door cylinder lock switch is located on the back of each front door lock cylinder. This switch provides an input to the

VTSS indicating whether the system should remain armed or be disarmed. (Refer to 8 - ELECTRICAL/POWER LOCKS/DOOR CYLINDER LOCK SWITCH - DESCRIPTION).

- **Horn Relay** - The horn relay is located in the Power Distribution Center (PDC) in the engine compartment near the battery. The horn relay is normally activated by the horn switch to control the sounding of the vehicle horn or horns. However, it can also be activated by an output of the Central Timer Module (CTM) to provide an audible indication that unauthorized vehicle use or tampering has been detected. (Refer to 8 - ELECTRICAL/HORN/HORN RELAY - DESCRIPTION).

- **Headlamp Relay** - The headlamp relay (also known as the security relay) is located in the Power Distribution Center (PDC) in the engine compartment near the battery. The headlamp relay is normally activated by the Central Timer Module (CTM) based upon inputs from the Remote Keyless Entry (RKE) panic mode feature. However, it can also be activated by an output of the CTM to flash the headlamp low beams to provide a highly visible indication that unauthorized vehicle use or tampering has been detected. (Refer to 8 - ELECTRICAL/LAMPS/LIGHTING - EXTERIOR/HEADLAMP RELAY - DESCRIPTION).

- **VTSS Indicator** - A red Light Emitting Diode (LED) located on the lower surface of the overhead console near the windshield is illuminated by an output of the Central Timer Module (CTM) to indicate the status of the VTSS. This LED is integral to the electronic circuit board for the Compass Mini-Trip Computer (CMTC). (Refer to 8 - ELECTRICAL/OVERHEAD CONSOLE/COMPASS/MINI-TRIP COMPUTER - DESCRIPTION).

The engine no-run feature of the VTSS relies upon communication between the high-line or premium CTM and the Powertrain Control Module (PCM) over the Chrysler Collision Detection (CCD) data bus network.

Hard wired circuitry connects many of the VTSS components to each other through the electrical sys-

## VEHICLE THEFT SECURITY (Continued)

tem of the vehicle. These hard wired circuits are integral to several wire harnesses, which are routed throughout the vehicle and retained by many different methods. These circuits may be connected to each other, to the vehicle electrical system and to the VTSS components through the use of a combination of soldered splices, splice block connectors, and many different types of wire harness terminal connectors and insulators. Refer to the appropriate wiring information. The wiring information includes wiring diagrams, proper wire and connector repair procedures, further details on wire harness routing and retention, as well as pin-out and location views for the various wire harness connectors, splices and grounds.

## OPERATION

A Central Timer Module (CTM) is used on this model to control and integrate many of the electronic functions and features included in the Vehicle Theft Security System (VTSS). In the VTSS, the CTM receives inputs indicating the status of the door ajar switches, the door cylinder lock switch, and the ignition switch. The programming in the CTM allows it to process the information from all of these inputs and send control outputs to energize or de-energize the horn relay, the headlamp relay, and the VTSS indicator. The control of these inputs and outputs are what constitute all of the features of the VTSS. Following is information on the operation of each of the VTSS features. Refer to the owner's manual in the vehicle glove box for more information on the features, use and operation of the VTSS.

## ENABLING

The high-line or premium version of the CTM must have the VTSS function electronically enabled in order for the VTSS to perform as designed. The logic in the CTM keeps its VTSS function dormant until it is enabled using a DRBIII® scan tool. The VTSS function of the high-line or premium CTM is enabled on vehicles equipped with the VTSS option at the factory, but a service replacement CTM must be VTSS-enabled by the dealer using a DRBIII® scan tool. Refer to the appropriate diagnostic information.

The VTSS engine no-run feature is disabled when it is shipped from the factory. This is done by programming within the Powertrain Control Module (PCM). The logic in the PCM prevents the VTSS engine no-run feature from arming until the engine start counter within the PCM sees twenty engine starts. The VTSS no-run feature must be enabled by the dealer when the vehicle is received from the assembly plant. Once the VTSS engine no-run feature has been enabled, it cannot be disabled unless the PCM is replaced with a new unit. The same

VTSS engine no-run feature enable logic will apply anytime the PCM is replaced with a new unit.

## ARMING

Passive arming of the VTSS occurs when the vehicle is exited with the key removed from the ignition switch, the headlamps are turned off, and the doors are locked while they are open using the power lock switch, or locked after they are closed by turning either front door lock cylinder to the lock position using the key. The power lock switch will not function if the key is in the ignition switch or the headlamps are turned on with the driver side front door open. The VTSS will not arm if the doors are locked using the mechanical lock button. Active arming of the VTSS occurs when the "Lock" button on the Remote Keyless Entry (RKE) transmitter is depressed to lock the vehicle. For active arming to occur, the doors must be closed and the ignition switch must be in the Off position when the RKE transmitter "Lock" button is depressed. However, once the VTSS arming process has been completed, the ignition switch can be turned to the Accessory position without triggering the alarm.

Once the VTSS begins passive or active arming, the security indicator lamp in the overhead console will flash rapidly for about fifteen seconds. This indicates that the VTSS arming is in progress. Turning a key in the ignition switch, opening a door, or unlocking a door by any means during the fifteen second arming process will cause the VTSS indicator to stop flashing and the arming process to abort. Once the fifteen second arming function is successfully completed, the indicator will flash at a slower rate, indicating that the VTSS is armed.

## DISARMING

Passive disarming of the VTSS occurs when the vehicle is unlocked using the key to unlock either front door. Active disarming of the VTSS occurs when the vehicle is unlocked by depressing the "Unlock" button of the RKE transmitter. Once the alarm has been activated (horn pulsing, headlamps flashing, and the engine no-run feature), either disarming method will also deactivate the alarm. Depressing the "Panic" button on the RKE transmitter will **not** disarm the VTSS.

## POWER-UP MODE

When the armed VTSS senses that the battery has been disconnected and reconnected, it enters its power-up mode. In the power-up mode the alarm system remains armed following a battery failure or disconnect. If the VTSS was armed prior to a battery disconnect or failure, the technician or vehicle operator will have to actively or passively disarm the alarm system after the battery is reconnected. The pow-



## VEHICLE THEFT SECURITY (Continued)

er-up mode will also apply if the battery goes dead while the system is armed, and battery jump-starting is attempted. The engine no-run feature will prevent the engine from starting until the alarm system has been actively or passively disarmed. The VTSS will be armed until the technician or vehicle operator has actively or passively disarmed the alarm system. If the VTSS is in the disarmed mode prior to a battery disconnect or failure, it will remain disarmed after the battery is reconnected or replaced, or if jump-starting is attempted.

### TAMPER ALERT

The VTSS tamper alert feature will sound the horn three times upon disarming, if the alarm was triggered and has since timed-out (about fifteen minutes). This feature alerts the vehicle operator that the VTSS alarm was activated while the vehicle was unattended.

## DIAGNOSIS AND TESTING - VEHICLE THEFT SECURITY SYSTEM

The VTSS-related hard wired inputs to and outputs from the high-line or premium Central Timer Module (CTM) may be diagnosed and tested using conventional diagnostic tools and procedures. Refer to the appropriate wiring information. The wiring information includes wiring diagrams, proper wire and connector repair procedures, further details on wire harness routing and retention, as well as pin-out and location views for the various wire harness connectors, splices and grounds.

However, conventional diagnostic methods may not prove conclusive in the diagnosis of the CTM, the Powertrain Control Module (PCM), or the Chrysler Collision Detection (CCD) data bus network. In order to obtain conclusive testing of the VTSS, the CTM, the PCM, and the CCD data bus network must also be checked. The most reliable, efficient, and accurate means to diagnose the VTSS requires the use of a DRBIII® scan tool. Refer to the appropriate diagnostic information. The DRBIII® scan tool can provide confirmation that the CCD data bus network is functional, that all of the electronic modules are sending and receiving the proper messages over the CCD data bus, and that these modules are receiving the proper hard wired inputs and responding with the proper hard wired outputs needed to perform their functions. See the "Vehicle Theft Security System" menu item on the DRBIII® scan tool.

**WARNING: ON VEHICLES EQUIPPED WITH AIRBAGS, DISABLE THE AIRBAG SYSTEM BEFORE ATTEMPTING ANY STEERING WHEEL, STEERING COLUMN, OR INSTRUMENT PANEL COMPONENT DIAGNOSIS OR SERVICE. DISCONNECT AND ISO-**

**LATE THE BATTERY NEGATIVE (GROUND) CABLE, THEN WAIT TWO MINUTES FOR THE AIRBAG SYSTEM CAPACITOR TO DISCHARGE BEFORE PERFORMING FURTHER DIAGNOSIS OR SERVICE. THIS IS THE ONLY SURE WAY TO DISABLE THE AIRBAG SYSTEM. FAILURE TO TAKE THE PROPER PRECAUTIONS COULD RESULT IN ACCIDENTAL AIRBAG DEPLOYMENT AND POSSIBLE PERSONAL INJURY.**

## VTSS INDICATOR

### DESCRIPTION

The Vehicle Theft Security System (VTSS) indicator consists of a red Light-Emitting Diode (LED) located on the electronic circuit board of the Compass Mini-Trip Computer (CMTC) within the overhead console. The LED extends through a hole in the CMTC lens located near the forward end of the overhead console housing near the windshield.

The VTSS indicator cannot be adjusted or repaired and, if faulty or damaged, the entire CMTC unit must be replaced. (Refer to 8 - ELECTRICAL/OVERHEAD CONSOLE/COMPASS/MINI-TRIP COMPUTER - DESCRIPTION).

### OPERATION

The Vehicle Theft Security System (VTSS) indicator gives a visible indication of the VTSS arming status. One side of Light-Emitting Diode (LED) in the VTSS indicator is connected to battery current through a fused B(+) circuit and a fuse in the Junction Block (JB), so the indicator remains functional regardless of the ignition switch position. The other side of the LED is hard wired to the Central Timer Module (CTM), which controls the operation of the VTSS indicator by pulling this side of the LED circuit to ground. When the VTSS arming is in progress, the CTM will flash the LED rapidly on and off for about fifteen seconds. When the VTSS has been successfully armed, the CTM will flash the LED on and off continually at a much slower rate until the VTSS has been disarmed. The VTSS indicator can be diagnosed using conventional diagnostic tools and methods.

## DIAGNOSIS AND TESTING - VTSS INDICATOR

The diagnosis found here addresses an inoperative Vehicle Theft Security System (VTSS) indicator condition. If the problem being diagnosed is related to indicator accuracy, be certain to confirm that the problem is with the indicator and not with an inoperative VTSS. (Refer to 8 - ELECTRICAL/VEHICLE THEFT SECURITY SYSTEM- DIAGNOSIS AND



## VTSS INDICATOR (Continued)

TESTING). If no VTSS problem is found, the following procedure will help to locate a short or open in the VTSS indicator control circuit. Refer to the appropriate wiring information. The wiring information includes wiring diagrams, proper wire and connector repair procedures, details of wire harness routing and retention, connector pin-out information and location views for the various wire harness connectors, splices and grounds.

**WARNING: ON VEHICLES EQUIPPED WITH AIRBAGS, DISABLE THE AIRBAG SYSTEM BEFORE ATTEMPTING ANY STEERING WHEEL, STEERING COLUMN, OR INSTRUMENT PANEL COMPONENT DIAGNOSIS OR SERVICE. DISCONNECT AND ISOLATE THE BATTERY NEGATIVE (GROUND) CABLE, THEN WAIT TWO MINUTES FOR THE AIRBAG SYSTEM CAPACITOR TO DISCHARGE BEFORE PERFORMING FURTHER DIAGNOSIS OR SERVICE. THIS IS THE ONLY SURE WAY TO DISABLE THE AIRBAG SYSTEM. FAILURE TO TAKE THE PROPER PRECAUTIONS COULD RESULT IN ACCIDENTAL AIRBAG DEPLOYMENT AND POSSIBLE PERSONAL INJURY.**

(1) Check the fused B(+) fuse (Fuse 12 - 10 ampere) in the Junction Block (JB). If OK, go to Step 2. If not OK, repair the shorted circuit or component as required and replace the faulty fuse.

(2) Check for battery voltage at the fused B(+) fuse (Fuse 12 - 10 ampere) in the JB. If OK, go to Step 3. If not OK, repair the open fused B(+) circuit between

the JB and the Power Distribution Center (PDC) as required.

(3) Disconnect and isolate the battery negative cable. Disconnect the body wire harness connector for the Compass Mini-Trip Computer (CMTC) from the CMTC connector receptacle. Reconnect the battery negative cable. Check for battery voltage at the fused B(+) circuit cavity of the body wire harness connector for the CMTC. If OK, go to Step 4. If not OK, repair the open fused B(+) circuit between the CMTC indicator and the JB as required.

(4) Disconnect and isolate the battery negative cable. Disconnect the instrument panel wire harness connector (Connector C2) for the Central Timer Module (CTM) from the CTM connector receptacle. Check for continuity between the VTSS indicator driver circuit cavity of the body wire harness connector for the CMTC and a good ground. There should be no continuity. If OK, go to Step 5. If not OK, repair the shorted VTSS indicator driver circuit between the CMTC and the CTM as required.

(5) Check for continuity between the VTSS indicator driver circuit cavities of the instrument panel wire harness connector (Connector C2) for the CTM and the body wire harness connector for the CMTC. There should be continuity. If OK, replace the faulty CMTC indicator. If not OK, repair the open VTSS indicator driver circuit between the CMTC and the CTM as required.

# WIPERS/WASHERS

## TABLE OF CONTENTS

	page		page
<b>WIPERS/WASHERS</b>		<b>OPERATION</b> .....	10
DESCRIPTION.....	1	REMOVAL.....	10
OPERATION.....	2	INSTALLATION.....	11
DIAGNOSIS AND TESTING.....	3	<b>WIPER ARM</b>	
WIPER & WASHER SYSTEM.....	3	DESCRIPTION.....	11
CLEANING.....	6	OPERATION.....	12
INSPECTION.....	6	REMOVAL.....	12
<b>WASHER FLUID LEVEL SWITCH</b>		INSTALLATION.....	12
DESCRIPTION.....	7	<b>WIPER BLADE</b>	
OPERATION.....	7	DESCRIPTION.....	12
REMOVAL.....	8	OPERATION.....	13
INSTALLATION.....	8	REMOVAL.....	13
<b>WASHER HOSES/TUBES</b>		INSTALLATION.....	13
DESCRIPTION.....	8	<b>WIPER MODULE</b>	
OPERATION.....	8	DESCRIPTION.....	14
<b>WASHER NOZZLE</b>		OPERATION.....	14
DESCRIPTION.....	9	REMOVAL.....	14
OPERATION.....	9	INSTALLATION.....	15
REMOVAL.....	9	<b>WIPER RELAY</b>	
INSTALLATION.....	9	DESCRIPTION.....	15
<b>WASHER PUMP/MOTOR</b>		OPERATION.....	15
DESCRIPTION.....	9	DIAGNOSIS AND TESTING.....	16
OPERATION.....	9	WIPER RELAY.....	16
REMOVAL.....	10	REMOVAL.....	17
INSTALLATION.....	10	INSTALLATION.....	17
<b>WASHER RESERVOIR</b>			
DESCRIPTION.....	10		

## WIPERS/WASHERS

### DESCRIPTION

An electrically operated intermittent wiper and washer system is standard factory-installed safety equipment on this model. The wiper and washer system includes the following major components, which are described in further detail elsewhere in this service information:

- **Central Timer Module** - The Central Timer Module (CTM) is located under the driver side end of the instrument panel, inboard of the instrument panel steering column opening. A base version of the CTM is used on base models of this vehicle. The base version of the CTM combines the functions of a chime module and an intermittent wipe module in a single unit. The high-line version of the CTM is used on high-line vehicles. The high-line CTM provides all of the functions of the base version of the CTM, but also is used to control and integrate many additional

electronic functions and features included on high-line models. The premium version of the CTM is the same as the high-line version, but is used only on models equipped with the heated seat option. The high-line and premium versions of the CTM contain integrated circuitry, a central processing unit and the programming to provide all of the proper wiper and washer system features based upon the monitored inputs. The high-line and premium CTM circuitry monitors hard wired switch inputs, as well as message inputs received from other vehicle electronic modules on the Chrysler Collision Detection (CCD) data bus network. (Refer to 8 - ELECTRICAL/ELECTRONIC CONTROL MODULES/BODY CONTROL/CENTRAL TIMER MODULE - DESCRIPTION).

- **Multi-Function Switch** - The multi-function switch is secured to the left side of the steering column, just below the steering wheel. Only the control stalk for the multi-function switch is visible, the remainder of the switch is concealed beneath the steering column shrouds. The multi-function switch

## WIPERS/WASHERS (Continued)

contains all of the switches for both the wiper and washer systems.

- **Washer Fluid Level Switch** - The washer fluid level switch is located in a dedicated hole on the lower rear side of the washer reservoir, above the washer pump/motor unit near the left front corner of the engine compartment.

- **Washer Nozzles** - The dual fluidic washer nozzles are secured with integral snap features to dedicated openings in the cowl plenum cover/grille panel located near the base of the windshield. The washer plumbing fittings for the washer nozzles are concealed beneath the cowl plenum cover/grille panel.

- **Washer Pump/Motor** - The washer pump/motor unit is located in a dedicated hole on the lower rear side of the washer reservoir near the left front corner of the engine compartment.

- **Washer Reservoir** - The washer reservoir is secured to the left side of the radiator fan shroud in the left front corner of the engine compartment.

- **Wiper Arms** - The two wiper arms are secured to the two wiper pivots, which extend through the cowl plenum cover/grille panel located near the base of the windshield.

- **Wiper Blades** - The two wiper blades are secured to the two wiper arms, and are parked on the glass near the bottom of the windshield when the wiper system is not in operation.

- **Wiper Module** - The wiper pivots are the only visible components of the wiper module. The remainder of the module is concealed within the cowl plenum beneath the cowl plenum cover/grille panel. The wiper module includes the module bracket, the single wiper motor, the wiper linkage, and the two wiper pivots.

- **Wiper Relay** - The wiper relay is located in the Power Distribution Center (PDC) in the engine compartment near the battery.

Features of the wiper and washer system include the following:

- **Continuous Wipe Modes** - The two-speed wiper motor and the internal circuitry of the multi-function switch work in concert to provide two continuous wipe cycles, low speed or high speed.

- **Intermittent Wipe Mode** - The internal circuitry of the multi-function switch, the CTM, and the wiper relay work in concert to provide an intermittent wipe mode with multiple delay interval selections. On models with a high-line or premium CTM, the CTM also automatically adjusts each manually selected delay interval to compensate for vehicle speed.

- **Washer Mode** - When the washer system is activated with the multi-function switch while the wiper system is operating, washer fluid will be dispensed onto the windshield glass through the washer

nozzles for as long as the washer pump/motor is energized.

- **Wipe-After-Wash Mode** - The internal circuitry of the CTM provides a wipe-after-wash feature which, if the wipers are turned Off, will operate the washer pump/motor and the wipers for as long as the washer system is activated, then provide several additional wipe cycles after the washer system is deactivated before parking the wiper blades near the base of the windshield.

Hard wired circuitry connects the wiper and washer system components to the electrical system of the vehicle. These hard wired circuits are integral to several wire harnesses, which are routed throughout the vehicle and retained by many different methods. These circuits may be connected to each other, to the vehicle electrical system and to the wiper and washer system components through the use of a combination of soldered splices, splice block connectors, and many different types of wire harness terminal connectors and insulators. Refer to the appropriate wiring information. The wiring information includes wiring diagrams, proper wire and connector repair procedures, further details on wire harness routing and retention, as well as pin-out and location views for the various wire harness connectors, splices and grounds.

## OPERATION

The wiper and washer system is intended to provide the vehicle operator with a convenient, safe, and reliable means of maintaining visibility through the windshield glass. The various components of this system are designed to convert electrical energy produced by the vehicle electrical system into the mechanical action of the wiper blades to wipe the outside surface of the glass, as well as into the hydraulic action of the washer system to apply washer fluid stored in an on-board reservoir to the area of the glass to be wiped. When combined, these components provide the means to effectively maintain clear visibility for the vehicle operator by removing excess accumulations of rain, snow, bugs, mud, or other minor debris from the outside windshield glass surface that might be encountered while driving the vehicle under numerous types of inclement operating conditions. The vehicle operator initiates all wiper and washer system functions with the multi-function switch control stalk that extends from the left side of the steering column, just below the steering wheel. Rotating the knob on the end of the multi-function switch control stalk selects the desired wiper system operating mode. The wiper system allows the vehicle operator to select from two continuous wiper speeds, Hi or Lo, or one of several intermittent wipe Delay mode intervals. Pushing the button on the end of the control stalk downwards towards the steering column

## WIPERS/WASHERS (Continued)

activates the washer pump/motor, which dispenses washer fluid onto the windshield glass through the washer nozzles.

When the ignition switch is in the Accessory or On positions, battery current from a fuse in the Junction Block (JB) is provided through a fused ignition switch output (run-acc) circuit to the wiper motor park switch, the wiper relay, and the multi-function switch. The internal circuitry of the multi-function switch provides a direct hard wired battery current output to the low speed or high speed brushes of the wiper motor when the Lo or Hi switch setting is selected, which causes the wipers to cycle at the selected speed. The intermittent wipe, and wipe-after-wash features of the wiper and washer system are provided by the electronic intermittent wipe logic circuit within the Central Timer Module (CTM). In order to provide the intermittent wipe feature, the CTM monitors the wiper switch state and the wiper motor park switch state. In order to provide the wipe-after-wash feature, the CTM monitors both the washer switch state and the wiper motor park switch state. When a Delay position is selected with the multi-function switch control knob, the CTM logic circuit responds by calculating the correct delay interval. The CTM then energizes the wiper relay by pulling the relay control coil to ground. The energized wiper relay directs battery current through the normally open contact of the relay back through the internal circuitry of the multi-function switch to the low speed brush of the wiper motor. The CTM monitors the wiper motor operation through the wiper park switch sense circuit, which allows the CTM to determine the proper timing to begin the next wiper blade sweep. The normal delay intervals are driver adjustable from about one-half second to about eighteen seconds.

The high-line and premium CTM also provides a speed sensitive intermittent wipe feature. By monitoring vehicle speed messages received from the Powertrain Control Module (PCM) over the Chrysler Collision Detection (CCD) data bus network, the high-line or premium CTM is able to adjust the delay intervals to compensate for vehicle speed. Above about sixteen kilometers-per-hour (ten miles-per-hour) the delay is driver adjustable from about one-half second to about eighteen seconds. Below about sixteen kilometers-per-hour (ten miles-per-hour) the delay times are doubled by the CTM, from about one second to about thirty-six seconds.

When the Off position of the multi-function switch wiper control knob is selected, one of two events is possible. The event that will occur depends upon the position of the wiper blades on the windshield at the moment that the Off position is selected. If the wiper blades are in the down position on the windshield

when the Off position is selected, the park switch that is integral to the wiper motor is closed to ground and the wiper motor ceases to operate. If the wiper blades are not in the down position on the windshield at the moment the Off position is selected, the park switch is closed to battery current through a fused ignition switch output (run-acc) circuit. The park switch sense circuit directs this battery current to the low speed brush of the wiper motor through the normally closed contact of the wiper relay and the internal Off position circuitry of the multi-function switch. This causes the wiper motor to continue running until the wiper blades are in the down position on the windshield and the park switch is again closed to ground.

When the Wash position of the multi-function switch is selected, the Wash position circuitry within the switch directs battery current to the washer pump/motor. The CTM monitors the washer switch state through a washer switch sense input. When the washer switch is closed with the wiper system turned Off, the CTM operates the wiper motor through the wiper relay in the same manner as it does to provide the Delay mode operation. After the state of the washer switch changes to open, the CTM monitors the wiper motor through the wiper park switch sense circuit, which allows the CTM to monitor the number of wiper blade sweeps.

Proper testing of the CTM, the PCM, or the CCD data bus vehicle speed messages requires a DRBIII® scan tool. Refer to the appropriate diagnostic information. Refer to the owner's manual in the vehicle glove box for more information on the features and operation of the wiper and washer system.

## DIAGNOSIS AND TESTING - WIPER & WASHER SYSTEM

### WIPER SYSTEM

The diagnosis found here addresses an electrically inoperative wiper system. If the wiper motor operates, but the wipers do not move on the windshield, replace the faulty wiper module. If the wipers operate, but chatter, lift, or do not clear the glass, clean and inspect the wiper system components as required. (Refer to 8 - ELECTRICAL/WIPERS/WASHERS - INSPECTION) and (Refer to 8 - ELECTRICAL/WIPERS/WASHERS - CLEANING). Refer to the appropriate wiring information. The wiring information includes wiring diagrams, proper wire and connector repair procedures, details of wire harness routing and retention, connector pin-out information and location views for the various wire harness connectors, splices and grounds.

The following tests will help to diagnose the hard wired components and circuits of the wiper system.



## WIPERS/WASHERS (Continued)

However, these tests may not prove conclusive in the diagnosis of this system on models equipped with a high-line or premium Central Timer Module (CTM). In order to obtain conclusive testing of the wiper system on models with a high-line or premium CTM, the Chrysler Collision Detection (CCD) data bus network and all of the electronic modules that provide inputs to or receive outputs from the wiper system components must be checked. The most reliable, efficient, and accurate means to diagnose the wiper system on models with a high-line or premium CTM requires the use of a DRBIII® scan tool. Refer to the appropriate diagnostic information. The DRBIII® scan tool can provide confirmation that the CCD data bus is functional, that all of the electronic modules are sending and receiving the proper messages on the CCD data bus, and that the wiper relay is being sent the proper hard wired outputs by the CTM for it to perform its wiper system functions.

**WARNING: ON VEHICLES EQUIPPED WITH AIRBAGS, DISABLE THE AIRBAG SYSTEM BEFORE ATTEMPTING ANY STEERING WHEEL, STEERING COLUMN, OR INSTRUMENT PANEL COMPONENT DIAGNOSIS OR SERVICE. DISCONNECT AND ISOLATE THE BATTERY NEGATIVE (GROUND) CABLE, THEN WAIT TWO MINUTES FOR THE AIRBAG SYSTEM CAPACITOR TO DISCHARGE BEFORE PERFORMING FURTHER DIAGNOSIS OR SERVICE. THIS IS THE ONLY SURE WAY TO DISABLE THE AIRBAG SYSTEM. FAILURE TO TAKE THE PROPER PRECAUTIONS COULD RESULT IN ACCIDENTAL AIRBAG DEPLOYMENT AND POSSIBLE PERSONAL INJURY.**

(1) Check the fused ignition switch output (run-acc) fuse (Fuse 6 - 25 ampere) in the Junction Block (JB). If OK, go to Step 2. If not OK, repair the shorted circuit or component as required and replace the faulty fuse.

(2) Turn the ignition switch to the On position. Check for battery voltage at the fused ignition switch output (run-acc) fuse (Fuse 6 - 25 ampere) in the JB. If OK, go to Step 3. If not OK, repair the open fused ignition switch output (run-acc) circuit between the JB and the ignition switch as required.

(3) Turn the ignition switch to the Off position. Disconnect and isolate the battery negative cable. Disconnect the instrument panel wire harness connector for the multi-function switch from the switch connector receptacle. Reconnect the battery negative cable. Turn the ignition switch to the On position. Check for battery voltage at the fused ignition switch output (run-acc) circuit cavity of the instrument panel wire harness connector for the multi-function switch. If OK, go to Step 4. If not OK, repair the

open fused ignition switch output circuit between the multi-function switch and the JB as required.

(4) If the problem being diagnosed involves only the intermittent wipe feature, go to Step 5. If the problem being diagnosed involves all wiper modes, or only the Low and/or High speed modes, go to Step 7.

(5) Turn the ignition switch to the Off position. Disconnect and isolate the battery negative cable. Disconnect the instrument panel wire harness connector (Connector C1) for the Central Timer Module (CTM) from the CTM connector receptacle. Check for continuity between the wiper switch mode sense circuit cavities of the instrument panel wire harness connector for the multi-function switch and the instrument panel wire harness connector (Connector C1) for the CTM. There should be continuity. If OK, go to Step 6. If not OK, repair the open wiper switch mode sense circuit between the multi-function switch and the CTM as required.

(6) Check for continuity between the wiper switch mode signal circuit cavities of the instrument panel wire harness connector for the multi-function switch and the instrument panel wire harness connector (Connector C1) for the CTM. There should be continuity. If OK, proceed to the diagnosis for the wiper relay. (Refer to 8 - ELECTRICAL/WIPERS/WASHERS/WIPER RELAY - DIAGNOSIS AND TESTING). If not OK, repair the open wiper switch mode signal circuit between the multi-function switch and the CTM as required.

(7) Check for continuity between the two wiper switch low speed output circuit cavities of the instrument panel wire harness connector for the multi-function switch. There should be continuity. If OK, go to Step 8. If not OK, repair the open wiper switch low speed output circuit between the two cavities of the instrument panel wire harness connector for the multi-function switch as required.

(8) Test the multi-function switch continuity. (Refer to 8 - ELECTRICAL/LAMPS/LIGHTING - EXTERIOR/MULTI-FUNCTION SWITCH - DIAGNOSIS AND TESTING). If the multi-function switch tests OK, reconnect the instrument panel wire harness connector for the multi-function switch to the switch connector receptacle and go to Step 9. If not OK, replace the faulty multi-function switch and test the wiper system operation again. If still not OK, go to Step 9.

(9) Turn the ignition switch to the Off position. Disconnect and isolate the battery negative cable. Measure the resistance between the headlamp and dash wire harness ground wire for the wiper motor and a good ground. The meter should read zero ohms. If OK, go to Step 10. If not OK, repair the open ground circuit to ground (G100) as required.



## WIPERS/WASHERS (Continued)

(10) Disconnect the headlamp and dash wire harness connector for the wiper module from the wiper motor pigtail wire connector. Reconnect the battery negative cable. Turn the ignition switch to the On position. Place the multi-function switch in the positions indicated in the tests below, and check for battery voltage at the appropriate cavity of the headlamp and dash wire harness connector for the wiper motor.

(a) Check for battery voltage at the fused ignition switch output (run-acc) circuit cavity of the headlamp and dash wire harness connector for the wiper module with the multi-function switch in any position. If OK, go to Step b. If not OK, repair the open fused ignition switch output (run-acc) circuit between the wiper module and the JB as required.

(b) Check for battery voltage at the wiper switch low speed output circuit cavity of the headlamp and dash wire harness connector for the wiper module with the multi-function switch in the Lo position. If OK, go to Step c. If not OK, repair the open wiper switch low speed output circuit between the wiper module and the multi-function switch as required.

(c) Check for battery voltage at the wiper switch high speed output circuit cavity of the headlamp and dash wire harness connector for the wiper module with the multi-function switch in the Hi position. If OK, go to Step d. If not OK, repair the open wiper switch high speed output circuit between the wiper module and the multi-function switch as required.

(d) Check for battery voltage at the wiper park switch sense circuit cavity of the headlamp and dash wire harness connector for the wiper module with the multi-function switch in the Lo or Hi position, then move the switch to the Off position. The meter should switch between battery voltage and zero volts while the wipers are cycling. The meter should read battery voltage when the switch is first moved to the Off position until the wipers park, and then read a steady zero volts. If not OK, replace the faulty wiper module.

## WASHER SYSTEM

The diagnosis found here addresses an electrically inoperative washer system. If the washer pump/motor operates, but no washer fluid is emitted from the washer nozzles, be certain to check the fluid level in the reservoir. Also inspect the washer system components as required. (Refer to 8 - ELECTRICAL/WIPERS/WASHERS - INSPECTION). Refer to the appropriate wiring information. The wiring information includes wiring diagrams, proper wire and connector repair procedures, details of wire harness

routing and retention, connector pin-out information and location views for the various wire harness connectors, splices and grounds.

**WARNING: ON VEHICLES EQUIPPED WITH AIRBAGS, DISABLE THE AIRBAG SYSTEM BEFORE ATTEMPTING ANY STEERING WHEEL, STEERING COLUMN, OR INSTRUMENT PANEL COMPONENT DIAGNOSIS OR SERVICE. DISCONNECT AND ISOLATE THE BATTERY NEGATIVE (GROUND) CABLE, THEN WAIT TWO MINUTES FOR THE AIRBAG SYSTEM CAPACITOR TO DISCHARGE BEFORE PERFORMING FURTHER DIAGNOSIS OR SERVICE. THIS IS THE ONLY SURE WAY TO DISABLE THE AIRBAG SYSTEM. FAILURE TO TAKE THE PROPER PRECAUTIONS COULD RESULT IN ACCIDENTAL AIRBAG DEPLOYMENT AND POSSIBLE PERSONAL INJURY.**

(1) Turn the ignition switch to the On position. Turn the multi-function switch wiper control knob to the Lo or Hi speed position. Check whether the wipers operate. If OK, go to Step 2. If not OK, repair the wiper system as required before proceeding with the following tests. Refer to WIPER SYSTEM .

(2) Turn the multi-function switch wiper control knob to the Off position. Depress the washer button. The washer pump should operate and the wipers should operate for as long as the washer button is depressed. The wipers should continue to operate for about three sweep cycles after the button is released before they park. If the wipers are OK, but the washers are not, go to Step 3. If the washers are OK, but the wipers are not, go to Step 5.

(3) Turn the ignition switch to the Off position. Disconnect and isolate the battery negative cable. Disconnect the headlamp and dash wire harness connector for the washer pump/motor from the motor connector receptacle. Measure the resistance between the ground circuit cavity of the headlamp and dash wire harness connector for the washer pump/motor and a good ground. The meter should read zero ohms. If OK, go to Step 4. If not OK, repair the open ground circuit to ground (G100) as required.

(4) Reconnect the battery negative cable. Turn the ignition switch to the On position. With the washer button depressed, check for battery voltage at the washer switch output circuit cavity of the headlamp and dash wire harness connector for the washer pump/motor. If OK, replace the faulty washer pump/motor. If not OK, repair the open washer switch output circuit between the washer pump/motor and the multi-function switch as required.

(5) Turn the ignition switch to the Off position. Disconnect and isolate the battery negative cable. Disconnect the instrument panel wire harness connector (Connector C1) for the Central Timer Module

## WIPERS/WASHERS (Continued)

(CTM) from the CTM connector receptacle. Reconnect the battery negative cable. Turn the ignition switch to the On position. With the washer button depressed, check for battery voltage at the washer switch sense circuit cavity of the instrument panel wire harness connector (Connector C1) for the CTM. If OK, proceed to the diagnosis for the wiper relay. (Refer to 8 - ELECTRICAL/WIPERS/WASHERS/WIPER RELAY - DIAGNOSIS AND TESTING). If not OK, repair the open washer switch sense circuit between the CTM and the multi-function switch as required.

**CLEANING - WIPER & WASHER SYSTEM****WIPER SYSTEM**

The squeegees of wiper blades exposed to the elements for a long time tend to lose their wiping effectiveness. Periodic cleaning of the squeegees is suggested to remove any deposits of salt or road film. The wiper blades, arms, and windshield glass should only be cleaned using a sponge or soft cloth and windshield washer fluid, a mild detergent, or a non-abrasive cleaner. If the wiper blades continue to leave streaks, smears, hazing, or beading on the glass after thorough cleaning of the squeegees and the glass, the entire wiper blade assembly must be replaced.

**CAUTION: Protect the rubber squeegees of the wiper blades from any petroleum-based cleaners, solvents, or contaminants. These products can rapidly deteriorate the rubber squeegees.**

**WASHER SYSTEM**

If the washer system is contaminated with foreign material, drain the washer reservoir by removing the front washer pump/motor from the reservoir. Clean foreign material from the inside of the washer reservoir using clean washer fluid, a mild detergent, or a non-abrasive cleaner. Flush foreign material from the washer system plumbing by first disconnecting the washer hoses from the washer nozzles, then running the washer pump/motor to run clean washer fluid or water through the system. Plugged or restricted washer nozzles should be carefully back-flushed using compressed air. If the washer nozzle obstruction cannot be cleared, replace the washer nozzle.

**CAUTION: Never introduce petroleum-based cleaners, solvents, or contaminants into the washer system. These products can rapidly deteriorate the rubber seals and hoses of the washer system, as well as the rubber squeegees of the wiper blades.**

**CAUTION: Never use compressed air to flush the washer system plumbing. Compressed air pressures are too great for the washer system plumbing components and will result in further system damage. Never use sharp instruments to clear a plugged washer nozzle or damage to the nozzle orifice and improper nozzle spray patterns will result.**

**INSPECTION - WIPER & WASHER SYSTEM****WIPER SYSTEM**

The wiper blades and wiper arms should be inspected periodically, not just when wiper performance problems are experienced. This inspection should include the following points:

(1) Inspect the wiper arms for any indications of damage, or contamination. If the wiper arms are contaminated with any foreign material, clean them as required. (Refer to 8 - ELECTRICAL/WIPERS/WASHERS - CLEANING). If a wiper arm is damaged or corrosion is evident, replace the wiper arm with a new unit. Do not attempt to repair a wiper arm that is damaged or corroded.

(2) Carefully lift the wiper blade off of the glass. Note the action of the wiper arm hinge. The wiper arm should pivot freely at the hinge, but with no side-to-side looseness evident. If there is any binding evident in the wiper arm hinge, or there is evident side-to-side play in the wiper arm hinge, replace the wiper arm.

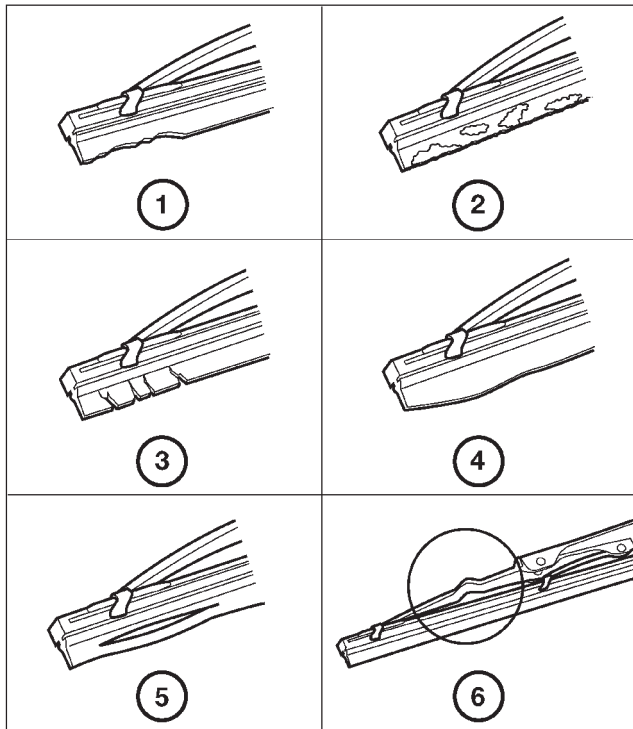
**CAUTION: Do not allow the wiper arm to spring back against the glass without the wiper blade in place or the glass may be damaged.**

(3) Once proper hinge action of the wiper arm is confirmed, check the hinge for proper spring tension. Remove the wiper blade from the wiper arm. Either place a small postal scale between the blade end of the wiper arm and the glass, or carefully lift the blade end of the arm away from the glass using a small fish scale. Compare the scale readings between the right and left wiper arms. Replace a wiper arm if it has comparatively lower spring tension, as evidenced by a lower scale reading.

(4) Inspect the wiper blades and squeegees for any indications of damage, contamination, or rubber deterioration (Fig. 1). If the wiper blades or squeegees are contaminated with any foreign material, clean them and the glass as required. (Refer to 8 - ELECTRICAL/WIPERS/WASHERS - CLEANING). After cleaning the wiper blade and the glass, if the wiper blade still fails to clear the glass without smearing, streaking, chattering, hazing, or beading, replace the wiper blade. Also, if a wiper blade is damaged or the squeegee rubber is damaged or deteriorated, replace

## WIPERS/WASHERS (Continued)

the wiper blade with a new unit. Do not attempt to repair a wiper blade that is damaged.



809ac961

**Fig. 1 Wiper Blade Inspection**

- 1 - WORN OR UNEVEN EDGES
- 2 - ROAD FILM OR FOREIGN MATERIAL DEPOSITS
- 3 - HARD, BRITTLE, OR CRACKED
- 4 - DEFORMED OR FATIGUED
- 5 - SPLIT
- 6 - DAMAGED SUPPORT COMPONENTS

### WASHER SYSTEM

The washer system components should be inspected periodically, not just when washer performance problems are experienced. This inspection should include the following points:

(1) Check for ice or other foreign material in the washer reservoir. If contaminated, clean and flush the washer system. (Refer to 8 - ELECTRICAL/WIPERS/WASHERS - CLEANING).

(2) Inspect the washer plumbing for pinched, leaking, deteriorated, or incorrectly routed hoses and damaged or disconnected hose fittings. Replace damaged or deteriorated hoses and hose fittings. Leaking washer hoses can sometimes be repaired by cutting the hose at the leak and splicing it back together using an in-line connector fitting. Similarly, sections of deteriorated hose can be cut out and replaced by splicing in new sections of hose using in-line connector fittings. Whenever routing a washer hose or a wire harness containing a washer hose, it must be routed away from hot, sharp, or moving parts. Also,

sharp bends that might pinch the washer hose must be avoided.

## WASHER FLUID LEVEL SWITCH

### DESCRIPTION

The washer fluid level switch is a single pole, single throw reed-type switch mounted on the rear of the washer reservoir above the washer pump/motor, in the left front corner of the engine compartment. Only the molded plastic switch mounting flange and connector receptacle are visible when the switch is installed in the reservoir. A short nipple formation extends from the inner surface of the switch mounting flange, and a barb on the nipple near the switch mounting flange is press-fit into a rubber grommet seal installed in the mounting hole of the reservoir. A small plastic float pivots on the end of a bracket that extends from the switch nipple formation. Within the float is a small magnet, which actuates the reed switch. The washer fluid level switch cannot be adjusted or repaired. If faulty or damaged, the switch must be replaced.

### OPERATION

The washer fluid level switch uses a pivoting, oblong float to monitor the level of the washer fluid in the washer reservoir. The float contains a small magnet. When the float pivots, the changing proximity of its magnetic field will cause the contacts of the small, stationary reed switch to open or close. When the fluid level in the washer reservoir is at or above the float level, the float moves to a vertical position and the switch contacts open. When the fluid level in the washer reservoir falls below the pivoting float, the float moves to a horizontal position and the switch contacts close. The switch contacts are connected in series between ground and the washer fluid switch sense input of the instrument cluster. The switch is connected to the vehicle electrical system through a dedicated take out and connector of the headlamp and dash wire harness. The switch receives ground through another take out of the headlamp and dash wire harness with a single eyelet terminal connector that is secured under a nut to a ground stud located on the front extension of the left front wheel housing in the engine compartment. The washer fluid level switch can be diagnosed using conventional diagnostic tools and methods. (Refer to 8 - ELECTRICAL/INSTRUMENT CLUSTER/WASHER FLUID INDICATOR - DIAGNOSIS AND TESTING).



## WASHER FLUID LEVEL SWITCH (Continued)

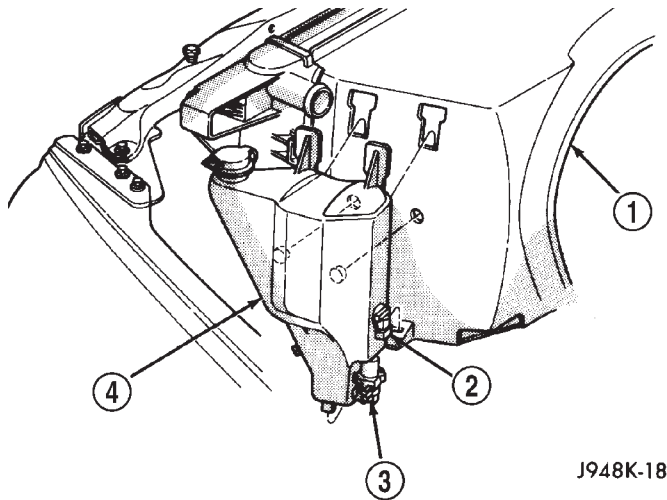
## REMOVAL

The washer fluid level switch can be removed from the washer reservoir without removing the reservoir from the vehicle.

(1) Disconnect and isolate the battery negative cable.

(2) Disconnect the washer hose from the barbed outlet nipple of the washer pump/motor unit and allow the washer fluid to drain into a clean container for reuse.

(3) Disconnect the headlamp and dash wire harness connector for the washer fluid level switch from the switch connector receptacle (Fig. 2).



J948K-18

**Fig. 2 Washer Reservoir**

- 1 - FAN SHROUD
- 2 - WASHER FLUID LEVEL SWITCH
- 3 - WASHER PUMP/MOTOR
- 4 - WASHER RESERVOIR

**NOTE:** The pivoting float of the washer fluid level switch must be in a horizontal position within the reservoir in order to be removed. With the reservoir empty and in an upright position, the pivoting float will orient itself to the horizontal position when the switch connector receptacle is pointed straight downwards.

(4) Using a trim stick or another suitable wide flat-bladed tool, gently pry the barbed nipple of the washer fluid level switch out of the rubber grommet seal on the rear of the reservoir. Care must be taken not to damage the reservoir.

(5) Remove the washer fluid level switch and float from the washer reservoir.

(6) Remove the rubber grommet seal from the washer fluid level switch mounting hole in the washer reservoir and discard.

## INSTALLATION

(1) Install a new rubber grommet seal into the washer fluid level switch mounting hole in the front of the washer reservoir. Always use a new rubber grommet seal on the reservoir.

(2) Position the float of the washer fluid level switch through the rubber grommet seal in the washer reservoir (Fig. 2). The connector receptacle of the washer fluid level switch should be pointed downward.

(3) Press firmly and evenly on the washer fluid level switch using hand pressure until the barbed nipple is fully seated in the rubber grommet seal in the washer reservoir mounting hole.

(4) Reconnect the headlamp and dash wire harness connector for the washer fluid level switch to the switch connector receptacle.

(5) Reconnect the washer hose to the barbed outlet nipple of the washer pump/motor unit.

(6) Refill the washer reservoir with the washer fluid drained from the reservoir during the removal procedure.

(7) Reconnect the battery negative cable.

## WASHER HOSES/TUBES

## DESCRIPTION

The washer plumbing consists of a small diameter rubber hose that is routed from the barbed outlet nipple of the washer pump/motor on the washer reservoir through the engine compartment along the left inner fender shield to a molded plastic in-line fitting with barbed nipples near the dash panel. A second section of washer hose passes from the engine compartment into the cowl plenum area through a dedicated hole with a rubber grommet near the left end of the cowl plenum panel. Beneath the cowl plenum cover/grille panel, a molded plastic wye fitting with barbed nipples joins the engine compartment hose to the two washer nozzle hoses. The two washer hoses are routed through locating clips on the underside of the cowl plenum cover/grille panel to the two washer nozzles.

Washer hose is available for service only as roll stock, which must then be cut to length. The molded plastic washer hose fittings cannot be repaired. If these fittings are faulty or damaged, they must be replaced.

## OPERATION

Washer fluid in the washer reservoir is pressurized and fed by the washer pump/motor through the washer system plumbing and fittings to the two washer nozzles. Whenever routing the washer hose or a wire harness containing a washer hose, it must

## WASHER HOSES/TUBES (Continued)

be routed away from hot, sharp, or moving parts; and, sharp bends that might pinch the hose must be avoided.

## WASHER NOZZLE

### DESCRIPTION

The two washer nozzles have integral snap features that secure them in dedicated holes in the cowl plenum cover/grille panel located near the base of the windshield. The domed upper surface of the washer nozzle is visible on the top of the plenum cover/grille panel, and the nozzle orifice is oriented towards the windshield glass. The washer plumbing fittings for the washer nozzles are concealed beneath the cowl plenum cover/grille panel. These fluidic washer nozzles are constructed of molded plastic. The cowl plenum cover/grille panel must be removed from the vehicle to access the nozzles for service. The washer nozzles cannot be adjusted or repaired and, if faulty or damaged, they must be replaced.

### OPERATION

The two washer nozzles are designed to dispense washer fluid into the wiper pattern area on the outside of the windshield glass. Pressurized washer fluid is fed to each nozzle from the washer reservoir by the washer pump/motor through rubber hoses, which are attached to a barbed nipple on each washer nozzle below the cowl plenum cover/grille panel. The washer nozzles incorporate a fluidic design, which causes the nozzle to emit the pressurized washer fluid as an oscillating stream to more effectively cover a larger area of the glass area to be cleaned.

### REMOVAL

(1) Remove the cowl plenum cover/grille panel from the cowl top. (Refer to 23 - BODY/EXTERIOR/COWL GRILLE - REMOVAL).

(2) From the underside of the cowl plenum cover/grille panel, disconnect the washer hose from the nozzle fitting.

(3) From the underside of the cowl plenum cover/grille panel, compress the snap features of the washer nozzle and push the nozzle out through the top of the panel.

### INSTALLATION

(1) From the top of the cowl plenum cover/grille panel, insert the barbed nipple of the washer nozzle through the nozzle mounting hole.

(2) With the orifice of the washer nozzle oriented toward the windshield, use hand pressure to push the nozzle into the mounting hole until the snap fea-

tures of the nozzle are fully engaged with the underside of the cowl plenum cover/grille panel.

(3) From the underside of the cowl plenum cover/grille panel, reconnect the washer hose to the washer nozzle fitting.

(4) Reinstall the cowl plenum cover/grille panel onto the cowl top. (Refer to 23 - BODY/EXTERIOR/COWL GRILLE - INSTALLATION).

## WASHER PUMP/MOTOR

### DESCRIPTION

The washer pump/motor unit is located on the rear of the washer reservoir, near the bottom in the left front corner of the engine compartment. A small permanently lubricated and sealed electric motor is coupled to the rotor-type washer pump. A seal flange with a large barbed inlet nipple on the pump housing passes through a rubber grommet seal installed in the dedicated mounting hole near the bottom of the washer reservoir. A smaller barbed outlet nipple on the pump housing connects the unit to the washer hose. The washer pump/motor unit is retained on the reservoir by the interference fit between the barbed pump inlet nipple and the grommet seal, which is a light press fit. An integral electrical connector receptacle is located on the motor housing. The washer pump/motor unit cannot be repaired. If faulty or damaged, the entire washer pump/motor unit must be replaced.

### OPERATION

The washer pump/motor unit is connected to the vehicle electrical system through a single take out and two-cavity connector of the headlamp and dash wire harness. The washer pump/motor is grounded at all times through a take out of the headlamp and dash wire harness with a single eyelet terminal connector that is secured by a nut to a ground stud located on the forward extension of the left front fender wheel housing in the engine compartment. The washer pump/motor receives battery current on a fused ignition switch output (run-acc) circuit through the closed contacts of the momentary washer switch within the multi-function switch only when the washer button on the end of the switch control stalk is depressed towards the steering column. Washer fluid is gravity-fed from the washer reservoir to the inlet side of the washer pump. When the pump motor is energized, the rotor-type pump pressurizes the washer fluid and forces it through the pump outlet nipple, the washer plumbing, and the washer nozzles onto the windshield glass.

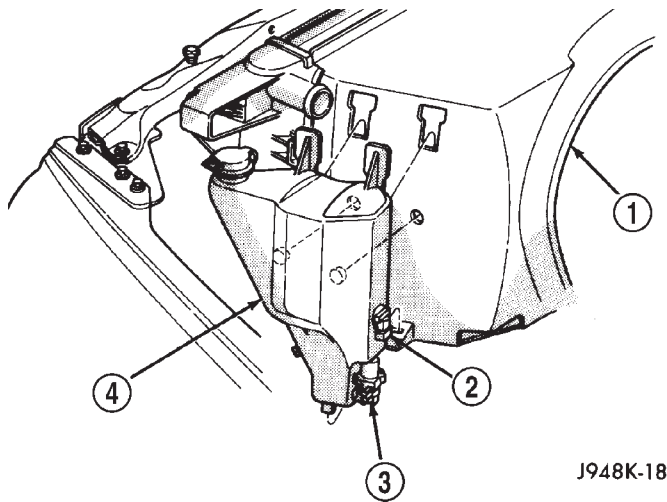


## WASHER PUMP/MOTOR (Continued)

**REMOVAL**

(1) Disconnect and isolate the battery negative cable.

(2) Disconnect the headlamp and dash wire harness connector for the washer pump/motor from the motor connector receptacle (Fig. 3).



**Fig. 3 Washer Reservoir**

- 1 - FAN SHROUD
- 2 - WASHER FLUID LEVEL SWITCH
- 3 - WASHER PUMP/MOTOR
- 4 - WASHER RESERVOIR

(3) Disconnect the washer hose from the barbed outlet nipple of the washer pump/motor and allow the washer fluid to drain into a clean container for reuse.

(4) Using a trim stick or another suitable wide flat-bladed tool, gently pry the barbed inlet nipple of the washer pump out of the rubber grommet seal in the reservoir. Care must be taken not to damage the reservoir.

(5) Remove the rubber grommet seal from the washer pump mounting hole in the washer reservoir and discard.

**INSTALLATION**

(1) Install a new rubber grommet seal into the washer pump mounting hole in the washer reservoir. Always use a new rubber grommet seal on the reservoir.

(2) Position the barbed inlet nipple of the washer pump to the rubber grommet seal in the reservoir.

(3) Press firmly and evenly on the washer pump until the barbed inlet nipple is fully seated in the rubber grommet seal in the washer reservoir mounting hole.

(4) Reconnect the washer hose to the barbed outlet nipple of the washer pump.

(5) Reconnect the headlamp and dash wire harness connector for the washer pump/motor unit to the motor connector receptacle (Fig. 3).

(6) Refill the washer reservoir with the washer fluid drained from the reservoir during the removal procedure.

(7) Reconnect the battery negative cable.

**WASHER RESERVOIR****DESCRIPTION**

The molded plastic washer fluid reservoir is secured with integral mounting tabs to keyed slots on the left side of the radiator fan shroud in the left front corner of the engine compartment. A bright yellow plastic filler cap with a rubber seal and an International Control and Display Symbol icon for "Windshield Washer" and the text "Washer Fluid Only" molded into it snaps over the open end of the filler neck. A bail strap that is integral to the cap secures the cap to the reservoir filler neck when it is removed for inspecting or adjusting the fluid level in the reservoir. There are separate, dedicated holes on the rear side of the reservoir provided for the mounting of the washer/pump motor unit and the washer fluid level switch.

The washer reservoir cannot be repaired and, if faulty or damaged, it must be replaced. The washer reservoir, the grommet seals for the washer pump/motor unit and the washer fluid level switch, and the filler cap are each available for service replacement.

**OPERATION**

The washer fluid reservoir provides a secure, on-vehicle storage location for a large reserve of washer fluid for operation of the washer system. The washer reservoir filler neck provides a clearly marked and readily accessible point from which to add washer fluid to the reservoir. The washer/pump motor unit is located in a sump area near the bottom of the reservoir to be certain that washer fluid will be available to the pump as the fluid level in the reservoir becomes depleted. The washer fluid level switch is mounted just above the sump area of the reservoir so that there will be adequate warning to the vehicle operator that the washer fluid level is low, before the washer system will no longer operate.

**REMOVAL**

(1) Disconnect and isolate the battery negative cable.

(2) Drain the engine cooling system. (Refer to 7 - COOLING - STANDARD PROCEDURE - DRAIN/ALL EXCEPT DIESEL ENGINE) or (Refer to 7 -

## WASHER RESERVOIR (Continued)

COOLING - STANDARD PROCEDURE - DRAIN/ DIESEL ENGINE).

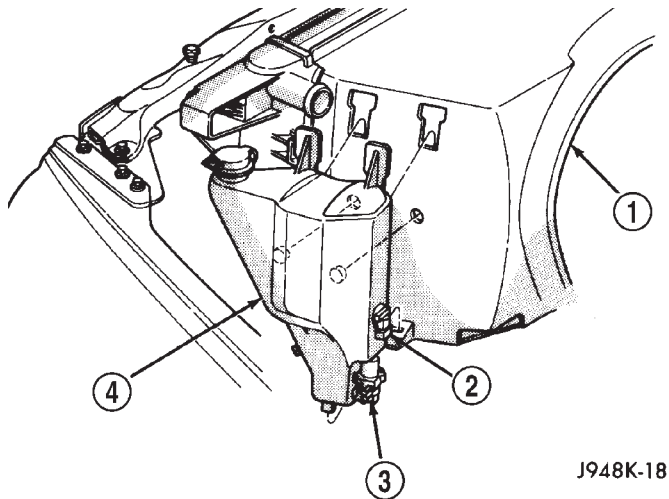
(3) Disconnect the upper radiator hose from the radiator.

(4) Disconnect the headlamp and dash wire harness connector for the washer fluid level switch from the switch connector receptacle.

(5) Disconnect the headlamp and dash wire harness connector for the washer pump/motor unit from the motor connector receptacle.

(6) Disconnect the washer hose from the barbed outlet nipple of the washer pump/motor and allow the washer fluid to drain into a clean container for reuse.

(7) While pulling the washer reservoir away from the fan shroud, lift the reservoir upwards far enough to disengage the reservoir mounting tabs from the keyed upper and lower mounting slots in the fan shroud (Fig. 4).



J948K-18

**Fig. 4 Washer Reservoir**

- 1 - FAN SHROUD
- 2 - WASHER FLUID LEVEL SWITCH
- 3 - WASHER PUMP
- 4 - WASHER RESERVOIR

(8) Remove the washer reservoir from the engine compartment.

## INSTALLATION

(1) Position the washer reservoir into the engine compartment (Fig. 4).

(2) Align and insert the upper and lower washer reservoir mounting tabs into the keyed upper and lower mounting slots in the radiator fan shroud. When all the tabs are inserted, use hand pressure to push the reservoir downwards far enough to engage the mounting tabs in the keyways of the mounting slots.

(3) Reconnect the washer hose to the barbed outlet nipple of the washer pump.

(4) Reconnect the headlamp and dash wire harness connector for the washer pump/motor unit to the motor connector receptacle.

(5) Reconnect the headlamp and dash wire harness connector for the washer fluid level switch to the switch connector receptacle.

(6) Reconnect the upper radiator hose to the radiator.

(7) Refill the engine cooling system. (Refer to 7 - COOLING - STANDARD PROCEDURE - REFILL/ ALL EXCEPT DIESEL ENGINE) or (Refer to 7 - COOLING - STANDARD PROCEDURE - REFILL/ DIESEL ENGINE).

(8) Refill the washer reservoir with the washer fluid drained from the reservoir during the removal procedure.

(9) Reconnect the battery negative cable.

## WIPER ARM

### DESCRIPTION

The wiper arms are the rigid members located between the wiper pivots that protrude from the cowl plenum cover/grille panel near the base of the windshield and the wiper blades on the windshield glass. The wiper arm has a die cast metal pivot end. On the underside of this pivot end is a socket formation with internal serrations and a small, movable, stamped steel latch plate that is secured loosely under a small strap that is staked to the pivot end. The wide end of a tapered, stamped steel channel hinges on and is secured with a hinge pin to the pivot end of the wiper arm. One end of a long, rigid, stamped steel strap, with a small hole near its pivot end, is riveted and crimped within the narrow end of the stamped steel channel. The tip of the wiper blade end of this strap is bent back under itself to form a small hook. Concealed within the stamped steel channel, one end of a long spring is hooked through a hole in a small stamped steel strap on the hinge pin within the die cast pivot end, while the other end of the spring is hooked through the small hole in the steel strap. The entire wiper arm has a satin black finish applied to all of its visible surfaces.

A wiper arm cannot be adjusted or repaired. If damaged or faulty, the entire wiper arm unit must be replaced.

## WIPER ARM (Continued)

## OPERATION

The wiper arms are designed to mechanically transmit the motion from the wiper pivots to the wiper blades. The wiper arm must be properly indexed to the wiper pivot in order to maintain the proper wiper blade travel on the glass. The socket formation with internal serrations in the wiper arm pivot end interlocks with the serrations on the outer circumference of the wiper pivot driver, allowing positive engagement and finite adjustment of this connection. The latch plate on the underside of the wiper arm pivot end locks the wiper arm to the wiper pivot when in its installed position and, when in its unlocked position, also serves as a blocker to hold the spring-loaded wiper arm off of the glass to facilitate removal and installation. The spring-loaded wiper arm hinge controls the down-force applied through the tip of the wiper arm to the wiper blade on the glass. The hook formation on the tip of the wiper arm provides a cradle for securing and latching the wiper blade pivot block to the wiper arm.

## REMOVAL

- (1) Unlatch and open the hood.
- (2) Lift the wiper arm far enough to raise the wiper blade off of the glass and permit the wiper arm latch plate to be pulled out to its holding position, then release the arm (Fig. 5). The wiper arm and blade will remain off the glass with the latch in this position.

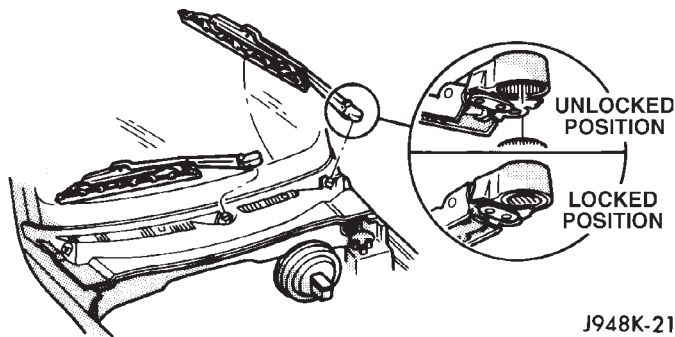


Fig. 5 Wiper Arm Remove/Install

**CAUTION:** The use of a screwdriver or other prying tool to remove a wiper arm may distort it. This distortion could allow the arm to come off of the wiper pivot during wiper operation, regardless of how carefully it is reinstalled.

- (3) Using a slight rocking motion, remove the wiper arm pivot end from the wiper pivot.

## INSTALLATION

**NOTE:** Be certain that the wiper motor is in the park position before attempting to install the wiper arms.

Turn the ignition switch to the On position and move the wiper control knob on the end of the multi-function switch control stalk to its Off position. If the wiper pivots move, wait until they stop moving, then turn the ignition switch back to the Off position. The wiper motor is now in its park position.

- (1) The wiper arms must be indexed to the wiper pivots with the wiper motor in the park position to be properly installed (Fig. 6). Position the wiper arm pivot ends onto the wiper pivots so that the lower edge of the wiper arm tip is on the upper edge of the lower windshield blackout area  $\pm 22$  millimeters ( $\pm 0.86$  inches).

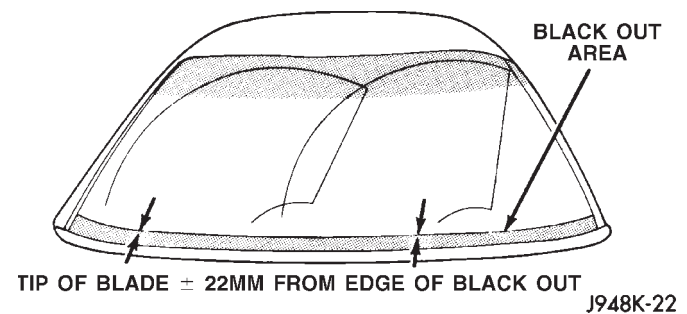


Fig. 6 Wiper Arm Installation

- (2) Once the wiper arm is indexed to the wiper pivot, lift the wiper arm away from the windshield slightly to relieve the spring tension on the latch plate, then push the latch plate into the locked position. Gently lower the wiper arm until the wiper blade rests on the glass.

- (3) Wet the windshield glass, then operate the wipers. Turn the wiper control knob on the end of the multi-function switch control stalk to the Off position, then check for the correct wiper arm position and adjust as required.

## WIPER BLADE

## DESCRIPTION

Each wiper blade is secured by an integral latching pivot block to the hook formation on the tip of the wiper arms, and rests on the glass near the base of the windshield when the wipers are not in operation. The wiper blade consists of the following components:

- **Superstructure** - The superstructure includes several stamped steel bridges and links with claw formations that grip the wiper blade element. Also included in this unit is the latching, molded plastic pivot block that secures the superstructure to the wiper arm. All of the metal components of the wiper blade have a satin black finish applied.

## WIPER BLADE (Continued)

- **Element** - The wiper element or squeegee is the resilient rubber member of the wiper blade that contacts the glass.

- **Flexor** - The flexor is a rigid metal component running along the length of each side of the wiper element where it is gripped by the claws of the superstructure.

All Ram truck models have two 50 centimeter (19.69 inch) wiper blades with non-replaceable rubber elements (squeegees). These wiper blades also include an anti-lift feature. The wiper blades cannot be adjusted or repaired. If faulty, worn, or damaged the entire wiper blade unit must be replaced.

## OPERATION

The wiper blade is moved back and forth across the glass by the wiper arms when the wipers are being operated. The wiper blade superstructure is the flexible frame that grips the wiper blade element and evenly distributes the force of the spring-loaded wiper arm along the length of the element. The combination of the wiper arm force and the flexibility of the superstructure makes the element conform to and maintain proper contact with the glass, even as the blade is moved over the varied curvature found across the glass surface. The wiper element flexor provides the claws of the blade superstructure with a rigid, yet flexible component on the element which can be gripped. The rubber element is designed to be stiff enough to maintain an even cleaning edge as it is drawn across the glass, but resilient enough to conform to the glass surface and flip from one cleaning edge to the other each time the wiper blade changes directions.

## REMOVAL

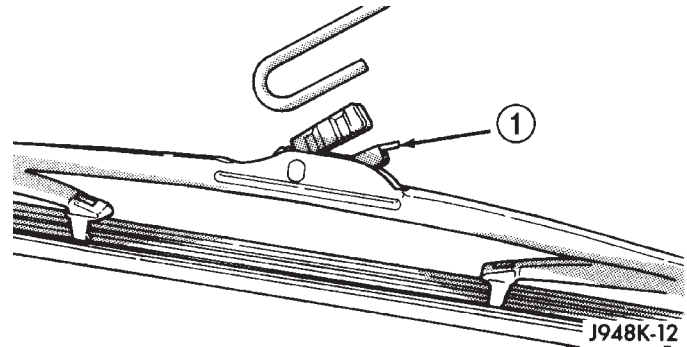
**NOTE:** The driver side and passenger side wiper blades are not interchangeable. The driver side wiper blade has an extra bridge and eight pairs of claws securing the wiper element. The passenger side wiper blade has six pairs of claws securing the wiper element. The notched retainer end of both wiper elements should always be oriented towards the end of the wiper blade that is nearest to the wiper pivot.

- (1) Turn the wiper control knob on the end of the multi-function switch control stalk to the On position. Cycle the wiper blades to a convenient working location on the windshield by turning the ignition switch to the On and Off positions.

- (2) Lift the wiper arm to raise the wiper blade and element off of the glass.

- (3) To remove the wiper blade from the wiper arm, push the pivot block latch release tab under the tip of the arm and slide the blade away from the tip

towards the pivot end of the arm far enough to disengage the pivot block from the hook (Fig. 7).



**Fig. 7 Wiper Blade Remove/Install - Typical**

1 - RELEASE TAB

- (4) Extract the hook formation on the tip of the wiper arm from the opening in the wiper blade superstructure ahead of the wiper blade pivot block/latch unit.

**CAUTION:** Do not allow the wiper arm to spring back against the glass without the wiper blade in place or the glass may be damaged.

- (5) Gently lower the wiper arm tip onto the glass.

## INSTALLATION

**NOTE:** The driver side and passenger side wiper blades are not interchangeable. The driver side wiper blade has an extra bridge and eight pairs of claws securing the wiper element. The passenger side wiper blade has six pairs of claws securing the wiper element. The notched retainer end of both wiper elements should always be oriented towards the end of the wiper blade that is nearest to the wiper pivot.

- (1) Lift the wiper arm off of the windshield glass.

- (2) Position the wiper blade near the hook formation on the tip of the arm with the notched retainer for the wiper element oriented towards the end of the wiper arm that is nearest to the wiper pivot.

- (3) Insert the hook formation on the tip of the wiper arm through the opening in the wiper blade superstructure ahead of the wiper blade pivot block/latch unit far enough to engage the pivot block with the hook (Fig. 7).

- (4) Slide the wiper blade pivot block/latch up into the hook formation on the tip of the wiper arm until the latch release tab snaps into its locked position.

- (5) Gently lower the wiper blade onto the glass.



## WIPER MODULE

### DESCRIPTION

The wiper module is secured with screws to the cowl plenum panel and concealed within the cowl plenum area beneath the cowl plenum cover/grille panel. The ends of the wiper pivot shafts that protrude through dedicated openings in the cowl plenum cover/grille panel to drive the wiper arms and blades are the only visible components of the wiper module. The wiper module consists of the following major components:

- **Bracket** - The wiper module bracket consists of a long tubular steel main member that has a stamped pivot bracket formation near each end where the two wiper pivots are secured. A stamped steel mounting plate for the wiper motor is secured with welds near the center of the main member.

- **Crank Arm** - The wiper motor crank arm is a stamped steel unit that has a slotted hole on the driven end that is secured to the wiper motor output shaft with a nut, and has a ball stud secured to the drive end.

- **Linkage** - The two wiper linkage members are each constructed of stamped steel. A driver side drive link with a plastic socket-type bushing in the left end, and a plastic sleeve-type bushing in the right end. Socket bushing is snap-fit over the pivot ball stud on the left pivot, while the sleeve bushing is fit over the longer wiper motor crank arm pivot stud. The passenger side drive link has a plastic socket-type bushing on each end. One end of this drive link is snap-fit over the pivot ball stud on the right pivot, while the other end is snap-fit over the exposed end of the longer ball stud on the wiper motor crank arm.

- **Motor** - The wiper motor is secured with three screws to the motor mounting plate near the center of the wiper module bracket. The wiper motor output shaft passes through a hole in the module bracket, where a nut secures the wiper motor crank arm to the motor output shaft. The two-speed permanent magnet wiper motor features an integral transmission, an internal park switch, and an internal Positive Temperature Coefficient (PTC) circuit breaker.

- **Pivots** - The two wiper pivots are secured to the ends of the wiper module bracket. The crank arms that extend from the bottom of the pivot shafts each have a ball stud on their end. The upper end of each pivot shaft where the wiper arms will be fastened each has an externally serrated drum secured to it.

The wiper module cannot be adjusted or repaired. If any component of the module is faulty or damaged, the entire wiper module unit must be replaced.

### OPERATION

The wiper module operation is controlled by the vehicle operator through battery current inputs received by the wiper motor from the multi-function switch on the steering column. The wiper motor speed is controlled by current flow to either the low speed or the high speed set of brushes. The park switch is a single pole, single throw, momentary switch within the wiper motor that is mechanically actuated by the wiper motor transmission components. The park switch alternately closes the wiper park switch sense circuit to ground or to battery current, depending upon the position of the wipers on the glass. This feature allows the motor to complete its current wipe cycle after the wiper system has been turned Off, and to park the wiper blades in the lowest portion of the wipe pattern. The automatic resetting circuit breaker protects the motor from overloads. The wiper motor crank arm, the two wiper linkage members, and the two wiper pivots mechanically convert the rotary output of the wiper motor to the back and forth wiping motion of the wiper arms and blades on the glass.

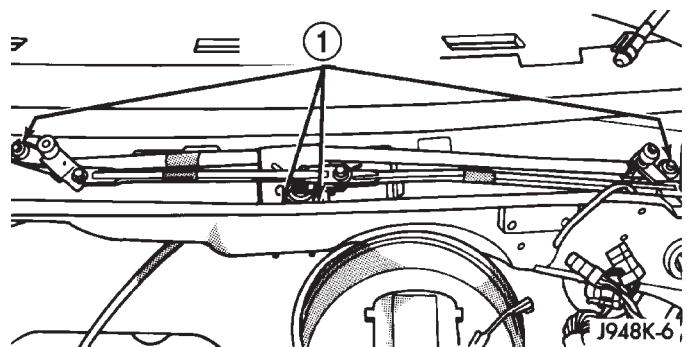
### REMOVAL

- (1) Disconnect and isolate the battery negative cable.

- (2) Remove the wiper arms from the wiper pivots. (Refer to 8 - ELECTRICAL/WIPERS/WASHERS/WIPER ARMS - REMOVAL).

- (3) Remove the cowl plenum cover/grille panel from the cowl plenum. (Refer to 23 - BODY/EXTERIOR/COWL GRILLE - REMOVAL).

- (4) Remove the four screws that secure the wiper module bracket to the cowl plenum panel and the dash panel (Fig. 8).



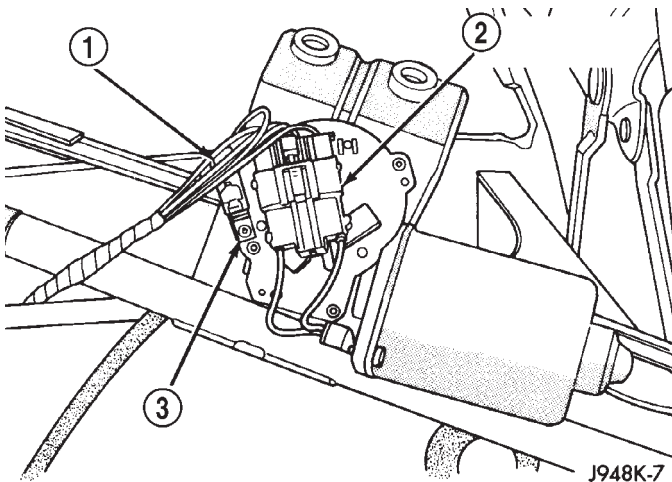
**Fig. 8 Wiper Module Remove/Install**

1 - WIPER MODULE MOUNTING SCREWS

- (5) Reach into the cowl plenum to move the wiper module far enough to access the wiper module electrical connections (Fig. 9).



## WIPER MODULE (Continued)



**Fig. 9 Wiper Module Electrical Connections**

- 1 - GROUND CONNECTOR  
 2 - WIPER MOTOR CONNECTOR  
 3 - GROUND TERMINAL

(6) Disconnect the headlamp and dash wire harness connector for the wiper motor from the wiper motor pigtail wire connector.

(7) Disconnect the headlamp and dash wire harness ground connector from the wiper motor ground terminal.

(8) Remove the wiper module from the cowl plenum as a unit.

## INSTALLATION

(1) Position the wiper module into the cowl plenum as a unit.

(2) Reconnect the headlamp and dash wire harness ground connector to the wiper motor ground terminal (Fig. 9).

(3) Reconnect the headlamp and dash wire harness connector for the wiper motor to the wiper motor pigtail wire connector.

(4) Reach into the cowl plenum to align the wiper module mounting bracket with the locations for the mounting screws (Fig. 8).

(5) Install and tighten the four screws that secure the wiper module bracket to the cowl plenum panel and the dash panel. Tighten the screws to 8 N·m (72 in. lbs.).

(6) Reinstall the cowl plenum cover/grille panel onto the cowl plenum. (Refer to 23 - BODY/EXTERIOR/COWL GRILLE - INSTALLATION).

(7) Reinstall the wiper arms onto the wiper pivots. (Refer to 8 - ELECTRICAL/WIPERS/WASHERS/WIPER ARMS - INSTALLATION).

(8) Reconnect the battery negative cable.

## WIPER RELAY

### DESCRIPTION

The wiper relay (or intermittent wiper relay) is located in the Power Distribution Center (PDC) near the battery in the engine compartment. See the fuse and relay layout label affixed to the inside surface of the PDC cover for wiper relay identification and location. The wiper relay is a conventional International Standards Organization (ISO) micro relay. Relays conforming to the ISO specifications have common physical dimensions, current capacities, terminal patterns, and terminal functions. The relay is contained within a small, rectangular, molded plastic housing. The relay is connected to all of the required inputs and outputs through its PDC receptacle by five male spade-type terminals that extend from the bottom of the relay base. The ISO designation for each terminal is molded into the base adjacent to the terminal. The ISO terminal designations are as follows:

- **30 (Common Feed)** - This terminal is connected to the movable contact point of the relay.
- **85 (Coil Ground)** - This terminal is connected to the ground feed side of the relay control coil.
- **86 (Coil Battery)** - This terminal is connected to the battery feed side of the relay control coil.
- **87 (Normally Open)** - This terminal is connected to the normally open fixed contact point of the relay.
- **87A (Normally Closed)** - This terminal is connected to the normally closed fixed contact point of the relay.

The wiper relay cannot be adjusted or repaired. If the relay is damaged or faulty, it must be replaced.

### OPERATION

The wiper relay (or intermittent wiper relay) is an electromechanical switch that uses a low current input from the Central Timer Module (CTM) to control a high current output to the low speed brush of the wiper motor. The movable common feed contact point is held against the fixed normally closed contact point by spring pressure. When the relay coil is energized, an electromagnetic field is produced by the coil windings. This electromagnetic field draws the movable relay contact point away from the fixed normally closed contact point, and holds it against the fixed normally open contact point. When the relay coil is de-energized, spring pressure returns the movable contact point back against the fixed normally closed contact point. A resistor or diode is connected in parallel with the relay coil in the relay, and helps to dissipate voltage spikes and electromagnetic interference that can be generated as the electromagnetic field of the relay coil collapses.

## WIPER MOTOR RELAY (Continued)

The wiper relay terminals are connected to the vehicle electrical system through a connector receptacle in the Power Distribution Center (PDC). The inputs and outputs of the wiper relay include:

- The common feed terminal (30) is connected to the wiper motor low speed brush through the wiper control circuitry of the multi-function switch on the steering column. When the wiper relay is de-energized, the common feed terminal is connected to the wiper park switch output through the wiper park switch sense circuit. The wiper park switch output may be battery current (wipers are not parked), or ground (wipers are parked). When the wiper relay is energized, the common feed terminal of the wiper is connected to battery current from a fuse in the Junction Block (JB) through a fused ignition switch output (run-acc) circuit.

- The coil ground terminal (85) is connected to the relay control output of the CTM through the wiper motor relay control circuit. The CTM controls the ground path for this circuit internally to energize or de-energize the wiper relay based upon its programming and inputs from the wiper and washer control circuitry of the multi-function switch and from the wiper motor park switch.

- The coil battery terminal (86) is connected to battery current from a fuse in the Junction Block (JB) through a fused ignition switch output (run-acc) circuit whenever the ignition switch is in the On or Accessory positions.

- The normally open terminal (87) is connected to battery current from a fuse in the Junction Block (JB) through a fused ignition switch output (run-acc) circuit whenever the wiper relay control coil is energized by the CTM. This circuit provides fused ignition switch output (run-acc) current to the wiper motor low speed brush only when the wiper relay control coil is energized.

- The normally closed terminal (87A) is connected to the output of the wiper motor park switch through the wiper motor park switch sense circuit. This circuit provides battery current (wipers are not parked) or ground (wipers are parked) to the wiper motor low speed brush whenever the wiper relay control coil is de-energized and the Off position of the wiper control of the multi-function switch is selected.

The wiper relay can be diagnosed using conventional diagnostic tools and methods.

## DIAGNOSIS AND TESTING - WIPER RELAY

The wiper relay (or intermittent wiper relay) (Fig. 10) is located in the Power Distribution Center (PDC) near the battery on the left side of the engine compartment. See the fuse and relay layout label affixed to the inside surface of the PDC cover for wiper relay identification and location. Refer to the appropriate

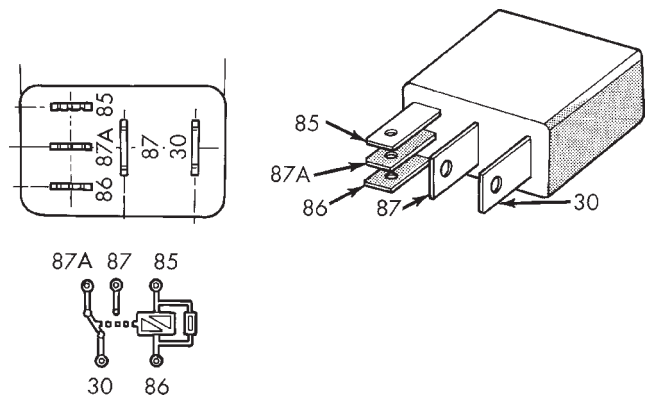
wiring information. The wiring information includes wiring diagrams, proper wire and connector repair procedures, details of wire harness routing and retention, connector pin-out information and location views for the various wire harness connectors, splices and grounds.

(1) Remove the wiper relay from the PDC. (Refer to 8 - ELECTRICAL/WIPERS/WASHERS/WIPER RELAY - REMOVAL).

(2) A relay in the de-energized position should have continuity between terminals 87A and 30, and no continuity between terminals 87 and 30. If OK, go to Step 3. If not OK, replace the faulty relay.

(3) Resistance between terminals 85 and 86 (electromagnet) should be  $75 \pm 5$  ohms. If OK, go to Step 4. If not OK, replace the faulty relay.

(4) Connect a battery to terminals 85 and 86. There should now be continuity between terminals 30 and 87, and no continuity between terminals 87A and 30. If OK, test the relay input and output circuits. Refer to RELAY CIRCUIT TEST . If not OK, replace the faulty relay.



**Fig. 10 Wiper Relay**

- 30 - COMMON FEED
- 85 - COIL GROUND
- 86 - COIL BATTERY
- 87 - NORMALLY OPEN
- 87A - NORMALLY CLOSED

## RELAY CIRCUIT TEST

(1) The relay common feed terminal cavity (30) is connected to the multi-function switch. There should be continuity between the receptacle for terminal 30 of the wiper relay in the PDC and both driver low speed wiper motor driver circuit cavities of the instrument panel wire harness connector for the multi-function switch at all times. If OK, go to Step 2. If not OK, repair the open driver low speed wiper motor driver circuit(s) between the PDC and the multi-function switch as required.

(2) The relay normally closed terminal (87A) is connected to the wiper motor park switch through the wiper motor park switch sense circuit. There

## WIPER MOTOR RELAY (Continued)

should be continuity between the receptacle for terminal 87A of the wiper relay in the PDC and the wiper motor park switch sense circuit cavity of the headlamp and dash wire harness connector for the wiper motor at all times. If OK, go to Step 3. If not OK, repair the open wiper motor park switch sense circuit between the PDC and the wiper motor as required.

(3) The relay normally open terminal (87) is connected to a fused ignition switch output (run-acc) fuse in the Junction Block (JB) through a fused ignition switch output (run-acc) circuit. There should be battery voltage at the receptacle for terminal 87 of the wiper relay in the PDC whenever the ignition switch is in the On or Accessory positions. If OK, go to Step 4. If not OK, repair the open fused ignition switch output (run-acc) circuit between the PDC and the JB as required.

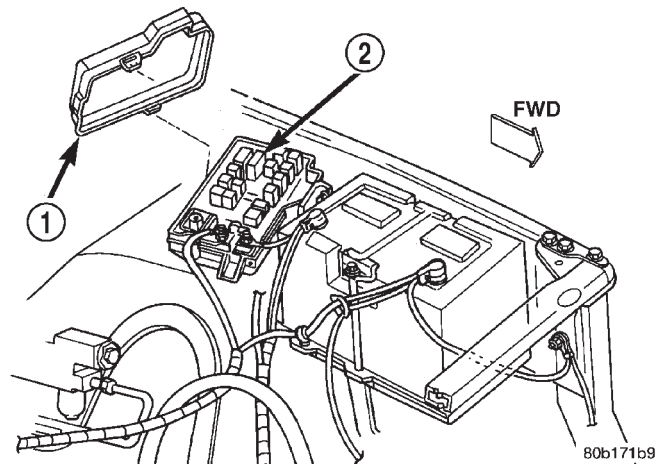
(4) The coil battery terminal (86) is connected to a fused ignition switch output (run-acc) fuse in the JB through a fused ignition switch output (run-acc) circuit. There should be battery voltage at the receptacle for terminal 86 of the wiper relay in the PDC whenever the ignition switch is in the On or Accessory positions. If OK, go to Step 5. If not OK, repair the open fused ignition switch output (run-acc) circuit between the PDC and the JB as required.

(5) The coil ground terminal (85) is connected to the output of the Central Timer Module (CTM) through the wiper motor relay control circuit. There should be continuity between the receptacle for terminal 85 of the wiper relay in the PDC and the wiper motor relay control circuit cavity of the instrument panel wire harness connector (Connector C1) for the CTM at all times. If not OK, repair the open wiper motor relay control circuit between the PDC and the CTM as required.

**REMOVAL**

(1) Disconnect and isolate the battery negative cable.

(2) Remove the cover from the Power Distribution Center (PDC) (Fig. 11).



**Fig. 11 Power Distribution Center**

- 1 - COVER  
2 - POWER DISTRIBUTION CENTER

(3) See the fuse and relay layout label affixed to the underside of the PDC cover for wiper relay identification and location.

(4) Remove the wiper relay by grasping it firmly and pulling it straight out from the receptacle in the PDC.

**INSTALLATION**

(1) See the fuse and relay layout label affixed to the underside of the PDC cover for the proper wiper relay location (Fig. 11).

(2) Position the wiper relay in the proper receptacle in the PDC.

(3) Align the wiper relay terminals with the terminal cavities in the PDC receptacle.

(4) Push firmly and evenly on the top of the wiper relay until the terminals are fully seated in the terminal cavities in the PDC receptacle.

(5) Reinstall the cover onto the PDC.



# WIRING

## TABLE OF CONTENTS

	page		page
WIRING DIAGRAM INFORMATION .....	8W-01-1	INTERIOR LIGHTING .....	8W-44-1
COMPONENT INDEX .....	8W-02-1	CENTRAL TIMER MODULE .....	8W-45-1
POWER DISTRIBUTION .....	8W-10-1	AUDIO SYSTEM .....	8W-47-1
JUNCTION BLOCK .....	8W-12-1	OVERHEAD CONSOLE .....	8W-49-1
GROUND DISTRIBUTION .....	8W-15-1	FRONT LIGHTING .....	8W-50-1
BUS COMMUNICATIONS .....	8W-18-1	REAR LIGHTING .....	8W-51-1
CHARGING SYSTEM .....	8W-20-1	TURN SIGNALS .....	8W-52-1
STARTING SYSTEM .....	8W-21-1	WIPERS .....	8W-53-1
<b>FUEL/IGNITION</b> SYSTEM .....	8W-30-1	TRAILER TOW .....	8W-54-1
TRANSMISSION CONTROL SYSTEM .....	8W-31-1	POWER WINDOWS .....	8W-60-1
VEHICLE SPEED CONTROL .....	8W-33-1	POWER DOOR LOCKS .....	8W-61-1
REAR WHEEL ANTILOCK BRAKES .....	8W-34-1	POWER MIRRORS .....	8W-62-1
ALL WHEEL ANTILOCK BRAKES .....	8W-35-1	POWER SEATS .....	8W-63-1
VEHICLE THEFT SECURITY SYSTEM .....	8W-39-1	SPLICE INFORMATION .....	8W-70-1
INSTRUMENT CLUSTER .....	8W-40-1	CONNECTOR PIN-OUTS .....	8W-80-1
HORN/CIGAR LIGHTER/POWER OUTLET ..	8W-41-1	CONNECTOR/GROUND LOCATIONS .....	8W-90-1
AIR CONDITIONING-HEATER .....	8W-42-1	SPLICE LOCATIONS .....	8W-95-1
AIRBAG SYSTEM .....	8W-43-1	POWER DISTRIBUTION .....	8W-97-1





## 8W-01 WIRING DIAGRAM INFORMATION

## TABLE OF CONTENTS

	page		page
<b>WIRING DIAGRAM INFORMATION</b>		<b>CONNECTOR - MOLEX</b>	
DESCRIPTION.....	1	REMOVAL.....	9
WARNING.....	5	INSTALLATION.....	9
DIAGNOSIS AND TESTING.....	5	<b>CONNECTOR - THOMAS AND BETTS</b>	
WIRING HARNESS.....	5	REMOVAL.....	9
STANDARD PROCEDURE.....	6	INSTALLATION.....	10
TESTING OF VOLTAGE POTENTIAL.....	6	<b>DIODE</b>	
TESTING FOR CONTINUITY.....	6	REMOVAL.....	10
TESTING FOR SHORT TO GROUND.....	6	INSTALLATION.....	10
TESTING FOR A SHORT TO GROUND ON		<b>TERMINAL</b>	
FUSES POWERING SEVERAL LOADS.....	7	REMOVAL.....	11
TESTING FOR VOLTAGE DROP.....	7	INSTALLATION.....	11
SPECIAL TOOLS.....	8	<b>WIRE</b>	
<b>CONNECTOR - AUGAT</b>		STANDARD PROCEDURE.....	12
REMOVAL.....	8	STANDARD PROCEDURE - WIRE SPLICING..	12
INSTALLATION.....	8		

WIRING DIAGRAM  
INFORMATIONDESCRIPTION - HOW TO USE WIRING  
DIAGRAMS

DaimlerChrysler Corporation wiring diagrams are designed to provide information regarding the vehicles wiring content. In order to effectively use the wiring diagrams to diagnose and repair DaimlerChrysler Corporation vehicles, it is important to understand all of their features and characteristics.

Diagrams are arranged such that the power (B+) side of the circuit is placed near the top of the page, and the ground (B-) side of the circuit is placed near the bottom of the page (Fig. 1).

All switches, components, and modules are shown in the at rest position with the doors closed and the key removed from the ignition (Fig. 2).

Components are shown two ways. A solid line around a component indicates that the component is complete. A dashed line around the component indicates that the component is being shown is not complete. Incomplete components have a reference number to indicate the page where the component is shown complete.

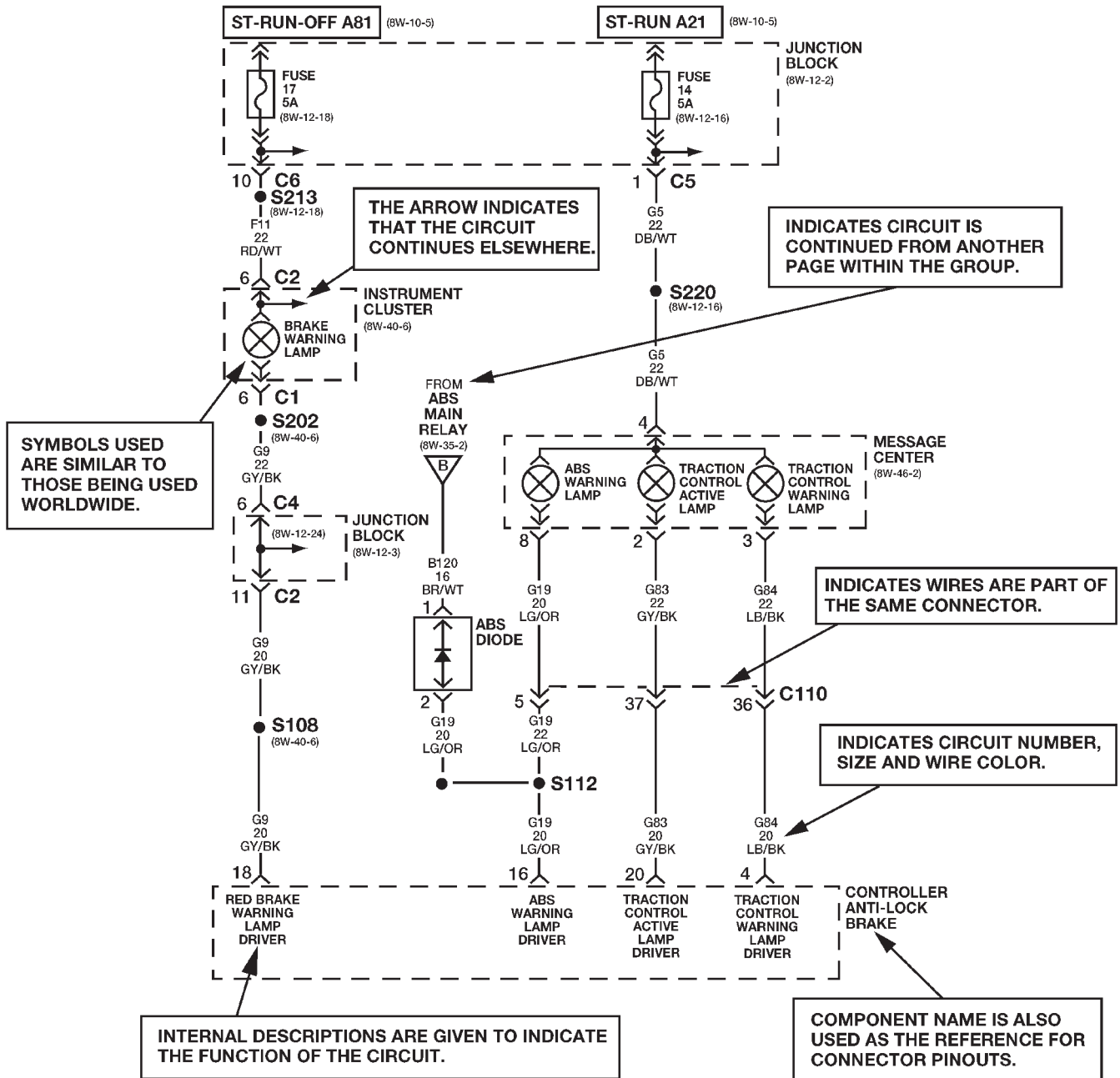
It is important to realize that no attempt is made on the diagrams to represent components and wiring as they appear on the vehicle. For example, a short piece of wire is treated the same as a long one. In addition, switches and other components are shown as simply as possible, with regard to function only.

## SYMBOLS

International symbols are used throughout the wiring diagrams. These symbols are consistent with those being used around the world (Fig. 3).

WIRING DIAGRAM INFORMATION (Continued)

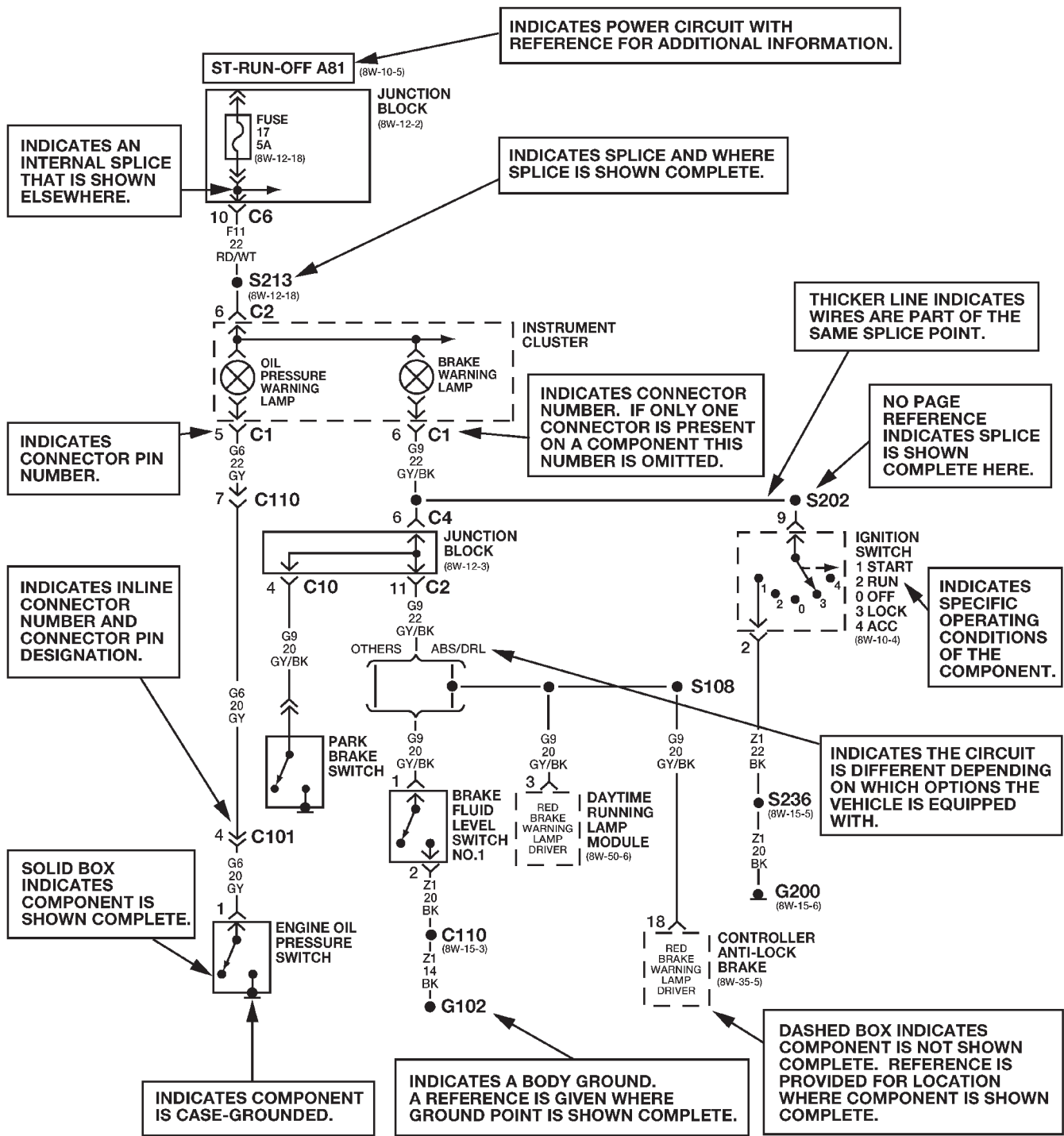
DIAGRAMS ARE ARRANGED WITH THE POWER B+ SIDE OF THE CIRCUIT NEAR THE TOP OF THE PAGE, AND THE GROUND SIDE OF THE CIRCUIT NEAR THE BOTTOM OF THE PAGE.



The System shown here is an **EXAMPLE ONLY**. It does not represent the actual circuit shown in the **WIRING DIAGRAM SECTION**.

**Fig. 1 WIRING DIAGRAM EXAMPLE 1**

WIRING DIAGRAM INFORMATION (Continued)



The System shown here is an EXAMPLE ONLY. It does not represent the actual circuit shown in the WIRING DIAGRAM SECTION.

Fig. 2 WIRING DIAGRAM EXAMPLE 2

WIRING DIAGRAM INFORMATION (Continued)



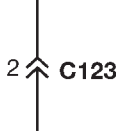
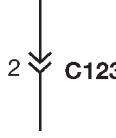



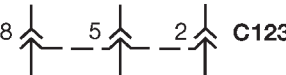




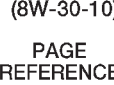









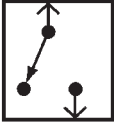
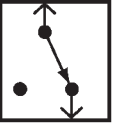




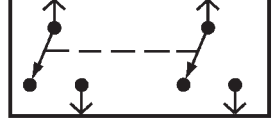




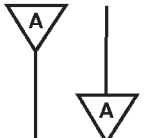


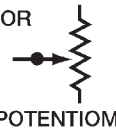



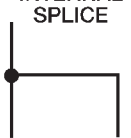








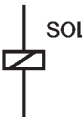

 BATTERY  GENERATOR STATOR COILS	 IN-LINE CONNECTORS 
 FUSIBLE LINK  FUSE  CIRCUIT BREAKER	 MULTIPLE CONNECTOR  MALE CONNECTOR  FEMALE CONNECTOR
 HOT BAR  CHOICE BRACKET  (8W-30-10) PAGE REFERENCE	 SINGLE FILAMENT LAMP  DUAL FILAMENT LAMP  ANTENNA
 CLOCKSPRING  GROUND G101  SCREW TERMINAL	 NPN TRANSISTOR  PNP TRANSISTOR  TONE GENERATOR
 OPEN SWITCH  CLOSED SWITCH	 LED  PHOTODIODE  DIODE  ZENER DIODE
 GANGED SWITCH  SLIDING DOOR CONTACT	 OXYGEN SENSOR  GAUGE  PIEZOELECTRIC CELL
 WIRE ORIGIN & DESTINATION SHOWN WITHIN CELL  WIRE DESTINATION SHOWN IN ANOTHER CELL	 RESISTOR  POTENTIOMETER  VARIABLE RESISTOR  HEATER ELEMENT
 EXTERNAL SPLICE S350  INTERNAL SPLICE  INCOMPLETE SPLICE (INTERNAL)	 NON-POLARIZED CAPACITOR  POLARIZED CAPACITOR  VARIABLE CAPACITOR
 ONE SPEED MOTOR  TWO SPEED MOTOR  REVERSIBLE MOTOR	 COIL  SOLENOID  SOLENOID VALVE

Fig. 3 WIRING DIAGRAM SYMBOLS





## WIRING DIAGRAM INFORMATION (Continued)

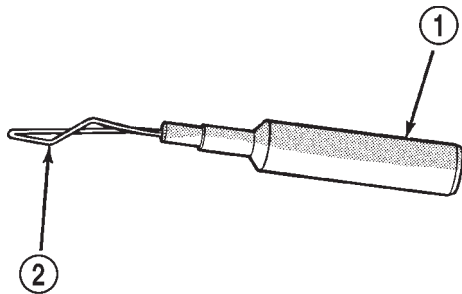


Fig. 4 PROBING TOOL

948W-233

- 1 - SPECIAL TOOL 6801  
2 - PROBING END

## INTERMITTENT AND POOR CONNECTIONS

Most intermittent electrical problems are caused by faulty electrical connections or wiring. It is also possible for a sticking component or relay to cause a problem. Before condemning a component or wiring assembly, check the following items.

- Connectors are fully seated
- Spread terminals, or terminal push out
- Terminals in the wiring assembly are fully seated into the connector/component and locked into position
  - Dirt or corrosion on the terminals. Any amount of corrosion or dirt could cause an intermittent problem
  - Damaged connector/component casing exposing the item to dirt or moisture
  - Wire insulation that has rubbed through causing a short to ground
  - Some or all of the wiring strands broken inside of the insulation
  - Wiring broken inside of the insulation

## TROUBLESHOOTING WIRING PROBLEMS

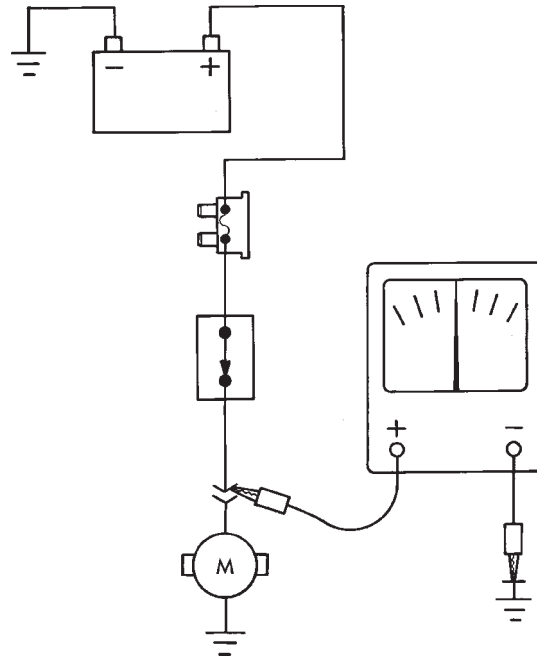
When troubleshooting wiring problems there are six steps which can aid in the procedure. The steps are listed and explained below. Always check for non-factory items added to the vehicle before doing any diagnosis. If the vehicle is equipped with these items, disconnect them to verify these add-on items are not the cause of the problem.

- (1) Verify the problem.
- (2) Verify any related symptoms. Do this by performing operational checks on components that are in the same circuit. Refer to the wiring diagrams.
- (3) Analyze the symptoms. Use the wiring diagrams to determine what the circuit is doing, where the problem most likely is occurring and where the diagnosis will continue.
- (4) Isolate the problem area.
- (5) Repair the problem area.
- (6) Verify the proper operation. For this step, check for proper operation of all items on the repaired circuit. Refer to the wiring diagrams.

## STANDARD PROCEDURE - TESTING FOR VOLTAGE POTENTIAL

(1) Connect the ground lead of a voltmeter to a known good ground (Fig. 5).

(2) Connect the other lead of the voltmeter to the selected test point. The vehicle ignition may need to be turned ON to check voltage. Refer to the appropriate test procedure.



948W-194

Fig. 5 TESTING FOR VOLTAGE POTENTIAL

## STANDARD PROCEDURE - TESTING FOR CONTINUITY

(1) Remove the fuse for the circuit being checked or, disconnect the battery.

(2) Connect one lead of the ohmmeter to one side of the circuit being tested (Fig. 6)

(3) Connect the other lead to the other end of the circuit being tested. Low or no resistance means good continuity.

## STANDARD PROCEDURE - TESTING FOR A SHORT TO GROUND

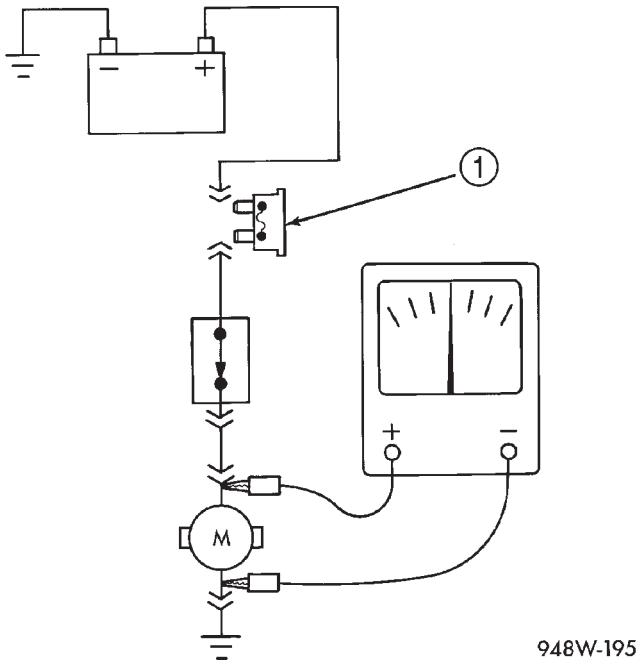
(1) Remove the fuse and disconnect all items involved with the fuse.

(2) Connect a test light or a voltmeter across the terminals of the fuse.

(3) Starting at the fuse block, wiggle the wiring harness about six to eight inches apart and watch the voltmeter/test lamp.

(4) If the voltmeter registers voltage or the test lamp glows, there is a short to ground in that general area of the wiring harness.

## WIRING DIAGRAM INFORMATION (Continued)

**Fig. 6 TESTING FOR CONTINUITY**

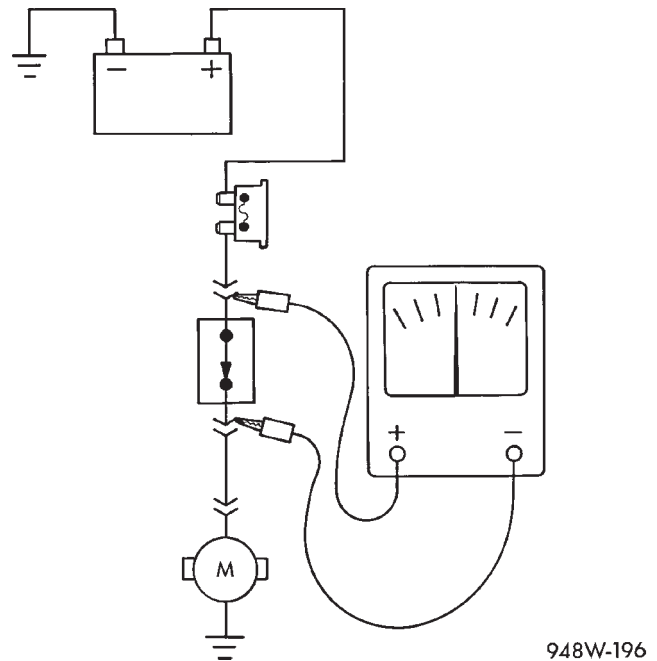
1 - FUSE REMOVED FROM CIRCUIT

**STANDARD PROCEDURE - TESTING FOR SHORT TO GROUND ON FUSES POWERING SEVERAL LOADS**

- (1) Refer to the wiring diagrams and disconnect or isolate all items on the suspected fused circuits.
- (2) Replace the blown fuse.
- (3) Supply power to the fuse by turning ON the ignition switch or re-connecting the battery.
- (4) Start connecting the items in the fuse circuit one at a time. When the fuse blows the circuit with the short to ground has been isolated.

**STANDARD PROCEDURE - TESTING FOR A VOLTAGE DROP**

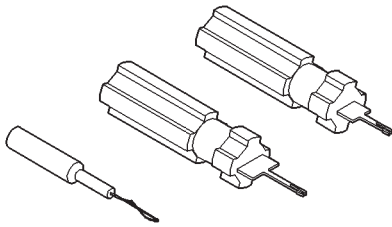
- (1) Connect the positive lead of the voltmeter to the side of the circuit closest to the battery (Fig. 7).
- (2) Connect the other lead of the voltmeter to the other side of the switch or component.
- (3) Operate the item.
- (4) The voltmeter will show the difference in voltage between the two points.

**Fig. 7 TESTING FOR VOLTAGE DROP**

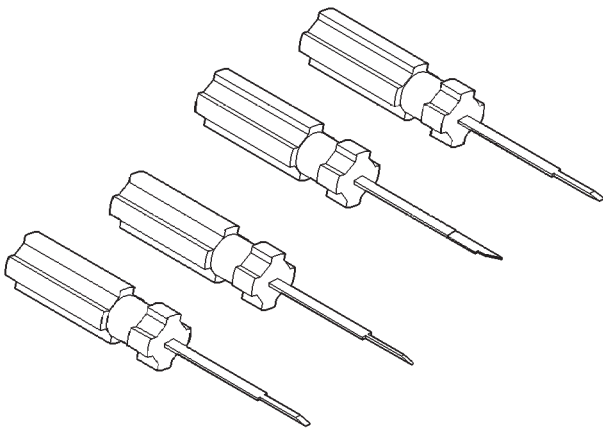
WIRING DIAGRAM INFORMATION (Continued)

SPECIAL TOOLS

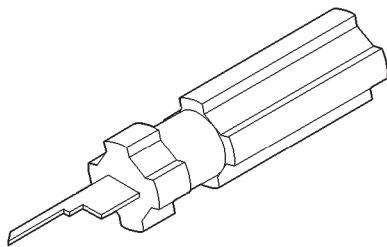
SPECIAL TOOLS - WIRING/TERMINAL



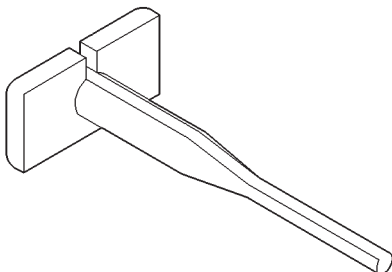
**PROBING TOOL PACKAGE 6807**



**TERMINAL PICK 6680**



**TERMINAL REMOVING TOOL 6932**

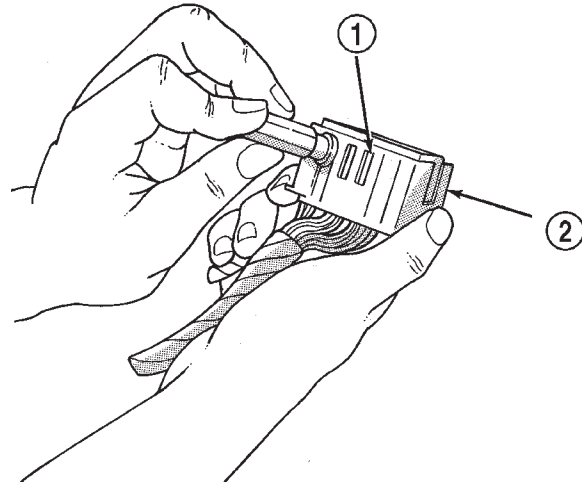


**TERMINAL REMOVING TOOL 6934**

CONNECTOR - AUGAT

REMOVAL

- (1) Disconnect battery.
- (2) Disconnect the connector from its mating half/component.
- (3) Push down on the yellow connector locking tab to release the terminals (Fig. 8).

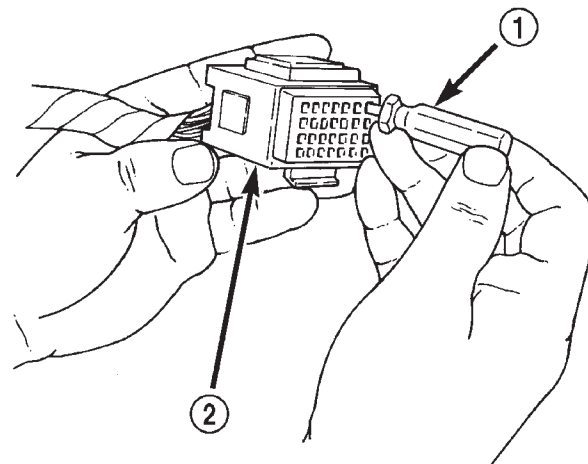


958W-54

**Fig. 8 AUGAT CONNECTOR REPAIR**

- 1 - LOCKING TAB
- 2 - CONNECTOR

- (4) Using special tool 6932, push the terminal to remove it from the connector (Fig. 9).



803f5845

**Fig. 9 USING**

- 1 - SPECIAL TOOL 6932
- 2 - CONNECTOR

- (5) Repair or replace the terminal as necessary.

INSTALLATION

- (1) Reset the terminal locking tang.

## CONNECTOR - AUGAT (Continued)

(2) Insert the removed wire in the same cavity on the repair connector.

(3) Repeat steps for each wire in the connector, being sure that all wires are inserted into the proper cavities. For additional connector pin-out identification, refer to the wiring diagrams.

(4) When the connector is re-assembled, the locking tab must be placed in the locked position to prevent terminal push out.

(5) Connect connector to its mating half/component.

(6) Connect battery and test all affected systems.

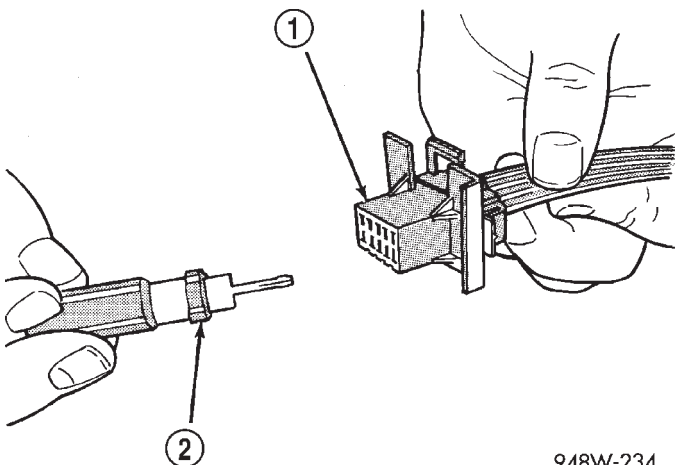
## CONNECTOR - MOLEX

## REMOVAL

(1) Disconnect battery.

(2) Disconnect the connector from its mating half/component.

(3) Insert special tool 6742 into the terminal end of the connector (Fig. 10).



948W-234

**Fig. 10 MOLEX CONNECTOR REPAIR**

1 - CONNECTOR

2 - SPECIAL TOOL 6742

(4) Using special tool 6742, release the locking fingers on the terminal (Fig. 11).

(5) Pull on the wire to remove it from the connector.

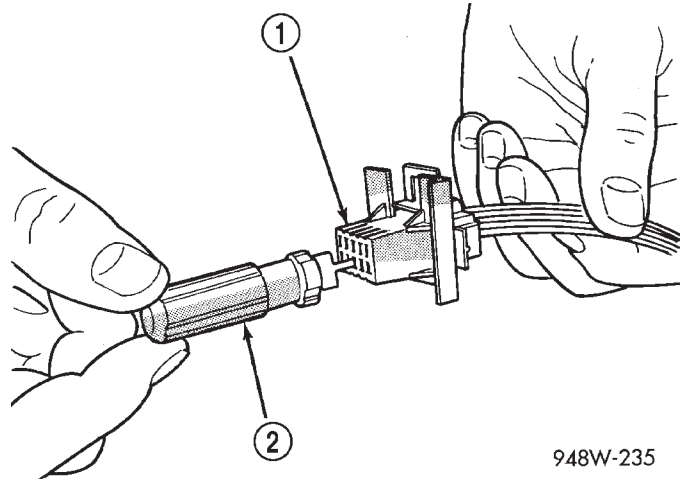
(6) Repair or replace the terminal as necessary.

## INSTALLATION

(1) Reset the terminal locking tang.

(2) Insert the removed wire in the same cavity on the repair connector.

(3) Repeat steps for each wire in the connector, being sure that all wires are inserted into the proper cavities. For additional connector pin-out identification, refer to the wiring diagrams.



948W-235

**Fig. 11 USING SPECIAL TOOL 6742**

1 - CONNECTOR

2 - SPECIAL TOOL 6742

(4) Connect connector to its mating half/component.

(5) Connect battery and test all affected systems.

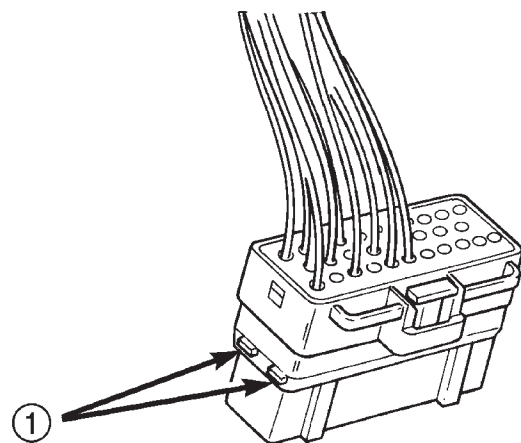
## CONNECTOR - THOMAS AND BETTS

## REMOVAL

(1) Disconnect battery.

(2) Disconnect the connector from its mating half/component.

(3) Push in the two lock tabs on the side of the connector (Fig. 12).



803f588a

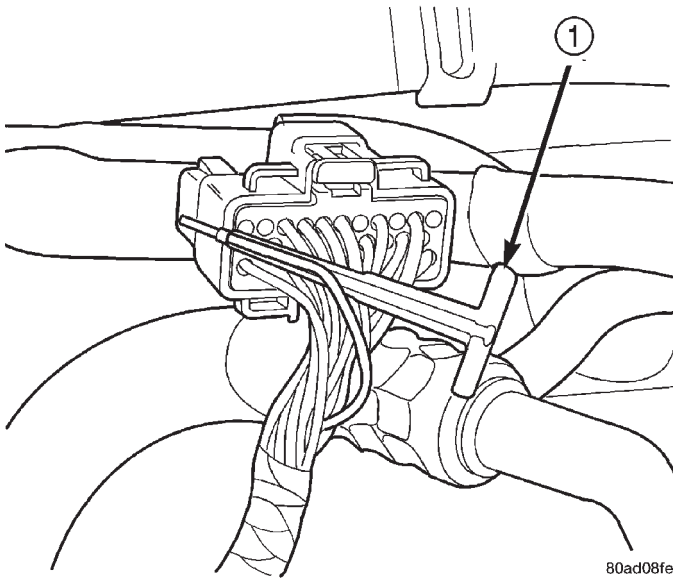
**Fig. 12 THOMAS AND BETTS CONNECTOR LOCK RELEASE TABS**

1 - LOCK TABS



## CONNECTOR - THOMAS AND BETTS (Continued)

(4) Insert the probe end of special tool 6934 into the back of the connector cavity (Fig. 13).



**Fig. 13 REMOVING WIRE TERMINAL**

1 - SPECIAL TOOL 6934

(5) Grasp the wire and tool 6934, then slowly remove the wire and terminal from the connector.

(6) Repair or replace the terminal as necessary.

## INSTALLATION

(1) Reset the terminal locking tang.

(2) Insert the removed wire in the same cavity on the repair connector.

(3) Repeat steps for each wire in the connector, being sure that all wires are fully seated into the proper cavities. For additional connector pin-out identification, refer to the wiring diagrams.

(4) Push in the single lock tab on the side of the connector (Fig. 14).

(5) Connect connector to its mating half/component.

(6) Connect battery and test all affected systems.

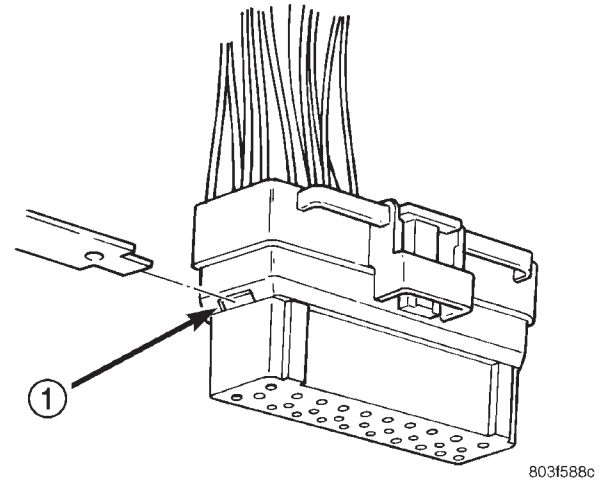
## DIODE

### REMOVAL

(1) Disconnect the battery.

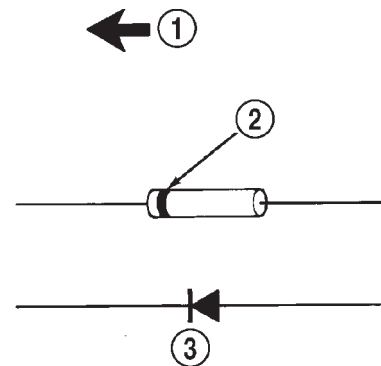
(2) Locate the diode in the harness, and remove the protective covering.

(3) Remove the diode from the harness, pay attention to the current flow direction (Fig. 15).



**Fig. 14 SINGLE LOCK TAB**

1 - SINGLE LOCK TAB



948W-197

**Fig. 15 DIODE IDENTIFICATION**

1 - CURRENT FLOW

2 - BAND AROUND DIODE INDICATES CURRENT FLOW

3 - DIODE AS SHOWN IN THE DIAGRAMS

### INSTALLATION

(1) Remove the insulation from the wires in the harness. Only remove enough insulation to solder in the new diode.

(2) Install the new diode in the harness, making sure current flow is correct. If necessary, refer to the appropriate wiring diagram for current flow (Fig. 15).

(3) Solder the connection together using rosin core type solder only. **Do not use acid core solder.**

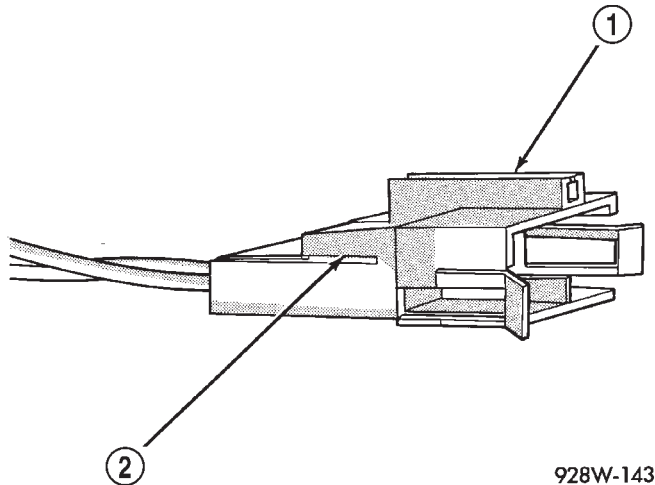
(4) Tape the diode to the harness using electrical tape. Make sure the diode is completely sealed from the elements.

(5) Re-connect the battery and test affected systems.

## TERMINAL

### REMOVAL

- (1) Disconnect battery.
- (2) Disconnect the connector being repaired from its mating half/component.
- (3) Remove the connector locking wedge, if required (Fig. 16).

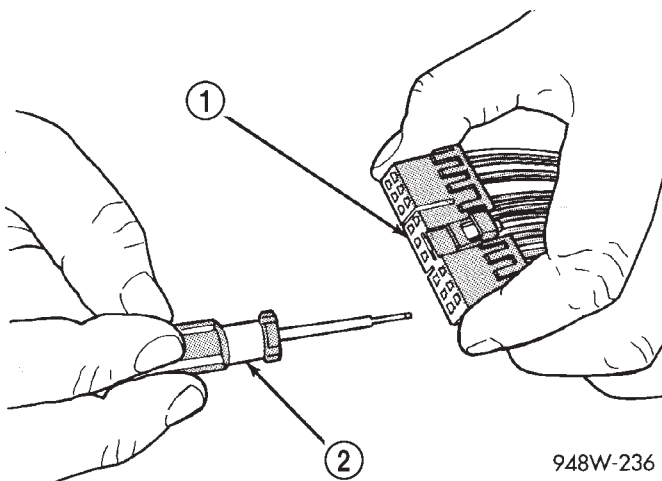


928W-143

**Fig. 16 CONNECTOR LOCKING WEDGE TAB (TYPICAL)**

- 1 - CONNECTOR
- 2 - CONNECTOR LOCKING WEDGE TAB

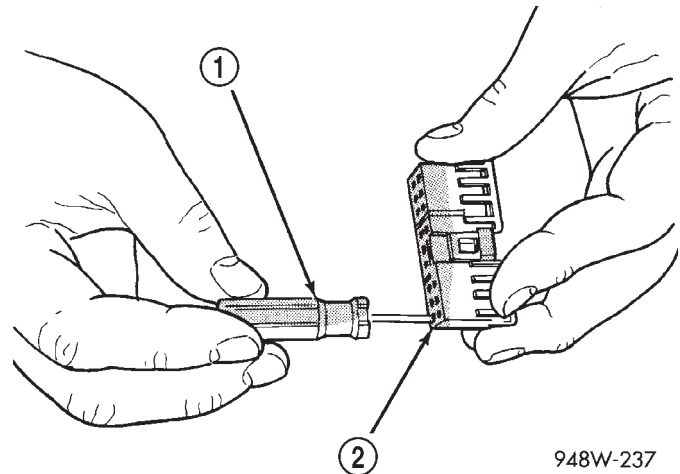
- (4) Position the connector locking finger away from the terminal using the proper pick from special tool kit 6680. Pull on the wire to remove the terminal from the connector (Fig. 17) (Fig. 18).



948W-236

**Fig. 17 TERMINAL REMOVAL**

- 1 - CONNECTOR
- 2 - FROM SPECIAL TOOL KIT 6680



948W-237

**Fig. 18 TERMINAL REMOVAL USING SPECIAL TOOL**

- 1 - FROM SPECIAL TOOL KIT 6680
- 2 - CONNECTOR

- (5) Cut the wire 6 inches from the back of the connector.

### INSTALLATION

- (1) Select a wire from the terminal repair assembly that best matches the color wire being repaired.
- (2) Cut the repair wire to the proper length and remove one-half (1/2) inch of insulation.
- (3) Splice the repair wire to the wire harness .
- (4) Insert the repaired wire into the connector.
- (5) Install the connector locking wedge, if required, and reconnect the connector to its mating half/component.
- (6) Re-tape the wire harness starting at 1-1/2 inches behind the connector and 2 inches past the repair.
- (7) Connect battery and test all affected systems.

## WIRE

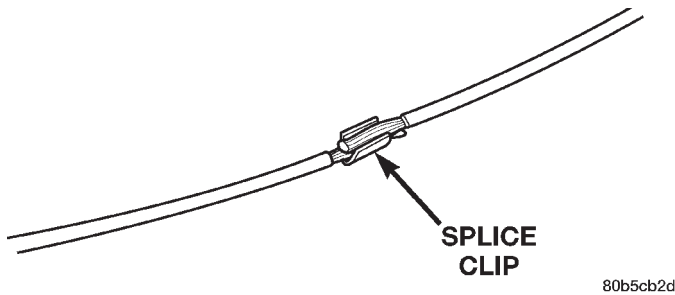
### STANDARD PROCEDURE - WIRE SPLICING

When splicing a wire, it is important that the correct gage be used as shown in the wiring diagrams.

(1) Remove one-half (1/2) inch of insulation from each wire that needs to be spliced.

(2) Place a piece of adhesive lined heat shrink tubing on one side of the wire. Make sure the tubing will be long enough to cover and seal the entire repair area.

(3) Place the strands of wire overlapping each other inside of the splice clip (Fig. 19).



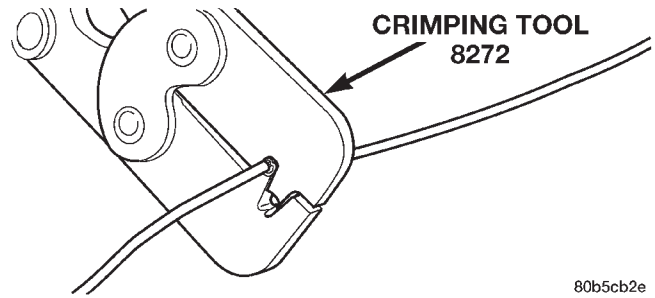
**Fig. 19 SPLICE CLIP**

(4) Using crimping tool, Miller p/n 8272, crimp the splice clip and wires together (Fig. 20)

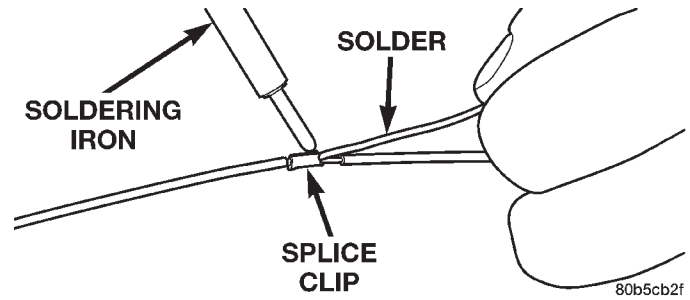
(5) Solder the connection together using rosin core type solder only (Fig. 21).

**CAUTION: DO NOT USE ACID CORE SOLDER.**

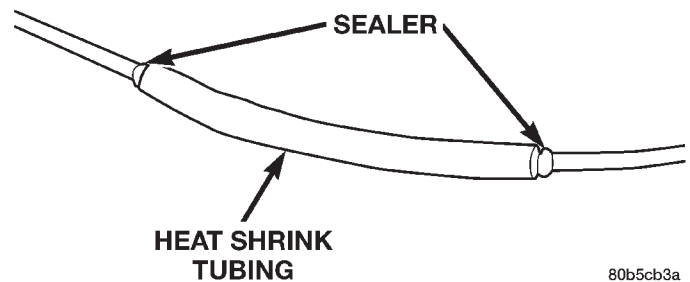
(6) Center the heat shrink tubing over the joint and heat using a heat gun. Heat the joint until the tubing is tightly sealed and sealant comes out of both ends of the tubing (Fig. 22).



**Fig. 20 CRIMPING TOOL**



**Fig. 21 SOLDER**



**Fig. 22 HEAT SHRINK TUBING**

## 8W-02 COMPONENT INDEX

<b>Component</b>	<b>Page</b>	<b>Component</b>	<b>Page</b>
4WD Switch . . . . .	8W-31	Electric Brake Provision . . . . .	8W-54
A/C Compressor Clutch Relay . . . . .	8W-42	Engine Control Module . . . . .	8W-30, 70
A/C Compressor Clutch . . . . .	8W-42	Engine Coolant Temperature Sensor . . . . .	8W-30
A/C-Heater Control . . . . .	8W-42	Engine Oil Pressure Sensor . . . . .	8W-30
A/C Heater Temperature Select . . . . .	8W-42	Engine Starter Motor Relay . . . . .	8W-21
A/C High Pressure Switch . . . . .	8W-42	Engine Starter Motor . . . . .	8W-21
A/C Low Pressure Switch . . . . .	8W-42	Fender Lamp . . . . .	8W-51
Accelerator Pedal Position Sensor . . . . .	8W-30	Fog Lamp Indicator . . . . .	8W-50
Aftermarket Center High Mounted Stop Lamp . . . . .	8W-51	Fog Lamp Relay . . . . .	8W-50
Aftermarket Trailer Tow Connector . . . . .	8W-54	Fog Lamp . . . . .	8W-50
Airbag Control Module . . . . .	8W-43	Fuel Heater Relay . . . . .	8W-30
Ambient Temperature Sensor . . . . .	8W-49	Fuel Heater . . . . .	8W-30
Ash Receiver Lamp . . . . .	8W-44	Fuel Injection Pump . . . . .	8W-30
Automatic Day/Night Mirror . . . . .	8W-49	Fuel Injectors . . . . .	8W-30
Automatic Shut Down Relay . . . . .	8W-30	Fuel Transfer Pump . . . . .	8W-30
Auxiliary Battery . . . . .	8W-20	Fuses (JB) . . . . .	8W-12
Back-Up Lamp Switch . . . . .	8W-51	Fuses (PDC) . . . . .	8W-10
Back-Up Lamps . . . . .	8W-51	Fusible Link . . . . .	8W-20, 30
Battery Temperature Sensor . . . . .	8W-30	Generator . . . . .	8W-20
Battery . . . . .	8W-20	Glove Box Lamp And Switch . . . . .	8W-44
Blend Door Actuator . . . . .	8W-42	Grounds . . . . .	8W-15
Blower Motor Relay . . . . .	8W-42	Headlamp Beam Select Switch . . . . .	8W-50
Blower Motor Resistor Block . . . . .	8W-42	Headlamp Switch . . . . .	8W-50
Blower Motor . . . . .	8W-42	Headlamp . . . . .	8W-50
Brake Lamp Switch . . . . .	8W-51	Heated Mirror Relay . . . . .	8W-62
Brake Pressure Switch . . . . .	8W-34, 35	Heated Mirror Switch . . . . .	8W-62
Bypass Jumper . . . . .	8W-21	Heated Seat Cushions . . . . .	8W-63
Camshaft Position Sensor . . . . .	8W-30	Heated Seat Relay . . . . .	8W-12
Capacitor . . . . .	8W-10, 30	Heated Seat Switches . . . . .	8W-63
Cargo Lamps . . . . .	8W-44	High Beam Indicator . . . . .	8W-40
Center High Mounted Stop Lamps . . . . .	8W-51	High Note Horn . . . . .	8W-41
Center Identification Lamp . . . . .	8W-50	Horn Relay . . . . .	8W-41
Central Timer Module . . . . .	8W-45	Horn Switch . . . . .	8W-41
Cigar Lighter . . . . .	8W-41	Idle Air Control Motor . . . . .	8W-30
Circuit Breakers . . . . .	8W-12	Ignition Coil 4-Pack . . . . .	8W-30
Clockspring . . . . .	8W-33, 41, 43, 47	Ignition Coil 6-Pack . . . . .	8W-30
Clutch Pedal Position Switch . . . . .	8W-21	Ignition Coil . . . . .	8W-30
Combination Flasher . . . . .	8W-52	Ignition Switch . . . . .	8W-10
Controller Antilock Brake . . . . .	8W-34, 35	Instrument Cluster . . . . .	8W-40
Crankshaft Position Sensor . . . . .	8W-30	Intake Air Heater Relays . . . . .	8W-30
Cummins Bus . . . . .	8W-18	Intake Air Heater . . . . .	8W-30
Cup Holder Lamp . . . . .	8W-44	Intake Air Temperature Sensor . . . . .	8W-30
Cylinder Lock Switches . . . . .	8W-39	Intermittent Wiper Switch . . . . .	8W-53
Data Link Connector . . . . .	8W-18	Joint Connectors . . . . .	8W-10, 12, 15, 30, 31, 34, 35, 40, 44, 45, 51, 53, 70
Daytime Running Lamp Module . . . . .	8W-50	Junction Block . . . . .	8W-12
Dome Lamp . . . . .	8W-44	Leak Detection Pump . . . . .	8W-30
Door Ajar Switches . . . . .	8W-45	License Lamp . . . . .	8W-51
Door Lock Motors . . . . .	8W-61	Low Note Horn . . . . .	8W-41
Door Window/Lock Switches . . . . .	8W-60, 61	Lumbar Motors . . . . .	8W-63
Driver Airbag . . . . .	8W-43	Manifold Absolute Pressure Sensor . . . . .	8W-30
Duty Cycle EVAP/Purge Solenoid . . . . .	8W-30	Manifold Air Pressure Sensor . . . . .	8W-30

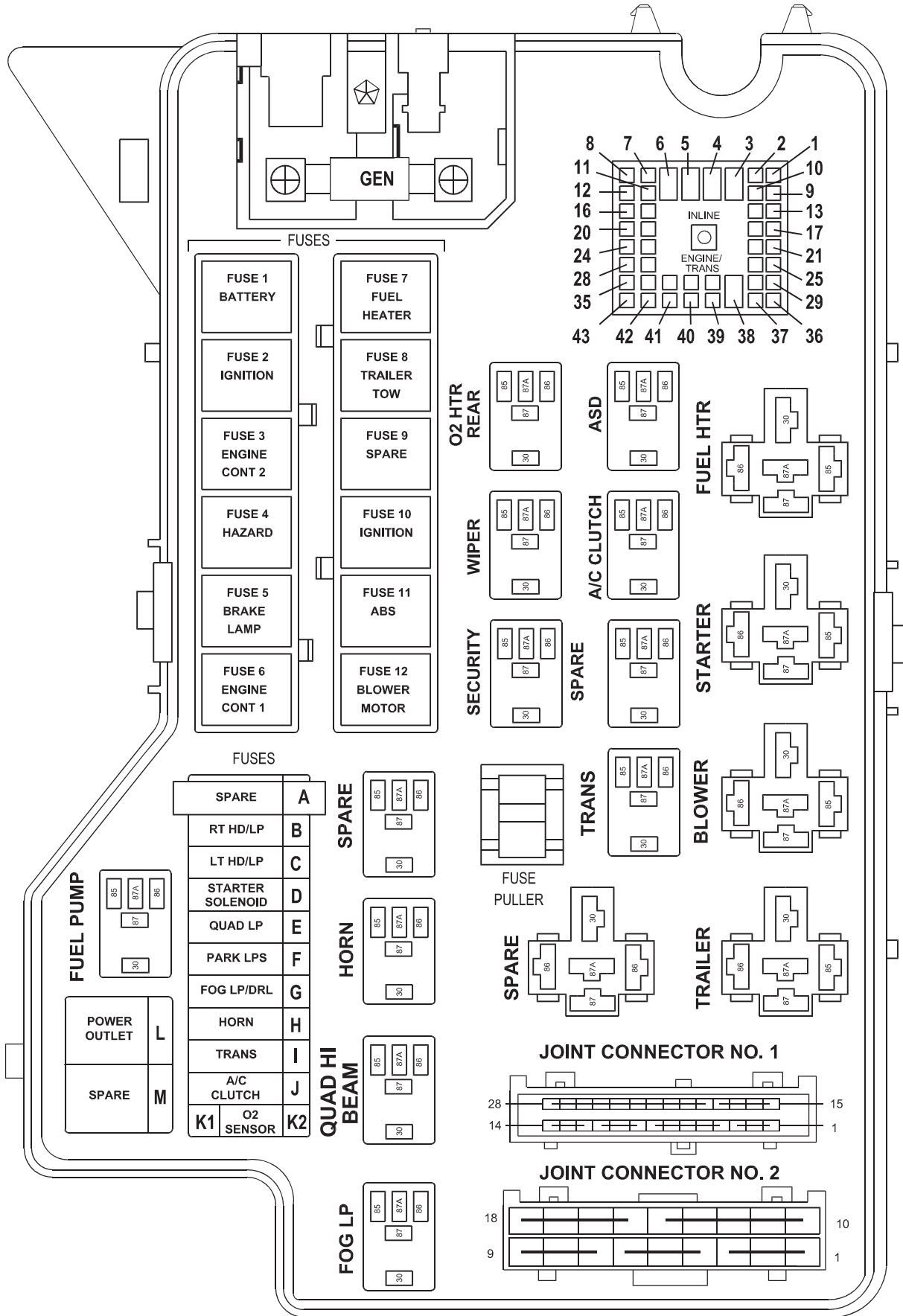
<b>Component</b>	<b>Page</b>	<b>Component</b>	<b>Page</b>
Map Lamps . . . . .	8W-49	Radio . . . . .	8W-47
Outboard Clearance Lamp . . . . .	8W-50	Remote Radio Switch . . . . .	8W-47
Outboard Headlamp . . . . .	8W-50	Seat Belt Switch . . . . .	8W-40
Outboard Identification Lamp . . . . .	8W-50	Seat Heat Interface Module . . . . .	8W-63
Output Speed Sensor . . . . .	8W-31	Security Relay . . . . .	8W-39
Overdrive Switch . . . . .	8W-31	Speakers . . . . .	8W-47
Overhead Console . . . . .	8W-49	Speed Control Servo . . . . .	8W-33
Oxygen Sensors . . . . .	8W-30	Speed Control Switch . . . . .	8W-33
Park Brake Switch . . . . .	8W-40, 50	Splice Information . . . . .	8W-70
Park/Neutral Position Switch . . . . .	8W-30, 51	Tail/Stop/Turn Signal Lamp . . . . .	8W-51
Park/Turn Signal Lamp . . . . .	8W-52	Tailgate Lamp . . . . .	8W-51
Passenger Airbag On/Off Switch . . . . .	8W-43	Throttle Position Sensor . . . . .	8W-30
Passenger Airbag . . . . .	8W-43	Trailer Tow Connector . . . . .	8W-54
Power Distribution Center . . . . .	8W-10	Trailer Tow Relay . . . . .	8W-54
Power Mirror Switch . . . . .	8W-62	Transmission Control Relay . . . . .	8W-31
Power Mirror . . . . .	8W-62	Transmission Solenoid Assembly . . . . .	8W-31
Power Outlet . . . . .	8W-41	Turn Signal/Hazard Switch . . . . .	8W-52
Power Seat Front Vertical Motors . . . . .	8W-63	Underhood Lamp . . . . .	8W-44
Power Seat Horizontal Motors . . . . .	8W-63	Visor/Vanity Lamp . . . . .	8W-44
Power Seat Rear Vertical Motor . . . . .	8W-63	Washer Fluid Level Switch . . . . .	8W-40
Power Seat Switch . . . . .	8W-63	Water In Fuel Sensor . . . . .	8W-30
Power Window Motors . . . . .	8W-60	Wheel Speed Sensors . . . . .	8W-34, 35
Powertrain Control Module . . . . .	8W-30	Windshield Washer Pump . . . . .	8W-53
PTO Switch . . . . .	8W-30	Wiper Motor Relay . . . . .	8W-53
Quad High Beam Relay . . . . .	8W-50	Wiper Motor . . . . .	8W-53
Radio Choke Relay . . . . .	8W-47		



## 8W-10 POWER DISTRIBUTION

<b>Component</b>	<b>Page</b>	<b>Component</b>	<b>Page</b>
A/C Compressor Clutch Relay . . . . .	8W-10-27	Fuse 14 (JB) . . . . .	8W-10-10
A/C Compressor Clutch . . . . .	8W-10-27	Fuse B (PDC) . . . . .	8W-10-24, 9
Aftermarket Center High Mounted Stop Lamp . . . . .	8W-10-13	Fuse C (PDC) . . . . .	8W-10-24, 9
Aftermarket Trailer Tow Connector . . . . .	8W-10-21	Fuse E (PDC) . . . . .	8W-10-24, 9
Automatic Shut Down Relay . . . . .	8W-10-14, 20	Fuse F (PDC) . . . . .	8W-10-24, 9
Auxiliary Battery . . . . .	8W-10-8	Fuse G (PDC) . . . . .	8W-10-25, 9
Battery . . . . .	8W-10-8	Fuse GEN (PDC) . . . . .	8W-10-27, 8
Blower Motor Relay . . . . .	8W-10-23	Fuse H (PDC) . . . . .	8W-10-26, 9
Blower Motor . . . . .	8W-10-23	Fuse I (PDC) . . . . .	8W-10-26, 9
Brake Lamp Switch . . . . .	8W-10-13	Fuse J (PDC) . . . . .	8W-10-27, 9
Capacitor . . . . .	8W-10-16	Fuse K (PDC) . . . . .	8W-10-14, 9
Center High Mounted Stop Lamp No. 1 . . . . .	8W-10-13	Fuse L (PDC) . . . . .	8W-10-27, 9
Center High Mounted Stop Lamp No. 2 . . . . .	8W-10-13	G201 . . . . .	8W-10-22
Central Timer Module C1 . . . . .	8W-10-22	Generator . . . . .	8W-10-27
Central Timer Module C2 . . . . .	8W-10-26	Headlamp Beam Select Switch . . . . .	8W-10-25
Circuit Breaker 2 . . . . .	8W-10-10	Headlamp Switch . . . . .	8W-10-24
Clockspring . . . . .	8W-10-26	High Note Horn . . . . .	8W-10-26
Combination Flasher . . . . .	8W-10-13	Horn Relay . . . . .	8W-10-26, 9
Controller Antilock Brake . . . . .	8W-10-23	Ignition Coil 4-Pack . . . . .	8W-10-16
Daytime Running Lamp Module . . . . .	8W-10-25	Ignition Coil 6-Pack . . . . .	8W-10-16
Electric Brake Provision . . . . .	8W-10-13, 21	Ignition Coil . . . . .	8W-10-15
Engine Control Module . . . . .	8W-10-12	Ignition Switch . . . . .	8W-10-10, 22
Engine Starter Motor Relay . . . . .	8W-10-23	Joint Connector No. 1 . . . . .	8W-10-25, 26
Engine Starter Motor . . . . .	8W-10-23	Joint Connector No. 2 . . . . .	8W-10-11, 12, 14, 20, 21
Fog Lamp Relay . . . . .	8W-10-25	Joint Connector No. 5 . . . . .	8W-10-22
Fuel Heater Relay . . . . .	8W-10-20	Joint Connector No. 6 . . . . .	8W-10-13, 22, 26
Fuel Heater . . . . .	8W-10-20	Joint Connector No. 8 . . . . .	8W-10-22
Fuel Injection Pump . . . . .	8W-10-12	Junction Block . . . . .	8W-10-10, 13
Fuel Injector No. 1 . . . . .	8W-10-15, 16	Left Fog Lamp . . . . .	8W-10-25
Fuel Injector No. 2 . . . . .	8W-10-15, 16	Left Headlamp . . . . .	8W-10-24
Fuel Injector No. 3 . . . . .	8W-10-15, 16	Left Outboard Headlamp . . . . .	8W-10-24, 25
Fuel Injector No. 4 . . . . .	8W-10-15, 16	Low Note Horn . . . . .	8W-10-26
Fuel Injector No. 5 . . . . .	8W-10-15, 16	Oxygen Sensor 1/1 Left Bank Up . . . . .	8W-10-17, 18, 19
Fuel Injector No. 6 . . . . .	8W-10-15, 16	Oxygen Sensor 1/1 Upstream . . . . .	8W-10-17
Fuel Injector No. 7 . . . . .	8W-10-15, 16	Oxygen Sensor 1/2 Downstream . . . . .	8W-10-17
Fuel Injector No. 8 . . . . .	8W-10-15, 16	Oxygen Sensor 1/2 Left Bank Down . . . . .	8W-10-19
Fuel Injector No. 9 . . . . .	8W-10-16	Oxygen Sensor 1/2 Pre-Catalyst . . . . .	8W-10-18
Fuel Injector No. 10 . . . . .	8W-10-16	Oxygen Sensor 1/3 Post-Catalyst . . . . .	8W-10-18
Fuel Pump Module . . . . .	8W-10-11	Oxygen Sensor 2/1 Right Bank Up . . . . .	8W-10-17, 18, 19
Fuel Pump Relay . . . . .	8W-10-11, 12	Oxygen Sensor 2/2 Right Bank Down . . . . .	8W-10-19
Fuse 1 (JB) . . . . .	8W-10-10	Oxygen Sensor Downstream Relay . . . . .	8W-10-18, 19
Fuse 1 (PDC) . . . . .	8W-10-10, 8	Power Distribution Center . . . . .	8W-10-2, 8, 9, 10, 11, 12, 13, 14, 20, 21, 22, 23, 24, 25, 26, 27
Fuse 2 (PDC) . . . . .	8W-10-8, 10, 22	Power Outlet . . . . .	8W-10-27
Fuse 3 (PDC) . . . . .	8W-10-8, 11, 12	Powertrain Control Module . . . . .	8W-10-11, 12, 15, 16, 20
Fuse 4 (JB) . . . . .	8W-10-10	Quad High Beam Relay . . . . .	8W-10-24
Fuse 4 (PDC) . . . . .	8W-10-13, 8	Right Fog Lamp . . . . .	8W-10-25
Fuse 5 (PDC) . . . . .	8W-10-13, 8	Right Headlamp . . . . .	8W-10-24
Fuse 6 (PDC) . . . . .	8W-10-14, 20, 8	Right Outboard Headlamp . . . . .	8W-10-24, 25
Fuse 7 (PDC) . . . . .	8W-10-20, 8	Security Relay . . . . .	8W-10-25
Fuse 8 (PDC) . . . . .	8W-10-21, 8	Trailer Tow Connector . . . . .	8W-10-21
Fuse 9 (PDC) . . . . .	8W-10-23, 8	Trailer Tow Relay . . . . .	8W-10-21
Fuse 10 (PDC) . . . . .	8W-10-22, 8	Transmission Control Relay . . . . .	8W-10-26
Fuse 11 (PDC) . . . . .	8W-10-23, 8	Transmission Solenoid Assembly . . . . .	8W-10-26
Fuse 12 (JB) . . . . .	8W-10-10	Turn Signal/Hazard Switch . . . . .	8W-10-13
Fuse 12 (PDC) . . . . .	8W-10-23, 8		
Fuse 13 (JB) . . . . .	8W-10-10		

POWER DISTRIBUTION CENTER



FUSE NO.	AMPS	FUSED CIRCUIT	FUNCTION
1	50	A7 10RD/BK	FUSED B(+)
2	30	A2 14PK/BK	FUSED B(+)
3	20	A14 16RD/WT	FUSED B(+)
4	20	L9 16BK/VT	FUSED B(+)
5	20	F32 16PK/DB	FUSED B(+)
6	30	A16 14RD/LB	FUSED B(+)
7 ■■	40	A112 12RD/TN	FUSED B(+)
8 ●●	40	A6 12RD/OR	FUSED B(+)
9	30	F45 14YL	FUSED B(+)
10	50	A1 10RD	FUSED B(+)
11	40	A10 10RD/DG	FUSED B(+)
12	40	C111 12DG/YL	FUSED B(+)
A	-	-	-
B	15	L44 18VT/RD	FUSED B(+)
C	15	L43 18VT	FUSED B(+)
D	-	-	-
E ▲▲	15	L45 18PK/RD	FUSED B(+)
F	20	F33 16PK/RD	FUSED B(+)
G ●	15	L34 20RD/OR	FUSED B(+)
H	20	INTERNAL	FUSED B(+)
I	20	T17 18YL	FUSED B(+)
J	10	C26 22PK/DB	FUSED B(+)
Kg ■	15	A141 20DG/WT	AUTOMATIC SHUT DOWN RELAY OUTPUT
Ki ■■	15	A142 20DG/OR	AUTOMATIC SHUT DOWN RELAY OUTPUT
L	20	A12 16RD/TN	FUSED B(+)
M	-	-	-
GEN	140	A11 4BK/GY ■	FUSED B(+)
		A11 4BK ■■	FUSED B(+)

- EXCEPT BASE
- TRAILER TOW
- ▲▲ QUAD HEADLAMPS
- GAS
- DIESEL

## RELAYS

A/C  
COMPRESSOR  
CLUTCH  
RELAY

CAVITY	CIRCUIT	FUNCTION
30	C26 22PK/DB	FUSED B(+)
85	C13 22DB/OR	A/C COMPRESSOR CLUTCH RELAY CONTROL
86	F12 20DB/WT	FUSED IGNITION SWITCH OUTPUT (RUN-START)
87	C3 22DB/BK	A/C COMPRESSOR CLUTCH RELAY OUTPUT
87A	-	-

AUTOMATIC  
SHUT  
DOWN  
RELAY

CAVITY	CIRCUIT	FUNCTION
30	A16 14RD/LB	FUSED B(+)
85	K51 20DB/YL	AUTOMATIC SHUT DOWN RELAY CONTROL
86	A16 14RD/LB	FUSED IGNITION SWITCH OUTPUT (RUN-START)
87	A142 14DG/OR	AUTOMATIC SHUT DOWN RELAY OUTPUT
87A	-	-

BLOWER  
MOTOR  
RELAY

CAVITY	CIRCUIT	FUNCTION
30	C111 12DG/YL	FUSED B(+)
85	Z1 22BK	GROUND
86	F15 22DB	FUSED IGNITION SWITCH OUTPUT (RUN)
87	C1 12DG	BLOWER MOTOR FEED
87A	-	-

ENGINE  
STARTER  
MOTOR  
RELAY

CAVITY	CIRCUIT	FUNCTION
30	F45 14YL	FUSED B(+) ENGINE STARTER MOTOR RELAY
85	T41 22BK/WT	PARK/NEUTRAL POSITION SWITCH SENSE
86	T141 14YL/RD	FUSED IGNITION SWITCH OUTPUT (START)
87	T40 14BR	STARTER RELAY OUTPUT
87A	-	-

FOG  
LAMP  
RELAY

CAVITY	CIRCUIT	FUNCTION
30	L39 20LB	FOG LAMP RELAY OUTPUT
85	L35 20BR/YL ■ ■	FOG LAMP SWITCH OUTPUT
85	L139 20VT ■	-
86	L34 20RD/OR ■	FUSED B(+)
86	L3 18RD/OR ■ ■	BEAM SELECT SWITCH HIGH BEAM OUTPUT
87	L35 20BR/YL ■ ■	FOG LAMP SWITCH OUTPUT
87A	L35 22BR/YL ■	FOG LAMP SWITCH OUTPUT

FUEL  
HEATER  
RELAY  
(DIESEL)

CAVITY	CIRCUIT	FUNCTION
30	A112 12RD/TN	FUSED B(+)
85	Z1 22BK	GROUND
86	F12 20DB/WT	FUSED IGNITION SWITCH OUTPUT (RUN-START)
87	A93 12RD/BK	FUEL HEATER RELAY OUTPUT
87A	-	-

FUEL  
PUMP  
RELAY

CAVITY	CIRCUIT	FUNCTION
30	A14 16RD/WT	FUSED B (+)
85	K31 20BR/WT •	FUEL PUMP RELAY CONTROL
85	Z1 20BK ••	GROUND
86	F18 20LG/BK •	FUSED IGNITION SWITCH OUTPUT (RUN-START)
86	K131 20BR/WT ••	FUEL PUMP RELAY CONTROL
87	A40 14RD/LG ••	FUEL PUMP RELAY OUTPUT
87	A61 16DG/BK •	FUEL PUMP RELAY OUTPUT
87A	-	-

- GAS
- DIESEL
- DRL
- ■ EXCEPT DRL



**HORN  
RELAY**

CAVITY	CIRCUIT	FUNCTION
30	INTERNAL	FUSED B(+)
85	X3 22BK/RD	HORN RELAY CONTROL
86	INTERNAL	FUSED B(+)
87	X2 18DG/RD	HORN RELAY OUTPUT
87A	-	-

**OXYGEN  
SENSOR  
DOWNSTREAM  
RELAY  
(CALIFORNIA)**

CAVITY	CIRCUIT	FUNCTION
30	A141 20DG/WT	AUTOMATIC SHUT DOWN RELAY OUTPUT
85	K145 20DG/PK	OXYGEN SENSOR DOWNSTREAM RELAY CONTROL
86	A141 20DG/WT	FUSED IGNITION SWITCH OUTPUT (RUN-START)
87	A341 20DG/YL	OXYGEN SENSOR DOWNSTREAM RELAY OUTPUT

**QUAD  
HIGH BEAM  
RELAY**

CAVITY	CIRCUIT	FUNCTION
30	L33 18LG/BR	QUAD HIGH BEAM RELAY OUTPUT
85	L3 18RD/OR ••	BEAM SELECT SWITCH HIGH BEAM OUTPUT
85	G34 20RD/GY •	HIGH BEAM INDICATOR DRIVER
86	L45 18PK/RD	FUSED B(+)
87	Z1 16BK	GROUND

- DRL
- EXCEPT DRL

**SECURITY  
RELAY**

CAVITY	CIRCUIT	FUNCTION
30	Z1 16BK	GROUND
85	G50 22RD/DB	SECURITY RELAY CONTROL
86	L34 20RD/OR	FUSED B(+)
87	L4 20VT/WT	BEAM SELECT SWITCH LOW BEAM OUTPUT
87A	-	-

**TRAILER  
TOW  
RELAY**

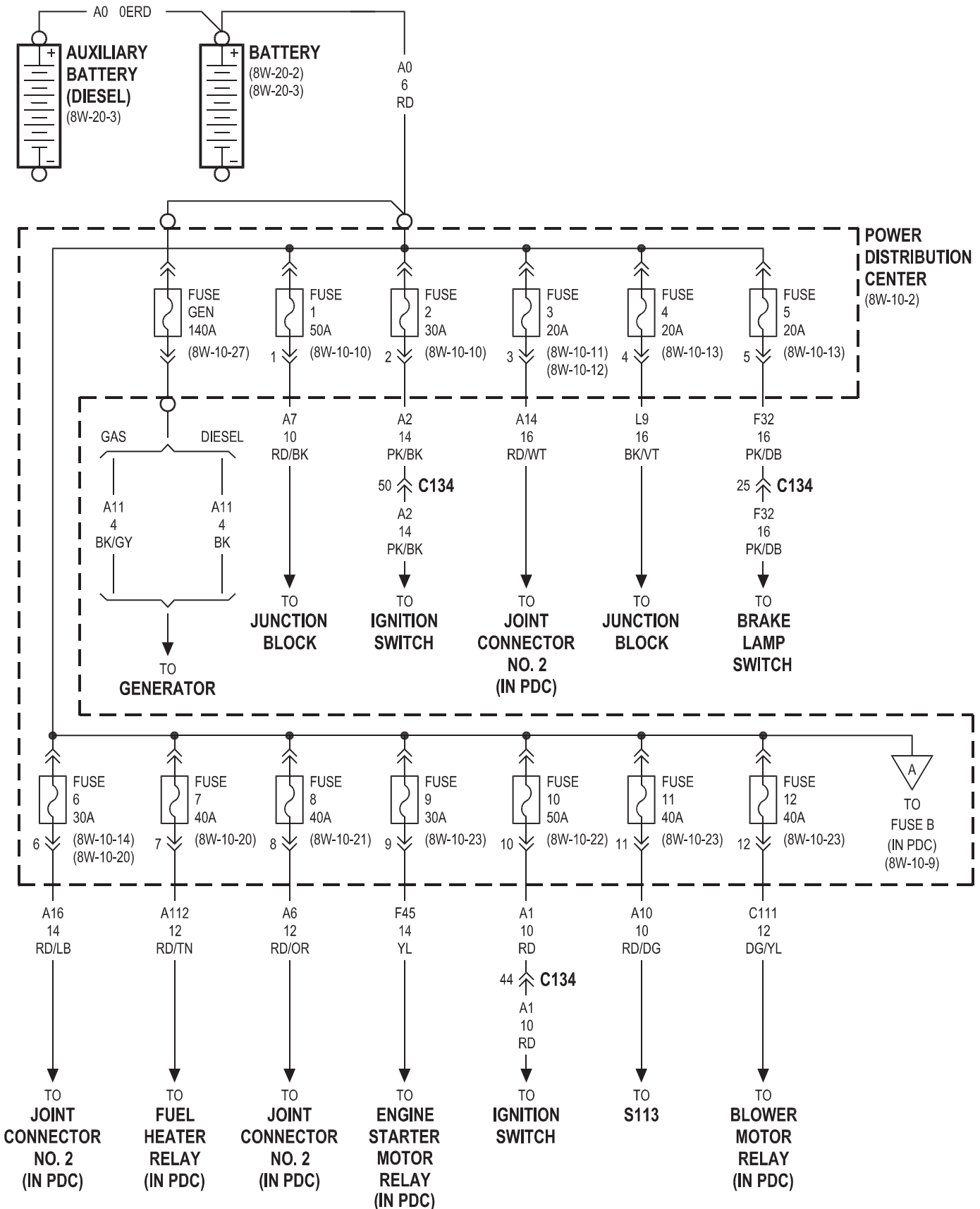
CAVITY	CIRCUIT	FUNCTION
30	A6 12RD/OR	FUSED B(+)
85	Z1 22BK	GROUND
86	L7 18BK/YL	PARK LAMP RELAY OUTPUT
87	L76 12BK/OR	TRAILER TOW RELAY OUTPUT
87A	-	-

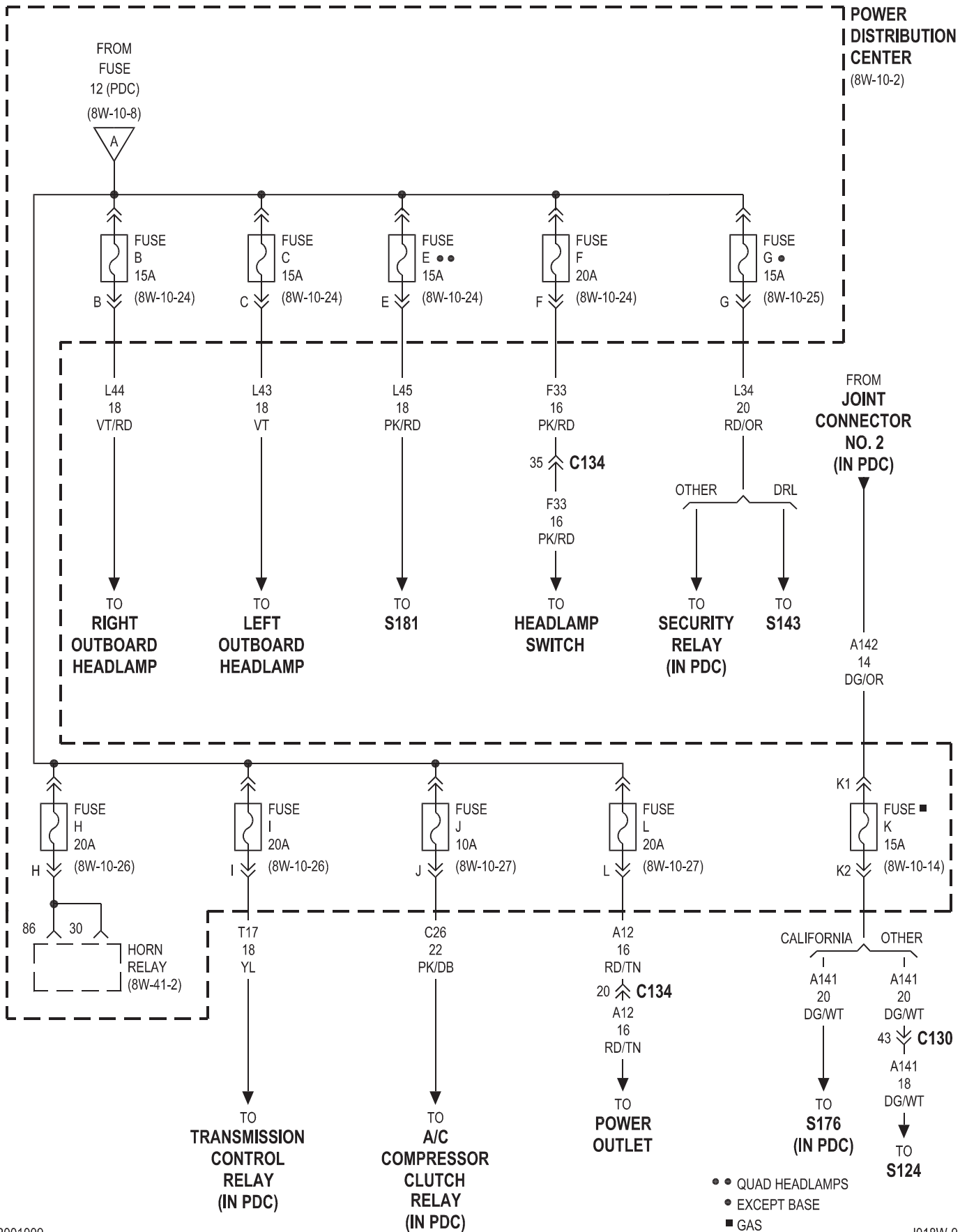
**TRANSMISSION  
CONTROL  
RELAY**

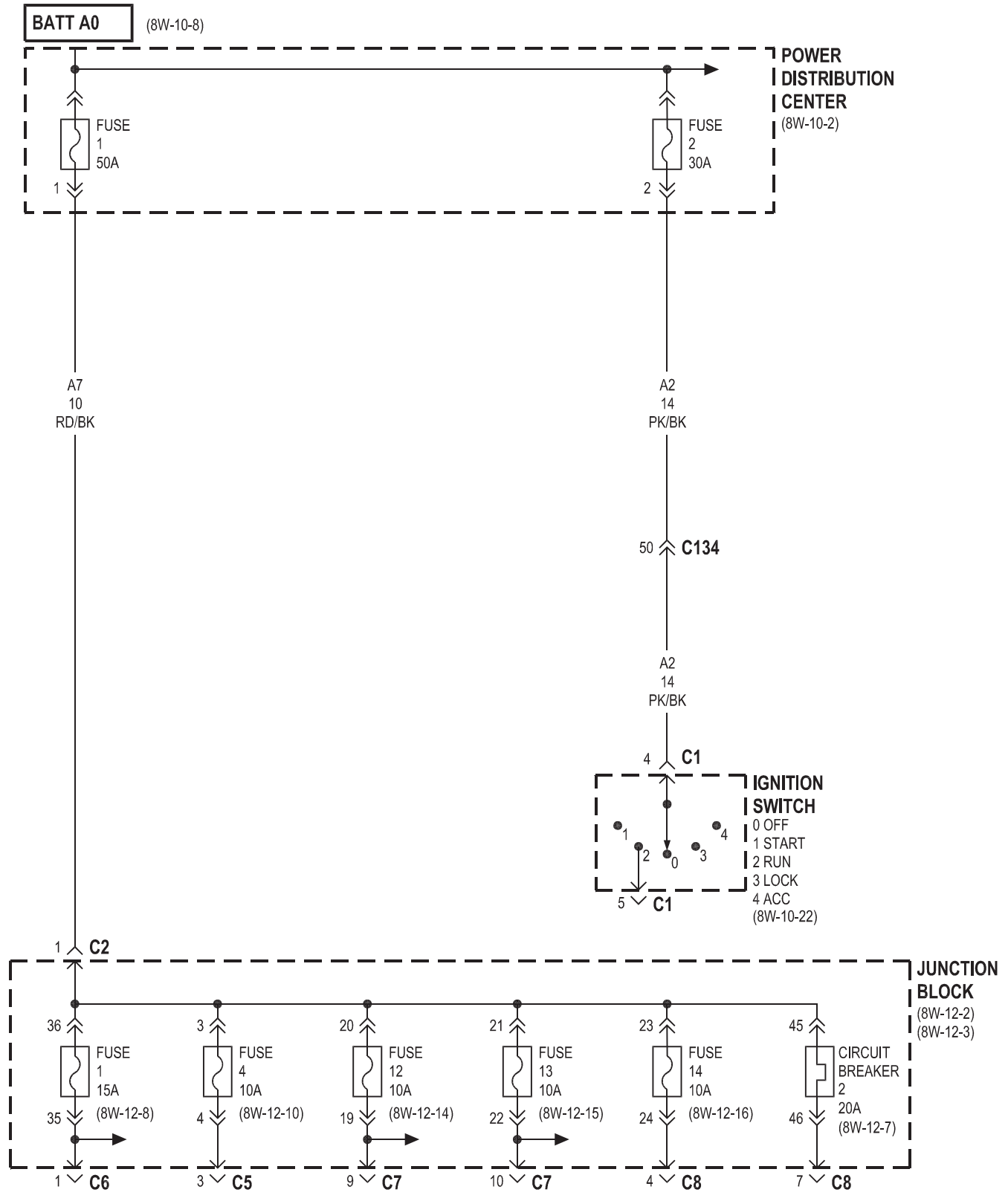
CAVITY	CIRCUIT	FUNCTION
30	T17 18YL	FUSED B(+)
85	K30 22PK	TRANSMISSION CONTROL RELAY CONTROL
86	T125 18DB	GENERATOR SOURCE
87	T16 18RD	TRANSMISSION CONTROL RELAY OUTPUT
87A	-	-

**WIPER  
MOTOR  
RELAY**

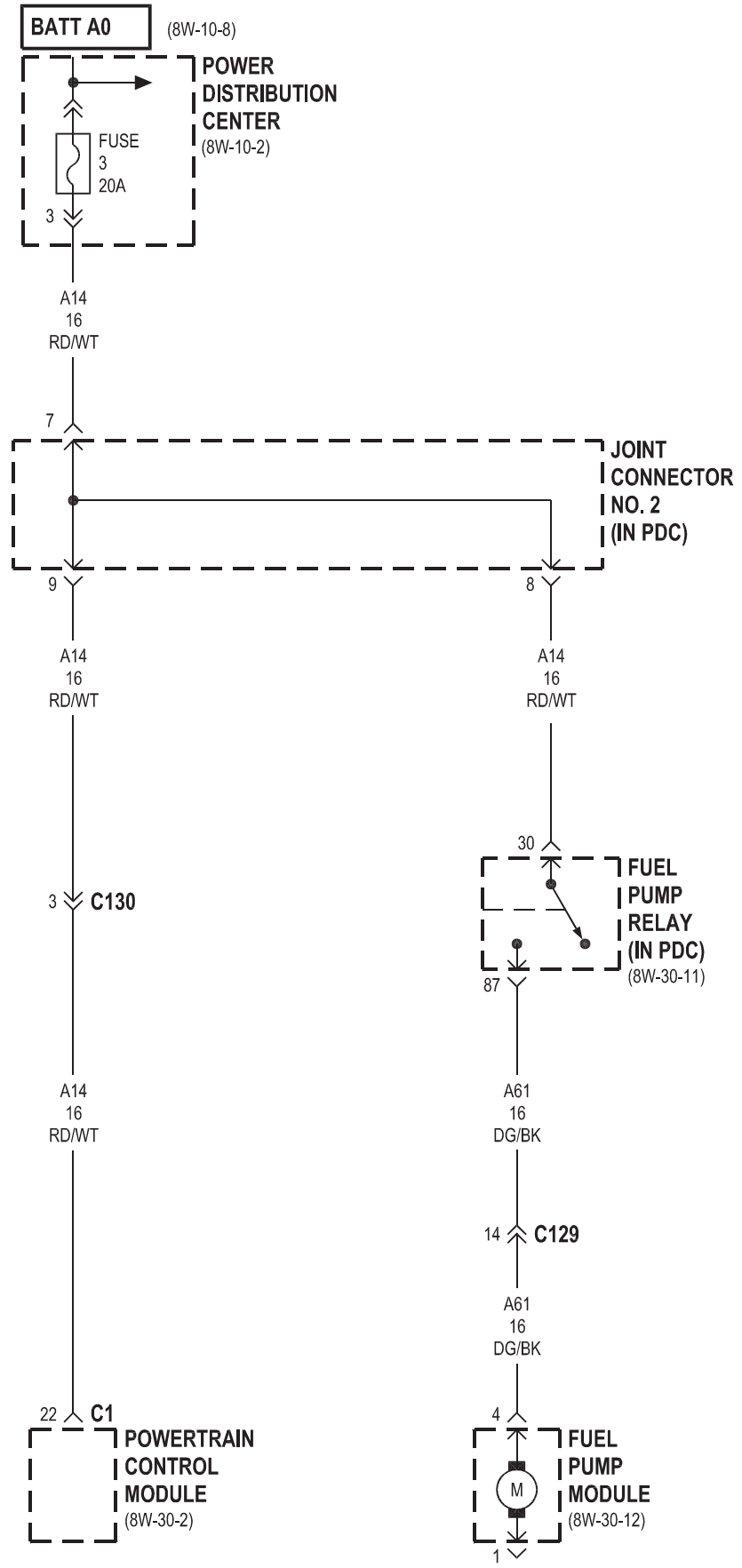
CAVITY	CIRCUIT	FUNCTION
30	V49 16RD/BK	DRIVER LOW SPEED WIPER MOTOR DRIVER
85	V18 22YL/DG	WIPER MOTOR RELAY CONTROL
86	V6 16DB	FUSED IGNITION SWITCH OUTPUT (RUN-ACC)
87	V6 16DB	FUSED IGNITION SWITCH OUTPUT (RUN-ACC)
87A	V5 16DG	WIPER PARK SWITCH SENSE

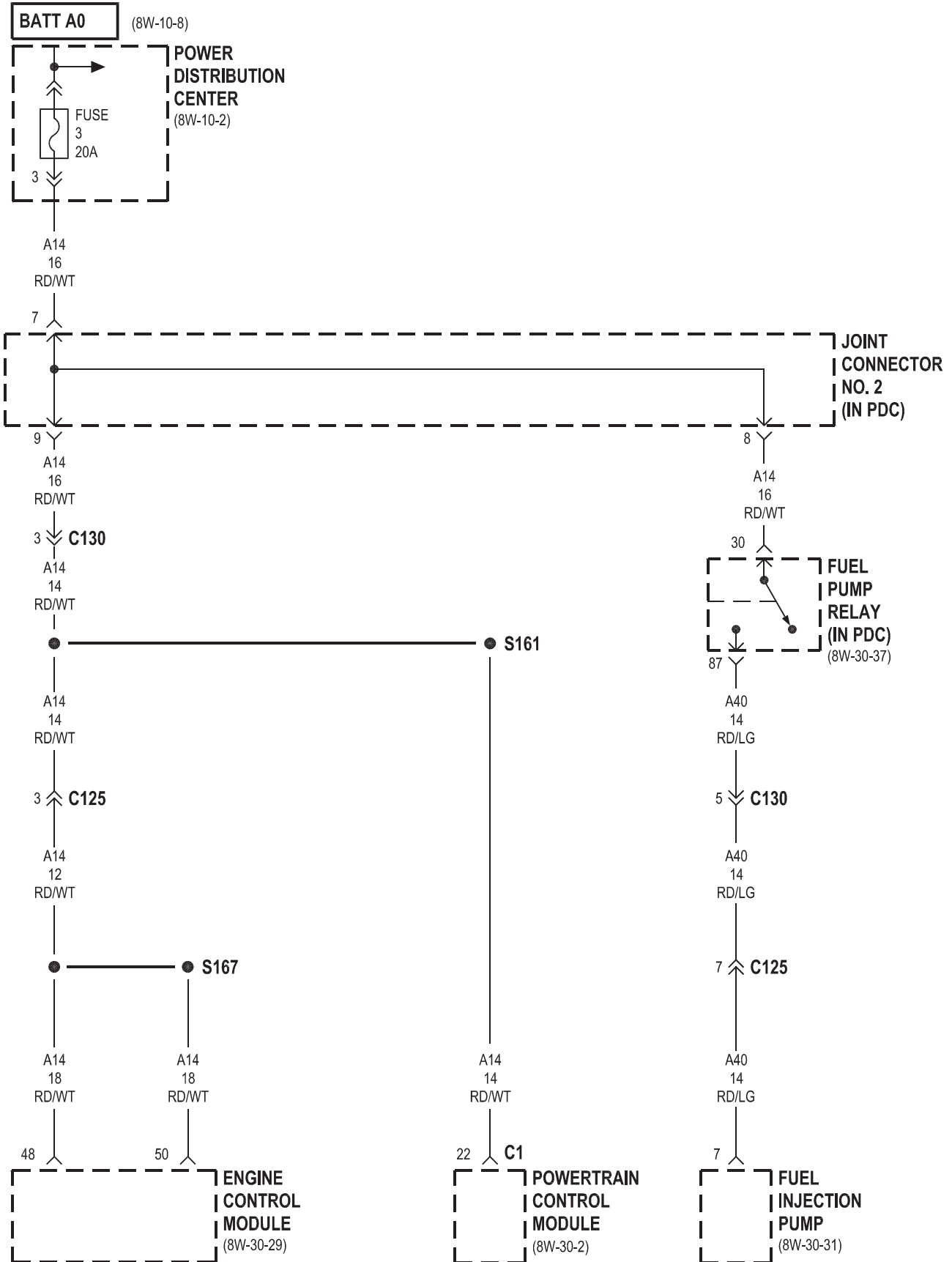


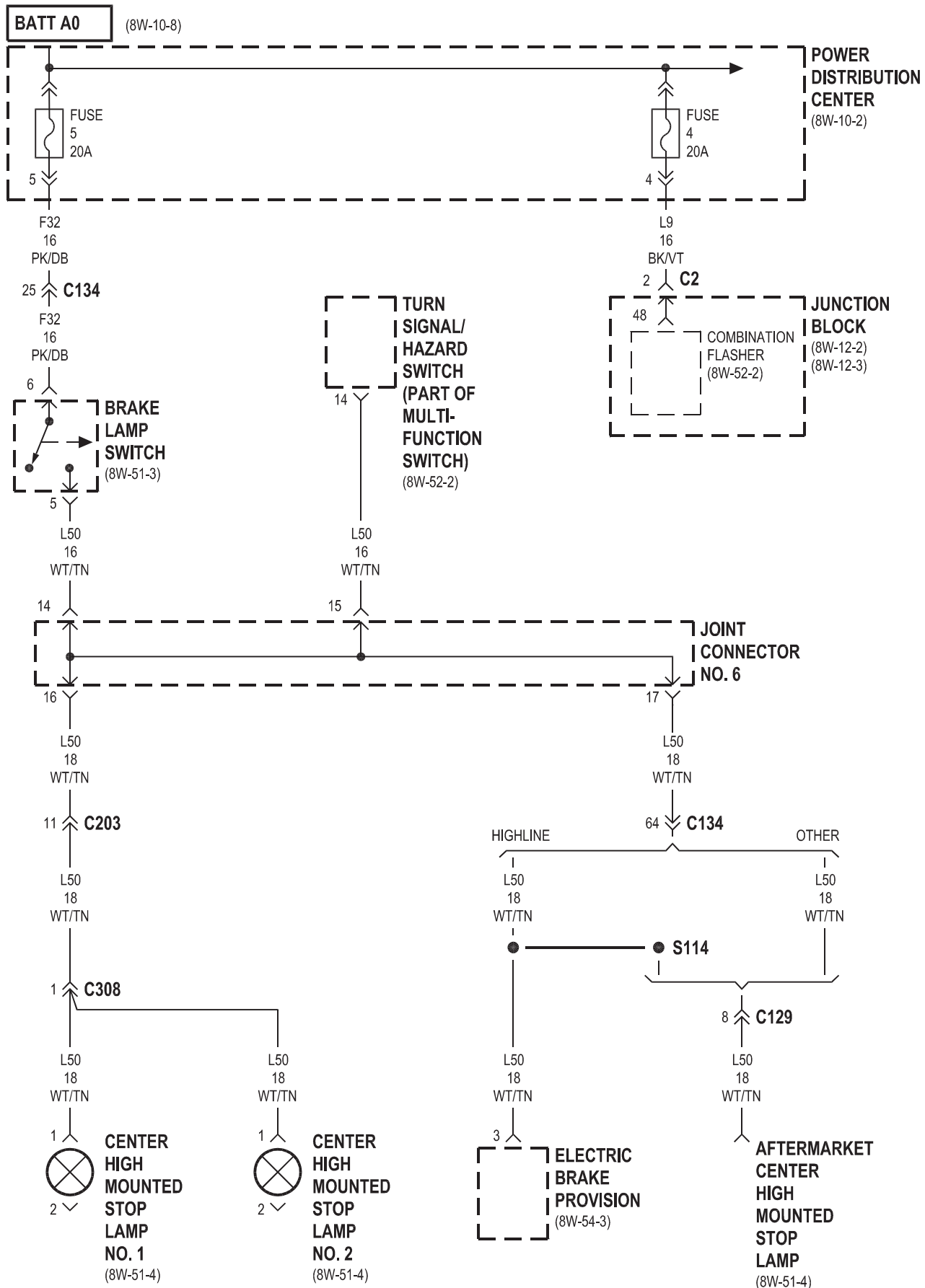


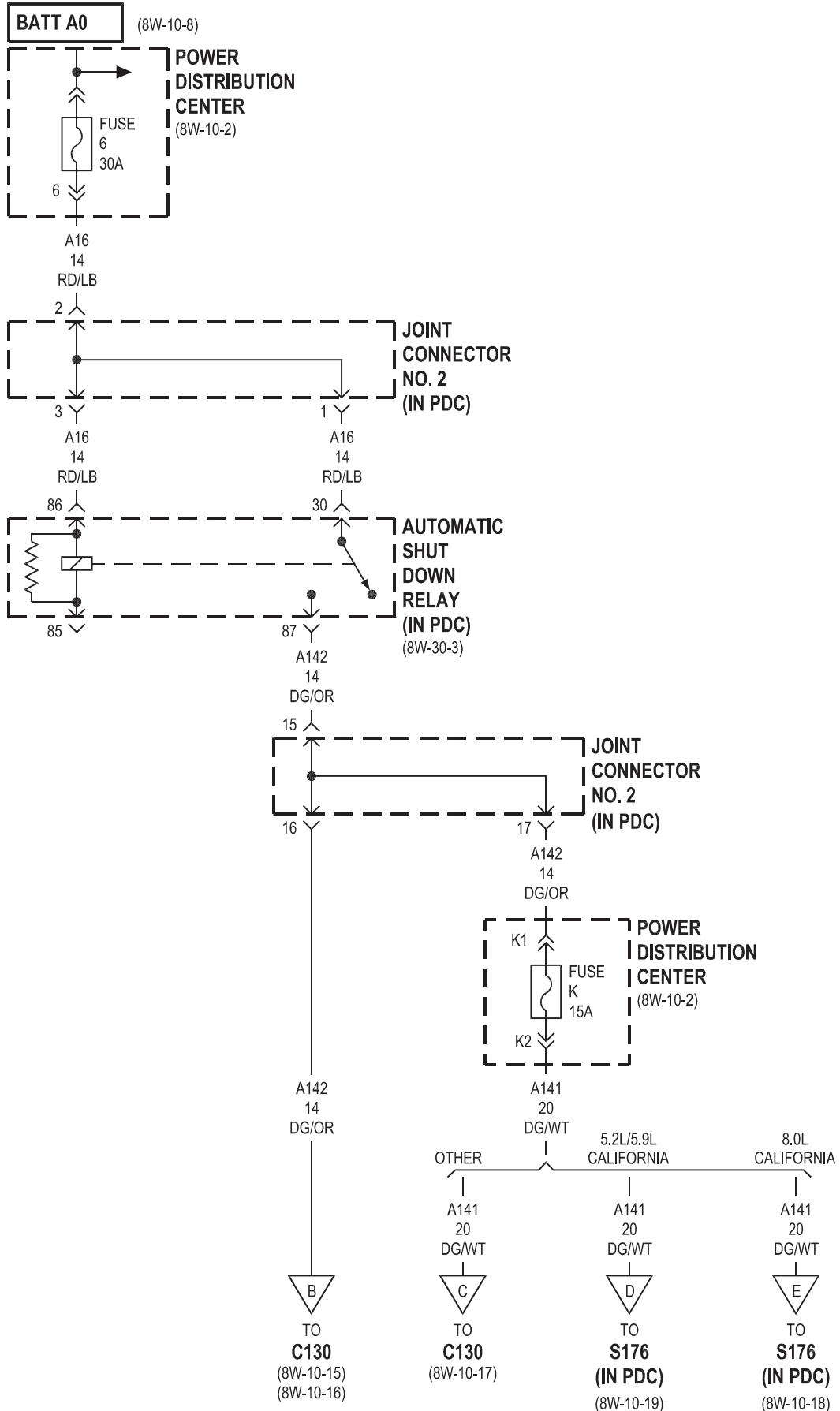


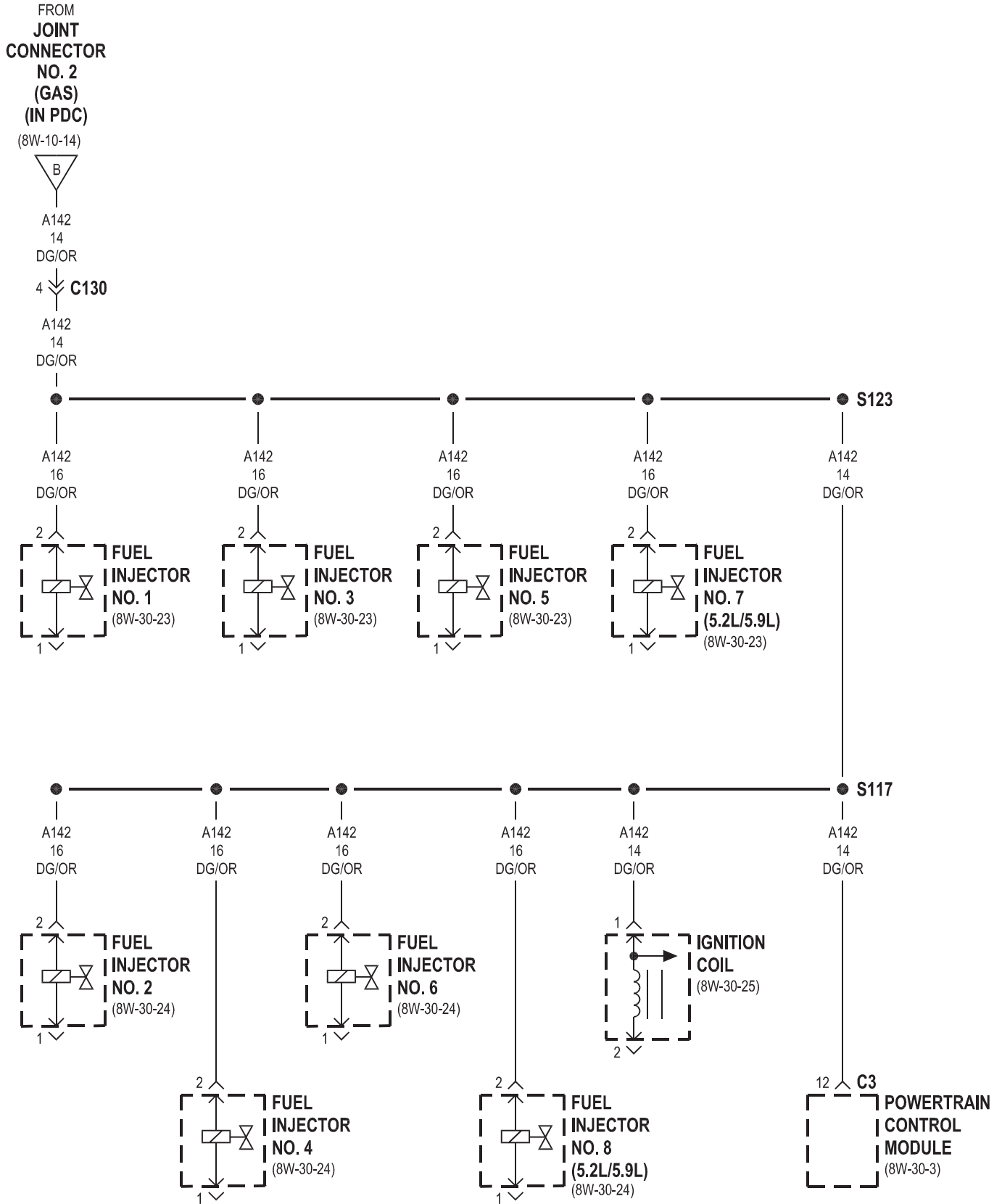








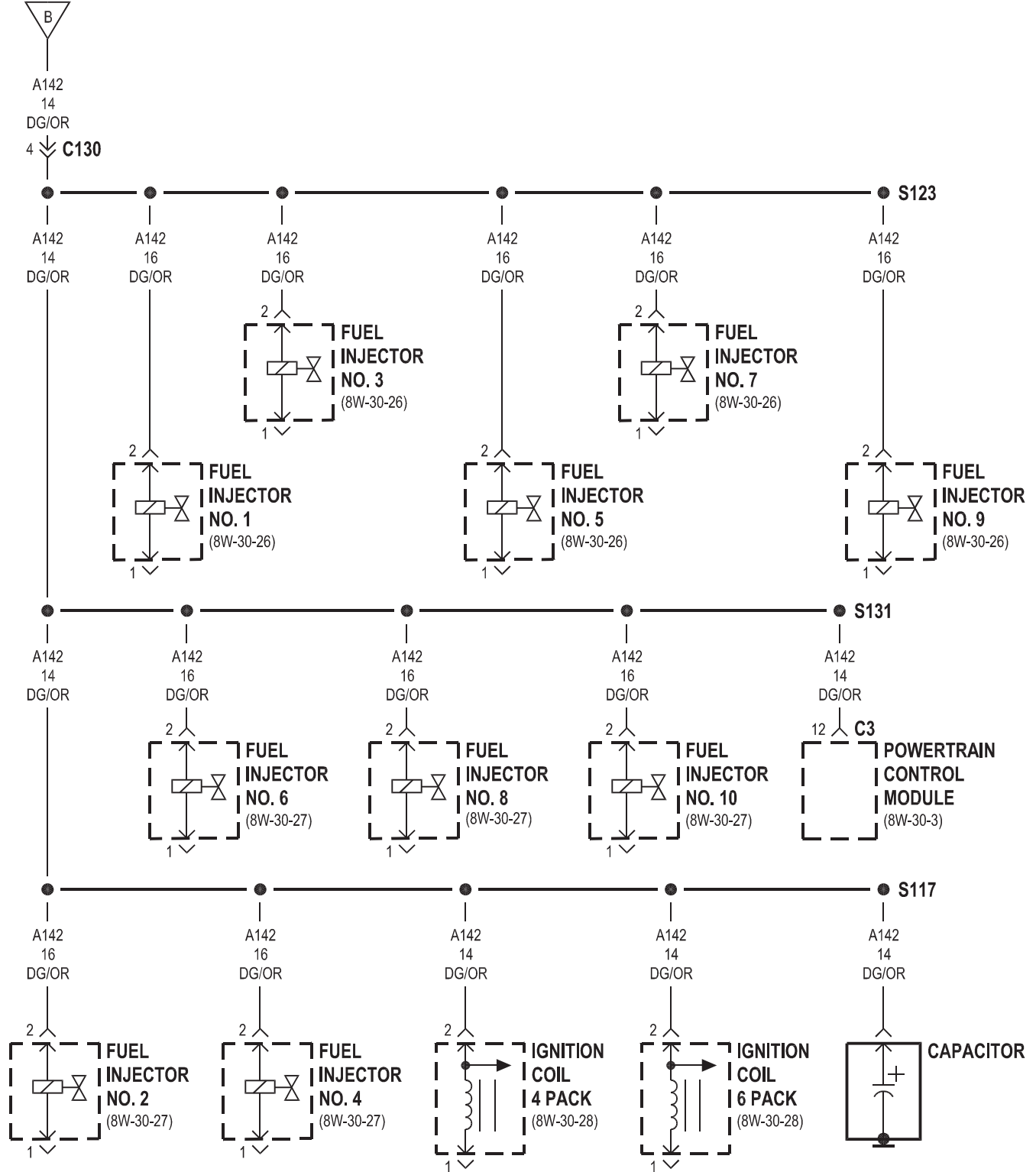


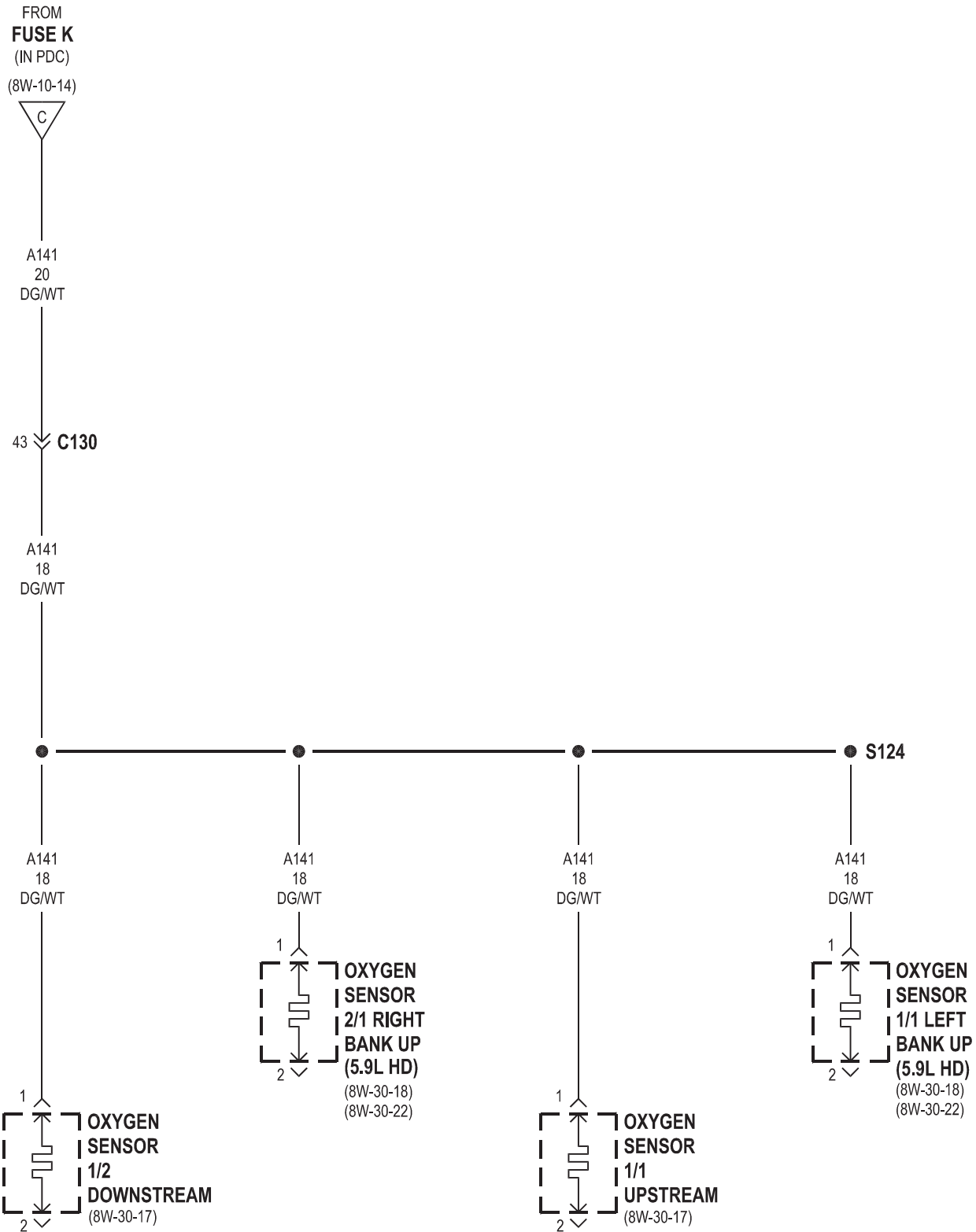


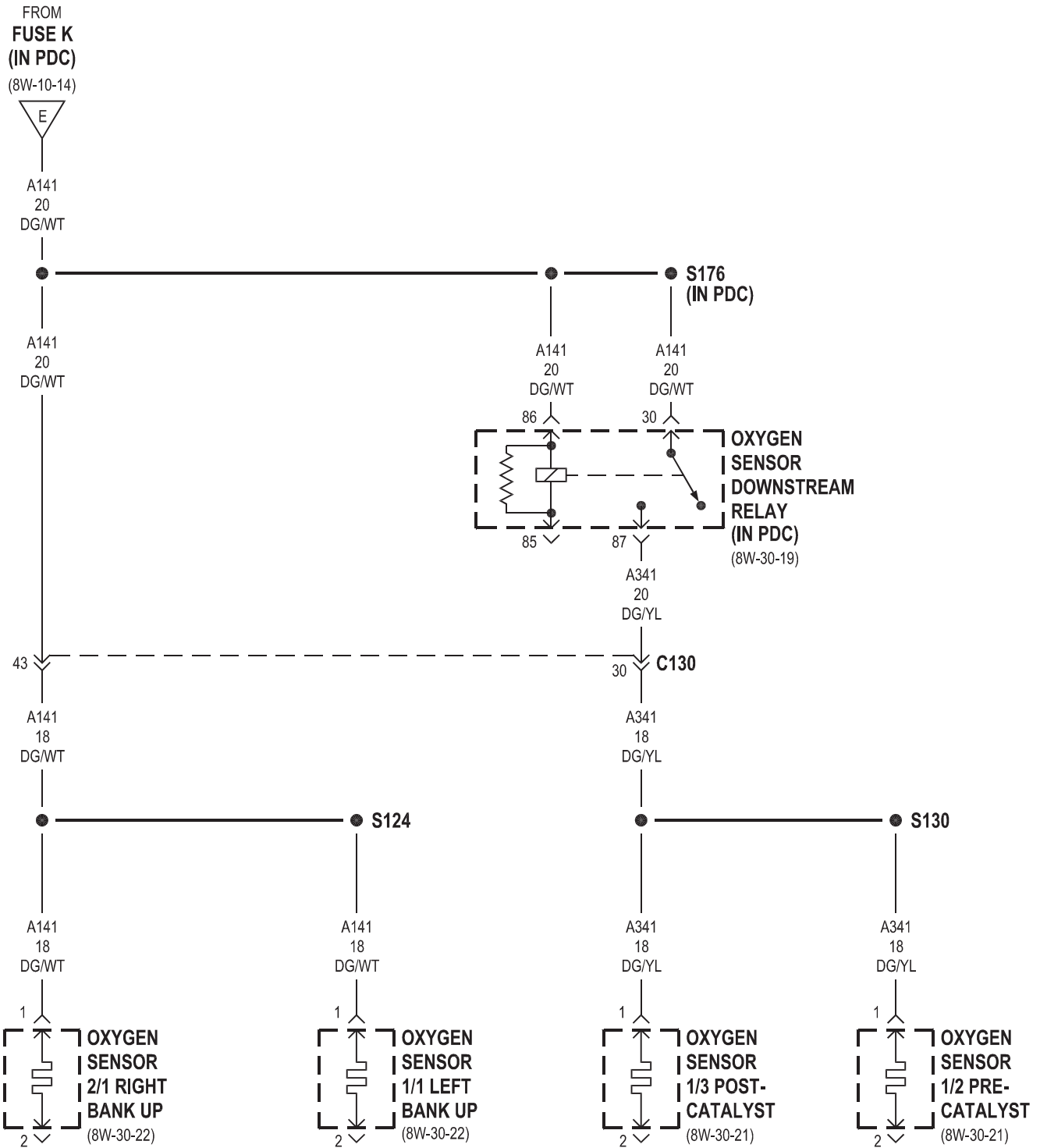


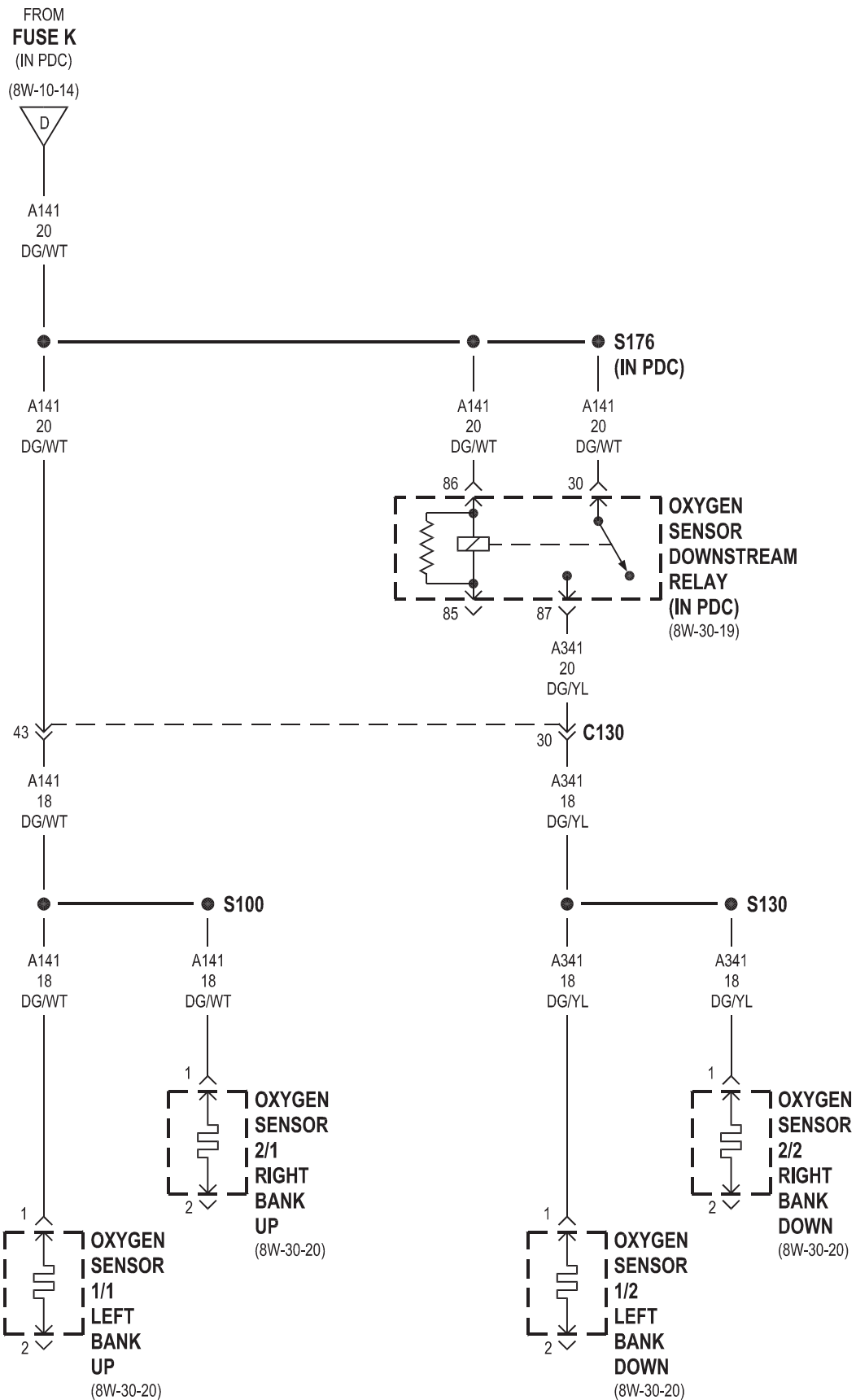
8.0L

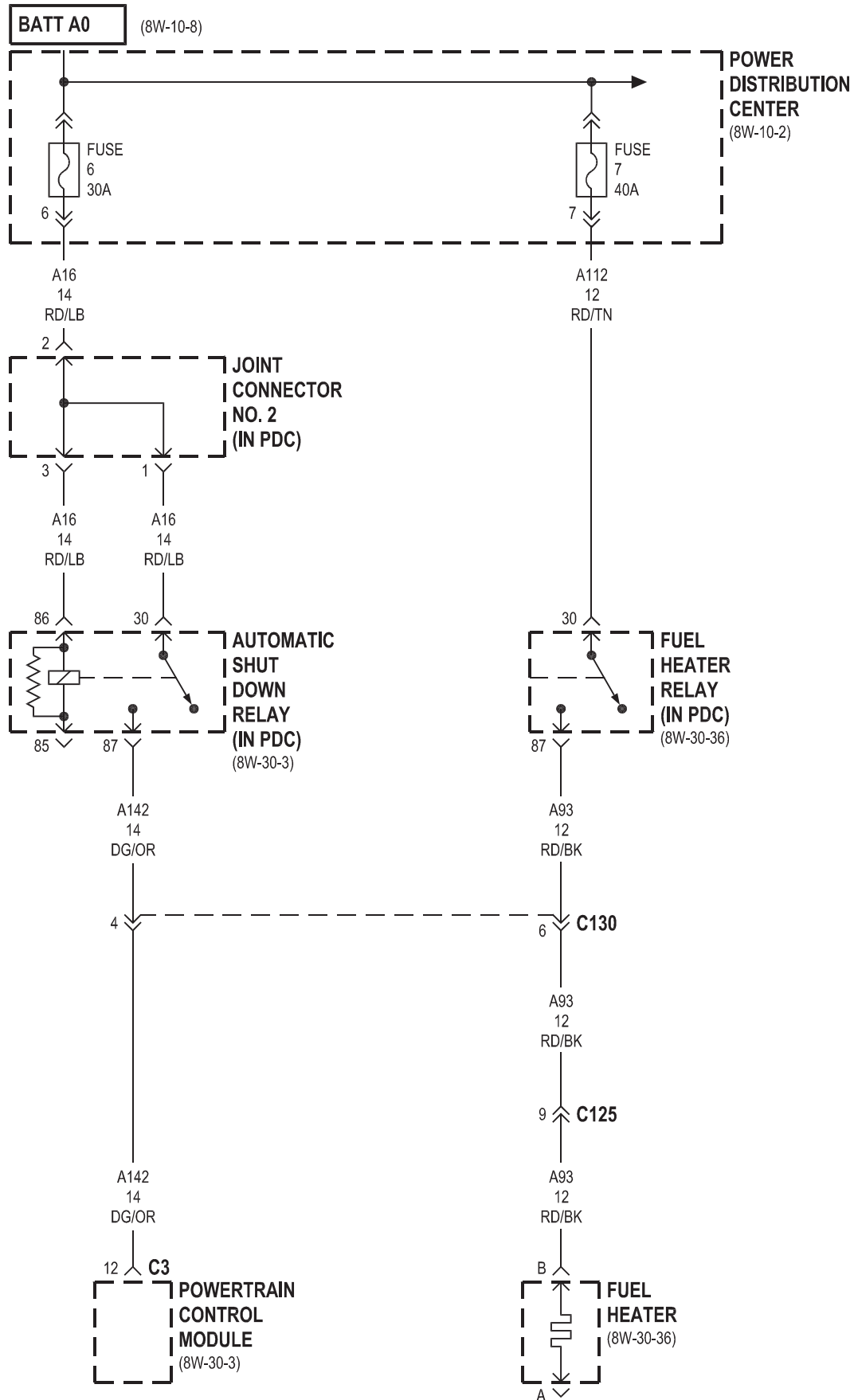
FROM  
JOINT  
CONNECTOR  
NO. 2  
(GAS)  
(IN PDC)  
(8W-10-14)



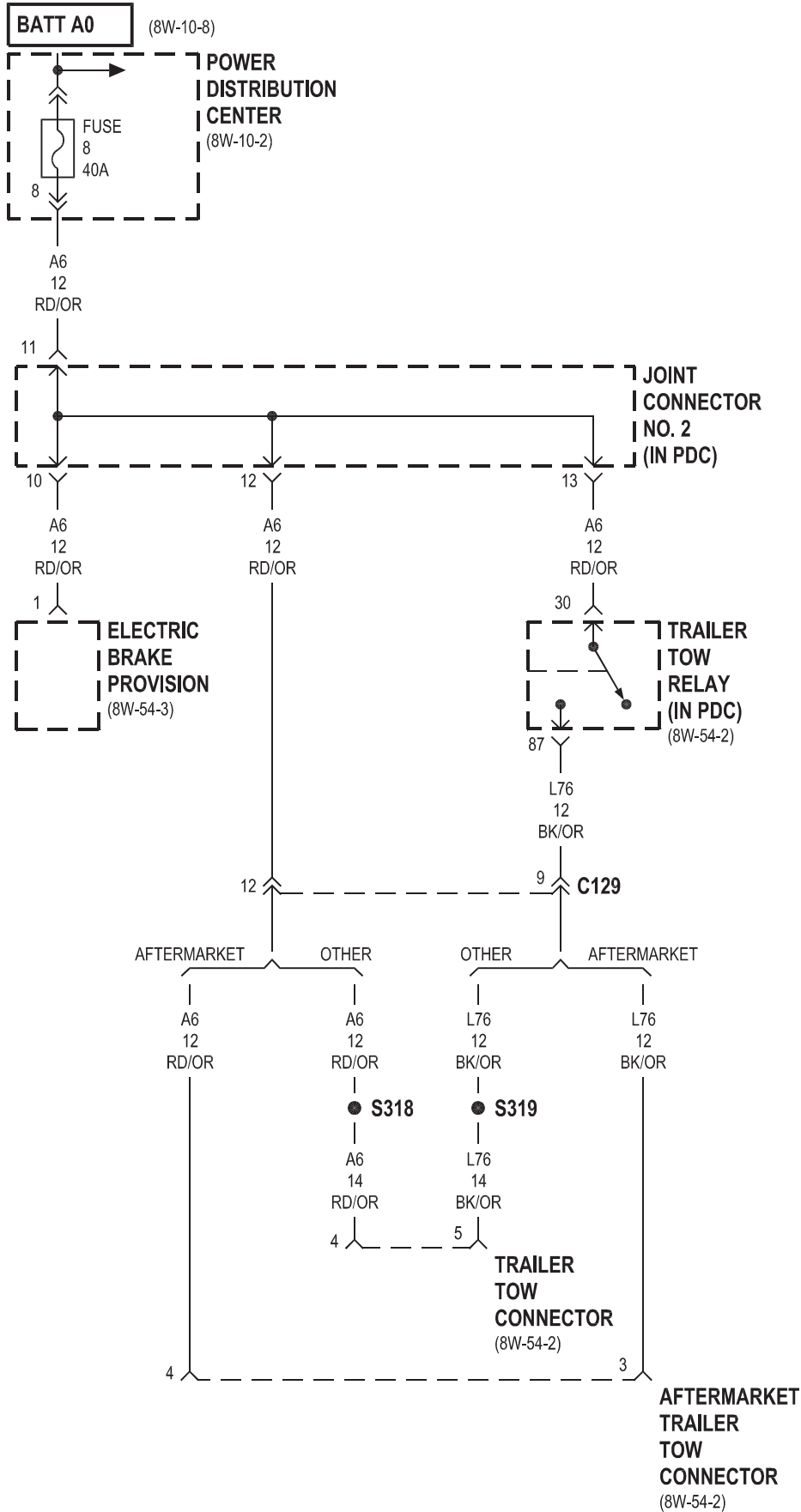


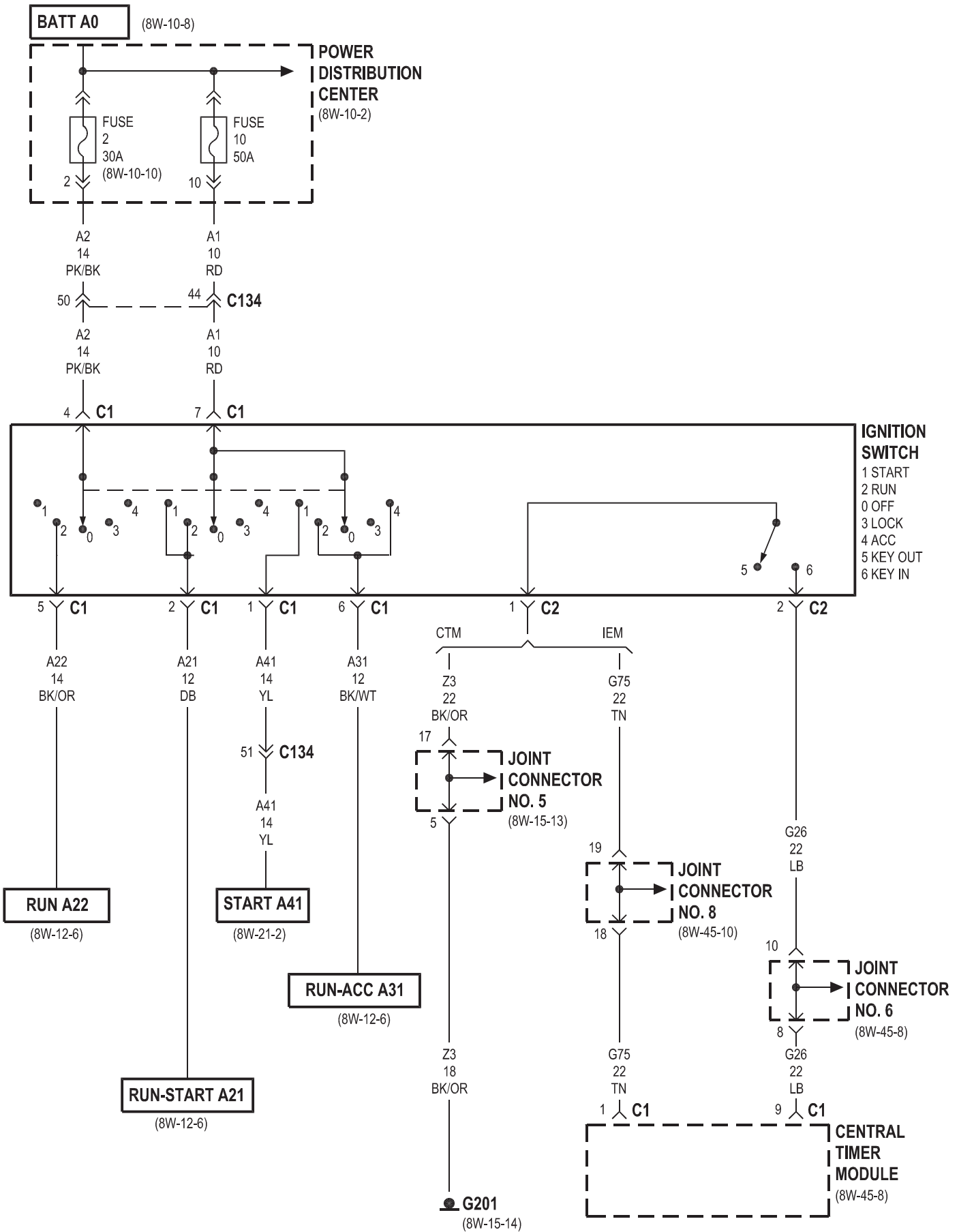


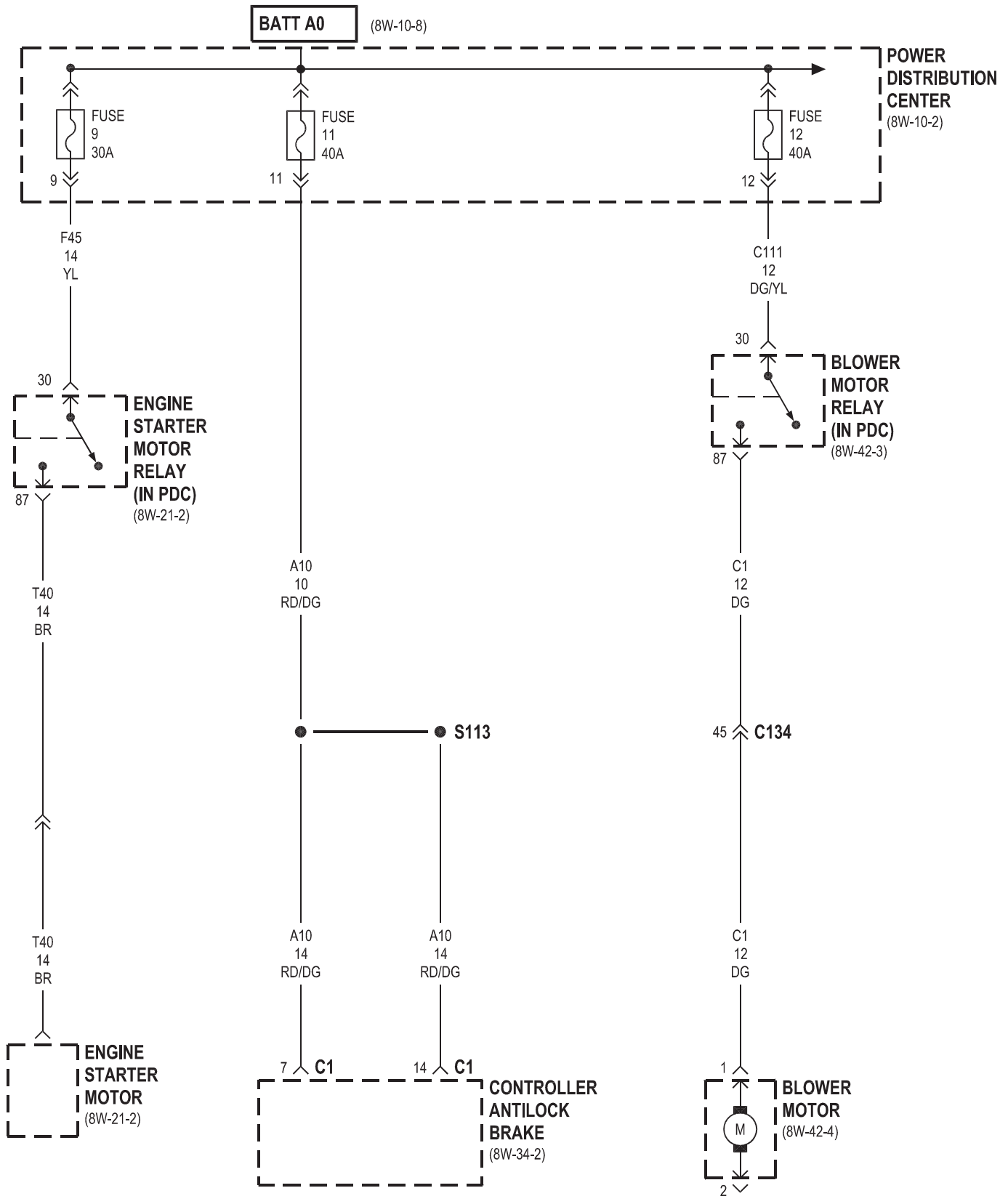


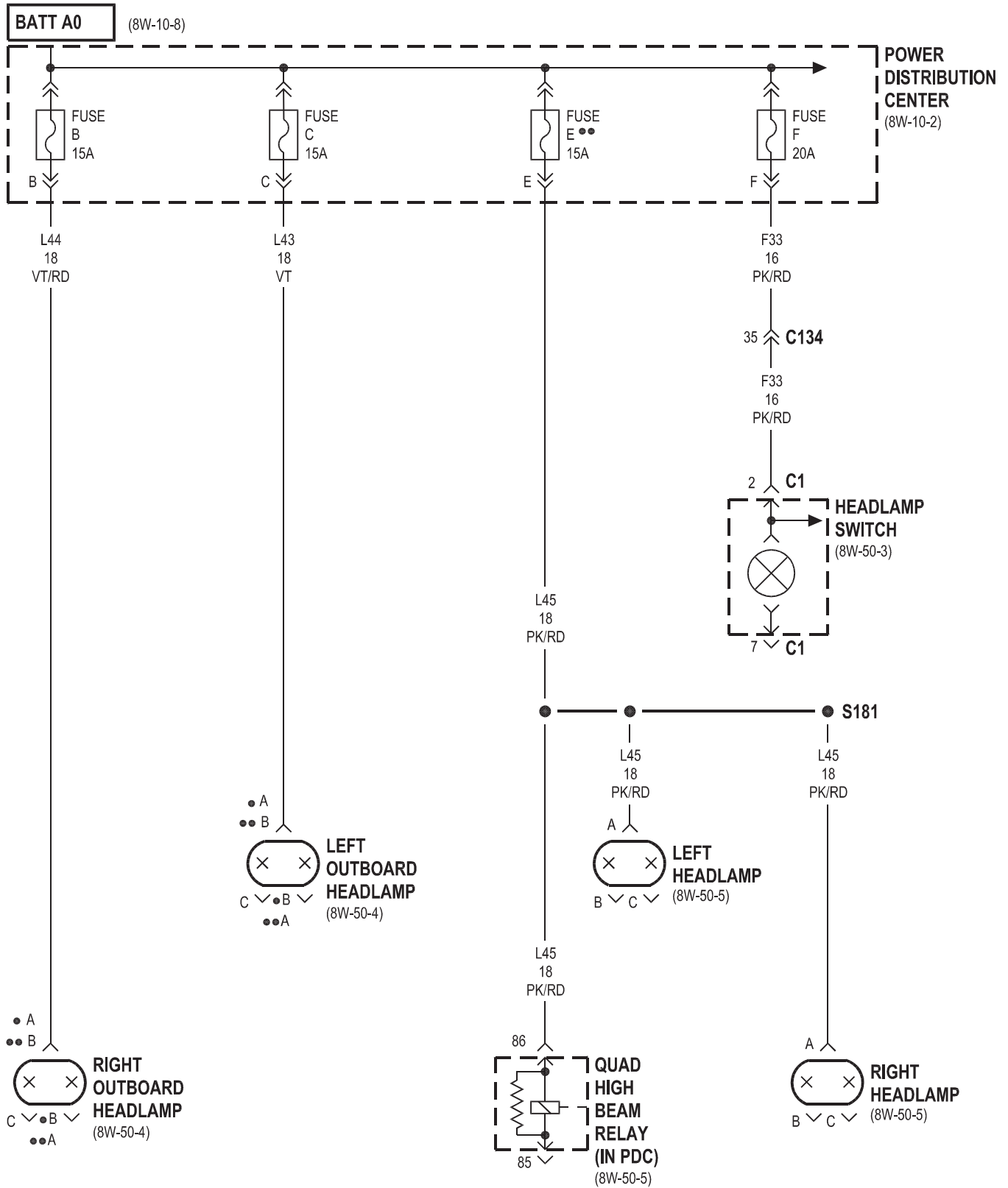




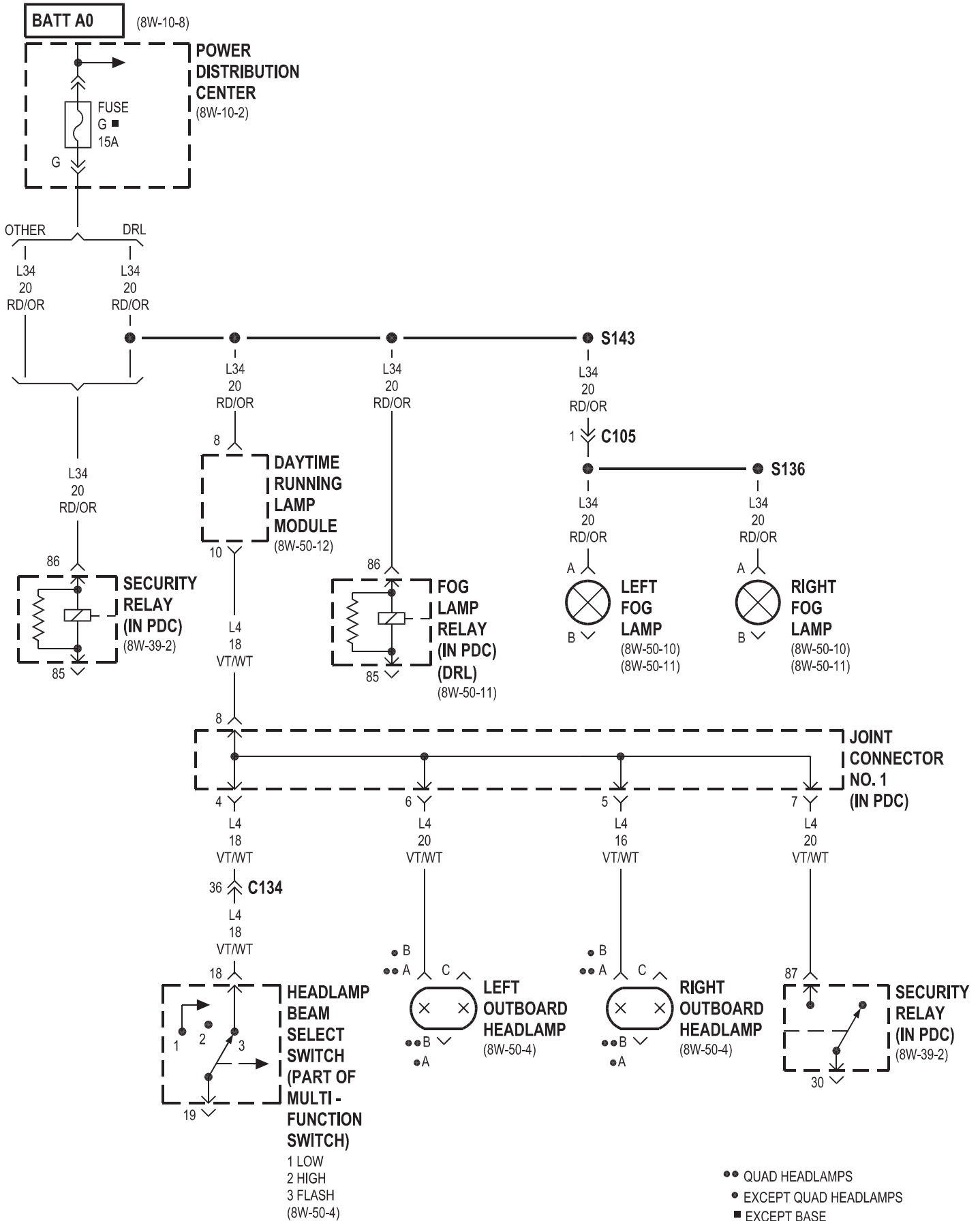




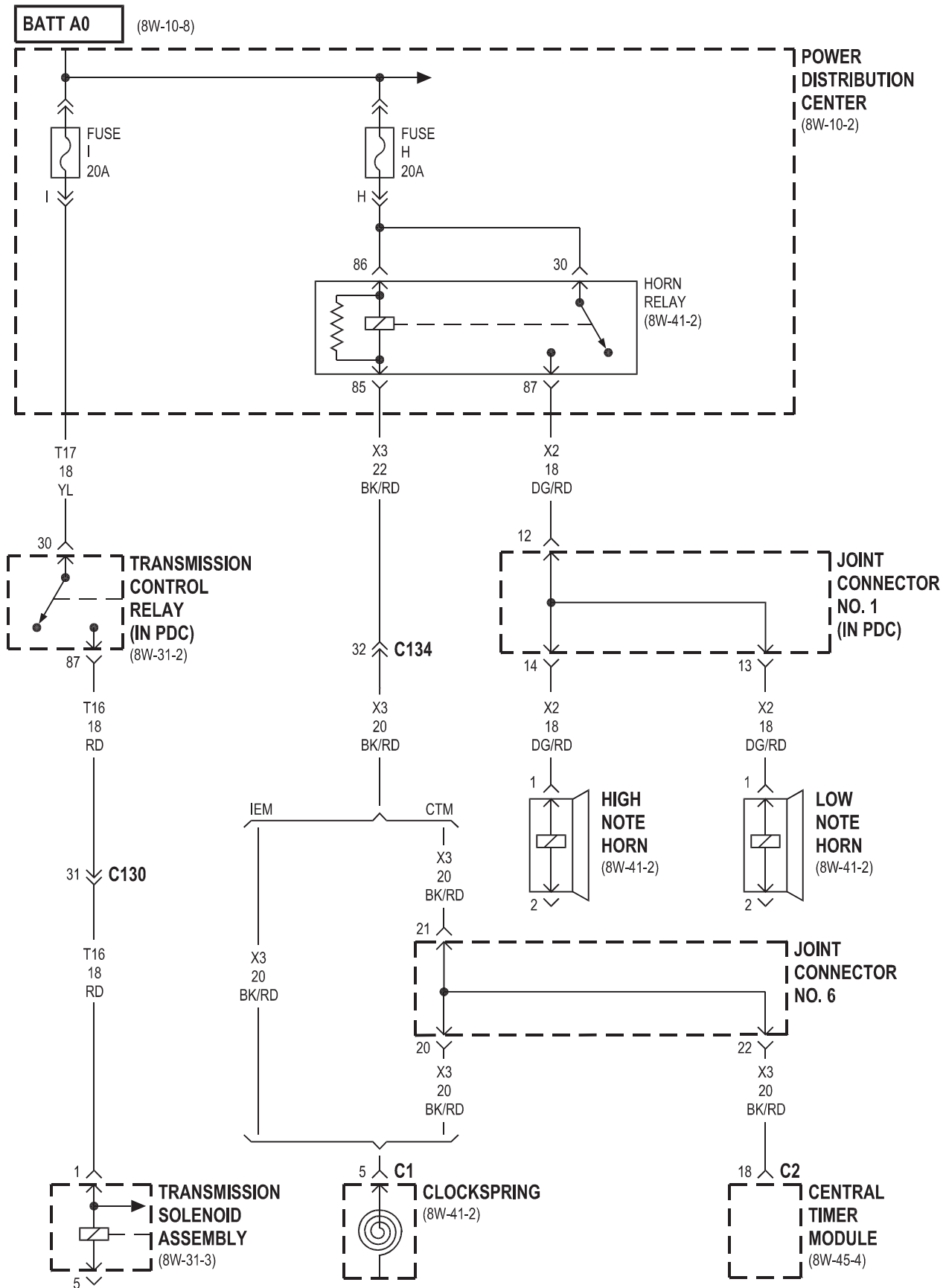


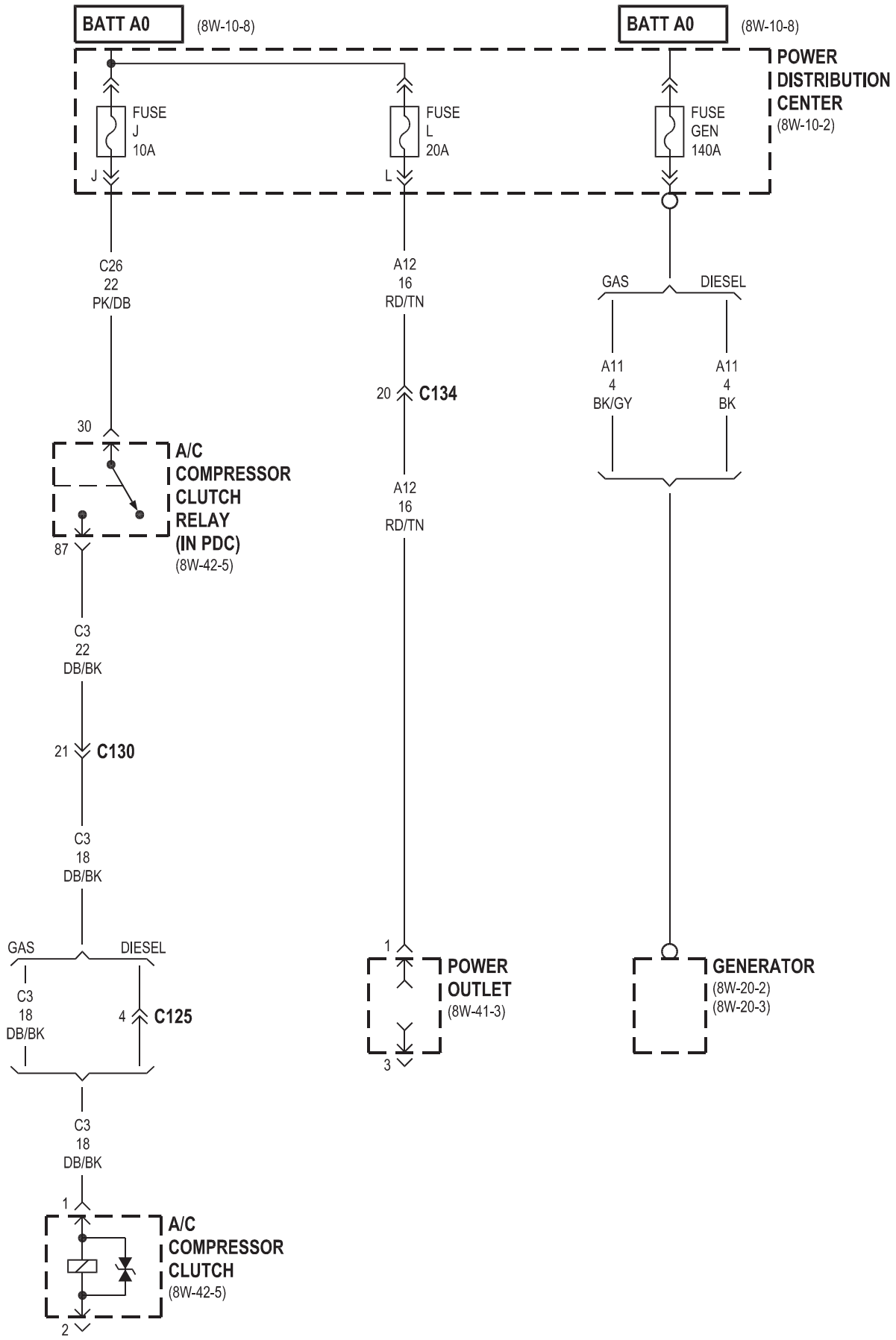


- EXCEPT QUAD HEADLAMPS
- QUAD HEADLAMPS







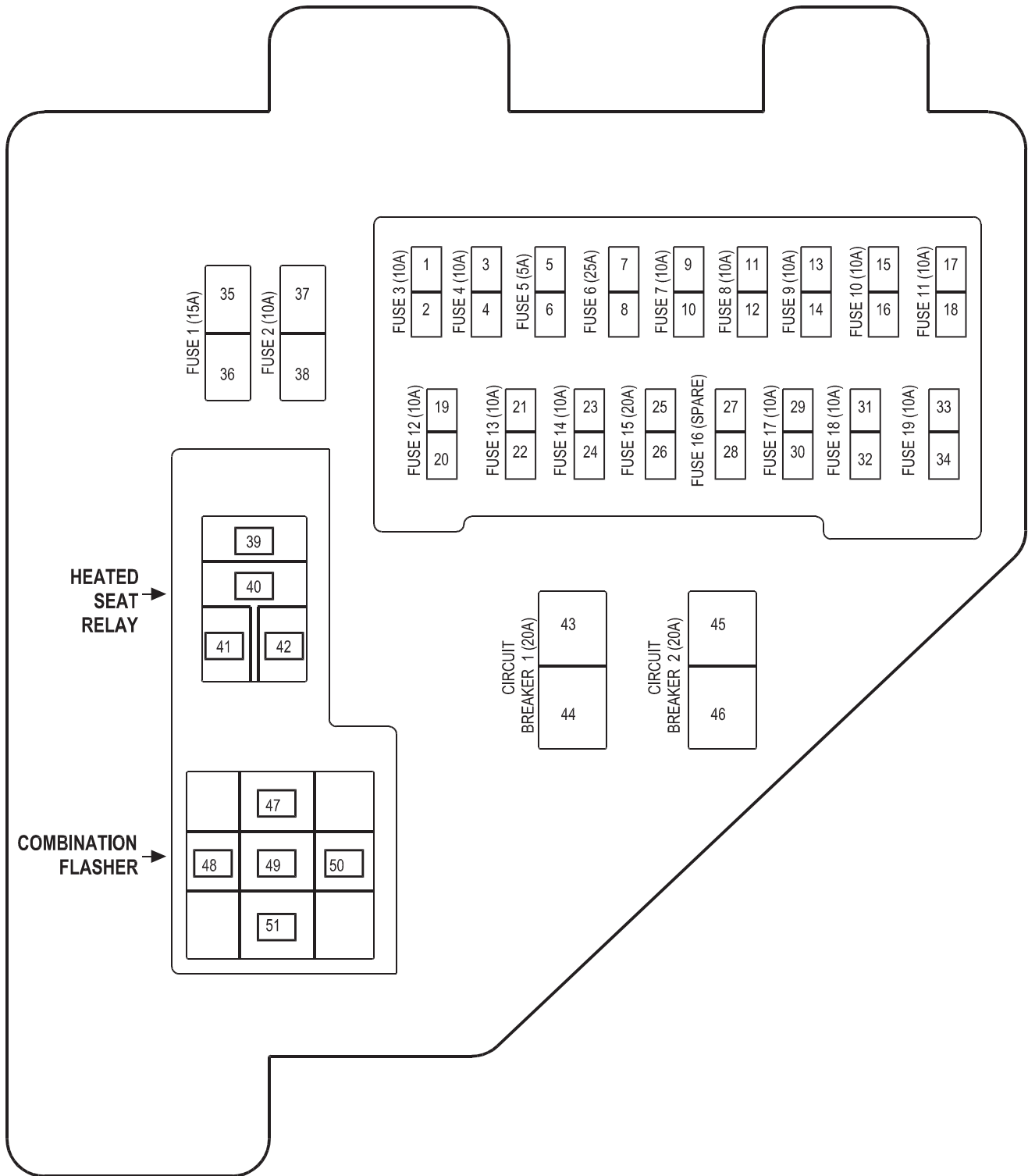




## 8W-12 JUNCTION BLOCK

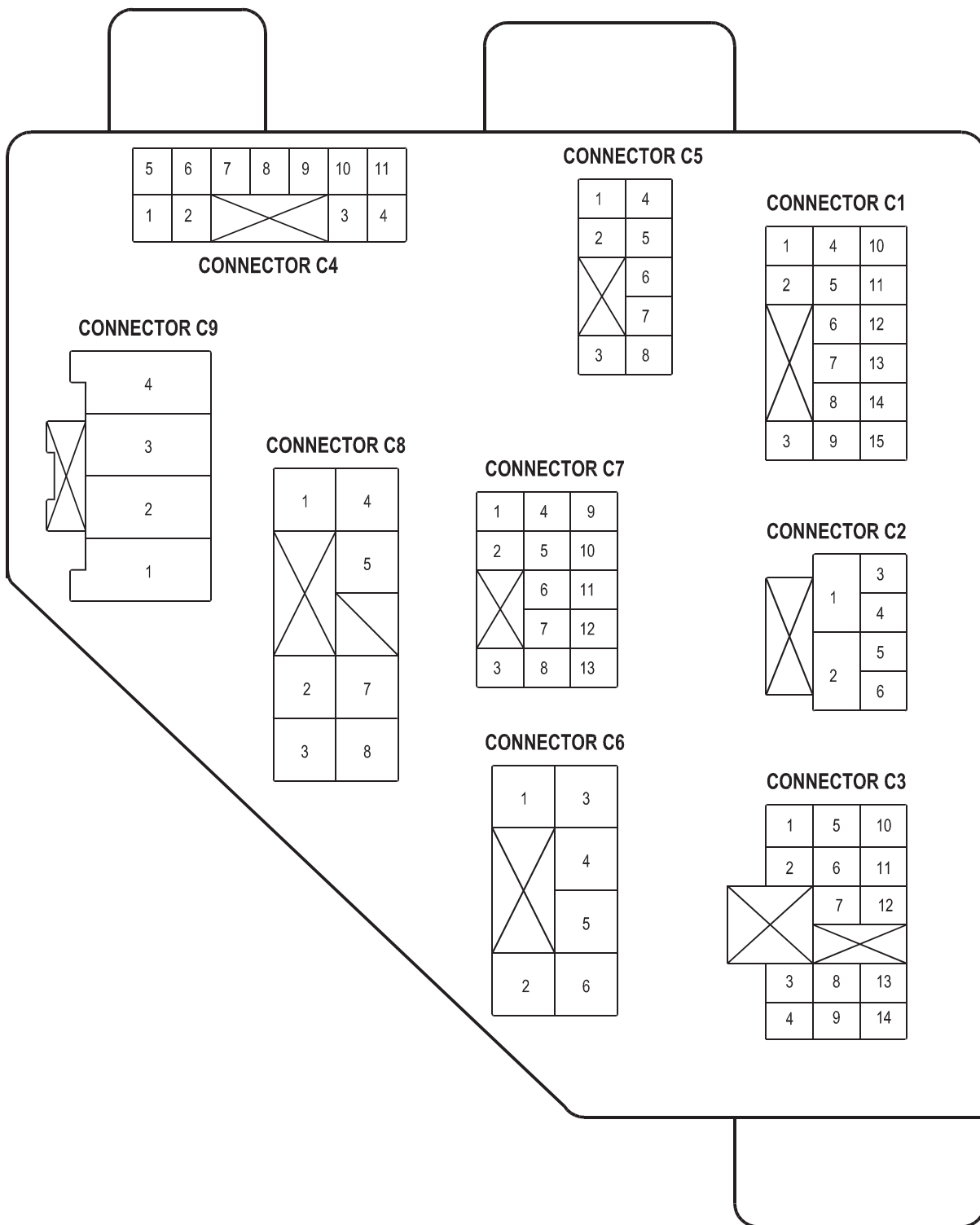
<b>Component</b>	<b>Page</b>	<b>Component</b>	<b>Page</b>
A/C Compressor Clutch Relay . . . . .	8W-12-13	Fuse 15 (JB) . . . . .	8W-12-6, 16
A/C-Heater Control . . . . .	8W-12-9	Fuse 16 (JB) . . . . .	8W-12-6, 16
A/C Heater Temperature Select . . . . .	8W-12-8	Fuse 17 (JB) . . . . .	8W-12-6, 17
Airbag Control Module . . . . .	8W-12-17	Fuse 18 (JB) . . . . .	8W-12-6, 17
Ambient Temperature Sensor . . . . .	8W-12-19	Fuse 19 (JB) . . . . .	8W-12-6, 17
Ash Receiver Lamp . . . . .	8W-12-9	G100 . . . . .	8W-12-18
Automatic Day/Night Mirror . . . . .	8W-12-13, 15, 21	G200 . . . . .	8W-12-15, 19
Back-Up Lamp Switch . . . . .	8W-12-11, 21	G201 . . . . .	8W-12-15, 18, 20
Blend Door Actuator . . . . .	8W-12-8	Glove Box Lamp And Switch . . . . .	8W-12-14
Blower Motor Relay . . . . .	8W-12-8	Headlamp Switch . . . . .	8W-12-9
Cargo Lamp No. 1 . . . . .	8W-12-14	Heated Mirror Switch . . . . .	8W-12-8
Cargo Lamp No. 2 . . . . .	8W-12-14	Heated Seat Relay . . . . .	8W-12-8
Central Timer Module C1 . . . . .	8W-12-10, 13, 15	Ignition Switch . . . . .	8W-12-6, 20
Central Timer Module C2 . . . . .	8W-12-8, 13	Instrument Cluster . . . . .	8W-12-9, 16, 17, 18
Cigar Lighter . . . . .	8W-12-16	Intermittent Wiper Switch . . . . .	8W-12-10
Circuit Breaker 1 . . . . .	8W-12-6, 7	Joint Connector No. 1 . . . . .	8W-12-11, 21
Circuit Breaker 2 . . . . .	8W-12-7	Joint Connector No. 3 . . . . .	8W-12-18
Combination Flasher . . . . .	8W-12-6, 12, 15, 20	Joint Connector No. 4 . . . . .	8W-12-18
Controller Antilock Brake . . . . .	8W-12-8	Joint Connector No. 5 . . . . .	8W-12-9, 14
Cup Holder Lamp . . . . .	8W-12-9	Joint Connector No. 6 . . . . .	8W-12-10
Data Link Connector . . . . .	8W-12-14	Joint Connector No. 8 . . . . .	8W-12- 8, 9, 17
Daytime Running Lamp Module . . . . .	8W-12-11	Junction Block . . . . .	8W-12-2, 3, 6, 7, 8, 9, 10, 11, 12, 13, 14, 15, 16, 17, 18, 19, 20, 21
Dome Lamp . . . . .	8W-12-14	Left Park/Turn Signal Lamp . . . . .	8W-12-18
Driver Door Window/Lock Switch . . . . .	8W-12-15, 7	Left Visor/Vanity Lamp . . . . .	8W-12-14, 15
Driver Heated Seat Switch . . . . .	8W-12-8, 9	Overhead Console . . . . .	8W-12-13, 14, 19, 21
Driver Power Seat Switch . . . . .	8W-12-7	Park/Neutral Position Switch . . . . .	8W-12-11, 21
Duty Cycle EVAP/Purge Solenoid . . . . .	8W-12-13	Passenger Airbag On/Off Switch . . . . .	8W-12-17
Engine Control Module . . . . .	8W-12-12	Passenger Door Window/Lock Switch . . . . .	8W-12-7, 15
Fuel Heater Relay . . . . .	8W-12-13	Passenger Heated Seat Switch . . . . .	8W-12-8, 9
Fuel Pump Relay . . . . .	8W-12-12	Passenger Power Seat Switch . . . . .	8W-12-7
Fuse 1 (JB) . . . . .	8W-12-8	Power Distribution Center . . . . .	8W-12-16, 20
Fuse 1 (PDC) . . . . .	8W-12-16	Power Mirror Switch . . . . .	8W-12-14, 21
Fuse 2 (JB) . . . . .	8W-12-6, 8	Powertrain Control Module . . . . .	8W-12-12
Fuse 3 (JB) . . . . .	8W-12-6, 8	Radio Choke Relay . . . . .	8W-12-10
Fuse 4 (JB) . . . . .	8W-12-10	Radio . . . . .	8W-12-9, 11, 14,
Fuse 4 (PDC) . . . . .	8W-12-20	Right Park/Turn Signal Lamp . . . . .	8W-12-18
Fuse 5 (JB) . . . . .	8W-12-9	Right Visor/Vanity Lamp . . . . .	8W-12-14, 15
Fuse 6 (JB) . . . . .	8W-12-6, 10	Seat Heat Interface Module . . . . .	8W-12-8
Fuse 7 (JB) . . . . .	8W-12-6, 11	Turn Signal/Hazard Switch . . . . .	8W-12-18, 20
Fuse 8 (JB) . . . . .	8W-12-6, 11	Underhood Lamp . . . . .	8W-12-14
Fuse 9 (JB) . . . . .	8W-12-6, 12	Windshield Washer Pump . . . . .	8W-12-10
Fuse 10 (JB) . . . . .	8W-12-6, 12, 20	Wiper Motor Relay . . . . .	8W-12-10
Fuse 11 (JB) . . . . .	8W-12-6, 13	Wiper Motor . . . . .	8W-12-10
Fuse 12 (JB) . . . . .	8W-12-14		
Fuse 13 (JB) . . . . .	8W-12-15		
Fuse 14 (JB) . . . . .	8W-12-16		

JUNCTION BLOCK  
(FRONT VIEW)





JUNCTION BLOCK  
(REAR VIEW)



## FUSES

FUSE NO.	AMPS	FUSED CIRCUIT	FUNCTION
1	15A	INTERNAL	FUSED B(+)
2	10A	F15 18DB	FUSED IGNITION SWITCH OUTPUT (RUN)
3	10A	A20 20RD/DB	FUSED IGNITION SWITCH OUTPUT (RUN)
4	10A	X60 16DG/RD	RADIO 12V OUTPUT
5	5A	E2 22OR	FUSED PANEL LAMPS DIMMER SWITCH SIGNAL
6	25A	INTERNAL	FUSED IGNITION SWITCH OUTPUT (RUN-ACC)
7	10A	L10 18BR/LG	FUSED IGNITION SWITCH OUTPUT (RUN)
8	10A	X12 16RD/WT	FUSED IGNITION SWITCH OUTPUT (RUN-ACC)
9	10A	F18 20LG/BK	FUSED IGNITION SWITCH OUTPUT (RUN-START)
10	10A	INTERNAL	FUSED IGNITION SWITCH OUTPUT (RUN-START)
11	10A	INTERNAL	FUSED IGNITION SWITCH OUTPUT (RUN-START)
12	10A	INTERNAL	FUSED B(+)
13	10A	INTERNAL	FUSED B(+)
14	10A	F73 20YL	FUSED B(+)
15	20A	F30 18RD/OR	FUSED IGNITION SWITCH OUTPUT (RUN-ACC)
16	-	-	-
17	10A	G5 22DB/WT	FUSED IGNITION SWITCH OUTPUT (RUN-START)
18	10A	F23 18DB/YL	FUSED IGNITION SWITCH OUTPUT (RUN)
19	10A	F14 18LG/YL	FUSED IGNITION SWITCH OUTPUT (RUN-START)

## CIRCUIT BREAKERS

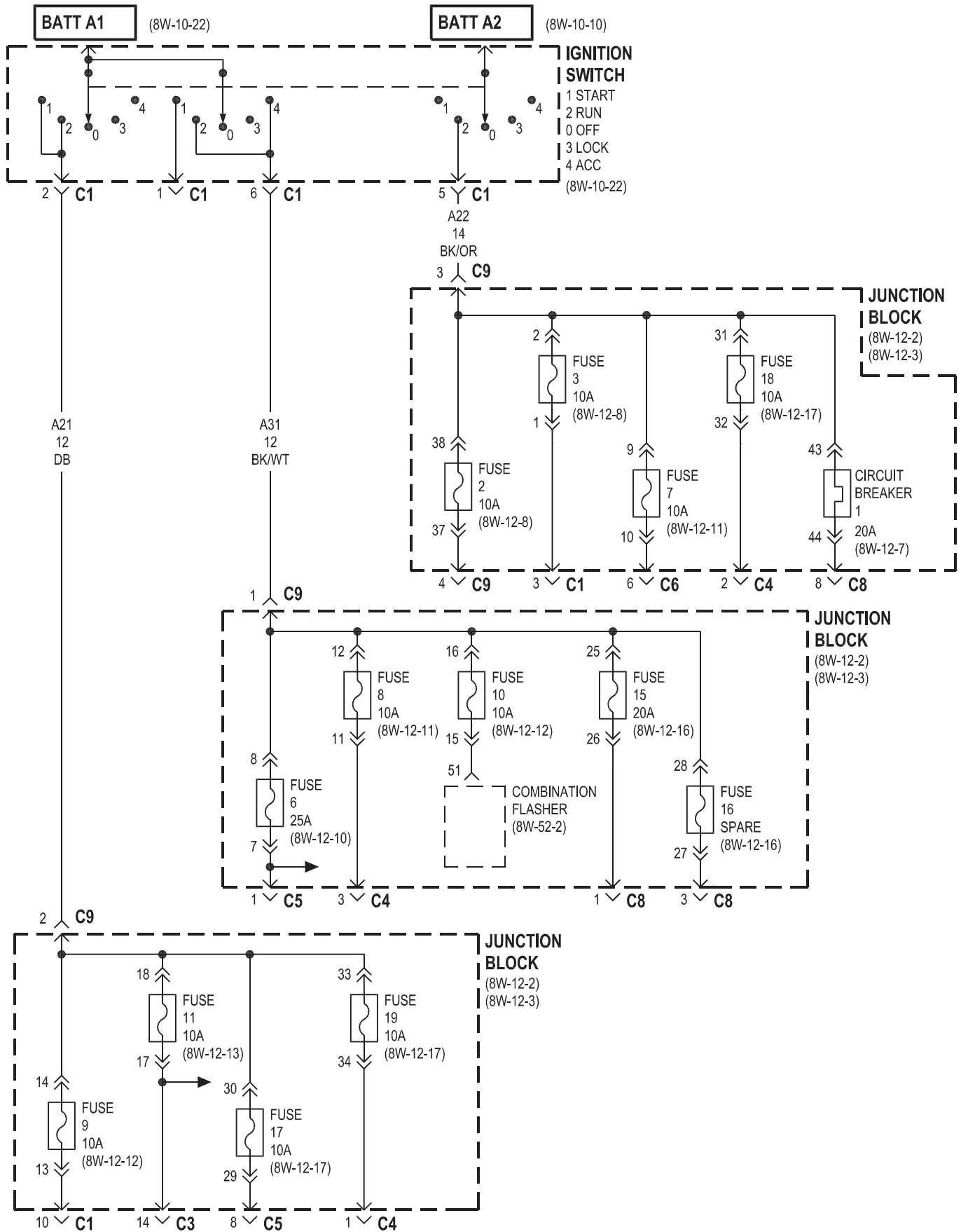
C.B. NO.	AMPS	CIRCUIT	FUNCTION
1	20A	F21 14TN	FUSED IGNITION SWITCH OUTPUT (RUN)
2	20A	F37 16RD/LB	FUSED B(+)

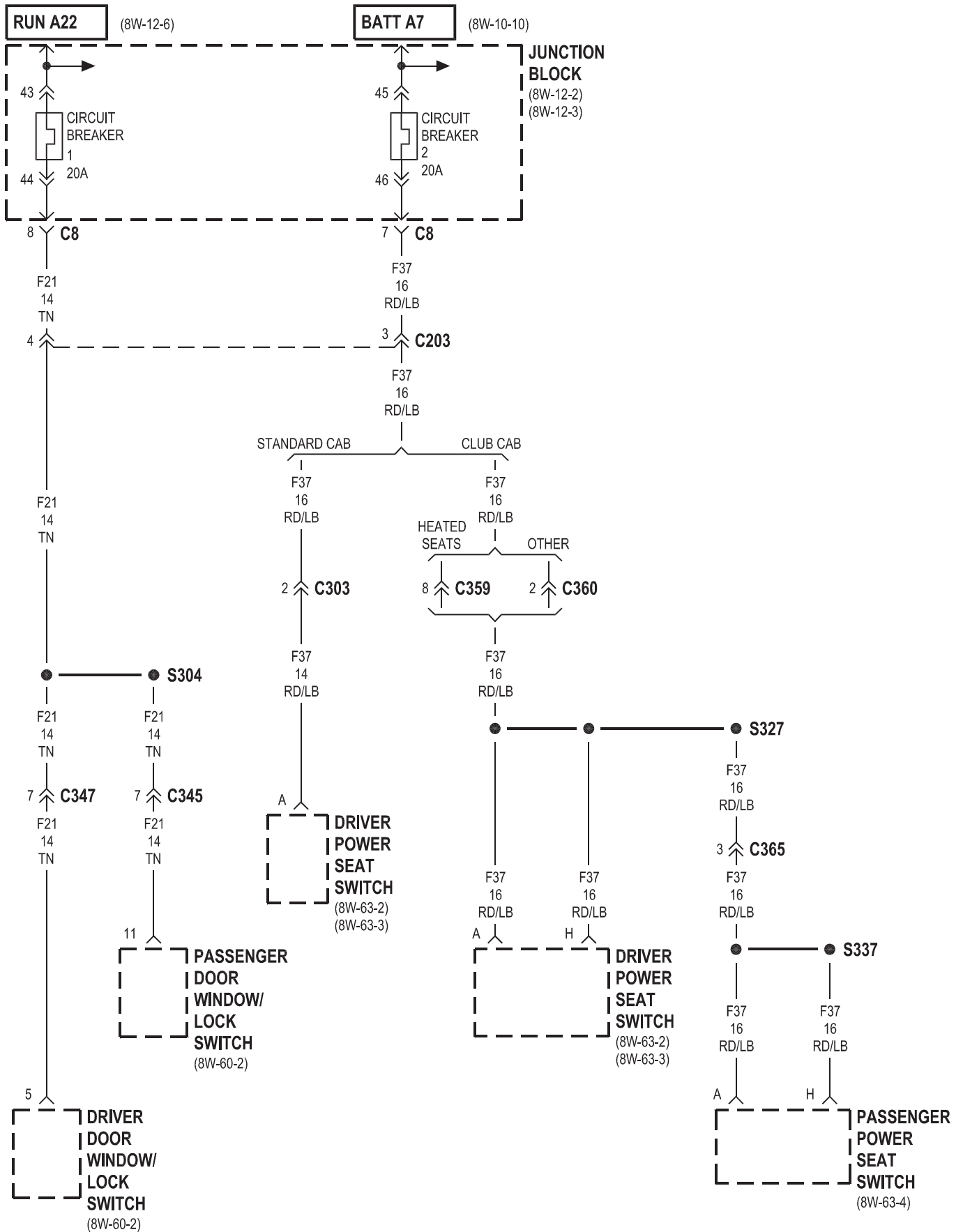
**COMBINATION  
FLASHER**

CAV	CIRCUIT	FUNCTION
47	L6 16RD/GY	FLASHER OUTPUT
48	L9 16BK/VT	FUSED FLASHER FEED
49	L19 16PK	HAZARD FLASHER SIGNAL
50	INTERNAL	GROUND
51	INTERNAL	FUSED IGNITION SWITCH OUTPUT (RUN-ACC)

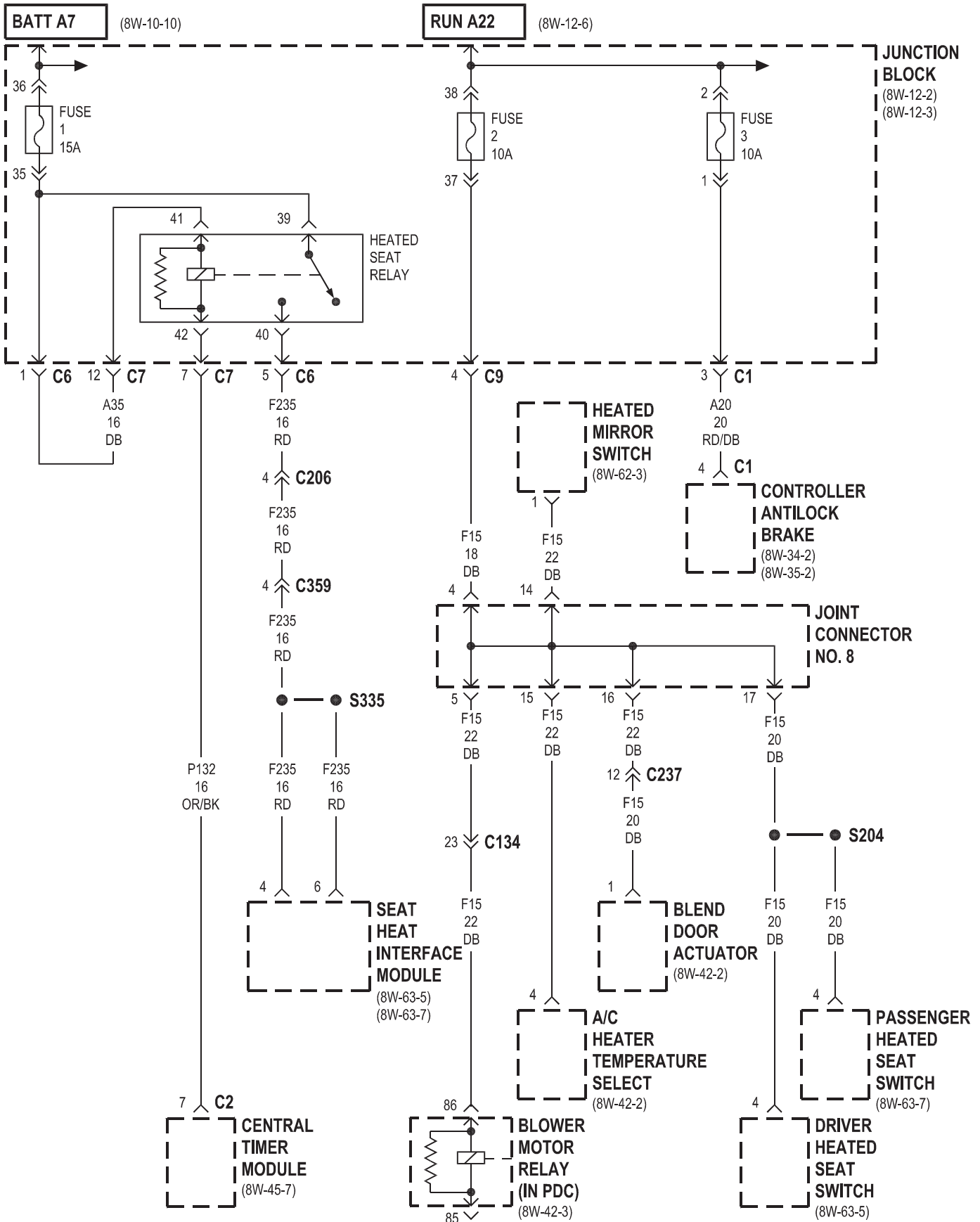
**HEATED  
SEAT  
RELAY**

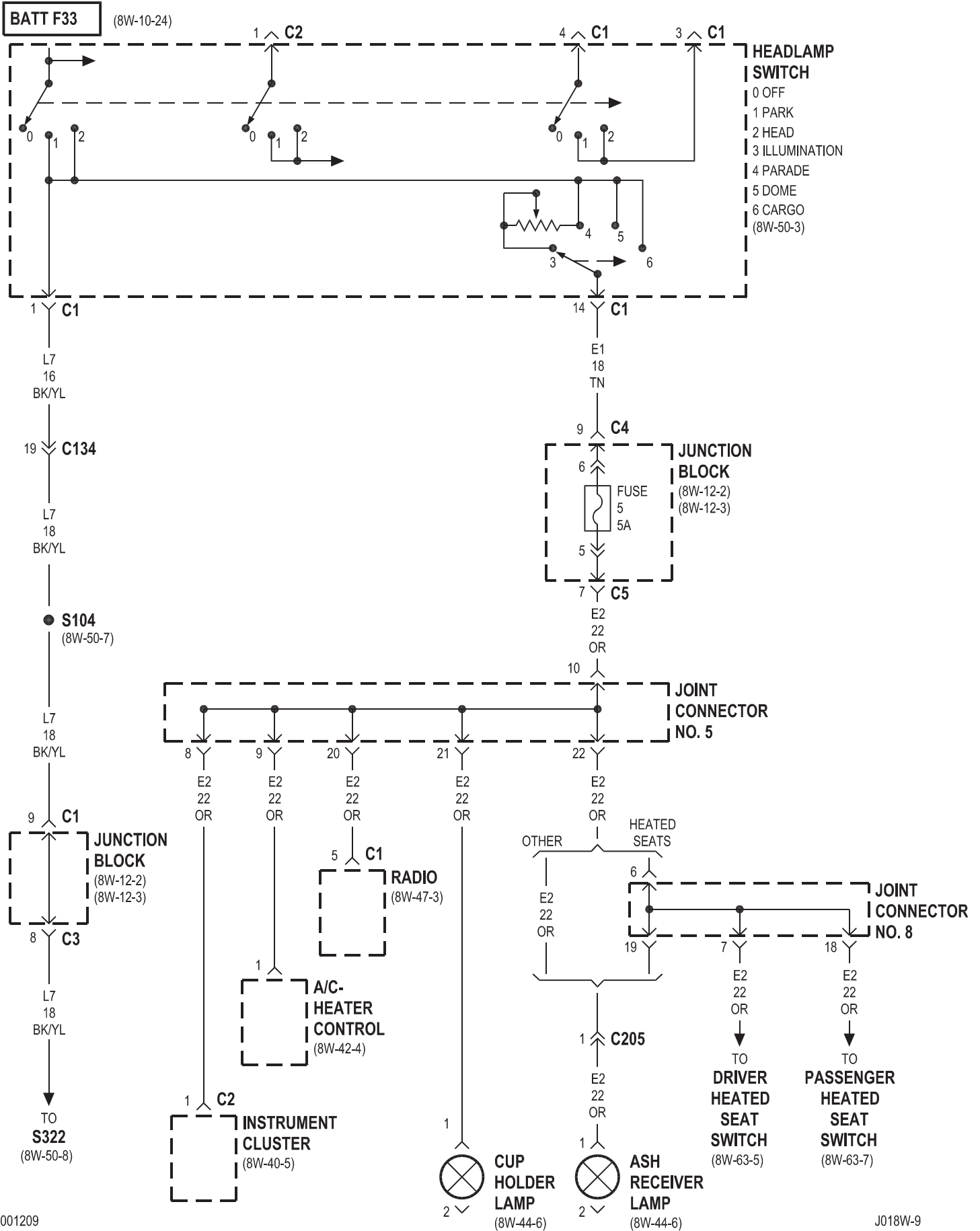
CAV	CIRCUIT	FUNCTION
39	INTERNAL	FUSED B(+)
40	F235 16RD	HEATED SEAT RELAY OUTPUT
41	A35 16DB	FUSED B(+)
42	P132 16OR/BK	HEATED SEAT ENABLE

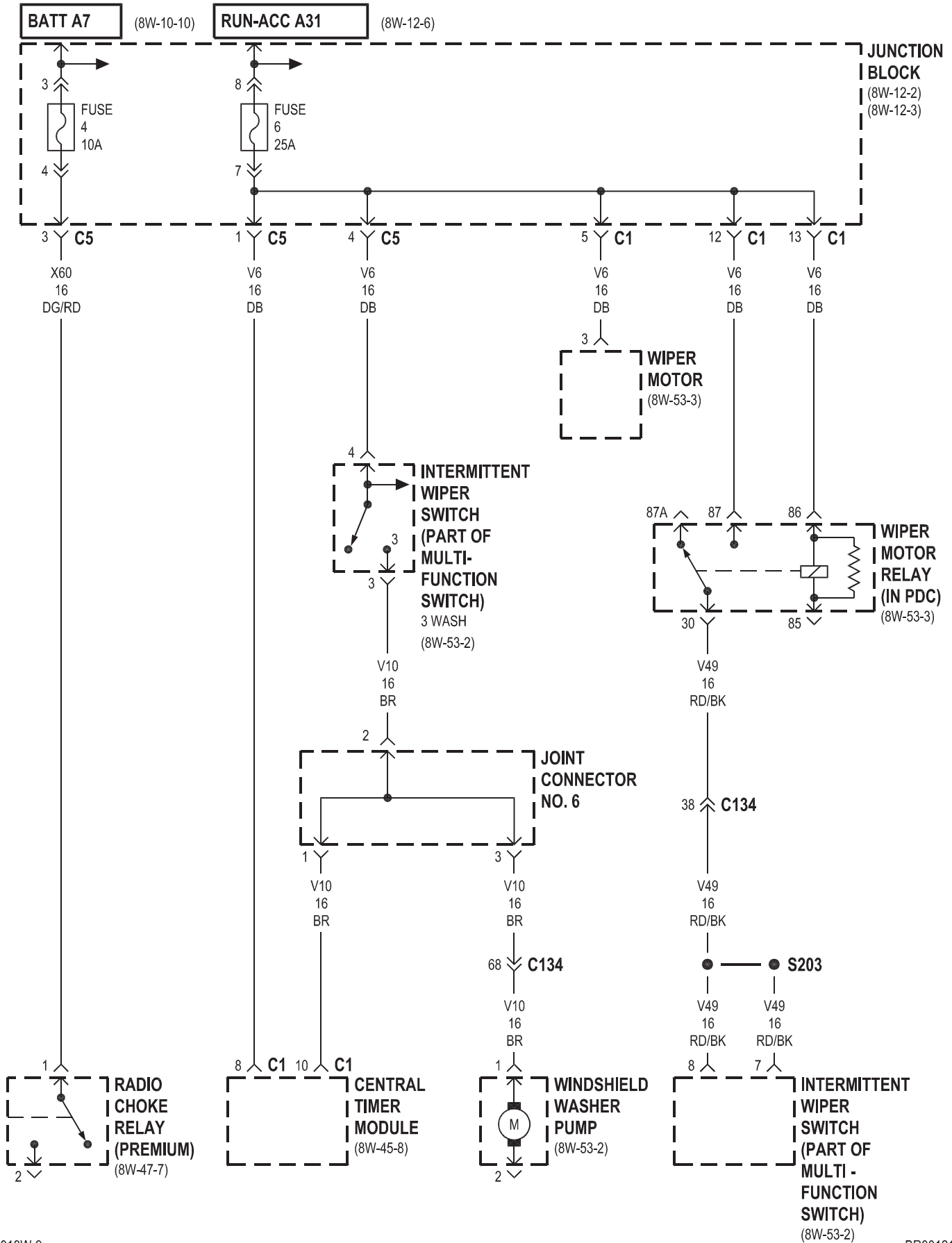


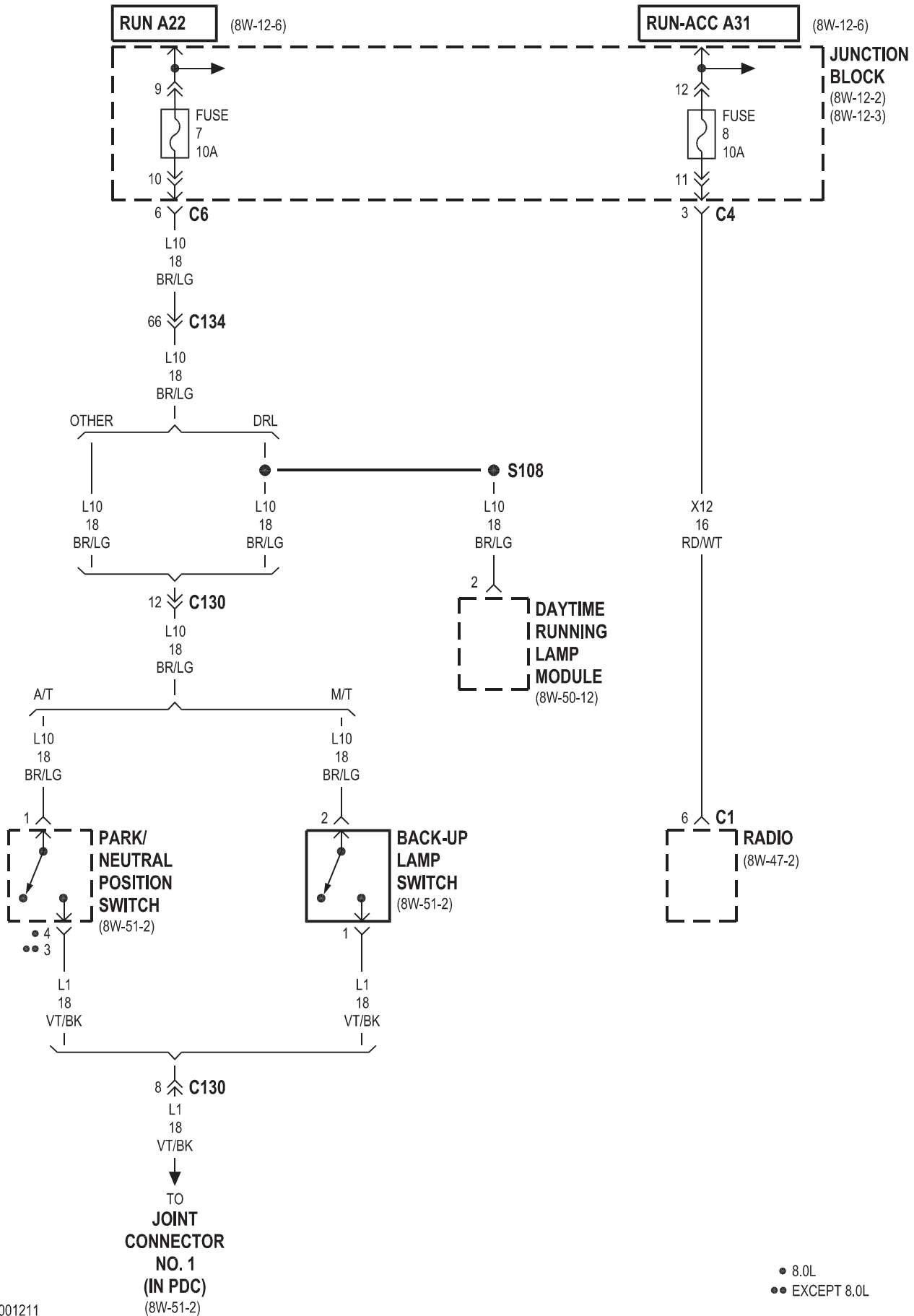




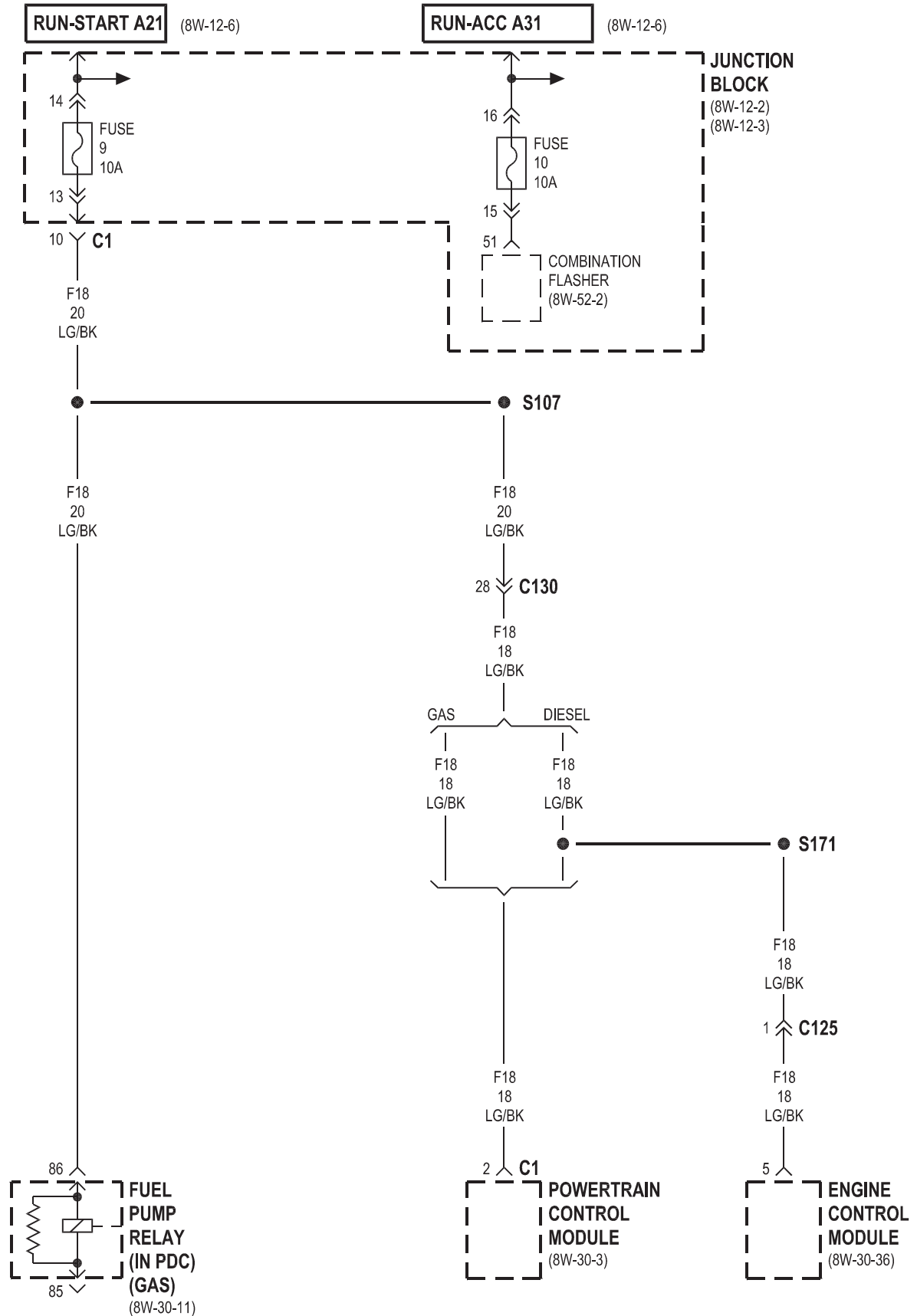






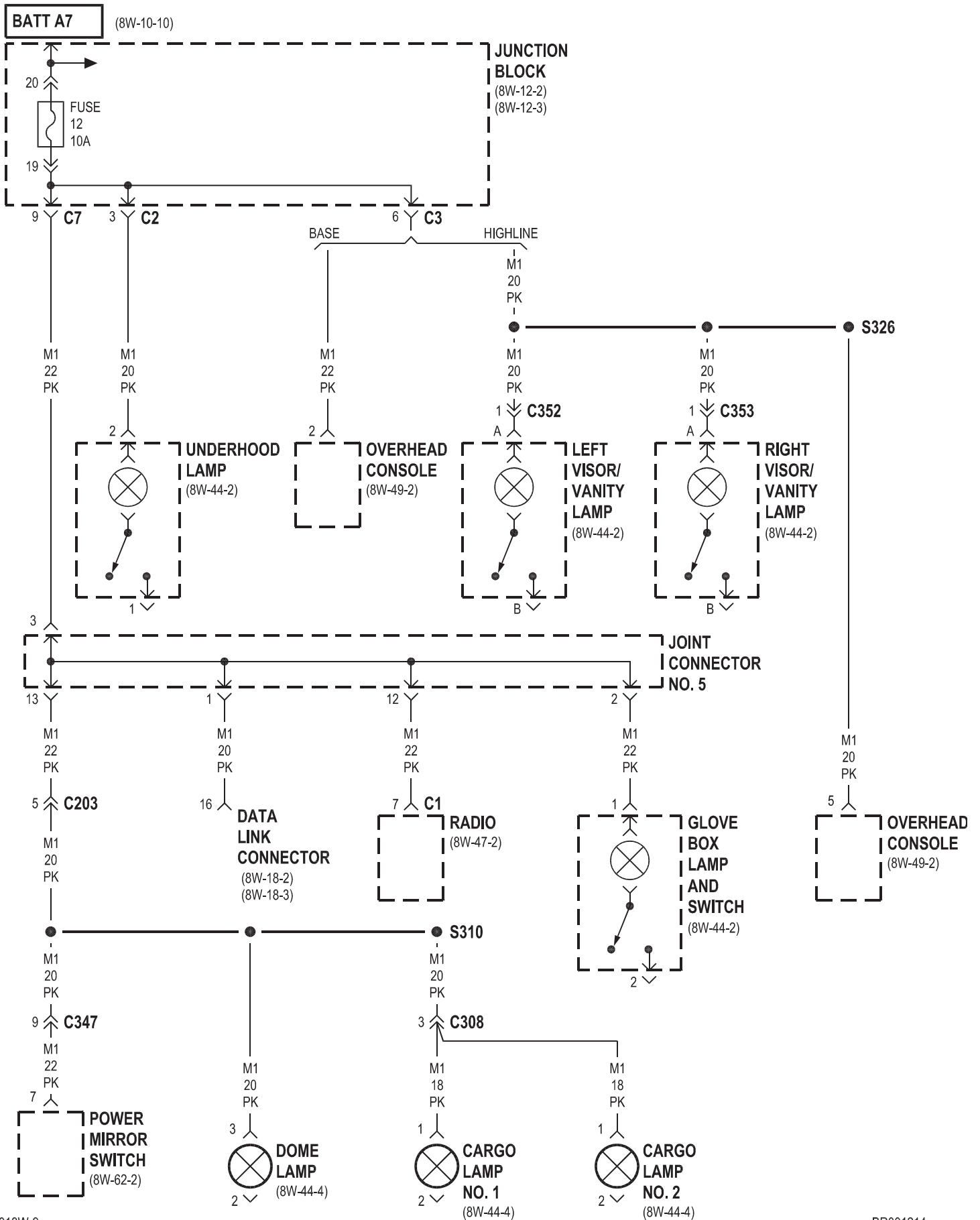


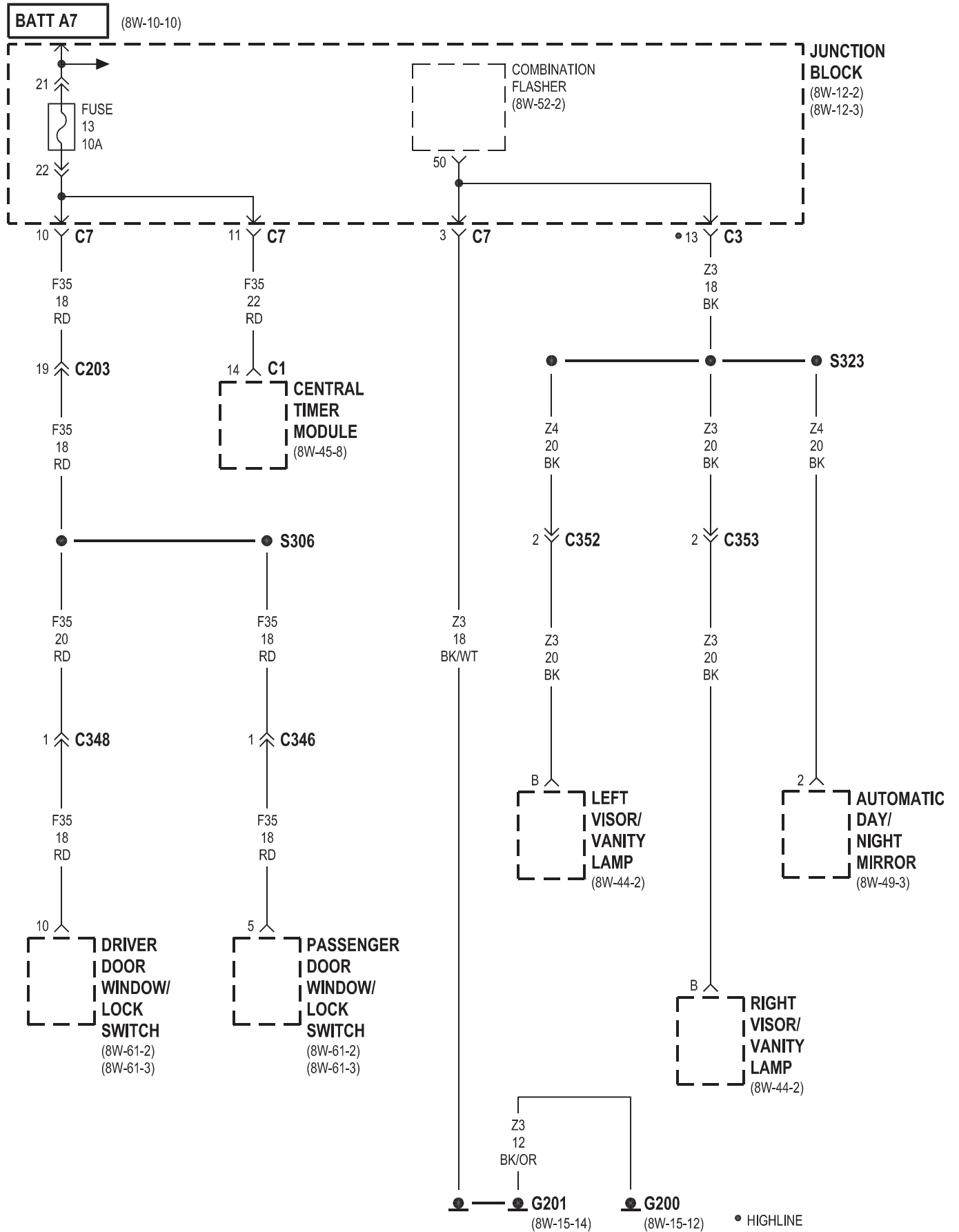
- 8.0L
- EXCEPT 8.0L

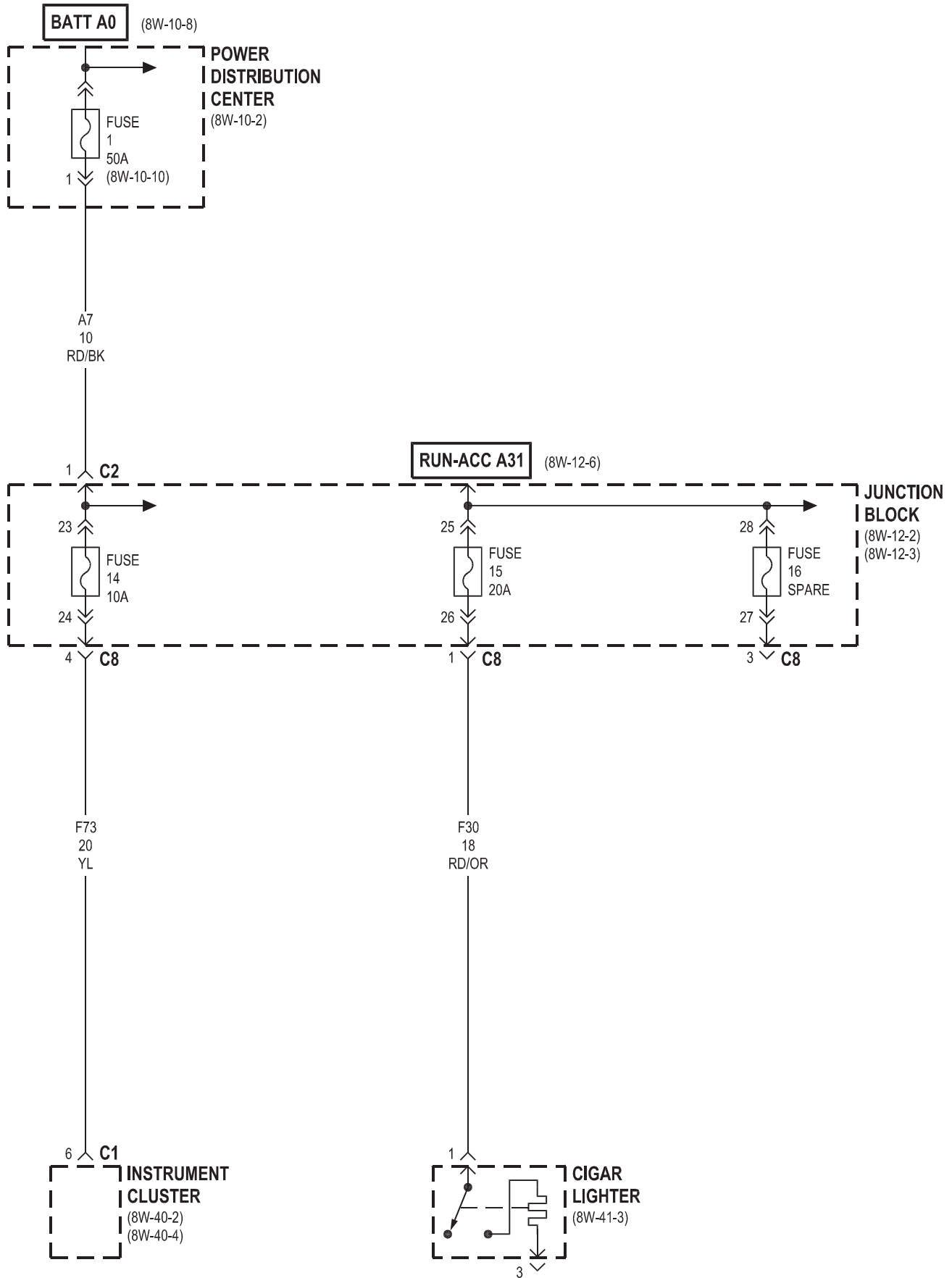


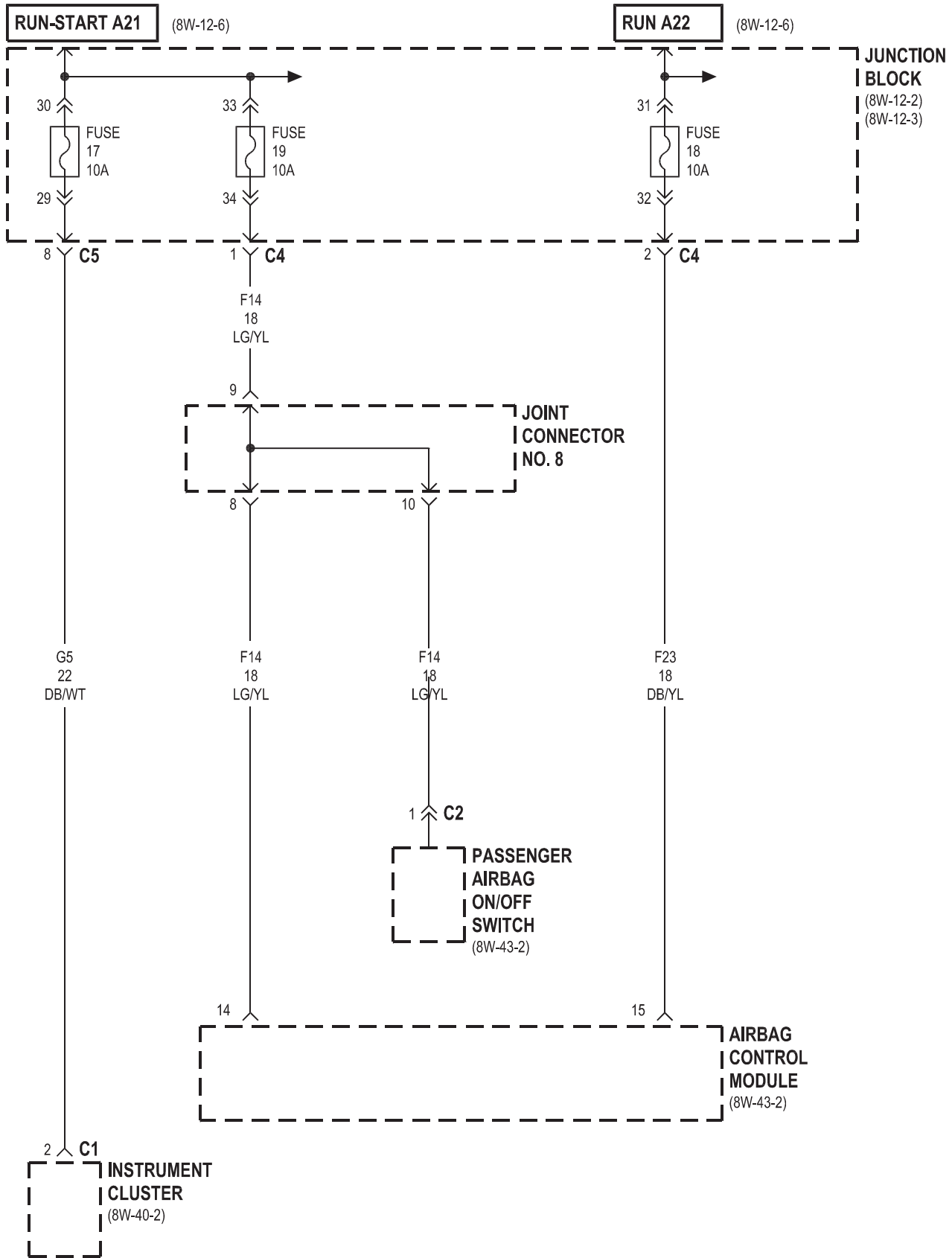




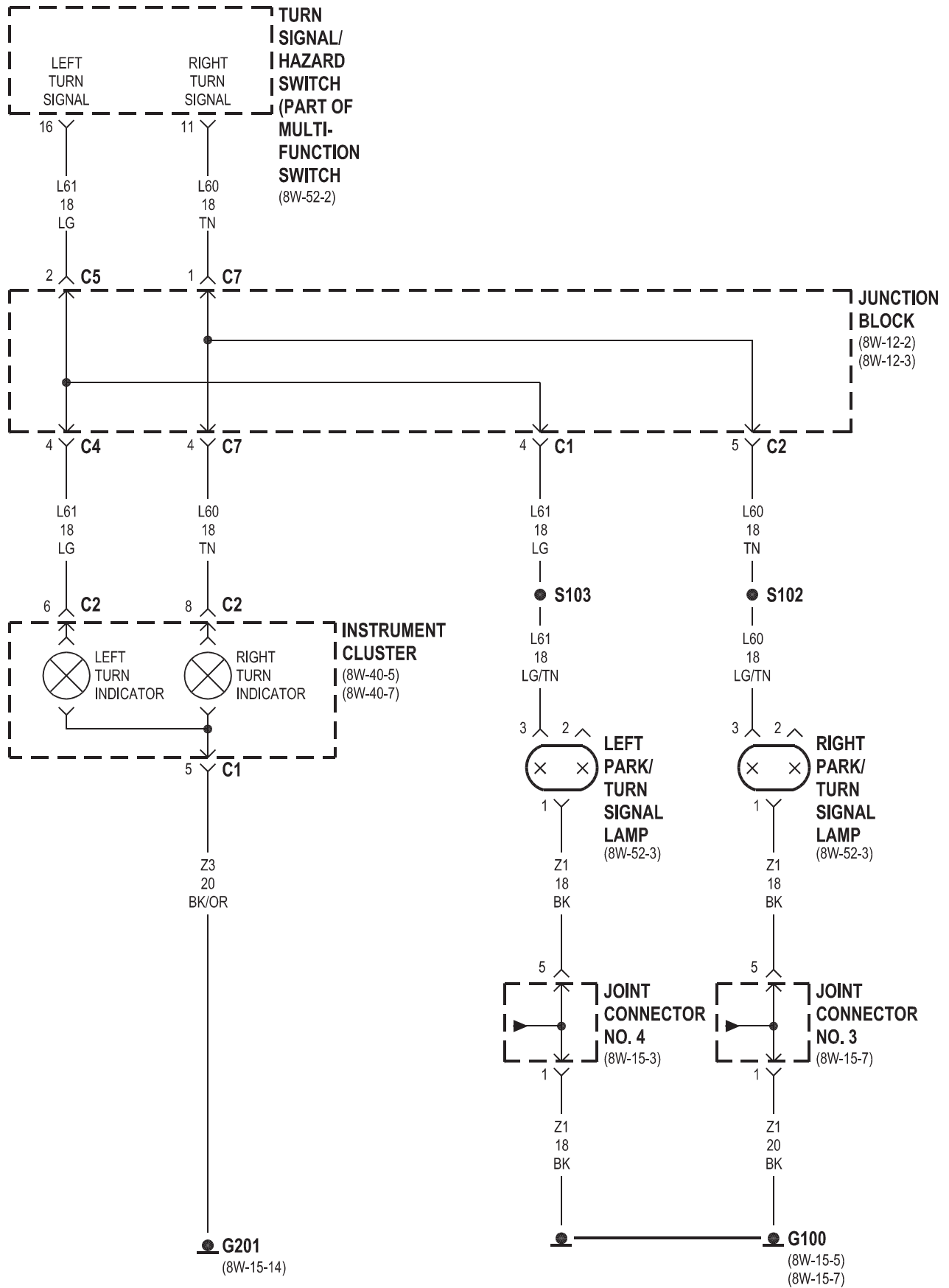


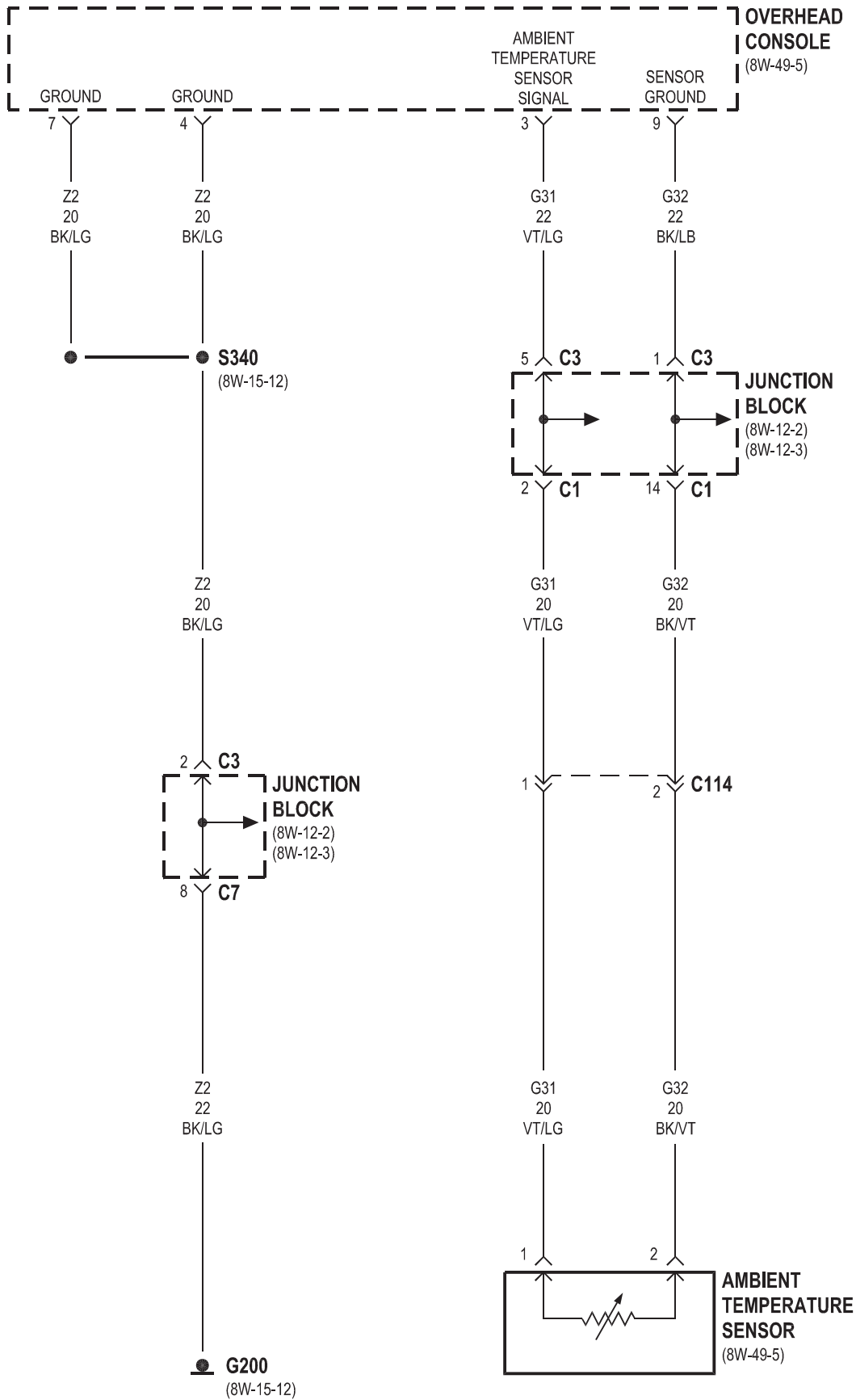


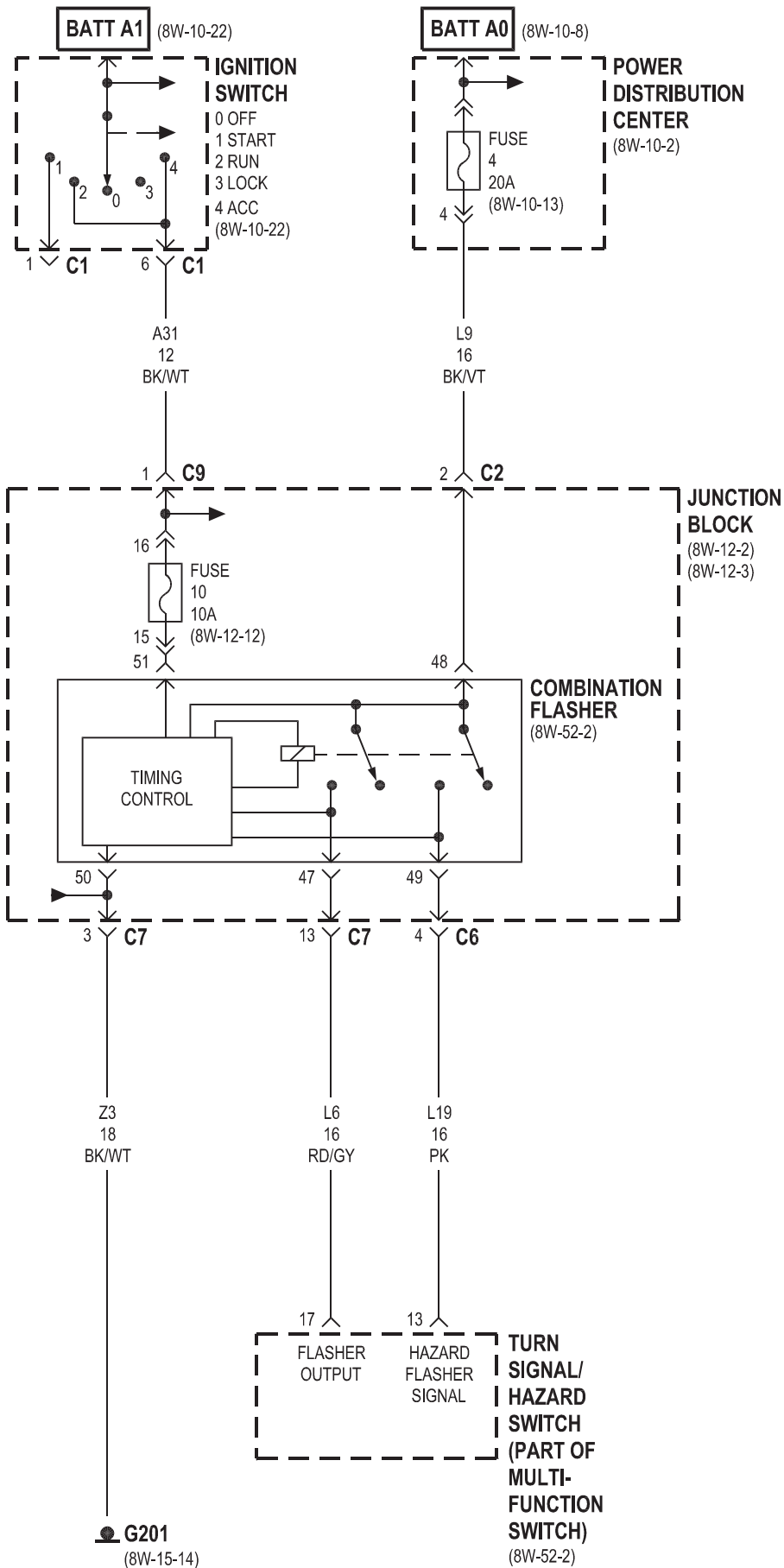


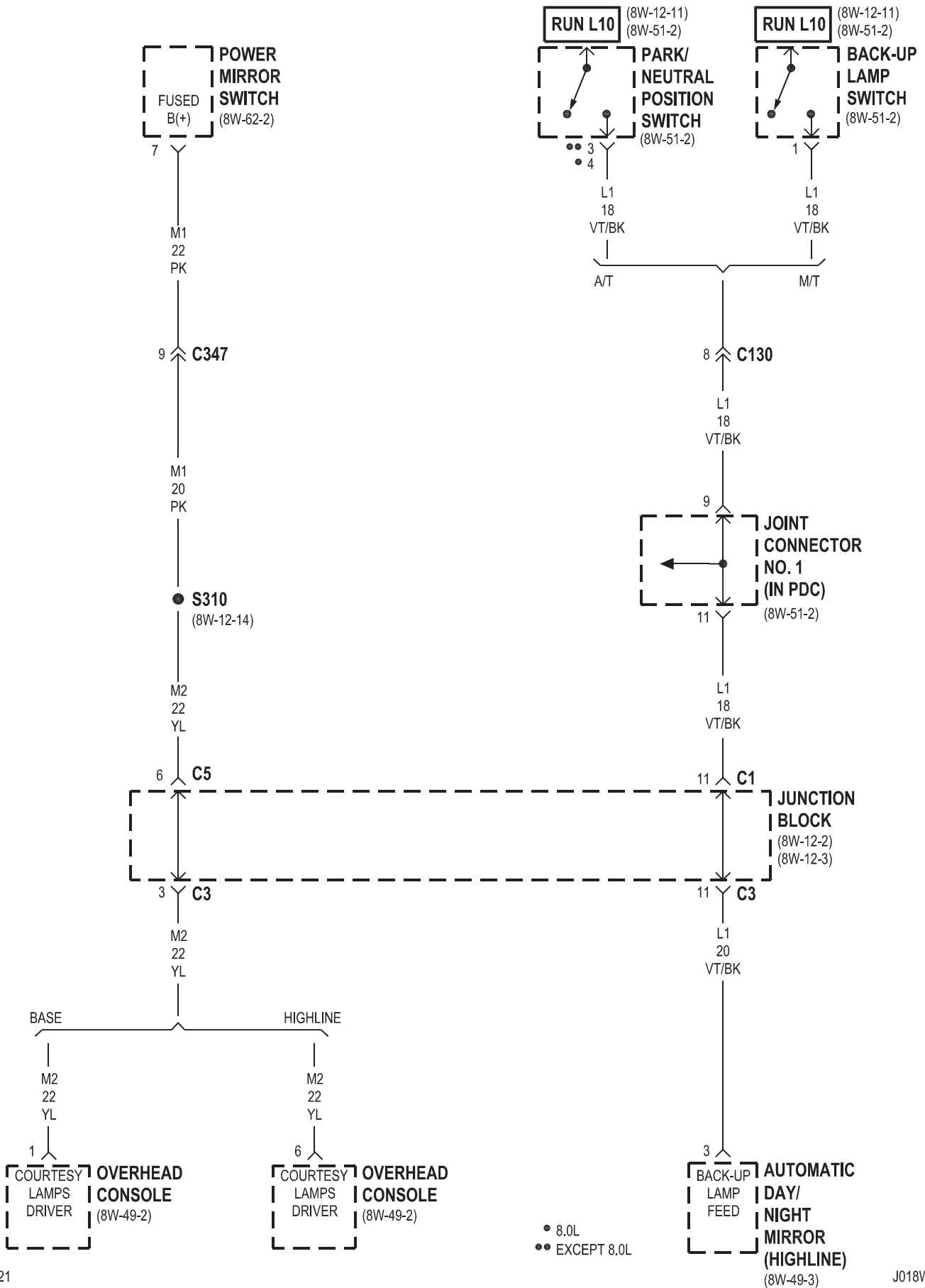










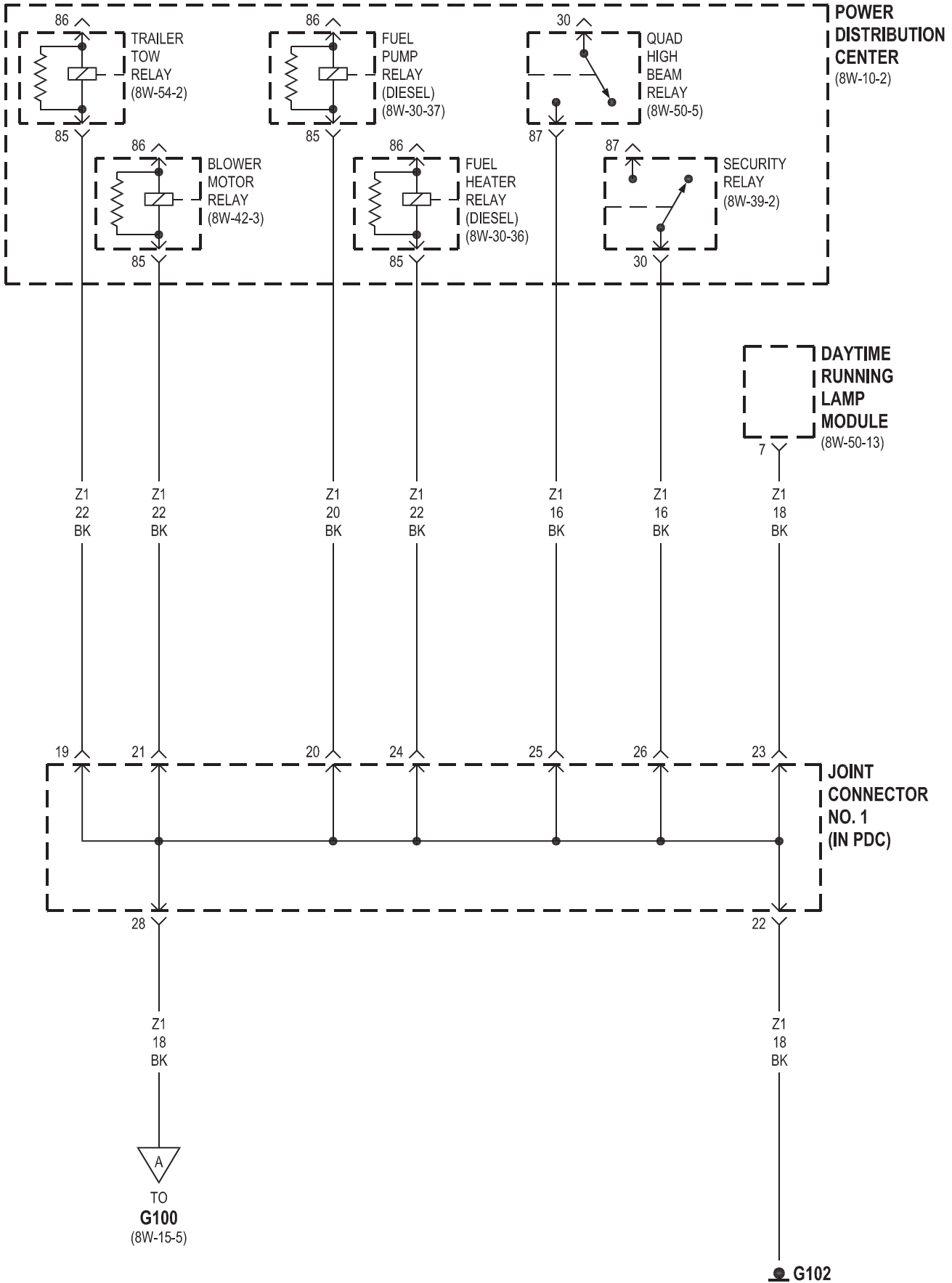


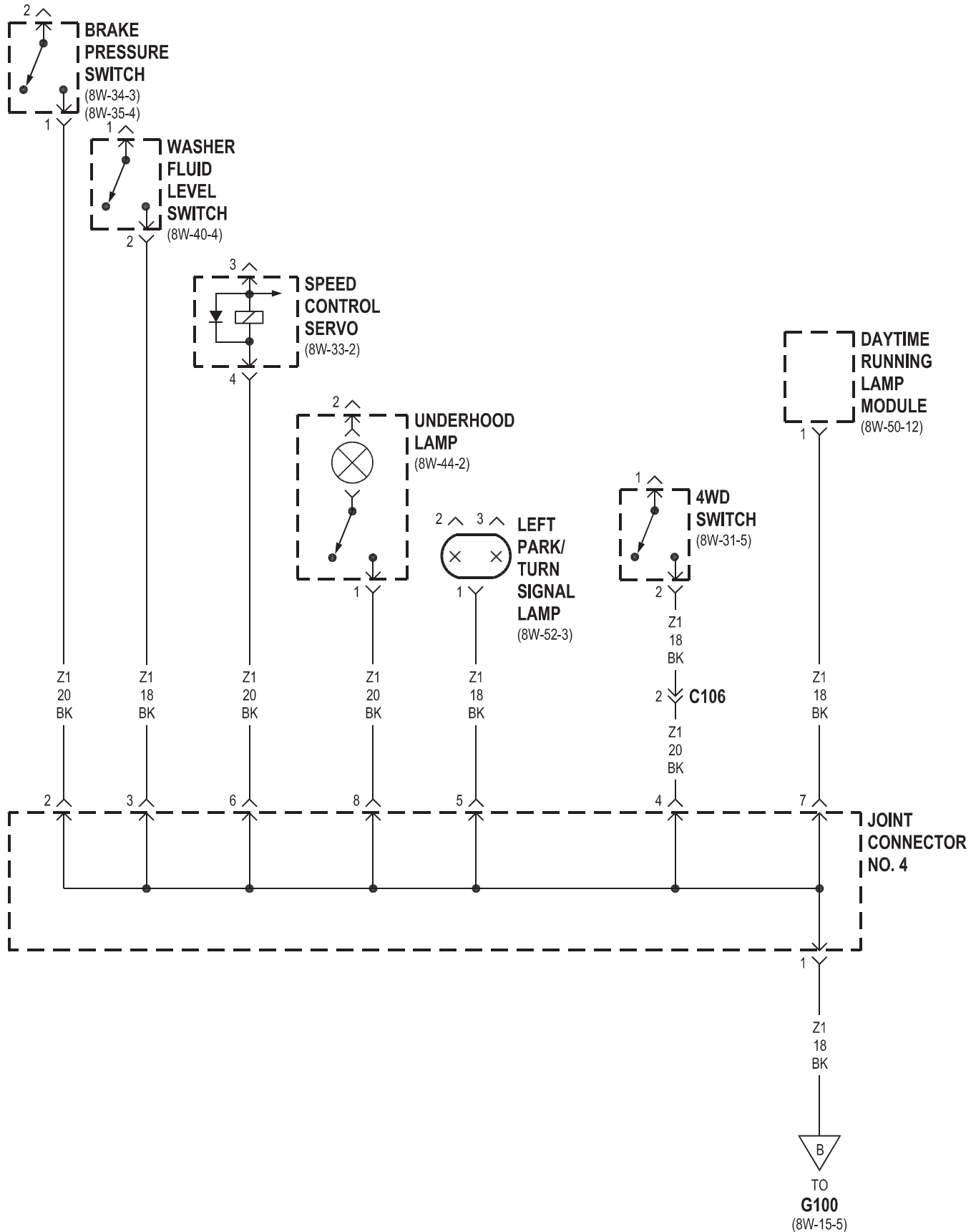


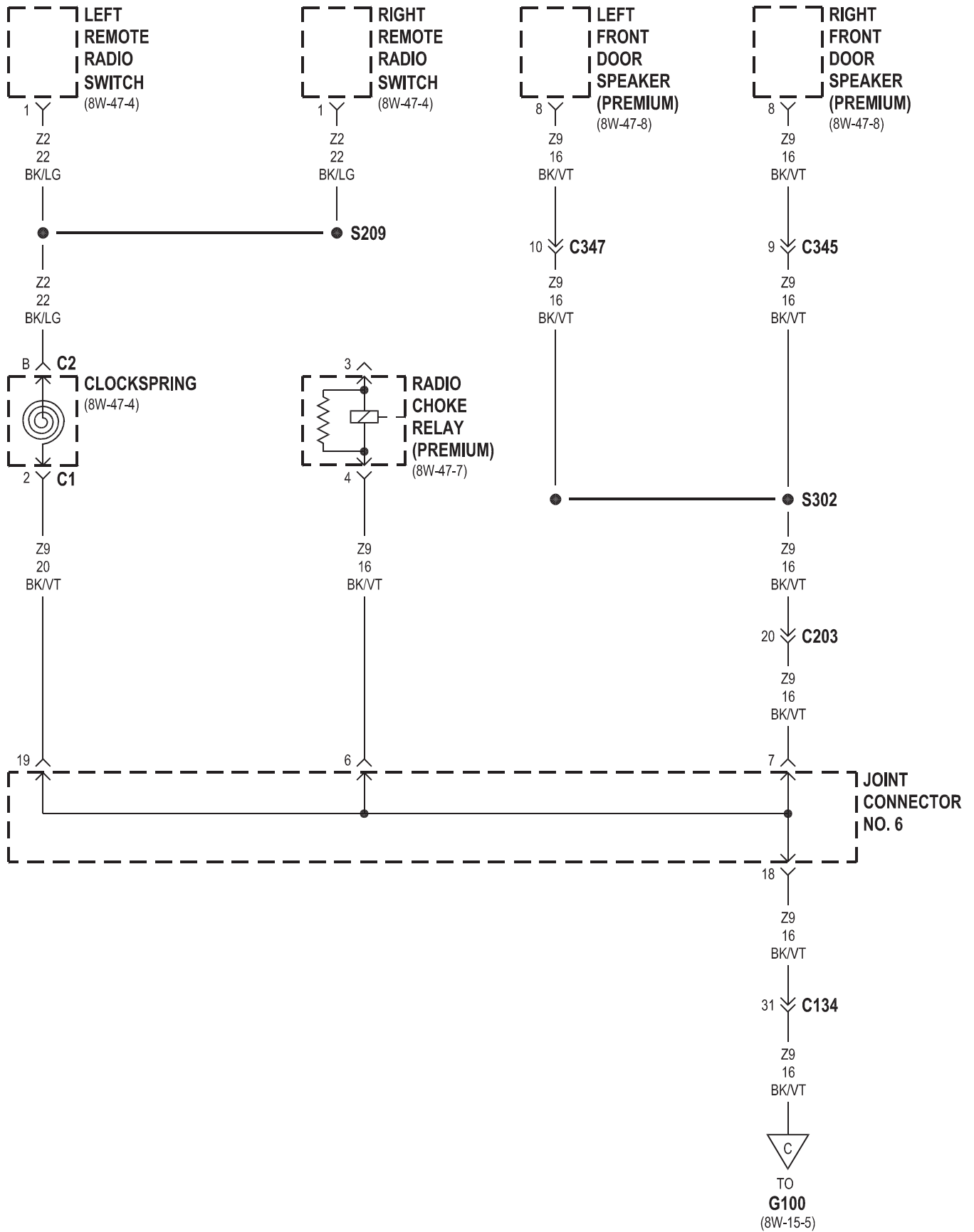


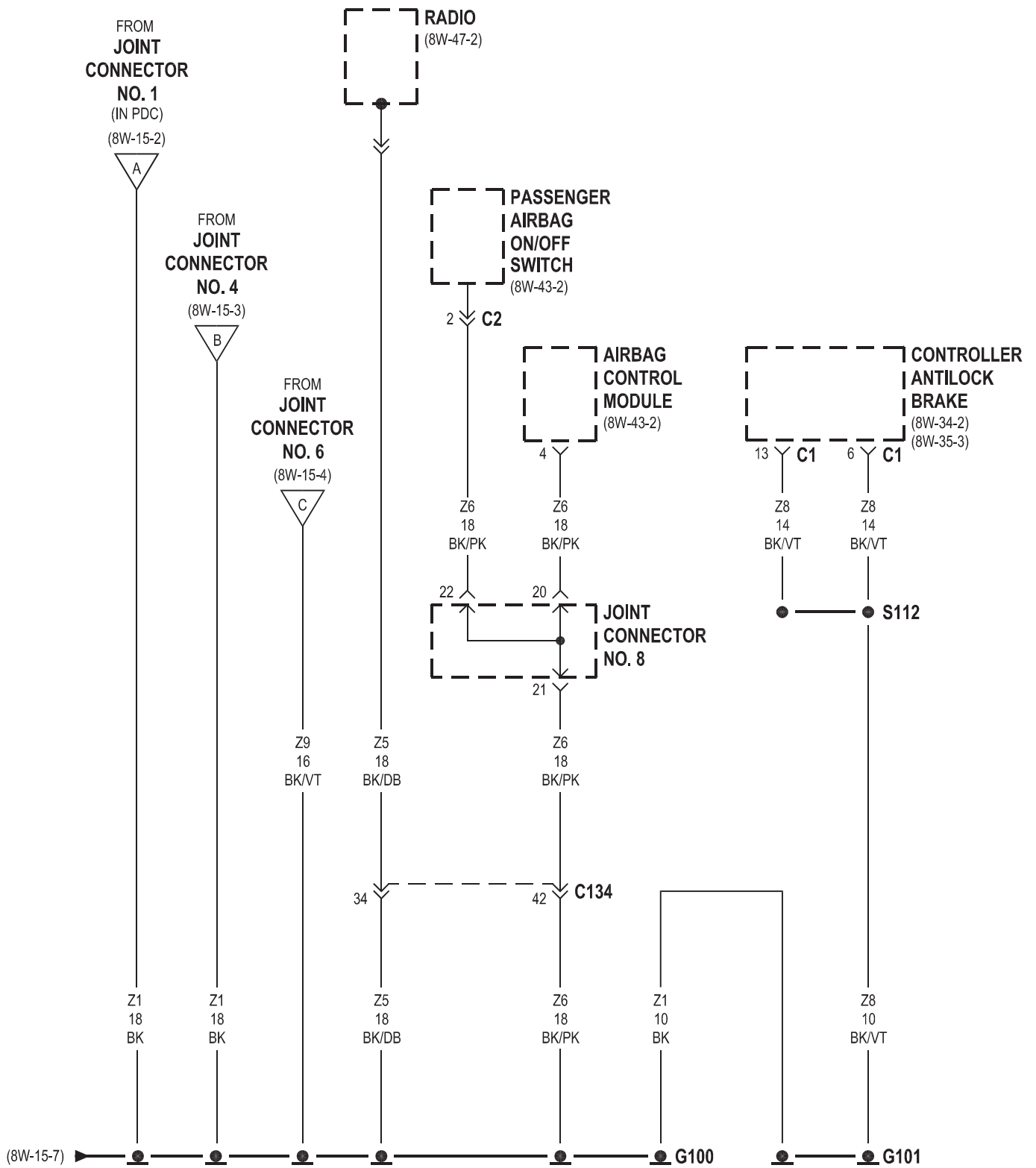
## 8W-15 GROUND DISTRIBUTION

<b>Component</b>	<b>Page</b>	<b>Component</b>	<b>Page</b>
A/C Compressor Clutch	8W-15-10, 8	Intake Air Heater Relay No. 2	8W-15-9
A/C-Heater Control	8W-15-14	Joint Connector No. 1	8W-15-2
A/C Heater Temperature Select	8W-15-12	Joint Connector No. 2	8W-15-9
Aftermarket Trailer Tow Connector	8W-15-6	Joint Connector No. 3	8W-15-7
Airbag Control Module	8W-15-5	Joint Connector No. 4	8W-15-3
Ash Receiver Lamp	8W-15-14	Joint Connector No. 5	8W-15-13
Automatic Day/Night Mirror	8W-15-13	Joint Connector No. 6	8W-15-4
Auxiliary Battery	8W-15-11	Joint Connector No. 8	8W-15-13, 5
Battery	8W-15-11	Junction Block	8W-15-12, 13
Blend Door Actuator	8W-15-12	Left Back-Up Lamp	8W-15-6
Blower Motor Relay	8W-15-2	Left Front Door Speaker	8W-15-4
Brake Lamp Switch	8W-15-12	Left Front Fender Lamp	8W-15-6
Brake Pressure Switch	8W-15-3	Left License Lamp	8W-15-6
Center High Mounted Stop Lamp No. 1	8W-15-17	Left Outboard Clearance Lamp	8W-15-18
Center High Mounted Stop Lamp No. 2	8W-15-17	Left Outboard Identification Lamp	8W-15-18
Center Identification Lamp	8W-15-18	Left Park/Turn Signal Lamp	8W-15-3
Central Timer Module C1	8W-15-12	Left Power Mirror	8W-15-16
Central Timer Module C2	8W-15-13	Left Rear Fender Lamp	8W-15-6
Cigar Lighter	8W-15-14	Left Remote Radio Switch	8W-15-4
Clockspring	8W-15-4	Left Tail/Stop/Turn Signal Lamp	8W-15-6
Combination Flasher	8W-15-13	Left Visor/Vanity Lamp	8W-15-13
Controller Antilock Brake	8W-15-5	Low Note Horn	8W-15-7
Cummins Bus	8W-15-10	Overdrive Switch	8W-15-12
Cup Holder Lamp	8W-15-14	Overhead Console	8W-15-12
Data Link Connector	8W-15-8, 10, 12	Oxygen Sensor 1/2 Left Bank Down	8W-15-8
Daytime Running Lamp Module	8W-15-2, 3	Oxygen Sensor 1/2 Pre-Catalyst	8W-15-8
Driver Cylinder Lock Switch	8W-15-16	Oxygen Sensor 1/3 Post-Catalyst	8W-15-8
Driver Door Ajar Switch	8W-15-16	Oxygen Sensor 2/2 Right Bank Down	8W-15-8
Driver Door Window/Lock Switch	8W-15-16, 17	Passenger Airbag On/Off Switch	8W-15-5
Driver Heated Seat Cushion	8W-15-15	Passenger Cylinder Lock Switch	8W-15-16
Driver Heated Seat Switch	8W-15-13	Passenger Door Ajar Switch	8W-15-16
Driver Power Seat Switch	8W-15-15, 17	Passenger Door Window/Lock Switch	8W-15-16
Electric Brake Provision	8W-15-14	Passenger Heated Seat Cushion	8W-15-15
Engine Control Module	8W-15-9	Passenger Heated Seat Switch	8W-15-13
Engine Starter Motor Relay	8W-15-8, 9	Passenger Power Seat Switch	8W-15-15
Fuel Heater Relay	8W-15-2	Power Distribution Center	8W-15-2
Fuel Heater	8W-15-10	Power Mirror Switch	8W-15-16
Fuel Injection Pump	8W-15-9	Power Outlet	8W-15-14
Fuel Pump Module	8W-15-7	Powertrain Control Module	8W-15-8, 10
Fuel Pump Relay	8W-15-2	Quad High Beam Relay	8W-15-2
Fuel Transfer Pump	8W-15-10	Radio Choke Relay	8W-15-4
G100	8W-15-12, 5, 7	Radio	8W-15-5
G101	8W-15-5	Right Back-Up Lamp	8W-15-6
G102	8W-15-2	Right Front Door Speaker	8W-15-4
G105	8W-15-8	Right Front Fender Lamp	8W-15-6
G107	8W-15-10	Right License Lamp	8W-15-6
G113	8W-15-11	Right Outboard Clearance Lamp	8W-15-18
G114	8W-15-11	Right Outboard Identification Lamp	8W-15-18
G115	8W-15-11	Right Park/Turn Signal Lamp	8W-15-7
G116	8W-15-11	Right Power Mirror	8W-15-16
G117	8W-15-11	Right Rear Fender Lamp	8W-15-6
G118	8W-15-11	Right Remote Radio Switch	8W-15-4
G120	8W-15-11	Right Tail/Stop/Turn Signal Lamp	8W-15-6
G200	8W-15-7, 12, 14	Right Visor/Vanity Lamp	8W-15-13
G201	8W-15-12, 14	Seat Belt Switch	8W-15-15, 17
G300	8W-15-16	Seat Heat Interface Module	8W-15-15
G301	8W-15-17	Security Relay	8W-15-2
G302	8W-15-18	Speed Control Servo	8W-15-3
Glove Box Lamp And Switch	8W-15-14	Tailgate Lamp	8W-15-6
Headlamp Beam Select Switch	8W-15-14	Trailer Tow Connector	8W-15-6
Headlamp Switch	8W-15-13, 14	Trailer Tow Relay	8W-15-2
Heated Mirror Switch	8W-15-13	Underhood Lamp	8W-15-3
High Note Horn	8W-15-7	Washer Fluid Level Switch	8W-15-3
Ignition Switch	8W-15-13	Windshield Washer Pump	8W-15-7
Instrument Cluster	8W-15-12, 14	Wiper Motor	8W-15-7
Intake Air Heater Relay No. 1	8W-15-9		

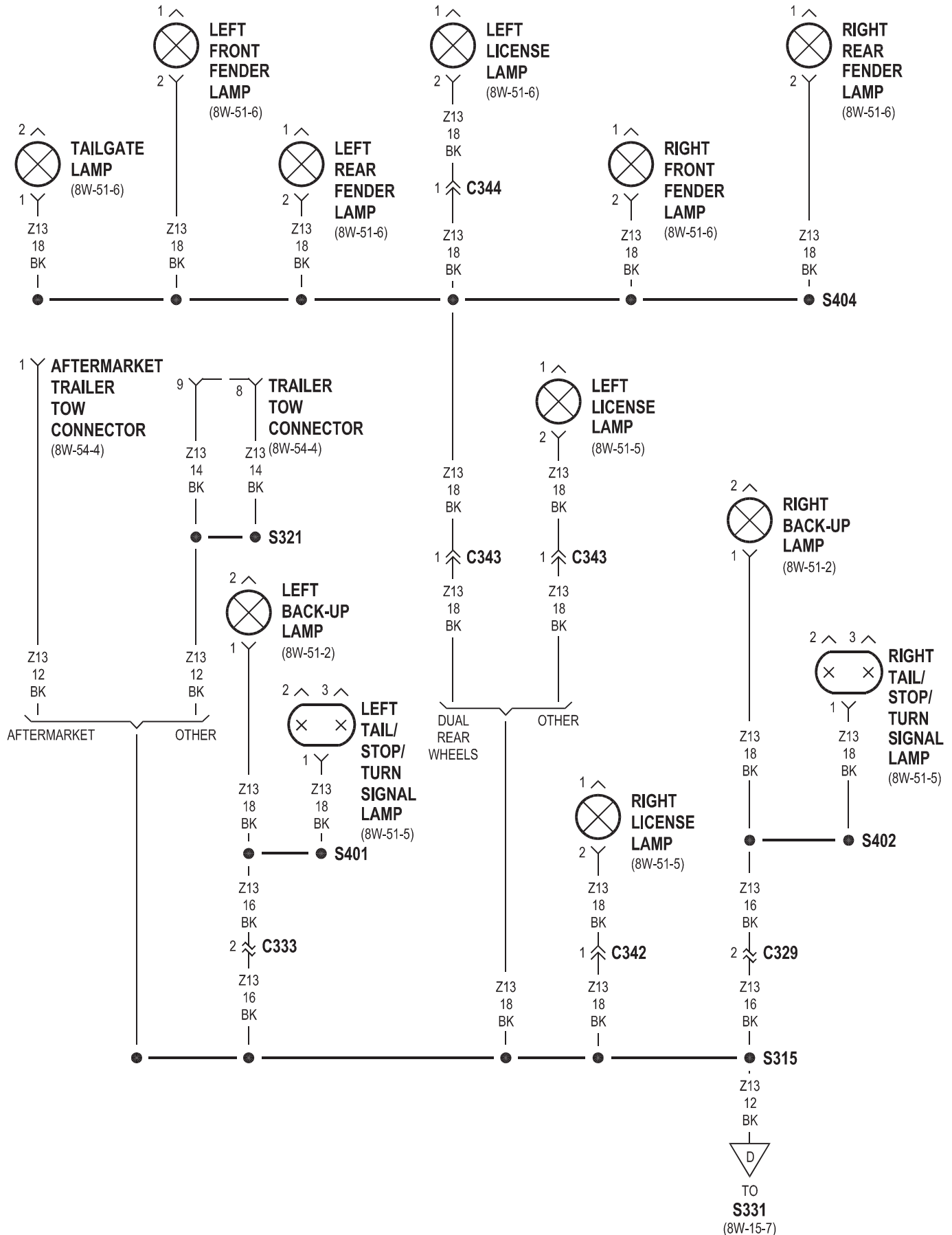


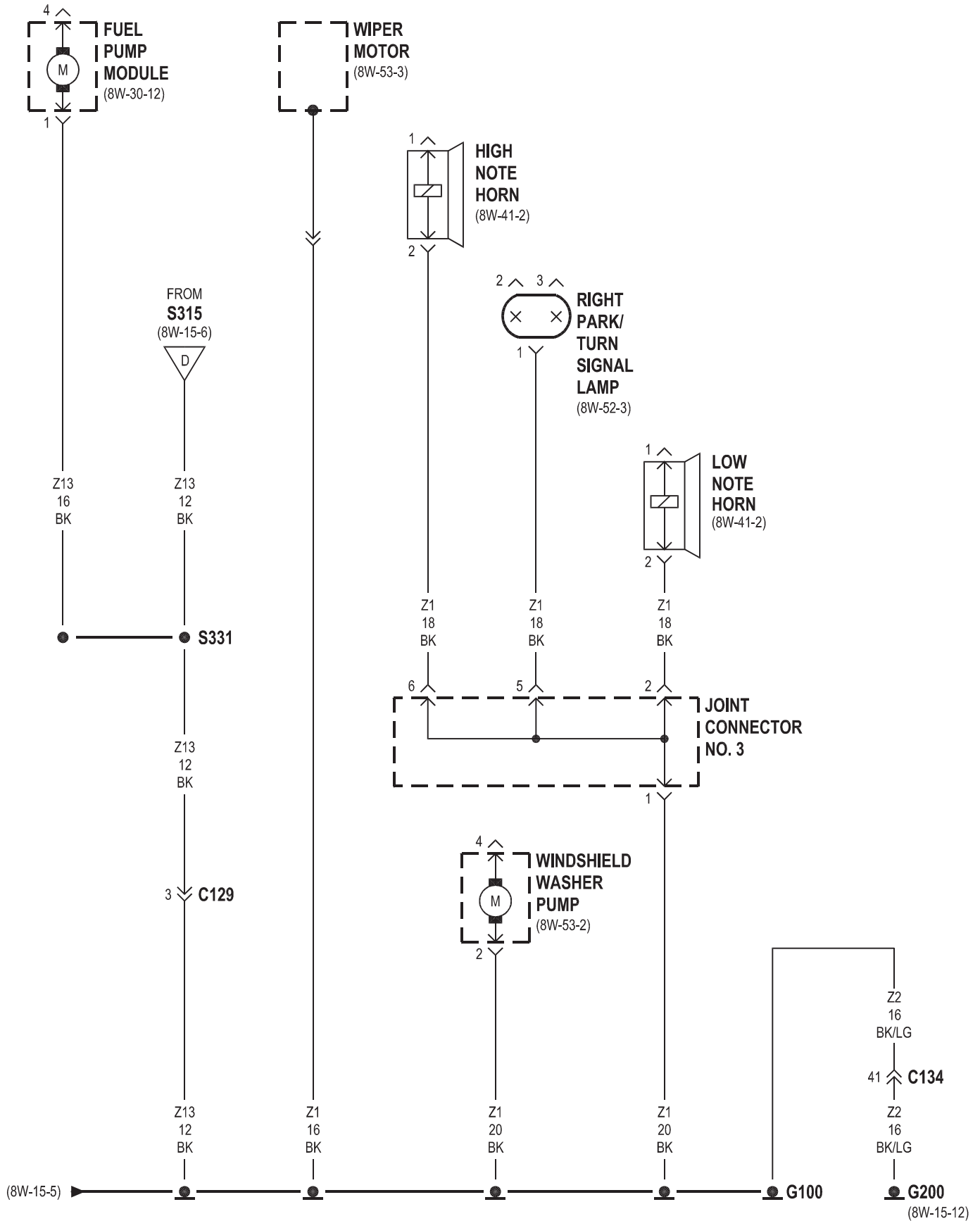


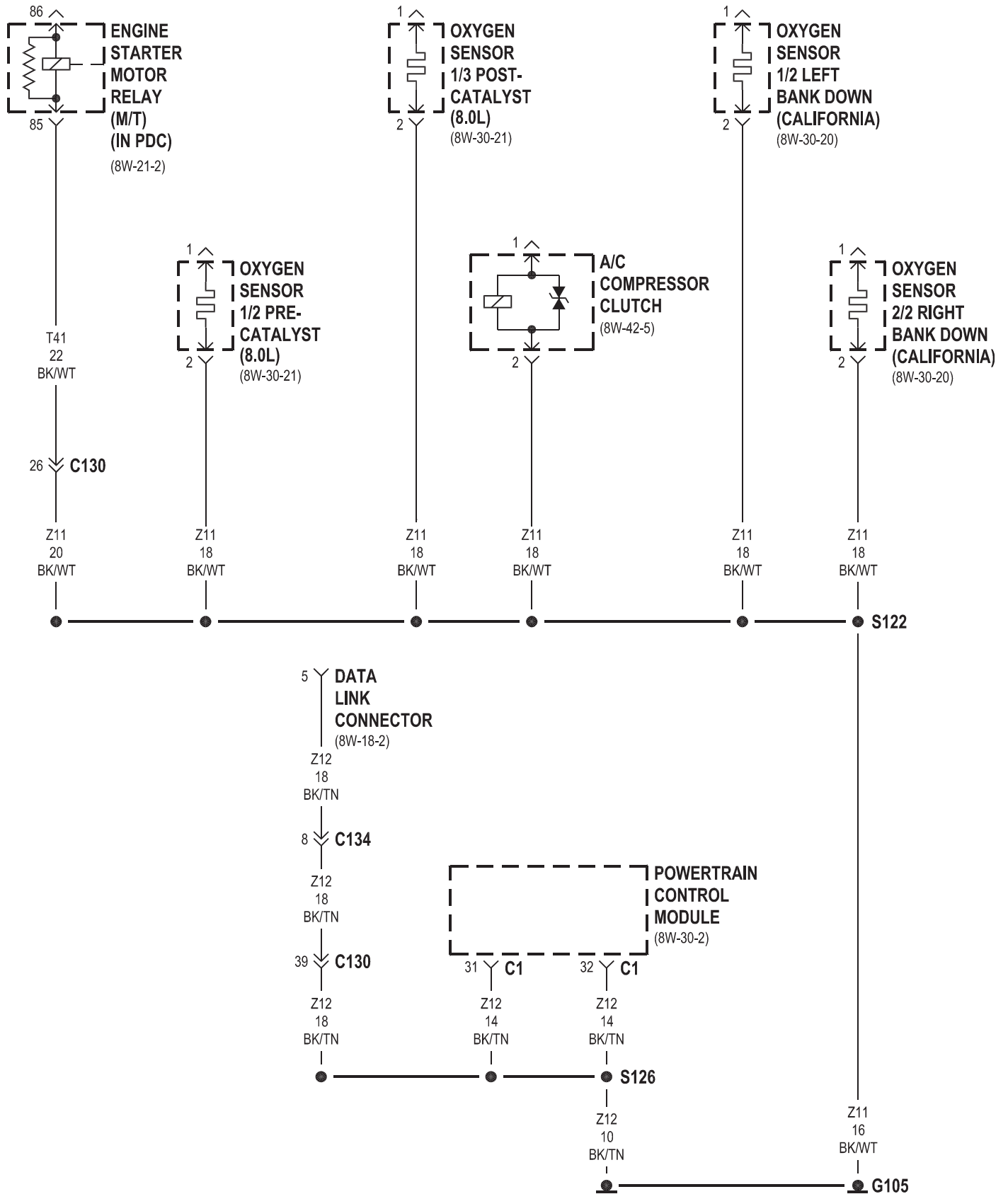


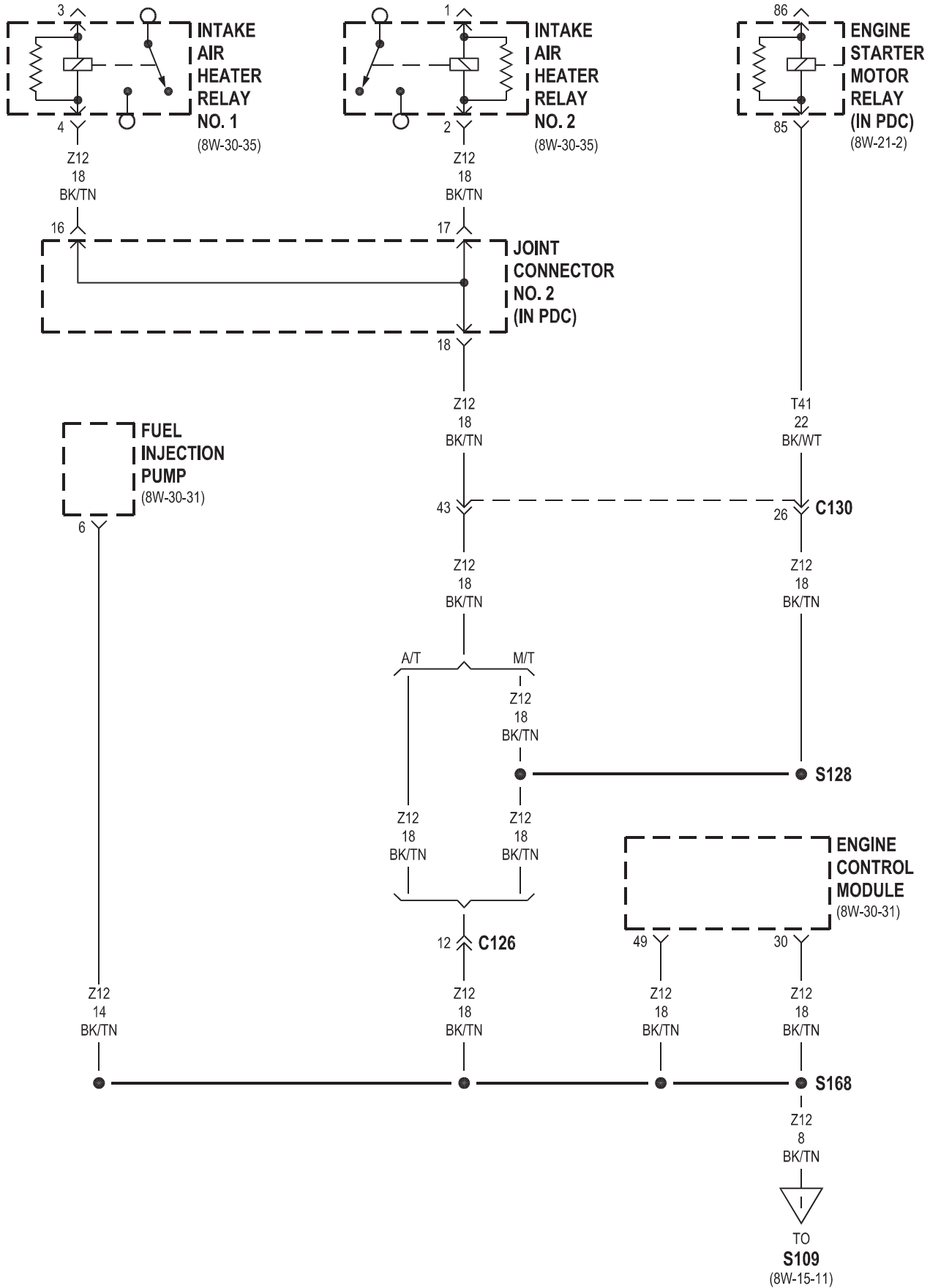


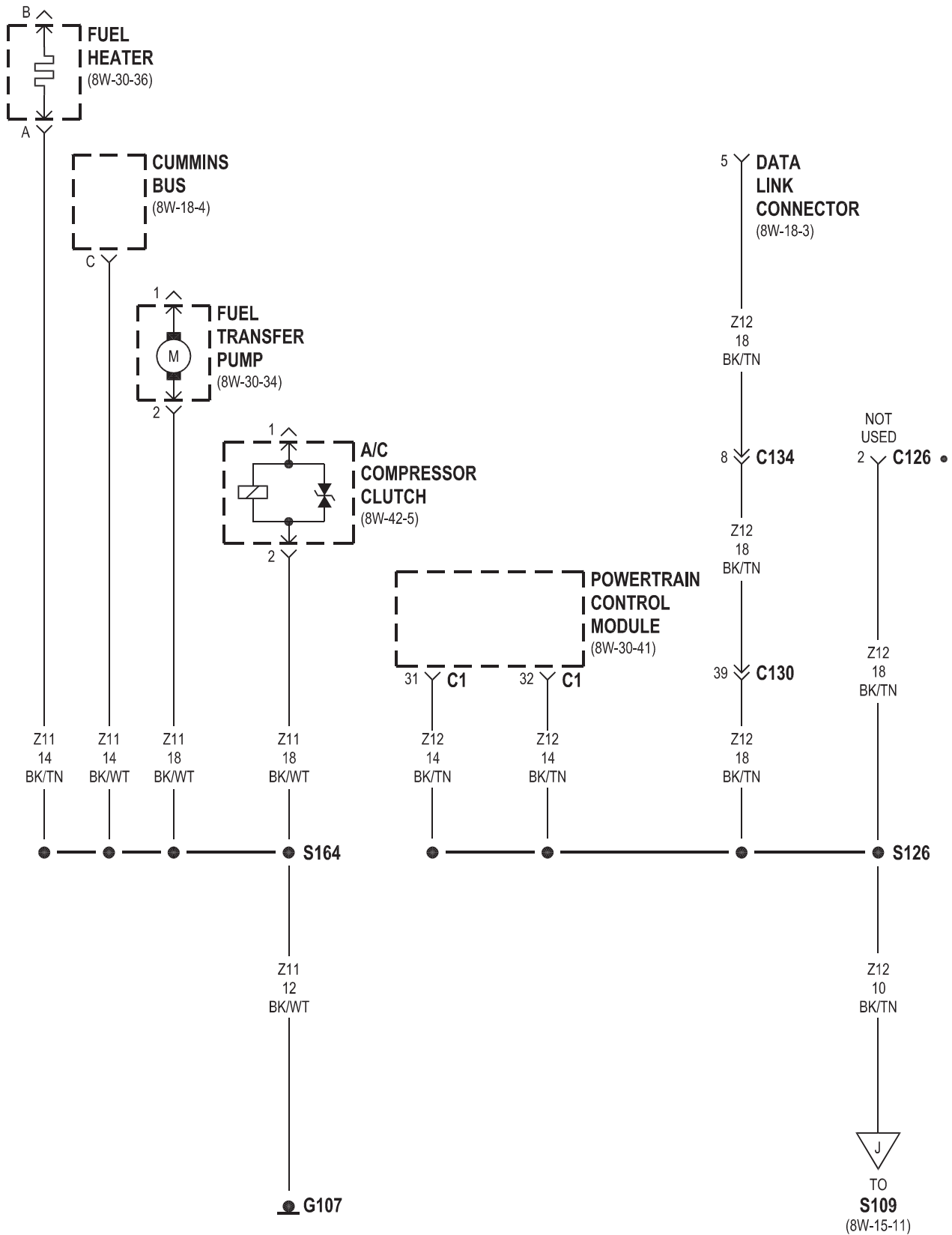




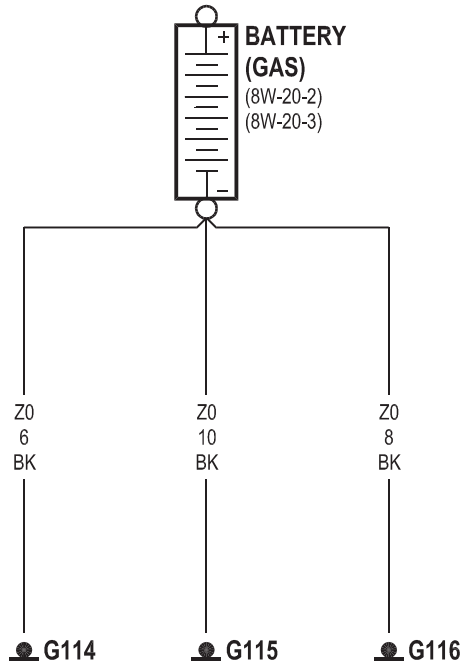
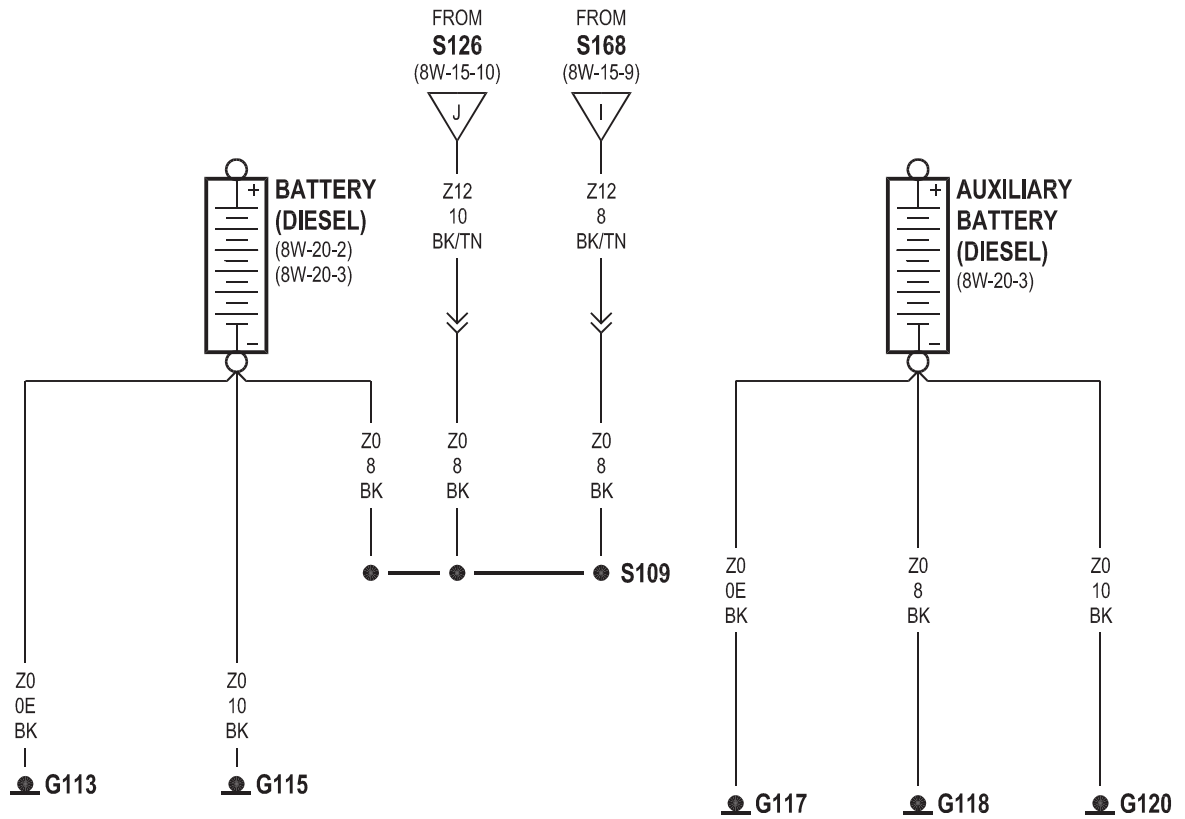


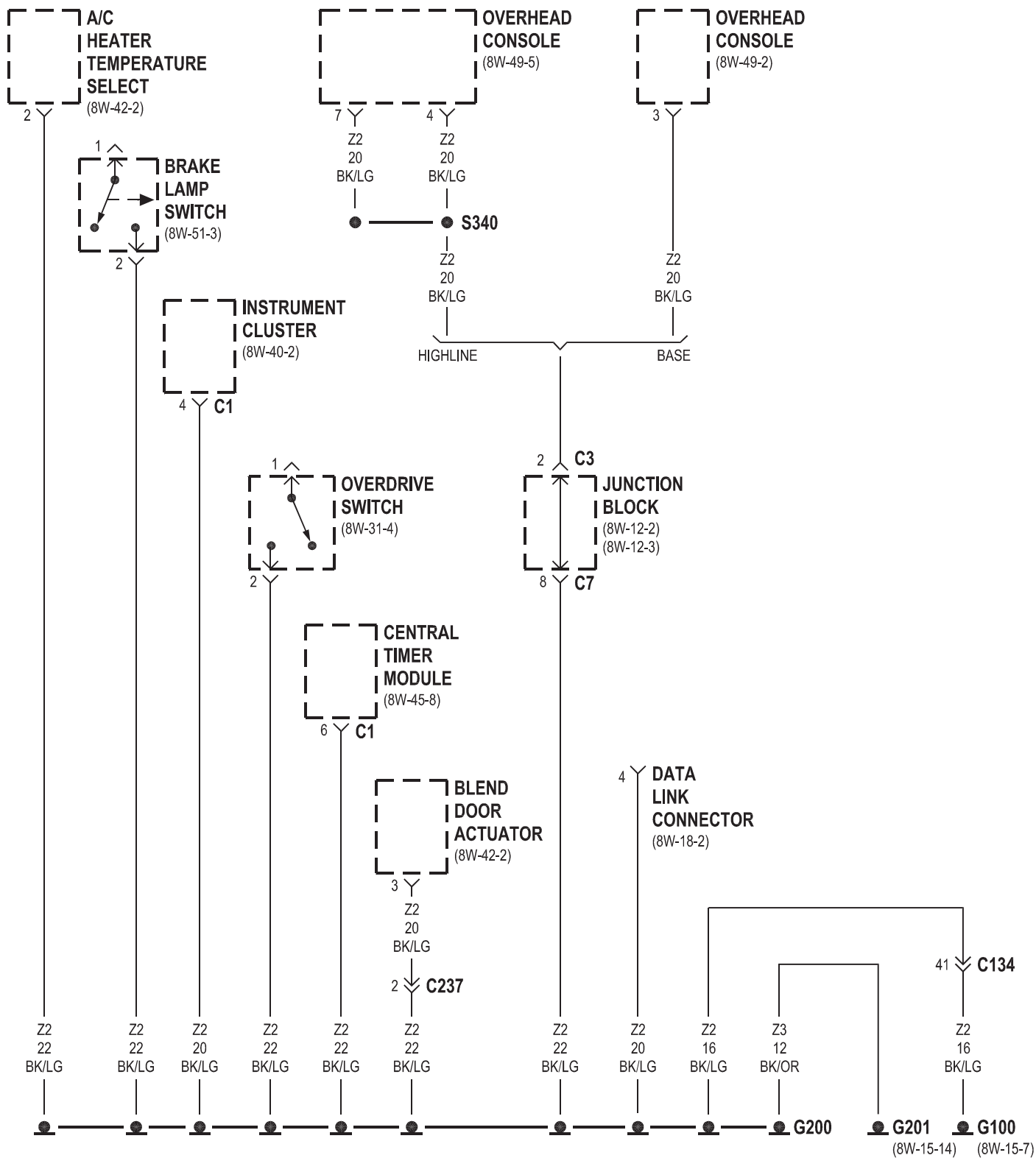


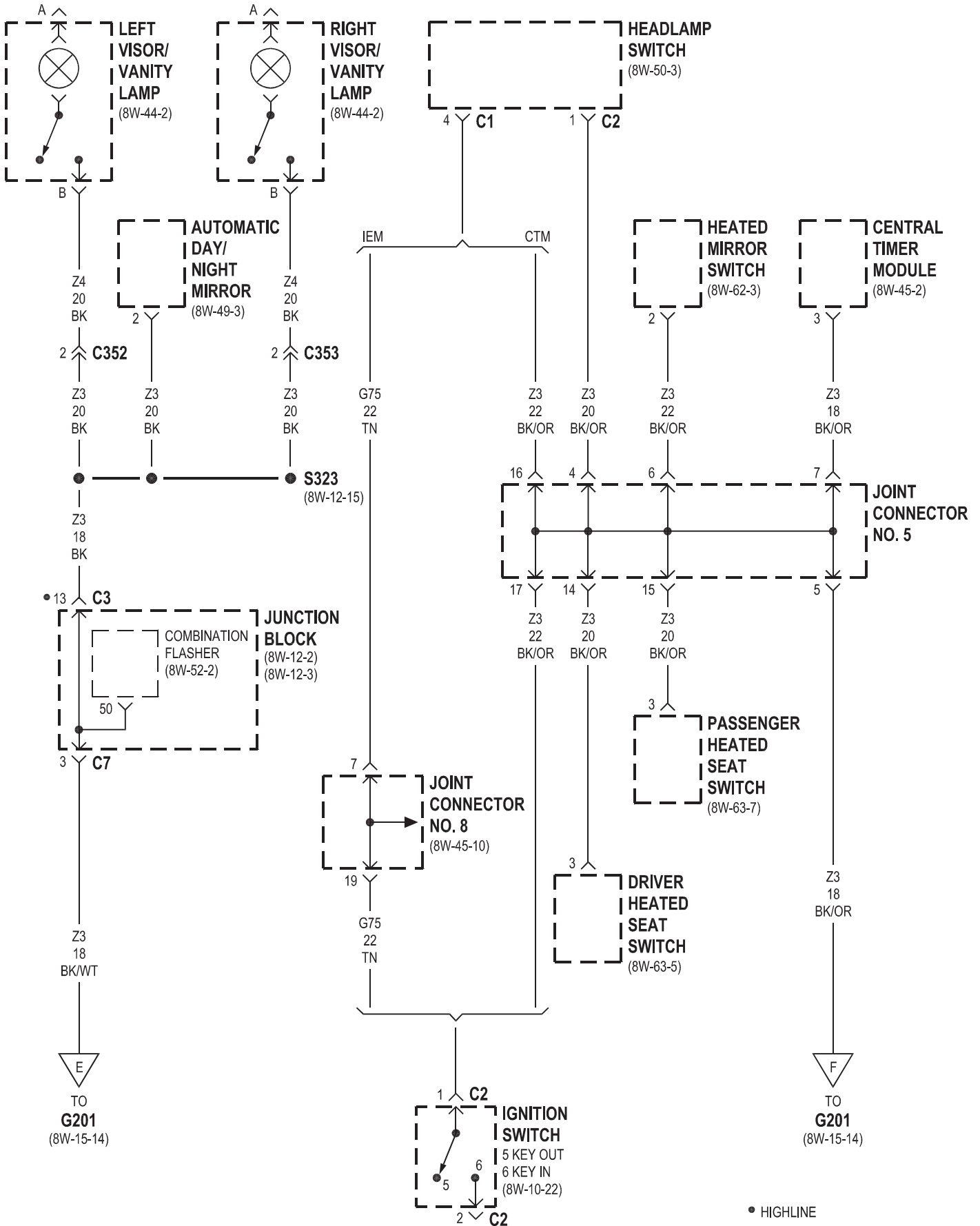




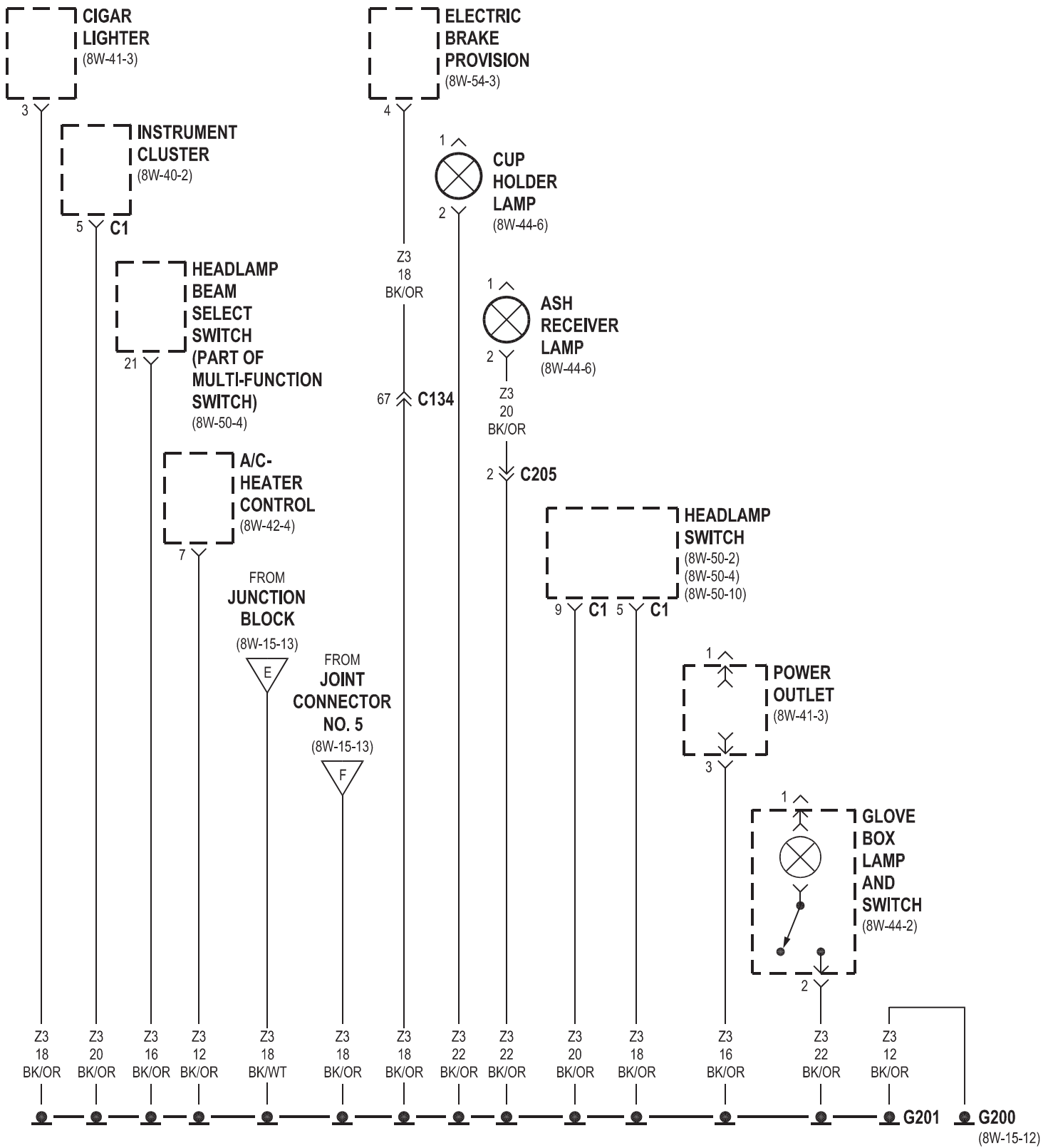


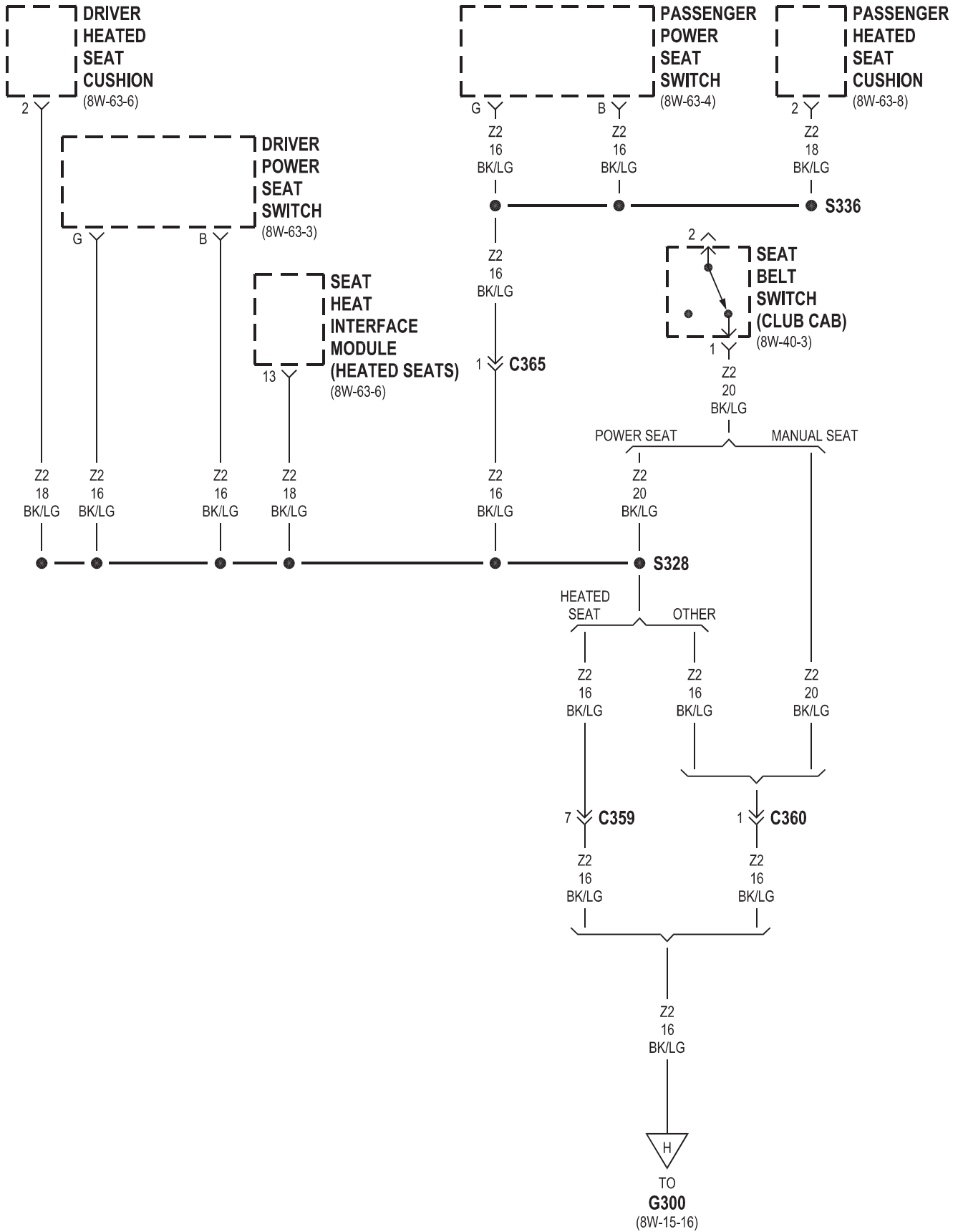




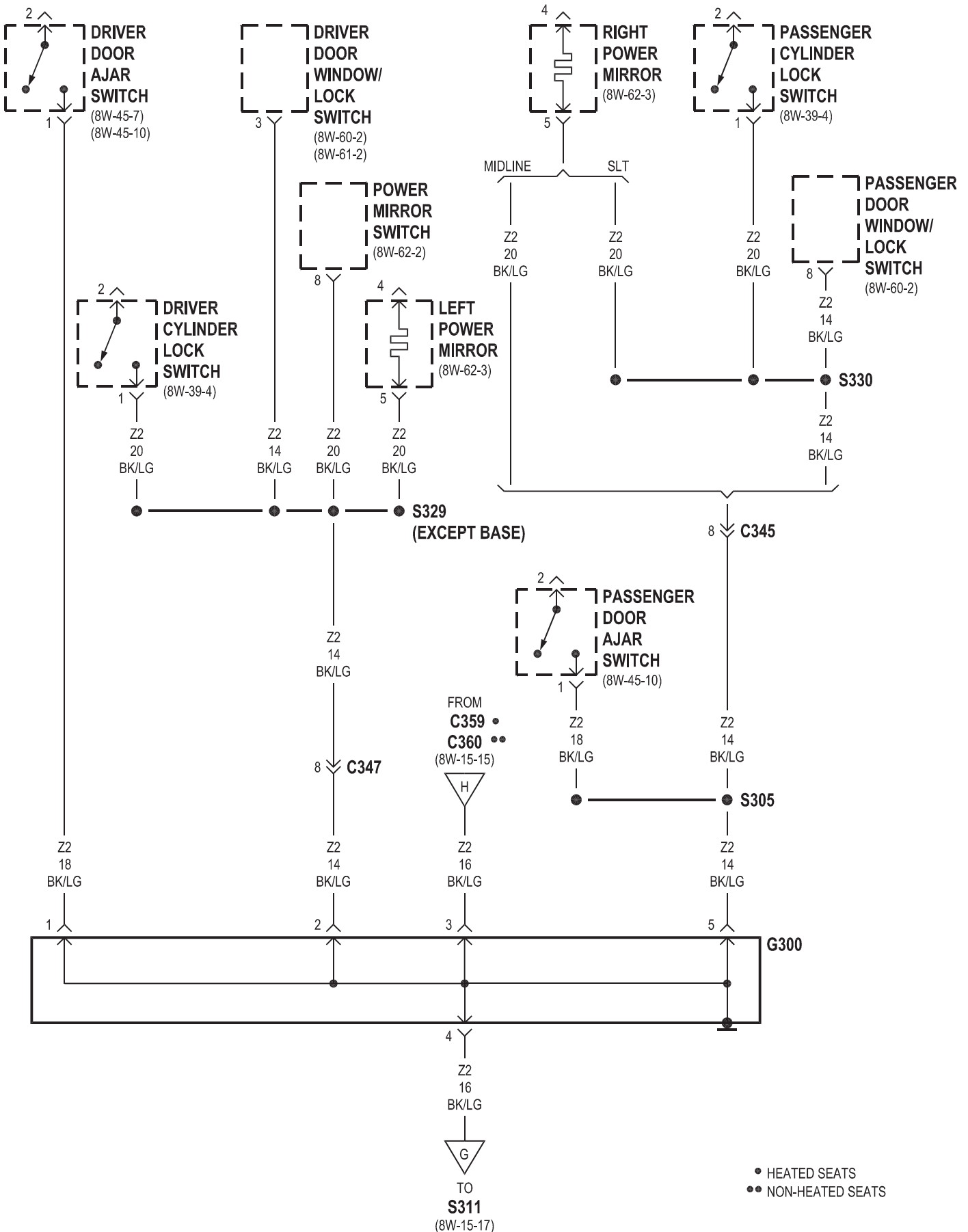


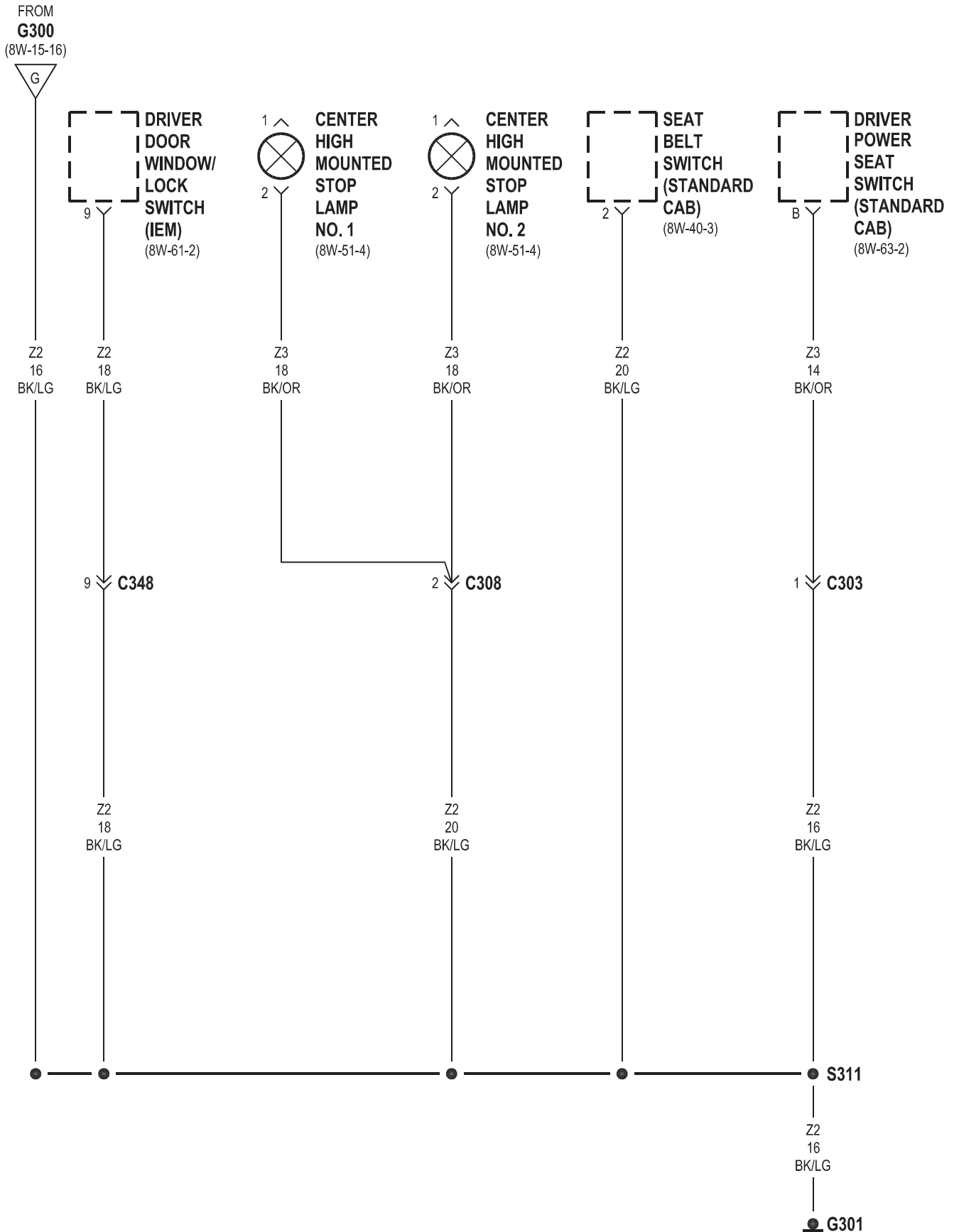
• HIGHLINE

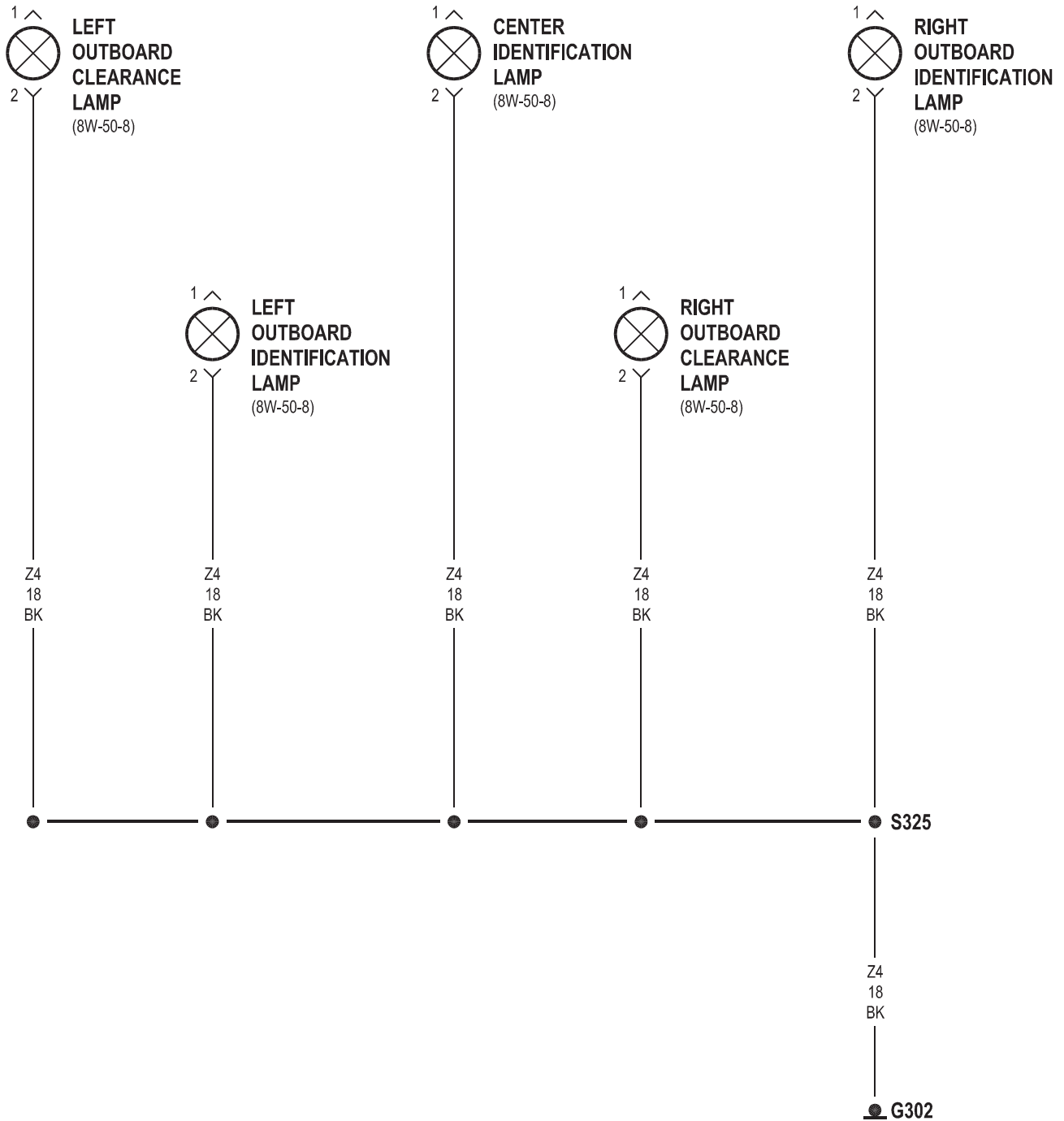






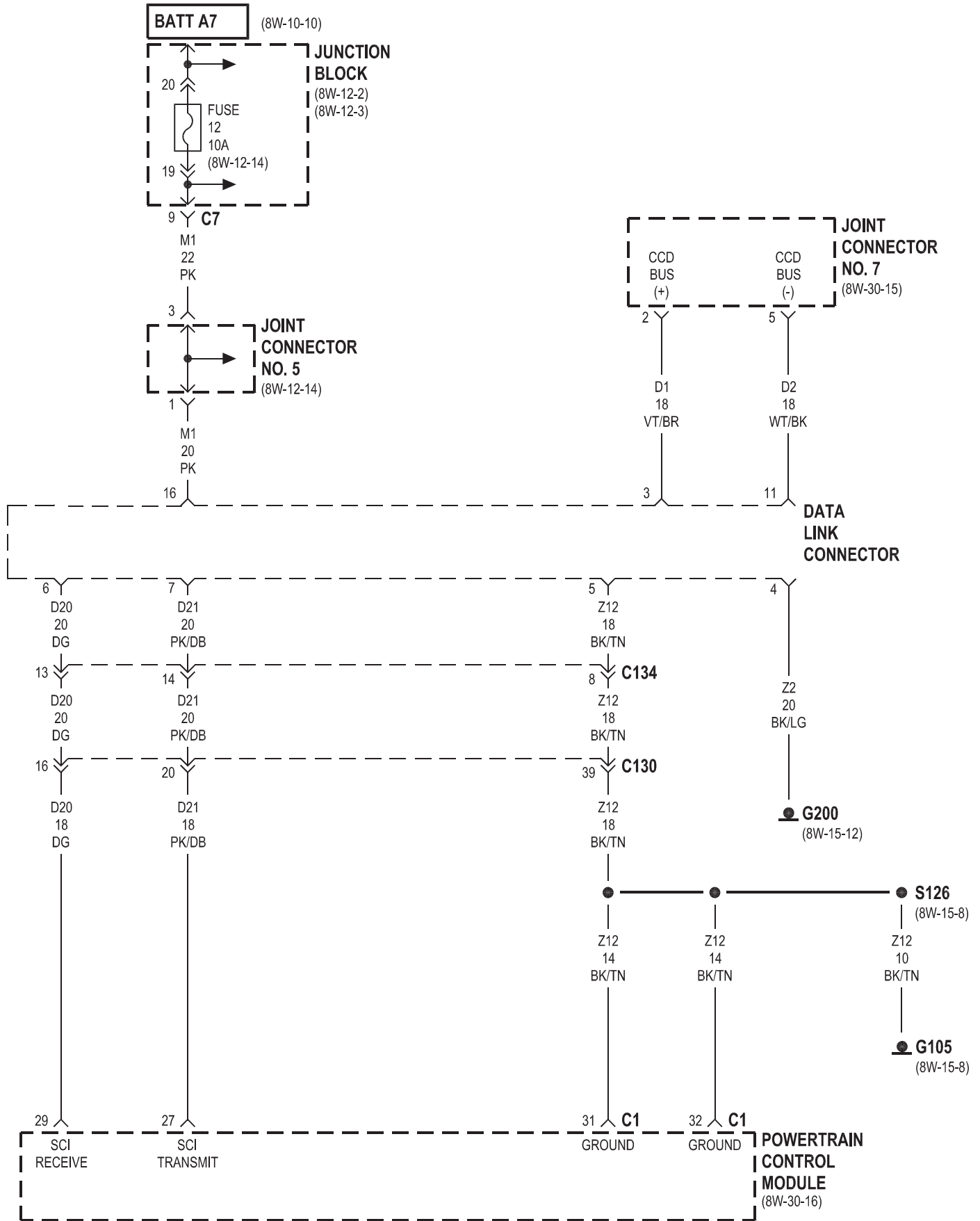




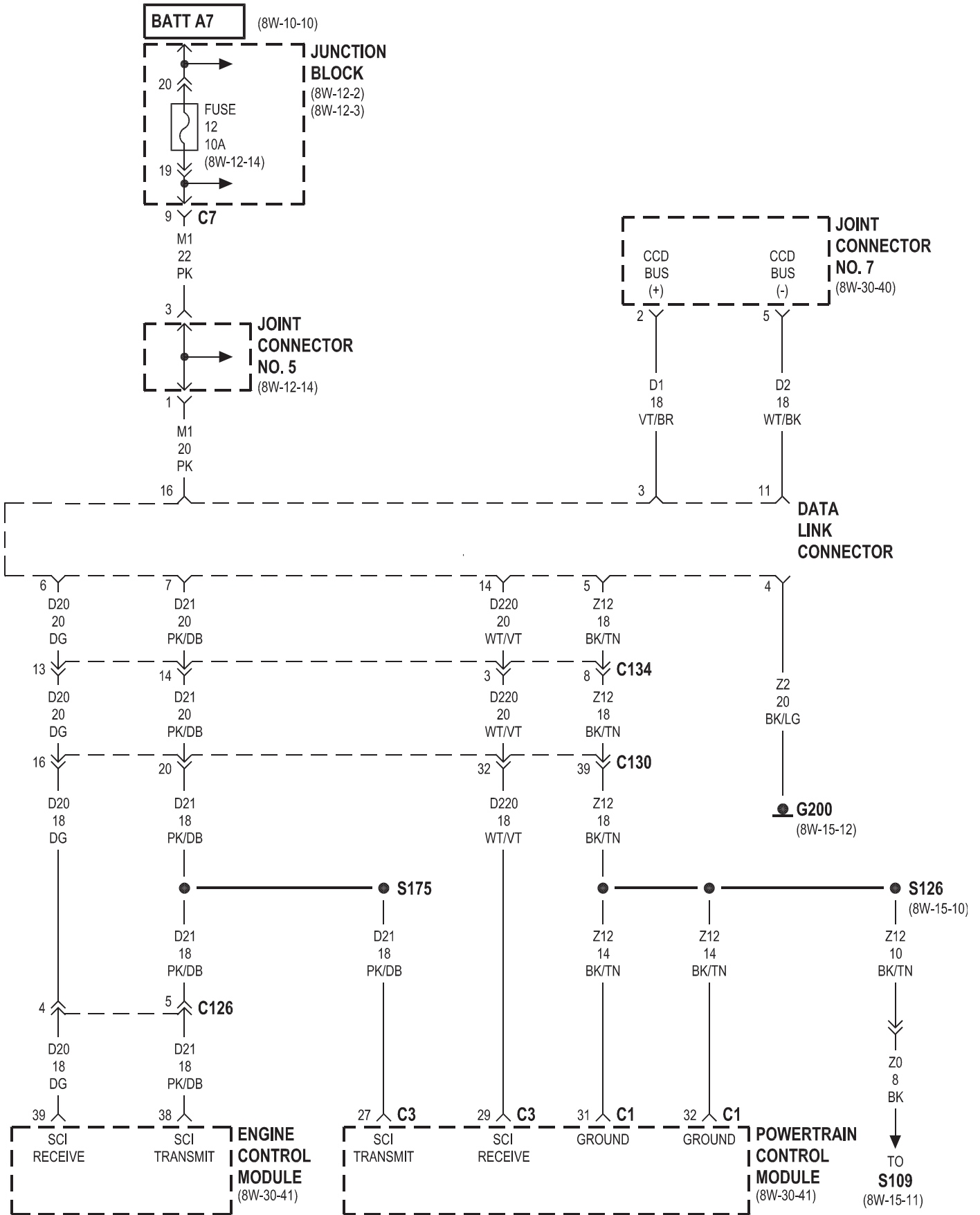


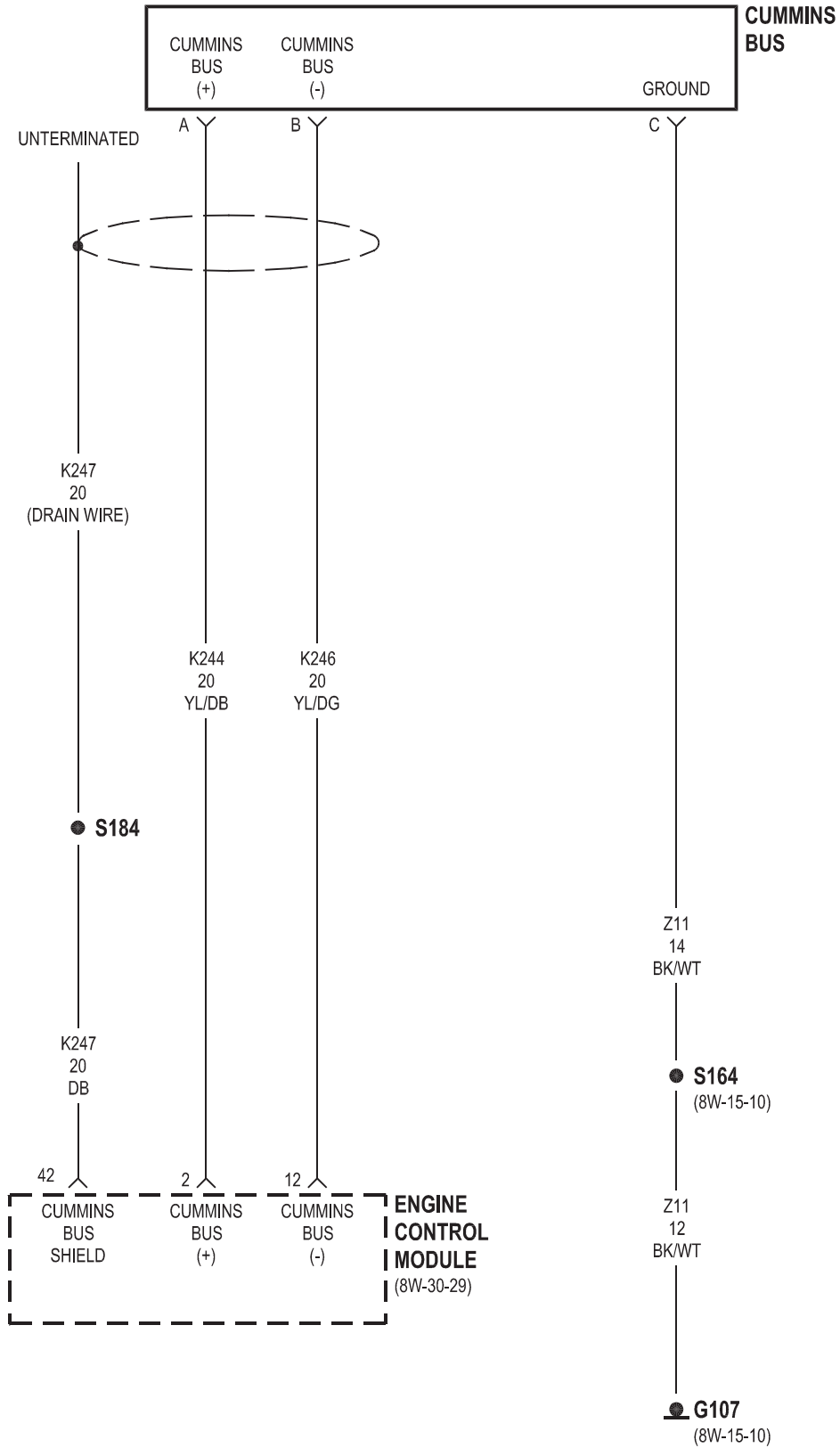
## 8W-18 BUS COMMUNICATIONS

<b>Component</b>	<b>Page</b>	<b>Component</b>	<b>Page</b>
Cummins Bus .....	8W-18-4	G200 .....	8W-18-2, 3
Data Link Connector .....	8W-18-2, 3	Joint Connector No. 5 .....	8W-18-2, 3
Engine Control Module .....	8W-18-3, 4	Joint Connector No. 7 .....	8W-18-2, 3
Fuse 12 (JB) .....	8W-18-2, 3	Junction Block .....	8W-18-2, 3
G105 .....	8W-18-2	Powertrain Control Module .....	8W-18-2, 3
G107 .....	8W-18-4		



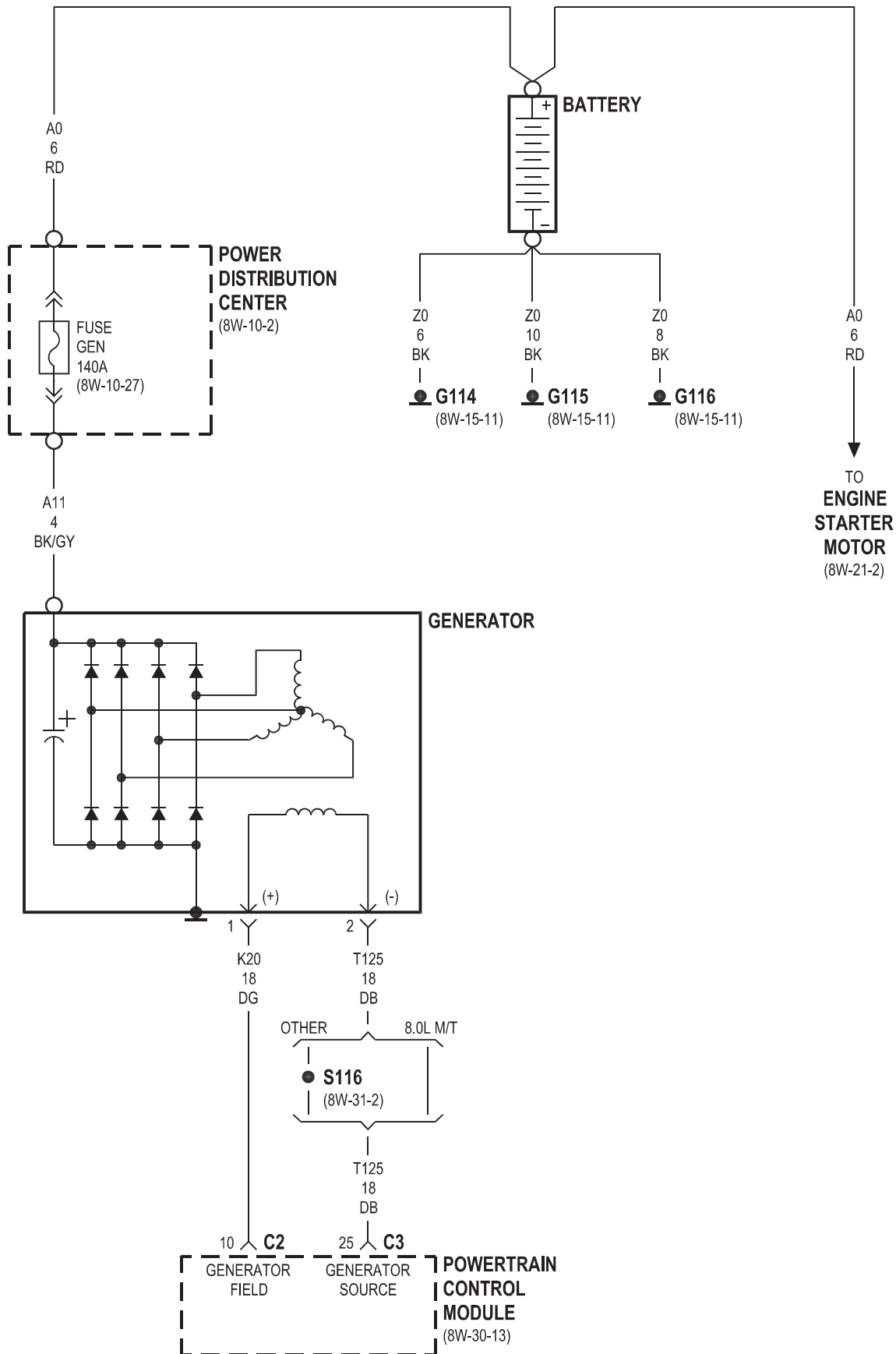


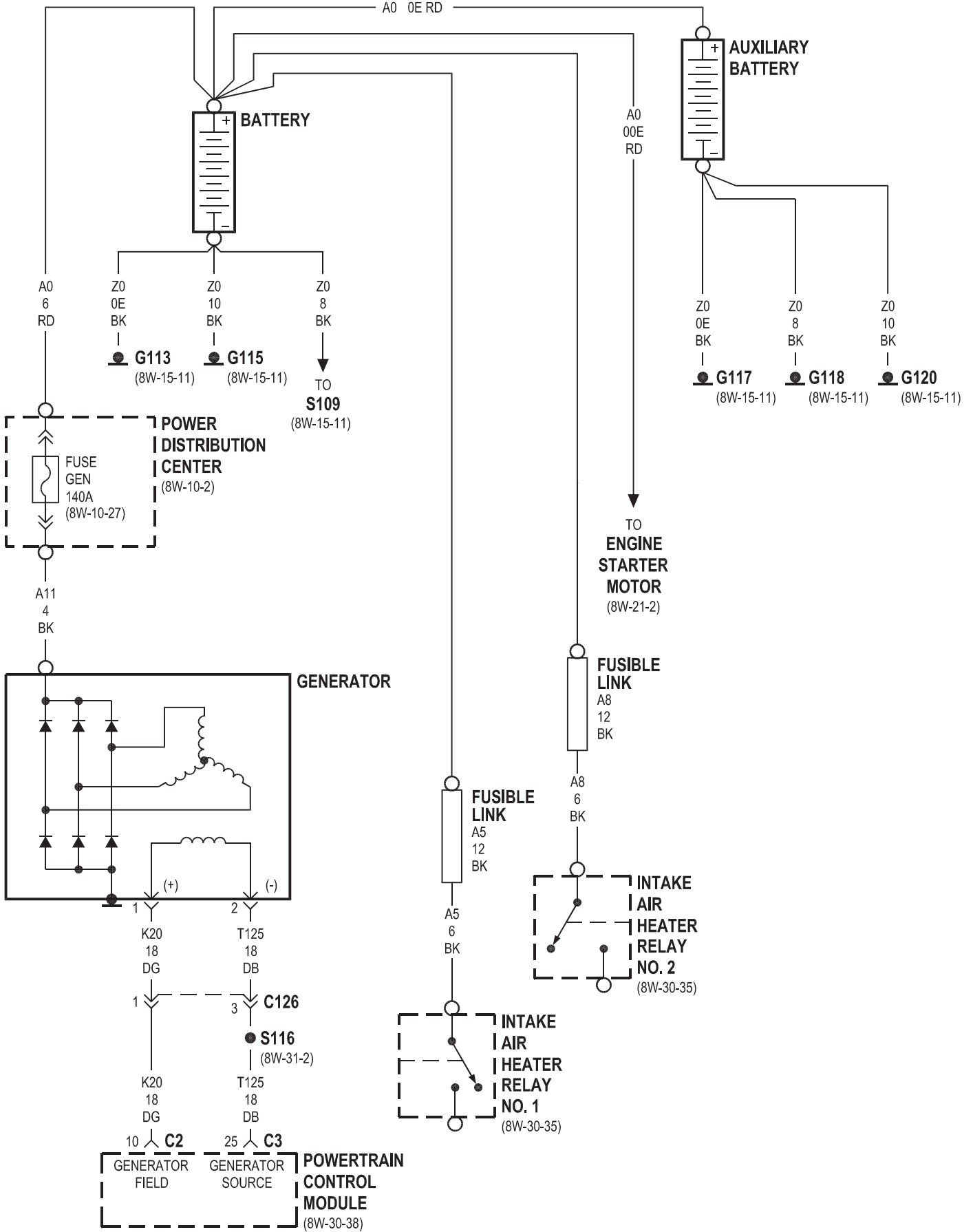




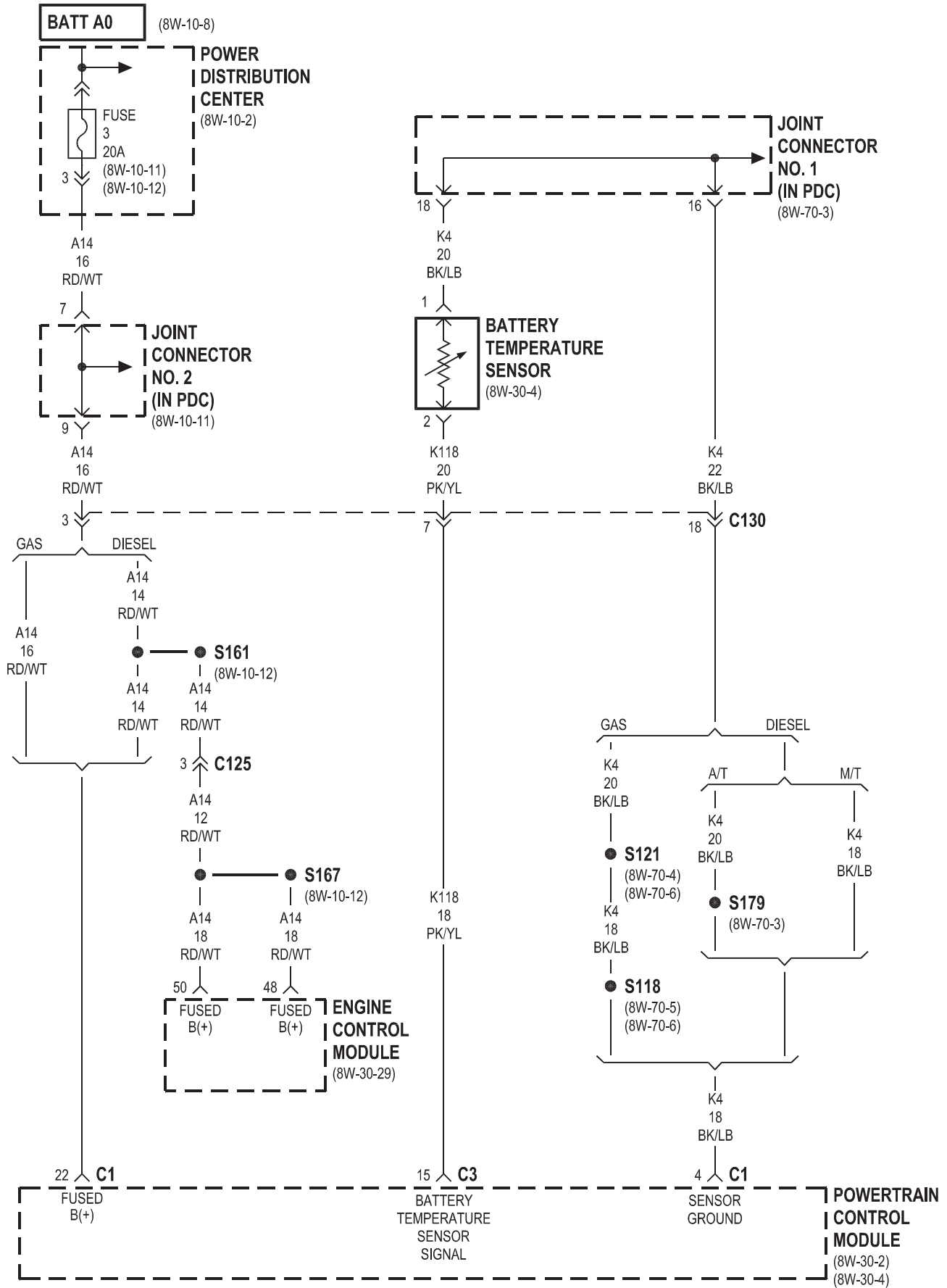
## 8W-20 CHARGING SYSTEM

<b>Component</b>	<b>Page</b>	<b>Component</b>	<b>Page</b>
Auxiliary Battery . . . . .	8W-20-3	G116 . . . . .	8W-20-2
Battery Temperature Sensor . . . . .	8W-20-4	G117 . . . . .	8W-20-3
Battery . . . . .	8W-20-2, 3	G118 . . . . .	8W-20-3
Engine Control Module . . . . .	8W-20-4	G120 . . . . .	8W-20-3
Engine Starter Motor . . . . .	8W-20-2, 3	Generator . . . . .	8W-20-2, 3
Fuse 3 (PDC) . . . . .	8W-20-4	Intake Air Heater Relay No. 1 . . . . .	8W-20-3
Fuse GEN (PDC) . . . . .	8W-20-2, 3	Intake Air Heater Relay No. 2 . . . . .	8W-20-3
Fusible Link . . . . .	8W-20-3	Joint Connector No. 1 . . . . .	8W-20-4
G113 . . . . .	8W-20-3	Joint Connector No. 2 . . . . .	8W-20-4
G114 . . . . .	8W-20-2	Power Distribution Center . . . . .	8W-20-2, 3, 4
G115 . . . . .	8W-20-2, 3	Powertrain Control Module . . . . .	8W-20-2, 3, 4



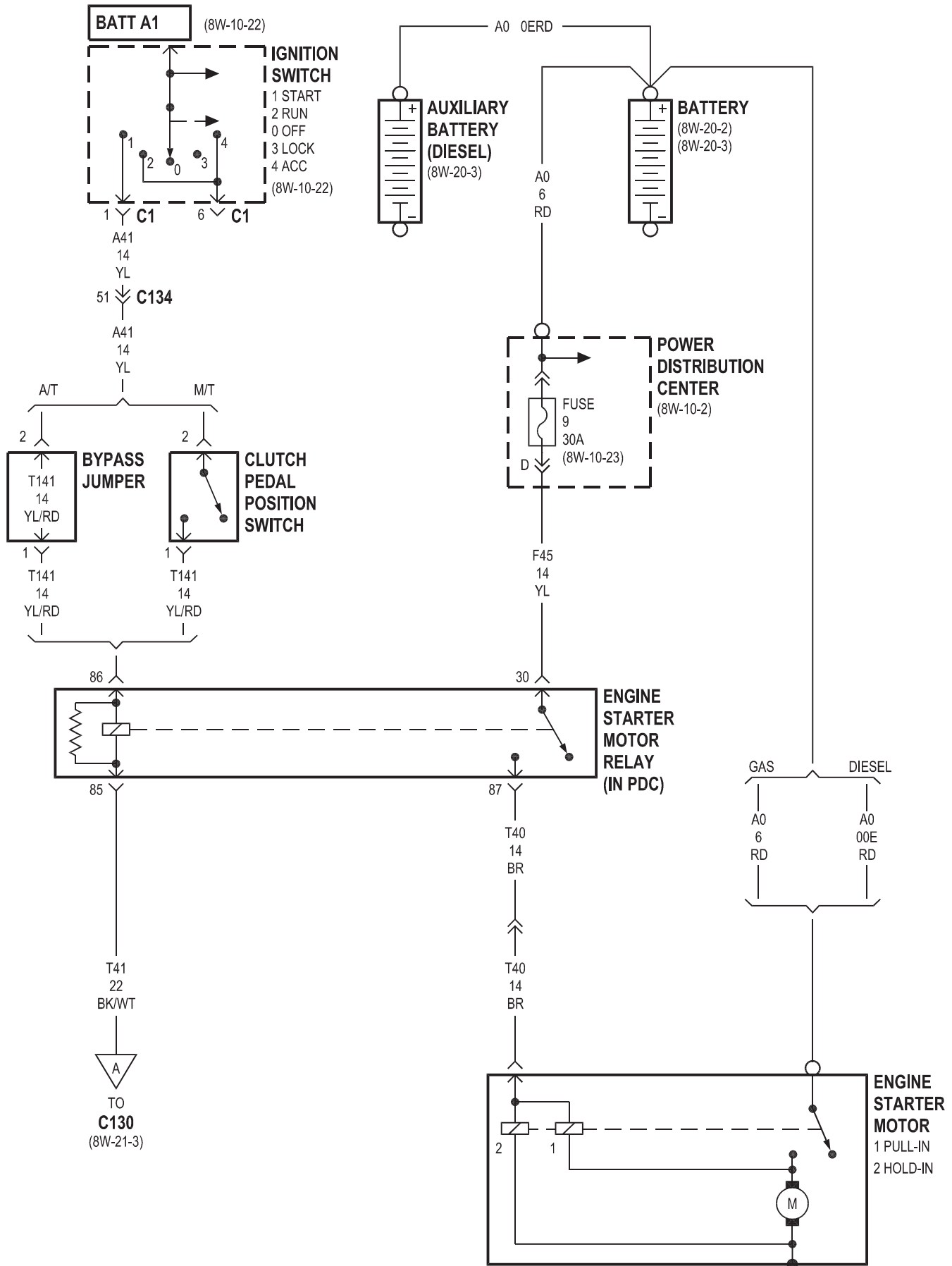


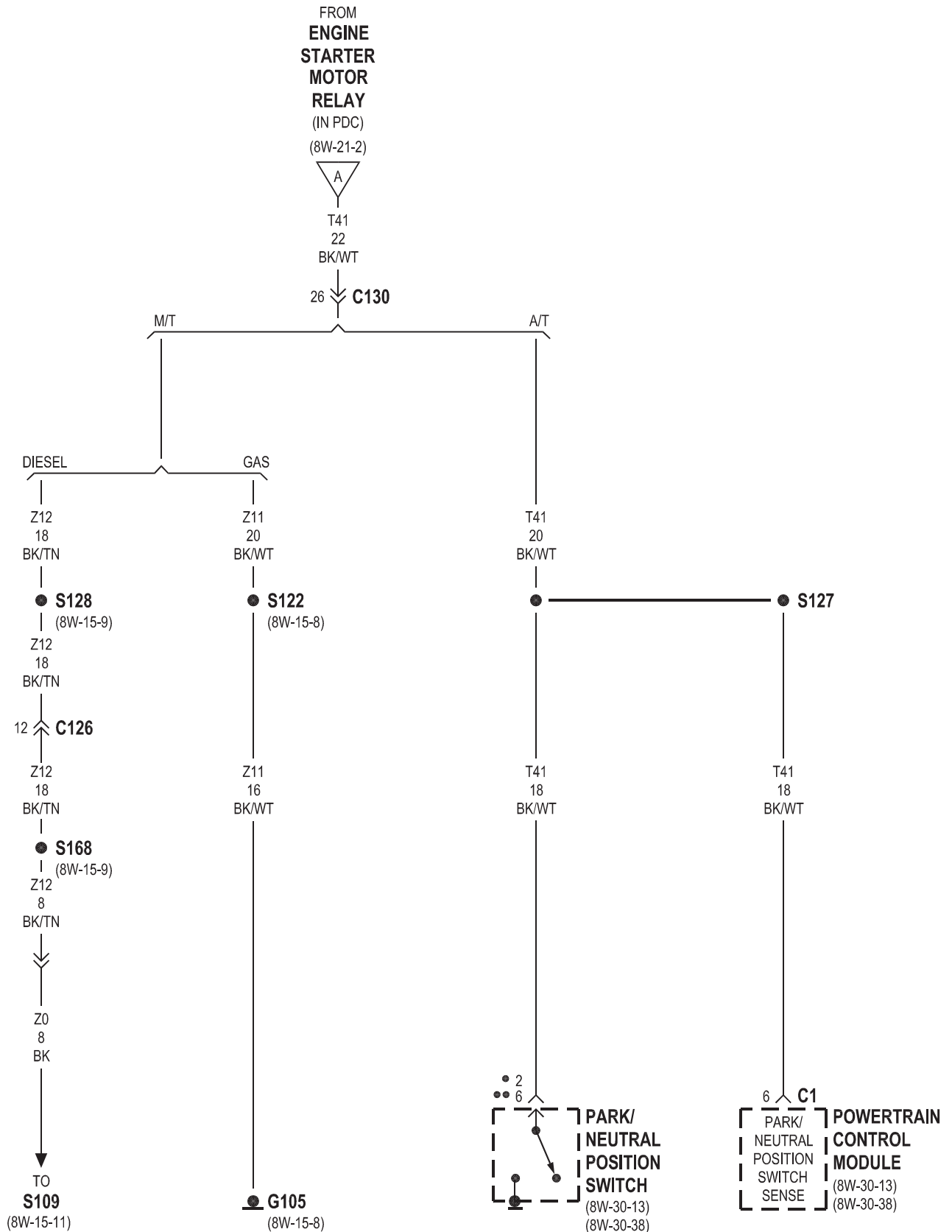




## 8W-21 STARTING SYSTEM

<b>Component</b>	<b>Page</b>	<b>Component</b>	<b>Page</b>
Auxiliary Battery .....	8W-21-2	Fuse 9 (PDC) .....	8W-21-2
Battery .....	8W-21-2	G105 .....	8W-21-3
Bypass Jumper .....	8W-21-2	Ignition Switch .....	8W-21-2
Clutch Pedal Position Switch .....	8W-21-2	Park/Neutral Position Switch .....	8W-21-3
Engine Starter Motor .....	8W-21-2	Power Distribution Center .....	8W-21-2
Engine Starter Motor Relay .....	8W-21-2	Powertrain Control Module .....	8W-21-3





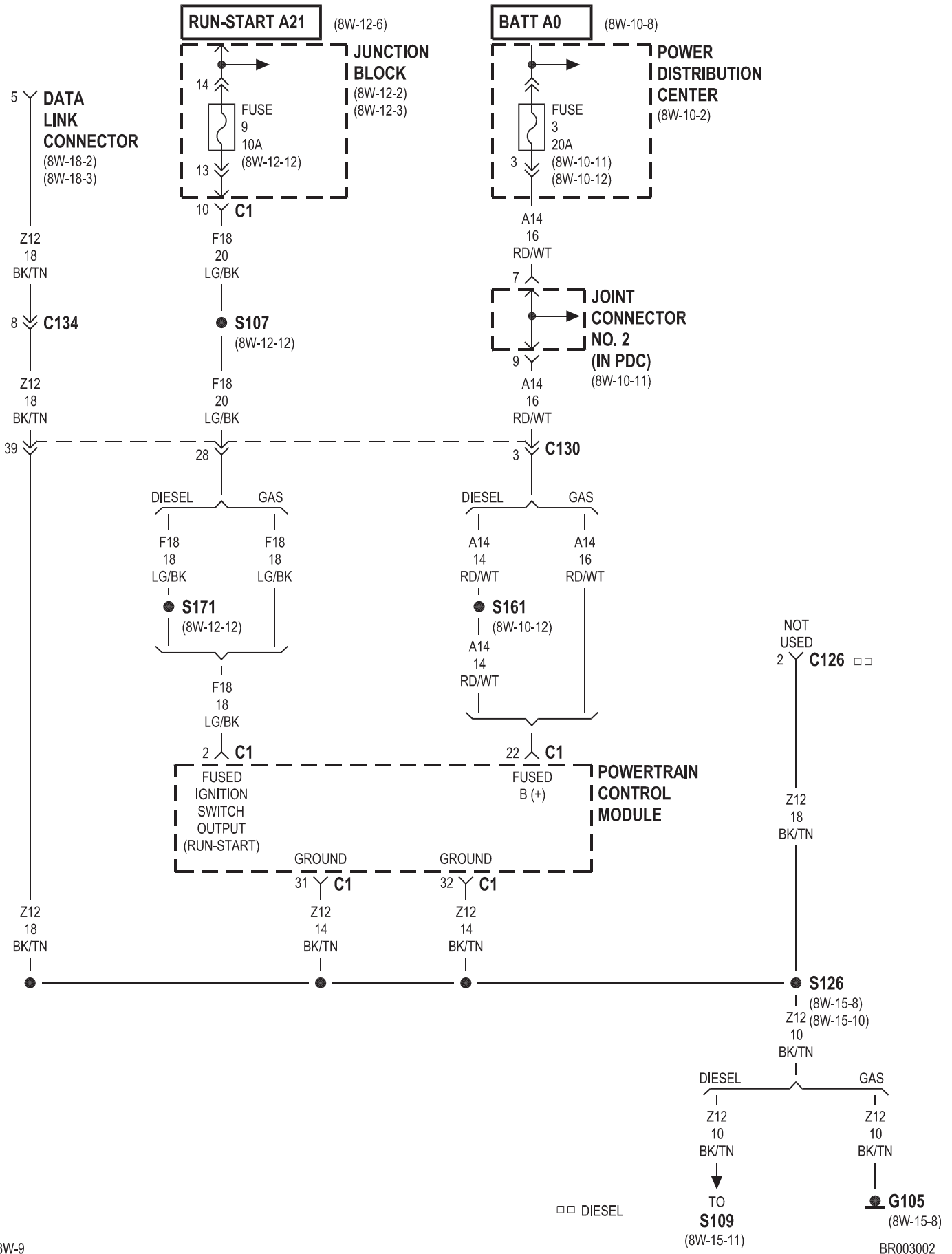
- EXCEPT 8.0L
- 8.0L

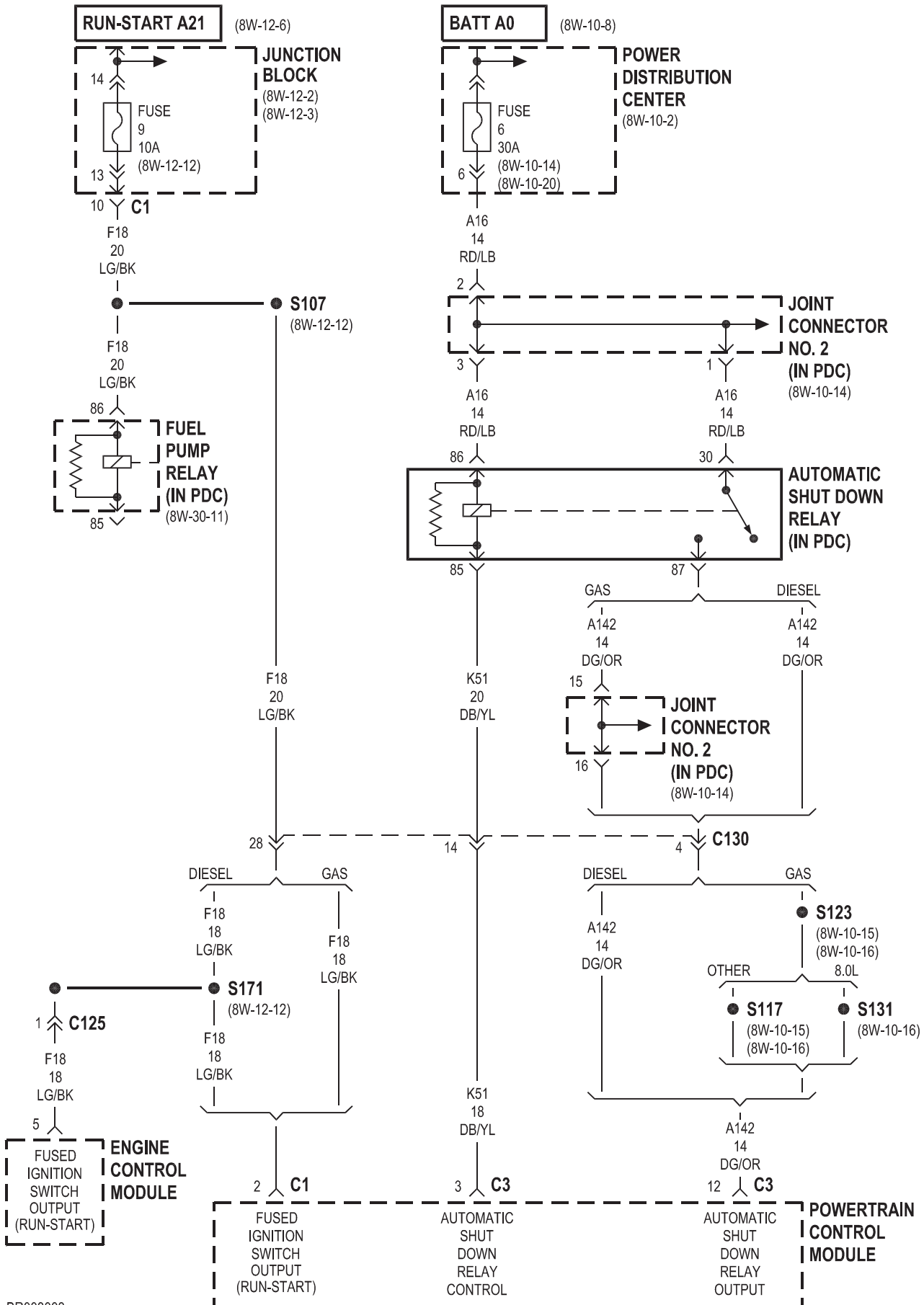


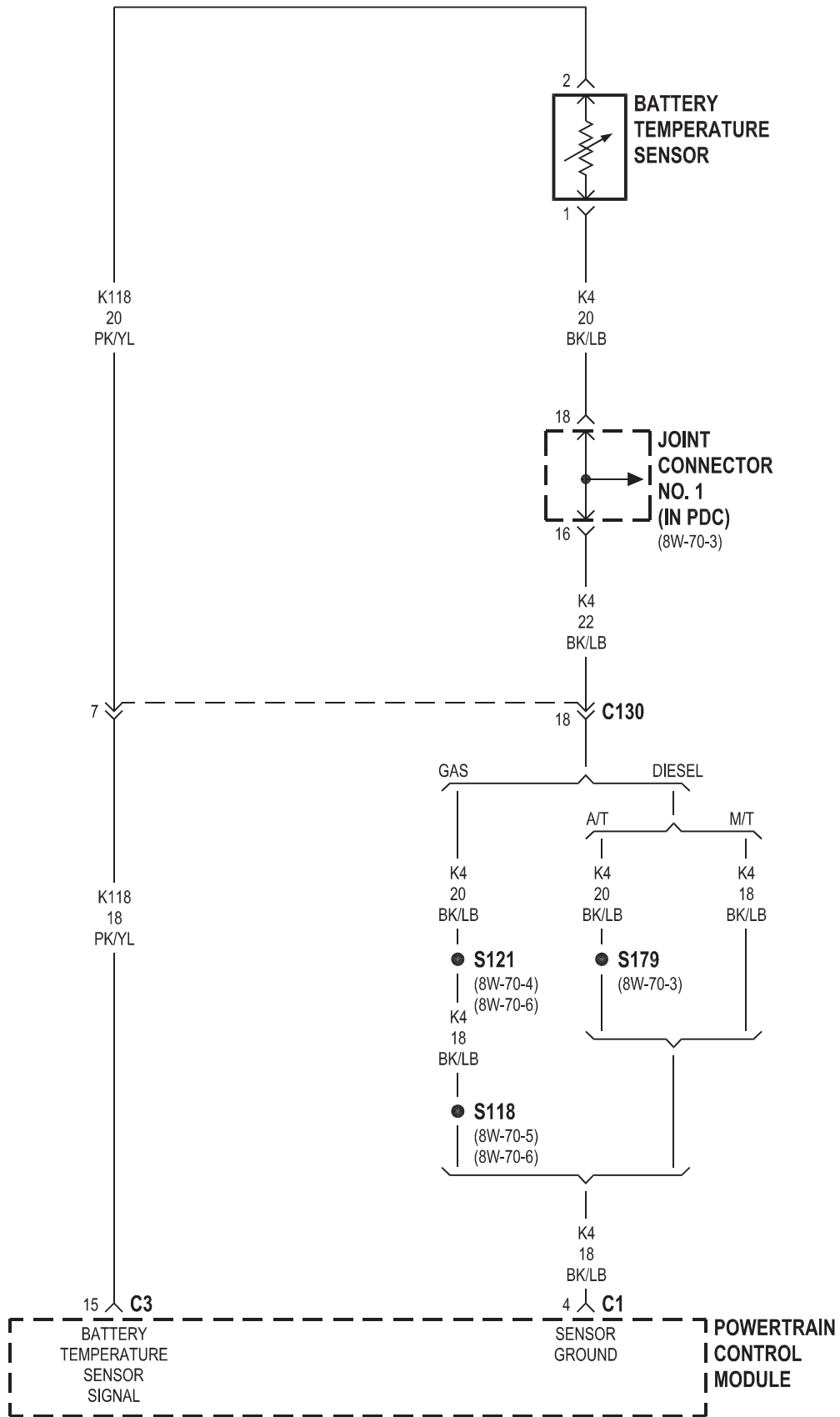


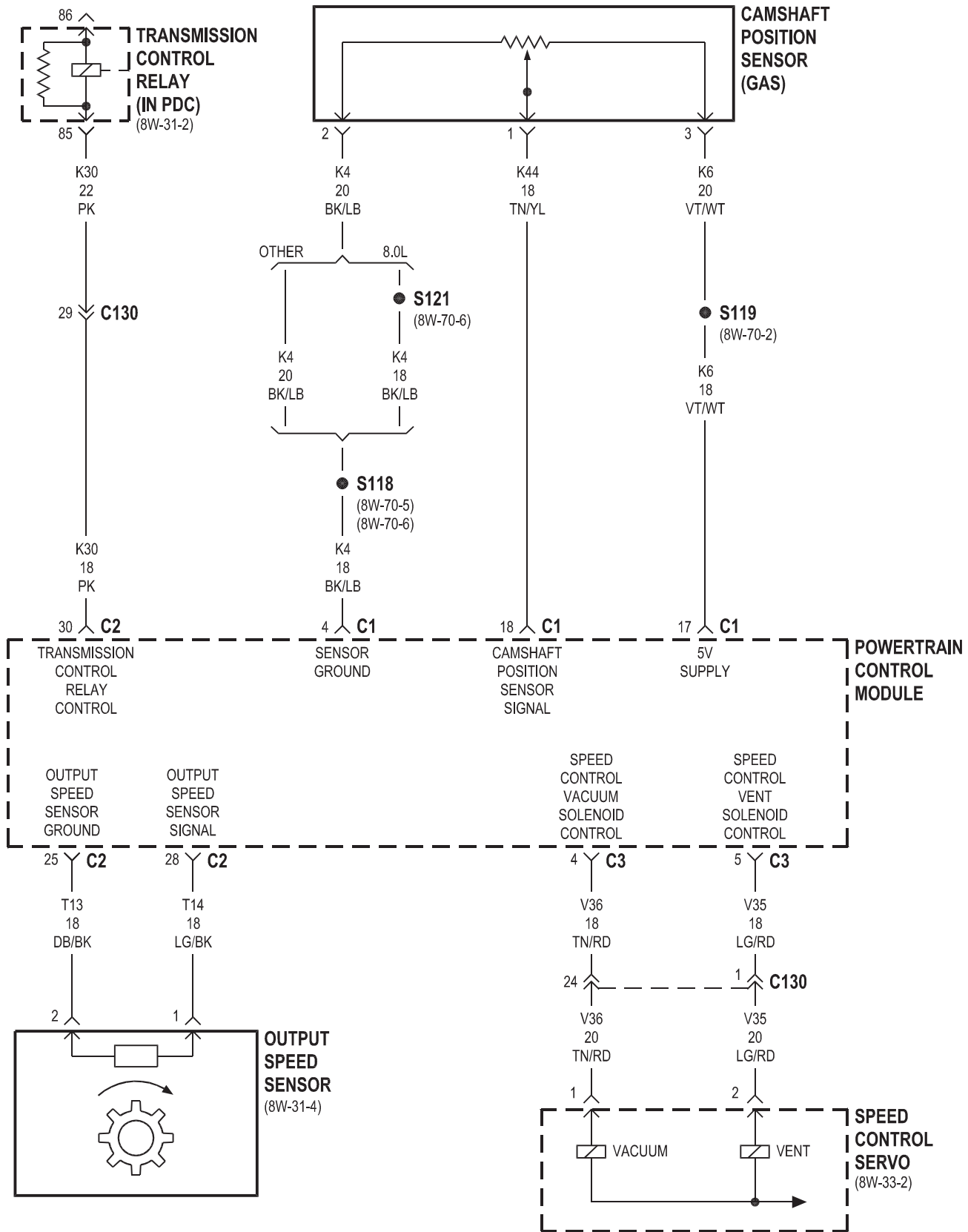
## 8W-30 FUEL/IGNITION SYSTEM

<b>Component</b>	<b>Page</b>	<b>Component</b>	<b>Page</b>
A/C Compressor Clutch Relay . . . .	8W-30-14, 38, 39	G107 . . . . .	8W-30-34, 36
A/C-Heater Control . . . . .	8W-30-14, 39	G113 . . . . .	8W-30-14, 34
A/C High Pressure Switch . . . . .	8W-30-14, 39	G200 . . . . .	8W-30-16, 37
A/C Low Pressure Switch . . . . .	8W-30-14, 39	Generator . . . . .	8W-30-13, 38
Accelerator Pedal Position Sensor . . . . .	8W-30-30	Idle Air Control Motor . . . . .	8W-30-9
Airbag Control Module . . . . .	8W-30-40, 15	Ignition Coil 4-Pack . . . . .	8W-30-28
Automatic Shut Down Relay . . . . .	8W-30-3, 17, 18, 19, 22, 23, 24, 25, 26, 27, 28	Ignition Coil 6-Pack . . . . .	8W-30-28
Battery Temperature Sensor . . . . .	8W-30-4	Ignition Coil . . . . .	8W-30-25
Battery . . . . .	8W-30-35	Instrument Cluster . . . . .	8W-30-15, 34, 40
Brake Lamp Switch . . . . .	8W-30-7, 8, 37	Intake Air Heater Relay No. 1 . . . . .	8W-30-35
Camshaft Position Sensor . . . . .	8W-30-5, 32	Intake Air Heater Relay No. 2 . . . . .	8W-30-35
Capacitor . . . . .	8W-30-28	Intake Air Heater . . . . .	8W-30-35
Central Timer Module C2 . . . . .	8W-30-15, 40	Intake Air Temperature Sensor . . . . .	8W-30-10, 32
Clockspring . . . . .	8W-30-7, 34	Joint Connector No. 1 . . . . .	8W-30-4, 7, 12, 36, 37, 42
Controller Antilock Brake . . . . .	8W-30-13, 15, 38, 40	Joint Connector No. 2 . . . . .	8W-30-2, 3, 11, 17, 18, 19, 22, 23, 24, 25, 26, 27, 28, 29, 35, 37
Crankshaft Position Sensor . . . . .	8W-30-13	Joint Connector No. 5 . . . . .	8W-30-16, 41
Cummins Bus . . . . .	8W-30-29	Joint Connector No. 7 . . . . .	8W-30-15, 40
Data Link Connector . . . . .	8W-30-2, 15, 16, 40, 41	Junction Block . . . . .	8W-30-2, 3, 11, 13, 16, 36, 39, 41
Duty Cycle EVAP/Purge Solenoid . . . . .	8W-30-13	Leak Detection Pump . . . . .	8W-30-8
Engine Control Module . . . . .	8W-30-3, 7, 29, 30, 31, 32, 33, 34, 35, 36, 37, 39, 40, 41	Left Speed Control Switch . . . . .	8W-30-7
Engine Coolant Temperature Sensor . . . . .	8W-30-9, 34	Manifold Absolute Pressure Sensor . . . . .	8W-30-10
Engine Oil Pressure Sensor . . . . .	8W-30-33, 13	Manifold Air Pressure Sensor . . . . .	8W-30-33
Fuel Heater Relay . . . . .	8W-30-36	Output Speed Sensor . . . . .	8W-30-5
Fuel Heater . . . . .	8W-30-36	Overdrive Switch . . . . .	8W-30-6
Fuel Injection Pump . . . . .	8W-30-31, 37	Overhead Console . . . . .	8W-30-40, 15
Fuel Injector No. 1 . . . . .	8W-30-23, 26	Oxygen Sensor 1/1 Left Bank Up . . . . .	8W-30-18, 22, 20
Fuel Injector No. 2 . . . . .	8W-30-24, 27	Oxygen Sensor 1/1 Upstream . . . . .	8W-30-17
Fuel Injector No. 3 . . . . .	8W-30-23, 26	Oxygen Sensor 1/2 Downstream . . . . .	8W-30-17
Fuel Injector No. 4 . . . . .	8W-30-24, 27	Oxygen Sensor 1/2 Left Bank Down . . . . .	8W-30-20
Fuel Injector No. 5 . . . . .	8W-30-23, 26	Oxygen Sensor 1/2 Pre-Catalyst . . . . .	8W-30-21
Fuel Injector No. 6 . . . . .	8W-30-24, 27	Oxygen Sensor 1/3 Post-Catalyst . . . . .	8W-30-21
Fuel Injector No. 7 . . . . .	8W-30-23, 26	Oxygen Sensor 2/1 Right Bank Up . . . . .	8W-30-18, 22, 20
Fuel Injector No. 8 . . . . .	8W-30-24, 27	Oxygen Sensor 2/2 Right Bank Down . . . . .	8W-30-20
Fuel Injector No. 9 . . . . .	8W-30-26	Oxygen Sensor Downstream Relay . . . . .	8W-30-19
Fuel Injector No. 10 . . . . .	8W-30-27	Park/Neutral Position Switch . . . . .	8W-30-13, 38
Fuel Pump Module . . . . .	8W-30-12	Power Distribution Center . . . . .	8W-30-2, 3, 11, 17, 18, 22, 23, 24, 25, 26, 27, 28, 29, 36, 37
Fuel Pump Relay . . . . .	8W-30-3, 11, 12, 31, 37	Powertrain Control Module . . . . .	8W-30-2, 3, 4, 5, 6, 7, 8, 9, 10, 11, 12, 13, 14, 15, 16 17, 18, 19, 20, 21, 22, 23, 24, 25 26, 27, 28, 36, 37,38, 39, 40, 41, 42
Fuel Tank Module . . . . .	8W-30-42	PTO Switch . . . . .	8W-30-14, 34
Fuel Transfer Pump . . . . .	8W-30-34	Radio . . . . .	8W-30-15, 40
Fuse 3 (PDC) . . . . .	8W-30-2, 11, 29, 37	Right Speed Control Switch . . . . .	8W-30-7
Fuse 6 (PDC) . . . . .	8W-30-3	Speed Control Servo . . . . .	8W-30-5
Fuse 7 (PDC) . . . . .	8W-30-36	Throttle Position Sensor . . . . .	8W-30-14
Fuse 9 (JB) . . . . .	8W-30-2, 3, 11, 36	Transmission Control Relay . . . . .	8W-30-5
Fuse 11 (JB) . . . . .	8W-30-13, 36, 39	Transmission Solenoid Assembly . . . . .	8W-30-6, 14, 39
Fuse 12 (JB) . . . . .	8W-30-16, 41	Water In Fuel Sensor . . . . .	8W-30-34
Fuse K (PDC) . . . . .	8W-30-17, 18, 19, 22		
Fusible Link . . . . .	8W-30-35		
G100 . . . . .	8W-30-12		
G102 . . . . .	8W-30-36, 37		
G105 . . . . .	8W-30-2, 16, 20, 21		

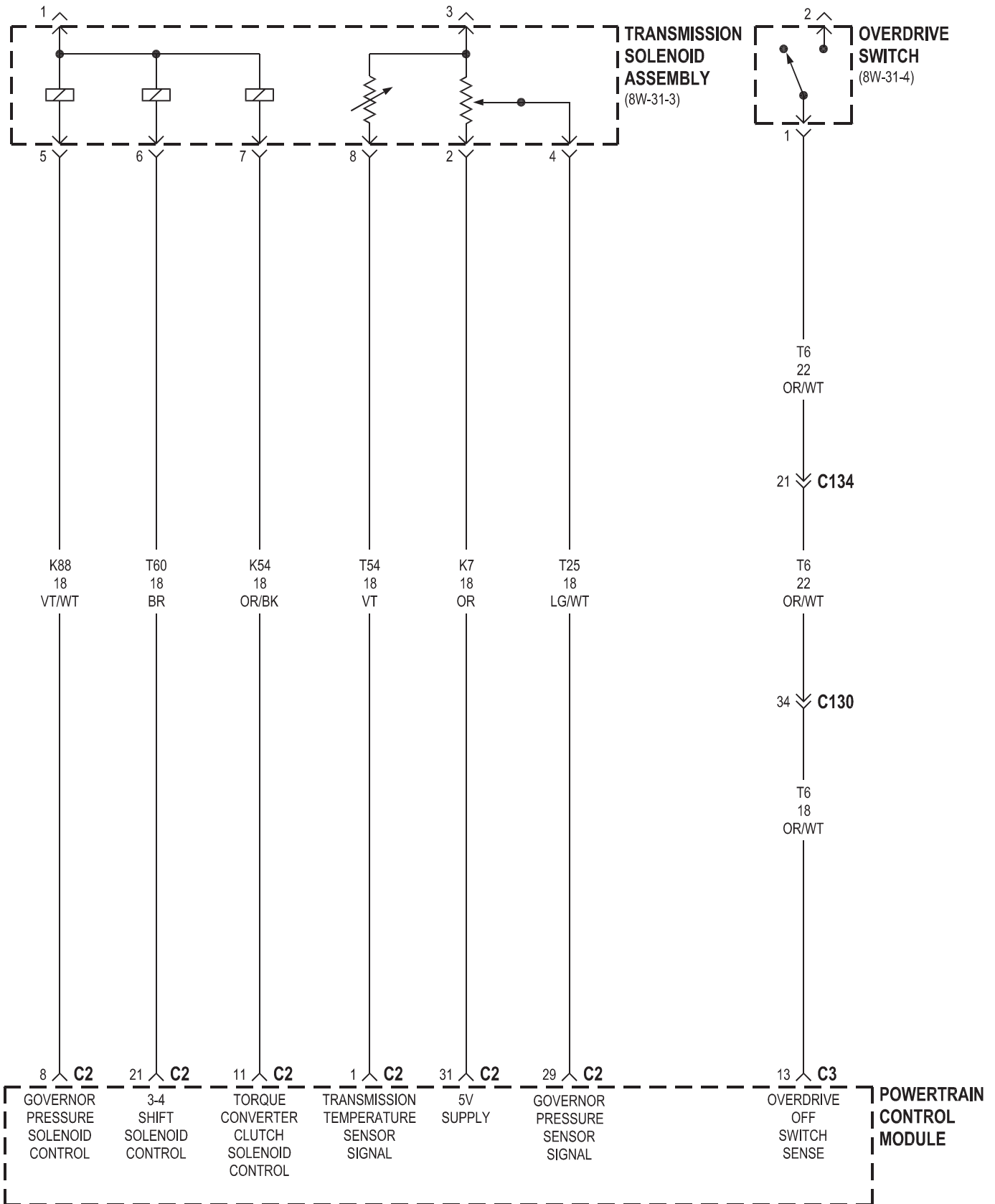


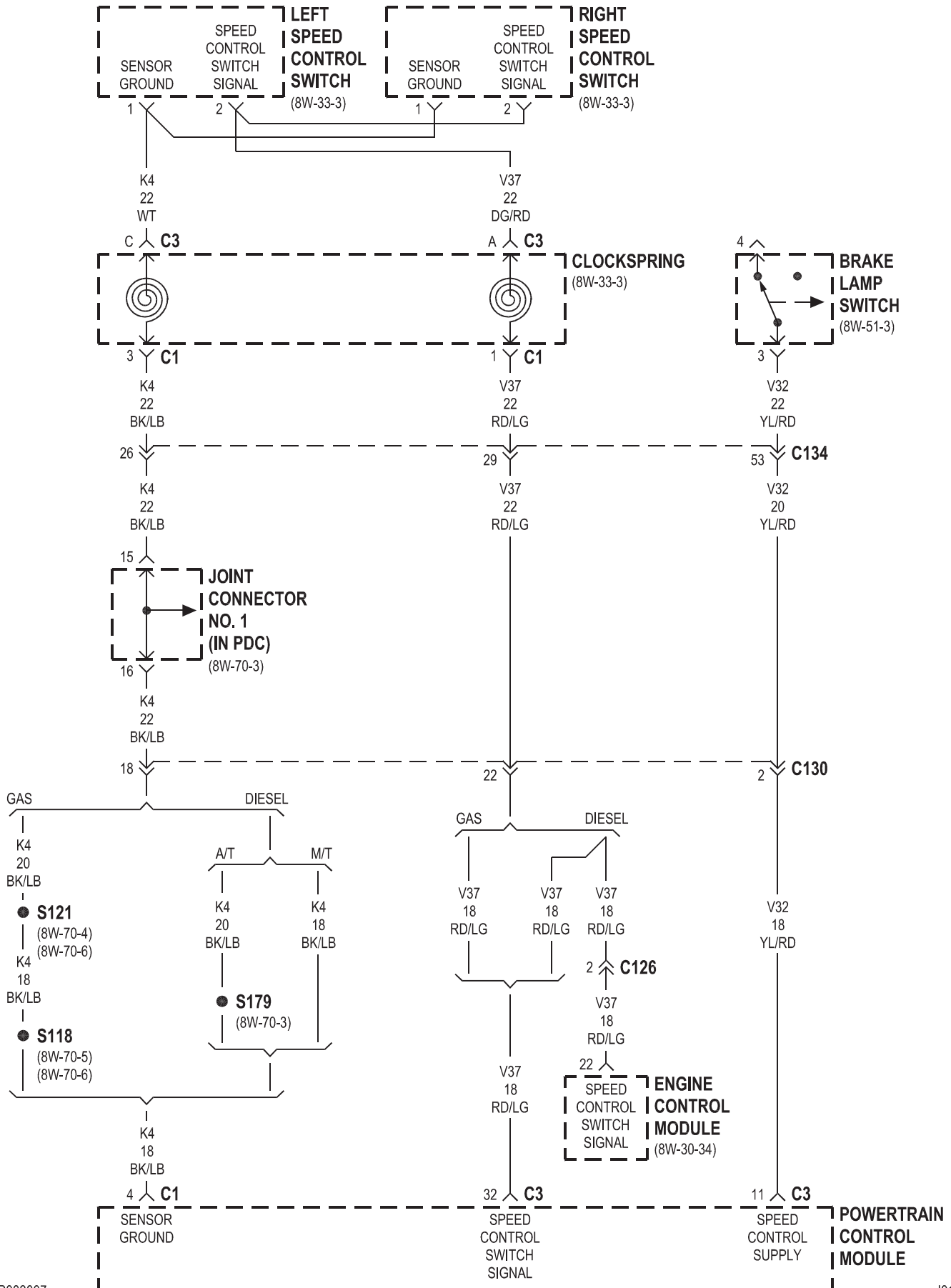


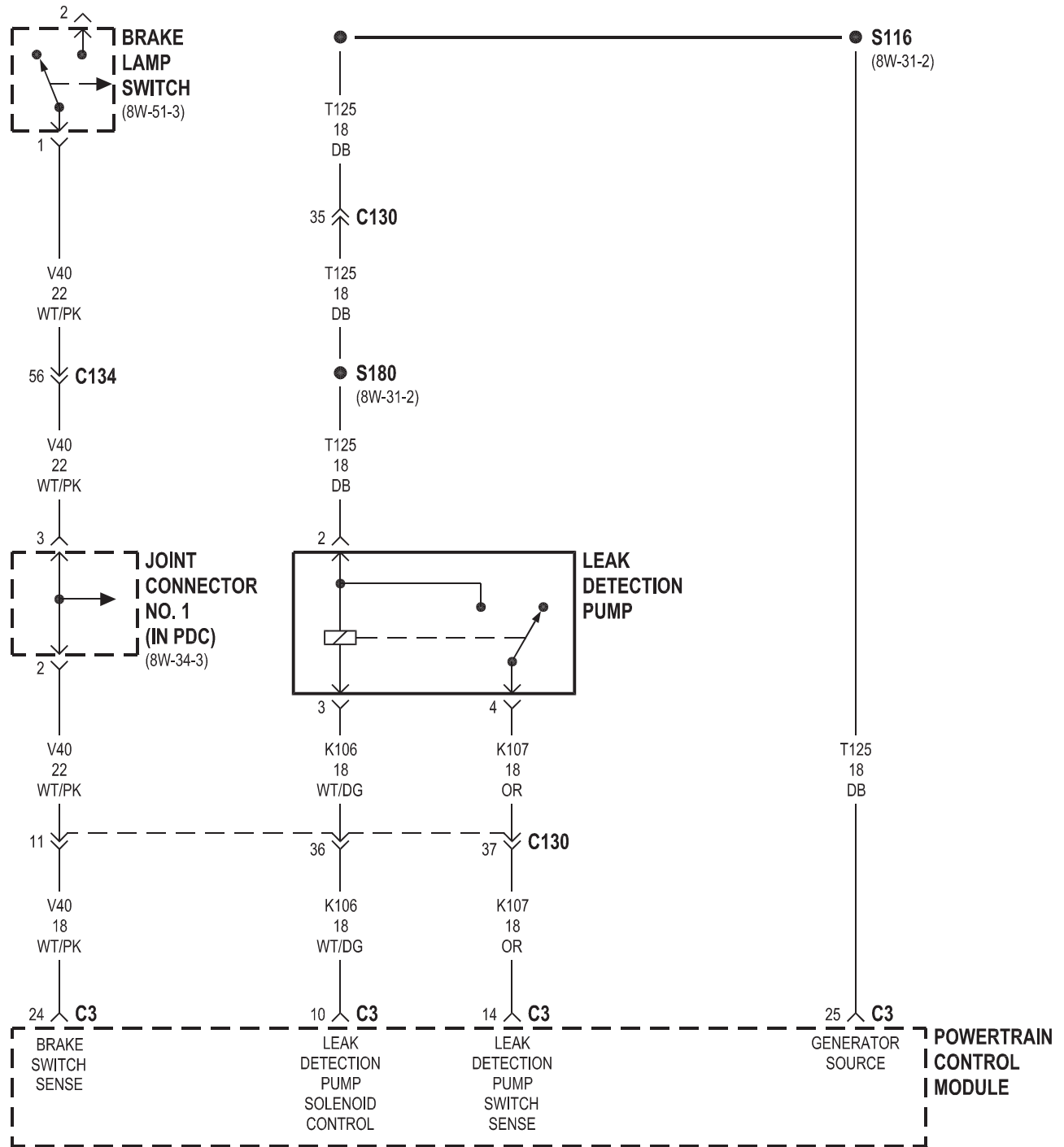


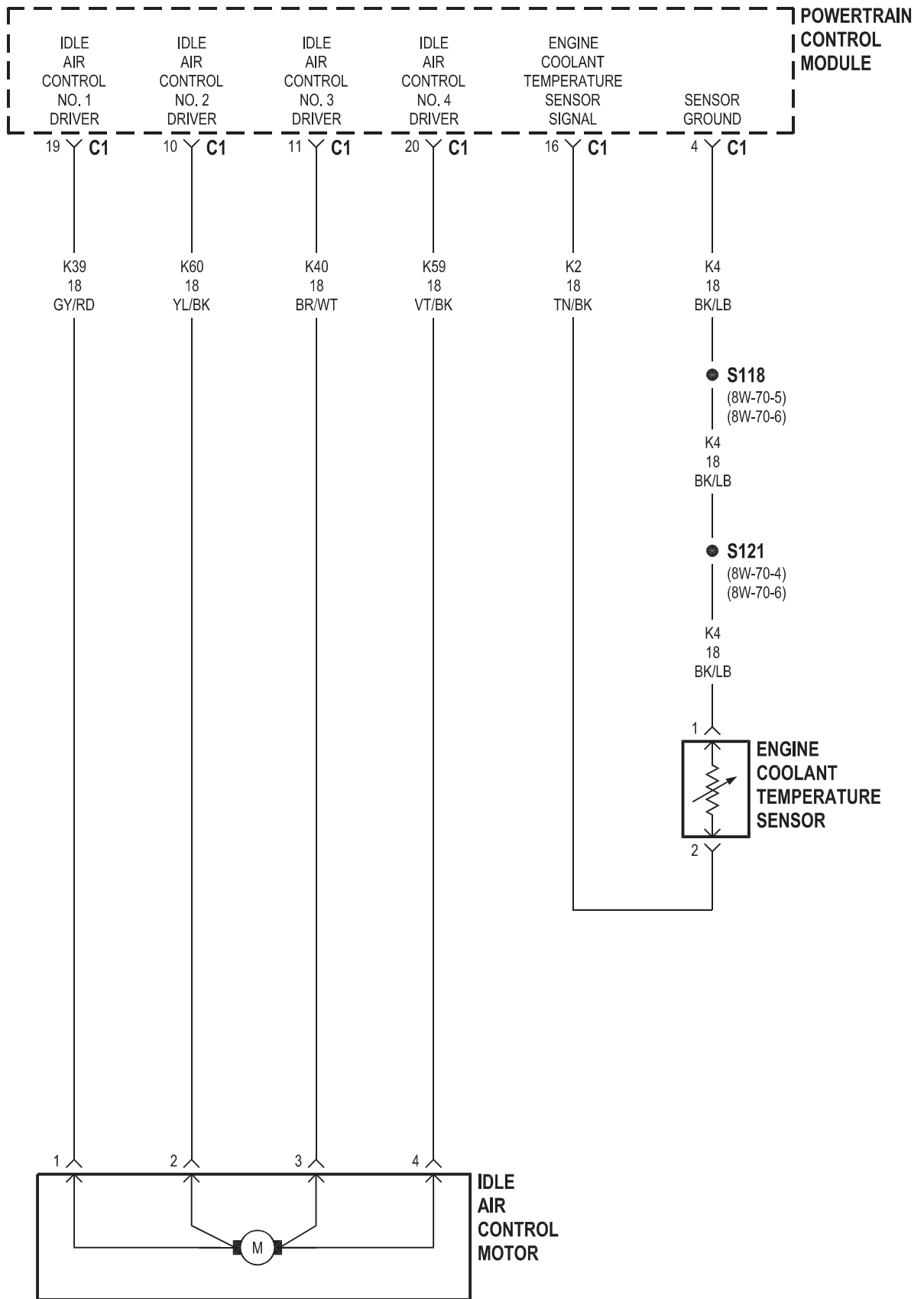


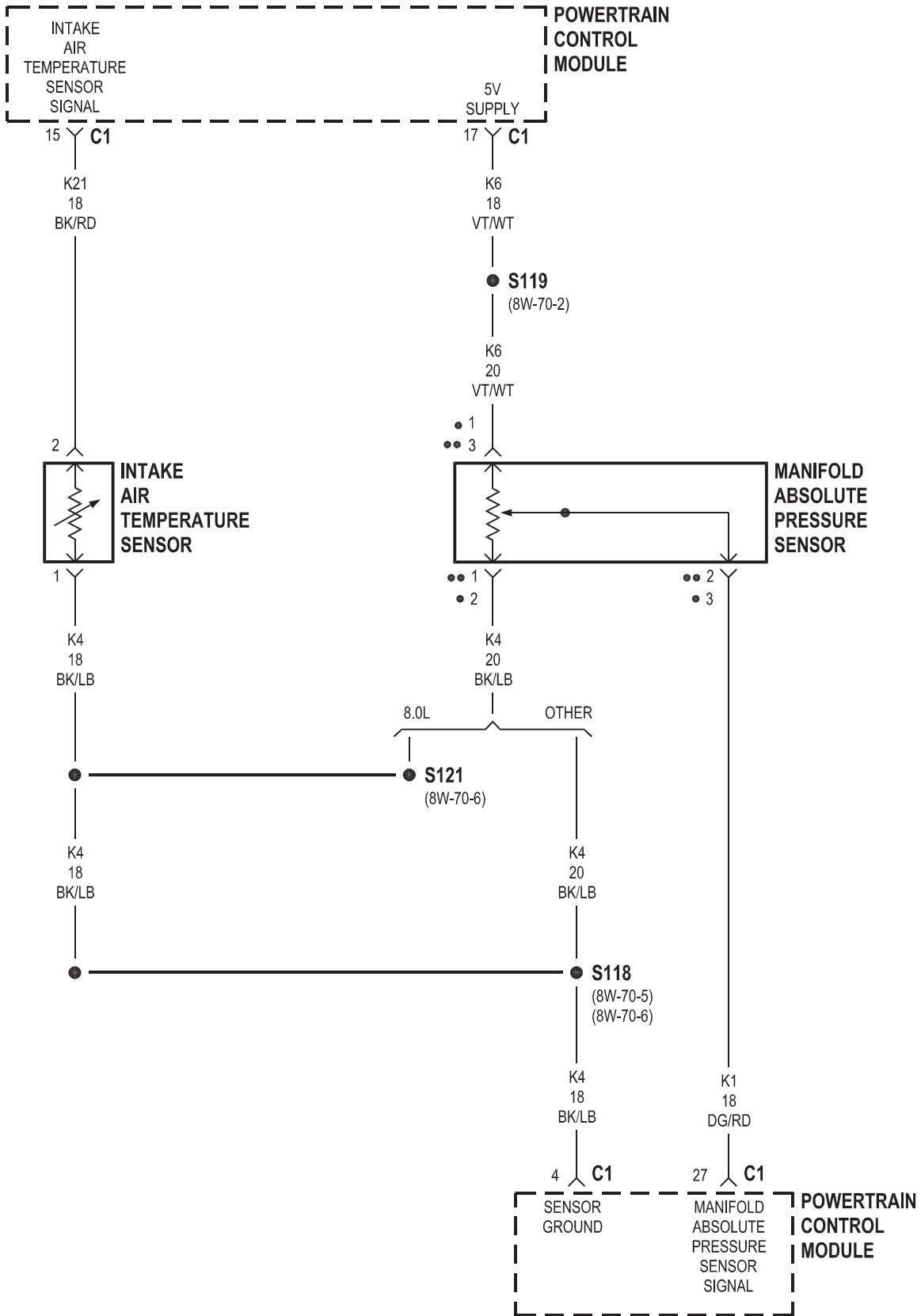






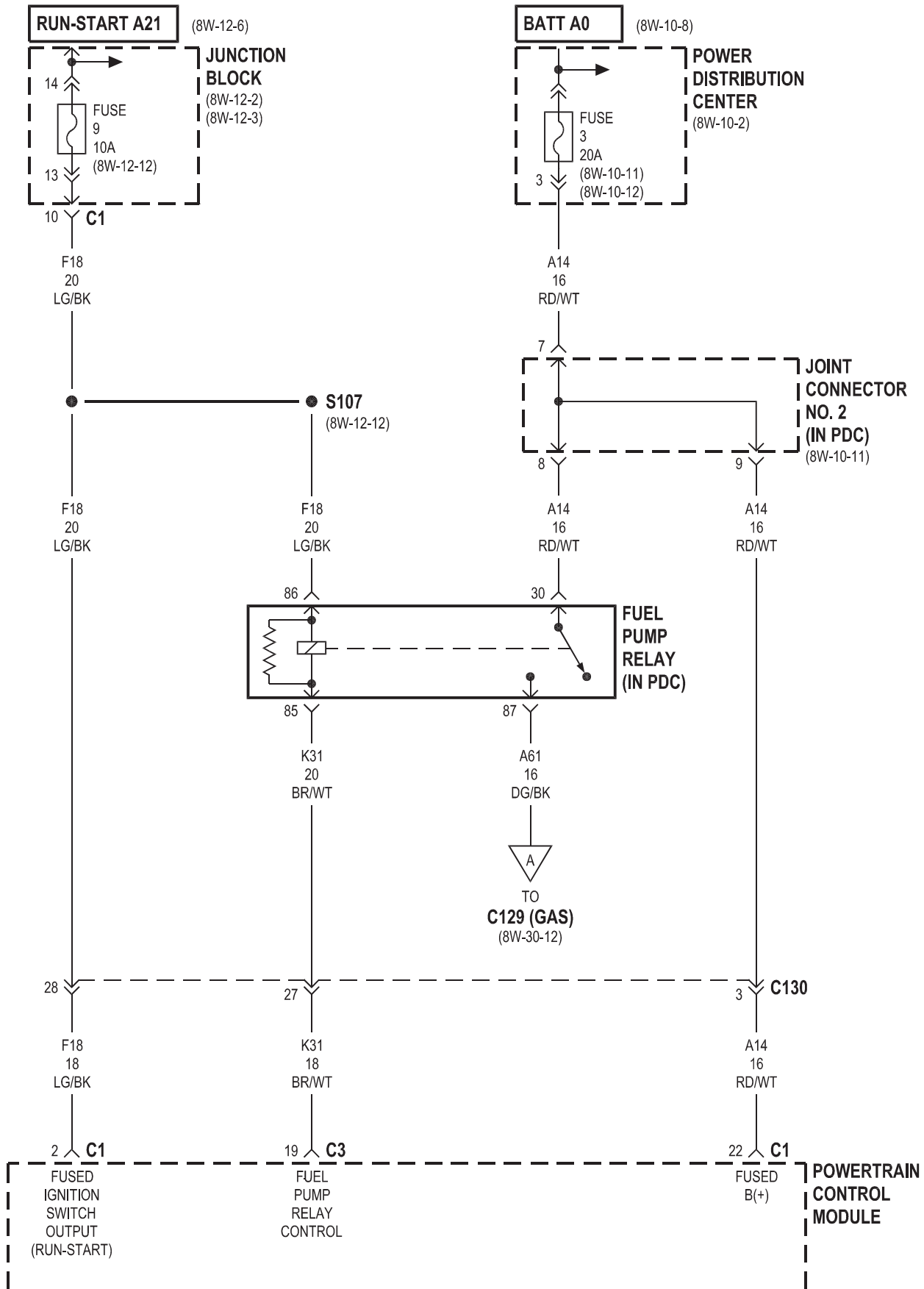


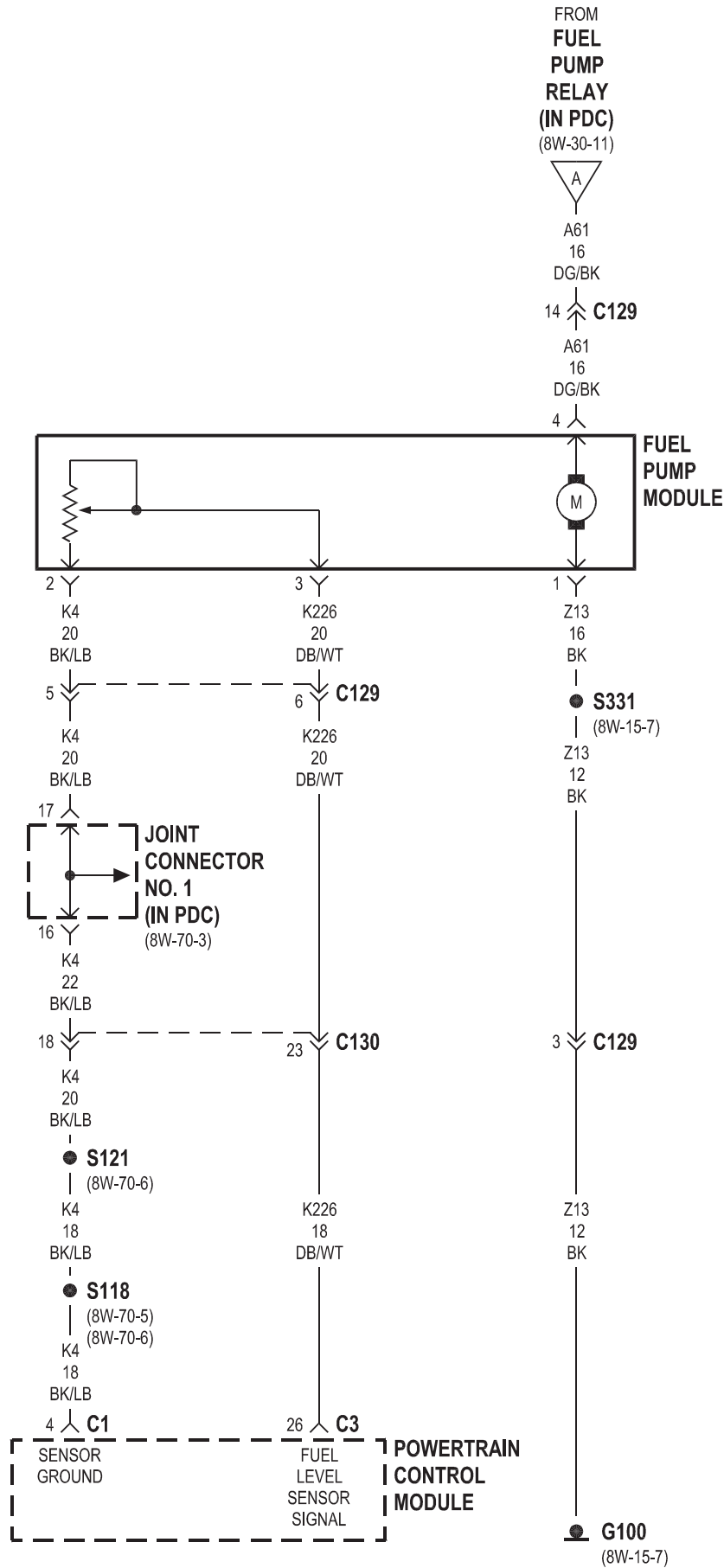


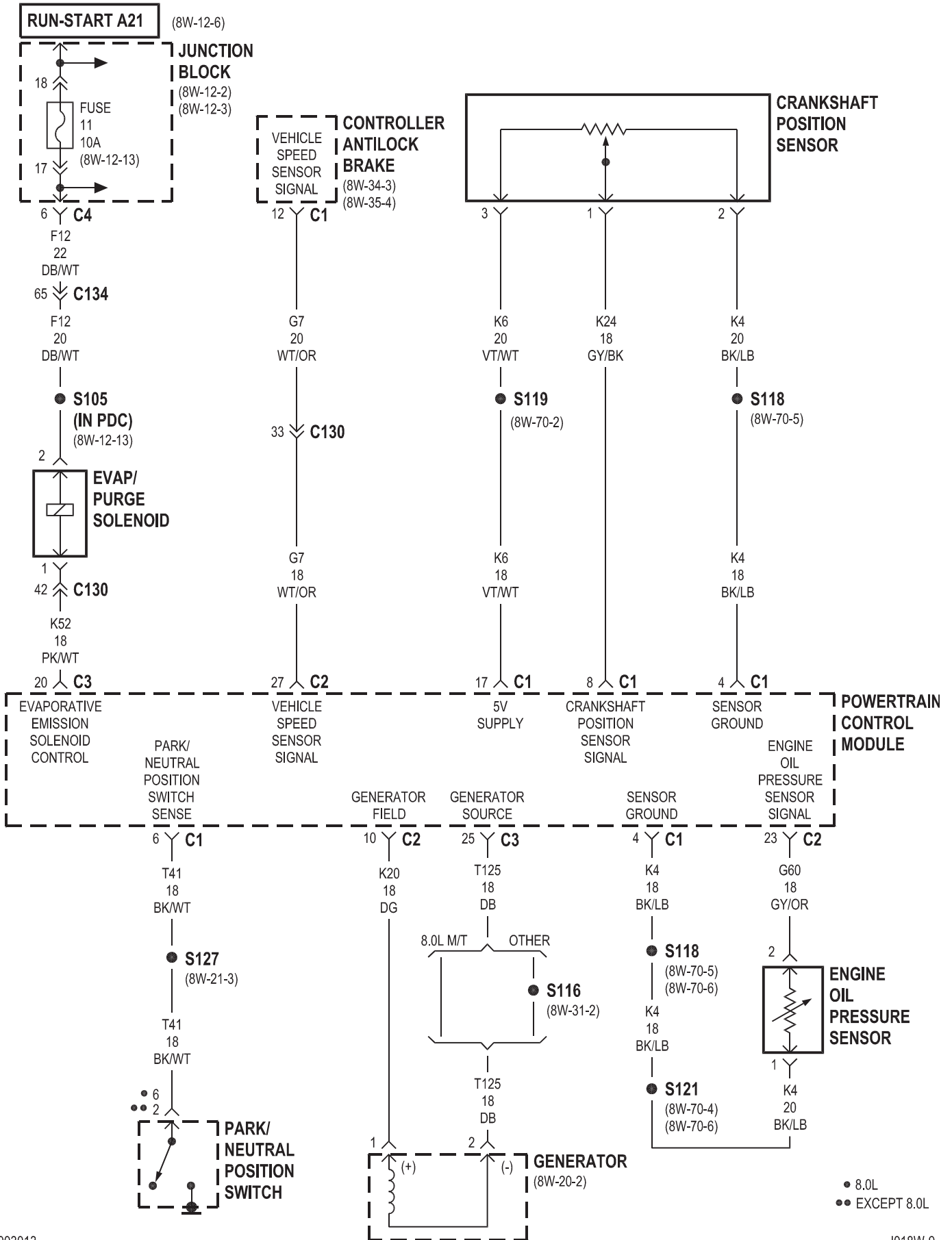


• 8.0L  
•• EXCEPT 8.0L

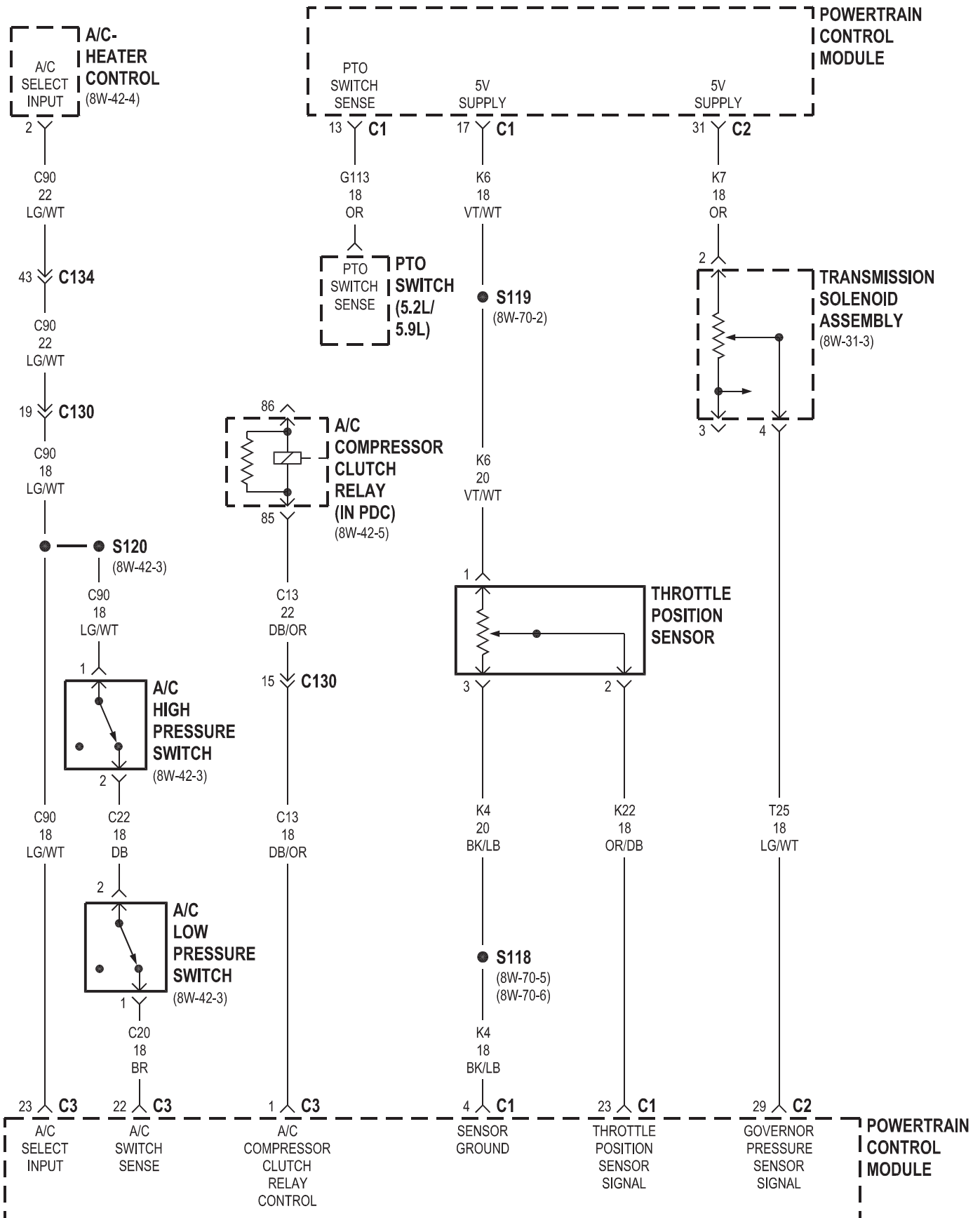


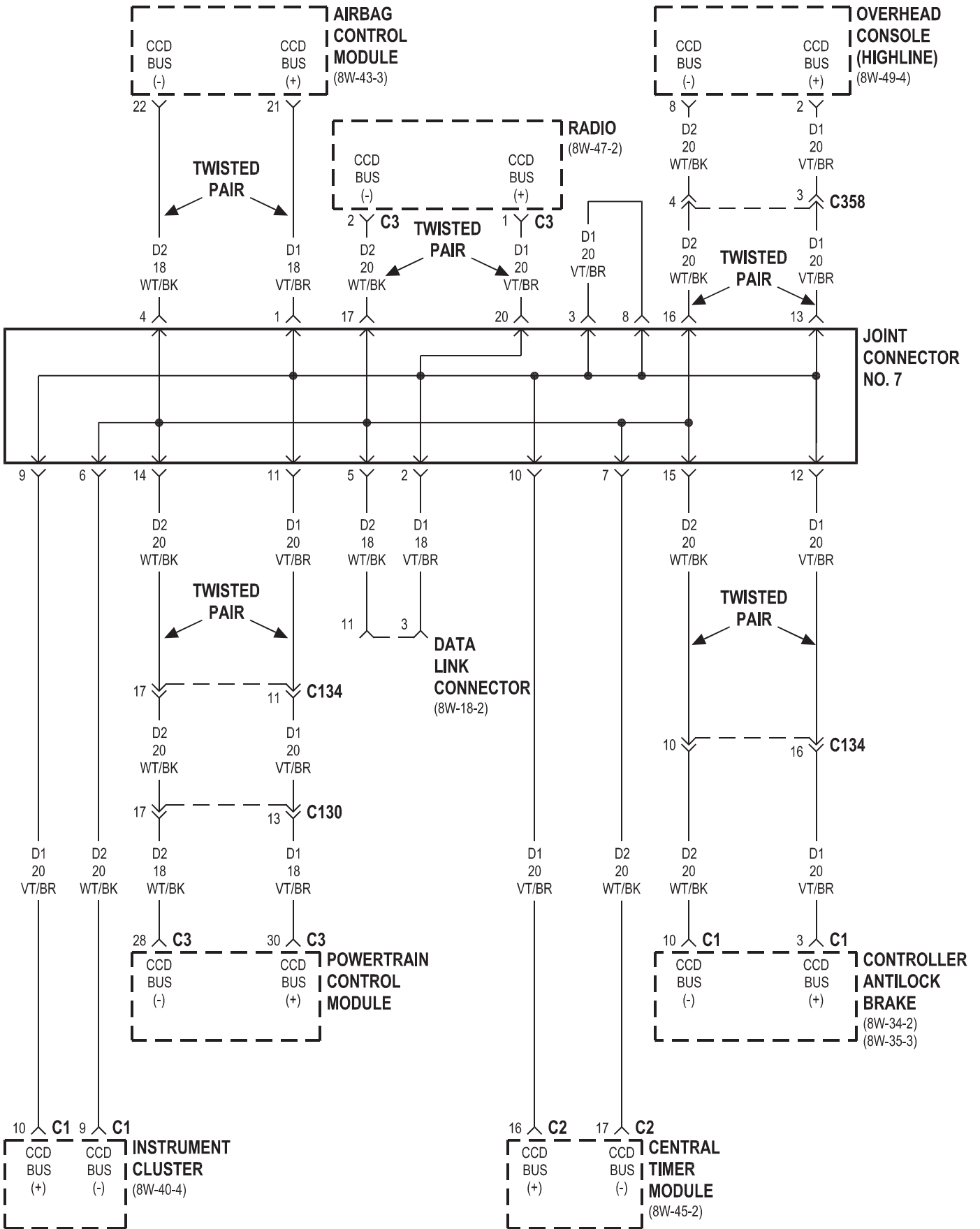




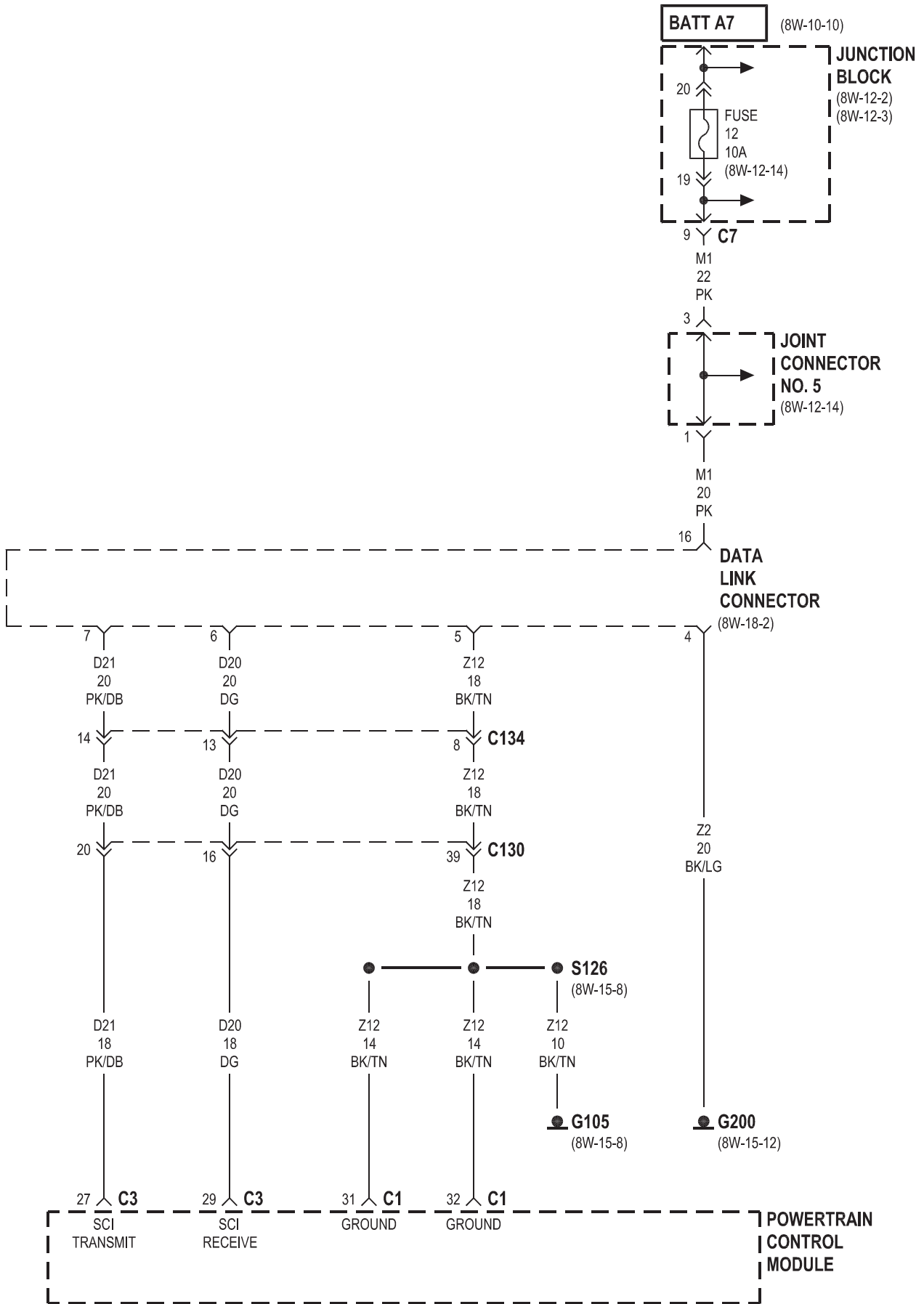


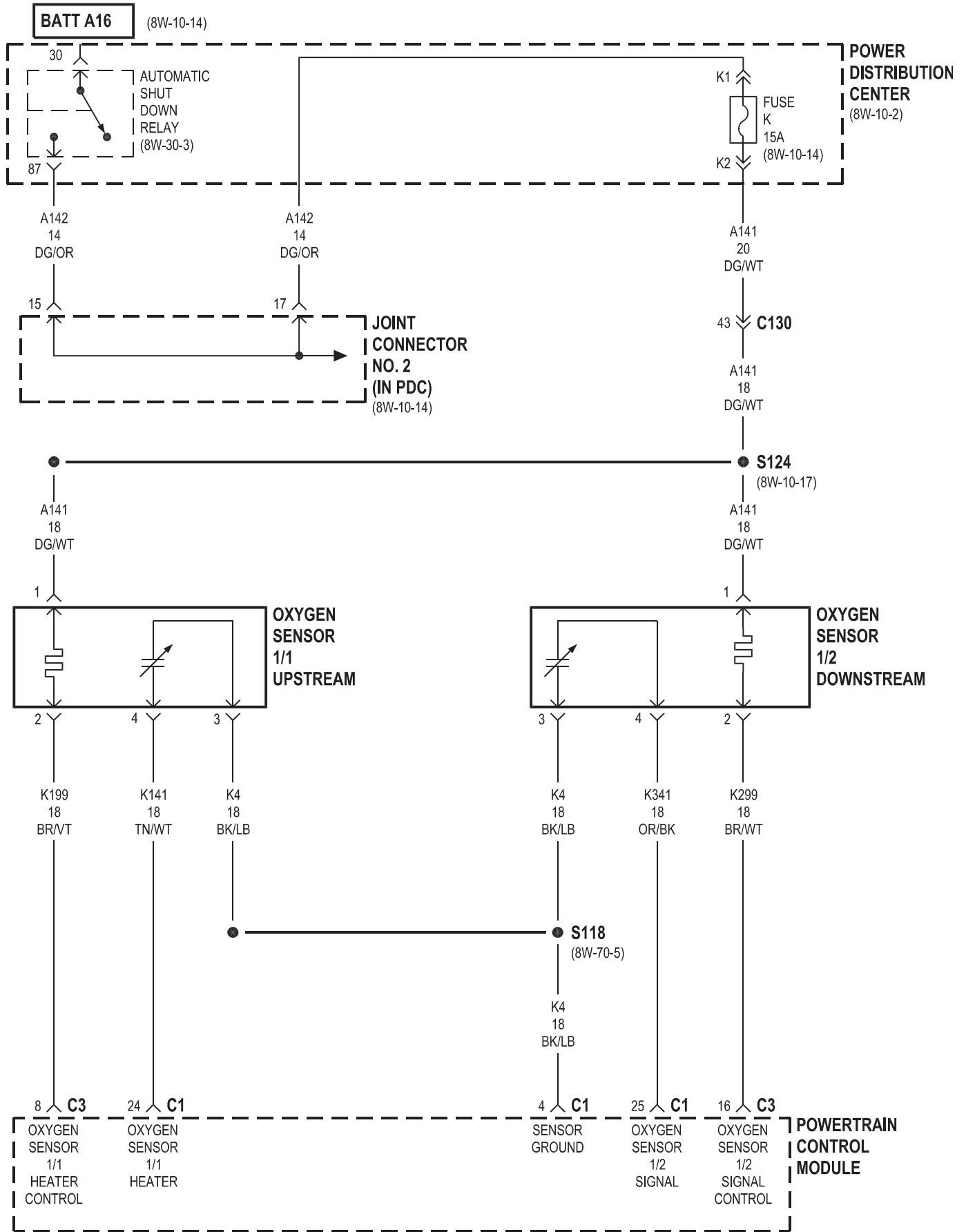
• 8.0L  
•• EXCEPT 8.0L

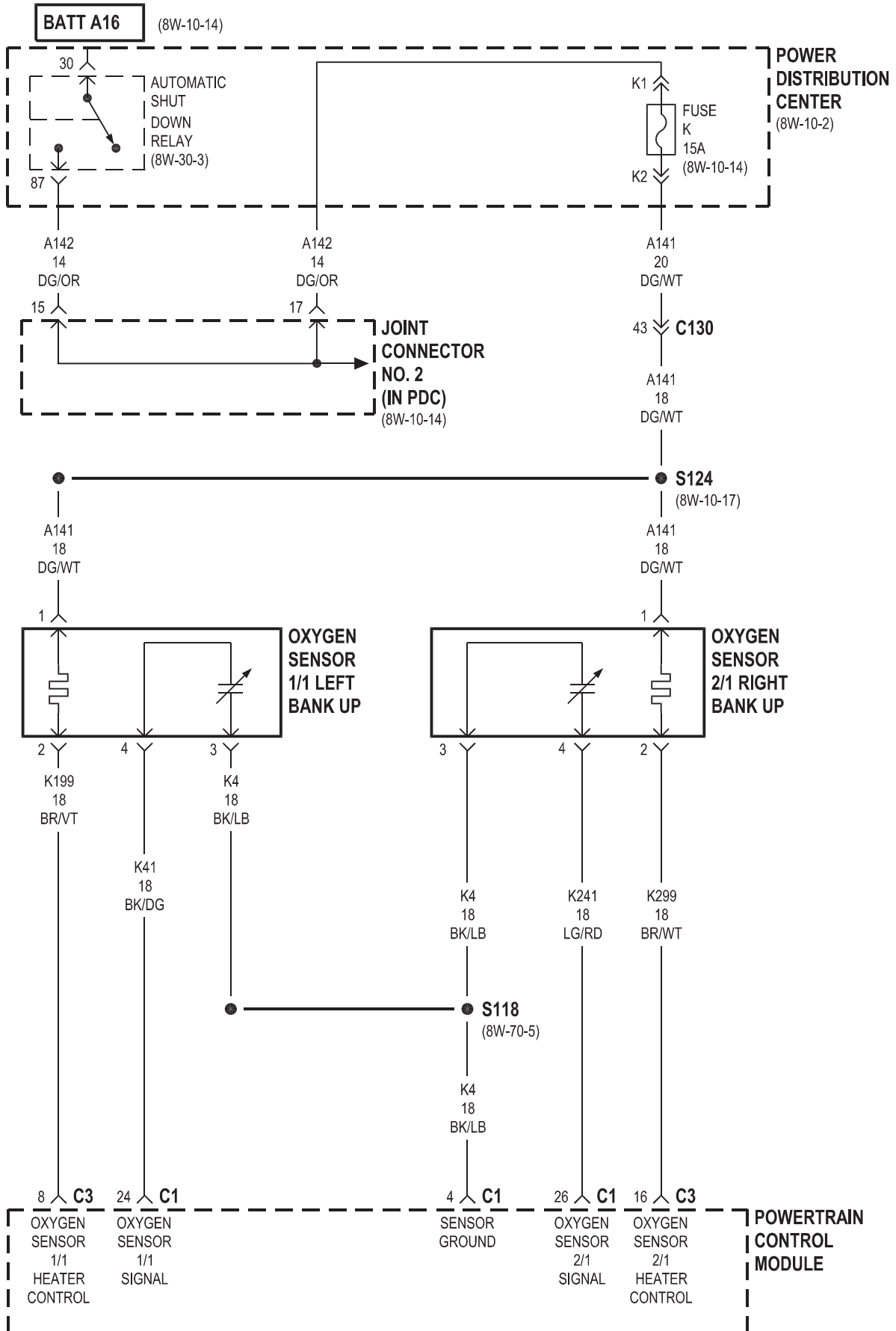


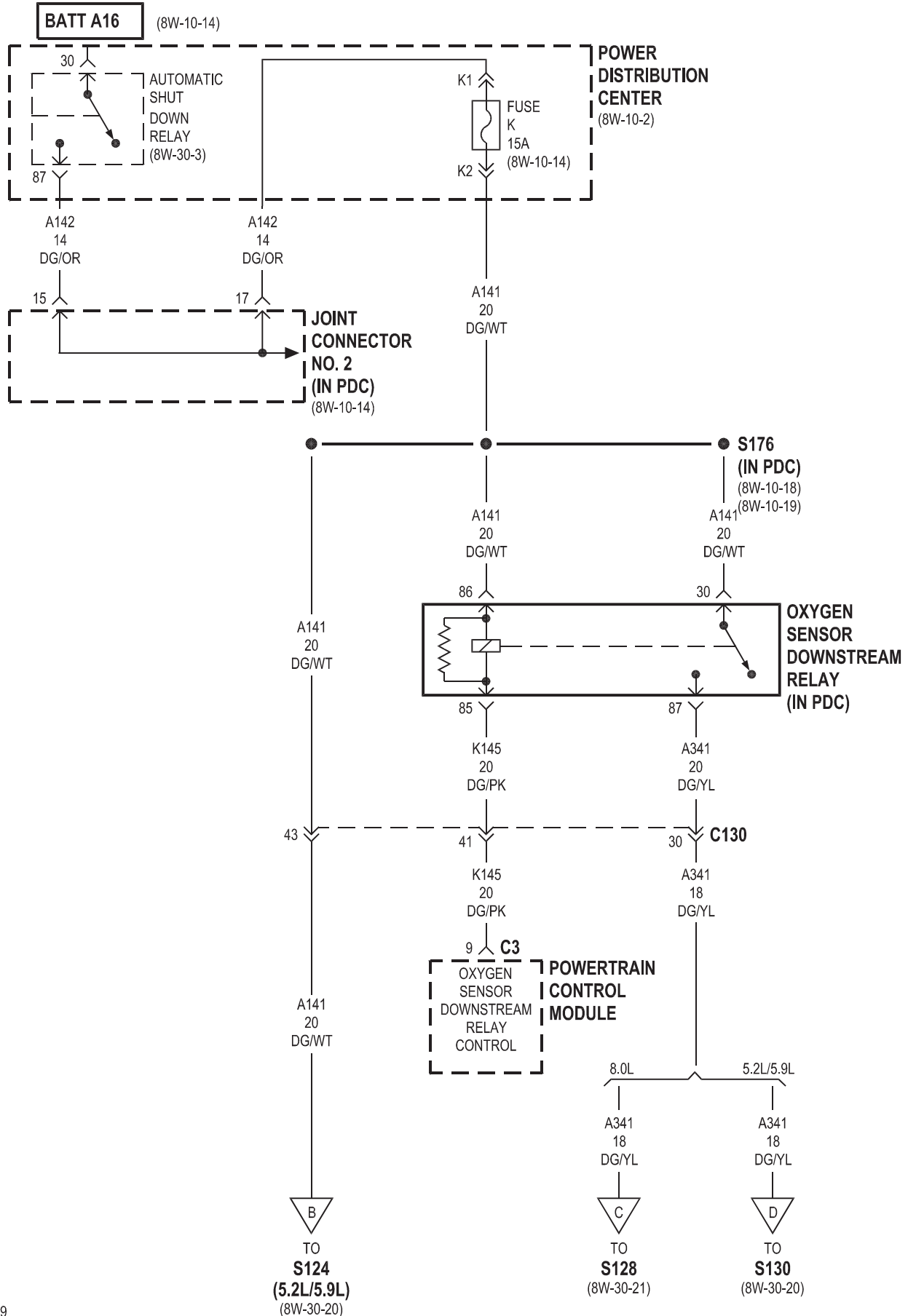


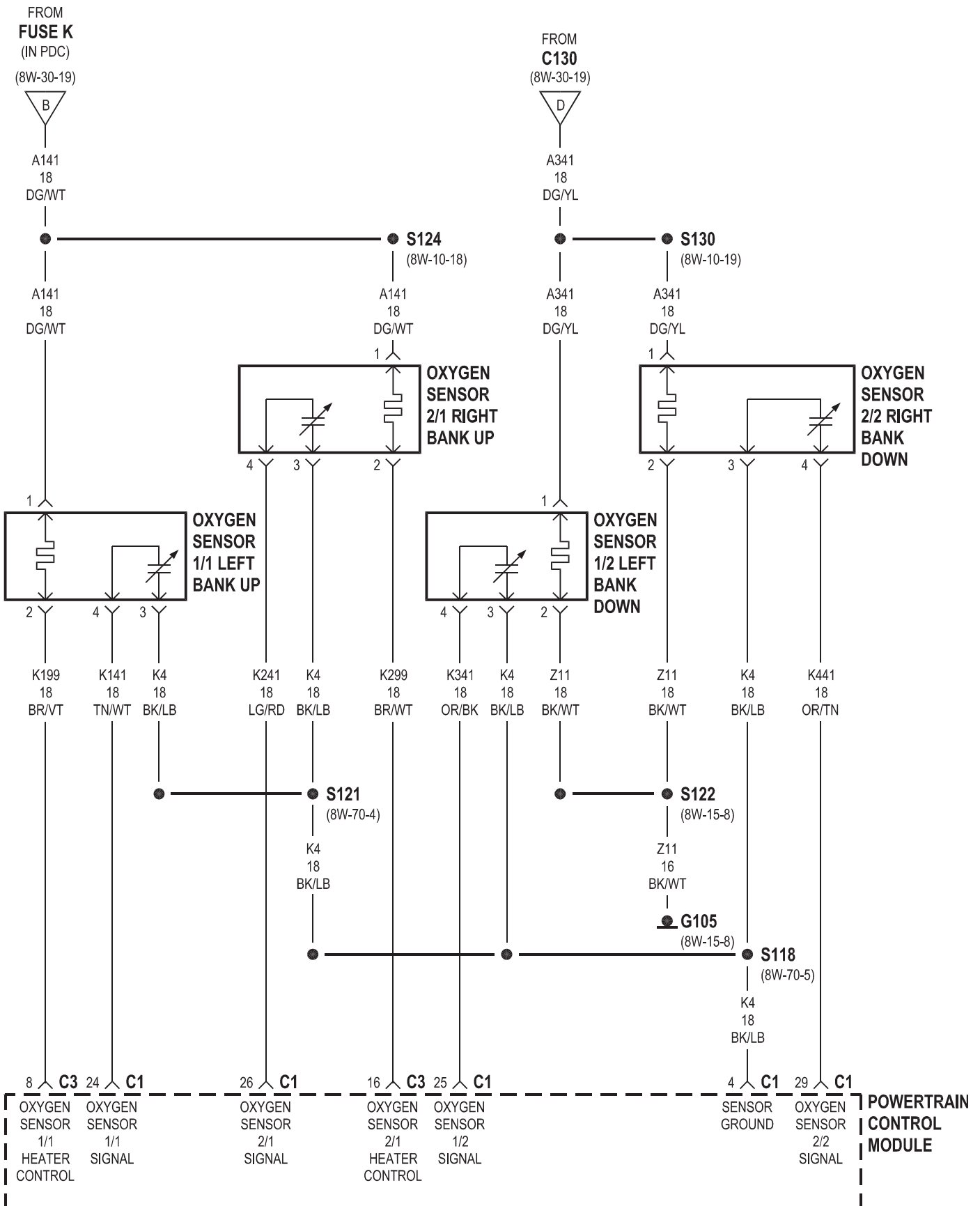




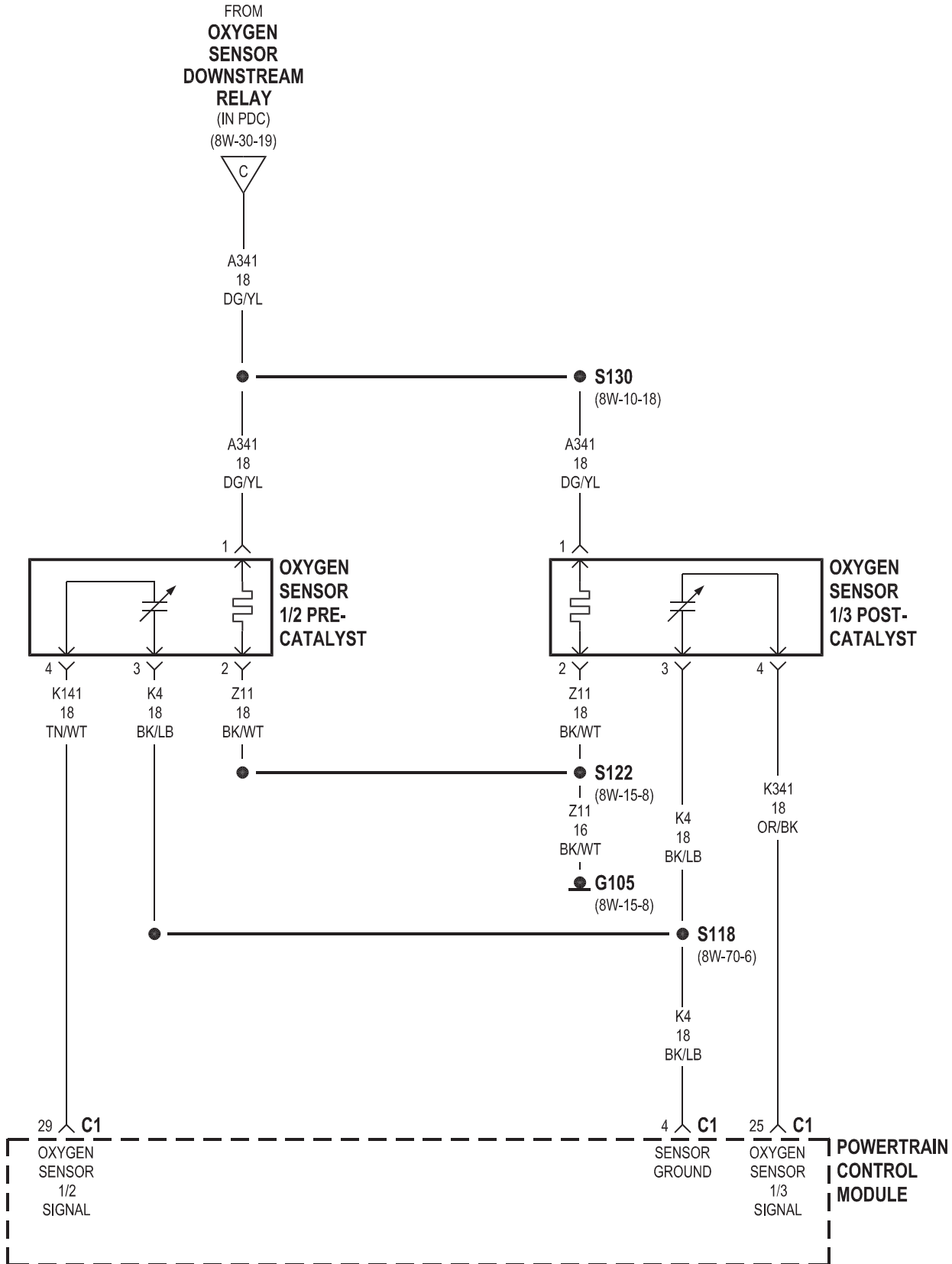




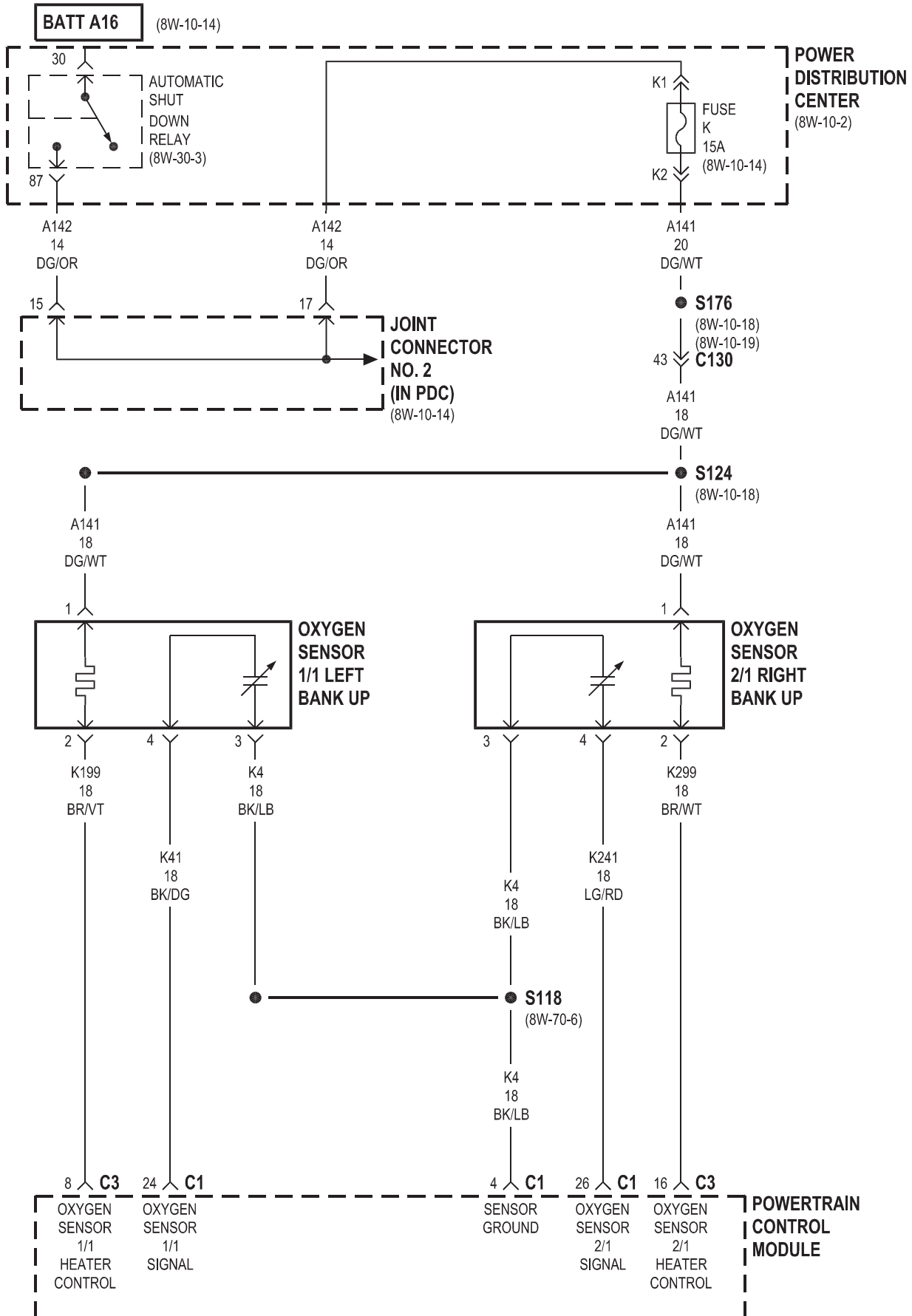


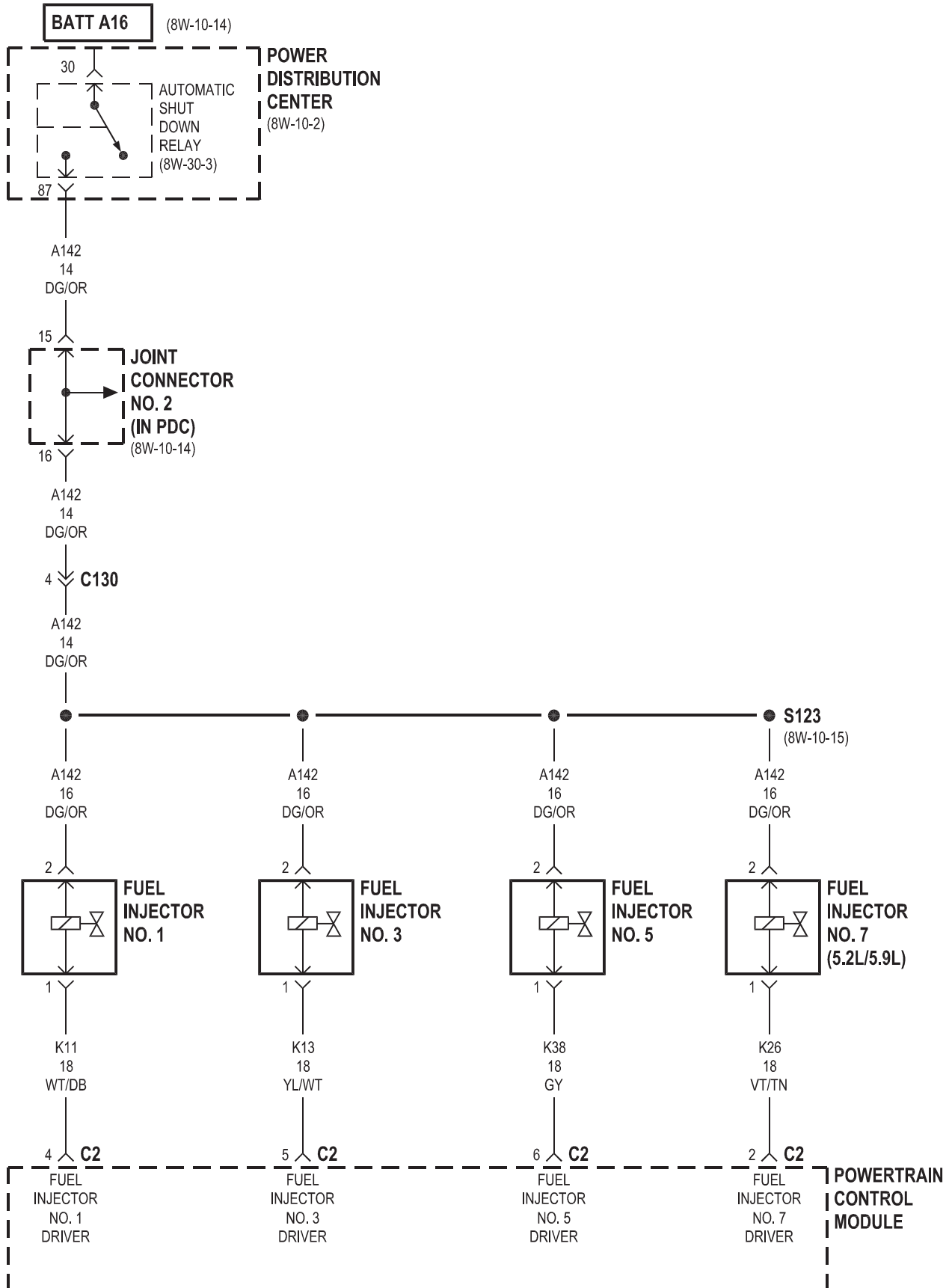


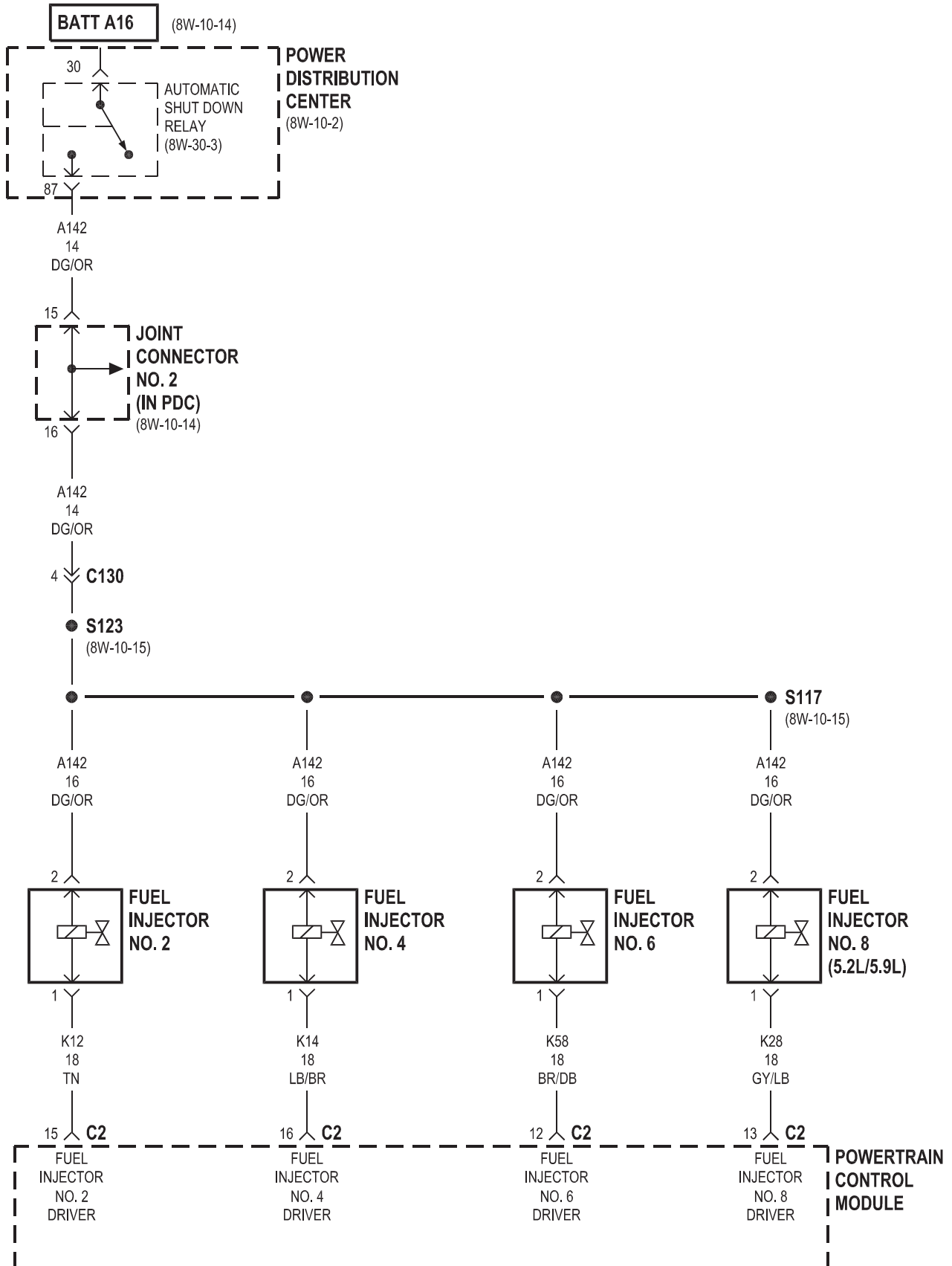


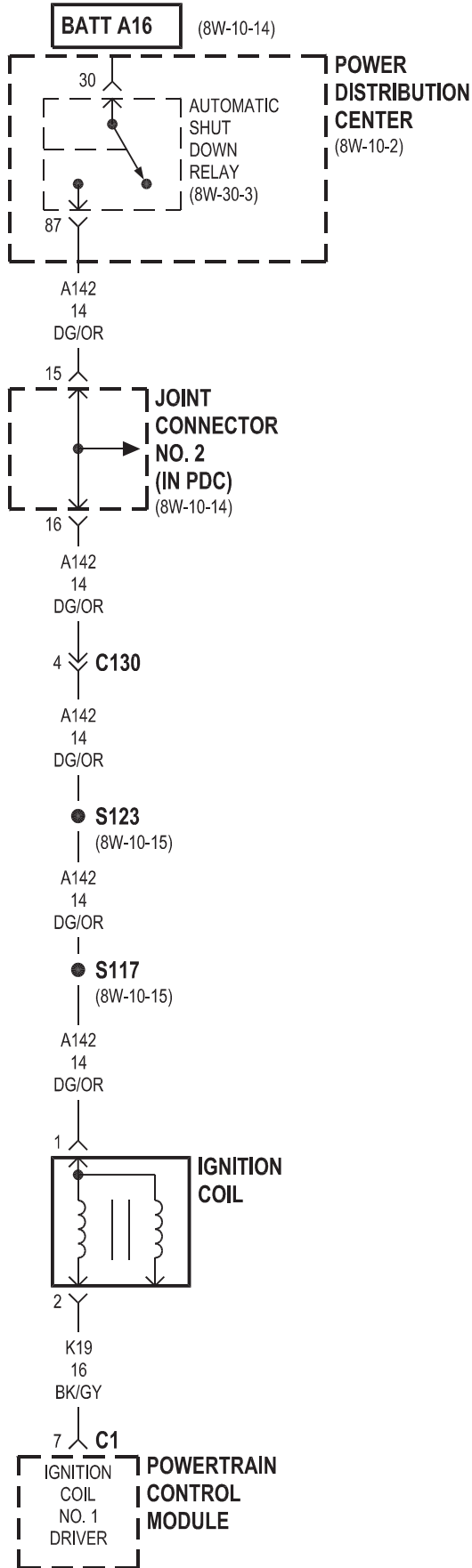


8.0L

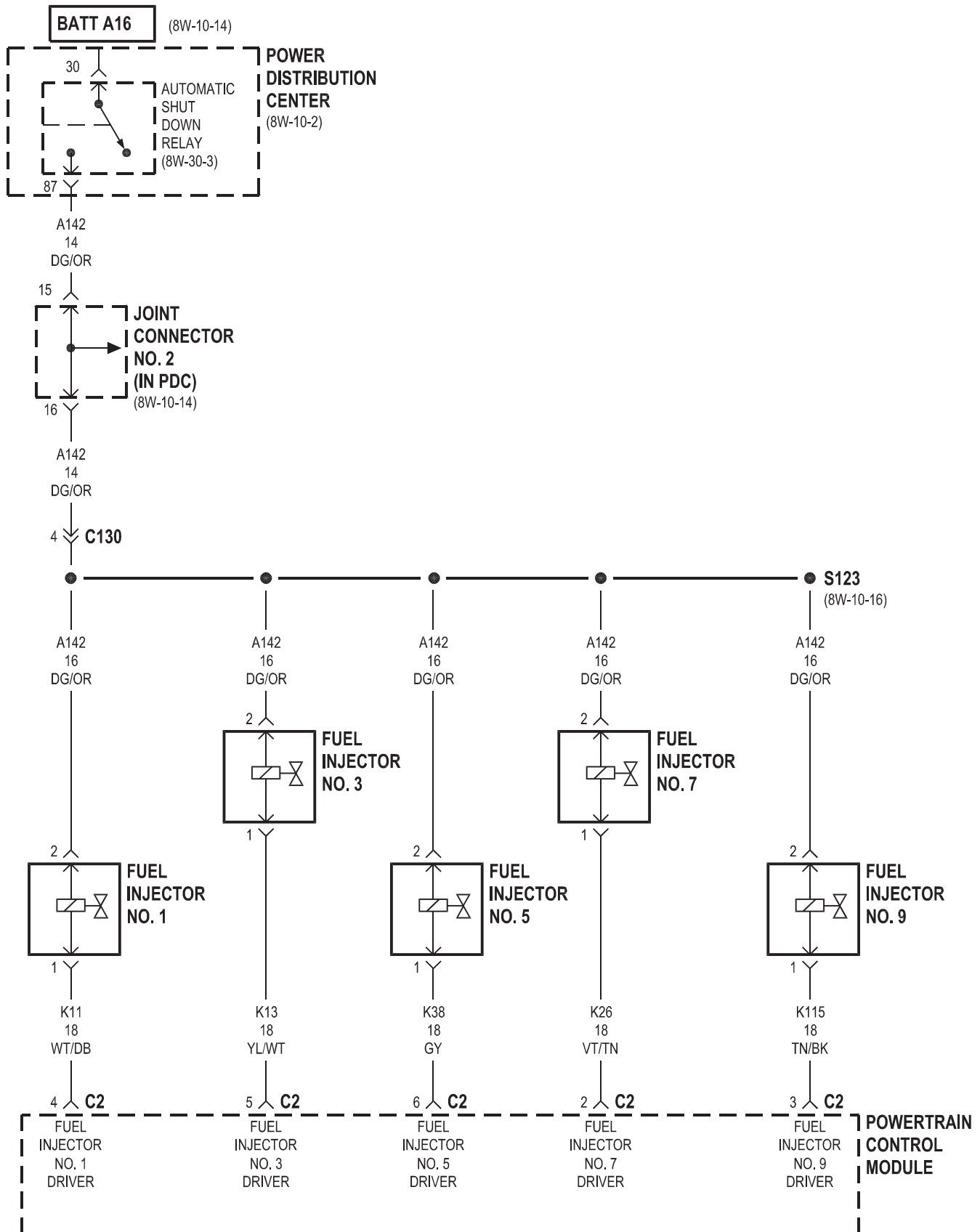


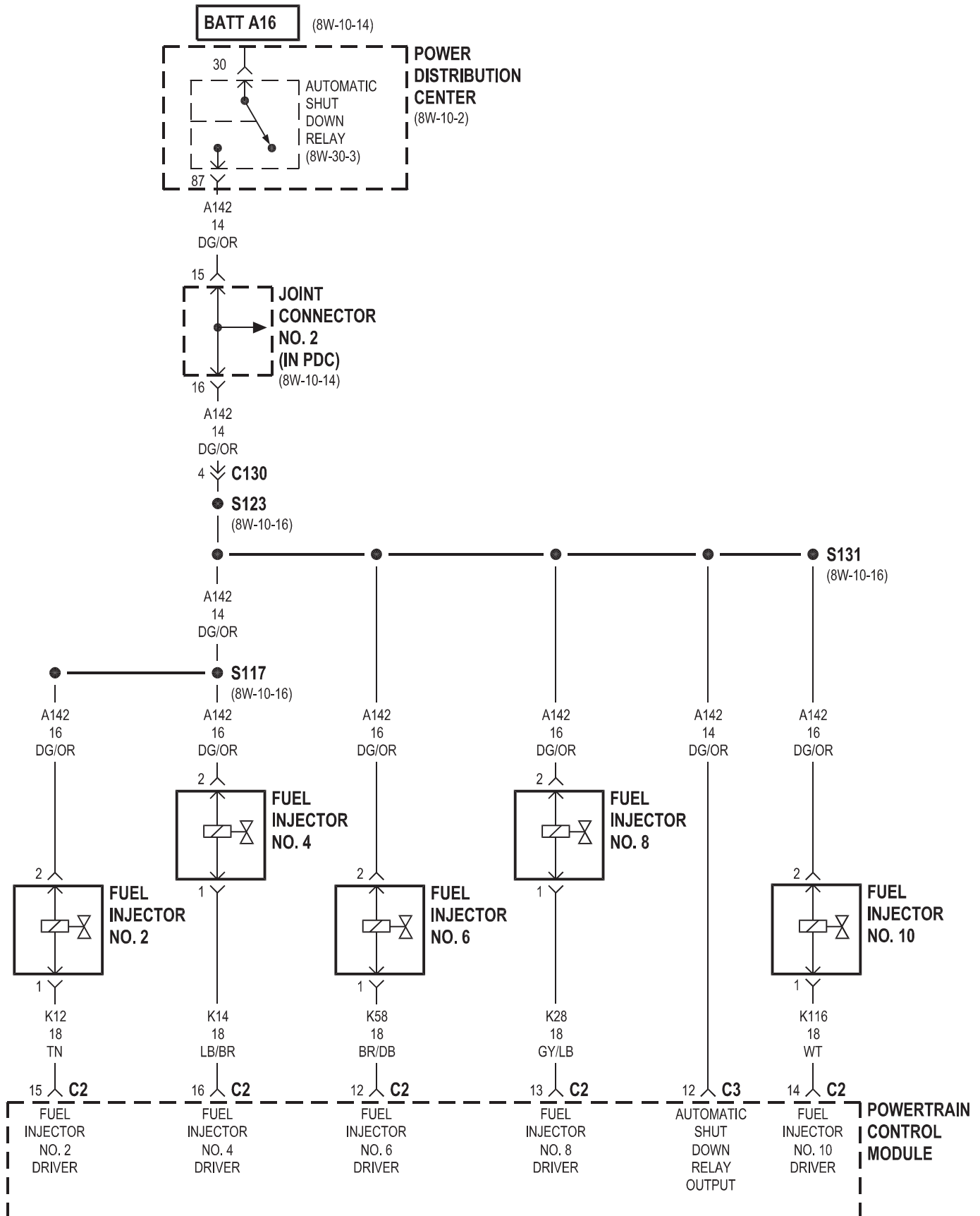


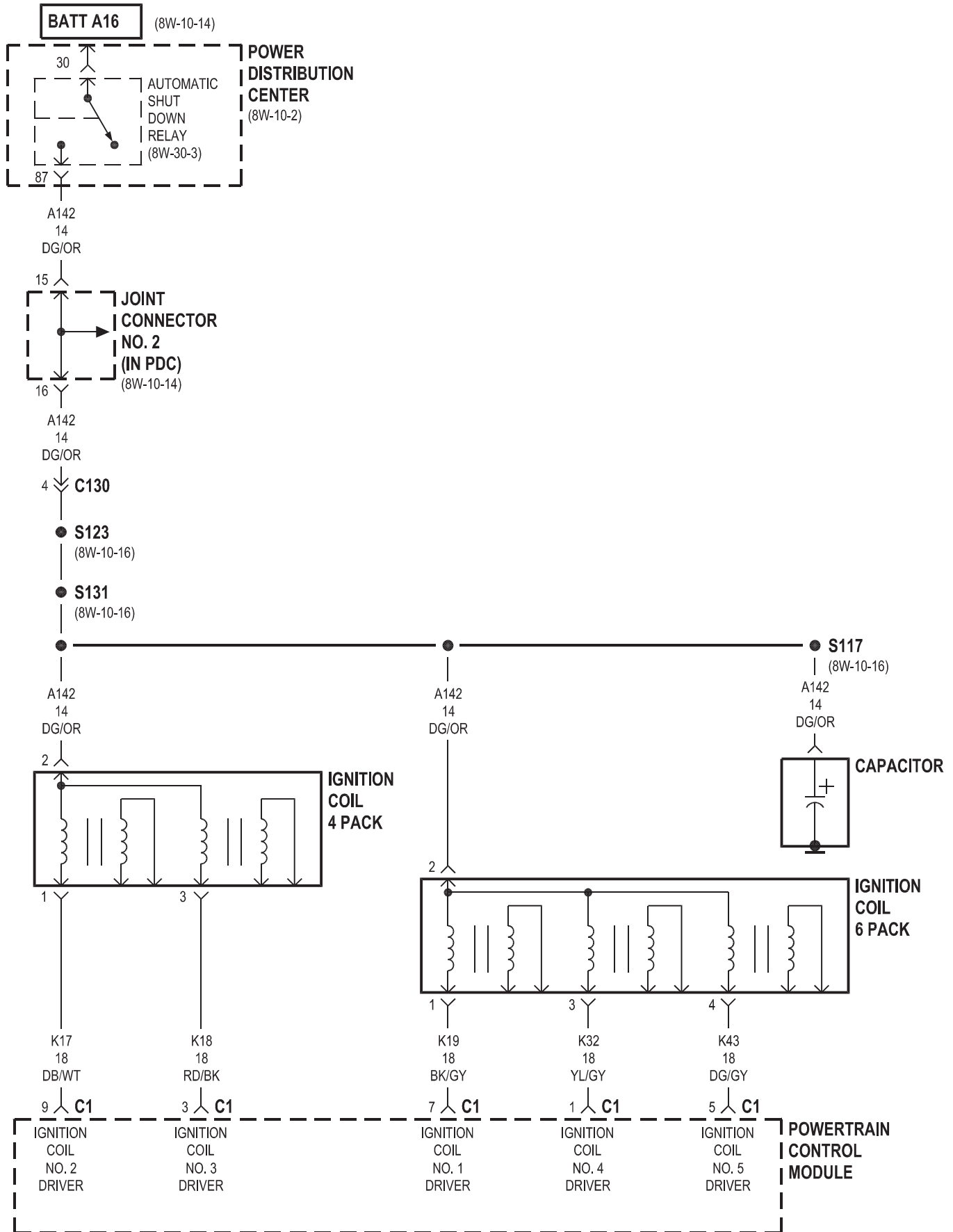


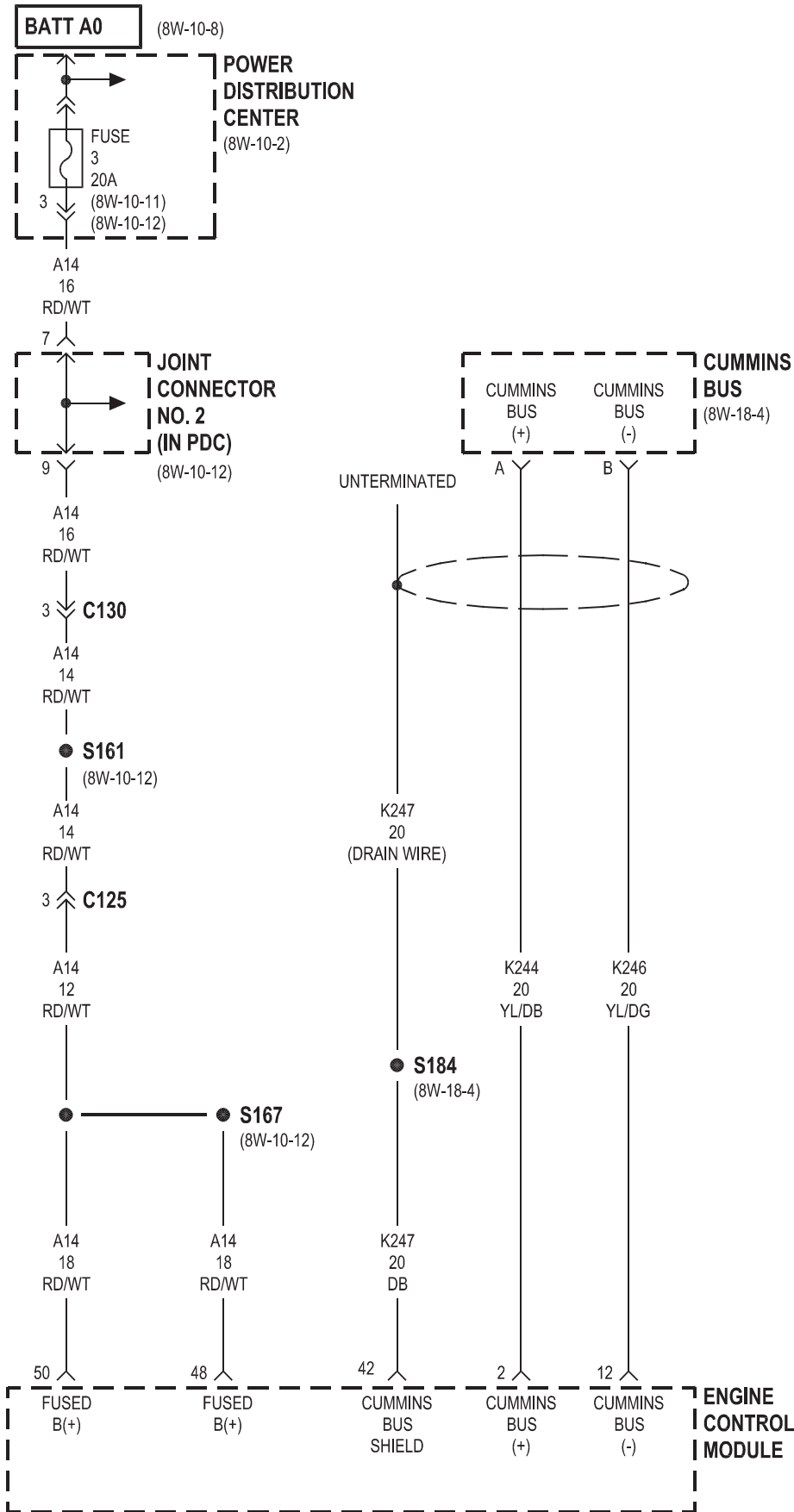


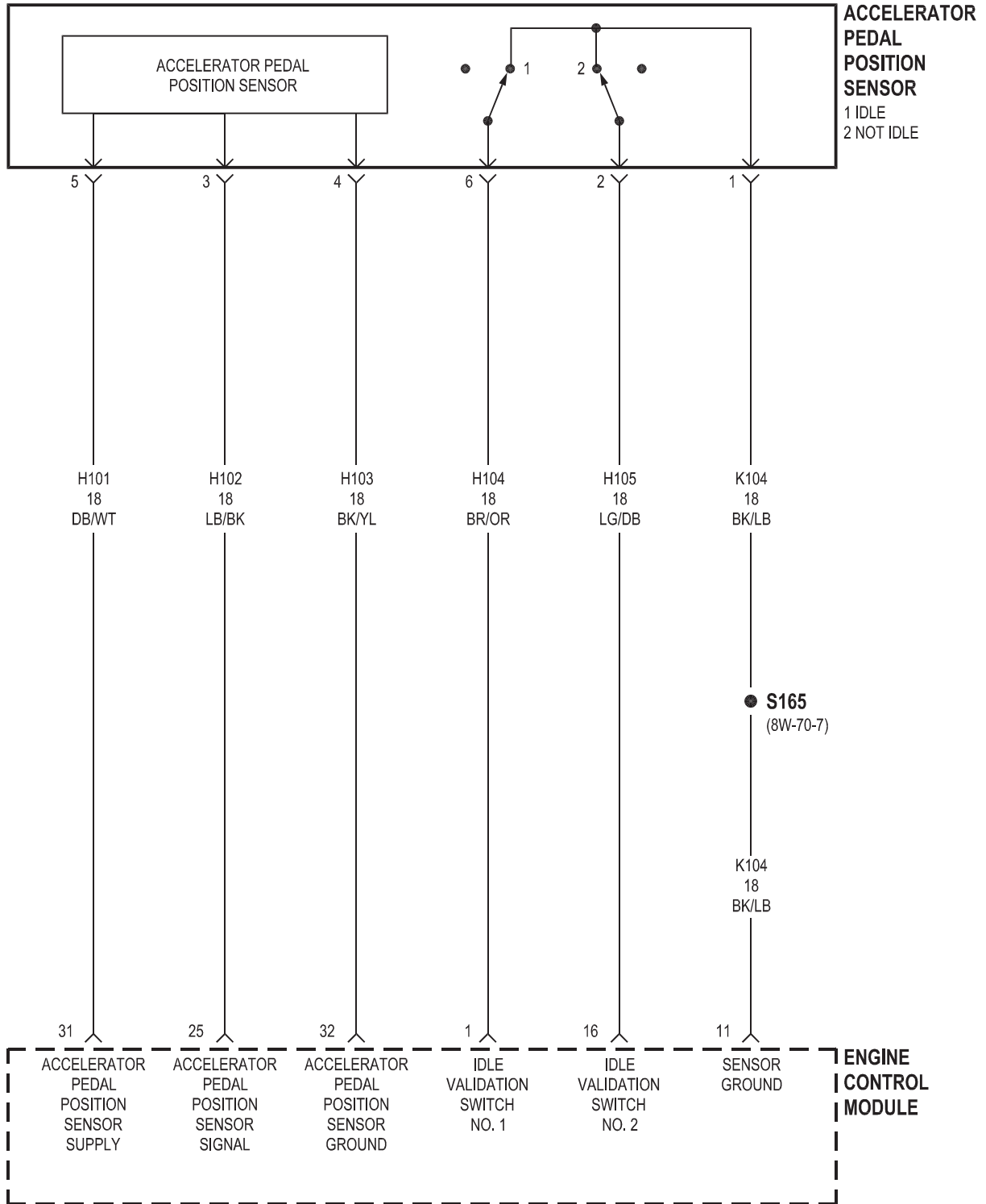




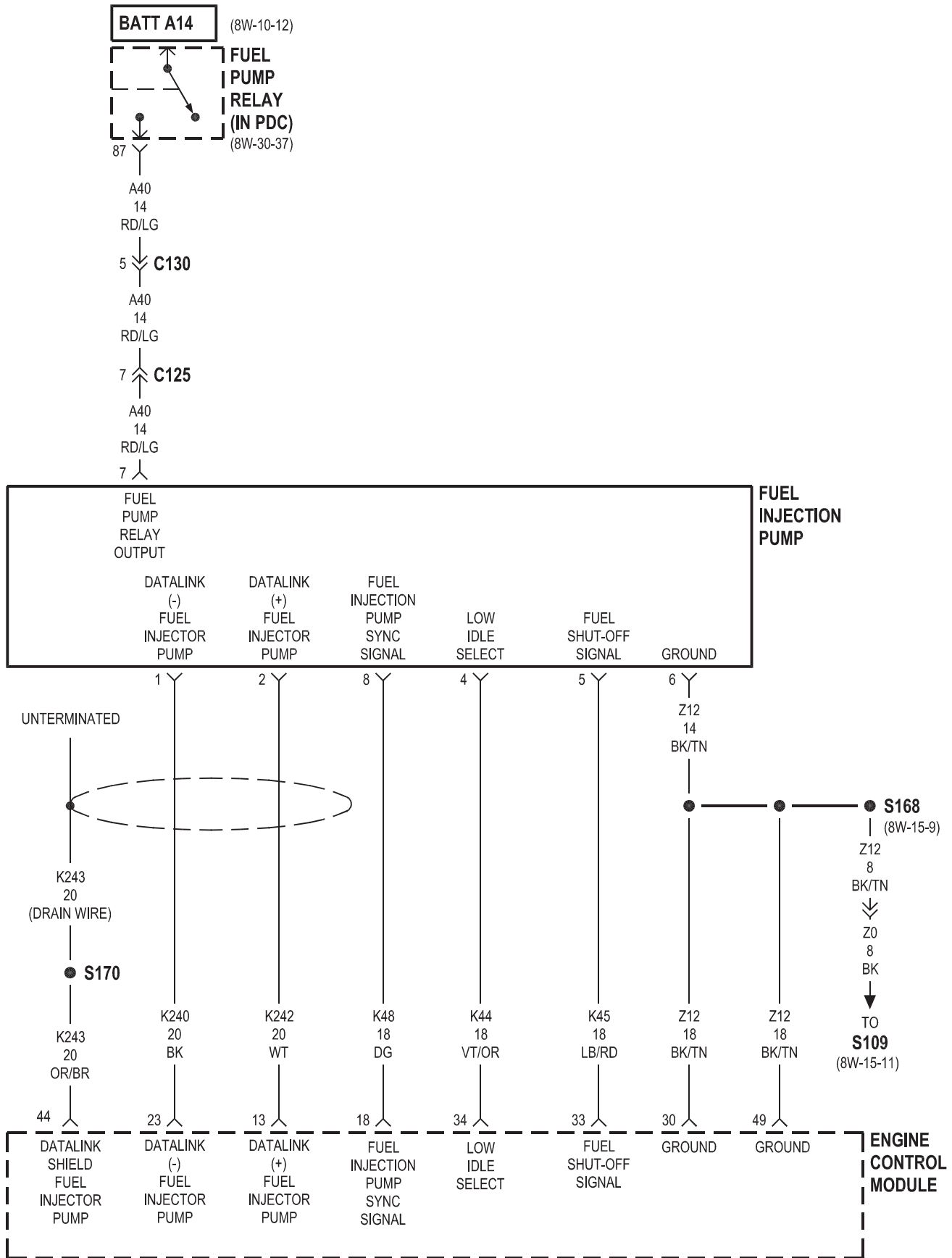


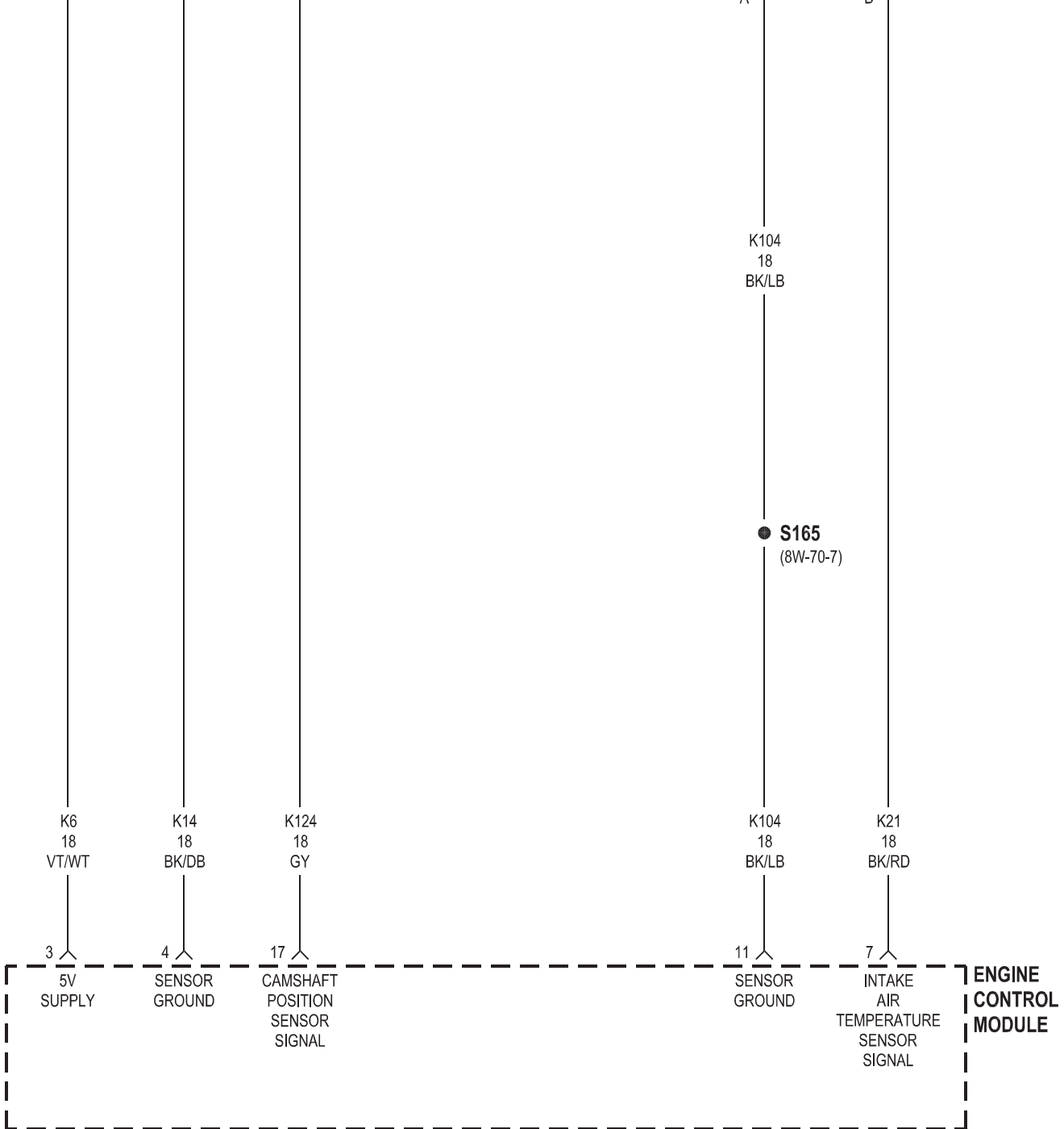
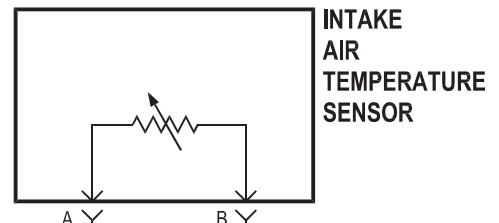
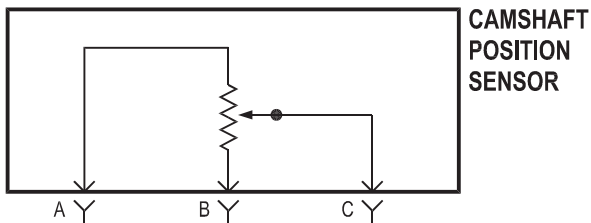


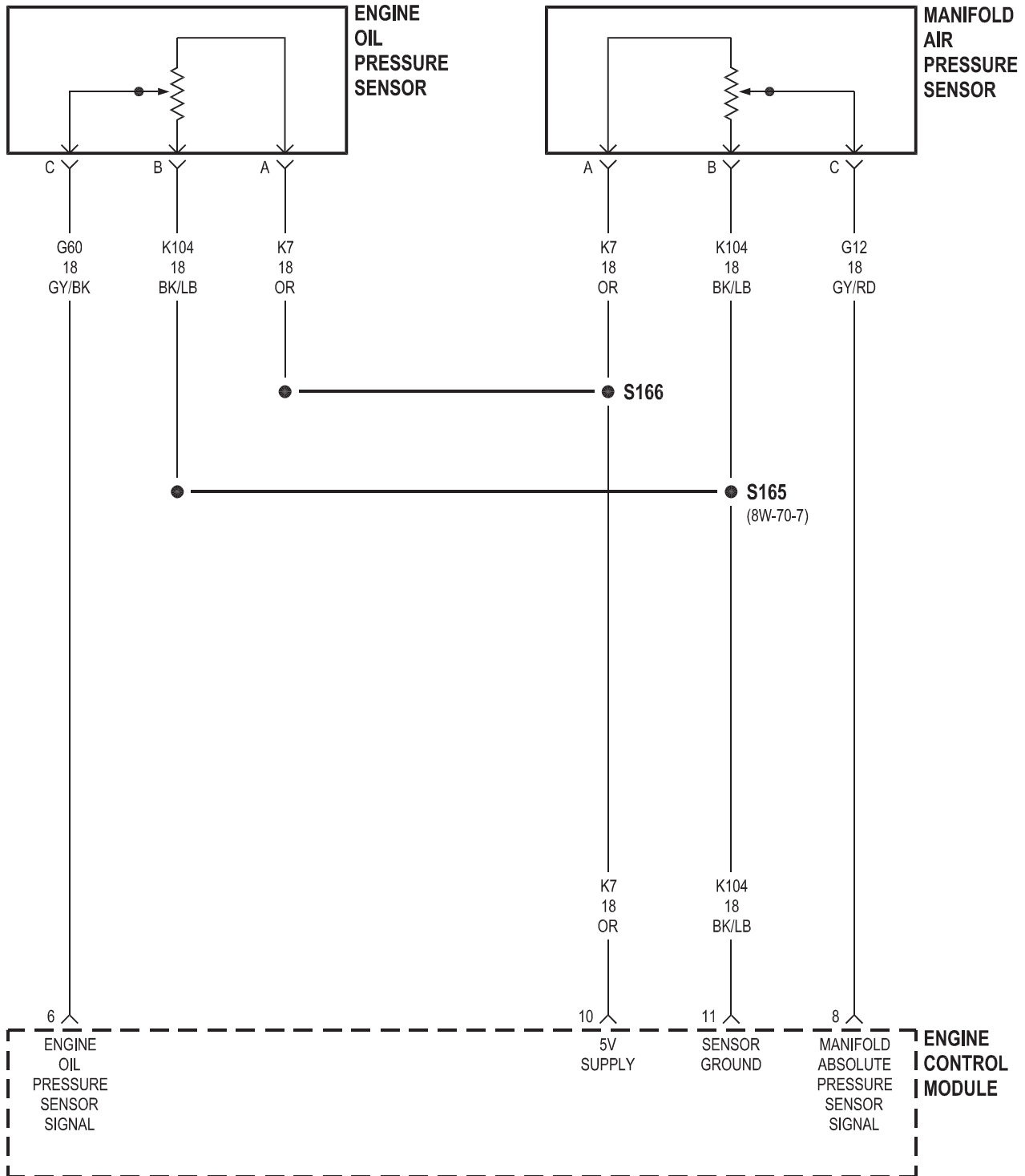


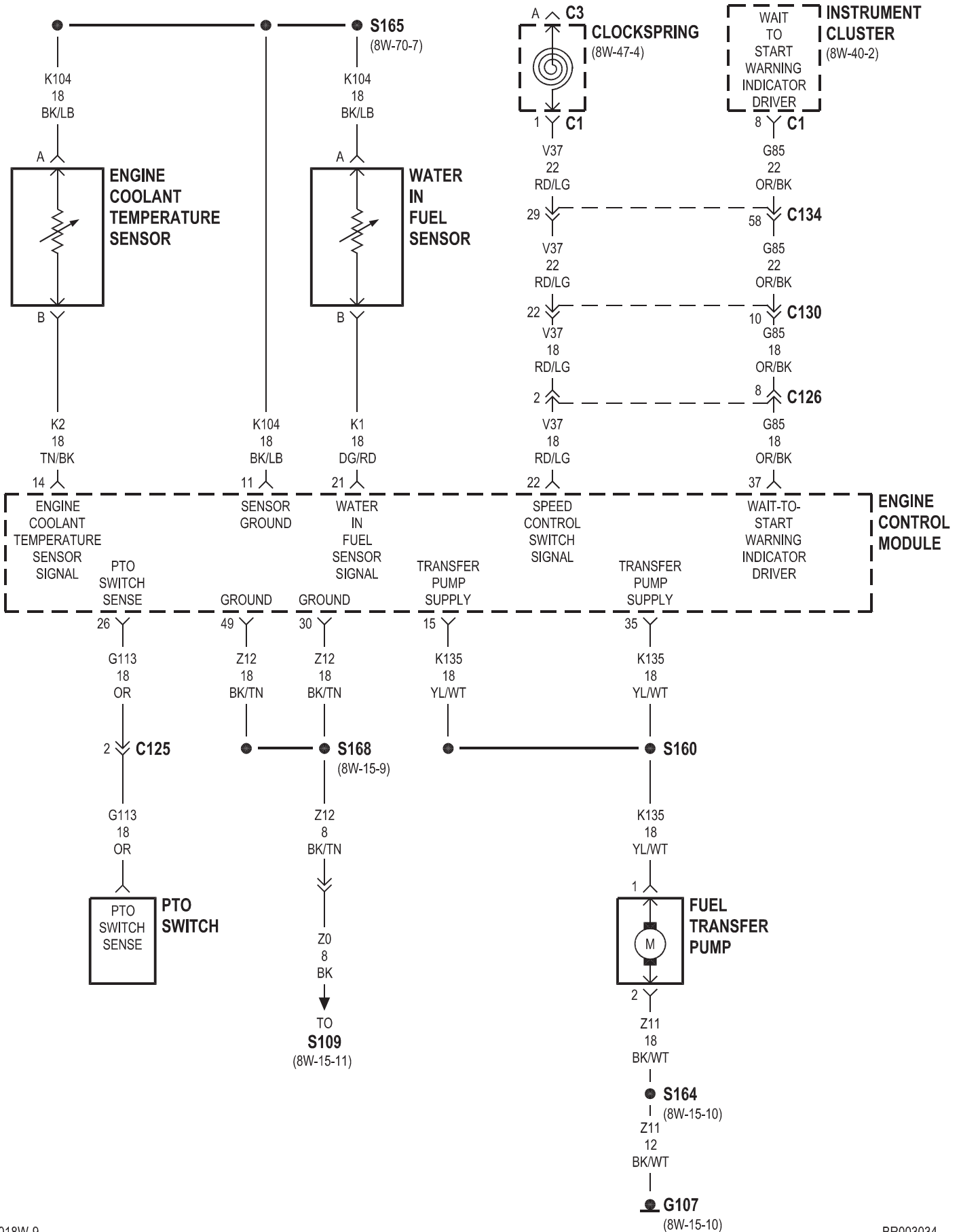




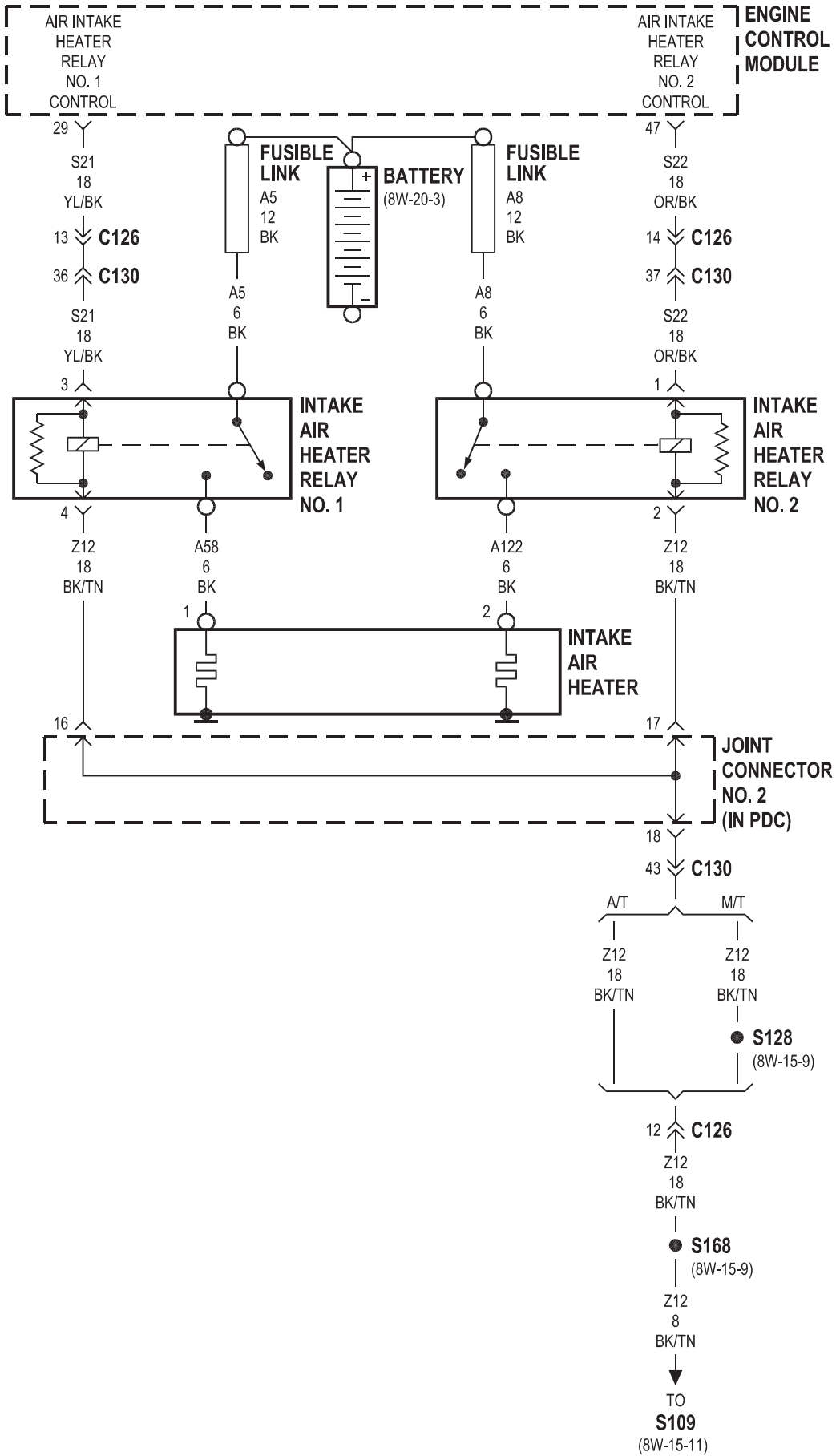




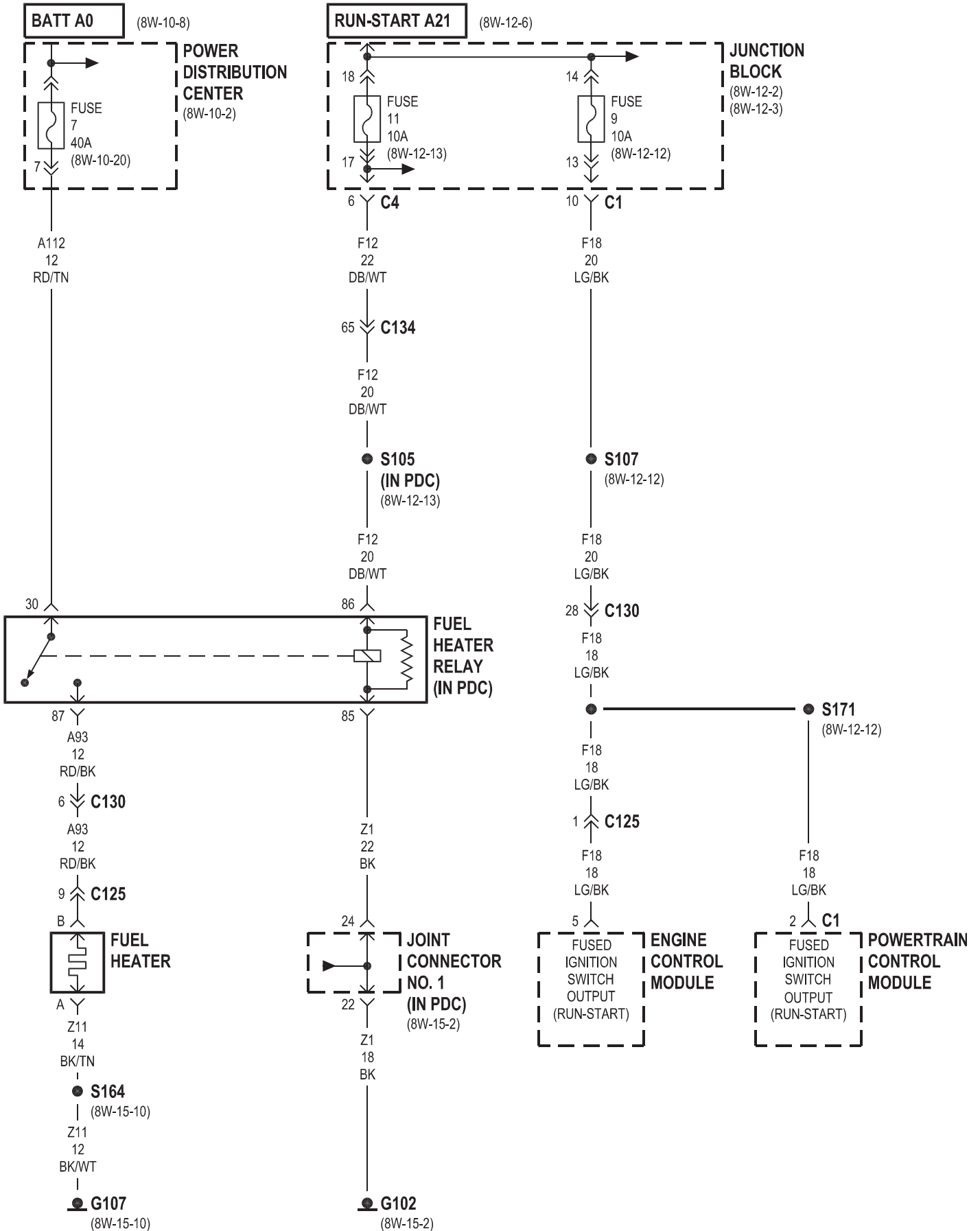


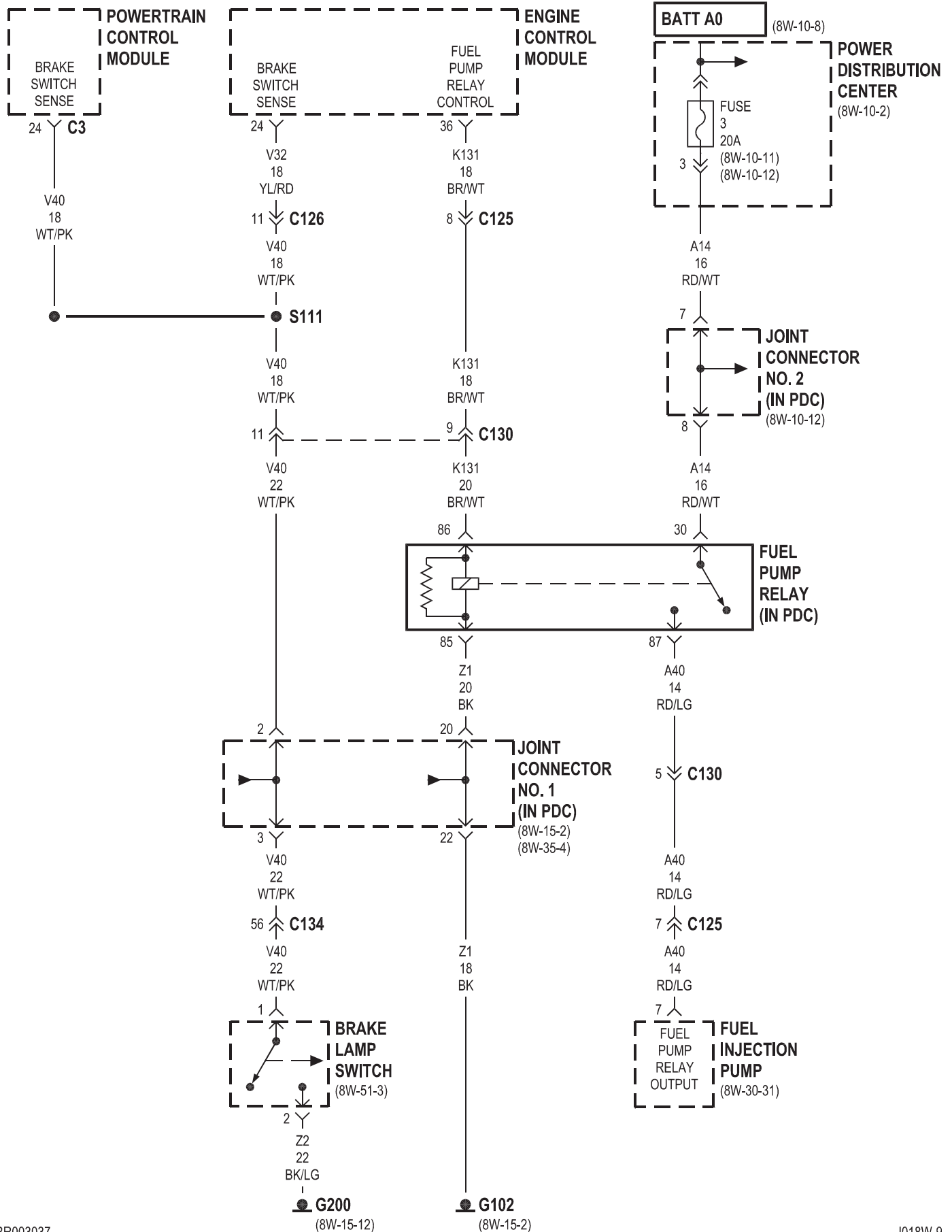


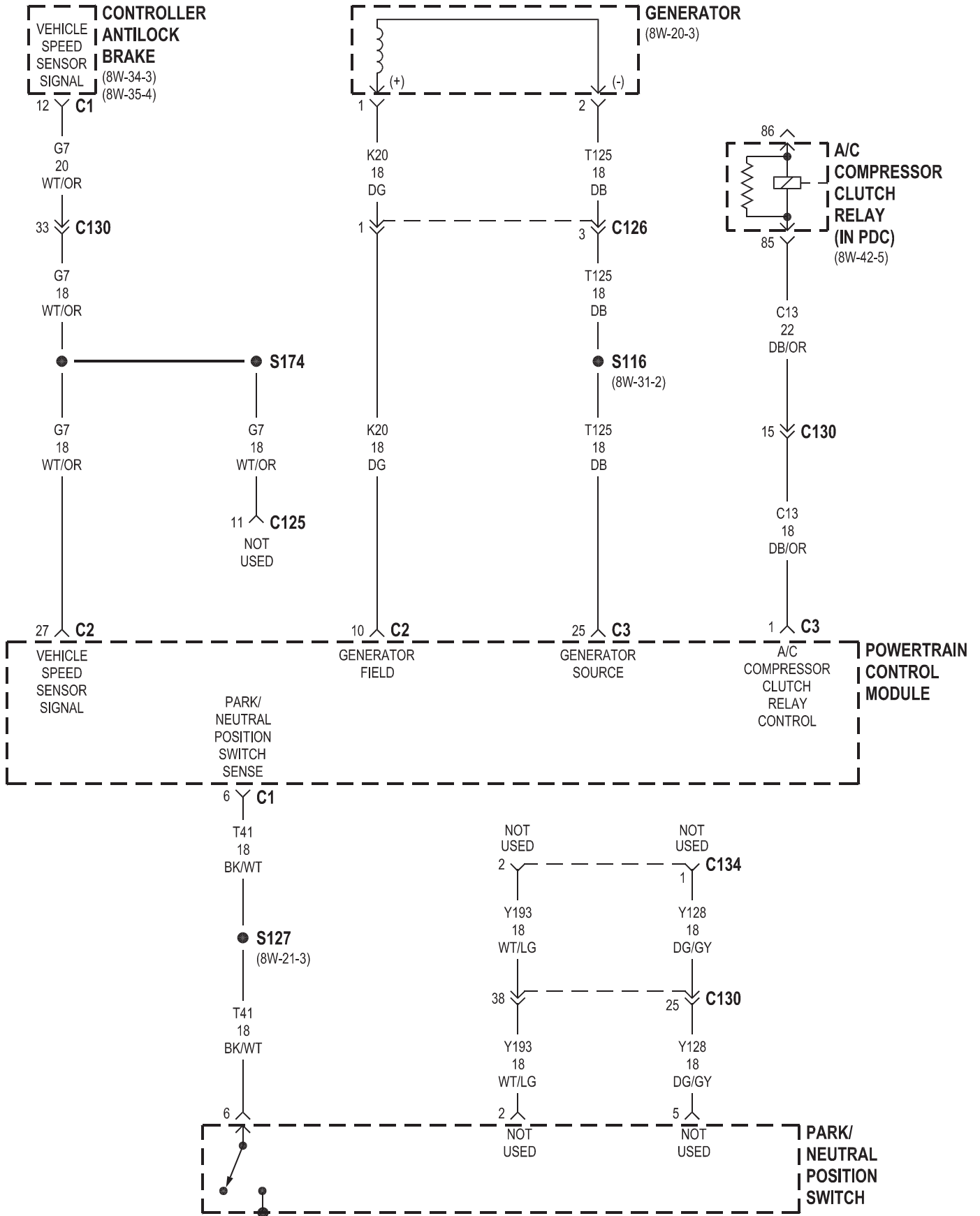
DIESEL

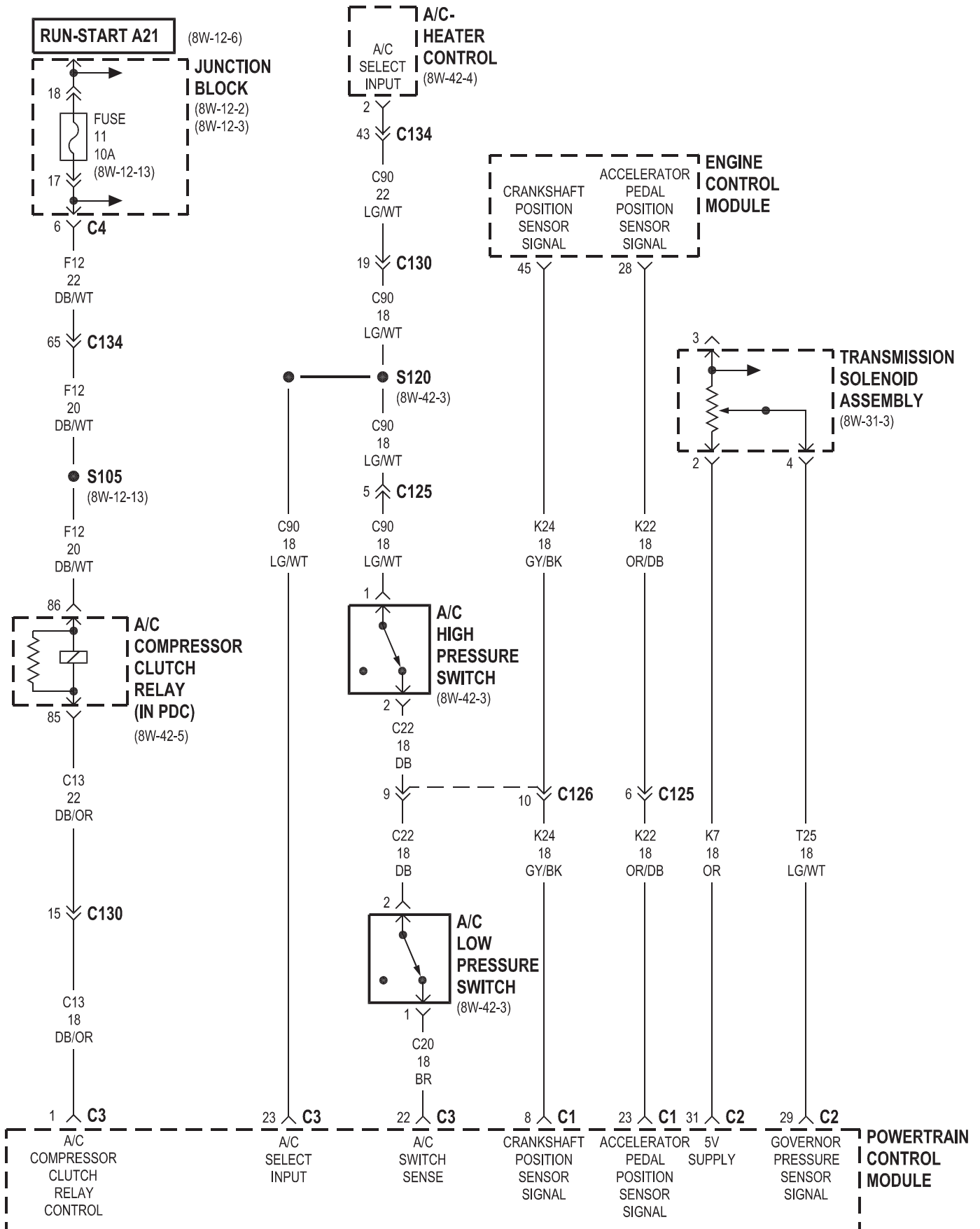


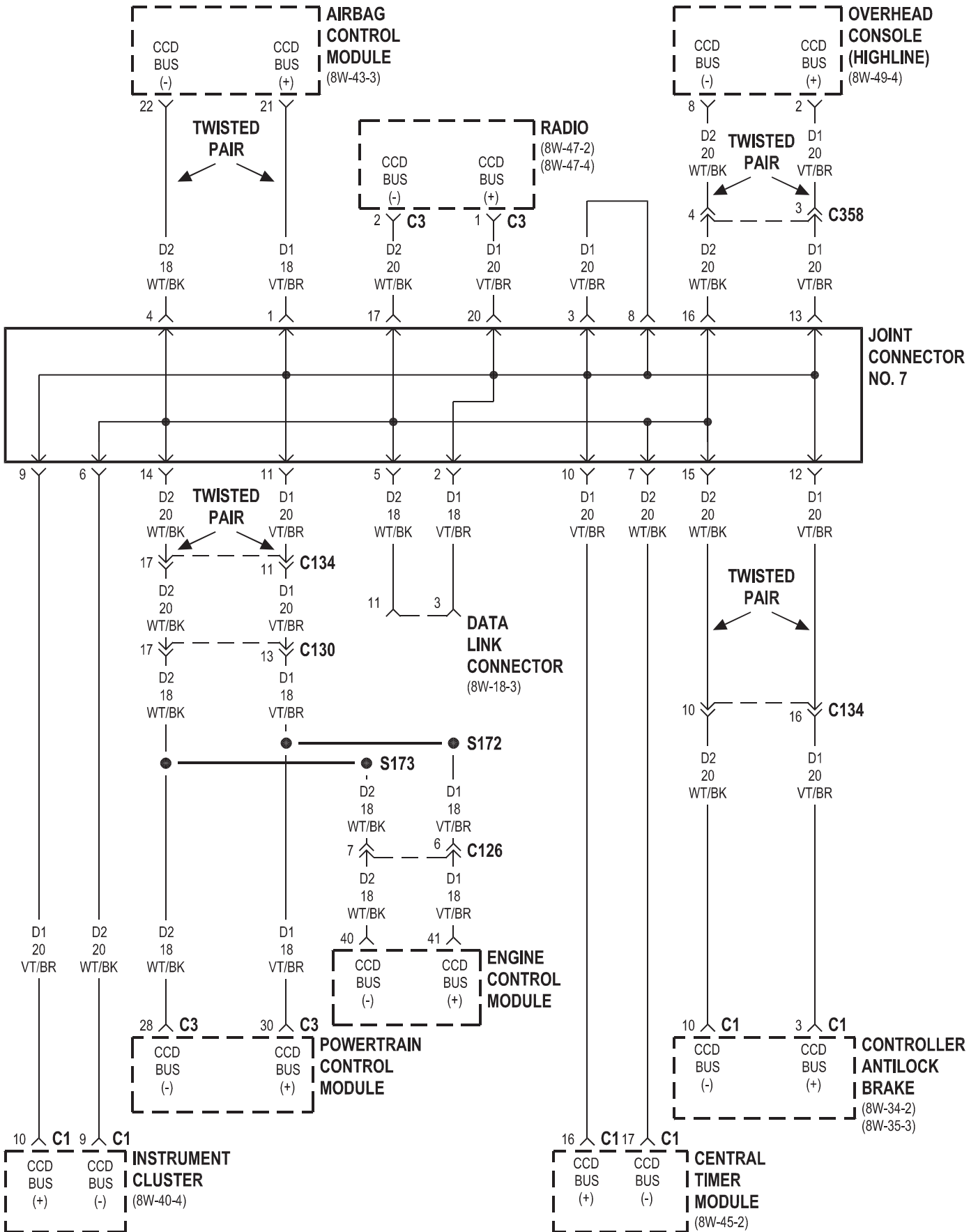




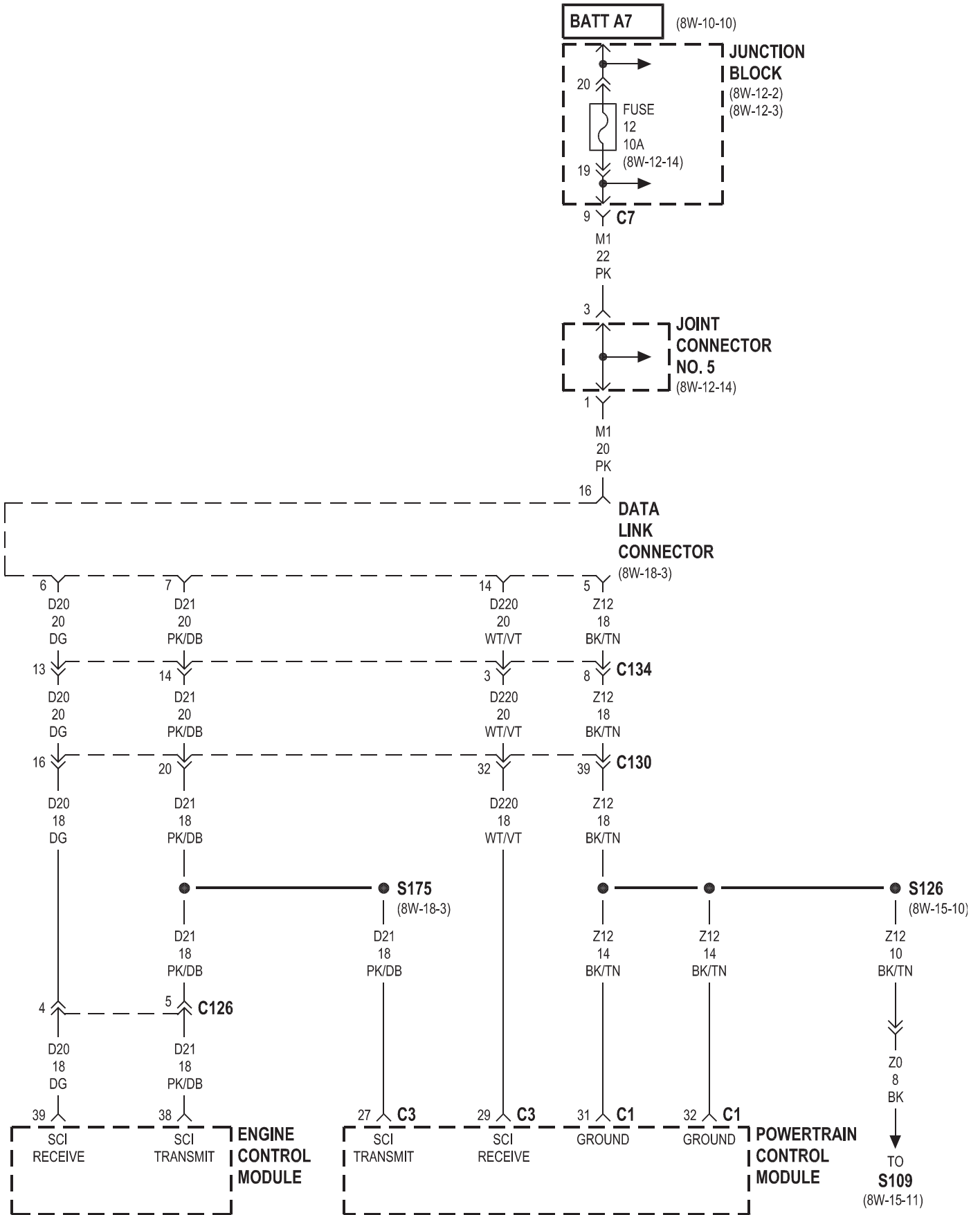


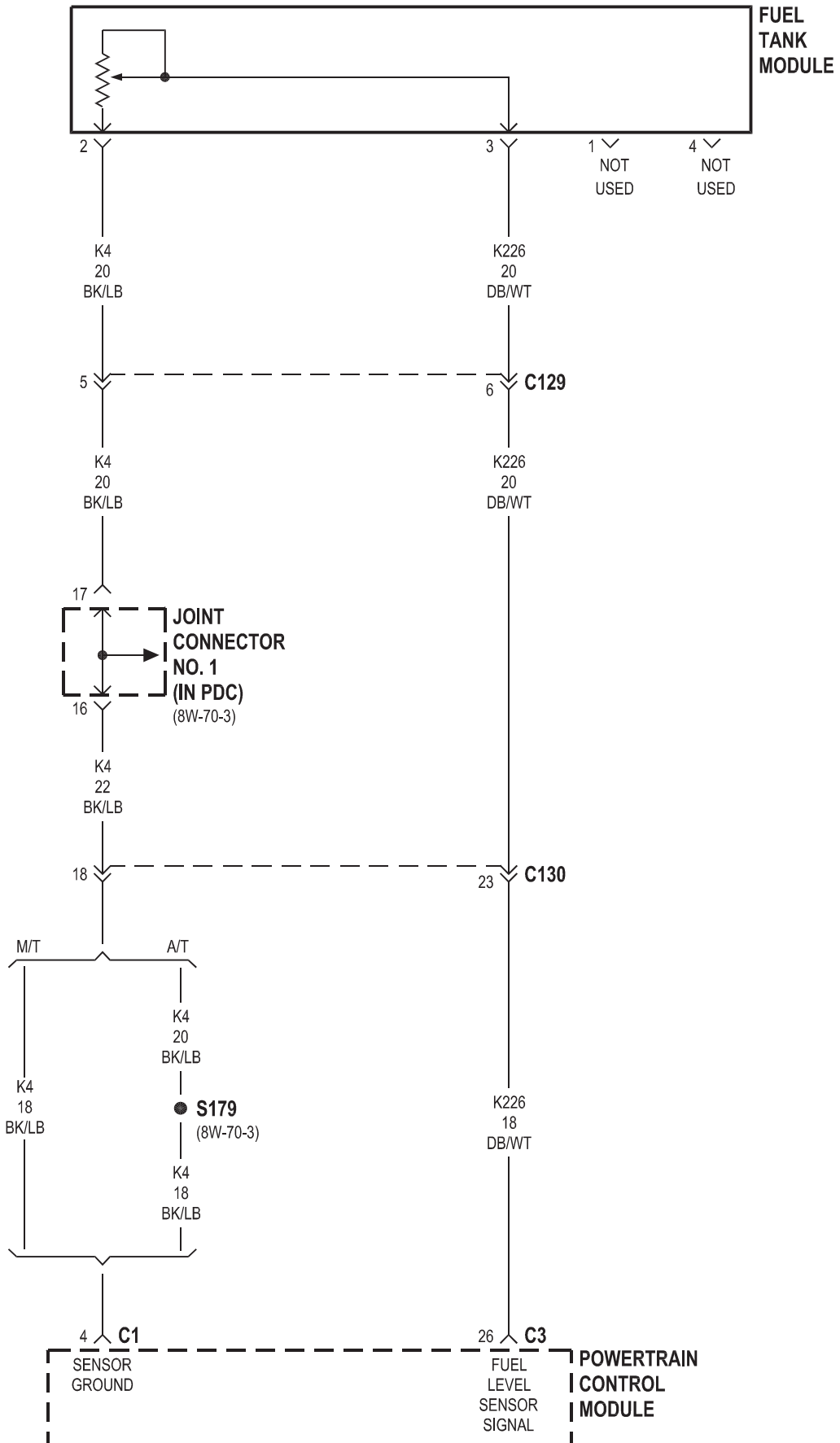






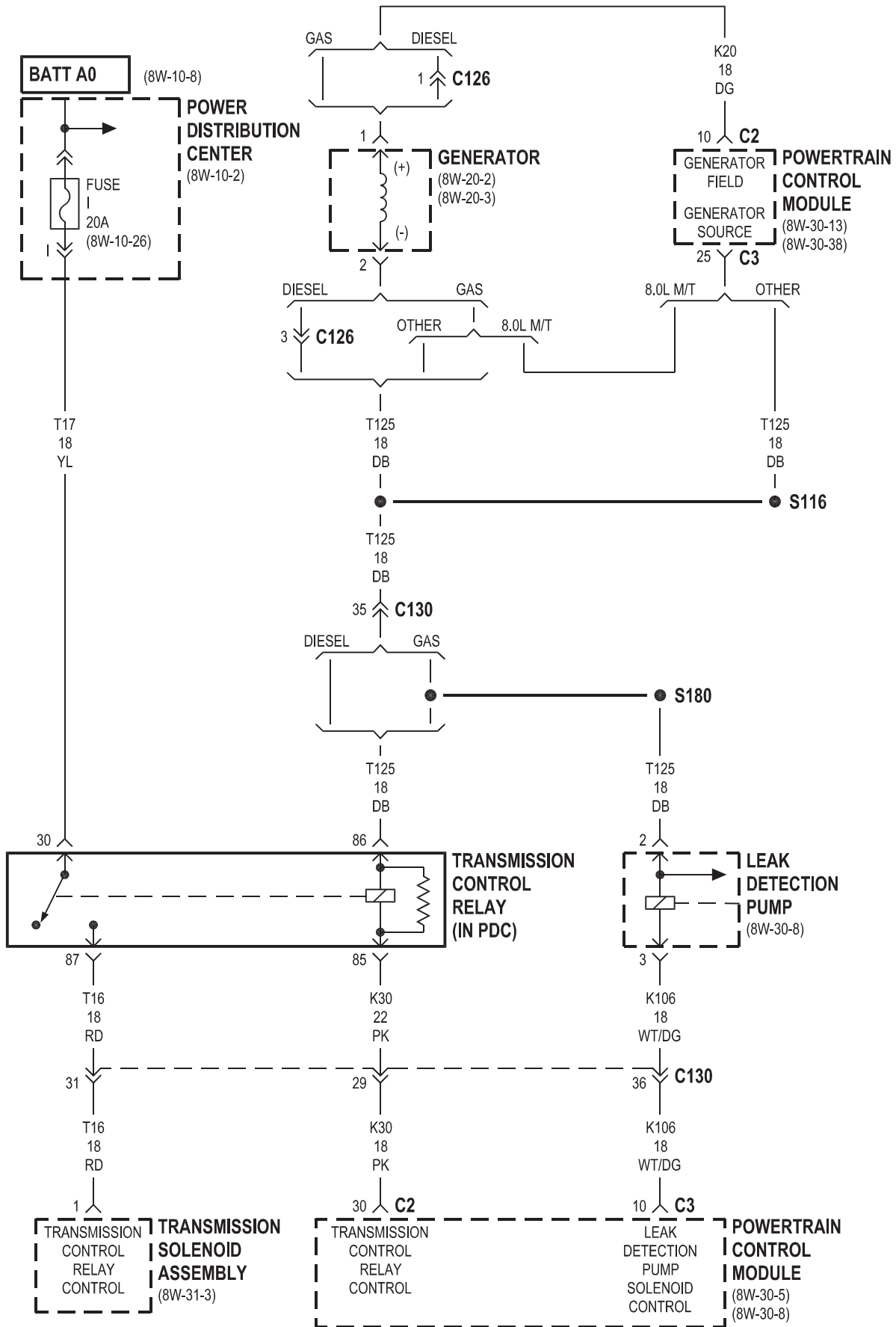


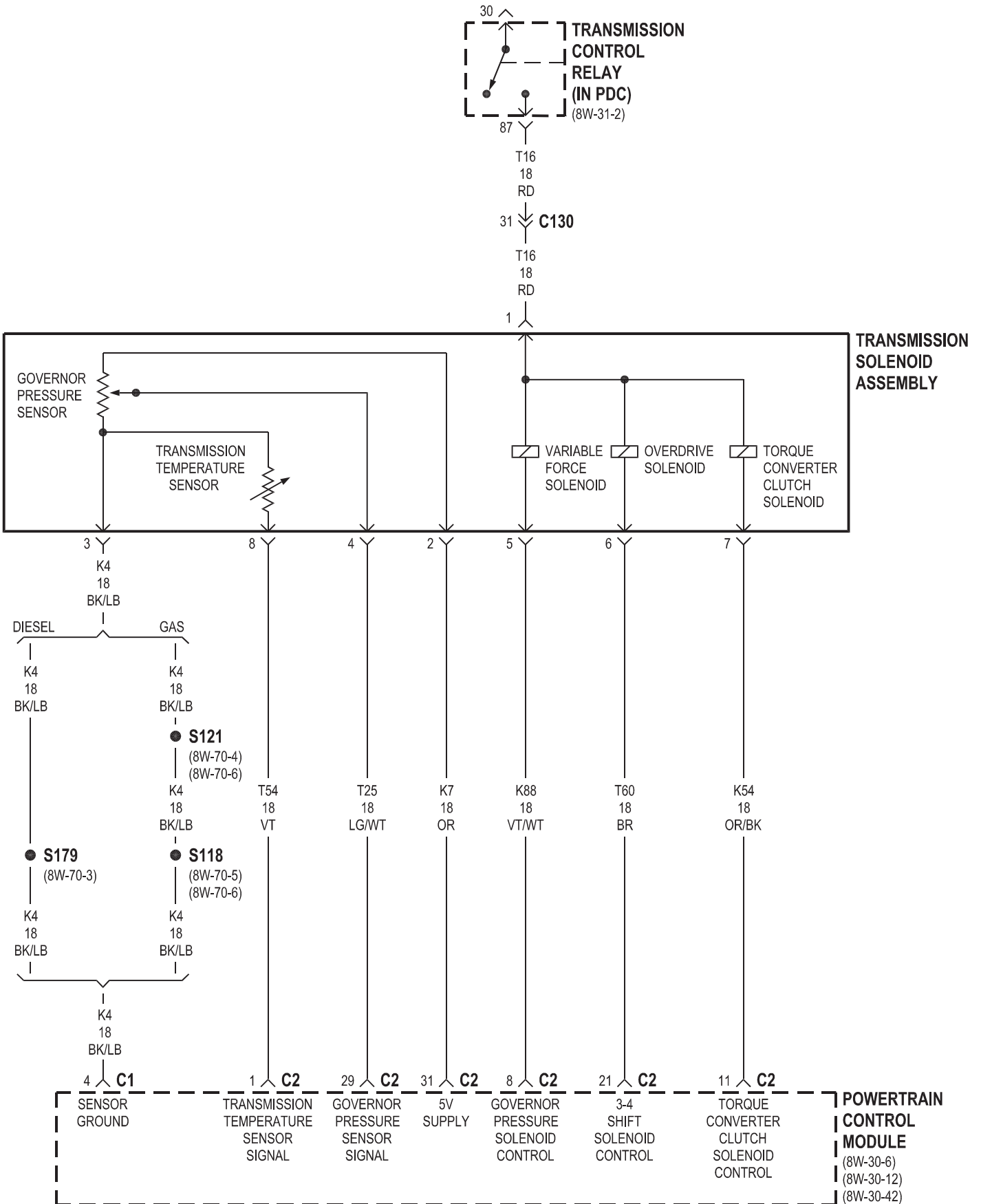




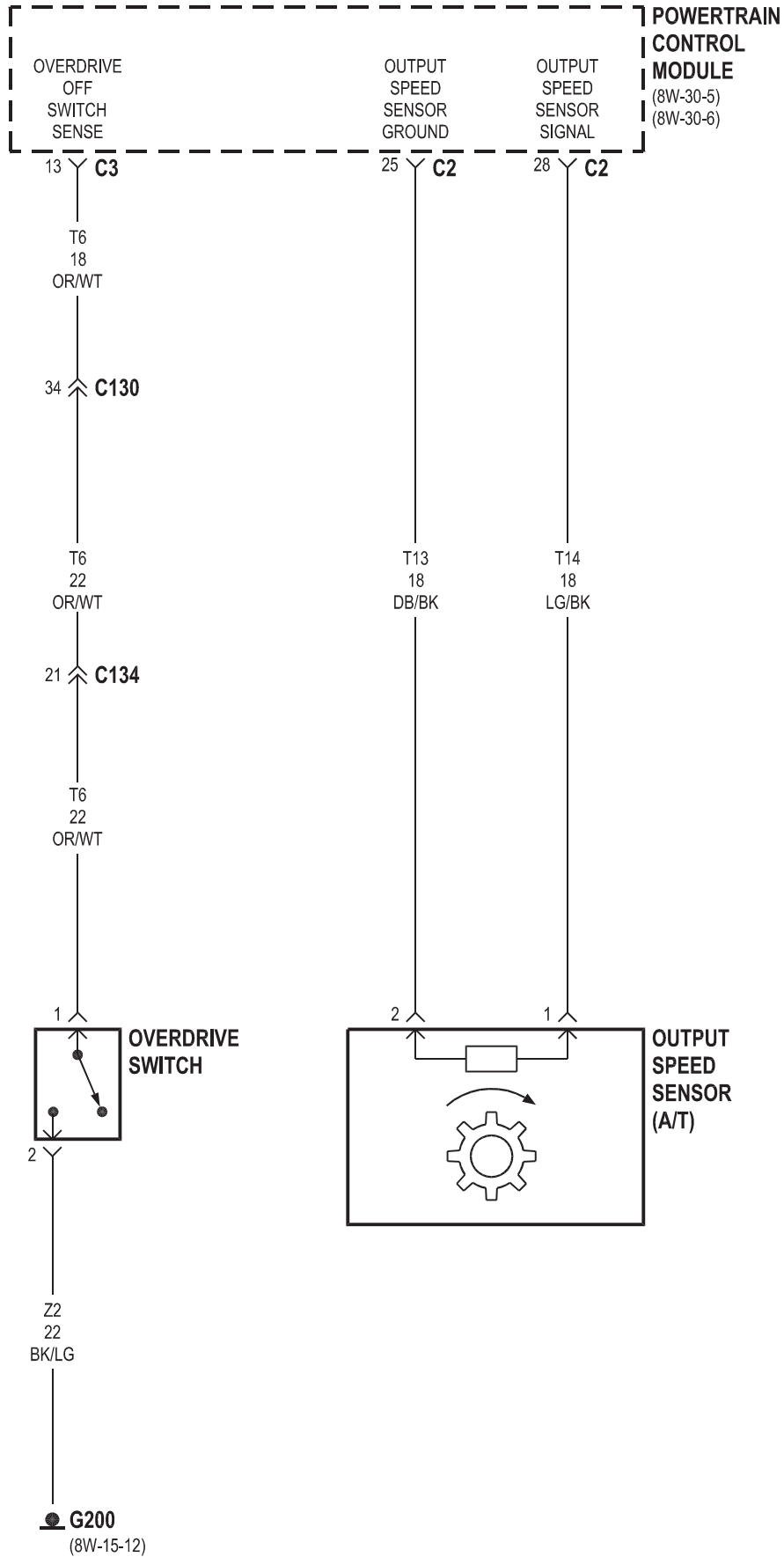
## 8W-31 TRANSMISSION CONTROL SYSTEM

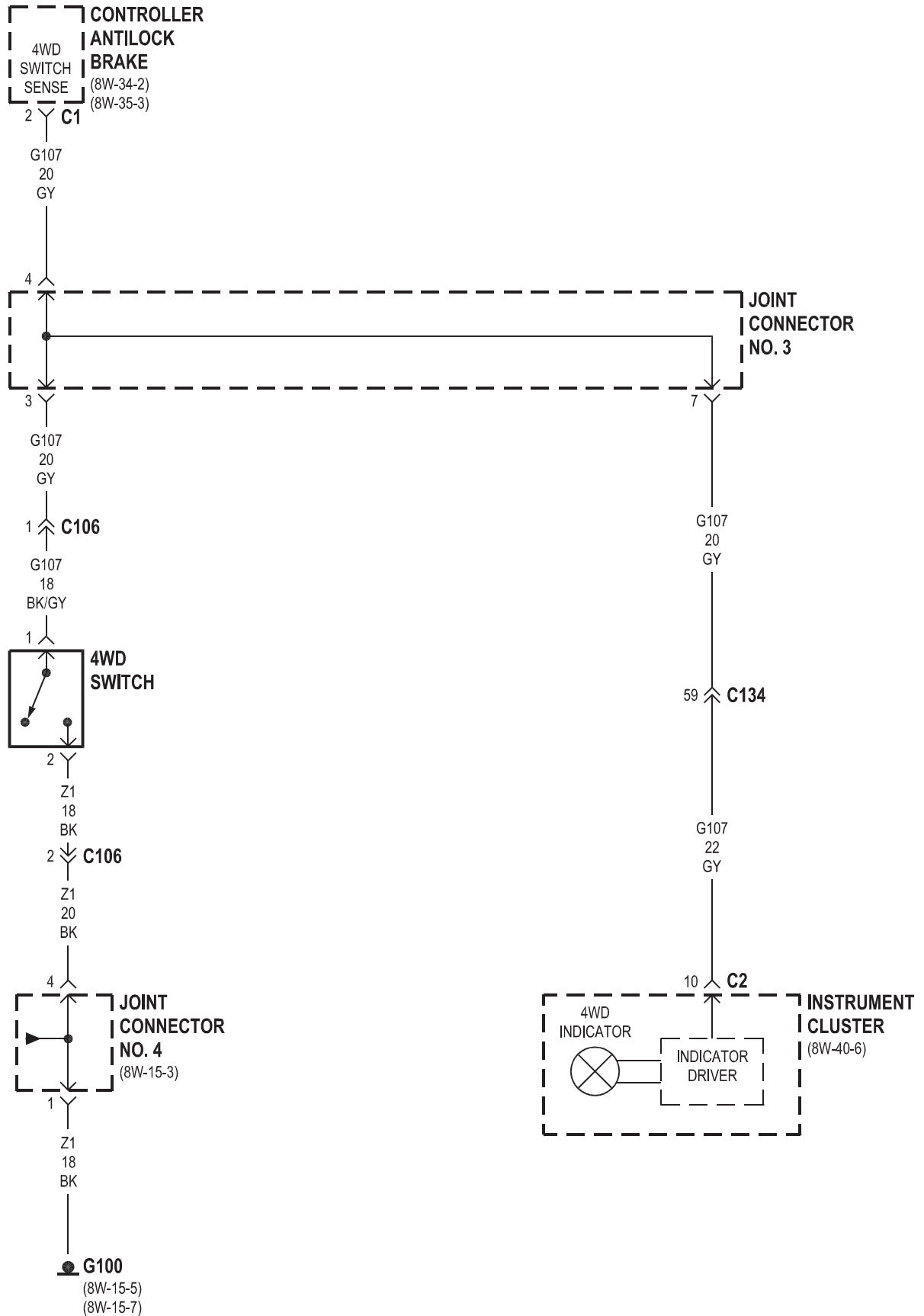
<b>Component</b>	<b>Page</b>	<b>Component</b>	<b>Page</b>
Controller Antilock Brake . . . . .	8W-31-5	Joint Connector No. 4 . . . . .	8W-31-5
Fuse I (PDC) . . . . .	8W-31-2	Leak Detection Pump . . . . .	8W-31-2
G100 . . . . .	8W-31-5	Output Speed Sensor . . . . .	8W-31-4
G107 . . . . .	8W-31-5	Overdrive Switch . . . . .	8W-31-4
G200 . . . . .	8W-31-4	Power Distribution Center . . . . .	8W-31-2
Generator . . . . .	8W-31-2	Powertrain Control Module . . . . .	8W-31-2, 3, 4
Instrument Cluster . . . . .	8W-31-5	Transmission Control Relay . . . . .	8W-31-2, 3
Joint Connector No. 3 . . . . .	8W-31-5	Transmission Solenoid Assembly . . . . .	8W-31-2, 3







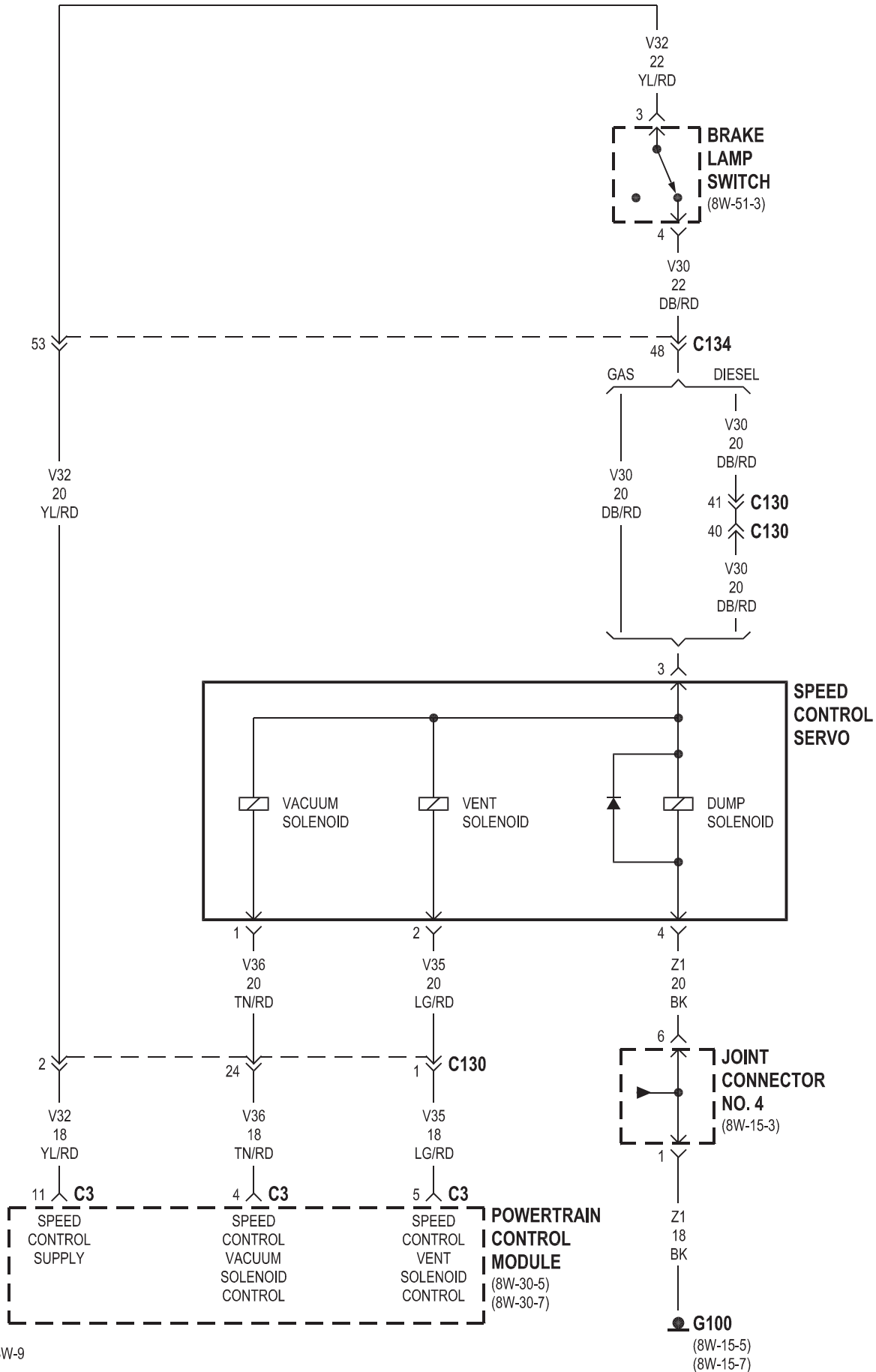




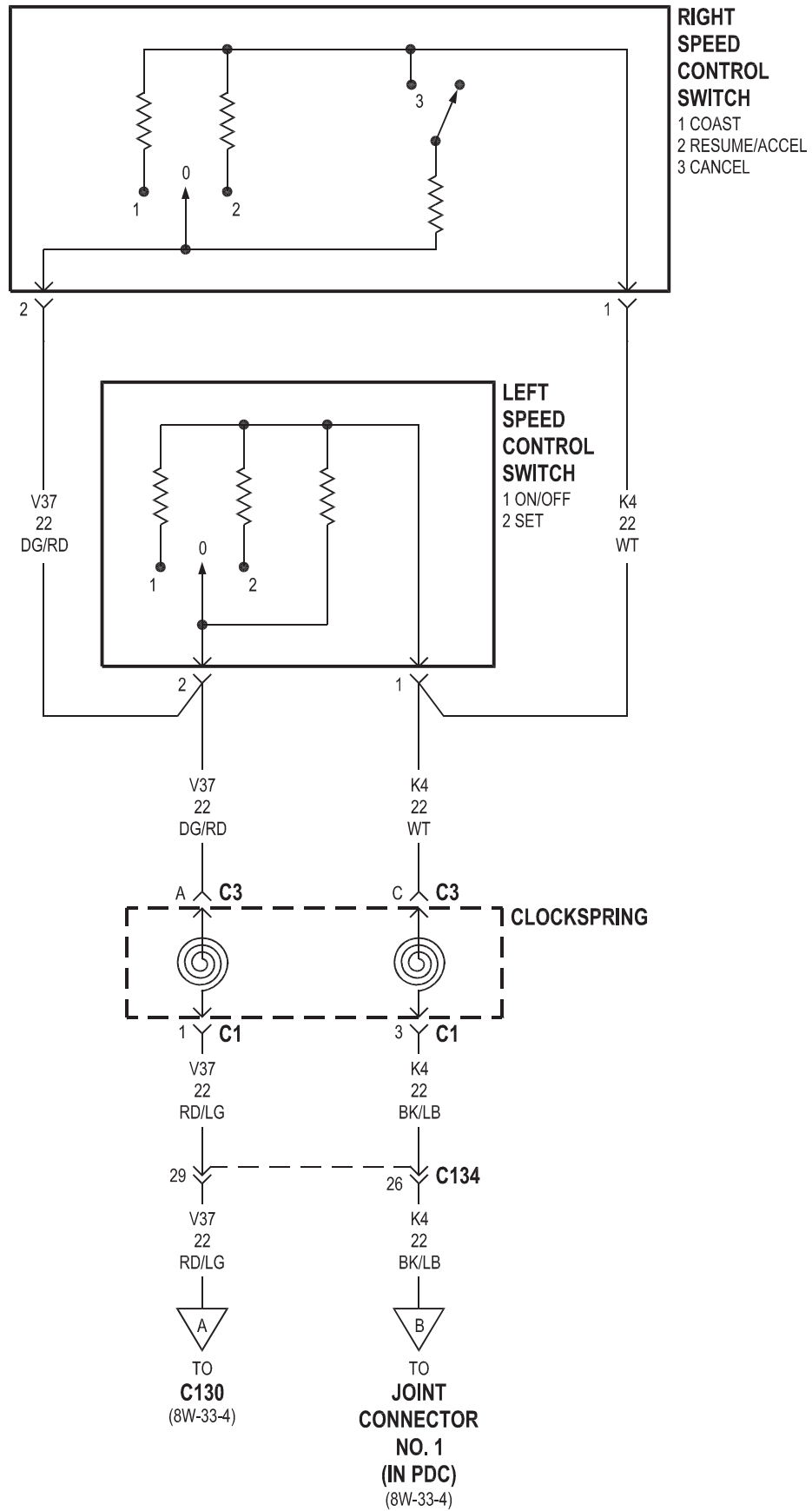


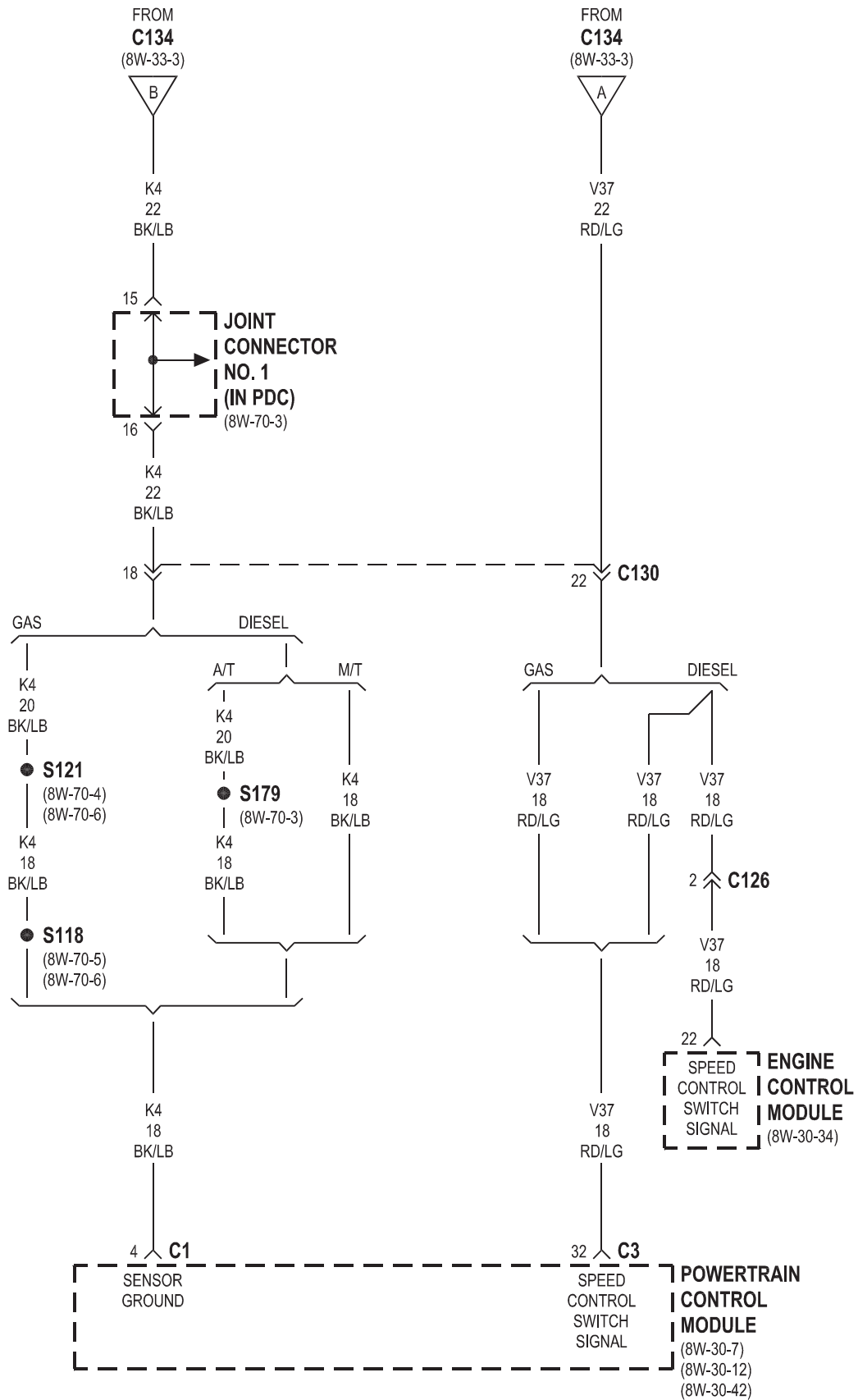
## 8W-33 VEHICLE SPEED CONTROL

<b>Component</b>	<b>Page</b>	<b>Component</b>	<b>Page</b>
Brake Lamp Switch . . . . .	8W-33-2	Joint Connector No. 4 . . . . .	8W-33-2
Clockspring . . . . .	8W-33-3	Left Speed Control Switch . . . . .	8W-33-3
Engine Control Module . . . . .	8W-33-4	Powertrain Control Module . . . . .	8W-33-2, 4
G100 . . . . .	8W-33-2	Right Speed Control Switch . . . . .	8W-33-3
Joint Connector No. 1 . . . . .	8W-33-4	Speed Control Servo . . . . .	8W-33-2



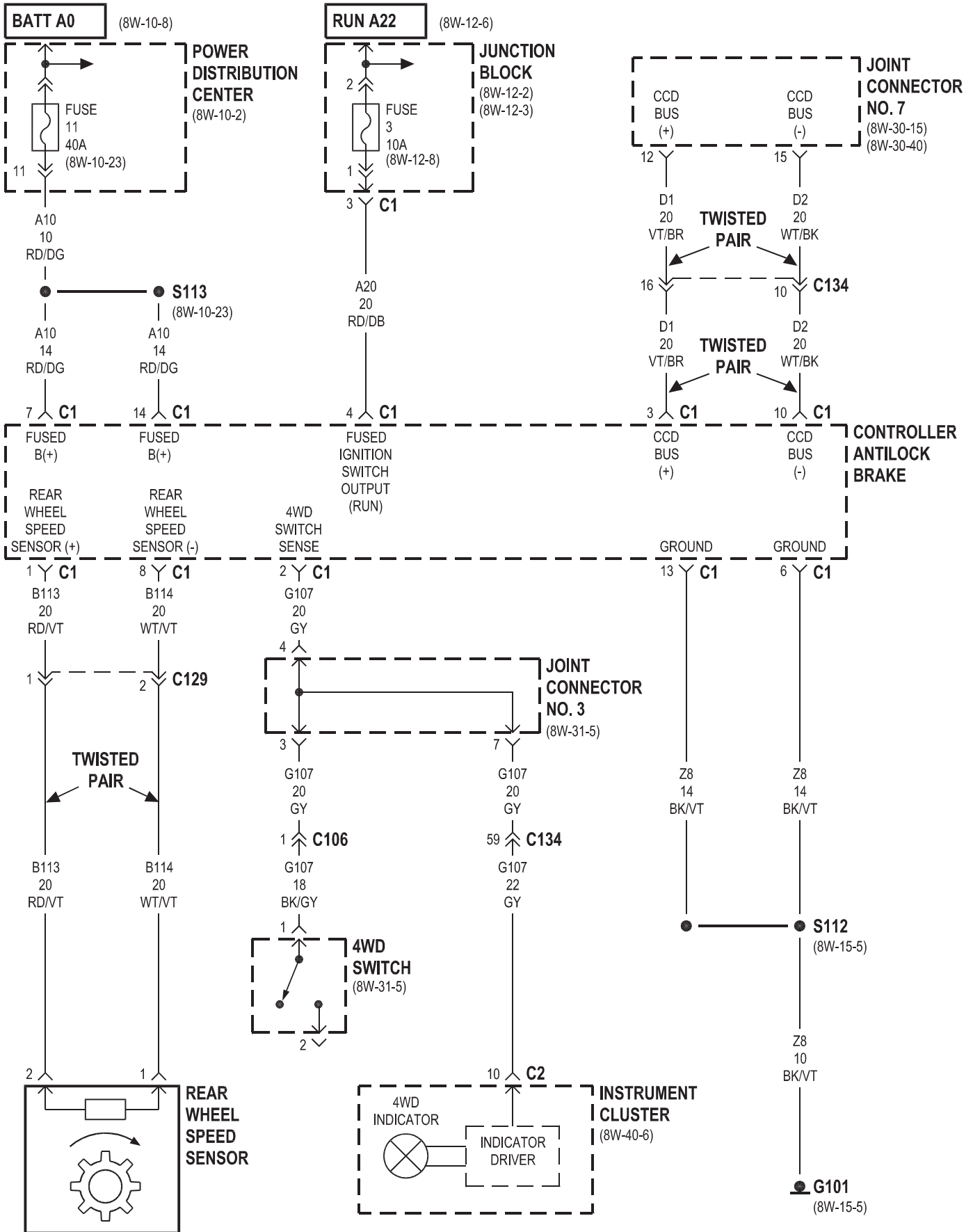


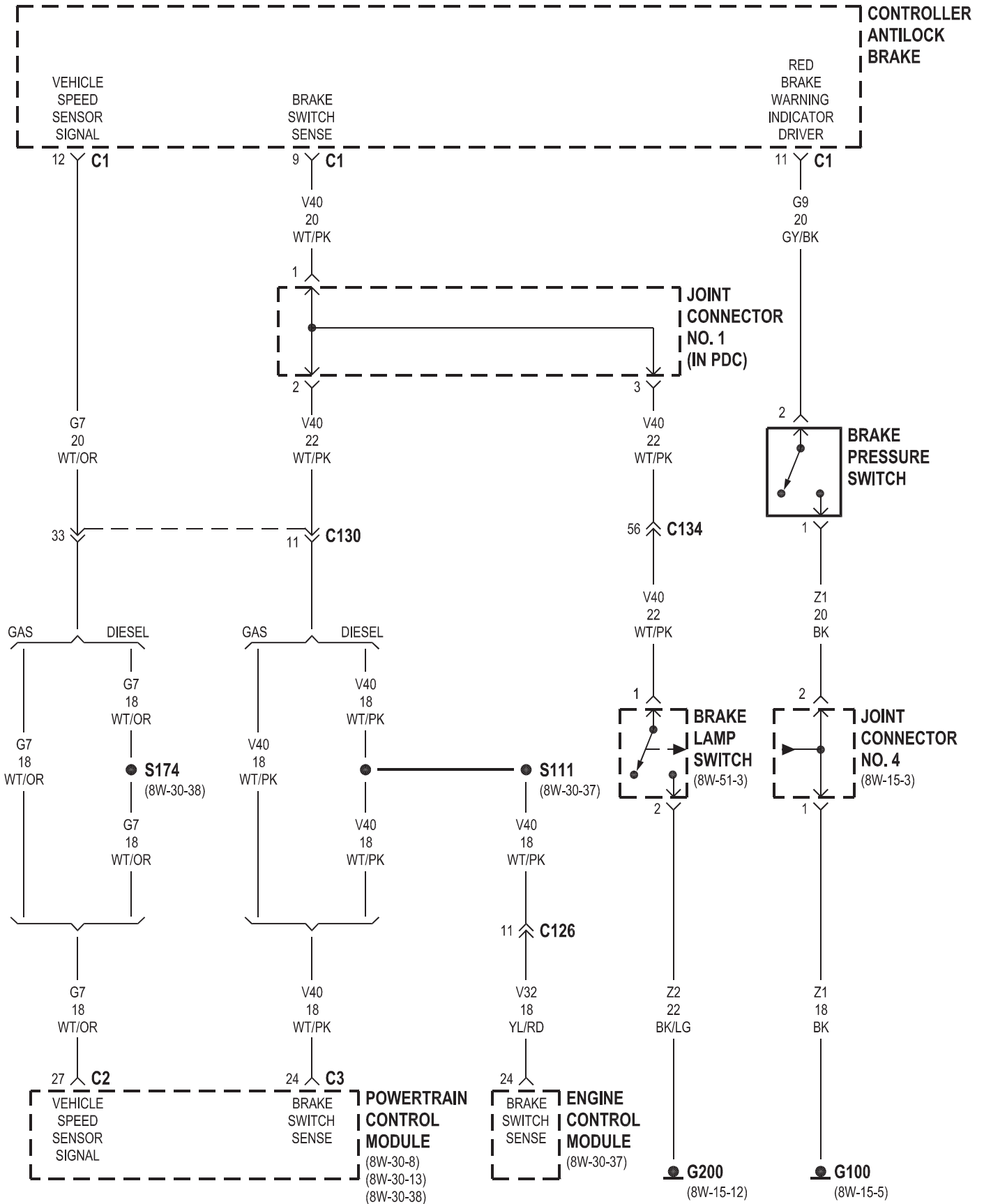




## 8W-34 REAR WHEEL ANTILOCK BRAKES

<b>Component</b>	<b>Page</b>	<b>Component</b>	<b>Page</b>
Brake Lamp Switch . . . . .	8W-34-3	Instrument Cluster . . . . .	8W-34-2
Brake Pressure Switch . . . . .	8W-34-3	Joint Connector No. 1 . . . . .	8W-34-3
Controller Antilock Brake . . . . .	8W-34-2, 3	Joint Connector No. 3 . . . . .	8W-34-2
Engine Control Module . . . . .	8W-34-3	Joint Connector No. 4 . . . . .	8W-34-3
Fuse 3 (JB) . . . . .	8W-34-2	Joint Connector No. 7 . . . . .	8W-34-2
Fuse 11 (PDC) . . . . .	8W-34-2	Junction Block . . . . .	8W-34-2
G100 . . . . .	8W-34-3	Power Distribution Center . . . . .	8W-34-2
G101 . . . . .	8W-34-2	Powertrain Control Module . . . . .	8W-34-3
G107 . . . . .	8W-34-2	Rear Wheel Speed Sensor . . . . .	8W-34-2
G200 . . . . .	8W-34-3		



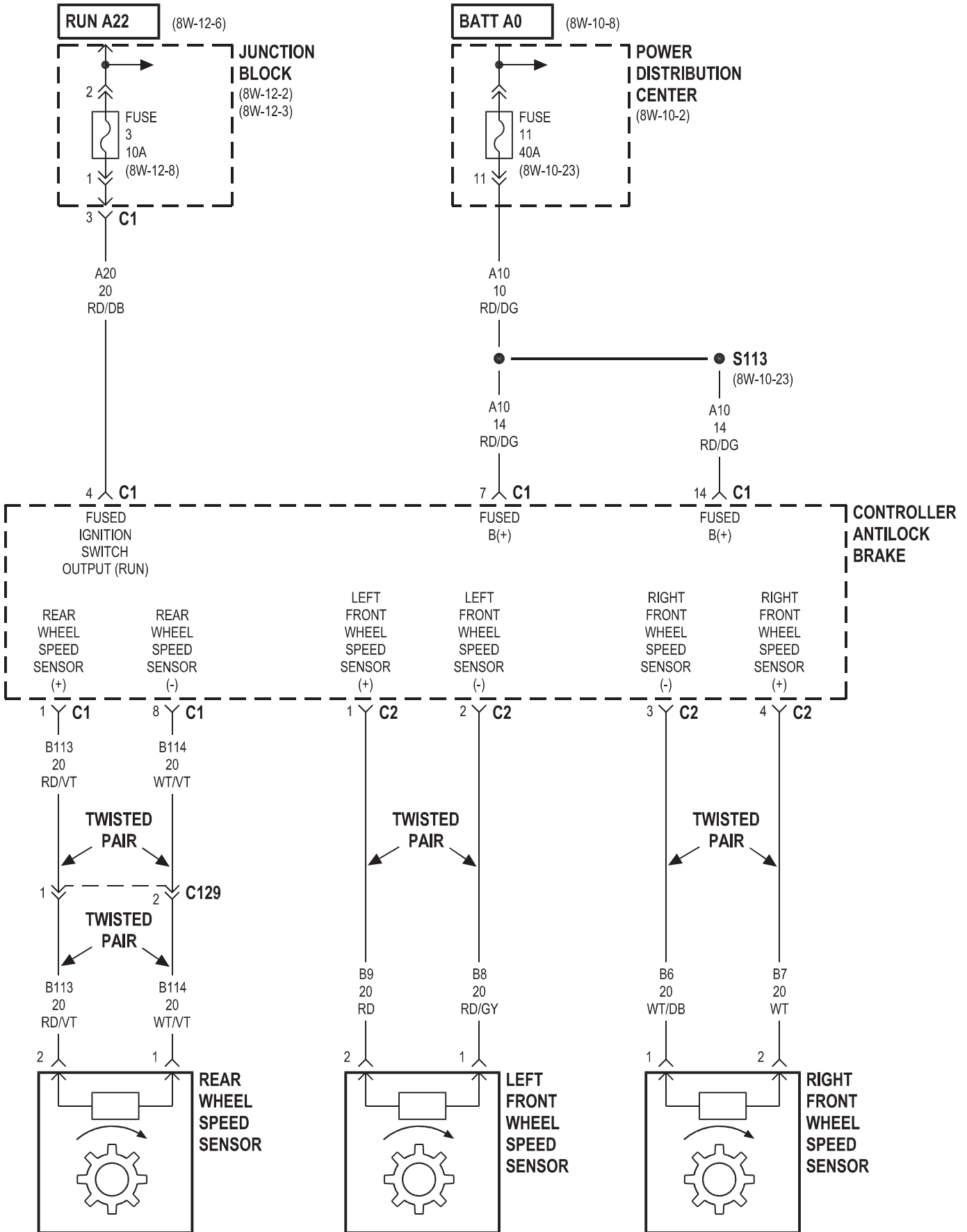


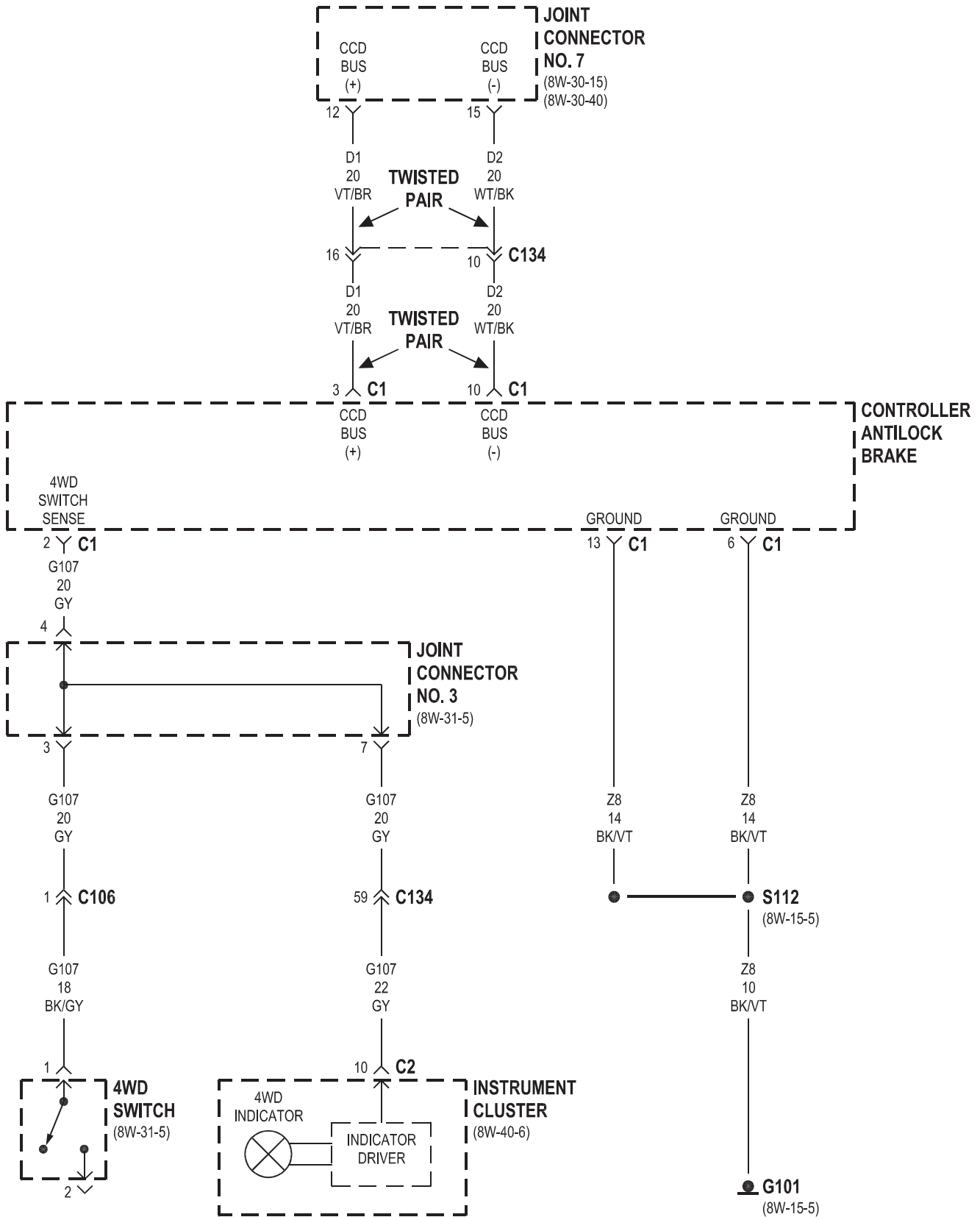


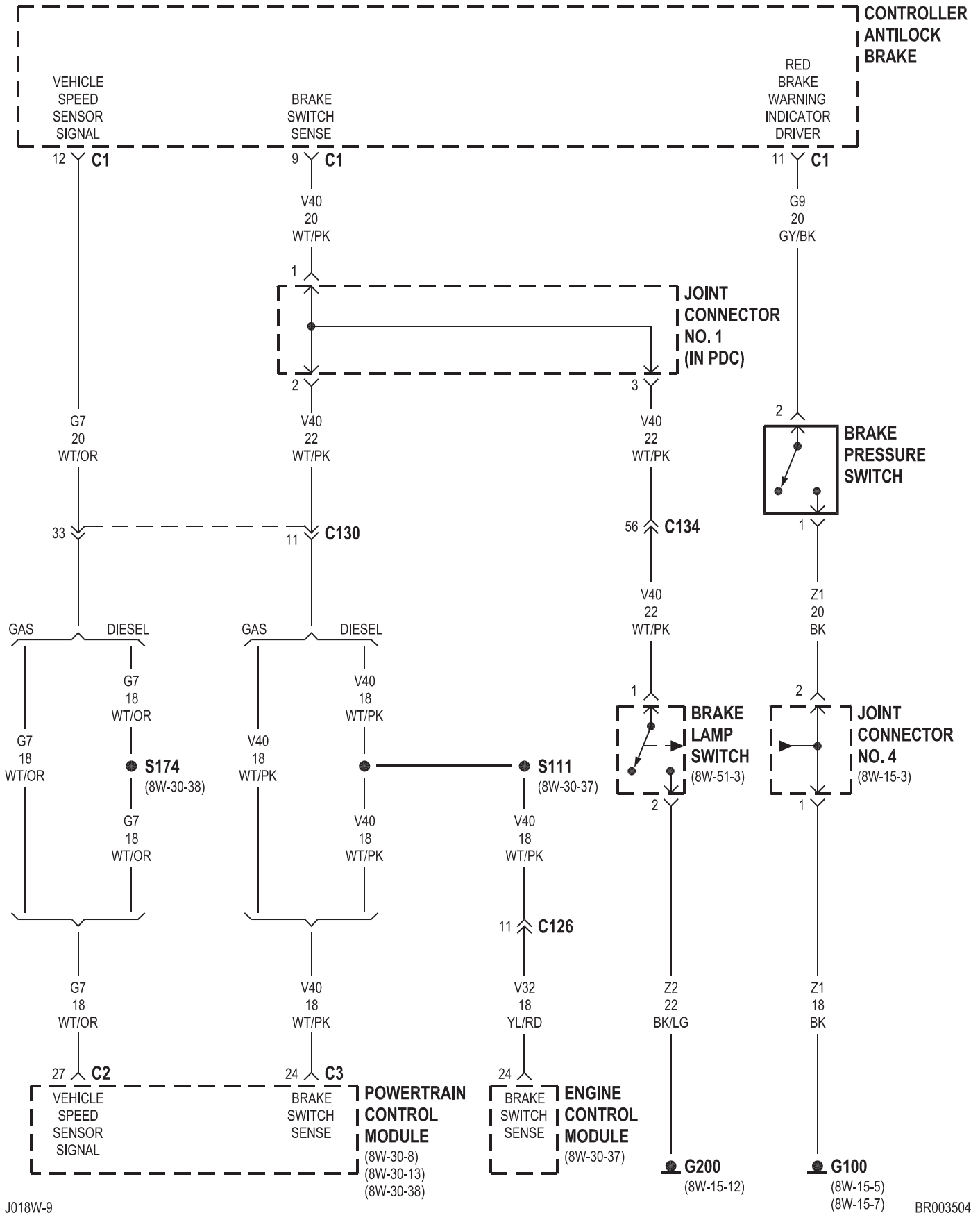


## 8W-35 ALL WHEEL ANTILOCK BRAKES

<b>Component</b>	<b>Page</b>	<b>Component</b>	<b>Page</b>
Brake Lamp Switch . . . . .	8W-35-4	Joint Connector No. 1 . . . . .	8W-35-4
Brake Pressure Switch . . . . .	8W-35-4	Joint Connector No. 3 . . . . .	8W-35-3
Controller Antilock Brake . . . . .	8W-35-2, 3, 4	Joint Connector No. 4 . . . . .	8W-35-4
Engine Control Module . . . . .	8W-35-4	Joint Connector No. 7 . . . . .	8W-35-3
Fuse 3 (JB) . . . . .	8W-35-2	Junction Block . . . . .	8W-35-2
Fuse 11 (PDC) . . . . .	8W-35-2	Left Front Wheel Speed Sensor . . . . .	8W-35-2
G100 . . . . .	8W-35-4	Power Distribution Center . . . . .	8W-35-2
G101 . . . . .	8W-35-3	Powertrain Control Module . . . . .	8W-35-4
G107 . . . . .	8W-35-3	Rear Wheel Speed Sensor . . . . .	8W-35-2
G200 . . . . .	8W-35-4	Right Front Wheel Speed Sensor . . . . .	8W-35-2
Instrument Cluster . . . . .	8W-35-3		



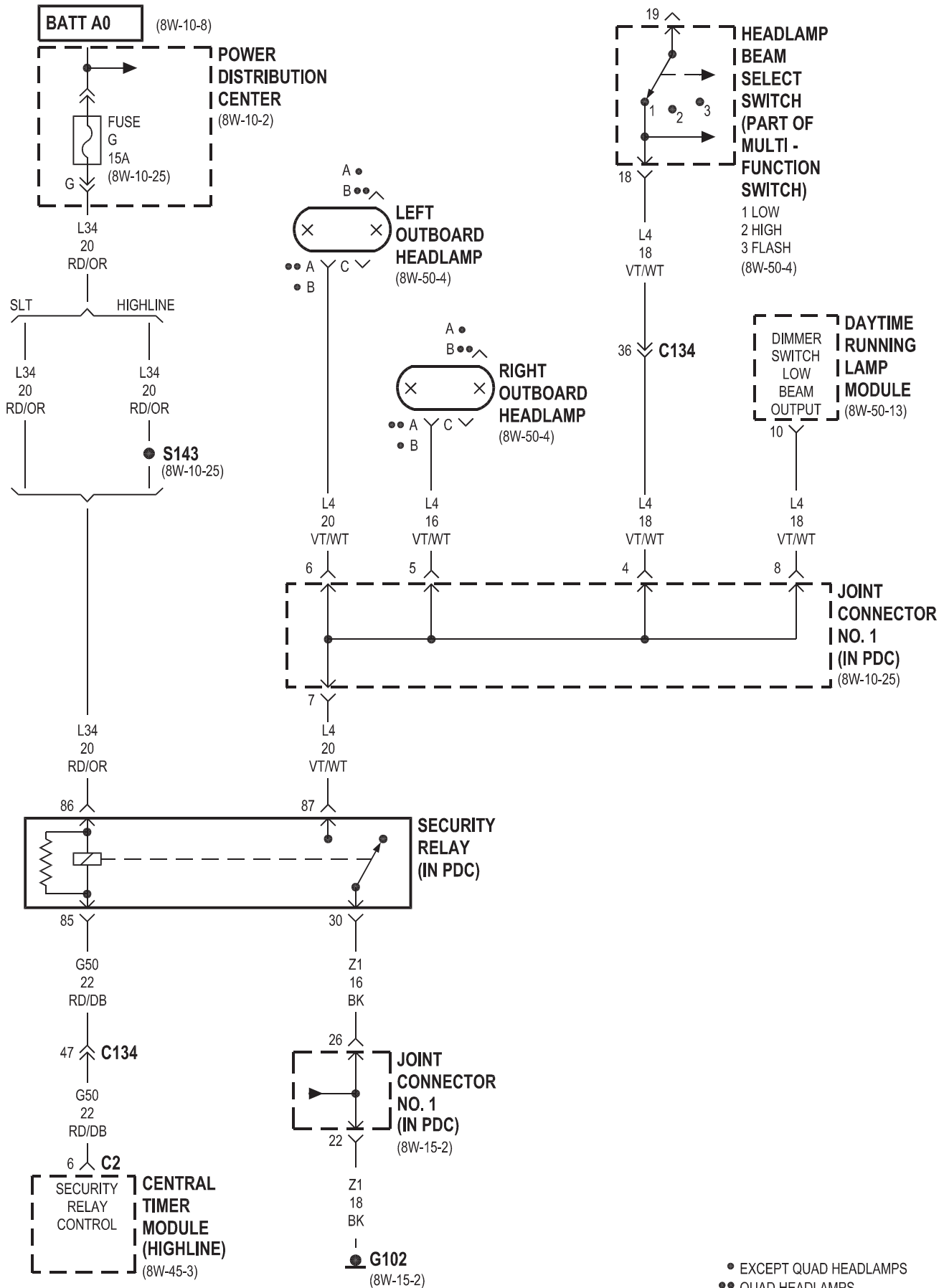




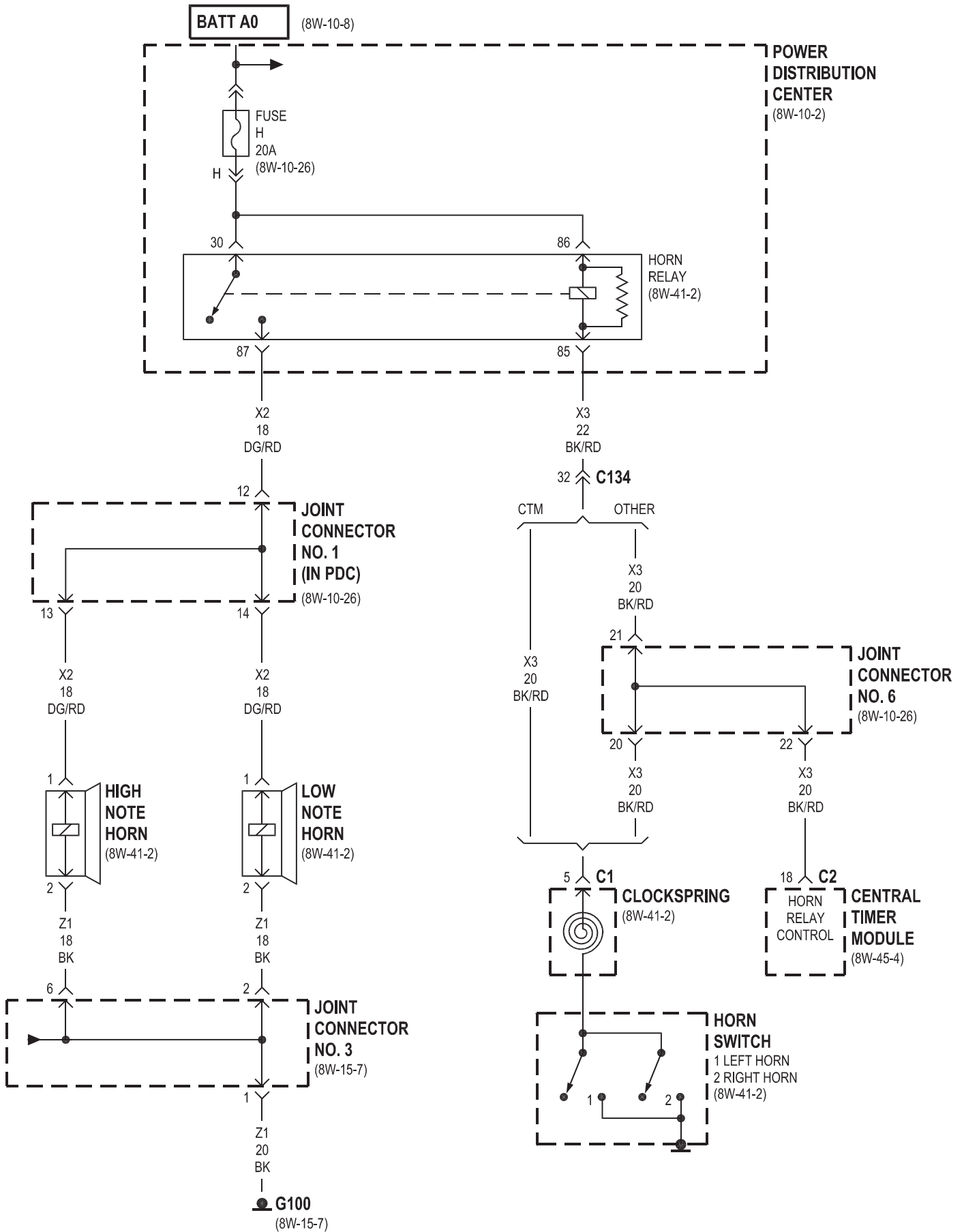


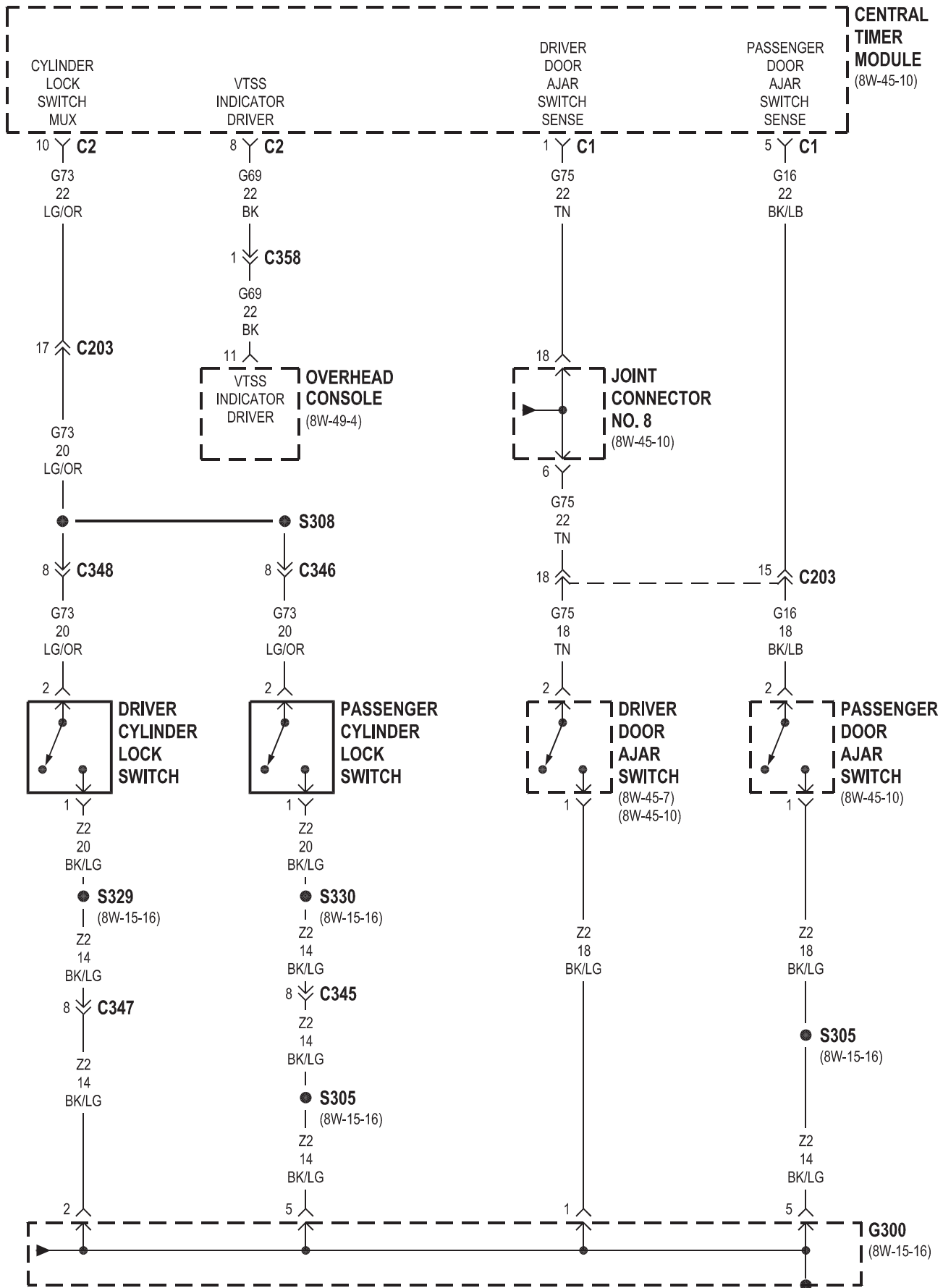
## 8W-39 VEHICLE THEFT SECURITY SYSTEM

<b>Component</b>	<b>Page</b>	<b>Component</b>	<b>Page</b>
Central Timer Module C1 . . . . .	8W-39-4	Horn Switch . . . . .	8W-39-3
Central Timer Module C2 . . . . .	8W-39-2, 3, 4	Joint Connector No. 1 . . . . .	8W-39-2, 3
Clockspring . . . . .	8W-39-3	Joint Connector No. 3 . . . . .	8W-39-3
Daytime Running Lamp Module . . . . .	8W-39-2	Joint Connector No. 6 . . . . .	8W-39-3
Driver Cylinder Lock Switch . . . . .	8W-39-4	Joint Connector No. 8 . . . . .	8W-39-4
Driver Door Ajar Switch . . . . .	8W-39-4	Left Outboard Headlamp . . . . .	8W-39-2
Fuse G (PDC) . . . . .	8W-39-2	Low Note Horn . . . . .	8W-39-3
Fuse H (PDC) . . . . .	8W-39-3	Overhead Console . . . . .	8W-39-4
G100 . . . . .	8W-39-3	Passenger Cylinder Lock Switch . . . . .	8W-39-4
G102 . . . . .	8W-39-2	Passenger Door Ajar Switch . . . . .	8W-39-4
G300 . . . . .	8W-39-4	Power Distribution Center . . . . .	8W-39-2, 3
Headlamp Beam Select Switch . . . . .	8W-39-2	Right Outboard Headlamp . . . . .	8W-39-2
High Note Horn . . . . .	8W-39-3	Security Relay . . . . .	8W-39-2
Horn Relay . . . . .	8W-39-3		



- EXCEPT QUAD HEADLAMPS
- QUAD HEADLAMPS



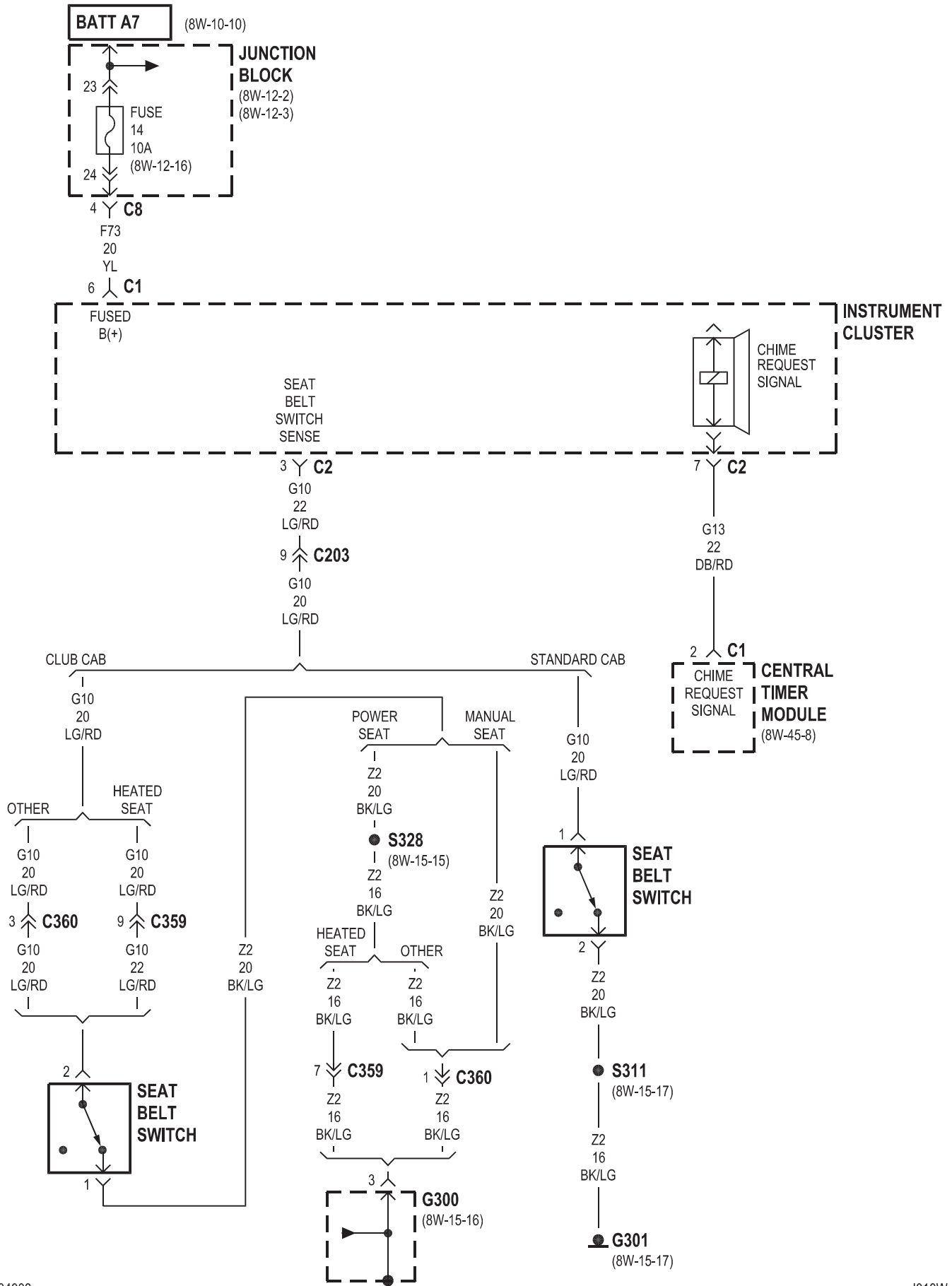


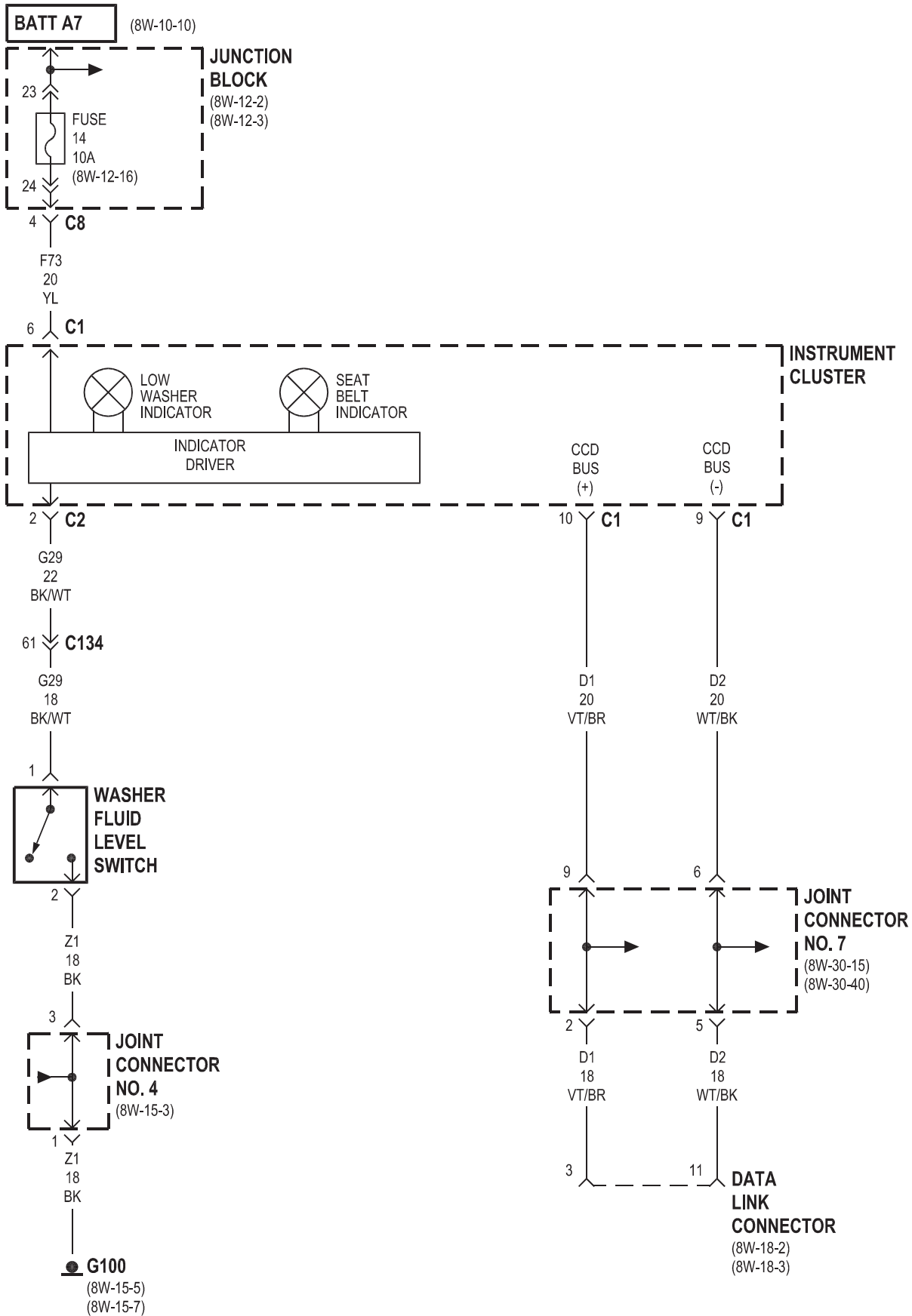
## 8W-40 INSTRUMENT CLUSTER

<b>Component</b>	<b>Page</b>	<b>Component</b>	<b>Page</b>
Data Link Connector . . . . .	8W-40-4	Joint Connector No. 3 . . . . .	8W-40-6
Daytime Running Lamp Module . . . . .	8W-40-2, 7	Joint Connector No. 4 . . . . .	8W-40-4, 6
Engine Control Module . . . . .	8W-40-2	Joint Connector No. 5 . . . . .	8W-40-5
Fuse 5 (JB) . . . . .	8W-40-5	Joint Connector No. 7 . . . . .	8W-40-4, 6
Fuse 14 (JB) . . . . .	8W-40-2, 3, 4, 7	Joint Connector No. 8 . . . . .	8W-40-5
Fuse 17 (JB) . . . . .	8W-40-2	Junction Block . . . . .	8W-40-2, 3, 4, 5, 7
Fuse F (PDC) . . . . .	8W-40-5	Left Turn Indicator . . . . .	8W-40-7
G100 . . . . .	8W-40-4, 6	Overdrive Switch . . . . .	8W-40-6
G200 . . . . .	8W-40-2, 6	Park Brake Switch . . . . .	8W-40-2
G201 . . . . .	8W-40-2, 5, 7	Power Distribution Center . . . . .	8W-40-5
G300 . . . . .	8W-40-3	Powertrain Control Module . . . . .	8W-40-6
G301 . . . . .	8W-40-3	Radio . . . . .	8W-40-5
Headlamp Beam Select Switch . . . . .	8W-40-7	Right Turn Indicator . . . . .	8W-40-7
Headlamp Switch . . . . .	8W-40-5	Seat Belt Switch . . . . .	8W-40-3
High Beam Indicator . . . . .	8W-40-7	Turn Signal/Hazard Switch . . . . .	8W-40-7
Instrument Cluster . . . . .	8W-40-2, 3, 4, 5, 6, 7	Washer Fluid Level Switch . . . . .	8W-40-4
Integrated Electronic Module . . . . .	8W-40-3		

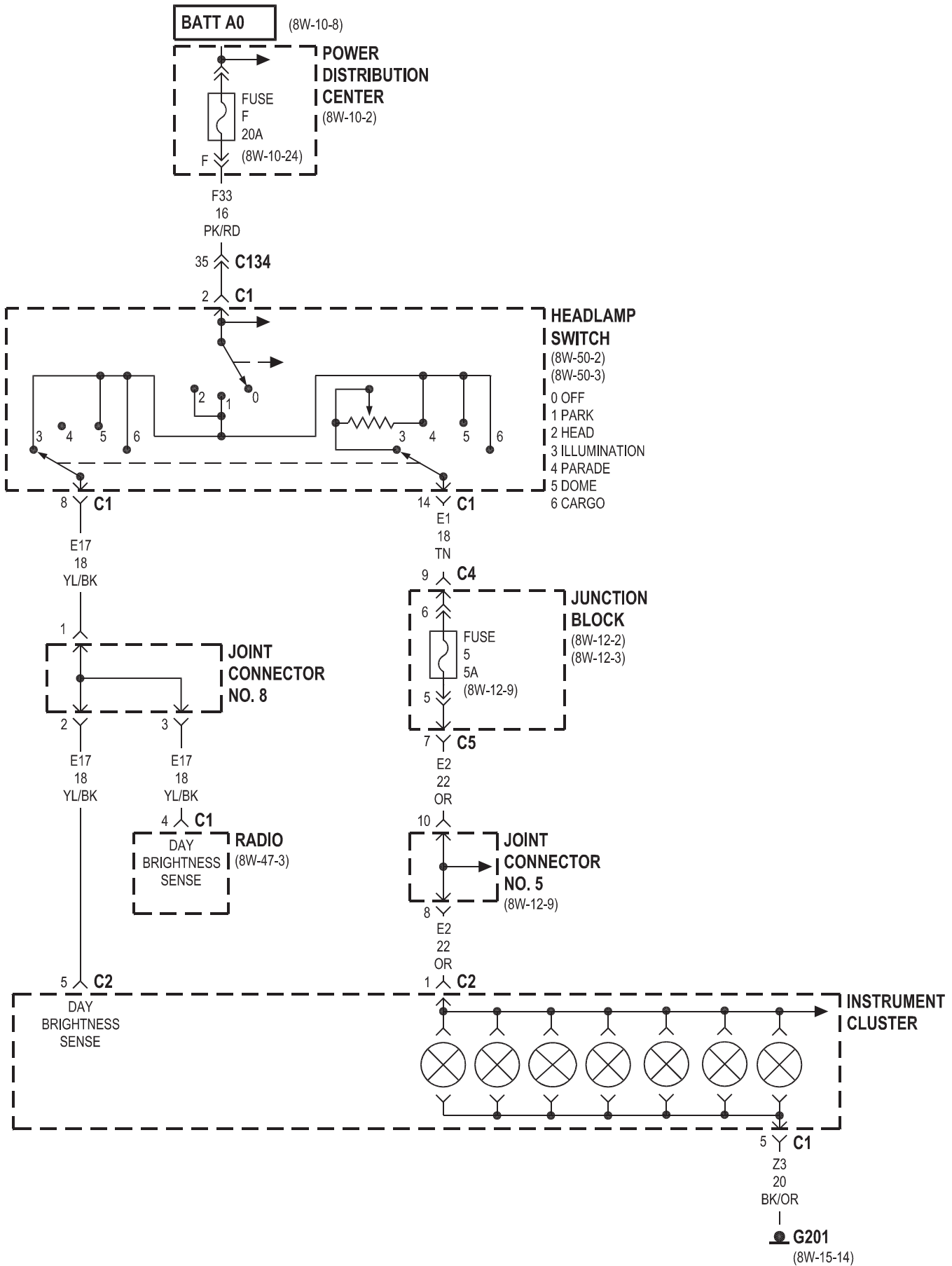


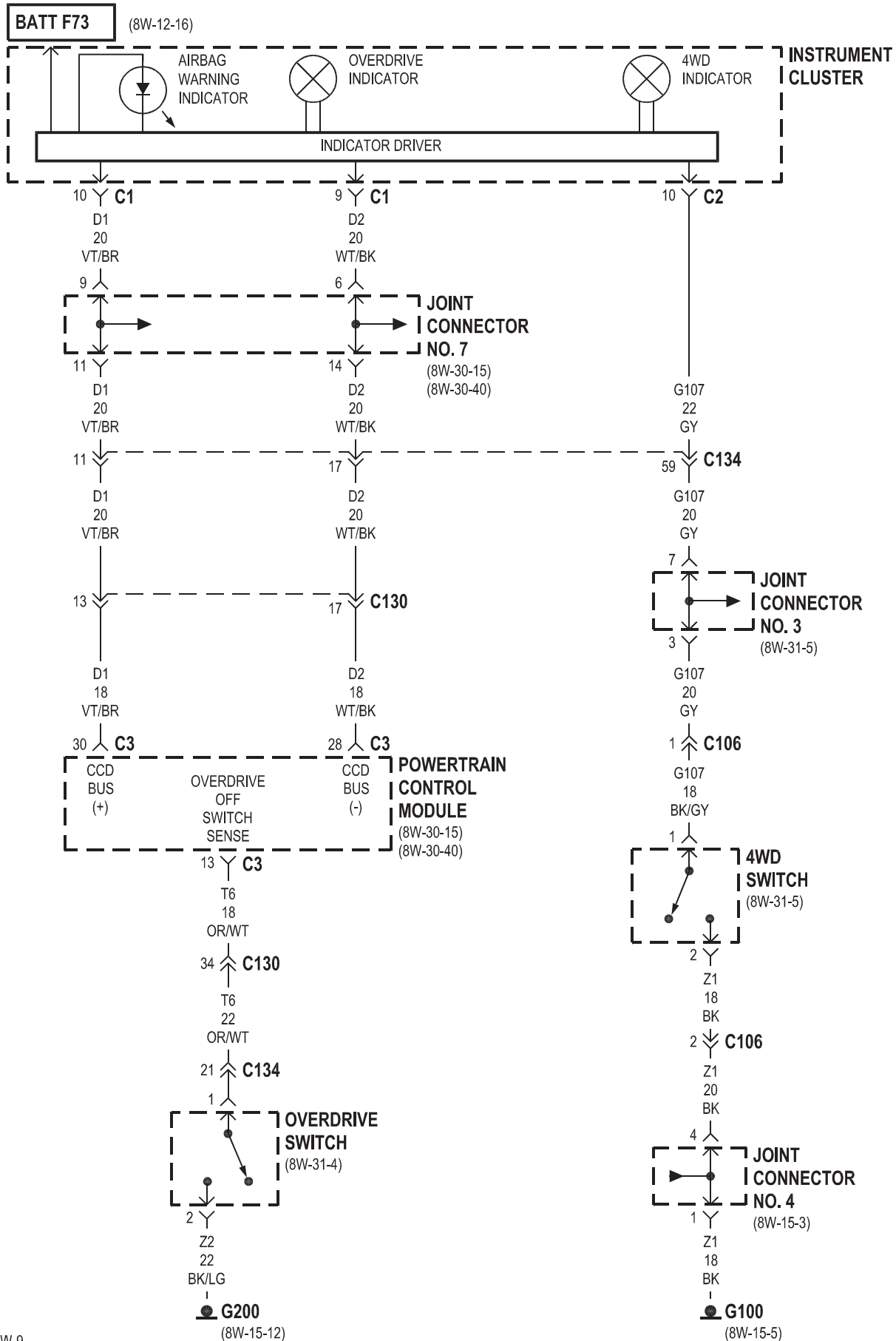




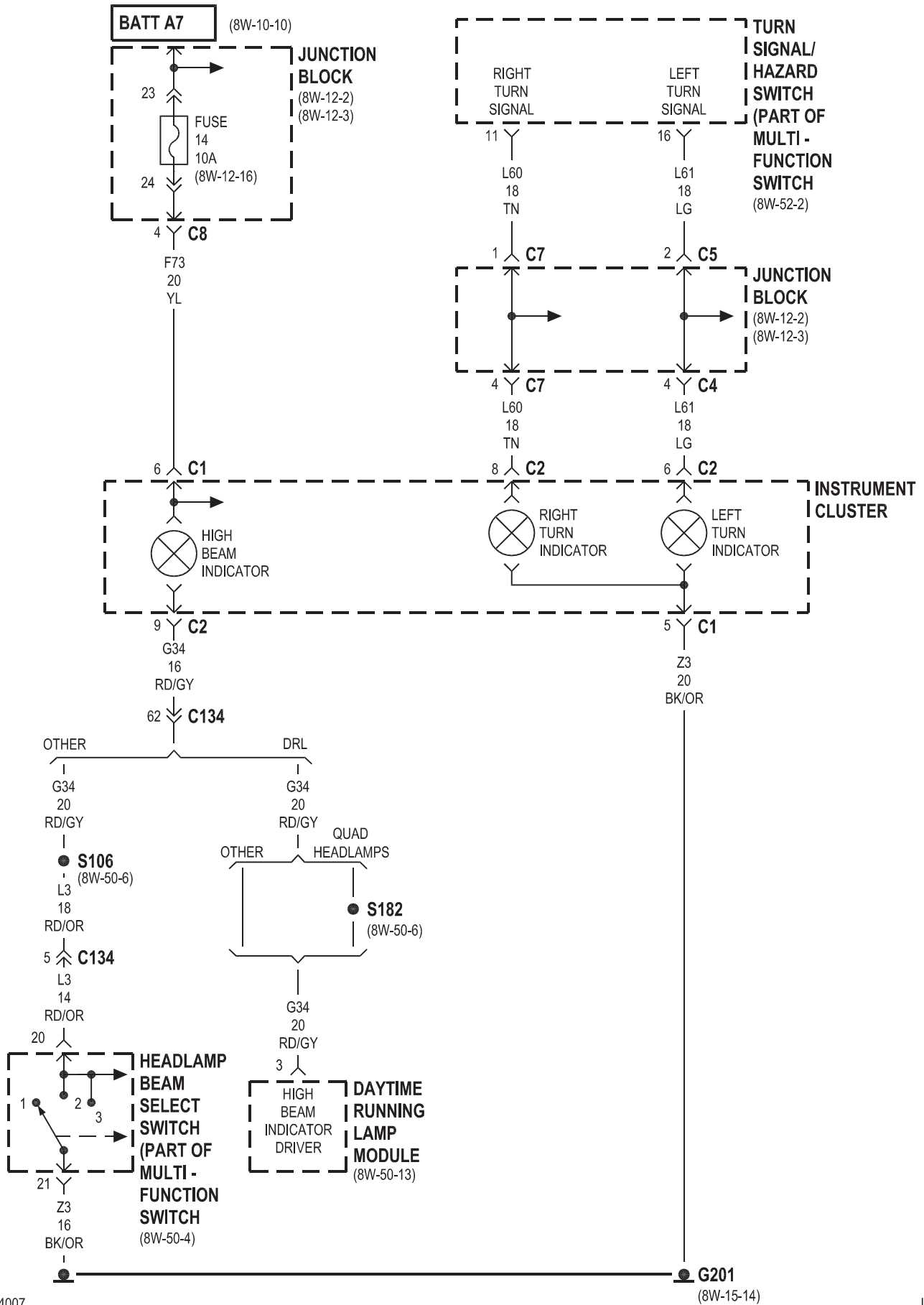


- STANDARD CAB
- CLUB CAB





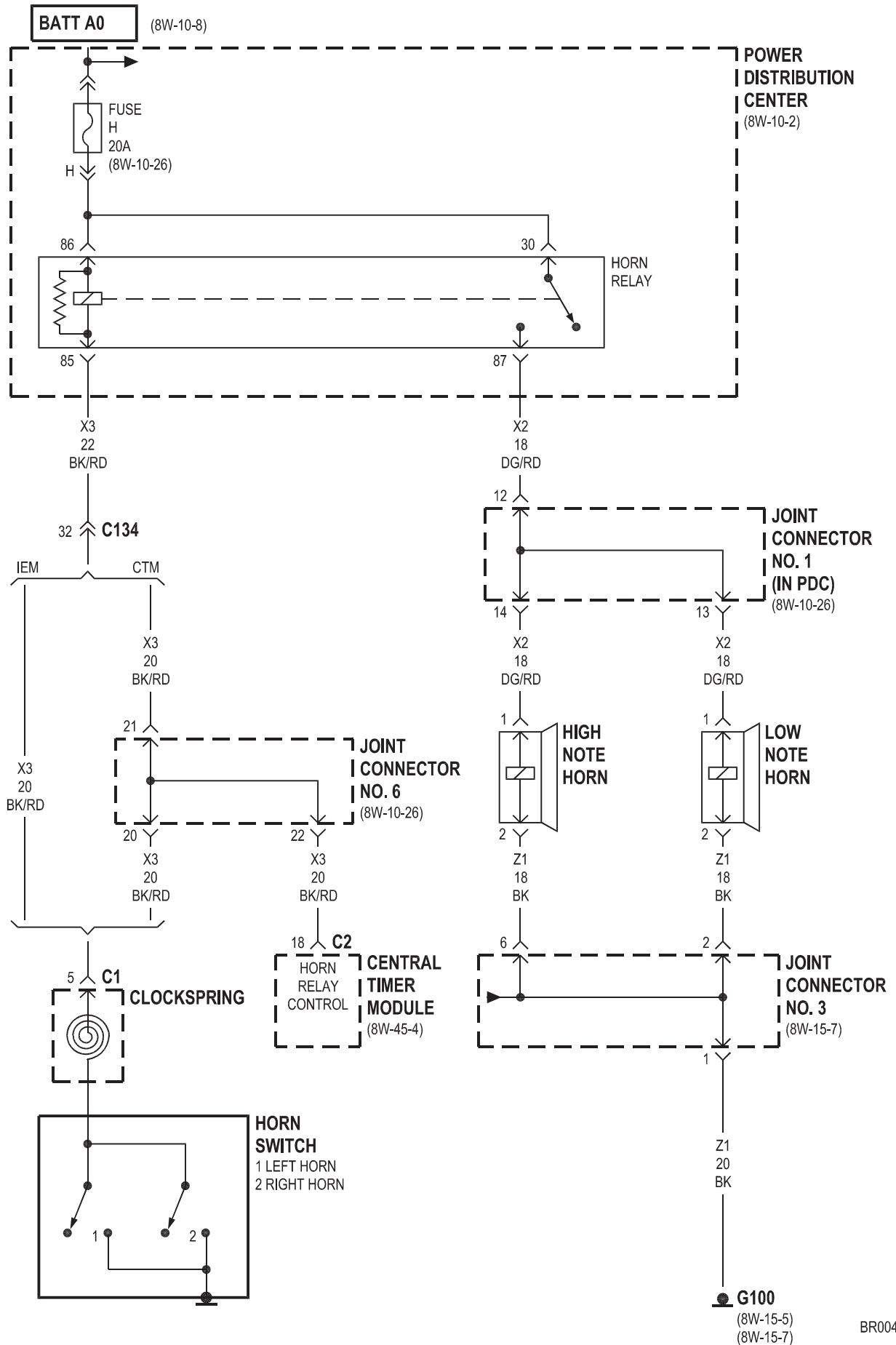


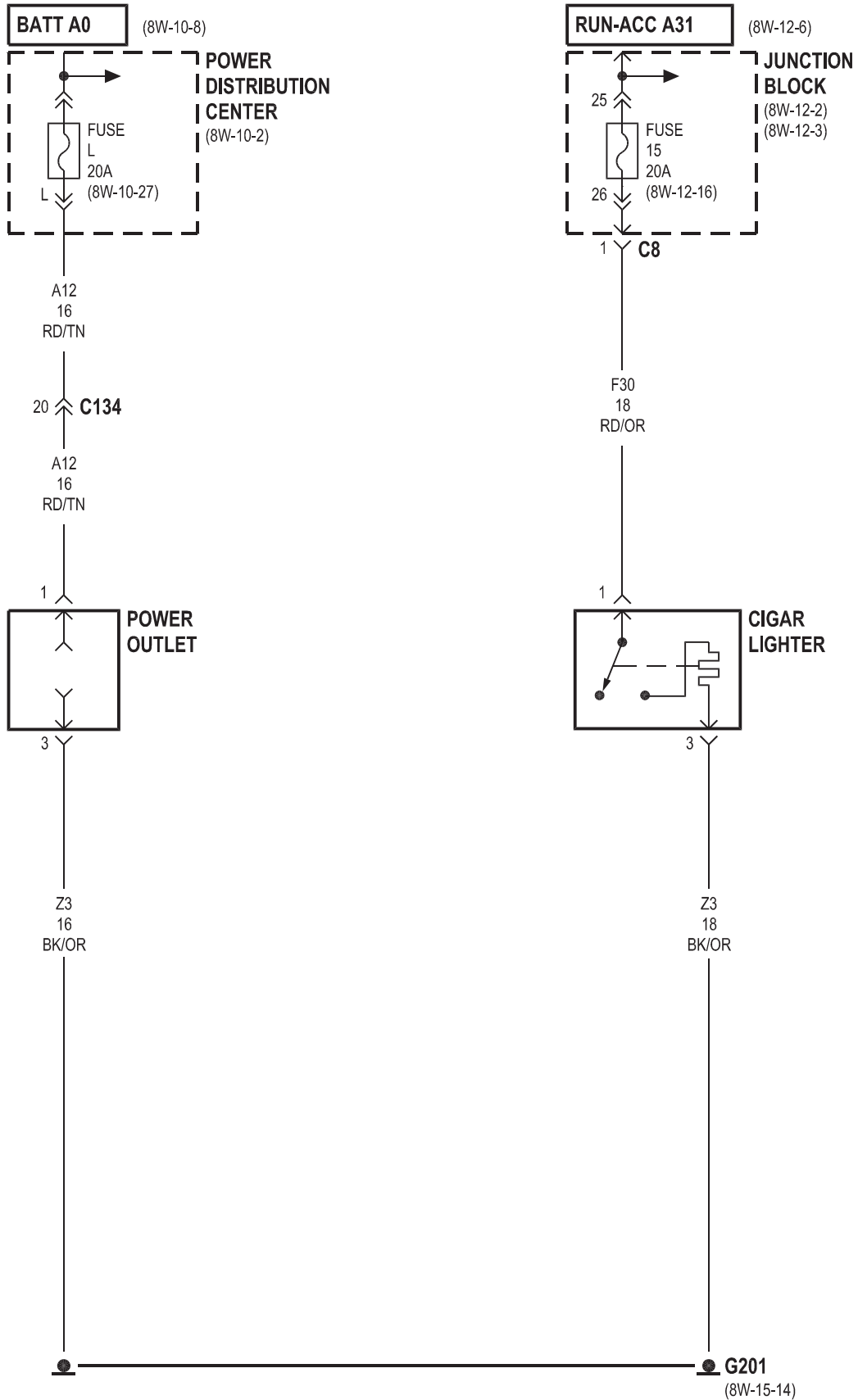




## 8W-41 HORN/CIGAR LIGHTER/POWER OUTLET

<b>Component</b>	<b>Page</b>	<b>Component</b>	<b>Page</b>
Central Timer Module . . . . .	8W-41-2	Horn Relay . . . . .	8W-41-2
Cigar Lighter . . . . .	8W-41-3	Horn Switch . . . . .	8W-41-2
Clockspring . . . . .	8W-41-2	Joint Connector No. 1 . . . . .	8W-41-2
Fuse 15 (JB) . . . . .	8W-41-3	Joint Connector No. 3 . . . . .	8W-41-2
Fuse H (PDC) . . . . .	8W-41-2	Joint Connector No. 6 . . . . .	8W-41-2
Fuse L (PDC) . . . . .	8W-41-3	Junction Block . . . . .	8W-41-3
G100 . . . . .	8W-41-2	Low Note Horn . . . . .	8W-41-2
G201 . . . . .	8W-41-3	Power Distribution Center . . . . .	8W-41-2, 3
High Note Horn . . . . .	8W-41-2	Power Outlet . . . . .	8W-41-3



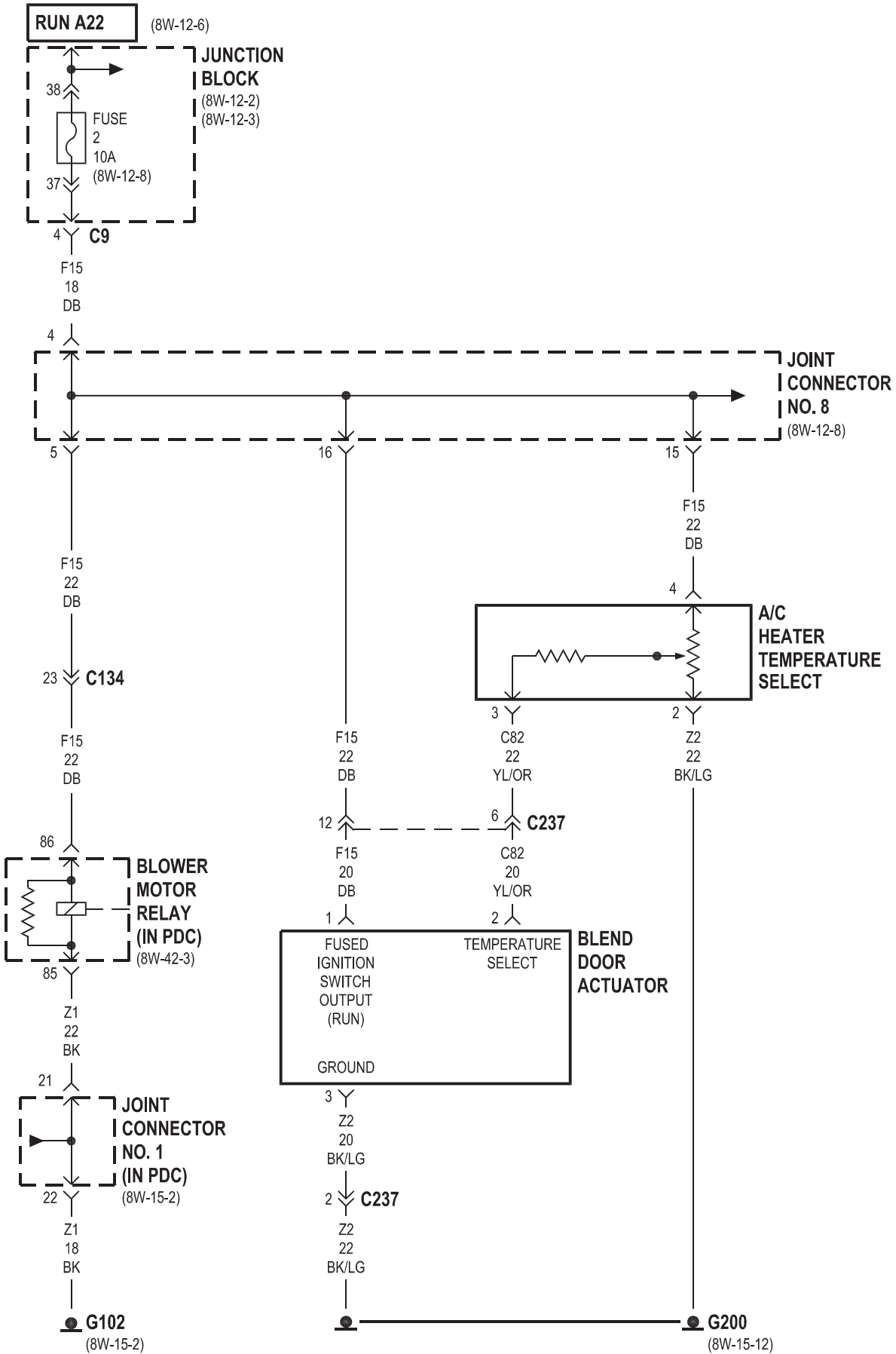


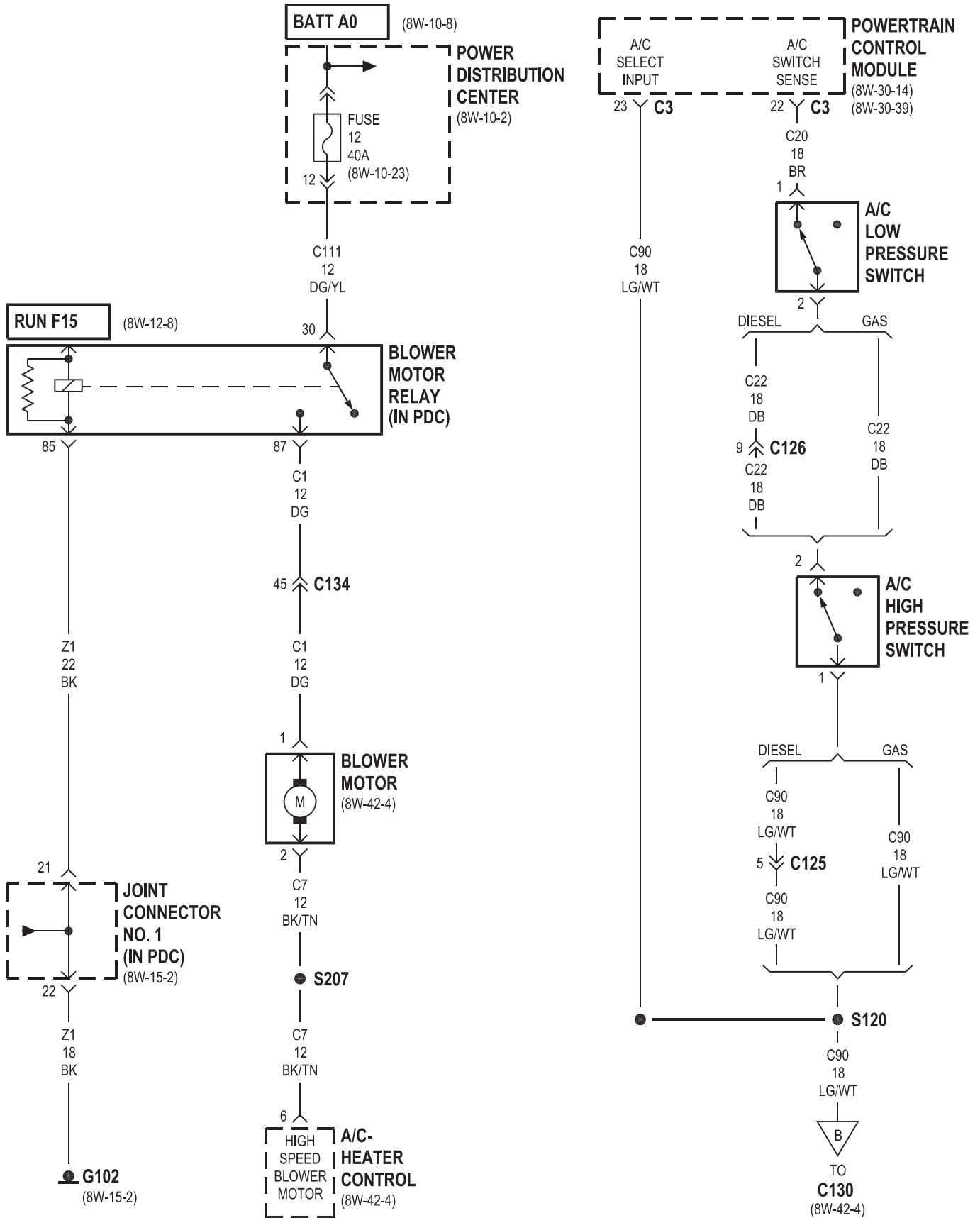


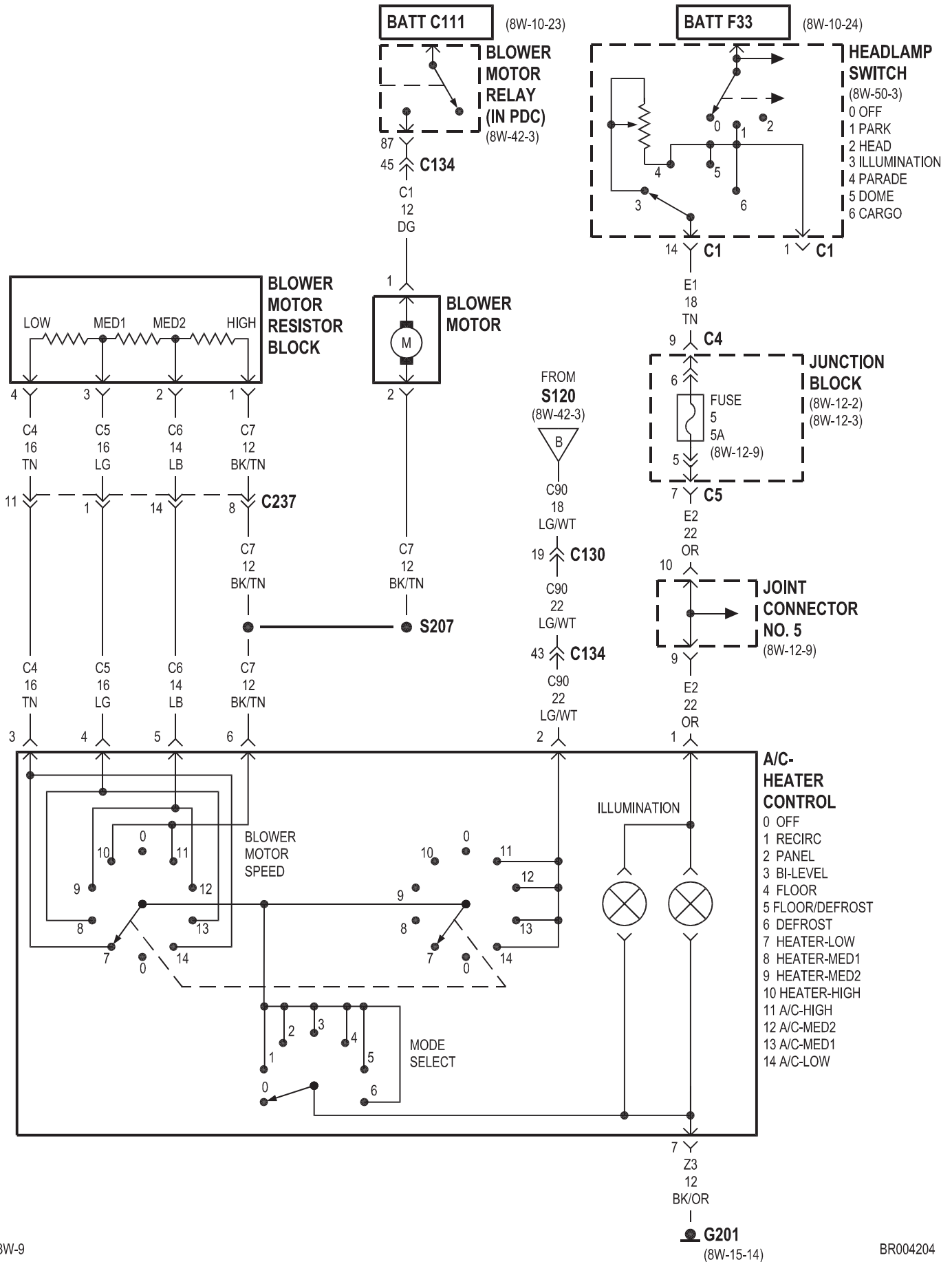


## 8W-42 AIR CONDITIONING-HEATER

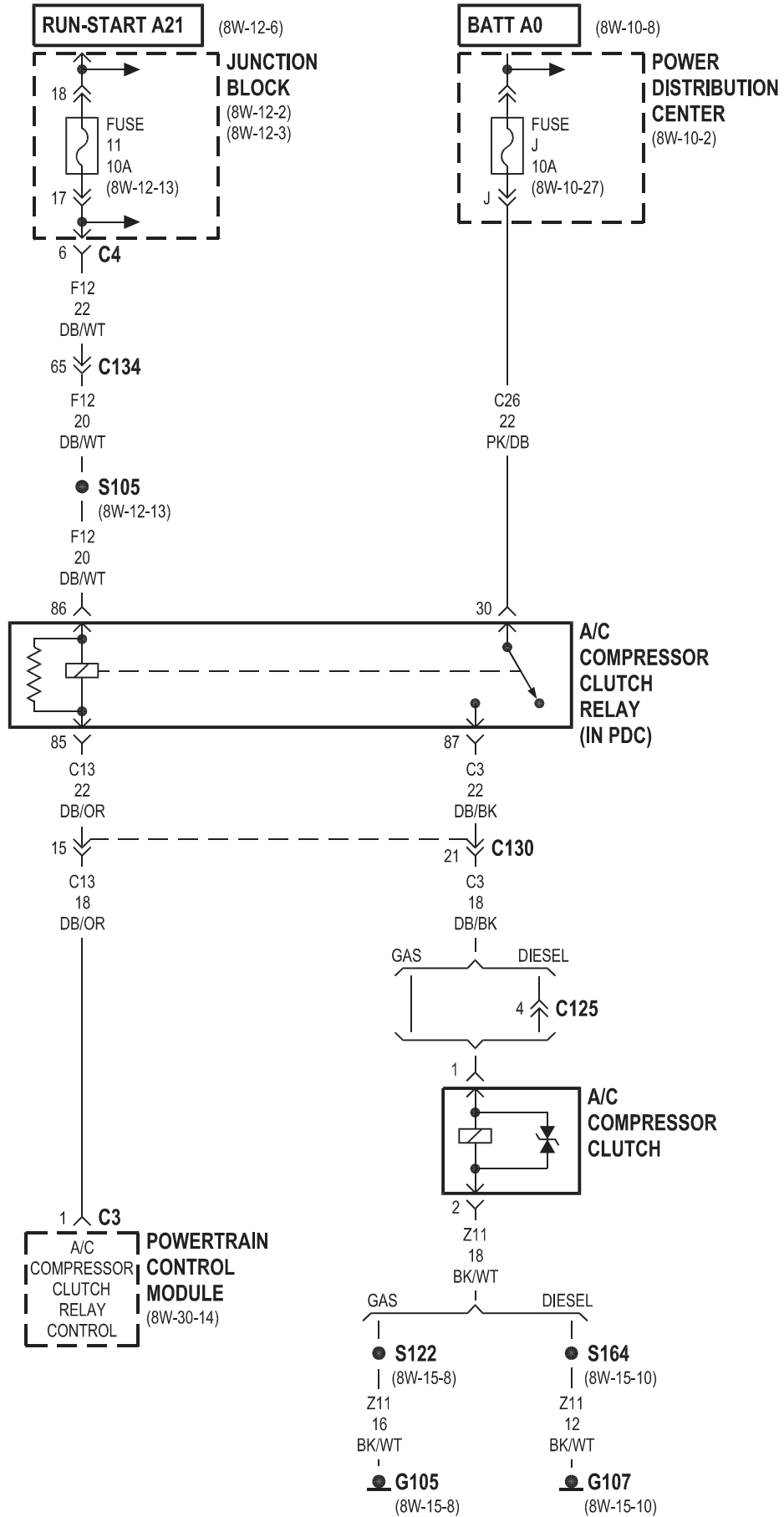
<b>Component</b>	<b>Page</b>	<b>Component</b>	<b>Page</b>
A/C Compressor Clutch . . . . .	8W-42-5	Fuse J (PDC) . . . . .	8W-42-5
A/C Compressor Clutch Relay . . . . .	8W-42-5	G102 . . . . .	8W-42-2, 3
A/C Heater Temperature Select . . . . .	8W-42-2	G105 . . . . .	8W-42-5
A/C High Pressure Switch . . . . .	8W-42-3	G107 . . . . .	8W-42-5
A/C Low Pressure Switch . . . . .	8W-42-3	G200 . . . . .	8W-42-2
A/C-Heater Control . . . . .	8W-42-3, 4	G201 . . . . .	8W-42-4
Blend Door Actuator . . . . .	8W-42-2	Headlamp Switch . . . . .	8W-42-4
Blower Motor . . . . .	8W-42-3, 4	Joint Connector No. 1 . . . . .	8W-42-2, 3
Blower Motor Relay . . . . .	8W-42-2, 3, 4	Joint Connector No. 5 . . . . .	8W-42-4
Blower Motor Resistor Block . . . . .	8W-42-4	Joint Connector No. 8 . . . . .	8W-42-2
Fuse 2 (JB) . . . . .	8W-42-2	Junction Block . . . . .	8W-42-2, 4, 5
Fuse 5 (JB) . . . . .	8W-42-4	Power Distribution Center . . . . .	8W-42-3, 5
Fuse 11 (JB) . . . . .	8W-42-5	Powertrain Control Module . . . . .	8W-42-3, 5
Fuse 12 (PDC) . . . . .	8W-42-3		









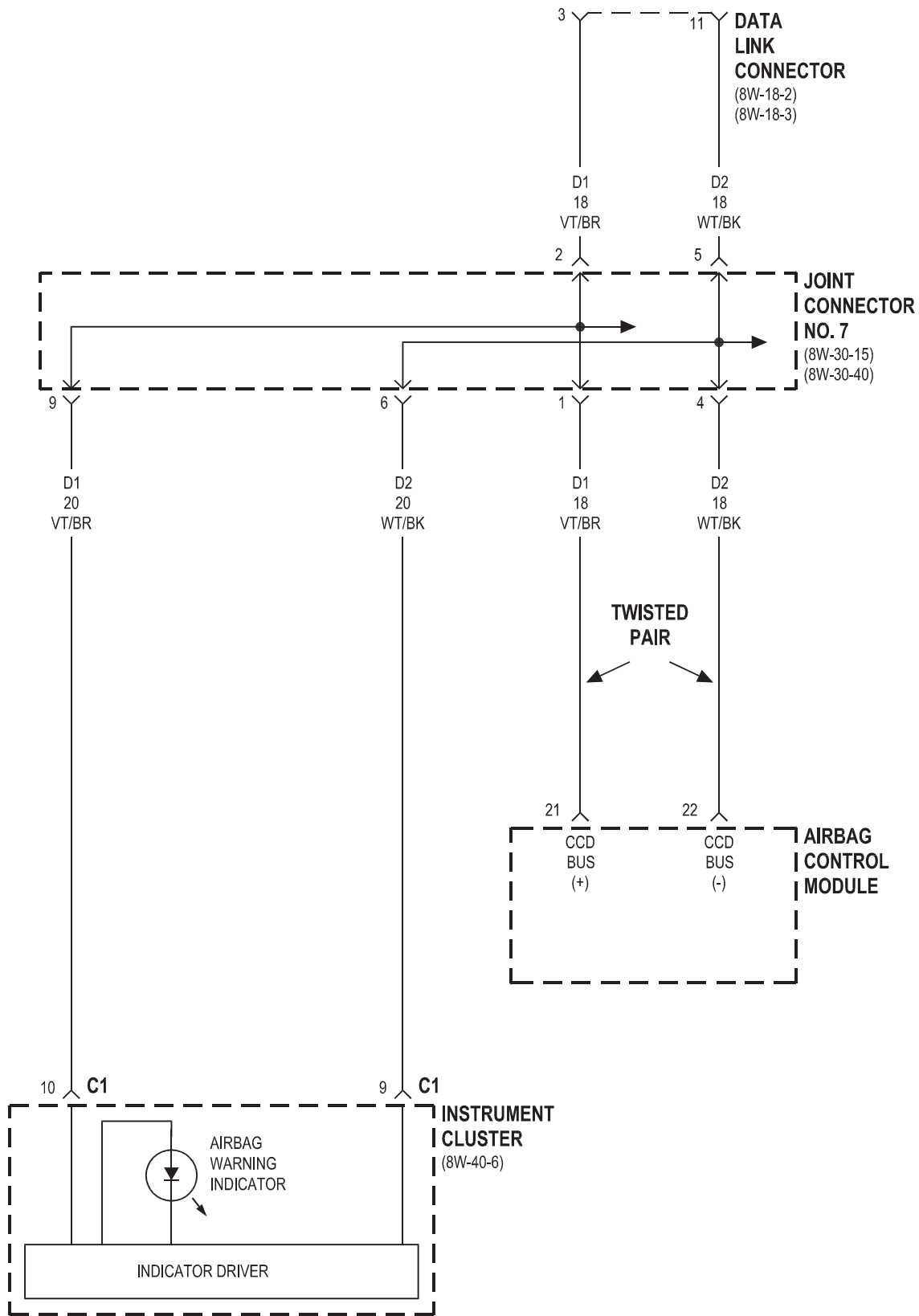




## 8W-43 AIRBAG SYSTEM

<b>Component</b>	<b>Page</b>	<b>Component</b>	<b>Page</b>
Airbag Control Module . . . . .	8W-43-2, 3	Instrument Cluster . . . . .	8W-43-3
Clockspring . . . . .	8W-43-2	Joint Connector No. 7 . . . . .	8W-43-3
Data Link Connector . . . . .	8W-43-3	Joint Connector No. 8 . . . . .	8W-43-2
Driver Airbag . . . . .	8W-43-2	Junction Block . . . . .	8W-43-2
Fuse 18 (JB) . . . . .	8W-43-2	Passenger Airbag . . . . .	8W-43-2
Fuse 19 (JB) . . . . .	8W-43-2	Passenger Airbag On/Off Switch . . . . .	8W-43-2
G100 . . . . .	8W-43-2		



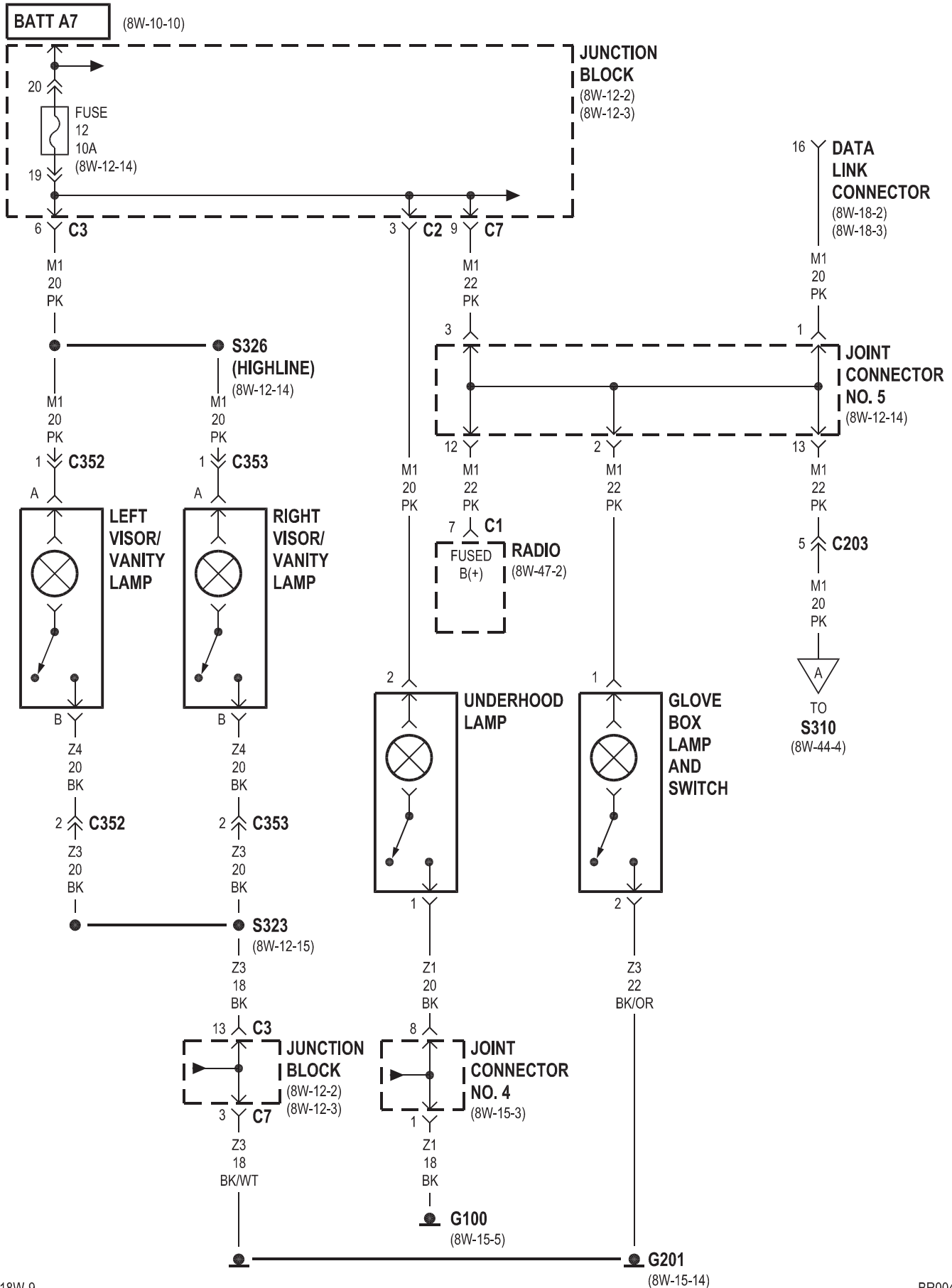


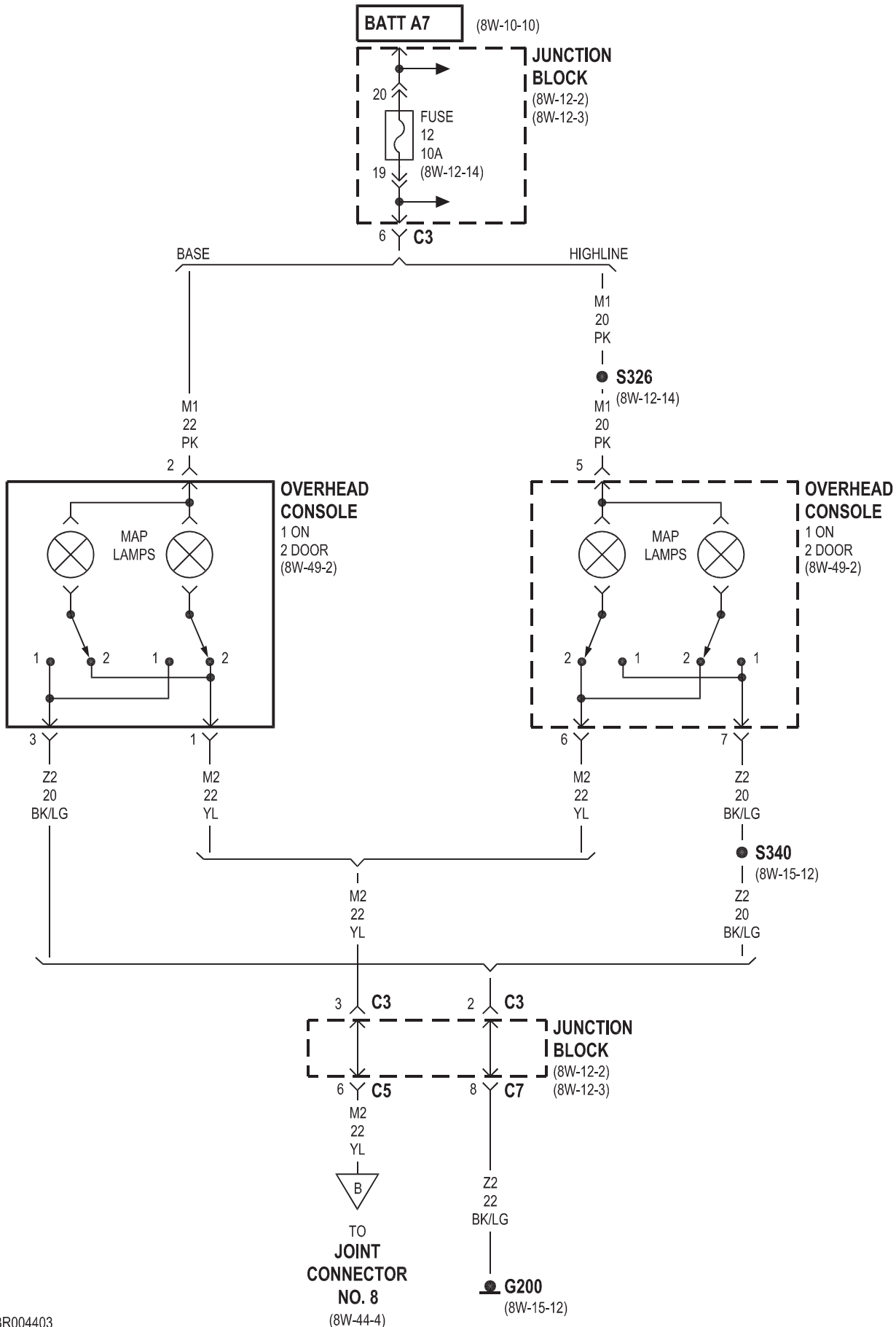


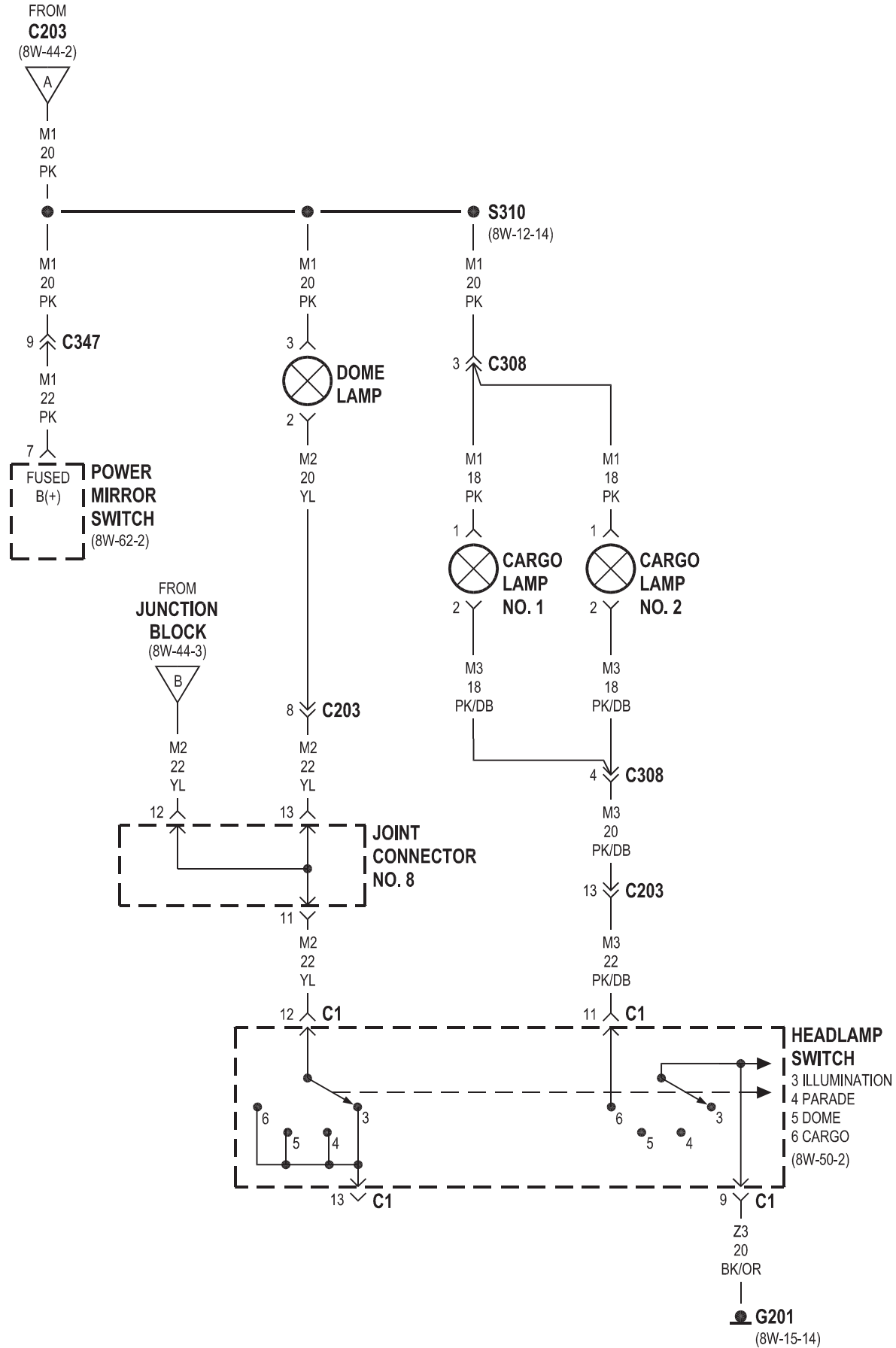


## 8W-44 INTERIOR LIGHTING

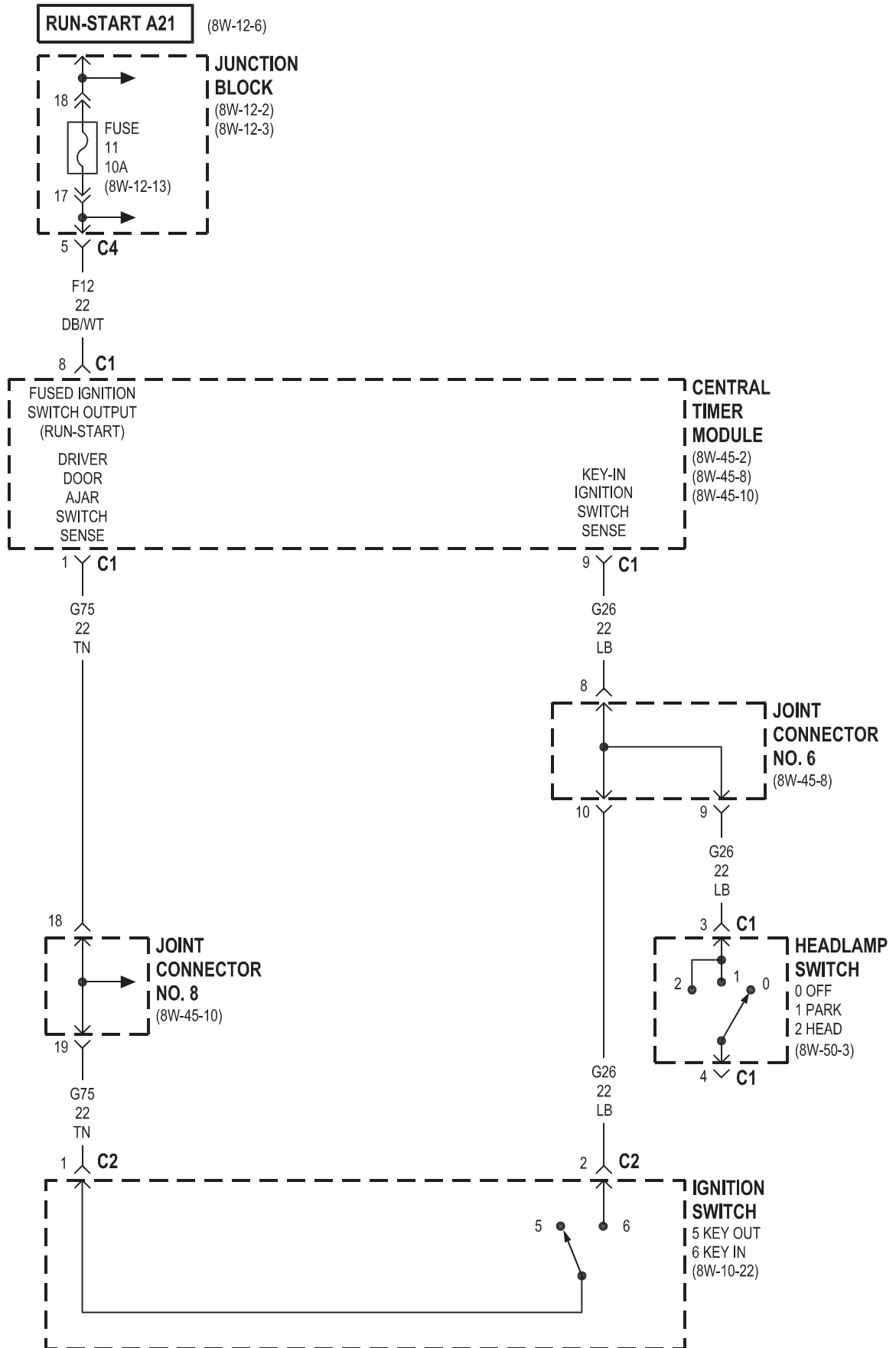
<b>Component</b>	<b>Page</b>	<b>Component</b>	<b>Page</b>
Ash Receiver Lamp . . . . .	8W-44-6	Headlamp Switch . . . . .	8W-44-4, 5, 6
Cargo Lamp No. 1 . . . . .	8W-44-4	Ignition Switch . . . . .	8W-44-5
Cargo Lamp No. 2 . . . . .	8W-44-4	Joint Connector No. 4 . . . . .	8W-44-2
Central Timer Module C1 . . . . .	8W-44-5	Joint Connector No. 5 . . . . .	8W-44-2, 6
Cup Holder Lamp . . . . .	8W-44-6	Joint Connector No. 6 . . . . .	8W-44-5
Data Link Connector . . . . .	8W-44-2	Joint Connector No. 8 . . . . .	8W-44-4, 5, 6
Dome Lamp . . . . .	8W-44-4	Junction Block . . . . .	8W-44-2, 3, 4, 5, 6
Fuse 5 (JB) . . . . .	8W-44-6	Left Visor/Vanity Lamp . . . . .	8W-44-2
Fuse 11 (JB) . . . . .	8W-44-5	Overhead Console . . . . .	8W-44-3
Fuse 12 (JB) . . . . .	8W-44-2, 3	Power Mirror Switch . . . . .	8W-44-4
G100 . . . . .	8W-44-2	Radio . . . . .	8W-44-2, 6
G200 . . . . .	8W-44-3	Right Visor/Vanity Lamp . . . . .	8W-44-2
G201 . . . . .	8W-44-2, 4, 6	Underhood Lamp . . . . .	8W-44-2
Glove Box Lamp And Switch . . . . .	8W-44-2		

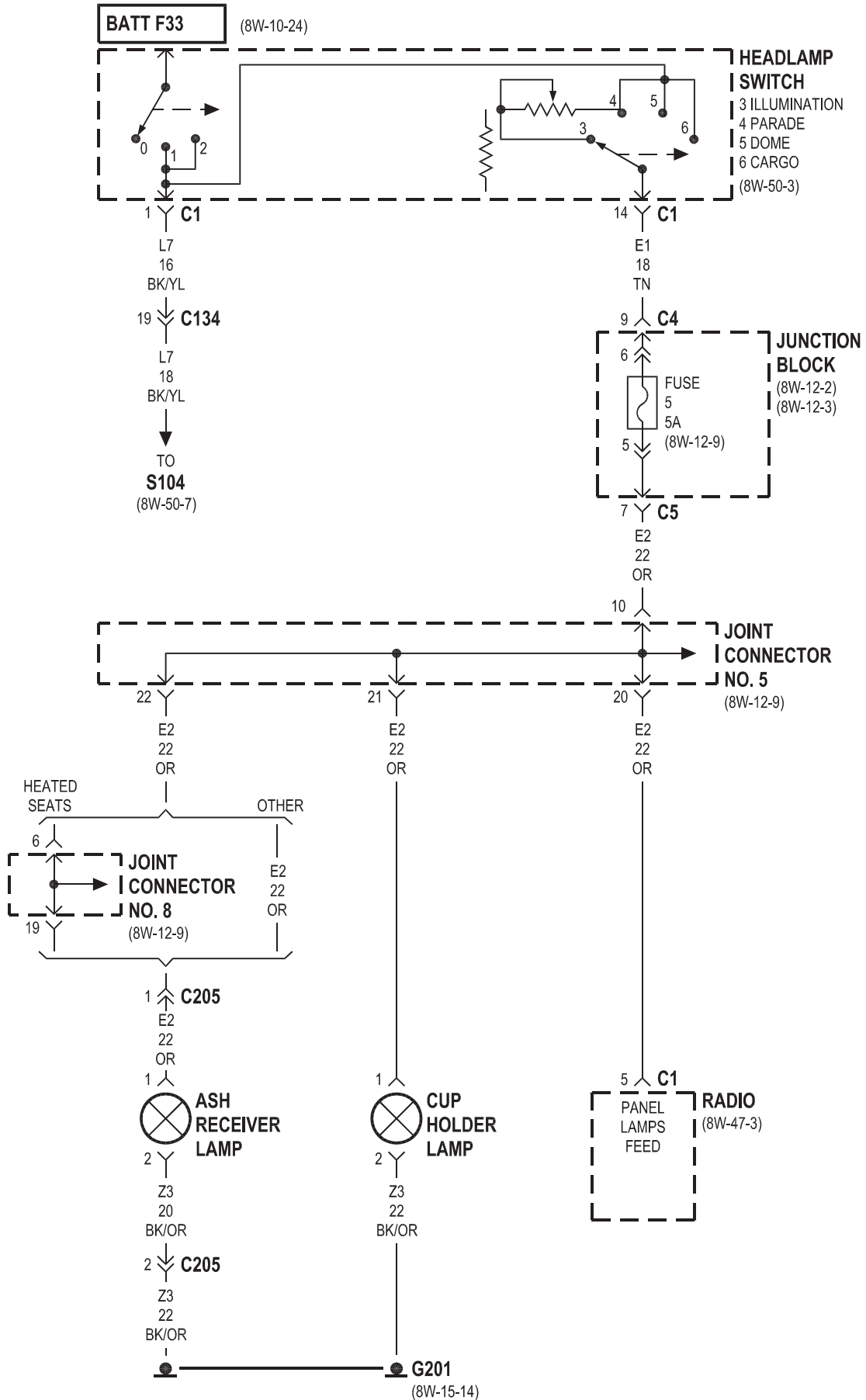






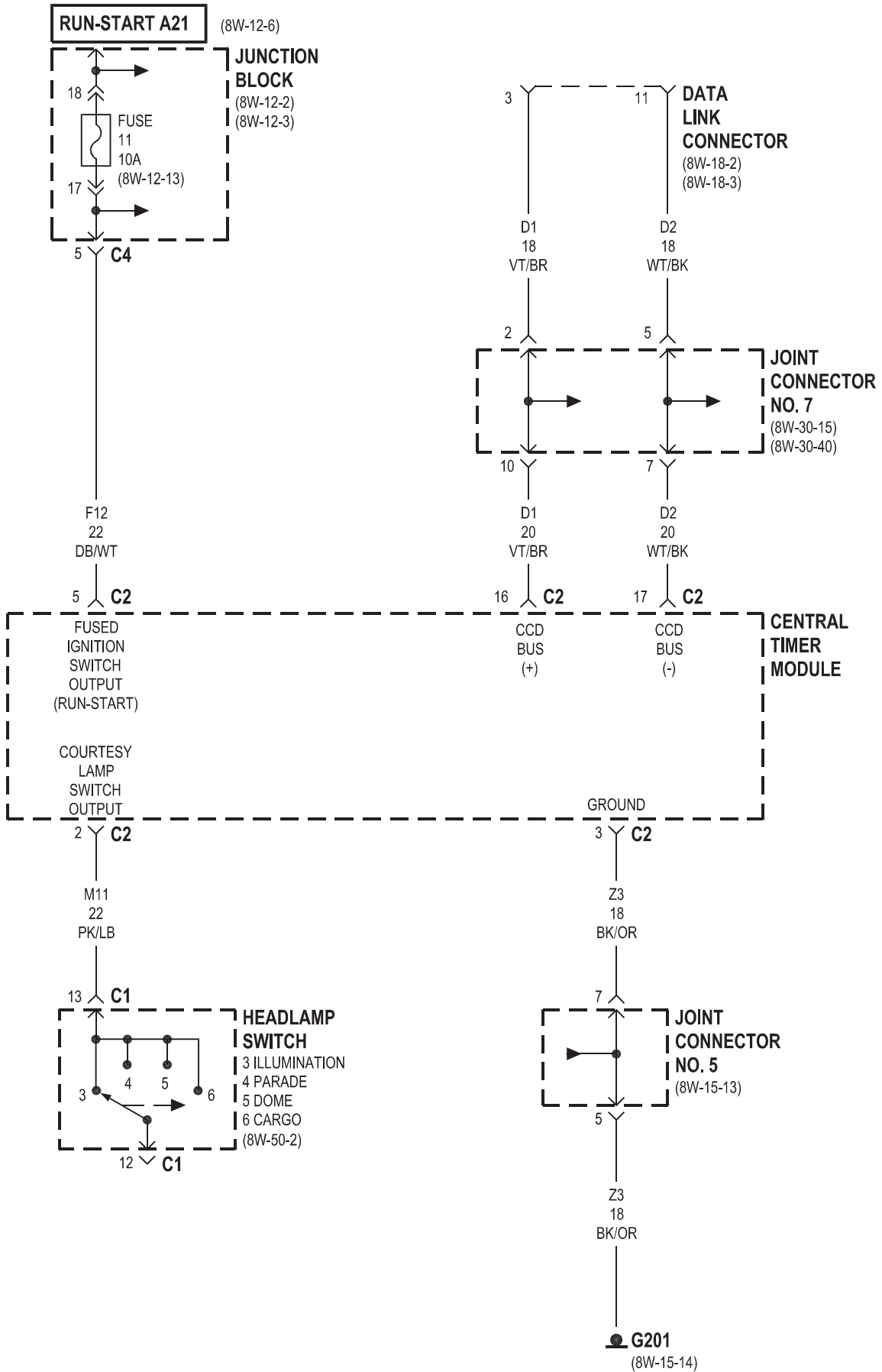


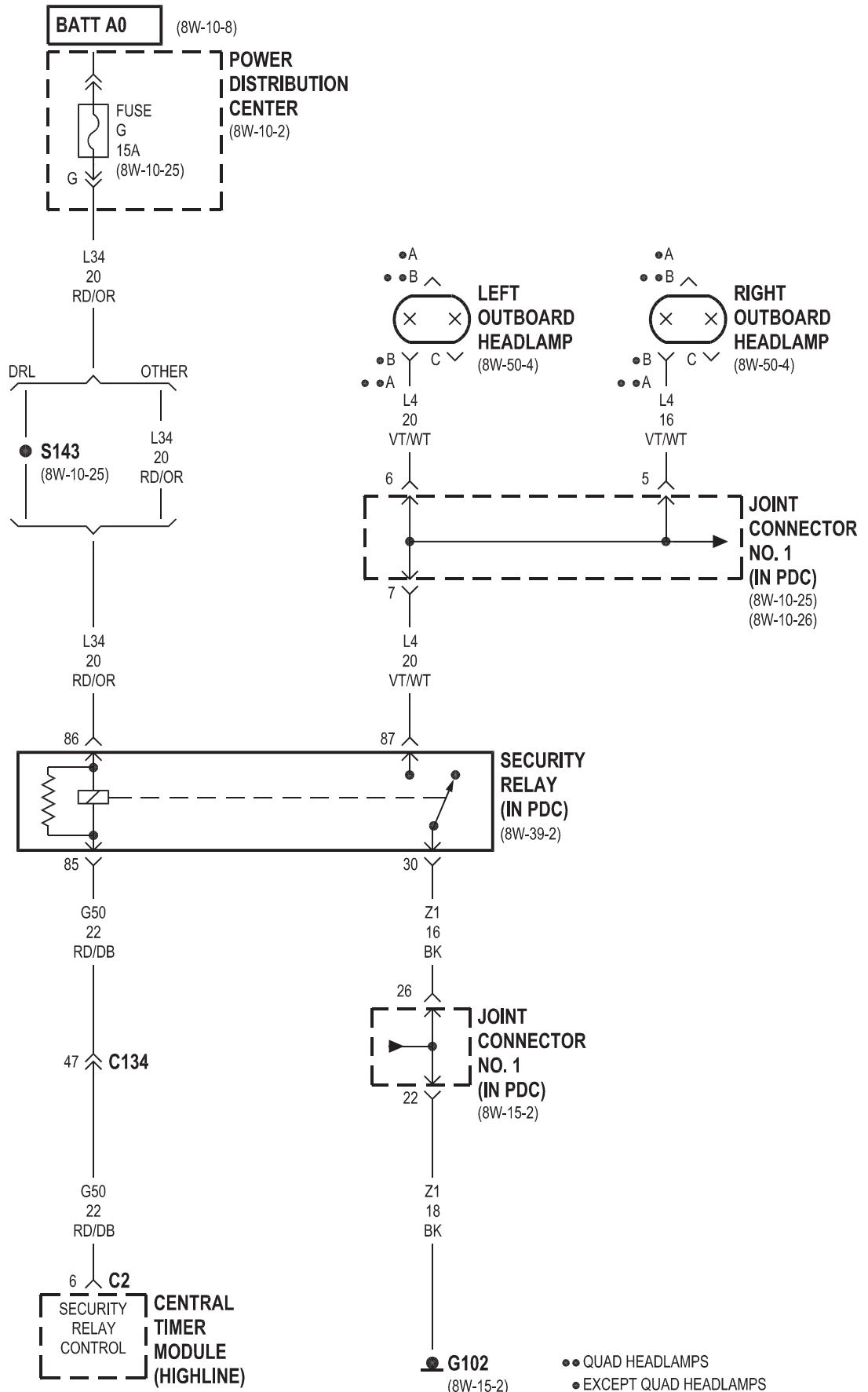




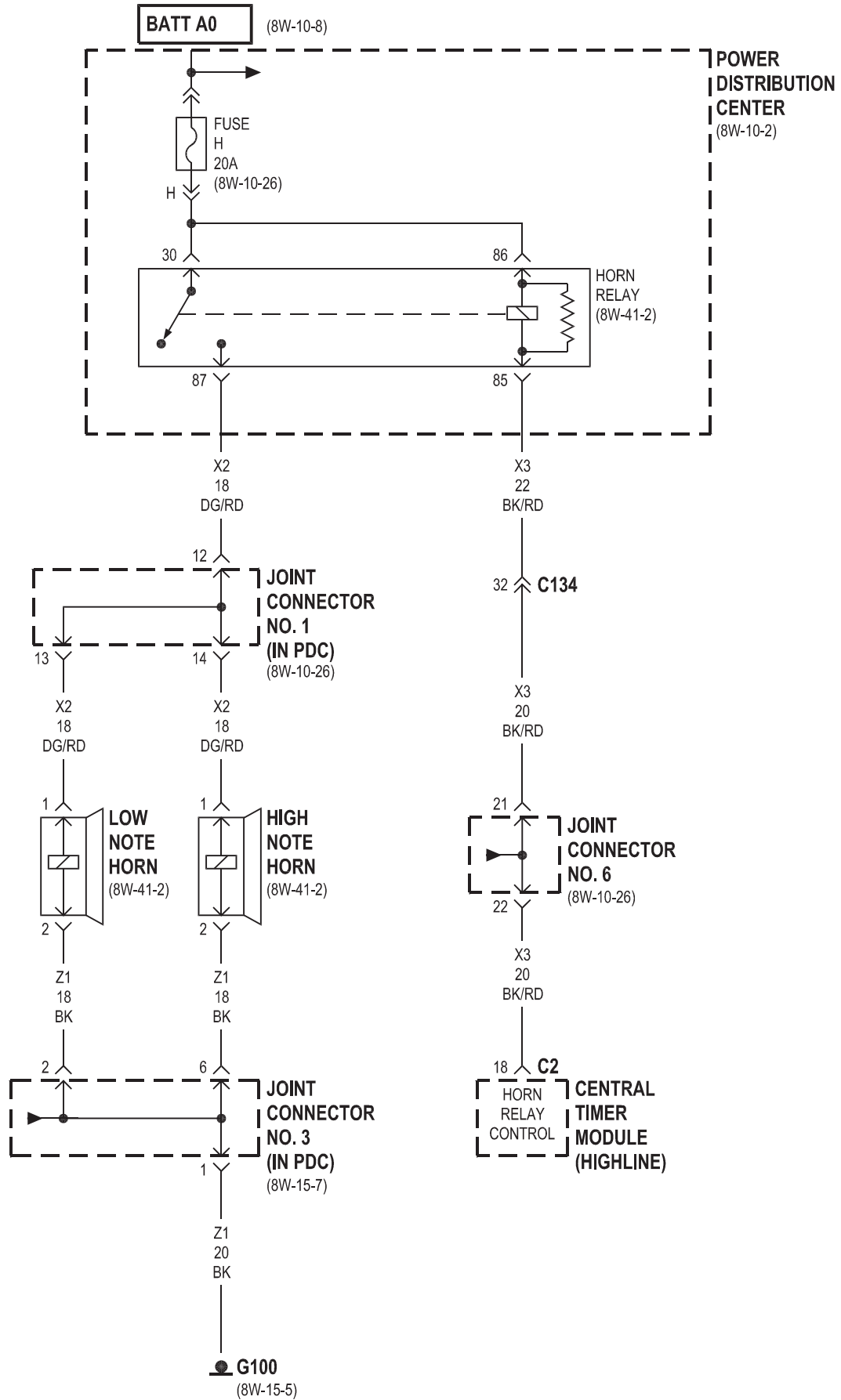
## 8W-45 CENTRAL TIMER MODULE

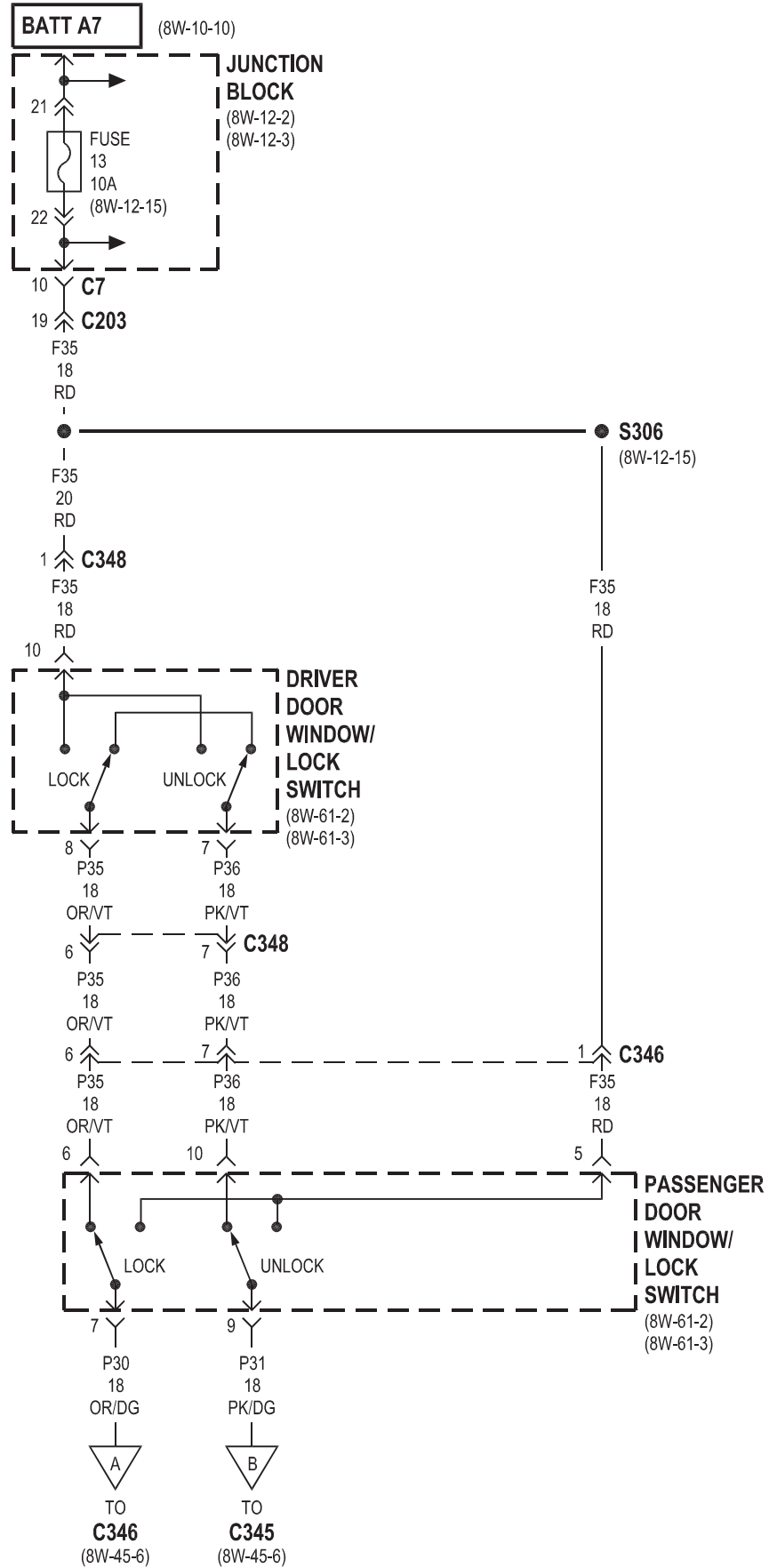
<b>Component</b>	<b>Page</b>	<b>Component</b>	<b>Page</b>
Central Timer Module C1 . . . . .	8W-45-8, 9, 10	Instrument Cluster . . . . .	8W-45-8
Central Timer Module C2 . . . . .	8W-45-2, 3, 4, 6, 7	Intermittent Wiper Switch . . . . .	8W-45-9
Clockspring . . . . .	8W-45-7	Joint Connector No. 1 . . . . .	8W-45-3, 4
Data Link Connector . . . . .	8W-45-2	Joint Connector No. 2 . . . . .	8W-45-9
Driver Cylinder Lock Switch . . . . .	8W-45-6	Joint Connector No. 3 . . . . .	8W-45-4
Driver Door Ajar Switch . . . . .	8W-45-10, 7	Joint Connector No. 5 . . . . .	8W-45-2
Driver Door Lock Motor . . . . .	8W-45-6	Joint Connector No. 6 . . . . .	8W-45-4, 7, 8, 9, 10
Driver Door Window/Lock Switch . . . . .	8W-45-5	Joint Connector No. 7 . . . . .	8W-45-2
Fuse 6 (JB) . . . . .	8W-45-8, 9	Joint Connector No. 8 . . . . .	8W-45-7, 8, 10
Fuse 11 (JB) . . . . .	8W-45-2, 8	Junction Block . . . . .	8W-45-2, 5, 7, 8, 9
Fuse 13 (JB) . . . . .	8W-45-5, 8	Left Outboard Headlamp . . . . .	8W-45-3
Fuse G (PDC) . . . . .	8W-45-3	Low Note Horn . . . . .	8W-45-4
Fuse H (PDC) . . . . .	8W-45-4	Overhead Console . . . . .	8W-45-6
G100 . . . . .	8W-45-4, 9	Passenger Cylinder Lock Switch . . . . .	8W-45-6
G102 . . . . .	8W-45-3	Passenger Door Ajar Switch . . . . .	8W-45-10
G200 . . . . .	8W-45-8	Passenger Door Lock Motor . . . . .	8W-45-6
G201 . . . . .	8W-45-2	Passenger Door Window/Lock Switch . . .	8W-45-5, 6
G300 . . . . .	8W-45-10, 6, 7	Power Distribution Center . . . . .	8W-45-3, 4
Headlamp Switch . . . . .	8W-45-10, 2, 7, 8	Right Outboard Headlamp . . . . .	8W-45-3
Heated Seat Relay . . . . .	8W-45-7	Security Relay . . . . .	8W-45-3
High Note Horn . . . . .	8W-45-4	Wiper Motor . . . . .	8W-45-9
Horn Relay . . . . .	8W-45-4	Wiper Motor Relay . . . . .	8W-45-9
Ignition Switch . . . . .	8W-45-10, 7, 8		



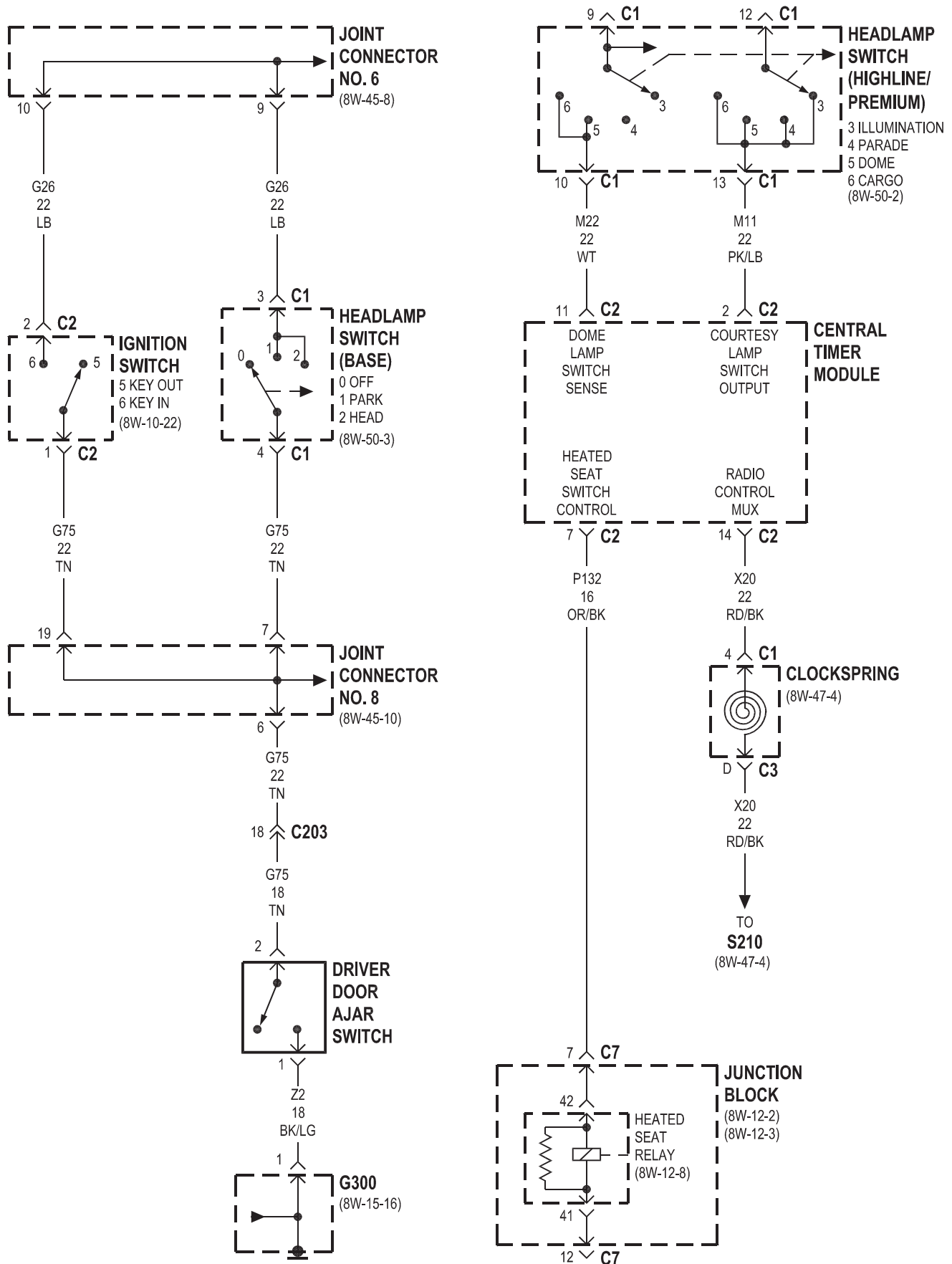


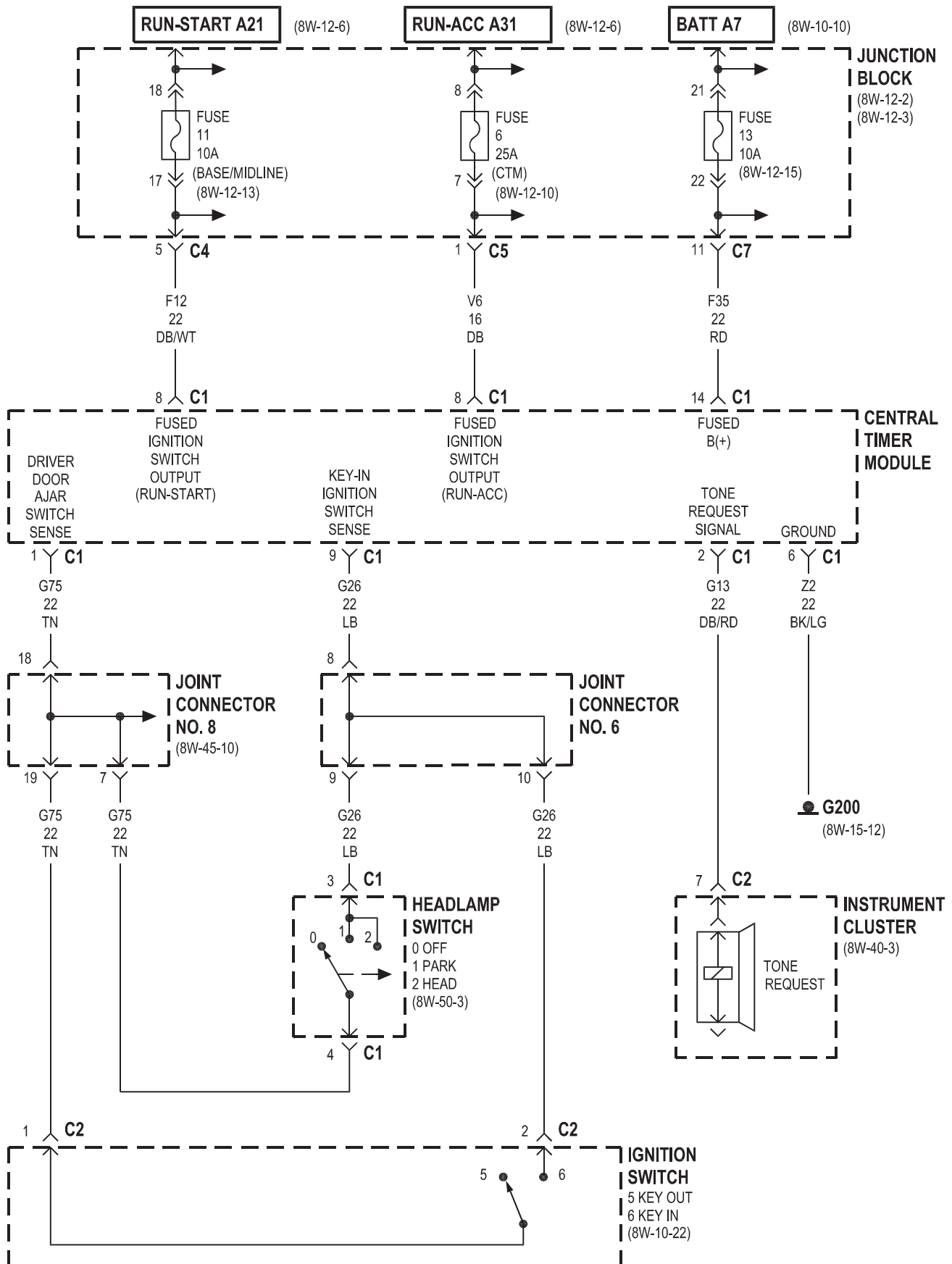




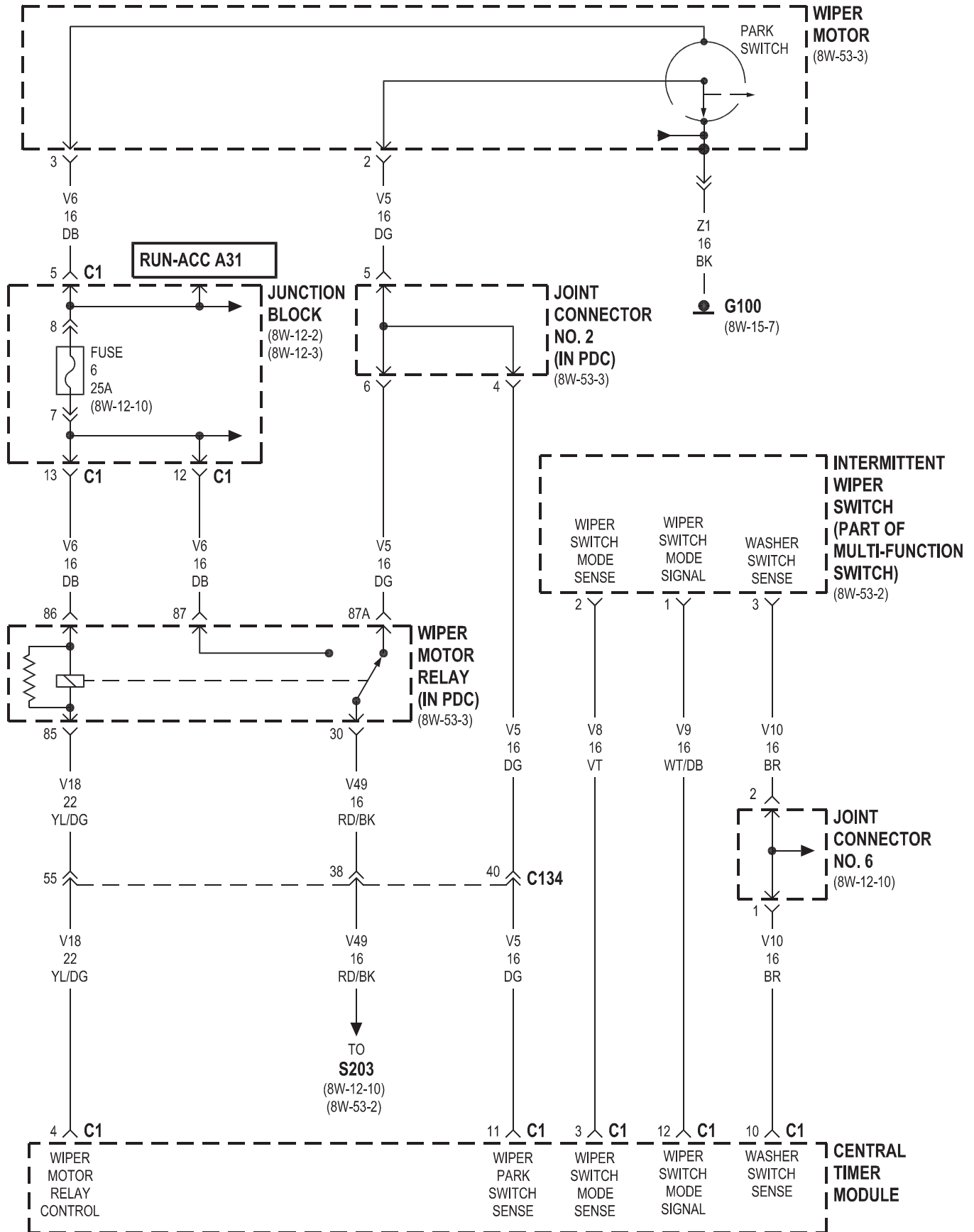


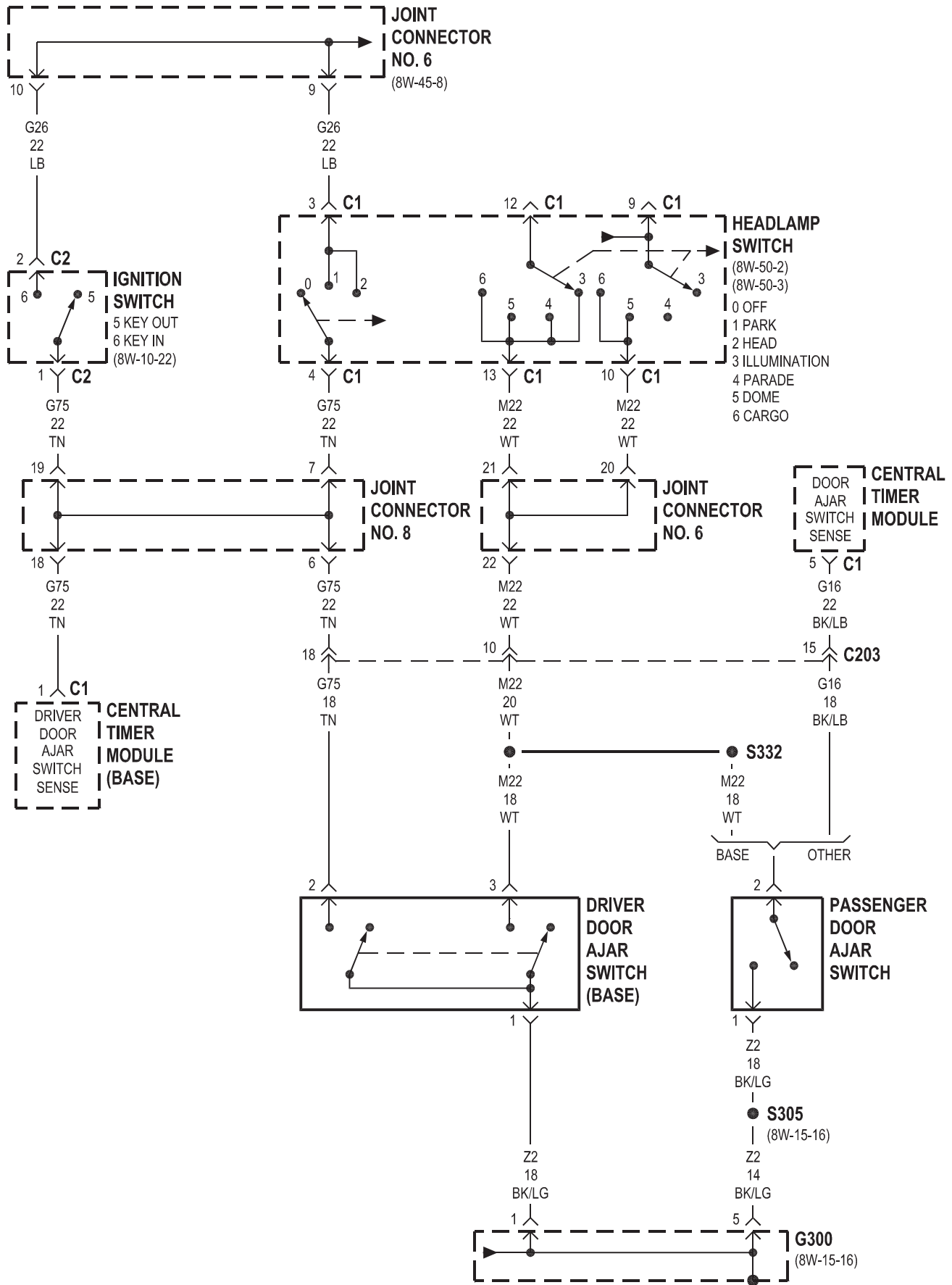






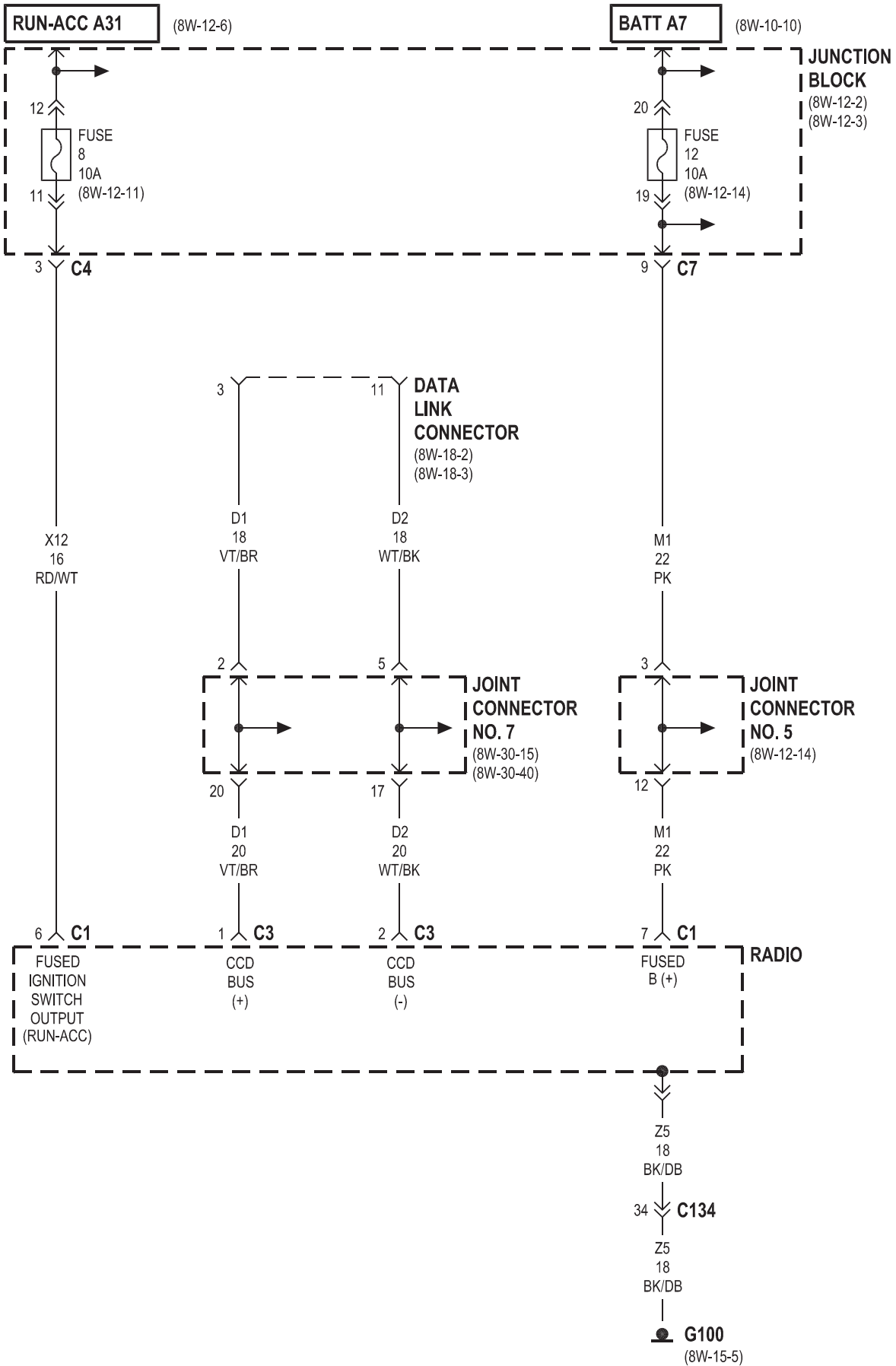


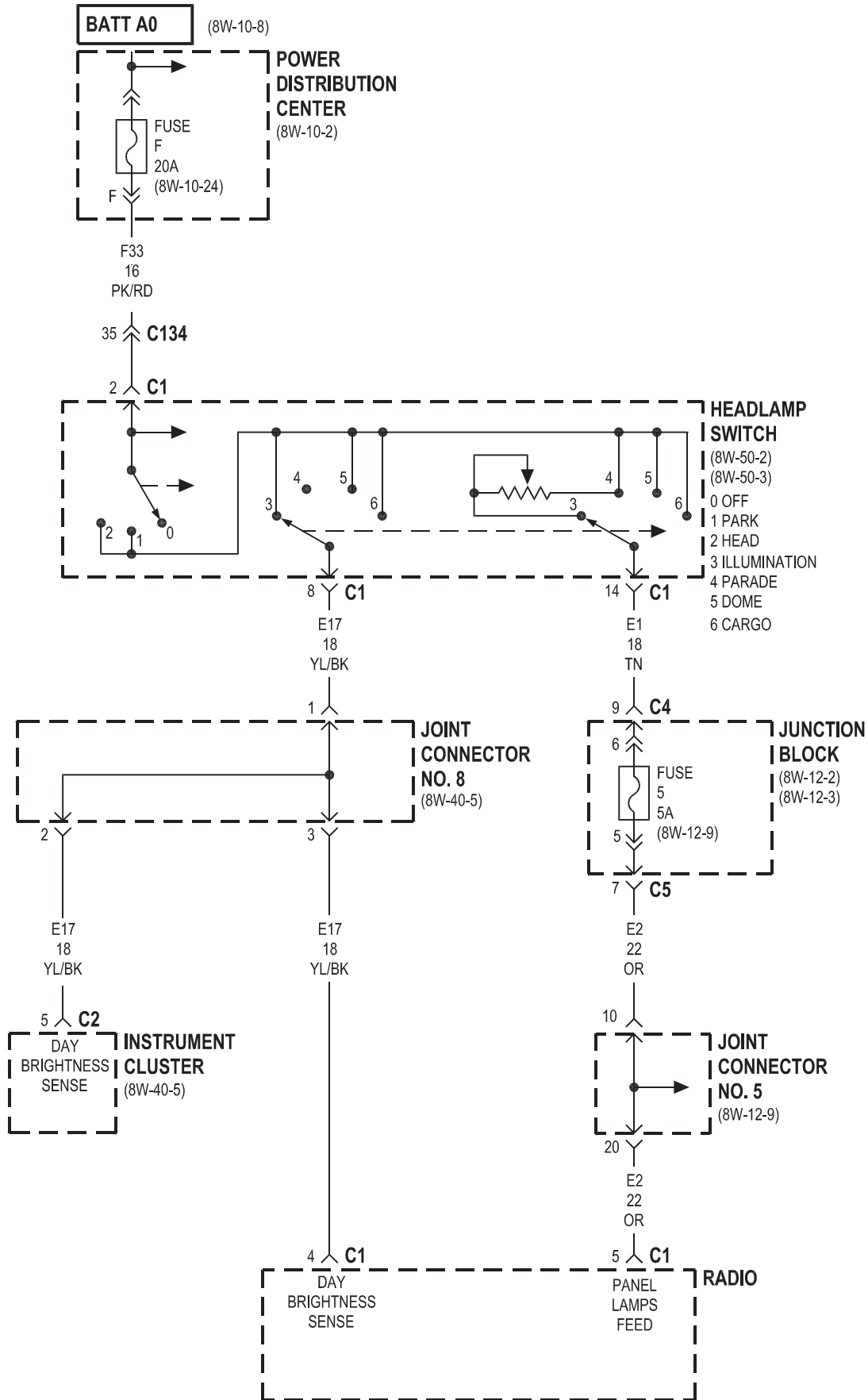




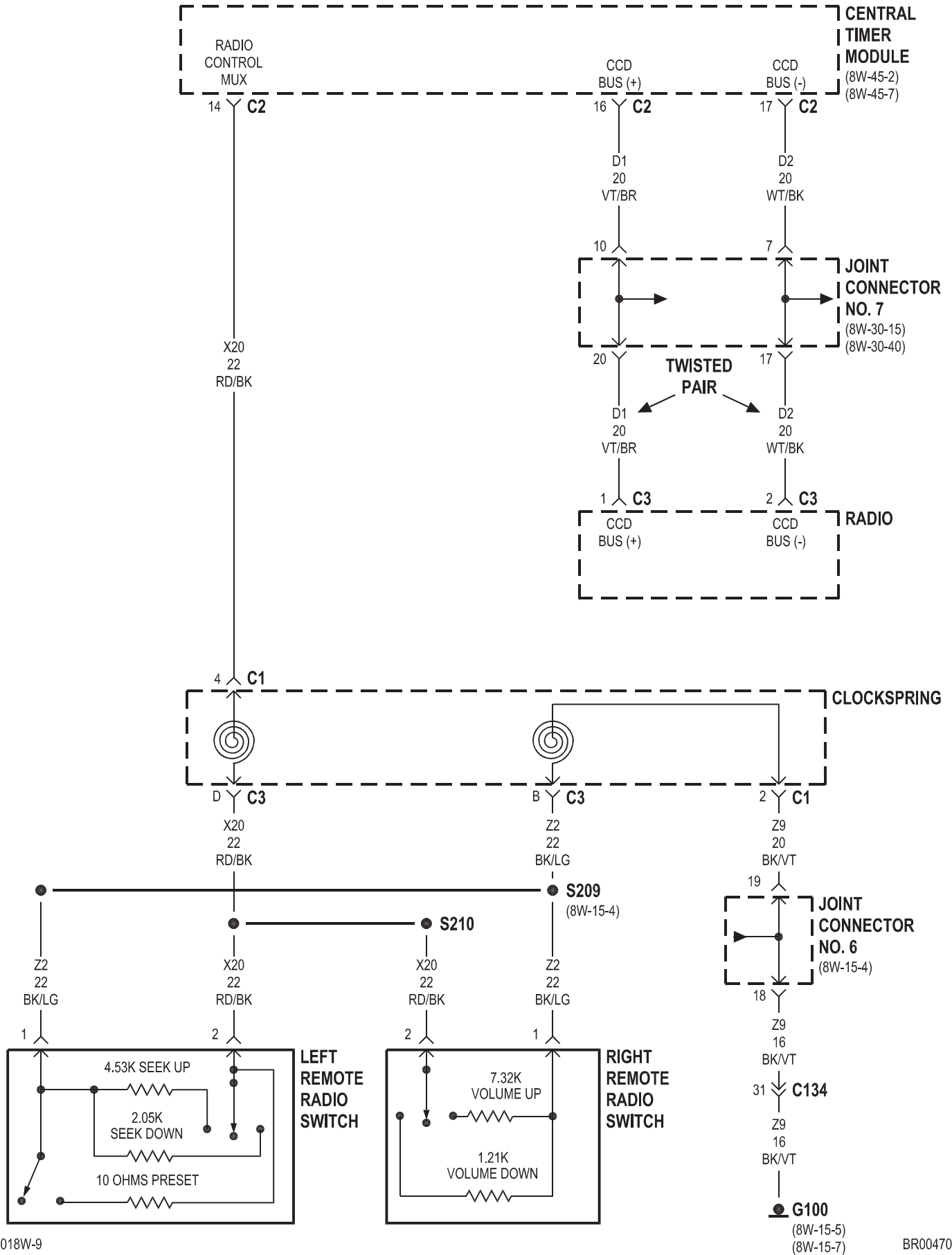
## 8W-47 AUDIO SYSTEM

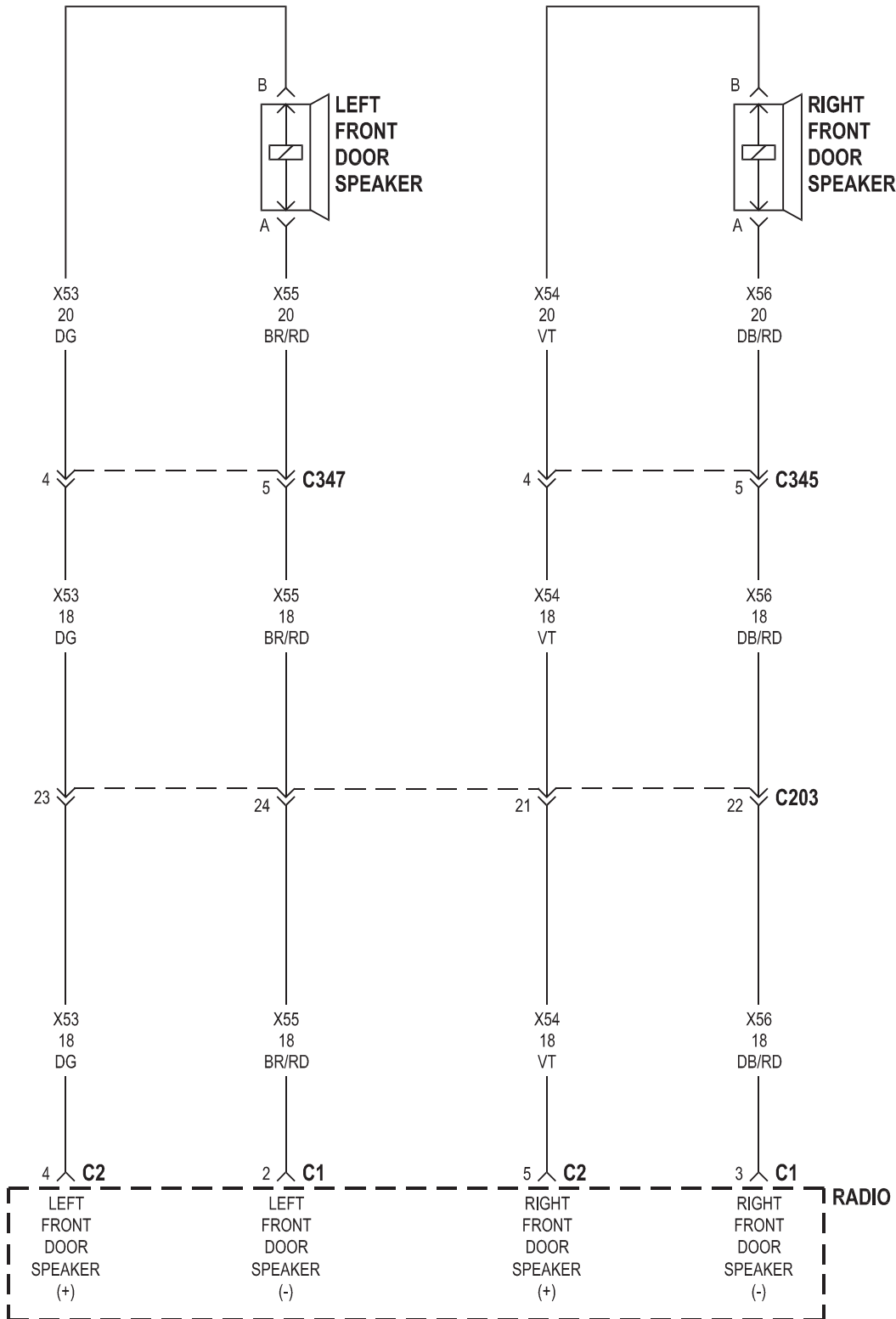
<b>Component</b>	<b>Page</b>	<b>Component</b>	<b>Page</b>
Central Timer Module C2 . . . . .	8W-47-4	Joint Connector No. 8 . . . . .	8W-47-3
Clockspring . . . . .	8W-47-4	Junction Block . . . . .	8W-47-2, 3, 7
Data Link Connector . . . . .	8W-47-2	Left Front Door Speaker . . . . .	8W-47-5, 7, 8, 9
Fuse 4 (JB) . . . . .	8W-47-7	Left Rear Speaker . . . . .	8W-47-6, 9
Fuse 5 (JB) . . . . .	8W-47-3	Left Remote Radio Switch . . . . .	8W-47-4
Fuse 8 (JB) . . . . .	8W-47-2	Left Tweeter . . . . .	8W-47-8
Fuse 12 (JB) . . . . .	8W-47-2	Power Distribution Center . . . . .	8W-47-3
Fuse F (PDC) . . . . .	8W-47-3	Radio . . . . .	8W-47-2, 3, 4, 5, 6, 7, 8, 9
G100 . . . . .	8W-47-2, 4, 7, 8	Radio Choke Relay . . . . .	8W-47-7, 8
Headlamp Switch . . . . .	8W-47-3	Right Front Door Speaker . . . . .	8W-47-5, 7, 8, 9
Instrument Cluster . . . . .	8W-47-3	Right Rear Speaker . . . . .	8W-47-6, 9
Joint Connector No. 5 . . . . .	8W-47-2, 3	Right Remote Radio Switch . . . . .	8W-47-4
Joint Connector No. 6 . . . . .	8W-47-4, 7, 8	Right Tweeter . . . . .	8W-47-8
Joint Connector No. 7 . . . . .	8W-47-2, 4		

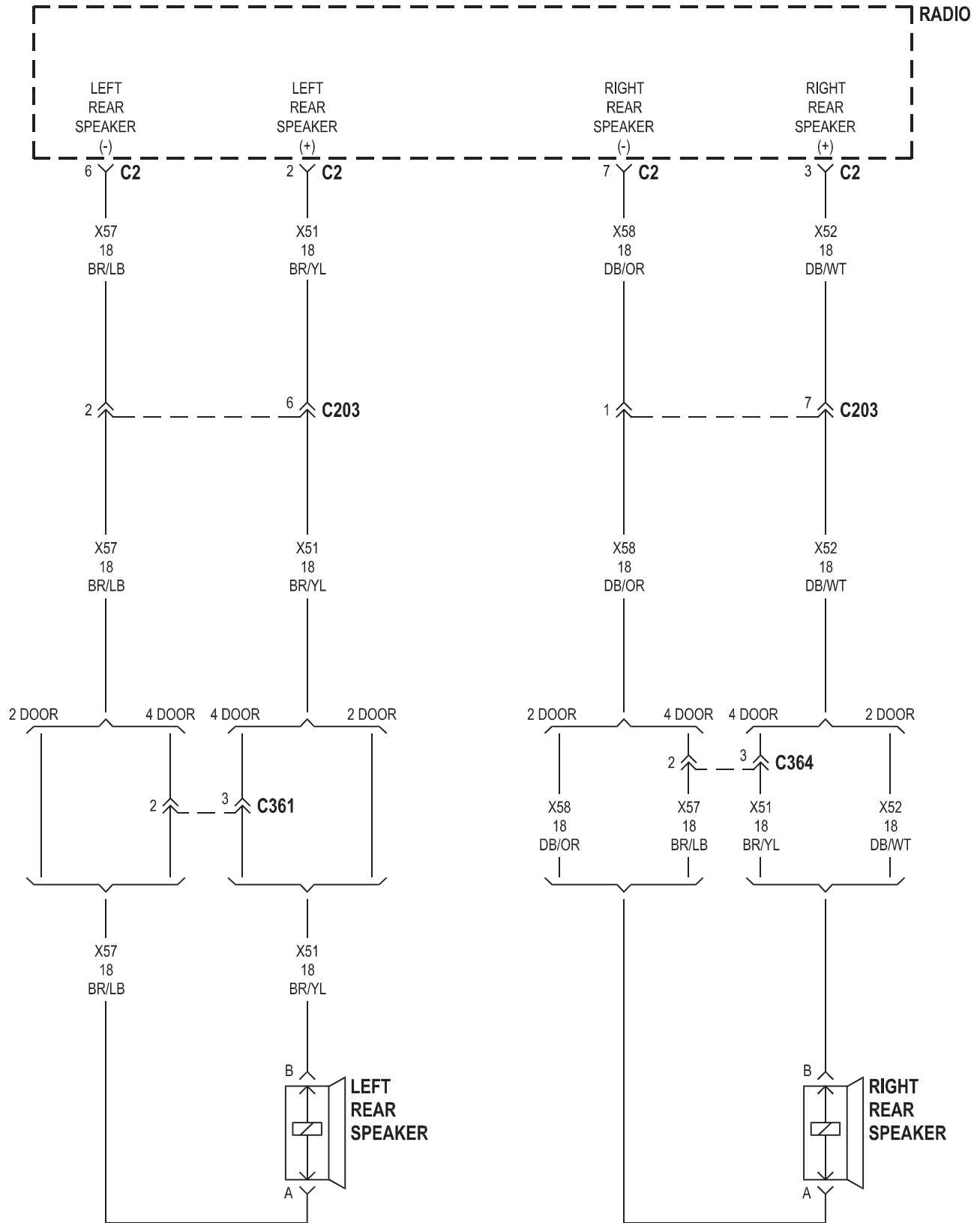


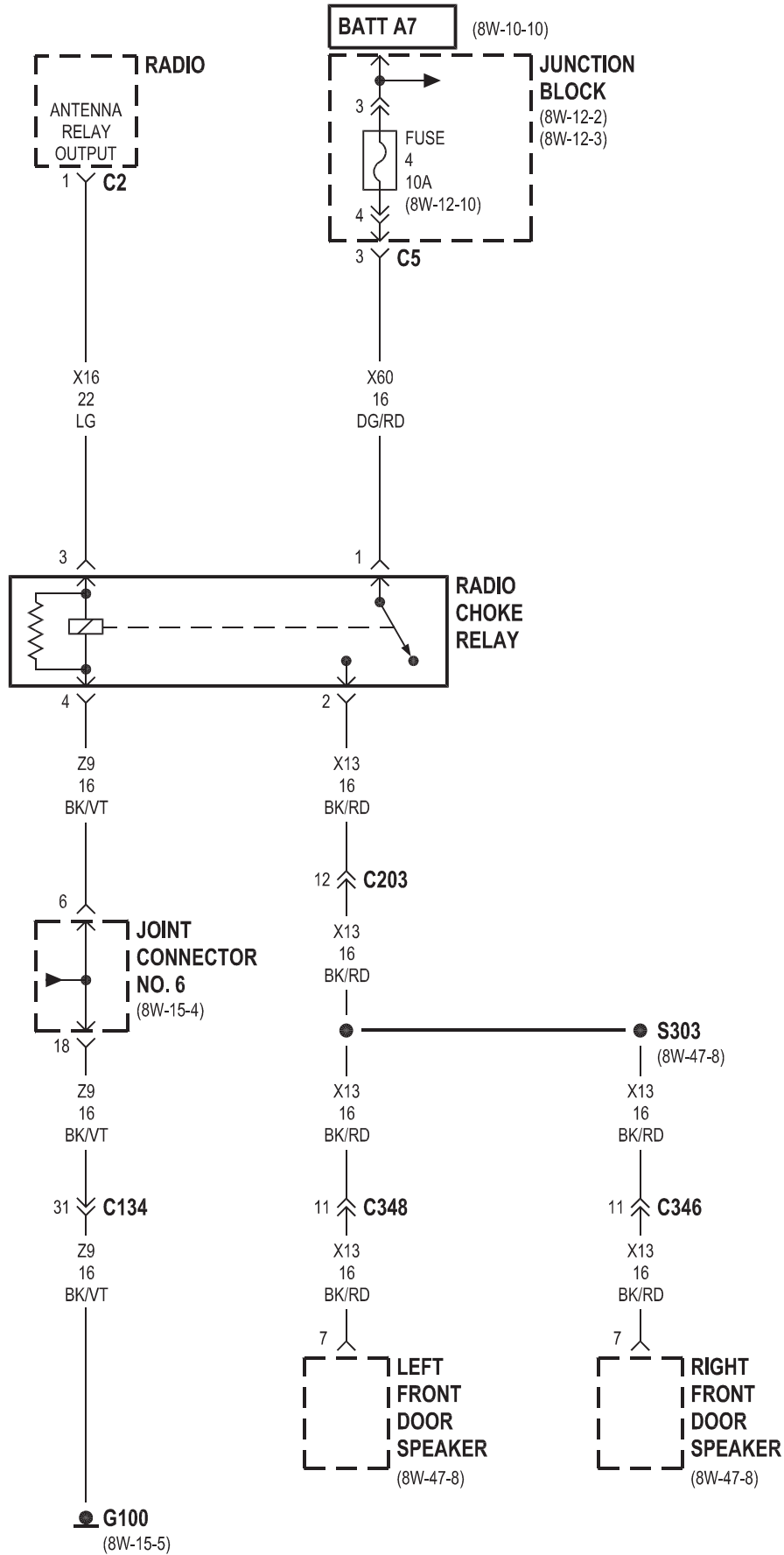


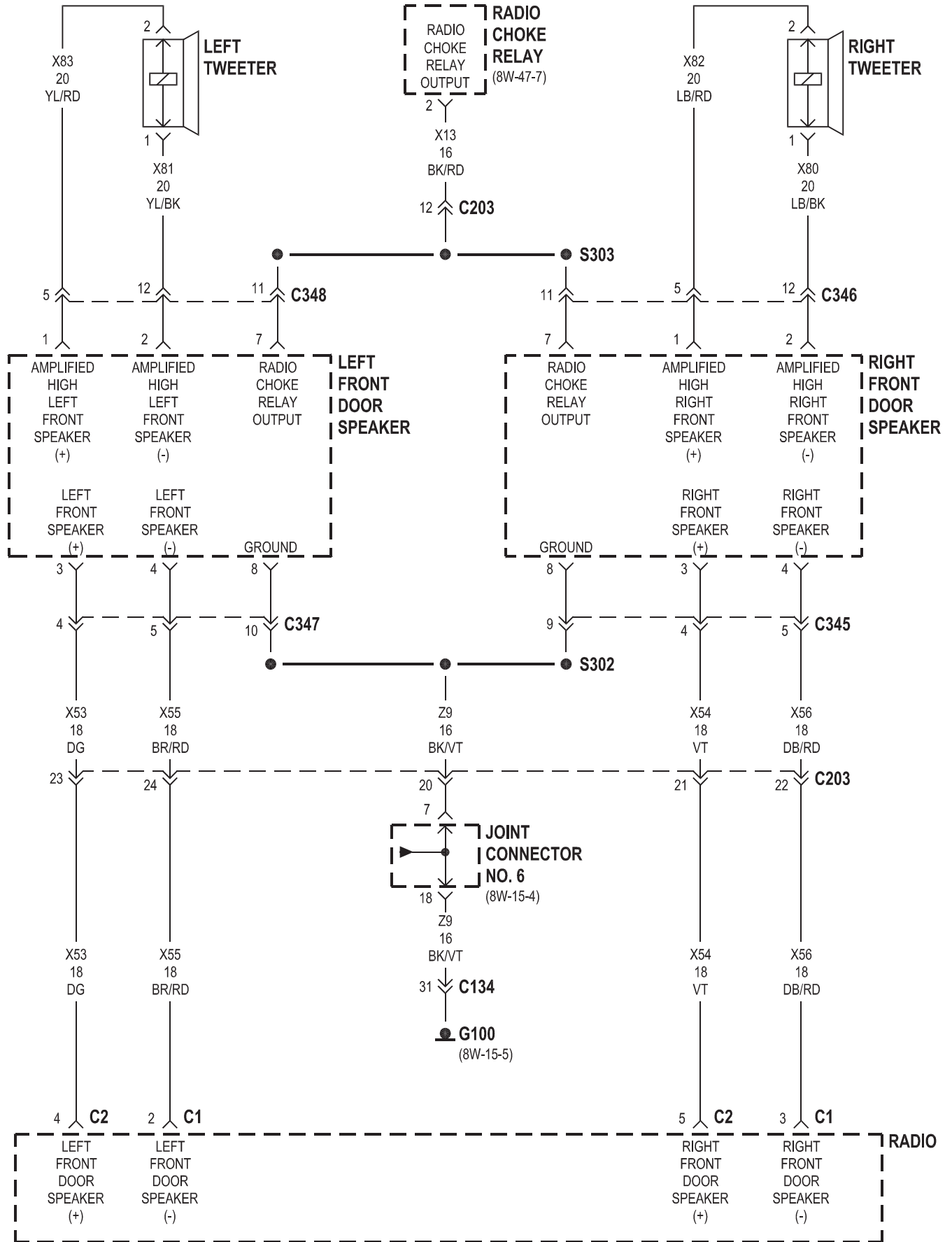


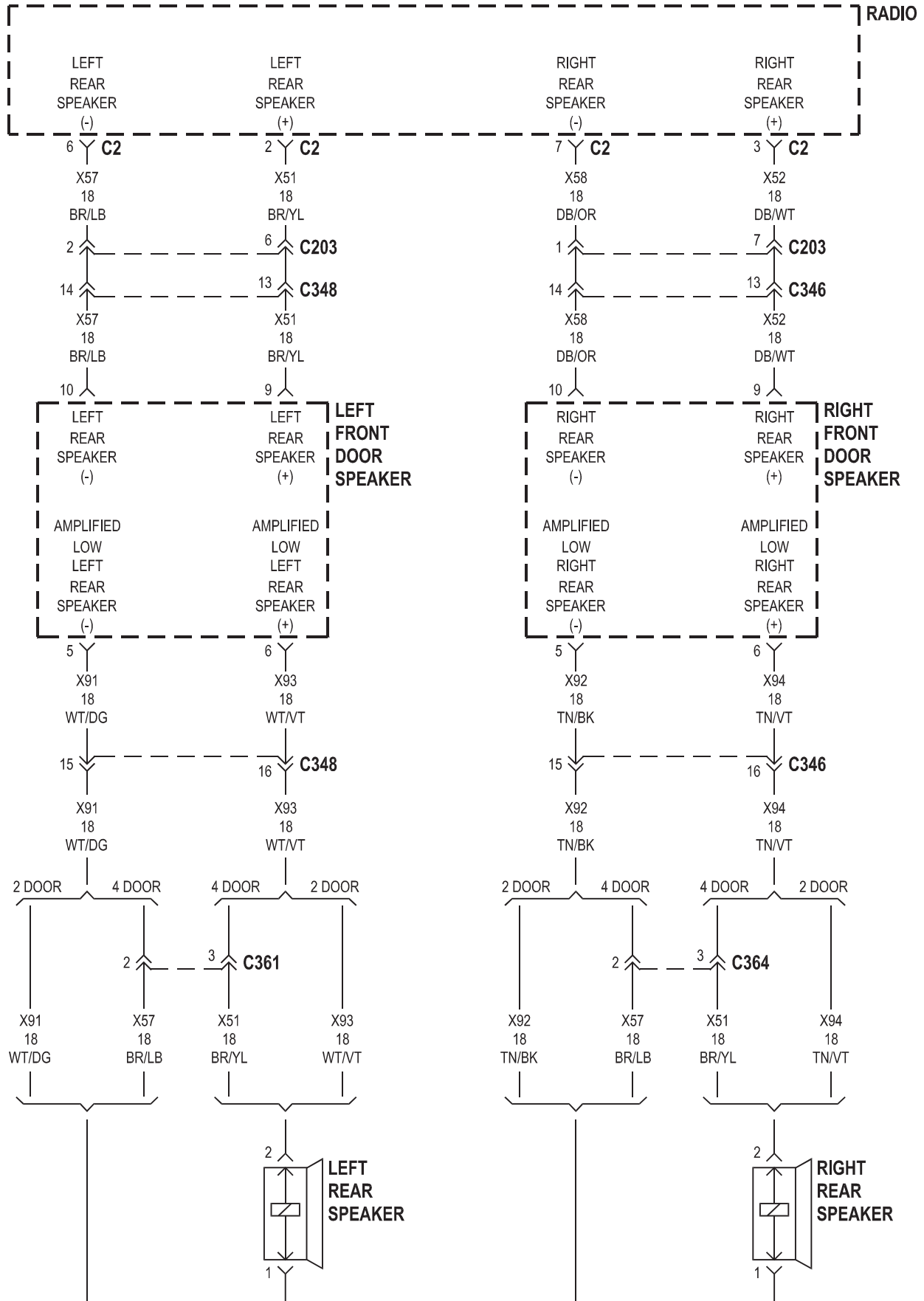










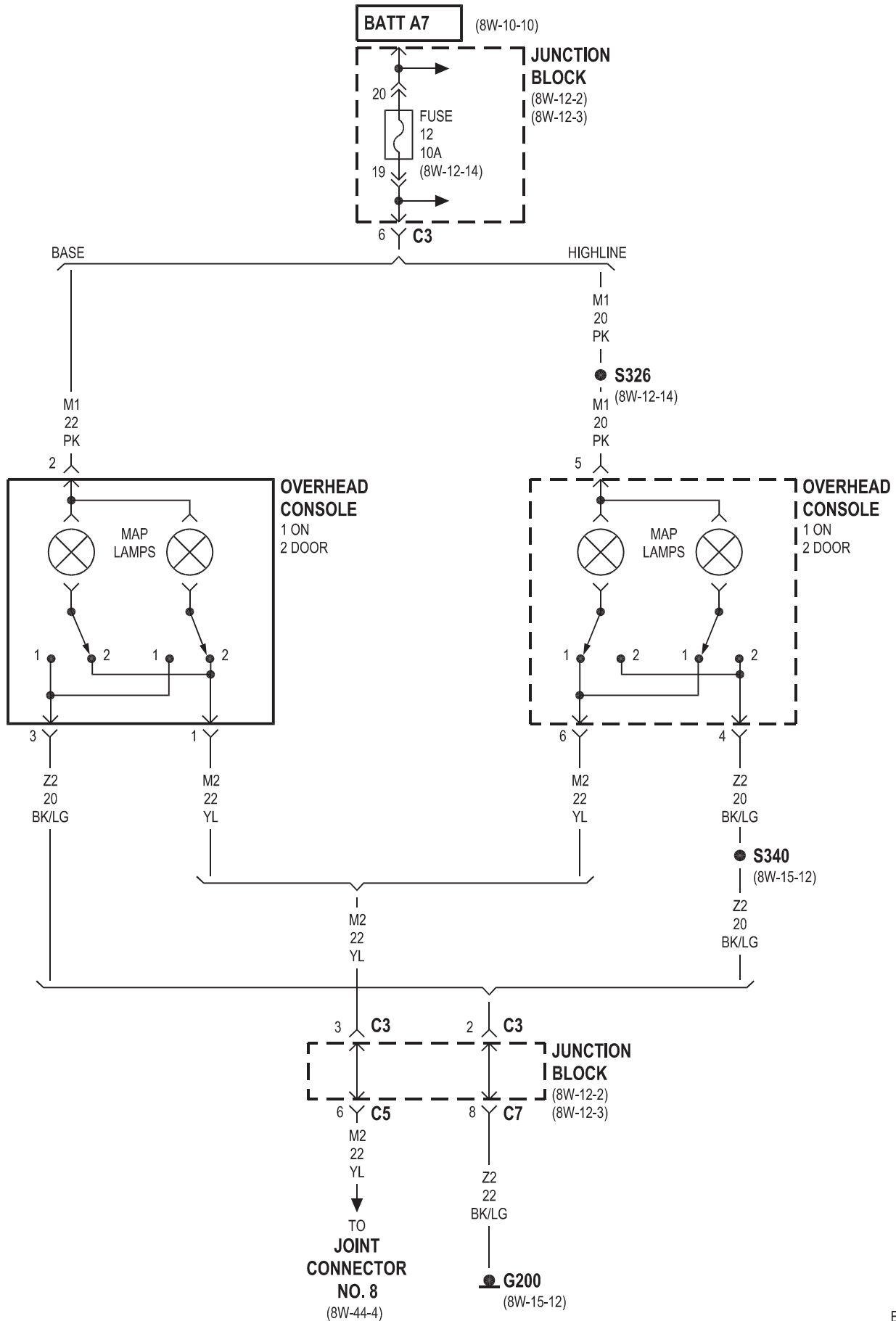


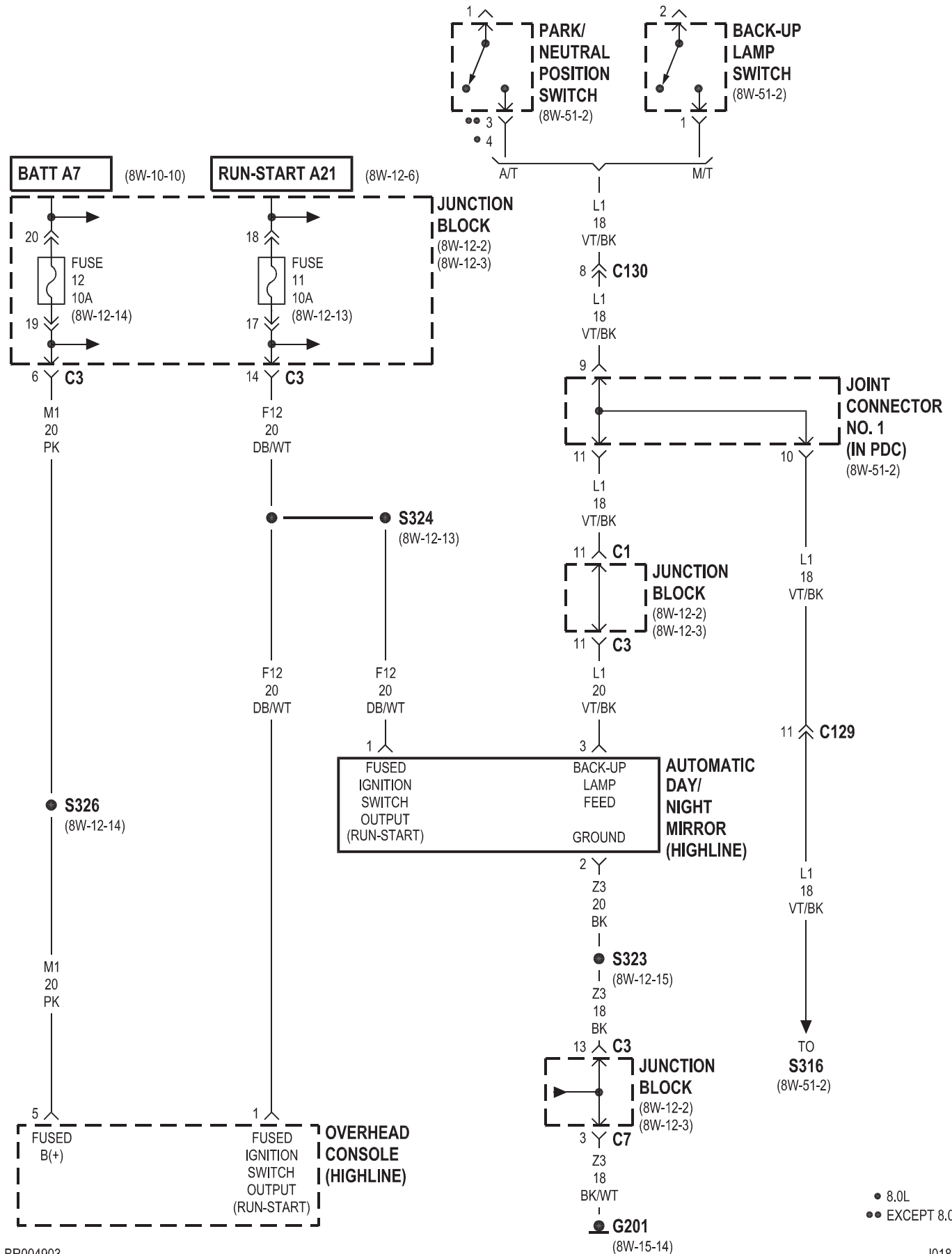




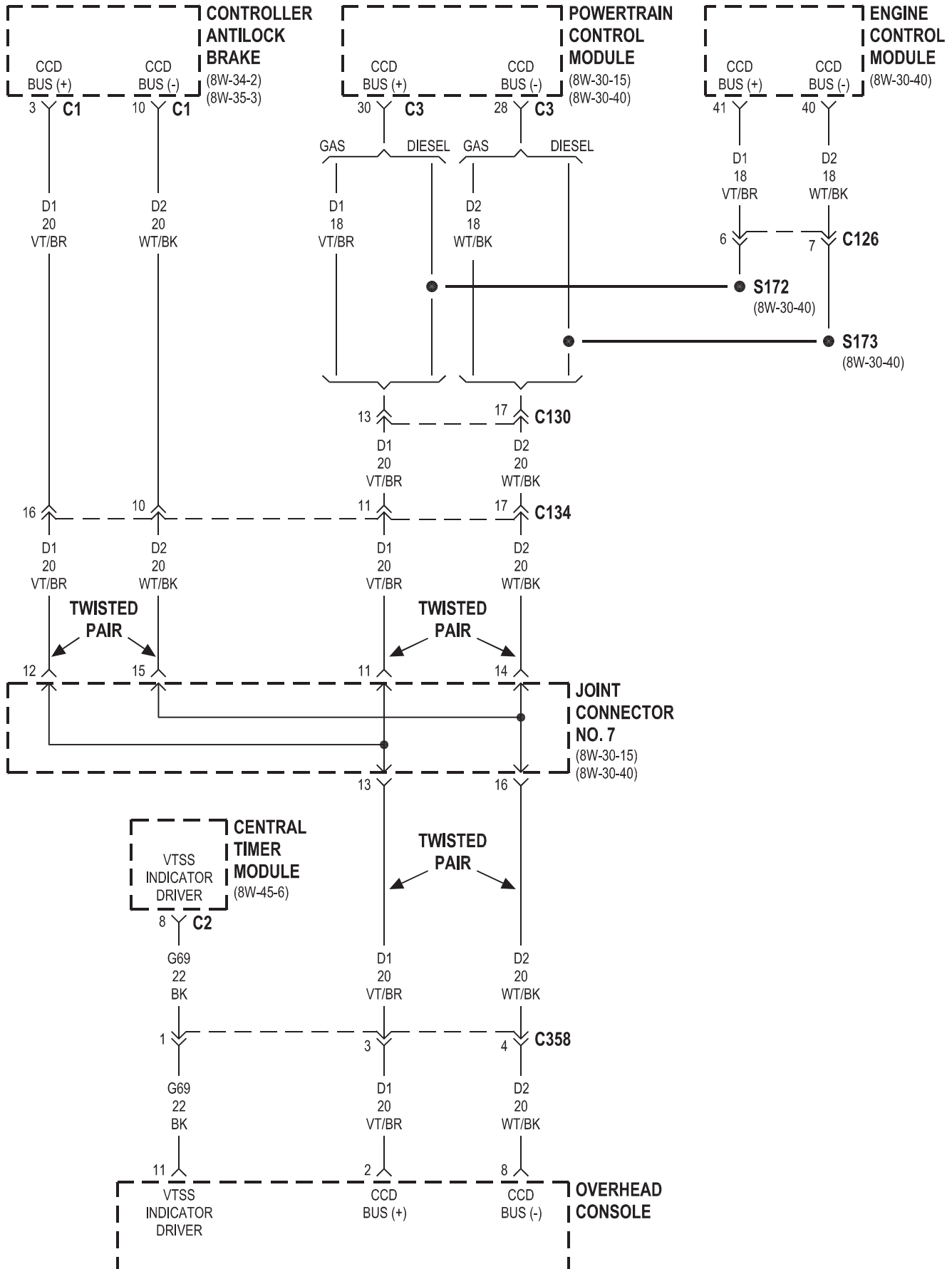
## 8W-49 OVERHEAD CONSOLE

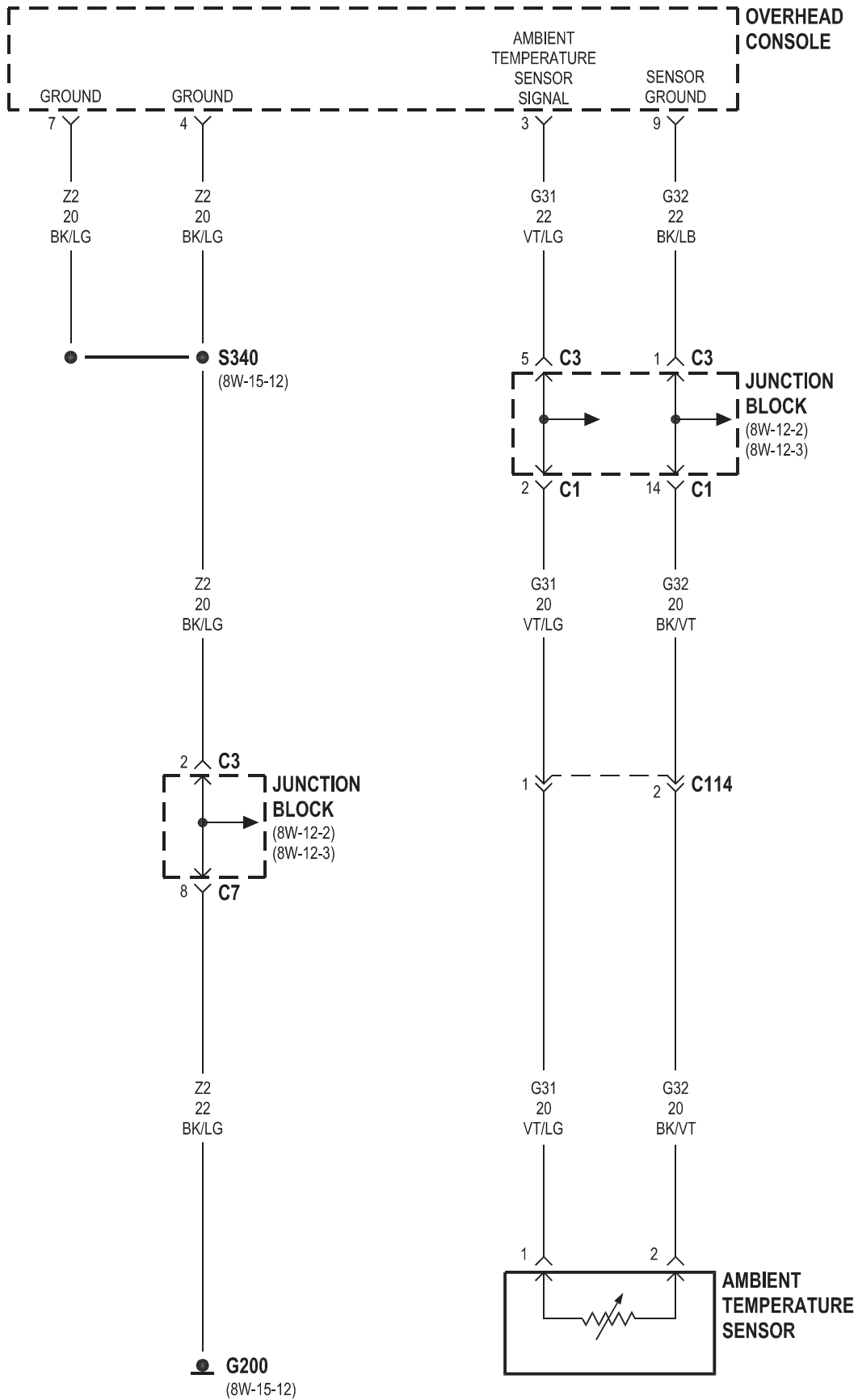
<b>Component</b>	<b>Page</b>	<b>Component</b>	<b>Page</b>
Ambient Temperature Sensor . . . . .	8W-49-5	Joint Connector No. 1 . . . . .	8W-49-3
Automatic Day/Night Mirror . . . . .	8W-49-3	Joint Connector No. 7 . . . . .	8W-49-4
Back-Up Lamp Switch . . . . .	8W-49-3	Joint Connector No. 8 . . . . .	8W-49-2
Central Timer Module C2 . . . . .	8W-49-4	Junction Block . . . . .	8W-49-2, 3, 5, 6
Controller Antilock Brake . . . . .	8W-49-4	Left Visor/Vanity Lamp . . . . .	8W-49-6
Engine Control Module . . . . .	8W-49-4	Map Lamps . . . . .	8W-49-2
Fuse 11 (JB) . . . . .	8W-49-3	Overhead Console . . . . .	8W-49-2, 3, 4, 5, 6
Fuse 12 (JB) . . . . .	8W-49-2, 3, 6	Park/Neutral Position Switch . . . . .	8W-49-3
G200 . . . . .	8W-49-2, 5	Powertrain Control Module . . . . .	8W-49-4
G201 . . . . .	8W-49-3, 6	Right Visor/Vanity Lamp . . . . .	8W-49-6



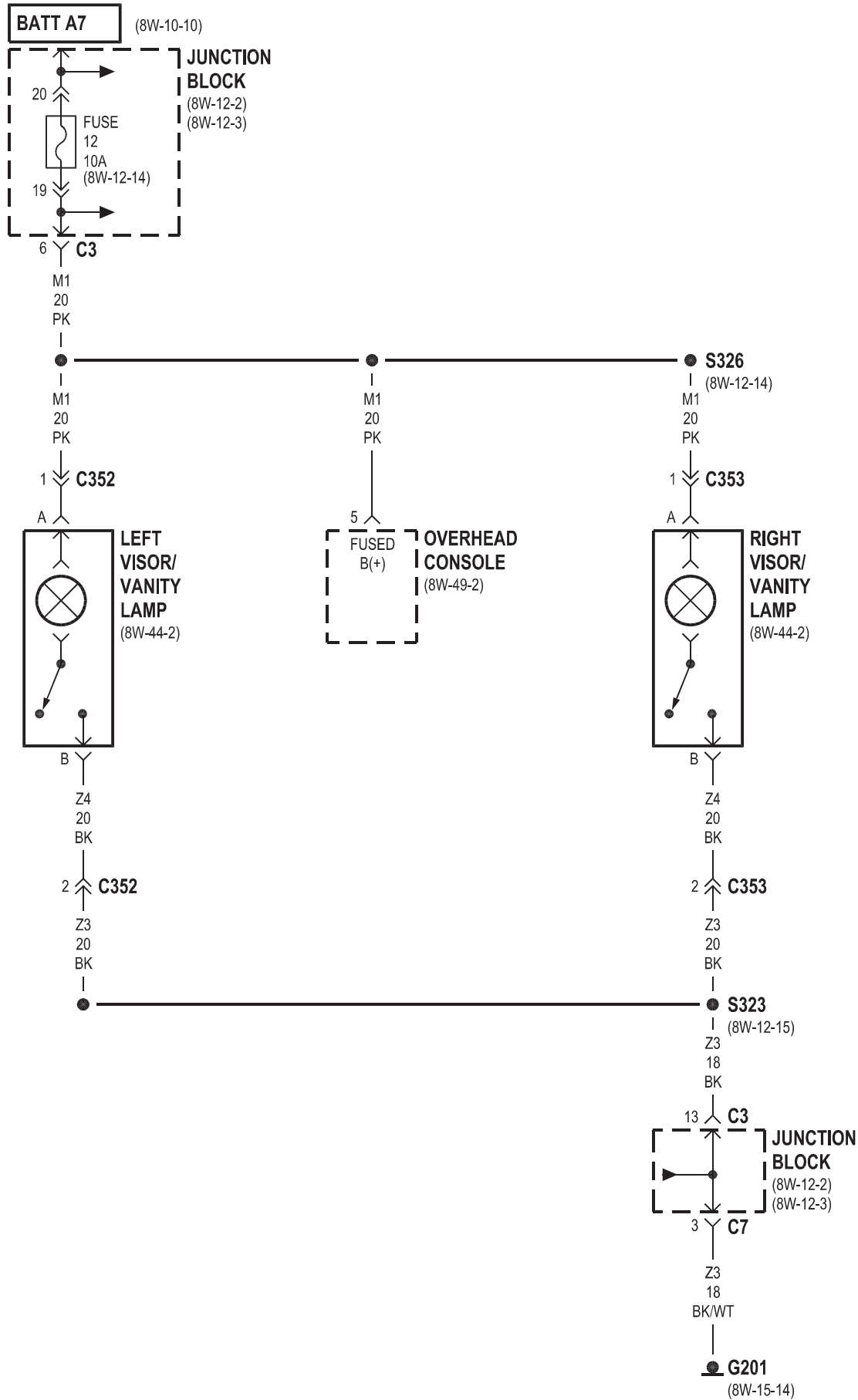


- 8.0L
- EXCEPT 8.0L



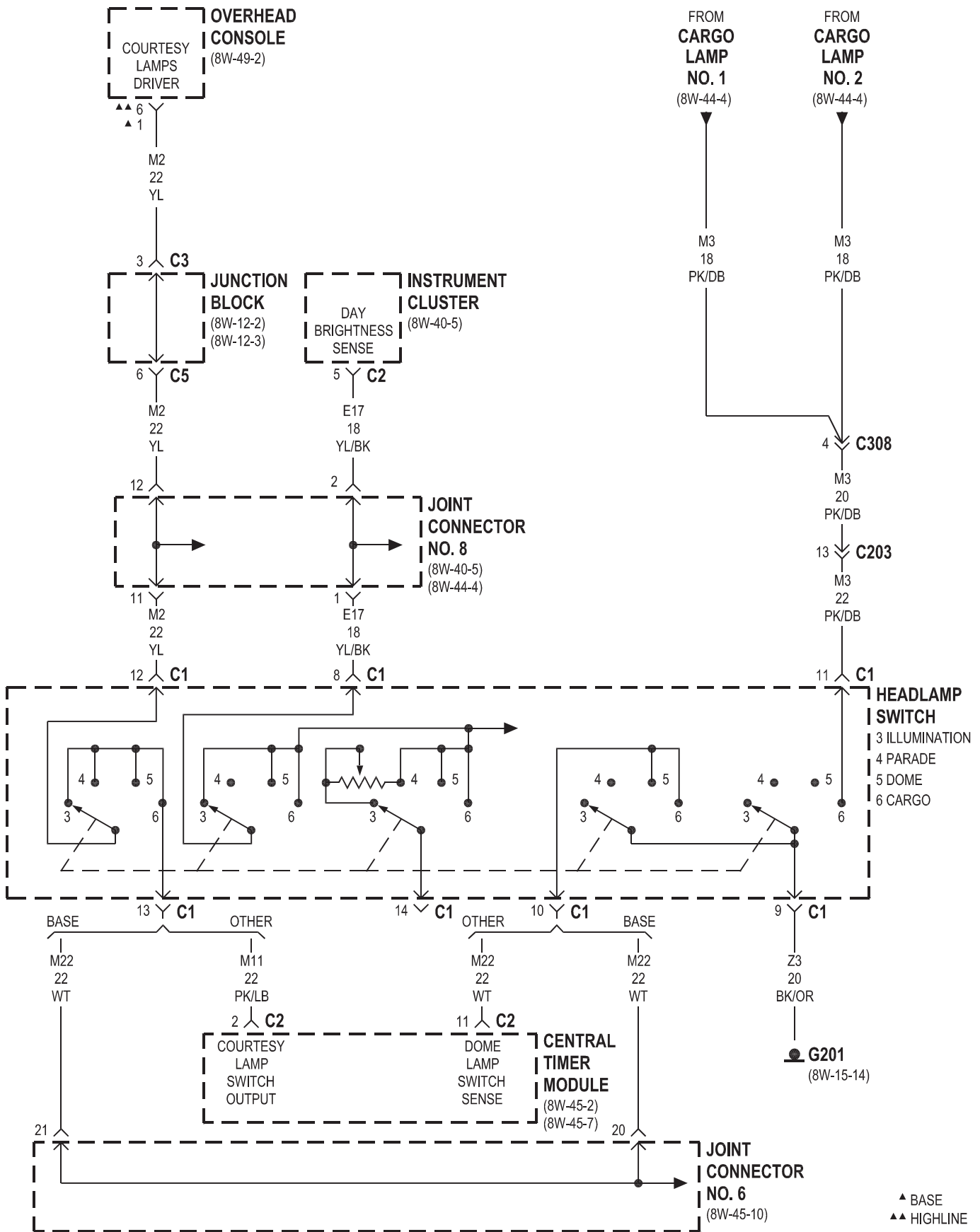


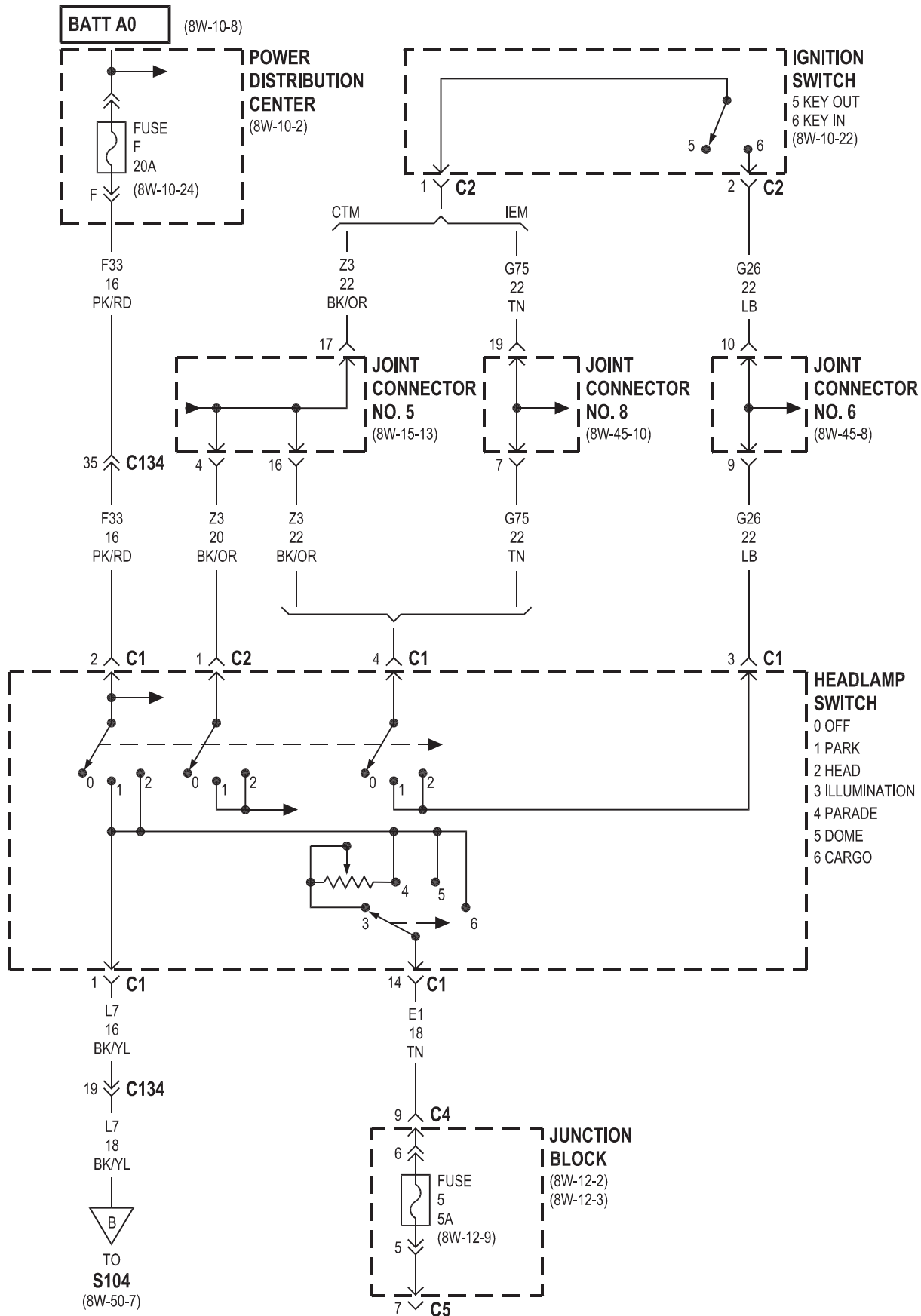


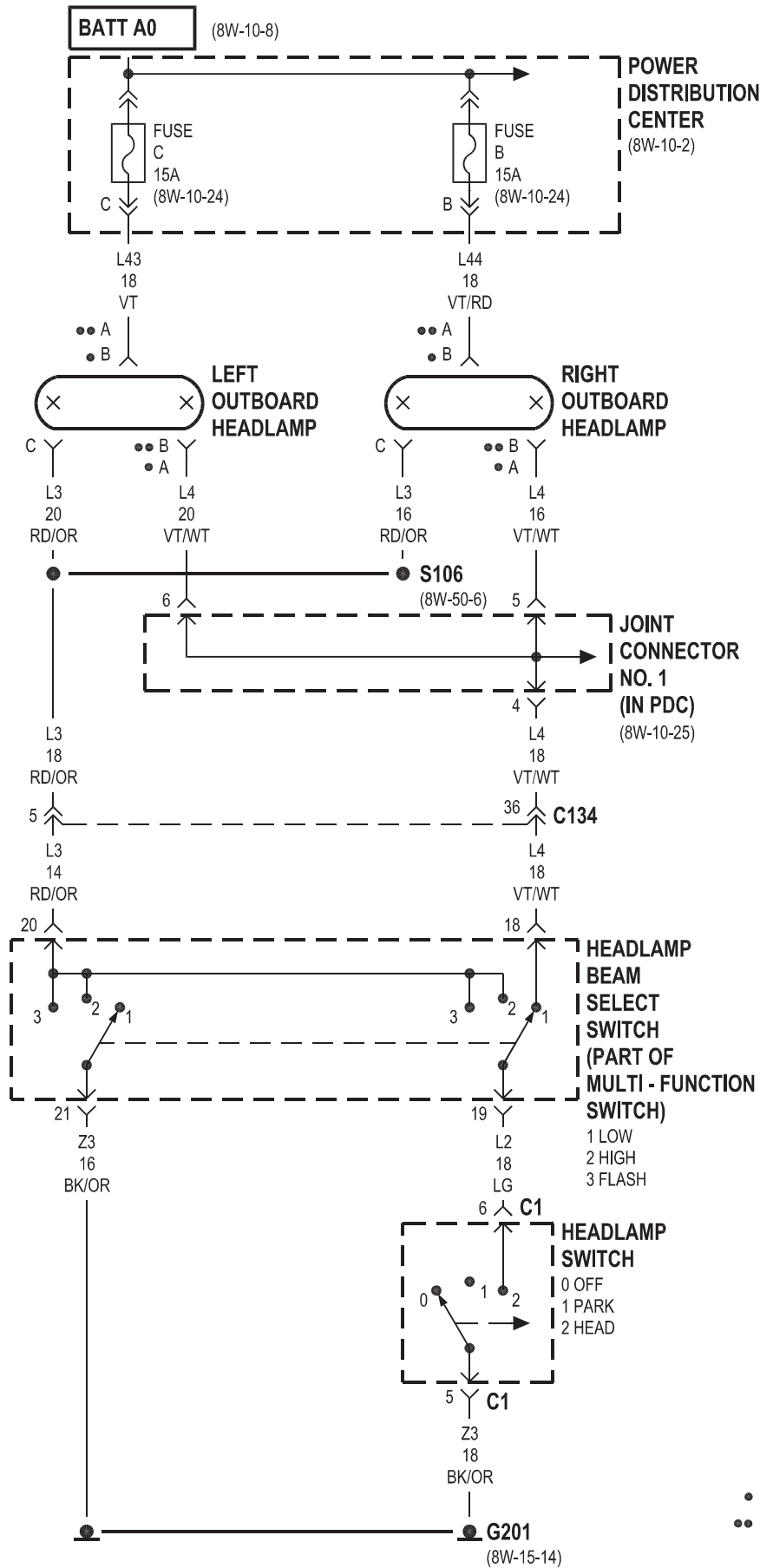


## 8W-50 FRONT LIGHTING

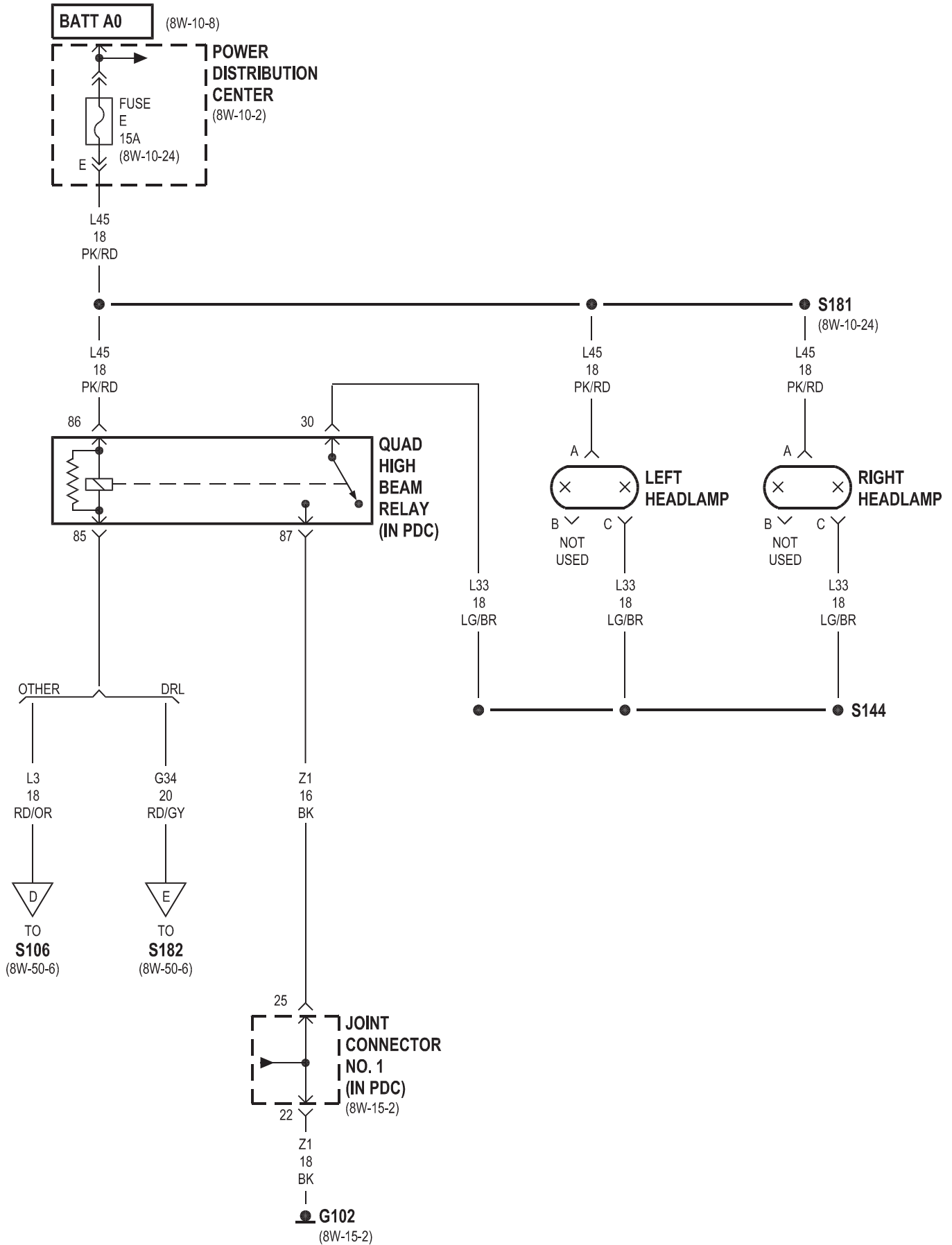
<b>Component</b>	<b>Page</b>	<b>Component</b>	<b>Page</b>
Cargo Lamp No. 1 . . . . .	8W-50-2	Joint Connector No. 3 . . . . .	8W-50-7
Cargo Lamp No. 2 . . . . .	8W-50-2	Joint Connector No. 4 . . . . .	8W-50-12, 7
Center Identification Lamp . . . . .	8W-50-8	Joint Connector No. 5 . . . . .	8W-50-3, 10, 11
Central Timer Module C2 . . . . .	8W-50-2	Joint Connector No. 6 . . . . .	8W-50-2, 3
Daytime Running Lamp Module . . . . .	8W-50-6, 9, 11, 12, 13	Joint Connector No. 8 . . . . .	8W-50-2, 3
Fog Lamp Indicator . . . . .	8W-50-10, 11	Junction Block . . . . .	8W-50-2, 3, 6, 7, 8, 9, 12
Fog Lamp Relay . . . . .	8W-50-6, 10, 11, 12	Left Fog Lamp . . . . .	8W-50-10, 11
Fuse 5 (JB) . . . . .	8W-50-3	Left Headlamp . . . . .	8W-50-5
Fuse 7 (JB) . . . . .	8W-50-12	Left Outboard Clearance Lamp . . . . .	8W-50-8
Fuse 14 (JB) . . . . .	8W-50-6, 9	Left Outboard Headlamp . . . . .	8W-50-4, 6
Fuse B (PDC) . . . . .	8W-50-4	Left Outboard Identification Lamp . . . . .	8W-50-8
Fuse C (PDC) . . . . .	8W-50-4	Left Park/Turn Signal Lamp . . . . .	8W-50-7
Fuse E (PDC) . . . . .	8W-50-5	Overhead Console . . . . .	8W-50-2
Fuse F (PDC) . . . . .	8W-50-10, 11, 3	Park Brake Switch . . . . .	8W-50-12
Fuse G (PDC) . . . . .	8W-50-10, 11, 12	Power Distribution Center . . . . .	8W-50-10, 11, 12, 3, 4, 5
G100 . . . . .	8W-50-7, 12	Quad High Beam Relay . . . . .	8W-50-13, 5
G102 . . . . .	8W-50-5, 13	Right Fog Lamp . . . . .	8W-50-10, 11
G201 . . . . .	8W-50-2, 4, 6, 9, 10, 11	Right Headlamp . . . . .	8W-50-5
G302 . . . . .	8W-50-8	Right Outboard Clearance Lamp . . . . .	8W-50-8
Headlamp Beam Select Switch . . . . .	8W-50-4, 6, 9, 10, 13	Right Outboard Headlamp . . . . .	8W-50-4, 6
Headlamp Switch . . . . .	8W-50-2, 3, 4, 10, 11	Right Outboard Identification Lamp . . . . .	8W-50-8
Ignition Switch . . . . .	8W-50-3	Right Park/Turn Signal Lamp . . . . .	8W-50-7
Instrument Cluster . . . . .	8W-50-2, 6, 9, 13	Security Relay . . . . .	8W-50-13
Joint Connector No. 1 . . . . .	8W-50-4, 5, 13	Trailer Tow Relay . . . . .	8W-50-7



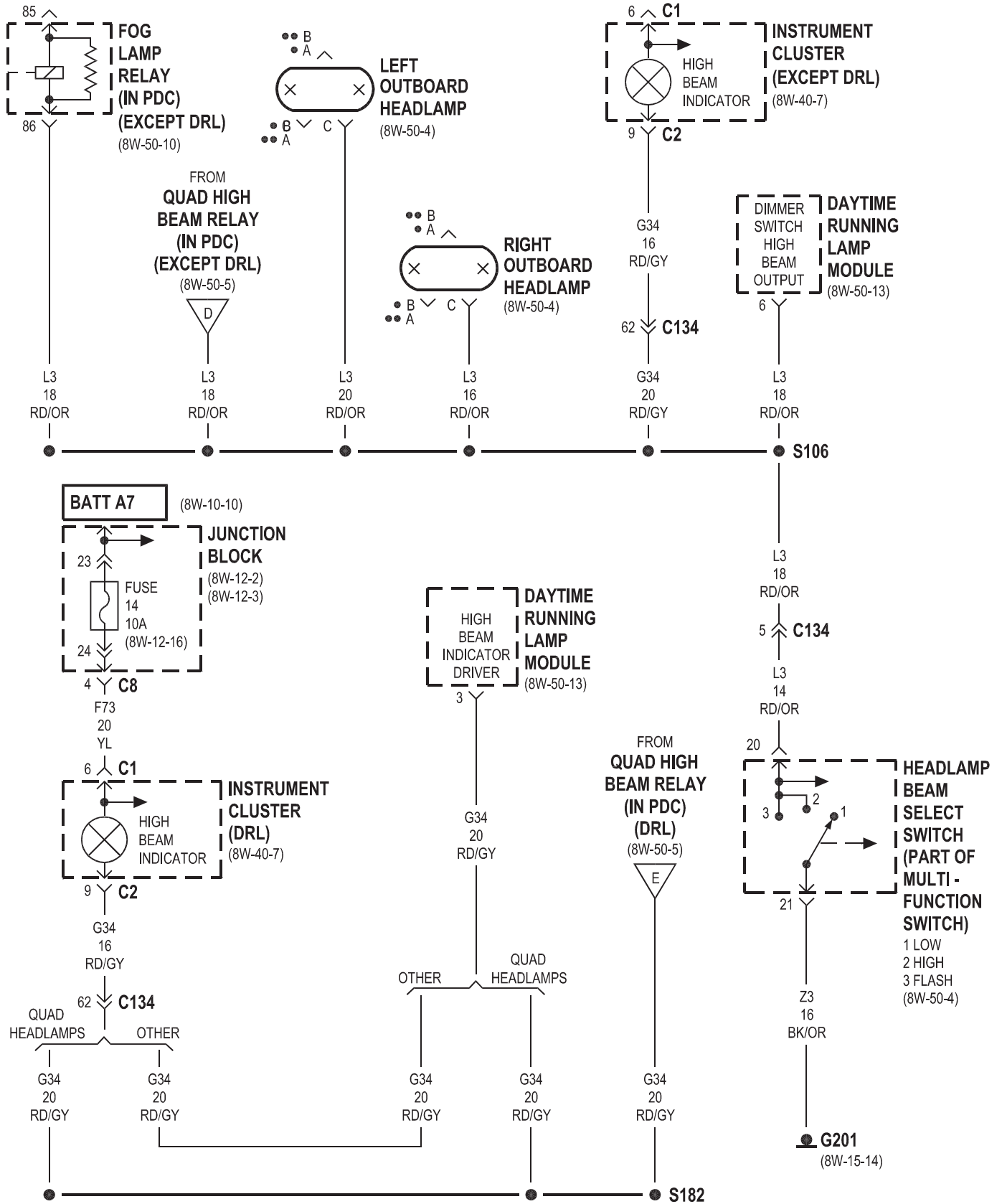




- QUAD HEADLAMPS
- EXCEPT QUAD HEADLAMPS

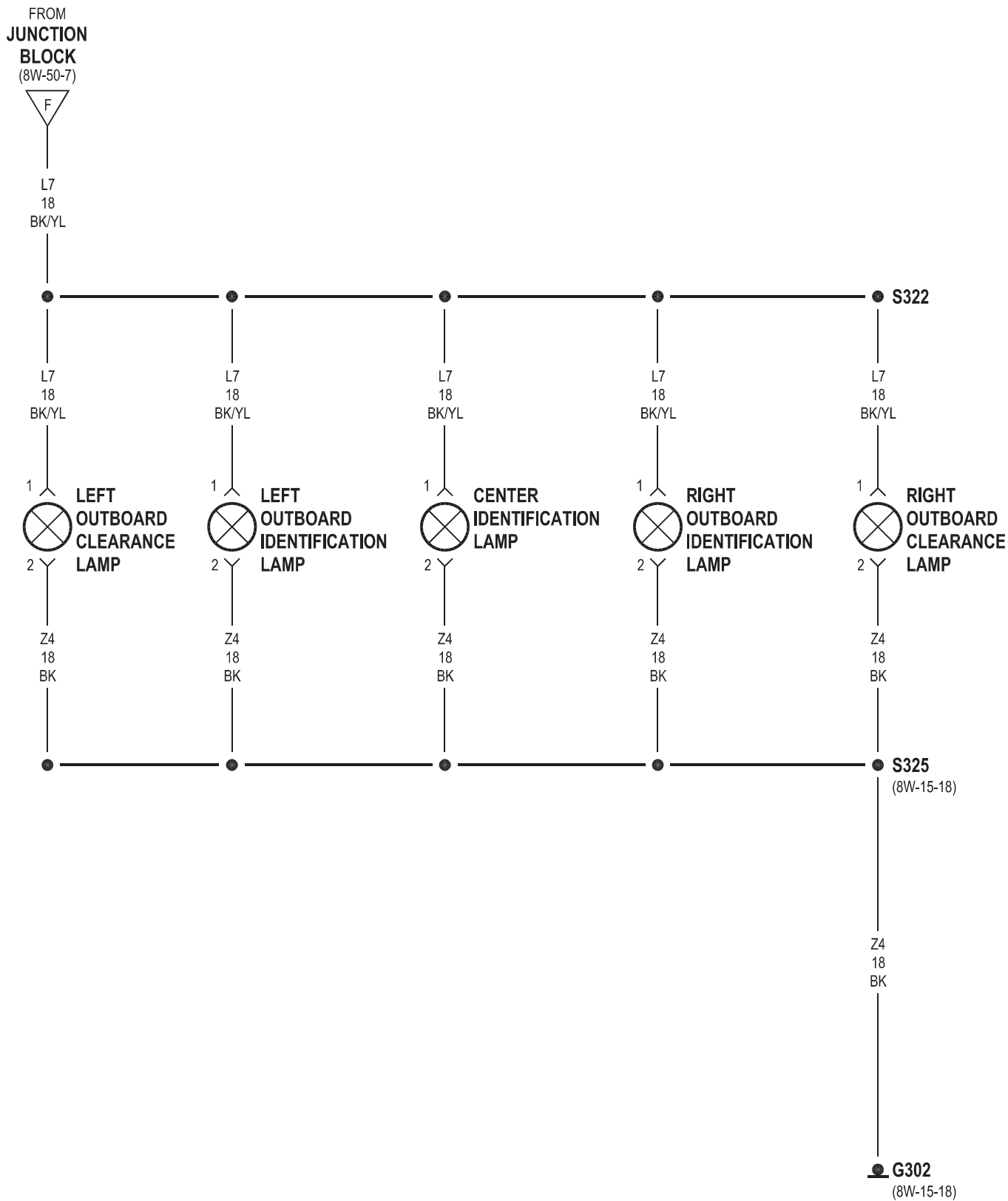


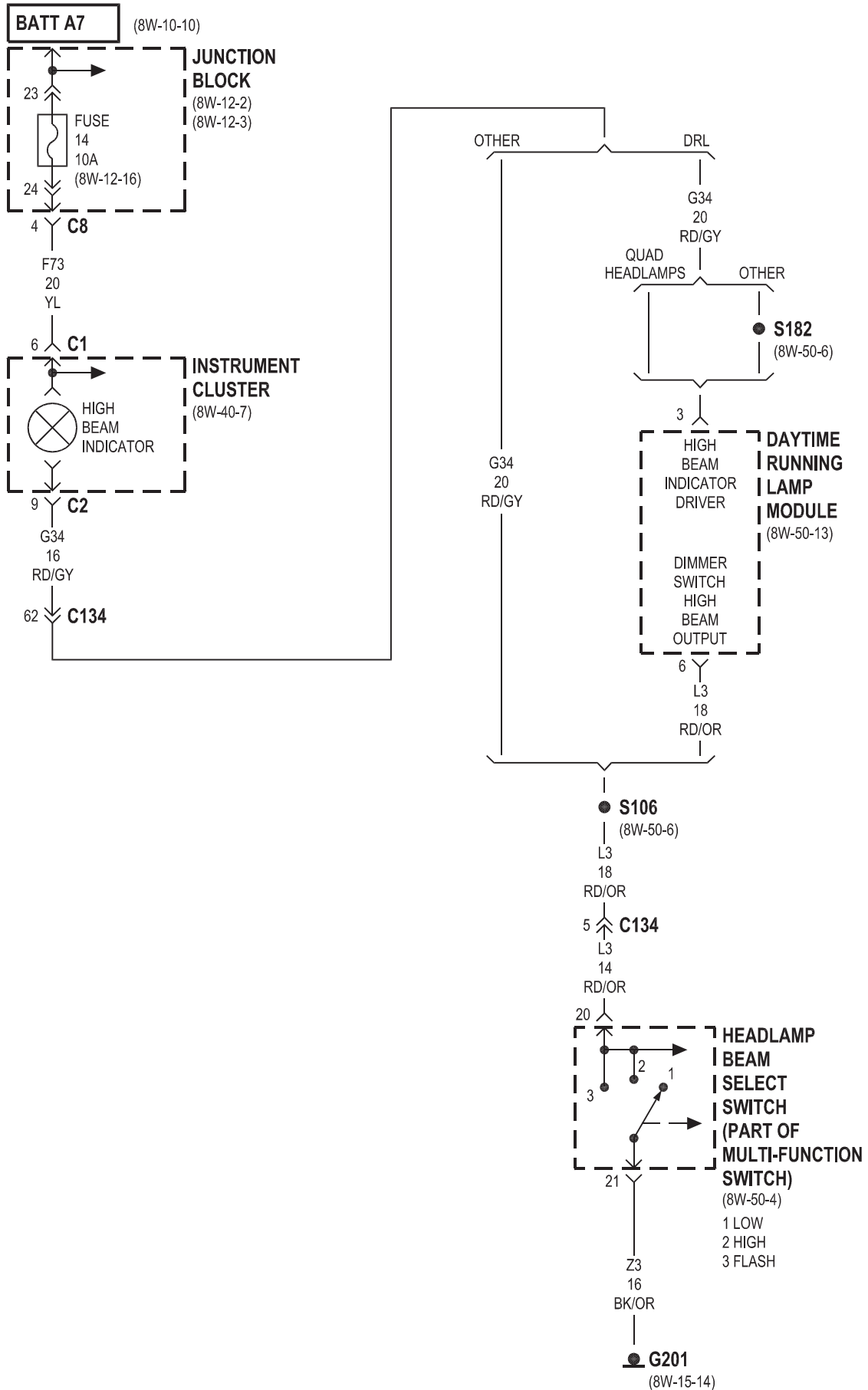




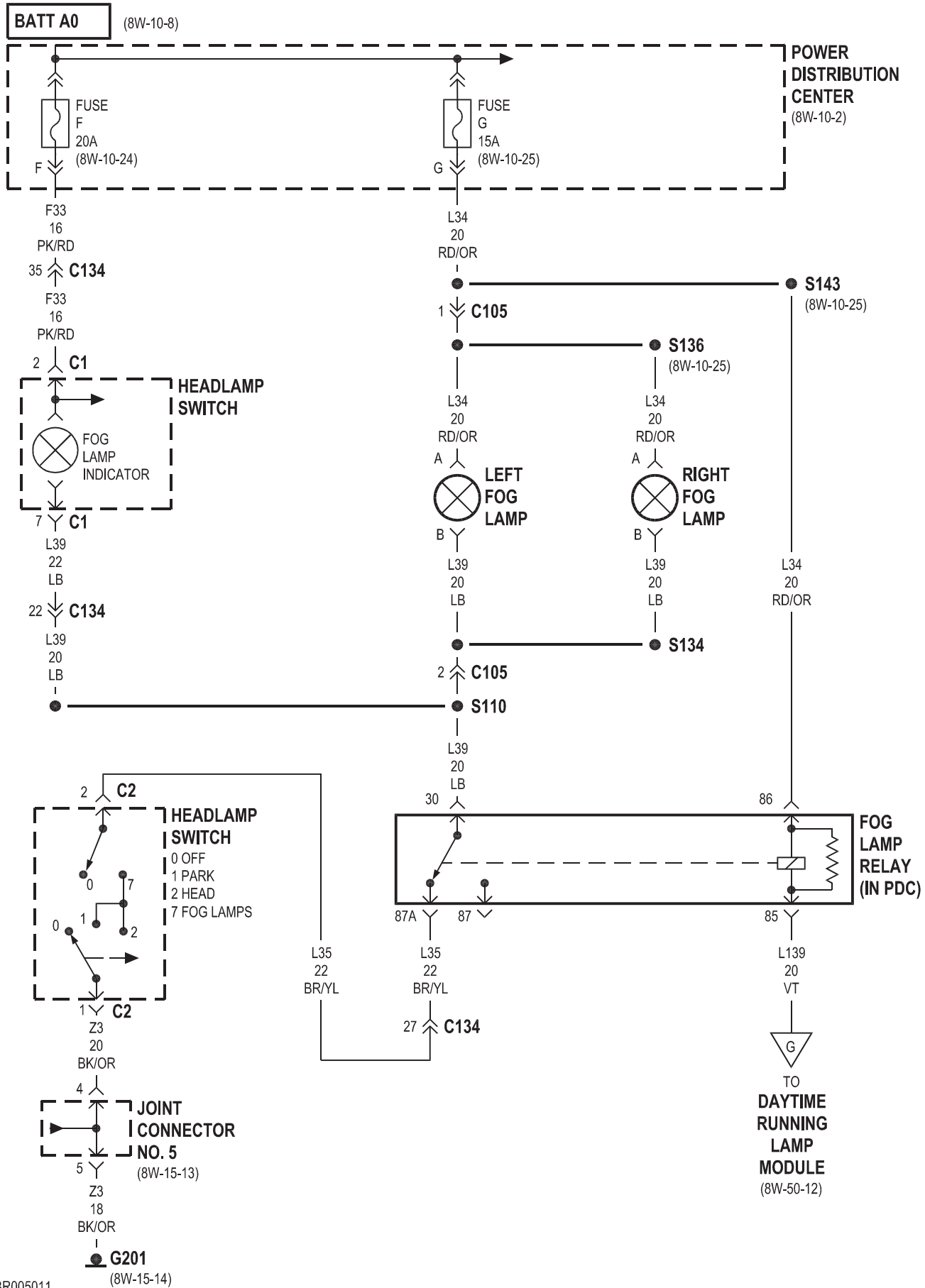
• EXCEPT QUAD HEADLAMPS  
 •• QUAD HEADLAMPS





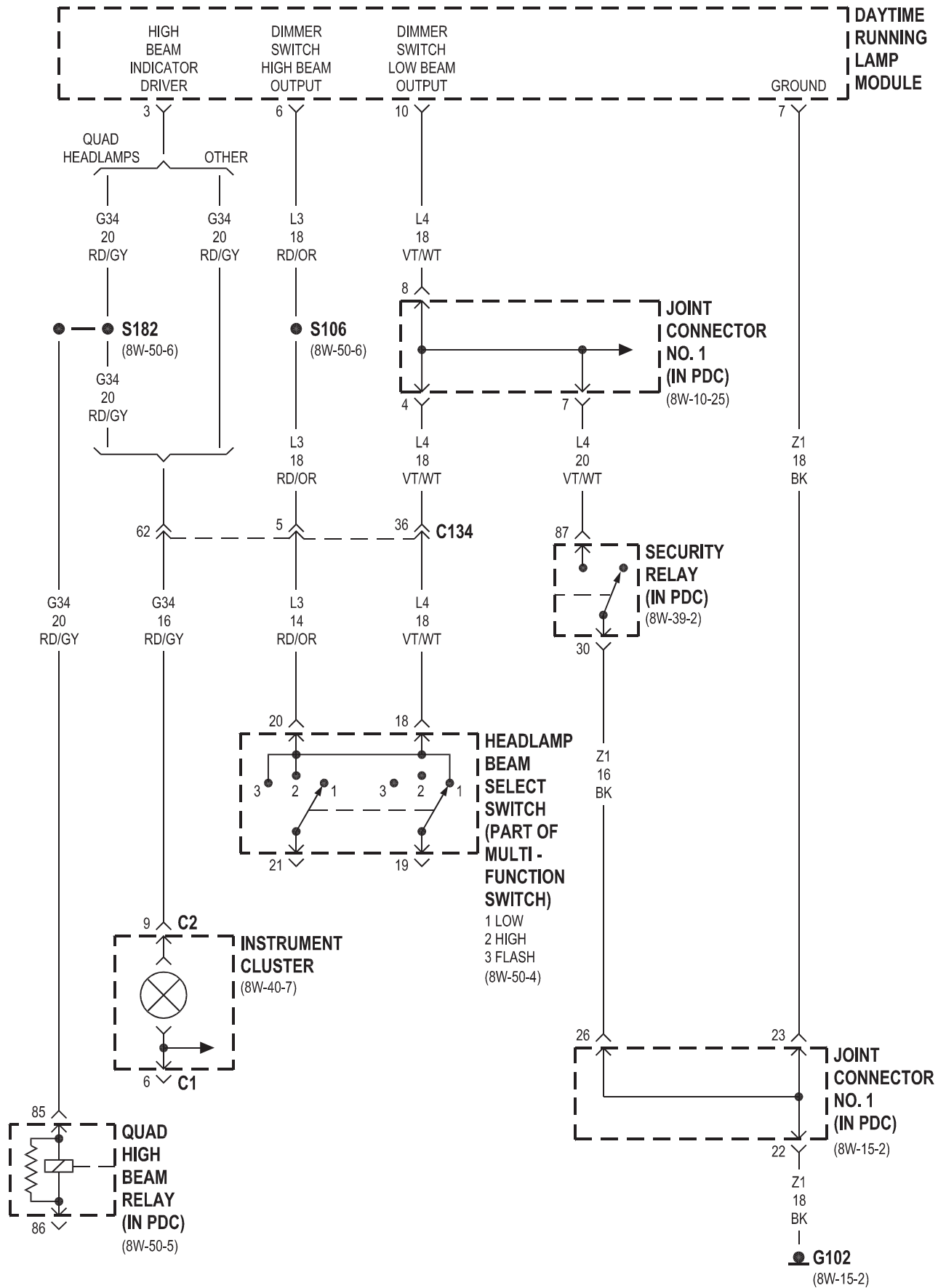








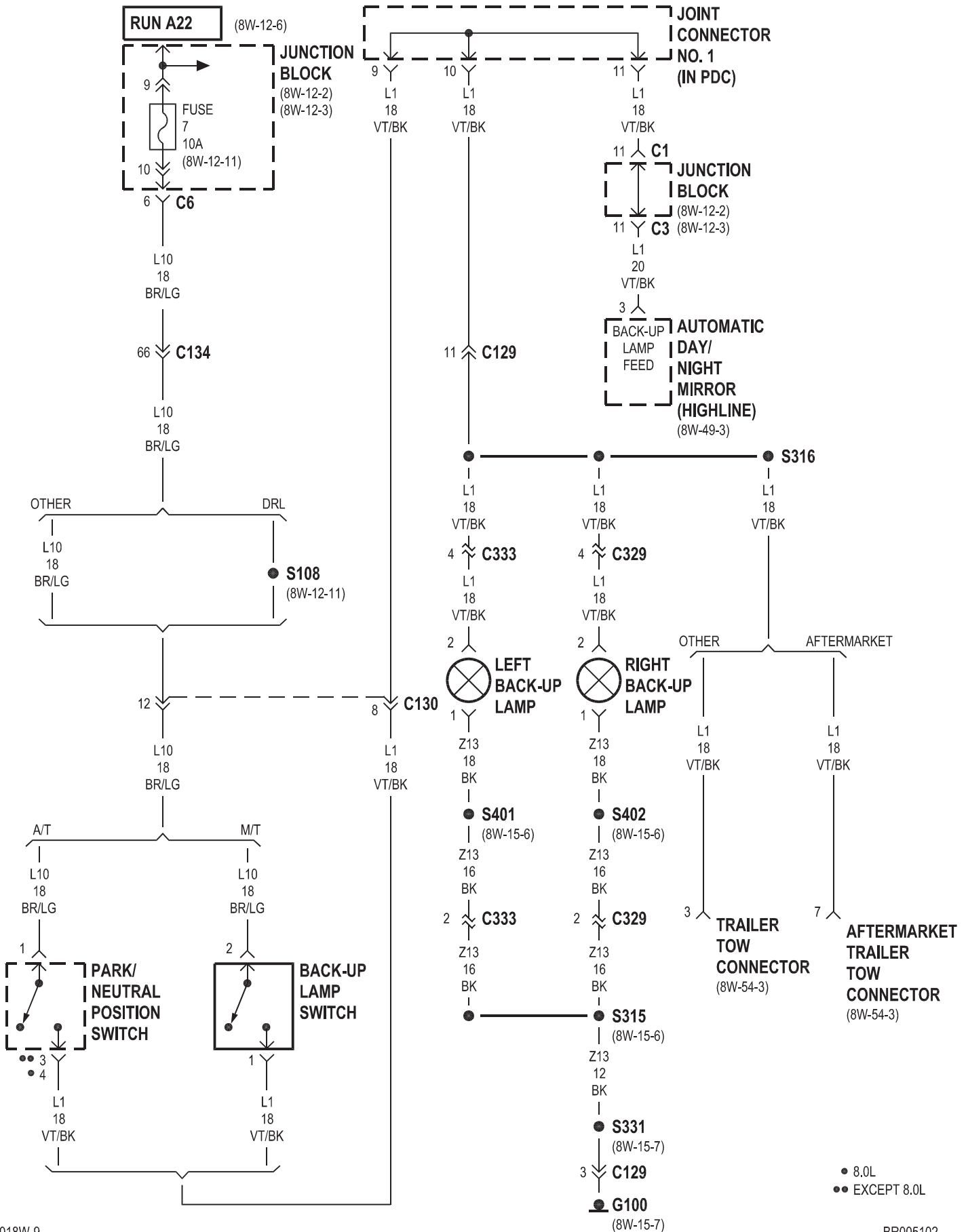




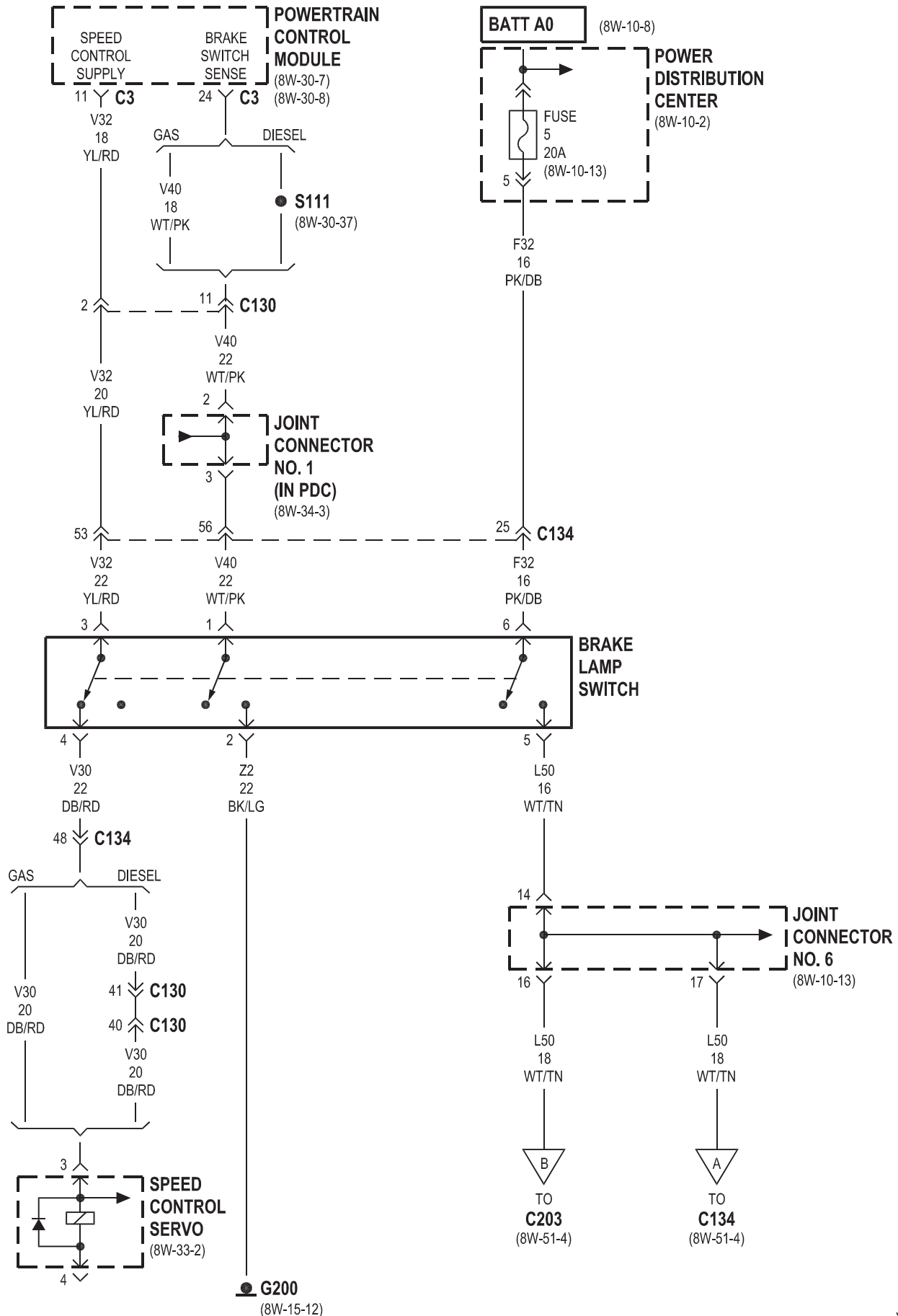


## 8W-51 REAR LIGHTING

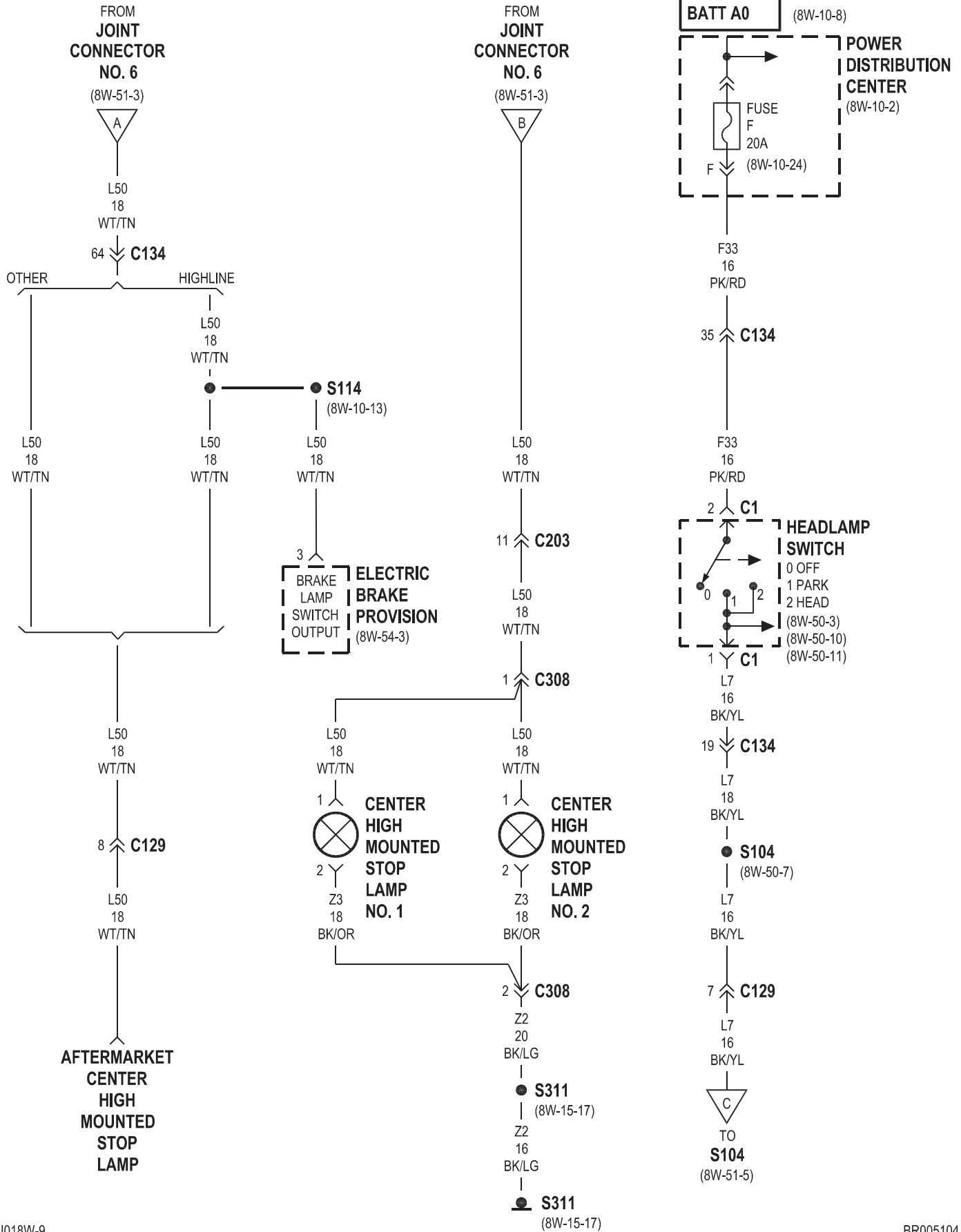
<b>Component</b>	<b>Page</b>	<b>Component</b>	<b>Page</b>
Aftermarket Center High Mounted Stop Lamp . . . . .	8W-51-4	Left Back-Up Lamp . . . . .	8W-51-2
Aftermarket Trailer Tow Connector . . . . .	8W-51-2	Left Front Fender Lamp . . . . .	8W-51-6
Automatic Day/Night Mirror . . . . .	8W-51-2	Left License Lamp . . . . .	8W-51-5, 6
Back-Up Lamp Switch . . . . .	8W-51-2	Left Rear Fender Lamp . . . . .	8W-51-6
Brake Lamp Switch . . . . .	8W-51-3	Left Tail/Stop/Turn Signal Lamp . . . . .	8W-51-5
Center High Mounted Stop Lamp No. 1 . . . . .	8W-51-4	Park/Neutral Position Switch . . . . .	8W-51-2
Center High Mounted Stop Lamp No. 2 . . . . .	8W-51-4	Power Distribution Center . . . . .	8W-51-3, 4
Electric Brake Provision . . . . .	8W-51-4	Powertrain Control Module . . . . .	8W-51-3
Fuse 7 (JB) . . . . .	8W-51-2	Right Back-Up Lamp . . . . .	8W-51-2
Fuse 5 (PDC) . . . . .	8W-51-3	Right Front Fender Lamp . . . . .	8W-51-6
Fuse F (PDC) . . . . .	8W-51-4	Right License Lamp . . . . .	8W-51-5
G100 . . . . .	8W-51-2, 5, 6	Right Rear Fender Lamp . . . . .	8W-51-6
G200 . . . . .	8W-51-3	Right Tail/Stop/Turn Signal Lamp . . . . .	8W-51-5
Headlamp Switch . . . . .	8W-51-4	Speed Control Servo . . . . .	8W-51-3
Joint Connector No. 1 . . . . .	8W-51-2, 3	Tailgate Lamp . . . . .	8W-51-6
Joint Connector No. 6 . . . . .	8W-51-3	Trailer Tow Connector . . . . .	8W-51-2
Junction Block . . . . .	8W-51-2	Turn Signal/Hazard Switch . . . . .	8W-51-5

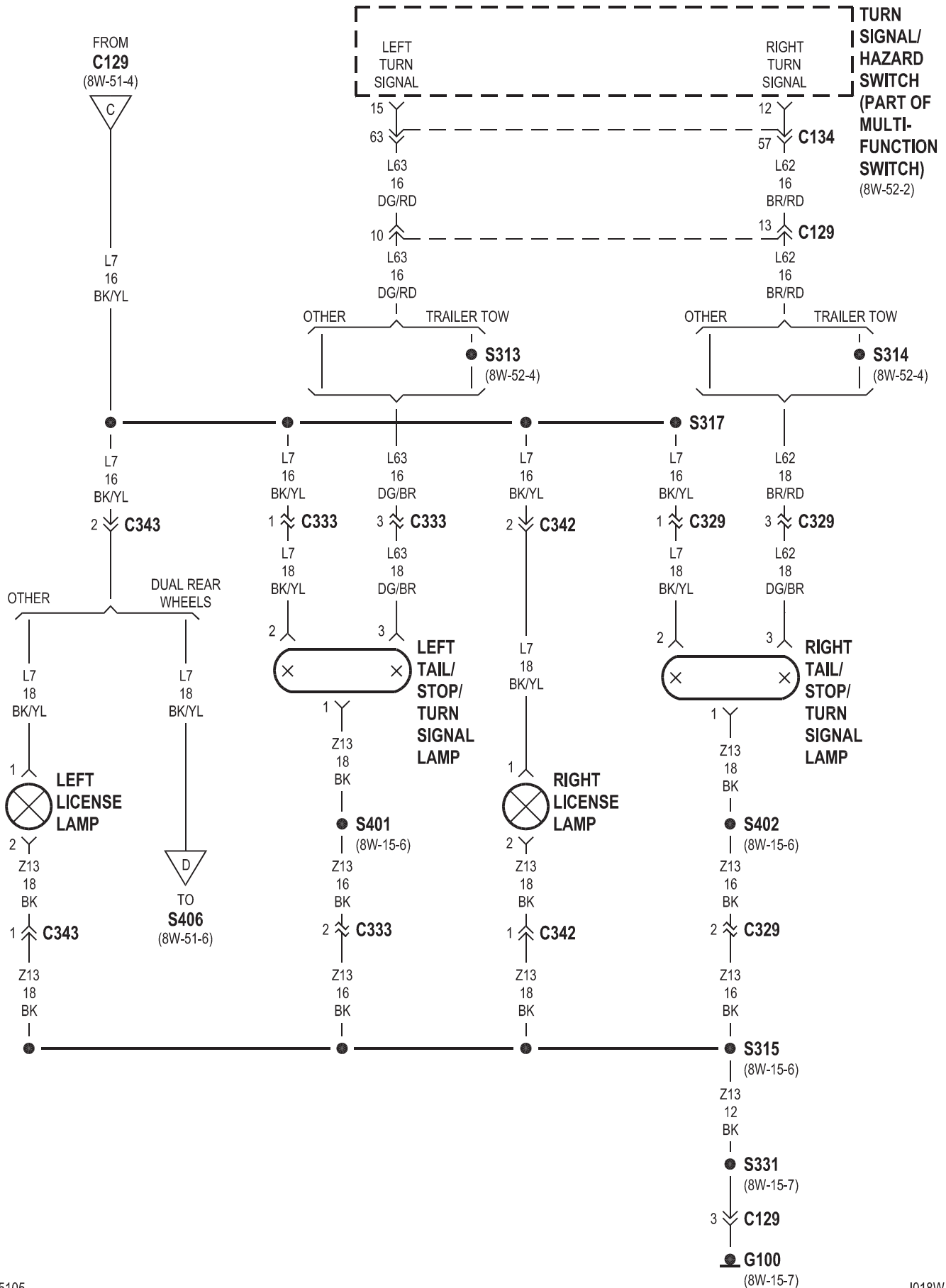


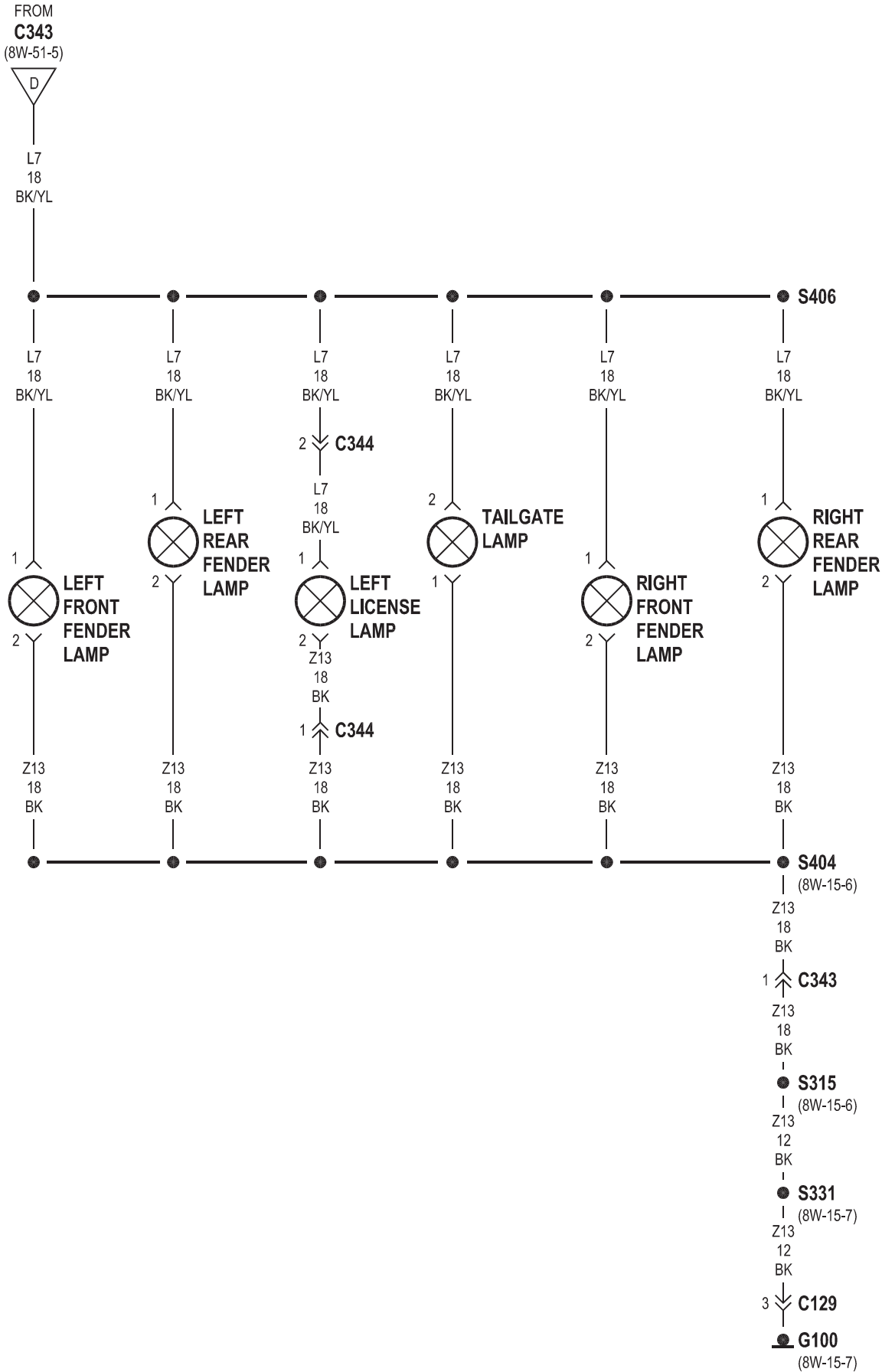
• 8.0L  
 •• EXCEPT 8.0L





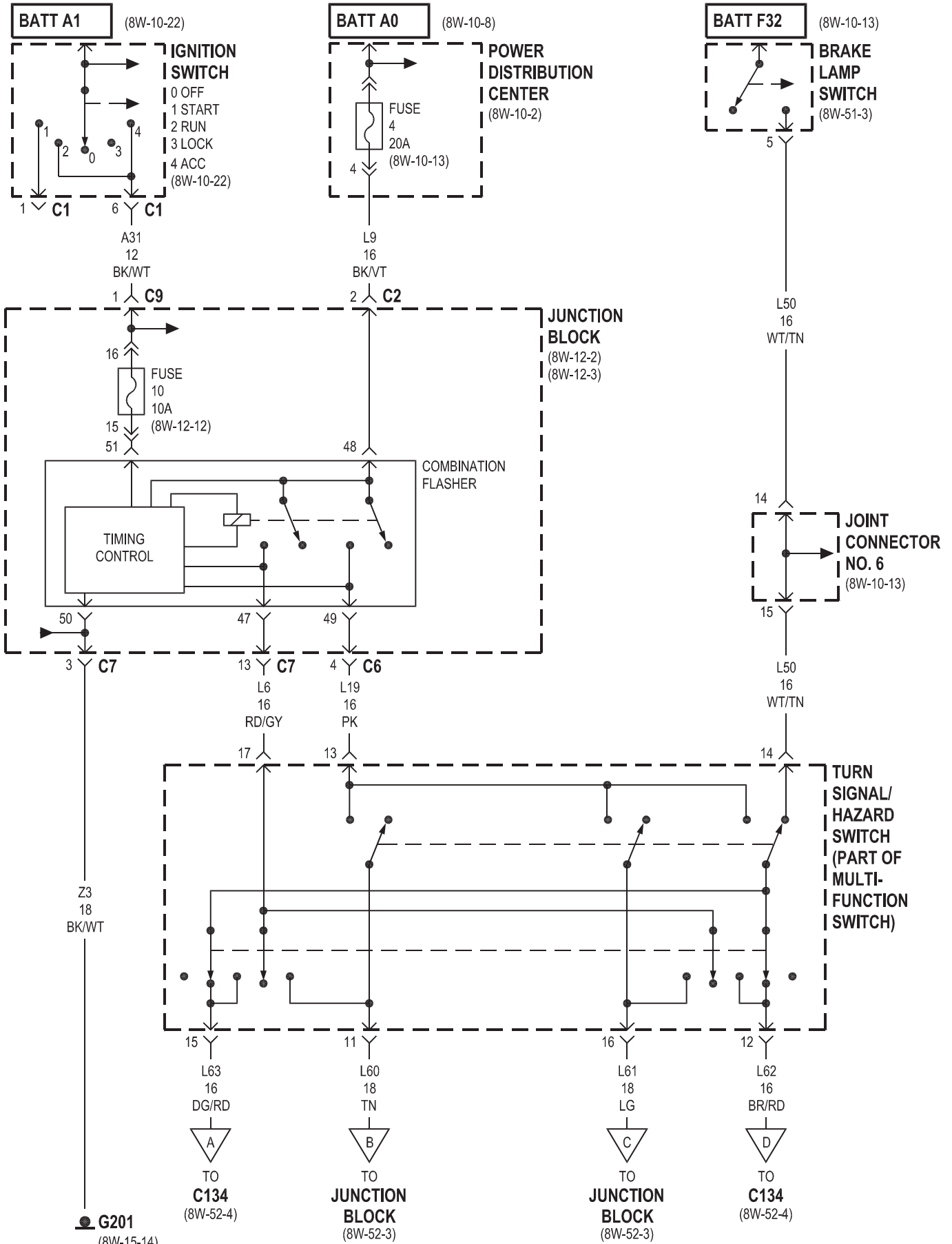


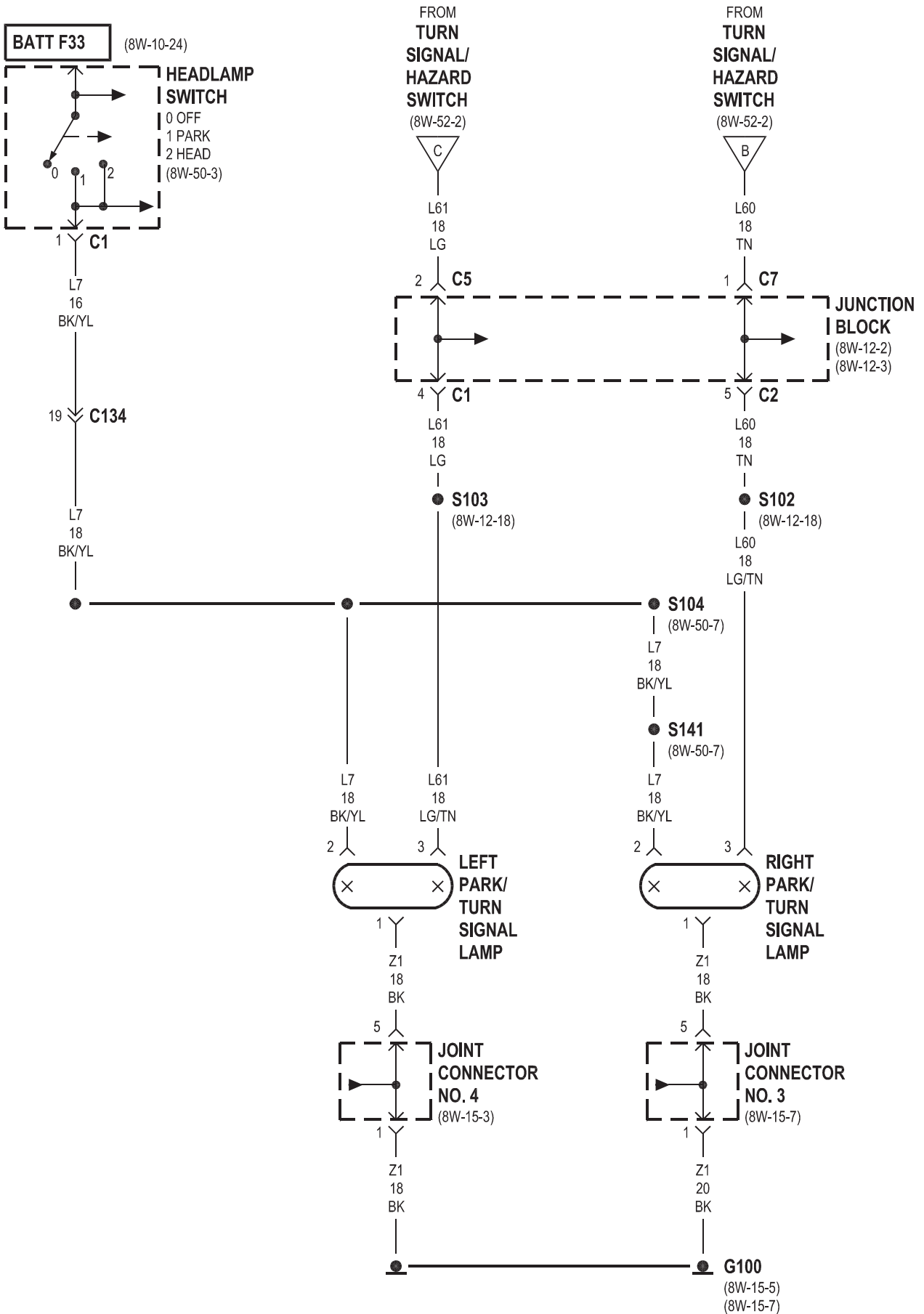




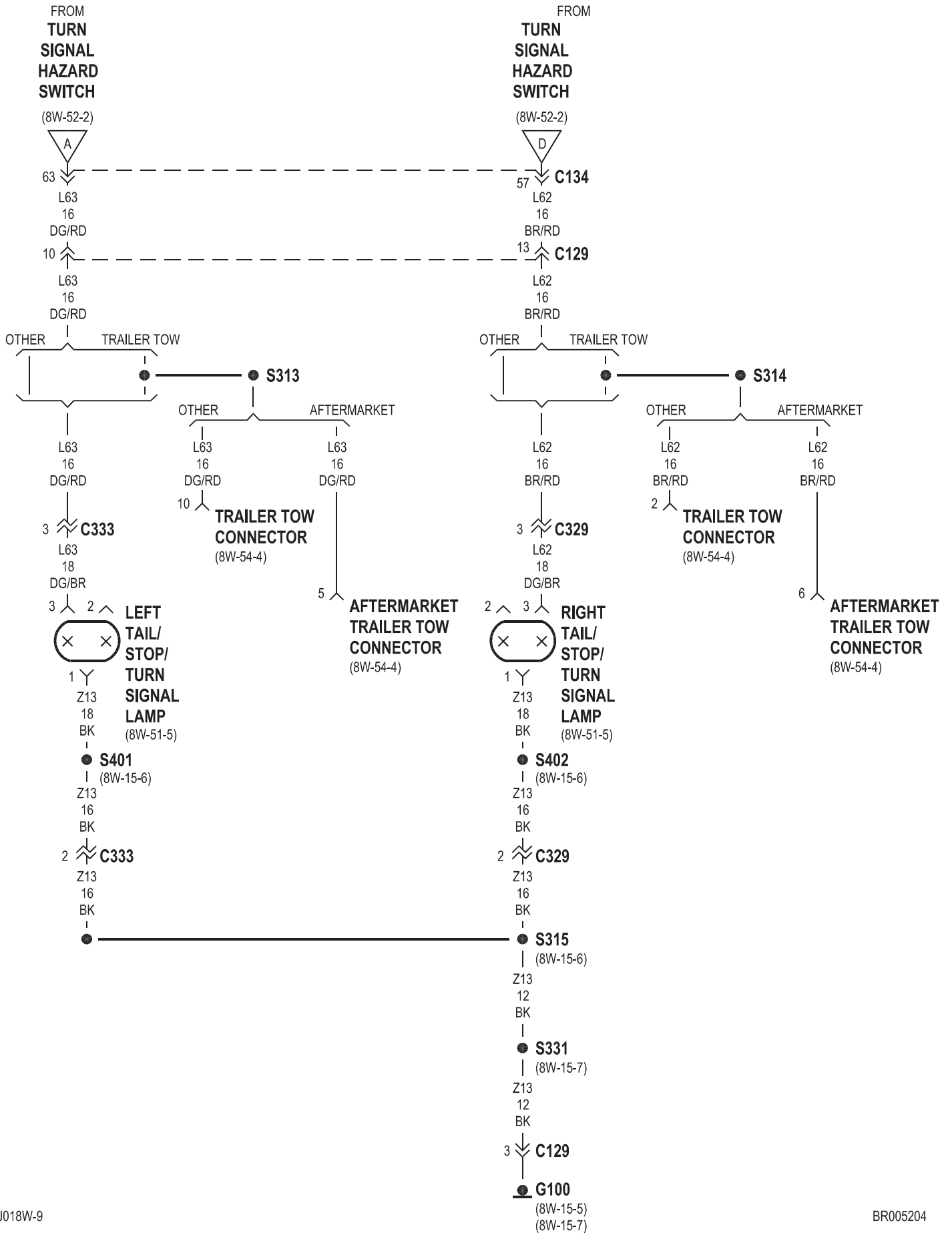
## 8W-52 TURN SIGNALS

<b>Component</b>	<b>Page</b>	<b>Component</b>	<b>Page</b>
Aftermarket Trailer Tow Connector . . . . .	8W-52-4	Joint Connector No. 4 . . . . .	8W-52-3
Brake Lamp Switch . . . . .	8W-52-2	Joint Connector No. 6 . . . . .	8W-52-2
Combination Flasher . . . . .	8W-52-2	Junction Block . . . . .	8W-52-2, 3
Fuse 4 (PDC) . . . . .	8W-52-2	Left Park/Turn Signal Lamp . . . . .	8W-52-3
Fuse 10 (JB) . . . . .	8W-52-2	Left Tail/Stop/Turn Signal Lamp . . . . .	8W-52-4
G100 . . . . .	8W-52-3, 4	Power Distribution Center . . . . .	8W-52-2
G201 . . . . .	8W-52-2	Right Park/Turn Signal Lamp . . . . .	8W-52-3
Headlamp Switch . . . . .	8W-52-3	Right Tail/Stop/Turn Signal Lamp . . . . .	8W-52-4
Ignition Switch . . . . .	8W-52-2	Trailer Tow Connector . . . . .	8W-52-4
Joint Connector No. 3 . . . . .	8W-52-3	Turn Signal/Hazard Switch . . . . .	8W-52-2



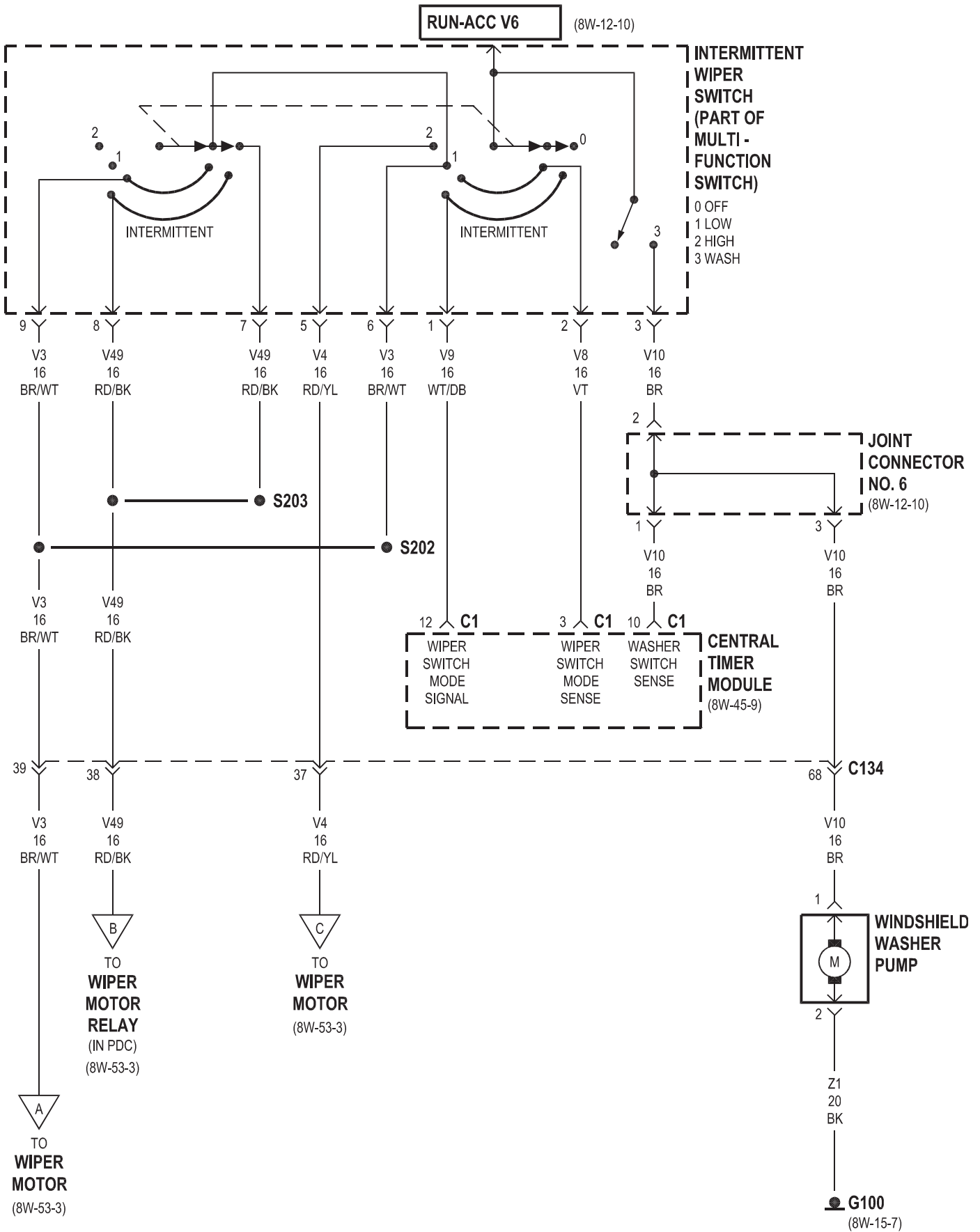


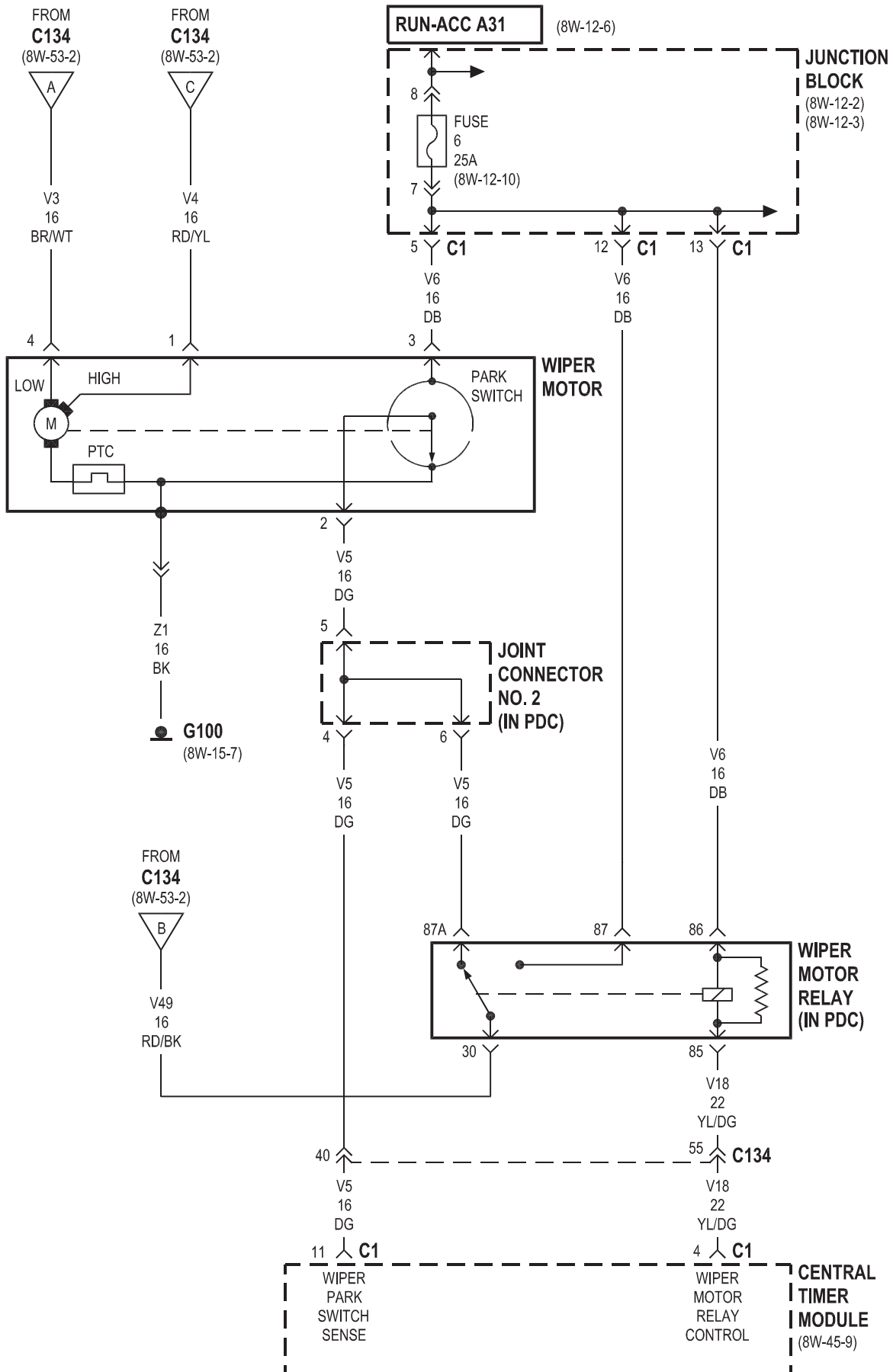




## 8W-53 WIPERS

<b>Component</b>	<b>Page</b>	<b>Component</b>	<b>Page</b>
Fuse 6 (JB) .....	8W-53-3	Joint Connector No. 6 .....	8W-53-2
G100 .....	8W-53-2, 3	Junction Block .....	8W-53-3
Central Timer Module C1 .....	8W-53-2, 3	Windshield Washer Pump .....	8W-53-2
Intermittent Wiper Switch .....	8W-53-2	Wiper Motor .....	8W-53-3
Joint Connector No. 2 .....	8W-53-3	Wiper Motor Relay .....	8W-53-3



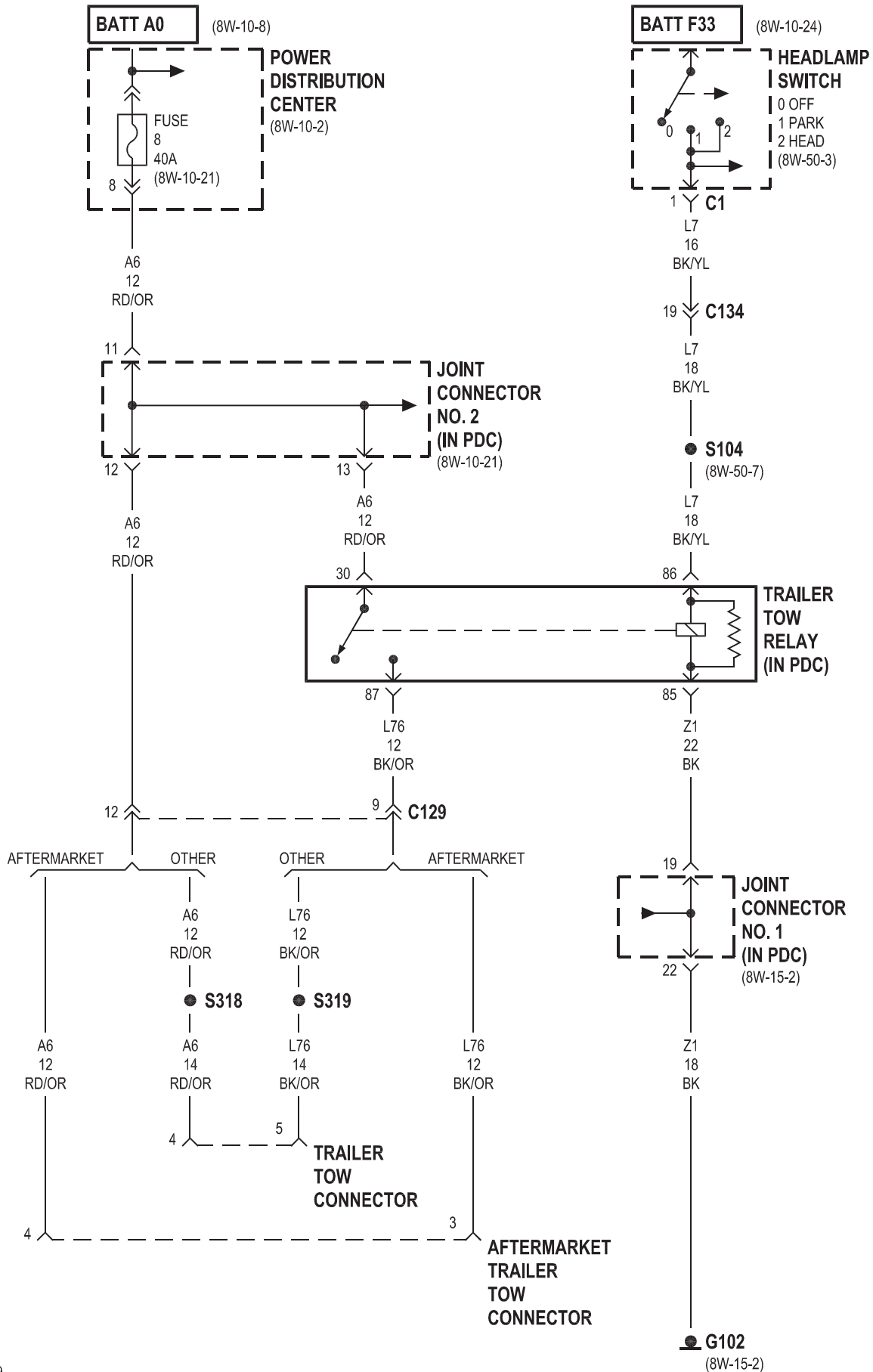


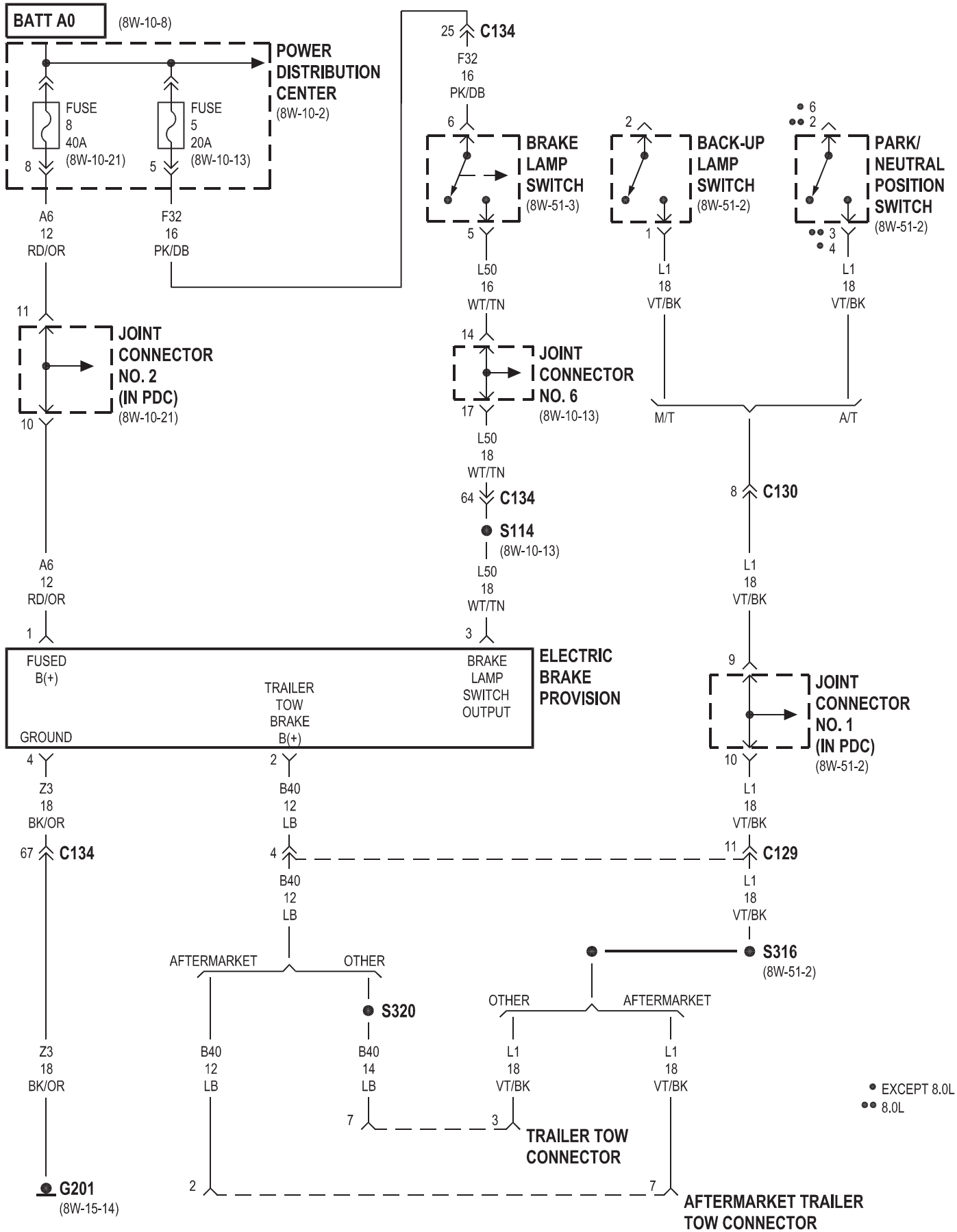


## 8W-54 TRAILER TOW

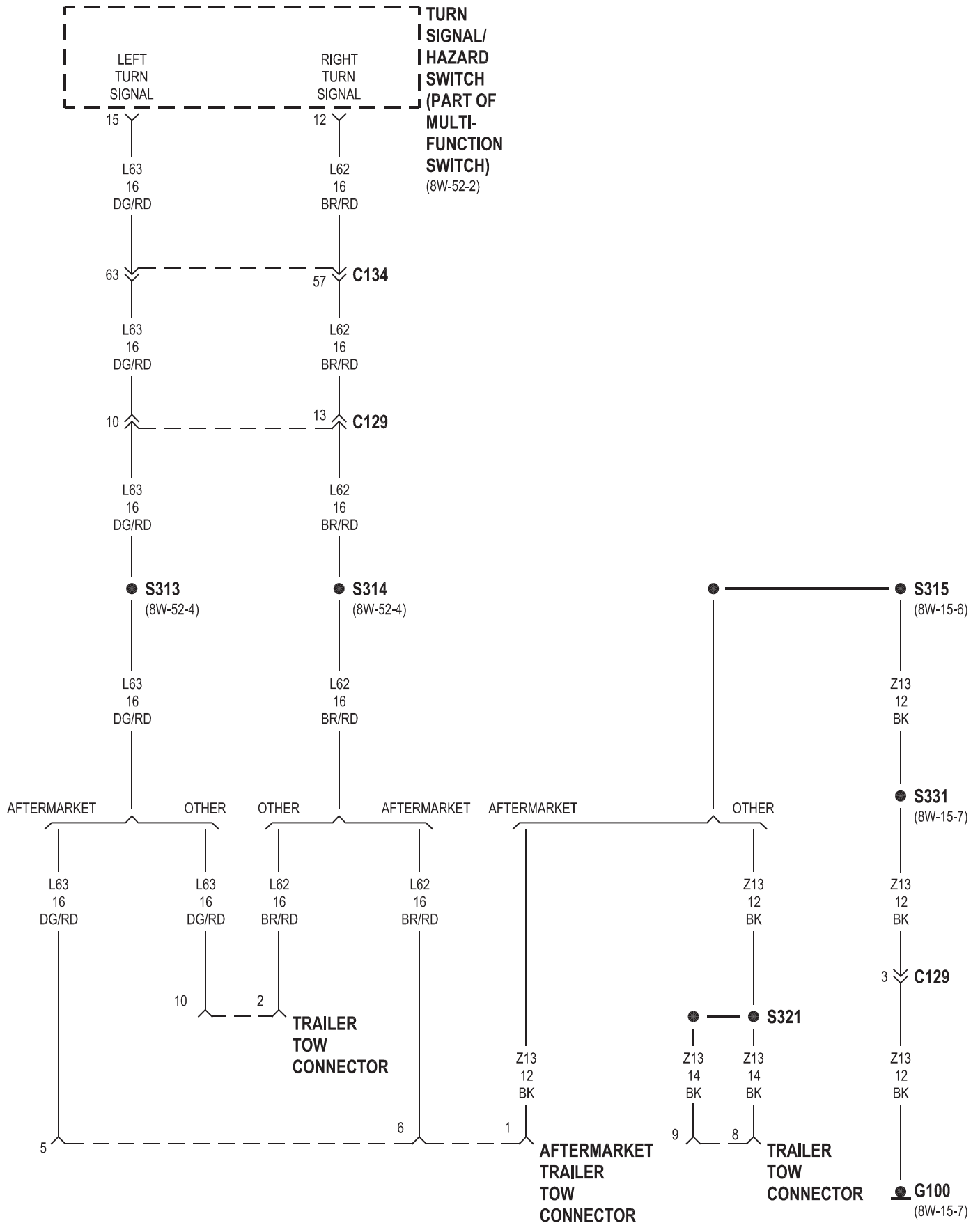
<b>Component</b>	<b>Page</b>	<b>Component</b>	<b>Page</b>
Aftermarket Trailer Tow Connector . . .	8W-54-2, 3, 4	Headlamp Switch . . . . .	8W-54-2
Back-Up Lamp Switch . . . . .	8W-54-3	Joint Connector No. 1 . . . . .	8W-54-2, 3
Brake Lamp Switch . . . . .	8W-54-3	Joint Connector No. 2 . . . . .	8W-54-2, 3
Electric Brake Provision . . . . .	8W-54-3	Joint Connector No. 6 . . . . .	8W-54-3
Fuse 5 (PDC) . . . . .	8W-54-3	Park/Neutral Position Switch . . . . .	8W-54-3
Fuse 8 (PDC) . . . . .	8W-54-2, 3	Power Distribution Center . . . . .	8W-54-2, 3
G100 . . . . .	8W-54-4	Trailer Tow Connector . . . . .	8W-54-2, 3, 4
G102 . . . . .	8W-54-2	Trailer Tow Relay . . . . .	8W-54-2
G201 . . . . .	8W-54-3	Turn Signal/Hazard Switch . . . . .	8W-54-4





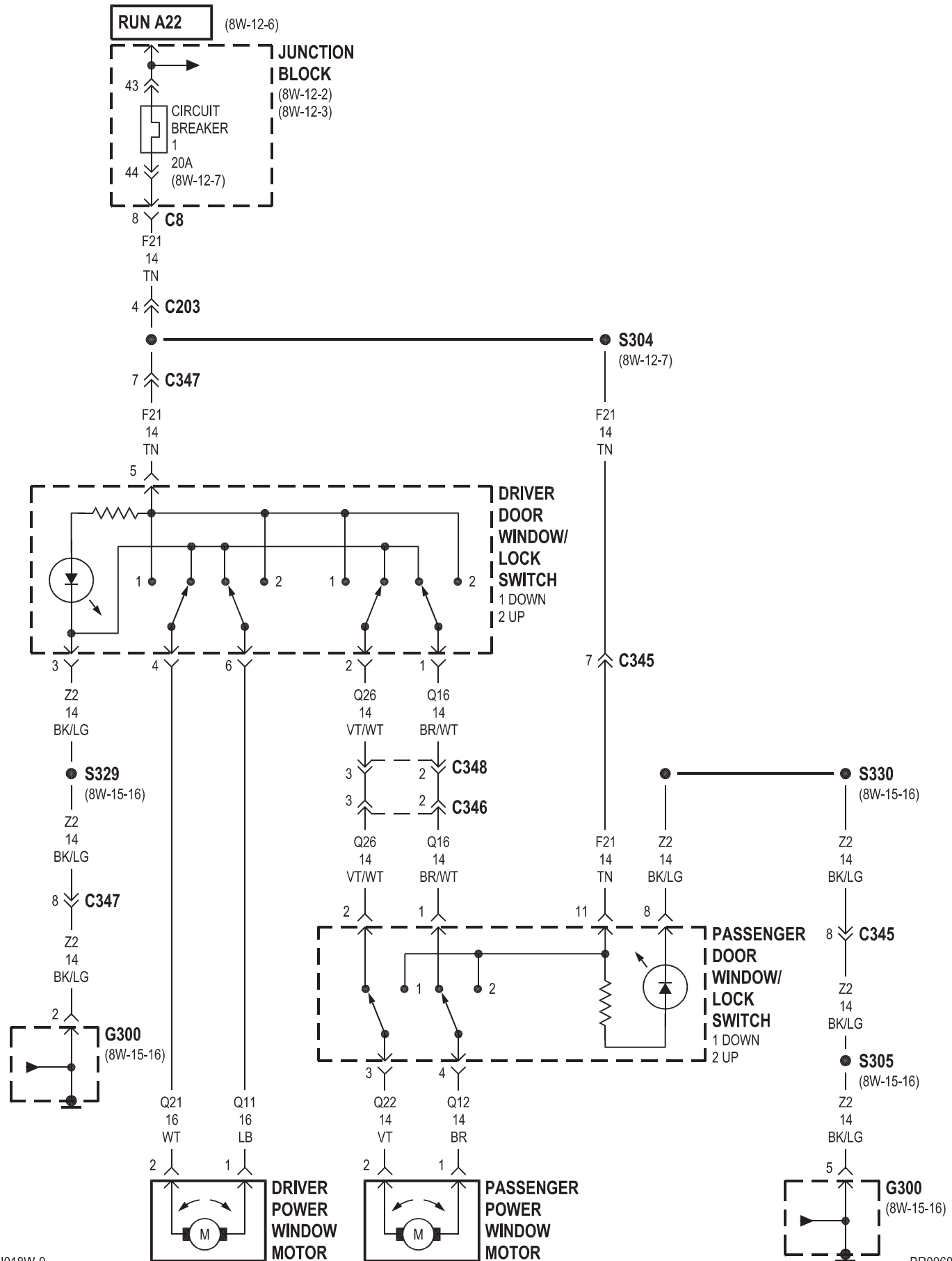


- EXCEPT 8.0L
- 8.0L



## 8W-60 POWER WINDOWS

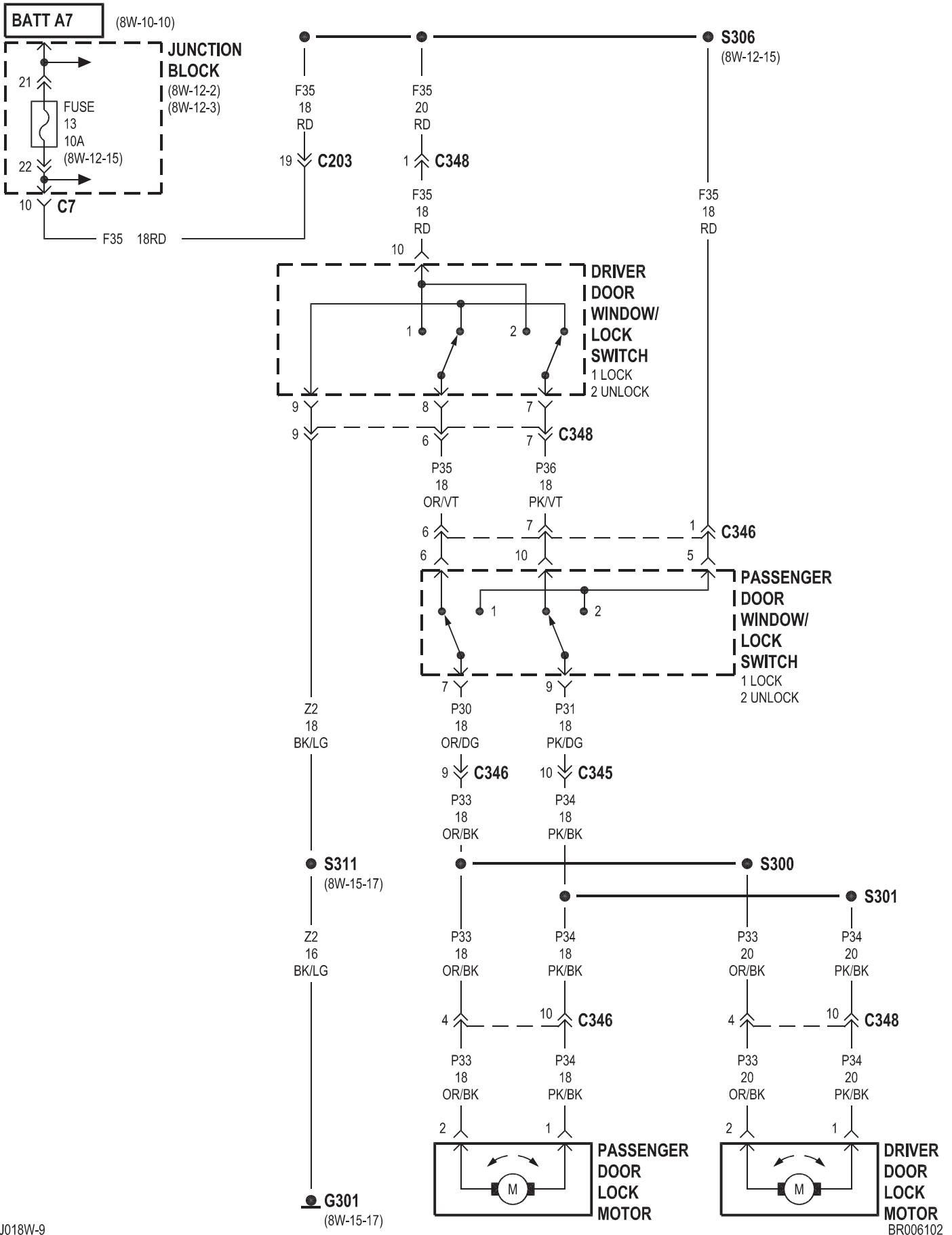
<b>Component</b>	<b>Page</b>	<b>Component</b>	<b>Page</b>
Circuit Breaker 1 8W-Cb .....	8W-60-2	Junction Block .....	8W-60-2
Driver Door Window/Lock Switch .....	8W-60-2	Passenger Door Window/Lock Switch .....	8W-60-2
Driver Power Window Motor .....	8W-60-2	Passenger Power Window Motor .....	8W-60-2
G300 .....	8W-60-2		

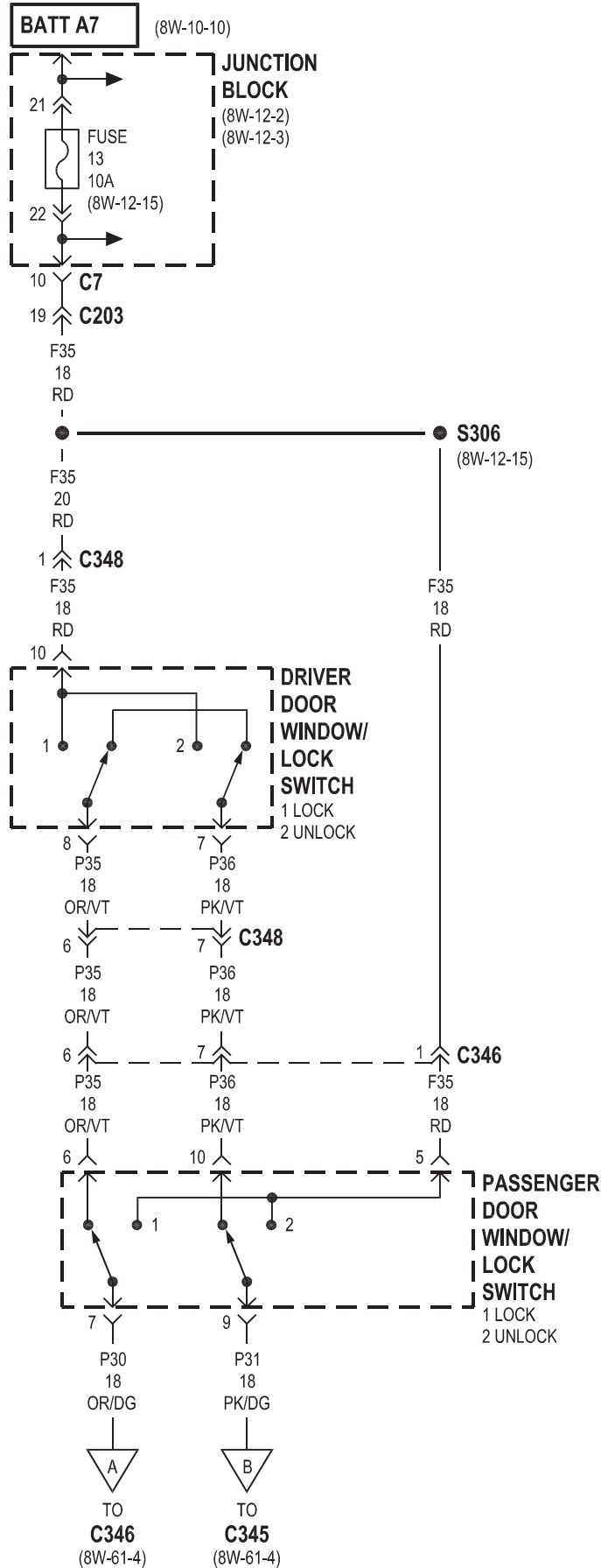


## 8W-61 POWER DOOR LOCKS

<b>Component</b>	<b>Page</b>	<b>Component</b>	<b>Page</b>
Central Timer Module C2 .....	8W-61-4	G301 .....	8W-61-2
Driver Door Lock Motor .....	8W-61-2, 4	Junction Block .....	8W-61-2, 3
Driver Door Window/Lock Switch .....	8W-61-2, 3	Passenger Door Lock Motor .....	8W-61-2, 4
Fuse 13 (JB) .....	8W-61-2, 3	Passenger Door Window/Lock Switch ...	8W-61-2, 3, 4







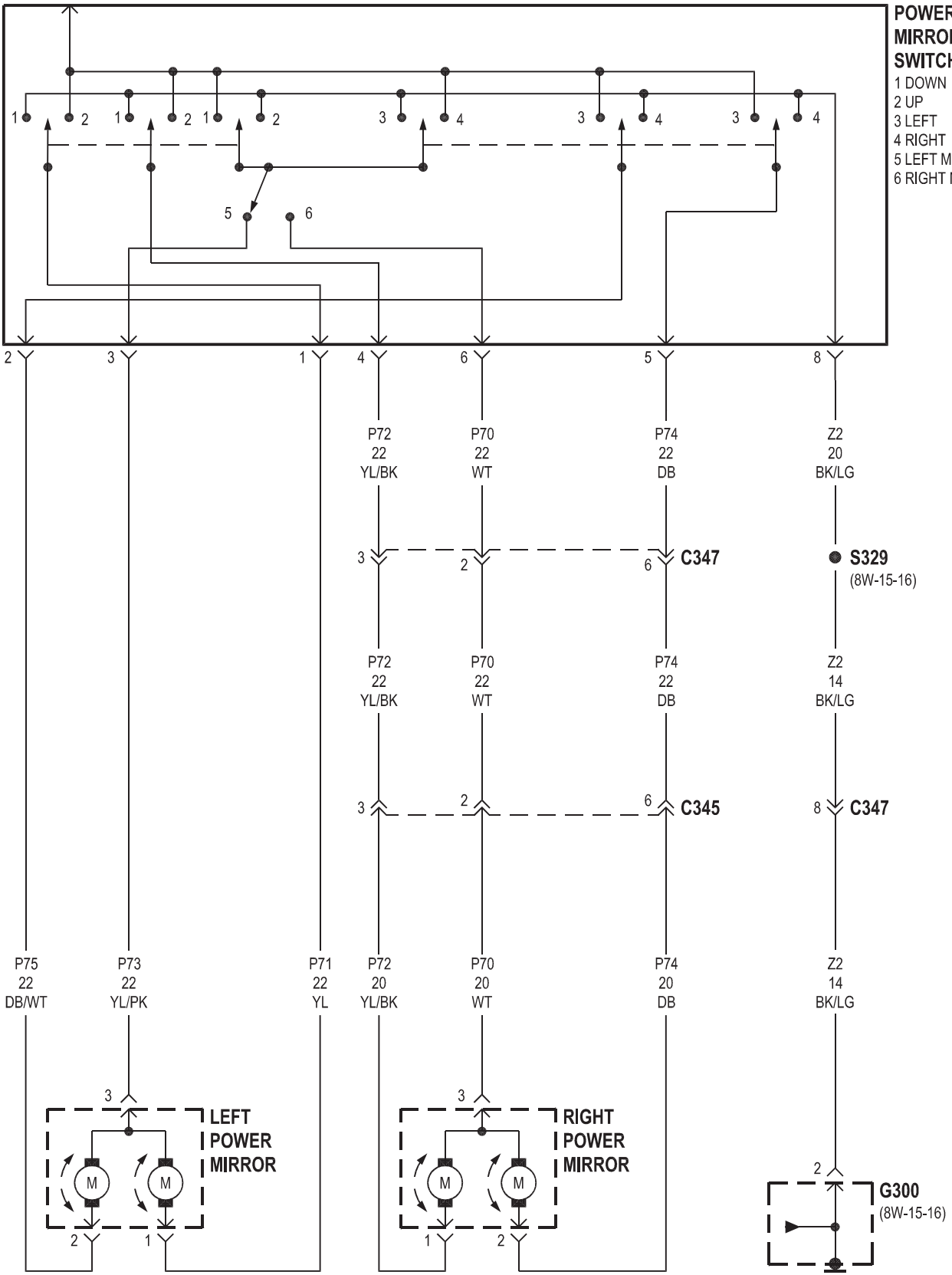


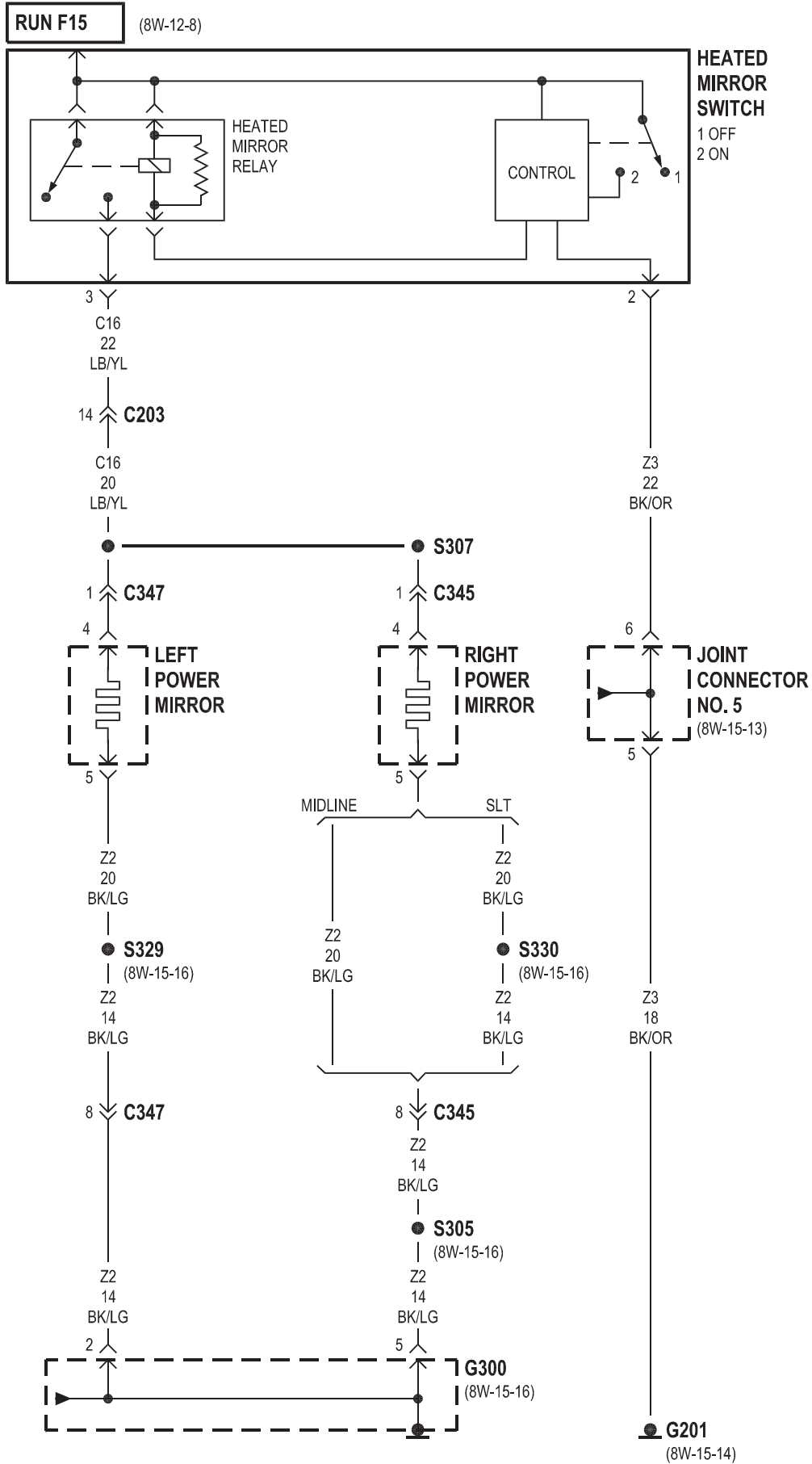
## 8W-62 POWER MIRRORS

<b>Component</b>	<b>Page</b>	<b>Component</b>	<b>Page</b>
G201 .....	8W-62-3	Joint Connector No. 5 .....	8W-62-3
G300 .....	8W-62-2, 3	Left Power Mirror .....	8W-62-2, 3
Heated Mirror Relay .....	8W-62-3	Power Mirror Switch .....	8W-62-2
Heated Mirror Switch .....	8W-62-3	Right Power Mirror .....	8W-62-2, 3

**BATT M1** (8W-12-14)

**POWER MIRROR SWITCH**  
1 DOWN  
2 UP  
3 LEFT  
4 RIGHT  
5 LEFT MIRROR  
6 RIGHT MIRROR



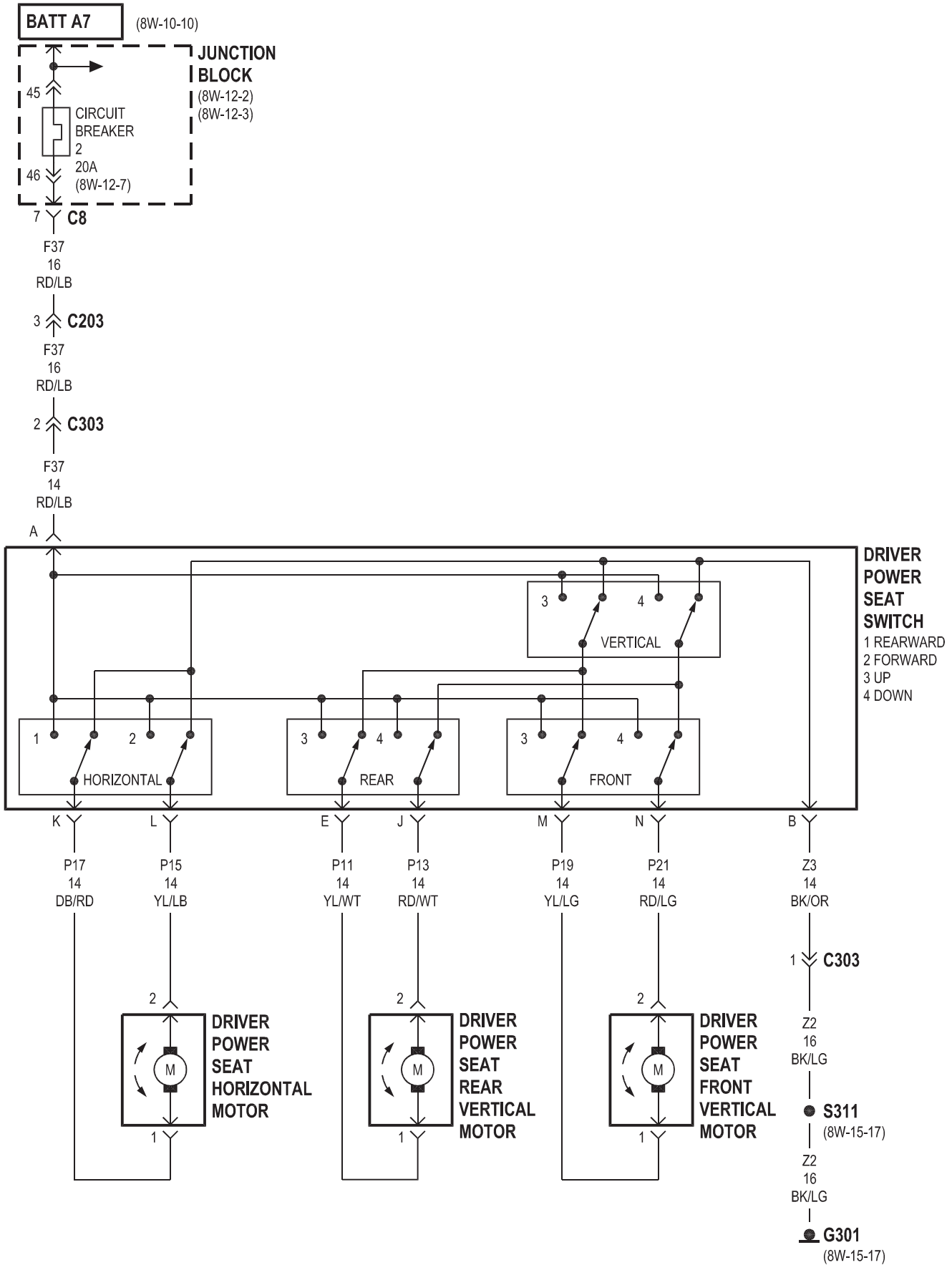


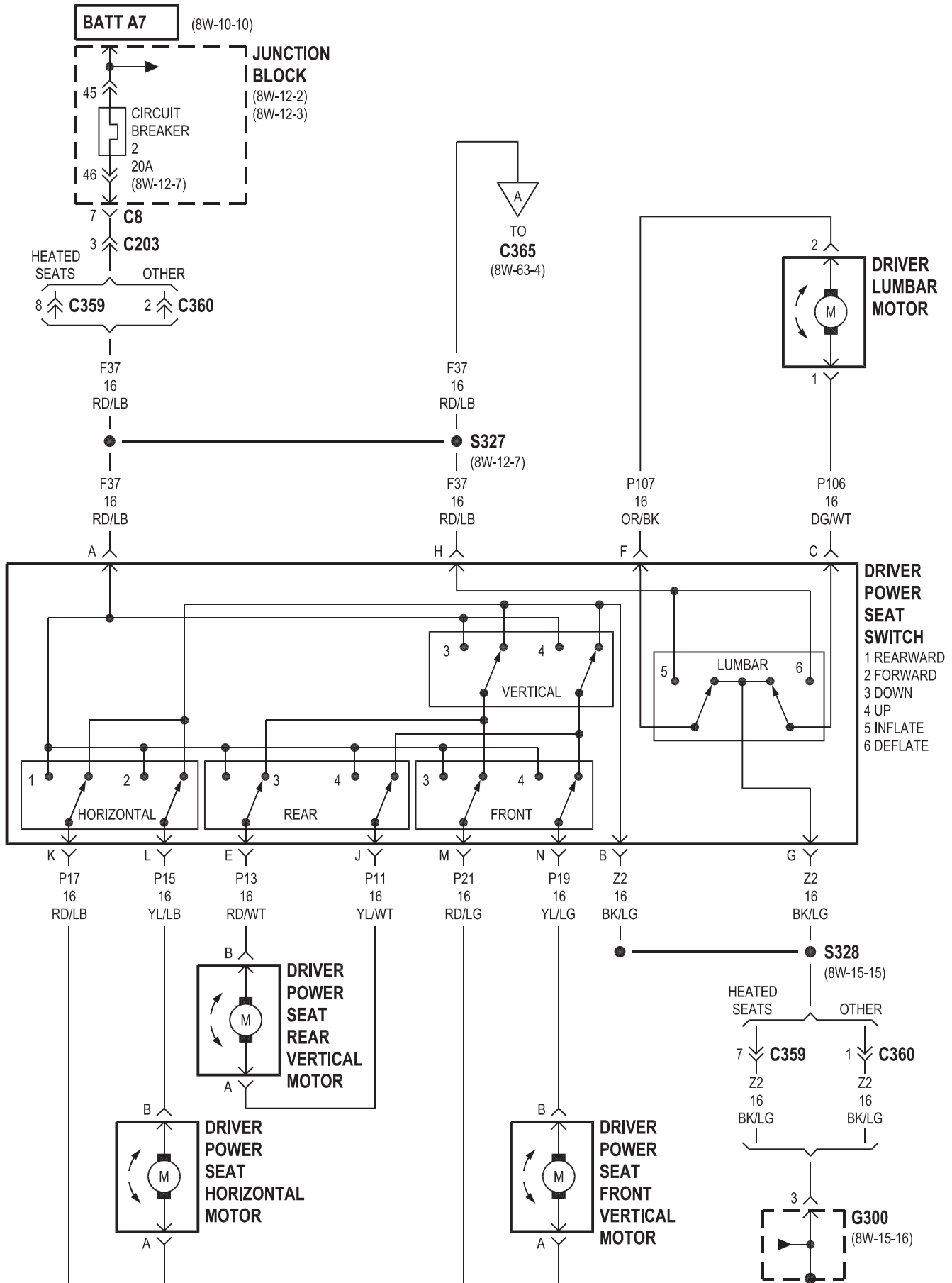


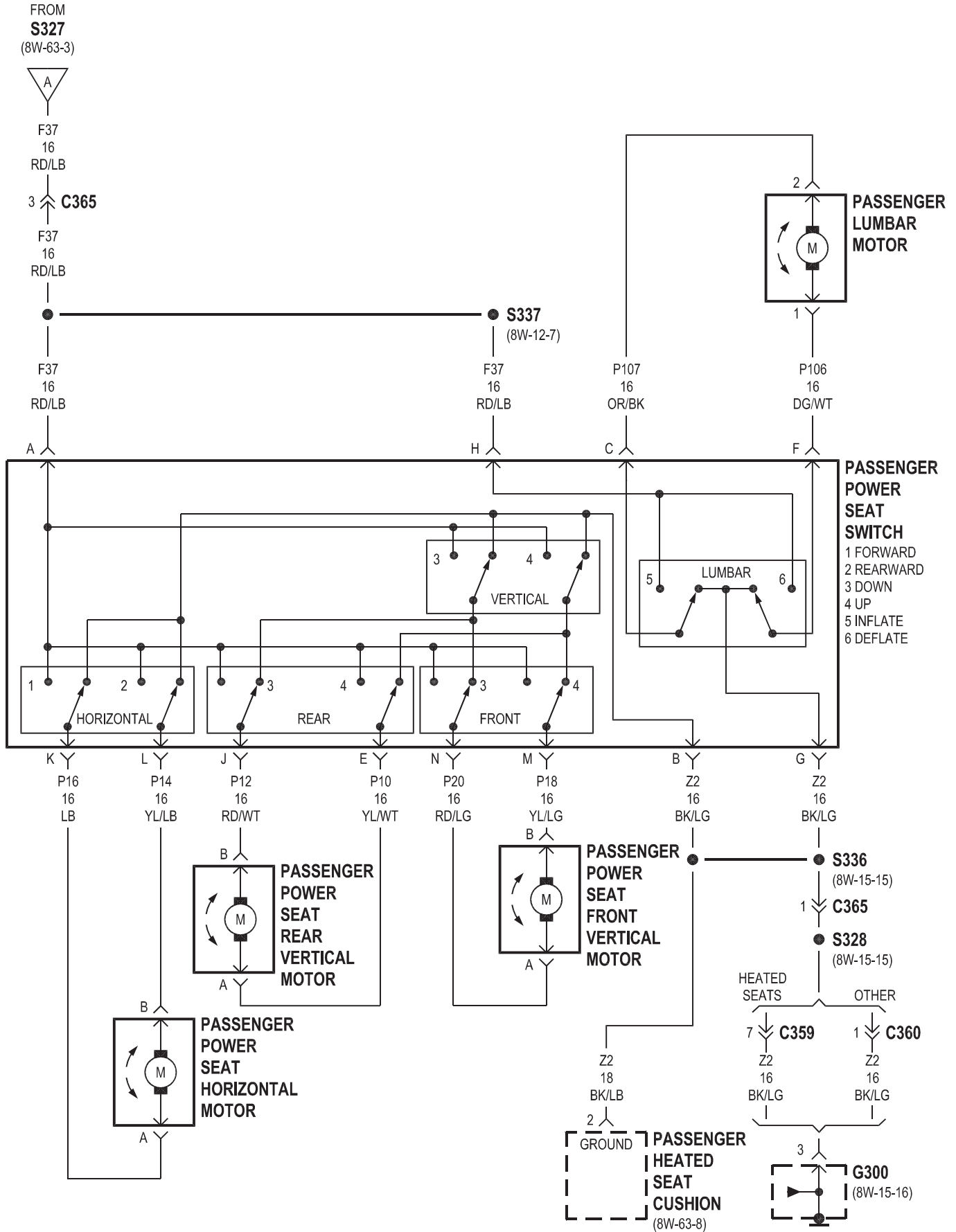


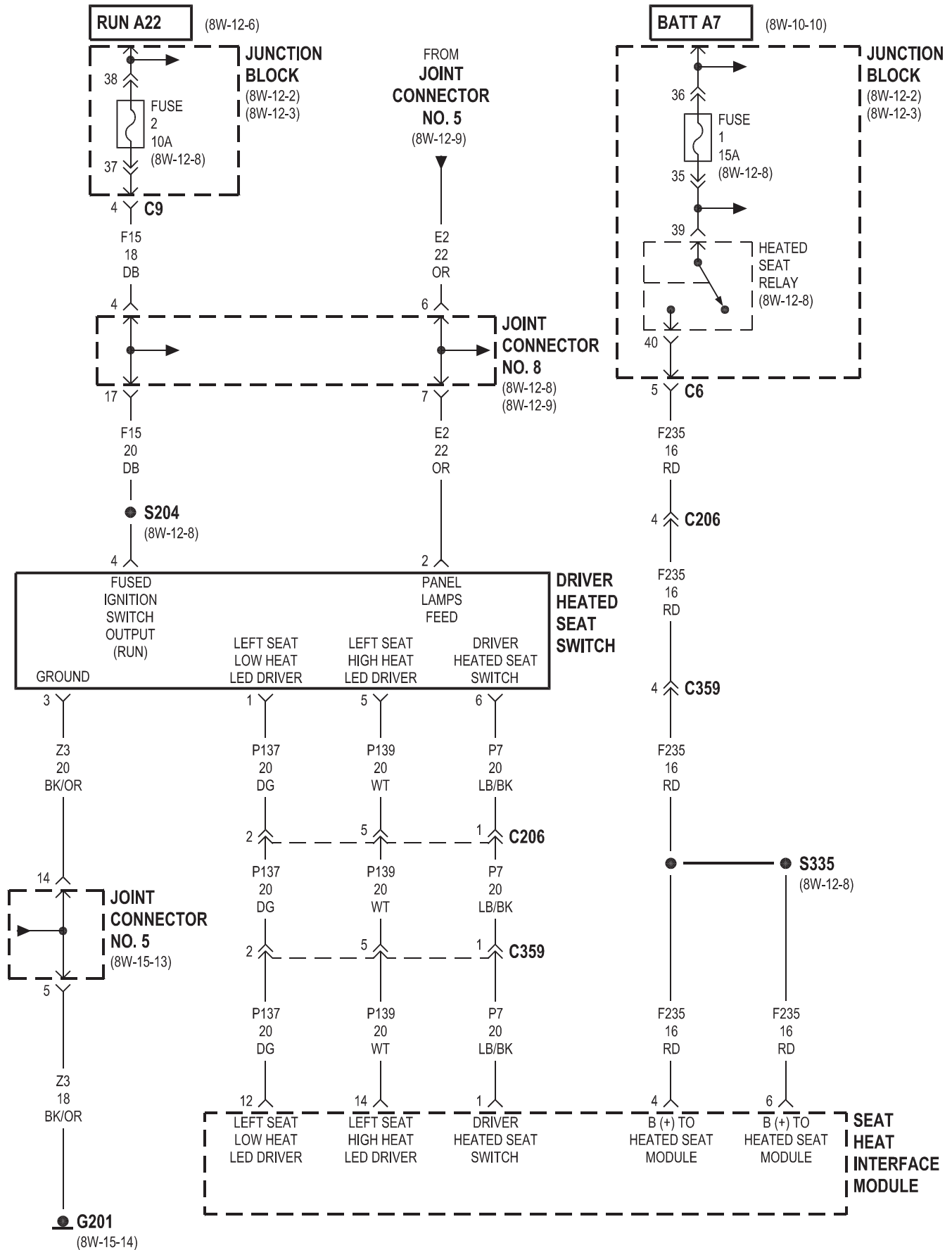
## 8W-63 POWER SEATS

<b>Component</b>	<b>Page</b>	<b>Component</b>	<b>Page</b>
Circuit Breaker 2 . . . . .	8W-63-2, 3	Heated Seat Relay . . . . .	8W-63-5, 7
Driver Heated Seat Cushion . . . . .	8W-63-6, 8	Joint Connector No. 5 . . . . .	8W-63-5, 7
Driver Heated Seat Switch . . . . .	8W-63-5	Joint Connector No. 8 . . . . .	8W-63-5, 7
Driver Lumbar Motor . . . . .	8W-63-3	Junction Block . . . . .	8W-63-2, 3, 5, 7
Driver Power Seat Front Vertical Motor . . .	8W-63-2, 3	Passenger Heated Seat Cushion . . . . .	8W-63-4, 6, 8
Driver Power Seat Horizontal Motor . . . .	8W-63-2, 3	Passenger Heated Seat Switch . . . . .	8W-63-7
Driver Power Seat Rear Vertical Motor . .	8W-63-2, 3	Passenger Lumbar Motor . . . . .	8W-63-4
Driver Power Seat Switch . . . . .	8W-63-2, 3	Passenger Power Seat Front Vertical Motor.	8W-63-4
Fuse 1 (JB) . . . . .	8W-63-5, 7	Passenger Power Seat Horizontal Motor . . .	8W-63-4
Fuse 2 (JB) . . . . .	8W-63-5, 7	Passenger Power Seat Rear Vertical Motor . . .	8W-63-4
G201 . . . . .	8W-63-5, 7	Passenger Power Seat Switch . . . . .	8W-63-4
G300 . . . . .	8W-63-3, 4, 6, 8	Seat Heat Interface Module . . . . .	8W-63-5, 6, 7, 8
G301 . . . . .	8W-63-2		

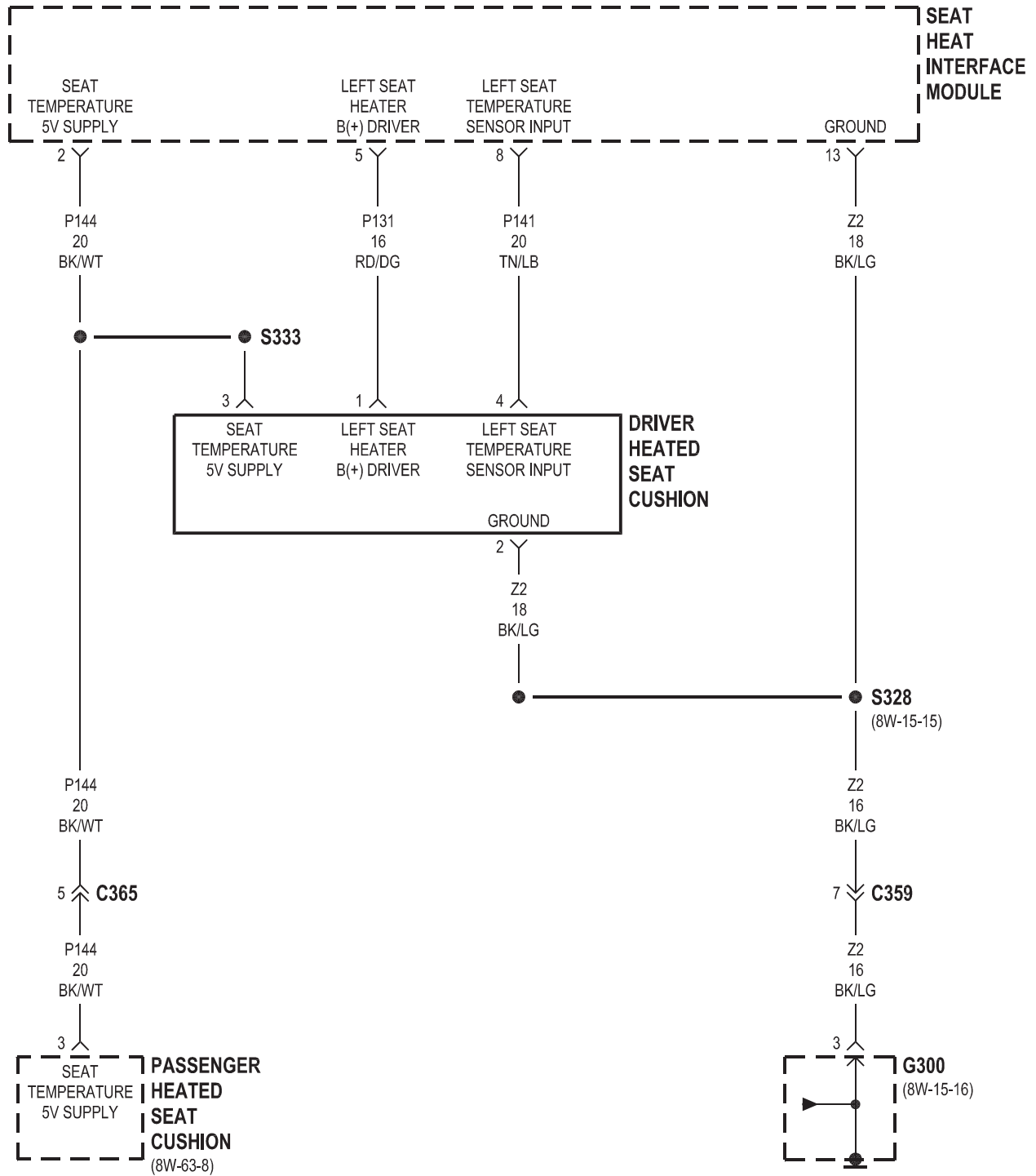


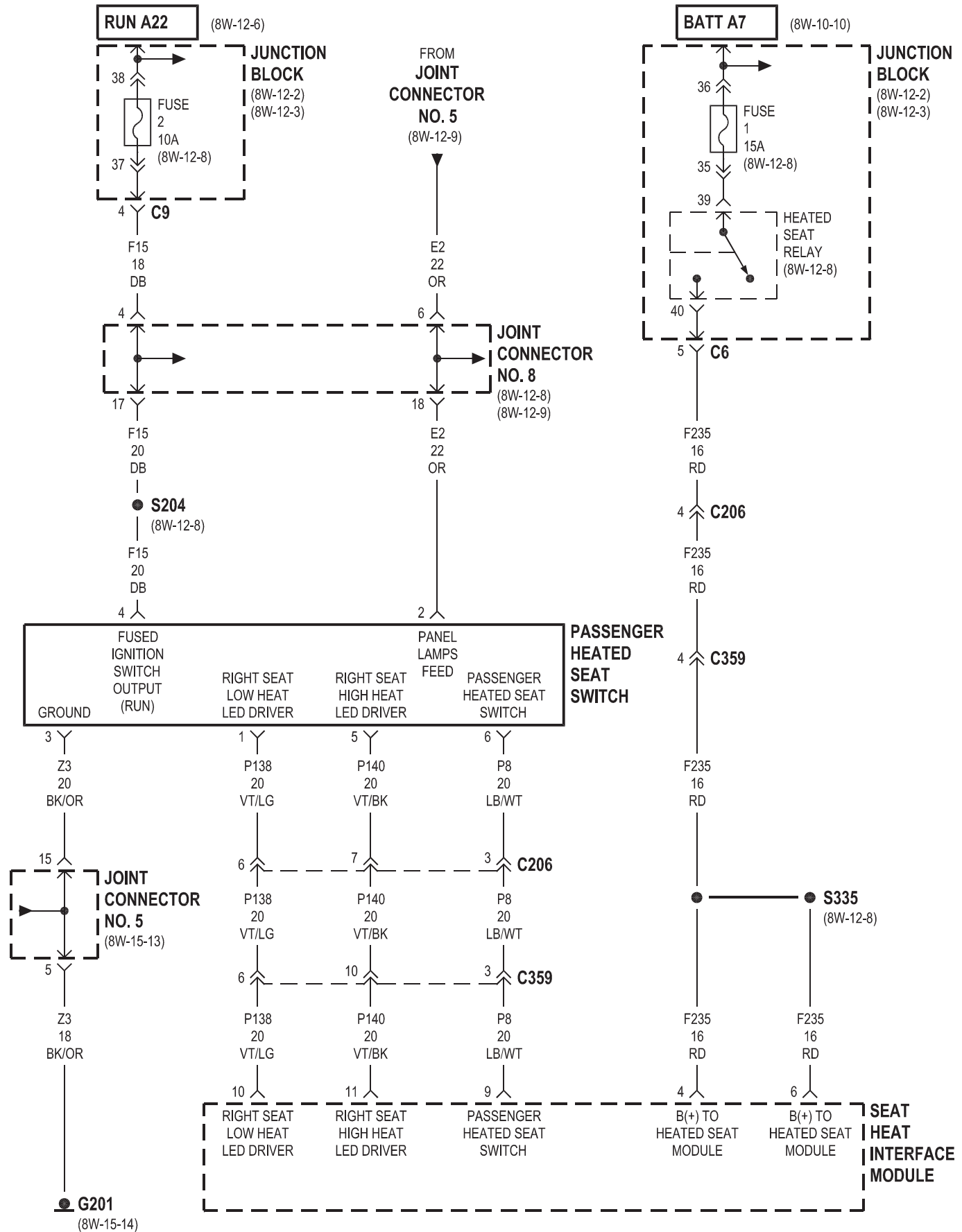


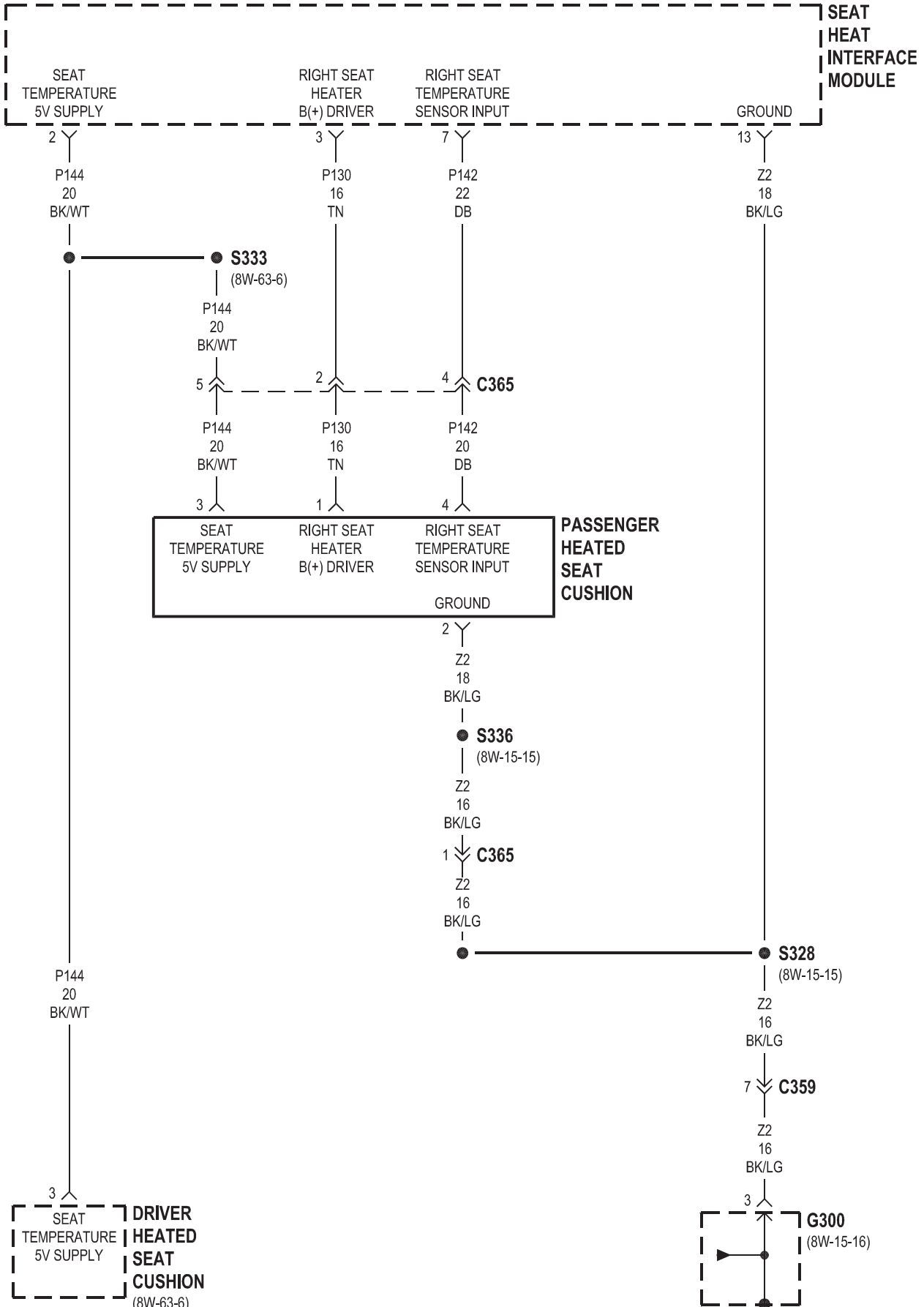






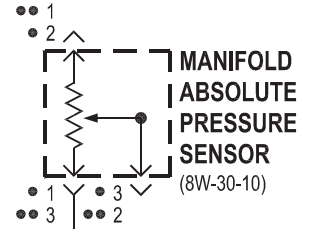
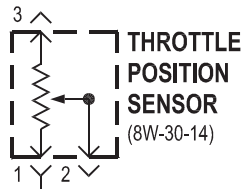
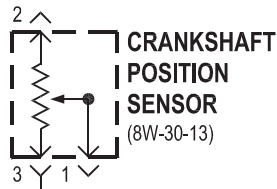
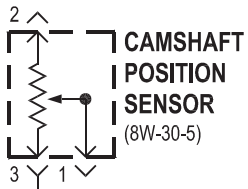






## 8W-70 SPLICE INFORMATION

<b>Component</b>	<b>Page</b>	<b>Component</b>	<b>Page</b>
S100	8W-10-19	S202	8W-53-2
S102	8W-12-18	S203	8W-12-10
S103	8W-12-18	S203	8W-53-2
S104	8W-50-7	S204	8W-12-8
S105	8W-12-13	S207	8W-42-3, 4
S106	8W-50-6	S209	8W-15-4
S107	8W-12-12	S210	8W-47-4
S108	8W-12-11	S300	8W-45-6
S109	8W-15-11	S300	8W-61-2, 4
S110	8W-50-10, 11	S301	8W-45-6
S111	8W-30-37	S301	8W-61-2, 4
S112	8W-15-5	S302	8W-15-4
S113	8W-10-23	S302	8W-47-8
S114	8W-10-13	S303	8W-47-8
S116	8W-31-2	S304	8W-12-7
S117	8W-10-15, 16	S305	8W-15-16
S118	8W-70-5, 6	S306	8W-12-15
S119	8W-70-2	S307	8W-62-3
S120	8W-42-3	S308	8W-39-4
S121	8W-70-4, 6	S308	8W-45-6
S122	8W-15-8	S310	8W-12-14
S123	8W-10-15, 16	S311	8W-15-17
S124	8W-10-17, 18	S313	8W-52-4
S126	8W-15-10, 8	S314	8W-52-4
S127	8W-21-3	S315	8W-15-6
S128	8W-15-9	S316	8W-51-2
S130	8W-10-18, 19	S317	8W-51-5
S131	8W-10-16	S318	8W-10-21
S134	8W-50-10, 11	S318	8W-54-2
S136	8W-10-25	S319	8W-10-21
S141	8W-50-7	S319	8W-54-2
S143	8W-10-25	S320	8W-54-3
S144	8W-50-5	S321	8W-15-6
S160	8W-30-34	S321	8W-54-4
S161	8W-10-12	S322	8W-50-8
S164	8W-15-10	S323	8W-12-15
S165	8W-70-7	S324	8W-12-13
S166	8W-30-33	S325	8W-15-18
S167	8W-10-12	S326	8W-12-14
S168	8W-15-9	S327	8W-12-7
S170	8W-30-31	S328	8W-15-15
S171	8W-12-12	S329	8W-15-16
S172	8W-30-40	S330	8W-15-16
S173	8W-30-40	S331	8W-15-7
S174	8W-30-38	S332	8W-45-10
S175	8W-18-3	S333	8W-63-6
S176	8W-10-18, 19	S335	8W-12-8
S177	8W-40-2	S336	8W-15-15
S179	8W-70-3	S337	8W-12-7
S180	8W-31-2	S340	8W-15-12
S181	8W-10-24	S401	8W-15-6
S182	8W-50-6	S402	8W-15-6
S183	8W-50-10	S404	8W-15-6
S184	8W-18-4	S406	8W-51-6



K6  
20  
VT/WT

K6  
20  
VT/WT

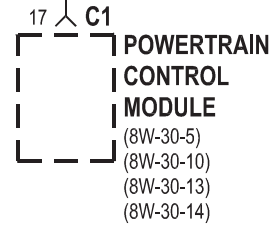
K6  
20  
VT/WT

K6  
20  
VT/WT

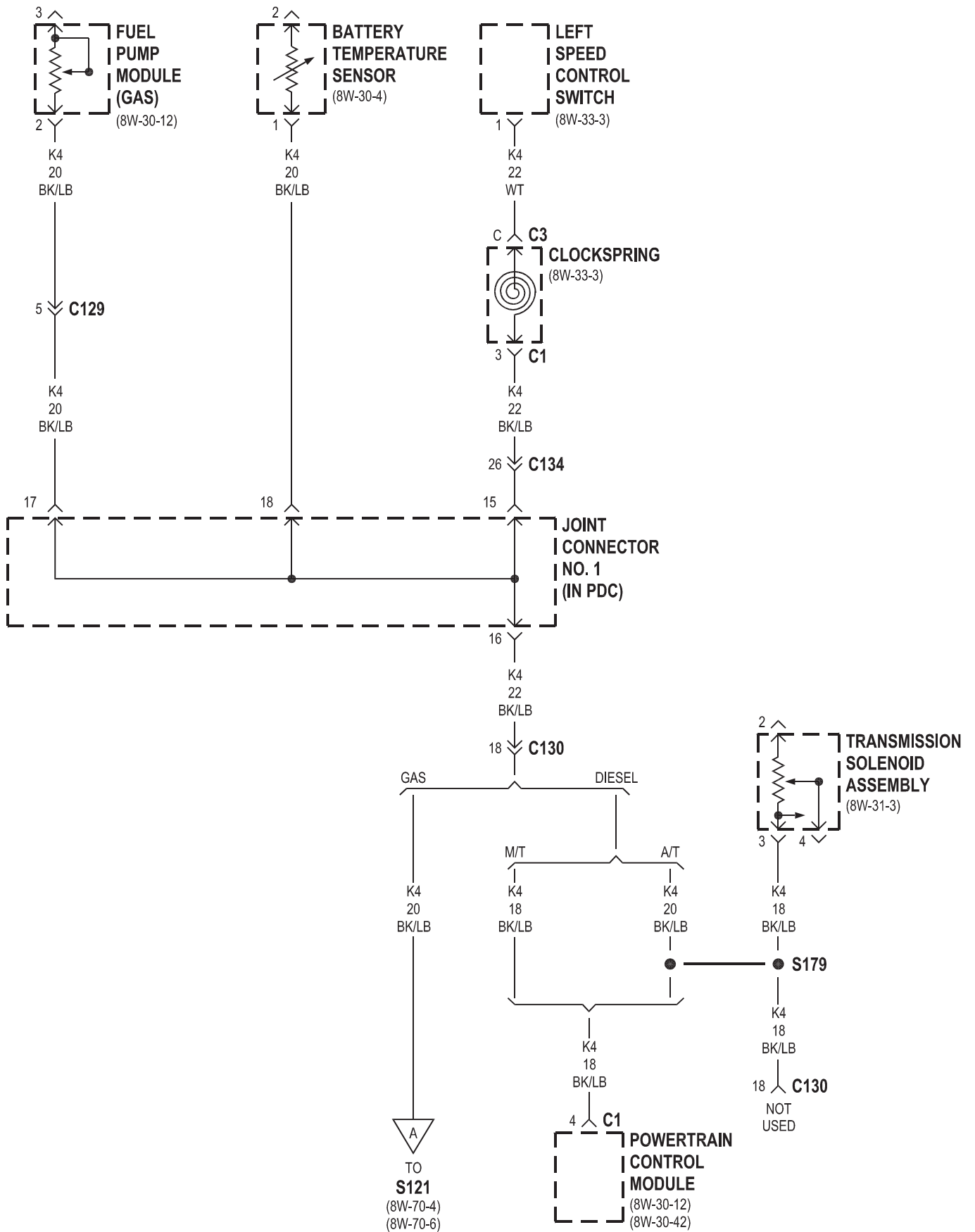


S119

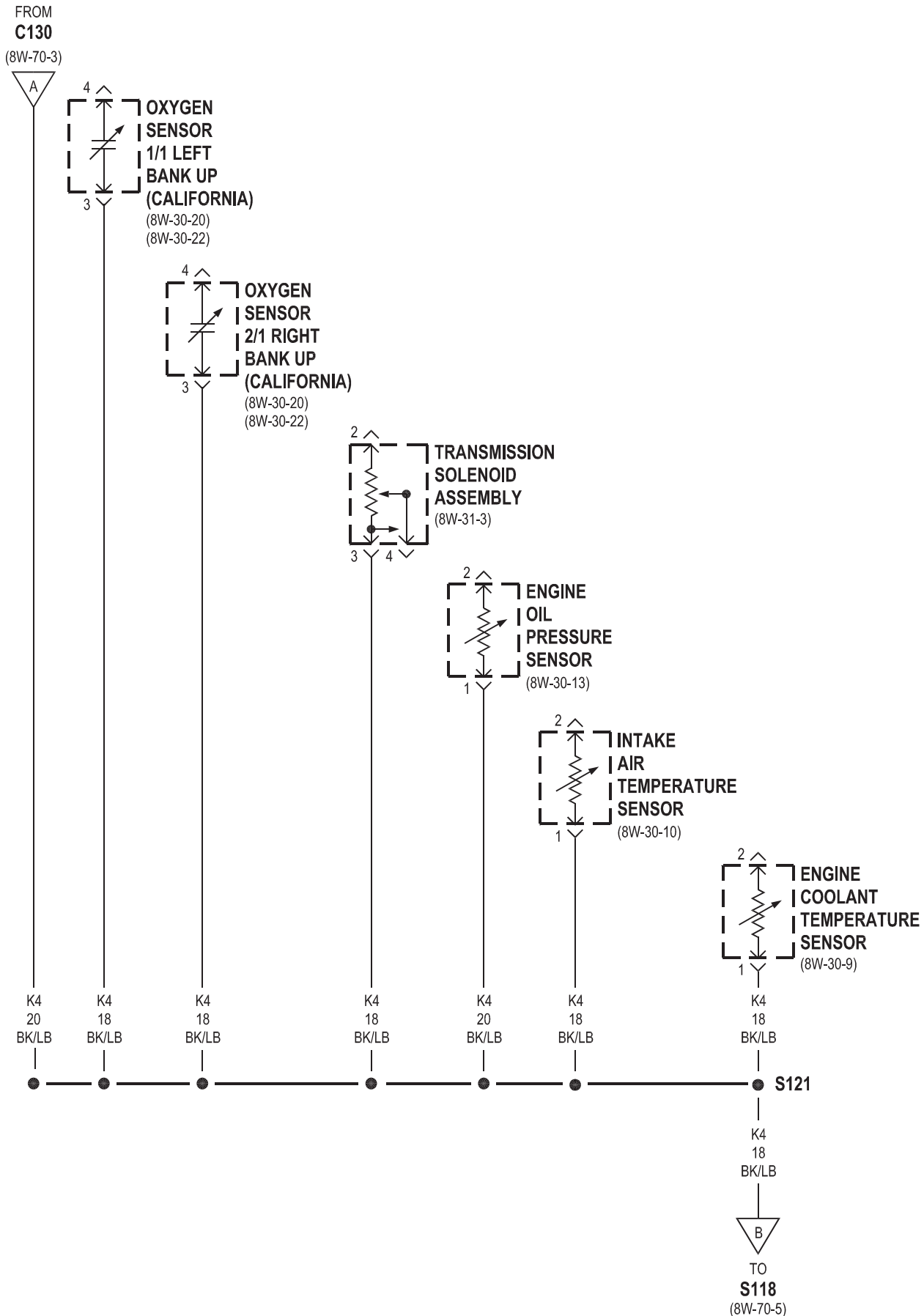
K6  
18  
VT/WT

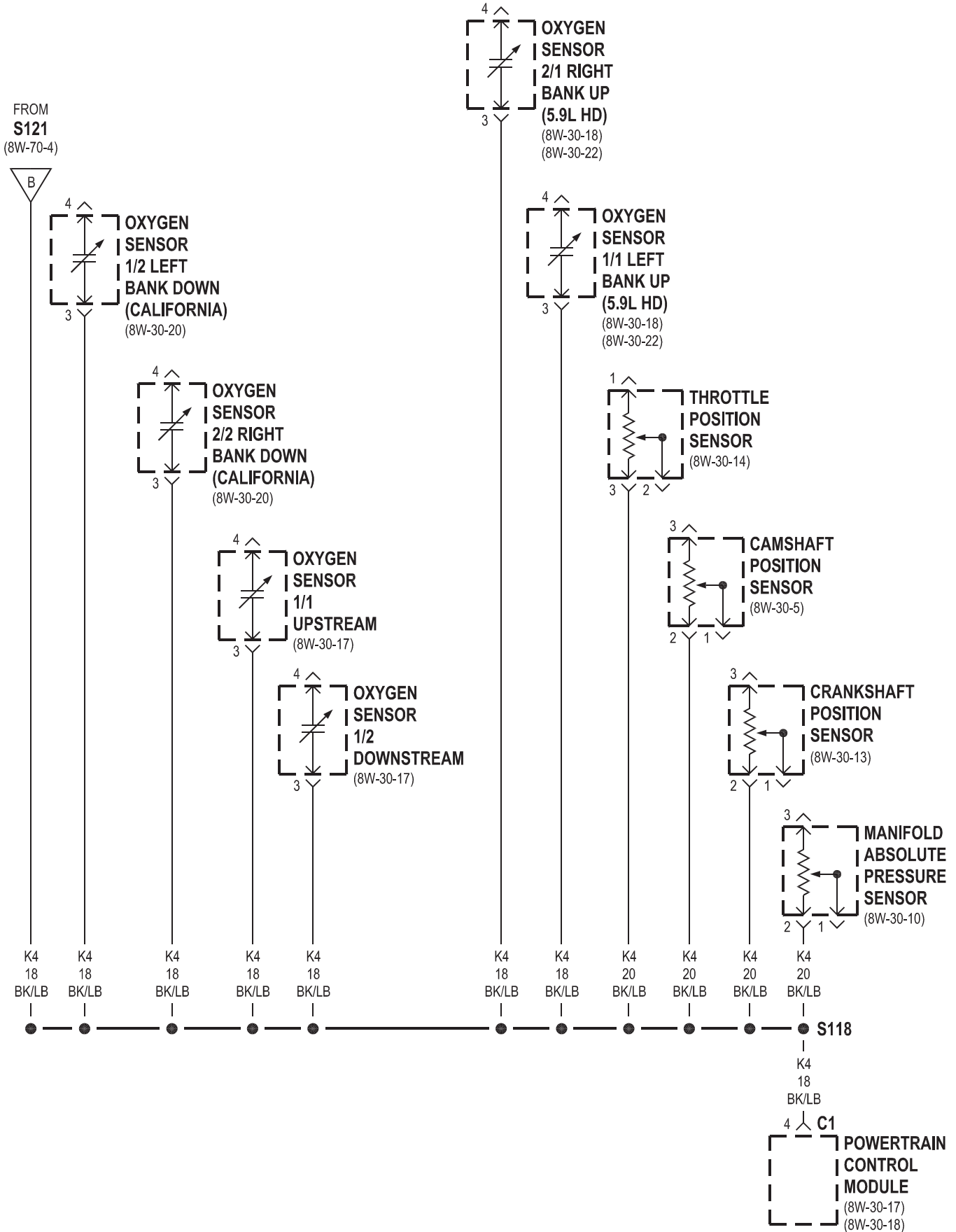


- 8.0L
- EXCEPT 8.0L

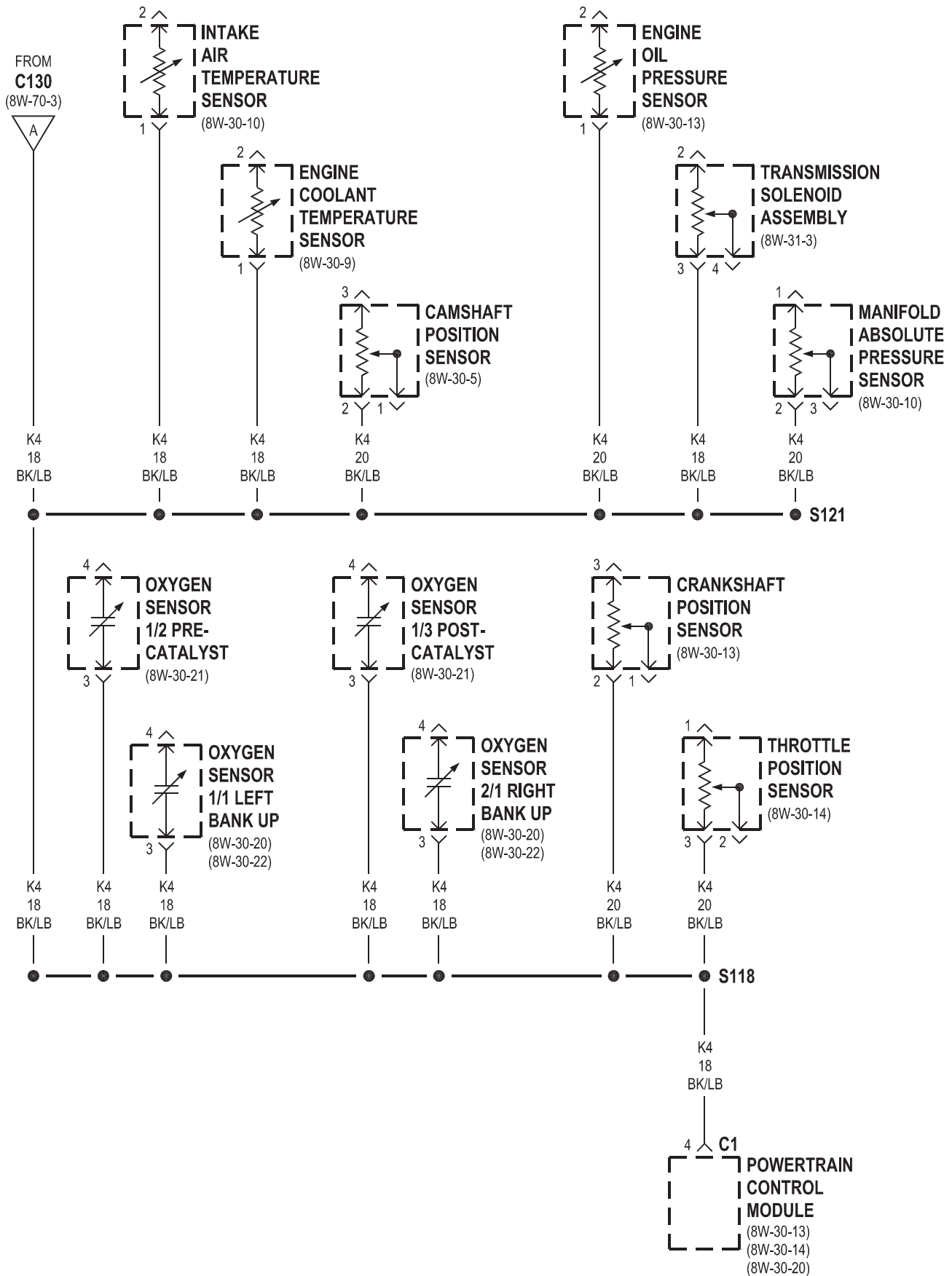


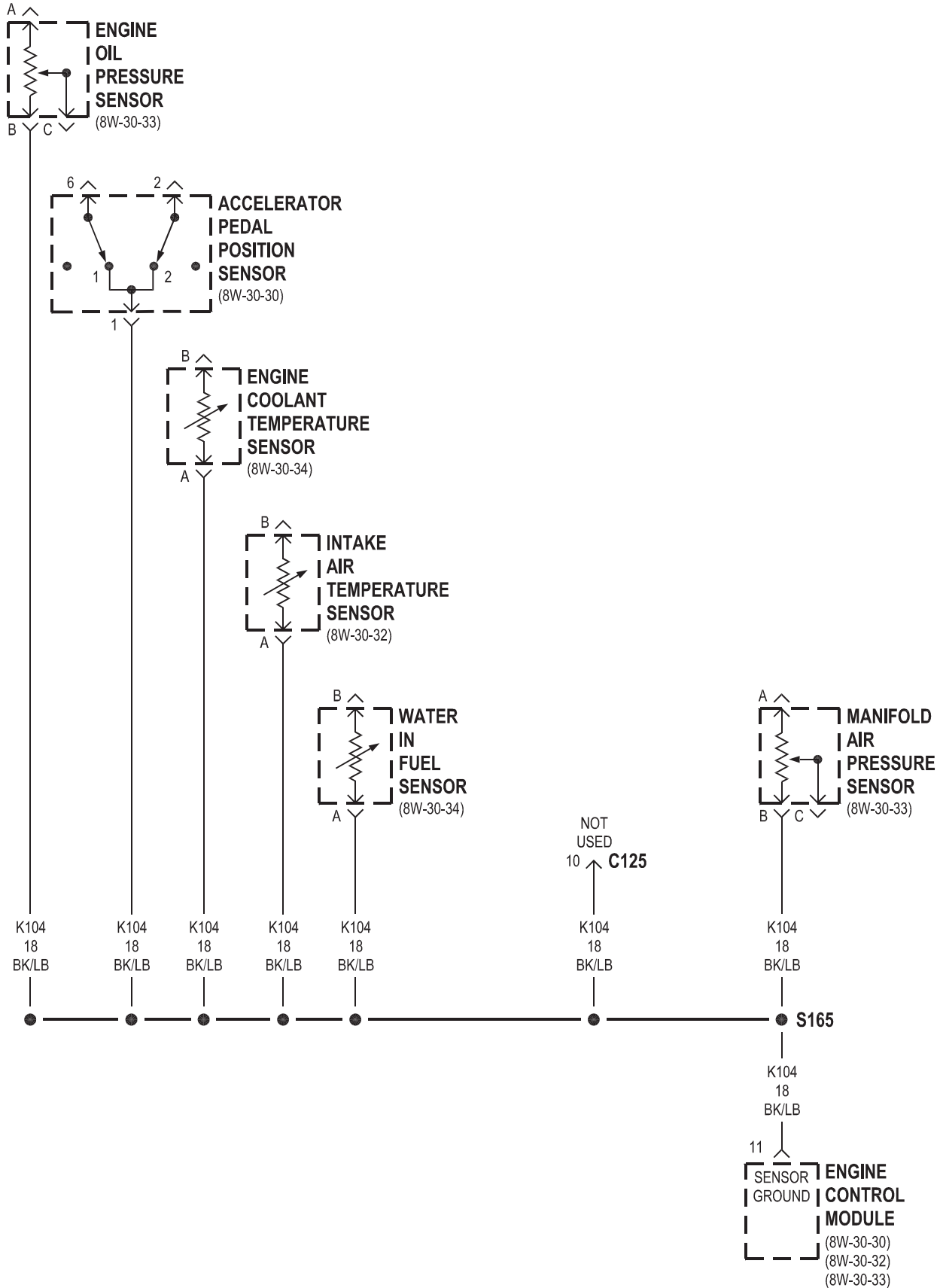






8.0L







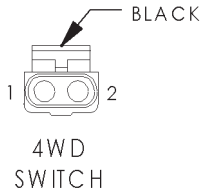
## 8W-80 CONNECTOR PIN-OUTS

<b>Component</b>	<b>Page</b>	<b>Component</b>	<b>Page</b>
4WD Switch	8W-80-4	C329 (Standard Cab)	8W-80-22
A/C Compressor Clutch	8W-80-4	C333 (Club Cab)	8W-80-22
A/C Heater Control	8W-80-4	C333 (Club Cab)	8W-80-22
A/C Heater Temperature Select	8W-80-4	C333 (Standard Cab)	8W-80-22
A/C High Pressure Switch	8W-80-4	C333 (Standard Cab)	8W-80-23
A/C Low Pressure Switch	8W-80-5	C342	8W-80-23
Accelerator Pedal Position Sensor (Diesel)	8W-80-5	C342	8W-80-23
Aftermarket Trailer Tow Connector	8W-80-5	C343	8W-80-23
Airbag Control Module	8W-80-5	C343	8W-80-23
Ambient Temperature Sensor	8W-80-6	C344 (Dual Rear Wheels)	8W-80-23
Ash Receiver Lamp	8W-80-6	C344 (Dual Rear Wheels)	8W-80-24
Automatic Day/Night Mirror	8W-80-6	C345	8W-80-24
Back-Up Lamp Switch (M/T)	8W-80-6	C345	8W-80-24
Battery Temperature Sensor	8W-80-6	C346	8W-80-25
Blend Door Actuator	8W-80-6	C346	8W-80-25
Blower Motor	8W-80-7	C347	8W-80-25
Blower Motor Resistor Block	8W-80-7	C347	8W-80-26
Brake Lamp Switch	8W-80-7	C348	8W-80-26
Brake Pressure Switch	8W-80-7	C348	8W-80-26
Bypass Jumper (A/T)	8W-80-7	C352	8W-80-27
C105	8W-80-7	C352	8W-80-27
C105	8W-80-8	C353	8W-80-27
C106	8W-80-8	C353	8W-80-27
C106	8W-80-8	C358	8W-80-27
C114	8W-80-8	C358	8W-80-27
C114	8W-80-8	C359 (Heated Seat)	8W-80-28
C125 (Diesel)	8W-80-8	C359 (Heated Seat)	8W-80-28
C125 (Diesel)	8W-80-9	C360 (Club Cab)	8W-80-28
C126 (Diesel)	8W-80-9	C360 (Club Cab)	8W-80-28
C126 (Diesel)	8W-80-9	C361	8W-80-29
C129	8W-80-10	C361	8W-80-29
C129	8W-80-10	C364	8W-80-29
C130 (Diesel)	8W-80-11	C364	8W-80-29
C130 (Diesel) (In PDC)	8W-80-12	C365 (Heated Seat)	8W-80-30
C130 (Gas)	8W-80-13	C365 (Heated Seat)	8W-80-30
C130 (Gas) (In PDC)	8W-80-14	Camshaft Position Sensor (Diesel)	8W-80-30
C134	8W-80-15	Camshaft Position Sensor (Gas Except 8.0L)	8W-80-30
C134	8W-80-16	Camshaft Position Sensor (8.0L Gas)	8W-80-30
C203	8W-80-18	Cargo Lamp No. 1	8W-80-31
C203	8W-80-18	Cargo Lamp No. 2	8W-80-31
C205	8W-80-19	Center High Mounted Stop Lamp No. 1	8W-80-31
C205	8W-80-19	Center High Mounted Stop Lamp No. 2	8W-80-31
C206 (Heated Seats)	8W-80-19	Center Identification Lamp	8W-80-31
C206 (Heated Seats)	8W-80-19	Central Timer Module C1	8W-80-32
C237	8W-80-20	Central Timer Module C2	8W-80-32
C237	8W-80-20	Cigar Lighter	8W-80-32
C303	8W-80-20	Clockspring C1	8W-80-33
C303	8W-80-20	Clockspring C2	8W-80-33
C308	8W-80-21	Clockspring C3	8W-80-33
C308	8W-80-21	Clutch Pedal Position Switch (M/T)	8W-80-33
C329 (Club Cab)	8W-80-21	Controller Antilock Brake C1	8W-80-33
C329 (Club Cab)	8W-80-21	Controller Antilock Brake C2 (ABS)	8W-80-34
C329 (Standard Cab)	8W-80-22	Crankshaft Position Sensor (Gas 8.0L)	8W-80-34



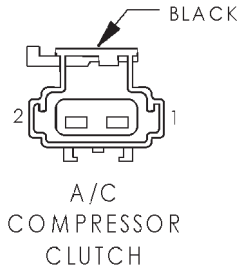
<b>Component</b>	<b>Page</b>	<b>Component</b>	<b>Page</b>
Crankshaft Position Sensor		G300	8W-80-44
(Gas Except 8.0L)	8W-80-34	Generator	8W-80-45
Cummins Bus (Diesel)	8W-80-34	Glove Box Lamp And Switch	8W-80-45
Cup Holder Lamp	8W-80-34	Headlamp Switch C1	8W-80-45
Data Link Connector	8W-80-35	Headlamp Switch C2	8W-80-45
Daytime Running Lamp Module	8W-80-35	Heated Mirror Switch	8W-80-45
Dome Lamp	8W-80-35	High Note Horn	8W-80-46
Driver Airbag	8W-80-35	Idle Air Control Motor	8W-80-46
Driver Cylinder Lock Switch	8W-80-36	Ignition Coil (3.9L/5.2L/5.9L)	8W-80-46
Driver Door Ajar Switch (Premium)	8W-80-36	Ignition Coil 4 Pack (8.0L)	8W-80-46
Driver Door Ajar Switch (Base)	8W-80-36	Ignition Coil 6 Pack (8.0L)	8W-80-46
Driver Door Lock Motor	8W-80-36	Ignition Switch C1	8W-80-47
Driver Door Window/Lock Switch	8W-80-36	Ignition Switch C2	8W-80-47
Driver Heated Seat Cushion	8W-80-37	Instrument Cluster C1	8W-80-47
Driver Heated Seat Switch	8W-80-37	Instrument Cluster C2	8W-80-47
Driver Lumbar Motor	8W-80-37	Intake Air Heater Relays (Diesel)	8W-80-47
Driver Power Seat Front Vertical Motor		Intake Air Temperature Sensor (Diesel)	8W-80-48
(Club Cab)	8W-80-37	Intake Air Temperature Sensor (Gas)	8W-80-48
Driver Power Seat Front Vertical Motor		Joint Connector No. 1 (In PDC)	8W-80-48
(Standard Cab)	8W-80-37	Joint Connector No. 2 (In PDC)	8W-80-49
Driver Power Seat Horizontal Motor		Joint Connector No. 3	8W-80-49
(Club Cab)	8W-80-38	Joint Connector No. 4	8W-80-49
Driver Power Seat Horizontal Motor		Joint Connector No. 5	8W-80-50
(Standard Cab)	8W-80-38	Joint Connector No. 6	8W-80-50
Driver Power Seat Rear Vertical Motor		Joint Connector No. 7	8W-80-51
(Club Cab)	8W-80-38	Joint Connector No. 8	8W-80-51
Driver Power Seat Rear Vertical Motor		Junction Block C1	8W-80-52
(Standard Cab)	8W-80-38	Junction Block C2	8W-80-52
Driver Power Seat Switch (Club Cab)	8W-80-38	Junction Block C3	8W-80-52
Driver Power Seat Switch		Junction Block C4	8W-80-53
(Standard Cab)	8W-80-39	Junction Block C5	8W-80-53
Driver Power Window Motor	8W-80-39	Junction Block C6	8W-80-53
Electric Brake Provision	8W-80-39	Junction Block C7	8W-80-53
Engine Control Module (Diesel)	8W-80-40	Junction Block C8	8W-80-54
Engine Coolant Temperature Sensor		Junction Block C9	8W-80-54
(Diesel)	8W-80-41	Leak Detection Pump (Gas)	8W-80-54
Engine Coolant Temperature Sensor		Left Back-Up Lamp	8W-80-54
(Gas)	8W-80-41	Left Fog Lamp	8W-80-54
Engine Oil Pressure Sensor (Diesel)	8W-80-41	Left Front Door Speaker (Premium)	8W-80-55
Engine Oil Pressure Sensor (Gas)	8W-80-41	Left Front Door Speaker (Standard)	8W-80-55
Evap/Purge Solenoid	8W-80-41	Left Front Fender Lamp	
Front Washer Pump	8W-80-41	(Dual Rear Wheels)	8W-80-55
Fuel Heater (Diesel)	8W-80-42	Left Front Wheel Speed Sensor (ABS)	8W-80-55
Fuel Injection Pump (Diesel)	8W-80-42	Left Headlamp	8W-80-55
Fuel Injector No. 1	8W-80-42	Left License Lamp	8W-80-56
Fuel Injector No. 2	8W-80-42	Left Outboard Clearance Lamp	8W-80-56
Fuel Injector No. 3	8W-80-42	Left Outboard Headlamp	8W-80-56
Fuel Injector No. 4	8W-80-43	Left Outboard Identification Lamp	8W-80-56
Fuel Injector No. 5	8W-80-43	Left Park/Turn Signal Lamp	8W-80-56
Fuel Injector No. 6	8W-80-43	Left Power Mirror	8W-80-56
Fuel Injector No. 7 (5.2L/5.9L/8.0L)	8W-80-43	Left Rear Fender Lamp	
Fuel Injector No. 8 (5.2L/5.9L/8.0L)	8W-80-43	(Dual Rear Wheels)	8W-80-57
Fuel Injector No. 9 (8.0L)	8W-80-43	Left Rear Speaker (Premium 2 Door)	8W-80-57
Fuel Injector No. 10 (8.0L)	8W-80-44	Left Rear Speaker (Premium 4 Door)	8W-80-57
Fuel Pump Module (Gas)	8W-80-44	Left Rear Speaker (Standard 2 Door)	8W-80-57
Fuel Tank Module (Diesel)	8W-80-44	Left Rear Speaker (Standard 4 Door)	8W-80-57
Fuel Transfer Pump (Diesel)	8W-80-44	Left Remote Radio Switch	8W-80-57

<b>Component</b>	<b>Page</b>	<b>Component</b>	<b>Page</b>
Left Speed Control Switch . . . . .	8W-80-58	Passenger Power Seat Switch (Club Cab) . . . . .	8W-80-65
Left Tail/Stop/Turn Signal Lamp . . . . .	8W-80-58	Passenger Power Window Motor . . . . .	8W-80-65
Left Tweeter (Premium) . . . . .	8W-80-58	Power Mirror Switch . . . . .	8W-80-65
Left Visor/Vanity Lamp . . . . .	8W-80-58	Power Outlet . . . . .	8W-80-66
Low Note Horn . . . . .	8W-80-58	Powertrain Control Module C1 (Diesel) . . .	8W-80-66
Manifold ABSolute Pressure Sensor (3.9L/5.2L/5.9L) . . . . .	8W-80-58	Powertrain Control Module C1 (Gas) . . . .	8W-80-67
Manifold ABSolute Pressure Sensor (8.0L) . . . . .	8W-80-59	Powertrain Control Module C2 (Diesel) . . .	8W-80-67
Manifold Air Pressure Sensor (Diesel) . . .	8W-80-59	Powertrain Control Module C2 (Gas) . . . .	8W-80-68
Multi-Function Switch . . . . .	8W-80-59	Powertrain Control Module C3 (Diesel) . . .	8W-80-69
Output Speed Sensor . . . . .	8W-80-59	Powertrain Control Module C3 (Gas) . . . .	8W-80-70
Overdrive Switch . . . . .	8W-80-60	Radio C1 . . . . .	8W-80-70
Overhead Console (Base) . . . . .	8W-80-60	Radio C2 . . . . .	8W-80-71
Overhead Console (Highline) . . . . .	8W-80-60	Radio C3 . . . . .	8W-80-71
Oxygen Sensor 1/1 Left Bank Up (5.9L HD/8.0L) . . . . .	8W-80-60	Radio Choke Relay . . . . .	8W-80-71
Oxygen Sensor 1/1 Left Bank Up (California) . . . . .	8W-80-60	Rear Wheel Speed Sensor (ABS) . . . . .	8W-80-71
Oxygen Sensor 1/1 Upstream (A/T Except 8.0L) . . . . .	8W-80-61	Right Back-Up Lamp . . . . .	8W-80-71
Oxygen Sensor 1/1 Upstream (M/T Except 8.0L) . . . . .	8W-80-61	Right Fog Lamp . . . . .	8W-80-72
Oxygen Sensor 1/2 Downstream (3.9L/5.2L) . . . . .	8W-80-61	Right Front Door Speaker (Premium) . . . .	8W-80-72
Oxygen Sensor 1/2 Left Bank Down (California) . . . . .	8W-80-61	Right Front Door Speaker (Standard) . . . .	8W-80-72
Oxygen Sensor 1/2 Pre-Catalyst (8.0L) . . .	8W-80-61	Right Front Fender Lamp (Dual Rear Wheels) . . . . .	8W-80-72
Oxygen Sensor 1/3 Post Catalyst (8.0L) . .	8W-80-62	Right Front Wheel Speed Sensor (ABS) . .	8W-80-72
Oxygen Sensor 2/1 Right Bank Up (5.9L HD) (5.2L/5.9L/8.0L California) . . . . .	8W-80-62	Right Headlamp . . . . .	8W-80-73
Oxygen Sensor 2/2 Right Bank Down (California) . . . . .	8W-80-62	Right License Lamp . . . . .	8W-80-73
Park/Neutral Position Switch (A/T Except 8.0L) . . . . .	8W-80-62	Right Outboard Clearance Lamp . . . . .	8W-80-73
Park/Neutral Position Switch (A/T 8.0L) . .	8W-80-62	Right Outboard Headlamp . . . . .	8W-80-73
Passenger Airbag . . . . .	8W-80-63	Right Outboard Identification Lamp . . . . .	8W-80-73
Passenger Airbag On/Off Switch C1 . . . . .	8W-80-63	Right Park/Turn Signal Lamp . . . . .	8W-80-73
Passenger Airbag On/Off Switch C2 . . . . .	8W-80-63	Right Power Mirror . . . . .	8W-80-74
Passenger Cylinder Lock Switch . . . . .	8W-80-63	Right Rear Fender Lamp (Dual Rear Wheels) . . . . .	8W-80-74
Passenger Door Ajar Switch . . . . .	8W-80-63	Right Rear Speaker (2 Door Premium) . . .	8W-80-74
Passenger Door Lock Motor . . . . .	8W-80-63	Right Rear Speaker (4 Door Premium) . . .	8W-80-74
Passenger Door Window/Lock Switch . . . .	8W-80-64	Right Rear Speaker (Standard 2 Door) . . .	8W-80-74
Passenger Heated Seat Cushion . . . . .	8W-80-64	Right Rear Speaker (Standard 4 Door) . . .	8W-80-74
Passenger Heated Seat Switch . . . . .	8W-80-64	Right Remote Radio Switch . . . . .	8W-80-75
Passenger Lumbar Motor . . . . .	8W-80-64	Right Speed Control Switch . . . . .	8W-80-75
Passenger Power Seat Front Vertical Motor (Club Cab) . . . . .	8W-80-64	Right Tail/Stop/Turn Signal Lamp . . . . .	8W-80-75
Passenger Power Seat Horizontal Motor (Club Cab) . . . . .	8W-80-65	Right Tweeter (Premium) . . . . .	8W-80-75
Passenger Power Seat Rear Vertical Motor (Club Cab) . . . . .	8W-80-65	Right Visor/Vanity Lamp . . . . .	8W-80-75
		Seat Belt Switch (Club Cab) . . . . .	8W-80-75
		Seat Belt Switch (Standard Cab) . . . . .	8W-80-76
		Seat Heat Interface Module . . . . .	8W-80-76
		Speed Control Servo . . . . .	8W-80-76
		Tailgate Lamp (Dual Rear Wheels) . . . . .	8W-80-76
		Throttle Position Sensor (Gas) . . . . .	8W-80-76
		Trailer Tow Connector . . . . .	8W-80-77
		Transmission Solenoid Assembly . . . . .	8W-80-77
		Underhood Lamp . . . . .	8W-80-77
		Washer Fluid Level Switch . . . . .	8W-80-77
		Water In Fuel Sensor (Diesel) . . . . .	8W-80-78
		Wiper Motor . . . . .	8W-80-78



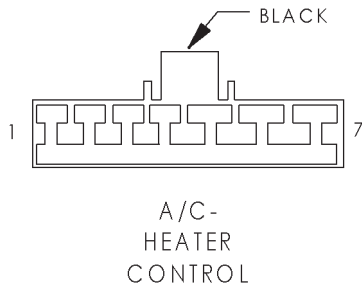
4WD SWITCH - BLACK 2

CAV	CIRCUIT	FUNCTION
1	G107 18BK/GY	4WD SWITCH SENSE
2	Z11 18BK	GROUND



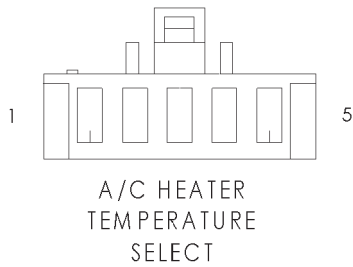
A/C COMPRESSOR CLUTCH - BLACK 2 WAY

CAV	CIRCUIT	FUNCTION
1	C3 18DB/BK	A/C COMPRESSOR CLUTCH RELAY OUTPUT
2	Z11 18BK/WT	GROUND



A/C HEATER CONTROL - BLACK 7 WAY

CAV	CIRCUIT	FUNCTION
1	E2 22OR	PANEL LAMPS FEED
2	C90 22LG/WT	A/C SELECT INPUT
3	C4 16TN	LOW SPEED BLOWER MOTOR
4	C5 16LG	M1 SPEED BLOWER MOTOR
5	C6 14LB	M2 SPEED BLOWER MOTOR
6	C7 12BK/TN	HIGH SPEED BLOWER MOTOR
7	Z3 12BK/OR	GROUND



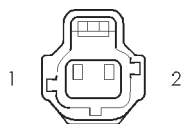
A/C HEATER TEMPERATURE SELECT - 5 WAY

CAV	CIRCUIT	FUNCTION
1	-	-
2	Z2 22BK/LG	GROUND
3	C82 22YL/OR	TEMPERATURE SELECT
4	F15 22DB	FUSED IGNITION SWITCH OUTPUT (RUN)
5	-	-



A/C HIGH PRESSURE SWITCH - 2 WAY

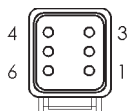
CAV	CIRCUIT	FUNCTION
1	C90 18LG/WT	A/C SELECT INPUT
2	C22 18DB	A/C SWITCH SENSE



A/C LOW PRESSURE SWITCH

A/C LOW PRESSURE SWITCH - 2 WAY

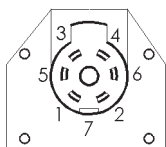
CAV	CIRCUIT	FUNCTION
1	C20 18BR	A/C SWITCH SENSE
2	C22 18DB	A/C SWITCH SENSE



ACCELERATOR PEDAL POSITION SENSOR (DIESEL)

ACCELERATOR PEDAL POSITION SENSOR (DIESEL) - 6 WAY

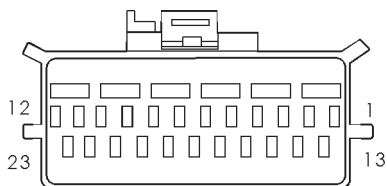
CAV	CIRCUIT	FUNCTION
1	K104 18BK/LB	SENSOR GROUND
2	H105 18LG/DB	IDLE VALIDATION SWITCH NO. 2
3	H102 18LB/BK	ACCELERATOR PEDAL POSITION SENSOR SIGNAL
4	H103 18BK/YL	ACCELERATOR PEDAL POSITION SENSOR GROUND
5	H101 18DB/WT	ACCELERATOR PEDAL POSITION SENSOR SUPPLY
6	H104 18BR/OR	IDLE VALIDATION SWITCH NO. 1



AFTERMARKET TRAILER TOW CONNECTOR

AFTERMARKET TRAILER TOW CONNECTOR - 7 WAY

CAV	CIRCUIT	FUNCTION
1	Z13 12BK	GROUND
2	B40 12LB	TRAILER TOW BRAKE B(+)
3	L76 12BK/OR	TRAILER TOW RELAY OUTPUT
4	A6 12RD/OR	FUSED B(+)
5	L63 16DG/RD	LEFT TURN SIGNAL
6	L62 16BR/RD	RIGHT TURN SIGNAL
7	L1 18VT/BK	BACK-UP LAMP FEED



AIRBAG CONTROL MODULE

AIRBAG CONTROL MODULE - 23 WAY

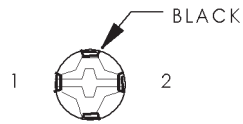
CAV	CIRCUIT	FUNCTION
1	-	-
2	-	-
3	-	-
4	Z6 18BK/PK	GROUND
5	R43 18BK/LB	DRIVER AIRBAG SQUIB LINE 2
6	R45 18DG/LB	DRIVER AIRBAG SQUIB LINE 1
7	R142 18BR/YL	PASSENGER AIRBAG SQUIB LINE 1
8	R144 18VT/YL	PASSENGER AIRBAG SQUIB LINE 2
9	-	-
10	-	-
11	-	-
12	-	-
13	-	-
14	F14 18LG/YL	FUSED IGNITION SWITCH OUTPUT (RUN-START)
15	F23 18DB/YL	FUSED IGNITION SWITCH OUTPUT (RUN)
16	-	-
17	-	-
18	-	-
19	-	-
20	-	-
21	D1 18VT/BR	CCD BUS (+)
22	D2 18WT/BK	CCD BUS (-)
23	-	-



AMBIENT TEMPERATURE SENSOR

AMBIENT TEMPERATURE SENSOR - 2 WAY

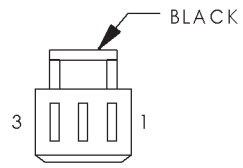
CAV	CIRCUIT	FUNCTION
1	G31 20VT/LG	AMBIENT TEMPERATURE SENSOR SIGNAL
2	G32 20BK/VT	SENSOR GROUND



ASH RECEIVER LAMP

ASH RECEIVER LAMP - BLACK 2 WAY

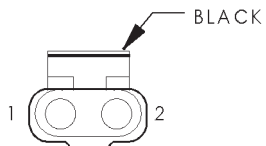
CAV	CIRCUIT	FUNCTION
1	E2 22OR	FUSED PANEL LAMPS DIMMER SWITCH SIGNAL
2	Z3 20BK/OR	GROUND



AUTOMATIC DAY/NIGHT MIRROR

AUTOMATIC DAY/NIGHT MIRROR - BLACK 3 WAY

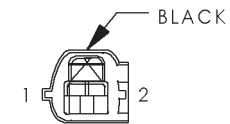
CAV	CIRCUIT	FUNCTION
1	F12 20DB/WT	FUSED IGNITION SWITCH OUTPUT (RUN-START)
2	Z3 20BK	GROUND
3	L1 20VT/BK	BACK-UP LAMP FEED



BACK-UP LAMP SWITCH (M/T)

BACK-UP LAMP SWITCH (M/T) - BLACK 2 WAY

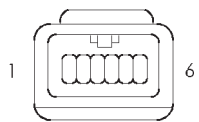
CAV	CIRCUIT	FUNCTION
1	L1 18VT/BK	BACK-UP LAMP FEED
2	L10 18BR/LG	FUSED IGNITION SWITCH OUTPUT (RUN)



BATTERY TEMPERATURE SENSOR

BATTERY TEMPERATURE SENSOR - BLACK 2 WAY

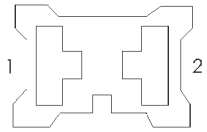
CAV	CIRCUIT	FUNCTION
1	K4 20BK/LB	SENSOR GROUND
2	K118 20PK/YL	BATTERY TEMPERATURE SENSOR SIGNAL



BLEND DOOR ACTUATOR

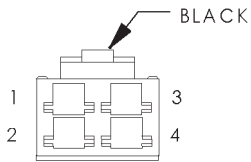
BLEND DOOR ACTUATOR - 6 WAY

CAV	CIRCUIT	FUNCTION
1	F15 20DB	FUSED IGNITION SWITCH OUTPUT (RUN)
2	C82 20YL/OR	TEMPERATURE SELECT
3	Z2 20BK/LG	GROUND
4	-	-
5	-	-
6	-	-

BLOWER  
MOTOR

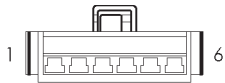
BLOWER MOTOR - 2 WAY

CAV	CIRCUIT	FUNCTION
1	C1 12DG	BLOWER MOTOR FEED
2	C7 12BK/TN	HIGH SPEED BLOWER MOTOR

BLOWER MOTOR  
RESISTOR BLOCK

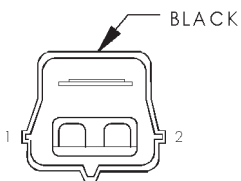
BLOWER MOTOR RESISTOR BLOCK - BLACK 4 WAY

CAV	CIRCUIT	FUNCTION
1	C7 12BK/TN	HIGH SPEED BLOWER MOTOR
2	C6 14LB	M2 SPEED BLOWER MOTOR
3	C5 16LG	M1 SPEED BLOWER MOTOR
4	C4 16TN	LOW SPEED BLOWER MOTOR

BRAKE LAMP  
SWITCH

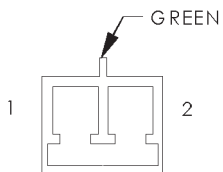
BRAKE LAMP SWITCH - 6 WAY

CAV	CIRCUIT	FUNCTION
1	V40 22WT/PK	BRAKE SWITCH SENSE
2	Z2 22BK/LG	GROUND
3	V32 22YL/RD	SPEED CONTROL SUPPLY
4	V30 22DB/RD	SPEED CONTROL BRAKE SWITCH OUTPUT
5	L50 16WT/TN	BRAKE LAMP SWITCH OUTPUT
6	F32 16PK/DB	FUSED B(+)

BRAKE PRESSURE  
SWITCH

BRAKE PRESSURE SWITCH - BLACK 2 WAY

CAV	CIRCUIT	FUNCTION
1	Z1 20BK	GROUND
2	G9 20GY/BK	RED BRAKE WARNING INDICATOR DRIVER

BYPASS JUMPER  
(A/T)

BYPASS JUMPER (A/T) - GREEN 2 WAY

CAV	CIRCUIT	FUNCTION
1	T141 14YL/RD	FUSED IGNITION SWITCH OUTPUT (START)
2	T141 14YL/RD	FUSED IGNITION SWITCH OUTPUT (START)

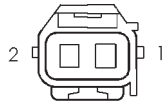


C105

C105 - (FOG LAMP JUMPER SIDE)

CAV	CIRCUIT
1	L34 20RD/OR
2	L39 20LB

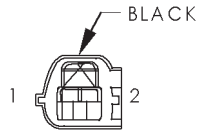




C 105

C105 - (HEADLAMP AND DASH SIDE)

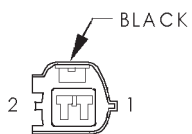
CAV	CIRCUIT
1	L34 20RD/OR
2	L39 20LB



C 106

C106 - BLACK (HEADLAMP AND DASH SIDE)

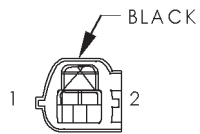
CAV	CIRCUIT
1	G107 20GY
2	Z1 20BK



C 106

C106 - BLACK (4X4 INDICATOR SIDE)

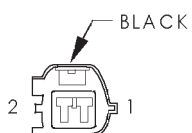
CAV	CIRCUIT
1	G107 18BK/GY
2	Z1 18BK



C 114

C114 - BLACK (AMBIENT TEMPERATURE SENSOR SIDE)

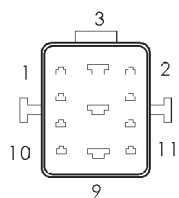
CAV	CIRCUIT
1	G31 20VT/LG
2	G32 20BK/VT



C 114

C114 - BLACK (HEADLAMP AND DASH SIDE)

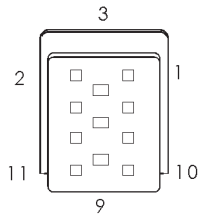
CAV	CIRCUIT
1	G31 20VT/LG
2	G32 20BK/VT



C 125  
(DIESEL)

C125 (DIESEL) - (TRANSMISSION SIDE)

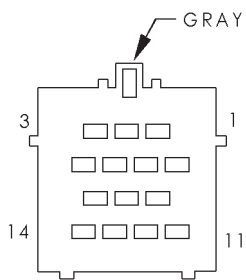
CAV	CIRCUIT
1	F18 18LG/BK
2	G113 18OR
3	A14 14RD/WT
4	C3 18DB/BK
5	C90 18LG/WT
6	K22 18OR/DB
7	A40 14RD/LG
8	K131 18BR/WT
9	A93 12RD/BK
10	K104 18BK/LB
11	G7 18WT/OR



C 125  
(DIESEL)

C125 (DIESEL) - (ENGINE SIDE)

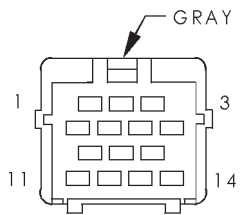
CAV	CIRCUIT
1	F18 18LG/BK
2	G113 18OR
3	A14 12RD/WT
4	C3 18DB/BK
5	C90 18LG/WT
6	K22 18OR/DB
7	A40 14RD/LG
8	K131 18BR/WT
9	A93 12RD/BK
10	K104 18BK/LB
11	G7 18WT/OR



C 126  
(DIESEL)

C126 (DIESEL) - GRAY (TRANSMISSION SIDE)

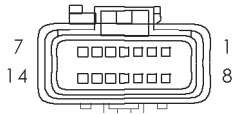
CAV	CIRCUIT
1	K20 18DG
2	V37 18RD/LG (A/T)
2	Z12 18BK/TN (M/T)
3	T125 18DB
4	D20 18DG
5	D21 18PK/DB
6	D1 18VT/BR
7	D2 18WT/BK
8	G85 18OR/BK
9	C22 18DB
10	K24 18GY/BK
11	V40 18WT/PK
12	Z12 18BK/TN
13	S21 18YL/BK
14	S22 18OR/BK



C 126  
(DIESEL)

C126 (DIESEL) - GRAY (ENGINE SIDE)

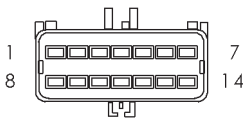
CAV	CIRCUIT
1	K20 18DG
2	V37 18RD/LG (M/T)
3	T125 18DB
4	D20 18DG
5	D21 18PK/DB
6	D1 18VT/BR
7	D2 18WT/BK
8	G85 18OR/BK
9	C22 18DB
10	K24 18GY/BK
11	V32 18YL/BK
12	Z12 18BK/TN
13	S21 18YL/BK
14	S22 18OR/BK



C129

C129 - (HEADLAMP AND DASH SIDE)

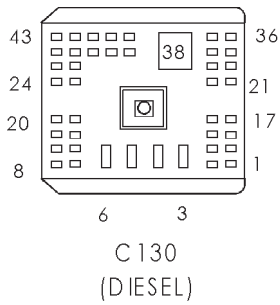
CAV	CIRCUIT
1	B113 20RD/VT
2	B114 20WT/VT
3	Z13 12BK
4	B40 12LB
5	K4 20BK/LB
6	K226 20DB/WT
7	L7 16BK/YL
8	L50 18WT/TN
9	L76 12BK/OR
10	L63 16DG/RD
11	L1 18VT/BK
12	A6 12RD/OR
13	L62 16BR/RD
14	A61 16DG/BK (GAS)



C129

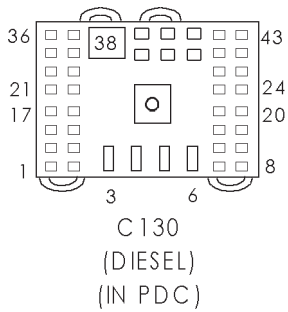
C129 - (CHASSIS HARNESS SIDE)

CAV	CIRCUIT
1	B113 20RD/VT
2	B114 20WT/VT
3	Z13 12BK
4	B40 12LB
5	K4 20BK/LB
6	K226 20DB/WT
7	L7 16BK/YL
8	L50 18WT/TN
9	L76 12BK/OR
10	L63 16DG/RD
11	L1 18VT/BK
12	A6 12RD/OR
13	L62 16BR/RD
14	A61 16DG/BK



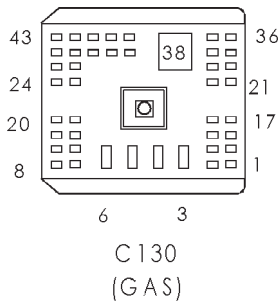
C130 (DIESEL) - (TRANSMISSION SIDE)

CAV	CIRCUIT
1	V35 18LG/RD
2	V32 18YL/RD
3	A14 14RD/WT
4	A142 14DG/OR
5	A40 14RD/LG
6	A93 12RD/BK
7	K118 18PK/YL
8	L1 18VT/BK
9	K131 18BR/WT
10	G85 18OR/BK
11	V40 18WT/PK
12	L10 18BR/LG
13	D1 18VT/BR
14	K51 18DB/YL
15	C13 18DB/OR
16	D20 18DG
17	D2 18WT/BK
18	K4 20BK/LB (A/T)
18	K4 18BK/LB (M/T)
19	C90 18LG/WT
20	D21 18PK/DB
21	C3 18DB/BK
22	V37 18RD/LG
23	K226 18DB/WT
24	V36 18TN/RD
25	Y128 18DG/GY
26	T41 20BK/WT (A/T)
26	Z12 18BK/TN (M/T)
27	-
28	F18 18LG/BK
29	K30 18PK (A/T)
30	K4 18BK/LB (A/T)
30	K104 18BK/LB (M/T)
31	T16 18RD
32	D220 18WT/VT
33	G7 18WT/OR(A/T)
34	T6 18OR/WT
35	T125 18DB
36	S21 18YL/BK
37	S22 18OR/BK
38	Y193 18WT/LG
39	Z12 18BK/TN (M/T)
40	Z12 18BK/TN (A/T)
40	V30 20DB/RD (A/T)
41	V30 20DB/RD
42	-
43	Z12 18BK/TN



C130 (DIESEL) (IN PDC) - (HEADLAMP AND DASH SIDE)

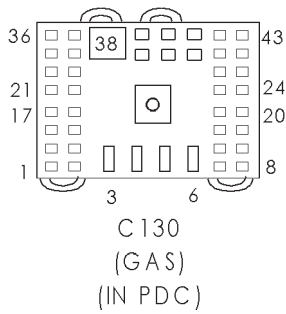
CAV	CIRCUIT
1	V35 20LG/RD
2	V32 20YL/RD
3	A14 16RD/WT
4	A142 14DG/OR
5	A40 14RD/LG
6	A93 12RD/BK
7	K118 20PK/YL
8	L1 18VT/BK
9	K131 20BR/WT
10	G85 22OR/BK
11	V40 22WT/PK
12	L10 18BR/LG
13	D1 20VT/BR
14	K51 20DB/YL
15	C13 22DB/OR
16	D20 20DG
17	D2 20WT/BK
18	K4 22BK/LB
19	C90 22LG/WT
20	D21 20PK/DB
21	C3 22DB/BK
22	V37 22RD/LG
23	K226 20DB/WT
24	V36 20TN/RD
25	Y128 18DG/GY
26	T41 22BK/WT
27	K31 20BR/WT
28	F18 20LG/BK
29	K30 22PK
30	A341 20DG/YL
31	T16 18RD
32	D220 20WT/VT
33	G7 20WT/OR
34	T6 22OR/WT
35	T125 18DB
36	S21 18YL/BK
37	S22 18OR/BK
38	Y193 18WT/LG
39	Z12 18BK/TN
40	V30 20DB/RD
41	V30 20DB/RD
42	K52 18PK/WT
43	Z12 18BK/TN



C130 (GAS) - (ENGINE HARNESS SIDE)

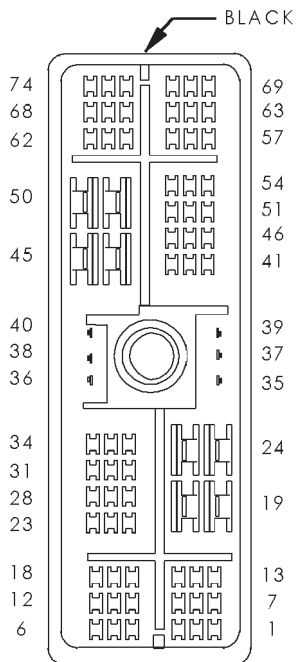
CAV	CIRCUIT
1	V35 18LG/RD
2	V32 18YL/RD
3	A14 16RD/WT
4	A142 14DG/OR
5	-
6	-
7	K118 18PK/YL
8	L1 18VT/BK
9	-
10	-
11	V40 18WT/PK
12	L10 18BR/LG
13	D1 18VT/BR
14	K51 18DB/YL
15	C13 18DB/OR
16	D20 18DG
17	D2 18WT/BK
18	K4 20BK/LB
19	C90 18LG/WT
20	D21 18PK/DB
21	C3 18DB/BK
22	V37 18RD/LG
23	K226 18DB/WT
24	V36 18TN/RD
25	Y128 18DG/GY (8.0L)
26	T41 22BK/WT (A/T)
26	Z11 20BK/WT (M/T)
27	K31 18BR/WT
28	F18 18LG/BK
29	K30 18PK (A/T)
30	A341 18DG/YL (CALIFORNIA)
31	T16 18RD
32	-
33	G7 18WT/OR
34	T6 18OR/WT (A/T)
35	T125 18DB (A/T)
36	K106 18WT/DG
37	K107 18OR
38	Y193 18WT/LG
39	Z12 18BK/TN
40	-
41	K145 18DG/PK
42	K52 18PK/WT
43	A141 20DG/WT (EXCEPT CALIFORNIA)





C130 (GAS) (IN PDC) - (HEADLAMP AND DASH SIDE)

CAV	CIRCUIT
1	V35 20LG/RD
2	V32 20YL/RD
3	A14 16RD/WT
4	A142 14DG/OR
5	-
6	A93 12RD/BK
7	K118 20PK/YL
8	L1 18VT/BK
9	-
10	-
11	V40 22WT/PK
12	L10 18BR/LG
13	D1 20VT/BR
14	K51 20DB/YL
15	C13 22DB/OR
16	D20 20DG
17	D2 20WT/BK
18	K4 22BK/LB
19	C90 22LG/WT
20	D21 20PK/DB
21	C3 22DB/BK
22	V37 22RD/LG
23	K226 20DB/WT
24	V36 18TN/RD
25	Y128 18DG/GY (8.0L)
26	T41 22BK/WT
27	K31 20BR/WT
28	F18 20LG/BK
29	K30 22PK (A/T)
30	A341 20DG/YL (CALIFORNIA)
31	T16 18RD
32	-
33	G7 20WT/OR
34	T6 22OR/WT (A/T)
35	T125 18DB (A/T)
36	K106 18WT/DG
37	K107 18OR
38	Y193 18WT/LG
39	Z12 18BK/TN
40	-
41	K145 20DG/PK
42	K52 18PK/WT
43	A141 20DG/WT (EXCEPT CALIFORNIA)



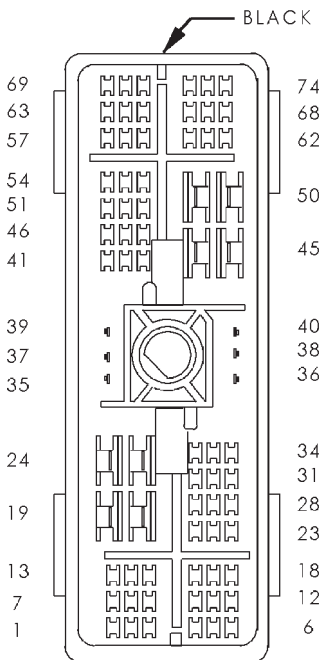
C134

C134 - (HEADLAMP AND DASH SIDE)

CAV	CIRCUIT
1	-
2	-
3	D220 20WT/VT (DIESEL)
4	-
5	L3 18RD/OR
6	-
7	-
8	Z12 18BK/TN
9	-
10	D2 20WT/BK
11	D1 20VT/BR
12	-
13	D20 20DG
14	D21 20PK/DB
15	-
16	D1 20VT/BR
17	D2 20WT/BK
18	-
19	L7 18BK/YL
20	A12 16RD/TN
21	T6 22OR/WT
22	L39 20LB (HIGHLINE)
23	F15 22DB
24	-
25	F32 16PK/DB
26	K4 22BK/LB
27	L35 22BR/YL (DRL)
27	L35 20BR/YL (EXCEPT DRL)
28	-
29	V37 22RD/LG
30	G11 20WT/LG
31	Z9 16BK/VT
32	X3 22BK/RD
33	-
34	Z5 18BK/DB
35	F33 16PK/RD
36	L4 18 VT/WT
37	V4 16RD/YL
38	V49 16RD/BK
39	V3 16BR/WT
40	V5 16DG
41	Z2 16BK/LG
42	Z6 18BK/PK
43	C90 22LG/WT
44	A1 10RD
45	C1 12DG
46	-
47	G50 22RD/DB
48	V30 20DB/RD
49	-
50	A2 14PK/BK
51	A41 14YL
52	-

C134 - (HEADLAMP AND DASH SIDE)

CAV	CIRCUIT
53	V32 20YL/RD
54	-
55	V18 22YL/DG
56	V40 22WT/PK
57	L62 16BR/RD
58	G85 22OR/BK (DIESEL)
59	G107 20GY
60	-
61	G29 18BK/WT
62	G34 20RD/GY
63	L63 16DG/RD
64	L50 18WT/TN
65	F12 20DB/WT
66	L10 18BR/LG
67	Z3 18BK/OR
68	V10 16BR
69	-
70	-
71	-
72	-
73	-
74	-



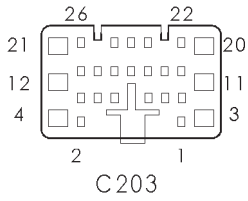
C134

C134 - (I/P HARNESS SIDE)

CAV	CIRCUIT
1	Y128 18DG/GY
2	Y193 18WT/LG
3	D220 20WT/VT (DIESEL)
4	-
5	L3 14RD/OR
6	-
7	-
8	Z12 18BK/TN
9	-
10	D2 20WT/BK
11	D1 20VT/BR
12	-
13	D20 20DG
14	D21 20PK/DB
15	-
16	D1 20VT/BR
17	D2 20WT/BK
18	-
19	L7 16BK/YL
20	A12 16RD/TN
21	T6 22OR/WT
22	L39 22LB
23	F15 22DB
24	-
25	F32 16PK/DB
26	K4 22BK/LB

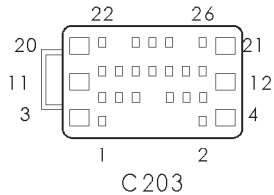
C134 - (I/P HARNESS SIDE)

CAV	CIRCUIT
27	L35 22BR/YL
27	L35 20BR/YL
28	-
29	V37 22RD/LG
30	G11 22WT/LG
31	Z9 16BK/VT (EXCEPT BASE/SLT)
32	X3 20BK/RD
33	-
34	Z5 18BK/DB
35	F33 16PK/RD
36	L4 14VT/WT
37	V4 16RD/YL
38	V49 16RD/BK
39	V3 16BR/WT
40	V5 16DG
41	Z2 16BK/LG
42	Z6 18BK/PK
43	C90 22LG/WT
44	A1 10RD
45	C1 12DG
46	-
47	G50 22RD/DB
48	V30 22DB/RD
49	-
50	A2 14PK/BK
51	A41 14YL
52	-
53	V32 22YL/RD
54	-
55	V18 22YL/DG
56	V40 22WT/PK
57	L62 16BR/RD
58	G85 22OR/BK (DIESEL)
59	G107 22GY
60	-
61	G29 22BK/WT
62	G34 16RD/GY
63	L63 16DG/RD
64	L50 18WT/TN
65	F12 22DB/WT
66	L10 18BR/LG
67	Z3 18BK/OR
68	V10 16BR
69	-
70	-
71	-
72	-
73	-
74	-



C203 - (I/P HARNESS SIDE)

CAV	CIRCUIT
1	X58 18DB/OR
2	X57 18BR/LB
3	F37 16RD/LB
4	F21 14TN
5	M1 22PK
6	X51 18BR/YL
7	X52 18DB/WT
8	M2 22YL
9	G10 22LG/RD
10	M22 22WT (BASE)
10	P30 22OR/RD (HIGHLINE/PREMIUM)
11	L50 18WT/TN
12	X13 16BK/RD (PREMIUM RADIO)
13	M3 22PK/DB
14	C16 22LB/YL
15	G16 22BK/LB (EXCEPT MIDLINE/BASE)
16	P33 22OR/BK (HIGHLINE/PREMIUM)
17	G73 22LG/OR
18	G75 22TN (EXCEPT MIDLINE/BASE)
19	F35 18RD
20	Z9 16BK/VT (EXCEPT BASE/LOWLINE (HIGHLINE/PREMIUM))
21	X54 18VT
22	X56 18DB/RD
23	X53 18DG
24	X55 18BR/RD
25	P31 22PK/DG (HIGHLINE/PREMIUM)
26	P34 22PK/BK (HIGHLINE/PREMIUM)

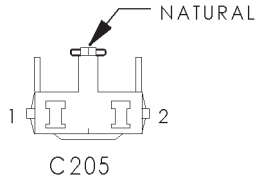


C203 - (BODY HARNESS SIDE)

CAV	CIRCUIT
1	X58 18DB/OR
2	X57 18BR/LB
3	F37 16RD/LB
4	F21 14TN (POWER LOCK/WINDOW)
5	M1 20PK
6	X51 18BR/YL
7	X52 18DB/WT
8	M2 20YL
9	G10 20LG/RD
10	M22 20WT (BASE)
10	P30 22OR/DG (HIGHLINE/PREMIUM)
11	L50 18WT/TN
12	X13 16BK/RD (PREMIUM RADIO)
13	M3 20PK/DB
14	C16 20LB/YL
15	G16 18BK/LB (HIGHLINE/PREMIUM)
16	P33 20OR/BK (POWER LOCK/WINDOW (HIGHLINE/PREMIUM))
17	G73 20LG/OR (HIGHLINE/PREMIUM)
18	G75 18TN
19	F35 18RD (POWER LOCK/WINDOW)
20	Z9 16BK/VT (PREMIUM RADIO)
21	X54 18VT

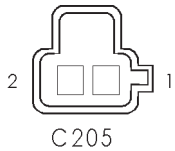
C203 - (BODY HARNESS SIDE)

CAV	CIRCUIT
22	X56 18DB/RD
23	X53 18DG
24	X55 18BR/RD
25	P31 22PK/DG (HIGHLINE/PREMIUM)
26	P34 20PK/BK (POWER LOCK/WINDOW (HIGHLINE/PREMIUM))



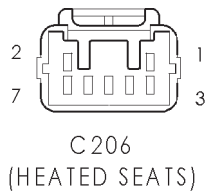
C205 - NATURAL (I/P SIDE)

CAV	CIRCUIT
1	E2 22OR
2	Z3 22BK/OR



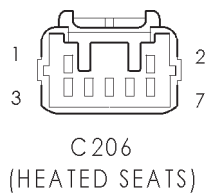
C205 - NATURAL (ASH RECEIVER LAMP SIDE)

CAV	CIRCUIT
1	E2 22OR
2	Z3 20BK/OR



C206 (HEATED SEATS) - (BODY SIDE)

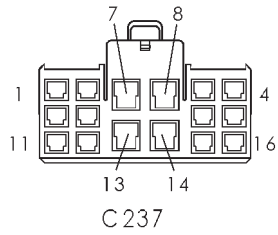
CAV	CIRCUIT
1	P7 20LB/BK
2	P137 20DG
3	P8 20LB/WT
4	F235 16RD
5	P139 20WT
6	P138 20VT/LG
7	P140 20VT/BK



C206 (HEATED SEATS) - (I/P SIDE)

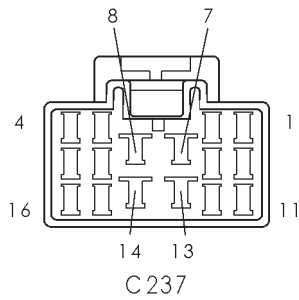
CAV	CIRCUIT
1	P7 20LB/BK
2	P137 20DG
3	P8 20LB/WT
4	F235 16RD
5	P139 20WT
6	P138 20VT/LG
7	P140 20VT/BK





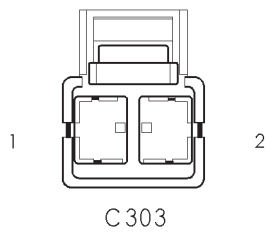
C237 - (I/P SIDE)

CAV	CIRCUIT
1	C5 16LG
2	Z2 22BK/LG
3	-
4	-
5	-
6	C82 22YL/OR
7	-
8	C7 12BK/TN
9	-
10	-
11	C4 16TN
12	F15 22DB
13	-
14	C6 14LB



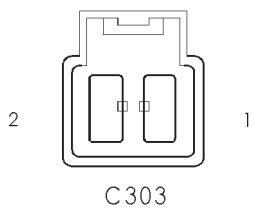
C237 - (RESISTOR BLOCK SIDE)

CAV	CIRCUIT
1	C5 16LG
2	Z2 20BK/LG
3	-
4	-
5	-
6	C82 20YL/OR
7	-
8	C7 12BK/TN
9	-
10	-
11	C4 16TN
12	F15 20DB
13	-
14	C6 14LB



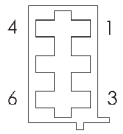
C303 - (BODY HARNESS SIDE)

CAV	CIRCUIT
1	Z2 16BK/LG
2	F37 16RD/LB



C303 - BLACK (POWER SEAT HARNESS SIDE)

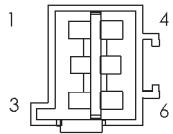
CAV	CIRCUIT
1	Z3 14BK/OR
2	F37 14RD/LB



C 308

C308 - (BODY HARNESS SIDE)

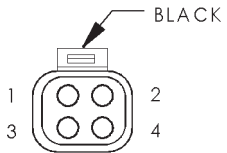
CAV	CIRCUIT
1	L50 18WT/TN
2	Z2 20BK/LG
3	M1 20PK
4	M3 20PK/DB
5	-
6	-



C 308

C308 - (CHMSL HARNESS SIDE)

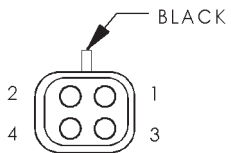
CAV	CIRCUIT
1	L50 18WT/TN
1	L50 18WT/TN
2	Z3 18BK/OR
2	Z3 18BK/OR
3	M1 18PK
3	M1 18PK
4	M3 18PK/DB
4	M3 18PK/DB
5	-
6	-



C 329  
(CLUB CAB)

C329 (CLUB CAB) - BLACK (RIGHT BACK-UP LAMP SIDE)

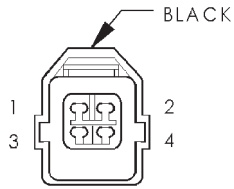
CAV	CIRCUIT
1	L7 16BK/YL
2	Z13 16BK
3	L62 16BR/RD
4	L1 18VT/BK



C 329  
(CLUB CAB)

C329 (CLUB CAB) - BLACK (CHASSIS HARNESS SIDE)

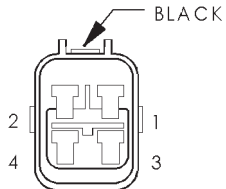
CAV	CIRCUIT
1	L7 18BK/YL
2	Z13 16BK
3	L62 18DG/BR
4	L1 18VT/BK



C329  
(STANDARD CAB)

C329 (STANDARD CAB) - BLACK (TAIL LAMP SIDE)

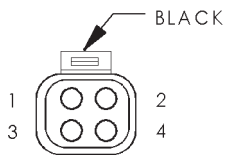
CAV	CIRCUIT
1	L7 18BK/YL
2	Z13 16BK
3	L62 18DG/BR
4	L1 18VT/BK



C329  
(STANDARD CAB)

C329 (STANDARD CAB) - BLACK (CHASSIS SIDE)

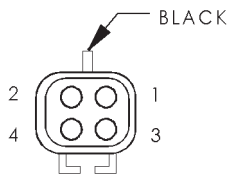
CAV	CIRCUIT
1	L7 16BK/YL
2	Z13 16BK
3	L62 16BR/RD
4	L1 18VT/BK



C333  
(CLUB CAB)

C333 (CLUB CAB) - BLACK (LEFT BACK-UP LAMP SIDE)

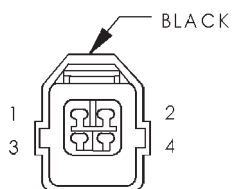
CAV	CIRCUIT
1	L7 16BK/YL
2	Z13 16BK
3	L63 16BR/RD
4	L1 18VT/BK



C333  
(CLUB CAB)

C333 (CLUB CAB) - BLACK (CHASSIS HARNESS SIDE)

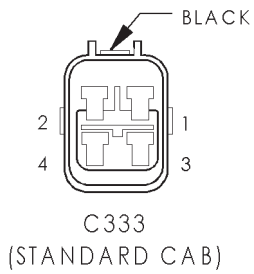
CAV	CIRCUIT
1	L7 18BK/YL
2	Z13 16BK
3	L63 18DG/RD
4	L1 18VT/BK



C333  
(STANDARD CAB)

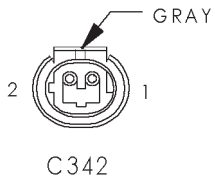
C333 (STANDARD CAB) - BLACK (TAIL LAMP SIDE)

CAV	CIRCUIT
1	L7 18BK/YL
2	Z13 16BK
3	L63 18DG/BR
4	L1 18VT/BK



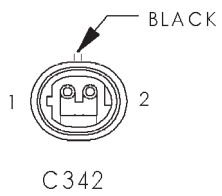
C333 (STANDARD CAB) - BLACK (CHASSIS SIDE)

CAV	CIRCUIT
1	L7 16BK/YL
2	Z13 16BK
3	L63 16DG/BR
4	L1 18VT/BK



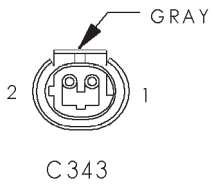
C342 - GRAY (VALANCE LICENSE LAMP JUMPER SIDE)

CAV	CIRCUIT
1	Z13 18BK
2	L7 18BK/YL



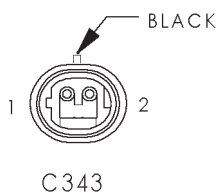
C342 - BLACK (CHASSIS HARNESS SIDE)

CAV	CIRCUIT
1	Z13 18BK
2	L7 16BK/YL



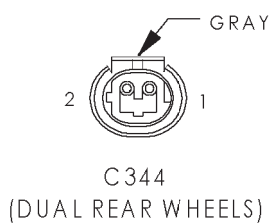
C343 - GRAY (FENDER LAMP SIDE)

CAV	CIRCUIT
1	Z13 18BK
2	L7 18BK/YL



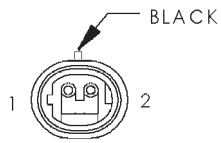
C343 - BLACK (LICENSE LAMP SIDE)

CAV	CIRCUIT
1	Z13 18BK
2	L7 16BK/YL



C344 (DUAL REAR WHEELS) - GRAY (LICENSE LAMP SIDE)

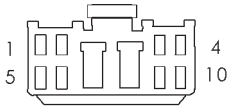
CAV	CIRCUIT
1	Z13 18BK
2	L7 18BK/YL



C344  
(DUAL REAR WHEELS)

C344 (DUAL REAR WHEELS) - BLACK (FENDER LAMPS SIDE)

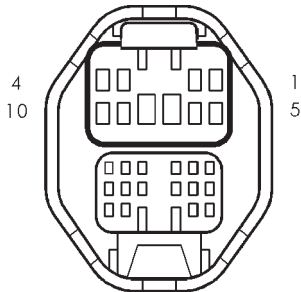
CAV	CIRCUIT
1	Z13 18BK
2	L7 18BK/YL



C345

C345 - (BODY HARNESS SIDE)

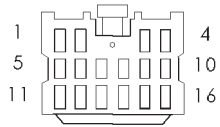
CAV	CIRCUIT
1	C16 20LB/YL
2	P70 22WT
3	P72 22YL/BK
4	X54 18VT
5	X56 18DB/RD
6	P74 22DB
7	F21 14TN (POWER LOCKS/ WINDOWS)
8	Z2 14BK/LG
9	Z9 16BK/VT (PREMIUM RADIO)
10	P34 18PK/BK (BASE, POWER LOCKS/ WINDOWS)
10	P31 22PK/DG (HIGHLINE/PREMIUM)



C345

C345 - (RIGHT DOOR HARNESS SIDE)

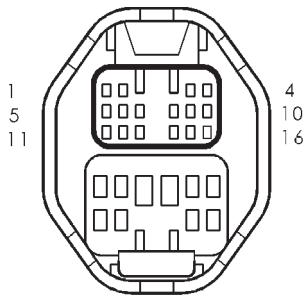
CAV	CIRCUIT
1	C16 20LB/YL (SLT)
2	P70 20WT (SLT)
3	P72 20YL/BK (SLT)
4	X54 20VT (STANDARD RADIO)
4	X54 18VT (PREMIUM RADIO)
5	X56 20DB/RD (STANDARD RADIO)
5	X56 18DB/RD (PREMIUM RADIO)
6	P74 20DB (SLT)
7	F21 14TN (SLT)
8	Z2 20BK/LG (MIDLINE)
8	Z2 14BK/LG (SLT)
9	Z9 16BK/VT (PREMIUM RADIO)
10	P31 18PK/DG (POWER LOCKS/WINDOWS)



C346

C346 - (BODY HARNESS SIDE)

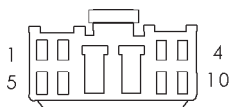
CAV	CIRCUIT
1	F35 18RD (POWER LOCKS/WINDOWS)
2	Q16 14BR/WT
3	Q26 14VT/WT
4	P33 18OR/BK (POWER LOCKS/WINDOWS)
5	X82 20LB/RD
6	P35 18OR/VT
7	P36 19PK/VT
8	G73 20LG/OR (HIGHLINE/PREMIUM)
9	P33 18OR/BK (BASE, POWER LOCKS/WINDOWS)
9	P30 22OR/DG (HIGHLINE/PREMIUM)
10	P34 18PK/BK (POWER LOCKS/WINDOWS)
11	X13 16BK/RD (PREMIUM RADIO)
12	X80 20LB/BK
13	X52 18DB/WT (PREMIUM RADIO)
14	X58 18DB/OR (PREMIUM RADIO)
15	X92 18TN/BK (PREMIUM RADIO)
16	X94 18TN/VT (PREMIUM RADIO)



C346

C346 - (RIGHT DOOR HARNESS SIDE)

CAV	CIRCUIT
1	F35 18RD
2	Q16 14BR/WT
3	Q26 14VT/WT
4	P33 18OR/BK
5	X82 20LB/RD
6	P35 18OR/VT
7	P36 19PK/VT
8	G73 20LG/OR
9	P30 18OR/DG
10	P34 18PK/BK
11	X13 16BK/RD (PREMIUM RADIO)
12	X80 20LB/BK
13	X52 18DB/WT (PREMIUM RADIO)
14	X58 18DB/OR (PREMIUM RADIO)
15	X92 18TN/BK (PREMIUM RADIO)
16	X94 18TN/VT (PREMIUM RADIO)

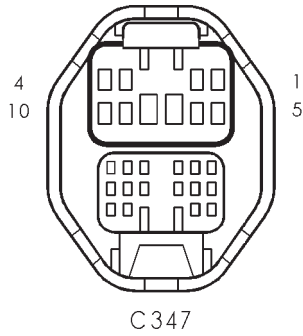


C347

C347 - (BODY HARNESS SIDE)

CAV	CIRCUIT
1	C16 20LB/YL
2	P70 22WT
3	P72 22YL/BK
4	X53 18DG
5	X55 18BR/RD
6	P74 22DB
7	F21 14TN (POWER LOCKS/WINDOWS)
8	Z2 14BK/LG
9	M1 20PK
10	Z9 16BK/VT (PREMIUM RADIO)

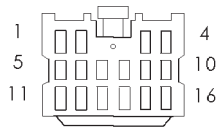




C 347

C347 - (LEFT DOOR HARNESS SIDE)

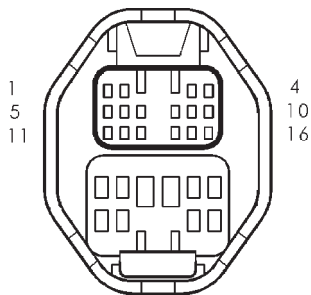
CAV	CIRCUIT
1	C16 20LB/YL
2	P70 22WT
3	P72 22YL/BK
4	X53 20DG (STANDARD RADIO)
4	X53 18DG (PREMIUM RADIO)
5	X55 20BR/RD (STANDARD RADIO)
5	X55 18BR/RD (PREMIUM RADIO)
6	P74 22DB
7	F21 14TN (EXCEPT BASE)
8	Z2 14BK/LG (EXCEPT BASE)
9	M1 22PK
10	Z9 16BK/VT (PREMIUM RADIO)



C 348

C348 - (BODY HARNESS SIDE)

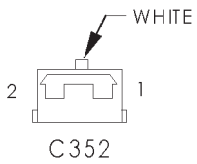
CAV	CIRCUIT
1	F35 20RD (POWER LOCKS/WINDOWS)
2	Q16 14BR/WT
3	Q26 14VT/WT
4	P33 20OR/BK (POWER LOCKS/WINDOWS)
5	X83 20YL/RD
6	P35 18OR/VT
7	P36 18PK/VT
8	G73 20LG/OR (HIGHLINE/PREMIUM)
9	Z2 18BK/LG (BASE)
10	P34 20PK/BK (POWER LOCKS/WINDOWS)
11	X13 16BK/RD (PREMIUM RADIO)
12	X81 20YL/BK
13	X51 18BR/YL (PREMIUM RADIO)
14	X57 18BR/LB (PREMIUM RADIO)
15	X91 18WT/DG (PREMIUM RADIO)
16	X93 18WT/VT (PREMIUM RADIO)



C 348

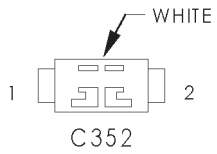
C348 - (LEFT DOOR HARNESS SIDE)

CAV	CIRCUIT
1	F35 18RD
2	Q16 14BR/WT
3	Q26 14VT/WT
4	P33 20OR/BK
5	X83 20YL/RD
6	P35 18OR/VT
7	P36 18PK/VT
8	G73 20LG/OR
9	Z2 18BK/LG (EXCEPT BASE)
10	P34 20PK/BK
11	X13 16BK/RD (PREMIUM RADIO)
12	X81 20YL/BK
13	X51 18BR/YL (PREMIUM RADIO)
14	X57 18BR/LB (PREMIUM RADIO)
15	X91 18WT/DG (PREMIUM RADIO)
16	X93 18WT/VT (PREMIUM RADIO)



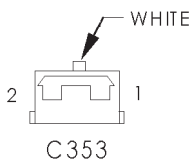
C352 - WHITE (VISOR MIRROR SIDE)

CAV	CIRCUIT
1	M1 20PK
2	Z4 20BK



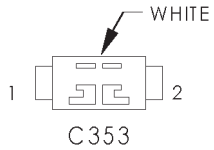
C352 - WHITE (OVERHEAD CONSOLE SIDE)

CAV	CIRCUIT
1	M1 20PK
2	Z3 20BK



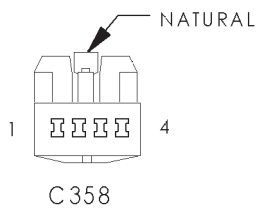
C353 - WHITE (VISOR MIRROR SIDE)

CAV	CIRCUIT
1	M1 20PK
2	Z4 20BK



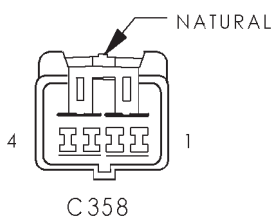
C353 - WHITE (OVERHEAD CONSOLE SIDE)

CAV	CIRCUIT
1	M1 20PK
2	Z3 20BK



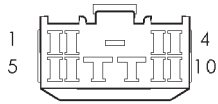
C358 - NATURAL (OVERHEAD CONSOLE SIDE)

CAV	CIRCUIT
1	G69 22BK
2	-
3	D1 20VT/BR
4	D2 20WT/BK



C358 - NATURAL (I/P HARNESS SIDE)

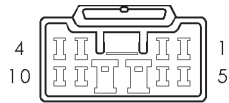
CAV	CIRCUIT
1	G69 22BK
2	-
3	D1 20VT/BR
4	D2 20WT/BK



C359  
(HEATED SEAT)

C359 (HEATED SEATS) - (BODY SIDE)

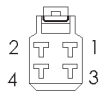
CAV	CIRCUIT
1	P7 20LB/BK
2	P137 20DG
3	P8 20LB/WT
4	F235 16RD
5	P139 20WT
6	P138 20VT/LG
7	Z2 16BK/LG
8	F37 16RD/LB
9	G10 20LG/RD
10	P140 20VT/BK



C359  
(HEATED SEAT)

C359 (HEATED SEATS) - (POWER SEAT SIDE)

CAV	CIRCUIT
1	P7 20LB/BK
2	P137 20DG
3	P8 20LB/WT
4	F235 16RD
5	P139 20WT
6	P138 20VT/LG
7	Z2 16BK/LG
8	F37 16RD/LB
9	G10 22LG/RD
10	P140 20VT/BK



C360  
(CLUB CAB)

C360 (CLUB CAB) - (BODY HARNESS SIDE)

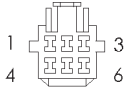
CAV	CIRCUIT
1	Z2 16BK/LG
2	F37 16RD/LB (POWER SEAT)
3	G10 20LG/RD
4	-



C360  
(CLUB CAB)

C360 (CLUB CAB) - (HEATED SEAT HARNESS SIDE)

CAV	CIRCUIT
1	Z2 16BK/LG (POWER SEAT)
1	Z2 20BK/LG (MANUAL SEAT)
2	F37 16RD/LB (POWER SEAT)
3	G10 20LG/RD (NON-HEATED SEAT)
4	-



C361

C361 - (BODY HARNESS SIDE)

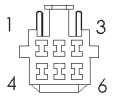
CAV	CIRCUIT
1	-
2	X91 18WT/DG (PREMIUM RADIO)
2	X57 18BR/LB (STANDARD RADIO)
3	X93 18WT/VT (PREMIUM RADIO)
3	X51 18BR/YL (STANDARD RADIO)
4	-
5	-
6	-



C361

C361 - (REAR DOOR HARNESS SIDE)

CAV	CIRCUIT
1	-
2	X57 18BR/LB
3	X51 18BR/YL
4	-
5	-
6	-



C364

C364 - (BODY HARNESS SIDE)

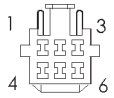
CAV	CIRCUIT
1	-
2	X92 18TN/BK (PREMIUM RADIO)
2	X58 18DB/OR (STANDARD RADIO)
3	X94 18TN/VT (PREMIUM RADIO)
3	X52 18DB/WT (STANDARD RADIO)
4	-
5	-
6	-



C364

C364 - (RIGHT REAR DOOR HARNESS SIDE)

CAV	CIRCUIT
1	-
2	X57 18BR/LB
3	X51 18BR/YL
4	-
5	-
6	-



C365  
(HEATED SEAT)

C365 (HEATED SEAT) - (DRIVER SEAT SIDE)

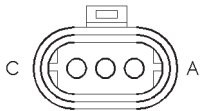
CAV	CIRCUIT
1	Z2 16BK/LG
2	P130 16TN
3	F37 16RD/LB
4	P142 22DB
5	P144 20BK/WT
6	-



C365  
(HEATED SEAT)

C365 (HEATED SEAT) - (PASSENGER SEAT SIDE)

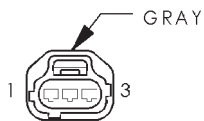
CAV	CIRCUIT
1	Z2 16BK/LG
2	P130 16TN
3	F37 16RD/LB
4	P142 20DB
5	P144 20BK/WT
6	-



CAMSHAFT  
POSITION  
SENSOR  
(DIESEL)

CAMSHAFT POSITION SENSOR (DIESEL) - 3 WAY

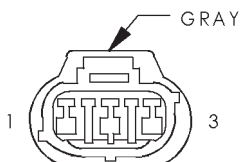
CAV	CIRCUIT	FUNCTION
A	K6 18VT/WT	5V SUPPLY
B	K14 18BK/DB	SENSOR GROUND
C	K124 18GY	CAMSHAFT POSITION SENSOR SIGNAL



CAMSHAFT  
POSITION  
SENSOR  
(GAS EXCEPT 8.0L)

CAMSHAFT POSITION SENSOR (GAS EXCEPT 8.0L) - GRAY 3 WAY

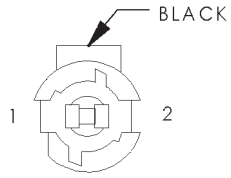
CAV	CIRCUIT	FUNCTION
1	K44 18TN/YL	CAMSHAFT POSITION SENSOR SIGNAL
2	K4 20BK/LB	SENSOR GROUND
3	K6 20VT/WT	5V SUPPLY



CAMSHAFT  
POSITION  
SENSOR  
(8.0L GAS)

CAMSHAFT POSITION SENSOR (8.0L GAS) - GRAY 3 WAY

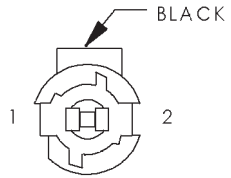
CAV	CIRCUIT	FUNCTION
1	K44 18TN/YL	CAMSHAFT POSITION SENSOR SIGNAL
2	K4 20BK/LB	SENSOR GROUND
3	K6 20VT/WT	5V SUPPLY



CARGO LAMP NO. 1

CARGO LAMP NO. 1 - BLACK 2 WAY

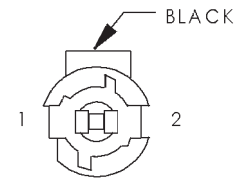
CAV	CIRCUIT	FUNCTION
1	M1 18PK	FUSED B(+)
2	M3 18PK/DB	CARGO LAMP DRIVER



CARGO LAMP NO. 2

CARGO LAMP NO. 2 - BLACK 2 WAY

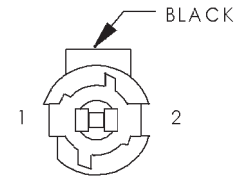
CAV	CIRCUIT	FUNCTION
1	M1 18PK	FUSED B(+)
2	M3 18PK/DB	CARGO LAMP DRIVER



CENTER HIGH MOUNTED STOP LAMP NO. 1

CENTER HIGH MOUNTED STOP LAMP NO. 1 - BLACK 2 WAY

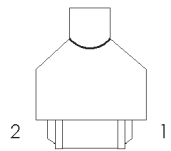
CAV	CIRCUIT	FUNCTION
1	L50 18WT/TN	BRAKE LAMP SWITCH OUTPUT
2	Z3 18BK/OR	GROUND



CENTER HIGH MOUNTED STOP LAMP NO. 2

CENTER HIGH MOUNTED STOP LAMP NO. 2 - BLACK 2 WAY

CAV	CIRCUIT	FUNCTION
1	L50 18WT/TN	BRAKE LAMP SWITCH OUTPUT
2	Z3 18BK/OR	GROUND

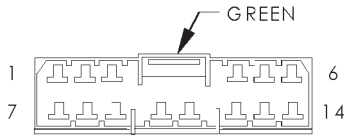


CENTER IDENTIFICATION LAMP

CENTER IDENTIFICATION LAMP - 2 WAY

CAV	CIRCUIT	FUNCTION
1	L7 18BK/YL	HEADLAMP SWITCH OUTPUT
2	Z4 18BK	GROUND

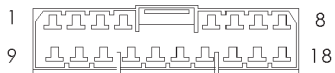




CENTRAL TIMER  
MODULE C1

CENTRAL TIMER MODULE C1 - GREEN 14 WAY

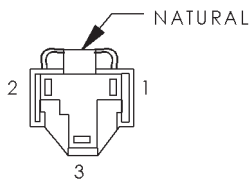
CAV	CIRCUIT	FUNCTION
1	G75 22TN	DRIVER DOOR AJAR SWITCH SENSE
2	G13 22DB/RD	CHIME REQUEST SIGNAL
3	V8 16VT	WIPER SWITCH MODE SENSE
4	V18 22YL/DG	WIPER MOTOR RELAY CONTROL
5	G16 22BK/LB	PASSENGER DOOR AJAR SWITCH SENSE
6	Z2 22BK/LG	GROUND
7	-	-
8	F12 22DB/WT (BASE/MIDLINE)	FUSED IGNITION SWITCH OUTPUT (RUN-START)
8	V6 16DB (HIGHLINE/PREMIUM)	FUSED IGNITION SWITCH OUTPUT (RUN-ACC)
9	G26 22LB	KEY-IN IGNITION SWITCH SENSE
10	V10 16BR	WASHER SWITCH SENSE
11	V5 16DG	WIPER PARK SWITCH SENSE
12	V9 16WT/DB	WIPER SWITCH MODE SIGNAL
13	-	-
14	F35 22RD	FUSED B(+)



CENTRAL TIMER  
MODULE C2

CENTRAL TIMER MODULE C2 - 18 WAY

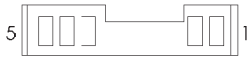
CAV	CIRCUIT	FUNCTION
1	P33 22OR/BK	DOOR LOCK DRIVER
2	M11 22PK/LB	COURTESY LAMP SWITCH OUTPUT
3	Z3 18BK/OR	GROUND
4	P30 22OR/DG	PASSENGER DOOR LOCK SWITCH OUTPUT
5	F12 22DB/WT	FUSED IGNITION SWITCH OUTPUT (RUN-START)
6	G50 22RD/DB	SECURITY RELAY CONTROL
7	P132 16OR/BK	HEATED SEAT RELAY CONTROL
8	G69 22BK	VTSS INDICATOR DRIVER
9	P34 22PK/BK	DOOR UNLOCK DRIVER
10	G73 22LG/OR	CYLINDER LOCK SWITCH MUX
11	M22 22WT	DOME LAMP SWITCH SENSE
12	-	-
13	P31 22PK/DG	PASSENGER DOOR UNLOCK SWITCH OUTPUT
14	X20 22RD/BK	RADIO CONTROL MUX
15	-	-
16	D1 20VT/BR	CCD BUS (+)
17	D2 20WT/BK	CCD BUS (-)
18	X3 20BK/RD	HORN RELAY CONTROL



CIGAR  
LIGHTER

CIGAR LIGHTER - NATURAL 3 WAY

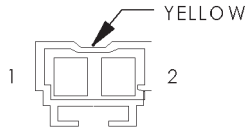
CAV	CIRCUIT	FUNCTION
1	F30 18RD/OR	FUSED IGNITION SWITCH OUTPUT (RUN-ACC)
2	-	-
3	Z3 18BK/OR	GROUND



CLOCKSPRING - C1

CLOCKSPRING C1 - 5 WAY

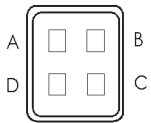
CAV	CIRCUIT	FUNCTION
1	V37 22RD/LG	SPEED CONTROL SWITCH SIGNAL
2	Z9 20BK/VT (SLT/HIGHLINE (REMOTE RADIO))	GROUND
3	K4 22BK/LB	SENSOR GROUND
4	X20 22RD/BK (BASE)	RADIO CONTROL MUX
5	X3 20BK/RD	HORN RELAY CONTROL



CLOCKSPRING C2

CLOCKSPRING C2 - YELLOW 2 WAY

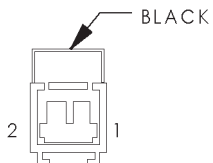
CAV	CIRCUIT	FUNCTION
1	R43 18BK/LB	DRIVER AIRBAG LINE 2
2	R45 18DG/LB	DRIVER AIRBAG LINE 1



CLOCKSPRING C3

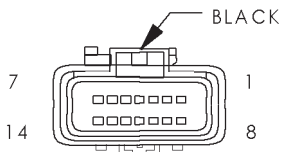
CLOCKSPRING C3 - 4 WAY

CAV	CIRCUIT	FUNCTION
A	V37 22DG/RD	SPEED CONTROL SWITCH SIGNAL
B	Z2 20BK/LG	GROUND
C	K4 22WT	SENSOR GROUND
D	X20 22RD/BK	RADIO CONTROL MUX

CLUTCH PEDAL  
POSITION SWITCH  
(M/T)

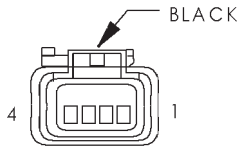
CLUTCH PEDAL POSITION SWITCH (M/T) - BLACK 2 WAY

CAV	CIRCUIT	FUNCTION
1	T141 14YL/RD	FUSED IGNITION SWITCH OUTPUT (START)
2	A41 14YL	FUSED IGNITION SWITCH OUTPUT (START)

CONTROLLER  
ANTILOCK  
BRAKE C1

CONTROLLER ANTILOCK BRAKE C1 - BLACK 14 WAY

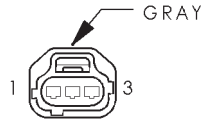
CAV	CIRCUIT	FUNCTION
1	B113 20RD/VT	REAR WHEEL SPEED SENSOR (+)
2	G107 20GY	4WD SWITCH SENSE
3	D1 20VT/BR	CCD BUS (+)
4	A20 20RD/DB	FUSED IGNITION SWITCH OUTPUT (RUN)
5	-	-
6	Z8 14BK/VT	GROUND
7	A10 14RD/DG	FUSED B(+)
8	B114 20WT/VT	REAR WHEEL SPEED SENSOR (-)
9	V40 20WT/PK	BRAKE SWITCH SENSE
10	D2 20WT/BK	CCD BUS (-)
11	G9 20GY/BK	RED BRAKE WARNING INDICATOR DRIVER
12	G7 20WT/OR	VEHICLE SPEED SENSOR SIGNAL
13	Z8 14BK/VT	GROUND
14	A10 14RD/DG	FUSED B(+)



CONTROLLER ANTILOCK BRAKE C2 (ABS)

CONTROLLER ANTILOCK BRAKE C2 (ABS) - BLACK 4 WAY

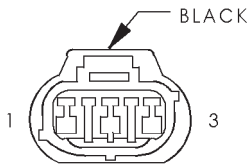
CAV	CIRCUIT	FUNCTION
1	B9 20RD	LEFT FRONT WHEEL SPEED SENSOR (+)
2	B8 20RD/GY	LEFT FRONT WHEEL SPEED SENSOR (-)
3	B6 20WT/DB	RIGHT FRONT WHEEL SPEED SENSOR (-)
4	B7 20WT	RIGHT FRONT WHEEL SPEED SENSOR (+)



CRANKSHAFT POSITION SENSOR (GAS 8.0L)

CRANKSHAFT POSITION SENSOR (GAS 8.0L) - GRAY 3 WAY

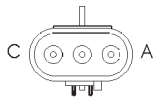
CAV	CIRCUIT	FUNCTION
1	K24 18GY/BK	CRANKSHAFT POSITION SENSOR SIGNAL
2	K4 20BK/LB	SENSOR GROUND
3	K6 20VT/WT	5V SUPPLY



CRANKSHAFT POSITION SENSOR (GAS EXCEPT 8.0L)

CRANKSHAFT POSITION SENSOR (GAS EXCEPT 8.0L) - BLACK 3 WAY

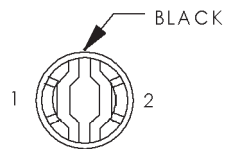
CAV	CIRCUIT	FUNCTION
1	K24 18GY/BK	CRANKSHAFT POSITION SENSOR SIGNAL
2	K4 20BK/LB	SENSOR GROUND
3	K6 20VT/WT	5V SUPPLY



CUMMINS BUS (DIESEL)

CUMMINS BUS (DIESEL) - 3 WAY

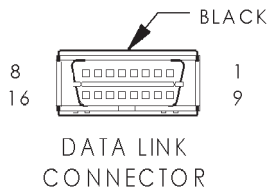
CAV	CIRCUIT	FUNCTION
A	K244 20YL/DB	CUMMINS BUS (+)
B	K246 20YL/DG	CUMMINS BUS (-)
C	Z11 14BK/WT	GROUND



CUP HOLDER LAMP

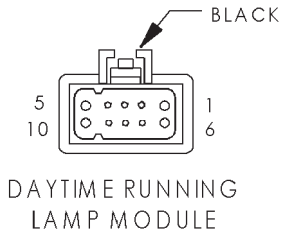
CUP HOLDER LAMP - BLACK 2 WAY

CAV	CIRCUIT	FUNCTION
1	E2 22OR	PANEL LAMPS FEED
2	Z3 22BK/OR	GROUND



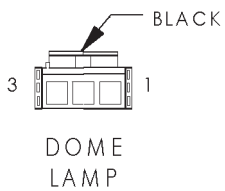
DATA LINK CONNECTOR - BLACK 16 WAY

CAV	CIRCUIT	FUNCTION
1	-	-
2	-	-
3	D1 18VT/BR	CCD BUS (+)
4	Z2 20BK/LG	GROUND
5	Z12 18BK/TN	GROUND
6	D20 20DG	SCI RECEIVE
7	D21 20PK/DB	SCI TRANSMIT
8	-	-
9	-	-
10	-	-
11	D2 18WT/BK	CCD BUS (-)
12	-	-
13	-	-
14	D220 20WT/VT (DIESEL)	SCI RECEIVE (PCM, DSL)
15	-	-
16	M1 20PK	FUSED B(+)



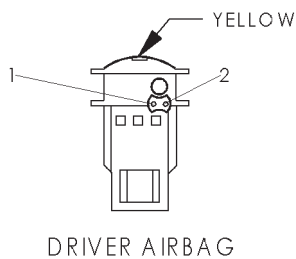
DAYTIME RUNNING LAMP MODULE - BLACK 10 WAY

CAV	CIRCUIT	FUNCTION
1	Z1 18BK	GROUND
2	L10 18BR/LG	FUSED IGNITION SWITCH OUTPUT (RUN)
3	G34 20RD/GY	HIGH BEAM INDICATOR DRIVER
4	G11 20WT/LG	PARK BRAKE SWITCH SENSE
5	-	-
6	L3 18RD/OR	DIMMER SWITCH HIGH BEAM OUTPUT
7	Z1 18BK	GROUND
8	L34 20RD/OR	FUSED B(+)
9	L139 20VT	FOG LAMP RELAY CONTROL
10	L4 18VT/WT	DIMMER SWITCH LOW BEAM OUTPUT



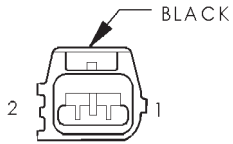
DOMELAMP - BLACK 3 WAY

CAV	CIRCUIT	FUNCTION
1	-	-
2	M2 20YL	COURTESY LAMP DRIVER
3	M1 20PK	FUSED B(+)



DRIVER AIRBAG - YELLOW 2WAY

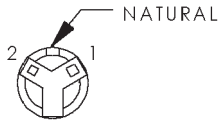
CAV	CIRCUIT	FUNCTION
1	R45 BK	DRIVER AIRBAG LINE1
2	R43 BK	DRIVER AIRBAG LINE2



DRIVER CYLINDER LOCK SWITCH

DRIVER CYLINDER LOCK SWITCH - BLACK 2 WAY

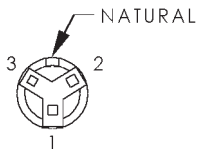
CAV	CIRCUIT	FUNCTION
1	Z2 20BK/LG	GROUND
2	G73 20LG/OR	CYLINDER LOCK SWITCH MUX



DRIVER DOOR AJAR SWITCH (PREMIUM)

DRIVER DOOR AJAR SWITCH (CTM) - NATURAL 2 WAY

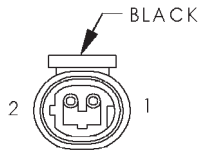
CAV	CIRCUIT	FUNCTION
1	Z2 18BK/LG	GROUND
2	G75 18TN	DRIVER DOOR AJAR SWITCH SENSE



DRIVER DOOR AJAR SWITCH (BASE)

DRIVER DOOR AJAR SWITCH (IEM) - NATURAL 3 WAY

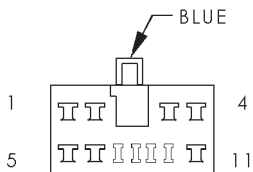
CAV	CIRCUIT	FUNCTION
1	Z2 18BK/LG	GROUND
2	G75 18TN	DRIVER DOOR AJAR SWITCH SENSE
3	M22 18WT	ILLUMINATED ENTRY SWITCH SENSE



DRIVER DOOR LOCK MOTOR

DRIVER DOOR LOCK MOTOR - BLACK 2 WAY

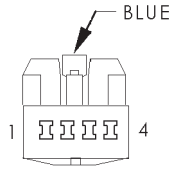
CAV	CIRCUIT	FUNCTION
1	P34 20PK/BK	DOOR UNLOCK DRIVER
2	P33 20OR/BK	DOOR LOCK DRIVER



DRIVER DOOR WINDOW/LOCK SWITCH

DRIVER DOOR WINDOW/LOCK SWITCH - BLUE 11 WAY

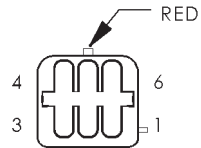
CAV	CIRCUIT	FUNCTION
1	Q16 14BR/WT	MASTER WINDOW SWITCH RIGHT FRONT UP
2	Q26 14VT/WT	MASTER WINDOW SWITCH RIGHT FRONT DOWN
3	Z2 14BK/LG	GROUND
4	Q21 16WT	LEFT FRONT WINDOW DRIVER (DOWN)
5	F21 14TN	FUSED IGNITION SWITCH OUTPUT (RUN)
6	Q11 16LB	LEFT WINDOW DRIVER (UP)
7	P36 18PK/VT	DOOR UNLOCK SWITCH CONTROL
8	P35 18OR/VT	DOOR LOCK SWITCH CONTROL
9	Z2 18BK/LG	GROUND
10	F35 18RD	FUSED B(+)
11	-	-



DRIVER HEATED SEAT CUSHION

DRIVER HEATED SEAT CUSHION - BLUE 4 WAY

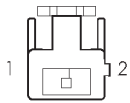
CAV	CIRCUIT	FUNCTION
1	P131 16RD/DG	LEFT SEAT HEATER B(+) DRIVER
2	Z2 18BK/LG	GROUND
3	P144 20BK/WT	SEAT TEMPERATURE 5V SUPPLY
4	P141 20TN/LB	LEFT SEAT TEMPERATURE SENSOR INPUT



DRIVER HEATED SEAT SWITCH

DRIVER HEATED SEAT SWITCH - RED 6 WAY

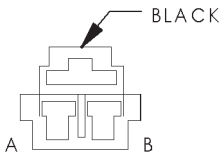
CAV	CIRCUIT	FUNCTION
1	P137 20DG	LEFT SEAT LOW HEAT LED DRIVER
2	E2 22OR	PANEL LAMPS FEED
3	Z3 20BK/OR	GROUND
4	F15 20DB	FUSED IGNITION SWITCH OUTPUT (RUN)
5	P139 20WT	LEFT SEAT HIGH HEAT LED DRIVER
6	P7 20LB/BK	DRIVER HEATED SEAT SWITCH



DRIVER LUMBAR MOTOR

DRIVER LUMBAR MOTOR - 2 WAY

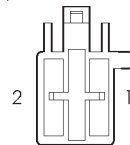
CAV	CIRCUIT	FUNCTION
1	P106 16DG/WT	LUMBAR MOTOR FORWARD
2	P107 16OR/BK	LUMBAR MOTOR REARWARD



DRIVER POWER SEAT FRONT VERTICAL MOTOR (CLUB CAB)

DRIVER POWER SEAT FRONT VERTICAL MOTOR (CLUB CAB) - BLACK 2 WAY

CAV	CIRCUIT	FUNCTION
B	P19 16YL/LG	LEFT POWER SEAT FRONT UP
A	P21 16RD/LG	LEFT POWER SEAT FRONT DOWN

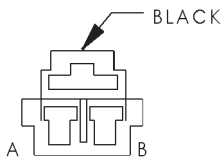


DRIVER POWER SEAT FRONT VERTICAL MOTOR (STANDARD CAB)

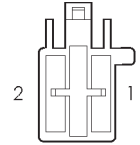
DRIVER POWER SEAT FRONT VERTICAL MOTOR (STANDARD CAB) - 2 WAY

CAV	CIRCUIT	FUNCTION
1	P19 14YL/LG	LEFT SEAT FRONT UP
2	P21 14RD/LG	LEFT SEAT FRONT DOWN

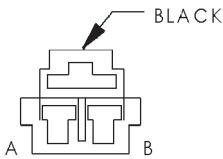




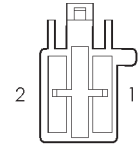
DRIVER POWER SEAT HORIZONTAL MOTOR (CLUB CAB)



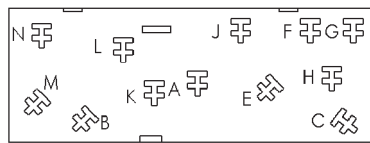
DRIVER POWER SEAT HORIZONTAL MOTOR (STANDARD CAB)



DRIVER POWER SEAT REAR VERTICAL MOTOR (CLUB CAB)



DRIVER POWER SEAT REAR VERTICAL MOTOR (STANDARD CAB)



DRIVER POWER SEAT SWITCH (CLUB CAB)

DRIVER POWER SEAT HORIZONTAL MOTOR (CLUB CAB) - BLACK - 2 WAY

CAV	CIRCUIT	FUNCTION
A	P17 16RD/LB	LEFT SEAT HORIZONTAL REARWARD
B	P15 16YL/LB	LEFT SEAT HORIZONTAL FORWARD

DRIVER POWER SEAT HORIZONTAL MOTOR (STANDARD CAB) - 2 WAY

CAV	CIRCUIT	FUNCTION
1	P17 14DB/RD	LEFT SEAT HORIZONTAL REARWARD
2	P15 14YL/LB	LEFT SEAT HORIZONTAL FORWARD

DRIVER POWER SEAT REAR VERTICAL MOTOR (CLUB CAB) - BLACK 2 WAY

CAV	CIRCUIT	FUNCTION
A	P11 16YL/WT	LEFT SEAT REAR UP
B	P13 16RD/WT	LEFT SEAT REAR DOWN

DRIVER POWER SEAT REAR VERTICAL MOTOR (STANDARD CAB) - 2 WAY

CAV	CIRCUIT	FUNCTION
1	P11 14YL/WT	LEFT SEAT REAR UP
2	P13 14RD/WT	LEFT SEAT REAR DOWN

DRIVER POWER SEAT SWITCH (CLUB CAB) - 14 WAY

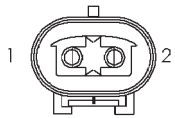
CAV	CIRCUIT	FUNCTION
A	F37 16RD/LB	FUSED B(+)
B	Z2 16BK/LG	GROUND
C	P106 16DG/WT	LUMBAR MOTOR FORWARD
D	-	-
E	P13 16RD/WT	LEFT SEAT REAR DOWN
F	P107 16OR/BK	LUMBAR DRIVER REARWARD
G	Z2 16BK/LG	GROUND
H	F37 16RD/LB	FUSED B(+)
I	-	-
J	P11 16YL/WT	LEFT SEAT REAR UP
K	P17 16RD/LB	LEFT SEAT HORIZONTAL REARWARD
L	P15 16YL/LB	LEFT SEAT HORIZONTAL FORWARD
M	P21 16RD/LG	LEFT SEAT FRONT DOWN
N	P19 16YL/LG	LEFT SEAT FRONT UP



DRIVER POWER  
SEAT SWITCH  
(STANDARD CAB)

DRIVER POWER SEAT SWITCH (STANDARD CAB) - 14 WAY

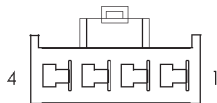
CAV	CIRCUIT	FUNCTION
A	F37 14RD/LB	FUSED B(+)
B	Z3 14BK/OR	GROUND
C	-	-
D	-	-
E	P11 14YL/WT	LEFT SEAT REAR UP
F	-	-
G	-	-
H	-	-
I	-	-
J	P13 14RD/WT	LEFT SEAT REAR DOWN
K	P17 14DB/RD	LEFT SEAT HORIZONTAL REARWARD
L	P15 14YL/LB	LEFT SEAT HORIZONTAL FORWARD
M	P19 14YL/LG	LEFT SEAT FRONT UP
N	P21 14RD/LG	LEFT SEAT FRONT DOWN



DRIVER POWER  
WINDOW MOTOR

DRIVER POWER WINDOW MOTOR - 2 WAY

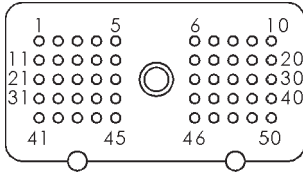
CAV	CIRCUIT	FUNCTION
1	Q11 16LB	LEFT WINDOW DRIVER (UP)
2	Q21 16WT	LEFT FRONT WINDOW DRIVER (DOWN)



ELECTRIC  
BRAKE  
PROVISION

ELECTRIC BRAKE PROVISION - 4 WAY

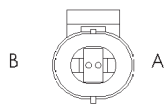
CAV	CIRCUIT	FUNCTION
1	A6 12RD/OR	FUSED B(+)
2	B40 12LB	TRAILER TOW BRAKE B(+)
3	L50 18WT/TN	BRAKE LAMP SWITCH OUTPUT
4	Z3 18BK/OR	GROUND



ENGINE CONTROL  
MODULE  
(DIESEL)

ENGINE CONTROL MODULE (DIESEL) - 50 WAY

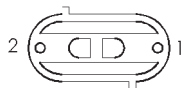
CAV	CIRCUIT	FUNCTION
1	H104 18BR/OR	IDLE VALIDATION SWITCH NO. 1
2	K244 20YL/DB	CUMMINS BUS (+)
3	K6 18VT/WT	5V SUPPLY
4	K14 18BK/DB	SENSOR GROUND
5	F18 18LG/BK	FUSED IGNITION SWITCH OUTPUT (RUN-START)
6	G60 18GY/BK	ENGINE OIL PRESSURE SENSOR SIGNAL
7	K21 18BK/RD	INTAKE AIR TEMPERATURE SENSOR SIGNAL
8	G12 18GY/RD	MANIFOLD AIR PRESSURE SENSOR SIGNAL
9	-	-
10	K7 18OR	5V SUPPLY
11	K104 18BK/LB	SENSOR GROUND
12	K246 20YL/DG	CUMMINS BUS (-)
13	K242 20WT	DATA LINK (+) FUEL INJECTION PUMP
14	K2 18TN/BK	ENGINE COOLANT TEMPERATURE SENSOR SIGNAL
15	K135 18YL/WT	TRANSFER PUMP SUPPLY
16	H105 18LG/DB	IDLE VALIDATION SWITCH NO. 2
17	K124 18GY	CAMSHAFT POSITION SENSOR SIGNAL
18	K48 18DG	FUEL INJECTION PUMP SYNC SIGNAL
19	-	-
20	-	-
21	K1 18DG/RD	WATER IN FUEL SENSOR SIGNAL
22	V37 18RD/LG	SPEED CONTROL SWITCH SIGNAL
23	K240 20BK	DATA LINK (-) FUEL INJECTOR PUMP
24	V32 18YL/RD	BRAKE SWITCH SENSE
25	H102 18LB/BK	ACCELERATOR PEDAL POSITION SENSOR SIGNAL
26	G113 18OR	PTO SWITCH SENSE
27	-	-
28	K22 18OR/DB	ACCELERATOR PEDAL POSITION SENSOR SIGNAL
29	S21 18YL/BK	AIR INTAKE HEATER RELAY NO.1
30	Z12 18BK/TN	GROUND
31	H101 18DB/WT	ACCELERATOR PEDAL POSITION SENSOR SUPPLY
32	H103 18BK/YL	ACCELERATOR PEDAL POSITION SENSOR GROUND
33	K45 18LB/RD	FUEL SHUT-OFF SIGNAL
34	K44 18VT/OR	LOW IDLE SELECT
35	K135 18YL/WT	TRANSFER PUMP SUPPLY
36	K131 18BR/WT	FUEL INJECTOR PUMP RELAY CONTROL
37	G85 18OR/BK	WAIT-TO-START WARNING INDICATOR DRIVER
38	D21 18PK/DB	SCI TRANSMIT
39	D20 18DG	SCI RECEIVE
40	D2 18WT/BK	CCD BUS (-)
41	D1 18VT/BR	CCD BUS (+)
42	K247 20DB	CUMMINS BUS SHIELD
43	G7 18WT/OR	VEHICLE SPEED SENSOR SIGNAL
44	K243 20OR/BR	DATA LINK SHIELD FUEL INJECTOR PUMP
45	K24 18GY/BK	CRANKSHAFT POSITION SENSOR SIGNAL
46	-	-
47	S22 18OR/BK	AIR INTAKE HEATER RELAY CONTROL NO. 2
48	A14 18RD/WT	FUSED B(+)
49	Z12 18BK/TN	GROUND
50	A14 18RD/WT	FUSED B(+)



ENGINE COOLANT TEMPERATURE SENSOR (DIESEL)

ENGINE COOLANT TEMPERATURE SENSOR (DIESEL) - 2 WAY

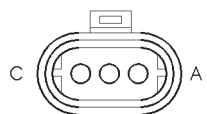
CAV	CIRCUIT	FUNCTION
B	K2 18TN/BK	ENGINE COOLANT TEMPERATURE SENSOR SIGNAL
A	K104 18BK/LB	SENSOR GROUND



ENGINE COOLANT TEMPERATURE SENSOR (GAS)

ENGINE COOLANT TEMPERATURE SENSOR (GAS) - 2 WAY

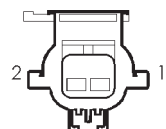
CAV	CIRCUIT	FUNCTION
1	K4 18BK/LB	SENSOR GROUND
2	K2 18TN/BK	ENGINE COOLANT TEMPERATURE SENSOR SIGNAL



ENGINE OIL PRESSURE SENSOR (DIESEL)

ENGINE OIL PRESSURE SENSOR (DIESEL) - 3 WAY

CAV	CIRCUIT	FUNCTION
A	K7 18OR	5V SUPPLY
B	K104 18BK/LB	SENSOR GROUND
C	G60 18GY/BK	ENGINE OIL PRESSURE SENSOR SIGNAL



ENGINE OIL PRESSURE SENSOR (GAS)

ENGINE OIL PRESSURE SENSOR (GAS) - 2 WAY

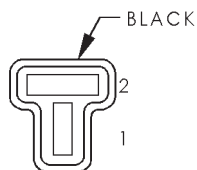
CAV	CIRCUIT	FUNCTION
1	K4 20BK/LB	SENSOR GROUND
2	G60 18GY/OR	ENGINE OIL PRESSURE SENSOR SIGNAL



EVAP/PURGE SOLENOID

EVAP/PURGE SOLENOID - 2 WAY

CAV	CIRCUIT	FUNCTION
1	K52 18PK/WT	EVAPORATIVE EMISSION SOLENOID CONTROL
2	F12 20DB/WT	FUSED IGNITION SWITCH OUTPUT (RUN-START)



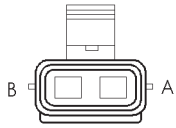
FRONT WASHER PUMP

FRONT WASHER PUMP - BLACK 2 WAY

CAV	CIRCUIT	FUNCTION
1	V10 16BR	WASHER SWITCH SENSE
2	Z1 20BK	GROUND

FRONT WASHER PUMP - BLACK 2 WAY

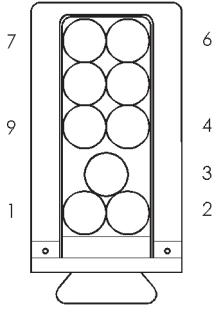
CAV	CIRCUIT	FUNCTION
1	V10 16BR	WASHER SWITCH SENSE
2	Z1 20BK	GROUND



FUEL HEATER  
(DIESEL)

FUEL HEATER (DIESEL) - 2 WAY

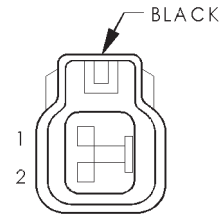
CAV	CIRCUIT	FUNCTION
A	Z11 14BK/TN	GROUND
B	A93 12RD/BK	FUEL HEATER RELAY OUTPUT



FUEL INJECTION PUMP  
(DIESEL)

FUEL INJECTION PUMP (DIESEL) - 9 WAY

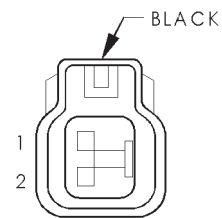
CAV	CIRCUIT	FUNCTION
1	K240 20BK	DATA LINK (-) FUEL INJECTION PUMP
2	K242 20WT	DATA LINK (+) FUEL INJECTION PUMP
3	-	-
4	K44 18VT/OR	LOW IDLE SELECT
5	K45 18LB/RD	FUEL SHUT-OFF SIGNAL
6	Z12 14BK/TN	GROUND
7	A40 14RD/LG	FUEL PUMP RELAY OUTPUT
8	K48 18DG	FUEL INJECTION PUMP SYNC SIGNAL
9	-	-



FUEL INJECTOR  
NO. 1

FUEL INJECTOR NO. 1 - BLACK 2 WAY

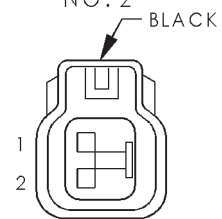
CAV	CIRCUIT	FUNCTION
1	K11 18WT/DB	FUEL INJECTOR NO. 1 DRIVER
2	A142 16DG/OR	AUTOMATIC SHUT DOWN RELAY OUTPUT



FUEL INJECTOR  
NO. 2

FUEL INJECTOR NO. 2 - BLACK 2 WAY

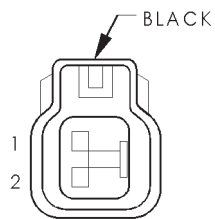
CAV	CIRCUIT	FUNCTION
1	K12 18TN	FUEL INJECTOR NO. 2 DRIVER
2	A142 16DG/OR	AUTOMATIC SHUT DOWN RELAY OUTPUT



FUEL INJECTOR  
NO. 3

FUEL INJECTOR NO. 3 - BLACK 2 WAY

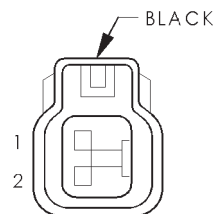
CAV	CIRCUIT	FUNCTION
1	K13 18YL/WT	FUEL INJECTOR NO. 3 DRIVER
2	A142 16DG/OR	AUTOMATIC SHUT DOWN RELAY OUTPUT



FUEL INJECTOR  
NO. 4

FUEL INJECTOR NO. 4 - BLACK 2 WAY

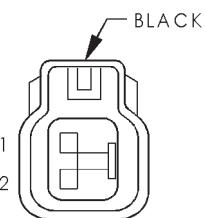
CAV	CIRCUIT	FUNCTION
1	K14 18LB/BR	FUEL INJECTOR NO. 4 DRIVER
2	A142 16DG/OR	AUTOMATIC SHUT DOWN RELAY OUTPUT



FUEL INJECTOR  
NO. 5

FUEL INJECTOR NO. 5 - BLACK 2 WAY

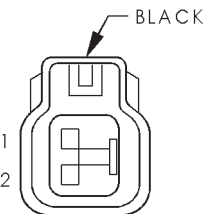
CAV	CIRCUIT	FUNCTION
1	K38 18GY	FUEL INJECTOR NO. 5 DRIVER
2	A142 16DG/OR	AUTOMATIC SHUT DOWN RELAY OUTPUT



FUEL INJECTOR  
NO. 6

FUEL INJECTOR NO. 6 - BLACK 2 WAY

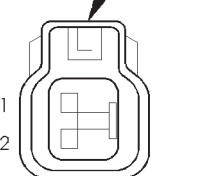
CAV	CIRCUIT	FUNCTION
1	K58 18BR/DB	FUEL INJECTOR NO. 6 DRIVER
2	A142 16DG/OR	AUTOMATIC SHUT DOWN RELAY OUTPUT



FUEL INJECTOR  
NO. 7  
(5.2L/5.9L/8.0L)

FUEL INJECTOR NO. 7 (5.2L/5.9L/8.0L) - BLACK 2 WAY

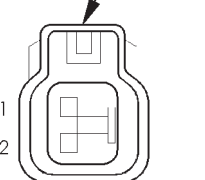
CAV	CIRCUIT	FUNCTION
1	K26 18VT/TN	FUEL INJECTOR NO. 7 DRIVER
2	A142 16DG/OR	AUTOMATIC SHUT DOWN RELAY OUTPUT



FUEL INJECTOR  
NO. 8  
(5.2L/5.9L/8.0L)

FUEL INJECTOR NO. 8 (5.2L/5.9L/8.0L) - BLACK 2 WAY

CAV	CIRCUIT	FUNCTION
1	K28 18GY/LB	FUEL INJECTOR NO. 8 DRIVER
2	A142 16DG/OR	AUTOMATIC SHUT DOWN RELAY OUTPUT

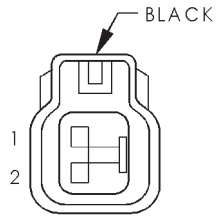


FUEL INJECTOR  
NO. 9  
(8.0L)

FUEL INJECTOR NO. 9 (8.0L) - BLACK 2 WAY

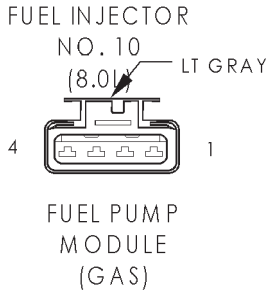
CAV	CIRCUIT	FUNCTION
1	K115 18TN/BK	FUEL INJECTOR NO. 9 DRIVER
2	A142 16DG/OR	AUTOMATIC SHUT DOWN RELAY OUTPUT





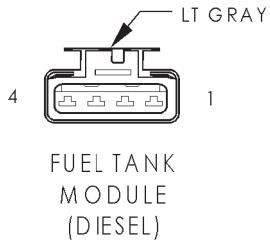
FUEL INJECTOR NO. 10 (8.0L) - BLACK 2 WAY

CAV	CIRCUIT	FUNCTION
1	K116 18WT	FUEL INJECTOR NO. 10 DRIVER
2	A142 16DG/OR	AUTOMATIC SHUT DOWN RELAY OUTPUT



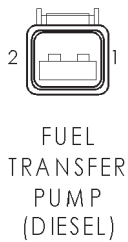
FUEL PUMP MODULE (GAS) - LT GRAY 4 WAY

CAV	CIRCUIT	FUNCTION
1	Z13 16BK	GROUND
2	K4 20BK/LB	SENSOR GROUND
3	K226 20DB/WT	FUEL LEVEL SENSOR SIGNAL
4	A61 16DG/BK	FUEL PUMP RELAY OUTPUT



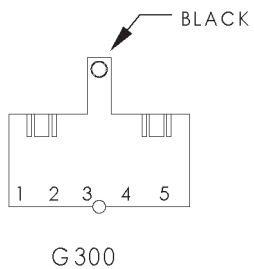
FUEL TANK MODULE (DIESEL) - LT GRAY 4 WAY

CAV	CIRCUIT	FUNCTION
1	-	-
2	K4 20BK/LB	SENSOR GROUND
3	K226 20DB/WT	FUEL LEVEL SENSOR SIGNAL
4	-	-



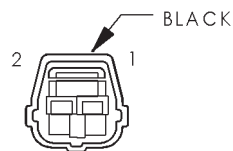
FUEL TRANSFER PUMP (DIESEL) - 2 WAY

CAV	CIRCUIT	FUNCTION
1	K135 18YL/WT	TRANSFER PUMP SUPPLY
2	Z11 18BK/WT	GROUND



G300 - BLACK 5 WAY

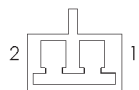
CAV	CIRCUIT	FUNCTION
1	Z2 18BK/LG	GROUND
2	Z2 14BK/LG	GROUND
3	Z2 16BK/LG	GROUND
4	Z2 16BK/LG	GROUND
5	Z2 14BK/LG	GROUND



GENERATOR

GENERATOR - BLACK 2 WAY

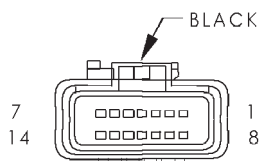
CAV	CIRCUIT	FUNCTION
1	K20 18DG	GENERATOR FIELD
2	T125 18DB	GENERATOR SOURCE



GLOVE BOX LAMP AND SWITCH

GLOVE BOX LAMP AND SWITCH - 2 WAY

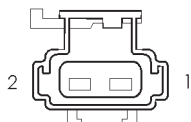
CAV	CIRCUIT	FUNCTION
1	M1 22PK	FUSED B(+)
2	Z3 22BK/OR	GROUND



HEADLAMP SWITCH C1

HEADLAMP SWITCH C1 - BLACK 14 WAY

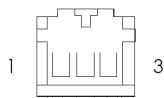
CAV	CIRCUIT	FUNCTION
1	L7 16BK/YL	HEADLAMP SWITCH OUTPUT
2	F33 16PK/RD	FUSED B(+)
3	G26 22LB	KEY-IN IGNITION SWITCH SENSE
4	G75 22TN (BASE)	DRIVER DOOR AJAR SWITCH SENSE
4	Z3 22BK/OR (HIGHLINE/PREMIUM)	GROUND
5	Z3 18BK/OR	GROUND
6	L2 18LG	HEADLAMP SWITCH OUTPUT
7	L39 22LB	FOG LAMP SWITCH OUTPUT
8	E17 18YL/BK	DAY BRIGHTNESS SENSE
9	Z3 20BK/OR	GROUND
10	M22 22WT	ILLUMINATED ENTRY SWITCH SENSE
11	M3 22PK/DB	CARGO LAMP DRIVER
12	M2 22YL	COURTESY LAMPS DRIVER
13	M11 22PK/LB (HIGHLINE/PREMIUM)	COURTESY LAMPS SWITCH OUTPUT
13	M22 22WT (BASE)	ILLUMINATED ENTRY SWITCH SENSE
14	E1 18TN	PANEL LAMPS DIMMER SWITCH SIGNAL



HEADLAMP SWITCH C2

HEADLAMP SWITCH C2 - 2 WAY

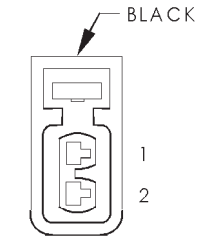
CAV	CIRCUIT	FUNCTION
1	Z3 20BK/OR	GROUND
2	L35 22BR/YL	FOG LAMP RELAY OUTPUT



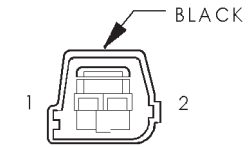
HEATED MIRROR SWITCH

HEATED MIRROR SWITCH - 3 WAY

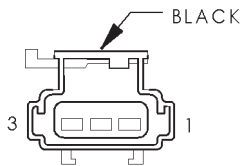
CAV	CIRCUIT	FUNCTION
1	F15 22DB	FUSED IGNITION SWITCH OUTPUT (RUN)
2	Z3 22BK/OR	GROUND
3	C16 22LB/YL	HEATED MIRROR



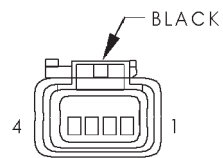
HIGH NOTE HORN  
 1  
 2  
 BLACK  
 1  
 4  
 IDLE AIR CONTROL MOTOR



IGNITION COIL  
 (3.9L/5.2L/5.9L)



IGNITION COIL  
 4 PACK  
 (8.0L)



IGNITION COIL  
 6 PACK  
 (8.0L)

HIGH NOTE HORN - BLACK 2 WAY

CAV	CIRCUIT	FUNCTION
1	X2 18DG/RD	HORN RELAY OUTPUT
2	Z1 18BK	GROUND

IDLE AIR CONTROL MOTOR - BLACK 4 WAY

CAV	CIRCUIT	FUNCTION
1	K39 18GY/RD	IDLE AIR CONTROL NO. 1 DRIVER
2	K60 18YL/BK	IDLE AIR CONTROL NO. 2 DRIVER
3	K40 18BR/WT	IDLE AIR CONTROL NO. 3 DRIVER
4	K59 18VT/BK	IDLE AIR CONTROL NO. 4 DRIVER

IGNITION COIL (3.9L/5.2L/5.9L) - BLACK 2 WAY

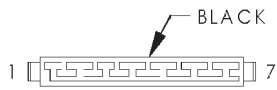
CAV	CIRCUIT	FUNCTION
1	A142 14DG/OR	AUTOMATIC SHUT DOWN RELAY OUTPUT
2	K19 16BK/GY	IGNITION COIL NO. 1 DRIVER

IGNITION COIL 4 PACK (8.0L) - BLACK 3 WAY

CAV	CIRCUIT	FUNCTION
1	K17 18DB/WT	IGNITION COIL NO. 2 DRIVER
2	A142 14DG/OR	AUTOMATIC SHUT DOWN RELAY OUTPUT
3	K18 18RD/BK	IGNITION COIL NO. 3 DRIVER

IGNITION COIL 6 PACK (8.0L) - BLACK 4 WAY

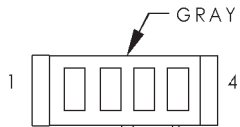
CAV	CIRCUIT	FUNCTION
1	K19 18BK/GY	IGNITION COIL NO. 1 DRIVER
2	A142 14DG/OR	AUTOMATIC SHUT DOWN RELAY OUTPUT
3	K32 18YL/GY	IGNITION COIL NO. 4 DRIVER
4	K43 18DG/GY	IGNITION COIL NO. 5 DRIVER



IGNITION  
SWITCH C1

IGNITION SWITCH C1 - BLACK 7 WAY

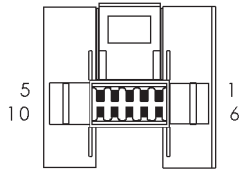
CAV	CIRCUIT	FUNCTION
1	A41 14YL	IGNITION SWITCH OUTPUT (START)
2	A21 12DB	IGNITION SWITCH OUTPUT (RUN-START)
3	-	-
4	A2 14PK/BK	FUSED B(+)
5	A22 14BK/OR	IGNITION SWITCH OUTPUT (RUN)
6	A31 12BK/WT	IGNITION SWITCH OUTPUT (RUN-ACC)
7	A1 10RD	FUSED B(+)



IGNITION  
SWITCH C2

IGNITION SWITCH C2 - GRAY 4 WAY

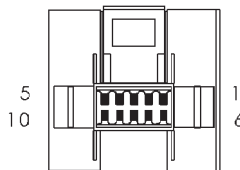
CAV	CIRCUIT	FUNCTION
1	Z3 22BK/OR ((HIGHLINE/PREMIUM))	GROUND
1	G75 22TN (BASE)	DRIVER DOOR AJAR SWITCH SENSE
2	G26 22LB	KEY-IN IGNITION SWITCH SENSE
3	-	-
4	-	-



INSTRUMENT  
CLUSTER C1

INSTRUMENT CLUSTER C1 - 10 WAY

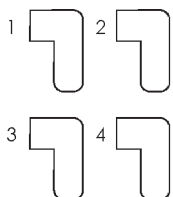
CAV	CIRCUIT	FUNCTION
1	-	-
2	G5 22DB/WT	FUSED IGNITION SWITCH OUTPUT (RUN-START)
3	G11 22WT/LG	PARK BRAKE SWITCH SENSE
4	Z2 20BK/LG	GROUND
5	Z3 20BK/OR	GROUND
6	F73 20YL	FUSED B(+)
7	-	-
8	G85 22OR/BK (DIESEL)	WAIT-TO-START WARNING INDICATOR DRIVER
9	D2 20WT/BK	CCD BUS (-)
10	D1 20VT/BR	CCD BUS (+)



INSTRUMENT  
CLUSTER C2

INSTRUMENT CLUSTER C2 - 10 WAY

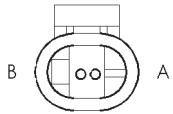
CAV	CIRCUIT	FUNCTION
1	E2 22OR	PANEL LAMPS FEED
2	G29 22BK/WT	WASHER FLUID SWITCH SENSE
3	G10 22LG/RD	SEAT BELT SWITCH SENSE
4	-	-
5	E17 18YL/BK	DAY BRIGHTNESS SENSE
6	L61 18LG	LEFT TURN SIGNAL
7	G13 22DB/RD	CHIME REQUEST SIGNAL
8	L60 18TN	RIGHT TURN SIGNAL
9	G34 16RD/GY	HIGH BEAM INDICATOR DRIVER
10	G107 22GY	4WD SWITCH SENSE



INTAKE AIR  
HEATER RELAYS  
(DIESEL)

INTAKE AIR HEATER RELAYS (DIESEL) - 4 WAY

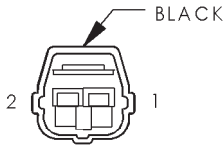
CAV	CIRCUIT	FUNCTION
1	S22 18OR/BK	AIR INTAKE HEATER RELAY CONTROL NO. 2
2	Z12 18BK/TN	GROUND
3	S21 18YL/BK	AIR INTAKE HEATER RELAY CONTROL NO. 1
4	Z12 18BK/TN	GROUND



INTAKE AIR TEMPERATURE SENSOR (DIESEL)

INTAKE AIR TEMPERATURE SENSOR (DIESEL) - 2 WAY

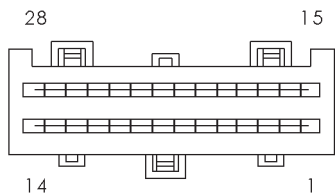
CAV	CIRCUIT	FUNCTION
A	K104 18BK/LB	SENSOR GROUND
B	K21 18BK/RD	INTAKE AIR TEMPERATURE SENSOR SIGNAL



INTAKE AIR TEMPERATURE SENSOR (GAS)

INTAKE AIR TEMPERATURE SENSOR (GAS) - BLACK 2 WAY

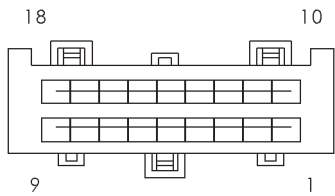
CAV	CIRCUIT	FUNCTION
1	K4 18BK/LB	SENSOR GROUND
2	K21 18BK/RD	INTAKE AIR TEMPERATURE SENSOR SIGNAL



JOINT CONNECTOR NO. 1 (IN PDC)

JOINT CONNECTOR NO. 1 (IN PDC) - 28 WAY

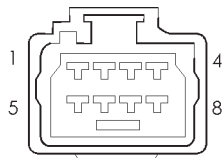
CAV	CIRCUIT	FUNCTION
1	V40 20WT/PK	BRAKE SWITCH SENSE
2	V40 22WT/PK	BRAKE SWITCH SENSE
3	V40 22WT/PK	BRAKE SWITCH SENSE
4	L4 18VT/WT	DIMMER SWITCH LOW BEAM OUTPUT
5	L4 16VT/WT	DIMMER SWITCH LOW BEAM OUTPUT
6	L4 20VT/WT	DIMMER SWITCH LOW BEAM OUTPUT
7	L4 20VT/WT	DIMMER SWITCH LOW BEAM OUTPUT
8	L4 18VT/WT	DIMMER SWITCH LOW BEAM OUTPUT
9	L1 18VT/BK	BACK-UP LAMP FEED
10	L1 18VT/BK	BACK-UP LAMP FEED
11	L1 18VT/BK	BACK-UP LAMP FEED
12	X2 18DG/RD	HORN RELAY OUTPUT
13	X2 18DG/RD	HORN RELAY OUTPUT
14	X2 18DG/RD	HORN RELAY OUTPUT
15	K4 22BK/LB	SENSOR GROUND
16	K4 22BK/LB	SENSOR GROUND
17	K4 20BK/LB	SENSOR GROUND
18	K4 20BK/LB	SENSOR GROUND
19	Z1 22BK	GROUND
20	Z1 20BK (DIESEL)	GROUND
21	Z1 22BK	GROUND
22	Z1 18BK	GROUND
23	Z1 18BK	GROUND
24	Z1 22BK (DIESEL)	GROUND
25	Z1 16BK	GROUND
26	Z1 16BK	GROUND
27	-	-
28	Z1 18BK	GROUND



JOINT  
CONNECTOR NO. 2  
(IN PDC)

JOINT CONNECTOR NO. 2 (IN PDC) - 18 WAY

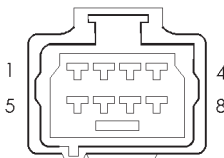
CAV	CIRCUIT	FUNCTION
1	A16 14RD/LB	FUSED B(+)
2	A16 14RD/LB	FUSED B(+)
3	A16 14RD/LB	FUSED B(+)
4	V5 16DG	WIPER PARK SWITCH SENSE
5	V5 16DG	WIPER PARK SWITCH SENSE
6	V5 16DG	WIPER PARK SWITCH SENSE
7	A14 16RD/WT	FUSED B(+)
8	A14 16RD/WT	FUSED B(+)
9	A14 16RD/WT	FUSED B(+)
10	A6 12RD/OR (TRAILER TOW)	FUSED B(+)
11	A6 12RD/OR (TRAILER TOW)	FUSED B(+)
12	A6 12RD/OR (TRAILER TOW)	FUSED B(+)
13	A6 12RD/OR (TRAILER TOW)	FUSED B(+)
14	-	-
15	A142 14DG/OR (GAS)	AUTOMATIC SHUT DOWN RELAY OUTPUT SENSE
16	A142 14DG/OR (GAS)	AUTOMATIC SHUT DOWN RELAY OUTPUT SENSE
16	Z12 18BK/TN (DIESEL)	GROUND
17	Z12 18BK/TN (DIESEL)	GROUND
17	A142 14DG/OR (GAS)	AUTOMATIC SHUT DOWN RELAY OUTPUT SENSE
18	Z12 18BK/TN (DIESEL)	GROUND



JOINT  
CONNECTOR NO. 3

JOINT CONNECTOR NO. 3 - 8 WAY

CAV	CIRCUIT	FUNCTION
1	Z1 20BK	GROUND
2	Z1 18BK	GROUND
3	G107 20GY	4WD SWITCH SENSE
4	G107 20GY	4WD SWITCH SENSE
5	Z1 18BK	GROUND
6	Z1 18BK	GROUND
7	G107 20GY	4WD SWITCH SENSE
8	-	-

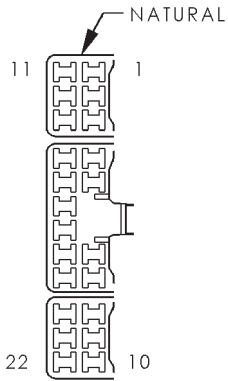


JOINT  
CONNECTOR NO. 4

JOINT CONNECTOR NO. 4 - 8 WAY

CAV	CIRCUIT	FUNCTION
1	Z1 18BK	GROUND
2	Z1 20BK	GROUND
3	Z1 18BK	GROUND
4	Z1 20BK	GROUND
5	Z1 18BK	GROUND
6	Z1 20BK	GROUND
7	Z1 18BK	GROUND
8	Z1 20BK	GROUND

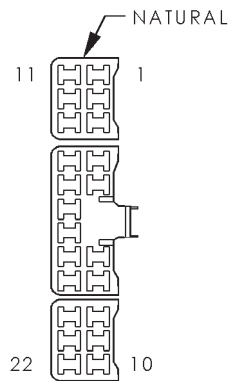




JOINT CONNECTOR NO. 5

JOINT CONNECTOR NO. 5 - NATURAL 22 WAY

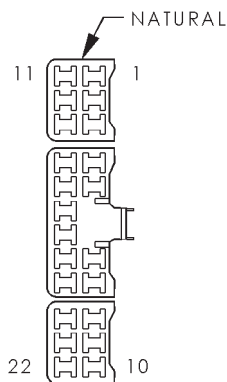
CAV	CIRCUIT	FUNCTION
1	M1 20PK	FUSED B(+)
2	M1 22PK	FUSED B(+)
3	M1 22PK	FUSED B(+)
4	Z3 20BK/OR	GROUND
5	Z3 18BK/OR	GROUND
6	Z3 22BK/OR	GROUND
7	Z3 18BK/OR	GROUND
8	E2 22OR	PANEL LAMPS FEED
9	E2 22OR	PANEL LAMPS FEED
10	E2 22OR	PANEL LAMPS FEED
11	-	-
12	M1 22PK	FUSED B(+)
13	M1 22PK	FUSED B(+)
14	Z3 20BK/OR (HEATED SEATS)	GROUND
15	Z3 20BK/OR (HEATED SEATS)	GROUND
16	Z3 22BK/OR (EXCEPT BASE/MIDLINE)	GROUND
17	Z3 22BK/OR (EXCEPT BASE/MIDLINE)	GROUND
18	-	-
19	-	-
20	E2 22OR	PANEL LAMPS FEED
21	E2 22OR	PANEL LAMPS FEED
22	E2 22OR	PANEL LAMPS FEED



JOINT CONNECTOR NO. 6

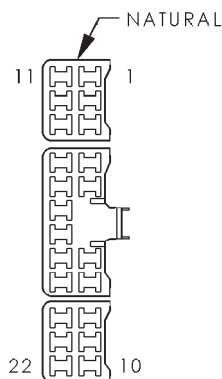
JOINT CONNECTOR NO. 6 - NATURAL 22 WAY

CAV	CIRCUIT	FUNCTION
1	V10 16BR	WASHER SWITCH SENSE
2	V10 16BR	WASHER SWITCH SENSE
3	V10 16BR	WASHER SWITCH SENSE
4	-	-
5	-	-
6	Z9 16BK/VT	GROUND
7	Z9 16BK/VT (EXCEPT BASE/LOWLINE)	GROUND
8	G26 22LB	KEY-IN IGNITION SWITCH SENSE
9	G26 22LB	KEY-IN IGNITION SWITCH SENSE
10	G26 22LB	KEY-IN IGNITION SWITCH SENSE
11	-	-
12	-	-
13	-	-
14	L50 16WT/TN	BRAKE LAMP SWITCH OUTPUT
15	L50 16WT/TN	BRAKE LAMP SWITCH OUTPUT
16	L50 18WT/TN	BRAKE LAMP SWITCH OUTPUT
17	L50 18WT/TN	BRAKE LAMP SWITCH OUTPUT
18	Z9 16BK/VT (EXCEPT BASE/LOWLINE)	GROUND
19	Z9 20BK/VT (SLT+/HIGHLINE)	GROUND
20	X3 20BK/RD (EXCEPT BASE/MIDLINE)	HORN RELAY CONTROL
20	M22 22WT (BASE/MIDLINE)	ILLUMINATED ENTRY SWITCH SENSE
21	X3 20BK/RD (EXCEPT BASE/MIDLINE)	HORN RELAY CONTROL
21	M22 22WT (BASE/MIDLINE)	ILLUMINATED ENTRY SWITCH SENSE
22	M22 22WT (BASE/MIDLINE)	ILLUMINATED ENTRY SWITCH SENSE
22	X3 20BK/RD (EXCEPT BASE/MIDLINE)	HORN RELAY CONTROL

JOINT  
CONNECTOR NO. 7

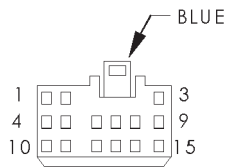
JOINT CONNECTOR NO. 7 - NATURAL 22 WAY

CAV	CIRCUIT	FUNCTION
1	D1 18VT/BR	CCD BUS (+)
2	D1 18VT/BR	CCD BUS (+)
3	D1 20VT/BR	CCD BUS (+)
4	D2 18WT/BK	CCD BUS (-)
5	D2 18WT/BK	CCD BUS (-)
6	D2 20WT/BK	CCD BUS (-)
7	D2 20WT/BK	CCD BUS (-)
8	D1 20VT/BR	CCD BUS (+)
9	D1 20VT/BR	CCD BUS (+)
10	D1 20VT/BR	CCD BUS (+)
11	D1 20VT/BR	CCD BUS (+)
12	D1 20VT/BR	CCD BUS (+)
13	D1 20VT/BR	CCD BUS (+)
14	D2 20WT/BK	CCD BUS (-)
15	D2 20WT/BK	CCD BUS (-)
16	D2 20WT/BK	CCD BUS (-)
17	D2 20WT/BK (REMOTE RADIO)	CCD BUS (-)
18	-	-
19	-	-
20	D1 20VT/BR (REMOTE RADIO)	CCD BUS (+)
21	-	-
22	-	-

JOINT  
CONNECTOR NO. 8

JOINT CONNECTOR NO. 8 - NATURAL 22 WAY

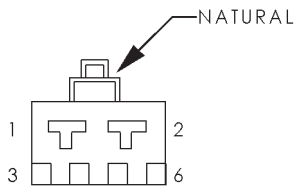
CAV	CIRCUIT	FUNCTION
1	E17 18YL/BK	DAY BRIGHTNESS SENSE
2	E17 18YL/BK	DAY BRIGHTNESS SENSE
3	E17 18YL/BK	DAY BRIGHTNESS SENSE
4	F15 18DB	FUSED IGNITION SWITCH OUTPUT (RUN)
5	F15 22DB	FUSED IGNITION SWITCH OUTPUT (RUN)
6	E2 22OR (HEATED SEATS)	PANEL LAMPS FEED
6	G75 22TN (BASE/MIDLINE)	DRIVER DOOR AJAR SWITCH SENSE
7	E2 22OR (HEATED SEATS)	PANEL LAMPS FEED
7	G75 22TN (BASE/MIDLINE)	DRIVER DOOR AJAR SWITCH SENSE
8	F14 18LG/YL	FUSED IGNITION SWITCH OUTPUT (RUN-START)
9	F14 18LG/YL	FUSED IGNITION SWITCH OUTPUT (RUN-START)
10	F14 18LG/YL	FUSED IGNITION SWITCH OUTPUT (RUN-START)
11	M2 22YL	COURTESY LAMPS DRIVER
12	M2 22YL	COURTESY LAMPS DRIVER
13	M2 22YL	COURTESY LAMPS DRIVER
14	F15 22DB	FUSED IGNITION SWITCH OUTPUT (RUN)
15	F15 22DB	FUSED IGNITION SWITCH OUTPUT (RUN)
16	F15 22DB	FUSED IGNITION SWITCH OUTPUT (RUN)
17	F15 20DB (HEATED SEATS)	FUSED IGNITION SWITCH OUTPUT (RUN)
18	G75 22TN (BASE/MIDLINE)	DRIVER DOOR AJAR SWITCH SENSE
18	E2 22OR (HEATED SEATS)	PANEL LAMPS FEED
19	E2 22OR (HEATED SEATS)	PANEL LAMPS FEED
19	G75 22TN (BASE/MIDLINE)	DRIVER DOOR AJAR SWITCH SENSE
20	Z6 18BK/PK	GROUND
21	Z6 18BK/PK	GROUND
22	Z6 18BK/PK	GROUND



JUNCTION BLOCK C1

JUNCTION BLOCK C1 - BLUE 15 WAY

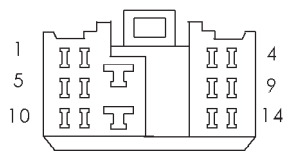
CAV	CIRCUIT	FUNCTION
1	-	-
2	G31 20VT/LG	AMBIENT TEMPERATURE SENSOR SIGNAL
3	A20 20RD/DB	FUSED IGNITION SWITCH OUTPUT (RUN)
4	L61 18LG	LEFT TURN SIGNAL
5	V6 16DB	FUSED IGNITION SWITCH OUTPUT (RUN-ACC)
6	-	-
7	-	-
8	-	-
9	L7 18BK/YL	PARK LAMP RELAY OUTPUT
10	F18 20LG/BK	FUSED IGNITION SWITCH OUTPUT (RUN-START)
11	L1 18VT/BK	BACK-UP LAMP FEED
12	V6 16DB	FUSED IGNITION SWITCH OUTPUT (RUN-ACC)
13	V6 16DB	FUSED IGNITION SWITCH OUTPUT (RUN-ACC)
14	G32 20BK/VT	SENSOR GROUND
15	-	-



JUNCTION BLOCK C2

JUNCTION BLOCK C2 - NATURAL 6 WAY

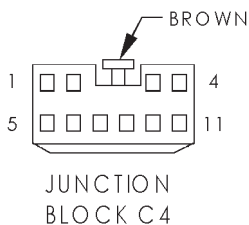
CAV	CIRCUIT	FUNCTION
1	A7 10RD/BK	FUSED B(+)
2	L9 16BK/VT	FUSED FLASHER FEED
3	M1 20PK	FUSED B(+)
4	-	-
5	L60 18TN	RIGHT TURN SIGNAL
6	-	-



JUNCTION BLOCK C3

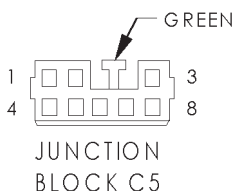
JUNCTION BLOCK C3 - 14 WAY

CAV	CIRCUIT	FUNCTION
1	G32 22BK/LB	SENSOR GROUND
2	Z2 20BK/LG	GROUND
3	M2 22YL	COURTESY LAMPS DRIVER
4	-	-
5	G31 22VT/LG	AMBIENT TEMPERATURE SENSOR SIGNAL
6	M1 22PK (BASE)	FUSED B(+)
6	M1 20PK (HIGHLINE)	FUSED B(+)
7	-	-
8	L7 18BK/YL (CLEARANCE/ID LAMPS)	PARK LAMP RELAY OUTPUT
9	-	-
10	-	-
11	L1 20VT/BK	BACK-UP LAMP FEED
12	-	-
13	Z3 18BK (HIGHLINE)	GROUND
14	F12 20DB/WT (HIGHLINE)	FUSED IGNITION SWITCH OUTPUT (RUN-START)



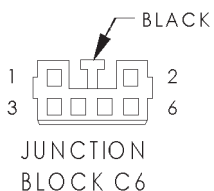
JUNCTION BLOCK C4 - BROWN 11 WAY

CAV	CIRCUIT	FUNCTION
1	F14 18LG/YL	FUSED IGNITION SWITCH OUTPUT (RUN-START)
2	F23 18DB/YL	FUSED IGNITION SWITCH OUTPUT (RUN)
3	X12 16RD/WT	FUSED IGNITION SWITCH OUTPUT (RUN-ACC)
4	L61 18LG	LEFT TURN SIGNAL
5	F12 22DB/WT	FUSED IGNITION SWITCH OUTPUT (RUN-START)
6	F12 22DB/WT	FUSED IGNITION SWITCH OUTPUT (RUN-START)
7	-	-
8	-	-
9	E1 18TN	PANEL LAMPS DIMMER SWITCH SIGNAL
10	-	-
11	-	-



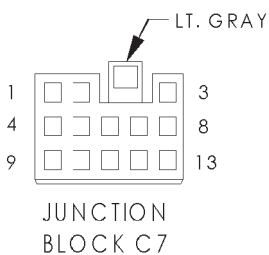
JUNCTION BLOCK C5 - GREEN 8 WAY

CAV	CIRCUIT	FUNCTION
1	V6 16DB (EXCEPT BASE/MIDLINE)	FUSED IGNITION SWITCH OUTPUT (RUN-ACC)
2	L61 18LG	LEFT TURN SIGNAL
3	X60 16DG/RD	FUSED IGNITION SWITCH OUTPUT (RUN-ACC)
4	V6 16DB	FUSED IGNITION SWITCH OUTPUT (RUN-ACC)
5	-	-
6	M2 22YL	COURTESY LAMPS DRIVER
7	E2 22OR	PANEL LAMPS FEED
8	G5 22DB/WT	FUSED IGNITION SWITCH OUTPUT (RUN-START)



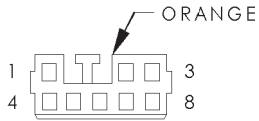
JUNCTION BLOCK C6 - BLACK 6 WAY

CAV	CIRCUIT	FUNCTION
1	A35 16DB (SLT)	FUSED B(+)
2	-	-
3	-	-
4	L19 16PK	HAZARD FLASHER SIGNAL
5	F235 16RD	B(+) TO HEATED SEAT MODULE
6	L10 18BR/LG	FUSED IGNITION SWITCH OUTPUT (RUN)



JUNCTION BLOCK C7 - LT. GRAY 13 WAY

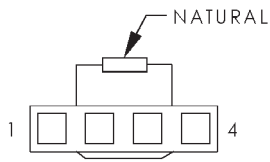
CAV	CIRCUIT	FUNCTION
1	L60 18TN	RIGHT TURN SIGNAL
2	-	-
3	Z3 18BK/WT	GROUND
4	L60 18TN	RIGHT TURN SIGNAL
5	-	-
6	-	-
7	P132 16OR/BK (SLT/BASE/MIDLINE)	HEATED SEAT ENABLE
8	Z2 22BK/LG	GROUND
9	M1 22PK	FUSED B(+)
10	F35 18RD	FUSED B(+)
11	F35 22RD	FUSED B(+)
12	A35 16DB (SLT)	FUSED B(+)
13	L6 16RD/GY	FLASHER OUTPUT



JUNCTION BLOCK C8

JUNCTION BLOCK C8 - ORANGE 8 WAY

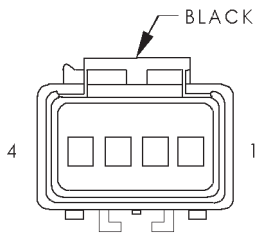
CAV	CIRCUIT	FUNCTION
1	F30 18RD/OR	FUSED IGNITION SWITCH OUTPUT (RUN-ACC)
2	-	-
3	-	-
4	F73 20YL	FUSED B(+)
5	-	-
6	-	-
7	F37 16RD/LB (HIGHLINE/PREMIUM)	FUSED B(+)
8	F21 14TN	FUSED IGNITION SWITCH OUTPUT (RUN)



JUNCTION BLOCK C9

JUNCTION BLOCK C9 - NATURAL 4 WAY

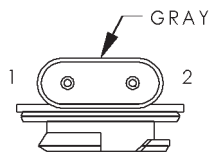
CAV	CIRCUIT	FUNCTION
1	A31 12BK/WT	FUSED IGNITION SWITCH OUTPUT (RUN-ACC)
2	A21 12DB	FUSED IGNITION SWITCH OUTPUT (RUN-START)
3	A22 14BK/OR	FUSED IGNITION SWITCH OUTPUT (RUN)
4	F15 18DB	FUSED IGNITION SWITCH OUTPUT (RUN)



LEAK DETECTION PUMP (GAS)

LEAK DETECTION PUMP (GAS) - BLACK 4 WAY

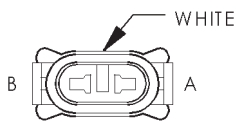
CAV	CIRCUIT	FUNCTION
1	-	-
2	T125 18DB	GENERATOR SOURCE
3	K106 18WT/DG	LEAK DETECTION PUMP SOLENOID CONTROL
4	K107 18OR	LEAK DETECTION PUMP SWITCH SENSE



LEFT BACK-UP LAMP

LEFT BACK-UP LAMP - GRAY 2 WAY

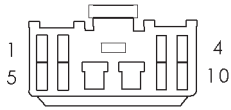
CAV	CIRCUIT	FUNCTION
1	Z13 18BK	GROUND
2	L1 18VT/BK	BACK-UP LAMP FEED



LEFT FOG LAMP

LEFT FOG LAMP - WHITE 2 WAY

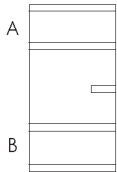
CAV	CIRCUIT	FUNCTION
A	L34 20RD/OR	FUSED B(+)
B	L39 20LB	FOG LAMP SWITCH OUTPUT



LEFT FRONT DOOR SPEAKER (PREMIUM)

LEFT FRONT DOOR SPEAKER (PREMIUM) - 10 WAY

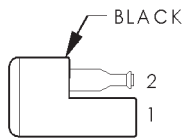
CAV	CIRCUIT	FUNCTION
1	X83 20YL/RD	AMPLIFIED HIGH LEFT FRONT SPEAKER (+)
2	X81 20YL/BK	AMPLIFIED HIGH LEFT FRONT SPEAKER (-)
3	X53 18DG	LEFT FRONT SPEAKER (+)
4	X55 18BR/RD	LEFT FRONT SPEAKER (-)
5	X91 18WT/DG	AMPLIFIED LOW LEFT REAR SPEAKER (-)
6	X93 18WT/VT	AMPLIFIED LOW LEFT REAR SPEAKER (+)
7	X13 16BK/RD	RADIO CHOKE RELAY OUTPUT
8	Z9 16BK/VT	GROUND
9	X51 18BR/YL	LEFT REAR SPEAKER (+)
10	X57 18BR/LB	LEFT REAR SPEAKER (-)



LEFT FRONT DOOR SPEAKER (STANDARD)

LEFT FRONT DOOR SPEAKER (STANDARD) - 2 WAY

CAV	CIRCUIT	FUNCTION
A	X55 20BR/RD	LEFT FRONT SPEAKER (-)
B	X53 20DG	LEFT FRONT SPEAKER (+)



LEFT FRONT FENDER LAMP (DUAL REAR WHEELS)

LEFT FRONT FENDER LAMP (DUAL REAR WHEELS) - BLACK 2 WAY

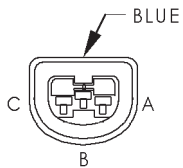
CAV	CIRCUIT	FUNCTION
1	L7 18BK/YL	HEADLAMP SWITCH OUTPUT
2	Z13 18BK	GROUND



LEFT FRONT WHEEL SPEED SENSOR (ABS)

LEFT FRONT WHEEL SPEED SENSOR (ABS) - 2 WAY

CAV	CIRCUIT	FUNCTION
1	B8 20RD/GY	LEFT FRONT WHEEL SPEED SENSOR (-)
2	B9 20RD	LEFT FRONT WHEEL SPEED SENSOR (+)

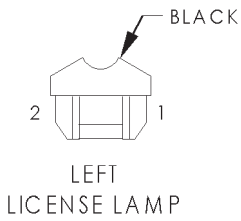


LEFT HEADLAMP

LEFT HEADLAMP - BLUE 3 WAY

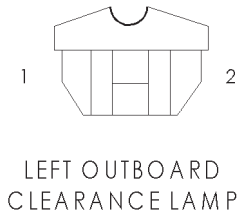
CAV	CIRCUIT	FUNCTION
A	L45 18PK/RD	FUSED B(+)
B	-	-
C	L33 18LG/BR	HIGH BEAM HEADLAMP DRIVER





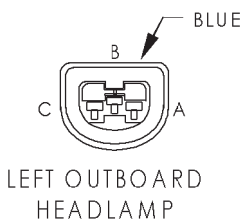
LEFT LICENSE LAMP - BLACK 2 WAY

CAV	CIRCUIT	FUNCTION
1	L7 18BK/YL	HEADLAMP SWITCH OUTPUT
2	Z13 18BK	GROUND



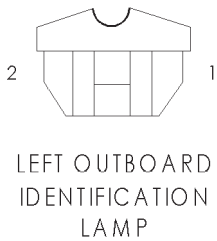
LEFT OUTBOARD CLEARANCE LAMP - 2 WAY

CAV	CIRCUIT	FUNCTION
1	L7 18BK/YL	HEADLAMP SWITCH OUTPUT
2	Z4 18BK	GROUND



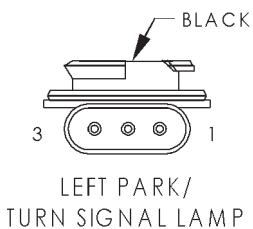
LEFT OUTBOARD HEADLAMP - BLUE 3 WAY

CAV	CIRCUIT	FUNCTION
A	L4 20VT/WT (QUAD HEADLAMP)	DIMMER SWITCH LOW BEAM OUTPUT
A	L43 18VT (EXCEPT QUAD HEADLAMP)	FUSED B(+)
B	L4 20VT/WT (EXCEPT QUAD HEAD-LAMP)	DIMMER SWITCH LOW BEAM OUTPUT
B	L43 18VT (QUAD HEADLAMP)	FUSED B(+)
C	L3 20RD/OR	DIMMER SWITCH HIGH BEAM OUTPUT



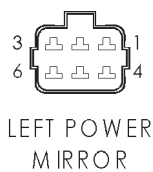
LEFT OUTBOARD IDENTIFICATION LAMP - 2 WAY

CAV	CIRCUIT	FUNCTION
1	L7 18BK/YL	HEADLAMP SWITCH OUTPUT
2	Z4 18BK	GROUND



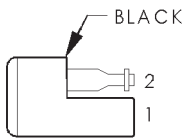
LEFT PARK/TURN SIGNAL LAMP - BLACK 3 WAY

CAV	CIRCUIT	FUNCTION
1	Z1 18BK	GROUND
2	L7 18BK/YL	PARK LAMP RELAY OUTPUT
3	L61 18LG/TN	LEFT TURN SIGNAL



LEFT POWER MIRROR - 6 WAY

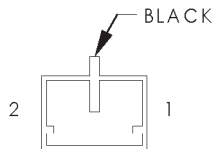
CAV	CIRCUIT	FUNCTION
1	P71 22YL	LEFT MIRROR UP DRIVER
2	P75 22DB/WT	LEFT MIRROR LEFT DRIVER
3	P73 22YL/PK	LEFT MIRROR COMMON DRIVER (RIGHT/DOWN)
4	C16 20LB/YL	HEATED MIRROR
5	Z2 20BK/LG	GROUND
6	-	-



LEFT REAR  
FENDER LAMP  
(DUAL REAR WHEELS)

LEFT REAR FENDER LAMP (DUAL REAR WHEELS) - BLACK 2 WAY

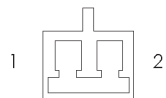
CAV	CIRCUIT	FUNCTION
1	L7 18BK/YL	HEADLAMP SWITCH OUTPUT
2	Z13 18BK	GROUND



LEFT REAR  
SPEAKER  
(PREMIUM 2 DOOR)

LEFT REAR SPEAKER (PREMIUM 2 DOOR) - BLACK 2 WAY

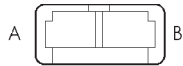
CAV	CIRCUIT	FUNCTION
1	X91 18WT/DG	AMPLIFIED LOW LEFT REAR SPEAKER (-)
2	X93 18WT/VT	AMPLIFIED LOW LEFT REAR SPEAKER (+)



LEFT REAR  
SPEAKER  
(PREMIUM 4 DOOR)

LEFT REAR SPEAKER (PREMIUM 4 DOOR) - 2 WAY

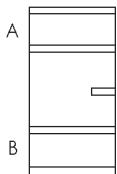
CAV	CIRCUIT	FUNCTION
1	X57 18BR/LB	AMPLIFIED LOW LEFT REAR SPEAKER (-)
2	X51 18BR/YL	AMPLIFIED LOW LEFT REAR SPEAKER (+)



LEFT REAR  
SPEAKER  
(STANDARD 2 DOOR)

LEFT REAR SPEAKER (STANDARD 2 DOOR) - 2 WAY

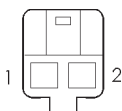
CAV	CIRCUIT	FUNCTION
A	X57 18BR/LB	LEFT REAR SPEAKER (-)
B	X51 18BR/YL	LEFT REAR SPEAKER (+)



LEFT REAR  
SPEAKER  
(STANDARD 4 DOOR)

LEFT REAR SPEAKER (STANDARD 4 DOOR) - 2 WAY

CAV	CIRCUIT	FUNCTION
A	X57 18BR/LB	LEFT REAR SPEAKER (-)
B	X51 18BR/YL	LEFT REAR SPEAKER (+)



LEFT REMOTE  
RADIO SWITCH

LEFT REMOTE RADIO SWITCH - 2 WAY

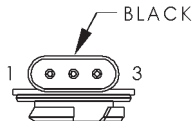
CAV	CIRCUIT	FUNCTION
1	Z2 22BK/LG	GROUND
2	X20 22RD/BK	RADIO CONTROL MUX



LEFT SPEED CONTROL SWITCH

LEFT SPEED CONTROL SWITCH - 2 WAY

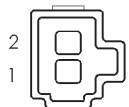
CAV	CIRCUIT	FUNCTION
1	K4 22WT	SENSOR GROUND
1	K4 22WT	SENSOR GROUND
2	V37 22DG/RD	SPEED CONTROL SWITCH SIGNAL
2	V37 22DG/RD	SPEED CONTROL SWITCH SIGNAL



LEFT TAIL/STOP/TURN SIGNAL LAMP

LEFT TAIL/STOP/TURN SIGNAL LAMP - BLACK 3 WAY

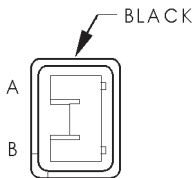
CAV	CIRCUIT	FUNCTION
1	Z13 18BK	GROUND
2	L7 18BK/YL	PARK LAMP RELAY OUTPUT
3	L63 18DG/BR	LEFT TURN SIGNAL



LEFT TWEETER (PREMIUM)

LEFT TWEETER (PREMIUM) - 2 WAY

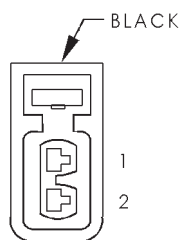
CAV	CIRCUIT	FUNCTION
1	X81 20YL/BK	AMPLIFIED HIGH LEFT FRONT SPEAKER (-)
2	X83 20YL/RD	AMPLIFIED HIGH LEFT FRONT SPEAKER (+)



LEFT VISOR/VANITY LAMP

LEFT VISOR/VANITY LAMP - BLACK 2 WAY

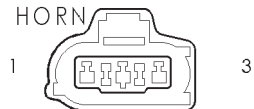
CAV	CIRCUIT	FUNCTION
A	M1 20PK	FUSED B(+)
B	Z4 20BK	GROUND



LOW NOTE HORN

LOW NOTE HORN - BLACK 2 WAY

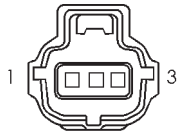
CAV	CIRCUIT	FUNCTION
1	X2 18DG/RD	HORN RELAY OUTPUT
2	Z1 18BK	GROUND



MANIFOLD ABSOLUTE PRESSURE SENSOR (3.9L/5.2L/5.9L)

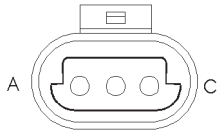
MANIFOLD ABSOLUTE PRESSURE SENSOR (3.9L/5.2L/5.9L) - 3 WAY

CAV	CIRCUIT	FUNCTION
1	K4 20BK/LB	SENSOR GROUND
2	K1 18DG/RD	MAP SENSOR SIGNAL
3	K6 20VT/WT	5V SUPPLY



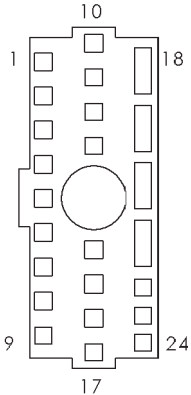
MANIFOLD ABSOLUTE PRESSURE SENSOR (8.0L)

MANIFOLD ABSOLUTE PRESSURE SENSOR (8.0L) - 3 WAY		
CAV	CIRCUIT	FUNCTION
1	K6 20VT/WT	5V SUPPLY
2	K4 20BK/LB	SENSOR GROUND
3	K1 18DG/RD	MAP SENSOR SIGNAL



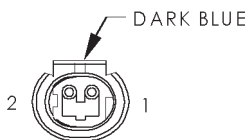
MANIFOLD AIR PRESSURE SENSOR (DIESEL)

MANIFOLD AIR PRESSURE SENSOR (DIESEL) - 3 WAY		
CAV	CIRCUIT	FUNCTION
A	K7 18OR	5V SUPPLY
B	K104 18BK/LB	SENSOR GROUND
C	G12 18GY/RD	MANIFOLD AIR PRESSURE SENSOR SIGNAL



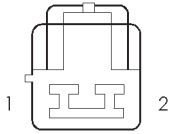
MULTI-FUNCTION SWITCH

MULTI-FUNCTION SWITCH - 24 WAY		
CAV	CIRCUIT	FUNCTION
1	V9 16WT/DB	WIPER SWITCH MODE SIGNAL
2	V8 16VT	WIPER SWITCH MODE SENSE
3	V10 16BR	WASHER SWITCH SENSE
4	V6 16DB	FUSED IGNITION SWITCH OUTPUT (RUN-ACC)
5	V4 16RD/YL	WIPER SWITCH HIGH SPEED OUTPUT
6	V3 16BR/WT	LOW SPEED WIPER SWITCH OUTPUT
7	V49 16RD/BK	DRIVER LOW SPEED WIPER MOTOR DRIVER
8	V49 16RD/BK	DRIVER LOW SPEED WIPER MOTOR DRIVER
9	V3 16BR/WT	LOW SPEED WIPER SWITCH OUTPUT
10	-	-
11	L60 18TN	RIGHT TURN SIGNAL
12	L62 16BR/RD	RIGHT TURN SIGNAL
13	L19 16PK	HAZARD FLASHER SIGNAL
14	L50 16WT/TN	BRAKE LAMP SWITCH OUTPUT
15	L63 16DG/RD	LEFT TURN SIGNAL
16	L61 18LG	LEFT TURN SIGNAL
17	L6 16RD/GY	FLASHER OUTPUT
18	L4 18VT/WT	DIMMER SWITCH LOW BEAM OUTPUT
19	L2 18LG	HEADLAMP SWITCH OUTPUT
20	L3 14RD/OR	DIMMER SWITCH HIGH BEAM OUTPUT
21	Z3 16BK/OR	GROUND
22	-	-
23	-	-
24	-	-



OUTPUT SPEED SENSOR

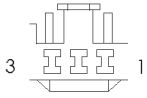
OUTPUT SPEED SENSOR - DK. BLUE 2 WAY		
CAV	CIRCUIT	FUNCTION
1	T14 18LG/BK	OUTPUT SPEED SENSOR SIGNAL
2	T13 18DB/BK	OUTPUT SPEED SENSOR GROUND



OVERDRIVE SWITCH

OVERDRIVE SWITCH - 2 WAY

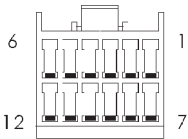
CAV	CIRCUIT	FUNCTION
1	T6 22OR/WT	OVERDRIVE OFF SWITCH SENSE
2	Z2 22BK/LG	GROUND



OVERHEAD CONSOLE  
(BASE)

OVERHEAD CONSOLE (BASE) - 3 WAY

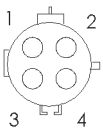
CAV	CIRCUIT	FUNCTION
1	M2 22YL	COURTESY LAMPS DRIVER
2	M1 22PK	FUSED B(+)
3	Z2 20BK/LG	GROUND



OVERHEAD CONSOLE  
(HIGHLINE)

OVERHEAD CONSOLE (HIGHLINE) - 12 WAY

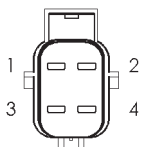
CAV	CIRCUIT	FUNCTION
1	F12 20DB/WT	FUSED IGNITION SWITCH OUTPUT (RUN-START)
2	D1 20VT/BR	CCD BUS(+)
3	G31 22VT/LG	AMBIENT TEMPERATURE SENSOR SIGNAL
4	Z2 20BK/LG	GROUND
5	M1 20PK	FUSED B(+)
6	M2 22YL	COURTESY LAMPS DRIVER
7	Z2 20BK/LG	GROUND
8	D2 20WT/BK	CCD BUS(-)
9	G32 22BK/LB	SENSOR GROUND
10	-	-
11	G69 22BK	VTSS INDICATOR DRIVER
12	-	-



OXYGEN SENSOR  
1/1 LEFT  
BANK UP  
(5.9L HD/8.0L)

OXYGEN SENSOR 1/1 LEFT BANK UP (5.9L HD/8.0L) - 4 WAY

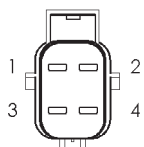
CAV	CIRCUIT	FUNCTION
1	A141 18DG/WT	AUTOMATIC SHUT DOWN RELAY OUTPUT
2	K199 18BR/VT	OXYGEN SENSOR 1/1 HEATER CONTROL
3	K4 18BK/LB	SENSOR GROUND
4	K41 18BK/DG	OXYGEN SENSOR 1/1 SIGNAL



OXYGEN SENSOR  
1/1 LEFT  
BANK UP  
(CALIFORNIA)

OXYGEN SENSOR 1/1 LEFT BANK UP (CALIFORNIA) - 4 WAY

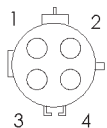
CAV	CIRCUIT	FUNCTION
1	A141 18DG/WT	FUSED OXYGEN SENSOR UPSTREAM RELAY OUTPUT
2	K199 18BR/VT	OXYGEN SENSOR 1/1 HEATER CONTROL
3	K4 18BK/LB	SENSOR GROUND
4	K141 18TN/WT	OXYGEN SENSOR 1/1 SIGNAL



OXYGEN SENSOR  
1/1 UPSTREAM  
(A/T EXCEPT 8.0L)

OXYGEN SENSOR 1/1 UPSTREAM (A/T EXCEPT 8.0L) - 4 WAY

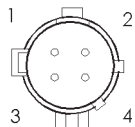
CAV	CIRCUIT	FUNCTION
1	A141 18DG/WT	AUTOMATIC SHUT DOWN RELAY OUTPUT
2	K199 18BR/WT	OXYGEN SENSOR 1/1 HEATER CONTROL
3	K4 18BK/LB	SENSOR GROUND
4	K141 18LG/RD	OXYGEN SENSOR 1/1 SIGNAL



OXYGEN SENSOR  
1/1 UPSTREAM  
(M/T EXCEPT 8.0L)

OXYGEN SENSOR 1/1 UPSTREAM (M/T EXCEPT 8.0L) - 4 WAY

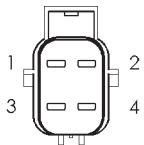
CAV	CIRCUIT	FUNCTION
1	A141 18DG/WT	AUTOMATIC SHUT DOWN RELAY OUTPUT
2	K199 18BR/VT	OXYGEN SENSOR 1/1 HEATER CONTROL
3	K4 18BK/LB	SENSOR GROUND
4	K141 18TN/WT	OXYGEN SENSOR 1/1 SIGNAL



OXYGEN SENSOR  
1/2 DOWNSTREAM  
(3.9L/5.2L)

OXYGEN SENSOR 1/2 DOWNSTREAM (3.9L/5.2L) - 4 WAY

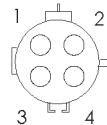
CAV	CIRCUIT	FUNCTION
1	A141 18DG/WT	AUTOMATIC SHUT DOWN RELAY OUTPUT
2	K299 18BR/WT	OXYGEN SENSOR 1/2 HEATER CONTROL
3	K4 18BK/LB	SENSOR GROUND
4	K341 18OR/BK	OXYGEN SENSOR 1/2 SIGNAL



OXYGEN SENSOR  
1/2 LEFT  
BANK DOWN  
(CALIFORNIA)

OXYGEN SENSOR 1/2 LEFT BANK DOWN (CALIFORNIA) - 4 WAY

CAV	CIRCUIT	FUNCTION
1	A341 18DG/YL	OXYGEN SENSOR DOWNSTREAM RELAY OUTPUT
2	Z11 18BK/WT	GROUND
3	K4 18BK/LB	SENSOR GROUND
4	K341 18OR/BK	OXYGEN SENSOR 1/2 SIGNAL

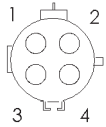


OXYGEN SENSOR  
1/2 PRE-  
CATALYST  
(8.0L)

OXYGEN SENSOR 1/2 PRE-CATALYST (8.0L) - 4 WAY

CAV	CIRCUIT	FUNCTION
1	A341 18DG/YL	AUTOMATIC SHUT DOWN RELAY OUTPUT
2	Z11 18BK/WT	GROUND
3	K4 18BK/LB	SENSOR GROUND
4	K141 18TN/WT	OXYGEN SENSOR 1/2 SIGNAL

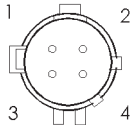




OXYGEN SENSOR  
1/3 POST  
CATALYST  
(8.0L)

OXYGEN SENSOR 1/3 POST CATALYST (8.0L) - 4 WAY

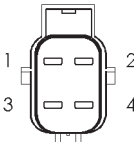
CAV	CIRCUIT	FUNCTION
1	A341 18DG/YL	AUTOMATIC SHUT DOWN RELAY OUTPUT
2	Z11 18BK/WT	GROUND
3	K4 18BK/LB	SENSOR GROUND
4	K341 18OR/BK	OXYGEN SENSOR 1/3 SIGNAL



OXYGEN SENSOR  
2/1 RIGHT  
BANK UP  
(5.9L HD)  
(5.2L/5.9L/8.0L  
CALIFORNIA)

OXYGEN SENSOR 2/1 RIGHT BANK UP (5.9L HD) (5.2L/5.9L/8.0L CALIFORNIA)

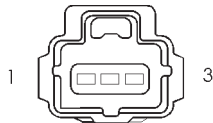
CAV	CIRCUIT	FUNCTION
1	A141 18DG/WT	AUTOMATIC SHUT DOWN RELAY OUTPUT
2	K299 18BR/WT	OXYGEN SENSOR 2/1 HEATER CONTROL
3	K4 18BK/LB	SENSOR GROUND
4	K241 18LG/RD	OXYGEN SENSOR 2/1 SIGNAL



OXYGEN SENSOR  
2/2 RIGHT  
BANK DOWN  
(CALIFORNIA)

OXYGEN SENSOR 2/2 RIGHT BANK DOWN (CALIFORNIA) - 4 WAY

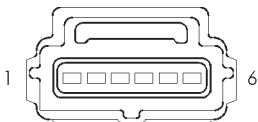
CAV	CIRCUIT	FUNCTION
1	A341 18DG/YL	OXYGEN SENSOR DOWNSTREAM RELAY OUTPUT
2	Z11 18BK/WT	GROUND
3	K4 18BK/LB	SENSOR GROUND
4	K441 18OR/TN	OXYGEN SENSOR 2/2 SIGNAL



PARK/NEUTRAL  
POSITION SWITCH  
(A/T EXCEPT 8.0L)

PARK/NEUTRAL POSITION SWITCH (A/T EXCEPT 8.0L) - 3 WAY

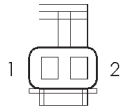
CAV	CIRCUIT	FUNCTION
1	L10 18BR/LG	FUSED IGNITION SWITCH OUTPUT (RUN)
2	T41 18BK/WT	PARK/NEUTRAL POSITION SWITCH SENSE
3	L1 18VT/BK	BACK-UP LAMP FEED



PARK/NEUTRAL  
POSITION SWITCH  
(A/T 8.0L)

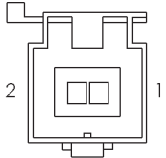
PARK/NEUTRAL POSITION SWITCH (A/T 8.0L) - 6 WAY

CAV	CIRCUIT	FUNCTION
1	L10 18BR/LG	FUSED IGNITION SWITCH OUTPUT (RUN)
2	Y193 18WT/LG	NOT USED
3	-	-
4	L1 18VT/BK	BACK-UP LAMP FEED
5	Y128 18DG/GY	NOT USED
6	T41 18BK/WT	PARK/NEUTRAL POSITION SWITCH SENSE

PASSENGER  
AIRBAG

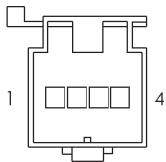
PASSENGER AIRBAG - 2 WAY

CAV	CIRCUIT	FUNCTION
1	R42 18BK/YL	PASSENGER AIRBAG LINE 1
2	R44 18DG/YL	PASSENGER AIRBAG LINE 2

PASSENGER AIRBAG  
ON/OFF SWITCH C1

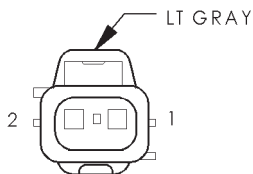
PASSENGER AIRBAG ON/OFF SWITCH C1 - 2 WAY

CAV	CIRCUIT	FUNCTION
1	F14 18LG/YL	FUSED IGNITION SWITCH OUTPUT (RUN-START)
2	Z6 18BK/PK	GROUND

PASSENGER AIRBAG  
ON/OFF SWITCH C2

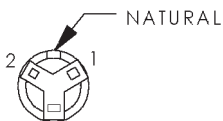
PASSENGER AIRBAG ON/OFF SWITCH C2 - 4 WAY

CAV	CIRCUIT	FUNCTION
1	R142 18BR/YL	PASSENGER AIRBAG SQUIB LINE 1
2	R144 18VT/YL	PASSENGER AIRBAG SQUIB LINE 2
3	R42 18BK/YL	PASSENGER AIRBAG LINE 1
4	R44 18DG/YL	PASSENGER AIRBAG LINE 2

PASSENGER  
CYLINDER LOCK  
SWITCH

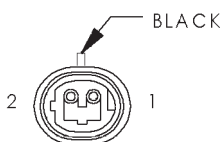
PASSENGER CYLINDER LOCK SWITCH - LT GRAY 2 WAY

CAV	CIRCUIT	FUNCTION
1	Z2 20BK/LG	GROUND
2	G73 20LG/OR	CYLINDER LOCK SWITCH MUX

PASSENGER DOOR  
AJAR SWITCH

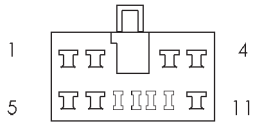
PASSENGER DOOR AJAR SWITCH - NATURAL 2 WAY

CAV	CIRCUIT	FUNCTION
1	Z2 18BK/LG	GROUND
2	G16 18BK/LB (HIGHLINE/PREMIUM)	PASSENGER DOOR AJAR SWITCH SENSE
2	M22 18WT (BASE)	ILLUMINATED ENTRY SWITCH SENSE

PASSENGER  
DOOR LOCK  
MOTOR

PASSENGER DOOR LOCK MOTOR - BLACK 2 WAY

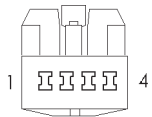
CAV	CIRCUIT	FUNCTION
1	P34 18PK/BK	DOOR UNLOCK DRIVER
2	P33 18OR/BK	DOOR LOCK DRIVER



PASSENGER DOOR WINDOW/LOCK SWITCH

PASSENGER DOOR WINDOW/LOCK SWITCH - 11 WAY

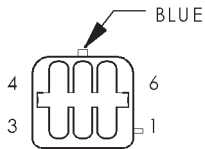
CAV	CIRCUIT	FUNCTION
1	Q16 14BR/WT	MASTER WINDOW SWITCH RIGHT FRONT (UP)
2	Q26 14VT/WT	MASTER WINDOW SWITCH RIGHT FRONT (DOWN)
3	Q22 14VT	RIGHT FRONT WINDOW DRIVER (DOWN)
4	Q12 14BR	RF WINDOW DRIVER (UP)
5	F35 18RD	FUSED B(+)
6	P35 18OR/VT	DOOR LOCK SWITCH CONTROL
7	P30 18OR/DG	PASSENGER DOOR LOCK SWITCH OUTPUT
8	Z2 14BK/LG	GROUND
9	P31 18PK/DG	PASSENGER DOOR UNLOCK SWITCH OUTPUT
10	P36 18PK/VT	DOOR UNLOCK SWITCH CONTROL
11	F21 14TN	FUSED IGNITION SWITCH OUTPUT (RUN)



PASSENGER HEATED SEAT CUSHION

PASSENGER HEATED SEAT CUSHION - 4 WAY

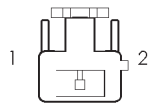
CAV	CIRCUIT	FUNCTION
1	P130 16TN	RIGHT SEAT HEATER B(+) DRIVER
2	Z2 18BK/LG	GROUND
3	P144 20BK/WT	SEAT TEMPERATURE 5V SUPPLY
4	P142 20DB	RIGHT SEAT TEMPERATURE SENSOR INPUT



PASSENGER HEATED SEAT SWITCH

PASSENGER HEATED SEAT SWITCH - BLUE 6 WAY

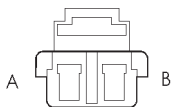
CAV	CIRCUIT	FUNCTION
1	P138 20VT/LG	RIGHT SEAT LOW HEAT LED DRIVER
2	E2 22OR	PANEL LAMPS FEED
3	Z3 20BK/OR	GROUND
4	F15 20DB	FUSED IGNITION SWITCH OUTPUT (RUN)
5	P140 20VT/BK	RIGHT SEAT HIGH HEAT LED DRIVER
6	P8 20LB/WT	PASSENGER HEATED SEAT SWITCH



PASSENGER LUMBAR MOTOR

PASSENGER LUMBAR MOTOR - 2 WAY

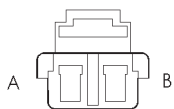
CAV	CIRCUIT	FUNCTION
1	P106 16DG/WT	LUMBAR MOTOR FORWARD
2	P107 16OR/BK	LUMBAR MOTOR REARWARD



PASSENGER POWER SEAT FRONT VERTICAL MOTOR (CLUB CAB)

PASSENGER POWER SEAT FRONT VERTICAL MOTOR (CLUB CAB) - 2 WAY

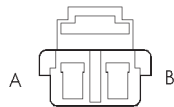
CAV	CIRCUIT	FUNCTION
A	P20 16RD/LG	RIGHT SEAT FRONT DOWN
B	P18 16YL/LG	RIGHT SEAT FRONT UP



PASSENGER POWER SEAT HORIZONTAL MOTOR (CLUB CAB)

PASSENGER POWER SEAT HORIZONTAL MOTOR (CLUB CAB) - 2 WAY

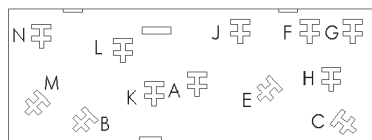
CAV	CIRCUIT	FUNCTION
A	P16 16LB	RIGHT SEAT HORIZONTAL REARWARD
B	P14 16YL/LB	RIGHT SEAT HORIZONTAL FORWARD



PASSENGER POWER SEAT REAR VERTICAL MOTOR (CLUB CAB)

PASSENGER POWER SEAT REAR VERTICAL MOTOR (CLUB CAB) - 2 WAY

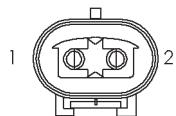
CAV	CIRCUIT	FUNCTION
A	P10 16YL/WT	RIGHT SEAT REAR UP
B	P12 16RD/WT'	RIGHT SEAT REAR DOWN



PASSENGER POWER SEAT SWITCH (CLUB CAB)

PASSENGER POWER SEAT SWITCH (CLUB CAB) - 14 WAY

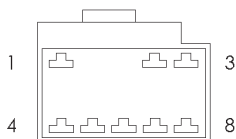
CAV	CIRCUIT	FUNCTION
A	F37 16RD/LB	FUSED B(+)
B	Z2 16BK/LG	GROUND
C	P107 16OR/BK	LUMBAR MOTOR REARWARD
D	-	-
E	P10 16YL/WT	RIGHT SEAT REAR UP
F	P106 16DG/WT	LUMBAR MOTOR FORWARD
G	Z2 16BK/LG	GROUND
H	F37 16RD/LB	FUSED B(+)
I	-	-
J	P12 16RD/WT	RIGHT SEAT REAR DOWN
K	P16 16LB	RIGHT SEAT HORIZONTAL FORWARD
L	P14 16YL/LB	RIGHT SEAT HORIZONTAL REARWARD
M	P18 16YL/LG	RIGHT SEAT FRONT UP
N	P20 16RD/LG	RIGHT SEAT FRONT DOWN



PASSENGER POWER WINDOW MOTOR

PASSENGER POWER WINDOW MOTOR - 2 WAY

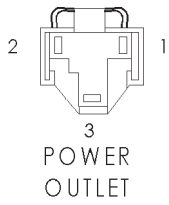
CAV	CIRCUIT	FUNCTION
1	Q12 14BR	RIGHT FRONT WINDOW DRIVER (UP)
2	Q22 14VT	RIGHT FRONT WINDOW DRIVER (DOWN)



POWER MIRROR SWITCH

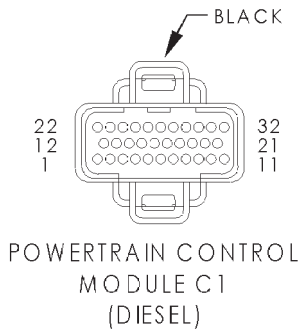
POWER MIRROR SWITCH - 8 WAY

CAV	CIRCUIT	FUNCTION
1	P71 22YL	LEFT MIRROR UP DRIVER
2	P75 22DB/WT	LEFT MIRROR LEFT DRIVER
3	P73 22YL/PK	LEFT MIRROR COMMON DRIVER (RIGHT/DOWN)
4	P72 22YL/BK	RIGHT MIRROR UP DRIVER
5	P74 22DB	RIGHT MIRROR LEFT DRIVER
6	P70 22WT	RIGHT MIRROR COMMON DRIVER (RIGHT/DOWN)
7	M1 22PK	FUSED B(+)
8	Z2 20BK/LG	GROUND



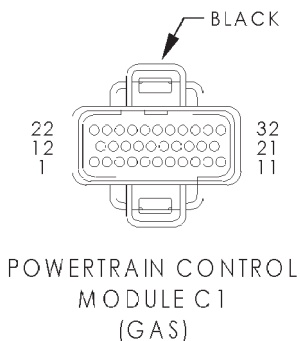
POWER OUTLET - 3 WAY

CAV	CIRCUIT	FUNCTION
1	A12 16RD/TN	OUTLET FEED
2	-	-
3	Z3 16BK/OR	GROUND



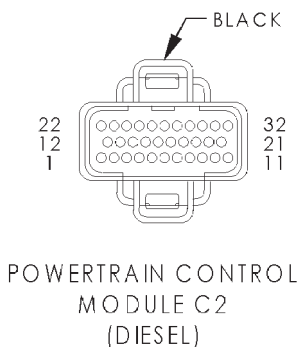
POWERTRAIN CONTROL MODULE C1 (DIESEL) - BLACK 32 WAY

CAV	CIRCUIT	FUNCTION
1	-	-
2	F18 18LG/BK	FUSED IGNITION SWITCH OUTPUT (RUN-START)
3	-	-
4	K4 18BK/LB	SENSOR GROUND
5	-	-
6	T41 18BK/WT (A/T)	PARK/NEUTRAL POSITION SWITCH SENSE
7	-	-
8	K24 18GY/BK	CRANKSHAFT POSITION SENSOR SIGNAL
9	-	-
10	-	-
11	-	-
12	-	-
13	-	-
14	-	-
15	-	-
16	-	-
17	-	-
18	-	-
19	-	-
20	-	-
21	-	-
22	A14 14RD/WT	FUSED B(+)
23	K22 18OR/DB	THROTTLE POSITION SENSOR SIGNAL
24	-	-
25	-	-
26	-	-
27	-	-
28	-	-
29	-	-
30	-	-
31	Z12 14BK/TN	GROUND
32	Z12 14BK/TN	GROUND



POWERTRAIN CONTROL MODULE C1 (GAS) - BLACK 32 WAY

CAV	CIRCUIT	FUNCTION
1	K32 18YL/GY (8.0L)	IGNITION COIL NO. 4 DRIVER
2	F18 18LG/BK	FUSED IGNITION SWITCH OUTPUT (RUN-START)
3	K18 18RD/BK (8.0L)	IGNITION COIL NO. 3 DRIVER
4	K4 18BK/LB	SENSOR GROUND
5	K43 18DG/GY (8.0L)	IGNITION COIL NO. 5 DRIVER
6	T41 18BK/WT (A/T)	PARK/NEUTRAL POSITION SWITCH SENSE
7	K19 16BK/GY (3.9L/5.2L/5.9L)	IGNITION COIL NO. 1 DRIVER
7	K19 18BK/GY (8.0L)	IGNITION COIL NO. 1 DRIVER
8	K24 18GY/BK	CRANKSHAFT POSITION SENSOR SIGNAL
9	K17 18DB/WT (8.0L)	IGNITION COIL NO. 2 DRIVER
10	K60 18YL/BK	IDLE AIR CONTROL NO. 2 DRIVER
11	K40 18BR/WT	IDLE AIR CONTROL NO. 3 DRIVER
12	-	-
13	G113 18OR	PTO SWITCH SENSE
14	-	-
15	K21 18BK/RD	INTAKE AIR TEMPERATURE SENSOR SIGNAL
16	K2 18TN/BK	ENGINE COOLANT TEMPERATURE SENSOR SIGNAL
17	K6 18VT/WT	5V SUPPLY
18	K44 18TN/YL	CAMSHAFT POSITION SENSOR SIGNAL
19	K39 18GY/RD	IDLE AIR CONTROL NO. 1 DRIVER
20	K59 18VT/BK	IDLE AIR CONTROL NO. 4 DRIVER
21	-	-
22	A14 16RD/WT	FUSED B(+)
23	K22 18OR/DB	THROTTLE POSITION SENSOR SIGNAL
24	K141 18TN/WT (3.9L/5.2L/5.9L) (CALIFORNIA EXCEPT 8.0L)	OXYGEN SENSOR 1/1 SIGNAL
24	K41 18BK/DG (5.9L HD/8.0L)	OXYGEN SENSOR 1/1 SIGNAL
25	K341 18OR/BK (3.9L/5.2L) (CALIFORNIA)	OXYGEN SENSOR 1/2 SIGNAL
25	K341 18OR/BK (8.0L)	OXYGEN SENSOR 1/3 SIGNAL
26	K241 18LG/RD (8.0L) (5.9L HD)	OXYGEN SENSOR 2/1 SIGNAL
26	K241 18LG/RD (CALIFORNIA)	OXYGEN SENSOR 2/1 SIGNAL
27	K1 18DG/RD	MAP SENSOR SIGNAL
28	-	-
29	K441 18OR/TN (CALIFORNIA)	OXYGEN SENSOR 2/2 SIGNAL
29	K141 18TN/WT (8.0L)	OXYGEN SENSOR 1/2 SIGNAL
30	-	-
31	Z12 14BK/TN	GROUND
32	Z12 14BK/TN	GROUND



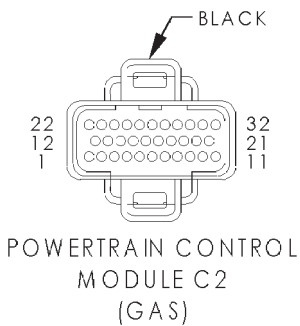
POWERTRAIN CONTROL MODULE C2 (DIESEL) - BLACK 32 WAY

CAV	CIRCUIT	FUNCTION
1	T54 18VT (A/T)	TRANSMISSION TEMPERATURE SENSOR SIGNAL
2	-	-
3	-	-
4	-	-
5	-	-
6	-	-
7	-	-
8	K88 18VT/WT (A/T)	GOVERNOR PRESSURE SOLENOID CONTROL



POWERTRAIN CONTROL MODULE C2 (DIESEL) - BLACK 32 WAY

CAV	CIRCUIT	FUNCTION
9	-	-
10	K20 18DG	GENERATOR FIELD
11	K54 18OR/BK (A/T)	TORQUE CONVERTER CLUTCH SOLENOID CONTROL
12	-	-
13	-	-
14	-	-
15	-	-
16	-	-
17	-	-
18	-	--
19	-	-
20	-	-
21	T60 18BR (A/T)	3-4 SHIFT SOLENOID CONTROL
22	-	-
23	-	-
24	-	-
25	T13 18DB/BK	OUTPUT SPEED SENSOR GROUND
26	-	-
27	G7 18WT/OR (A/T)	VEHICLE SPEED SENSOR SIGNAL
28	T14 18LG/BK	OUTPUT SPEED SENSOR SIGNAL
29	T25 18LG/WT (A/T)	GOVERNOR PRESSURE SENSOR SIGNAL
30	K30 18PK (A/T)	TRANSMISSION CONTROL RELAY CONTROL
31	K7 18OR (A/T)	5V SUPPLY
32	-	-

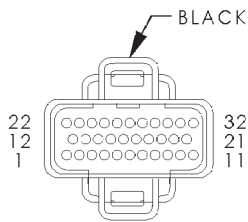


POWERTRAIN CONTROL MODULE C2 (GAS) - BLACK 32 WAY

CAV	CIRCUIT	FUNCTION
1	T54 18VT (A/T)	TRANSMISSION TEMPERATURE SENSOR SIGNAL
2	K26 18VT/TN (5.2L/5.9L/8.0L)	FUEL INJECTOR NO. 7 DRIVER
3	K115 18TN/BK (8.0L)	FUEL INJECTOR NO. 9 DRIVER
4	K11 18WT/DB	FUEL INJECTOR NO. 1 DRIVER
5	K13 18YL/WT	FUEL INJECTOR NO. 3 DRIVER
6	K38 18GY	FUEL INJECTOR NO. 5 DRIVER
7	-	-
8	K88 18VT/WT (A/T)	GOVERNOR PRESSURE SOLENOID CONTROL
9	-	-
10	K20 18DG	GENERATOR FIELD
11	K54 18OR/BK	TORQUE CONVERTER CLUTCH SOLENOID CONTROL
12	K58 18BR/DB	FUEL INJECTOR NO. 6 DRIVER
13	K28 18GY/LB (5.2L/5.9L/8.0L)	FUEL INJECTOR NO. 8 DRIVER
14	K116 18WT (8.0L)	FUEL INJECTOR NO. 10 DRIVER
15	K12 18TN	FUEL INJECTOR NO. 2 DRIVER
16	K14 18LB/BR	FUEL INJECTOR NO. 4 DRIVER
17	-	-
18	-	-
19	-	-
20	-	-
21	T60 18BR (A/T)	3-4 SHIFT SOLENOID CONTROL
22	-	-
23	G60 18GY/OR	ENGINE OIL PRESSURE SENSOR SIGNAL
24	-	-

POWERTRAIN CONTROL MODULE C2 (GAS) - BLACK 32 WAY

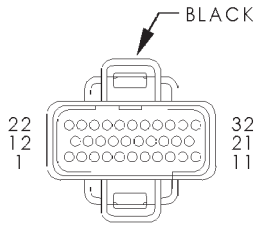
CAV	CIRCUIT	FUNCTION
25	T13 18DB/BK (A/T)	OUTPUT SPEED SENSOR GROUND
26	-	-
27	G7 18WT/OR (A/T)	VEHICLE SPEED SENSOR SIGNAL
28	T14 18LG/BK (A/T)	OUTPUT SPEED SENSOR SIGNAL
29	T25 18LG/WT (A/T)	GOVERNOR PRESSURE SENSOR SIGNAL
30	K30 18PK (A/T)	TRANSMISSION CONTROL RELAY CONTROL
31	K7 18OR (A/T)	5V SUPPLY
32	-	-



POWERTRAIN CONTROL  
MODULE C3  
(DIESEL)

POWERTRAIN CONTROL MODULE C3 (DIESEL) - BLACK 32 WAY

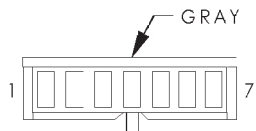
CAV	CIRCUIT	FUNCTION
1	C13 18DB/OR	A/C COMPRESSOR CLUTCH RELAY CONTROL
2	-	-
3	K51 18DB/YL	AUTOMATIC SHUT DOWN RELAY CONTROL
4	V36 18TN/RD	SPEED CONTROL VACUUM SOLENOID CONTROL
5	V35 18LG/RD	SPEED CONTROL VENT SOLENOID CONTROL
6	-	-
7	-	-
8	-	-
9	-	-
10	-	-
11	V32 18YL/RD	SPEED CONTROL SUPPLY
12	A142 14DG/OR	AUTOMATIC SHUT DOWN RELAY OUTPUT
13	T6 18OR/WT (A/T)	OVERDRIVE OFF SWITCH SENSE
14	-	-
15	K118 18PK/YL	BATTERY TEMPERATURE SENSOR SIGNAL
16	-	-
17	-	-
18	-	-
19	-	-
20	-	-
21	-	-
22	C20 18BR	A/C SWITCH SENSE
23	C90 18LG/WT	A/C SELECT INPUT
24	V40 18WT/PK	BRAKE SWITCH SENSE
25	T125 18DB	GENERATOR SOURCE
26	K226 18DB/WT	FUEL LEVEL SENSOR SIGNAL
27	D21 18PK/DB	SCI TRANSMIT
28	D2 18WT/BK	CCD BUS(-)
29	D220 18WT/VT	SCI RECEIVE
30	D1 18VT/BR	CCD BUS(+)
31	-	-
32	V37 18RD/LG	SPEED CONTROL SWITCH SIGNAL



POWERTRAIN CONTROL  
MODULE C3  
(GAS)

POWERTRAIN CONTROL MODULE C3 (GAS) - BLACK 32 WAY

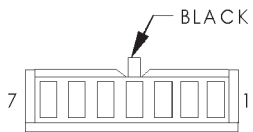
CAV	CIRCUIT	FUNCTION
1	C13 18DB/OR	A/C COMPRESSOR CLUTCH RELAY CONTROL
2	-	-
3	K51 18DB/YL	AUTOMATIC SHUT DOWN RELAY CONTROL
4	V36 18TN/RD	SPEED CONTROL VACUUM SOLENOID CONTROL
5	V35 18LG/RD	SPEED CONTROL VENT SOLENOID CONTROL
6	-	-
7	-	-
8	K199 18BR/VT (CALIFORNIA)	OXYGEN SENSOR 1/1 HEATER CONTROL
9	K145 20DG/PK (CALIFORNIA)	OXYGEN SENSOR DOWNSTREAM RELAY CONTROL
10	K106 18WT/DG	LEAK DETECTION PUMP SOLENOID CONTROL
11	V32 18YL/RD	SPEED CONTROL SUPPLY
12	A142 14DG/OR	AUTOMATIC SHUT DOWN RELAY OUTPUT
13	T6 18OR/WT (A/T)	OVERDRIVE OFF SWITCH SENSE
14	K107 18OR	LEAK DETECTION PUMP SWITCH SENSE
15	K118 18PK/YL	BATTERY TEMPERATURE SENSOR SIGNAL
16	K299 18BR.WT	OXYGEN SENSOR 2/1 HEATER CONTROL
17	-	-
18	-	-
19	K31 18BR/WT	FUEL PUMP RELAY CONTROL
20	K52 18PK/WT	EVAPORATIVE EMISSION SOLENOID CONTROL
21	-	-
22	C20 18BR	A/C SWITCH SENSE
23	C90 18LG/WT	A/C SELECT INPUT
24	V40 18WT/PK	BRAKE SWITCH SENSE
25	T125 18DB	GENERATOR SOURCE
26	K226 18DB/WT	FUEL LEVEL SENSOR SIGNAL
27	D21 18PK/DB	SCI TRANSMIT
28	D2 18WT/BK	CCD BUS (-)
29	D20 18DG	SCI RECEIVE
30	D1 18VT/BR	CCD BUS (+)
31	-	-
32	V37 18RD/LG	SPEED CONTROL SWITCH SIGNAL



RADIO C1

RADIO C1 - GRAY 7 WAY

CAV	CIRCUIT	FUNCTION
1	-	-
2	X55 18BR/RD	LEFT FRONT DOOR SPEAKER (-)
3	X56 18DB/RD	RIGHT FRONT DOOR SPEAKER (-)
4	E17 18YL/BK	DAY BRIGHTNESS SENSE
5	E2 22OR	PANEL LAMPS FEED
6	X12 16RD/WT	FUSED IGNITION SWITCH OUTPUT (RUN-ACC)
7	M1 22PK	FUSED B(+)



RADIO C2

RADIO C2 - BLACK 7 WAY

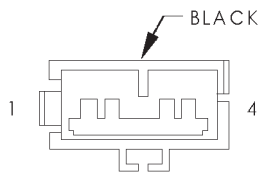
CAV	CIRCUIT	FUNCTION
1	X16 22LG	ANTENNA RELAY OUTPUT
2	X51 18BR/YL	LEFT REAR SPEAKER (+)
3	X52 18DB/WT	RIGHT REAR SPEAKER (+)
4	X53 18DG	LEFT FRONT DOOR SPEAKER (+)
5	X54 18VT	RIGHT FRONT DOOR SPEAKER (+)
6	X57 18BR/LB	LEFT REAR SPEAKER (-)
7	X58 18DB/OR	RIGHT REAR SPEAKER (-)



RADIO C3

RADIO C3 - 2 WAY

CAV	CIRCUIT	FUNCTION
1	D1 20VT/BR	CCD BUS (+)
2	D2 20WT/BK	CCD BUS (-)

RADIO CHOKE  
RELAY

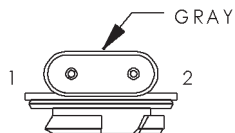
RADIO CHOKE RELAY - BLACK 4 WAY

CAV	CIRCUIT	FUNCTION
1	X60 16DG/RD	FUSED IGNITION SWITCH OUTPUT (RUN-ACC)
2	X13 16BK/RD	RADIO CHOKE RELAY OUTPUT
3	X16 22LG	ANTENNA RELAY OUTPUT
4	Z9 16BK/VT	GROUND

REAR WHEEL  
SPEED SENSOR  
(ABS)

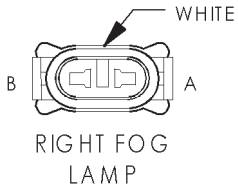
REAR WHEEL SPEED SENSOR (ABS) - 2 WAY

CAV	CIRCUIT	FUNCTION
1	B114 20WT/VT	REAR WHEEL SPEED SENSOR (-)
2	B113 20RD/VT	REAR WHEEL SPEED SENSOR (+)

RIGHT  
BACK-UP LAMP

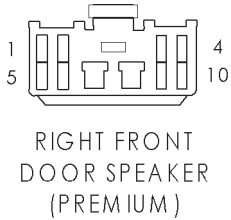
RIGHT BACK-UP LAMP- GRAY 2 WAY

CAV	CIRCUIT	FUNCTION
1	Z13 18BK	GROUND
2	L1 18VT/BK	BACK-UP LAMP FEED



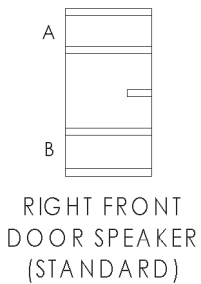
RIGHT FOG LAMP - WHITE 2 WAY

CAV	CIRCUIT	FUNCTION
A	L34 20RD/OR	FUSED B(+)
B	L39 20LB	FOG LAMP SWITCH OUTPUT



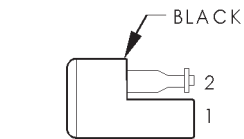
RIGHT FRONT DOOR SPEAKER (PREMIUM) - 10 WAY

CAV	CIRCUIT	FUNCTION
1	X82 20LB/RD	AMPLIFIED HIGH RIGHT FRONT DOOR SPEAKER (+)
2	X80 20LB/BK	AMPLIFIED HIGH RIGHT FRONT DOOR SPEAKER (-)
3	X54 18VT	RIGHT FRONT SPEAKER (+)
4	X56 18DB/RD	RIGHT FRONT SPEAKER (-)
5	X92 18TN/BK	AMPLIFIED LOW RIGHT REAR SPEAKER (-)
6	X94 18TN/VT	AMPLIFIED LOW RIGHT REAR SPEAKER (+)
7	X13 16BK/RD	RADIO CHOKE RELAY OUTPUT
8	Z9 16BK/VT	GROUND
9	X52 18DB/WT	RIGHT REAR SPEAKER (+)
10	X58 18DB/OR	RIGHT REAR SPEAKER (-)



RIGHT FRONT DOOR SPEAKER (STANDARD) - 2 WAY

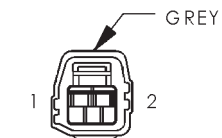
CAV	CIRCUIT	FUNCTION
A	X56 20DB/RD	RIGHT FRONT SPEAKER (-)
B	X54 20VT	RIGHT FRONT SPEAKER (+)



RIGHT FRONT FENDER LAMP (DUAL REAR WHEELS) - BLACK 2 WAY

CAV	CIRCUIT	FUNCTION
1	L7 18BK/YL	HEADLAMP SWITCH OUTPUT
2	Z13 18BK	GROUND

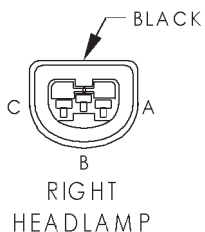
RIGHT FRONT FENDER LAMP (DUAL REAR WHEELS)



RIGHT FRONT WHEEL SPEED SENSOR (ABS) - GRAY 2 WAY

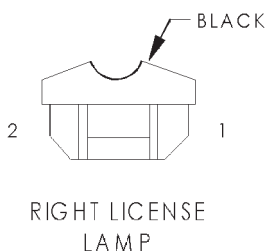
CAV	CIRCUIT	FUNCTION
1	B6 20WT/DB	RIGHT FRONT WHEEL SPEED SENSOR (-)
2	B7 20WT	RIGHT FRONT WHEEL SPEED SENSOR (+)

RIGHT FRONT WHEEL SPEED SENSOR (ABS)



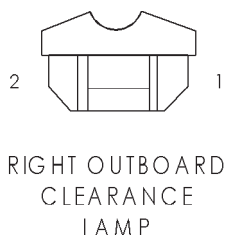
RIGHT HEADLAMP - BLACK 3 WAY

CAV	CIRCUIT	FUNCTION
A	L45 18PK/RD	FUSED B(+)
B	-	-
C	L33 18LG/BR	HIGH BEAM HEADLAMP DRIVER



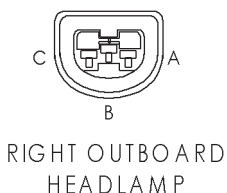
RIGHT LICENSE LAMP - BLACK 2 WAY

CAV	CIRCUIT	FUNCTION
1	L7 18BK/YL	PARK LAMP RELAY OUTPUT
2	Z13 18BK	GROUND



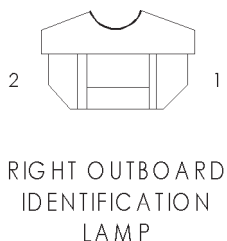
RIGHT OUTBOARD CLEARANCE LAMP - 2 WAY

CAV	CIRCUIT	FUNCTION
1	L7 18BK/YL	HEADLAMP SWITCH OUTPUT
2	Z4 18BK	GROUND



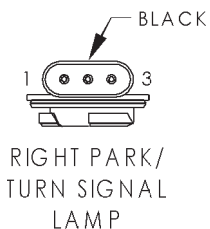
RIGHT OUTBOARD HEADLAMP - 3 WAY

CAV	CIRCUIT	FUNCTION
A	L4 16VT/WT (QUAD HEADLAMP)	DIMMER SWITCH LOW BEAM OUTPUT
A	L44 18VT/RD (EXCEPT QUAD HEADLAMP)	FUSED B(+)
B	L4 16VT/WT (EXCEPT QUAD HEADLAMP)	DIMMER SWITCH LOW BEAM OUTPUT
B	L44 18VT/RD (QUAD HEADLAMP)	FUSED B(+)
C	L3 16RD/OR	DIMMER SWITCH HIGH BEAM OUTPUT



RIGHT OUTBOARD IDENTIFICATION LAMP - 2 WAY

CAV	CIRCUIT	FUNCTION
1	L7 18BK/YL	HEADLAMP SWITCH OUTPUT
2	Z4 18BK	GROUND



RIGHT PARK/TURN SIGNAL LAMP - BLACK 3 WAY

CAV	CIRCUIT	FUNCTION
1	Z1 18BK	GROUND
2	L7 18BK/YL	PARK LAMP RELAY OUTPUT
3	L60 18LG/TN	RIGHT TURN SIGNAL

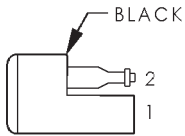




RIGHT POWER MIRROR

RIGHT POWER MIRROR - 6 WAY

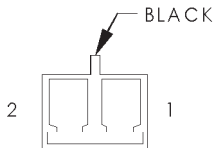
CAV	CIRCUIT	FUNCTION
1	P72 20YL/BK	RIGHT MIRROR UP DRIVER
2	P74 20DB	RIGHT MIRROR LEFT DRIVER
3	P70 20WT	RIGHT MIRROR COMMON DRIVER (RIGHT/DOWN)
4	C16 20LB/YL	HEATED MIRROR
5	Z2 20BK/LG	GROUND
6	-	-



RIGHT REAR FENDER LAMP (DUAL REAR WHEELS)

RIGHT REAR FENDER LAMP (DUAL REAR WHEELS) - BLACK 2 WAY

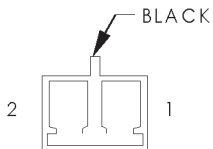
CAV	CIRCUIT	FUNCTION
1	L7 18BK/YL	HEADLAMP SWITCH OUTPUT
2	Z13 18BK	GROUND



RIGHT REAR SPEAKER (2 DOOR PREMIUM)

RIGHT REAR SPEAKER (2 DOOR PREMIUM) - BLACK 2 WAY

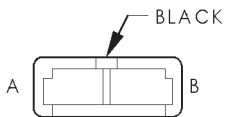
CAV	CIRCUIT	FUNCTION
1	X92 18TN/BK	AMPLIFIED LOW RIGHT REAR SPEAKER (-)
2	X94 18TN/VT	AMPLIFIED LOW RIGHT REAR SPEAKER (+)



RIGHT REAR SPEAKER (4 DOOR PREMIUM)

RIGHT REAR SPEAKER (4 DOOR PREMIUM) - BLACK 2 WAY

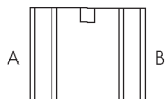
CAV	CIRCUIT	FUNCTION
1	X57 18BR/LB	AMPLIFIED LOW RIGHT REAR SPEAKER (-)
2	X51 18BR/YL	AMPLIFIED LOW RIGHT REAR SPEAKER (+)



RIGHT REAR SPEAKER (STANDARD 2 DOOR)

RIGHT REAR SPEAKER (STANDARD 2 DOOR) - BLACK 2 WAY

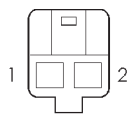
CAV	CIRCUIT	FUNCTION
A	X58 18DB/OR	RIGHT REAR SPEAKER (-)
B	X52 18DB/WT	RIGHT REAR SPEAKER (+)



RIGHT REAR SPEAKER (STANDARD 4 DOOR)

RIGHT REAR SPEAKER (STANDARD 4 DOOR) - 2 WAY

CAV	CIRCUIT	FUNCTION
A	X57 18BR/LB	RIGHT REAR SPEAKER (-)
B	X51 18BR/YL	RIGHT REAR SPEAKER (+)



RIGHT REMOTE RADIO SWITCH

RIGHT REMOTE RADIO SWITCH - 2 WAY

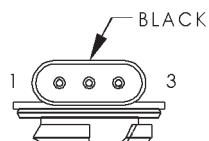
CAV	CIRCUIT	FUNCTION
1	Z2 22BK/LG	GROUND
2	X20 22RD/BK	RADIO CONTROL MUX



RIGHT SPEED CONTROL SWITCH

RIGHT SPEED CONTROL SWITCH - 2 WAY

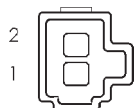
CAV	CIRCUIT	FUNCTION
1	K4 22WT	SENSOR GROUND
2	V37 22DG/RD	SPEED CONTROL SWITCH SIGNAL



RIGHT TAIL/ STOP/TURN SIGNAL LAMP

RIGHT TAIL/STOP/TURN SIGNAL LAMP - BLACK 3 WAY

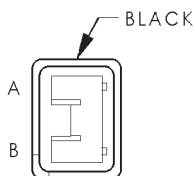
CAV	CIRCUIT	FUNCTION
1	Z13 18BK	GROUND
2	L7 18BK/YL	PARK LAMP RELAY OUTPUT
3	L62 18DG/BR	RIGHT TURN SIGNAL



RIGHT TWEETER (PREMIUM)

RIGHT TWEETER (PREMIUM) - 2 WAY

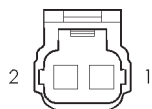
CAV	CIRCUIT	FUNCTION
1	X80 20LB/BK	AMPLIFIED HIGH RIGHT FRONT SPEAKER (-)
2	X82 20LB/RD	AMPLIFIED HIGH RIGHT FRONT SPEAKER (+)



RIGHT VISOR/VANITY LAMP

RIGHT VISOR/VANITY LAMP - BLACK 2 WAY

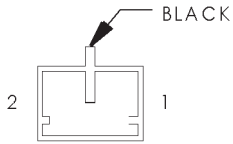
CAV	CIRCUIT	FUNCTION
A	M1 20PK	FUSED B(+)
B	Z4 20BK	GROUND



SEAT BELT SWITCH (CLUB CAB)

SEAT BELT SWITCH (CLUB CAB) - 2 WAY

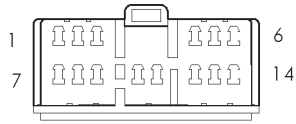
CAV	CIRCUIT	FUNCTION
1	Z2 20BK/LG	GROUND
2	G10 22LG/RD (HEATED SEATS)	SEAT BELT SWITCH SENSE
2	G10 20LG/RD (MANUAL NON-HEATED SEATS)	SEAT BELT SWITCH SENSE



SEAT BELT SWITCH  
(STANDARD CAB)

SEAT BELT SWITCH (STANDARD CAB) - BLACK 2 WAY

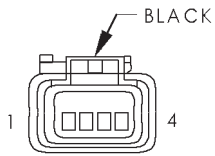
CAV	CIRCUIT	FUNCTION
1	G10 20LG/RD	SEAT BELT SWITCH SENSE
2	Z2 20BK/LG	GROUND



SEAT HEAT INTERFACE MODULE

SEAT HEAT INTERFACE MODULE - 14 WAY

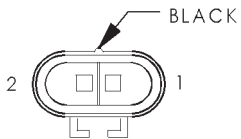
CAV	CIRCUIT	FUNCTION
1	P7 20LB/BK	DRIVER HEATED SEAT SWITCH
2	P144 20BK/WT	SEAT TEMPERATURE 5V SUPPLY
3	P130 16TN	RIGHT SEAT HEATER B(+) DRIVER
4	F235 16RD	B(+) TO HEATED SEAT MODULE
5	P131 16RD/DG	LEFT SEAT HEATER B(+) DRIVER
6	F235 16RD	B(+) TO HEATED SEAT MODULE
7	P142 22DB	RIGHT SEAT TEMPERATURE SENSOR INPUT
8	P141 20TN/LB	LEFT SEAT TEMPERATURE SENSOR INPUT
9	P8 20LB/WT	PASSENGER HEATED SEAT SWITCH
10	P138 20VT/LG	RIGHT SEAT LOW HEAT LED DRIVER
11	P140 20VT/BK	RIGHT SEAT HIGH HEAT LED DRIVER
12	P137 20DG	LEFT SEAT LOW HEAT LED DRIVER
13	Z2 18BK/LG	GROUND
14	P139 20WT	LEFT SEAT HIGH HEAT LED DRIVER



SPEED CONTROL SERVO

SPEED CONTROL SERVO - BLACK 4 WAY

CAV	CIRCUIT	FUNCTION
1	V36 20TN/RD	SPEED CONTROL VACUUM SOLENOID CONTROL
2	V35 20LG/RD	SPEED CONTROL VENT SOLENOID CONTROL
3	V30 20DB/RD	SPEED CONTROL BRAKE SWITCH OUTPUT
4	Z1 20BK	GROUND



TAILGATE LAMP  
(DUAL REAR WHEELS)

TAILGATE LAMP (DUAL REAR WHEELS) - BLACK 2 WAY

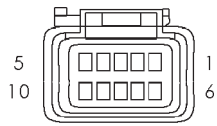
CAV	CIRCUIT	FUNCTION
1	Z13 18BK	GROUND
2	L7 18BK/YL	HEADLAMP SWITCH OUTPUT



THROTTLE POSITION SENSOR  
(GAS)

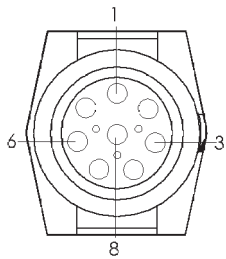
THROTTLE POSITION SENSOR (GAS) - 3 WAY

CAV	CIRCUIT	FUNCTION
1	K6 20VT/WT	5V OUTPUT
2	K22 18OR/DB	THROTTLE POSITION SENSOR SIGNAL
3	K4 20BK/LB	SENSOR GROUND

TRAILER TOW  
CONNECTOR

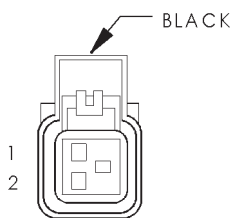
TRAILER TOW CONNECTOR - 10 WAY

CAV	CIRCUIT	FUNCTION
1	-	-
2	L62 16BR/RD	RIGHT TURN SIGNAL
3	L1 18VT/BK	BACK-UP LAMP FEED
4	A6 14RD/OR	FUSED B(+)
5	L76 14BK/OR	TRAILER TOW RELAY OUTPUT
6	-	-
7	B40 14LB	TRAILER TOW BRAKE B(+)
8	Z13 14BK	GROUND
9	Z13 14BK	GROUND
10	L63 16DG/RD	LEFT TURN SIGNAL

TRANSMISSION  
SOLENOID ASSEMBLY

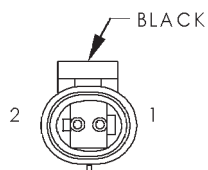
TRANSMISSION SOLENOID ASSEMBLY - 8 WAY

CAV	CIRCUIT	FUNCTION
1	T16 18RD	TRANSMISSION CONTROL RELAY OUTPUT
2	K7 18OR	5V SUPPLY
3	K4 18BK/LB	SENSOR GROUND
4	T25 18LG/WT	GOVERNOR PRESSURE SENSOR SIGNAL
5	K88 18VT/WT	GOVERNOR PRESSURE SOLENOID CONTROL
6	T60 18BR	3-4 SHIFT SOLENOID CONTROL
7	K54 18OR/BK	TORQUE CONVERTER CLUTCH SOLENOID CONTROL
8	T54 18VT	TRANSMISSION TEMPERATURE SENSOR SIGNAL

UNDERHOOD  
LAMP

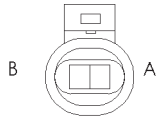
UNDERHOOD LAMP - BLACK 2 WAY

CAV	CIRCUIT	FUNCTION
1	Z1 20BK	GROUND
2	M1 20PK	FUSED B(+)

WASHER FLUID  
LEVEL SWITCH

WASHER FLUID LEVEL SWITCH - BLACK 2 WAY

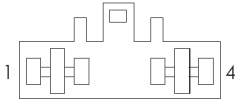
CAV	CIRCUIT	FUNCTION
1	G29 18BK/WT	WASHER FLUID SWITCH SENSE
2	Z1 18BK	GROUND



WATER IN FUEL  
SENSOR  
(DIESEL)

WATER IN FUEL SENSOR (DIESEL) - 2 WAY

CAV	CIRCUIT	FUNCTION
A	K104 18BK/LB	SENSOR GROUND
B	K1 18DG/RD	WATER IN FUEL SENSOR SIGNAL



WIPER MOTOR

WIPER MOTOR - 4 WAY

CAV	CIRCUIT	FUNCTION
1	V4 16RD/YL	WIPER SWITCH HIGH SPEED OUTPUT
2	V5 16DG	WIPER PARK SWITCH SENSE
3	V6 16DB	FUSED IGNITION SWITCH OUTPUT (RUN-ACC)
4	V3 16BR/WT	LOW SPEED WIPER SWITCH OUTPUT

## 8W-90 CONNECTOR/GROUND LOCATIONS

## TABLE OF CONTENTS

page

**CONNECTOR/GROUND LOCATIONS**

DESCRIPTION..... 1

**CONNECTOR/GROUND  
LOCATIONS****DESCRIPTION**

This section provides illustrations identifying connector and ground locations in the vehicle. A connec-

tor and ground index is provided. Use the wiring diagrams in each section for connector and ground identification. Refer to the index for the proper figure number. For items that are not shown in this section N/S is placed in the Fig. column.

Connector Name/Number	Color	Location	Fig.
4WD Switch	BK	On Front Axle	N/S
A/C Compressor Clutch	BK	Rear of A/C Compressor	4,5,6,8
A/C Heater Control	BK	Center of Instrument Panel	25
A/C Heater Temperature Select	NAT	Center of Instrument Panel	25
A/C High Pressure Switch	BK	At A/C Compressor	4,5,6,8
A/C Low Pressure Switch	BK	Top of A/C Accumulator	1,2
Accelerator Pedal Position Sensor (Diesel)		Left Front of Engine	10,11
Aftermarket Trailer Tow Connector		Rear of Vehicle	N/S
Airbag Control Module		Center of I.P. at Airbag Control Module	23
Ambient Temperature Sensor	BK	Radiator Left Support	N/S
Ash Receiver Lamp		Center of Instrument Panel	26
Back-up Lamp Switch	BK	Top of Transmission	13
Battery Temperature Sensor	BK	Below Battery Tray	16
Blend Door Actuator		Center of Instrument Panel	N/S
Blower Motor	BK	Bottom Right of Instrument Panel	23
Blower Motor Resistor Block	BK	Bottom Right of Instrument Panel	26
Brake Lamp Switch		Brake Pedal Arm	23,24
Brake Pressure Switch		At Master Cylinder	14
Bypass Jumper	GN	Top Of Clutch Pedal	27
C105		Rear of Front Bumper	N/S
C106	BK	Rear of Front Bumper	17
C114	BK	Radiator Left Support	15
C125 (Diesel)	BK	Left Rear of Engine Compartment	2
C126 (Diesel)	GY	Left Rear of Engine Compartment	2
C129	BK	Above Left Front Body Cushion	15,22
C130		At Power Distribution Center	1,2
C134	BK	Left Cowl	23,25,27



## CONNECTOR/GROUND LOCATIONS (Continued)

Connector Name/Number	Color	Location	Fig.
C203		Left Cowl	23,25
C204		Left Cowl	25
C205		Instrument Panel Center Support	N/S
C206		Left Cowl	23,25
C237		Bottom Right of Instrument Panel	23,26
C303	BK	Below Driver's Seat	18
C308		Center Rear of Headliner	N/S
C329	BK	Below Right Tail Lamp	21
C333	BK	Below Left Tail Lamp	21
C342	BK	Left Rear of Frame	21
C343	BK	Left Rear of Frame	21
C345		Right Door	N/S
C346		Right Door	N/S
C347		Left Door	20
C348		Left Door	20
C352	BK	Left A-Pillar	20
C353	BK	Right A-Pillar	20
C358	NAT	Left Side Instrument Panel	20,23,27
C359		Heated Seat To Body Wiring	18
C360		Below Driver's Seat	18
C361		Left Rear Speaker Wiring	N/S
C364		Right Rear Speaker Wiring	N/S
C365		Under Passenger Power Seat	N/S
Camshaft Position Sensor (V6, V8)		Near of Distributor	3
Camshaft Position Sensor (V10)		Front of Engine	6
Camshaft Position Sensor (Diesel)		Left Front of Engine	10
Cargo Lamp No. 1	BK	Rear of Lamp	N/S
Cargo Lamp No. 2	BK	Rear of Lamp	N/S
Center High Mounted Stop Lamp No. 1	BK	Rear of Cab	18
Center High Mounted Stop Lamp No. 2	BK	Rear of Cab	18
Center Identification Lamp	BK	Behind Front of Headliner	20
Central Timer Module C1		Left Side Under Instrument Panel	23,24
Central Timer Module C2		Left Side Under Instrument Panel	23,24
Cigar Lighter	NAT	Center of Instrument Panel	25
Clockspring No.1		Steering Column	24
Clockspring No.2		Steering Column	24
Clockspring No.3		Steering Column	24
Clutch Pedal Position Switch	BK	Top of Clutch Pedal	27
Controller Anti-Lock Brake C1		Left Fender Side Shield	14
Controller Anti-Lock Brake C2		Left Fender Side Shield	14
Crankshaft Position Sensor (V6, V8)		Rear of Engine Block	3
Crankshaft Position Sensor (V10)		Right Side of Engine Block	6

## CONNECTOR/GROUND LOCATIONS (Continued)

Connector Name/Number	Color	Location	Fig.
Cummins Bus (-)		Left Front of Engine	10
Cup Holder Lamp		Center of Instrument Panel	23, 26
Data Link Connector	BK	Left Bottom of Instrument Panel	23,24
Day/Night Mirror	BK	Day/Night Mirror	N/S
Daytime Running Lamp Module	BK	Left Fender Side Shield	14
Dome Lamp		Rear of Cab	18
Driver Airbag	BK	Steering Wheel	N/S
Driver Door Arm/Disarm Switch	BK	In Door	19
Driver Door Jamb Switch	NAT	Door Jamb	19
Driver Door Lock Motor	BK	In Door	19
Driver Door Window/Lock Switch	BL	In Door	19
Driver Heated Seat Module	BL	Under Seat	N/S
Driver Heated Seat Switch	RD	Center of Instrument Panel	N/S
Driver Lumbar Motor		Under Seat	N/S
Driver Power Seat Front Vertical Motor	BK	Under Seat	N/S
Driver Power Seat Horizontal Motor	BK	Under Seat	N/S
Driver Power Seat Rear Vertical Motor		Under Seat	N/S
Driver Power Seat Switch		At Seat	N/S
Driver Power Window Motor		In Door	19
Duty Cycle EVAP/Purge Solenoid	BK	Right Fender Side Shield	17
Electric Brake Provision		Bottom Left of Instrument Panel	N/S
Engine Control Module (Diesel)		Left Side Engine	12
Engine Coolant Temperature Sensor (Diesel)	BK	Left Front of Cylinder Head (Diesel)	10
Engine Coolant Temperature Sensor (Gas)	BK	On Thermostat Housing	3,6
Engine Oil Pressure Sensor (V6, V8)	BK	Near Distributor	3
Engine Oil Pressure Sensor (V10)		Near Oil Filter	6
Engine Oil Pressure Sensor (Diesel)		Left Side of Engine	12
Fuel Heater (Diesel)		Left Side of Engine	10
Fuel Injection Pump (Diesel)		Left Side of Engine, Below ECM	10
Fuel Injector No.1	BK	At Fuel Injector	4,5
Fuel Injector No. 2	BK	At Fuel Injector	4,5,6
Fuel Injector No. 3	BK	At Fuel Injector	4,5,6
Fuel Injector No. 4	BK	At Fuel Injector	4,5,6
Fuel Injector No. 5	BK	At Fuel Injector	4,5,6
Fuel Injector No. 6	BK	At Fuel Injector	4,5,6
Fuel Injector No. 7	BK	At Fuel Injector	4,6
Fuel Injector No. 8	BK	At Fuel Injector	4,6
Fuel Injector No. 9	BK	At Fuel Injector	6
Fuel Injector No. 10	BK	At Fuel Injector	6
Fuel Pump Module	LTYG	At Frame Rail	22
Fuel Transfer Pump (Diesel)		Left Rear of Engine Bottom of Pump	10

## CONNECTOR/GROUND LOCATIONS (Continued)

Connector Name/Number	Color	Location	Fig.
G100		Left Fender Side Shield	16
G101		Left Fender Side Shield	16
G102		Left Fender Side Shield (RWAL Ground)	N/S
G103		Near T/O for Wiper Motor	14
G105		Front of Engine (Engine Ground)	4,5,6,9
G107 (Diesel)		Left Rear of Engine	10
G113 (Diesel)		Primary Battery Engine Ground	N/S
G114		Battery Engine Ground	N/S
G115 (Diesel)		Primary Battery Body Ground	N/S
G116		Battery Frame Ground	N/S
G117 (Diesel)		Auxiliary Battery Engine Ground	N/S
G118 (Diesel)		Primary Frame Ground	N/S
G120 (Diesel)		Auxiliary Battery Body Ground	N/S
G200		Left Cowl	24
G201		Instrument Panel Right Center Support	23,25
G300		Left Lower Cowl	20
G301		Below Left Rear Speaker	18
G302		At Overhead Console	20
Generator	BK	Front of Engine	7,8
Glove Box Lamp		At Glove Box	23
Headlamp Switch C1	BK	Left Side of Instrument Panel	23,26
Headlamp Switch C2		Left Side of Instrument Panel	23,26
Heated Mirror Switch		Center of Instrument Panel	25
High Note Horn	BK	Front Bumper Right Support	17
Idle Air Control Motor	BK	On Throttle Body	9
Ignition Coil	GY	Right Front of Engine	4,5,9
Ignition Coil 4 Pack	BK	Right Side of Engine	9
Ignition Coil 6 Pack	BK	Right Side of Engine	9
Ignition Switch C1		Steering Column	24
Ignition Switch C2		Steering Column	24
Instrument Cluster C1		Rear of Instrument Cluster	23
Instrument Cluster C2		Rear of Instrument Cluster	23
Intake Air Heater Relay		Left Fender Side Shield	16
Intake Air Temperature Sensor (Diesel)		Left Rear of Engine	10
Intake Air Temperature Sensor (Gas)	GY	On Intake Manifold	4,5,6
Joint Connector No. 1		In Power Distribution Center	N/S
Joint Connector No. 2		In Power Distribution Center	N/S
Joint Connector No. 3		Front Bumper Right support	17
Joint Connector No. 4		Left Front Engine Compartment	16
Joint Connector No. 5	NAT	Left Side of Instrument Panel	24
Joint Connector No. 6	NAT	Left Side of Instrument Pane	24

## CONNECTOR/GROUND LOCATIONS (Continued)

Connector Name/Number	Color	Location	Fig.
Joint Connector No. 7	NAT	Left Side of Instrument Pane	24
Joint Connector No. 8	NAT	Center of Instrument Panel	23
Junction Block C1	BL	Left Cowl	27
Junction Block C2	NAT	Left Cowl	27
Junction Block C3		Left Cowl	20
Junction Block C4	BR	Left Cowl	25
Junction Block C5	GN	Left Cowl	25
Junction Block C6	BK	Left Cowl	25
Junction Block C7	LTTY	Left Cowl	25
Junction Block C8	OR	Left Cowl	25
Junction Block C9	NAT	Left Cowl	25
Leak Detection Pump	BK	Right Fender Side Shield	17
Left Back-Up Lamp	GY	Rear of Lamp	N/S
Left Fog Lamp	BK	Rear of Fog Lamp	N/S
Left Front Door Speaker (Premium)	BK	In Door	19
Left Front Door Speaker (Standard)	BK	In Door	19
Left Front Fender Lamp		On Fender	21
Left Front Wheel Speed Sensor	BK	Left Fender Side Shield	14
Left Headlamp	BK	At Headlamp	N/S
Left License Lamp	BK	At Rear Bumper	21
Left Outboard Clearance Lamp	BK	Behind Front of Headliner	20
Left Outboard Headlamp	BL	At Headlamp	N/S
Left Outboard Identification Lamp	BK	Behind Front of Headliner	20
Left Park/Turn Signal Lamp	BK	At Lamp	N/S
Left Power Mirror	BK	In Door	19
Left Rear Fender Lamp	BK	On Fender	21
Left Rear Speaker (Premium)		At B Pillar	18
Left Rear Speaker (Standard)		At B Pillar	18
Left Rear Door Speaker		In Door	18
Left Remote Radio Switch		Steering Wheel	N/S
Left Speed Control Switch		Steering Wheel	N/S
Left Tail/Stop Turn Signal Lamp	BK	At Rear Bumper	21
Left Tweeter		Left A Pillar	N/S
Left Visor/Vanity Lamp	BK	Left A-Pillar	20
Low Note Horn	BK	Front Bumper Right Support	17
Manifold Absolute Pressure Sensor (V6, V8)	BK	On Throttle Body	4,5
Manifold Absolute Pressure Sensor (V10)	BK	Top of Intake Manifold	9
Manifold Air Pressure Sensor (Diesel)	BK	Rear of Intake Manifold	10
Multi-Function Switch		On Steering Column	24
Output Speed Sensor	BK	Left Side of Transmission	13
Overdrive Switch		On Shift Lever Arm	N/S
Overhead Console	BK	Front of Headliner	20

## CONNECTOR/GROUND LOCATIONS (Continued)

Connector Name/Number	Color	Location	Fig.
Oxygen Sensor 1/1 Left Bank Up		Left Exhaust Manifold Downpipe	13
Oxygen Sensor 1/1 Upstream		Catalytic Converter Inlet Side	13
Oxygen Sensor 1/2 Downstream		Catalytic Converter Outlet Side	13
Oxygen Sensor 1/2 Left Bank Down		Catalytic Converter Outlet Side	13
Oxygen Sensor 1/2 Pre-catalyst		Catalytic Converter Inlet Side	13
Oxygen Sensor 1/3 Post Catalyst		Catalytic Converter Outlet Side	13
Oxygen Sensor 1/3 Post Catalyst		Post Catalyst	13
Oxygen Sensor 2/1 Right Bank Up		Right Exhaust Manifold Downpipe	13
Oxygen Sensor 2/2 Right Bank Down		Catalytic Converter Outlet Side	13
Park/Neutral Position Switch	BK	Left Side of Transmission	13
Passenger Airbag		At Glove Box	23,26
Passenger Airbag On/Off Switch C1		Lower Right Side of Instrument Panel	23
Passenger Airbag On/Off Switch C2		Lower Right Side of Instrument Panel	23
Passenger Door Arm/Disarm Switch	LTGY	In Door	19
Passenger Door Jamb Switch	NAT	In Door	19
Passenger Door Lock Motor	BK	In Door	19
Passenger Door Window/Lock Switch		In Door	19
Passenger Heated Seat Switch	BL	Center of Instrument Panel	N/S
Passenger Heated Seat Module		Under Seat	N/S
Passenger Lumbar Motor		Under Seat	N/S
Passenger Power Seat Front Vertical Motor		Under Seat	N/S
Passenger Power Seat Horizontal Motor		Under Seat	N/S
Passenger Power Seat Rear Vertical Motor		Under Seat	N/S
Passenger Power Seat Switch		At Seat	N/S
Passenger Power Window Motor		In Door	N/S
Power Seat Heater Control Module		Under Seat	N/S
Power Mirror Switch		Driver Door	19
Power Outlet	BK	Center of I.P.	25
Powertrain Control Module C1		Right Rear Engine Compartment	1,2
Powertrain Control Module C2		Right Rear Engine Compartment	1,2
Powertrain Control Module C3		Right Rear Engine Compartment	1,2
Radio Choke Relay	BK	Instrument Panel Center support	23,25
Radio C1	GY	Rear of Radio	25
Radio C2	BK	Rear of Radio	25
Radio C3	BK	Instrument Panel Center support	25
Rear Wheel Speed Sensor	BK	Left Frame Rail, Near Fuel Tank	21,22
Right Back-Up Lamp	BK	Rear of Lamp	N/S
Right Fog Lamp	BK	Rear of Fog Lamp	N/S
Right Front Door Speaker(Premium	BK	In Door	19
Right Front Door Speaker(Standard	BK	In Door	19
Right Front Fender Lamp		On Fender	21

## CONNECTOR/GROUND LOCATIONS (Continued)

Connector Name/Number	Color	Location	Fig.
Right Front Wheel Speed Sensor	BK	Right Fender Side Shield	17
Right Headlamp	BL	At Headlamp	N/S
Right License Lamp	BK	At Rear Bumper	21
Right Outboard Clearance Lamp	BK	Behind Front of Headliner	20
Right Outboard Headlamp		At Headlamp	N/S
Right Outboard Identification Lamp	BK	Behind Front of Headliner	20
Right Park/Turn Signal Lamp	BK	At Lamp	N/S
Right Power Mirror	BK	In Door	19
Right Rear Fender Lamp		On Fender	21
Right Rear Speaker		Bottom of Right B Pillar	18
Right Remote Radio Switch		Steering Wheel	N/S
Right Speed Control Switch		Steering Wheel	N/S
Right Tail/Stop Turn Signal Lamp	BK	At Rear Bumper	21
Right Tweeter		Right A Pillar	N/S
Right Visor/Vanity Lamp	BK	Right A-Pillar	N/S
Seat Belt Switch		Above Left Rear Speaker	18
Tailgate Lamp		On Tailgate	21
Throttle Position Sensor		Throttle Body	4,5,9
Trailer Tow Connector	BK	On Trailer Hitch	21
Transmission Solenoid Assembly	BK	Side of Transmission	13
Under Hood Lamp	BK	Underside of Hood	15
Vehicle Speed Control Servo	BK	Below Battery	16
Washer Fluid Level Switch		At Reservoir	16
Water In Fuel Sensor	BK	Bottom of Fuel Filter/Water Separator	10
Windshield Washer Pump	BK	Bottom of Washer Fluid Reservoir	16
Wiper Motor	BK	Center Rear Engine Compartment	14



CONNECTOR/GROUND LOCATIONS (Continued)

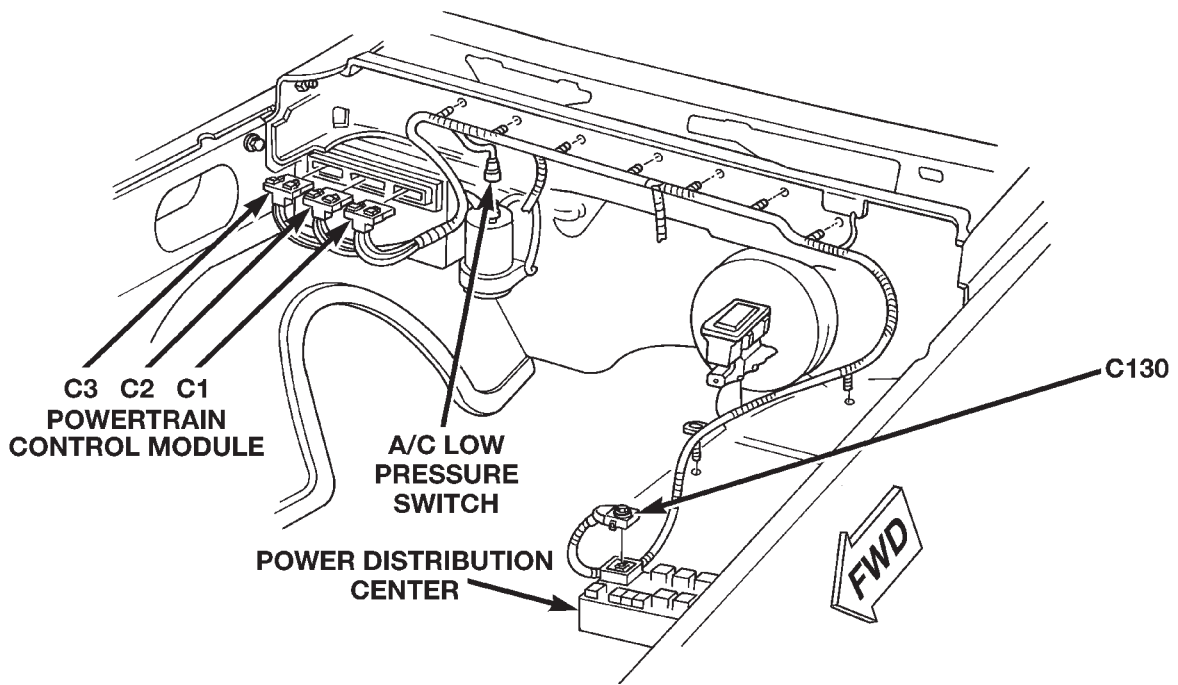


Fig. 1 ENGINE COMPARTMENT (GAS )

80b46c29

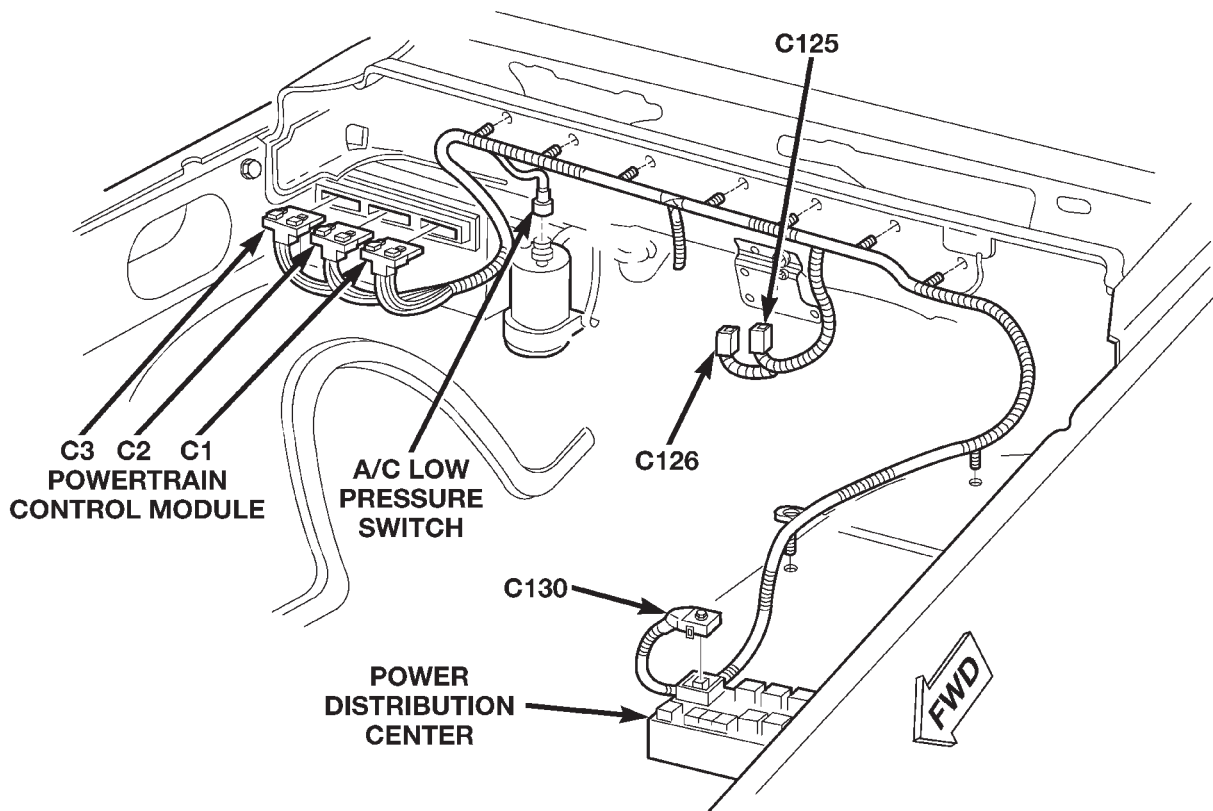
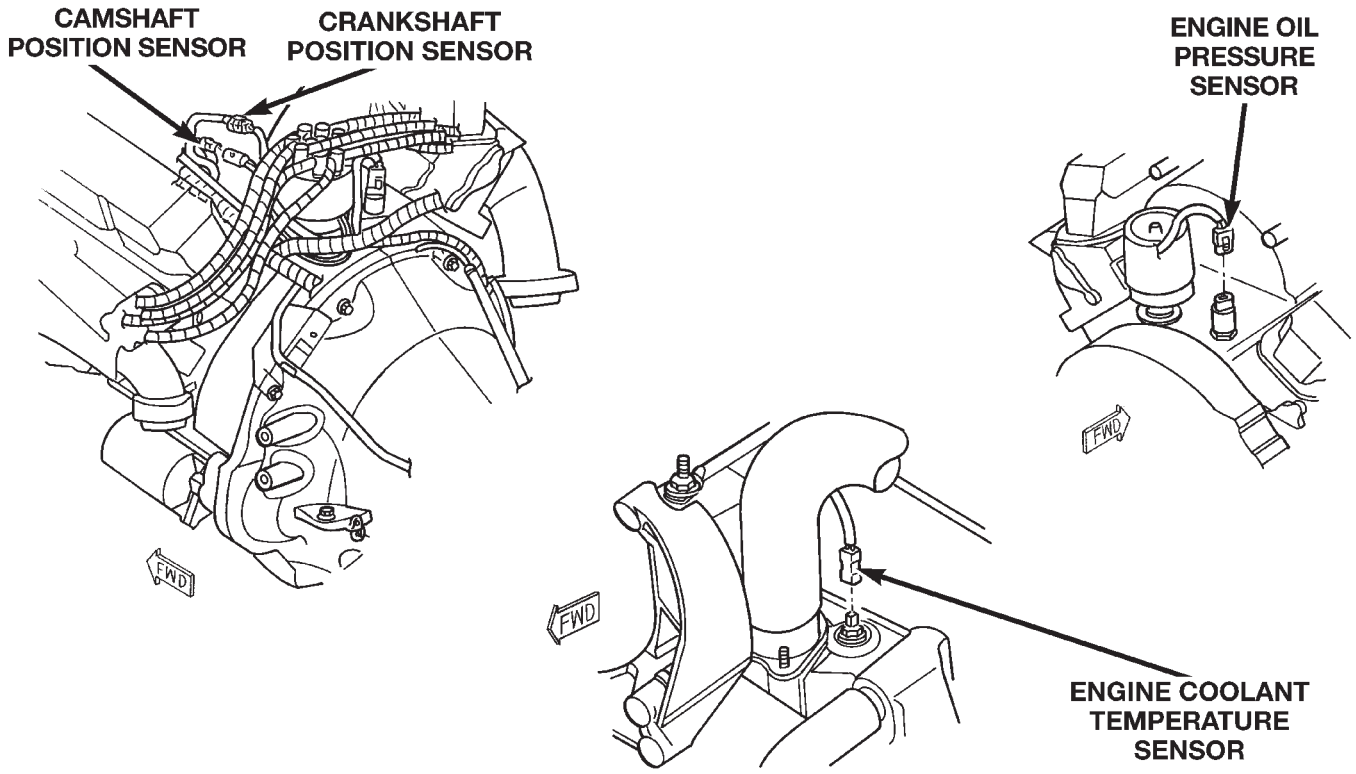


Fig. 2 ENGINE COMPARTMENT (DIESEL ENGINE)

80b46c31

CONNECTOR/GROUND LOCATIONS (Continued)



80be47b1

Fig. 3 3.9-5.2-5.9 LITER ENGINE

80br958a

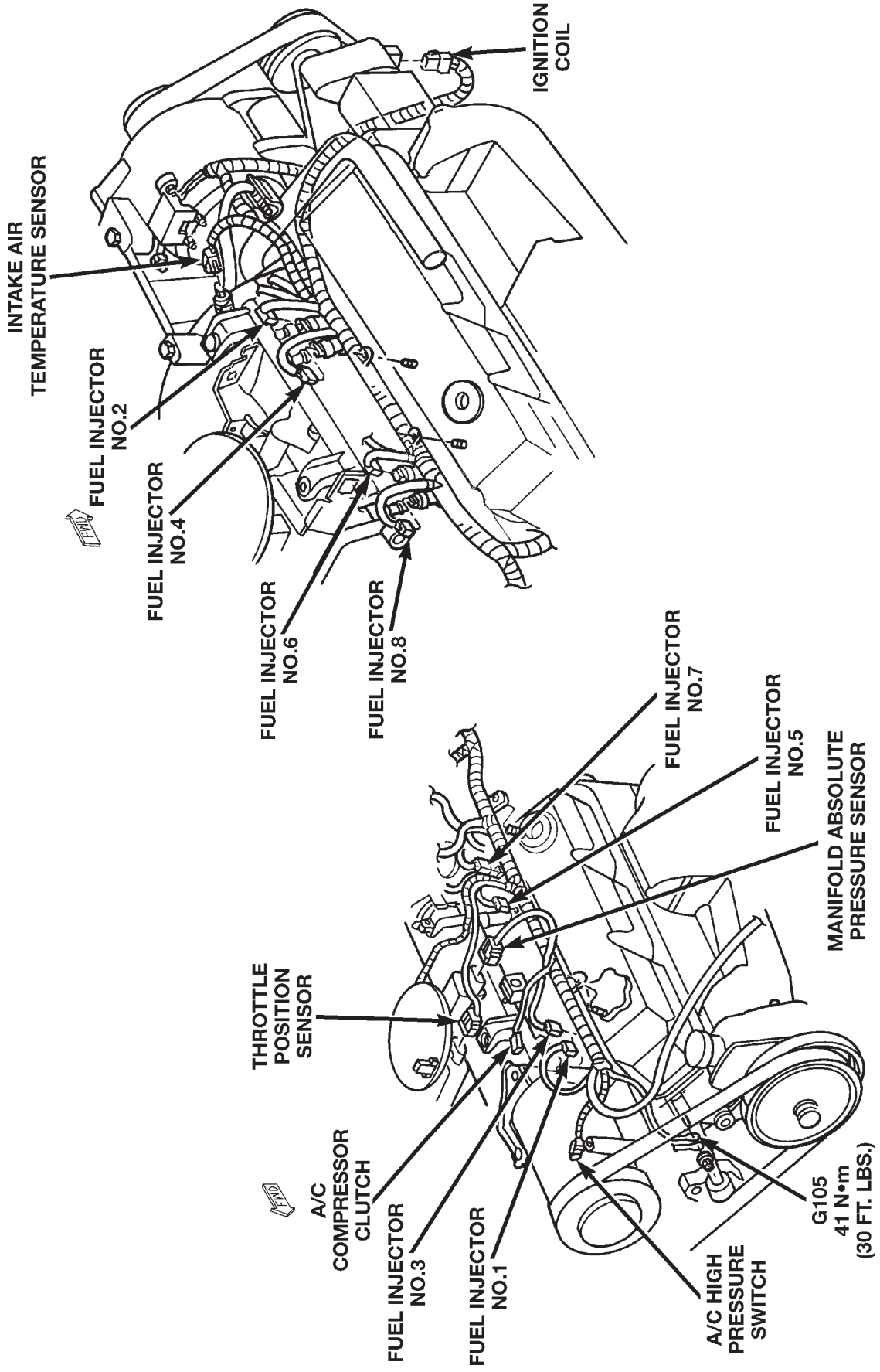
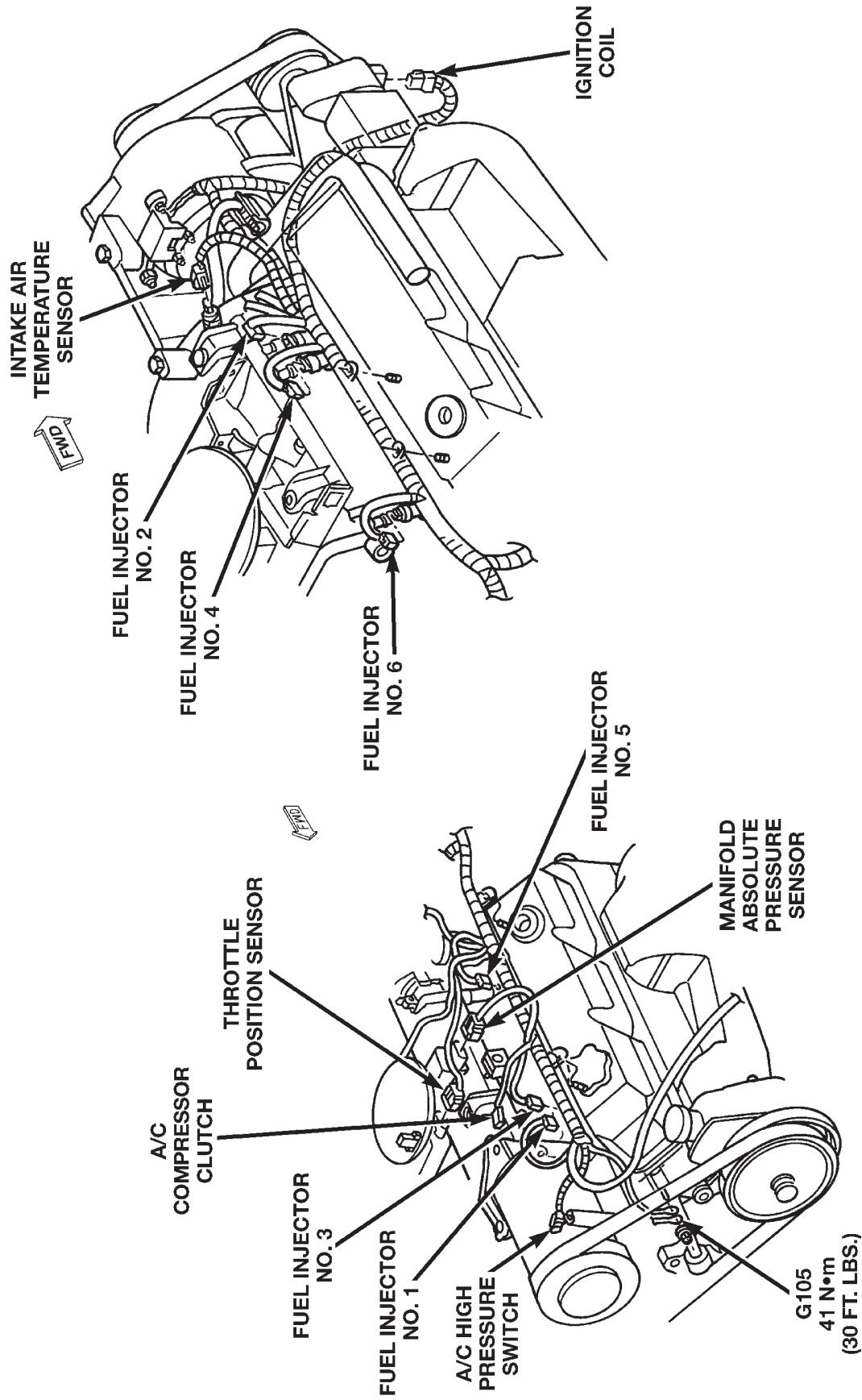


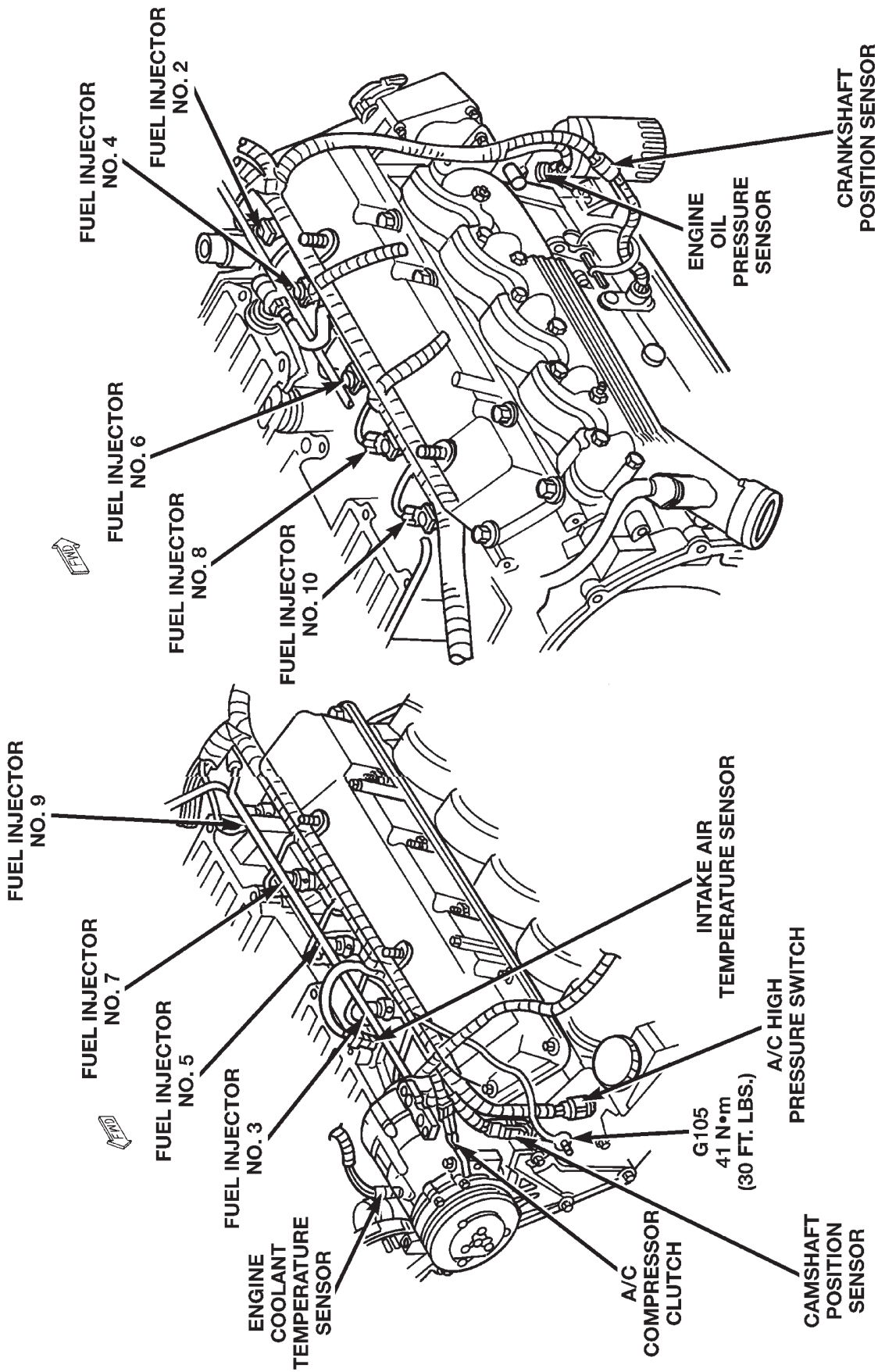
Fig. 4 5.2-5.9 LITER ENGINE



80b1668b

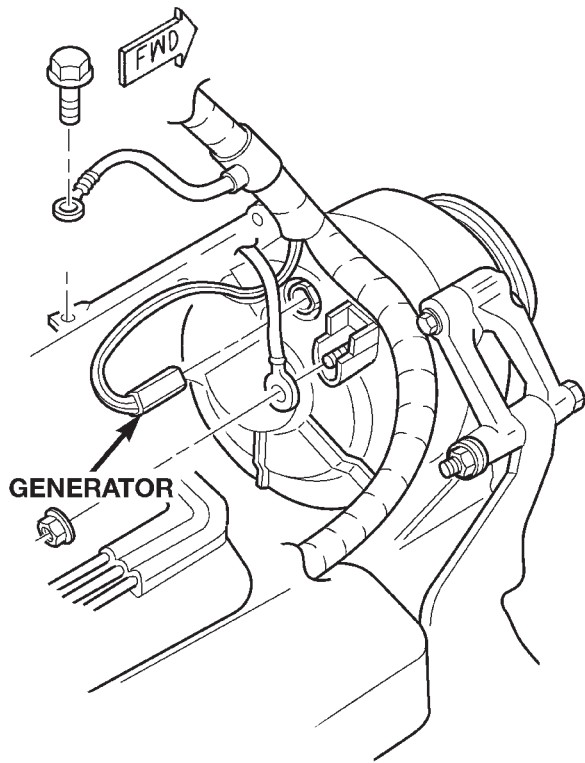
Fig. 5 3.9 LITER ENGINE

CONNECTOR/GROUND LOCATIONS (Continued)

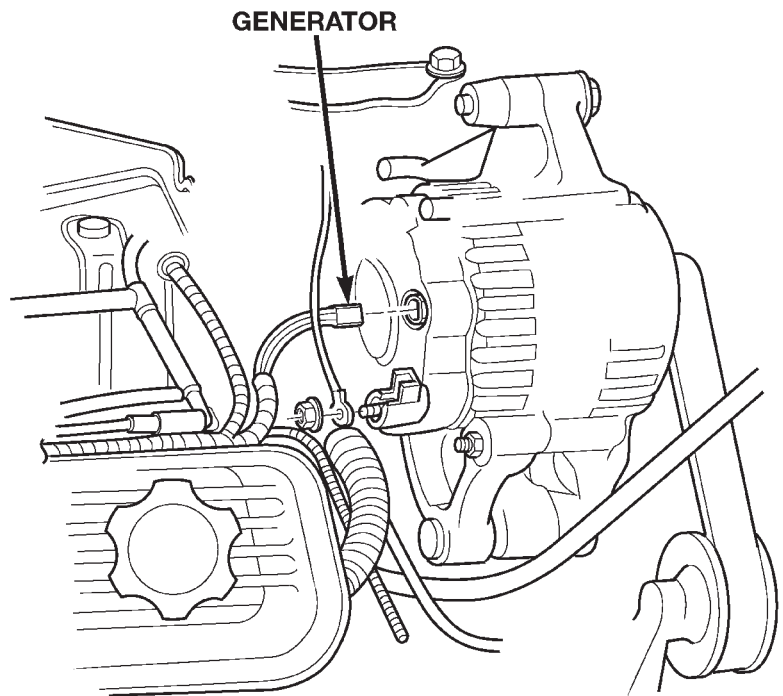


80B1668C

Fig. 6 8.0 LITER ENGINE



8.0 LITER ENGINE



3.9-5.2-5.9 LITER ENGINE

Fig. 7 GENERATOR (GAS ENGINE)

80be47b2

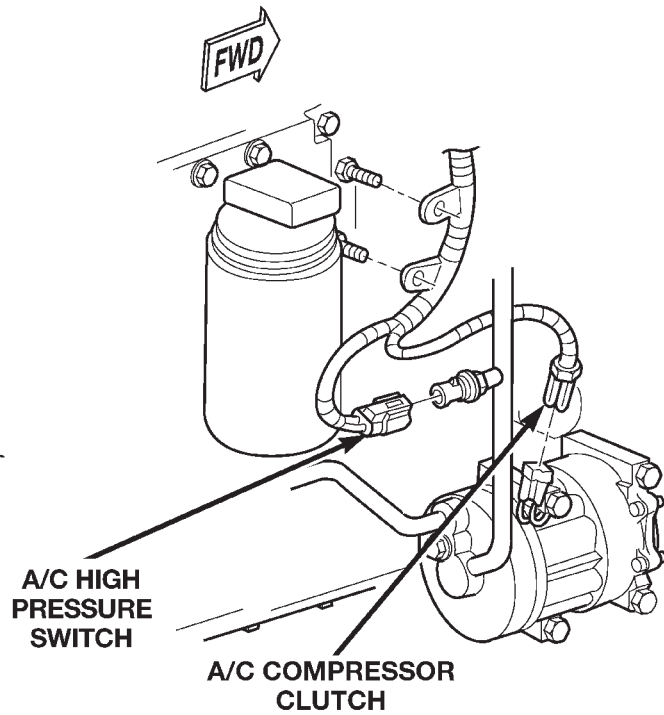
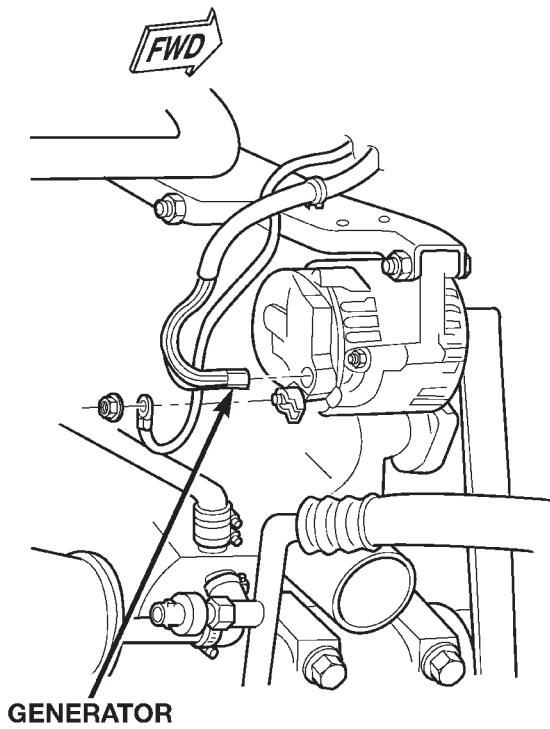


Fig. 8 GENERATOR (DIESEL ENGINE)

80be47b3



CONNECTOR/GROUND LOCATIONS (Continued)

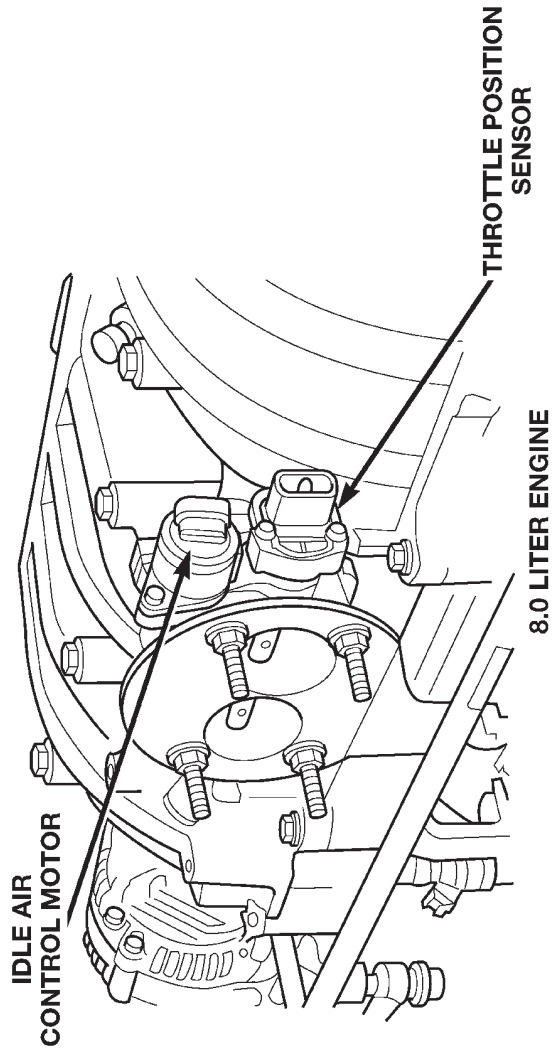
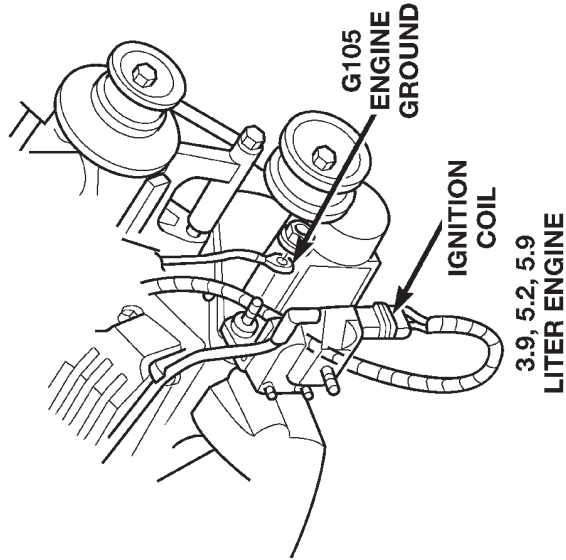
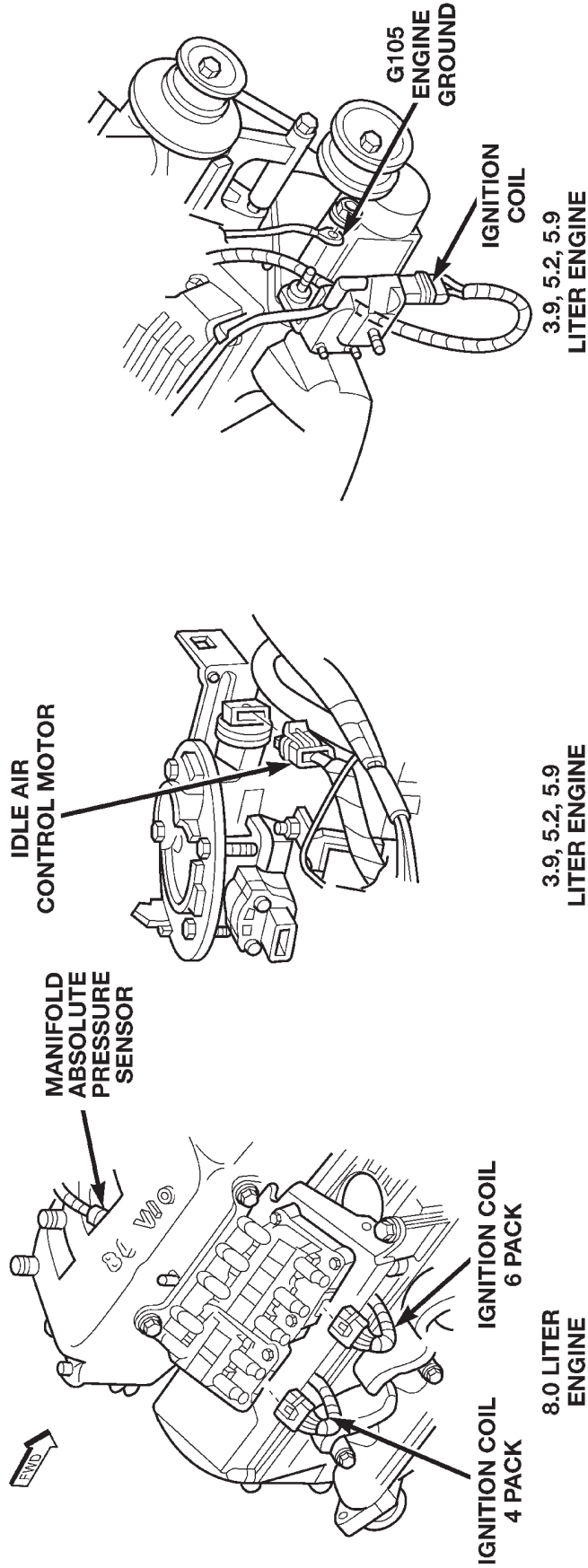


Fig. 9 IGNITION COIL (GAS ENGINE)

CONNECTOR/GROUND LOCATIONS (Continued)

80c06ef6

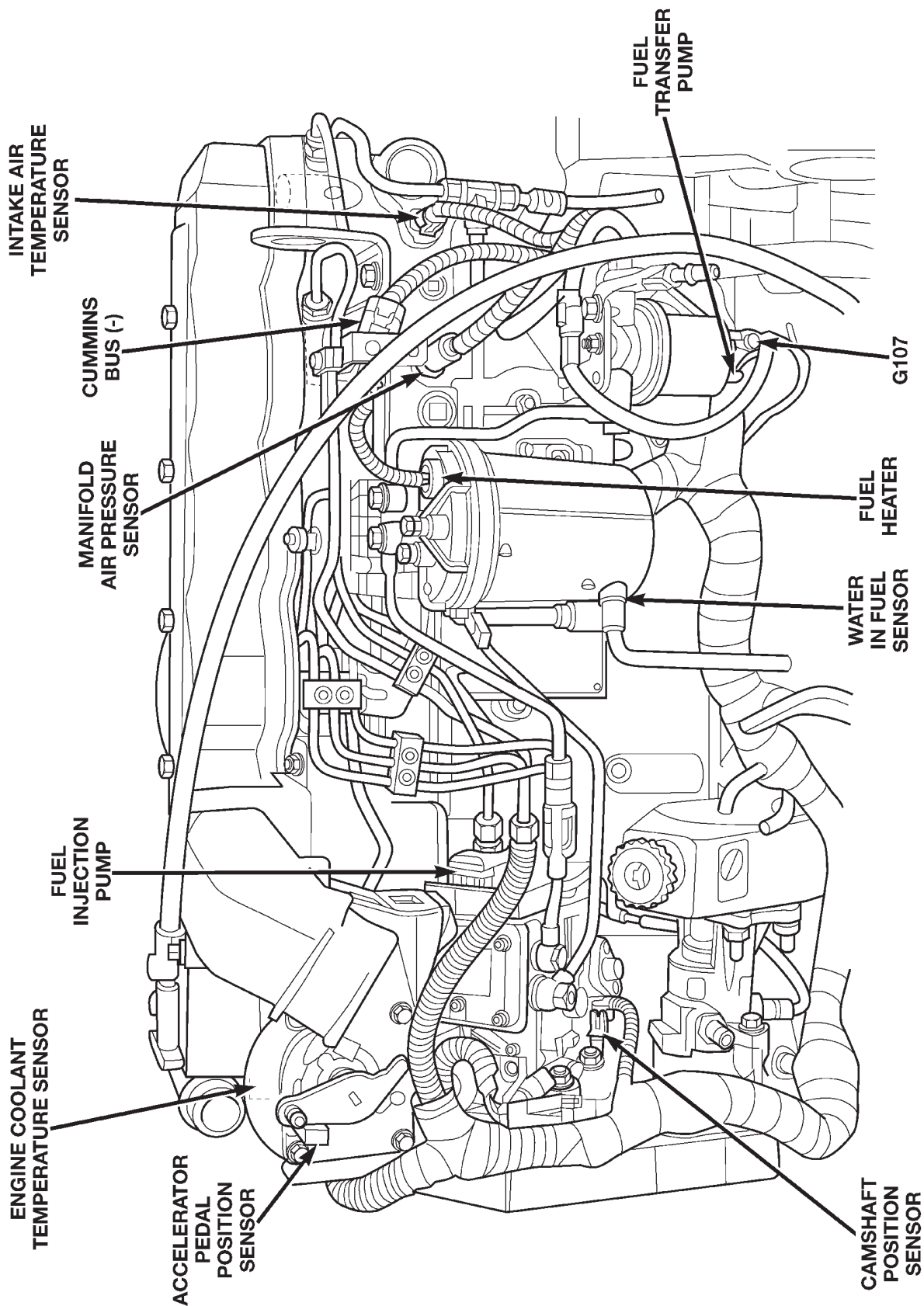


Fig. 10 DIESEL COMPONENTS

CONNECTOR/GROUND LOCATIONS (Continued)

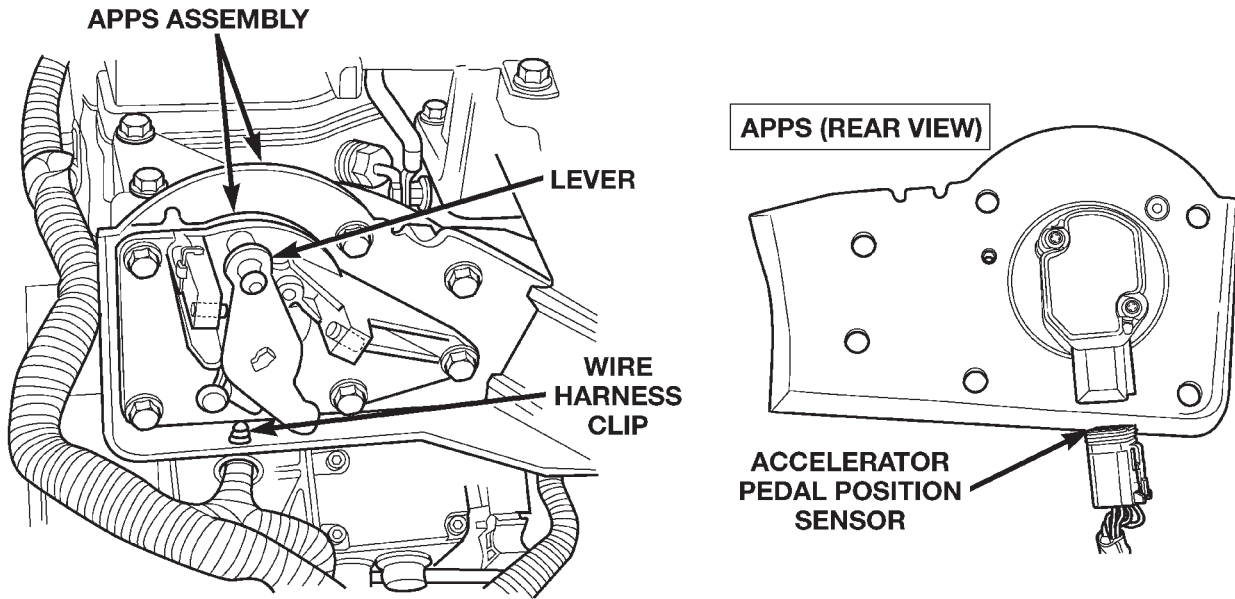


Fig. 11 ACCELERATOR PEDAL POSITION SENSOR

80b46c2c

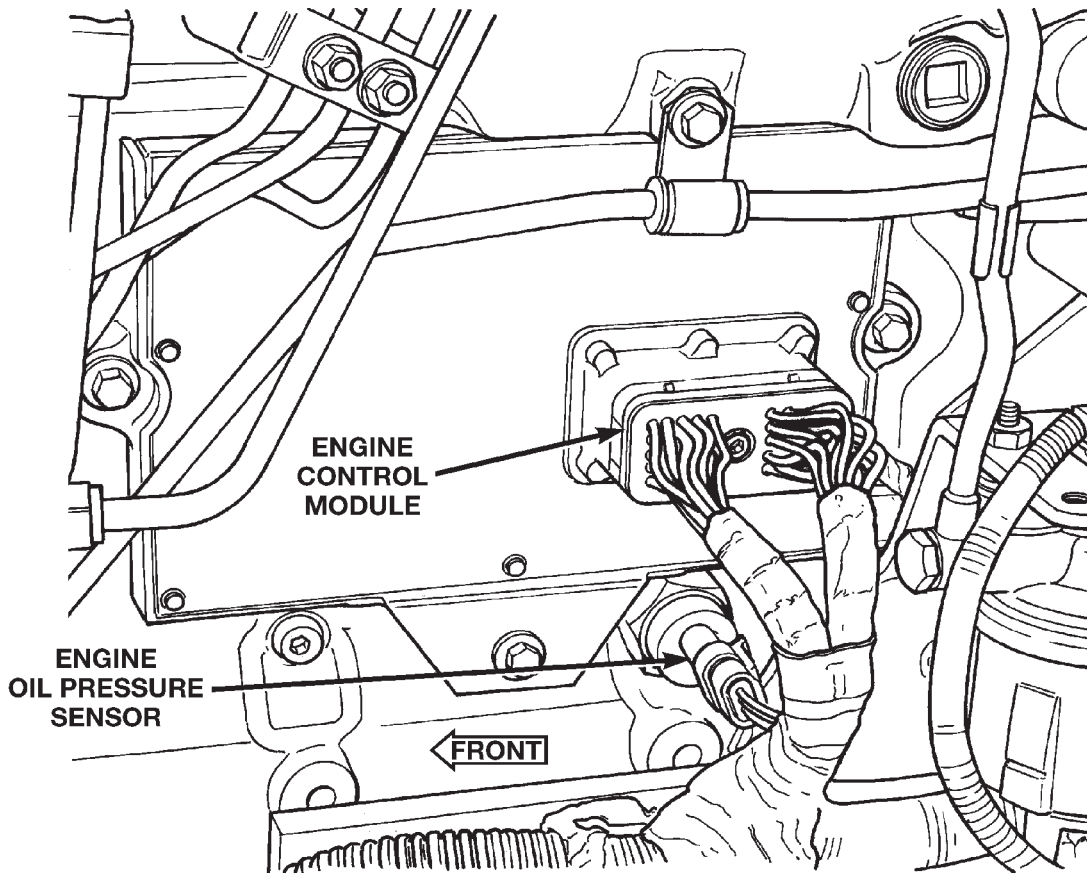
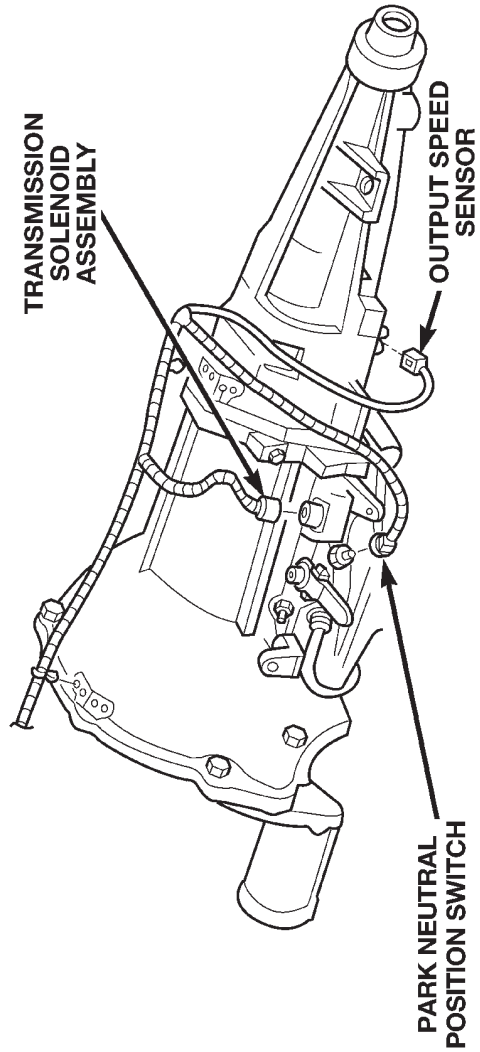
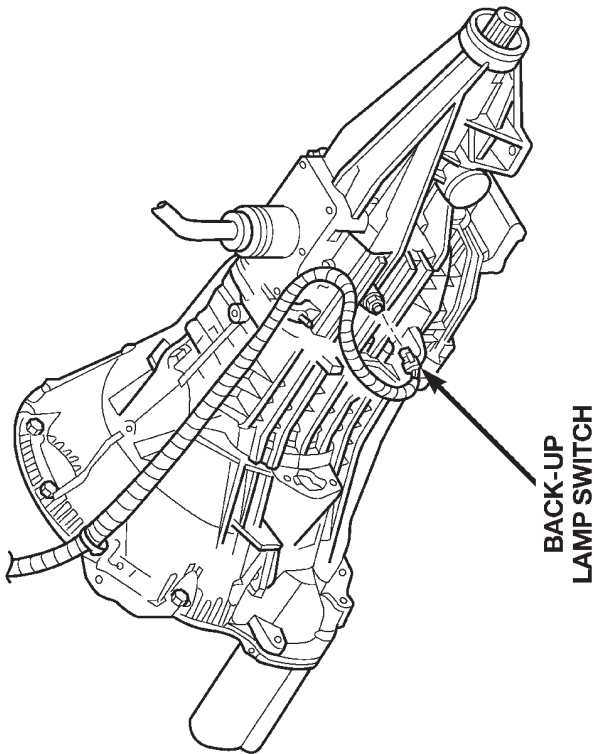
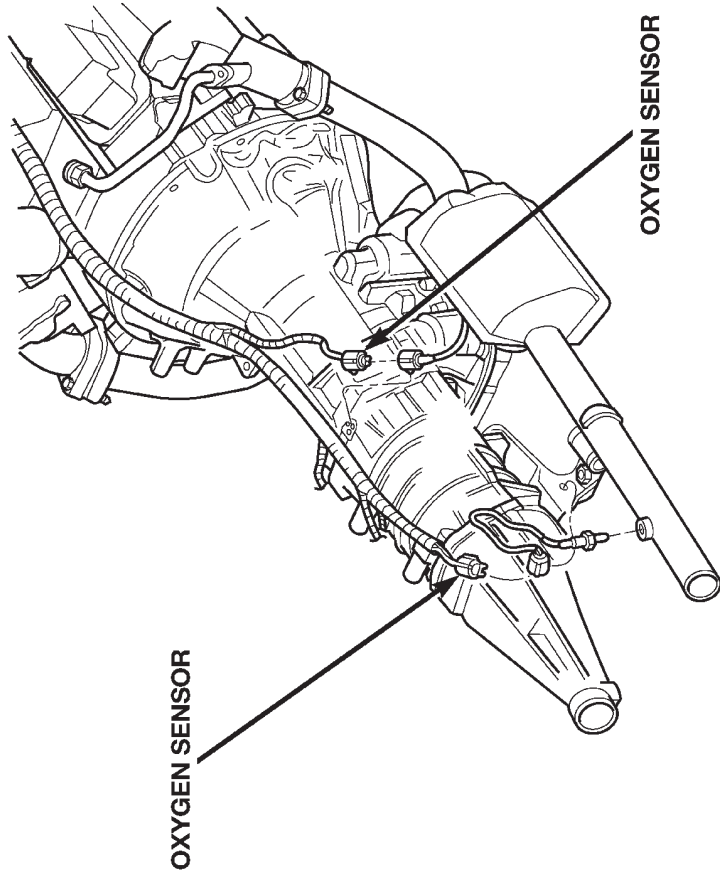


Fig. 12 ENGINE CONTROL MODULE

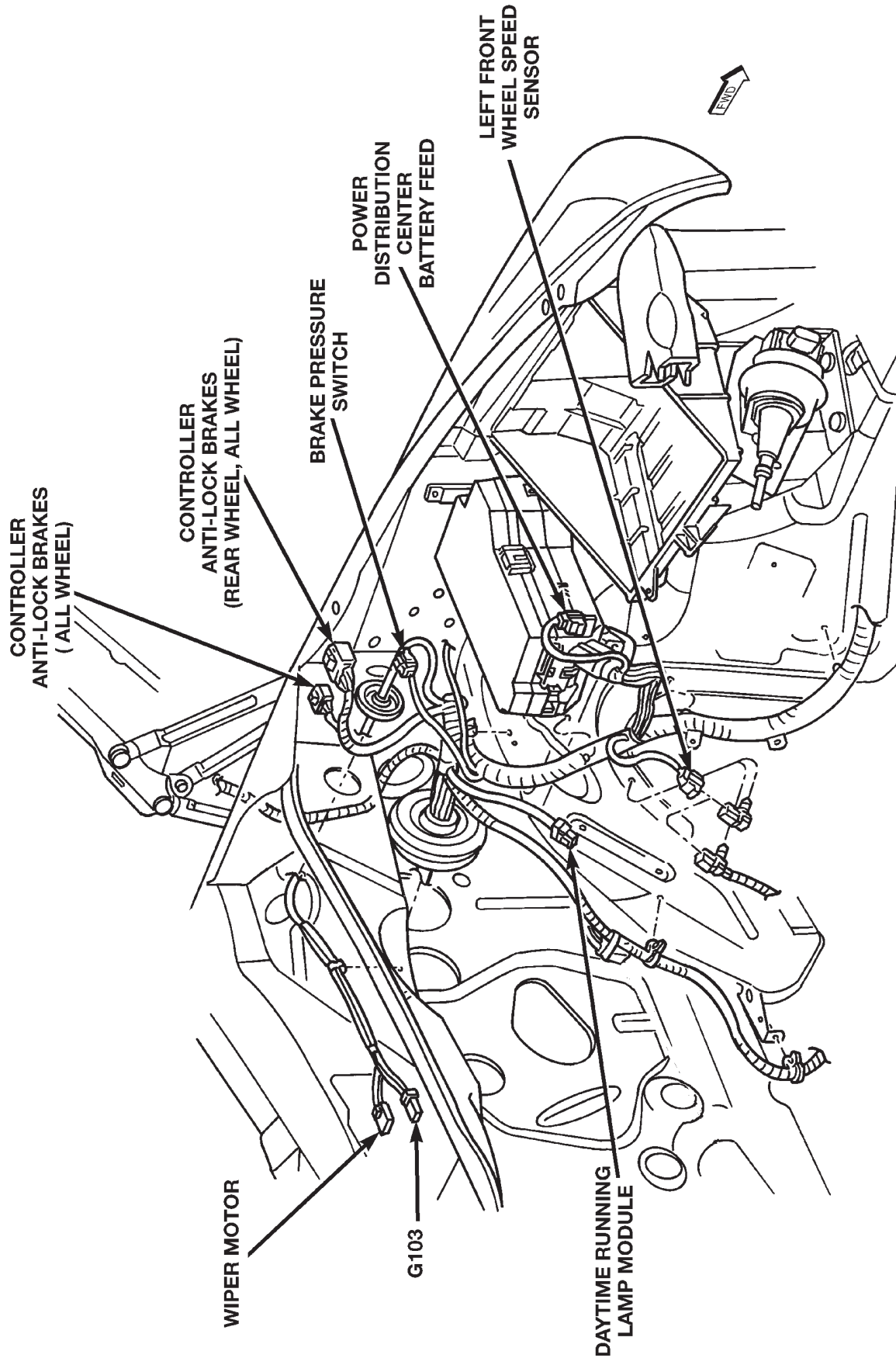
80be47b4



80a373c2

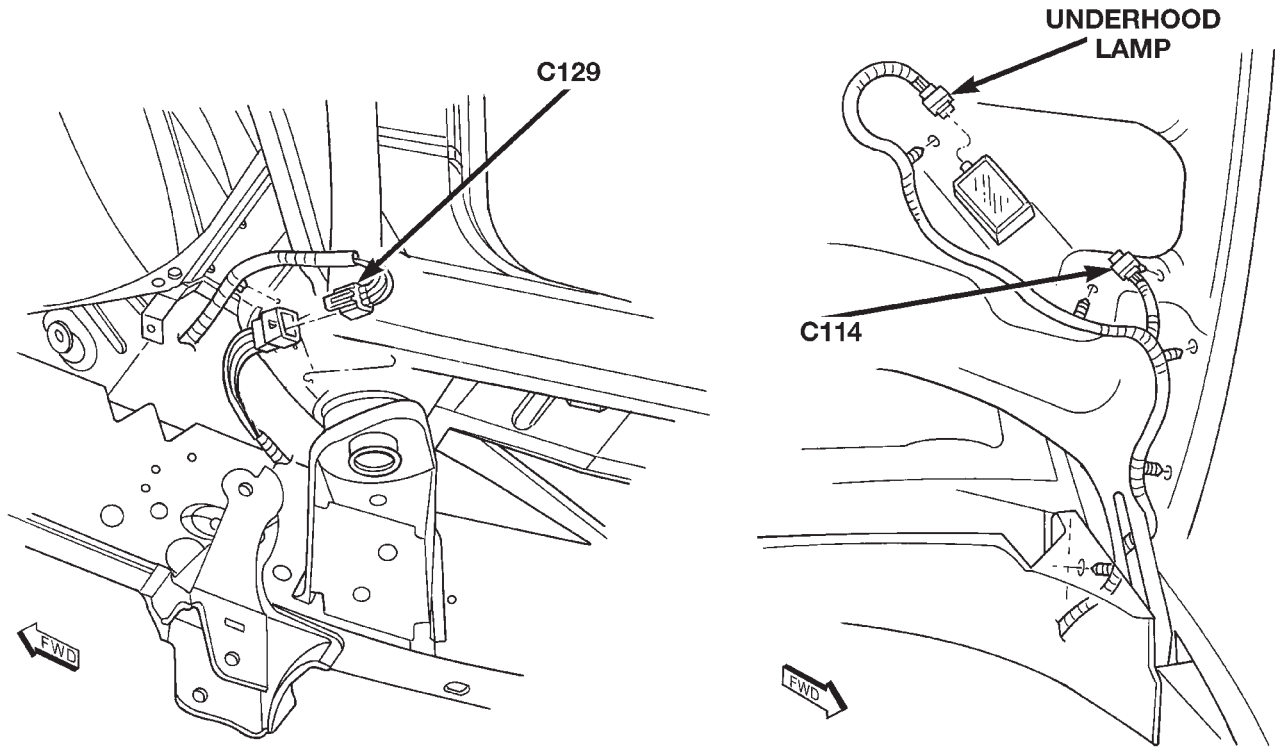
Fig. 13 TRANSMISSION CONNECTORS

CONNECTOR/GROUND LOCATIONS (Continued)



80a373c9

Fig. 14 LEFT SIDE ENGINE COMPARTMENT



80a373ce

**Fig. 15 UNDER HOOD**



CONNECTOR/GROUND LOCATIONS (Continued)

80b19697

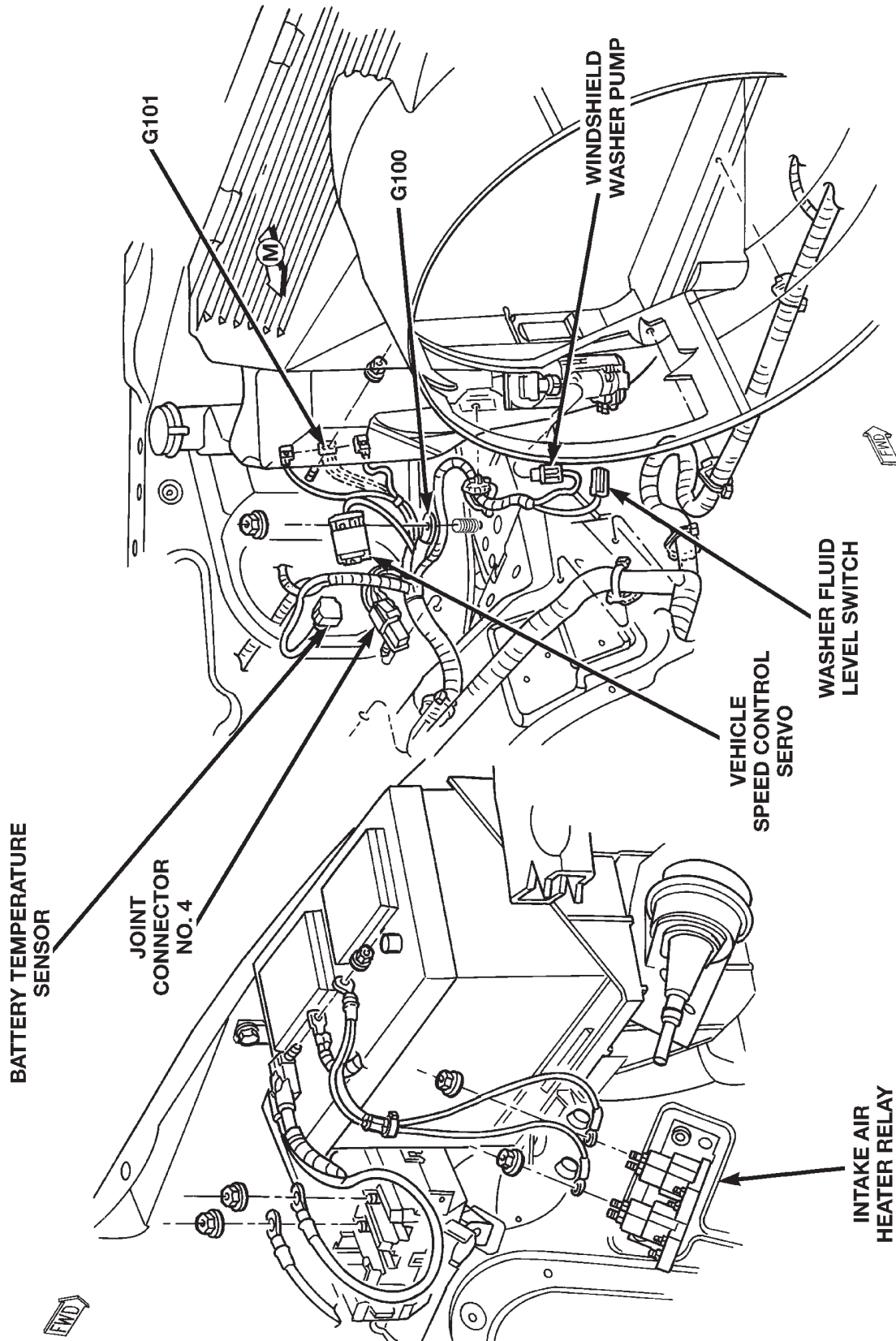


Fig. 16 UNDER HOOD

CONNECTOR/GROUND LOCATIONS (Continued)

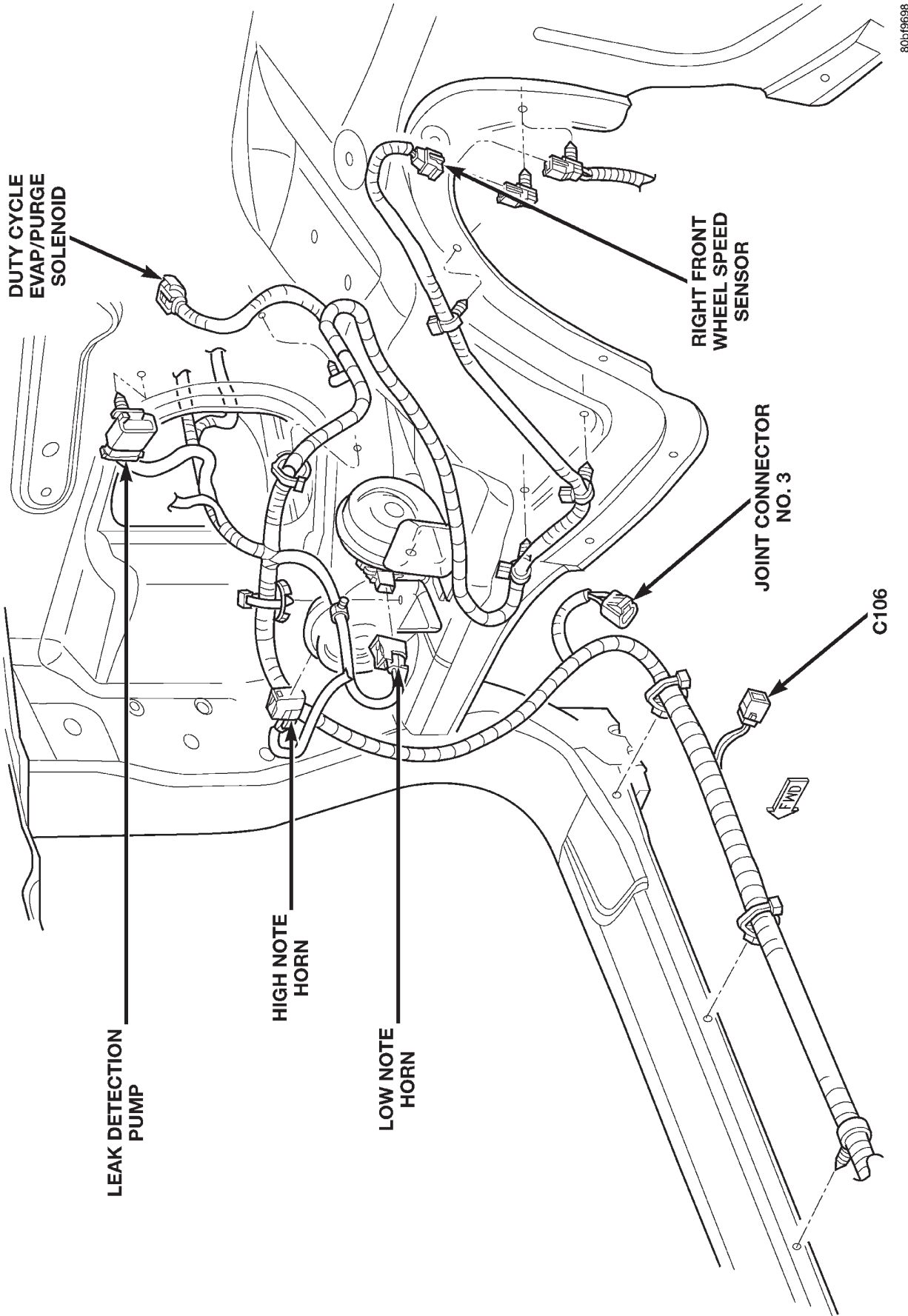
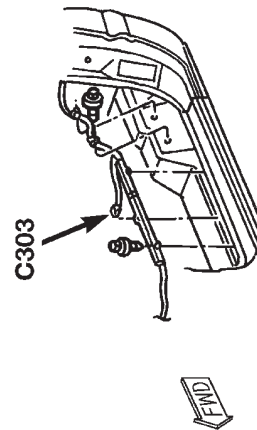
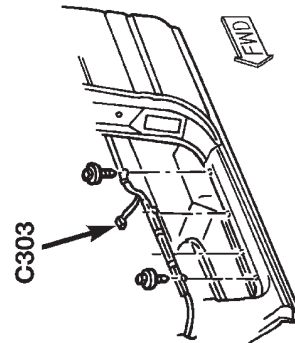
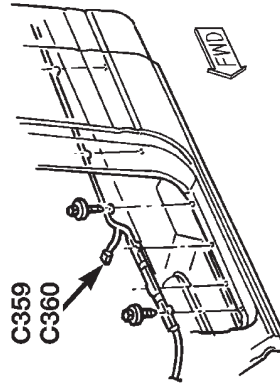
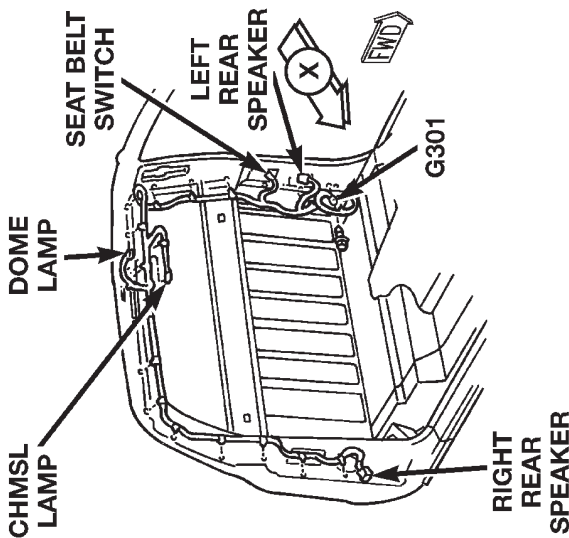
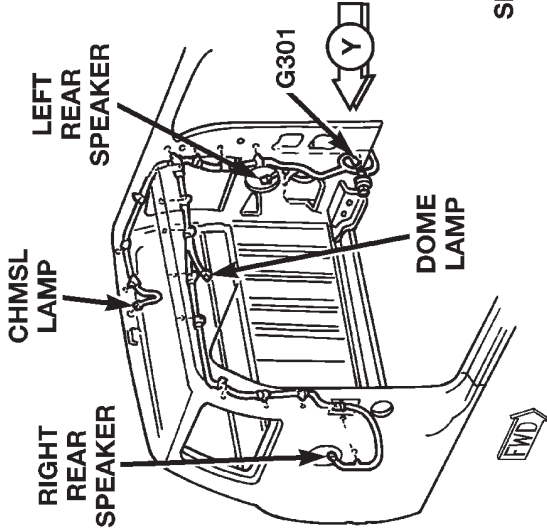
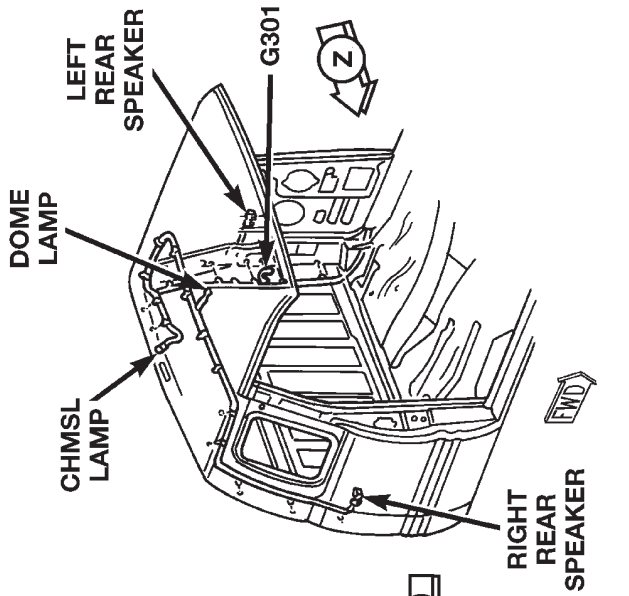


Fig. 17 RIGHT FENDER SHIELD

CONNECTOR/GROUND LOCATIONS (Continued)



VIEW IN DIRECTION OF ARROW Z

VIEW IN DIRECTION OF ARROW Y

VIEW IN DIRECTION OF ARROW X

80bf9699

Fig. 18 CENTER HIGH MOUNTED STOP LAMP

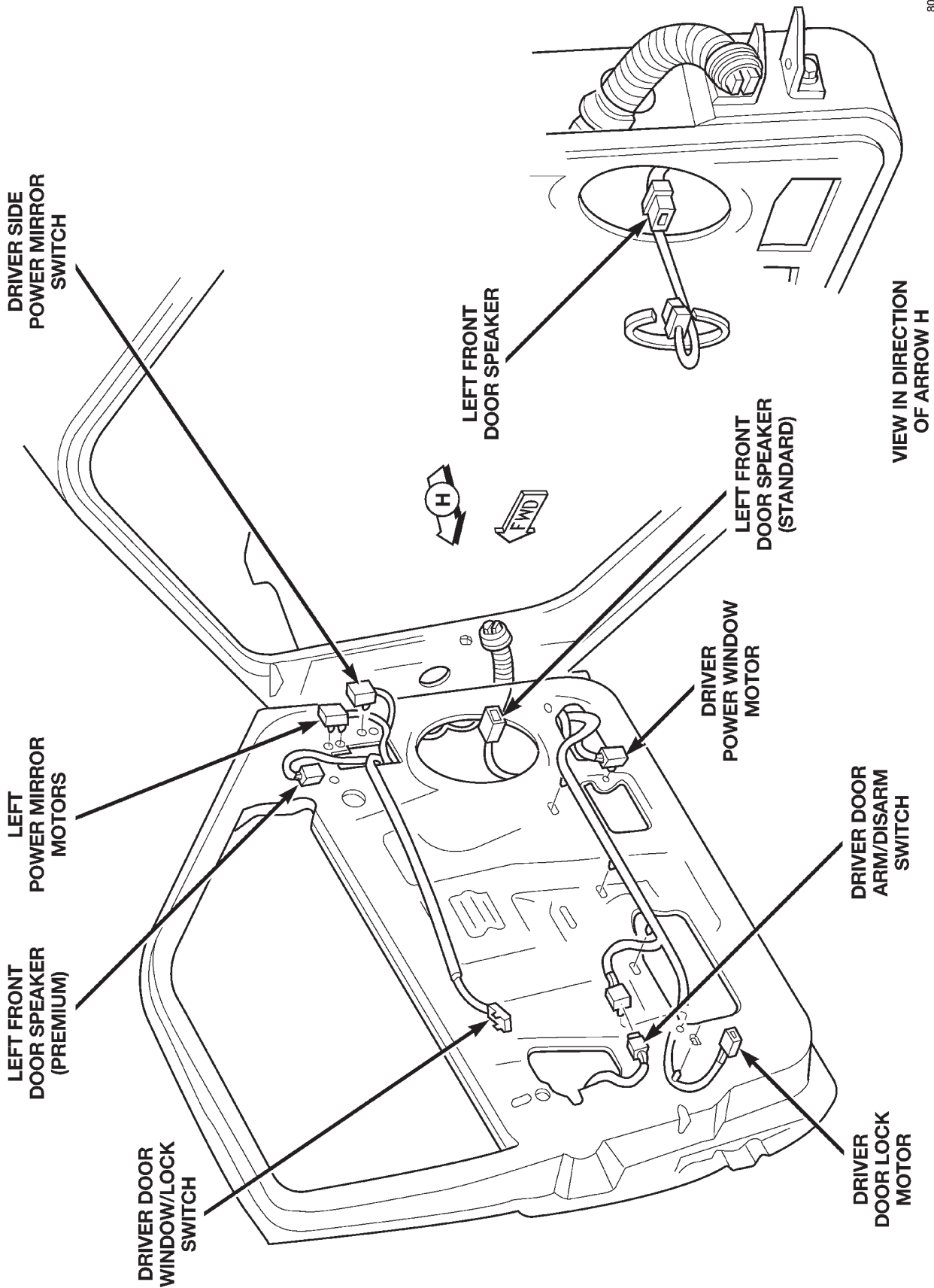


Fig. 19 DOOR

CONNECTOR/GROUND LOCATIONS (Continued)

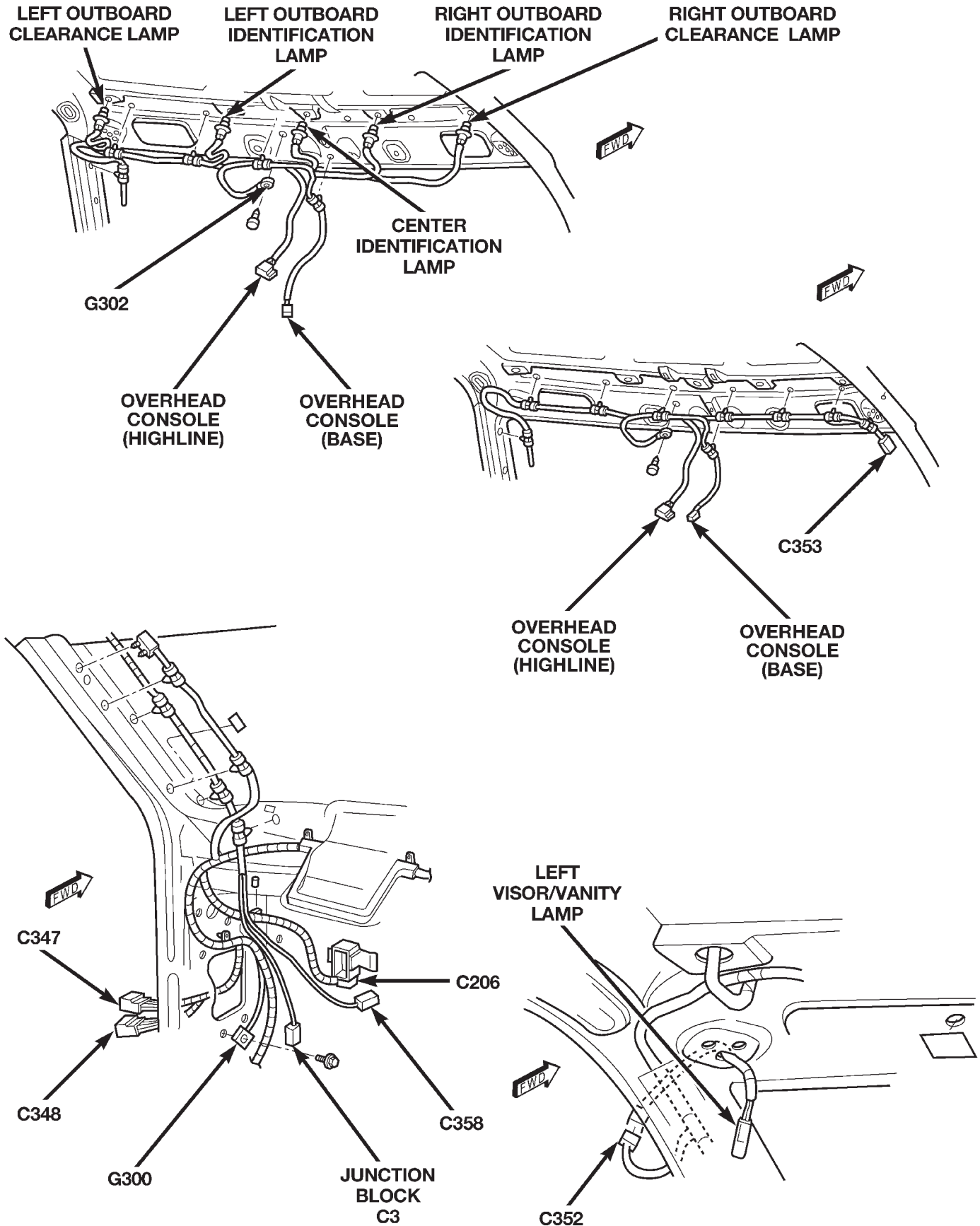


Fig. 20 OVERHEAD CONSOLE

CONNECTOR/GROUND LOCATIONS (Continued)

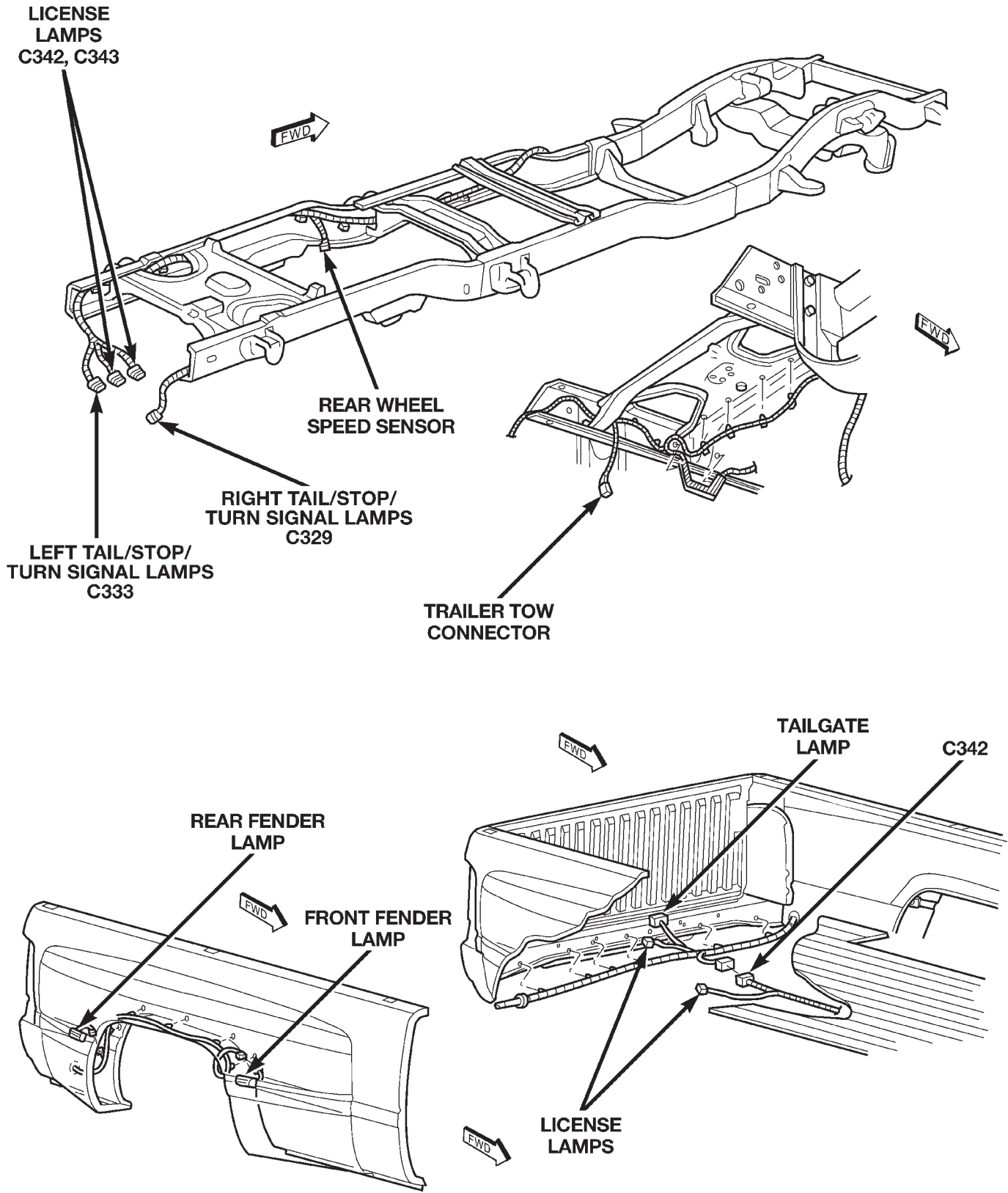
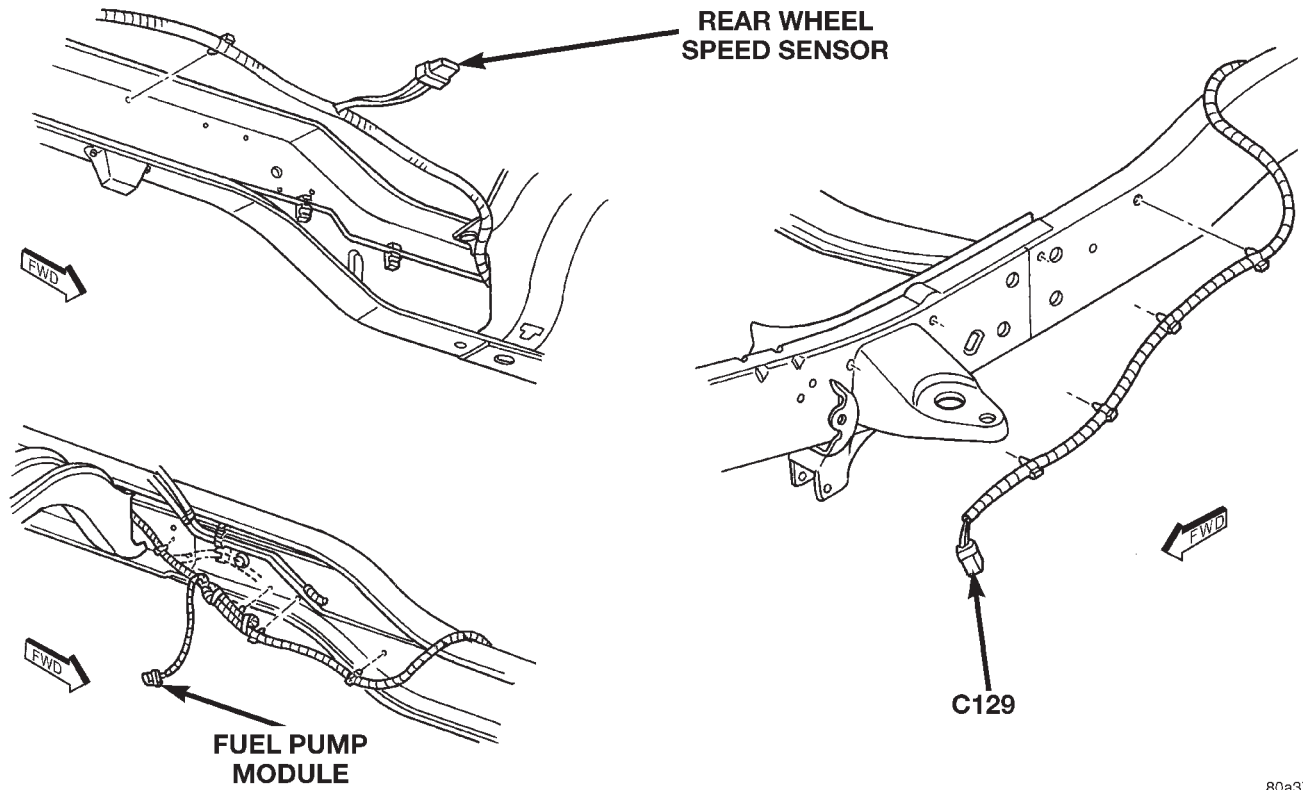


Fig. 21 TAIL LAMPS





**Fig. 22 FRAME RAIL**

CONNECTOR/GROUND LOCATIONS (Continued)

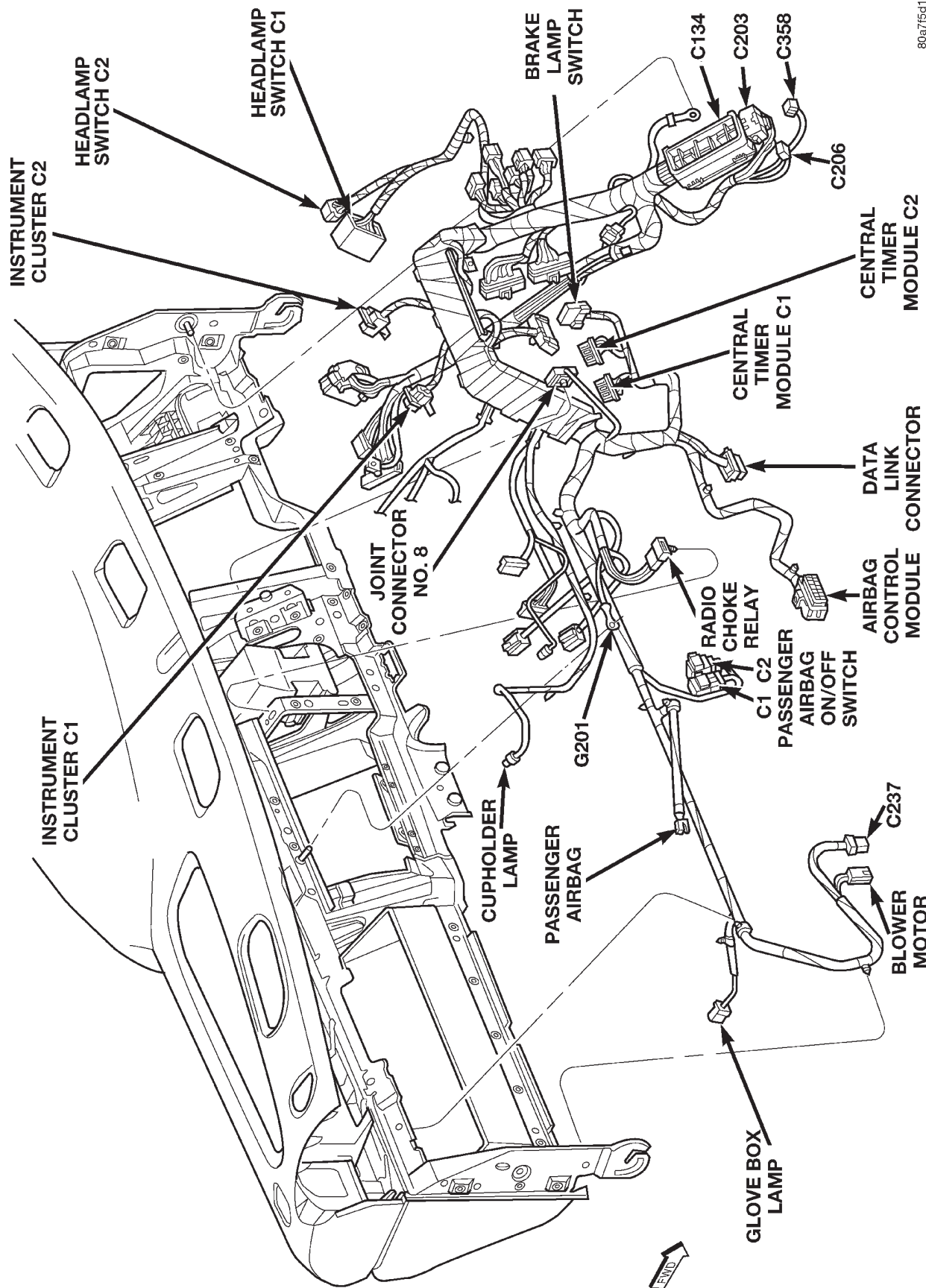


Fig. 23 INSTRUMENT PANEL

CONNECTOR/GROUND LOCATIONS (Continued)

80a7f691

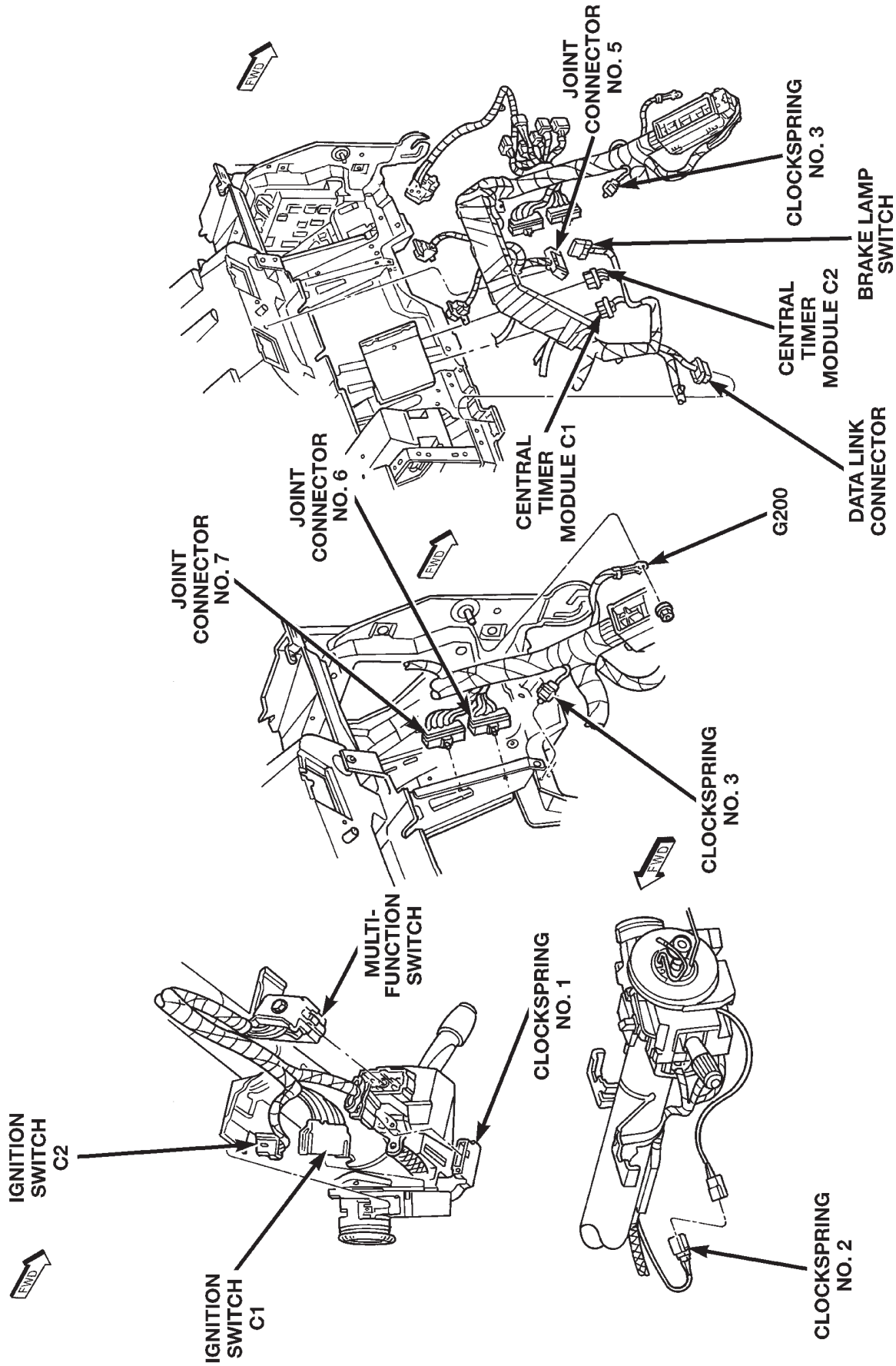


Fig. 24 STEERING COLUMN

CONNECTOR/GROUND LOCATIONS (Continued)

80b1969e

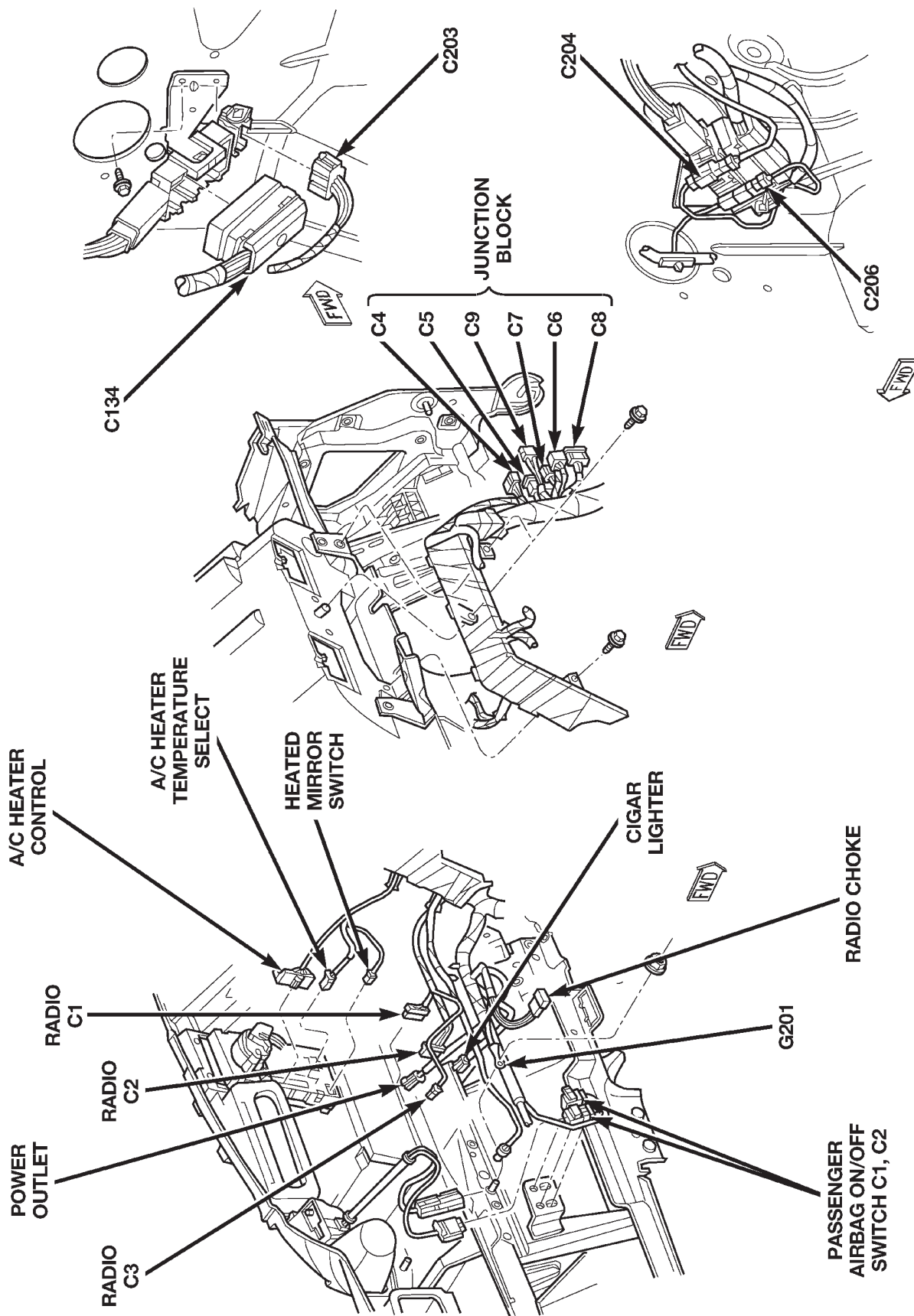
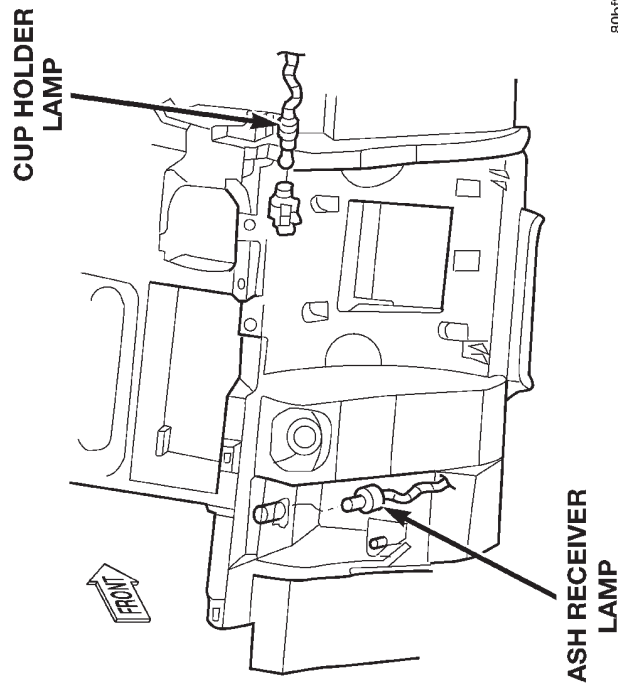
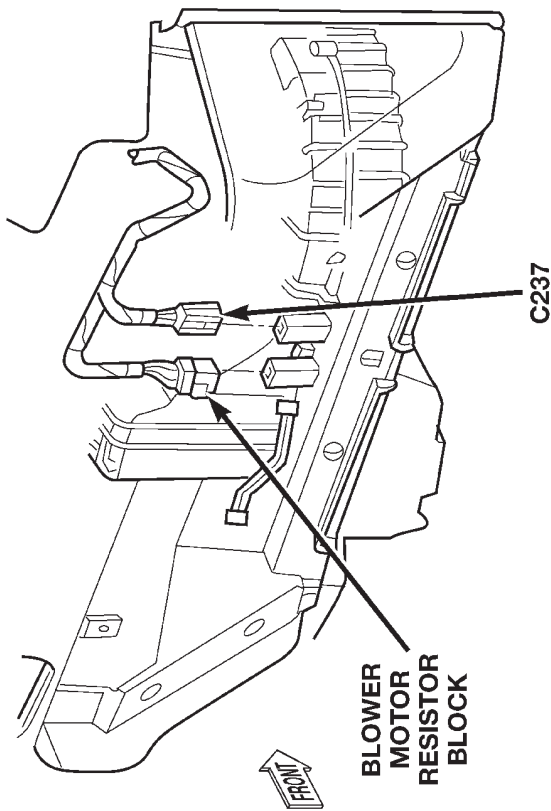


Fig. 25 INSTRUMENT PANEL

CONNECTOR/GROUND LOCATIONS (Continued)



80b1969f

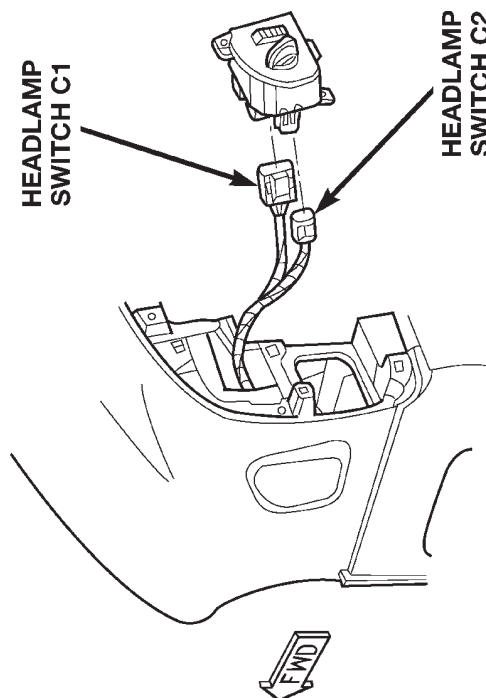
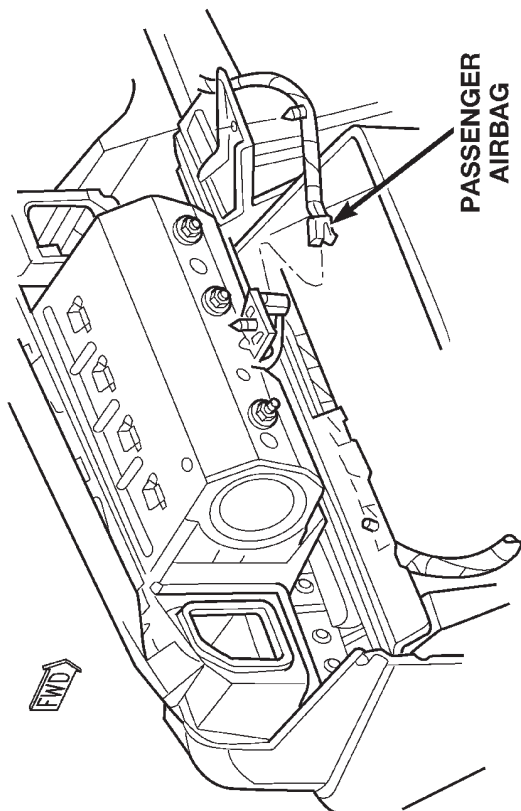
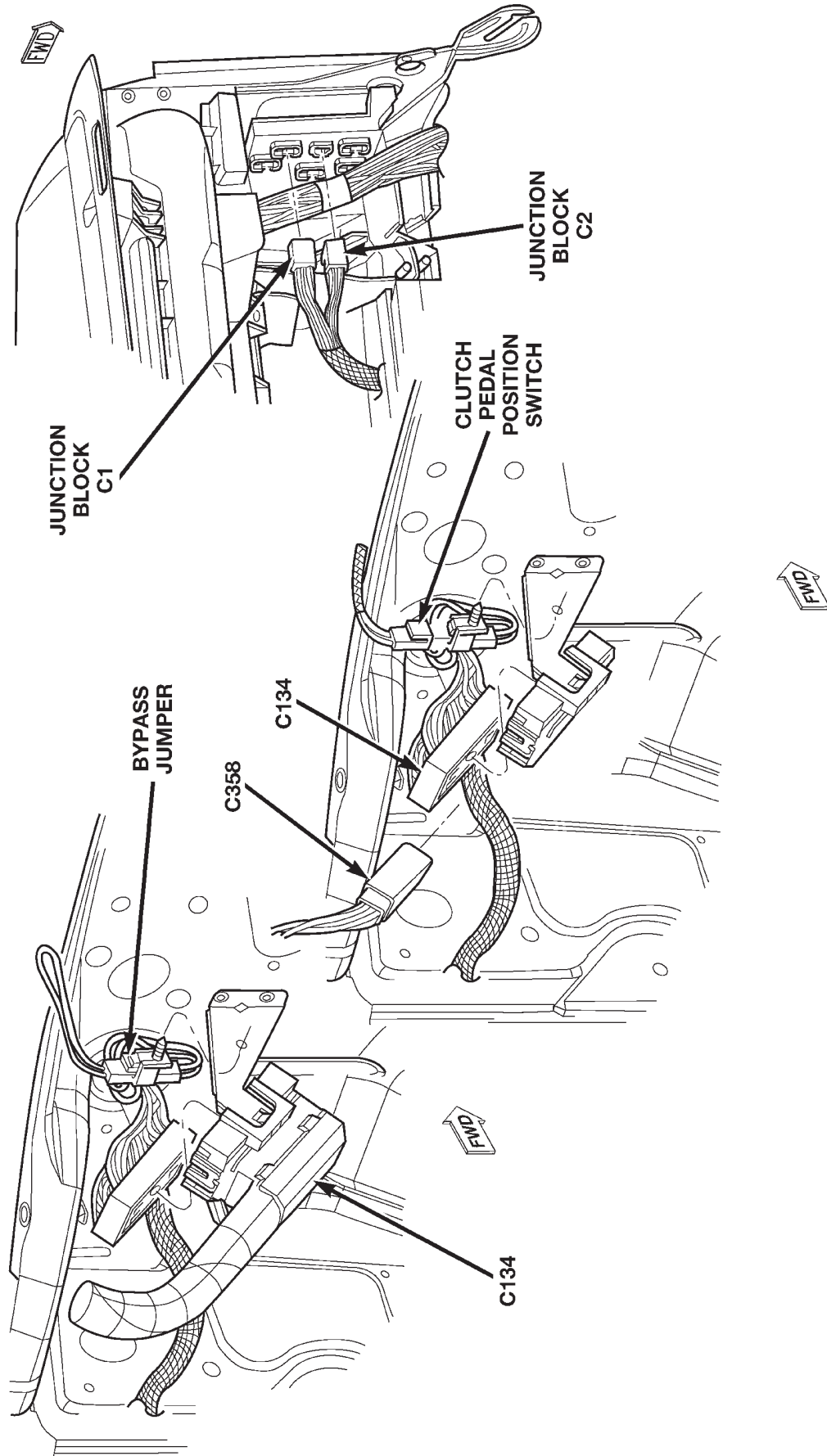


Fig. 26 INSTRUMENT PANEL



80b196a9

Fig. 27 LEFT COWL





## 8W-95 SPLICE LOCATIONS

## TABLE OF CONTENTS

page

**SPLICE LOCATIONS**

DESCRIPTION..... 1

**SPLICE LOCATIONS****DESCRIPTION**

This section provides illustrations identifying the general location of the splices in this vehicle. A splice

index is provided. Use the wiring diagrams in each section for splice number identification. Refer to the index for proper splice number. For splices that are not shown in the figures N/S appears in the Fig. column.

Splice Number	Location	Fig.
S100	Engine Harness Near T/O to Oil Pressure Sensor	3
S102	Headlamp and Dash Harness, Near T/O to Right Park/Turn Lamp	8
S103	Headlamp and Dash Harness, Near T/O to Left Park/Turn Lamp	N/S
S104	Headlamp and Dash Harness, Near T/O to Left Front Headlamp	N/S
S105	Headlamp and Dash Harness, In Power Distribution Center	7
S106	Headlamp and Dash Harness, In Power Distribution Center	7
S107	Headlamp and Dash Harness, Near Left Wheel Speed Sensor	7
S108	Headlamp and Dash Harness, Near Daytime Running Lamp Module	7
S109	Battery Harness, In T/O for Engine and Transmission Ground	N/S
S110	Headlamp and Dash Harness, Near Left Wheel Speed Sensor	7
S111	Transmission Harness Near T/O to A/C Low Pressure Switch	2
S112	Headlamp and Dash Harness, Near Antilock Brake Controller	7
S113	Headlamp and Dash Harness, Near Antilock Brake Controller	7
S114	Headlamp and Dash Harness, In T/O to Chassis Harness	7
S116(V6, V8)	Engine Harness, Near T/O to Fuel Injectors	1
S116 (V10)	Engine Harness Rear of Engine	2, 4
S116 (Diesel)	Transmission Harness, In T/O to Power Distribution Center	2
S117 (V6, V8)	Engine Harness, Near T/O to Fuel Injectors	1
S117 (V10)	Engine Harness, Near T/O to fuel Injector No. 8	1, 4
S118 (V6, V8)	Engine Harness, Near T/O to Fuel Injectors	1
S118 (V10)	Engine Harness, Rear of Engine	1, 4
S119 (V6, V8)	Engine Harness, Near T/O to Fuel Injectors	1
S119 (V10)	Engine Harness, Rear of Engine	1, 4
S120 (V6, V8)	Engine Harness, Near T/O to Fuel Injectors	1
S120 (V10)	Engine Harness, Rear of Engine	2, 4, 6
S120 (Diesel)	Transmission Harness, Near T/O to A/C Low Pressure Switch	2
S121 (V6, V8)	Engine Harness, Near T/O to Fuel Injector No. 5	3
S121 (V10)	Engine Harness, Near T/O to Fuel Injector No. 7	4
S122 (V6, V8)	Engine Harness, Top of Transmission	5
S122 (V10)	Engine Harness, In T/O to Transmission	N/S
S123 (V6, V8)	Engine Harness, Near T/O to Fuel Injector No. 3	3

## SPLICE LOCATIONS (Continued)

Splice Number	Location	Fig.
S123 (V10)	Engine Harness, Near T/O to Fuel Injector No. 3	4
S124 (V6, V8)	Engine Harness, Top of Transmission	5
S124 (V10)	Engine Harness, In T/O to Transmission	N/S
S126 (V6, V8)	Engine Harness, Near T/O to Fuel Injector No. 1	3
S126 (V10)	Engine Harness, Near T/O to Engine Ground	4, 6
S126 (Diesel)	Transmission Harness, Near T/O to Powertrain Control Module	2
S127 (V6, V8)	Engine Harness, on Top of Transmission	6, 5
S127 (V10)	Engine Harness, Near T/O to Transmission	6
S127 (Diesel)	Transmission Harness, Near T/O to A/C Low Pressure Switch	2
S128 (Diesel)	Transmission Harness, Near T/O to Power Distribution Center	2
S130(V6, V8)	Engine Harness, Near T/O to Oil Pressure Sensor	3
S131 (V10)	Engine Harness, Rear of Engine	4
S134	Fog Lamp Harness, In T/O to Right Fog Lamp	N/S
S136	Fog Lamp Harness, In T/O to Right Fog Lamp	N/S
S141	Headlamp and Dash Harness, Near T/O to Joint Connector No. 3	8
S143	Headlamp and Dash Harness, Near T/O to Power Distribution Center	7
S144	Headlamp and Dash Harness, Near T/O to Joint Connector No. 3	8
S160 (Diesel)	Engine Harness, Near Fuel Transfer Pump	N/S
S161 (Diesel)	Transmission Harness, In T/O to Power Distribution Center	2
S164 (Diesel)	Engine Harness, Near Fuel Transfer Pump	N/S
S165 (Diesel)	Engine Harness, Near Engine Control Module	N/S
S166 (Diesel)	Engine Harness, Near Engine Control Module	N/S
S167 (Diesel)	Engine Harness, Near Fuel Transfer Pump	N/S
S168 (Diesel)	Engine Harness, Near T/O to Engine Coolant Temperature Sensor	N/S
S170 (Diesel)	Engine Harness, In T/O to Engine Control Module	N/S
S171	Transmission Harness, In T/O to Power Distribution Center	2
S172 (Diesel)	Transmission Harness, Near T/O to A/C Low Pressure Switch	2
S173 (Diesel)	Transmission Harness, Near T/O to A/C Low Pressure Switch	2
S174 (Diesel)	Transmission Harness, In T/O to Power Distribution Center	2
S175	Transmission Harness, In T/O to Power Distribution Center	2
S176	Headlamp and Dash Harness, In Power Distribution Center	7
S177	Headlamp and Dash Harness, In T/O to Daytime Running Lamps Module	7
S179	Transmission Harness, In T/O to Power Distribution Center	2
S180	Headlamp and Dash Harness, Near Intake Air Heater Relay	8
S181	Headlamp and Dash Harness, Near Intake Air Heater Relay	8
S182	Headlamp and Dash Harness, In T/O to Daytime Running Lamps Module	7
S183	Headlamp and Dash Harness, In Power Distribution Center	7
S184 (Diesel)	Engine Harness, in T/O to Engine Control Module	N/S
S202	Instrument Panel Harness, Near Overdrive Switch	12
S203	Instrument Panel Harness, Near Overdrive Switch	12
S204	instrument Panel Harness, In T/O to Cup Holder Lamp	12
S207	Instrument Panel Harness, Near Blower Motor	12
S209	Steering Wheel Harness, Near Remote Radio Switch	N/S
S210	Steering Wheel Harness, Near Remote Radio Switch	N/S
S300	Body Harness, Left Side Instrument Panel	10

## SPLICE LOCATIONS (Continued)

<b>Splice Number</b>	<b>Location</b>	<b>Fig.</b>
S301	Body Harness, Left Side Instrument Panel	10
S302	Body Harness, Left Side Instrument Panel	10
S303	Body Harness, Left Side Instrument Panel	10
S304	Body Harness, Left Side Instrument Panel	10
S305	Body Harness, Right Side Instrument Panel	N/S
S306	Body Harness, Left Side Instrument Panel	10
S307	Body Harness, Left Cowl	10
S308	Body Harness, Left Cowl	10
S310	At Left Body Ground	N/S
S311	At Left Body Ground	N/S
S313	Left Rear Frame Rail	11
S314	Left Rear Frame Rail	N/S
S315	Left Rear Frame Rail	11
S316	Left Rear Frame Rail	11
S317	Left Rear Frame Rail	11
S318	In T/O to Trailer Tow	11
S319	In T/O to Left Rear Lamps	11
S320	In T/O to Trailer Tow	11
S321	In T/O to Left Rear Lamps	11
S322	Overhead Console Harness, At Roof Lamps	9
S323	Overhead Console Harness, At Roof Lamps	9
S324	Overhead Console Harness, At Roof Lamps	9
S325	Overhead Console Harness, At Roof Lamps	9
S326	Overhead Console Harness, At Roof Lamps	9
S327	Power Seat Harness, Near Switch	N/S
S328	Power Seat Harness, Near T/O to Body Wiring	N/S
S329	Door Harness, Near Left Door Near Grommet	N/S
S330	Door Harness, Near Right Door Near Grommet	N/S
S331	Chassis Harness, Near T/O to Fuel Pump Module	11
S332	Body Harness, Left Side Instrument Panel	10
S333	Power Seat Harness, Near T/O to Passenger Seat Jumper	N/S
S335	Power Seat harness, Near T/O to Body Wiring	N/S
S336	Power Seat Harness, Under Passenger Seat	N/S
S337	Power Seat Harness, Under Passenger Seat	N/S
S340	Overhead Console Harness, At Roof Lamps	9
S401	Tail/Stop/Turn and Back-up Lamp Harness, Near T/O to Left Back-up Lamp	N/S
S402	Tail/Stop/Turn and Back-up Lamp Harness, Near T/O to Right Back-up Lamp	N/S
S404	Fender Lamp Harness, Near T/O to Tailgate Lamp	N/S
S406	Fender Lamp Harness, Near T/O to Tailgate Lamp	N/S

SPLICE LOCATIONS (Continued)

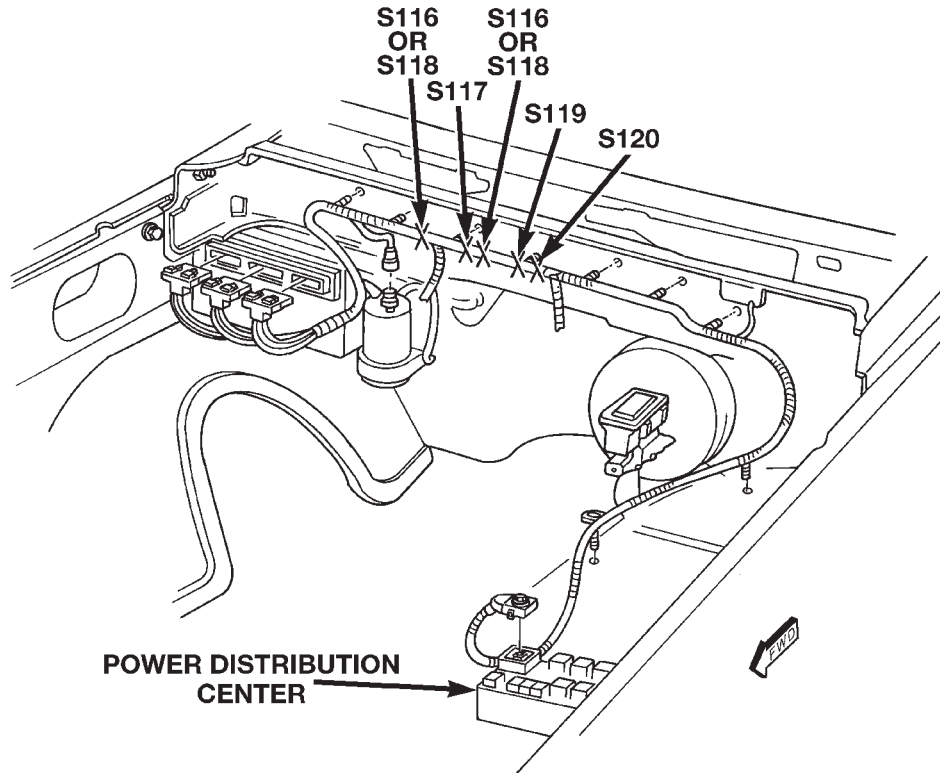


Fig. 1 DASH PANEL (GAS ENGINES)

80a37f1e

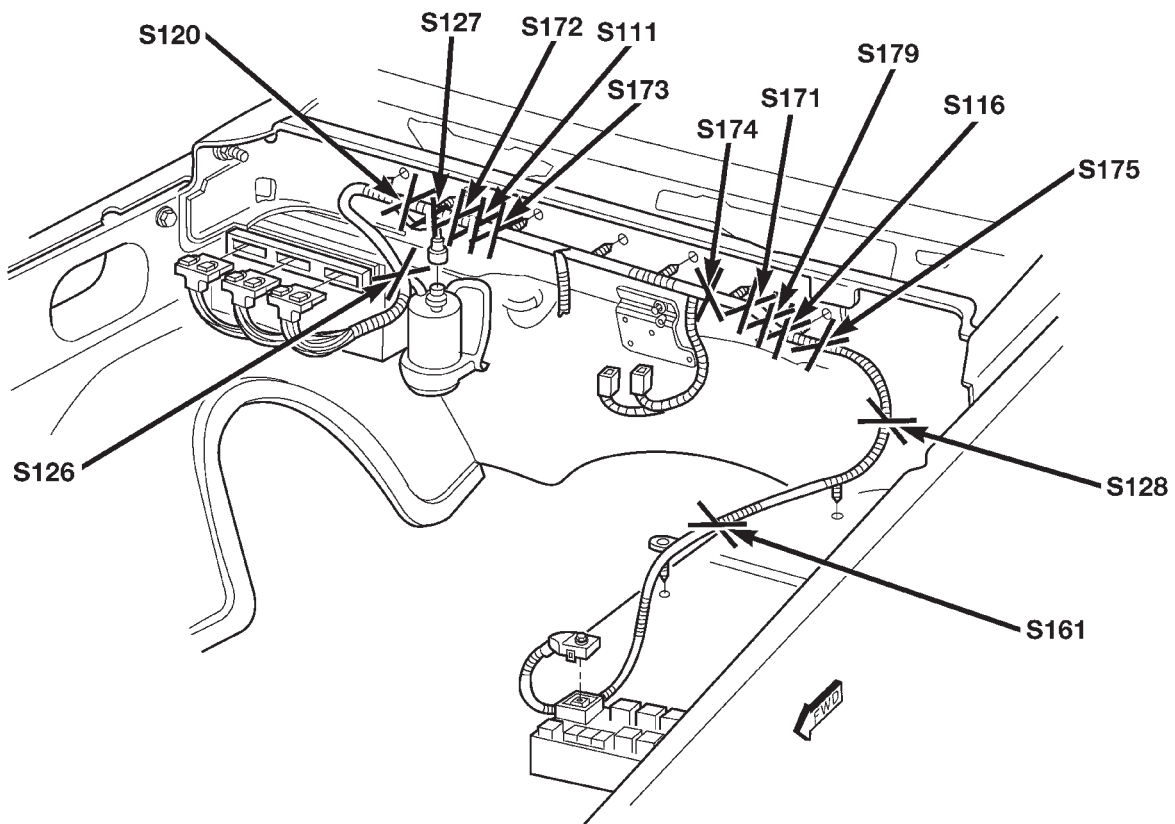
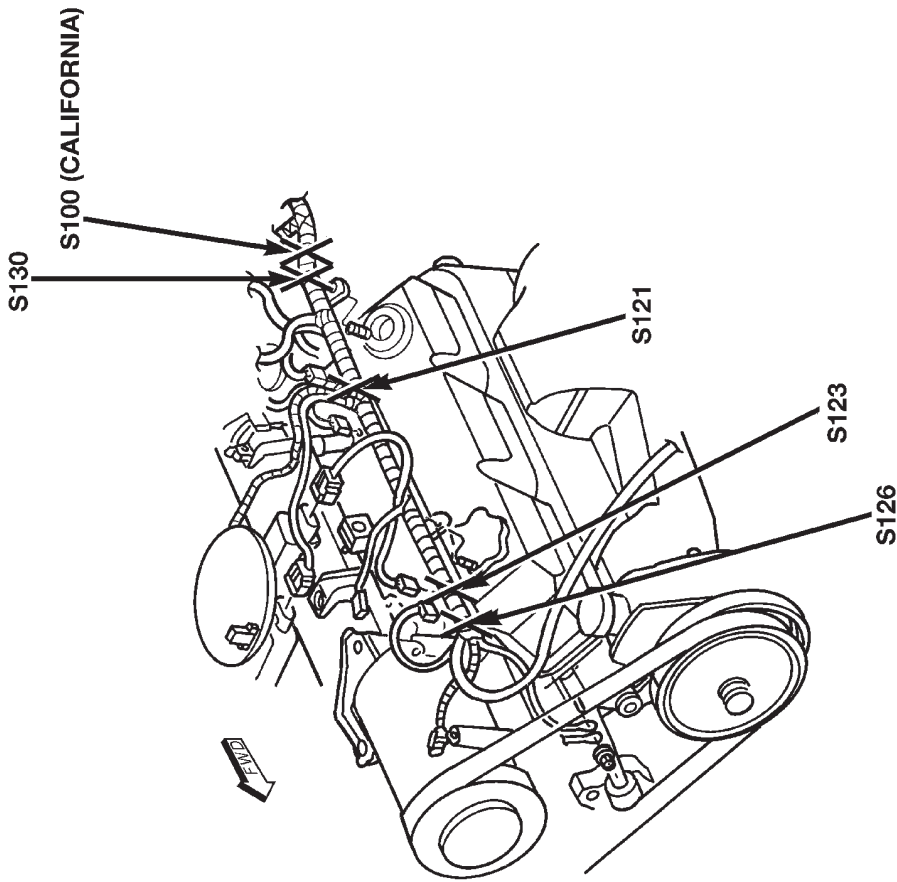
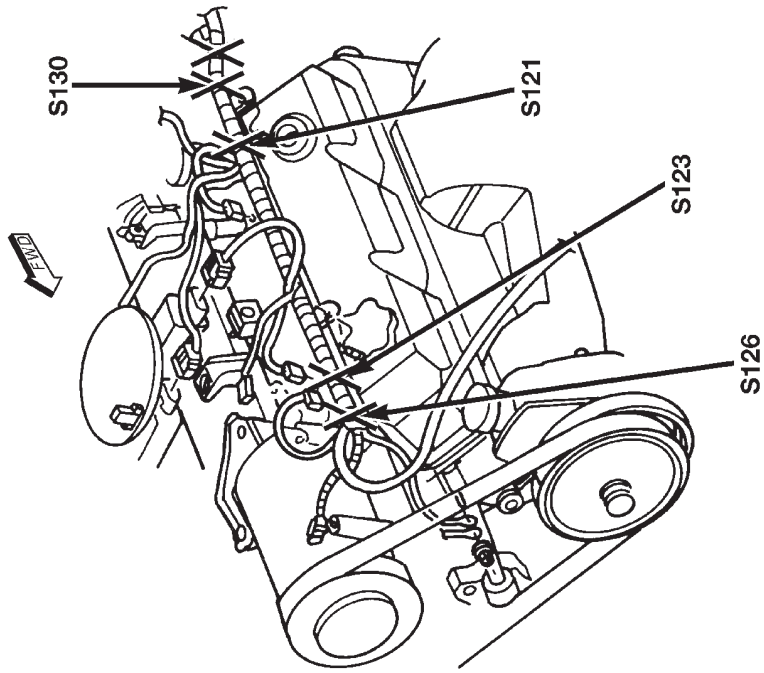


Fig. 2 DASH PANEL (DIESEL ENGINE)

80a37fc



5.2/5.9 LITER ENGINE



3.9 LITER ENGINE

80a38011

Fig. 3 3.9-5.2-5.9 LITER ENGINE



SPLICE LOCATIONS (Continued)

80a3809d

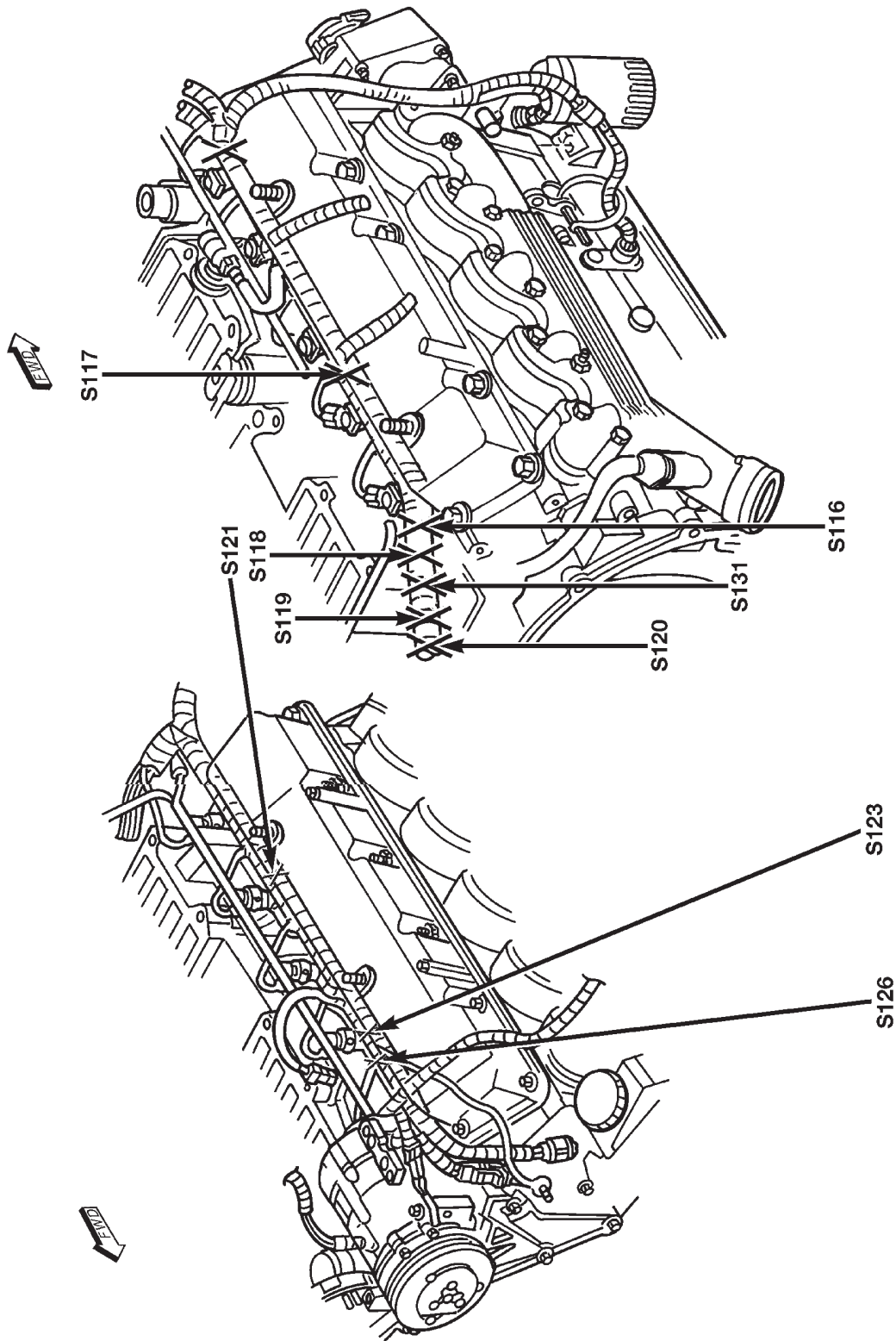
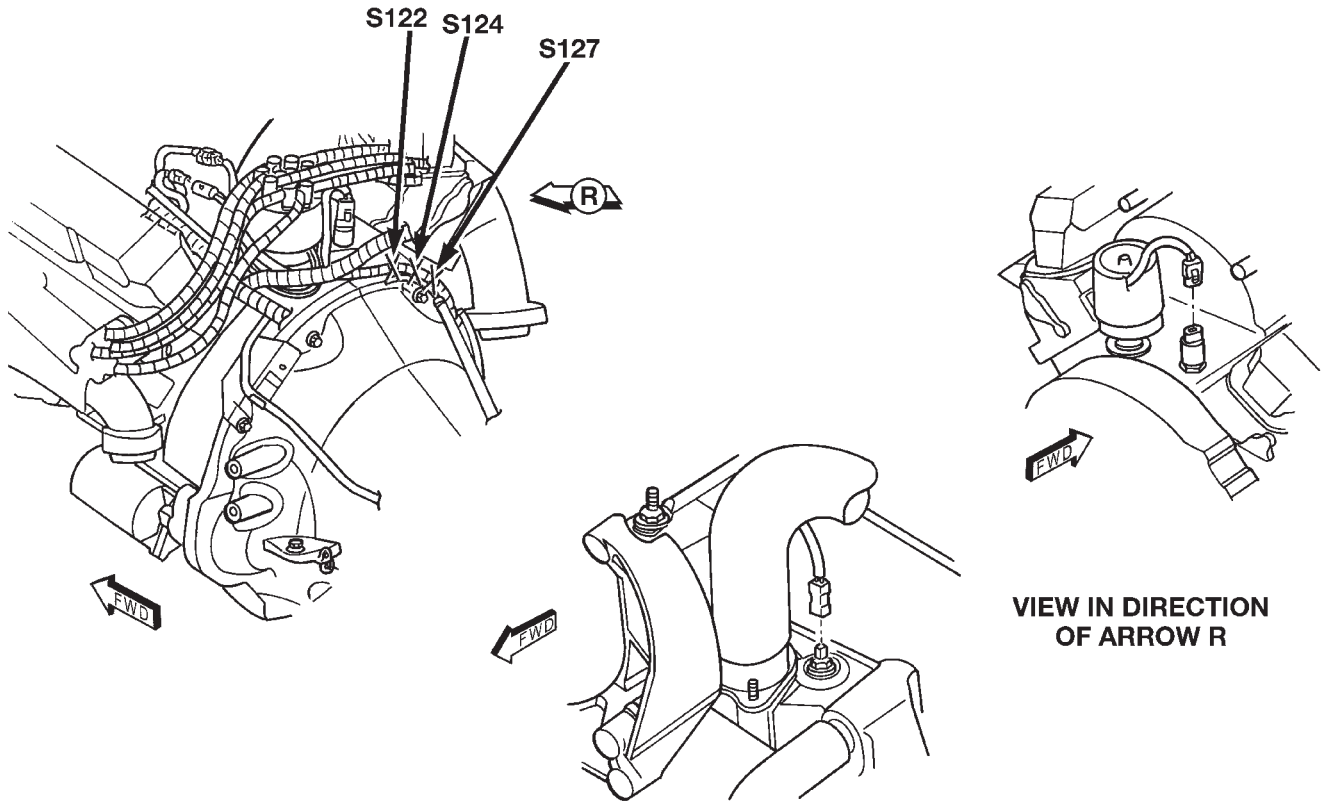


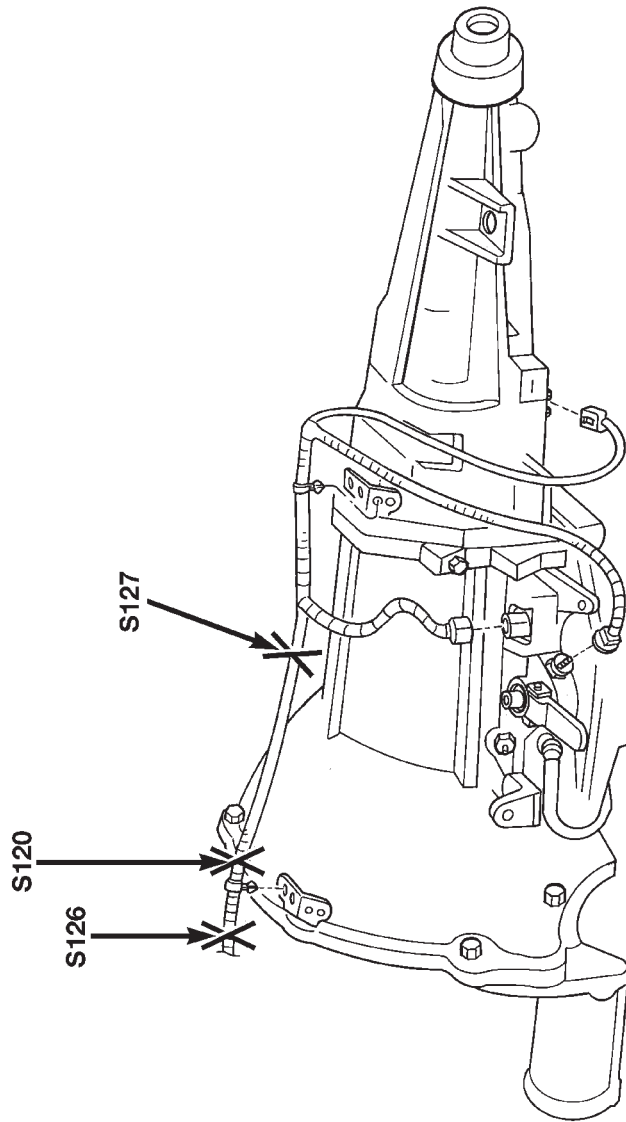
Fig. 4 8.0 LITER ENGINE

SPLICE LOCATIONS (Continued)



**Fig. 5 5.2-5.9 LITER ENGINE**

SPLICE LOCATIONS (Continued)



80a381bb

**Fig. 6 LEFT SIDE TRANSMISSION 8.0 LITER ENGINE**

SPLICE LOCATIONS (Continued)

80a382d7

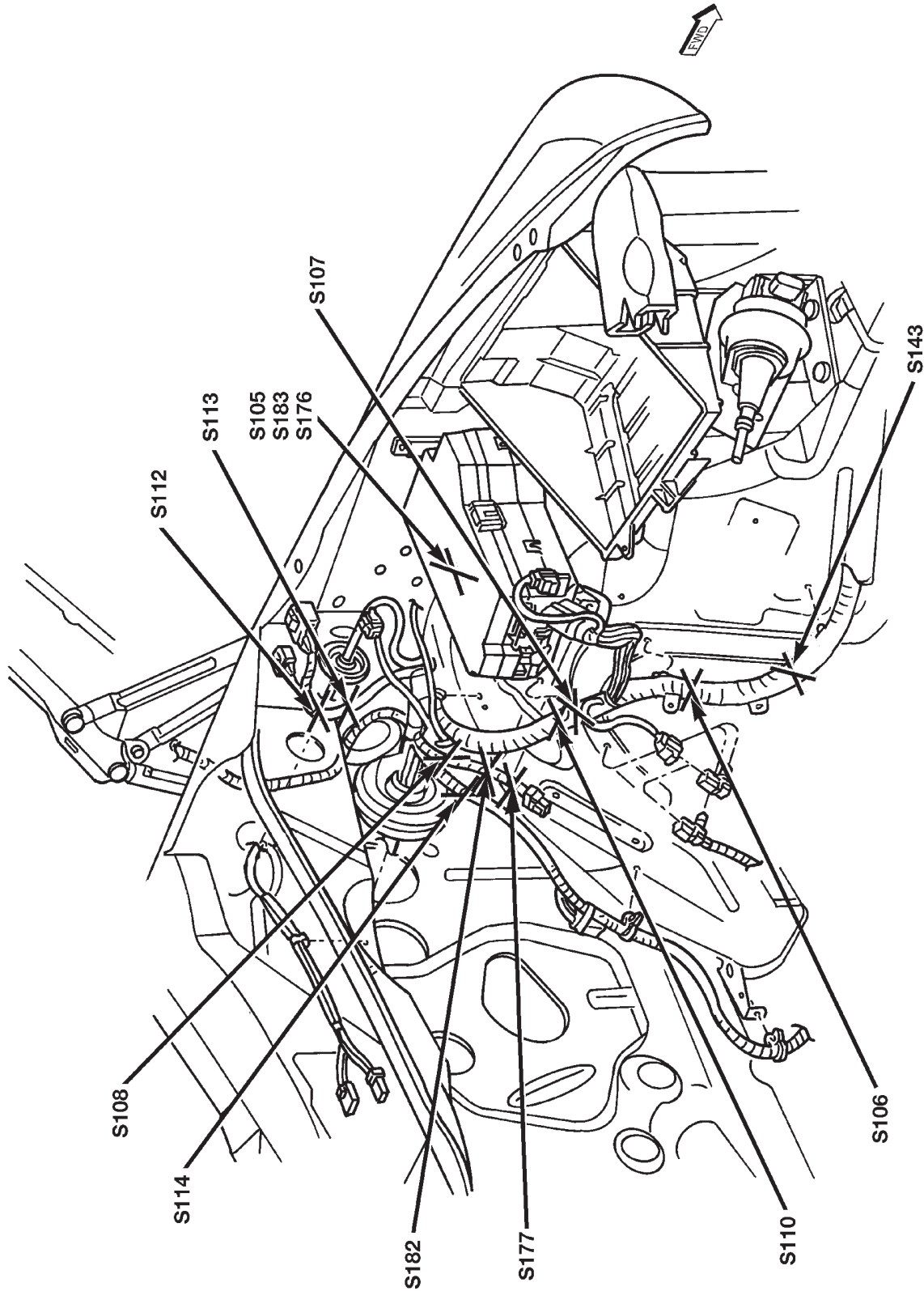


Fig. 7 LEFT SIDE ENGINE COMPARTMENT

SPLICE LOCATIONS (Continued)

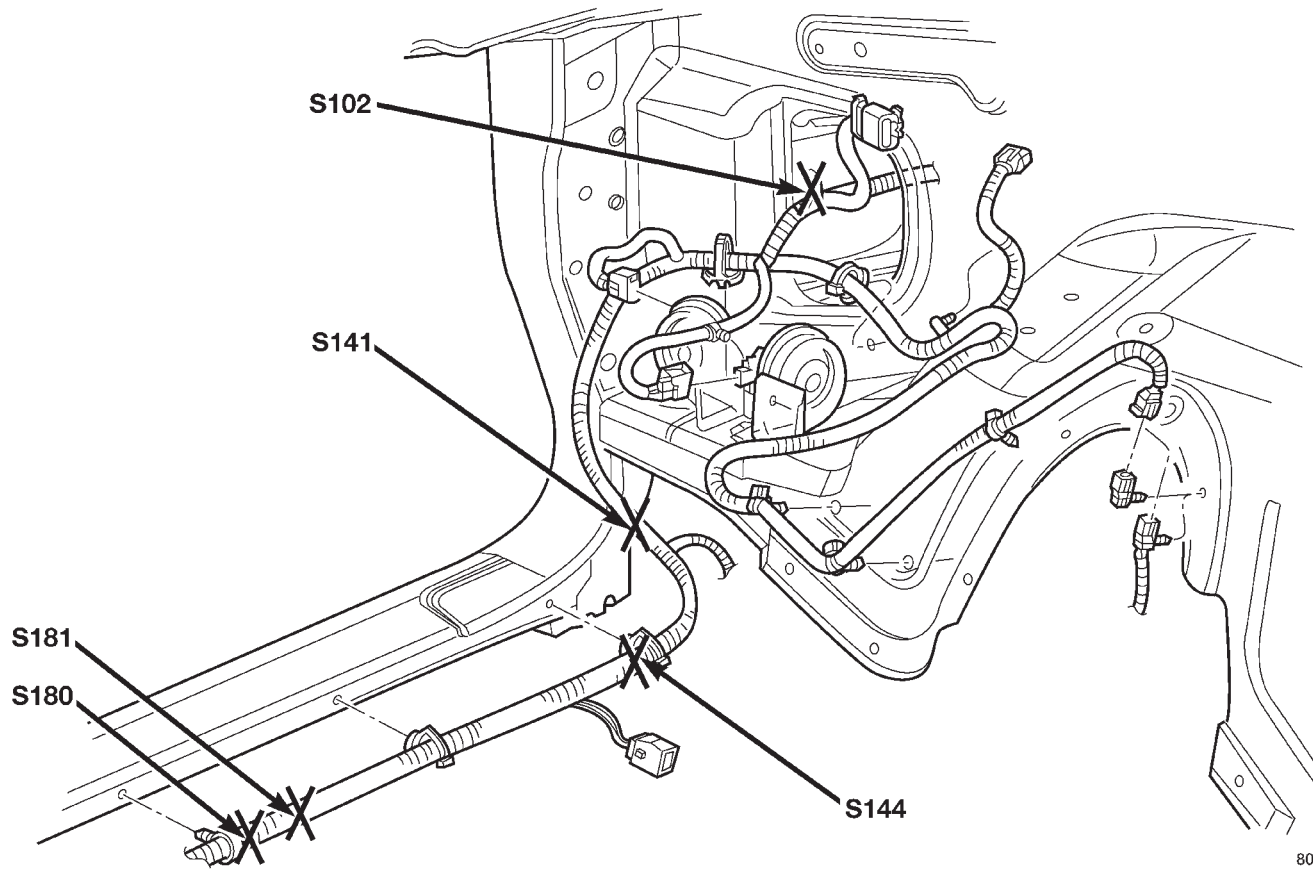


Fig. 8 RIGHT FENDER SIDE SHIELD

80be47c4

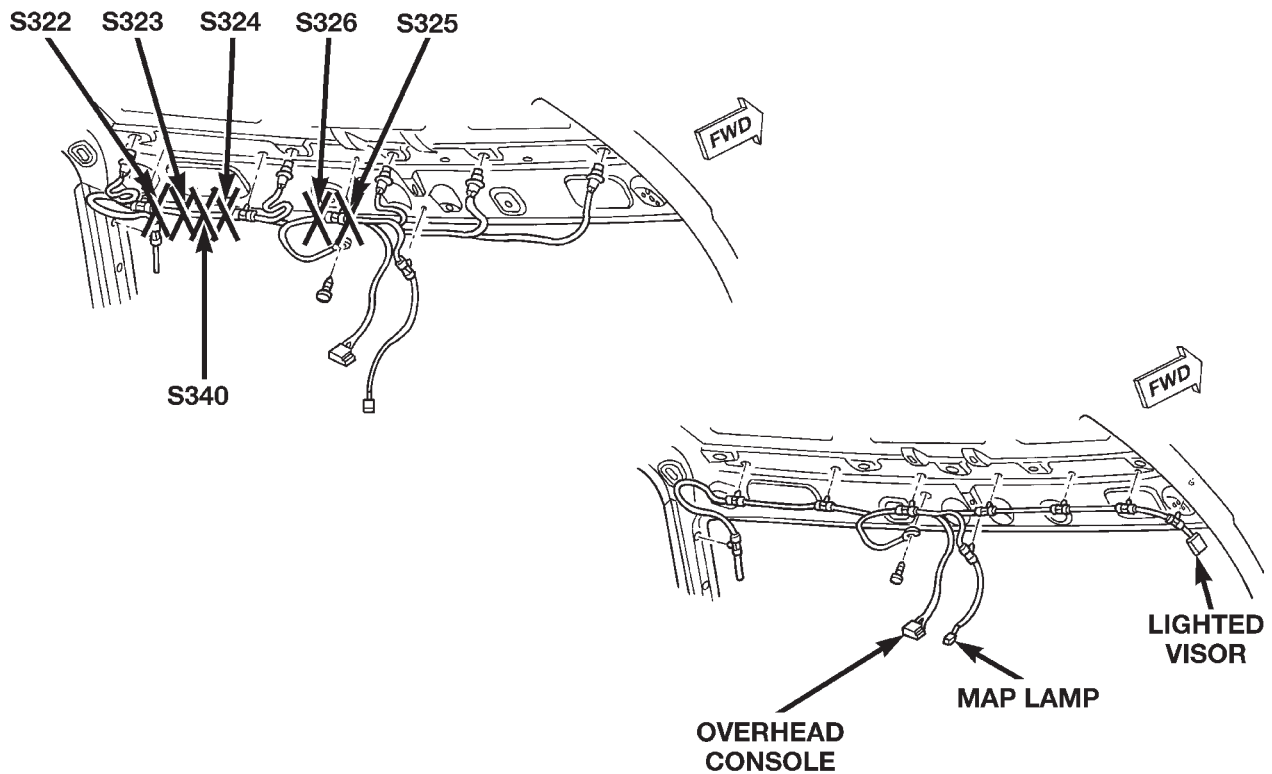


Fig. 9 OVERHEAD CONSOLE

80be47c5

SPLICE LOCATIONS (Continued)

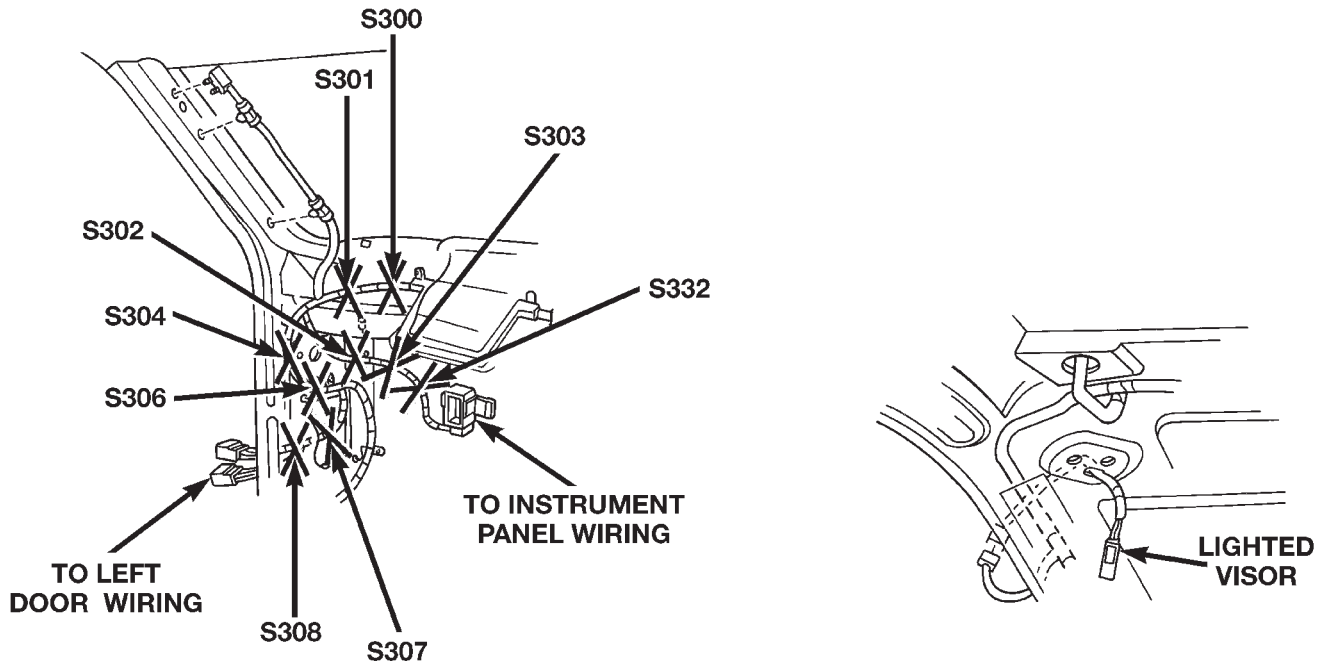


Fig. 10 LEFT COWL PANEL

80be47c6

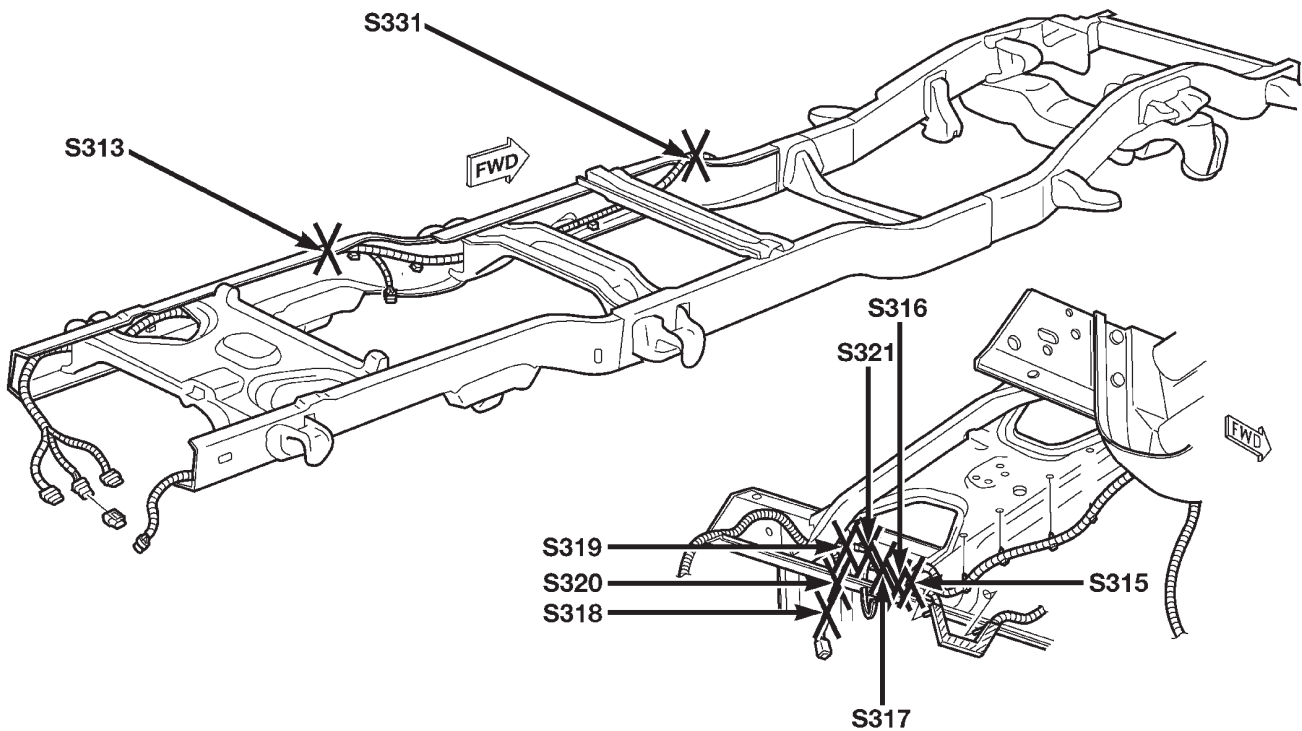
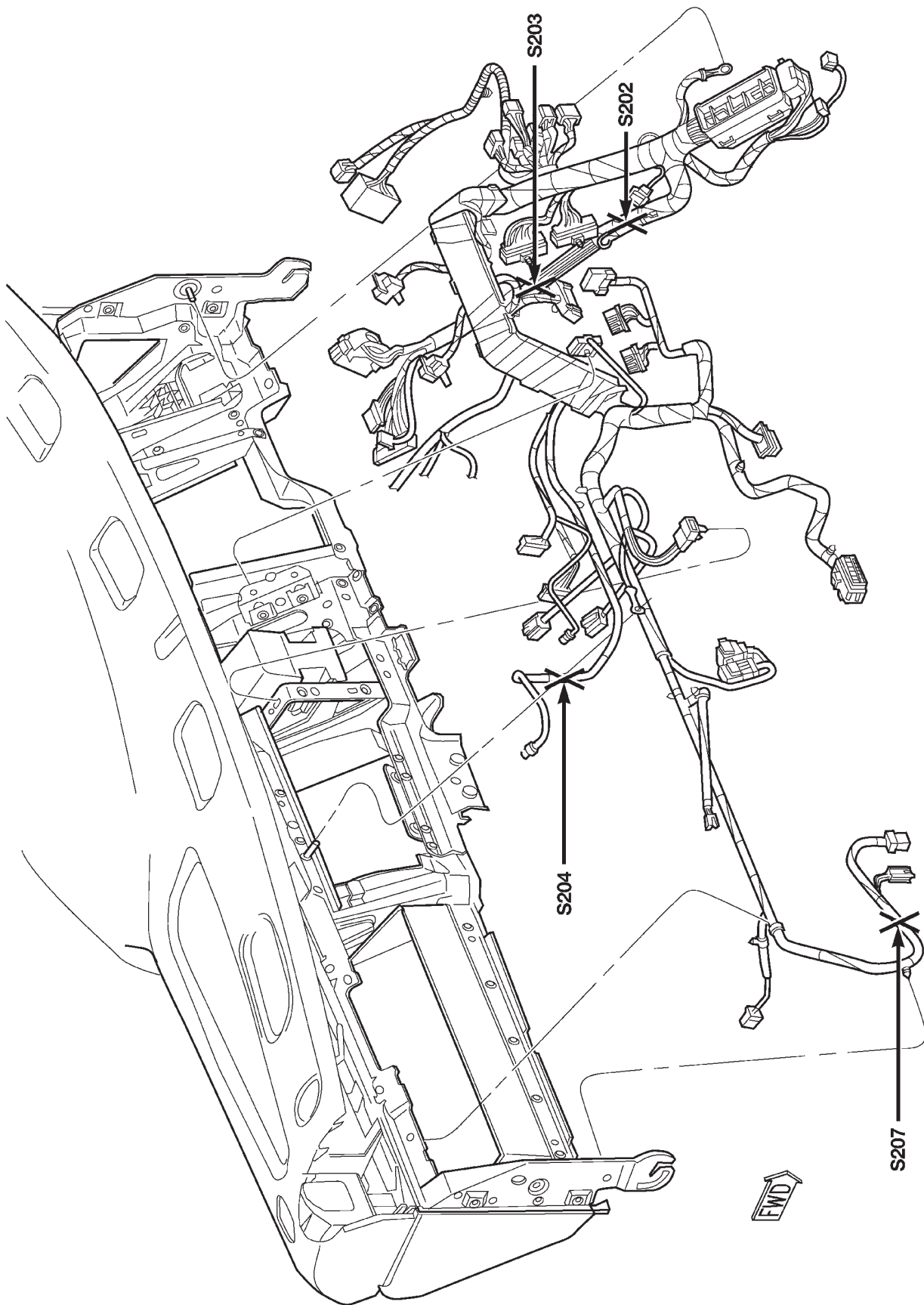


Fig. 11 CHASSIS

80be47c7



SPLICE LOCATIONS (Continued)



80b196ad

Fig. 12 INSTRUMENT PANEL

## 8W-97 POWER DISTRIBUTION

## TABLE OF CONTENTS

	page		page
<b>POWER DISTRIBUTION</b>		<b>OPERATION</b> .....	5
DESCRIPTION .....	1	REMOVAL .....	5
OPERATION .....	1	INSTALLATION .....	5
SPECIAL TOOLS .....	2	<b>JUNCTION BLOCK</b>	
<b>CIGAR LIGHTER OUTLET</b>		DESCRIPTION .....	6
DESCRIPTION .....	2	OPERATION .....	6
OPERATION .....	2	REMOVAL .....	6
DIAGNOSIS AND TESTING .....	2	INSTALLATION .....	7
CIGAR LIGHTER .....	2	<b>POWER DISTRIBUTION CENTER</b>	
REMOVAL .....	3	DESCRIPTION .....	7
INSTALLATION .....	3	OPERATION .....	8
<b>CIRCUIT BREAKER</b>		REMOVAL .....	8
DESCRIPTION .....	4	INSTALLATION .....	8
DIAGNOSIS AND TESTING .....	4	<b>POWER OUTLET</b>	
CIRCUIT BREAKER .....	4	DESCRIPTION .....	9
<b>GENERATOR CARTRIDGE FUSE</b>		OPERATION .....	10
DESCRIPTION .....	4	DIAGNOSIS AND TESTING .....	10
OPERATION .....	4	POWER OUTLET .....	10
REMOVAL .....	4	REMOVAL .....	10
INSTALLATION .....	4	INSTALLATION .....	11
<b>IOD FUSE</b>			
DESCRIPTION .....	4		

## POWER DISTRIBUTION

## DESCRIPTION

This group covers the various standard and optional power distribution components used on this model. The power distribution system for this vehicle consists of the following components:

- Power Distribution Center (PDC)
- Junction Block (JB).

The power distribution system also incorporates various types of circuit control and protection features, including:

- Automatic resetting circuit breakers
- Blade-type fuses
- Cartridge fuses
- Circuit splice blocks
- Flashers
- Relays.

Following are general descriptions of the major components in the power distribution system. See the owner's manual in the vehicle glove box for more information on the features and use of all of the

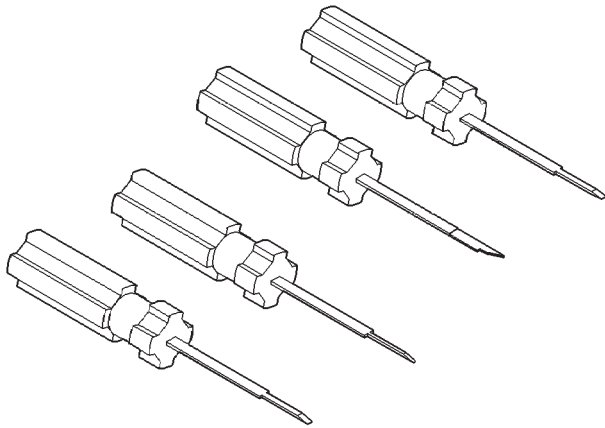
power distribution system components. Refer to the index in this service manual for the location of complete circuit diagrams for the various power distribution system components.

## OPERATION

The power distribution system for this vehicle is designed to provide safe, reliable, and centralized distribution points for the electrical current required to operate all of the many standard and optional factory-installed electrical and electronic powertrain, chassis, safety, security, comfort and convenience systems. At the same time, the power distribution system was designed to provide ready access to these electrical distribution points for the vehicle technician to use when conducting diagnosis and repair of faulty circuits. The power distribution system can also prove useful for the sourcing of additional electrical circuits that may be required to provide the electrical current needed to operate many accessories that the vehicle owner may choose to have installed in the aftermarket.

## SPECIAL TOOLS

### POWER DISTRIBUTION SYSTEMS



*Terminal Pick Kit 6680*

## CIGAR LIGHTER OUTLET

### DESCRIPTION

A cigar lighter is standard equipment on this model. The cigar lighter is installed in the instrument panel next to the ash receiver, which is located near the center of the instrument panel, below the radio. The cigar lighter base is secured by a snap fit within the instrument panel.

The cigar lighter knob and heating element unit, and the cigar lighter receptacle unit are available for service. These components cannot be repaired and, if faulty or damaged, they must be replaced.

### OPERATION

The cigar lighter consists of two major components: a knob and heating element unit, and the cigar lighter base or receptacle shell. The receptacle shell is connected to ground, and an insulated contact in the bottom of the shell is connected to battery current. The cigar lighter receives battery voltage from a fuse in the junction block only when the ignition switch is in the Accessory or On positions.

The knob and heating element are encased within a spring-loaded housing, which also features a sliding protective heat shield. When the knob and heating element are inserted in the receptacle shell, the heating element resistor coil is grounded through its housing to the receptacle shell. If the cigar lighter knob is pushed inward, the heat shield slides up toward the knob exposing the heating element, and the heating element extends from the housing toward the insulated contact in the bottom of the receptacle shell.

Two small spring-clip retainers are located on either side of the insulated contact inside the bottom

of the receptacle shell. These clips engage and hold the heating element against the insulated contact long enough for the resistor coil to heat up. When the heating element is engaged with the contact, battery current can flow through the resistor coil to ground, causing the resistor coil to heat.

When the resistor coil becomes sufficiently heated, excess heat radiates from the heating element causing the spring-clips to expand. Once the spring-clips expand far enough to release the heating element, the spring-loaded housing forces the knob and heating element to pop back outward to their relaxed position. When the cigar lighter knob and element are pulled out of the receptacle shell, the protective heat shield slides downward on the housing so that the heating element is recessed and shielded around its circumference for safety.

### DIAGNOSIS & TESTING - CIGAR LIGHTER

For complete circuit diagrams, refer to **Cigar Lighter** in Wiring Diagrams.

**WARNING: ON VEHICLES EQUIPPED WITH AIR-BAGS, REFER TO GROUP 8M - PASSIVE RESTRAINT SYSTEMS BEFORE ATTEMPTING ANY STEERING WHEEL, STEERING COLUMN, OR INSTRUMENT PANEL COMPONENT DIAGNOSIS OR SERVICE. FAILURE TO TAKE THE PROPER PRECAUTIONS COULD RESULT IN ACCIDENTAL AIR-BAG DEPLOYMENT AND POSSIBLE PERSONAL INJURY.**

(1) Check the fused ignition switch output (run/accessory) fuse in the junction block. If OK, go to Step 2. If not OK, repair the shorted circuit or component as required and replace the faulty fuse.

(2) Turn the ignition switch to the On position. Check for battery voltage at the fused ignition switch output (run/accessory) fuse in the junction block. If OK, go to Step 3. If not OK, repair the open fused ignition switch output (run/accessory) circuit to the ignition switch as required.

(3) Turn the ignition switch to the Off position. Remove the cigar lighter knob and element from the cigar lighter receptacle. Check for continuity between the inside circumference of the cigar lighter receptacle and a good ground. There should be continuity. If OK, go to Step 4. If not OK, go to Step 5.

(4) Turn the ignition switch to the On position. Check for battery voltage at the insulated contact located at the back of the cigar lighter receptacle. If OK, replace the faulty cigar lighter knob and element. If not OK, go to Step 5.

(5) Turn the ignition switch to the Off position. Disconnect and isolate the battery negative cable. Remove the cigar lighter receptacle from the instrument panel and disconnect the wire harness connec-

## CIGAR LIGHTER OUTLET (Continued)

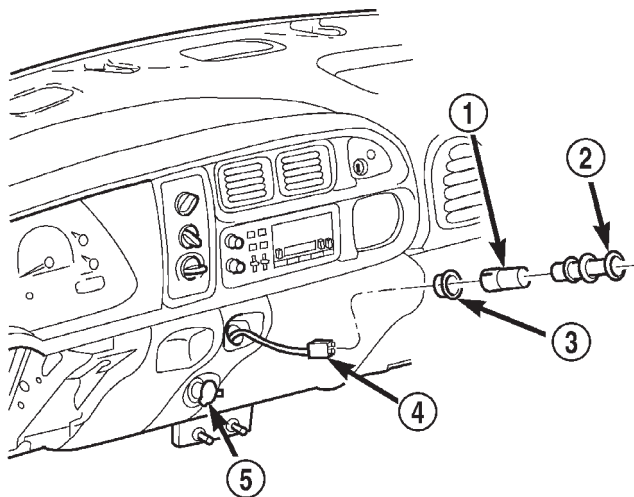
tor. Check for continuity between the ground circuit cavity of the cigar lighter wire harness connector and a good ground. There should be continuity. If OK, go to Step 6. If not OK, repair the open ground circuit to ground as required.

(6) Connect the battery negative cable. Turn the ignition switch to the On position. Check for battery voltage at the fused ignition switch output (run/accessory) circuit cavity of the cigar lighter wire harness connector. If OK, replace the faulty cigar lighter receptacle. If not OK, repair the open fused ignition switch output (run/accessory) circuit to the junction block fuse as required.

## REMOVAL

(1) Disconnect and isolate the battery negative cable.

(2) Pull the cigar lighter knob and element out of the cigar lighter receptacle base, or unsnap the protective cap from the power outlet receptacle base (Fig. 1).



80b89821

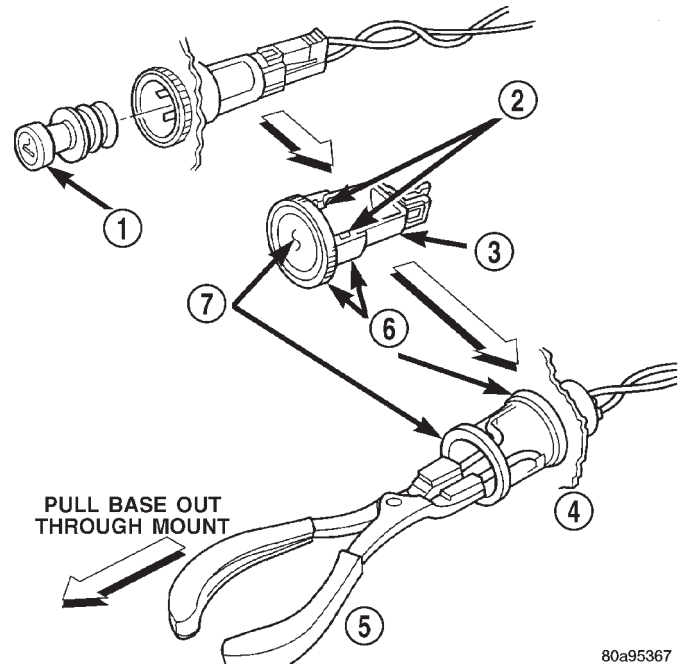
**Fig. 1 Cigar Lighter and Power Outlet**

- 1 - RECEPTACLE BASE
- 2 - KNOB & ELEMENT
- 3 - MOUNT
- 4 - WIRE HARNESS CONNECTOR
- 5 - POWER OUTLET

(3) Look inside the cigar lighter or power outlet receptacle base and note the position of the rectangular retaining bosses of the mount that secures the receptacle base to the instrument panel (Fig. 2).

(4) Insert a pair of external snap ring pliers into the cigar lighter or power outlet receptacle base and engage the tips of the pliers with the retaining bosses of the mount.

(5) Squeeze the pliers to disengage the mount retaining bosses from the receptacle base and, using



80a95367

**Fig. 2 Cigar Lighter and Power Outlet Remove/Install**

- 1 - KNOB AND ELEMENT
- 2 - RETAINING BOSSES-ENGAGE PLIERS HERE
- 3 - BASE
- 4 - PARTIALLY REMOVED
- 5 - EXTERNAL SNAP-RING PLIERS
- 6 - MOUNT
- 7 - BASE

a gentle rocking motion, pull the pliers and the receptacle base out of the mount.

(6) Pull the receptacle base away from the instrument panel far enough to access the instrument panel wire harness connector.

(7) Disconnect the instrument panel wire harness connector from the cigar lighter or power outlet receptacle base connector receptacle.

(8) Remove the cigar lighter or power outlet mount from the instrument panel.

## INSTALLATION

(1) Install the cigar lighter or power outlet mount into the instrument panel.

(2) Reconnect the instrument panel wire harness connector to the cigar lighter or power outlet receptacle base connector receptacle.

(3) Align the splines on the outside of the cigar lighter or power outlet receptacle base connector receptacle with the grooves on the inside of the mount.

(4) Press firmly on the cigar lighter or power outlet receptacle base until the retaining bosses of the mount are fully engaged in their receptacles.



## CIGAR LIGHTER OUTLET (Continued)

(5) Install the cigar lighter knob and element into the cigar lighter receptacle base, or the protective cap into the power outlet receptacle base.

(6) Reconnect the battery negative cable.

## CIRCUIT BREAKER

## DESCRIPTION

An automatic resetting circuit breaker in the junction block is used to protect the system from a short circuit, or from an overload condition caused by an obstructed or stuck seat adjuster.

The circuit breaker cannot be repaired and, if faulty or damaged, it must be replaced.

## DIAGNOSIS &amp; TESTING - CIRCUIT BREAKER

For circuit descriptions and diagrams, refer to Wiring Diagrams.

(1) Locate the correct circuit breaker in the junction block. Pull out the circuit breaker slightly, but be certain that the circuit breaker terminals still contact the terminals in the junction block cavities.

(2) Connect the negative lead of a 12-volt DC voltmeter to a good ground.

(3) With the voltmeter positive lead, check both terminals of the circuit breaker for battery voltage.

If only one terminal has battery voltage, the circuit breaker is faulty and must be replaced. If neither terminal has battery voltage, repair the open circuit from the Power Distribution Center (PDC) as required.

## GENERATOR CARTRIDGE FUSE

## DESCRIPTION

A 140 ampere generator cartridge fuse is used on this model. The generator cartridge fuse is similar to other cartridge fuses found in the Power Distribution Center (PDC). This fuse has a color-coded plastic housing and a clear plastic fuse conductor inspection cover like other cartridge fuses, but has a higher current rating and is connected and secured with screws instead of being pushed onto male spade-type terminals. The generator cartridge fuse cannot be repaired and, if faulty or damaged, it must be replaced.

## OPERATION

The generator cartridge fuse is secured between the two B(+) terminal stud connection bus bars within the Power Distribution Center (PDC). This fuse protects the vehicle electrical system from damage that could be caused by excessive charging system output and/or excessive electrical system current

levels resulting from a faulty generator or faulty charging system control circuits. If the current rating of the fuse is exceeded, the fuse conductor melts to open the generator output circuit connection to the PDC. If a generator cartridge fuse fails, be certain to completely inspect and test the vehicle charging system before replacing the fuse and returning the vehicle to service. Refer to **Charging System** in the index of this service manual for the charging system diagnostic procedures. Refer to **Power Distribution** in the index of this service manual for the location of complete PDC circuit diagrams.

## REMOVAL

If a generator cartridge fuse fails, be certain to inspect and test the vehicle charging system before replacing the cartridge fuse and returning the vehicle to service. Refer to **Charging System** in the index of this service manual for the charging system diagnostic procedures.

(1) Disconnect and isolate the battery negative cable.

(2) Unlatch and remove the cover from the Power Distribution Center (PDC).

(3) Remove the two screws that secure the generator cartridge fuse to the two B(+) terminal stud bus bars within the PDC.

(4) Remove the generator cartridge fuse from the PDC.

## INSTALLATION

If a generator cartridge fuse fails, be certain to inspect and test the vehicle charging system before replacing the cartridge fuse and returning the vehicle to service. Refer to **Charging System** in the index of this service manual for the charging system diagnostic procedures.

(1) Position the generator cartridge fuse onto the two B(+) terminal stud bus bars within the PDC.

(2) Install and tighten the two screws that secure the generator cartridge fuse to the two B(+) terminal stud bus bars within the PDC. Tighten the screws to 3.4 N·m (30 in. lbs.). **Be certain that both screws are tightened to the proper torque value.**

(3) Install and latch the cover onto the PDC.

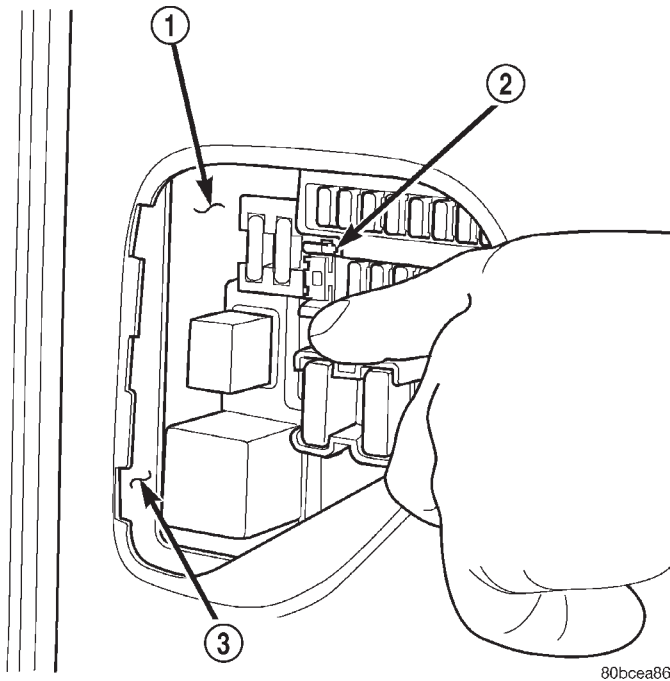
(4) Reconnect the battery negative cable.

## IOD FUSE

## DESCRIPTION

All vehicles are equipped with an Ignition-Off Draw (IOD) fuse (Fig. 3) that is disconnected within the Junction Block (JB) when the vehicle is shipped from the factory. Dealer personnel are to reconnect the IOD fuse in the JB as part of the preparation

## IOD FUSE (Continued)



**Fig. 3 Ignition-Off Draw Fuse**

- 1 - JUNCTION BLOCK
- 2 - IGNITION-OFF DRAW FUSE AND HOLDER
- 3 - LEFT INSTRUMENT PANEL END BRACKET

procedures performed just prior to new vehicle delivery.

The left end of the instrument panel cover has a snap-fit fuse access panel that can be removed to provide service access to the fuses in the JB. A finger recess is molded into the access panel for easy removal. An adhesive-backed fuse layout map is secured to the instrument panel side of the access panel to ensure proper fuse identification. The IOD fuse is a 10 ampere mini blade-type fuse. The fuse is secured within a black molded plastic fuse holder and puller unit that serves both as a tool for disconnecting and reconnecting the fuse in its JB cavity, and as a fuse holder that conveniently stores the fuse in the same JB cavity after it has been disconnected.

## OPERATION

The term ignition-off draw identifies a normal condition where power is being drained from the battery with the ignition switch in the Off position. The IOD fuse feeds the memory and sleep mode functions for some of the electronic modules in the vehicle as well as various other accessories that require battery current when the ignition switch is in the Off position, including the clock. The only reason the IOD fuse is disconnected is to reduce the normal IOD of the vehicle electrical system during new vehicle transportation and pre-delivery storage to reduce battery depletion, while still allowing vehicle operation so

that the vehicle can be loaded, unloaded and moved as needed by both vehicle transportation company and dealer personnel.

The IOD fuse is disconnected from JB fuse cavity 12 when the vehicle is shipped from the assembly plant. Dealer personnel must reconnect the IOD fuse when the vehicle is being prepared for delivery in order to restore full electrical system operation. Once the vehicle is prepared for delivery, the IOD function of this fuse becomes transparent and the fuse that has been assigned the IOD designation becomes only another Fused B(+) circuit fuse. The IOD fuse serves no useful purpose to the dealer technician in the service or diagnosis of any vehicle system or condition, other than the same purpose as that of any other standard circuit protection device.

The IOD fuse can be used by the vehicle owner as a convenient means of reducing battery depletion when a vehicle is to be stored for periods not to exceed about thirty days. However, it must be remembered that disconnecting the IOD fuse will not eliminate IOD, but only reduce this normal condition. If a vehicle will be stored for more than about thirty days, the battery negative cable should be disconnected to eliminate normal IOD; and, the battery should be tested and recharged at regular intervals during the vehicle storage period to prevent the battery from becoming discharged or damaged. Refer to **Battery** in the index of this service manual for the location of additional service information covering the battery.

## REMOVAL

The Ignition-Off Draw (IOD) fuse is disconnected from Junction Block (JB) fuse cavity 12 when the vehicle is shipped from the assembly plant. Dealer personnel must reconnect the IOD fuse when the vehicle is being prepared for delivery in order to restore full electrical system operation.

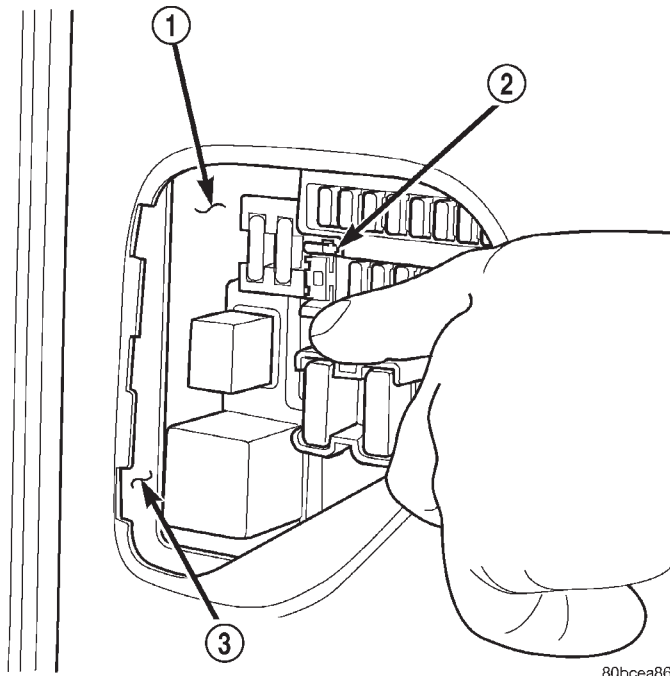
- (1) Turn the ignition switch to the Off position.
- (2) Remove the fuse access panel by unsnapping it from the left outboard end of the instrument panel.
- (3) Grasp the upper and lower tabs of the IOD fuse holder unit in fuse cavity 12 of the JB between the thumb and forefinger and pull the unit firmly outward.
- (4) Install the fuse access panel by snapping it onto the left outboard end of the instrument panel.

## INSTALLATION

The Ignition-Off Draw (IOD) fuse is disconnected from Junction Block (JB) fuse cavity 12 (Fig. 4) when the vehicle is shipped from the assembly plant. Dealer personnel must reconnect the IOD fuse when the vehicle is being prepared for delivery in order to restore full electrical system operation.



## IOD FUSE (Continued)



80bcea86

**Fig. 4 Ignition-Off Draw Fuse**

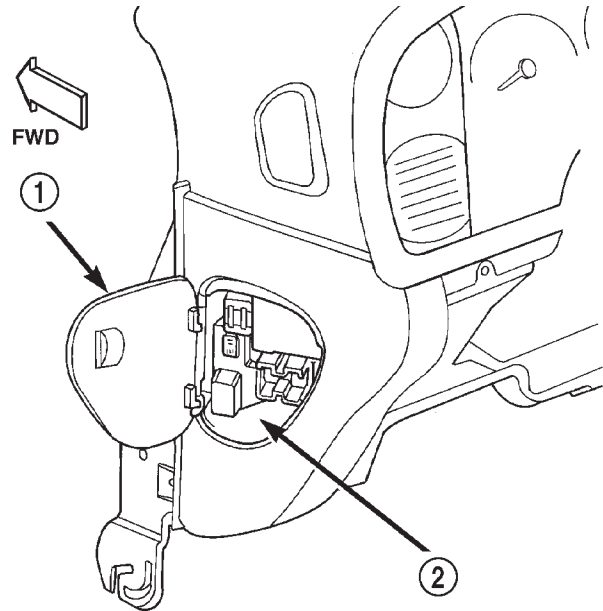
- 1 - JUNCTION BLOCK
- 2 - IGNITION-OFF DRAW FUSE AND HOLDER
- 3 - LEFT INSTRUMENT PANEL END BRACKET

- (1) Turn the ignition switch to the Off position.
- (2) To install the IOD fuse, use a thumb to press the IOD fuse holder unit in fuse cavity 12 firmly into the JB.
- (3) Install the fuse access panel by snapping it onto the left outboard end of the instrument panel.

## JUNCTION BLOCK

### DESCRIPTION

An electrical Junction Block (JB) is concealed behind the left outboard end of the instrument panel cover (Fig. 5). The JB combines the functions previously provided by a separate fuseblock module and relay center, serves to simplify and centralize numerous electrical components, and to distribute electrical current to many of the accessory systems in the vehicle. It also eliminates the need for numerous splice connections and serves in place of a bulkhead connector between many of the engine compartment, instrument panel, and body wire harnesses. The JB houses up to nineteen blade-type fuses (two standard-type and seventeen mini-type), up to two blade-type automatic resetting circuit breakers, the electronic combination turn signal and hazard warning flasher, and one International Standards Organization (ISO) micro-relay.



80b171c0

**Fig. 5 Junction Block Location**

- 1 - JUNCTION BLOCK
- 2 - FUSE ACCESS PANEL

The molded plastic JB housing has integral mounting brackets that are secured with two screws to the left instrument panel end bracket. The left end of the instrument panel cover has a snap-fit fuse access panel that can be removed for service of the JB. A fuse puller and spare fuse holders are located on the back of the fuse access cover, as well as an adhesive-backed fuse layout map to ensure proper fuse identification.

The JB unit cannot be repaired and is only serviced as an assembly. If any internal circuit or the JB housing is faulty or damaged, the entire JB unit must be replaced.

### OPERATION

All of the circuits entering and leaving the JB do so through up to nine wire harness connectors, which are connected to the JB through integral connector receptacles molded into the JB housing. Internal connection of all of the JB circuits is accomplished by an intricate combination of hard wiring and bus bars. Refer to **Junction Block** in the index of this service manual for the location of complete JB circuit diagrams.

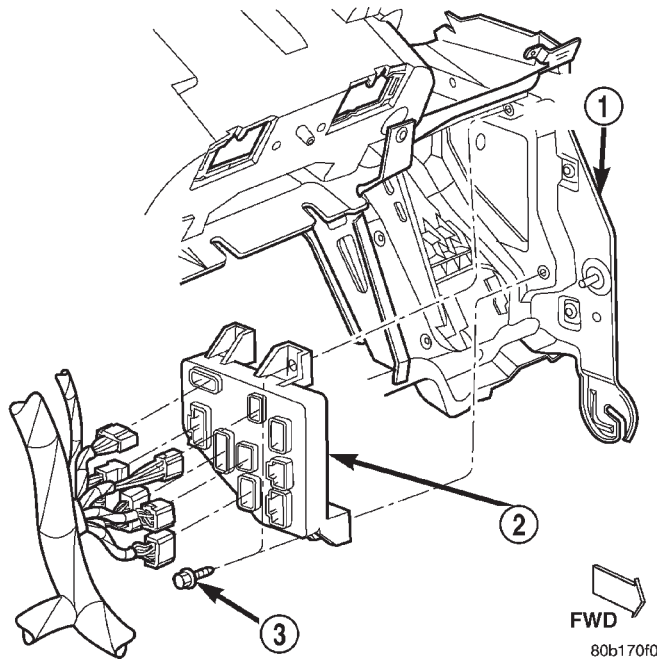
### REMOVAL

- (1) Disconnect and isolate the battery negative cable.

## JUNCTION BLOCK (Continued)

(2) Roll down the instrument panel from the dash panel, but do not remove it from the vehicle. Refer to **Instrument Panel Assembly** in the index of this service manual for the instrument panel assembly removal procedures.

(3) Reach through the outboard side of the instrument panel steering column opening to access and disconnect all of the wire harness connectors from the Junction Block (JB) connector receptacles (Fig. 6).



**Fig. 6 Junction Block Remove/Install**

- 1 - END BRACKET
- 2 - JUNCTION BLOCK
- 3 - SCREWS

(4) Reach through the outboard side of the instrument panel steering column opening to access and remove the two screws that secure the JB to the left instrument panel end bracket.

(5) Reach through the outboard side of the instrument panel steering column opening to remove the JB from the left instrument panel end bracket.

## INSTALLATION

**NOTE:** If the Junction Block (JB) is being replaced with a new unit, be certain to transfer each of the fuses, circuit breakers and relays from the faulty JB to the proper cavities of the replacement JB. Refer to Junction Block in the index of this service manual for the location of complete circuit diagrams and cavity assignments for the JB.

(1) Reach through the outboard side of the instrument panel steering column opening to position the JB onto the left instrument panel end bracket.

(2) Reach through the outboard side of the instrument panel steering column opening to install and tighten the two screws that secure the JB to the left instrument panel end bracket. Tighten the screws to 2.85 N-m (25 in. lbs.).

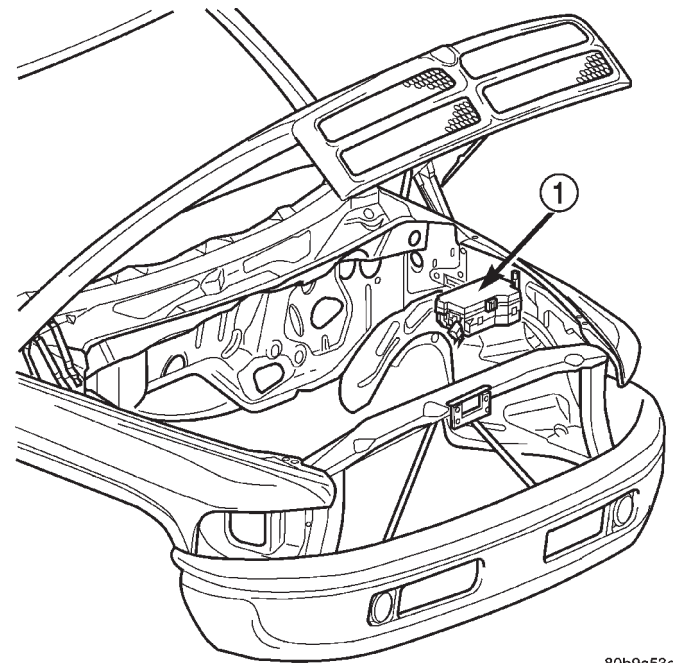
(3) Reach through the outboard side of the instrument panel steering column opening to access and reconnect all of the wire harness connectors to the JB connector receptacles.

(4) Install the instrument panel onto the dash panel. Refer to **Instrument Panel Assembly** in the index of this service manual for the location of the instrument panel assembly installation procedures.

(5) Reconnect the battery negative cable.

## POWER DISTRIBUTION CENTER

## DESCRIPTION



80b9a53c

**Fig. 7 Power Distribution Center Location**

- 1 - POWER DISTRIBUTION CENTER

All of the electrical current distributed throughout this vehicle is directed through the standard equipment Power Distribution Center (PDC) (Fig. 7). The molded plastic PDC housing is located in the left front corner of the engine compartment, just behind the battery. The PDC houses the generator cartridge fuse and up to twelve maxi-type cartridge fuses,

## POWER DISTRIBUTION CENTER (Continued)

which replace all in-line fusible links. The PDC also houses up to thirteen blade-type fuses (two standard-type and eleven mini-type), up to seventeen International Standards Organization (ISO) relays (five standard-type and twelve micro-type), two joint connectors (one eighteen-way and one twenty-eight-way), a forty-three-way engine wire harness in-line connector and a fuse puller.

The PDC housing is secured in the engine compartment on the outboard side with two screws to the left front inner fender shield, and with a screw on the inboard side to the left front inner wheel house. The PDC housing has a molded plastic cover that includes two integral latches, one on each side. The PDC cover is easily opened and removed for service access and has a convenient adhesive-backed fuse and relay layout map affixed to the inside surface of the cover to ensure proper component identification.

The PDC unit cannot be repaired and is only serviced as a unit with the headlamp and dash wire harness. If the internal circuits or the PDC housing are faulty or damaged, the headlamp and dash wire harness unit must be replaced.

## OPERATION

All of the current from the battery and the generator output enters the PDC through two cables with eyelets that are secured with nuts to the two B(+) terminal studs located just inside the inboard end of the PDC housing. The PDC cover is unlatched and removed to access the battery and generator output connection B(+) terminal studs, the fuses, the relays, the joint connectors and the engine wire harness in-line connector. Internal connection of all of the PDC circuits is accomplished by an intricate combination of hard wiring and bus bars. Refer to **Power Distribution** in the index of this service manual for the location of complete PDC circuit diagrams.

## REMOVAL

The Power Distribution Center (PDC) is serviced as a unit with the headlamp and dash wire harness. If any internal circuit of the PDC or the PDC housing is faulty or damaged, the entire PDC and headlamp and dash wire harness unit must be replaced.

(1) Disconnect and isolate the battery negative cable.

(2) Disconnect each of the headlamp and dash wire harness connectors. Refer to **Connector Locations** in the index of this service manual for the location of more information on the headlamp and dash wire harness connector locations.

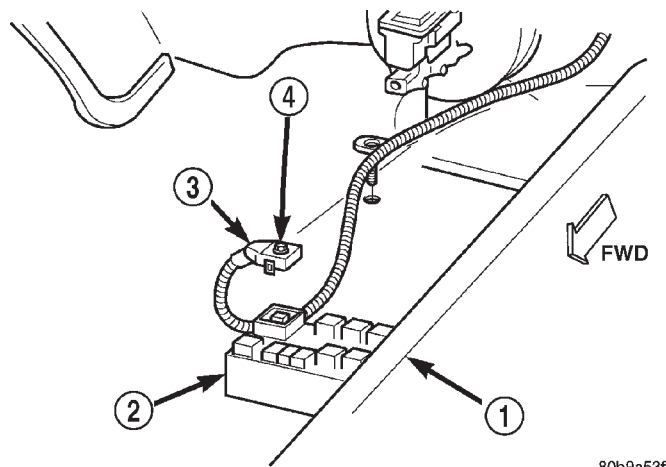
(3) Remove all of the fasteners that secure each of the headlamp and dash wire harness ground eyelets to the vehicle body and chassis components. Refer to **Connector Locations** in the index of this service

manual for the location of more information on the ground eyelet locations.

(4) Disengage each of the retainers that secure the headlamp and dash wire harness to the vehicle body and chassis components. Refer to **Connector Locations** in the index of this service manual for the location of more information on the headlamp and dash wire harness retainer locations.

(5) Unlatch and remove the cover from the PDC.

(6) Remove the screw that secures the engine wire harness in-line connector to the PDC and disconnect the connector (Fig. 8).



80b9a53f

**Fig. 8 Engine Wire Harness In-Line Connector**

- 1 - LEFT FENDER
- 2 - POWER DISTRIBUTION CENTER
- 3 - ENGINE WIRE HARNESS IN-LINE CONNECTOR
- 4 - SCREW

(7) Remove the nut that secures the eyelet of the battery negative cable generator output take out to the rearward B(+) terminal stud in the PDC and remove the eyelet from the stud (Fig. 9).

(8) Remove the nut that secures the eyelet of the battery positive cable PDC take out to the forward B(+) terminal stud in the PDC and remove the eyelet from the stud.

(9) Remove the screw that secures the PDC housing to the left front fender wheel housing (Fig. 10).

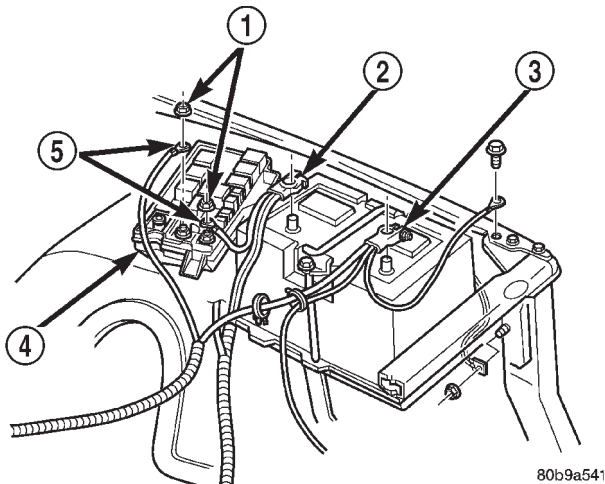
(10) Remove the two screws that secure the PDC housing to the left front fender inner shield.

(11) Remove the PDC and the headlamp and dash wire harness from the engine compartment as a unit.

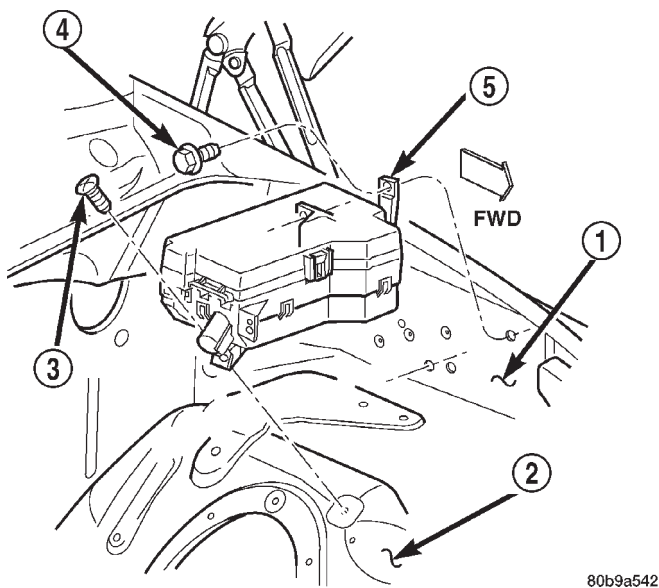
## INSTALLATION

The Power Distribution Center (PDC) is serviced as a unit with the headlamp and dash wire harness. If any internal circuit of the PDC or the PDC housing is faulty or damaged, the entire PDC and headlamp and dash wire harness unit must be replaced.

## POWER DISTRIBUTION CENTER (Continued)

**Fig. 9 Battery and Generator Connections to PDC**

- 1 - NUTS
- 2 - BATTERY POSITIVE CABLE
- 3 - BATTERY NEGATIVE CABLE
- 4 - POWER DISTRIBUTION CENTER
- 5 - CABLE EYELETS

**Fig. 10 Power Distribution Center**

- 1 - FENDER INNER SHIELD
- 2 - INNER WHEEL HOUSE
- 3 - SCREW
- 4 - SCREW
- 5 - POWER DISTRIBUTION CENTER

**NOTE:** If the PDC is being replaced with a new unit, be certain to transfer each of the blade-type fuses, cartridge fuses and relays from the faulty PDC to the proper cavities of the replacement PDC. Refer to Power Distribution in the index of this service manual for the location of complete PDC circuit diagrams and cavity assignments.

(1) Position the PDC and the headlamp and dash wire harness unit in the engine compartment.

(2) Install and tighten the two screws that secure the PDC housing to the left front fender inner shield. Tighten the screws to 8.4 N·m (75 in. lbs.).

(3) Install and tighten the screw that secures the PDC housing to the left front fender wheel housing. Tighten the screw to 2.2 N·m (20 in. lbs.).

(4) Install the eyelet of the battery positive cable PDC take out onto the forward B(+) terminal stud in the PDC.

(5) Install and tighten the nut that secures the eyelet of the battery positive cable PDC take out to the forward B(+) terminal stud in the PDC. Tighten the nut to 8.4 N·m (75 in. lbs.).

(6) Install the eyelet of the battery negative cable generator output take out onto the rearward B(+) terminal stud in the PDC.

(7) Install and tighten the nut that secures the eyelet of the battery negative cable generator output take out to the rearward B(+) terminal stud in the PDC. Tighten the nut to 75 in. lbs.

(8) Reconnect the engine wire harness in-line connector to the PDC.

(9) Install and tighten the screw that secures the engine wire harness in-line connector to the PDC. Tighten the screw until a distinct audible click is heard.

(10) Install and latch the cover onto the PDC.

(11) Engage each of the retainers that secure the headlamp and dash wire harness to the vehicle body and chassis components. Refer to **Connector Locations** in the index of this service manual for the location of more information on the headlamp and dash wire harness retainer locations.

(12) Install all of the fasteners that secure each of the headlamp and dash wire harness ground eyelets to the vehicle body and chassis components. Refer to **Connector Locations** in the index of this service manual for the location of more information on the ground eyelet locations.

(13) Reconnect each of the headlamp and dash wire harness connectors. Refer to **Connector Locations** in the index of this service manual for the location of more information on the headlamp and dash wire harness connector locations.

(14) Reconnect the battery negative cable.

## POWER OUTLET

### DESCRIPTION

An accessory power outlet is standard equipment on this model. The power outlet is installed in the instrument panel below the cigar lighter and next to the ash receiver, which is located near the center of



## POWER OUTLET (Continued)

the instrument panel, below the radio. The power outlet base is secured by a snap fit within the instrument panel. A plastic protective cap snaps into the power outlet base when the power outlet is not being used, and hangs from the power outlet base mount by an integral bail strap while the power outlet is in use.

The power outlet receptacle unit and the accessory power outlet protective cap are available for service. The power outlet receptacle cannot be repaired and, if faulty or damaged, it must be replaced.

## OPERATION

The power outlet base or receptacle shell is connected to ground, and an insulated contact in the bottom of the shell is connected to battery current. The power outlet receives battery voltage from a fuse in the Power Distribution Center (PDC) at all times.

While the power outlet is very similar to a cigar lighter base unit, it does not include the two small spring-clip retainers inside the bottom of the receptacle shell that are used to secure the cigar lighter heating element to the insulated contact.

## DIAGNOSIS &amp; TESTING - POWER OUTLET

For complete circuit diagrams, refer to **Power Outlet** in Wiring Diagrams.

**WARNING: ON VEHICLES EQUIPPED WITH AIR-BAGS, REFER TO GROUP 8M - PASSIVE RESTRAINT SYSTEMS BEFORE ATTEMPTING ANY STEERING WHEEL, STEERING COLUMN, OR INSTRUMENT PANEL COMPONENT DIAGNOSIS OR SERVICE. FAILURE TO TAKE THE PROPER PRECAUTIONS COULD RESULT IN ACCIDENTAL AIR-BAG DEPLOYMENT AND POSSIBLE PERSONAL INJURY.**

(1) Check the fused B(+) fuse in the Power Distribution Center (PDC). If OK, go to Step 2. If not OK, repair the shorted circuit or component as required and replace the faulty fuse.

(2) Check for battery voltage at the fused B(+) fuse in the PDC. If OK, go to Step 3. If not OK, repair the open fused B(+) circuit to the battery as required.

(3) Remove the plastic protective cap from the power outlet receptacle. Check for continuity between the inside circumference of the power outlet receptacle and a good ground. There should be continuity. If OK, go to Step 4. If not OK, go to Step 5.

(4) Check for battery voltage at the insulated contact located at the back of the power outlet receptacle. If not OK, go to Step 5.

(5) Disconnect and isolate the battery negative cable. Remove the power outlet receptacle from the instrument panel. Disconnect the wire harness connector from the power outlet receptacle. Check for

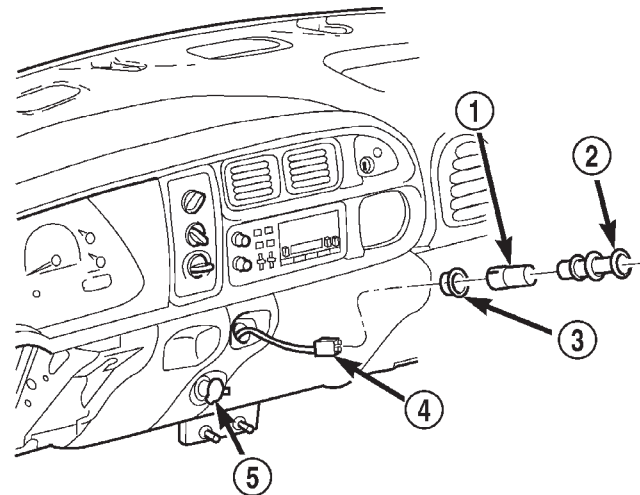
continuity between the ground circuit cavity of the power outlet wire harness connector and a good ground. There should be continuity. If OK, go to Step 6. If not OK, repair the open ground circuit to ground as required.

(6) Connect the battery negative cable. Check for battery voltage at the fused B(+) circuit cavity of the power outlet wire harness connector. If OK, replace the faulty power outlet receptacle. If not OK, repair the open fused B(+) circuit to the PDC fuse as required.

## REMOVAL

(1) Disconnect and isolate the battery negative cable.

(2) Pull the cigar lighter knob and element out of the cigar lighter receptacle base, or unsnap the protective cap from the power outlet receptacle base (Fig. 11).



80b89821

**Fig. 11 Cigar Lighter and Power Outlet**

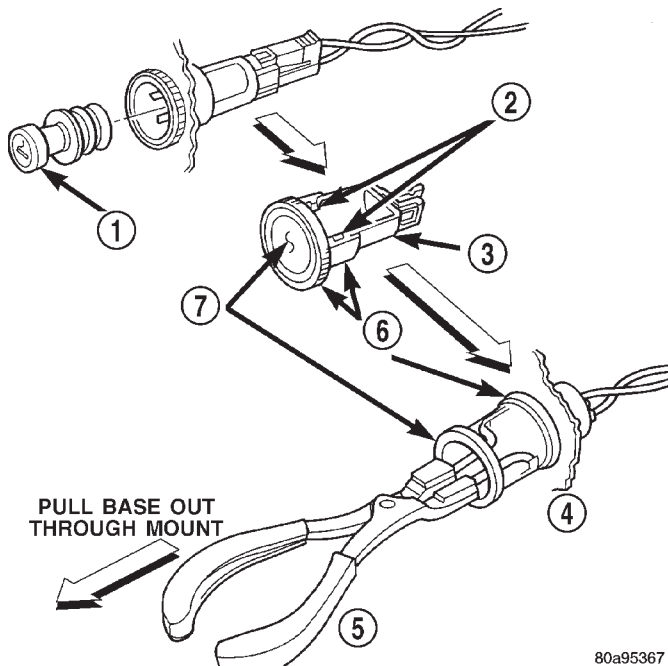
- 1 - RECEPTACLE BASE
- 2 - KNOB & ELEMENT
- 3 - MOUNT
- 4 - WIRE HARNESS CONNECTOR
- 5 - POWER OUTLET

(3) Look inside the cigar lighter or power outlet receptacle base and note the position of the rectangular retaining bosses of the mount that secures the receptacle base to the instrument panel (Fig. 12).

(4) Insert a pair of external snap ring pliers into the cigar lighter or power outlet receptacle base and engage the tips of the pliers with the retaining bosses of the mount.

(5) Squeeze the pliers to disengage the mount retaining bosses from the receptacle base and, using a gentle rocking motion, pull the pliers and the receptacle base out of the mount.

## POWER OUTLET (Continued)



80a95367

**Fig. 12 Cigar Lighter and Power Outlet Remove/Install**

- 1 - KNOB AND ELEMENT
- 2 - RETAINING BOSSES-ENGAGE PLIERS HERE
- 3 - BASE
- 4 - PARTIALLY REMOVED
- 5 - EXTERNAL SNAP-RING PLIERS
- 6 - MOUNT
- 7 - BASE

(6) Pull the receptacle base away from the instrument panel far enough to access the instrument panel wire harness connector.

(7) Disconnect the instrument panel wire harness connector from the cigar lighter or power outlet receptacle base connector receptacle.

(8) Remove the cigar lighter or power outlet mount from the instrument panel.

### INSTALLATION

(1) Install the cigar lighter or power outlet mount into the instrument panel.

(2) Reconnect the instrument panel wire harness connector to the cigar lighter or power outlet receptacle base connector receptacle.

(3) Align the splines on the outside of the cigar lighter or power outlet receptacle base connector receptacle with the grooves on the inside of the mount.

(4) Press firmly on the cigar lighter or power outlet receptacle base until the retaining bosses of the mount are fully engaged in their receptacles.

(5) Install the cigar lighter knob and element into the cigar lighter receptacle base, or the protective cap into the power outlet receptacle base.

(6) Reconnect the battery negative cable.





# ENGINE

## TABLE OF CONTENTS

	page		page
ENGINE 3.9L.....	1	ENGINE 8.0L.....	171
ENGINE 5.2L.....	59	ENGINE 5.9L DIESEL.....	229
ENGINE 5.9L.....	116		

## ENGINE 3.9L

### TABLE OF CONTENTS

	page		page
<b>ENGINE 3.9L</b>		INSPECTION.....	24
DESCRIPTION.....	3	INSTALLATION.....	24
DIAGNOSIS AND TESTING.....	3	<b>INTAKE/EXHAUST VALVES &amp; SEATS</b>	
ENGINE DIAGNOSIS - INTRODUCTION.....	3	DESCRIPTION.....	25
PERFORMANCE.....	4	STANDARD PROCEDURE.....	25
MECHANICAL.....	6	VALVES, GUIDES AND SPRINGS.....	25
LUBRICATION.....	8	REMOVAL.....	27
CYLINDER COMPRESSION PRESSURE.....	9	CLEANING.....	27
CYLINDER COMBUSTION PRESSURE		INSPECTION.....	27
LEAKAGE.....	9	INSTALLATION.....	28
REAR SEAL AREA LEAKS.....	10	<b>ENGINE BLOCK</b>	
STANDARD PROCEDURE.....	10	CLEANING.....	28
CYLINDER BORE HONING.....	10	INSPECTION.....	28
HYDROSTATIC LOCK.....	11	<b>CAMSHAFT &amp; BEARINGS (IN BLOCK)</b>	
REPAIR DAMAGED OR WORN THREADS.....	11	REMOVAL.....	29
FORM-IN-PLACE GASKETS AND SEALERS.....	11	INSTALLATION.....	29
REMOVAL.....	12	<b>CONNECTING ROD BEARINGS</b>	
INSTALLATION.....	13	STANDARD PROCEDURE.....	31
SPECIFICATIONS.....	14	CONNECTING ROD BEARING FITTING.....	31
SPECIAL TOOLS.....	19	<b>CRANKSHAFT</b>	
<b>AIR CLEANER ELEMENT</b>		DESCRIPTION.....	31
REMOVAL.....	21	OPERATION.....	31
INSTALLATION.....	21	REMOVAL.....	31
<b>CYLINDER HEAD</b>		INSTALLATION.....	32
DESCRIPTION.....	22	<b>CRANKSHAFT MAIN BEARINGS</b>	
OPERATION.....	22	DESCRIPTION.....	32
DIAGNOSIS AND TESTING.....	22	OPERATION.....	32
CYLINDER HEAD GASKET FAILURE.....	22	STANDARD PROCEDURE.....	33
REMOVAL.....	23	MAIN BEARING FITTING.....	33
CLEANING.....	23	REMOVAL.....	33
INSPECTION.....	23	INSTALLATION.....	34
INSTALLATION.....	23	<b>CRANKSHAFT OIL SEAL - FRONT</b>	
<b>CYLINDER HEAD COVER(S)</b>		DESCRIPTION.....	34
REMOVAL.....	24	OPERATION.....	34
CLEANING.....	24	REMOVAL.....	34

INSTALLATION . . . . .	34	<b>OIL FILTER</b>	
<b>CRANKSHAFT OIL SEAL - REAR</b>		REMOVAL . . . . .	48
DESCRIPTION . . . . .	34	INSTALLATION . . . . .	48
OPERATION . . . . .	34	<b>OIL PAN</b>	
REMOVAL . . . . .	35	REMOVAL . . . . .	48
INSTALLATION . . . . .	35	CLEANING . . . . .	49
<b>DISTRIBUTOR BUSHING</b>		INSPECTION . . . . .	49
REMOVAL . . . . .	37	INSTALLATION . . . . .	49
INSTALLATION . . . . .	37	<b>OIL PRESSURE SENSOR/SWITCH</b>	
<b>HYDRAULIC LIFTERS (CAM IN BLOCK)</b>		DESCRIPTION . . . . .	49
DIAGNOSIS AND TESTING . . . . .	38	OPERATION . . . . .	49
HYDRAULIC TAPPETS . . . . .	38	<b>OIL PUMP</b>	
REMOVAL . . . . .	39	REMOVAL . . . . .	50
CLEANING . . . . .	39	DISASSEMBLY . . . . .	50
INSTALLATION . . . . .	39	CLEANING . . . . .	50
<b>PISTON &amp; CONNECTING ROD</b>		INSPECTION . . . . .	50
DESCRIPTION . . . . .	40	ASSEMBLY . . . . .	51
STANDARD PROCEDURE . . . . .	40	INSTALLATION . . . . .	52
PISTON FITTING . . . . .	40	<b>INTAKE MANIFOLD</b>	
REMOVAL . . . . .	40	DESCRIPTION . . . . .	52
CLEANING . . . . .	41	OPERATION . . . . .	52
INSPECTION . . . . .	41	DIAGNOSIS AND TESTING . . . . .	53
INSTALLATION . . . . .	41	INTAKE MANIFOLD LEAKAGE . . . . .	53
<b>PISTON RINGS</b>		REMOVAL . . . . .	53
STANDARD PROCEDURE . . . . .	41	CLEANING . . . . .	53
PISTON RING FITTING . . . . .	41	INSPECTION . . . . .	53
<b>VIBRATION DAMPER</b>		INSTALLATION . . . . .	53
REMOVAL . . . . .	42	<b>EXHAUST MANIFOLD</b>	
INSTALLATION . . . . .	42	DESCRIPTION . . . . .	55
<b>FRONT MOUNT</b>		OPERATION . . . . .	55
REMOVAL . . . . .	43	REMOVAL . . . . .	55
INSTALLATION . . . . .	43	CLEANING . . . . .	55
<b>REAR MOUNT</b>		INSPECTION . . . . .	55
REMOVAL . . . . .	44	INSTALLATION . . . . .	55
INSTALLATION . . . . .	44	<b>TIMING BELT / CHAIN COVER(S)</b>	
<b>LUBRICATION</b>		REMOVAL . . . . .	56
DESCRIPTION . . . . .	45	INSTALLATION . . . . .	56
OPERATION . . . . .	45	<b>TIMING BELT/CHAIN TENSIONER</b>	
DIAGNOSIS AND TESTING . . . . .	47	DESCRIPTION . . . . .	57
ENGINE OIL PRESSURE . . . . .	47	OPERATION . . . . .	57
ENGINE OIL LEAKS . . . . .	47	<b>TIMING BELT/CHAIN AND SPROCKETS</b>	
<b>OIL</b>		REMOVAL . . . . .	57
STANDARD PROCEDURE . . . . .	47	INSPECTION . . . . .	58
ENGINE OIL . . . . .	47	INSTALLATION . . . . .	58

## ENGINE 3.9L (Continued)

## ENGINE 3.9L

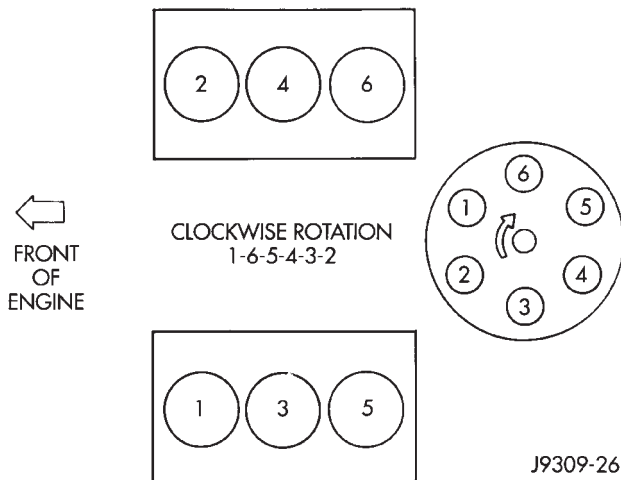
## DESCRIPTION

The 3.9 Liter (238 CID) six-cylinder engine is a V-Type, lightweight, single cam, overhead valve engine with hydraulic roller tappets. This engine is designed to use unleaded fuel.

The engine lubrication system consists of a rotor type oil pump and a full-flow oil filter.

The cylinders are numbered from front to rear; 1, 3, 5 on the left bank and 2, 4, 6 on the right bank. The firing order is 1-6-5-4-3-2 (Fig. 1).

The engine serial number is stamped into a machined pad located on the left front corner of the cylinder block. When component part replacement is necessary, use the engine type and serial number for reference (Fig. 2).



**Fig. 1 Firing Order**

X M AAA YYYY 0000

X = Last Digit of Model Year

M = Plant-M Mound Road

S Saltillo

T Trenton

K Toluca

AAA = Engine Displacement (CID)

YYYY = Month/Day

0000 = Engine Serial Code

80bbd9ce

**Fig. 2 Engine Identification (Serial) Number**

## DIAGNOSIS AND TESTING—ENGINE

### DIAGNOSIS - INTRODUCTION

Engine diagnosis is helpful in determining the causes of malfunctions not detected and remedied by routine maintenance.

These malfunctions may be classified as either mechanical (e.g., a strange noise), or performance (e.g., engine idles rough and stalls).

(Refer to 9 - ENGINE - DIAGNOSIS AND TESTING - Performance) or (Refer to 9 - ENGINE - DIAGNOSIS AND TESTING - Mechanical). Refer to 14 - FUEL SYSTEM for fuel system diagnosis.

Additional tests and diagnostic procedures may be necessary for specific engine malfunctions that cannot be isolated with the Service Diagnosis charts. Information concerning additional tests and diagnosis is provided within the following:

- Cylinder Compression Pressure Test
- Cylinder Combustion Pressure Leakage Test
- Cylinder Head Gasket Failure Diagnosis
- Intake Manifold Leakage Diagnosis
- Lash Adjuster (Tappet) Noise Diagnosis
- Engine Oil Leak Inspection

## ENGINE 3.9L (Continued)

**DIAGNOSIS AND TESTING—PERFORMANCE***PERFORMANCE DIAGNOSIS CHART—GASOLINE ENGINES*

<b>CONDITION</b>	<b>POSSIBLE CAUSES</b>	<b>CORRECTION</b>
ENGINE WILL NOT CRANK	<ol style="list-style-type: none"> <li>1. Weak or dead battery</li> <li>2. Corroded or loose battery connections</li> <li>3. Faulty starter or related circuit(s)</li> <li>4. Seized accessory drive component</li> <li>5. Engine internal mechanical failure or hydro-static lock</li> </ol>	<ol style="list-style-type: none"> <li>1. Charge/Replace Battery. (Refer to 8 - ELECTRICAL/BATTERY SYSTEM/ BATTERY - STANDARD PROCEDURE). Check charging system. (Refer to 8 - ELECTRICAL/CHARGING - DIAGNOSIS AND TESTING).</li> <li>2. Clean/tighten suspect battery/starter connections</li> <li>3. Check starting system. (Refer to 8 - ELECTRICAL/STARTING - DIAGNOSIS AND TESTING)</li> <li>4. Remove accessory drive belt and attempt to start engine. If engine starts, repair/replace seized component.</li> <li>5. Refer to (Refer to 9 - ENGINE - DIAGNOSIS AND TESTING)</li> </ol>
ENGINE CRANKS BUT WILL NOT START	<ol style="list-style-type: none"> <li>1. No spark</li> <li>2. No fuel</li> <li>3. Low or no engine compression</li> </ol>	<ol style="list-style-type: none"> <li>1. Check for spark. (Refer to 8 - ELECTRICAL/IGNITION CONTROL - DESCRIPTION)</li> <li>2. Perform fuel pressure test, and if necessary, inspect fuel injector(s) and driver circuits. (Refer to 14 - FUEL SYSTEM/FUEL DELIVERY/FUEL PUMP - DIAGNOSIS AND TESTING).</li> <li>3. Perform cylinder compression pressure test. (Refer to 9 - ENGINE - DIAGNOSIS AND TESTING).</li> </ol>
ENGINE LOSS OF POWER	<ol style="list-style-type: none"> <li>1. Worn or burned distributor rotor</li> <li>2. Worn distributor shaft</li> <li>3. Worn or incorrect gapped spark plugs</li> <li>4. Dirt or water in fuel system</li> <li>5. Faulty fuel pump</li> <li>6. Incorrect valve timing</li> <li>7. Blown cylinder head gasket</li> <li>8. Low compression</li> <li>9. Burned, warped, or pitted valves</li> <li>10. Plugged or restricted exhaust system</li> </ol>	<ol style="list-style-type: none"> <li>1. Install new distributor rotor</li> <li>2. Remove and repair distributor (Refer to 8 - ELECTRICAL/IGNITION CONTROL/ DISTRIBUTOR - REMOVAL).</li> <li>3. Clean plugs and set gap. (Refer to 8 - ELECTRICAL/IGNITION CONTROL/ SPARK PLUG - CLEANING).</li> <li>4. Clean system and replace fuel filter</li> <li>5. Install new fuel pump</li> <li>6. Correct valve timing</li> <li>7. Install new cylinder head gasket</li> <li>8. Test cylinder compression (Refer to 9 - ENGINE - DIAGNOSIS AND TESTING).</li> <li>9. Install/Reface valves as necessary</li> <li>10. Install new parts as necessary</li> </ol>

## ENGINE 3.9L (Continued)

CONDITION	POSSIBLE CAUSES	CORRECTION
	11. Faulty ignition cables 12. Faulty ignition coil	11. Replace any cracked or shorted cables 12. Test and replace, as necessary (Refer to 8 - ELECTRICAL/IGNITION CONTROL/IGNITION COIL - REMOVAL).
ENGINE STALLS OR ROUGH IDLE	1. Carbon build-up on throttle plate 2. Engine idle speed too low 3. Worn or incorrectly gapped spark plugs 4. Worn or burned distributor rotor 5. Spark plug cables defective or crossed 6. Faulty coil 7. Intake manifold vacuum leak	1. Remove throttle body and de-carbon. (Refer to 14 - FUEL SYSTEM/FUEL INJECTION/THROTTLE BODY - REMOVAL). 2. Check Idle Air Control circuit. (Refer to 14 - FUEL SYSTEM/FUEL INJECTION/ IDLE AIR CONTROL MOTOR - DESCRIPTION) 3. Replace or clean and re-gap spark plugs (Refer to 8 - ELECTRICAL/IGNITION CONTROL/SPARK PLUG - CLEANING) 4. Install new distributor rotor 5. Check for correct firing order or replace spark plug cables. (Refer to 8 - ELECTRICAL/IGNITION CONTROL/ SPARK PLUG CABLE - DIAGNOSIS AND TESTING) 6. Test and replace, if necessary (Refer to 8 - ELECTRICAL/IGNITION CONTROL/IGNITION COIL - REMOVAL) 7. Inspect intake manifold gasket and vacuum hoses (Refer to 9 - ENGINE/ MANIFOLDS/INTAKE MANIFOLD - DIAGNOSIS AND TESTING).
ENGINE MISSES ON ACCELERATION	1. Worn or incorrectly gapped spark plugs 2. Spark plug cables defective or crossed 3. Dirt in fuel system 4. Burned, warped or pitted valves 5. Faulty coil	1. Replace spark plugs or clean and set gap. (Refer to 8 - ELECTRICAL/IGNITION CONTROL/SPARK PLUG - CLEANING) 2. Replace or rewire secondary ignition cables. (Refer to 8 - ELECTRICAL/IGNITION CONTROL/SPARK PLUG CABLE - REMOVAL) 3. Clean fuel system 4. Install new valves 5. Test and replace as necessary (Refer to 8 - ELECTRICAL/IGNITION CONTROL/IGNITION COIL - REMOVAL)



## ENGINE 3.9L (Continued)

## DIAGNOSIS AND TESTING— MECHANICAL

## ENGINE MECHANICAL DIAGNOSIS CHART

CONDITION	POSSIBLE CAUSES	CORRECTION
NOISY VALVES/LIFTERS	<ol style="list-style-type: none"> <li>1. High or low oil level in crankcase</li> <li>2. Thin or diluted oil</li> <li>3. Low oil pressure</li> <li>4. Dirt in tappets/lash adjusters</li> <li>5. Bent push rod(s)</li> <li>6. Worn rocker arms</li> <li>7. Worn tappets/lash adjusters</li> <li>8. Worn valve guides</li> <li>9. Excessive runout of valve seats or valve faces</li> </ol>	<ol style="list-style-type: none"> <li>1. Check for correct oil level. Adjust oil level by draining or adding as needed</li> <li>2. Change oil. (Refer to 9 - ENGINE/LUBRICATION/OIL - STANDARD PROCEDURE)</li> <li>3. Check engine oil level. If ok, Perform oil pressure test. (Refer to 9 - ENGINE/LUBRICATION - DIAGNOSIS AND TESTING) for engine oil pressure test/specifications</li> <li>4. Clean/replace hydraulic tappets/lash adjusters</li> <li>5. Install new push rods</li> <li>6. Inspect oil supply to rocker arms and replace worn arms as needed</li> <li>7. Install new hydraulic tappets/lash adjusters</li> <li>8. Inspect all valve guides and replace as necessary</li> <li>9. Grind valves and seats</li> </ol>
CONNECTING ROD NOISE	<ol style="list-style-type: none"> <li>1. Insufficient oil supply</li> <li>2. Low oil pressure</li> <li>3. Thin or diluted oil</li> <li>4. Excessive connecting rod bearing clearance</li> <li>5. Connecting rod journal out of round</li> <li>6. Misaligned connecting rods</li> </ol>	<ol style="list-style-type: none"> <li>1. Check engine oil level.</li> <li>2. Check engine oil level. If ok, Perform oil pressure test. (Refer to 9 - ENGINE/LUBRICATION - DIAGNOSIS AND TESTING) engine oil pressure test/specifications</li> <li>3. Change oil to correct viscosity. (Refer to 9 - ENGINE/LUBRICATION/OIL - STANDARD PROCEDURE) for correct procedure/engine oil specifications</li> <li>Measure bearings for correct clearance with plasti-gage. Repair as necessary</li> <li>5. Replace crankshaft or grind journals</li> <li>6. Replace bent connecting rods</li> </ol>
MAIN BEARING NOISE	<ol style="list-style-type: none"> <li>1. Insufficient oil supply</li> <li>2. Low oil pressure</li> <li>3. Thin or diluted oil</li> </ol>	<ol style="list-style-type: none"> <li>1. Check engine oil level.</li> <li>2. Check engine oil level. If ok, Perform oil pressure test. (Refer to 9 - ENGINE/LUBRICATION - DIAGNOSIS AND TESTING)</li> <li>3. Change oil to correct viscosity.</li> </ol>

## ENGINE 3.9L (Continued)

CONDITION	POSSIBLE CAUSES	CORRECTION
	<ol style="list-style-type: none"> <li>4. Excessive main bearing clearance</li> <li>5. Excessive end play</li> <li>6. Crankshaft main journal out of round or worn</li> <li>7. Loose flywheel or torque converter</li> </ol>	<ol style="list-style-type: none"> <li>4. Measure bearings for correct clearance. Repair as necessary</li> <li>5. Check crankshaft thrust bearing for excessive wear on flanges</li> <li>6. Grind journals or replace crankshaft</li> <li>7. Inspect crankshaft, flexplate/flywheel and bolts for damage. Tighten to correct torque</li> </ol>
LOW OIL PRESSURE	<ol style="list-style-type: none"> <li>1. Low oil level</li> <li>2. Faulty oil pressure sending unit</li> <li>3. Clogged oil filter</li> <li>4. Worn oil pump</li> <li>5. Thin or diluted oil</li> <li>6. Excessive bearing clearance</li> <li>7. Oil pump relief valve stuck</li> <li>8. Oil pump suction tube loose, broken, bent or clogged</li> <li>9. Oil pump cover warped or cracked</li> </ol>	<ol style="list-style-type: none"> <li>1. Check oil level and fill if necessary</li> <li>2. Install new sending unit</li> <li>3. Install new oil filter</li> <li>4. Replace oil pump assembly.</li> <li>5. Change oil to correct viscosity.</li> <li>6. Measure bearings for correct clearance</li> <li>7. Remove valve to inspect, clean and reinstall</li> <li>8. Inspect suction tube and clean or replace if necessary</li> <li>9. Install new oil pump</li> </ol>
OIL LEAKS	<ol style="list-style-type: none"> <li>1. Misaligned or deteriorated gaskets</li> <li>2. Loose fastener, broken or porous metal part</li> <li>3. Front or rear crankshaft oil seal leaking</li> <li>4. Leaking oil gallery plug or cup plug</li> </ol>	<ol style="list-style-type: none"> <li>1. Replace gasket</li> <li>2. Tighten, repair or replace the part</li> <li>3. Replace seal</li> <li>4. Remove and reseal threaded plug. Replace cup style plug</li> </ol>
EXCESSIVE OIL CONSUMPTION OR SPARK PLUGS OIL FOULED	<ol style="list-style-type: none"> <li>1. CCV System malfunction</li> <li>2. Defective valve stem seal(s)</li> <li>3. Worn or broken piston rings</li> <li>4. Scuffed pistons/cylinder walls</li> <li>5. Carbon in oil control ring groove</li> <li>6. Worn valve guides</li> <li>7. Piston rings fitted too tightly in grooves</li> </ol>	<ol style="list-style-type: none"> <li>1. (Refer to 25 - EMISSIONS CONTROL/ EVAPORATIVE EMISSIONS - DESCRIPTION) for correct operation</li> <li>2. Repair or replace seal(s)</li> <li>3. Hone cylinder bores. Install new rings</li> <li>4. Hone cylinder bores and replace pistons as required</li> <li>5. Remove rings and de-carbon piston</li> <li>6. Inspect/replace valve guides as necessary</li> <li>7. Remove rings and check ring end gap and side clearance. Replace if necessary</li> </ol>

## ENGINE 3.9L (Continued)

## DIAGNOSIS AND TESTING—LUBRICATION

CONDITION	POSSIBLE CAUSES	CORRECTION
OIL LEAKS	<ol style="list-style-type: none"> <li>1. Gaskets and O-Rings.               <ol style="list-style-type: none"> <li>(a) Misaligned or damaged.</li> <li>(b) Loose fasteners, broken or porous metal parts.</li> </ol> </li> <li>2. Crankshaft rear seal</li> <li>3. Crankshaft seal flange. Scratched, nicked or grooved.</li> <li>4. Oil pan flange cracked.</li> <li>5. Timing chain cover seal, damaged or misaligned.</li> <li>6. Scratched or damaged vibration damper hub.</li> </ol>	<ol style="list-style-type: none"> <li>1.               <ol style="list-style-type: none"> <li>(a) Replace as necessary.</li> <li>(b) Tighten fasteners, Repair or replace metal parts.</li> </ol> </li> <li>2. Replace as necessary.</li> <li>3. Polish or replace crankshaft.</li> <li>4. Replace oil pan.</li> <li>5. Replace seal.</li> <li>6. Polish or replace damper.</li> </ol>
OIL PRESSURE DROP	<ol style="list-style-type: none"> <li>1. Low oil level.</li> <li>2. Faulty oil pressure sending unit.</li> <li>3. Low oil pressure.</li> <li>4. Clogged oil filter.</li> <li>5. Worn oil pump.</li> <li>6. Thin or diluted oil.</li> <li>7. Excessive bearing clearance.</li> <li>8. Oil pump relief valve stuck.</li> <li>9. Oil pump suction tube loose or damaged.</li> </ol>	<ol style="list-style-type: none"> <li>1. Check and correct oil level.</li> <li>2. Replace sending unit.</li> <li>3. Check pump and bearing clearance.</li> <li>4. Replace oil filter.</li> <li>5. Replace as necessary.</li> <li>6. Change oil and filter.</li> <li>7. Replace as necessary.</li> <li>8. Clean or replace relief valve.</li> <li>9. Replace as necessary.</li> </ol>
OIL PUMPING AT RINGS; SPARK PLUGS FOULING	<ol style="list-style-type: none"> <li>1. Worn or damaged rings.</li> <li>2. Carbon in oil ring slots.</li> <li>3. Incorrect ring size installed.</li> <li>4. Worn valve guides.</li> <li>5. Leaking intake gasket.</li> <li>6. Leaking valve guide seals.</li> </ol>	<ol style="list-style-type: none"> <li>1. Hone cylinder bores and replace rings.</li> <li>2. Replace rings.</li> <li>3. Replace rings.</li> <li>4. Ream guides and replace valves.</li> <li>5. Replace intake gaskets.</li> <li>6. Replace valve guide seals.</li> </ol>

## ENGINE 3.9L (Continued)

**DIAGNOSIS AND TESTING—CYLINDER COMPRESSION PRESSURE**

The results of a cylinder compression pressure test can be utilized to diagnose several engine malfunctions.

Ensure the battery is completely charged and the engine starter motor is in good operating condition. Otherwise, the indicated compression pressures may not be valid for diagnosis purposes.

- (1) Clean the spark plug recesses with compressed air.
- (2) Remove the spark plugs (Refer to 8 - ELECTRICAL/IGNITION CONTROL/SPARK PLUG - REMOVAL).
- (3) Secure the throttle in the wide-open position.
- (4) Disconnect the ignition coil.
- (5) Insert a compression pressure gauge and rotate the engine with the engine starter motor for three revolutions.
- (6) Record the compression pressure on the third revolution. Continue the test for the remaining cylinders.

(Refer to 9 - ENGINE - SPECIFICATIONS) for the correct engine compression pressures.

**DIAGNOSIS AND TESTING—CYLINDER COMBUSTION PRESSURE LEAKAGE**

The combustion pressure leakage test provides an accurate means for determining engine condition.

Combustion pressure leakage testing will detect:

- Exhaust and intake valve leaks (improper seating)
- Leaks between adjacent cylinders or into water jacket

- Any causes for combustion/compression pressure loss

**WARNING: DO NOT REMOVE THE RADIATOR CAP WITH THE SYSTEM HOT AND UNDER PRESSURE. SERIOUS BURNS FROM HOT COOLANT CAN OCCUR.**

Check the coolant level and fill as required. DO NOT install the radiator cap.

Start and operate the engine until it attains normal operating temperature, then turn OFF the engine.

Remove the spark plugs.

Remove the oil filler cap.

Remove the air cleaner.

Calibrate the tester according to the manufacturer's instructions. The shop air source for testing should maintain 483 kPa (70 psi) minimum, 1,379 kPa (200 psi) maximum and 552 kPa (80 psi) recommended.

Perform the test procedure on each cylinder according to the tester manufacturer's instructions. While testing, listen for pressurized air escaping through the throttle body, tailpipe or oil filler cap opening. Check for bubbles in the radiator coolant.

All gauge pressure indications should be equal, with no more than 25% leakage.

**FOR EXAMPLE:** At 552 kPa (80 psi) input pressure, a minimum of 414 kPa (60 psi) should be maintained in the cylinder.

Refer to CYLINDER COMBUSTION PRESSURE LEAKAGE DIAGNOSIS CHART below

*CYLINDER COMBUSTION PRESSURE LEAKAGE DIAGNOSIS CHART*

CONDITION	POSSIBLE CAUSE	CORRECTION
AIR ESCAPES THROUGH THROTTLE BODY	Intake valve bent, burnt, or not seated properly	Inspect valve and valve seat. Reface or replace, as necessary
AIR ESCAPES THROUGH TAILPIPE	Exhaust valve bent, burnt, or not seated properly	Inspect valve and valve seat. Reface or replace, as necessary
AIR ESCAPES THROUGH RADIATOR	Head gasket leaking or cracked cylinder head or block	Remove cylinder head and inspect. Replace defective part
MORE THAN 50% LEAKAGE FROM ADJACENT CYLINDERS	Head gasket leaking or crack in cylinder head or block between adjacent cylinders	Remove cylinder head and inspect. Replace gasket, head, or block as necessary
MORE THAN 25% LEAKAGE AND AIR ESCAPES THROUGH OIL FILLER CAP OPENING ONLY	Stuck or broken piston rings; cracked piston; worn rings and/or cylinder wall	Inspect for broken rings or piston. Measure ring gap and cylinder diameter, taper and out-of-round. Replace defective part as necessary

## ENGINE 3.9L (Continued)

**DIAGNOSIS AND TESTING—REAR SEAL AREA LEAKS**

Since it is sometimes difficult to determine the source of an oil leak in the rear seal area of the engine, a more involved inspection is necessary. The following steps should be followed to help pinpoint the source of the leak.

If the leakage occurs at the crankshaft rear oil seal area:

- (1) Disconnect the battery.
- (2) Raise the vehicle.
- (3) Remove torque converter or clutch housing cover and inspect rear of block for evidence of oil.

Use a black light to check for the oil leak:

- (a) Circular spray pattern generally indicates seal leakage or crankshaft damage.
- (b) Where leakage tends to run straight down, possible causes are a porous block, distributor seal, camshaft bore cup plugs, oil galley pipe plugs, oil filter runoff, and main bearing cap to cylinder block mating surfaces.
- (4) If no leaks are detected, pressurized the crankcase as outlined in (Refer to 9 - ENGINE/LUBRICATION - DIAGNOSIS AND TESTING)

**CAUTION: Do not exceed 20.6 kPa (3 psi).**

(5) If the leak is not detected, very slowly turn the crankshaft and watch for leakage. If a leak is detected between the crankshaft and seal while slowly turning the crankshaft, it is possible the crankshaft seal surface is damaged. The seal area on the crankshaft could have minor nicks or scratches that can be polished out with emery cloth.

**CAUTION: Use extreme caution when crankshaft polishing is necessary to remove minor nicks or scratches. The crankshaft seal flange is specially machined to complement the function of the rear oil seal.**

(6) For bubbles that remain steady with shaft rotation, no further inspection can be done until disassembled. Refer to the service Diagnosis—Mechanical, under the Oil Leak row, for components inspections on possible causes and corrections.

(7) After the oil leak root cause and appropriate corrective action have been identified, (Refer to 9 - ENGINE/ENGINE BLOCK/CRANKSHAFT OIL SEAL - REAR - REMOVAL), for proper replacement procedures.

**STANDARD PROCEDURE—CYLINDER BORE HONING**

Before honing, stuff plenty of clean shop towels under the bores and over the crankshaft to keep abrasive materials from entering the crankshaft area.

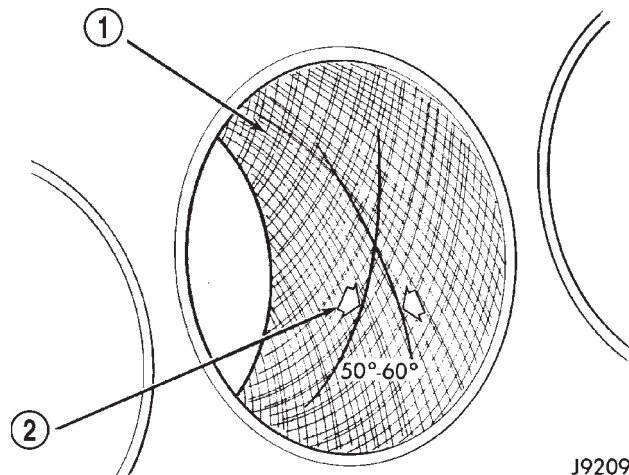
(1) Used carefully, the Cylinder Bore Sizing Hone C-823, equipped with 220 grit stones, is the best tool for this job. In addition to deglazing, it will reduce taper and out-of-round, as well as removing light scuffing, scoring and scratches. Usually, a few strokes will clean up a bore and maintain the required limits.

**CAUTION: DO NOT use rigid type hones to remove cylinder wall glaze.**

(2) Deglazing of the cylinder walls may be done if the cylinder bore is straight and round. Use a cylinder surfacing hone, Honing Tool C-3501, equipped with 280 grit stones (C-3501-3810). about 20-60 strokes, depending on the bore condition, will be sufficient to provide a satisfactory surface. Using honing oil C-3501-3880, or a light honing oil, available from major oil distributors.

**CAUTION: DO NOT use engine or transmission oil, mineral spirits, or kerosene.**

(3) Honing should be done by moving the hone up and down fast enough to get a crosshatch pattern. The hone marks should INTERSECT at 50° to 60° for proper seating of rings (Fig. 3).



J9209-12

**Fig. 3 Cylinder Bore Crosshatch Pattern**

- 1 - CROSSHATCH PATTERN
- 2 - INTERSECT ANGLE



## ENGINE 3.9L (Continued)

(4) A controlled hone motor speed between 200 and 300 RPM is necessary to obtain the proper cross-hatch angle. The number of up and down strokes per minute can be regulated to get the desired 50° to 60° angle. Faster up and down strokes increase the cross-hatch angle.

(5) After honing, it is necessary that the block be cleaned to remove all traces of abrasive. Use a brush to wash parts with a solution of hot water and detergent. Dry parts thoroughly. Use a clean, white, lint-free cloth to check that the bore is clean. Oil the bores after cleaning to prevent rusting.

### STANDARD PROCEDURE—HYDROSTATIC LOCK

**CAUTION: DO NOT use the starter motor to rotate the crankshaft. Severe damage could occur.**

When an engine is suspected of hydrostatic lock (regardless of what caused the problem), follow the steps below.

(1) Perform the Fuel Pressure Release Procedure (Refer to 14 - FUEL SYSTEM/FUEL DELIVERY - STANDARD PROCEDURE).

(2) Disconnect the negative cable(s) from the battery.

(3) Inspect air cleaner, induction system, and intake manifold to ensure system is dry and clear of foreign material.

(4) Place a shop towel around the spark plugs to catch any fluid that may possibly be under pressure in the cylinder head. Remove the spark plugs.

(5) With all spark plugs removed, rotate the crankshaft using a breaker bar and socket.

(6) Identify the fluid in the cylinders (coolant, fuel, oil, etc.).

(7) Be sure all fluid has been removed from the cylinders.

(8) Repair engine or components as necessary to prevent this problem from occurring again.

(9) Squirt a small amount of engine oil into the cylinders to lubricate the walls. This will prevent damage on restart.

(10) Install new spark plugs. Tighten the spark plugs to 41 N·m (30 ft. lbs.) torque.

(11) Drain engine oil. Remove and discard the oil filter.

(12) Install the drain plug. Tighten the plug to 34 N·m (25 ft. lbs.) torque.

(13) Install a new oil filter.

(14) Fill engine crankcase with the specified amount and grade of oil. (Refer to LUBRICATION & MAINTENANCE - SPECIFICATIONS).

(15) Connect the negative cable(s) to the battery.

(16) Start the engine and check for any leaks.

### STANDARD PROCEDURE—REPAIR DAMAGED OR WORN THREADS

**CAUTION: Be sure that the tapped holes maintain the original center line.**

Damaged or worn threads can be repaired. Essentially, this repair consists of:

- Drilling out worn or damaged threads.
- Tapping the hole with a special Heli-Coil Tap, or equivalent.
- Installing an insert into the tapped hole to bring the hole back to its original thread size.

### STANDARD PROCEDURE—FORM-IN-PLACE GASKETS & SEALERS

There are numerous places where form-in-place gaskets are used on the engine. Care must be taken when applying form-in-place gaskets to assure obtaining the desired results. **Do not use form-in-place gasket material unless specified.** Bead size, continuity, and location are of great importance. Too thin a bead can result in leakage while too much can result in spill-over which can break off and obstruct fluid feed lines. A continuous bead of the proper width is essential to obtain a leak-free gasket.

There are numerous types of form-in-place gasket materials that are used in the engine area. Mopar® Engine RTV GEN II, Mopar® ATF-RTV, and Mopar® Gasket Maker gasket materials, each have different properties and can not be used in place of the other.

#### MOPAR® ENGINE RTV GEN II

Mopar® Engine RTV GEN II is used to seal components exposed to engine oil. This material is a specially designed black silicone rubber RTV that retains adhesion and sealing properties when exposed to engine oil. Moisture in the air causes the material to cure. This material is available in three ounce tubes and has a shelf life of one year. After one year this material will not properly cure. Always inspect the package for the expiration date before use.

#### MOPAR® ATF RTV

Mopar® ATF RTV is a specifically designed black silicone rubber RTV that retains adhesion and sealing properties to seal components exposed to automatic transmission fluid, engine coolants, and moisture. This material is available in three ounce tubes and has a shelf life of one year. After one year this material will not properly cure. Always inspect the package for the expiration date before use.

#### MOPAR® GASKET MAKER

Mopar® Gasket Maker is an anaerobic type gasket material. The material cures in the absence of air when squeezed between two metallic surfaces. It will not cure if left in the uncovered tube. The anaerobic



## ENGINE 3.9L (Continued)

material is for use between two machined surfaces. Do not use on flexible metal flanges.

**MOPAR® GASKET SEALANT**

Mopar® Gasket Sealant is a slow drying, permanently soft sealer. This material is recommended for sealing threaded fittings and gaskets against leakage of oil and coolant. Can be used on threaded and machined parts under all temperatures. This material is used on engines with multi-layer steel (MLS) cylinder head gaskets. This material also will prevent corrosion. Mopar® Gasket Sealant is available in a 13 oz. aerosol can or 4oz./16 oz. can w/applicator.

**FORM-IN-PLACE GASKET AND SEALER APPLICATION**

Assembling parts using a form-in-place gasket requires care but it's easier than using pre-cut gaskets.

Mopar® Gasket Maker material should be applied sparingly 1 mm (0.040 in.) diameter or less of sealant to one gasket surface. Be certain the material surrounds each mounting hole. Excess material can easily be wiped off. Components should be torqued in place within 15 minutes. The use of a locating dowel is recommended during assembly to prevent smearing material off the location.

Mopar® Engine RTV GEN II or ATF RTV gasket material should be applied in a continuous bead approximately 3 mm (0.120 in.) in diameter. All mounting holes must be circled. For corner sealing, a 3.17 or 6.35 mm (1/8 or 1/4 in.) drop is placed in the center of the gasket contact area. Uncured sealant may be removed with a shop towel. Components should be torqued in place while the sealant is still wet to the touch (within 10 minutes). The usage of a locating dowel is recommended during assembly to prevent smearing material off the location.

Mopar® Gasket Sealant in an aerosol can should be applied using a thin, even coat sprayed completely over both surfaces to be joined, and both sides of a gasket. Then proceed with assembly. Material in a can w/applicator can be brushed on evenly over the sealing surfaces. Material in an aerosol can should be used on engines with multi-layer steel gaskets.

**REMOVAL**

- (1) Disconnect the negative cable from the battery.
- (2) Drain cooling system (Refer to 7 - COOLING - STANDARD PROCEDURE).
- (3) Remove the upper crossmember and top core support.
- (4) Remove the transmission oil cooler (Refer to 7 - COOLING/TRANSMISSION/TRANS COOLER - REMOVAL).

(5) Discharge the air conditioning system, if equipped (Refer to 24 - HEATING & AIR CONDITIONING/PLUMBING - STANDARD PROCEDURE).

(6) Remove accessory drive belt (Refer to 7 - COOLING/ACCESSORY DRIVE/DRIVE BELTS - REMOVAL).

(7) Remove the A/C compressor with the lines attached. Set aside.

(8) If equipped, remove the condenser (Refer to 24 - HEATING & AIR CONDITIONING/PLUMBING/A/C CONDENSER - REMOVAL).

(9) Remove the washer bottle.

(10) Remove the fan and fan shroud (Refer to 7 - COOLING/ENGINE/RADIATOR FAN - REMOVAL).

(11) Remove radiator (Refer to 7 - COOLING/ENGINE/RADIATOR - REMOVAL).

(12) Remove the generator with the wire connections (Refer to 8 - ELECTRICAL/CHARGING/GENERATOR - REMOVAL).

(13) Remove the air cleaner box.

(14) Disconnect the throttle linkage.

(15) Remove throttle body (Refer to 14 - FUEL SYSTEM/FUEL INJECTION/THROTTLE BODY - REMOVAL).

(16) Remove the intake manifold (Refer to 9 - ENGINE/MANIFOLDS/INTAKE MANIFOLD - REMOVAL).

(17) Remove the distributor cap and wiring.

(18) Disconnect the heater hoses.

(19) Disconnect the power steering hoses, if equipped.

(20) Perform the Fuel System Pressure release procedure (Refer to 14 - FUEL SYSTEM/FUEL DELIVERY - STANDARD PROCEDURE). Disconnect the fuel supply line (Refer to 14 - FUEL SYSTEM/FUEL DELIVERY/QUICK CONNECT FITTING - STANDARD PROCEDURE).

(21) On Manual Transmission vehicles, remove the shift lever.

(22) Raise and support the vehicle on a hoist.

(23) Remove the drain plug and drain the engine oil.

(24) Remove engine front mount through-bolt nuts.

(25) **Automatic Transmission** Remove the transmission cooler line brackets from oil pan.

(26) Disconnect exhaust pipe at manifold.

(27) Remove starter motor (Refer to 8 - ELECTRICAL/STARTING/STARTER MOTOR - REMOVAL).

(28) **Manual Transmission** Remove the transmission. (Refer to 21 - TRANSMISSION/TRANSAXLE/MANUAL - REMOVAL).

(29) Lower the vehicle.

**CAUTION: DO NOT lift the engine by the intake manifold.**

(30) Install an engine lifting fixture.

## ENGINE 3.9L (Continued)

(31) Remove engine from vehicle and install engine assembly on a repair stand.

**INSTALLATION**

(1) Remove engine from the repair stand and position in the engine compartment. Position the through-bolt into the support cushion brackets.

(2) Install an engine support fixture.

(3) Raise and support the vehicle on a hoist.

(4) **Manual Transmission** Install the transmission (Refer to 21 - TRANSMISSION/TRANSAXLE/MANUAL - INSTALLATION).

(5) Install the starter and connect the starter wires (Refer to 8 - ELECTRICAL/STARTING/STARTER MOTOR - INSTALLATION).

(6) Install exhaust pipe to manifold.

(7) **Automatic Transmission** Install the transmission cooler line brackets on oil pan.

(8) Install engine front mount through-bolt nuts. Tighten the nuts.

(9) Install the drain plug and tighten to 34 N·m (25 ft. lbs.) torque.

(10) Lower the vehicle.

(11) Remove engine-lifting fixture.

(12) On Manual Transmission vehicles, install the shift lever.

(13) Connect the fuel supply line (Refer to 14 - FUEL SYSTEM/FUEL DELIVERY/QUICK CONNECT FITTING - STANDARD PROCEDURE).

(14) Connect the power steering hoses, if equipped.

(15) Connect the heater hoses.

(16) Install the distributor cap and wiring.

(17) Install the intake manifold (Refer to 9 - ENGINE/MANIFOLDS/INTAKE MANIFOLD - INSTALLATION).

(18) Using a new gasket, install throttle body (Refer to 14 - FUEL SYSTEM/FUEL INJECTION/THROTTLE BODY - INSTALLATION).

(19) Connect the throttle linkage.

(20) Install the air cleaner box.

(21) Install the generator and wire connections (Refer to 8 - ELECTRICAL/STARTING/STARTER MOTOR - INSTALLATION).

(22) Install radiator (Refer to 7 - COOLING/ENGINE/RADIATOR - INSTALLATION).

(23) Install the fan and fan shroud (Refer to 7 - COOLING/ENGINE/RADIATOR FAN - INSTALLATION).

(24) Install the washer bottle.

(25) If equipped, install the condenser (Refer to 24 - HEATING & AIR CONDITIONING/PLUMBING/A/C CONDENSER - INSTALLATION).

(26) Install the A/C compressor with the lines attached.

(27) Install accessory drive belt (Refer to 7 - COOLING/ACCESSORY DRIVE/DRIVE BELTS - INSTALLATION).

(28) Evacuate and charge the air conditioning system, if equipped (Refer to 24 - HEATING & AIR CONDITIONING/PLUMBING - STANDARD PROCEDURE).

(29) Install the transmission oil cooler (Refer to 7 - COOLING/TRANSMISSION/TRANS COOLER - INSTALLATION).

(30) Install the upper crossmember and top core support.

(31) Refill cooling system (Refer to 7 - COOLING - STANDARD PROCEDURE).

(32) Connect the negative cable to the battery.

(33) Start engine and check for leaks.

## ENGINE 3.9L (Continued)

## SPECIFICATIONS

## 3.9L ENGINE

## GENERAL DESCRIPTION

DESCRIPTION	SPECIFICATION
Engine Type	90° V-6 OHV
Bore and Stroke	99.3 x 84.0 mm (3.91 x 3.31 in.)
Displacement	3.9L (238 c.i.)
Compression Ratio	9.1:1
Firing Order	1-6-5-4-3-2
Cylinder Compression Pressure (Min.)	689.5 kPa (100 psi)
CAMSHAFT	
Bearing Diameter (Inside)	
No. 1	50.800 - 50.825 mm (2.000 - 2.001 in.)
No. 2	50.394 - 50.825 mm (1.984 - 1.985 in.)
No. 3	49.606 - 49.632 mm (1.953 - 1.954 in.)
No. 4	39.688 - 39.713 mm (1.5265 - 1.5653 in.)
Journal Diameter	
No. 1	50.749 - 50.775 mm (1.998 - 1.999 in.)
No. 2	50.343 - 50.368 mm (1.982 - 1.983 in.)
No. 3	49.555 - 49.581 mm (1.951 - 1.952 in.)
No. 4	39.637 - 39.662 mm (1.5605 - 1.5615 in.)
Bearing to Journal Clearance	
Standard	0.0254 - 0.0762 mm (0.001 - 0.003 in.)
Max Allowable	0.127 mm (0.005 in.)

DESCRIPTION	SPECIFICATION
End Play	0.051 - 0.254 mm (0.002 - 0.010 in.)
CONNECTING RODS	
Piston Pin Bore Diameter	24.940 - 24.978 mm (0.9819 - 0.9834 in.)
Side Clearance (Two Rods)	0.152 - 0.356 mm (0.006 - 0.014 in.)
Total Weight	762 grams (25.61 oz.)
CRANKSHAFT	
Rod Journal Diameter	53.950 - 53.975 mm (2.124 - 2.125 in.)
Rod Journal Out of Round (Max)	0.0254 mm (0.001 in.)
Rod Journal Taper (Max)	0.0254 mm (0.001 in.)
Rod Journal Bearing Clearance	0.013 - 0.056 mm (0.0005 - 0.0022 in.)
Rod Journal Service Limit	0.08 mm (0.003 in.)
Main Journal Diameter	63.487 - 63.513 mm (2.4995 - 2.5005 in.)
Main Journal Out of Round (Max)	0.0254 mm (0.001 in.)
Main Journal Taper (Max)	0.0254 mm (0.001 in.)

## ENGINE 3.9L (Continued)

DESCRIPTION	SPECIFICATION
Main Journal Beraing Clearance	
No. 1	0.013 - 0.038 mm (0.0005 - 0.0015 in.)
No. 2 - 4	0.013 - 0.051 mm (0.0005 - 0.0020 in.)
Service Limit	0.064 mm (0.0025 in.)
End Play	0.051 - 0.178 mm (0.002 - 0.007 in.)
End Play Service Limit	0.254 mm (0.010 in.)
<b>CYLINDER BLOCK</b>	
Cylinder Bore Diameter	99.308 - 99.371 mm (3.9098 - 3.9122 in.)
Cylinder Bore Out of Round and taper  (Max)	0.025 mm (0.001 in.)
Lifter Bore Diameter	22.99 - 23.01 mm (0.9501 - 0.9059 in.)
Distributor Drive Bushing to Bore Interference (Press Fit)	0.0127 - 0.3556 mm (0.0005 - 0.0140 in.)
Distributor Shaft to Bushing Clearance	0.0178 - 0.0686 mm (0.0007 - 0.0027 in.)
<b>CYLINDER HEAD and VALVES</b>	
Valve Seat Angle	44.25° - 44.75°
Valve Seat Runout  (Max)	0.0762 mm (0.003 in.)
Valve Seat Width (Finish)  Intake	1.016 - 1.542 mm

DESCRIPTION	SPECIFICATION
Exhaust	(0.040 - 0.060 in.) 1.524 - 2.032 mm (0.040 - 0.060 in.)
Valve Face Angle	43.25° - 43.75°
Valve Head Diameter	
Intake	48.666 mm (1.916 in.)
Exhaust	41.250 mm (1.624 in.)
Valve Length (Overall)	
Intake	124.28 - 125.92 mm (4.893 - 4.918 in.)
Exhaust	124.64 - 125.27 mm (4.907 - 4.932 in.)
Valve Lift (@ Zero Lash)	10.973 mm (0.432 in.)
Valve Stem Diameter	7.899 - 7.925 mm (0.311 - 0.312 in.)
Valve Guide Bore Diameter	7.950 - 7.976 mm (0.313 - 0.314 in.)
Valve Stem to Guide Clearance	0.0254 - 0.0762 mm (0.001 - 0.003 in.)
Valve Stem to Guide Clearance Service Limit (Rocking Method)	0.4318 mm (0.017 in.)
<b>VALVE SPRINGS</b>	
Free Length	49.962 mm (1.967 in.)
Spring Tension	
Valve Closed	378 N @ 41.66 mm (85 lbs. @ 1.64 in.)
Valve Open	890 N @ 30.89 mm (200 lbs. @ 1.212 in.)

## ENGINE 3.9L (Continued)

DESCRIPTION	SPECIFICATION
Number of Coils	6.8
Installed Height	41.66 mm (1.64 in.)
Wire Diameter	4.50 mm (0.177 in.)
<b>HYDRAULIC TAPPETS</b>	
Body Diameter	22.949 - 22.962 mm (0.9035 - 0.9040 in.)
Clearance in Block	0.0279 - 0.0610 mm (0.0011 - 0.210 in.)
Dry Lash	1.524 - 5.334 mm (0.060 - 0.210 in.)
Push Rod Length	175.64 - 176.15 mm (6.915 - 6.935 in.)
<b>OIL PRESSURE</b>	
@ Curb Idle (Min.)*	41.4 kPa (6 psi)
@ 3000 rpm	207 - 552 kPa (30 - 80 psi)
Bypass Valve Setting	62 - 103 kPa (9 - 15 psi)
Switch Actuating Pressure	34.5 - 48.3 kPa (5 - 7 psi)
<b>* If oil pressure is zero at curb idle, DO NOT RUN ENGINE.</b>	
<b>OIL PUMP</b>	
Clearance Over Rotors (Max)	0.1016 mm (0.004 in.)
Cover Out of Flat (Max)	0.0381 mm (0.0015 in.)
Inner Rotor Thickness (Min)	20.955 mm (0.825 in.)

DESCRIPTION	SPECIFICATION
Outer Rotor Clearance (Max)	0.3556 mm (0.014 in.)
Outer Rotor Diameter (Min)	62.7126 mm (2.469 in.)
Outer Rotor Thickness (Min)	20.955 mm (0.825 in.)
Tip Clearance Between Rotors (Max)	0.2032 mm (0.008 in.)
<b>PISTONS</b>	
Clearance at Top of Skirt	0.0127 - 0.0381 mm (0.0005 - 0.0015 in.)
Land Clearance (Diameter)	0.635 - 1.016 mm (0.025 - 0.040 in.)
Piston Length	86.360 mm (3.40 in.)
Ring Groove Depth #1 & 2	4.572 - 4.826 mm (0.180 - 0.190 in.)
#3	3.810 - 4.064 mm (0.150 - 0.160 in.)
Weight	592.6 - 596.6 grams (20.90 - 21.04 oz.)
<b>PISTON PINS</b>	
Clearance in Piston	0.0064 - 0.0191 mm (0.00025 - 0.00075 in.)
Clearance in Rod (Interference)	0.0178 - 0.0356 mm (0.0007 - 0.0014 in.)
Diameter	24.996 - 25.001 mm (0.9841 - 0.9843 in.)

## ENGINE 3.9L (Continued)

DESCRIPTION	SPECIFICATION
End Play	None
Length	75.946 - 76.454 mm (2.990 - 3.010 in.)
<b>PISTON RINGS</b>	
Ring Gap Compression Rings	0.254 - 0.508 mm (0.010 - 0.020 in.)
Oil Control (Steel Rails)	0.254 - 1.270 mm (0.010 - 0.050 in.)
Ring Side Clearance Compression Rings	0.038 - 0.076 mm (0.0015 - 0.0030 in.)
Oil Control (Steel Rails)	0.06 - 0.21 mm (0.002 - 0.008 in.)
Ring Width Compression Rings	1.971 - 1.989 mm (0.0776 - 0.0783 in.)
Oil Control (Steel Rails)	3.848 - 3.975 mm (0.1515 - 0.1565 in.)
<b>VALVE TIMING</b>	
Exhaust Valve Closes Opens Duration	16° (ATDC) 52° (BBDC) 248°
Intake Valve Closes Opens Duration	50° (ABDC) 10° (BTDC) 240°
Valve Overlap	26°

OVERSIZE AND UNDERSIZE ENGINE  
COMPONENT MARKINGS CHART

OS-US	Item	Identification	Location of Identification
U/S .0254 MM (.001 IN.)	Crankshaft	R or M M-2-3 ect. (indicating No. 2 & 3 main bearing journal) and/or R-1-4 ect. (indicating No. 1 & 4 connecting rod journal)	Milled flat on  No. eight crankshaft counterweight.
O/S .2032 mm (.008 in.)	Tappets	◇	3/8" diamound  -shaped stamp Top pad — Front of engine and flat ground on outside surface of each O/S tappet bore.
O/S .127 mm  (0.005 in.)	Valve Stems	X	Milled pad  adjacent to two 3/8" tapped  holes on each end of cylinder head.



## ENGINE 3.9L (Continued)

## TORQUE

## TORQUE CHART 3.9L ENGINE

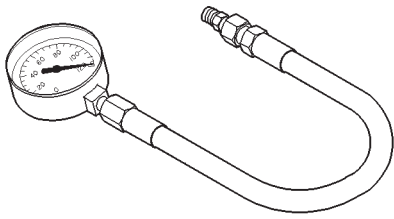
DESCRIPTION	N·m	In. Lbs.	Ft. Lbs.
Camshaft Sprocket—Bolt	68	—	50
Camshaft Thrust Plate—Bolts	24	210	—
Timing Chain Case Cover—Bolts	41	—	30
Connecting Rod Cap—Bolts	61	—	45
Main Bearing Cap—Bolts	115	—	85
Crankshaft Pulley—Bolts	24	210	—
Cylinder Head—Bolts			
Step 1	68	—	50
Step 2	143	—	105
Cylinder Head Cover—Bolts	11	95	—
Engine Support Bracket to Block (4wd)—Bolts	41	—	30
Exhaust Manifold to Cylinder Head—bolts/nuts	34	—	25
Flywheel—Bolts	75	—	55
Front Insulator—through Bolts	95	—	70
Front Insulator to Support Bracket (4wd)			
—Stud Nut	41	—	30
—Through Bolt/Nut	102	—	75
Front Insulator to Block—Bolts (2wd)	95	—	70
Generator—Mounting Bolt	41	—	30
Intake Manifold—Bolts	Refer to Procedure		
Oil Pan—Bolts	24	215	—
Oil Pan—Drain Plug	34	—	25
Oil Pump—Mounting Bolts	41	—	30
Oil Pump Cover—Bolts	11	95	—
Rear Insulator to Bracket—	68	—	50

DESCRIPTION	N·m	In. Lbs.	Ft. Lbs.
Through-Bolt (2WD)			
Rear Insulator to Crossmember Support Bracket—Nut (2WD)	41	—	30
Rear Insulator to Crossmember—Nuts (4WD)	68	—	50
Rear Insulator to Transmission — Bolts (4WD)	68	—	50
Rear Insulator Bracket—Bolts (4WD Automatic)	68	—	50
Rear Support Bracket to Crossmember Flange—Nuts	41	—	30
Rear Support Plate to Transfer Case—Bolts	41	—	30
Rocker Arm—Bolts	28	—	21
Spark Plugs	41	—	30
Starter Motor—Mounting Bolts	68	—	50
Thermostat Housing—Bolts	25	225	—
Throttle Body—Bolts	23	200	—
Torque Converter Drive Plate—Bolts	31	270	—
Transfer Case to Insulator Mounting Plate—Nuts	204	—	150
Transmission Support Bracket —Bolts (2WD)	68	—	50
Vibration Damper—Bolt	183	—	135
Water Pump to Timing Chain Case Cover— Bolts	41	—	30

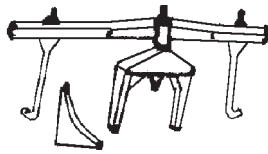
ENGINE 3.9L (Continued)

SPECIAL TOOLS

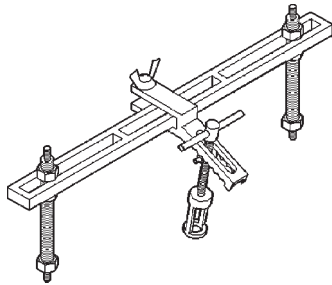
ENGINE—3.9L



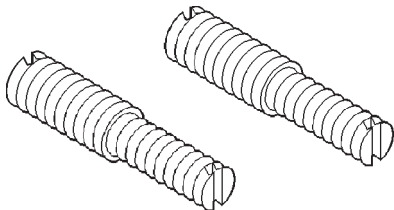
**Oil Pressure Gauge C-3292**



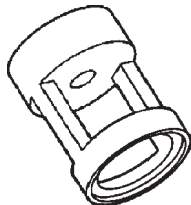
**Engine Support Fixture C-3487-A**



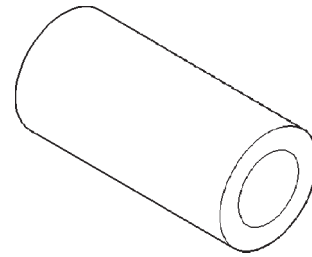
**Valve Spring Compressor MD-998772-A**



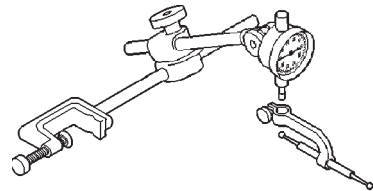
**Adapter 6633**



**Adapter 6716A**

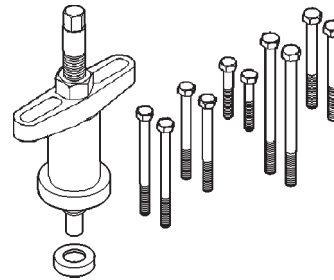


**Valve Guide Sleeve C-3973**

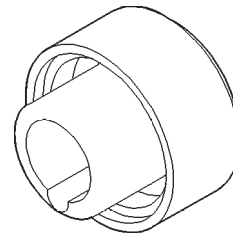


80110420

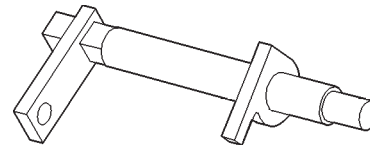
**Dial Indicator C-3339**



**Puller C-3688**



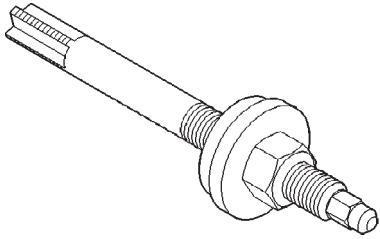
**Front Oil Seal Installer 6635**



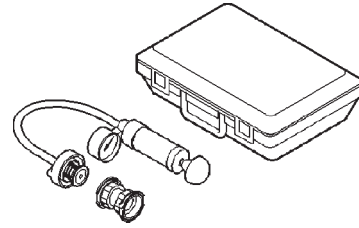
c-3509-80110343

**Camshaft Holder C-3509**

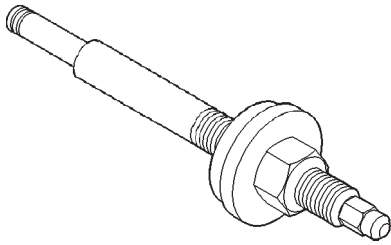
ENGINE 3.9L (Continued)



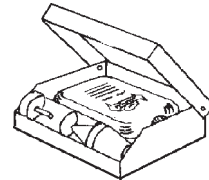
**Distributor Bushing Puller C-3052**



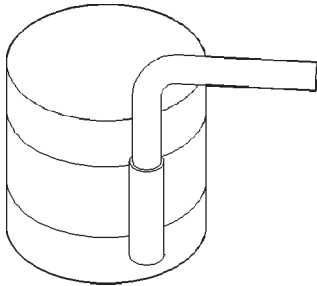
**Pressure Tester Kit 7700**



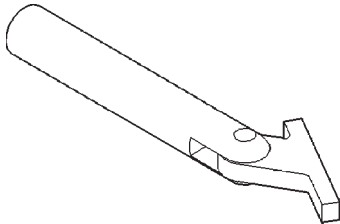
**Distributor Bushing Driver/Burnisher C-3053**



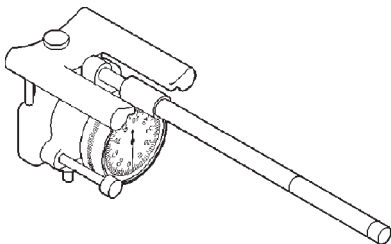
**Bloc-Chek-Kit C-3685-A**



**Piston Ring Compressor C-385**



**Crankshaft Main Bearing Remover C-3059**



8011c9fa

**Cylinder Bore Gauge C-119**

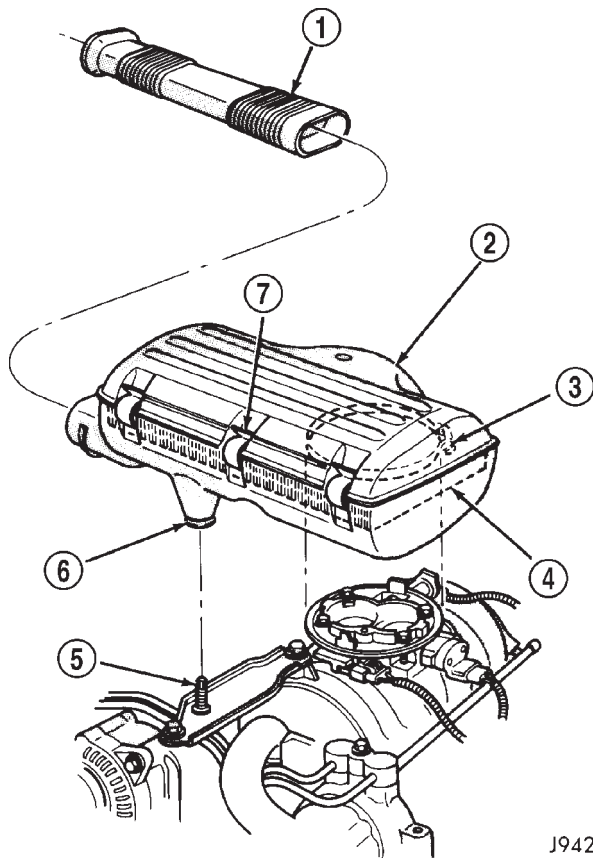
## AIR CLEANER ELEMENT

### REMOVAL - 3.9L/5.2L/5.9L

For air cleaner element required maintenance schedules (listed in time or mileage intervals), refer to 0, Lubrication and Maintenance.

**CAUTION:** Do not attempt to remove air cleaner element (filter) from housing by removing top cover only. To prevent damage to air cleaner housing, the entire air cleaner housing assembly must be removed from engine for air cleaner element replacement.

(1) Remove air inlet tube (Fig. 4) at side of air cleaner housing.



J9425-5

**Fig. 4 Air Cleaner Housing—3.9L/5.2L/5.9L Engines**

- 1 - AIR INLET TUBE
- 2 - HOUSING TOP COVER
- 3 - CLAMP
- 4 - AIR FILTER ELEMENT
- 5 - MOUNTING STUD
- 6 - RUBBER GROMMET
- 7 - SPRING CLIPS

(2) A band-type screw clamp secures the air cleaner housing to throttle body. Loosen, but do not remove, this screw clamp (Fig. 4). Note clamp positioning tabs on air cleaner housing.

(3) All Engines: Disconnect breather hose at rear of air cleaner housing.

(4) 5.9L V-8 HDC Engine Only: Disconnect air pump hose at air cleaner housing.

(5) The bottom/front of air cleaner housing is equipped with a rubber grommet (Fig. 4). A mounting stud is attached to intake manifold (Fig. 4) and is used to position air cleaner housing into this grommet. Lift assembly from throttle body while slipping assembly from mounting stud (Fig. 4).

(6) Check condition of gasket at throttle body and replace as necessary.

(7) The housing cover is equipped with three (3) spring clips (Fig. 4) and is hinged at rear with plastic tabs. Unlatch clips from top of air cleaner housing and tilt housing cover up and rearward for cover removal.

(8) Remove air cleaner element from air cleaner housing.

(9) Before installing new air cleaner element, clean inside of air cleaner housing.

### INSTALLATION - 3.9L/5.2L/5.9L

For air cleaner element required maintenance schedules (listed in time or mileage intervals), refer to Group 0, Lubrication and Maintenance.

(1) Position air cleaner cover to tabs on rear of air cleaner housing. Latch three spring clips to seal cover to housing.

(2) Position air cleaner housing assembly to throttle body while guiding rubber grommet over mounting stud. The lower part of screw clamp should be below top lip of throttle body.

(3) Push down on air cleaner housing at rubber grommet to seat housing at intake manifold.

(4) Tighten throttle body-to-air cleaner housing clamp to 4 N·m (35 in. lbs.) torque.

(5) Install air inlet tube at air cleaner housing inlet.

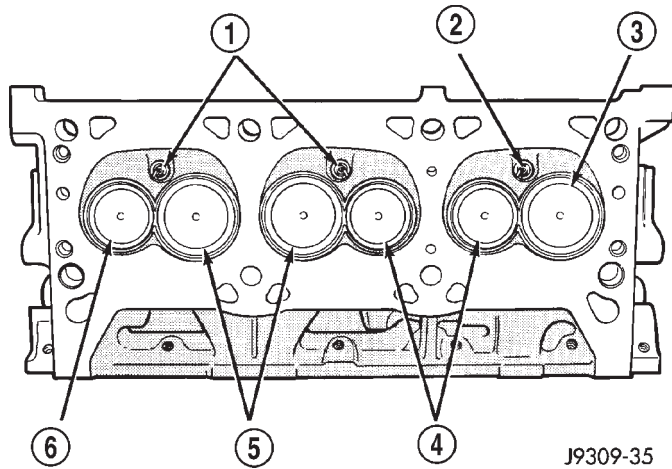
(6) Install breather hose.

(7) Install secondary air hose (if equipped).

## CYLINDER HEAD

### DESCRIPTION—CYLINDER HEAD

The cast iron cylinder heads (Fig. 5) are mounted to the cylinder block using eight bolts. The spark plugs are located in the peak of the wedge between the valves.

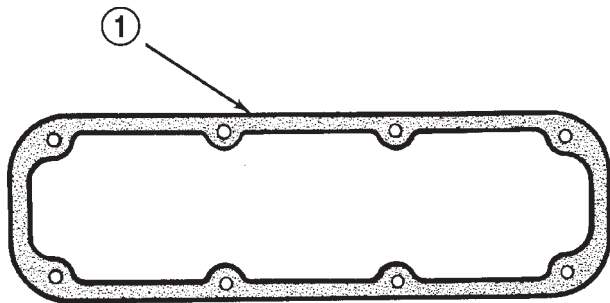


**Fig. 5 Cylinder Head Assembly—3.9L Engine**

- 1 - SPARK PLUGS
- 2 - SPARK PLUG
- 3 - INTAKE VALVE
- 4 - EXHAUST VALVES
- 5 - INTAKE VALVES
- 6 - EXHAUST VALVE

### DESCRIPTION—CYLINDER HEAD COVER GASKET

The cylinder head cover gasket (Fig. 6) is a steel-backed silicone gasket, designed for long life usage.



**Fig. 6 Cylinder Head Cover Gasket**

- 1 - CYLINDER HEAD COVER GASKET

### OPERATION—CYLINDER HEAD

The cylinder head closes the combustion chamber allowing the pistons to compress the air fuel mixture to the correct ratio for ignition. The valves located in the cylinder head open and close to either allow clean air into the combustion chamber or to allow the exhaust gases out, depending on the stroke of the engine.

### OPERATION—CYLINDER HEAD COVER GASKET

The steel-backed silicone gasket is designed to seal the cylinder head cover for long periods of time through extensive heat and cold, without failure. The gasket is designed to be reusable.

### DIAGNOSIS AND TESTING—CYLINDER HEAD GASKET FAILURE

A cylinder head gasket leak can be located between adjacent cylinders or between a cylinder and the adjacent water jacket.

• Possible indications of the cylinder head gasket leaking between adjacent cylinders are:

- Loss of engine power
- Engine misfiring
- Poor fuel economy

• Possible indications of the cylinder head gasket leaking between a cylinder and an adjacent water jacket are:

- Engine overheating
- Loss of coolant
- Excessive steam (white smoke) emitting from exhaust
- Coolant foaming

### CYLINDER-TO-CYLINDER LEAKAGE TEST

To determine if an engine cylinder head gasket is leaking between adjacent cylinders, follow the procedures in Cylinder Compression Pressure Test in this section. An engine cylinder head gasket leaking between adjacent cylinders will result in approximately a 50–70% reduction in compression pressure.

### CYLINDER-TO-WATER JACKET LEAKAGE TEST

**WARNING: USE EXTREME CAUTION WHEN THE ENGINE IS OPERATING WITH COOLANT PRESSURE CAP REMOVED.**

### VISUAL TEST METHOD

With the engine cool, remove the coolant pressure cap. Start the engine and allow it to warm up until thermostat opens.

If a large combustion/compression pressure leak exists, bubbles will be visible in the coolant.

## CYLINDER HEAD (Continued)

## COOLING SYSTEM TESTER METHOD

**WARNING: WITH COOLING SYSTEM TESTER IN PLACE, PRESSURE WILL BUILD UP FAST. EXCESSIVE PRESSURE BUILT UP, BY CONTINUOUS ENGINE OPERATION, MUST BE RELEASED TO A SAFE PRESSURE POINT. NEVER PERMIT PRESSURE TO EXCEED 138 kPa (20 psi).**

Install Cooling System Tester 7700 or equivalent to pressure cap neck. Start the engine and observe the tester's pressure gauge. If gauge pulsates with every power stroke of a cylinder a combustion pressure leak is evident.

## CHEMICAL TEST METHOD

Combustion leaks into the cooling system can also be checked by using Bloc-Chek Kit C-3685-A or equivalent. Perform test following the procedures supplied with the tool kit.

## REMOVAL

The alloy cast iron cylinder heads (Fig. 7) are held in place by eight bolts. The spark plugs are located at the peak of the wedge between the valves.

(1) Disconnect the battery negative cable from the battery.

(2) Drain cooling system. (Refer to 7 - COOLING - STANDARD PROCEDURE).

(3) Remove the intake manifold-to-generator bracket support rod. Remove the generator.

(4) Remove closed crankcase ventilation system.

(5) Disconnect the evaporation control system.

(6) Remove the air cleaner, air in-let hose and resonator.

(7) Perform fuel system pressure release procedure (Refer to 14 - FUEL SYSTEM/FUEL DELIVERY - STANDARD PROCEDURE).

(8) Disconnect the fuel supply line from the fuel rail (Refer to 14 - FUEL SYSTEM/FUEL DELIVERY/QUICK CONNECT FITTING - STANDARD PROCEDURE).

(9) Disconnect accelerator linkage and if so equipped, the speed control and transmission kick-down cables.

(10) Remove distributor cap and wires.

(11) Disconnect the coil wires.

(12) Disconnect coolant temperature sending unit wire.

(13) Disconnect heater hoses and bypass hose.

(14) Disconnect the vacuum supply hoses from the intake manifold.

(15) Disconnect the fuel injector harness and secure out of the way.

(16) Remove cylinder head covers and gaskets (Refer to 9 - ENGINE/CYLINDER HEAD/CYLINDER HEAD COVER(S) - REMOVAL).

(17) Remove intake manifold and throttle body as an assembly. Discard the flange side gaskets and the front and rear cross-over gaskets.

(18) Remove exhaust manifolds (Refer to 9 - ENGINE/MANIFOLDS/EXHAUST MANIFOLD - REMOVAL).

(19) Remove rocker arm assemblies and push rods. Identify to ensure installation in original locations.

(20) Remove the head bolts from each cylinder head and remove cylinder heads. Discard the cylinder head gasket.

(21) Remove spark plugs.

## CLEANING

Clean all surfaces of cylinder block and cylinder heads.

Clean cylinder block front and rear gasket surfaces using a suitable solvent.

## INSPECTION

Inspect all surfaces with a straightedge if there is any reason to suspect leakage. If out-of-flatness exceeds 0.00075mm (0.0001in.) times the span length in any direction, either replace head or lightly machine the head surface.

**FOR EXAMPLE:**—A 305 mm (12 in.) span is 0.102 mm (0.004 in.) out-of-flat. The allowable out-of-flat is  $305 \times 0.00075$  (12 x 0.00075) equals 0.23 mm (0.009 in.). This amount of out-of-flat is acceptable.

The cylinder head surface finish should be 1.78-3.00 microns (70-125 microinches).

Inspect push rods. Replace worn or bent rods.

## INSTALLATION

The alloy cast iron cylinder heads (Fig. 7) are held in place by eight bolts. The spark plugs are located at the peak of the wedge between the valves.

(1) Position the new cylinder head gaskets onto the cylinder block.

(2) Position the cylinder heads onto head gaskets and cylinder block.

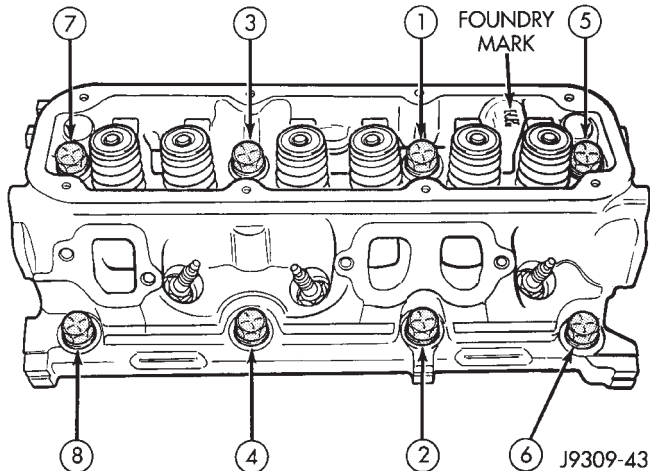
(3) Starting at top center, tighten all cylinder head bolts, in sequence, to 68 N·m (50 ft. lbs.) torque (Fig. 7). Repeat procedure, tighten all cylinder head bolts to 143 N·m (105 ft. lbs.) torque. Repeat procedure to confirm that all bolts are at 143 N·m (105 ft. lbs.) torque.

**CAUTION: When tightening the rocker arm bolts, be sure the piston in that cylinder is NOT at TDC. Contact between the valves and piston could occur.**

(4) Install push rods and rocker arm assemblies in their original positions. Tighten the bolts to 28 N·m (21 ft. lbs.) torque.



## CYLINDER HEAD (Continued)



**Fig. 7 Cylinder Head Bolt -Tightening Sequence**

(5) Install the intake manifold (Refer to 9 - ENGINE/MANIFOLDS/INTAKE MANIFOLD - INSTALLATION) and throttle body assembly.

(6) Install exhaust manifolds (Refer to 9 - ENGINE/MANIFOLDS/EXHAUST MANIFOLD - INSTALLATION).

(7) Adjust spark plugs to specifications. Install the plugs and tighten to 41 N·m (30 ft. lbs.) torque.

(8) Install coil wires.

(9) Connect coolant temperature sending unit wire.

(10) Connect the fuel injector harness.

(11) Connect the vacuum supply hoses to the intake manifold.

(12) Connect the heater hoses and bypass hose.

(13) Install distributor cap and wires.

(14) Connect the accelerator linkage and, if so equipped, the speed control and transmission kick-down cables.

(15) Install the fuel supply line.

(16) Install the generator and accessory drive belt (Refer to 7 - COOLING/ACCESSORY DRIVE/DRIVE BELTS - INSTALLATION). Tighten generator mounting bolt to 41 N·m (30 ft. lbs.) torque.

(17) Install the intake manifold-to-generator bracket support rod. Tighten the bolts.

(18) Install cylinder head covers. (Refer to 9 - ENGINE/CYLINDER HEAD/CYLINDER HEAD COVER(S) - INSTALLATION).

(19) Install closed crankcase ventilation system.

(20) Connect the evaporation control system.

(21) Install the resonator assembly, air in-let hose and air cleaner.

(22) Install the heat shields. Tighten the bolts to 41 N·m (30 ft. lbs.) torque.

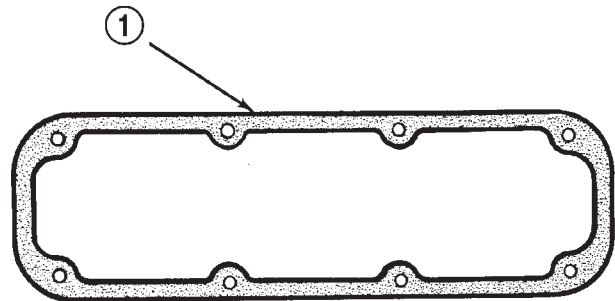
(23) Fill cooling system (Refer to 7 - COOLING - STANDARD PROCEDURE).

(24) Connect the battery negative cable.

## CYLINDER HEAD COVER(S)

## REMOVAL

A steel-backed silicone gasket is used with the cylinder head cover (Fig. 8). This gasket can be used again.



J9209-104

**Fig. 8 Cylinder Head Cover Gasket**

1 - CYLINDER HEAD COVER GASKET

- (1) Disconnect the negative cable from the battery.
- (2) Disconnect closed ventilation system and evaporation control system from cylinder head cover.
- (3) Remove cylinder head cover bolts, cover and gasket. The gasket may be used again.

## CLEANING

Clean cylinder head cover gasket surface.  
Clean head rail, if necessary.

## INSPECTION

Inspect cover for distortion and straighten, if necessary.

Check the gasket for use in head cover installation. If damaged, use a new gasket.

## INSTALLATION

A steel-backed silicone gasket is used with the cylinder head cover (Fig. 8). This gasket can be used again.

- (1) Position the cylinder head cover gasket onto the head rail.
- (2) Position the cylinder head cover onto the gasket and install the bolts. Tighten the bolts to 11 N·m (95 in. lbs.) torque.
- (3) Install closed crankcase ventilation system and evaporation control system.
- (4) Connect the negative cable to the battery.
- (5) Start engine and check for leaks.

## INTAKE/EXHAUST VALVES & SEATS

### DESCRIPTION

Both the intake and exhaust valves are made of steel. The intake valve is 48.768 mm (1.92 inches) in diameter and the exhaust valve is 41.148 mm (1.62 inches) in diameter and has a 2.032 mm (0.080 inch) wafer intertia welded to the tip for durability. These valves are not splayed.

### STANDARD PROCEDURE—VALVES, GUIDES AND SPRINGS

#### VALVE CLEANING

Clean valves thoroughly. Discard burned, warped, or cracked valves.

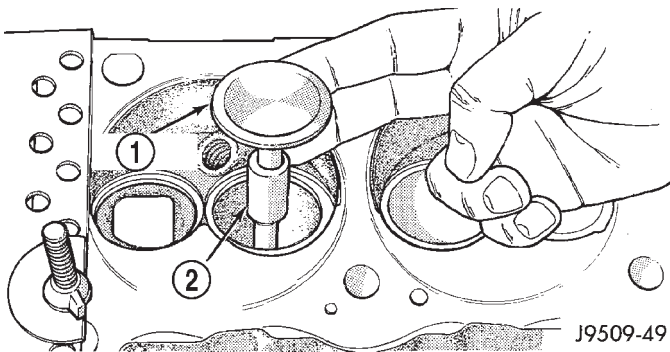
Remove carbon and varnish deposits from inside of valve guides with a reliable guide cleaner.

#### VALVE GUIDES

Measure valve stems for wear. If wear exceeds 0.051 mm (0.002 in.), replace the valve.

Measure valve stem guide clearance as follows:

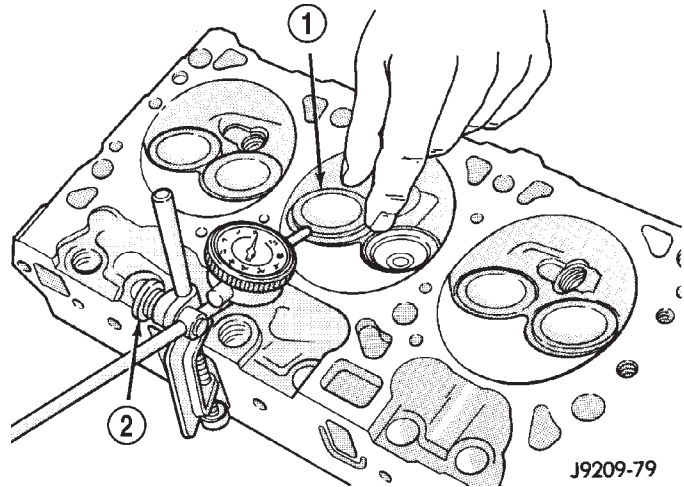
(1) Install Valve Guide Sleeve Tool C-3973 over valve stem and install valve (Fig. 9). The special sleeve places the valve at the correct height for checking with a dial indicator.



**Fig. 9 Positioning Valve with Tool C-3973**

1 - VALVE  
2 - SPACER TOOL

(2) Attach dial indicator Tool C-3339 to cylinder head and set it at right angles to valve stem being measured (Fig. 10).



**Fig. 10 Measuring Valve Guide Wear**

1 - VALVE  
2 - SPECIAL TOOL C-3339

(3) Move valve to and from the indicator. The total dial indicator reading should not exceed 0.432 mm (0.017 in.). Ream the guides for valves with oversize stems if dial indicator reading is excessive or if the stems are scuffed or scored.

#### VALVE GUIDES

Service valves with oversize stems are available. Refer to REAMER SIZES CHART

#### REAMER SIZES CHART

REAMER O/S	VALVE GUIDE SIZE
0.076 mm (0.003 in.)	8.026 - 8.052 mm (0.316 - 0.317 in.)
0.381 mm (0.015 in.)	8.331 - 8.357 mm (0.328 - 0.329 in.)

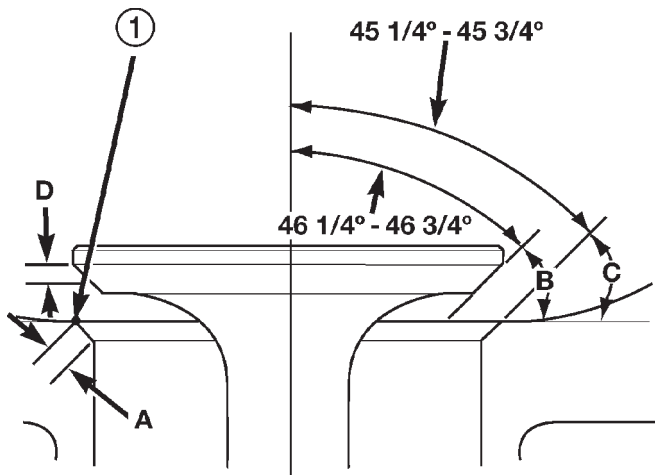
(1) Slowly turn reamer by hand and clean guide thoroughly before installing new valve. **Ream the valve guides from standard to 0.381 mm (0.015 in.). Use a two step procedure so the valve guides are reamed true in relation to the valve seat:**

- Step 1—Ream to 0.0763 mm (0.003 inch).
- Step 2—Ream to 0.381 mm (0.015 inch).

INTAKE/EXHAUST VALVES & SEATS (Continued)

REFACING VALVES AND VALVE SEATS

The intake and exhaust valves have a 43-1/4° to 43-3/4° face angle and a 44-1/4° to 44-3/4° seat angle (Fig. 11).



80ba7a5f

**Fig. 11 Valve Face and Seat Angles**

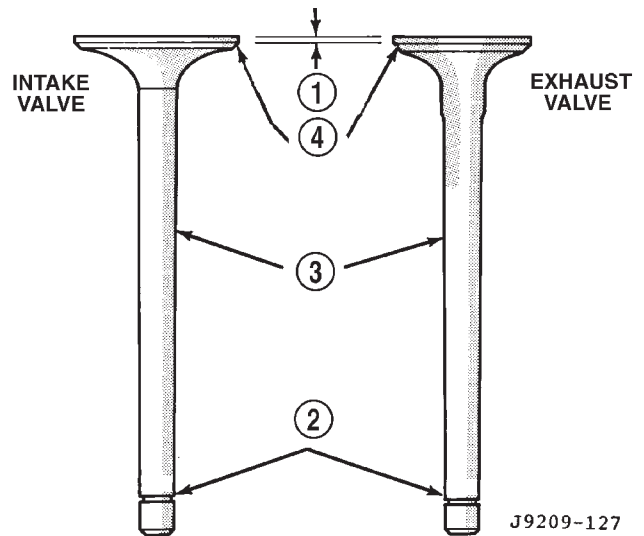
1 - CONTACT POINT  
A,B,C and D Refer to VALVE FACE AND VALVE SEAT ANGLE CHART

VALVE FACE AND VALVE SEAT ANGLE CHART

ITEM	DESCRIPTION	SPECIFICATION
A	SEAT WIDTH INTAKE	1.016 - 1.524 mm (0.040 - 0.060 in.)
	EXHAUST	1.524 - 2.032 mm (0.060 - 0.080 in.)
B	FACE ANGLE (INT. AND EXT.)	43 <sup>1</sup> / <sub>4</sub> ° - 43 <sup>3</sup> / <sub>4</sub> °
C	SEAT ANGLE (INT. AND EXT.)	44 <sup>1</sup> / <sub>4</sub> ° - 44 <sup>3</sup> / <sub>4</sub> °
D	CONTACT SURFACE	—

VALVES

Inspect the remaining margin after the valves are refaced (Fig. 12). Valves with less than 1.190 mm (0.047 in.) margin should be discarded.



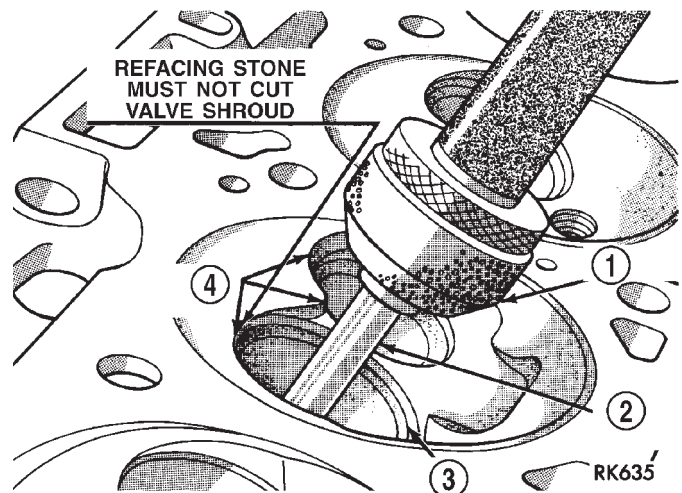
J9209-127

**Fig. 12 Intake and Exhaust Valves**

- 1 - MARGIN
- 2 - VALVE SPRING RETAINER LOCK GROOVE
- 3 - STEM
- 4 - FACE

VALVE SEATS

**CAUTION: DO NOT un-shroud valves during valve seat refacing (Fig. 13).**



**Fig. 13 Refacing Valve Seats**

- 1 - STONE
- 2 - PILOT
- 3 - VALVE SEAT
- 4 - SHROUD

## INTAKE/EXHAUST VALVES & SEATS (Continued)

(1) When refacing valve seats, it is important that the correct size valve guide pilot be used for reseating stones. A true and complete surface must be obtained.

(2) Measure the concentricity of valve seat using a dial indicator. Total runout should not exceed 0.051 mm (0.002 in.) total indicator reading.

(3) Inspect the valve seat with Prussian blue, to determine where the valve contacts the seat. To do this, coat valve seat **LIGHTLY** with Prussian blue then set valve in place. Rotate the valve with light pressure. If the blue is transferred to the center of valve face, contact is satisfactory. If the blue is transferred to the top edge of valve face, lower valve seat with a 15° stone. If the blue is transferred to bottom edge of valve face raise valve seat with a 60° stone.

(4) When seat is properly positioned the width of intake seats should be 1.016-1.524 mm (0.040-0.060 in.). The width of the exhaust seats should be 1.524-2.032 mm (0.060-0.080 in.).

### VALVE SPRINGS

Whenever valves have been removed for inspection, reconditioning or replacement, valve springs should be tested. As an example the compression length of the spring to be tested is 1-5/16 in.. Turn table of Universal Valve Spring Tester Tool until surface is in line with the 1-5/16 in. mark on the threaded stud. Be sure the zero mark is to the front (Fig. 14). Place spring over stud on the table and lift compressing lever to set tone device. Pull on torque wrench until ping is heard. Take reading on torque wrench at this instant. Multiply this reading by 2. This will give the spring load at test length. Fractional measurements are indicated on the table for finer adjustments. Refer to specifications to obtain specified height and allowable tensions. Discard the springs that do not meet specifications.

### REMOVAL

(1) Remove the cylinder head (Refer to 9 - ENGINE/CYLINDER HEAD - REMOVAL).

(2) Compress valve springs using Valve Spring Compressor Tool MD- 998772A and adapter 6716A.

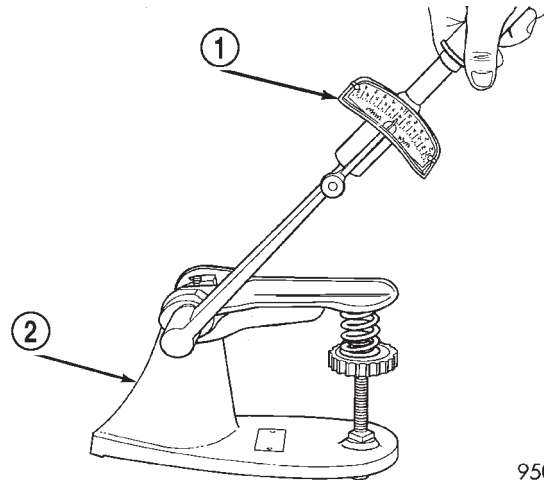
(3) Remove valve retaining locks, valve spring retainers, valve stem seals and valve springs.

(4) Before removing valves, remove any burrs from valve stem lock grooves to prevent damage to the valve guides. Identify valves to ensure installation in original location.

### CLEANING

Clean valves thoroughly. Discard burned, warped, or cracked valves.

Remove carbon and varnish deposits from inside of valve guides with a reliable guide cleaner.



9509-79

**Fig. 14 Testing Valve Spring for Compressed Length**

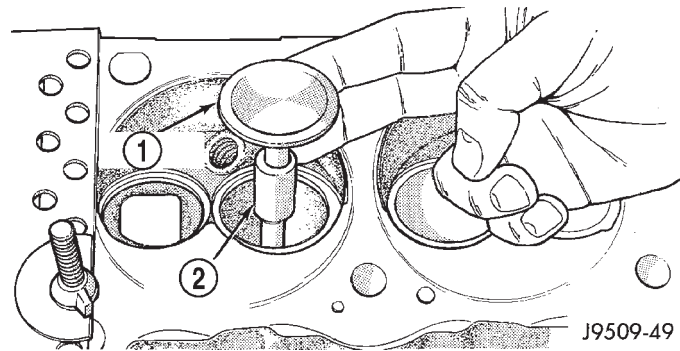
- 1 - TORQUE WRENCH  
2 - VALVE SPRING TESTER

### INSPECTION

Measure valve stems for wear. If wear exceeds 0.051 mm (0.002 in.), replace the valve.

Measure valve stem guide clearance as follows:

(1) Install Valve Guide Sleeve Tool C-3973 over valve stem and install valve (Fig. 15). The special sleeve places the valve at the correct height for checking with a dial indicator.



J9509-49

**Fig. 15 Positioning Valve with Tool C-3973**

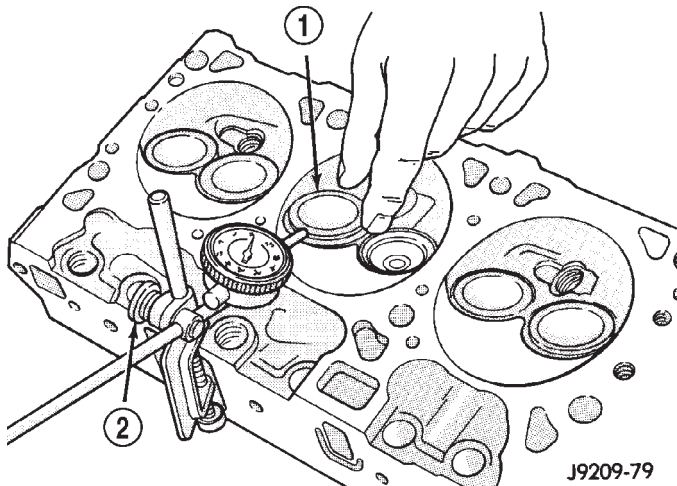
- 1 - VALVE  
2 - SPACER TOOL

(2) Attach dial indicator Tool C-3339 to cylinder head and set it at right angles to valve stem being measured (Fig. 16).

(3) Move valve to and from the indicator. The total dial indicator reading should not exceed 0.432 mm (0.017 in.). Ream the guides for valves with oversize stems if dial indicator reading is excessive or if the stems are scuffed or scored.



## INTAKE/EXHAUST VALVES &amp; SEATS (Continued)



**Fig. 16 Measuring Valve Guide Wear**

- 1 - VALVE  
2 - SPECIAL TOOL C-3339

## INSTALLATION

- (1) Clean valves thoroughly. Discard burned, warped and cracked valves.
- (2) Remove carbon and varnish deposits from inside of valve guides with a reliable guide cleaner.
- (3) Measure valve stems for wear. If wear exceeds 0.051 mm (0.002 inch), replace the valve.
- (4) Coat valve stems with lubrication oil and insert them in cylinder head.
- (5) If valves or seats are reground, check valve stem height. If valve is too long, replace cylinder head.
- (6) Install new seals on all valve guides. Install valve springs and valve retainers.
- (7) Compress valve springs with Valve Spring Compressor Tool MD-998772A and adapter 6716A, install locks and release tool. If valves and/or seats are ground, measure the installed height of springs. Make sure the measurement is taken from bottom of spring seat in cylinder head to the bottom surface of spring retainer. If spacers are installed, measure from the top of spacer. If height is greater than 42.86 mm (1-11/16 inches), install a 1.587 mm (1/16 inch) spacer in head counterbore. This should bring spring height back to normal 41.27 to 42.86 mm (1-5/8 to 1-11/16 inch).
- (8) Install cylinder head (Refer to 9 - ENGINE/CYLINDER HEAD - INSTALLATION).

## ENGINE BLOCK

## CLEANING

Clean cylinder block thoroughly and check all core hole plugs for evidence of leakage.

## INSPECTION

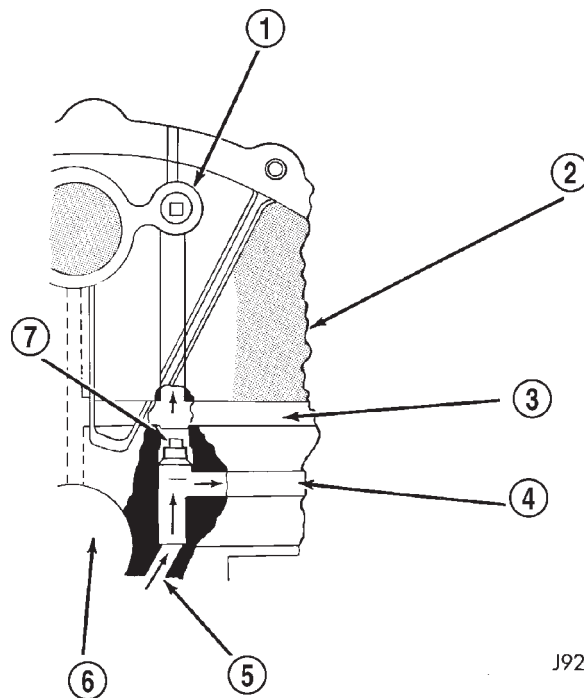
Examine block for cracks or fractures.

The cylinder walls should be checked for out-of-round and taper. Refer to Honing Cylinder Bores in the Service Procedures portion of this Section.

Inspect the oil line plug, the oil line plug is located in the vertical passage at the rear of the block between the oil-to-filter and oil-from-filter passages (Fig. 17). Improper installation or missing plug could cause erratic, low, or no oil pressure.

The oil plug must come out the bottom. Use flat dowel, down the oil pressure sending unit hole from the top, to remove oil plug.

- (1) Remove oil pressure sending unit from back of block.
- (2) Insert a 3.175 mm (1/8 in.) finish wire, or equivalent, into passage.
- (3) Plug should be 190.0 to 195.2 mm (7-1/2 to 7-11/16 in.) from machined surface of block (Fig. 17). If plug is too high, use a suitable flat dowel to position properly.



**Fig. 17 Oil Line Plug**

- 1 - RIGHT OIL GALLERY  
2 - CYLINDER BLOCK  
3 - OIL FROM FILTER TO SYSTEM  
4 - OIL TO FILTER  
5 - FROM OIL PUMP  
6 - CRANKSHAFT  
7 - PLUG

(4) If plug is too low, remove oil pan and No. 4 main bearing cap. Use suitable flat dowel to position properly. Coat outside diameter of plug with Mopar® Stud and

## ENGINE BLOCK (Continued)

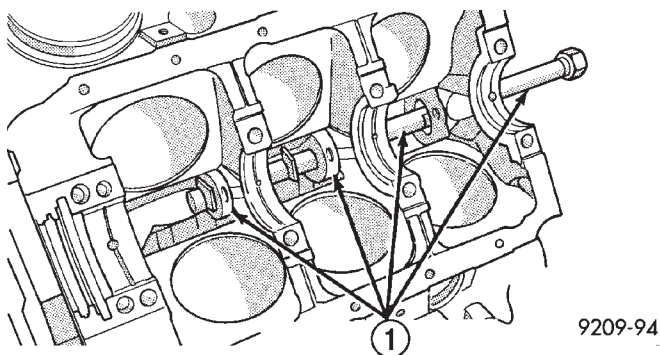
Bearing Mount Adhesive. Plug should be 54.0 to 57.7 mm (2-1/8 to 2-5/16 in.) from bottom of the block.

## CAMSHAFT &amp; BEARINGS (IN BLOCK)

## REMOVAL—CAMSHAFT BEARINGS

(1) With engine completely disassembled, drive out rear cam bearing core hole plug.

(2) Install proper size adapters and horseshoe washers (part of Camshaft Bearing Remover/Installer Tool C-3132-A) at back of each bearing shell. Drive out bearing shells (Fig. 18).



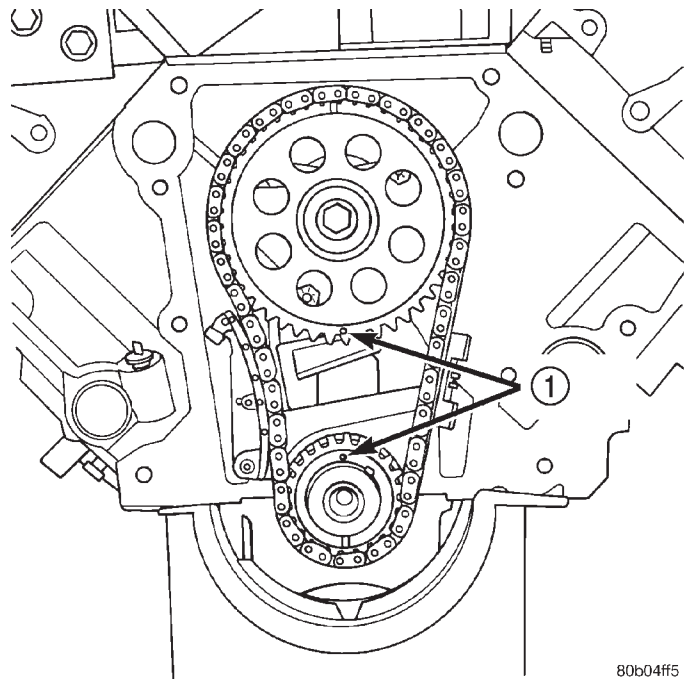
**Fig. 18 Camshaft Bearings Removal and Installation with Tool C-3132-A**

1 - SPECIAL TOOL C-3132A

## REMOVAL—CAMSHAFT

- (1) Disconnect battery negative cable.
- (2) Remove radiator. (Refer to 7 - COOLING/ENGINE/RADIATOR - REMOVAL).
- (3) Remove intake manifold. (Refer to 9 - ENGINE/MANIFOLDS/INTAKE MANIFOLD - REMOVAL).
- (4) Remove distributor assembly. Refer to Ignition Systems for the correct procedure.
- (5) Remove cylinder head covers (Refer to 9 - ENGINE/CYLINDER HEAD/CYLINDER HEAD COVER(S) - REMOVAL).
- (6) Remove rocker arms.
- (7) Remove push rods and tappets (Refer to 9 - ENGINE/ENGINE BLOCK/HYDRAULIC LIFTERS (CAM IN BLOCK) - REMOVAL). Identify each part so it can be installed in the original locations.
- (8) Remove timing chain cover. (Refer to 9 - ENGINE/VALVE TIMING/TIMING BELT / CHAIN COVER(S) - REMOVAL).
- (9) Align timing marks (Fig. 19) and remove timing chain and sprockets.
- (10) Remove the three tensioner to block mounting bolts and remove tensioner.

(11) Install a long bolt into front of camshaft to aid in removal of the camshaft. Remove camshaft, being careful not to damage cam bearings with the cam lobes.



**Fig. 19 Alignment of Timing Marks**

1 - TIMING MARKS

## INSTALLATION—CAMSHAFT BEARINGS

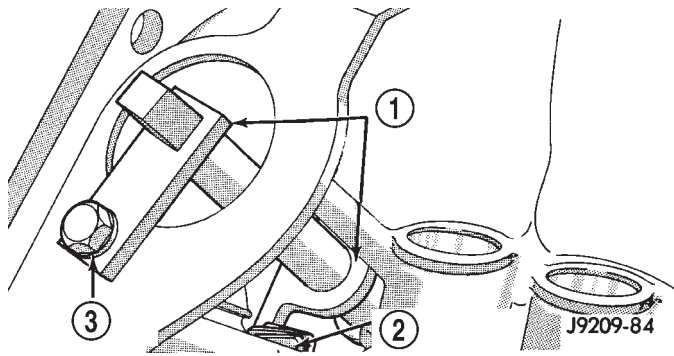
- (1) Install new camshaft bearings with Camshaft Bearing Remover/Installer Tool C-3132-A by sliding the new camshaft bearing shell over proper adapter.
- (2) Position rear bearing in the tool. Install horseshoe lock and, by reversing removal procedure, carefully drive bearing shell into place.
- (3) Install remaining bearings in the same manner. Bearings must be carefully aligned to bring oil holes into full register with oil passages from the main bearing. If the camshaft bearing shell oil holes are not in exact alignment, remove and install them correctly. Install a new core hole plug at the rear of camshaft. **Be sure this plug does not leak.**

## INSTALLATION—CAMSHAFT

- (1) Lubricate camshaft lobes and camshaft bearing journals and insert the camshaft to within 51 mm (2 inches) of its final position in cylinder block.
- (2) Install Camshaft Holding Tool C-3509 with tongue back of distributor drive gear (Fig. 20).
- (3) Hold tool in position with a distributor lock-plate bolt. This tool will restrict camshaft from being pushed in too far and prevent knocking out the welch plug in rear of cylinder block. **Tool should remain**

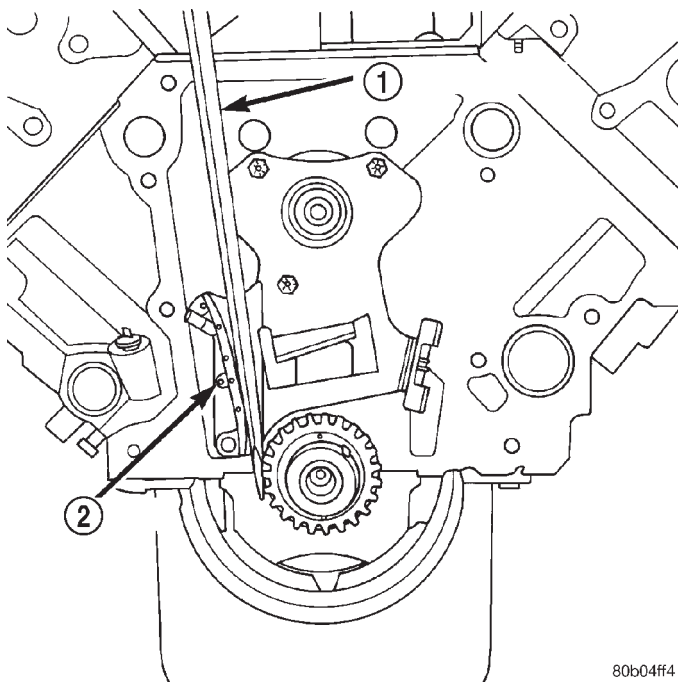


CAMSHAFT & BEARINGS (IN BLOCK) (Continued)



**Fig. 20 Camshaft Holding Tool C-3509 (Installed Position)**

- 1 - SPECIAL TOOL C-3509
- 2 - DRIVE GEAR
- 3 - DISTRIBUTOR LOCK BOLT



**Fig. 21 Compressing Tensioner Shoe For Timing Chain Installation**

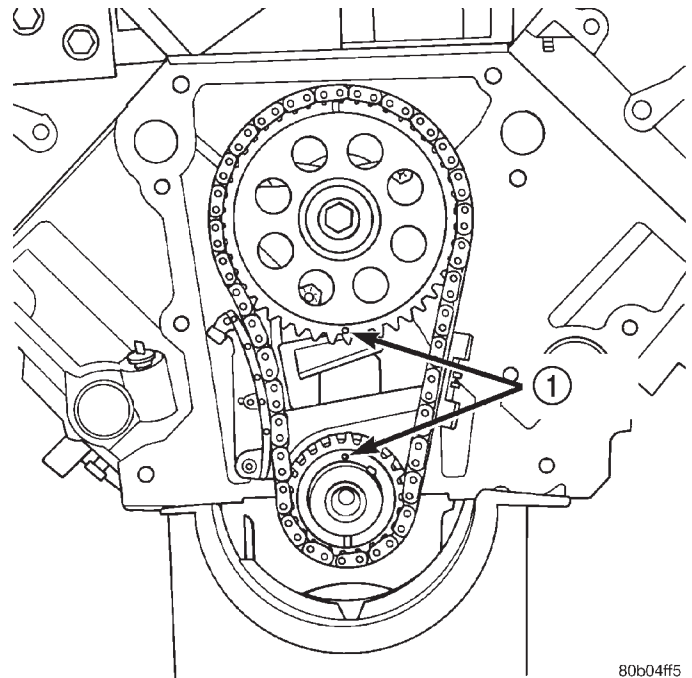
- 1 - SCREWDRIVER
- 2 - INSERT PIN HERE

**installed until the camshaft and crankshaft sprockets and timing chain have been installed.**

(4) Install timing chain tensioner. Torque bolts to 24 N·m (210 in. lbs.) torque.

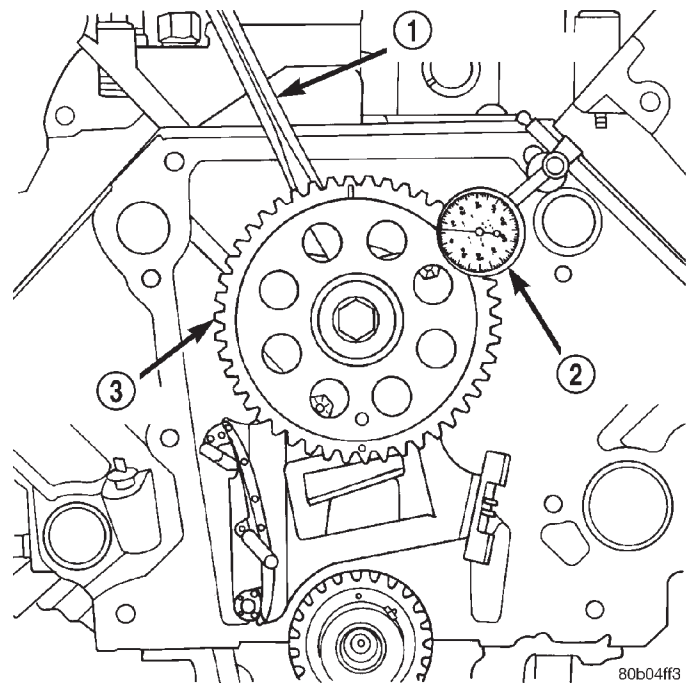
(5) Compress tensioner shoe (Fig. 21) and install a suitable sized pin to retain shoe for chain installation.

(6) Place both camshaft sprocket and crankshaft sprocket on the bench with timing marks on an exact imaginary center line through both camshaft and crankshaft bores.



**Fig. 22 Alignment of Timing Marks**

- 1 - TIMING MARKS



**Fig. 23 Checking Camshaft End Play**

- 1 - SCREWDRIVER
- 2 - DIAL INDICATOR
- 3 - CAM SPROCKET

(7) Place timing chain around both sprockets.

## CAMSHAFT &amp; BEARINGS (IN BLOCK) (Continued)

(8) Turn crankshaft and camshaft to line up with keyway location in crankshaft sprocket and in camshaft sprocket.

(9) Lift sprockets and chain (keep sprockets tight against the chain in position as described).

(10) Slide both sprockets evenly over their respective shafts and use a straightedge to check alignment of timing marks (Fig. 22).

(11) Install the camshaft bolt/cup washer. Tighten bolt to 68 N·m (50 ft. lbs.) torque.

(12) Measure camshaft end play (Fig. 23). (Refer to 9 - ENGINE - SPECIFICATIONS) for proper clearance. If not within limits, install a new timing chain tensioner.

(13) Each tappet reused must be installed in the same position at which it was removed. **When camshaft is replaced, all of the tappets must be replaced.** Install hydraulic tappets (Refer to 9 - ENGINE/ENGINE BLOCK/HYDRAULIC LIFTERS (CAM IN BLOCK) - INSTALLATION).

(14) Install timing chain cover (Refer to 9 - ENGINE/VALVE TIMING/TIMING BELT / CHAIN COVER(S) - INSTALLATION).

(15) Install intake manifold (Refer to 9 - ENGINE/MANIFOLDS/INTAKE MANIFOLD - INSTALLATION).

(16) Install distributor.

(17) Install cylinder head covers (Refer to 9 - ENGINE/CYLINDER HEAD/CYLINDER HEAD COVER(S) - INSTALLATION).

(18) Install radiator (Refer to 7 - COOLING/ENGINE/RADIATOR - INSTALLATION).

(19) Fill cooling system (Refer to 7 - COOLING - STANDARD PROCEDURE).

(20) Connect battery negative cable.

(21) Start engine and check for leaks.

The bearing shells must be installed so that the tangs are in the machined grooves in the rods and caps.

Limits of taper or out-of-round on any crankshaft journals should be held to 0.025 mm (0.001 in.). Bearings are available in 0.025 mm (0.001 in.), 0.051 mm (0.002 in.), 0.076 mm (0.003 in.), 0.254 mm (0.010 in.) and 0.305 mm (0.012 in.) undersize. **Install the bearings in pairs. DO NOT use a new bearing half with an old bearing half. DO NOT file the rods or bearing caps.**

## CRANKSHAFT

## DESCRIPTION

The crankshaft (Fig. 24) is of a forged steel splayed type design, with four main bearing journals. The crankshaft is located at the bottom of the engine block and is held in place with four main bearing caps.

Undersize Journal	Identification Stamp
ROD - 0.025mm (0.001 in.)	R1-R2-R3-Etc.
MAIN - 0.025mm (0.001 in.)	M1-M2-M3 or M4

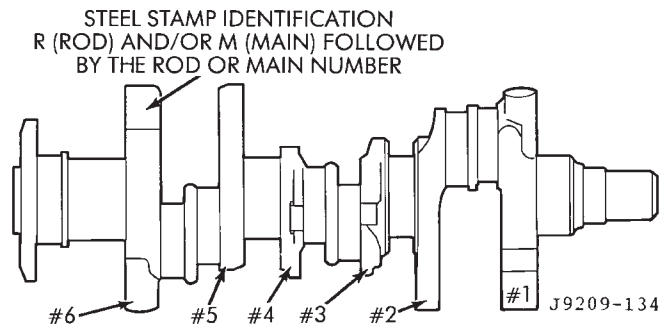


Fig. 24 Crankshaft—3.9L Engine

## CONNECTING ROD BEARINGS

## STANDARD PROCEDURE-CONNECTING ROD BEARING FITTING

Fit all rods on a bank until completed. DO NOT alternate from one bank to another, because connecting rods and pistons are not interchangeable from one bank to another.

The bearing caps are not interchangeable and should be marked at removal to ensure correct assembly.

Each bearing cap has a small V-groove across the parting face. When installing the lower bearing shell, be certain that the V-groove in the shell is in line with the V-groove in the cap. This provides lubrication of the cylinder wall in the opposite bank.

## OPERATION

The crankshaft transfers force generated by combustion within the cylinder bores to the flywheel or flexplate.

## REMOVAL

(1) Remove the oil pan (Refer to 9 - ENGINE/LUBRICATION/OIL PAN - REMOVAL).

(2) Remove the oil pump (Refer to 9 - ENGINE/LUBRICATION/OIL PUMP - REMOVAL).

(3) Identify bearing caps before removal. Remove bearing caps and bearings one at a time.

(4) Lift the crankshaft out of the block.

## CRANKSHAFT (Continued)

(5) Remove and discard the crankshaft rear oil seals.

(6) Remove and discard the front crankshaft oil seal.

## INSTALLATION

(1) Lightly oil the new upper seal lips with engine oil.

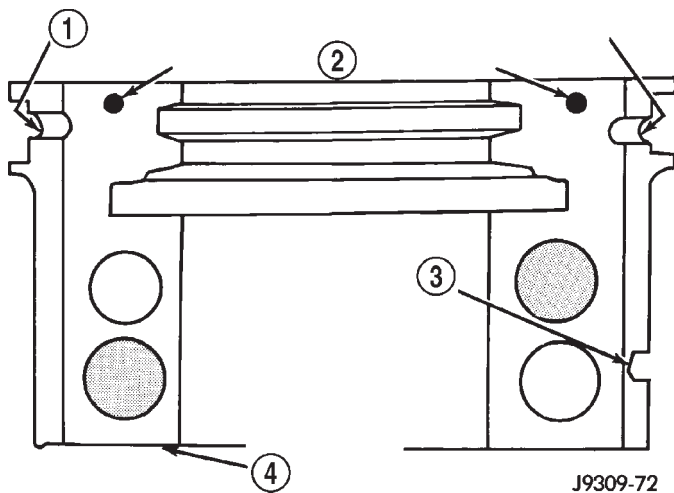
(2) Install the new upper rear bearing oil seal with the white paint facing towards the rear of the engine.

(3) Position the crankshaft into the cylinder block.

(4) Lightly oil the new lower seal lips with engine oil.

(5) Install the new lower rear bearing oil seal into the bearing cap with the white paint facing towards the rear of the engine.

(6) Apply 5 mm (0.20 in.) drop of Loctite 518, or equivalent, on each side of the rear main bearing cap (Fig. 25). DO NOT over-apply sealant or allow the sealant to contact the rubber seal. Assemble bearing cap to cylinder block immediately after sealant application.



**Fig. 25 Sealant Application to Bearing Cap**

- 1 - MOPAR SILICONE RUBBER ADHESIVE SEALANT SLOTS
- 2 - LOCTITE 515 (OR EQUIVALENT)
- 3 - CAP ALIGNMENT SLOT
- 4 - REAR MAIN BEARING CAP

(7) To align the bearing cap, use cap slot, alignment dowel, and cap bolts. DO NOT remove excess material after assembly. DO NOT strike rear cap more than two times for proper engagement.

(8) Clean and oil all cap bolts. Install all main bearing caps. Install all cap bolts and alternately tighten to 115 N·m (85 ft. lbs.) torque.

(9) Install oil pump (Refer to 9 - ENGINE/LUBRICATION/OIL PUMP - INSTALLATION).

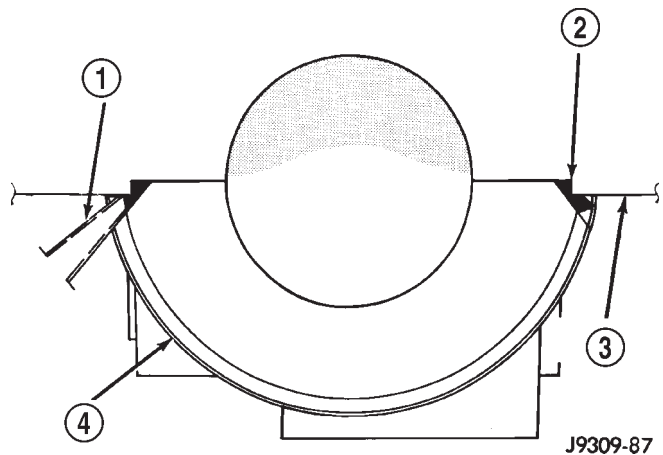
(10) Apply Mopar® Silicone Rubber Adhesive Sealant, or equivalent, at bearing cap-to-block joint to provide cap-to-block and oil pan sealing (Fig. 26).

Apply enough sealant so that a small amount is squeezed out. Withdraw nozzle and wipe excess sealant off the oil pan seal groove.

(11) Install new front crankshaft oil seal (Refer to 9 - ENGINE/ENGINE BLOCK/CRANKSHAFT OIL SEAL - FRONT - INSTALLATION).

(12) Immediately install the oil pan (Refer to 9 - ENGINE/LUBRICATION/OIL PAN - INSTALLATION).

(13) Install new rear oil seal (Refer to 9 - ENGINE/ENGINE BLOCK/CRANKSHAFT OIL SEAL - REAR - INSTALLATION).



**Fig. 26 Apply Sealant to Bearing Cap-to-Block Joint**

- 1 - MOPAR® GEN II SILICONE RUBBER ADHESIVE SEALANT NOZZLE TIP
- 2 - SEALANT APPLIED
- 3 - CYLINDER BLOCK
- 4 - REAR MAIN BEARING CAP

## CRANKSHAFT MAIN BEARINGS

## DESCRIPTION

Main bearings (Fig. 27) are located in the cylinder block. One half of the main bearing is located in the crankshaft main bore the other half of the matching bearing is located in the main bearing cap. there are four main bearings. Number two main bearing is flanged, this flange controls crankshaft thrust.

## OPERATION

The main bearings encircle the crankshaft main bearing journals, this aligns the crankshaft to the centerline of the engine and allows the crankshaft to turn without wobbling or shaking therefore eliminating vibration. The main bearings are available in standard and undersizes.

## CRANKSHAFT MAIN BEARINGS (Continued)

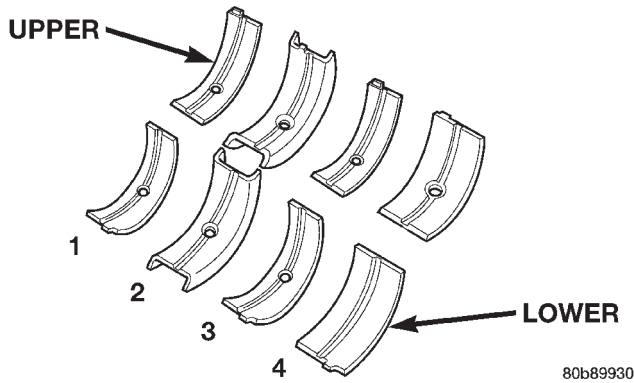


Fig. 27 Main Bearing Orientation

## STANDARD PROCEDURE—MAIN BEARING FITTING

Bearing caps are NOT interchangeable and should be marked at removal to ensure correct assembly. Upper and lower bearing halves are NOT interchangeable. Lower main bearing halves of No. 1 and 3 are interchangeable.

Upper and lower No. 2 bearing halves are flanged to carry the crankshaft thrust loads. They are NOT interchangeable with any other bearing halves in the engine (Fig. 28). Bearing shells are available in standard and the following undersizes: 0.25 mm (0.001 in.), 0.051 mm (0.002 in.), 0.076 mm (0.003 in.), 0.254 mm (0.010 in.) and 0.305 mm (0.012 in.). Never install an undersize bearing that will reduce clearance below specifications.

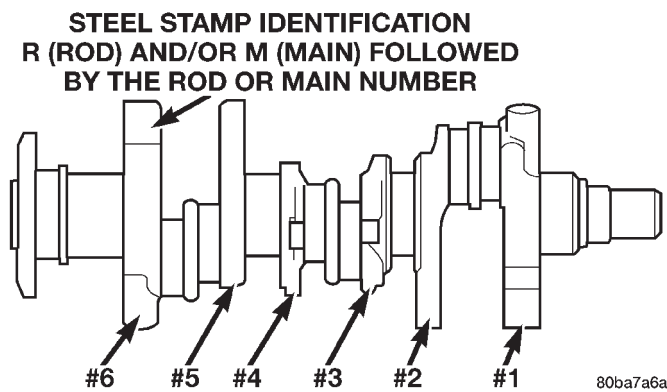


Fig. 28 Main Bearing Identification

## CRANKSHAFT IDENTIFICATION LOCATION CHART

ITEM	MEASUREMENT	IDENTIFICATION
ROD U/S	0.025 mm (0.001 in.)	R1-R2-R3 ect. indicates rod journal No. 1, 2 and 3.
MAIN U/S	0.025 mm (0.001 in.)	M1-M2-M3 or M4 indicates main journal No. 1, 2, 3, and 4.

## REMOVAL

- (1) Remove the oil pan (Refer to 9 - ENGINE/LUBRICATION/OIL PAN - REMOVAL).
- (2) Remove the oil pump (Refer to 9 - ENGINE/LUBRICATION/OIL PUMP - REMOVAL).
- (3) Identify bearing caps before removal. Remove bearing caps one at a time.
- (4) Remove upper half of bearing by inserting Crankshaft Main Bearing Remover/Installer Tool C-3059 into the oil hole of crankshaft (Fig. 29).
- (5) Slowly rotate crankshaft clockwise, forcing out upper half of bearing shell.

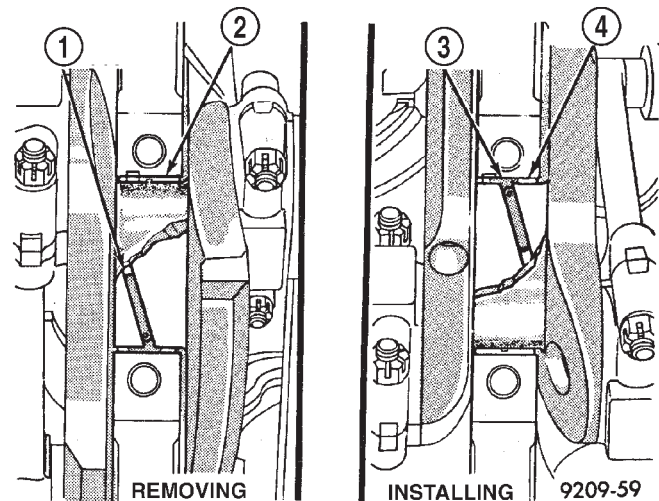


Fig. 29 Upper Main Bearing Removal and Installation with Tool C-3059

- 1 - SPECIAL TOOL C-3059
- 2 - BEARING
- 3 - SPECIAL TOOL C-3059
- 4 - BEARING



## CRANKSHAFT MAIN BEARINGS (Continued)

**INSTALLATION**

Only one main bearing should be selectively fitted while all other main bearing caps are properly tightened. All bearing capbolts removed during service procedures are to be cleaned and oiled before installation. DO NOT use a new bearing half with an old bearing half.

When installing a new upper bearing shell, slightly chamfer the sharp edges from the plain side.

(1) Start bearing in place, and insert Crankshaft Main Bearing Remover/Installer Tool C-3059 into oil hole of crankshaft (Fig. 29).

(2) Slowly rotate crankshaft counterclockwise sliding the bearing into position. Remove Tool C-3059.

(3) Install the bearing caps. Clean and oil the bolts. Tighten the capbolts to 115 N·m (85 ft. lbs.) torque.

(4) Install the oil pump (Refer to 9 - ENGINE/LUBRICATION/OIL PUMP - INSTALLATION).

(5) Install the oil pan (Refer to 9 - ENGINE/LUBRICATION/OIL PAN - INSTALLATION).

## CRANKSHAFT OIL SEAL - FRONT

**DESCRIPTION**

The crankshaft rear seal is a two piece viton seal. The crankshaft front seal is a one piece viton seal with a steel housing. The front seal is located in the engine front cover. One part of the two piece rear seal is located in a slot in the number four (4) crankshaft main bore, the second part of the two piece seal is located in the number four (4) main bearing cap.

**OPERATION**

The crankshaft seals prevent oil from leaking from around the crankshaft, either from the rear of the engine or from the engine front cover.

**REMOVAL**

The oil seal can be replaced without removing the timing chain cover, provided that the cover is not misaligned.

(1) Disconnect the negative cable from the battery.

(2) Remove vibration damper (Refer to 9 - ENGINE/ENGINE BLOCK/VIBRATION DAMPER - REMOVAL).

(3) If front seal is suspected of leaking, check front oil seal alignment to crankshaft. The seal installation/alignment Tool 6635, should fit with minimum interference. If tool does not fit, the cover must be removed and installed properly.

(4) Place a suitable tool behind the lips of the oil seal to pry the oil seal outward. Be careful not to damage the crankshaft seal bore of cover.

**INSTALLATION**

(1) Place the smaller diameter of the oil seal over Front Oil Seal Installation Tool 6635 (Fig. 30). Seat the oil seal in the groove of the tool.

(2) Position the seal and tool onto the crankshaft (Fig. 31).

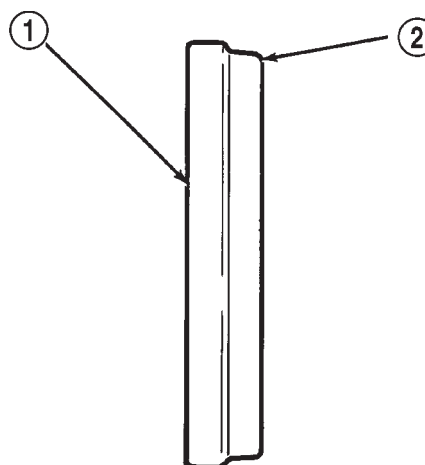
(3) Using the vibration damper bolt, tighten the bolt to draw the seal into position on the crankshaft (Fig. 32).

(4) Remove the vibration damper bolt and seal installation tool.

(5) Inspect the seal flange on the vibration damper.

(6) Install the vibration damper (Refer to 9 - ENGINE/ENGINE BLOCK/VIBRATION DAMPER - INSTALLATION).

(7) Connect the negative cable to the battery.



J9309-44

**Fig. 30 Placing Oil Seal on Installation Tool 6635**

1 - CRANKSHAFT FRONT OIL SEAL

2 - INSTALL THIS END INTO SPECIAL TOOL 6635

## CRANKSHAFT OIL SEAL - REAR

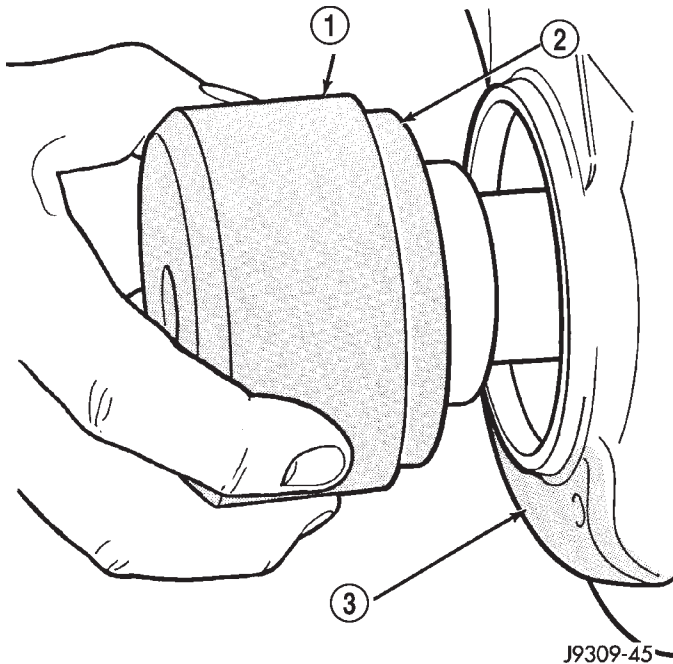
**DESCRIPTION**

The crankshaft rear seal is a two piece viton seal. The crankshaft front seal is a one piece viton seal with a steel housing. The front seal is located in the engine front cover. One part of the two piece rear seal is located in a slot in the number four (4) crankshaft main bore, the second part of the two piece seal is located in the number four (4) main bearing cap.

**OPERATION**

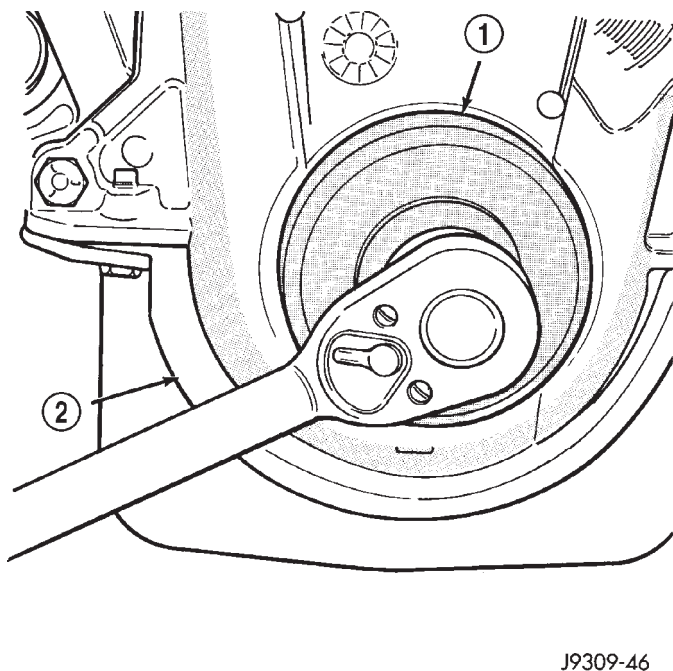
The crankshaft seals prevent oil from leaking from around the crankshaft, either from the rear of the engine or from the engine front cover.

## CRANKSHAFT OIL SEAL - REAR (Continued)



**Fig. 31 Position Tool and Seal onto Crankshaft**

- 1 - SPECIAL TOOL 6635
- 2 - OIL SEAL
- 3 - TIMING CHAIN COVER



**Fig. 32 Installing Oil Seal**

- 1 - SPECIAL TOOL 6635
- 2 - TIMING CHAIN COVER

## REMOVAL

The service seal is a two piece, Viton seal. The upper seal half can be installed with crankshaft

removed from engine or with crankshaft installed. When a new upper seal is installed, install a new lower seal. The lower seal half can be installed only with the rear main bearing cap removed.

## UPPER SEAL —CRANKSHAFT REMOVED

(1) Remove the crankshaft (Refer to 9 - ENGINE/ENGINE BLOCK/CRANKSHAFT - REMOVAL). Discard the old upper seal.

## UPPER SEAL—CRANKSHAFT INSTALLED

- (1) Remove the oil pan (Refer to 9 - ENGINE/LUBRICATION/OIL PAN - REMOVAL).
- (2) Remove the oil pump (Refer to 9 - ENGINE/LUBRICATION/OIL PUMP - REMOVAL).
- (3) Remove the rear main bearing cap. Remove and discard the old lower oil seal.
- (4) Carefully remove and discard the old upper oil seal.

## LOWER SEAL

- (1) Remove the oil pan (Refer to 9 - ENGINE/LUBRICATION/OIL PAN - REMOVAL).
- (2) Remove the oil pump (Refer to 9 - ENGINE/LUBRICATION/OIL PUMP - REMOVAL).
- (3) Remove the rear main bearing cap and discard the old lower seal.

## INSTALLATION

The service seal is a two piece, Viton seal. The upper seal half can be installed with crankshaft removed from engine or with crankshaft installed. When a new upper seal is installed, install a new lower seal. The lower seal half can be installed only with the rear main bearing cap removed.

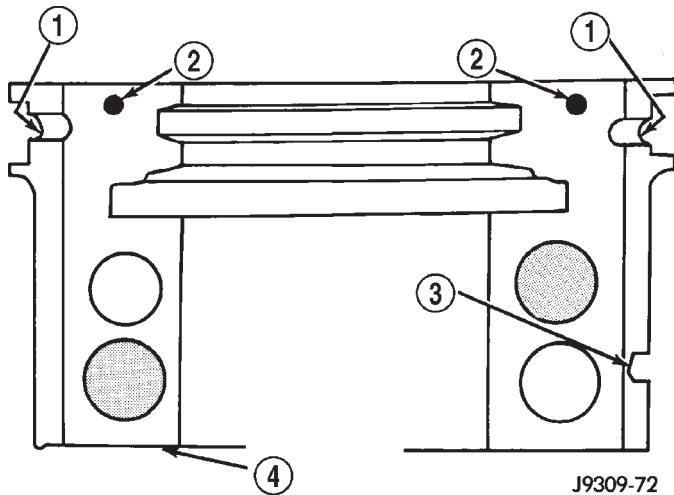
## UPPER SEAL —CRANKSHAFT REMOVED

- (1) Clean the cylinder block rear cap mating surface. Be sure the seal groove is free of debris. Check for burrs at the oil hole on the cylinder block mating surface to rear cap.
- (2) Lightly oil the new upper seal lips with engine oil.
- (3) Install the new upper rear bearing oil seal with the white paint facing toward the rear of the engine.
- (4) Position the crankshaft into the cylinder block.
- (5) Lightly oil the new lower seal lips with engine oil.
- (6) Install the new lower rear bearing oil seal into the bearing cap with the white paint facing towards the rear of the engine.
- (7) Apply 5 mm (0.20 in.) drop of Mopar® Gasket Maker, or equivalent, on each side of the rear main bearing cap (Fig. 33). DO NOT over-apply sealant or allow the sealant to contact the rubber seal. Assem-



## CRANKSHAFT OIL SEAL - REAR (Continued)

ble bearing cap to cylinder block immediately after sealant application.



**Fig. 33 Sealant Application to Bearing Cap**

- 1 - MOPAR SILICONE RUBBER ADHESIVE SEALANT SLOTS
- 2 - MOPAR® GASKET MAKER (OR EQUIVALENT)
- 3 - CAP ALIGNMENT SLOT
- 4 - REAR MAIN BEARING CAP

(8) To align the bearing cap, use cap slot, alignment dowel, and cap bolts. DO NOT remove excess material after assembly. DO NOT strike rear cap more than two times for proper engagement.

(9) Clean and oil all cap bolts. Install all main bearing caps. Install all cap bolts and alternately tighten to 115 N·m (85 ft. lbs.) torque.

(10) Install oil pump (Refer to 9 - ENGINE/LUBRICATION/OIL PUMP - INSTALLATION).

(11) Apply Mopar® GEN II Silicone Rubber Adhesive Sealant, or equivalent, at bearing cap-to-block joint to provide cap to block and oil pan sealing (Fig. 34). Apply enough sealant so that a small amount is squeezed out. Withdraw nozzle and wipe excess sealant off the oil pan seal groove.

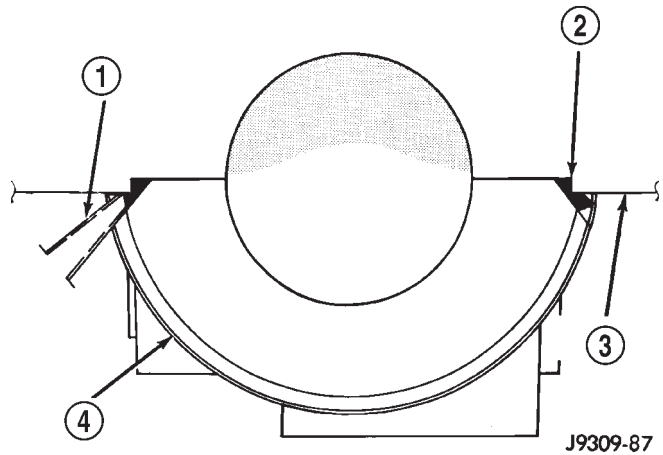
(12) Install new front crankshaft oil seal (Refer to 9 - ENGINE/ENGINE BLOCK/CRANKSHAFT OIL SEAL - FRONT - INSTALLATION).

(13) Immediately install the oil pan (Refer to 9 - ENGINE/LUBRICATION/OIL PAN - INSTALLATION).

#### UPPER SEAL—CRANKSHAFT INSTALLED

(1) Clean the cylinder block mating surfaces before oil seal installation. Check for burrs at the oil hole on the cylinder block mating surface to rear cap.

(2) Lightly oil the new upper seal lips with engine oil. To allow ease of installation of the seal, loosen at least the two main bearing caps forward of the rear bearing cap.



**Fig. 34 Apply Sealant to Bearing Cap-to-Block Joint**

- 1 - MOPAR® GEN II SILICONE RUBBER ADHESIVE SEALANT NOZZLE TIP
- 2 - SEALANT APPLIED
- 3 - CYLINDER BLOCK
- 4 - REAR MAIN BEARING CAP

(3) Rotate the new upper seal into the cylinder block, being careful not to shave or cut the outer surface of the seal. To ensure proper installation, use the installation tool provided with the kit. Install the new seal with the white paint facing toward the rear of the engine.

(4) Install the new lower rear bearing oil seal into the bearing cap with the white paint facing toward the rear of the engine.

(5) Apply 5 mm (0.20 in.) drop of Mopar® Gasket Maker, or equivalent, on each side of the rear main bearing cap (Fig. 33). DO NOT over-apply sealant or allow the sealant to contact the rubber seal. Assemble bearing cap to cylinder block immediately after sealant application. Be sure the white paint faces toward the rear of the engine.

(6) To align the bearing cap, use cap slot, alignment dowel, and cap bolts. DO NOT remove excess material after assembly. DO NOT strike rear cap more than two times for proper engagement.

(7) Install the rear main bearing cap with cleaned and oiled cap bolts. Alternately tighten ALL cap bolts to 115 N·m (85 ft. lbs.) torque.

(8) Install oil pump (Refer to 9 - ENGINE/LUBRICATION/OIL PUMP - INSTALLATION).

(9) Apply Mopar® GEN II Silicone Rubber Adhesive Sealant, or equivalent, at bearing cap-to-block joint to provide cap-to-block and oil pan sealing (Fig. 34). Apply enough sealant until a small amount is squeezed out. Withdraw nozzle and wipe excess sealant off the oil pan seal groove.

(10) Immediately install the oil pan (Refer to 9 - ENGINE/LUBRICATION/OIL PAN - INSTALLATION).

## CRANKSHAFT OIL SEAL - REAR (Continued)

## LOWER SEAL

(1) Clean the rear main cap mating surfaces including the oil pan gasket groove.

(2) Carefully install a new upper seal. Refer to UPPER SEAL—CRANKSHAFT INSTALLED.

(3) Lightly oil the new lower seal lips with engine oil.

(4) Install a new lower seal in bearing cap with the white paint facing the rear of engine.

(5) Apply 5 mm (0.20 in.) drop of Mopar® Gasket Maker, or equivalent, on each side of the rear main bearing cap (Fig. 33). DO NOT over-apply sealant or allow the sealant to contact the rubber seal. Assemble bearing cap to cylinder block immediately after sealant application.

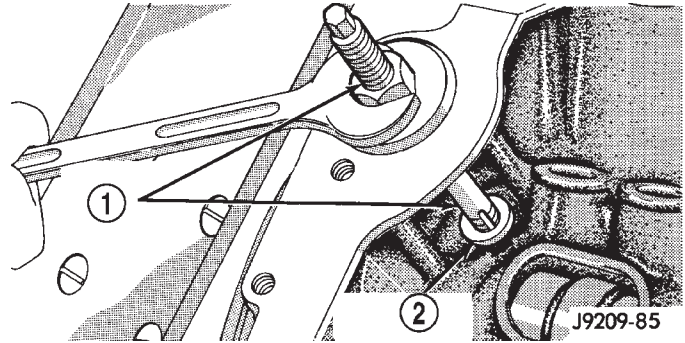
(6) To align the bearing cap, use cap slot, alignment dowel, and cap bolts. DO NOT remove excess material after assembly. DO NOT strike rear cap more than two times for proper engagement.

(7) Install the rear main bearing cap with cleaned and oiled cap bolts. Alternately tighten the cap bolts to 115 N·m (85 ft. lbs.) torque.

(8) Install oil pump (Refer to 9 - ENGINE/LUBRICATION/OIL PUMP - INSTALLATION).

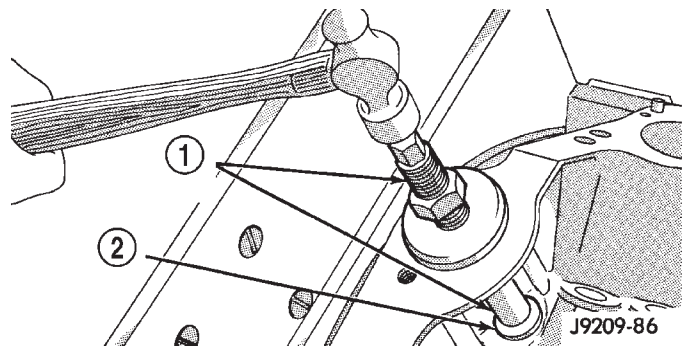
(9) Apply Mopar® GEN II Silicone Rubber Adhesive Sealant, or equivalent, at bearing cap-to-block joint to provide cap to block and oil pan sealing. Apply enough sealant so that a small amount is squeezed out. Withdraw nozzle and wipe excess sealant off the oil pan seal groove.

(10) Immediately install the oil pan (Refer to 9 - ENGINE/LUBRICATION/OIL PAN - INSTALLATION).



**Fig. 35 Distributor Driveshaft Bushing Removal**

- 1 - SPECIAL TOOL C-3052  
2 - BUSHING



**Fig. 36 Distributor Driveshaft Bushing Installation**

- 1 - SPECIAL TOOL C-3053  
2 - BUSHING

## DISTRIBUTOR BUSHING

## REMOVAL

(1) Remove distributor.

(2) Remove the intake manifold (Refer to 9 - ENGINE/MANIFOLDS/INTAKE MANIFOLD - REMOVAL).

(3) Insert Distributor Drive Shaft Bushing Puller Tool C-3052 into old bushing and thread down until a tight fit is obtained (Fig. 35).

(4) Hold puller screw and tighten puller nut until bushing is removed.

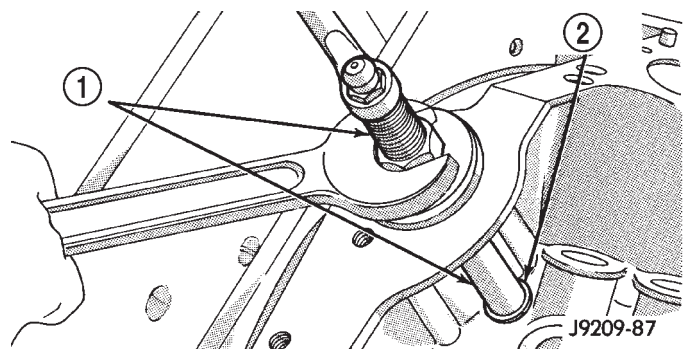
## INSTALLATION

(1) Slide new bushing over burnishing end of Distributor Drive Shaft Bushing Driver/Burnisher Tool C-3053. Insert the tool and bushing into the bore.

(2) Drive bushing and tool into position, using a hammer (Fig. 36).

(3) As the burnisher is pulled through the bushing, the bushing is expanded tight in the block and burnished to correct size (Fig. 37). **DO NOT ream this bushing.**

**CAUTION:** This procedure **MUST** be followed when installing a new bushing or seizure to shaft may occur.



**Fig. 37 Burnishing Distributor Bushing**

- 1 - SPECIAL TOOL C-3053  
2 - BUSHING

(4) Install the intake manifold. (Refer to 9 - ENGINE/MANIFOLDS/INTAKE MANIFOLD - INSTALLATION).

(5) Install the distributor.

## HYDRAULIC LIFTERS (CAM IN BLOCK)

### DIAGNOSIS AND TESTING—HYDRAULIC TAPPETS

Before disassembling any part of the engine to correct tappet noise, check the oil pressure. If vehicle has no oil pressure gauge, install a reliable gauge at the pressure sending-unit. The pressure should be between 207-552 kPa (30-80 psi) at 3,000 RPM.

Check the oil level after the engine reaches normal operating temperature. Allow 5 minutes to stabilize oil level, check dipstick. The oil level in the pan should never be above the FULL mark or below the ADD OIL mark on dipstick. Either of these two conditions could be responsible for noisy tappets.

#### OIL LEVEL

##### HIGH

If oil level is above the FULL mark, it is possible for the connecting rods to dip into the oil. With the engine running, this condition could create foam in the oil pan. Foam in oil pan would be fed to the hydraulic tappets by the oil pump causing them to lose length and allow valves to seat noisily.

##### LOW

Low oil level may allow oil pump to take in air. When air is fed to the tappets, they lose length, which allows valves to seat noisily. Any leaks on intake side of oil pump through which air can be drawn will create the same tappet action. Check the lubrication system from the intake strainer to the pump cover, including the relief valve retainer cap. When tappet noise is due to aeration, it may be intermittent or constant, and usually more than one tappet will be noisy. When oil level and leaks have been corrected, operate the engine at fast idle. Run engine for a sufficient time to allow all of the air inside the tappets to be bled out.

#### TAPPET NOISE DIAGNOSIS

(1) To determine source of tappet noise, operate engine at idle with cylinder head covers removed.

(2) Feel each valve spring or rocker arm to detect noisy tappet. The noisy tappet will cause the affected spring and/or rocker arm to vibrate or feel rough in operation.

**NOTE:** Worn valve guides or cocked springs are sometimes mistaken for noisy tappets. If such is the case, noise may be dampened by applying side thrust on the valve spring. If noise is not appreciably reduced, it can be assumed the noise is in the

tappet. Inspect the rocker arm push rod sockets and push rod ends for wear.

(3) Valve tappet noise ranges from light noise to a heavy click. A light noise is usually caused by excessive leak-down around the unit plunger, or by the plunger partially sticking in the tappet body cylinder. The tappet should be replaced. A heavy click is caused by a tappet check valve not seating, or by foreign particles wedged between the plunger and the tappet body. This will cause the plunger to stick in the down position. This heavy click will be accompanied by excessive clearance between the valve stem and rocker arm as valve closes. In either case, tappet assembly should be removed for inspection and cleaning.

(4) The valve train generates a noise very much like a light tappet noise during normal operation. Care must be taken to ensure that tappets are making the noise. If more than one tappet seems to be noisy, it's probably not the tappets.

#### LEAK-DOWN TEST

After cleaning and inspection, test each tappet for specified leak-down rate tolerance to ensure zero-lash operation (Fig. 38).

Swing the weighted arm of the hydraulic valve tappet tester away from the ram of the Universal Leak-Down Tester.

(1) Place a 7.925-7.950 mm (0.312-0.313 inch) diameter ball bearing on the plunger cap of the tappet.

(2) Lift the ram and position the tappet (with the ball bearing) inside the tester cup.

(3) Lower the ram, then adjust the nose of the ram until it contacts the ball bearing. DO NOT tighten the hex nut on the ram.

(4) Fill the tester cup with hydraulic valve tappet test oil until the tappet is completely submerged.

(5) Swing the weighted arm onto the push rod and pump the tappet plunger up and down to remove air. When the air bubbles cease, swing the weighted arm away and allow the plunger to rise to the normal position.

(6) Adjust the nose of the ram to align the pointer with the SET mark on the scale of the tester and tighten the hex nut.

(7) Slowly swing the weighted arm onto the push rod.

(8) Rotate the cup by turning the handle at the base of the tester clockwise one revolution every 2 seconds.

(9) Observe the leak-down time interval from the instant the pointer aligns with the START mark on the scale until the pointer aligns with the 0.125 mark. A normally functioning tappet will require

## HYDRAULIC LIFTERS (CAM IN BLOCK) (Continued)

20-110 seconds to leak-down. Discard tappets with leak-down time interval not within this specification.

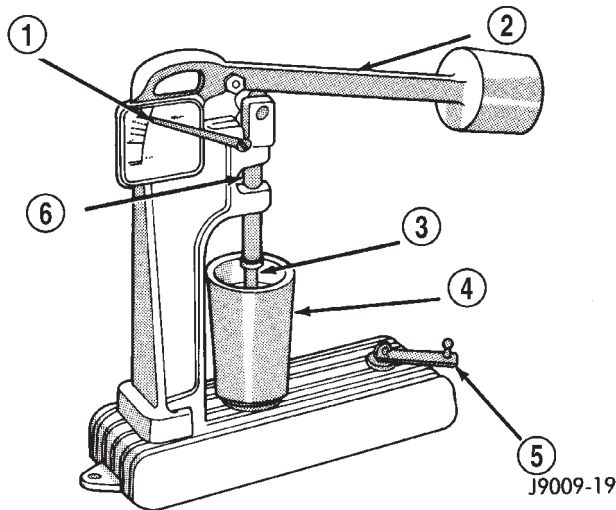


Fig. 38 Leak-Down Tester

- 1 - POINTER
- 2 - WEIGHTED ARM
- 3 - RAM
- 4 - CUP
- 5 - HANDLE
- 6 - PUSH ROD

## REMOVAL

- (1) Remove the air cleaner assembly and air in-let hose.
- (2) Remove cylinder head cover (Refer to 9 - ENGINE/CYLINDER HEAD/CYLINDER HEAD COVER(S) - REMOVAL).
- (3) Remove rocker assembly and push rods. Identify push rods to ensure installation in original locations.
- (4) Remove intake manifold (Refer to 9 - ENGINE/MANIFOLDS/INTAKE MANIFOLD - REMOVAL).

- (5) Remove yoke retainer and aligning yokes.
- (6) Slide Hydraulic Tappet Remover/Installer Tool C-4129-A through opening in cylinder head and seat tool firmly in the head of tappet.
- (7) Pull tappet out of bore with a twisting motion. If all tappets are to be removed, identify tappets to ensure installation in original location.
- (8) If the tappet or bore in cylinder block is scored, scuffed, or shows signs of sticking, ream the bore to next oversize. Replace with oversize tappet.

## CLEANING

Clean tappet with a suitable solvent. Rinse in hot water and blow dry with a clean shop rag or compressed air.

## INSTALLATION

- (1) Lubricate tappets.
- (2) Install tappets and push rods in their original positions. Ensure that the oil feed hole in the side of the tappet body faces up (away from the crankshaft).
- (3) Install aligning yokes with ARROW toward camshaft.
- (4) Install yoke retainer. Tighten the bolts to 23 N·m (200 in. lbs.) torque. Install intake manifold (Refer to 9 - ENGINE/MANIFOLDS/INTAKE MANIFOLD - INSTALLATION).
- (5) Install push rods in original positions.
- (6) Install rocker arms.
- (7) Install cylinder head cover (Refer to 9 - ENGINE/CYLINDER HEAD/CYLINDER HEAD COVER(S) - INSTALLATION).
- (8) Install air cleaner assembly and air in-let hose.
- (9) Start and operate engine. Warm up to normal operating temperature.

**CAUTION:** To prevent damage to valve mechanism, engine must not be run above fast idle until all hydraulic tappets have filled with oil and have become quiet.



## PISTON & CONNECTING ROD

### PISTON MEASUREMENTS CHART

#### DESCRIPTION

The pistons are made of aluminum and have three ring grooves, the top two grooves are for the compression rings and the bottom groove is for the oil control ring. The connecting rods are forged steel and are coined prior to heat treat. The piston pins are press fit.

#### STANDARD PROCEDURE—PISTON FITTING

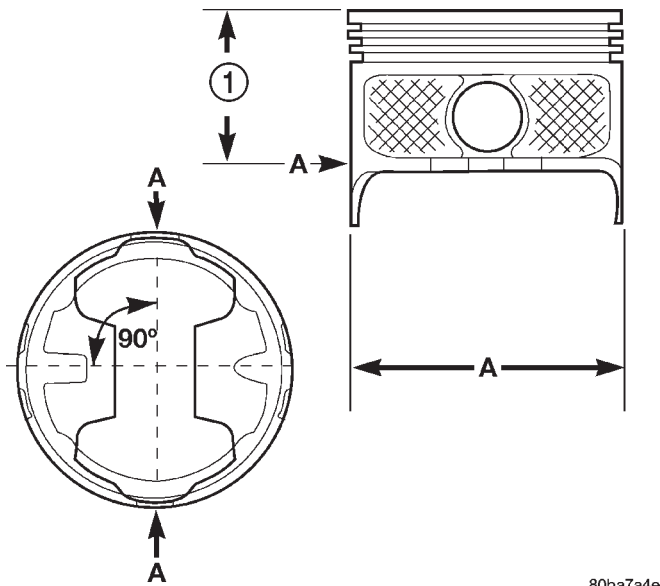
Check the cylinder block bore for out-of-round, taper, scoring, or scuffing.

Check the pistons for taper and elliptical shape before they are fitted into the cylinder bore (Fig. 39).

Piston and cylinder wall must be clean and dry. Specified clearance between the piston and the cylinder wall is 0.013-0.038 mm (0.0005-0.0015 in.) at 21°C (70°F).

Piston diameter should be measured at the top of skirt, 90° to piston pin axis. Cylinder bores should be measured halfway down the cylinder bore and transverse to the engine crankshaft center line.

Pistons and cylinder bores should be measured at normal room temperature, 21°C (70°F).



**Fig. 39 Piston Measurements**

1 - 62.230 mm  
(2.45 IN.)

PISTON SIZE	A DIA = PISTON DIAMETER		BORE DIAMETER	
	MIN. mm (in.)	MAX. mm (in.)	MIN. mm (in.)	MAX. mm (in.)
<b>A</b>	99.280 (3.9087)	99.294 (3.9092)	99.308 (3.9098)	99.320 (3.9103)
<b>B</b>	99.294 (3.9092)	99.306 (3.9097)	99.320 (3.9103)	99.333 (3.9108)
<b>C</b>	99.306 (3.9097)	99.319 (3.9102)	99.333 (3.9108)	99.345 (3.9113)
<b>D</b>	99.319 (3.9102)	99.332 (3.9107)	99.346 (3.9113)	99.358 (3.9118)
<b>E</b>	99.332 (3.9107)	99.344 (3.9112)	99.358 (3.9118)	99.371 (3.9123)
DESCRIPTION		SPECIFICATION		
PISTON PIN BORE		25.007 - 25.014 mm (.9845 - .9848 in.)		
RING GROOVE HEIGHT (OIL RAIL)		4.0309 - 4.0538 mm (.1587 - .1596 in.)		
RING GROOVE HEIGHT (COMPRESSION RAIL)		2.0294 - 2.0548 mm (.0799 - .0809 in.)		
TOTAL FINISHED WEIGHT		594.6 ± 2 grams (20.974 ± .0706 ounces)		

#### REMOVAL

(1) Remove the engine from the vehicle (Refer to 9 - ENGINE - REMOVAL).

(2) Remove the cylinder head (Refer to 9 - ENGINE/CYLINDER HEAD - REMOVAL).

(3) Remove the oil pan (Refer to 9 - ENGINE/LUBRICATION/OIL PAN - REMOVAL).

(4) Remove top ridge of cylinder bores with a reliable ridge reamer before removing pistons from cylinder block. Be sure to keep tops of pistons covered during this operation.

(5) Be sure each connecting rod and connecting rod cap is identified with the cylinder number. Remove connecting rod cap. Install connecting rod bolt guide set on connecting rod bolts.

(6) Pistons and connecting rods must be removed from top of cylinder block. When removing the assemblies from the engine, rotate crankshaft so that

## PISTON &amp; CONNECTING ROD (Continued)

the connecting rod is centered in cylinder bore and at BDC. **Be careful not to nick crankshaft journals.**

(7) After removal, install bearing cap on the mating rod.

## CLEANING

Clean the piston and connecting rod assembly using a suitable solvent.

## INSPECTION

Check the connecting rod journal for excessive wear, taper and scoring (Refer to 9 - ENGINE/ENGINE BLOCK/CONNECTING ROD BEARINGS - STANDARD PROCEDURE).

Check the connecting rod for signs of twist or bending.

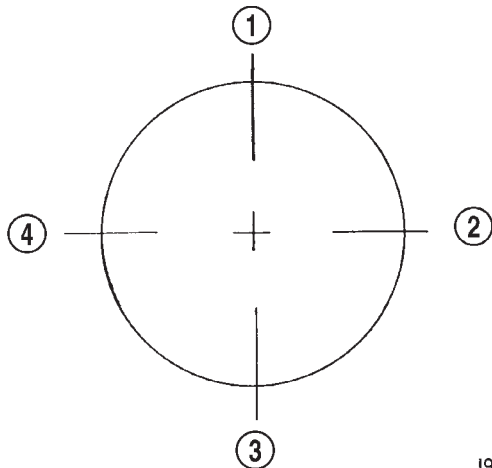
Check the piston for taper and elliptical shape before it is fitted into the cylinder bore (Refer to 9 - ENGINE/ENGINE BLOCK/PISTON & CONNECTING ROD - STANDARD PROCEDURE).

Check the piston for scoring, or scraping marks in the piston skirts. Check the ring lands for cracks and/or deterioration.

## INSTALLATION

(1) Be sure that compression ring gaps are staggered so that neither is in line with oil ring rail gap.

(2) Before installing the ring compressor, be sure the oil ring expander ends are butted and the rail gaps located properly (Fig. 40).



J9309-80

**Fig. 40 Proper Ring Installation**

- 1 - OIL RING SPACER GAP
- 2 - SECOND COMPRESSION RING GAP OIL RING RAIL GAP (TOP)
- 3 - OIL RING RAIL GAP (BOTTOM)
- 4 - TOP COMPRESSION RING GAP

(3) Immerse the piston head and rings in clean engine oil. Slide Piston Ring Compressor Tool C-385 over the piston and tighten with the special wrench (part of Tool C-385). **Be sure position of rings does not change during this operation.**

(4) Install connecting rod bolt protectors on rod bolts. The long protector should be installed on the numbered side of the connecting rod.

(5) Rotate crankshaft so that the connecting rod journal is on the center of the cylinder bore. Be sure connecting rod and cylinder bore number are the same. Insert rod and piston into cylinder bore and guide rod over the crankshaft journal.

(6) Tap the piston down in cylinder bore, using a hammer handle. At the same time, guide connecting rod into position on crankshaft journal.

(7) The notch, or groove, on top of piston must be pointing toward front of engine. The larger chamfer of the connecting rod bore must be installed toward crankshaft journal fillet.

(8) Install rod caps. Be sure connecting rod, connecting rod cap, and cylinder bore number are the same. Install nuts on cleaned and oiled rod bolts and tighten nuts to 61 N·m (45 ft. lbs.) torque.

(9) Install the oil pan (Refer to 9 - ENGINE/LUBRICATION/OIL PAN - INSTALLATION).

(10) Install the cylinder head (Refer to 9 - ENGINE/CYLINDER HEAD - INSTALLATION).

(11) Install the engine into the vehicle (Refer to 9 - ENGINE - INSTALLATION).

## PISTON RINGS

## STANDARD PROCEDURE—PISTON RING FITTING

(1) Measurement of end gaps:

(a) Measure piston ring gap 2 in. from bottom of cylinder bore. An inverted piston can be used to push the rings down to ensure positioning rings squarely in the cylinder bore before measuring.

(b) Insert feeler gauge in the gap. The top compression ring gap should be between 0.254-0.508 mm (0.010-0.020 in.). The second compression ring gap should be between 0.508-0.762 mm (0.020-0.030 in.). The oil ring gap should be 0.254-1.270 mm (0.010-0.050 in.).

(c) Rings with insufficient end gap may be properly filed to the correct dimension. Rings with excess gaps should not be used.

(2) Install rings, and confirm ring side clearance:

(a) Install oil rings being careful not to nick or scratch the piston. Install the oil control rings according to instructions in the package. It is not necessary to use a tool to install the upper and



PISTON RINGS (Continued)

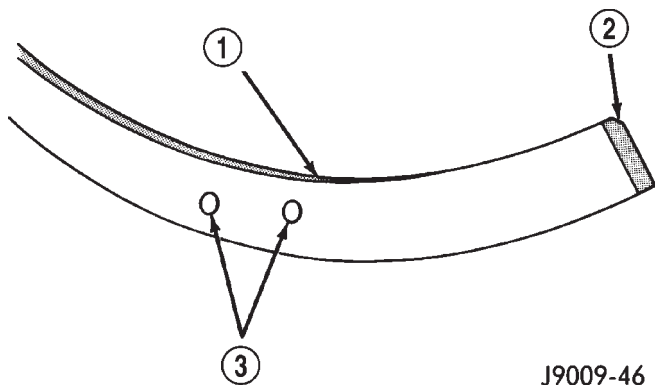
lower rails. Insert oil rail spacer first, then side rails.

(b) Install the second compression rings using Installation Tool C-4184. The compression rings must be installed with the identification mark face up (toward top of piston) and chamfer facing down. An identification mark on the ring is a drill point, a stamped letter "O", an oval depression, or the word "TOP" (Fig. 41) (Fig. 43).

(c) Using a ring installer, install the top compression ring with the chamfer facing up (Fig. 42) (Fig. 43). An identification mark on the ring is a drill point, a stamped letter "O", an oval depression or the word "TOP" facing up.

(d) Measure side clearance between piston ring and ring land. Clearance should be 0.074-0.097 mm (0.0029-0.0038 in.) for the compression rings. The steel rail oil ring should be free in groove, but should not exceed 0.246 mm (0.0097 in.) side clearance.

(e) Pistons with insufficient, or excessive, side clearance should be replaced.



J9009-46

**Fig. 41 Second Compression Ring Identification (Typical)**

- 1 - SECOND COMPRESSION RING (BLACK CAST IRON)
- 2 - CHAMFER
- 3 - TWO DOTS

(3) Orient the rings:

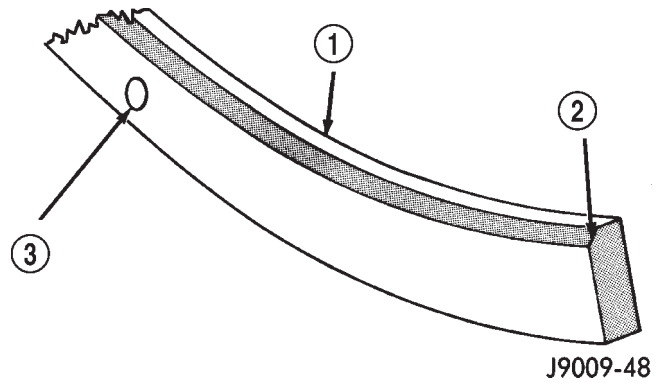
(a) Arrange top compression ring 90° counter-clockwise from the oil ring rail gap (Fig. 44).

(b) Arrange second compression ring 90° clockwise from the oil ring rail gap (Fig. 44).

VIBRATION DAMPER

REMOVAL

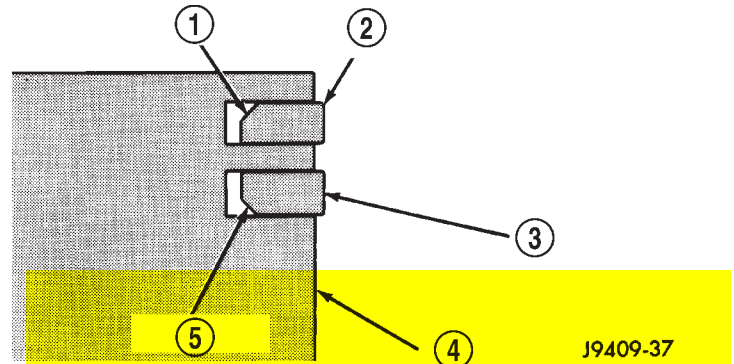
- (1) Disconnect the negative cable from the battery.
- (2) Remove fan, and fan drive (Refer to 7 - COOLING/ENGINE/FAN DRIVE VISCOUS CLUTCH - REMOVAL).



J9009-48

**Fig. 42 Top Compression Ring Identification (Typical)**

- 1 - TOP COMPRESSION RING (GRAY IN COLOR)
- 2 - CHAMFER
- 3 - ONE DOT



J9409-37

**Fig. 43 Compression Ring Chamfer Location (Typical)**

- 1 - CHAMFER
- 2 - TOP COMPRESSION RING
- 3 - SECOND COMPRESSION RING
- 4 - PISTON
- 5 - CHAMFER

(3) Remove the accessory drive belt (Refer to 7 - COOLING/ACCESSORY DRIVE/DRIVE BELTS - REMOVAL).

(4) Remove the vibration damper pulley.

(5) Remove vibration damper bolt and washer from end of crankshaft.

(6) Install bar and screw from Puller Tool Set C-3688. Install two bolts with washers through the puller tool and into the vibration damper (Fig. 45).

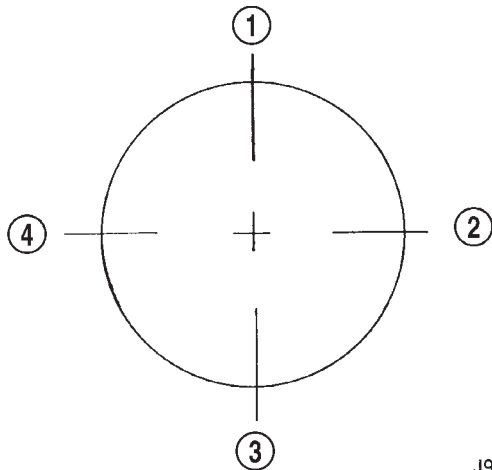
(7) Pull vibration damper off of the crankshaft.

INSTALLATION

(1) Position the vibration damper onto the crankshaft.

(2) Place installing tool, part of Puller Tool Set C-3688, in position and press the vibration damper onto the crankshaft (Fig. 46).

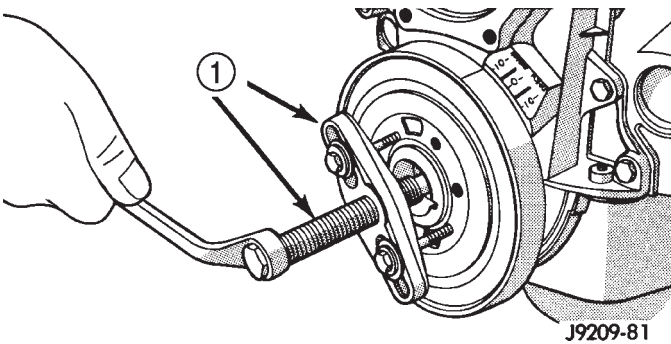
## VIBRATION DAMPER (Continued)



J9309-80

**Fig. 44 Proper Ring Installation**

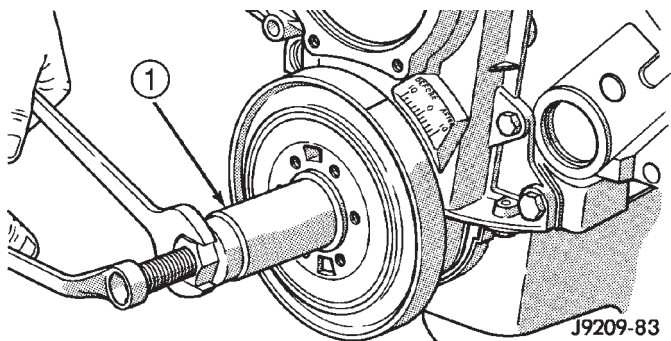
- 1 - OIL RING SPACER GAP
- 2 - SECOND COMPRESSION RING GAP OIL RING RAIL GAP (TOP)
- 3 - OIL RING RAIL GAP (BOTTOM)
- 4 - TOP COMPRESSION RING GAP



J9209-81

**Fig. 45 Vibration Damper Assembly**

- 1 - SPECIAL TOOL C-3688



J9209-83

**Fig. 46 Installing Vibration Damper**

- 1 - SPECIAL TOOL C-3688

(3) Install the crankshaft bolt and washer. Tighten the bolt to 244 N·m (180 ft. lbs.) torque.

(4) Install the crankshaft pulley. Tighten the pulley bolts to 23 N·m (200 in. lbs.) torque.

(5) Install the serpentine belt (Refer to 7 - COOLING/ACCESSORY DRIVE/DRIVE BELTS - INSTALLATION).

(6) Install viscous fan drive and fan (Refer to 7 - COOLING/ENGINE/FAN DRIVE VISCOUS CLUTCH - INSTALLATION).

(7) Install the fan shroud.

(8) Connect the negative cable to the battery.

## FRONT MOUNT

## REMOVAL

(1) Disconnect the battery negative cable.

(2) Position fan to ensure clearance for radiator top tank and hose.

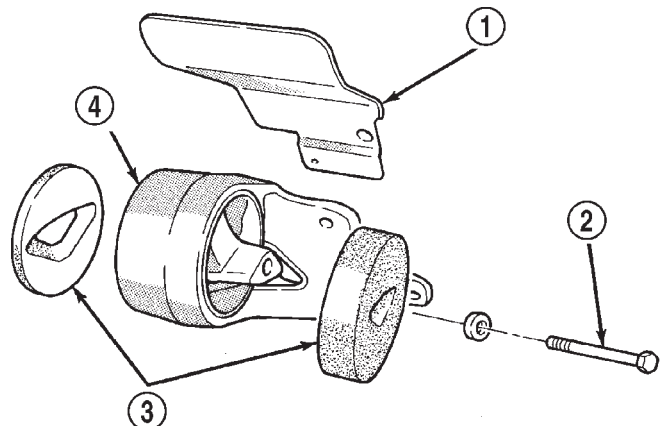
**CAUTION: DO NOT lift the engine by the intake manifold.**

(3) Install engine support/lifting fixture.

(4) Raise vehicle on hoist.

(5) Lift the engine SLIGHTLY and remove the thru-bolt and nut (Fig. 47).

(6) Remove engine support bracket/cushion bolts (Fig. 47). Remove the support bracket/cushion and heat shields.



J9409-144

**Fig. 47 Engine Front Mounts**

- 1 - ENGINE MOUNT HEAT SHIELD
- 2 - THRU-BOLT
- 3 - RESTRICTION PADS
- 4 - ENGINE SUPPORT BRACKET/CUSHION

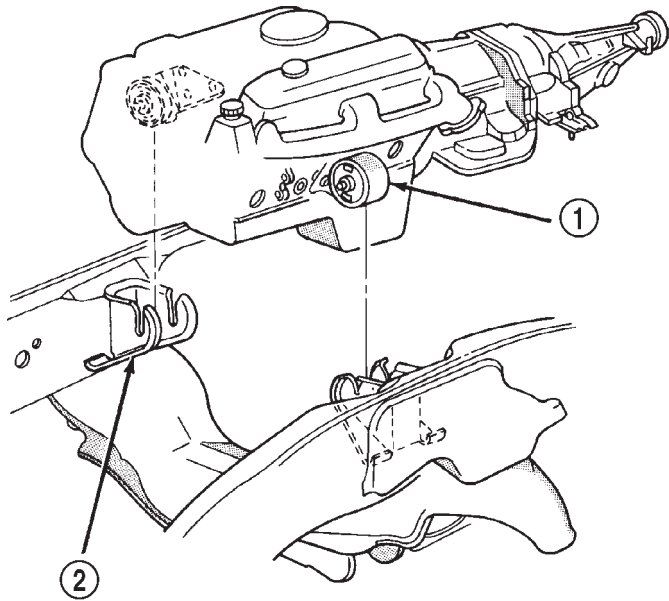
## INSTALLATION

(1) With engine raised SLIGHTLY, position the engine support bracket/cushion and heat shields to the block. Install new bolts and tighten to 81 N·m (60 ft. lbs.) torque.

(2) Install the through-bolt into the engine support bracket/cushion.

FRONT MOUNT (Continued)

(3) Lower engine with support/lifting fixture while guiding the engine bracket/cushion and through-bolt into support cushion brackets (Fig. 48).



**Fig. 48 Positioning Engine Front Mounts** J9409-54

- 1 - ENGINE SUPPORT BRACKET/CUSHION
- 2 - SUPPORT CUSHION BRACKET

- (4) Install through-bolt nuts and tighten the nuts to 102 N·m (75 ft. lbs.) torque.
- (5) Lower the vehicle.
- (6) Remove lifting fixture.

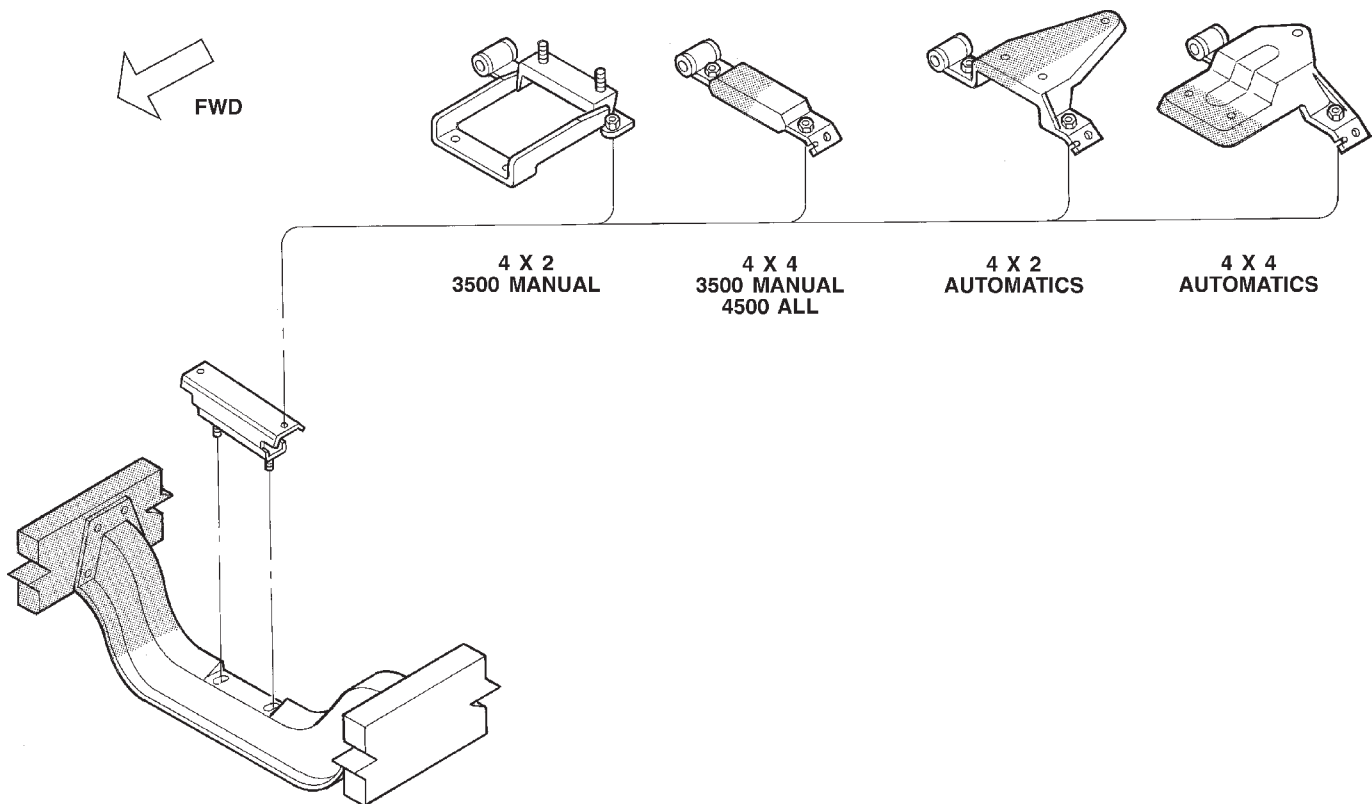
REAR MOUNT

REMOVAL

- (1) Raise the vehicle on a hoist.
- (2) Position a transmission jack in place.
- (3) Remove support cushion stud nuts (Fig. 49).
- (4) Raise rear of transmission and engine SLIGHTLY.
- (5) Remove the bolts holding the support cushion to the transmission support bracket. Remove the support cushion.
- (6) If necessary, remove the bolts holding the transmission support bracket to the transmission.

INSTALLATION

- (1) If removed, position the transmission support bracket to the transmission. Install new attaching bolts and tighten to 88 N·m (65 ft. lbs.) torque.
- (2) Position support cushion to transmission support bracket. Install stud nuts and tighten to 41 N·m (30 ft. lbs.) torque.



**Fig. 49 Engine Rear Support Cushion Assemblies**

## REAR MOUNT (Continued)

(3) Using the transmission jack, lower the transmission and support cushion onto the crossmember (Fig. 49).

(4) Install the support cushion bolts and tighten to 41 N·m (30 ft. lbs.) torque.

(5) Remove the transmission jack.

(6) Lower the vehicle.

## LUBRICATION

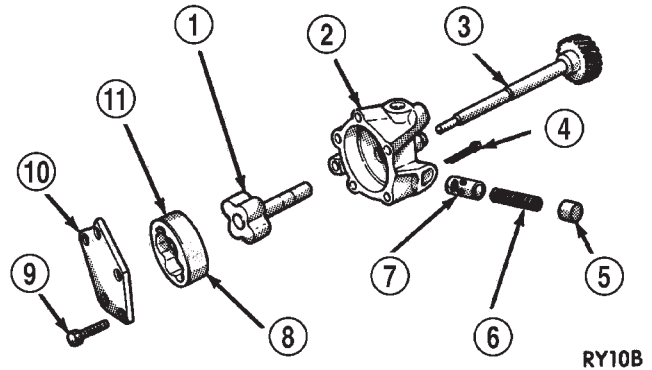
## DESCRIPTION

A gear-type positive displacement pump (Fig. 50) is mounted at the underside of the rear main bearing cap. The pump uses a pick-up tube and screen assembly to gather engine oil from the oil pan.

## OPERATION

The pump draws oil through the screen and inlet tube from the sump at the rear of the oil pan. The oil is driven between the drive and idler gears and pump body, then forced through the outlet to the block. An oil gallery in the block channels the oil to the inlet side of the full flow oil filter. After passing through the filter element, the oil passes from the center outlet of the filter through an oil gallery that channels the oil up to the main gallery, which extends the entire length on the right side of the block. The oil then goes down to the No. 1 main bearing, back up to the left side of the block, and into the oil gallery on the left side of the engine.

Galleries extend downward from the main oil gallery to the upper shell of each main bearing. The crankshaft is drilled internally to pass oil from the main bearing journals to the connecting rod journals. Each connecting rod bearing has half a hole in it, oil passes through the hole when the rods rotate and the hole lines up, oil is then thrown off as the rod rotates. This oil throwoff lubricates the camshaft lobes, distributor drive gear, cylinder walls, and piston pins.



RY10B

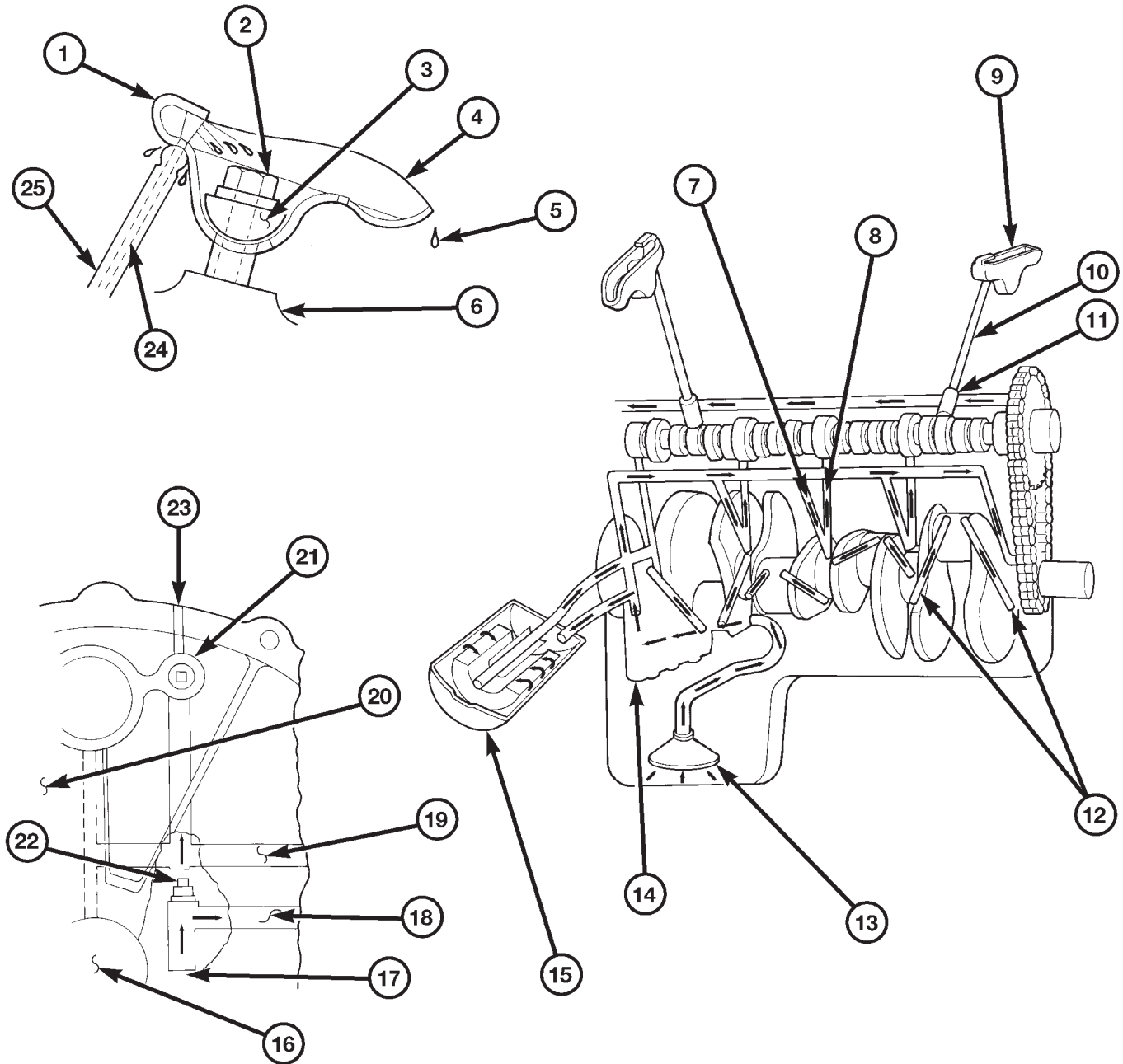
**Fig. 50 Positive Displacement Oil Pump—Typical**

- 1 - INNER ROTOR AND SHAFT
- 2 - BODY
- 3 - DISTRIBUTOR DRIVESHAFT (REFERENCE)
- 4 - COTTER PIN
- 5 - RETAINER CAP
- 6 - SPRING
- 7 - RELIEF VALVE
- 8 - LARGE CHAMFERED EDGE
- 9 - BOLT
- 10 - COVER
- 11 - OUTER ROTOR

The hydraulic valve tappets receive oil directly from the main oil gallery. The camshaft bearings receive oil from the main bearing galleries. The front camshaft bearing journal passes oil through the camshaft sprocket to the timing chain. Oil drains back to the oil pan under the No. 1 main bearing cap.

The oil supply for the rocker arms and bridged pivot assemblies is provided by the hydraulic valve tappets, which pass oil through hollow push rods to a hole in the corresponding rocker arm. Oil from the rocker arm lubricates the valve train components. The oil then passes down through the push rod guide holes and the oil drain-back passages in the cylinder head, past the valve tappet area, and then returns to the oil pan (Fig. 51).

LUBRICATION (Continued)



**Fig. 51 Oil Lubrication System**

8087d0cf

- |   |   |
|---|---|
| <ul style="list-style-type: none"> <li>1 - OIL DEFLECTOR TAB</li> <li>2 - BOLT</li> <li>3 - ROCKER ARM PIVOT</li> <li>4 - ROCKER ARM</li> <li>5 - DRIP OILING FOR VALVE TIP</li> <li>6 - CYLINDER HEAD BOSS</li> <li>7 - TO MAIN BEARINGS</li> <li>8 - TO CAMSHAFT BEARINGS</li> <li>9 - ROCKER ARM</li> <li>10 - HOLLOW PUSH ROD</li> <li>11 - TAPPET</li> <li>12 - TO CONNECTING ROD BEARINGS</li> <li>13 - OIL INTAKE</li> </ul> | <ul style="list-style-type: none"> <li>14 - OIL PUMP</li> <li>15 - OIL FILTER</li> <li>16 - CRANKSHAFT</li> <li>17 - FROM OIL PUMP</li> <li>18 - OIL TO FILTER</li> <li>19 - OIL FROM FILTER TO SYSTEM</li> <li>20 - PASSAGE TO CAMSHAFT REAR BEARING</li> <li>21 - RIGHT OIL GALLERY</li> <li>22 - PLUG</li> <li>23 - OIL PASSAGE FOR OIL PRESSURE INDICATOR LIGHT</li> <li>24 - OIL SUPPLY VIA HOLLOW PUSH ROD SUPPLY IS FROM OIL GALLERY METERED THROUGH HYDRAULIC TAPPET</li> <li>25 - OIL SUPPLY FROM HOLLOW PUSH ROD</li> </ul> |
|---|---|



## LUBRICATION (Continued)

**DIAGNOSIS AND TESTING—ENGINE OIL PRESSURE**

- (1) Remove oil pressure sending unit.
- (2) Install Oil Pressure Line and Gauge Tool C-3292. Start engine and record pressure. (Refer to 9 - ENGINE - SPECIFICATIONS).

**DIAGNOSIS AND TESTING—ENGINE OIL LEAKS**

Begin with a through visual inspection of the engine, particularly at the area of the suspected leak. If an oil leak source is not readily identifiable, the following steps should be followed:

- (1) Do not clean or degrease the engine at this time because some solvents may cause rubber to swell, temporarily stopping the leak.
- (2) Add an oil-soluble dye (use as recommended by manufacturer). Start the engine and let idle for approximately 15 minutes. Check the oil dipstick to be sure the dye is thoroughly mixed as indicated with a bright yellow color under a black light source.
- (3) Using a black light, inspect the entire engine for fluorescent dye, particularly at the suspected area of oil leak. If the oil leak is found and identified, repair per service manual instructions.
- (4) If dye is not observed, drive the vehicle at various speeds for approximately 24km (15 miles), and repeat previous step.
- (5) If the oil leak source is not positively identified at this time, proceed with the air leak detection test method as follows:
  - (6) Disconnect the breather cap to air cleaner hose at the breather cap end. Cap or plug breather cap nipple.
  - (7) Remove the PCV valve from the cylinder head cover. Cap or plug the PCV valve grommet.
  - (8) Attach an air hose with pressure gauge and regulator to the dipstick tube.

**CAUTION:** Do not subject the engine assembly to more than 20.6 kpa (3 PSI) of test pressure.

(9) Gradually apply air pressure from 1 psi to 2.5 psi maximum while applying soapy water at the suspected source. Adjust the regulator to the suitable test pressure that provide the best bubbles which will pinpoint the leak source. If the oil leak is detected and identified, repair per service manual procedures.

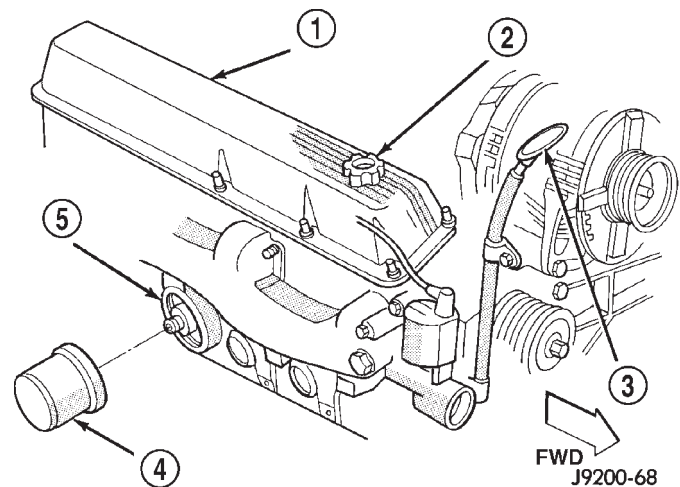
(10) If the leakage occurs at the rear oil seal area, refer to the section, Inspection for Rear Seal Area Leak.

(11) If no leaks are detected, turn off the air supply and remove the air hose and all plugs and caps. Install the PCV valve and breather cap hose. Proceed to next step.

(12) Clean the oil off the suspect oil leak area using a suitable solvent. Drive the vehicle at various speeds approximately 24 km (15 miles). Inspect the engine for signs of an oil leak by using a black light.

**OIL****STANDARD PROCEDURE—ENGINE OIL****OIL LEVEL INDICATOR (DIPSTICK)**

The engine oil level indicator is located at the right front of the engine, left of the generator on 3.9L engines (Fig. 52).



**Fig. 52 Oil Level Indicator Location**

- 1 - CYLINDER HEAD COVER
- 2 - ENGINE OIL FILL CAP
- 3 - DIPSTICK
- 4 - ENGINE OIL FILTER
- 5 - FILTER BOSS

**CRANKCASE OIL LEVEL INSPECTION**

**CAUTION:** Do not overfill crankcase with engine oil, oil foaming and oil pressure loss can result.

To ensure proper lubrication of an engine, the engine oil must be maintained at an acceptable level. The acceptable levels are indicated between the ADD and SAFE marks on the engine oil dipstick.

- (1) Position vehicle on level surface.
- (2) With engine OFF, allow approximately ten minutes for oil to settle to bottom of crankcase, remove engine oil dipstick.
- (3) Wipe dipstick clean.
- (4) Install dipstick and verify it is seated in the tube.
- (5) Remove dipstick, with handle held above the tip, take oil level reading.



## OIL (Continued)

(6) Add oil only if level is below the ADD mark on dipstick.

**ENGINE OIL CHANGE:**

Change engine oil at mileage and time intervals described in the Maintenance Schedule. This information can be found in the owner's manual.

**TO CHANGE ENGINE OIL**

Run engine until achieving normal operating temperature.

(1) Position the vehicle on a level surface and turn engine off.

(2) Hoist vehicle.

(3) Remove oil fill cap.

(4) Place a suitable drain pan under crankcase drain.

(5) Remove drain plug from crankcase and allow oil to drain into pan. Inspect drain plug threads for stretching or other damage. Replace drain plug and gasket if damaged.

(6) Install drain plug in crankcase.

(7) Change oil filter (Refer to 9 - ENGINE/LUBRICATION/OIL FILTER - REMOVAL).

(8) Lower vehicle and fill crankcase with specified type (Refer to LUBRICATION & MAINTENANCE/FLUID TYPES - DESCRIPTION) and amount of engine oil (Refer to LUBRICATION & MAINTENANCE - SPECIFICATIONS).

(9) Install oil fill cap.

(10) Start engine and inspect for leaks.

(11) Stop engine and inspect oil level.

**OIL FILTER****REMOVAL**

All engines are equipped with a high quality full-flow, disposable type oil filter. DaimlerChrysler Corporation recommends a Mopar® or equivalent oil filter be used.

(1) Position a drain pan under the oil filter.

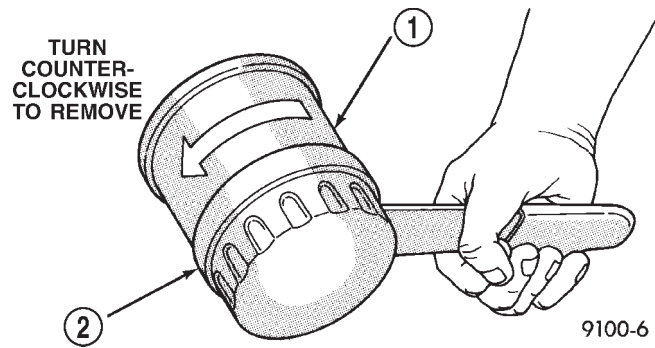
(2) Using a suitable oil filter wrench loosen filter.

(3) Rotate the oil filter counterclockwise to remove it from the cylinder block oil filter boss (Fig. 53).

(4) When filter separates from adapter nipple, tip gasket end upward to minimize oil spill. Remove filter from vehicle.

(5) With a wiping cloth, clean the gasket sealing surface (Fig. 54) of oil and grime.

(6) Install new filter (Refer to 9 - ENGINE/LUBRICATION/OIL FILTER - INSTALLATION).



**Fig. 53 Oil Filter Removal—Typical**

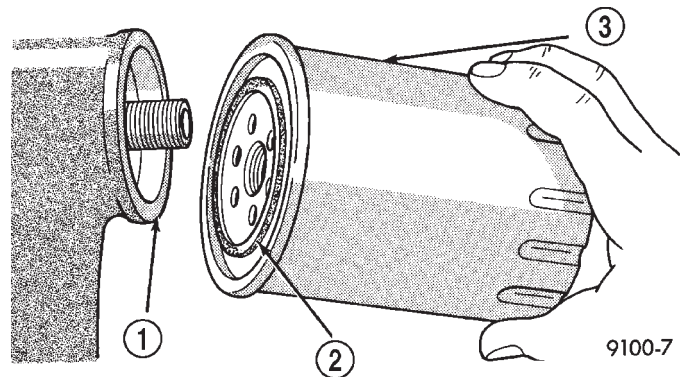
- 1 - ENGINE OIL FILTER  
2 - OIL FILTER WRENCH

**INSTALLATION**

(1) Lightly lubricate oil filter gasket with engine oil or chassis grease.

(2) Thread filter onto adapter nipple. When gasket makes contact with sealing surface, (Fig. 54) hand tighten filter one full turn, do not over tighten.

(3) Add oil (Refer to 9 - ENGINE/LUBRICATION/OIL - STANDARD PROCEDURE).



**Fig. 54 Oil Filter Sealing Surface—Typical**

- 1 - SEALING SURFACE  
2 - RUBBER GASKET  
3 - OIL FILTER

**OIL PAN****REMOVAL**

(1) Disconnect the negative cable from the battery.

(2) Remove engine oil dipstick.

(3) Raise vehicle.

(4) Drain engine oil.

(5) Remove exhaust pipe.

(6) Remove left engine to transmission strut.

(7) Loosen the right side engine support bracket cushion through-bolt nut and raise the engine slightly. Remove oil pan by sliding backward and out.

(8) Remove the one-piece gasket.

## OIL PAN (Continued)

## CLEANING

Clean the block and pan gasket surfaces.

Trim or remove excess sealant film in the rear main cap oil pan gasket groove. **DO NOT remove the sealant inside the rear main cap slots.**

If present, trim excess sealant from inside the engine.

Clean oil pan in solvent and wipe dry with a clean cloth.

Clean oil screen and pipe thoroughly in clean solvent. Inspect condition of screen.

## INSPECTION

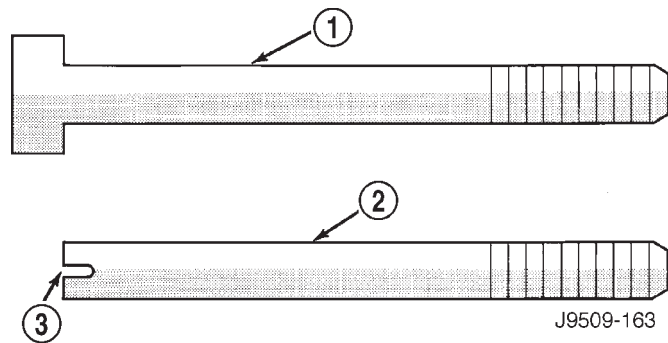
Inspect oil drain plug and plug hole for stripped or damaged threads. Repair as necessary.

Inspect oil pan mounting flange for bends or distortion. Straighten flange, if necessary.

## INSTALLATION

(1) Clean the block and pan gasket surfaces.

(2) Fabricate four alignment dowels from 5/16 X 1 1/2 inch bolts. Cut the head off the bolts and cut a slot into the top of the dowel. This will allow easier installation and removal with a screwdriver (Fig. 55).



**Fig. 55 Fabrication of Alignment Dowels**

- 1 - 5/16" X 1 1/2" BOLT  
2 - DOWEL  
3 - SLOT

(3) Install the dowels in the cylinder block (Fig. 56).

(4) Apply small amount of Mopar® Silicone Rubber Adhesive Sealant, or equivalent, in the corner of the cap and the cylinder block.

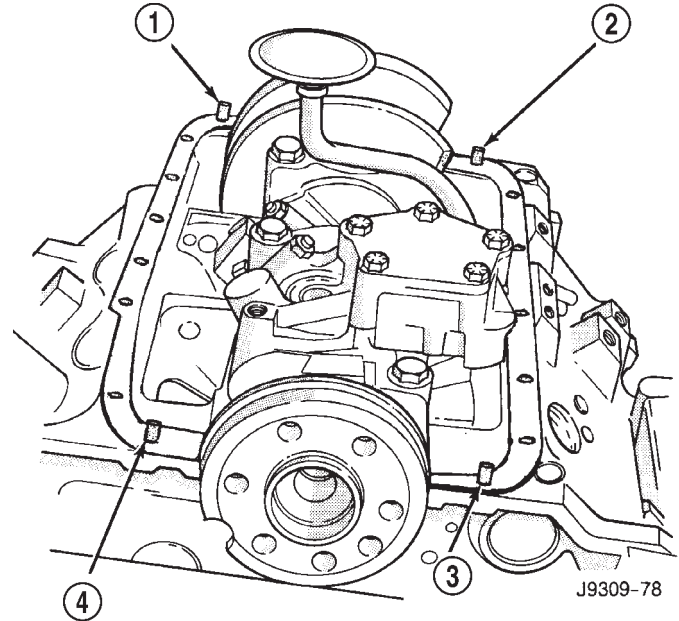
(5) Slide the one-piece gasket over the dowels and onto the block.

(6) Position the oil pan over the dowels and onto the gasket.

(7) Install the oil pan bolts. Tighten the bolts to 24 N·m (215 in. lbs.) torque.

(8) Remove the dowels. Install the remaining oil pan bolts. Tighten these bolts to 24 N·m (215 in. lbs.) torque.

(9) Lower the engine into the support cushion brackets and tighten the through-bolt nut to the proper torque.



**Fig. 56 Position of Dowels in Cylinder Block**

- 1 - DOWEL  
2 - DOWEL  
3 - DOWEL  
4 - DOWEL

(10) Install the drain plug. Tighten drain plug to 34 N·m (27 ft. lbs.) torque.

(11) Install the engine to transmission strut.

(12) Install exhaust pipe.

(13) Lower vehicle.

(14) Install dipstick.

(15) Connect the negative cable to the battery.

(16) Fill crankcase with oil to proper level.

OIL PRESSURE SENSOR/  
SWITCH

## DESCRIPTION

The 2-wire, electrical/mechanical engine oil pressure sensor (sending unit) is located in an engine oil pressure gallery.

## OPERATION

The oil pressure sensor uses two circuits. They are:

- A signal to the PCM relating to engine oil pressure
- A sensor ground through the PCM's sensor return

The oil pressure sensor returns a voltage signal back to the PCM relating to engine oil pressure. This signal is then transferred (bussed) to the instrument panel on a CCD bus circuit to operate the oil pressure gauge and the check gauges lamp. Ground for the sensor is provided by the PCM through a low-noise sensor return.

## OIL PUMP

### REMOVAL

(1) Remove the oil pan (Refer to 9 - ENGINE/LUBRICATION/OIL PAN - REMOVAL).

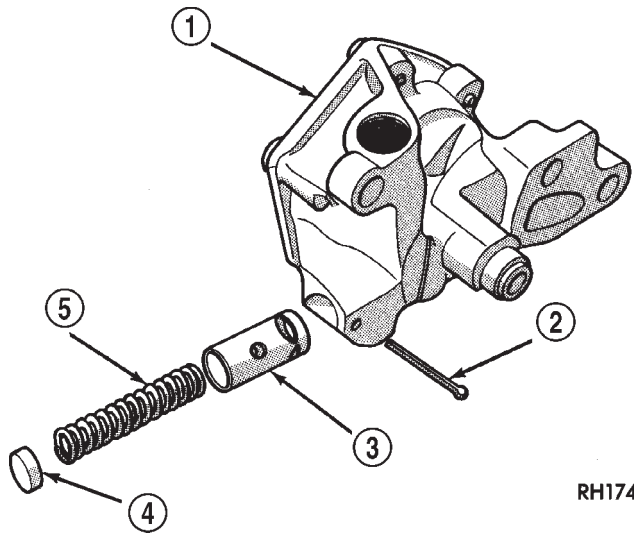
(2) Remove the oil pump from rear main bearing cap.

### DISASSEMBLE

(1) Remove the relief valve as follows:

(a) Remove cotter pin. Drill a 3.175 mm (1/8 in.) hole into the relief valve retainer cap and insert a self-threading sheet metal screw into cap.

(b) Clamp screw into a vise and while supporting oil pump, remove cap by tapping pump body using a soft hammer. Discard retainer cap and remove spring and relief valve (Fig. 57).



RH174

**Fig. 57 Oil Pressure Relief Valve**

- 1 - OIL PUMP ASSEMBLY
- 2 - COTTER PIN
- 3 - RELIEF VALVE
- 4 - RETAINER CAP
- 5 - SPRING

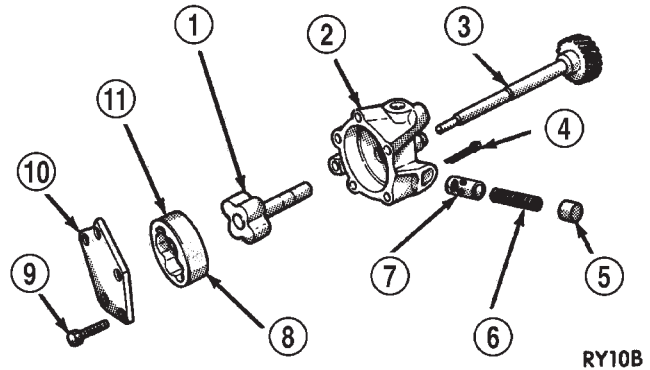
- (2) Remove oil pump cover (Fig. 58).
- (3) Remove pump outer rotor and inner rotor with shaft (Fig. 58).
- (4) Wash all parts in a suitable solvent and inspect carefully for damage or wear.

### CLEANING

Use only mild solvents to clean the oil pump. Do not use any abrasive material to clean the oil pump housing or rotors.

### INSPECTION

Mating surface of the oil pump cover should be smooth. Replace pump assembly if cover is scratched or grooved.

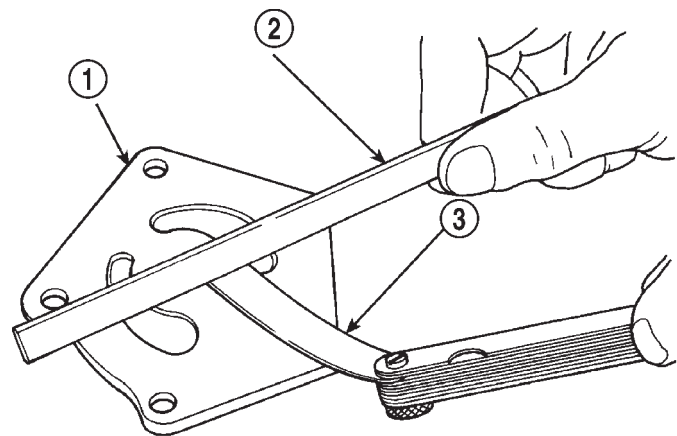


RY10B

**Fig. 58 Oil Pump**

- 1 - INNER ROTOR AND SHAFT
- 2 - BODY
- 3 - DISTRIBUTOR DRIVESHAFT (REFERENCE)
- 4 - COTTER PIN
- 5 - RETAINER CAP
- 6 - SPRING
- 7 - RELIEF VALVE
- 8 - LARGE CHAMFERED EDGE
- 9 - BOLT
- 10 - COVER
- 11 - OUTER ROTOR

Lay a straightedge across the pump cover surface (Fig. 59). If a 0.038 mm (0.0015 in.) feeler gauge can be inserted between cover and straightedge, pump assembly should be replaced.



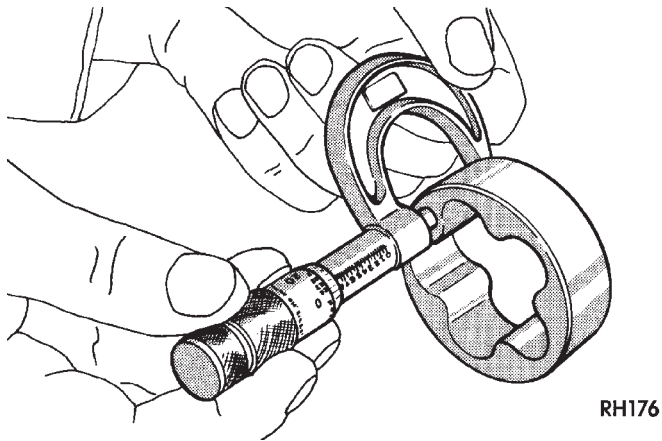
8020cd6e

**Fig. 59 Checking Oil Pump Cover Flatness**

- 1 - COVER
- 2 - STRAIGHT EDGE
- 3 - FEELER GAUGE

## OIL PUMP (Continued)

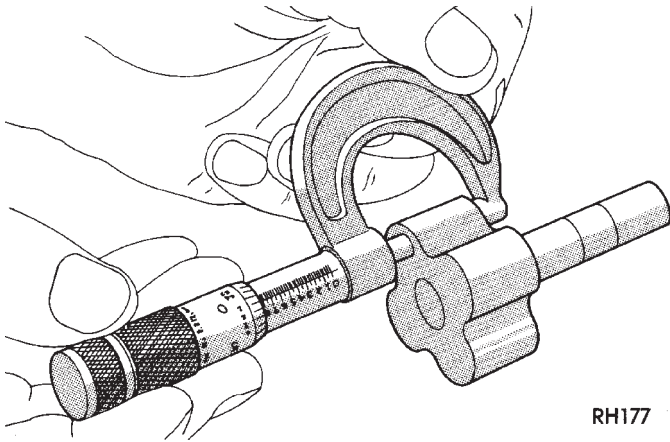
Measure thickness and diameter of outer rotor. If outer rotor thickness measures 20.9 mm (0.825 in.) or less, or if the diameter is 62.7 mm (2.469 in.) or less, replace outer rotor (Fig. 60).



RH176

**Fig. 60 Measuring Outer Rotor Thickness**

If inner rotor measures 20.9 mm (0.825 in.) or less, replace inner rotor and shaft assembly (Fig. 61).



RH177

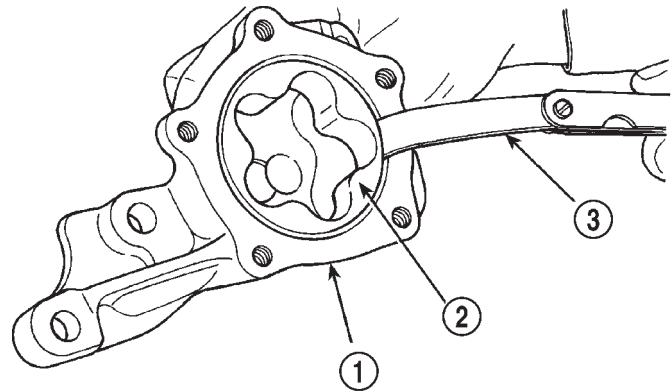
**Fig. 61 Measuring Inner Rotor Thickness**

Slide outer rotor into pump body. Press rotor to the side with your fingers and measure clearance between rotor and pump body (Fig. 62). If clearance is 0.356 mm (0.014 in.) or more, replace oil pump assembly.

Install inner rotor and shaft into pump body. If clearance between inner and outer rotors is 0.203 mm (0.008 in.) or more, replace shaft and both rotors (Fig. 63).

Place a straightedge across the face of the pump, between bolt holes. If a feeler gauge of 0.102 mm (0.004 in.) or more can be inserted between rotors and the straightedge, replace pump assembly (Fig. 64).

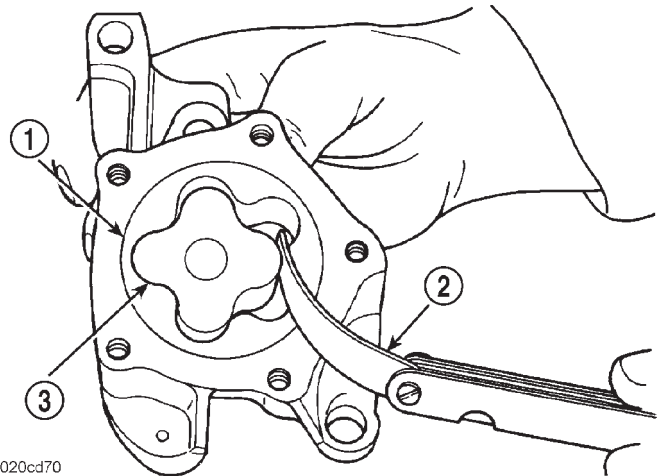
Inspect oil pressure relief valve plunger for scoring and free operation in its bore. Small marks may be removed with 400-grit wet or dry sandpaper.



8020cd6f

**Fig. 62 Measuring Outer Rotor Clearance in Housing**

- 1 - PUMP BODY
- 2 - OUTER ROTOR
- 3 - FEELER GAUGE



8020cd70

**Fig. 63 Measuring Clearance Between Rotors**

- 1 - OUTER ROTOR
- 2 - FEELER GAUGE
- 3 - INNER ROTOR

The relief valve spring has a free length of approximately 49.5 mm (1.95 in.). The spring should test between 19.5 and 20.5 pounds when compressed to 34 mm (1-11/32 in.). Replace spring that fails to meet these specifications (Fig. 65).

If oil pressure was low and pump is within specifications, inspect for worn engine bearings or other reasons for oil pressure loss.

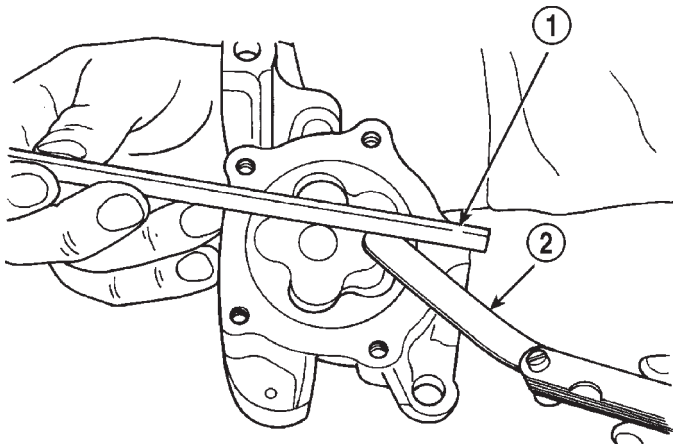
## ASSEMBLY

(1) Install pump rotors and shaft, using new parts as required.

(2) Position the oil pump cover onto the pump body. Tighten cover bolts to 11 N·m (95 in. lbs.) torque.



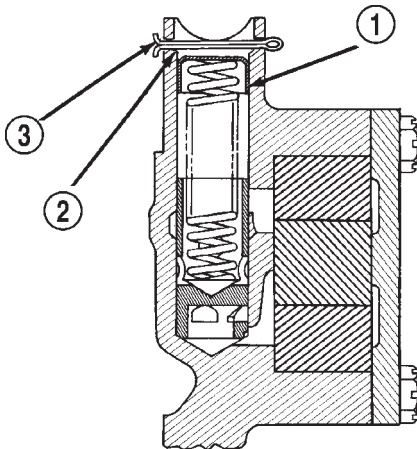
OIL PUMP (Continued)



8020cd71

**Fig. 64 Measuring Clearance Over Rotors**

- 1 - STRAIGHT EDGE
- 2 - FEELER GAUGE



RN98

**Fig. 65 Proper Installation of Retainer Cap**

- 1 - RETAINER CAP
- 2 - CHAMFER
- 3 - COTTER KEY

(3) Install the relief valve and spring. Insert the cotter pin.

(4) Tap on a new retainer cap.

(5) Prime oil pump before installation by filling rotor cavity with engine oil.

**INSTALLATION**

(1) Install oil pump. During installation, slowly rotate pump body to ensure driveshaft-to-pump rotor shaft engagement.

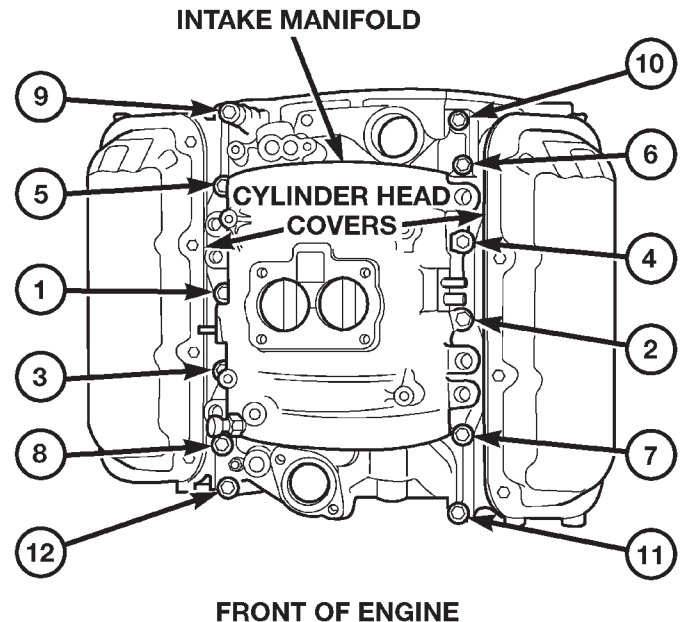
(2) Hold the oil pump base flush against mating surface on No. 4 main bearing cap. Finger-tighten pump attaching bolts. Tighten attaching bolts to 41 N·m (30 ft. lbs.) torque.

(3) Install the oil pan (Refer to 9 - ENGINE/LUBRICATION/OIL PAN - INSTALLATION).

**INTAKE MANIFOLD**

**DESCRIPTION**

The aluminum intake manifold (Fig. 66) is a single plane design with equal length runners. This manifold uses a separate plenum pan and gasket, therefore the plenum gasket is servicable. It also uses separate flange gaskets and front and rear cross-over gaskets. Extreme care must be used when sealing the gaskets to ensure that excess sealant does not enter the intake runners causing a restriction.



80c071ac

**Fig. 66 Intake Manifold with Tightening Sequence—3.9L Engine**

**OPERATION**

The intake manifold, meters and delivers air to the combustion chambers allowing the fuel delivered by the fuel injectors to ignite, thus producing power.

## INTAKE MANIFOLD (Continued)

**DIAGNOSIS AND TESTING—INTAKE MANIFOLD LEAKAGE**

An intake manifold air leak is characterized by lower than normal manifold vacuum. Also, one or more cylinders may not be functioning.

**WARNING: USE EXTREME CAUTION WHEN THE ENGINE IS OPERATING. DO NOT STAND IN A DIRECT LINE WITH THE FAN. DO NOT PUT YOUR HANDS NEAR THE PULLEYS, BELTS, OR THE FAN. DO NOT WEAR LOOSE CLOTHING.**

- (1) Start the engine.
- (2) Spray a small stream of water at the suspected leak area.
- (3) If a change in RPMs, the area of the suspected leak has been found.
- (4) Repair as required.

**REMOVAL**

- (1) Disconnect the negative cable from the battery.
- (2) Drain the cooling system (Refer to 7 - COOLING - STANDARD PROCEDURE).
- (3) Remove the A/C compressor (Refer to 24 - HEATING & AIR CONDITIONING/PLUMBING/A/C COMPRESSOR - REMOVAL).
- (4) Remove the generator (Refer to 8 - ELECTRICAL/CHARGING/GENERATOR - REMOVAL).
- (5) Remove the accessory drive bracket.
- (6) Remove the air cleaner.
- (7) Perform the Fuel System Pressure release procedure (Refer to 14 - FUEL SYSTEM/FUEL DELIVERY - STANDARD PROCEDURE). Disconnect the fuel lines (Refer to 14 - FUEL SYSTEM/FUEL DELIVERY/QUICK CONNECT FITTING - STANDARD PROCEDURE).
- (8) Disconnect the accelerator linkage (Refer to 14 - FUEL SYSTEM/FUEL INJECTION/THROTTLE CONTROL CABLE - REMOVAL) and if so equipped, the speed control and transmission kickdown cables.
- (9) Remove the return spring.
- (10) Remove the distributor cap and wires.
- (11) Disconnect the coil wires.
- (12) Disconnect the heat indicator sending unit wire.
- (13) Disconnect the heater hoses and bypass hose.
- (14) Remove the closed crankcase ventilation and evaporation control systems.
- (15) Remove intake manifold bolts.
- (16) Lift the intake manifold and throttle body out of the engine compartment as an assembly.
- (17) Remove and discard the flange side gaskets and the front and rear cross-over gaskets.

(18) Remove the throttle body (Refer to 14 - FUEL SYSTEM/FUEL INJECTION/THROTTLE BODY - REMOVAL).

(19) If required, remove the plenum pan and gasket. Discard gasket.

**CLEANING**

Clean manifold in solvent and blow dry with compressed air.

Clean cylinder block front and rear gasket surfaces using a suitable solvent.

The plenum pan rail must be clean and dry (free of all foreign material).

**INSPECTION**

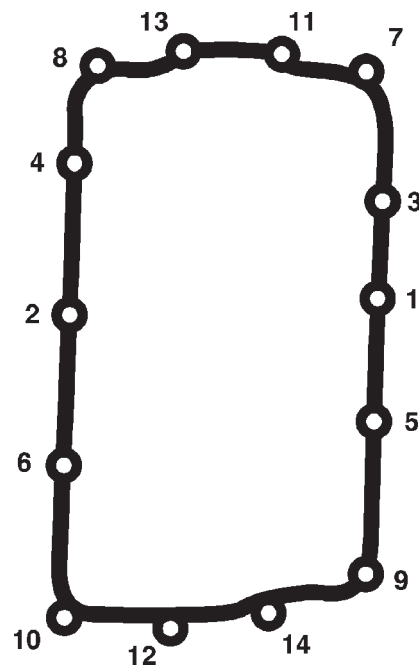
Inspect manifold for cracks.

Inspect mating surfaces of manifold for flatness with a straightedge.

**INSTALLATION**

(1) If the plenum pan was removed, position a new gasket and install the plenum pan (Fig. 67). Tighten bolts in the following sequence:

- Step 1. Tighten bolts to 5.4 N·m (48 in. lbs.)
- Step 2. Tighten bolts to 9.5 N·m (84 in. lbs.)
- Step 3. Check bolts to 9.5 N·m (84 in. lbs.)



80c071ea

**Fig. 67 Plenum Pan Bolt Tightening Sequence**

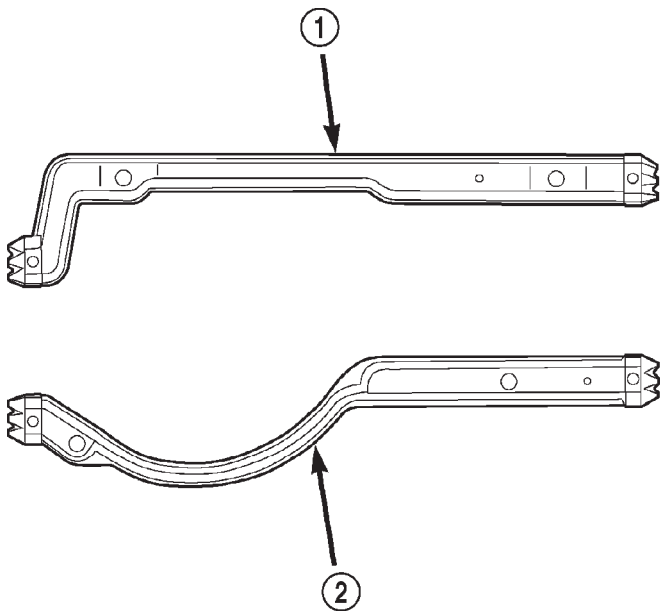
(2) Install the flange gaskets. Ensure that the vertical port alignment tab is resting on the deck face of the block. Also the horizontal alignment tabs must be in position with the mating cylinder head gasket tabs (Fig. 69). The words MANIFOLD SIDE should be visible on the center of each flange gasket.



INTAKE MANIFOLD (Continued)

(3) Apply Mopar® GEN II Silicone Rubber Adhesive Sealant, or equivalent, to the four corner joints. An excessive amount of sealant is not required to ensure a leak proof seal. However, an excessive amount of sealant may reduce the effectiveness of the flange gasket and cross-over gaskets (Fig. 68). The sealant should be approximately 5 mm (0.2 in) in diameter.

(4) Install the front and rear cross-over gaskets.



80c071ad

**Fig. 68 Cross-Over Gaskets**

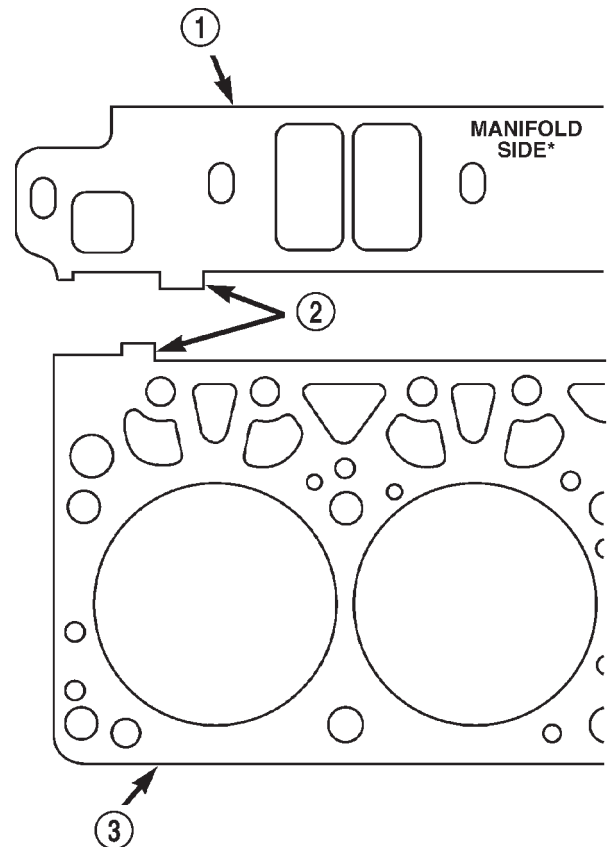
- 1 - FRONT CROSS-OVER GASKET
- 2 - REAR CROSS-OVER GASKET

(5) Using a new gasket, install the throttle body onto the intake manifold (Refer to 14 - FUEL SYSTEM/FUEL INJECTION/THROTTLE BODY - INSTALLATION).

(6) Carefully lower intake manifold into position on the cylinder block and cylinder heads. After intake manifold is in place, inspect to make sure seals are in place.

(7) Install the intake manifold bolts and tighten as follows (Fig. 70):

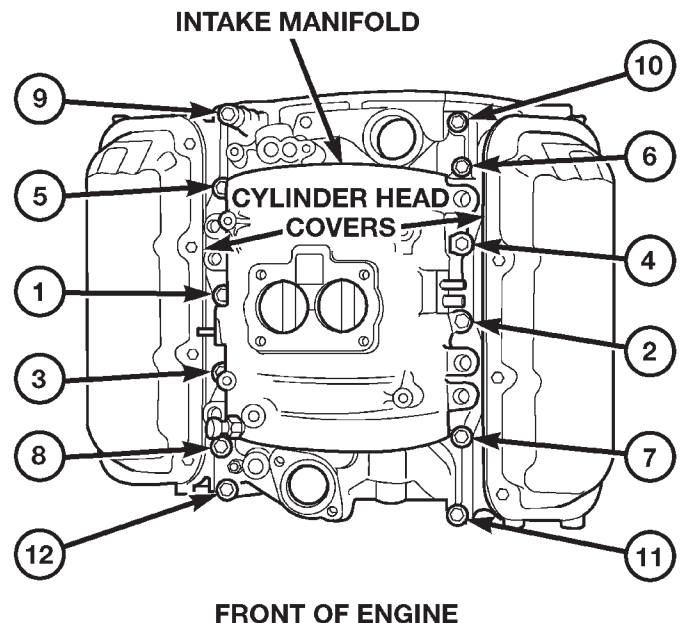
- Step 1. Tighten bolts 1 and 2 to 8 N·m (72 in. lbs.) Tighten in alternating steps 1.4 N·m (12 in. lbs.) at a time
- Step 2. Tighten bolts 3 through 12 to 8 N·m (72 in. lbs.)
- Step 3. Check all bolts are torqued to 8 N·m (72 in. lbs.)
- Step 4. Tighten all bolts in sequence to 16 N·m (12 ft. lbs.)
- Step 5. Check all bolts are torqued to 16 N·m (12 ft. lbs.)



80c071ae

**Fig. 69 Intake Manifold Flange Gasket Alignment**

- 1 - FLANGE GASKET
- 2 - ALIGNMENT TABS
- 3 - CYLINDER HEAD GASKET



80c071ac

**Fig. 70 Intake Manifold Bolt Tightening Sequence**

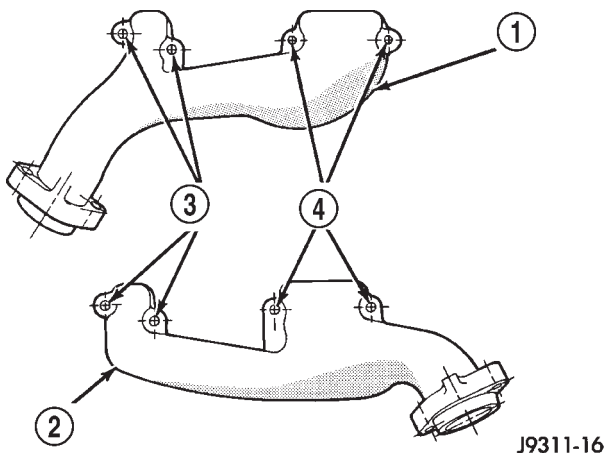
## INTAKE MANIFOLD (Continued)

- (8) Install closed crankcase ventilation and evaporation control systems.
- (9) Connect the coil wires.
- (10) Connect the heat indicator sending unit wire.
- (11) Connect the heater hoses and bypass hose.
- (12) Install distributor cap and wires.
- (13) Hook up the return spring.
- (14) Connect the accelerator linkage (Refer to 14 - FUEL SYSTEM/FUEL INJECTION/THROTTLE CONTROL CABLE - INSTALLATION) and if so equipped, the speed control and transmission kick-down cables.
- (15) Install the fuel lines (Refer to 14 - FUEL SYSTEM/FUEL DELIVERY/QUICK CONNECT FITTING - STANDARD PROCEDURE).
- (16) Install the accessory drive bracket and A/C Compressor (Refer to 24 - HEATING & AIR CONDITIONING/PLUMBING/A/C COMPRESSOR - INSTALLATION).
- (17) Install the generator (Refer to 8 - ELECTRICAL/CHARGING/GENERATOR - INSTALLATION) and drive belt (Refer to 7 - COOLING/ACCESSORY DRIVE/DRIVE BELTS - INSTALLATION).
- (18) Install the air cleaner.
- (19) Fill cooling system (Refer to 7 - COOLING - STANDARD PROCEDURE).
- (20) Connect the negative cable to the battery.

## EXHAUST MANIFOLD

### DESCRIPTION

The exhaust manifolds (Fig. 71) are constructed of cast iron and are LOG type with balanced flow. One exhaust manifold is attached to each cylinder head.



**Fig. 71 Exhaust Manifolds—3.9L Engine**

- 1 - EXHAUST MANIFOLD (RIGHT)
- 2 - EXHAUST MANIFOLD (LEFT)
- 3 - BOLTS & WASHERS
- 4 - NUTS & WASHERS

### OPERATION

The exhaust manifolds collect the engine exhaust exiting the combustion chambers, then channels the exhaust gases to the exhaust pipes attached to the manifolds.

### REMOVAL

- (1) Disconnect the negative cable from the battery.
- (2) Raise and support the vehicle.
- (3) Disconnect the exhaust pipe from the exhaust manifold (Refer to 11 - EXHAUST SYSTEM/EXHAUST PIPE - REMOVAL).
- (4) Lower the vehicle.
- (5) Remove the exhaust heat shields.
- (6) Remove bolts, nuts and washers attaching manifold to cylinder head.
- (7) Remove manifold from the cylinder head.

### CLEANING

Clean mating surfaces on cylinder head and manifold. Wash with solvent and blow dry with compressed air.

### INSPECTION

Inspect manifold for cracks.

Inspect mating surfaces of manifold for flatness with a straight edge. Gasket surfaces must be flat within 0.2 mm per 300 mm (0.008 inch per foot).

### INSTALLATION

**CAUTION:** If the studs came out with the nuts when removing the engine exhaust manifold, install new studs. Apply sealer on the coarse thread ends. Water leaks may develop at the studs if this precaution is not taken.

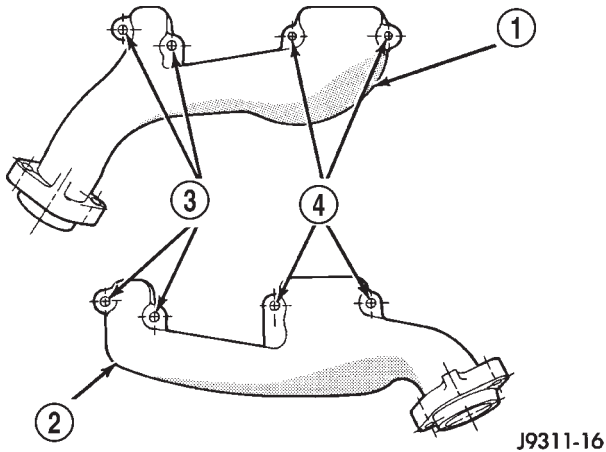
- (1) Position the engine exhaust manifolds on the two studs located on the cylinder head. Install conical washers and nuts on these studs (Fig. 72).
- (2) Install two bolts and conical washers at the inner ends of the engine exhaust manifold outboard arms. Install two bolts **WITHOUT** washers on the center arm of engine exhaust manifold (Fig. 72). Starting at the center arm and working outward, tighten the bolts and nuts to 34 N·m (25 ft. lbs.) torque.
- (3) Install the exhaust heat shields.
- (4) Raise and support the vehicle.

## EXHAUST MANIFOLD (Continued)

(5) Assemble exhaust pipe to manifold and secure with bolts, nuts and retainers. Tighten the bolts and nuts to 34 N·m (25 ft. lbs.) torque.

(6) Lower the vehicle.

(7) Connect the negative cable to the battery.



**Fig. 72 Engine Exhaust Manifold Installation—3.9L Engine**

- 1 - EXHAUST MANIFOLD (RIGHT)
- 2 - EXHAUST MANIFOLD (LEFT)
- 3 - BOLTS & WASHERS
- 4 - NUTS & WASHERS

## TIMING BELT / CHAIN COVER(S)

## REMOVAL

- (1) Disconnect the battery negative cable.
- (2) Drain cooling system (Refer to 7 - COOLING - STANDARD PROCEDURE).
- (3) Remove the serpentine belt (Refer to 7 - COOLING/ACCESSORY DRIVE/DRIVE BELTS - REMOVAL).
- (4) Remove water pump (Refer to 7 - COOLING/ENGINE/WATER PUMP - REMOVAL).
- (5) Remove power steering pump (Refer to 19 - STEERING/PUMP - REMOVAL).
- (6) Remove vibration damper (Refer to 9 - ENGINE/ENGINE BLOCK/VIBRATION DAMPER - REMOVAL).
- (7) Loosen oil pan bolts and remove the front bolt at each side.
- (8) Remove the cover bolts.
- (9) Remove chain case cover and gasket using extreme caution to avoid damaging oil pan gasket.
- (10) From the inside of the cover tap the front crankshaft oil seal outward. Be careful not to damage the timing cover sealing surface.

## INSTALLATION

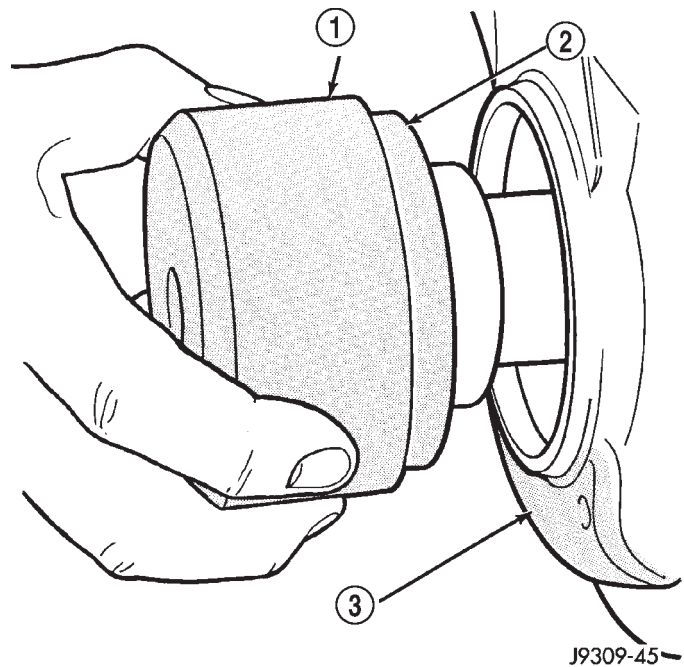
(1) Be sure mating surfaces of chain case cover and cylinder block are clean and free from burrs.

(2) Using a new cover gasket, carefully install chain case cover to avoid damaging oil pan gasket. Use a small amount of Mopar® GEN II Silicone Rubber Adhesive Sealant, or equivalent, at the joint between timing chain cover gasket and the oil pan gasket. Finger tighten the timing chain cover bolts at this time.

**CAUTION:** If chain cover is replaced for any reason, be sure the oil hole (passenger side of cover) is plugged.

**NOTE:** Special Tool 6635 must be used to align cover and seal with crankshaft.

(3) Position the special tool 6635 onto the crankshaft (Fig. 73).



**Fig. 73 Position Special Tool 6635 onto Crankshaft**

- 1 - SPECIAL TOOL 6635
- 2 - OIL SEAL
- 3 - TIMING CHAIN COVER

(4) Tighten chain case cover bolts to 41 N·m (30 ft. lbs.) torque. Tighten oil pan bolts to 24 N·m (215 in. lbs.) torque.

(5) Remove special tool 6635.

(6) Inspect the seal flange on the vibration damper.

(7) Install vibration damper (Refer to 9 - ENGINE/ENGINE BLOCK/VIBRATION DAMPER - INSTALLATION).

## TIMING BELT / CHAIN COVER(S) (Continued)

(8) Install water pump (Refer to 7 - COOLING/ENGINE/WATER PUMP - INSTALLATION).

(9) Install power steering pump (Refer to 19 - STEERING/PUMP - INSTALLATION).

(10) Install the serpentine belt (Refer to 7 - COOLING/ACCESSORY DRIVE/DRIVE BELTS - INSTALLATION).

(11) Install the cooling system fan (Refer to 7 - COOLING/ENGINE/FAN DRIVE VISCOUS CLUTCH - INSTALLATION).

(12) Position the fan shroud and install the bolts. Tighten the bolts to 11 N-m (95 in. lbs.) torque.

(13) Fill cooling system (Refer to 7 - COOLING - STANDARD PROCEDURE).

(14) Connect the negative cable to the battery.

## TIMING BELT/CHAIN TENSIONER

## DESCRIPTION

The timing chain tensioner is a stamped steel constant tension mechanical design. It is mounted to the front of the engine, behind the timing chain drive.

## OPERATION

The timing chain tension is maintained by routing the timing chain through the tensioner assembly. A nylon covered spring steel arm presses on the timing chain maintaining the correct chain tension.

## TIMING BELT/CHAIN AND SPROCKETS

## REMOVAL

(1) Disconnect battery negative cable.

(2) Drain cooling system (Refer to 7 - COOLING - STANDARD PROCEDURE).

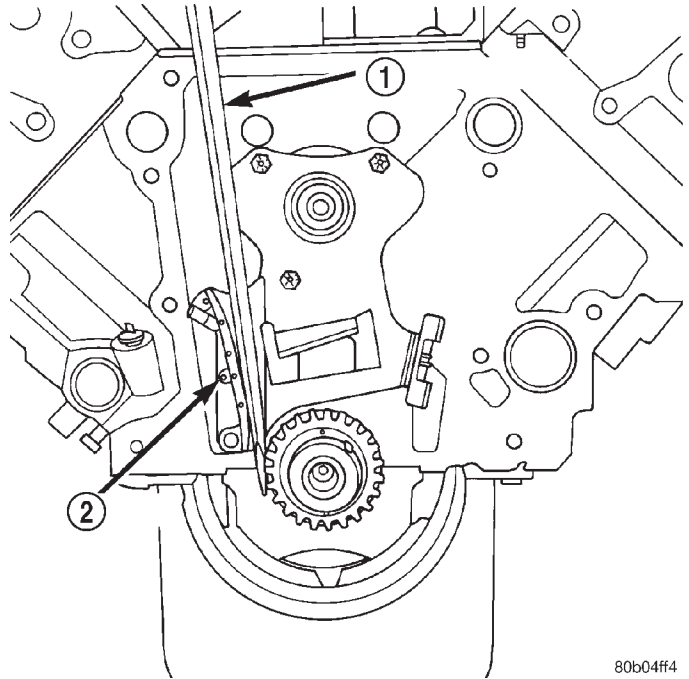
(3) Remove timing chain cover (Refer to 9 - ENGINE/VALVE TIMING/TIMING BELT / CHAIN COVER(S) - REMOVAL).

(4) Rotate crankshaft to align timing marks (Fig. 75) to #1 TDC.

(5) Remove camshaft sprocket attaching bolt and remove timing chain with crankshaft and camshaft sprockets.

(6) Slip crankshaft sprocket onto crankshaft and compress tensioner shoe by placing a large screwdriver between crankshaft sprocket and tensioner shoe (Fig. 74). Compress shoe until hole in shoe lines up with hole in bracket. Slide a suitable pin into the holes (Fig. 74) and remove screwdriver.

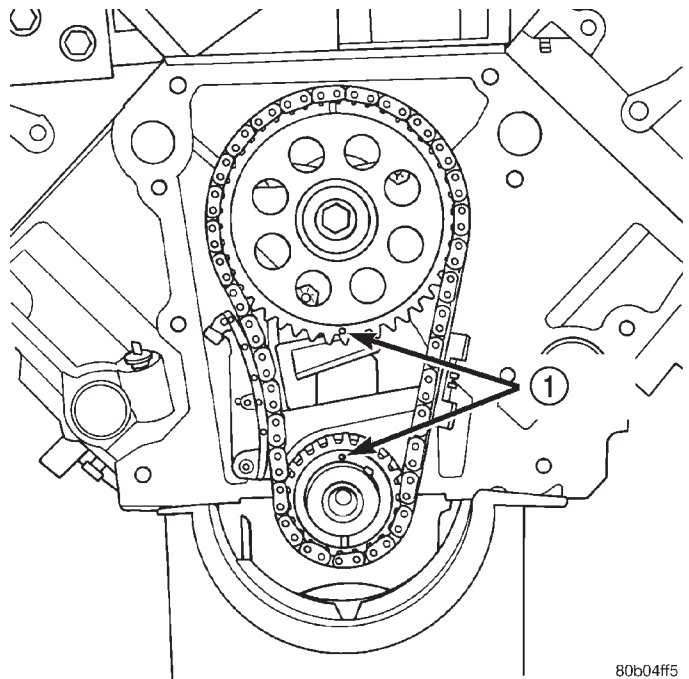
(7) If tensioner assembly is to be replaced, remove the three tensioner to block bolts and remove tensioner assembly.



80b04ff4

**Fig. 74 Compressing Tensioner For Chain Installation**

- 1 - SCREWDRIVER  
2 - INSERT PIN HERE



80b04ff5

**Fig. 75 Alignment of Timing Marks**

- 1 - TIMING MARKS



## TIMING BELT/CHAIN AND SPROCKETS (Continued)

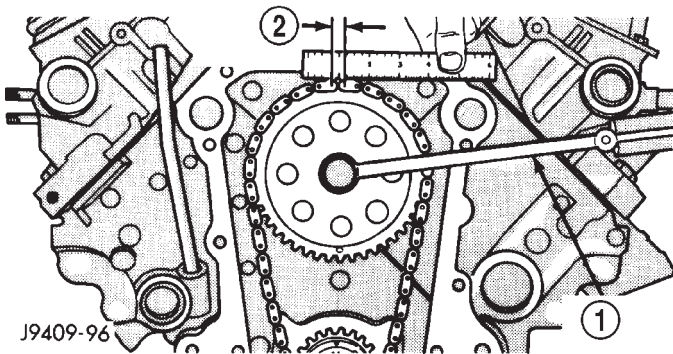
**INSPECTION—MEASURING TIMING CHAIN STRETCH**

**NOTE:** Timing chain tensioner must be removed for this operation.

(1) Place a scale next to the timing chain so that any movement of the chain can be measured.

(2) Place a torque wrench and socket over camshaft sprocket attaching bolt. Apply torque in the direction of crankshaft rotation to take up slack; 41 N·m (30 ft. lbs.) torque with cylinder head installed or 20 N·m (15 ft. lbs.) torque with cylinder head removed. With torque applied to the camshaft sprocket bolt, crankshaft should not be permitted to move. It may be necessary to block the crankshaft to prevent rotation.

(3) Hold a scale with dimensional reading even with the edge of a chain link. With cylinder heads installed, apply 14 N·m (30 ft. lbs.) torque in the reverse direction. With the cylinder heads removed, apply 20 N·m (15 ft. lbs.) torque in the reverse direction. Note the amount of chain movement (Fig. 76).



**Fig. 76 Measuring Timing Chain Wear and Stretch**

- 1 - TORQUE WRENCH  
2 - 3.175 MM  
(0.125 IN.)

(4) Install a new timing chain, if its movement exceeds 3.175 mm (1/8 inch).

**INSTALLATION**

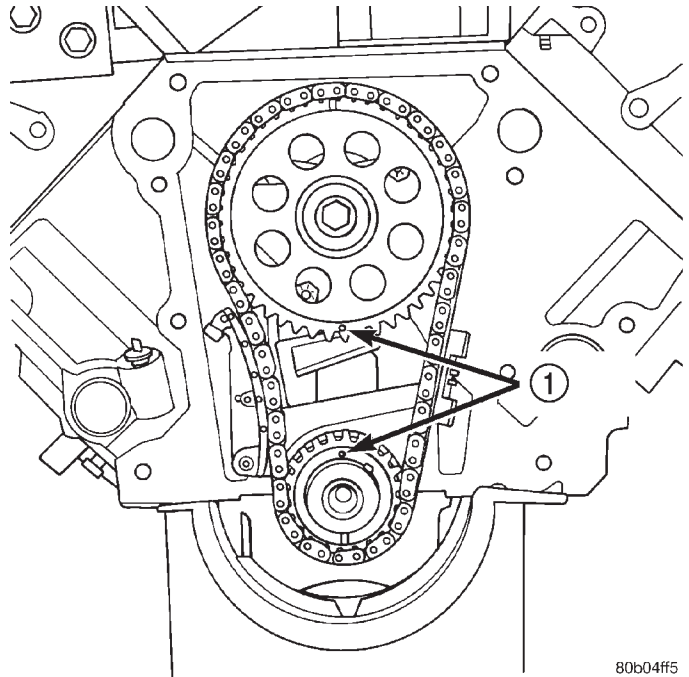
(1) If tensioner assembly is being replaced, install tensioner and mounting bolts. Torque bolts to 24 N·m (210 in. lbs.).

(2) Place both camshaft sprocket and crankshaft sprocket on the bench with timing marks on an exact imaginary center line through both camshaft and crankshaft bores.

(3) Place timing chain around both sprockets.

(4) Lift sprockets and chain (keep sprockets tight against the chain in position as described).

(5) Slide both sprockets evenly over their respective shafts and verify alignment of timing marks (Fig. 77) with a straight-edge if necessary.



**Fig. 77 Alignment of Timing Marks**

- 1 - TIMING MARKS

(6) Install the camshaft bolt. Tighten the bolt to 68 N·m (50 ft. lbs.) torque.

(7) **Remove tensioner pin.** Again, verify alignment of timing marks.

(8) Install timing cover (Refer to 9 - ENGINE/ VALVE TIMING/TIMING BELT / CHAIN COVER(S) - INSTALLATION).

(9) Fill cooling system (Refer to 7 - COOLING - STANDARD PROCEDURE).

(10) Connect battery negative cable.

(11) Start engine and check for oil and coolant leaks.

## ENGINE 5.2L

## TABLE OF CONTENTS

	page		page
<b>ENGINE 5.2L</b>		<b>INSTALLATION</b> . . . . .	87
DESCRIPTION . . . . .	60	<b>CONNECTING ROD BEARINGS</b>	
DIAGNOSIS AND TESTING . . . . .	61	STANDARD PROCEDURE . . . . .	88
ENGINE DIAGNOSIS - INTRODUCTION . . . . .	61	CONNECTING ROD BEARING FITTING . . . . .	88
PERFORMANCE . . . . .	61	<b>CRANKSHAFT</b>	
MECHANICAL . . . . .	63	DESCRIPTION . . . . .	88
LUBRICATION . . . . .	66	OPERATION . . . . .	88
CYLINDER COMPRESSION PRESSURE . . . . .	67	REMOVAL . . . . .	88
CYLINDER COMBUSTION PRESSURE LEAKAGE . . . . .	67	INSTALLATION . . . . .	89
STANDARD PROCEDURE . . . . .	68	<b>CRANKSHAFT MAIN BEARINGS</b>	
FORM-IN-PLACE GASKETS AND SEALERS . . . . .	68	DESCRIPTION . . . . .	90
REPAIR DAMAGED OR WORN THREADS . . . . .	68	OPERATION . . . . .	90
HYDROSTATIC LOCK . . . . .	68	STANDARD PROCEDURE . . . . .	90
CYLINDER BORE HONING . . . . .	69	CRANKSHAFT MAIN BEARING FITTING . . . . .	90
REMOVAL . . . . .	69	REMOVAL . . . . .	90
INSTALLATION . . . . .	70	INSTALLATION . . . . .	90
SPECIFICATIONS . . . . .	72	<b>CRANKSHAFT OIL SEAL - FRONT</b>	
SPECIAL TOOLS . . . . .	77	DESCRIPTION . . . . .	91
<b>CYLINDER HEAD</b>		OPERATION . . . . .	91
DESCRIPTION . . . . .	79	REMOVAL . . . . .	91
OPERATION . . . . .	79	INSTALLATION . . . . .	91
DIAGNOSIS AND TESTING . . . . .	79	<b>CRANKSHAFT OIL SEAL - REAR</b>	
CYLINDER HEAD GASKET FAILURE . . . . .	79	DESCRIPTION . . . . .	91
REMOVAL . . . . .	80	OPERATION . . . . .	92
CLEANING . . . . .	80	REMOVAL . . . . .	92
INSPECTION . . . . .	80	INSTALLATION . . . . .	92
INSTALLATION . . . . .	80	<b>DISTRIBUTOR BUSHING</b>	
<b>CYLINDER HEAD COVER(S)</b>		REMOVAL . . . . .	94
REMOVAL . . . . .	81	INSTALLATION . . . . .	94
CLEANING . . . . .	81	<b>HYDRAULIC LIFTERS (CAM IN BLOCK)</b>	
INSPECTION . . . . .	81	DIAGNOSIS AND TESTING . . . . .	95
INSTALLATION . . . . .	81	HYDRAULIC TAPPETS . . . . .	95
<b>INTAKE/EXHAUST VALVES &amp; SEATS</b>		REMOVAL . . . . .	96
DESCRIPTION . . . . .	81	CLEANING . . . . .	96
STANDARD PROCEDURE . . . . .	82	INSTALLATION . . . . .	96
VALVES, GUIDES AND SPRINGS . . . . .	82	<b>PISTON &amp; CONNECTING ROD</b>	
REMOVAL . . . . .	84	DESCRIPTION . . . . .	97
CLEANING . . . . .	84	STANDARD PROCEDURE . . . . .	97
INSPECTION . . . . .	84	PISTON FITTING . . . . .	97
INSTALLATION . . . . .	85	REMOVAL . . . . .	97
<b>ROCKER ARM / ADJUSTER ASSEMBLY</b>		CLEANING . . . . .	98
REMOVAL . . . . .	85	INSPECTION . . . . .	98
INSTALLATION . . . . .	85	INSTALLATION . . . . .	98
<b>ENGINE BLOCK</b>		<b>PISTON RINGS</b>	
CLEANING . . . . .	86	STANDARD PROCEDURE . . . . .	98
INSPECTION . . . . .	86	PISTON RING FITTING . . . . .	98
<b>CAMSHAFT &amp; BEARINGS (IN BLOCK)</b>		<b>VIBRATION DAMPER</b>	
REMOVAL . . . . .	86	REMOVAL . . . . .	99
		INSTALLATION . . . . .	99



**FRONT MOUNT**  
 REMOVAL ..... 100  
 INSTALLATION..... 100

**REAR MOUNT**  
 REMOVAL ..... 101  
 INSTALLATION..... 101

**LUBRICATION**  
 DESCRIPTION ..... 102  
 OPERATION..... 102  
 DIAGNOSIS AND TESTING ..... 104  
     ENGINE OIL LEAKS ..... 104  
     ENGINE OIL PRESSURE ..... 104

**OIL**  
 STANDARD PROCEDURE ..... 104  
 ENGINE OIL..... 104

**OIL FILTER**  
 REMOVAL ..... 105  
 INSTALLATION..... 105

**OIL PAN**  
 REMOVAL ..... 105  
 CLEANING..... 106  
 INSPECTION ..... 106  
 INSTALLATION..... 106

**OIL PUMP**  
 REMOVAL ..... 107  
 DISASSEMBLY..... 107

INSPECTION ..... 107  
 ASSEMBLY ..... 109  
 INSTALLATION..... 109

**INTAKE MANIFOLD**  
 DESCRIPTION ..... 109  
 OPERATION..... 109  
 DIAGNOSIS AND TESTING ..... 110  
     INTAKE MANIFOLD LEAKAGE ..... 110  
 REMOVAL ..... 110  
 CLEANING ..... 110  
 INSPECTION ..... 110  
 INSTALLATION ..... 111

**EXHAUST MANIFOLD**  
 DESCRIPTION ..... 112  
 OPERATION..... 112  
 REMOVAL ..... 112  
 CLEANING ..... 112  
 INSPECTION ..... 112  
 INSTALLATION..... 113

**TIMING BELT / CHAIN COVER(S)**  
 REMOVAL ..... 113  
 INSTALLATION..... 113

**TIMING BELT/CHAIN AND SPROCKETS**  
 REMOVAL ..... 114  
 INSPECTION ..... 114  
 INSTALLATION..... 115

**ENGINE 5.2L**

**DESCRIPTION**

The 5.2 Liter (318 CID) eight-cylinder engine is a V-Type lightweight, single cam, overhead valve engine with hydraulic roller tappets. This engine is designed for unleaded fuel.

Engine lubrication system consists of a rotor type oil pump and a full flow oil filter.

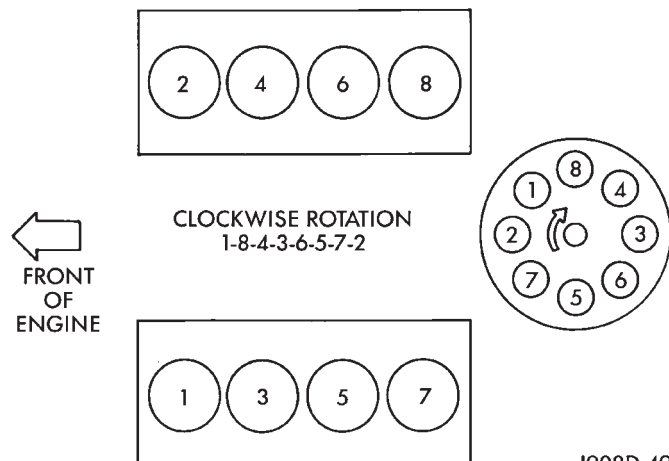
The cylinders are numbered from front to rear; 1, 3, 5, 7 on the left bank and 2, 4, 6, 8 on the right bank. The firing order is 1-8-4-3-6-5-7-2 (Fig. 1).

The engine serial number is stamped into a machined pad located on the left, front corner of the cylinder block. When component part replacement is necessary, use the engine type and serial number for reference (Fig. 2).



- X = Last Digit of Model Year
- M = Plant-M Mound Road
  - S Saltillo
  - T Trenton
  - K Toluca
- AAA = Engine Displacement (CID)
- YYYY = Month/Day
- 0000 = Engine Serial Code

80bbc9ce



J908D-49

**Fig. 1 Firing Order**

**Fig. 2 Engine Identification (Serial) Number**

## ENGINE 5.2L (Continued)

**DIAGNOSIS AND TESTING-ENGINE DIAGNOSIS  
- INTRODUCTION**

Engine diagnosis is helpful in determining the causes of malfunctions not detected and remedied by routine maintenance.

These malfunctions may be classified as either mechanical (e.g., a strange noise), or performance (e.g., engine idles rough and stalls).

(Refer to 9 - ENGINE - DIAGNOSIS AND TESTING - Performance) or (Refer to 9 - ENGINE - DIAGNOSIS AND TESTING - Mechanical). Refer to 14 - FUEL SYSTEM for fuel system diagnosis.

Additional tests and diagnostic procedures may be necessary for specific engine malfunctions that cannot be isolated with the Service Diagnosis charts. Information concerning additional tests and diagnosis is provided within the following:

- Cylinder Compression Pressure Test
- Cylinder Combustion Pressure Leakage Test
- Cylinder Head Gasket Failure Diagnosis
- Intake Manifold Leakage Diagnosis
- Lash Adjuster (Tappet) Noise Diagnosis
- Engine Oil Leak Inspection

**DIAGNOSIS AND TESTING—PERFORMANCE***PERFORMANCE DIAGNOSIS CHART—GASOLINE ENGINES*

<b>CONDITION</b>	<b>POSSIBLE CAUSES</b>	<b>CORRECTION</b>
ENGINE WILL NOT CRANK	<ol style="list-style-type: none"> <li>1. Weak or dead battery</li> <li>2. Corroded or loose battery connections</li> <li>3. Faulty starter or related circuit(s)</li> <li>4. Seized accessory drive component</li> <li>5. Engine internal mechanical failure or hydro-static lock</li> </ol>	<ol style="list-style-type: none"> <li>1. Charge/Replace Battery. (Refer to 8 - ELECTRICAL/BATTERY SYSTEM/ BATTERY - STANDARD PROCEDURE). Check charging system. (Refer to 8 - ELECTRICAL/ CHARGING - DIAGNOSIS AND TESTING).</li> <li>2. Clean/tighten suspect battery/starter connections</li> <li>3. Check starting system. (Refer to 8 - ELECTRICAL/STARTING - DIAGNOSIS AND TESTING)</li> <li>4. Remove accessory drive belt and attempt to start engine. If engine starts, repair/replace seized component.</li> <li>5. Refer to (Refer to 9 - ENGINE - DIAGNOSIS AND TESTING)</li> </ol>
ENGINE CRANKS BUT WILL NOT START	<ol style="list-style-type: none"> <li>1. No spark</li> <li>2. No fuel</li> <li>3. Low or no engine compression</li> </ol>	<ol style="list-style-type: none"> <li>1. Check for spark. (Refer to 8 - ELECTRICAL/IGNITION CONTROL - DESCRIPTION)</li> <li>2. Perform fuel pressure test, and if necessary, inspect fuel injector(s) and driver circuits. (Refer to 14 - FUEL SYSTEM/FUEL DELIVERY/FUEL PUMP - DIAGNOSIS AND TESTING).</li> <li>3. Perform cylinder compression pressure test. (Refer to 9 - ENGINE - DIAGNOSIS AND TESTING).</li> </ol>
ENGINE LOSS OF POWER	<ol style="list-style-type: none"> <li>1. Worn or burned distributor rotor</li> <li>2. Worn distributor shaft</li> </ol>	<ol style="list-style-type: none"> <li>1. Install new distributor rotor</li> <li>2. Remove and repair distributor (Refer to 8 - ELECTRICAL/IGNITION CONTROL/DISTRIBUTOR - REMOVAL).</li> </ol>

## ENGINE 5.2L (Continued)

CONDITION	POSSIBLE CAUSES	CORRECTION
	3. Worn or incorrect gapped spark plugs 4. Dirt or water in fuel system 5. Faulty fuel pump 6. Incorrect valve timing 7. Blown cylinder head gasket 8. Low compression  9. Burned, warped, or pitted valves 10. Plugged or restricted exhaust system 11. Faulty ignition cables 12. Faulty ignition coil	3. Clean plugs and set gap. (Refer to 8 - ELECTRICAL/IGNITION CONTROL/ SPARK PLUG - CLEANING). 4. Clean system and replace fuel filter 5. Install new fuel pump 6. Correct valve timing 7. Install new cylinder head gasket 8. Test cylinder compression (Refer to 9 - ENGINE - DIAGNOSIS AND TESTING). 9. Install/Reface valves as necessary 10. Install new parts as necessary 11. Replace any cracked or shorted cables 12. Test and replace, as necessary (Refer to 8 - ELECTRICAL/IGNITION CONTROL/IGNITION COIL - REMOVAL).
ENGINE STALLS OR ROUGH IDLE	1. Carbon build-up on throttle plate  2. Engine idle speed too low  3. Worn or incorrectly gapped spark plugs  4. Worn or burned distributor rotor 5. Spark plug cables defective or crossed  6. Faulty coil  7. Intake manifold vacuum leak	1. Remove throttle body and de-carbon. (Refer to 14 - FUEL SYSTEM/ FUEL INJECTION/THROTTLE BODY - REMOVAL). 2. Check Idle Air Control circuit. (Refer to 14 - FUEL SYSTEM/FUEL INJECTION/IDLE AIR CONTROL MOTOR - DESCRIPTION) 3. Replace or clean and re-gap spark plugs (Refer to 8 - ELECTRICAL/ IGNITION CONTROL/SPARK PLUG - CLEANING) 4. Install new distributor rotor 5. Check for correct firing order or replace spark plug cables. (Refer to 8 - ELECTRICAL/IGNITION CONTROL/ SPARK PLUG CABLE - DIAGNOSIS AND TESTING) 6. Test and replace, if necessary (Refer to 8 - ELECTRICAL/IGNITION CONTROL/IGNITION COIL - REMOVAL) 7. Inspect intake manifold gasket and vacuum hoses (Refer to 9 - ENGINE/ MANIFOLDS/INTAKE MANIFOLD - DIAGNOSIS AND TESTING).

## ENGINE 5.2L (Continued)

CONDITION	POSSIBLE CAUSES	CORRECTION
ENGINE MISSES ON ACCELERATION	<ol style="list-style-type: none"> <li>1. Worn or incorrectly gapped spark plugs</li> <li>2. Spark plug cables defective or crossed</li> <li>3. Dirt in fuel system</li> <li>4. Burned, warped or pitted valves</li> <li>5. Faulty coil</li> </ol>	<ol style="list-style-type: none"> <li>1. Replace spark plugs or clean and set gap. (Refer to 8 - ELECTRICAL/IGNITION CONTROL/SPARK PLUG - CLEANING)</li> <li>2. Replace or rewire secondary ignition cables. (Refer to 8 - ELECTRICAL/IGNITION CONTROL/SPARK PLUG CABLE - REMOVAL)</li> <li>3. Clean fuel system</li> <li>4. Install new valves</li> <li>5. Test and replace as necessary (Refer to 8 - ELECTRICAL/IGNITION CONTROL/IGNITION COIL - REMOVAL)</li> </ol>

## DIAGNOSIS AND TESTING— MECHANICAL

## ENGINE MECHANICAL DIAGNOSIS CHART

CONDITION	POSSIBLE CAUSES	CORRECTION
NOISY VALVES/LIFTERS	<ol style="list-style-type: none"> <li>1. High or low oil level in crankcase</li> <li>2. Thin or diluted oil</li> <li>3. Low oil pressure</li> <li>4. Dirt in tappets/lash adjusters</li> <li>5. Bent push rod(s)</li> <li>6. Worn rocker arms</li> <li>7. Worn tappets/lash adjusters</li> <li>8. Worn valve guides</li> <li>9. Excessive runout of valve seats or valve faces</li> </ol>	<ol style="list-style-type: none"> <li>1. Check for correct oil level. Adjust oil level by draining or adding as needed</li> <li>2. Change oil. (Refer to 9 - ENGINE/LUBRICATION/OIL - STANDARD PROCEDURE)</li> <li>3. Check engine oil level. If ok, Perform oil pressure test. (Refer to 9 - ENGINE/LUBRICATION - DIAGNOSIS AND TESTING) for engine oil pressure test/specifications</li> <li>4. Clean/replace hydraulic tappets/lash adjusters</li> <li>5. Install new push rods</li> <li>6. Inspect oil supply to rocker arms and replace worn arms as needed</li> <li>7. Install new hydraulic tappets/lash adjusters</li> <li>8. Inspect all valve guides and replace as necessary</li> <li>9. Grind valves and seats</li> </ol>

## ENGINE 5.2L (Continued)

CONDITION	POSSIBLE CAUSES	CORRECTION
CONNECTING ROD NOISE	<ol style="list-style-type: none"> <li>1. Insufficient oil supply</li> <li>2. Low oil pressure</li>   <li>3. Thin or diluted oil</li>   <li>4. Excessive connecting rod bearing clearance</li>   <li>5. Connecting rod journal out of round</li> <li>6. Misaligned connecting rods</li> </ol>	<ol style="list-style-type: none"> <li>1. Check engine oil level.</li> <li>2. Check engine oil level. If ok, Perform oil pressure test. (Refer to 9 - ENGINE/LUBRICATION - DIAGNOSIS AND TESTING) engine oil pressure test/specifications</li> <li>3. Change oil to correct viscosity. (Refer to 9 - ENGINE/LUBRICATION/OIL - STANDARD PROCEDURE) for correct procedure/engine oil specifications</li> <li>Measure bearings for correct clearance with plasti-gage. Repair as necessary</li> <li>5. Replace crankshaft or grind journals</li> <li>6. Replace bent connecting rods</li> </ol>
MAIN BEARING NOISE	<ol style="list-style-type: none"> <li>1. Insufficient oil supply</li> <li>2. Low oil pressure</li>   <li>3. Thin or diluted oil</li> <li>4. Excessive main bearing clearance</li> <li>5. Excessive end play</li>   <li>6. Crankshaft main journal out of round or worn</li> <li>7. Loose flywheel or torque converter</li> </ol>	<ol style="list-style-type: none"> <li>1. Check engine oil level.</li> <li>2. Check engine oil level. If ok, Perform oil pressure test. (Refer to 9 - ENGINE/LUBRICATION - DIAGNOSIS AND TESTING)</li> <li>3. Change oil to correct viscosity.</li> <li>4. Measure bearings for correct clearance. Repair as necessary</li> <li>5. Check crankshaft thrust bearing for excessive wear on flanges</li> <li>6. Grind journals or replace crankshaft</li> <li>7. Inspect crankshaft, flexplate/flywheel and bolts for damage. Tighten to correct torque</li> </ol>
LOW OIL PRESSURE	<ol style="list-style-type: none"> <li>1. Low oil level</li> <li>2. Faulty oil pressure sending unit</li> <li>3. Clogged oil filter</li> <li>4. Worn oil pump</li> <li>5. Thin or diluted oil</li> <li>6. Excessive bearing clearance</li>   <li>7. Oil pump relief valve stuck</li>   <li>8. Oil pump suction tube loose, broken, bent or clogged</li> <li>9. Oil pump cover warped or cracked</li> </ol>	<ol style="list-style-type: none"> <li>1. Check oil level and fill if necessary</li> <li>2. Install new sending unit</li> <li>3. Install new oil filter</li> <li>4. Replace oil pump assembly.</li> <li>5. Change oil to correct viscosity.</li> <li>6. Measure bearings for correct clearance</li> <li>7. Remove valve to inspect, clean and reinstall</li> <li>8. Inspect suction tube and clean or replace if necessary</li> <li>9. Install new oil pump</li> </ol>

## ENGINE 5.2L (Continued)

CONDITION	POSSIBLE CAUSES	CORRECTION
OIL LEAKS	<ol style="list-style-type: none"> <li>1. Misaligned or deteriorated gaskets</li> <li>2. Loose fastener, broken or porous metal part</li> <li>3. Front or rear crankshaft oil seal leaking</li> <li>4. Leaking oil gallery plug or cup plug</li> </ol>	<ol style="list-style-type: none"> <li>1. Replace gasket</li> <li>2. Tighten, repair or replace the part</li> <li>3. Replace seal</li> <li>4. Remove and reseal threaded plug. Replace cup style plug</li> </ol>
EXCESSIVE OIL CONSUMPTION OR SPARK PLUGS OIL FOULED	<ol style="list-style-type: none"> <li>1. CCV System malfunction</li> <li>2. Defective valve stem seal(s)</li> <li>3. Worn or broken piston rings</li> <li>4. Scuffed pistons/cylinder walls</li> <li>5. Carbon in oil control ring groove</li> <li>6. Worn valve guides</li> <li>7. Piston rings fitted too tightly in grooves</li> </ol>	<ol style="list-style-type: none"> <li>1. (Refer to 25 - EMISSIONS CONTROL/EVAPORATIVE EMISSIONS - DESCRIPTION) for correct operation</li> <li>2. Repair or replace seal(s)</li> <li>3. Hone cylinder bores. Install new rings</li> <li>4. Hone cylinder bores and replace pistons as required</li> <li>5. Remove rings and de-carbon piston</li> <li>6. Inspect/replace valve guides as necessary</li> <li>7. Remove rings and check ring end gap and side clearance. Replace if necessary</li> </ol>



## ENGINE 5.2L (Continued)

## DIAGNOSIS AND TESTING—LUBRICATION

CONDITION	POSSIBLE CAUSES	CORRECTION
OIL LEAKS	<ol style="list-style-type: none"> <li>1. Gaskets and O-Rings.               <ol style="list-style-type: none"> <li>(a) Misaligned or damaged.</li> <li>(b) Loose fasteners, broken or porous metal parts.</li> </ol> </li> <li>2. Crankshaft rear seal</li> <li>3. Crankshaft seal flange. Scratched, nicked or grooved.</li> <li>4. Oil pan flange cracked.</li> <li>5. Timing chain cover seal, damaged or misaligned.</li> <li>6. Scratched or damaged vibration damper hub.</li> </ol>	<ol style="list-style-type: none"> <li>1.               <ol style="list-style-type: none"> <li>(a) Replace as necessary.</li> <li>(b) Tighten fasteners, Repair or replace metal parts.</li> </ol> </li> <li>2. Replace as necessary.</li> <li>3. Polish or replace crankshaft.</li> <li>4. Replace oil pan.</li> <li>5. Replace seal.</li> <li>6. Polish or replace damper.</li> </ol>
OIL PRESSURE DROP	<ol style="list-style-type: none"> <li>1. Low oil level.</li> <li>2. Faulty oil pressure sending unit.</li> <li>3. Low oil pressure.</li> <li>4. Clogged oil filter.</li> <li>5. Worn oil pump.</li> <li>6. Thin or diluted oil.</li> <li>7. Excessive bearing clearance.</li> <li>8. Oil pump relief valve stuck.</li> <li>9. Oil pump suction tube loose or damaged.</li> </ol>	<ol style="list-style-type: none"> <li>1. Check and correct oil level.</li> <li>2. Replace sending unit.</li> <li>3. Check pump and bearing clearance.</li> <li>4. Replace oil filter.</li> <li>5. Replace as necessary.</li> <li>6. Change oil and filter.</li> <li>7. Replace as necessary.</li> <li>8. Clean or replace relief valve.</li> <li>9. Replace as necessary.</li> </ol>
OIL PUMPING AT RINGS; SPARK PLUGS FOULING	<ol style="list-style-type: none"> <li>1. Worn or damaged rings.</li> <li>2. Carbon in oil ring slots.</li> <li>3. Incorrect ring size installed.</li> <li>4. Worn valve guides.</li> <li>5. Leaking intake gasket.</li> <li>6. Leaking valve guide seals.</li> </ol>	<ol style="list-style-type: none"> <li>1. Hone cylinder bores and replace rings.</li> <li>2. Replace rings.</li> <li>3. Replace rings.</li> <li>4. Ream guides and replace valves.</li> <li>5. Replace intake gaskets.</li> <li>6. Replace valve guide seals.</li> </ol>

## ENGINE 5.2L (Continued)

**DIAGNOSIS AND TESTING—CYLINDER COMPRESSION PRESSURE**

The results of a cylinder compression pressure test can be utilized to diagnose several engine malfunctions.

Ensure the battery is completely charged and the engine starter motor is in good operating condition. Otherwise, the indicated compression pressures may not be valid for diagnosis purposes.

- (1) Clean the spark plug recesses with compressed air.
- (2) Remove the spark plugs (Refer to 8 - ELECTRICAL/IGNITION CONTROL/SPARK PLUG - REMOVAL).
- (3) Secure the throttle in the wide-open position.
- (4) Disconnect the ignition coil.
- (5) Insert a compression pressure gauge and rotate the engine with the engine starter motor for three revolutions.
- (6) Record the compression pressure on the third revolution. Continue the test for the remaining cylinders.

(Refer to 9 - ENGINE - SPECIFICATIONS) for the correct engine compression pressures.

**DIAGNOSIS AND TESTING—CYLINDER COMBUSTION PRESSURE LEAKAGE**

The combustion pressure leakage test provides an accurate means for determining engine condition.

Combustion pressure leakage testing will detect:

- Exhaust and intake valve leaks (improper seating)
- Leaks between adjacent cylinders or into water jacket

- Any causes for combustion/compression pressure loss

**WARNING: DO NOT REMOVE THE RADIATOR CAP WITH THE SYSTEM HOT AND UNDER PRESSURE. SERIOUS BURNS FROM HOT COOLANT CAN OCCUR.**

Check the coolant level and fill as required. DO NOT install the radiator cap.

Start and operate the engine until it attains normal operating temperature, then turn OFF the engine.

Remove the spark plugs.

Remove the oil filler cap.

Remove the air cleaner.

Calibrate the tester according to the manufacturer's instructions. The shop air source for testing should maintain 483 kPa (70 psi) minimum, 1,379 kPa (200 psi) maximum and 552 kPa (80 psi) recommended.

Perform the test procedure on each cylinder according to the tester manufacturer's instructions. While testing, listen for pressurized air escaping through the throttle body, tailpipe or oil filler cap opening. Check for bubbles in the radiator coolant.

All gauge pressure indications should be equal, with no more than 25% leakage.

**FOR EXAMPLE:** At 552 kPa (80 psi) input pressure, a minimum of 414 kPa (60 psi) should be maintained in the cylinder.

Refer to CYLINDER COMBUSTION PRESSURE LEAKAGE DIAGNOSIS CHART below

*CYLINDER COMBUSTION PRESSURE LEAKAGE DIAGNOSIS CHART*

CONDITION	POSSIBLE CAUSE	CORRECTION
AIR ESCAPES THROUGH THROTTLE BODY	Intake valve bent, burnt, or not seated properly	Inspect valve and valve seat. Reface or replace, as necessary
AIR ESCAPES THROUGH TAILPIPE	Exhaust valve bent, burnt, or not seated properly	Inspect valve and valve seat. Reface or replace, as necessary
AIR ESCAPES THROUGH RADIATOR	Head gasket leaking or cracked cylinder head or block	Remove cylinder head and inspect. Replace defective part
MORE THAN 50% LEAKAGE FROM ADJACENT CYLINDERS	Head gasket leaking or crack in cylinder head or block between adjacent cylinders	Remove cylinder head and inspect. Replace gasket, head, or block as necessary
MORE THAN 25% LEAKAGE AND AIR ESCAPES THROUGH OIL FILLER CAP OPENING ONLY	Stuck or broken piston rings; cracked piston; worn rings and/or cylinder wall	Inspect for broken rings or piston. Measure ring gap and cylinder diameter, taper and out-of-round. Replace defective part as necessary

## ENGINE 5.2L (Continued)

**STANDARD PROCEDURE—FORM-IN-PLACE GASKETS & SEALERS**

There are numerous places where form-in-place gaskets are used on the engine. Care must be taken when applying form-in-place gaskets to assure obtaining the desired results. **Do not use form-in-place gasket material unless specified.** Bead size, continuity, and location are of great importance. Too thin a bead can result in leakage while too much can result in spill-over which can break off and obstruct fluid feed lines. A continuous bead of the proper width is essential to obtain a leak-free gasket.

There are numerous types of form-in-place gasket materials that are used in the engine area. Mopar® Engine RTV GEN II, Mopar® ATF-RTV, and Mopar® Gasket Maker gasket materials, each have different properties and can not be used in place of the other.

**MOPAR® ENGINE RTV GEN II**

Mopar® Engine RTV GEN II is used to seal components exposed to engine oil. This material is a specially designed black silicone rubber RTV that retains adhesion and sealing properties when exposed to engine oil. Moisture in the air causes the material to cure. This material is available in three ounce tubes and has a shelf life of one year. After one year this material will not properly cure. Always inspect the package for the expiration date before use.

**MOPAR® ATF RTV**

Mopar® ATF RTV is a specifically designed black silicone rubber RTV that retains adhesion and sealing properties to seal components exposed to automatic transmission fluid, engine coolants, and moisture. This material is available in three ounce tubes and has a shelf life of one year. After one year this material will not properly cure. Always inspect the package for the expiration date before use.

**MOPAR® GASKET MAKER**

Mopar® Gasket Maker is an anaerobic type gasket material. The material cures in the absence of air when squeezed between two metallic surfaces. It will not cure if left in the uncovered tube. The anaerobic material is for use between two machined surfaces. Do not use on flexible metal flanges.

**MOPAR® GASKET SEALANT**

Mopar® Gasket Sealant is a slow drying, permanently soft sealer. This material is recommended for sealing threaded fittings and gaskets against leakage of oil and coolant. Can be used on threaded and machined parts under all temperatures. This material is used on engines with multi-layer steel (MLS) cylinder head gaskets. This material also will prevent corrosion. Mopar® Gasket Sealant is available in a 13 oz. aerosol can or 4oz./16 oz. can w/applicator.

**FORM-IN-PLACE GASKET AND SEALER APPLICATION**

Assembling parts using a form-in-place gasket requires care but it's easier than using pre-cut gaskets.

Mopar® Gasket Maker material should be applied sparingly 1 mm (0.040 in.) diameter or less of sealant to one gasket surface. Be certain the material surrounds each mounting hole. Excess material can easily be wiped off. Components should be torqued in place within 15 minutes. The use of a locating dowel is recommended during assembly to prevent smearing material off the location.

Mopar® Engine RTV GEN II or ATF RTV gasket material should be applied in a continuous bead approximately 3 mm (0.120 in.) in diameter. All mounting holes must be circled. For corner sealing, a 3.17 or 6.35 mm (1/8 or 1/4 in.) drop is placed in the center of the gasket contact area. Uncured sealant may be removed with a shop towel. Components should be torqued in place while the sealant is still wet to the touch (within 10 minutes). The usage of a locating dowel is recommended during assembly to prevent smearing material off the location.

Mopar® Gasket Sealant in an aerosol can should be applied using a thin, even coat sprayed completely over both surfaces to be joined, and both sides of a gasket. Then proceed with assembly. Material in a can w/applicator can be brushed on evenly over the sealing surfaces. Material in an aerosol can should be used on engines with multi-layer steel gaskets.

**STANDARD PROCEDURE—REPAIR DAMAGED OR WORN THREADS**

**CAUTION: Be sure that the tapped holes maintain the original center line.**

Damaged or worn threads can be repaired. Essentially, this repair consists of:

- Drilling out worn or damaged threads.
- Tapping the hole with a special Heli-Coil Tap, or equivalent.
- Installing an insert into the tapped hole to bring the hole back to its original thread size.

**STANDARD PROCEDURE—HYDROSTATIC LOCK**

**CAUTION: DO NOT use the starter motor to rotate the crankshaft. Severe damage could occur.**

When an engine is suspected of hydrostatic lock (regardless of what caused the problem), follow the steps below.

## ENGINE 5.2L (Continued)

(1) Perform the Fuel Pressure Release Procedure (Refer to 14 - FUEL SYSTEM/FUEL DELIVERY - STANDARD PROCEDURE).

(2) Disconnect the negative cable(s) from the battery.

(3) Inspect air cleaner, induction system, and intake manifold to ensure system is dry and clear of foreign material.

(4) Place a shop towel around the spark plugs to catch any fluid that may possibly be under pressure in the cylinder head. Remove the spark plugs.

(5) With all spark plugs removed, rotate the crankshaft using a breaker bar and socket.

(6) Identify the fluid in the cylinders (coolant, fuel, oil, etc.).

(7) Be sure all fluid has been removed from the cylinders.

(8) Repair engine or components as necessary to prevent this problem from occurring again.

(9) Squirt a small amount of engine oil into the cylinders to lubricate the walls. This will prevent damage on restart.

(10) Install new spark plugs. Tighten the spark plugs to 41 N·m (30 ft. lbs.) torque.

(11) Drain engine oil. Remove and discard the oil filter.

(12) Install the drain plug. Tighten the plug to 34 N·m (25 ft. lbs.) torque.

(13) Install a new oil filter.

(14) Fill engine crankcase with the specified amount and grade of oil. (Refer to LUBRICATION & MAINTENANCE - SPECIFICATIONS).

(15) Connect the negative cable(s) to the battery.

(16) Start the engine and check for any leaks.

## STANDARD PROCEDURE—CYLINDER BORE HONING

Before honing, stuff plenty of clean shop towels under the bores and over the crankshaft to keep abrasive materials from entering the crankshaft area.

(1) Used carefully, the Cylinder Bore Sizing Hone C-823, equipped with 220 grit stones, is the best tool for this job. In addition to deglazing, it will reduce taper and out-of-round, as well as removing light scuffing, scoring and scratches. Usually, a few strokes will clean up a bore and maintain the required limits.

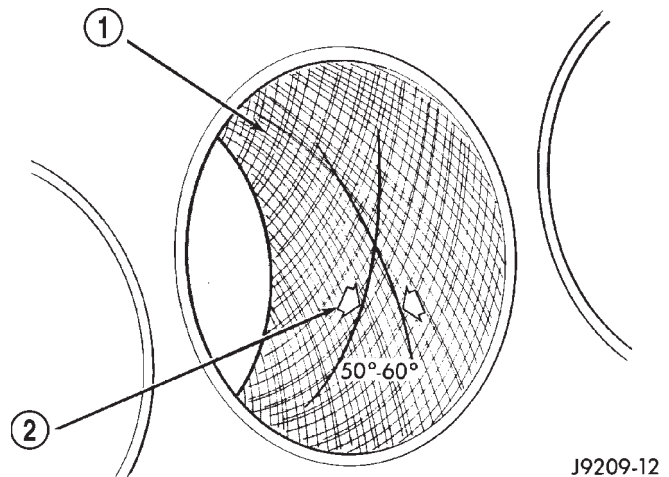
**CAUTION: DO NOT use rigid type hones to remove cylinder wall glaze.**

(2) Deglazing of the cylinder walls may be done if the cylinder bore is straight and round. Use a cylinder surfacing hone, Honing Tool C-3501, equipped with 280 grit stones (C-3501-3810). about 20-60

strokes, depending on the bore condition, will be sufficient to provide a satisfactory surface. Using honing oil C-3501-3880, or a light honing oil, available from major oil distributors.

**CAUTION: DO NOT use engine or transmission oil, mineral spirits, or kerosene.**

(3) Honing should be done by moving the hone up and down fast enough to get a crosshatch pattern. The hone marks should INTERSECT at 50° to 60° for proper seating of rings (Fig. 3).



J9209-12

**Fig. 3 Cylinder Bore Crosshatch Pattern**

- 1 - CROSSHATCH PATTERN  
2 - INTERSECT ANGLE

(4) A controlled hone motor speed between 200 and 300 RPM is necessary to obtain the proper crosshatch angle. The number of up and down strokes per minute can be regulated to get the desired 50° to 60° angle. Faster up and down strokes increase the crosshatch angle.

(5) After honing, it is necessary that the block be cleaned to remove all traces of abrasive. Use a brush to wash parts with a solution of hot water and detergent. Dry parts thoroughly. Use a clean, white, lint-free cloth to check that the bore is clean. Oil the bores after cleaning to prevent rusting.

## REMOVAL

(1) Disconnect the battery negative cable.

(2) Drain cooling system (Refer to 7 - COOLING - STANDARD PROCEDURE).

(3) Recover refrigerant from a/c system, if equipped (Refer to 24 - HEATING & AIR CONDITIONING/PLUMBING - STANDARD PROCEDURE).

(4) Remove the a/c condenser, if equipped (Refer to 24 - HEATING & AIR CONDITIONING/PLUMBING/A/C CONDENSER - REMOVAL).



## ENGINE 5.2L (Continued)

(5) Remove the transmission oil cooler (Refer to 7 - COOLING/TRANSMISSION/TRANS COOLER - REMOVAL).

(6) Remove the washer bottle from the fan shroud.

(7) Remove the viscous fan/drive (Refer to 7 - COOLING/ENGINE/RADIATOR FAN - REMOVAL).

(8) Remove radiator (Refer to 7 - COOLING/ENGINE/RADIATOR - REMOVAL).

(9) Remove the upper crossmember and top core support.

(10) Remove the accessory drive belt (Refer to 7 - COOLING/ACCESSORY DRIVE/DRIVE BELTS - REMOVAL).

(11) Remove the A/C compressor with the lines attached. Secure compressor out of the way.

(12) Remove generator assembly (Refer to 8 - ELECTRICAL/CHARGING/GENERATOR - REMOVAL).

(13) Remove the air cleaner resonator and duct work as an assembly.

(14) Disconnect the throttle linkage (Refer to 14 - FUEL SYSTEM/FUEL INJECTION/THROTTLE CONTROL CABLE - REMOVAL).

(15) Remove throttle body (Refer to 14 - FUEL SYSTEM/FUEL INJECTION/THROTTLE BODY - REMOVAL).

(16) Remove the intake manifold (Refer to 9 - ENGINE/MANIFOLDS/INTAKE MANIFOLD - REMOVAL).

(17) Remove the distributor cap and wiring.

(18) Disconnect the heater hoses.

(19) Disconnect the power steering hoses, if equipped.

(20) Perform the Fuel System Pressure Release procedure (Refer to 14 - FUEL SYSTEM/FUEL DELIVERY - STANDARD PROCEDURE).

(21) Disconnect the fuel supply line (Refer to 14 - FUEL SYSTEM/FUEL DELIVERY/QUICK CONNECT FITTING - STANDARD PROCEDURE).

(22) On Manual Transmission vehicles, remove the shift lever (Refer to 21 - TRANSMISSION/TRAN-SAXLE/MANUAL/SHIFT COVER - REMOVAL).

(23) Raise and support the vehicle on a hoist and drain the engine oil.

(24) Remove engine front mount thru-bolt nuts.

(25) Disconnect the transmission oil cooler lines from their retainers at the oil pan bolts.

(26) Disconnect exhaust pipe at manifolds.

(27) Disconnect the starter wires. Remove starter motor (Refer to 8 - ELECTRICAL/STARTING/STARTER MOTOR - REMOVAL).

(28) Remove the dust shield and transmission inspection cover.

(29) Remove drive plate to converter bolts (Automatic transmission equipped vehicles).

(30) Remove transmission bell housing to engine block bolts.

(31) Lower the vehicle.

(32) Install an engine lifting fixture.

(33) Separate engine from transmission, remove engine from vehicle, and install engine assembly on a repair stand.

## INSTALLATION

(1) Remove engine from the repair stand and position in the engine compartment. Position the thru-bolt into the support cushion brackets.

(2) Install engine lifting device.

(3) Lower engine into compartment and align engine with transmission:

- Manual Transmission: Align clutch disc assembly (if disturbed). Install transmission input shaft into clutch disc while mating engine and transmission surfaces. Install two transmission to engine block mounting bolts finger tight.

- Automatic Transmission: Mate engine and transmission and install two transmission to engine block mounting bolts finger tight.

(4) Lower engine assembly until engine mount through bolts rest in mount perches.

(5) Install remaining transmission to engine block mounting bolts and tighten.

(6) Tighten engine mount through bolts.

(7) Install drive plate to torque converter bolts. (Automatic transmission models)

(8) Install the dust shield and transmission cover.

(9) Install the starter and connect the starter wires (Refer to 8 - ELECTRICAL/STARTING/STARTER MOTOR - INSTALLATION).

(10) Install exhaust pipe to manifold.

(11) Install the transmission cooler line brackets to the oil pan.

(12) Install the drain plug and tighten to 34 N·m (25 ft. lbs.) torque.

(13) Lower the vehicle.

(14) Remove engine lifting fixture.

(15) On Manual Transmission vehicles, install the shift lever (Refer to 21 - TRANSMISSION/TRAN-SAXLE/MANUAL/SHIFT COVER - INSTALLATION).

(16) Connect the fuel supply line (Refer to 14 - FUEL SYSTEM/FUEL DELIVERY/QUICK CONNECT FITTING - STANDARD PROCEDURE).

(17) Connect the power steering hoses, if equipped.

(18) Connect the heater hoses.

(19) Install the distributor cap and wiring.

(20) Install the intake manifold (Refer to 9 - ENGINE/MANIFOLDS/INTAKE MANIFOLD - INSTALLATION).

## ENGINE 5.2L (Continued)

(21) Using a new gasket, install throttle body (Refer to 14 - FUEL SYSTEM/FUEL INJECTION/THROTTLE BODY - INSTALLATION).

(22) Connect the throttle linkage (Refer to 14 - FUEL SYSTEM/FUEL INJECTION/THROTTLE CONTROL CABLE - INSTALLATION).

(23) Install the air cleaner resonator and duct work..

(24) Install the generator and wire connections (Refer to 8 - ELECTRICAL/CHARGING/GENERATOR - INSTALLATION).

(25) Install a/c compressor and lines (Refer to 24 - HEATING & AIR CONDITIONING/PLUMBING/A/C COMPRESSOR - INSTALLATION).

(26) Install the accessory drive belt (Refer to 7 - COOLING/ACCESSORY DRIVE/DRIVE BELTS - INSTALLATION).

(27) Install upper radiator support crossmember.

(28) Install radiator (Refer to 7 - COOLING/ENGINE/RADIATOR - INSTALLATION).

(29) Connect the radiator lower hose.

(30) Connect the transmission oil cooler lines to the radiator.

(31) Install the fan shroud.

(32) Install the fan (Refer to 7 - COOLING/ENGINE/RADIATOR FAN - INSTALLATION).

(33) Connect the radiator upper hose.

(34) Install the washer bottle.

(35) Install the transmission oil cooler (Refer to 7 - COOLING/TRANSMISSION/TRANS COOLER - INSTALLATION).

(36) Connect the transmission cooler lines.

(37) If equipped, install the condenser (Refer to 24 - HEATING & AIR CONDITIONING/PLUMBING/A/C CONDENSER - INSTALLATION).

(38) Evacuate and charge the air conditioning system, if equipped (Refer to 24 - HEATING & AIR CONDITIONING/PLUMBING - STANDARD PROCEDURE).

(39) Add engine oil to crankcase (Refer to LUBRICATION & MAINTENANCE/FLUID TYPES - SPECIFICATIONS).

(40) Fill cooling system (Refer to 7 - COOLING - STANDARD PROCEDURE).

(41) Connect battery negative cable.

(42) Start engine and inspect for leaks.

(43) Road test vehicle.



## ENGINE 5.2L (Continued)

## SPECIFICATIONS

## 5.2L ENGINE

## ENGINE SPECIFICATIONS

DESCRIPTION	SPECIFICATION
<b>GENERAL SPECIFICATIONS</b>	
Engine Type	90° V-8 OHV
Bore and Stroke	99.3 x 84.0 mm (3.91 x 3.31 in.)
Displacement	5.2L (318 c.i.)
Compression Ratio	9.1:1
Firing Order	1-8-4-3-6-5-7-2
Lubrication	Pressure Feed— Full Flow Filtration
Cooling System	Liquid Cooled— Forced Circulation
Cylinder Block	Cast Iron
Crankshaft	Nodular Iron
Cylinder Head	Cast Iron
Combustion Chambers	Wedge-High Swirl Valve shrouding
Camshaft	Nodular Cast Iron
Pistons	Aluminum Alloy w/strut
Connecting Rods	Forged Steel
Cylinder Compression Pressure (Min.)	689.5 kPa (100 psi)
<b>CAMSHAFT</b>	
Bearing Diameter	
No. 1	50.800 – 50.825 mm (2.000 – 2.001 in.)
No. 2	50.394 – 50.419 mm (1.984 – 1.985 in.)
No. 3	50.013 – 50.038 mm (1.969 – 1.970 in.)
No. 4	49.606 – 49.632 mm (1.953 – 1.954 in.)

DESCRIPTION	SPECIFICATION
No. 5	39.688 – 39.713 mm (1.5625 – 1.5635 in.)
Bearing Journal Diameter	
No. 1	50.749 – 50.775 mm (1.998 – 1.999 in.)
No. 2	50.343 – 50.368 mm (1.982 – 1.983 in.)
No. 3	49.962 – 49.987 mm (1.967 – 1.968 in.)
No. 4	49.555 – 49.581 mm (1.951 – 1.952 in.)
No. 5	39.637 – 39.662 mm (1.5605 – 1.5615 in.)
Bearing to Journal Clearance	
Standard	0.0254 – 0.0762 mm (0.001 – 0.003 in.)
Service Limit	0.127 mm (0.005 in.)
End Play	0.051 – 0.254 mm (0.002 – 0.010 in.)
<b>CONNECTING RODS</b>	
Piston Pin bore Diameter	24.966 – 24.978 mm (0.9829 – 0.9834 in.)
Side Clearance	0.152 – 0.356 mm (0.006 – 0.014 in.)
<b>CRANKSHAFT</b>	
Rod Journal	
Diameter	53.950 – 53.975 mm (2.124 – 2.125 in.)
Out of Round (Max.)	0.0254 mm (0.001 in.)
Taper (Max.)	0.0254 mm (0.001 in.)
Bearing Clearance	0.013 – 0.056 mm (0.0005 – 0.0022 in.)
Service Limit	0.0762 mm (0.003 in.)

## ENGINE 5.2L (Continued)

DESCRIPTION	SPECIFICATION
Main Bearing Journal	
Diameter	63.487 – 63.513 mm (2.4995 – 2.5005 in.)
Out of Round (Max.)	0.127 mm (0.001 in.)
Taper (Max.)	0.0254 mm (0.001 in.)
Bearing Clearance (#1 Journal)	0.013 – 0.038 mm (0.0005 – 0.0015 in.)
(#2-5 Journals)	0.013 – 0.051 mm (0.0005 – 0.002 in.)
Service Limit (#1 Journal)	0.0381 mm (0.0015 in.)
(#2-5 Journals)	0.064 mm (0.0025 in.)
End Play	0.051 – 0.178 mm (0.002 – 0.007 in.)
Service Limit	0.254 mm (0.010 in.)
<b>CYLINDER BLOCK</b>	
Cylinder Bore	
Diameter	99.308 – 99.371 mm (3.9098 – 3.9122 in.)
Out of Round (Max.)	0.025 mm (0.001 in.)
Taper (Max.)	0.025 mm (0.001 in.)
Oversize Limit	1.016 mm (0.040 in.)
Lifter Bore Diameter	22.99 – 23.01 mm (0.9051 – 0.9059 in.)
Distributor Drive Bushing (Press Fit)	
Bushings to Bore Interference	0.0127 – 0.3556 mm (0.0005 – 0.0140 in.)
Shaft to Bushing Clearance	0.0178 – 0.0686 mm (0.0007 – 0.0027 in.)

DESCRIPTION	SPECIFICATION
<b>CYLINDER HEAD</b>	
Valve Seat	
Angle	44.25° – 44.75°
Runout (Max.)	0.0762 mm (0.003 in.)
Width (Finish)	
Intake	1.016 – 1.524 mm (0.040 – 0.060 in.)
Exhaust	1.524 – 2.032 mm (0.060 – 0.080 in.)
<b>VALVES</b>	
Face Angle	43.25° – 43.75°
Head Diameter	
Intake	48.666 mm (1.916 in.)
Exhaust	41.250 mm (1.624 in.)
Length (Overall)	
Intake	124.28 – 125.92 mm (4.893 – 4.918 in.)
Exhaust	124.64 – 125.27 mm (4.907 – 4.932 in.)
Lift (@ zero lash)	10.973 mm (0.432 in.)
Stem Diameter	7.899 – 7.925 mm (0.311 – 0.312 in.)
Guide Bore	7.950 – 7.976 mm (0.313 – 0.314 in.)
Stem to Guide Clearance	0.0254 – 0.0762 mm (0.001 – 0.003 in.)
Service Limit (rocking method)	0.4318 mm (0.017 in.)
<b>VALVE SPRINGS</b>	
Free Length	49.962 mm (1.967 in.)
Spring Tension	

## ENGINE 5.2L (Continued)

DESCRIPTION	SPECIFICATION
valve closed	378 N @ 41.66 mm (85 lbs. @ 1.64 in.)
valve open	890 N @ 30.89 mm (200 lbs. @ 1.212 in.)
Number of Coils	6.5
Installed Height	41.66 mm (1.64 in.)
Wire Diameter	4.50 mm (0.177 in.)
<b>HYDRAULIC TAPPETS</b>	
Body Diameter	22.949 – 22.962 mm (0.9035 – 0.9040 in.)
Clearance (to bore)	0.0279 – 0.0610 mm (0.0011 – 0.0024 in.)
Dry Lash	1.524 – 5.334 mm (0.060 – 0.210 in.)
Push Rod Length	175.64 – 176.15 mm (6.915 – 6.935 in.)
<b>OIL PRESSURE</b>	
Curb Idle (Min.*) @ 3000 rpm	41.4 kPa (6 psi) 207 – 552 kPa (30 – 80 psi)
Oil Pressure Bypass Valve Setting	62 – 103 kPa (9 – 15 psi)
Switch Actuating Pressure	34.5 – 48.3 kPa (5 – 7 psi)
<b>* If oil pressure is zero at curb idle, DO NOT RUN ENGINE.</b>	
<b>OIL PUMP</b>	
Clearance over Rotors (Max.)	0.0381 mm (0.0015 in.)

DESCRIPTION	SPECIFICATION
Inner Rotor Thickness (Min.)	20.955 mm (0.825 in.)
Outer Rotor Clearance (Max.)	0.3556 mm (0.014 in.)
Outer Rotor Diameter (Min.)	62.7126 mm (2.469 in.)
Outer Rotor Thickness (Min.)	20.955 mm (0.825 in.)
Tip Clearance between Rotors (Max.)	0.2032 mm (0.008 in.)
<b>PISTONS</b>	
Clearance at Top of Skirt	0.013 – 0.038 mm (0.0005 – 0.0015 in.)
Land Clearance (Diam.)	0.635 – 1.016 mm (0.025 – 0.040 in.)
Piston Length	86.360 mm (3.40 in.)
Piston Ring Groove Depth	
Groove #1&2	4.572 – 4.826 mm (0.180 – 0.190 in.)
Groove #3	3.810 – 4.064 mm (0.150 – 0.160 in.)
Weight	592.6 – 596.6 grams (20.90 – 21.04 oz.)
<b>PISTON PIN</b>	
Clearance in Piston	0.00635 – 0.01905 mm (0.00025 – 0.00075 in.)
Diameter	24.996 – 25.001 mm (0.9841 – 0.9843 in.)
End Play	NONE
Length	75.946 – 76.454 mm (2.990 – 3.010 in.)

## ENGINE 5.2L (Continued)

DESCRIPTION	SPECIFICATION
<b>PISTON RINGS</b>	
Ring Gap Compression Rings	0.254 – 0.508 mm (0.010 – 0.020 in.)
Oil Control (Steel Rails)	0.254 – 1.270 mm (0.010 – 0.050 in.)
Ring Side Clearance Compression Rings	0.038 – 0.076 mm (0.0015 – 0.0030 in.)
Oil Ring (Steel Rails)	0.06 – 0.21 mm (0.002 – 0.008 in.)
Ring Width Compression rings	1.971 – 1.989 mm (0.0776 – 0.0783 in.)
Oil Ring (Steel Rails) – Max.	3.848 – 3.975 mm (0.1515 – 0.1565 in.)
<b>VALVE TIMING</b>	
Exhaust Valve	
Closes (ATDC)	21°
Opens (BBDC)	60°
Duration	264°
Intake Valve	
Closes (ATDC)	61°
Opens (BBDC)	10°
Duration	250°
Valve Overlap	31°

OVERSIZE AND UNDERSIZE ENGINE  
COMPONENT MARKINGS CHART

U/S-O/S	Item	Identification	Identification Location
U/S .0254 mm (0.001 in.)	Rod/ Main Journal	R or M R-1-4 ect. (indicating No. 1 and 4 connecting rod journal) and/or M-2-3 ect. (indicating No. 2 and 3 main bearing journal)	Milled flat on No.8 crankshaft counterweight.
O/S .2032 mm (.008 in.)	Hydraulic Tappets	◇	Diamond- shaped stamp top pad - front of engine and flat ground on outside surface of each O/S tappet bore.
O/S .127 mm (.005 in.)	Valve Stems	X	Milled pad adjacent to two tapped holes (3/8 in.) on each end of cylinder head.

## ENGINE 5.2L (Continued)

## TORQUE

## TORQUE CHART 5.2L ENGINE

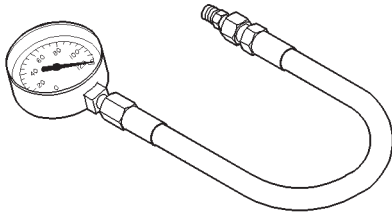
DESCRIPTION	N·m	In. Lbs.	Ft. Lbs.
Camshaft Sprocket—Bolt	68	—	50
Camshaft Thrust Plate—Bolts	24	210	—
Chain Case Cover—Bolts	41	—	30
Connecting Rod Cap—Bolts	61	—	45
Main Bearing Cap—Bolts	115	—	85
Crankshaft Pulley—Bolts	24	210	—
Cylinder Head—Bolts			
Step 1	68	—	50
Step 2	143	—	105
Cylinder Head Cover—Bolts	11	95	—
Engine Support Bracket to Block— Bolts (4WD)	41	—	30
Exhaust Manifold to Cylinder Head— Bolts/Nuts	34	—	25
Flywheel—Bolts	75	—	55
Front Insulator—Through bolt/nut	95	—	70
Front Insulator to Support Bracket—			
Stud Nut (4WD)	41	—	30
Through Bolt/Nut	102	—	75
Front Insulator to Block— Bolts (2WD)	95	—	70
Generator—Mounting Bolts	41	—	30
Intake Manifold—Bolts	Refer to Procedure		
Oil Pan—Bolts	24	215	—
Oil Pan—Drain Plug	34	—	25
Oil Pump—Mounting Bolts	41	—	30
Oil Pump Cover—Bolts	11	95	—
Rear Insulator to Bracket— Through Bolt (2WD)	68	—	50
Rear Insulator to Crossmember Support Bracket—Nut (2WD)	41	—	30
Rear Insulator to Crossmember— Nuts (4WD)	68	—	50

DESCRIPTION	N·m	In. Lbs.	Ft. Lbs.
Rear Insulator to Transmission— Bolts (4WD)	68	—	50
Rear Insulator Bracket—Bolts (4WD Automatic)	68	—	50
Rear Support Plate to Transfer Case —Bolts	41	—	30
Rocker Arm—Bolts	28	—	21
Spark Plugs	41	—	30
Starter Motor—Mounting Bolts	68	—	50
Thermostat Housing—Bolts	25	225	—
Throttle Body—Bolts	23	200	—
Torque Converter Drive Plate—Bolts	31	270	—
Transfer Case to Insulator Mounting Plate—Nuts	204	—	150
Transmission Support Bracket— Bolts (2WD)	68	—	50
Vibration Damper—Bolt	183	—	135
Water Pump to Timing Chain Case Cover—Bolts	41	—	30

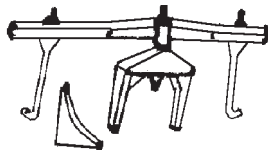
ENGINE 5.2L (Continued)

SPECIAL TOOLS

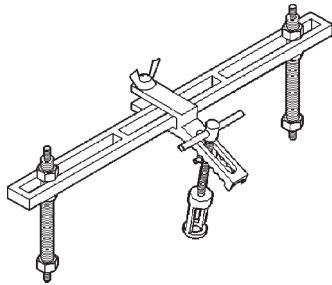
5.2L ENGINE



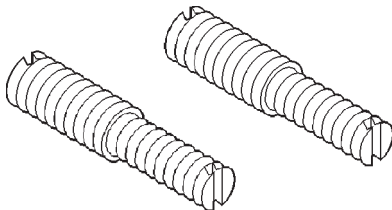
**Oil Pressure Gauge C-3292**



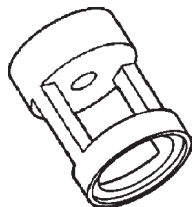
**Engine Support Fixture C-3487-A**



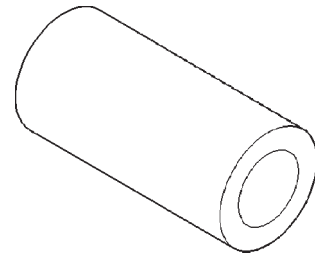
**Valve Spring Compressor MD-998772-A**



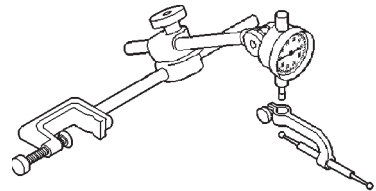
**Adaptor 6633**



**Adaptor 6716A**

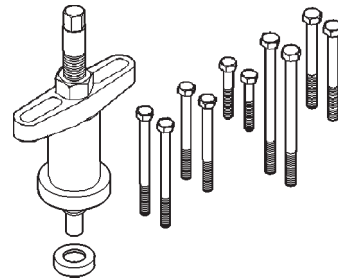


**Valve Guide Sleeve C-3973**

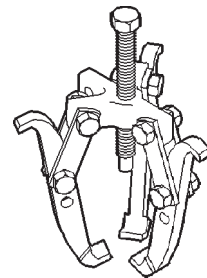


9011462b

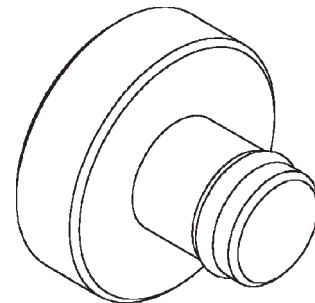
**Dial Indicator C-3339**



**Puller C-3688**



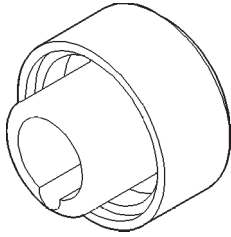
**Puller 1026**



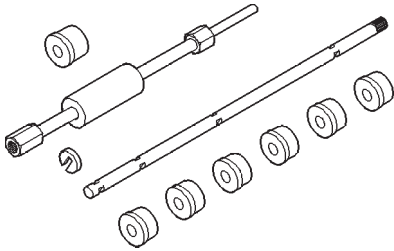
**Crankshaft Damper Removal Insert 8513**



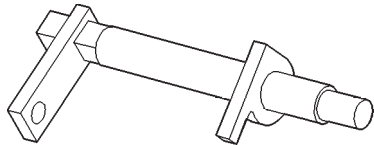
ENGINE 5.2L (Continued)



**Front Oil Seal Installer 6635**

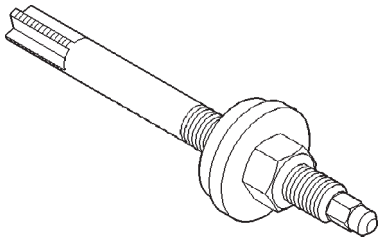


**Cam Bearing Remover/Installer C3132-A**

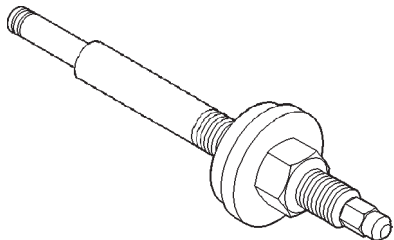


c-3509-8011d343

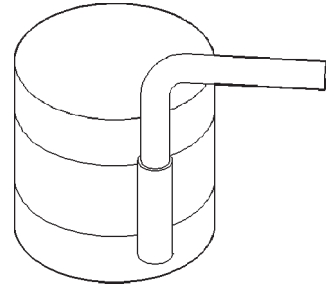
**Camshaft Holder C-3509**



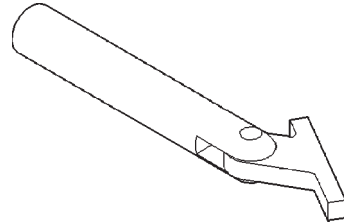
**Distributor Bushing Puller C-3052**



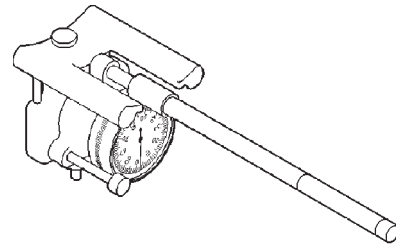
**Distributor Bushing Driver/Burnisher C-3053**



**Piston Ring Compressor C-385**

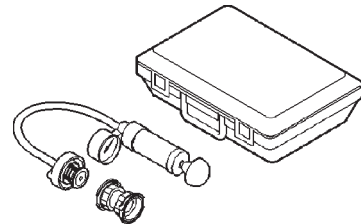


**Crankshaft Main Bearing Remover C-3059**



8011c91a

**Cylinder Bore Gauge C-119**



**Pressure Tester Kit 7700**

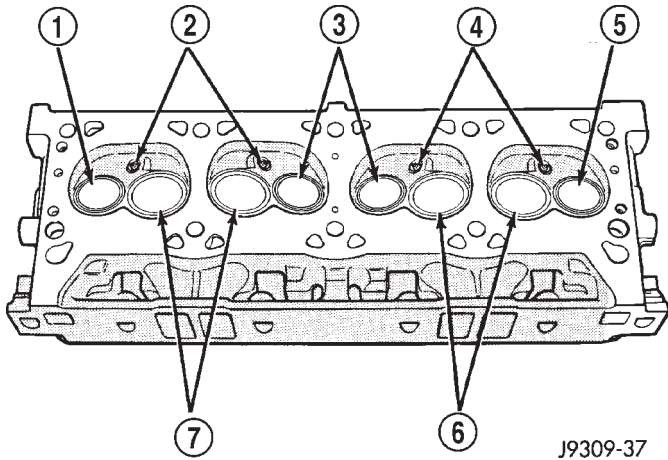


**Bloc-Check-Kit C-3685-A**

## CYLINDER HEAD

### DESCRIPTION—CYLINDER HEAD

The cast iron cylinder heads (Fig. 4) are mounted to the cylinder block using ten bolts. The spark plugs are located in the peak of the wedge between the valves.

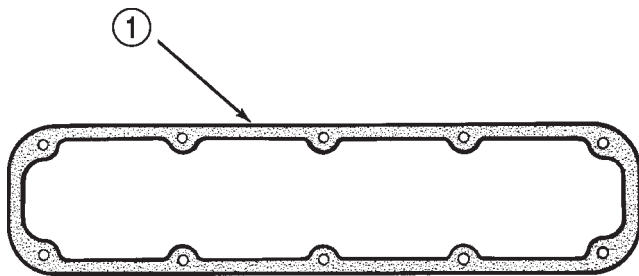


**Fig. 4 Cylinder Head Assembly—V-8 Gas Engines**

- 1 - EXHAUST VALVE
- 2 - SPARK PLUGS
- 3 - EXHAUST VALVES
- 4 - SPARK PLUGS
- 5 - EXHAUST VALVE
- 6 - INTAKE VALVES
- 7 - INTAKE VALVES

### DESCRIPTION—CYLINDER COVER GASKET

The cylinder head cover gasket (Fig. 5) is a steel-backed silicone gasket, designed for long life usage.



**Fig. 5 Cylinder Head Cover Gasket V-8 Gas Engines**

- 1 - CYLINDER HEAD COVER GASKET

### OPERATION—CYLINDER HEAD

The cylinder head closes the combustion chamber allowing the pistons to compress the air fuel mixture to the correct ratio for ignition. The valves located in the cylinder head open and close to either allow clean air into the combustion chamber or to allow the

exhaust gases out, depending on the stroke of the engine.

### OPERATION

The steel-backed silicone gasket is designed to seal the cylinder head cover for long periods of time through extensive heat and cold, without failure. The gasket is designed to be reusable.

### DIAGNOSIS AND TESTING—CYLINDER HEAD GASKET FAILURE

A cylinder head gasket leak can be located between adjacent cylinders or between a cylinder and the adjacent water jacket.

• Possible indications of the cylinder head gasket leaking between adjacent cylinders are:

- Loss of engine power
- Engine misfiring
- Poor fuel economy

• Possible indications of the cylinder head gasket leaking between a cylinder and an adjacent water jacket are:

- Engine overheating
- Loss of coolant
- Excessive steam (white smoke) emitting from exhaust
- Coolant foaming

### CYLINDER-TO-CYLINDER LEAKAGE TEST

To determine if an engine cylinder head gasket is leaking between adjacent cylinders, follow the procedures in Cylinder Compression Pressure Test in this section. An engine cylinder head gasket leaking between adjacent cylinders will result in approximately a 50–70% reduction in compression pressure.

### CYLINDER-TO-WATER JACKET LEAKAGE TEST

**WARNING: USE EXTREME CAUTION WHEN THE ENGINE IS OPERATING WITH COOLANT PRESSURE CAP REMOVED.**

### VISUAL TEST METHOD

With the engine cool, remove the coolant pressure cap. Start the engine and allow it to warm up until thermostat opens.

If a large combustion/compression pressure leak exists, bubbles will be visible in the coolant.

## CYLINDER HEAD (Continued)

## COOLING SYSTEM TESTER METHOD

**WARNING: WITH COOLING SYSTEM TESTER IN PLACE, PRESSURE WILL BUILD UP FAST. EXCESSIVE PRESSURE BUILT UP, BY CONTINUOUS ENGINE OPERATION, MUST BE RELEASED TO A SAFE PRESSURE POINT. NEVER PERMIT PRESSURE TO EXCEED 138 kPa (20 psi).**

Install Cooling System Tester 7700 or equivalent to pressure cap neck. Start the engine and observe the tester's pressure gauge. If gauge pulsates with every power stroke of a cylinder a combustion pressure leak is evident.

## CHEMICAL TEST METHOD

Combustion leaks into the cooling system can also be checked by using Bloc-Chek Kit C-3685-A or equivalent. Perform test following the procedures supplied with the tool kit.

## REMOVAL

- (1) Disconnect the battery negative cable.
- (2) Drain cooling system (Refer to 7 - COOLING - STANDARD PROCEDURE).
- (3) Remove the air cleaner resonator and duct work.
- (4) Remove the intake manifold-to-generator bracket support rod. Remove the generator.
- (5) Remove closed crankcase ventilation system.
- (6) Disconnect the evaporation control system.
- (7) Perform the Fuel System Pressure Release procedure (Refer to 14 - FUEL SYSTEM/FUEL DELIVERY - STANDARD PROCEDURE). Disconnect the fuel supply line (Refer to 14 - FUEL SYSTEM/FUEL DELIVERY/QUICK CONNECT FITTING - STANDARD PROCEDURE).
- (8) Disconnect accelerator linkage and if so equipped, the speed control and transmission kick-down cables.
- (9) Remove distributor cap and wires.
- (10) Disconnect the coil wires.
- (11) Disconnect heat indicator sending unit wire.
- (12) Disconnect heater hoses and bypass hose.
- (13) Remove cylinder head covers and gaskets (Refer to 9 - ENGINE/CYLINDER HEAD/CYLINDER HEAD COVER(S) - REMOVAL).
- (14) Remove intake manifold (Refer to 9 - ENGINE/MANIFOLDS/INTAKE MANIFOLD - REMOVAL) and throttle body as an assembly. Discard the flange side gaskets and the front and rear cross-over gaskets.
- (15) Remove exhaust manifolds (Refer to 9 - ENGINE/MANIFOLDS/EXHAUST MANIFOLD - REMOVAL).
- (16) Remove rocker arm assemblies and push rods. Identify to ensure installation in original locations.

(17) Remove the head bolts from each cylinder head and remove cylinder heads. Discard the cylinder head gasket.

(18) Remove spark plugs.

## CLEANING

Clean all surfaces of cylinder block and cylinder heads.

Clean cylinder block front and rear gasket surfaces using a suitable solvent.

## INSPECTION

Inspect all surfaces with a straightedge if there is any reason to suspect leakage. If out-of-flatness exceeds 0.00075mm (0.0001in.) times the span length in any direction, either replace head or lightly machine the head surface.

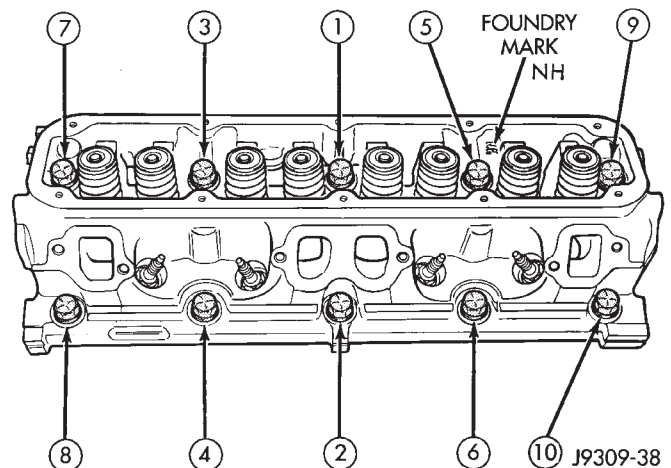
**FOR EXAMPLE:**—A 305 mm (12 in.) span is 0.102 mm (0.004 in.) out-of-flat. The allowable out-of-flat is  $305 \times 0.00075$  ( $12 \times 0.00075$ ) equals 0.23 mm (0.009 in.). This amount of out-of-flat is acceptable.

The cylinder head surface finish should be 1.78-3.00 microns (70-125 microinches).

Inspect push rods. Replace worn or bent rods.

## INSTALLATION

- (1) Clean all surfaces of cylinder block and cylinder heads.
- (2) Clean cylinder block front and rear gasket surfaces using a suitable solvent.
- (3) Position new cylinder head gaskets onto the cylinder block.
- (4) Position cylinder heads onto head gaskets and cylinder block.
- (5) Starting at top center, tighten all cylinder head bolts, in sequence (Fig. 6).



**Fig. 6 Cylinder Head Bolt Tightening Sequence**

## CYLINDER HEAD (Continued)

**CAUTION:** When tightening the rocker arm bolts, make sure the piston in that cylinder is NOT at TDC. Contact between the valves and piston could occur.

(6) Install push rods and rocker arm assemblies in their original position. Tighten the bolts to 28 N·m (21 ft. lbs.) torque.

(7) Install the intake manifold (Refer to 9 - ENGINE/MANIFOLDS/INTAKE MANIFOLD - INSTALLATION) and throttle body assembly.

(8) Install exhaust manifolds (Refer to 9 - ENGINE/MANIFOLDS/EXHAUST MANIFOLD - INSTALLATION).

(9) If required, adjust spark plugs to specifications. Install the plugs and tighten to 41 N·m (30 ft. lbs.) torque.

(10) Install coil wire.

(11) Connect heat indicator sending unit wire.

(12) Connect the heater hoses and bypass hose.

(13) Install distributor cap and wires.

(14) Connect the accelerator linkage and if so equipped, the speed control and transmission kick-down cables.

(15) Install the fuel supply line (Refer to 14 - FUEL SYSTEM/FUEL DELIVERY/QUICK CONNECT FITTING - STANDARD PROCEDURE).

(16) Install the generator and drive belt (Refer to 7 - COOLING/ACCESSORY DRIVE/DRIVE BELTS - INSTALLATION). Tighten generator mounting bolt to 41 N·m (30 ft. lbs.) torque. Tighten the adjusting strap bolt to 23 N·m (200 in. lbs.) torque.

(17) Install the intake manifold-to-generator bracket support rod. Tighten the bolts.

(18) Place the cylinder head cover gaskets in position and install cylinder head covers (Refer to 9 - ENGINE/CYLINDER HEAD/CYLINDER HEAD COVER(S) - INSTALLATION).

(19) Install closed crankcase ventilation system.

(20) Connect the evaporation control system.

(21) Install the air cleaner.

(22) Fill cooling system (Refer to 7 - COOLING - STANDARD PROCEDURE).

(23) Connect the negative cable to the battery.

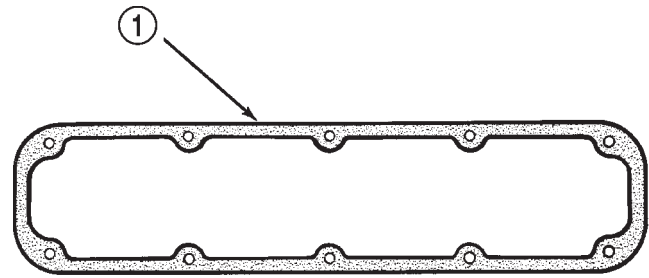
(24) Start engine check for leaks.

## CYLINDER HEAD COVER(S)

## REMOVAL

**NOTE:** A steel backed silicon gasket is used with the cylinder head cover (Fig. 7). This gasket can be used again.

(1) Disconnect the negative cable from the battery.



J9209-105

**Fig. 7 Cylinder Head Cover Gasket**

1 - CYLINDER HEAD COVER GASKET

(2) Disconnect the spark plug wires from the spark plugs and set aside.

(3) Disconnect closed ventilation system and evaporation control system from cylinder head cover.

(4) Remove cylinder head cover and gasket.

## CLEANING

Clean cylinder head cover gasket surface.

Clean head rail, if necessary.

## INSPECTION

Inspect cover for distortion and straighten, if necessary.

Check the gasket for use in head cover installation. If damaged, use a new gasket.

## INSTALLATION

(1) The cylinder head cover gasket can be used again. Install the gasket onto the head rail.

(2) Position the cylinder head cover onto the gasket. Tighten the bolts to 11 N·m (95 in. lbs.) torque.

(3) Install closed crankcase ventilation system and evaporation control system.

(4) Connect the spark plug wires to the spark plugs.

(5) Connect the negative cable to the battery.

## INTAKE/EXHAUST VALVES &amp; SEATS

## DESCRIPTION

Both the intake and exhaust valves are made of steel. The intake valve is 48.768 mm (1.92 inches) in diameter and the exhaust valve is 41.148 mm (1.62 inches) in diameter and has a 2.032 mm (0.080 inch) wafer interior welded to the tip for durability. These valves are not splayed.

## INTAKE/EXHAUST VALVES &amp; SEATS (Continued)

## STANDARD PROCEDURE—VALVES, GUIDES AND SPRINGS

## VALVE CLEANING

Clean valves thoroughly. Discard burned, warped, or cracked valves.

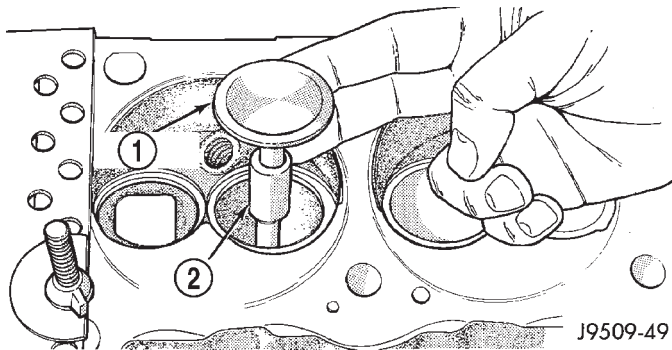
Remove carbon and varnish deposits from inside of valve guides with a reliable guide cleaner.

## VALVE GUIDES

Measure valve stems for wear. If wear exceeds 0.051 mm (0.002 in.), replace the valve.

Measure valve stem guide clearance as follows:

(1) Install Valve Guide Sleeve Tool C-3973 over valve stem and install valve (Fig. 8). The special sleeve places the valve at the correct height for checking with a dial indicator.



**Fig. 8 Positioning Valve with Tool C-3973**

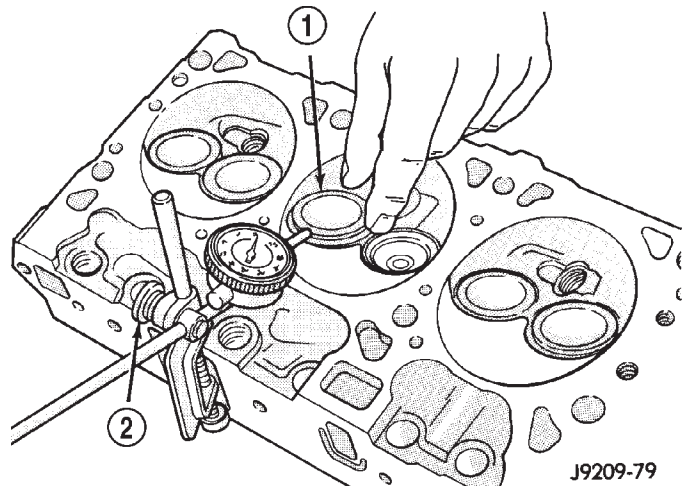
- 1 - VALVE  
2 - SPACER TOOL

(2) Attach dial indicator Tool C-3339 to cylinder head and set it at right angles to valve stem being measured (Fig. 9).

(3) Move valve to and from the indicator. The total dial indicator reading should not exceed 0.432 mm (0.017 in.). Ream the guides for valves with oversize stems if dial indicator reading is excessive or if the stems are scuffed or scored.

## VALVE GUIDES

Service valves with oversize stems are available. Refer to REAMER SIZES CHART



**Fig. 9 Measuring Valve Guide Wear**

- 1 - VALVE  
2 - SPECIAL TOOL C-3339

## REAMER SIZES CHART

REAMER O/S	VALVE GUIDE SIZE
0.076 mm (0.003 in.)	8.026 - 8.052 mm (0.316 - 0.317 in.)
0.381 mm (0.015 in.)	8.331 - 8.357 mm (0.328 - 0.329 in.)

(1) Slowly turn reamer by hand and clean guide thoroughly before installing new valve. **Ream the valve guides from standard to 0.381 mm (0.015 in.). Use a two step procedure so the valve guides are reamed true in relation to the valve seat:**

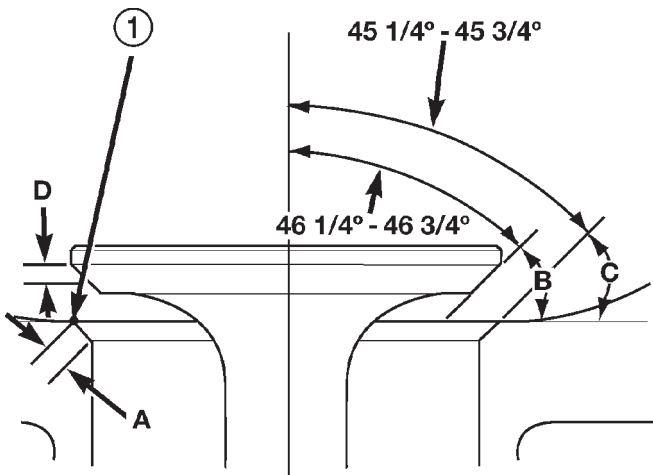
- Step 1—Ream to 0.0763 mm (0.003 inch).
- Step 2—Ream to 0.381 mm (0.015 inch).



INTAKE/EXHAUST VALVES & SEATS (Continued)

REFACING VALVES AND VALVE SEATS

The intake and exhaust valves have a 43-1/4° to 43-3/4° face angle and a 44-1/4° to 44-3/4° seat angle (Fig. 10).



80ba7a5f

Fig. 10 Valve Face and Seat Angles

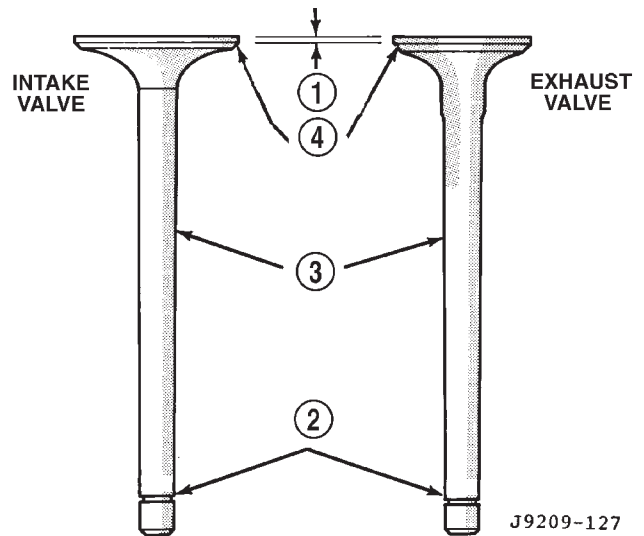
1 - CONTACT POINT  
A,B,C and D Refer to VALVE FACE AND VALVE SEAT ANGLE CHART

VALVE FACE AND VALVE SEAT ANGLE CHART

ITEM	DESCRIPTION	SPECIFICATION
A	SEAT WIDTH INTAKE	1.016 - 1.524 mm (0.040 - 0.060 in.)
	EXHAUST	1.524 - 2.032 mm (0.060 - 0.080 in.)
B	FACE ANGLE (INT. AND EXT.)	43 <sup>1</sup> / <sub>4</sub> ° - 43 <sup>3</sup> / <sub>4</sub> °
C	SEAT ANGLE (INT. AND EXT.)	44 <sup>1</sup> / <sub>4</sub> ° - 44 <sup>3</sup> / <sub>4</sub> °
D	CONTACT SURFACE	—

VALVES

Inspect the remaining margin after the valves are refaced (Fig. 11). Valves with less than 1.190 mm (0.047 in.) margin should be discarded.



J9209-127

Fig. 11 Intake and Exhaust Valves

- 1 - MARGIN
- 2 - VALVE SPRING RETAINER LOCK GROOVE
- 3 - STEM
- 4 - FACE

VALVE SEATS

CAUTION: DO NOT un-shroud valves during valve seat refacing (Fig. 12).

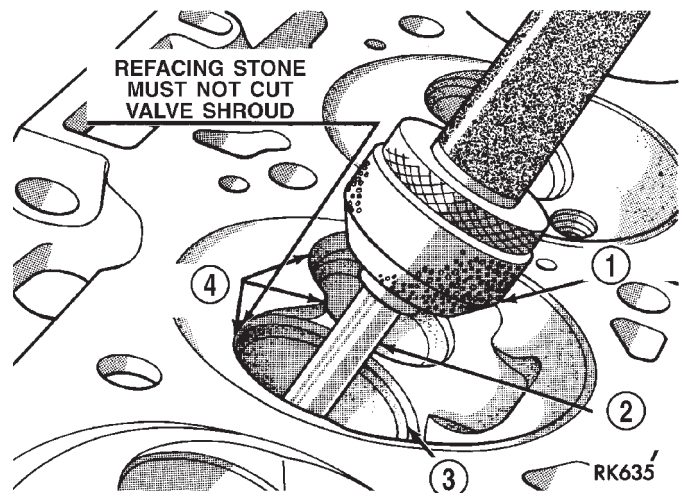


Fig. 12 Refacing Valve Seats

- 1 - STONE
- 2 - PILOT
- 3 - VALVE SEAT
- 4 - SHROUD



## INTAKE/EXHAUST VALVES &amp; SEATS (Continued)

(1) When refacing valve seats, it is important that the correct size valve guide pilot be used for reseating stones. A true and complete surface must be obtained.

(2) Measure the concentricity of valve seat using a dial indicator. Total runout should not exceed 0.051 mm (0.002 in.) total indicator reading.

(3) Inspect the valve seat with Prussian blue, to determine where the valve contacts the seat. To do this, coat valve seat LIGHTLY with Prussian blue then set valve in place. Rotate the valve with light pressure. If the blue is transferred to the center of valve face, contact is satisfactory. If the blue is transferred to the top edge of valve face, lower valve seat with a 15° stone. If the blue is transferred to bottom edge of valve face raise valve seat with a 60° stone.

(4) When seat is properly positioned the width of intake seats should be 1.016-1.524 mm (0.040-0.060 in.). The width of the exhaust seats should be 1.524-2.032 mm (0.060-0.080 in.).

## VALVE SPRINGS

Whenever valves have been removed for inspection, reconditioning or replacement, valve springs should be tested. As an example the compression length of the spring to be tested is 1-5/16 in.. Turn table of Universal Valve Spring Tester Tool until surface is in line with the 1-5/16 in. mark on the threaded stud. Be sure the zero mark is to the front (Fig. 13). Place spring over stud on the table and lift compressing lever to set tone device. Pull on torque wrench until ping is heard. Take reading on torque wrench at this instant. Multiply this reading by 2. This will give the spring load at test length. Fractional measurements are indicated on the table for finer adjustments. Refer to specifications to obtain specified height and allowable tensions. Discard the springs that do not meet specifications.

## REMOVAL

(1) Remove the cylinder head (Refer to 9 - ENGINE/CYLINDER HEAD - REMOVAL).

(2) Compress valve springs using Valve Spring Compressor Tool MD- 998772A and adapter 6716A.

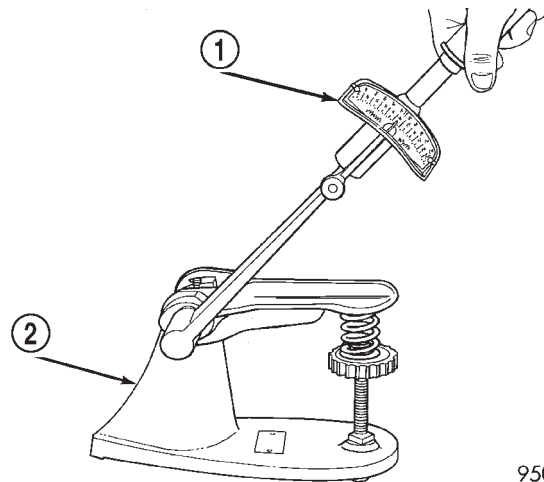
(3) Remove valve retaining locks, valve spring retainers, valve stem seals and valve springs.

(4) Before removing valves, remove any burrs from valve stem lock grooves to prevent damage to the valve guides. Identify valves to ensure installation in original location.

## CLEANING

Clean valves thoroughly. Discard burned, warped, or cracked valves.

Remove carbon and varnish deposits from inside of valve guides with a reliable guide cleaner.



9509-79

**Fig. 13 Testing Valve Spring for Compressed Length**

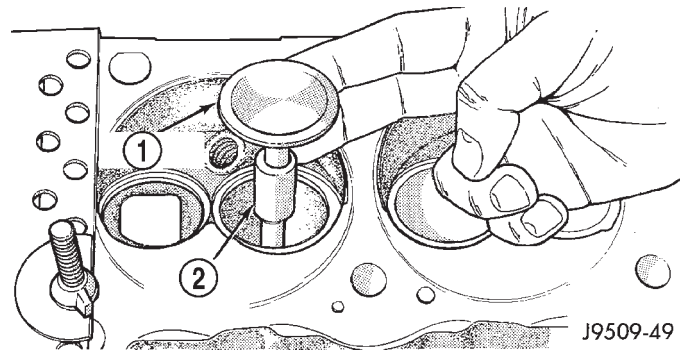
- 1 - TORQUE WRENCH  
2 - VALVE SPRING TESTER

## INSPECTION

Measure valve stems for wear. If wear exceeds 0.051 mm (0.002 in.), replace the valve.

Measure valve stem guide clearance as follows:

(1) Install Valve Guide Sleeve Tool C-3973 over valve stem and install valve (Fig. 14). The special sleeve places the valve at the correct height for checking with a dial indicator.



J9509-49

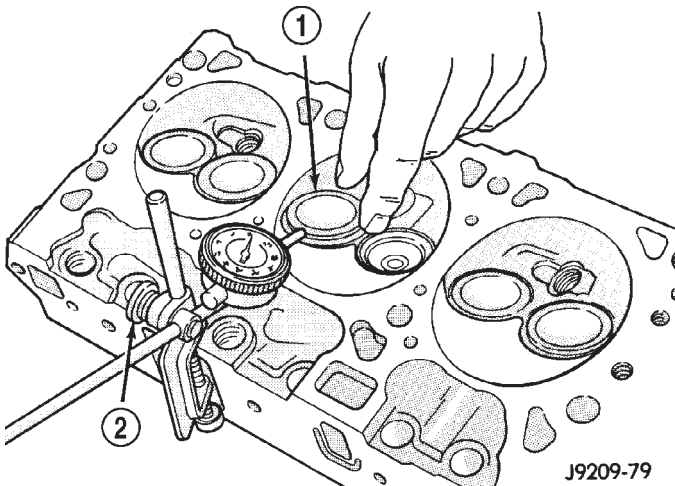
**Fig. 14 Positioning Valve with Tool C-3973**

- 1 - VALVE  
2 - SPACER TOOL

(2) Attach dial indicator Tool C-3339 to cylinder head and set it at right angles to valve stem being measured (Fig. 15).

(3) Move valve to and from the indicator. The total dial indicator reading should not exceed 0.432 mm (0.017 in.). Ream the guides for valves with oversize stems if dial indicator reading is excessive or if the stems are scuffed or scored.

## INTAKE/EXHAUST VALVES &amp; SEATS (Continued)



**Fig. 15 Measuring Valve Guide Wear**

- 1 - VALVE  
2 - SPECIAL TOOL C-3339

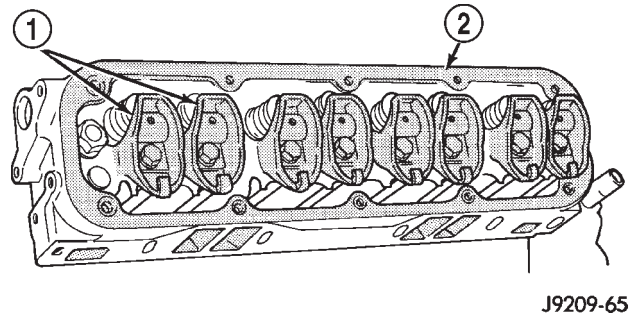
## INSTALLATION

- (1) Clean valves thoroughly. Discard burned, warped and cracked valves.
- (2) Remove carbon and varnish deposits from inside of valve guides with a reliable guide cleaner.
- (3) Measure valve stems for wear. If wear exceeds 0.051 mm (0.002 inch), replace the valve.
- (4) Coat valve stems with lubrication oil and insert them in cylinder head.
- (5) If valves or seats are reground, check valve stem height. If valve is too long, replace cylinder head.
- (6) Install new seals on all valve guides. Install valve springs and valve retainers.
- (7) Compress valve springs with Valve Spring Compressor Tool MD-998772A and adapter 6716A, install locks and release tool. If valves and/or seats are ground, measure the installed height of springs. Make sure the measurement is taken from bottom of spring seat in cylinder head to the bottom surface of spring retainer. If spacers are installed, measure from the top of spacer. If height is greater than 42.86 mm (1-11/16 inches), install a 1.587 mm (1/16 inch) spacer in head counterbore. This should bring spring height back to normal 41.27 to 42.86 mm (1-5/8 to 1-11/16 inch).
- (8) Install cylinder head (Refer to 9 - ENGINE/CYLINDER HEAD - INSTALLATION).

## ROCKER ARM / ADJUSTER ASSEMBLY

## REMOVAL

- (1) Remove cylinder head cover and gasket (Refer to 9 - ENGINE/CYLINDER HEAD/CYLINDER HEAD COVER(S) - REMOVAL).
- (2) Remove the rocker arm bolts and pivots (Fig. 16). Place them on a bench in the same order as removed.
- (3) Remove the push rods and place them on a bench in the same order as removed.



**Fig. 16 Rocker Arms**

- 1 - ROCKER ARMS  
2 - CYLINDER HEAD

## INSTALLATION

- (1) Rotate the crankshaft until the "V8" mark lines up with the TDC mark on the timing chain case cover. This mark is located 147° ATDC from the No.1 firing position.
  - (2) Install the push rods in the same order as removed.
  - (3) Install rocker arm and pivot assemblies in the same order as removed. Tighten the rocker arm bolts to 28 N·m (21 ft. lbs.) torque.
- CAUTION: DO NOT rotate or crank the engine during or immediately after rocker arm installation. Allow the hydraulic roller tappets adequate time to bleed down (about 5 minutes).**
- (4) Install cylinder head cover (Refer to 9 - ENGINE/CYLINDER HEAD/CYLINDER HEAD COVER(S) - INSTALLATION).

## ENGINE BLOCK

### CLEANING

Clean cylinder block thoroughly and check all core hole plugs for evidence of leakage.

### INSPECTION

Examine block for cracks or fractures.

The cylinder walls should be checked for out-of-round and taper. Refer to Honing Cylinder Bores in the Service Procedures portion of this Section.

Inspect the oil line plug, the oil line plug is located in the vertical passage at the rear of the block between the oil-to-filter and oil-from-filter passages (Fig. 17). Improper installation or missing plug could cause erratic, low, or no oil pressure.

The oil plug must come out the bottom. Use flat dowel, down the oil pressure sending unit hole from the top, to remove oil plug.

- (1) Remove oil pressure sending unit from back of block.
- (2) Insert a 3.175 mm (1/8 in.) finish wire, or equivalent, into passage.
- (3) Plug should be 190.0 to 195.2 mm (7-1/2 to 7-11/16 in.) from machined surface of block (Fig. 17). If plug is too high, use a suitable flat dowel to position properly.

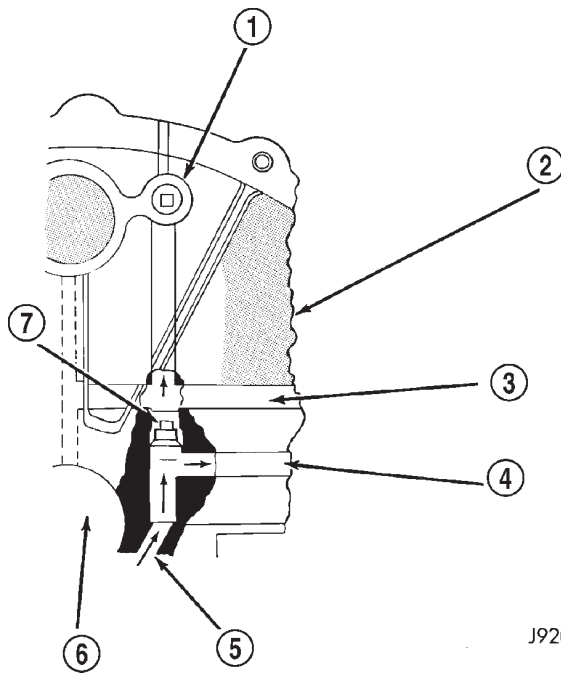


Fig. 17 Oil Line Plug

- 1 - RIGHT OIL GALLERY
- 2 - CYLINDER BLOCK
- 3 - OIL FROM FILTER TO SYSTEM
- 4 - OIL TO FILTER
- 5 - FROM OIL PUMP
- 6 - CRANKSHAFT
- 7 - PLUG

J9209-147

- (4) If plug is too low, remove oil pan and No. 4 main bearing cap. Use suitable flat dowel to position properly. Coat outside diameter of plug with Mopar® Stud and Bearing Mount Adhesive. Plug should be 54.0 to 57.7 mm (2-1/8 to 2-5/16 in.) from bottom of the block.

## CAMSHAFT & BEARINGS (IN BLOCK)

### REMOVAL—CAMSHAFT BEARINGS

**NOTE:** This procedure requires that the engine is removed from the vehicle.

(1) With engine completely disassembled, drive out rear cam bearing core plug.

(2) Install proper size adapters and horseshoe washers (part of Camshaft Bearing Remover/Installer Tool C-3132-A) at back of each bearing shell. Drive out bearing shells (Fig. 18).

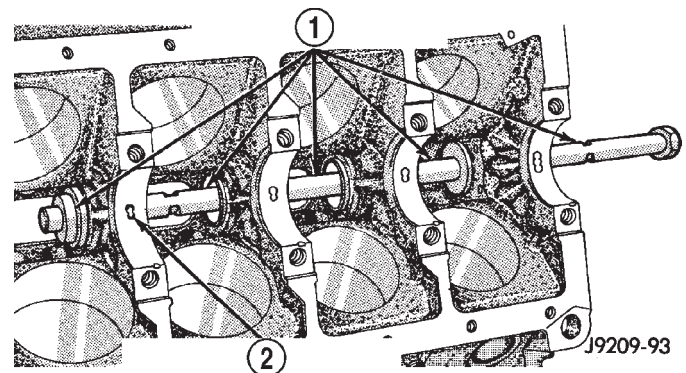


Fig. 18 Camshaft Bearings

- 1 - SPECIAL TOOL C-3132-A
- 2 - MAIN BEARING OIL HOLE

### REMOVAL—CAMSHAFT

**NOTE:** The camshaft has an integral oil pump and distributor drive gear (Fig. 19).

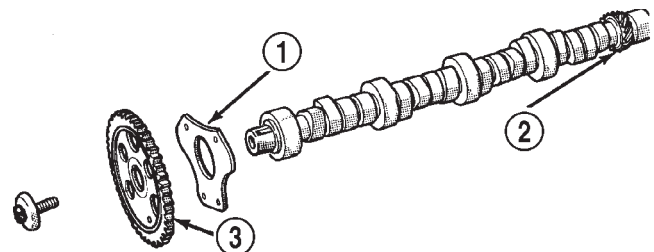


Fig. 19 Camshaft and Sprocket Assembly

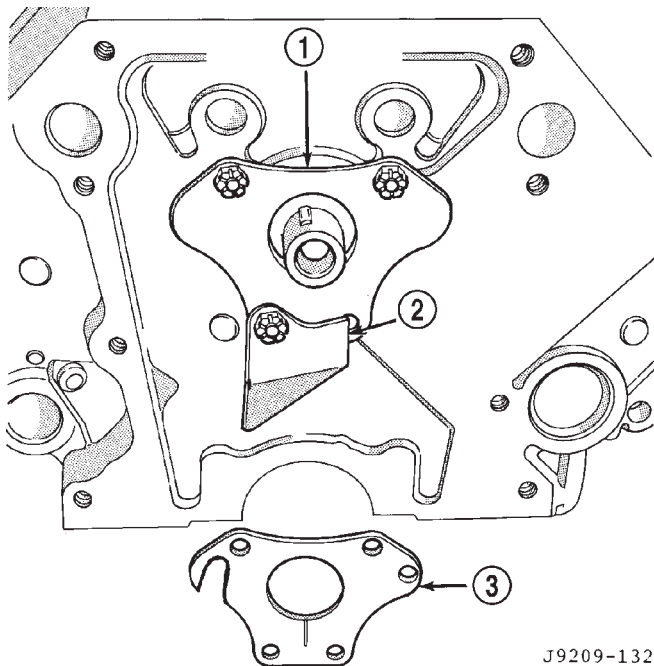
- 1 - THRUST PLATE
- 2 - OIL PUMP AND DISTRIBUTOR DRIVE GEAR INTEGRAL WITH CAMSHAFT
- 3 - CAMSHAFT SPROCKET

J9309-71



## CAMSHAFT &amp; BEARINGS (IN BLOCK) (Continued)

- (1) Remove the radiator (Refer to 7 - COOLING/ENGINE/RADIATOR - REMOVAL).
- (2) Remove the A/C Condenser (if equipped)
- (3) Remove the engine cover.
- (4) Remove intake manifold (Refer to 9 - ENGINE/MANIFOLDS/INTAKE MANIFOLD - REMOVAL).
- (5) Remove cylinder head covers (Refer to 9 - ENGINE/CYLINDER HEAD/CYLINDER HEAD COVER(S) - REMOVAL).
- (6) Remove timing case cover (Refer to 9 - ENGINE/VALVE TIMING/TIMING BELT / CHAIN COVER(S) - REMOVAL) and timing chain (Refer to 9 - ENGINE/VALVE TIMING/TIMING BELT/CHAIN AND SPROCKETS - REMOVAL).
- (7) Remove rocker arms.
- (8) Remove push rods and tappets. Identify each part so it can be installed in its original location.
- (9) Remove distributor and lift out the oil pump and distributor drive shaft.
- (10) Remove camshaft thrust plate, note location of oil tab (Fig. 20).



**Fig. 20 Timing Chain Oil**

- 1 - THRUST PLATE FRONT SIDE
- 2 - CHAIN OIL TAB
- 3 - THRUST PLATE REAR SIDE

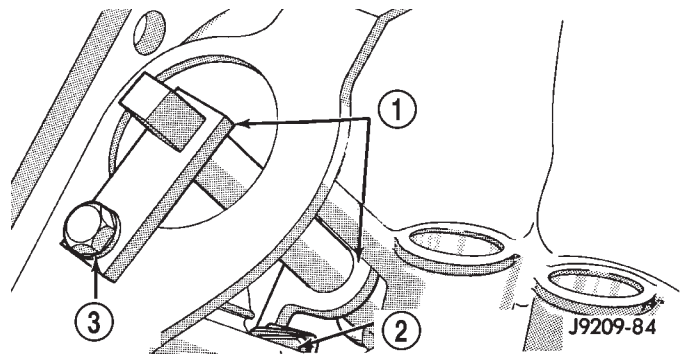
- (11) Install a long bolt into front of camshaft to aid in removal of the camshaft. Remove camshaft, being careful not to damage cam bearings with the cam lobes.

## INSTALLATION—CAMSHAFT BEARINGS

- (1) Install new camshaft bearings with Camshaft Bearing Remover/Installer Tool C-3132-A by sliding the new camshaft bearing shell over proper adapter.
- (2) Position rear bearing in the tool. Install horse-shoe lock and by reversing removal procedure, carefully drive bearing shell into place.
- (3) Install remaining bearings in the same manner. Bearings must be carefully aligned to bring oil holes into full register with oil passages from the main bearing. If the camshaft bearing shell oil holes are not in exact alignment, remove and install them correctly. Install a new core hole plug at the rear of camshaft. **Be sure this plug does not leak.**

## INSTALLATION—CAMSHAFT

- (1) Lubricate camshaft lobes and camshaft bearing journals and insert the camshaft to within 51 mm (2 inches) of its final position in cylinder block.
- (2) Install Camshaft Holder Tool C-3509 with tongue back of distributor drive gear (Fig. 21).



**Fig. 21 Camshaft Holding Tool C-3509 (Installed Position)**

- 1 - SPECIAL TOOL C-3509
- 2 - DRIVE GEAR
- 3 - DISTRIBUTOR LOCK BOLT

- (3) Hold tool in position with a distributor lock-plate bolt. This tool will restrict camshaft from being pushed in too far and prevent knocking out the welch plug in rear of cylinder block. **Tool should remain installed until the camshaft and crankshaft sprockets and timing chain have been installed.**

- (4) Install camshaft thrust plate and chain oil tab. **Make sure tang enters lower right hole in thrust plate.** Tighten bolts to 24 N·m (210 in. lbs.) torque. Top edge of tab should be flat against thrust plate in order to catch oil for chain lubrication.

- (5) Install timing chain and gears (Refer to 9 - ENGINE/VALVE TIMING/TIMING BELT/CHAIN AND SPROCKETS - INSTALLATION).

- (6) Measure camshaft end play (Refer to 9 - ENGINE - SPECIFICATIONS). If not within limits install a new thrust plate.

## CAMSHAFT &amp; BEARINGS (IN BLOCK) (Continued)

(7) Each tappet reused must be installed in the same position from which it was removed. **When camshaft is replaced, all of the tappets must be replaced.**

(8) Install distributor and distributor drive shaft.

(9) Install push rods and tappets.

(10) Install rocker arms.

(11) Install timing case cover (Refer to 9 - ENGINE/VALVE TIMING/TIMING BELT / CHAIN COVER(S) - INSTALLATION).

(12) Install cylinder head covers (Refer to 9 - ENGINE/CYLINDER HEAD/CYLINDER HEAD COVER(S) - INSTALLATION).

(13) Install intake manifold (Refer to 9 - ENGINE/MANIFOLDS/INTAKE MANIFOLD - INSTALLATION).

(14) Install the engine cover.

(15) Install the A/C Condenser (if equipped)

(16) Install the radiator (Refer to 7 - COOLING/ENGINE/RADIATOR - INSTALLATION).

(17) Start engine check for leaks.

## CONNECTING ROD BEARINGS

## STANDARD PROCEDURE—CONNECTING ROD BEARING FITTING

Fit all rods on a bank until completed. DO NOT alternate from one bank to another, because connecting rods and pistons are not interchangeable from one bank to another.

The bearing caps are not interchangeable and should be marked at removal to ensure correct assembly.

Each bearing cap has a small V-groove across the parting face. When installing the lower bearing shell, be certain that the V-groove in the shell is in line with the V-groove in the cap. This provides lubrication of the cylinder wall in the opposite bank.

The bearing shells must be installed so that the tangs are in the machined grooves in the rods and caps.

Limits of taper or out-of-round on any crankshaft journals should be held to 0.025 mm (0.001 in.). Bearings are available in 0.025 mm (0.001 in.), 0.051 mm (0.002 in.), 0.076 mm (0.003 in.), 0.254 mm (0.010 in.) and 0.305 mm (0.012 in.) undersize. **Install the bearings in pairs. DO NOT use a new bearing half with an old bearing half. DO NOT file the rods or bearing caps.**

## CRANKSHAFT

## DESCRIPTION

The crankshaft (Fig. 22) is of a cast nodular steel splayed type design, with five main bearing journals. The crankshaft is located at the bottom of the engine block and is held in place with five main bearing caps. The number 3 counterweight is the location for journal size identification.

Undersize Journal	Identification Stamp
0.025 mm (0.001 inch) (Rod)	R1-R2-R3 or R4
0.025 mm (0.001 inch) (Main)	M1-M2-M3-M4 or M5

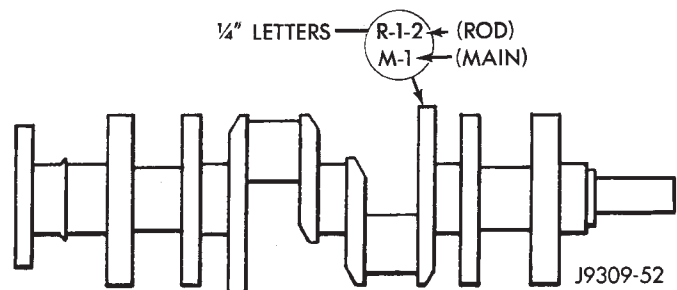


Fig. 22 Crankshaft with Journal Size Identification

## OPERATION

The crankshaft transfers force generated by combustion within the cylinder bores to the flywheel or flexplate.

## REMOVAL

**NOTE:** This procedure can be done in vehicle. However the transmission must be removed first.

(1) If crankshaft is to be removed while engine is in vehicle remove the transmission. Refer to Group 21, for correct procedure.

(2) Remove the oil pan (Refer to 9 - ENGINE/LUBRICATION/OIL PAN - REMOVAL).

(3) Remove the oil pump from the rear main bearing cap (Refer to 9 - ENGINE/LUBRICATION/OIL PUMP - REMOVAL).

(4) Remove the vibration damper (Refer to 9 - ENGINE/ENGINE BLOCK/VIBRATION DAMPER - REMOVAL).

(5) Remove the timing chain cover (Refer to 9 - ENGINE/VALVE TIMING/TIMING BELT / CHAIN COVER(S) - REMOVAL).

(6) Identify rod bearing caps before removal. Remove rod bearing caps with bearings.

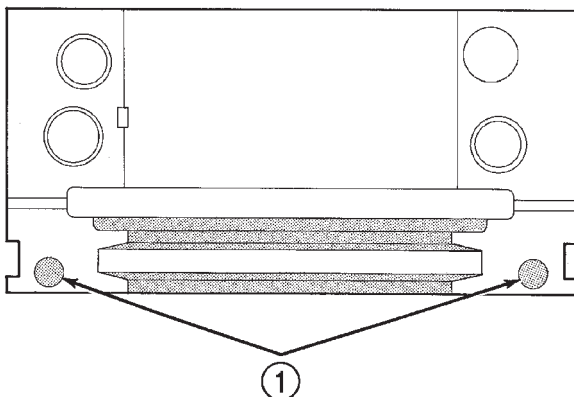
## CRANKSHAFT (Continued)

**CAUTION:** Support crankshaft before removing main bearing caps. Failure to do so will allow the crankshaft to fall damaging the crankshaft.

- (7) Using a suitable jack, support the crankshaft.
- (8) Identify main bearing caps before removal. Remove main bearing caps and bearings one at a time.
- (9) Lower the crankshaft out of the block.
- (10) Remove and discard the crankshaft rear oil seals.
- (11) Remove and discard the front crankshaft oil seal.

**INSTALLATION**

- (1) Clean Gasket Maker residue and sealant from the cylinder block and rear cap mating surface. Do this before applying the Mopar® Gasket Maker and the installation of rear cap.
- (2) Lightly oil the new upper seal lips with engine oil.
- (3) Install the new upper rear bearing oil seal with the white paint facing towards the rear of the engine.
- (4) Position the crankshaft into the cylinder block.
- (5) Lightly oil the new lower seal lips with engine oil.
- (6) Install the new lower rear bearing oil seal into the bearing cap with the white paint facing towards the rear of the engine.
- (7) Apply 5 mm (0.20 in) drop of Mopar® Gasket Maker, or equivalent, on each side of the rear main bearing cap (Fig. 23). DO NOT over apply sealant or allow the sealant to contact the rubber seal. Assemble bearing cap to cylinder block immediately after sealant application.



J9509-75

**Fig. 23 Sealant Application to Bearing Cap**

1 - .25 DROP OF LOCTITE 515 ON BOTH SIDES OF REAR MAIN CAP

- (8) To align the bearing cap, use cap slot, alignment dowel and cap bolts. DO NOT remove excess

material after assembly. DO NOT strike rear cap more than 2 times for proper engagement.

- (9) Clean and oil all cap bolts. Install all main bearing caps. Install all cap bolts and alternately tighten to 115 N-m (85 ft. lbs.) torque.

(10) Install oil pump (Refer to 9 - ENGINE/LUBRICATION/OIL PUMP - INSTALLATION).

(11) Install the timing chain cover (Refer to 9 - ENGINE/VALVE TIMING/TIMING BELT / CHAIN COVER(S) - INSTALLATION).

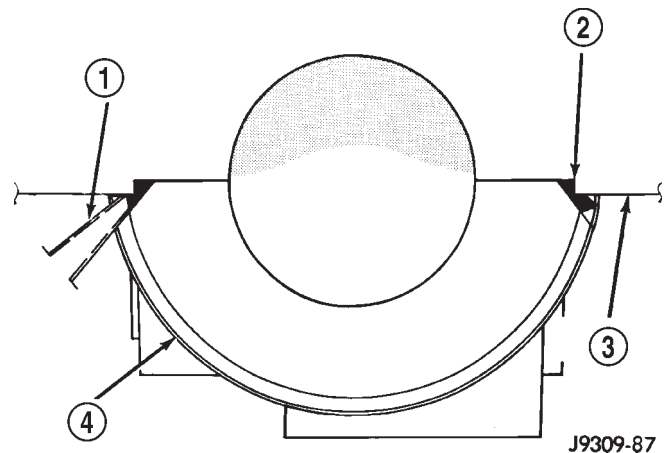
(12) Install the vibration damper (Refer to 9 - ENGINE/ENGINE BLOCK/VIBRATION DAMPER - INSTALLATION).

(13) Position the connecting rods onto the crankshaft and install the rod bearing caps. Tighten the nuts to 61 N-m (45 ft. lbs.).

(14) Apply Mopar® Silicone Rubber Adhesive Sealant, or equivalent, at bearing cap to block joint to provide cap to block and oil pan sealing (Fig. 24). Apply enough sealant until a small amount is squeezed out. Withdraw nozzle and wipe excess sealant off the oil pan seal groove.

(15) Install new front crankshaft oil seal (Refer to 9 - ENGINE/ENGINE BLOCK/CRANKSHAFT OIL SEAL - FRONT - INSTALLATION).

(16) Immediately install the oil pan (Refer to 9 - ENGINE/LUBRICATION/OIL PAN - INSTALLATION).



J9309-87

**Fig. 24 Apply Sealant to Bearing Cap to Block Joint**

- 1 - MOPAR® GEN II SILICONE RUBBER ADHESIVE SEALANT NOZZLE TIP
- 2 - SEALANT APPLIED
- 3 - CYLINDER BLOCK
- 4 - REAR MAIN BEARING CAP

- (17) If the transmission was removed, install the transmission.



## CRANKSHAFT MAIN BEARINGS

### DESCRIPTION

Main bearings (Fig. 25) are located in the cylinder block. One half of the main bearing is located in the crankshaft main bore the other half of the matching bearing is located in the main bearing cap. there are five main bearings. Number three main bearing is flanged, this flange controls crankshaft thrust.

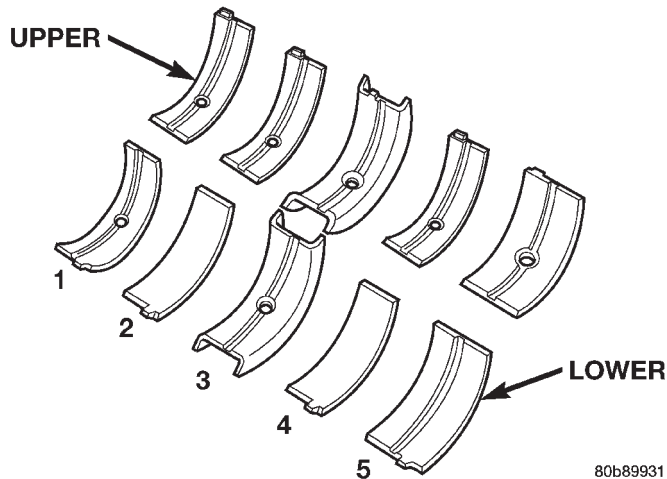


Fig. 25 Main Bearing Orientation

### OPERATION

The main bearings encircle the crankshaft main bearing journals, this aligns the crankshaft to the centerline of the engine and allows the crankshaft to turn without wobbling or shaking therefore eliminating vibration. The main bearings are available in standard and undersizes.

### STANDARD PROCEDURE—CRANKSHAFT MAIN BEARING FITTING

Bearing caps are not interchangeable and should be marked at removal to ensure correct assembly. Upper and lower bearing halves are NOT interchangeable. Lower main bearing halves of No.2 and 4 are interchangeable.

Upper and lower No.3 bearing halves are flanged to carry the crankshaft thrust loads. They are NOT interchangeable with any other bearing halves in the engine (Fig. 26). Bearing shells are available in standard and the following undersizes: Never install an undersize bearing that will reduce clearance below specifications.

### Main Bearing Undersize Availability List

- 0.25 mm (0.001 inch)
- 0.051 mm (0.002 inch)
- 0.076 mm (0.003 inch)
- 0.254 mm (0.010 inch)
- 0.305 mm (0.012 inch)

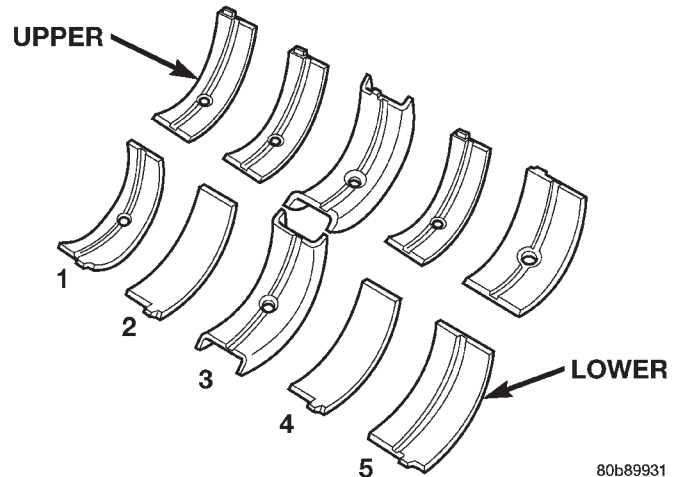


Fig. 26 Main Bearing

### REMOVAL

- (1) Remove the oil pan (Refer to 9 - ENGINE/LUBRICATION/OIL PAN - REMOVAL).
- (2) Remove the oil pump from the rear main bearing cap (Refer to 9 - ENGINE/LUBRICATION/OIL PUMP - REMOVAL).
- (3) Identify bearing caps before removal. Remove bearing caps one at a time.
- (4) Remove upper half of bearing by inserting Crankshaft Main Bearing Remover/Installer Tool C-3059 into the oil hole of crankshaft (Fig. 27).
- (5) Slowly rotate crankshaft clockwise, forcing out upper half of bearing shell.

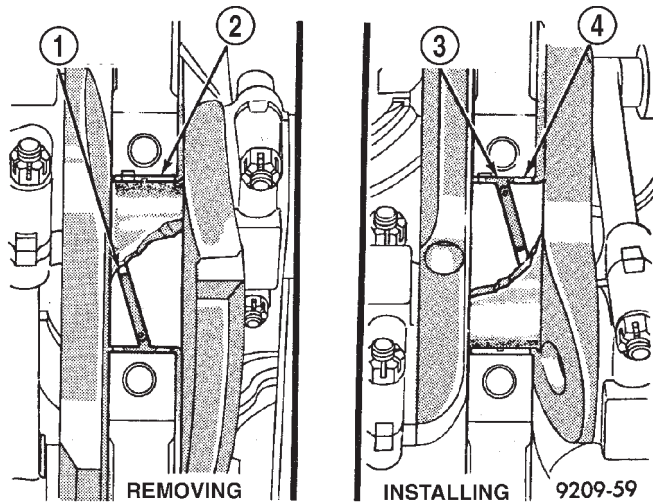
### INSTALLATION

Only one main bearing should be selectively fitted while all other main bearing caps are properly tightened. All bearing capbolts removed during service procedures are to be cleaned and oiled before installation.

When installing a new upper bearing shell, slightly chamfer the sharp edges from the plain side.

- (1) Start bearing in place, and insert Crankshaft Main Bearing Remover/Installer Tool C-3059 into oil hole of crankshaft (Fig. 27).
- (2) Slowly rotate crankshaft counterclockwise sliding the bearing into position. Remove Tool C-3059.
- (3) Install the bearing caps. Clean and oil the bolts. Tighten the capbolts to 115 N·m (85 ft. lbs.) torque.
- (4) Install the oil pump (Refer to 9 - ENGINE/LUBRICATION/OIL PUMP - INSTALLATION).

## CRANKSHAFT MAIN BEARINGS (Continued)



**Fig. 27 Upper Main Bearing Removal and Installation with Tool C-3059**

- 1 - SPECIAL TOOL C-3059
- 2 - BEARING
- 3 - SPECIAL TOOL C-3059
- 4 - BEARING

(5) Install the oil pan (Refer to 9 - ENGINE/LUBRICATION/OIL PAN - INSTALLATION).

(6) Start engine check for leaks.

## CRANKSHAFT OIL SEAL - FRONT

### DESCRIPTION

The crankshaft rear seal is a two piece viton seal. The crankshaft front seal is a one piece viton seal with a steel housing. The front seal is located in the engine front cover. One part of the two piece rear seal is located in a slot in the number four (4) crankshaft main bore, the second part of the two piece seal is located in the number four (4) main bearing cap.

### OPERATION

The crankshaft seals prevent oil from leaking from around the crankshaft, either from the rear of the engine or from the engine front cover.

### REMOVAL

The oil seal can be replaced without removing the timing chain cover, provided that the cover is not misaligned.

- (1) Disconnect the negative cable from the battery.
- (2) Remove vibration damper (Refer to 9 - ENGINE/ENGINE BLOCK/VIBRATION DAMPER - REMOVAL).
- (3) If front seal is suspected of leaking, check front oil seal alignment to crankshaft. The seal installa-

tion/alignment Tool 6635, should fit with minimum interference. If tool does not fit, the cover must be removed and installed properly.

(4) Place a suitable tool behind the lips of the oil seal to pry the oil seal outward. Be careful not to damage the crankshaft seal bore of cover.

### INSTALLATION

(1) Place the smaller diameter of the oil seal over Front Oil Seal Installation Tool 6635 (Fig. 28). Seat the oil seal in the groove of the tool.

(2) Position the seal and tool onto the crankshaft (Fig. 29).

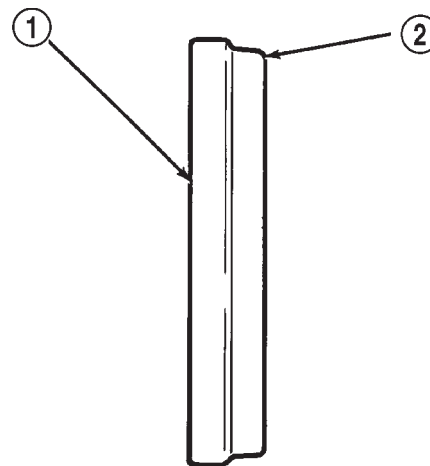
(3) Using the vibration damper bolt, tighten the bolt to draw the seal into position on the crankshaft (Fig. 30).

(4) Remove the vibration damper bolt and seal installation tool.

(5) Inspect the seal flange on the vibration damper.

(6) Install the vibration damper (Refer to 9 - ENGINE/ENGINE BLOCK/VIBRATION DAMPER - INSTALLATION).

(7) Connect the negative cable to the battery.



J9309-44

**Fig. 28 Placing Oil Seal on Installation Tool 6635**

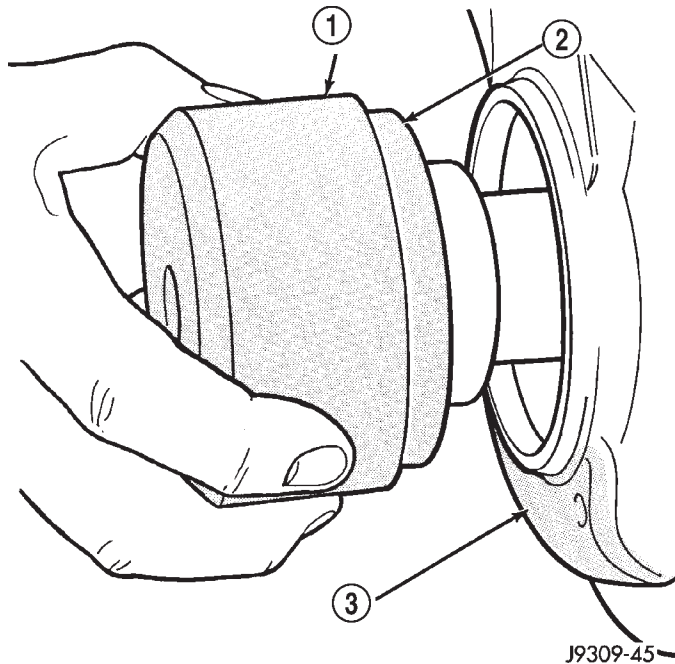
- 1 - CRANKSHAFT FRONT OIL SEAL
- 2 - INSTALL THIS END INTO SPECIAL TOOL 6635

## CRANKSHAFT OIL SEAL - REAR

### DESCRIPTION

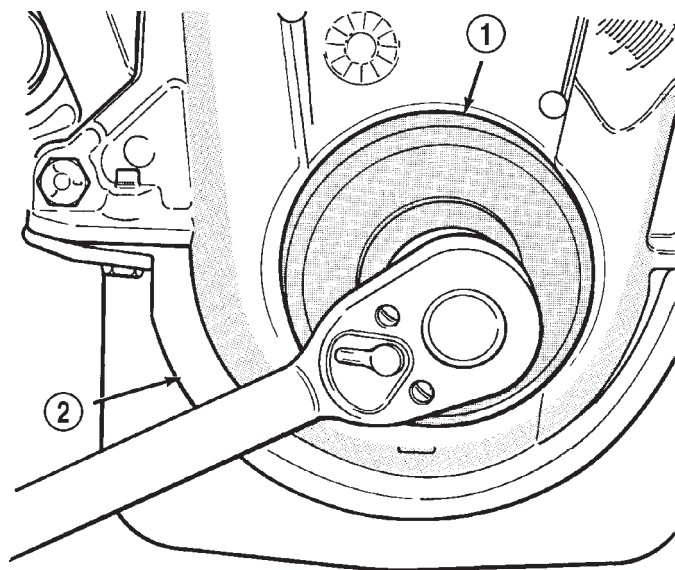
The crankshaft rear seal is a two piece viton seal. The crankshaft front seal is a one piece viton seal with a steel housing. The front seal is located in the engine front cover. One part of the two piece rear seal is located in a slot in the cylinder block opposite the crankshaft main bearing cap, the second part of the two piece seal is located in the main bearing cap itself.

## CRANKSHAFT OIL SEAL - REAR (Continued)



**Fig. 29 Position Tool and Seal onto Crankshaft**

- 1 - SPECIAL TOOL 6635
- 2 - OIL SEAL
- 3 - TIMING CHAIN COVER



**Fig. 30 Installing Oil Seal**

- 1 - SPECIAL TOOL 6635
- 2 - TIMING CHAIN COVER

## OPERATION

The crankshaft seals prevent oil from leaking from around the crankshaft, either from the rear of the engine or from the engine front cover.

## REMOVAL

The service seal is a two piece, Viton seal. The upper seal half can be installed with crankshaft removed from engine or with crankshaft installed. When a new upper seal is installed, install a new lower seal. The lower seal half can be installed only with the rear main bearing cap removed.

## UPPER SEAL —CRANKSHAFT REMOVED

(1) Remove the crankshaft (Refer to 9 - ENGINE/ENGINE BLOCK/CRANKSHAFT - REMOVAL). Discard the old upper seal.

## UPPER SEAL—CRANKSHAFT INSTALLED

(1) Remove the oil pan (Refer to 9 - ENGINE/LUBRICATION/OIL PAN - REMOVAL).

(2) Remove the oil pump (Refer to 9 - ENGINE/LUBRICATION/OIL PUMP - REMOVAL).

(3) Remove the rear main bearing cap. Remove and discard the old lower oil seal.

(4) Carefully remove and discard the old upper oil seal.

## LOWER SEAL

(1) Remove the oil pan (Refer to 9 - ENGINE/LUBRICATION/OIL PAN - REMOVAL).

(2) Remove the oil pump (Refer to 9 - ENGINE/LUBRICATION/OIL PUMP - REMOVAL).

(3) Remove the rear main bearing cap and discard the old lower seal.

## INSTALLATION

The service seal is a two piece, Viton seal. The upper seal half can be installed with crankshaft removed from engine or with crankshaft installed. When a new upper seal is installed, install a new lower seal. The lower seal half can be installed only with the rear main bearing cap removed.

## UPPER SEAL —CRANKSHAFT REMOVED

(1) Clean the cylinder block rear cap mating surface. Be sure the seal groove is free of debris. Check for burrs at the oil hole on the cylinder block mating surface to rear cap.

(2) Lightly oil the new upper seal lips with engine oil.

(3) Install the new upper rear bearing oil seal with the white paint facing toward the rear of the engine.

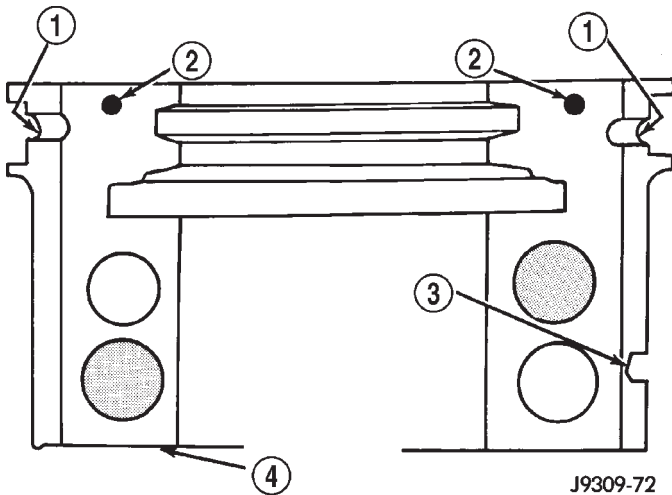
(4) Position the crankshaft into the cylinder block.

(5) Lightly oil the new lower seal lips with engine oil.

## CRANKSHAFT OIL SEAL - REAR (Continued)

(6) Install the new lower rear bearing oil seal into the bearing cap with the white paint facing towards the rear of the engine.

(7) Apply 5 mm (0.20 in.) drop of Mopar® Gasket Maker, or equivalent, on each side of the rear main bearing cap (Fig. 31). DO NOT over-apply sealant or allow the sealant to contact the rubber seal. Assemble bearing cap to cylinder block immediately after sealant application.



**Fig. 31 Sealant Application to Bearing Cap**

- 1 - MOPAR SILICONE RUBBER ADHESIVE SEALANT SLOTS
- 2 - MOPAR® GASKET MAKER (OR EQUIVALENT)
- 3 - CAP ALIGNMENT SLOT
- 4 - REAR MAIN BEARING CAP

(8) To align the bearing cap, use cap slot, alignment dowel, and cap bolts. DO NOT remove excess material after assembly. DO NOT strike rear cap more than two times for proper engagement.

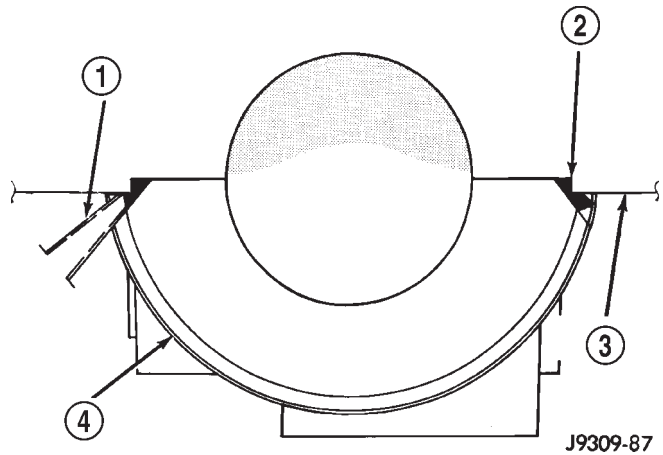
(9) Clean and oil all cap bolts. Install all main bearing caps. Install all cap bolts and alternately tighten to 115 N·m (85 ft. lbs.) torque.

(10) Install oil pump (Refer to 9 - ENGINE/LUBRICATION/OIL PUMP - INSTALLATION).

(11) Apply Mopar® GEN II Silicone Rubber Adhesive Sealant, or equivalent, at bearing cap-to-block joint to provide cap to block and oil pan sealing (Fig. 32). Apply enough sealant so that a small amount is squeezed out. Withdraw nozzle and wipe excess sealant off the oil pan seal groove.

(12) Install new front crankshaft oil seal (Refer to 9 - ENGINE/ENGINE BLOCK/CRANKSHAFT OIL SEAL - FRONT - INSTALLATION).

(13) Immediately install the oil pan (Refer to 9 - ENGINE/LUBRICATION/OIL PAN - INSTALLATION).



**Fig. 32 Apply Sealant to Bearing Cap-to-Block Joint**

- 1 - MOPAR® GEN II SILICONE RUBBER ADHESIVE SEALANT NOZZLE TIP
- 2 - SEALANT APPLIED
- 3 - CYLINDER BLOCK
- 4 - REAR MAIN BEARING CAP

### UPPER SEAL—CRANKSHAFT INSTALLED

(1) Clean the cylinder block mating surfaces before oil seal installation. Check for burrs at the oil hole on the cylinder block mating surface to rear cap.

(2) Lightly oil the new upper seal lips with engine oil. To allow ease of installation of the seal, loosen at least the two main bearing caps forward of the rear bearing cap.

(3) Rotate the new upper seal into the cylinder block, being careful not to shave or cut the outer surface of the seal. To ensure proper installation, use the installation tool provided with the kit. Install the new seal with the white paint facing toward the rear of the engine.

(4) Install the new lower rear bearing oil seal into the bearing cap with the white paint facing toward the rear of the engine.

(5) Apply 5 mm (0.20 in.) drop of Mopar® Gasket Maker, or equivalent, on each side of the rear main bearing cap (Fig. 31). DO NOT over-apply sealant or allow the sealant to contact the rubber seal. Assemble bearing cap to cylinder block immediately after sealant application. Be sure the white paint faces toward the rear of the engine.

(6) To align the bearing cap, use cap slot, alignment dowel, and cap bolts. DO NOT remove excess material after assembly. DO NOT strike rear cap more than two times for proper engagement.

(7) Install the rear main bearing cap with cleaned and oiled cap bolts. Alternately tighten ALL cap bolts to 115 N·m (85 ft. lbs.) torque.

(8) Install oil pump (Refer to 9 - ENGINE/LUBRICATION/OIL PUMP - INSTALLATION).



## CRANKSHAFT OIL SEAL - REAR (Continued)

(9) Apply Mopar® GEN II Silicone Rubber Adhesive Sealant, or equivalent, at bearing cap-to-block joint to provide cap-to-block and oil pan sealing (Fig. 32). Apply enough sealant until a small amount is squeezed out. Withdraw nozzle and wipe excess sealant off the oil pan seal groove.

(10) Immediately install the oil pan (Refer to 9 - ENGINE/LUBRICATION/OIL PAN - INSTALLATION).

## LOWER SEAL

(1) Clean the rear main cap mating surfaces including the oil pan gasket groove.

(2) Carefully install a new upper seal. Refer to UPPER SEAL—CRANKSHAFT INSTALLED.

(3) Lightly oil the new lower seal lips with engine oil.

(4) Install a new lower seal in bearing cap with the white paint facing the rear of engine.

(5) Apply 5 mm (0.20 in.) drop of Mopar® Gasket Maker, or equivalent, on each side of the rear main bearing cap (Fig. 31). DO NOT over-apply sealant or allow the sealant to contact the rubber seal. Assemble bearing cap to cylinder block immediately after sealant application.

(6) To align the bearing cap, use cap slot, alignment dowel, and cap bolts. DO NOT remove excess material after assembly. DO NOT strike rear cap more than two times for proper engagement.

(7) Install the rear main bearing cap with cleaned and oiled cap bolts. Alternately tighten the cap bolts to 115 N·m (85 ft. lbs.) torque.

(8) Install oil pump (Refer to 9 - ENGINE/LUBRICATION/OIL PUMP - INSTALLATION).

(9) Apply Mopar® GEN II Silicone Rubber Adhesive Sealant, or equivalent, at bearing cap-to-block joint to provide cap to block and oil pan sealing. Apply enough sealant so that a small amount is squeezed out. Withdraw nozzle and wipe excess sealant off the oil pan seal groove.

(10) Immediately install the oil pan (Refer to 9 - ENGINE/LUBRICATION/OIL PAN - INSTALLATION).

## DISTRIBUTOR BUSHING

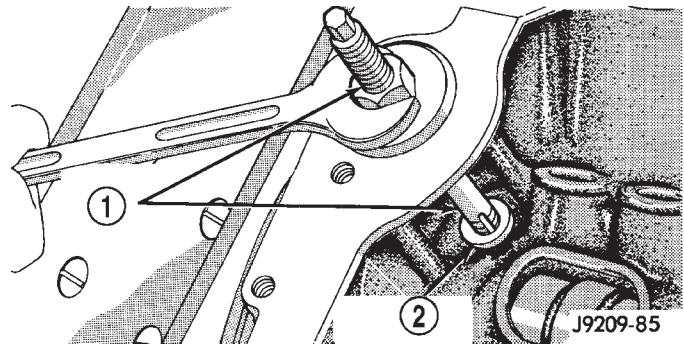
## REMOVAL

(1) Remove distributor (Refer to 8 - ELECTRICAL/IGNITION CONTROL/DISTRIBUTOR - REMOVAL).

(2) Remove the intake manifold (Refer to 9 - ENGINE/MANIFOLDS/INTAKE MANIFOLD - REMOVAL).

(3) Insert Distributor Drive Shaft Bushing Puller Tool C-3052 into old bushing and thread down until a tight fit is obtained (Fig. 33).

(4) Hold puller screw and tighten puller nut until bushing is removed.



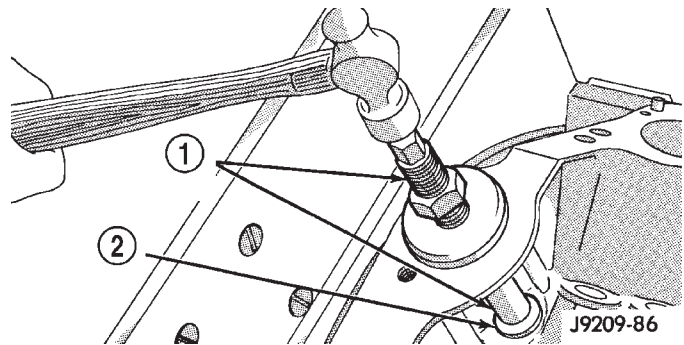
**Fig. 33 Distributor Driveshaft Bushing Removal**

- 1 - SPECIAL TOOL C-3052  
2 - BUSHING

## INSTALLATION

(1) Slide new bushing over burnishing end of Distributor Drive Shaft Bushing Driver/Burnisher Tool C-3053. Insert the tool and bushing into the bore.

(2) Drive bushing and tool into position, using a hammer (Fig. 34).



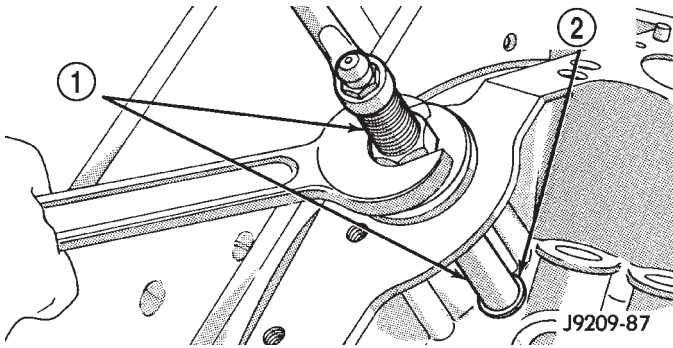
**Fig. 34 Distributor Driveshaft Bushing Installation**

- 1 - SPECIAL TOOL C-3053  
2 - BUSHING

(3) As the burnisher is pulled through the bushing, the bushing is expanded tight in the block and burnished to correct size (Fig. 35). **DO NOT ream this bushing.**

**CAUTION:** This procedure **MUST** be followed when installing a new bushing or seizure to shaft may occur.

## DISTRIBUTOR BUSHING (Continued)



**Fig. 35 Burnishing Distributor Driveshaft Bushing**

- 1 - SPECIAL TOOL C-3053  
2 - BUSHING

(4) Install the intake manifold (Refer to 9 - ENGINE/MANIFOLDS/INTAKE MANIFOLD INSTALLATION).

(5) Install the distributor (Refer to 8 - ELECTRICAL/IGNITION CONTROL/DISTRIBUTOR INSTALLATION).

## HYDRAULIC LIFTERS (CAM IN BLOCK)

### DIAGNOSIS AND TESTING—HYDRAULIC TAPPETS

Before disassembling any part of the engine to correct tappet noise, check the oil pressure. If vehicle has no oil pressure gauge, install a reliable gauge at the pressure sending-unit. The pressure should be between 207-552 kPa (30-80 psi) at 3,000 RPM.

Check the oil level after the engine reaches normal operating temperature. Allow 5 minutes to stabilize oil level, check dipstick. The oil level in the pan should never be above the FULL mark or below the ADD OIL mark on dipstick. Either of these two conditions could be responsible for noisy tappets.

### OIL LEVEL

#### HIGH

If oil level is above the FULL mark, it is possible for the connecting rods to dip into the oil. With the engine running, this condition could create foam in the oil pan. Foam in oil pan would be fed to the hydraulic tappets by the oil pump causing them to lose length and allow valves to seat noisily.

#### LOW

Low oil level may allow oil pump to take in air. When air is fed to the tappets, they lose length, which allows valves to seat noisily. Any leaks on intake side of oil pump through which air can be drawn will create the same tappet action. Check the lubrication system from the intake strainer to the pump cover, including the relief valve retainer cap. When tappet noise is due to aeration, it may be intermittent or constant, and usually more than one tappet will be noisy. When oil level and leaks have been corrected, operate the engine at fast idle. Run engine for a sufficient time to allow all of the air inside the tappets to be bled out.

### TAPPET NOISE DIAGNOSIS

(1) To determine source of tappet noise, operate engine at idle with cylinder head covers removed.

(2) Feel each valve spring or rocker arm to detect noisy tappet. The noisy tappet will cause the affected spring and/or rocker arm to vibrate or feel rough in operation.

**NOTE:** Worn valve guides or cocked springs are sometimes mistaken for noisy tappets. If such is the case, noise may be dampened by applying side thrust on the valve spring. If noise is not appreciably reduced, it can be assumed the noise is in the tappet. Inspect the rocker arm push rod sockets and push rod ends for wear.

(3) Valve tappet noise ranges from light noise to a heavy click. A light noise is usually caused by excessive leak-down around the unit plunger, or by the plunger partially sticking in the tappet body cylinder. The tappet should be replaced. A heavy click is caused by a tappet check valve not seating, or by foreign particles wedged between the plunger and the tappet body. This will cause the plunger to stick in the down position. This heavy click will be accompanied by excessive clearance between the valve stem and rocker arm as valve closes. In either case, tappet assembly should be removed for inspection and cleaning.

(4) The valve train generates a noise very much like a light tappet noise during normal operation. Care must be taken to ensure that tappets are making the noise. If more than one tappet seems to be noisy, it's probably not the tappets.

### LEAK-DOWN TEST

After cleaning and inspection, test each tappet for specified leak-down rate tolerance to ensure zero-lash operation (Fig. 36).

Swing the weighted arm of the hydraulic valve tappet tester away from the ram of the Universal Leak-Down Tester.



## HYDRAULIC LIFTERS (CAM IN BLOCK) (Continued)

(1) Place a 7.925-7.950 mm (0.312-0.313 inch) diameter ball bearing on the plunger cap of the tappet.

(2) Lift the ram and position the tappet (with the ball bearing) inside the tester cup.

(3) Lower the ram, then adjust the nose of the ram until it contacts the ball bearing. DO NOT tighten the hex nut on the ram.

(4) Fill the tester cup with hydraulic valve tappet test oil until the tappet is completely submerged.

(5) Swing the weighted arm onto the push rod and pump the tappet plunger up and down to remove air. When the air bubbles cease, swing the weighted arm away and allow the plunger to rise to the normal position.

(6) Adjust the nose of the ram to align the pointer with the SET mark on the scale of the tester and tighten the hex nut.

(7) Slowly swing the weighted arm onto the push rod.

(8) Rotate the cup by turning the handle at the base of the tester clockwise one revolution every 2 seconds.

(9) Observe the leak-down time interval from the instant the pointer aligns with the START mark on the scale until the pointer aligns with the 0.125 mark. A normally functioning tappet will require 20-110 seconds to leak-down. Discard tappets with leak-down time interval not within this specification.

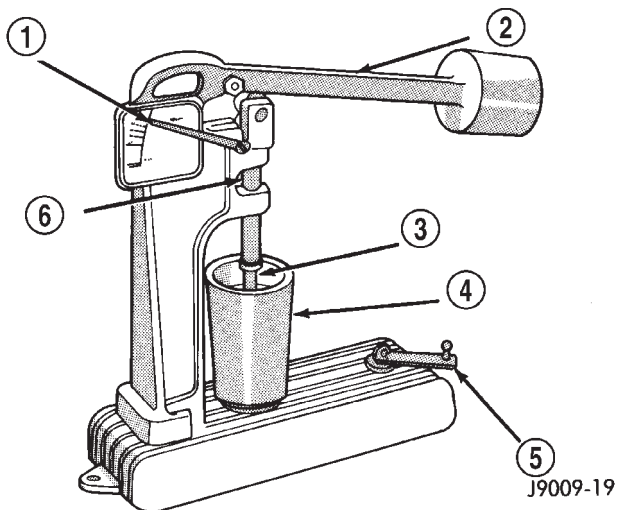


Fig. 36 Leak-Down Tester

- 1 - POINTER
- 2 - WEIGHTED ARM
- 3 - RAM
- 4 - CUP
- 5 - HANDLE
- 6 - PUSH ROD

## REMOVAL

(1) Remove the air cleaner assembly and air in-let hose.

(2) Remove cylinder head cover (Refer to 9 - ENGINE/CYLINDER HEAD/CYLINDER HEAD COVER(S) - REMOVAL).

(3) Remove rocker assembly and push rods. Identify push rods to ensure installation in original locations.

(4) Remove intake manifold (Refer to 9 - ENGINE/MANIFOLDS/INTAKE MANIFOLD - REMOVAL).

(5) Remove yoke retainer and aligning yokes.

(6) Slide Hydraulic Tappet Remover/Installer Tool C-4129-A through opening in cylinder head and seat tool firmly in the head of tappet.

(7) Pull tappet out of bore with a twisting motion. If all tappets are to be removed, identify tappets to ensure installation in original location.

(8) If the tappet or bore in cylinder block is scored, scuffed, or shows signs of sticking, ream the bore to next oversize. Replace with oversize tappet.

## CLEANING

Clean tappet with a suitable solvent. Rinse in hot water and blow dry with a clean shop rag or compressed air.

## INSTALLATION

(1) Lubricate tappets.

(2) Install tappets and push rods in their original positions. Ensure that the oil feed hole in the side of the tappet body faces up (away from the crankshaft).

(3) Install aligning yokes with ARROW toward camshaft.

(4) Install yoke retainer. Tighten the bolts to 23 N·m (200 in. lbs.) torque. Install intake manifold (Refer to 9 - ENGINE/MANIFOLDS/INTAKE MANIFOLD - INSTALLATION).

(5) Install push rods in original positions.

(6) Install rocker arms.

(7) Install cylinder head cover (Refer to 9 - ENGINE/CYLINDER HEAD/CYLINDER HEAD COVER(S) - INSTALLATION).

(8) Install air cleaner assembly and air in-let hose.

(9) Start and operate engine. Warm up to normal operating temperature.

**CAUTION:** To prevent damage to valve mechanism, engine must not be run above fast idle until all hydraulic tappets have filled with oil and have become quiet.

## PISTON & CONNECTING ROD

### PISTON MEASUREMENTS CHART

#### DESCRIPTION

The pistons are made of aluminum and have three ring grooves, the top two grooves are for the compression rings and the bottom groove is for the oil control ring. The connecting rods are forged steel and are coined prior to heat treat. The piston pins are press fit.

#### STANDARD PROCEDURE—PISTON FITTING

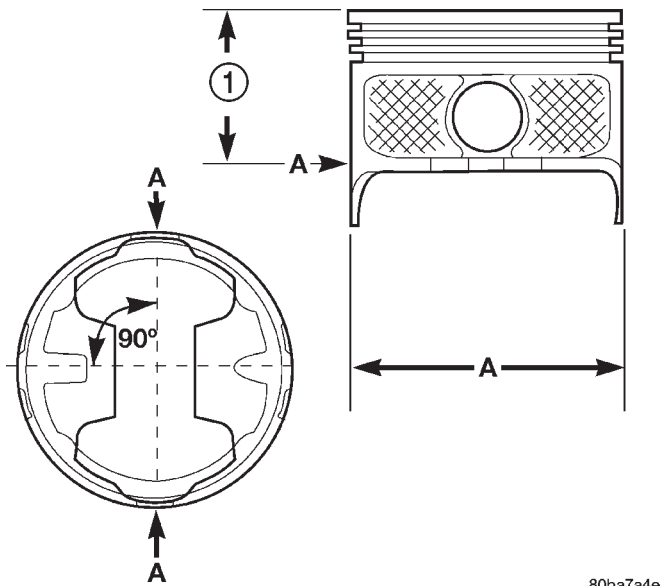
Check the cylinder block bore for out-of-round, taper, scoring, or scuffing.

Check the pistons for taper and elliptical shape before they are fitted into the cylinder bore (Fig. 37).

Piston and cylinder wall must be clean and dry. Specified clearance between the piston and the cylinder wall is 0.013-0.038 mm (0.0005-0.0015 in.) at 21°C (70°F).

Piston diameter should be measured at the top of skirt, 90° to piston pin axis. Cylinder bores should be measured halfway down the cylinder bore and transverse to the engine crankshaft center line.

Pistons and cylinder bores should be measured at normal room temperature, 21°C (70°F).



80ba7a4e

**Fig. 37 Piston Measurements**

1 - 62.230 mm (2.45 IN.)

PISTON SIZE	A DIA = PISTON DIAMETER		BORE DIAMETER	
	MIN. mm (in.)	MAX. mm (in.)	MIN. mm (in.)	MAX. mm (in.)
<b>A</b>	99.280 (3.9087)	99.294 (3.9092)	99.308 (3.9098)	99.320 (3.9103)
<b>B</b>	99.294 (3.9092)	99.306 (3.9097)	99.320 (3.9103)	99.333 (3.9108)
<b>C</b>	99.306 (3.9097)	99.319 (3.9102)	99.333 (3.9108)	99.345 (3.9113)
<b>D</b>	99.319 (3.9102)	99.332 (3.9107)	99.346 (3.9113)	99.358 (3.9118)
<b>E</b>	99.332 (3.9107)	99.344 (3.9112)	99.358 (3.9118)	99.371 (3.9123)
DESCRIPTION		SPECIFICATION		
PISTON PIN BORE		25.007 - 25.014 mm (.9845 - .9848 in.)		
RING GROOVE HEIGHT (OIL RAIL)		4.0309 - 4.0538 mm (.1587 - .1596 in.)		
RING GROOVE HEIGHT (COMPRESSION RAIL)		2.0294 - 2.0548 mm (.0799 - .0809 in.)		
TOTAL FINISHED WEIGHT		594.6 ± 2 grams (20.974 ± .0706 ounces)		

#### REMOVAL

(1) Remove the engine from the vehicle (Refer to 9 - ENGINE - REMOVAL).

(2) Remove the cylinder head (Refer to 9 - ENGINE/CYLINDER HEAD - REMOVAL).

(3) Remove the oil pan (Refer to 9 - ENGINE/LUBRICATION/OIL PAN - REMOVAL).

(4) Remove top ridge of cylinder bores with a reliable ridge reamer before removing pistons from cylinder block. Be sure to keep tops of pistons covered during this operation.

(5) Be sure each connecting rod and connecting rod cap is identified with the cylinder number. Remove connecting rod cap. Install connecting rod bolt guide set on connecting rod bolts.

(6) Pistons and connecting rods must be removed from top of cylinder block. When removing the assemblies from the engine, rotate crankshaft so that

## PISTON &amp; CONNECTING ROD (Continued)

the connecting rod is centered in cylinder bore and at BDC. **Be careful not to nick crankshaft journals.**

(7) After removal, install bearing cap on the mating rod.

## CLEANING

Clean the piston and connecting rod assembly using a suitable solvent.

## INSPECTION

Check the connecting rod journal for excessive wear, taper and scoring (Refer to 9 - ENGINE/ENGINE BLOCK/CONNECTING ROD BEARINGS - STANDARD PROCEDURE).

Check the connecting rod for signs of twist or bending.

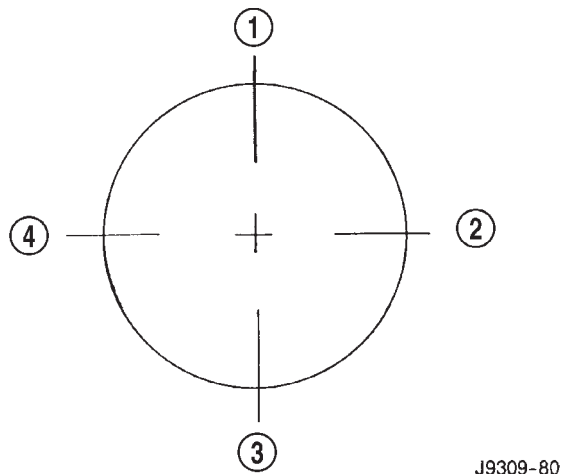
Check the piston for taper and elliptical shape before it is fitted into the cylinder bore (Refer to 9 - ENGINE/ENGINE BLOCK/PISTON & CONNECTING ROD - STANDARD PROCEDURE).

Check the piston for scoring, or scraping marks in the piston skirts. Check the ring lands for cracks and/or deterioration.

## INSTALLATION

(1) Be sure that compression ring gaps are staggered so that neither is in line with oil ring rail gap.

(2) Before installing the ring compressor, be sure the oil ring expander ends are butted and the rail gaps located properly (Fig. 38).



**Fig. 38 Proper Ring Installation**

- 1 - OIL RING SPACER GAP
- 2 - SECOND COMPRESSION RING GAP OIL RING RAIL GAP (TOP)
- 3 - OIL RING RAIL GAP (BOTTOM)
- 4 - TOP COMPRESSION RING GAP

(3) Immerse the piston head and rings in clean engine oil. Slide Piston Ring Compressor Tool C-385 over the piston and tighten with the special wrench

(part of Tool C-385). **Be sure position of rings does not change during this operation.**

(4) Install connecting rod bolt protectors on rod bolts. The long protector should be installed on the numbered side of the connecting rod.

(5) Rotate crankshaft so that the connecting rod journal is on the center of the cylinder bore. Be sure connecting rod and cylinder bore number are the same. Insert rod and piston into cylinder bore and guide rod over the crankshaft journal.

(6) Tap the piston down in cylinder bore, using a hammer handle. At the same time, guide connecting rod into position on crankshaft journal.

(7) The notch, or groove, on top of piston must be pointing toward front of engine. The larger chamfer of the connecting rod bore must be installed toward crankshaft journal fillet.

(8) Install rod caps. Be sure connecting rod, connecting rod cap, and cylinder bore number are the same. Install nuts on cleaned and oiled rod bolts and tighten nuts to 61 N·m (45 ft. lbs.) torque.

(9) Install the oil pan (Refer to 9 - ENGINE/LUBRICATION/OIL PAN - INSTALLATION).

(10) Install the cylinder head (Refer to 9 - ENGINE/CYLINDER HEAD - INSTALLATION).

(11) Install the engine into the vehicle (Refer to 9 - ENGINE - INSTALLATION).

## PISTON RINGS

## STANDARD PROCEDURE—PISTON RING FITTING

(1) Measurement of end gaps:

(a) Measure piston ring gap 2 in. from bottom of cylinder bore. An inverted piston can be used to push the rings down to ensure positioning rings squarely in the cylinder bore before measuring.

(b) Insert feeler gauge in the gap. The top compression ring gap should be between 0.254-0.508 mm (0.010-0.020 in.). The second compression ring gap should be between 0.508-0.762 mm (0.020-0.030 in.). The oil ring gap should be 0.254-1.270 mm (0.010-0.050 in.).

(c) Rings with insufficient end gap may be properly filed to the correct dimension. Rings with excess gaps should not be used.

(2) Install rings, and confirm ring side clearance:

(a) Install oil rings being careful not to nick or scratch the piston. Install the oil control rings according to instructions in the package. It is not necessary to use a tool to install the upper and lower rails. Insert oil rail spacer first, then side rails.

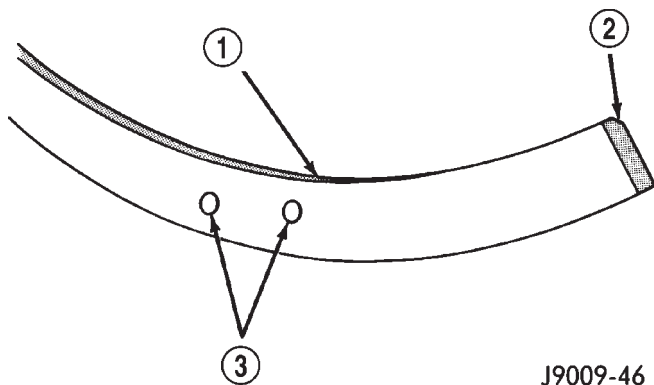
## PISTON RINGS (Continued)

(b) Install the second compression rings using Installation Tool C-4184. The compression rings must be installed with the identification mark face up (toward top of piston) and chamfer facing down. An identification mark on the ring is a drill point, a stamped letter "O", an oval depression, or the word "TOP" (Fig. 39) (Fig. 41).

(c) Using a ring installer, install the top compression ring with the chamfer facing up (Fig. 40) (Fig. 41). An identification mark on the ring is a drill point, a stamped letter "O", an oval depression or the word "TOP" facing up.

(d) Measure side clearance between piston ring and ring land. Clearance should be 0.074-0.097 mm (0.0029-0.0038 in.) for the compression rings. The steel rail oil ring should be free in groove, but should not exceed 0.246 mm (0.0097 in.) side clearance.

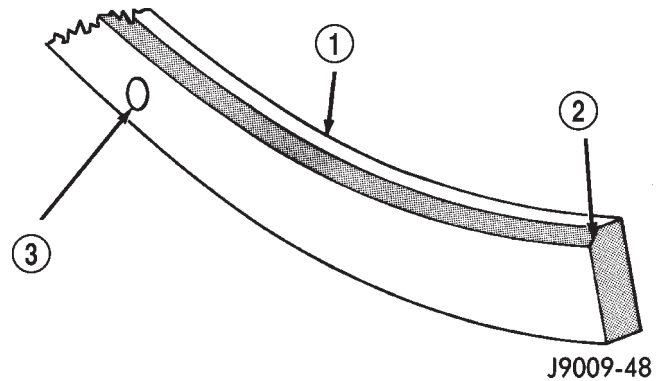
(e) Pistons with insufficient, or excessive, side clearance should be replaced.



J9009-46

**Fig. 39 Second Compression Ring Identification (Typical)**

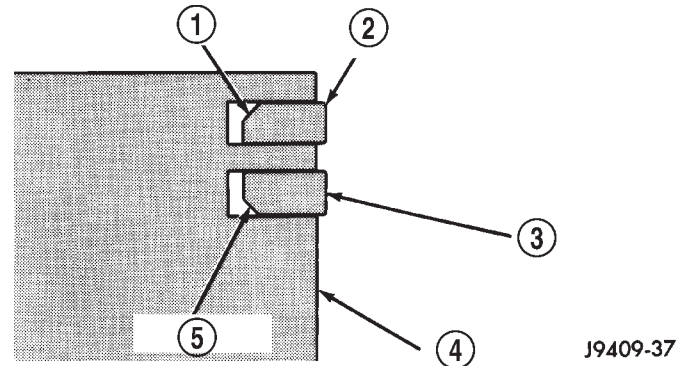
- 1 - SECOND COMPRESSION RING (BLACK CAST IRON)
- 2 - CHAMFER
- 3 - TWO DOTS



J9009-48

**Fig. 40 Top Compression Ring Identification (Typical)**

- 1 - TOP COMPRESSION RING (GRAY IN COLOR)
- 2 - CHAMFER
- 3 - ONE DOT



J9409-37

**Fig. 41 Compression Ring Chamfer Location (Typical)**

- 1 - CHAMFER
- 2 - TOP COMPRESSION RING
- 3 - SECOND COMPRESSION RING
- 4 - PISTON
- 5 - CHAMFER

(3) Orient the rings:

(a) Arrange top compression ring 90° counter-clockwise from the oil ring rail gap (Fig. 42).

(b) Arrange second compression ring 90° clockwise from the oil ring rail gap (Fig. 42).

## VIBRATION DAMPER

## REMOVAL

(1) Disconnect the negative cable from the battery.

(2) Remove fan, and fan drive (Refer to 7 - COOLING/ENGINE/FAN DRIVE VISCOUS CLUTCH - REMOVAL).

(3) Remove the accessory drive belt (Refer to 7 - COOLING/ACCESSORY DRIVE/DRIVE BELTS - REMOVAL).

(4) Remove the vibration damper pulley.

(5) Remove vibration damper bolt and washer from end of crankshaft.

(6) Install bar and screw from Puller Tool Set C-3688. Install two bolts with washers through the puller tool and into the vibration damper (Fig. 43).

(7) Pull vibration damper off of the crankshaft.

## INSTALLATION

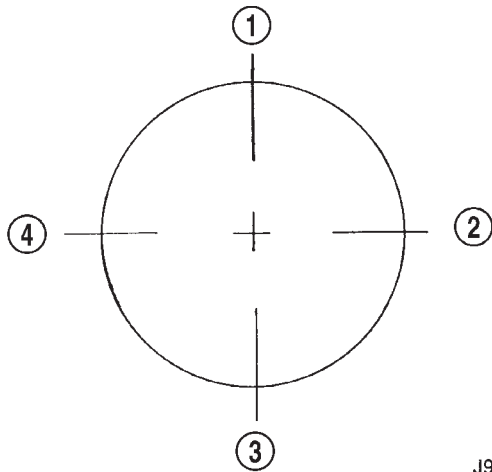
(1) Position the vibration damper onto the crankshaft.

(2) Place installing tool, part of Puller Tool Set C-3688, in position and press the vibration damper onto the crankshaft (Fig. 44).

(3) Install the crankshaft bolt and washer. Tighten the bolt to 244 N·m (180 ft. lbs.) torque.



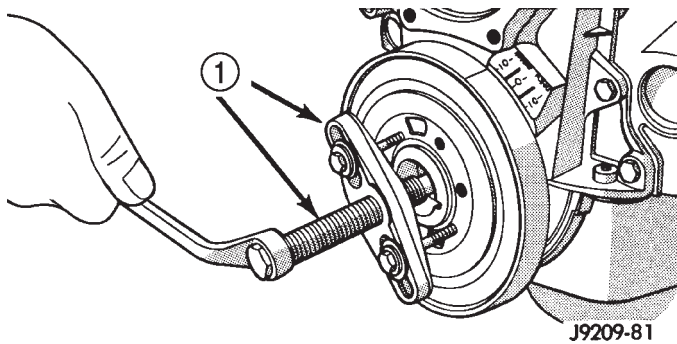
VIBRATION DAMPER (Continued)



J9309-80

**Fig. 42 Proper Ring Installation**

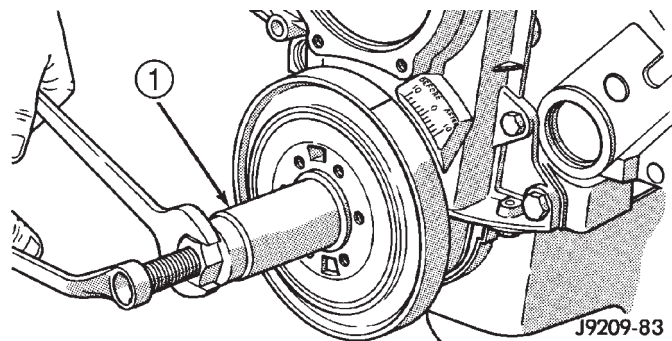
- 1 - OIL RING SPACER GAP
- 2 - SECOND COMPRESSION RING GAP OIL RING RAIL GAP (TOP)
- 3 - OIL RING RAIL GAP (BOTTOM)
- 4 - TOP COMPRESSION RING GAP



J9209-81

**Fig. 43 Vibration Damper Assembly**

- 1 - SPECIAL TOOL C-3688



J9209-83

**Fig. 44 Installing Vibration Damper**

- 1 - SPECIAL TOOL C-3688

(4) Install the crankshaft pulley. Tighten the pulley bolts to 23 N·m (200 in. lbs.) torque.

(5) Install the serpentine belt (Refer to 7 - COOLING/ACCESSORY DRIVE/DRIVE BELTS - INSTALLATION).

(6) Install viscous fan drive and fan (Refer to 7 - COOLING/ENGINE/FAN DRIVE VISCOUS CLUTCH - INSTALLATION).

(7) Install the fan shroud.

(8) Connect the negative cable to the battery.

FRONT MOUNT

REMOVAL

(1) Disconnect the battery negative cable.

(2) Position fan to ensure clearance for radiator top tank and hose.

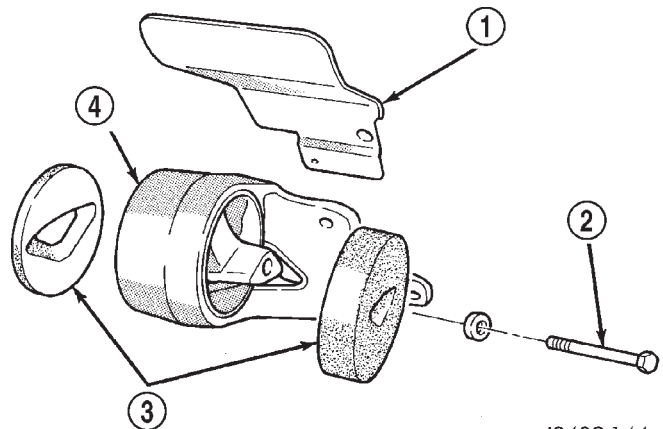
**CAUTION: DO NOT lift the engine by the intake manifold.**

(3) Install engine support/lifting fixture.

(4) Raise vehicle on hoist.

(5) Lift the engine SLIGHTLY and remove the thru-bolt and nut (Fig. 45).

(6) Remove engine support bracket/cushion bolts (Fig. 45). Remove the support bracket/cushion and heat shields.



J9409-144

**Fig. 45 Engine Front Mounts**

- 1 - ENGINE MOUNT HEAT SHIELD
- 2 - THRU-BOLT
- 3 - RESTRICTION PADS
- 4 - ENGINE SUPPORT BRACKET/CUSHION

INSTALLATION

(1) With engine raised SLIGHTLY, position the engine support bracket/cushion and heat shields to the block. Install new bolts and tighten to 81 N·m (60 ft. lbs.) torque.

(2) Install the through-bolt into the engine support bracket/cushion.

## FRONT MOUNT (Continued)

(3) Lower engine with support/lifting fixture while guiding the engine bracket/cushion and through-bolt into support cushion brackets (Fig. 46).

(4) Install through-bolt nuts and tighten the nuts to 102 N-m (75 ft. lbs.) torque.

(5) Lower the vehicle.

(6) Remove lifting fixture.

## REAR MOUNT

## REMOVAL

(1) Raise the vehicle on a hoist.

(2) Position a transmission jack in place.

(3) Remove support cushion stud nuts (Fig. 47).

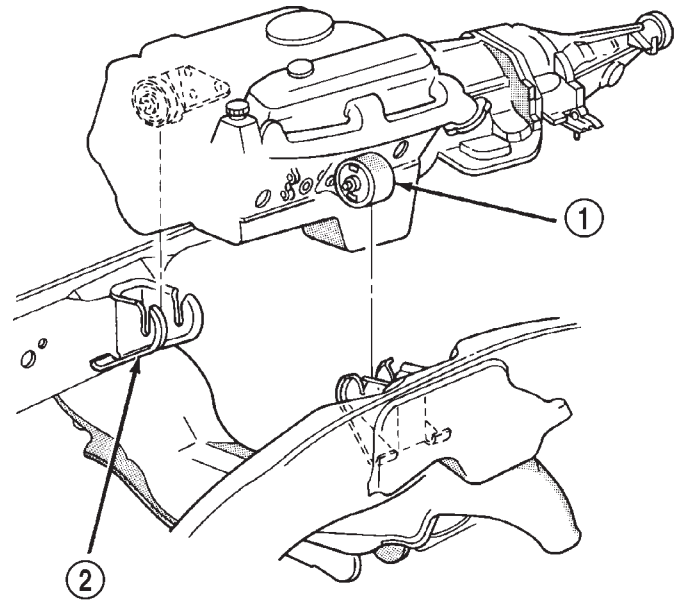
(4) Raise rear of transmission and engine SLIGHTLY.

(5) Remove the bolts holding the support cushion to the transmission support bracket. Remove the support cushion.

(6) If necessary, remove the bolts holding the transmission support bracket to the transmission.

## INSTALLATION

(1) If removed, position the transmission support bracket to the transmission. Install new attaching bolts and tighten to 88 N-m (65 ft. lbs.) torque.

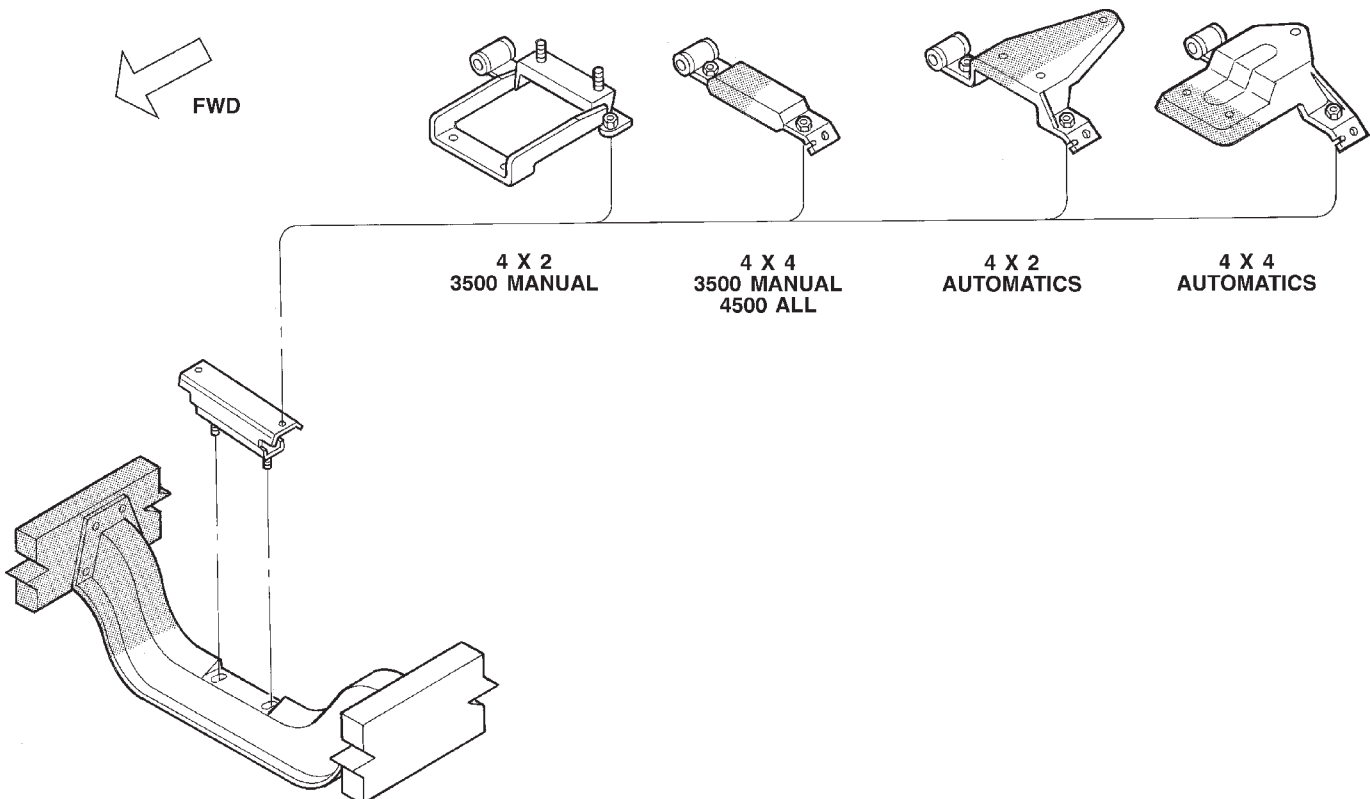


J9409-54

**Fig. 46 Positioning Engine Front Mounts**

- 1 - ENGINE SUPPORT BRACKET/CUSHION  
2 - SUPPORT CUSHION BRACKET

(2) Position support cushion to transmission support bracket. Install stud nuts and tighten to 41 N-m (30 ft. lbs.) torque.



J9509-126

**Fig. 47 Engine Rear Support Cushion Assemblies**



## REAR MOUNT (Continued)

(3) Using the transmission jack, lower the transmission and support cushion onto the crossmember (Fig. 49).

(4) Install the support cushion bolts and tighten to 41 N·m (30 ft. lbs.) torque.

(5) Remove the transmission jack.

(6) Lower the vehicle.

## LUBRICATION

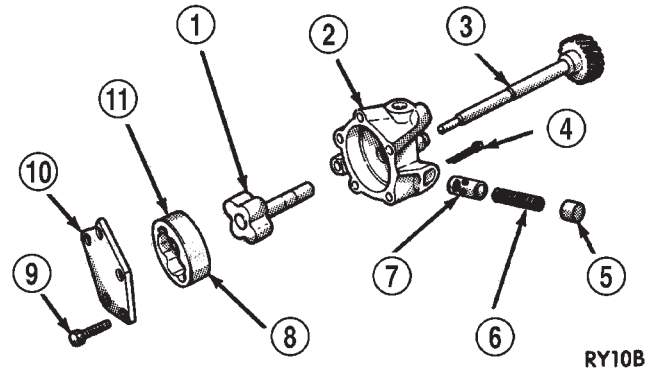
## DESCRIPTION

A gear-type positive displacement pump (Fig. 48) is mounted at the underside of the rear main bearing cap. The pump uses a pick-up tube and screen assembly to gather engine oil from the oil pan.

## OPERATION

The pump draws oil through the screen and inlet tube from the sump at the rear of the oil pan. The oil is driven between the drive and idler gears and pump body, then forced through the outlet to the block. An oil gallery in the block channels the oil to the inlet side of the full flow oil filter. After passing through the filter element, the oil passes from the center outlet of the filter through an oil gallery that channels the oil up to the main gallery, which extends the entire length on the right side of the block. The oil then goes down to the No. 1 main bearing, back up to the left side of the block, and into the oil gallery on the left side of the engine.

Galleries extend downward from the main oil gallery to the upper shell of each main bearing. The crankshaft is drilled internally to pass oil from the main bearing journals to the connecting rod journals. Each connecting rod bearing has half a hole in it, oil passes through the hole when the rods rotate and the hole lines up, oil is then thrown off as the rod rotates. This oil throwoff lubricates the camshaft lobes, distributor drive gear, cylinder walls, and piston pins.



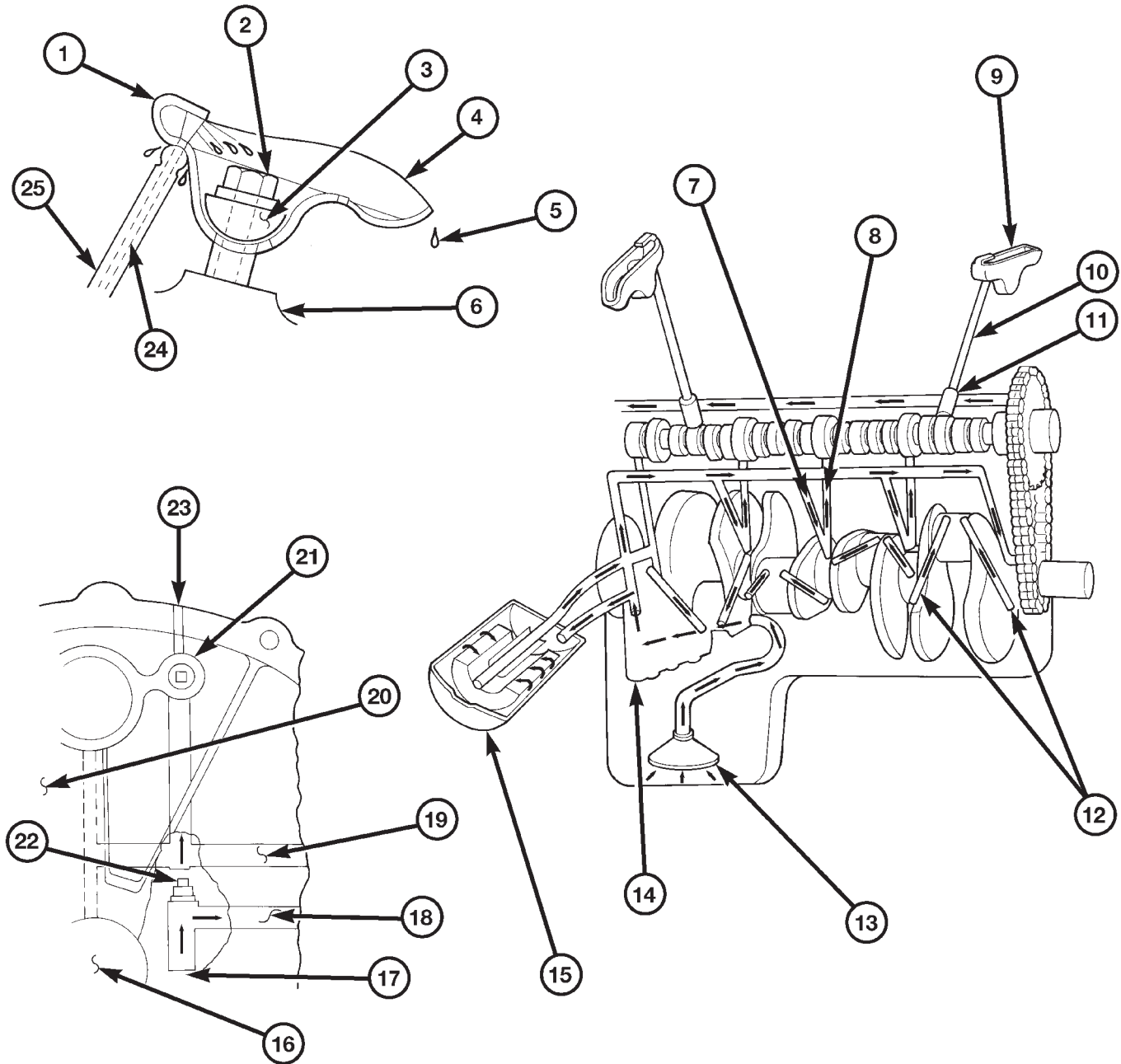
**Fig. 48 Positive Displacement Oil Pump—Typical**

- 1 - INNER ROTOR AND SHAFT
- 2 - BODY
- 3 - DISTRIBUTOR DRIVESHAFT (REFERENCE)
- 4 - COTTER PIN
- 5 - RETAINER CAP
- 6 - SPRING
- 7 - RELIEF VALVE
- 8 - LARGE CHAMFERED EDGE
- 9 - BOLT
- 10 - COVER
- 11 - OUTER ROTOR

The hydraulic valve tappets receive oil directly from the main oil gallery. The camshaft bearings receive oil from the main bearing galleries. The front camshaft bearing journal passes oil through the camshaft sprocket to the timing chain. Oil drains back to the oil pan under the No. 1 main bearing cap.

The oil supply for the rocker arms and bridged pivot assemblies is provided by the hydraulic valve tappets, which pass oil through hollow push rods to a hole in the corresponding rocker arm. Oil from the rocker arm lubricates the valve train components. The oil then passes down through the push rod guide holes and the oil drain-back passages in the cylinder head, past the valve tappet area, and then returns to the oil pan (Fig. 49).

## LUBRICATION (Continued)

**Fig. 49 Oil Lubrication System**

8087d0cf

- |                                 |   |
|---------------------------------|---|
| 1 - OIL DEFLECTOR TAB           | 14 - OIL PUMP   |
| 2 - BOLT                        | 15 - OIL FILTER   |
| 3 - ROCKER ARM PIVOT            | 16 - CRANKSHAFT   |
| 4 - ROCKER ARM                  | 17 - FROM OIL PUMP  |
| 5 - DRIP OILING FOR VALVE TIP   | 18 - OIL TO FILTER  |
| 6 - CYLINDER HEAD BOSS          | 19 - OIL FROM FILTER TO SYSTEM  |
| 7 - TO MAIN BEARINGS            | 20 - PASSAGE TO CAMSHAFT REAR BEARING   |
| 8 - TO CAMSHAFT BEARINGS        | 21 - RIGHT OIL GALLERY  |
| 9 - ROCKER ARM                  | 22 - PLUG   |
| 10 - HOLLOW PUSH ROD            | 23 - OIL PASSAGE FOR OIL PRESSURE INDICATOR LIGHT   |
| 11 - TAPPET                     | 24 - OIL SUPPLY VIA HOLLOW PUSH ROD SUPPLY IS FROM OIL GALLERY METERED THROUGH HYDRAULIC TAPPET |
| 12 - TO CONNECTING ROD BEARINGS | 25 - OIL SUPPLY FROM HOLLOW PUSH ROD  |
| 13 - OIL INTAKE                 |   |

## LUBRICATION (Continued)

**DIAGNOSIS AND TESTING—ENGINE OIL LEAKS**

Begin with a through visual inspection of the engine, particularly at the area of the suspected leak. If an oil leak source is not readily identifiable, the following steps should be followed:

(1) Do not clean or degrease the engine at this time because some solvents may cause rubber to swell, temporarily stopping the leak.

(2) Add an oil-soluble dye (use as recommended by manufacturer). Start the engine and let idle for approximately 15 minutes. Check the oil dipstick to be sure the dye is thoroughly mixed as indicated with a bright yellow color under a black light source.

(3) Using a black light, inspect the entire engine for fluorescent dye, particularly at the suspected area of oil leak. If the oil leak is found and identified, repair per service manual instructions.

(4) If dye is not observed, drive the vehicle at various speeds for approximately 24km (15 miles), and repeat previous step.

(5) If the oil leak source is not positively identified at this time, proceed with the air leak detection test method as follows:

(6) Disconnect the breather cap to air cleaner hose at the breather cap end. Cap or plug breather cap nipple.

(7) Remove the PCV valve from the cylinder head cover. Cap or plug the PCV valve grommet.

(8) Attach an air hose with pressure gauge and regulator to the dipstick tube.

**CAUTION: Do not subject the engine assembly to more than 20.6 kpa (3 PSI) of test pressure.**

(9) Gradually apply air pressure from 1 psi to 2.5 psi maximum while applying soapy water at the suspected source. Adjust the regulator to the suitable test pressure that provide the best bubbles which will pinpoint the leak source. If the oil leak is detected and identified, repair per service manual procedures.

(10) If the leakage occurs at the rear oil seal area, refer to the section, Inspection for Rear Seal Area Leak.

(11) If no leaks are detected, turn off the air supply and remove the air hose and all plugs and caps. Install the PCV valve and breather cap hose. Proceed to next step.

(12) Clean the oil off the suspect oil leak area using a suitable solvent. Drive the vehicle at various speeds approximately 24 km (15 miles). Inspect the engine for signs of an oil leak by using a black light.

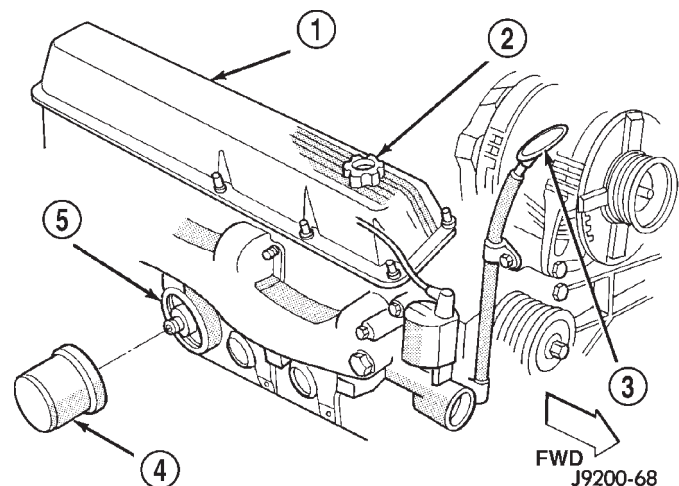
**DIAGNOSIS AND TESTING—ENGINE OIL PRESSURE**

(1) Remove oil pressure sending unit.

(2) Install Oil Pressure Line and Gauge Tool C-3292. Start engine and record pressure. (Refer to 9 - ENGINE - SPECIFICATIONS).

**OIL****STANDARD PROCEDURE—ENGINE OIL****OIL LEVEL INDICATOR (DIPSTICK)**

The engine oil level indicator is located at the right front of the engine, left of the generator on 3.9L engines (Fig. 50).



**Fig. 50 Oil Level Indicator Location**

- 1 - CYLINDER HEAD COVER
- 2 - ENGINE OIL FILL CAP
- 3 - DIPSTICK
- 4 - ENGINE OIL FILTER
- 5 - FILTER BOSS

**CRANKCASE OIL LEVEL INSPECTION**

**CAUTION: Do not overfill crankcase with engine oil, oil foaming and oil pressure loss can result.**

To ensure proper lubrication of an engine, the engine oil must be maintained at an acceptable level. The acceptable levels are indicated between the ADD and SAFE marks on the engine oil dipstick.

(1) Position vehicle on level surface.

(2) With engine OFF, allow approximately ten minutes for oil to settle to bottom of crankcase, remove engine oil dipstick.

(3) Wipe dipstick clean.

(4) Install dipstick and verify it is seated in the tube.

## OIL (Continued)

(5) Remove dipstick, with handle held above the tip, take oil level reading.

(6) Add oil only if level is below the ADD mark on dipstick.

## ENGINE OIL CHANGE

Change engine oil at mileage and time intervals described in the Maintenance Schedule. This information can be found in the owner's manual.

## TO CHANGE ENGINE OIL

Run engine until achieving normal operating temperature.

(1) Position the vehicle on a level surface and turn engine off.

(2) Hoist vehicle.

(3) Remove oil fill cap.

(4) Place a suitable drain pan under crankcase drain.

(5) Remove drain plug from crankcase and allow oil to drain into pan. Inspect drain plug threads for stretching or other damage. Replace drain plug and gasket if damaged.

(6) Install drain plug in crankcase.

(7) Change oil filter (Refer to 9 - ENGINE/LUBRICATION/OIL FILTER - REMOVAL).

(8) Lower vehicle and fill crankcase with specified type (Refer to LUBRICATION & MAINTENANCE/FLUID TYPES - DESCRIPTION) and amount of engine oil (Refer to LUBRICATION & MAINTENANCE - SPECIFICATIONS).

(9) Install oil fill cap.

(10) Start engine and inspect for leaks.

(11) Stop engine and inspect oil level.

## OIL FILTER

## REMOVAL

All engines are equipped with a high quality full-flow, disposable type oil filter. DaimlerChrysler Corporation recommends a Mopar® or equivalent oil filter be used.

(1) Position a drain pan under the oil filter.

(2) Using a suitable oil filter wrench loosen filter.

(3) Rotate the oil filter counterclockwise to remove it from the cylinder block oil filter boss (Fig. 51).

(4) When filter separates from adapter nipple, tip gasket end upward to minimize oil spill. Remove filter from vehicle.

(5) With a wiping cloth, clean the gasket sealing surface (Fig. 54) of oil and grime.

(6) Install new filter (Refer to 9 - ENGINE/LUBRICATION/OIL FILTER - INSTALLATION).

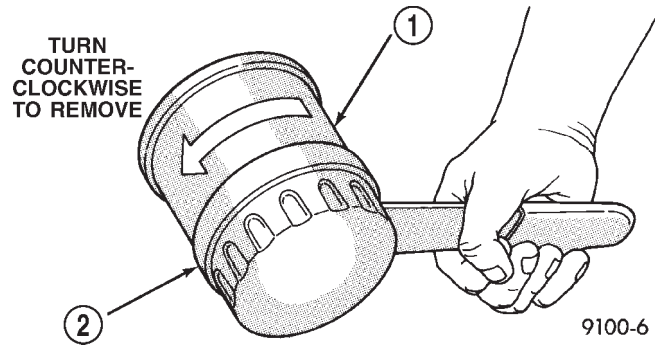


Fig. 51 Oil Filter Removal—Typical

- 1 - ENGINE OIL FILTER  
2 - OIL FILTER WRENCH

## INSTALLATION

(1) Lightly lubricate oil filter gasket with engine oil or chassis grease.

(2) Thread filter onto adapter nipple. When gasket makes contact with sealing surface, (Fig. 52) hand tighten filter one full turn, do not over tighten.

(3) Add oil (Refer to 9 - ENGINE/LUBRICATION/OIL - STANDARD PROCEDURE).

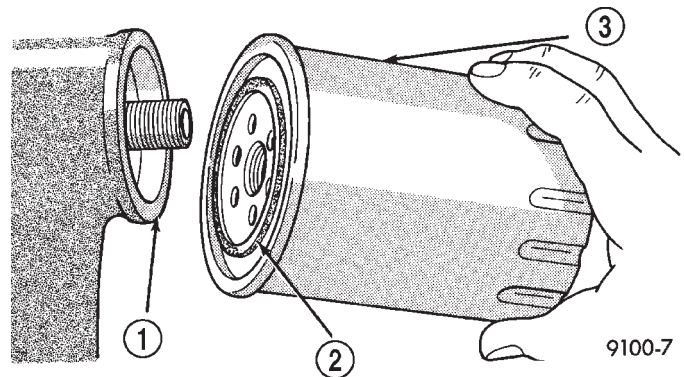


Fig. 52 Oil Filter Sealing Surface—Typical

- 1 - SEALING SURFACE  
2 - RUBBER GASKET  
3 - OIL FILTER

## OIL PAN

## REMOVAL

(1) Disconnect the negative cable from the battery.

(2) Remove engine oil dipstick.

(3) Raise vehicle.

(4) Drain engine oil.

(5) Remove exhaust pipe.

(6) Remove left engine to transmission strut.

(7) Loosen the right side engine support bracket cushion thru-bolt nut and raise the engine slightly. Remove oil pan by sliding backward and out.

(8) Remove the one-piece gasket.



## OIL PAN (Continued)

## CLEANING

Clean the block and pan gasket surfaces.

Trim or remove excess sealant film in the rear main cap oil pan gasket groove. **DO NOT remove the sealant inside the rear main cap slots.**

If present, trim excess sealant from inside the engine.

Clean oil pan in solvent and wipe dry with a clean cloth.

Clean oil screen and pipe thoroughly in clean solvent. Inspect condition of screen.

## INSPECTION

Inspect oil drain plug and plug hole for stripped or damaged threads. Repair as necessary.

Inspect oil pan mounting flange for bends or distortion. Straighten flange, if necessary.

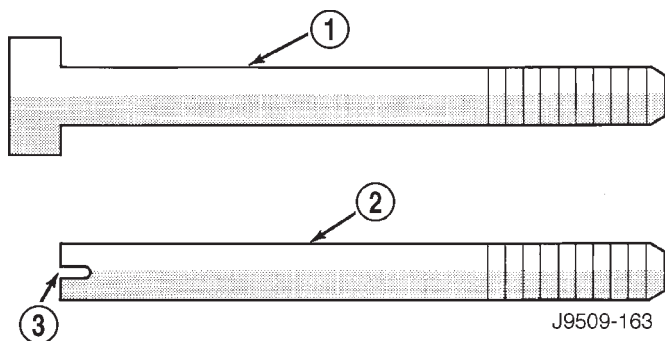
## INSTALLATION

(1) Clean the block and pan gasket surfaces.

(2) Trim or remove excess sealant film in the rear main cap oil pan gasket groove. **DO NOT remove the sealant inside the rear main cap slots.**

(3) If present, trim excess sealant from inside the engine.

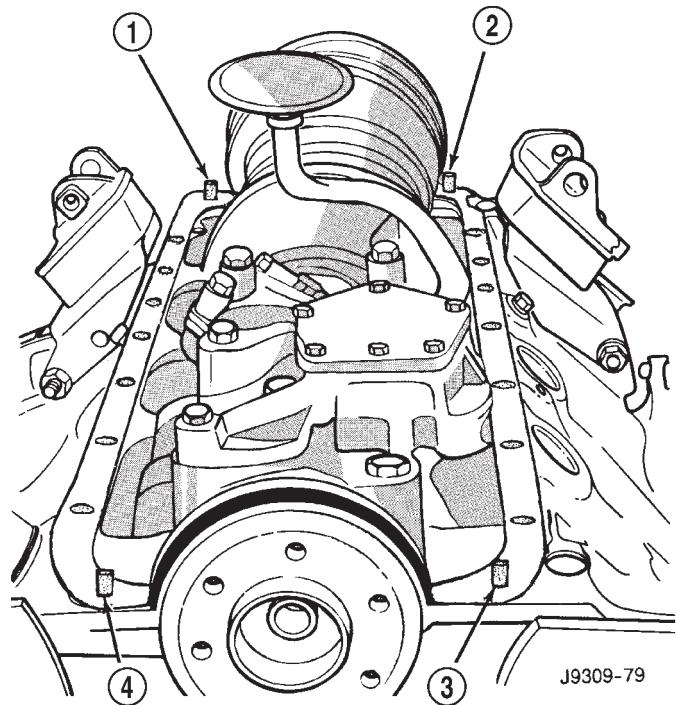
(4) Fabricate 4 alignment dowels from 5/16 x 1 1/2 inch bolts. Cut the head off the bolts and cut a slot into the top of the dowel. This will allow easier installation and removal with a screwdriver (Fig. 53).



**Fig. 53 Fabrication of Alignment Dowels**

- 1 - 5/16" X 1 1/2" BOLT
- 2 - DOWEL
- 3 - SLOT

(5) Install the dowels in the cylinder block (Fig. 54).



**Fig. 54 Position of Dowels in Cylinder Block**

- 1 - DOWEL
- 2 - DOWEL
- 3 - DOWEL
- 4 - DOWEL

(6) Apply small amount of Mopar® Silicone Rubber Adhesive Sealant, or equivalent in the corner of the cap and the cylinder block.

(7) Slide the one-piece gasket over the dowels and onto the block.

(8) Position the oil pan over the dowels and onto the gasket.

(9) Install the oil pan bolts. Tighten the bolts to 24 N·m (215 in. lbs.) torque.

(10) Remove the dowels. Install the remaining oil pan bolts. Tighten these bolts to 24 N·m (215 in. lbs.) torque.

(11) Lower the engine into the support cushion brackets and tighten the thru bolt nut to the proper torque.

(12) Install the drain plug. Tighten drain plug to 34 N·m (25 ft. lbs.) torque.

(13) Install the engine to transmission strut.

(14) Install exhaust pipe.

(15) Lower vehicle.

(16) Install dipstick.

(17) Connect the negative cable to the battery.

(18) Fill crankcase with oil to proper level.

## OIL PUMP

### REMOVAL

(1) Remove the oil pan (Refer to 9 - ENGINE/LUBRICATION/OIL PAN - REMOVAL).

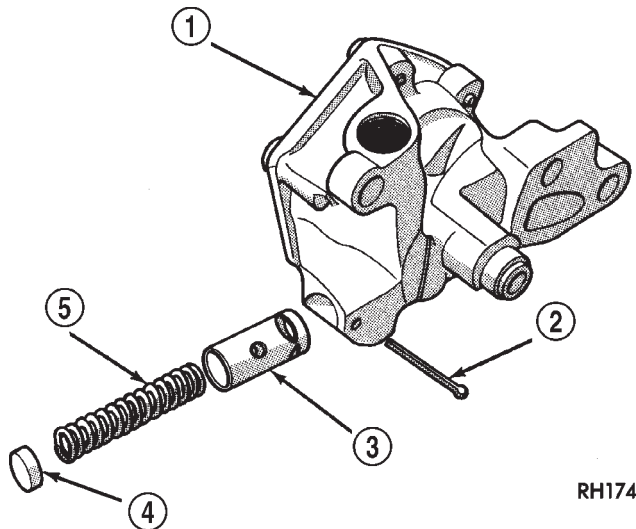
(2) Remove the oil pump from rear main bearing cap.

### DISASSEMBLE

(1) Remove the relief valve as follows:

(a) Remove cotter pin. Drill a 3.175 mm (1/8 inch) hole into the relief valve retainer cap and insert a self-threading sheet metal screw.

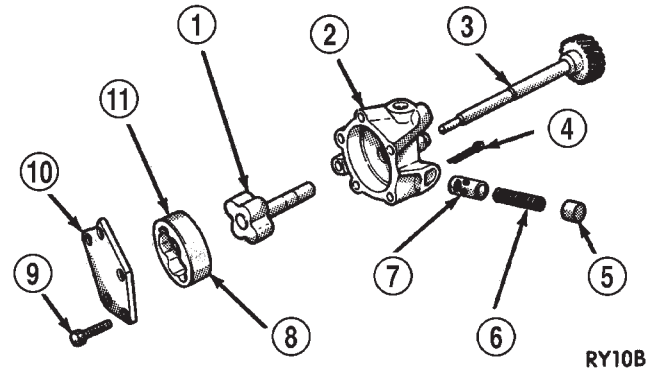
(b) Clamp screw into a vise and while supporting oil pump, remove cap by tapping pump body using a soft hammer. Discard retainer cap and remove spring and relief valve (Fig. 55).



RH174

**Fig. 55 Oil Pressure Relief Valve**

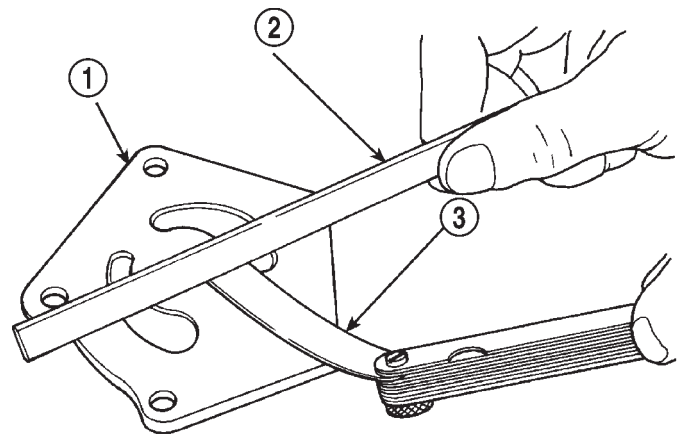
- 1 - OIL PUMP ASSEMBLY
- 2 - COTTER PIN
- 3 - RELIEF VALVE
- 4 - RETAINER CAP
- 5 - SPRING



RY10B

**Fig. 56 Oil Pump**

- 1 - INNER ROTOR AND SHAFT
- 2 - BODY
- 3 - DISTRIBUTOR DRIVESHAFT (REFERENCE)
- 4 - COTTER PIN
- 5 - RETAINER CAP
- 6 - SPRING
- 7 - RELIEF VALVE
- 8 - LARGE CHAMFERED EDGE
- 9 - BOLT
- 10 - COVER
- 11 - OUTER ROTOR



8020cd6e

**Fig. 57 Checking Oil Pump Cover Flatness**

- 1 - COVER
- 2 - STRAIGHT EDGE
- 3 - FEELER GAUGE

(2) Remove oil pump cover (Fig. 56).

(3) Remove pump outer rotor and inner rotor with shaft (Fig. 56).

(4) Wash all parts in a suitable solvent and inspect carefully for damage or wear.

### INSPECTION

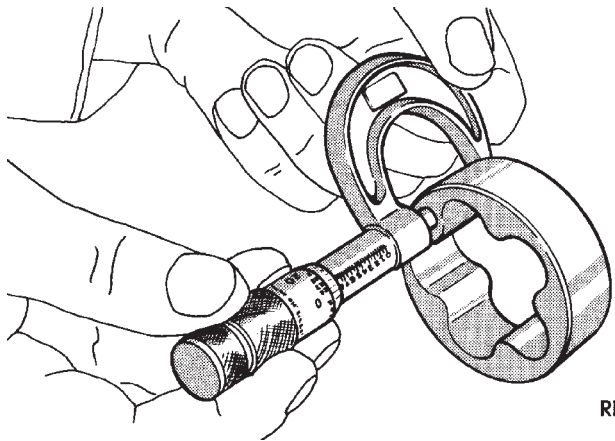
Mating surface of the oil pump cover should be smooth. Replace pump assembly if cover is scratched or grooved.

Lay a straightedge across the pump cover surface (Fig. 57). If a 0.038 mm (0.0015 inch) feeler gauge can be inserted between cover and straightedge, pump assembly should be replaced.



OIL PUMP (Continued)

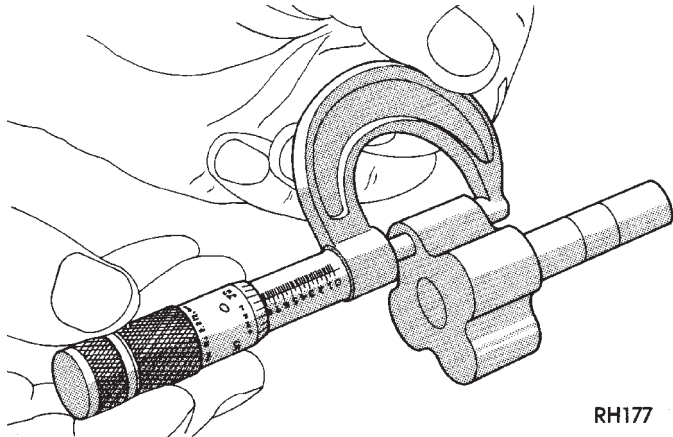
Measure thickness and diameter of OUTER rotor. If outer rotor thickness measures 20.9 mm (0.825 inch) or less or if the diameter is 62.7 mm (2.469 inches) or less, replace outer rotor (Fig. 58).



RH176

**Fig. 58 Measuring Outer Rotor Thickness**

If inner rotor measures 20.9 mm (0.825 inch) or less, replace inner rotor and shaft assembly (Fig. 59).



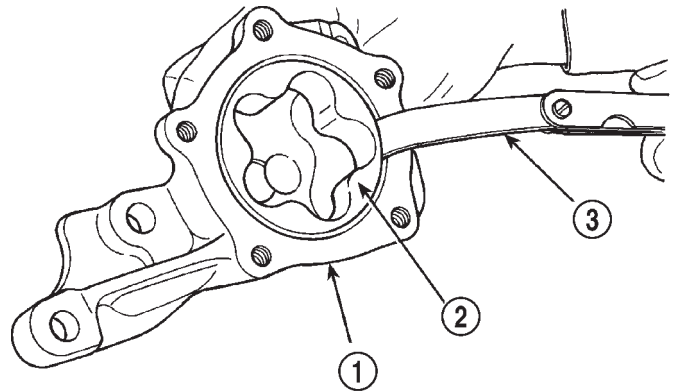
RH177

**Fig. 59 Measuring Inner Rotor Thickness**

Slide outer rotor into pump body. Press rotor to the side with your fingers and measure clearance between rotor and pump body (Fig. 60). If clearance is 0.356 mm (0.014 inch) or more, replace oil pump assembly.

Install inner rotor and shaft into pump body. If clearance between inner and outer rotors is 0.203 mm (0.008 inch) or more, replace shaft and both rotors (Fig. 61).

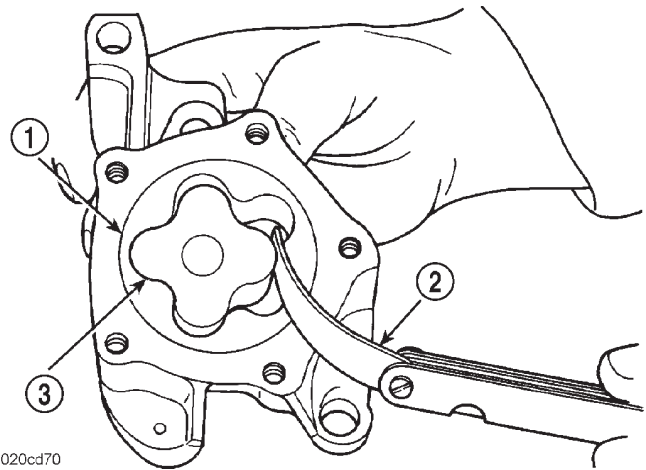
Place a straightedge across the face of the pump, between bolt holes. If a feeler gauge of 0.102 mm (0.004 inch) or more can be inserted between rotors and the straightedge, replace pump assembly (Fig. 62).



8020cd6f

**Fig. 60 Measuring Outer Rotor Clearance in Housing**

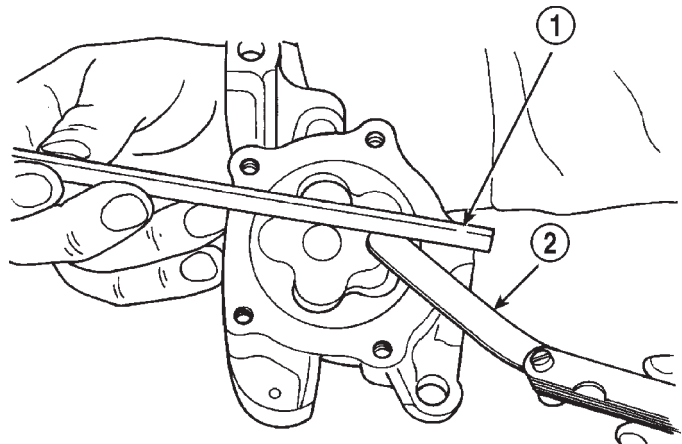
- 1 - PUMP BODY
- 2 - OUTER ROTOR
- 3 - FEELER GAUGE



8020cd70

**Fig. 61 Measuring Clearance Between Rotors**

- 1 - OUTER ROTOR
- 2 - FEELER GAUGE
- 3 - INNER ROTOR



8020cd71

**Fig. 62 Measuring Clearance Over Rotors**

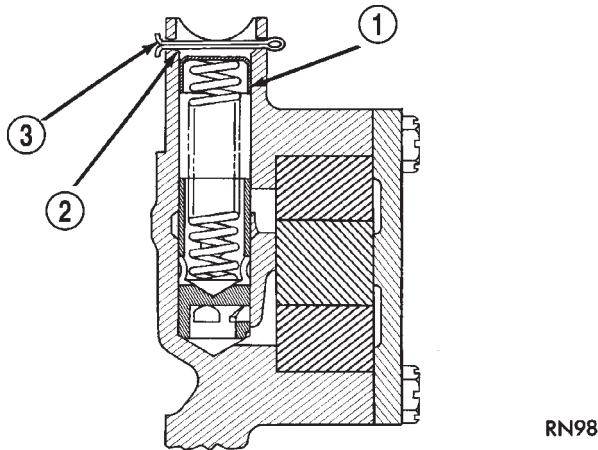
- 1 - STRAIGHT EDGE
- 2 - FEELER GAUGE

## OIL PUMP (Continued)

Inspect oil pressure relief valve plunger for scoring and free operation in its bore. Small marks may be removed with 400-grit wet or dry sandpaper.

The relief valve spring has a free length of approximately 49.5 mm (1.95 inches). The spring should test between 19.5 and 20.5 pounds when compressed to 34 mm (1-11/32 inches). Replace spring that fails to meet these specifications (Fig. 63).

If oil pressure was low and pump is within specifications, inspect for worn engine bearings or other reasons for oil pressure loss.



**Fig. 63 Proper Installation of Retainer Cap**

- 1 - RETAINER CAP
- 2 - CHAMFER
- 3 - COTTER KEY

## ASSEMBLE

(1) Install pump rotors and shaft, using new parts as required.

(2) Position the oil pump cover onto the pump body. Tighten cover bolts to 11 N·m (95 in. lbs.) torque.

(3) Install the relief valve and spring. Insert the cotter pin.

(4) Tap on a new retainer cap.

(5) Prime oil pump before installation by filling rotor cavity with engine oil.

## INSTALLATION

(1) Install oil pump. During installation slowly rotate pump body to ensure driveshaft-to-pump rotor shaft engagement.

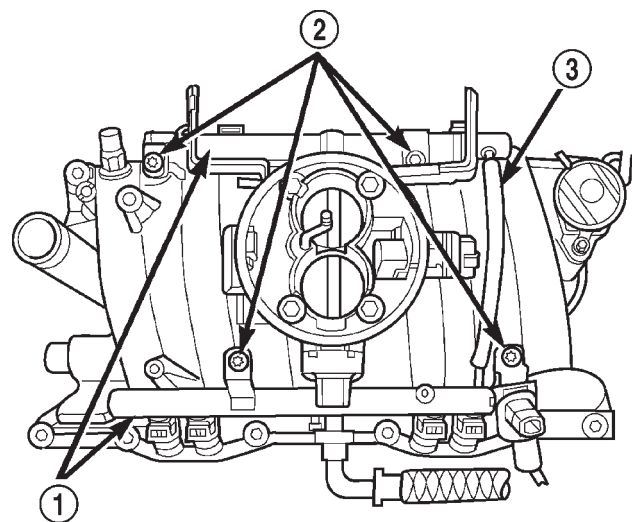
(2) Hold the oil pump base flush against mating surface on No.5 main bearing cap. Finger tighten pump attaching bolts. Tighten attaching bolts to 41 N·m (30 ft. lbs.) torque.

(3) Install the oil pan (Refer to 9 - ENGINE/LUBRICATION/OIL PAN - INSTALLATION).

## INTAKE MANIFOLD

## DESCRIPTION

The aluminum intake manifold (Fig. 64) is a single plane design with equal length runners and uses a separate plenum, therefore the manifold does have a plenum gasket. It also uses separate flange gaskets and front and rear cross-over gaskets. Extreme care must be used when sealing the gaskets to ensure that excess sealant does not enter the intake runners causing a restriction. Whenever the intake manifold is removed inspect the plenum pan for evidence of excess oil buildup, this condition indicates that the plenum pan gasket is leaking.



80c071af

**Fig. 64 Intake Manifold and Throttle Body—V-8 Gas Engines Typical**

- 1 - FUEL RAIL ASSEMBLY
- 2 - FUEL RAIL MOUNTING BOLTS
- 3 - FUEL RAIL CONNECTING HOSES

## OPERATION

The intake manifold, meters and delivers air to the combustion chambers allowing the fuel delivered by the fuel injectors to ignite, thus producing power.

## INTAKE MANIFOLD (Continued)

**DIAGNOSIS AND TESTING—INTAKE MANIFOLD LEAKAGE**

An intake manifold air leak is characterized by lower than normal manifold vacuum. Also, one or more cylinders may not be functioning.

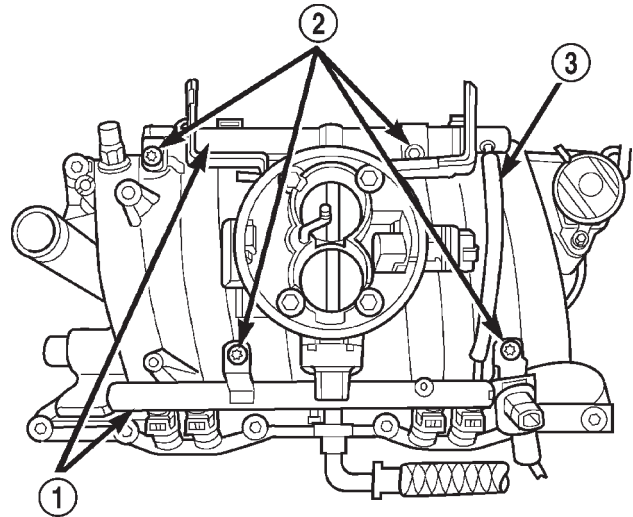
**WARNING: USE EXTREME CAUTION WHEN THE ENGINE IS OPERATING. DO NOT STAND IN A DIRECT LINE WITH THE FAN. DO NOT PUT YOUR HANDS NEAR THE PULLEYS, BELTS, OR THE FAN. DO NOT WEAR LOOSE CLOTHING.**

- (1) Start the engine.
- (2) Spray a small stream of water at the suspected leak area.
- (3) If a change in RPMs, the area of the suspected leak has been found.
- (4) Repair as required.

**REMOVAL**

- (1) Disconnect the negative cable from the battery.
- (2) Drain the cooling system (Refer to 7 - COOLING - STANDARD PROCEDURE).
- (3) Remove the A/C compressor (Refer to 24 - HEATING & AIR CONDITIONING/PLUMBING/A/C COMPRESSOR - REMOVAL).
- (4) Remove the generator (Refer to 8 - ELECTRICAL/CHARGING/GENERATOR - REMOVAL).
- (5) Remove the accessory drive bracket.
- (6) Remove the air cleaner.
- (7) Perform the Fuel System Pressure release procedure (Refer to 14 - FUEL SYSTEM/FUEL DELIVERY - STANDARD PROCEDURE). Disconnect the fuel lines (Refer to 14 - FUEL SYSTEM/FUEL DELIVERY/QUICK CONNECT FITTING - STANDARD PROCEDURE).
- (8) Disconnect the accelerator linkage (Refer to 14 - FUEL SYSTEM/FUEL INJECTION/THROTTLE CONTROL CABLE - REMOVAL) and if so equipped, the speed control and transmission kickdown cables.
- (9) Remove the return spring.
- (10) Remove the distributor cap and wires.
- (11) Disconnect the coil wires.
- (12) Disconnect the heat indicator sending unit wire.
- (13) Disconnect the heater hoses and bypass hose.
- (14) Remove the closed crankcase ventilation and evaporation control systems.

- (15) Remove intake manifold bolts.
- (16) Lift the intake manifold and throttle body out of the engine compartment as an assembly.
- (17) Remove and discard the flange side gaskets and the front and rear cross-over gaskets.
- (18) Remove the throttle body bolts and lift the throttle body off the intake manifold (Fig. 65). Discard the gasket.



80c071af

**Fig. 65 Throttle Body Assembly**

- 1 - FUEL RAIL ASSEMBLY
- 2 - FUEL RAIL MOUNTING BOLTS
- 3 - FUEL RAIL CONNECTING HOSES

- (19) If required, remove the plenum pan and gasket. Discard gasket.

**CLEANING**

Clean manifold in solvent and blow dry with compressed air.

Clean cylinder block front and rear gasket surfaces using a suitable solvent.

The plenum pan rail must be clean and dry (free of all foreign material).

**INSPECTION**

Inspect manifold for cracks.

Inspect mating surfaces of manifold for flatness with a straightedge.

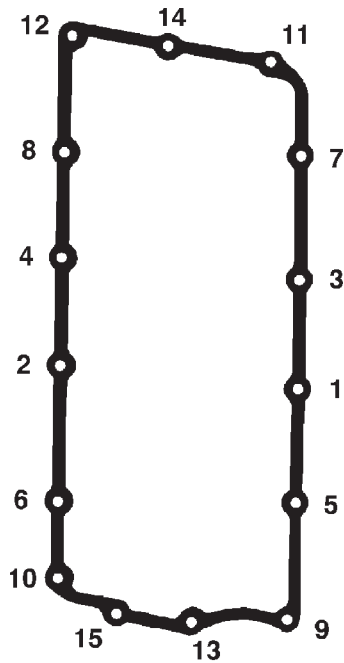
## INTAKE MANIFOLD (Continued)

## INSTALLATION

(1) If removed, position new plenum gasket and install plenum pan (Fig. 66).

(2) Tighten plenum pan mounting bolts as follows:

- Step 1. Tighten bolts to 5.4 N·m (48 in. lbs.)
- Step 2. Tighten bolts to 9.5 N·m (84 in. lbs.)
- Step 3. Check all bolts are at 9.5 N·m (84 in. lbs.)



80c071eb

**Fig. 66 Plenum Pan Bolt Tightening Sequence**

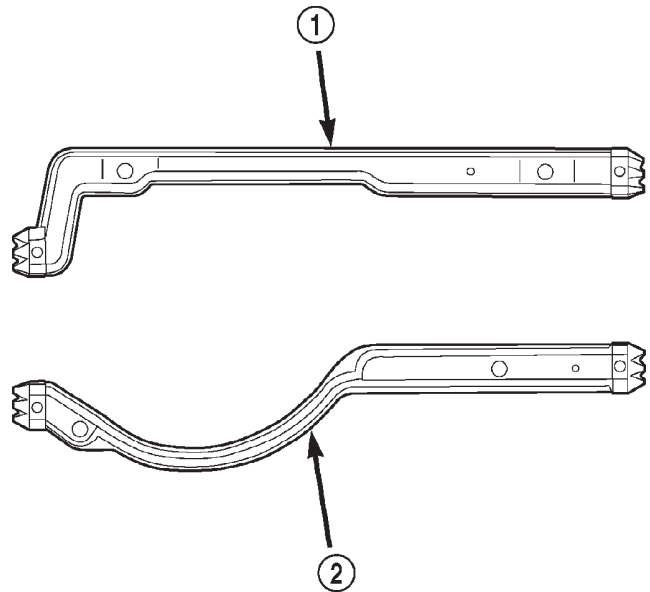
(3) Install the flange gaskets. Ensure that the vertical port alignment tab is resting on the deck face of the block. Also the horizontal alignment tabs must be in position with the mating cylinder head gasket tabs (Fig. 68). The words MANIFOLD SIDE should be visible on the center of each flange gasket.

(4) Apply Mopar® GEN II Silicone Rubber Adhesive Sealant, or equivalent, to the four corner joints. An excessive amount of sealant is not required to ensure a leak proof seal. However, an excessive amount of sealant may reduce the effectiveness of the flange gasket. The sealant should be approximately 5 mm (0.2 in) in diameter.

(5) Install the front and rear cross-over gaskets (Fig. 67).

(6) Using a new gasket, install the throttle body onto the intake manifold. Tighten the bolts to 23 N·m (200 in. lbs.) torque.

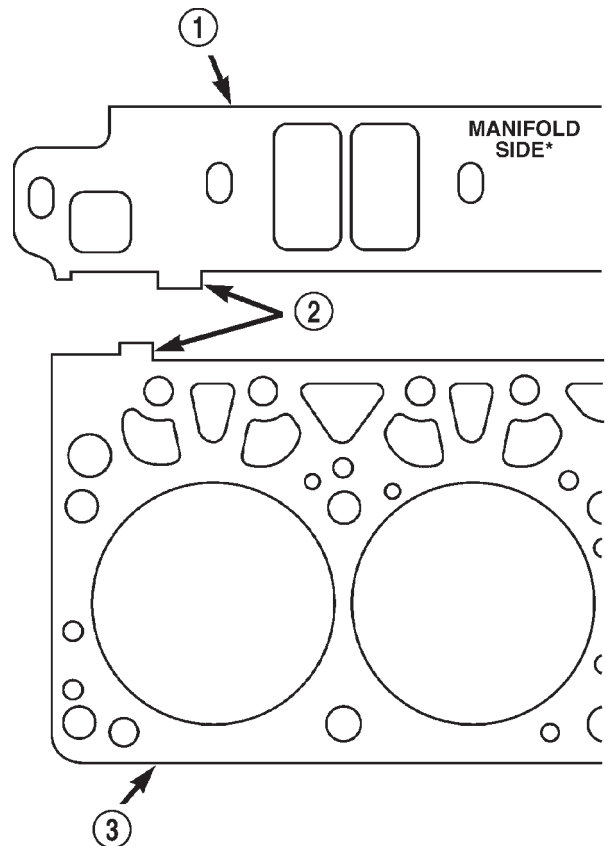
(7) Carefully lower intake manifold into position on the cylinder block and cylinder heads. After intake manifold is in place, inspect to make sure seals are in place.



80c071ad

**Fig. 67 Cross-Over Gaskets**

- 1 - FRONT CROSS-OVER GASKET
- 2 - REAR CROSS-OVER GASKET



80c071ae

**Fig. 68 Intake Manifold Flange Gasket Alignment**

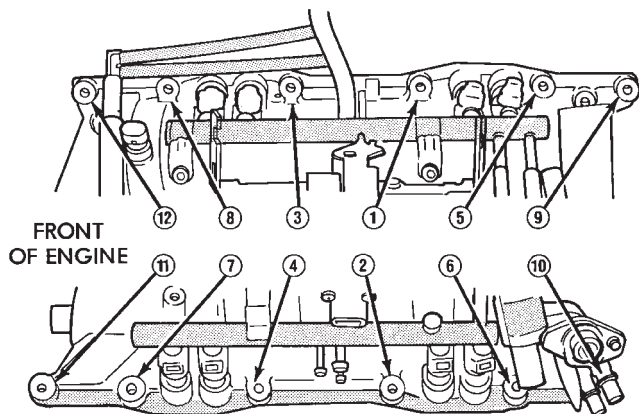
- 1 - FLANGE GASKET
- 2 - ALIGNMENT TABS
- 3 - CYLINDER HEAD GASKET



## INTAKE MANIFOLD (Continued)

(8) Install the intake manifold bolts and tighten as follows (Fig. 69):

- Step 1. Tighten bolts 1 through 4 to 8 N·m (72 in. lbs.) Tighten in alternating steps 1.4 N·m (12 in. lbs.) at a time
- Step 2. Tighten bolts 5 through 12 to 8 N·m (72 in. lbs.)
- Step 3. Check all bolts are torqued to 8 N·m (72 in. lbs.)
- Step 4. Tighten all bolts in sequence to 16 N·m (12 ft. lbs.)
- Step 5. Check all bolts are torqued to 16 N·m (12 ft. lbs.)



J9209-60

**Fig. 69 Intake Manifold Bolt Tightening Sequence**

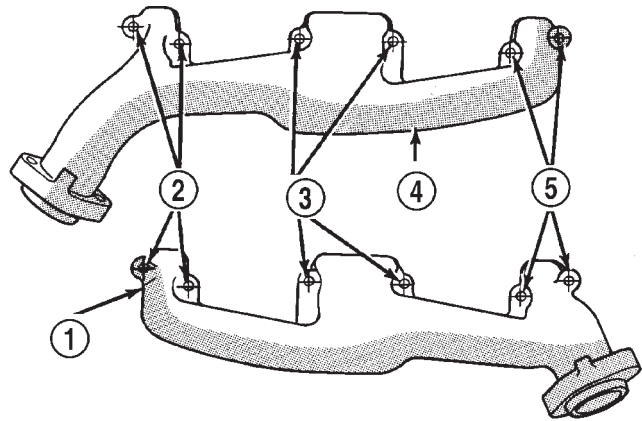
(9) Install closed crankcase ventilation and evaporation control systems.

- (10) Connect the coil wires.
- (11) Connect the heat indicator sending unit wire.
- (12) Connect the heater hoses and bypass hose.
- (13) Install distributor cap and wires.
- (14) Hook up the return spring.
- (15) Connect the accelerator linkage (Refer to 14 - FUEL SYSTEM/FUEL INJECTION/THROTTLE CONTROL CABLE - INSTALLATION) and if so equipped, the speed control and transmission kick-down cables.
- (16) Install the fuel lines (Refer to 14 - FUEL SYSTEM/FUEL DELIVERY/QUICK CONNECT FITTING - STANDARD PROCEDURE).
- (17) Install the accessory drive bracket and A/C compressor (Refer to 24 - HEATING & AIR CONDITIONING/PLUMBING/A/C COMPRESSOR - INSTALLATION).
- (18) Install the generator and drive belt (Refer to 7 - COOLING/ACCESSORY DRIVE/DRIVE BELTS - INSTALLATION). Tighten generator mounting bolt to 41 N·m (30 ft. lbs.) torque.
- (19) Install the air cleaner.
- (20) Fill cooling system (Refer to 7 - COOLING - STANDARD PROCEDURE).
- (21) Connect the negative cable to the battery.

## EXHAUST MANIFOLD

## DESCRIPTION

The exhaust manifolds (Fig. 70) are constructed of cast iron and are LOG type with balanced flow. One exhaust manifold is attached to each cylinder head.



J9311-11

**Fig. 70 Exhaust Manifolds—V-8 Gas Engines Typical**

- 1 - EXHAUST MANIFOLD (LEFT)
- 2 - BOLTS & WASHERS
- 3 - NUTS & WASHERS
- 4 - EXHAUST MANIFOLD (RIGHT)
- 5 - BOLTS & WASHERS

## OPERATION

The exhaust manifolds collect the engine exhaust exiting the combustion chambers, then channels the exhaust gases to the exhaust pipes attached to the manifolds.

## REMOVAL

- (1) Disconnect the negative cable from the battery.
- (2) Raise and support the vehicle.
- (3) Remove the bolts and nuts attaching the exhaust pipe to the engine exhaust manifold.
- (4) Lower the vehicle.
- (5) Remove the exhaust heat shields.
- (6) Remove bolts, nuts and washers attaching manifold to cylinder head.
- (7) Remove manifold from the cylinder head.

## CLEANING

Clean mating surfaces on cylinder head and manifold. Wash with solvent and blow dry with compressed air.

## INSPECTION

Inspect manifold for cracks.

## EXHAUST MANIFOLD (Continued)

Inspect mating surfaces of manifold for flatness with a straight edge. Gasket surfaces must be flat within 0.2 mm per 300 mm (0.008 inch per foot).

## INSTALLATION

**CAUTION:** If the studs came out with the nuts when removing the engine exhaust manifold, install new studs. Apply sealer on the coarse thread ends. Water leaks may develop at the studs if this precaution is not taken.

(1) Position the engine exhaust manifolds on the two studs located on the cylinder head. Install conical washers and nuts on these studs (Fig. 71).

(2) Install two bolts and conical washers at the inner ends of the engine exhaust manifold outboard arms. Install two bolts **WITHOUT** washers on the center arm of engine exhaust manifold (Fig. 71). Starting at the center arm and working outward, tighten the bolts and nuts to 34 N·m (25 ft. lbs.) torque.

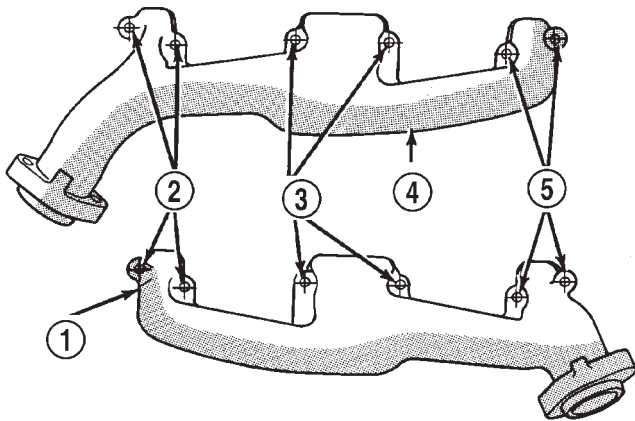
(3) Install the exhaust heat shields.

(4) Raise and support the vehicle.

(5) Assemble exhaust pipe to manifold and secure with bolts, nuts and retainers. Tighten the bolts and nuts to 34 N·m (25 ft. lbs.) torque.

(6) Lower the vehicle.

(7) Connect the negative cable to the battery.



J9311-11

**Fig. 71 Engine Exhaust Manifold Installation—5.2L/5.9L Engines**

- 1 - EXHAUST MANIFOLD (LEFT)
- 2 - BOLTS & WASHERS
- 3 - NUTS & WASHERS
- 4 - EXHAUST MANIFOLD (RIGHT)
- 5 - BOLTS & WASHERS

## TIMING BELT / CHAIN COVER(S)

## REMOVAL

(1) Disconnect the negative cable from the battery.

(2) Remove water pump (Refer to 7 - COOLING/ENGINE/WATER PUMP - REMOVAL).

(3) Remove power steering pump (Refer to 19 - STEERING/PUMP - REMOVAL).

(4) Remove vibration damper (Refer to 9 - ENGINE/ENGINE BLOCK/VIBRATION DAMPER - REMOVAL).

(5) Loosen oil pan bolts and remove the front bolt at each side.

(6) Remove the cover bolts.

(7) Remove chain case cover and gasket using extreme caution to avoid damaging oil pan gasket.

## INSTALLATION

(1) Be sure mating surfaces of chain case cover and cylinder block are clean and free from burrs.

(2) The water pump mounting surface must be cleaned.

(3) Using a new cover gasket, carefully install chain case cover to avoid damaging oil pan gasket. Use a small amount of Mopar® Silicone Rubber Adhesive Sealant, or equivalent, at the joint between timing chain cover gasket and the oil pan gasket. Finger tighten the timing chain cover bolts at this time.

**NOTE:** Special Tool 6635 must be used to align the front cover and seal with the crankshaft.

(4) Position the special tool 6635 onto the crankshaft (Fig. 72).

(5) Tighten chain case cover bolts to 41 N·m (30 ft.lbs.) torque. Tighten oil pan bolts to 24 N·m (215 in. lbs.) torque.

(6) Remove special tool 6635.

(7) Inspect the seal flange on the vibration damper.

(8) Install vibration damper (Refer to 9 - ENGINE/ENGINE BLOCK/VIBRATION DAMPER - INSTALLATION).

(9) Install water pump and housing assembly using new gaskets (Refer to 7 - COOLING/ENGINE/WATER PUMP - INSTALLATION).

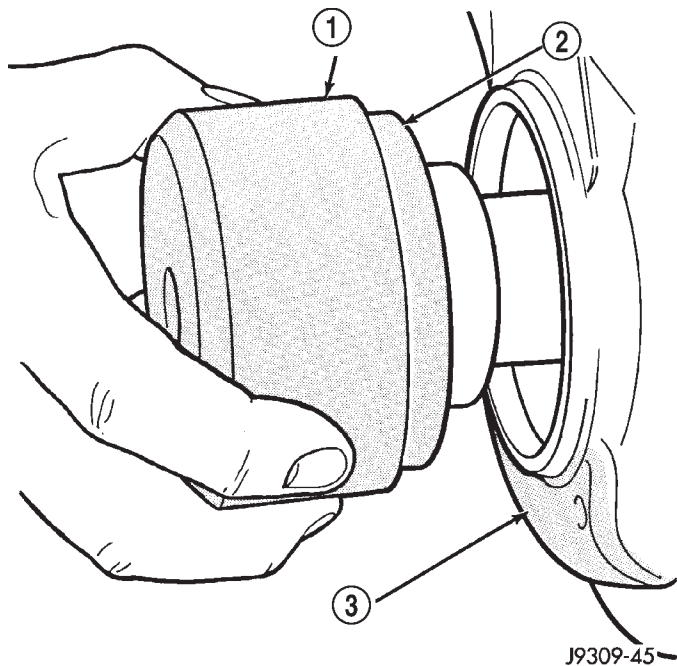
(10) Install power steering pump (Refer to 19 - STEERING/PUMP - INSTALLATION).

(11) Install the serpentine belt (Refer to 7 - COOLING/ACCESSORY DRIVE/DRIVE BELTS - INSTALLATION).

(12) Install the cooling system fan (Refer to 7 - COOLING/ENGINE/RADIATOR FAN - INSTALLATION).



## TIMING BELT / CHAIN COVER(S) (Continued)

**Fig. 72 Position Special Tool 6635 onto Crankshaft**

- 1 - SPECIAL TOOL 6635
- 2 - OIL SEAL
- 3 - TIMING CHAIN COVER

(13) Position the fan shroud and install the bolts. Tighten the bolts to 11 N·m (95 in. lbs.) torque.

(14) Fill cooling system (Refer to 7 - COOLING - STANDARD PROCEDURE).

(15) Connect the negative cable to the battery.

(16) Start engine check for leaks.

## TIMING BELT/CHAIN AND SPROCKETS

### REMOVAL

(1) Disconnect battery negative cable.

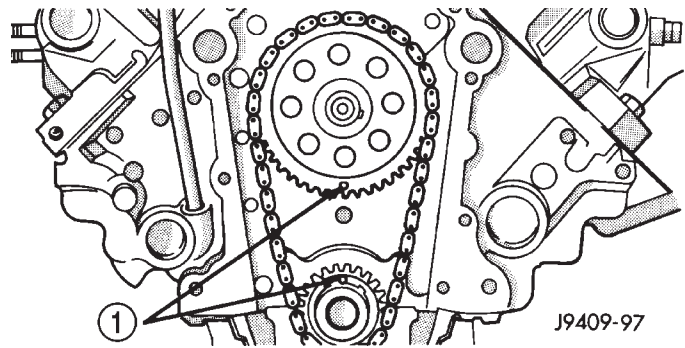
(2) Remove Timing Chain Cover (Refer to 9 - ENGINE/VALVE TIMING/TIMING BELT / CHAIN COVER(S) - REMOVAL).

(3) Re-install the vibration damper bolt finger tight. Using a suitable socket and breaker bar, rotate the crankshaft to align timing marks as shown in (Fig. 73).

(4) Remove camshaft sprocket attaching bolt and remove timing chain with crankshaft and camshaft sprockets.

### INSPECTION—MEASURING TIMING CHAIN STRETCH

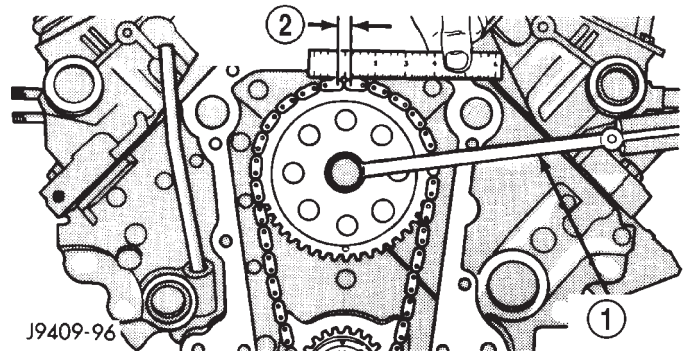
(1) Place a scale next to the timing chain so that any movement of the chain may be measured.

**Fig. 73 Alignment of Timing Marks**

- 1 - TIMING MARKS

(2) Place a torque wrench and socket over camshaft sprocket attaching bolt. Apply torque in the direction of crankshaft rotation to take up slack; 41 N·m (30 ft. lbs.) torque with cylinder head installed or 20 N·m (15 ft. lbs.) torque with cylinder head removed. With a torque applied to the camshaft sprocket bolt, crankshaft should not be permitted to move. It may be necessary to block the crankshaft to prevent rotation.

(3) Hold a scale with dimensional reading even with the edge of a chain link. With cylinder heads installed, apply 14 N·m (30 ft. lbs.) torque in the reverse direction. With the cylinder heads removed, apply 20 N·m (15 ft. lbs.) torque in the reverse direction. Note the amount of chain movement (Fig. 74).

**Fig. 74 Measuring Timing Chain Stretch**

- 1 - TORQUE WRENCH
- 2 - 3.175 MM  
(0.125 IN.)

(4) Install a new timing chain, if its movement exceeds 3.175 mm (1/8 inch).

## TIMING BELT/CHAIN AND SPROCKETS (Continued)

**INSTALLATION**

(1) Place both camshaft sprocket and crankshaft sprocket on the bench with timing marks on exact imaginary center line through both camshaft and crankshaft bores.

(2) Place timing chain around both sprockets.

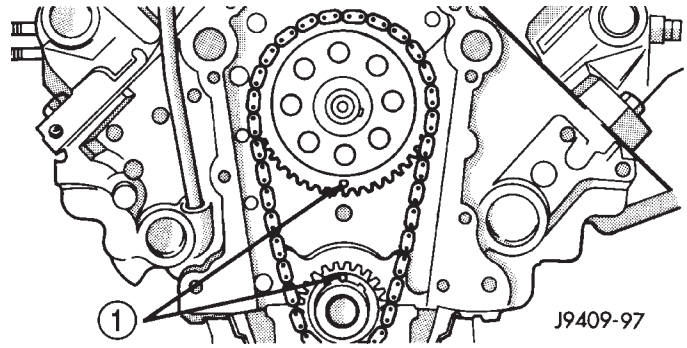
(3) Turn crankshaft and camshaft to line up with keyway location in crankshaft sprocket and in camshaft sprocket.

(4) Lift sprockets and chain (keep sprockets tight against the chain in position as described).

(5) Slide both sprockets evenly over their respective shafts and use a straightedge to check alignment of timing marks (Fig. 75).

(6) Install the camshaft bolt. Tighten the bolt to 68 N·m (50 ft. lbs.) torque.

(7) Check camshaft end play. The end play should be 0.051-0.152 mm (0.002-0.006 inch) with a new thrust plate and up to 0.254 mm (0.010 inch) with a used thrust plate. If not within these limits install a new thrust plate.



**Fig. 75 Alignment of Timing Marks**

1 - TIMING MARKS

(8) Install the timing chain cover (Refer to 9 - ENGINE/VALVE TIMING/TIMING BELT / CHAIN COVER(S) - INSTALLATION).

## ENGINE 5.9L

## TABLE OF CONTENTS

	page		page
<b>ENGINE 5.9L</b>		<b>INSTALLATION</b> . . . . .	144
DESCRIPTION . . . . .	117	<b>CONNECTING ROD BEARINGS</b>	
DIAGNOSIS AND TESTING . . . . .	118	STANDARD PROCEDURE . . . . .	144
ENGINE DIAGNOSIS - INTRODUCTION . . . . .	118	CONNECTING ROD BEARING FITTING . . . . .	144
PERFORMANCE . . . . .	118	<b>CRANKSHAFT</b>	
MECHANICAL . . . . .	120	DESCRIPTION . . . . .	145
LUBRICATION . . . . .	123	OPERATION . . . . .	145
CYLINDER COMPRESSION PRESSURE . . . . .	124	REMOVAL . . . . .	145
CYLINDER COMBUSTION PRESSURE LEAKAGE . . . . .	124	INSTALLATION . . . . .	145
STANDARD PROCEDURE . . . . .	125	<b>CRANKSHAFT MAIN BEARINGS</b>	
FORM-IN-PLACE GASKETS AND SEALERS . . . . .	125	DESCRIPTION . . . . .	146
REPAIR DAMAGED OR WORN THREADS . . . . .	125	OPERATION . . . . .	146
HYDROSTATIC LOCK . . . . .	125	STANDARD PROCEDURE . . . . .	146
CYLINDER BORE HONING . . . . .	126	CRANKSHAFT MAIN BEARING FITTING . . . . .	146
REMOVAL . . . . .	126	REMOVAL . . . . .	147
INSTALLATION . . . . .	127	INSTALLATION . . . . .	147
SPECIFICATIONS . . . . .	129	<b>CRANKSHAFT OIL SEAL - FRONT</b>	
SPECIAL TOOLS . . . . .	134	DESCRIPTION . . . . .	147
<b>CYLINDER HEAD</b>		OPERATION . . . . .	147
DESCRIPTION . . . . .	136	REMOVAL . . . . .	147
OPERATION . . . . .	136	INSTALLATION . . . . .	148
DIAGNOSIS AND TESTING . . . . .	136	<b>CRANKSHAFT OIL SEAL - REAR</b>	
CYLINDER HEAD GASKET FAILURE . . . . .	136	DESCRIPTION . . . . .	148
REMOVAL . . . . .	137	OPERATION . . . . .	148
CLEANING . . . . .	137	REMOVAL . . . . .	149
INSPECTION . . . . .	137	INSTALLATION . . . . .	149
INSTALLATION . . . . .	137	<b>DISTRIBUTOR BUSHING</b>	
<b>CYLINDER HEAD COVER(S)</b>		REMOVAL . . . . .	150
REMOVAL . . . . .	138	INSTALLATION . . . . .	150
CLEANING . . . . .	138	<b>HYDRAULIC LIFTERS</b>	
INSPECTION . . . . .	138	DIAGNOSIS AND TESTING . . . . .	151
INSTALLATION . . . . .	138	HYDRAULIC TAPPETS . . . . .	151
<b>INTAKE/EXHAUST VALVES &amp; SEATS</b>		REMOVAL . . . . .	152
DESCRIPTION . . . . .	138	CLEANING . . . . .	152
STANDARD PROCEDURE . . . . .	138	INSTALLATION . . . . .	152
VALVES, GUIDES AND SPRINGS . . . . .	138	<b>PISTON &amp; CONNECTING ROD</b>	
REMOVAL . . . . .	140	DESCRIPTION . . . . .	153
CLEANING . . . . .	140	STANDARD PROCEDURE . . . . .	153
INSPECTION . . . . .	141	PISTON FITTING . . . . .	153
INSTALLATION . . . . .	141	REMOVAL . . . . .	154
<b>ROCKER ARM / ADJUSTER ASSY</b>		CLEANING . . . . .	154
REMOVAL . . . . .	142	INSPECTION . . . . .	154
INSTALLATION . . . . .	142	INSTALLATION . . . . .	154
<b>ENGINE BLOCK</b>		<b>PISTON RINGS</b>	
CLEANING . . . . .	142	STANDARD PROCEDURE . . . . .	154
INSPECTION . . . . .	142	PISTON RING FITTING . . . . .	154
<b>CAMSHAFT &amp; BEARINGS (IN BLOCK)</b>		<b>VIBRATION DAMPER</b>	
REMOVAL . . . . .	143	REMOVAL . . . . .	155
		INSTALLATION . . . . .	156

<b>FRONT MOUNT</b>			
REMOVAL .....	156	INSPECTION .....	163
INSTALLATION .....	156	ASSEMBLY .....	165
<b>REAR MOUNT</b>		INSTALLATION .....	165
REMOVAL .....	157	<b>INTAKE MANIFOLD</b>	
INSTALLATION .....	158	DESCRIPTION .....	165
<b>LUBRICATION</b>		OPERATION .....	165
DESCRIPTION .....	158	DIAGNOSIS AND TESTING .....	165
OPERATION .....	158	INTAKE MANIFOLD LEAKAGE .....	165
DIAGNOSIS AND TESTING .....	160	REMOVAL .....	166
ENGINE OIL LEAKS .....	160	CLEANING .....	166
ENGINE OIL PRESSURE .....	160	INSPECTION .....	166
<b>OIL</b>		INSTALLATION .....	166
STANDARD PROCEDURE .....	160	<b>EXHAUST MANIFOLD</b>	
ENGINE OIL .....	160	DESCRIPTION .....	168
<b>OIL FILTER</b>		OPERATION .....	168
REMOVAL .....	161	REMOVAL .....	168
INSTALLATION .....	161	CLEANING .....	168
<b>OIL PAN</b>		INSPECTION .....	168
REMOVAL .....	161	INSTALLATION .....	168
CLEANING .....	162	<b>TIMING BELT / CHAIN COVER(S)</b>	
INSPECTION .....	162	REMOVAL .....	169
INSTALLATION .....	162	INSTALLATION .....	169
<b>OIL PUMP</b>		<b>TIMING BELT/CHAIN AND SPROCKETS</b>	
REMOVAL .....	162	REMOVAL .....	170
DISASSEMBLY .....	163	INSPECTION .....	170
		INSTALLATION .....	170

## ENGINE 5.9L

### DESCRIPTION

The 5.9 Liter (360 CID) eight-cylinder engine is a V-Type lightweight, single cam, overhead valve engine with hydraulic roller tappets. This engine is designed for unleaded fuel.

The engine lubrication system consists of a rotor type oil pump and a full flow oil filter.

The cylinders are numbered from front to rear; 1, 3, 5, 7 on the left bank and 2, 4, 6, 8 on the right bank. The firing order is 1-8-4-3-6-5-7-2 (Fig. 1).

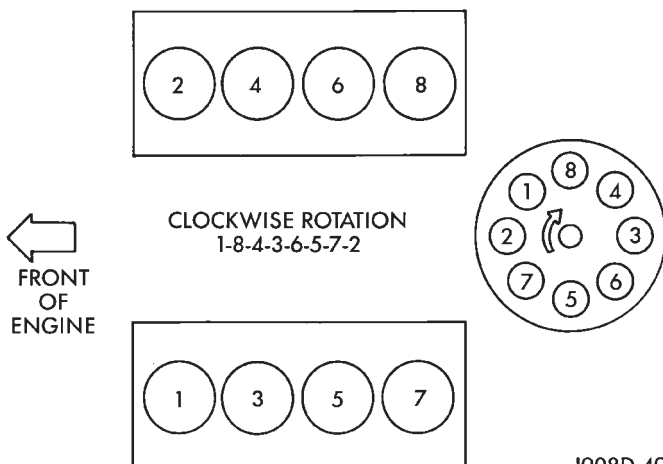


Fig. 1 Firing Order

J908D-49

The engine serial number is stamped into a machined pad located on the left, front corner of the cylinder block. When component part replacement is necessary, use the engine type and serial number for reference (Fig. 2).

1NK 5.9L XXXY S PPPPP NNNN

1 = 2001 Model

NK = Toluca Engine

5.9L = Displacement In Liters

XXX = Engine Build Day (e.g., 027 = 27th Day of the Year)

Y = Last Digit of Year Engine Build (0 = 2000)

S = Shift Engine Built

PPPPP = Last 5 Digits of Engine Assembly Part Number

NNNN = Engine Serial Code (1263 = The 1263rd engine built that day)

8087d8b1

Fig. 2 Engine Identification Number

## ENGINE 5.9L (Continued)

**DIAGNOSIS AND TESTING—ENGINE****DIAGNOSIS - INTRODUCTION**

Engine diagnosis is helpful in determining the causes of malfunctions not detected and remedied by routine maintenance.

These malfunctions may be classified as either mechanical (e.g., a strange noise), or performance (e.g., engine idles rough and stalls).

(Refer to 9 - ENGINE - DIAGNOSIS AND TESTING - Performance) or (Refer to 9 - ENGINE - DIAGNOSIS AND TESTING - Mechanical). Refer to 14 - FUEL SYSTEM for fuel system diagnosis.

Additional tests and diagnostic procedures may be necessary for specific engine malfunctions that cannot be isolated with the Service Diagnosis charts. Information concerning additional tests and diagnosis is provided within the following:

- Cylinder Compression Pressure Test
- Cylinder Combustion Pressure Leakage Test
- Cylinder Head Gasket Failure Diagnosis
- Intake Manifold Leakage Diagnosis
- Lash Adjuster (Tappet) Noise Diagnosis
- Engine Oil Leak Inspection

**DIAGNOSIS AND TESTING—PERFORMANCE***PERFORMANCE DIAGNOSIS CHART—GASOLINE ENGINES*

CONDITION	POSSIBLE CAUSES	CORRECTION
ENGINE WILL NOT CRANK	<ol style="list-style-type: none"> <li>1. Weak or dead battery</li> <li>2. Corroded or loose battery connections</li> <li>3. Faulty starter or related circuit(s)</li> <li>4. Seized accessory drive component</li> <li>5. Engine internal mechanical failure or hydro-static lock</li> </ol>	<ol style="list-style-type: none"> <li>1. Charge/Replace Battery. (Refer to 8 - ELECTRICAL/BATTERY SYSTEM/BATTERY - STANDARD PROCEDURE). Check charging system. (Refer to 8 - ELECTRICAL/CHARGING - DIAGNOSIS AND TESTING).</li> <li>2. Clean/tighten suspect battery/starter connections</li> <li>3. Check starting system. (Refer to 8 - ELECTRICAL/STARTING - DIAGNOSIS AND TESTING)</li> <li>4. Remove accessory drive belt and attempt to start engine. If engine starts, repair/replace seized component.</li> <li>5. Refer to (Refer to 9 - ENGINE - DIAGNOSIS AND TESTING)</li> </ol>
ENGINE CRANKS BUT WILL NOT START	<ol style="list-style-type: none"> <li>1. No spark</li> <li>2. No fuel</li> <li>3. Low or no engine compression</li> </ol>	<ol style="list-style-type: none"> <li>1. Check for spark. (Refer to 8 - ELECTRICAL/IGNITION CONTROL - DESCRIPTION)</li> <li>2. Perform fuel pressure test, and if necessary, inspect fuel injector(s) and driver circuits. (Refer to 14 - FUEL SYSTEM/FUEL DELIVERY/FUEL PUMP - DIAGNOSIS AND TESTING).</li> <li>3. Perform cylinder compression pressure test. (Refer to 9 - ENGINE - DIAGNOSIS AND TESTING).</li> </ol>

## ENGINE 5.9L (Continued)

CONDITION	POSSIBLE CAUSES	CORRECTION
ENGINE LOSS OF POWER	<ol style="list-style-type: none"> <li>1. Worn or burned distributor rotor</li> <li>2. Worn distributor shaft</li>   <li>3. Worn or incorrect gapped spark plugs</li> <li>4. Dirt or water in fuel system</li> <li>5. Faulty fuel pump</li> <li>6. Incorrect valve timing</li> <li>7. Blown cylinder head gasket</li> <li>8. Low compression</li>   <li>9. Burned, warped, or pitted valves</li> <li>10. Plugged or restricted exhaust system</li> <li>11. Faulty ignition cables</li> <li>12. Faulty ignition coil</li> </ol>	<ol style="list-style-type: none"> <li>1. Install new distributor rotor</li> <li>2. Remove and repair distributor (Refer to 8 - ELECTRICAL/IGNITION CONTROL/DISTRIBUTOR - REMOVAL).</li> <li>3. Clean plugs and set gap. (Refer to 8 - ELECTRICAL/IGNITION CONTROL/SPARK PLUG - CLEANING).</li> <li>4. Clean system and replace fuel filter</li> <li>5. Install new fuel pump</li> <li>6. Correct valve timing</li> <li>7. Install new cylinder head gasket</li> <li>8. Test cylinder compression (Refer to 9 - ENGINE - DIAGNOSIS AND TESTING).</li> <li>9. Install/Reface valves as necessary</li> <li>10. Install new parts as necessary</li> <li>11. Replace any cracked or shorted cables</li> <li>12. Test and replace, as necessary (Refer to 8 - ELECTRICAL/IGNITION CONTROL/IGNITION COIL - REMOVAL).</li> </ol>
ENGINE STALLS OR ROUGH IDLE	<ol style="list-style-type: none"> <li>1. Carbon build-up on throttle plate</li>   <li>2. Engine idle speed too low</li>   <li>3. Worn or incorrectly gapped spark plugs</li> <li>4. Worn or burned distributor rotor</li> <li>5. Spark plug cables defective or crossed</li>   <li>6. Faulty coil</li> </ol>	<ol style="list-style-type: none"> <li>1. Remove throttle body and de-carbon. (Refer to 14 - FUEL SYSTEM/FUEL INJECTION/THROTTLE BODY - REMOVAL).</li> <li>2. Check Idle Air Control circuit. (Refer to 14 - FUEL SYSTEM/FUEL INJECTION/IDLE AIR CONTROL MOTOR - DESCRIPTION)</li> <li>3. Replace or clean and re-gap spark plugs (Refer to 8 - ELECTRICAL/IGNITION CONTROL/SPARK PLUG - CLEANING)</li> <li>4. Install new distributor rotor</li> <li>5. Check for correct firing order or replace spark plug cables. (Refer to 8 - ELECTRICAL/IGNITION CONTROL/SPARK PLUG CABLE - DIAGNOSIS AND TESTING)</li> <li>6. Test and replace, if necessary (Refer to 8 - ELECTRICAL/IGNITION CONTROL/IGNITION COIL - REMOVAL)</li> </ol>



## ENGINE 5.9L (Continued)

CONDITION	POSSIBLE CAUSES	CORRECTION
	7. Intake manifold vacuum leak	7. Inspect intake manifold gasket and vacuum hoses (Refer to 9 - ENGINE/MANIFOLDS/INTAKE MANIFOLD - DIAGNOSIS AND TESTING).
ENGINE MISSES ON ACCELERATION	1. Worn or incorrectly gapped spark plugs 2. Spark plug cables defective or crossed 3. Dirt in fuel system 4. Burned, warped or pitted valves 5. Faulty coil	1. Replace spark plugs or clean and set gap. (Refer to 8 - ELECTRICAL/IGNITION CONTROL/SPARK PLUG - CLEANING) 2. Replace or rewire secondary ignition cables. (Refer to 8 - ELECTRICAL/IGNITION CONTROL/SPARK PLUG CABLE - REMOVAL) 3. Clean fuel system 4. Install new valves 5. Test and replace as necessary (Refer to 8 - ELECTRICAL/IGNITION CONTROL/IGNITION COIL - REMOVAL)

## DIAGNOSIS AND TESTING— MECHANICAL

## ENGINE MECHANICAL DIAGNOSIS CHART

CONDITION	POSSIBLE CAUSES	CORRECTION
NOISY VALVES/LIFTERS	1. High or low oil level in crankcase 2. Thin or diluted oil 3. Low oil pressure 4. Dirt in tappets/lash adjusters 5. Bent push rod(s) 6. Worn rocker arms 7. Worn tappets/lash adjusters 8. Worn valve guides 9. Excessive runout of valve seats or valve faces	1. Check for correct oil level. Adjust oil level by draining or adding as needed 2. Change oil. (Refer to 9 - ENGINE/LUBRICATION/OIL - STANDARD PROCEDURE) 3. Check engine oil level. If ok, Perform oil pressure test. (Refer to 9 - ENGINE/LUBRICATION - DIAGNOSIS AND TESTING) for engine oil pressure test/specifications 4. Clean/replace hydraulic tappets/lash adjusters 5. Install new push rods 6. Inspect oil supply to rocker arms and replace worn arms as needed 7. Install new hydraulic tappets/lash adjusters 8. Inspect all valve guides and replace as necessary 9. Grind valves and seats

## ENGINE 5.9L (Continued)

CONDITION	POSSIBLE CAUSES	CORRECTION
CONNECTING ROD NOISE	<ol style="list-style-type: none"> <li>1. Insufficient oil supply</li> <li>2. Low oil pressure</li> <li>3. Thin or diluted oil</li> <li>4. Excessive connecting rod bearing clearance</li> <li>5. Connecting rod journal out of round</li> <li>6. Misaligned connecting rods</li> </ol>	<ol style="list-style-type: none"> <li>1. Check engine oil level.</li> <li>2. Check engine oil level. If ok, Perform oil pressure test. (Refer to 9 - ENGINE/LUBRICATION - DIAGNOSIS AND TESTING) engine oil pressure test/specifications</li> <li>3. Change oil to correct viscosity. (Refer to 9 - ENGINE/LUBRICATION/OIL - STANDARD PROCEDURE) for correct procedure/engine oil specifications</li> <li>Measure bearings for correct clearance with plasti-gage. Repair as necessary</li> <li>5. Replace crankshaft or grind journals</li> <li>6. Replace bent connecting rods</li> </ol>
MAIN BEARING NOISE	<ol style="list-style-type: none"> <li>1. Insufficient oil supply</li> <li>2. Low oil pressure</li> <li>3. Thin or diluted oil</li> <li>4. Excessive main bearing clearance</li> <li>5. Excessive end play</li> <li>6. Crankshaft main journal out of round or worn</li> <li>7. Loose flywheel or torque converter</li> </ol>	<ol style="list-style-type: none"> <li>1. Check engine oil level.</li> <li>2. Check engine oil level. If ok, Perform oil pressure test. (Refer to 9 - ENGINE/LUBRICATION - DIAGNOSIS AND TESTING)</li> <li>3. Change oil to correct viscosity.</li> <li>4. Measure bearings for correct clearance. Repair as necessary</li> <li>5. Check crankshaft thrust bearing for excessive wear on flanges</li> <li>6. Grind journals or replace crankshaft</li> <li>7. Inspect crankshaft, flexplate/flywheel and bolts for damage. Tighten to correct torque</li> </ol>
LOW OIL PRESSURE	<ol style="list-style-type: none"> <li>1. Low oil level</li> <li>2. Faulty oil pressure sending unit</li> <li>3. Clogged oil filter</li> <li>4. Worn oil pump</li> <li>5. Thin or diluted oil</li> <li>6. Excessive bearing clearance</li> <li>7. Oil pump relief valve stuck</li> <li>8. Oil pump suction tube loose, broken, bent or clogged</li> <li>9. Oil pump cover warped or cracked</li> </ol>	<ol style="list-style-type: none"> <li>1. Check oil level and fill if necessary</li> <li>2. Install new sending unit</li> <li>3. Install new oil filter</li> <li>4. Replace oil pump assembly.</li> <li>5. Change oil to correct viscosity.</li> <li>6. Measure bearings for correct clearance</li> <li>7. Remove valve to inspect, clean and reinstall</li> <li>8. Inspect suction tube and clean or replace if necessary</li> <li>9. Install new oil pump</li> </ol>

## ENGINE 5.9L (Continued)

CONDITION	POSSIBLE CAUSES	CORRECTION
OIL LEAKS	<ol style="list-style-type: none"> <li>1. Misaligned or deteriorated gaskets</li> <li>2. Loose fastener, broken or porous metal part</li> <li>3. Front or rear crankshaft oil seal leaking</li> <li>4. Leaking oil gallery plug or cup plug</li> </ol>	<ol style="list-style-type: none"> <li>1. Replace gasket</li> <li>2. Tighten, repair or replace the part</li> <li>3. Replace seal</li> <li>4. Remove and reseal threaded plug. Replace cup style plug</li> </ol>
EXCESSIVE OIL CONSUMPTION OR SPARK PLUGS OIL FOULED	<ol style="list-style-type: none"> <li>1. CCV System malfunction</li> <li>2. Defective valve stem seal(s)</li> <li>3. Worn or broken piston rings</li> <li>4. Scuffed pistons/cylinder walls</li> <li>5. Carbon in oil control ring groove</li> <li>6. Worn valve guides</li> <li>7. Piston rings fitted too tightly in grooves</li> </ol>	<ol style="list-style-type: none"> <li>1. (Refer to 25 - EMISSIONS CONTROL/EVAPORATIVE EMISSIONS - DESCRIPTION) for correct operation</li> <li>2. Repair or replace seal(s)</li> <li>3. Hone cylinder bores. Install new rings</li> <li>4. Hone cylinder bores and replace pistons as required</li> <li>5. Remove rings and de-carbon piston</li> <li>6. Inspect/replace valve guides as necessary</li> <li>7. Remove rings and check ring end gap and side clearance. Replace if necessary</li> </ol>

## ENGINE 5.9L (Continued)

## DIAGNOSIS AND TESTING—LUBRICATION

CONDITION	POSSIBLE CAUSES	CORRECTION
OIL LEAKS	<ol style="list-style-type: none"> <li>1. Gaskets and O-Rings.               <ol style="list-style-type: none"> <li>(a) Misaligned or damaged.</li> <li>(b) Loose fasteners, broken or porous metal parts.</li> </ol> </li> <li>2. Crankshaft rear seal</li> <li>3. Crankshaft seal flange. Scratched, nicked or grooved.</li> <li>4. Oil pan flange cracked.</li> <li>5. Timing chain cover seal, damaged or misaligned.</li> <li>6. Scratched or damaged vibration damper hub.</li> </ol>	<ol style="list-style-type: none"> <li>1.               <ol style="list-style-type: none"> <li>(a) Replace as necessary.</li> <li>(b) Tighten fasteners, Repair or replace metal parts.</li> </ol> </li> <li>2. Replace as necessary.</li> <li>3. Polish or replace crankshaft.</li> <li>4. Replace oil pan.</li> <li>5. Replace seal.</li> <li>6. Polish or replace damper.</li> </ol>
OIL PRESSURE DROP	<ol style="list-style-type: none"> <li>1. Low oil level.</li> <li>2. Faulty oil pressure sending unit.</li> <li>3. Low oil pressure.</li> <li>4. Clogged oil filter.</li> <li>5. Worn oil pump.</li> <li>6. Thin or diluted oil.</li> <li>7. Excessive bearing clearance.</li> <li>8. Oil pump relief valve stuck.</li> <li>9. Oil pump suction tube loose or damaged.</li> </ol>	<ol style="list-style-type: none"> <li>1. Check and correct oil level.</li> <li>2. Replace sending unit.</li> <li>3. Check pump and bearing clearance.</li> <li>4. Replace oil filter.</li> <li>5. Replace as necessary.</li> <li>6. Change oil and filter.</li> <li>7. Replace as necessary.</li> <li>8. Clean or replace relief valve.</li> <li>9. Replace as necessary.</li> </ol>
OIL PUMPING AT RINGS; SPARK PLUGS FOULING	<ol style="list-style-type: none"> <li>1. Worn or damaged rings.</li> <li>2. Carbon in oil ring slots.</li> <li>3. Incorrect ring size installed.</li> <li>4. Worn valve guides.</li> <li>5. Leaking intake gasket.</li> <li>6. Leaking valve guide seals.</li> </ol>	<ol style="list-style-type: none"> <li>1. Hone cylinder bores and replace rings.</li> <li>2. Replace rings.</li> <li>3. Replace rings.</li> <li>4. Ream guides and replace valves.</li> <li>5. Replace intake gaskets.</li> <li>6. Replace valve guide seals.</li> </ol>

ENGINE 5.9L (Continued)

**DIAGNOSIS AND TESTING—CYLINDER COMPRESSION PRESSURE**

The results of a cylinder compression pressure test can be utilized to diagnose several engine malfunctions.

Ensure the battery is completely charged and the engine starter motor is in good operating condition. Otherwise, the indicated compression pressures may not be valid for diagnosis purposes.

- (1) Clean the spark plug recesses with compressed air.
- (2) Remove the spark plugs (Refer to 8 - ELECTRICAL/IGNITION CONTROL/SPARK PLUG - REMOVAL).
- (3) Secure the throttle in the wide-open position.
- (4) Disconnect the ignition coil.
- (5) Insert a compression pressure gauge and rotate the engine with the engine starter motor for three revolutions.
- (6) Record the compression pressure on the third revolution. Continue the test for the remaining cylinders.

(Refer to 9 - ENGINE - SPECIFICATIONS) for the correct engine compression pressures.

**DIAGNOSIS AND TESTING—CYLINDER COMBUSTION PRESSURE LEAKAGE**

The combustion pressure leakage test provides an accurate means for determining engine condition.

Combustion pressure leakage testing will detect:

- Exhaust and intake valve leaks (improper seating)
- Leaks between adjacent cylinders or into water jacket

- Any causes for combustion/compression pressure loss

**WARNING: DO NOT REMOVE THE RADIATOR CAP WITH THE SYSTEM HOT AND UNDER PRESSURE. SERIOUS BURNS FROM HOT COOLANT CAN OCCUR.**

Check the coolant level and fill as required. DO NOT install the radiator cap.

Start and operate the engine until it attains normal operating temperature, then turn OFF the engine.

- Remove the spark plugs.
- Remove the oil filler cap.
- Remove the air cleaner.

Calibrate the tester according to the manufacturer's instructions. The shop air source for testing should maintain 483 kPa (70 psi) minimum, 1,379 kPa (200 psi) maximum and 552 kPa (80 psi) recommended.

Perform the test procedure on each cylinder according to the tester manufacturer's instructions. While testing, listen for pressurized air escaping through the throttle body, tailpipe or oil filler cap opening. Check for bubbles in the radiator coolant.

All gauge pressure indications should be equal, with no more than 25% leakage.

**FOR EXAMPLE:** At 552 kPa (80 psi) input pressure, a minimum of 414 kPa (60 psi) should be maintained in the cylinder.

Refer to CYLINDER COMBUSTION PRESSURE LEAKAGE DIAGNOSIS CHART below

*CYLINDER COMBUSTION PRESSURE LEAKAGE DIAGNOSIS CHART*

CONDITION	POSSIBLE CAUSE	CORRECTION
AIR ESCAPES THROUGH THROTTLE BODY	Intake valve bent, burnt, or not seated properly	Inspect valve and valve seat. Reface or replace, as necessary
AIR ESCAPES THROUGH TAILPIPE	Exhaust valve bent, burnt, or not seated properly	Inspect valve and valve seat. Reface or replace, as necessary
AIR ESCAPES THROUGH RADIATOR	Head gasket leaking or cracked cylinder head or block	Remove cylinder head and inspect. Replace defective part
MORE THAN 50% LEAKAGE FROM ADJACENT CYLINDERS	Head gasket leaking or crack in cylinder head or block between adjacent cylinders	Remove cylinder head and inspect. Replace gasket, head, or block as necessary
MORE THAN 25% LEAKAGE AND AIR ESCAPES THROUGH OIL FILLER CAP OPENING ONLY	Stuck or broken piston rings; cracked piston; worn rings and/or cylinder wall	Inspect for broken rings or piston. Measure ring gap and cylinder diameter, taper and out-of-round. Replace defective part as necessary

## ENGINE 5.9L (Continued)

**STANDARD PROCEDURE—FORM-IN-PLACE GASKETS & SEALERS**

There are numerous places where form-in-place gaskets are used on the engine. Care must be taken when applying form-in-place gaskets to assure obtaining the desired results. **Do not use form-in-place gasket material unless specified.** Bead size, continuity, and location are of great importance. Too thin a bead can result in leakage while too much can result in spill-over which can break off and obstruct fluid feed lines. A continuous bead of the proper width is essential to obtain a leak-free gasket.

There are numerous types of form-in-place gasket materials that are used in the engine area. Mopar® Engine RTV GEN II, Mopar® ATF-RTV, and Mopar® Gasket Maker gasket materials, each have different properties and can not be used in place of the other.

**MOPAR® ENGINE RTV GEN II**

Mopar® Engine RTV GEN II is used to seal components exposed to engine oil. This material is a specially designed black silicone rubber RTV that retains adhesion and sealing properties when exposed to engine oil. Moisture in the air causes the material to cure. This material is available in three ounce tubes and has a shelf life of one year. After one year this material will not properly cure. Always inspect the package for the expiration date before use.

**MOPAR® ATF RTV**

Mopar® ATF RTV is a specifically designed black silicone rubber RTV that retains adhesion and sealing properties to seal components exposed to automatic transmission fluid, engine coolants, and moisture. This material is available in three ounce tubes and has a shelf life of one year. After one year this material will not properly cure. Always inspect the package for the expiration date before use.

**MOPAR® GASKET MAKER**

Mopar® Gasket Maker is an anaerobic type gasket material. The material cures in the absence of air when squeezed between two metallic surfaces. It will not cure if left in the uncovered tube. The anaerobic material is for use between two machined surfaces. Do not use on flexible metal flanges.

**MOPAR® GASKET SEALANT**

Mopar® Gasket Sealant is a slow drying, permanently soft sealer. This material is recommended for sealing threaded fittings and gaskets against leakage of oil and coolant. Can be used on threaded and machined parts under all temperatures. This material is used on engines with multi-layer steel (MLS) cylinder head gaskets. This material also will prevent corrosion. Mopar® Gasket Sealant is available in a 13 oz. aerosol can or 4oz./16 oz. can w/applicator.

**FORM-IN-PLACE GASKET AND SEALER APPLICATION**

Assembling parts using a form-in-place gasket requires care but it's easier than using pre-cut gaskets.

Mopar® Gasket Maker material should be applied sparingly 1 mm (0.040 in.) diameter or less of sealant to one gasket surface. Be certain the material surrounds each mounting hole. Excess material can easily be wiped off. Components should be torqued in place within 15 minutes. The use of a locating dowel is recommended during assembly to prevent smearing material off the location.

Mopar® Engine RTV GEN II or ATF RTV gasket material should be applied in a continuous bead approximately 3 mm (0.120 in.) in diameter. All mounting holes must be circled. For corner sealing, a 3.17 or 6.35 mm (1/8 or 1/4 in.) drop is placed in the center of the gasket contact area. Uncured sealant may be removed with a shop towel. Components should be torqued in place while the sealant is still wet to the touch (within 10 minutes). The usage of a locating dowel is recommended during assembly to prevent smearing material off the location.

Mopar® Gasket Sealant in an aerosol can should be applied using a thin, even coat sprayed completely over both surfaces to be joined, and both sides of a gasket. Then proceed with assembly. Material in a can w/applicator can be brushed on evenly over the sealing surfaces. Material in an aerosol can should be used on engines with multi-layer steel gaskets.

**STANDARD PROCEDURE—REPAIR DAMAGED OR WORN THREADS**

**CAUTION: Be sure that the tapped holes maintain the original center line.**

Damaged or worn threads can be repaired. Essentially, this repair consists of:

- Drilling out worn or damaged threads.
- Tapping the hole with a special Heli-Coil Tap, or equivalent.
- Installing an insert into the tapped hole to bring the hole back to its original thread size.

**STANDARD PROCEDURE—HYDROSTATIC LOCK**

**CAUTION: DO NOT use the starter motor to rotate the crankshaft. Severe damage could occur.**

When an engine is suspected of hydrostatic lock (regardless of what caused the problem), follow the steps below.



## ENGINE 5.9L (Continued)

(1) Perform the Fuel Pressure Release Procedure (Refer to 14 - FUEL SYSTEM/FUEL DELIVERY - STANDARD PROCEDURE).

(2) Disconnect the negative cable(s) from the battery.

(3) Inspect air cleaner, induction system, and intake manifold to ensure system is dry and clear of foreign material.

(4) Place a shop towel around the spark plugs to catch any fluid that may possibly be under pressure in the cylinder head. Remove the spark plugs.

(5) With all spark plugs removed, rotate the crankshaft using a breaker bar and socket.

(6) Identify the fluid in the cylinders (coolant, fuel, oil, etc.).

(7) Be sure all fluid has been removed from the cylinders.

(8) Repair engine or components as necessary to prevent this problem from occurring again.

(9) Squirt a small amount of engine oil into the cylinders to lubricate the walls. This will prevent damage on restart.

(10) Install new spark plugs. Tighten the spark plugs to 41 N·m (30 ft. lbs.) torque.

(11) Drain engine oil. Remove and discard the oil filter.

(12) Install the drain plug. Tighten the plug to 34 N·m (25 ft. lbs.) torque.

(13) Install a new oil filter.

(14) Fill engine crankcase with the specified amount and grade of oil. (Refer to LUBRICATION & MAINTENANCE - SPECIFICATIONS).

(15) Connect the negative cable(s) to the battery.

(16) Start the engine and check for any leaks.

## STANDARD PROCEDURE—CYLINDER BORE HONING

Before honing, stuff plenty of clean shop towels under the bores and over the crankshaft to keep abrasive materials from entering the crankshaft area.

(1) Used carefully, the Cylinder Bore Sizing Hone C-823, equipped with 220 grit stones, is the best tool for this job. In addition to deglazing, it will reduce taper and out-of-round, as well as removing light scuffing, scoring and scratches. Usually, a few strokes will clean up a bore and maintain the required limits.

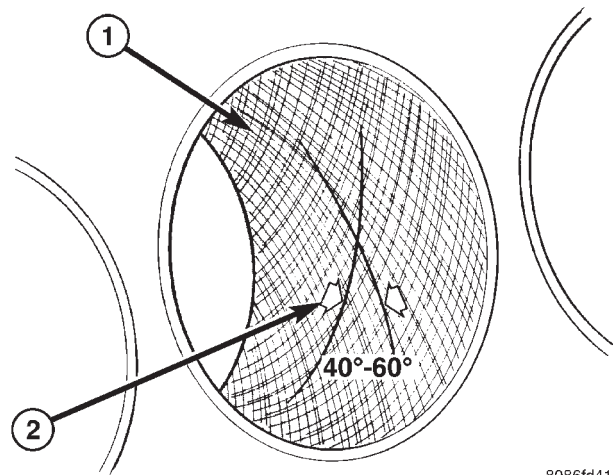
**CAUTION: DO NOT use rigid type hones to remove cylinder wall glaze.**

(2) Deglazing of the cylinder walls may be done if the cylinder bore is straight and round. Use a cylinder surfacing hone, Honing Tool C-3501, equipped with 280 grit stones (C-3501-3810). about 20-60

strokes, depending on the bore condition, will be sufficient to provide a satisfactory surface. Using honing oil C-3501-3880, or a light honing oil, available from major oil distributors.

**CAUTION: DO NOT use engine or transmission oil, mineral spirits, or kerosene.**

(3) Honing should be done by moving the hone up and down fast enough to get a crosshatch pattern. The hone marks should INTERSECT at 40° to 60° for proper seating of rings (Fig. 3).



**Fig. 3 Cylinder Bore Crosshatch Pattern**

1 - CROSSHATCH PATTERN

2 - INTERSECT ANGLE

(4) A controlled hone motor speed between 200 and 300 RPM is necessary to obtain the proper crosshatch angle. The number of up and down strokes per minute can be regulated to get the desired 40° to 60° angle. Faster up and down strokes increase the crosshatch angle.

(5) After honing, it is necessary that the block be cleaned to remove all traces of abrasive. Use a brush to wash parts with a solution of hot water and detergent. Dry parts thoroughly. Use a clean, white, lint-free cloth to check that the bore is clean. Oil the bores after cleaning to prevent rusting.

## REMOVAL

(1) Disconnect the battery negative cable.

(2) Drain cooling system (Refer to 7 - COOLING - STANDARD PROCEDURE).

(3) Recover refrigerant from a/c system, if equipped (Refer to 24 - HEATING & AIR CONDITIONING/PLUMBING - STANDARD PROCEDURE).

(4) Remove the a/c condenser, if equipped (Refer to 24 - HEATING & AIR CONDITIONING/PLUMBING/A/C CONDENSER - REMOVAL).

## ENGINE 5.9L (Continued)

(5) Remove the transmission oil cooler (Refer to 7 - COOLING/TRANSMISSION/TRANS COOLER - REMOVAL).

(6) Remove the washer bottle from the fan shroud.

(7) Remove the viscous fan/drive (Refer to 7 - COOLING/ENGINE/RADIATOR FAN - REMOVAL).

(8) Remove radiator (Refer to 7 - COOLING/ENGINE/RADIATOR - REMOVAL).

(9) Remove the upper crossmember and top core support.

(10) Remove the accessory drive belt (Refer to 7 - COOLING/ACCESSORY DRIVE/DRIVE BELTS - REMOVAL).

(11) Remove the A/C compressor with the lines attached. Secure compressor out of the way.

(12) Remove generator assembly (Refer to 8 - ELECTRICAL/CHARGING/GENERATOR - REMOVAL).

(13) Remove the air cleaner resonator and duct work as an assembly.

(14) Disconnect the throttle linkage (Refer to 14 - FUEL SYSTEM/FUEL INJECTION/THROTTLE CONTROL CABLE - REMOVAL).

(15) Remove throttle body (Refer to 14 - FUEL SYSTEM/FUEL INJECTION/THROTTLE BODY - REMOVAL).

(16) Remove the intake manifold (Refer to 9 - ENGINE/MANIFOLDS/INTAKE MANIFOLD - REMOVAL).

(17) Remove the distributor cap and wiring.

(18) Disconnect the heater hoses.

(19) Disconnect the power steering hoses, if equipped.

(20) Perform the Fuel System Pressure Release procedure (Refer to 14 - FUEL SYSTEM/FUEL DELIVERY - STANDARD PROCEDURE).

(21) Disconnect the fuel supply line (Refer to 14 - FUEL SYSTEM/FUEL DELIVERY/QUICK CONNECT FITTING - STANDARD PROCEDURE).

(22) On Manual Transmission vehicles, remove the shift lever (Refer to 21 - TRANSMISSION/TRAN-SAXLE/MANUAL/SHIFT COVER - REMOVAL).

(23) Raise and support the vehicle on a hoist and drain the engine oil.

(24) Remove engine front mount thru-bolt nuts.

(25) Disconnect the transmission oil cooler lines from their retainers at the oil pan bolts.

(26) Disconnect exhaust pipe at manifolds.

(27) Disconnect the starter wires. Remove starter motor (Refer to 8 - ELECTRICAL/STARTING/STARTER MOTOR - REMOVAL).

(28) Remove the dust shield and transmission inspection cover.

(29) Remove drive plate to converter bolts (Automatic transmission equipped vehicles).

(30) Remove transmission bell housing to engine block bolts.

(31) Lower the vehicle.

(32) Install an engine lifting fixture.

(33) Separate engine from transmission, remove engine from vehicle, and install engine assembly on a repair stand.

## INSTALLATION

(1) Remove engine from the repair stand and position in the engine compartment. Position the thru-bolt into the support cushion brackets.

(2) Install engine lifting device.

(3) Lower engine into compartment and align engine with transmission:

- Manual Transmission: Align clutch disc assembly (if disturbed). Install transmission input shaft into clutch disc while mating engine and transmission surfaces. Install two transmission to engine block mounting bolts finger tight.

- Automatic Transmission: Mate engine and transmission and install two transmission to engine block mounting bolts finger tight.

(4) Lower engine assembly until engine mount through bolts rest in mount perches.

(5) Install remaining transmission to engine block mounting bolts and tighten.

(6) Tighten engine mount through bolts.

(7) Install drive plate to torque converter bolts. (Automatic transmission models)

(8) Install the dust shield and transmission cover.

(9) Install the starter and connect the starter wires (Refer to 8 - ELECTRICAL/STARTING/STARTER MOTOR - INSTALLATION).

(10) Install exhaust pipe to manifold.

(11) Install the transmission cooler line brackets to the oil pan.

(12) Install the drain plug and tighten to 34 N·m (25 ft. lbs.) torque.

(13) Lower the vehicle.

(14) Remove engine lifting fixture.

(15) On Manual Transmission vehicles, install the shift lever (Refer to 21 - TRANSMISSION/TRAN-SAXLE/MANUAL/SHIFT COVER - INSTALLATION).

(16) Connect the fuel supply line (Refer to 14 - FUEL SYSTEM/FUEL DELIVERY/QUICK CONNECT FITTING - STANDARD PROCEDURE).

(17) Connect the power steering hoses, if equipped.

(18) Connect the heater hoses.

(19) Install the distributor cap and wiring.

(20) Install the intake manifold (Refer to 9 - ENGINE/MANIFOLDS/INTAKE MANIFOLD - INSTALLATION).

## ENGINE 5.9L (Continued)

(21) Using a new gasket, install throttle body (Refer to 14 - FUEL SYSTEM/FUEL INJECTION/THROTTLE BODY - INSTALLATION).

(22) Connect the throttle linkage (Refer to 14 - FUEL SYSTEM/FUEL INJECTION/THROTTLE CONTROL CABLE - INSTALLATION).

(23) Install the air cleaner resonator and duct work..

(24) Install the generator and wire connections (Refer to 8 - ELECTRICAL/CHARGING/GENERATOR - INSTALLATION).

(25) Install a/c compressor and lines (Refer to 24 - HEATING & AIR CONDITIONING/PLUMBING/A/C COMPRESSOR - INSTALLATION).

(26) Install the accessory drive belt (Refer to 7 - COOLING/ACCESSORY DRIVE/DRIVE BELTS - INSTALLATION).

(27) Install upper radiator support crossmember.

(28) Install radiator (Refer to 7 - COOLING/ENGINE/RADIATOR - INSTALLATION).

(29) Connect the radiator lower hose.

(30) Connect the transmission oil cooler lines to the radiator.

(31) Install the fan shroud.

(32) Install the fan (Refer to 7 - COOLING/ENGINE/RADIATOR FAN - INSTALLATION).

(33) Connect the radiator upper hose.

(34) Install the washer bottle.

(35) Install the transmission oil cooler (Refer to 7 - COOLING/TRANSMISSION/TRANS COOLER - INSTALLATION).

(36) Connect the transmission cooler lines.

(37) If equipped, install the condenser (Refer to 24 - HEATING & AIR CONDITIONING/PLUMBING/A/C CONDENSER - INSTALLATION).

(38) Evacuate and charge the air conditioning system, if equipped (Refer to 24 - HEATING & AIR CONDITIONING/PLUMBING - STANDARD PROCEDURE).

(39) Add engine oil to crankcase (Refer to LUBRICATION & MAINTENANCE/FLUID TYPES - SPECIFICATIONS).

(40) Fill cooling system (Refer to 7 - COOLING - STANDARD PROCEDURE).

(41) Connect battery negative cable.

(42) Start engine and inspect for leaks.

(43) Road test vehicle.

## ENGINE 5.9L (Continued)

## SPECIFICATIONS

## 5.9L ENGINE

## ENGINE SPECIFICATIONS

DESCRIPTION	SPECIFICATION
<b>GENERAL SPECIFICATIONS</b>	
Engine Type	90° V-8 OHV
Bore and Stroke	101.6 x 90.9 mm (4.00 x 3.58 in.)
Displacement	5.9L (360 c.i.)
Compression Ratio	9.1:1
Firing Order	1-8-4-3-6-5-7-2
Lubrication	Pressure Feed – Full Flow Filtration
Cooling System	Liquid Cooled – Forced Circulation
Cylinder Block	Cast Iron
Cylinder Head	Cast Iron
Crankshaft	Nodular Iron
Camshaft	Nodular Cast Iron
Pistons	Aluminum Alloy w/strut
Connecting Rods	Forged Steel
Compression Pressure	689.5 kPa (100 psi) (Min.)
<b>CAMSHAFT</b>	
Bearing Diameter	
No. 1	50.800 – 50.825 mm (2.000 – 2.001 in.)
No. 2	50.394 – 50.419 mm (1.984 – 1.985 in.)
No. 3	50.013 – 50.038 mm (1.969 – 1.970 in.)
No. 4	49.606 – 49.632 mm (1.953 – 1.954 in.)
No. 5	39.688 – 39.713 mm (1.5625 – 1.5635 in.)

DESCRIPTION	SPECIFICATION
Bearing Journal Diameter	
No. 1	50.723 – 50.775 mm (1.997 – 1.999 in.)
No. 2	50.317 – 50.368 mm (1.981 – 1.983 in.)
No. 3	49.936 – 49.987 mm (1.966 – 1.968 in.)
No. 4	49.53 – 49.581 mm (1.950 – 1.952 in.)
No. 5	39.611 – 39.662 mm (1.5595 – 1.5615 in.)
Bearing to Journal Clearance	
Standard	0.0254 – 0.0762 mm (0.001 – 0.003 in.)
Service Limit	0.127 mm (0.005 in.)
Camshaft End Play	0.051 – 0.254 mm (0.002 – 0.010 in.)
<b>CONNECTING RODS</b>	
Piston Pin bore Diameter	24.966 – 24.978 mm (0.9829 – 0.9834 in.)
Side Clearance	0.152 – 0.356 mm (0.006 – 0.014 in.)
<b>CRANKSHAFT</b>	
Rod Journal Diameter	53.950 – 53.975 mm (2.124 – 2.125 in.)
Out of Round (Max.)	0.0254 mm (0.001 in.)
Taper (Max.)	0.0254 mm (0.001 in.)
Bearing Clearance	0.013 – 0.056 mm (0.0005 – 0.0022 in.)
Main Bearing Journal	
Diameter	71.361 – 71.387 mm (2.8095 – 2.8105 in.)
Out of Round (Max.)	0.127 mm (0.001 in.)
Taper (Max.)	0.0254 mm (0.001 in.)

## ENGINE 5.9L (Continued)

DESCRIPTION	SPECIFICATION
Bearing Clearance	
Journal #1	0.013 – 0.038 mm (0.0005 – 0.0015 in.)
Journals # 2 - 5	0.013 – 0.051 mm (0.0005 – 0.002 in.)
Service Limit	
Journal #1	0.0381 mm (0.0015 in.)
Journals #2-5	0.064 mm (0.0025 in.)
Crankshaft End Play	0.051 – 0.178 mm (0.002 – 0.007 in.)
Service Limit	0.254 mm (0.010 in.)
<b>CYLINDER BLOCK</b>	
Cylinder Bore	
Diameter	101.60 – 101.65 mm (4.000 – 4.002 in.)
Out of Round (Max.)	0.0254 mm (0.001 in.)
Taper (Max.)	0.0254 mm (0.001 in.)
Lifter Bore	
Diameter	22.99 – 23.01 mm (0.9051 – 0.9059 in.)
Distributor Drive Bushing	
Press Fit	
Bushing to Bore	0.0127 – 0.3556 mm
Interference	(0.0005 – 0.0140 in.)
Shaft to Bushing	0.0178 – 0.0686 mm
Clearance	(0.0007 – 0.0027 in.)
<b>CYLINDER HEAD AND VALVES</b>	
Valve Seat	
Angle	44.25° – 44.75°
Runout (Max.)	0.0762 mm (0.003 in.)
Width (Finish)	
Intake	1.016 – 1.524 mm (0.040 – 0.060 in.)
Exhaust	1.524 – 2.032 mm (0.060 – 0.080 in.)

DESCRIPTION	SPECIFICATION
Valves	
Face Angle	43.25° – 43.75°
Head Diameter	
Intake	47.752 mm (1.88 in.)
Exhaust	41.072 (1.617 in.)
Length (Overall)	
Intake	126.21 – 126.85 mm (4.969 – 4.994 in.)
Exhaust	126.44 – 127.30 mm (4.978 – 5.012 in.)
Lift (@ zero lash)	
Intake	10.414 mm (0.410 in.)
Exhaust	10.592 mm (0.417 in.)
Stem Diameter	
Intake	9.449 – 9.474 mm (0.372 – 0.373 in.)
Exhaust	9.423 – 9.449 mm (0.371 – 0.372 in.)
Guide Bore	9.500 – 9.525 mm (0.374 – 0.375 on.)
Stem to Guide Clearance	
Intake	0.0254 – 0.0762 mm (0.001 – 0.003 in.)
Exhaust	0.0508 – 0.1016 mm (0.002 – 0.004 in.)
Service Limit	0.4318 (0.017 in.)
Valve Springs	
Free Length	49.962 mm (1.967 in.)
Spring Tension	
Valve closed	378 N @ 41.66 mm (85 lbs. @ 1.64 in.)
Valve open	890 N @ 30.89 mm (200 lbs. @ 1.212 in.)
Number of Coils	6.8
Installed Height	41.66 mm (1.64 in.)
Wire Diameter	4.50 mm (0.177 in.)

## ENGINE 5.9L (Continued)

DESCRIPTION	SPECIFICATION
<b>HYDRAULIC TAPPETS</b>	
Body Diameter	22.949 – 22.962 mm (0.9035 – 0.9040 in.)
Clearance (to bore)	0.0279 – 0.0610 mm (0.0011 – 0.0024 in.)
Dry Lash	1.524 – 5.334 mm (0.060 – 0.210 in.)
Push Rod Length	175.64 – 176.15 mm (6.915 – 6.935 in.)
<b>OIL PRESSURE</b>	
Curb Idle (Min.*)	41.4 kPa (6 psi)
@ 3000 rpm	207 – 552 kPa (30 – 80 psi)
Oil Pressure Bypass Valve Setting	62 – 103 kPa (9 – 15 psi)
Switch Actuating Pressure	34.5 – 48.3 kPa (5 – 7 psi)
<b>* If oil pressure is zero at curb idle, DO NOT RUN ENGINE.</b>	
<b>OIL PUMP</b>	
Clearance over Rotors (Max.)	0.1016 mm (0.004 in.)
Cover Out of Flat (Max.)	0.0381 mm (0.0015 in.)
Inner Rotor Thickness (Min.)	20.955 mm (0.825 in.)
Outer Rotor Clearance (Max.)	0.3556 mm (0.014 in.)
Diameter (Min.)	62.7126 mm (2.469 in.)
Thickness (Min.)	20.955 mm (0.825 in.)
Tip Clearance between Rotors (Max.)	0.2032 mm (0.008 in.)
<b>PISTONS</b>	
Clearance at Top of Skirt	0.013 – 0.038 mm (0.0005 – 0.0015 in.)
Land Clearance (Diam.)	0.508 – 0.660 mm (0.020 – 0.026 in.)

DESCRIPTION	SPECIFICATION
Piston Length	81.03 mm (3.19 in.)
Piston Ring Groove Depth	
Groove #1&2	4.761 – 4.912 mm (0.187 – 0.193 in.)
Groove #3	3.996 – 4.177 mm (0.157 – 0.164 in.)
Weight	582 – 586 grams (20.53 – 20.67 oz.)
<b>PISTON PINS</b>	
Clearance in Piston	0.006 – 0.019 mm (0.00023 – 0.00074 in.)
Diameter	25.007 – 25.015 mm (0.9845 – 0.9848 in.)
End Play	NONE
Length	67.8 – 68.3 mm (2.67 – 2.69 in.)
<b>PISTON RINGS</b>	
Ring Gap	
Compression Ring (Top)	0.30 – 0.55 mm (0.012 – 0.022 in.)
Compression Ring (2nd)	0.55 – 0.80 mm (0.022 – 0.031 in.)
Oil Control (Steel Rails)	0.381 – 1.397 mm (0.015 – 0.055 in.)
Ring Side Clearance	
Compression Rings	0.040 – 0.085 mm (0.0016 – 0.0033 in.)
Oil Ring (Steel Rails)	0.05 – 0.21 mm (0.002 – 0.008 in.)
Ring Width	
Compression rings	1.530 – 1.555 mm (0.060 – 0.061 in.)
Oil Ring (Steel Rails) – Max.	0.447 – 0.473 mm (0.018 – 0.019 in.)



## ENGINE 5.9L (Continued)

DESCRIPTION	SPECIFICATION
<b>VALVE TIMING</b>	
Exhaust Valve	
Closes (ATDC)	33°
Opens (BBDC)	56°
Duration	269°
Intake Valve	
Closes (ATDC)	62°
Opens (BBDC)	7°
Duration	249°
Valve Overlap	41°

OVERSIZE AND UNDERSIZE ENGINE  
COMPONENT MARKINGS CHART

OS-US	Item	Identification	Location of Identification
U/S .025 MM (.001 IN.)	Crankshaft	R or M M-2-3 ect. (indicating No. 2 & 3 main bearing journal) and/or R-1-4 ect. (indicating No. 1 & 4 connecting rod journal)	Milled flat on No. three crankshaft counterweight.
O/S .508 mm (.020 in.)	Cylinder Bores	A	Following engine serial number.
O/S .203 mm (.008 in.)	Tappets	◇	3/8" diamound-shaped stamp Top pad — Front of engine and flat ground on outside surface of each O/S tappet bore.
O/S .127 mm (0.005 in.)	Valve Stems	X	Milled pad adjacent to two 3/8" tapped holes on each end of cylinder head.

## ENGINE 5.9L (Continued)

## TORQUE

## TORQUE CHART 5.9L ENGINE

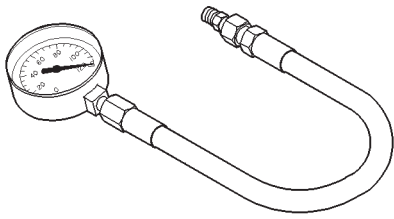
DESCRIPTION	N·m	Ft. Lbs.	In. Lbs.
Camshaft Sprocket—Bolt	68	50	—
Camshaft Thrust Plate—Bolts	24	—	210
Timing Chain Case Cover—Bolts	41	30	—
Connecting Rod Cap—Bolts	61	45	—
Main Bearing Cap—Bolts	115	85	—
Crankshaft Pulley—Bolts	24	—	210
Cylinder Head—Bolts			
Step 1	68	50	—
Step 2	143	105	—
Cylinder Head Cover—Bolts	11	—	95
Engine Support Bracket to Block—Bolts (4WD)	41	30	—
Exhaust Manifold to Cylinder Head—Bolts/Nuts	34	25	—
Flywheel—Bolts	75	55	—
Front Insulator—Through bolt/nut	95	70	—
Front Insulator to Support Bracket			
—Stud Nut (4WD)	41	30	—
—Through Bolt/Nut (4WD)	102	75	—
Front Insulator to Block—Bolts (2WD)	95	70	—
Generator—Mounting Bolt	41	30	—
Intake Manifold—Bolts	Refer to Procedure		
Oil Pan—Bolts	24	—	215
Oil Pan—Drain Plug	34	25	—
Oil Pump—Attaching Bolts	41	30	—
Oil Pump Cover—Bolts	11	—	95
Rear Insulator to Bracket—Through-Bolt (2WD)	68	50	—
Rear Insulator to Crossmember Support Bracket—Nut (2WD)	41	30	—
Rear Insulator to Crossmember—Nuts (4WD)	68	50	—

DESCRIPTION	N·m	Ft. Lbs.	In. Lbs.
Rear Insulator to Transmission—Bolts (4WD)	68	50	—
Rear Insulator Bracket—Bolts (4WD Automatic)	68	50	—
Rear Support Bracket to Crossmember Flange—Nuts	41	30	—
Rear Support Plate to Transfer Case—Bolts	41	30	—
Rocker Arm—Bolts	28	21	—
Spark Plugs	41	30	—
Starter Motor—Mounting Bolts	68	50	—
Thermostat Housing—Bolts	25	—	225
Throttle Body—Bolts	23	—	200
Torque Converter Drive Plate—Bolts	31	—	270
Transfer Case to Insulator Mounting Plate—Nuts	204	105	—
Transmission Support Bracket—Bolts (2WD)	68	50	—
Vibration Damper—Bolt	244	180	—
Water Pump to Timing Chain Case Cover—Bolts	41	30	—

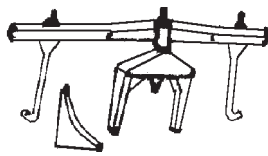
ENGINE 5.9L (Continued)

SPECIAL TOOLS

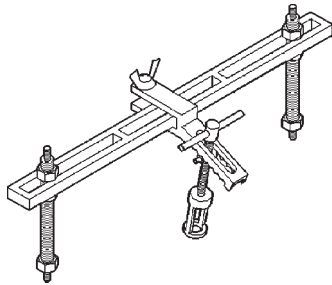
5.9L ENGINE



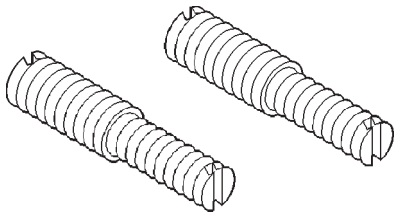
**Oil Pressure Gauge C-3292**



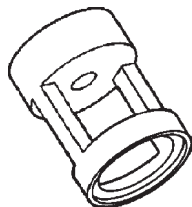
**Engine Support Fixture C-3487-A**



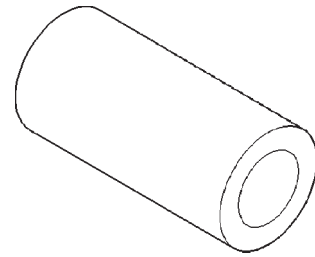
**Valve Spring Compressor MD-998772-A**



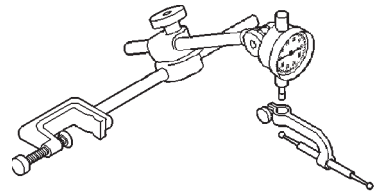
**Adaptor 6633**



**Adaptor 6716A**

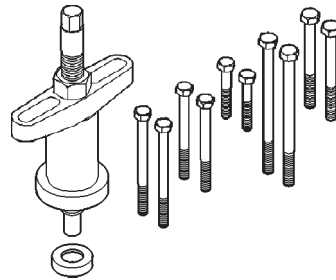


**Valve Guide Sleeve C-3973**

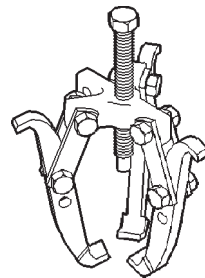


9011442b

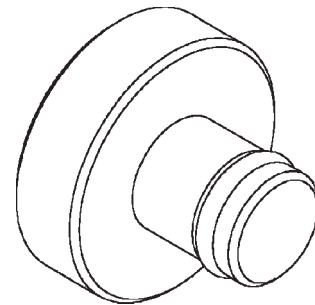
**Dial Indicator C-3339**



**Puller C-3688**

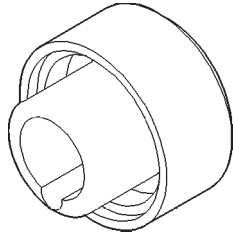


**Puller 1026**

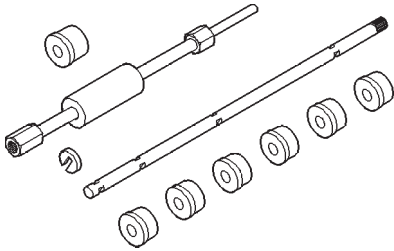


**Crankshaft Damper Removal Insert 8513**

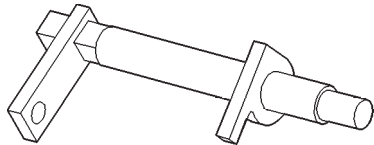
ENGINE 5.9L (Continued)



**Front Oil Seal Installer 6635**

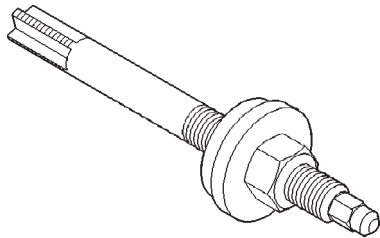


**Cam Bearing Remover/Installer C3132-A**

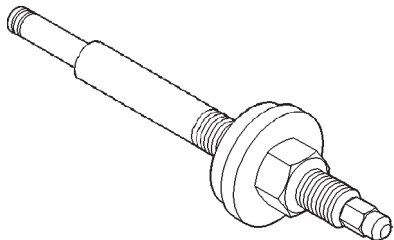


c-3509-8011d343

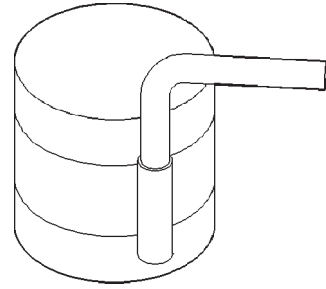
**Camshaft Holder C-3509**



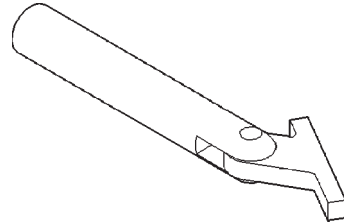
**Distributor Bushing Puller C-3052**



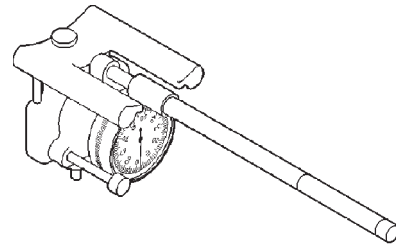
**Distributor Bushing Driver/Burnisher C-3053**



**Piston Ring Compressor C-385**

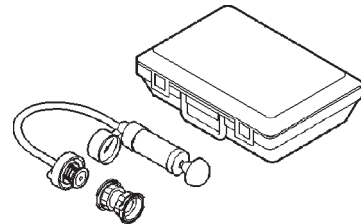


**Crankshaft Main Bearing Remover C-3059**

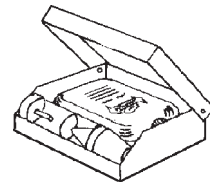


8011c91a

**Cylinder Bore Gauge C-119**



**Pressure Tester Kit 7700**

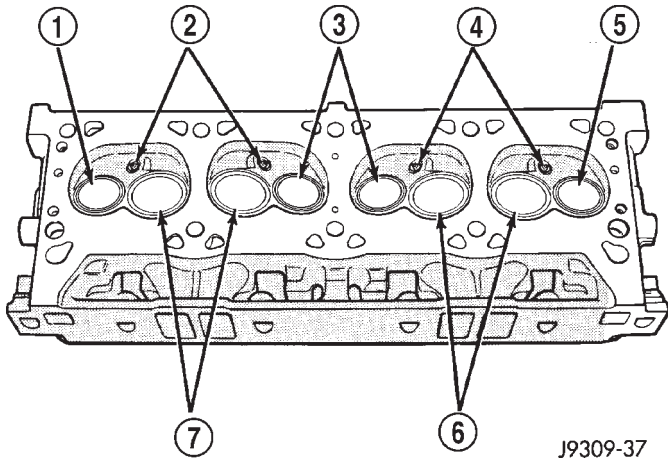


**Bloc-Check-Kit C-3685-A**

## CYLINDER HEAD

### DESCRIPTION—CYLINDER HEAD

The cast iron cylinder heads (Fig. 4) are mounted to the cylinder block using ten bolts. The spark plugs are located in the peak of the wedge between the valves.



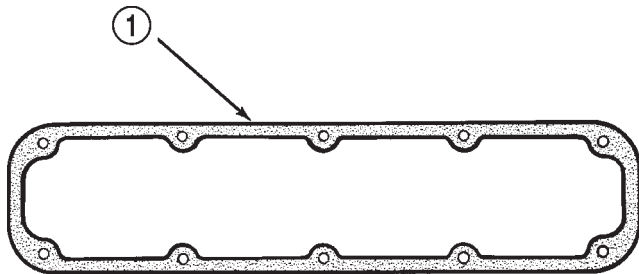
J9309-37

**Fig. 4 Cylinder Head Assembly—V-8 Gas Engines**

- 1 - EXHAUST VALVE
- 2 - SPARK PLUGS
- 3 - EXHAUST VALVES
- 4 - SPARK PLUGS
- 5 - EXHAUST VALVE
- 6 - INTAKE VALVES
- 7 - INTAKE VALVES

### DESCRIPTION—CYLINDER HEAD COVER GASKET

The cylinder head cover gasket (Fig. 5) is a steel-backed silicone gasket, designed for long life usage.



J9209-105

**Fig. 5 Cylinder Head Cover Gasket V-8 Gas Engines**

- 1 - CYLINDER HEAD COVER GASKET

### OPERATION—CYLINDER HEAD

The cylinder head closes the combustion chamber allowing the pistons to compress the air fuel mixture to the correct ratio for ignition. The valves located in the cylinder head open and close to either allow clean air

into the combustion chamber or to allow the exhaust gases out, depending on the stroke of the engine.

### OPERATION

The steel-backed silicone gasket is designed to seal the cylinder head cover for long periods of time through extensive heat and cold, without failure. The gasket is designed to be reusable.

### DIAGNOSIS AND TESTING—CYLINDER HEAD GASKET FAILURE

A cylinder head gasket leak can be located between adjacent cylinders or between a cylinder and the adjacent water jacket.

• Possible indications of the cylinder head gasket leaking between adjacent cylinders are:

- Loss of engine power
- Engine misfiring
- Poor fuel economy

• Possible indications of the cylinder head gasket leaking between a cylinder and an adjacent water jacket are:

- Engine overheating
- Loss of coolant
- Excessive steam (white smoke) emitting from exhaust
- Coolant foaming

### CYLINDER-TO-CYLINDER LEAKAGE TEST

To determine if an engine cylinder head gasket is leaking between adjacent cylinders, follow the procedures in Cylinder Compression Pressure Test in this section. An engine cylinder head gasket leaking between adjacent cylinders will result in approximately a 50–70% reduction in compression pressure.

### CYLINDER-TO-WATER JACKET LEAKAGE TEST

**WARNING: USE EXTREME CAUTION WHEN THE ENGINE IS OPERATING WITH COOLANT PRESSURE CAP REMOVED.**

#### VISUAL TEST METHOD

With the engine cool, remove the coolant pressure cap. Start the engine and allow it to warm up until thermostat opens.

If a large combustion/compression pressure leak exists, bubbles will be visible in the coolant.

#### COOLING SYSTEM TESTER METHOD

**WARNING: WITH COOLING SYSTEM TESTER IN PLACE, PRESSURE WILL BUILD UP FAST. EXCESSIVE PRESSURE BUILT UP, BY CONTINUOUS ENGINE OPERATION, MUST BE RELEASED TO A SAFE PRESSURE POINT. NEVER PERMIT PRESSURE TO EXCEED 138 kPa (20 psi).**

## CYLINDER HEAD (Continued)

Install Cooling System Tester 7700 or equivalent to pressure cap neck. Start the engine and observe the tester's pressure gauge. If gauge pulsates with every power stroke of a cylinder a combustion pressure leak is evident.

## CHEMICAL TEST METHOD

Combustion leaks into the cooling system can also be checked by using Bloc-Chek Kit C-3685-A or equivalent. Perform test following the procedures supplied with the tool kit.

## REMOVAL

- (1) Disconnect the battery negative cable.
- (2) Drain cooling system (Refer to 7 - COOLING - STANDARD PROCEDURE).
- (3) Remove the air cleaner resonator and duct work.
- (4) Remove the intake manifold-to-generator bracket support rod. Remove the generator.
- (5) Remove closed crankcase ventilation system.
- (6) Disconnect the evaporation control system.
- (7) Perform the Fuel System Pressure Release procedure (Refer to 14 - FUEL SYSTEM/FUEL DELIVERY - STANDARD PROCEDURE). Disconnect the fuel supply line (Refer to 14 - FUEL SYSTEM/FUEL DELIVERY/QUICK CONNECT FITTING - STANDARD PROCEDURE).
- (8) Disconnect accelerator linkage and if so equipped, the speed control and transmission kick-down cables.
- (9) Remove distributor cap and wires.
- (10) Disconnect the coil wires.
- (11) Disconnect heat indicator sending unit wire.
- (12) Disconnect heater hoses and bypass hose.
- (13) Remove cylinder head covers and gaskets (Refer to 9 - ENGINE/CYLINDER HEAD/CYLINDER HEAD COVER(S) - REMOVAL).
- (14) Remove intake manifold (Refer to 9 - ENGINE/MANIFOLDS/INTAKE MANIFOLD - REMOVAL) and throttle body as an assembly. Discard the flange side gaskets and the front and rear cross-over gaskets.
- (15) Remove exhaust manifolds (Refer to 9 - ENGINE/MANIFOLDS/EXHAUST MANIFOLD - REMOVAL).
- (16) Remove rocker arm assemblies and push rods. Identify to ensure installation in original locations.
- (17) Remove the head bolts from each cylinder head and remove cylinder heads. Discard the cylinder head gasket.
- (18) Remove spark plugs.

## CLEANING

Clean all surfaces of cylinder block and cylinder heads.

Clean cylinder block front and rear gasket surfaces using a suitable solvent.

## INSPECTION

Inspect all surfaces with a straightedge if there is any reason to suspect leakage. If out-of-flatness exceeds 0.00075mm/mm (0.0001in./in.) times the span length in any direction, either replace head or lightly machine the head surface.

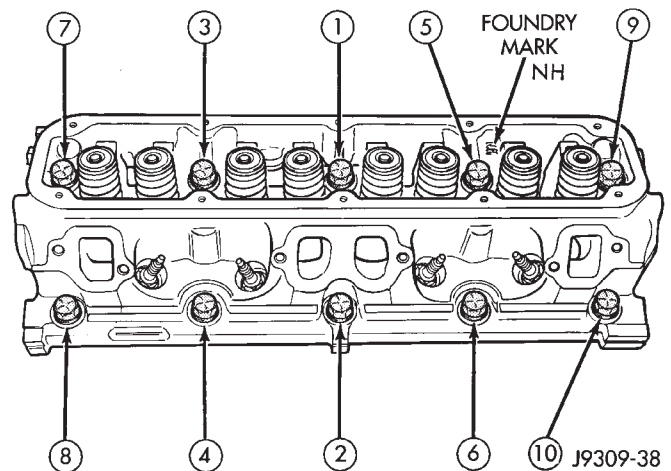
**FOR EXAMPLE:**—A 305 mm (12 in.) span is 0.102 mm (0.004 in.) out-of-flat. The allowable out-of-flat is  $305 \times 0.00075$  ( $12 \times 0.00075$ ) equals 0.23 mm (0.009 in.). This amount of out-of-flat is acceptable.

The cylinder head surface finish should be 1.78-3.00 microns (70-125 microinches).

Inspect push rods. Replace worn or bent rods.

## INSTALLATION

- (1) Clean all surfaces of cylinder block and cylinder heads.
- (2) Clean cylinder block front and rear gasket surfaces using a suitable solvent.
- (3) Position new cylinder head gaskets onto the cylinder block.
- (4) Position cylinder heads onto head gaskets and cylinder block.
- (5) Starting at top center, tighten all cylinder head bolts, in sequence (Fig. 6).



**Fig. 6 Cylinder Head Bolt Tightening Sequence**

**CAUTION:** When tightening the rocker arm bolts, make sure the piston in that cylinder is **NOT** at TDC. Contact between the valves and piston could occur.

(6) Install push rods and rocker arm assemblies in their original position. Tighten the bolts to 28 N·m (21 ft. lbs.) torque.

(7) Install the intake manifold (Refer to 9 - ENGINE/MANIFOLDS/INTAKE MANIFOLD - INSTALLATION) and throttle body assembly.

(8) Install exhaust manifolds (Refer to 9 - ENGINE/MANIFOLDS/EXHAUST MANIFOLD - INSTALLATION).



## CYLINDER HEAD (Continued)

(9) If required, adjust spark plugs to specifications. Install the plugs and tighten to 41 N·m (30 ft. lbs.) torque.

(10) Install coil wire.

(11) Connect heat indicator sending unit wire.

(12) Connect the heater hoses and bypass hose.

(13) Install distributor cap and wires.

(14) Connect the accelerator linkage and if so equipped, the speed control and transmission kick-down cables.

(15) Install the fuel supply line (Refer to 14 - FUEL SYSTEM/FUEL DELIVERY/QUICK CONNECT FITTING - STANDARD PROCEDURE).

(16) Install the generator and drive belt (Refer to 7 - COOLING/ACCESSORY DRIVE/DRIVE BELTS - INSTALLATION). Tighten generator mounting bolt to 41 N·m (30 ft. lbs.) torque. Tighten the adjusting strap bolt to 23 N·m (200 in. lbs.) torque.

(17) Install the intake manifold-to-generator bracket support rod. Tighten the bolts.

(18) Place the cylinder head cover gaskets in position and install cylinder head covers (Refer to 9 - ENGINE/CYLINDER HEAD/CYLINDER HEAD COVER(S) - INSTALLATION).

(19) Install closed crankcase ventilation system.

(20) Connect the evaporation control system.

(21) Install the air cleaner.

(22) Fill cooling system (Refer to 7 - COOLING - STANDARD PROCEDURE).

(23) Connect the negative cable to the battery.

(24) Start engine check for leaks.

(2) Disconnect the spark plug wires from the spark plugs and set aside.

(3) Disconnect closed ventilation system and evaporation control system from cylinder head cover.

(4) Remove cylinder head cover and gasket.

## CLEANING

Clean cylinder head cover gasket surface.

Clean head rail, if necessary.

## INSPECTION

Inspect cover for distortion and straighten, if necessary.

Check the gasket for use in head cover installation. If damaged, use a new gasket.

## INSTALLATION

(1) The cylinder head cover gasket can be used again. Install the gasket onto the head rail.

(2) Position the cylinder head cover onto the gasket. Tighten the bolts to 11 N·m (95 in. lbs.) torque.

(3) Install closed crankcase ventilation system and evaporation control system.

(4) Connect the spark plug wires to the spark plugs.

(5) Connect the negative cable to the battery.

## INTAKE/EXHAUST VALVES &amp; SEATS

## DESCRIPTION

Both the intake and exhaust valves are made of steel. The intake valve is 48.768 mm (1.92 inches) in diameter and the exhaust valve is 41.148 mm (1.62 inches) in diameter and has a 2.032 mm (0.080 inch) wafer intertia welded to the tip for durability. These valves are not splayed.

## STANDARD PROCEDURE—VALVES, GUIDES AND SPRINGS

## VALVE CLEANING

Clean valves thoroughly. Discard burned, warped, or cracked valves.

Remove carbon and varnish deposits from inside of valve guides with a reliable guide cleaner.

## VALVE GUIDES

Measure valve stems for wear. If wear exceeds 0.051 mm (0.002 in.), replace the valve.

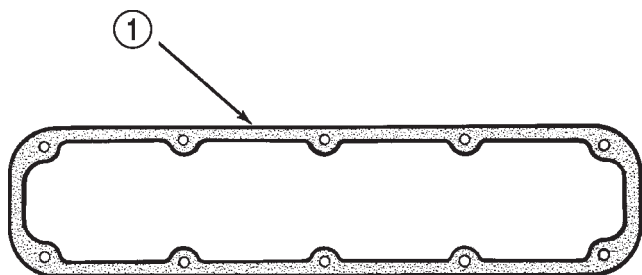
Measure valve stem guide clearance as follows:

(1) Install Valve Guide Sleeve Tool C-3973 over valve stem and install valve (Fig. 8). The special sleeve places the valve at the correct height for checking with a dial indicator.

## CYLINDER HEAD COVER(S)

## REMOVAL

**NOTE:** A steel backed silicon gasket is used with the cylinder head cover (Fig. 7). This gasket can be used again.



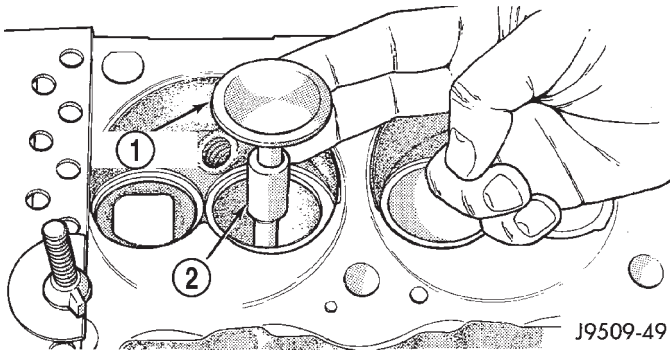
J9209-105

**Fig. 7 Cylinder Head Cover Gasket**

1 - CYLINDER HEAD COVER GASKET

(1) Disconnect the negative cable from the battery.

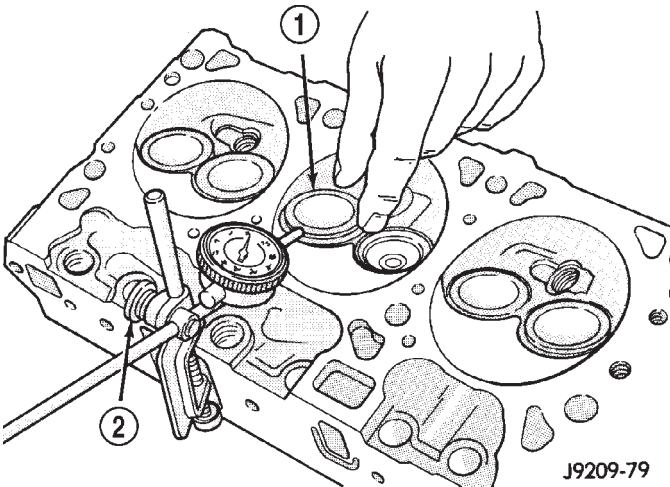
## INTAKE/EXHAUST VALVES &amp; SEATS (Continued)



**Fig. 8 Positioning Valve with Tool C-3973**

- 1 - VALVE  
2 - SPACER TOOL

(2) Attach dial indicator Tool C-3339 to cylinder head and set it at right angles to valve stem being measured (Fig. 9).



**Fig. 9 Measuring Valve Guide Wear**

- 1 - VALVE  
2 - SPECIAL TOOL C-3339

(3) Move valve to and from the indicator. The total dial indicator reading should not exceed 0.432 mm (0.017 in.). Ream the guides for valves with oversize stems if dial indicator reading is excessive or if the stems are scuffed or scored.

### VALVE GUIDES

Service valves with oversize stems are available. Refer to REAMER SIZES CHART

#### REAMER SIZES CHART

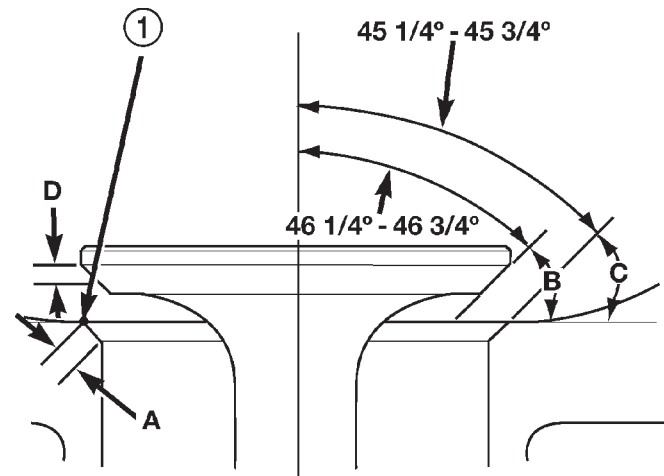
REAMER O/S	VALVE GUIDE SIZE
0.076 mm (0.003 in.)	8.026 - 8.052 mm (0.316 - 0.317 in.)
0.381 mm (0.015 in.)	8.331 - 8.357 mm (0.328 - 0.329 in.)

(1) Slowly turn reamer by hand and clean guide thoroughly before installing new valve. **Ream the valve guides from standard to 0.381 mm (0.015 in.). Use a two step procedure so the valve guides are reamed true in relation to the valve seat:**

- Step 1—Ream to 0.0763 mm (0.003 inch).
- Step 2—Ream to 0.381 mm (0.015 inch).

### REFACING VALVES AND VALVE SEATS

The intake and exhaust valves have a 43-1/4° to 43-3/4° face angle and a 44-1/4° to 44-3/4° seat angle (Fig. 10).



**Fig. 10 Valve Face and Seat Angles**

80ba7a5f

- 1 - CONTACT POINT  
A,B,C and D Refer to VALVE FACE AND VALVE SEAT ANGLE CHART

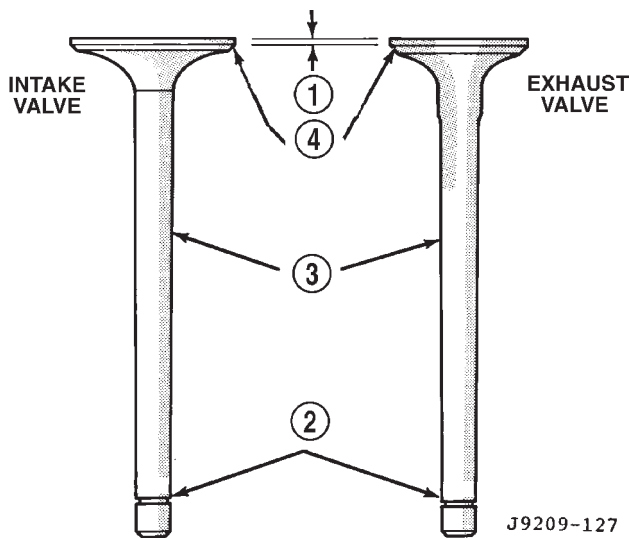
#### VALVE FACE AND VALVE SEAT ANGLE CHART

ITEM	DESCRIPTION	SPECIFICATION
A	SEAT WIDTH	
	INTAKE	1.016 - 1.524 mm (0.040 - 0.060 in.)
	EXHAUST	1.524 - 2.032 mm (0.060 - 0.080 in.)
B	FACE ANGLE (INT. AND EXT.)	43¼° - 43¾°
C	SEAT ANGLE (INT. AND EXT.)	44¼° - 44¾°
D	CONTACT SURFACE	—

## INTAKE/EXHAUST VALVES &amp; SEATS (Continued)

## VALVES

Inspect the remaining margin after the valves are refaced (Fig. 11). Valves with less than 1.190 mm (0.047 in.) margin should be discarded.

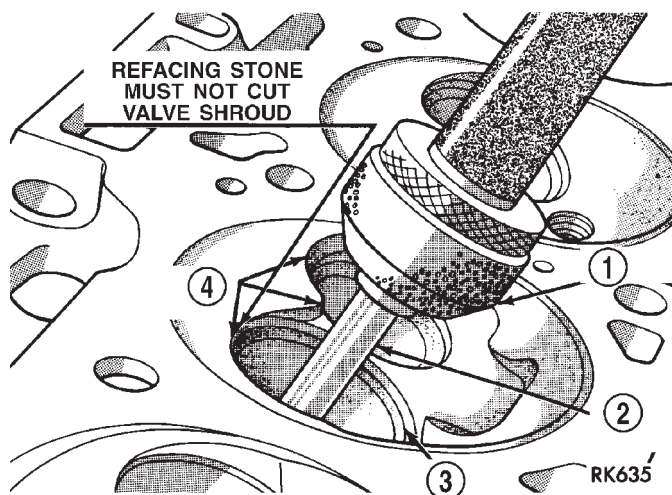


**Fig. 11 Intake and Exhaust Valves**

- 1 - MARGIN
- 2 - VALVE SPRING RETAINER LOCK GROOVE
- 3 - STEM
- 4 - FACE

## VALVE SEATS

**CAUTION: DO NOT un-shroud valves during valve seat refacing (Fig. 12).**



**Fig. 12 Refacing Valve Seats**

- 1 - STONE
- 2 - PILOT
- 3 - VALVE SEAT
- 4 - SHROUD

(1) When refacing valve seats, it is important that the correct size valve guide pilot be used for reseating stones. A true and complete surface must be obtained.

(2) Measure the concentricity of valve seat using a dial indicator. Total runout should not exceed 0.051 mm (0.002 in.) total indicator reading.

(3) Inspect the valve seat with Prussian blue, to determine where the valve contacts the seat. To do this, coat valve seat **LIGHTLY** with Prussian blue then set valve in place. Rotate the valve with light pressure. If the blue is transferred to the center of valve face, contact is satisfactory. If the blue is transferred to the top edge of valve face, lower valve seat with a 15° stone. If the blue is transferred to bottom edge of valve face raise valve seat with a 60° stone.

(4) When seat is properly positioned the width of intake seats should be 1.016-1.524 mm (0.040-0.060 in.). The width of the exhaust seats should be 1.524-2.032 mm (0.060-0.080 in.).

## VALVE SPRINGS

Whenever valves have been removed for inspection, reconditioning or replacement, valve springs should be tested. As an example the compression length of the spring to be tested is 1-5/16 in.. Turn table of Universal Valve Spring Tester Tool until surface is in line with the 1-5/16 in. mark on the threaded stud. Be sure the zero mark is to the front (Fig. 13). Place spring over stud on the table and lift compressing lever to set tone device. Pull on torque wrench until ping is heard. Take reading on torque wrench at this instant. Multiply this reading by 2. This will give the spring load at test length. Fractional measurements are indicated on the table for finer adjustments. Refer to specifications to obtain specified height and allowable tensions. Discard the springs that do not meet specifications.

## REMOVAL

(1) Remove the cylinder head (Refer to 9 - ENGINE/CYLINDER HEAD - REMOVAL).

(2) Compress valve springs using Valve Spring Compressor Tool MD- 998772A and adapter 6716A.

(3) Remove valve retaining locks, valve spring retainers, valve stem seals and valve springs.

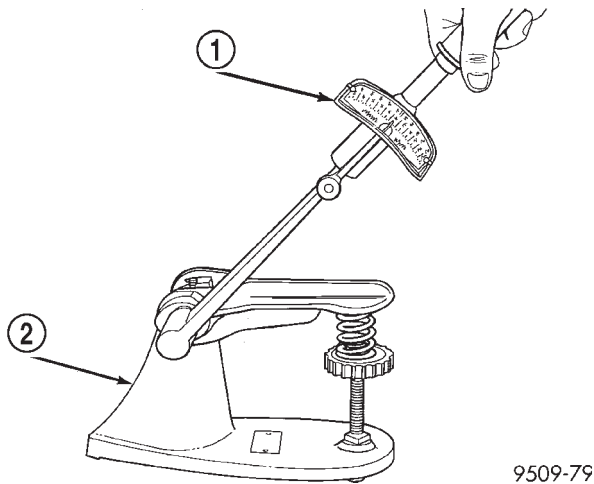
(4) Before removing valves, remove any burrs from valve stem lock grooves to prevent damage to the valve guides. Identify valves to ensure installation in original location.

## CLEANING

Clean valves thoroughly. Discard burned, warped, or cracked valves.

Remove carbon and varnish deposits from inside of valve guides with a reliable guide cleaner.

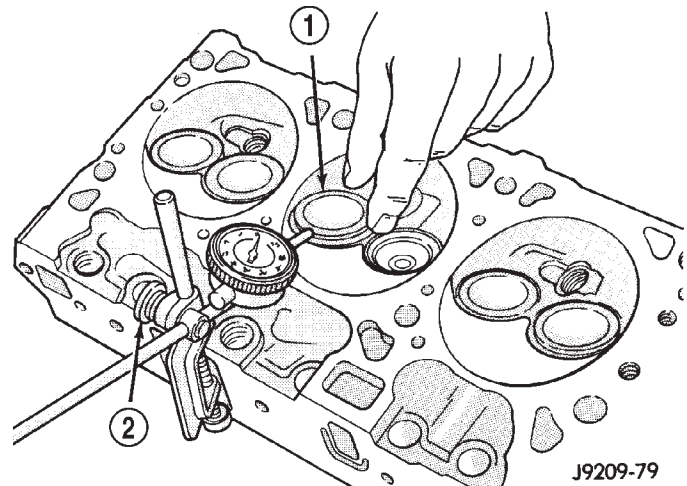
## INTAKE/EXHAUST VALVES &amp; SEATS (Continued)



9509-79

**Fig. 13 Testing Valve Spring for Compressed Length**

- 1 - TORQUE WRENCH  
2 - VALVE SPRING TESTER



J9209-79

**Fig. 15 Measuring Valve Guide Wear**

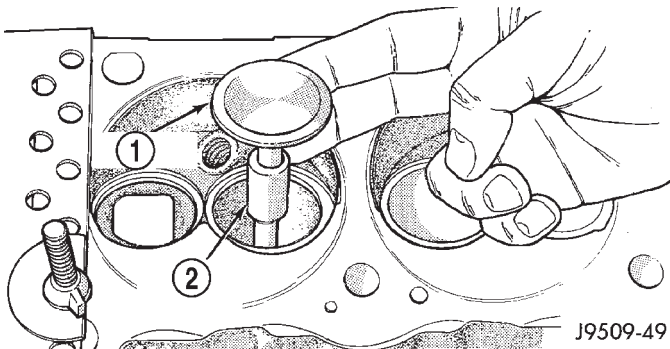
- 1 - VALVE  
2 - SPECIAL TOOL C-3339

## INSPECTION

Measure valve stems for wear. If wear exceeds 0.051 mm (0.002 in.), replace the valve.

Measure valve stem guide clearance as follows:

(1) Install Valve Guide Sleeve Tool C-3973 over valve stem and install valve (Fig. 14). The special sleeve places the valve at the correct height for checking with a dial indicator.



J9509-49

**Fig. 14 Positioning Valve with Tool C-3973**

- 1 - VALVE  
2 - SPACER TOOL

(2) Attach dial indicator Tool C-3339 to cylinder head and set it at right angles to valve stem being measured (Fig. 15).

(3) Move valve to and from the indicator. The total dial indicator reading should not exceed 0.432 mm (0.017 in.). Ream the guides for valves with oversize stems if dial indicator reading is excessive or if the stems are scuffed or scored.

## INSTALLATION

(1) Clean valves thoroughly. Discard burned, warped and cracked valves.

(2) Remove carbon and varnish deposits from inside of valve guides with a reliable guide cleaner.

(3) Measure valve stems for wear. If wear exceeds 0.051 mm (0.002 inch), replace the valve.

(4) Coat valve stems with lubrication oil and insert them in cylinder head.

(5) If valves or seats are reground, check valve stem height. If valve is too long, replace cylinder head.

(6) Install new seals on all valve guides. Install valve springs and valve retainers.

(7) Compress valve springs with Valve Spring Compressor Tool MD-998772A and adapter 6716A, install locks and release tool. If valves and/or seats are ground, measure the installed height of springs. Make sure the measurement is taken from bottom of spring seat in cylinder head to the bottom surface of spring retainer. If spacers are installed, measure from the top of spacer. If height is greater than 42.86 mm (1-11/16 inches), install a 1.587 mm (1/16 inch) spacer in head counterbore. This should bring spring height back to normal 41.27 to 42.86 mm (1-5/8 to 1-11/16 inch).

(8) Install cylinder head (Refer to 9 - ENGINE/CYLINDER HEAD - INSTALLATION).



## ROCKER ARM / ADJUSTER ASSY

### REMOVAL

(1) Remove cylinder head cover and gasket (Refer to 9 - ENGINE/CYLINDER HEAD/CYLINDER HEAD COVER(S) - REMOVAL).

(2) Remove the rocker arm bolts and pivots (Fig. 16). Place them on a bench in the same order as removed.

(3) Remove the push rods and place them on a bench in the same order as removed.

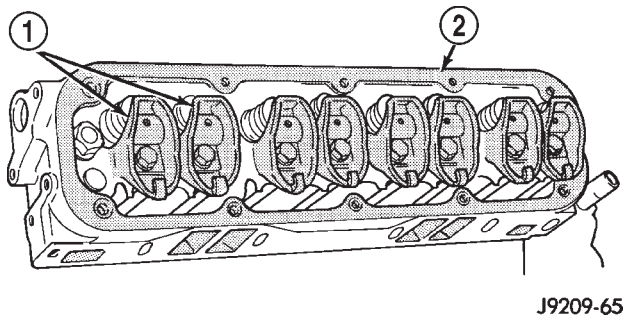


Fig. 16 Rocker Arms

- 1 - ROCKER ARMS  
2 - CYLINDER HEAD

### INSTALLATION

(1) Rotate the crankshaft until the "V8" mark lines up with the TDC mark on the timing chain case cover. This mark is located 147° ATDC from the No.1 firing position.

(2) Install the push rods in the same order as removed.

(3) Install rocker arm and pivot assemblies in the same order as removed. Tighten the rocker arm bolts to 28 N·m (21 ft. lbs.) torque.

**CAUTION: DO NOT rotate or crank the engine during or immediately after rocker arm installation. Allow the hydraulic roller tappets adequate time to bleed down (about 5 minutes).**

(4) Install cylinder head cover (Refer to 9 - ENGINE/CYLINDER HEAD/CYLINDER HEAD COVER(S) - INSTALLATION).

## ENGINE BLOCK

### CLEANING

Clean cylinder block thoroughly and check all core hole plugs for evidence of leakage.

### INSPECTION

Examine block for cracks or fractures.

The cylinder walls should be checked for out-of-round and taper. Refer to Honing Cylinder Bores in the Service Procedures portion of this Section.

Inspect the oil line plug, the oil line plug is located in the vertical passage at the rear of the block between the oil-to-filter and oil-from-filter passages (Fig. 17). Improper installation or missing plug could cause erratic, low, or no oil pressure.

The oil plug must come out the bottom. Use flat dowel, down the oil pressure sending unit hole from the top, to remove oil plug.

(1) Remove oil pressure sending unit from back of block.

(2) Insert a 3.175 mm (1/8 in.) finish wire, or equivalent, into passage.

(3) Plug should be 190.0 to 195.2 mm (7-1/2 to 7-11/16 in.) from machined surface of block (Fig. 17). If plug is too high, use a suitable flat dowel to position properly.

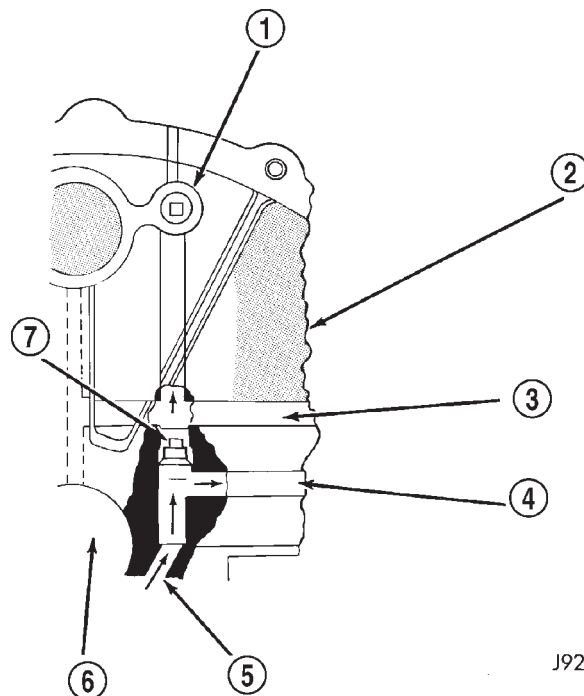


Fig. 17 Oil Line Plug

- 1 - RIGHT OIL GALLERY  
2 - CYLINDER BLOCK  
3 - OIL FROM FILTER TO SYSTEM  
4 - OIL TO FILTER  
5 - FROM OIL PUMP  
6 - CRANKSHAFT  
7 - PLUG

(4) If plug is too low, remove oil pan and No. 4 main bearing cap. Use suitable flat dowel to position properly. Coat outside diameter of plug with Mopar®

## ENGINE BLOCK (Continued)

Stud and Bearing Mount Adhesive. Plug should be 54.0 to 57.7 mm (2-1/8 to 2-5/16 in.) from bottom of the block.

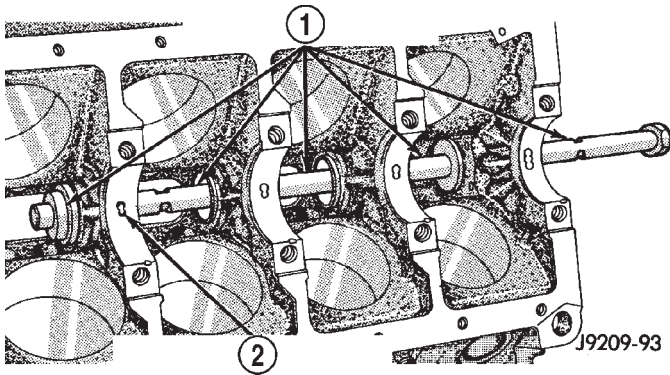
## CAMSHAFT &amp; BEARINGS (IN BLOCK)

## REMOVAL—CAMSHAFT BEARINGS

**NOTE:** This procedure requires that the engine is removed from the vehicle.

(1) With engine completely disassembled, drive out rear cam bearing core plug.

(2) Install proper size adapters and horseshoe washers (part of Camshaft Bearing Remover/Installer Tool C-3132-A) at back of each bearing shell. Drive out bearing shells (Fig. 18).

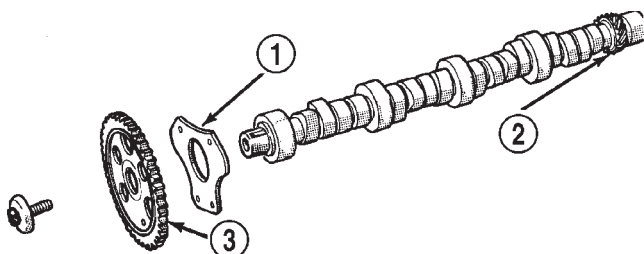


**Fig. 18 Camshaft Bearings**

- 1 - SPECIAL TOOL C-3132-A  
2 - MAIN BEARING OIL HOLE

## REMOVAL—CAMSHAFT

**NOTE:** The camshaft has an integral oil pump and distributor drive gear (Fig. 19).



**Fig. 19 Camshaft and Sprocket Assembly**

- 1 - THRUST PLATE  
2 - OIL PUMP AND DISTRIBUTOR DRIVE GEAR INTEGRAL WITH CAMSHAFT  
3 - CAMSHAFT SPROCKET

(1) Remove the radiator (Refer to 7 - COOLING/ENGINE/RADIATOR - REMOVAL).

(2) Remove the A/C Condenser (if equipped)

(3) Remove the engine cover.

(4) Remove intake manifold (Refer to 9 - ENGINE/MANIFOLDS/INTAKE MANIFOLD - REMOVAL).

(5) Remove cylinder head covers (Refer to 9 - ENGINE/CYLINDER HEAD/CYLINDER HEAD COVER(S) - REMOVAL).

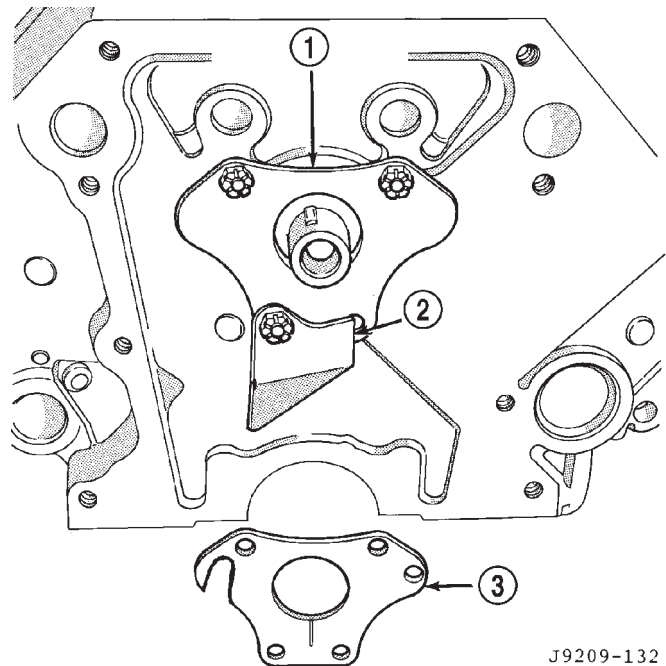
(6) Remove timing case cover (Refer to 9 - ENGINE/VALVE TIMING/TIMING BELT / CHAIN COVER(S) - REMOVAL) and timing chain (Refer to 9 - ENGINE/VALVE TIMING/TIMING BELT/CHAIN AND SPROCKETS - REMOVAL).

(7) Remove rocker arms.

(8) Remove push rods and tappets. Identify each part so it can be installed in its original location.

(9) Remove distributor and lift out the oil pump and distributor drive shaft.

(10) Remove camshaft thrust plate, note location of oil tab (Fig. 20).



**Fig. 20 Timing Chain Oil**

- 1 - THRUST PLATE FRONT SIDE  
2 - CHAIN OIL TAB  
3 - THRUST PLATE REAR SIDE

(11) Install a long bolt into front of camshaft to aid in removal of the camshaft. Remove camshaft, being careful not to damage cam bearings with the cam lobes.



## CAMSHAFT &amp; BEARINGS (IN BLOCK) (Continued)

**INSTALLATION—CAMSHAFT BEARINGS**

(1) Install new camshaft bearings with Camshaft Bearing Remover/Installer Tool C-3132-A by sliding the new camshaft bearing shell over proper adapter.

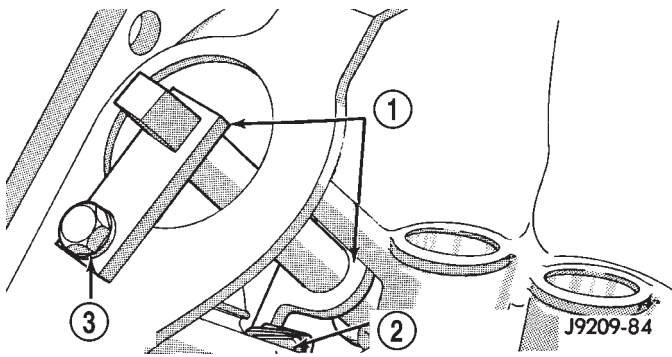
(2) Position rear bearing in the tool. Install horse-shoe lock and by reversing removal procedure, carefully drive bearing shell into place.

(3) Install remaining bearings in the same manner. Bearings must be carefully aligned to bring oil holes into full register with oil passages from the main bearing. If the camshaft bearing shell oil holes are not in exact alignment, remove and install them correctly. Install a new core hole plug at the rear of camshaft. **Be sure this plug does not leak.**

**INSTALLATION—CAMSHAFT**

(1) Lubricate camshaft lobes and camshaft bearing journals and insert the camshaft to within 51 mm (2 inches) of its final position in cylinder block.

(2) Install Camshaft Holder Tool C-3509 with tongue back of distributor drive gear (Fig. 21).



**Fig. 21 Camshaft Holding Tool C-3509 (Installed Position)**

- 1 - SPECIAL TOOL C-3509
- 2 - DRIVE GEAR
- 3 - DISTRIBUTOR LOCK BOLT

(3) Hold tool in position with a distributor lock-plate bolt. This tool will restrict camshaft from being pushed in too far and prevent knocking out the Welch plug in rear of cylinder block. **Tool should remain installed until the camshaft and crankshaft sprockets and timing chain have been installed.**

(4) Install camshaft thrust plate and chain oil tab. **Make sure tang enters lower right hole in thrust plate.** Tighten bolts to 24 N·m (210 in. lbs.) torque. Top edge of tab should be flat against thrust plate in order to catch oil for chain lubrication.

(5) Install timing chain and gears (Refer to 9 - ENGINE/VALVE TIMING/TIMING BELT/CHAIN AND SPROCKETS - INSTALLATION).

(6) Measure camshaft end play (Refer to 9 - ENGINE - SPECIFICATIONS). If not within limits install a new thrust plate.

(7) Each tappet reused must be installed in the same position from which it was removed. **When camshaft is replaced, all of the tappets must be replaced.**

(8) Install distributor and distributor drive shaft.

(9) Install push rods and tappets.

(10) Install rocker arms.

(11) Install timing case cover (Refer to 9 - ENGINE/VALVE TIMING/TIMING BELT / CHAIN COVER(S) - INSTALLATION).

(12) Install cylinder head covers (Refer to 9 - ENGINE/CYLINDER HEAD/CYLINDER HEAD COVER(S) - INSTALLATION).

(13) Install intake manifold (Refer to 9 - ENGINE/MANIFOLDS/INTAKE MANIFOLD - INSTALLATION).

(14) Install the engine cover.

(15) Install the A/C Condenser (if equipped)

(16) Install the radiator (Refer to 7 - COOLING/ENGINE/RADIATOR - INSTALLATION).

(17) Start engine check for leaks.

**CONNECTING ROD BEARINGS****STANDARD PROCEDURE—CONNECTING ROD BEARING FITTING**

Fit all rods on a bank until completed. **DO NOT** alternate from one bank to another, because connecting rods and pistons are not interchangeable from one bank to another.

The bearing caps are not interchangeable and should be marked at removal to ensure correct assembly.

Each bearing cap has a small V-groove across the parting face. When installing the lower bearing shell, be certain that the V-groove in the shell is in line with the V-groove in the cap. This provides lubrication of the cylinder wall in the opposite bank.

The bearing shells must be installed so that the tangs are in the machined grooves in the rods and caps.

Limits of taper or out-of-round on any crankshaft journals should be held to 0.025 mm (0.001 in.). Bearings are available in 0.025 mm (0.001 in.), 0.051 mm (0.002 in.), 0.076 mm (0.003 in.), 0.254 mm (0.010 in.) and 0.305 mm (0.012 in.) undersize. **Install the bearings in pairs. DO NOT use a new bearing half with an old bearing half. DO NOT file the rods or bearing caps.**

## CRANKSHAFT

### DESCRIPTION

The crankshaft (Fig. 22) is of a cast nodular steel splayed type design, with five main bearing journals. The crankshaft is located at the bottom of the engine block and is held in place with five main bearing caps. The number 3 counterweight is the location for journal size identification.

Undersize Journal	Identification Stamp
0.025 mm (0.001 inch) (Rod)	R1-R2-R3 or R4
0.025 mm (0.001 inch) (Main)	M1-M2-M3-M4 or M5

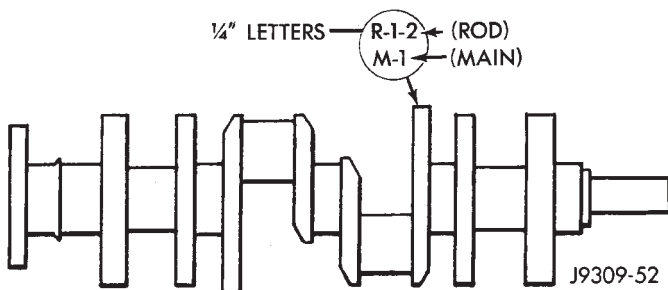


Fig. 22 Crankshaft with Journal Size Identification

### OPERATION

The crankshaft transfers force generated by combustion within the cylinder bores to the flywheel or flexplate.

### REMOVAL

**NOTE:** This procedure can be done in vehicle. However the transmission must be removed first.

(1) If crankshaft is to be removed while engine is in vehicle remove the transmission. Refer to Group 21, for correct procedure.

(2) Remove the oil pan (Refer to 9 - ENGINE/LUBRICATION/OIL PAN - REMOVAL).

(3) Remove the oil pump from the rear main bearing cap (Refer to 9 - ENGINE/LUBRICATION/OIL PUMP - REMOVAL).

(4) Remove the vibration damper (Refer to 9 - ENGINE/ENGINE BLOCK/VIBRATION DAMPER - REMOVAL).

(5) Remove the timing chain cover (Refer to 9 - ENGINE/VALVE TIMING/TIMING BELT / CHAIN COVER(S) - REMOVAL).

(6) Identify rod bearing caps before removal. Remove rod bearing caps with bearings.

**CAUTION:** Support crankshaft before removing main bearing caps. Failure to do so will allow the crankshaft to fall damaging the crankshaft.

(7) Using a suitable jack, support the crankshaft.

(8) Identify main bearing caps before removal. Remove main bearing caps and bearings one at a time.

(9) Lower the crankshaft out of the block.

(10) Remove and discard the crankshaft rear oil seals.

(11) Remove and discard the front crankshaft oil seal.

### INSTALLATION

(1) Clean Gasket Maker residue and sealant from the cylinder block and rear cap mating surface. Do this before applying the Mopar® Gasket Maker and the installation of rear cap.

(2) Lightly oil the new upper seal lips with engine oil.

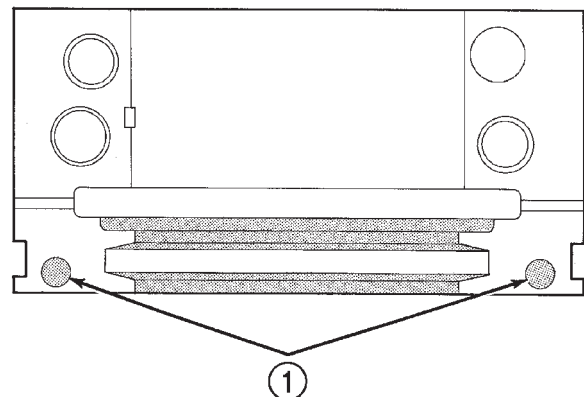
(3) Install the new upper rear bearing oil seal with the white paint facing towards the rear of the engine.

(4) Position the crankshaft into the cylinder block.

(5) Lightly oil the new lower seal lips with engine oil.

(6) Install the new lower rear bearing oil seal into the bearing cap with the white paint facing towards the rear of the engine.

(7) Apply 5 mm (0.20 in) drop of Mopar® Gasket Maker, or equivalent, on each side of the rear main bearing cap (Fig. 23). DO NOT over apply sealant or allow the sealant to contact the rubber seal. Assemble bearing cap to cylinder block immediately after sealant application.



J9509-75

Fig. 23 Sealant Application to Bearing Cap

1 - .25 DROP OF LOCTITE 515 ON BOTH SIDES OF REAR MAIN CAP

(8) To align the bearing cap, use cap slot, alignment dowel and cap bolts. DO NOT remove excess

## CRANKSHAFT (Continued)

material after assembly. DO NOT strike rear cap more than 2 times for proper engagement.

(9) Clean and oil all cap bolts. Install all main bearing caps. Install all cap bolts and alternately tighten to 115 N·m (85 ft. lbs.) torque.

(10) Install oil pump (Refer to 9 - ENGINE/LUBRICATION/OIL PUMP - INSTALLATION).

(11) Install the timing chain cover (Refer to 9 - ENGINE/VALVE TIMING/TIMING BELT / CHAIN COVER(S) - INSTALLATION).

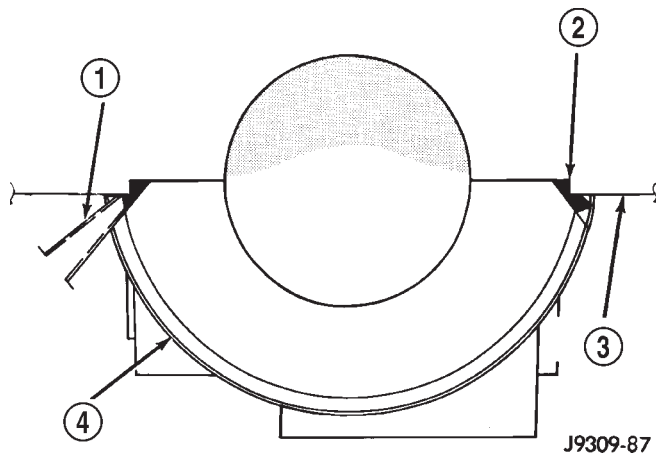
(12) Install the vibration damper (Refer to 9 - ENGINE/ENGINE BLOCK/VIBRATION DAMPER - INSTALLATION).

(13) Position the connecting rods onto the crankshaft and install the rod bearing caps. Tighten the nuts to 61 N·m (45 ft. lbs.).

(14) Apply Mopar® Silicone Rubber Adhesive Sealant, or equivalent, at bearing cap to block joint to provide cap to block and oil pan sealing (Fig. 24). Apply enough sealant until a small amount is squeezed out. Withdraw nozzle and wipe excess sealant off the oil pan seal groove.

(15) Install new front crankshaft oil seal (Refer to 9 - ENGINE/ENGINE BLOCK/CRANKSHAFT OIL SEAL - FRONT - INSTALLATION).

(16) Immediately install the oil pan (Refer to 9 - ENGINE/LUBRICATION/OIL PAN - INSTALLATION).



**Fig. 24 Apply Sealant to Bearing Cap to Block Joint**

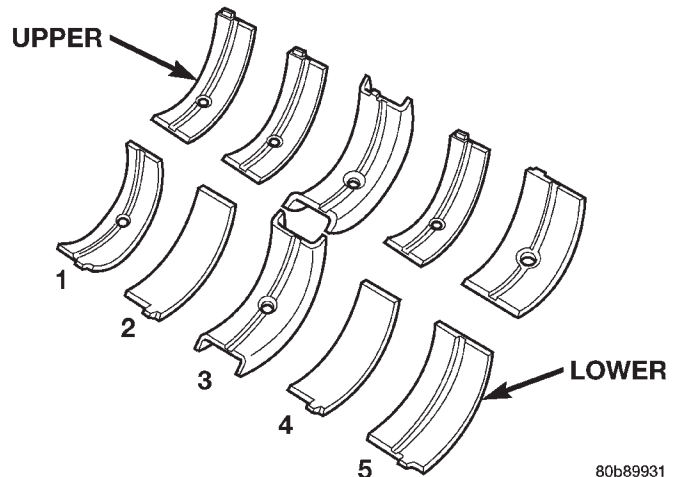
- 1 - MOPAR® GEN II SILICONE RUBBER ADHESIVE SEALANT NOZZLE TIP
- 2 - SEALANT APPLIED
- 3 - CYLINDER BLOCK
- 4 - REAR MAIN BEARING CAP

(17) If the transmission was removed, install the transmission.

## CRANKSHAFT MAIN BEARINGS

## DESCRIPTION

Main bearings (Fig. 25) are located in the cylinder block. One half of the main bearing is located in the crankshaft main bore the other half of the matching bearing is located in the main bearing cap. there are five main bearings. Number three main bearing is flanged, this flange controls crankshaft thrust.



**Fig. 25 Main Bearing Orientation**

## OPERATION

The main bearings encircle the crankshaft main bearing journals, this aligns the crankshaft to the centerline of the engine and allows the crankshaft to turn without wobbling or shaking therefore eliminating vibration. The main bearings are available in standard and undersizes.

## STANDARD PROCEDURE—CRANKSHAFT MAIN BEARING FITTING

Bearing caps are not interchangeable and should be marked at removal to ensure correct assembly. Upper and lower bearing halves are NOT interchangeable. Lower main bearing halves of No.2 and 4 are interchangeable.

Upper and lower No.3 bearing halves are flanged to carry the crankshaft thrust loads. They are NOT interchangeable with any other bearing halves in the engine (Fig. 26). Bearing shells are available in standard and the following undersizes: Never install an undersize bearing that will reduce clearance below specifications.

**Main Bearing Undersize Availability List**

- 0.25 mm (0.001 inch)
- 0.051 mm (0.002 inch)
- 0.076 mm (0.003 inch)

## CRANKSHAFT MAIN BEARINGS (Continued)

- 0.254 mm (0.010 inch)
- 0.305 mm (0.012 inch)

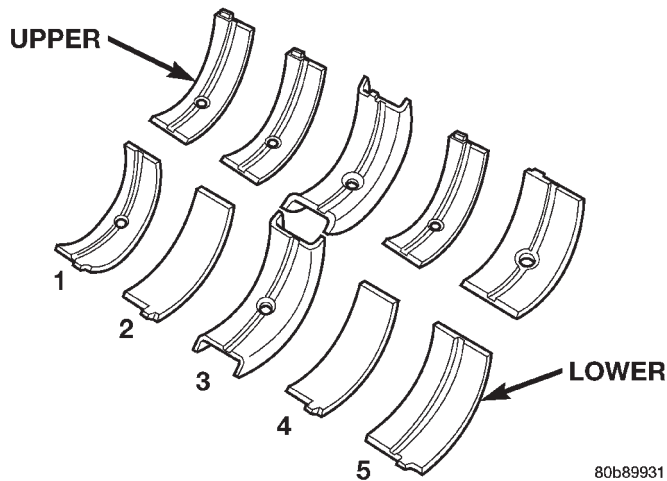


Fig. 26 Main Bearing

### REMOVAL

- (1) Remove the oil pan (Refer to 9 - ENGINE/LUBRICATION/OIL PAN - REMOVAL).
- (2) Remove the oil pump from the rear main bearing cap (Refer to 9 - ENGINE/LUBRICATION/OIL PUMP - REMOVAL).
- (3) Identify bearing caps before removal. Remove bearing caps one at a time.
- (4) Remove upper half of bearing by inserting Crankshaft Main Bearing Remover/Installer Tool C-3059 into the oil hole of crankshaft (Fig. 27).
- (5) Slowly rotate crankshaft clockwise, forcing out upper half of bearing shell.

### INSTALLATION

Only one main bearing should be selectively fitted while all other main bearing caps are properly tightened. All bearing capbolts removed during service procedures are to be cleaned and oiled before installation.

When installing a new upper bearing shell, slightly chamfer the sharp edges from the plain side.

- (1) Start bearing in place, and insert Crankshaft Main Bearing Remover/Installer Tool C-3059 into oil hole of crankshaft (Fig. 27).
- (2) Slowly rotate crankshaft counterclockwise sliding the bearing into position. Remove Tool C-3059.
- (3) Install the bearing caps. Clean and oil the bolts. Tighten the capbolts to 115 N·m (85 ft. lbs.) torque.
- (4) Install the oil pump (Refer to 9 - ENGINE/LUBRICATION/OIL PUMP - INSTALLATION).
- (5) Install the oil pan (Refer to 9 - ENGINE/LUBRICATION/OIL PAN - INSTALLATION).
- (6) Start engine check for leaks.

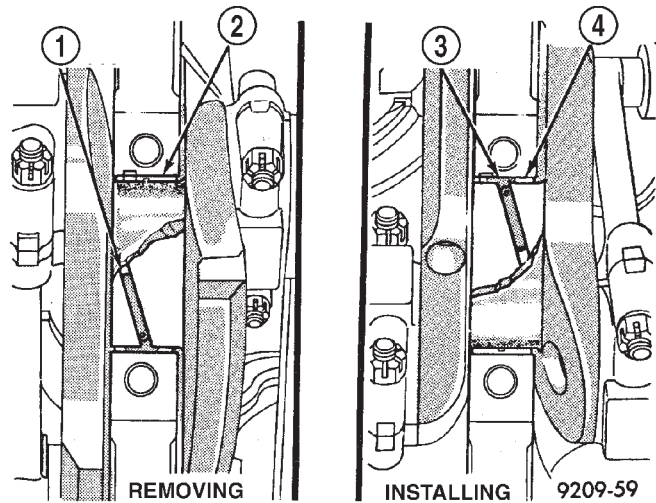


Fig. 27 Upper Main Bearing Removal and Installation with Tool C-3059

- 1 - SPECIAL TOOL C-3059
- 2 - BEARING
- 3 - SPECIAL TOOL C-3059
- 4 - BEARING

## CRANKSHAFT OIL SEAL - FRONT

### DESCRIPTION

The crankshaft rear seal is a two piece viton seal. The crankshaft front seal is a one piece viton seal with a steel housing. The front seal is located in the engine front cover. One part of the two piece rear seal is located in a slot in the number four (4) crankshaft main bore, the second part of the two piece seal is located in the number four (4) main bearing cap.

### OPERATION

The crankshaft seals prevent oil from leaking from around the crankshaft, either from the rear of the engine or from the engine front cover.

### REMOVAL

The oil seal can be replaced without removing the timing chain cover, provided that the cover is not misaligned.

- (1) Disconnect the negative cable from the battery.
- (2) Remove vibration damper (Refer to 9 - ENGINE/ENGINE BLOCK/VIBRATION DAMPER - REMOVAL).
- (3) If front seal is suspected of leaking, check front oil seal alignment to crankshaft. The seal installation/alignment Tool 6635, should fit with minimum interference. If tool does not fit, the cover must be removed and installed properly.



## CRANKSHAFT OIL SEAL - FRONT (Continued)

(4) Place a suitable tool behind the lips of the oil seal to pry the oil seal outward. Be careful not to damage the crankshaft seal bore of cover.

**INSTALLATION**

(1) Place the smaller diameter of the oil seal over Front Oil Seal Installation Tool 6635 (Fig. 28). Seat the oil seal in the groove of the tool.

(2) Position the seal and tool onto the crankshaft (Fig. 29).

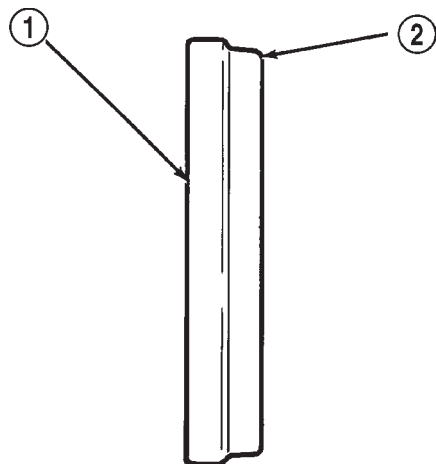
(3) Using the vibration damper bolt, tighten the bolt to draw the seal into position on the crankshaft (Fig. 30).

(4) Remove the vibration damper bolt and seal installation tool.

(5) Inspect the seal flange on the vibration damper.

(6) Install the vibration damper (Refer to 9 - ENGINE/ENGINE BLOCK/VIBRATION DAMPER - INSTALLATION).

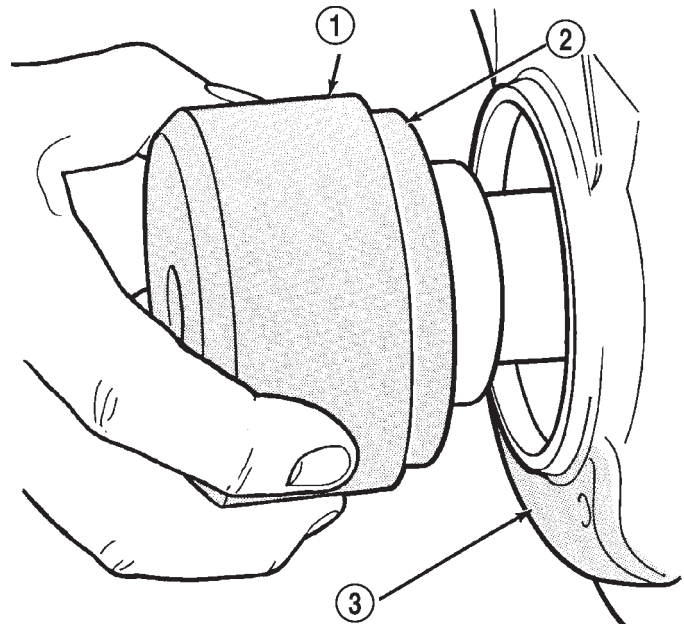
(7) Connect the negative cable to the battery.



J9309-44

**Fig. 28 Placing Oil Seal on Installation Tool 6635**

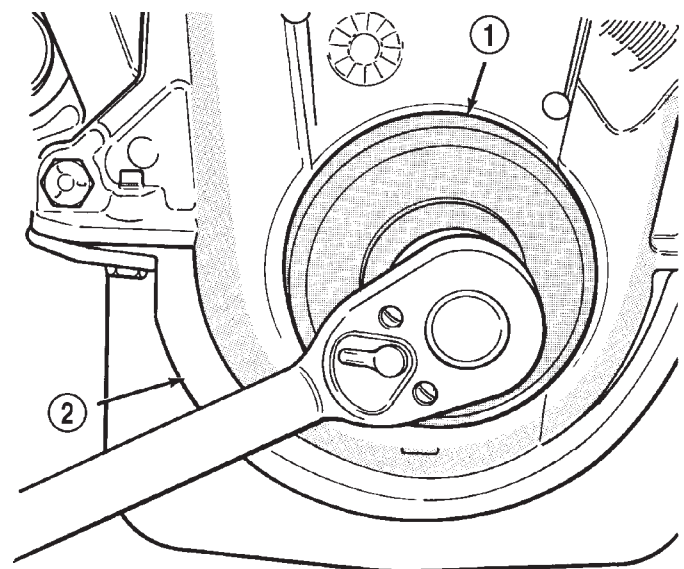
- 1 - CRANKSHAFT FRONT OIL SEAL
- 2 - INSTALL THIS END INTO SPECIAL TOOL 6635



J9309-45

**Fig. 29 Position Tool and Seal onto Crankshaft**

- 1 - SPECIAL TOOL 6635
- 2 - OIL SEAL
- 3 - TIMING CHAIN COVER



J9309-46

**Fig. 30 Installing Oil Seal**

- 1 - SPECIAL TOOL 6635
- 2 - TIMING CHAIN COVER

## CRANKSHAFT OIL SEAL - REAR

**DESCRIPTION**

The crankshaft rear seal is a two piece viton seal. The crankshaft front seal is a one piece viton seal with a steel housing. The front seal is located in the engine front cover. One part of the two piece rear seal is located in a slot in the cylinder block oppsite the crankshaft main bearing cap, the second part of the two piece seal is located in the main bearing cap itself.

**OPERATION**

The crankshaft seals prevent oil from leaking from around the crankshaft, either from the rear of the engine or from the engine front cover.

## CRANKSHAFT OIL SEAL - REAR (Continued)

**REMOVAL**

The service seal is a two piece, Viton seal. The upper seal half can be installed with crankshaft removed from engine or with crankshaft installed. When a new upper seal is installed, install a new lower seal. The lower seal half can be installed only with the rear main bearing cap removed.

**UPPER SEAL —CRANKSHAFT REMOVED**

(1) Remove the crankshaft (Refer to 9 - ENGINE/ENGINE BLOCK/CRANKSHAFT - REMOVAL). Discard the old upper seal.

**UPPER SEAL—CRANKSHAFT INSTALLED**

- (1) Remove the oil pan (Refer to 9 - ENGINE/LUBRICATION/OIL PAN - REMOVAL).
- (2) Remove the oil pump (Refer to 9 - ENGINE/LUBRICATION/OIL PUMP - REMOVAL).
- (3) Remove the rear main bearing cap. Remove and discard the old lower oil seal.
- (4) Carefully remove and discard the old upper oil seal.

**LOWER SEAL**

- (1) Remove the oil pan (Refer to 9 - ENGINE/LUBRICATION/OIL PAN - REMOVAL).
- (2) Remove the oil pump (Refer to 9 - ENGINE/LUBRICATION/OIL PUMP - REMOVAL).
- (3) Remove the rear main bearing cap and discard the old lower seal.

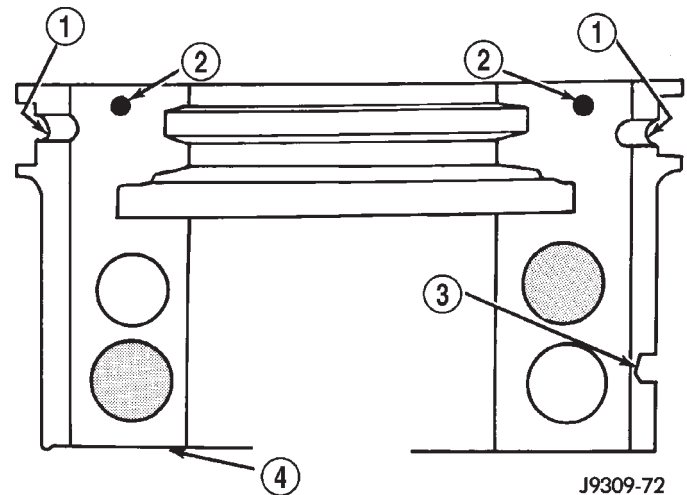
**INSTALLATION**

The service seal is a two piece, Viton seal. The upper seal half can be installed with crankshaft removed from engine or with crankshaft installed. When a new upper seal is installed, install a new lower seal. The lower seal half can be installed only with the rear main bearing cap removed.

**UPPER SEAL —CRANKSHAFT REMOVED**

- (1) Clean the cylinder block rear cap mating surface. Be sure the seal groove is free of debris. Check for burrs at the oil hole on the cylinder block mating surface to rear cap.
- (2) Lightly oil the new upper seal lips with engine oil.
- (3) Install the new upper rear bearing oil seal with the white paint facing toward the rear of the engine.
- (4) Position the crankshaft into the cylinder block.
- (5) Lightly oil the new lower seal lips with engine oil.
- (6) Install the new lower rear bearing oil seal into the bearing cap with the white paint facing towards the rear of the engine.
- (7) Apply 5 mm (0.20 in.) drop of Mopar® Gasket Maker, or equivalent, on each side of the rear main

bearing cap (Fig. 31). DO NOT over-apply sealant or allow the sealant to contact the rubber seal. Assemble bearing cap to cylinder block immediately after sealant application.



**Fig. 31 Sealant Application to Bearing Cap**

- 1 - MOPAR SILICONE RUBBER ADHESIVE SEALANT SLOTS
- 2 - MOPAR® GASKET MAKER (OR EQUIVALENT)
- 3 - CAP ALIGNMENT SLOT
- 4 - REAR MAIN BEARING CAP

(8) To align the bearing cap, use cap slot, alignment dowel, and cap bolts. DO NOT remove excess material after assembly. DO NOT strike rear cap more than two times for proper engagement.

(9) Clean and oil all cap bolts. Install all main bearing caps. Install all cap bolts and alternately tighten to 115 N·m (85 ft. lbs.) torque.

(10) Install oil pump (Refer to 9 - ENGINE/LUBRICATION/OIL PUMP - INSTALLATION).

(11) Apply Mopar® GEN II Silicone Rubber Adhesive Sealant, or equivalent, at bearing cap-to-block joint to provide cap to block and oil pan sealing (Fig. 32). Apply enough sealant so that a small amount is squeezed out. Withdraw nozzle and wipe excess sealant off the oil pan seal groove.

(12) Install new front crankshaft oil seal (Refer to 9 - ENGINE/ENGINE BLOCK/CRANKSHAFT OIL SEAL - FRONT - INSTALLATION).

(13) Immediately install the oil pan (Refer to 9 - ENGINE/LUBRICATION/OIL PAN - INSTALLATION).

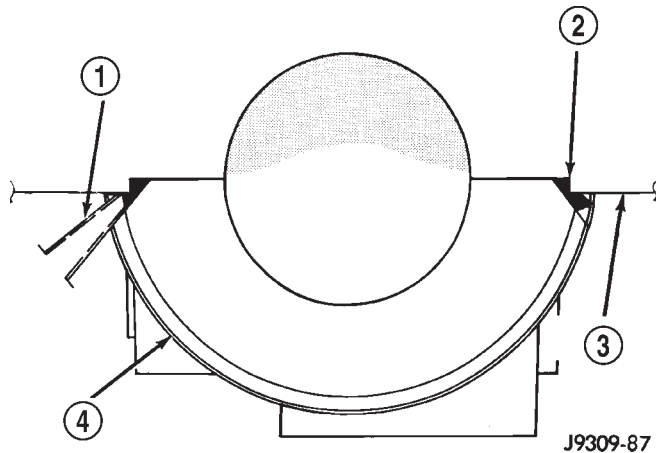
**UPPER SEAL—CRANKSHAFT INSTALLED**

(1) Clean the cylinder block mating surfaces before oil seal installation. Check for burrs at the oil hole on the cylinder block mating surface to rear cap.

(2) Lightly oil the new upper seal lips with engine oil. To allow ease of installation of the seal, loosen at least the two main bearing caps forward of the rear bearing cap.



## CRANKSHAFT OIL SEAL - REAR (Continued)



**Fig. 32 Apply Sealant to Bearing Cap-to-Block Joint**

- 1 - MOPAR® GEN II SILICONE RUBBER ADHESIVE SEALANT NOZZLE TIP
- 2 - SEALANT APPLIED
- 3 - CYLINDER BLOCK
- 4 - REAR MAIN BEARING CAP

(3) Rotate the new upper seal into the cylinder block, being careful not to shave or cut the outer surface of the seal. To ensure proper installation, use the installation tool provided with the kit. Install the new seal with the white paint facing toward the rear of the engine.

(4) Install the new lower rear bearing oil seal into the bearing cap with the white paint facing toward the rear of the engine.

(5) Apply 5 mm (0.20 in.) drop of Mopar® Gasket Maker, or equivalent, on each side of the rear main bearing cap (Fig. 31). DO NOT over-apply sealant or allow the sealant to contact the rubber seal. Assemble bearing cap to cylinder block immediately after sealant application. Be sure the white paint faces toward the rear of the engine.

(6) To align the bearing cap, use cap slot, alignment dowel, and cap bolts. DO NOT remove excess material after assembly. DO NOT strike rear cap more than two times for proper engagement.

(7) Install the rear main bearing cap with cleaned and oiled cap bolts. Alternately tighten ALL cap bolts to 115 N·m (85 ft. lbs.) torque.

(8) Install oil pump (Refer to 9 - ENGINE/LUBRICATION/OIL PUMP - INSTALLATION).

(9) Apply Mopar® GEN II Silicone Rubber Adhesive Sealant, or equivalent, at bearing cap-to-block joint to provide cap-to-block and oil pan sealing (Fig. 32). Apply enough sealant until a small amount is squeezed out. Withdraw nozzle and wipe excess sealant off the oil pan seal groove.

(10) Immediately install the oil pan (Refer to 9 - ENGINE/LUBRICATION/OIL PAN - INSTALLATION).

## LOWER SEAL

(1) Clean the rear main cap mating surfaces including the oil pan gasket groove.

(2) Carefully install a new upper seal. Refer to UPPER SEAL—CRANKSHAFT INSTALLED.

(3) Lightly oil the new lower seal lips with engine oil.

(4) Install a new lower seal in bearing cap with the white paint facing the rear of engine.

(5) Apply 5 mm (0.20 in.) drop of Mopar® Gasket Maker, or equivalent, on each side of the rear main bearing cap (Fig. 31). DO NOT over-apply sealant or allow the sealant to contact the rubber seal. Assemble bearing cap to cylinder block immediately after sealant application.

(6) To align the bearing cap, use cap slot, alignment dowel, and cap bolts. DO NOT remove excess material after assembly. DO NOT strike rear cap more than two times for proper engagement.

(7) Install the rear main bearing cap with cleaned and oiled cap bolts. Alternately tighten the cap bolts to 115 N·m (85 ft. lbs.) torque.

(8) Install oil pump (Refer to 9 - ENGINE/LUBRICATION/OIL PUMP - INSTALLATION).

(9) Apply Mopar® GEN II Silicone Rubber Adhesive Sealant, or equivalent, at bearing cap-to-block joint to provide cap to block and oil pan sealing. Apply enough sealant so that a small amount is squeezed out. Withdraw nozzle and wipe excess sealant off the oil pan seal groove.

(10) Immediately install the oil pan (Refer to 9 - ENGINE/LUBRICATION/OIL PAN - INSTALLATION).

## DISTRIBUTOR BUSHING

### REMOVAL

(1) Remove distributor (Refer to 8 - ELECTRICAL/IGNITION CONTROL/DISTRIBUTOR - REMOVAL).

(2) Remove the intake manifold (Refer to 9 - ENGINE/MANIFOLDS/INTAKE MANIFOLD - REMOVAL).

(3) Insert Distributor Drive Shaft Bushing Puller Tool C-3052 into old bushing and thread down until a tight fit is obtained (Fig. 33).

(4) Hold puller screw and tighten puller nut until bushing is removed.

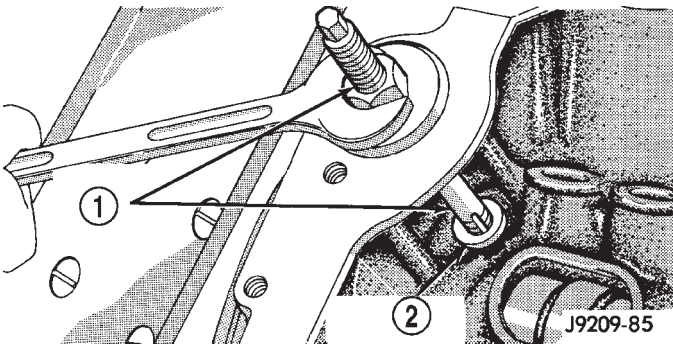
### INSTALLATION

(1) Slide new bushing over burnishing end of Distributor Drive Shaft Bushing Driver/Burnisher Tool C-3053. Insert the tool and bushing into the bore.

(2) Drive bushing and tool into position, using a hammer (Fig. 34).

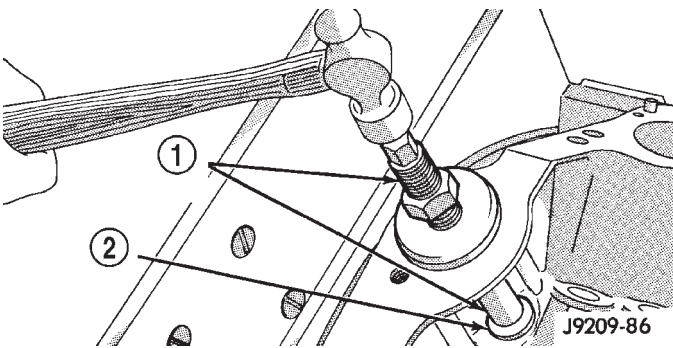
(3) As the burnisher is pulled through the bushing, the bushing is expanded tight in the block and bur-

## DISTRIBUTOR BUSHING (Continued)



**Fig. 33 Distributor Driveshaft Bushing Removal**

- 1 - SPECIAL TOOL C-3052  
2 - BUSHING

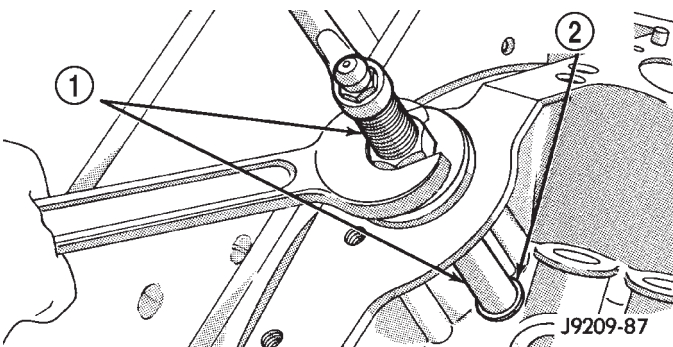


**Fig. 34 Distributor Driveshaft Bushing Installation**

- 1 - SPECIAL TOOL C-3053  
2 - BUSHING

nished to correct size (Fig. 35). **DO NOT ream this bushing.**

**CAUTION:** This procedure **MUST** be followed when installing a new bushing or seizure to shaft may occur.



**Fig. 35 Burnishing Distributor Driveshaft Bushing**

- 1 - SPECIAL TOOL C-3053  
2 - BUSHING

(4) Install the intake manifold (Refer to 9 - ENGINE/MANIFOLDS/INTAKE MANIFOLD - INSTALLATION).

(5) Install the distributor (Refer to 8 - ELECTRICAL/IGNITION CONTROL/DISTRIBUTOR - INSTALLATION).

## HYDRAULIC LIFTERS

## DIAGNOSIS AND TESTING—HYDRAULIC TAPPETS

Before disassembling any part of the engine to correct tappet noise, check the oil pressure. If vehicle has no oil pressure gauge, install a reliable gauge at the pressure sending-unit. The pressure should be between 207-552 kPa (30-80 psi) at 3,000 RPM.

Check the oil level after the engine reaches normal operating temperature. Allow 5 minutes to stabilize oil level, check dipstick. The oil level in the pan should never be above the FULL mark or below the ADD OIL mark on dipstick. Either of these two conditions could be responsible for noisy tappets.

## OIL LEVEL

## HIGH

If oil level is above the FULL mark, it is possible for the connecting rods to dip into the oil. With the engine running, this condition could create foam in the oil pan. Foam in oil pan would be fed to the hydraulic tappets by the oil pump causing them to lose length and allow valves to seat noisily.

## LOW

Low oil level may allow oil pump to take in air. When air is fed to the tappets, they lose length, which allows valves to seat noisily. Any leaks on intake side of oil pump through which air can be drawn will create the same tappet action. Check the lubrication system from the intake strainer to the pump cover, including the relief valve retainer cap. When tappet noise is due to aeration, it may be intermittent or constant, and usually more than one tappet will be noisy. When oil level and leaks have been corrected, operate the engine at fast idle. Run engine for a sufficient time to allow all of the air inside the tappets to be bled out.

## TAPPET NOISE DIAGNOSIS

(1) To determine source of tappet noise, operate engine at idle with cylinder head covers removed.

(2) Feel each valve spring or rocker arm to detect noisy tappet. The noisy tappet will cause the affected spring and/or rocker arm to vibrate or feel rough in operation.

## HYDRAULIC LIFTERS (Continued)

**NOTE:** Worn valve guides or cocked springs are sometimes mistaken for noisy tappets. If such is the case, noise may be dampened by applying side thrust on the valve spring. If noise is not appreciably reduced, it can be assumed the noise is in the tappet. Inspect the rocker arm push rod sockets and push rod ends for wear.

(3) Valve tappet noise ranges from light noise to a heavy click. A light noise is usually caused by excessive leak-down around the unit plunger, or by the plunger partially sticking in the tappet body cylinder. The tappet should be replaced. A heavy click is caused by a tappet check valve not seating, or by foreign particles wedged between the plunger and the tappet body. This will cause the plunger to stick in the down position. This heavy click will be accompanied by excessive clearance between the valve stem and rocker arm as valve closes. In either case, tappet assembly should be removed for inspection and cleaning.

(4) The valve train generates a noise very much like a light tappet noise during normal operation. Care must be taken to ensure that tappets are making the noise. If more than one tappet seems to be noisy, it's probably not the tappets.

**LEAK-DOWN TEST**

After cleaning and inspection, test each tappet for specified leak-down rate tolerance to ensure zero-lash operation (Fig. 36).

Swing the weighted arm of the hydraulic valve tappet tester away from the ram of the Universal Leak-Down Tester.

(1) Place a 7.925-7.950 mm (0.312-0.313 inch) diameter ball bearing on the plunger cap of the tappet.

(2) Lift the ram and position the tappet (with the ball bearing) inside the tester cup.

(3) Lower the ram, then adjust the nose of the ram until it contacts the ball bearing. **DO NOT** tighten the hex nut on the ram.

(4) Fill the tester cup with hydraulic valve tappet test oil until the tappet is completely submerged.

(5) Swing the weighted arm onto the push rod and pump the tappet plunger up and down to remove air. When the air bubbles cease, swing the weighted arm away and allow the plunger to rise to the normal position.

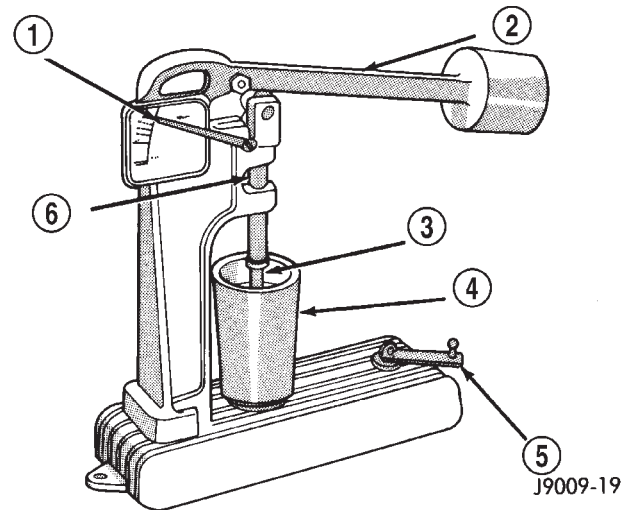
(6) Adjust the nose of the ram to align the pointer with the SET mark on the scale of the tester and tighten the hex nut.

(7) Slowly swing the weighted arm onto the push rod.

(8) Rotate the cup by turning the handle at the base of the tester clockwise one revolution every 2 seconds.

(9) Observe the leak-down time interval from the instant the pointer aligns with the START mark on the scale until the pointer aligns with the 0.125 mark. A normally functioning tappet will require

20-110 seconds to leak-down. Discard tappets with leak-down time interval not within this specification.



**Fig. 36 Leak-Down Tester**

- 1 - POINTER
- 2 - WEIGHTED ARM
- 3 - RAM
- 4 - CUP
- 5 - HANDLE
- 6 - PUSH ROD

**REMOVAL**

(1) Remove the air cleaner assembly and air in-let hose.

(2) Remove cylinder head cover (Refer to 9 - ENGINE/CYLINDER HEAD/CYLINDER HEAD COVER(S) - REMOVAL).

(3) Remove rocker assembly and push rods. Identify push rods to ensure installation in original locations.

(4) Remove intake manifold (Refer to 9 - ENGINE/MANIFOLDS/INTAKE MANIFOLD - REMOVAL).

(5) Remove yoke retainer and aligning yokes.

(6) Slide Hydraulic Tappet Remover/Installer Tool C-4129-A through opening in cylinder head and seat tool firmly in the head of tappet.

(7) Pull tappet out of bore with a twisting motion. If all tappets are to be removed, identify tappets to ensure installation in original location.

(8) If the tappet or bore in cylinder block is scored, scuffed, or shows signs of sticking, ream the bore to next oversize. Replace with oversize tappet.

**CLEANING**

Clean tappet with a suitable solvent. Rinse in hot water and blow dry with a clean shop rag or compressed air.

**INSTALLATION**

- (1) Lubricate tappets.

## HYDRAULIC LIFTERS (Continued)

(2) Install tappets and push rods in their original positions. Ensure that the oil feed hole in the side of the tappet body faces up (away from the crankshaft).

(3) Install aligning yokes with ARROW toward camshaft.

(4) Install yoke retainer. Tighten the bolts to 23 N·m (200 in. lbs.) torque. Install intake manifold (Refer to 9 - ENGINE/MANIFOLDS/INTAKE MANIFOLD - INSTALLATION).

(5) Install push rods in original positions.

(6) Install rocker arms.

(7) Install cylinder head cover (Refer to 9 - ENGINE/CYLINDER HEAD/CYLINDER HEAD COVER(S) - INSTALLATION).

(8) Install air cleaner assembly and air in-let hose.

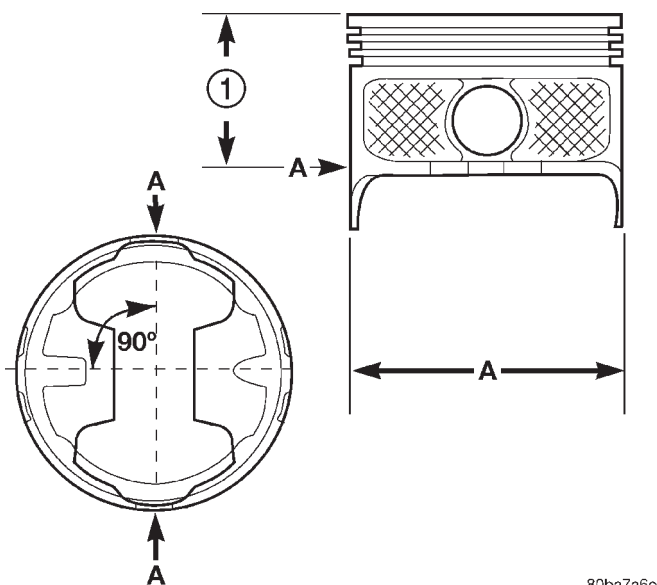
(9) Start and operate engine. Warm up to normal operating temperature.

**CAUTION:** To prevent damage to valve mechanism, engine must not be run above fast idle until all hydraulic tappets have filled with oil and have become quiet.

## PISTON &amp; CONNECTING ROD

## DESCRIPTION

The pistons are made of aluminum and have three ring grooves, the top two grooves are for the compression rings and the bottom groove is for the oil control ring. The connecting rods are forged steel and are coined prior to heat treat. The piston pins are press fit.



80ba7a6c

**Fig. 37 Piston Measurements**

1 - 49.53 mm (1.95 IN.)

## STANDARD PROCEDURE—PISTON FITTING

Piston and cylinder wall must be clean and dry. Specified clearance between the piston and the cylinder wall is 0.013-0.038 mm (0.0005-0.0015 inch) at 21°C (70°F).

Piston diameter should be measured at the top of skirt, 90° to piston pin axis. Cylinder bores should be measured halfway down the cylinder bore and transverse to the engine crankshaft center line.

Pistons and cylinder bores should be measured at normal room temperature, 21°C (70°F).

Check the pistons for taper and elliptical shape before they are fitted into the cylinder bore (Fig. 37).

## PISTON MEASUREMENT CHART

PISTON SIZE	A DIA = PISTON DIAMETER		BORE DIAMETER	
	MIN. mm (in.)	MAX. mm (in.)	MIN. mm (in.)	MAX. mm (in.)
A	—	—	—	—
B	101.580 (3.9992)	101.592 (3.9997)	101.605 (4.0002)	101.618 (4.0007)
C	101.592 (3.9997)	101.605 (4.0002)	101.618 (4.0007)	101.630 (4.0012)
D	101.605 (4.0002)	101.618 (4.0007)	101.630 (4.0012)	101.643 (4.0017)
E	—	—	—	—
DESCRIPTION		SPECIFICATION		
PISTON PIN BORE		25.007 - 25.015 mm (.9845 - .9848 in.)		
RING GROOVE HEIGHT OIL RAIL		4.033 - 4.058 mm (.1588 - .1598 in.)		
COMPRESSION RAIL		1.529 - 1.554 mm (.0602 - .0612 in.)		
TOTAL FINISHED WEIGHT		470.8 ± 2 grams (16.607 ± .0706 ounces)		



## PISTON &amp; CONNECTING ROD (Continued)

## REMOVAL

(1) Remove the engine from the vehicle (Refer to 9 - ENGINE - REMOVAL).

(2) Remove the cylinder head (Refer to 9 - ENGINE/CYLINDER HEAD - REMOVAL).

(3) Remove the oil pan (Refer to 9 - ENGINE/LUBRICATION/OIL PAN - REMOVAL).

(4) Remove top ridge of cylinder bores with a reliable ridge reamer before removing pistons from cylinder block. Be sure to keep tops of pistons covered during this operation.

(5) Be sure each connecting rod and connecting rod cap is identified with the cylinder number. Remove connecting rod cap. Install connecting rod bolt guide set on connecting rod bolts.

(6) Pistons and connecting rods must be removed from top of cylinder block. When removing the assemblies from the engine, rotate crankshaft so that the connecting rod is centered in cylinder bore and at BDC. **Be careful not to nick crankshaft journals.**

(7) After removal, install bearing cap on the mating rod.

## CLEANING

Clean the piston and connecting rod assembly using a suitable solvent.

## INSPECTION

Check the connecting rod journal for excessive wear, taper and scoring (Refer to 9 - ENGINE/ENGINE BLOCK/CONNECTING ROD BEARINGS - STANDARD PROCEDURE).

Check the connecting rod for signs of twist or bending.

Check the piston for taper and elliptical shape before it is fitted into the cylinder bore (Refer to 9 - ENGINE/ENGINE BLOCK/PISTON & CONNECTING ROD - STANDARD PROCEDURE).

Check the piston for scoring, or scraping marks in the piston skirts. Check the ring lands for cracks and/or deterioration.

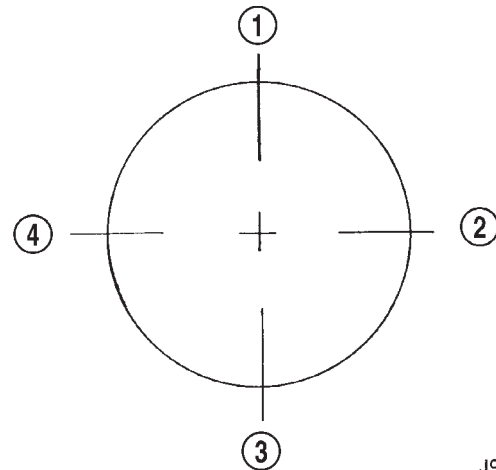
## INSTALLATION

(1) Be sure that compression ring gaps are staggered so that neither is in line with oil ring rail gap.

(2) Before installing the ring compressor, be sure the oil ring expander ends are butted and the rail gaps located properly (Fig. 38).

(3) Immerse the piston head and rings in clean engine oil. Slide Piston Ring Compressor Tool C-385 over the piston and tighten with the special wrench (part of Tool C-385). **Be sure position of rings does not change during this operation.**

(4) Install connecting rod bolt protectors on rod bolts. The long protector should be installed on the numbered side of the connecting rod.



J9309-80

**Fig. 38 Proper Ring Installation**

- 1 - OIL RING SPACER GAP
- 2 - SECOND COMPRESSION RING GAP OIL RING RAIL GAP (TOP)
- 3 - OIL RING RAIL GAP (BOTTOM)
- 4 - TOP COMPRESSION RING GAP

(5) Rotate crankshaft so that the connecting rod journal is on the center of the cylinder bore. Be sure connecting rod and cylinder bore number are the same. Insert rod and piston into cylinder bore and guide rod over the crankshaft journal.

(6) Tap the piston down in cylinder bore, using a hammer handle. At the same time, guide connecting rod into position on crankshaft journal.

(7) The notch, or groove, on top of piston must be pointing toward front of engine. The larger chamfer of the connecting rod bore must be installed toward crankshaft journal fillet.

(8) Install rod caps. Be sure connecting rod, connecting rod cap, and cylinder bore number are the same. Install nuts on cleaned and oiled rod bolts and tighten nuts to 61 N·m (45 ft. lbs.) torque.

(9) Install the oil pan (Refer to 9 - ENGINE/LUBRICATION/OIL PAN - INSTALLATION).

(10) Install the cylinder head (Refer to 9 - ENGINE/CYLINDER HEAD - INSTALLATION).

(11) Install the engine into the vehicle (Refer to 9 - ENGINE - INSTALLATION).

## PISTON RINGS

## STANDARD PROCEDURE—PISTON RING FITTING

(1) Measurement of end gaps:

(a) Measure piston ring gap 2 in. from bottom of cylinder bore. An inverted piston can be used to push the rings down to ensure positioning rings squarely in the cylinder bore before measuring.

## PISTON RINGS (Continued)

(b) Insert feeler gauge in the gap. The top compression ring gap should be between 0.254-0.508 mm (0.010-0.020 in.). The second compression ring gap should be between 0.508-0.762 mm (0.020-0.030 in.). The oil ring gap should be 0.254-1.270 mm (0.010-0.050 in.).

(c) Rings with insufficient end gap may be properly filed to the correct dimension. Rings with excess gaps should not be used.

(2) Install rings, and confirm ring side clearance:

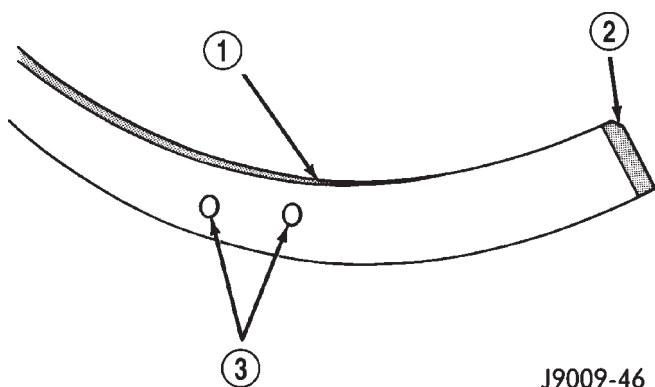
(a) Install oil rings being careful not to nick or scratch the piston. Install the oil control rings according to instructions in the package. It is not necessary to use a tool to install the upper and lower rails. Insert oil rail spacer first, then side rails.

(b) Install the second compression rings using Installation Tool C-4184. The compression rings must be installed with the identification mark face up (toward top of piston) and chamfer facing down. An identification mark on the ring is a drill point, a stamped letter "O", an oval depression, or the word "TOP" (Fig. 39) (Fig. 41).

(c) Using a ring installer, install the top compression ring with the chamfer facing up (Fig. 40) (Fig. 41). An identification mark on the ring is a drill point, a stamped letter "O", an oval depression or the word "TOP" facing up.

(d) Measure side clearance between piston ring and ring land. Clearance should be 0.074-0.097 mm (0.0029-0.0038 in.) for the compression rings. The steel rail oil ring should be free in groove, but should not exceed 0.246 mm (0.0097 in.) side clearance.

(e) Pistons with insufficient, or excessive, side clearance should be replaced.



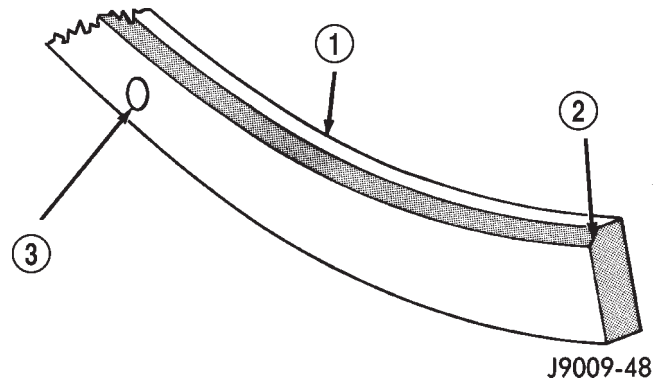
J9009-46

**Fig. 39 Second Compression Ring Identification (Typical)**

- 1 - SECOND COMPRESSION RING (BLACK CAST IRON)
- 2 - CHAMFER
- 3 - TWO DOTS

(3) Orient the rings:

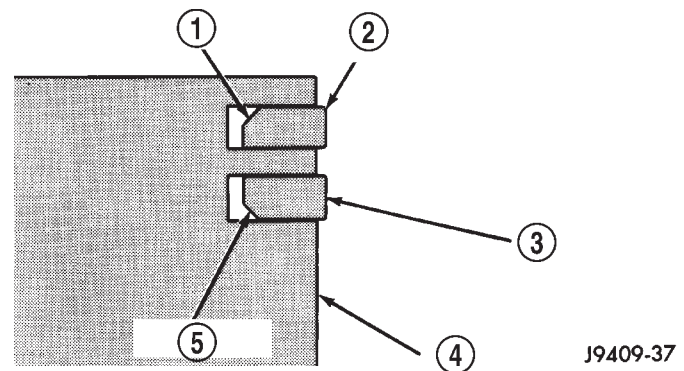
(a) Arrange top compression ring 90° counter-clockwise from the oil ring rail gap (Fig. 42).



J9009-48

**Fig. 40 Top Compression Ring Identification (Typical)**

- 1 - TOP COMPRESSION RING (GRAY IN COLOR)
- 2 - CHAMFER
- 3 - ONE DOT



J9409-37

**Fig. 41 Compression Ring Chamfer Location (Typical)**

- 1 - CHAMFER
- 2 - TOP COMPRESSION RING
- 3 - SECOND COMPRESSION RING
- 4 - PISTON
- 5 - CHAMFER

(b) Arrange second compression ring 90° clockwise from the oil ring rail gap (Fig. 42).

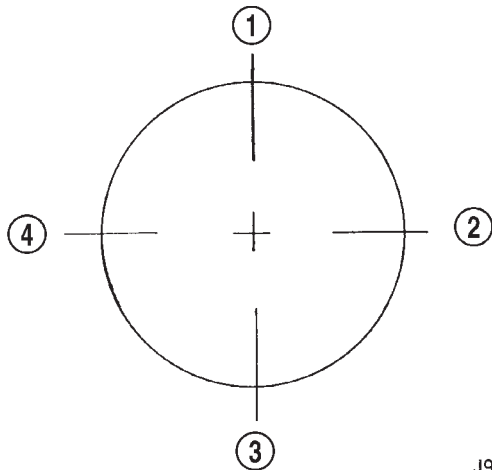
## VIBRATION DAMPER

### REMOVAL

- (1) Disconnect the battery negative cable.
- (2) Remove the cooling system fan (Refer to 7 - COOLING/ENGINE/FAN DRIVE VISCOUS CLUTCH - REMOVAL).
- (3) Remove the accessory drive belt (Refer to 7 - COOLING/ACCESSORY DRIVE/DRIVE BELTS - REMOVAL).
- (4) Remove vibration damper bolt and washer from end of crankshaft.
- (5) Position Special Tool 8513 Insert into the crankshaft nose.



## VIBRATION DAMPER (Continued)

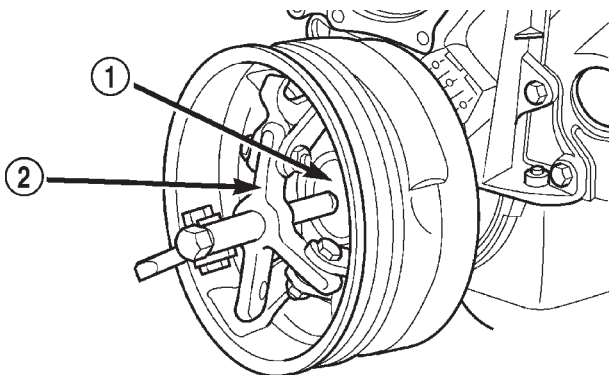


J9309-80

**Fig. 42 Proper Ring Installation**

- 1 - OIL RING SPACER GAP
- 2 - SECOND COMPRESSION RING GAP OIL RING RAIL GAP (TOP)
- 3 - OIL RING RAIL GAP (BOTTOM)
- 4 - TOP COMPRESSION RING GAP

(6) Install Special Tool 1026 Three Jaw Puller onto the vibration damper (Fig. 43).



80c0722d

**Fig. 43 Vibration Damper Removal**

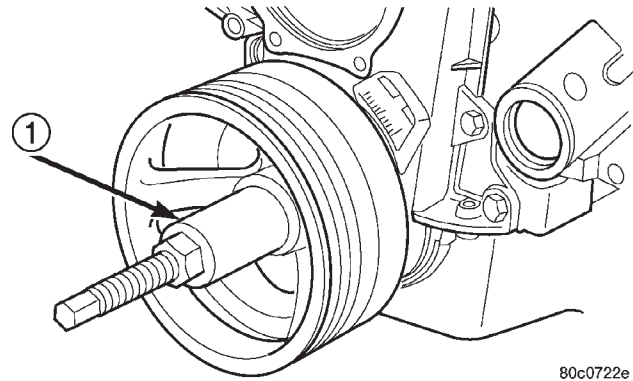
- 1 - SPECIAL TOOL 8513 INSERT
- 2 - SPECIAL TOOL 1026

(7) Pull vibration damper off of the crankshaft.

**INSTALLATION**

**CAUTION:** Thoroughly remove any contaminants from the crankshaft nose and the vibration damper bore. Failure to do so can cause sever damage to the crankshaft.

- (1) Position the vibration damper onto the crankshaft.
- (2) Place installing tool, part of Puller Tool Set C-3688 in position and press the vibration damper onto the crankshaft (Fig. 44).



80c0722e

**Fig. 44 Vibration Damper Installation**

- 1 - SPECIAL TOOL C-3688

(3) Install the crankshaft bolt and washer. Tighten the bolt to 244 N·m (180 ft. lbs.) torque.

(4) Install the accessory drive belt (Refer to 7 - COOLING/ACCESSORY DRIVE/DRIVE BELTS - INSTALLATION).

(5) Position the fan shroud and install the bolts. Tighten the retainer bolts to 11 N·m (95 in. lbs.) torque.

(6) Install the cooling fan (Refer to 7 - COOLING/ENGINE/FAN DRIVE VISCOUS CLUTCH - INSTALLATION).

(7) Connect the battery negative cable.

**FRONT MOUNT****REMOVAL**

- (1) Disconnect the battery negative cable.
- (2) Position fan to ensure clearance for radiator top tank and hose.

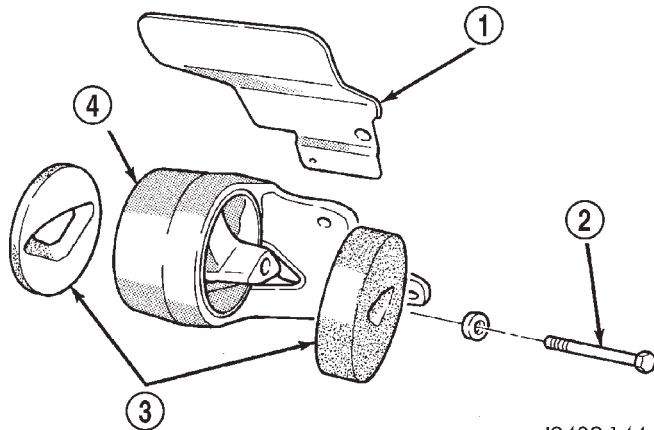
**CAUTION:** DO NOT lift the engine by the intake manifold.

- (3) Install engine support/lifting fixture.
- (4) Raise vehicle on hoist.
- (5) Lift the engine SLIGHTLY and remove the thru-bolt and nut (Fig. 45).
- (6) Remove engine support bracket/cushion bolts (Fig. 45). Remove the support bracket/cushion and heat shields.

**INSTALLATION**

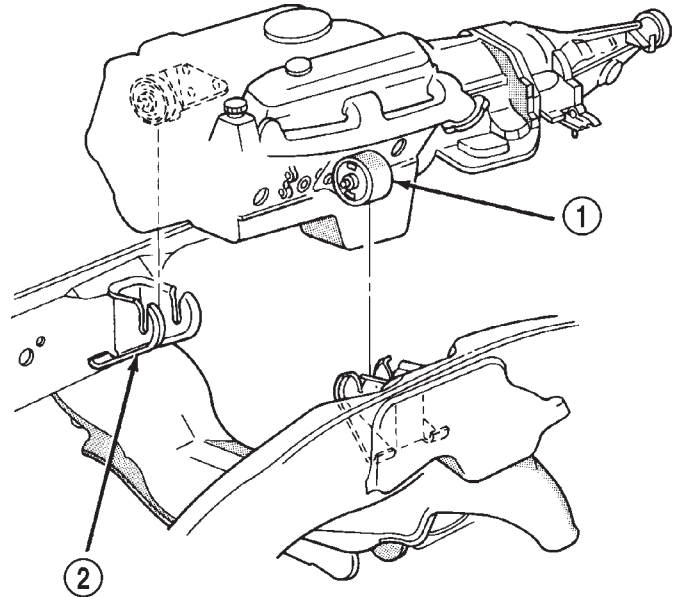
- (1) With engine raised SLIGHTLY, position the engine support bracket/cushion and heat shields to the block. Install new bolts and tighten to 81 N·m (60 ft. lbs.) torque.
- (2) Install the through-bolt into the engine support bracket/cushion.
- (3) Lower engine with support/lifting fixture while guiding the engine bracket/cushion and through-bolt into support cushion brackets (Fig. 46).

## FRONT MOUNT (Continued)

**Fig. 45 Engine Front Mounts**

J9409-144

- 1 - ENGINE MOUNT HEAT SHIELD
- 2 - THRU-BOLT
- 3 - RESTRICTION PADS
- 4 - ENGINE SUPPORT BRACKET/CUSHION

**Fig. 46 Positioning Engine Front Mounts**

J9409-54

- 1 - ENGINE SUPPORT BRACKET/CUSHION
- 2 - SUPPORT CUSHION BRACKET

(4) Install through-bolt nuts and tighten the nuts to 102 N·m (75 ft. lbs.) torque.

(5) Lower the vehicle.

(6) Remove lifting fixture.

## REAR MOUNT

## REMOVAL

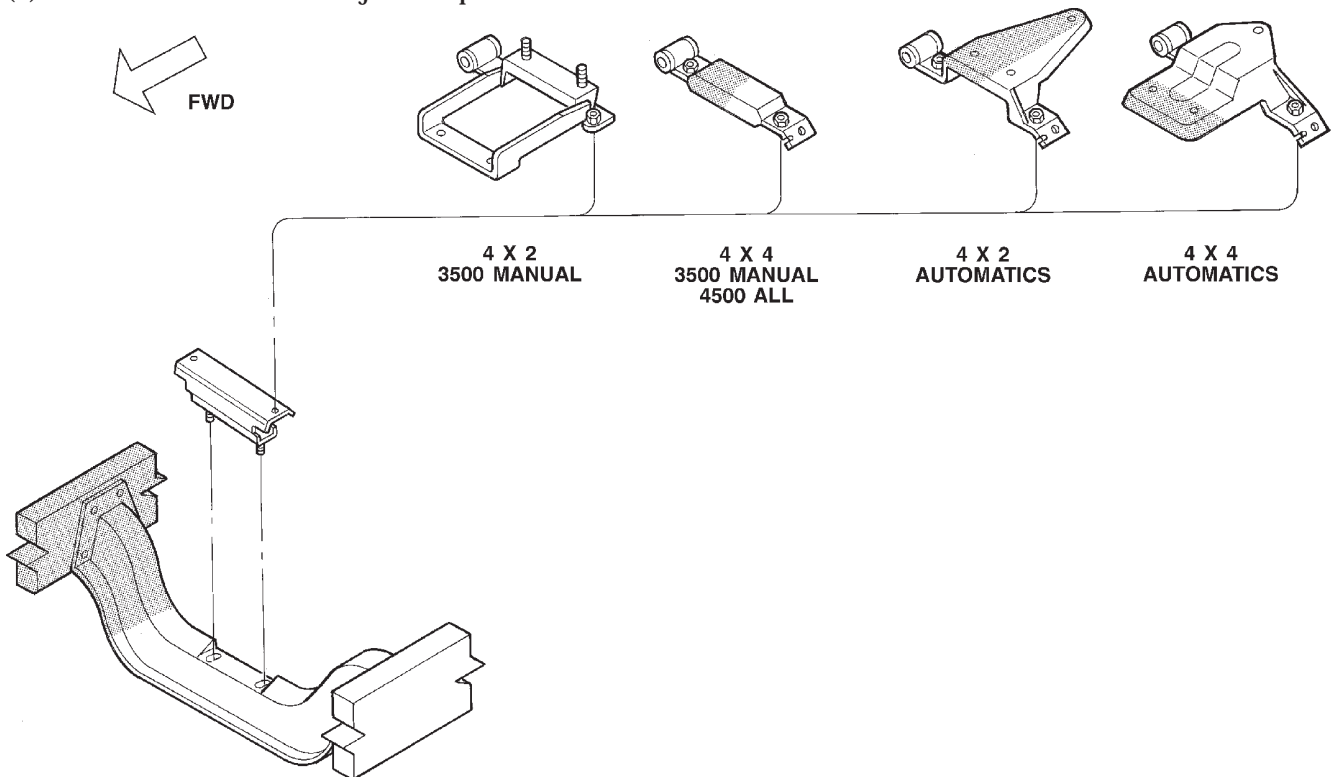
(1) Raise the vehicle on a hoist.

(2) Position a transmission jack in place.

(3) Remove support cushion stud nuts (Fig. 47).

(4) Raise rear of transmission and engine SLIGHTLY.

(5) Remove the bolts holding the support cushion to the transmission support bracket. Remove the support cushion.

**Fig. 47 Engine Rear Support Cushion Assemblies**

J9509-126

## REAR MOUNT (Continued)

(6) If necessary, remove the bolts holding the transmission support bracket to the transmission.

## INSTALLATION

(1) If removed, position the transmission support bracket to the transmission. Install new attaching bolts and tighten to 88 N·m (65 ft. lbs.) torque.

(2) Position support cushion to transmission support bracket. Install stud nuts and tighten to 41 N·m (30 ft. lbs.) torque.

(3) Using the transmission jack, lower the transmission and support cushion onto the crossmember (Fig. 49).

(4) Install the support cushion bolts and tighten to 41 N·m (30 ft. lbs.) torque.

(5) Remove the transmission jack.

(6) Lower the vehicle.

## LUBRICATION

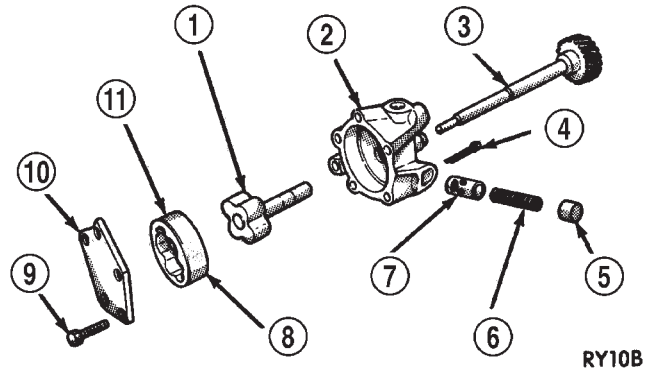
## DESCRIPTION

A gear-type positive displacement pump (Fig. 48) is mounted at the underside of the rear main bearing cap. The pump uses a pick-up tube and screen assembly to gather engine oil from the oil pan.

## OPERATION

The pump draws oil through the screen and inlet tube from the sump at the rear of the oil pan. The oil is driven between the drive and idler gears and pump body, then forced through the outlet to the block. An oil gallery in the block channels the oil to the inlet side of the full flow oil filter. After passing through the filter element, the oil passes from the center outlet of the filter through an oil gallery that channels the oil up to the main gallery, which extends the entire length on the right side of the block. The oil then goes down to the No. 1 main bearing, back up to the left side of the block, and into the oil gallery on the left side of the engine.

Galleries extend downward from the main oil gallery to the upper shell of each main bearing. The crankshaft is drilled internally to pass oil from the main bearing journals to the connecting rod journals. Each connecting rod bearing has half a hole in it, oil



RY10B

**Fig. 48 Positive Displacement Oil Pump—Typical**

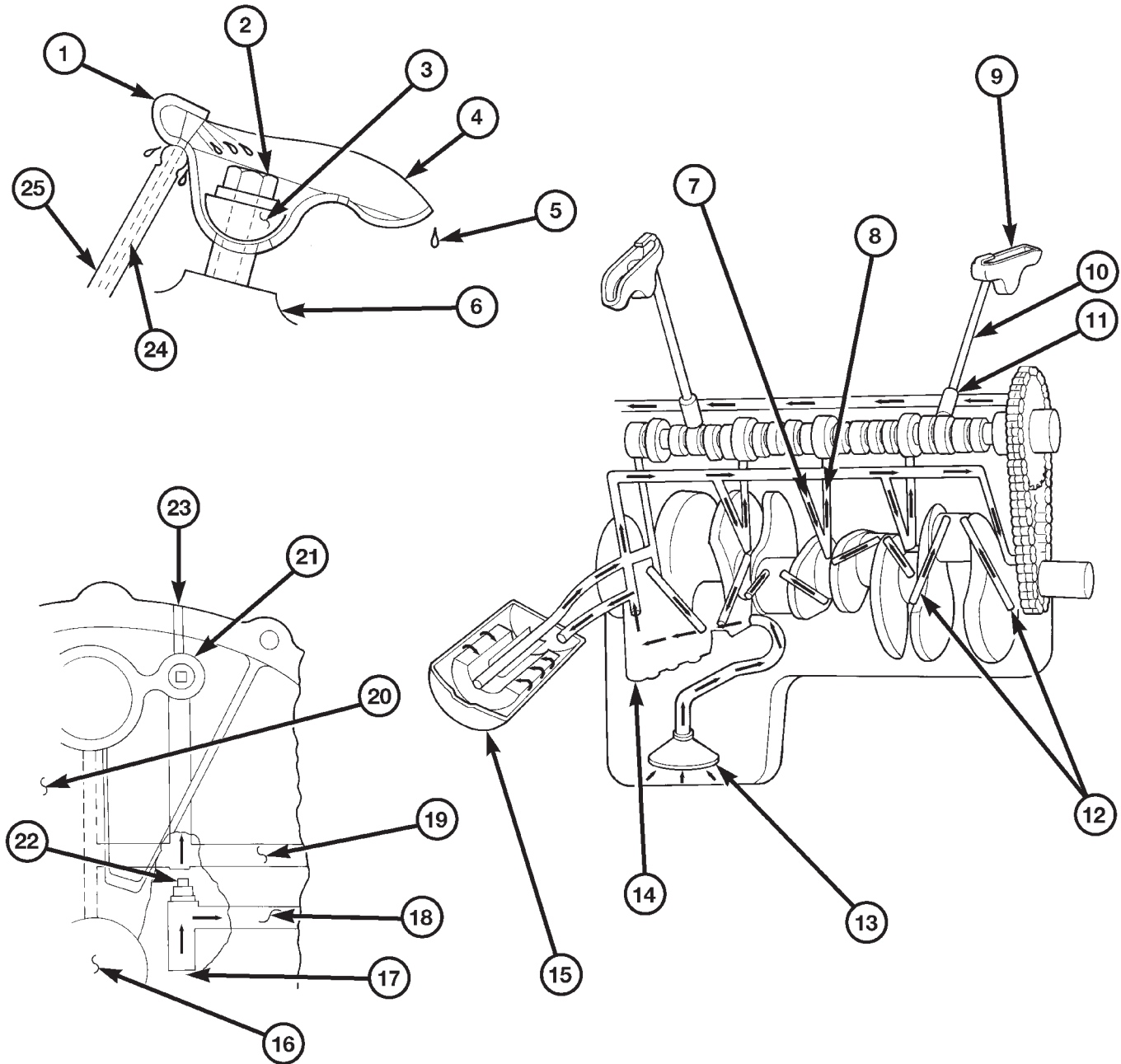
- 1 - INNER ROTOR AND SHAFT
- 2 - BODY
- 3 - DISTRIBUTOR DRIVESHAFT (REFERENCE)
- 4 - COTTER PIN
- 5 - RETAINER CAP
- 6 - SPRING
- 7 - RELIEF VALVE
- 8 - LARGE CHAMFERED EDGE
- 9 - BOLT
- 10 - COVER
- 11 - OUTER ROTOR

passes through the hole when the rods rotate and the hole lines up, oil is then thrown off as the rod rotates. This oil throwoff lubricates the camshaft lobes, distributor drive gear, cylinder walls, and piston pins.

The hydraulic valve tappets receive oil directly from the main oil gallery. The camshaft bearings receive oil from the main bearing galleries. The front camshaft bearing journal passes oil through the camshaft sprocket to the timing chain. Oil drains back to the oil pan under the No. 1 main bearing cap.

The oil supply for the rocker arms and bridged pivot assemblies is provided by the hydraulic valve tappets, which pass oil through hollow push rods to a hole in the corresponding rocker arm. Oil from the rocker arm lubricates the valve train components. The oil then passes down through the push rod guide holes and the oil drain-back passages in the cylinder head, past the valve tappet area, and then returns to the oil pan (Fig. 49).

## LUBRICATION (Continued)

**Fig. 49 Oil Lubrication System**

8087d0cf

- |                                 |   |
|---------------------------------|---|
| 1 - OIL DEFLECTOR TAB           | 14 - OIL PUMP   |
| 2 - BOLT                        | 15 - OIL FILTER   |
| 3 - ROCKER ARM PIVOT            | 16 - CRANKSHAFT   |
| 4 - ROCKER ARM                  | 17 - FROM OIL PUMP  |
| 5 - DRIP OILING FOR VALVE TIP   | 18 - OIL TO FILTER  |
| 6 - CYLINDER HEAD BOSS          | 19 - OIL FROM FILTER TO SYSTEM  |
| 7 - TO MAIN BEARINGS            | 20 - PASSAGE TO CAMSHAFT REAR BEARING   |
| 8 - TO CAMSHAFT BEARINGS        | 21 - RIGHT OIL GALLERY  |
| 9 - ROCKER ARM                  | 22 - PLUG   |
| 10 - HOLLOW PUSH ROD            | 23 - OIL PASSAGE FOR OIL PRESSURE INDICATOR LIGHT   |
| 11 - TAPPET                     | 24 - OIL SUPPLY VIA HOLLOW PUSH ROD SUPPLY IS FROM OIL GALLERY METERED THROUGH HYDRAULIC TAPPET |
| 12 - TO CONNECTING ROD BEARINGS | 25 - OIL SUPPLY FROM HOLLOW PUSH ROD  |
| 13 - OIL INTAKE                 |   |

## LUBRICATION (Continued)

**DIAGNOSIS AND TESTING—ENGINE OIL LEAKS**

Begin with a through visual inspection of the engine, particularly at the area of the suspected leak. If an oil leak source is not readily identifiable, the following steps should be followed:

(1) Do not clean or degrease the engine at this time because some solvents may cause rubber to swell, temporarily stopping the leak.

(2) Add an oil-soluble dye (use as recommended by manufacturer). Start the engine and let idle for approximately 15 minutes. Check the oil dipstick to be sure the dye is thoroughly mixed as indicated with a bright yellow color under a black light source.

(3) Using a black light, inspect the entire engine for fluorescent dye, particularly at the suspected area of oil leak. If the oil leak is found and identified, repair per service manual instructions.

(4) If dye is not observed, drive the vehicle at various speeds for approximately 24km (15 miles), and repeat previous step.

(5) If the oil leak source is not positively identified at this time, proceed with the air leak detection test method as follows:

(6) Disconnect the breather cap to air cleaner hose at the breather cap end. Cap or plug breather cap nipple.

(7) Remove the PCV valve from the cylinder head cover. Cap or plug the PCV valve grommet.

(8) Attach an air hose with pressure gauge and regulator to the dipstick tube.

**CAUTION: Do not subject the engine assembly to more than 20.6 kpa (3 PSI) of test pressure.**

(9) Gradually apply air pressure from 1 psi to 2.5 psi maximum while applying soapy water at the suspected source. Adjust the regulator to the suitable test pressure that provide the best bubbles which will pinpoint the leak source. If the oil leak is detected and identified, repair per service manual procedures.

(10) If the leakage occurs at the rear oil seal area, refer to the section, Inspection for Rear Seal Area Leak.

(11) If no leaks are detected, turn off the air supply and remove the air hose and all plugs and caps. Install the PCV valve and breather cap hose. Proceed to next step.

(12) Clean the oil off the suspect oil leak area using a suitable solvent. Drive the vehicle at various speeds approximately 24 km (15 miles). Inspect the engine for signs of an oil leak by using a black light.

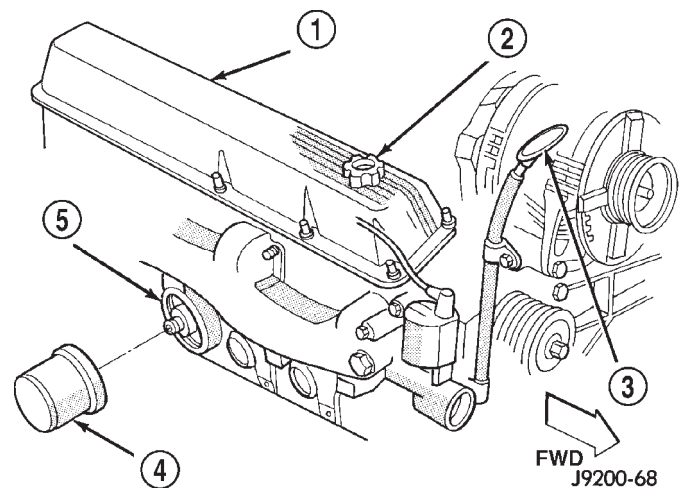
**DIAGNOSIS AND TESTING—ENGINE OIL PRESSURE**

(1) Remove oil pressure sending unit.

(2) Install Oil Pressure Line and Gauge Tool C-3292. Start engine and record pressure. (Refer to 9 - ENGINE - SPECIFICATIONS).

**OIL****STANDARD PROCEDURE—ENGINE OIL****OIL LEVEL INDICATOR (DIPSTICK)**

The engine oil level indicator is located at the right front of the engine, left of the generator on 3.9L engines (Fig. 50).



**Fig. 50 Oil Level Indicator Location**

- 1 - CYLINDER HEAD COVER
- 2 - ENGINE OIL FILL CAP
- 3 - DIPSTICK
- 4 - ENGINE OIL FILTER
- 5 - FILTER BOSS

**CRANKCASE OIL LEVEL INSPECTION**

**CAUTION: Do not overfill crankcase with engine oil, oil foaming and oil pressure loss can result.**

To ensure proper lubrication of an engine, the engine oil must be maintained at an acceptable level. The acceptable levels are indicated between the ADD and SAFE marks on the engine oil dipstick.

(1) Position vehicle on level surface.

(2) With engine OFF, allow approximately ten minutes for oil to settle to bottom of crankcase, remove engine oil dipstick.

(3) Wipe dipstick clean.

(4) Install dipstick and verify it is seated in the tube.



## OIL (Continued)

(5) Remove dipstick, with handle held above the tip, take oil level reading.

(6) Add oil only if level is below the ADD mark on dipstick.

## ENGINE OIL CHANGE

Change engine oil at mileage and time intervals described in the Maintenance Schedule. This information can be found in the owner's manual.

## TO CHANGE ENGINE OIL

Run engine until achieving normal operating temperature.

(1) Position the vehicle on a level surface and turn engine off.

(2) Hoist vehicle.

(3) Remove oil fill cap.

(4) Place a suitable drain pan under crankcase drain.

(5) Remove drain plug from crankcase and allow oil to drain into pan. Inspect drain plug threads for stretching or other damage. Replace drain plug and gasket if damaged.

(6) Install drain plug in crankcase.

(7) Change oil filter (Refer to 9 - ENGINE/LUBRICATION/OIL FILTER - REMOVAL).

(8) Lower vehicle and fill crankcase with specified type (Refer to LUBRICATION & MAINTENANCE/FLUID TYPES - DESCRIPTION) and amount of engine oil (Refer to LUBRICATION & MAINTENANCE - SPECIFICATIONS).

(9) Install oil fill cap.

(10) Start engine and inspect for leaks.

(11) Stop engine and inspect oil level.

## OIL FILTER

## REMOVAL

All engines are equipped with a high quality full-flow, disposable type oil filter. DaimlerChrysler Corporation recommends a Mopar® or equivalent oil filter be used.

(1) Position a drain pan under the oil filter.

(2) Using a suitable oil filter wrench loosen filter.

(3) Rotate the oil filter counterclockwise to remove it from the cylinder block oil filter boss (Fig. 51).

(4) When filter separates from adapter nipple, tip gasket end upward to minimize oil spill. Remove filter from vehicle.

(5) With a wiping cloth, clean the gasket sealing surface (Fig. 54) of oil and grime.

(6) Install new filter (Refer to 9 - ENGINE/LUBRICATION/OIL FILTER - INSTALLATION).

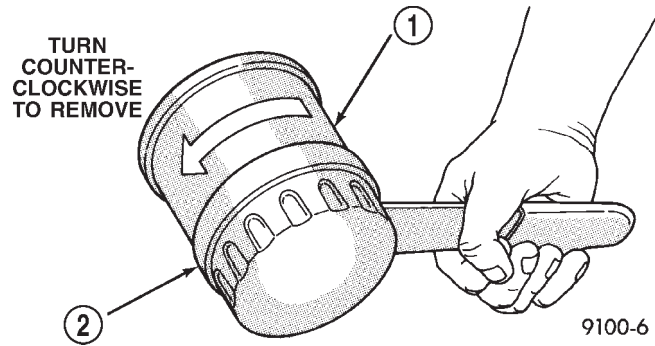


Fig. 51 Oil Filter Removal—Typical

- 1 - ENGINE OIL FILTER  
2 - OIL FILTER WRENCH

## INSTALLATION

(1) Lightly lubricate oil filter gasket with engine oil or chassis grease.

(2) Thread filter onto adapter nipple. When gasket makes contact with sealing surface, (Fig. 52) hand tighten filter one full turn, do not over tighten.

(3) Add oil (Refer to 9 - ENGINE/LUBRICATION/OIL - STANDARD PROCEDURE).

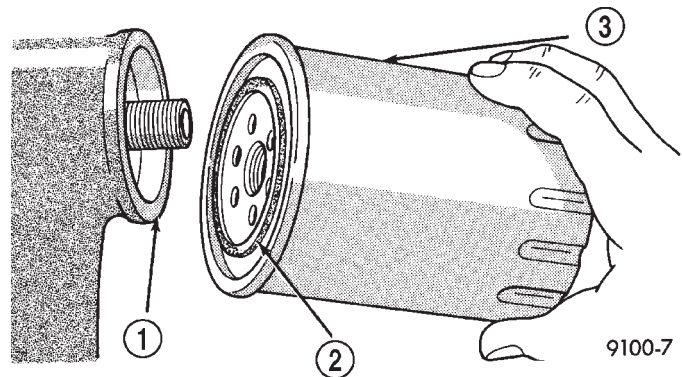


Fig. 52 Oil Filter Sealing Surface—Typical

- 1 - SEALING SURFACE  
2 - RUBBER GASKET  
3 - OIL FILTER

## OIL PAN

## REMOVAL

(1) Disconnect the negative cable from the battery.

(2) Remove engine oil dipstick.

(3) Raise vehicle.

(4) Drain engine oil.

(5) Remove exhaust pipe.

(6) Remove left engine to transmission strut.

(7) Loosen the right side engine support bracket cushion thru-bolt nut and raise the engine slightly. Remove oil pan by sliding backward and out.

(8) Remove the one-piece gasket.



## OIL PAN (Continued)

## CLEANING

Clean the block and pan gasket surfaces.

Trim or remove excess sealant film in the rear main cap oil pan gasket groove. **DO NOT remove the sealant inside the rear main cap slots.**

If present, trim excess sealant from inside the engine.

Clean oil pan in solvent and wipe dry with a clean cloth.

Clean oil screen and pipe thoroughly in clean solvent. Inspect condition of screen.

## INSPECTION

Inspect oil drain plug and plug hole for stripped or damaged threads. Repair as necessary.

Inspect oil pan mounting flange for bends or distortion. Straighten flange, if necessary.

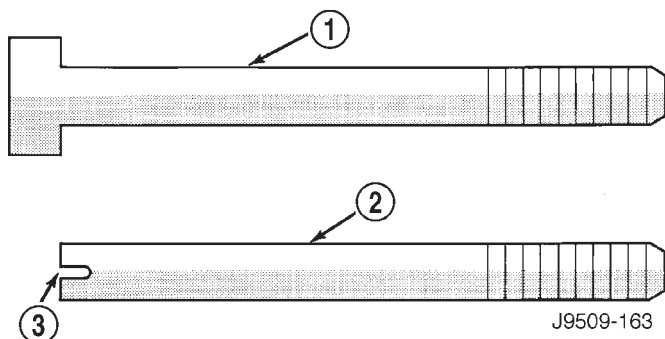
## INSTALLATION

(1) Clean the block and pan gasket surfaces.

(2) Trim or remove excess sealant film in the rear main cap oil pan gasket groove. **DO NOT remove the sealant inside the rear main cap slots.**

(3) If present, trim excess sealant from inside the engine.

(4) Fabricate 4 alignment dowels from 5/16 x 1 1/2 inch bolts. Cut the head off the bolts and cut a slot into the top of the dowel. This will allow easier installation and removal with a screwdriver (Fig. 53).



**Fig. 53 Fabrication of Alignment Dowels**

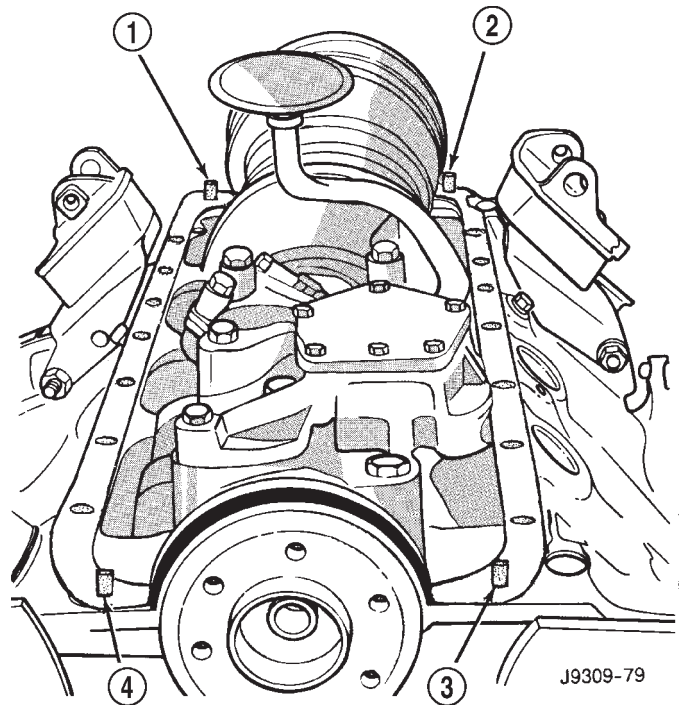
- 1 - 5/16" X 1 1/2" BOLT
- 2 - DOWEL
- 3 - SLOT

(5) Install the dowels in the cylinder block (Fig. 54).

(6) Apply small amount of Mopar® Silicone Rubber Adhesive Sealant, or equivalent in the corner of the cap and the cylinder block.

(7) Slide the one-piece gasket over the dowels and onto the block.

(8) Position the oil pan over the dowels and onto the gasket.



**Fig. 54 Position of Dowels in Cylinder Block**

- 1 - DOWEL
- 2 - DOWEL
- 3 - DOWEL
- 4 - DOWEL

(9) Install the oil pan bolts. Tighten the bolts to 24 N·m (215 in. lbs.) torque.

(10) Remove the dowels. Install the remaining oil pan bolts. Tighten these bolts to 24 N·m (215 in. lbs.) torque.

(11) Lower the engine into the support cushion brackets and tighten the thru bolt nut to the proper torque.

(12) Install the drain plug. Tighten drain plug to 34 N·m (25 ft. lbs.) torque.

(13) Install the engine to transmission strut.

(14) Install exhaust pipe.

(15) Lower vehicle.

(16) Install dipstick.

(17) Connect the negative cable to the battery.

(18) Fill crankcase with oil to proper level.

## OIL PUMP

## REMOVAL

(1) Remove the oil pan (Refer to 9 - ENGINE/LUBRICATION/OIL PAN - REMOVAL).

(2) Remove the oil pump from rear main bearing cap.

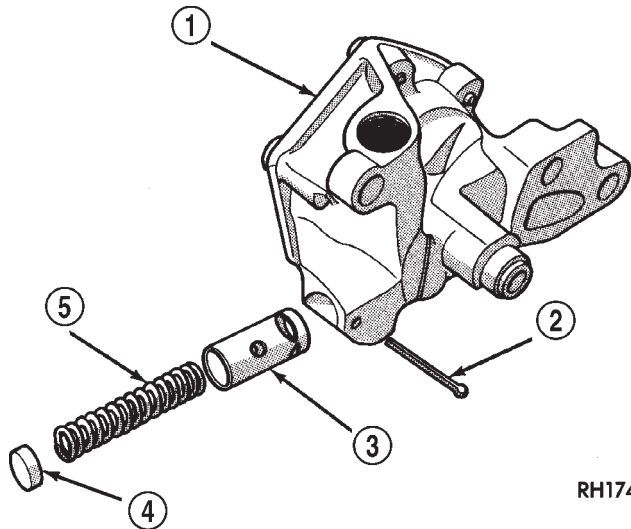
## OIL PUMP (Continued)

## DISASSEMBLE

(1) Remove the relief valve as follows:

(a) Remove cotter pin. Drill a 3.175 mm (1/8 inch) hole into the relief valve retainer cap and insert a self-threading sheet metal screw.

(b) Clamp screw into a vise and while supporting oil pump, remove cap by tapping pump body using a soft hammer. Discard retainer cap and remove spring and relief valve (Fig. 55).



**Fig. 55 Oil Pressure Relief Valve**

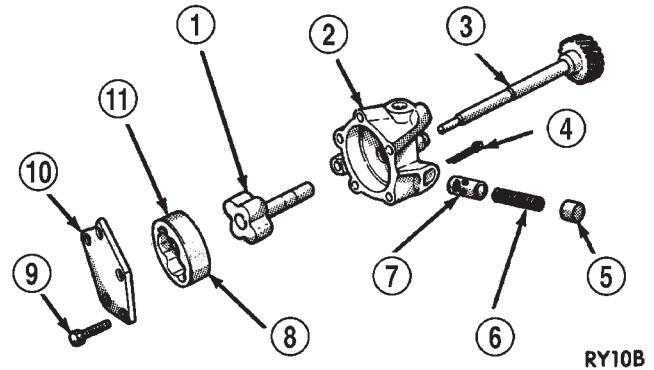
- 1 - OIL PUMP ASSEMBLY
- 2 - COTTER PIN
- 3 - RELIEF VALVE
- 4 - RETAINER CAP
- 5 - SPRING

- (2) Remove oil pump cover (Fig. 56).
- (3) Remove pump outer rotor and inner rotor with shaft (Fig. 56).
- (4) Wash all parts in a suitable solvent and inspect carefully for damage or wear.

## INSPECTION

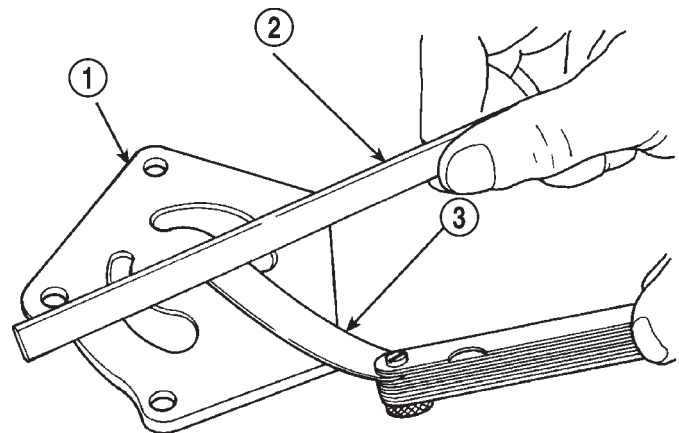
Mating surface of the oil pump cover should be smooth. Replace pump assembly if cover is scratched or grooved.

Lay a straightedge across the pump cover surface (Fig. 57). If a 0.038 mm (0.0015 inch) feeler gauge can be inserted between cover and straightedge, pump assembly should be replaced.



**Fig. 56 Oil Pump**

- 1 - INNER ROTOR AND SHAFT
- 2 - BODY
- 3 - DISTRIBUTOR DRIVESHAFT (REFERENCE)
- 4 - COTTER PIN
- 5 - RETAINER CAP
- 6 - SPRING
- 7 - RELIEF VALVE
- 8 - LARGE CHAMFERED EDGE
- 9 - BOLT
- 10 - COVER
- 11 - OUTER ROTOR



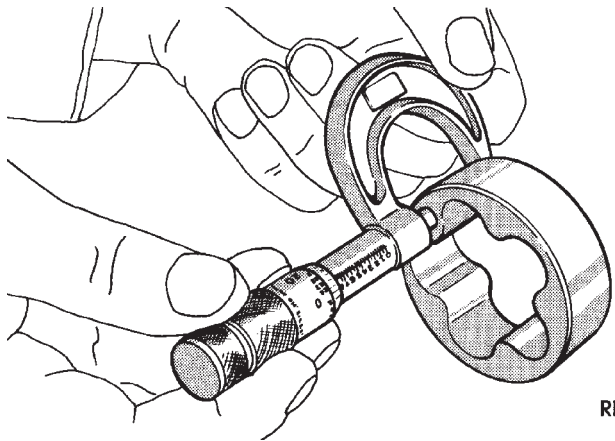
**Fig. 57 Checking Oil Pump Cover Flatness**

- 1 - COVER
- 2 - STRAIGHT EDGE
- 3 - FEELER GAUGE

8020cd6e

OIL PUMP (Continued)

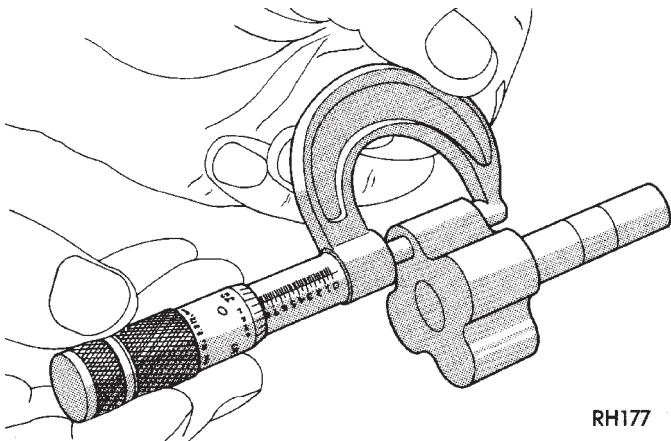
Measure thickness and diameter of OUTER rotor. If outer rotor thickness measures 20.9 mm (0.825 inch) or less or if the diameter is 62.7 mm (2.469 inches) or less, replace outer rotor (Fig. 58).



RH176

**Fig. 58 Measuring Outer Rotor Thickness**

If inner rotor measures 20.9 mm (0.825 inch) or less, replace inner rotor and shaft assembly (Fig. 59).



RH177

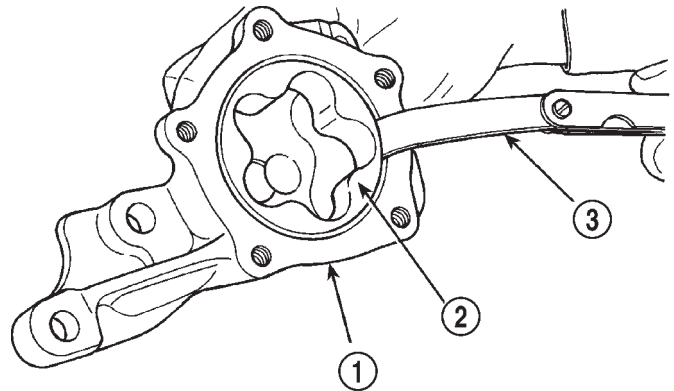
**Fig. 59 Measuring Inner Rotor Thickness**

Slide outer rotor into pump body. Press rotor to the side with your fingers and measure clearance between rotor and pump body (Fig. 60). If clearance is 0.356 mm (0.014 inch) or more, replace oil pump assembly.

Install inner rotor and shaft into pump body. If clearance between inner and outer rotors is 0.203 mm (0.008 inch) or more, replace shaft and both rotors (Fig. 61).

Place a straightedge across the face of the pump, between bolt holes. If a feeler gauge of 0.102 mm (0.004 inch) or more can be inserted between rotors and the straightedge, replace pump assembly (Fig. 62).

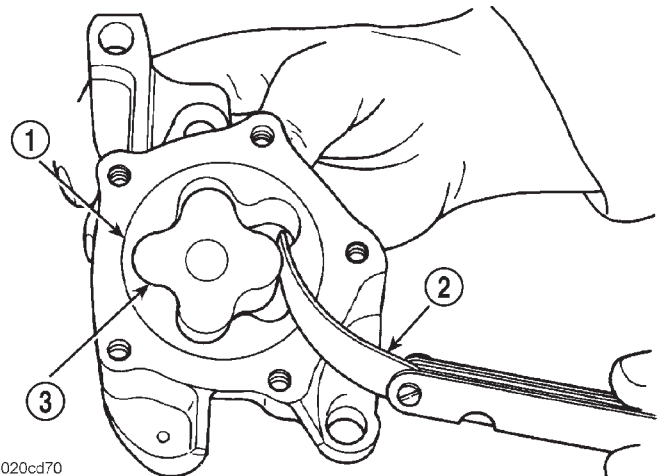
Inspect oil pressure relief valve plunger for scoring and free operation in its bore. Small marks may be removed with 400-grit wet or dry sandpaper.



8020cd6f

**Fig. 60 Measuring Outer Rotor Clearance in Housing**

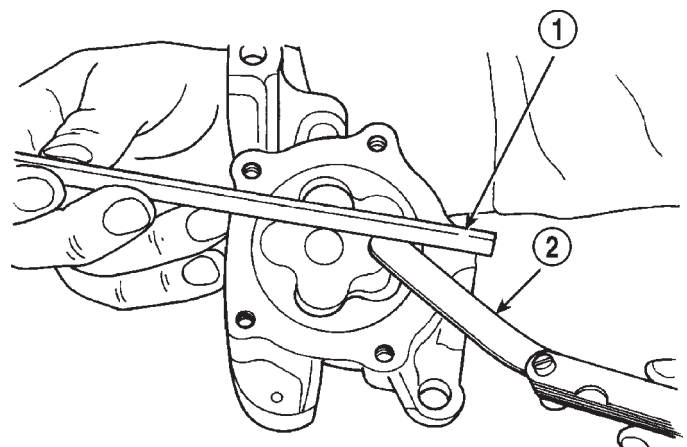
- 1 - PUMP BODY
- 2 - OUTER ROTOR
- 3 - FEELER GAUGE



8020cd70

**Fig. 61 Measuring Clearance Between Rotors**

- 1 - OUTER ROTOR
- 2 - FEELER GAUGE
- 3 - INNER ROTOR



8020cd71

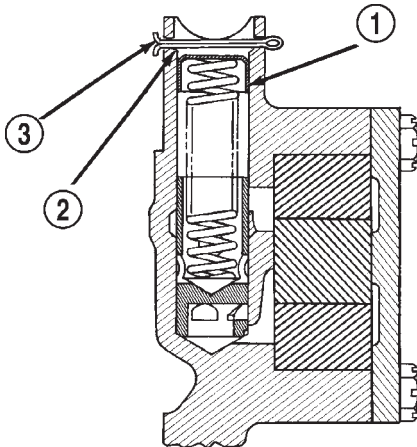
**Fig. 62 Measuring Clearance Over Rotors**

- 1 - STRAIGHT EDGE
- 2 - FEELER GAUGE

## OIL PUMP (Continued)

The relief valve spring has a free length of approximately 49.5 mm (1.95 inches). The spring should test between 19.5 and 20.5 pounds when compressed to 34 mm (1-11/32 inches). Replace spring that fails to meet these specifications (Fig. 63).

If oil pressure was low and pump is within specifications, inspect for worn engine bearings or other reasons for oil pressure loss.



RN98

**Fig. 63 Proper Installation of Retainer Cap**

- 1 - RETAINER CAP
- 2 - CHAMFER
- 3 - COTTER KEY

## ASSEMBLE

- (1) Install pump rotors and shaft, using new parts as required.
- (2) Position the oil pump cover onto the pump body. Tighten cover bolts to 11 N·m (95 in. lbs.) torque.
- (3) Install the relief valve and spring. Insert the cotter pin.
- (4) Tap on a new retainer cap.
- (5) Prime oil pump before installation by filling rotor cavity with engine oil.

## INSTALLATION

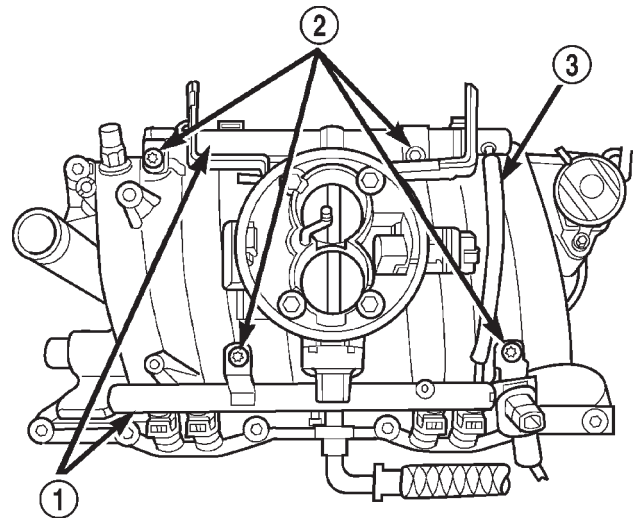
- (1) Install oil pump. During installation slowly rotate pump body to ensure driveshaft-to-pump rotor shaft engagement.
- (2) Hold the oil pump base flush against mating surface on No.5 main bearing cap. Finger tighten pump attaching bolts. Tighten attaching bolts to 41 N·m (30 ft. lbs.) torque.
- (3) Install the oil pan (Refer to 9 - ENGINE/LUBRICATION/OIL PAN - INSTALLATION).

## INTAKE MANIFOLD

## DESCRIPTION

The aluminum intake manifold (Fig. 64) is a single plane design with equal length runners and uses a

separate plenum, therefore the manifold does have a plenum gasket. It also uses separate flange gaskets and front and rear cross-over gaskets. Extreme care must be used when sealing the gaskets to ensure that excess sealant does not enter the intake runners causing a restriction. Whenever the intake manifold is removed inspect the plenum pan for evidence of excess oil buildup, this condition indicates that the plenum pan gasket is leaking.



80c071af

**Fig. 64 Intake Manifold and Throttle Body—V-8 Gas Engines Typical**

- 1 - FUEL RAIL ASSEMBLY
- 2 - FUEL RAIL MOUNTING BOLTS
- 3 - FUEL RAIL CONNECTING HOSES

## OPERATION

The intake manifold, meters and delivers air to the combustion chambers allowing the fuel delivered by the fuel injectors to ignite, thus producing power.

## DIAGNOSIS AND TESTING—INTAKE MANIFOLD LEAKAGE

An intake manifold air leak is characterized by lower than normal manifold vacuum. Also, one or more cylinders may not be functioning.

**WARNING: USE EXTREME CAUTION WHEN THE ENGINE IS OPERATING. DO NOT STAND IN A DIRECT LINE WITH THE FAN. DO NOT PUT YOUR HANDS NEAR THE PULLEYS, BELTS, OR THE FAN. DO NOT WEAR LOOSE CLOTHING.**

- (1) Start the engine.
- (2) Spray a small stream of water at the suspected leak area.



## INTAKE MANIFOLD (Continued)

- (3) If a change in RPMs occurs, the area of the suspected leak has been found.
- (4) Repair as required.

## REMOVAL

- (1) Disconnect the negative cable from the battery.
- (2) Drain the cooling system (Refer to 7 - COOLING - STANDARD PROCEDURE).
- (3) Remove the A/C compressor (Refer to 24 - HEATING & AIR CONDITIONING/PLUMBING/A/C COMPRESSOR - REMOVAL).
- (4) Remove the generator (Refer to 8 - ELECTRICAL/CHARGING/GENERATOR - REMOVAL).
- (5) Remove the accessory drive bracket.
- (6) Remove the air cleaner.
- (7) Perform the Fuel System Pressure release procedure (Refer to 14 - FUEL SYSTEM/FUEL DELIVERY - STANDARD PROCEDURE). Disconnect the fuel lines (Refer to 14 - FUEL SYSTEM/FUEL DELIVERY/QUICK CONNECT FITTING - STANDARD PROCEDURE).
- (8) Disconnect the accelerator linkage (Refer to 14 - FUEL SYSTEM/FUEL INJECTION/THROTTLE CONTROL CABLE - REMOVAL) and if so equipped, the speed control and transmission kickdown cables.
- (9) Remove the return spring.
- (10) Remove the distributor cap and wires.
- (11) Disconnect the coil wires.
- (12) Disconnect the heat indicator sending unit wire.
- (13) Disconnect the heater hoses and bypass hose.
- (14) Remove the closed crankcase ventilation and evaporation control systems.
- (15) Remove intake manifold bolts.
- (16) Lift the intake manifold and throttle body out of the engine compartment as an assembly.
- (17) Remove and discard the flange side gaskets and the front and rear end seals.
- (18) Remove the throttle body bolts and lift the throttle body off the intake manifold (Fig. 65). Discard the gasket.
- (19) If required, remove the plenum pan and gasket. Discard gasket.

## CLEANING

Clean manifold in solvent and blow dry with compressed air.

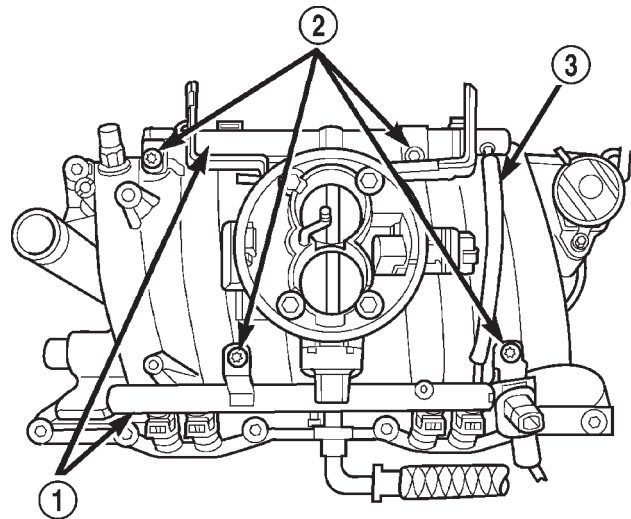
Clean cylinder block front and rear gasket surfaces using a suitable solvent.

The plenum pan rail must be clean and dry (free of all foreign material).

## INSPECTION

Inspect manifold for cracks.

Inspect mating surfaces of manifold for flatness with a straightedge.



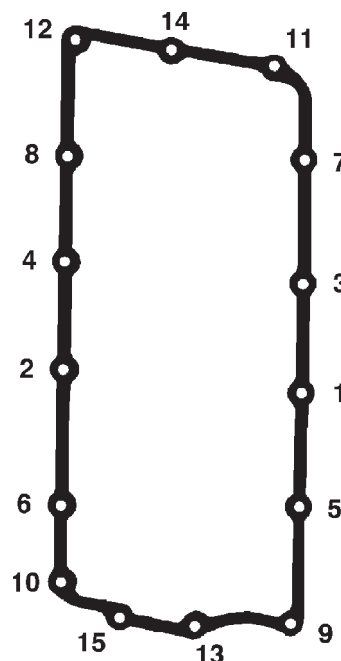
80c071af

**Fig. 65 Throttle Body Assembly**

- 1 - FUEL RAIL ASSEMBLY
- 2 - FUEL RAIL MOUNTING BOLTS
- 3 - FUEL RAIL CONNECTING HOSES

## INSTALLATION

- (1) If removed, position new plenum gasket and install plenum pan (Fig. 66).
- (2) Tighten plenum pan mounting bolts as follows:
  - Step 1. Tighten bolts to 5.4 N·m (48 in. lbs.)
  - Step 2. Tighten bolts to 9.5 N·m (84 in. lbs.)
  - Step 3. Check all bolts are at 9.5 N·m (84 in. lbs.)



80c071eb

**Fig. 66 Plenum Pan Bolt Tightening Sequence**

## INTAKE MANIFOLD (Continued)

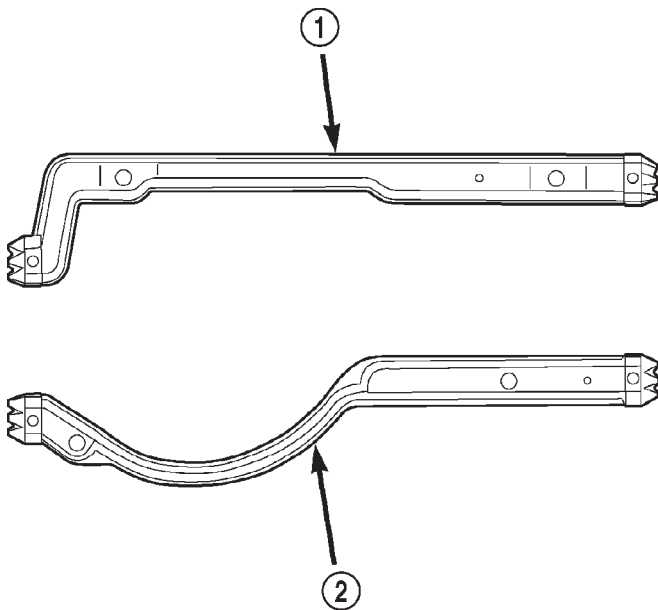
(3) Install the flange gaskets. Ensure that the vertical port alignment tab is resting on the deck face of the block. Also the horizontal alignment tabs must be in position with the mating cylinder head gasket tabs (Fig. 68). The words MANIFOLD SIDE should be visible on the center of each flange gasket.

(4) Apply Mopar® GEN II Silicone Rubber Adhesive Sealant, or equivalent, to the four corner joints. An excessive amount of sealant is not required to ensure a leak proof seal. However, an excessive amount of sealant may reduce the effectiveness of the flange gasket. The sealant should be approximately 5 mm (0.2 in) in diameter and 15mm (0.6 in.) long.

(5) Install the front and rear end seals (Fig. 67). Make sure the molded dowel pins on the end seals fully enter the corresponding holes in the cylinder block.

(6) Carefully lower intake manifold into position on the cylinder block and cylinder heads. After intake manifold is in place, inspect to make sure seals are in place.

(7) Using a new gasket, install the throttle body onto the intake manifold. Tighten the bolts to 23 N-m (200 in. lbs.) torque.



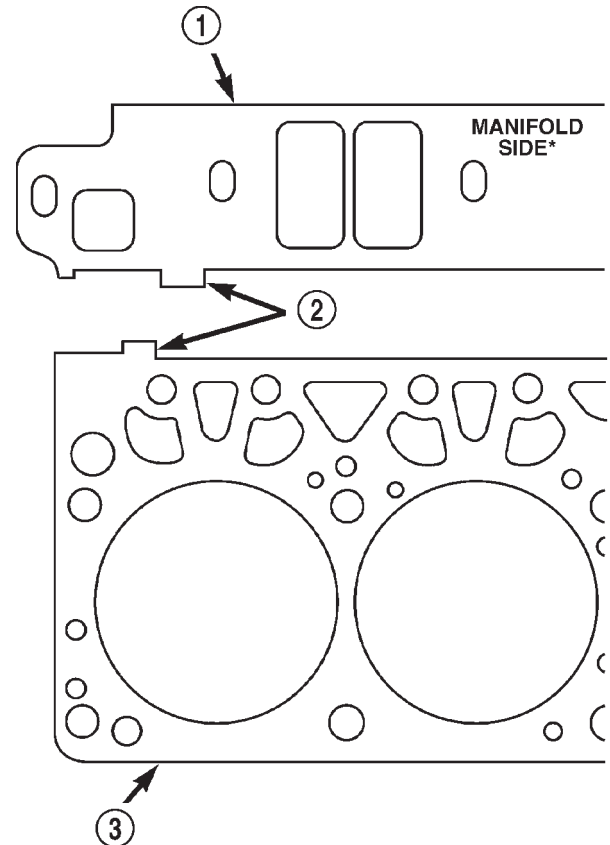
**Fig. 67 Front and Rear End Seals**

80c071ad

- 1 - FRONT END SEAL  
2 - REAR END SEAL

(8) Install the intake manifold bolts and tighten as follows (Fig. 69):

• Step 1. Tighten bolts 1 through 4 to 8 N-m (72 in. lbs.) Tighten in alternating steps 1.4 N-m (12 in. lbs.) at a time

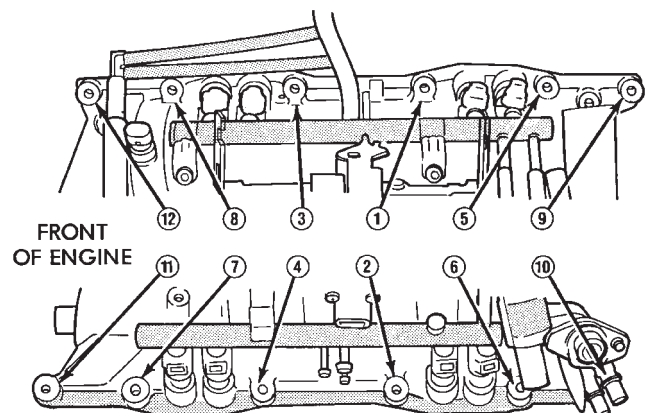


80c071ae

**Fig. 68 Intake Manifold Flange Gasket Alignment**

- 1 - FLANGE GASKET  
2 - ALIGNMENT TABS  
3 - CYLINDER HEAD GASKET

- Step 2. Tighten bolts 5 through 12 to 8 N-m (72 in. lbs.)
- Step 3. Check all bolts are torqued to 8 N-m (72 in. lbs.)
- Step 4. Tighten all bolts in sequence to 16 N-m (12 ft. lbs.)
- Step 5. Check all bolts are torqued to 16 N-m (12 ft. lbs.)



J9209-60

**Fig. 69 Intake Manifold Bolt Tightening Sequence**



## INTAKE MANIFOLD (Continued)

(9) Install closed crankcase ventilation and evaporation control systems.

(10) Connect the coil wires.

(11) Connect the heat indicator sending unit wire.

(12) Connect the heater hoses and bypass hose.

(13) Install distributor cap and wires.

(14) Hook up the return spring.

(15) Connect the accelerator linkage (Refer to 14 - FUEL SYSTEM/FUEL INJECTION/THROTTLE CONTROL CABLE - INSTALLATION) and if so equipped, the speed control and transmission kick-down cables.

(16) Install the fuel lines (Refer to 14 - FUEL SYSTEM/FUEL DELIVERY/QUICK CONNECT FITTING - STANDARD PROCEDURE).

(17) Install the accessory drive bracket and A/C compressor (Refer to 24 - HEATING & AIR CONDITIONING/PLUMBING/A/C COMPRESSOR - INSTALLATION).

(18) Install the generator and drive belt (Refer to 7 - COOLING/ACCESSORY DRIVE/DRIVE BELTS - INSTALLATION). Tighten generator mounting bolt to 41 N·m (30 ft. lbs.) torque.

(19) Install the air cleaner.

(20) Fill cooling system (Refer to 7 - COOLING - STANDARD PROCEDURE).

(21) Connect the negative cable to the battery.

## EXHAUST MANIFOLD

## DESCRIPTION

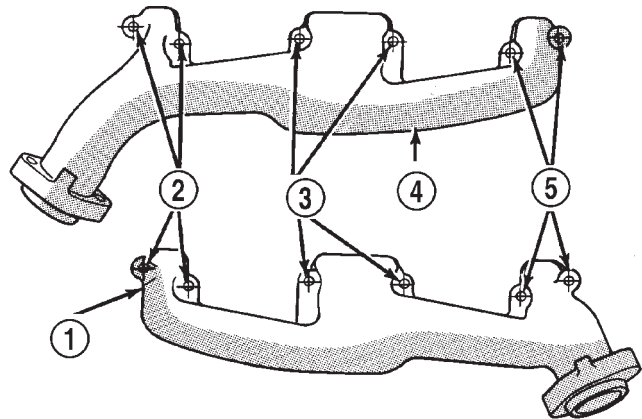
The exhaust manifolds (Fig. 70) are constructed of cast iron and are LOG type with balanced flow. One exhaust manifold is attached to each cylinder head.

## OPERATION

The exhaust manifolds collect the engine exhaust exiting the combustion chambers, then channels the exhaust gases to the exhaust pipes attached to the manifolds.

## REMOVAL

- (1) Disconnect the negative cable from the battery.
- (2) Raise and support the vehicle.
- (3) Remove the bolts and nuts attaching the exhaust pipe to the engine exhaust manifold.
- (4) Lower the vehicle.
- (5) Remove the exhaust heat shields.
- (6) Remove bolts, nuts and washers attaching manifold to cylinder head.
- (7) Remove manifold from the cylinder head.



J9311-11

**Fig. 70 Exhaust Manifolds—V-8 Gas Engines Typical**

- 1 - EXHAUST MANIFOLD (LEFT)
- 2 - BOLTS & WASHERS
- 3 - NUTS & WASHERS
- 4 - EXHAUST MANIFOLD (RIGHT)
- 5 - BOLTS & WASHERS

## CLEANING

Clean mating surfaces on cylinder head and manifold. Wash with solvent and blow dry with compressed air.

## INSPECTION

Inspect manifold for cracks.

Inspect mating surfaces of manifold for flatness with a straight edge. Gasket surfaces must be flat within 0.2 mm per 300 mm (0.008 inch per foot).

## INSTALLATION

**CAUTION:** If the studs came out with the nuts when removing the engine exhaust manifold, install new studs. Apply sealer on the coarse thread ends. Water leaks may develop at the studs if this precaution is not taken.

(1) Position the engine exhaust manifolds on the two studs located on the cylinder head. Install conical washers and nuts on these studs (Fig. 71).

(2) Install two bolts and conical washers at the inner ends of the engine exhaust manifold outboard arms. Install two bolts WITHOUT washers on the center arm of engine exhaust manifold (Fig. 71). Starting at the center arm and working outward, tighten the bolts and nuts to 34 N·m (25 ft. lbs.) torque.

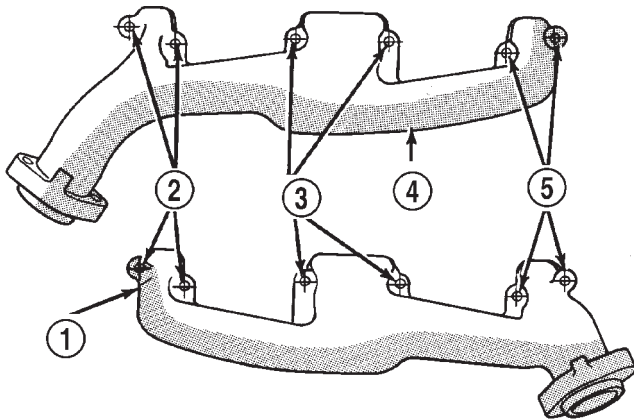
(3) Install the exhaust heat shields.

(4) Raise and support the vehicle.

(5) Assemble exhaust pipe to manifold and secure with bolts, nuts and retainers. Tighten the bolts and nuts to 34 N·m (25 ft. lbs.) torque.

## EXHAUST MANIFOLD (Continued)

- (6) Lower the vehicle.
- (7) Connect the negative cable to the battery.



J9311-11

**Fig. 71 Engine Exhaust Manifold Installation—5.2L/5.9L Engines**

- 1 - EXHAUST MANIFOLD (LEFT)
- 2 - BOLTS & WASHERS
- 3 - NUTS & WASHERS
- 4 - EXHAUST MANIFOLD (RIGHT)
- 5 - BOLTS & WASHERS

## TIMING BELT / CHAIN COVER(S)

## REMOVAL

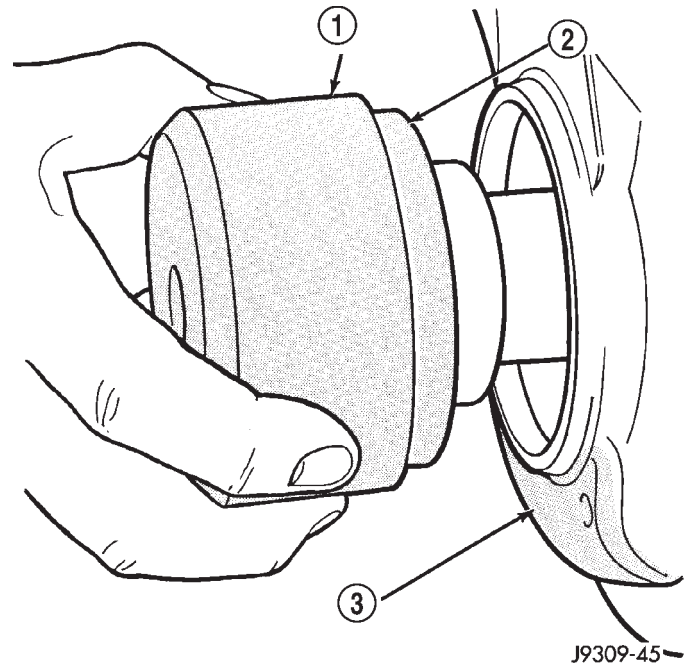
- (1) Disconnect the negative cable from the battery.
- (2) Remove water pump (Refer to 7 - COOLING/ENGINE/WATER PUMP - REMOVAL).
- (3) Remove power steering pump (Refer to 19 - STEERING/PUMP - REMOVAL).
- (4) Remove vibration damper (Refer to 9 - ENGINE/ENGINE BLOCK/VIBRATION DAMPER - REMOVAL).
- (5) Loosen oil pan bolts and remove the front bolt at each side.
- (6) Remove the cover bolts.
- (7) Remove chain case cover and gasket using extreme caution to avoid damaging oil pan gasket.

## INSTALLATION

- (1) Be sure mating surfaces of chain case cover and cylinder block are clean and free from burrs.
- (2) The water pump mounting surface must be cleaned.
- (3) Using a new cover gasket, carefully install chain case cover to avoid damaging oil pan gasket. Use a small amount of Mopar® Silicone Rubber Adhesive Sealant, or equivalent, at the joint between timing chain cover gasket and the oil pan gasket. Finger tighten the timing chain cover bolts at this time.

**NOTE: Special Tool 6635 must be used to align the front cover and seal with the crankshaft.**

- (4) Position the special tool 6635 onto the crankshaft (Fig. 72).



J9309-45

**Fig. 72 Position Special Tool 6635 onto Crankshaft**

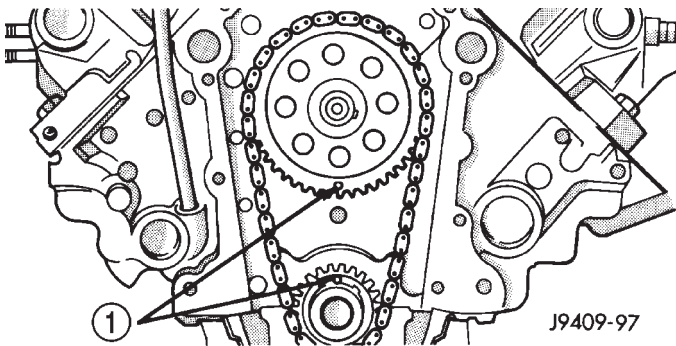
- 1 - SPECIAL TOOL 6635
- 2 - OIL SEAL
- 3 - TIMING CHAIN COVER

- (5) Tighten chain case cover bolts to 41 N·m (30 ft.lbs.) torque. Tighten oil pan bolts to 24 N·m (215 in. lbs.) torque.
- (6) Remove special tool 6635.
- (7) Inspect the seal flange on the vibration damper.
- (8) Install vibration damper (Refer to 9 - ENGINE/ENGINE BLOCK/VIBRATION DAMPER - INSTALLATION).
- (9) Install water pump and housing assembly using new gaskets (Refer to 7 - COOLING/ENGINE/WATER PUMP - INSTALLATION).
- (10) Install power steering pump (Refer to 19 - STEERING/PUMP - INSTALLATION).
- (11) Install the serpentine belt (Refer to 7 - COOLING/ACCESSORY DRIVE/DRIVE BELTS - INSTALLATION).
- (12) Install the cooling system fan (Refer to 7 - COOLING/ENGINE/RADIATOR FAN - INSTALLATION).
- (13) Position the fan shroud and install the bolts. Tighten the bolts to 11 N·m (95 in. lbs.) torque.
- (14) Fill cooling system (Refer to 7 - COOLING - STANDARD PROCEDURE).
- (15) Connect the negative cable to the battery.
- (16) Start engine check for leaks.

## TIMING BELT/CHAIN AND SPROCKETS

### REMOVAL

- (1) Disconnect battery negative cable.
- (2) Remove Timing Chain Cover (Refer to 9 - ENGINE/VALVE TIMING/TIMING BELT / CHAIN COVER(S) - REMOVAL).
- (3) Re-install the vibration damper bolt finger tight. Using a suitable socket and breaker bar, rotate the crankshaft to align timing marks as shown in (Fig. 73).
- (4) Remove camshaft sprocket attaching bolt and remove timing chain with crankshaft and camshaft sprockets.

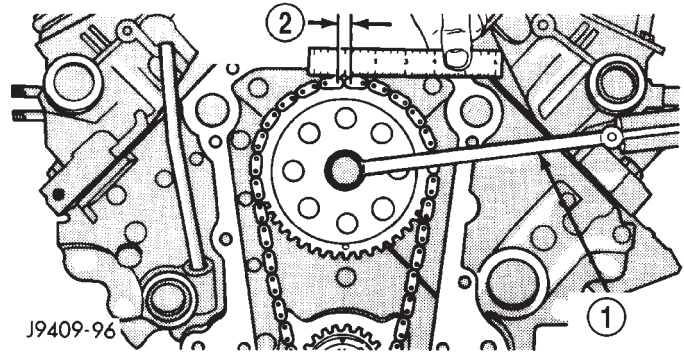


**Fig. 73 Alignment of Timing Marks**

1 - TIMING MARKS

### INSPECTION—MEASURING TIMING CHAIN STRETCH

- (1) Place a scale next to the timing chain so that any movement of the chain may be measured.
- (2) Place a torque wrench and socket over camshaft sprocket attaching bolt. Apply torque in the direction of crankshaft rotation to take up slack; 41 N·m (30 ft. lbs.) torque with cylinder head installed or 20 N·m (15 ft. lbs.) torque with cylinder head removed. With a torque applied to the camshaft sprocket bolt, crankshaft should not be permitted to move. It may be necessary to block the crankshaft to prevent rotation.
- (3) Hold a scale with dimensional reading even with the edge of a chain link. With cylinder heads installed, apply 14 N·m (30 ft. lbs.) torque in the reverse direction. With the cylinder heads removed, apply 20 N·m (15 ft. lbs.) torque in the reverse direction. Note the amount of chain movement (Fig. 74).
- (4) Install a new timing chain, if its movement exceeds 3.175 mm (1/8 inch).

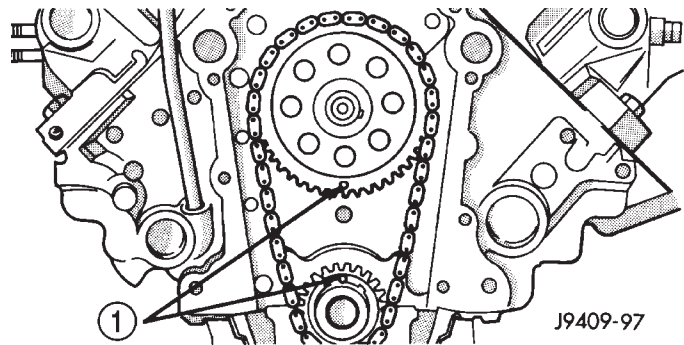


**Fig. 74 Measuring Timing Chain Stretch**

1 - TORQUE WRENCH  
2 - 3.175 MM (0.125 IN.)

### INSTALLATION

- (1) Place both camshaft sprocket and crankshaft sprocket on the bench with timing marks on exact imaginary center line through both camshaft and crankshaft bores.
- (2) Place timing chain around both sprockets.
- (3) Turn crankshaft and camshaft to line up with keyway location in crankshaft sprocket and in camshaft sprocket.
- (4) Lift sprockets and chain (keep sprockets tight against the chain in position as described).
- (5) Slide both sprockets evenly over their respective shafts and use a straightedge to check alignment of timing marks (Fig. 75).



**Fig. 75 Alignment of Timing Marks**

1 - TIMING MARKS

- (6) Install the camshaft bolt. Tighten the bolt to 68 N·m (50 ft. lbs.) torque.
- (7) Check camshaft end play. The end play should be 0.051-0.152 mm (0.002-0.006 inch) with a new thrust plate and up to 0.254 mm (0.010 inch) with a used thrust plate. If not within these limits install a new thrust plate.
- (8) Install the timing chain cover (Refer to 9 - ENGINE/VALVE TIMING/TIMING BELT / CHAIN COVER(S) - INSTALLATION).

## ENGINE 8.0L

## TABLE OF CONTENTS

	page		page
<b>ENGINE 8.0L</b>		<b>CAMSHAFT &amp; BEARINGS (IN BLOCK)</b>	
DESCRIPTION . . . . .	172	REMOVAL . . . . .	200
DIAGNOSIS AND TESTING . . . . .	173	INSTALLATION . . . . .	201
ENGINE DIAGNOSIS - INTRODUCTION . . . . .	173	<b>CONNECTING ROD BEARINGS</b>	
PERFORMANCE . . . . .	173	STANDARD PROCEDURE . . . . .	202
MECHANICAL . . . . .	175	CONNECTING ROD BEARING FITTING . . . . .	202
LUBRICATION . . . . .	178	<b>CRANKSHAFT</b>	
CYLINDER COMPRESSION PRESSURE . . . . .	179	REMOVAL . . . . .	202
CYLINDER COMBUSTION PRESSURE		INSTALLATION . . . . .	203
LEAKAGE . . . . .	179	<b>CRANKSHAFT MAIN BEARINGS</b>	
STANDARD PROCEDURE . . . . .	180	STANDARD PROCEDURE . . . . .	203
CYLINDER BORE HONING . . . . .	180	MAIN BEARING FITTING . . . . .	203
FORM-IN-PLACE GASKETS AND SEALERS . . . . .	180	REMOVAL . . . . .	204
REPAIR DAMAGED OR WORN THREADS . . . . .	181	INSTALLATION . . . . .	204
HYDROSTATIC LOCK . . . . .	181	<b>CRANKSHAFT OIL SEAL - FRONT</b>	
REMOVAL . . . . .	181	REMOVAL . . . . .	204
INSTALLATION . . . . .	182	INSTALLATION . . . . .	205
SPECIFICATIONS . . . . .	184	<b>CRANKSHAFT OIL SEAL - REAR</b>	
SPECIAL TOOLS . . . . .	188	REMOVAL . . . . .	206
<b>AIR CLEANER ELEMENT</b>		INSTALLATION . . . . .	206
REMOVAL . . . . .	190	<b>CRANKSHAFT REAR OIL SEAL RETAINER</b>	
INSTALLATION . . . . .	190	REMOVAL . . . . .	206
<b>CYLINDER HEAD</b>		INSTALLATION . . . . .	206
DESCRIPTION . . . . .	191	<b>HYDRAULIC LIFTERS</b>	
DIAGNOSIS AND TESTING . . . . .	191	DIAGNOSIS AND TESTING . . . . .	206
CYLINDER HEAD GASKET FAILURE . . . . .	191	HYDRAULIC TAPPETS . . . . .	206
REMOVAL . . . . .	192	REMOVAL . . . . .	207
CLEANING . . . . .	193	CLEANING . . . . .	208
INSPECTION . . . . .	193	INSTALLATION . . . . .	208
INSTALLATION . . . . .	193	<b>PISTON &amp; CONNECTING ROD</b>	
<b>CYLINDER HEAD COVER(S)</b>		DESCRIPTION . . . . .	208
DESCRIPTION . . . . .	194	STANDARD PROCEDURE . . . . .	208
REMOVAL . . . . .	194	PISTON FITTING . . . . .	208
CLEANING . . . . .	194	REMOVAL . . . . .	209
INSPECTION . . . . .	194	CLEANING . . . . .	209
INSTALLATION . . . . .	194	INSPECTION . . . . .	209
<b>INTAKE/EXHAUST VALVES &amp; SEATS</b>		INSTALLATION . . . . .	210
DESCRIPTION . . . . .	195	<b>PISTON RINGS</b>	
STANDARD PROCEDURE . . . . .	195	STANDARD PROCEDURE . . . . .	211
VALVE SERVICE . . . . .	195	FITTING PISTON RINGS . . . . .	211
REMOVAL . . . . .	197	<b>VIBRATION DAMPER</b>	
CLEANING . . . . .	198	REMOVAL . . . . .	212
INSPECTION . . . . .	198	INSTALLATION . . . . .	212
INSTALLATION . . . . .	198	<b>FRONT MOUNT</b>	
<b>ROCKER ARM / ADJUSTER ASSY</b>		REMOVAL . . . . .	213
REMOVAL . . . . .	200	INSTALLATION . . . . .	213
INSTALLATION . . . . .	200	<b>REAR MOUNT</b>	
<b>ENGINE BLOCK</b>		REMOVAL . . . . .	213
CLEANING . . . . .	200	INSTALLATION . . . . .	213
INSPECTION . . . . .	200		



**LUBRICATION**

DESCRIPTION . . . . . 214  
 OPERATION . . . . . 214  
 DIAGNOSIS AND TESTING . . . . . 215  
     ENGINE OIL LEAKS . . . . . 215  
     ENGINE OIL PRESSURE . . . . . 215

**OIL**

STANDARD PROCEDURE . . . . . 217  
 ENGINE OIL . . . . . 217

**OIL FILTER**

REMOVAL . . . . . 218  
 INSTALLATION . . . . . 218

**OIL PAN**

REMOVAL . . . . . 218  
 CLEANING . . . . . 218  
 INSPECTION . . . . . 219  
 INSTALLATION . . . . . 219

**OIL PUMP**

REMOVAL . . . . . 219  
 CLEANING . . . . . 220  
 INSPECTION . . . . . 220  
 INSTALLATION . . . . . 221

**INTAKE MANIFOLD**

DESCRIPTION . . . . . 222  
 DIAGNOSIS AND TESTING . . . . . 222  
     INTAKE MANIFOLD LEAKAGE . . . . . 222  
 REMOVAL . . . . . 222  
 CLEANING . . . . . 223  
 INSPECTION . . . . . 223  
 INSTALLATION . . . . . 223

**EXHAUST MANIFOLD**

DESCRIPTION . . . . . 224  
 OPERATION . . . . . 224  
 REMOVAL . . . . . 225  
 CLEANING . . . . . 225  
 INSPECTION . . . . . 225  
 INSTALLATION . . . . . 225

**TIMING BELT / CHAIN COVER(S)**

REMOVAL . . . . . 225  
 INSTALLATION . . . . . 226

**TIMING BELT/CHAIN AND SPROCKETS**

REMOVAL . . . . . 226  
 INSPECTION . . . . . 227  
 INSTALLATION . . . . . 227

**ENGINE 8.0L**

**DESCRIPTION**

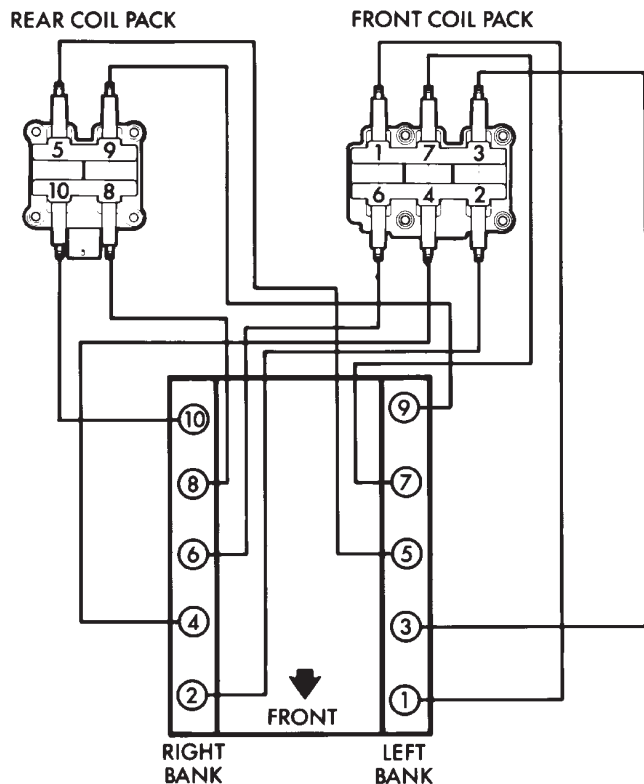
The 8.0 Liter (488 CID) ten-cylinder engine is a V-Type lightweight, single cam, overhead valve

engine with hydraulic roller tappets. This engine is designed for unleaded fuel.

Engine lubrication system consists of a gerotor type oil pump mounted in the timing chain cover and driven by the crankshaft. The V-10 uses a full flow oil filter.

The cylinders are numbered from front to rear; 1, 3, 5, 7, 9 on the left bank and 2, 4, 6, 8, 10 on the right bank. The firing order is 1-10-9-4-3-6-5-8-7-2 (Fig. 1).

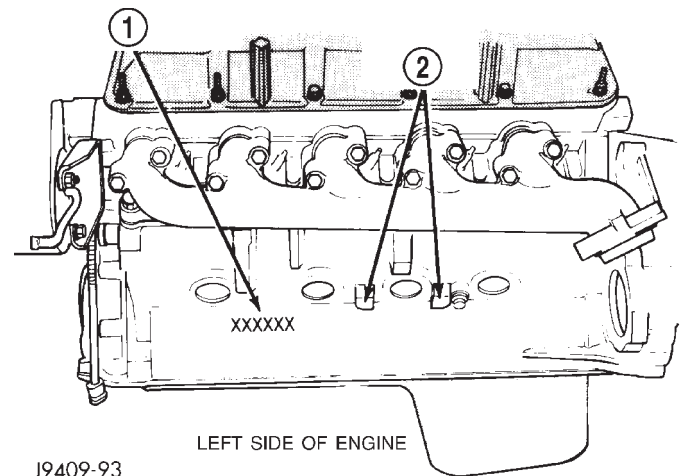
The engine serial number is located on the lower left front of the cylinder block in front of the engine mount (Fig. 2). When component part replacement is necessary, use the engine type and serial number for reference.



**FIRING ORDER**  
 1-10-9-4-3-6-5-8-7-2

**Fig. 1 Firing Order**

J948D-12



J9409-93

**Fig. 2 Engine Identification—(Serial Number)**

- 1 - ENGINE SERIAL NO.
- 2 - ENGINE MOUNT LOCATION

## ENGINE 8.0L (Continued)

**DIAGNOSIS AND TESTING—ENGINE****DIAGNOSIS - INTRODUCTION**

Engine diagnosis is helpful in determining the causes of malfunctions not detected and remedied by routine maintenance.

These malfunctions may be classified as either mechanical (e.g., a strange noise), or performance (e.g., engine idles rough and stalls).

(Refer to 9 - ENGINE - DIAGNOSIS AND TESTING - Performance) or (Refer to 9 - ENGINE - DIAGNOSIS AND TESTING - Mechanical). Refer to 14 - FUEL SYSTEM for fuel system diagnosis.

Additional tests and diagnostic procedures may be necessary for specific engine malfunctions that cannot be isolated with the Service Diagnosis charts. Information concerning additional tests and diagnosis is provided within the following:

- Cylinder Compression Pressure Test
- Cylinder Combustion Pressure Leakage Test
- Cylinder Head Gasket Failure Diagnosis
- Intake Manifold Leakage Diagnosis
- Lash Adjuster (Tappet) Noise Diagnosis
- Engine Oil Leak Inspection

**DIAGNOSIS AND TESTING—PERFORMANCE***PERFORMANCE DIAGNOSIS CHART—GASOLINE ENGINES*

<b>CONDITION</b>	<b>POSSIBLE CAUSES</b>	<b>CORRECTION</b>
ENGINE WILL NOT CRANK	<ol style="list-style-type: none"> <li>1. Weak or dead battery</li> <li>2. Corroded or loose battery connections</li> <li>3. Faulty starter or related circuit(s)</li> <li>4. Seized accessory drive component</li> <li>5. Engine internal mechanical failure or hydro-static lock</li> </ol>	<ol style="list-style-type: none"> <li>1. Charge/Replace Battery. (Refer to 8 - ELECTRICAL/BATTERY SYSTEM/ BATTERY - STANDARD PROCEDURE). Check charging system. (Refer to 8 - ELECTRICAL/ CHARGING - DIAGNOSIS AND TESTING).</li> <li>2. Clean/tighten suspect battery/ starter connections</li> <li>3. Check starting system. (Refer to 8 - ELECTRICAL/STARTING - DIAGNOSIS AND TESTING)</li> <li>4. Remove accessory drive belt and attempt to start engine. If engine starts, repair/replace seized component.</li> <li>5. Refer to (Refer to 9 - ENGINE - DIAGNOSIS AND TESTING)</li> </ol>
ENGINE CRANKS BUT WILL NOT START	<ol style="list-style-type: none"> <li>1. No spark</li> <li>2. No fuel</li> <li>3. Low or no engine compression</li> </ol>	<ol style="list-style-type: none"> <li>1. Check for spark. (Refer to 8 - ELECTRICAL/IGNITION CONTROL - DESCRIPTION)</li> <li>2. Perform fuel pressure test, and if necessary, inspect fuel injector(s) and driver circuits. (Refer to 14 - FUEL SYSTEM/FUEL DELIVERY/FUEL PUMP - DIAGNOSIS AND TESTING).</li> <li>3. Perform cylinder compression pressure test. (Refer to 9 - ENGINE - DIAGNOSIS AND TESTING).</li> </ol>



## ENGINE 8.0L (Continued)

CONDITION	POSSIBLE CAUSES	CORRECTION
ENGINE LOSS OF POWER	<ol style="list-style-type: none"> <li>1. Worn or burned distributor rotor</li> <li>2. Worn distributor shaft</li>   <li>3. Worn or incorrect gapped spark plugs</li> <li>4. Dirt or water in fuel system</li> <li>5. Faulty fuel pump</li> <li>6. Incorrect valve timing</li> <li>7. Blown cylinder head gasket</li> <li>8. Low compression</li>   <li>9. Burned, warped, or pitted valves</li> <li>10. Plugged or restricted exhaust system</li> <li>11. Faulty ignition cables</li>   <li>12. Faulty ignition coil</li> </ol>	<ol style="list-style-type: none"> <li>1. Install new distributor rotor</li> <li>2. Remove and repair distributor (Refer to 8 - ELECTRICAL/IGNITION CONTROL/DISTRIBUTOR - REMOVAL).</li> <li>3. Clean plugs and set gap. (Refer to 8 - ELECTRICAL/IGNITION CONTROL/SPARK PLUG - CLEANING).</li> <li>4. Clean system and replace fuel filter</li> <li>5. Install new fuel pump</li> <li>6. Correct valve timing</li> <li>7. Install new cylinder head gasket</li> <li>8. Test cylinder compression (Refer to 9 - ENGINE - DIAGNOSIS AND TESTING).</li> <li>9. Install/Reface valves as necessary</li> <li>10. Install new parts as necessary</li>   <li>11. Replace any cracked or shorted cables</li> <li>12. Test and replace, as necessary (Refer to 8 - ELECTRICAL/IGNITION CONTROL/IGNITION COIL - REMOVAL).</li> </ol>
ENGINE STALLS OR ROUGH IDLE	<ol style="list-style-type: none"> <li>1. Carbon build-up on throttle plate</li>   <li>2. Engine idle speed too low</li>   <li>3. Worn or incorrectly gapped spark plugs</li>   <li>4. Worn or burned distributor rotor</li> <li>5. Spark plug cables defective or crossed</li>   <li>6. Faulty coil</li> </ol>	<ol style="list-style-type: none"> <li>1. Remove throttle body and de-carbon. (Refer to 14 - FUEL SYSTEM/FUEL INJECTION/ THROTTLE BODY - REMOVAL).</li> <li>2. Check Idle Air Control circuit. (Refer to 14 - FUEL SYSTEM/FUEL INJECTION/IDLE AIR CONTROL MOTOR - DESCRIPTION)</li> <li>3. Replace or clean and re-gap spark plugs (Refer to 8 - ELECTRICAL/IGNITION CONTROL/SPARK PLUG - CLEANING)</li> <li>4. Install new distributor rotor</li> <li>5. Check for correct firing order or replace spark plug cables. (Refer to 8 - ELECTRICAL/IGNITION CONTROL/ SPARK PLUG CABLE - DIAGNOSIS AND TESTING)</li> <li>6. Test and replace, if necessary (Refer to 8 - ELECTRICAL/IGNITION CONTROL/IGNITION COIL - REMOVAL)</li> </ol>

## ENGINE 8.0L (Continued)

CONDITION	POSSIBLE CAUSES	CORRECTION
	7. Intake manifold vacuum leak	7. Inspect intake manifold gasket and vacuum hoses (Refer to 9 - ENGINE/MANIFOLDS/INTAKE MANIFOLD - DIAGNOSIS AND TESTING).
ENGINE MISSES ON ACCELERATION	1. Worn or incorrectly gapped spark plugs 2. Spark plug cables defective or crossed 3. Dirt in fuel system 4. Burned, warped or pitted valves 5. Faulty coil	1. Replace spark plugs or clean and set gap. (Refer to 8 - ELECTRICAL/IGNITION CONTROL/SPARK PLUG - CLEANING) 2. Replace or rewire secondary ignition cables. (Refer to 8 - ELECTRICAL/IGNITION CONTROL/SPARK PLUG CABLE - REMOVAL) 3. Clean fuel system 4. Install new valves 5. Test and replace as necessary (Refer to 8 - ELECTRICAL/IGNITION CONTROL/IGNITION COIL - REMOVAL)

## DIAGNOSIS AND TESTING— MECHANICAL

## ENGINE MECHANICAL DIAGNOSIS CHART

CONDITION	POSSIBLE CAUSES	CORRECTION
NOISY VALVES/LIFTERS	1. High or low oil level in crankcase 2. Thin or diluted oil 3. Low oil pressure 4. Dirt in tappets/lash adjusters 5. Bent push rod(s) 6. Worn rocker arms 7. Worn tappets/lash adjusters 8. Worn valve guides 9. Excessive runout of valve seats or valve faces	1. Check for correct oil level. Adjust oil level by draining or adding as needed 2. Change oil. (Refer to 9 - ENGINE/LUBRICATION/OIL - STANDARD PROCEDURE) 3. Check engine oil level. If ok, Perform oil pressure test. (Refer to 9 - ENGINE/LUBRICATION - DIAGNOSIS AND TESTING) for engine oil pressure test/specifications 4. Clean/replace hydraulic tappets/lash adjusters 5. Install new push rods 6. Inspect oil supply to rocker arms and replace worn arms as needed 7. Install new hydraulic tappets/lash adjusters 8. Inspect all valve guides and replace as necessary 9. Grind valves and seats

## ENGINE 8.0L (Continued)

CONDITION	POSSIBLE CAUSES	CORRECTION
CONNECTING ROD NOISE	<ol style="list-style-type: none"> <li>1. Insufficient oil supply</li> <li>2. Low oil pressure</li>   <li>3. Thin or diluted oil</li>   <li>4. Excessive connecting rod bearing clearance</li>   <li>5. Connecting rod journal out of round</li> <li>6. Misaligned connecting rods</li> </ol>	<ol style="list-style-type: none"> <li>1. Check engine oil level.</li> <li>2. Check engine oil level. If ok, Perform oil pressure test. (Refer to 9 - ENGINE/LUBRICATION - DIAGNOSIS AND TESTING) engine oil pressure test/specifications</li> <li>3. Change oil to correct viscosity. (Refer to 9 - ENGINE/LUBRICATION/OIL - STANDARD PROCEDURE) for correct procedure/engine oil specifications</li> <li>Measure bearings for correct clearance with plasti-gage. Repair as necessary</li> <li>5. Replace crankshaft or grind journals</li> <li>6. Replace bent connecting rods</li> </ol>
MAIN BEARING NOISE	<ol style="list-style-type: none"> <li>1. Insufficient oil supply</li> <li>2. Low oil pressure</li>   <li>3. Thin or diluted oil</li> <li>4. Excessive main bearing clearance</li> <li>5. Excessive end play</li>   <li>6. Crankshaft main journal out of round or worn</li> <li>7. Loose flywheel or torque converter</li> </ol>	<ol style="list-style-type: none"> <li>1. Check engine oil level.</li> <li>2. Check engine oil level. If ok, Perform oil pressure test. (Refer to 9 - ENGINE/LUBRICATION - DIAGNOSIS AND TESTING)</li> <li>3. Change oil to correct viscosity.</li> <li>4. Measure bearings for correct clearance. Repair as necessary</li> <li>5. Check crankshaft thrust bearing for excessive wear on flanges</li> <li>6. Grind journals or replace crankshaft</li> <li>7. Inspect crankshaft, flexplate/flywheel and bolts for damage. Tighten to correct torque</li> </ol>
LOW OIL PRESSURE	<ol style="list-style-type: none"> <li>1. Low oil level</li> <li>2. Faulty oil pressure sending unit</li> <li>3. Clogged oil filter</li> <li>4. Worn oil pump</li> <li>5. Thin or diluted oil</li> <li>6. Excessive bearing clearance</li>   <li>7. Oil pump relief valve stuck</li>   <li>8. Oil pump suction tube loose, broken, bent or clogged</li> <li>9. Oil pump cover warped or cracked</li> </ol>	<ol style="list-style-type: none"> <li>1. Check oil level and fill if necessary</li> <li>2. Install new sending unit</li> <li>3. Install new oil filter</li> <li>4. Replace oil pump assembly.</li> <li>5. Change oil to correct viscosity.</li> <li>6. Measure bearings for correct clearance</li> <li>7. Remove valve to inspect, clean and reinstall</li> <li>8. Inspect suction tube and clean or replace if necessary</li> <li>9. Install new oil pump</li> </ol>

## ENGINE 8.0L (Continued)

CONDITION	POSSIBLE CAUSES	CORRECTION
OIL LEAKS	<ol style="list-style-type: none"> <li>1. Misaligned or deteriorated gaskets</li> <li>2. Loose fastener, broken or porous metal part</li> <li>3. Front or rear crankshaft oil seal leaking</li> <li>4. Leaking oil gallery plug or cup plug</li> </ol>	<ol style="list-style-type: none"> <li>1. Replace gasket</li> <li>2. Tighten, repair or replace the part</li> <li>3. Replace seal</li> <li>4. Remove and reseal threaded plug. Replace cup style plug</li> </ol>
EXCESSIVE OIL CONSUMPTION OR SPARK PLUGS OIL FOULED	<ol style="list-style-type: none"> <li>1. CCV System malfunction</li> <li>2. Defective valve stem seal(s)</li> <li>3. Worn or broken piston rings</li> <li>4. Scuffed pistons/cylinder walls</li> <li>5. Carbon in oil control ring groove</li> <li>6. Worn valve guides</li> <li>7. Piston rings fitted too tightly in grooves</li> </ol>	<ol style="list-style-type: none"> <li>1. (Refer to 25 - EMISSIONS CONTROL/EVAPORATIVE EMISSIONS - DESCRIPTION) for correct operation</li> <li>2. Repair or replace seal(s)</li> <li>3. Hone cylinder bores. Install new rings</li> <li>4. Hone cylinder bores and replace pistons as required</li> <li>5. Remove rings and de-carbon piston</li> <li>6. Inspect/replace valve guides as necessary</li> <li>7. Remove rings and check ring end gap and side clearance. Replace if necessary</li> </ol>

## ENGINE 8.0L (Continued)

## DIAGNOSIS AND TESTING—LUBRICATION

CONDITION	POSSIBLE CAUSES	CORRECTION
OIL LEAKS	<ol style="list-style-type: none"> <li>1. Gaskets and O-Rings.               <ol style="list-style-type: none"> <li>(a) Misaligned or damaged.</li> <li>(b) Loose fasteners, broken or porous metal parts.</li> </ol> </li> <li>2. Crankshaft rear seal</li> <li>3. Crankshaft seal flange. Scratched, nicked or grooved.</li> <li>4. Oil pan flange cracked.</li> <li>5. Timing chain cover seal, damaged or misaligned.</li> <li>6. Scratched or damaged vibration damper hub.</li> </ol>	<ol style="list-style-type: none"> <li>1.               <ol style="list-style-type: none"> <li>(a) Replace as necessary.</li> <li>(b) Tighten fasteners, Repair or replace metal parts.</li> </ol> </li> <li>2. Replace as necessary.</li> <li>3. Polish or replace crankshaft.</li> <li>4. Replace oil pan.</li> <li>5. Replace seal.</li> <li>6. Polish or replace damper.</li> </ol>
OIL PRESSURE DROP	<ol style="list-style-type: none"> <li>1. Low oil level.</li> <li>2. Faulty oil pressure sending unit.</li> <li>3. Low oil pressure.</li> <li>4. Clogged oil filter.</li> <li>5. Worn oil pump.</li> <li>6. Thin or diluted oil.</li> <li>7. Excessive bearing clearance.</li> <li>8. Oil pump relief valve stuck.</li> <li>9. Oil pump suction tube loose or damaged.</li> </ol>	<ol style="list-style-type: none"> <li>1. Check and correct oil level.</li> <li>2. Replace sending unit.</li> <li>3. Check pump and bearing clearance.</li> <li>4. Replace oil filter.</li> <li>5. Replace as necessary.</li> <li>6. Change oil and filter.</li> <li>7. Replace as necessary.</li> <li>8. Clean or replace relief valve.</li> <li>9. Replace as necessary.</li> </ol>
OIL PUMPING AT RINGS; SPARK PLUGS FOULING	<ol style="list-style-type: none"> <li>1. Worn or damaged rings.</li> <li>2. Carbon in oil ring slots.</li> <li>3. Incorrect ring size installed.</li> <li>4. Worn valve guides.</li> <li>5. Leaking intake gasket.</li> <li>6. Leaking valve guide seals.</li> </ol>	<ol style="list-style-type: none"> <li>1. Hone cylinder bores and replace rings.</li> <li>2. Replace rings.</li> <li>3. Replace rings.</li> <li>4. Ream guides and replace valves.</li> <li>5. Replace intake gaskets.</li> <li>6. Replace valve guide seals.</li> </ol>

## ENGINE 8.0L (Continued)

**DIAGNOSIS AND TESTING—CYLINDER COMPRESSION PRESSURE**

The results of a cylinder compression pressure test can be utilized to diagnose several engine malfunctions.

Ensure the battery is completely charged and the engine starter motor is in good operating condition. Otherwise, the indicated compression pressures may not be valid for diagnosis purposes.

(1) Clean the spark plug recesses with compressed air.

(2) Remove the spark plugs (Refer to 8 - ELECTRICAL/IGNITION CONTROL/SPARK PLUG - REMOVAL).

(3) Secure the throttle in the wide-open position.

(4) Disconnect the ignition coil.

(5) Insert a compression pressure gauge and rotate the engine with the engine starter motor for three revolutions.

(6) Record the compression pressure on the third revolution. Continue the test for the remaining cylinders.

(Refer to 9 - ENGINE - SPECIFICATIONS) for the correct engine compression pressures.

**DIAGNOSIS AND TESTING—CYLINDER COMBUSTION PRESSURE LEAKAGE**

The combustion pressure leakage test provides an accurate means for determining engine condition.

Combustion pressure leakage testing will detect:

- Exhaust and intake valve leaks (improper seating)
- Leaks between adjacent cylinders or into water jacket

- Any causes for combustion/compression pressure loss

**WARNING: DO NOT REMOVE THE RADIATOR CAP WITH THE SYSTEM HOT AND UNDER PRESSURE. SERIOUS BURNS FROM HOT COOLANT CAN OCCUR.**

Check the coolant level and fill as required. DO NOT install the radiator cap.

Start and operate the engine until it attains normal operating temperature, then turn OFF the engine.

Remove the spark plugs.

Remove the oil filler cap.

Remove the air cleaner.

Calibrate the tester according to the manufacturer's instructions. The shop air source for testing should maintain 483 kPa (70 psi) minimum, 1,379 kPa (200 psi) maximum and 552 kPa (80 psi) recommended.

Perform the test procedure on each cylinder according to the tester manufacturer's instructions. While testing, listen for pressurized air escaping through the throttle body, tailpipe or oil filler cap opening. Check for bubbles in the radiator coolant.

All gauge pressure indications should be equal, with no more than 25% leakage.

**FOR EXAMPLE:** At 552 kPa (80 psi) input pressure, a minimum of 414 kPa (60 psi) should be maintained in the cylinder.

Refer to CYLINDER COMBUSTION PRESSURE LEAKAGE DIAGNOSIS CHART below

*CYLINDER COMBUSTION PRESSURE LEAKAGE DIAGNOSIS CHART*

CONDITION	POSSIBLE CAUSE	CORRECTION
AIR ESCAPES THROUGH THROTTLE BODY	Intake valve bent, burnt, or not seated properly	Inspect valve and valve seat. Reface or replace, as necessary
AIR ESCAPES THROUGH TAILPIPE	Exhaust valve bent, burnt, or not seated properly	Inspect valve and valve seat. Reface or replace, as necessary
AIR ESCAPES THROUGH RADIATOR	Head gasket leaking or cracked cylinder head or block	Remove cylinder head and inspect. Replace defective part
MORE THAN 50% LEAKAGE FROM ADJACENT CYLINDERS	Head gasket leaking or crack in cylinder head or block between adjacent cylinders	Remove cylinder head and inspect. Replace gasket, head, or block as necessary
MORE THAN 25% LEAKAGE AND AIR ESCAPES THROUGH OIL FILLER CAP OPENING ONLY	Stuck or broken piston rings; cracked piston; worn rings and/or cylinder wall	Inspect for broken rings or piston. Measure ring gap and cylinder diameter, taper and out-of-round. Replace defective part as necessary



## ENGINE 8.0L (Continued)

**STANDARD PROCEDURE—CYLINDER BORE HONING**

Before honing, stuff plenty of clean shop towels under the bores and over the crankshaft to keep abrasive materials from entering the crankshaft area.

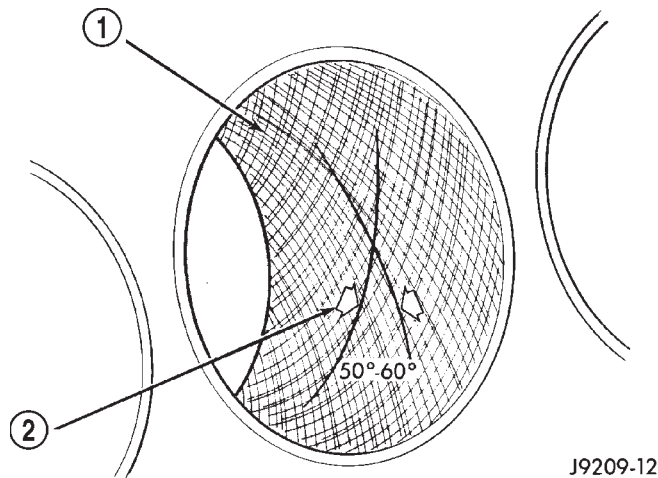
(1) Used carefully, the Cylinder Bore Sizing Hone C-823, equipped with 220 grit stones, is the best tool for this job. In addition to deglazing, it will reduce taper and out-of-round, as well as removing light scuffing, scoring and scratches. Usually, a few strokes will clean up a bore and maintain the required limits.

**CAUTION: DO NOT use rigid type hones to remove cylinder wall glaze.**

(2) Deglazing of the cylinder walls may be done if the cylinder bore is straight and round. Use a cylinder surfacing hone, Honing Tool C-3501, equipped with 280 grit stones (C-3501-3810). about 20-60 strokes, depending on the bore condition, will be sufficient to provide a satisfactory surface. Using honing oil C-3501-3880, or a light honing oil, available from major oil distributors.

**CAUTION: DO NOT use engine or transmission oil, mineral spirits, or kerosene.**

(3) Honing should be done by moving the hone up and down fast enough to get a crosshatch pattern. The hone marks should INTERSECT at 50° to 60° for proper seating of rings (Fig. 3).



J9209-12

**Fig. 3 Cylinder Bore Crosshatch Pattern**

- 1 - CROSSHATCH PATTERN  
2 - INTERSECT ANGLE

(4) A controlled hone motor speed between 200 and 300 RPM is necessary to obtain the proper crosshatch angle. The number of up and down strokes per minute can be regulated to get the desired 50° to 60° angle. Faster up and down strokes increase the crosshatch angle.

(5) After honing, it is necessary that the block be cleaned to remove all traces of abrasive. Use a brush to wash parts with a solution of hot water and detergent. Dry parts thoroughly. Use a clean, white, lint-free cloth to check that the bore is clean. Oil the bores after cleaning to prevent rusting.

**STANDARD PROCEDURE—FORM-IN-PLACE GASKETS & SEALERS**

There are numerous places where form-in-place gaskets are used on the engine. Care must be taken when applying form-in-place gaskets to assure obtaining the desired results. **Do not use form-in-place gasket material unless specified.** Bead size, continuity, and location are of great importance. Too thin a bead can result in leakage while too much can result in spill-over which can break off and obstruct fluid feed lines. A continuous bead of the proper width is essential to obtain a leak-free gasket.

There are numerous types of form-in-place gasket materials that are used in the engine area. Mopar® Engine RTV GEN II, Mopar® ATF-RTV, and Mopar® Gasket Maker gasket materials, each have different properties and can not be used in place of the other.

**MOPAR® ENGINE RTV GEN II**

Mopar® Engine RTV GEN II is used to seal components exposed to engine oil. This material is a specially designed black silicone rubber RTV that retains adhesion and sealing properties when exposed to engine oil. Moisture in the air causes the material to cure. This material is available in three ounce tubes and has a shelf life of one year. After one year this material will not properly cure. Always inspect the package for the expiration date before use.

**MOPAR® ATF RTV**

Mopar® ATF RTV is a specifically designed black silicone rubber RTV that retains adhesion and sealing properties to seal components exposed to automatic transmission fluid, engine coolants, and moisture. This material is available in three ounce tubes and has a shelf life of one year. After one year this material will not properly cure. Always inspect the package for the expiration date before use.

**MOPAR® GASKET MAKER**

Mopar® Gasket Maker is an anaerobic type gasket material. The material cures in the absence of air when squeezed between two metallic surfaces. It will not cure if left in the uncovered tube. The anaerobic material is for use between two machined surfaces. Do not use on flexible metal flanges.

## ENGINE 8.0L (Continued)

**MOPAR® GASKET SEALANT**

Mopar® Gasket Sealant is a slow drying, permanently soft sealer. This material is recommended for sealing threaded fittings and gaskets against leakage of oil and coolant. Can be used on threaded and machined parts under all temperatures. This material is used on engines with multi-layer steel (MLS) cylinder head gaskets. This material also will prevent corrosion. Mopar® Gasket Sealant is available in a 13 oz. aerosol can or 4oz./16 oz. can w/applicator.

**FORM-IN-PLACE GASKET AND SEALER APPLICATION**

Assembling parts using a form-in-place gasket requires care but it's easier than using pre-cut gaskets.

Mopar® Gasket Maker material should be applied sparingly 1 mm (0.040 in.) diameter or less of sealant to one gasket surface. Be certain the material surrounds each mounting hole. Excess material can easily be wiped off. Components should be torqued in place within 15 minutes. The use of a locating dowel is recommended during assembly to prevent smearing material off the location.

Mopar® Engine RTV GEN II or ATF RTV gasket material should be applied in a continuous bead approximately 3 mm (0.120 in.) in diameter. All mounting holes must be circled. For corner sealing, a 3.17 or 6.35 mm (1/8 or 1/4 in.) drop is placed in the center of the gasket contact area. Uncured sealant may be removed with a shop towel. Components should be torqued in place while the sealant is still wet to the touch (within 10 minutes). The usage of a locating dowel is recommended during assembly to prevent smearing material off the location.

Mopar® Gasket Sealant in an aerosol can should be applied using a thin, even coat sprayed completely over both surfaces to be joined, and both sides of a gasket. Then proceed with assembly. Material in a can w/applicator can be brushed on evenly over the sealing surfaces. Material in an aerosol can should be used on engines with multi-layer steel gaskets.

**STANDARD PROCEDURE—REPAIR DAMAGED OR WORN THREADS**

**CAUTION:** Be sure that the tapped holes maintain the original center line.

Damaged or worn threads can be repaired. Essentially, this repair consists of:

- Drilling out worn or damaged threads.
- Tapping the hole with a special Heli-Coil Tap, or equivalent.
- Installing an insert into the tapped hole to bring the hole back to its original thread size.

**STANDARD PROCEDURE—HYDROSTATIC LOCK**

**CAUTION:** DO NOT use the starter motor to rotate the crankshaft. Severe damage could occur.

When an engine is suspected of hydrostatic lock (regardless of what caused the problem), follow the steps below.

(1) Perform the Fuel Pressure Release Procedure (Refer to 14 - FUEL SYSTEM/FUEL DELIVERY - STANDARD PROCEDURE).

(2) Disconnect the negative cable(s) from the battery.

(3) Inspect air cleaner, induction system, and intake manifold to ensure system is dry and clear of foreign material.

(4) Place a shop towel around the spark plugs to catch any fluid that may possibly be under pressure in the cylinder head. Remove the spark plugs.

(5) With all spark plugs removed, rotate the crankshaft using a breaker bar and socket.

(6) Identify the fluid in the cylinders (coolant, fuel, oil, etc.).

(7) Be sure all fluid has been removed from the cylinders.

(8) Repair engine or components as necessary to prevent this problem from occurring again.

(9) Squirt a small amount of engine oil into the cylinders to lubricate the walls. This will prevent damage on restart.

(10) Install new spark plugs. Tighten the spark plugs to 41 N·m (30 ft. lbs.) torque.

(11) Drain engine oil. Remove and discard the oil filter.

(12) Install the drain plug. Tighten the plug to 34 N·m (25 ft. lbs.) torque.

(13) Install a new oil filter.

(14) Fill engine crankcase with the specified amount and grade of oil. (Refer to LUBRICATION & MAINTENANCE - SPECIFICATIONS).

(15) Connect the negative cable(s) to the battery.

(16) Start the engine and check for any leaks.

**REMOVAL**

(1) Remove the battery.

(2) Drain cooling system (Refer to 7 - COOLING - STANDARD PROCEDURE).

(3) Discharge the air conditioning system, if equipped (Refer to 24 - HEATING & AIR CONDITIONING/PLUMBING - STANDARD PROCEDURE).

(4) Remove the upper crossmember.

(5) Remove the transmission oil cooler (Refer to 7 - COOLING/TRANSMISSION/TRANS COOLER - REMOVAL).

## ENGINE 8.0L (Continued)

(6) Remove the serpentine belt (Refer to 7 - COOLING/ACCESSORY DRIVE/DRIVE BELTS - REMOVAL).

(7) Remove the A/C compressor with the lines attached (Refer to 24 - HEATING & AIR CONDITIONING/PLUMBING/A/C COMPRESSOR - REMOVAL). Set aside.

(8) If equipped, remove the condenser (Refer to 24 - HEATING & AIR CONDITIONING/PLUMBING/A/C CONDENSER - REMOVAL).

(9) Remove the washer fluid reservoir bottle (Refer to 8 - ELECTRICAL/WIPERS/WASHERS - REMOVAL AND INSTALLATION).

(10) Disconnect the top radiator hose.

(11) Remove the fan (Refer to 7 - COOLING/ENGINE/RADIATOR FAN - REMOVAL).

(12) Remove the fan shroud.

(13) Disconnect the lower radiator hose.

(14) Disconnect the transmission cooler lines.

(15) Remove radiator (Refer to 7 - COOLING/ENGINE/RADIATOR - REMOVAL).

(16) Remove the generator with the wire connections (Refer to 8 - ELECTRICAL/CHARGING/GENERATOR - REMOVAL).

(17) Remove the air cleaner.

(18) Disconnect the throttle linkage.

(19) Remove throttle body (Refer to 14 - FUEL SYSTEM/FUEL INJECTION/THROTTLE BODY - REMOVAL).

(20) Remove the upper intake manifold (Refer to 9 - ENGINE/MANIFOLDS/INTAKE MANIFOLD - REMOVAL).

(21) Remove the coil assemblies with the ignition cables.

(22) Disconnect the heater hoses.

(23) Disconnect the power steering hoses, if equipped.

(24) Perform the Fuel System Pressure release procedure (Refer to 14 - FUEL SYSTEM/FUEL DELIVERY - STANDARD PROCEDURE). Disconnect the fuel line (Refer to 14 - FUEL SYSTEM/FUEL DELIVERY/QUICK CONNECT FITTING - STANDARD PROCEDURE).

(25) On Manual Transmission vehicles, remove the shift lever.

(26) Raise and support the vehicle on a hoist.

(27) Remove the drain plug and drain the engine oil.

(28) Loosen front engine mount thru-bolt nuts.

(29) Remove the transmission cooler line brackets from oil pan.

(30) Disconnect exhaust pipe at manifold.

(31) Disconnect the starter wires. Remove starter motor (Refer to 8 - ELECTRICAL/STARTING/STARTER MOTOR - REMOVAL).

(32) Remove transmission.

(33) Lower vehicle.

**CAUTION: DO NOT lift the engine by the intake manifold.**

(34) Install an engine lifting fixture.

(35) Remove engine from vehicle and install engine assembly on a repair stand.

## INSTALLATION

(1) Remove engine from the repair stand and position in the engine compartment. Position the thru-bolt into the support cushion brackets.

(2) Install an engine support fixture.

(3) Raise and support the vehicle on a hoist.

(4) Install Transmission.

(5) Install the starter and connect the starter wires (Refer to 8 - ELECTRICAL/STARTING/STARTER MOTOR - INSTALLATION).

(6) Install exhaust pipe to manifold.

(7) Install the transmission cooler line brackets from oil pan.

(8) Tighten the Front mount thru-bolts and nuts to 102N·m (75 ft. lbs.).

(9) Install the drain plug and tighten to 34 N·m (25 ft. lbs.) torque.

(10) Prime oil pump by squirting oil in the oil filter mounting hole and filling the J-trap of the front timing cover. When oil is running out, install oil filter that has been filled with oil.

(11) Lower the vehicle.

(12) Remove engine lifting fixture.

(13) On Manual Transmission vehicles, install the shift lever.

(14) Connect the fuel lines (Refer to 14 - FUEL SYSTEM/FUEL DELIVERY/QUICK CONNECT FITTING - STANDARD PROCEDURE).

(15) Connect the heater hoses.

(16) Install the upper intake manifold (Refer to 9 - ENGINE/MANIFOLDS/INTAKE MANIFOLD - INSTALLATION).

(17) Install the coil assemblies with the ignition cables.

(18) Using a new gasket, install throttle body (Refer to 14 - FUEL SYSTEM/FUEL INJECTION/THROTTLE BODY - INSTALLATION).

(19) Connect the throttle linkage.

(20) Install the air cleaner box.

(21) Install the generator and wire connections (Refer to 8 - ELECTRICAL/CHARGING/GENERATOR - INSTALLATION).

(22) Install the upper crossmember.

(23) Install radiator (Refer to 7 - COOLING/ENGINE/RADIATOR - INSTALLATION).

(24) Connect the lower radiator hose.

## ENGINE 8.0L (Continued)

(25) Install the transmission oil cooler (Refer to 7 - COOLING/TRANSMISSION/TRANS COOLER - INSTALLATION).

(26) Connect the transmission cooler lines.

(27) Connect the power steering hoses, if equipped.

(28) Install the fan shroud.

(29) Install the fan (Refer to 7 - COOLING/ENGINE/RADIATOR FAN - INSTALLATION).

(30) Connect the top radiator hose.

(31) Install the washer fluid reservoir bottle (Refer to 8 - ELECTRICAL/WIPERS/WASHERS - INSTALLATION).

(32) If equipped, install the condenser (Refer to 24 - HEATING & AIR CONDITIONING/PLUMBING/A/C CONDENSER - INSTALLATION).

(33) Install the A/C compressor with the lines attached (Refer to 24 - HEATING & AIR CONDI-

TIONING/PLUMBING/A/C COMPRESSOR - INSTALLATION).

(34) Install the serpentine belt (Refer to 7 - COOLING/ACCESSORY DRIVE/DRIVE BELTS - INSTALLATION).

(35) Evacuate (Refer to 24 - HEATING & AIR CONDITIONING/PLUMBING - STANDARD PROCEDURE) and charge the air conditioning system, if equipped (Refer to 24 - HEATING & AIR CONDITIONING/PLUMBING - STANDARD PROCEDURE).

(36) Add coolant to the cooling system (Refer to 7 - COOLING - STANDARD PROCEDURE).

(37) Install the battery.

(38) Warm engine and adjust as required.

(39) Road test vehicle.

## ENGINE 8.0L (Continued)

## SPECIFICATIONS

## 8.0L ENGINE

DESCRIPTION	SPECIFICATION
<b>CAMSHAFT</b>	
Bearing Diameter	
No. 1	53.16 – 53.19 mm (2.093 – 2.094 in.)
No. 2	52.76 – 52.78 mm (2.077 – 2.078 in.)
No. 3	52.35 – 52.37 mm
No. 4	51.94 – 51.97 mm (2.045 – 2.046 in.)
No. 5	51.54 – 51.56 mm (2.029 – 2.030 in.)
No. 6	48.74 – 48.77 mm (1.919 – 1.920 in.)
Bearing Journal Diameter	
No. 1	53.11 – 53.14 mm (2.091 – 2.092 in.)
No. 2	52.69 – 52.72 mm (2.0745 – 2.0755 in.)
No. 3	52.30 – 52.32 mm (2.059 – 2.060 in.)
No. 4	51.89 – 51.92 mm (2.043 – 2.044 in.)
No. 5	51.49 – 51.51 mm (2.027 – 2.028 in.)
No. 6	48.69 – 48.72 mm (1.917 – 1.918 in.)
Bearing to Journal Clearance	
No. 1,3,4,5,6	0.0254 – 0.0762 mm (0.001 – 0.003 in.)
No. 2	0.0381 – 0.0889 mm (0.0005 – 0.0035 in.)
Service Limit	0.127 mm (0.005 in.)
End Play	0.127 – 0.381 mm (0.005 – 0.015 in.)

DESCRIPTION	SPECIFICATION
<b>CONNECTING RODS</b>	
Piston Pin bore Diameter	24.940 – 24.978 mm (0.9819 – 0.9834 in.)
Side Clearance	0.25 – 0.46 mm (0.010 – 0.018 in.)
Total Weight (Less Bearing)	744 gms. (26.24 oz.)
<b>CRANKSHAFT</b>	
Rod Journal Diameter	53.950 – 53.975 mm (2.124 – 2.125 in.)
Out of Round (Max.)	0.0254 mm (0.001 in.)
Taper (Max.)	0.0254 mm (0.001 in.)
Bearing Clearance	0.005 – 0.074 mm (0.0002 – 0.0029 in.)
Service Limit	0.0762 mm (0.003 in.)
Main Bearing Journal Diameter	76.187 – 76.213 mm (2.8995 – 3.0005 in.)
Out of Round (Max.)	0.0254 mm (0.001 in.)
Taper (Max.)	0.0254 mm (0.001 in.)
Bearing Clearance	0.0051 – 0.058 mm (0.0002 – 0.0023 in.)
Service Limit	0.071 mm (0.0028 in.)
End Play	0.076 – 0.305 mm (0.003 – 0.012 in.)
Service Limit—End Play	0.381 mm (0.015 in.)
<b>CYLINDER BLOCK</b>	
Cylinder Bore Diameter	101.60 – 101.65 mm (4.0003 – 4.0008 in.)
Out of Round (Max.)	0.0762 mm (0.003 in.)
Taper (Max.)	0.127 mm (0.005 in.)
Lifter Bore Diameter	22.982 – 23.010 mm (0.9048 – 0.9059 in.)



## ENGINE 8.0L (Continued)

DESCRIPTION	SPECIFICATION
<b>CYLINDER HEAD AND VALVES</b>	
Valve Seat Angle	44.5°
Runout (Max.)	0.0762 mm (0.003 in.)
Width (Finish) – Intake	1.016 – 1.524 mm (0.040 – 0.060 in.)
Valve Face Angle	45°
Valve Head Diameter	
Intake	48.640 – 48.900 mm (1.915 – 1.925 in.)
Exhaust	41.123 – 41.377 mm (1.619 – 1.629 in.)
Overall Length	
Intake	145.19 – 145.82 mm (5.716 – 5.741 in.)
Exhaust	145.54 – 146.18 mm (5.730 – 5.755 in.)
Lift (@ zero lash)	
Intake	9.91 mm (0.390 in.)
Exhaust	10.34 mm (0.407 in.)
Stem Diameter	7.900 – 7.920 mm (0.311 – 0.312 in.)
Guide Bore	9.500 – 9.525 mm (0.374 – 0.375 in.)
Stem to Guide Clearance	0.025 – 0.076 mm (0.001 – 0.003 in.)
Service Limit	0.4318 (0.017 in.)
Valve Spring Free Length	49.962 mm (1.967 in.)
Spring Tension	
Valve Closed	378 N @ 41.66 mm (85 lbs. @ 1.64 in.)
Valve Open	890 N @ 30.89 mm (200 lbs. @ 1.212 in.)
Number of Coils	6.8
Installed Height	41.66 mm (1.64 in.)
Wire Diameter	4.50 mm (0.177 in.)

DESCRIPTION	SPECIFICATION
<b>HYDRAULIC TAPPETS</b>	
Body Diameter	22.949 – 22.962 mm (0.9035 – 0.9040 in.)
Clearance (to bore)	0.0203 – 0.0610 mm (0.0008 – 0.0024 in.)
Dry Lash	1.524 – 5.334 mm (0.060 – 0.210 in.)
Push Rod Length	195.52 – 196.02 mm (7.698 – 7.717 in.)
<b>OIL PRESSURE</b>	
Curb Idle (Min.*)	83 kPa (12 psi)
@ 3000 rpm	345 – 414 kPa (50 – 60 psi)
* If oil pressure is zero at curb idle, DO NOT RUN ENGINE.	
<b>OIL PUMP</b>	
Clearance over Rotors (Max.)	0.1906 mm (0.0075 in.)
Cover Out of Flat (Max.)	0.051 mm (0.002 in.)
Inner Rotor Thickness (Min.)	14.925 – 14.950 mm (0.5876 – 0.5886 in.)
Outer Rotor	
Clearance (Max.)	0.1626 mm (0.006 in.)
Diameter (Min.)	82.461 mm (3.246 in.)
Thickness (Min.)	14.925 mm (0.5876 in.)
Tip Clearance between Rotors (Max.)	0.584 mm (0.0230 in.)
<b>PISTONS</b>	
Clearance at Top of Skirt	0.013 – 0.038 mm (0.0005 – 0.0015 in.)
Piston Length	82.5 mm (3.25 in.)
Piston Ring Groove Depth	
#1&2	91.30 – 91.55 mm (3.594 – 3.604 in.)
#3	92.90 – 93.15 mm (3.657 – 3.667 in.)



## ENGINE 8.0L (Continued)

DESCRIPTION	SPECIFICATION
Weight	463 – 473 grams (16.33 – 16.68 oz.)
Piston to Bore Clearance	0.013 – 0.038 mm (0.0005 – 0.0015 in.)
Service Limit	0.0762 mm (0.003 in.)
<b>PISTON PINS</b>	
Clearance in Piston	0.010 – 0.020 mm (0.0004 – 0.0008 in.)
Diameter	24.996 – 25.001 mm (0.9841 – 0.9843 in.)
End Play	NONE
Length	67.8 – 68.3 mm (2.67 – 2.69 in.)
<b>PISTON RINGS</b>	
Ring Gap Compression Rings	0.254 – 0.508 mm (0.010 – 0.020 in.)
Oil Control (Steel Rails)	0.381 – 1.397 mm (0.015 – 0.055 in.)
Ring Side Clearance Compression Rings	0.074 – 0.097 mm (0.0029 – 0.0038 in.)
Oil Ring (Steel Rails)	2.591 – 2.743 mm (0.102 – 0.108 in.)
<b>VALVE TIMING</b>	
Exhaust Valve Closes (ATDC) Opens (BBDC) Duration	25° 60° 265°
Intake Valve Closes (ATDC) Opens (BBDC) Duration	61° 6° 246°
Valve Overlap	31°

CRANKSHAFT JOURNAL MARKING  
LOCATION

MEASURE- MENT	ITEM	IDENTIFI- CATION	LOCATION OF IDENTIFI- CATION
0.0254 mm (0.001 in.) U/S	Crankshaft Journals	R or M M-2-3 ect. (indicating No. 2 and 3 main bearing journal) and/or R-1-4 ect. (indicating No. 1 and 4 connecting rod journal)	Milled flat on No. 8 crankshaft counter- weight.
0.508 mm (0.020 in.) O/S	Cylinder Bores	A	Following engine serial number.
0.2032 mm (0.008 in.) O/S	Hydraulic Tappets	◇	Diamond- shaped stamp top pad - front of engine and flat ground on outside surface of each O/S tappet bore.
0.127 mm (0.005 in.)	Valve Stems	X	Milled pad adjacent to two tapped holes 3/8" on each end of cylinder head.

## ENGINE 8.0L (Continued)

## TORQUE

## TORQUE CHART 8.0L ENGINE

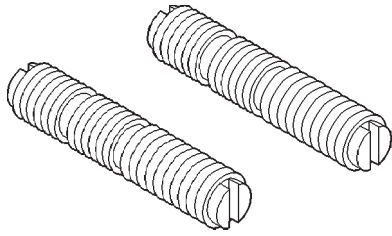
DESCRIPTION	N-m	Ft. Lbs.	In. Lbs.
Camshaft Sprocket—Bolt	75	55	—
Camshaft Thrust Plate— Bolts	22	16	—
Coil Pack Bracket—Bolts	21	—	190
Connecting Rod Cap—Bolts	61	45	—
Main Bearing—Bolts			
Step 1	27	20	—
Step 2	115	85	—
Crankshaft Pulley/Damper— Bolt	312	230	—
Crankshaft Rear Seal Retainer— Bolts	22	16	—
Cylinder Head—Bolts			
Step 1	58	43	—
Step 2	143	105	—
Cylinder Head Cover—Bolts	16	—	144
Drive Plate to Crankshaft— Bolts	75	55	—
Drive Plate to Torque Converter— Bolts	47	35	—
EGR Tube—Nut	34	25	—
EGR Valve—Bolts	20	—	174
Engine Support Bracket/ Insulator— Through Bolt	68	50	—
Engine Support Bracket/ Insulator to Block—Bolts	47	35	—
Exhaust Manifold to Cylinder Head— Bolt	22	16	—
Generator Mounting—Bolt	41	30	—
Generator to Intake Manifold Bracket —Bolts	41	30	—
Heat Shield—Nuts	20	—	175
Hydraulic Tappet Yoke Retaining	22	16	—

DESCRIPTION	N-m	Ft. Lbs.	In. Lbs.
Spider—Bolts			
Intake Manifold (Lower)— Bolts	54	40	—
Intake Manifold (Upper)— Bolts	22	16	—
Oil Filter	9	—	80 + 45°
Oil Filter Connector	46	34	—
Oil Pan			
—1/4 - 20 Bolts	11	—	96
—5/16 - 18 Bolts	16	—	144
—Stud Bolts	16	—	144
—Drain Plug	34	25	—
Oil Pan Pick Up Tube—Bolts	16	—	144
Oil Pump Attaching—Bolts	41	30	—
Oil Pump Cover—Bolts	14	—	125
Oil Pump Pressure Relief—Plug	20	15	—
Rocker Arm—Bolts	28	21	—
Spark Plugs	41	30	—
Starter Mounting—Bolts	68	50	—
Timing Chain Cover—Bolts	47	35	—
Thermostat Housing—Bolts	25	—	220
Throttle Body—Nuts	11	—	96
Transfer Case to Insulator Mounting Plate—Nuts	204	150	—
Transmission Support Bracket— Bolts	102	75	—
Transmission Support Cushion— Bolts	47	35	—
Transmission Support Cushion Stud—Nuts	47	35	—
Water Pump to Chain Case Cover— Bolts	41	30	—

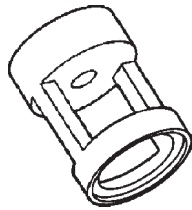
ENGINE 8.0L (Continued)

SPECIAL TOOLS

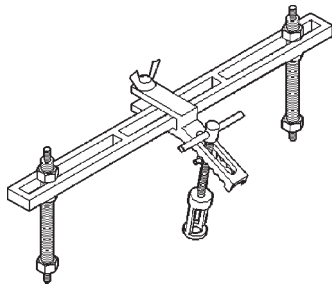
8.0L ENGINE



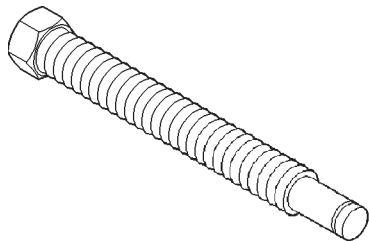
**Valve Compressor Adapting Stud Tool 6715**



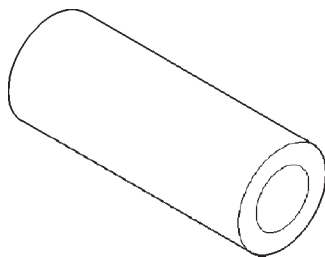
**Valve Spring Compressor Adapter Tool 6716A**



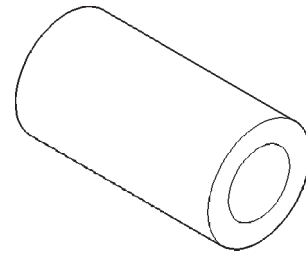
**Valve Spring Compressor Tool MD-998772A**



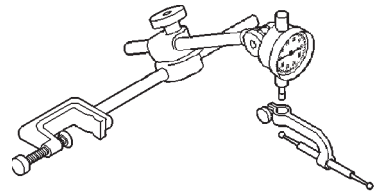
**Valve Spring Compressor Screw Tool 6756**



**Black Valve Guide Sleeve Tool C6819**

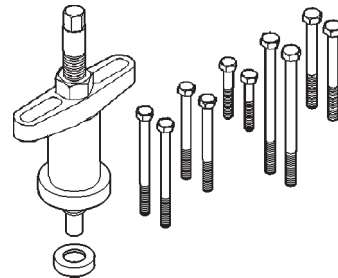


**Silver Valve Guide Sleeve Tool C6818**

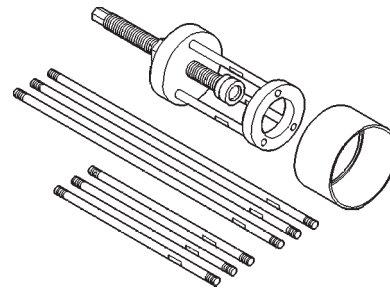


8011d42b

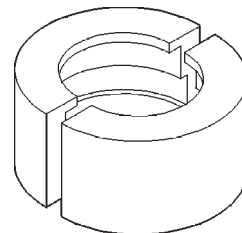
**Dial Indicator Tool C3339**



**Crankshaft Pulley/Damper Installer Tool C3688**

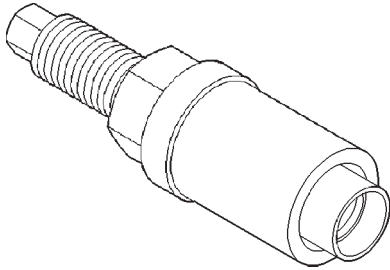


**Crankshaft Sprocket Puller Tool 6444**

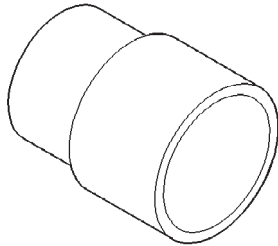


**Crankshaft Sprocket Puller Jaws Tool 6820**

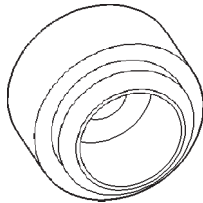
ENGINE 8.0L (Continued)



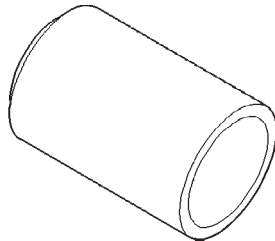
**Crankshaft Sprocket Installer Tool 3718**



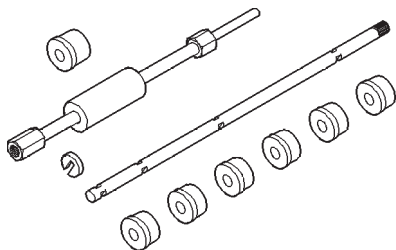
**Crankshaft Sprocket Installer Tool MD990799**



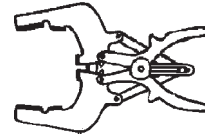
**Front Oil Seal Installer Tool 6806**



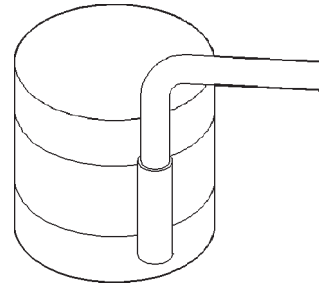
**Front Oil Seal Installer Tool 6761**



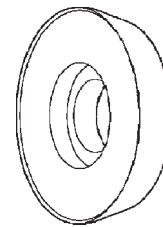
**Camshaft Bearing Installer Tool C3132A**



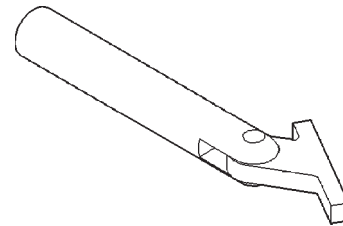
**Compression Ring Installer Tool C4184**



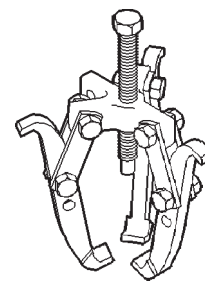
**Piston Ring Compressor Tool C385**



**Seal Installer Tool 6687**

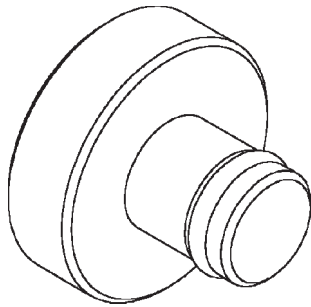


**Crankshaft Main Bearing Remover/Installer Tool C3059**

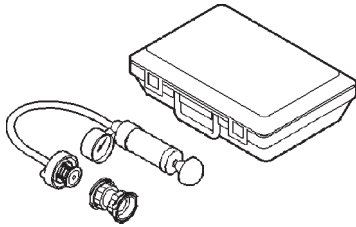


**Puller 1026**

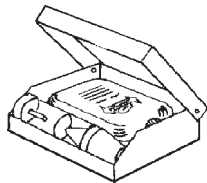
ENGINE 8.0L (Continued)



**Crankshaft Damper Removal Insert 8513**



**Pressure Tester Kit 7700**



**Bloc-Chek-Kit C-3685-A**

**AIR CLEANER ELEMENT**

**REMOVAL - 8.0L**

For air cleaner element required maintenance schedules (listed in time or mileage intervals), refer to 0, Lubrication and Maintenance.

A small amount of engine oil wetting the inside of the air cleaner housing is normal. When servicing, wipe out oil from air cleaner housing.

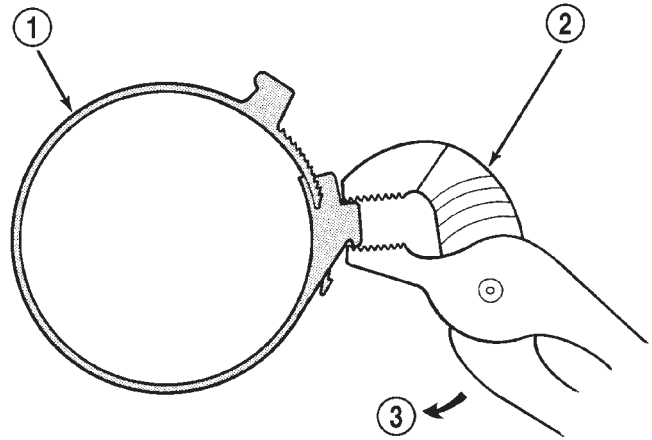
(1) Loosen clamp (Fig. 4) and remove air inlet tube (Fig. 5) at front of air cleaner housing cover.

(2) The air cleaner housing and air cleaner element cover are equipped with spring clips to seal cover to housing (Fig. 5). Unlatch clips from air cleaner cover and remove cover from air cleaner housing.

(3) Remove air cleaner element from air cleaner cover.

(4) Before installing a new air cleaner element, clean inside of air cleaner housing.

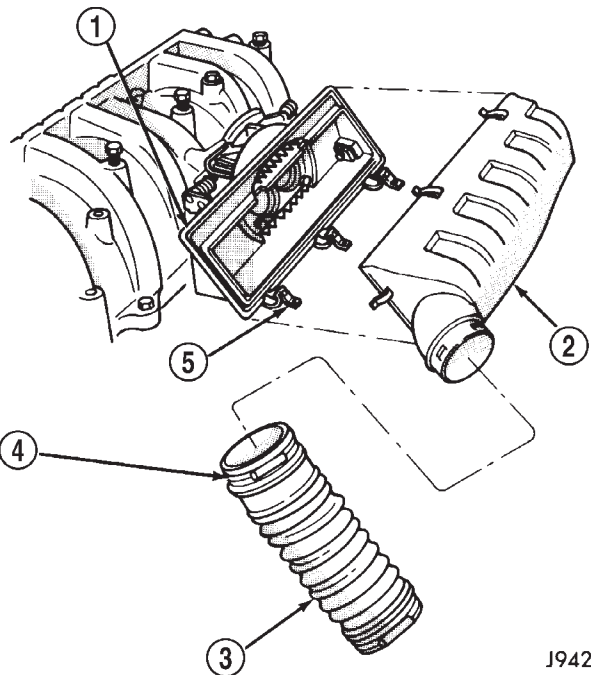
(5) If housing removal is necessary, disconnect crankcase vent hose and remove 4 housing-to-throttle body nuts.



J9314-136

**Fig. 4 Clamp Removal—8.0L Engine**

- 1 - CLAMP
- 2 - ADJUSTABLE PLIERS
- 3 - REMOVAL



J9425-6

**Fig. 5 Air Cleaner Housing—8.0L V-10 Engine**

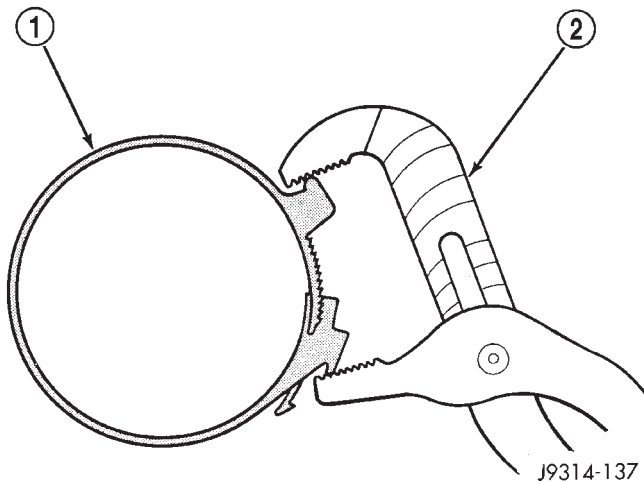
- 1 - HOUSING
- 2 - HOUSING COVER
- 3 - AIR INLET TUBE
- 4 - CLAMP
- 5 - SPRING CLIPS

**INSTALLATION - 8.0L**

For air cleaner element required maintenance schedules (listed in time or mileage intervals), refer to Group 0, Lubrication and Maintenance.

## AIR CLEANER ELEMENT (Continued)

(1) After installing housing, tighten 4 nuts to 11 N·m (96 in. lbs.) torque and connect crankcase vent hose.



**Fig. 6 Clamp Installation—8.0L Engine**

- 1 - CLAMP  
2 - ADJUSTABLE PLIERS

(2) Position air cleaner element (filter) into air cleaner cover. Latch spring clips to seal cover to housing.

(3) Install air inlet tube at air cleaner housing inlet.

(4) Install and tighten clamp at air inlet tube (Fig. 6).

## CYLINDER HEAD

## DESCRIPTION

The alloy cast iron cylinder heads (Fig. 7) are held in place by 12 bolts. The spark plugs are located in the peak of the wedge between the valves.

## DIAGNOSIS AND TESTING—CYLINDER HEAD GASKET FAILURE

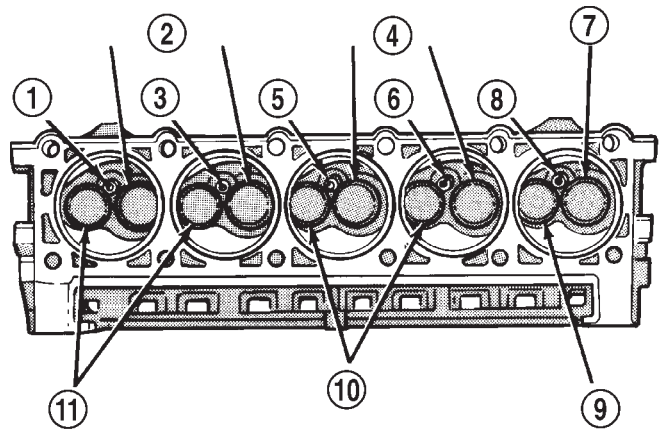
A cylinder head gasket leak can be located between adjacent cylinders or between a cylinder and the adjacent water jacket.

• Possible indications of the cylinder head gasket leaking between adjacent cylinders are:

- Loss of engine power
- Engine misfiring
- Poor fuel economy

• Possible indications of the cylinder head gasket leaking between a cylinder and an adjacent water jacket are:

- Engine overheating
- Loss of coolant



**Fig. 7 Cylinder Head Assembly**

- 1 - SPARK PLUG  
2 - INTAKE VALVES  
3 - SPARK PLUG  
4 - INTAKE VALVES  
5 - SPARK PLUG  
6 - SPARK PLUG  
7 - INTAKE VALVE  
8 - SPARK PLUG  
9 - EXHAUST VALVE  
10 - EXHAUST VALVES  
11 - EXHAUST VALVES

- Excessive steam (white smoke) emitting from exhaust
- Coolant foaming

## CYLINDER-TO-CYLINDER LEAKAGE TEST

To determine if an engine cylinder head gasket is leaking between adjacent cylinders, follow the procedures in Cylinder Compression Pressure Test in this section. An engine cylinder head gasket leaking between adjacent cylinders will result in approximately a 50–70% reduction in compression pressure.

## CYLINDER-TO-WATER JACKET LEAKAGE TEST

**WARNING: USE EXTREME CAUTION WHEN THE ENGINE IS OPERATING WITH COOLANT PRESSURE CAP REMOVED.**

## VISUAL TEST METHOD

With the engine cool, remove the coolant pressure cap. Start the engine and allow it to warm up until thermostat opens.

If a large combustion/compression pressure leak exists, bubbles will be visible in the coolant.



## CYLINDER HEAD (Continued)

## COOLING SYSTEM TESTER METHOD

**WARNING: WITH COOLING SYSTEM TESTER IN PLACE, PRESSURE WILL BUILD UP FAST. EXCESSIVE PRESSURE BUILT UP, BY CONTINUOUS ENGINE OPERATION, MUST BE RELEASED TO A SAFE PRESSURE POINT. NEVER PERMIT PRESSURE TO EXCEED 138 kPa (20 psi).**

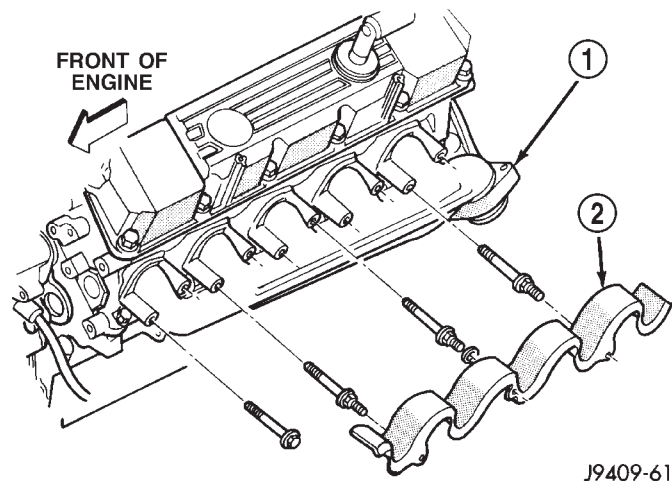
Install Cooling System Tester 7700 or equivalent to pressure cap neck. Start the engine and observe the tester's pressure gauge. If gauge pulsates with every power stroke of a cylinder a combustion pressure leak is evident.

## CHEMICAL TEST METHOD

Combustion leaks into the cooling system can also be checked by using Bloc-Chek Kit C-3685-A or equivalent. Perform test following the procedures supplied with the tool kit.

## REMOVAL

- (1) Disconnect the negative cable from the battery.
- (2) Drain cooling system (Refer to 7 - COOLING - STANDARD PROCEDURE).
- (3) Remove the heat shields (Fig. 8).



**Fig. 8 Spark Plug Wire Heat Shields (Left Side Shown)**

- 1 - EXHAUST MANIFOLD
- 2 - HEAT SHIELD

(4) Remove the intake manifold-to-generator bracket support rod. Remove the generator (Refer to 8 - ELECTRICAL/CHARGING/GENERATOR - REMOVAL).

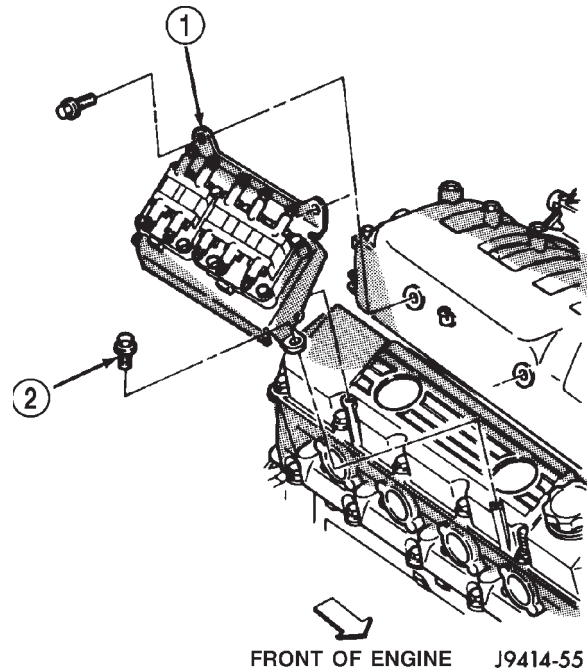
- (5) Remove closed crankcase ventilation system.
- (6) Disconnect the evaporation control system.
- (7) Remove the air cleaner.

(8) Perform the Fuel System Pressure release procedure (Refer to 14 - FUEL SYSTEM/FUEL DELIV-

ERY - STANDARD PROCEDURE). Disconnect the fuel line (Refer to 14 - FUEL SYSTEM/FUEL DELIVERY/QUICK CONNECT FITTING - STANDARD PROCEDURE).

(9) Disconnect accelerator linkage and if so equipped, the speed control and transmission kick-down cables.

(10) Remove coil pack and bracket (Fig. 9).



**Fig. 9 Coil Pack and Bracket**

- 1 - COIL PACKS AND BRACKET
- 2 - MOUNTING BOLTS (4)

- (11) Disconnect the coil wires.
- (12) Disconnect heat indicator sending unit wire.
- (13) Disconnect heater hoses and bypass hose.
- (14) Remove upper intake manifold and throttle body as an assembly (Refer to 9 - ENGINE/MANIFOLDS/INTAKE MANIFOLD - REMOVAL).

(15) Remove cylinder head covers and gaskets (Refer to 9 - ENGINE/CYLINDER HEAD/CYLINDER HEAD COVER(S) - REMOVAL).

(16) Remove the EGR tube. Discard the gasket, for right side only.

(17) Remove lower intake manifold (Refer to 9 - ENGINE/MANIFOLDS/INTAKE MANIFOLD - REMOVAL). Discard the flange side gaskets and the front and rear cross-over gaskets.

(18) Disconnect exhaust pipe from exhaust manifold.

(19) Remove exhaust manifolds and gaskets (Refer to 9 - ENGINE/MANIFOLDS/EXHAUST MANIFOLD - REMOVAL).

(20) Remove rocker arm assemblies and push rods (Refer to 9 - ENGINE/CYLINDER HEAD/ROCKER

## CYLINDER HEAD (Continued)

ARM / ADJUSTER ASSY - REMOVAL). Identify to ensure installation in original locations.

(21) Remove the head bolts from each cylinder head and remove cylinder heads. Discard the cylinder head gasket.

(22) Remove spark plugs.

## CLEANING

Clean all surfaces of cylinder block and cylinder heads. Be sure material does not fall into the lifters and surrounding valley.

Clean cylinder block front and rear gasket surfaces using a suitable solvent.

Clean the exhaust manifold to cylinder head mating areas.

## INSPECTION

Inspect all surfaces with a straightedge if there is any reason to suspect leakage. The out-of-flatness specifications are 0.0007 mm/mm (0.0004 inch/inch), 0.127 mm/152 mm (0.005 inch/6 inches) any direction or 0.254 mm (0.010 inch) overall across head. If exceeded, either replace head or lightly machine the head surface.

The cylinder head surface finish should be 1.78-4.57 microns (15-80 microinches).

Inspect push rods. Replace worn or bent rods.

Inspect rocker arms. Replace if worn or scored.

## INSTALLATION

(1) Position the new cylinder head gaskets onto the cylinder block.

(2) Position the cylinder heads onto head gaskets and cylinder block.

(3) Tighten the cylinder head bolts in two steps (Fig. 10):

- Step 1—Tighten all cylinder head bolts, in sequence, to 58 N·m (43 ft. lbs.) torque.

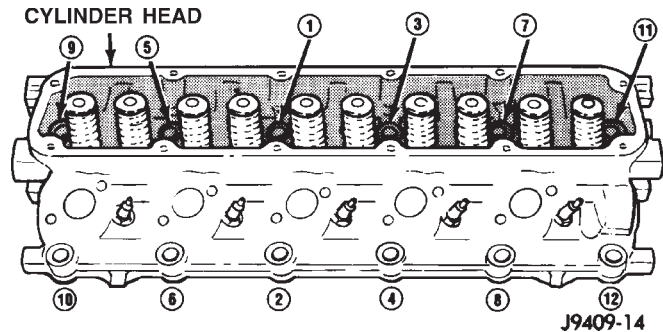
- Step 2—Tighten all cylinder head bolts, in sequence, to 143 N·m (105 ft. lbs.) torque.

- 

**CAUTION:** When tightening the rocker arm bolts, make sure the piston in that cylinder is NOT at TDC. Contact between the valves and piston could occur.

(4) Install push rods and rocker arm assemblies in their original position (Refer to 9 - ENGINE/CYLINDER HEAD/ROCKER ARM / ADJUSTER ASSY - INSTALLATION).

(5) Install lower intake manifold (Refer to 9 - ENGINE/MANIFOLDS/INTAKE MANIFOLD - INSTALLATION).



**Fig. 10 Cylinder Head Bolt Tightening Sequence**

(6) Install the upper intake manifold onto the lower intake manifold (Refer to 9 - ENGINE/MANIFOLDS/INTAKE MANIFOLD - INSTALLATION).

(7) Install the exhaust manifolds and new gaskets (Refer to 9 - ENGINE/MANIFOLDS/EXHAUST MANIFOLD - INSTALLATION).

(8) Install exhaust pipe to the exhaust manifold. Tighten the bolts to 34 N·m (25 ft. lbs.) torque.

(9) Using a new gasket, position the EGR tube to the intake manifold and the exhaust manifold. Tighten the EGR tube nut to 34 N·m (25 ft. lbs.) torque. Tighten the bolts to 20 N·m (174 in. lbs.) torque.

(10) Install the heat shields and the washers. **Make sure that heat shields tabs hook over the exhaust gasket.** Tighten the nuts to 15 N·m (132 in. lbs.) torque.

(11) Adjust and Install the spark plugs (Refer to 8 - ELECTRICAL/IGNITION CONTROL/SPARK PLUG - INSTALLATION).

(12) Install coil packs and bracket. Tighten the bracket bolts to 21 N·m (190 in. lbs.) torque. Connect the coil wires.

(13) Connect heat indicator sending unit wire.

(14) Connect the heater hoses and bypass hose.

(15) Connect the accelerator linkage and if so equipped, the speed control and transmission kick-down cables.

(16) Install the fuel line (Refer to 14 - FUEL SYSTEM/FUEL DELIVERY/QUICK CONNECT FITTING - STANDARD PROCEDURE).

(17) Install the generator (Refer to 8 - ELECTRICAL/CHARGING/GENERATOR - INSTALLATION) and drive belt (Refer to 7 - COOLING/ACCESSORY DRIVE/DRIVE BELTS - INSTALLATION).

(18) Install the intake manifold-to-generator bracket support rod. Tighten the bolts to 41 N·m (30 ft. lbs.) torque.

(19) The cylinder head cover gasket can be used again. Install the gasket onto the head rail. **For the left side the number tab is at the front of engine with the number up. For the right side the number tab is at the rear of engine with the number up.**

## CYLINDER HEAD (Continued)

**CAUTION:** The cylinder head cover fasteners have a special plating. **DO NOT** use alternative fasteners.

(20) Install cylinder head cover (Refer to 9 - ENGINE/CYLINDER HEAD/CYLINDER HEAD COVER(S) - INSTALLATION).

(21) Install closed crankcase ventilation system.

(22) Connect the evaporation control system.

(23) Install the air cleaner.

(24) Fill cooling system (Refer to 7 - COOLING - STANDARD PROCEDURE).

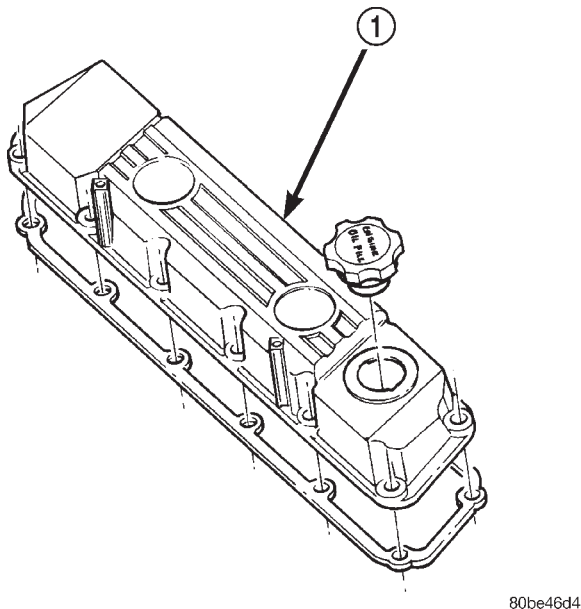
(25) Connect the negative cable to the battery.

(26) Check for leaks (fuel, oil, antifreeze, etc.).

## CYLINDER HEAD COVER(S)

## DESCRIPTION

Die-cast magnesium cylinder head covers (Fig. 11) reduce noise and provide a good sealing surface. A steel backed silicon gasket is used with the cylinder head cover. This gasket can be used again.



**Fig. 11** Cylinder Head Cover

1 - CYLINDER HEAD COVER

## REMOVAL

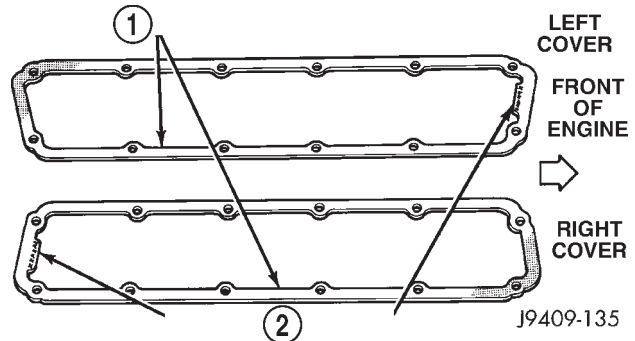
Die-cast magnesium cylinder head covers (Fig. 13) reduce noise and provide a good sealing surface. A steel backed silicon gasket is used with the cylinder head cover (Fig. 12).

(1) Disconnect the negative cable from the battery.

(2) Disconnect closed ventilation system and evaporation control system from cylinder head cover. Identify each system for installation.

(3) Remove the upper intake manifold to remove the right side head cover (Refer to 9 - ENGINE/MANIFOLDS/INTAKE MANIFOLD - REMOVAL).

(4) Remove cylinder head cover bolts and stud bolts. Remove the covers and gaskets (Fig. 12). The gasket may be used again.



**Fig. 12** Cylinder Head Cover Gaskets

1 - CYLINDER HEAD COVER GASKETS

2 - TAB WITH NUMBER UP

## CLEANING

Clean cylinder head cover gasket surface.

Clean head rail, if necessary.

## INSPECTION

Inspect cover for distortion and straighten, if necessary.

Check the gasket for use in head cover installation. If damaged, use a new gasket.

## INSTALLATION

(1) Check the gasket for use in head cover installation. If damaged, use a new gasket.

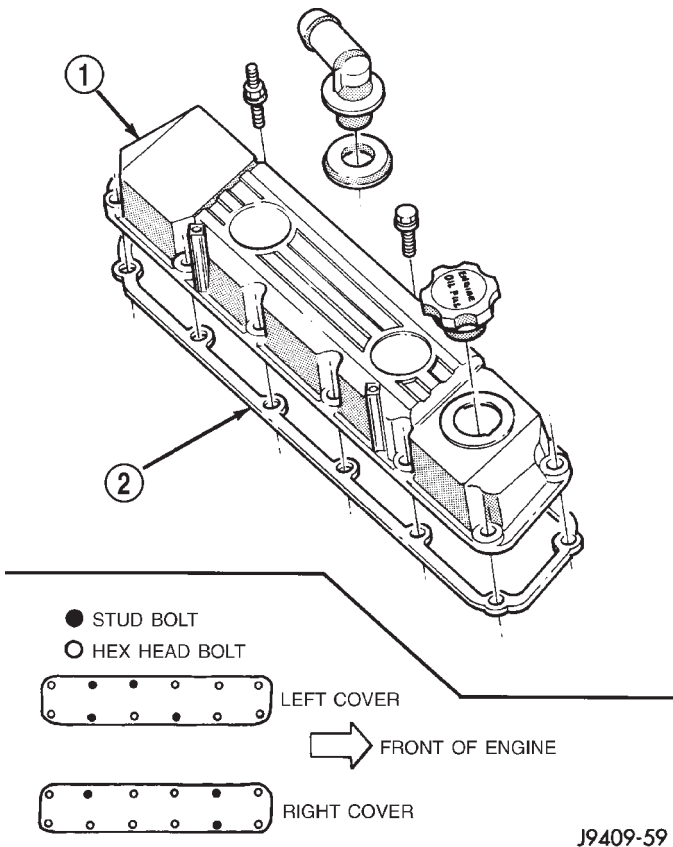
(2) Install the gasket onto the head rail. **For the left side the number tab is at the front of engine with the number up. For the right side the number tab is at the rear of engine with the number up.**

**CAUTION:** The cylinder head cover fasteners have a special plating. **DO NOT** use alternative fasteners.

(3) Position the cylinder head cover onto the gasket. Install the stud bolts and hex head bolts in the proper positions (Fig. 13). Tighten the stud bolts and the bolts to 16 N·m (144 in. lbs.) torque.

(4) If removed, install the upper intake manifold (Refer to 9 - ENGINE/MANIFOLDS/INTAKE MANIFOLD - INSTALLATION).

## CYLINDER HEAD COVER(S) (Continued)

**Fig. 13 Cylinder Head Covers**

- 1 - CYLINDER HEAD COVER
- 2 - CYLINDER HEAD COVER GASKET

(5) Install closed crankcase ventilation system and evaporation control system onto the proper head cover. **DO NOT** switch the systems.

(6) Connect the negative cable to the battery.

(7) Start engine and check for leaks.

## INTAKE/EXHAUST VALVES & SEATS

### DESCRIPTION

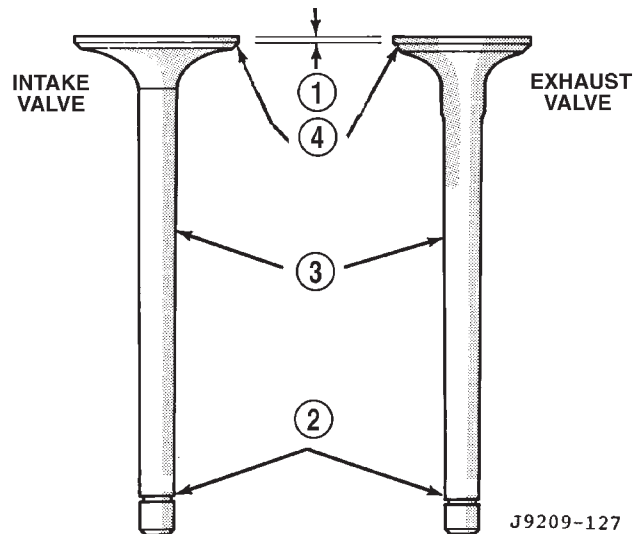
The valves (Fig 14) are arranged in-line and inclined 18°. The rocker pivot support and the valve guides are cast integral with the heads.

### VALVE SERVICE

#### VALVE GUIDES

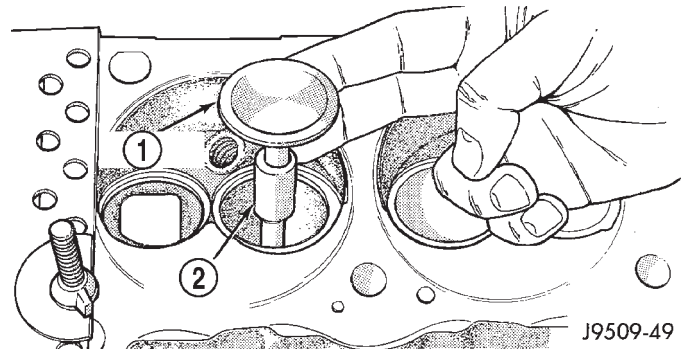
Measure valve stem guide clearance as follows:

(1) Install Black Valve Guide Sleeve Tool C-6819 over valve stem for the **INTAKE** valve and install valve (Fig. 15). The special sleeve places the valve at the correct height for checking with a dial indicator.

**Fig. 14 Intake and Exhaust Valves—8.0L Engine**

- 1 - MARGIN
- 2 - VALVE SPRING RETAINER LOCK GROOVE
- 3 - STEM
- 4 - FACE

(2) Install Silver Valve Guide Sleeve Tool C-6818 over valve stem for the **EXHAUST** valve and install valve. The special sleeve places the valve at the correct height for checking with a dial indicator.

**Fig. 15 Positioning Valve Spacer Tool (Typical)**

- 1 - VALVE
- 2 - SPACER TOOL

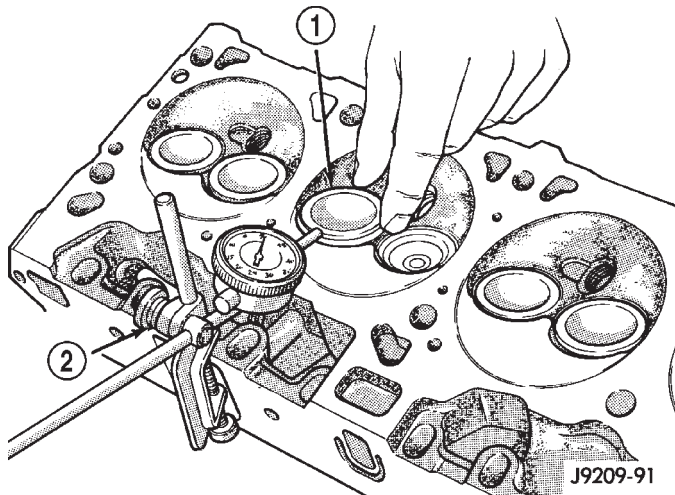
(3) Attach Dial Indicator Tool C-3339 to cylinder head and set it at right angle of valve stem being measured (Fig. 16).

(4) Move valve to and from the indicator. The total dial indicator reading should not exceed 0.432 mm (0.017 inch). Ream the guides for valves with over-size stems if dial indicator reading is excessive or if the stems are scuffed or scored.

Service valves with oversize stems are available as shown below

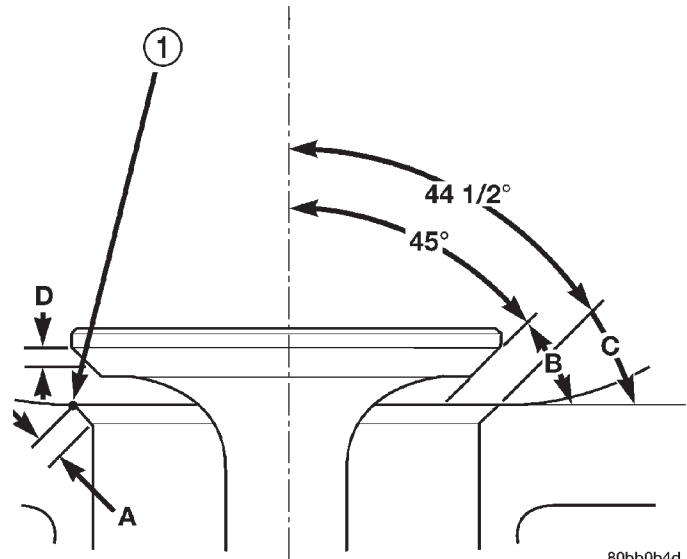


INTAKE/EXHAUST VALVES & SEATS (Continued)



**Fig. 16 Measuring Valve Guide Wear**

- 1 - VALVE
- 2 - SPECIAL TOOL C-3339



**Fig. 17 Valve Face and Seat Angles**

- 1 - CONTACT POINT

REAMER SIZE CHART

REAMER O/S	VALVE GUIDE SIZE
0.076 mm (0.003 in.)	8.026 - 8.052 mm (0.316 - 0.317 in.)
0.381 mm (0.015 in.)	8.331 - 8.357 mm (0.316 - 0.329 in.)

(5) Slowly turn reamer by hand and clean guide thoroughly before installing new valve. **Ream the valve guides from standard to 0.381 mm (0.015 inch). Use a 2 step procedure so the valve guides are reamed true in relation to the valve seat:**

- Step 1—Ream to 0.0763 mm (0.003 inch).
- Step 2—Ream to 0.381 mm (0.015 inch).

REFACING VALVES AND VALVE SEATS

The intake and exhaust valves have a 45° face angle and a 45° to 44 1/2° seat angle (Fig. 17).

VALVE FACE AND SEAT ANGLES CHART

ITEM	DESCRIPTION	SPECIFICATION
A	SEAT WIDTH	1.016 - 1.524 mm
	INTAKE	(0.040 - 0.060 in.)
B	SEAT WIDTH	1.016 - 1.524 mm
	EXHAUST	(0.040 - 0.060 in.)
B	FACE ANGLE (INT. and EXT.)	45°
C	SEAT ANGLE (INT. and EXT.)	44½°
D	CONTACT SURFACE	—

VALVES

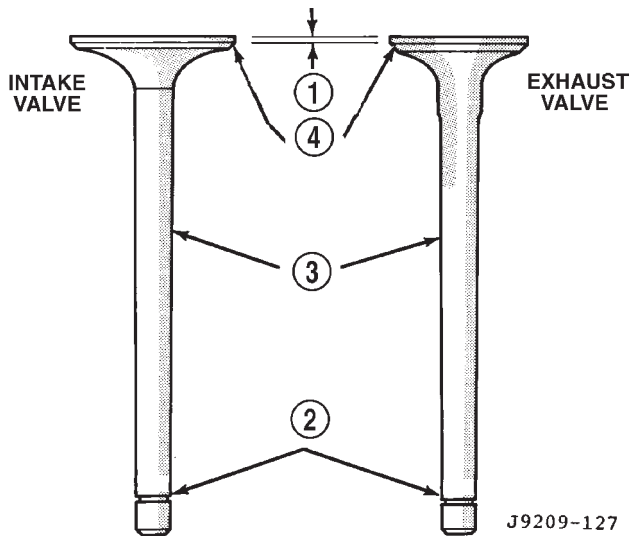
Inspect the remaining margin after the valves are refaced (Fig. 18). Valves with less than 1.190 mm (0.047 inch) margin should be discarded.

VALVE SEATS

(1) When refacing valve seats, it is important that the correct size valve guide pilot be used for reseating stones. A true and complete surface must be obtained.

(2) Measure the concentricity of valve seat using a dial indicator. Total runout should not exceed 0.038 mm (0.0015 inch) total indicator reading.

## INTAKE/EXHAUST VALVES &amp; SEATS (Continued)



**Fig. 18 Intake and Exhaust Valves**

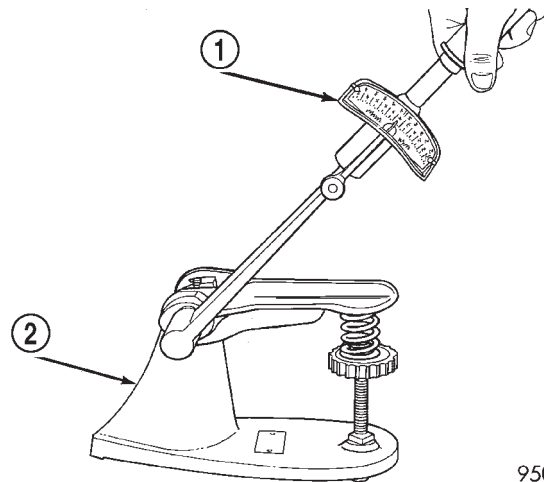
- 1 - MARGIN
- 2 - VALVE SPRING RETAINER LOCK GROOVE
- 3 - STEM
- 4 - FACE

(3) Inspect the valve seat with Prussian blue to determine where the valve contacts the seat. To do this, coat valve seat **LIGHTLY** with Prussian blue then set valve in place. Rotate the valve with light pressure. If the blue is transferred to the center of valve face, contact is satisfactory. If the blue is transferred to the top edge of valve face, lower valve seat with a 15° stone. If the blue is transferred to bottom edge of valve face raise valve seat with a 60° stone.

(4) When seat is properly positioned the width of valve seats should be 1.016-1.524 mm (0.040-0.060 inch).

### VALVE SPRING INSPECTION

Whenever valves have been removed for inspection, reconditioning or replacement, valve springs should be tested. As an example the compression length of the spring to be tested is 1-5/16 inch. Turn table of Universal Valve Spring Tester Tool until surface is in line with the 1-5/16 inch mark on the threaded stud. Be sure the zero mark is to the front (Fig. 19). Place spring over stud on the table and lift compressing lever to set tone device. Pull on torque wrench until ping is heard. Take reading on torque wrench at this instant. Multiply this reading by 2. This will give the spring load at test length. Fractional measurements are indicated on the table for finer adjustments. Refer to specifications to obtain specified height and allowable tensions. Discard the springs that do not meet specifications.



9509-79

**Fig. 19 Testing Valve Spring for Compressed**

- 1 - TORQUE WRENCH
- 2 - VALVE SPRING TESTER

### REMOVAL—VALVE STEM SEALS

**NOTE:** This procedure is done with the cylinder head installed.

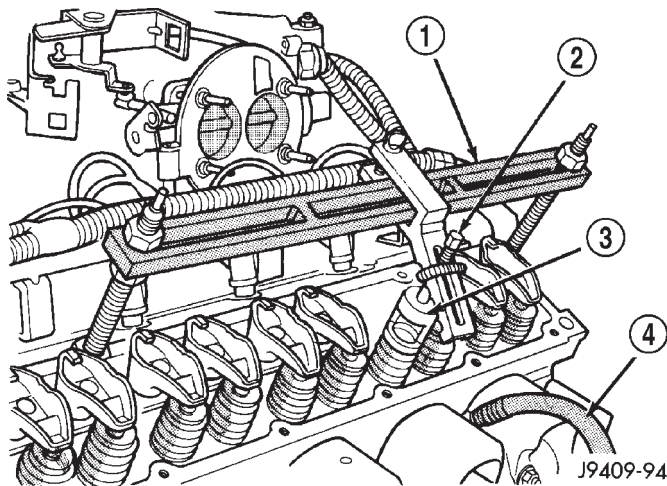
- (1) Disconnect the negative cable from the battery.
- (2) Set engine basic timing to Top Dead Center (TDC) and remove air cleaner.
- (3) Remove cylinder head covers (Refer to 9 - ENGINE/CYLINDER HEAD/CYLINDER HEAD COVER(S) - REMOVAL) and spark plugs (Refer to 8 - ELECTRICAL/IGNITION CONTROL/SPARK PLUG - REMOVAL).
- (4) Using suitable socket and flex handle at crankshaft retaining bolt, turn engine so that the piston of the cylinder to be worked on, is at TDC on the compression stroke.
- (5) Remove rocker arms (Refer to 9 - ENGINE/CYLINDER HEAD/ROCKER ARM / ADJUSTER ASSY - REMOVAL).
- (6) With air hose attached to an adapter installed in the spark plug hole, apply 620-689 kPa (90-100 psi) air pressure.
- (7) Using Valve Spring Compressor Tool MD-998772A with adapter 6716A (Fig. 20), compress valve spring and remove retainer valve locks and valve spring.
- (8) Remove the valve stem seal.

### REMOVAL—VALVES AND VALVE SPRINGS

- (1) Remove the cylinder head (Refer to 9 - ENGINE/CYLINDER HEAD - REMOVAL).
- (2) Special studs must be used to adapt the Valve Spring Compressor Tool to the V-10 cylinder head (Fig. 21). Install the metric end into the Special Tool MD998772A and the 5/16 end into the cylinder head.

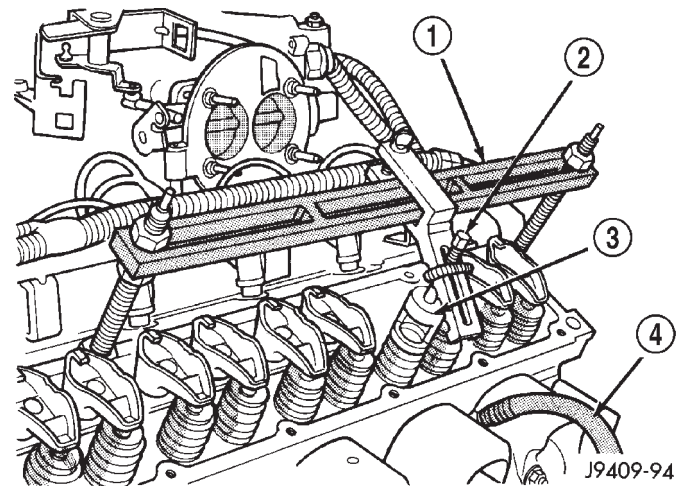


## INTAKE/EXHAUST VALVES &amp; SEATS (Continued)



**Fig. 20 Valve Spring Compressor MD-998772A with Adaptor 6716-A and Screw 6765**

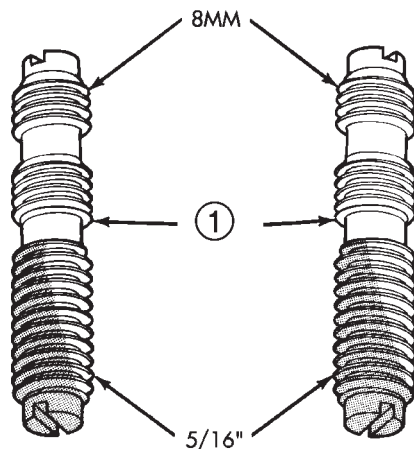
- 1 - SPECIAL TOOL MD 998772A
- 2 - SPECIAL TOOL 6765
- 3 - SPECIAL TOOL 6716A
- 4 - AIR HOSE



**Fig. 22 Valve Spring Compressor MD-998772A with Adaptor 6716-A and Screw 6765**

- 1 - SPECIAL TOOL MD 998772A
- 2 - SPECIAL TOOL 6765
- 3 - SPECIAL TOOL 6716A
- 4 - AIR HOSE

FITS INTO TOOL MD 998772A



FITS INTO CYLINDER HEAD

J9409-95

**Fig. 21 Special Studs 6715 for V-10 Engine**

- 1 - SPECIAL TOOL 6715

(3) Compress valve springs using Valve Spring Compressor Tool MD-998772A with Adapter 6716A and Screw 6765 (Fig. 22). Tap the retainer using a brass drift and ball peen hammer to loosen locks away from retainer.

(4) Remove valve retaining locks, valve spring retainers and valve springs. Check for abnormal wear, replace as required.

(5) Remove the valve stem seals.

(6) Before removing valves, remove any burrs from valve stem lock grooves to prevent damage to the valve guides. Identify valves to ensure installation in original location.

## CLEANING

Clean valves thoroughly. Discard burned, warped, or cracked valves.

Remove carbon and varnish deposits from inside of valve guides with a reliable guide cleaner.

## INSPECTION

Measure valve stems for wear. If wear exceeds 0.051 mm (0.002 in.), replace the valve.

Measure valve stem guide clearance as follows:

(1) Install Valve Guide Sleeve Tool C-3973 over valve stem and install valve (Fig. 23). The special sleeve places the valve at the correct height for checking with a dial indicator.

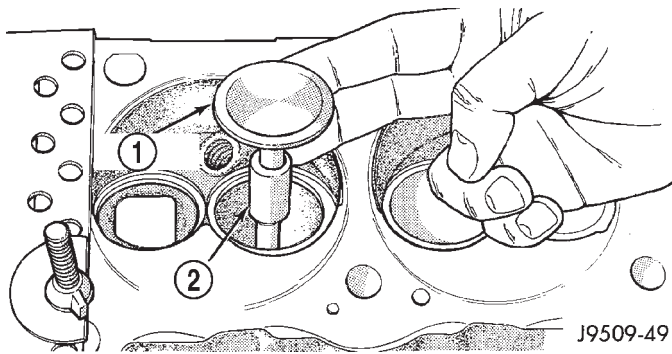
(2) Attach dial indicator Tool C-3339 to cylinder head and set it at right angles to valve stem being measured (Fig. 24).

(3) Move valve to and from the indicator. The total dial indicator reading should not exceed 0.432 mm (0.017 in.). Ream the guides for valves with oversize stems if dial indicator reading is excessive or if the stems are scuffed or scored.

## INSTALLATION—VALVE STEM SEAL

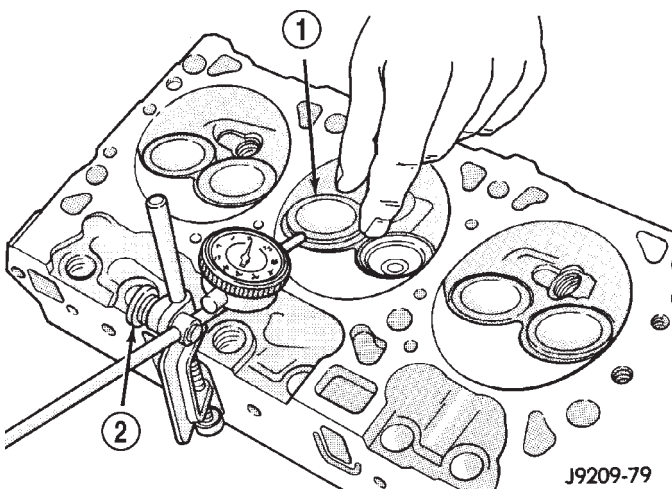
- (1) Install new seal onto valve stem.
- (2) Position valve spring onto valve stem.
- (3) Position Valve Spring Compressor with Adapter Studs onto cylinder head

## INTAKE/EXHAUST VALVES &amp; SEATS (Continued)



**Fig. 23 Positioning Valve with Tool C-3973**

- 1 - VALVE  
2 - SPACER TOOL



**Fig. 24 Measuring Valve Guide Wear**

- 1 - VALVE  
2 - SPECIAL TOOL C-3339

(4) Compress valve spring and install retainer valve locks.

(5) Remove air hose and adapter from spark plug hole.

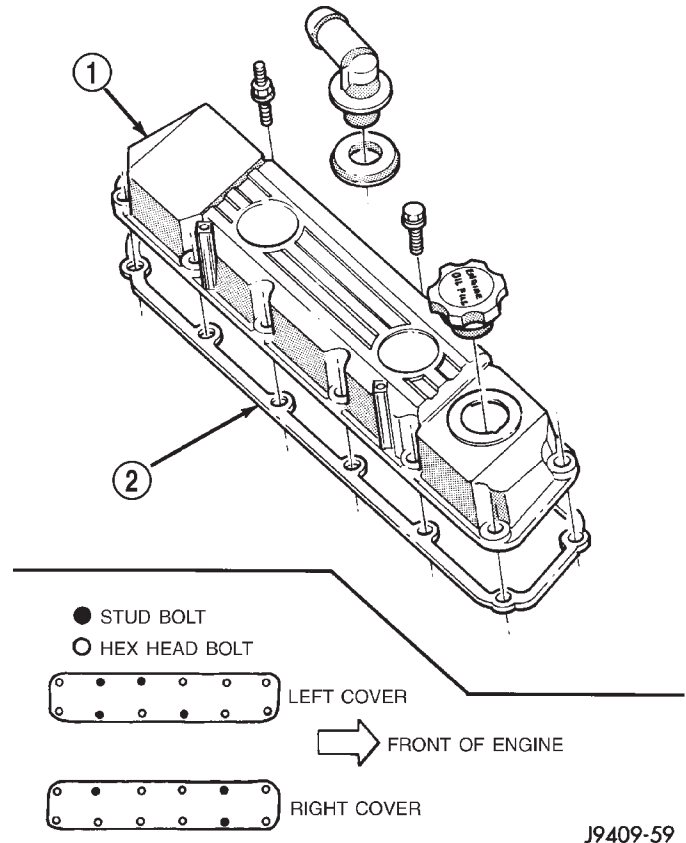
(6) Remove Valve Spring Compressor and Adapter Studs.

(7) Install rocker arms (Refer to 9 - ENGINE/CYLINDER HEAD/ROCKER ARM / ADJUSTER ASSY - INSTALLATION).

(8) The cylinder head cover gasket can be used again. Install the gasket onto the head rail. **For the left side the number tab is at the front of engine with the number up. For the right side the number tab is at the rear of engine with the number up.**

**CAUTION:** The cylinder head cover fasteners have a special plating. **DO NOT** use alternative fasteners.

(9) Install cylinder head cover (Refer to 9 - ENGINE/CYLINDER HEAD/CYLINDER HEAD COVER(S) - INSTALLATION) (Fig. 25).



**Fig. 25 Cylinder Head Covers**

- 1 - CYLINDER HEAD COVER  
2 - CYLINDER HEAD COVER GASKET

(10) Install closed crankcase ventilation system.

(11) Connect the evaporation control system.

(12) Install air cleaner.

(13) Connect the negative cable to the battery.

(14) Road test vehicle and check for leaks.

### INSTALLATION—VALVES AND VALVE SPRINGS

(1) Clean valves thoroughly. Discard burned, warped and cracked valves.

(2) Remove carbon and varnish deposits from inside of valve guides with a reliable guide cleaner.

(3) Measure valve stems for wear. If wear exceeds 0.051 mm (0.002 inch), replace the valve.

(4) Make sure there are no burrs on valve stems.

(5) Coat valve stems with lubrication oil. Insert valves into valve guides in cylinder head.

(6) Install new seals on all valve guides (**BLACK on intake and BROWN on exhaust**). Install valve springs and valve retainers.

(7) Compress valve springs with Valve Spring Compressor Tool MD-998772A and adapter 6716A,

## INTAKE/EXHAUST VALVES &amp; SEATS (Continued)

install locks and release tool. Tap the retainer with a brass or heavy plastic hammer to ensure locks have been seated.

(8) If valves and/or seats were ground, measure the installed height of springs. Make sure the measurement is taken from bottom of spring seat in cylinder head to the bottom surface of spring retainer. If spacers are installed, measure from the top of spacer. If height is greater than 42.86 mm (1-11/16 inches), install a 1.587 mm (1/16 inch) spacer in head counterbore. Ensure this brings spring height back to normal, 41.27 to 42.86 mm (1-5/8 to 1-11/16 inch).

(9) Install the cylinder head (Refer to 9 - ENGINE/CYLINDER HEAD - INSTALLATION).

## ROCKER ARM / ADJUSTER ASSY

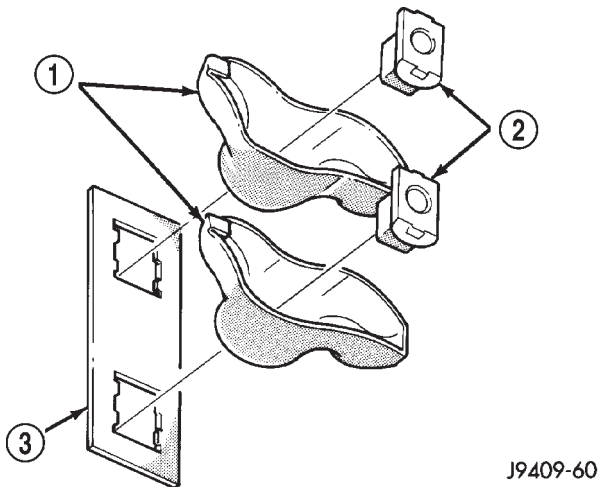
## REMOVAL

(1) Disconnect spark plug wires by pulling the boot straight out in line with plug.

(2) Remove cylinder head cover and gasket (Refer to 9 - ENGINE/CYLINDER HEAD/CYLINDER HEAD COVER(S) - REMOVAL).

(3) Remove the rocker arm bolts and the rocker arm assembly (Fig. 26). Place rocker arm assemblies on a bench in the same order as removed.

(4) Remove the push rods and place them on a bench in the same order as removed.



J9409-60

**Fig. 26 Rocker Arm**

- 1 - ROCKER ARMS  
2 - ROCKER ARM PEDESTALS  
3 - RETAINER

## INSTALLATION

**CAUTION: DO NOT rotate or crank the engine during or immediately after rocker arm installation. Allow the hydraulic roller tappets adequate time to bleed down (about 5 minutes).**

(1) Install the push rods in the same order as removed.

(2) Install rocker arm assemblies in the same order as removed. Tighten the rocker arm bolts to 28 N·m (21 ft. lbs.) torque.

(3) Install cylinder head cover and gasket (Refer to 9 - ENGINE/CYLINDER HEAD/CYLINDER HEAD COVER(S) - INSTALLATION).

(4) Connect spark plug wires.

## ENGINE BLOCK

## CLEANING

Clean cylinder block thoroughly and check all core hole plugs for evidence of leaking.

## INSPECTION

Examine block for cracks or fractures.

The cylinder walls should be checked for out-of-round and taper with Cylinder Bore Indicator Tool, Special tool 6879 or equivalent. The cylinder block should be bored and honed with new pistons and rings fitted if:

- The cylinder bores show more than 0.127 mm (0.005 inch) out-of-round.
- The cylinder bores show a taper of more than 0.254 mm (0.010 inch).
- The cylinder walls are badly scuffed or scored.

Boring and honing operation should be closely coordinated with the fitting of pistons and rings so specified clearances may be maintained.

## CAMSHAFT &amp; BEARINGS (IN BLOCK)

## REMOVAL—CAMSHAFT BEARINGS

This procedure requires that the engine is removed from the vehicle.

(1) With engine completely disassembled, drive out rear cam bearing core hole plug.

**NOTE: It is not advisable to attempt to replace camshaft bearings unless special removal and installation tools are available, such as recommended tool 8544 Camshaft Bushing Remover Installer.**

## CAMSHAFT &amp; BEARINGS (IN BLOCK) (Continued)

(2) Using recommended tool 8544 Camshaft Bushing Remover Installer, Drive out bearing shells.

**REMOVAL—CAMSHAFT**

(1) Remove rocker arms and push rods (Refer to 9 - ENGINE/CYLINDER HEAD/ROCKER ARM / ADJUSTER ASSY - REMOVAL). Identify each part so it can be installed in its original location.

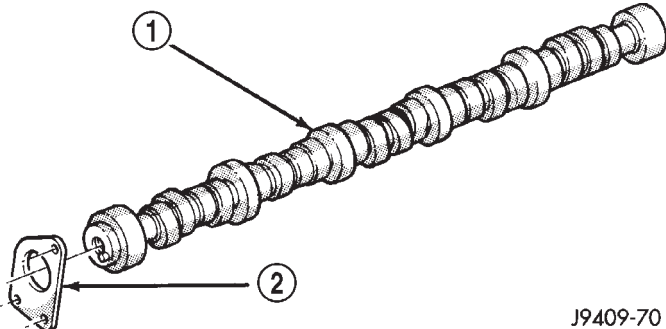
**NOTE:** The 4 corner tappets can not be removed without removing the cylinder heads and gaskets. However, they can be lifted and retained for camshaft removal.

(2) Remove the Bolts retaining the yoke retaining spider. Remove the yoke retaining spider, tappet aligning yokes and tappets.

(3) Remove upper and lower intake manifolds (Refer to 9 - ENGINE/MANIFOLDS/INTAKE MANIFOLD - REMOVAL).

(4) Remove timing chain cover (Refer to 9 - ENGINE/VALVE TIMING/TIMING BELT / CHAIN COVER(S) - REMOVAL) and timing chain and sprockets (Refer to 9 - ENGINE/VALVE TIMING/TIMING BELT/CHAIN AND SPROCKETS - REMOVAL).

(5) Remove camshaft thrust plate (Fig. 27).



J9409-70

**Fig. 27 Camshaft**

- 1 - CAMSHAFT  
2 - THRUST PLATE

(6) Install a long bolt into front of camshaft to aid in removal of the camshaft. Remove camshaft, being careful not to damage cam bearings with the cam lobes.

**INSTALLATION—CAMSHAFT BEARINGS**

(1) Install new camshaft bearings using recommended Tool 8544 Camshaft Bushing Remover Installer, by sliding the new camshaft bearing shell over proper adapter.

(2) Bearings must be carefully aligned to bring oil holes into full register with oil passages from the main bearing. If the camshaft bearing shell oil holes

are not in exact alignment, remove and install them correctly. Install a new core hole plug at the rear of camshaft. **Be sure this plug does not leak.**

**INSTALLATION—CAMSHAFT**

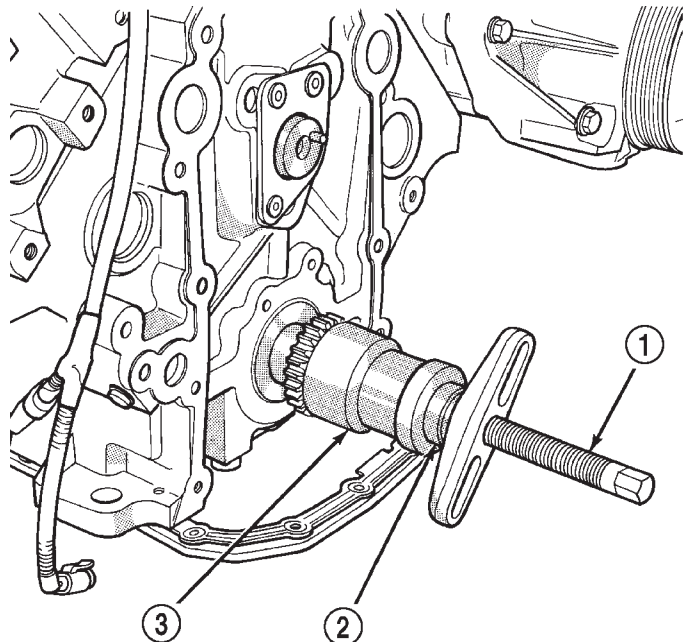
(1) Lubricate camshaft lobes and camshaft bearing journals. Using a long bolt, insert the camshaft into the cylinder block.

**NOTE:** Whenever an engine has been rebuilt, a new camshaft and/or new tappets installed, add 1 pint of Mopar® Crankcase Conditioner, or equivalent. The oil mixture should be left in engine for a minimum of 805 km (500 miles). Drain at the next normal oil change.

(2) Install camshaft thrust plate. Tighten the torx bolts to 22 N·m (16 ft. lbs.) torque.

(3) Check camshaft end play. The end play should be 0.051-0.152 mm (0.002-0.006 inch) with a new thrust plate and up to 0.254 mm (0.010 inch) with a used thrust plate. If not within these limits install a new thrust plate.

(4) Line up key with keyway in sprocket, then using Special Tools C-3688, C-3718 and MB990799 install crankshaft timing sprocket. Make sure the sprocket seats against the crankshaft shoulder (Fig. 28).



J9409-140

**Fig. 28 Crankshaft Sprocket Installation**

- 1 - SPECIAL TOOL C-3688  
2 - SPECIAL TOOL C-3718  
3 - SPECIAL TOOL MD990799



## CAMSHAFT &amp; BEARINGS (IN BLOCK) (Continued)

(5) Install timing chain and sprocket (Refer to 9 - ENGINE/VALVE TIMING/TIMING BELT/CHAIN AND SPROCKETS - INSTALLATION).

(6) Install the timing chain cover (Refer to 9 - ENGINE/VALVE TIMING/TIMING BELT / CHAIN COVER(S) - INSTALLATION).

(7) Install the crankshaft pulley/damper (Refer to 9 - ENGINE/ENGINE BLOCK/VIBRATION DAMPER - INSTALLATION).

(8) Prime oil pump by squirting oil in the oil filter mounting hole and filling the J-trap of the front timing cover. When oil is running out, install oil filter that has been filled with oil.

(9) Each tappet reused must be installed in the same position from which it was removed. **When camshaft is replaced, all of the tappets must be replaced.**

(10) Install tappets and push rods in their original location.

(11) Position the tappet aligning yokes and yoke retaining spider.

(12) Install the retaining spider mounting bolts. Tighten bolts to 22 N·m (16 ft. lbs.).

(13) Install the rocker arms (Refer to 9 - ENGINE/CYLINDER HEAD/ROCKER ARM / ADJUSTER ASSY - INSTALLATION).

(14) The cylinder head cover gasket can be used again. Install the gasket onto the head rail. **For the left side the number tab is at the front of engine with the number up. For the right side the number tab is at the rear of engine with the number up.**

**CAUTION:** The cylinder head cover fasteners have a special plating. **DO NOT** use alternative fasteners.

(15) Install cylinder head cover (Fig. 29) (Refer to 9 - ENGINE/CYLINDER HEAD/CYLINDER HEAD COVER(S) - INSTALLATION).

(16) Install the intake manifolds (Refer to 9 - ENGINE/MANIFOLDS/INTAKE MANIFOLD - INSTALLATION).

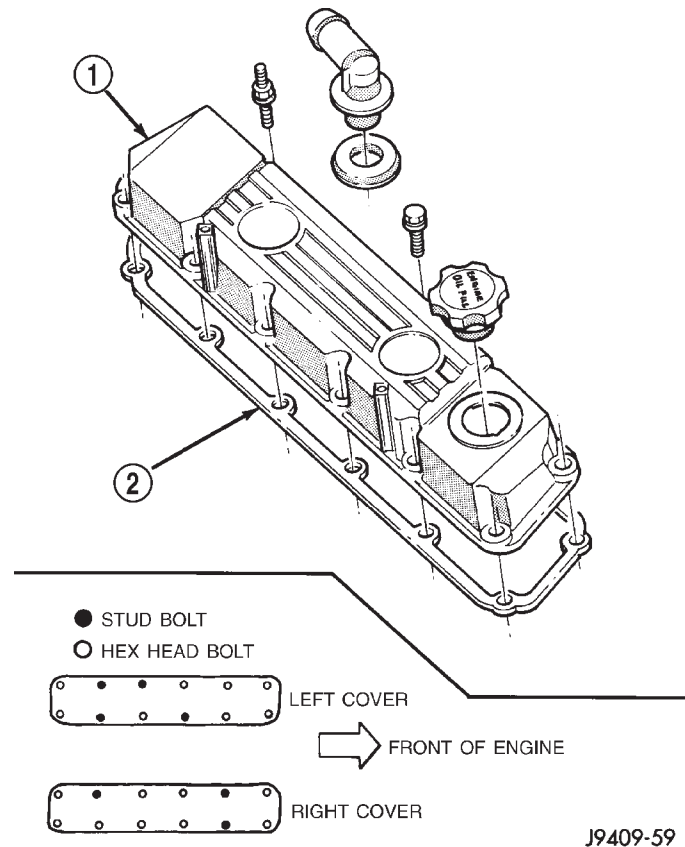
(17) Start engine and check for leaks.

## CONNECTING ROD BEARINGS

## STANDARD PROCEDURE—CONNECTING ROD BEARING FITTING

Fit all rods on a bank until completed. **DO NOT** alternate from one bank to another, because connecting rods and pistons are not interchangeable from one bank to another.

The bearing caps are not interchangeable and should be marked at removal to ensure correct assembly.



J9409-59

**Fig. 29 Cylinder Head Cover**

- 1 - CYLINDER HEAD COVER
- 2 - CYLINDER HEAD COVER GASKET

Each bearing cap has a small V-groove across the parting face. When installing the lower bearing shell, be certain that the V-groove in the shell is in line with the V-groove in the cap. This provides lubrication of the cylinder wall in the opposite bank.

The bearing shells must be installed so that the tangs are in the machined grooves in the rods and caps.

Limits of taper or out-of-round on any crankshaft journals should be held to 0.025 mm (0.001 in.). Bearings are available in 0.025 mm (0.001 in.), 0.051 mm (0.002 in.), 0.076 mm (0.003 in.), 0.254 mm (0.010 in.) and 0.305 mm (0.012 in.) undersize. **Install the bearings in pairs. DO NOT use a new bearing half with an old bearing half. DO NOT file the rods or bearing caps.**

## CRANKSHAFT

## REMOVAL

When a crankshaft is replaced, all main and connecting rod bearings should be replaced with new bearings. Therefore, selective fitting of the bearings

## CRANKSHAFT (Continued)

is not required when a crankshaft and bearings are replaced.

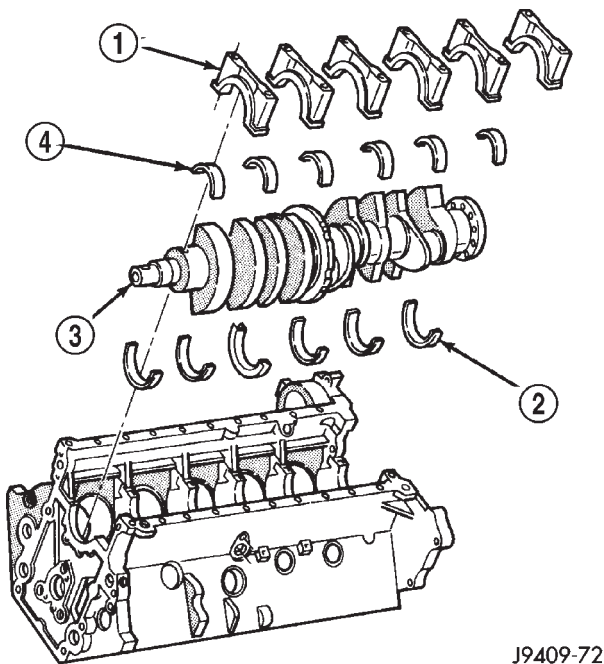
(1) Remove the oil pan and oil pickup tube (refer to Oil Pan in this section for correct procedure).

(2) Remove the timing chain cover and gasket. Remove and discard the front crankshaft oil seal and cover gasket.

(3) Remove Transmission (refer to Group 21, Transmission).

(4) Remove the rear seal retainer (refer to Crankshaft Rear Seal Retainer in this section for correct procedure).

(5) Identify main bearing caps before removal (Fig. 30). Remove bearing caps and lower bearings one at a time.



J9409-72

**Fig. 30 Main Bearing Identification**

- 1 - MAIN BEARING CAP
- 2 - UPPER MAIN BEARINGS
- 3 - CRANKSHAFT
- 4 - LOWER MAIN BEARINGS

- (6) Remove the connecting rod bearing caps.
- (7) Lift the crankshaft straight out of the block.
- (8) Remove the upper main bearings from the block.

## INSTALLATION

When a crankshaft is replaced, all main and connecting rod bearings should be replaced with new bearings. Therefore, selective fitting of the bearings is not required when a crankshaft and bearings are replaced.

**NOTE: Lubricate crankshaft main bearings with clean engine oil.**

- (1) Position upper main bearings into block.
- (2) Position the crankshaft into the cylinder block.
- (3) Lubricate the main journals with clean engine oil. Install upper main bearings, caps and bolts. Follow the 2 step tightening sequence, starting with main bearing cap 1.

(4) Lubricate the connecting rod bearings and journals with clean engine oil. Carefully install connecting rods to the crankshaft.

(5) Using Special Tool 8359 Seal Installer install new oil into oil seal retainer.

(6) Using Special Tool 6687 Guide, install the rear seal retainer with a new gasket.

(7) Install the timing chain cover with a new gasket and oil seal.

(8) Prime oil pump by squirt oil in the oil filter mounting hole and filling the J-trap of the front timing cover. When oil is running out, install oil filter that has been filled with oil.

(9) Apply a rearward axial load of 667 N (150 lbs-f) on crankshaft centerline, driving No.3 main cap and thrust bearing against No.3 bulkhead. Repeat procedure, driving crankshaft forward to align rear flange of thrust bearings in a common plane. Front face of No.1 main cap must not extend forward in front of face of No.1 bulkhead.

(10) Install the oil pickup tube. Tighten the bolts to 16 N·m (144 in. lbs.) torque.

(11) Install the oil pan.

## CRANKSHAFT MAIN BEARINGS

### STANDARD PROCEDURE—MAIN BEARING FITTING

Bearing caps are not interchangeable and should be marked at removal to ensure correct assembly. Upper and lower bearing halves are NOT interchangeable. All lower main bearing halves are interchangeable. Upper main bearing halves of No. 2, 4, and 5 are interchangeable. Upper main bearing halves of No. 1 and 6 are interchangeable, this also applies to the lower bearing halves.

The No.3 main bearing is flanged to carry the crankshaft thrust loads. This bearing is NOT interchangeable with any other bearing halves in the engine. Bearing shells are available in standard and the following undersizes: 0.25 mm (0.001 inch), 0.051 mm (0.002 inch), 0.076 mm (0.003 inch), 0.254 mm (0.010 inch) and 0.305 mm (0.012 inch). Never install an undersize bearing that will reduce clearance below specifications.



## CRANKSHAFT MAIN BEARINGS (Continued)

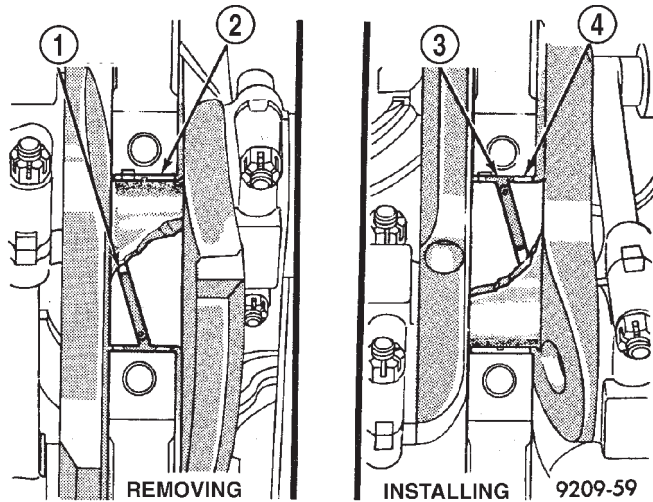
**REMOVAL**

(1) Remove the oil pan and oil pump pick-up tube (Refer to 9 - ENGINE/LUBRICATION/OIL PAN - REMOVAL).

(2) Identify bearing caps before removal. Remove bearing caps one at a time.

(3) Remove upper half of bearing by inserting Crankshaft Main Bearing Remover/Installer Tool C-3059 into the oil hole of crankshaft (Fig. 31).

(4) Slowly rotate crankshaft clockwise, forcing out upper half of bearing shell.



**Fig. 31 Upper Main Bearing Removal and Installation with Tool C-3059**

- 1 - SPECIAL TOOL C-3059
- 2 - BEARING
- 3 - SPECIAL TOOL C-3059
- 4 - BEARING

**INSTALLATION**

Only one main bearing should be selectively fitted while all other main bearing caps are properly tightened. All bearing capbolts removed during service procedures are to be cleaned and oiled before installation.

When installing a new upper bearing shell, slightly chamfer the sharp edges from the plain side.

(1) Start bearing in place, and insert Crankshaft Main Bearing Remover/Installer Tool C-3059 into oil hole of crankshaft (Fig. 31).

(2) Slowly rotate crankshaft counterclockwise sliding the bearing into position. Remove Tool C-3059.

(3) Lubricate the main journals with clean engine oil. Install main bearing caps and bolts. Follow the 2 step tightening sequence, starting with No. 1 main bearing cap.

(4) Apply a rearward axial load of 667 N (150 lbs-f) on crankshaft centerline, driving No.3 main cap and thrust bearing against No.3 bulkhead. Repeat

procedure, driving crankshaft forward to align rear flange of thrust bearings in a common plane. Front face of No.1 main cap must not extend forward in front of face of No.1 bulkhead.

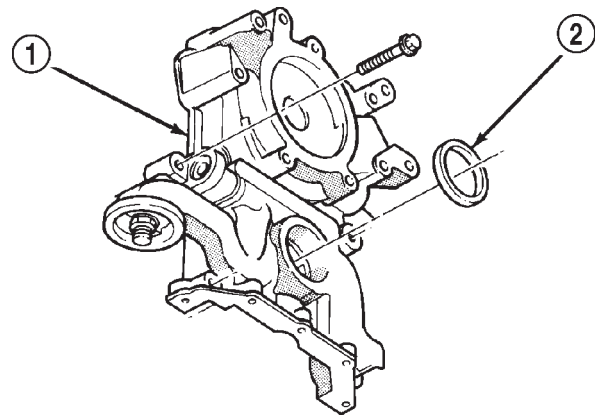
(5) Install the oil pump pick-up tube and oil pan (Refer to 9 - ENGINE/LUBRICATION/OIL PAN - INSTALLATION).

**CRANKSHAFT OIL SEAL - FRONT****REMOVAL—FRONT OIL SEAL - FRONT COVER INSTALLED**

(1) Disconnect the negative cable from the battery.

(2) Remove vibration damper from the crankshaft (Refer to 9 - ENGINE/ENGINE BLOCK/VIBRATION DAMPER - REMOVAL).

(3) Place a suitable tool behind the lips of the oil seal to pry the oil seal outward. Be careful not to damage the crankshaft seal surface of the cover (Fig. 32).



J9409-68

**Fig. 32 Timing Chain Cover and Oil Seal**

- 1 - TIMING CHAIN COVER
- 2 - OIL SEAL

**REMOVAL—FRONT OIL SEAL - FRONT COVER REMOVED**

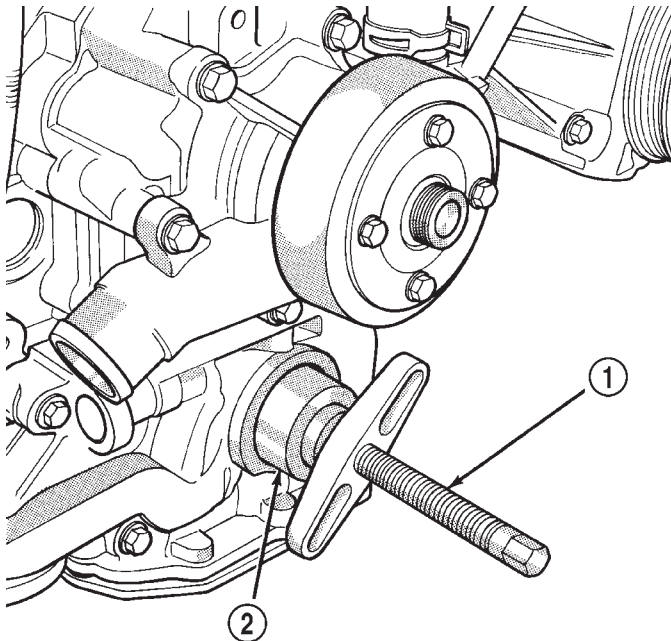
(1) Remove engine front cover (Refer to 9 - ENGINE/VALVE TIMING/TIMING BELT / CHAIN COVER(S) - REMOVAL).

(2) Place a suitable tool behind the lips of the oil seal to pry the oil seal outward. Be careful not to damage the crankshaft seal surface of the cover.

## CRANKSHAFT OIL SEAL - FRONT (Continued)

**INSTALLATION—FRONT OIL SEAL - FRONT COVER INSTALLED**

(1) Position the crankshaft front oil seal onto seal installer special tool 6806 and C-3688 (Fig. 33). Install seal.



J9409-136

**Fig. 33 Timing Chain Cover and Oil Seal**

- 1 - SPECIAL TOOL C-3688
- 2 - SPECIAL TOOL 6806

(2) Install vibration damper (Refer to 9 - ENGINE/ENGINE BLOCK/VIBRATION DAMPER - INSTALLATION).

(3) Install serpentine belt (Refer to 7 - COOLING/ACCESSORY DRIVE/DRIVE BELTS - INSTALLATION).

(4) Install cooling fan and shroud (Refer to 7 - COOLING/ENGINE/RADIATOR FAN - INSTALLATION).

(5) Connect negative cable to the battery.

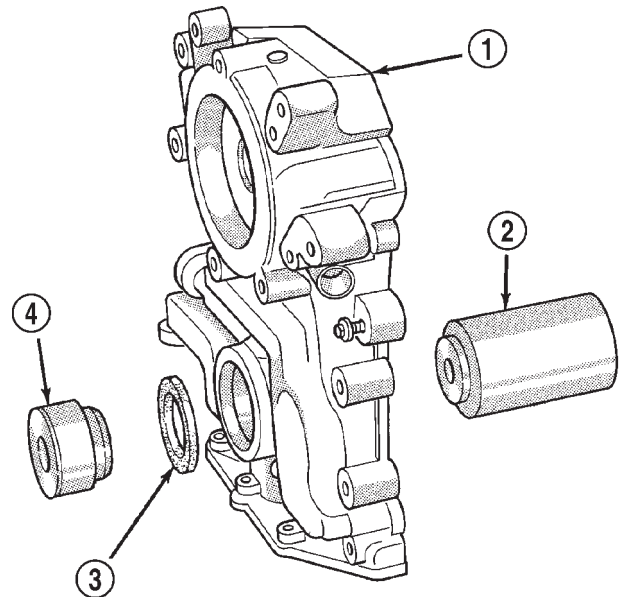
(6) Start engine and check for leaks.

**INSTALLATION—FRONT OIL SEAL - FRONT COVER REMOVED**

(1) Position the crankshaft front oil seal onto seal installer special tool 6806.

(2) Use tool 6761 to support timing chain cover when installing oil seal with tool 6806 (Fig. 34) install seal (Fig. 35).

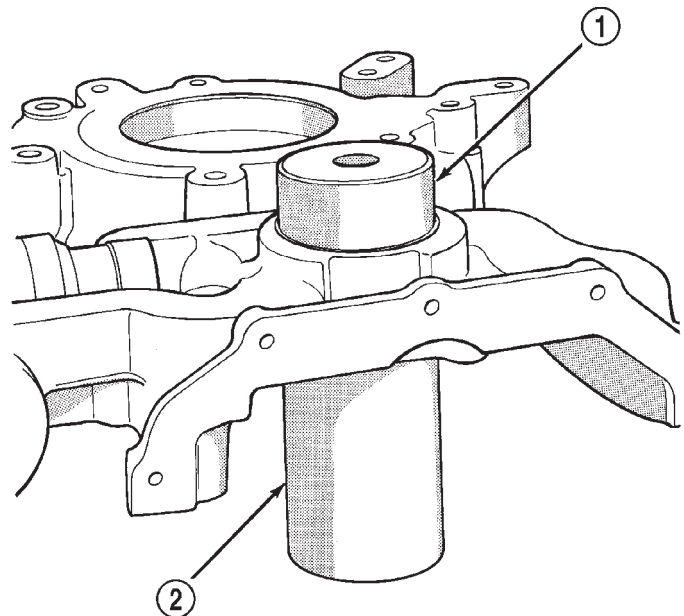
(3) Install engine front cover (Refer to 9 - ENGINE/VALVE TIMING/TIMING BELT / CHAIN COVER(S) - INSTALLATION).



J9409-137

**Fig. 34 Oil Seal, Tools—6806 and 6761**

- 1 - FRONT COVER
- 2 - SPECIAL TOOL 6761
- 3 - FRONT OIL SEAL
- 4 - SPECIAL TOOL 6806



J9409-143

**Fig. 35 Oil Seal Installed**

- 1 - SPECIAL TOOL 6806
- 2 - SPECIAL TOOL 6761

## CRANKSHAFT OIL SEAL - REAR

### REMOVAL

**NOTE:** This procedure does not require the removal of the seal retainer from the engine block.

- (1) Remove the transmission.
- (2) Carefully, remove the rear seal from the retainer. Discard the oil seal.

### INSTALLATION

- (1) Wash all parts in a suitable solvent and inspect carefully for damage or wear.
- (2) Position Special Tool 6687 Seal Guide, onto the crankshaft.
- (3) Position the oil seal onto the Seal guide, then using Special Tool 8359 Seal Installer and C-4171 Driver Handle, Install the oil seal.
- (4) The seal face surface must be countersunk into the retainer.762-1.27mm (0.030-0.050 in.).
- (5) Install the transmission.
- (6) Check and verify engine oil is at correct level.
- (7) Start engine and check for leaks.

## CRANKSHAFT REAR OIL SEAL RETAINER

### REMOVAL

- (1) Disconnect negative cable from battery.
- (2) Remove the transmission.
- (3) Remove the drive plate / flywheel.
- (4) Remove the oil pan (Refer to 9 - ENGINE/LUBRICATION/OIL PAN - REMOVAL).
- (5) Remove the rear oil seal retainer mounting bolts.
- (6) Carefully remove the retainer from the engine block.

### INSTALLATION

- (1) Thoroughly clean all gasket residue from the engine block.
- (2) Use extreme care and clean all gasket residue from the retainer.
- (3) Apply a small amount of Mopar® Silicone Rubber Adhesive Sealant to the retainer gasket. Position the gasket onto the retainer.
- (4) Position Special Tool 6687 Seal Guide onto the crankshaft.
- (5) Position the retainer and seal over the guide and onto the engine block.
- (6) Install the retainer mounting bolts. Tighten the bolts to 22 N·m (16 ft. lbs.).

- (7) Install the oil pan (Refer to 9 - ENGINE/LUBRICATION/OIL PAN - INSTALLATION).
- (8) Install the drive plate / flywheel.
- (9) Install the transmission.
- (10) Check and verify engine oil level.
- (11) Start engine and check for leaks.

## HYDRAULIC LIFTERS

### DIAGNOSIS AND TESTING—HYDRAULIC TAPPETS

Before disassembling any part of the engine to correct tappet noise, check the oil pressure. If vehicle has no oil pressure gauge, install a reliable gauge at the pressure sending-unit. The pressure should be between 207-552 kPa (30-80 psi) at 3,000 RPM.

Check the oil level after the engine reaches normal operating temperature. Allow 5 minutes to stabilize oil level, check dipstick. The oil level in the pan should never be above the FULL mark or below the ADD OIL mark on dipstick. Either of these two conditions could be responsible for noisy tappets.

### OIL LEVEL

#### HIGH

If oil level is above the FULL mark, it is possible for the connecting rods to dip into the oil. With the engine running, this condition could create foam in the oil pan. Foam in oil pan would be fed to the hydraulic tappets by the oil pump causing them to lose length and allow valves to seat noisily.

#### LOW

Low oil level may allow oil pump to take in air. When air is fed to the tappets, they lose length, which allows valves to seat noisily. Any leaks on intake side of oil pump through which air can be drawn will create the same tappet action. Check the lubrication system from the intake strainer to the pump cover, including the relief valve retainer cap. When tappet noise is due to aeration, it may be intermittent or constant, and usually more than one tappet will be noisy. When oil level and leaks have been corrected, operate the engine at fast idle. Run engine for a sufficient time to allow all of the air inside the tappets to be bled out.

### TAPPET NOISE DIAGNOSIS

- (1) To determine source of tappet noise, operate engine at idle with cylinder head covers removed.
- (2) Feel each valve spring or rocker arm to detect noisy tappet. The noisy tappet will cause the affected spring and/or rocker arm to vibrate or feel rough in operation.

## HYDRAULIC LIFTERS (Continued)

**NOTE: Worn valve guides or cocked springs are sometimes mistaken for noisy tappets. If such is the case, noise may be dampened by applying side thrust on the valve spring. If noise is not appreciably reduced, it can be assumed the noise is in the tappet. Inspect the rocker arm push rod sockets and push rod ends for wear.**

(3) Valve tappet noise ranges from light noise to a heavy click. A light noise is usually caused by excessive leak-down around the unit plunger, or by the plunger partially sticking in the tappet body cylinder. The tappet should be replaced. A heavy click is caused by a tappet check valve not seating, or by foreign particles wedged between the plunger and the tappet body. This will cause the plunger to stick in the down position. This heavy click will be accompanied by excessive clearance between the valve stem and rocker arm as valve closes. In either case, tappet assembly should be removed for inspection and cleaning.

(4) The valve train generates a noise very much like a light tappet noise during normal operation. Care must be taken to ensure that tappets are making the noise. If more than one tappet seems to be noisy, it's probably not the tappets.

**LEAK-DOWN TEST**

After cleaning and inspection, test each tappet for specified leak-down rate tolerance to ensure zero-lash operation (Fig. 36).

Swing the weighted arm of the hydraulic valve tappet tester away from the ram of the Universal Leak-Down Tester.

(1) Place a 7.925-7.950 mm (0.312-0.313 inch) diameter ball bearing on the plunger cap of the tappet.

(2) Lift the ram and position the tappet (with the ball bearing) inside the tester cup.

(3) Lower the ram, then adjust the nose of the ram until it contacts the ball bearing. **DO NOT** tighten the hex nut on the ram.

(4) Fill the tester cup with hydraulic valve tappet test oil until the tappet is completely submerged.

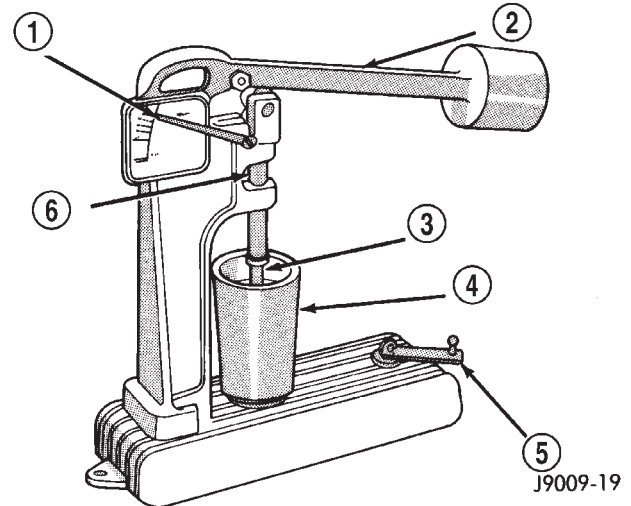
(5) Swing the weighted arm onto the push rod and pump the tappet plunger up and down to remove air. When the air bubbles cease, swing the weighted arm away and allow the plunger to rise to the normal position.

(6) Adjust the nose of the ram to align the pointer with the SET mark on the scale of the tester and tighten the hex nut.

(7) Slowly swing the weighted arm onto the push rod.

(8) Rotate the cup by turning the handle at the base of the tester clockwise one revolution every 2 seconds.

(9) Observe the leak-down time interval from the instant the pointer aligns with the START mark on the scale until the pointer aligns with the 0.125 mark. A normally functioning tappet will require 20-110 seconds to leak-down. Discard tappets with leak-down time interval not within this specification.



**Fig. 36 Leak-Down Tester**

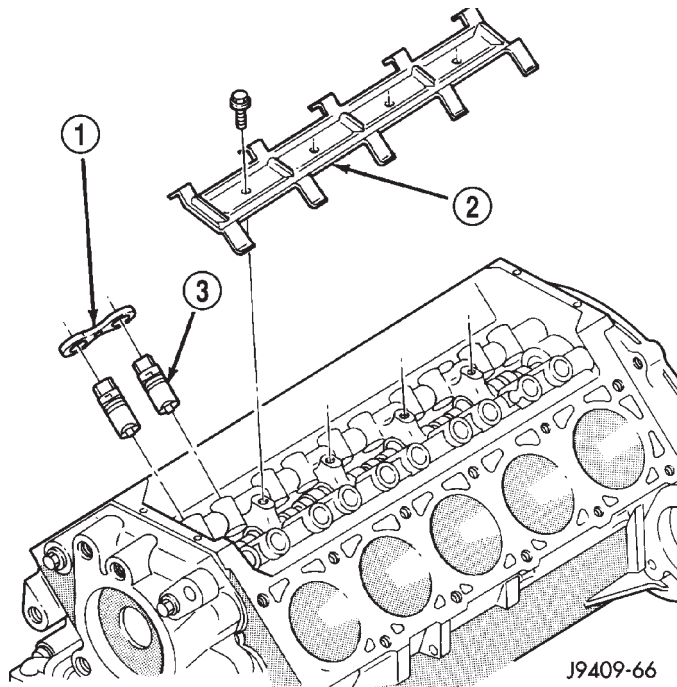
- 1 - POINTER
- 2 - WEIGHTED ARM
- 3 - RAM
- 4 - CUP
- 5 - HANDLE
- 6 - PUSH ROD

**REMOVAL**

- (1) Disconnect the negative cable from the battery.
- (2) Remove the air cleaner.
- (3) Remove cylinder head cover (Refer to 9 - ENGINE/CYLINDER HEAD/CYLINDER HEAD COVER(S) - REMOVAL).
- (4) Remove rocker arm assembly and push rods (Refer to 9 - ENGINE/CYLINDER HEAD/ROCKER ARM / ADJUSTER ASSY - REMOVAL). Identify push rods to ensure installation in original location.
- (5) Remove upper and lower intake manifold (Refer to 9 - ENGINE/MANIFOLDS/INTAKE MANIFOLD - REMOVAL).
- (6) Cut the cylinder head gasket for accessibility if the end tappets are to be removed.
- (7) Remove yoke retainer spider and tappet aligning yokes (Fig. 37).
- (8) Pull tappet out of bore with a twisting motion. If all tappets are to be removed, identify tappets to ensure installation in original location.
- (9) If the tappet or bore in cylinder block is scored, scuffed, or shows signs of sticking, ream the bore to next oversize. Replace with oversize tappet.
- (10) Check camshaft lobes for abnormal wear.



## HYDRAULIC LIFTERS (Continued)



**Fig. 37 Tappets, Aligning Yoke and Yoke Retaining Spider**

- 1 - TAPPET ALIGNING YOLK  
2 - YOKE RETAINING SPIDER  
3 - TAPPET

## CLEANING

Clean tappet with a suitable solvent. Rinse in hot water and blow dry with a clean shop rag or compressed air.

## INSTALLATION

- (1) Lubricate tappets.
- (2) Install tappets in their original positions. **Ensure that the oil bleed hole (if so equipped) faces forward.**
- (3) Install tappet aligning yokes. Position the yoke retainer spider over the tappet aligning yokes (Fig. 37) Install the yoke retaining spider bolts and tighten to 22 N·m (16 ft. lbs.) torque.
- (4) Install the push rods in their original location.
- (5) Install the rocker arms (Refer to 9 - ENGINE/CYLINDER HEAD/ROCKER ARM / ADJUSTER ASSY - INSTALLATION).
- (6) Install lower and upper intake manifold (Refer to 9 - ENGINE/MANIFOLDS/INTAKE MANIFOLD - INSTALLATION).
- (7) The cylinder head cover gasket can be used again. Install the gasket onto the head rail. **For the left side the number tab is at the front of engine with the number up. For the right side the number tab is at the rear of engine with the number up.**

(8) Install cylinder head cover (Refer to 9 - ENGINE/CYLINDER HEAD/CYLINDER HEAD COVER(S) - INSTALLATION).

(9) Install the air cleaner.

**CAUTION:** To prevent damage to valve mechanism, engine must not be run above fast idle until all hydraulic tappets have filled with oil and have become quiet.

(10) Connect the negative cable to the battery.

(11) Road test vehicle and check for leaks.

## PISTON &amp; CONNECTING ROD

## DESCRIPTION

The pistons (Fig. 38) are elliptically turned so that the diameter at the pin boss is less than its diameter across the thrust face. This allows for expansion under normal operating conditions. Under operating temperatures, expansion forces the pin bosses away from each other, causing the piston to assume a more nearly round shape.

All pistons are machined to the same weight, regardless of size, to maintain piston balance.

The piston pin rotates in the piston only and is retained by the press interference fit of the piston pin in the connecting rod.

The pistons have a unique dry-film lubricant coating baked onto the skirts to reduce friction. The lubricant is particularly effective during engine break-in, but with time, the material becomes embedded into cylinder bore walls and continues to reduce friction.

The pistons are LH and RH bank specific.

## STANDARD PROCEDURE—PISTON FITTING

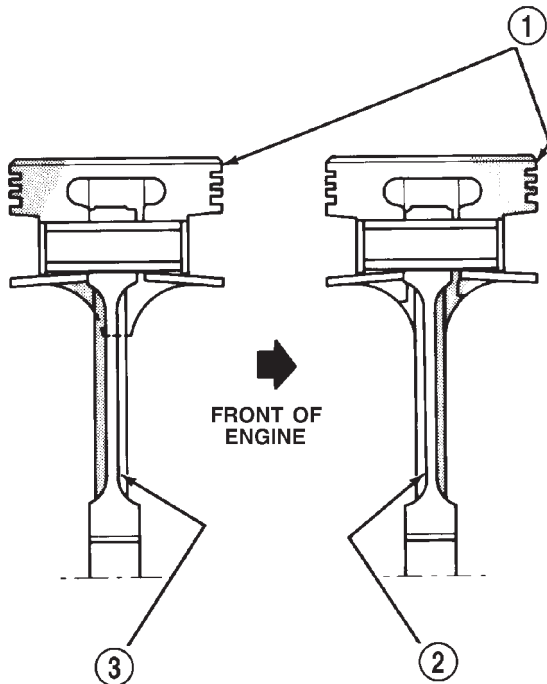
Piston and cylinder wall must be clean and dry. Specified clearance between the piston and the cylinder wall is 0.013-0.038 mm (0.0005-0.0015 inch). The max. allowable clearance is 0.0762 mm (0.003 in.).

Piston diameter should be measured at the top of skirt, 90° to piston pin axis. Cylinder bores should be measured halfway down the cylinder bore and transverse to the engine crankshaft center line.

Pistons and cylinder bores should be measured at normal room temperature, 21°C (70°F).

(1) To correctly select the proper size piston, a cylinder bore gauge, capable of reading in.0001" INCREMENTS is required (Fig. 39). If a bore gauge is not available, do not use an inside micrometer. The coating material is applied to the piston after the final piston machining process. Measuring the outside diameter of a coated piston will not provide accurate results. Therefore measuring the inside diameter of the cylinder bore with a dial Bore Gauge is **MANDA-**

## PISTON &amp; CONNECTING ROD (Continued)



J9409-78

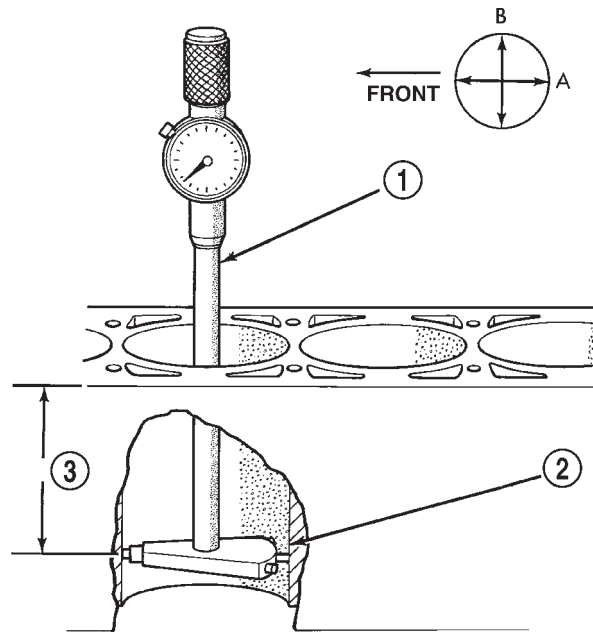
**Fig. 38 Piston and Connecting Rod—8.0L Engine**

- 1 - FRONT I.D. TOWARDS THIS SIDE
- 2 - ORIENTATION BUTTON TOWARDS REAR  
(R.H. ONLY)  
2, 4, 6, 8, 10
- 3 - ORIENTATION BUTTON TOWARDS FRONT  
(L.H. ONLY)  
1, 3, 5, 7, 9

**TORY.** To correctly select the proper size piston, a cylinder bore gauge capable of reading in .0001" increments is required. Piston installation into the cylinder bore require slightly more pressure than that required for non-coated pistons. The bonded coating on the piston will give the appearance of a line-to-line fit with the cylinder bore.

**REMOVAL**

- (1) Remove the engine from the vehicle (Refer to 9 - ENGINE - REMOVAL).
- (2) Remove cylinder head (Refer to 9 - ENGINE/CYLINDER HEAD - REMOVAL).
- (3) Remove the oil pan and oil pump pick-up tube (Refer to 9 - ENGINE/LUBRICATION/OIL PAN - REMOVAL).
- (4) Remove top ridge of cylinder bores with a reliable ridge reamer before removing pistons from cylinder block. Be sure to keep tops of pistons covered during this operation.



J9509-125

**Fig. 39 Bore Gauge**

- 1 - BORE GAUGE
- 2 - CYLINDER BORE
- 3 - 2-5/16 in.

(5) Be sure the connecting rod and connecting rod cap are identified with the cylinder number. Remove connecting rod cap. Install connecting rod bolt guide set on connecting rod bolts.

(6) Pistons and connecting rods must be removed from top of cylinder block. When removing piston and connecting rod assemblies, rotate crankshaft center the connecting rod in the cylinder bore and at BDC. **Be careful not to nick crankshaft journals. DO NOT try to remove black coating on skirt. This is the dry film lubricant.**

(7) After removal, install bearing cap on the mating rod.

**CLEANING**

Clean the piston and connecting rod assembly using a suitable solvent.

**INSPECTION**

Check the connecting rod journal for excessive wear, taper and scoring (Refer to 9 - ENGINE/ENGINE BLOCK/CONNECTING ROD BEARINGS - STANDARD PROCEDURE).

Check the connecting rod for signs of twist or bending.

Check the piston for taper and elliptical shape before it is fitted into the cylinder bore (Refer to 9 - ENGINE/ENGINE BLOCK/PISTON & CONNECTING ROD - STANDARD PROCEDURE).



## PISTON &amp; CONNECTING ROD (Continued)

Check the piston for scoring, or scraping marks in the piston skirts. Check the ring lands for cracks and/or deterioration.

**INSTALLATION**

(1) Check the crankshaft connecting rod journal for excessive wear, taper and scoring.

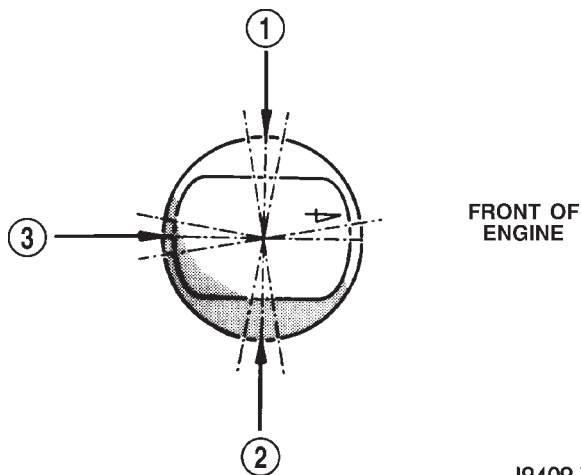
(2) Check the cylinder block bore for out-of-round, taper, scoring and scuffing.

(3) Be sure that compression ring gaps are staggered so that neither is in line with oil ring rail gap.

(4) Before installing the ring compressor, make sure the oil ring expander ends are butted and the rail gaps located properly (Fig. 40).

**NOTE:** Be sure position of rings does not change during the following step.

(5) Immerse the piston head and rings in clean engine oil. Slide Piston Ring Compressor Tool C-385 over the piston and tighten with the special wrench (part of Tool C-385).



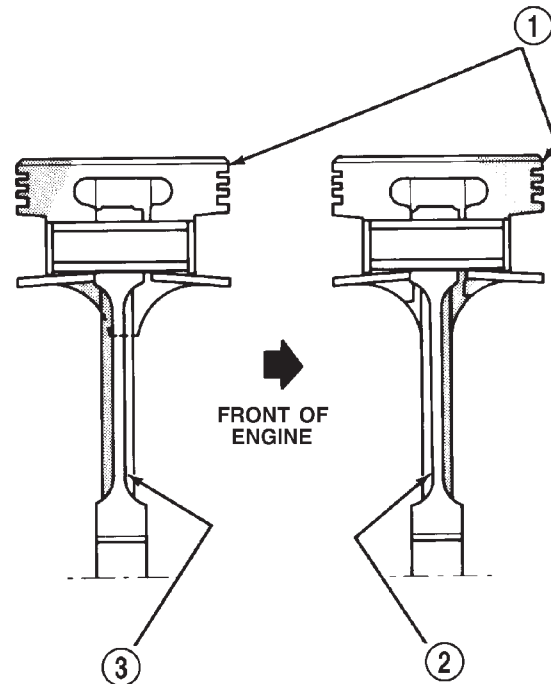
**Fig. 40 Proper Ring Installation**

- 1 - TOP COMPRESSION RING GAP  
UPPER OIL RING GAP  
2 - 2ND COMPRESSION RING GAP  
LOWER OIL RAIL GAP  
3 - SPACER GAP

(6) Install connecting rod bolt protectors on rod bolts, a long protector should be installed on the numbered side of the connecting rod.

(7) Rotate crankshaft so that the connecting rod journal is on the center of the cylinder bore in the bottom dead center (BDC) position. Be sure connecting rod and cylinder bore number are the same. Insert rod and piston into cylinder bore. Be sure the piston and rod assemblies are installed in the proper orientation (Fig. 41).

(8) The notch, groove or arrow on top of piston must be pointing toward front of engine. The larger



J9409-78

**Fig. 41 Piston and Rod Orientation**

- 1 - FRONT I.D. TOWARDS THIS SIDE  
2 - ORIENTATION BUTTON TOWARDS REAR  
(R.H. ONLY) 2, 4, 6, 8, 10  
3 - ORIENTATION BUTTON TOWARDS FRONT  
(L.H. ONLY) 1, 3, 5, 7, 9

chamfer of the connecting rod bore must be installed toward crankshaft journal fillet.

(9) While tapping the piston down in cylinder bore with the handle of a hammer, guide the connecting rod over the crankshaft journal.

(10) Install rod caps. Install nuts on cleaned and oiled rod bolts and tighten nuts to 61 N·m (45 ft. lbs.) torque.

(11) Install the oil pump pick-up tube and oil pan (Refer to 9 - ENGINE/LUBRICATION/OIL PAN - INSTALLATION).

(12) Install the cylinder head (Refer to 9 - ENGINE/CYLINDER HEAD - INSTALLATION) and cylinder head cover (Refer to 9 - ENGINE/CYLINDER HEAD/CYLINDER HEAD COVER(S) - INSTALLATION).

(13) Install intake manifold (Refer to 9 - ENGINE/MANIFOLDS/INTAKE MANIFOLD - INSTALLATION).

(14) Install the engine into the vehicle (Refer to 9 - ENGINE - INSTALLATION).

## PISTON RINGS

### STANDARD PROCEDURE—FITTING PISTON RINGS

#### (1) Measurement of end gaps:

(a) Measure piston ring gap 2 inches from bottom of cylinder bore. An inverted piston can be used to push the rings down to ensure positioning rings squarely in the cylinder bore before measuring.

(b) Insert feeler stock in the gap. Gap for compression rings should be between 0.254-0.508 mm (0.010-0.020 inch). The oil ring gap should be 0.381- 1.397 mm (0.015-0.055 inch).

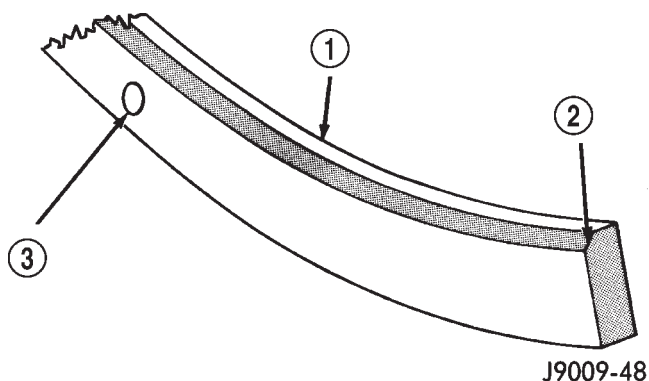
(c) Rings with insufficient end gap may be properly filed to the correct dimension. Ends should be stoned smooth after filing with Arkansas White Stone. Rings with excess gaps should not be used.

#### (2) Install rings and confirm ring side clearance:

(a) Install oil rings being careful not to nick or scratch the piston. Install the oil control rings according to instructions in the package. It is not necessary to use a tool to install the upper and lower rails. Insert oil rail spacer first, then side rails.

(b) Install the second compression rings using Installation Tool C-4184. The compression rings must be installed with the identification mark face up (toward top of piston) and chamfer facing down. An identification mark on the ring is a drill point, a stamped letter O, an oval depression or the word TOP (Fig. 42) (Fig. 44).

(c) Using a ring installer, install the top compression ring with the chamfer facing up (Fig. 44). An identification mark on the ring is a drill point,



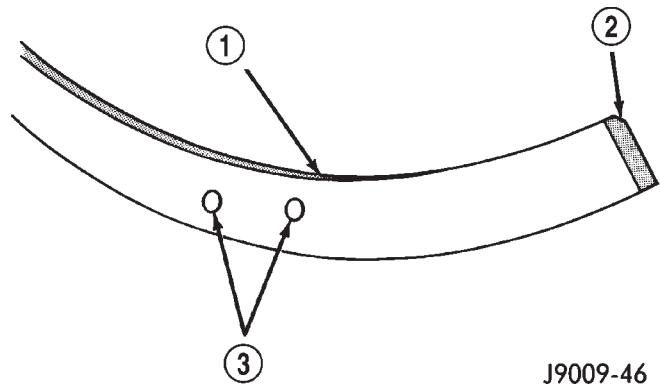
**Fig. 43 Top Compression Ring Identification—Typical**

- 1 - TOP COMPRESSION RING (GRAY IN COLOR)
- 2 - CHAMFER
- 3 - ONE DOT

a stamped letter O, an oval depression or the word TOP facing up (Fig. 43).

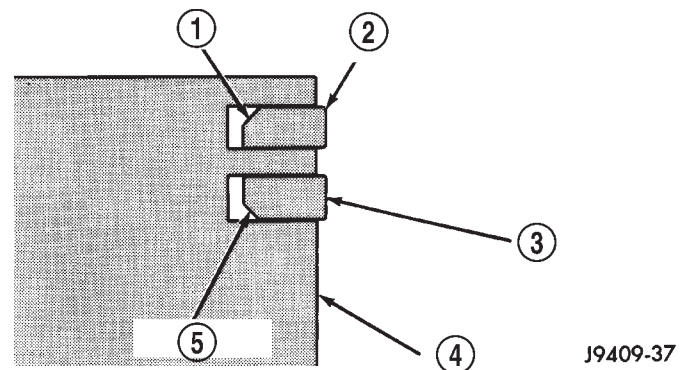
(d) Measure side clearance between piston ring and ring land. Clearance should be 0.074-0.097 mm (0.0029-0.0038 inch) for the compression rings. The steel rail oil ring should be free in groove, but should not exceed 0.246 mm (0.0097 inch) side clearance.

(e) Pistons with insufficient or excessive side clearance should be replaced.



**Fig. 42 Second Compression Ring Identification—Typical**

- 1 - SECOND COMPRESSION RING (BLACK CAST IRON)
- 2 - CHAMFER
- 3 - TWO DOTS

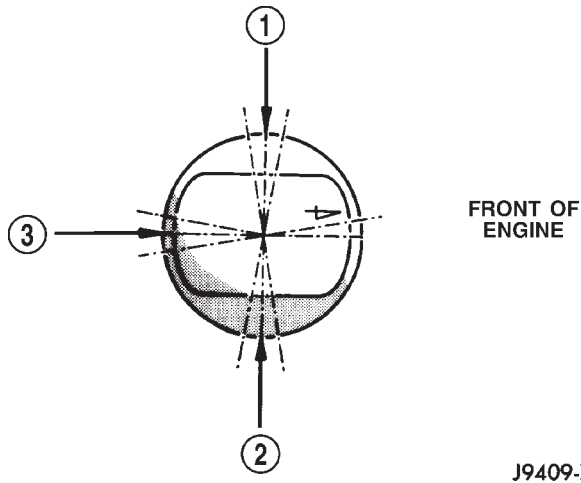


**Fig. 44 Compression Ring Chamfer Location—Typical**

- 1 - CHAMFER
- 2 - TOP COMPRESSION RING
- 3 - SECOND COMPRESSION RING
- 4 - PISTON
- 5 - CHAMFER

## PISTON RINGS (Continued)

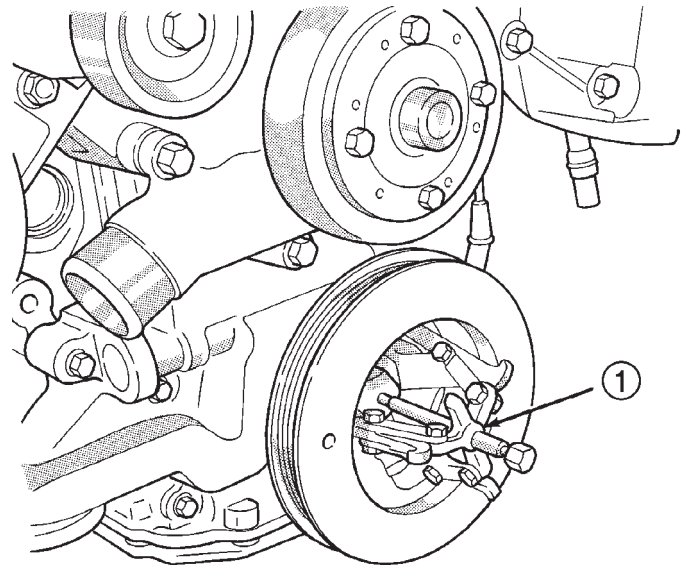
(3) Arrange ring gaps 180° apart as shown in (Fig. 45).



J9409-77

**Fig. 45 Proper Ring Installation**

- 1 - TOP COMPRESSION RING GAP  
UPPER OIL RING GAP
- 2 - 2ND COMPRESSION RING GAP  
LOWER OIL RAIL GAP
- 3 - SPACER GAP



J9409-138

**Fig. 46 Crankshaft Pulley—Damper Removal**

1 - 3 JAW PULLER

## VIBRATION DAMPER

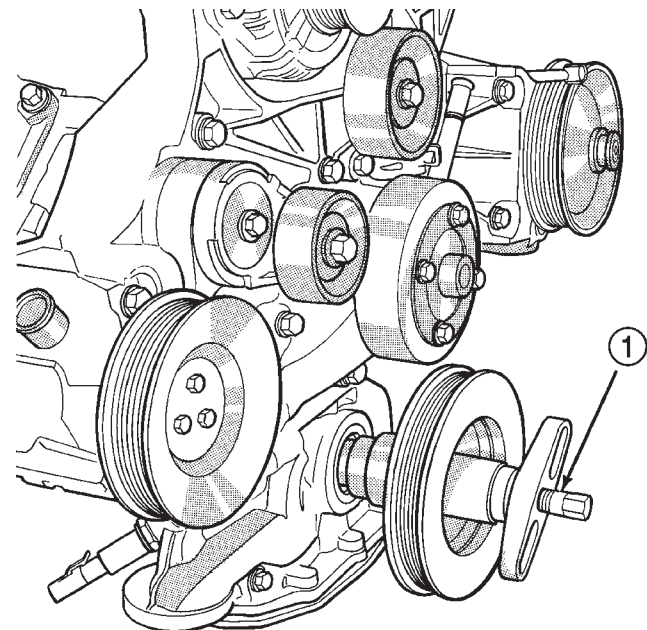
## REMOVAL

- (1) Disconnect the negative cable from the battery.
- (2) Remove the following:
  - Radiator fan (Refer to 7 - COOLING/ENGINE/RADIATOR FAN - REMOVAL)
  - Accessory drive belt (Refer to 7 - COOLING/ACCESSORY DRIVE/DRIVE BELTS - REMOVAL)
  - Radiator (Refer to 7 - COOLING/ENGINE/RADIATOR - REMOVAL)
- (3) Remove crankshaft pulley/damper bolt and washer from end of crankshaft.
- (4) Using Special Tool, 1026 3 Jaw Puller and Special Tool 8513 Insert, remove pulley—damper from the crankshaft (Fig. 46).
- (5) Inspect crankshaft oil seal. If damaged or worn, replace the front oil seal (Refer to 9 - ENGINE/ENGINE BLOCK/CRANKSHAFT OIL SEAL - FRONT - REMOVAL).

## INSTALLATION

- (1) Position the crankshaft pulley/damper onto the crankshaft.
- (2) Use Special Tool, C-3688 Crankshaft Pulley/Damper Installer to press the pulley—damper onto the crankshaft. Install crankshaft bolt and washer and tighten to 312 N·m (230 ft. lbs.) torque (Fig. 47).
- (3) Install the following:
  - Radiator (Refer to 7 - COOLING/ENGINE/RADIATOR - INSTALLATION)

- Accessory drive belt (Refer to 7 - COOLING/ACCESSORY DRIVE/DRIVE BELTS - INSTALLATION)
  - Radiator fan (Refer to 7 - COOLING/ENGINE/RADIATOR FAN - INSTALLATION)
- (4) Connect the negative cable to the battery.



J9409-142

**Fig. 47 Installing Crankshaft Pulley—Damper**

1 - SPECIAL TOOL C-3688

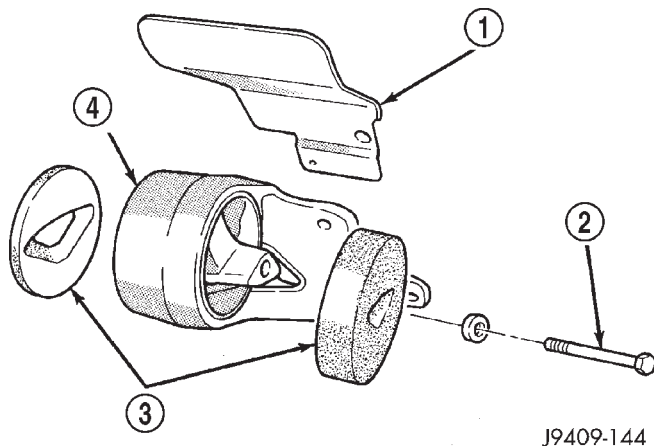
## FRONT MOUNT

### REMOVAL

- (1) Disconnect the negative cable from the battery.
- (2) Position fan to assure clearance for radiator top tank and hose.

**CAUTION: DO NOT** lift the engine by the intake manifold.

- (3) Install engine support/lifting fixture.
- (4) Raise vehicle on hoist.
- (5) Lift the engine **SLIGHTLY** and remove the thru-bolt and nut (Fig. 48).
- (6) Remove engine support bracket/cushion bolts (Fig. 48). Remove the support bracket/cushion and heat shields.



J9409-144

**Fig. 48 Engine Front Mounts**

- 1 - ENGINE MOUNT HEAT SHIELD
- 2 - THRU-BOLT
- 3 - RESTRICTION PADS
- 4 - ENGINE SUPPORT BRACKET/CUSHION

### INSTALLATION

(1) With engine raised **SLIGHTLY**, position the engine support bracket/cushion and heat shields to the block. Install new bolts and tighten to 81 N·m (60 ft. lbs.) torque.

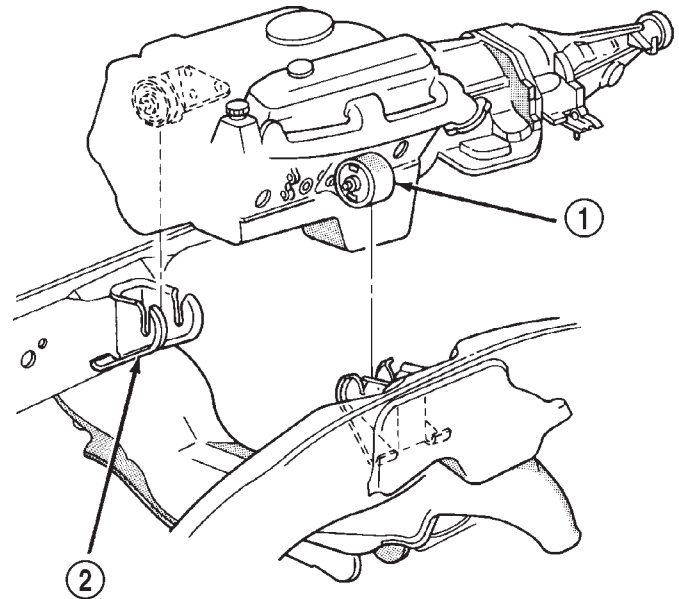
(2) Install the thru-bolt and 2 piece rubber engine rubber restrictors onto the engine support bracket/cushion.

(3) Lower engine with support/lifting fixture while guiding the engine bracket/cushion and thru-bolt into support cushion brackets (Fig. 49).

(4) Install thru-bolt nuts and tighten the nuts to 68 N·m (50 ft. lbs.) torque.

(5) Lower the vehicle.

(6) Remove lifting fixture.



J9409-54

**Fig. 49 Positioning Engine Mounts—Front**

- 1 - ENGINE SUPPORT BRACKET/CUSHION
- 2 - SUPPORT CUSHION BRACKET

## REAR MOUNT

### REMOVAL

- (1) Raise the vehicle on a hoist.
- (2) Position a transmission jack in place.
- (3) Remove support cushion stud nuts (Fig. 50).
- (4) Raise rear of transmission and engine **SLIGHTLY**.

(5) Remove the bolts holding the support cushion to the transmission support bracket. Remove the support cushion.

(6) If necessary, remove the bolts holding the transmission support bracket to the transmission.

### INSTALLATION

(1) If removed, position the transmission support bracket to the transmission. Install new attaching bolts and tighten to 102 N·m (75 ft. lbs.) torque.

(2) Position support cushion to transmission support bracket. Install stud nuts and tighten to 47 N·m (35 ft. lbs.) torque.

(3) Using the transmission jack, lower the transmission and support cushion onto the crossmember (Fig. 50).

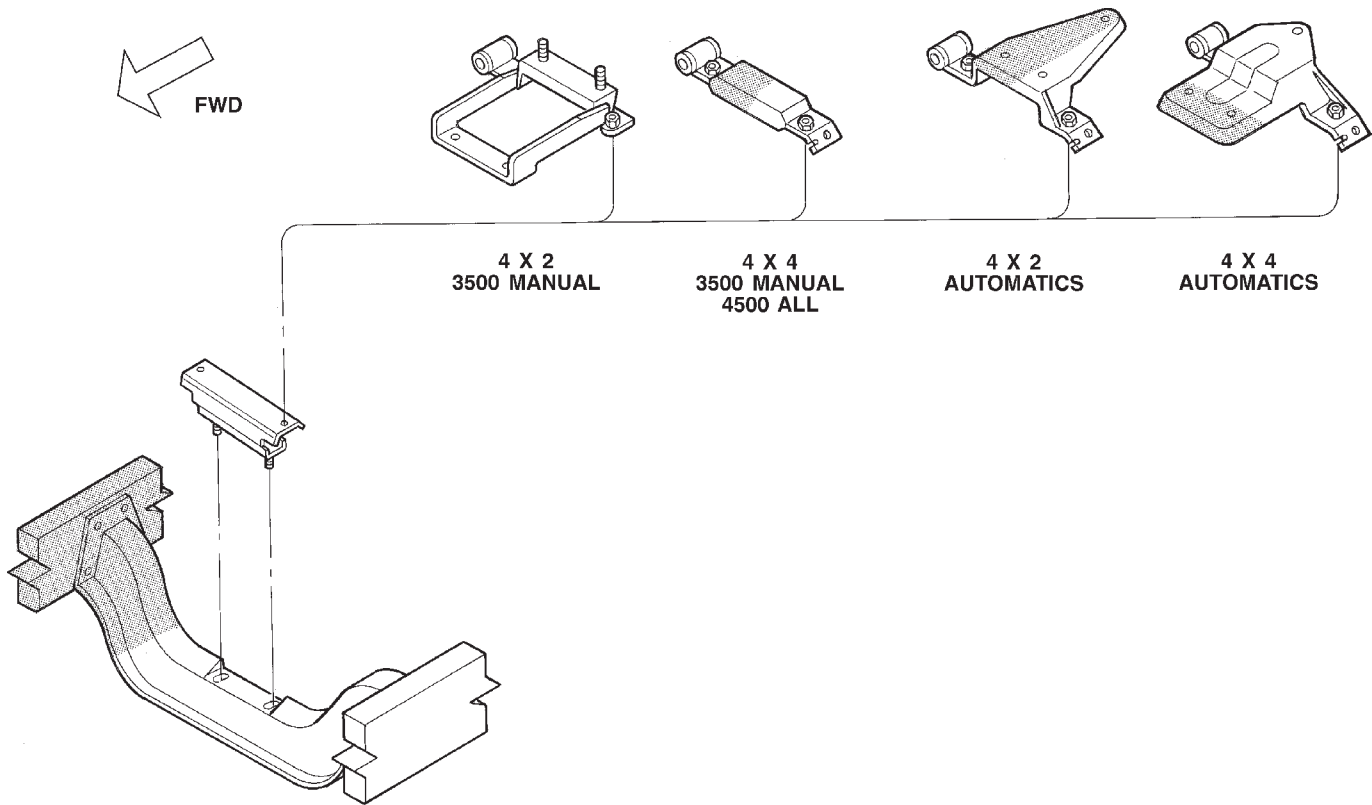
(4) Install the support cushion bolts and tighten to 47 N·m (35 ft. lbs.) torque.

(5) Remove the transmission jack.

(6) Lower the vehicle.



REAR MOUNT (Continued)



J9509-126

**Fig. 50 Engine Rear Support Cushion Assembly**

LUBRICATION

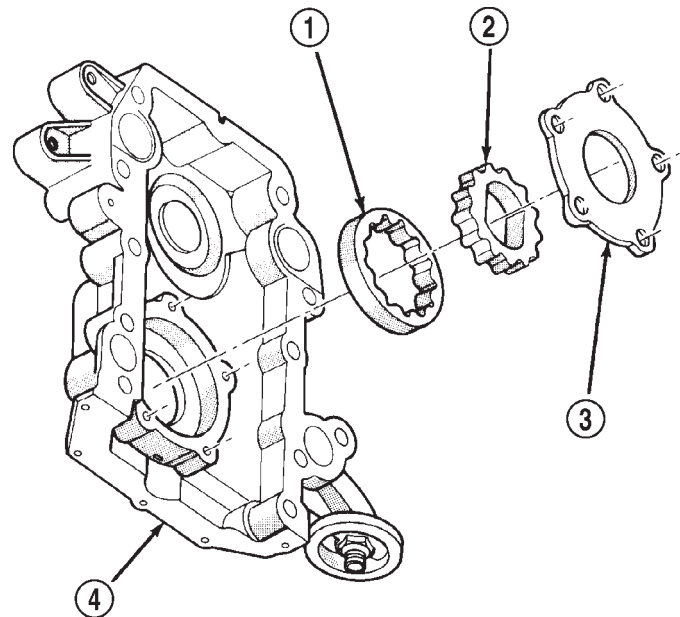
DESCRIPTION

A pressure feed type (gerotor) oil pump is located in the engine front cover. The pump uses a pick-up tube and screen assembly to gather engine oil from the oil pan (Fig. 51).

OPERATION

The pump draws oil through the screen and inlet tube from the sump at the rear of the oil pan. The oil is driven between the inner and outer gears of the oil pump, then forced through the outlet in the engine front cover. An oil gallery in the front cover channels the oil to the inlet side of the full flow oil filter. After passing through the filter element, the oil passes from the center outlet of the filter through an oil gallery that channels the oil up to the tappet galleries, which extends the entire length of block.

Galleries extend downward from the main oil gallery to the upper shell of each main bearing. The crankshaft is drilled internally to pass oil from the main bearing journals to the connecting rod journals. Each connecting rod bearing has half a hole in it, oil passes through the hole when the rods rotate and the hole lines up, oil is then thrown off as the rod



J9409-71

**Fig. 51 Pressure Feed Type (Gerotor) Oil Pump—Typical**

- 1 - OUTER ROTOR
- 2 - INNER ROTOR
- 3 - OIL PUMP COVER
- 4 - TIMING CHAIN COVER

## LUBRICATION (Continued)

rotates. This oil throwoff lubricates the camshaft lobes, cylinder walls, and piston pins.

The hydraulic valve tappets receive oil directly from the main oil gallery. The camshaft bearings receive oil from the main bearing galleries. The front camshaft bearing journal passes oil through the camshaft sprocket to the timing chain. Oil drains back to the oil pan under the No. 1 main bearing cap.

The oil supply for the rocker arms and bridged pivot assemblies is provided by the hydraulic valve tappets, which pass oil through hollow push rods to a hole in the corresponding rocker arm. Oil from the rocker arm lubricates the valve train components. The oil then passes down through the push rod guide holes and the oil drain-back passages in the cylinder head, past the valve tappet area, and then returns to the oil pan (Fig. 52).

## DIAGNOSIS AND TESTING—ENGINE OIL LEAKS

Begin with a through visual inspection of the engine, particularly at the area of the suspected leak. If an oil leak source is not readily identifiable, the following steps should be followed:

(1) Do not clean or degrease the engine at this time because some solvents may cause rubber to swell, temporarily stopping the leak.

(2) Add an oil-soluble dye (use as recommended by manufacturer). Start the engine and let idle for approximately 15 minutes. Check the oil dipstick to be sure the dye is thoroughly mixed as indicated with a bright yellow color under a black light source.

(3) Using a black light, inspect the entire engine for fluorescent dye, particularly at the suspected area of oil leak. If the oil leak is found and identified, repair per service manual instructions.

(4) If dye is not observed, drive the vehicle at various speeds for approximately 24km (15 miles), and repeat previous step.

(5) If the oil leak source is not positively identified at this time, proceed with the air leak detection test method as follows:

(6) Disconnect the breather cap to air cleaner hose at the breather cap end. Cap or plug breather cap nipple.

(7) Remove the PCV valve from the cylinder head cover. Cap or plug the PCV valve grommet.

(8) Attach an air hose with pressure gauge and regulator to the dipstick tube.

**CAUTION: Do not subject the engine assembly to more than 20.6 kpa (3 PSI) of test pressure.**

(9) Gradually apply air pressure from 1 psi to 2.5 psi maximum while applying soapy water at the suspected source. Adjust the regulator to the suitable test pressure that provide the best bubbles which will pinpoint the leak source. If the oil leak is detected and identified, repair per service manual procedures.

(10) If the leakage occurs at the rear oil seal area, refer to the section, Inspection for Rear Seal Area Leak.

(11) If no leaks are detected, turn off the air supply and remove the air hose and all plugs and caps. Install the PCV valve and breather cap hose. Proceed to next step.

(12) Clean the oil off the suspect oil leak area using a suitable solvent. Drive the vehicle at various speeds approximately 24 km (15 miles). Inspect the engine for signs of an oil leak by using a black light.

## DIAGNOSIS AND TESTING—ENGINE OIL PRESSURE

(1) Remove oil pressure sending unit.

(2) Install Oil Pressure Line and Gauge Tool C-3292. Start engine and record pressure. (Refer to 9 - ENGINE - SPECIFICATIONS).



LUBRICATION (Continued)

J9509-144

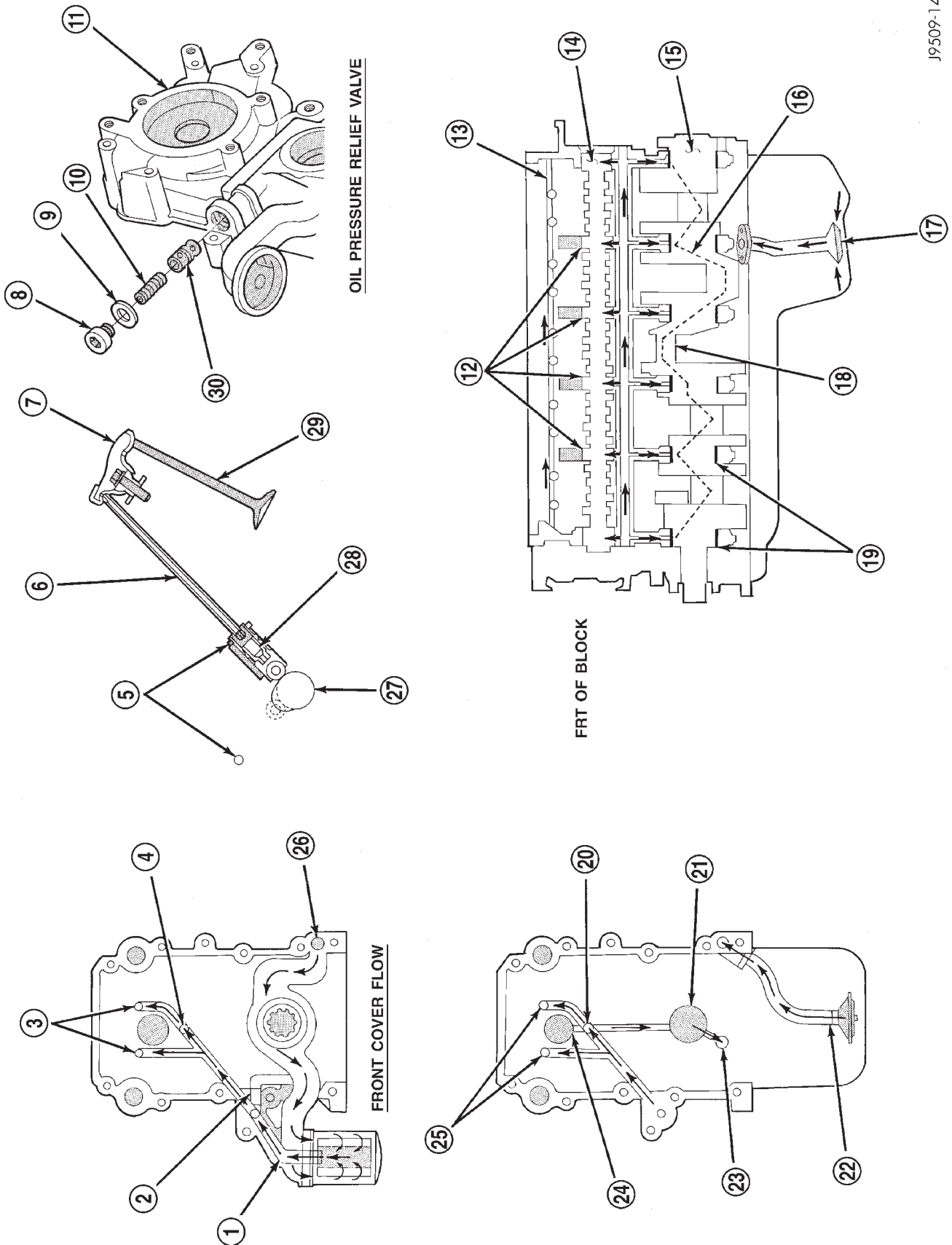


Fig. 52 Engine Lubrication System

## LUBRICATION (Continued)

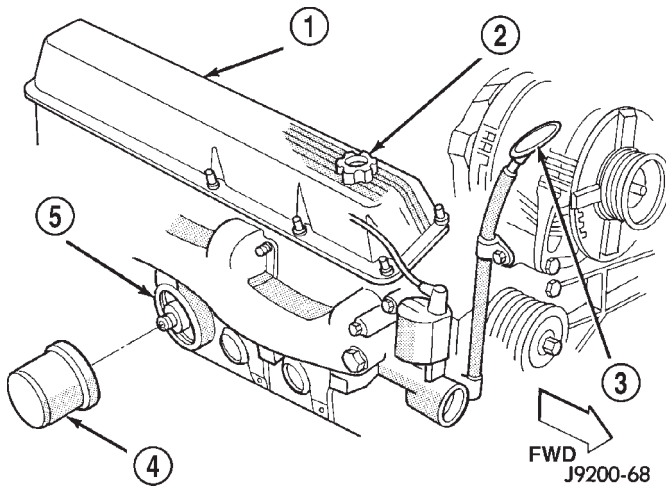
- |   |                              |
|---|------------------------------|
| 1 - OIL TO MAIN OIL GALLERIES               | 17 - OIL PICKUP              |
| 2 - RELIEF VALVE                            | 18 - CONNECTING ROD JOURNALS |
| 3 - OIL GALLERY FOR TAPPETS                 | 19 - CRANKSHAFT BEARINGS     |
| 4 - MAIN OIL GALLERY                        | 20 - MAIN OIL GALLERY        |
| 5 - TAPPET OIL GALLERY                      | 21 - CRANKSHAFT              |
| 6 - HOLLOW PUSH ROD                         | 22 - OIL PICKUP TUBE         |
| 7 - ROCKER ARM                              | 23 - CONNECT ROD JOURNALS    |
| 8 - PLUG                                    | 24 - CAMSHAFT BEARINGS       |
| 9 - GASKET                                  | 25 - TAPPET OIL GALLERY      |
| 10 - SPRING                                 | 26 - OIL FROM PICKUP TUBE    |
| 11 - TIMING CHAIN COVER                     | 27 - CAMSHAFT                |
| 12 - CAM BEARINGS                           | 28 - TAPPET                  |
| 13 - HYDRAULIC TAPPET GALLERIES             | 29 - VALVE                   |
| 14 - CAMSHAFT                               | 30 - OIL PUMP RELIEF VALVE   |
| 15 - CRANKSHAFT                             |                              |
| 16 - OIL PASSAGE TO CONNECTING ROD JOURNALS |                              |

## OIL

## STANDARD PROCEDURE—ENGINE OIL

## OIL LEVEL INDICATOR (DIPSTICK)

The engine oil level indicator is located at the right front of the engine, left of the generator on 3.9L engines (Fig. 53).



**Fig. 53 Oil Level Indicator Location**

- 1 - CYLINDER HEAD COVER
- 2 - ENGINE OIL FILL CAP
- 3 - DIPSTICK
- 4 - ENGINE OIL FILTER
- 5 - FILTER BOSS

## CRANKCASE OIL LEVEL INSPECTION

**CAUTION:** Do not overfill crankcase with engine oil, oil foaming and oil pressure loss can result.

To ensure proper lubrication of an engine, the engine oil must be maintained at an acceptable level.

The acceptable levels are indicated between the ADD and SAFE marks on the engine oil dipstick.

- (1) Position vehicle on level surface.
- (2) With engine OFF, allow approximately ten minutes for oil to settle to bottom of crankcase, remove engine oil dipstick.
- (3) Wipe dipstick clean.
- (4) Install dipstick and verify it is seated in the tube.
- (5) Remove dipstick, with handle held above the tip, take oil level reading.
- (6) Add oil only if level is below the ADD mark on dipstick.

## ENGINE OIL CHANGE

Change engine oil at mileage and time intervals described in the Maintenance Schedule. This information can be found in the owner's manual.

## TO CHANGE ENGINE OIL

Run engine until achieving normal operating temperature.

- (1) Position the vehicle on a level surface and turn engine off.
- (2) Hoist vehicle.
- (3) Remove oil fill cap.
- (4) Place a suitable drain pan under crankcase drain.
- (5) Remove drain plug from crankcase and allow oil to drain into pan. Inspect drain plug threads for stretching or other damage. Replace drain plug and gasket if damaged.
- (6) Install drain plug in crankcase.

(7) Change oil filter (Refer to 9 - ENGINE/LUBRICATION/OIL FILTER - REMOVAL).

(8) Lower vehicle and fill crankcase with specified type (Refer to LUBRICATION & MAINTENANCE/FLUID TYPES - DESCRIPTION) and amount of engine oil (Refer to LUBRICATION & MAINTENANCE - SPECIFICATIONS).

## OIL (Continued)

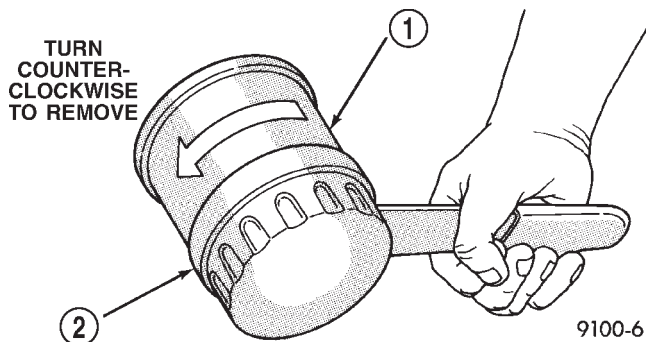
- (9) Install oil fill cap.
- (10) Start engine and inspect for leaks.
- (11) Stop engine and inspect oil level.

## OIL FILTER

## REMOVAL

All engines are equipped with a high quality full-flow, disposable type oil filter. DaimlerChrysler Corporation recommends a Mopar® or equivalent oil filter be used.

- (1) Position a drain pan under the oil filter.
- (2) Using a suitable oil filter wrench loosen filter.
- (3) Rotate the oil filter counterclockwise to remove it from the cylinder block oil filter boss (Fig. 54).



**Fig. 54 Oil Filter Removal—Typical**

- 1 - ENGINE OIL FILTER
- 2 - OIL FILTER WRENCH

(4) When filter separates from adapter nipple, tip gasket end upward to minimize oil spill. Remove filter from vehicle.

(5) With a wiping cloth, clean the gasket sealing surface (Fig. 54) of oil and grime.

(6) Install new filter (Refer to 9 - ENGINE/LUBRICATION/OIL FILTER - INSTALLATION).

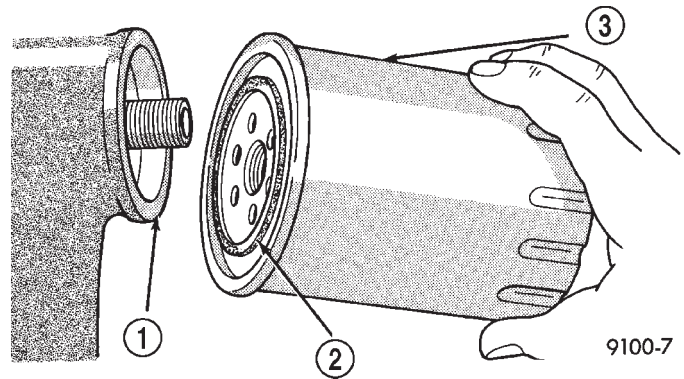
## INSTALLATION

- (1) Lightly lubricate oil filter gasket with engine oil or chassis grease.
- (2) Thread filter onto adapter nipple. When gasket makes contact with sealing surface, (Fig. 55) hand tighten filter one full turn, do not over tighten.
- (3) Add oil (Refer to 9 - ENGINE/LUBRICATION/OIL - STANDARD PROCEDURE).

## OIL PAN

## REMOVAL

- (1) Disconnect the negative cable from the battery.
- (2) Raise vehicle.
- (3) Drain engine oil.



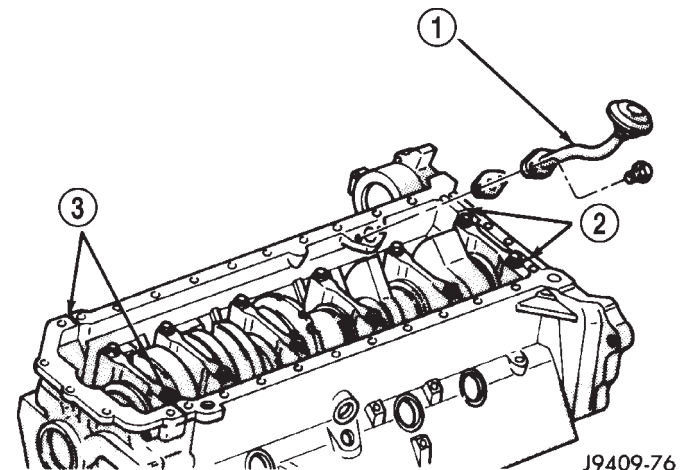
**Fig. 55 Oil Filter Sealing Surface—Typical**

- 1 - SEALING SURFACE
- 2 - RUBBER GASKET
- 3 - OIL FILTER

(4) Remove left engine to transmission strut.

(5) Remove oil pan mounting bolts, pan and one-piece gasket. The engine may have to be raised slightly on 2WD vehicles.

(6) Remove the oil pick-up tube assembly (Fig. 56). Discard the gasket.



**Fig. 56 Oil Pick-Up Tube**

- 1 - PICK-UP TUBE
- 2 - SEALANT AT SPLIT-LINES
- 3 - SEALANT AT SPLIT-LINE

## CLEANING

Clean the block and pan gasket surfaces.

If present, trim excess sealant from inside the engine.

Clean oil pan in solvent and wipe dry with a clean cloth.

Clean oil screen and pipe thoroughly in clean solvent. Inspect condition of screen.

## OIL PAN (Continued)

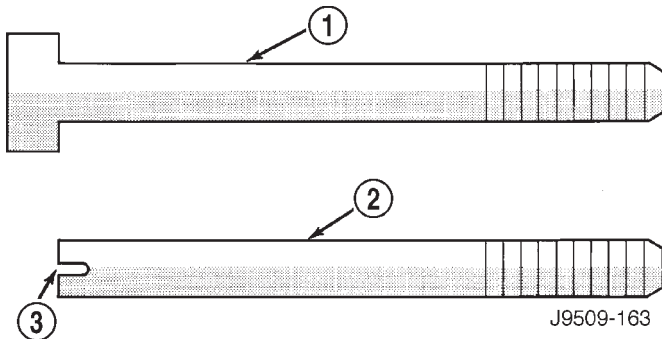
## INSPECTION

Inspect oil drain plug and plug hole for stripped or damaged threads. Repair as necessary.

Inspect oil pan mounting flange for bends or distortion. Straighten flange, if necessary.

## INSTALLATION

(1) Fabricate 4 alignment dowels from 5/16 x 1 1/2 inch bolts. Cut the head off the bolts and cut a slot into the top of the dowel. This will allow easier installation and removal with a screwdriver (Fig. 57).



**Fig. 57 Fabrication of Alignment Dowels**

- 1 - 5/16" X 1 1/2" BOLT
- 2 - DOWEL
- 3 - SLOT

(2) Install the dowels in the cylinder block at the four corners.

(3) Apply small amount of Mopar® Silicone Rubber Adhesive Sealant, or equivalent at the split lines. The split lines are between the cylinder block, the timing chain cover and the rear crankshaft seal assembly (Fig. 56). **After the sealant is applied you have 3 minutes to install the gasket and oil pan.**

(4) Slide the one-piece gasket over the dowels and onto the block.

(5) Position the oil pan over the dowels and onto the gasket. The engine may have to be slightly raised on 2WD vehicles.

(6) Install the oil pan bolts (Fig. 58). Tighten the bolts to as shown in Oil Pan Bolts Torque Chart.

(7) Remove the dowels. Install the remaining 5/16 inch oil pan bolts. Torque these bolts as shown in Oil Pan Bolts Torque Chart.

(8) Install the drain plug. Tighten drain plug to 34 N·m (25 ft. lbs.) torque.

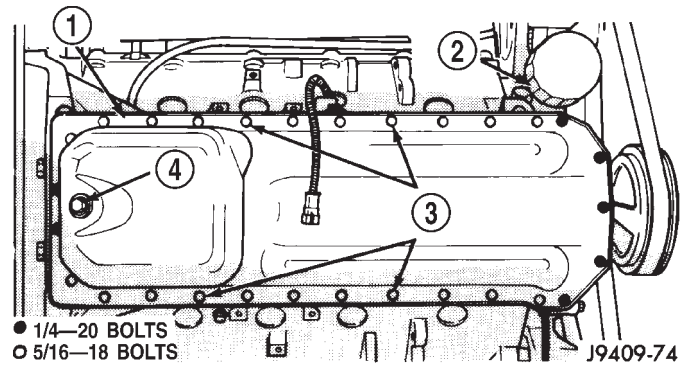
(9) Install the engine to transmission strut.

(10) Lower vehicle.

(11) Connect the negative cable to the battery.

(12) Fill crankcase with oil to proper level.

(13) Start engine and check for leaks.



**Fig. 58 Oil Pan Bolt Location**

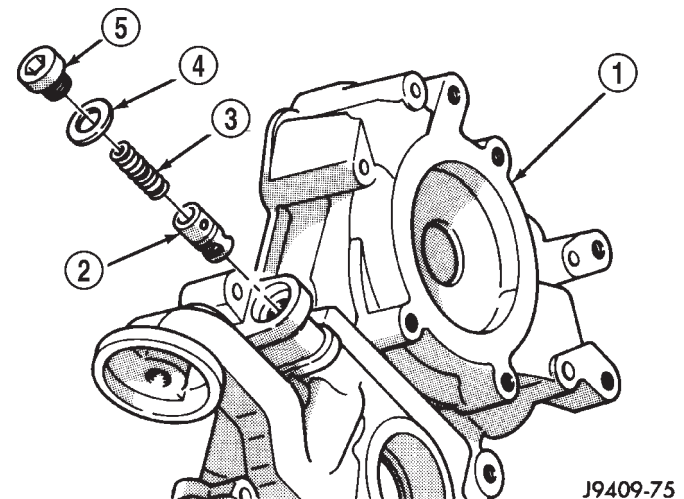
- 1 - OIL PAN
- 2 - OIL FILTER
- 3 - STUD BOLTS
- 4 - DRAIN PLUG

## OIL PUMP

## REMOVAL

(1) Remove the timing chain cover (Refer to 9 - ENGINE/VALVE TIMING/TIMING BELT / CHAIN COVER(S) - REMOVAL).

(2) Remove the relief valve plug, gasket, spring and valve (Fig. 59). Discard the gasket.



**Fig. 59 Oil Pressure Relief Valve**

- 1 - TIMING CHAIN COVER
- 2 - OIL PUMP RELIEF VALVE
- 3 - SPRING
- 4 - GASKET
- 5 - PLUG

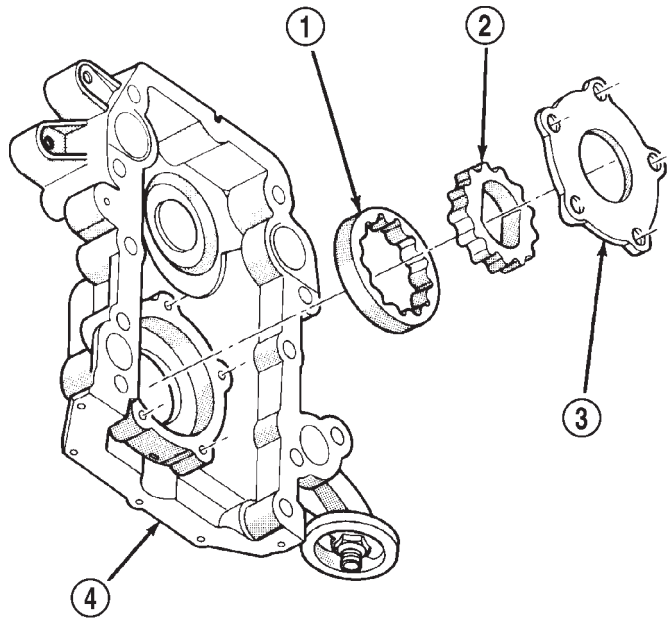
(3) Remove mounting screws and oil pump cover (Fig. 60).

(4) Remove oil pump inner and outer rotors (Fig. 60).



OIL PUMP (Continued)

(5) Inspect oil pump for wear (Refer to 9 - ENGINE/LUBRICATION/OIL PUMP - INSPECTION).



J9409-71

**Fig. 60 Oil Pump**

- 1 - OUTER ROTOR
- 2 - INNER ROTOR
- 3 - OIL PUMP COVER
- 4 - TIMING CHAIN COVER

**CLEANING**

Wash all parts in a suitable solvent and inspect carefully for damage or wear.

**INSPECTION**

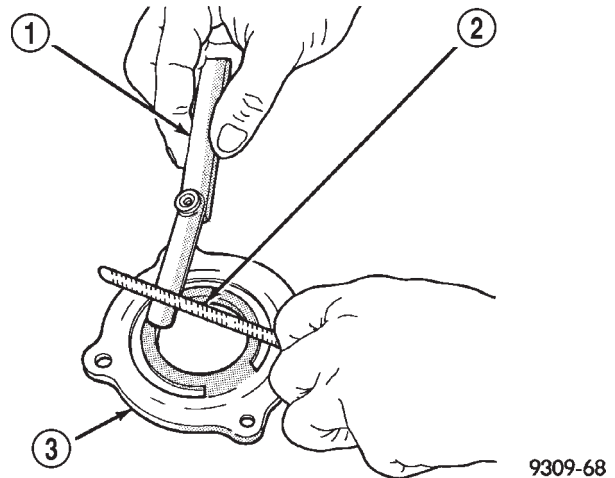
Mating surface of the oil pump cover should be smooth. Replace pump cover if scratched or grooved.

Lay a straightedge across the pump cover surface (Fig. 61). If a 0.076 mm (0.003 inch) feeler gauge can be inserted between cover and straightedge, cover should be replaced.

Measure thickness (Fig. 62) (Fig. 63) and diameter of rotors. If either rotor thickness measures 14.956 mm (0.5876 inch) or less, or if the diameter is 82.45 mm (3.246 inches) or less, replace rotor set.

Slide outer rotor into timing chain cover pump body. Press rotor to the side with your fingers and measure clearance between rotor and pump body (Fig. 64). If clearance is 0.19 mm (0.007 inch) or more, and outer rotor is within specifications, replace timing chain cover.

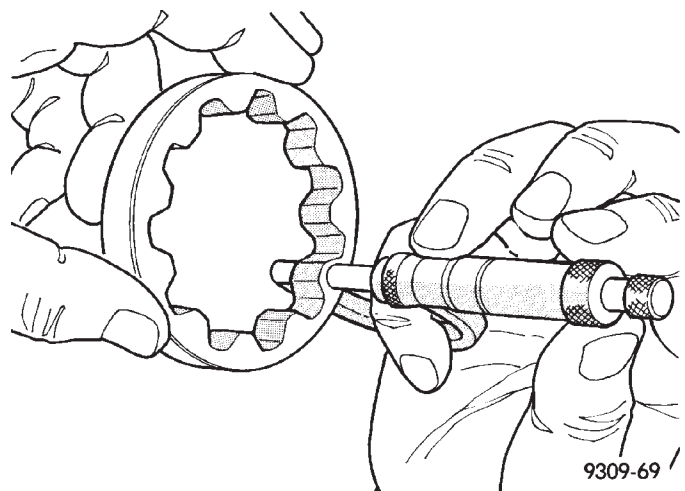
Install inner rotor into timing chain cover pump body (Fig. 65). Inner rotor should be positioned with chamfer up or toward engine when cover is installed. This allows easy installation over crankshaft. If



9309-68

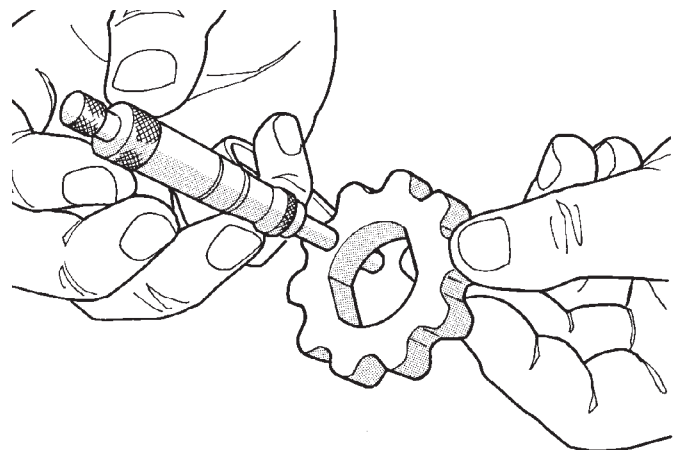
**Fig. 61 Checking Oil Pump Cover Flatness**

- 1 - FEELER GAUGE
- 2 - STRAIGHT EDGE
- 3 - OIL PUMP COVER



9309-69

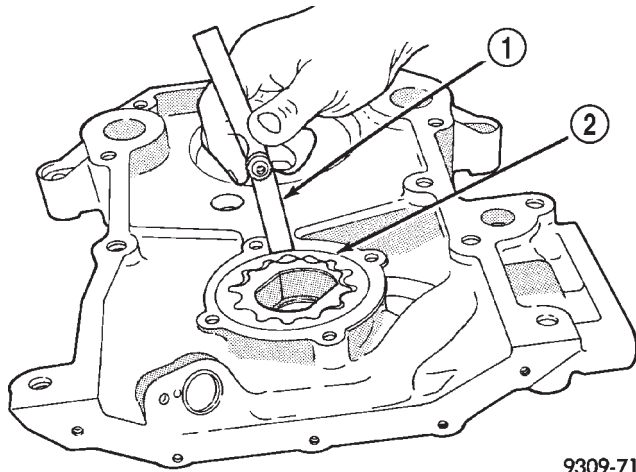
**Fig. 62 Measuring Outer Rotor Thickness**



9309-70

**Fig. 63 Measuring Inner Rotor Thickness**

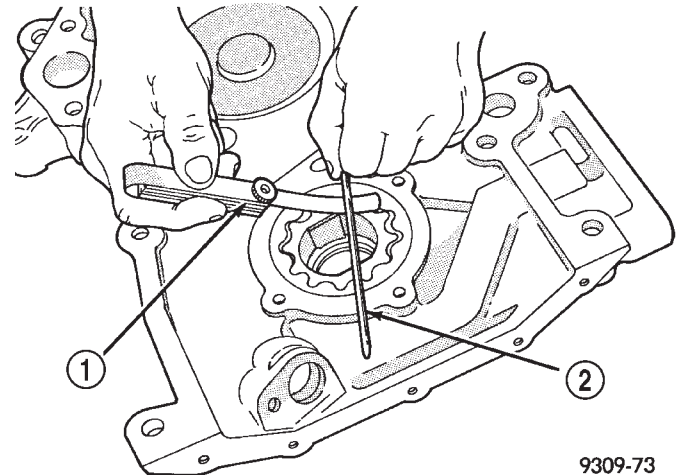
## OIL PUMP (Continued)



9309-71

**Fig. 64 Measuring Outer Rotor Clearance in Cover**

- 1 - FEELER GAUGE
- 2 - OUTER ROTOR

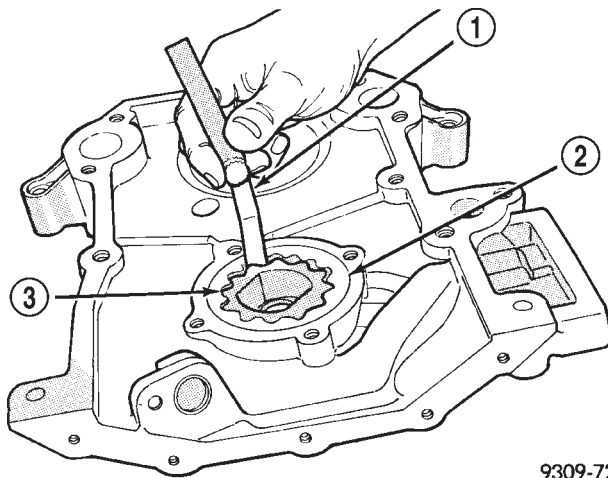


9309-73

**Fig. 66 Measuring Clearance Over Rotors**

- 1 - FEELER GAUGE
- 2 - STRAIGHT EDGE

clearance between inner and outer rotors is 0.150 mm (0.006 inch) or more, replace both rotors.



9309-72

**Fig. 65 Measuring Inner Rotor Clearance in Cover**

- 1 - FEELER GAUGE
- 2 - OUTER ROTOR
- 3 - INNER ROTOR

Place a straightedge across the face of the timing chain cover pump body, between bolt holes (Fig. 66). If a feeler gauge of 0.077 mm (0.003 inch) or more can be inserted between rotors and the straightedge, and the rotors are within specifications, replace timing chain cover.

Inspect oil pressure relief valve plunger for scoring and free operation in its bore. Small marks may be removed with 400-grit wet or dry sandpaper.

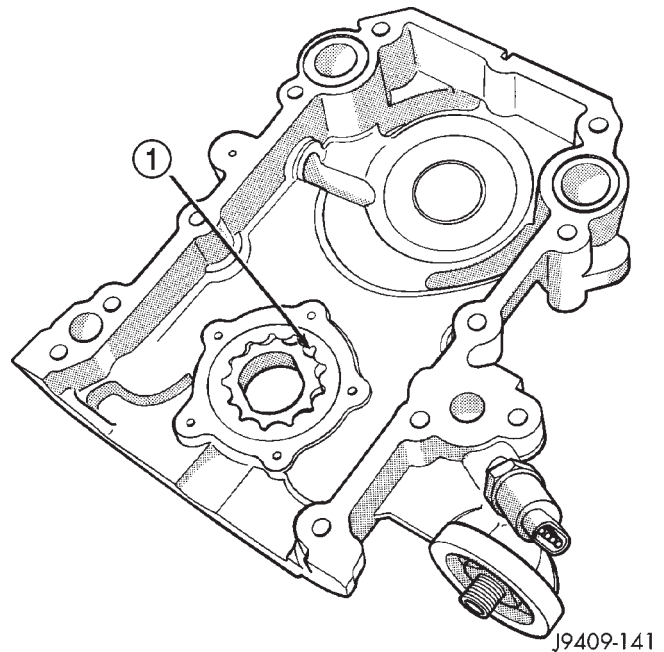
The relief valve spring has a free length of approximately 49.5 mm (1.95 inches). The spring should test between 100 and 109 N (22.5 and 24.5 pounds)

when compressed to 34 mm (1-11/32 inches). Replace spring that fails to meet these specifications.

If oil pressure was low and pump is within specifications, inspect for worn engine bearings or other reasons for oil pressure loss.

**INSTALLATION**

(1) Lubricate both oil pump rotors using petroleum jelly or lubriplate and install in the timing chain cover. Use new parts as required (Fig. 67).



J9409-141

**Fig. 67 Priming Oil Pump.**

- 1 - FILL WITH PETROLEUM JELLY OR LUBER PLATE



## OIL PUMP (Continued)

(2) Position the oil pump cover onto the timing chain cover. Tighten cover screws to 14 N·m (125 in. lbs.) torque.

(3) Make sure that inner ring moves freely after cover is installed.

(4) Install the timing chain cover (Refer to 9 - ENGINE/VALVE TIMING/TIMING BELT / CHAIN COVER(S) - INSTALLATION).

(5) Squirt oil into relief valve hole until oil runs out.

(6) Install the relief valve and spring.

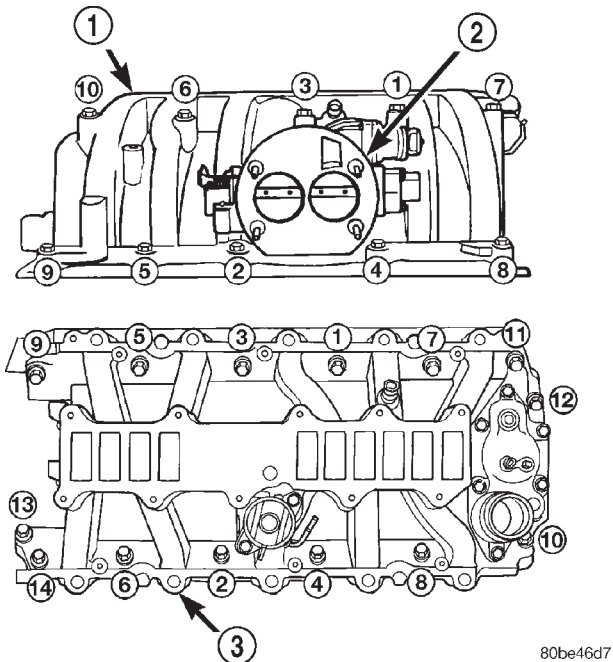
(7) Using a new pressure relief valve gasket, install the relief valve plug. Tighten the plug to 20 N·m (15 ft. lbs.) torque.

(8) Install oil filter that has been filled with oil.

## INTAKE MANIFOLD

## DESCRIPTION

The aluminum intake manifold (Fig. 68) has two plenum chambers an upper and lower which supply air to five runners each. Passages across the longitudinal center of the manifold feed air from the throttle body to the plenum chambers.



**Fig. 68 Upper and Lower Intake Manifold—8.0L Engine**

- 1 - UPPER INTAKE MANIFOLD
- 2 - THROTTLE BODY (MPI)
- 3 - LOWER INTAKE MANIFOLD

## DIAGNOSIS AND TESTING—INTAKE MANIFOLD LEAKAGE

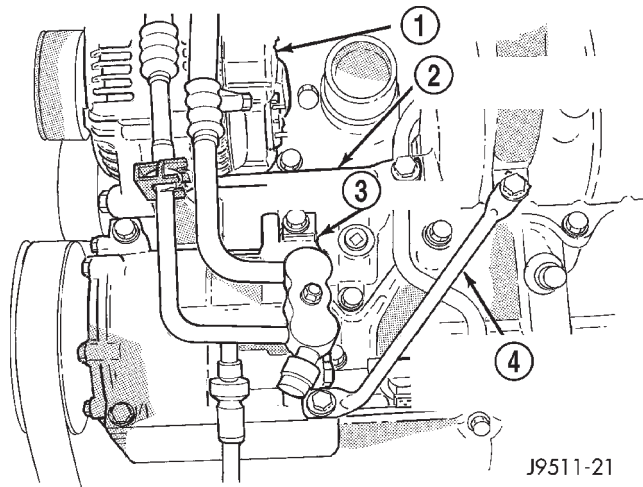
An intake manifold air leak is characterized by lower than normal manifold vacuum. Also, one or more cylinders may not be functioning.

**WARNING: USE EXTREME CAUTION WHEN THE ENGINE IS OPERATING. DO NOT STAND IN A DIRECT LINE WITH THE FAN. DO NOT PUT YOUR HANDS NEAR THE PULLEYS, BELTS, OR THE FAN. DO NOT WEAR LOOSE CLOTHING.**

- (1) Start the engine.
- (2) Spray a small stream of water at the suspected leak area.
- (3) If a change in RPMs occurs, the area of the suspected leak has been found.
- (4) Repair as required.

## REMOVAL

- (1) Disconnect the negative cable from the battery.
- (2) Drain the cooling system (Refer to 7 - COOLING - STANDARD PROCEDURE).
- (3) Remove the accessory drive belt (Refer to 7 - COOLING/ACCESSORY DRIVE/DRIVE BELTS - REMOVAL).
- (4) Remove the generator brace and generator (Fig. 69).
- (5) Remove the A/C compressor brace (Fig. 69). Remove the compressor and set aside.

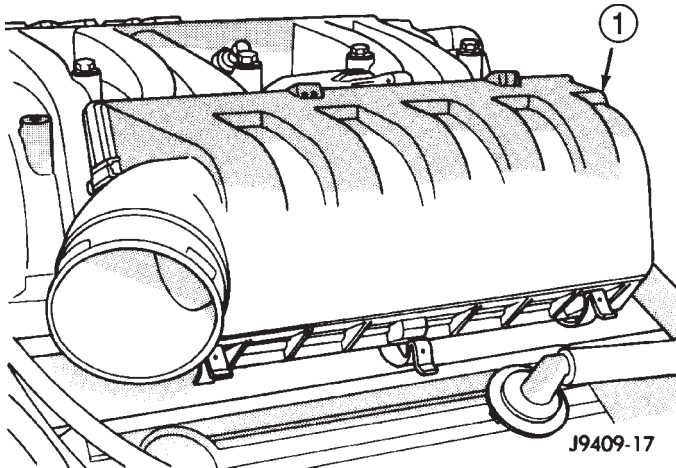


**Fig. 69 Generator and A/C Compressor Braces**

- 1 - GENERATOR
- 2 - INTAKE MANIFOLD TO GENERATOR BRACE
- 3 - A/C COMPRESSOR
- 4 - INTAKE MANIFOLD TO A/C COMPRESSOR BRACE

## INTAKE MANIFOLD (Continued)

(6) Remove the air cleaner cover and filter. Remove the air cleaner housing (Fig. 70). Discard the gasket.



**Fig. 70 Air Intake Housing**

1 - AIR INTAKE HOUSING

(7) Perform the Fuel System Pressure release procedure (Refer to 14 - FUEL SYSTEM/FUEL DELIVERY - STANDARD PROCEDURE). Disconnect the fuel lines (Refer to 14 - FUEL SYSTEM/FUEL DELIVERY/QUICK CONNECT FITTING - STANDARD PROCEDURE).

(8) Disconnect the accelerator linkage and if so equipped, the speed control and transmission kick-down cables.

(9) Remove the coil assemblies with the ignition wires.

(10) Disconnect the vacuum lines.

(11) Disconnect the heater hoses and bypass hose.

(12) Remove the closed crankcase ventilation and evaporation control systems.

(13) Remove the throttle body bolts and lift the throttle body off the upper intake manifold (Fig. 71). Discard the gasket.

(14) Remove upper intake manifold bolts.

(15) Lift the upper intake manifold out of the engine compartment (Fig. 71). Discard the gasket.

(16) Remove the lower intake manifold bolts and remove the manifold (Fig. 72).

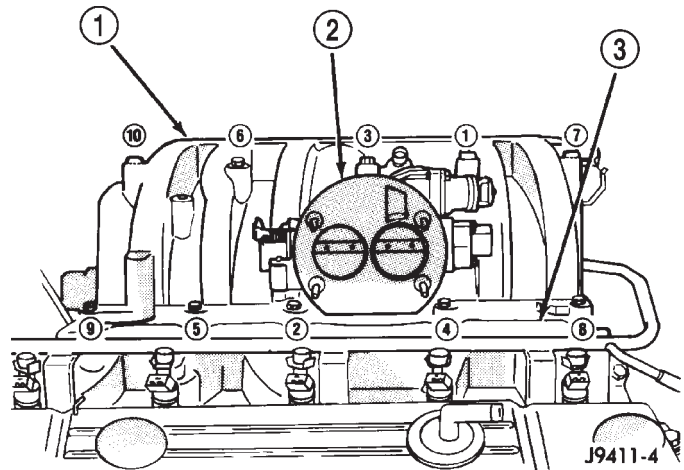
(17) Discard the lower intake manifold gaskets (Fig. 73).

## CLEANING

Clean manifold in solvent and blow dry with compressed air.

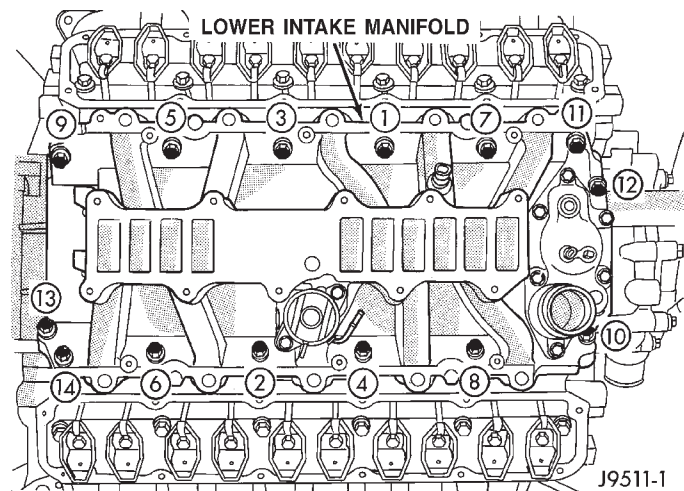
Clean cylinder block front and rear gasket surfaces using a suitable solvent.

The plenum pan rail must be clean and dry (free of all foreign material).



**Fig. 71 Upper Intake Manifold and Throttle Body**

1 - UPPER INTAKE MANIFOLD  
2 - THROTTLE BODY (MPI)  
3 - LOWER INTAKE MANIFOLD



**Fig. 72 Lower Intake Manifold**

## INSPECTION

Inspect manifold for cracks.

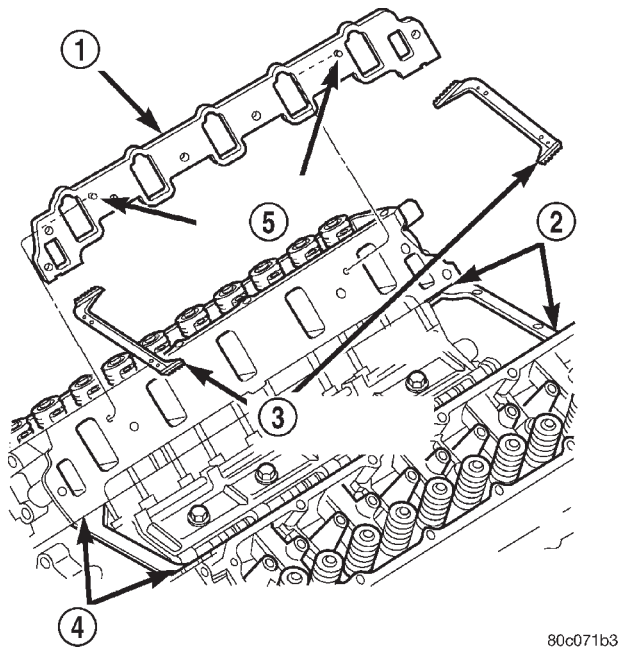
Inspect mating surfaces of manifold for flatness with a straightedge.

## INSTALLATION

(1) Install the intake manifold side gaskets. Be sure that the locator dowels are positioned in the head (Fig. 74).

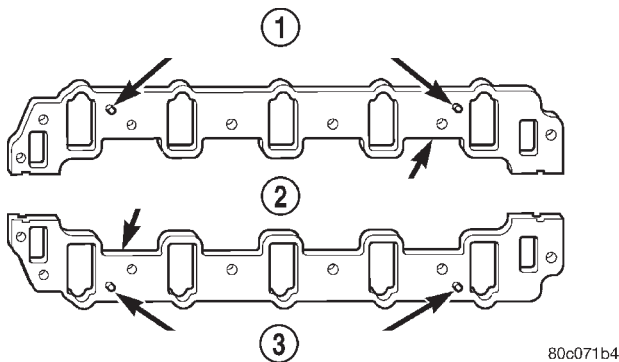
(2) Insert Mopar® GEN II Silicone Rubber Adhesive Sealant, or equivalent, into the four corner joints an excessive amount of sealant is not required to ensure a leak proof seal. However, an excessive amount of sealant may reduce the effectiveness of the flange gasket. The sealant should be approximately 5 mm (0.2 in.) in diameter. (Fig. 73).

## INTAKE MANIFOLD (Continued)



**Fig. 73 Lower Intake Manifold Gaskets**

- 1 - INTAKE MANIFOLD GASKET
- 2 - SEALANT
- 3 - CROSS-OVER GASKETS
- 4 - SEALANT
- 5 - LOCATOR DOWELS



**Fig. 74 Intake Manifold Flange**

- 1 - LOCATOR DOWELS
- 2 - INTAKE MANIFOLD GASKETS
- 3 - LOCATOR DOWELS

(3) Position the cross-over gaskets and press firmly onto the block (Fig. 73). **BE SURE THE BLOCK IS OIL FREE.**

(4) The lower intake manifold **MUST** be installed within 3 minutes of sealant application. Carefully lower intake manifold into position on the cylinder block and heads. After intake manifold is in place, inspect to make sure seals and gaskets are in place. Finger start all the lower intake bolts.

(5) Tighten the lower intake manifold bolts in sequence to 54 N·m (40 ft. lbs.) torque (Fig. 72).

Recheck all bolts are tightened to 54 N·m (40 ft. lbs.) torque.

(6) Using a new gasket, position the upper intake manifold onto the lower intake manifold.

(7) Finger start all bolts, alternate one side to the other.

(8) Tighten upper intake manifold bolts in sequence to 22 N·m (16 ft. lbs.) torque (Fig. 71).

(9) Using a new gasket, install the throttle body onto the upper intake manifold. Tighten the bolts to 23 N·m (200 in. lbs.) torque.

(10) Install closed crankcase ventilation and evaporation control systems.

(11) Connect the heater hoses and bypass hose.

(12) Connect the vacuum lines.

(13) Install the coil assemblies and the ignition wires.

(14) Connect the accelerator linkage and if so equipped, the speed control and transmission kick-down cables.

(15) Install the fuel lines (Refer to 14 - FUEL SYSTEM/FUEL DELIVERY/QUICK CONNECT FITTING - STANDARD PROCEDURE).

(16) Using a new gasket, install the air cleaner housing. Tighten the nuts to 11 N·m (96 in. lbs.) torque. Install the air cleaner filter and cover.

(17) Install the A/C compressor (Refer to 24 - HEATING & AIR CONDITIONING/PLUMBING/A/C COMPRESSOR - INSTALLATION). Position the compressor brace and install the bolts. Tighten the brace bolts to 41 N·m (30 ft. lbs.) torque.

(18) Install the generator (Refer to 8 - ELECTRICAL/CHARGING/GENERATOR - INSTALLATION). Position the generator brace and install the bolts. Tighten the brace bolts to 41 N·m (30 ft. lbs.) torque.

(19) Install the accessory drive belt (Refer to 7 - COOLING/ACCESSORY DRIVE/DRIVE BELTS - INSTALLATION).

(20) Fill cooling system (Refer to 7 - COOLING - STANDARD PROCEDURE).

(21) Connect the negative cable to the battery.

(22) Start engine check for leaks.

## EXHAUST MANIFOLD

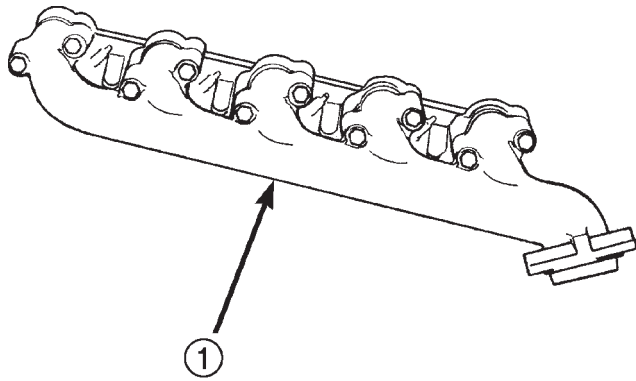
### DESCRIPTION

Engine exhaust manifolds (Fig. 75) are made of high molybdenum ductile cast iron. A special ribbed design helps control permanent dimensional changes during heat cycles.

### OPERATION

The exhaust manifolds collect the engine exhaust exiting the combustion chambers, then channels the

## EXHAUST MANIFOLD (Continued)



80be16d5

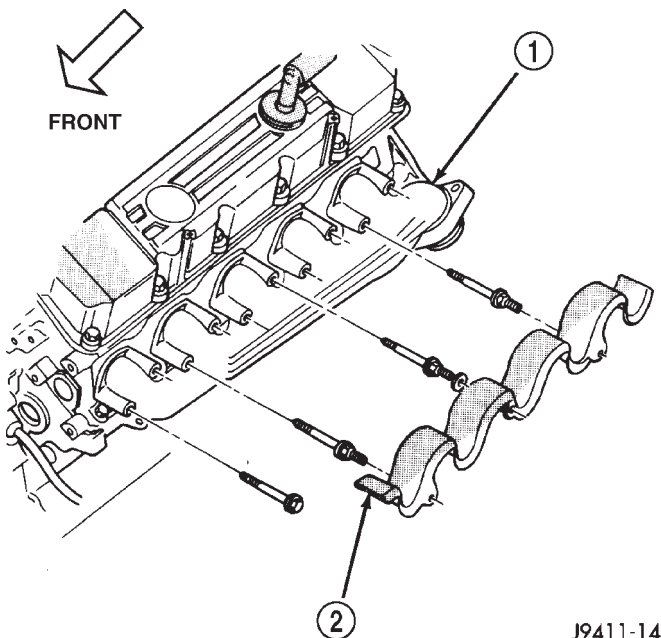
**Fig. 75 Exhaust Manifold—8.0L Engine**

1 - EXHAUST MANIFOLD

exhaust gases to the exhaust pipes attached to the manifolds.

**REMOVAL**

- (1) Disconnect the negative cable from the battery.
- (2) Raise and support the vehicle.
- (3) Remove the bolts and nuts attaching the exhaust pipe to the engine exhaust manifold.
- (4) Lower the vehicle.
- (5) Remove the exhaust heat shields (Fig. 76).



J9411-14

**Fig. 76 8.0L Engine Exhaust Manifold—Typical**

1 - EXHAUST MANIFOLD  
2 - HEAT SHIELD

- (6) Remove the dipstick bracket from the exhaust manifold (right side only).

- (7) Remove bolts attaching manifold to cylinder head.

- (8) Remove manifold from the cylinder head. Discard the gasket.

**CLEANING**

Clean mating surfaces on cylinder head and manifold. Wash with solvent and blow dry with compressed air.

**INSPECTION**

Inspect manifold for cracks.

Inspect mating surfaces of manifold for flatness with a straight edge. Gasket surfaces must be flat within 0.2 mm per 300 mm (0.008 inch per foot).

**INSTALLATION**

- (1) Using a new gasket position the engine exhaust manifold onto the cylinder head. Install bolts and stud bolts in the proper position. (Fig. 76) Tighten the bolts to 22 N·m (16 ft. lbs.) torque.

- (2) Install the dipstick bracket on to the exhaust manifold (right side only).

- (3) Position washers and exhaust heat shields onto the manifold stud bolts (Fig. 76). Be sure the tabs on the heat shields are hooked over the top of the exhaust gasket. Install the nuts and tighten to 20 N·m (175 in. lbs.) torque.

- (4) Raise and support the vehicle.
- (5) Assemble exhaust pipe to manifold.
- (6) Lower the vehicle.
- (7) Connect the negative cable to the battery.
- (8) Start engine check for leaks.

**TIMING BELT / CHAIN COVER(S)****REMOVAL**

- (1) Disconnect the negative cable from the battery.
- (2) Drain cooling system (Refer to 7 - COOLING - STANDARD PROCEDURE).

- (3) Remove the serpentine belt (Refer to 7 - COOLING/ACCESSORY DRIVE/DRIVE BELTS - REMOVAL).

- (4) Remove fan and fan shroud (Refer to 7 - COOLING/ENGINE/RADIATOR FAN - REMOVAL).

- (5) Unbolt A/C compressor and set on top of engine.

- (6) Remove generator, air pump, and bracket assembly.

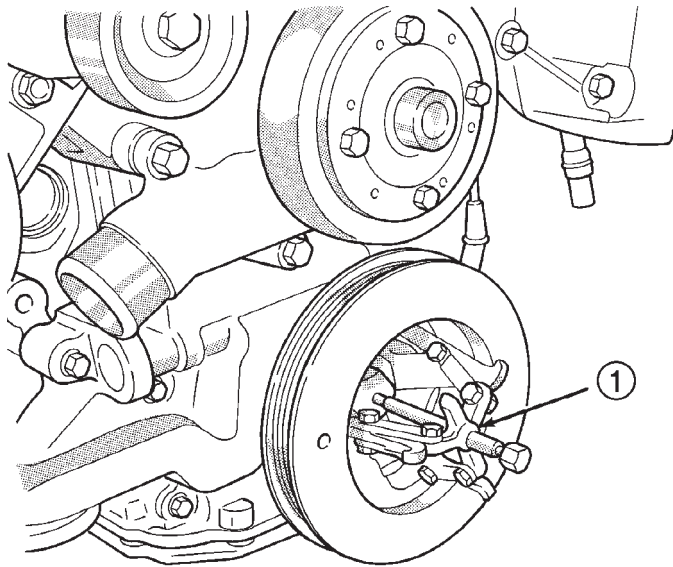
- (7) Remove water pump (Refer to 7 - COOLING/ENGINE/WATER PUMP - REMOVAL).

- (8) Remove damper bolt and washer.

- (9) Using Special Tool 1026 3-Jaw Puller remove pulley/damper from the crankshaft. (Fig. 77)



## TIMING BELT / CHAIN COVER(S) (Continued)



J9409-138

**Fig. 77 Pulley—Damper Removal**

1 - 3 JAW PULLER

(10) Loosen oil pan bolts and remove the front oil pan bolts that mount the pan to the timing chain cover.

(11) Remove the cover bolts.

(12) Remove timing chain cover and gasket using extreme caution to avoid damaging oil pan gasket.

(13) Inspect surface of cover. Remove any burrs or high spots.

**INSTALLATION**

(1) Be sure mating surfaces of timing chain cover and cylinder block are clean and free from burrs.

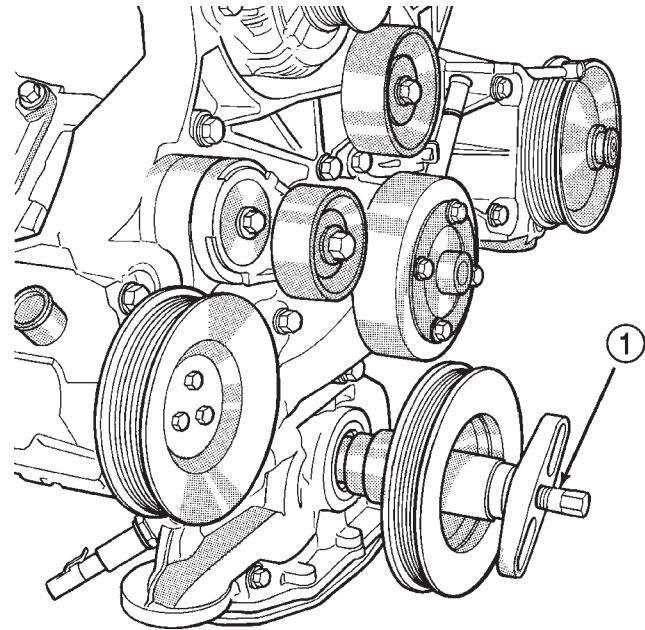
(2) Lubricate the pump rotors using petroleum jelly or lubriplate (Refer to 9 - ENGINE/LUBRICATION/OIL PUMP - INSTALLATION).

(3) Using a new cover gasket, carefully install timing chain cover to avoid damaging oil pan gasket. Use a small amount of Mopar® Silicone Rubber Adhesive Sealant, or equivalent, at the joint between timing chain cover gasket and the oil pan gasket. Finger tighten the timing chain cover bolts at this time.

(4) Tighten timing chain cover bolts to 47 N·m (35 ft. lbs.) torque. Tighten oil pan bolts to 24 N·m (215 in. lbs.) torque.

(5) Using Special Tool C-3688 Crankshaft Pulley/Damper Installer Install pulley/vibration damper (Fig. 78)

(6) Prime oil pump by squirting oil in the oil filter mounting hole and filling the J-trap of the front timing cover. When oil is running out, install oil filter that has been filled with oil.



J9409-142

**Fig. 78 Installing Crankshaft**

1 - SPECIAL TOOL C-3688

(7) Install water pump and housing assembly using new o-ring (Refer to 7 - COOLING/ENGINE/WATER PUMP - INSTALLATION).

(8) Install generator, air pump, and bracket assembly.

(9) Install A/C compressor (Refer to 24 - HEATING & AIR CONDITIONING/PLUMBING/A/C COMPRESSOR - INSTALLATION).

(10) (10) Install the radiator fan (Refer to 7 - COOLING/ENGINE/RADIATOR FAN - INSTALLATION).

(11) Position the fan shroud and install the bolts. Tighten the bolts to 11 N·m (95 in. lbs.) torque.

(12) Install the serpentine belt (Refer to 7 - COOLING/ACCESSORY DRIVE/DRIVE BELTS - INSTALLATION).

(13) Fill cooling system (Refer to 7 - COOLING - STANDARD PROCEDURE).

(14) Connect the negative cable to the battery.

(15) Road test vehicle and check for leaks.

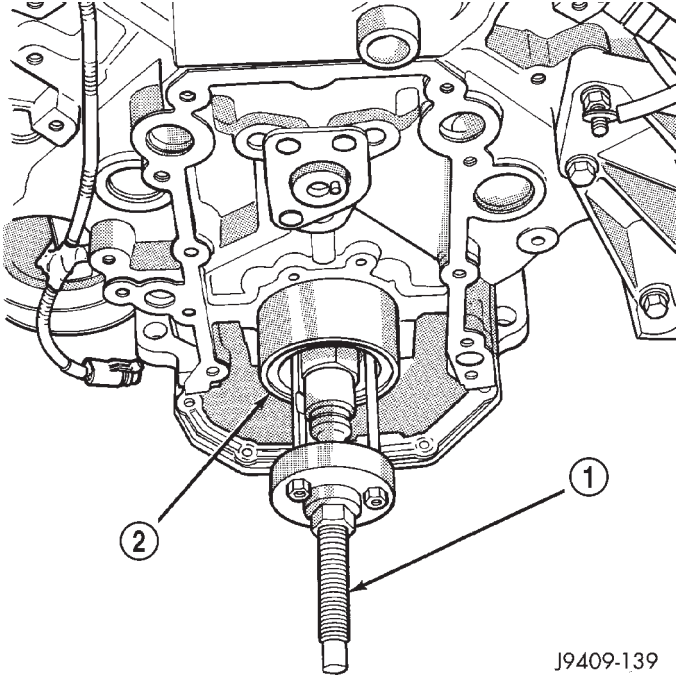
**TIMING BELT/CHAIN AND SPROCKETS****REMOVAL**

(1) Remove timing chain cover and gasket using extreme caution to avoid damaging oil pan gasket (Refer to 9 - ENGINE/VALVE TIMING/TIMING BELT / CHAIN COVER(S) - REMOVAL).

## TIMING BELT/CHAIN AND SPROCKETS (Continued)

(2) Aline camshaft and crankshaft centerline. Remove camshaft sprocket attaching bolt and remove timing chain and camshaft sprockets.

(3) Use puller 6444 and jaws 6820 to remove crankshaft sprocket (Fig. 79).



**Fig. 79 Crankshaft Sprocket Removal.**

- 1 - SPECIAL TOOL 6444  
2 - SPECIAL TOOL 6820

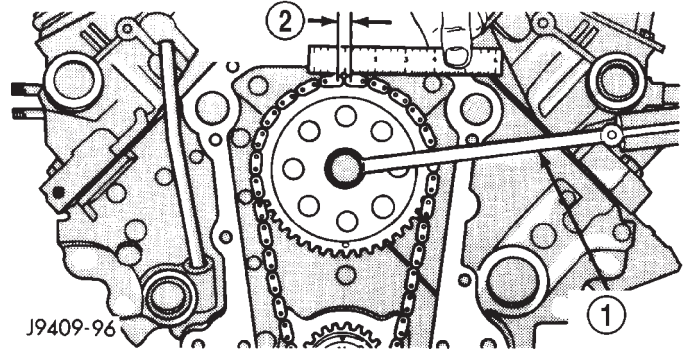
## INSPECTION—MEASURING TIMING CHAIN STRETCH

(1) Place a scale next to the timing chain so that any movement of the chain may be measured.

(2) Place a torque wrench and socket over camshaft sprocket attaching bolt. Apply torque in the direction of crankshaft rotation to take up slack; 41 N·m (30 ft. lbs.) torque with cylinder head installed or 20 N·m (15 ft. lbs.) torque with cylinder head removed. With a torque applied to the camshaft sprocket bolt, crankshaft should not be permitted to move. It may be necessary to block the crankshaft to prevent rotation.

(3) Hold a scale with dimensional reading even with the edge of a chain link. With cylinder heads installed, apply 14 N·m (30 ft. lbs.) torque in the reverse direction. With the cylinder heads removed, apply 20 N·m (15 ft. lbs.) torque in the reverse direction. Note the amount of chain movement (Fig. 80).

(4) Install a new timing chain, if its movement exceeds 3.175 mm (1/8 inch).

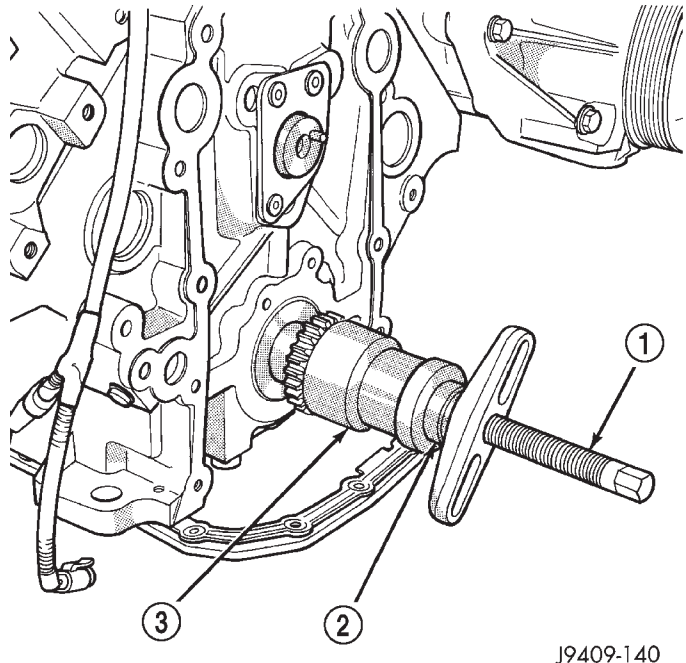


**Fig. 80 Measuring Timing Chain Stretch**

- 1 - TORQUE WRENCH  
2 - 3.175 MM (0.125 IN.)

## INSTALLATION

(1) Line up key in crankshaft with keyway in sprocket, press on crankshaft timing sprocket, use tools C-3688, C-3718 and MB-990799, seat sprocket against crankshaft shoulder (Fig. 81).



**Fig. 81 Crankshaft Sprocket Installation**

- 1 - SPECIAL TOOL C-3688  
2 - SPECIAL TOOL C-3718  
3 - SPECIAL TOOL MD990799



## TIMING BELT/CHAIN AND SPROCKETS (Continued)

(2) Turn crankshaft to line up the timing mark with the crankshaft and camshaft centerline.

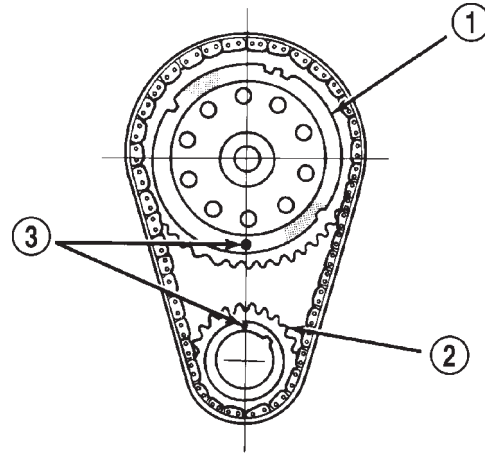
(3) Put chain on camshaft sprocket.

(4) Align timing marks and install chain and camshaft sprocket onto crankshaft sprocket. Check to see that timing marks are on the centerline of the crankshaft and camshaft centerline (Fig. 82).

(5) Install the camshaft bolt. Tighten the bolt to 61 N·m (45 ft. lbs.) torque.

(6) Check camshaft end play. The end play should be 0.051-0.152 mm (0.002-0.006 inch) with a new thrust plate and up to 0.254 mm (0.010 inch) with a used thrust plate. If not within these limits install a new thrust plate.

(7) Install timing chain cover (Refer to 9 - ENGINE/VALVE TIMING/TIMING BELT / CHAIN COVER(S) - INSTALLATION).



J9409-69

**Fig. 82 Alignment of Timing Marks**

- 1 - CAMSHAFT SPROCKET
- 2 - CRANKSHAFT SPROCKET
- 3 - TIMING MARKS

## ENGINE 5.9L DIESEL

## TABLE OF CONTENTS

	page		page
<b>ENGINE 5.9L DIESEL</b>		<b>INSPECTION</b> . . . . .	267
DESCRIPTION . . . . .	231	<b>CAMSHAFT &amp; BEARINGS (IN BLOCK)</b>	
DIAGNOSIS AND TESTING . . . . .	232	REMOVAL . . . . .	268
ENGINE DIAGNOSIS - MECHANICAL . . . . .	232	INSPECTION . . . . .	272
SMOKE DIAGNOSIS CHARTS . . . . .	234	INSTALLATION . . . . .	273
STANDARD PROCEDURE . . . . .	237	<b>CONNECTING ROD BEARINGS</b>	
FORM-IN-PLACE GASKETS AND SEALERS . . . . .	237	STANDARD PROCEDURE . . . . .	274
REPAIR DAMAGED OR WORN THREADS . . . . .	238	CONNECTING ROD BEARING AND	
HYDROSTATIC LOCK . . . . .	238	CRANKSHAFT JOURNAL CLEARANCE . . . . .	274
REMOVAL . . . . .	238	<b>CRANKSHAFT</b>	
INSTALLATION . . . . .	241	DESCRIPTION . . . . .	275
SPECIFICATIONS . . . . .	242	<b>CRANKSHAFT MAIN BEARINGS</b>	
SPECIAL TOOLS . . . . .	244	STANDARD PROCEDURE . . . . .	275
<b>ENGINE DATA PLATE</b>		MAIN BEARING CLEARANCE . . . . .	275
DESCRIPTION . . . . .	244	<b>CRANKSHAFT OIL SEAL - FRONT</b>	
<b>AIR CLEANER ELEMENT</b>		REMOVAL . . . . .	276
REMOVAL . . . . .	244	INSTALLATION . . . . .	277
INSTALLATION . . . . .	245	<b>CRANKSHAFT OIL SEAL - REAR</b>	
<b>CYLINDER HEAD</b>		REMOVAL . . . . .	278
DESCRIPTION . . . . .	246	INSTALLATION . . . . .	278
REMOVAL . . . . .	246	<b>CRANKSHAFT REAR OIL SEAL RETAINER</b>	
CLEANING . . . . .	248	REMOVAL . . . . .	278
INSPECTION . . . . .	250	INSTALLATION . . . . .	279
INSTALLATION . . . . .	250	<b>SOLID LIFTERS/TAPPETS</b>	
<b>CYLINDER HEAD COVER(S)</b>		REMOVAL . . . . .	280
REMOVAL . . . . .	253	CLEANING . . . . .	281
CLEANING . . . . .	253	INSPECTION . . . . .	281
INSPECTION . . . . .	253	INSTALLATION . . . . .	281
INSTALLATION . . . . .	253	<b>PISTON &amp; CONNECTING ROD</b>	
<b>INTAKE/EXHAUST VALVES &amp; SEATS</b>		DESCRIPTION . . . . .	282
DESCRIPTION . . . . .	253	STANDARD PROCEDURE . . . . .	282
STANDARD PROCEDURE . . . . .	253	PISTON GRADING . . . . .	282
VALVES, GUIDES AND SPRINGS . . . . .	253	REMOVAL . . . . .	285
VALVE LASH ADJUSTMENT AND		CLEANING . . . . .	285
VERIFICATION . . . . .	256	INSPECTION . . . . .	285
REMOVAL . . . . .	258	INSTALLATION . . . . .	287
INSTALLATION . . . . .	260	<b>PISTON RINGS</b>	
<b>ROCKER ARM / ADJUSTER ASSY</b>		STANDARD PROCEDURE . . . . .	288
DESCRIPTION . . . . .	261	PISTON RINGS - FITTING . . . . .	288
REMOVAL . . . . .	261	<b>VIBRATION DAMPER</b>	
CLEANING . . . . .	262	REMOVAL . . . . .	289
INSPECTION . . . . .	262	INSPECTION . . . . .	289
INSTALLATION . . . . .	263	INSTALLATION . . . . .	289
<b>ENGINE BLOCK</b>		<b>FRONT MOUNT</b>	
STANDARD PROCEDURE . . . . .	263	REMOVAL . . . . .	290
CYLINDER BORE REFACING . . . . .	263	INSTALLATION . . . . .	290
CYLINDER BORE DE-GLAZE . . . . .	264	<b>REAR MOUNT</b>	
CYLINDER BORE REPAIR . . . . .	265	REMOVAL . . . . .	291
CAM BORE REPAIR . . . . .	267	INSTALLATION . . . . .	291

**LUBRICATION**

DESCRIPTION .....	292
OPERATION .....	292
DIAGNOSIS AND TESTING .....	295
ENGINE OIL PRESSURE .....	295

**OIL**

STANDARD PROCEDURE .....	295
ENGINE OIL LEVEL .....	295
ENGINE OIL SERVICE .....	295

**OIL COOLER & LINES**

CLEANING .....	296
----------------	-----

**OIL FILTER**

REMOVAL .....	296
INSTALLATION .....	296

**OIL PAN**

REMOVAL .....	296
CLEANING .....	297
INSPECTION .....	297
INSTALLATION .....	297

**OIL PRESSURE RELIEF VALVE**

REMOVAL .....	297
CLEANING .....	297
INSPECTION .....	297
INSTALLATION .....	298

**OIL PRESSURE SENSOR/SWITCH**

DESCRIPTION .....	298
-------------------	-----

OPERATION .....	298
REMOVAL .....	298
INSTALLATION .....	299

**OIL PUMP**

REMOVAL .....	299
CLEANING .....	299
INSPECTION .....	299
INSTALLATION .....	300

**INTAKE MANIFOLD**

REMOVAL .....	301
CLEANING .....	302
INSPECTION .....	302
INSTALLATION .....	302

**EXHAUST MANIFOLD**

REMOVAL .....	303
CLEANING .....	304
INSPECTION .....	304
INSTALLATION .....	304

**GEAR HOUSING**

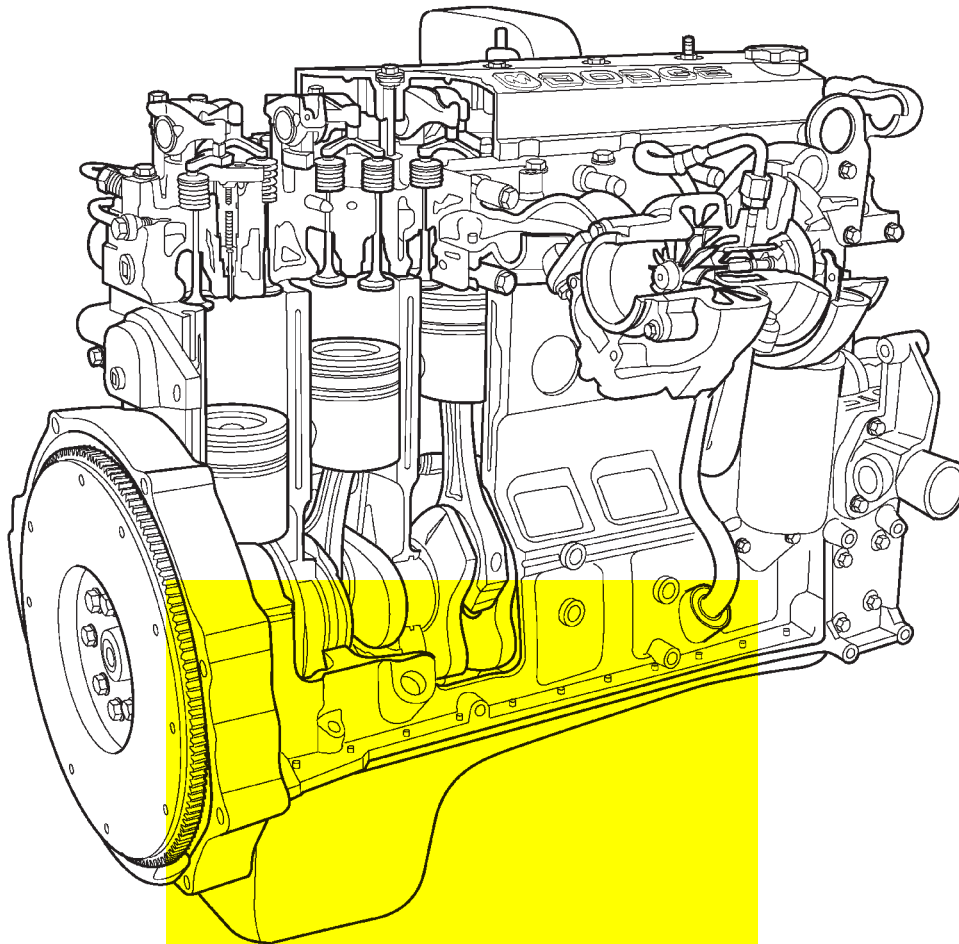
REMOVAL .....	304
INSTALLATION .....	305

**GEAR HOUSING COVER**

REMOVAL .....	306
INSTALLATION .....	307

## ENGINE 5.9L DIESEL

## DESCRIPTION



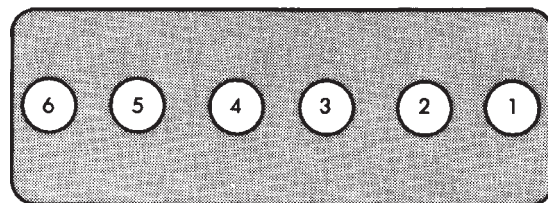
**Cummins® 24 Valve Turbo Diesel Engine**

80c06e38

The cylinder block is constructed of cast iron. The casting is a skirted design which incorporates longitudinal ribs for superior strength and noise reduction. The block incorporates metric straight thread o-ring fittings at lubrication oil access points. The engine is manufactured with the cylinders being a non-sleeved type cylinder. However, one approved service method is to bore out the cylinders and add cylinder sleeves to the cylinder block.

The cylinders are numbered front front to rear (Fig. 1); 1 to 6. The firing order is 1-5-3-6-2-4.

1-5-3-6-2-4



J9409-107

**Fig. 1 Cylinder Numbering**

## ENGINE 5.9L DIESEL (Continued)

## DIAGNOSIS AND TESTING—ENGINE DIAGNOSIS - MECHANICAL

CONDITION	POSSIBLE CAUSES	CORRECTION
LUBRICATING OIL PRESSURE LOW	<ol style="list-style-type: none"> <li>1. Low oil level.</li> <li>2. Oil viscosity thin, diluted or wrong specification.</li> <li>3. Improperly operating pressure switch/gauge.</li> <li>4. Relief valve stuck open.</li> <li>5. Plugged oil filter.</li> <li>6. If cooler was replaced, shipping plugs may have been left in cooler</li> <li>7. Worn oil pump.</li> <li>8. Suction tube loose or seal leaking.</li> <li>9. Loose main bearing cap.</li> <li>10. Worn bearings or wrong bearings installed.</li> <li>11. Oil jet under piston bad fit into main carrier.</li> </ol>	<ol style="list-style-type: none"> <li>1. (a) Check and fill with clean engine oil.  (b) Check for a severe external oil leak that could reduce the pressure.</li> <li>2. Verify the correct engine oil is being used. (Refer to LUBRICATION &amp; MAINTENANCE/FLUID TYPES - DESCRIPTION).</li> <li>3. Verify the pressure switch is functioning correctly. If not, replace switch/gauge.</li> <li>4. Check/replace valve.</li> <li>5. Change oil filter.</li> <li>6. Check/remove shipping plugs.</li> <li>7. Check and replace oil pump.</li> <li>8. Check and replace seal.</li> <li>9. Check and install new bearing. Tighten cap to proper torque.</li> <li>10. Inspect and replace connecting rod or main bearings. Check and replace piston cooling nozzles.</li> <li>11. Check oil jet position.</li> </ol>
LUBRICATING OIL PRESSURE TOO HIGH	<ol style="list-style-type: none"> <li>1. Pressure switch/gauge not operating properly.</li> <li>2. Engine running to cold.</li> <li>3. Oil viscosity too thick.</li> <li>4. Oil pressure relief valve stuck closed or binding</li> </ol>	<ol style="list-style-type: none"> <li>1. Verify pressure switch is functioning correctly. If not, replace switch/gauge.</li> <li>2. Refer to Coolant Temperature Below Normal (Refer to 7 - COOLING - DIAGNOSIS AND TESTING).</li> <li>3. Make sure the correct oil is being used. (Refer to LUBRICATION &amp; MAINTENANCE/FLUID TYPES - DESCRIPTION).</li> <li>4. Check and replace valve.</li> </ol>
LUBRICATING OIL LOSS	<ol style="list-style-type: none"> <li>1. External leaks.</li> <li>2. Crankcase being overfilled.</li> <li>3. Incorrect oil specification or viscosity.</li> </ol>	<ol style="list-style-type: none"> <li>1. Visually inspect for oil leaks. Repair as required.</li> <li>2. Verify that the correct dipstick is being used.</li> <li>3. (a) Make sure the correct oil is being used (Refer to LUBRICATION &amp; MAINTENANCE/FLUID TYPES - DESCRIPTION).  (b) Look for reduced viscosity from dilution with fuel.  (c) Review/reduce oil change intervals.</li> </ol>

## ENGINE 5.9L DIESEL (Continued)

CONDITION	POSSIBLE CAUSES	CORRECTION
	4. Oil cooler leak 5. High blow-by forcing oil out the breather. 6. Turbocharger leaking oil to the air intake. 7. Piston rings not sealing (oil being consumed by the engine).	4. Check and replace the oil cooler. 5. Check the breather tube area for signs of oil loss. Perform the required repairs. 6. Inspect the air ducts for evidence of oil transfer. Repair as required. 7. Perform blow-by check. Repair as required.
COMPRESSION KNOCKS	1. Air in the fuel system.  2. Poor quality fuel or water/gasoline contaminated fuel.  3. Engine overloaded.  4. Incorrect injection pump timing.  5. Improperly operating injectors.	1. Bleed the fuel system (Refer to 14 - FUEL SYSTEM/FUEL DELIVERY - STANDARD PROCEDURE). 2. Verify by operating from a temporary tank with good fuel. Clean and flush the fuel tank. Replace fuel/water separator filter. 3. Verify the engine load rating is not being exceeded. 4. Check injection pump for proper installation. 5. Check and replace inoperative injectors.
EXCESSIVE VIBRATION	1. Loose or broken engine mounts. 2. Damaged fan or improperly operating accessories. 3. Improperly operating vibration damper 4. Improperly operating viscous fan drive. 5. Worn or damaged generator bearing. 6. Flywheel housing misaligned. 7. Loose or broken power component.  8. Worn or unbalanced driveline components.	1. Replace engine mounts. 2. Check and replace the vibrating components. 3. Inspect/replace vibration damper.  4. Inspect/replace fan drive.  5. Check/replace generator.  6. Check/correct flywheel alignment. 7. Inspect the crankshaft and rods for damage that causes an unbalance condition. Repair/replace as required. 8. Check/repair driveline components.
EXCESSIVE ENGINE NOISES	1. Drive belt squeal, insufficient tension or abnormally high loading.  2. Intake air or exhaust leaks.  3. Excessive valve lash.	1. Check the automatic tensioner and inspect the drive belt. Make sure water pump, tensioner pulley, fan hub and generator turn freely. 2. Refer to Excessive Exhaust Smoke (Refer to 9 - ENGINE - DIAGNOSIS AND TESTING). 3. Adjust valves. Make sure the push rods are not bent and rocker arms, adjusting screws, crossheads, are not severely worn. Replace bent or severely worn components.



## ENGINE 5.9L DIESEL (Continued)

CONDITION	POSSIBLE CAUSES	CORRECTION
	4. Turbocharger noise.	4. Check turbocharger impeller and turbine wheel for housing contact. Repair/replace as required.
	5. Gear train noise.	5. Visually inspect and measure gear backlash. Replace gears as required.
	6. Power function knock.	6. Check/replace rod and main bearings.

## DIAGNOSIS AND TESTING—SMOKE DIAGNOSIS CHARTS

The following charts include possible causes and corrections for **excess or abnormal** exhaust smoke.

Small amounts of exhaust smoke (at certain times) are to be considered normal for a diesel powered engine.

EXCESSIVE BLACK SMOKE	
POSSIBLE CAUSE	CORRECTION
Air filter dirty or plugged.	Check Filter Minder® at air filter (Refer to 9 - ENGINE/AIR INTAKE SYSTEM/AIR CLEANER ELEMENT - REMOVAL).
Air intake system restricted.	Check entire air intake system including all hoses and tubes for restrictions, collapsed parts or damage. Repair/replace as necessary.
Air Leak in Intake System.	Check entire air intake system including all hoses and tubes for cracks, loose clamps and/or holes in rubber ducts. Also check intake manifold for loose mounting hardware.
Diagnostic Trouble Codes (DTC's) active or multiple, intermittent DTC's.	Refer to Powertrain Diagnostic Procedures Information.
Engine Control Module (ECM) not calibrated or ECM has incorrect calibration.	Refer to Powertrain Diagnostic Procedures Information.
Exhaust system restriction is above specifications.	Check exhaust pipes for damage/restrictions. Repair as necessary.
Fuel grade is not correct or fuel quality is poor.	Temporarily change fuel brands and note condition. Change brand if necessary.
Fuel injection pump malfunctioning.	A DTC should have been set. If so, refer to Powertrain Diagnostic Procedures Information.
Fuel injector malfunctioning.	A DTC should have been set. Perform "Cylinder Balance Test" using DRB scan tool to isolate individual cylinders. Also refer to Powertrain Diagnostic Procedures Information and, to (Refer to 14 - FUEL SYSTEM/FUEL INJECTION/FUEL INJECTOR - DIAGNOSIS AND TESTING).
Fuel return system restricted.	Check fuel return line by checking overflow valve (Refer to 14 - FUEL SYSTEM/FUEL DELIVERY - DIAGNOSIS AND TESTING).
Intake manifold restricted.	Remove restriction.
Manifold Air Pressure (Boost) Sensor or sensor circuit malfunctioning.	A DTC should have been set. Refer to Powertrain Diagnostic Procedures Information.

## ENGINE 5.9L DIESEL (Continued)

<b>EXCESSIVE BLACK SMOKE</b>	
<b>POSSIBLE CAUSE</b>	<b>CORRECTION</b>
Raw fuel in intake manifold.	Fuel injectors leaking on engine shutdown. Do Fuel Injector Test (Refer to 14 - FUEL SYSTEM/FUEL INJECTION/FUEL INJECTOR - DIAGNOSIS AND TESTING).
Static timing not correct.	A DTC should have been set. If so, refer to Powertrain Diagnostic Procedures Information. Also (Refer to 14 - FUEL SYSTEM/FUEL DELIVERY/FUEL INJECTION PUMP - DIAGNOSIS AND TESTING).
Turbocharger air intake restriction.	Remove restriction.
Turbocharger damaged.	(Refer to 11 - EXHAUST SYSTEM/TURBOCHARGER SYSTEM/TURBOCHARGER - INSPECTION).
Turbocharger has excess build up on compressor wheel and/or diffuser vanes.	(Refer to 11 - EXHAUST SYSTEM/TURBOCHARGER SYSTEM/TURBOCHARGER - CLEANING).
Turbocharger wheel clearance out of specification.	(Refer to 11 - EXHAUST SYSTEM/TURBOCHARGER SYSTEM/TURBOCHARGER - INSPECTION).

<b>EXCESSIVE WHITE SMOKE</b>	
<b>POSSIBLE CAUSE</b>	<b>CORRECTION</b>
Air in fuel supply: Possible leak in fuel supply side (between transfer pump and fuel tank module).	(Refer to 14 - FUEL SYSTEM/FUEL DELIVERY/FUEL TRANSFER PUMP - DIAGNOSIS AND TESTING).
Coolant leaking into combustion chamber.	Do pressure test of cooling system (Refer to 7 - COOLING - DIAGNOSIS AND TESTING).
Diagnostic Trouble Codes (DTC's) active or multiple, intermittent DTC's.	Refer to Powertrain Diagnostic Procedures Information.
In very cold ambient temperatures, engine block heater is malfunctioning (if equipped).	(Refer to 7 - COOLING/ENGINE/ENGINE BLOCK HEATER - REMOVAL).
Engine coolant temperature sensor malfunctioning.	A DTC should have been set. Refer to Powertrain Diagnostic Procedures Information. Also check thermostat operation (Refer to 7 - COOLING/ENGINE/ENGINE COOLANT THERMOSTAT - DIAGNOSIS AND TESTING).
Engine Control Module (ECM) not calibrated or has incorrect calibration.	A DTC should have been set. Refer to Powertrain Diagnostic Procedures Information.
Fuel filter plugged.	Perform Fuel Pressure Drop Test (Refer to 14 - FUEL SYSTEM/FUEL DELIVERY/FUEL TRANSFER PUMP - DIAGNOSIS AND TESTING).
Fuel grade not correct or fuel quality is poor.	Temporarily change fuel brands and note condition. Change brand if necessary.
Fuel heater element or fuel heater temperature sensor malfunctioning. This will cause wax type build-up in fuel filter.	Refer to Fuel Heater Testing (Refer to 14 - FUEL SYSTEM/FUEL DELIVERY/FUEL HEATER - DIAGNOSIS AND TESTING).
Fuel injector malfunctioning.	A DTC should have been set. Perform "Cylinder Balance Test" using DRB scan tool to isolate individual cylinders. Also refer to Powertrain Diagnostic Procedures Information and, (Refer to 14 - FUEL SYSTEM/FUEL INJECTION/FUEL INJECTOR - DIAGNOSIS AND TESTING).
Fuel injector hold-downs loose.	Torque to specifications.

## ENGINE 5.9L DIESEL (Continued)

<b>EXCESSIVE WHITE SMOKE</b>	
<b>POSSIBLE CAUSE</b>	<b>CORRECTION</b>
Fuel injector protrusion not correct.	Check washer (shim) at bottom of fuel injector for correct thickness. (Refer to 14 - FUEL SYSTEM/FUEL INJECTION/FUEL INJECTOR - INSTALLATION)
Fuel injection pump malfunctioning.	A DTC should have been set. Refer to Powertrain Diagnostic Procedures Information.
Fuel supply side restriction to transfer pump.	Refer to Fuel Transfer Pump Pressure (Refer to 14 - FUEL SYSTEM/FUEL DELIVERY/FUEL TRANSFER PUMP - DIAGNOSIS AND TESTING)
Fuel transfer (lift) pump malfunctioning.	A DTC should have been set. Refer to Powertrain Diagnostic Procedures Information. Also refer to Fuel Transfer Pump Pressure Testing (Refer to 14 - FUEL SYSTEM/FUEL DELIVERY/FUEL TRANSFER PUMP - DIAGNOSIS AND TESTING).
Intake/Exhaust valve adjustments not correct (too tight).	(Refer to 9 - ENGINE/CYLINDER HEAD/INTAKE/EXHAUST VALVES & SEATS - STANDARD PROCEDURE).
Intake manifold air temperature sensor malfunctioning.	A DTC should have been set. Refer to Powertrain Diagnostic Procedures Information.
Intake manifold heater circuit not functioning correctly in cold weather.	A DTC should have been set. Refer to Powertrain Diagnostic Procedures Information. Also check heater elements for correct operation.
Intake manifold heater elements not functioning correctly in cold weather.	A diagnostic trouble code WILL NOT BE SET if heater elements are malfunctioning. Refer to NTC tests in Powertrain Diagnostic Procedures Information.
Internal engine damage (scuffed cylinder).	Analyze engine oil and inspect oil filter to locate area of probable damage.
Restriction in fuel supply side of fuel system.	Refer to Fuel Transfer Pump Pressure Testing (Refer to 14 - FUEL SYSTEM/FUEL DELIVERY/FUEL TRANSFER PUMP - DIAGNOSIS AND TESTING).
Static timing incorrect.	A DTC should have been set. If so, (Refer to 14 - FUEL SYSTEM/FUEL DELIVERY/FUEL INJECTION PUMP - DIAGNOSIS AND TESTING).

<b>EXCESSIVE BLUE SMOKE</b>	
<b>POSSIBLE CAUSE</b>	<b>CORRECTION</b>
Dirty air cleaner or restricted turbocharger intake duct.	Check Filter Minder® at air filter housing. (Refer to 9 - ENGINE/AIR INTAKE SYSTEM/AIR CLEANER ELEMENT - REMOVAL).
Air leak in boost system between turbocharger compressor outlet and intake manifold.	Service air charge system..
Obstruction in exhaust manifold.	Remove exhaust manifold and inspect for blockage (Refer to 9 - ENGINE/MANIFOLDS/EXHAUST MANIFOLD - REMOVAL).
Restricted turbocharger drain tube.	Remove turbocharger drain tube and remove obstruction.
Crankcase ventilation system plugged.	Inspect crankcase breather and vent tube for sludge formation or obstructions.

## ENGINE 5.9L DIESEL (Continued)

EXCESSIVE BLUE SMOKE	
POSSIBLE CAUSE	CORRECTION
Valve seals are worn, brittle, or improperly installed.	Replace valve stem oil seals (Refer to 9 - ENGINE/CYLINDER HEAD/INTAKE/EXHAUST VALVES & SEATS - REMOVAL).
Valve stems and/or guides are worn.	Remove valves and inspect valves and guides. (Refer to 9 - ENGINE/CYLINDER HEAD/INTAKE/EXHAUST VALVES & SEATS - STANDARD PROCEDURE).
Broken or Improperly installed piston rings.	Tear down engine and inspect piston rings.
Excessive piston ring end gap.	Remove pistons and measure piston ring end gap (Refer to 9 - ENGINE/ENGINE BLOCK/PISTON RINGS - STANDARD PROCEDURE).
Excessive cylinder bore wear and taper.	Remove pistons and measure cylinder bore wear and taper (Refer to 9 - ENGINE/ENGINE BLOCK - STANDARD PROCEDURE).
Cylinder damage.	Remove pistons and inspect cylinder bore for cracks or porosity. Repair with cylinder liner if necessary. (Refer to 9 - ENGINE/ENGINE BLOCK - STANDARD PROCEDURE).
Piston damage.	Remove pistons and inspect for cracks, holes. Measure piston for out-of-round and taper (Refer to 9 - ENGINE/ENGINE BLOCK/PISTON & CONNECTING ROD - INSPECTION).
Turbocharger failure.	(Refer to 11 - EXHAUST SYSTEM/TURBOCHARGER SYSTEM/TURBOCHARGER - INSPECTION).

## STANDARD PROCEDURE—FORM-IN-PLACE GASKETS & SEALERS

There are numerous places where form-in-place gaskets are used on the engine. Care must be taken when applying form-in-place gaskets to assure obtaining the desired results. **Do not use form-in-place gasket material unless specified.** Bead size, continuity, and location are of great importance. Too thin a bead can result in leakage while too much can result in spill-over which can break off and obstruct fluid feed lines. A continuous bead of the proper width is essential to obtain a leak-free gasket.

There are numerous types of form-in-place gasket materials that are used in the engine area. Mopar® Engine RTV GEN II, Mopar® ATF-RTV, and Mopar® Gasket Maker gasket materials, each have different properties and can not be used in place of the other.

### MOPAR® ENGINE RTV GEN II

Mopar® Engine RTV GEN II is used to seal components exposed to engine oil. This material is a specially designed black silicone rubber RTV that retains adhesion and sealing properties when exposed to engine oil. Moisture in the air causes the material to cure. This material is available in three ounce tubes and has a shelf life of one year. After one year this material will not properly cure. Always

inspect the package for the expiration date before use.

### MOPAR® ATF RTV

Mopar® ATF RTV is a specifically designed black silicone rubber RTV that retains adhesion and sealing properties to seal components exposed to automatic transmission fluid, engine coolants, and moisture. This material is available in three ounce tubes and has a shelf life of one year. After one year this material will not properly cure. Always inspect the package for the expiration date before use.

### MOPAR® GASKET MAKER

Mopar® Gasket Maker is an anaerobic type gasket material. The material cures in the absence of air when squeezed between two metallic surfaces. It will not cure if left in the uncovered tube. The anaerobic material is for use between two machined surfaces. Do not use on flexible metal flanges.

### MOPAR® GASKET SEALANT

Mopar® Gasket Sealant is a slow drying, permanently soft sealer. This material is recommended for sealing threaded fittings and gaskets against leakage of oil and coolant. Can be used on threaded and machined parts under all temperatures. This material is used on engines with multi-layer steel (MLS) cylinder head gaskets. This material also will pre-

## ENGINE 5.9L DIESEL (Continued)

vent corrosion. Mopar® Gasket Sealant is available in a 13 oz. aerosol can or 4oz./16 oz. can w/applicator.

### FORM-IN-PLACE GASKET AND SEALER APPLICATION

Assembling parts using a form-in-place gasket requires care but it's easier than using pre-cut gaskets.

Mopar® Gasket Maker material should be applied sparingly 1 mm (0.040 in.) diameter or less of sealant to one gasket surface. Be certain the material surrounds each mounting hole. Excess material can easily be wiped off. Components should be torqued in place within 15 minutes. The use of a locating dowel is recommended during assembly to prevent smearing material off the location.

Mopar® Engine RTV GEN II or ATF RTV gasket material should be applied in a continuous bead approximately 3 mm (0.120 in.) in diameter. All mounting holes must be circled. For corner sealing, a 3.17 or 6.35 mm (1/8 or 1/4 in.) drop is placed in the center of the gasket contact area. Uncured sealant may be removed with a shop towel. Components should be torqued in place while the sealant is still wet to the touch (within 10 minutes). The usage of a locating dowel is recommended during assembly to prevent smearing material off the location.

Mopar® Gasket Sealant in an aerosol can should be applied using a thin, even coat sprayed completely over both surfaces to be joined, and both sides of a gasket. Then proceed with assembly. Material in a can w/applicator can be brushed on evenly over the sealing surfaces. Material in an aerosol can should be used on engines with multi-layer steel gaskets.

### STANDARD PROCEDURE—REPAIR DAMAGED OR WORN THREADS

**CAUTION:** Be sure that the tapped holes maintain the original center line.

Damaged or worn threads can be repaired. Essentially, this repair consists of:

- Drilling out worn or damaged threads.
- Tapping the hole with a special Heli-Coil Tap, or equivalent.
- Installing an insert into the tapped hole to bring the hole back to its original thread size.

### STANDARD PROCEDURE—HYDROSTATIC LOCK

**CAUTION:** DO NOT use the starter motor to rotate the crankshaft. Severe damage could occur.

When an engine is suspected of hydrostatic lock (regardless of what caused the problem), follow the steps below.

- (1) Disconnect the negative cable(s) from the battery.
- (2) Inspect air cleaner, induction system, and intake manifold to ensure system is dry and clear of foreign material.
- (3) Place a shop towel around the fuel injectors to catch any fluid that may possibly be under pressure in the cylinder head. Remove the fuel injectors (Refer to 14 - FUEL SYSTEM/FUEL INJECTION/FUEL INJECTOR - REMOVAL).
- (4) With all injectors removed, rotate the crankshaft using a breaker bar and socket.
- (5) Identify the fluid in the cylinders (coolant, fuel, oil, etc.).
- (6) Be sure all fluid has been removed from the cylinders.
- (7) Repair engine or components as necessary to prevent this problem from occurring again.
- (8) Squirt a small amount of engine oil into the cylinders to lubricate the walls. This will prevent damage on restart.
- (9) Install new fuel injectors (Refer to 14 - FUEL SYSTEM/FUEL INJECTION/FUEL INJECTOR - INSTALLATION).
- (10) Drain engine oil. Remove and discard the oil filter (Refer to 9 - ENGINE/LUBRICATION/OIL FILTER - REMOVAL).
- (11) Install the drain plug. Tighten the plug to 34 N·m (25 ft. lbs.) torque.
- (12) Install a new oil filter (Refer to 9 - ENGINE/LUBRICATION/OIL FILTER - INSTALLATION).
- (13) Fill engine crankcase with the specified amount and grade of oil (Refer to LUBRICATION & MAINTENANCE/FLUID TYPES - SPECIFICATIONS).
- (14) Connect the negative cable(s) to the battery.
- (15) Start the engine and check for any leaks.

### REMOVAL—ENGINE

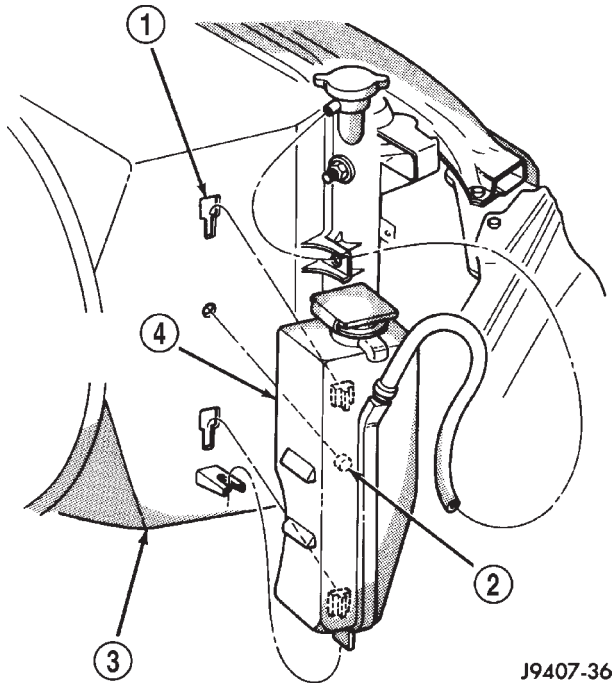
- (1) Disconnect both battery negative cables.
- (2) Recover A/C refrigerant (if A/C equipped) (Refer to 24 - HEATING & AIR CONDITIONING/PLUMBING - STANDARD PROCEDURE).
- (3) Raise vehicle on hoist.
- (4) Drain engine coolant (Refer to 7 - COOLING - STANDARD PROCEDURE).
- (5) Remove engine oil drain plug and drain engine oil.
- (6) Lower vehicle.
- (7) Remove radiator upper hose.
- (8) Remove the cooling fan shroud-to-radiator mounting bolts.



## ENGINE 5.9L DIESEL (Continued)

(9) Remove viscous fan/drive assembly (Refer to 7 - COOLING/ENGINE/RADIATOR FAN - REMOVAL). Remove the cooling fan and shroud together.

(10) Disconnect the coolant recovery bottle hose from the radiator filler neck and remove bottle from fan shroud (Fig. 2).



**Fig. 2 Coolant Recovery Bottle**

- 1 - T-SLOTS
- 2 - ALIGNMENT PIN
- 3 - FAN SHROUD
- 4 - COOLANT RESERVE/OVERFLOW TANK

(11) Disconnect heater core supply and return hoses from the cylinder head fitting and coolant pipe.

(12) Raise vehicle on hoist.

(13) Remove transmission and transfer case (if equipped.).

(14) Disconnect exhaust pipe from turbocharger extension pipe (Fig. 3).

(15) Remove starter motor (Refer to 8 - ELECTRICAL/STARTING/STARTER MOTOR - REMOVAL).

(16) Disconnect A/C suction/discharge hose from the rear of the A/C compressor.

(17) Lower vehicle.

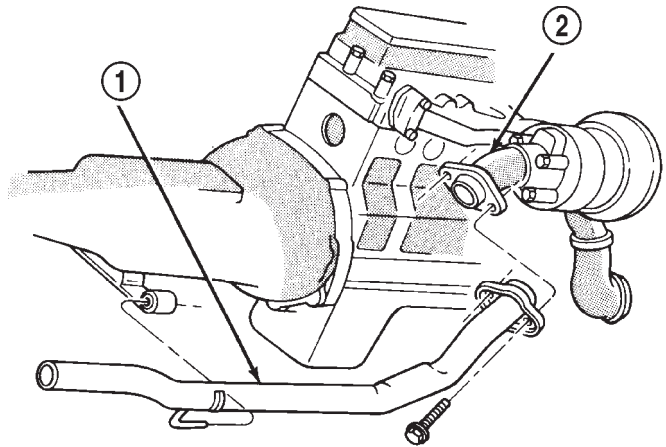
(18) Disconnect lower radiator hose from radiator outlet.

(19) **Automatic Transmission models:** Disconnect transmission oil cooler lines from radiator using special tool #6931.

(20) Remove radiator (Refer to 7 - COOLING/ENGINE/RADIATOR - REMOVAL).

(21) Remove upper radiator support panel.

(22) Remove front bumper (Refer to 13 - FRAMES & BUMPERS/BUMPERS/FRONT BUMPER - REMOVAL).



**Fig. 3 Exhaust Pipe Connection at Turbocharger**

- 1 - EXHAUST PIPE
- 2 - TURBOCHARGER EXHAUST PIPE

(23) If A/C equipped, disconnect A/C condenser refrigerant lines.

(24) Disconnect charge air cooler piping.

(25) Remove the two charge air cooler mounting bolts.

(26) Remove charge air cooler (and A/C condenser if equipped) from vehicle.

(27) Disconnect engine block heater connector.

(28) Disconnect A/C compressor electrical connectors.

(29) Remove the passenger battery ground cable from the engine block.

(30) Disconnect power steering pump pressure and return lines.

(31) Remove accelerator linkage cover.

(32) Leaving all cables attached, remove accelerator pedal position sensor assy. (APPS) (Fig. 4) from cylinder head bracket and secure out of the way.

(33) Disconnect APPS connector (Fig. 5).

(34) Disconnect vacuum pump supply hose (Fig. 6).

(35) Disconnect the engine harness and ground cable from the PDC.

(36) Disconnect the fuel supply and return hoses (Fig. 7).

(37) Remove the cylinder head cover (Refer to 9 - ENGINE/CYLINDER HEAD/CYLINDER HEAD COVER(S) - REMOVAL).

(38) Remove the #5 and #6 cylinder intake and exhaust rocker arms and pedestals (Fig. 8). Note the original location for re-assembly.

(39) Loosen but do not remove engine mount through bolts and nuts.

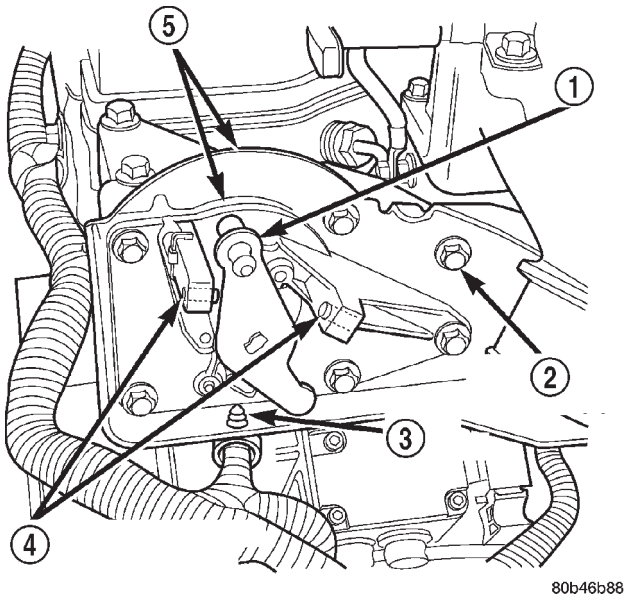
(40) Attach chain across engine lift brackets.

(41) Lift engine up and out of engine compartment.

(42) Install engine to suitable engine stand.

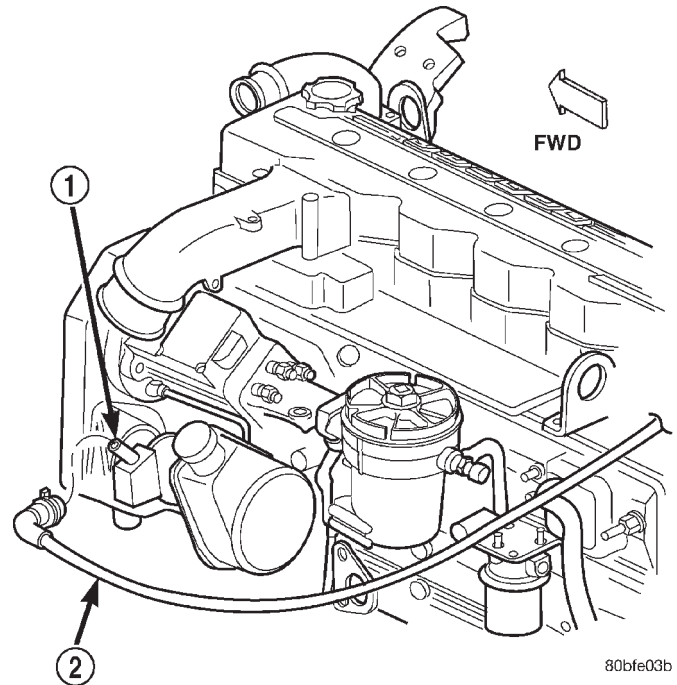


ENGINE 5.9L DIESEL (Continued)



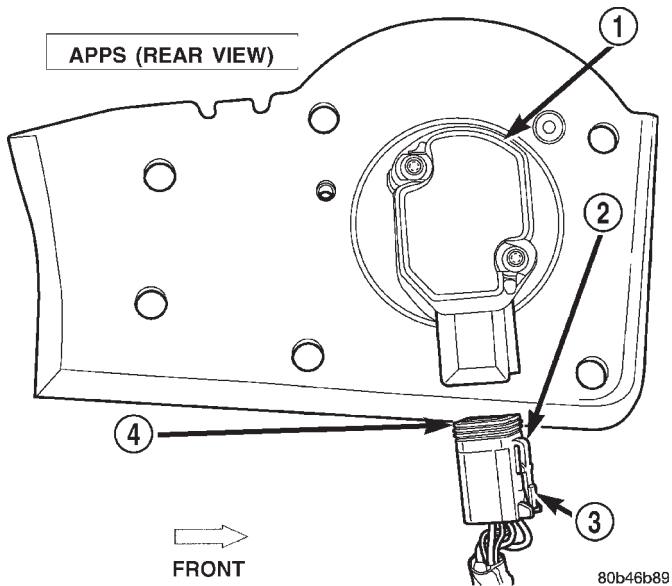
**Fig. 4 APPS Assembly**

- 1 - LEVER
- 2 - MOUNTING BOLTS (6)
- 3 - WIRE HARNESS CLIP
- 4 - CALIBRATION SCREWS (NO ADJUSTMENT)
- 5 - APPS ASSEMBLY



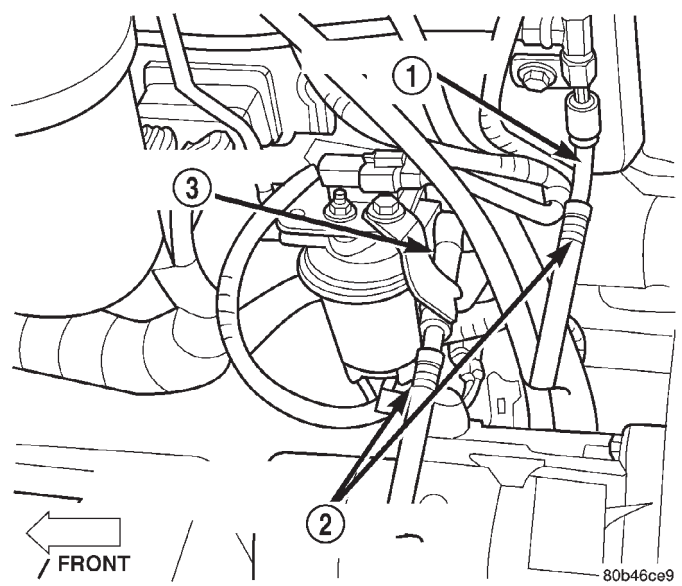
**Fig. 6 Vacuum Pump Supply Hose**

- 1 - VACUUM CHECK VALVE
- 2 - VACUUM SUPPLY LINE



**Fig. 5 APPS Connector**

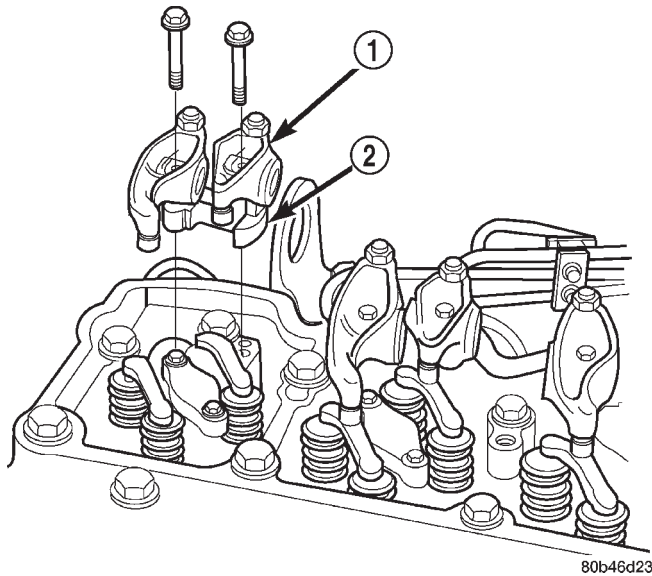
- 1 - APPS
- 2 - TAB
- 3 - PUSH FOR REMOVAL
- 4 - APPS CONNECTOR



**Fig. 7 Fuel Return and Supply Line Quick-Connect Locations**

- 1 - FUEL RETURN LINE
- 2 - QUICK-CONNECT FITTINGS
- 3 - FUEL SUPPLY LINE

## ENGINE 5.9L DIESEL (Continued)



**Fig. 8 Rocker Arm and Pedestal—Removal/Installation**

- 1 - ROCKER ARM
- 2 - PEDESTAL

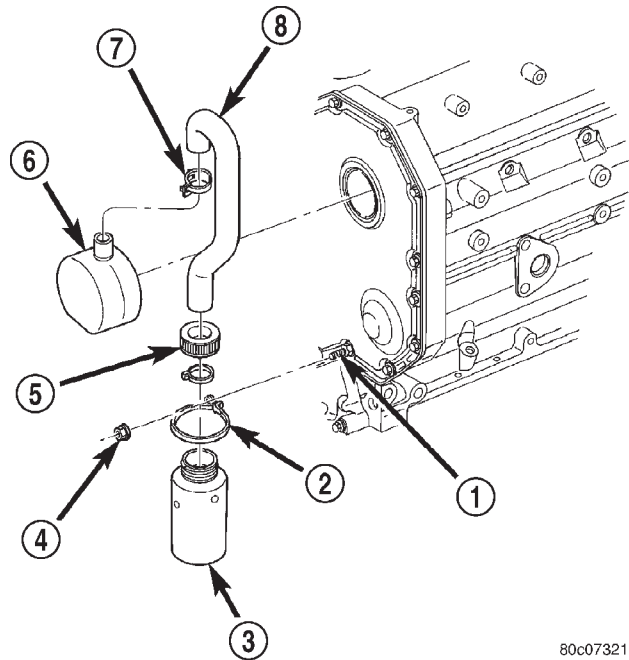
## REMOVAL—CRANKCASE BREATHER VAPOR CANISTER

**NOTE:** It is recommended to empty the contents of the vapor canister at each oil and filter service interval.

- (1) Loosen cap from top of vapor canister.
- (2) Remove nut retaining canister to engine front cover.
- (3) Slide clamp upwards on hose, then remove hose from crankcase breather.

## INSTALLATION—ENGINE

- (1) Install the engine with the cylinder head cover and the #5 and #6 rocker arm assemblies removed.
- (2) Lower the engine into the compartment and install the engine mount through bolts and nuts.
- (3) Tighten the mount through bolts and nuts to 88 N·m (65 ft. lbs.) torque.
- (4) Remove the engine lifting device.
- (5) Install the #5 and #6 rocker arms and pedestals in their original locations (Fig. 8). Torque the mounting bolts to 36 N·m (27 ft. lbs.) torque.
- (6) Install the cylinder head cover and gasket (Refer to 9 - ENGINE/CYLINDER HEAD - INSTALLATION).
- (7) Connect the fuel supply and return hoses (Fig. 7).
- (8) Connect the engine harness connector and ground cable to the PDC.
- (9) Connect the vacuum pump supply hose.



**Fig. 9 Crankcase Breather Vapor Canister**

- 1 - ENGINE FRONT COVER STUD
- 2 - STRAP
- 3 - VAPOR CANISTER
- 4 - NUT
- 5 - CAP
- 6 - CRANKCASE BREATHER
- 7 - CLAMP
- 8 - HOSE

- (10) Connect the APPS connector (Fig. 5).
- (11) Install the APPS assembly bracket to the cylinder head bracket.
- (12) Install the throttle linkage cover.
- (13) Connect the power steering pressure and return lines.
- (14) Connect the passenger battery ground cable to the engine block. Tighten the bolt to 77 N·m (57 ft. lbs.) torque.
- (15) Connect the engine block heater connector.
- (16) Connect the a/c compressor electrical connectors.
- (17) Install the charge air cooler and a/c condenser (if a/c equipped). Install and tighten the charge air cooler mounting bolts to 2 N·m (17 in. lbs.) torque.
- (18) Connect the charge air cooler piping. Torque all clamps to 8 N·m (72 in. lbs.) torque.
- (19) Connect the a/c refrigerant lines to the a/c condenser (if equipped).
- (20) Install the front bumper (Refer to 13 - FRAMES & BUMPERS/BUMPERS/FRONT BUMPER - INSTALLATION).
- (21) Install the radiator upper support panel.
- (22) Install the radiator (Refer to 7 - COOLING/ENGINE/RADIATOR - INSTALLATION).

## ENGINE 5.9L DIESEL (Continued)

(23) Connect the transmission quick-connect oil cooler lines to the radiator. Push together until an audible "click" is heard. Verify connection by pulling apart.

(24) Raise vehicle.

(25) Connect a/c compressor suction/discharge hose (if a/c equipped).

(26) Install the radiator lower hose and clamps.

(27) Install the starter motor (Refer to 8 - ELECTRICAL/STARTING/STARTER MOTOR - INSTALLATION).

(28) Install the transmission and transfer case (if equipped).

(29) Connect the exhaust pipe to the turbocharger elbow (Fig. 3). Torque the bolts to 34 N·m (25 ft. lbs.) torque.

(30) Connect the transmission auxiliary oil cooler lines (if equipped).

(31) Lower the vehicle

(32) Connect the heater core supply and return hoses.

(33) Install the cooling fan and shroud at the same time (Refer to 7 - COOLING/ENGINE/RADIATOR FAN - INSTALLATION).

(34) Install the coolant recovery bottle to the fan shroud (Fig. 2) and connect the hose to the radiator filler neck.

(35) Install the windshield washer bottle to the fan shroud and connect the pump supply hose and electrical connections.

(36) Install the radiator upper hose and clamps.

(37) Change oil filter and install new engine oil.

(38) Fill cooling system with coolant (Refer to 7 - COOLING - STANDARD PROCEDURE).

(39) Connect battery negative cables.

(40) Perform the fuel line air bleed procedure (Refer to 14 - FUEL SYSTEM/FUEL DELIVERY - STANDARD PROCEDURE).

(41) Start engine and inspect for engine oil, coolant, and fuel leaks.

## INSTALLATION—CRANKCASE BREATHER VAPOR CANISTER

(1) Position vapor canister with strap over stud on engine front cover. Install retaining nut. Tighten nut 10 N·m ( 89 in. lbs.).

(2) If removed, position hose onto crankcase breather, then position clamp.

(3) Position lower portion of hose into vapor canister, then install and tighten cap.

## SPECIFICATIONS

### 5.9L DIESEL

DESCRIPTION	SPECIFICATION
Engine Type	In-Line 6 Cyl. Turbo Diesel
Bore and Stroke	102.0 X 120.0 mm (4.02 X 4.72 in.)
Displacement	5.9L (359 cu. in.)
Compression Ratio	
245 H.P. Version	17.0:1
235 H.P. Version	16.3:1
Horsepower (A/T and 5 Speed M/T)	235 @ 2700 rpm
Horsepower (6 Speed M/T Only)	245 @ 2700 rpm
Torque Rating (A/T and 5 Speed M/T)	460 ft. lbs. @ 1600 rpm
Torque Rating (6 Speed M/T Only)	505 ft. lbs. @ 1600 rpm
Firing Order	1-5-3-6-2-4
Lubrication System	Pressure Feed-Full Flow With Bypass Valve
Cylinder Block	Cast Iron
Crankshaft	Induction Hardened Forged Steel
Cylinder Head	Cast Iron With Valve Seat Inserts
Combustion Chambers	High Swirl Bowl
Camshaft	Chilled Ductile Iron
Pistons	Cast Aluminum
Connecting Rods	Cross Rolled Micro Alloy
<b>PISTONS AND CONNECTING RODS</b>	
Piston	
Skirt Diameter	101.864 – 101.88 mm (4.0104 – 4.011 in.)
Ring Groove Clearance	
Intermediate (Max.)	0.095 mm (0.0037 in.)
Oil Control (Max.)	0.085 mm (0.0033 in.)
Piston Pins	
Pin Diameter (Min.)	39.990 mm (1.5744 in.)
Bore Diameter (Max.)	40.025 mm (1.5758 in.)
Piston Ring End Gap	
Top Ring	0.35 – 0.45 mm

## ENGINE 5.9L DIESEL (Continued)

DESCRIPTION	SPECIFICATION
Intermediate	(0.014 – 0.0177 in.) 0.85 – 1.15 mm
Oil Control	(0.0334 – 0.0452 in.) 0.250 – 0.550 mm (0.010 – 0.0215 in.)
Connecting Rods	
Pin Bore Diameter (Max.)	40.042 mm (1.5764 in.)
Side Clearance	0.100 – 0.330 mm (0.004 – 0.013 in.)
<b>CYLINDER HEAD</b>	
Overall Flatness End to End (Max.)	0.30 mm (0.012 in.)
Overall Flatness Side to Side (Max.)	0.076 mm (0.003 in.)
Intake Valve Seat Angle	30°
Exhaust Valve Seat Angle	45°
Valve Seat Width	
(Min.)	1.49 mm (0.059 in.)
(Max.)	1.80 mm (0.071 in.)
Valve Margin (Min.)	0.72 mm (0.031 in.)
<b>OIL PRESSURE</b>	
At Idle	69 kPa (10 psi)
At 2,500 rpm	207 kPa (30 psi)
Regulating Valve Opening Pressure	448 kPa (65 psi)
Oil Filter Bypass Pressure Setting	344.75 kPa (50 psi)

## TORQUE

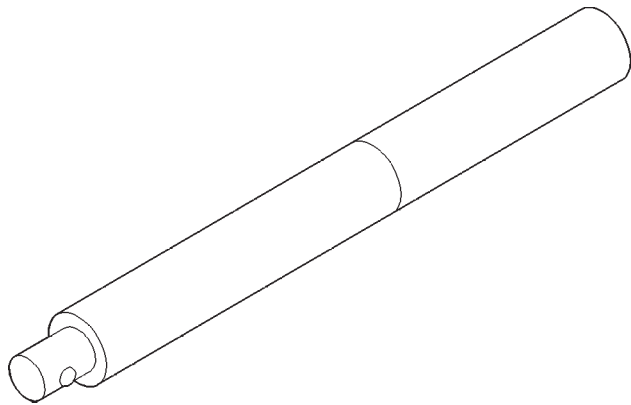
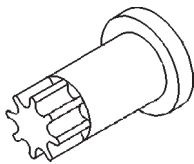
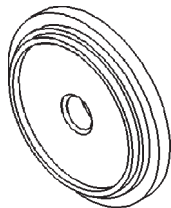
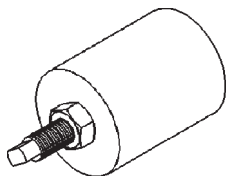
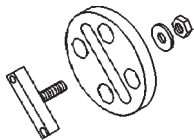
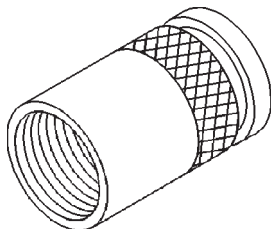
## TORQUE CHART 5.9L DIESEL ENGINE

DESCRIPTION	N-m	In. Lbs.	Ft. Lbs.
Connecting Rod—Bolts			
Step 1	35	—	26
Step 2	70	—	51
Step 3	100	—	73
Cylinder Head—Bolts			
Step 1	80	—	59
Step 2	105	—	77
Step 3 Verify	105	—	77
Step 4	Rotate All Bolts 1/4 Turn		
Cylinder Head Cover—Bolts	24	18	—
Fuel Delivery Lines (High Pressure)			
At Pump	24	—	18
At Cylinder Head	38	—	28
Fuel Drain Line—Banjo (rear of head)	24	—	18
Oil Pan—Bolts	24	—	18
Oil Pan—Drain Plug	60	—	44
Oil Pressure Regulator—Plug	80	—	60
Oil Pressure Sender/Switch	16	—	12
Oil Pump—Bolts	24	—	18
Oil Suction Tube (Flange)—Bolts	24	—	18
Oil Suction Tube (Brace)—Bolt	24	—	18
Rocker Arm/Pedestal—Bolts	36	—	27

ENGINE 5.9L DIESEL (Continued)

## SPECIAL TOOLS

## 5.9L DIESEL ENGINE

**Universal Driver Handle—C 4171****Crankshaft Barring Tool—7471-B****Crankshaft Front Oil Seal Installer—8281****Injector Removal Tool—8318****Valve Spring Compressor—8319-A****Injector Connector Removal Tool—8324**

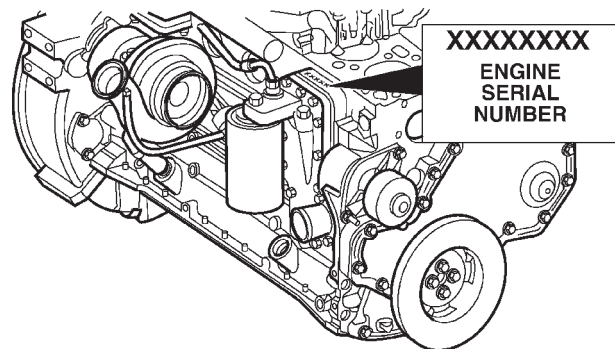
## ENGINE DATA PLATE

## DESCRIPTION

The engine data plate contains specific information that is helpful to servicing and obtaining parts for the engine. The data plate is located on the left side of the engine, affixed to the gear housing. Information that can be found on the data plate includes:

- Date of Engine Manufacture
- Engine Serial Number
- Control Parts List (CPL)
- Engine Rated Horsepower
- Engine Firing Order
- Engine Displacement
- Valve Lash Reset Specifications

If the engine data plate is missing or not legible, the engine serial number is used for engine identification. The engine serial number is stamped on the right side of the block, on top of the oil cooler cavity (Fig. 10).



80b4fb42

**Fig. 10 Engine Serial Number Location**

## AIR CLEANER ELEMENT

## REMOVAL

Testing Air Cleaner Element using Filter Minder

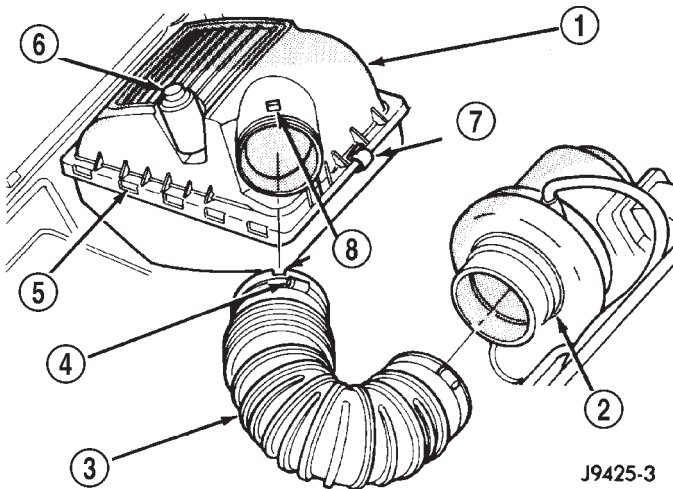
**Do not attempt to unnecessarily remove the top of the air cleaner housing for air cleaner element inspection on diesel engines.**

The air cleaner (filter) housing is equipped with an air Filter Minder™ gauge (Fig. 11). This air flow restriction gauge will determine when the air cleaner element is restricted and should be replaced.

The Filter Minder™ consists of a diaphragm and calibrated spring sealed inside of a plastic housing (Fig. 12). A yellow colored disc attached to the diaphragm moves along a graduated scale on the side of the Filter Minder. After the engine has been shut off, a ratcheting device located within the Filter Minder will hold the yellow disc at the highest restriction that the air cleaner element has experienced. A drop



## AIR CLEANER ELEMENT (Continued)



J9425-3

**Fig. 11 Filter Minder™—Location—Diesel Engine**

- 1 - AIR FILTER HOUSING COVER
- 2 - TURBOCHARGER
- 3 - AIR INLET TUBE
- 4 - HOSE CLAMP
- 5 - HINGE TABS
- 6 - FILTER MINDER
- 7 - CLIPS (4)
- 8 - TUBE ALIGNMENT NOTCHES

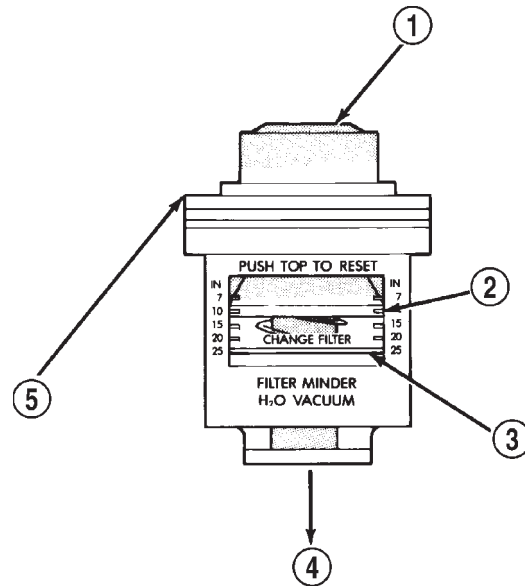
in air pressure due to an air cleaner element restriction moves the diaphragm and the yellow disc will indicate the size of the air drop.

**CAUTION:** Certain engine degreasers or cleaners may discolor or damage the plastic housing of the Filter Minder. Cover and tape the Filter Minder if any engine degreasers or cleaners are to be used.

To test, turn the engine off. If the yellow disc (Fig. 12) has reached the red colored zone on the graduated scale, the air cleaner element should be replaced. Refer to the preceding removal/installation paragraphs.

**Resetting the Filter Minder:** After the air cleaner (filter) element has been replaced, press the rubber button on the top of the Filter Minder (Fig. 12). This will allow the yellow colored disc to reset. After the button has been pressed, the yellow disc should spring back to the UP position.

If the Filter Minder gauge has reached the red colored zone, and after an examination of the air cleaner (filter) element, the element appears to be clean, the high reading may be due to a temporary condition such as snow build-up at the air intake. Temporary high restrictions may also occur if the air cleaner (filter) element has gotten wet such as during a heavy rain or snow. If this occurs, allow the element to dry out during normal engine operation. Reset the rubber button on the top of the Filter Minder and retest after the element has dried.



J9425-4

**Fig. 12 Filter Minder™—Diesel Engine**

- 1 - PRESS BUTTON TO RESET
- 2 - YELLOW DISC
- 3 - RED ZONE
- 4 - TO AIR FILTER HOUSING
- 5 - FILTER MINDER

### Removal

(1) Loosen air inlet tube clamp at air cleaner housing inlet (Fig. 11). Remove this tube at air cleaner housing cover.

(2) The housing cover is equipped with four (4) spring clips (Fig. 11) and is hinged at front with plastic tabs. Unlatch clips from top of air cleaner housing and tilt housing cover up and forward for cover removal.

(3) Remove air cleaner element from air cleaner housing.

### INSTALLATION

(1) Before installing a new air cleaner element, clean inside of air cleaner housing.

(2) Position air cleaner cover to tabs on front of air cleaner housing. Latch four spring clips to seal cover to housing.

(3) Install air inlet tube at air cleaner housing inlet. Note hose alignment notches at both inlet hose and air cleaner cover (Fig. 11).

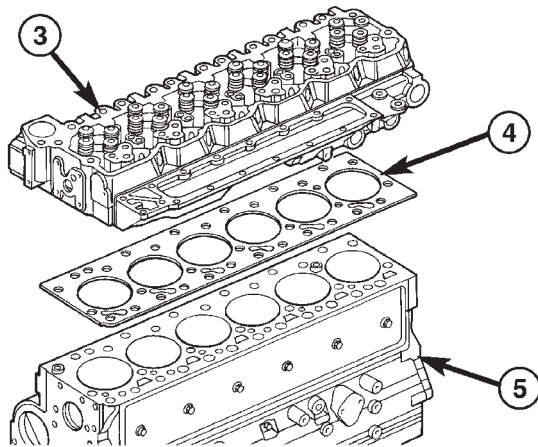
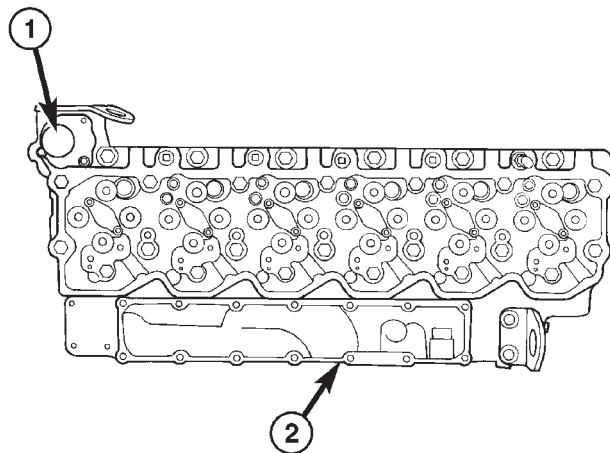
(4) Position tube clamp to inlet tube and tighten to 3 N·m (25 in. lbs.) torque.



## CYLINDER HEAD

### DESCRIPTION

The cylinder head (Fig. 13) is constructed of cast iron and is a one piece cross flow design with four valves per cylinder. The arrangement of two intake and two exhaust valves per cylinder allows for a centrally located injector. The cylinder head also includes an integral intake manifold, an integral thermostat housing, and a longitudinal fuel return rifle, which exits at the rear of the head. The 24 valve design also includes integrally cast valve guides and hardened intake and exhaust valve seat inserts.



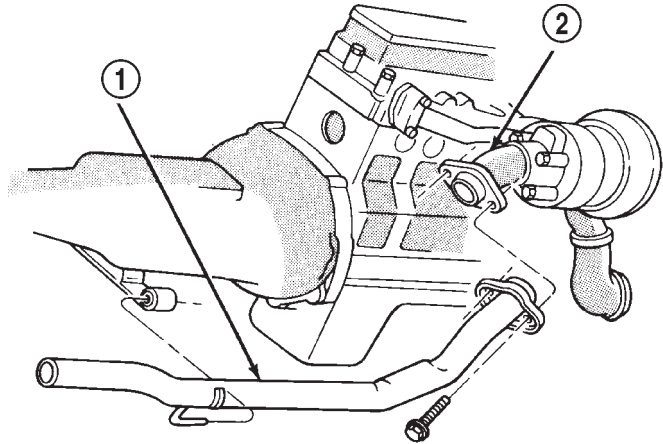
80c41fb7

**Fig. 13 Cylinder Head and Gasket**

- 1 - THERMOSTAT BORE
- 2 - INTAKE RUNNER
- 3 - CYLINDER HEAD
- 4 - CYLINDER HEAD GASKET
- 5 - CYLINDER BLOCK

### REMOVAL

- (1) Disconnect battery negative cables.
- (2) Raise vehicle on hoist.
- (3) Drain engine coolant.
- (4) Disconnect exhaust pipe from turbocharger elbow (Fig. 14).



J9411-18

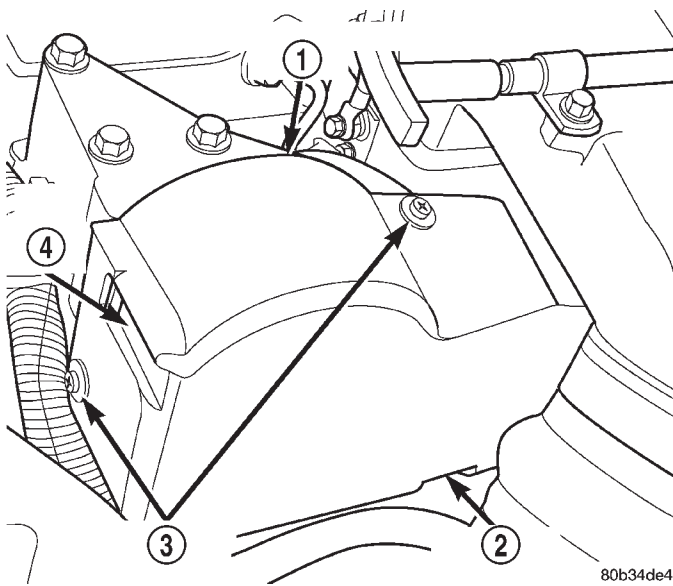
**Fig. 14 Exhaust Pipe-to-Turbocharger Elbow**

- 1 - EXHAUST PIPE
- 2 - TURBOCHARGER EXHAUST PIPE

- (5) Lower vehicle.
- (6) Remove air cleaner housing and snorkel from the vehicle. Cap off turbocharger air inlet to prevent intrusion of dirt or foreign material.
- (7) Disconnect cab heater core supply and return hoses from the cylinder head and heater pipe.
- (8) Disconnect turbocharger oil drain tube at rubber hose connection. Cap off open ports to prevent intrusion of dirt or foreign material.
- (9) Disconnect turbocharger oil supply line at the turbocharger end. Cap off open ports to prevent intrusion of dirt or foreign material.
- (10) Remove exhaust manifold-to-cylinder head bolts and spacers. Remove exhaust manifold and turbocharger from the vehicle as an assembly.
- (11) Remove accessory drive belt (Refer to 7 - COOLING/ACCESSORY DRIVE/DRIVE BELTS - REMOVAL).
- (12) Remove generator upper bracket.
- (13) Disconnect radiator upper hose from the thermostat housing.
- (14) Disconnect the coolant temperature sensor connector.
- (15) Remove the engine harness to cylinder head attaching bolt at front of head.
- (16) Remove the engine harness ground fastener at front of head below the thermostat housing.

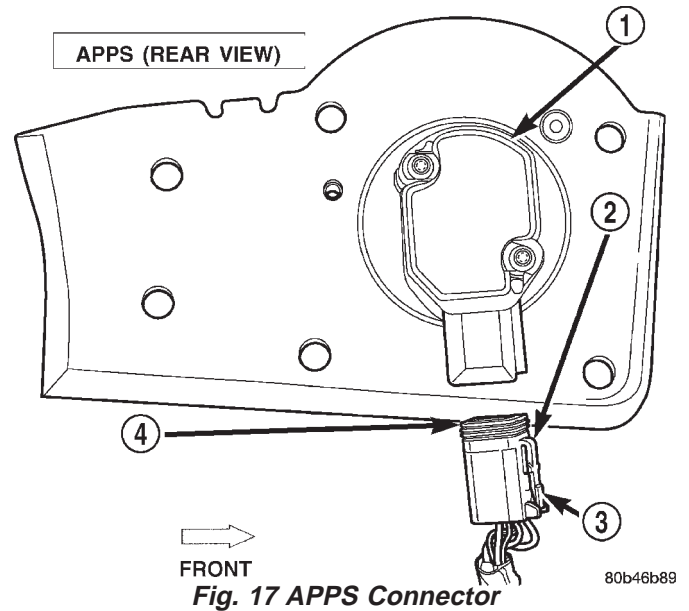
## CYLINDER HEAD (Continued)

(17) Remove the throttle linkage cover (Fig. 15).



**Fig. 15 Throttle Linkage Cover**

- 1 - CABLE/LEVER/LINKAGE COVER
- 2 - PUSH UP LOWER TAB
- 3 - SCREWS/CLIPS (2)
- 4 - TAB PUSH HERE



**Fig. 17 APPS Connector**

- 1 - APPS
- 2 - TAB
- 3 - PUSH FOR REMOVAL
- 4 - APPS CONNECTOR

**necessary to disconnect the cables from the throttle control assembly.**

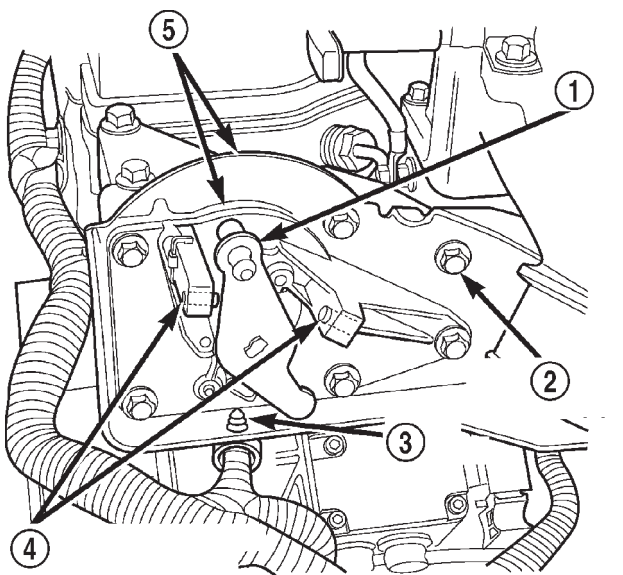
(19) Remove the intake air grid heater wires from the grid heater.

(20) Remove engine oil level indicator tube attaching bolt from the air inlet housing.

(21) Remove the charge air cooler-to-air inlet housing pipe.

(22) Remove the air inlet housing and intake grid heater from the intake manifold cover.

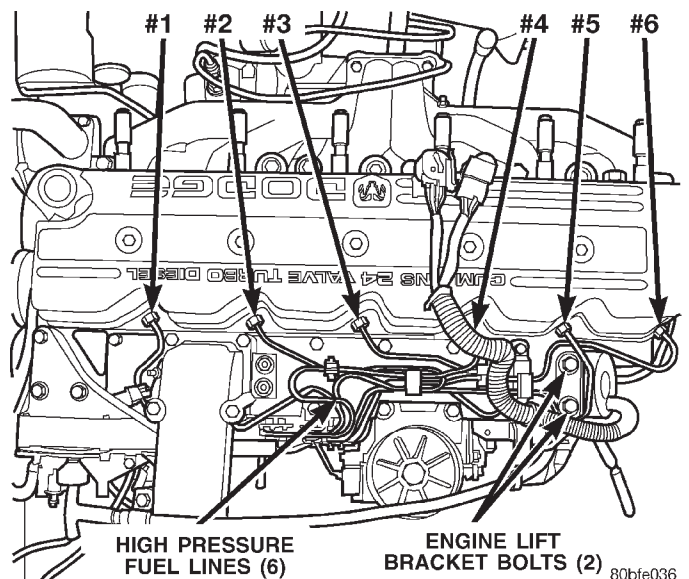
(23) Remove the engine lift bracket from the rear of the cylinder head.



**Fig. 16 APPS Assembly**

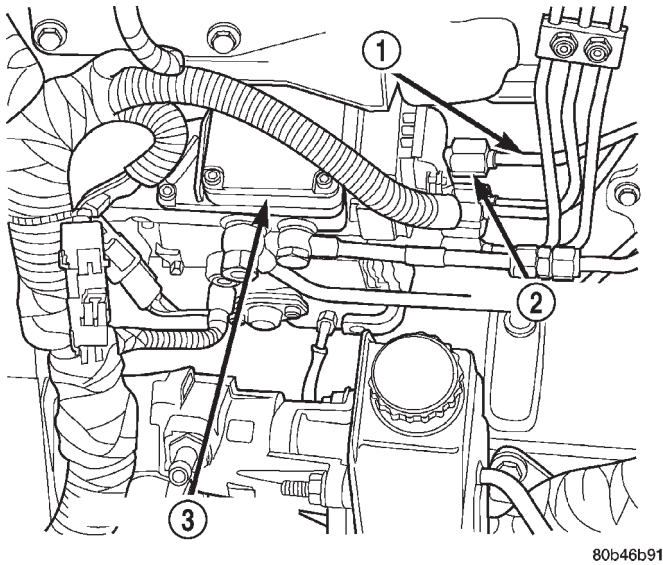
- 1 - LEVER
- 2 - MOUNTING BOLTS (6)
- 3 - WIRE HARNESS CLIP
- 4 - CALIBRATION SCREWS (NO ADJUSTMENT)
- 5 - APPS ASSEMBLY

(18) Remove the six (6) accelerator pedal position sensor assembly-to-cylinder head bracket bolts (Fig. 16) and secure the entire assembly out of the way. Disconnect the APPS connector (Fig. 17). **It is not**



**Fig. 18 High-Pressure Lines at Cylinder Head**

## CYLINDER HEAD (Continued)



**Fig. 19 High-Pressure Lines at Fuel Injection Pump**

- 1 - HIGH-PRESSURE LINES AT INJECTION PUMP
- 2 - FITTINGS
- 3 - FUEL INJECTION PUMP

(24) Remove the high pressure fuel lines (Fig. 18) (Fig. 19) from the engine as follows:

- (a) Remove all injection line-to-intake manifold cover support bracket bolts.
  - (b) Loosen the #1, 2, and 4 cylinder high pressure lines at the injection pump.
  - (c) Loosen the #1, 2, and 4 cylinder high pressure lines at the cylinder head.
  - (d) Remove the #1, 2, and 4 cylinder high pressure line bundle from the engine.
  - (e) Loosen the #3, 5, and 6 cylinder high pressure lines at the injection pump.
  - (f) Loosen the #3, 5, and 6 cylinder high pressure lines at the cylinder head.
  - (g) Remove the #3, 5, and 6 cylinder high pressure line bundle from the engine.
- (25) Remove the lift pump-to-fuel filter low pressure line.
- (26) Remove the fuel filter-to-injection pump low pressure line.
- (27) Disconnect the water-in-fuel and fuel heater connectors.

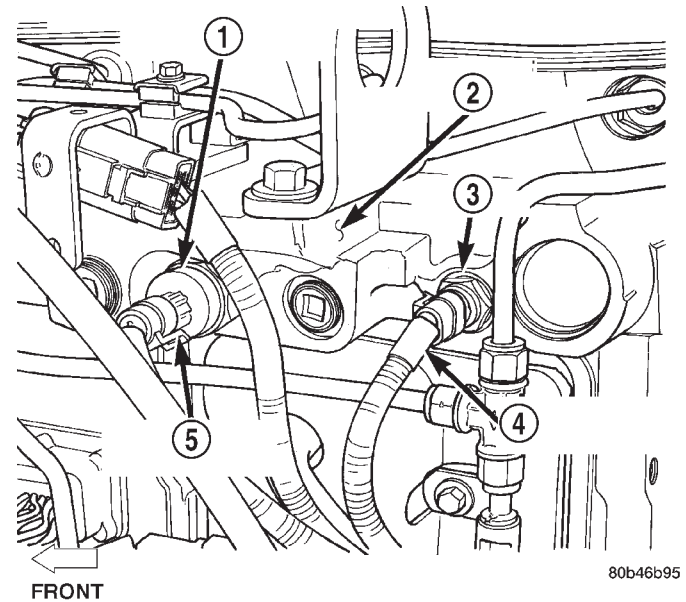
(28) Remove the fuel filter assembly-to-manifold cover bolts and remove filter assembly from vehicle.

(29) Disconnect the Intake Air Temperature and Manifold Air Pressure sensor connectors (Fig. 20).

(30) Remove the cylinder head cover (Fig. 21) (Refer to 9 - ENGINE/CYLINDER HEAD/CYLINDER HEAD COVER(S) - REMOVAL).

(31) Remove the rocker levers (Fig. 22), cross heads and push rods (Fig. 23). Mark each component so they can be installed in their original positions.

**NOTE:** The #5 cylinder exhaust and the #6 cylinder intake and exhaust push rods are removed by lifting them up and through the provided cowl panel access holes. Remove the rubber plugs to expose these relief holes.



**Fig. 20 IAT and MAP Sensor Location**

- 1 - MANIFOLD AIR PRESSURE (MAP) SENSOR
- 2 - REAR OF CYLINDER HEAD
- 3 - IAT SENSOR
- 4 - ELECTRICAL CONNECTOR
- 5 - ELECTRICAL CONNECTOR

(32) Remove the fuel return line banjo bolt at the rear of the cylinder head (Fig. 24). Be careful not to drop the two (2) sealing washers.

(33) Reinstall the engine lift bracket at the rear of cylinder head.

(34) Remove twenty six (26) cylinder head-to-block bolts.

(35) Attach an engine lift crane to engine lift brackets and lift cylinder head off engine and out of vehicle.

(36) Remove the head gasket and inspect for failure.

## CLEANING—CYLINDER HEAD

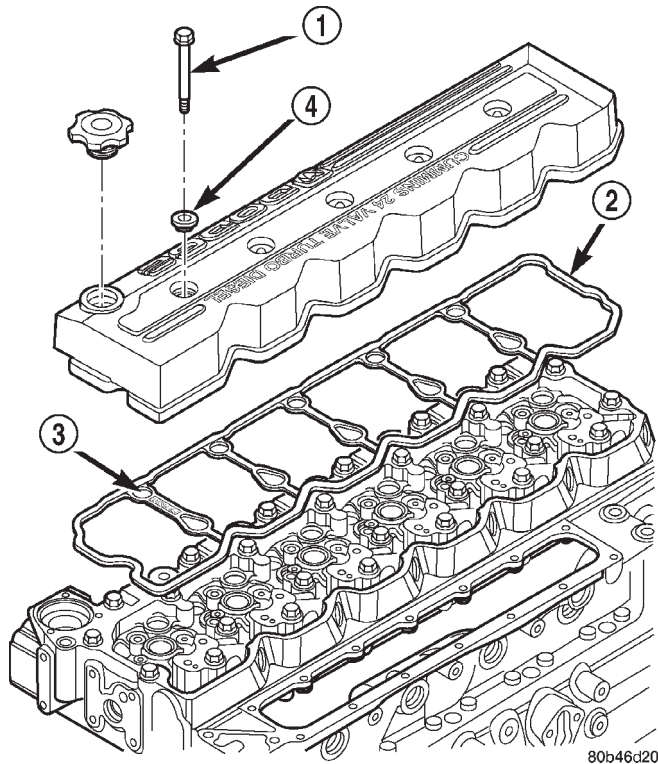
**CAUTION:** Do not wire brush head surface while fuel injectors are still installed. Fuel injector damage can result.

Clean the carbon from the injector nozzle seat with a nylon or brass brush.

Scrape the gasket residue from all gasket surfaces.

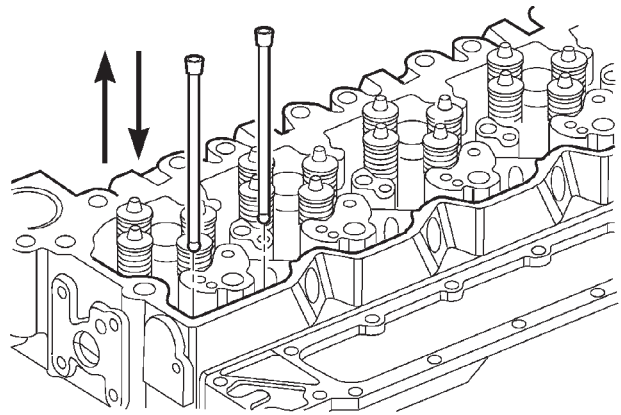
Wash the cylinder head in hot soapy water solution (88°C or 140°F).

## CYLINDER HEAD (Continued)



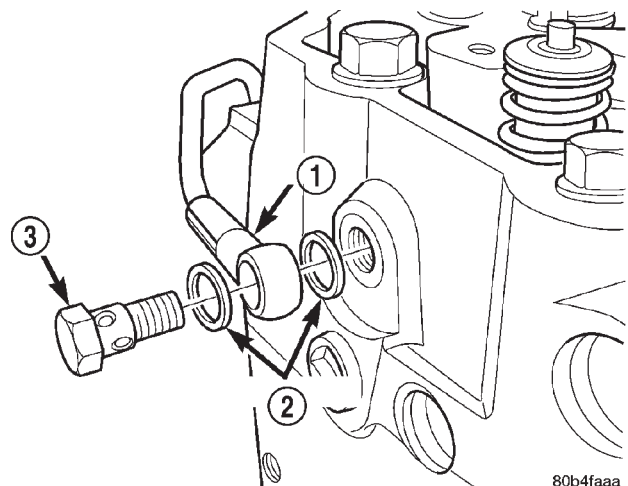
**Fig. 21 Cylinder Head Cover Removal**

- 1 - BOLT (5)
- 2 - GASKET
- 3 - "TOP FRONT"
- 4 - ISOLATOR (5)



80b4fa25

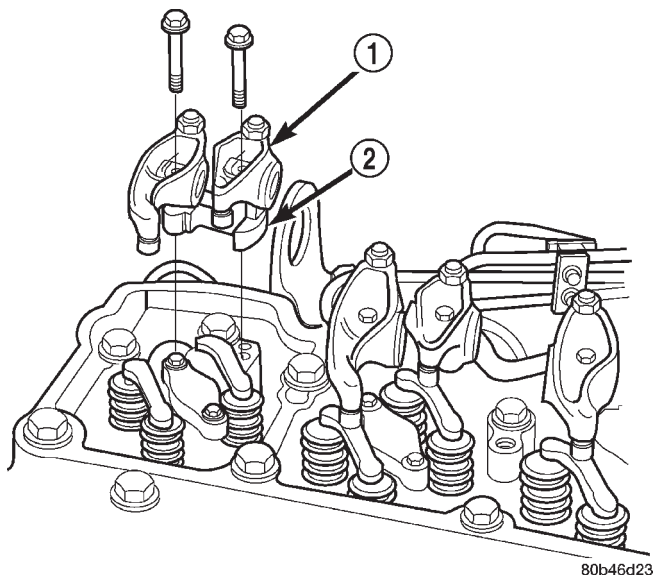
**Fig. 23 Push Rod Removal**



80b4faaa

**Fig. 24 Fuel Drain Fitting at Rear of Head**

- 1 - LINE
- 2 - WASHERS
- 3 - BANJO BOLT



80b46d23

**Fig. 22 Rocker Arms and Pedestal Removal**

- 1 - ROCKER ARM
- 2 - PEDESTAL

After rinsing, use compressed air to dry the cylinder head.

Polish the gasket surface with 400 grit paper. Use an orbital sander or sanding block to maintain a flat surface.

### CLEANING—CROSSHEADS

Clean all crossheads in a suitable solvent. If necessary, use a wire brush or wheel to remove stubborn deposits. Rinse in hot water and blow dry with compressed air.

### CLEANING—PUSHRODS

Clean the pushrods in a suitable solvent. Rinse in hot water and blow dry with compressed air. If necessary, use a wire brush or wheel to remove stubborn deposits.



## CYLINDER HEAD (Continued)

## INSPECTION—CYLINDER HEAD

Inspect the cylinder head for cracks in the combustion surface. Pressure test any cylinder head that is visibly cracked. A cylinder head that is cracked between the injector bore and valve seat can be pressure tested and reused if OK; however, if the crack extends **into** the valve seat, the valve seat **must** be replaced.

Visually inspect the cylinder block and head combustion surfaces for localized dips or imperfections. Check the cylinder head and block combustion surfaces for overall out-of-flatness. If either the visual or manual inspection exceeds the limits, then the head or block must be surfaced.

Check the top surface for damage caused by the cylinder head gasket leaking between cylinders.

Inspect the block and head surface for nicks, erosion, etc.

Check the head distortion (Fig. 25). The distortion of the combustion deck face is not to exceed 0.010 mm (0.0004 inch) in any 50.8 mm (2.00 inch) diameter. Overall variation end to end or side to side 0.30 mm (0.012 inch).

DO NOT proceed with the in-chassis overhaul if the cylinder head or block surface is damaged or not flat (within specifications).

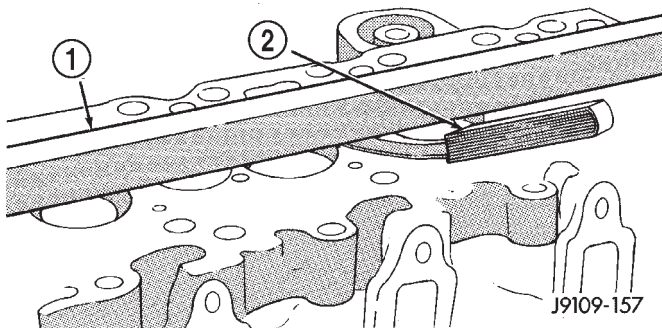
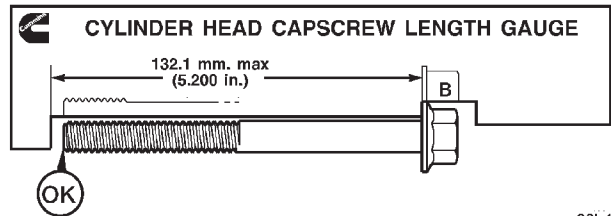
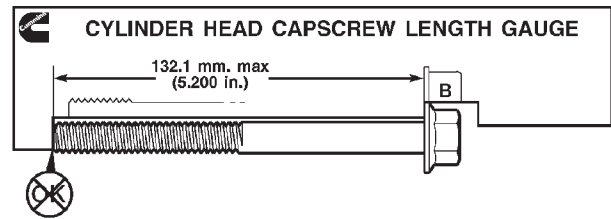


Fig. 25 Cylinder Head Combustion Deck Face

- 1 - STRAIGHT EDGE  
2 - FEELER GAUGE

Visually inspect the cylinder head bolts for damaged threads, corroded/pitted surfaces, or a reduced diameter due to bolt stretching.

If the bolts are not damaged, their “free length” should be measured using the cap screw stretch gauge provided with the replacement head gasket. Place the head of the bolt against the base of the slot and align the bolt with the straight edge of gauge (Fig. 26). If the end of the bolt touches the foot of the gauge, the bolt **must** be discarded. **The maximum bolt free length is 132.1 mm (5.200 in.).**

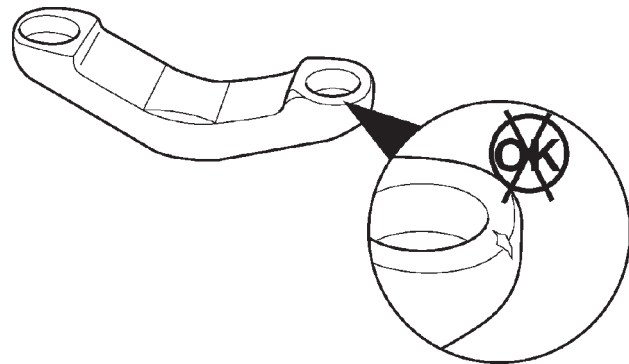


80b4faa9

Fig. 26 Head Bolt Stretch Gauge

## INSPECTION—CROSSHEADS

Inspect the crossheads for cracks and/or excessive wear on rocker lever and valve tip mating surfaces (Fig. 27). Replace any crossheads that exhibit abnormal wear or cracks.



80b4fa27

Fig. 27 Inspecting Crosshead for Cracks

## INSPECTION—PUSHRODS

Inspect the push rod ball and socket for signs of scoring. Check for cracks where the ball and the socket are pressed into the tube (Fig. 28).

Roll the push rod on a flat work surface with the socket end hanging off the edge (Fig. 29). Replace any push rod that appears to be bent.

## INSTALLATION

**WARNING: THE OUTSIDE EDGE OF THE HEAD GASKET IS VERY SHARP. WHEN HANDLING THE NEW HEAD GASKET, USE CARE NOT TO INJURE YOURSELF.**

(1) Install a new gasket with the part number side up, and locate the gasket over the dowel sleeves.

(2) Using an engine lifting crane, lower the cylinder head onto the engine.

## CYLINDER HEAD (Continued)

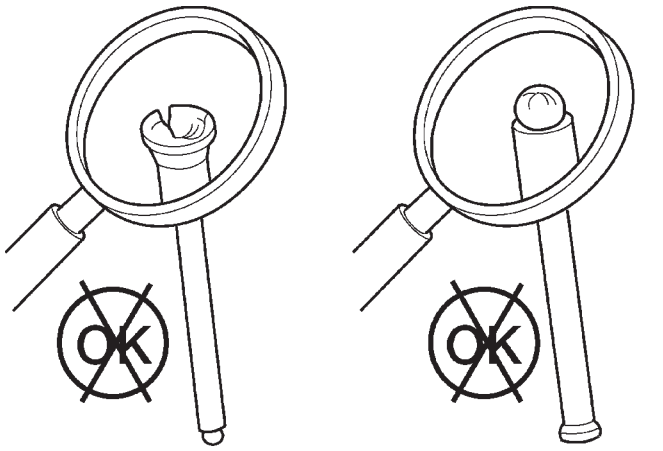


Fig. 28 Inspecting Push Rod for Cracks

80b4fa24

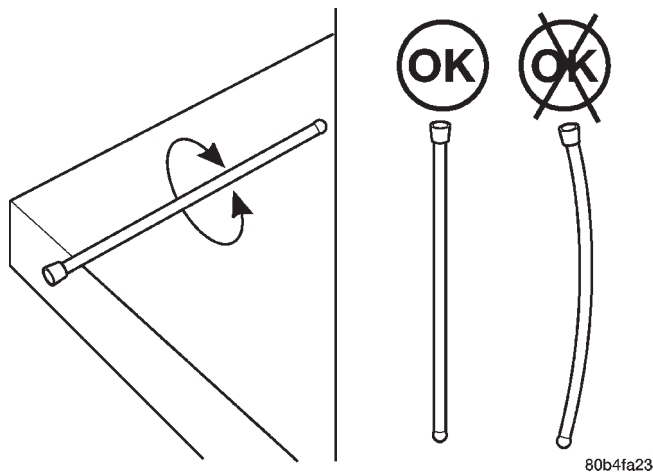


Fig. 29 Inspecting Push Rod for Flatness

80b4fa23

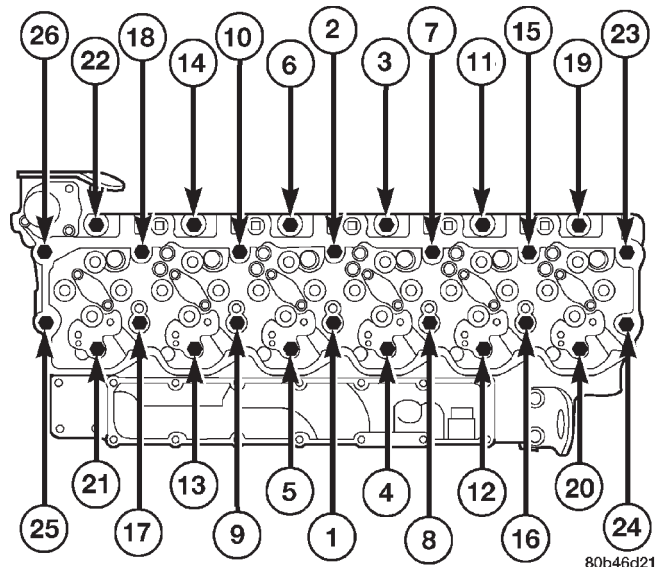


Fig. 30 Cylinder Head Bolt Torque Sequence

80b46d21

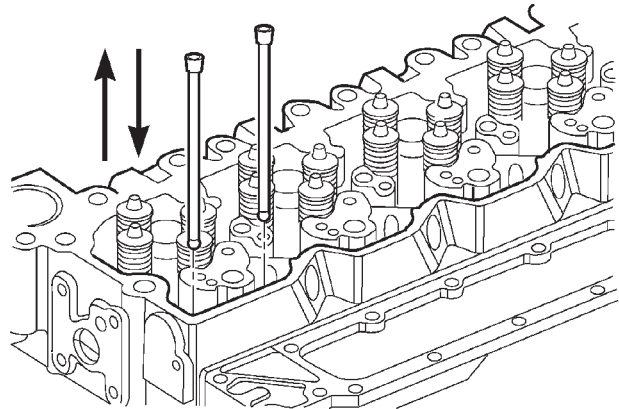


Fig. 31 Push Rod Installation

80b4fa25

(3) Lightly lubricate head bolts with engine oil and install. Using the sequence shown in (Fig. 30), tighten bolts in the following steps:

- Torque bolts to 80 N·m (59 ft. lbs.)
- Torque bolts to 105 N·m (77 ft. lbs.)
- Re-check all bolts to 105 N·m (77 ft. lbs.)
- Tighten all bolts an additional  $\frac{1}{4}$  turn ( $90^\circ$ )

(4) Connect fuel return line at rear of head (Fig. 24). Install both sealing washers and torque banjo bolt to 24 N·m (18 ft. lbs.).

(5) Install push rods into their original locations (Fig. 31). **Verify that they are seated in the tappets.**

(6) Lubricate valve stem tips and install the cross-heads in their original locations.

(7) Lubricate the rocker arms and pedestals and install them in their original locations (Fig. 32). Install the bolts and torque them to 36 N·m (27 ft. lbs.).

(8) Verify that the valve lash settings are maintained (Refer to 9 - ENGINE/CYLINDER HEAD/INTAKE/EXHAUST VALVES & SEATS - STANDARD PROCEDURE).

(9) Install cylinder head cover (Fig. 33) (Refer to 9 - ENGINE/CYLINDER HEAD/CYLINDER HEAD COVER(S) - INSTALLATION).

(10) Connect the IAT and MAP sensor connectors.  
 (11) Install the fuel filter canister assembly and torque mounting bolts to 24 N·m (18 ft. lbs.).

(12) Connect the lift pump to fuel filter low pressure line. Torque fittings to 24 N·m (18 ft. lbs.).

(13) Connect the Water-in-Fuel and Fuel Heater Element connectors at the filter assembly.

(14) Remove the engine lift bracket at rear of cylinder head.

(15) **Install the high pressure fuel lines (Fig. 18) (Fig. 19) as follows:**

(a) Lubricate the threads (both ends) of the high pressure line nuts with diesel fuel or engine oil.

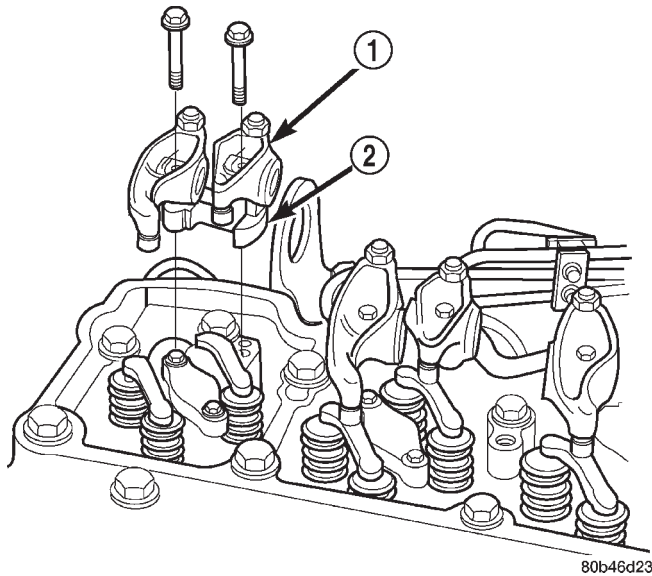
(b) Install the rear line bundle (cyls. #3, 5, and 6), and tighten the threads at the head and pump by hand.

(c) Torque the connections at the cylinder head first. Torque connections to 38 N·m (28 ft. lbs.).

(d) Torque the line connections at the injection pump to 24 N·m (18 ft. lbs.).

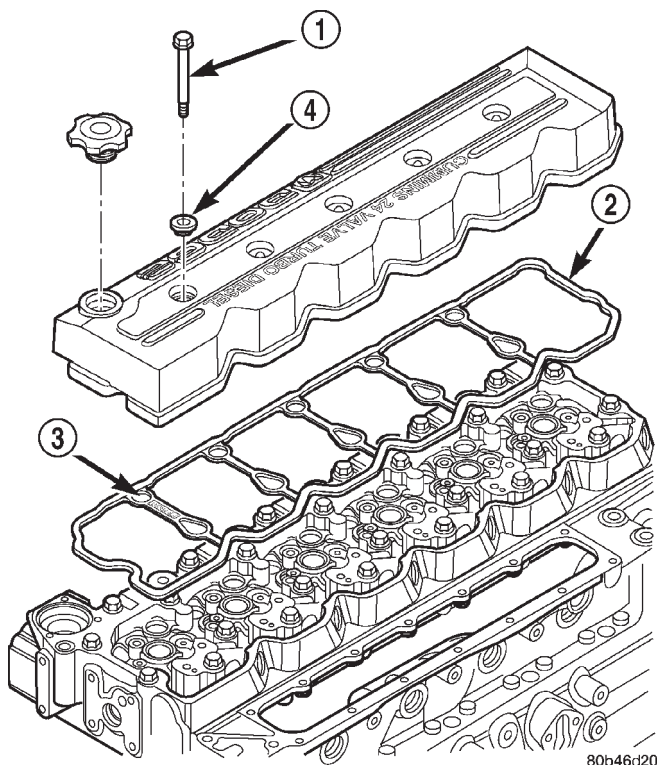


## CYLINDER HEAD (Continued)



**Fig. 32 Rocker Arms and Pedestal Installation**

- 1 - ROCKER ARM  
2 - PEDESTAL



**Fig. 33 Cylinder Head Cover Installation**

- 1 - BOLT (5)  
2 - GASKET  
3 - "TOP FRONT"  
4 - ISOLATOR (5)

(e) Install the front line bundle (cyls. #1, 2, and 4) following the same procedure used for the rear line bundle.

(f) Torque the connections at the cylinder head first. Torque connections to 38 N·m (28 ft. lbs.).

(g) Torque the line connections at the injection pump to 24 N·m (18 ft. lbs.).

(h) Install the injection line support bracket to intake cover/cylinder head bolts and torque to 24 N·m (18 ft. lbs.).

(16) Install the engine lift bracket at the rear of cylinder head. Torque to 77 N·m (57 ft. lbs.).

(17) Install the fuel filter to injection pump low pressure line. Inspect and replace sealing washers if necessary. Torque banjo bolts to 24 N·m (18 ft. lbs.).

(18) Using new gaskets, install the intake grid heater and air inlet housing. Torque bolts to 24 N·m (18 ft. lbs.).

(19) Connect the APPS connector (Fig. 17).

(20) Install the APPS assembly to the cylinder head bracket and torque bolts to 12 N·m (105 in. lbs.).

(21) Install the throttle linkage cover (Fig. 15).

(22) Install the charge air cooler-to-air inlet housing duct assembly. Torque all clamps to 11 N·m (100 in. lbs.).

(23) Connect intake grid heater wires.

(24) Fasten engine harness to front of cylinder head with bolt.

(25) Install engine harness ground wire and torque bolt to 24 N·m (18 ft. lbs.).

(26) Connect engine coolant temperature sensor connector.

(27) Connect radiator upper hose to thermostat housing.

(28) Install generator upper bracket and torque bolts to 41 N·m (31 ft. lbs.).

(29) Install accessory drive belt (Refer to 7 - COOLING/ACCESSORY DRIVE/DRIVE BELTS - INSTALLATION).

(30) Install exhaust manifold/turbocharger assembly and start all bolts/spacers by hand. Torque bolts to 43 N·m (32 ft. lbs.).

(31) Connect turbocharger oil drain tube.

(32) Perform the turbocharger pre-lube procedure. Refer to Group 11, Exhaust System and Turbocharger for the correct procedure.

(33) Connect the turbocharger oil supply line.

(34) Install air cleaner housing and duct.

(35) Raise vehicle on hoist.

(36) Install exhaust pipe to turbocharger elbow (Fig. 14). Torque bolts to 34 N·m (25 ft. lbs.).

(37) Lower vehicle.

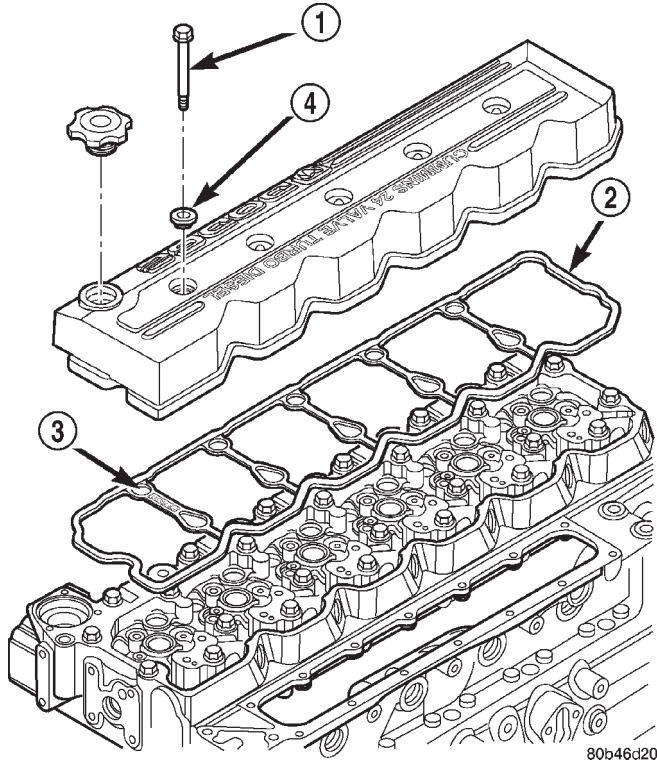
(38) Fill engine coolant (Refer to 7 - COOLING - STANDARD PROCEDURE).

(39) Start engine and check for leaks.

## CYLINDER HEAD COVER(S)

### REMOVAL

- (1) Disconnect both battery negative cables.
- (2) Loosen the five (5) cylinder head cover bolts (Fig. 34). Remove the front three bolts and leave the rear two bolts in the cover.
- (3) Lift cover off of cylinder head.



**Fig. 34 Cylinder Head Cover and Gasket**

- 1 - BOLT (5)
- 2 - GASKET
- 3 - "TOP FRONT"
- 4 - ISOLATOR (5)

### CLEANING

Using a suitable solvent, Clean and dry gasket mating surfaces on cylinder head and cover. Wipe gasket dry and inspect for re-use.

### INSPECTION

**The cylinder head cover gasket and isolators are reusable.** However, should cracks be present in the rubber/silicone construction, the defective components should be replaced.

### INSTALLATION

- (1) Install the gasket as shown in (Fig. 34). Make sure the gasket is properly located around the cylinder head bolts, with the words "top front" facing up and towards front of engine.

- (2) Place two bolts and isolators into the rear two mounting holes and install the cover.

- (3) Install the remaining bolts and isolators. Starting with the center bolt, torque in a circular pattern to 24 N-m (18 ft. lbs.).

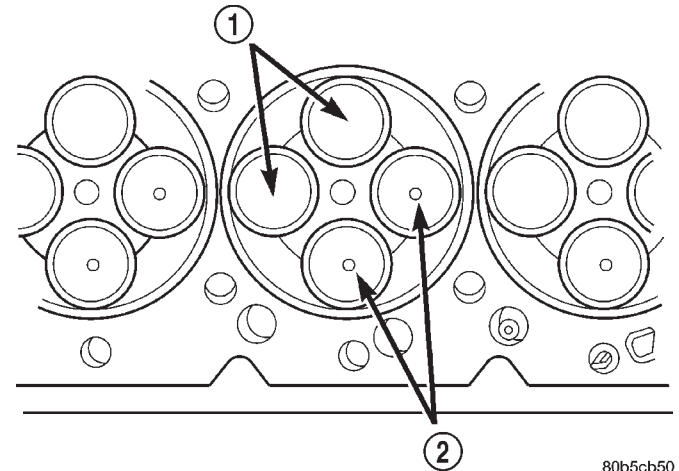
- (4) Connect both battery negative cables.

## INTAKE/EXHAUST VALVES & SEATS

### DESCRIPTION

The valves are made of heat resistant steel, and have chrome plated stems to prevent scuffing. The intake and exhaust valves are both similar in head diameter and overall length, but they have unique face angles which makes them non-interchangeable. The valves are distinguished by unique dimples on the exhaust valve head (Fig. 35).

The exhaust valve springs are made from high strength, chrome silicon steel. The exhaust valve springs are also exhaust brake compatible.



**Fig. 35 Valve Identification**

- 1 - INTAKE VALVES
- 2 - EXHAUST VALVES

## STANDARD PROCEDURE-VALVES, GUIDES AND SPRINGS

### REMOVAL

- (1) Remove cylinder head (Refer to 9 - ENGINE/CYLINDER HEAD - REMOVAL).

- (2) Support cylinder head on stands, or install head bolts upside down (through combustion surface side) to protect injector tips from damage from work bench.

- (3) Remove the injector clamp (Fig. 36) from the cylinder(s) to be serviced. **Do not remove the bolt shown in (Fig. 36).**

INTAKE/EXHAUST VALVES & SEATS (Continued)

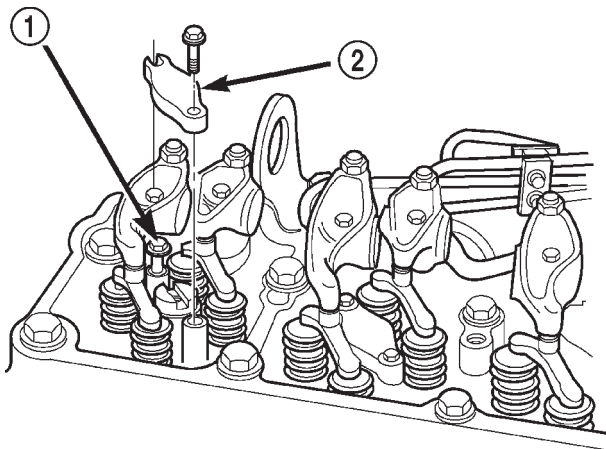
(4) Install the valve spring compressor mounting base (special tool 8319-A) as shown in (Fig. 37). Reinstall the injector clamp bolt finger tight.

(5) Install the compressor top plate, washer, and nut. Using a suitable wrench, tighten the nut (clockwise) to compress the valve springs (Fig. 38) and remove the locks.

(6) Rotate the compressor nut counter-clockwise to relieve tension on the springs. Remove the spring compressor.

(7) Remove the retainers, springs, valve seals (if necessary), and valves (Fig. 39). Arrange or number all components so they can be installed in their original locations.

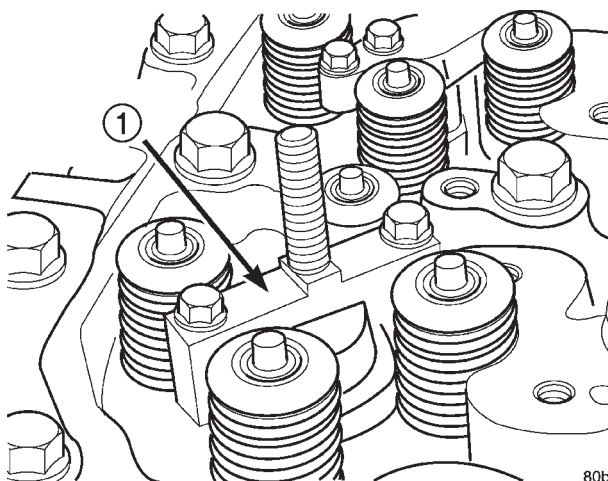
(8) Repeat the procedure on all cylinders to be serviced.



**Fig. 36 Injector Clamp Removal/Installation**

80b46d22

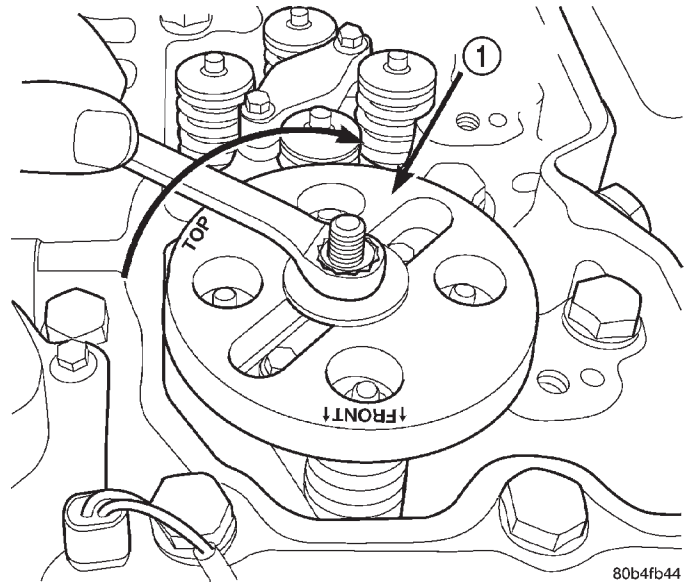
- 1 - DO NOT REMOVE
- 2 - INJECTOR CLAMP



80b4fb43

**Fig. 37 Spring Compressor Mounting Base—Part of Tool 8319-A**

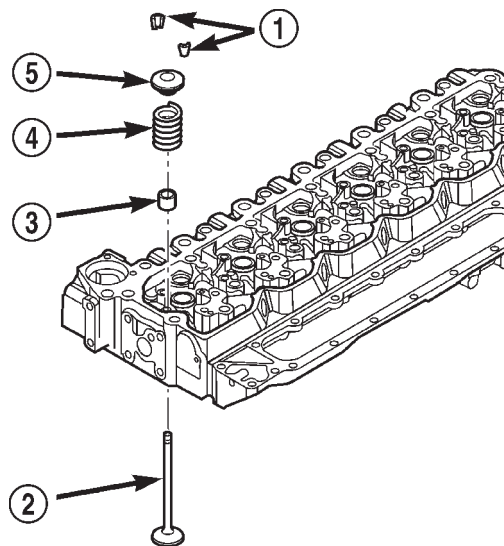
- 1 - COMPRESSOR MOUNTING BASE



80b4fb44

**Fig. 38 Compressing Valve Springs with Tool 8319-A**

- 1 - SPECIAL TOOL 8319-A



80b5cb55

**Fig. 39 Valve Spring, Seal, and Retainers**

- 1 - VALVE RETAINING LOCKS
- 2 - VALVE
- 3 - SEAL
- 4 - SPRING
- 5 - RETAINER

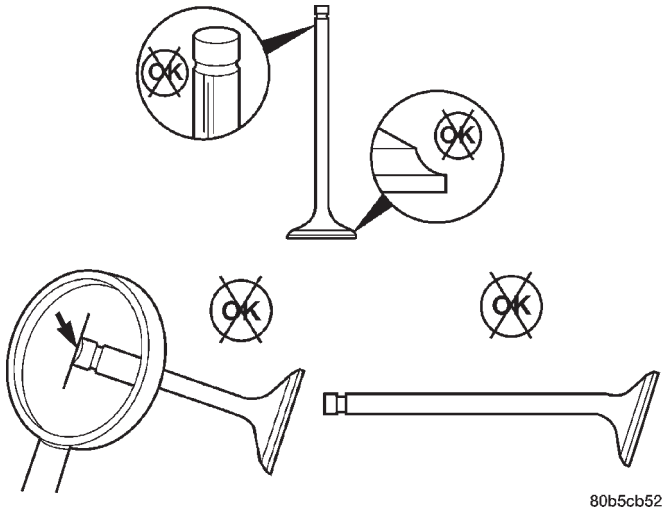
## INTAKE/EXHAUST VALVES &amp; SEATS (Continued)

**CLEANING**

Clean the valve stems with crocus cloth or a Scotch-Brite™ pad. Remove carbon with a soft wire brush. Clean valves, springs, retainers, and valve retaining locks in a suitable solvent. Rinse in hot water and blow dry with compressed air.

**INSPECTION**

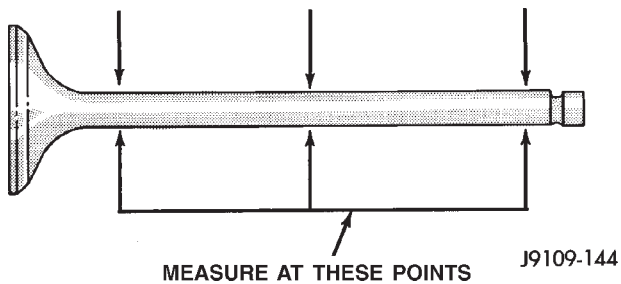
Visually inspect the valves for abnormal wear on the heads, stems, and tips. Replace any valve that is worn out or bent (Fig. 40).



80b5cb52

**Fig. 40 Visually Inspect Valves for Abnormal Wear**

Measure the valve stem diameter in three places as shown in (Fig. 41).

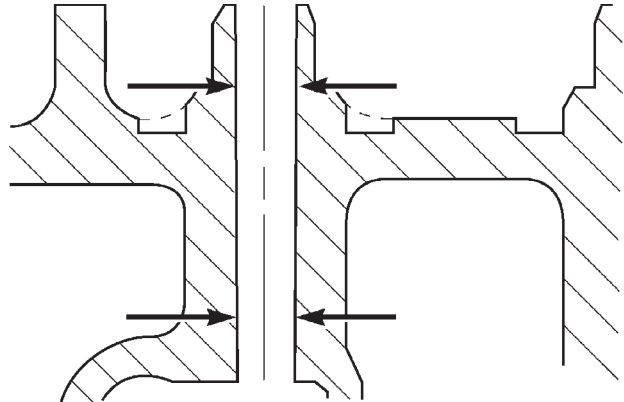


J9109-144

**Fig. 41 Measure Valve Stem Diameter**

**VALVE STEM DIAMETER**  
6.96 mm (0.2740 in.) MIN  
7.010 mm (0.2760 in.) MAX

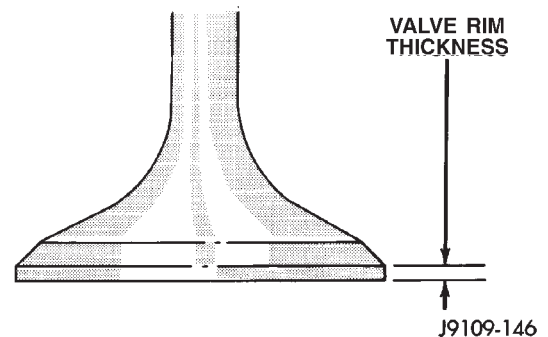
Measure the cylinder head valve guide bore (Fig. 42). Subtract the corresponding valve stem diameter to obtain valve stem-to-guide clearance.



80b5cb54

**Fig. 42 Measure Valve Guide Bore**

Measure valve margin (rim thickness) (Fig. 43).



J9109-146

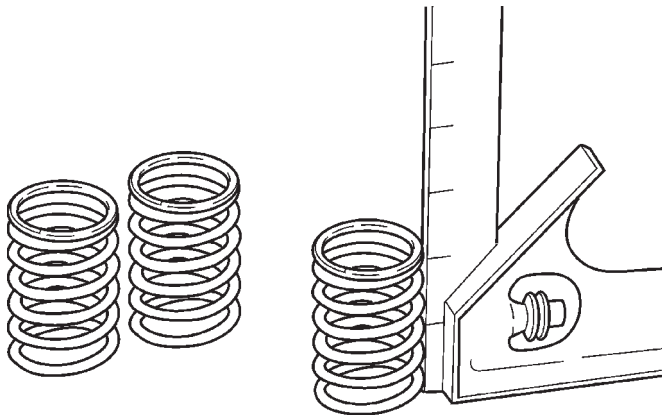
**Fig. 43 Measure Valve Margin (Rim Thickness)**

**VALVE MARGIN (RIM THICKNESS)**  
0.72 mm (0.031 in.) MIN.



## INTAKE/EXHAUST VALVES &amp; SEATS (Continued)

Measure the valve spring free length and maximum inclination (Fig. 44).

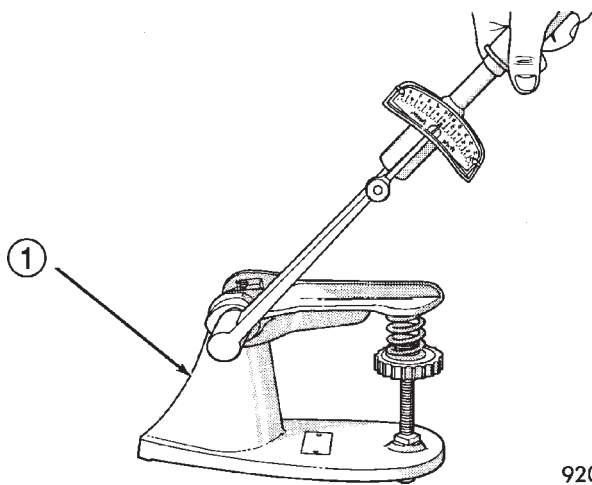


80b5cb53

**Fig. 44 Measure Valve Spring Free Length and Max. Inclination**

**VALVE SPRING FREE LENGTH**  
47.75 mm (1.88 in.)

**MAX INCLINATION**  
1.5 mm (.059 in.)



9209-37

**Fig. 45 Testing Valve Spring with Tool C-647**

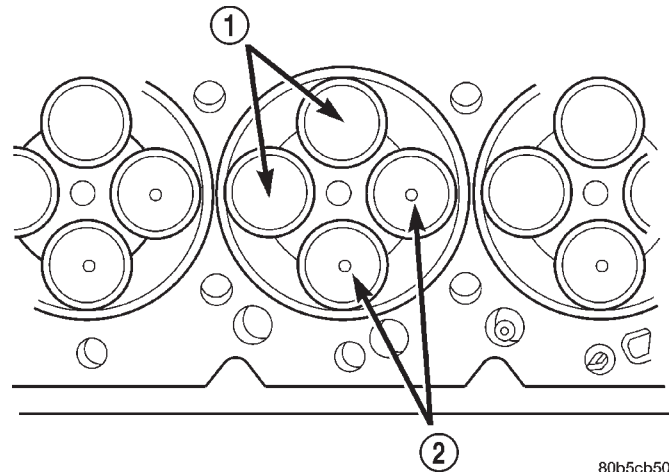
1 - SPECIAL TOOL C-647  
VALVE SPRING FORCE 35.33 mm @ 339.8 N (1.39 IN. @76.4 lbs.)

Test valve spring force with tool C-647 (Fig. 45).

## INSTALLATION

(1) Install new valve seals. The yellow springs are for the intake valves and the green seals are for the exhaust valves.

(2) Install the valves in their original position. The exhaust valves are identified by a dimple on the valve head (Fig. 46).



80b5cb50

**Fig. 46 Valve Identification**

1 - INTAKE VALVES  
2 - EXHAUST VALVES

- (3) Install the valve springs and retainer.
- (4) Install the valve spring compressor tool 8319-A as shown in (Fig. 37) and (Fig. 38).
- (5) Compress the valve springs and install the valve retaining locks (Fig. 39).
- (6) Remove the compressor and repeat the procedure on the remaining cylinders.
- (7) Install the injector clamp and hold down bolts and tighten to 10 N·m (89 in. lbs.) torque.
- (8) Install the cylinder head (Refer to 9 - ENGINE/CYLINDER HEAD - INSTALLATION).

## STANDARD PROCEDURE—VALVE LASH ADJUSTMENT AND VERIFICATION

**NOTE:** To obtain accurate readings, valve lash measurements AND adjustments should only be performed when the engine coolant temperature is less than 60° C (140° F).

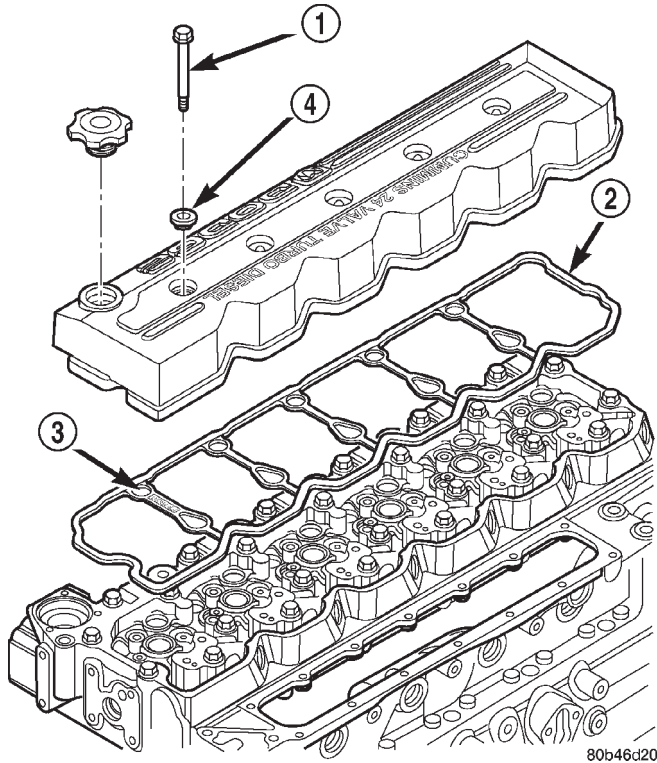
The 24-valve overhead system is a “low-maintenance” design. Routine adjustments are no longer necessary, however, measurement should still take place when trouble-shooting performance problems, or upon completion of a repair that includes removal and installation of the valve train components.

- (1) Disconnect battery negative cables.

## INTAKE/EXHAUST VALVES &amp; SEATS (Continued)

(2) Remove cylinder head cover (Fig. 47) (Refer to 9 - ENGINE/CYLINDER HEAD/CYLINDER HEAD COVER(S) - REMOVAL).

(3) Remove the crankcase breather and vapor canister (Fig. 48).

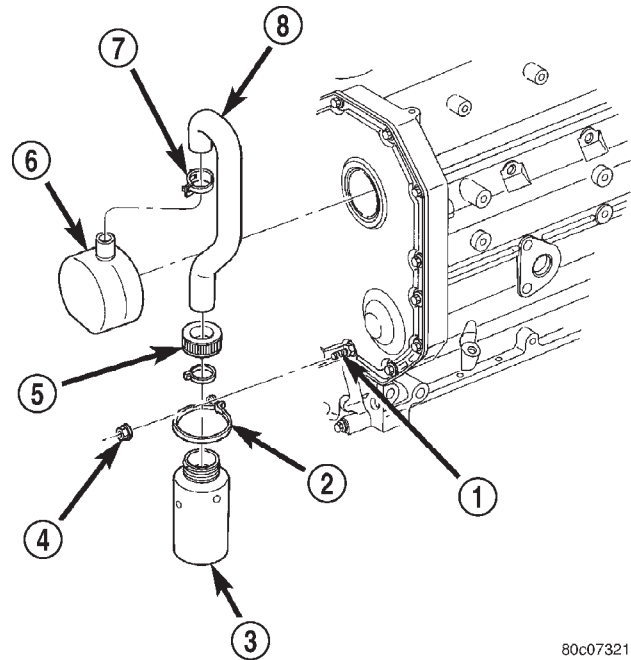


**Fig. 47 Cylinder Head Cover and Gasket**

- 1 - BOLT (5)
- 2 - GASKET
- 3 - "TOP FRONT"
- 4 - ISOLATOR (5)

(4) Using the crankshaft barring tool #7471-B, rotate the engine and align the pump gear mark with the top dead center (TDC) mark on the gear housing cover (Fig. 49).

(5) With the engine in this position (pump gear mark at 12 o'clock), valve lash can be measured at the following rocker arms: **INTAKE 1-2-4 / EXHAUST 1-3-5**. Measure the valve lash by inserting a feeler gauge between the rocker arm socket and crosshead (Fig. 50). Refer to VALVE LASH LIMIT CHART for the correct specifications. If the measurement falls **within** the limits, adjustment/resetting **is not** necessary. If measurement finds the lash **outside** of the limits, adjustment/resetting **is** required.



**Fig. 48 Crankcase Breather Vapor Canister**

- 1 - ENGINE FRONT COVER STUD
- 2 - STRAP
- 3 - VAPOR CANISTER
- 4 - NUT
- 5 - CAP
- 6 - CRANKCASE BREATHER
- 7 - CLAMP
- 8 - HOSE

80c07321

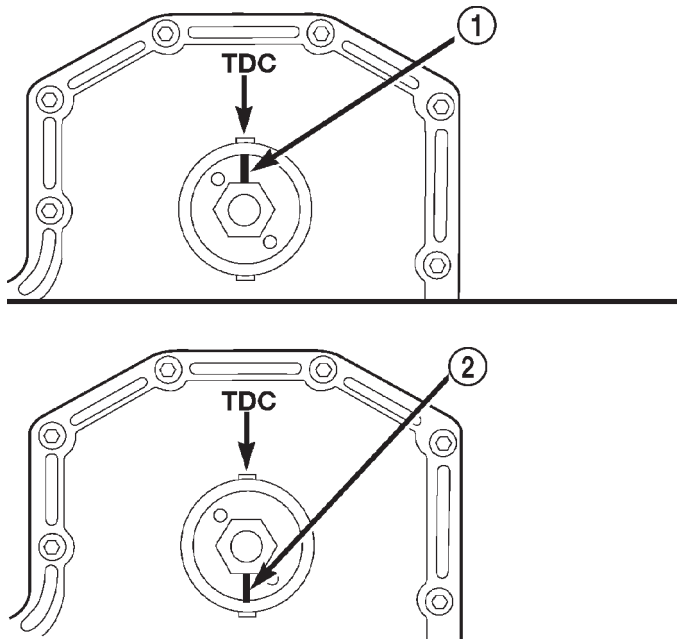
## VALVE LASH LIMIT CHART

INTAKE	EXHAUST
0.152 mm ( 0.006 in.) MIN.	0.381 mm (0.015 in.) MIN.
0.381 mm (0.015 in.) MAX.	0.762 mm (0.030 in.) MAX.

**note:**  
If measured valve lash falls within these specifications, no adjustment/reset is necessary. Engine operation within these ranges has no adverse affect on performance, emissions, fuel economy or level of engine noise.



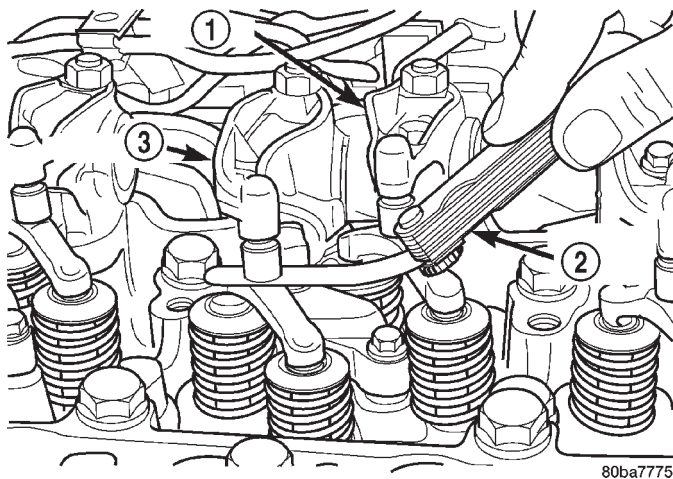
## INTAKE/EXHAUST VALVES &amp; SEATS (Continued)



80b4fb45

**Fig. 49 Fuel Pump Gear Timing Mark Orientation**

- 1 - MEASURE/ADJUST INTAKE 1, 2, 4 EXHAUST 1, 3, 5  
2 - MEASURE/ADJUST INTAKE 3, 5, 6 EXHAUST 2, 4, 6



80ba7775

**Fig. 50 Measuring Valve Lash**

- 1 - INTAKE  
2 - FEELER GAUGE  
3 - EXHAUST

(6) If adjustment/resetting is required, loosen the lock nut on rocker arms and turn the adjusting screw until the desired lash is obtained:

- **INTAKE** 0.254 mm (0.010 in.)
- **EXHAUST** 0.508 mm (0.020 in.) Tighten the lock nut and re-check the valve lash.

(7) Using the crankshaft barring tool, rotate the **crankshaft** one revolution (360°) to align the pump gear mark to the 6 o'clock position in relation to the TDC mark on the gear housing cover (Fig. 49).

(8) With the engine in this position (pump gear mark at 6 o'clock), valve lash can be measured at the remaining rocker arms: **INTAKE 3-5-6 / EXHAUST 2-4-6**. Use the same method as above for determining whether adjustment is necessary, and adjust those that are found to be outside of the limits.

(9) Install the cylinder head cover (Fig. 47) (Refer to 9 - ENGINE/CYLINDER HEAD/CYLINDER HEAD COVER(S) - INSTALLATION).

(10) Install the fuel pump gear access cover.

(11) Connect the battery negative cables.

## REMOVAL

(1) Disconnect the battery negative cables.

(2) Remove the cylinder head cover (Fig. 52) (Refer to 9 - ENGINE/CYLINDER HEAD/CYLINDER HEAD COVER(S) - REMOVAL).

(3) Remove the rocker arms and crossheads (Fig. 53) from the cylinder(s) to be serviced. Mark each component so they can be installed in their original position.

(4) Remove the crankcase breather vapor canister and breather housing (Fig. 55).

(5) Using the crankshaft barring tool #7471-B (Fig. 51), rotate the engine to line up the mark on the pump gear with the TDC mark on the cover. **At this engine position, cylinders #1 and #6 can be serviced.**

(6) Remove the accessory drive belt (Refer to 7 - COOLING/ACCESSORY DRIVE/DRIVE BELTS - REMOVAL).

(7) With the fuel injection pump gear mark aligned at TDC, add a paint mark anywhere on the gear housing cover next to the crankshaft damper. Place another mark on the vibration damper in alignment with the mark you just made on the cover.

(8) Divide the crankshaft damper into three equally sized segments as follows:

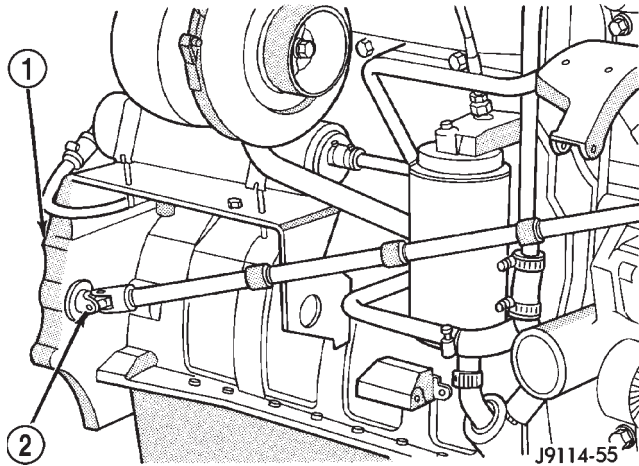
(a) Using a tape measure, measure the circumference of the crankshaft damper and divide the measurement by three (3).

(b) Measure that distance in a counter-clockwise direction from the first balancer mark and place another mark on the balancer.

(c) From the second damper mark, again measure in a counter-clockwise direction and place a mark on the damper at the same distance you measured when placing the second damper mark.

## INTAKE/EXHAUST VALVES &amp; SEATS (Continued)

The damper should now be marked in three equally spaced locations and the fuel pump gear mark should still be aligned with the TDC mark on the cover.



**Fig. 51 Rotating Engine with Barring Tool**

- 1 - REAR FLANGE  
2 - BARRING TOOL

(9) Compress the valve springs at cyls. #1 and #6 as follows:

(a) Remove the injector clamp (Fig. 54) from the cylinder(s) to be serviced. **Do not remove the bolt shown in (Fig. 54).**

(b) Install the valve spring compressor mounting base as shown in (Fig. 56). Reinstall the injector clamp bolt finger tight.

(c) Install the top plate, washer, and nut. Using a suitable wrench tighten the nut (clock-wise) (Fig. 57) to compress the valve springs and remove the collets.

(d) Rotate the compressor nut counter-clockwise to relieve tension on springs. Remove spring compressor.

(e) Remove and replace retainers, springs, and seals as necessary.

(f) **Do not rotate the engine until the springs and retainers are re-installed.**

(g) Install seals, springs and retainers. Install spring compressor, compress valve springs and install the collets.

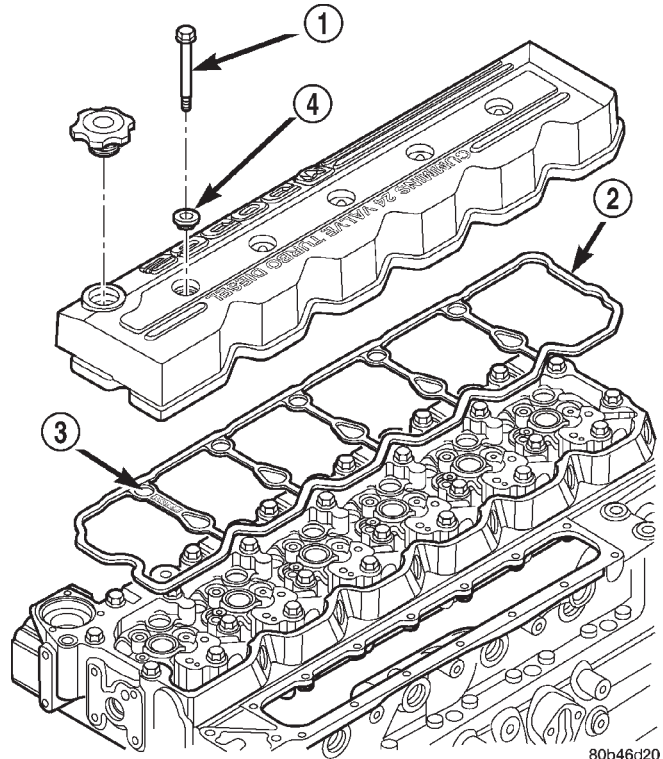
(h) Release the spring tension and remove the compressor. Verify that the collets are seated by tapping on the valve stem with a plastic hammer.

(10) Using the crankshaft barring tool, rotate the engine until the next crankshaft damper paint mark aligns with the mark you placed on the cover. **In this position, cylinders #2 and #5 can be serviced.**

(11) Repeat the valve spring compressing procedure previously performed and service the retainers, springs, and seals as necessary.

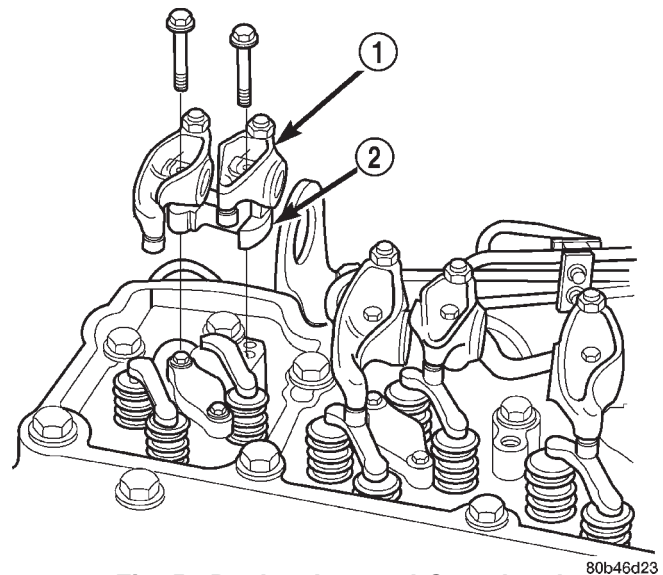
(12) Using the crankshaft barring tool, rotate the engine until the next crankshaft damper paint mark aligns with the mark you placed on the cover. **In this position, cylinders #3 and #4 can be serviced.**

(13) Repeat the spring compressing procedure previously performed and service the retainers, springs, and seals as necessary.



**Fig. 52 Cylinder Head Cover Removal/Installation**

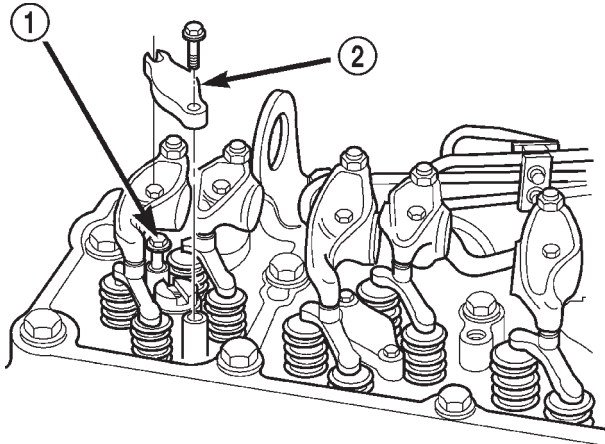
- 1 - BOLT (5)  
2 - GASKET  
3 - "TOP FRONT"  
4 - ISOLATOR (5)



**Fig. 53 Rocker Arm and Crosshead Removal/Installation**

- 1 - ROCKER ARM  
2 - PEDESTAL

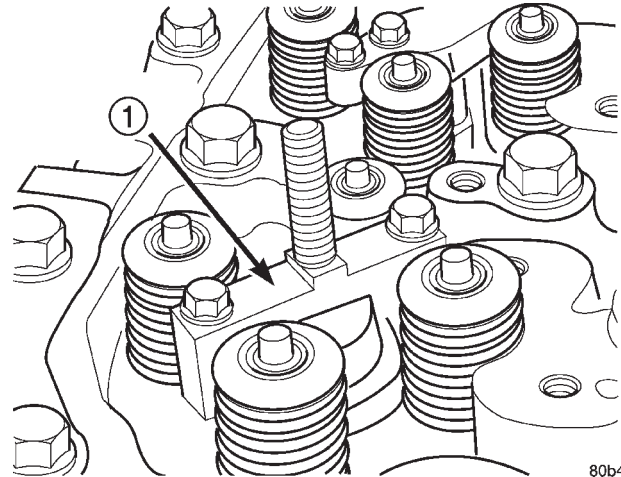
INTAKE/EXHAUST VALVES & SEATS (Continued)



80b46d22

**Fig. 54 Injector Clamp Removal/Installation**

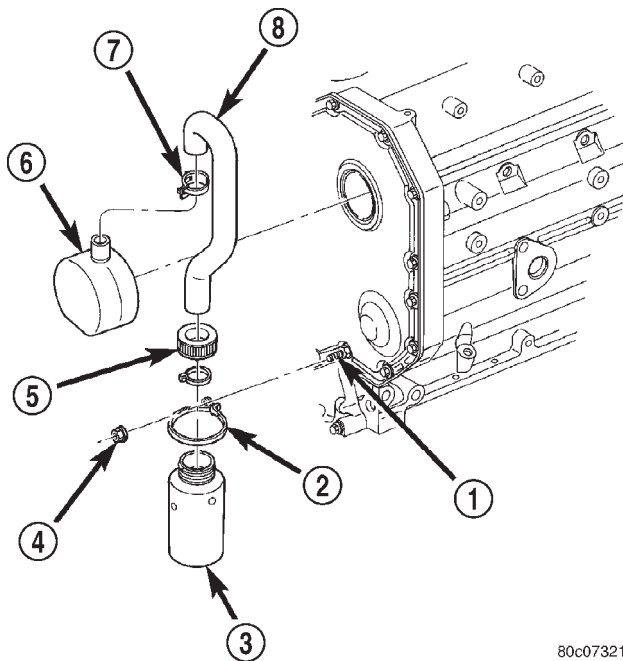
- 1 - DO NOT REMOVE
- 2 - INJECTOR CLAMP



80b4fb43

**Fig. 56 Spring Compressor Mounting Base—Part of Tool 8319-A**

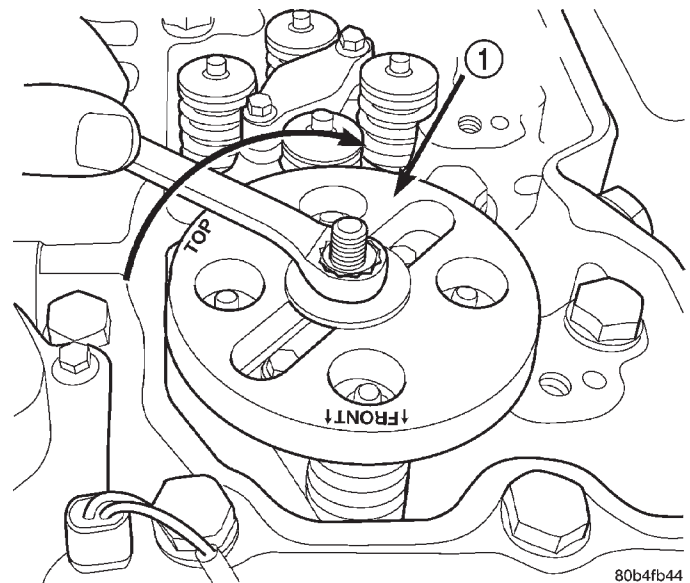
- 1 - COMPRESSOR MOUNTING BASE



80c07321

**Fig. 55 Crankcase Breather Vapor Canister**

- 1 - ENGINE FRONT COVER STUD
- 2 - STRAP
- 3 - VAPOR CANISTER
- 4 - NUT
- 5 - CAP
- 6 - CRANKCASE BREATHER
- 7 - CLAMP
- 8 - HOSE



80b4fb44

**Fig. 57 Compressing Valve Springs with Tool 8319-A**

- 1 - SPECIAL TOOL 8319-A

**INSTALLATION**

(1) Install all injector clamps into their original location (Fig. 54). Tighten the hold down bolt to 10 N·m (89 in. lbs.) torque.

(2) Lubricate the valve tips and install the cross-heads in their original locations.

(3) Lubricate the crossheads and push rod sockets and install the rocker arms and pedestals in their original locations (Fig. 53). Tighten bolts to 36 N·m (27 ft. lbs.) torque.



## INTAKE/EXHAUST VALVES &amp; SEATS (Continued)

(4) **Verify valve lash adjustment (Refer to 9 - ENGINE/CYLINDER HEAD/INTAKE/EXHAUST VALVES & SEATS - STANDARD PROCEDURE).**

(5) Install cylinder head cover and reusable gasket (Fig. 52) (Refer to 9 - ENGINE/CYLINDER HEAD/CYLINDER HEAD COVER(S) - INSTALLATION).

(6) Install the accessory drive belt (Refer to 7 - COOLING/ACCESSORY DRIVE/DRIVE BELTS - INSTALLATION).

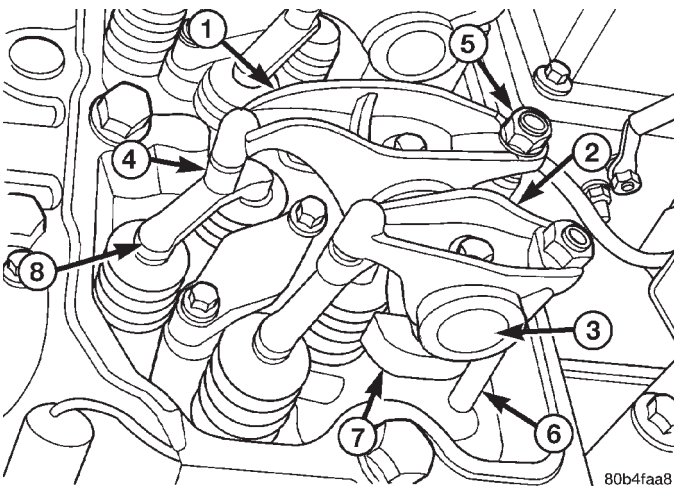
(7) Connect battery negative cables.

## ROCKER ARM / ADJUSTER ASSY

## DESCRIPTION

The 24-valve overhead system incorporates rocker arms that are designed to allow fuel injector service without removing the rocker arms and pedestals. The unique intake and exhaust rocker arms have their own rocker shafts and are lubricated by passages intersecting the cylinder block main oil rifle. Cross-heads are used (Fig. 58), which allow each rocker arm to operate two valves.

The solid push rods are hardened at the rocker arm and tappet contact areas for superior strength and durability.



**Fig. 58 Overhead System Components**

- 1 - EXHAUST ROCKER ARM
- 2 - INTAKE ROCKER ARM
- 3 - ROCKER SHAFT
- 4 - SOCKET
- 5 - ADJUSTING SCREW LOCK NUT
- 6 - PUSH ROD
- 7 - PEDESTAL
- 8 - CROSSHEAD

## REMOVAL

(1) Disconnect the battery negative cables.

(2) Remove cylinder head cover (Fig. 59) (Refer to 9 - ENGINE/CYLINDER HEAD/CYLINDER HEAD COVER(S) - REMOVAL).

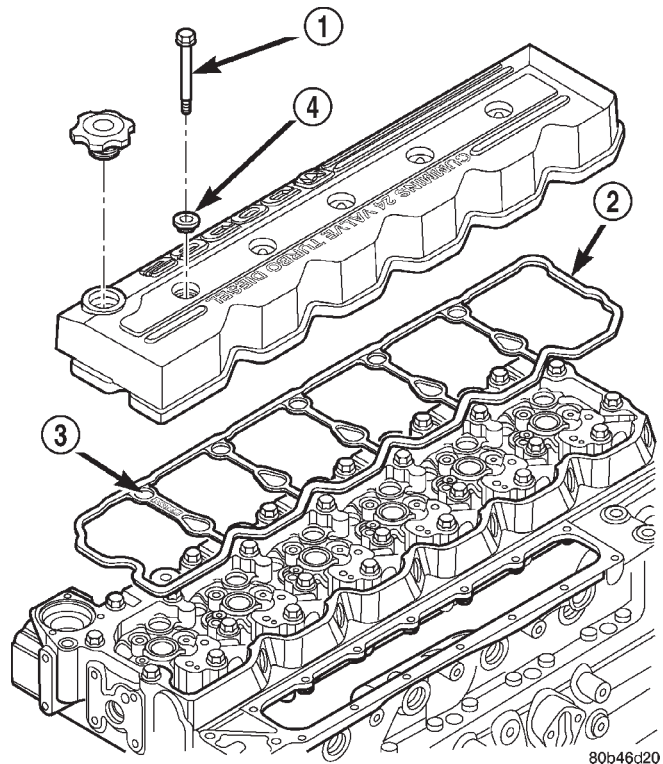
(3) Remove the rocker arm/pedestal fasteners (Fig. 60) and remove rocker arm and pedestal from cylinder head. Mark the arms and pedestals so they can be installed in their original position.

**CAUTION:** When removing the rocker arms, the sockets (Fig. 61) may come loose and fall into the engine. Make sure they stay with the arm upon removal/installation.

(4) Lift the push rod(s) up and out of the engine (Fig. 62). Mark them so they can be installed in their original position.

**NOTE:** The #5 cyl. exhaust and #6 cyl. intake and exhaust push rods must be raised through the provided cowl panel access holes.

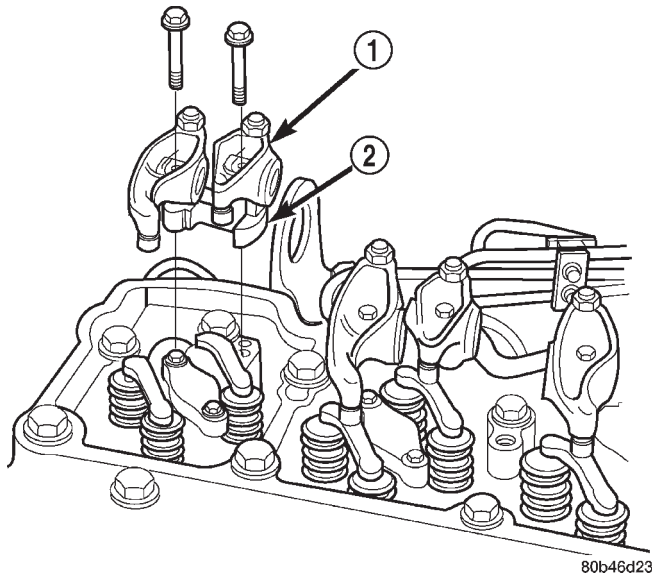
(5) Lift the crosshead(s) off of the valve stems. Mark them so they can be installed in their original position.



**Fig. 59 Cylinder Head Cover—Removal/Installation**

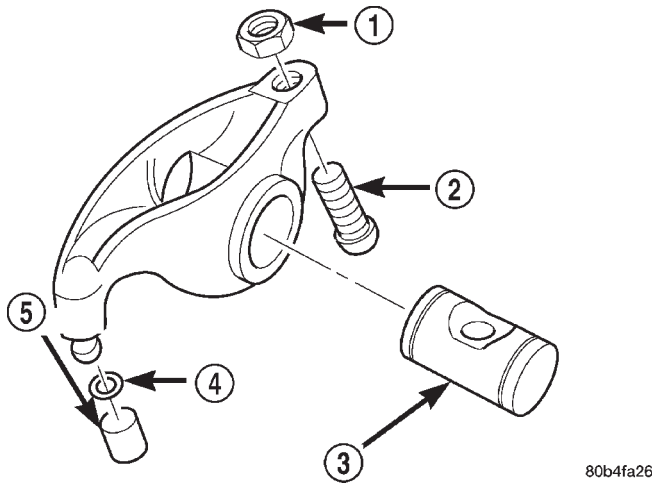
- 1 - BOLT (5)
- 2 - GASKET
- 3 - "TOP FRONT"
- 4 - ISOLATOR (5)

ROCKER ARM / ADJUSTER ASSY (Continued)



**Fig. 60 Rocker Arms and Pedestals—Removal/Installation**

- 1 - ROCKER ARM
- 2 - PEDESTAL

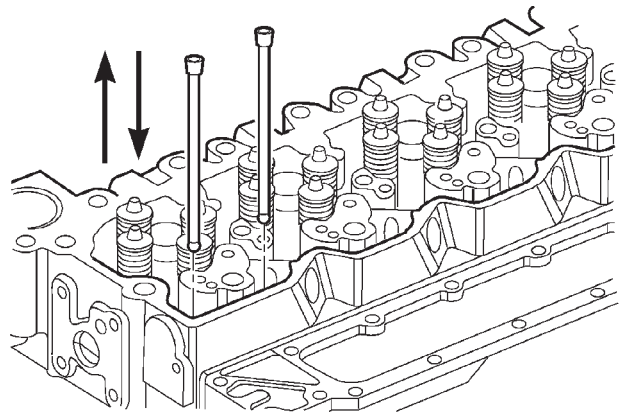


**Fig. 61 Rocker Arm Assembly Identification**

- 1 - NUT
- 2 - ADJUSTING SCREW
- 3 - ROCKER SHAFT
- 4 - RETAINER
- 5 - SOCKET

**CLEANING**

Clean all components in a suitable solvent. If necessary, use a wire brush or wheel to remove stubborn deposits. Rinse in hot water and blow dry with compressed air. Inspect oil passages in rocker arms and pedestals. Apply compressed air to lubrication orifices to purge contaminants.



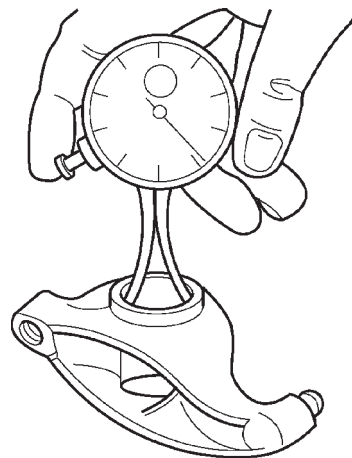
**Fig. 62 Push Rod Removal/Installation**

**INSPECTION**

**Rocker Arms**

(1) Remove rocker shaft and inspect for cracks and excessive wear in the bore or shaft. Remove socket and inspect ball insert and socket for signs of wear. Replace retainer if necessary.

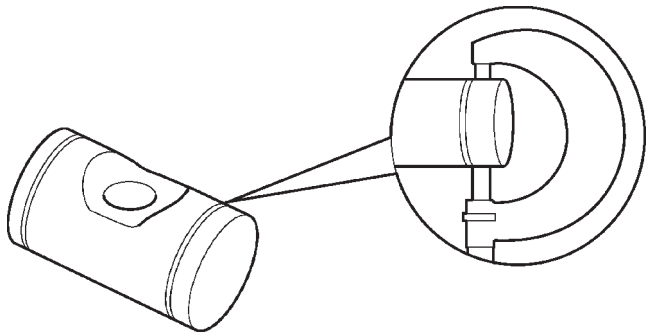
Measure the rocker arm bore and shaft (Fig. 63) (Fig. 64).



**Fig. 63 Measuring Rocker Arm Bore**

**ROCKER ARM BORE (MAX.)**  
22.027 mm (.867 in.)

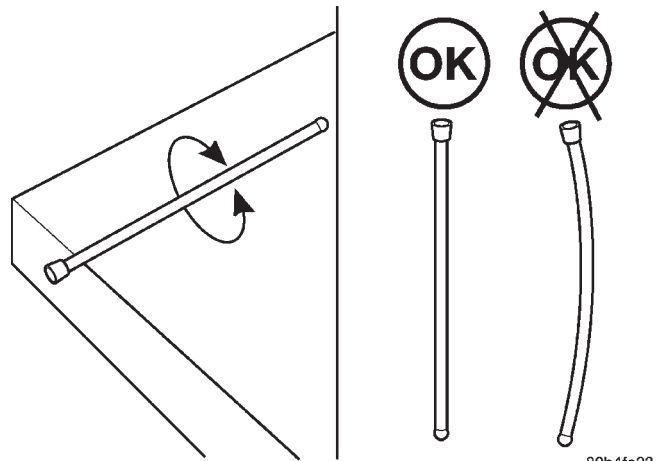
## ROCKER ARM / ADJUSTER ASSY (Continued)



80b4fa29

**Fig. 64 Measuring Rocker Arm Shaft**

ROCKER ARM SHAFT (MIN.)  
21.965 mm (.865 in.)

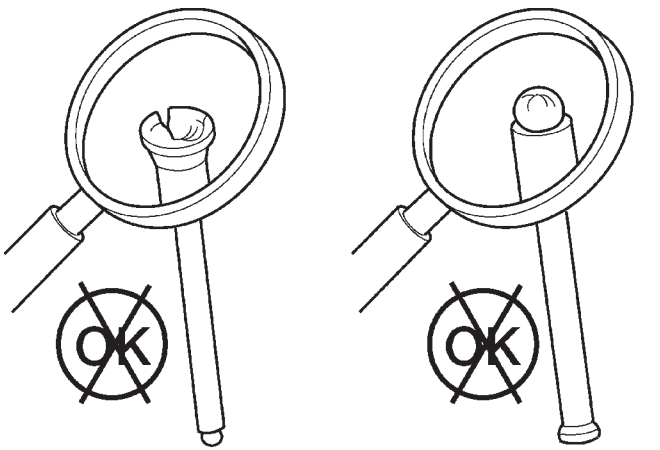


80b4fa23

**Fig. 66 Inspecting Push Rod for Flatness****Push Rods**

Inspect the push rod ball and socket for signs of scoring. Check for cracks where the ball and the socket are pressed into the tube (Fig. 65).

Roll the push rod on a flat work surface with the socket end hanging off the edge (Fig. 66). Replace any push rod that appears to be bent.



80b4fa24

**Fig. 65 Inspecting Push Rod for Cracks****Crossheads**

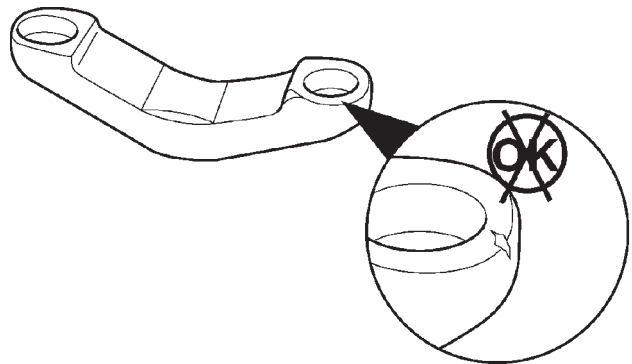
Inspect the crossheads for cracks and/or excessive wear on rocker lever and valve tip mating surfaces (Fig. 67).

**INSTALLATION**

(1) If previously removed, install the push rods in their original location. **Verify that they are seated in the tappets.**

(2) Lubricate the valve tips and install the crossheads in their original locations.

(3) Lubricate the crossheads and push rod sockets and install the rocker arms and pedestals (Fig. 60) in



80b4fa27

**Fig. 67 Inspecting Crosshead for Cracks**

their original locations. Tighten bolts to 36 N·m (27 ft. lbs.) torque.

(4) **Verify valve lash adjustment (Refer to 9 - ENGINE/CYLINDER HEAD/INTAKE/EXHAUST VALVES & SEATS - STANDARD PROCEDURE).**

(5) Install cylinder head cover and reusable gasket (Fig. 59) (Refer to 9 - ENGINE/CYLINDER HEAD/CYLINDER HEAD COVER(S) - INSTALLATION).

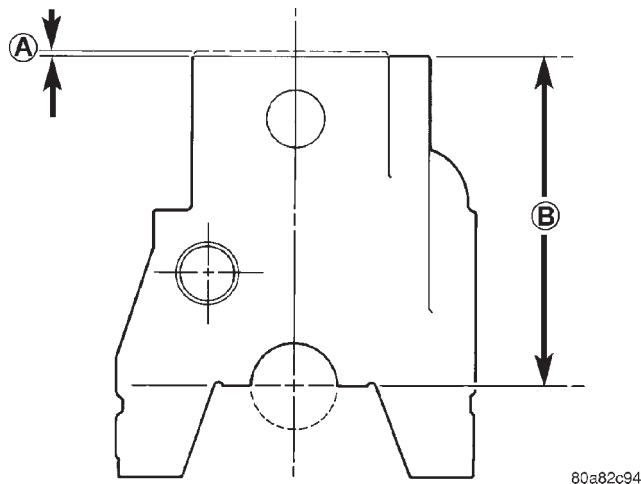
(6) Connect battery negative cables.

**ENGINE BLOCK****STANDARD PROCEDURE-CYLINDER BLOCK REFACING**

(1) The combustion deck can be refaced twice. The first reface should be 0.25 mm (0.0098 inch). If additional refacing is required, an additional 0.25 mm (0.0098 inch) can be removed. Total allowed refacing is 0.50 mm (0.0197 inch) - (Fig. 68).



ENGINE BLOCK (Continued)



80a82c94

**Fig. 68 Refacing Dimensions of the Cylinder Block**

CYLINDER BLOCK REFACING DIMENSIONS

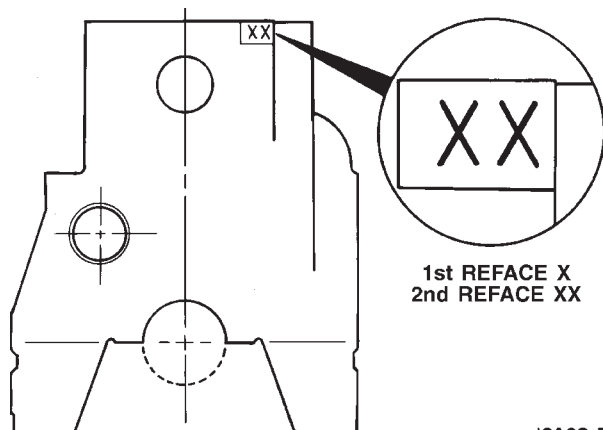
**DIMENSION "A"**

1st Reface	0.25mm	(0.0098 in.)
2nd Reface	0.25mm	(0.0098 in.)
Dim (A) Total	0.50 mm	(0.0197 in.)

**DIMENSION "B"**

Dim. "B" (STD.)	323.00 mm ± 0.10 mm	(12.7165 in. ± 0.0039 in.)
1st Reface	322.75 mm ± 0.10 mm	(12.7067 in. ± 0.0039 in.)
2nd Reface	322.50 mm ± 0.10 mm	(12.6968 in. ± 0.0039 in.)

(2) The upper right corner of the rear face of the block must be stamped with a X when the block is refaced to 0.25 mm (0.0098 inch). A second X must be stamped beside the first when the block is refaced to 0.50 mm (0.0197 inch) - (Fig. 69).



J9109-116

**Fig. 69 Stamp Block after Reface**

(3) Consult the parts catalog for the proper head gaskets which must be used with refaced blocks to ensure proper piston-to-valve clearance.

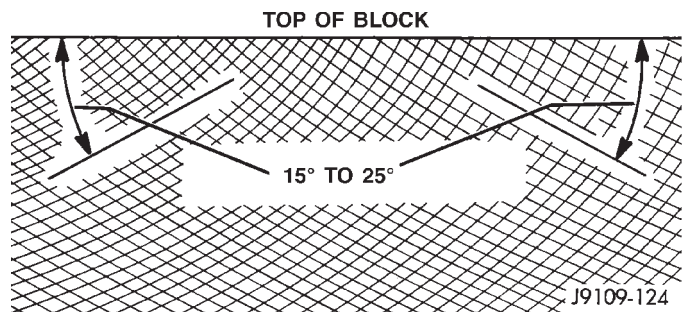
**STANDARD PROCEDURE-CYLINDER BORE - DE-GLAZE**

(1) New piston rings may not seat in glazed cylinder bores.

(2) De-glazing gives the bore the correct surface finish required to seat the rings. The size of the bore is not changed by proper de-glazing.

(3) Cover the lube holes in the top of the block with waterproof tape.

(4) A correctly honed surface will have a cross-hatch appearance with the lines at 15° to 25° angles (Fig. 70). For the rough hone, use 80 grit honing stones. To finish hone, use 280 grit honing stones.

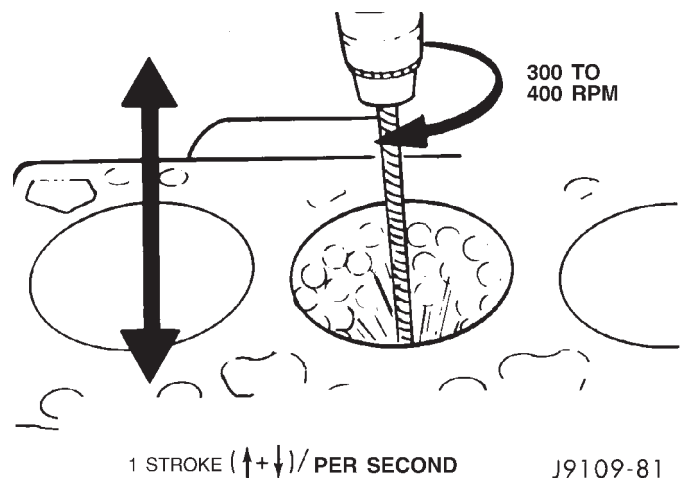


**Fig. 70 Cylinder Bore Crosshatch Pattern**

(5) Use a drill, a fine grit Flex-hone and a mixture of equal parts of mineral spirits and SAE 30W engine oil to de-glaze the bores.

(6) The crosshatch angle is a function of drill speed and how fast the hone is moved vertically (Fig. 71).

(7) Vertical strokes **MUST** be smooth continuous passes along the full length of the bore (Fig. 71).



**Fig. 71 De-Glazing Drill Speed and Vertical Speed**

(8) Inspect the bore after 10 strokes.

(9) Use a strong solution of hot water and laundry detergent to clean the bores. Clean the cylinder bores immediately after de-glazing.

(10) Rinse the bores until the detergent is removed and blow the block dry with compressed air.

## ENGINE BLOCK (Continued)

(11) Check the bore cleanliness by wiping with a white, lint free, lightly oiled cloth. If grit residue is still present, repeat the cleaning process until all residue is removed. Wash the bores and the complete block assembly with solvent and dry with compressed air.

(12) Be sure to remove the tape covering the lube holes after the cleaning process is complete.

## STANDARD PROCEDURE—CYLINDER BORE REPAIR

Cylinder bore(s) can be repaired by one of two methods:

- Method 1:—Over boring and using oversize pistons and rings.
- Method 2:—Boring and installing a repair sleeve to return the bore to standard dimensions.

### METHOD 1—OVERSIZE BORE

Cylinder bore(s) can be repaired by one of two methods:

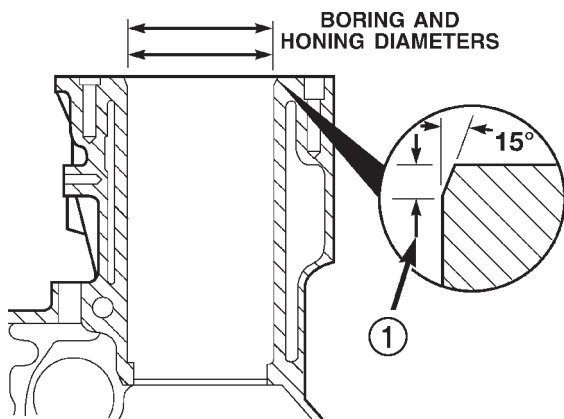
Oversize pistons and rings are available in two sizes - 0.50 mm (0.0197 inch) and 1.00 mm (0.0393 inch).

Any combination of standard, 0.50 mm (0.0197 inch) or 1.00 mm (0.0393 inch) overbore may be used in the same engine.

If more than 1.00 mm (0.0393 inch) overbore is needed, a repair sleeve can be installed (refer to Method 2—Repair Sleeve).

Cylinder block bores may be bored twice before use of a repair sleeve is required (Fig. 72). The first bore is 0.50 mm (0.0197 inch) oversize. The second bore is 1.00 mm (0.0393 inch) oversize.

After boring to size, use a honing stone to chamfer the edge of the bore (Fig. 72).



**Fig. 72 Cylinder Bore Dimensions**

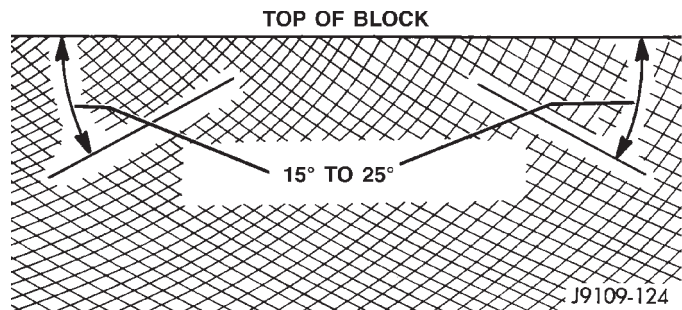
80bb0c38

1 - CHAMFER

## CYLINDER BORE DIMENSION CHART

DESCRIPTION	MEASUREMENT
BORING DIAMETER DIMENSION	1st. REBORE - 102.469 mm (4.0342 in.)
	2nd. REBORE - 102.969 mm (4.0539 in.)
HONING DIAMETER DIMENSIONS	STANDARD - 102.020 ± 0.020 mm (4.0165 ± 0.0008 in.)
	1st. REBORE - 102.520 ± 0.020 mm (4.0362 ± 0.0008 in.)
	2nd. REBORE - 103.020 ± 0.020 mm (4.0559 ± 0.0008 in.)
CHAMFER DIMENSIONS	Approx. 1.25 mm (0.049 in.) by 15°

A correctly honed surface will have a crosshatch appearance with the lines at 15° to 25° angles with the top of the cylinder block (Fig. 73). For the rough hone, use 80 grit honing stones. To finish hone, use 280 grit honing stones.



**Fig. 73 Crosshatch Pattern of Repaired Sleeve(s)**

A maximum of 1.2 micrometer (48 microinch) surface finish must be obtained.

After finish honing is complete, immediately clean the cylinder bores with a strong solution of laundry detergent and hot water.

After rinsing, blow the block dry.

Check the bore cleanliness by wiping with a white, lint-free, lightly-oiled cloth. There should be no grit residue present.

If the block is not to be used right away, coat it with a rust-preventing compound.

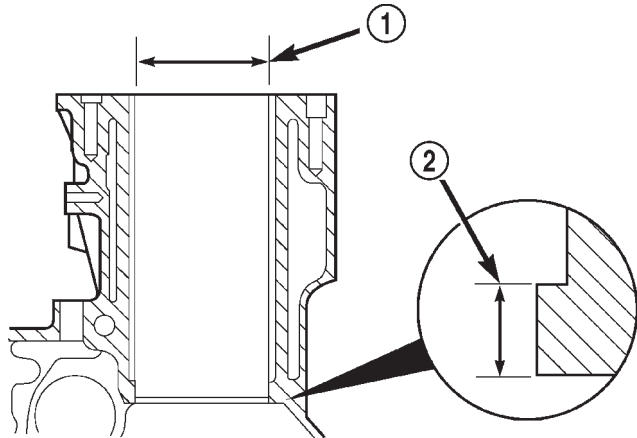
### METHOD 2—REPAIR SLEEVE

If more than a 1.00 mm (0.03937 inch) diameter oversize bore is required, the block must be bored and a repair sleeve installed.

Bore the block cylinder bore to 104.500-104.515 mm (4.1142-4.1148 inch) - (Fig. 74).

ENGINE BLOCK (Continued)

Repair sleeves can be replaced by using a boring bar to bore out the old sleeve. DO NOT cut the cylinder bore beyond the oversize limit.



80bb0c37

**Fig. 74 Block Bore for Repair Sleeve Dimensions**

- 1 - BORE DIAMETER
- 2 - STEP DIMENSION

REPAIR SLEEVE BLOCK REBORE DIMENSIONS CHART

BORE DIAMETER	STEP DIAMETER
104.500 + 0.015 mm (4.1142 + 0.0006 in.)	6.35 mm (0.25 in.)

After machining the block for the new repair sleeve, thoroughly clean the bore of all metal chips, debris and oil residue before installing the sleeve.

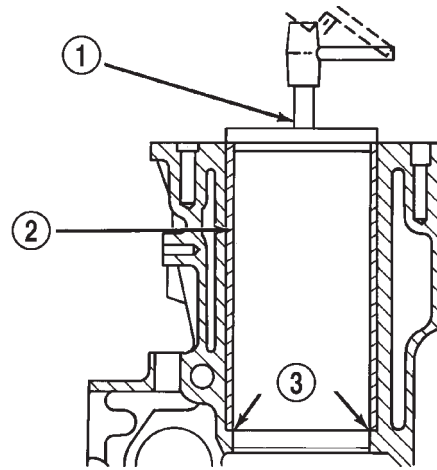
Cool the repair sleeve(s) to a temperature of -12°C (10°F) or below for a minimum of one hour. Be ready to install the sleeve immediately after removing it from the freezer.

Apply a coat of Loctite 620, or equivalent to the bore that is to be sleeved.

Wear protective gloves to push the cold sleeve into the bore as far as possible.

Using a sleeve driver, drive the sleeve downward until it contacts the step at the bottom of the bore (Fig. 75).

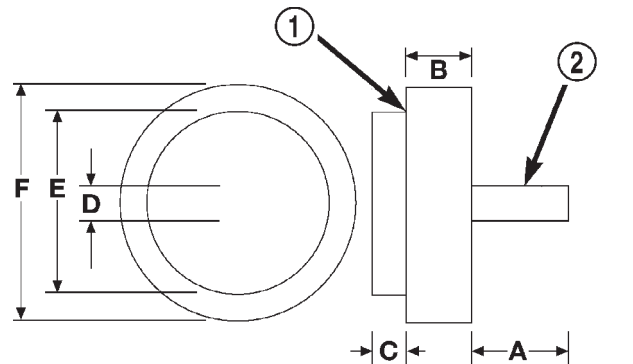
A sleeve driver can be constructed as follows (Fig. 76).



J9109-121

**Fig. 75 Sleeve Installation**

- 1 - SLEEVE DRIVER
- 2 - SLEEVE
- 3 - CONTACT



80bb0c3a

**Fig. 76 Sleeve Driver Construction**

- 1 - DRIVE
- 2 - HANDLE

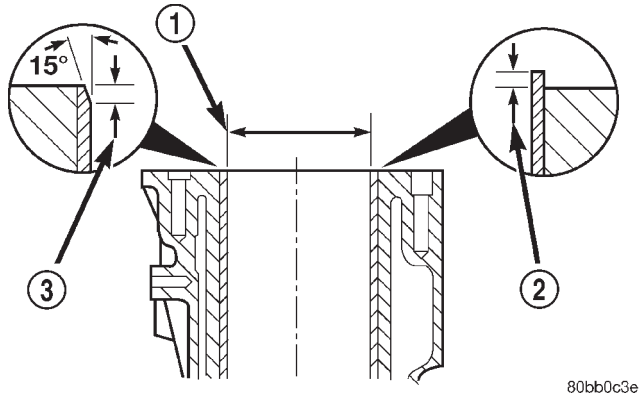
SLEEVE DRIVER CONSTRUCTION SPECIFICATION CHART

ITEM	MEASUREMENT
A	127 mm (5 in.)
B	38 mm (1.5 in.)
C	6.35 mm (0.25 in.)
D	25.4 mm (1 in.)
E	101 mm (3.976 in.)
F	107.343 mm (4.226 in.)

## ENGINE BLOCK (Continued)

Set up a boring bar and machine the sleeve to 101.956 mm (4.014 inch) - (Fig. 77).

After removing the boring bar, use a honing stone to chamfer the corner of the repair sleeve(s) - (Fig. 77).



80bb0c3e

**Fig. 77 Sleeve Machining Dimensions**

- 1 - DIAMETER
- 2 - PROTRUSION
- 3 - CHAMFER

## SLEEVE MACHINING DIMENSIONS CHART

ITEM	MEASUREMENT
SLEEVE PROTRUSION	MIN. - FLUSH WITH BLOCK
	MAX. - 0.050 mm (0.0019 in.)
SLEEVE DIAMETER	101.956 mm (4.014 in.)
SLEEVE CHAMFER	APPROX. 1.25 mm (0.049 in.) by 15°

A correctly honed surface will have a crosshatch appearance with the lines at 15° to 25° angles with the top of the cylinder block. For the rough hone, use 80 grit honing stones. To finish hone, use 280 grit honing stones.

Finished bore inside dimension is 102.020 ±0.020 mm (4.0165 ±0.0008 inch).

A maximum of 1.2 micrometer (48 microinch) surface finish must be obtained.

After finish honing is complete, immediately clean the cylinder bores with a strong solution of laundry detergent and hot water.

After rinsing, blow the block dry with compressed air.

Wipe the bore with a white, lint-free, lightly oiled cloth. Make sure there is no grit residue present.

Apply a rust-preventing compound if the block will not be used immediately.

A standard diameter piston and a piston ring set must be used with a sleeved cylinder bore.

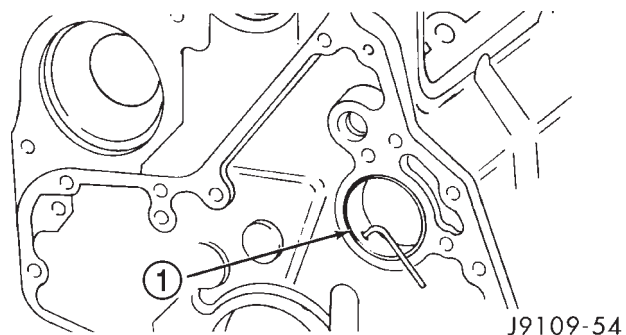
## STANDARD PROCEDURE—CAM BORE REPAIR

The front cam bushing bore can be bored to 59.235 Mm ±0.013 mm (2.332 inch ±0.0006 inch) oversize. DO NOT bore the intermediate or rear cam bore to the front cam bore oversize dimensions. Intermediate and rear cam bores may be bored to 57.235 mm ±0.013 mm (2.253 inch ±0.0006- inch) oversize.

A surface finish of 2.3 micrometers (92 microinch) must be maintained. Not more than 20% of an area of any one bore may be 3.2 micrometers (126 microinch).

Camshaft bores can be repaired individually. It is not necessary to repair undamaged cam bores in order to repair individually damaged cam bores. The standard front bushing cannot be used to repair intermediate or rear bores.

Install all cam bushings flush or below the front cam bore surface. The oil hole must align to allow a 3.2 mm (0.125 inch) rod to pass through freely (Fig. 78).



J9109-54

**Fig. 78 Oil Hole Alignment**

- 1 - CAMSHAFT BUSHING

## INSPECTION

Measure the combustion deck face using a straight edge and a feeler gauge (Fig. 79). The distortion of the combustion deck face is not to exceed 0.010 mm (0.0004 inch) in any 50.00 mm (2.0 inch) diameter. Overall variation end to end or side to side is 0.075 mm (0.003 inch).

If the surface exceeds the limit,

Inspect the cylinder bores for damage or excessive wear.

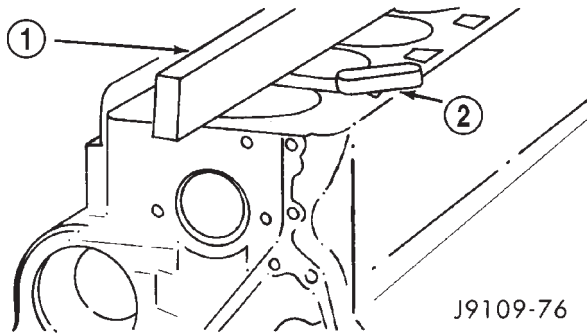
Measure the cylinder bores (Fig. 80). If the cylinder bores exceeds the limit, (Refer to 9 - ENGINE/ENGINE BLOCK - STANDARD PROCEDURE).

Inspect the camshaft bores for scoring or excessive wear.

Measure the camshaft bores (Refer to 9 - ENGINE - SPECIFICATIONS). Limit for the No.1 bore applies to the ID of the bushing.

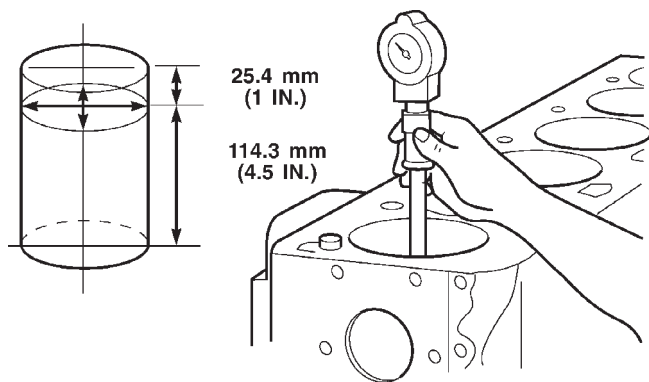
If a bore exceeds the limit, (Refer to 9 - ENGINE/ENGINE BLOCK/CAMSHAFT & BEARINGS (IN BLOCK) - STANDARD PROCEDURE).

## ENGINE BLOCK (Continued)



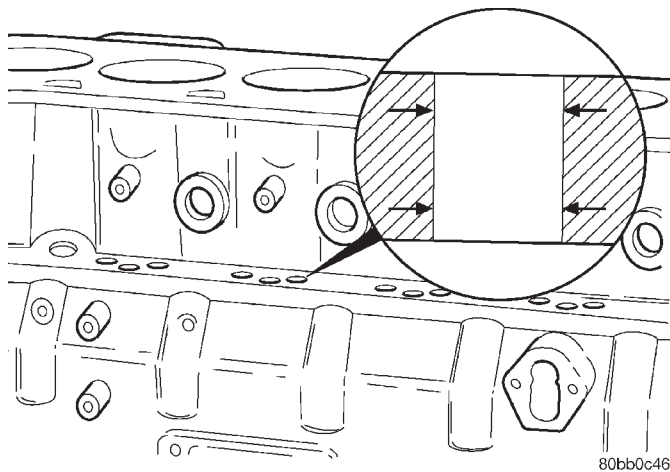
**Fig. 79 Combustion Deck Face Measurement**

- 1 - STRAIGHT EDGE  
2 - FEELER GAUGE



**Fig. 80 Cylinder Bore Diameter**

Inspect the tappet bores for scoring or excessive wear 16.000 mm min - 16.055 mm max ( .63 in. min - .6321 in. max ) (Fig. 81). If out of limits, replace the cylinder block.



**Fig. 81 Tappet Bore Diameter**

## CAMSHAFT & BEARINGS (IN BLOCK)

### REMOVAL—CAMSHAFT BEARINGS

**NOTE:** Measure the diameter of each bore. (The limit for the bushing in the No.1 bore is the same as for the other bores without bushings). The limit of the inside diameter is 54.089 min. - 54.164 max. mm (2.1295 min. - 2.1325 max. inch). If the camshaft bore for the first cam bushing is worn beyond the limit, install a new service bushing. Inspect the rest of the camshaft bores for damage or excessive wear. If the bores without a bushing are worn beyond the limit, the engine must be removed for machining and installation of service bushings. If badly worn, replace the cylinder block.

- (1) Remove the camshaft (Refer to 9 - ENGINE/ENGINE BLOCK/CAMSHAFT & BEARINGS (IN BLOCK) - REMOVAL).
- (2) Remove the bushing from the No.1 bore, using a universal cam bushing tool.
- (3) Mark the cylinder block so you can align the oil hole in the cylinder block with the oil hole in the bushing.

### REMOVAL—CAMSHAFT

- (1) Disconnect both battery negative cables.
- (2) Recover A/C refrigerant (if A/C equipped) (Refer to 24 - HEATING & AIR CONDITIONING/PLUMBING - STANDARD PROCEDURE).
- (3) Raise vehicle on hoist.
- (4) Drain engine coolant into container suitable for re-use (Refer to 7 - COOLING - STANDARD PROCEDURE).
- (5) Lower vehicle.
- (6) Remove radiator upper hose.
- (7) Remove viscous fan/drive assembly and fan shroud (Refer to 7 - COOLING/ENGINE/RADIATOR FAN - REMOVAL).
- (8) Disconnect the coolant recovery bottle hose from the radiator filler neck.
- (9) Disconnect lower radiator hose from radiator outlet.
- (10) **Automatic Transmission models:** Disconnect transmission oil cooler lines from radiator using Special Tool 6931 (unless equipped with finger-release disconnect).
- (11) Remove radiator mounting screws and lift radiator out of engine compartment.
- (12) Remove upper radiator support panel.
- (13) Remove front bumper assembly (Refer to 13 - FRAMES & BUMPERS/BUMPERS/FRONT BUMPER - REMOVAL).



## CAMSHAFT &amp; BEARINGS (IN BLOCK) (Continued)

(14) If A/C equipped, disconnect A/C condenser refrigerant lines.

(15) Disconnect charge air cooler piping from the cooler inlet and outlet.

(16) Remove the two charge air cooler mounting bolts.

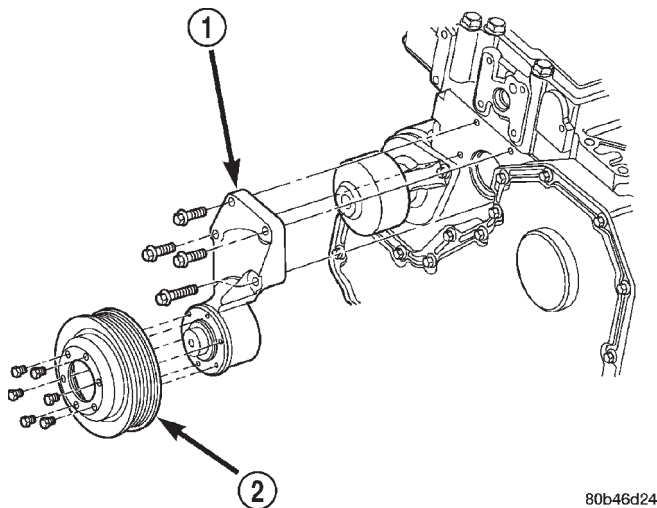
(17) Remove charge air cooler (and A/C condenser if equipped) from vehicle.

(18) Remove accessory drive belt (Refer to 7 - COOLING/ACCESSORY DRIVE/DRIVE BELTS - REMOVAL).

(19) Remove the fan support/hub assembly (Fig. 82).

(20) Remove crankshaft damper (Fig. 83) (Refer to 9 - ENGINE/ENGINE BLOCK/VIBRATION DAMPER - REMOVAL).

(21) Remove the crankcase breather vapor canister from the gear housing cover (Fig. 84).



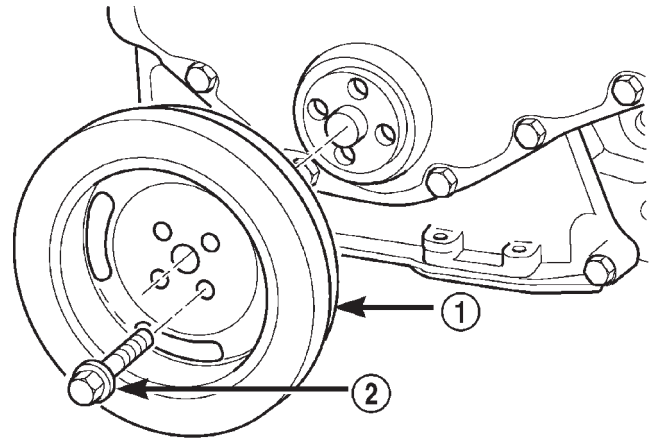
80b46d24

**Fig. 82 Fan Support/Hub Removal/Installation**

- 1 - FAN SUPPORT/HUB
- 2 - FAN PULLEY

(22) Using Special Tool 7471-B Crankshaft Barring Tool, rotate the crankshaft to bring the engine to TDC #1.

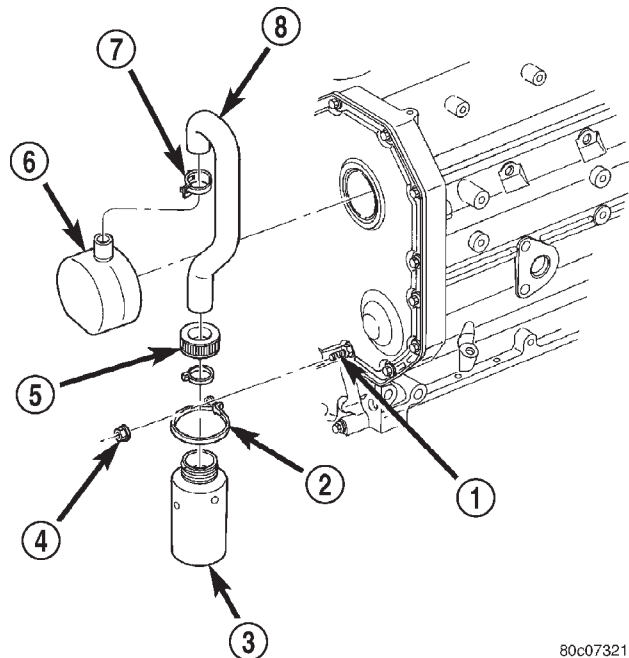
(23) Remove the gear cover-to-housing bolts and gently pry the cover away from the housing, taking care not to mar the sealing surfaces.



80b46d29

**Fig. 83 Crankshaft Damper Removal/Installation**

- 1 - DAMPER
- 2 - BOLT



80c07321

**Fig. 84 Crankcase Breather Vapor Canister**

- 1 - ENGINE FRONT COVER STUD
- 2 - STRAP
- 3 - VAPOR CANISTER
- 4 - NUT
- 5 - CAP
- 6 - CRANKCASE BREATHER
- 7 - CLAMP
- 8 - HOSE

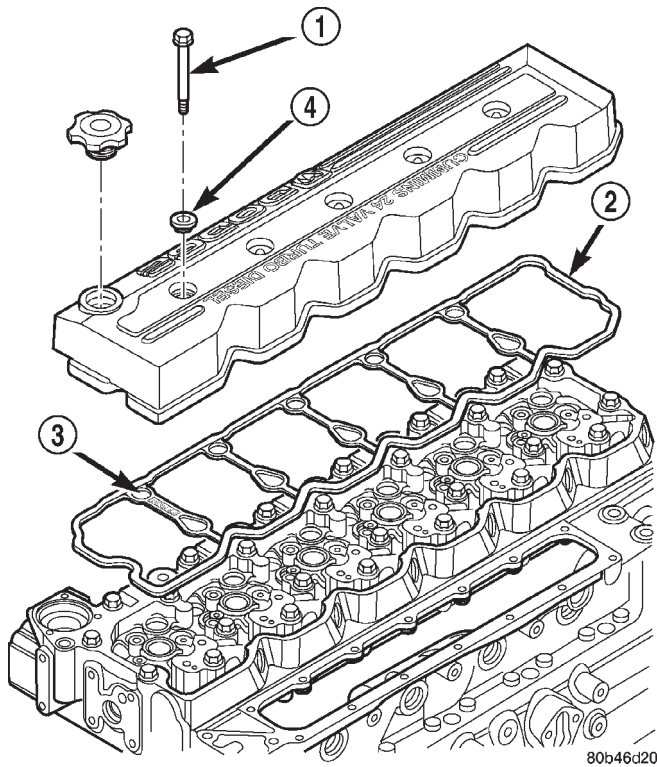


CAMSHAFT & BEARINGS (IN BLOCK) (Continued)

(24) Remove the cylinder head cover (Fig. 85) (Refer to 9 - ENGINE/CYLINDER HEAD/CYLINDER HEAD COVER(S) - REMOVAL).

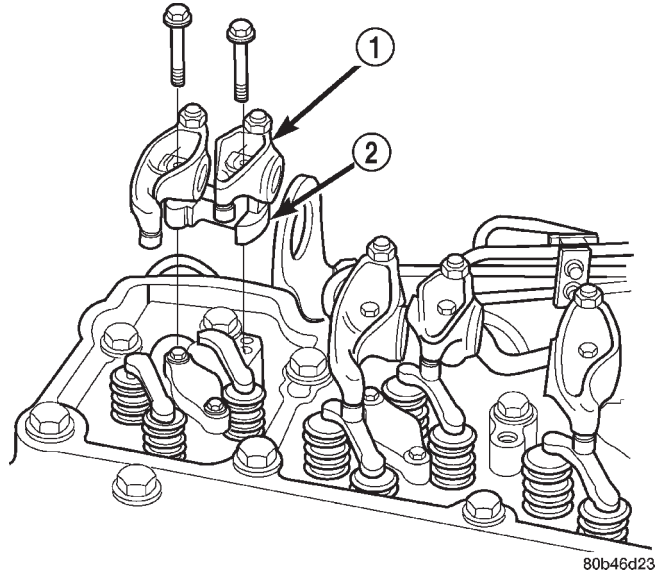
(25) Remove the rocker arms (Fig. 86), cross heads, and push rods (Fig. 87). Mark each component so they can be installed in their original positions.

**NOTE:** The #5 cylinder exhaust and the #6 cylinder intake and exhaust pushrods are removed by lifting them up and through the provided cowl panel access holes. Remove the rubber plugs to expose these relief holes.



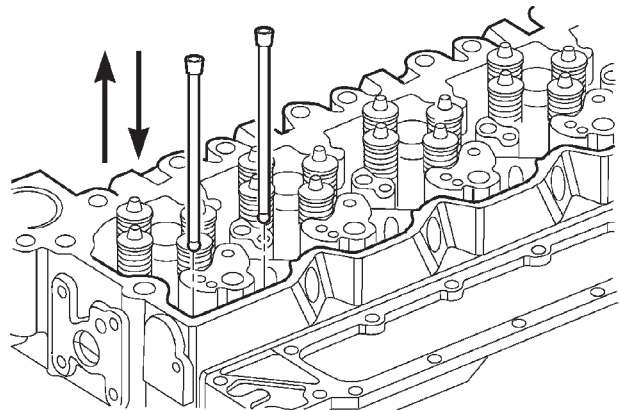
**Fig. 85 Cylinder Head Cover Removal/Installation**

- 1 - BOLT (5)
- 2 - GASKET
- 3 - "TOP FRONT"
- 4 - ISOLATOR (5)



**Fig. 86 Rocker Arm and Pedestal Removal/Installation**

- 1 - ROCKER ARM
- 2 - PEDESTAL



**Fig. 87 Push Rod Removal/Installation**

80b4fa25

## CAMSHAFT &amp; BEARINGS (IN BLOCK) (Continued)

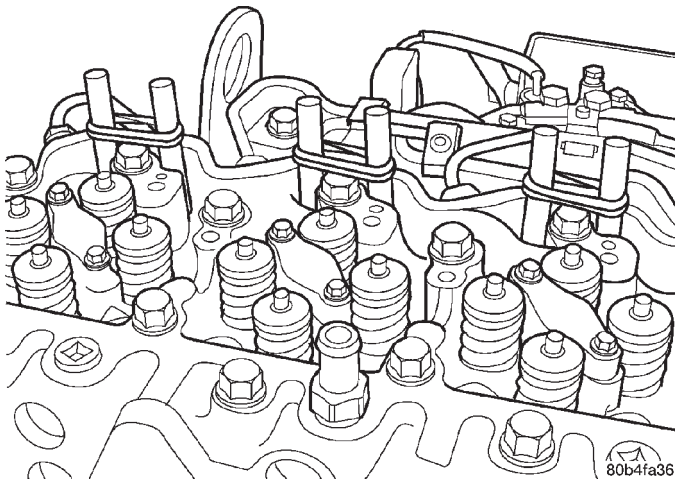
(26) Raise the tappets as follows, using the wooden dowel rods (Fig. 88) provided with the Miller Tool Kit 8502 or Cummins tappet replacement tool kit #3822513:

(a) Insert the slotted end of the dowel rod into the tappet. **The dowel rods for the rear two cylinders will have to be cut for cowl panel clearance.** Press firmly to ensure that it is seated in the tappet.

(b) Raise the dowel rod to bring the tappet to the top of its travel, and wrap a rubber band around the dowel rods (Fig. 88) to prevent the tappets from dropping into the crankcase.

(c) Repeat this procedure for the remaining cylinders.

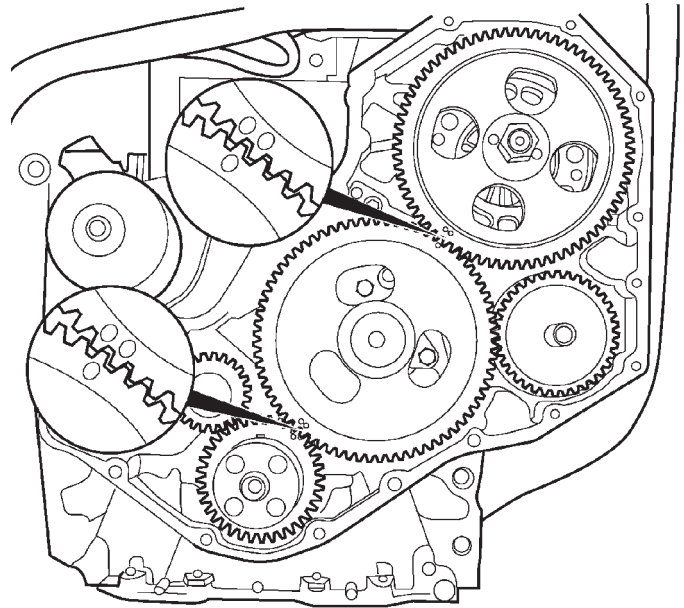
(27) Verify that the camshaft timing marks are aligned with the crankshaft and injection pump marks (Fig. 89).



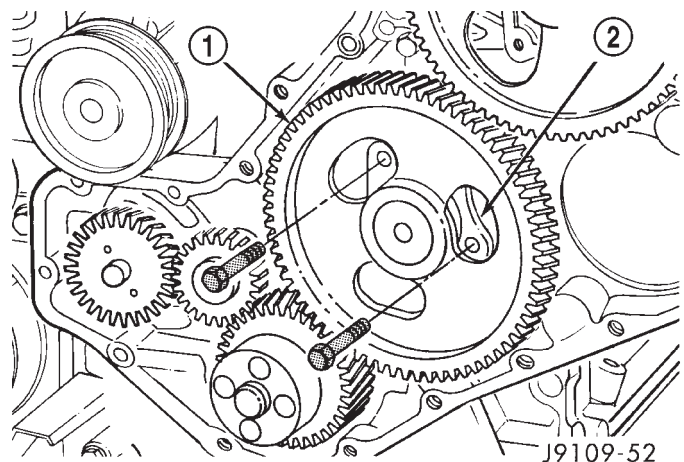
**Fig. 88 Use Wooden Dowel Rods to Secure Tappets in Place**

(28) Remove the bolts from the thrust plate (Fig. 90).

**CAUTION:** When removing the camshaft and thrust plate, grab the thrust plate to prevent it from falling into the crankcase.



**Fig. 89 Timing Mark Alignment**



**Fig. 90 Thrust Plate Bolt Location**

- 1 - CAMSHAFT GEAR
- 2 - THRUST PLATE

CAMSHAFT & BEARINGS (IN BLOCK) (Continued)

(29) Remove the camshaft (Fig. 91) and thrust plate.

**CAUTION:** If Camshaft lobes are worn, requiring camshaft replacement, it is necessary to replace the tappets also. (Refer to 9 - ENGINE/ENGINE BLOCK/SOLID LIFTERS - REMOVAL).

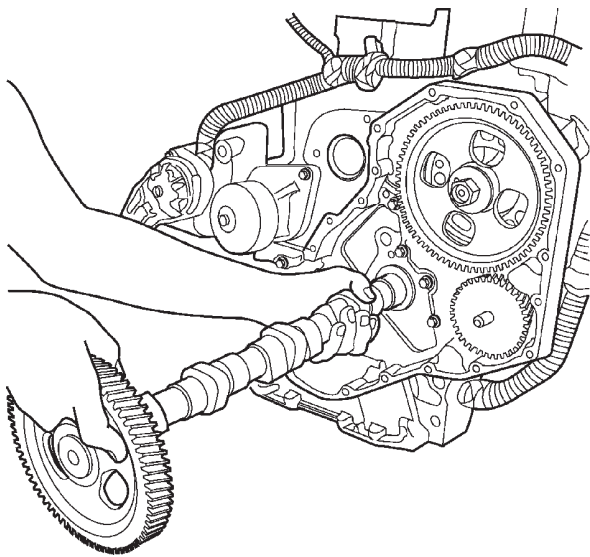


Fig. 91 Camshaft Removal/Installation

80b4fa35

INSPECTION

Camshaft

- (1) Inspect the valve lobes and bearing journals for cracks, pitting, scoring, or generally excessive wear. Replace any camshaft that exceeds the allowable limits.
- (2) Measure the bearing journals and lobes (Fig. 92).

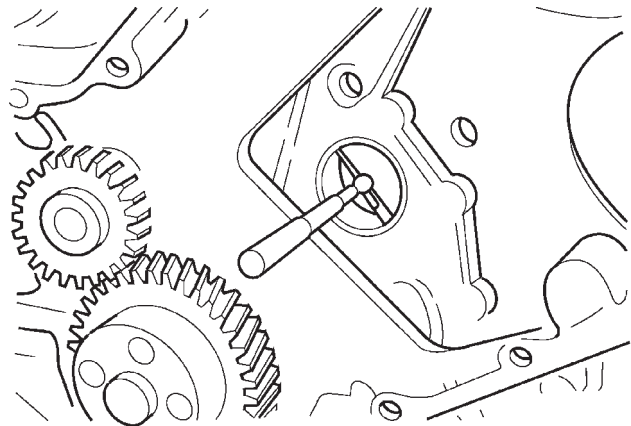
Camshaft Bushing/Bores

Camshaft bores No. 2-7 **do not** use a bushing.

(1) Inspect the camshaft bushing and bores for signs of excessive wear.

(2) Measure the camshaft bushing and bores (Fig. 93) with a telescoping bore gauge and micrometer. If out of specification, (Refer to 9 - ENGINE/ENGINE BLOCK/CAMSHAFT & BEARINGS (IN BLOCK) - REMOVAL).

(3) Inspect the camshaft bushing oil hole for alignment with cylinder block (Fig. 94).



80b4fa38

Fig. 93 Measuring Camshaft Bushing and Bores

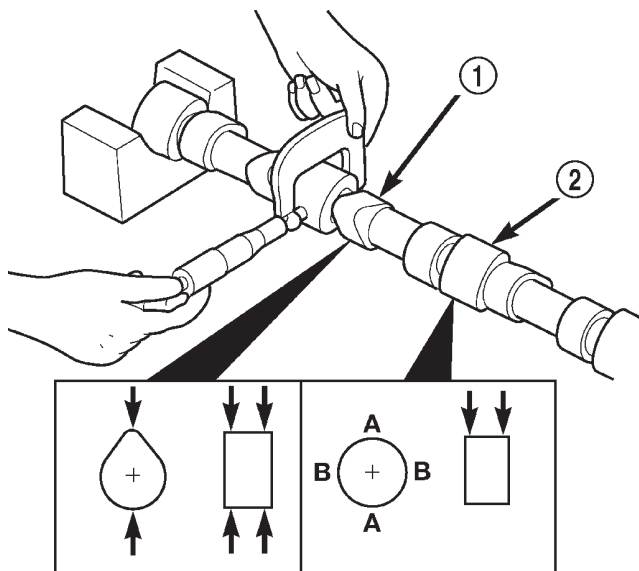


Fig. 92 Measuring

80b4fa37

1 - VALVE LOBE

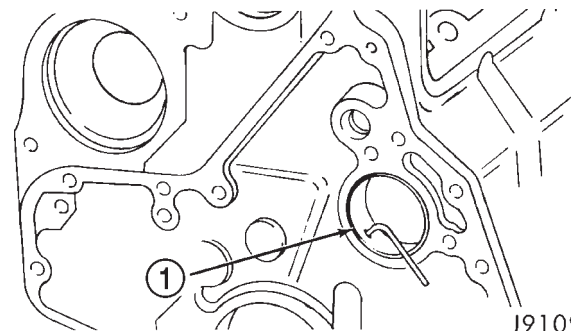
2 - CAMSHAFT JOURNAL

JOURNAL DIAMETER #1 54.028 mm (2.1270 in.) MIN.

JOURNAL DIAMETER #2 - 7 53.987 mm (2.1245 in.) MIN.

LOBE HEIGHT INTAKE 47.173 mm (1.857 in.) MIN.

LOBE HEIGHT EXHAUST 45.636 mm (1.796 in.) MIN.



J9109-54

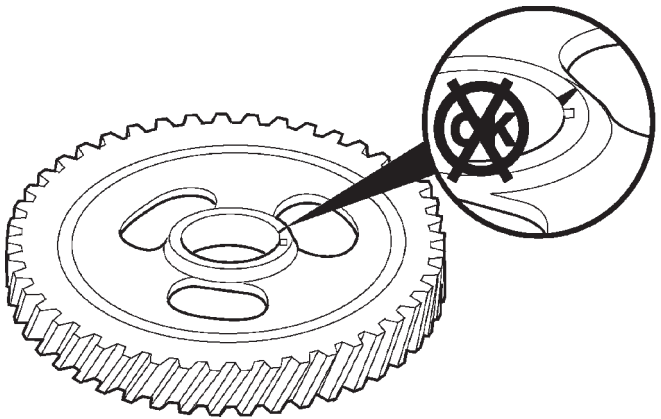
Fig. 94 Inspecting Oil Hole Alignment

1 - CAMSHAFT BUSHING

## CAMSHAFT &amp; BEARINGS (IN BLOCK) (Continued)

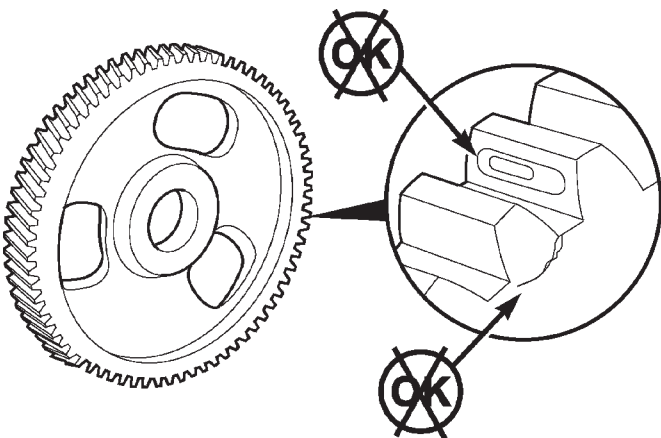
## Camshaft Gear

Inspect the camshaft gear for cracks (gear and hub) (Fig. 95), and chipped/broken/fretted teeth (Fig. 96). If replacement is necessary, (Refer to 9 - ENGINE/ENGINE BLOCK/CAMSHAFT & BEARINGS (IN BLOCK) - REMOVAL).



80b4fa30

**Fig. 95 Inspect Camshaft Gear Hub for Cracks**



80b4fa31

**Fig. 96 Inspect Camshaft Gear for Cracks and Fretting**

## Thrust Plate

Inspect the camshaft thrust plate for excessive wear in the camshaft contact area. Measure thrust plate thickness using the CAMSHAFT THRUST PLATE THICKNESS CHART. Replace any thrust plate that falls outside of these specifications:

CAMSHAFT THRUST PLATE THICKNESS  
CHART

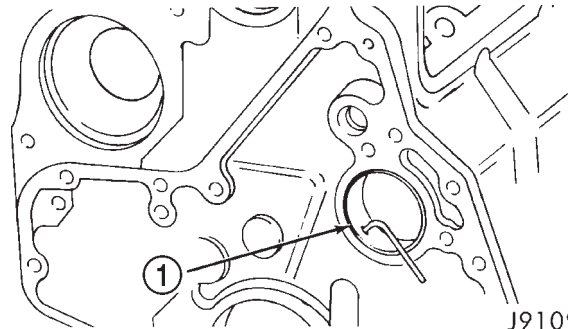
9.34 mm (0.368 in.) MIN.
9.58 mm (0.377 in.) MAX.

## INSTALLATION—CAMSHAFT BEARINGS

(1) Apply a coating of Loctite® 640 Adhesive to the backside of the new bushing. Avoid getting adhesive in the oil hole.

(2) Use a universal cam bushing installation tool and install the bushing so that it is even with the front face of the cylinder block. The oil hole must be aligned. A 3.2 mm (0.128 inch) diameter rod must be able to pass through the hole (Fig. 97).

(3) Measure the installed bushing. The limit of the inside diameter is 54.133 mm (2.1312 inch).



J9109-54

**Fig. 97 Oil Hole Alignment**

1 - CAMSHAFT BUSHING

## INSTALLATION—CAMSHAFT

(1) Lubricate the camshaft bushing and bores with fresh engine oil or suitable equivalent.

(2) Liberally coat the camshaft lobes, journals, and thrust washer with fresh engine oil or suitable equivalent.

**CAUTION:** When installing the camshaft (Fig. 91), DO NOT push it in farther than it will go with the thrust washer in place. Pushing it too far can dislodge the plug in the rear of the camshaft bore and cause an oil leak.

(3) Install the camshaft (Fig. 91) and thrust plate. Align the timing marks as shown in (Fig. 89).

(4) Install the thrust plate bolts and tighten to 24 N·m (18 ft. lbs.) torque.

(5) Measure camshaft back lash and end clearance (Fig. 98).

(6) Remove the wooden dowel rods and rubber bands from the tappets.

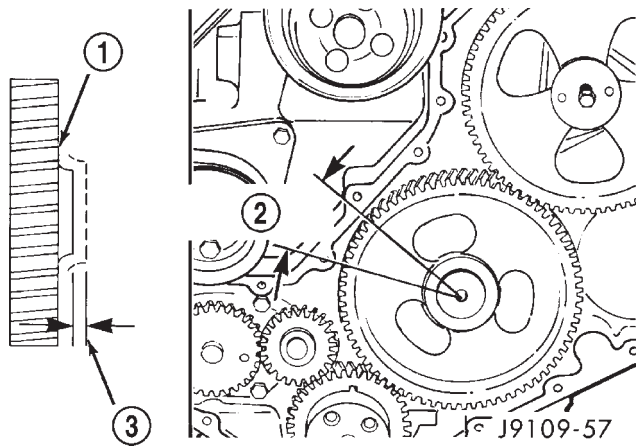
(7) Lubricate the push rods with engine oil and install in their original location (Fig. 87). **Verify that they are seated in the tappets.**

(8) Lubricate the valve tips with engine oil and install the crossheads in their original locations.

(9) Lubricate the crossheads and push rod sockets with engine oil and install the rocker arms and pedestals in their original locations (Fig. 86). Tighten bolts to 36 N·m (27 ft. lbs.) torque.



## CAMSHAFT &amp; BEARINGS (IN BLOCK) (Continued)



**Fig. 98 Camshaft Backlash and End Clearance**

- 1 - CAMSHAFT GEAR
- 2 - CAMSHAFT GEAR BACKLASH
- 3 - CAMSHAFT GEAR CLEARANCE

BACKLASH — 0.152—0.33 mm  
(0.006—0.013 inch)

CLEARANCE — 0.1—0.46 mm  
(0.004—0.0182 inch)

(10) **Verify valve lash adjustment (Refer to 9 - ENGINE/CYLINDER HEAD/INTAKE/EXHAUST VALVES & SEATS - STANDARD PROCEDURE).**

(11) Install the cylinder head cover and reusable gasket (Fig. 85) (Refer to 9 - ENGINE/CYLINDER HEAD/CYLINDER HEAD COVER(S) - INSTALLATION).

(12) Install gear housing cover (Refer to 9 - ENGINE/VALVE TIMING/GEAR HOUSING COVER - INSTALLATION).

(13) Install the crankshaft damper (Fig. 83) (Refer to 9 - ENGINE/ENGINE BLOCK/VIBRATION DAMPER - INSTALLATION).

(14) Install the fan support/hub assembly (Fig. 82) and tighten bolts to 24 N·m (18 ft. lbs.) torque.

(15) Install the crankcase breather housing (Refer to 9 - ENGINE - INSTALLATION).

(16) Install the charge air cooler (with a/c condenser and auxiliary transmission oil cooler, if equipped) and tighten the mounting bolts to 2 N·m (17 in. lbs.) torque.

(17) Connect charge air cooler inlet and outlet pipes. Tighten clamps to 10 N·m (100 in. lbs.) torque.

(18) Install the radiator upper support panel.

(19) Close radiator petcock and lower the radiator into the engine compartment. Tighten the mounting bolts to 11 N·m (95 in. lbs.) torque.

(20) Raise vehicle on hoist.

(21) Connect radiator lower hose and install clamp.

(22) Connect transmission auxiliary oil cooler lines (if equipped).

(23) Lower vehicle.

(24) Install the fan shroud and tighten the mounting screws to 6 N·m (50 in. lbs.) torque.

(25) Install the viscous fan/drive assembly (Refer to 7 - COOLING/ENGINE/RADIATOR FAN - INSTALLATION).

(26) Install the coolant recovery and windshield washer fluid reservoirs to the fan shroud.

(27) Connect the coolant recovery hose to the radiator filler neck.

(28) Install the accessory drive belt (Refer to 7 - COOLING/ACCESSORY DRIVE/DRIVE BELTS - INSTALLATION).

(29) Install the front bumper assembly (Refer to 13 - FRAMES & BUMPERS/BUMPERS/FRONT BUMPER - INSTALLATION).

(30) Add engine coolant (Refer to 7 - COOLING - STANDARD PROCEDURE).

(31) Charge A/C system with refrigerant (if A/C equipped) (Refer to 24 - HEATING & AIR CONDITIONING/PLUMBING - STANDARD PROCEDURE).

(32) Connect the battery negative cables.

(33) Start engine and check for engine oil and coolant leaks.

## CONNECTING ROD BEARINGS

### STANDARD PROCEDURE—CONNECTING ROD BEARING AND CRANKSHAFT JOURNAL CLEARANCE

Measure the connecting rod bore with the bearings installed and the bolts tightened to 100 N·m (73 ft. lbs.) torque.

Record the smaller diameter.

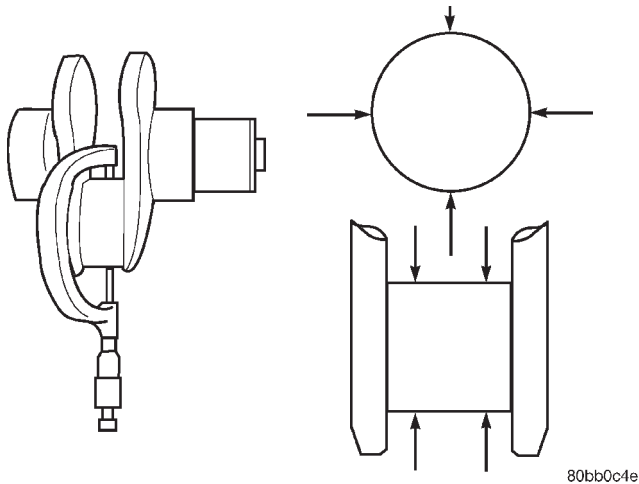
Measure the diameter of the rod journal at the location shown (Fig. 99). Calculate the average diameter for each side of the journal.

The clearance is the difference between the connecting rod bore (smallest diameter) and the average diameter for each side of the crankshaft journal.

#### CONNECTING ROD JOURNAL DIAMETER LIMITS CHART

DESCRIPTION	MEASUREMENT
CRANKSHAFT ROD JOURNAL DIAMETER	MINIMUM 68.962 mm (2.715 in.)
	MAXIMUM 69.013 mm (2.717 in.)
OUT-OF-ROUND	MAXIMUM 0.050 mm (0.002 in.)
TAPER	MAXIMUM 0.013 mm (0.0005 in.)
BEARING CLEARANCE	MAXIMUM 0.089 mm (0.0035 in.)

## CONNECTING ROD BEARINGS (Continued)



80bb0c4e

**Fig. 99 Connecting Rod Journal Diameter Limits**  
CONNECTING ROD JOURNAL DIAMETER  
LIMITS CHART

DESCRIPTION	MEASUREMENT
CRANKSHAFT ROD JOURNAL DIAMETER	MINIMUM 68.962 mm (2.715 in.) MAXIMUM 69.013 mm (2.717 in.)
OUT-OF-ROUND	MAXIMUM 0.050 mm (0.002 in.)
TAPER	MAXIMUM 0.013 mm (0.0005 in.)
BEARING CLEARANCE	MAXIMUM 0.089 mm (0.0035 in.)

If the crankshaft is within limits, replace the bearing. If the crankshaft is out of limits, grind the crankshaft to the next smaller size and use oversize rod bearings.

## CRANKSHAFT

## DESCRIPTION

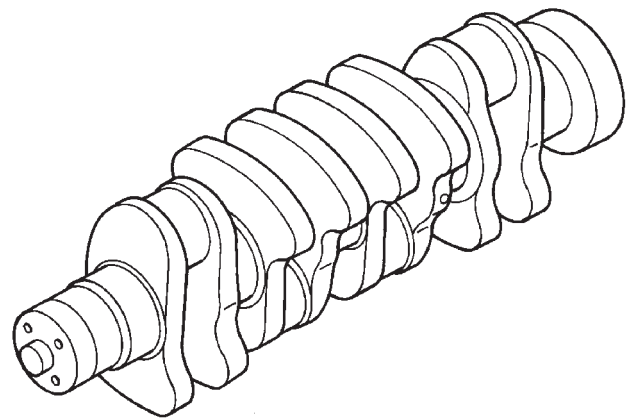
The crankshaft (Fig. 100) is a forged steel, integrally balanced unit. It is supported by seven main bearings, with position number six designated as the thrust journal. The crankshaft is held in place by main caps and 12 mm capscrews. The crankshaft also has internal cross drillings to supply the connecting rods with engine oil.

## CRANKSHAFT MAIN BEARINGS

## STANDARD PROCEDURE—MAIN BEARING CLEARANCE

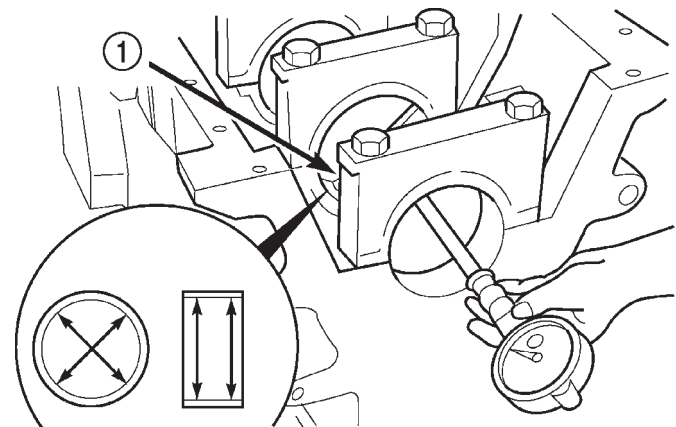
Inspect the main bearing bores for damage or abnormal wear.

Install the crankshaft main bearings and measure main bearing bore diameter with the main bolts tightened to 176 N·m (130 ft. lbs.) torque (Fig. 101).



80c41fb5

**Fig. 100 Crankshaft**



80bb0c4b

**Fig. 101 Crankshaft Main Bearing Bore Diameter**

1 - MAIN BEARING CAPS

## MAIN BEARING BORE DIAMETER CHART

ITEM	MAIN BEARING BORE DIAMETER (MAXIMUM)
A	83.106 mm 3.2719 in.)

Measure the diameter of the main journal at the locations shown (Fig. 102). Calculate the average diameter for each side of the journal.



CRANKSHAFT MAIN BEARINGS (Continued)

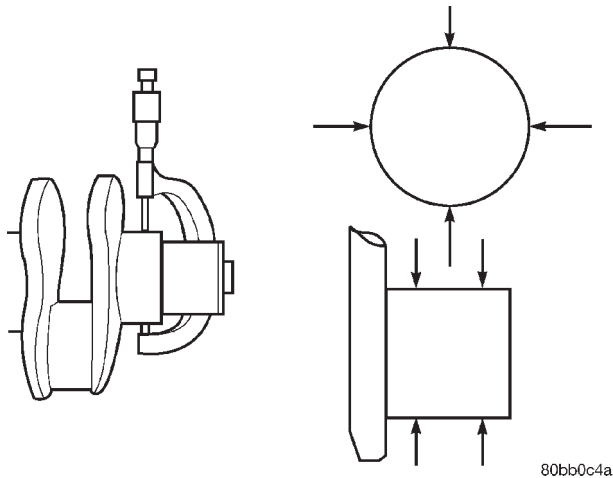


Fig. 102 Crankshaft Main Journal Diameter

CRANKSHAFT MAIN JOURNAL DIAMETER CHART

ITEM	SPECIFICATION
MINIMUM DIAMETER	82.962 mm (3.2662 in.)
MAXIMUM DIAMETER	83.013 mm (3.2682 in.)

Calculate the main bearing journal to bearing clearance. The clearance specifications are 0.119 mm (0.00475 inch). If the crankshaft journal is within limits, replace the main bearings. If not within specifications, grind the crankshaft to next size and use oversize bearings.

CRANKSHAFT OIL SEAL - FRONT

REMOVAL

- (1) Disconnect both battery negative cables.
- (2) Raise vehicle on hoist.
- (3) Partially drain engine coolant into container suitable for re-use (Refer to 7 - COOLING - STANDARD PROCEDURE).
- (4) Lower vehicle.
- (5) Remove radiator upper hose.
- (6) Disconnect coolant recovery bottle from radiator filler neck and lift bottle off of fan shroud.
- (7) Disconnect windshield washer pump supply hose and electrical connections and lift washer bottle off of fan shroud.
- (8) Remove the fan shroud-to-radiator mounting bolts.
- (9) Remove viscous fan/drive assembly. **The fan drive nut has left handed threads.** (Refer to 7 - COOLING/ENGINE/RADIATOR FAN - REMOVAL).
- (10) Remove cooling fan shroud and fan assembly from the vehicle.

(11) Remove the accessory drive belt (Refer to 7 - COOLING/ACCESSORY DRIVE/DRIVE BELTS - REMOVAL).

(12) Remove the cooling fan support/hub from the front of the engine (Fig. 103).

(13) Raise the vehicle on hoist.

(14) Remove the crankshaft damper (Fig. 104).

(15) Remove the gear cover-to-housing bolts and gently pry the cover away from the housing, taking care not to mar the gasket surfaces.

(16) Support the cover on a flat work surface with wooden blocks (Fig. 105), and using a suitable punch and hammer, drive the old seal out of the cover from the outside of the cover (Fig. 105).

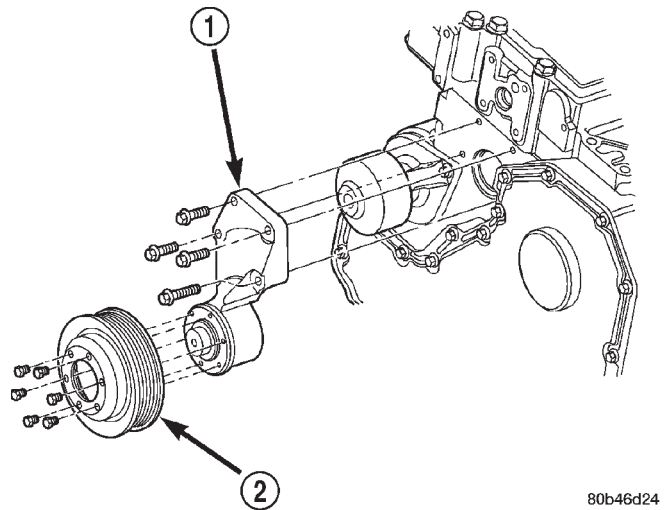


Fig. 103 Fan Support Hub Assembly—Removal/Installation

- 1 - FAN SUPPORT/HUB
- 2 - FAN PULLEY

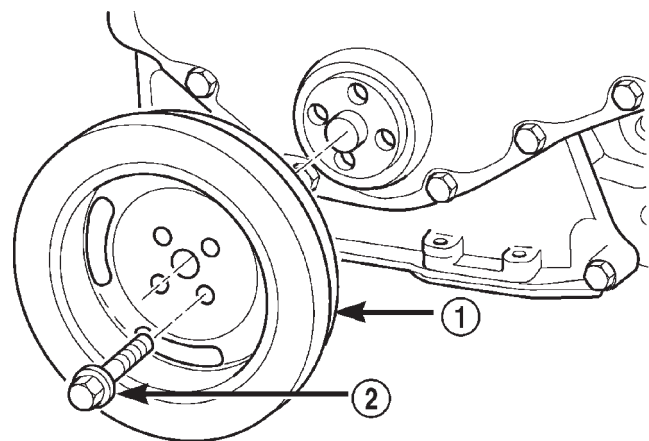
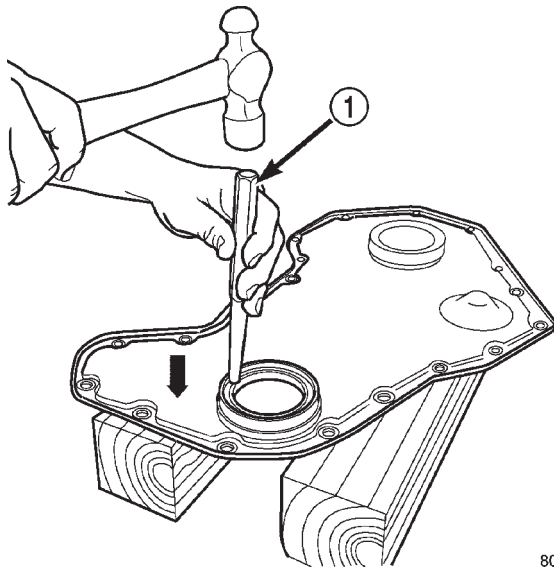


Fig. 104 Crankshaft Damper—Removal/Installation

- 1 - DAMPER
- 2 - BOLT

## CRANKSHAFT OIL SEAL - FRONT (Continued)



80b46d25

**Fig. 105 Removing Seal from Cover**

1 - PUNCH

**INSTALLATION**

(1) Clean cover and housing gasket mating surfaces. Use a suitable scraper and be careful not to damage the gear housing surface, since it is aluminum. Remove any old sealer from the oil seal bore. Thoroughly clean the front seal area of the crankshaft. The seal lip and the sealing surface on the crankshaft must be free from all oil residue to prevent seal leaks.

(2) Inspect the gear housing and cover for cracks and replace if necessary. Carefully straighten any bends or imperfections in the gear cover with a ball-peen hammer on a flat surface. Inspect the crankshaft front journal for any grooves or nicks that would affect the integrity of the new seal.

(3) Apply a bead of Mopar® Stud & Bearing Mount to the outside diameter of the seal. Do not lubricate the inside diameter of the new seal.

(4) With the cover supported by wood blocks, install the seal into the rear of the cover using crankshaft seal installer Special Tool 8281 and driver handle C-4171 (Fig. 106). Strike the driver handle until the installation tool bottoms out on the inside of the cover.

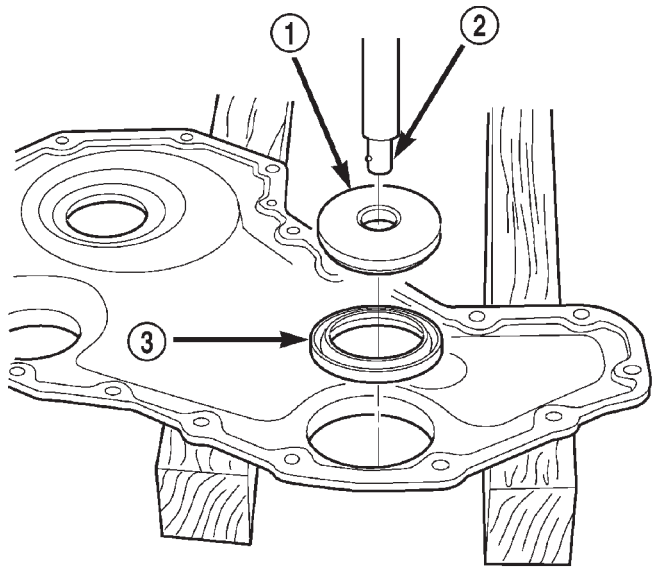
(5) Install the plastic seal pilot (provided with seal kit) into the crankshaft seal.

(6) Apply a bead of Mopar® Silicone Rubber Adhesive Sealant or equivalent to the gear housing cover sealing surface.

(7) Install the cover to the gear housing, aligning the seal pilot with the nose of the crankshaft (Fig. 107).

(8) Install the cover bolts and tighten to 24 N·m (18 ft. lbs.) torque. Remove pilot tool.

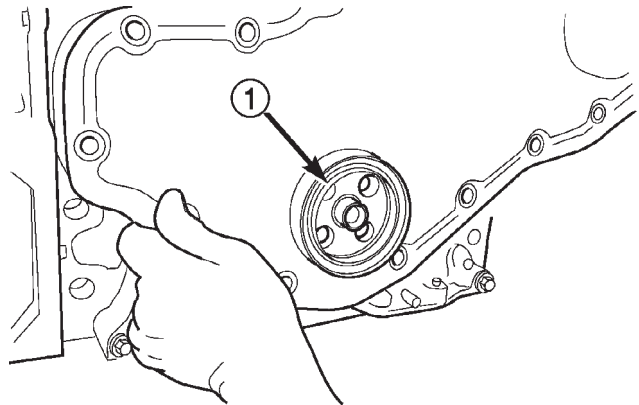
(9) Install the crankshaft damper (Fig. 104) and torque the bolts to 125 N·m (92 ft. lbs.). Use the



80b46d26

**Fig. 106 Installing Seal Into Cover With Tool 8281**

1 - SEAL INSTALLER 8281  
2 - DRIVER HANDLE C4171  
3 - SEAL



80b46d27

**Fig. 107 Installing Front Cover with Seal Pilot**

1 - SEAL PILOT

engine barring tool to keep the engine from rotating during tightening operation.

(10) Install the fan support/hub assembly (Fig. 103) and torque bolts to 24 N·m (18 ft. lbs.).

(11) Install cooling fan (Refer to 7 - COOLING/ENGINE/RADIATOR FAN - INSTALLATION).

(12) Install the accessory drive belt (Refer to 7 - COOLING/ACCESSORY DRIVE/DRIVE BELTS - INSTALLATION).

(13) Refill cooling system (Refer to 7 - COOLING - STANDARD PROCEDURE).

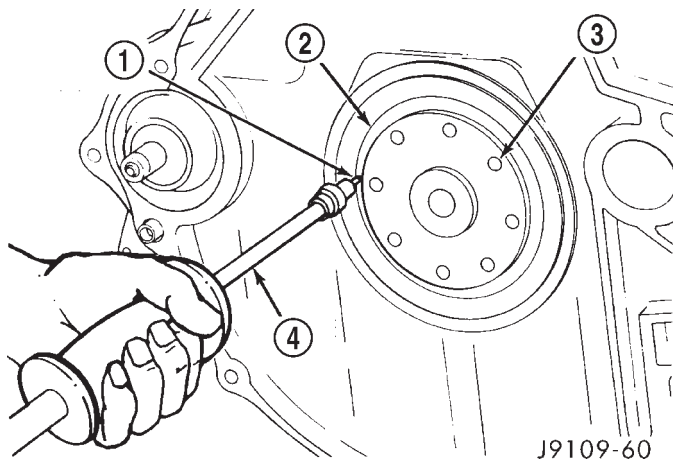
(14) Connect battery negative cables.

(15) Start engine and check for oil leaks.

## CRANKSHAFT OIL SEAL - REAR

### REMOVAL

- (1) Disconnect the battery negative cables.
- (2) Remove the transmission and transfer case (if equipped).
- (3) Remove the clutch cover and disc (if manual transmission equipped) (Refer to 6 - CLUTCH/CLUTCH DISC - REMOVAL).
- (4) Remove the flywheel or converter drive plate.
- (5) Drill holes 180° apart into the seal. Be careful not to contact the drill against the crankshaft.
- (6) Install #10 sheet metal screws in the drilled holes and remove the rear seal with a slide hammer (Fig. 108).



**Fig. 108 Crankshaft Rear Seal Removal**

- 1 - NO. 10 SCREW
- 2 - REAR SEAL
- 3 - CRANKSHAFT
- 4 - SLIDE HAMMER

### INSTALLATION

**CAUTION:** The seal lip and the sealing surface on the crankshaft must be free from all oil residue to prevent seal leaks. The crankshaft and seal surfaces must be completely dry when the seal is installed. Use a soap and water solution on outside diameter of seal to ease assembly.

- (1) Clean the crankshaft journal with a suitable solvent and dry with a clean shop towel or compressed air. Wipe the inside bore of the crankshaft seal retainer with a clean shop towel.
- (2) Inspect the crankshaft journal for gouges, nicks, or other imperfections. If the seal groove in the crankshaft is excessively deep, install the new seal 1/8" deeper into the retainer bore, or obtain a crank-

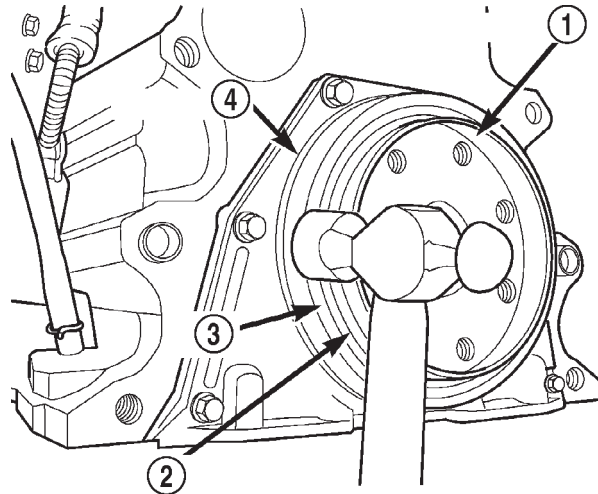
shaft wear sleeve that is available in the aftermarket.

(3) Install the seal pilot, provided in the replacement kit, onto the crankshaft.

(4) Using the provided alignment/installation tool, start the seal over the pilot and into the retainer by hand.

(5) Using a ball peen hammer, strike the tool at the 12, 3, 6, and 9 o'clock positions until the alignment tool bottoms out on the retainer (Fig. 109).

(6) Remove the seal pilot.



80b4faab

**Fig. 109 Seal Installation Using Alignment Tool and Hammer**

- 1 - SEAL PILOT TOOL
- 2 - INSTALLATION TOOL
- 3 - SEAL
- 4 - RETAINER

(7) Install the flywheel or converter drive plate. Tighten the bolts to 137 N·m (101 ft. lbs.) torque.

(8) Install the clutch cover and disc (if equipped) (Refer to 6 - CLUTCH/CLUTCH DISC - INSTALLATION).

(9) Install the transmission and transfer case (if equipped).

(10) Lower vehicle.

(11) Connect battery negative cables.

(12) Check engine oil level and adjust, if necessary.

(13) Start engine and check for oil leaks.

## CRANKSHAFT REAR OIL SEAL RETAINER

### REMOVAL

- (1) Disconnect the battery negative cables.
- (2) Raise vehicle on hoist.

## CRANKSHAFT REAR OIL SEAL RETAINER (Continued)

(3) Remove the oil pan drain plug and drain the engine oil. Re-install plug and torque to 60 N·m (44 ft. lbs.) torque.

(4) Remove transmission and transfer case (if equipped) from vehicle.

(5) Remove flywheel or torque converter drive plate.

(6) Disconnect starter cables from starter motor.

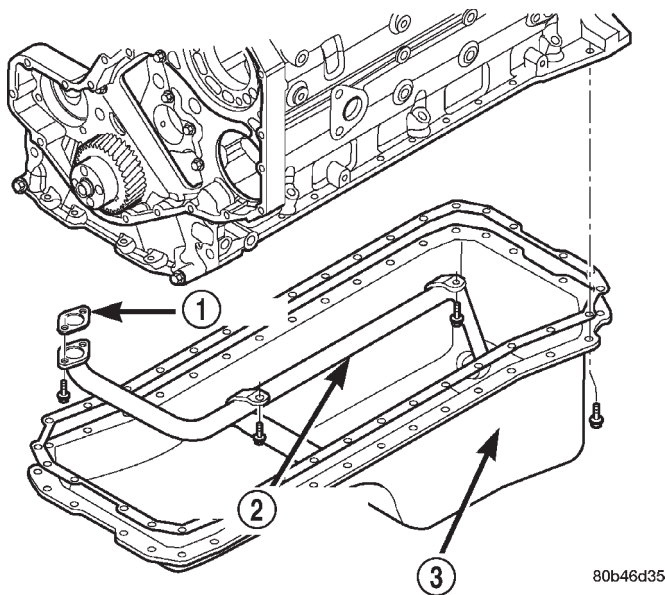
(7) Remove starter motor (Refer to 8 - ELECTRICAL/STARTING/STARTER MOTOR - REMOVAL) and transmission adapter plate assembly.

(8) Disconnect cables from starter motor.

(9) Remove the eight flywheel housing to block bolts and remove housing and starter motor as an assembly.

(10) Remove oil pan bolts, break the pan to block seal, and lower pan slightly and remove oil suction tube fasteners.

(11) Remove oil pan and suction tube (Fig. 110) (Refer to 9 - ENGINE/LUBRICATION/OIL PAN - REMOVAL).



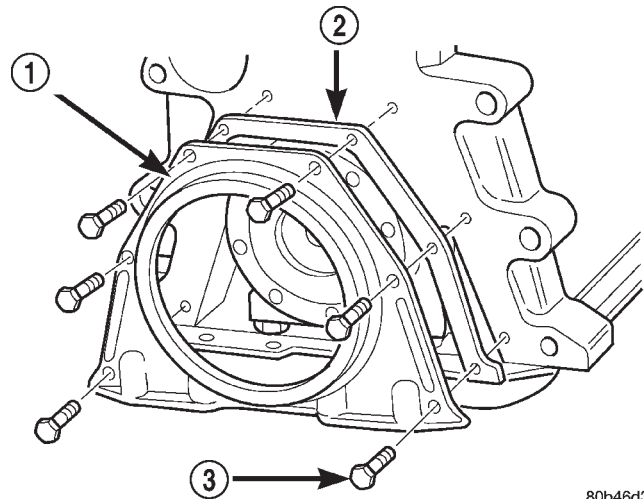
**Fig. 110 Oil Pan, Suction Tube and Gasket**

- 1 - GASKET
- 2 - SUCTION TUBE
- 3 - OIL PAN

(12) Remove the six (6) retainer-to-block bolts (Fig. 111).

(13) Remove the rear seal retainer and gasket (Fig. 111).

(14) Support the seal retainer and drive out the crankshaft seal with a hammer and suitable punch.



80b46d30

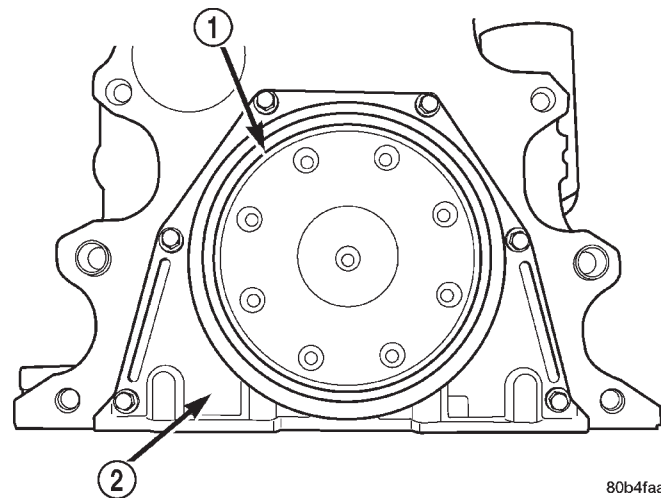
**Fig. 111 Crankshaft Rear Seal Retainer and Gasket**

- 1 - RETAINER
- 2 - GASKET
- 3 - BOLT

## INSTALLATION

(1) If using the old seal retainer, it is recommended that the crankshaft seal is replaced. Support the seal retainer and drive out the old seal.

(2) Using the retainer alignment/seal installation tool provided in the seal service kit, install the alignment tool into the retainer and install to the cylinder block (Fig. 112), using a new gasket. Tighten the six (6) mounting bolts by hand.



80b4faac

**Fig. 112 Aligning Seal Retainer with Alignment/Installation Tool**

- 1 - ALIGNMENT / INSTALLATION TOOL
- 2 - SEAL RETAINER

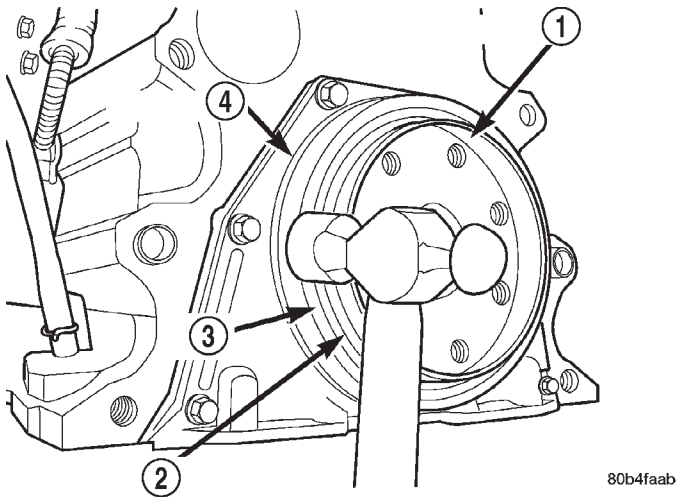
(3) Starting with the center two bolts, tighten the retainer in a circular pattern to 9 N·m (80 in. lbs.). Remove the alignment tool.



## CRANKSHAFT REAR OIL SEAL RETAINER (Continued)

**CAUTION:** The seal lip and the sealing surface on the crankshaft must be free from all oil residue to prevent seal leaks. The crankshaft and seal surfaces must be completely dry when the seal is installed. Use a soap and water solution on outside diameter of seal to ease assembly.

(4) Make sure the provided seal pilot is installed into the new crankshaft seal. Use the alignment/installation tool and press the seal onto the crankshaft (Fig. 113). Alternately drive the seal at the 12, 3, 6 and 9 o'clock positions.



80b4faab

**Fig. 113 Installing Seal Using Alignment Tool and Hammer**

- 1 - SEAL PILOT TOOL
- 2 - INSTALLATION TOOL
- 3 - SEAL
- 4 - RETAINER

(5) Remove the alignment tool and trim the retainer gasket even with the oil pan mounting surface (Fig. 114).

(6) Remove the seal pilot.

(7) Apply a small amount of Mopar® Silicone Rubber Adhesive Sealant to the oil pan rail T-joints.

(8) Install the oil pan, suction tube and gaskets (Refer to 9 - ENGINE/LUBRICATION/OIL PAN - INSTALLATION).

(9) Install the flywheel housing and bolts. Tighten the bolts to 60 N·m (44 ft. lbs.) torque.

(10) Install the starter motor (Refer to 8 - ELECTRICAL/STARTING/STARTER MOTOR - INSTALLATION).

(11) Install the flywheel or converter drive plate. Tighten bolts to 137 N·m (101 ft. lbs.)

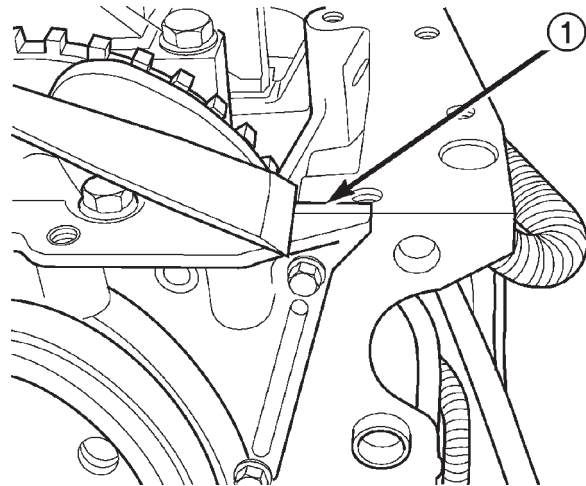
(12) Install the transmission and transfer case (if equipped).

(13) Lower vehicle.

(14) Fill the crankcase with new engine oil.

(15) Connect the battery negative cables.

(16) Start engine and check for oil leaks.



80b4fb40

**Fig. 114 Trimming Excess Gasket Material**

- 1 - GASKET

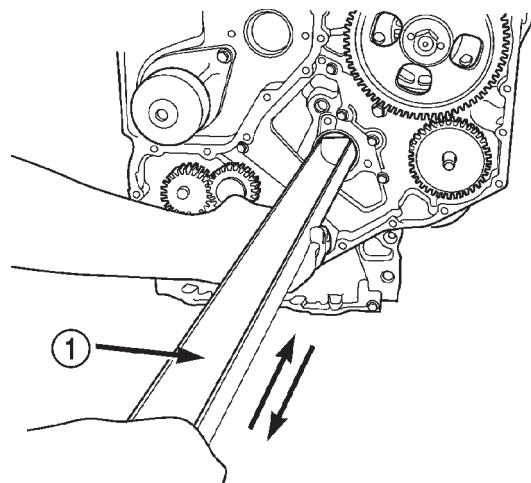
## SOLID LIFTERS/TAPPETS

## REMOVAL

**NOTE:** This procedure requires use of Miller Tool 8502 Tappet Replacement Kit, or Cummins Tool Kit #3822513.

(1) Remove camshaft (Refer to 9 - ENGINE/ENGINE BLOCK/CAMSHAFT & BEARINGS (IN BLOCK) - REMOVAL).

(2) Insert the trough (provided with tool kit) the full length of the camshaft bore (Fig. 115). Make sure the cap end goes in first and the open side faces up (towards tappets).



80b4fa39

**Fig. 115 Inserting the Trough**

- 1 - TROUGH

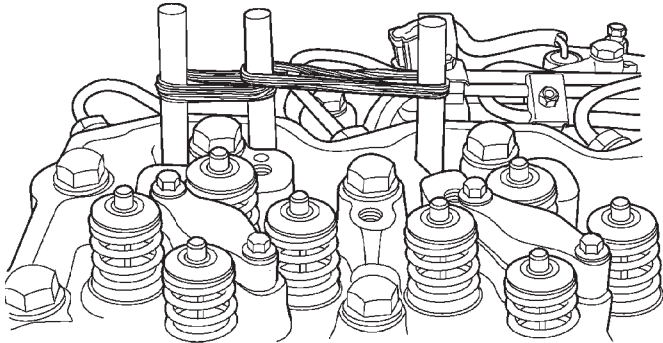
## SOLID LIFTERS/TAPPETS (Continued)

(3) **Remove only one tappet at a time.** Remove rubber band from one cylinder pair and attach tappet dowel not being removed to the next cylinder pair (Fig. 116).

(4) Raise dowel rod (disengage from tappet) and allow tappet to fall into trough (Fig. 117).

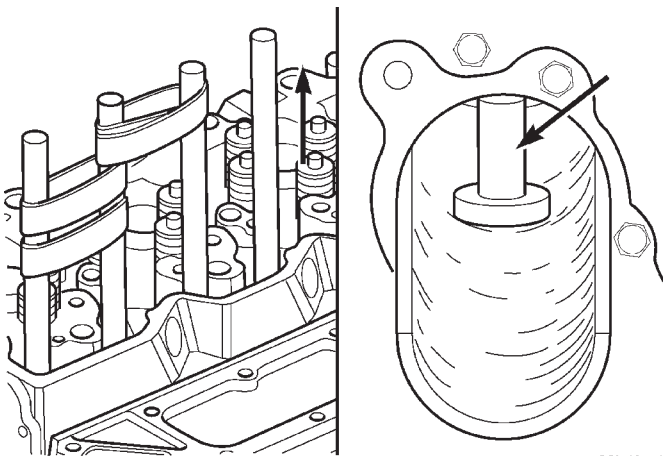
(5) Carefully remove trough (**do not rotate**) and tappet. If the tappet is not being replaced, mark it so it can be installed in its original location.

(6) Re-install trough and repeat procedure on remaining tappets.



80b4faa0

**Fig. 116 Secure Dowel/Tappet to Adjacent Cylinder**



80b4faa1

**Fig. 117 Lift Dowel Rod to Disengage from Tappet**

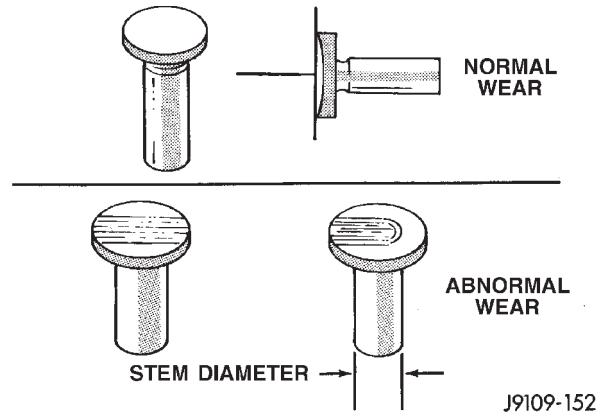
## CLEANING

Clean tappet with a suitable solvent. Rinse in hot water and blow dry with a clean shop rag or compressed air.

## INSPECTION

(1) Visually inspect the tappet the tappet socket, stem, and face for excessive wear, cracks, or obvious damage (Fig. 118).

(2) Measure the tappet stem diameter. Replace the tappet if it falls below the minimum size (Fig. 118).



J9109-152

**Fig. 118 Tappet Inspection**

## TAPPET STEM DIAMETER

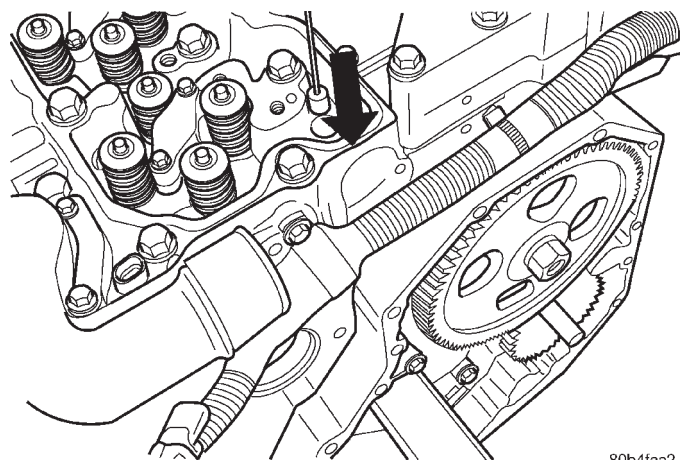
15.925 mm (0.627 in.) MIN.

15.977 mm (0.629 in.) MAX.

## INSTALLATION

(1) Insert the trough the full length of the camshaft bore (Fig. 115). Again, make sure the cap end goes in first and the open side faces up (towards tappets).

(2) Lower the tappet installation tool through the push rod hole (Fig. 119) and into the trough.



80b4faa2

**Fig. 119 Insert Installation Tool through Push Rod Hole**

(3) Retrieve the tappet installation tool using the hooked rod provided with the tool kit (Fig. 120).

(4) Lubricate the tappet with clean engine oil or suitable equivalent and install the tappet to the installation tool (Fig. 121).

(5) Pull the tappet up and into position (Fig. 121). If difficulty is experienced getting the tappet to make the turn into the tappet bore, wiggle the trough while **gently** pulling up on the tappet.

(6) With the tappet in place, rotate the trough one half turn so the open side is down (toward crankshaft) (Fig. 122).



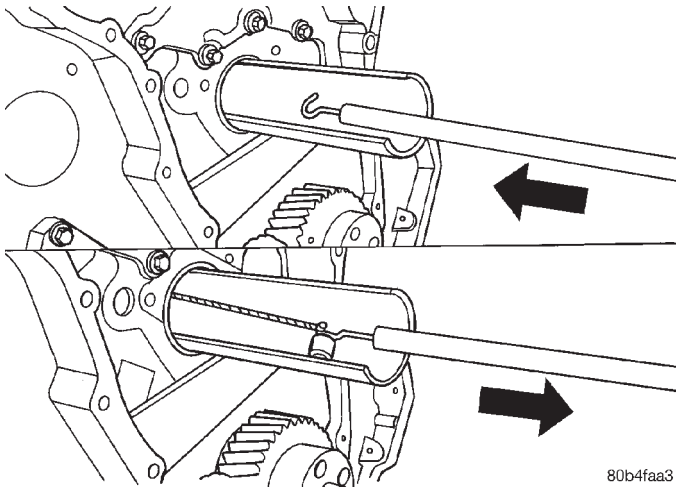
## SOLID LIFTERS/TAPPETS (Continued)

(7) Remove the tappet installation tool from the tappet.

(8) Re-install a dowel rod and secure the rod with a rubber band.

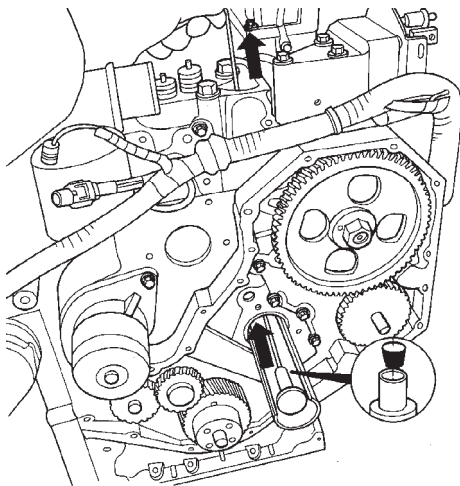
(9) Rotate the trough one half turn and repeat the procedure for the remaining tappets.

(10) Install the camshaft (Refer to 9 - ENGINE/ENGINE BLOCK/CAMSHAFT & BEARINGS (IN BLOCK) - INSTALLATION).



80b4faa3

**Fig. 120 Retrieve Tappet Installation Tool through Cam Bore**



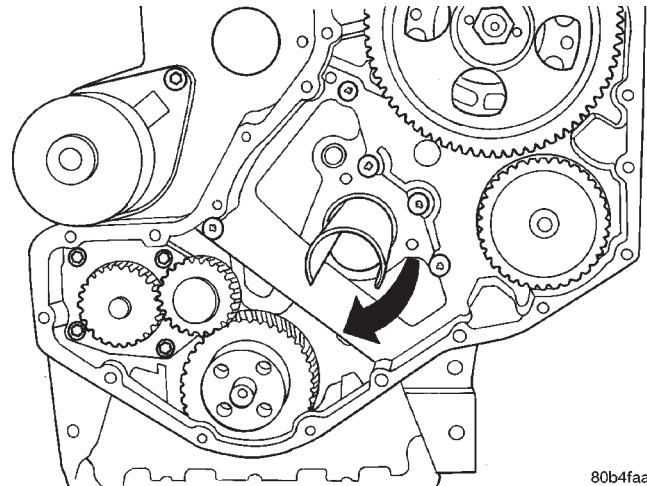
80b4faa4

**Fig. 121 Insert Tool and Pull Tappet Into Place**

## PISTON &amp; CONNECTING ROD

## DESCRIPTION

The piston (Fig. 123) is constructed of aluminum and is gravity cast, free floating design. The piston incorporates a centrally located high swirl combustion bowl, and utilizes a "keystone" style top compression ring (Fig. 124), and a "Tapered Face" intermediate ring (Fig. 124), for superior cylinder wall scraping. Piston cooling nozzles cool the piston

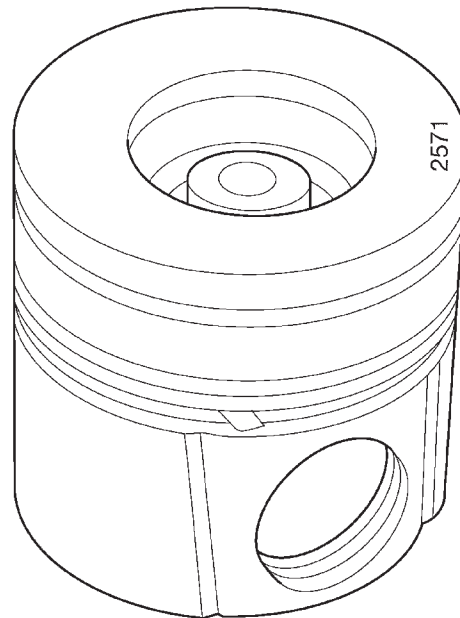


80b4faa5

**Fig. 122 Rotate Trough One Half Turn (180°)**

and pin with engine oil supplied by the crankshaft main journals.

The connecting rods (Fig. 125) are a split angle design constructed of micro alloy. The rods have a pressed in place wrist pin bushing which is lubricated by the piston cooling nozzle oil spray.



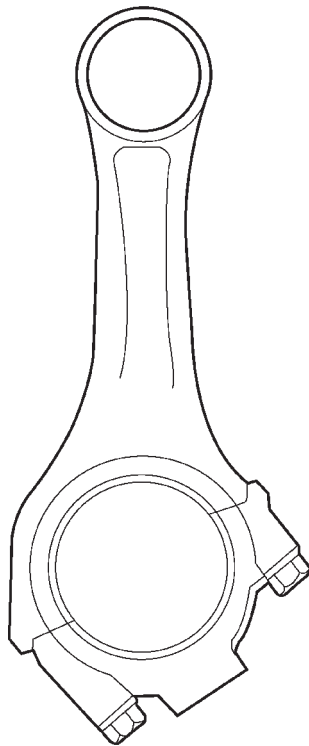
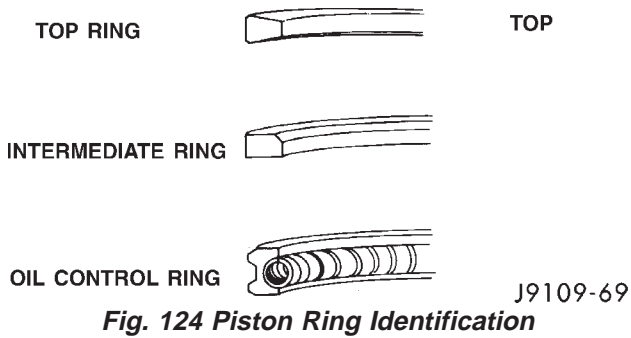
80c41f5a

**Fig. 123 Piston**

## STANDARD PROCEDURE—PISTON GRADING

- When rebuilding an engine with the original cylinder block, crankshaft and pistons, make sure the pistons are installed in their original cylinder.
- If replacing the piston(s), make sure the replacement piston(s) are the same grade as the one being replaced.

## PISTON &amp; CONNECTING ROD (Continued)



- If a new cylinder block and/or crankshaft is used, the piston grading procedure **MUST** be performed to determine the proper piston grade for each cylinder.

(1) Install any of the original connecting rod and piston assemblies into the No.1 cylinder. **DO NOT** install the piston rings.

(2) Install the upper bearing shell in the connecting rod with the tang of the bearing in the slot of the connecting rod. The connecting rod bearing shell must be installed in the original connecting rod and cap. Use clean lubricating oil to coat the inside diameter of the connecting rod bearing shell.

(3) Install the bearing shell in the connecting rod cap with the tang of the bearing in the slot to the cap. Use clean lubricating oil to coat the inside diameter of the bearing shell.

(4) The four digit number stamped on the connecting rod and cap at the parting line must match and be installed on the oil cooler side of the engine. Install the connecting rod cap and cap screws. Tighten the cap screws to 35 N·m (26 ft. lbs.) torque.

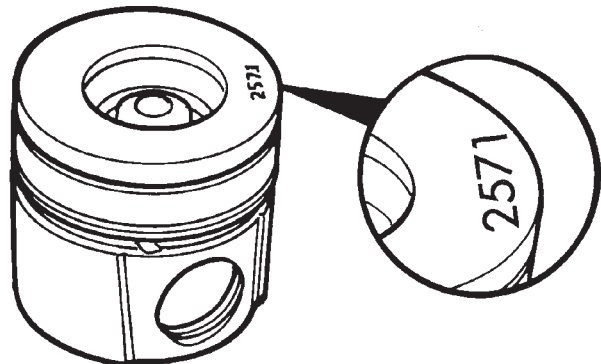
(5) Use a fine grit stone to remove any burrs from the cylinder block head deck. Zero the dial indicator to the cylinder block head deck.

(6) Move the dial indicator directly over the piston pin to eliminate any side-to-side movement.

(7) Rotate the crankshaft to top dead center (TDC). Rotate the crankshaft clockwise and counter-clockwise to find the highest dial indicator reading. Record the reading.

(8) Remove the piston and connecting rod assembly from the No.1 cylinder and install the assembly into the No.2 cylinder. Repeat the procedure for every cylinder using the same piston and connecting rod assembly.

(9) Determine the grade of the piston being used by referring to the Piston Protrusion Chart below. Four digits on top of the piston can be cross referenced to a DaimlerChrysler part number for replacement (Fig. 126). If the number on the piston cannot be seen, measure from the top of the piston to the top of the piston pin to see what grade piston is used (Fig. 127).



**NOTE: NEVER INTERMIX PISTONS FROM ONE ENGINE APPLICATION TO ANOTHER ENGINE APPLICATION. SEVER DRIVEABILITY CONCERNS MAY RESULT.**

PISTON & CONNECTING ROD (Continued)

PISTON PROTRUSION CHART

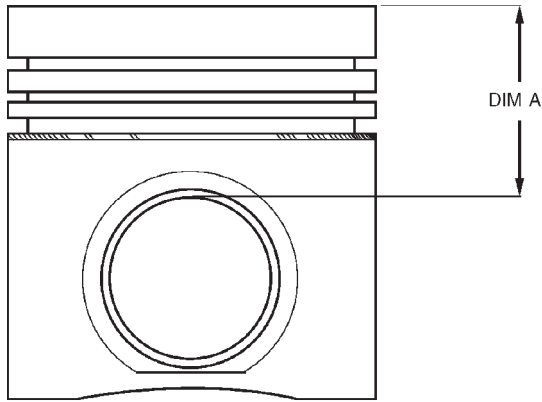
IF MEASURING PISTON IS	AND	USE	
GRADING #:		PROTRUSION IS	GRADE:
245 HP	235 HP		
6050	6153	0.609-0.711 mm (0.024-0.028 in.)	A
6050	6153	0.508-0.609mm (0.020-0.024 in.)	B
6050	6153	0.406-0.508 mm (0.016-0.020 in.)	C
6051	6154	0.711-0.813 mm (0.028-0.032 in.)	A
6051	6154	0.609-0.711 mm (0.024-0.028 in.)	B
6051	6154	0.508-0.609 mm (0.020-0.024 in.)	C
6052	6155	0.813-0.914 mm (0.032-0.036 in.)	A
6052	6155	0.711-0.813 mm (0.028-0.032 in.)	B
6052	6155	0.609-0.711 mm (0.024-0.028 in.)	C

**NOTE:** Use the table below when piston grading numbers are missing or not legible.

ALTERNATIVE GRADE IDENTIFICATION METHOD

DIMENSION "A"	REF. NUMBER		GRADE
	235 HP	245 HP	
51.554-51.607 mm (2.029-2.031 in.)	6153	6050	A
51.654-51.707 mm (2.033-2.035 in.)	6154	6051	B
51.754-51.807 mm (2.037-2.039 in.)	6155	6052	C

## PISTON &amp; CONNECTING ROD (Continued)



80a82c90

**Fig. 127 Piston Grading Measurement**

### REMOVAL

- (1) Disconnect the battery cables.
- (2) Remove the cylinder head (Refer to 9 - ENGINE/CYLINDER HEAD - REMOVAL).
- (3) Remove the oil pan and suction tube (Refer to 9 - ENGINE/LUBRICATION/OIL PAN - REMOVAL).
- (4) Using Miller Tool 7471-B crankshaft barring tool, rotate the crankshaft so all of the pistons are below TDC.
- (5) Before removing the piston(s) from the bore(s):
  - (a) Remove any carbon ridge formations or deposits at the top of the bore with a dull scraper or soft wire brush.
  - (b) If cylinder bore wear ridges are found, use a ridge reamer to cut the ridge from the bore. DO NOT remove more metal than necessary to remove the ridge.

**NOTE:** If cylinders have ridges, the cylinders are oversize and will more than likely need boring.

- (6) Using a hammer and steel stamp, identify the front of the piston by stamping the cylinder number in each piston to be removed at the top of the piston toward the front of the engine. DO NOT stamp in the outside 5 mm (.197 in.) of the piston diameter.

- (7) Mark the connecting rod and cap with the corresponding cylinder numbers.

- (8) Remove the connecting rod bolts and rod caps. Use care so the cylinder bores and connecting rods are not damaged.

- (9) Use a hammer handle or similar object to push the piston and connecting rod through the cylinder bore.

- (10) Store the piston/rod assemblies in a rack.

- (11) If a piston must be replaced, replace with the same part number (grading) that was removed.

### CLEANING

**CAUTION:** DO NOT use bead blast to clean the pistons. DO NOT clean the pistons and rods in an acid tank.

Clean the pistons and pins in a suitable solvent, rinse in hot water and blow dry with compressed air. Soaking the pistons over night will loosen most of the carbon build up. De-carbon the ring grooves with a broken piston ring and again clean the pistons in solvent. Rinse in hot water and blow dry with compressed air.

### INSPECTION

Inspect the pistons for damage and excessive wear. Check top of the piston, ring grooves, skirt and pin bore. Measure the piston skirt diameter (Fig. 128). If the piston is out of limits, replace the piston.

The upper groove only needs to be inspected for damage. Use a new piston ring to measure the clearance in the intermediate ring groove (Fig. 129). If the clearance of the intermediate ring exceeds 0.095 mm (0.0038 inch), replace the piston.

Use a new oil ring to measure the clearance in the oil groove (Fig. 129). If the clearance exceeds 0.085 mm (0.0034 inch), replace the piston.

Measure the pin bore (Fig. 130). The maximum diameter is 40.012 mm (1.5753 inch). If the bore is over limits, replace the piston.

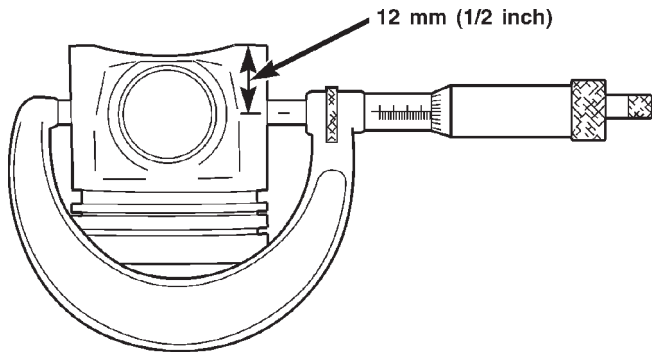
Inspect the piston pin for nicks, gouges and excessive wear. Measure the pin diameter (Fig. 131). The minimum diameter is 39.990 mm (1.5744 inch). If the diameter is out of limits, replace the pin.

PISTON & CONNECTING ROD (Continued)

Connecting Rods

CLEANING

Clean the connecting rods in a suitable solvent, rinse in hot water and blow dry with compressed air.

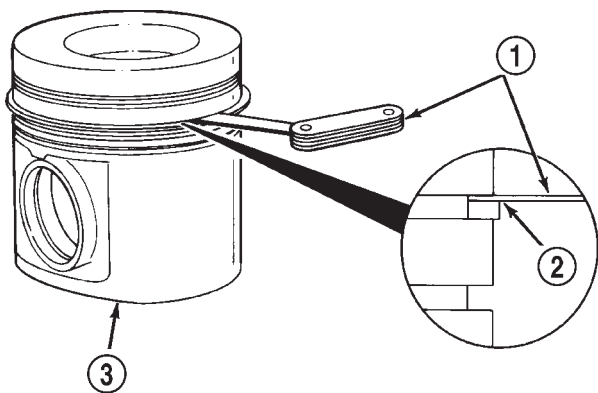


80b3b0a2

**Fig. 128 Piston Skirt Diameter**

PISTON SKIRT DIAMETER (MIN.)  
101.864 mm (4.0104 in.)

INSPECTION



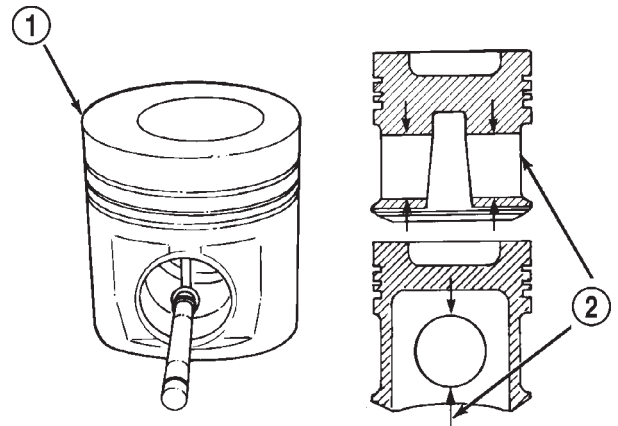
J9109-64

**Fig. 129 Intermediate and Oil Ring Clearances**

- 1 - FEELER GAUGE
- 2 - RING
- 3 - PISTON

Inspect the connecting rod for damage and wear. The I-Beam section of the connecting rod cannot have dents or other damage. Damage to this part can cause stress risers which will progress to breakage.

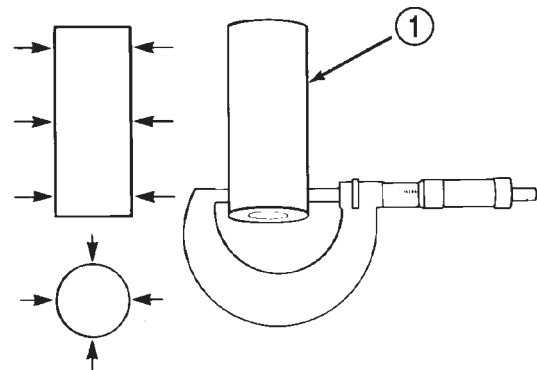
Measure the connecting rod pin bore (Fig. 132). The maximum diameter is 40.042 mm (1.5764 inch). If out of limits, replace the connecting rod.



J9109-65

**Fig. 130 Piston Pin Bore**

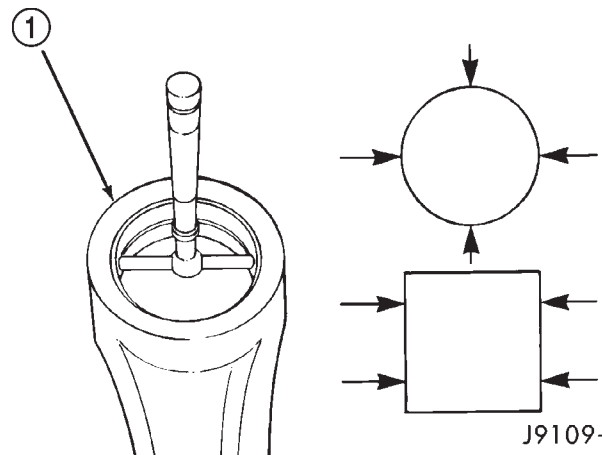
- 1 - PISTON
- 2 - PIN BORE



J9109-66

**Fig. 131 Piston Pin Diameter**

- 1 - PISTON PIN



J9109-67

**Fig. 132 Connecting Rod Pin Bore**

- 1 - CONNECTING ROD

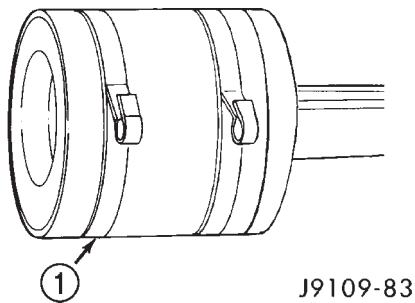
## PISTON &amp; CONNECTING ROD (Continued)

**INSTALLATION**

(1) Lubricate the cylinder bores with clean engine oil.

(2) Generously lubricate the rings and piston skirts with clean engine oil.

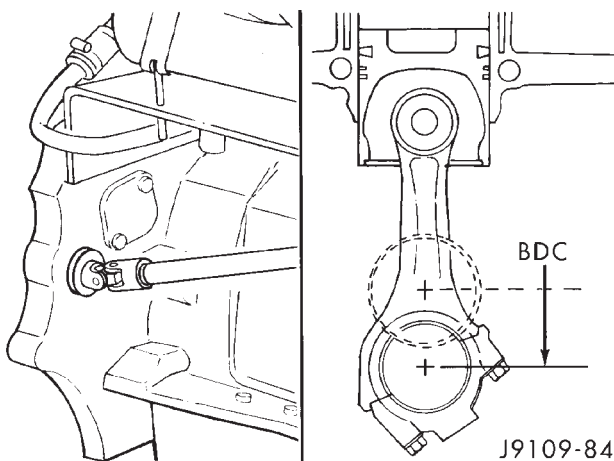
(3) Compress the rings using a piston ring compressor tool (Fig. 133). If using a strap-type ring compressor, make sure the inside end of the strap does not hook on a ring gap and break the ring.



**Fig. 133 Piston Ring Compressor Tool**

1 - PISTON RING COMPRESSOR TOOL

(4) Bar the crankshaft so the rod journal for the piston to be installed is at BDC (Bottom Dead Center) - (Fig. 134).



**Fig. 134 Piston/Rod Assembly at BDC**

(5) Be sure the mark you made on the piston and the numbers on the rod and cap are oriented as illustrated.

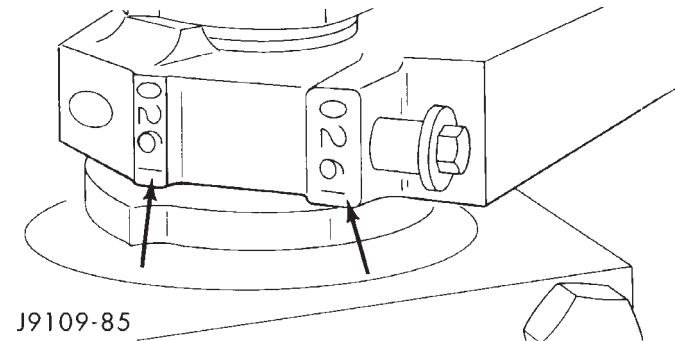
(6) Position the piston and rod assembly into the cylinder bore with the mark you made on the piston towards the front of the cylinder block. In this position the numbers on the connecting rod should be facing the oil cooler side of the engine, and the rod bolt holes toward the camshaft. Use care when you install the piston and connecting rod so the cylinder bore is not damaged.

(7) Push the piston into the bore until the top of the piston is approximately 50 mm (2 inch) below the

top of the block. Carefully pull the connecting rod onto the crankshaft journal.

(8) Use clean engine oil to lubricate the threads and under the heads of the connecting rod bolts.

(9) The number stamped on the rod cap at the parting line must match and be installed towards the oil cooler side of the engine (Fig. 135).



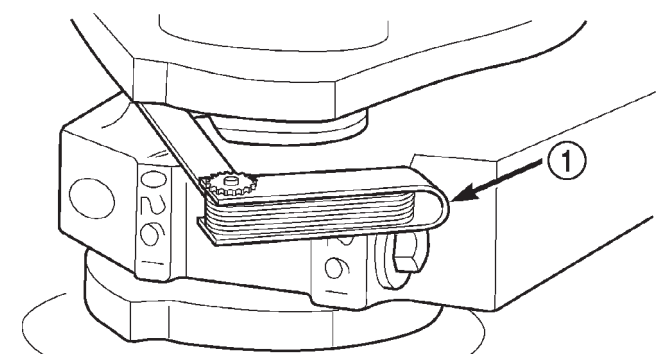
**Fig. 135 Correct Rod Cap Installation**

(10) Install the rod cap and bolts to the connecting rod. Tighten the connecting rod and bolt evenly in 3 steps.

- Tighten the bolts to 35 N·m (26 ft. lbs.) torque.
- Tighten the bolts to 70 N·m (51 ft. lbs.) torque.
- Tighten the bolts to 100 N·m (73 ft. lbs.) torque.

(11) The crankshaft must rotate freely. Check for freedom of rotation as the caps are installed. If the crankshaft does not rotate freely, check the installation of the rod bearing and the bearing size.

(12) Measure the side clearance between the connecting rod and the crankshaft (Fig. 136). DO NOT measure the clearance between the cap and crankshaft.



80bb0c54

**Fig. 136 Side Clearance between Connecting Rod/Crankshaft**

1 - FEELER GAUGE

CONNECTING ROD SIDE CLEARANCE 0.1 - 0.33 mm ( .004 - .013 inch)



PISTON & CONNECTING ROD (Continued)

(13) Install the suction tube and oil pan (Refer to 9 - ENGINE/LUBRICATION/OIL PAN - INSTALLATION).

(14) Install the cylinder head onto the engine (Refer to 9 - ENGINE/CYLINDER HEAD - INSTALLATION).

(15) Install a new filter and fill the crankcase with new engine oil.

(16) Connect the battery negative cables and start engine.

PISTON RINGS

STANDARD PROCEDURE-PISTON RING FITTING

(1) Determine the piston diameter and obtain the appropriate ring set. The piston rings can be identified as shown in (Fig. 137).

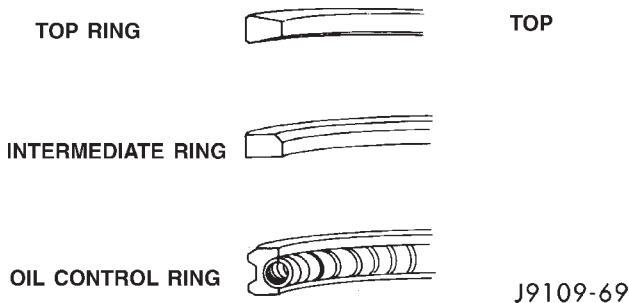


Fig. 137 Piston Ring Identification

(2) Position each ring in the cylinder and use a piston to square it with the bore at a depth of 89.0 mm (3.5 inch) - (Fig. 138).

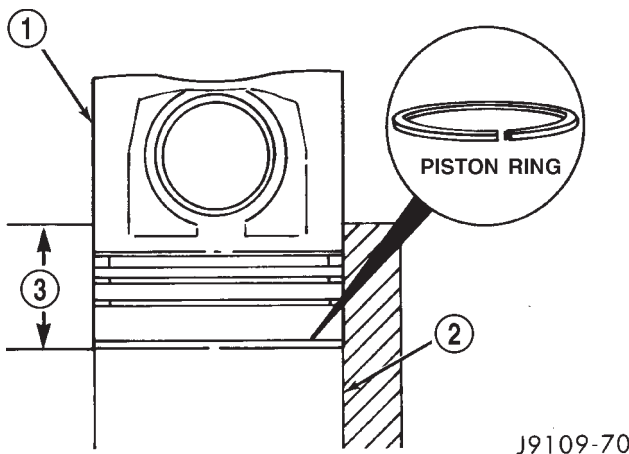


Fig. 138 Position of Ring in Cylinder Bore

- 1 - PISTON
- 2 - CYLINDER BORE
- 3 - DEPTH

(3) Use a feeler gauge to measure the piston ring gap.

PISTON RING GAP CHART		
TOP RING	0.35 - 0.45 mm	(0.014 - 0.0177 in.)
INTERMEDIATE RING	0.85-1.15 mm	(0.0334 - 0.0452 in.)
OIL CONTROL RING	0.250-0.550 mm	(0.0100 - 0.0215 in.)

(4) The top surface of all of the rings are identified with the word TOP or the supplier's MARK. Assemble the rings with the word TOP or the supplier's MARK up.

(5) Position the oil ring expander in the oil control ring groove (bottom groove).

(6) Install the oil control ring with the end gap OPPOSITE the ends on the expander (Fig 139).

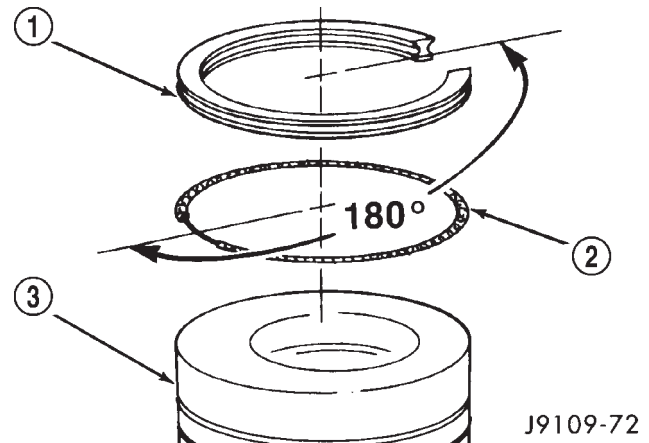


Fig. 139 Oil Control Ring/Expander Location in Groove

- 1 - OIL CONTROL RING
- 2 - EXPANDER
- 3 - PISTON

(7) Install the intermediate piston ring in the second groove.

(8) Install the top piston ring in the top groove (Fig. 140).

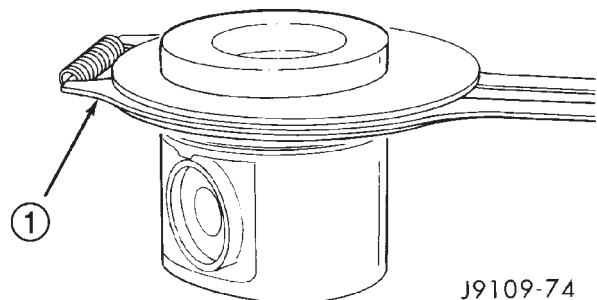
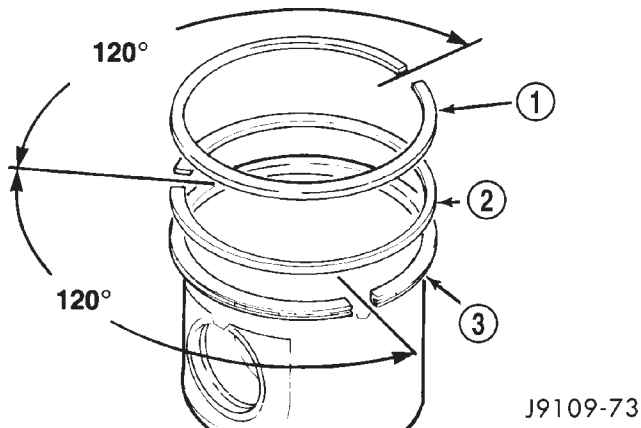


Fig. 140 Piston Ring Installation Tool

- 1 - PISTON RING INSTALLATION TOOL

## PISTON RINGS (Continued)

(9) Position the rings as shown in (Fig. 141).



**Fig. 141 Piston Ring Orientation**

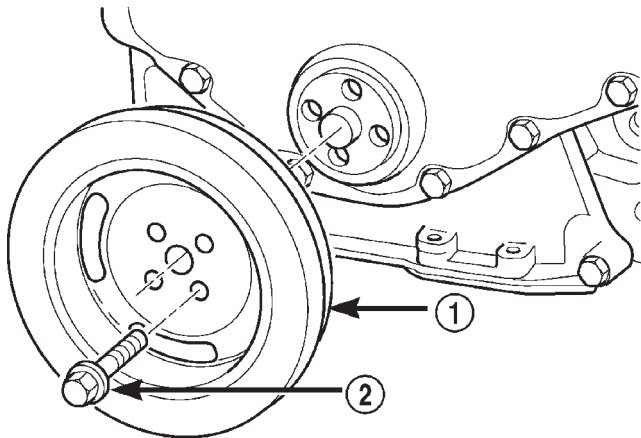
- 1 - TOP RING
- 2 - INTERMEDIATE RING
- 3 - OIL CONTROL RING

## VIBRATION DAMPER

## REMOVAL

(1) Remove the accessory drive belt (Refer to 7 - COOLING/ACCESSORY DRIVE/DRIVE BELTS - REMOVAL).

(2) Remove the four (4) damper to crankshaft bolts and remove damper (Fig. 142).



**Fig. 142 Crankshaft Damper Removal/Installation**

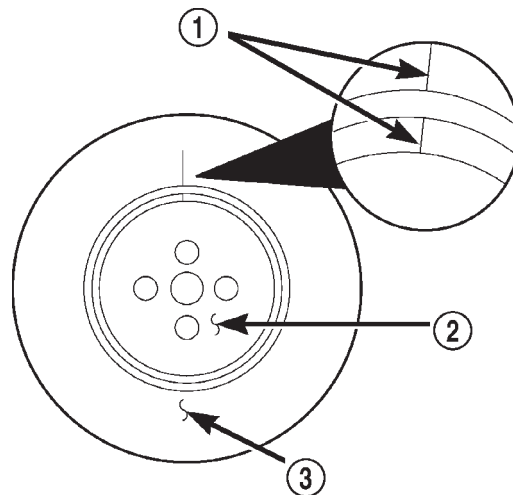
- 1 - DAMPER
- 2 - BOLT

## INSPECTION

(1) Inspect the damper hub for cracks and replace if any are found.

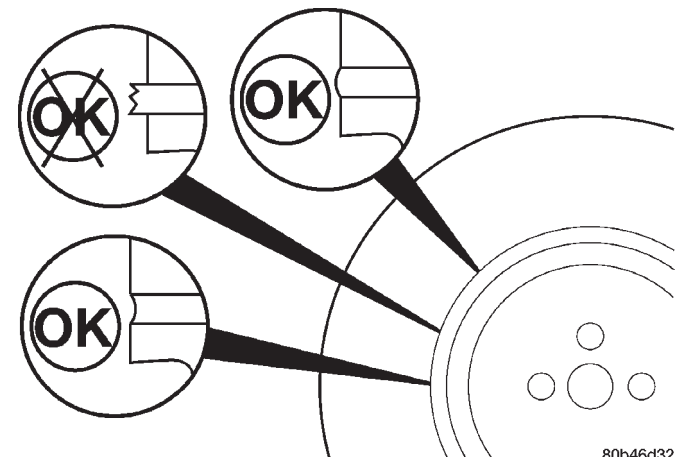
(2) Inspect the index lines on the damper hub and the inertia member (Fig. 143). If the lines are more than 1.59 mm (1/16 in.) out of alignment, replace the damper.

(3) Inspect the rubber member for deterioration or missing segments (Fig. 144).



**Fig. 143 Inspect Index Lines for Alignment**

- 1 - INDEX LINES
- 2 - HUB
- 3 - INERTIA MEMBER



**Fig. 144 Inspect Damper Rubber Member**

## INSTALLATION

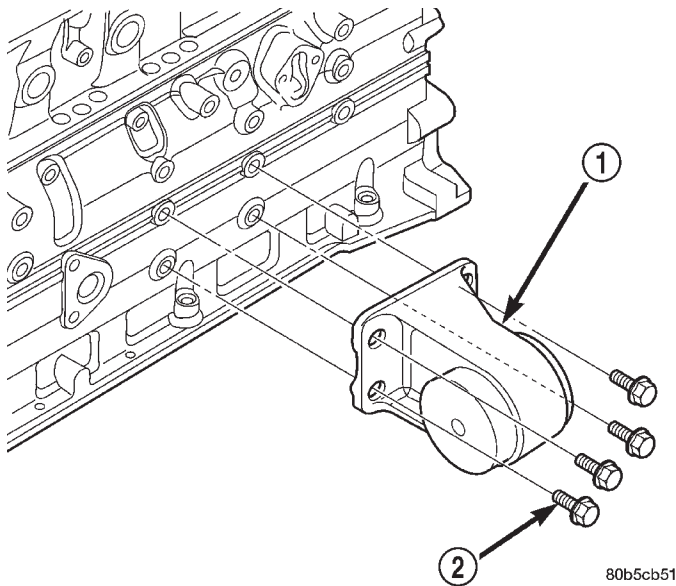
(1) Install the crankshaft damper and bolts (Fig. 142). Tighten bolts to 125 N·m (92 ft. lbs.) torque.

(2) Install the accessory drive belt (Refer to 7 - COOLING/ACCESSORY DRIVE/DRIVE BELTS - INSTALLATION).

## FRONT MOUNT

### REMOVAL

- (1) Disconnect the battery negative cables.
- (2) Remove the viscous fan/drive assembly (Refer to 7 - COOLING/ENGINE/RADIATOR FAN - REMOVAL).
- (3) Raise vehicle on hoist.
- (4) Support engine with a screw jack and wood block.
- (5) Loosen the thru-bolt and nut (Fig. 145).
- (6) Passenger side mount: Remove the two (2) transmission oil cooler bracket to engine mount bolts.
- (7) Lift the engine SLIGHTLY and remove the four (4) mount to block bolts.
- (8) Remove the mount from the vehicle.

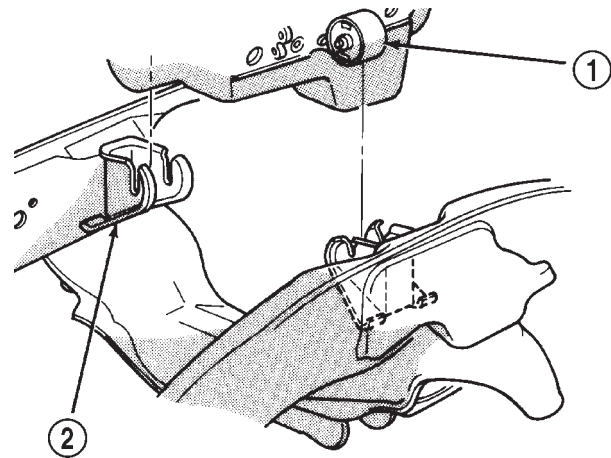


**Fig. 145 Front Engine Mount—Typical**

- 1 - MOUNT
- 2 - BOLT (4)

### INSTALLATION

- (1) With engine raised SLIGHTLY, position the engine mount to the block. Install the bolts and tighten to 149 N·m (110 ft. lbs.) torque.
- (2) Install the thru-bolt into the engine mount.
- (3) Lower the engine while guiding the mount and thru-bolt into the frame mounted support cushion brackets (Fig. 146).



J9409-122

**Fig. 146 Positioning Engine Front Mounts**

- 1 - ENGINE SUPPORT BRACKET/CUSHION
- 2 - SUPPORT CUSHION BRACKET

- (4) Install the thru-bolt nut and tighten the nut to 88 N·m (65 ft. lbs.) torque.
- (5) Passenger side: Install the two (2) transmission oil cooler bracket to mount bolts. Tighten the bolts to 47 N·m (35 ft. lbs.) torque.
- (6) Remove lifting fixture.
- (7) Lower the vehicle.
- (8) Install the viscous fan/drive assembly (Refer to 7 - COOLING/ENGINE/RADIATOR FAN - INSTALLATION).
- (9) Connect the battery negative cables.

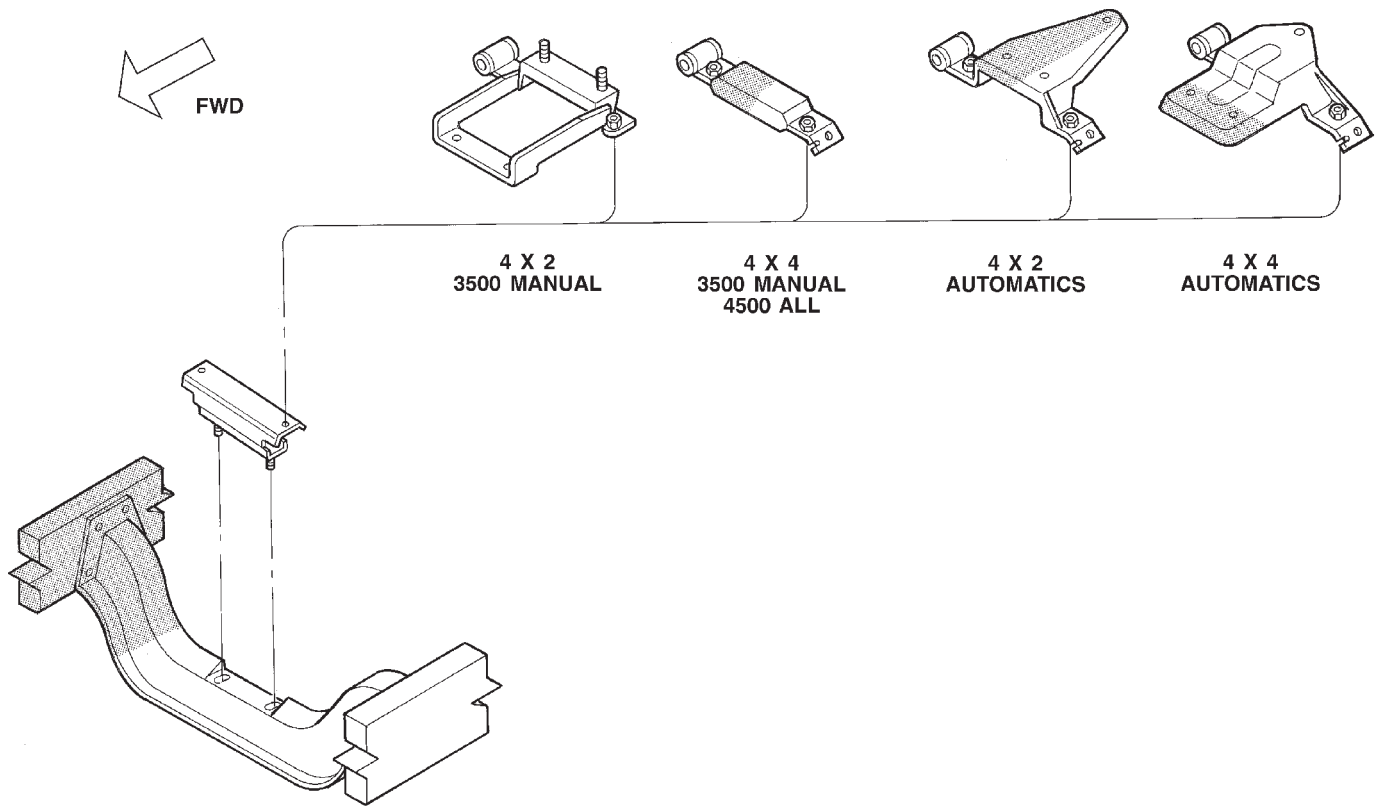
## REAR MOUNT

### REMOVAL

- (1) Raise the vehicle on a hoist.
- (2) Position a transmission jack in place.
- (3) Remove support cushion stud nuts (Fig. 147).
- (4) Raise rear of transmission and engine SLIGHTLY.
- (5) Remove the bolts holding the support cushion to the transmission support bracket. Remove the support cushion.
- (6) If necessary, remove the bolts holding the transmission support bracket to the transmission.

### INSTALLATION

- (1) If removed, position the transmission support bracket to the transmission. Install new attaching bolts and tighten to 102 N·m (75 ft. lbs.) torque.
- (2) Position support cushion to transmission support bracket. Install stud nuts and tighten to 47 N·m (35 ft. lbs.) torque.
- (3) Using the transmission jack, lower the transmission and support cushion onto the crossmember (Fig. 50).
- (4) Install the support cushion bolts and tighten to 47 N·m (35 ft. lbs.) torque.
- (5) Remove the transmission jack.
- (6) Lower the vehicle.



J9509-126

**Fig. 147 Engine Rear Support Cushion Assembly**

## LUBRICATION

### DESCRIPTION

**NOTE:** Refer to (Fig. 148) and (Fig. 149) for circuit illustrations.

A gear driven gerotor type oil pump is mounted behind the front gear cover in the lower right portion on the engine.

### OPERATION

A gerotor style oil pump draws oil from the crankcase through the suction tube and delivers it through the block where it enters the oil cooler cover and pressure regulator valve. When oil pressure exceeds 449 kPa (65 PSI), the valve opens exposing the dump port, which routes excess oil back to the oil sump.

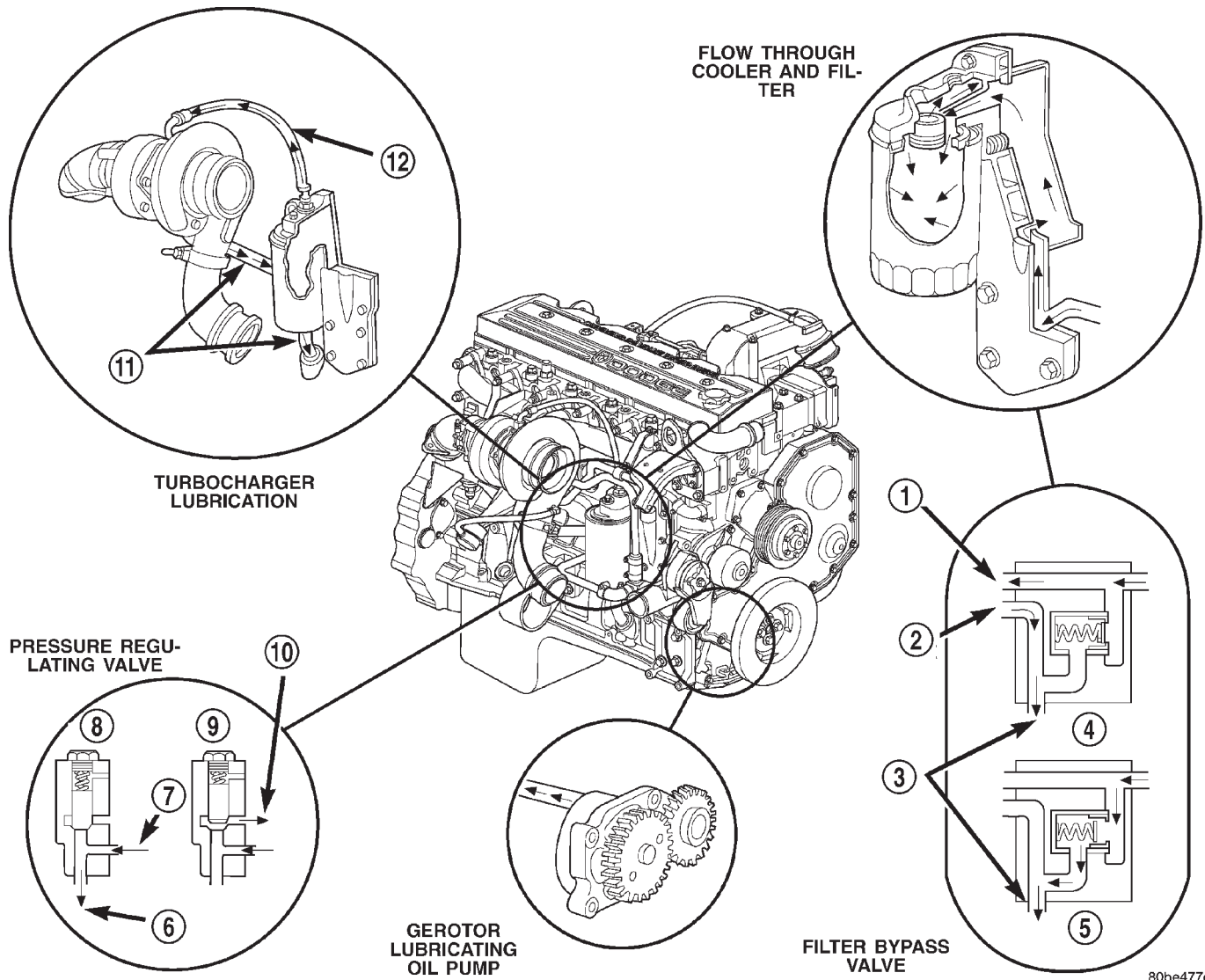
At the same time, oil is directed to a cast in passage in the oil cooler cover, leading to the oil cooler element. As the oil travels through the element plates, it is cooled by engine coolant traveling past the outside of the plates. It is then routed to the oil filter head and through a full flow oil filter. If a plugged filter is encountered, the filter by-pass valve opens, allowing unfiltered oil to lubricate the engine. This condition can be avoided by frequent oil and filter changes, per the maintenance schedules found in the owners manual. The by-pass valve is calibrated to open when it sees a pressure drop of more than 344 kPa (50 psi) across the oil filter.

The oil filter head then divides the oil between the engine and the turbocharger. The turbocharger receives filtered, cooled and pressurized oil through a supply line from the filter head. The oil lubricates the turbocharger and returns to the pan by way of a drain tube connecting the bottom of the turbocharger to a pressed in tube in the cylinder block.

Oil is then carried across the block to an angle drilling which intersects the main oil rifle. The main oil rifle runs the length of the block and delivers oil to the crankshaft main journals and valve train. Oil travels to the crankshaft through a series of transfer drillings (one for each main bearing) and lubricates a groove in the main bearing upper shell. From there another drilling feeds the camshaft main journals. The piston cooling nozzles are also supplied by the main bearing upper shell. Crankshaft internal cross-drillings supply oil to the connecting rod journals.

Another series of transfer drillings intersecting the main oil rifle supply the valve train components. Oil travels up the drilling, through a hole in the head gasket, and through a drilling in the cylinder head (one per cylinder), where it enters the rocker arm pedestal and is divided between the intake and exhaust rocker arm. Oil travels up and around the rocker arm mounting bolt, and lubricates the rocker shaft by cross drillings that intersect the mounting bolt hole. Grooves at both ends of the rocker shaft supply oil through the rocker arm where the oil travels to the push rod and socket balls (Fig. 148) and (Fig. 149).

LUBRICATION (Continued)



80be477c

**Fig. 148 Lubrication System Circulation**

- |                       |                  |
|-----------------------|------------------|
| 1 - TO FILTER         | 8 - CLOSED       |
| 2 - FROM FILTER       | 9 - OPEN         |
| 3 - TO MAIN OIL RIFLE | 10 - TO OIL SUMP |
| 4 - CLOSED            | 11 - OIL DRAIN   |
| 5 - OPEN              | 12 - OIL SUPPLY  |
| 6 - TO COOLER         |                  |
| 7 - FROM PUMP         |                  |



LUBRICATION (Continued)

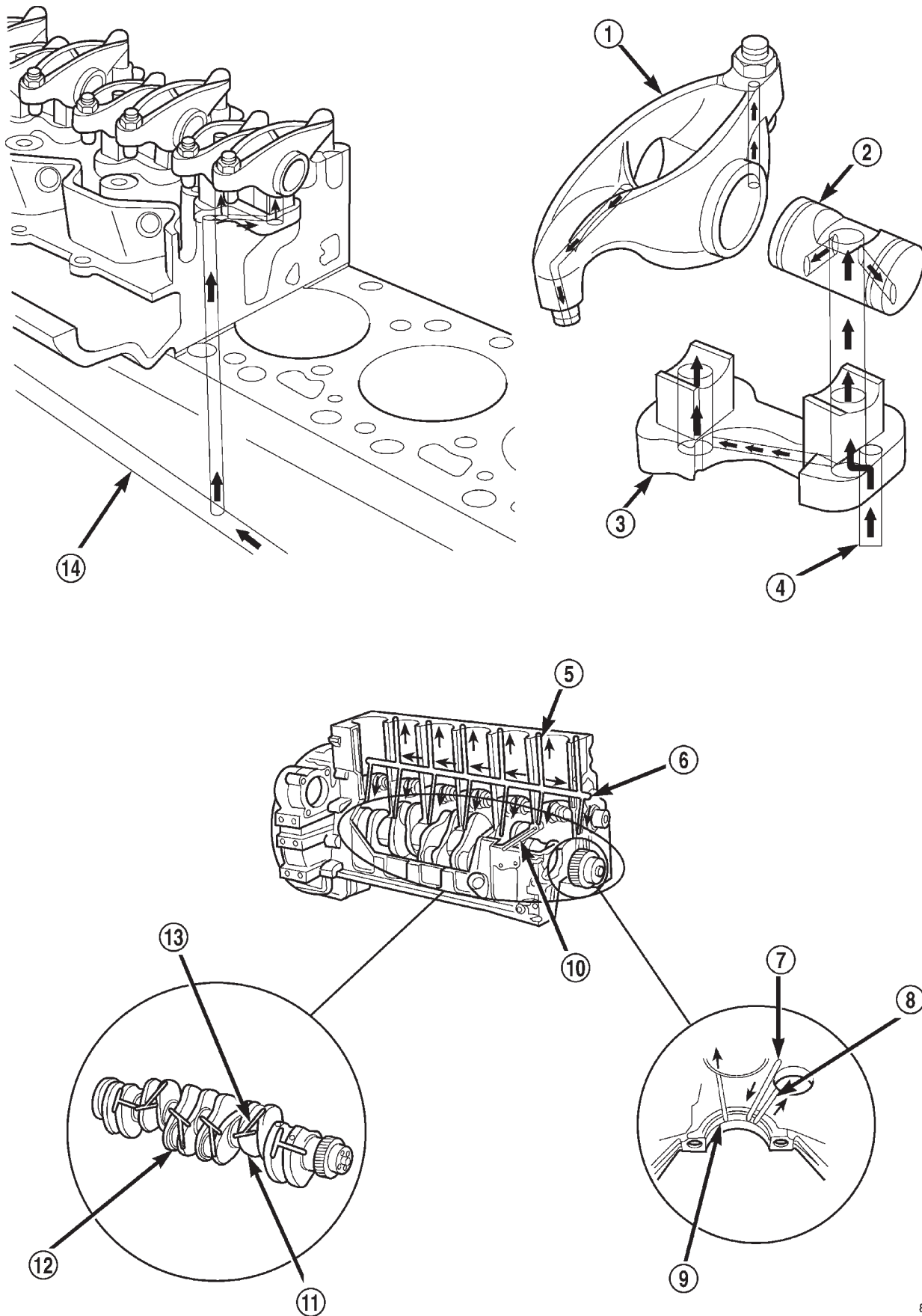


Fig. 149 Lubrication System Circulation—Cont'd

## LUBRICATION (Continued)

- 1 - ROCKER ARM
- 2 - ROCKER SHAFT
- 3 - PEDESTAL
- 4 - FROM MAIN OIL RIFLE
- 5 - TO VALVE TRAIN
- 6 - MAIN OIL RIFLE
- 7 - FROM MAIN OIL RIFLE
- 8 - TO CAMSHAFT

- 9 - TO PISTON COOLING NOZZLE
- 10 - FROM OIL COOLER
- 11 - CRANKSHAFT MAIN JOURNAL
- 12 - ROD JOURNAL
- 13 - TO ROD BEARING
- 14 - MAIN OIL RIFLE

## DIAGNOSIS AND TESTING—ENGINE OIL PRESSURE

(1) Remove the engine oil pressure sensor and install Oil Pressure Line and Gauge Tool C-3292 with a suitable adapter.

(2) Start engine and warm to operating temperature.

(3) Record engine oil pressure and compare with engine oil pressure chart.

**CAUTION: If engine oil pressure is zero at idle, DO NOT RUN THE ENGINE.**

Engine Oil Pressure (MIN)	
At Idle	103.4 kPa (15 psi)
At 2000 rpm	310.2 kPa (45 psi)

If minimum engine oil pressure is below these ranges, (Refer to 9 - ENGINE - DIAGNOSIS AND TESTING).

(4) Remove oil pressure gauge and install the oil pressure sensor. Tighten the sensor to 16 N·m (144 in. lbs.) torque.

## OIL

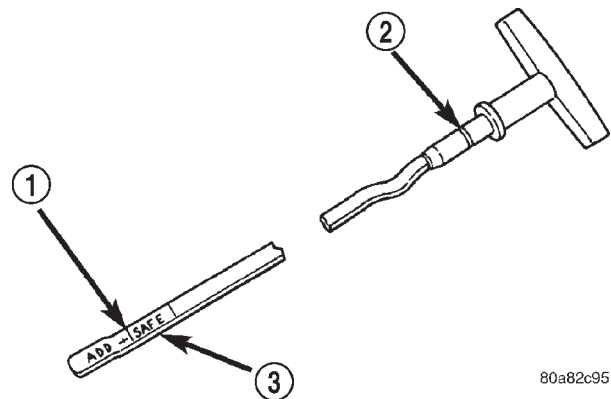
### STANDARD PROCEDURE-ENGINE OIL LEVEL

**CAUTION: Do not overfill crankcase with engine oil, oil foaming and oil pressure loss can result.**

To ensure proper lubrication of an engine, the engine oil must be maintained at an acceptable level. The acceptable oil level is in the SAFE RANGE on the engine oil dipstick (Fig. 150).

Unless the engine has exhibited loss of oil pressure, run the engine for about five minutes before checking oil level. Checking engine oil level of a cold engine is not accurate.

- (1) Position vehicle on level surface.
- (2) With engine OFF, allow approximately ten minutes for oil to settle to bottom of crankcase, remove engine oil dipstick.
- (3) Wipe dipstick clean.



80a82c95

**Fig. 150 Oil Level Indicator (Dipstick)**

- 1 - ADD OIL MARK
- 2 - O-RING
- 3 - SAFE RANGE

(4) Replace dipstick and verify it is seated in the tube.

(5) Remove dipstick, with handle held above the tip, take oil level reading.

(6) Add oil only if level is below the SAFE RANGE area on the dipstick.

(7) Replace dipstick

### STANDARD PROCEDURE-ENGINE OIL SERVICE

**WARNING: HOT OIL CAN CAUSE PERSONAL INJURY.**

**NOTE: Change engine oil and filter at intervals specified in the owner's manual.**

(1) Operate the engine until the water temperature reaches 60°C (140°F). Shut the engine off.

(2) Use a container that can hold at least 14 liters (15 quarts) to hold the used oil. Remove the oil drain plug and drain the used engine oil into the container.

(3) Always check the condition of the used oil. This can give you an indication of engine problems that might exist.

- Thin, black oil indicates fuel dilution.

## OIL (Continued)

- Milky discoloration indicates coolant dilution.

(4) Clean the area around the oil filter head. Remove the filter (Refer to 9 - ENGINE/LUBRICATION/OIL FILTER - REMOVAL).

(5) Install new oil filter (Refer to 9 - ENGINE/LUBRICATION/OIL FILTER - INSTALLATION).

(6) Clean the drain plug and the sealing surface of the pan. Check the condition of the threads and sealing surface on the oil pan and drain plug.

(7) Install the drain plug. Tighten the plug to 60 N·m (44 ft. lbs.) torque.

(8) Use only High-Quality Multi-Viscosity lubricating oil in the Cummins Turbo Diesel engine. Choose the correct oil for the operating conditions (Refer to LUBRICATION & MAINTENANCE/FLUID TYPES - DESCRIPTION).

(9) Fill the engine with the correct grade of new oil (Refer to LUBRICATION & MAINTENANCE/FLUID CAPACITIES - SPECIFICATIONS).

(10) Start the engine and operate it at idle for several minutes. Check for leaks at the filter and drain plug.

(11) Stop engine. Wait several minutes to allow the oil to drain back to the pan and check the level again.

**USED ENGINE OIL DISPOSAL** Care should be exercised when disposing of used engine oil after it has been drained from a vehicle's engine.

## OIL COOLER &amp; LINES

## CLEANING AND INSPECTION

Clean the sealing surfaces.

Apply 483 kPa (70 psi) air pressure to the element to check for leaks. If the element leaks, replace the element.

## OIL FILTER

## REMOVAL

(1) Clean the area around the oil filter head. Remove the filter using a 90-95 mm filter wrench.

(2) Clean the gasket surface of the filter head. The filter canister O-Ring seal can stick on the filter head. Make sure it is removed.

## INSTALLATION

(1) Fill the oil filter element with clean oil before installation. Use the same type oil that will be used in the engine.

(2) Apply a light film of lubricating oil to the sealing surface before installing the filter.

**CAUTION:** Mechanical over-tightening may distort the threads or damage the filter element seal.

(3) Install the filter until it contacts the sealing surface of the oil filter adapter. Tighten filter an additional ½ turn.

## OIL PAN

## REMOVAL

(1) Disconnect the battery negative cables.

(2) Raise vehicle on hoist.

(3) Remove transmission and transfer case (if equipped).

(4) Remove flywheel.

(5) Disconnect starter cables from starter motor.

(6) Remove starter motor (Refer to 8 - ELECTRICAL/STARTING/STARTER MOTOR - REMOVAL) and transmission adapter plate assembly.

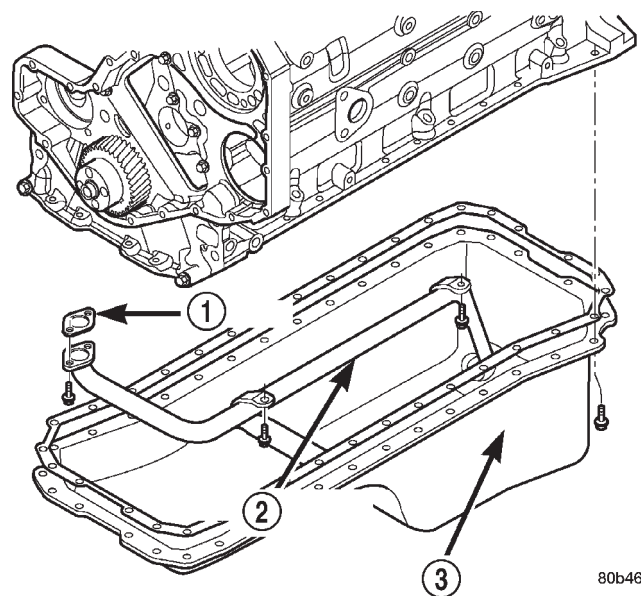
**WARNING:** HOT OIL CAN CAUSE PERSONAL INJURY.

(7) Drain the engine oil (Refer to 9 - ENGINE/LUBRICATION/OIL - STANDARD PROCEDURE).

(8) Install the oil pan drain plug with a new sealing washer and tighten to 60 N·m (44 ft. lbs.) torque.

(9) Remove oil pan bolts, break the pan to block seal, and lower pan slightly and remove oil suction tube fasteners.

(10) Remove oil pan and suction tube (Fig. 151).



80b46d35

**Fig. 151 Oil Pan, Suction Tube and Gasket**

- 1 - GASKET
- 2 - SUCTION TUBE
- 3 - OIL PAN

## OIL PAN (Continued)

## CLEANING

Remove all gasket material from the oil pan and cylinder block sealing surfaces. Extra effort may be required around T-joint areas. Clean oil pan and flush suction tube with a suitable solvent.

## INSPECTION

Inspect the oil pan, suction tube, and tube braces for cracks and damage. Replace any defective component. Inspect the oil drain plug and drain hole threads. Inspect the oil pan sealing surface for straightness. Repair any minor imperfections with a ball-peen hammer. Do not attempt to repair an oil pan by welding.

## INSTALLATION

(1) Fill the T-joint between the pan rail/gear housing and pan rail/rear seal retainer with sealant. Use Mopar® Silicone Rubber Adhesive Sealant or equivalent.

(2) Place suction tube in oil pan and guide them into place (Fig. 151). Using a new tube to oil pump gasket, install and tighten the suction tube bolts by hand. Starting with the oil pump inlet bolts, tighten the bolts to 24 N·m (18 ft. lbs.) torque. Tighten the remaining tube brace bolts to 24 N·m (18 ft. lbs.) torque.

(3) Starting in the center and working outward, tighten the oil pan bolts to 24 N·m (18 ft. lbs.) torque.

(4) Install the flywheel housing assembly with the starter motor attached and tighten bolts to 60 N·m (44 ft. lbs.) torque.

(5) Connect starter motor cables.

(6) Install transmission and transfer case (if equipped).

(7) Lower vehicle.

(8) Install battery negative cables.

(9) Fill the crankcase with new engine oil.

(10) Start engine and check for leaks. Stop engine, check oil level, and adjust, if necessary.

## OIL PRESSURE RELIEF VALVE

## REMOVAL

(1) Disconnect the battery negative cables.

(2) Remove the threaded plug, spring and plunger (Fig. 152). Insert a finger or a seal pick to lift the plunger from the bore.

**NOTE:** If the plunger is stuck in the bore, it will be necessary to remove the filter head.

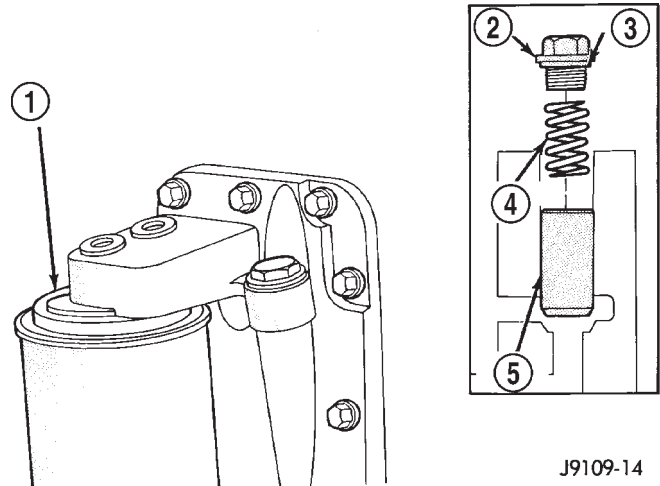


Fig. 152 Oil Pressure Regulator

- 1 - OIL FILTER
- 2 - PLUG
- 3 - GASKET
- 4 - SPRING
- 5 - VALVE

## CLEANING

(1) Clean the regulator spring and plunger with a suitable solvent and blow dry with compressed air. If the plunger bore requires cleaning, it is necessary to remove the oil filter head to avoid getting debris into the engine.

## INSPECTION

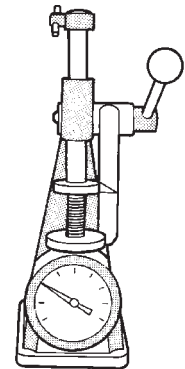
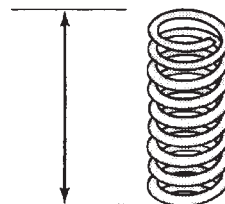
Inspect the plunger and plunger bore for cracks and excessive wear. Polished surfaces are acceptable. Verify that the plunger moves freely in the bore.

Check the spring for height and load limitations (Fig. 153). Replace the spring if out of limits shown in the figure.

## VALVE OPEN

- HEIGHT: 41.25mm (1.62 inch)
- LOAD: 126 N (28.4 lb)

FREE LENGTH: 66mm (2.6 inch)



J9509-161

Fig. 153 Oil Pressure Regulator Spring Check

## OIL PRESSURE RELIEF VALVE (Continued)

## INSTALLATION

(1) Install the plunger, spring, and plug as shown in (Fig. 152). Tighten the plug to 80 N·m (60 ft. lbs.) torque.

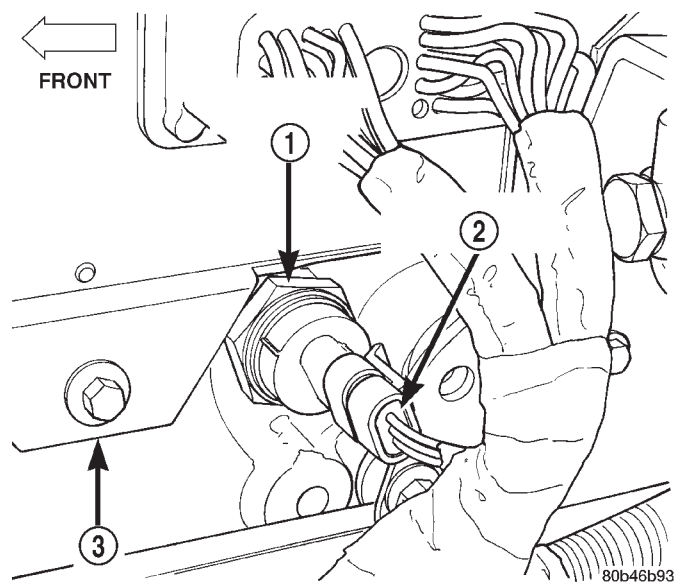
(2) Connect the battery negative cables.

(3) Start the engine and verify that it has oil pressure.

OIL PRESSURE SENSOR/  
SWITCH

## DESCRIPTION

The 3-wire, solid-state oil pressure sensor is installed into the oil pressure galley on the engine block. It is located below and to the rear of the Engine Control Module (ECM) (Fig. 154).



**Fig. 154 Oil Pressure Sensor (Engine) Location**

- 1 - ENGINE OIL PRESSURE SENSOR  
2 - ELECTRICAL CONNECTOR  
3 - ECM

## OPERATION

Operation of the oil pressure sensor on the diesel engine is controlled by the Engine Control Module (ECM). The Powertrain Control Module (PCM) does not have any control over the sensor.

The oil pressure sensor uses three circuits. They are:

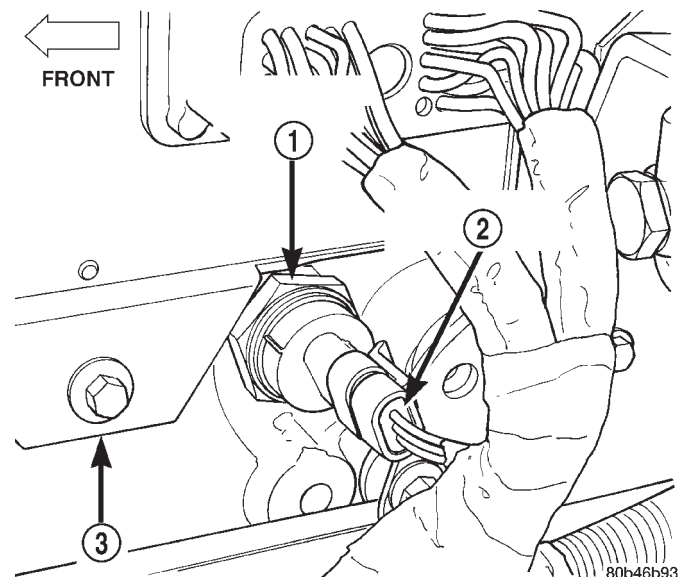
- A 5-volt power supply from the ECM
- A sensor ground through the ECM's sensor return
- A signal to the ECM relating to engine oil pressure

The oil pressure sensor has a 3-wire electrical function very much like the Manifold Absolute Pressure (MAP) sensor on the gasoline powered engine. Meaning different pressures relate to different output voltages.

A 5-volt supply is sent to the sensor from the ECM to power up the sensor. The sensor returns a voltage signal back to the ECM relating to engine oil pressure. This signal is then transferred (bussed) to the instrument panel on the CCD bus circuit to operate the oil pressure gauge and the check gauges lamp. Ground for the sensor is provided by the ECM through a low-noise sensor return.

## REMOVAL

- (1) Disconnect the battery negative cables.
- (2) Disconnect the oil pressure sensor connector (Fig. 155).
- (3) Using a suitable socket, remove the oil pressure sensor from the block (counter-clockwise).



**Fig. 155 Oil Pressure Sensor Location**

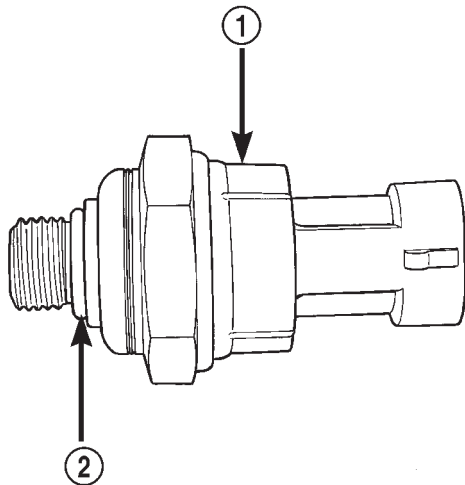
- 1 - ENGINE OIL PRESSURE SENSOR  
2 - ELECTRICAL CONNECTOR  
3 - ECM



## OIL PRESSURE SENSOR/SWITCH (Continued)

## INSTALLATION

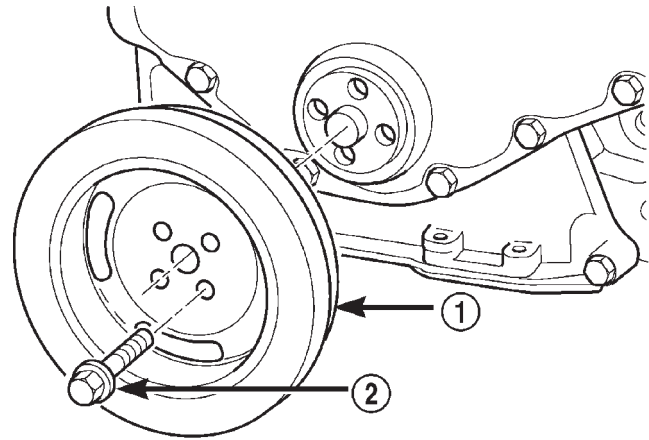
- (1) If the sensor is not being replaced, inspect the o-ring (Fig. 156) and replace if necessary.
- (2) Install the oil pressure sensor and tighten to 16 N·m (144 in. lbs.) torque.
- (3) Connect the battery negative cables.
- (4) Start engine and check for oil leaks at the sensor.



80b46b94

Fig. 156 Oil Pressure Sensor and

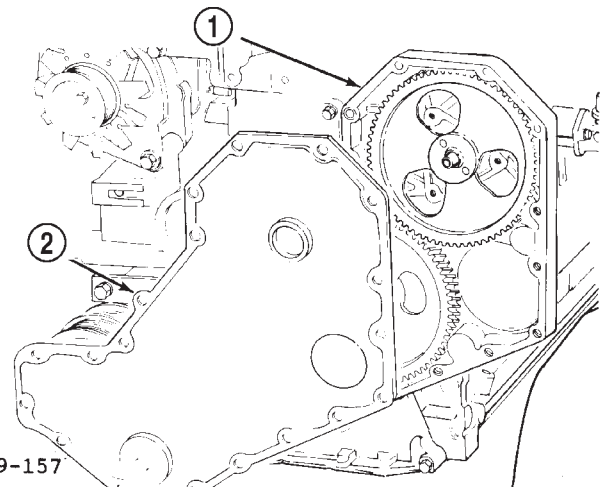
- 1 - ENGINE OIL PRESSURE SENSOR
- 2 - O-RING



80b46d29

Fig. 157 Crankshaft Damper Removal/Installation

- 1 - DAMPER
- 2 - BOLT



J9209-157

Fig. 158 Gear Housing and Cover

- 1 - GEAR HOUSING
- 2 - GEAR HOUSING COVER

## OIL PUMP

## REMOVAL

- (1) Disconnect the battery negative cables.
- (2) Remove fan/drive assembly (Refer to 7 - COOLING/ENGINE/RADIATOR FAN - REMOVAL).
- (3) Remove the accessory drive belt (Refer to 7 - COOLING/ACCESSORY DRIVE/DRIVE BELTS - REMOVAL).
- (4) Remove the fan support/hub assembly.
- (5) Remove crankshaft damper (Fig. 157) (Refer to 9 - ENGINE/ENGINE BLOCK/VIBRATION DAMPER - REMOVAL).
- (6) Remove the gear housing cover (Fig. 158) (Refer to 9 - ENGINE/VALVE TIMING/GEAR HOUSING COVER - REMOVAL).
- (7) Remove the four mounting bolts and pull the pump from the bore in the cylinder block (Fig. 159).

## CLEANING

Clean all parts in solvent and dry with compressed air. Clean the old sealer residue from the back of the gear housing cover and front of the gear housing.

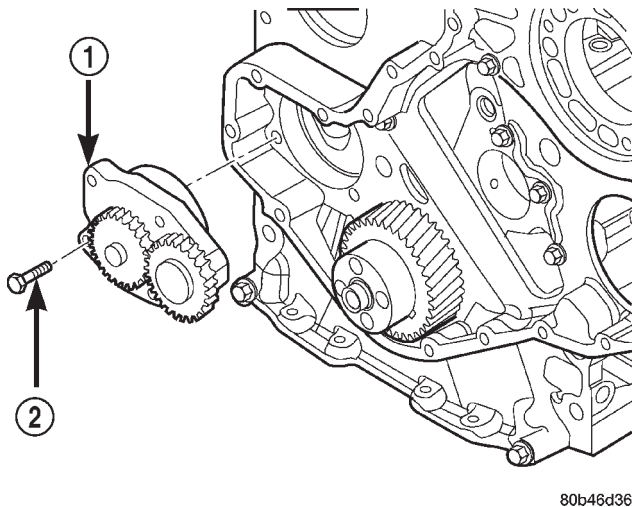
## INSPECTION

**Disassemble and inspect the oil pump as follows:**

- (1) Visually inspect the lube pump gears for chips, cracks or excessive wear.
- (2) Remove the back plate (Fig. 160).
- (3) Mark TOP on the gerotor planetary using a felt tip pen (Fig. 160).
- (4) Remove the gerotor planetary (Fig. 160). Inspect for excessive wear or damage. Inspect the pump housing and gerotor drive for damaged and excessive wear.
- (5) Install the gerotor planetary in the original position. The chamfer must be on the O.D. and down.



## OIL PUMP (Continued)



80b46d36

**Fig. 159 Oil Pump Removal/Installation**

- 1 - OIL PUMP  
2 - BOLT (4)

(6) Measure the tip clearance (Fig. 161). Maximum clearance is 0.1778 mm (0.007 inch). If the oil pump is out of limits, replace the pump.

(7) Measure the clearance of the gerotor drive/gerotor planetary to port plate (Fig. 162). Maximum clearance is 0.127 mm (0.005 inch). If the oil pump is out of limits, replace the pump.

(8) Measure the clearance of the gerotor planetary to the body bore (Fig. 163). Maximum clearance is 0.381 mm (0.015 inch). If the oil pump is out of limits, replace the pump.

(9) Measure the gears backlash (Fig. 164). The limits of a used pump is 0.075- 0.85 mm (0.0296-0.0335 inch). If the backlash is out of limits, replace the oil pump.

(10) Install the back plate.

**INSTALLATION**

(1) Lubricate the pump with clean engine oil. Filling the pump with clean engine oil during installation will help to prime the pump at engine start up.

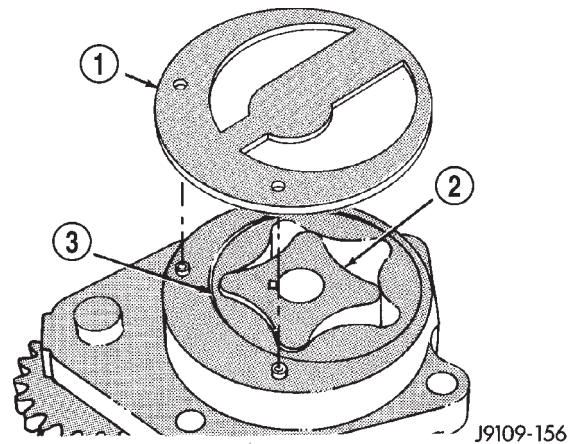
(2) Verify the idler gear pin is installed in the locating bore in the cylinder block.

(3) Install the pump (Fig. 159). Tighten the oil pump mounting bolts in two steps, in the sequence shown in (Fig. 165).

- Step 1—Tighten to 5 N·m (44 in. lbs.) torque.
- Step 2—Tighten to 24 N·m (18 ft. lbs.) torque.

(4) The back plate on the pump seats against the bottom of the bore in the cylinder block. When the pump is correctly installed, the flange on the pump will not touch the cylinder block.

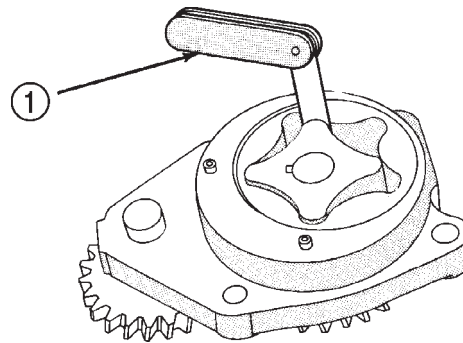
(5) Measure the idler gear to pump drive gear backlash and the idler gear to crankshaft gear backlash (Fig. 166). The backlash should be 0.75- 0.85



J9109-156

**Fig. 160 Gerotor Planetary and Gerotor**

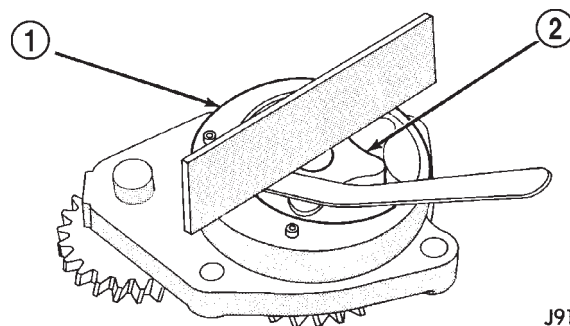
- 1 - OIL PUMP BACK PLATE  
2 - GEROTOR  
3 - GEROTOR PLANETARY



J9109-21

**Fig. 161 Measuring Tip Clearance**

- 1 - FEELER GAUGE



J9109-22

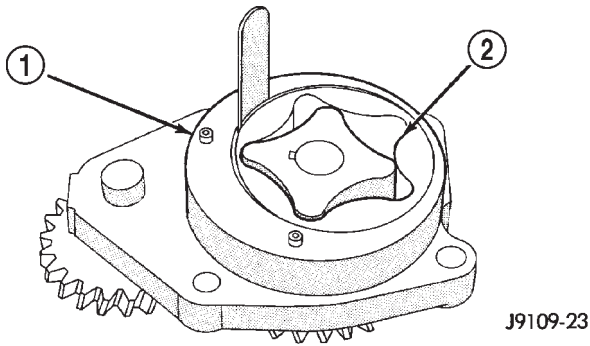
**Fig. 162 Measuring Gerotor to Port Plate Clearance**

- 1 - PORT PLATE  
2 - GEROTOR

mm (0.0296-0.0335 inch). If the backlash is out of limits, replace the oil pump.

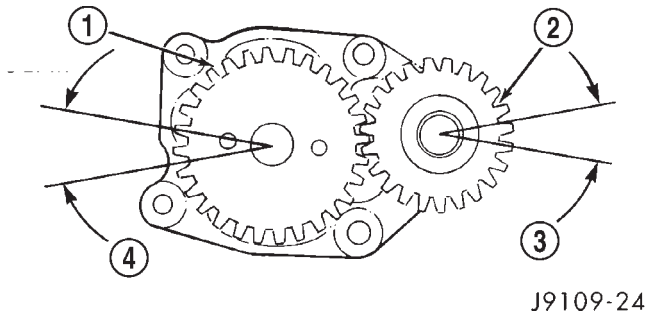
(6) If the adjoining gear moves when you measure the backlash, the reading will be incorrect.

## OIL PUMP (Continued)



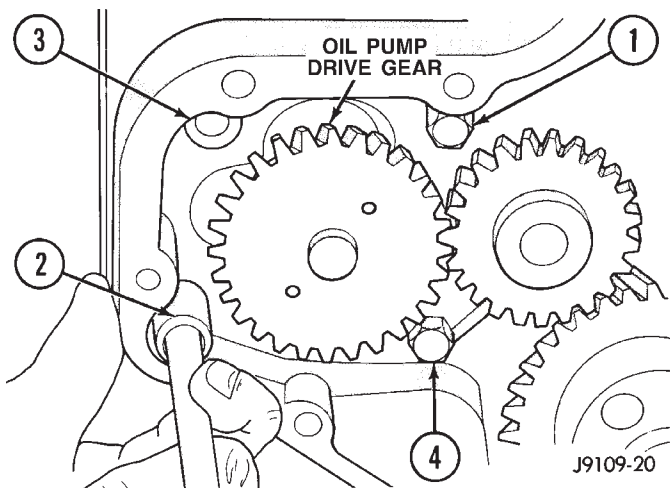
**Fig. 163 Measuring Gerotor Planetary to Body Bore Clearance**

- 1 - BODY BORE  
2 - GEROTOR PLANETARY



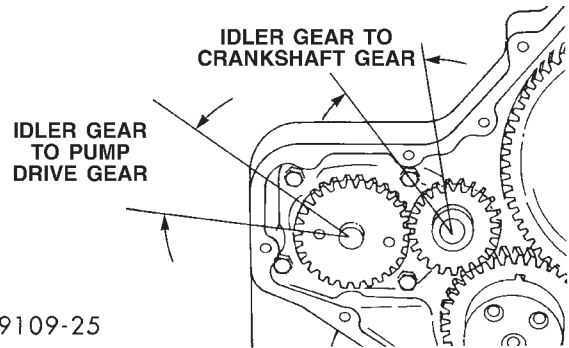
**Fig. 164 Measure Gear Backlash**

- 1 - OIL PUMP DRIVE GEAR  
2 - IDLER GEAR  
3 - BACKLASH  
4 - BACKLASH



**Fig. 165 Oil Pump Mounting Bolt Torque Sequence**

(7) Apply a bead of Mopar® Silicone Rubber Adhesive Sealant or equivalent to the gear housing cover sealing surface.



**Fig. 166 Idler Gear to Pump Drive Gear and Crankshaft Gear Backlash**

(8) Install the gear housing cover (Refer to 9 - ENGINE/VALVE TIMING/GEAR HOUSING COVER - INSTALLATION).

(9) Install the vibration damper (Refer to 9 - ENGINE/ENGINE BLOCK/VIBRATION DAMPER - INSTALLATION).

(10) Install the fan support/hub assembly and torque bolts to 24 N·m (18 ft. lbs.).

(11) Install the accessory drive belt (Refer to 7 - COOLING/ACCESSORY DRIVE/DRIVE BELTS - INSTALLATION).

(12) Install the cooling fan (Refer to 7 - COOLING/ENGINE/RADIATOR FAN - INSTALLATION).

(13) Connect battery negative cables.

(14) Start engine and check for oil leaks.

## INTAKE MANIFOLD

### REMOVAL

(1) Disconnect the battery negative cables.

(2) Remove the charge air cooler outlet tube from the air inlet housing (Fig. 167).

(3) Remove the engine oil dipstick tube mounting bolt (Fig. 167). Position dipstick tube to the side.

(4) Disconnect the air grid heater power cables at the cable mounting studs (Fig. 168).

(5) Remove the four (4) air inlet housing mounting bolts (Fig. 168) and remove the housing from top of the heater elements.

(6) Remove the intake air grid heater from the manifold (Fig. 169).

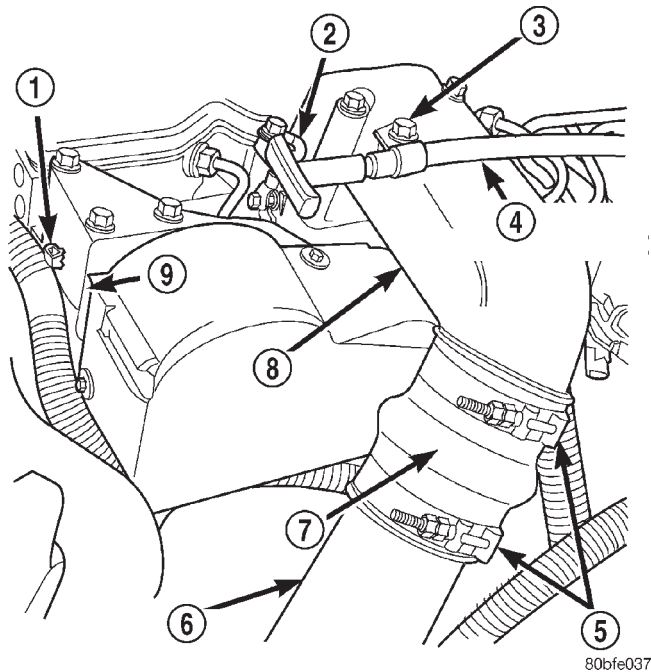
(7) Remove the high pressure fuel lines. (Refer to 14 - FUEL SYSTEM/FUEL DELIVERY/FUEL LINES - REMOVAL).

(8) Remove the remaining intake manifold cover-to-cylinder head bolts.

(9) Remove the intake manifold cover and gasket. Keep the gasket material and any other material out of the air intake.

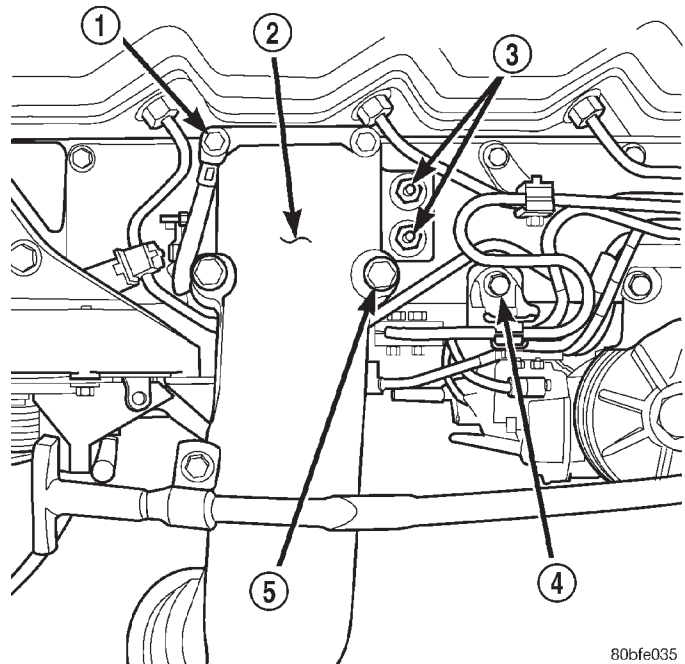
(10) Clean the intake manifold cover and cylinder head sealing surface.

INTAKE MANIFOLD (Continued)



**Fig. 167 Charge Air Cooler Air Tube**

- 1 - FRONT WIRING CLIP
- 2 - GROUND CABLE
- 3 - TUBE BOLT
- 4 - ENGINE OIL DIPSTICK TUBE
- 5 - CLAMPS
- 6 - AIR TUBE (INT. MAN.-TO-INTERCOOLER)
- 7 - RUBBER HOSE
- 8 - AIR INTAKE HOUSING
- 9 - CABLE BRACKET HOUSING



**Fig. 168 Air Inlet Housing**

- 1 - GROUND STRAP
- 2 - AIR INTAKE HOUSING
- 3 - HEATER POWER CABLE MOUNTING STUDS
- 4 - FUEL LINE BRACKET BOLT
- 5 - HOUSING BOLTS (4)

**CLEANING**

Clean manifold in solvent and blow dry with compressed air.

Clean cylinder block front and rear gasket surfaces using a suitable solvent.

The plenum pan rail must be clean and dry (free of all foreign material).

**INSPECTION**

Inspect manifold for cracks.

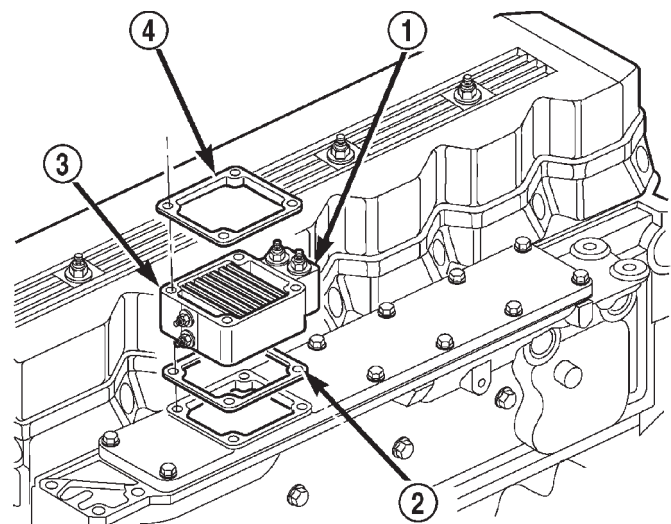
Inspect mating surfaces of manifold for flatness with a straightedge.

**INSTALLATION**

(1) Using a new gasket, install the intake manifold cover.

(2) Install the cover-to-cylinder head bolts that do not hold down the high pressure fuel line support brackets. Tighten the bolts to 24 N·m (18 ft. lbs.) torque.

(3) Install the high pressure fuel lines (Refer to 14 - FUEL SYSTEM/FUEL DELIVERY/FUEL LINES - INSTALLATION).



**Fig. 169 Intake Air Grid Heater**

- 1 - AIR HEATER ELEMENTS
- 2 - LOWER GASKET
- 3 - BLOCK
- 4 - UPPER GASKET

(4) Install the high pressure fuel line support bracket-to-intake manifold cover bolts and tighten to 24 N·m (18 ft. lbs.) torque.

## INTAKE MANIFOLD (Continued)

(5) Using two (2) new gaskets, install the intake air grid heater and air inlet housing (Fig. 168). Position the ground cable and install and tighten the bolts to 24 N·m (18 ft. lbs.) torque.

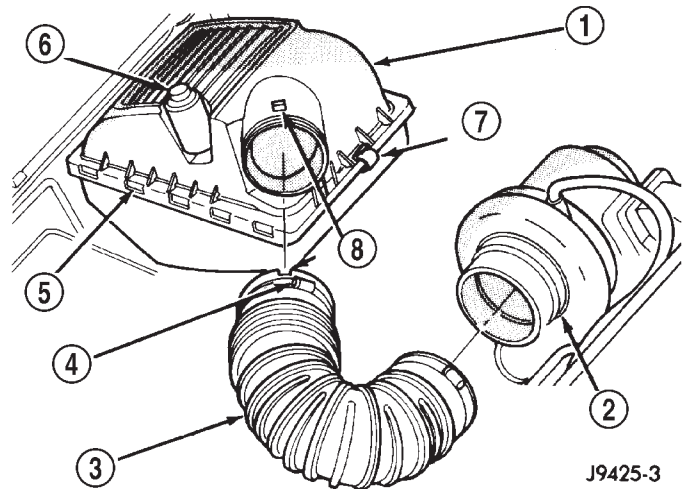
(6) Install and tighten the air intake heater power supply nuts to 14 N·m (120 in. lbs.) torque.

(7) Install the engine oil dipstick tube and mounting bolt (Fig. 167).

(8) Position the charge air cooler outlet tube onto the air inlet housing (Fig. 167). Tighten the clamps to 8 N·m (72 in. lbs.) torque.

(9) Perform the fuel system air bleed procedure (Refer to 14 - FUEL SYSTEM/FUEL DELIVERY - STANDARD PROCEDURE).

(10) Connect the battery negative cables.



**Fig. 171 Turbocharger Air Inlet Hose**

- 1 - AIR FILTER HOUSING COVER
- 2 - TURBOCHARGER
- 3 - AIR INLET TUBE
- 4 - HOSE CLAMP
- 5 - HINGE TABS
- 6 - FILTER MINDER
- 7 - CLIPS (4)
- 8 - TUBE ALIGNMENT NOTCHES

## EXHAUST MANIFOLD

### REMOVAL

(1) Disconnect the battery negative cables.

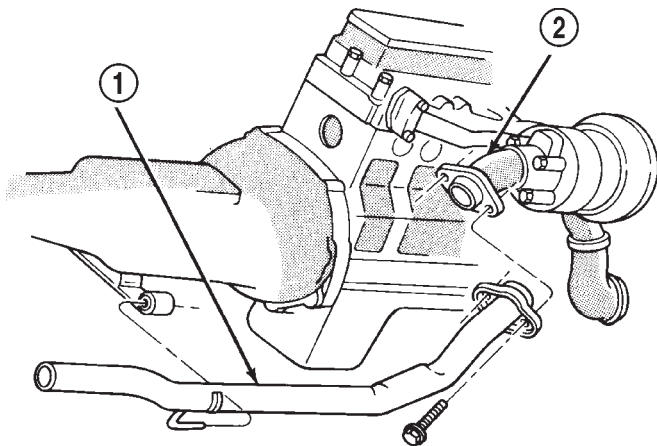
(2) Raise vehicle on hoist.

(3) Disconnect the exhaust pipe from the turbocharger elbow (Fig. 170).

(4) Lower vehicle.

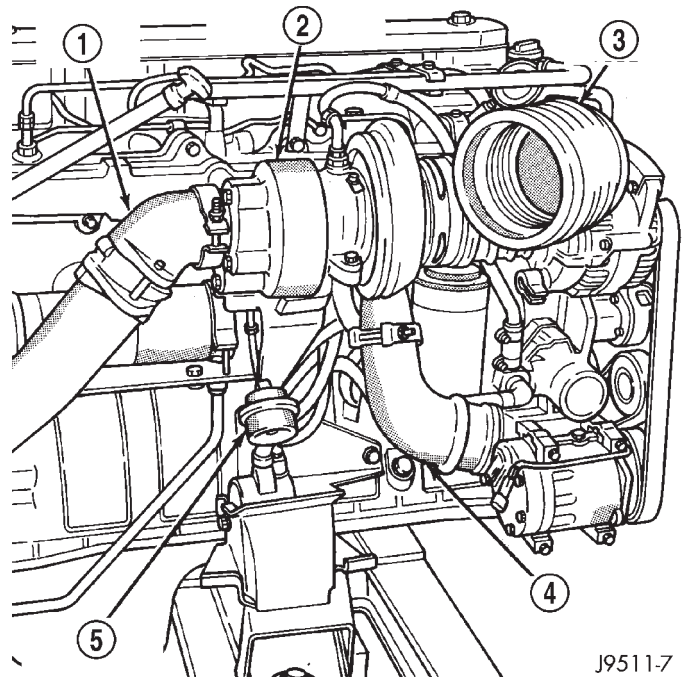
(5) Disconnect the turbocharger air inlet hose (Fig. 171).

(6) Disconnect the turbocharger oil supply line and the oil drain tube from the turbocharger (Fig. 172).



**Fig. 170 Exhaust Pipe**

- 1 - EXHAUST PIPE
- 2 - TURBOCHARGER EXHAUST PIPE



**Fig. 172 Oil Supply Line and Charge Air Cooler Inlet Duct**

- 1 - EXHAUST PIPE
- 2 - TURBOCHARGER
- 3 - AIR INLET TUBE
- 4 - INTERCOOLER INLET DUCT
- 5 - WASTE GATE ACTUATOR

(7) Disconnect the charge air cooler inlet pipe from the turbocharger (Fig. 172).

(8) Remove the turbocharger and gasket from the exhaust manifold.

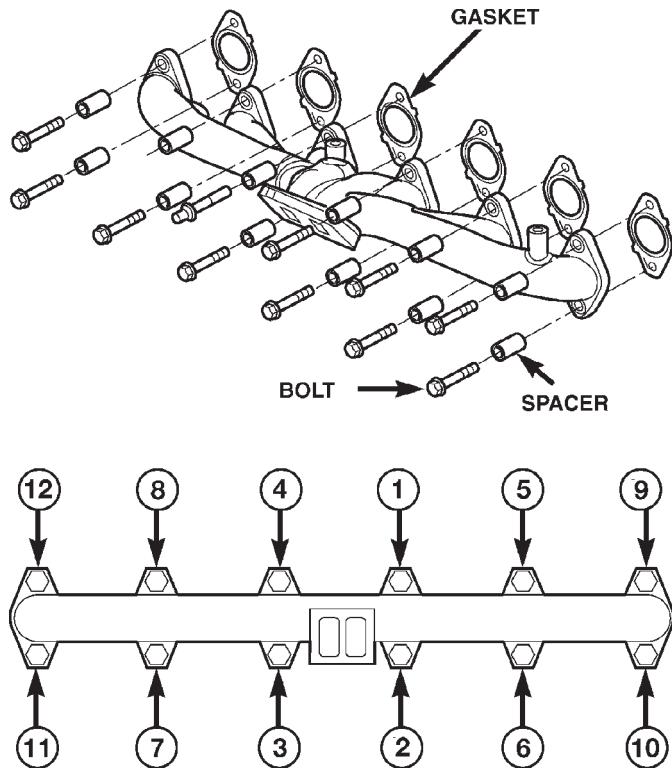
(9) Remove the cab heater return pipe nut from the exhaust manifold stud. Position the tube out of the way.



## EXHAUST MANIFOLD (Continued)

(10) Remove the exhaust manifold-to-cylinder head bolts and spacers (Fig. 173).

(11) Remove the exhaust manifold and gaskets (Fig. 173).



80b5cc58

Fig. 173 Exhaust Manifold and Gaskets

## CLEANING

Clean the cylinder head and exhaust manifold sealing surfaces with a suitable scraper. Use a Scotch-Brite™ pad or equivalent.

## INSPECTION

Inspect the exhaust manifold for cracks. Measure the exhaust manifold for flatness. Place a ruler over all of the exhaust ports and insert a feeler gauge between the port flange and the ruler.

## INSTALLATION

(1) Using new gaskets, install the exhaust manifold and gaskets. Install the bolts and spacers and tighten the bolts in the sequence shown in (Fig. 173) to 43 N·m (32 ft. lbs.) torque.

(2) Install the cab heater return hose to the manifold bolt stud. Tighten the nut to 24 N·m (18 ft. lbs.) torque.

(3) Install the turbocharger. Apply anti-seize to the studs and then tighten the turbocharger mounting nuts to 32 N·m (24 ft. lbs.) torque.

(4) Install the oil drain tube and oil supply line to the turbocharger. Tighten the drain tube bolts to 24 N·m (18 ft. lbs.) torque.

(5) **Pre-lube the turbocharger.** Pour 50 to 60 cc (2 to 3 oz.) clean engine oil in the oil supply line fitting. Rotate the turbocharger impeller by hand to distribute the oil thoroughly.

(6) Install and tighten the oil supply line fitting nut to 20 N·m (133 in. lbs.) torque.

(7) Position the charge air cooler inlet pipe to the turbocharger. With the clamp in position, tighten the clamp nut to 8 N·m (72 in. lbs.) torque.

(8) Position the air inlet hose to the turbocharger (Fig. 171). Tighten the clamp to 8 N·m (72 in. lbs.) torque.

(9) Raise vehicle on hoist.

(10) Connect the exhaust pipe to the turbocharger (Fig. 170) and tighten the bolts to 34 N·m (25 ft. lbs.) torque.

(11) Lower the vehicle.

(12) Connect the battery negative cables.

(13) Start the engine to check for leaks.

## GEAR HOUSING

## REMOVAL

(1) Disconnect the battery negative cables.

(2) Raise vehicle on hoist.

(3) Remove the oil pan and suction tube (Refer to 9 - ENGINE/LUBRICATION/OIL PAN - REMOVAL).

(4) Partially drain engine coolant into container suitable for re-use (Refer to 7 - COOLING - STANDARD PROCEDURE).

(5) Lower vehicle.

(6) Remove radiator upper hose.

(7) Disconnect coolant recovery bottle hose from radiator filler neck and lift bottle off of fan shroud.

(8) Disconnect windshield washer pump supply hose and electrical connections and lift washer bottle off of fan shroud.

(9) Remove the fan shroud-to-radiator mounting bolts.

(10) Remove viscous fan/drive assembly (Refer to 7 - COOLING/ENGINE/RADIATOR FAN - REMOVAL).

(11) Remove the accessory drive belt (Refer to 7 - COOLING/ACCESSORY DRIVE/DRIVE BELTS - REMOVAL).

(12) Remove the cooling fan support/hub from the front of the engine (Fig. 174).

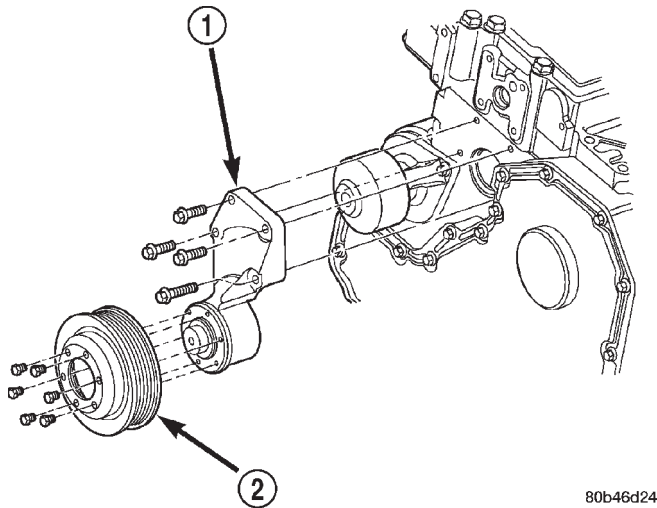
(13) Raise the vehicle on hoist.

(14) Remove the crankshaft damper (Fig. 175) (Refer to 9 - ENGINE/ENGINE BLOCK/VIBRATION DAMPER - REMOVAL).

(15) Lower the vehicle.

## GEAR HOUSING (Continued)

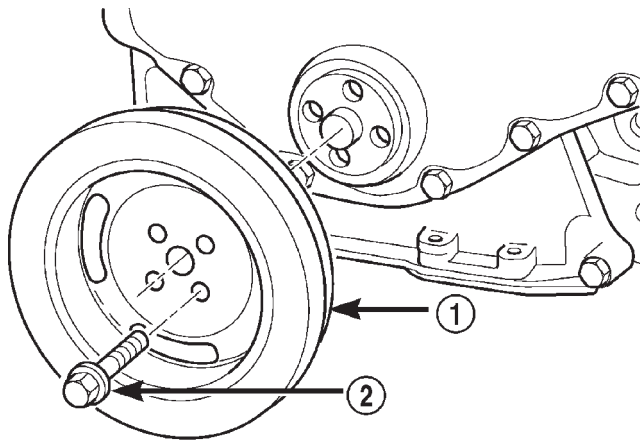
(16) Remove the gear cover-to-housing bolts and gently pry the cover away from the housing (Fig. 176), taking care not to mar the gasket surfaces.



80b46d24

**Fig. 174 Fan Support/Hub Assembly—Removal/Installation**

- 1 - FAN SUPPORT/HUB  
2 - FAN PULLEY



80b46d29

**Fig. 175 Crankshaft Damper—Removal/Installation**

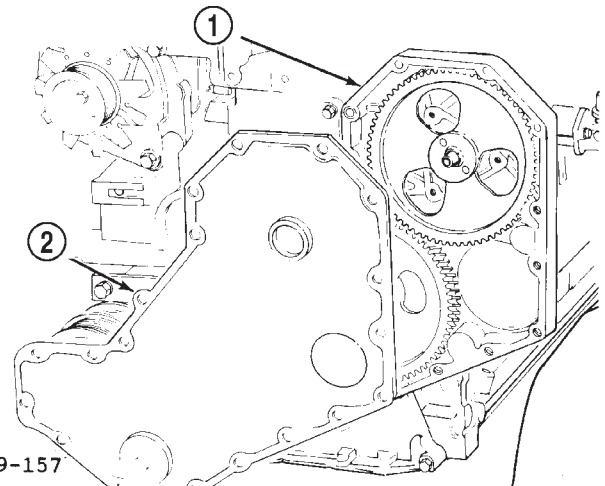
- 1 - DAMPER  
2 - BOLT

(17) Remove the fuel injection pump (Refer to 14 - FUEL SYSTEM/FUEL DELIVERY/FUEL INJECTION PUMP - REMOVAL).

(18) Disconnect the camshaft position sensor connector.

(19) Remove the camshaft (Refer to 9 - ENGINE/ENGINE BLOCK/CAMSHAFT & BEARINGS (IN BLOCK) - REMOVAL).

(20) Remove the gear housing and gasket (Fig. 177).

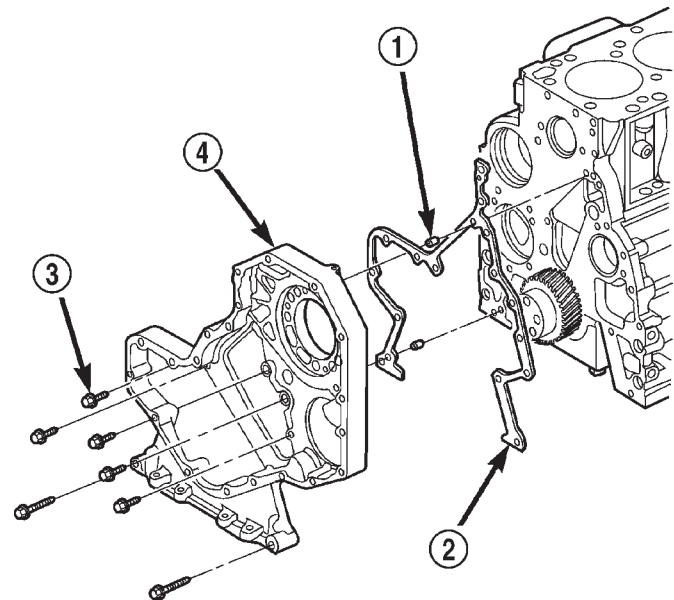


J9209-157

**Fig. 176 Gear Housing and Cover**

- 1 - GEAR HOUSING  
2 - GEAR HOUSING COVER

(21) Clean the gasket material from the cylinder block.



80b46d28

**Fig. 177 Gear Housing and Gasket**

- 1 - DOWEL  
2 - GASKET  
3 - BOLT  
4 - GEAR HOUSING

## INSTALLATION

(1) Install a new gasket and the gear housing (Fig. 177). Tighten the bolts to 24 N·m (18 ft. lbs.) torque.

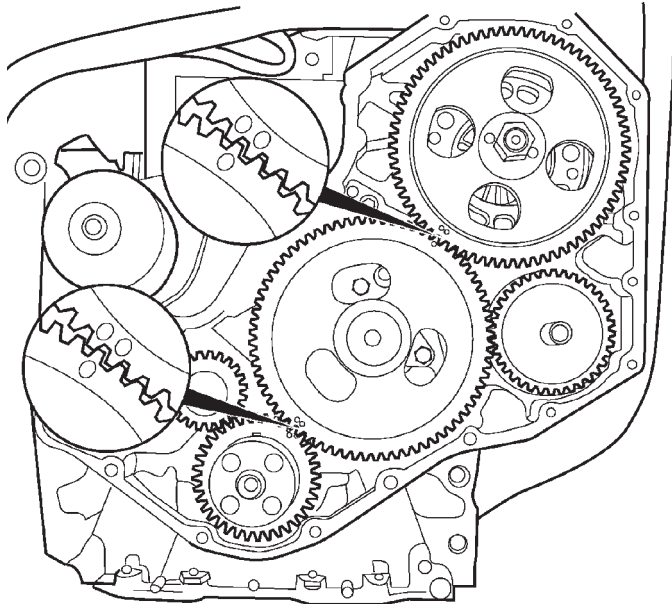
(2) Connect the camshaft position sensor connector.



## GEAR HOUSING (Continued)

(3) Install the injection pump (Refer to 14 - FUEL SYSTEM/FUEL DELIVERY/FUEL INJECTION PUMP - INSTALLATION).

(4) Install the camshaft (Refer to 9 - ENGINE/ENGINE BLOCK/CAMSHAFT & BEARINGS (IN BLOCK) - INSTALLATION). Align the crankshaft, camshaft, and injection pump gear marks as shown in (Fig. 178).



80b4fa34

**Fig. 178 Camshaft/Crankshaft Gear Alignment**

(5) If a new housing is installed, the camshaft position sensor must be transferred to the new housing.

(6) Obtain a seal pilot/installation tool from a crankshaft front seal service kit and install the pilot into the crankshaft front oil seal.

(7) Apply a bead of Mopar® Silicone Rubber Adhesive Sealant or equivalent to the gear housing cover. Be sure to surround all through holes.

(8) Using the seal pilot to align the cover (Fig. 179), install the cover to the housing and install the bolts. Tighten the bolts to 24 N·m (18 ft. lbs.) torque.

(9) Remove the seal pilot.

(10) Raise the vehicle.

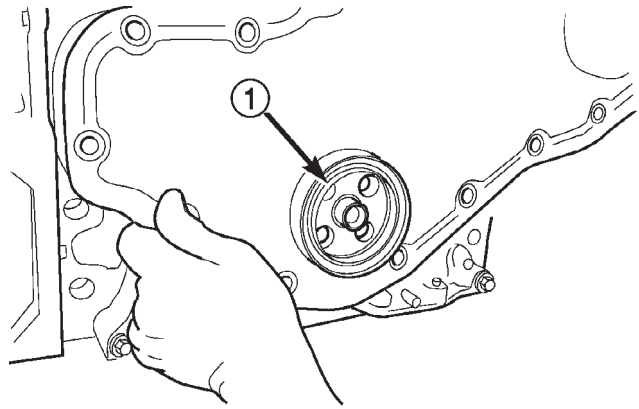
(11) Trim any excess gear housing gasket to make it flush with the oil pan rail.

(12) Using a new gasket, install the oil pan and suction tube (Refer to 9 - ENGINE/LUBRICATION/OIL PAN - INSTALLATION).

(13) Install the crankshaft damper (Fig. 175) (Refer to 9 - ENGINE/ENGINE BLOCK/VIBRATION DAMPER - INSTALLATION).

(14) Lower vehicle.

(15) Install the fan support/hub assembly (Fig. 174) and tighten bolts to 24 N·m (18 ft. lbs.) torque.



80b46d27

**Fig. 179 Installing Cover with Seal Pilot**

1 - SEAL PILOT

(16) Install the accessory drive belt (Refer to 7 - COOLING/ACCESSORY DRIVE/DRIVE BELTS - INSTALLATION).

(17) Install the cooling fan and shroud together (Refer to 7 - COOLING/ENGINE/RADIATOR FAN - INSTALLATION).

(18) Install the windshield washer reservoir to the fan shroud and connect the washer pump supply hose and electrical connection.

(19) Install the coolant recovery bottle to the fan shroud and connect the hose to the radiator filler neck.

(20) Install the radiator upper hose and clamps.

(21) Add engine oil.

(22) Add coolant (Refer to 7 - COOLING - STANDARD PROCEDURE).

(23) Connect the battery cables.

(24) Start engine and inspect for leaks.

## GEAR HOUSING COVER

### REMOVAL

(1) Disconnect both battery negative cables.

(2) Raise vehicle on hoist.

(3) Partially drain engine coolant into container suitable for re-use (Refer to 7 - COOLING - STANDARD PROCEDURE).

(4) Lower vehicle.

(5) Remove radiator upper hose.

(6) Disconnect coolant recovery bottle hose from radiator filler neck and lift bottle off of fan shroud.

(7) Disconnect windshield washer pump supply hose and electrical connections and lift washer bottle off of fan shroud.

(8) Remove viscous fan/drive assembly (Refer to 7 - COOLING/ENGINE/RADIATOR FAN - REMOVAL).

## GEAR HOUSING COVER (Continued)

(9) Remove the accessory drive belt (Refer to 7 - COOLING/ACCESSORY DRIVE/DRIVE BELTS - REMOVAL).

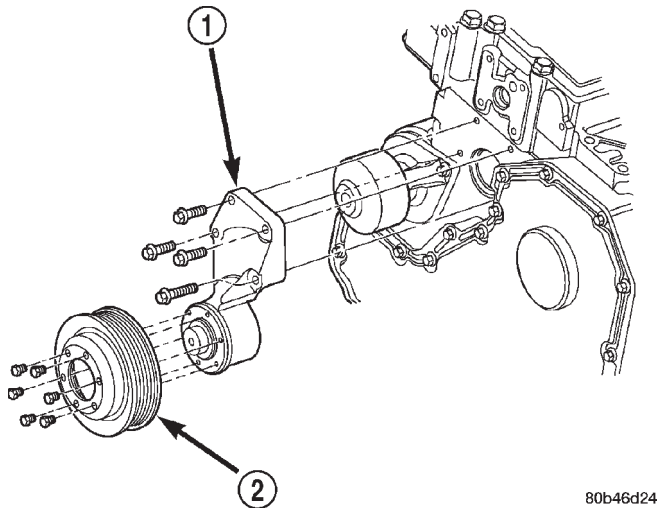
(10) Remove the cooling fan support/hub from the front of the engine (Fig. 180).

(11) Raise the vehicle on hoist.

(12) Remove the crankshaft damper (Fig. 181) (Refer to 9 - ENGINE/ENGINE BLOCK/VIBRATION DAMPER - REMOVAL).

(13) Lower the vehicle.

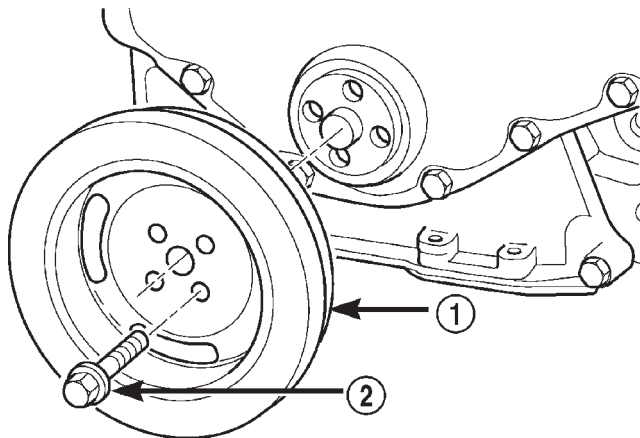
(14) Remove the gear cover-to-housing bolts and gently pry the cover away from the housing, taking care not to mar the gasket surfaces.



80b46d24

**Fig. 180 Fan Support/Hub Assembly—Removal/Installation**

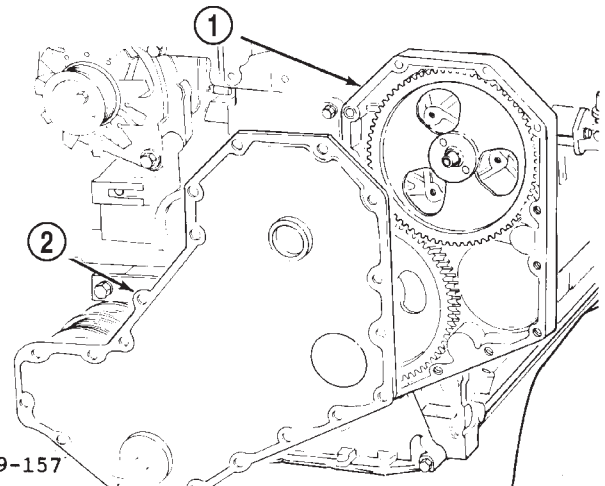
- 1 - FAN SUPPORT/HUB  
2 - FAN PULLEY



80b46d29

**Fig. 181 Crankshaft Damper—Removal/Installation**

- 1 - DAMPER  
2 - BOLT



J9209-157

**Fig. 182 Gear Housing and Cover**

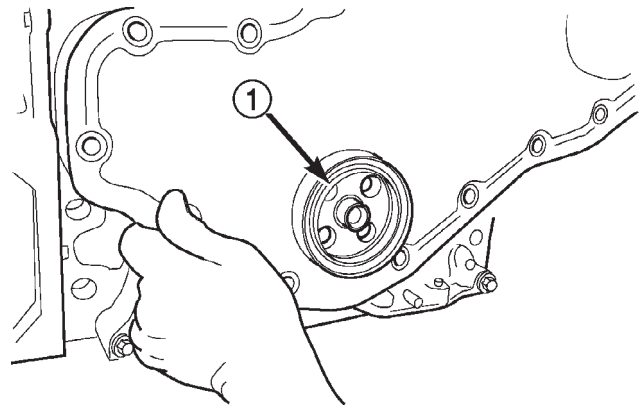
- 1 - GEAR HOUSING  
2 - GEAR HOUSING COVER

## INSTALLATION

(1) Obtain a seal pilot/installation tool from a crankshaft front seal service kit and install the pilot into the seal.

(2) Apply a bead of Mopar® Silicone Rubber Adhesive Sealant or equivalent to the gear housing cover. Be sure to surround all through holes.

(3) Using the seal pilot to align the cover (Fig. 183), install the cover to the housing and install the bolts. Tighten the bolts to 24 N·m (18 ft. lbs.) torque.



80b46d27

**Fig. 183 Installing Cover with Seal Pilot**

- 1 - SEAL PILOT

- (4) Remove the seal pilot.  
(5) Raise the vehicle.  
(6) Install the crankshaft damper (Fig. 181) (Refer to 9 - ENGINE/ENGINE BLOCK/VIBRATION DAMPER - INSTALLATION).  
(7) Lower vehicle.

## GEAR HOUSING COVER (Continued)

(8) Install the fan support/hub assy. (Fig. 180) and tighten bolts to 24 N·m (18 ft. lbs.) torque.

(9) Install the accessory drive belt (Refer to 7 - COOLING/ACCESSORY DRIVE/DRIVE BELTS - INSTALLATION).

(10) Install the cooling fan and shroud together (Refer to 7 - COOLING/ENGINE/RADIATOR FAN - INSTALLATION).

(11) Install the windshield washer reservoir to the fan shroud and connect the washer pump supply hose and electrical connection.

(12) Install the coolant recovery bottle to the fan shroud and connect the hose to the radiator filler neck.

(13) Install the radiator upper hose and clamps.

(14) Add coolant (Refer to 7 - COOLING - STANDARD PROCEDURE).

(15) Connect the battery cables.

(16) Start engine and inspect for leaks.

# EXHAUST SYSTEM

## TABLE OF CONTENTS

	page		page
<b>EXHAUST SYSTEM</b>		<b>MUFFLER - 3.9L/5.2L/5.9L/8.0L</b>	
DESCRIPTION . . . . .	1	REMOVAL . . . . .	10
DIAGNOSIS AND TESTING . . . . .	4	INSTALLATION . . . . .	11
GAS ENGINE . . . . .	4	<b>MUFFLER - 5.9L DIESEL</b>	
DIESEL ENGINE . . . . .	4	REMOVAL . . . . .	11
SPECIFICATIONS . . . . .	5	INSTALLATION . . . . .	11
<b>CATALYTIC CONVERTER - 3.9L/5.2L/5.9L</b>		<b>TAILPIPE - 3.9L/5.2L/5.9L</b>	
DESCRIPTION . . . . .	5	REMOVAL . . . . .	11
OPERATION . . . . .	5	INSPECTION . . . . .	11
REMOVAL . . . . .	5	INSTALLATION . . . . .	12
INSPECTION . . . . .	5	<b>TAILPIPE - 5.9L HEAVY DUTY/8.0L</b>	
INSTALLATION . . . . .	5	REMOVAL . . . . .	12
<b>CATALYTIC CONVERTER - 5.9L HEAVY DUTY/8.0L</b>		INSPECTION . . . . .	12
DESCRIPTION . . . . .	6	INSTALLATION . . . . .	12
OPERATION . . . . .	6	<b>TAILPIPE - 5.9L DIESEL</b>	
REMOVAL . . . . .	6	REMOVAL . . . . .	12
INSPECTION . . . . .	7	INSPECTION . . . . .	12
INSTALLATION . . . . .	7	INSTALLATION . . . . .	12
<b>EXHAUST PIPE - 3.9L/5.2L/5.9L</b>		<b>RESONATOR</b>	
REMOVAL . . . . .	7	REMOVAL . . . . .	13
INSPECTION . . . . .	7	INSTALLATION . . . . .	13
INSTALLATION . . . . .	7	<b>TURBOCHARGER</b>	
<b>EXHAUST PIPE - 5.9L HEAVY DUTY/8.0L</b>		DESCRIPTION . . . . .	13
REMOVAL . . . . .	8	OPERATION . . . . .	13
INSPECTION . . . . .	9	REMOVAL . . . . .	15
INSTALLATION . . . . .	9	CLEANING . . . . .	16
<b>EXHAUST PIPE - 5.9L DIESEL</b>		INSPECTION . . . . .	16
REMOVAL . . . . .	9	INSTALLATION . . . . .	16
INSPECTION . . . . .	9	<b>CHARGE AIR COOLER AND PLUMBING</b>	
INSTALLATION . . . . .	10	DESCRIPTION . . . . .	17
<b>HEAT SHIELDS</b>		OPERATION . . . . .	17
DESCRIPTION . . . . .	10	REMOVAL . . . . .	17
REMOVAL . . . . .	10	CLEANING . . . . .	18
INSTALLATION . . . . .	10	INSPECTION . . . . .	18
		INSTALLATION . . . . .	18

## EXHAUST SYSTEM

### DESCRIPTION—3.9L/5.2L/5.9/8.0L

**CAUTION:** Avoid application of rust prevention compounds or undercoating materials to exhaust sys-

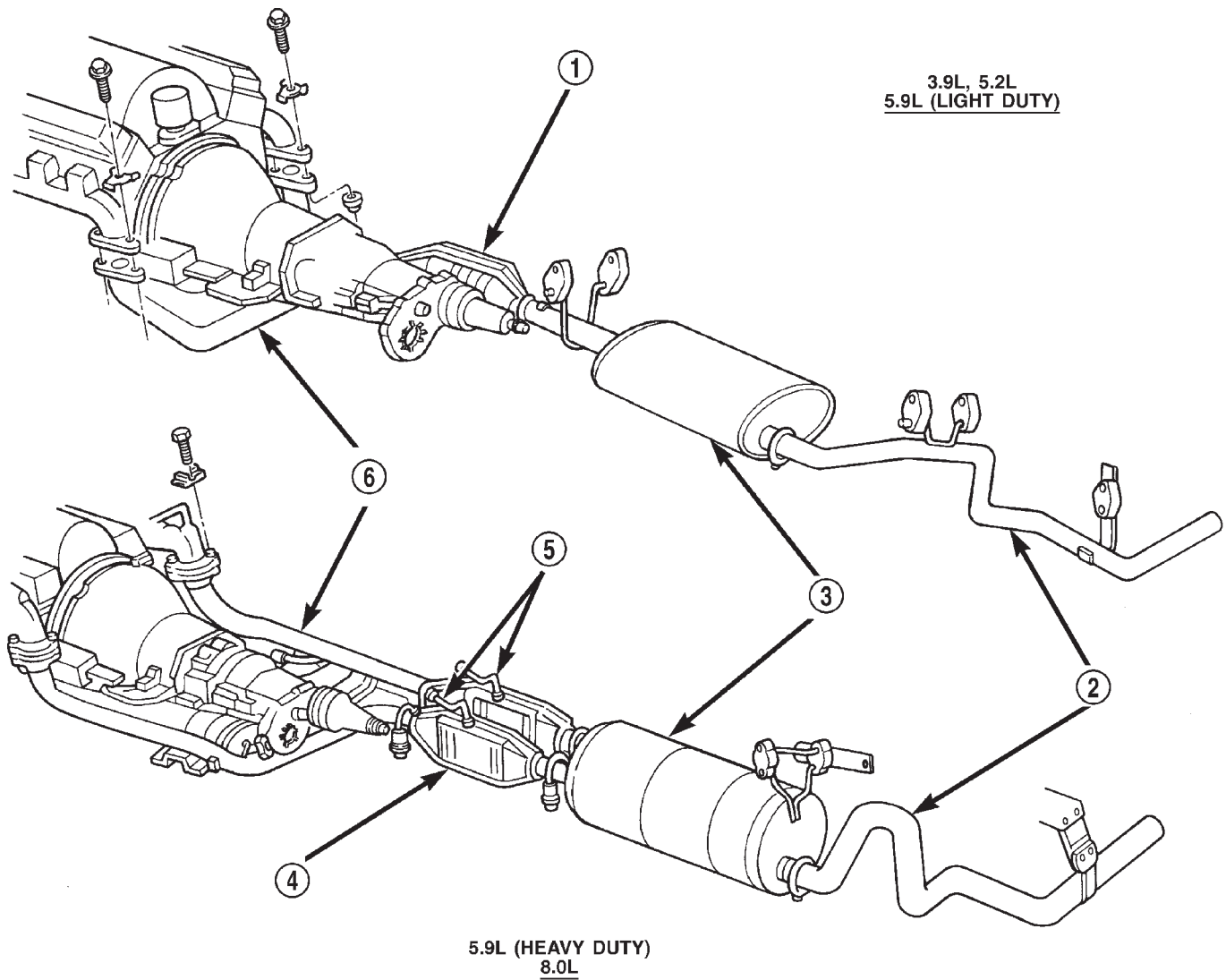
tem floor pan exhaust heat shields. Light overspray near the edges is permitted. Application of coating will result in excessive floor pan temperatures and objectionable fumes.

EXHAUST SYSTEM (Continued)

The federal gasoline engine exhaust system (Fig. 1) consists of engine exhaust manifolds, exhaust pipes, catalytic converter(s), extension pipe (if needed), exhaust heat shields, muffler and exhaust tailpipe.

The California emission vehicles exhaust system also contains the above components as well as mini catalytic converters added to the exhaust pipe (Fig. 2).

The exhaust system must be properly aligned to prevent stress, leakage and body contact. Minimum clearance between any exhaust component and the body or frame is 25.4 mm (1.0 in.). If the system contacts any body panel, it may amplify objectionable noises from the engine or body.

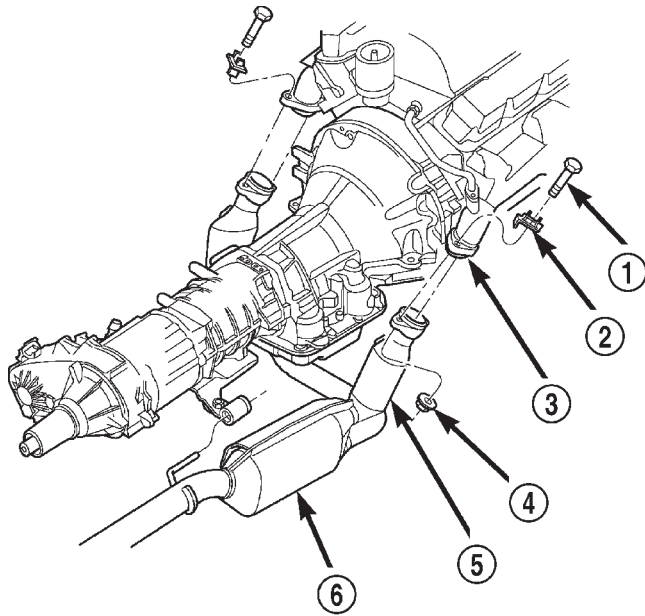


**Fig. 1 Exhaust System Gasoline Engines—Federal Emissions (Typical)**

- 1 - CATALYTIC CONVERTER
- 2 - TAILPIPE
- 3 - MUFFLER
- 4 - CATALYTIC CONVERTERS

- 5 - AIR INDUCTION LINES
- 6 - EXHAUST PIPE

## EXHAUST SYSTEM (Continued)



80bfe1e1

**Fig. 2 Catalytic Converter with Pipes and Mini Catalytic Converters**

- 1 - BOLT
- 2 - RETAINER
- 3 - EXHAUST MANIFOLD
- 4 - NUT
- 5 - MINI CATALYTIC CONVERTER
- 6 - CATALYTIC CONVERTER WITH PIPES

**DESCRIPTION—5.9L DIESEL**

**CAUTION:** Avoid application of rust prevention compounds or undercoating materials to exhaust system floor pan exhaust heat shields. Light overspray near the edges is permitted. Application of coating will result in excessive floor pan temperatures and objectionable fumes.

The diesel engine exhaust system consists of an engine exhaust manifold, turbocharger, exhaust pipe, resonator, extension pipe (if needed), muffler and exhaust tailpipe.

The exhaust system must be properly aligned to prevent stress, leakage and body contact. The exhaust components should be kept a minimum of 25.4 mm (1.0 in.) away from the body and frame. If the system contacts any body panel, it may amplify objectionable noises from the engine or body.



## EXHAUST SYSTEM (Continued)

## DIAGNOSIS AND TESTING - GAS ENGINE

## EXHAUST SYSTEM DIAGNOSIS CHART

CONDITION	POSSIBLE CAUSE	CORRECTION
EXCESSIVE EXHAUST NOISE OR LEAKING EXHAUST GASES	<ol style="list-style-type: none"> <li>1. Leaks at pipe joints.</li> <li>2. Rusted or blown out muffler.</li> <li>3. Broken or rusted out exhaust pipe.</li> <li>4. Exhaust pipe leaking at manifold flange.</li> <li>5. Exhaust manifold cracked or broken.</li> <li>6. Leak between exhaust manifold and cylinder head.</li> <li>7. Catalytic converter rusted or blown out.</li> <li>8. Restriction in exhaust system.</li> </ol>	<ol style="list-style-type: none"> <li>1. Tighten clamps/bolts at leaking joints.</li> <li>2. Replace muffler. Inspect exhaust system.</li> <li>3. Replace exhaust pipe.</li> <li>4. Tighten/replace flange attaching nuts/bolts.</li> <li>5. Replace exhaust manifold.</li> <li>6. Tighten exhaust manifold to cylinder head bolts.</li> <li>7. Replace catalytic converter assy.</li> <li>8. Remove restriction, if possible. Replace restricted part if necessary.</li> </ol>
<p><b>caution:</b>  <b>When servicing and replacing exhaust system components, disconnect the oxygen sensor connector(s). Allowing the exhaust to hang by the oxygen sensor wires will damage the harness and/or sensor.</b></p>		

## DIAGNOSIS AND TESTING - DIESEL ENGINE

## EXHAUST SYSTEM DIAGNOSIS CHART

CONDITION	POSSIBLE CAUSE	CORRECTION
EXCESSIVE EXHAUST NOISE OR LEAKING EXHAUST GASES	<ol style="list-style-type: none"> <li>1. Leaks at pipe joints.</li> <li>2. Rusted or blown out muffler.</li> <li>3. Broken or rusted out exhaust pipe.</li> <li>4. Exhaust pipe leaking at manifold flange.</li> <li>5. Exhaust manifold cracked or broken.</li> <li>6. Leak between exhaust manifold and cylinder head.</li> <li>7. Turbocharger mounting flange cracked.</li> <li>8. Restriction in exhaust system.</li> </ol>	<ol style="list-style-type: none"> <li>1. Tighten clamps/bolts at leaking joints.</li> <li>2. Replace muffler. Inspect exhaust system.</li> <li>3. Replace exhaust pipe.</li> <li>4. Tighten/replace flange attaching nuts/bolts.</li> <li>5. Replace exhaust manifold.</li> <li>6. Tighten exhaust manifold to cylinder head bolts.</li> <li>7. Remove turbocharger and inspect. (Refer to 11 - EXHAUST SYSTEM/TURBOCHARGER SYSTEM/TURBOCHARGER - REMOVAL).</li> <li>8. Remove restriction, if possible. Replace restricted part if necessary.</li> </ol>

## SPECIFICATIONS

## TORQUE

DESCRIPTION	N-m	Ft. Lbs.	In. Lbs.
Adjusting Strap—Bolt	23	—	200
Air Heater Power Supply—Nuts	14	—	124
Air Inlet Housing—Bolts	24	18	—
Cab Heater Supply/Return Line—Nuts	24	18	—
Exhaust Clamp—Nuts	48	35	—
Exhaust Manifold to Cylinder Head—Bolts (Diesel Engine)	43	32	—
Exhaust Manifold to Cylinder Head—Bolts (3.9L/5.2L/5.9L)	31	23	—
Exhaust Manifold to Cylinder Head—Bolts (8.0L)	22	—	195
Exhaust Pipe to Manifold—Bolts	31	23	—
Generator Mounting—Bolts	41	30	—
Charge Air Cooler Mounting—Bolts	2	—	17
Charge Air Cooler Duct—Nuts	8	—	72
Heat Shield—Nuts and Bolts	11	—	100
Turbocharger Mounting—Nuts	32	24	—
Turbocharger Oil Drain Tube—Bolts	24	18	—
Turbocharger Oil Supply Line—Fitting	15	—	133
Turbocharger V-Band Clamp—Nut	9	—	75

CATALYTIC CONVERTER -  
3.9L/5.2L/5.9L

## DESCRIPTION

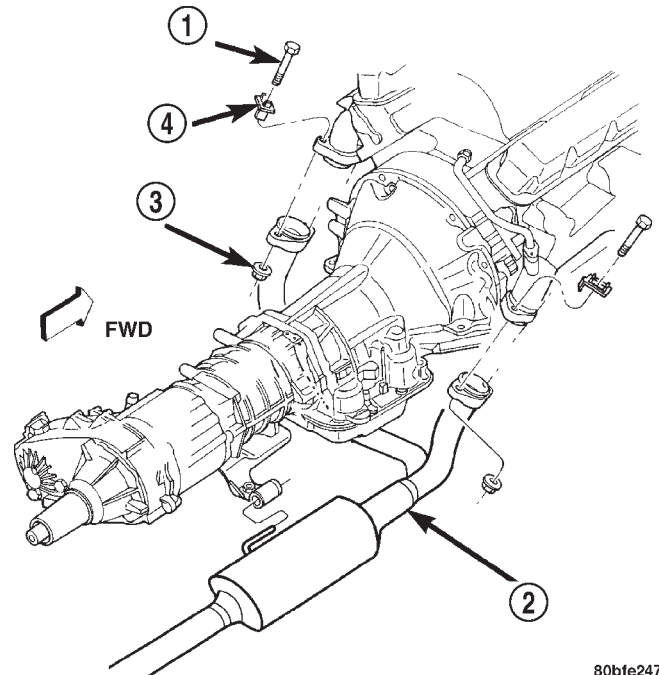
The stainless steel catalytic converter is located under the vehicle, integral to the exhaust pipe(s).

## OPERATION

The catalytic converter captures and burns any unburned fuel mixture exiting the combustion chambers during the exhaust stroke of the engine. This process aids in reducing emissions output.

## REMOVAL

- (1) Raise and support vehicle.
- (2) Saturate the bolts and nuts with heat valve lubricant. Allow 5 minutes for penetration.
- (3) Remove clamps and nuts (Fig. 3) (Fig. 4).



80bfe247

**Fig. 3 Catalytic Converter and Exhaust Pipe 3.9L, 5.2L and 5.9L Light Duty ( Federal )**

- 1 - BOLT
- 2 - EXHAUST PIPE W/CONVERTER
- 3 - NUT
- 4 - RETAINER

- (4) Remove the catalytic converter.

## INSPECTION

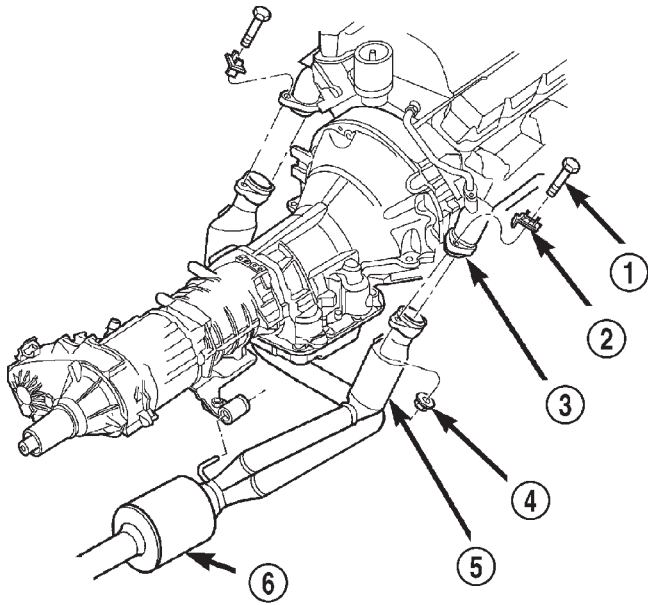
Look at the stainless steel body of the converter, inspect for bulging or other distortion that could be a result of overheating. If the converter has a heat shield attached make sure it is not bent or loose.

If you suspect internal damage to the catalyst, tapping the bottom of the catalyst with a rubber mallet may indicate a damaged core.

## INSTALLATION

- (1) Assemble converter and clamps loosely in place.

CATALYTIC CONVERTER - 3.9L/5.2L/5.9L (Continued)



80bfe248

**Fig. 4 Catalytic Converter and Exhaust Pipe 3.9L, 5.2L and 5.9L Light Duty ( California )**

- 1 - BOLT
- 2 - RETAINER
- 3 - EXHAUST MANIFOLD
- 4 - NUT
- 5 - MINI CATALYTIC CONVERTER
- 6 - CATALYTIC CONVERTER WITH PIPES

(2) Install the exhaust pipe onto exhaust manifolds, tighten 31 N·m (23 ft. lbs.).

(3) Tighten all clamp nuts to 48 N·m (35 ft. lbs.) torque.

(4) Lower the vehicle.

(5) Start the engine and inspect for exhaust leaks and exhaust system contact with the body panels. A minimum of 25.4 mm (1.0 in.) is required between exhaust system components and body/frame parts. Adjust the alignment, if needed.

CATALYTIC CONVERTER - 5.9L HEAVY DUTY/8.0L

DESCRIPTION

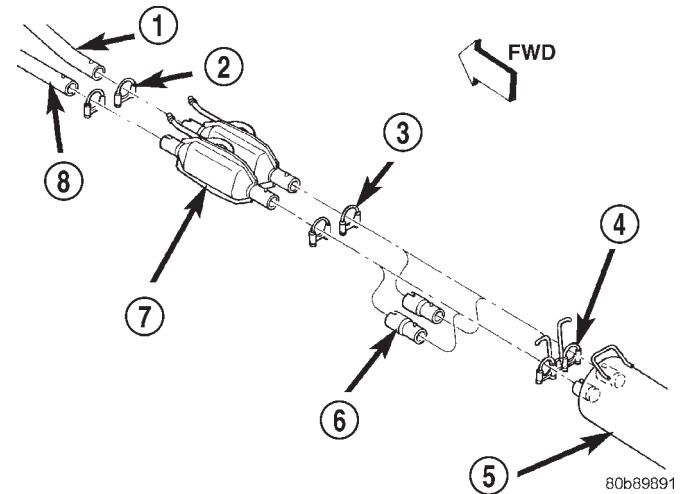
The stainless steel catalytic converter is located under the vehicle, attached to the exhaust pipe(s).

OPERATION

The catalytic converter captures and burns any unburned fuel mixture exiting the combustion chambers during the exhaust stroke of the engine. This process aids in reducing emissions output.

REMOVAL

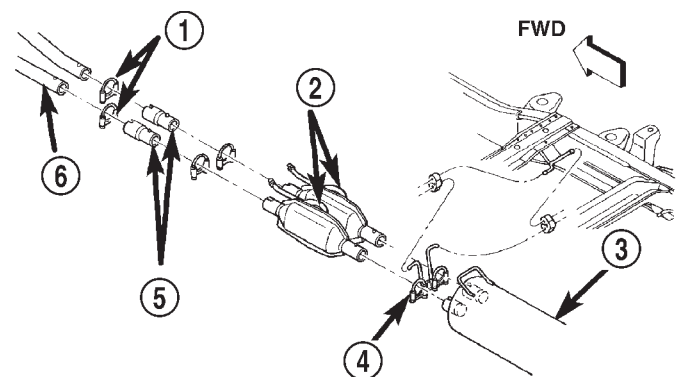
- (1) Raise and support vehicle.
- (2) Saturate the bolts and nuts with heat valve lubricant. Allow 5 minutes for penetration.
- (3) Remove clamps and nuts (Fig. 5) (Fig. 6).



80b89891

**Fig. 5 Catalytic Converter 5.9L Heavy Duty**

- 1 - DOWN PIPE RIGHT
- 2 - CLAMP
- 3 - CLAMP
- 4 - HANGER ASSY. DUAL CLAMP
- 5 - MUFFLER
- 6 - EXTENSION PIPE
- 7 - CATALYTIC CONVERTER
- 8 - DOWN PIPE LEFT



80b89892

**Fig. 6 Catalytic Converter 8.0L**

- 1 - CLAMPS
- 2 - CATALYTIC CONVERTERS
- 3 - MUFFLER
- 4 - HANGER ASSY. DUAL CLAMP
- 5 - EXTENSION PIPES
- 6 - DOWN PIPE

(4) Remove the catalytic converter.

## CATALYTIC CONVERTER - 5.9L HEAVY DUTY/8.0L (Continued)

**INSPECTION**

Look at the stainless steel body of the converter, inspect for bulging or other distortion that could be a result of overheating. If the converter has a heat shield attached make sure it is not bent or loose.

If you suspect internal damage to the catalyst, tapping the bottom of the catalyst with a rubber mallet may indicate a damaged core.

**INSTALLATION**

(1) Assemble converter and clamps loosely in place.

(2) Tighten all clamp nuts to 48 N·m (35 ft. lbs.) torque.

(3) Lower the vehicle.

(4) Start the engine and inspect for exhaust leaks and exhaust system contact with the body panels. A minimum of 25.4 mm (1.0 in.) is required between exhaust system components and body/frame parts. Adjust the alignment, if needed.

**EXHAUST PIPE - 3.9L/5.2L/  
5.9L****REMOVAL**

(1) Raise and support the vehicle.

(2) Saturate the bolts and nuts with heat valve lubricant. Allow 5 minutes for penetration.

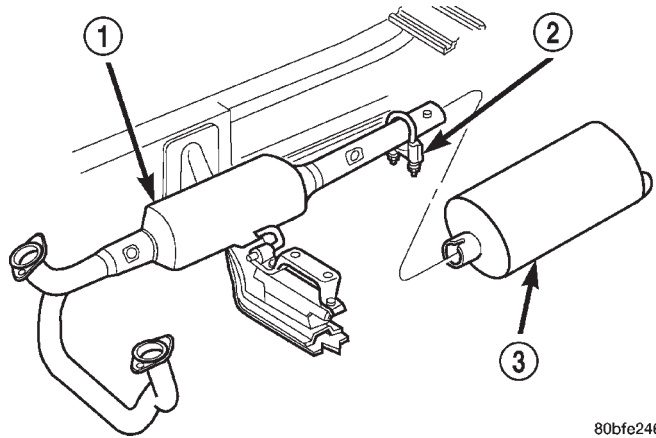
(3) Remove exhaust pipe to manifold bolts, retainers and nuts (Fig. 7).

(4) Remove the clamp nuts (Fig. 7).

(5) Remove the exhaust pipe.

**INSPECTION**

Discard rusted clamps, broken or worn supports and attaching parts. Replace a component with orig-



80bfe246

**Fig. 7 Exhaust Pipe 3.9L,5.2L, 5.9L Light Duty**

- 1 - EXHAUST PIPE WITH CATALYTIC CONVERTER  
2 - CLAMP  
3 - MUFFLER

inal equipment parts, or equivalent. This will assure proper alignment with other parts in the system and provide acceptable exhaust noise levels.

**INSTALLATION**

(1) Position the exhaust pipe for proper clearance with the frame and underbody parts. A minimum clearance of 25.4 mm (1.0 in.) is required.

(2) Position the exhaust pipe to manifold. Install the bolts, retainers and nuts. Tighten the nuts to 31 N·m (23 ft. lbs.) torque.

(3) Tighten the clamp nuts to 48 N·m (35 ft. lbs.) torque.

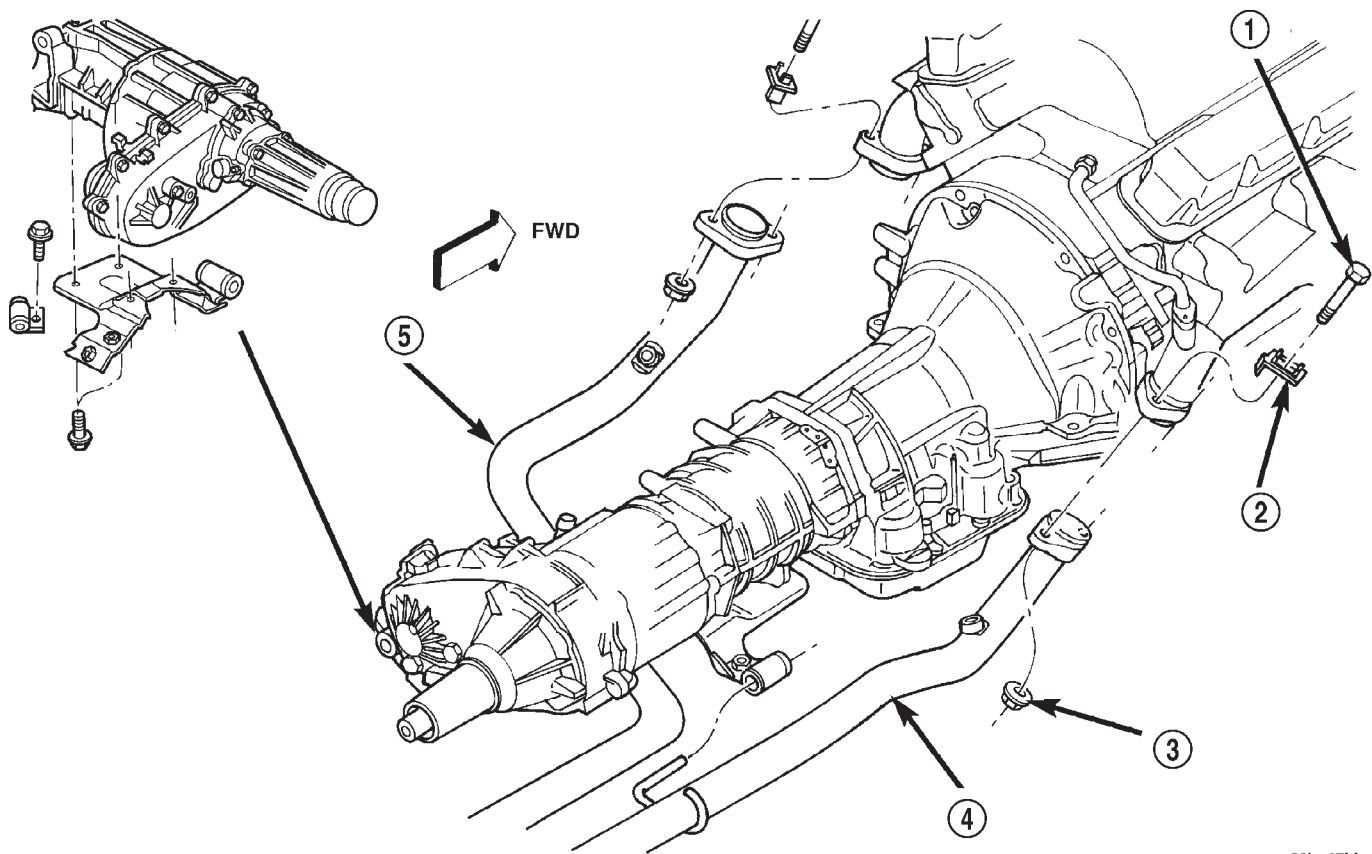
(4) Lower the vehicle.

(5) Start the engine and inspect for exhaust leaks and exhaust system contact with the body panels. Adjust the alignment, if needed.

## EXHAUST PIPE - 5.9L HEAVY DUTY/8.0L

### REMOVAL

- (1) Raise and support the vehicle.
- (2) Saturate the bolts and nuts with heat valve lubricant. Allow 5 minutes for penetration.
- (3) Remove exhaust pipe to manifold bolts, retainers and nuts (Fig. 8).
- (4) Remove the clamp nuts (Fig. 9) (Fig. 10).
- (5) Disconnect the exhaust pipe from the support hangers on the 5.9L (Heavy Duty) and the 8.0L engines (Fig. 8).
- (6) Remove the exhaust pipe.



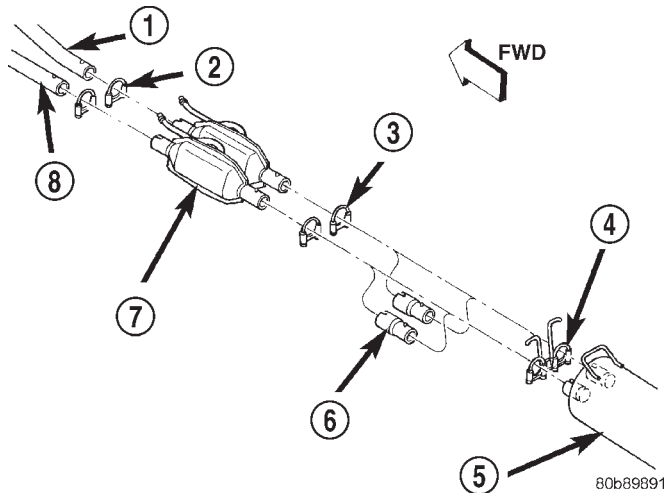
80be47bb

**Fig. 8 Exhaust Pipe 8.0L and 5.9L Heavy Duty**

1 - BOLT  
2 - RETAINER  
3 - NUT

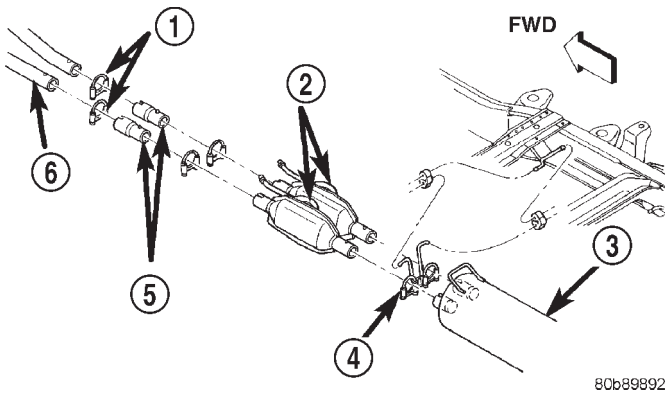
4 - DOWN PIPE  
5 - DOWN PIPE

## EXHAUST PIPE - 5.9L HEAVY DUTY/8.0L (Continued)



**Fig. 9 Catalytic Converter and Clamp Location 5.9L Heavy Duty**

- 1 - DOWN PIPE RIGHT
- 2 - CLAMP
- 3 - CLAMP
- 4 - HANGER ASSY. DUAL CLAMP
- 5 - MUFFLER
- 6 - EXTENSION PIPE
- 7 - CATALYTIC CONVERTER
- 8 - DOWN PIPE LEFT



**Fig. 10 Catalytic Converter and Clamp Location 8.0L**

- 1 - CLAMPS
- 2 - CATALYTIC CONVERTERS
- 3 - MUFFLER
- 4 - HANGER ASSY. DUAL CLAMP
- 5 - EXTENSION PIPES
- 6 - DOWN PIPE

## INSPECTION

Discard rusted clamps, broken or worn supports and attaching parts. Replace a component with original equipment parts, or equivalent. This will assure proper alignment with other parts in the system and provide acceptable exhaust noise levels.

## INSTALLATION

(1) Connect the exhaust pipe support hangers on the (Fig. 8).

(2) Position the exhaust pipe for proper clearance with the frame and underbody parts. A minimum clearance of 25.4 mm (1.0 in.) is required.

(3) Position the exhaust pipe to manifold. Install the bolts, retainers and nuts. Tighten the nuts to 31 N·m (23 ft. lbs.) torque.

(4) Tighten the clamp nuts to 48 N·m (35 ft. lbs.) torque.

(5) Lower the vehicle.

(6) Start the engine and inspect for exhaust leaks and exhaust system contact with the body panels. Adjust the alignment, if needed.

## EXHAUST PIPE - 5.9L DIESEL

## REMOVAL

(1) Disconnect the battery negative cables.

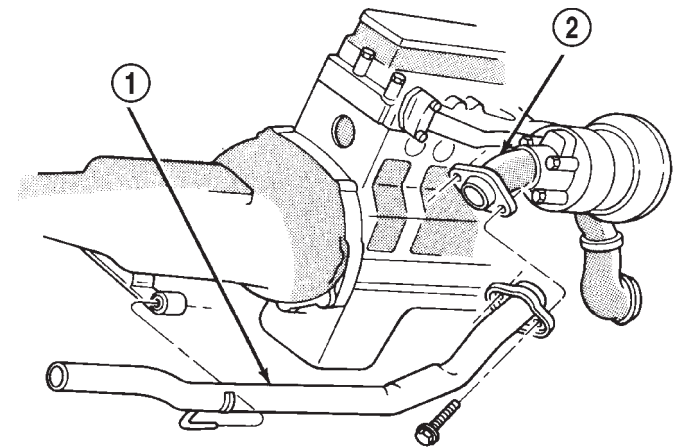
(2) Raise and support the vehicle on a hoist.

(3) Saturate the bolts and nuts with heat valve lubricant. Allow 5 minutes for penetration.

(4) Remove the exhaust pipe-to-extension pipe clamp. Separate the exhaust pipe and extension pipe.

(5) Remove the exhaust pipe-to-turbocharger elbow bolts (Fig. 11).

(6) Remove the exhaust pipe from the transmission support (Fig. 11).



J9411-18

**Fig. 11 Exhaust Pipe Removal/Installation**

- 1 - EXHAUST PIPE
- 2 - TURBOCHARGER EXHAUST PIPE

## INSPECTION

Discard rusted clamps, broken or worn supports and attaching parts. Replace a component with original equipment parts, or equivalent. This will assure



## EXHAUST PIPE - 5.9L DIESEL (Continued)

proper alignment with other parts in the system and provide acceptable exhaust noise levels.

**INSTALLATION**

- (1) Install the exhaust pipe into the transmission support and onto the turbocharger flange (Fig. 11).
- (2) Install the exhaust pipe-to-turbocharger elbow bolts and tighten to 31 N·m (23 ft. lbs.) torque.
- (3) Install the extension pipe and clamp to the exhaust pipe using a new clamp and tighten the clamp nuts to 48 N·m (35 ft. lbs.) torque.
- (4) Lower the vehicle.
- (5) Connect the battery negative cables.
- (6) Start the engine and inspect for exhaust leaks and exhaust system contact with the body panels. A minimum of 25.4 mm (1.0 in.) is required. Adjust the alignment, if needed.

**HEAT SHIELDS****DESCRIPTION**

There are two types of heat shields used. One is stamped steel the other is molded foil sheets. The shields attach to the vehicle around the exhaust system to prevent heat from the exhaust system from

entering the passenger area and other areas where the heat can cause damage to other components.

**REMOVAL**

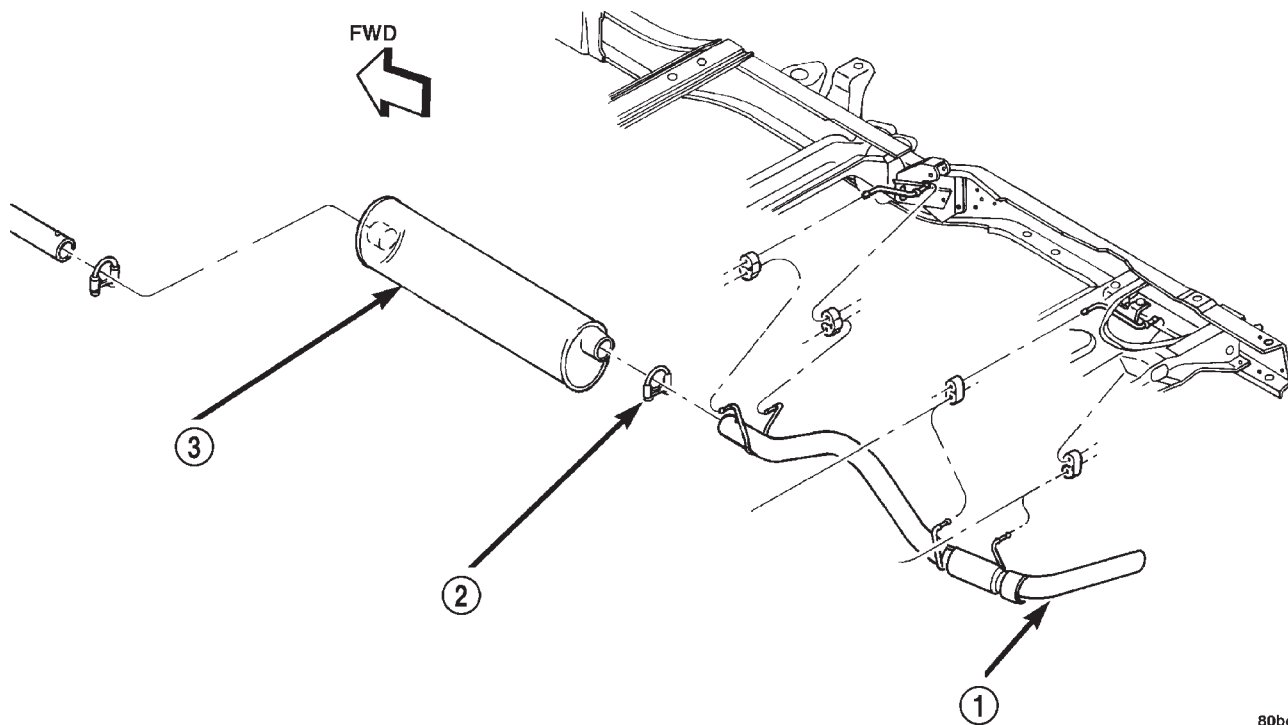
- (1) Raise and support the vehicle.
- (2) Remove the nuts or bolts holding the exhaust heat shield to the floor pan, crossmember or bracket.
- (3) Slide the shield out around the exhaust system.

**INSTALLATION**

- (1) Position the exhaust heat shield to the floor pan, crossmember or bracket and install the nuts or bolts.
- (2) Tighten the nuts and bolts 11 N·m (100 in. lbs.).
- (3) Lower the vehicle.

**MUFFLER - 3.9L/5.2L/5.9L/8.0L****REMOVAL**

- (1) Raise and support the vehicle.
- (2) Saturate the clamp nuts with heat valve lubricant. Allow 5 minutes for penetration.
- (3) Disconnect the muffler hanger (Fig. 12) (Fig. 13).
- (4) Remove clamps and nuts (Fig. 12) (Fig. 13).
- (5) Remove the muffler.

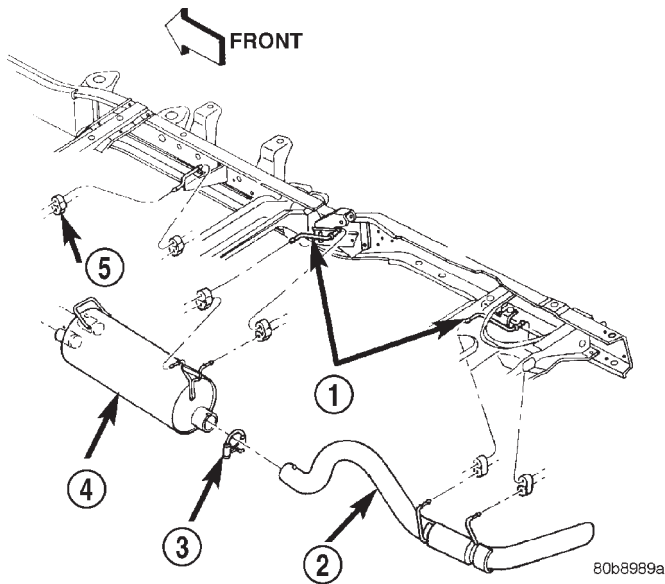


80be47bc

**Fig. 12 Muffler for 3.9L, 5.2L and 5.9L-Light Duty Engines**

- 1 - TAILPIPE
- 2 - CLAMP
- 3 - MUFFLER LIGHT DUTY

## MUFFLER - 3.9L/5.2L/5.9L/8.0L (Continued)

**Fig. 13 Muffler for 5.9L Heavy Duty and 8.0L**

- 1 - HANGER
- 2 - TAILPIPE
- 3 - CLAMP
- 4 - MUFFLER
- 5 - INSULATOR

**INSTALLATION**

- (1) Assemble muffler and clamps loosely to permit proper alignment of all parts.
- (2) Connect the muffler hanger.
- (3) Tighten the clamp nuts to 48 N·m (35 ft. lbs.) torque.
- (4) Lower the vehicle.
- (5) Start the engine and inspect for exhaust leaks and exhaust system contact with the body panels. A minimum of 25.4 mm (1.0 in.) is required between exhaust system components and body/frame parts. Adjust the alignment, if needed.

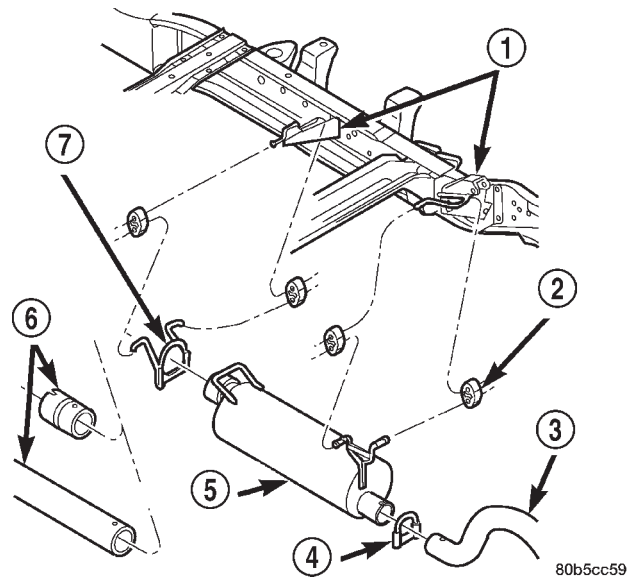
## MUFFLER - 5.9L DIESEL

**REMOVAL**

- (1) Disconnect the battery negative cables.
- (2) Raise and support the vehicle.
- (3) Remove the muffler to tail pipe and extension pipe clamps (Fig. 14).
- (4) Disconnect the muffler from the hanger isolators (Fig. 14).
- (5) Disconnect the muffler from the tailpipe.
- (6) Disconnect the muffler from the extension pipe and remove from the vehicle..

**INSTALLATION**

- (1) Install the muffler hanger rods into the isolators (Fig. 14).

**Fig. 14 Muffler Removal/Installation**

- 1 - HANGER BRACKETS
- 2 - ISOLATOR
- 3 - TAILPIPE
- 4 - CLAMP
- 5 - MUFFLER
- 6 - EXTENSION PIPE
- 7 - HANGER W/CLAMP

- (2) Install the muffler into the extension pipe.
- (3) Install the muffler into the tail pipe.
- (4) Install the exhaust clamps, align the exhaust system, and tighten the exhaust clamps to 48 N·m (35 ft. lbs.) torque.
- (5) Lower the vehicle.
- (6) Connect the battery negative cables.
- (7) Start the engine and inspect for exhaust leaks and exhaust system contact with the body panels. A minimum of 25.4 mm (1.0 in.) is required between exhaust system components and body/frame parts. Adjust the alignment, if needed.

## TAILPIPE - 3.9L/5.2L/5.9L

**REMOVAL**

- (1) Raise and support the vehicle.
- (2) Saturate the clamp nuts with heat valve lubricant. Allow 5 minutes for penetration.
- (3) Disconnect the exhaust tailpipe support hanger.
- (4) Remove clamps and nuts.
- (5) Remove the exhaust tailpipe.

**INSPECTION**

Discard rusted clamps, broken or worn supports and attaching parts. Replace a component with orig-

## TAILPIPE - 3.9L/5.2L/5.9L (Continued)

inal equipment parts, or equivalent. This will assure proper alignment with other parts in the system and provide acceptable exhaust noise levels.

**INSTALLATION**

- (1) Loosely assemble exhaust tailpipe to permit proper alignment of all parts.
- (2) Connect the support hangers.
- (3) Position the exhaust tailpipe for proper clearance with the underbody parts.
- (4) Tighten all clamp nuts to 48 N·m (35 ft. lbs.) torque.
- (5) Lower the vehicle.
- (6) Start the engine and inspect for exhaust leaks and exhaust system contact with the body panels. A minimum of 25.4 mm (1.0 in.) is required between the exhaust system components and body/frame parts. Adjust the alignment, if needed.

## TAILPIPE - 5.9L HEAVY DUTY/8.0L

**REMOVAL**

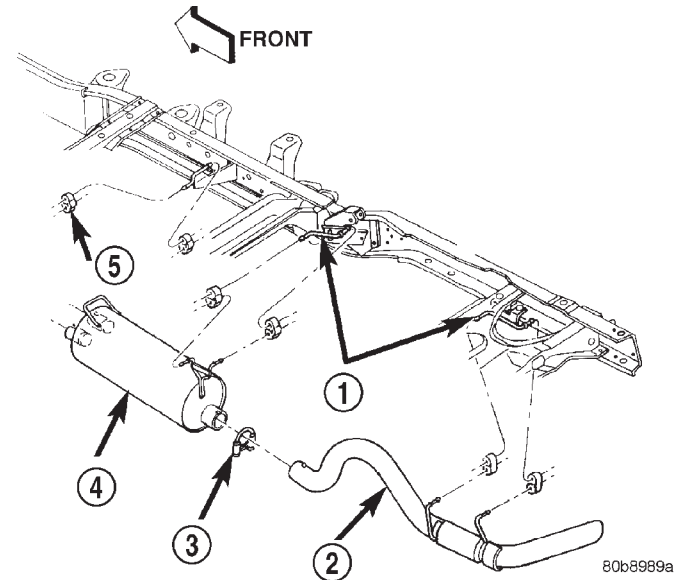
- (1) Raise and support the vehicle.
- (2) Saturate the clamp nuts with Mopar® Rust Penetrant. Allow 5 minutes for penetration.
- (3) Disconnect the exhaust tailpipe support hangers (Fig. 15).
- (4) Remove clamps and nuts.
- (5) Remove the exhaust tailpipe.

**INSPECTION**

Discard rusted clamps, broken or worn supports and attaching parts. Replace a component with original equipment parts, or equivalent. This will assure proper alignment with other parts in the system and provide acceptable exhaust noise levels.

**INSTALLATION**

- (1) Loosely assemble exhaust tailpipe to permit proper alignment of all parts (Fig. 15).
- (2) Connect the support hangers (Fig. 15).
- (3) Position the exhaust tailpipe for proper clearance with the underbody parts.
- (4) Tighten all clamp nuts to 48 N·m (35 ft. lbs.) torque.
- (5) Lower the vehicle.
- (6) Start the engine and inspect for exhaust leaks and exhaust system contact with the body panels. A minimum of 25.4 mm (1.0 in.) is required between the exhaust system components and body/frame parts. Adjust the alignment, if needed.



**Fig. 15 TAILPIPE 8.0L AND 5.9L HEAVY DUTY**

- 1 - HANGER
- 2 - TAILPIPE
- 3 - CLAMP
- 4 - MUFFLER
- 5 - INSULATOR

## TAILPIPE - 5.9L DIESEL

**REMOVAL**

- (1) Disconnect the battery negative cables.
- (2) Raise and support the vehicle.
- (3) Saturate the clamp nuts with heat valve lubricant. Allow 5 minutes for penetration.
- (4) Disconnect the exhaust tailpipe support hanger isolators (Fig. 16).
- (5) Remove the muffler-to-tailpipe clamps (Fig. 16).
- (6) Remove the tailpipe from the vehicle.

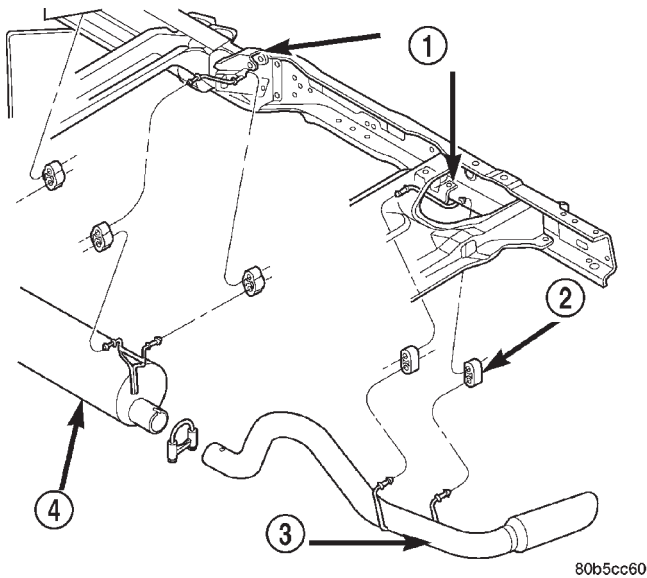
**INSPECTION**

Discard rusted clamps, broken or worn supports and attaching parts. Replace a component with original equipment parts, or equivalent. This will assure proper alignment with other parts in the system and provide acceptable exhaust noise levels.

**INSTALLATION**

- (1) Install the tailpipe into the muffler.
- (2) Install the tailpipe hanger rods into the isolators (Fig. 16)
- (3) Install the exhaust clamp, align the exhaust system, and tighten the clamp 48 N·m (35 ft. lbs.) torque.
- (4) Lower the vehicle.
- (5) Connect the battery negative cables.

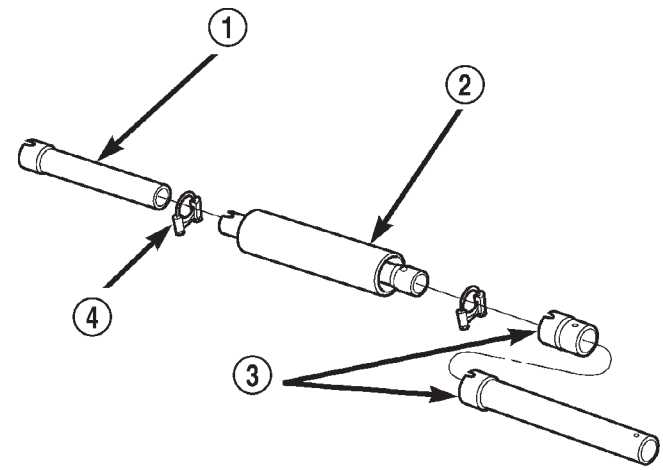
## TAILPIPE - 5.9L DIESEL (Continued)



80b5cc60

**Fig. 16 Tailpipe Removal/Installation**

- 1 - HANGER BRACKETS
- 2 - ISOLATOR
- 3 - TAILPIPE
- 4 - MUFFLER



80b5cc61

**Fig. 17 Resonator Removal/Installation**

- 1 - EXTENSION PIPE
- 2 - RESONATOR
- 3 - EXTENSION PIPE
- 4 - CLAMP

(6) Start the engine and inspect for exhaust leaks and exhaust system contact with the body panels. Adjust the alignment, if needed.

## RESONATOR

### REMOVAL

- (1) Disconnect the battery negative cables.
- (2) Raise vehicle on hoist.
- (3) Remove the exhaust clamps from the resonator to extension pipes (Fig. 17).
- (4) Separate the resonator from the front and rear extension pipes (Fig. 17) and remove the resonator from the vehicle.

### INSTALLATION

- (1) Assemble the resonator to the front and rear extension pipes (Fig. 17).
- (2) Install new exhaust clamps, align the exhaust system, and tighten the exhaust clamps to 48 N·m (35 ft. lbs.) torque.
- (3) Lower the vehicle.
- (4) Connect the battery negative cables.
- (5) Start the engine and inspect for exhaust leaks.

## TURBOCHARGER

### DESCRIPTION

The turbocharger is an exhaust-driven supercharger which increases the pressure and density of the air entering the engine. With the increase of air entering the engine, more fuel can be injected into the cylinders, which creates more power during combustion.

The turbocharger assembly consists of four (4) major component systems (Fig. 18) (Fig. 19):

- Turbine section
- Compressor section
- Bearing housing
- Wastegate

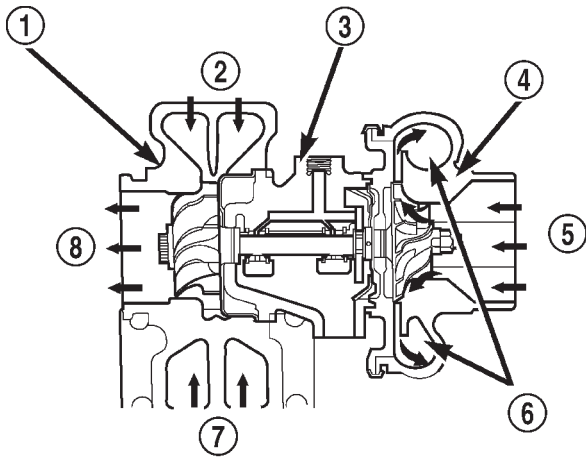
### OPERATION

Exhaust gas pressure and energy drive the turbine, which in turn drives a centrifugal compressor that compresses the inlet air, and forces the air into the engine through the charge air cooler and plumbing. Since heat is a by-product of this compression, the air must pass through a charge air cooler to cool the incoming air and maintain power and efficiency.

#### **Increasing air flow to the engine provides:**

- Improved engine performance
- Lower exhaust smoke density
- Improved operating economy
- Altitude compensation
- Noise reduction.

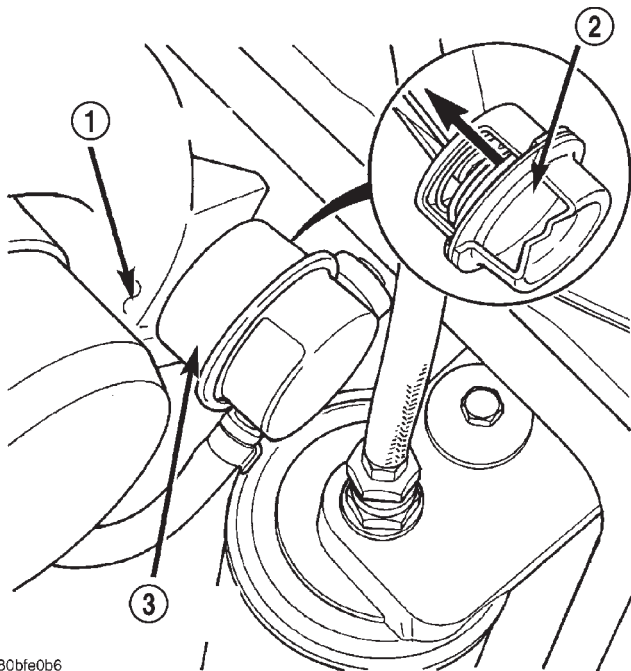
TURBOCHARGER (Continued)



80b5cc50

**Fig. 18 Turbocharger Operation**

- 1 - TURBINE SECTION
- 2 - EXHAUST GAS
- 3 - BEARING HOUSING
- 4 - COMPRESSOR SECTION
- 5 - INLET AIR
- 6 - COMPRESSED AIR TO ENGINE
- 7 - EXHAUST GAS
- 8 - EXHAUST GAS TO EXHAUST PIPE



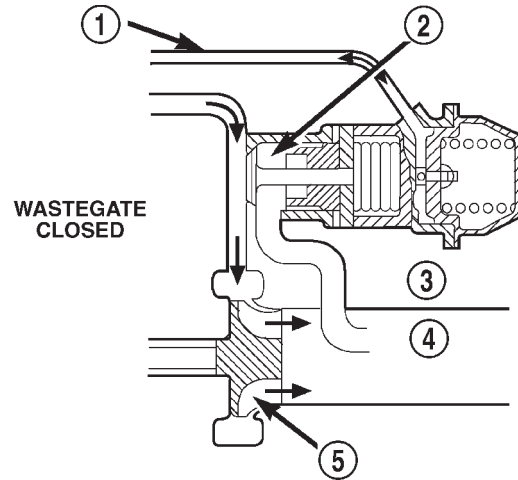
80bfe0b6

**Fig. 19 Turbocharger Wastegate Actuator**

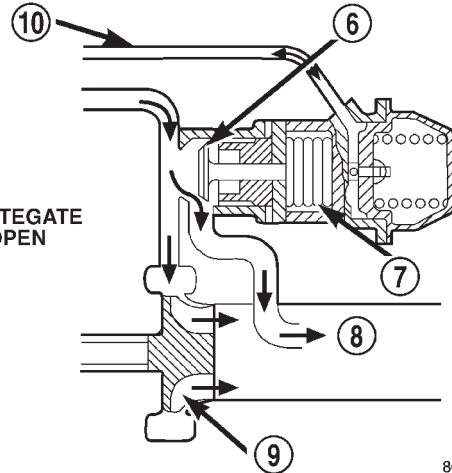
- 1 - TURBOCHARGER
- 2 - DIAPHRAGM
- 3 - WASTE GATE ACTUATOR

The turbocharger also uses a wastegate (Fig. 20), which regulates intake manifold air pressure and

prevents over boosting at high engine speeds. When the wastegate valve is closed, all of the exhaust gases flow through the turbine wheel. As the intake manifold pressure increases, the wastegate actuator opens the valve, diverting some of the exhaust gases away from the turbine wheel. This limits turbine shaft speed and air output from the impeller.



WASTEGATE CLOSED



WASTEGATE OPEN

80b5cc53

**Fig. 20 Wastegate Operation**

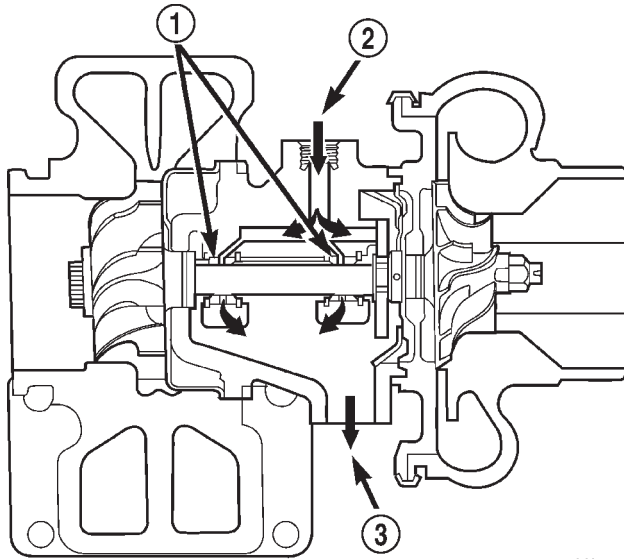
- 1 - SIGNAL LINE
- 2 - EXHAUST BYPASS VALVE
- 3 - WASTEGATE
- 4 - EXHAUST
- 5 - TURBINE
- 6 - EXHAUST BYPASS VALVE
- 7 - WASTEGATE
- 8 - EXHAUST
- 9 - TURBINE
- 10 - SIGNAL LINE

The turbocharger is lubricated by engine oil that is pressurized, cooled, and filtered. The oil is delivered to the turbocharger by a supply line that is tapped into the oil filter head. The oil travels into the bearing housing, where it lubricates the shaft and bearings (Fig. 21). A return pipe at the bottom of the



## TURBOCHARGER (Continued)

bearing housing, routes the engine oil back to the crankcase.



80b5cc57

**Fig. 21 Turbocharger Oil Supply and Drain**

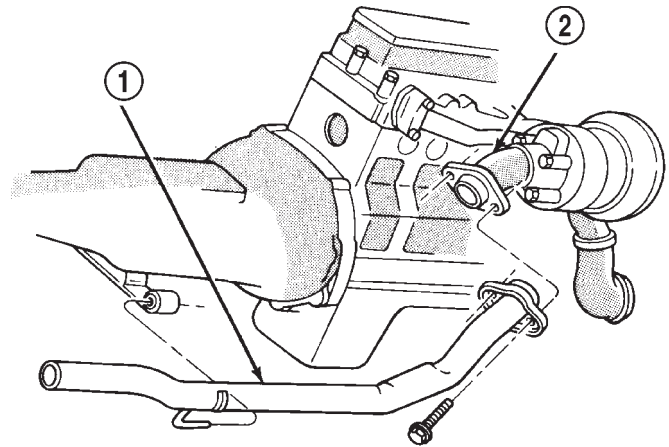
- 1 - BEARINGS
- 2 - OIL SUPPLY (FROM FILTER HEAD)
- 3 - OIL RETURN (TO SUMP)

The most common turbocharger failure is bearing failure related to repeated hot shutdowns with inadequate "cool-down" periods. A sudden engine shut down after prolonged operation will result in the transfer of heat from the turbine section of the turbocharger to the bearing housing. This causes the oil to overheat and break down, which causes bearing and shaft damage the next time the vehicle is started.

Letting the engine idle after extended operation allows the turbine housing to cool to normal operating temperature. The following chart should be used as a guide in determining the amount of engine idle time required to sufficiently cool down the turbocharger before shut down, depending upon the type of driving and the amount of cargo.

## REMOVAL

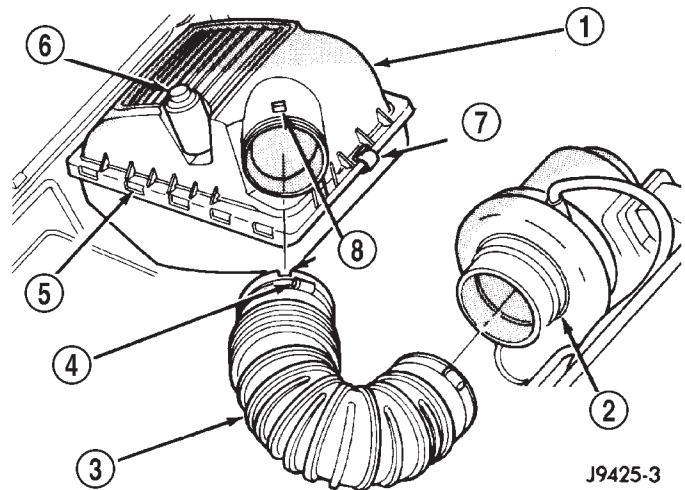
- (1) Disconnect the battery negative cables.
- (2) Raise vehicle on hoist.
- (3) Disconnect the exhaust pipe from the turbocharger elbow (Fig. 22).
- (4) Lower vehicle.
- (5) Disconnect the turbocharger air inlet hose (Fig. 23).
- (6) Disconnect the turbocharger oil supply line and the oil drain tube from the turbocharger (Fig. 24).
- (7) Disconnect the charge air cooler inlet pipe from the turbocharger (Fig. 24).



J9411-18

**Fig. 22 Exhaust Pipe Removal/Installation**

- 1 - EXHAUST PIPE
- 2 - TURBOCHARGER EXHAUST PIPE



J9425-3

**Fig. 23 Turbocharger Air Inlet Hose**

- 1 - AIR FILTER HOUSING COVER
- 2 - TURBOCHARGER
- 3 - AIR INLET TUBE
- 4 - HOSE CLAMP
- 5 - HINGE TABS
- 6 - FILTER MINDER
- 7 - CLIPS (4)
- 8 - TUBE ALIGNMENT NOTCHES

(8) Remove the turbocharger and gasket from the exhaust manifold.

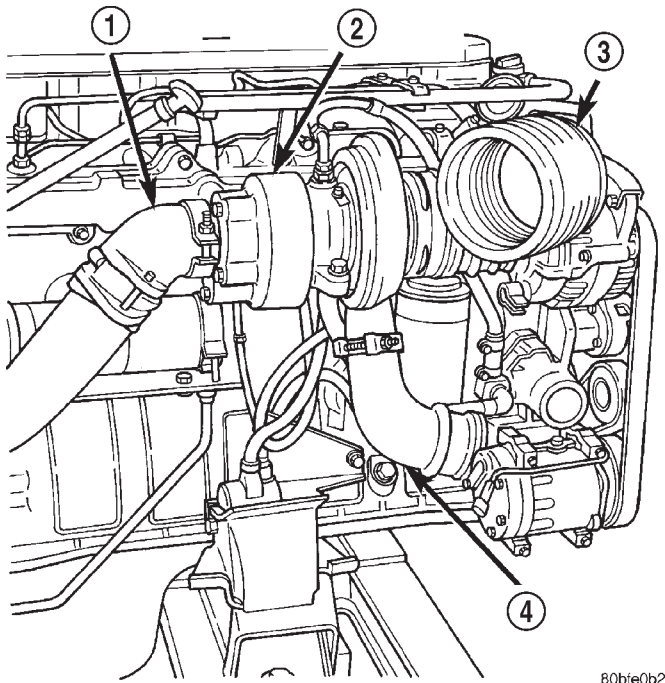
(9) If the turbocharger is not to be installed immediately, cover the opening to prevent material from entering into the manifold.

(10) If replacing the turbocharger, transfer the discharge elbow and clamp to the new assembly.

(11) Clean and inspect the sealing surface.



## TURBOCHARGER (Continued)



80bre0b2

**Fig. 24 Oil Supply Line and Charge Air Cooler Inlet Duct**

- 1 - EXHAUST PIPE
- 2 - TURBOCHARGER
- 3 - AIR INLET TUBE
- 4 - COOLER INLET DUCT

**CAUTION:** The turbocharger is only serviced as an assembly. Do not attempt to repair the turbocharger as turbocharger and/or engine damage can result.

## CLEANING

Clean the turbocharger and exhaust manifold mounting surfaces with a suitable scraper.

## INSPECTION

Visually inspect the turbocharger and exhaust manifold gasket surfaces. Replace stripped or eroded mounting studs.

(1) Visually inspect the turbocharger for cracks. The following cracks are NOT acceptable:

- Cracks in the turbine and compressor housing that go completely through.
- Cracks in the mounting flange that are longer than 15 mm (0.6 in.).
- Cracks in the mounting flange that intersect bolt through-holes.
- Two (2) Cracks in the mounting flange that are closer than 6.4 mm (0.25 in.) together.

(2) Visually inspect the impeller and compressor wheel fins for nicks, cracks, or chips. Note: Some impellers may have a factory placed paint mark which, after normal operation, appears to be a crack.

Remove this mark with a suitable solvent to verify that it is not a crack.

(3) Visually inspect the turbocharger compressor housing for an impeller rubbing condition (Fig. 25). Replace the turbocharger if the condition exists.

(4) Measure the turbocharger axial end play:

(a) Install a dial indicator as shown in (Fig. 26). Zero the indicator at one end of travel.

(b) Move the impeller shaft fore and aft and record the measurement. Allowable end play is 0.038 mm (0.0015 in.) MIN. and 0.089 mm (0.0035 in.) MAX. If the recorded measurement falls outside these parameters, replace the turbocharger assembly.

(5) Measure the turbocharger bearing radial clearance:

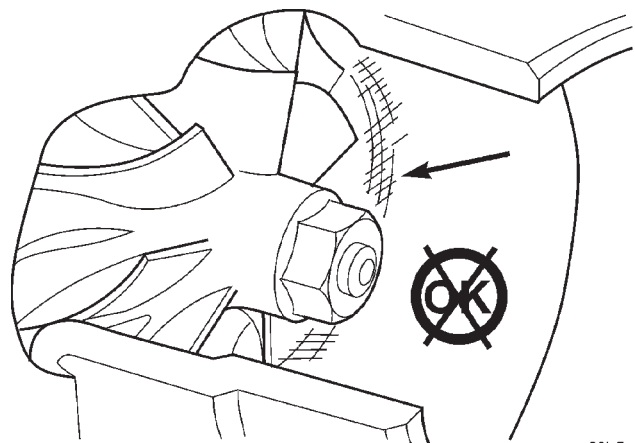
(a) Insert a narrow blade or wire style feeler gauge between the compressor wheel and the housing (Fig. 27).

(b) Gently push the compressor wheel toward the housing and record the clearance.

(c) With the feeler gauge in the same location, gently push the compressor wheel away from the housing and again record the clearance.

(d) Subtract the smaller clearance from the larger clearance. This is the radial bearing clearance.

(e) Allowable radial bearing clearance is 0.326 mm (0.0128 in.) MIN. and 0.496 mm (0.0195 in.) MAX. If the recorded measurement falls outside these specifications, replace the turbocharger assy.



80b5cc56

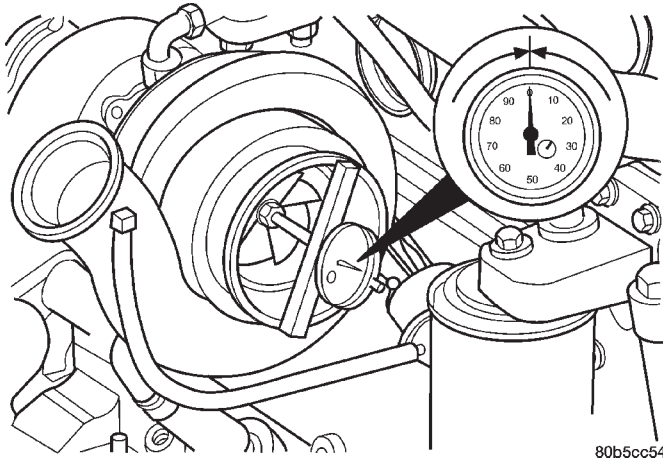
**Fig. 25 Inspect Compressor Housing for Impeller Rubbing Condition**

## INSTALLATION

(1) Install the turbocharger. Apply anti-seize to the studs and then tighten the turbocharger mounting nuts to 32 N·m (24 ft. lbs.) torque.

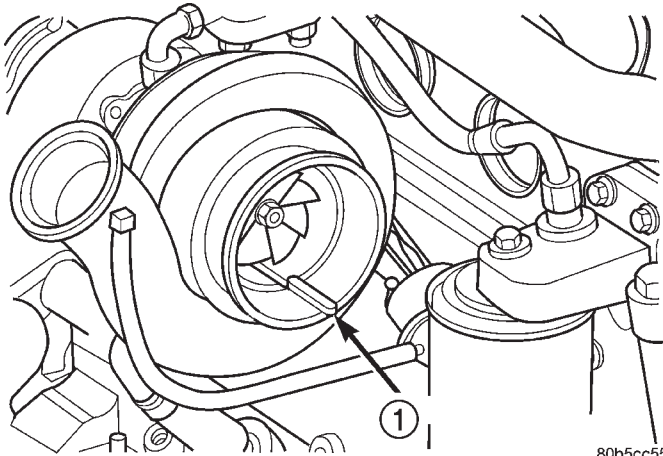
(2) Install the oil drain tube and oil supply line to the turbocharger (Fig. 24). Tighten the drain tube bolts to 24 N·m (18 ft. lbs.) torque.

## TURBOCHARGER (Continued)



80b5cc54

**Fig. 26 Measure Turbocharger Axial End Play**



80b5cc55

**Fig. 27 Measure Turbocharger Bearing Radial Clearance**

1 - FEELER GAUGE

(3) **Pre-lube the turbocharger.** Pour 50 to 60 cc (2 to 3 oz.) clean engine oil in the oil supply line fitting. Carefully rotate the turbocharger impeller by hand to distribute the oil thoroughly.

(4) Install and tighten the oil supply line fitting nut to 20 N·m (133 in. lbs.) torque.

(5) Position the charge air cooler inlet pipe to the turbocharger. With the clamp in position, tighten the clamp nut to 11 N·m (95 in. lbs.) torque.

(6) Position the air inlet hose to the turbocharger (Fig. 23). Tighten the clamp to 11 N·m (95 in. lbs.) torque.

(7) Raise vehicle on hoist.

(8) Connect the exhaust pipe to the turbocharger (Fig. 22) and tighten the bolts to 34 N·m (25 ft. lbs.) torque.

(9) Lower the vehicle.

(10) Connect the battery negative cables.

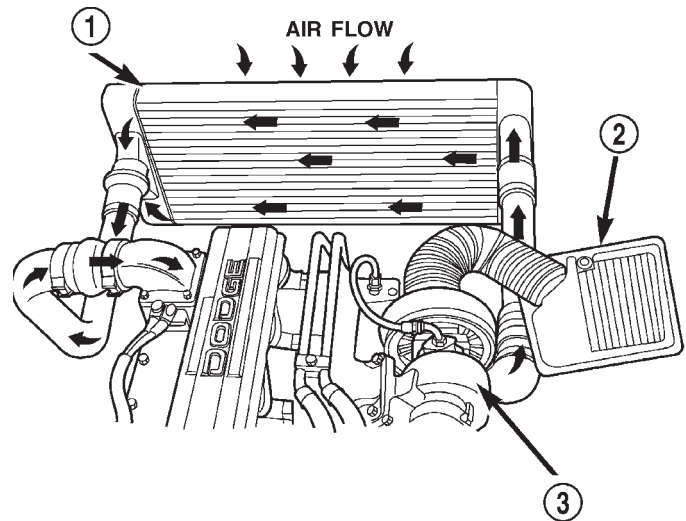
(11) Start the engine to check for leaks.

## CHARGE AIR COOLER AND PLUMBING

### DESCRIPTION

The charge air system (Fig. 28) consists of the charge air cooler piping, charge air cooler and intake air grid heater.

The charge air cooler is a heat exchanger that uses air flow from vehicle motion to dissipate heat from the intake air. As the turbocharger increases air pressure, the air temperature increases. Lowering the intake air temperature increases engine efficiency and power.



80b5cc52

**Fig. 28 Intake Air Circulation**

- 1 - CHARGE AIR COOLER  
2 - AIRFILTER  
3 - TURBOCHARGER

### OPERATION

Intake air is drawn through the air cleaner and into the turbocharger compressor housing. Pressurized air from the turbocharger then flows forward through the charge air cooler located in front of the radiator. From the charge air cooler the air flows back into the intake manifold.

### REMOVAL

**WARNING: IF THE ENGINE WAS JUST TURNED OFF, THE AIR INTAKE SYSTEM TUBES MAY BE HOT.**

(1) Disconnect the battery negative cables.

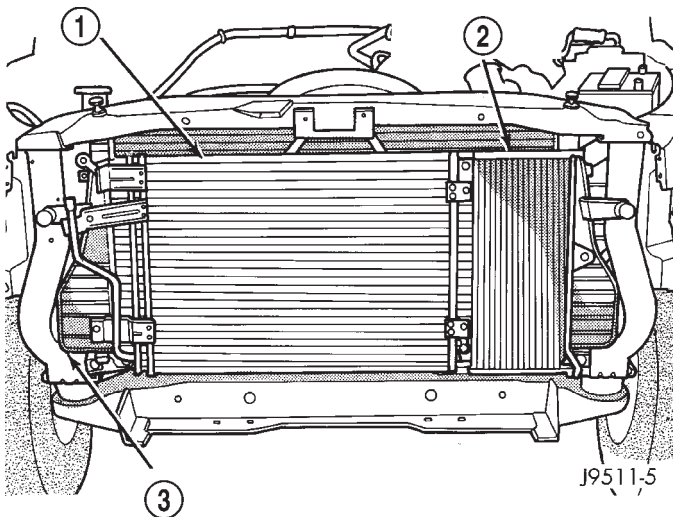
(2) Remove the front bumper (Refer to 13 - FRAMES & BUMPERS/BUMPERS/Front BUMPER - REMOVAL).

## CHARGE AIR COOLER AND PLUMBING (Continued)

(3) Remove the front support bracket.

(4) Discharge the A/C system (Refer to 24 - HEATING & AIR CONDITIONING/PLUMBING - STANDARD PROCEDURE) and remove the A/C condenser (Refer to 24 - HEATING & AIR CONDITIONING/PLUMBING/A/C CONDENSER - REMOVAL) (Fig. 29) (if A/C equipped) .

(5) Remove the transmission auxiliary cooler (Fig. 29) (Refer to 7 - COOLING/TRANSMISSION/TRANSCOOLER - REMOVAL).



**Fig. 29 Condenser and Transmission Auxiliary Cooler**

- 1 - A/C CONDENSOR
- 2 - TRANSMISSION COOLER
- 3 - INTERCOOLER

(6) Remove the boost tubes from the charge air cooler (Fig. 30).

(7) Remove the charge air cooler bolts. Pivot the charge air cooler forward and up to remove.

## CLEANING

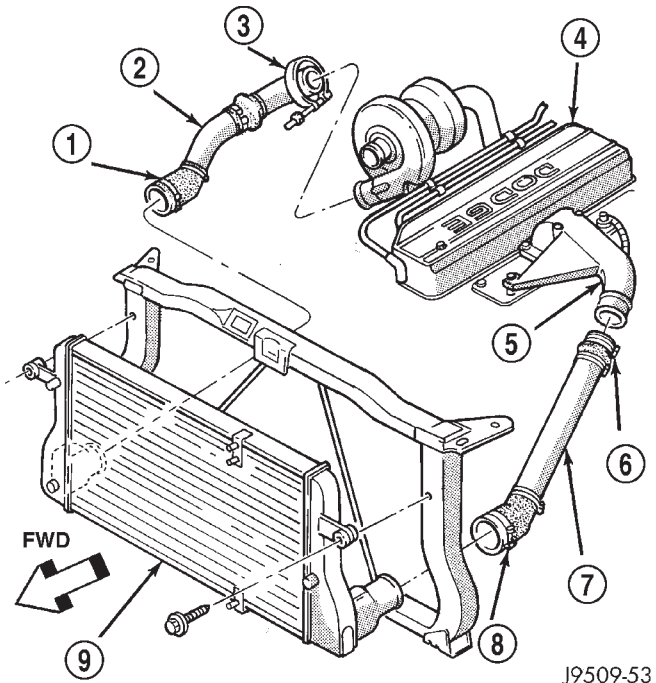
**CAUTION:** Do not use caustic cleaners to clean the charge air cooler. Damage to the charge air cooler will result.

**NOTE:** If internal debris cannot be removed from the cooler, the charge air cooler **MUST** be replaced.

(1) If the engine experiences a turbocharger failure or any other situation where oil or debris get into the charge air cooler, the charge air cooler must be cleaned internally.

(2) Position the charge air cooler so the inlet and outlet tubes are vertical.

(3) Flush the cooler internally with solvent in the direction opposite of normal air flow.



**Fig. 30 Air Intake System Tubes**

- 1 - CLAMP
- 2 - INTERCOOLER INLET DUCT
- 3 - CLAMP
- 4 - VALVE COVER
- 5 - AIR INLET HOUSING
- 6 - CLAMP
- 7 - INTERCOOLER OUTLET DUCT
- 8 - CLAMP
- 9 - INTERCOOLER

(4) Shake the cooler and lightly tap on the end tanks with a rubber mallet to dislodge trapped debris.

(5) Continue flushing until all debris or oil are removed.

(6) Rinse the cooler with hot soapy water to remove any remaining solvent.

(7) Rinse thoroughly with clean water and blow dry with compressed air.

## INSPECTION

Visually inspect the charge air cooler for cracks, holes, or damage. Inspect the tubes, fins, and welds for tears, breaks, or other damage. Replace the charge air cooler if damage is found.

Pressure test the charge air cooler, using Charge Air Cooler Tester Kit #3824556. This kit is available through Cummins® Service Products. Instructions are provided with the kit.

## INSTALLATION

(1) Position the charge air cooler. Install the bolts and tighten to 2 N·m (17 in. lbs.) torque.

## CHARGE AIR COOLER AND PLUMBING (Continued)

(2) Install the air intake system tubes to the charge air cooler . With the clamps in position, tighten the clamps to 11 N·m (95 in. lbs.) torque.

(3) Install the transmission auxiliary cooler (if equipped) (Refer to 7 - COOLING/TRANSMISSION/TRANS COOLER - INSTALLATION).

(4) Install the A/C condenser (if A/C equipped) (Refer to 24 - HEATING & AIR CONDITIONING/PLUMBING/A/C CONDENSER - INSTALLATION). Recharge A/C system (Refer to 24 - HEATING & AIR

CONDITIONING/PLUMBING - STANDARD PROCEDURE).

(5) Install the front support bracket. Install and tighten the bolts.

(6) Install the front bumper (Refer to 13 - FRAMES & BUMPERS/BUMPERS/FRONT BUMPER - INSTALLATION).

(7) Connect the battery negative cables.

(8) Start engine and check for boost system leaks.



# FRAME & BUMPERS

## TABLE OF CONTENTS

	page		page
<b>BUMPERS</b>		<b>REAR BUMPER</b>	
DESCRIPTION . . . . .	1	REMOVAL . . . . .	5
<b>FRONT AIR DAM</b>		INSTALLATION . . . . .	5
REMOVAL . . . . .	1	<b>FRAME</b>	
INSTALLATION . . . . .	2	DESCRIPTION . . . . .	6
<b>FRONT FASCIA</b>		SPECIFICATIONS . . . . .	7
REMOVAL . . . . .	2	<b>CAB CHASSIS ADAPTER BRACKET</b>	
INSTALLATION . . . . .	2	REMOVAL . . . . .	9
ADJUSTMENT . . . . .	2	INSTALLATION . . . . .	9
<b>FRONT LOWER FASCIA</b>		<b>FRONT TOW HOOK</b>	
REMOVAL . . . . .	3	REMOVAL . . . . .	9
INSTALLATION . . . . .	3	INSTALLATION . . . . .	10
<b>FRONT FASCIA—SPORT</b>		<b>SPARE TIRE WINCH</b>	
REMOVAL . . . . .	3	REMOVAL . . . . .	10
INSTALLATION . . . . .	3	INSTALLATION . . . . .	10
<b>FRONT BUMPER</b>		<b>TRAILER HITCH</b>	
REMOVAL . . . . .	3	REMOVAL . . . . .	10
INSTALLATION . . . . .	4	INSTALLATION . . . . .	10
<b>FRONT BUMPER—SPORT</b>		<b>TRANSFER CASE SKID PLATE</b>	
REMOVAL . . . . .	4	REMOVAL . . . . .	11
INSTALLATION . . . . .	4	INSTALLATION . . . . .	11

## BUMPERS

### DESCRIPTION

Bumpers are used at the front and rear of the vehicle. Bumpers may be chrome or painted.

Bumpers are designed to protect the exterior sheet-metal in low impact situations. The bumpers are attached to the frame and provide mounting points for some optional accessories such as fog lights and tow hooks.

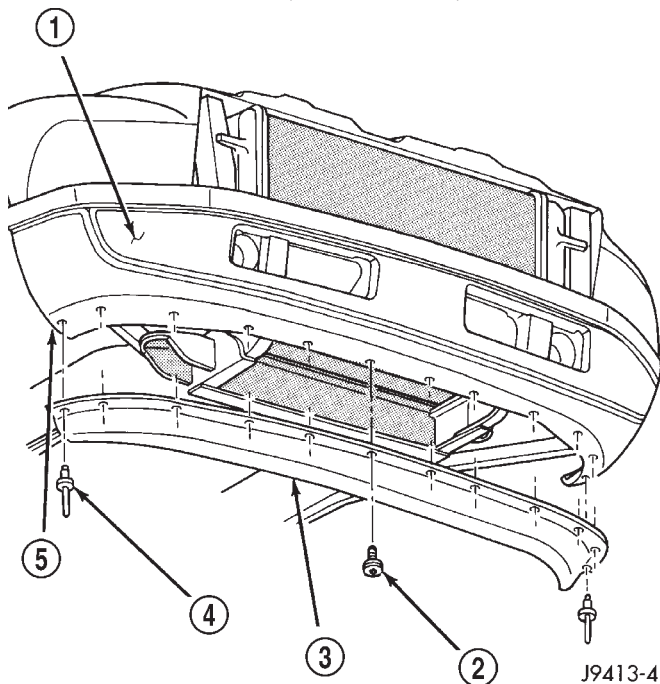
## FRONT AIR DAM

### REMOVAL

- (1) Remove Pin-type fasteners attaching air dam to bottom of front bumper (Fig. 1).
- (2) Remove screws attaching air dam to bottom of front bumper.
- (3) Separate air dam from bumper.



## FRONT AIR DAM (Continued)



**Fig. 1 Front Bumper Air Dam**

- 1 - BUMPER
- 2 - SCREW
- 3 - LOWER AIR DAM
- 4 - PIN TYPE FASTENER
- 5 - LOWER FASCIA

## INSTALLATION

- (1) Position air dam on bumper.
- (2) Install screws attaching air dam to bottom of front bumper.
- (3) Install Pin-type fasteners attaching air dam to bottom of front bumper.

## FRONT FASCIA

## REMOVAL

- (1) Open hood.
- (2) Remove fasteners at fender side openings.
- (3) Separate fascia from bumper.

## INSTALLATION

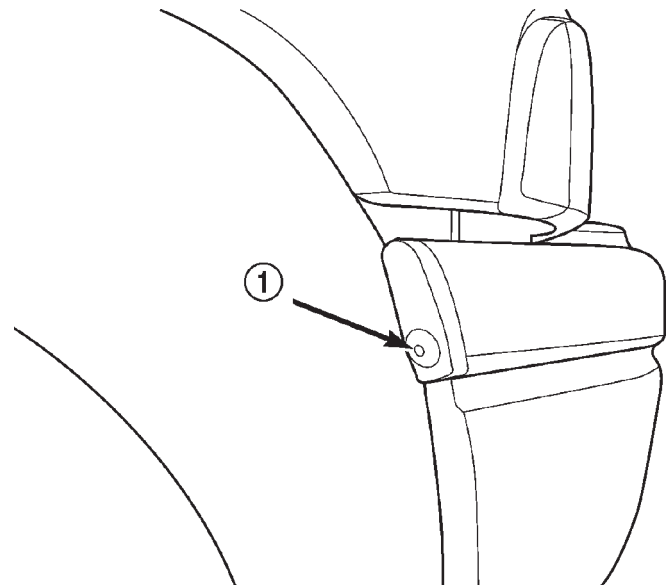
- (1) Position fascia on bumper.
- (2) Install front fascia. See fascia adjustment procedure in this section.
- (3) Install fasteners at fender side openings.

## ADJUSTMENT

- (1) Remove the plastic rivet that secures the front upper fascia to the front lower fascia (Fig. 2).
- (2) Position the upper front fascia so that there is approximately a 19 mm (3/4 in.) gap between the

lower portion of the front fender and the upper portion of the front upper fascia (Fig. 3). The gap should ideally be 19 mm (3/4 in.), but it is more important to avoid a V-Gap between the lower portion of the front fender and the upper portion of the front upper fascia than maintaining the gap. There are ribs in the front upper fascia and lower fascia that will hold the front upper fascia in position (Fig. 4).

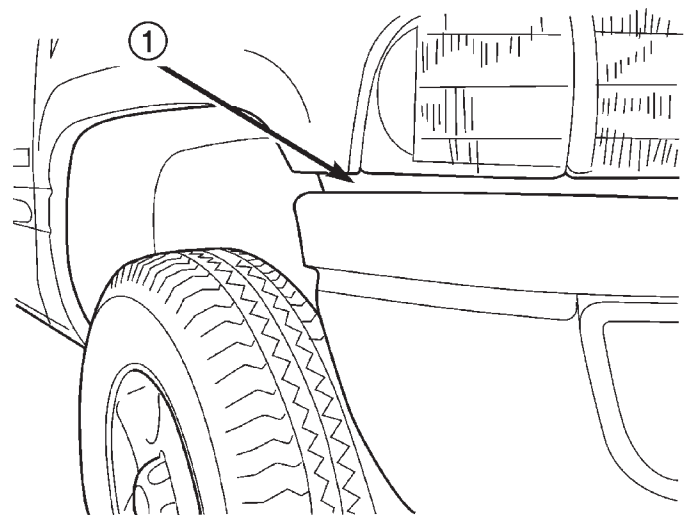
- (3) Attach the front upper fascia to the front lower fascia using a new plastic rivet.



80bcea80

**Fig. 2 Fascia Rivet**

1 - RIVET MUST BE REPLACED AFTER EACH ADJUSTMENT

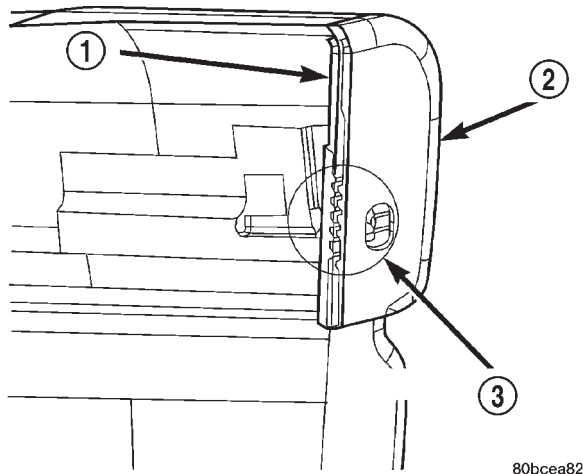


80bcea81

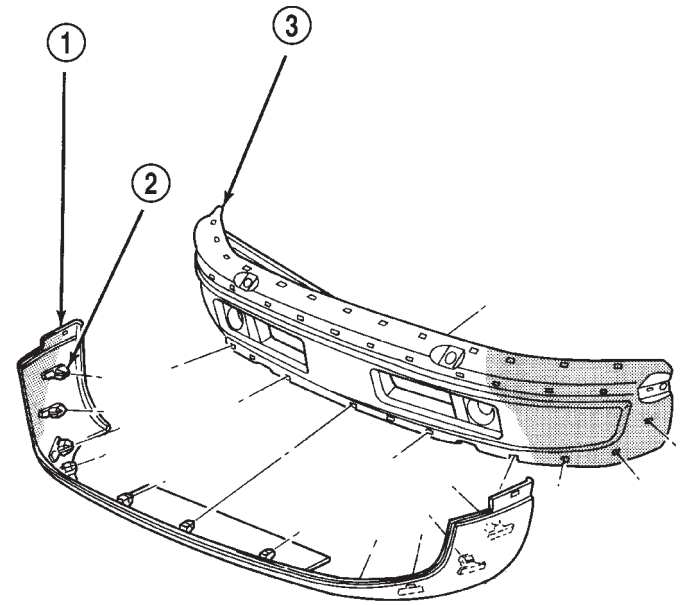
**Fig. 3 Fascia Gap**

1 - GAP — 19 mm PARALLELISM MOST IMPORTANT

## FRONT FASCIA (Continued)

**Fig. 4 Fascia Adjustment Ribs**

- 1 - FRONT UPPER FASCIA
- 2 - ADJUSTMENT RIBS
- 3 - FRONT LOWER FASCIA

**Fig. 5 Front Bumper Lower Fascia**

- 1 - LOWER FASCIA
- 2 - RETAINING CLIP
- 3 - BUMPER

J9413-2

## FRONT LOWER FASCIA

**REMOVAL**

- (1) Open hood.
- (2) Remove fasteners at side fender openings.
- (3) Remove lower air dam. (Refer to 13 - FRAMES & BUMPERS/BUMPERS/FRONT AIR DAM - REMOVAL)
- (4) Disengage clips attaching end of upper fascia to bumper face bar (Fig. 5).
- (5) Disengage clips attaching lower fascia to bumper face bar.
- (6) Separate lower fascia from bumper.

**INSTALLATION**

- (1) Position lower fascia on bumper.
- (2) Engage clips attaching lower fascia to bumper face bar.
- (3) Install lower air dam. (Refer to 13 - FRAMES & BUMPERS/BUMPERS/FRONT AIR DAM - INSTALLATION)
- (4) Install fasteners at side fender openings.

## FRONT FASCIA—SPORT

**REMOVAL**

The fascia can be removed from the vehicle without removing the bumper.

- (1) Disconnect wire connectors from fog lamps.
- (2) Remove screws attaching rearward edges of fascia to outer bumper brackets (Fig. 7).
- (3) Remove screws attaching bottom of air deflector.

- (4) Lift top of fascia upward to disengage from retaining clips on front bumper.
- (5) Pull fascia from front bumper and separate from vehicle.

**INSTALLATION**

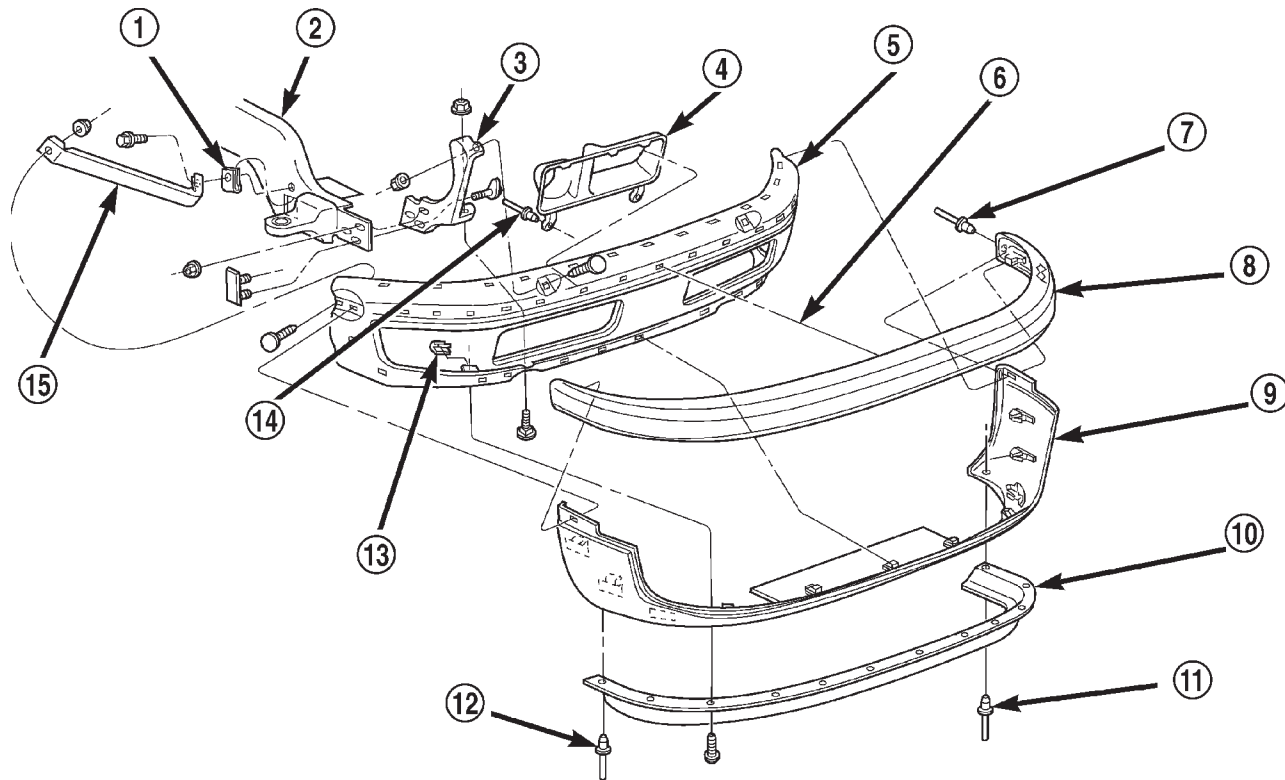
- (1) Position fascia on front bumper.
- (2) Engage fascia with retaining clips on front bumper.
- (3) Install screws attaching bottom of fascia to air deflector.
- (4) Align fascia and wheelhouse liners with outer bumper brackets and install screws.
- (5) Connect harness connectors to fog lamps.

## FRONT BUMPER

**REMOVAL**

- (1) Support front bumper on a suitable lifting device.
- (2) Remove bolts attaching front bumper outer bracket to frame rail (Fig. 6).
- (3) Remove nuts and stud plates attaching front bumper to end of frame rail.
- (4) Disengage wire connectors from fog lamps, if equipped.
- (5) Separate front bumper from vehicle.

## FRONT BUMPER (Continued)



80b3b1d7

**Fig. 6 Front Bumper**

- |                          |                           |
|--------------------------|---------------------------|
| 1 - U-NUT                | 9 - LOWER FASCIA          |
| 2 - FRAME                | 10 - AIR DAM              |
| 3 - INNER BUMPER BRACKET | 11 - BLIND PLASTIC RIVET  |
| 4 - FOGLAMP SIGHT SHIELD | 12 - BLIND PLASTIC RIVET  |
| 5 - BUMPER               | 13 - U-NUT                |
| 6 - 4-WAY CENTER LOCATOR | 14 - BLIND RIVET          |
| 7 - BLIND PLASTIC RIVET  | 15 - OUTER BUMPER BRACKET |
| 8 - UPPER FASCIA         |                           |

**INSTALLATION**

(1) Support front bumper on a suitable lifting device.

(2) Position front bumper on vehicle.

(3) Engage fog lamp wire connectors, if equipped.

(4) Install nuts and stud plates attaching front bumper to end of frame rail. Tighten nuts to 94 N·m (70 ft. lbs.) torque.

(5) Install bolts attaching front bumper outer bracket to frame rail. Tighten bolts to 94 N·m (70 ft. lbs.) torque.

**FRONT BUMPER—SPORT****REMOVAL**

(1) Disconnect wire connectors from fog lamps.

(2) Remove screws attaching fascia and outer bumper brackets to wheelhouse liners.

(3) Remove screws and push-in fasteners attaching bottom of fascia to air deflector.

(4) Support bumper on a suitable lifting device.

(5) Remove nuts attaching bumper to inner bumper brackets (Fig. 7).

(6) Separate bumper from vehicle.

**INSTALLATION**

(1) Support bumper on a suitable lifting device.

(2) Position bumper on vehicle.

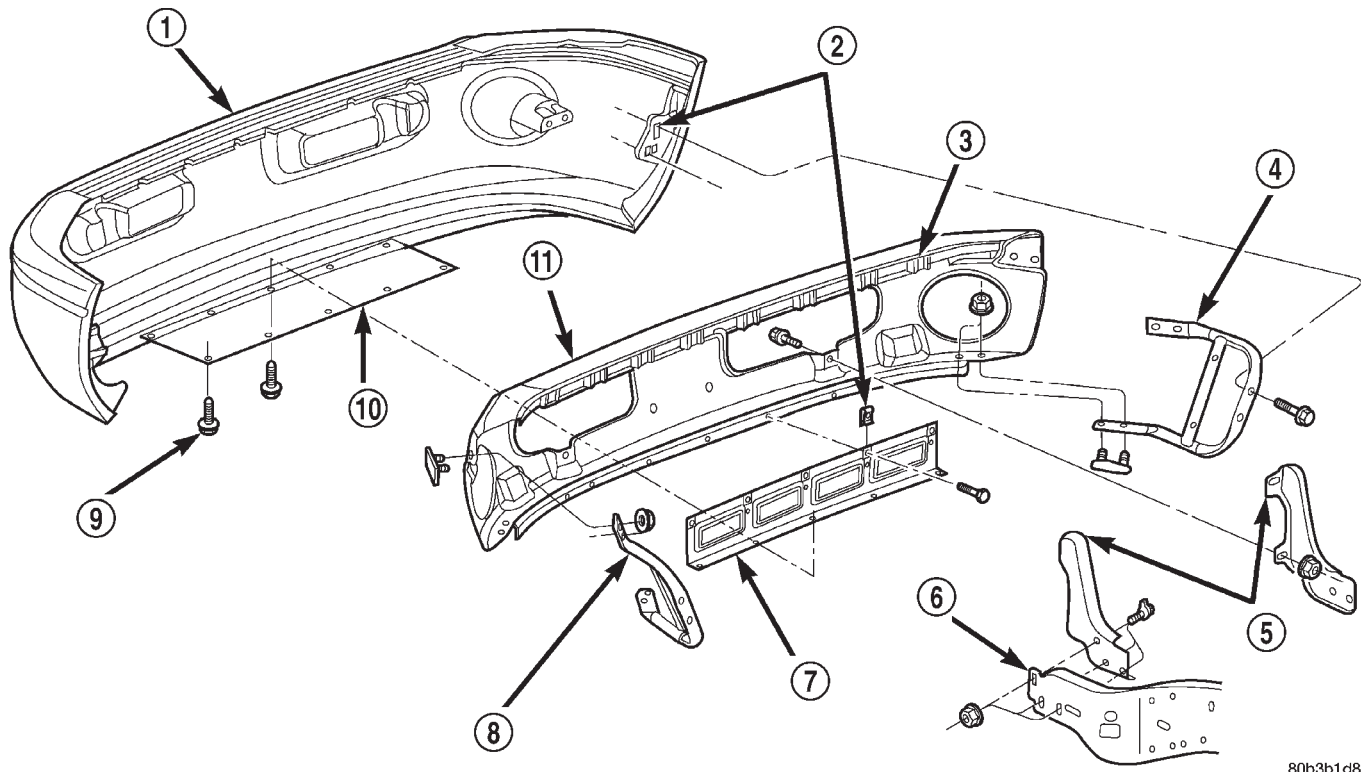
(3) Install nuts attaching bumper to inner bumper brackets. Tighten nuts to 94 N·m (70 ft. lbs.) torque.

(4) Install screws and push-in fasteners attaching bottom of fascia to air deflector.

(5) Align fascia and wheelhouse liners with outer bumper brackets and install screws. See fascia adjustment in this section.

(6) Connect wire connectors to fog lamps.

## FRONT BUMPER—SPORT (Continued)



80b3b1d8

**Fig. 7 Front Bumper & Fascia — Sport**

- |                    |                      |
|--------------------|----------------------|
| 1 - FASCIA         | 7 - FASCIA SUPPORT   |
| 2 - U-NUT          | 8 - OUTER BRACKET    |
| 3 - RETAINING CLIP | 9 - PUSH-IN FASTENER |
| 4 - OUTER BRACKET  | 10 - AIR DEFLECTOR   |
| 5 - INNER BRACKET  | 11 - BUMPER          |
| 6 - FRAME          |                      |

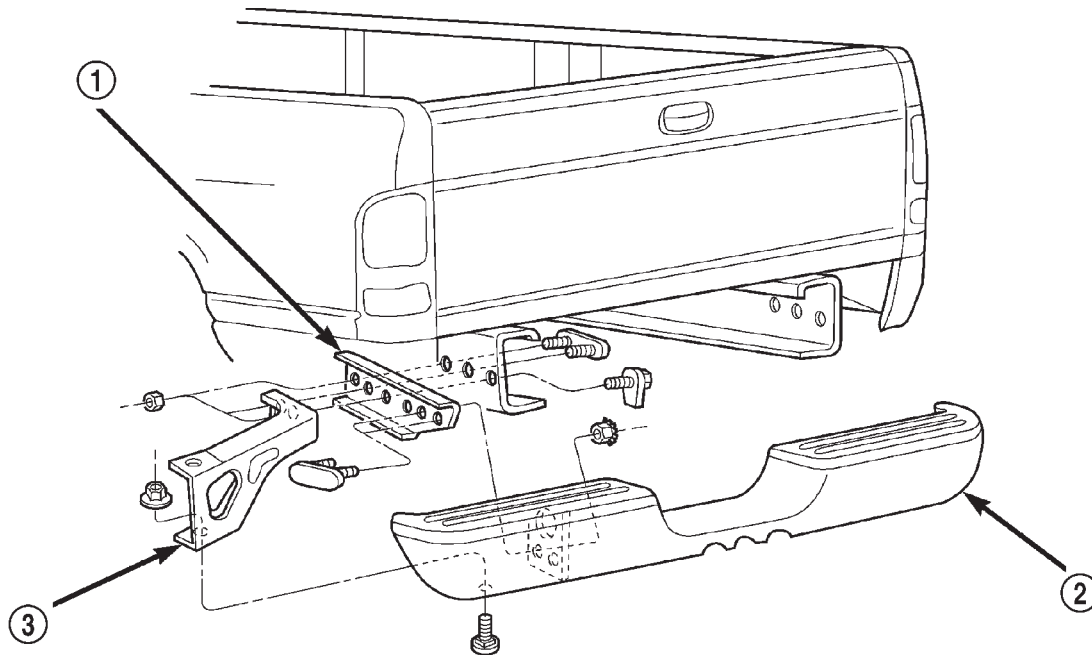
**REAR BUMPER****REMOVAL**

- (1) Support rear bumper on a suitable lifting device.
- (2) Remove nuts attaching rear bumper to inner and outer brackets (Fig. 8).
- (3) Disengage license plate lamp wire connector from body wire harness, if equipped.
- (4) Separate rear bumper from vehicle.

**INSTALLATION**

- (1) Support rear bumper on a suitable lifting device.
- (2) Position rear bumper on vehicle.
- (3) Engage license plate lamp wire connector to body wire harness, if equipped.
- (4) Install nuts attaching rear bumper to inner and outer brackets. Tighten nuts to 94 N·m (70 ft. lbs.) torque.

## REAR BUMPER (Continued)



80b3b1d6

**Fig. 8 Rear Bumper**

1 - INNER BRACKET  
2 - BUMPER

3 - OUTER BRACKET

**FRAME****DESCRIPTION**

The BR/BE frame is the structural center of the vehicle. In addition to supporting the body and payload, the frame provides a station for the engine and drivetrain. BR/BE trucks have a ladder type frame with Box-section front rails, dropped center section, and open-channel side rails in the rear.

Cross members attach to the side rails with rivets, welds, or bolts. The cab is isolated from the frame with rubber load cushions with through bolts. The cargo box or bed is attached to the frame with bolts.

The frame is designed to absorb and dissipate flexing and twisting due to acceleration, braking, cornering, and road surface variances without bending when subjected to normal driving conditions.

**FRAME SERVICE****SAFETY PRECAUTIONS AND WARNINGS**

**WARNING: USE EYE PROTECTION WHEN GRINDING OR WELDING METAL, SERIOUS EYE INJURY CAN RESULT. BEFORE PROCEEDING WITH FRAME REPAIR INVOLVING GRINDING OR WELDING, VERIFY THAT VEHICLE FUEL SYSTEM IS NOT LEAKING OR IN CONTACT WITH REPAIR AREA, PERSONAL INJURY CAN RESULT. DO NOT ALLOW OPEN FLAME TO CONTACT PLASTIC BODY PANELS. FIRE OR EXPLOSION CAN RESULT. WHEN WELDED FRAME COMPONENTS ARE REPLACED, 100% PENETRATION WELD MUST BE ACHIEVED DURING INSTALLATION. IF NOT, DANGEROUS OPERATING CONDITIONS CAN RESULT. STAND CLEAR OF CABLES OR CHAINS ON PULLING EQUIPMENT DURING FRAME STRAIGHTENING OPERATIONS, PERSONAL INJURY CAN RESULT. DO NOT VENTURE UNDER A HOISTED VEHICLE THAT IS NOT SUPPORTED ON SAFETY STANDS, PERSONAL INJURY CAN RESULT.**



## FRAME (Continued)

**CAUTION:** Do not reuse damaged fasteners, quality of repair would be suspect. Do not drill holes in top or bottom frame rail flanges, frame rail failure can result. Do Not use softer than Grade 5 bolts to replace production fasteners, loosening or failure can result. When using heat to straighten frame components do not exceed 566°C (1050°F), metal fatigue can result. Welding the joints around riveted cross members and frame side rails can weaken frame.

## FRAME STRAIGHTENING

When necessary, a conventional frame that is bent or twisted can be straightened by application of heat. The temperature must not exceed 566°C (1050°F). The metal will have a dull red glow at the desired temperature. Excessive heat will decrease the strength of the metal and result in a weakened frame.

Welding the joints around riveted cross members and frame side rails is not recommended.

A straightening repair process should be limited to frame members that are not severely damaged. The replacement bolts, nuts and rivets that are used to join the frame members should conform to the same specifications as the original bolts, nuts and rivets.

## FRAME REPAIRS

## DRILLING HOLES

Do not drill holes in frame side rail top and bottom flanges, metal fatigue can result causing frame failure. Holes drilled in the side of the frame rail must be at least 38 mm (1.5 in.) from the top and bottom flanges.

Additional drill holes should be located away from existing holes.

## WELDING

Use MIG, TIG or arc welding equipment to repair welded frame components.

Frame components that have been damaged should be inspected for cracks before returning the vehicle to use. If cracks are found in accessible frame components perform the following procedures.

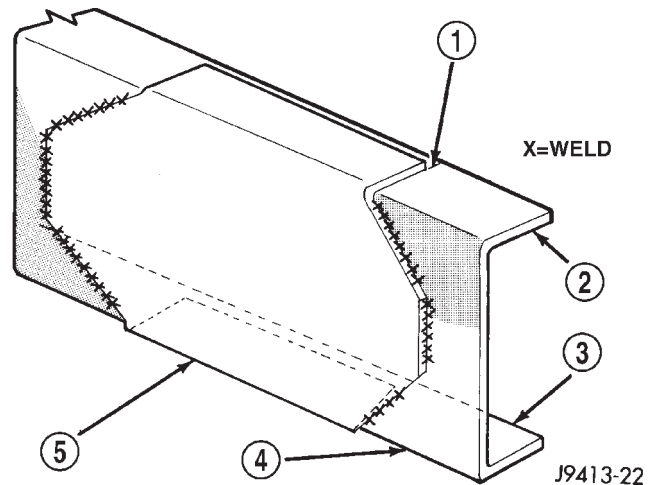
(1) Drill a hole at each end of the crack with a 3 mm (0.125 in.) diameter drill bit.

(2) Using a suitable die grinder with 3 inch cut off wheel, V-groove the crack to allow 100% weld penetration.

(3) Weld the crack.

(4) If necessary when a side rail is repaired, grind the weld smooth and install a reinforcement channel (Fig. 9) over the repaired area.

**NOTE:** If a reinforcement channel is required, the top and bottom flanges should be 0.250 inches narrower than the side rail flanges. Weld only in the areas indicated (Fig. 9).



**Fig. 9 Frame Reinforcement**

- 1 - .250 IN FROM EDGE
- 2 - TOP FLANGE
- 3 - BOTTOM FLANGE
- 4 - FRAME RAIL
- 5 - FRAME REPAIR REINFORCEMENT

## FRAME FASTENERS

Bolts, nuts and rivets can be used to repair frames or to install a reinforcement section on the frame. Bolts can be used in place of rivets. When replacing rivets with bolts, install the next larger size diameter bolt to assure proper fit. If necessary, ream the hole out just enough to sufficiently receive the bolt.

Conical-type washers are preferred over the splitting type lock washers. Normally, grade-5 bolts are adequate for frame repair. **Grade-3 bolts or softer should not be used.** Tightening bolts/nuts with the correct torque, refer to the Introduction Group at the front of this manual for tightening information.

## SPECIFICATIONS

## FRAME DIMENSION

Frame dimensions are listed in Millimeters (mm) scale. All dimensions are from center to center of Principal Locating Point (PLP), or from center to center of PLP and fastener location (Fig. 10).



SPECIFICATIONS (Continued)

601634a6

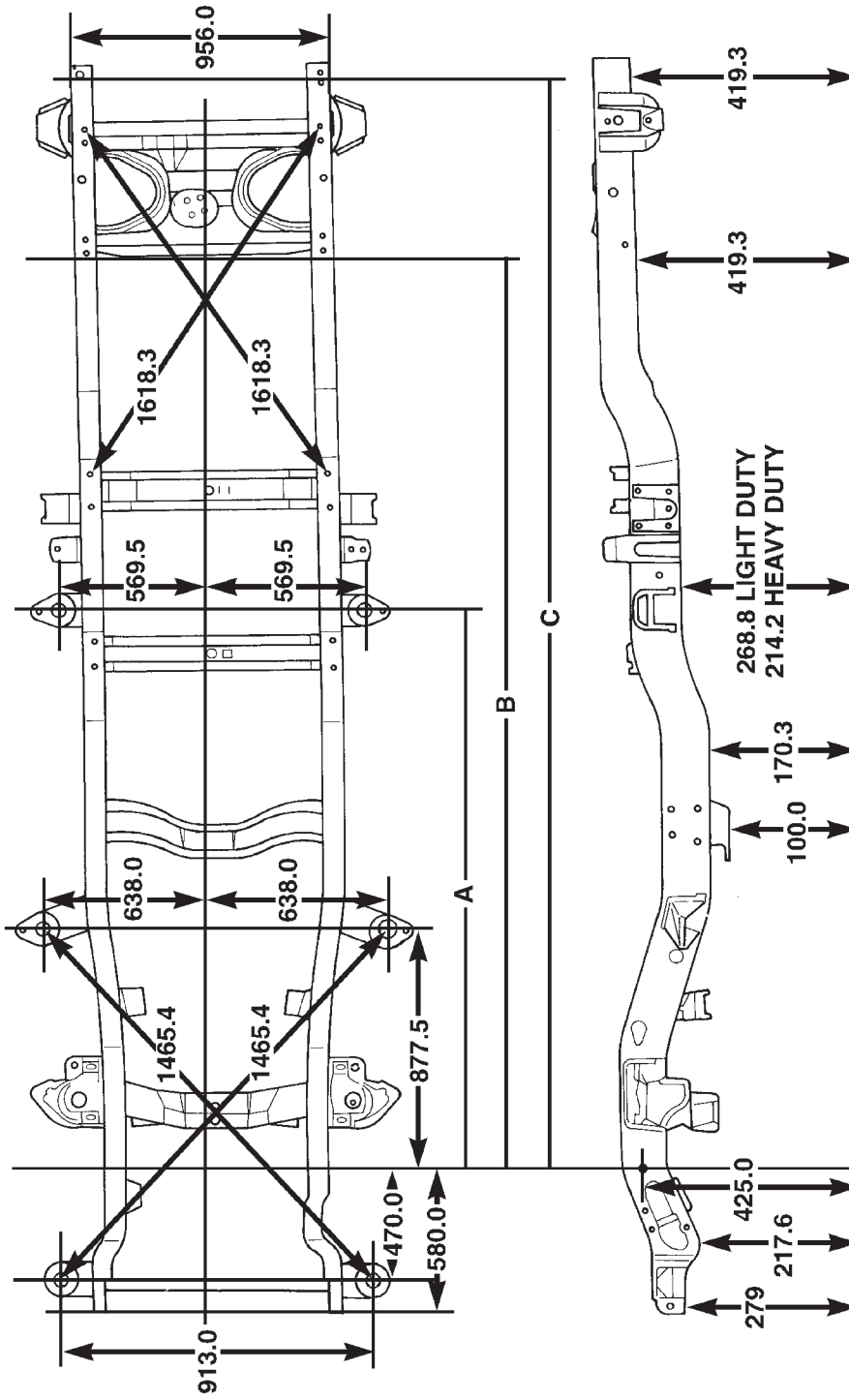


Fig. 10 Frame Dimensions

SPECIFICATIONS (Continued)

DIMENSIONS FOR DIFFERING WHEELBASES\*

WHEELBASE	LENGTH A	LENGTH B	LENGTH C
118	2118.0	3663.6	4185.4
134	2118.0	3994.5	4693.4
138	2626.0	4096.1	4693.4
154	2626.0	4502.5	5201.4
162	2118.0	4705.0	5042.5

\*Measurements are in Millimeters (mm).

TORQUE SPECIFICATIONS

DESCRIPTION TORQUE

- Cab Chassis adapter nut . . . . . 108 N·m (80 ft. lbs.)
- Front bumper brkt-to-frame nut . 68 N·m (50 ft. lbs.)
- Front bumper outer brace bolt . . 68 N·m (50 ft. lbs.)
- Rear bumper-to-brace nut . . . . . 40 N·m (30 ft. lbs.)
- Rear bumper brace-to-brkt nut . 101 N·m (75 ft. lbs.)
- Rear bumper brkt-to-frame nut . . . . . 101 N·m (75 ft. lbs.)
- Skid plate crossmember-to-frame bolt . . . . . 54 N·m (40 ft. lbs.)
- Skid plate-to-crossmember bolt . 40 N·m (30 ft. lbs.)
- Skid plate-to-trans crossmember bolt . . . . . 54 N·m (40 ft. lbs.)
- Spare tire winch bolt . . . . . 27 N·m (20 ft. lbs.)
- Trailer hitch nut . . . . . 108 N·m (80 ft. lbs.)

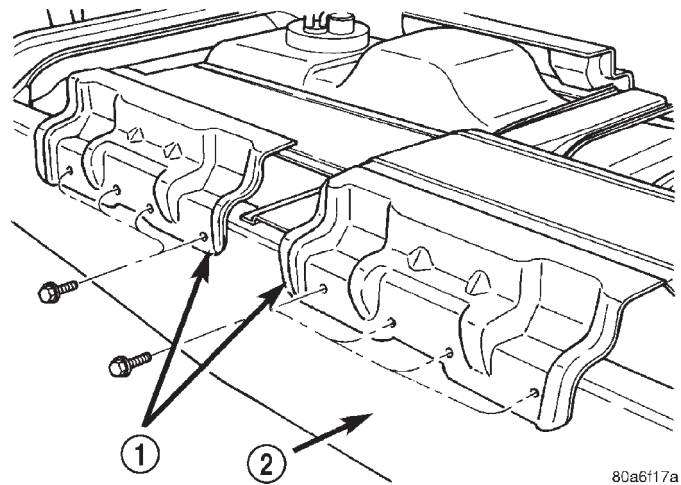


Fig. 11 Cab Chassis Adapter Brackets

- 1 - ADAPTER BRACKETS
- 2 - FRAME

CAB CHASSIS ADAPTER BRACKET

REMOVAL

- (1) Remove bolts attaching cab chassis adapter brackets to frame rail (Fig. 11)
- (2) Separate cab chassis adapter brackets from frame rail

INSTALLATION

- (1) Position cab chassis adapter brackets on frame rail
- (2) Install bolts attaching cab chassis adapter brackets to frame rail.

FRONT TOW HOOK

REMOVAL

Some vehicles are equipped with front tow hooks. The tow hooks are to be used for **EMERGENCY** purposes only.

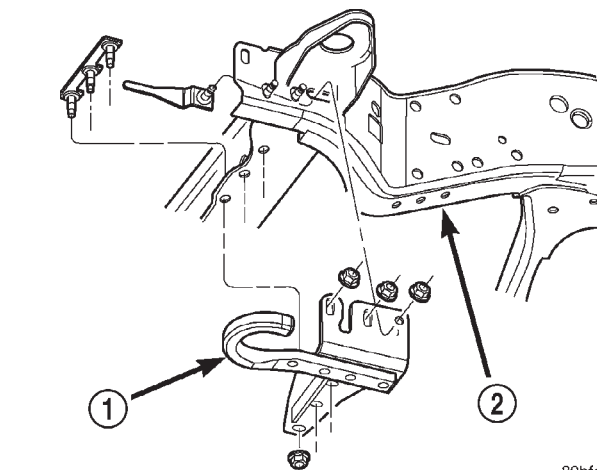


Fig. 12 Front Tow Hooks

- 1 - TOW HOOK
- 2 - FRAME

## FRONT TOW HOOK (Continued)

**Installation**

Some vehicles are equipped with front tow hooks. The tow hooks are to be used for **EMERGENCY** purposes only.

- (1) Position the tow hooks on the frame.
- (2) Install the fasteners that attach the tow hooks to the frame.
- (3) Tighten the nuts to 108 N·m (80 ft. lbs.) torque.

**SPARE TIRE WINCH****REMOVAL**

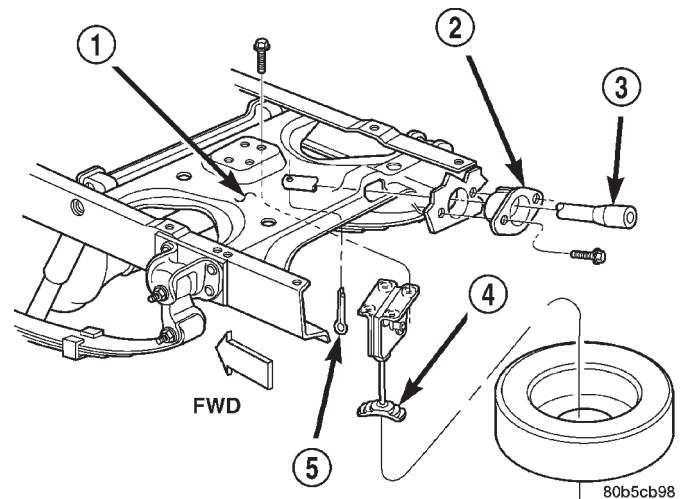
- (1) Remove spare tire from under vehicle.
- (2) Remove cotter pin attaching winch tube to spare tire winch.
- (3) Pull winch tube from spare tire winch.
- (4) Remove bolts attaching spare tire winch to crossmember (Fig. 13).
- (5) Separate spare tire winch from vehicle.

**INSTALLATION**

- (1) Position spare tire winch on vehicle.
- (2) Install bolts holding spare tire winch to spare crossmember.
- (3) Insert winch tube into spare tire winch.
- (4) Install cotter pin attaching winch tube to spare tire winch.
- (5) Install spare tire.

**TRAILER HITCH****REMOVAL**

- (1) Support trailer hitch on a suitable lifting device.

**Fig. 13 Spare Tire Winch**

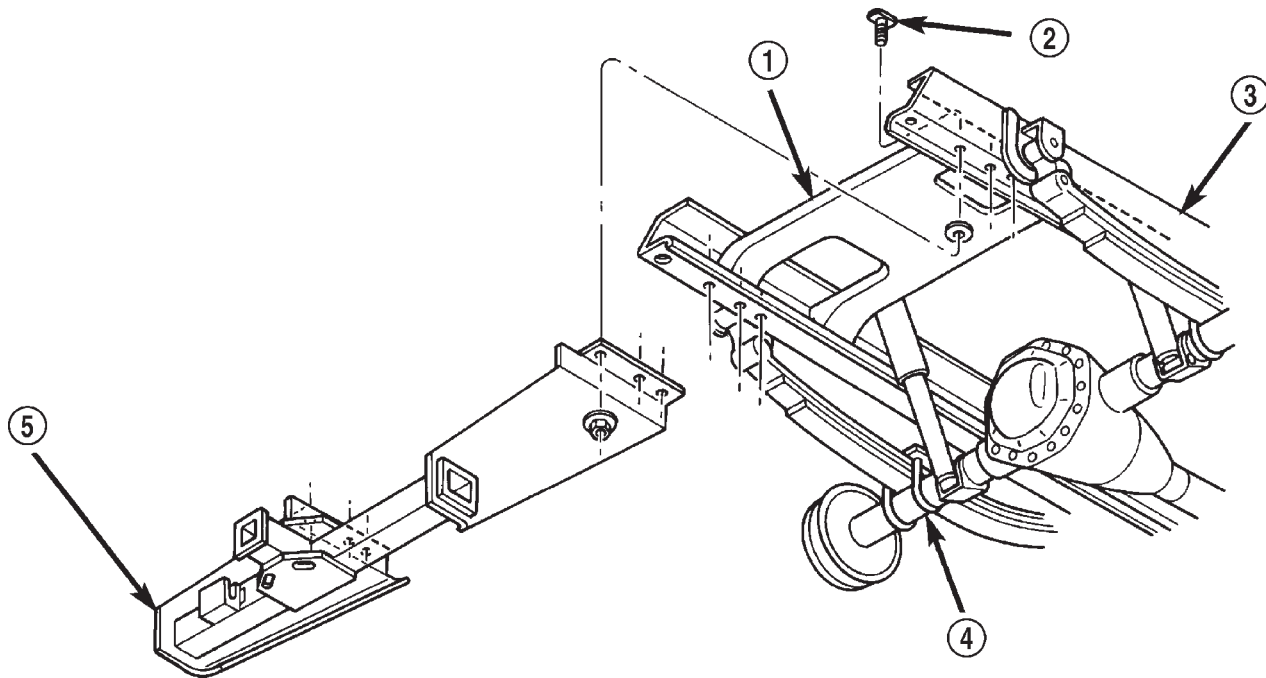
- 1 - CROSSMEMBER
- 2 - GROMMET
- 3 - WINCH TUBE
- 4 - SPARE TIRE WINCH
- 5 - COTTER PIN

- (2) Remove fasteners attaching trailer wiring connector to trailer hitch, if equipped.
- (3) Remove bolts attaching trailer hitch to frame rails (Fig. 14).
- (4) Separate trailer hitch from vehicle.

**INSTALLATION**

- (1) Position trailer hitch on vehicle.
- (2) Install nuts attaching trailer hitch to frame rails. Tighten nuts to 108 N·m (80 ft. lbs.) torque.
- (3) Install fasteners attaching trailer wiring connector to trailer hitch, if equipped.

## TRAILER HITCH (Continued)



80a53b61

**Fig. 14 Trailer Hitch**

- 1 - SPARE TIRE WINCH SUPPORT
- 2 - FLAG BOLT
- 3 - FRAME RAIL

- 4 - REAR AXLE HOUSING
- 5 - HITCH

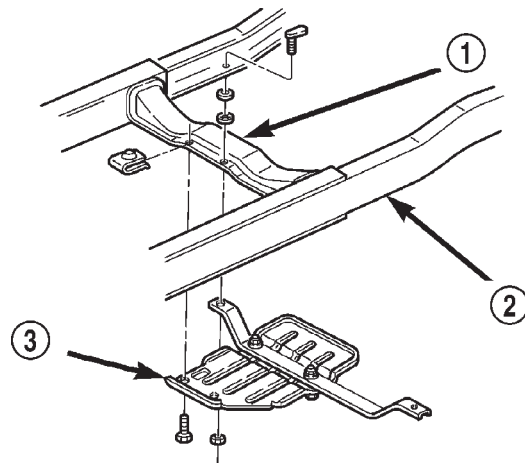
## TRANSFER CASE SKID PLATE

**REMOVAL**

- (1) Hoist and support vehicle on safety stands.
- (2) Remove bolts holding skid plate to frame rails (Fig. 15).
- (3) Separate skid plate from vehicle.

**INSTALLATION**

- (1) Position skid plate on vehicle.
- (2) Install bolts holding skid plate to frame rails.
- (3) Remove safety stands and lower vehicle.



80bfe0c2

**Fig. 15 Skid Plate**

- 1 - TRANSMISSION CROSS MEMBER
- 2 - FRAME RAIL
- 3 - SKID PLATE



# FUEL SYSTEM

## TABLE OF CONTENTS

	page		page
<b>FUEL DELIVERY - GASOLINE</b> .....	1	<b>FUEL DELIVERY - DIESEL</b> .....	54
<b>FUEL INJECTION - GASOLINE</b> .....	28	<b>FUEL INJECTION - DIESEL</b> .....	87

## FUEL DELIVERY - GASOLINE

### TABLE OF CONTENTS

	page		page
<b>FUEL DELIVERY - GASOLINE</b>		<b>FUEL PUMP PRESSURE TEST</b> .....	10
DESCRIPTION .....	2	<b>FUEL PUMP AMPERAGE TEST</b> .....	10
OPERATION .....	2	<b>FUEL PUMP MODULE</b>	
DIAGNOSIS AND TESTING .....	2	DESCRIPTION .....	12
FUEL PRESSURE LEAK DOWN TEST .....	2	OPERATION .....	13
STANDARD PROCEDURE .....	3	REMOVAL .....	13
FUEL SYSTEM PRESSURE RELEASE		INSTALLATION .....	13
PROCEDURE .....	3	<b>FUEL RAIL</b>	
SPECIFICATIONS .....	4	DESCRIPTION .....	15
SPECIAL TOOLS .....	4	OPERATION .....	15
<b>FUEL FILTER/PRESSURE REGULATOR</b>		REMOVAL .....	16
DESCRIPTION .....	5	INSTALLATION .....	18
OPERATION .....	5	<b>FUEL TANK</b>	
REMOVAL .....	5	DESCRIPTION .....	19
INSTALLATION .....	6	OPERATION .....	19
<b>FUEL LEVEL SENDING UNIT / SENSOR</b>		REMOVAL .....	19
DESCRIPTION .....	7	INSTALLATION .....	20
OPERATION .....	7	<b>INLET FILTER</b>	
DIAGNOSIS AND TESTING .....	8	REMOVAL .....	22
FUEL GAUGE SENDING UNIT .....	8	INSTALLATION .....	22
REMOVAL .....	8	<b>QUICK CONNECT FITTING</b>	
INSTALLATION .....	9	DESCRIPTION .....	22
<b>FUEL LINES</b>		STANDARD PROCEDURE .....	22
DESCRIPTION .....	9	QUICK-CONNECT FITTINGS .....	22
<b>FUEL PUMP</b>		<b>ROLLOVER VALVE</b>	
DESCRIPTION .....	9	DESCRIPTION .....	25
OPERATION .....	9	REMOVAL .....	26
DIAGNOSIS AND TESTING .....	9	INSTALLATION .....	27
FUEL PUMP CAPACITY TEST .....	9		



## FUEL DELIVERY - GASOLINE

### DESCRIPTION - FUEL DELIVERY SYSTEM

The fuel delivery system consists of:

- the fuel pump module containing the electric fuel pump, fuel filter/fuel pressure regulator, rollover valve (certain modules), fuel gauge sending unit (fuel level sensor) and a separate fuel filter located at bottom of pump module
- fuel tubes/lines/hoses
- quick-connect fittings
- fuel injector rail
- fuel injectors
- fuel tank
- fuel tank filler/vent tube assembly
- fuel tank filler tube cap
- accelerator pedal
- throttle cable

### OPERATION - FUEL DELIVERY SYSTEM

Fuel is returned through the fuel pump module and back into the fuel tank through the fuel filter/fuel pressure regulator. A separate fuel return line from the engine to the tank is not used with any gasoline powered engine.

The fuel tank assembly consists of: the fuel tank, fuel pump module assembly, fuel pump module lock-nut/gasket and rollover valve(s) (refer to 25, Emission Control System for rollover valve information).

A fuel filler/vent tube assembly using a pressure/vacuum, 1/4 turn fuel filler cap is used. The fuel filler tube contains a flap door located below the fuel fill cap.

Also to be considered part of the fuel system is the evaporation control system. This is designed to reduce the emission of fuel vapors into the atmosphere. The description and function of the Evaporative Control System is found in 25, Emission Control Systems.

Both fuel filters (at bottom of fuel pump module and within fuel pressure regulator) are designed for extended service. They do not require normal scheduled maintenance. Filters should only be replaced if a diagnostic procedure indicates to do so.

### DIAGNOSIS AND TESTING - FUEL PRESSURE LEAK DOWN TEST

Use this test in conjunction with the Fuel Pump Pressure Test and Fuel Pump Capacity Test.

**Check Valve Operation:** The electric fuel pump outlet contains a one-way check valve to prevent fuel flow back into the tank and to maintain fuel supply line pressure (engine warm) when pump is not operational. It is also used to keep the fuel supply line full of gasoline when pump is not operational. After

the vehicle has cooled down, fuel pressure may drop to 0 psi (cold fluid contracts), but liquid gasoline will remain in fuel supply line between the check valve and fuel injectors. **Fuel pressure that has dropped to 0 psi on a cooled down vehicle (engine off) is a normal condition.** When the electric fuel pump is activated, fuel pressure should **immediately** (1–2 seconds) rise to specification.

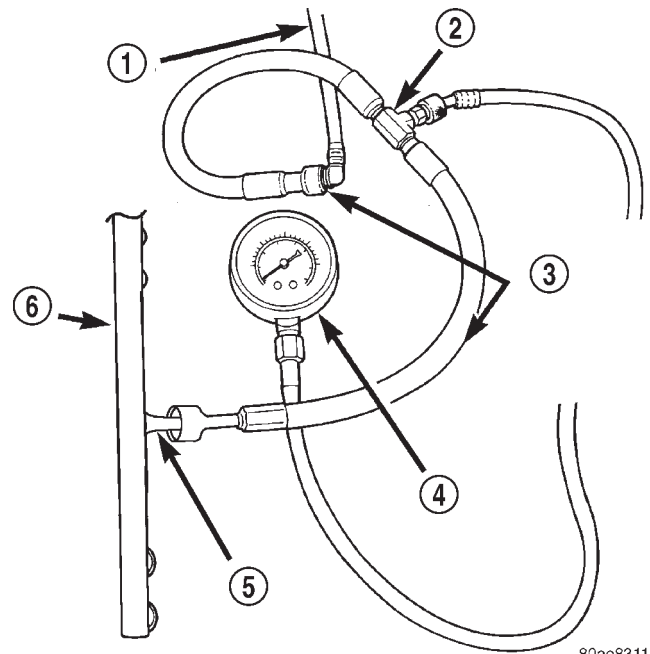
Abnormally long periods of cranking to restart a **hot** engine that has been shut down for a short period of time may be caused by:

- Fuel pressure bleeding past a fuel injector(s).
- Fuel pressure bleeding past the check valve in the fuel pump module.

(1) Disconnect the fuel inlet line at fuel rail. Refer to Fuel Tubes/Lines/Hoses and Clamps for procedures. On some engines, air cleaner housing removal may be necessary before fuel line disconnection.

(2) Obtain correct Fuel Line Pressure Test Adapter Tool Hose. Tool number 6539 is used for 5/16" fuel lines and tool number 6631 is used for 3/8" fuel lines.

(3) Connect correct Fuel Line Pressure Test Adapter Tool Hose between disconnected fuel line and fuel rail (Fig. 1).



80ae8311

**Fig. 1 Connecting Adapter Tool—Typical**

- 1 - VEHICLE FUEL LINE
- 2 - TEST PORT "T"
- 3 - SPECIAL TOOL 6923, 6631, 6541 OR 6539
- 4 - FUEL PRESSURE TEST GAUGE
- 5 - FUEL LINE CONNECTION AT RAIL
- 6 - FUEL RAIL

## FUEL DELIVERY - GASOLINE (Continued)

(4) Connect the 0-414 kPa (0-60 psi) fuel pressure test gauge (from Gauge Set 5069) to the test port on the appropriate Adaptor Tool. **The DRB® III Scan Tool along with the PEP module, the 500 psi pressure transducer, and the transducer-to-test port adapter may also be used in place of the fuel pressure gauge.**

**The fittings on both tools must be in good condition and free from any small leaks before performing the proceeding test.**

(5) Start engine and bring to normal operating temperature.

(6) Observe test gauge. Normal operating pressure should be 339 kPa +/-34 kPa (49.2 psi +/-5 psi).

(7) Shut engine off.

(8) Pressure should not fall below **30 psi for five minutes.**

(9) If pressure falls below 30 psi, it must be determined if a fuel injector, the check valve within the fuel pump module, or a fuel tube/line is leaking.

(10) Again, start engine and bring to normal operating temperature.

(11) Shut engine off.

(12) **Testing for fuel injector or fuel rail leakage:** Clamp off the rubber hose portion of Adaptor Tool between the fuel rail and the test port "T" on Adapter Tool. If pressure now holds at or above 30 psi, a fuel injector or the fuel rail is leaking.

(13) **Testing for fuel pump check valve, filter/regulator check valve or fuel tube/line leakage:** Clamp off the rubber hose portion of Adaptor Tool between the vehicle fuel line and test port "T" on Adapter Tool. If pressure now holds at or above 30 psi, a leak may be found at a fuel tube/line. If no leaks are found at fuel tubes or lines, one of the check valves in either the electric fuel pump or filter/regulator may be leaking.

Note: A quick loss of pressure usually indicates a defective check valve in the filter/regulator. A slow loss of pressure usually indicates a defective check valve in the electric fuel pump.

The electric fuel pump is not serviced separately. Replace the fuel pump module assembly. The filter/regulator may be replaced separately on certain applications. Refer to Fuel Filter/Fuel Pressure Regulator Removal/Installation for additional information.

## STANDARD PROCEDURE - FUEL SYSTEM PRESSURE RELEASE

**Use following procedure if the fuel injector rail is, or is not equipped with a fuel pressure test port.**

(1) Remove fuel fill cap.

(2) Remove fuel pump relay from Power Distribution Center (PDC). For location of relay, refer to label on underside of PDC cover.

(3) Start and run engine until it stalls.

(4) Attempt restarting engine until it will no longer run.

(5) Turn ignition key to OFF position.

**CAUTION: Steps 1, 2, 3 and 4 must be performed to relieve high pressure fuel from within fuel rail. Do not attempt to use following steps to relieve this pressure as excessive fuel will be forced into a cylinder chamber.**

(6) Unplug connector from any fuel injector.

(7) Attach one end of a jumper wire with alligator clips (18 gauge or smaller) to either injector terminal.

(8) Connect other end of jumper wire to positive side of battery.

(9) Connect one end of a second jumper wire to remaining injector terminal.

**CAUTION: Powering an injector for more than a few seconds will permanently damage the injector.**

(10) Momentarily touch other end of jumper wire to negative terminal of battery for no more than a few seconds.

(11) Place a rag or towel below fuel line quick-connect fitting at fuel rail.

(12) Disconnect quick-connect fitting at fuel rail. Refer to Quick-Connect Fittings.

(13) Return fuel pump relay to PDC.

(14) One or more Diagnostic Trouble Codes (DTC's) may have been stored in PCM memory due to fuel pump relay removal. The DRB® scan tool must be used to erase a DTC.

FUEL DELIVERY - GASOLINE (Continued)

SPECIFICATIONS

SPECIFICATIONS - FUEL SYSTEM PRESSURE - GAS ENGINES

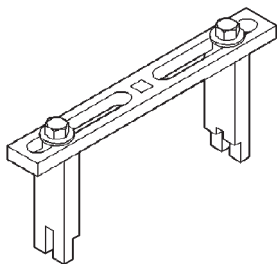
**All Gasoline Powered Engines:** 339 kPa ± 34 kPa (49.2 psi ± 5 psi)

SPECIFICATIONS - TORQUE - FUEL DELIVERY

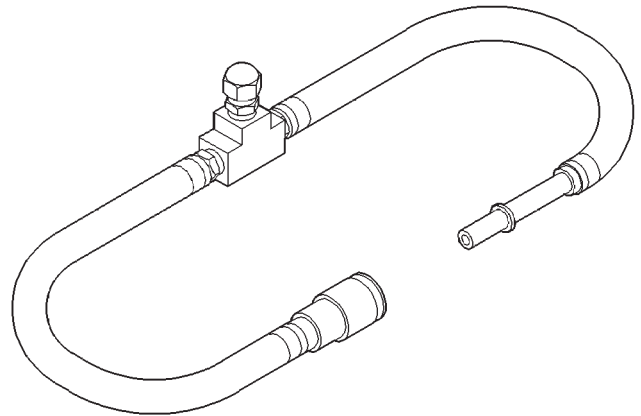
DESCRIPTION	N-m	Ft. Lbs.	In. Lbs.
Fuel Pump Module Locknut	24-44	18-32	
Fuel Rail Mounting Bolts—3.9L/5.2L/5.9L Engines	23		200
Fuel Rail Mounting Bolts—8.0L Engine	15		136
Fuel Tank Mounting Nuts	41	30	
Fuel Hose Clamps	1		15

SPECIAL TOOLS

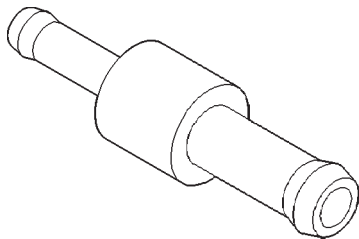
FUEL SYSTEM



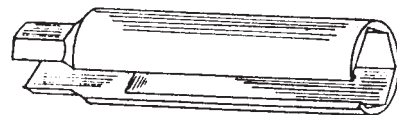
**Spanner Wrench—6856**



**Adapters, Fuel Pressure Test—6539 and/or 6631**

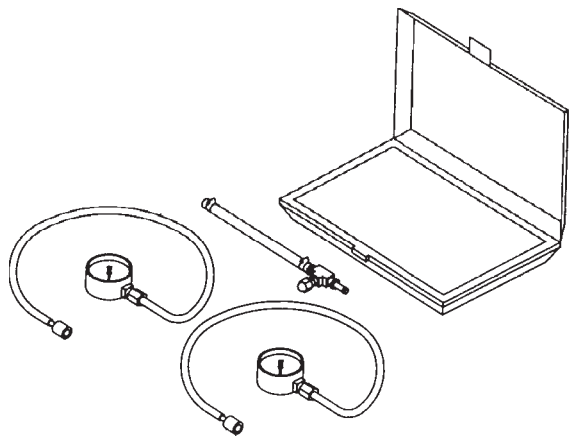


**Fitting, Air Metering—6714**

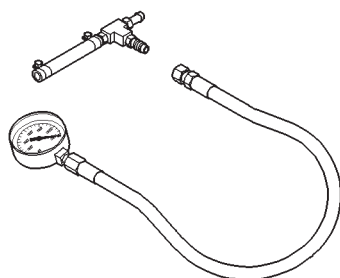


**O2S (Oxygen Sensor) Remover/Installer—C-4907**

## FUEL DELIVERY - GASOLINE (Continued)



**Test Kit, Fuel Pressure—5069**



**Test Kit, Fuel Pressure—C-4799-B**



**Fuel Line Removal Tool—6782**

## FUEL FILTER/PRESSURE REGULATOR

### DESCRIPTION

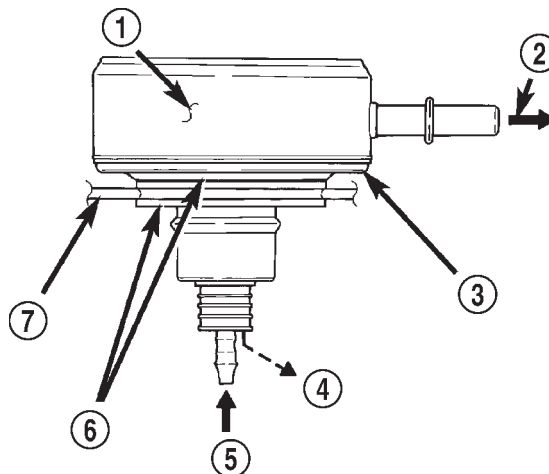
A combination fuel filter and fuel pressure regulator (Fig. 2) is used on all engines. It is located on the top of the fuel pump module. A separate frame mounted fuel filter is not used with any engine.

Both fuel filters (at bottom of fuel pump module and within fuel pressure regulator) are designed for extended service. They do not require normal scheduled maintenance. Filters should only be replaced if a diagnostic procedure indicates to do so.

### OPERATION

**Fuel Pressure Regulator Operation:** The pressure regulator is a mechanical device that is not controlled by engine vacuum or the powertrain control module (PCM).

The regulator is calibrated to maintain fuel system operating pressure of approximately 339 kPa  $\pm$  34 kPa (49.2 psi  $\pm$  5 psi) at the fuel injectors. It contains a diaphragm, calibrated springs and a fuel



80a92a65

**Fig. 2 Side View—Filter/Regulator**

- 1 - INTERNAL FUEL FILTER
- 2 - FUEL FLOW TO FUEL INJECTORS
- 3 - FUEL FILTER/FUEL PRESSURE REGULATOR
- 4 - EXCESS FUEL BACK TO TANK
- 5 - FUEL INLET
- 6 - RUBBER GROMMET
- 7 - TOP OF PUMP MODULE

return valve. The internal fuel filter (Fig. 2) is also part of the assembly.

Fuel is supplied to the filter/regulator by the electric fuel pump through an opening tube at the bottom of filter/regulator (Fig. 2).

The regulator acts as a check valve to maintain some fuel pressure when the engine is not operating. This will help to start the engine. A second check valve is located at the outlet end of the electric fuel pump. **Refer to Fuel Pump—Description and Operation for more information. Also refer to the Fuel Pressure Leak Down Test and the Fuel Pump Pressure Tests.**

If fuel pressure at the pressure regulator exceeds approximately 49.2 psi, an internal diaphragm opens and excess fuel pressure is routed back into the tank through the bottom of pressure regulator.

Both fuel filters (at bottom of fuel pump module and within fuel pressure regulator) are designed for extended service. They do not require normal scheduled maintenance. Filters should only be replaced if a diagnostic procedure indicates to do so.

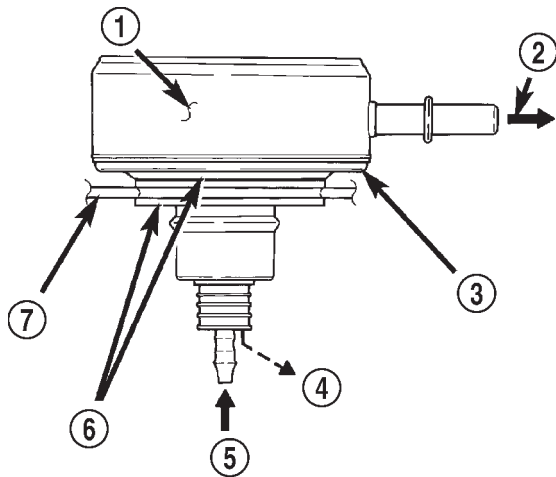
### REMOVAL

**WARNING: THE FUEL SYSTEM IS UNDER A CONSTANT PRESSURE, EVEN WITH ENGINE OFF. BEFORE SERVICING FUEL FILTER/FUEL PRESSURE REGULATOR, FUEL SYSTEM PRESSURE MUST BE RELEASED.**

## FUEL FILTER/PRESSURE REGULATOR (Continued)

Refer to Fuel System Pressure Release in Fuel Delivery System section of this group.

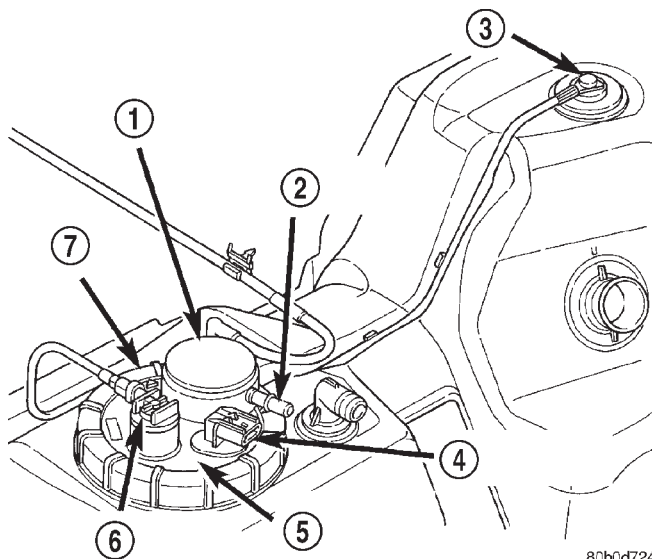
The fuel filter/fuel pressure regulator (Fig. 3) is located at top of fuel pump module (Fig. 4) or (Fig. 5).



80a92a65

**Fig. 3 Fuel Filter/Fuel Pressure Regulator**

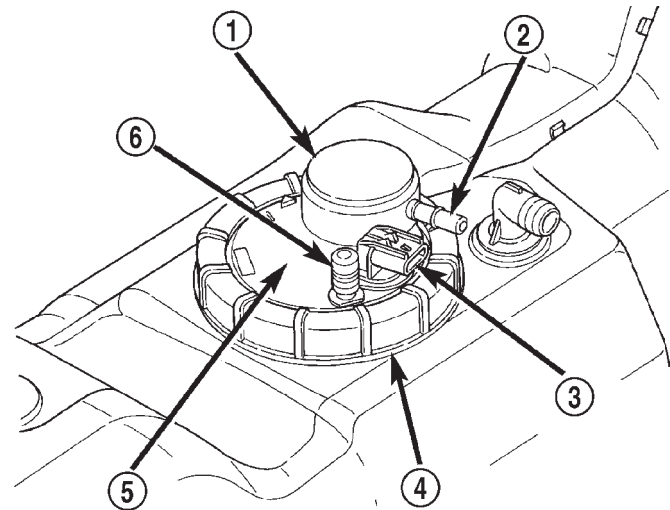
- 1 - INTERNAL FUEL FILTER
- 2 - FUEL FLOW TO FUEL INJECTORS
- 3 - FUEL FILTER/FUEL PRESSURE REGULATOR
- 4 - EXCESS FUEL BACK TO TANK
- 5 - FUEL INLET
- 6 - RUBBER GROMMET
- 7 - TOP OF PUMP MODULE



80b0d724

**Fig. 4 Filter/Regulator Location—With 26 or 34 Gallon Fuel Tank**

- 1 - FUEL FILTER/PRESSURE REGULATOR
- 2 - FUEL SUPPLY FITTING
- 3 - REAR ROLLOVER VALVE
- 4 - ELECTRICAL CONNECTOR
- 5 - FUEL PUMP MODULE
- 6 - FRONT ROLLOVER VALVE
- 7 - LOCKNUT



80b0d722

**Fig. 5 Filter/Regulator Location—With 35 Gallon Fuel Tank**

- 1 - FUEL FILTER/PRESSURE REGULATOR
- 2 - FUEL SUPPLY FITTING
- 3 - ELECTRICAL CONNECTOR
- 4 - LOCKNUT
- 5 - FUEL PUMP MODULE
- 6 - AUXILIARY CAPPED FITTING

Fuel pump module removal is not necessary.

(1) Drain fuel tank and remove tank. Refer to Fuel Tank Removal/Installation.

(2) The fuel filter/regulator is pressed into a rubber grommet. Remove by twisting and pulling straight up (Fig. 6).

**CAUTION:** Do not pull filter/regulator more than three inches from fuel pump module. Damage to coiled fuel tube (line) may result.

(3) Gently cut old fuel tube (line) clamp (Fig. 7) taking care not to damage plastic fuel tube. Remove and discard old fuel tube clamp.

(4) Remove plastic fuel tube from filter/regulator by gently pulling downward. Remove filter/regulator from fuel pump module.

## INSTALLATION

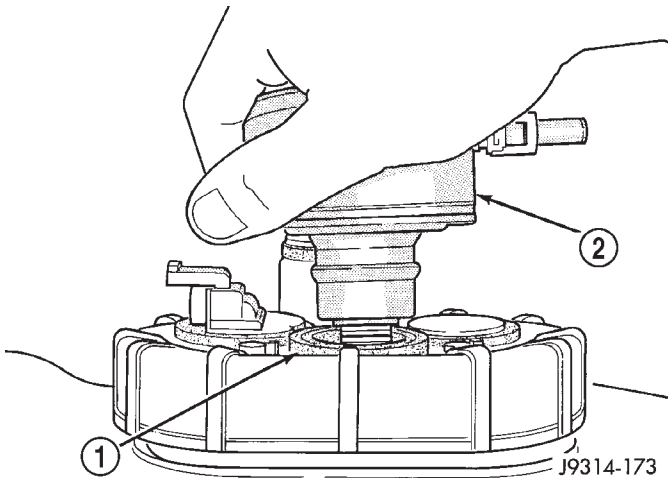
(1) Install a new clamp over plastic fuel tube.

(2) Install filter/regulator to fuel tube. Rotate filter/regulator in fuel tube (line) (Fig. 8) until it is pointed to drivers side of vehicle (Fig. 4) or (Fig. 5).

(3) Tighten line clamp to fuel line using special Hose Clamp Pliers number C-4124 or equivalent (Fig. 8). **Do not use conventional side cutters to tighten this type of clamp.**

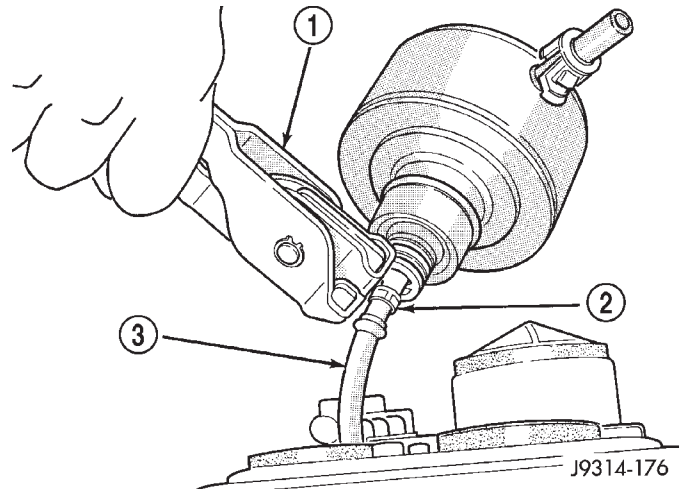


## FUEL FILTER/PRESSURE REGULATOR (Continued)



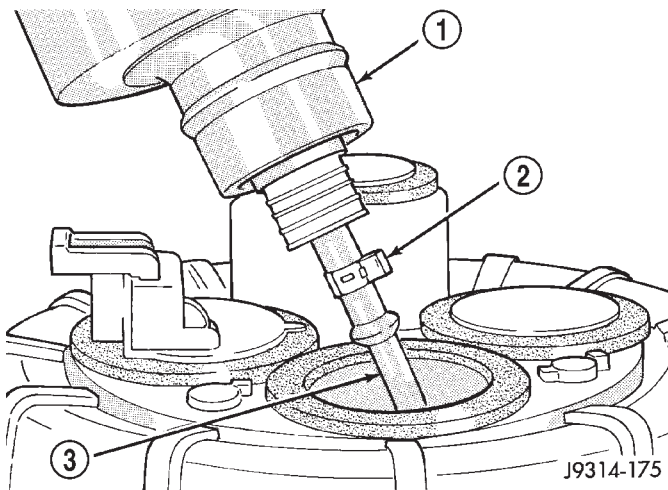
**Fig. 6 Filter/Regulator Removal and Installation—TYPICAL**

- 1 - RUBBER GROMMET
- 2 - FUEL FILTER/FUEL PRESSURE REGULATOR



**Fig. 8 Tightening Fuel Tube Clamp—TYPICAL**

- 1 - TOOL C-4124
- 2 - TUBE CLAMP
- 3 - FUEL TUBE



**Fig. 7 Fuel Tube and Clamp—TYPICAL**

- 1 - FUEL FILTER/FUEL PRESSURE REGULATOR
- 2 - TUBE CLAMP
- 3 - FUEL TUBE

(4) Press filter/regulator (by hand) into rubber grommet. The assembly should be pointed towards drivers side of vehicle (Fig. 4) or (Fig. 5).

(5) Install fuel tank. Refer to Fuel Tank Removal/Installation.

(6) Check for fuel leaks.

## FUEL LEVEL SENDING UNIT / SENSOR

### DESCRIPTION

The fuel gauge sending unit (fuel level sensor) is attached to the side of the fuel pump module. The sending unit consists of a float, an arm, and a variable resistor track (card).

### OPERATION

The fuel pump module has 4 different circuits (wires). Two of these circuits are used for the fuel gauge sending unit for fuel gauge operation, and for certain OBD II emission requirements. The other 2 wires are used for electric fuel pump operation.

**For Fuel Gauge Operation:** A constant current source of about 32 mA is supplied to the resistor track on the fuel gauge sending unit. This is fed directly from the Powertrain Control Module (PCM). The resistor track is used to vary the voltage depending on fuel tank float level. As fuel level increases, the float and arm move up, which decreases voltage. As fuel level decreases, the float and arm move down, which increases voltage. The varied voltage signal is returned back to the PCM through the sensor return circuit. Output voltages will vary from about .6 volts at FULL, to about 8.6 volts at EMPTY (Jeep models), or, about 7.0 volts at EMPTY (Dodge Truck models). **NOTE: For diagnostic purposes, this voltage can only be verified with the fuel gauge sending unit circuit closed (i.e. having all of the sending units electrical connectors connected).**



## FUEL LEVEL SENDING UNIT / SENSOR (Continued)

Both of the electrical circuits between the fuel gauge sending unit and the PCM are hard-wired (not multi-plexed). After the voltage signal is sent from the resistor track, and back to the PCM, the PCM will interpret the resistance (voltage) data and send a message across the multi-plex bus circuits to the instrument panel cluster. Here it is translated into the appropriate fuel gauge level reading. Refer to Instrument Panel for additional information.

**For OBD II Emission Monitor Requirements:** The PCM will monitor the voltage output sent from the resistor track on the sending unit to indicate fuel level. The purpose of this feature is to prevent the OBD II system from recording/setting false misfire and fuel system monitor diagnostic trouble codes. The feature is activated if the fuel level in the tank is less than approximately 15 percent of its rated capacity. If equipped with a Leak Detection Pump (EVAP system monitor), this feature will also be activated if the fuel level in the tank is more than approximately 85 percent of its rated capacity.

## DIAGNOSIS AND TESTING - FUEL GAUGE SENDING UNIT

The fuel gauge sending unit contains a variable resistor (track). As the float moves up or down, electrical resistance will change. Refer to 8, Instrument Panel and Gauges for Fuel Gauge testing. To test the gauge sending unit only, it must be removed from vehicle. The unit is part of the fuel pump module. Refer to Fuel Pump Module Removal/Installation for procedures. Measure the resistance across the sending unit terminals. With float in up position, resistance should be 20 ohms  $\pm$ 6 ohms. With float in down position, resistance should be 220 ohms  $\pm$ 6 ohms.

## REMOVAL

The fuel gauge sending unit (fuel level sensor) and float assembly is located on the side of fuel pump module (Fig. 9). The fuel pump module is located inside of fuel tank.

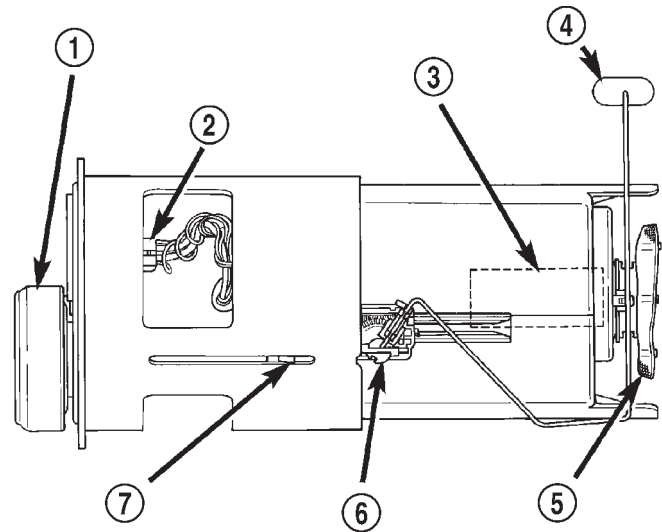
(1) Remove fuel tank. Refer to Fuel Tank—All Engines in the Removal/Installation section.

(2) Remove fuel pump module. Refer to Fuel Pump Module Removal/Installation.

(3) Unplug 4-way electrical connector (Fig. 9).

(4) Disconnect 2 sending unit wires at 4-way connector. The locking collar of connector must be removed before wires can be released from connector. Note location of wires within 4-way connector.

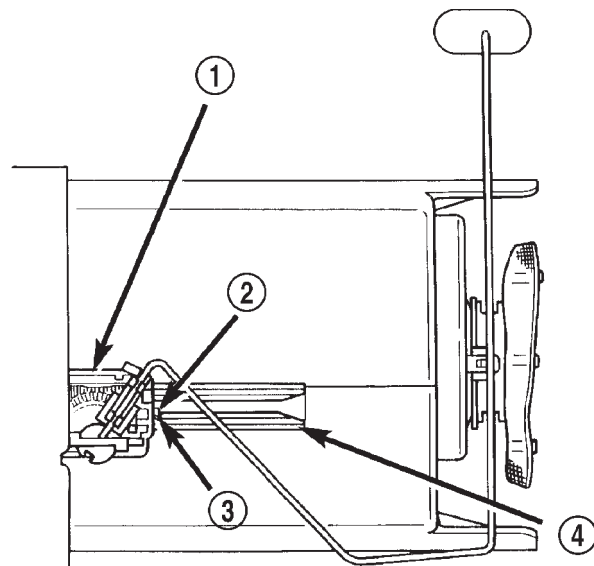
(5) The sending unit is retained to pump module with a small lock tab and notch (Fig. 10). Carefully push lock tab to the side and away from notch while sliding sending unit downward on tracks for removal. Note wire routing while removing unit from module.



80b0d725

**Fig. 9 Fuel Gauge Sending Unit Location—TYPICAL Module**

- 1 - FUEL FILTER/PRESSURE REGULATOR
- 2 - ELECTRICAL CONNECTOR
- 3 - ELECTRIC FUEL PUMP
- 4 - FUEL GAUGE FLOAT
- 5 - FUEL PUMP INLET FILTER
- 6 - FUEL GAUGE SENDING UNIT
- 7 - MODULE LOCK TABS (3)



80a61215

**Fig. 10 Fuel Gauge Sending Unit Lock Tab/Tracks**

- 1 - FUEL GAUGE SENDING UNIT
- 2 - LOCK TAB
- 3 - NOTCH
- 4 - TRACKS

## FUEL LEVEL SENDING UNIT / SENSOR (Continued)

**INSTALLATION**

The fuel gauge sending unit (fuel level sensor) and float assembly is located on the side of fuel pump module (Fig. 9). The fuel pump module is located inside of fuel tank.

- (1) Position sending unit into tracks. Note wire routing.
- (2) Push unit on tracks until lock tab snaps into notch.
- (3) Connect 2 sending unit wires into 4-way connector and install locking collar.
- (4) Connect 4-way electrical connector to module.
- (5) Install fuel pump module. Refer to Fuel Pump Module Removal/Installation.
- (6) Install fuel tank. Refer to Fuel Tank-All Engines in the Removal/Installation section.

**FUEL LINES****DESCRIPTION**

Also refer to Quick-Connect Fittings.

**WARNING: THE FUEL SYSTEM IS UNDER A CONSTANT PRESSURE (EVEN WITH THE ENGINE OFF). BEFORE SERVICING ANY FUEL SYSTEM HOSES, FITTINGS OR LINES, THE FUEL SYSTEM PRESSURE MUST BE RELEASED. REFER TO THE FUEL SYSTEM PRESSURE RELEASE PROCEDURE IN THIS GROUP.**

The lines/tubes/hoses used on fuel injected vehicles are of a special construction. This is due to the higher fuel pressures and the possibility of contaminated fuel in this system. If it is necessary to replace these lines/tubes/hoses, only those marked EFM/EFI may be used.

**If equipped:** The hose clamps used to secure rubber hoses on fuel injected vehicles are of a special rolled edge construction. This construction is used to prevent the edge of the clamp from cutting into the hose. Only these rolled edge type clamps may be used in this system. All other types of clamps may cut into the hoses and cause high-pressure fuel leaks.

Use new original equipment type hose clamps.

**FUEL PUMP****DESCRIPTION**

The fuel pump is located inside of the fuel pump module. A 12 volt, permanent magnet, electric motor powers the fuel pump.

**OPERATION**

Voltage to operate the electric pump is supplied through the fuel pump relay.

Fuel is drawn in through a filter at the bottom of the module and pushed through the electric motor gearset to the pump outlet.

**Check Valve Operation:** The pump outlet contains a one-way check valve to prevent fuel flow back into the tank and to maintain fuel supply line pressure (engine warm) when pump is not operational. It is also used to keep the fuel supply line full of gasoline when pump is not operational. After the vehicle has cooled down, fuel pressure may drop to 0 psi (cold fluid contracts), but liquid gasoline will remain in fuel supply line between the check valve and fuel injectors. **Fuel pressure that has dropped to 0 psi on a cooled down vehicle (engine off) is a normal condition.** Refer to the Fuel Pressure Leak Down Test for more information.

**DIAGNOSIS AND TESTING - FUEL PUMP CAPACITY TEST**

**Before performing this test, verify fuel pump pressure. Refer to Fuel Pump Pressure Test. Use this test in conjunction with the Fuel Pressure Leak Down Test.**

- (1) Release fuel system pressure. Refer to Fuel Pressure Release Procedure.
- (2) Disconnect fuel supply line at fuel rail. Refer to Quick-Connect Fittings. Some engines may require air cleaner housing removal before line disconnection.
- (3) Obtain correct Fuel Line Pressure Test Adapter Tool Hose. Tool number 6539 is used for 5/16" fuel lines and tool number 6631 is used for 3/8" fuel lines.
- (4) Connect correct Fuel Line Pressure Test Adapter Tool Hose into disconnected fuel supply line. Insert other end of Adaptor Tool Hose into a graduated container.
- (5) Remove fuel fill cap.
- (6) To activate fuel pump and pressurize system, obtain DRB® scan tool and actuate ASD Fuel System Test.
- (7) A good fuel pump will deliver at least 1/4 liter of fuel in 7 seconds. Do not operate fuel pump for longer than 7 seconds with fuel line disconnected as fuel pump module reservoir may run empty.
  - (a) If capacity is lower than specification, but fuel pump can be heard operating through fuel fill cap opening, check for a kinked/damaged fuel supply line somewhere between fuel rail and fuel pump module.
  - (b) If line is not kinked/damaged, and fuel pressure is OK, but capacity is low, replace fuel filter/fuel pressure regulator. The filter/regulator may be serviced separately on certain applications. Refer to Fuel Filter/Fuel Pressure Regulator Removal/Installation for additional information.
  - (c) If both fuel pressure and capacity are low, replace fuel pump module assembly. Refer to Fuel Pump Module Removal/Installation.

## FUEL PUMP (Continued)

DIAGNOSIS AND TESTING - FUEL PUMP  
PRESSURE TEST

Use this test in conjunction with the Fuel Pump Capacity Test, Fuel Pressure Leak Down Test and Fuel Pump Amperage Test found elsewhere in this group.

**Check Valve Operation:** The electric fuel pump outlet contains a one-way check valve to prevent fuel flow back into the tank and to maintain fuel supply line pressure (engine warm) when pump is not operational. It is also used to keep the fuel supply line full of gasoline when pump is not operational. After the vehicle has cooled down, fuel pressure may drop to 0 psi (cold fluid contracts), but liquid gasoline will remain in fuel supply line between the check valve and fuel injectors. **Fuel pressure that has dropped to 0 psi on a cooled down vehicle (engine off) is a normal condition.** When the electric fuel pump is activated, fuel pressure should **immediately** (1–2 seconds) rise to specification.

All fuel systems are equipped with a fuel tank module mounted, combination fuel filter/fuel pressure regulator. The fuel pressure regulator is not controlled by engine vacuum.

**WARNING: THE FUEL SYSTEM IS UNDER CONSTANT FUEL PRESSURE EVEN WITH THE ENGINE OFF. BEFORE DISCONNECTING FUEL LINE AT FUEL RAIL, THIS PRESSURE MUST BE RELEASED. REFER TO THE FUEL SYSTEM PRESSURE RELEASE PROCEDURE.**

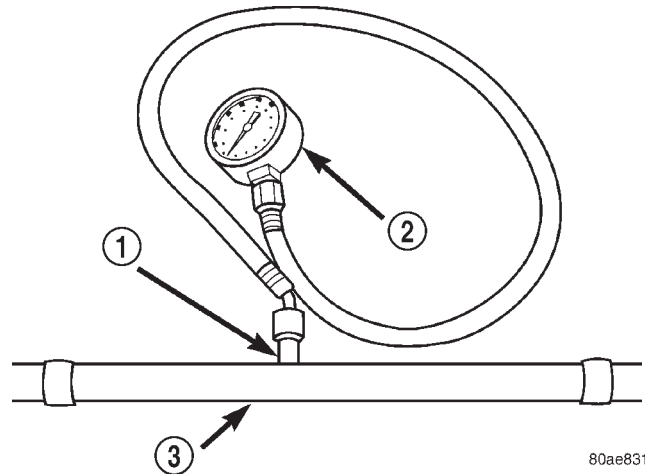
(1) Remove protective cap at fuel rail test port. Connect the 0–414 kPa (0-60 psi) fuel pressure gauge (from gauge set 5069) to test port pressure fitting on fuel rail (Fig. 11). **The DRB® III Scan Tool along with the PEP module, the 500 psi pressure transducer, and the transducer-to-test port adapter may also be used in place of the fuel pressure gauge.**

(2) Start and warm engine and note pressure gauge reading. Fuel pressure should be 339 kPa  $\pm$  34 kPa (49.2 psi  $\pm$  5 psi) at idle.

(3) If engine runs, but pressure is below 44.2 psi, check for a kinked fuel supply line somewhere between fuel rail and fuel pump module. If line is not kinked, but specifications for either the Fuel Pump Capacity, Fuel Pump Amperage or Fuel Pressure Leak Down Tests were not met, replace fuel pump module assembly. Refer to Fuel Pump Module Removal/Installation.

(4) If operating pressure is above 54.2 psi, electric fuel pump is OK, but fuel pressure regulator is defective. Replace fuel filter/fuel pressure regulator. Refer to Fuel Filter/Fuel Pressure Regulator Removal/Installation for more information.

(5) Install protective cap to fuel rail test port.



80ae8310

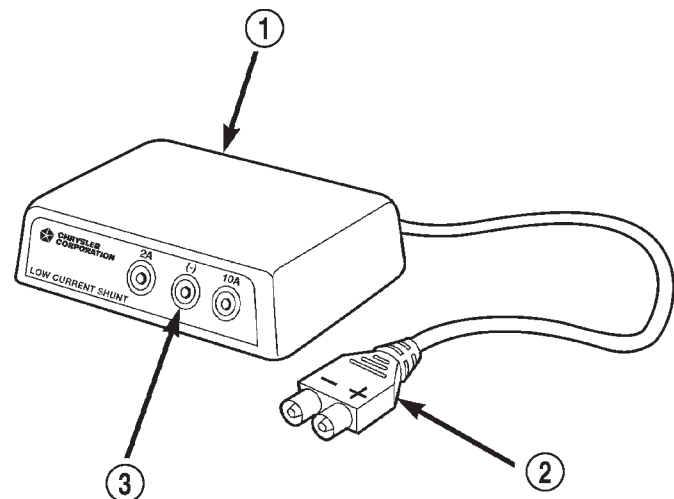
**Fig. 11 Fuel Pressure Test Gauge (Typical Gauge Installation at Test Port)**

- 1 - SERVICE (TEST) PORT
- 2 - FUEL PRESSURE TEST GAUGE
- 3 - FUEL RAIL

DIAGNOSIS AND TESTING - FUEL PUMP  
AMPERAGE TEST

This amperage (current draw) test is to be done in conjunction with the Fuel Pump Pressure Test, Fuel Pump Capacity Test and Fuel Pressure Leak Down Test. Before performing the amperage test, be sure the temperature of the fuel tank is above 50° F (10° C).

The DRB® Scan Tool along with the DRB Low Current Shunt (LCS) adapter (Fig. 12) and its test leads will be used to check fuel pump amperage specifications.



80add391

**Fig. 12 Low Current Shunt**

- 1 - LOW CURRENT SHUNT ADAPTER
- 2 - PLUG TO DRB
- 3 - TEST LEAD RECEPTACLES

## FUEL PUMP (Continued)

(1) Be sure fuel tank contains fuel before starting test. If tank is empty or near empty, amperage readings will be incorrect.

(2) Obtain LCS adapter.

(3) Plug cable from LCS adapter into DRB scan tool at SET 1 receptacle.

(4) Plug DRB into vehicle 16-way connector (data link connector).

(5) Connect (-) and (+) test cable leads into LCS adapter receptacles. Use **10 amp (10A +)** receptacle and common (-) receptacles.

(6) Gain access to MAIN MENU on DRB screen.

(7) Press DVOM button on DRB.

(8) Using left/right arrow keys, highlight CHANNEL 1 function on DRB screen.

(9) Press ENTER three times.

(10) Using up/down arrow keys, highlight RANGE on DRB screen (screen will default to 2 amp scale).

(11) Press ENTER to change 2 amp scale to 10 amp scale. **This step must be done to prevent damage to DRB scan tool or LCS adapter (blown fuse).**

(12) Remove cover from Power Distribution Center (PDC).

(13) Remove fuel pump relay from PDC. Refer to label on PDC cover for relay location.

**WARNING: BEFORE PROCEEDING TO NEXT STEP, NOTE THE FUEL PUMP WILL BE ACTIVATED AND SYSTEM PRESSURE WILL BE PRESENT. THIS WILL OCCUR AFTER CONNECTING TEST LEADS FROM LCS ADAPTER INTO FUEL PUMP RELAY CAVITIES. THE FUEL PUMP WILL OPERATE EVEN WITH IGNITION KEY IN OFF POSITION. BEFORE ATTACHING TEST LEADS, BE SURE ALL FUEL LINES AND FUEL SYSTEM COMPONENTS ARE CONNECTED.**

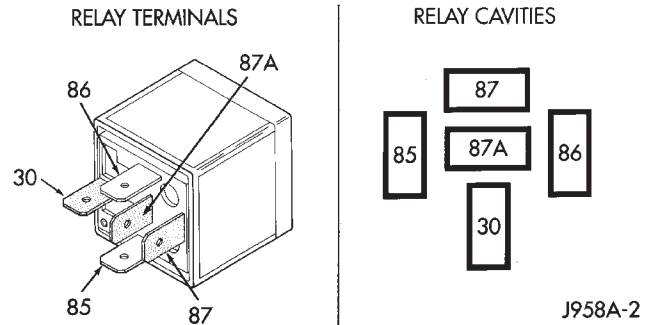
**CAUTION: To prevent possible damage to the vehicle electrical system and LCS adapter, the test leads must be connected into relay cavities exactly as shown in following steps.**

Depending upon vehicle model, year or engine configuration, three different types of relays may be used: Type-1, type-2 and type-3.

(14) If equipped with **type-1 relay** (Fig. 13), attach test leads from LCS adapter into PDC relay cavities number 30 and 87. For location of these cavities, refer to numbers stamped to bottom of relay (Fig. 13).

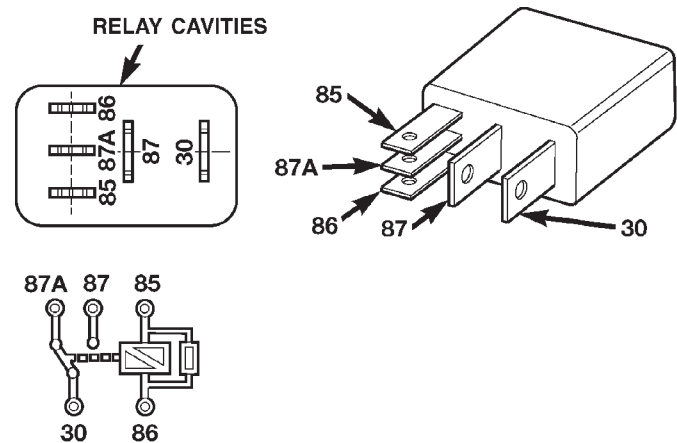
(15) If equipped with **type-2 relay** (Fig. 14), attach test leads from LCS adapter into PDC relay cavities number 30 and 87. For location of these cavities, refer to numbers stamped to bottom of relay (Fig. 14).

(16) If equipped with **type-3 relay** (Fig. 15), attach test leads from LCS adapter into PDC relay cavities number 3 and 5. For location of these cavities, refer to numbers stamped to bottom of relay (Fig. 15).



**Fig. 13 FUEL PUMP RELAY - TYPE 1**

TERMINAL LEGEND	
NUMBER	IDENTIFICATION
30	COMMON FEED
85	COIL GROUND
86	COIL BATTERY
87	NORMALLY OPEN
87A	NORMALLY CLOSED



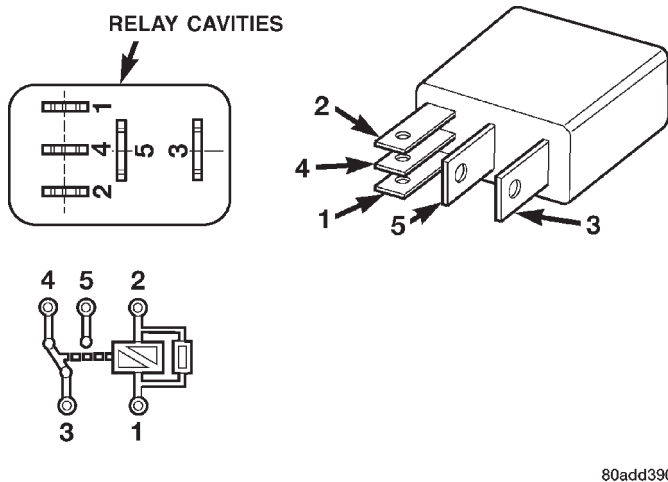
**Fig. 14 FUEL PUMP RELAY - TYPE 2**

TERMINAL LEGEND	
NUMBER	IDENTIFICATION
30	COMMON FEED
85	COIL GROUND
86	COIL BATTERY
87	NORMALLY OPEN
87A	NORMALLY CLOSED

80add392



## FUEL PUMP (Continued)



80add390

Fig. 15 FUEL PUMP RELAY - TYPE 3

TERMINAL LEGEND	
NUMBER	IDENTIFICATION
1	COIL BATTERY
2	COIL GROUND
3	COMMON FEED
4	NORMALLY CLOSED
5	NORMALLY OPEN

(17) When LCS adapter test leads are attached into relay cavities, fuel pump **will be activated**. Determine fuel pump amperage on DRB screen. Amperage should be below 10.0 amps. If amperage is below 10.0 amps, and specifications for the Fuel Pump Pressure, Fuel Pump Capacity and Fuel Pressure Leak Down tests were met, the fuel pump module is OK.

(18) If amperage is more than 10.0 amps, replace fuel pump module assembly. The electric fuel pump is not serviced separately.

(19) Disconnect test leads from relay cavities immediately after testing.

## FUEL PUMP MODULE

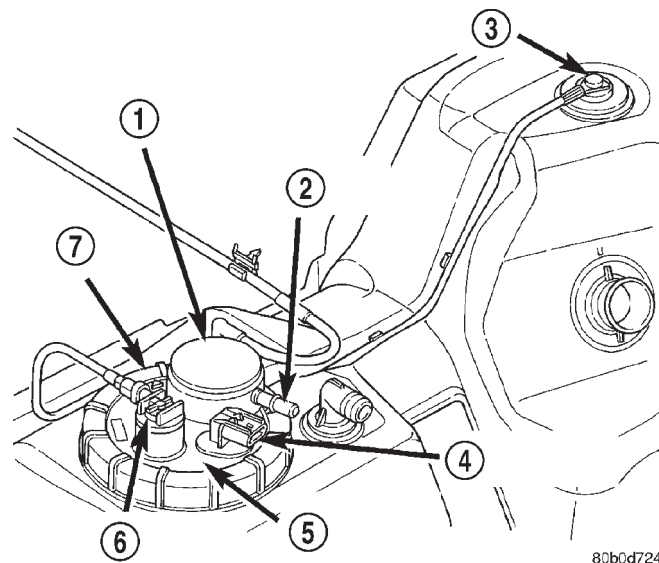
## DESCRIPTION

The fuel pump module on all gas powered engines is installed in the top of the fuel tank (Fig. 16) or (Fig. 17). The fuel pump module (Fig. 16), (Fig. 17) or (Fig. 18) contains the following:

- A combination fuel filter/fuel pressure regulator
- Electric fuel pump
- Fuel pump reservoir
- A separate in-tank fuel filter (at bottom of module)

- Rollover valve (certain modules)
- Fuel gauge sending unit (fuel level sensor)
- Fuel supply line connection at filter/regulator
- A threaded locknut retaining pump module to fuel tank
- A gasket between tank flange and module
- Auxiliary non-pressurized fuel supply fitting (not all engines)

The fuel gauge sending unit (fuel level sensor), and pick-up filter (at bottom of module) may be serviced separately. If the electrical fuel pump requires service, the entire fuel pump module must be replaced. The fuel filter/fuel pressure regulator may be serviced separately. Refer to Fuel Filter/Fuel Pressure Regulator Removal/Installation for additional information.

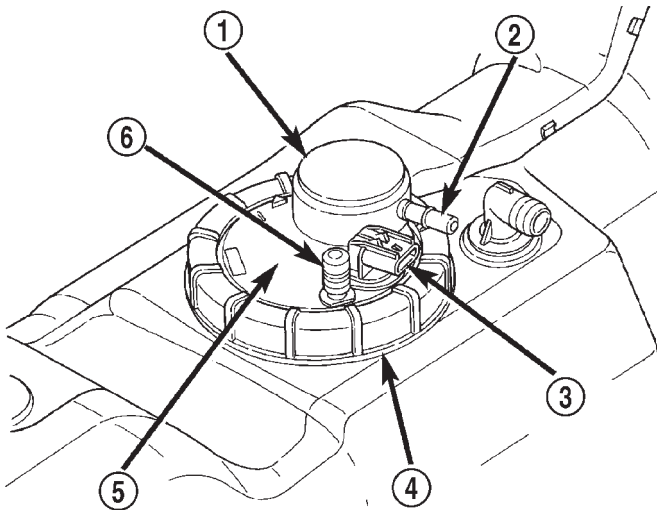


80b0d724

Fig. 16 Fuel Pump Module - Gas Powered With 26 or 34 Gallon Tank—Typical

- 1 - FUEL FILTER/PRESSURE REGULATOR
- 2 - FUEL SUPPLY FITTING
- 3 - REAR ROLLOVER VALVE
- 4 - ELECTRICAL CONNECTOR
- 5 - FUEL PUMP MODULE
- 6 - FRONT ROLLOVER VALVE
- 7 - LOCKNUT

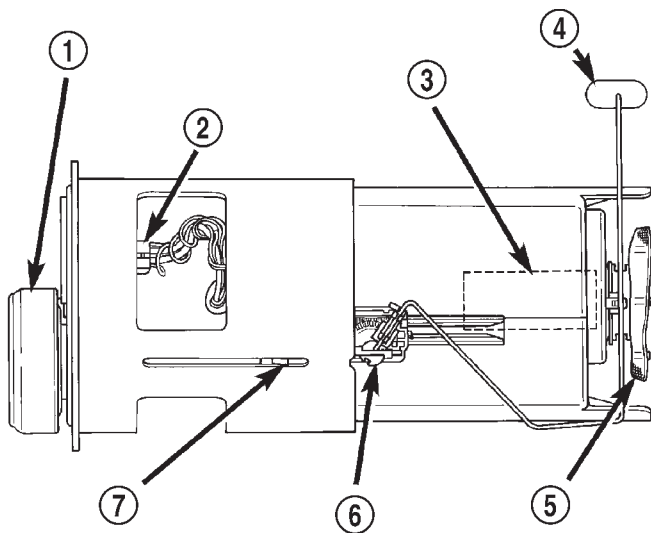
## FUEL PUMP MODULE (Continued)



80b0d722

**Fig. 17 Fuel Pump Module - Gas Powered with 35 Gal. Tank**

- 1 - FUEL FILTER/PRESSURE REGULATOR
- 2 - FUEL SUPPLY FITTING
- 3 - ELECTRICAL CONNECTOR
- 4 - LOCKNUT
- 5 - FUEL PUMP MODULE
- 6 - AUXILIARY CAPPED FITTING



80b0d725

**Fig. 18 Fuel Pump Module Components - Gas Powered Engines - Typical**

- 1 - FUEL FILTER/PRESSURE REGULATOR
- 2 - ELECTRICAL CONNECTOR
- 3 - ELECTRIC FUEL PUMP
- 4 - FUEL GAUGE FLOAT
- 5 - FUEL PUMP INLET FILTER
- 6 - FUEL GAUGE SENDING UNIT
- 7 - MODULE LOCK TABS (3)

## OPERATION

Refer to Fuel Pump, Fuel Filter/Fuel Pressure Regulator and Fuel Gauge Sending Unit.

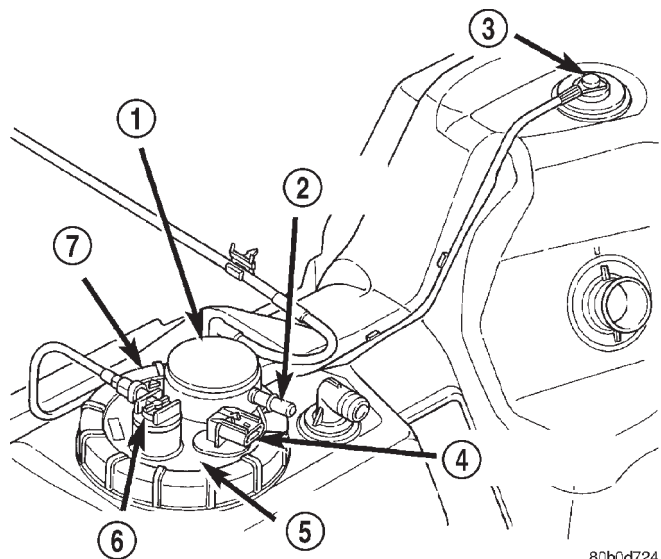
## REMOVAL

**WARNING: THE FUEL SYSTEM IS UNDER A CONSTANT PRESSURE (EVEN WITH THE ENGINE OFF). BEFORE SERVICING THE FUEL PUMP MODULE, THE FUEL SYSTEM PRESSURE MUST BE RELEASED.**

(1) Drain and remove fuel tank. Refer to Fuel Tank - All Engines in the Removal/Installation section.

(2) The plastic fuel pump module locknut is threaded onto fuel tank (Fig. 19) or (Fig. 20). Install Special Tool 6856 to locknut and remove locknut (Fig. 21). The fuel pump module will spring up when locknut is removed.

(3) Remove module from fuel tank.



80b0d724

**Fig. 19 Fuel Pump Module—26 or 34 Gallon Fuel Tank**

- 1 - FUEL FILTER/PRESSURE REGULATOR
- 2 - FUEL SUPPLY FITTING
- 3 - REAR ROLLOVER VALVE
- 4 - ELECTRICAL CONNECTOR
- 5 - FUEL PUMP MODULE
- 6 - FRONT ROLLOVER VALVE
- 7 - LOCKNUT

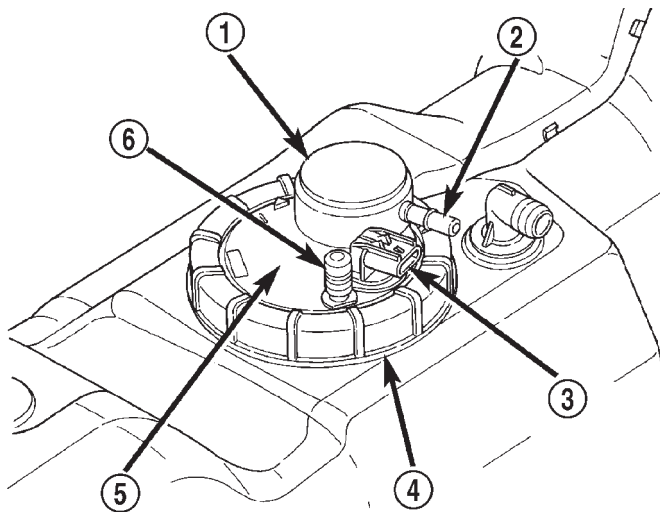
## INSTALLATION

**CAUTION: Whenever the fuel pump module is serviced, the rubber gasket must be replaced.**

(1) Using a new gasket, position fuel pump module into opening in fuel tank.



FUEL PUMP MODULE (Continued)

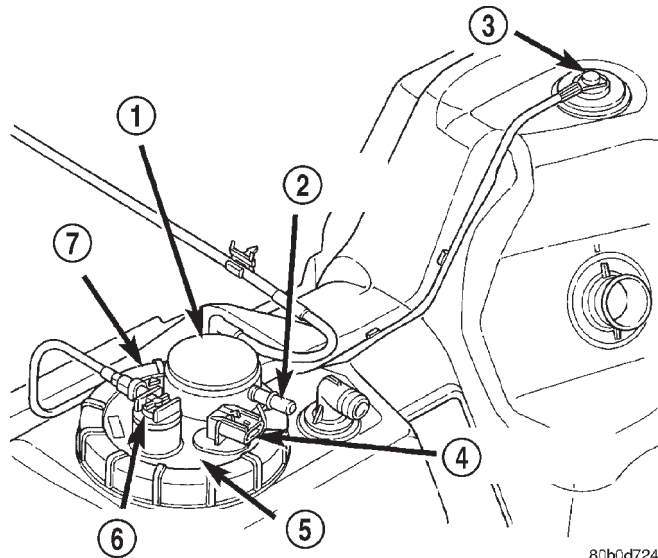


80b0d722

**Fig. 20 Fuel Pump Module—35 Gallon Fuel Tank**

- 1 - FUEL FILTER/PRESSURE REGULATOR
- 2 - FUEL SUPPLY FITTING
- 3 - ELECTRICAL CONNECTOR
- 4 - LOCKNUT
- 5 - FUEL PUMP MODULE
- 6 - AUXILIARY CAPPED FITTING

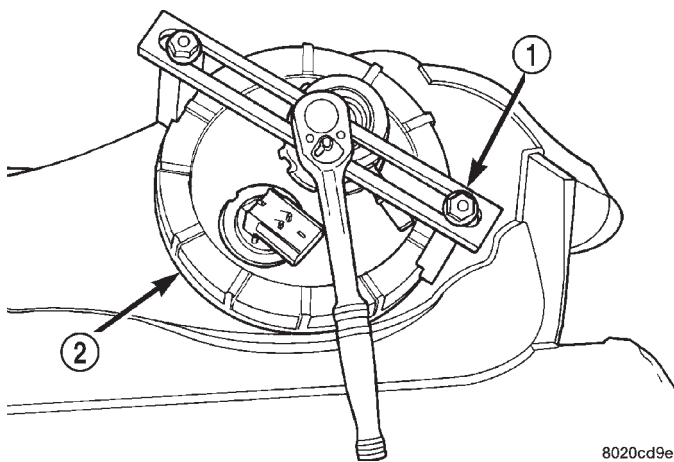
(6) Install fuel tank. Refer to Fuel Tank - All Engines in the Removal/Installation section.



80b0d724

**Fig. 22 Fuel Pump Module—26 or 34 Gallon Fuel Tank**

- 1 - FUEL FILTER/PRESSURE REGULATOR
- 2 - FUEL SUPPLY FITTING
- 3 - REAR ROLLOVER VALVE
- 4 - ELECTRICAL CONNECTOR
- 5 - FUEL PUMP MODULE
- 6 - FRONT ROLLOVER VALVE
- 7 - LOCKNUT



8020cd9e

**Fig. 21 Locknut Removal/Installation—TYPICAL**

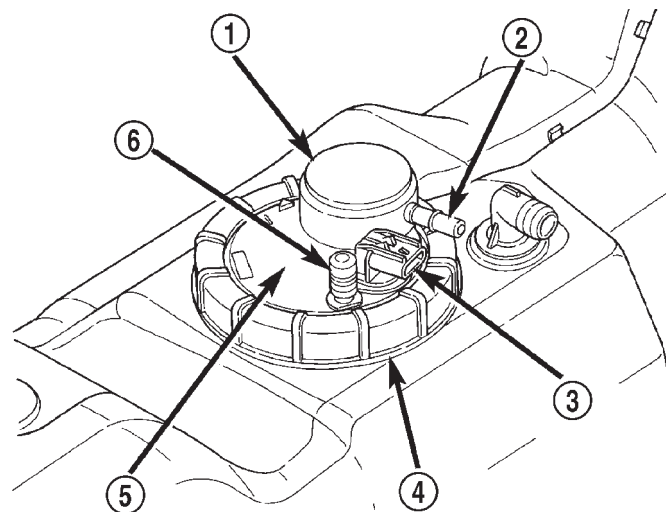
- 1 - SPECIAL TOOL 6856
- 2 - LOCKNUT

(2) Position locknut over top of fuel pump module. Install locknut finger tight.

(3) Rotate module until positioned as shown in (Fig. 22) or (Fig. 23). This step must be performed to prevent float from contacting side of fuel tank. Be sure fuel filter/fuel pressure regulator is pointed to drivers side of vehicle.

(4) Install Special Tool 6856 (Fig. 24) to locknut.

(5) Tighten locknut to 24- 44 N·m (18-32 ft. lbs.) torque.

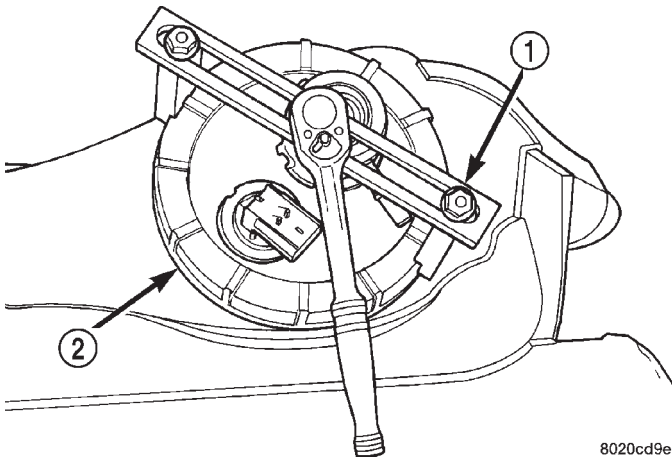


80b0d722

**Fig. 23 Fuel Pump Module—35 Gallon Fuel Tank**

- 1 - FUEL FILTER/PRESSURE REGULATOR
- 2 - FUEL SUPPLY FITTING
- 3 - ELECTRICAL CONNECTOR
- 4 - LOCKNUT
- 5 - FUEL PUMP MODULE
- 6 - AUXILIARY CAPPED FITTING

## FUEL PUMP MODULE (Continued)



8020cd9e

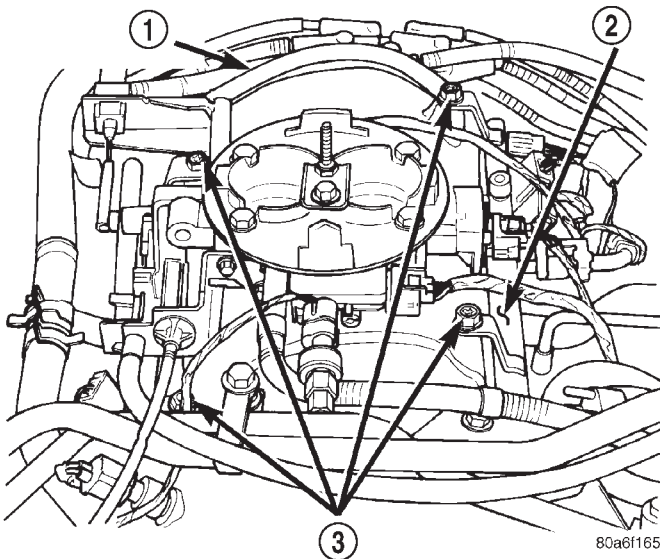
**Fig. 24 Locknut Removal/Installation—TYPICAL**

- 1 - SPECIAL TOOL 6856
- 2 - LOCKNUT

## FUEL RAIL

## DESCRIPTION - 3.9L/5.2L/5.9L

The fuel injector rail is used to attach the fuel injectors to the engine. It is mounted to the engine (Fig. 25).



80a6f165

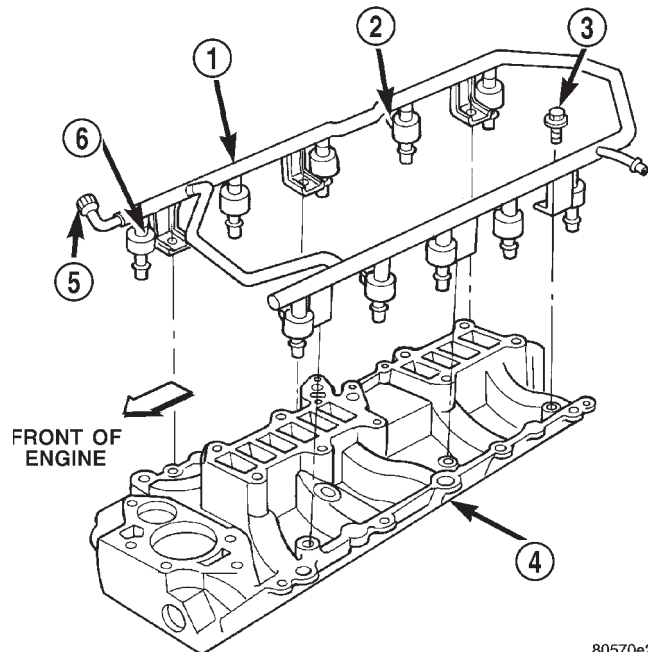
**Fig. 25 Fuel Rail—3.9/5.2/5.9L Engine—Typical**

- 1 - FUEL RAIL CONNECTING HOSE
- 2 - FUEL RAIL
- 3 - MOUNTING BOLTS (4)

## DESCRIPTION - 8.0L

The fuel injector rail is used to attach the fuel injectors to the engine. The fuel rail supplies the necessary fuel to each individual fuel injector and is mounted to the lower half of the two-piece intake

manifold (Fig. 26). The metal, one-piece fuel rail is not repairable.



80570e20

**Fig. 26 Fuel Rail—8.0L Engine**

- 1 - FUEL RAIL
- 2 - ELECTRICAL CONNECTOR
- 3 - MOUNTING BOLTS (6)
- 4 - INTAKE MANIFOLD LOWER HALF
- 5 - FUEL PRESSURE TEST PORT
- 6 - FUEL INJECTORS (10)

## OPERATION - 3.9L/5.2L/5.9L

High pressure from the fuel pump is routed to the fuel rail. The fuel rail then supplies the necessary fuel to each individual fuel injector.

A fuel pressure test port is located on the fuel rail. A quick-connect fitting with a safety latch clip is used to attach the fuel line to the fuel rail.

The fuel rail is not repairable.

**CAUTION:** The left and right sections of the fuel rail are connected with a flexible connecting hose. Do not attempt to separate the rail halves at this connecting hose. Due to the design of this connecting hose, it does not use any clamps. Never attempt to install a clamping device of any kind to the hose. When removing the fuel rail assembly for any reason, be careful not to bend or kink the connecting hose.

## OPERATION - 8.0L

High pressure from the fuel pump is routed to the fuel rail. The fuel rail then supplies the necessary fuel to each individual fuel injector.

FUEL RAIL (Continued)

A fuel pressure test port is located on the fuel rail. A quick-connect fitting with a safety latch clip is used to attach the fuel line to the fuel rail.

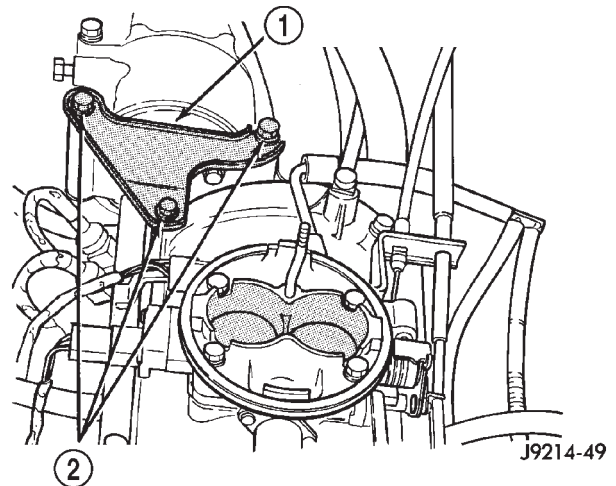
The fuel rail is not repairable.

REMOVAL - 3.9L/5.2L/5.9L

**WARNING: THE FUEL SYSTEM IS UNDER A CONSTANT PRESSURE (EVEN WITH ENGINE TURNED OFF). BEFORE SERVICING FUEL RAIL ASSEMBLY, FUEL SYSTEM PRESSURE MUST BE RELEASED.**

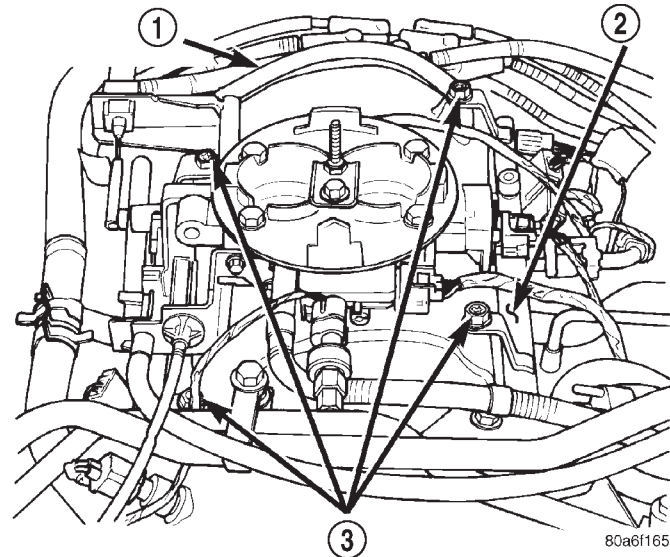
To release fuel pressure, refer to Fuel System Pressure Release Procedure found in this group.

**CAUTION:** The left and right fuel rails are replaced as an assembly. Do not attempt to separate the rail halves at the connecting hose (Fig. 27). Due to the design of this connecting hose, it does use any clamps. Never attempt to install a clamping device of any kind to the hose. When removing the fuel rail assembly for any reason, be careful not to bend or kink the connecting hose.



**Fig. 28 A/C Compressor Support Bracket—Typical**

- 1 - AIR CONDITIONING COMPRESSOR SUPPORT BRACKET
- 2 - MOUNTING BOLTS



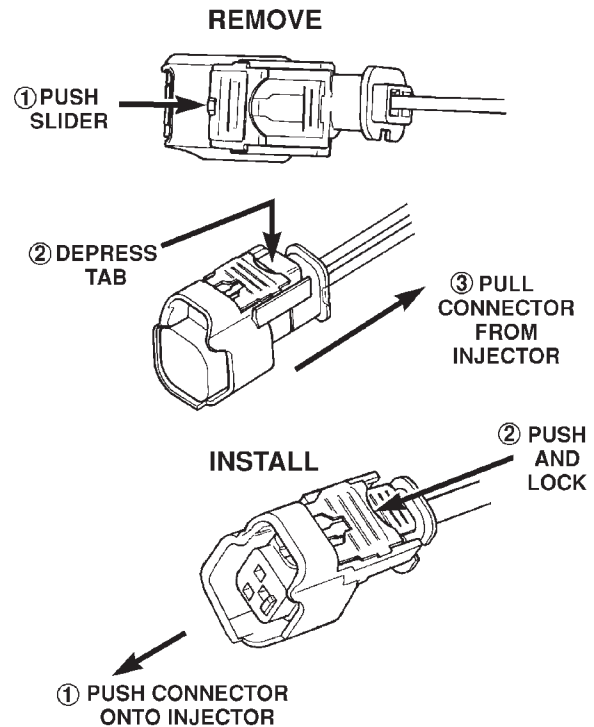
**Fig. 27 Fuel Rail Assembly—Typical**

- 1 - FUEL RAIL CONNECTING HOSE
- 2 - FUEL RAIL
- 3 - MOUNTING BOLTS (4)

- (1) Remove negative battery cable at battery.
- (2) Remove air cleaner.
- (3) Perform fuel pressure release procedure.
- (4) Remove throttle body from intake manifold. Refer to Throttle Body removal in this group.

(5) If equipped with air conditioning, remove the A-shaped A/C compressor-to-intake manifold support bracket (three bolts) (Fig. 28).

(6) Disconnect electrical connectors at all fuel injectors. To remove connector refer to (Fig. 29). Push red colored slider away from injector (1). While pushing slider, depress tab (2) and remove connector (3) from injector. The factory fuel injection wiring harness is numerically tagged (INJ 1, INJ 2, etc.) for injector position identification. If harness is not tagged, note wiring location before removal.



**Fig. 29 Remove/Install Fuel Injector Connector**

80b6f033

## FUEL RAIL (Continued)

(7) 3.9L (V-6) engine only: Disconnect electrical connector at intake manifold air temperature sensor. Do not remove sensor.

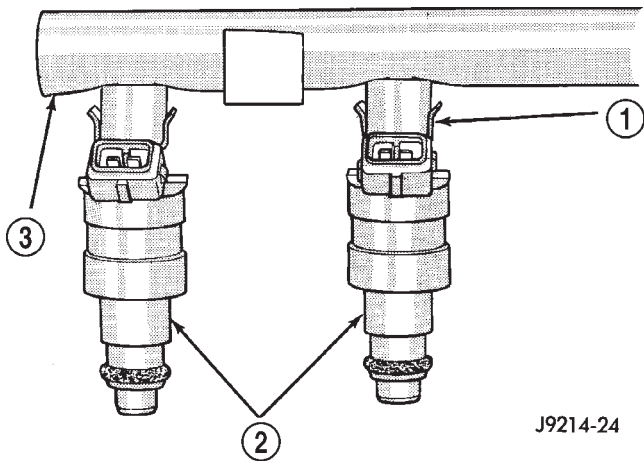
(8) Disconnect fuel tube (line) at side of fuel rail. Refer to Quick-Connect Fittings for procedures.

(9) Remove the remaining fuel rail mounting bolts.

(10) Gently rock and pull the **left** fuel rail until the fuel injectors just start to clear the intake manifold. Gently rock and pull the **right** fuel rail until the fuel injectors just start to clear the intake manifold. Repeat this procedure (left/right) until all fuel injectors have cleared the intake manifold.

(11) Remove fuel rail (with injectors attached) from engine.

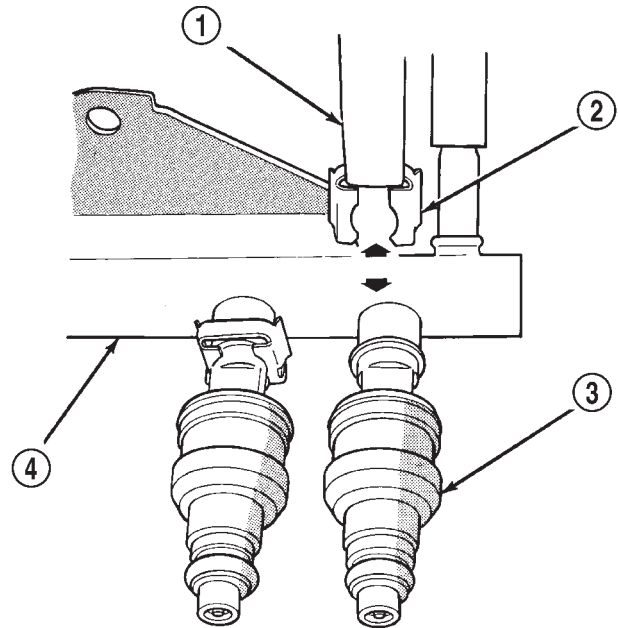
(12) Remove the clip(s) retaining the injector(s) to fuel rail (Fig. 30) or (Fig. 31).



J9214-24

**Fig. 30 Fuel Injector Mounting—Typical**

- 1 - CLIP
- 2 - INJECTOR
- 3 - FUEL RAIL



J9414-156

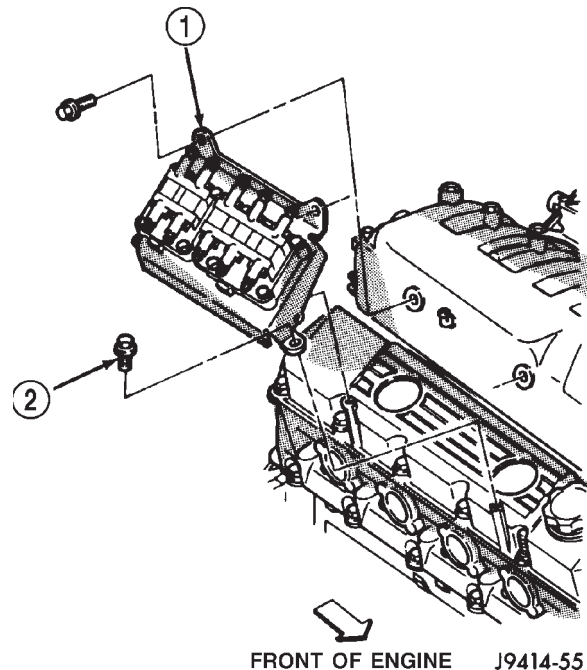
**Fig. 31 Injector Retaining Clips—Typical Injector**

- 1 - PLIERS
- 2 - INJECTOR CLIP
- 3 - FUEL INJECTOR
- 4 - FUEL RAIL

## REMOVAL - 8.0L

**WARNING: THE FUEL SYSTEM IS UNDER A CONSTANT PRESSURE EVEN WITH THE ENGINE OFF. BEFORE SERVICING FUEL RAIL, FUEL SYSTEM PRESSURE MUST BE RELEASED.**

- (1) Remove negative battery cable at battery.
- (2) Remove air cleaner housing and tube.
- (3) Perform fuel pressure release procedure. Refer to Fuel Delivery System section of this group.
- (4) Disconnect throttle body linkage and remove throttle body from intake manifold. Refer to Throttle Body removal in this group.
- (5) Remove ignition coil pack and bracket assembly (Fig. 32) at intake manifold and right engine valve cover (four bolts).
- (6) Remove upper half of intake manifold. Refer to Engines for procedures.



FRONT OF ENGINE J9414-55

**Fig. 32 Ignition Coil Pack and Mounting Bracket—8.0L V-10 Engine**

- 1 - COIL PACKS AND BRACKET
- 2 - MOUNTING BOLTS (4)

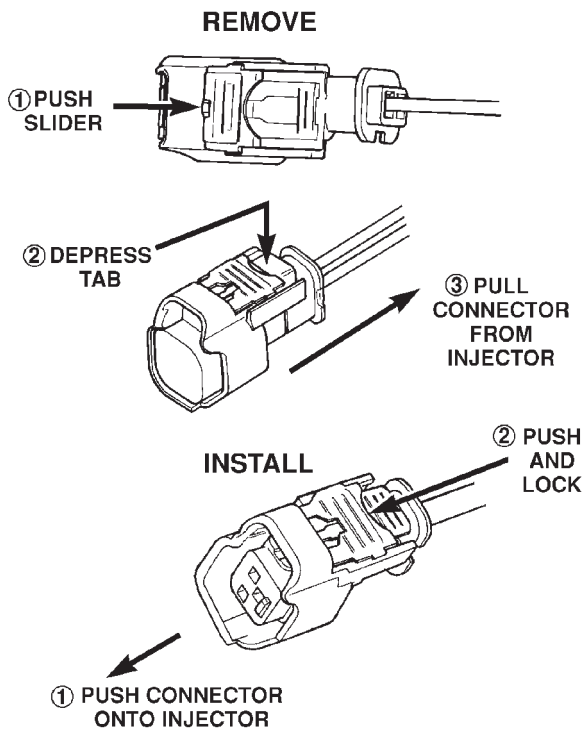


## FUEL RAIL (Continued)

(7) Disconnect electrical connectors at all fuel injectors. To remove connector refer to (Fig. 33). Push red colored slider away from injector (1). While pushing slider, depress tab (2) and remove connector (3) from injector. The factory fuel injection wiring harness is numerically tagged (INJ 1, INJ 2, etc.) for injector position identification.

(8) Disconnect fuel line quick-connect fitting at left-rear end of fuel rail. A special 3/8 inch fuel line disconnection tool will be necessary.

(9) Remove the six fuel rail mounting bolts from the lower half of intake manifold (Fig. 34).



**Fig. 33 Remove/Install Fuel Injector Connector**

(10) Gently rock and pull the **left** fuel rail until the fuel injectors just start to clear the intake manifold. Gently rock and pull the **right** fuel rail until the fuel injectors just start to clear the intake manifold. Repeat this procedure (left/right) until all fuel injectors have cleared the intake manifold.

(11) Remove fuel rail (with injectors attached) from engine.

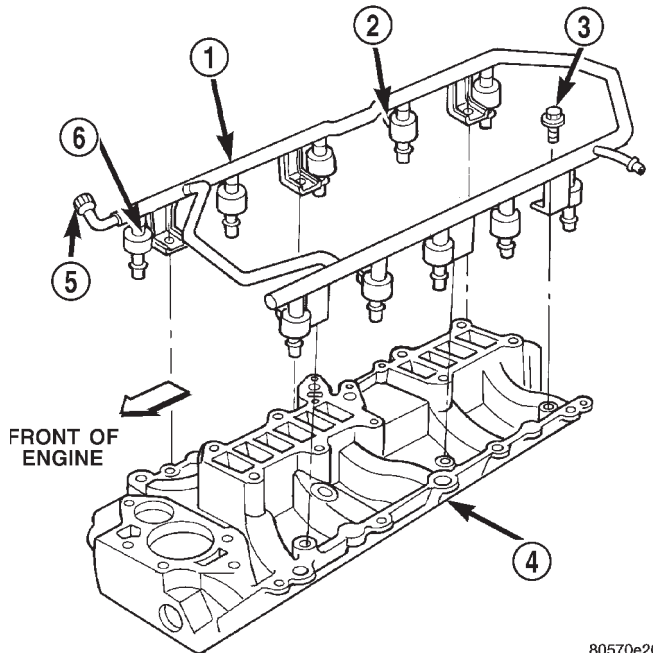
(12) Remove the clip(s) retaining the injector(s) to fuel rail (Fig. 30) or (Fig. 31).

### INSTALLATION - 3.9L/5.2L/5.9L

(1) Apply a small amount of engine oil to each fuel injector o-ring. This will help in fuel rail installation.

(2) Install injector(s) and injector clip(s) to fuel rail.

(3) Position the fuel rail/fuel injector assembly to the injector openings on the intake manifold.



80570e20

**Fig. 34 Fuel Rail Mounting Bolts—8.0L V-10 Engine—Typical**

- 1 - FUEL RAIL
- 2 - ELECTRICAL CONNECTOR
- 3 - MOUNTING BOLTS (6)
- 4 - INTAKE MANIFOLD LOWER HALF
- 5 - FUEL PRESSURE TEST PORT
- 6 - FUEL INJECTORS (10)

(4) Guide each injector into the intake manifold. Be careful not to tear the injector o-ring.

(5) Push the **right** fuel rail down until fuel injectors have bottomed on injector shoulder. Push the **left** fuel rail down until fuel injectors have bottomed on injector shoulder.

(6) Install fuel rail mounting bolts.

(7) Connect electrical connector to intake manifold air temperature sensor.

(8) Connect electrical connectors at all fuel injectors. To install connector, refer to (Fig. 29). Push connector onto injector (1) and then push and lock red colored slider (2). Verify connector is locked to injector by lightly tugging on connector.

(9) Install the A/C support bracket (if equipped).

(10) Install throttle body to intake manifold. Refer to Throttle Body installation in this section of the group.

(11) Install fuel tube (line) at side of fuel rail. Refer to Quick-Connect Fittings for procedures.

(12) Install air cleaner.

(13) Connect battery cable to battery.

(14) Start engine and check for leaks.

80b6f033

## FUEL RAIL (Continued)

**INSTALLATION - 8.0L**

(1) Apply a small amount of engine oil to each fuel injector o-ring. This will help in fuel rail installation.

(2) Install injector(s) and injector clip(s) to fuel rail.

**NOTE: The fuel injector electrical connectors on all 10 injectors should be facing to the right (passenger) side of the vehicle (Fig. 34).**

(3) Position the fuel rail/fuel injector assembly to the injector openings on the intake manifold.

(4) Guide each injector into the intake manifold. Be careful not to tear the injector o-ring.

(5) Push the **right** fuel rail down until fuel injectors have bottomed on injector shoulder. Push the **left** fuel rail down until fuel injectors have bottomed on injector shoulder.

(6) Install the six fuel rail mounting bolts into the lower half of intake manifold. Tighten bolts to 15 N·m (136 in. lbs.) torque.

(7) Connect electrical connectors at all fuel injectors. To install connector, refer to (Fig. 33). Push connector onto injector (1) and then push and lock red colored slider (2). Verify connector is locked to injector by lightly tugging on connector. The injector wiring harness is numerically tagged.

(8) Install upper half of intake manifold. Refer to Engines for procedures.

(9) Connect main fuel line at fuel rail. Refer to Quick-Connect Fittings for procedures.

(10) Install ignition coil pack and bracket assembly at intake manifold and right engine valve cover (four bolts).

(11) Install throttle body to intake manifold. Refer to Throttle Body removal in this group.

(12) Install throttle body linkage to throttle body.

(13) Install air cleaner tube and housing.

(14) Install negative battery cable at battery.

(15) Start engine and check for leaks.

A rollover valve(s) is mounted into the top of the fuel tank (or pump module). Refer to Emission Control System for rollover valve information.

An evaporation control system is connected to the rollover valve(s) to reduce emissions of fuel vapors into the atmosphere. When fuel evaporates from the fuel tank, vapors pass through vent hoses or tubes to a charcoal canister where they are temporarily held. When the engine is running, the vapors are drawn into the intake manifold. Certain models are also equipped with a self-diagnosing system using a Leak Detection Pump (LDP). Refer to Emission Control System for additional information.

**REMOVAL**

**WARNING: GASOLINE POWERED ENGINES: THE FUEL SYSTEM IS UNDER A CONSTANT PRESSURE EVEN WITH THE ENGINE OFF. BEFORE SERVICING THE FUEL TANK, FUEL SYSTEM PRESSURE MUST BE RELEASED. REFER TO THE FUEL SYSTEM PRESSURE RELEASE PROCEDURE BEFORE SERVICING THE FUEL TANK.**

Two different procedures may be used to drain fuel tank (lowering tank or using DRB scan tool). When equipped with a diesel engine, the DRB scan tool cannot be used (no electric fuel pump).

The quickest draining procedure involves lowering the fuel tank.

**Gasoline Powered Engines:** As an alternative procedure, the electric fuel pump may be activated allowing tank to be drained at fuel rail connection. Refer to DRB scan tool for fuel pump activation procedures. Before disconnecting fuel line at fuel rail, release fuel pressure. Refer to the Fuel System Pressure Release Procedure in this group for procedures. Attach end of special test hose tool number 6541, 6539, 6631 or 6923 at fuel rail disconnection (tool number will depend on model and/or engine application). Position opposite end of this hose tool to an approved gasoline draining station. Activate fuel pump and drain tank until empty.

If electric fuel pump is not operating, tank must be lowered for fuel draining. Refer to following procedures.

(1) Remove fuel tank filler tube cap.

(2) Perform Fuel System Pressure Release procedure as described in this group.

(3) Gasoline Engines: Disconnect negative battery cable at battery. Diesel Engines: Disconnect both negative battery cables at both batteries.

(4) Raise vehicle on hoist.

(5) Certain models are equipped with a separate grounding wire (strap) connecting the fuel fill tube assembly to the body. Disconnect wire by removing screw.

**FUEL TANK****DESCRIPTION**

The fuel tank is constructed of a plastic material. Its main functions are for fuel storage and for placement of the fuel pump module.

**OPERATION**

All models pass a full 360 degree rollover test without fuel leakage. To accomplish this, fuel and vapor flow controls are required for all fuel tank connections.



## FUEL TANK (Continued)

(6) Open fuel fill door and remove screws mounting fuel filler tube assembly to body. Do not disconnect rubber fuel fill or vent hoses from tank at this time.

(7) Place a transmission jack under center of fuel tank. Apply a slight amount of pressure to fuel tank with transmission jack.

(8) Remove fuel tank mounting strap nuts from mounting strap studs (Fig. 35). If equipped, remove fuel tank shield bolts.

(9) Lower fuel tank only enough to allow access to top of tank. The 2 tank fittings (where rubber fuel fill and vent hose connections are made) must be positioned above tank level. Rotate tank slightly to allow these fittings to be above tank level.

**WARNING: WRAP SHOP TOWELS AROUND HOSES TO CATCH ANY GASOLINE SPILLAGE.**

(10) While working over left rear tire/wheel, disconnect rubber fuel vent hose at fuel tank (Fig. 35) (vent hose is the smallest of 2 hoses). Position fuel siphoning/drain hose into this fitting at tank. Drain fuel into an approved portable holding tank or a properly labeled gasoline (or diesel fuel) safety container.

(11) Disconnect rubber fuel fill hose at fuel tank (Fig. 35).

**(12) Gas Powered Engines:**

(a) While working over left rear tire/wheel, disconnect wiring harness connector from electrical connector at top of fuel pump module (Fig. 36) or (Fig. 37).

(b) If equipped with 26 or 34 gallon fuel tank, two EVAP lines are connected to rollover valves. Disconnect EVAP line from rollover valve at top of module (Fig. 36). Disconnect other EVAP line from rollover valve near rear of tank (Fig. 36).

(c) If equipped with 35 gallon fuel tank, two EVAP lines are connected to rollover valves. Disconnect EVAP lines from rollover valves at top-front and top-rear of fuel tank (Fig. 38).

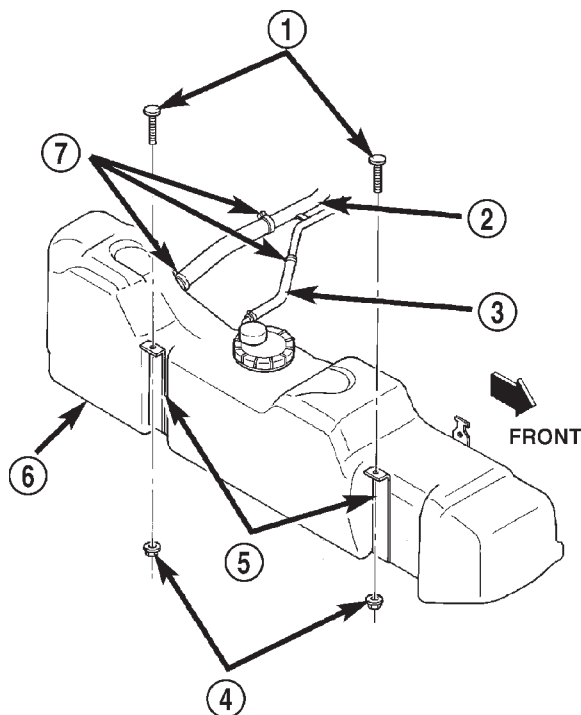
(d) Disconnect fuel supply line at fuel filter/fuel pressure regulator supply fitting (Fig. 36) or (Fig. 37). Refer to Quick-Connect Fittings for procedures.

**(13) Diesel Powered Engines:**

(a) While working over left rear tire/wheel, disconnect wiring harness connector from electrical connector at top of fuel tank module (Fig. 39).

(b) Disconnect fuel supply and fuel return lines at the fuel tank module fittings (Fig. 39). Refer to Quick-Connect Fittings for procedures.

(14) Gasoline Engines: If fuel pump module removal is necessary, refer to Fuel Pump Module Removal/Installation in this group. Diesel Engines: If fuel tank module removal is necessary, refer to Fuel Tank Module Removal/Installation in this group.



80b0d726

**Fig. 35 Fuel Tank Mounting—Typical**

- 1 - STRAP MOUNTING STUDS (AT FRAME)
- 2 - FUEL FILL HOSE
- 3 - FUEL VENT HOSE
- 4 - STRAP MOUNTING NUTS (2)
- 5 - FUEL TANK STRAPS (2)
- 6 - FUEL TANK
- 7 - CLAMPS

## INSTALLATION

(1) Gasoline Engines: If fuel pump module is being installed, refer to Fuel Pump Module Removal/Installation in this group. Diesel Engines: If fuel tank module is being installed, refer to Fuel Tank Module Removal/Installation in this group.

(2) Place fuel tank on top of transmission jack.

(3) Install rubber fill and vent lines to tank. Tighten hose clamps to 2.3 N·m (20 in. lbs.) torque.

(4) Raise tank into position while guiding fill and vent hoses to body. Raise tank only enough to allow access to top of tank.

**(5) Gas Powered Engines:**

(a) Connect electrical connector to fuel pump module.

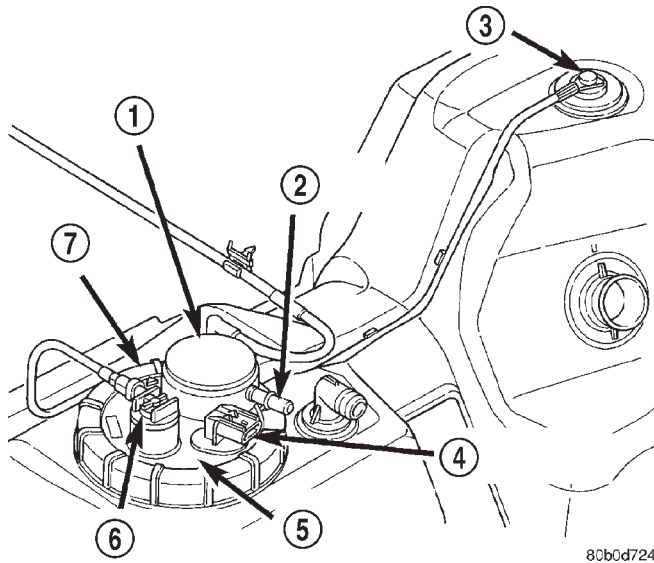
(b) Connect EVAP hoses at rollover valves.

(c) Connect fuel supply line at fuel filter/fuel pressure regulator. Refer to Quick-Connect Fittings for procedures.

**(6) Diesel Powered Engines:**

(a) Connect electrical connector to fuel tank module.

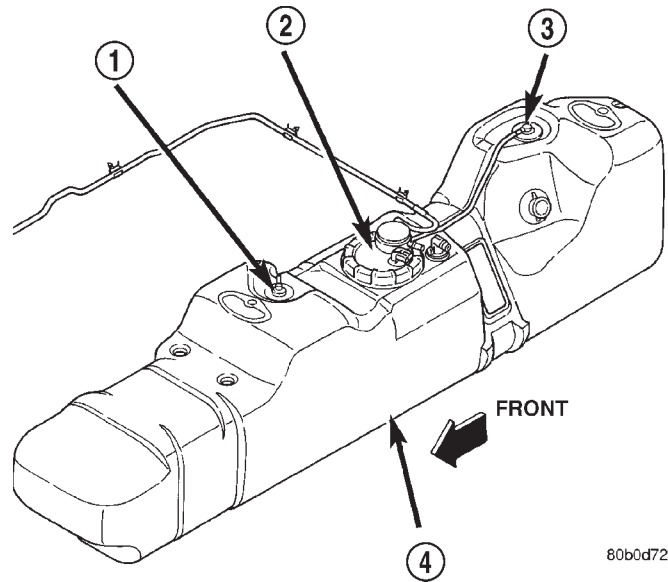
FUEL TANK (Continued)



80b0d724

**Fig. 36 Fuel Pump Module—Gas Engine With 26 or 34 Gallon Tank**

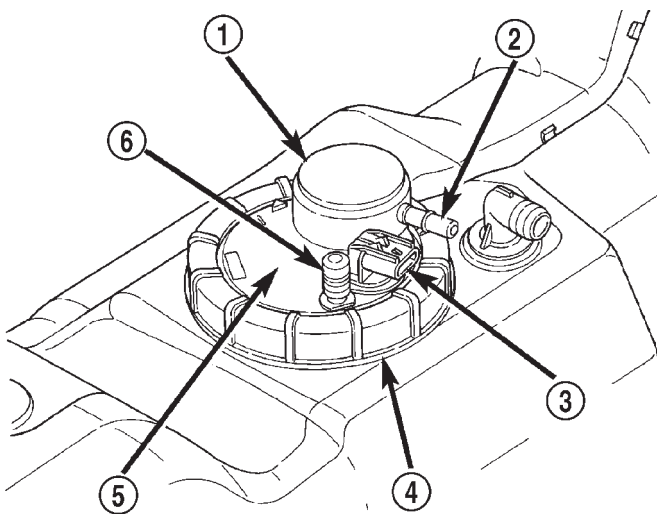
- 1 - FUEL FILTER/PRESSURE REGULATOR
- 2 - FUEL SUPPLY FITTING
- 3 - REAR ROLLOVER VALVE
- 4 - ELECTRICAL CONNECTOR
- 5 - FUEL PUMP MODULE
- 6 - FRONT ROLLOVER VALVE
- 7 - LOCKNUT



80b0d723

**Fig. 38 Rollover Valve Locations—Gas Engine With 35 Gallon Tank**

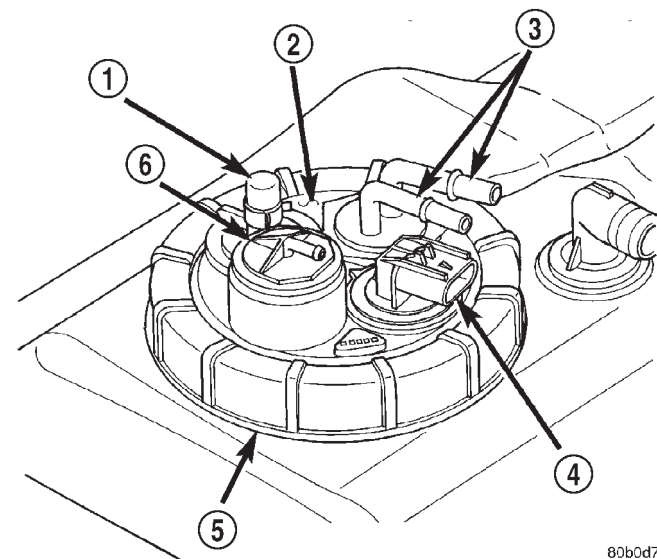
- 1 - FRONT ROLLOVER VALVE
- 2 - FUEL PUMP MODULE
- 3 - REAR ROLLOVER VALVE
- 4 - FUEL TANK



80b0d722

**Fig. 37 Fuel Pump Module—Gas Engine With 35 Gallon Tank**

- 1 - FUEL FILTER/PRESSURE REGULATOR
- 2 - FUEL SUPPLY FITTING
- 3 - ELECTRICAL CONNECTOR
- 4 - LOCKNUT
- 5 - FUEL PUMP MODULE
- 6 - AUXILIARY CAPPED FITTING



80b0d721

**Fig. 39 Fuel Tank**

- 1 - AUXILIARY CAPPED FITTING
- 2 - FUEL PUMP MODULE
- 3 - FUEL SUPPLY/RETURN FITTINGS
- 4 - ELECTRICAL CONNECTOR
- 5 - LOCKNUT
- 6 - ROLLOVER VALVE

(b) Connect fuel supply and fuel return lines to fuel tank module fittings. Refer to Quick-Connect Fittings in this group.

## FUEL TANK (Continued)

(7) Connect two mounting straps and mounting strap nuts.

(8) Tighten strap nuts to 41 N·m (30 ft. lbs.) torque. Do not over tighten retaining strap nuts.

(9) Remove transmission jack.

(10) Connect fuel filler tube assembly to body.

(11) If equipped, connect grounding wire (strap) and screw.

(12) Refill fuel tank and inspect all hoses and lines for leaks.

(13) Connect negative battery cable(s) to battery(s).

## INLET FILTER

## REMOVAL

The fuel pump inlet filter (strainer) is located on the bottom of the fuel pump module (Fig. 40). The fuel pump module is located inside of fuel tank.

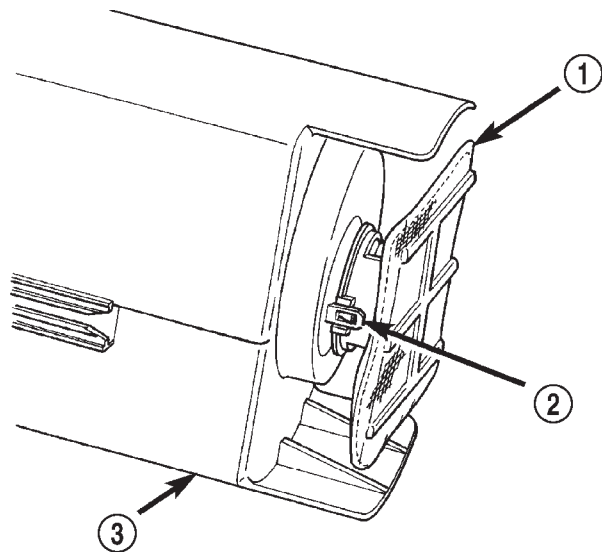


Fig. 40 Fuel Pump Inlet Filter

80a61216

- 1 - FUEL PUMP INLET FILTER  
2 - LOCK TABS (2)  
3 - FUEL PUMP MODULE (BOTTOM)

(1) Remove fuel tank. Refer to Fuel Tank Removal/Installation.

(2) Remove fuel pump module. Refer to Fuel Pump Module Removal/Installation.

(3) Remove filter by carefully prying 2 lock tabs at bottom of module with 2 screwdrivers. Filter is snapped to module.

(4) Clean bottom of pump module.

## INSTALLATION

The fuel pump inlet filter (strainer) is located on the bottom of the fuel pump module (Fig. 40). The fuel pump module is located inside of fuel tank.

(1) Snap new filter to bottom of module. Be sure o-ring is in correct position.

(2) Install fuel pump module. Refer to Fuel Pump Module Removal/Installation.

(3) Install fuel tank. Refer to Fuel Tank Removal/Installation.

## QUICK CONNECT FITTING

## DESCRIPTION

Different types of quick-connect fittings are used to attach various fuel system components, lines and tubes. These are: a single-tab type, a two-tab type or a plastic retainer ring type. Some are equipped with safety latch clips. Some may require the use of a special tool for disconnection and removal. Refer to Quick-Connect Fittings Removal/Installation for more information.

**CAUTION:** The interior components (o-rings, clips) of quick-connect fittings are not serviced separately, but new plastic spacers are available for some types. If service parts are not available, do not attempt to repair the damaged fitting or fuel line (tube). If repair is necessary, replace the complete fuel line (tube) assembly.

## STANDARD PROCEDURES - QUICK-CONNECT FITTINGS

Also refer to Fuel Tubes/Lines/Hoses and Clamps.

Different types of quick-connect fittings are used to attach various fuel system components, lines and tubes. These are: a single-tab type, a two-tab type or a plastic retainer ring type. Safety latch clips are used on certain components/lines. Certain fittings may require use of a special tool for disconnection.

## DISCONNECTING

**WARNING: THE FUEL SYSTEM IS UNDER A CONSTANT PRESSURE (EVEN WITH ENGINE OFF). BEFORE SERVICING ANY FUEL SYSTEM HOSE, FITTING OR LINE, FUEL SYSTEM PRESSURE MUST BE RELEASED. REFER TO FUEL SYSTEM PRESSURE RELEASE PROCEDURE.**

**CAUTION:** The interior components (o-rings, spacers) of some types of quick-connect fitting are not serviced separately. If service parts are not available, do not attempt to repair a damaged fitting or fuel line. If repair is necessary, replace complete fuel line assembly.

(1) Perform fuel pressure release procedure. Refer to Fuel Pressure Release Procedure.

(2) Disconnect negative battery cable from battery.

## QUICK CONNECT FITTING (Continued)

(3) Clean fitting of any foreign material before disassembly.

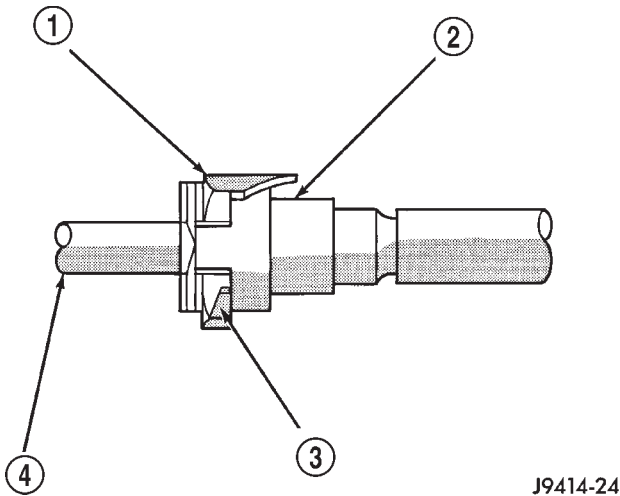
(4) **Single-Tab Type Fitting:** This type of fitting is equipped with a single pull tab (Fig. 41). The tab is removable. After tab is removed, quick-connect fitting can be separated from fuel system component.

(a) Press release tab on side of fitting to release pull tab (Fig. 42). **If release tab is not pressed prior to releasing pull tab, pull tab will be damaged.**

(b) While pressing release tab on side of fitting, use screwdriver to pry up pull tab (Fig. 42).

(c) Raise pull tab until it separates from quick-connect fitting (Fig. 43).

(5) **Two-Tab Type Fitting:** This type of fitting is equipped with tabs located on both sides of fitting (Fig. 44). The tabs are supplied for disconnecting quick-connect fitting from component being serviced.



J9414-24

**Fig. 41 Single-Tab Type Fitting**

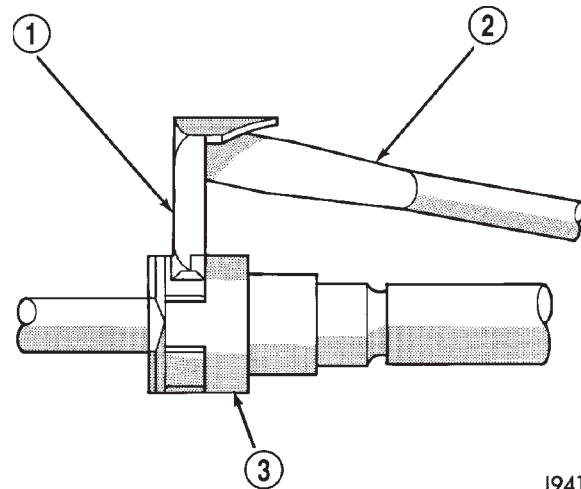
- 1 - PULL TAB
- 2 - QUICK-CONNECT FITTING
- 3 - PRESS HERE TO REMOVE PULL TAB
- 4 - INSERTED TUBE END

(a) To disconnect quick-connect fitting, squeeze plastic retainer tabs (Fig. 44) against sides of quick-connect fitting with your fingers. Tool use is not required for removal and may damage plastic retainer.

(b) Pull fitting from fuel system component being serviced.

(c) The plastic retainer will remain on component being serviced after fitting is disconnected. The o-rings and spacer will remain in quick-connect fitting connector body.

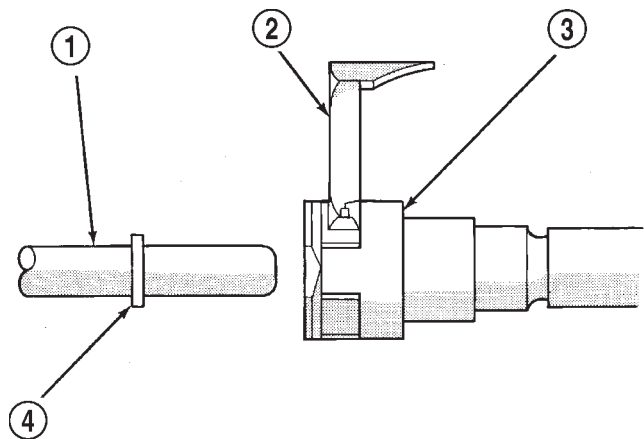
(6) **Plastic Retainer Ring Type Fitting:** This type of fitting can be identified by the use of a full-round plastic retainer ring (Fig. 45) usually black in color.



J9414-25

**Fig. 42 Disconnecting Single-Tab Type Fitting**

- 1 - PULL TAB
- 2 - SCREWDRIVER
- 3 - QUICK-CONNECT FITTING



J9414-26

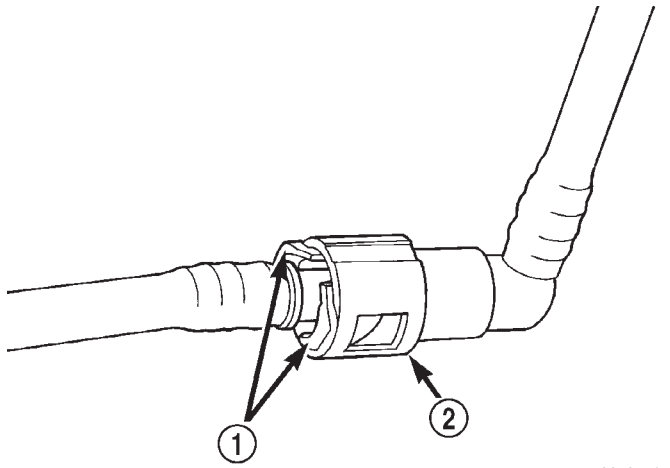
**Fig. 43 Removing Pull Tab**

- 1 - FUEL TUBE OR FUEL SYSTEM COMPONENT
- 2 - PULL TAB
- 3 - QUICK-CONNECT FITTING
- 4 - FUEL TUBE STOP

(a) To release fuel system component from quick-connect fitting, firmly push fitting towards component being serviced while firmly pushing plastic retainer ring into fitting (Fig. 45). With plastic ring depressed, pull fitting from component. **The plastic retainer ring must be pressed squarely into fitting body. If this retainer is cocked during removal, it may be difficult to disconnect fitting. Use an open-end wrench on shoulder of plastic retainer ring to aid in disconnection.**

(b) After disconnection, plastic retainer ring will remain with quick-connect fitting connector body.

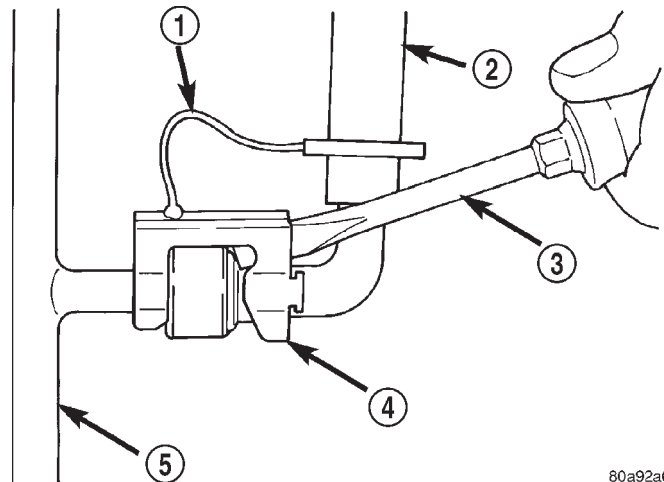
QUICK CONNECT FITTING (Continued)



80a35405

**Fig. 44 Typical Two-Tab Type Quick-Connect Fitting**

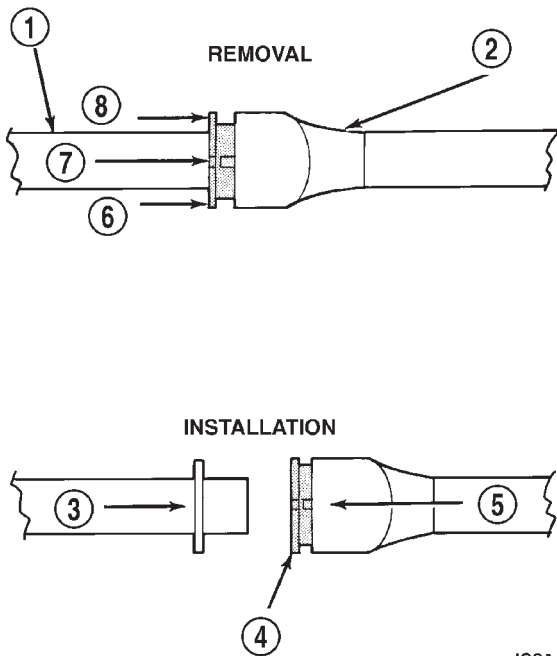
- 1 - TAB(S)
- 2 - QUICK-CONNECT FITTING



80a92a66

**Fig. 46 Latch Clip—Type 1**

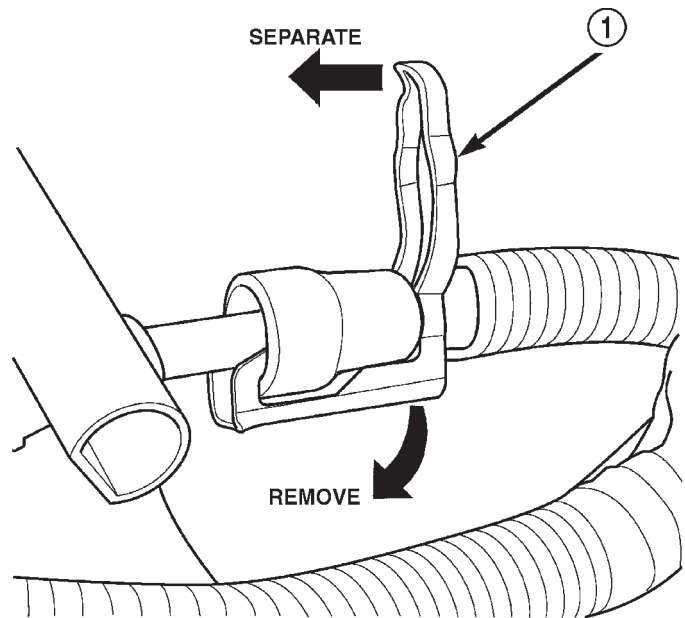
- 1 - TETHER STRAP
- 2 - FUEL LINE
- 3 - SCREWDRIVER
- 4 - LATCH CLIP
- 5 - FUEL RAIL



J9314-100

**Fig. 45 Plastic Retainer Ring Type Fitting**

- 1 - FUEL TUBE
- 2 - QUICK CONNECT FITTING
- 3 - PUSH
- 4 - PLASTIC RETAINER
- 5 - PUSH
- 6 - PUSH
- 7 - PUSH
- 8 - PUSH



80b898e5

**Fig. 47 Latch Clip—Type 2**

- 1 - LATCH CLIP

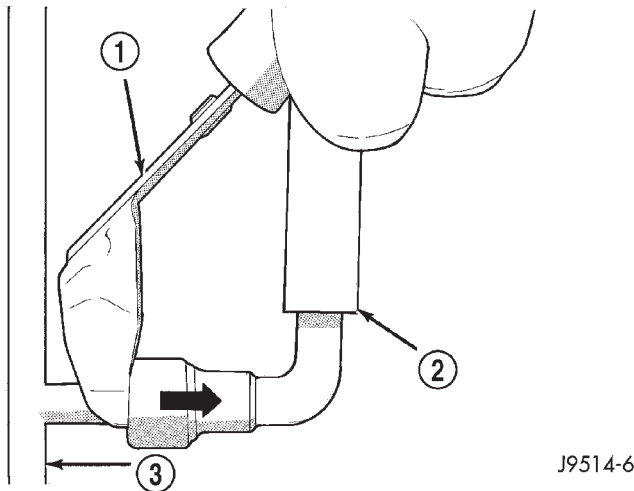
(7) **Latch Clips:** Depending on vehicle model and engine, 2 different types of safety latch clips are used (Fig. 46) or (Fig. 47). Type-1 is tethered to fuel line and type-2 is not. A special tool will be necessary to disconnect fuel line after latch clip is removed. The latch clip may be used on certain fuel line/fuel rail connection, or to join fuel lines together.

(a) Type 1: Pry up on latch clip with a screwdriver (Fig. 46).

(c) Inspect fitting connector body, plastic retainer ring and fuel system component for damage. Replace as necessary.



## QUICK CONNECT FITTING (Continued)



**Fig. 48 Fuel Line Disconnection Using Special Tool**

- 1 - SPECIAL FUEL LINE TOOL
- 2 - FUEL LINE
- 3 - FUEL RAIL

(b) Type 2: Separate and unlatch 2 small arms on end of clip (Fig. 47) and swing away from fuel line.

(c) Slide latch clip toward fuel rail while lifting with screwdriver.

(d) Insert special fuel line removal tool (Snap-On number FIH 9055-1 or equivalent) into fuel line (Fig. 48). Use tool to release locking fingers in end of line.

(e) With special tool still inserted, pull fuel line from fuel rail.

(f) After disconnection, locking fingers will remain within quick-connect fitting at end of fuel line.

(8) Disconnect quick-connect fitting from fuel system component being serviced.

## CONNECTING

(1) Inspect quick-connect fitting body and fuel system component for damage. Replace as necessary.

(2) Prior to connecting quick-connect fitting to component being serviced, check condition of fitting and component. Clean parts with a lint-free cloth. Lubricate with clean engine oil.

(3) Insert quick-connect fitting into fuel tube or fuel system component until built-on stop on fuel tube or component rests against back of fitting.

(4) Continue pushing until a click is felt.

(5) Single-tab type fitting: Push new tab down until it locks into place in quick-connect fitting.

(6) Verify a locked condition by firmly pulling on fuel tube and fitting (15-30 lbs.).

(7) Latch Clip Equipped: Install latch clip (snaps into position). **If latch clip will not fit, this indicates fuel line is not properly installed to fuel rail (or other fuel line). Recheck fuel line connection.**

(8) Connect negative cable to battery.

(9) Start engine and check for leaks.

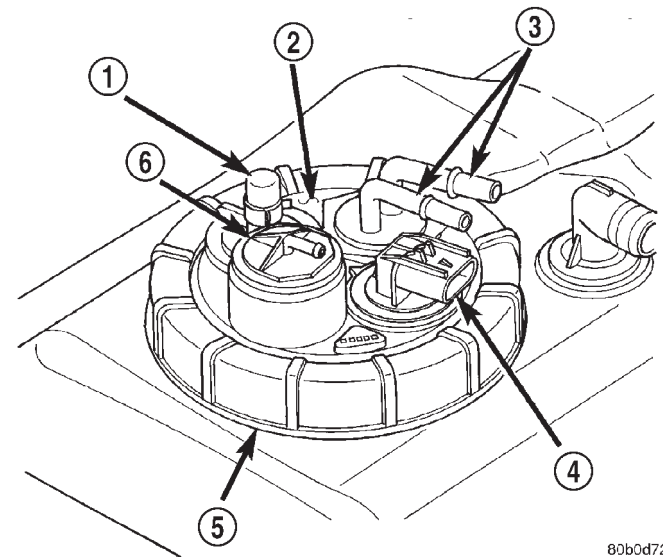
## ROLLOVER VALVE

## DESCRIPTION

**Diesel Powered Engine:** One rollover valve is used. The rollover valve is located on the top of the fuel tank module (Fig. 49). The valve may be serviced separately.

**Gasoline Powered Engines:** If equipped with a 26 or 34 gallon fuel tank, two rollover valves are used. One of the valves is permanently mounted to the top of fuel tank (Fig. 50). If replacement of this particular valve is necessary, the fuel tank must be replaced. The other rollover valve is located on the top of the fuel pump module (Fig. 50). This valve may be serviced separately. If replacement is necessary, refer to the Removal/Installation section of this group.

If equipped with a 35 gallon fuel tank, two rollover valves are used. Both valves are permanently mounted to the top of fuel tank (Fig. 51). If replacement is necessary, the fuel tank must be replaced.



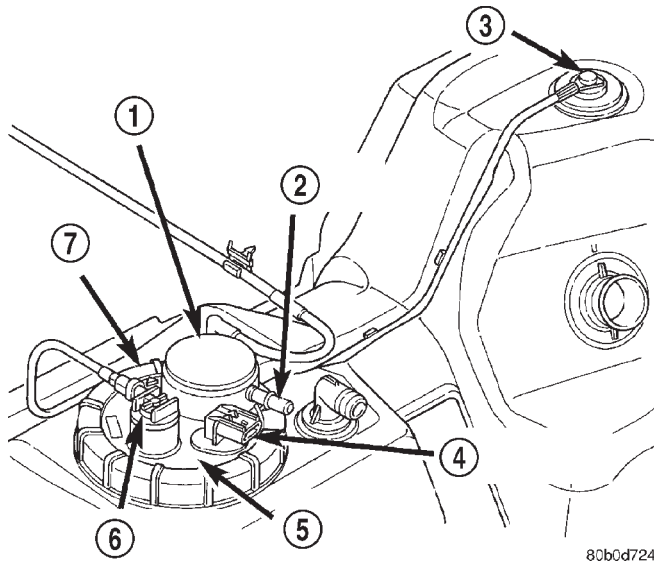
80b0d721

**Fig. 49 Rollover Valve Location—Diesel Powered**

- 1 - AUXILIARY CAPPED FITTING
- 2 - FUEL PUMP MODULE
- 3 - FUEL SUPPLY/RETURN FITTINGS
- 4 - ELECTRICAL CONNECTOR
- 5 - LOCKNUT
- 6 - ROLLOVER VALVE



ROLLOVER VALVE (Continued)



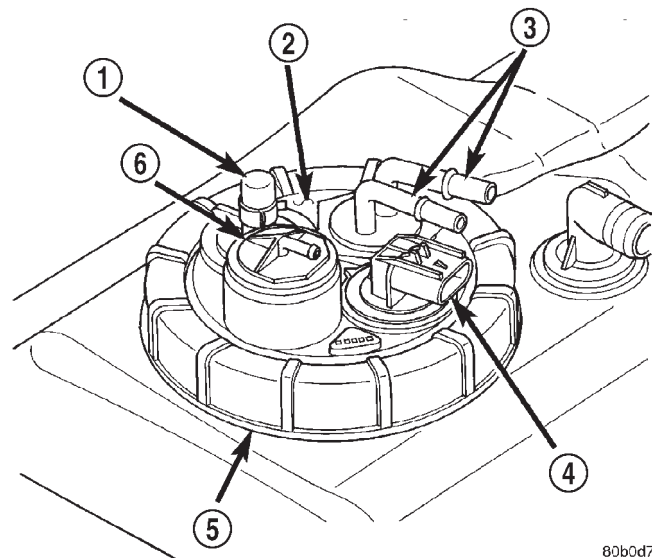
80b0d724

**Fig. 50 Rollover Valve Locations—Gas**

- 1 - FUEL FILTER/PRESSURE REGULATOR
- 2 - FUEL SUPPLY FITTING
- 3 - REAR ROLLOVER VALVE
- 4 - ELECTRICAL CONNECTOR
- 5 - FUEL PUMP MODULE
- 6 - FRONT ROLLOVER VALVE
- 7 - LOCKNUT

REMOVAL

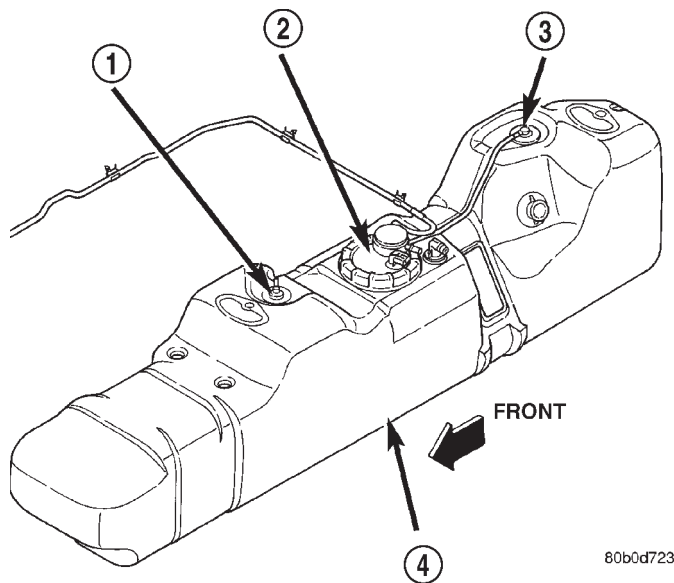
**WARNING: THE FUEL SYSTEM IS UNDER A CONSTANT PRESSURE (EVEN WITH THE ENGINE OFF). BEFORE SERVICING THE ROLLOVER VALVE, FUEL SYSTEM PRESSURE MUST BE RELEASED (GASOLINE POWERED ENGINES ONLY). REFER TO THE FUEL PRESSURE RELEASE PROCEDURE IN GROUP 14, FUEL SYSTEM.**



80b0d721

**Fig. 52 Rollover Valve Location - Diesel Powered**

- 1 - AUXILIARY CAPPED FITTING
- 2 - FUEL PUMP MODULE
- 3 - FUEL SUPPLY/RETURN FITTINGS
- 4 - ELECTRICAL CONNECTOR
- 5 - LOCKNUT
- 6 - ROLLOVER VALVE



80b0d723

**Fig. 51 Rollover Valve Locations—Gas Powered with 35 Gallon Tank**

- 1 - FRONT ROLLOVER VALVE
- 2 - FUEL PUMP MODULE
- 3 - REAR ROLLOVER VALVE
- 4 - FUEL TANK

(1) **Diesel Powered Engine:** One rollover valve is used. The valve is located on top of fuel tank module (Fig. 52) and may be serviced separately.

(a) Disconnect both negative battery cables at both batteries.

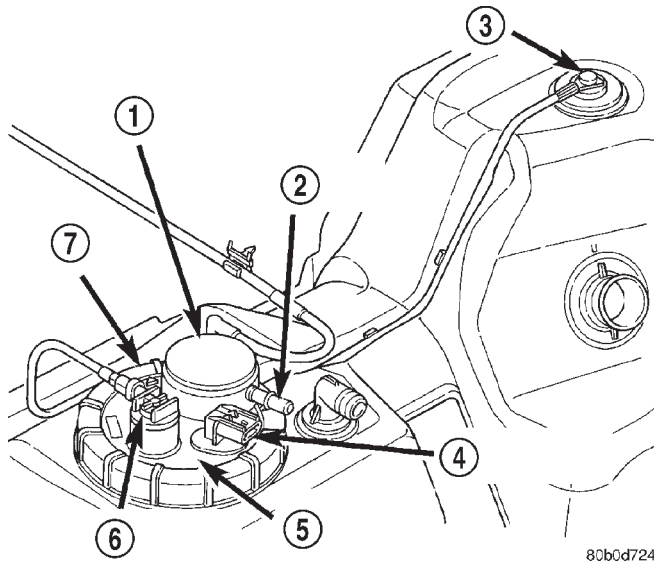
(b) Remove fuel filler cap and drain fuel tank.

(c) Remove fuel tank. Refer to Fuel Tank Removal/Installation in Fuel System.

(d) The rollover valve is seated into a rubber grommet. Remove valve by prying one side upward and then roll valve out of grommet.

(e) Discard old grommet.

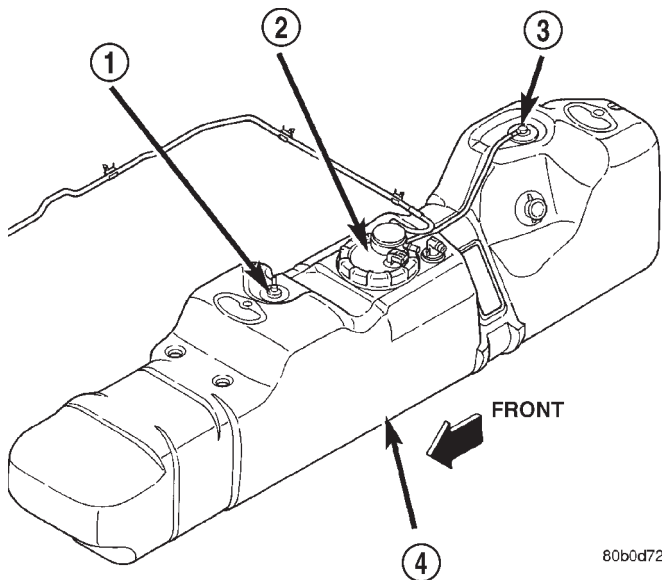
## ROLLOVER VALVE (Continued)



80b0d724

**Fig. 53 Rollover Valve Locations - Gas Powered - 26/34 Gallon Tank**

- 1 - FUEL FILTER/PRESSURE REGULATOR
- 2 - FUEL SUPPLY FITTING
- 3 - REAR ROLLOVER VALVE
- 4 - ELECTRICAL CONNECTOR
- 5 - FUEL PUMP MODULE
- 6 - FRONT ROLLOVER VALVE
- 7 - LOCKNUT



80b0d723

**Fig. 54 Rollover Valve Locations - Gas Powered with 35 Gallon Tank**

- 1 - FRONT ROLLOVER VALVE
- 2 - FUEL PUMP MODULE
- 3 - REAR ROLLOVER VALVE
- 4 - FUEL TANK

(2) **Gasoline Powered Engines:** If equipped with a 26 or 34 gallon fuel tank, two rollover valves are used. One of the valves is permanently mounted to top of fuel tank (Fig. 53). If replacement of this particular valve is necessary, fuel tank must be replaced. Refer to Fuel Tank Removal/Installation in Group 14, Fuel System. The other rollover valve is located on top of fuel pump module (Fig. 53). This valve may be serviced separately. Refer to following steps for procedures.

If equipped with a 35 gallon fuel tank, two rollover valves are also used, but both valves are permanently mounted to top of fuel tank (Fig. 54). If replacement is necessary, fuel tank must be replaced. Refer to Fuel Tank Removal/Installation in Group 14, Fuel System.

- (a) Disconnect negative battery cable at battery.
- (b) Remove fuel filler cap and drain fuel tank.
- (c) Remove fuel tank. Refer to Fuel Tank Removal/Installation in Fuel System.
- (d) Disconnect tube (line) at valve.
- (e) The rollover valve is seated into a rubber grommet. Remove valve by prying one side upward and then roll valve out of grommet.
- (f) Discard old grommet.

## INSTALLATION

- (1) Install new grommet into fuel pump (or fuel tank) module.
- (2) Using finger pressure only, press valve into place.
- (3) Install fuel tank. Refer to Fuel Tank Installation.
- (4) Fill fuel tank. Install fuel tank filler cap.
- (5) Connect negative battery cable(s).
- (6) Start vehicle and check for leaks.

# FUEL INJECTION - GASOLINE

## TABLE OF CONTENTS

	page		page
<b>FUEL INJECTION - GASOLINE</b>			
DIAGNOSIS AND TESTING . . . . .	28	OPERATION . . . . .	44
VISUAL INSPECTION - 3.9L/5.2L/5.9L ENGINES . . . . .	28	REMOVAL . . . . .	45
VISUAL INSPECTION - 8.0L ENGINE . . . . .	32	INSTALLATION . . . . .	45
SPECIFICATIONS . . . . .	35	<b>O2 SENSOR</b>	
SPECIAL TOOLS . . . . .	36	DESCRIPTION . . . . .	46
<b>ACCELERATOR PEDAL</b>		OPERATION . . . . .	46
REMOVAL . . . . .	37	REMOVAL . . . . .	47
INSTALLATION . . . . .	37	INSTALLATION . . . . .	48
<b>CRANKSHAFT POSITION SENSOR</b>		<b>PTO SWITCH</b>	
DESCRIPTION . . . . .	38	DESCRIPTION . . . . .	48
OPERATION . . . . .	38	OPERATION . . . . .	48
REMOVAL . . . . .	39	<b>THROTTLE BODY</b>	
INSTALLATION . . . . .	40	DESCRIPTION . . . . .	48
<b>FUEL PUMP RELAY</b>		OPERATION . . . . .	48
DESCRIPTION . . . . .	41	REMOVAL . . . . .	48
OPERATION . . . . .	41	INSTALLATION . . . . .	49
REMOVAL . . . . .	41	<b>THROTTLE CONTROL CABLE</b>	
INSTALLATION . . . . .	41	REMOVAL . . . . .	50
<b>IDLE AIR CONTROL MOTOR</b>		INSTALLATION . . . . .	50
DESCRIPTION . . . . .	41	<b>THROTTLE POSITION SENSOR</b>	
OPERATION . . . . .	41	DESCRIPTION . . . . .	51
REMOVAL . . . . .	42	OPERATION . . . . .	51
INSTALLATION . . . . .	42	REMOVAL . . . . .	51
<b>INTAKE AIR TEMPERATURE SENSOR</b>		INSTALLATION . . . . .	52
DESCRIPTION . . . . .	43	<b>FUEL INJECTOR</b>	
OPERATION . . . . .	43	DESCRIPTION . . . . .	53
REMOVAL . . . . .	43	OPERATION . . . . .	53
INSTALLATION . . . . .	43	DIAGNOSIS AND TESTING . . . . .	53
<b>MANIFOLD ABSOLUTE PRESSURE SENSOR</b>		FUEL INJECTOR TEST . . . . .	53
DESCRIPTION . . . . .	44	REMOVAL . . . . .	53
		INSTALLATION . . . . .	53

## FUEL INJECTION - GASOLINE

### VISUAL INSPECTION—3.9L/5.2L/5.9L ENGINES

A visual inspection for loose, disconnected or incorrectly routed wires and hoses should be made. This should be done before attempting to diagnose or service the fuel injection system. A visual check will help spot these faults and save unnecessary test and diagnostic time. A thorough visual inspection will include the following checks:

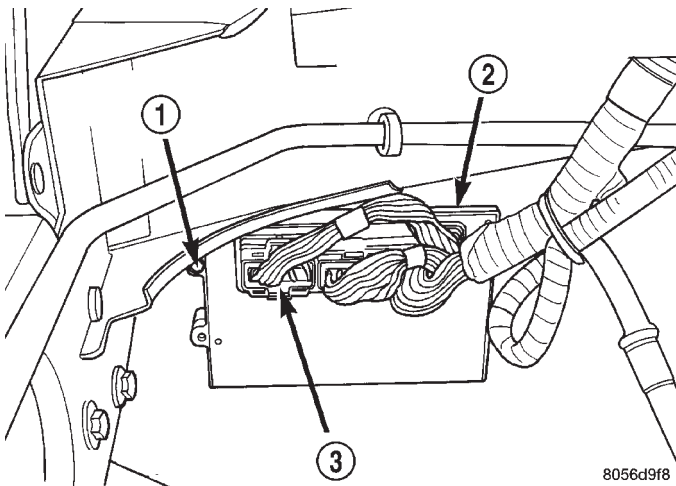
(1) Verify that the three 32-way electrical connectors are fully inserted into the connector of the powertrain control module (PCM) (Fig. 1).

(2) Inspect the battery cable connections. Be sure that they are clean and tight.

(3) Inspect fuel pump relay and air conditioning compressor clutch relay (if equipped). Inspect the ASD relay connections. Inspect starter motor relay connections. Inspect relays for signs of physical damage and corrosion. The relays are located in the Power Distribution Center (PDC) (Fig. 2). Refer to label on PDC cover for relay location.

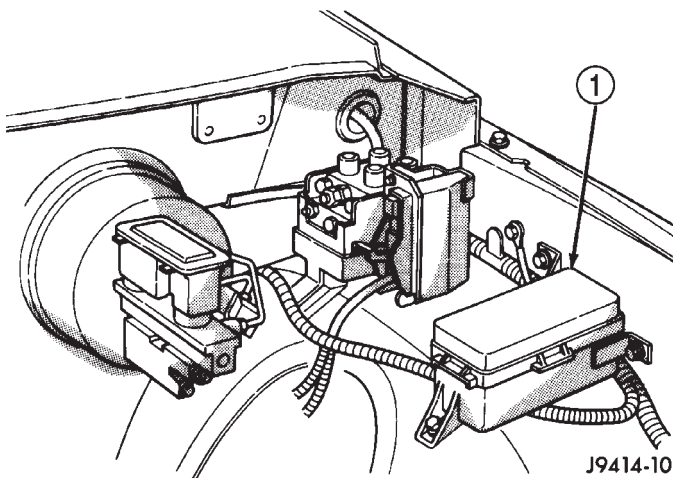
(4) Inspect ignition coil connections. Verify that coil secondary cable is firmly connected to coil (Fig. 3).

## FUEL INJECTION - GASOLINE (Continued)



**Fig. 1 Powertrain Control Module (PCM)**

- 1 - PCM MOUNTING BOLTS (3)
- 2 - POWERTRAIN CONTROL MODULE (PCM)
- 3 - (3) 32-WAY CONNECTORS

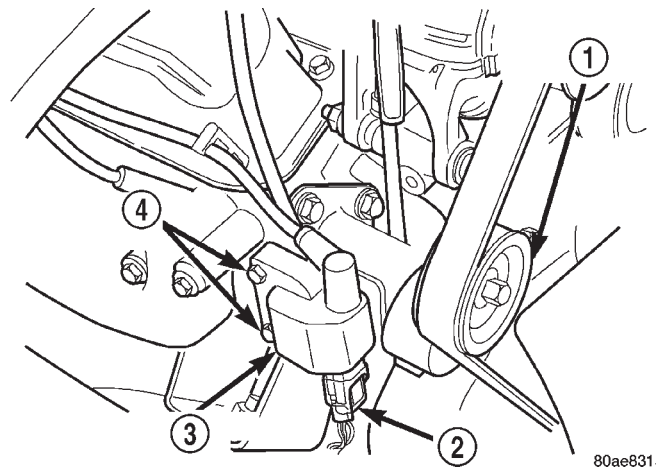


**Fig. 2 Power Distribution Center (PDC)**

- 1 - POWER DISTRIBUTION CENTER (PDC)

(5) Verify that distributor cap is correctly attached to distributor. Be sure that spark plug cables are firmly connected to the distributor cap and the spark plugs are in their correct firing order. Be sure that coil cable is firmly connected to distributor cap and coil. Be sure that camshaft position sensor wire connector (at the distributor) is firmly connected to harness connector. Inspect spark plug condition. Refer to 8, Ignition. Connect vehicle to an oscilloscope and inspect spark events for fouled or damaged spark plugs or cables.

(6) Verify that generator output wire, generator connector and ground wire are firmly connected to the generator.

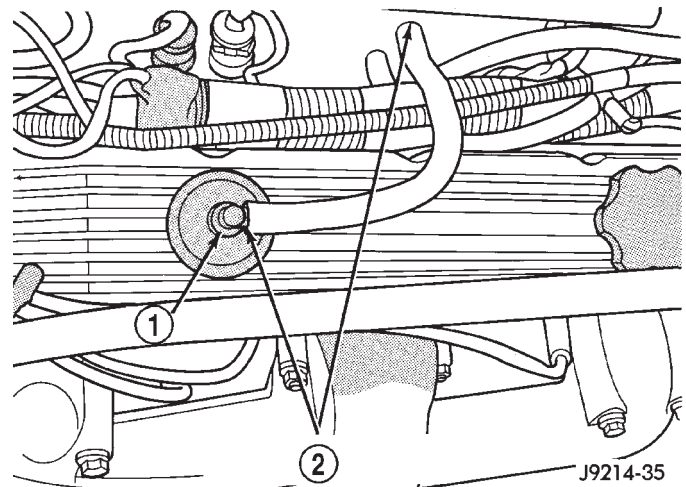


**Fig. 3 Ignition Coil—3.9L/5.2L/5.9L Engines—Typical**

- 1 - ACCESSORY DRIVE BELT TENSIONER
- 2 - COIL CONNECTOR
- 3 - IGNITION COIL
- 4 - COIL MOUNTING BOLTS

(7) Inspect the system body grounds for loose or dirty connections. Refer to 8, Wiring for ground locations.

(8) Verify positive crankcase ventilation (PCV) valve operation. Refer to 25, Emission Control System for additional information. Verify PCV valve hose is firmly connected to PCV valve and manifold (Fig. 4).



**Fig. 4 PCV Valve**

- 1 - PCV VALVE
- 2 - PCV VALVE HOSE CONNECTIONS

(9) Inspect fuel tube quick-connect fitting-to-fuel rail connections.

(10) Verify that hose connections to all ports of vacuum fittings on intake manifold are tight and not leaking.



## FUEL INJECTION - GASOLINE (Continued)

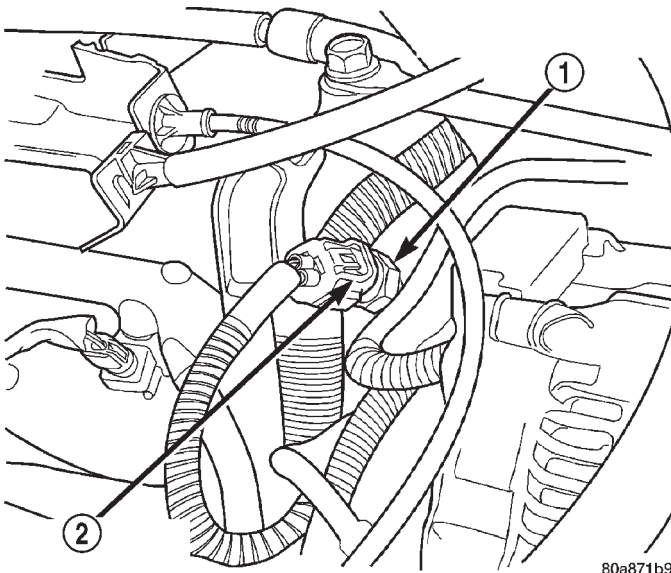
(11) Inspect accelerator cable, transmission throttle cable (if equipped) and cruise control cable connections (if equipped). Check their connections to the throttle arm of throttle body for any binding or restrictions.

(12) If equipped with vacuum brake booster, verify that vacuum booster hose is firmly connected to fitting on intake manifold. Also check connection to brake vacuum booster.

(13) Inspect the air cleaner inlet and air cleaner element for dirt or restrictions.

(14) Inspect radiator grille area, radiator fins and air conditioning condenser for restrictions.

(15) Verify that the intake manifold air temperature sensor wire connector is firmly connected to harness connector (Fig. 5).



**Fig. 5 Air Temperature**

- 1 - INTAKE MANIFOLD AIR TEMPERATURE SENSOR
- 2 - ELECTRICAL CONNECTOR

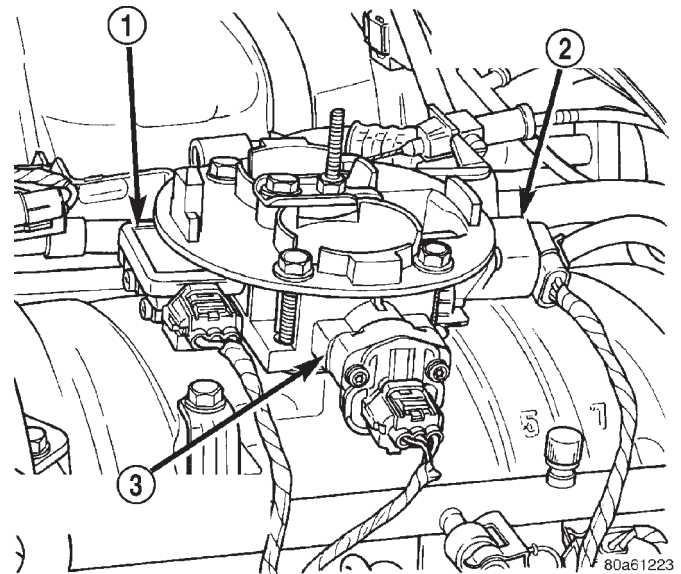
(16) Verify that MAP sensor electrical connector is firmly connected to MAP sensor (Fig. 6). Also verify that rubber L-shaped fitting from MAP sensor to the throttle body is firmly connected (Fig. 7).

(17) Verify that fuel injector wire harness connectors are firmly connected to injectors in the correct order. Each harness connector is numerically tagged with the injector number (INJ 1, INJ 2 etc.) of its corresponding fuel injector and cylinder number.

(18) Verify harness connectors are firmly connected to idle air control (IAC) motor, throttle position sensor (TPS) and manifold absolute pressure (MAP) sensor (Fig. 6).

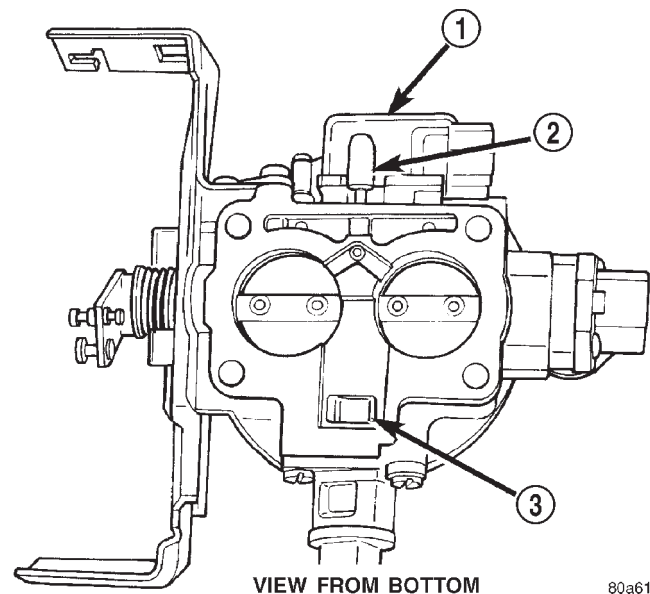
(19) Verify that wire harness connector is firmly connected to the engine coolant temperature sensor (Fig. 8).

(20) Raise and support the vehicle.



**Fig. 6 Sensor and IAC Motor Location—Typical (V-8 Shown)**

- 1 - MAP SENSOR
- 2 - IDLE AIR CONTROL MOTOR
- 3 - THROTTLE POSITION SENSOR



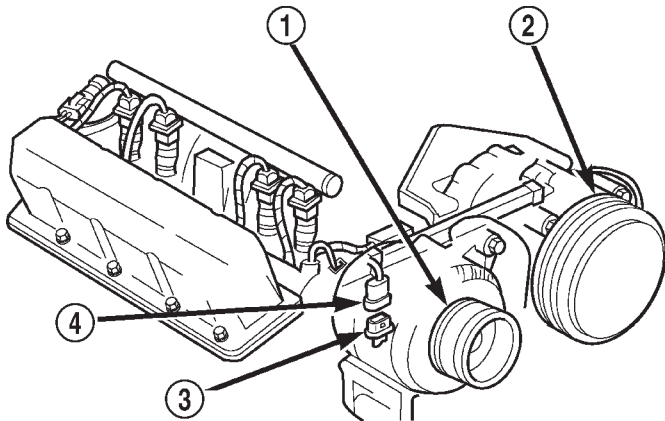
**Fig. 7 Rubber L-Shaped Fitting—MAP Sensor-to-Throttle Body—3.9L/5.2L/5.9L Engines**

- 1 - MAP SENSOR
- 2 - RUBBER FITTING
- 3 - IDLE AIR PASSAGE

(21) Verify oxygen sensor wire connectors are firmly connected to the sensors. Inspect sensors and connectors for damage (Fig. 9), (Fig. 10) or (Fig. 11).

(22) Inspect for pinched or leaking fuel tubes. Inspect for pinched, cracked or leaking fuel hoses.

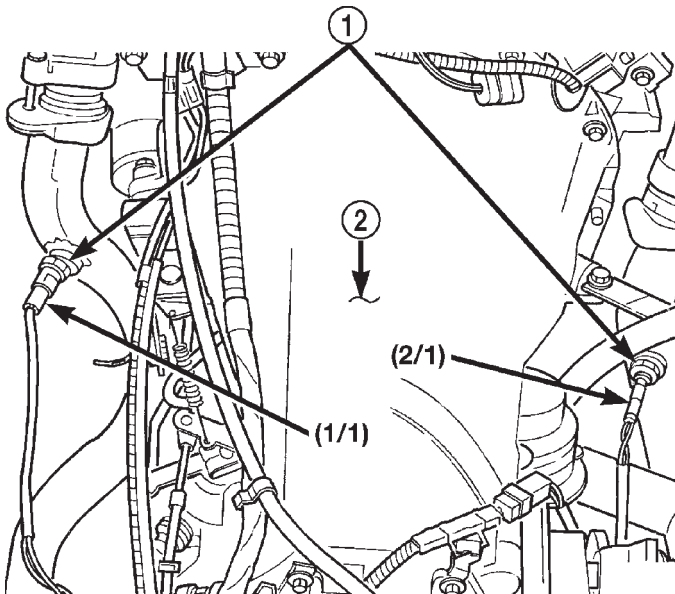
## FUEL INJECTION - GASOLINE (Continued)



80b1b2f7

**Fig. 8 Engine Coolant Temperature**

- 1 - GENERATOR
- 2 - A/C COMPRESSOR
- 3 - ENGINE COOLANT TEMPERATURE SENSOR
- 4 - ELEC. CONN.



80bfe0e7

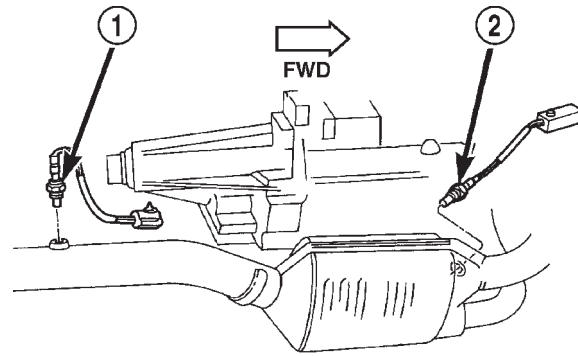
**Fig. 9 Left/Right Oxygen Sensors—HDC Engines**

- 1 - DUAL OXYGEN SENSORS
- 2 - TOP OF TRANSMISSION

(23) Inspect for exhaust system restrictions such as pinched exhaust pipes, collapsed muffler or plugged catalytic convertor.

(24) If equipped with automatic transmission, verify that electrical harness is firmly connected to park/neutral switch. Refer to 21, Automatic Transmission.

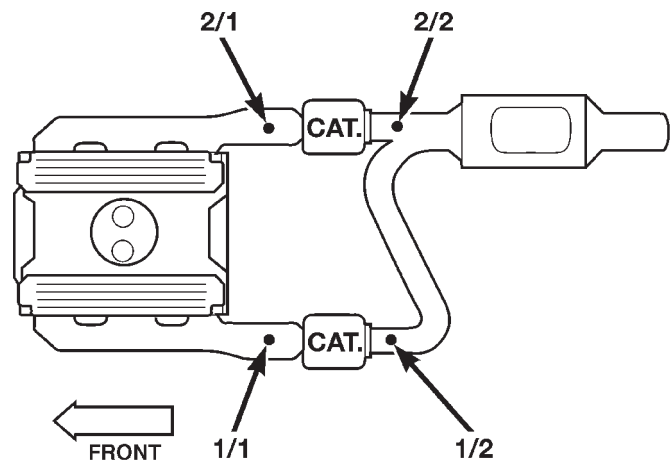
(25) Verify electrical harness is firmly connected to rear wheel speed sensor. Verify rear wheel speed sen-



80bfe0e6

**Fig. 10 Pre-Catalyst/Post-Catalyst Sensors**

- 1 - POST CATALYST OXYGEN SENSOR (1/3)
- 2 - PRE-CATALYST OXYGEN SENSOR (1/2)



80bfe0e8

**Fig. 11 Oxygen Sensors**

sor is firmly attached to rear axle with proper air gap. Refer to 5, Brakes for information.

(26) If equipped with 4-wheel antilock brake system, verify electrical harness is firmly connected to each front wheel speed sensor. Verify both front wheel speed sensors are firmly attached. Refer to 5, Brakes for information.

(27) Verify that fuel pump/gauge sender unit wire connector is firmly connected to harness connector.

(28) Inspect fuel hoses at fuel pump/gauge sender unit for cracks or leaks.

(29) Inspect transmission torque convertor housing (automatic transmission) or clutch housing (manual transmission) for damage to timing ring on drive plate/flywheel.

(30) Verify that battery cable and solenoid feed wire connections to the starter solenoid are tight and clean. Inspect for chafed wires or wires rubbing up against other components.

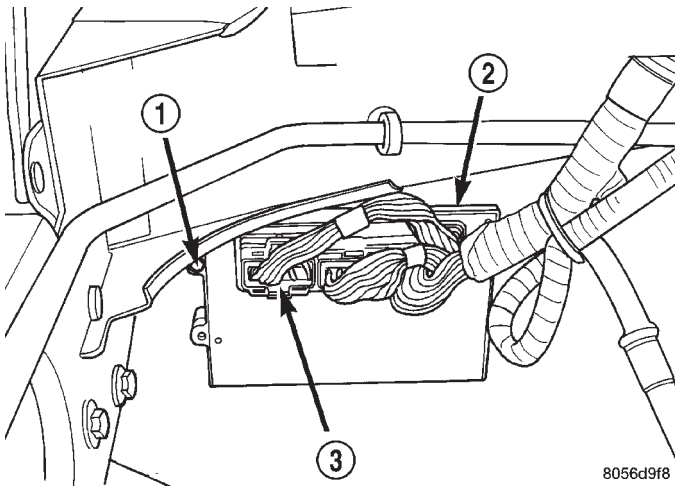


## FUEL INJECTION - GASOLINE (Continued)

## VISUAL INSPECTION—8.0L ENGINE

A visual inspection for loose, disconnected or incorrectly routed wires and hoses should be made. This should be done before attempting to diagnose or service the fuel injection system. A visual check will help spot these faults and save unnecessary test and diagnostic time. A thorough visual inspection will include the following checks:

(1) Verify that the three 32-way electrical connectors are fully inserted into the connector of the powertrain control module (PCM) (Fig. 12).



**Fig. 12 Powertrain Control Module (PCM)**

- 1 - PCM MOUNTING BOLTS (3)
- 2 - POWERTRAIN CONTROL MODULE (PCM)
- 3 - (3) 32-WAY CONNECTORS

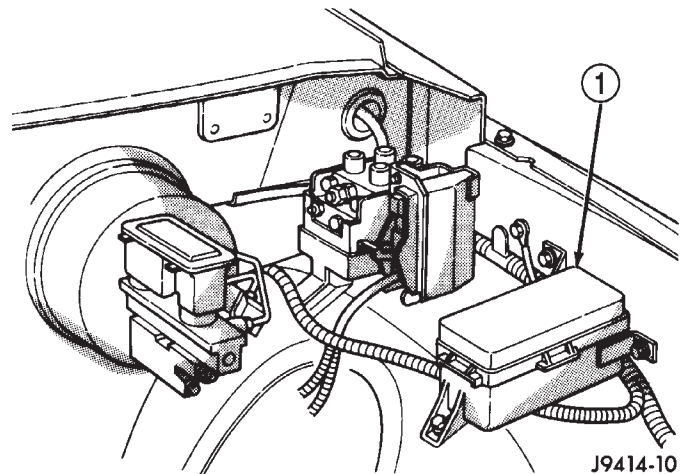
(2) Inspect the battery cable connections. Be sure that they are clean and tight.

(3) Inspect fuel pump relay and air conditioning compressor clutch relay (if equipped). Inspect the ASD relay connections. Inspect starter motor relay connections. Inspect relays for signs of physical damage and corrosion. The relays are located in the Power Distribution Center (PDC) (Fig. 13). Refer to label on PDC cover for relay location.

(4) Inspect ignition coil pack primary connections. Verify that secondary cables are firmly connected to coils (Fig. 14).

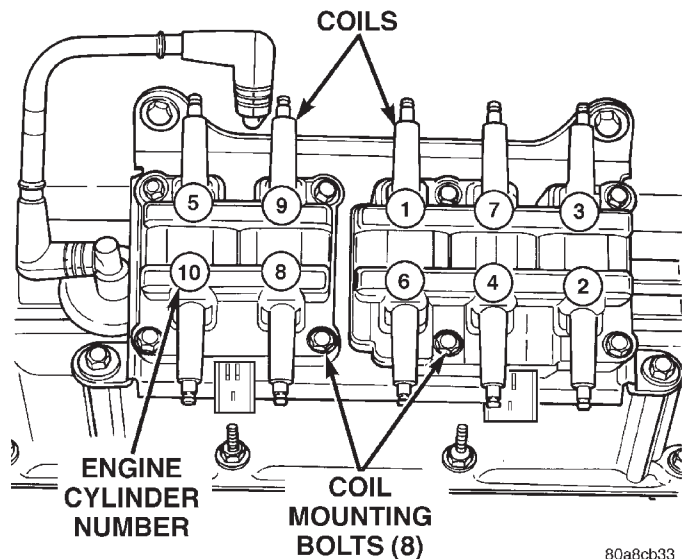
(5) Be sure that spark plug cables are firmly connected and the spark plugs are in their correct firing order. Be sure that camshaft position sensor wire connector is firmly connected to harness connector. Inspect spark plug condition. Refer to 8, Ignition. Connect vehicle to an oscilloscope and inspect spark events for fouled or damaged spark plugs or cables.

(6) Verify that generator output wire, generator connector and ground wire are firmly connected to the generator.



**Fig. 13 Power Distribution Center (PDC)**

- 1 - POWER DISTRIBUTION CENTER (PDC)



**Fig. 14 Ignition Coil Pack—8.0L Engine**

(7) Inspect the system body grounds for loose or dirty connections. Refer to 8, Wiring for ground locations.

(8) Verify crankcase ventilation (CCV) operation. Refer to 25, Emission Control System for additional information.

(9) Inspect fuel tube quick-connect fitting-to-fuel rail connections.

(10) Verify that hose connections to all ports of vacuum fittings on intake manifold are tight and not leaking.

(11) Inspect accelerator cable, transmission throttle cable (if equipped) and cruise control cable connections (if equipped). Check their connections to the throttle arm of throttle body for any binding or restrictions.

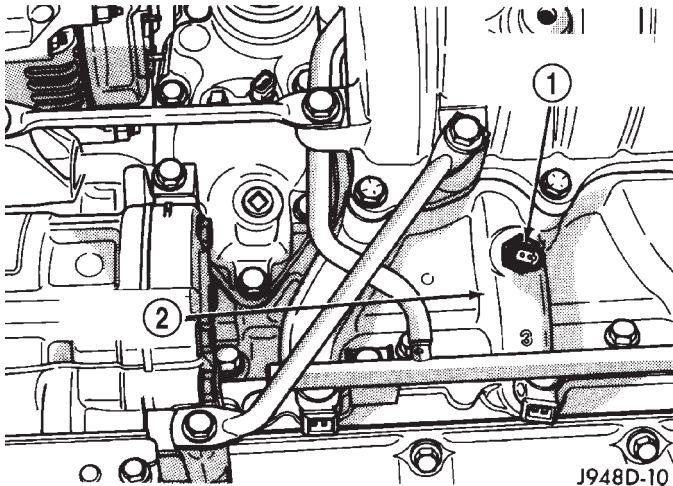
## FUEL INJECTION - GASOLINE (Continued)

(12) If equipped with vacuum brake booster, verify that vacuum booster hose is firmly connected to fitting on intake manifold. Also check connection to brake vacuum booster.

(13) Inspect the air cleaner inlet and air cleaner element for dirt or restrictions.

(14) Inspect radiator grille area, radiator fins and air conditioning condenser for restrictions.

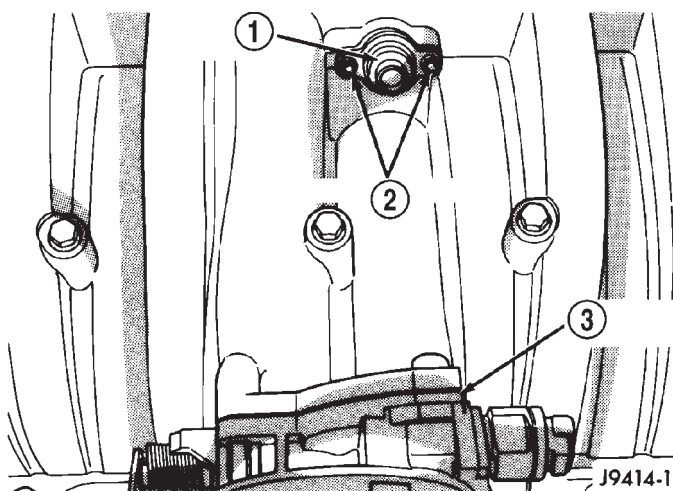
(15) Verify that the intake manifold air temperature sensor wire connector is firmly connected to harness connector (Fig. 15).



**Fig. 15 Air Temperature Sensor—8.0L Engine**

- 1 - INTAKE MANIFOLD AIR TEMP. SENSOR
- 2 - INTAKE MANIFOLD

(16) Verify that MAP sensor electrical connector is firmly connected to MAP sensor (Fig. 16).



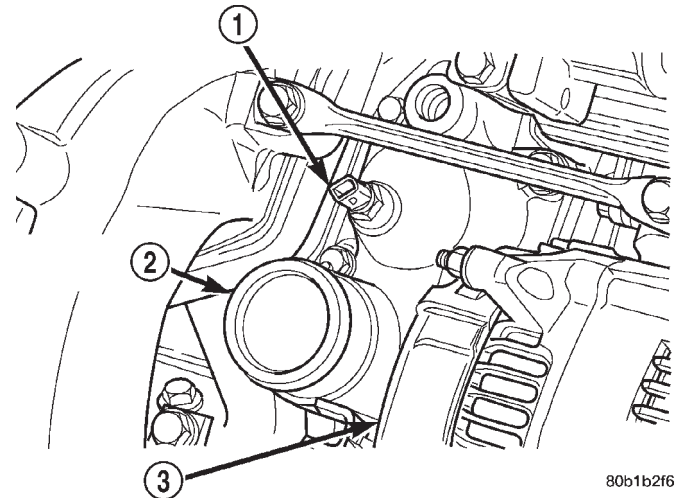
**Fig. 16 Map Sensor —8.0L Engine**

- 1 - MAP SENSOR
- 2 - MOUNTING BOLTS
- 3 - THROTTLE BODY

(17) Verify that fuel injector wire harness connectors are firmly connected to injectors in the correct order. Each harness connector is numerically tagged with the injector number (INJ 1, INJ 2 etc.) of its corresponding fuel injector and cylinder number.

(18) Verify harness connectors are firmly connected to idle air control (IAC) motor and throttle position sensor (TPS).

(19) Verify that wire harness connector is firmly connected to the engine coolant temperature sensor (Fig. 17).



**Fig. 17 Engine Coolant Temperature Sensor—8.0L Engine**

- 1 - ENGINE COOLANT TEMP. SENSOR
- 2 - THERMOSTAT HOUSING
- 3 - GENERATOR

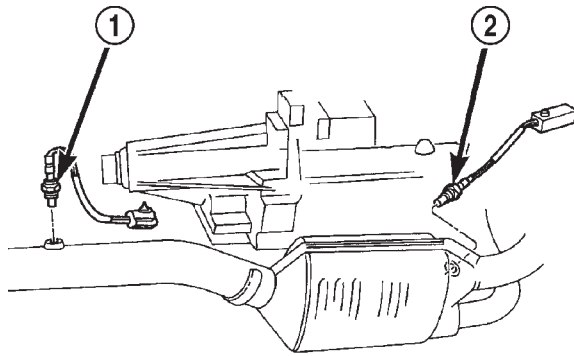
(20) Raise and support the vehicle.  
 (21) Verify that all oxygen sensor wire connectors are firmly connected to the sensors. Inspect sensors and connectors for damage (Fig. 18), (Fig. 19) or (Fig. 20).

(22) Inspect for pinched or leaking fuel tubes. Inspect for pinched, cracked or leaking fuel hoses.

(23) Inspect for exhaust system restrictions such as pinched exhaust pipes, collapsed muffler or plugged catalytic convertor.

(24) If equipped with automatic transmission, verify that electrical harness is firmly connected to park/neutral switch. Refer to 21, Automatic Transmission.

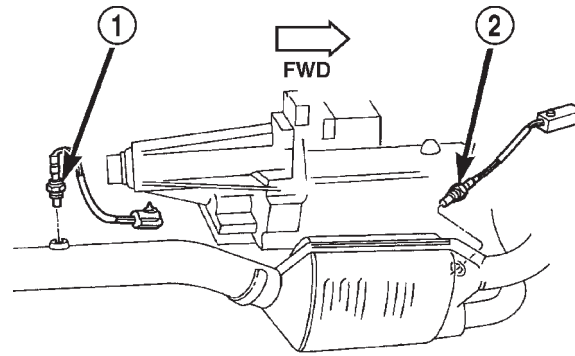
## FUEL INJECTION - GASOLINE (Continued)



80bfe0e5

**Fig. 18 Upstream/Downstream Oxygen Sensors**

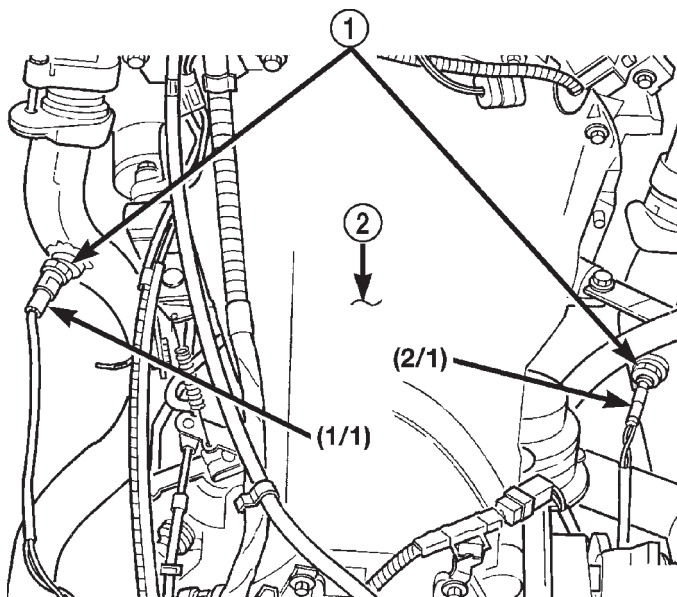
- 1 - DOWN STREAM OXYGEN SENSOR (1/2)  
2 - UP STREAM OXYGEN SENSOR (1/1)



80bfe0e6

**Fig. 20 Pre-Catalyst/Post Catalyst Oxygen Sensors**

- 1 - POST CATALYST OXYGEN SENSOR (1/3)  
2 - PRE-CATALYST OXYGEN SENSOR (1/2)



80bfe0e7

**Fig. 19 Left/Right**

- 1 - DUAL OXYGEN SENSORS  
2 - TOP OF TRANSMISSION

(25) Verify electrical harness is firmly connected to rear wheel speed sensor. Verify rear wheel speed sensor is firmly attached to rear axle with proper air gap. Refer to 5, Brakes for information.

(26) If equipped with 4-wheel antilock brake system, verify electrical harness is firmly connected to each front wheel speed sensor. Verify both front wheel speed sensors are firmly attached. Refer to 5, Brakes for information.

(27) Verify that fuel pump/gauge sender unit wire connector is firmly connected to harness connector.

(28) Inspect fuel hoses at fuel pump/gauge sender unit for cracks or leaks.

(29) Inspect transmission torque converter housing (automatic transmission) or clutch housing (manual transmission) for damage to timing ring on drive plate/flywheel.

(30) Verify that battery cable and solenoid feed wire connections to the starter solenoid are tight and clean. Inspect for chaffed wires or wires rubbing up against other components.

## FUEL INJECTION - GASOLINE (Continued)

## SPECIFICATIONS

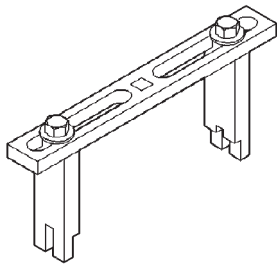
## SPECIFICATIONS - TORQUE - GAS FUEL INJECTION

DESCRIPTION	N-m	Ft. Lbs.	In. Lbs.
Air Cleaner Housing Mount. Nuts—8.0L Engine	11		96
Air Cleaner Housing Metal Clamp—3.9L/5.2L/5.9L Engines	4		35
Crankshaft Position Sensor Mounting Bolts—All Engines	8		70
Camshaft Position Sensor Mounting—8.0L Engine	6		50
Engine Coolant Temperature Sensor—All Engines	6-8		55-75
Fuel Tank Mounting Nuts	41	30	
Fuel Hose Clamps	1		10
IAC Motor-To-Throttle Body Bolts	7		60
Intake Manifold Air Temp. Sensor—All Engines	12-15		110-130
MAP Sensor Mounting Screws—3.9L/5.2L/5.9L Engines	3		25
MAP Sensor Mounting Screws—8.0L Engine	2		20
Oxygen Sensor—All Engines	30	22	
Powertrain Control Module Mounting Screws	4		35
Throttle Body Mounting Bolts—3.9L/5.2L/5.9L Engines	23		200
Throttle Body Mounting Bolts—8.0L Engine	22		192
Throttle Position Sensor Mounting Screws—All Engines	7		60

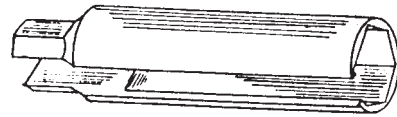
FUEL INJECTION - GASOLINE (Continued)

SPECIAL TOOLS

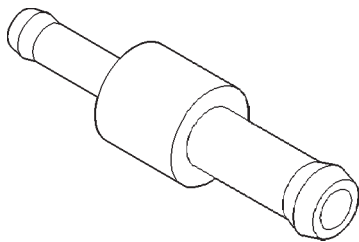
FUEL SYSTEM



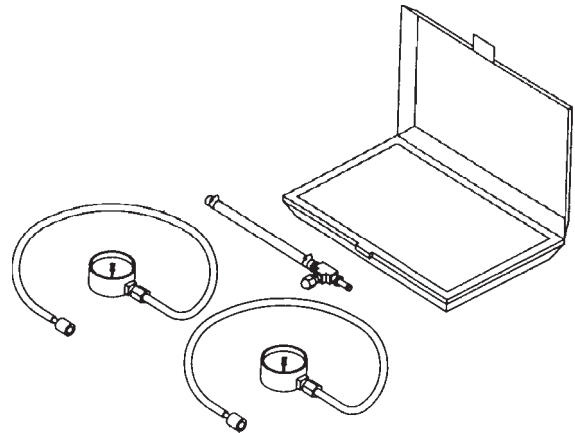
**Spanner Wrench—6856**



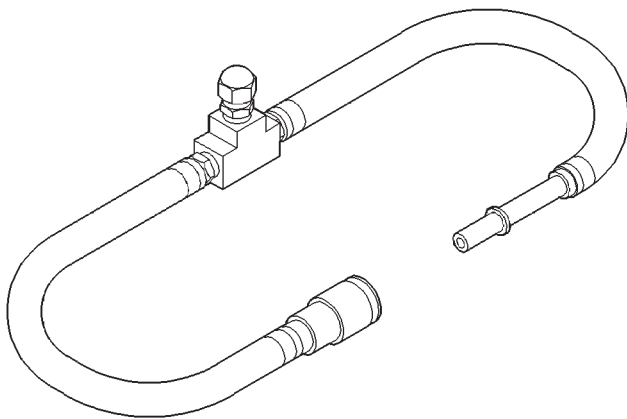
**O2S (Oxygen Sensor) Remover/Installer—C-4907**



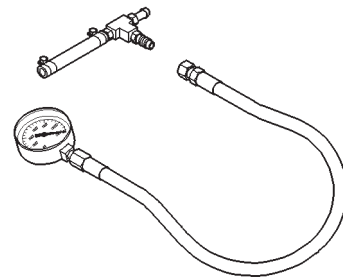
**Fitting, Air Metering—6714**



**Test Kit, Fuel Pressure—5069**



**Adapters, Fuel Pressure Test—6539 and/or 6631**



**Test Kit, Fuel Pressure—C-4799-B**



**Fuel Line Removal Tool—6782**

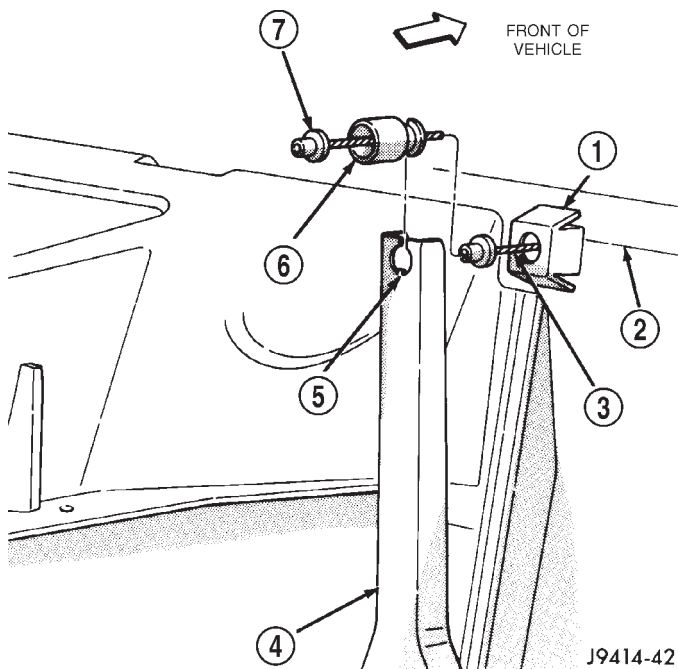


## ACCELERATOR PEDAL

### REMOVAL

**CAUTION:** Be careful not to damage or kink the cable core wire (within the cable sheathing) while servicing accelerator pedal or cables.

(1) From inside vehicle, hold up accelerator pedal. Remove plastic cable retainer and throttle cable core wire from upper end of pedal arm (Fig. 21). The plastic cable retainer snaps into pedal arm.

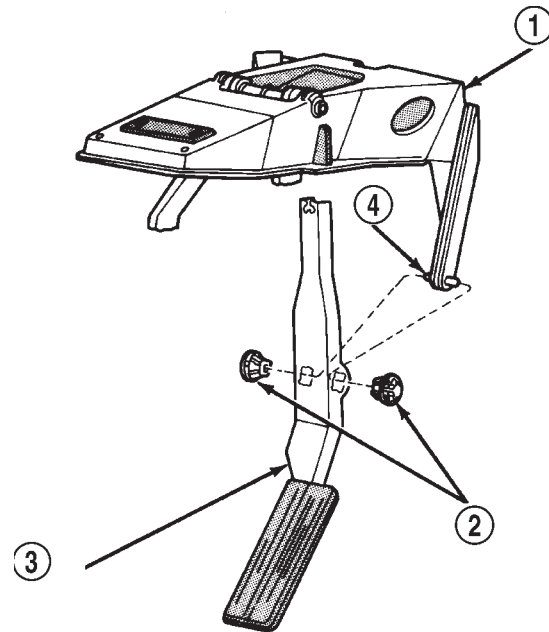


**Fig. 21 Cable Removal/Installation at Pedal**

- 1 - PINCH TWO TABS FOR CABLE REMOVAL
- 2 - DASH PANEL
- 3 - CABLE CORE WIRE
- 4 - THROTTLE PEDAL ARM
- 5 - INDEX TAB
- 6 - CABLE RETAINER
- 7 - CABLE STOP

(2) Insert a small screwdriver into square holes located on pivots/bushings (Fig. 22). Twist screwdriver to disengage pivot locks from pivot pin. Pivots will be damaged when removing. Discard old pivots.

(3) Remove pedal/bracket assembly from vehicle.



J9414-40

**Fig. 22 Accelerator Pedal—Removal or Installation**

- 1 - PEDAL MOUNTING BRACKET
- 2 - PIVOTS/BUSHINGS
- 3 - PEDAL/BACKET
- 4 - PIVOT PIN

### INSTALLATION

(1) Position pedal/bracket assembly over pivot pin (Fig. 22).

(2) Install two new pivots/bushings. Using large pliers, press both bushings together until they bottom on sides of pedal/bracket assembly. Bushing retaining ears will snap into position when properly installed.

(3) From inside vehicle, hold up accelerator pedal. Install throttle cable core wire and plastic cable retainer into and through upper end of pedal arm (the plastic retainer is snapped into pedal arm). When installing plastic retainer to accelerator pedal arm, note index tab on pedal arm (Fig. 21). Align index slot on plastic cable retainer to this index tab.



## CRANKSHAFT POSITION SENSOR

### DESCRIPTION - 3.9L

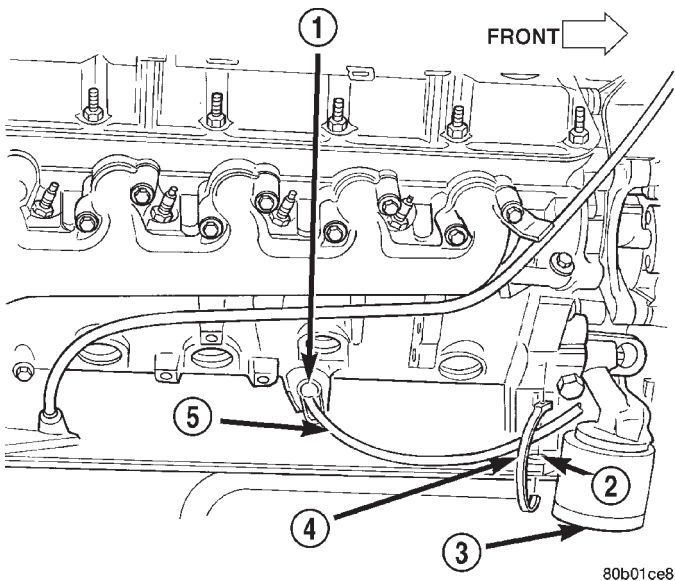
The Crankshaft Position (CKP) sensor is located near the outer edge of the flywheel (starter ringear).

### DESCRIPTION - 5.2L/5.9L

The Crankshaft Position (CKP) sensor is located near the outer edge of the flywheel (starter ringear).

### DESCRIPTION - 8.0L

The Crankshaft Position (CKP) sensor is located on the right-lower side of the cylinder block, forward of the right engine mount, just above the oil pan rail (Fig. 23).



**Fig. 23 CKP Sensor Location—8.0L V-10 Engine**

- 1 - CRANKSHAFT POSITION SENSOR
- 2 - HOLE
- 3 - OIL FILTER
- 4 - PLASTIC TIE STRAP
- 5 - PIGTAIL HARNESS

### OPERATION - 3.9L

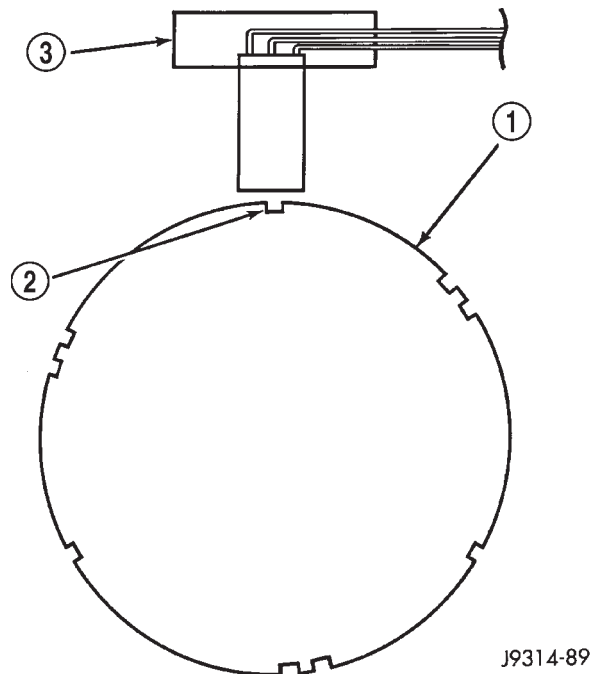
Engine speed and crankshaft position are provided through the CKP sensor. The sensor generates pulses that are the input sent to the Powertrain Control Module (PCM). The PCM interprets the sensor input to determine the crankshaft position. The PCM then uses this position, along with other inputs, to determine injector sequence and ignition timing.

The sensor is a hall effect device combined with an internal magnet. It is also sensitive to steel within a certain distance from it.

The flywheel/drive plate has groups of notches at its outer edge. On 3.9L V-6 engines, there are three sets of double notches and three sets of single notches (Fig. 24).

The notches cause a pulse to be generated when they pass under the sensor. The pulses are the input to the PCM.

The engine will not operate if the PCM does not receive a CKP sensor input.



**Fig. 24 CKP Sensor Operation—3.9L Engine**

- 1 - FLYWHEEL
- 2 - NOTCHES
- 3 - CRANKSHAFT POSITION SENSOR

### OPERATION - 5.2L/5.9L

Engine speed and crankshaft position are provided through the CKP sensor. The sensor generates pulses that are the input sent to the Powertrain Control Module (PCM). The PCM interprets the sensor input to determine the crankshaft position. The PCM then uses this position, along with other inputs, to determine injector sequence and ignition timing.

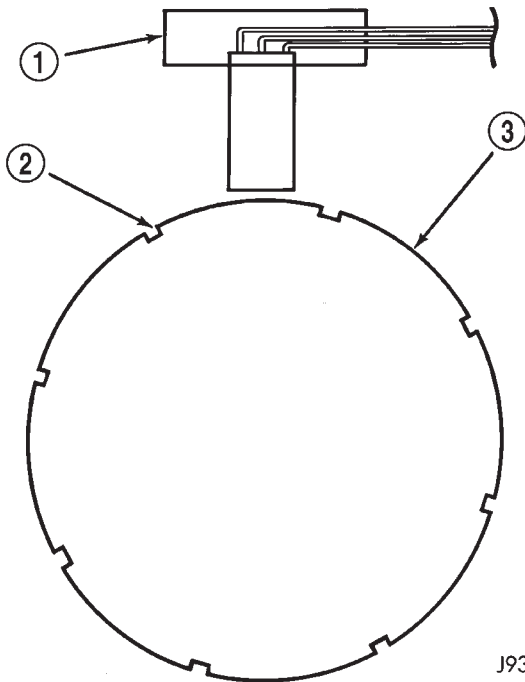
The sensor is a hall effect device combined with an internal magnet. It is also sensitive to steel within a certain distance from it.

On 5.2/5.9L V-8 engines, the flywheel/drive plate has 8 single notches, spaced every 45 degrees, at its outer edge (Fig. 25).

The notches cause a pulse to be generated when they pass under the sensor. The pulses are the input to the PCM. For each engine revolution, there are 8 pulses generated on V-8 engines.

## CRANKSHAFT POSITION SENSOR (Continued)

The engine will not operate if the PCM does not receive a CKP sensor input.



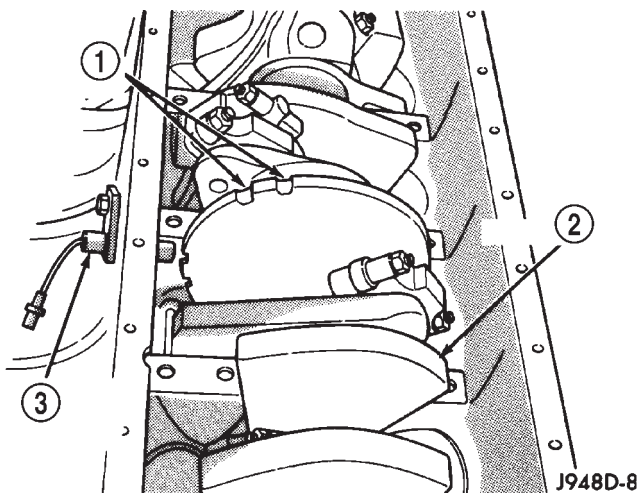
J9314-88

**Fig. 25 CKP Sensor Operation—5.2L/5.9L Engine**

- 1 - CRANKSHAFT POSITION SENSOR
- 2 - NOTCHES
- 3 - FLYWHEEL

## OPERATION - 8.0L

The Crankshaft Position (CKP) sensor detects notches machined into the middle of the crankshaft (Fig. 26).



J948D-8

**Fig. 26 CKP Sensor Operation—8.0L V-10 Engine**

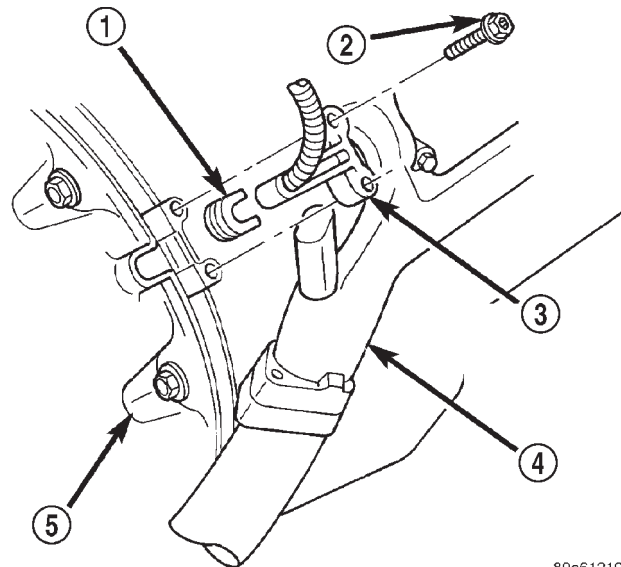
- 1 - CRANKSHAFT NOTCHES
- 2 - CRANKSHAFT
- 3 - CRANKSHAFT POSITION SENSOR

There are five sets of notches. Each set contains two notches. Basic ignition timing is determined by the position of the last notch in each set of notches. Once the Powertrain Control Module (PCM) senses the last notch, it will determine crankshaft position (which piston will next be at Top Dead Center). An input from the camshaft position sensor is also needed. It may take the module up to one complete engine revolution to determine crankshaft position during engine cranking.

The PCM uses the signal from the camshaft position sensor to determine fuel injector sequence. Once crankshaft position has been determined, the PCM begins energizing a ground circuit to each fuel injector to provide injector operation.

## REMOVAL - 3.9L/5.2L/5.9L

The sensor is bolted to the top of the cylinder block near the rear of right cylinder head (Fig. 27).



80a61219

**Fig. 27 Crankshaft Position Sensor**

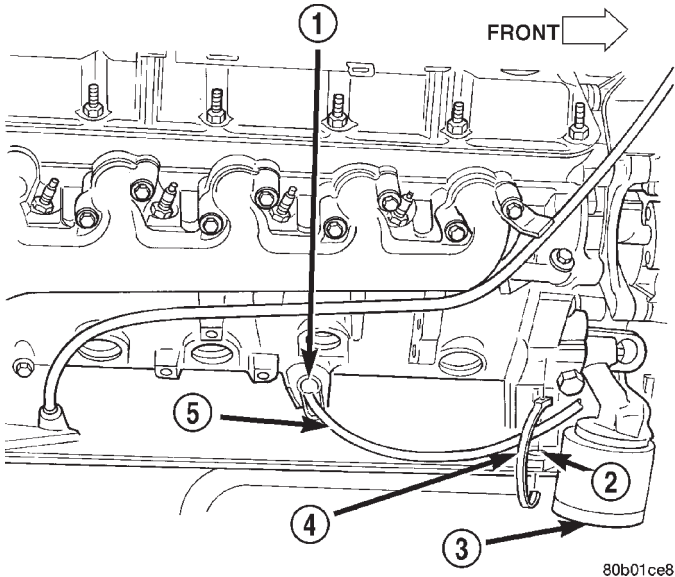
- 1 - GROMMET
- 2 - MOUNTING BOLTS (2)
- 3 - CRANKSHAFT POSITION SENSOR
- 4 - RIGHT EXHAUST MANIFOLD
- 5 - TRANSMISSION BELL HOUSING

- (1) Remove the air cleaner intake tube.
- (2) Disconnect crankshaft position sensor pigtail harness from main wiring harness.
- (3) Remove two sensor (recessed hex head) mounting bolts (Fig. 27).
- (4) Remove sensor from engine.

## CRANKSHAFT POSITION SENSOR (Continued)

## REMOVAL - 8.0L

The crankshaft position sensor is located on the right-lower side of the cylinder block, forward of the right engine mount, just above the oil pan rail (Fig. 28).



**Fig. 28 Crankshaft Position Sensor Location—8.0L V-10 Engine**

- 1 - CRANKSHAFT POSITION SENSOR
- 2 - HOLE
- 3 - OIL FILTER
- 4 - PLASTIC TIE STRAP
- 5 - PIGTAIL HARNESS

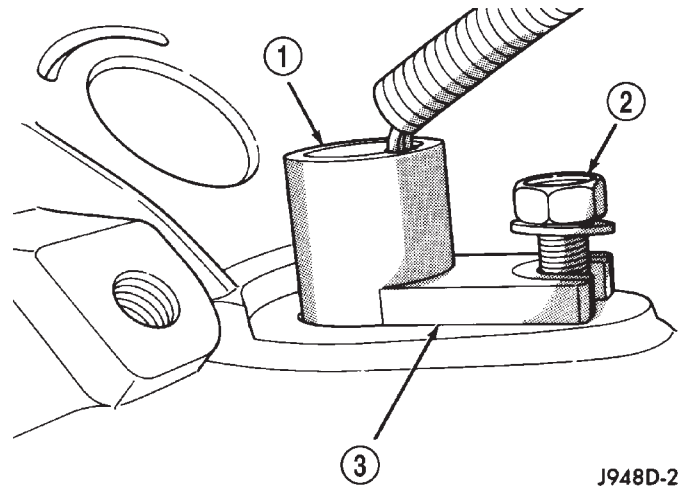
- (1) Raise and support vehicle.
- (2) Disconnect sensor pigtail harness from main engine wiring harness.
- (3) Remove sensor mounting bolt (Fig. 29).
- (4) Cut plastic tie strap (Fig. 28) securing sensor pigtail harness to side of engine block.
- (5) Carefully pry sensor from cylinder block in a rocking action with two small screwdrivers.
- (6) Remove sensor from vehicle.
- (7) Check condition of sensor o-ring (Fig. 30).

## INSTALLATION - 3.9L/5.2L/5.9L

- (1) Position crankshaft position sensor to engine.
- (2) Install mounting bolts and tighten to 8 N·m (70 in. lbs.) torque.
- (3) Connect main harness electrical connector to sensor.
- (4) Install air cleaner tube.

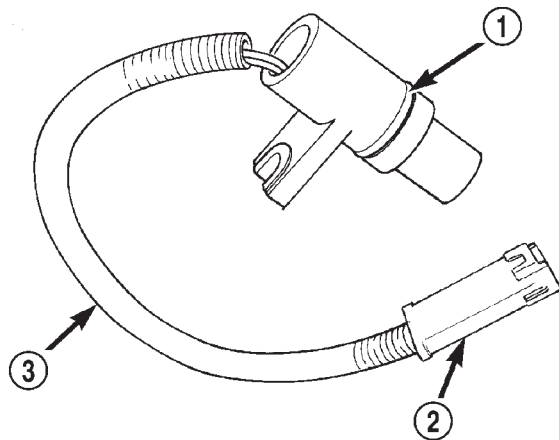
## INSTALLATION - 8.0L

The crankshaft position sensor is located on the right-lower side of the cylinder block, forward of the right engine mount, just above the oil pan rail (Fig. 28).



**Fig. 29 Sensor Removal/Installation—8.0L V-10 Engine**

- 1 - CRANKSHAFT POSITION SENSOR
- 2 - MOUNTING BOLT
- 3 - SENSOR POSITIONED FLUSH TO CYLINDER BLOCK



**Fig. 30 Sensor O-Ring—8.0L V-10 Engine**

- 1 - CRANKSHAFT POSITION SENSOR O-RING
- 2 - ELECTRICAL CONNECTOR
- 3 - PIGTAIL HARNESS

- (1) Apply a small amount of engine oil to sensor o-ring (Fig. 30).
- (2) Install sensor into cylinder block with a slight rocking action. Do not twist sensor into position as damage to o-ring may result.

**CAUTION:** Before tightening sensor mounting bolt, be sure sensor is completely flush to cylinder block (Fig. 29). If sensor is not flush, damage to sensor mounting tang may result.

- (3) Install mounting bolt and tighten to 8 N·m (70 in. lbs.) torque.
- (4) Connect sensor pigtail harness to main engine wiring harness

## CRANKSHAFT POSITION SENSOR (Continued)

(5) Install new plastic tie strap (Fig. 28) to secure sensor pigtail harness to side of engine block. Thread tie strap through casting hole on cylinder block.

## FUEL PUMP RELAY

## DESCRIPTION

The 5-pin, 12-volt, fuel pump relay is located in the Power Distribution Center (PDC). Refer to the label on the PDC cover for relay location.

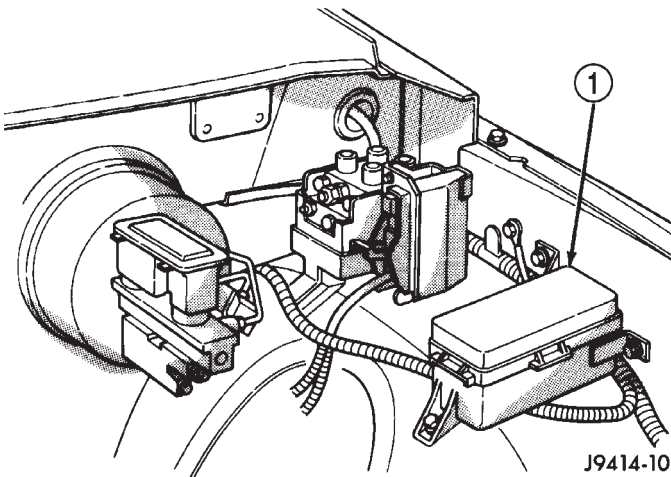
## OPERATION

The Powertrain Control Module (PCM) energizes the electric fuel pump through the fuel pump relay. The fuel pump relay is energized by first applying battery voltage to it when the ignition key is turned ON, and then applying a ground signal to the relay from the PCM.

Whenever the ignition key is turned ON, the electric fuel pump will operate. But, the PCM will shut-down the ground circuit to the fuel pump relay in approximately 1-3 seconds unless the engine is operating or the starter motor is engaged.

## REMOVAL

The fuel pump relay is located in the Power Distribution Center (PDC) (Fig. 31). Refer to label on PDC cover for relay location.



**Fig. 31 Power Distribution Center (PDC)**

1 - POWER DISTRIBUTION CENTER (PDC)

- (1) Remove PDC cover.
- (2) Remove relay from PDC.
- (3) Check condition of relay terminals and PDC connector terminals for damage or corrosion. Repair if necessary before installing relay.
- (4) Check for pin height (pin height should be the same for all terminals within the PDC connector). Repair if necessary before installing relay.

## INSTALLATION

The fuel pump relay is located in the Power Distribution Center (PDC) (Fig. 31). Refer to label on PDC cover for relay location.

- (1) Install relay to PDC.
- (2) Install cover to PDC.

## IDLE AIR CONTROL MOTOR

## DESCRIPTION

The IAC stepper motor is mounted to the throttle body, and regulates the amount of air bypassing the control of the throttle plate. As engine loads and ambient temperatures change, engine rpm changes. A pintle on the IAC stepper motor protrudes into a passage in the throttle body, controlling air flow through the passage. The IAC is controlled by the Powertrain Control Module (PCM) to maintain the target engine idle speed.

## OPERATION

At idle, engine speed can be increased by retracting the IAC motor pintle and allowing more air to pass through the port, or it can be decreased by restricting the passage with the pintle and diminishing the amount of air bypassing the throttle plate.

The IAC is called a stepper motor because it is moved (rotated) in steps, or increments. Opening the IAC opens an air passage around the throttle blade which increases RPM.

The PCM uses the IAC motor to control idle speed (along with timing) and to reach a desired MAP during decel (keep engine from stalling).

The IAC motor has 4 wires with 4 circuits. Two of the wires are for 12 volts and ground to supply electrical current to the motor windings to operate the stepper motor in one direction. The other 2 wires are also for 12 volts and ground to supply electrical current to operate the stepper motor in the opposite direction.

To make the IAC go in the opposite direction, the PCM just reverses polarity on both windings. If only 1 wire is open, the IAC can only be moved 1 step (increment) in either direction. To keep the IAC motor in position when no movement is needed, the PCM will energize both windings at the same time. This locks the IAC motor in place.

In the IAC motor system, the PCM will count every step that the motor is moved. This allows the PCM to determine the motor pintle position. If the memory is cleared, the PCM no longer knows the position of the pintle. So at the first key ON, the PCM drives the IAC motor closed, regardless of where it was before. This zeros the counter. From this point the PCM will back out the IAC motor and keep track of its position again.



## IDLE AIR CONTROL MOTOR (Continued)

When engine rpm is above idle speed, the IAC is used for the following:

- Off-idle dashpot (throttle blade will close quickly but idle speed will not stop quickly)
- Deceleration air flow control
- A/C compressor load control (also opens the passage slightly before the compressor is engaged so that the engine rpm does not dip down when the compressor engages)
- Power steering load control

The PCM can control polarity of the circuit to control direction of the stepper motor.

**IAC Stepper Motor Program:** The PCM is also equipped with a memory program that records the number of steps the IAC stepper motor most recently advanced to during a certain set of parameters. For example: The PCM was attempting to maintain a 1000 rpm target during a cold start-up cycle. The last recorded number of steps for that may have been 125. That value would be recorded in the memory cell so that the next time the PCM recognizes the identical conditions, the PCM recalls that 125 steps were required to maintain the target. This program allows for greater customer satisfaction due to greater control of engine idle.

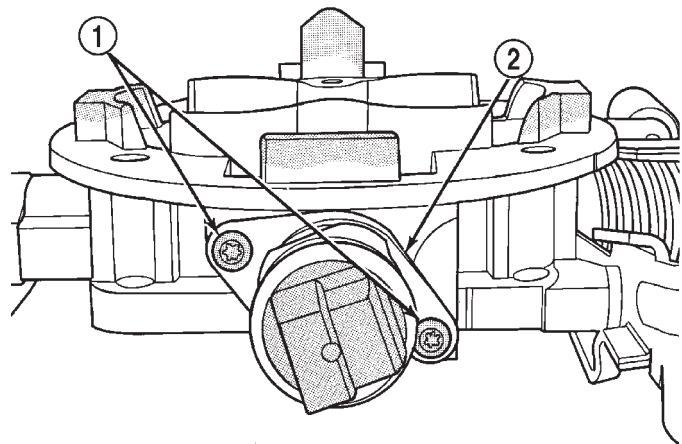
Another function of the memory program, which occurs when the power steering switch (if equipped), or the A/C request circuit, requires that the IAC stepper motor control engine rpm, is the recording of the last targeted steps into the memory cell. The PCM can anticipate A/C compressor loads. This is accomplished by delaying compressor operation for approximately 0.5 seconds until the PCM moves the IAC stepper motor to the recorded steps that were loaded into the memory cell. Using this program helps eliminate idle-quality changes as loads change. Finally, the PCM incorporates a "No-Load" engine speed limiter of approximately 1800 - 2000 rpm, when it recognizes that the TPS is indicating an idle signal and IAC motor cannot maintain engine idle.

A (factory adjusted) set screw is used to mechanically limit the position of the throttle body throttle plate. **Never attempt to adjust the engine idle speed using this screw.** All idle speed functions are controlled by the IAC motor through the PCM.

## REMOVAL - 3.9L/5.2L/5.9L

The IAC motor is located on the back of the throttle body (Fig. 32).

- (1) Remove air cleaner assembly.
- (2) Disconnect electrical connector from IAC motor.
- (3) Remove two mounting bolts (screws) (Fig. 32).
- (4) Remove IAC motor from throttle body.



J9214-23

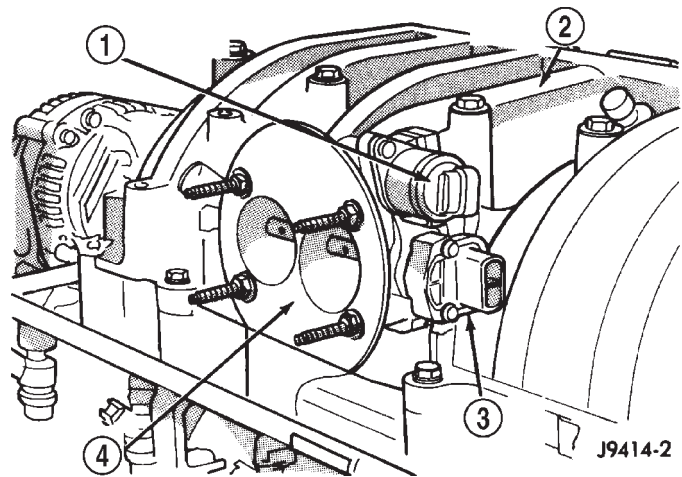
**Fig. 32 Mounting Bolts (Screws)—IAC Motor—3.9L/5.2L/5.9L Engines**

- 1 - MOUNTING SCREWS  
2 - IDLE SPEED MOTOR

## REMOVAL - 8.0L

The IAC motor is located on the back of the throttle body (Fig. 33).

- (1) Remove the air cleaner cover.
- (2) Remove the 4 air cleaner housing mounting nuts and remove housing from throttle body.
- (3) Disconnect electrical connector from IAC motor.
- (4) Remove two mounting bolts (screw).



J9414-2

**Fig. 33 IAC Motor—8.0L Engine**

- 1 - IDLE AIR CONTROL MOTOR  
2 - INTAKE MANIFOLD (UPPER HALF)  
3 - THROTTLE POSITION SENSOR  
4 - THROTTLE BODY

- (5) Remove IAC motor from throttle body.

## INSTALLATION - 3.9L/5.2L/5.9L

The IAC motor is located on the back of the throttle body (Fig. 32).

## IDLE AIR CONTROL MOTOR (Continued)

- (1) Install IAC motor to throttle body.
- (2) Install and tighten two mounting bolts (screws) to 7 N-m (60 in. lbs.) torque.
- (3) Install electrical connector.
- (4) Install air cleaner assembly.

## INSTALLATION - 8.0L

The IAC motor is located on the back of the throttle body (Fig. 33).

- (1) Install IAC motor to throttle body.
- (2) Install and tighten two mounting bolts (screws) to 7 N-m (60 in. lbs.) torque.
- (3) Install electrical connector.
- (4) Install air cleaner housing to throttle body.
- (5) Install 4 air cleaner housing mounting nuts. Tighten nuts to 11 N-m (96 in. lbs.) torque.
- (6) Install air cleaner housing cover.

## INTAKE AIR TEMPERATURE SENSOR

### DESCRIPTION - 3.9L/5.2L/5.9L/8.0L

The 2-wire Intake Manifold Air Temperature (IAT) sensor is installed in the intake manifold with the sensor element extending into the air stream.

The IAT sensor is a two-wire Negative Thermal Coefficient (NTC) sensor. Meaning, as intake manifold temperature increases, resistance (voltage) in the sensor decreases. As temperature decreases, resistance (voltage) in the sensor increases.

### OPERATION - 3.9L/5.2L/5.9L/8.0L

The IAT sensor provides an input voltage to the Powertrain Control Module (PCM) indicating the density of the air entering the intake manifold based upon intake manifold temperature. At key-on, a 5-volt power circuit is supplied to the sensor from the PCM. The sensor is grounded at the PCM through a low-noise, sensor-return circuit.

The PCM uses this input to calculate the following:

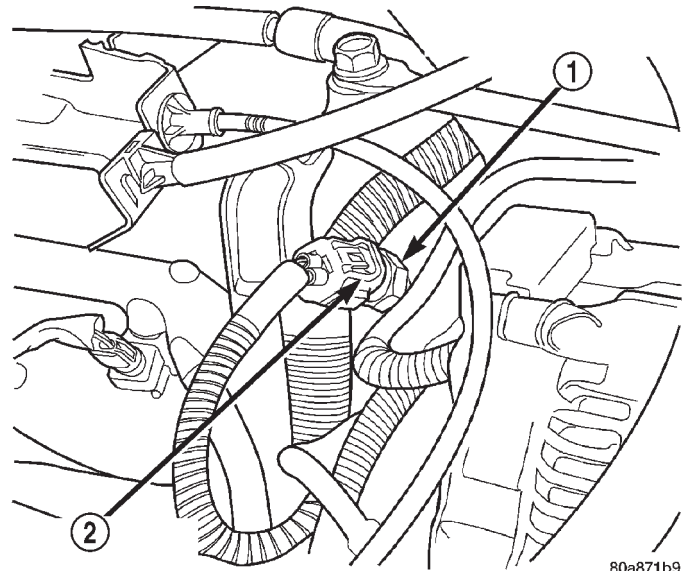
- Injector pulse-width
- Adjustment of spark timing (to help prevent spark knock with high intake manifold air-charge temperatures)

The resistance values of the IAT sensor is the same as for the Engine Coolant Temperature (ECT) sensor.

### REMOVAL - 3.9L/5.2L/5.9L

The intake manifold air temperature sensor is located in the front/side of the intake manifold (Fig. 34).

- (1) Remove air cleaner assembly.
- (2) Disconnect electrical connector at sensor (Fig. 34).
- (3) Remove sensor from intake manifold.



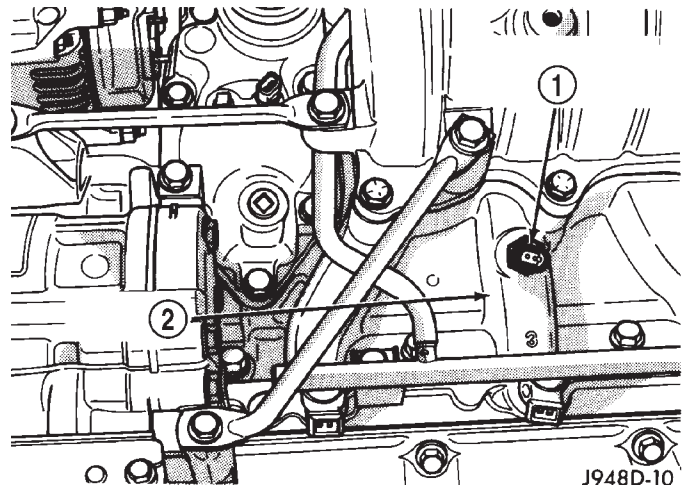
**Fig. 34 Air Temperature Sensor—3.9L/5.2L/5.9L**

- 1 - INTAKE MANIFOLD AIR TEMPERATURE SENSOR
- 2 - ELECTRICAL CONNECTOR

### REMOVAL - 8.0L

The intake manifold air temperature sensor is located in the side of the intake manifold near the front of throttle body (Fig. 35).

- (1) Disconnect electrical connector at sensor.
- (2) Remove sensor from intake manifold.



**Fig. 35 Air Temperature Sensor—8.0L Engine**

- 1 - INTAKE MANIFOLD AIR TEMP. SENSOR
- 2 - INTAKE MANIFOLD

### INSTALLATION - 3.9L/5.2L/5.9L

The intake manifold air temperature sensor is located in the front/side of the intake manifold (Fig. 34).



## INTAKE AIR TEMPERATURE SENSOR (Continued)

- (1) Install sensor to intake manifold. Tighten to 12–15 N·m (110–130 in. lbs.) torque.
- (2) Install electrical connector.
- (3) Install air cleaner.

**INSTALLATION - 8.0L**

The intake manifold air temperature sensor is located in the side of the intake manifold near the front of throttle body (Fig. 35).

- (1) Install sensor to intake manifold. Tighten to 12–15 N·m (110–130 in. lbs.) torque.
- (2) Install electrical connector.

**MANIFOLD ABSOLUTE PRESSURE SENSOR****DESCRIPTION - 3.9L/5.2L/5.9L/8.0L**

On 3.9L/5.2L/5.9L engines, the MAP sensor is mounted on the side of the engine throttle body. The sensor is connected to the throttle body with a rubber L-shaped fitting.

On the 8.0L 10-cylinder engine, the MAP sensor is mounted into the right side of the intake manifold.

**OPERATION - 3.9L/5.2L/5.9L/8.0L**

The MAP sensor is used as an input to the Powertrain Control Module (PCM). It contains a silicon based sensing unit to provide data on the manifold vacuum that draws the air/fuel mixture into the combustion chamber. The PCM requires this information to determine injector pulse width and spark advance. When manifold absolute pressure (MAP) equals Barometric pressure, the pulse width will be at maximum.

A 5 volt reference is supplied from the PCM and returns a voltage signal to the PCM that reflects manifold pressure. The zero pressure reading is 0.5V and full scale is 4.5V. For a pressure swing of 0–15 psi, the voltage changes 4.0V. To operate the sensor, it is supplied a regulated 4.8 to 5.1 volts. Ground is provided through the low-noise, sensor return circuit at the PCM.

The MAP sensor input is the number one contributor to fuel injector pulse width. The most important function of the MAP sensor is to determine barometric pressure. The PCM needs to know if the vehicle is at sea level or at a higher altitude, because the air density changes with altitude. It will also help to correct for varying barometric pressure. Barometric pressure and altitude have a direct inverse correlation; as altitude goes up, barometric goes down. At key-on, the PCM powers up and looks at MAP voltage, and based upon the voltage it sees, it knows the current barometric pressure (relative to altitude). Once the engine starts, the PCM looks at the voltage

again, continuously every 12 milliseconds, and compares the current voltage to what it was at key-on. The difference between current voltage and what it was at key-on, is manifold vacuum.

During key-on (engine not running) the sensor reads (updates) barometric pressure. A normal range can be obtained by monitoring a known good sensor.

As the altitude increases, the air becomes thinner (less oxygen). If a vehicle is started and driven to a very different altitude than where it was at key-on, the barometric pressure needs to be updated. Any time the PCM sees Wide Open Throttle (WOT), based upon Throttle Position Sensor (TPS) angle and RPM, it will update barometric pressure in the MAP memory cell. With periodic updates, the PCM can make its calculations more effectively.

The PCM uses the MAP sensor input to aid in calculating the following:

- Manifold pressure
- Barometric pressure
- Engine load
- Injector pulse-width
- Spark-advance programs
- Shift-point strategies (certain automatic transmissions only)
- Idle speed
- Decel fuel shutoff

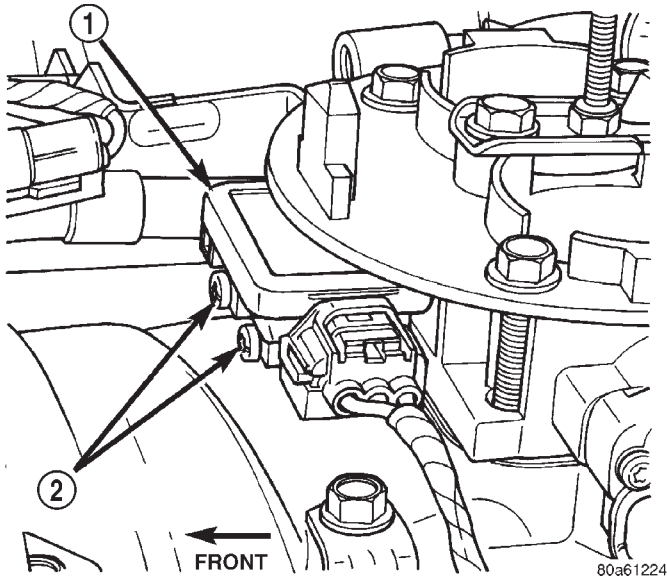
The MAP sensor signal is provided from a single piezoresistive element located in the center of a diaphragm. The element and diaphragm are both made of silicone. As manifold pressure changes, the diaphragm moves causing the element to deflect, which stresses the silicone. When silicone is exposed to stress, its resistance changes. As manifold vacuum increases, the MAP sensor input voltage decreases proportionally. The sensor also contains electronics that condition the signal and provide temperature compensation.

The PCM recognizes a decrease in manifold pressure by monitoring a decrease in voltage from the reading stored in the barometric pressure memory cell. The MAP sensor is a linear sensor; meaning as pressure changes, voltage changes proportionately. The range of voltage output from the sensor is usually between 4.6 volts at sea level to as low as 0.3 volts at 26 in. of Hg. Barometric pressure is the pressure exerted by the atmosphere upon an object. At sea level on a standard day, no storm, barometric pressure is approximately 29.92 in Hg. For every 100 feet of altitude, barometric pressure drops .10 in. Hg. If a storm goes through it can change barometric pressure from what should be present for that altitude. You should know what the average pressure and corresponding barometric pressure is for your area.

## MANIFOLD ABSOLUTE PRESSURE SENSOR (Continued)

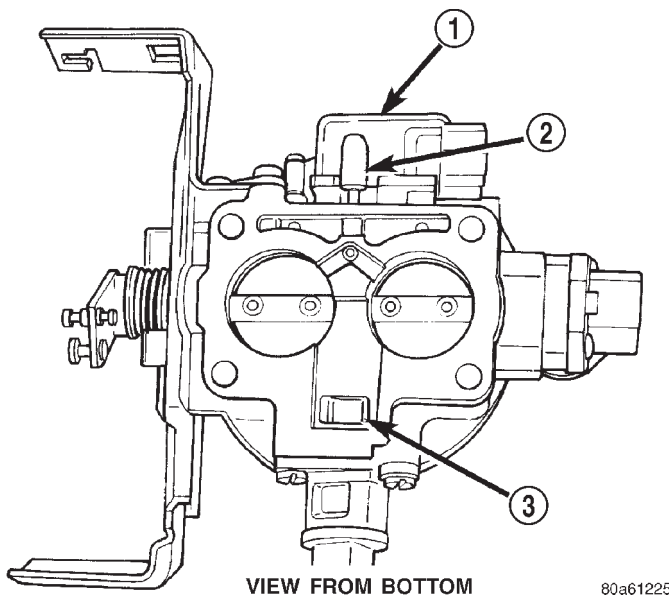
**REMOVAL - 3.9L/5.2L/5.9L**

The MAP sensor is located on the front of the throttle body (Fig. 36). An L-shaped rubber fitting is used to connect the MAP sensor to throttle body (Fig. 37).



**Fig. 36 MAP Sensor Location—3.9L/5.2L/5.9L Engines**

- 1 - MAP SENSOR  
2 - MOUNTING SCREWS (2)



**Fig. 37 MAP Sensor L-Shaped Rubber Fitting—3.9L/5.2L/5.9L Engines**

- 1 - MAP SENSOR  
2 - RUBBER FITTING  
3 - IDLE AIR PASSAGE

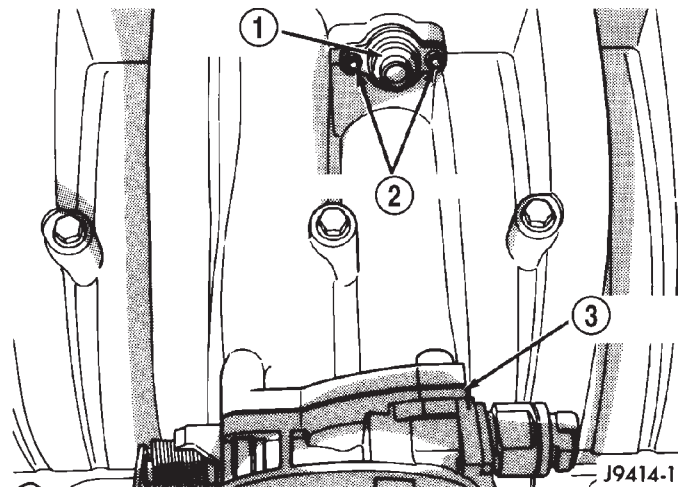
The MAP sensor is located on the front of the throttle body (Fig. 36). An L-shaped rubber fitting is used to connect the MAP sensor to throttle body (Fig. 37).

- (1) Remove air cleaner assembly.
- (2) Remove two MAP sensor mounting bolts (screws) (Fig. 36).
- (3) While removing MAP sensor, slide the vacuum rubber L-shaped fitting (Fig. 37) from the throttle body.
- (4) Remove rubber L-shaped fitting from MAP sensor.

**REMOVAL - 8.0L**

The MAP sensor is mounted into the right upper side of the intake manifold (Fig. 38). A rubber gasket is used to seal the sensor to the intake manifold. The rubber gasket is part of the sensor and is not serviced separately.

- (1) Remove the electrical connector at the sensor.
- (2) Clean the area around the sensor before removal.
- (3) Remove the two sensor mounting bolts.
- (4) Remove the sensor from the intake manifold.



**Fig. 38 MAP Sensor Location—8.0L V-10 Engine—Typical**

- 1 - MAP SENSOR  
2 - MOUNTING BOLTS  
3 - THROTTLE BODY

**INSTALLATION - 3.9L/5.2L/5.9L**

The MAP sensor is located on the front of the throttle body (Fig. 36). An L-shaped rubber fitting is used to connect the MAP sensor to throttle body (Fig. 37).

- (1) Install rubber L-shaped fitting to MAP sensor.
- (2) Position sensor to throttle body while guiding rubber fitting over throttle body vacuum nipple.

## MANIFOLD ABSOLUTE PRESSURE SENSOR (Continued)

- (3) Install MAP sensor mounting bolts (screws). Tighten screws to 3 N·m (25 in. lbs.) torque.
- (4) Install air cleaner.

**INSTALLATION - 8.0L**

The MAP sensor is mounted into the right upper side of the intake manifold (Fig. 38). A rubber gasket is used to seal the sensor to the intake manifold. The rubber gasket is part of the sensor and is not serviced separately.

- (1) Check the condition of the sensor seal. Clean the sensor and lubricate the rubber gasket with clean engine oil.
- (2) Clean the sensor opening in the intake manifold.
- (3) Install the sensor into the intake manifold.
- (4) Install sensor mounting bolts. Tighten bolts to 2 N·m (20 in. lbs.) torque.
- (5) Install the electrical connector to sensor.

**O2 SENSOR****DESCRIPTION**

The Oxygen Sensors (O2S) are attached to, and protrude into the vehicle exhaust system. Depending on the emission package, the vehicle may use a total of either 2 or 4 sensors.

**3.9L/5.2L/Light Duty 5.9L Engine:** Four sensors are used: 2 upstream (referred to as 1/1 and 2/1) and 2 downstream (referred to as 1/2 and 2/2). With this emission package, the right upstream sensor (2/1) is located in the right exhaust downpipe just before the mini-catalytic converter. The left upstream sensor (1/1) is located in the left exhaust downpipe just before the mini-catalytic converter. The right downstream sensor (2/2) is located in the right exhaust downpipe just after the mini-catalytic converter, and before the main catalytic converter. The left downstream sensor (1/2) is located in the left exhaust downpipe just after the mini-catalytic converter, and before the main catalytic converter.

**Medium and Heavy Duty 8.0L V-10 Engine:** Four sensors are used (2 upstream, 1 pre-catalyst and 1 post-catalyst). With this emission package, the 1/1 upstream sensor (left side) is located in the left exhaust downpipe before both the pre-catalyst sensor (1/2), and the main catalytic converter. The 2/1 upstream sensor (right side) is located in the right exhaust downpipe before both the pre-catalyst sensor (1/2), and the main catalytic converter. The pre-catalyst sensor (1/2) is located after the 1/1 and 2/1 sensors, and just before the main catalytic converter. The post-catalyst sensor (1/3) is located just after the main catalytic converter.

**Heavy Duty 5.9L Engine:** Two sensors are used. They are **both** referred to as upstream sensors (left side is referred to as 1/1 and right side is referred to as 2/1). With this emission package, a sensor is located in each of the exhaust downpipes before the main catalytic converter.

**OPERATION**

An O2 sensor is a galvanic battery that provides the PCM with a voltage signal (0-1 volt) inversely proportional to the amount of oxygen in the exhaust. In other words, if the oxygen content is low, the voltage output is high; if the oxygen content is high the output voltage is low. The PCM uses this information to adjust injector pulse-width to achieve the 14.7-to-1 air/fuel ratio necessary for proper engine operation and to control emissions.

The O2 sensor must have a source of oxygen from outside of the exhaust stream for comparison. Current O2 sensors receive their fresh oxygen (outside air) supply through the wire harness. This is why it is important to never solder an O2 sensor connector, or pack the connector with grease.

Four wires (circuits) are used on each O2 sensor: a 12-volt feed circuit for the sensor heating element; a ground circuit for the heater element; a low-noise sensor return circuit to the PCM, and an input circuit from the sensor back to the PCM to detect sensor operation.

**Oxygen Sensor Heaters/Heater Relays:** Depending on the emissions package, the heating elements within the sensors will be supplied voltage from either the ASD relay, or 2 separate oxygen sensor relays. Refer to 8, Wiring Diagrams to determine which relays are used.

The O2 sensor uses a Positive Thermal Co-efficient (PTC) heater element. As temperature increases, resistance increases. At ambient temperatures around 70°F, the resistance of the heating element is approximately 4.5 ohms. As the sensor's temperature increases, resistance in the heater element increases. This allows the heater to maintain the optimum operating temperature of approximately 930°-1100°F (500°-600° C). Although the sensors operate the same, there are physical differences, due to the environment that they operate in, that keep them from being interchangeable.

Maintaining correct sensor temperature at all times allows the system to enter into closed loop operation sooner. Also, it allows the system to remain in closed loop operation during periods of extended idle.

In Closed Loop operation, the PCM monitors certain O2 sensor input(s) along with other inputs, and adjusts the injector pulse width accordingly. During Open Loop operation, the PCM ignores the O2 sensor input. The PCM adjusts injector pulse width based

## O2 SENSOR (Continued)

on preprogrammed (fixed) values and inputs from other sensors.

**Upstream Sensors:** Two upstream sensors are used (1/1 and 2/1). The 1/1 sensor is the first sensor to receive exhaust gases from the #1 cylinder. They provide an input voltage to the PCM. The input tells the PCM the oxygen content of the exhaust gas. The PCM uses this information to fine tune fuel delivery to maintain the correct oxygen content at the downstream oxygen sensors. The PCM will change the air/fuel ratio until the upstream sensors input a voltage that the PCM has determined will make the downstream sensors output (oxygen content) correct.

The upstream oxygen sensors also provide an input to determine mini-catalyst efficiency. Main catalytic convertor efficiency is not calculated with this package.

**Downstream Sensors:** Two downstream sensors are used (1/2 and 2/2). The downstream sensors are used to determine the correct air-fuel ratio. As the oxygen content changes at the downstream sensor, the PCM calculates how much air-fuel ratio change is required. The PCM then looks at the upstream oxygen sensor voltage, and changes fuel delivery until the upstream sensor voltage changes enough to correct the downstream sensor voltage (oxygen content).

The downstream oxygen sensors also provide an input to determine mini-catalyst efficiency. Main catalytic convertor efficiency is not calculated with this package.

**Medium and Heavy Duty 8.0L V-10 Engine:** Four oxygen sensors are used (2 upstream, 1 pre-catalyst and 1 post-catalyst). The upstream sensors (1/1 and 2/1) will fine-tune the air-fuel ratio through the Powertrain Control Module (PCM). The pre-catalyst (1/2) and post-catalyst (1/3) sensors will determine catalytic convertor efficiency (efficiency of the main catalytic convertor). This is also done through the PCM.

**Heavy Duty 5.9L Engine:** Downstream sensors are not used with this emissions package, meaning catalytic convertor efficiency is not calculated with this package. Two upstream sensors are used. The left upstream sensor (1/1) will monitor cylinders 1, 3, 5 and 7. The right upstream sensor (2/1) will monitor cylinders 2, 4, 6 and 8. The PCM monitors the oxygen content of the sensors, and will fine-tune the air-fuel ratio.

Engines equipped with either a downstream sensor(s), or a post-catalytic sensor, will monitor catalytic convertor efficiency. If efficiency is below emission standards, the Malfunction Indicator Lamp (MIL) will be illuminated and a Diagnostic Trouble Code (DTC) will be set. Refer to Monitored Systems in Emission Control Systems for additional information.

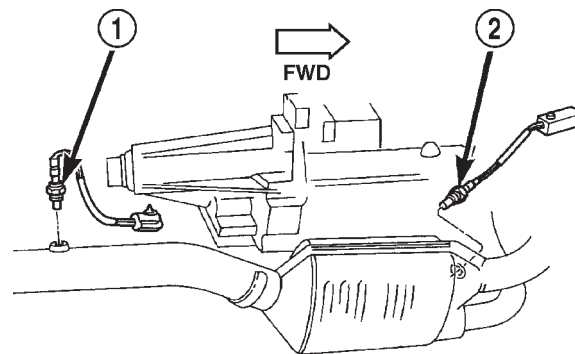
## REMOVAL

**Never apply any type of grease to the oxygen sensor electrical connector, or attempt any soldering of the sensor wiring harness. For sensor operation, it must have a comparison source of oxygen from outside the exhaust system. This fresh air is supplied to the sensor through its pigtail wiring harness.**

The O2S (oxygen sensors) are numbered 1/1, 1/2, 1/3, 2/1 and 2/2.

On HDC engines, the pre-catalyst/post catalyst O2S sensors are located at the inlet and outlet ends of the catalytic converter (Fig. 39).

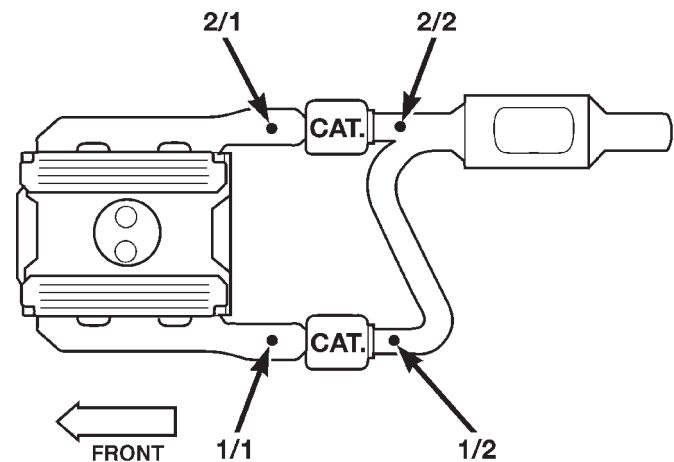
The 1/1 and 2/1 sensors are located before the mini-cats (Fig. 40). The 1/2 and 2/2 sensors are located after the mini-cats (Fig. 40).



80bfe0e6

**Fig. 39 Pre-catalyst/Post catalyst Oxygen Sensors—HDC Engines**

- 1 - POST CATALYST OXYGEN SENSOR (1/3)
- 2 - PRE-CATALYST OXYGEN SENSOR (1/2)



80bfe0e8

**Fig. 40 Oxygen Sensors—5.2L/5.9L California Engines**



## O2 SENSOR (Continued)

**WARNING: THE EXHAUST MANIFOLD, EXHAUST PIPES AND CATALYTIC CONVERTER BECOME VERY HOT DURING ENGINE OPERATION. ALLOW ENGINE TO COOL BEFORE REMOVING OXYGEN SENSOR.**

- (1) Raise and support the vehicle.
- (2) Disconnect the wire connector from the O2S sensor.

**CAUTION: When disconnecting the sensor electrical connector, do not pull directly on wire going into sensor.**

- (3) Remove the O2S sensor with an oxygen sensor removal and installation tool.

## INSTALLATION

Threads of new oxygen sensors are factory coated with anti-seize compound to aid in removal. **DO NOT add any additional anti-seize compound to the threads of a new oxygen sensor.**

- (1) Install the O2S sensor. Tighten to 30 N·m (22 ft. lbs.) torque.
- (2) Connect the O2S sensor wire connector.
- (3) Lower the vehicle.

## PTO SWITCH

## DESCRIPTION

This Powertrain Control Module (PCM) input is used only on models equipped with aftermarket Power Take Off (PTO) units.

## OPERATION

The input is used only to tell the PCM that the PTO has been engaged. The PCM will disable (temporarily shut down) certain OBD II diagnostic trouble codes when the PTO is engaged.

When the aftermarket PTO switch has been engaged, a 12V + signal is sent through circuit G113 to PCM pin A13. The PCM will then sense and determine that the PTO has been activated.

## THROTTLE BODY

## DESCRIPTION

The throttle body is located on the intake manifold. Fuel does not enter the intake manifold through the throttle body. Fuel is sprayed into the manifold by the fuel injectors.

## OPERATION

Filtered air from the air cleaner enters the intake manifold through the throttle body. The throttle body contains an air control passage controlled by an Idle Air Control (IAC) motor. The air control passage is used to supply air for idle conditions. A throttle valve (plate) is used to supply air for above idle conditions.

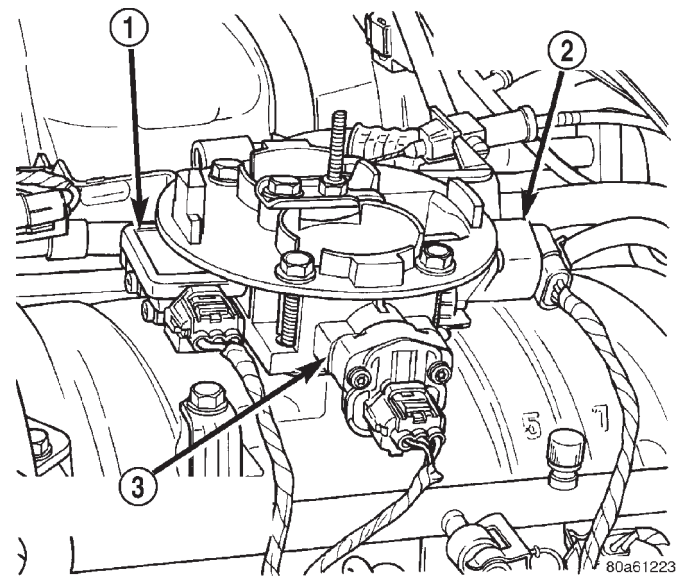
Certain sensors are attached to the throttle body. The accelerator pedal cable, speed control cable and transmission control cable (when equipped) are connected to the throttle body linkage arm.

A (factory adjusted) set screw is used to mechanically limit the position of the throttle body throttle plate. **Never attempt to adjust the engine idle speed using this screw.** All idle speed functions are controlled by the PCM.

## REMOVAL - 3.9L/5.2L/5.9L

A (factory adjusted) set screw is used to mechanically limit the position of the throttle body throttle plate. **Never attempt to adjust the engine idle speed using this screw.** All idle speed functions are controlled by the powertrain control module (PCM).

- (1) Remove the air cleaner.
- (2) Disconnect throttle body electrical connectors at MAP sensor, IAC motor and TPS (Fig. 41).



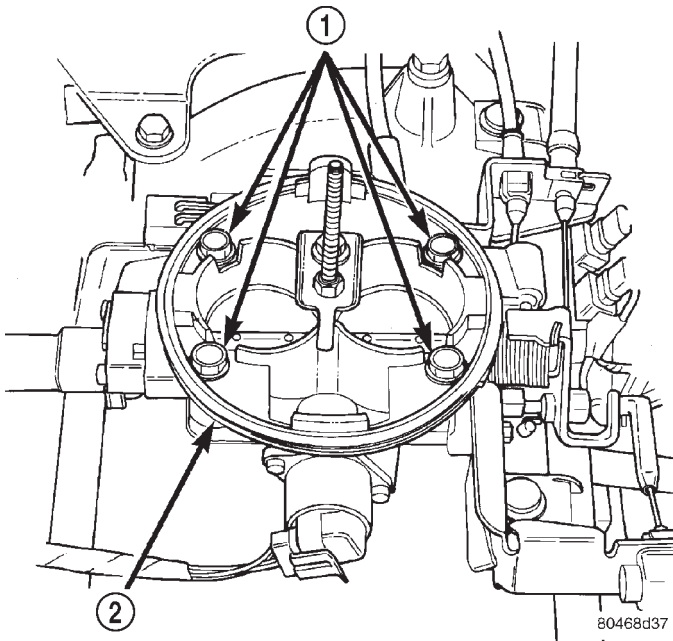
**Fig. 41 Sensor Electrical Connectors—3.9L/5.2L/5.9L Engines—Typical**

- 1 - MAP SENSOR
- 2 - IDLE AIR CONTROL MOTOR
- 3 - THROTTLE POSITION SENSOR

- (3) Remove vacuum line at throttle body.
- (4) Remove all control cables from throttle body (lever) arm. Refer to the Accelerator Pedal and Throttle Cable section of this group for additional information.

## THROTTLE BODY (Continued)

(5) Remove four throttle body mounting bolts (Fig. 42).



**Fig. 42 Throttle Body**

- 1 - THROTTLE BODY MOUNTING BOLTS (4)  
2 - THROTTLE BODY

(6) Remove throttle body from intake manifold.  
(7) Discard old throttle body-to-intake manifold gasket.

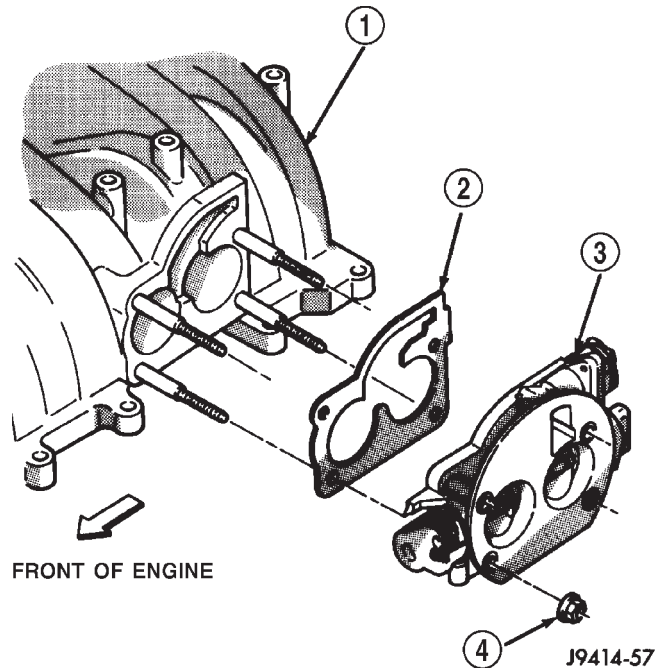
## REMOVAL - 8.0L

A (factory adjusted) set screw is used to mechanically limit the position of the throttle body throttle plate. **Never attempt to adjust the engine idle speed using this screw.** All idle speed functions are controlled by the powertrain control module (PCM).

- (1) Remove the air cleaner cover.
- (2) Remove the 4 air cleaner housing mounting nuts and remove housing from throttle body.
- (3) Disconnect throttle body electrical connectors at the IAC motor and TPS.
- (4) Remove all control cables from throttle body (lever) arm. Refer to the Accelerator Pedal and Throttle Cable section of this group for additional information.
- (5) Remove four throttle body mounting nuts (Fig. 43).
- (6) Remove throttle body from intake manifold.
- (7) Discard old throttle body-to-intake manifold gasket.

## INSTALLATION - 3.9L/5.2L/5.9L

A (factory adjusted) set screw is used to mechanically limit the position of the throttle body throttle



**Fig. 43 Throttle Body Mounting Nuts—8.0L Engine**

- 1 - INTAKE MANIFOLD UPPER HALF  
2 - GASKET  
3 - THROTTLE BODY  
4 - MOUNTING NUTS (4)

plate. **Never attempt to adjust the engine idle speed using this screw.** All idle speed functions are controlled by the powertrain control module (PCM).

- (1) Clean the mating surfaces of the throttle body and the intake manifold.
- (2) Install new throttle body-to-intake manifold gasket.
- (3) Install throttle body to intake manifold.
- (4) Install four mounting bolts. Tighten bolts to 23 N-m (200 in. lbs.) torque.
- (5) Install control cables.
- (6) Install vacuum line to throttle body.
- (7) Install electrical connectors.
- (8) Install air cleaner.

## INSTALLATION - 8.0L

A (factory adjusted) set screw is used to mechanically limit the position of the throttle body throttle plate. **Never attempt to adjust the engine idle speed using this screw.** All idle speed functions are controlled by the powertrain control module (PCM).

- (1) Clean the mating surfaces of the throttle body and the intake manifold.
- (2) Install new throttle body-to-intake manifold gasket.
- (3) Install throttle body to intake manifold.
- (4) Install four mounting nuts. Tighten nuts to 22 N-m (192 in. lbs.) torque.



## THROTTLE BODY (Continued)

- (5) Install control cables.
- (6) Install electrical connectors.
- (7) Install air cleaner housing to throttle body.
- (8) Install 4 air cleaner housing mounting nuts. Tighten nuts to 11 N·m (96 in. lbs.) torque.
- (9) Install air cleaner housing cover.

## THROTTLE CONTROL CABLE

## REMOVAL

**CAUTION:** Be careful not to damage or kink the cable core wire (within the cable sheathing) while servicing accelerator pedal or cables.

(1) From inside the vehicle, hold up the accelerator pedal. Remove the plastic cable retainer and throttle cable core wire from upper end of pedal arm (Fig. 21). The plastic cable retainer snaps into pedal the arm.

(2) Remove the cable core wire at the pedal arm.

(3) Remove the air cleaner housing.

(4) From inside the vehicle, pinch both sides of the plastic cable housing retainer tabs at the dash panel (Fig. 21).

(5) Remove cable housing from dash panel and pull the cable into the engine compartment.

(6) **3.9L/5.2L/5.9L Engines:** Disconnect the cable from the routing/holddown clip at the radiator fan shroud.

(7) **8.0L V-10 Engine:** Remove the throttle cable socket at throttle lever ball. (Fig. 45) (snaps off).

(8) **3.9L/5.2L/5.9L Engines:** Slip the cable end rearward from pin on throttle body (Fig. 44).

(9) Remove cable housing at throttle body mounting bracket by pressing on release tab with a small screwdriver (Fig. 46) or (Fig. 45). **To prevent cable housing breakage, press on the tab only enough to release the cable from the bracket.** Lift the cable housing straight up from bracket while pressing on release tab. Remove throttle cable from vehicle.

## INSTALLATION

(1) **3.9L/5.2L/5.9L Engines:**

(a) Rotate and hold the throttle cam in the full wide open position. Snap the cable end onto lever pin (Fig. 44).

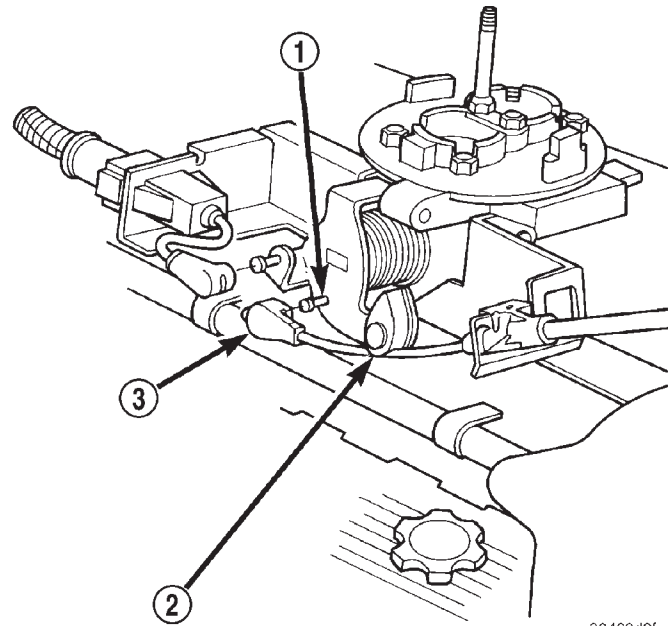
(b) Connect cable to throttle body mounting bracket (push down and lock).

(c) Connect cable to fan shroud routing clip.

(2) **8.0L V-10 Engine:**

(a) Connect cable end socket to throttle body lever ball (snaps on) (Fig. 45).

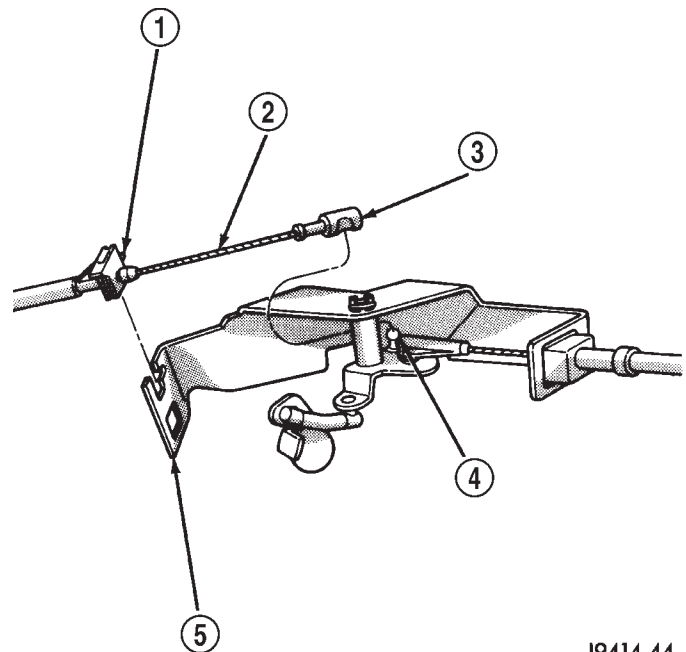
(b) Connect cable to throttle body mounting bracket (push down and lock).



80468d2f

**Fig. 44 Throttle Cable at Throttle Body—3.9L/5.2L/5.9L Engines—Typical**

- 1 - THROTTLE LEVER PIN
- 2 - CAM (V-8 ENGINE ONLY)
- 3 - THROTTLE CABLE END

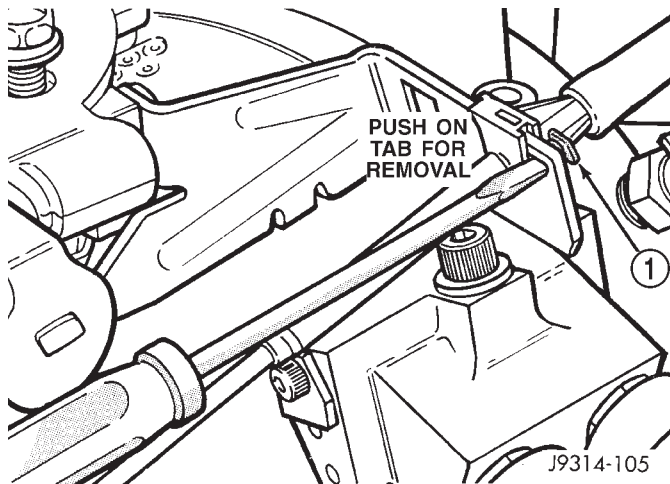


J9414-44

**Fig. 45 Throttle Cable at Throttle Body—8.0L V-10 Engine**

- 1 - PRESS TAB FOR CABLE REMOVAL
- 2 - THROTTLE CABLE
- 3 - CABLE SOCKET
- 4 - LEVER BALL
- 5 - MOUNTING BRACKET

## THROTTLE CONTROL CABLE (Continued)

**Fig. 46 Cable Release**

1 - TAB

(3) Install the remaining cable housing end into and through the dash panel opening (snaps into position). The two plastic pinch tabs (Fig. 21) should lock the cable to dash panel.

(4) From inside the vehicle, hold up the accelerator pedal. Install the throttle cable core wire and plastic cable retainer into and through the upper end of the pedal arm (the plastic retainer is snapped into the pedal arm). When installing the plastic retainer to the accelerator pedal arm, note the index tab on the pedal arm (Fig. 21). Align the index slot on the plastic cable retainer to this index tab.

## THROTTLE POSITION SENSOR

## DESCRIPTION

The 3-wire Throttle Position Sensor (TPS) is mounted on the throttle body and is connected to the throttle blade.

## OPERATION

The TPS is a 3-wire variable resistor that provides the Powertrain Control Module (PCM) with an input signal (voltage) that represents the throttle blade position of the throttle body. The sensor is connected to the throttle blade shaft. As the position of the throttle blade changes, the resistance (output voltage) of the TPS changes.

The PCM supplies approximately 5 volts to the TPS. The TPS output voltage (input signal to the PCM) represents the throttle blade position. The PCM receives an input signal voltage from the TPS. This will vary in an approximate range of from .26 volts at minimum throttle opening (idle), to 4.49 volts at wide open throttle. Along with inputs from other sensors, the PCM uses the TPS input to determine current engine operating conditions. In response to engine operating conditions, the PCM will adjust fuel injector pulse width and ignition timing.

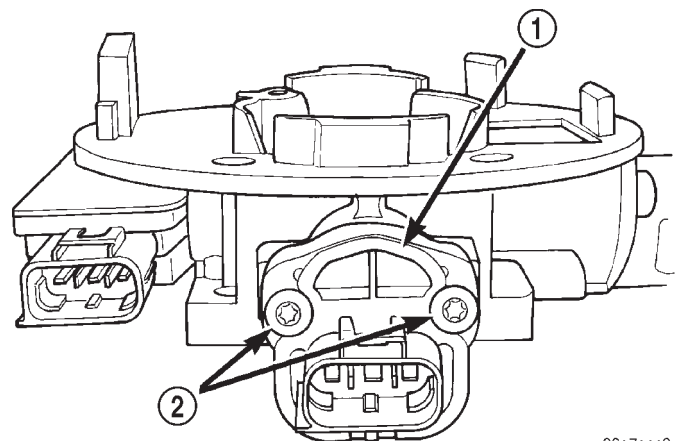
The PCM needs to identify the actions and position of the throttle blade at all times. This information is needed to assist in performing the following calculations:

- Ignition timing advance
- Fuel injection pulse-width
- Idle (learned value or minimum TPS)
- Off-idle (0.06 volt)
- Wide Open Throttle (WOT) open loop (2.608 volts above learned idle voltage)
- Deceleration fuel lean out
- Fuel cutoff during cranking at WOT (2.608 volts above learned idle voltage)
- A/C WOT cutoff (certain automatic transmissions only)

## REMOVAL - 3.9L/5.2L/5.9L

The TPS is located on the side of the throttle body.

- (1) Remove air intake tube at throttle body.
- (2) Disconnect TPS electrical connector.
- (3) Remove two TPS mounting bolts (Fig. 47).

**Fig. 47 TPS Mounting Bolts—3.9L/5.2L/5.9L Engines**

- 1 - THROTTLE POSITION SENSOR
- 2 - MOUNTING SCREWS

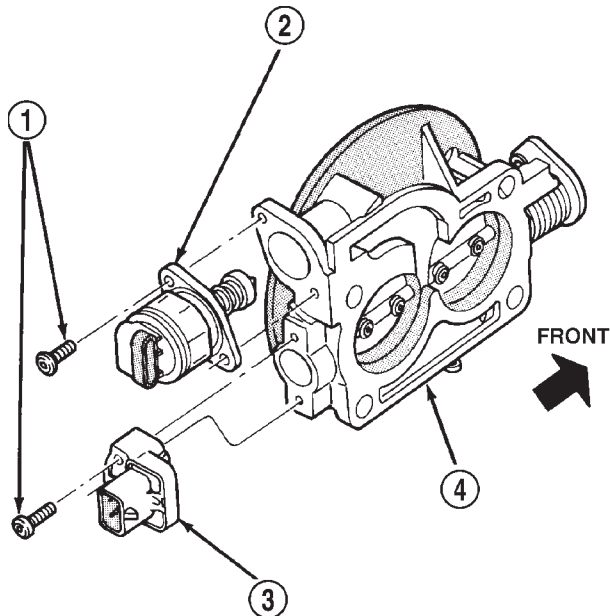
- (4) Remove TPS from throttle body.

## THROTTLE POSITION SENSOR (Continued)

## REMOVAL - 8.0L

The TPS is located on the side of the throttle body (Fig. 48).

- (1) Remove air intake tube at air cleaner housing.
- (2) Remove the air cleaner cover.
- (3) Remove the 4 air cleaner housing mounting nuts and remove housing from throttle body.
- (4) Disconnect TPS electrical connector.
- (5) Remove two TPS mounting bolts (Fig. 48).



J9414-3

**Fig. 48 TPS Mounting Bolts—8.0L Engine**

- 1 - MOUNTING BOLTS (2)
- 2 - IDLE AIR CONTROL MOTOR
- 3 - THROTTLE POSITION SENSOR
- 4 - THROTTLE BODY

- (6) Remove TPS from throttle body.

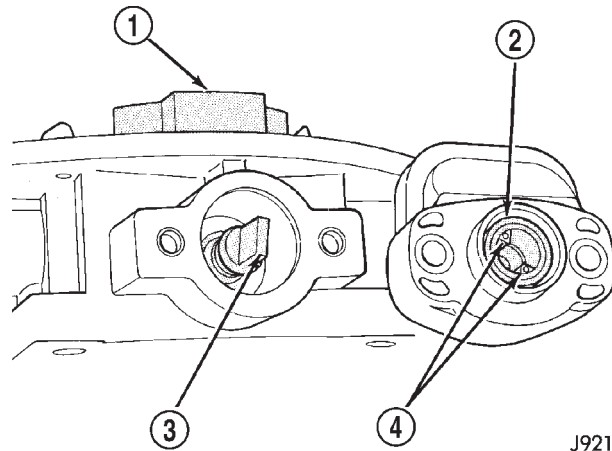
## INSTALLATION - 3.9L/5.2L/5.9L

The throttle shaft end of the throttle body slides into a socket in the TPS (Fig. 49). The TPS must be installed so that it can be rotated a few degrees. If the sensor will not rotate, install the sensor with the throttle shaft on the other side of the socket tangs. The TPS will be under slight tension when rotated.

- (1) Install the TPS and two retaining bolts.
- (2) Tighten bolts to 7 N·m (60 in. lbs.) torque.
- (3) Manually operate the throttle control lever by hand to check for any binding of the TPS.
- (4) Connect TPS electrical connector to TPS.
- (5) Install air intake tube.

## INSTALLATION - 8.0L

The throttle shaft end of the throttle body slides into a socket in the TPS (Fig. 50). The TPS must be

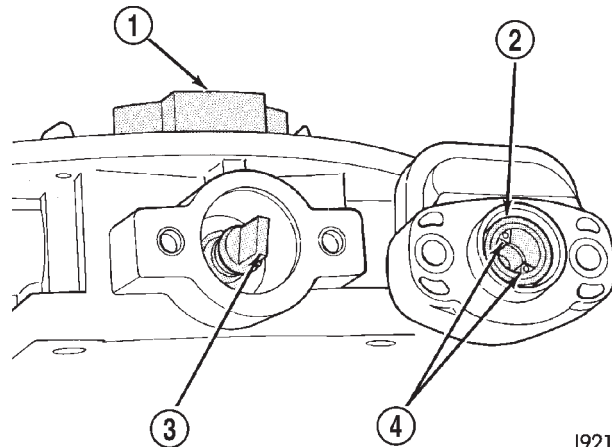


J9214-52

**Fig. 49 Installation—3.9L/5.2L/5.9L Engines—Typical**

- 1 - THROTTLE BODY
- 2 - THROTTLE POSITION SENSOR
- 3 - THROTTLE SHAFT
- 4 - SOCKET LOCATING TANGS

installed so that it can be rotated a few degrees. If the sensor will not rotate, install the sensor with the throttle shaft on the other side of the socket tangs. The TPS will be under slight tension when rotated.



J9214-52

**Fig. 50 Installation—Typical Mounting**

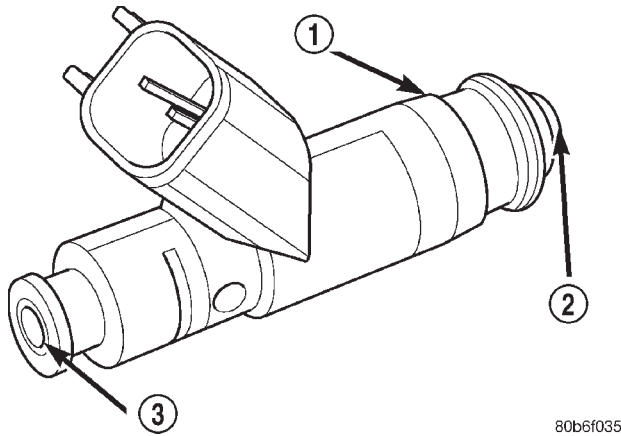
- 1 - THROTTLE BODY
- 2 - THROTTLE POSITION SENSOR
- 3 - THROTTLE SHAFT
- 4 - SOCKET LOCATING TANGS

- (1) Install the TPS and two retaining bolts.
- (2) Tighten bolts to 7 N·m (60 in. lbs.) torque.
- (3) Manually operate the throttle control lever by hand to check for any binding of the TPS.
- (4) Connect TPS electrical connector to TPS.
- (5) Install air cleaner housing to throttle body.
- (6) Install 4 air cleaner housing mounting nuts. Tighten nuts to 11 N·m (96 in. lbs.) torque.
- (7) Install air cleaner housing cover.
- (8) Install air intake tube to cover.

## FUEL INJECTOR

### DESCRIPTION

A separate fuel injector (Fig. 51) is used for each individual cylinder.



**Fig. 51 Fuel Injector**

- 1 - FUEL INJECTOR
- 2 - NOZZLE
- 3 - TOP (FUEL ENTRY)

80b6f035

### OPERATION

The fuel injectors are electrical solenoids. The injector contains a pintle that closes off an orifice at the nozzle end. When electric current is supplied to the injector, the armature and needle move a short distance against a spring, allowing fuel to flow out the orifice. Because the fuel is under high pressure, a fine spray is developed in the shape of a pencil stream. The spraying action atomizes the fuel, adding it to the air entering the combustion chamber.

An individual fuel injector is used for each individual cylinder. The top (fuel entry) end of the injector is attached into an opening on the fuel rail.

The nozzle (outlet) ends of the injectors are positioned into openings in the intake manifold just above the intake valve ports of the cylinder head. The engine wiring harness connector for each fuel injector is equipped with an attached numerical tag (INJ 1, INJ 2 etc.). This is used to identify each fuel injector.

The injectors are energized individually in a sequential order by the Powertrain Control Module (PCM). The PCM will adjust injector pulse width by switching the ground path to each individual injector on and off. Injector pulse width is the period of time that the injector is energized. The PCM will adjust injector pulse width based on various inputs it receives.

Battery voltage is supplied to the injectors through the ASD relay.

The PCM determines injector pulse width based on various inputs.

### OPERATION - PCM OUTPUT

The nozzle ends of the injectors are positioned into openings in the intake manifold just above the intake valve ports of the cylinder head. The engine wiring harness connector for each fuel injector is equipped with an attached numerical tag (INJ 1, INJ 2 etc.). This is used to identify each fuel injector with its respective cylinder number.

The injectors are energized individually in a sequential order by the Powertrain Control Module (PCM). The PCM will adjust injector pulse width by switching the ground path to each individual injector on and off. Injector pulse width is the period of time that the injector is energized. The PCM will adjust injector pulse width based on various inputs it receives.

Battery voltage (12 volts +) is supplied to the injectors through the ASD relay. The ASD relay will shut-down the 12 volt power source to the fuel injectors if the PCM senses the ignition is on, but the engine is not running. This occurs after the engine has not been running for approximately 1.8 seconds.

The PCM determines injector on-time (pulse width) based on various inputs.

### DIAGNOSIS AND TESTING - FUEL INJECTOR TEST

To perform a complete test of the fuel injectors and their circuitry, use the DRB scan tool and refer to the appropriate Powertrain Diagnostics Procedures manual. To test the injector only, refer to the following:

Disconnect the fuel injector wire harness connector from the injector. The injector is equipped with 2 electrical terminals (pins). Place an ohmmeter across the terminals. Resistance reading should be approximately 12 ohms  $\pm$ 1.2 ohms at 20°C (68°F).

### REMOVAL

- (1) Remove air cleaner assembly.
- (2) Remove fuel injector rail assembly. Refer to Fuel Injector Rail removal in this section.
- (3) Remove the clip(s) retaining the injector(s) to fuel rail (Fig. 30) or (Fig. 31).
- (4) Remove injector(s) from fuel rail.

### INSTALLATION

- (1) Apply a small amount of engine oil to each fuel injector o-ring. This will help in fuel rail installation.
- (2) Install injector(s) and injector clip(s) to fuel rail.
- (3) Install fuel rail assembly. Refer to Fuel Injector Rail installation.
- (4) Install air cleaner.
- (5) Start engine and check for leaks.



# FUEL DELIVERY - DIESEL

## TABLE OF CONTENTS

	page		page
<b>FUEL DELIVERY - DIESEL</b>		<b>FUEL LEVEL SENDING UNIT / SENSOR</b>	
DESCRIPTION . . . . .	54	DESCRIPTION . . . . .	73
OPERATION . . . . .	56	OPERATION . . . . .	73
DIAGNOSIS AND TESTING . . . . .	56	<b>FUEL LINES</b>	
AIR IN FUEL SYSTEM . . . . .	56	DESCRIPTION . . . . .	73
FUEL SUPPLY RESTRICTIONS . . . . .	56	OPERATION . . . . .	74
STANDARD PROCEDURE . . . . .	56	DIAGNOSIS AND TESTING . . . . .	74
WATER DRAINING AT FUEL FILTER . . . . .	56	HIGH-PRESSURE FUEL LINE LEAK . . . . .	74
CLEANING FUEL SYSTEM PARTS . . . . .	57	REMOVAL . . . . .	75
AIR BLEED . . . . .	57	INSTALLATION . . . . .	77
SPECIFICATIONS . . . . .	58	<b>FUEL TANK</b>	
SPECIAL TOOLS . . . . .	59	DESCRIPTION . . . . .	78
<b>FUEL FILTER / WATER SEPARATOR</b>		<b>FUEL TANK MODULE</b>	
DESCRIPTION . . . . .	59	DESCRIPTION . . . . .	78
OPERATION . . . . .	59	OPERATION . . . . .	78
REMOVAL . . . . .	60	REMOVAL . . . . .	78
INSTALLATION . . . . .	61	INSTALLATION . . . . .	79
<b>FUEL HEATER</b>		<b>FUEL TRANSFER PUMP</b>	
DESCRIPTION . . . . .	62	DESCRIPTION . . . . .	79
OPERATION . . . . .	62	OPERATION . . . . .	79
DIAGNOSIS AND TESTING . . . . .	62	DIAGNOSIS AND TESTING . . . . .	80
FUEL HEATER . . . . .	62	FUEL TRANSFER PUMP PRESSURE . . . . .	80
REMOVAL . . . . .	63	REMOVAL . . . . .	83
<b>FUEL HEATER RELAY</b>		INSTALLATION . . . . .	83
DESCRIPTION . . . . .	63	<b>OVERFLOW VALVE</b>	
OPERATION . . . . .	63	DESCRIPTION . . . . .	83
DIAGNOSIS AND TESTING . . . . .	64	OPERATION . . . . .	83
FUEL HEATER RELAY . . . . .	64	DIAGNOSIS AND TESTING . . . . .	84
REMOVAL . . . . .	65	OVERFLOW VALVE . . . . .	84
INSTALLATION . . . . .	65	REMOVAL . . . . .	84
<b>FUEL INJECTION PUMP</b>		INSTALLATION . . . . .	85
DESCRIPTION . . . . .	65	<b>WATER IN FUEL SENSOR</b>	
OPERATION . . . . .	66	DESCRIPTION . . . . .	85
DIAGNOSIS AND TESTING . . . . .	66	OPERATION . . . . .	85
FUEL INJECTION PUMP TIMING . . . . .	66	REMOVAL . . . . .	85
REMOVAL . . . . .	68	<b>FUEL DRAIN MANIFOLD</b>	
INSTALLATION . . . . .	71	DESCRIPTION . . . . .	86
<b>FUEL INJECTION PUMP DATA PLATE</b>		OPERATION . . . . .	86
SPECIFICATIONS . . . . .	73	REMOVAL . . . . .	86
		INSTALLATION . . . . .	86

## FUEL DELIVERY - DIESEL

### DESCRIPTION - DIESEL FUEL DELIVERY SYSTEM

The fuel system on the Cummins 24 valve—Turbo Diesel Engine uses an **electronic** fuel injection pump with three control modules.

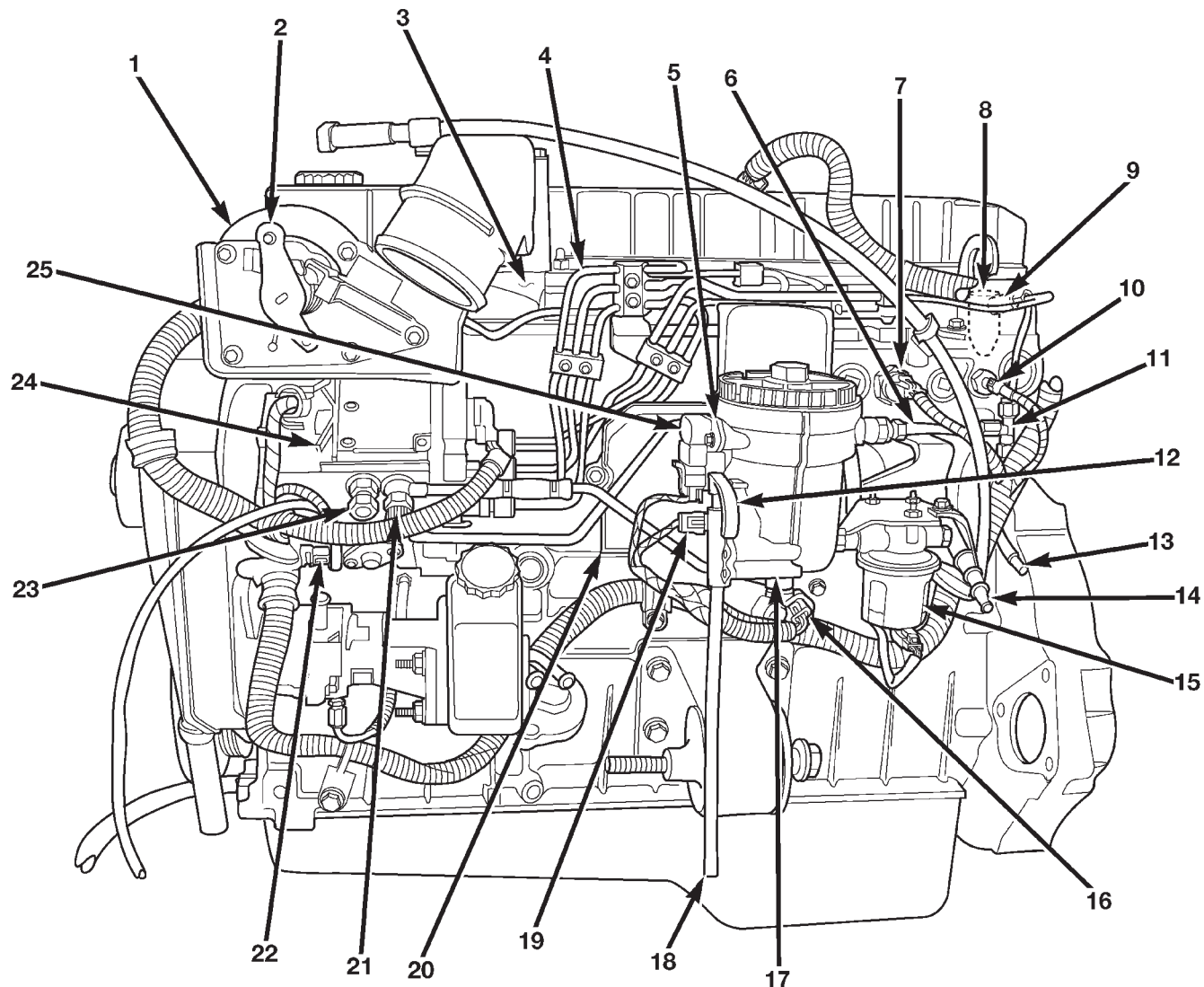
Also refer to the Powertrain Control Module (PCM) or Engine Control Module sections.

Some fuel system components are shown in (Fig. 1).

The fuel delivery system consists of the:

- Accelerator pedal
- Air cleaner housing/element
- Fuel drain manifold (passage)

## FUEL DELIVERY - DIESEL (Continued)



80a10a53

**Fig. 1 Fuel System Components - Diesel**

- |   |  |
|---|--|
| 1 - ENGINE COOLANT TEMPERATURE (ECT) SENSOR                               | 14 - FUEL SUPPLY LINE (LOW-PRESSURE, TO ENGINE)  |
| 2 - THROTTLE LEVER BELLCRANK AND APPS (ACCELERATOR PEDAL POSITION SENSOR) | 15 - FUEL TRANSFER (LIFT) PUMP                   |
| 3 - INTAKE MANIFOLD AIR HEATER/ELEMENTS                                   | 16 - OIL PRESSURE SENSOR                         |
| 4 - HIGH-PRESSURE FUEL LINES  | 17 - FUEL FILTER/WATER SEPARATOR                 |
| 5 - FUEL HEATER   | 18 - DRAIN TUBE                                  |
| 6 - FUEL PRESSURE TEST PORT   | 19 - WATER-IN-FUEL (WIF) SENSOR                  |
| 7 - MAP (BOOST) SENSOR  | 20 - ENGINE CONTROL MODULE (ECM)                 |
| 8 - FUEL INJECTORS  | 21 - FUEL PRESSURE TEST PORT                     |
| 9 - FUEL INJECTOR CONNECTOR   | 22 - CAMSHAFT POSITION SENSOR (CMP)              |
| 10 - INTAKE AIR TEMPERATURE (IAT) SENSOR                                  | 23 - OVERFLOW VALVE                              |
| 11 - FUEL DRAIN MANIFOLD  | 24 - FUEL INJECTION PUMP                         |
| 12 - DRAIN VALVE  | 25 - FUEL HEATER TEMPERATURE SENSOR (THERMOSTAT) |
| 13 - FUEL RETURN LINE (TO FUEL TANK)                                      |  |



## FUEL DELIVERY - DIESEL (Continued)

- Fuel filter/water separator
- Fuel heater
- Fuel heater relay
- Fuel transfer (lift) pump
- Fuel injection pump
- Fuel injectors
- Fuel heater temperature sensor
- Fuel tank
- Fuel tank filler/vent tube assembly
- Fuel tank filler tube cap
- Fuel tank module containing the rollover valve, fuel gauge sending unit (fuel level sensor) and a separate fuel filter located at bottom of tank module
  - Fuel tubes/lines/hoses
  - High-pressure fuel injector lines
  - In-tank fuel filter (at bottom of fuel tank module)
  - Low-pressure fuel supply lines
  - Low-pressure fuel return line
  - Overflow valve
  - Quick-connect fittings
  - Throttle cable
  - Water draining

## OPERATION

**WARNING: HIGH-PRESSURE FUEL LINES DELIVER DIESEL FUEL UNDER EXTREME PRESSURE FROM THE INJECTION PUMP TO THE FUEL INJECTORS. THIS MAY BE AS HIGH AS 120,000 KPA (17,405 PSI). USE EXTREME CAUTION WHEN INSPECTING FOR HIGH-PRESSURE FUEL LEAKS. INSPECT FOR HIGH-PRESSURE FUEL LEAKS WITH A SHEET OF CARDBOARD. HIGH FUEL INJECTION PRESSURE CAN CAUSE PERSONAL INJURY IF CONTACT IS MADE WITH THE SKIN.**

## DIAGNOSIS AND TESTING - AIR IN FUEL SYSTEM

Air will enter the fuel system whenever fuel supply lines, separator filters, injection pump, high-pressure lines or injectors are removed or disconnected. Air trapped in the fuel system can result in hard starting, a rough running engine, engine misfire, low power, excessive smoke and fuel knock. After service is performed, air must be bled from the system before starting the engine.

Inspect the fuel system from the fuel transfer pump to the injectors for loose connections. Leaking fuel is an indicator of loose connections or defective seals. Air can also enter the fuel system between the fuel tank and the transfer pump. Inspect the fuel tank and fuel lines for damage that might allow air into the system.

For air bleeding, refer to the Air Bleed Procedure.

## DIAGNOSIS AND TESTING - FUEL SUPPLY RESTRICTIONS

## LOW-PRESSURE LINES

Fuel supply line restrictions or a defective fuel transfer pump can cause starting problems and prevent engine from accelerating. The starting problems include; low power and/or white fog like exhaust.

Test all fuel supply lines for restrictions or blockage. Flush or replace as necessary. Bleed fuel system of air once a fuel supply line has been replaced. Refer to Air Bleed Procedure for procedures.

To test for fuel line restrictions, a vacuum restriction test may be performed. Refer to Fuel Transfer Pump Pressure Test.

## HIGH-PRESSURE LINES

Restricted (kinked or bent) high-pressure lines can cause starting problems, poor engine performance, engine mis-fire and white smoke from exhaust.

Examine all high-pressure lines for any damage. Each radius on each high-pressure line must be smooth and free of any bends or kinks.

Replace damaged, restricted or leaking high-pressure fuel lines with correct replacement line.

**CAUTION: All high-pressure fuel lines must be clamped securely in place in holders. Lines cannot contact each other or other components. Do not attempt to weld high-pressure fuel lines or to repair lines that are damaged. If line is kinked or bent, it must be replaced. Use only recommended lines when replacement of high-pressure fuel line is necessary.**

## STANDARD PROCEDURES - WATER DRAINING AT FUEL FILTER

Refer to Fuel Filter/Water Separator removal/installation for procedures.

## FUEL DELIVERY - DIESEL (Continued)

## STANDARD PROCEDURES - CLEANING FUEL SYSTEM PARTS

**CAUTION:** Cleanliness cannot be overemphasized when handling or replacing diesel fuel system components. This especially includes the fuel injectors, high-pressure fuel lines and fuel injection pump. Very tight tolerances are used with these parts. Dirt contamination could cause rapid part wear and possible plugging of fuel injector nozzle tip holes. This in turn could lead to possible engine misfire. Always wash/clean any fuel system component thoroughly before disassembly and then air dry. Cap or cover any open part after disassembly. Before assembly, examine each part for dirt, grease or other contaminants and clean if necessary. When installing new parts, lubricate them with clean engine oil or clean diesel fuel only.

## STANDARD PROCEDURE - AIR BLEED

A certain amount of air becomes trapped in the fuel system when fuel system components on the supply and/or high-pressure side are serviced or replaced. Primary air bleeding is accomplished using the electric fuel transfer (lift) pump. If the vehicle has been allowed to run completely out of fuel, the fuel injectors must also be bled as the fuel injection pump **is not** self-bleeding (priming).

Servicing or replacing components on the fuel return side will not require air bleeding.

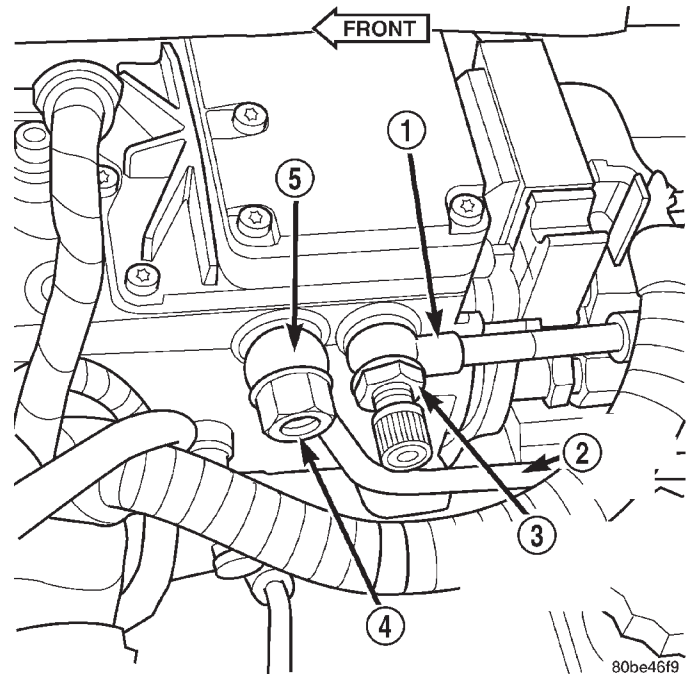
**WARNING: DO NOT BLEED AIR FROM THE FUEL SYSTEM OF A HOT ENGINE.**

(1) Loosen, but do not remove, banjo bolt (test port fitting) holding low-pressure fuel supply line to side of fuel injection pump (Fig. 2). Place a shop towel around banjo fitting to catch excess fuel.

The fuel transfer (lift) pump is self-priming: When the key is first turned on (without cranking engine), the pump operates for approximately 2 seconds and then shuts off. The pump will also operate for up to 25 seconds after the starter is quickly engaged, and then disengaged without allowing the engine to start. The pump shuts off immediately if the key is on and the engine stops running.

(2) Turn key to CRANK position and quickly release key to ON position before engine starts. This will operate fuel transfer pump for approximately 25 seconds.

(3) If fuel is not present at fuel supply line after 25 seconds, turn key OFF. Repeat previous step until fuel is exiting at fuel supply line.



**Fig. 2 Fuel Supply Line Banjo Bolt**

- 1 - FUEL SUPPLY LINE
- 2 - FUEL RETURN LINE
- 3 - BANJO BOLT (TEST PORT FITTING)
- 4 - OVERFLOW VALVE
- 5 - BANJO FITTING

(4) Tighten banjo bolt at fuel supply line to 24 N·m (18 ft. lbs.) torque. Primary air bleeding is now completed.

(5) Attempt to start engine. If engine will not start, proceed to following steps. **If engine does start, it may run erratically and be very noisy for a few minutes. This is a normal condition.**

(6) **Continue to next step if:**

- The vehicle fuel tank has been allowed to run empty
- The fuel injection pump has been replaced
- High-pressure fuel lines have been replaced
- Vehicle has not been operated after an extended period

**CAUTION: Do not engage the starter motor for more than 30 seconds at a time. Allow two minutes between cranking intervals.**

(7) Perform previous air bleeding procedure steps using fuel transfer pump. Be sure fuel is present at fuel supply line (Fig. 2) before proceeding.

(8) Crank the engine for 30 seconds at a time to allow air trapped in the injection pump to vent out the drain manifold.

## FUEL DELIVERY - DIESEL (Continued)

**WARNING: THE FUEL INJECTION PUMP SUPPLIES EXTREMELY HIGH FUEL PRESSURE TO EACH INDIVIDUAL INJECTOR THROUGH THE HIGH-PRESSURE LINES. FUEL UNDER THIS AMOUNT OF PRESSURE CAN PENETRATE THE SKIN AND CAUSE PERSONAL INJURY. WEAR SAFETY GOGGLES AND ADEQUATE PROTECTIVE CLOTHING AND AVOID CONTACT WITH FUEL SPRAY WHEN BLEEDING HIGH-PRESSURE FUEL LINES.**

**WARNING: ENGINE MAY START WHILE CRANKING STARTER MOTOR.**

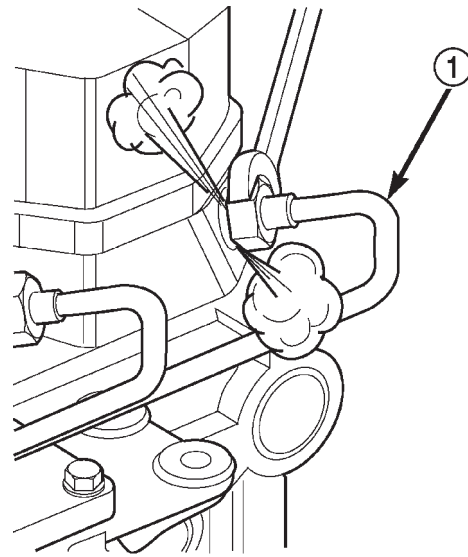
**Engine may start, may run erratically and be very noisy for a few minutes. This is a normal condition.**

(9) Thoroughly clean area around injector fittings where they join injector connector tubes.

(10) Bleed air by loosening high-pressure fuel line fittings (Fig. 3) at cylinders number 3, 4 and 5.

(11) Continue bleeding injectors until engine runs smoothly. It may take a few minutes for engine to run smooth.

(12) Tighten fuel line(s) at injector(s) to 38 N·m (28 ft. lbs.) torque.



80b46b80

**Fig. 3 Bleeding High-Pressure Fuel Lines at Injectors**

1 - HIGH-PRESSURE FUEL LINE

## SPECIFICATIONS

## FUEL SYSTEM PRESSURES—DIESEL ENGINES

DESCRIPTION	PRESSURE
Fuel Transfer (Lift) Pump Pressure With Engine Running	Minimum 69 kPa (10 psi)
Fuel Transfer (Lift) Pump Pressure With Engine Cranking	Minimum 48 kPa (7 psi)
Fuel Injector "Pop Off" Pressure	31,026 kPa (310 bars) or (4500 psi $\pm$ 250 psi)
Fuel Injector Leak-Down Pressure	Approximately 20 bars (291 psi) lower than pop pressure
Fuel Pressure Drop Across Fuel Filter Test Ports	34 kPa max. (5 psi. max.) at 2500 rpm (rated rpm)
Overflow Valve Release Pressure	97 kPa max. (14 psi.) at 2500 rpm (rated rpm)

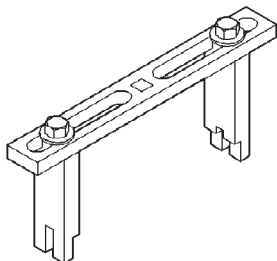
## FUEL INJECTOR FIRING ORDER—DIESEL

1-5-3-6-2-4

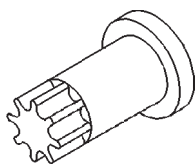
## FUEL DELIVERY - DIESEL (Continued)

## SPECIAL TOOLS

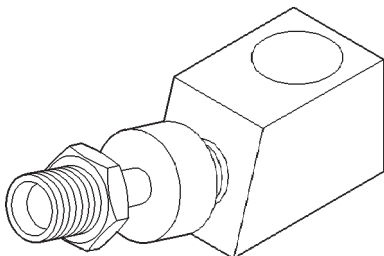
## DIESEL FUEL SYSTEM



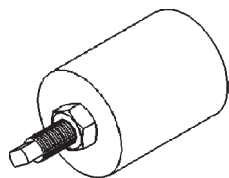
**Spanner Wrench (Fuel Tank Module Removal/Installation)—6856**



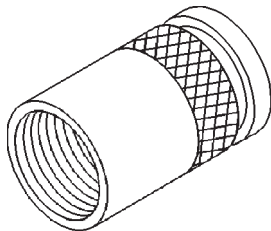
**Engine Barring (Rotating) Tool—7471B (also part of Kit #6860)**



**Fuel Injector Pop Pressure Adaptor—8301**



**Fuel Injector Remover—8318**

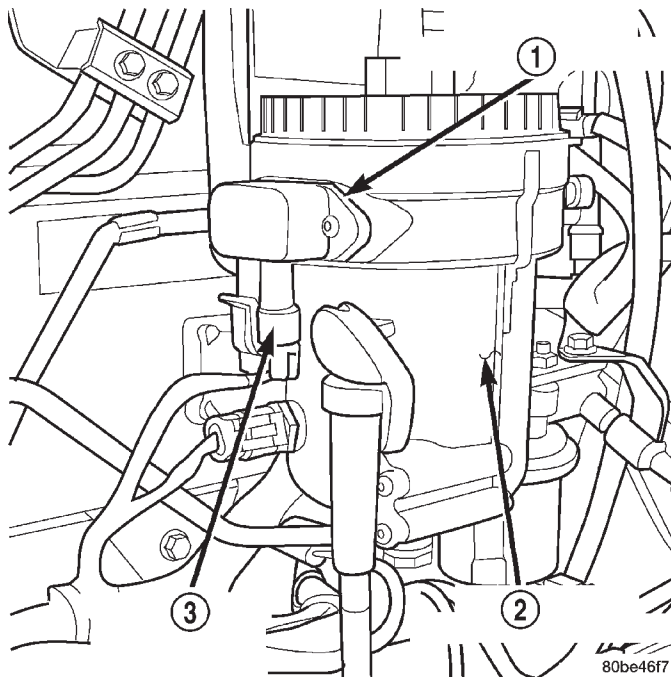


**Fuel Injector Tube (Connector) Remover—8324**

## FUEL FILTER / WATER SEPARATOR

## DESCRIPTION

The fuel filter/water separator assembly is located on left side of engine above starter motor (Fig. 4). The assembly also includes the fuel heater and Water-In-Fuel (WIF) sensor.



**Fig. 4 Fuel Filter/Water Separator Location**

- 1 - FUEL HEATER AND TEMP. SENSOR
- 2 - FUEL FILTER/WATER SEPARATOR
- 3 - FUEL HEATER ELECTRICAL CONNECTOR

## OPERATION

The fuel filter/water separator protects the fuel injection pump by removing water and contaminants from the fuel. The construction of the filter/separator allows fuel to pass through it, but helps prevent moisture (water) from doing so. Moisture collects at the bottom of the canister.

Refer to the maintenance schedules for the recommended fuel filter replacement intervals.

For draining of water from canister, refer to Fuel Filter/Water Separator Removal/Installation section.

A Water-In-Fuel (WIF) sensor is attached to side of canister. Refer to Water-In-Fuel Sensor Description/Operation.

The fuel heater is installed into the top of the filter/separator housing. Refer to Fuel Heater Description/Operation.

## FUEL FILTER / WATER SEPARATOR (Continued)

## REMOVAL

Refer to maintenance schedules in this manual for recommended fuel filter replacement intervals.

**Draining water from fuel filter/water separator housing:**

The housing drain valve (Fig. 5) serves two purposes. One is to **partially** drain filter housing of excess water. The other is to **completely** drain housing for fuel filter, drain valve, heater element or water-in-fuel sensor replacement.

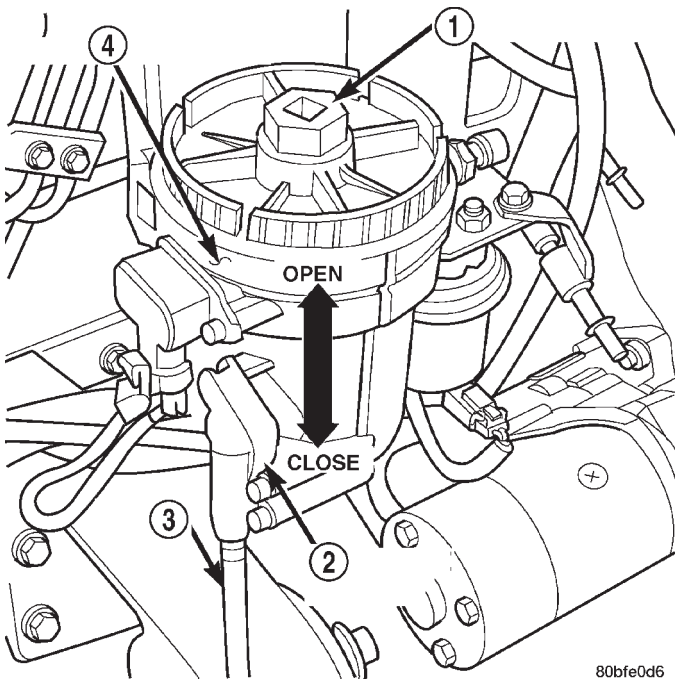
The filter housing should be drained whenever water-in-fuel warning lamp remains illuminated. (Note that lamp will be illuminated for approximately two seconds when ignition key is initially placed in ON position for a bulb check).

(1) A drain hose is located at bottom of drain valve (Fig. 5). Place drain pan under drain hose.

(2) **With engine not running**, pull drain valve handle upward to OPEN (DRAIN) position (Fig. 5). Hold drain valve open until all water and contaminants have been removed and clean fuel exits drain hose.

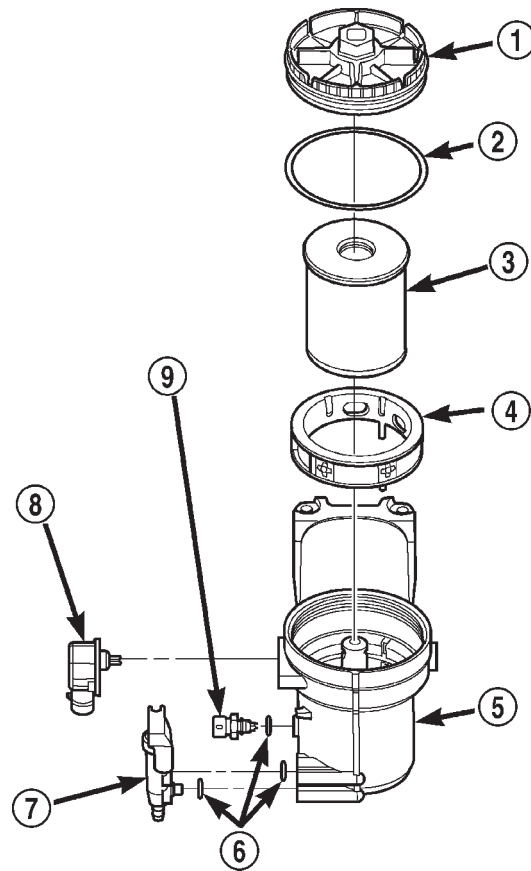
(3) If drain valve, fuel heater element or Water-In-Fuel (WIF) sensor is being replaced, drain housing completely. Dispose of mixture in drain pan according to applicable regulations.

(4) After draining operation, push valve handle downward to CLOSE position (Fig. 5).



**Fig. 5 Water Drain Valve and Drain Hose**

- 1 - FUEL FILTER CAP
- 2 - DRAIN VALVE HANDLE
- 3 - DRAIN HOSE
- 4 - FUEL FILTER/WATER SEPARATOR



80bfe0e4

**Fig. 6 Fuel Filter/Water Separator Components**

- 1 - CAP
- 2 - O-RING
- 3 - FUEL FILTER
- 4 - FUEL HEATER ELEMENT
- 5 - HOUSING
- 6 - O-RINGS
- 7 - DRAIN VALVE
- 8 - FUEL HEATER THERMOSTAT
- 9 - WATER-IN-FUEL SENSOR

(5) **Fuel Filter Replacement:** The fuel filter is located inside of the fuel filter housing (Fig. 6).

(a) Unscrew and remove fuel filter cap at top of fuel filter housing (Fig. 5). To unscrew, attach tool to 6-sided hex center of cap. Do not attempt to loosen cap at outer edge. The fuel filter cap is designed to remove filter while pulling up on cap.

(b) Remove o-ring (Fig. 6) from filter cap and discard.

(c) The filter is retained to the cap with a series of locking fingers. Carefully pry back a few of the fingers to unlock filter from cap.

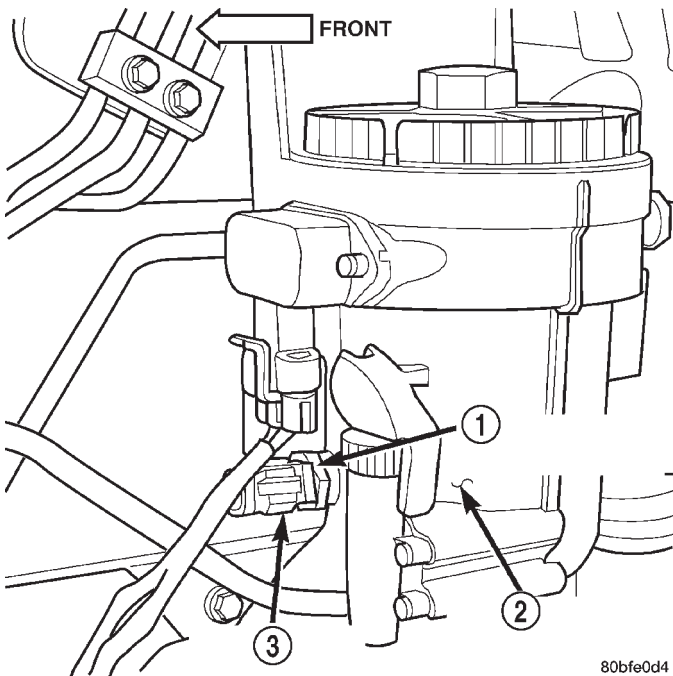
(6) **Water-In-Fuel (WIF) Sensor Replacement:** The WIF sensor is located on the side of the fuel filter housing (Fig. 6).

(a) Disconnect electrical connector at sensor (Fig. 7).

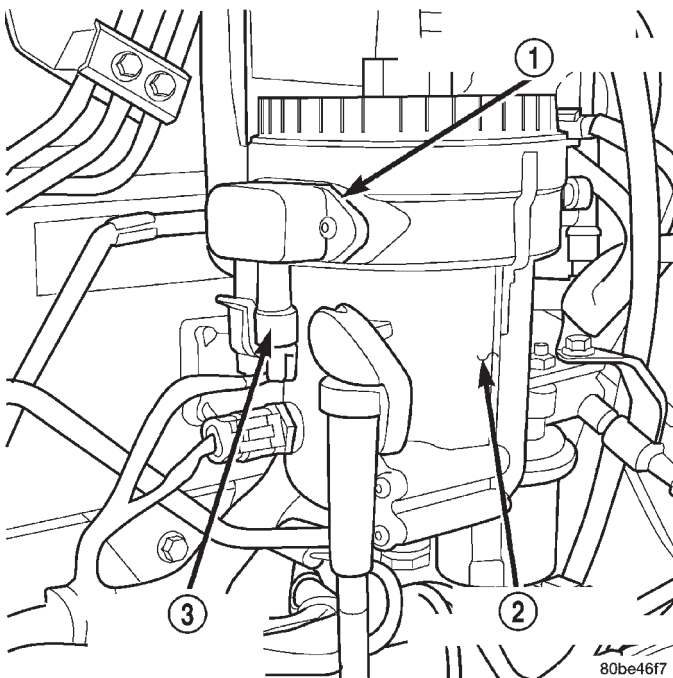
(b) Unscrew sensor from filter housing.



## FUEL FILTER / WATER SEPARATOR (Continued)

**Fig. 7 Water-In-Fuel Sensor**

- 1 - WATER-IN-FUEL (WIF) SENSOR
- 2 - FUEL FILTER/WATER SEPARATOR
- 3 - WIF SENSOR CONNECTOR

**Fig. 8 Fuel Filter/Water Separator Location**

- 1 - FUEL HEATER AND TEMP. SENSOR
- 2 - FUEL FILTER/WATER SEPARATOR
- 3 - FUEL HEATER ELECTRICAL CONNECTOR

(c) Check condition of o-ring.

(d) Inspect the 2 WIF sensor probes. Carefully clean contaminants from sensor probes with a cloth if necessary. Replace sensor if probes are covered with contaminants and will not clean up.

(7) **Fuel Heater Element Replacement:** The heater element is located in the fuel filter housing (Fig. 6).

(a) Remove fuel filter. See previous steps.

(b) Disconnect electrical connector from fuel temperature sensor housing at side of fuel filter housing (Fig. 8).

(c) Remove 2 temperature sensor housing mounting screws and carefully remove sensor housing from fuel filter housing.

(d) Pry round wiring connector from fuel filter housing and heater element. This connector passes through the fuel filter housing and is plugged directly into the heater element.

(e) Unlock heater element fingers and pry heater element from filter housing.

(8) **Drain Valve Replacement:** The drain valve is located on the side of the fuel filter housing (Fig. 6).

(a) Disconnect drain hose (Fig. 5) at bottom of drain valve.

(b) Remove 4 drain valve mounting screws.

(c) Remove drain valve from filter housing.

(d) Remove 2 drain valve o-rings from filter housing.

**INSTALLATION**

Refer to maintenance schedules in this manual for recommended fuel filter replacement intervals.

(1) Thoroughly clean inside of filter housing, filter cap and all related components.

(2) **Fuel Filter:**

(a) Fill fuel filter housing with clean diesel fuel. **If filter housing (canister) is not filled with clean diesel fuel before installation, manual air bleeding of fuel system may be necessary (temporary rough engine running may occur). If necessary, refer to Air Bleed Procedures.**

(b) Snap new filter into locking fingers on cap. Hole in filter should face downward.

(c) Install new o-ring to cap.

(d) Apply a light film of clean diesel oil to cap o-ring seal.

(e) Load filter and cap into housing.

(f) Tighten cap to 25 ft. lbs. torque. Do not over-tighten cap.

(3) **Water-In-Fuel (WIF) Sensor:**

(a) Install new o-ring seal to WIF sensor.

(b) Apply a light film of clean diesel oil to o-ring seal.

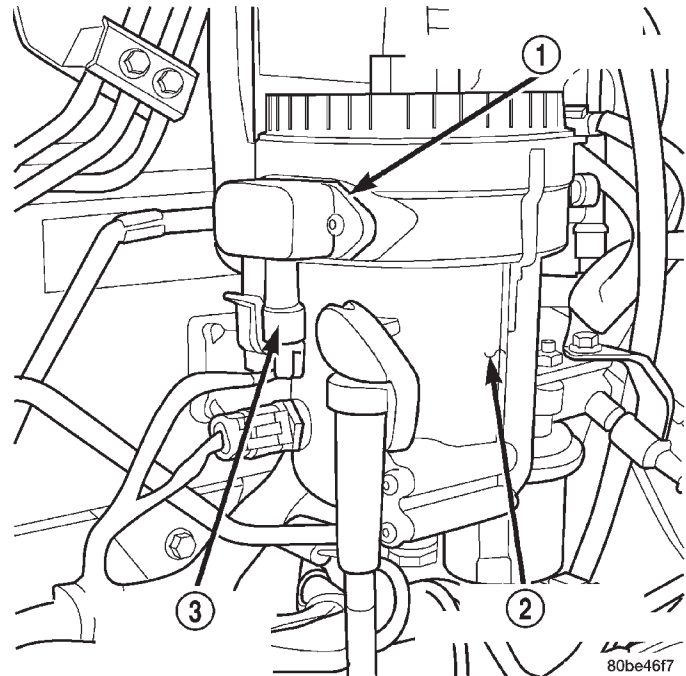
(c) Install sensor into housing.

(d) Tighten sensor to 2–3 N·m (15–20 in. lbs.) torque.



## FUEL FILTER / WATER SEPARATOR (Continued)

- (e) Connect electrical connector to WIF sensor.
- (f) Install fuel filter. Refer to previous steps.
- (4) **Fuel Heater Element:**
  - (a) Do not install fuel filter until heater element is installed.
  - (b) Position heater element into filter housing (fingers downward). Lock fingers into housing.
  - (c) Install new o-ring to electrical connector (where connector passes through filter housing). Apply a light film of clean diesel oil to o-ring seal. Press this connector into filter housing until it snaps into heater element.
  - (d) Install temperature sensor housing and 2 mounting screws to fuel filter housing.
  - (e) Connect electrical connector.
  - (f) Install fuel filter. Refer to previous steps.
- (5) **Drain Valve:**
  - (a) Install 2 new o-rings to valve and filter housing.
  - (b) Apply a light film of clean diesel oil to both seals.
  - (c) Position valve to filter housing.
  - (d) Install 4 mounting screws and tighten to 3–5 N·m (30–40 in. lbs.) torque.
  - (e) Connect drain hose to drain valve.
  - (f) Install fuel filter. Refer to previous steps.
- (6) Start engine and check for leaks.



**Fig. 9 Fuel Heater Location**

- 1 - FUEL HEATER AND TEMP. SENSOR
- 2 - FUEL FILTER/WATER SEPARATOR
- 3 - FUEL HEATER ELECTRICAL CONNECTOR

## FUEL HEATER

### DESCRIPTION

The fuel heater assembly is located on the side of the fuel filter housing (Fig. 9).

The heater/element assembly is equipped with a temperature sensor (thermostat) that senses fuel temperature. This sensor is attached to the fuel heater/element assembly.

### OPERATION

The fuel heater is used to prevent diesel fuel from waxing during cold weather operation.

When the temperature is below  $45 \pm 8$  degrees F, the temperature sensor allows current to flow to the heater element warming the fuel. When the temperature is above  $75 \pm 8$  degrees F, the sensor stops current flow to the heater element.

Battery voltage to operate the fuel heater element is supplied from the ignition switch and through the fuel heater relay. Also refer to Fuel Heater Relay. **The fuel heater element and fuel heater relay are not computer controlled.**

The heater element operates on 12 volts, 300 watts at 0 degrees F.

### DIAGNOSIS AND TESTING - FUEL HEATER

The fuel heater is used to prevent diesel fuel from waxing during cold weather operation.

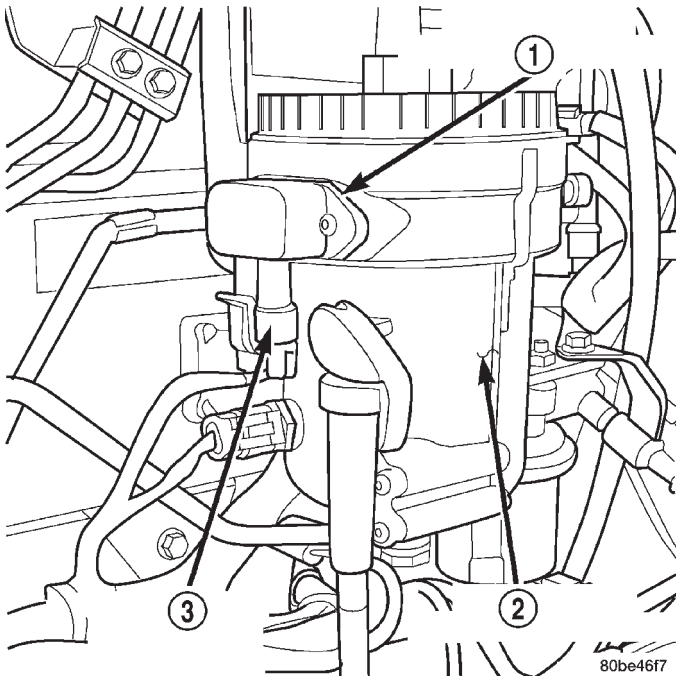
**NOTE: The fuel heater element, fuel heater relay and fuel heater temperature sensor are not controlled by the Powertrain Control Module (PCM).**

A malfunctioning fuel heater can cause a wax build-up in the fuel filter/water separator. Wax build-up in the filter/separator can cause engine starting problems and prevent the engine from revving up. It can also cause blue or white fog-like exhaust. If the heater is not operating in cold temperatures, the engine may not operate due to fuel waxing.

The fuel heater assembly is located on the side of the fuel filter housing (Fig. 10).

The heater assembly is equipped with a built-in fuel temperature sensor (thermostat) that senses fuel temperature. When fuel temperature drops below 45 degrees  $\pm$  8 degrees F, the sensor allows current to flow to the built-in heater element to warm the fuel. When fuel temperature rises above 75 degrees  $\pm$  8 degrees F, the sensor stops current flow to the heater element (circuit is open).

## FUEL HEATER (Continued)



**Fig. 10 Fuel Heater Location**

- 1 - FUEL HEATER AND TEMP. SENSOR
- 2 - FUEL FILTER/WATER SEPARATOR
- 3 - FUEL HEATER ELECTRICAL CONNECTOR

Voltage to operate the fuel heater element is supplied from the ignition switch, through the fuel heater relay (also refer to Fuel Heater Relay), to the fuel temperature sensor and on to the fuel heater element.

The heater element operates on 12 volts, 300 watts at 0 degrees F. As temperature increases, power requirements decrease.

A minimum of 7 volts is required to operate the fuel heater. The resistance value of the heater element is less than 1 ohm (cold) and up to 1000 ohms warm.

## TESTING

(1) Disconnect electrical connector at sensor (Fig. 10).

Turn key to ON position. 12 volts should be present at red wire. If not, check fuel heater relay and related wiring. Refer to Relay Test—Fuel Heater. If OK, proceed.

Turn key OFF. Check black wire in connector for ground continuity with an ohmmeter. If continuity is not present, correct open ground circuit. This test can also be performed with a voltmeter by backprobing black wire with it connected to sensor. Reconnect electrical connector and turn key ON. Voltage drop should not exceed 2 volts (2 volts lower than checked at 12V+ connector). If voltage is lower, check for dirty

or corroded ground connection and repair. If OK, proceed.

(2) With electrical connector disconnected at sensor and key OFF, check electrical/mechanical operation of fuel temperature sensor. Proceed to next step:

(3) Using an ohmmeter, check for continuity across two terminals in electrical connector at side of sensor. Sensor circuit should be open if fuel temperature has risen above 75 degrees  $\pm$  8 degrees F. Sensor circuit should be closed if fuel temperature has dropped below 45 degrees  $\pm$  8 degrees F. If not, replace fuel heater assembly. This same test can also be performed using a voltmeter, with key ON, and by backprobing connector.

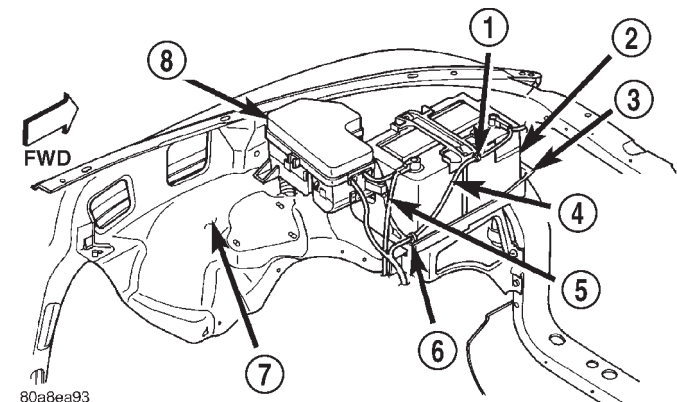
## REMOVAL/INSTALLATION

The fuel heater/element/sensor assembly is located inside of the fuel filter housing. Refer to Fuel Filter/Water Separator Removal/Installation for procedures.

## FUEL HEATER RELAY

## DESCRIPTION

The fuel heater relay is located in Power Distribution Center (PDC) (Fig. 11). Refer to label on inside of PDC cover for relay location.



**Fig. 11 Power Distribution Center Location**

- 1 - CLIP
- 2 - BATTERY
- 3 - TRAY
- 4 - NEGATIVE CABLE
- 5 - POSITIVE CABLE
- 6 - CLIP
- 7 - FENDER INNER SHIELD
- 8 - POWER DISTRIBUTION CENTER

## OPERATION

Battery voltage to operate the fuel heater element is supplied from the ignition switch through the fuel heater relay. **The fuel heater element and fuel heater relay are not computer controlled.**

## FUEL HEATER RELAY (Continued)

**DIAGNOSIS AND TESTING - FUEL HEATER RELAY**

The fuel heater relay is located in the Power Distribution Center (PDC). Refer to label under PDC cover for relay location.

To test the fuel heater, refer to Fuel Heater Test.

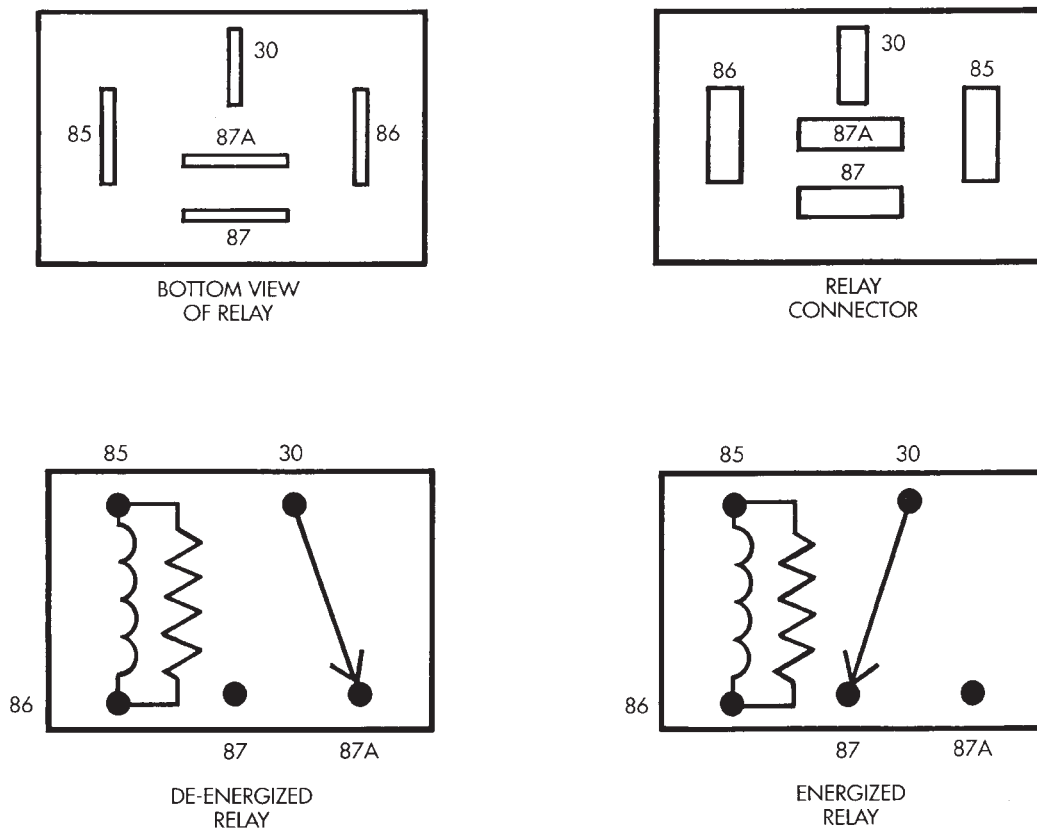
To test the heater relay only, refer to following:

The relay terminal numbers from (Fig. 12) can be found on the bottom of the relay.

- Terminal number 30 is connected to battery voltage and can be switched or B+ (hot) at all times.
- The center terminal number 87A is connected (a circuit is formed) to terminal 30 in the de-energized (normally OFF) position.
- Terminal number 87 is connected (a circuit is formed) to terminal 30 in the energized (ON) position. Terminal number 87 then supplies battery voltage to the component being operated.
- Terminal number 86 is connected to a switched (+) power source.
- Terminal number 85 is grounded by the power-train control module (PCM).

**TESTING**

- (1) Remove relay before testing.
- (2) Using an ohmmeter, perform a resistance test between terminals 85 and 86. Resistance value (ohms) should be  $75 \pm 5$  ohms for resistor equipped relays.
- (3) Connect the ohmmeter between terminals number 87A and 30. Continuity should be present at this time.
- (4) Connect the ohmmeter between terminals number 87 and 30. Continuity should not be present at this time.
- (5) Use a set of jumper wires (16 gauge or smaller). Connect one jumper wire between terminal number 85 (on the relay) to the ground side (-) of a 12 Volt power source.
- (6) Attach the other jumper wire to the positive side (+) of a 12V power source. Do not connect this jumper wire to relay at this time.



**Fig. 12 Relay Terminals**

## FUEL HEATER RELAY (Continued)

**CAUTION:** Do not allow the ohmmeter to contact terminals 85 or 86 during these tests. Damage to ohmmeter may result.

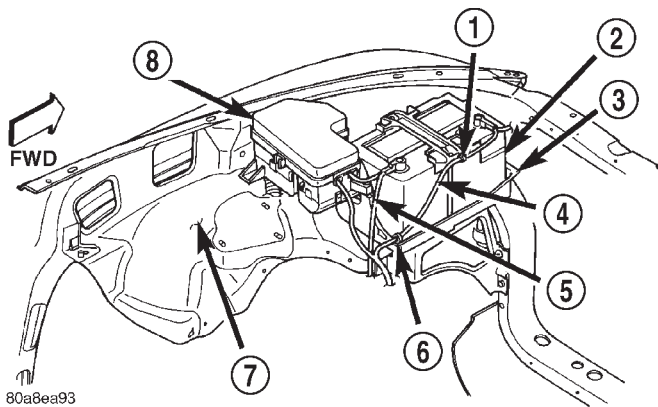
(7) Attach the other jumper wire (12V +) to terminal number 86. This will activate the relay. Continuity should now be present between terminals number 87 and 30. Continuity should not be present between terminals number 87A and 30.

(8) Disconnect jumper wires from relay and 12 Volt power source.

(9) If continuity or resistance tests did not pass, replace relay. If tests passed, refer to 8, Wiring Diagrams for (fuel system) relay wiring schematics and for additional circuit information.

## REMOVAL

The fuel heater relay is located in the Power Distribution Center (PDC) (Fig. 13). Refer to label under PDC cover for relay location.



80a8ea93

**Fig. 13 Power Distribution Center (PDC) Location**

- 1 - CLIP
- 2 - BATTERY
- 3 - TRAY
- 4 - NEGATIVE CABLE
- 5 - POSITIVE CABLE
- 6 - CLIP
- 7 - FENDER INNER SHIELD
- 8 - POWER DISTRIBUTION CENTER

- (1) Remove PDC cover.
- (2) Remove relay from PDC.
- (3) Check condition of relay terminals and PDC connector terminals for damage or corrosion. Repair if necessary before installing relay.
- (4) Check for pin height (pin height should be the same for all terminals within the PDC connector). Repair if necessary before installing relay.

## INSTALLATION

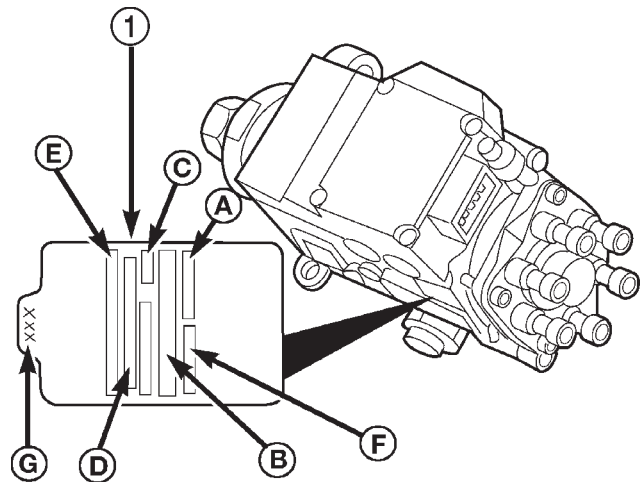
The fuel heater relay is located in the Power Distribution Center (PDC) (Fig. 13). Refer to label under PDC cover for relay location.

- (1) Install relay to PDC.
- (2) Install cover to PDC.

## FUEL INJECTION PUMP

## DESCRIPTION—FUEL PUMP 245 H.P.

Although the fuel injection pump on the 245 horsepower engine appears similar to other VP 44 injection pumps, there are internal differences that make it unique. If pump replacement is necessary, be sure to verify pump number. The pump number can be found on the Fuel Injection Pump Data Plate (Fig. 14).



- A. ORDER NUMBER
- B. BOSCH PART NUMBER
- C. FACTORY CODE
- D. CUMMINS PART NUMBER
- E. MANUFACTURE DATE
- F. PUMP SERIAL NUMBER
- G. LAST THREE DIGITS OF KEY PART NUMBER

80b4b8c9

**Fig. 14 Fuel Injection Pump Data Plate Location**

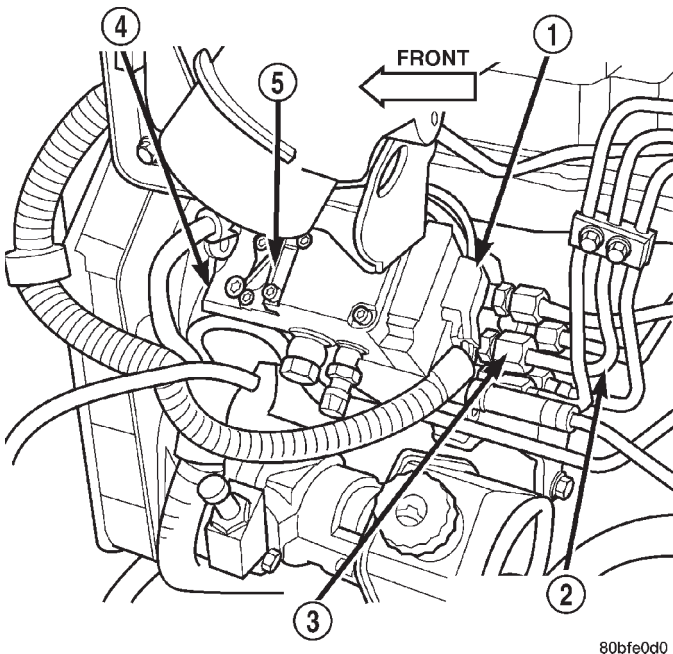
- 1 - PUMP DATA PLATE



## FUEL INJECTION PUMP (Continued)

## DESCRIPTION—FUEL PUMP 235 H.P.

The fuel injection pump is mounted to the rear of the timing gear housing on the left side of engine (Fig. 15).



**Fig. 15 Fuel Injection Pump Location**

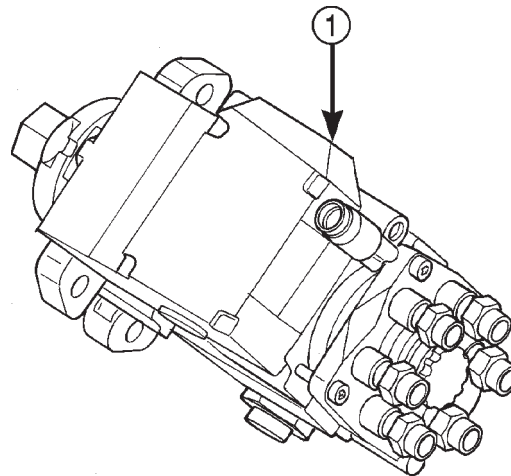
- 1 - FPCM ELECTRICAL CONNECTOR
- 2 - HIGH-PRESSURE FUEL LINES
- 3 - FITTINGS
- 4 - FUEL INJECTION PUMP
- 5 - FPCM

## OPERATION

The Bosch VP44 fuel injection pump (Fig. 16) is a solenoid-valve controlled-radial-piston-distributor type pump.

The injection pump is driven by the engine camshaft. A gear on the end of the pump shaft meshes with the camshaft gear. The pump is timed to the engine. The VP44 is controlled by an integral (and non-serviceable) Fuel Pump Control Module (FPCM) (Fig. 15). The FPCM can operate the engine as an engine controller if a Crankshaft Position Sensor (CKP) signal is not present.

Fuel from the transfer (lift) pump enters the VP44 where it is pressurized and then distributed through high-pressure lines to the fuel injectors. The VP44 is cooled by the fuel that flows through it. A greater quantity of fuel is required for cooling the VP44 than what is necessary for engine operation. Because of this, approximately 70 percent of fuel entering the pump is returned to the fuel tank through the overflow valve and fuel return line. Refer to Overflow Valve Description/Operation for additional information.



80b46ce2

**Fig. 16 Bosch VP44 Fuel Injection Pump**

1 - BOSCH VP44 PUMP

The VP44 is not self-priming. At least two fuel injectors must be bled to remove air from the system. When servicing the fuel system, disconnecting components up to the pump will usually not require air bleeding from the fuel system. However, removal of the high-pressure lines, removal of the VP44 pump, or allowing the vehicle to completely run out of fuel, will require bleeding air from the high-pressure lines at the fuel injectors.

VP44 timing is matched to engine timing by an offset keyway that fits into the pump shaft. This keyway has a stamped number on it that is matched to a number on the VP44 pump (each keyway is calibrated to each pump).

**When removing/installing the VP44, the same numbered keyway must always be installed. Also, the arrow on the top of the keyway should be installed pointed rearward towards the pump.**

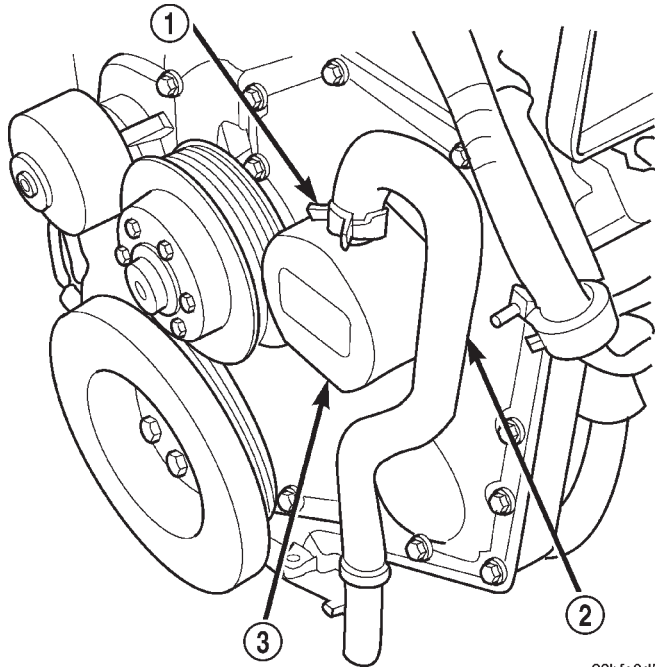
Because of electrical control, the injection pump high and low idle speeds are not adjustable. Also, adjustment of fuel pump timing is not required and is not necessary.

## DIAGNOSIS AND TESTING—FUEL INJECTION PUMP TIMING

With the Bosch VP44 injection pump, there are no mechanical adjustments needed for fuel injection timing. All timing and fuel adjustments are made by the Engine Control Module (ECM). However, if a Diagnostic Trouble Code (DTC) has been stored indicating an "engine sync error" or a "static timing error", perform the following.

## FUEL INJECTION PUMP (Continued)

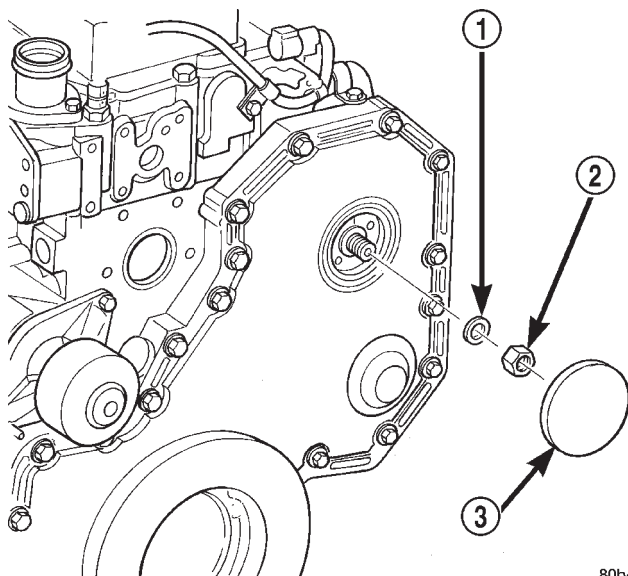
**Note: If this DTC appears after installation of a new or rebuilt injection pump, the pump keyway has probably been installed backwards. Refer to Fuel Injection Pump Removal/Installation for keyway information.**



80bfe0d5

**Fig. 17 Crankcase Vent Hose**

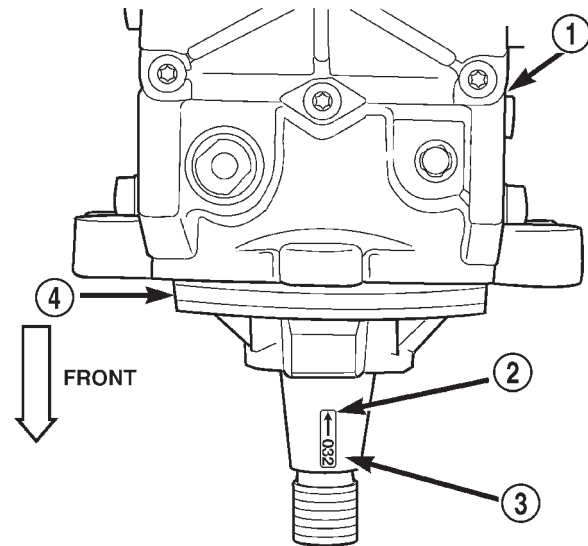
- 1 - HOSE CLAMP
- 2 - CRANKCASE VENT HOSE
- 3 - CRANKCASE BREATHER



80b4b8b4

**Fig. 18 Injection Pump Gear Nut/Washer**

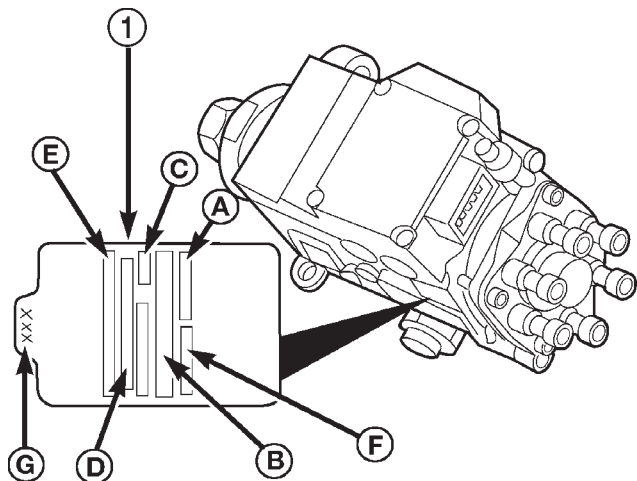
- 1 - WASHER
- 2 - PUMP NUT
- 3 - ACCESS CAP



80b4b8c5

**Fig. 19 Pump Keyway, Keyway Arrow and Keyway Number**

- 1 - INJECTION PUMP
- 2 - DIRECTIONAL ARROW
- 3 - 3-DIGIT KEYWAY NUMBER
- 4 - O-RING



- A. ORDER NUMBER
- B. BOSCH PART NUMBER
- C. FACTORY CODE
- D. CUMMINS PART NUMBER
- E. MANUFACTURE DATE
- F. PUMP SERIAL NUMBER
- G. LAST THREE DIGITS OF KEY PART NUMBER

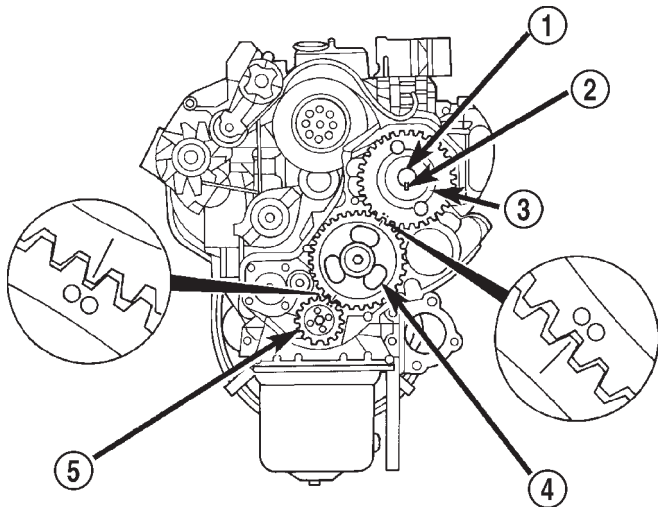
**Fig. 20 Pump Data Plate Location**

- 1 - PUMP DATA PLATE

80b4b8c9



## FUEL INJECTION PUMP (Continued)



80b4b8c6

**Fig. 21 Checking Fuel Injection Pump Gear Timing**

- 1 - PUMP SHAFT
- 2 - KEYWAY
- 3 - PUMP GEAR
- 4 - CAM GEAR
- 5 - CRANKSHAFT GEAR

(1) Remove hose clamp and crankcase vent hose at crankcase breather (Fig. 17). Remove crankcase breather from gear cover. Breather threads into cover.

(2) Remove injection pump nut and washer (Fig. 18). Locate keyway behind washer.

(3) Be sure keyway aligning fuel injection pump shaft to injection pump gear is in proper position and pump gear has not slipped on pump shaft.

The following steps will require removing timing gear cover to gain access to timing gears. Refer to Group 9, Engines for procedures.

(4) Use a T-type puller to separate injection pump gear from pump shaft.

(5) Be sure keyway has been installed with arrow pointed to rear of pump (Fig. 19).

(6) **Pump timing has been calibrated to pump keyway. Be sure 3-digit number on pump keyway (Fig. 19) matches 3-digit number on fuel injection pump data plate. Plate is located on side of injection pump (Fig. 20). Twenty-one different calibrated keyways/pumps are available.**

(7) Verify timing marks on crank, cam and pump are aligned (Fig. 21).

(8) Perform necessary gear alignment/repairs as needed.

(9) Install crankcase breather to gear cover. Install hose clamp and crankcase vent hose to breather (Fig. 17).

(10) After repairs are completed, erase DTC using DRB Scan Tool.

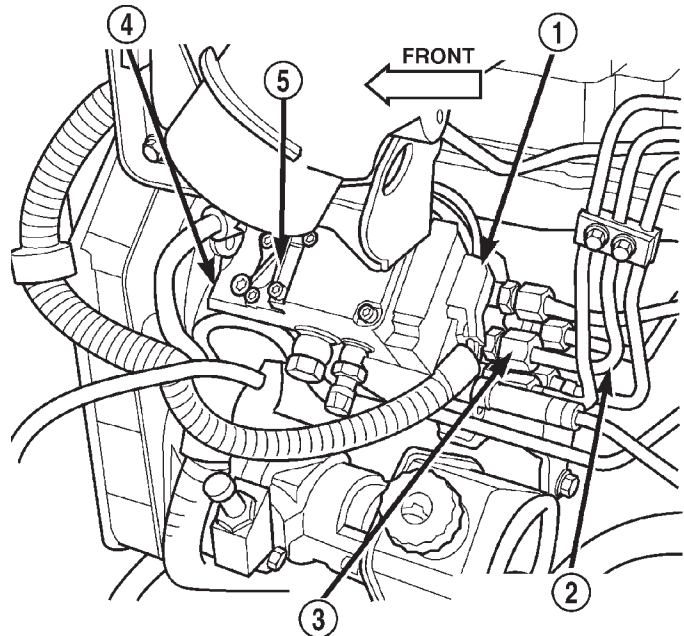
## REMOVAL

**CAUTION: Refer to Cleaning Fuel System Parts.**

(1) Disconnect both negative battery cables at both batteries. Cover and isolate ends of cables.

(2) Thoroughly clean fuel lines at cylinder head and injection pump ends. Thoroughly clean fuel injection pump and supply/return lines at side of pump.

(3) Disconnect 9-way electrical connector at Fuel Pump Control Module (FPCM) (Fig. 22).



80bfe0d0

**Fig. 22 FPCM 9-Way Connector**

- 1 - FPCM ELECTRICAL CONNECTOR
- 2 - HIGH-PRESSURE FUEL LINES
- 3 - FITTINGS
- 4 - FUEL INJECTION PUMP
- 5 - FPCM

(4) Remove fuel return line at side of injection pump by removing overflow valve (Fig. 23). Place rag beneath overflow valve to catch excess fuel.

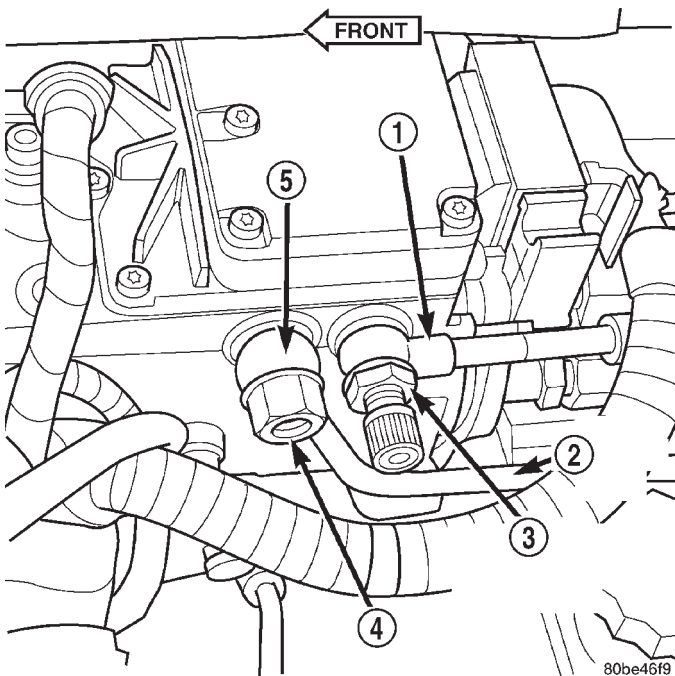
(5) Remove fuel supply line at side of injection pump by removing banjo bolt (Fig. 23). Also remove same line at top of fuel filter housing (banjo bolt).

(6) Remove all high-pressure fuel lines, intake air tube, accelerator pedal position sensor, air intake housing, engine oil dipstick tube, wiring clips, electrical cables at intake heaters and engine lifting bracket. Refer to High-Pressure Fuel Line Removal/Installation. All of these items are covered in this procedure.

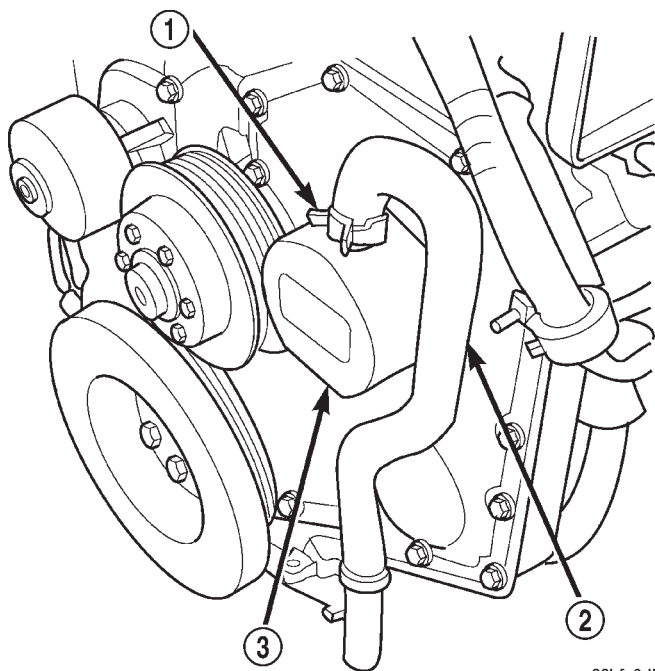
(7) Remove hose clamp at crankcase vent hose (Fig. 24) and remove hose from canister.

(8) Remove (unscrew) canister (Fig. 24) from gear cover.

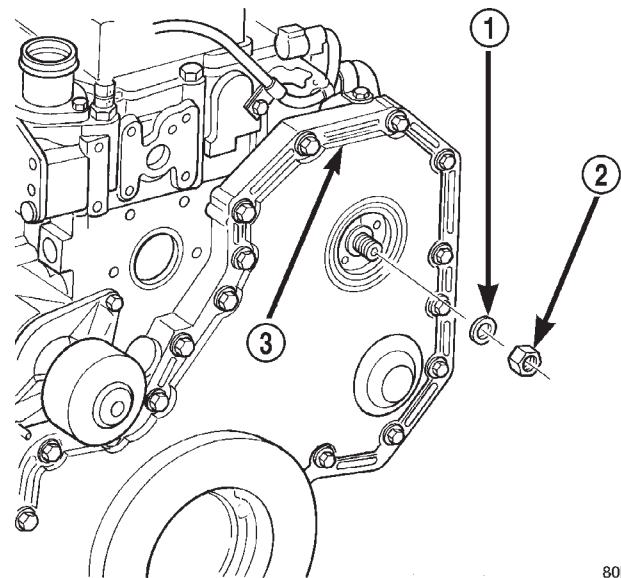
## FUEL INJECTION PUMP (Continued)

**Fig. 23 Fuel Supply and Return Lines at Pump**

- 1 - FUEL SUPPLY LINE
- 2 - FUEL RETURN LINE
- 3 - BANJO BOLT (TEST PORT FITTING)
- 4 - OVERFLOW VALVE
- 5 - BANJO FITTING

**Fig. 24 Crankcase Vent Hose**

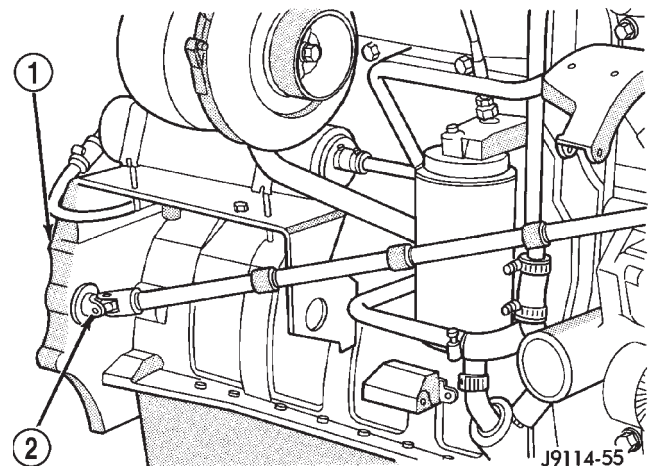
- 1 - HOSE CLAMP
- 2 - CRANKCASE VENT HOSE
- 3 - CRANKCASE BREATHER



80bfe0e3

**Fig. 25 Pump Shaft Nut/Washer**

- 1 - WASHER
- 2 - PUMP NUT
- 3 - GEAR COVER



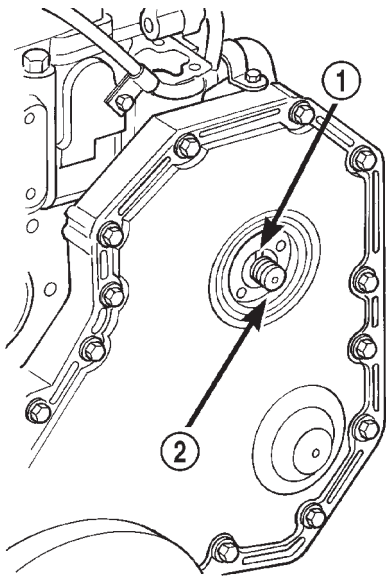
J9114-55

**Fig. 26 Rotating Engine with Barring Tool**

- 1 - REAR FLANGE
- 2 - BARRING TOOL

**CAUTION:** To prevent pump/gear keyway from falling into gear housing, engine must be rotated until keyway is at 12 o'clock position (Fig. 27). If gear retainer nut, washer or key drops into gear housing, cover may have to be removed to retrieve them before engine is started.

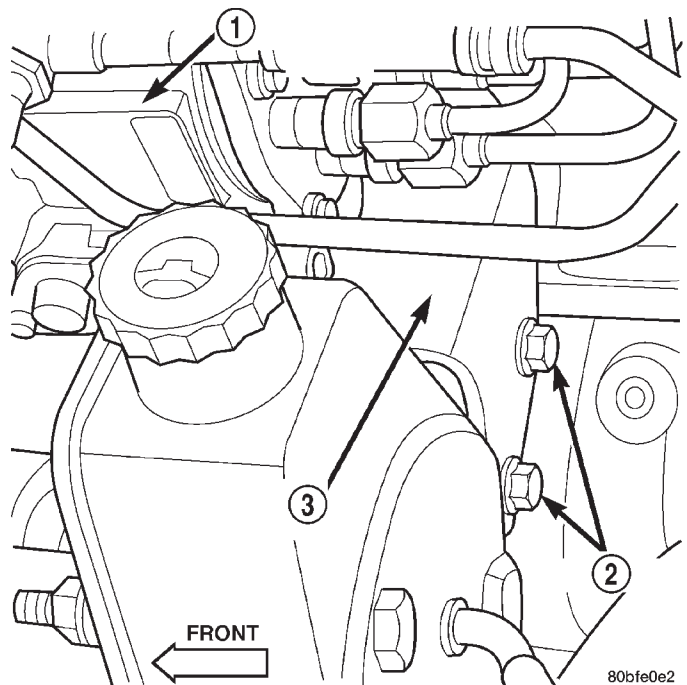
FUEL INJECTION PUMP (Continued)



80b4b8b6

**Fig. 27 Placing Keyway at 12 O'clock Position**

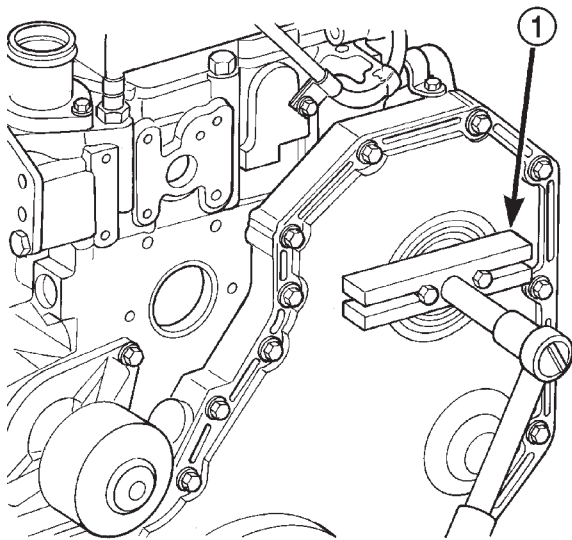
- 1 - KEYWAY AT 12 O'CLOCK POSITION
- 2 - PUMP GEAR



80bfe0e2

**Fig. 29 Rear/Lower Pump Bracket and Mounting Bolts**

- 1 - FUEL INJECTION PUMP
- 2 - BOLTS (2)
- 3 - REAR/LOWER BRACKET



80b4b8b5

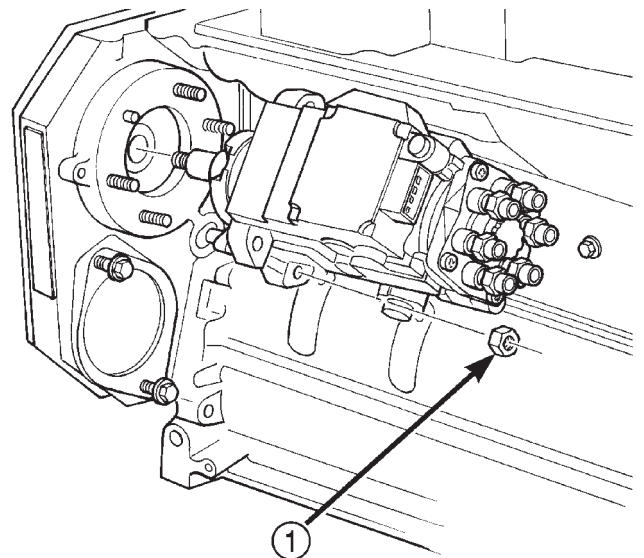
**Fig. 28 Separating Injection Pump Gear from Pump Shaft**

- 1 - T-BAR PULLER

(9) Remove nut and washer retaining injection pump gear to injection pump shaft (Fig. 25).

(10) The engine can be rotated with a barring tool such as Snap-On No. SP371, MTE No. 3377371 (Cummins Tool Division), or an equivalent. The opening for barring tool is located in rear flange of engine on exhaust manifold side (Fig. 26). Remove rubber access plug covering this opening.

(11) Insert barring tool into flywheel housing opening (Fig. 26).



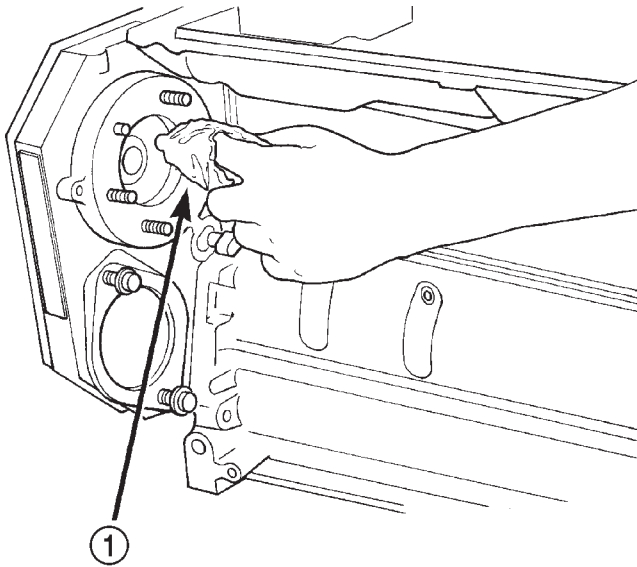
80b4b8b8

**Fig. 30 Injection Pump Mounting Nuts**

- 1 - PUMP MOUNTING NUTS (4)

(12) Rotate engine until keyway is at 12 o'clock position (Fig. 27).

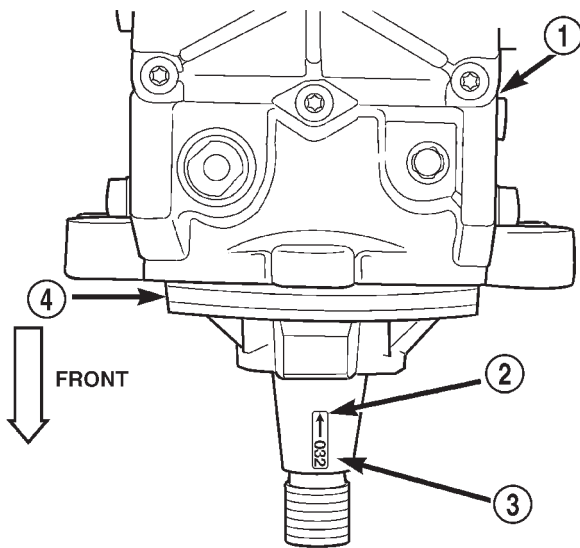
## FUEL INJECTION PUMP (Continued)



80b4b8b9

**Fig. 31 Cleaning Pump Mounting Flange**

1 - PUMP MOUNTING FLANGE



80b4b8c5

**Fig. 32 Keyway, Keyway Arrow and Keyway Number**

1 - INJECTION PUMP  
 2 - DIRECTIONAL ARROW  
 3 - 3-DIGIT KEYWAY NUMBER  
 4 - O-RING

(13) Use T-bar type puller (Fig. 28) to separate injection pump gear from injection pump shaft. Attach two M8 X 1.24 MM (metric) screws through puller and into two threaded holes supplied in pump gear. Pull injection pump gear forward until it loosens from injection pump shaft. **Pull on gear only enough to loosen it from injection pump shaft. Pulling gear too far may cause damage or breakage to gear cover.**

(14) Remove 2 rear/lower pump bracket bolts (Fig. 29).

(15) Remove 4 injection pump-to-gear housing mounting nuts (Fig. 30).

(16) Remove injection pump from gear housing. **Take care not to nick injection pump shaft on aluminum gear housing when removing pump. Also be very careful not to drop pump keyway (Fig. 32) into gear housing.**

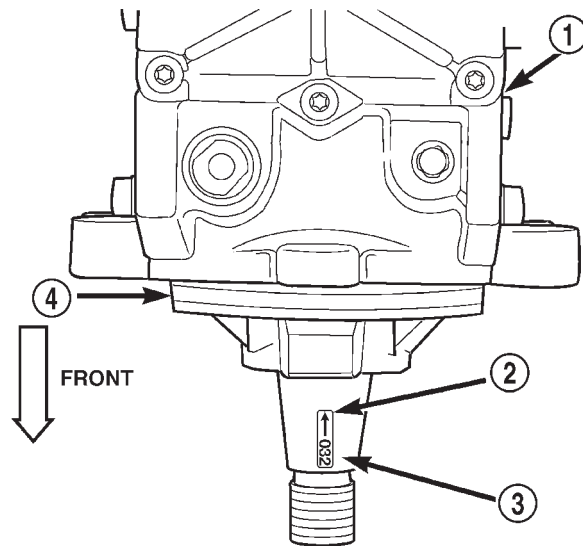
**CAUTION:** Whenever the fuel injection pump is removed from the engine, the pump drive gear is laying loose on the camshaft drive gear. Never attempt to crank or rotate the engine with the pump removed from the engine. Serious damage will occur.

**INSTALLATION**

(1) Inspect pump mounting surfaces at pump and mounting flange for nicks, cuts or damage. Inspect o-ring surfaces for nicks, cuts or damage.

(2) Clean injection pump mounting flange (Fig. 31) at gear housing. Also clean front of injection pump.

(3) Install new rubber o-ring (Fig. 33) at pump mounting area.



80b4b8c5

**Fig. 33 Keyway, Keyway Arrow and Keyway Number**

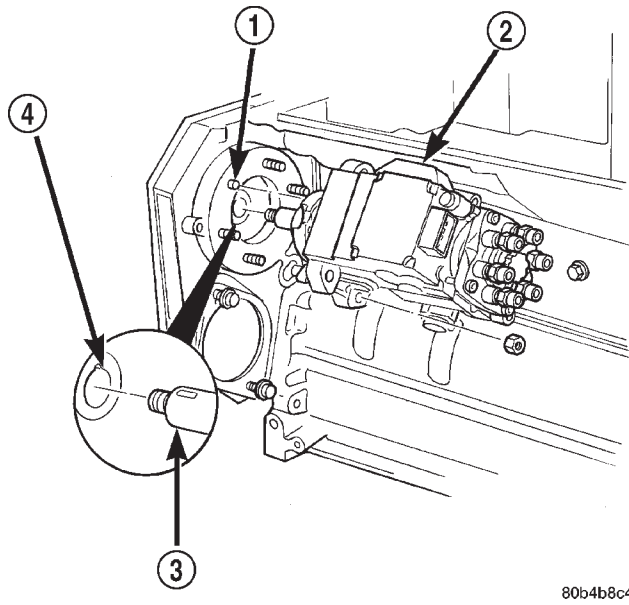
1 - INJECTION PUMP  
 2 - DIRECTIONAL ARROW  
 3 - 3-DIGIT KEYWAY NUMBER  
 4 - O-RING

(4) Apply clean engine oil to **injection pump o-ring only.**

**The machined tapers on both injection pump shaft and injection pump gear (Fig. 34) must be absolutely dry, clean and free of any dirt or oil film. This will ensure proper gear-to-shaft tightening.**



## FUEL INJECTION PUMP (Continued)



**Fig. 34 Injection Pump Installation**

- 1 - DOWEL
- 2 - PUMP
- 3 - PUMP SHAFT TAPER
- 4 - INJECTION PUMP GEAR TAPER

(5) Clean pump gear and pump shaft at machined tapers (Fig. 34) with an evaporative type cleaner such as brake cleaner.

**Keyway Installation:**

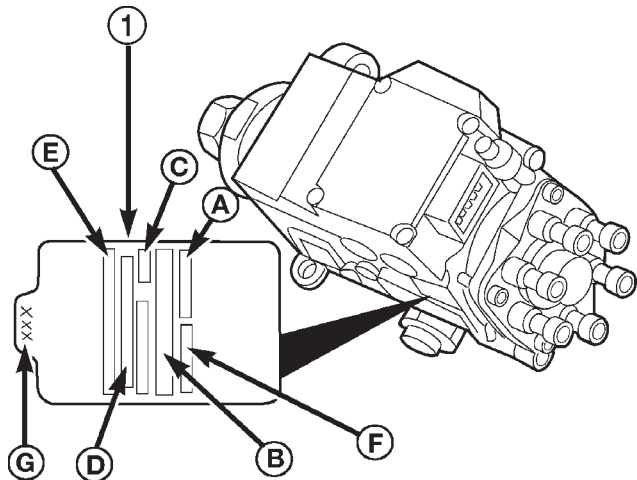
(6) The pump/gear keyway has an arrow and a 3-digit number stamped at top edge (Fig. 33). Position keyway into pump shaft with **arrow pointed to rear of pump**. Also be sure 3-digit number stamped to top of keyway is same as 3-digit number stamped to injection pump data plate (Fig. 35). If wrong keyway is installed, a diagnostic trouble code may be set.

(7) Position pump assembly to mounting flange on gear cover while aligning injection pump shaft through back of injection pump gear. When installing pump, dowel (Fig. 34) on mounting flange must align to hole in front of pump.

(8) After pump is positioned flat to mounting flange, install four pump mounting nuts and tighten finger tight only. Do not attempt a final tightening at this time. **Do not attempt to tighten (pull) pump to gear cover using mounting nuts. Damage to pump or gear cover may occur. The pump must be positioned flat to its mounting flange before attempting to tighten mounting nuts.**

(9) To prevent damage or cracking of components, tighten nuts/bolts in the following sequence:

- (a) Install injection pump shaft washer and nut to pump shaft. Tighten nut **finger tight only**.
- (b) Install 2 rear/lower pump mounting bolts **finger tight only**.



- A. ORDER NUMBER
- B. BOSCH PART NUMBER
- C. FACTORY CODE
- D. CUMMINS PART NUMBER
- E. MANUFACTURE DATE
- F. PUMP SERIAL NUMBER
- G. LAST THREE DIGITS OF KEY PART NUMBER

**Fig. 35 Injection Pump Data Plate Location**

- 1 - PUMP DATA PLATE

(c) Do preliminary tightening of injection pump shaft nut to 30 N·m (15–22 ft. lbs.) torque. **This is not the final torque.**

(d) Tighten 4 pump mounting nuts to 43 N·m (32 ft. lbs.) torque.

(e) Tighten 2 rear/lower pump bracket-to-pump bolts 24 N·m (18 ft. lbs.) torque.

(f) Do final tightening of injection pump shaft nut to 170 N·m (125 ft. lbs.) torque. Use barring tool to prevent engine from rotating when tightening gear.

(10) Install canister (Fig. 24) to gear cover.

(11) Install crankcase vent hose (Fig. 24) to canister and install hose clamp.

(12) Using new gaskets, install fuel return line and overflow valve to side of injection pump (Fig. 23). Tighten overflow valve to 24 N·m (18 ft. lbs.) torque.

(13) Using new gaskets, install fuel supply line to side of injection pump and top of fuel filter housing (Fig. 23). Tighten banjo bolts to 24 N·m (18 ft. lbs.) torque.

(14) Install all high-pressure fuel lines, intake air tube, accelerator pedal position sensor, air intake housing, engine oil dipstick tube, wiring clips, electrical cables at intake heaters and engine lifting bracket. Refer to High-Pressure Fuel Line Removal/Installation. All of these items are covered in this procedure.

## FUEL INJECTION PUMP (Continued)

(15) Connect 9-way electrical connector to Fuel Pump Control Module (FPCM) (Fig. 22).

(16) Connect both negative battery cables to both batteries.

(17) Bleed air from fuel system.(Refer to 14 - FUEL SYSTEM/FUEL DELIVERY - STANDARD PROCEDURE).

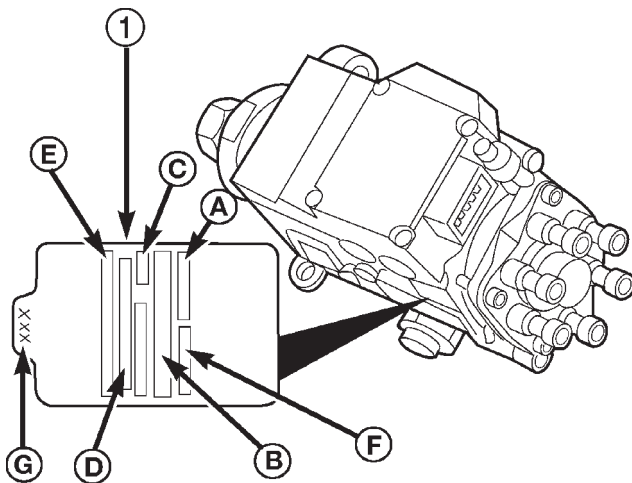
(18) Check system for fuel or engine oil leaks.

## FUEL INJECTION PUMP DATA PLATE

## SPECIFICATIONS

## FUEL INJECTION PUMP DATA PLATE

Pertinent information about the fuel injection pump is machined into a boss on the drivers side of the fuel injection pump (Fig. 36).



- A. ORDER NUMBER
- B. BOSCH PART NUMBER
- C. FACTORY CODE
- D. CUMMINS PART NUMBER
- E. MANUFACTURE DATE
- F. PUMP SERIAL NUMBER
- G. LAST THREE DIGITS OF KEY PART NUMBER

80b4b8c9

**Fig. 36 Fuel Injection Pump Data Plate Location**

1 - PUMP DATA PLATE

## FUEL LEVEL SENDING UNIT / SENSOR

## DESCRIPTION

The fuel gauge sending unit (fuel level sensor) is attached to the side of the fuel tank module. The sending unit consists of a float, an arm, and a variable resistor track (card).

## OPERATION

The fuel tank module on diesel powered models has 3 different circuits (wires). Two of these circuits are used at the fuel gauge sending unit for fuel gauge operation. The other wire is used for a ground. The diesel engine does not have a fuel tank module mounted electric fuel pump. The electric fuel pump (fuel transfer pump) is mounted to the engine.

**For Fuel Gauge Operation:** A constant input voltage source of about 12 volts (battery voltage) is supplied to the resistor track on the fuel gauge sending unit. This is fed directly from the Powertrain Control Module (PCM). **NOTE: For diagnostic purposes, this 12V power source can only be verified with the circuit opened (fuel tank module electrical connector unplugged). With the connectors plugged, output voltages will vary from about .6 volts at FULL, to about 7.0 volts at EMPTY.** The resistor track is used to vary the voltage (resistance) depending on fuel tank float level. As fuel level increases, the float and arm move up, which decreases voltage. As fuel level decreases, the float and arm move down, which increases voltage. The varied voltage signal is returned back to the PCM through the sensor return circuit.

Both of the electrical circuits between the fuel gauge sending unit and the PCM are hard-wired (not multi-plexed). After the voltage signal is sent from the resistor track, and back to the PCM, the PCM will interpret the resistance (voltage) data and send a message across the multi-plex bus circuits to the instrument panel cluster. Here it is translated into the appropriate fuel gauge level reading. Refer to Instrument Panel for additional information.

## FUEL LINES

## DESCRIPTION

All fuel lines up to the fuel injection pump are considered low-pressure. This includes the fuel lines from: the fuel tank to the fuel transfer pump, and the fuel transfer pump to the fuel injection pump. The fuel return lines, the fuel drain manifold and the fuel drain manifold lines are also considered low-pressure lines. High-pressure lines are used between

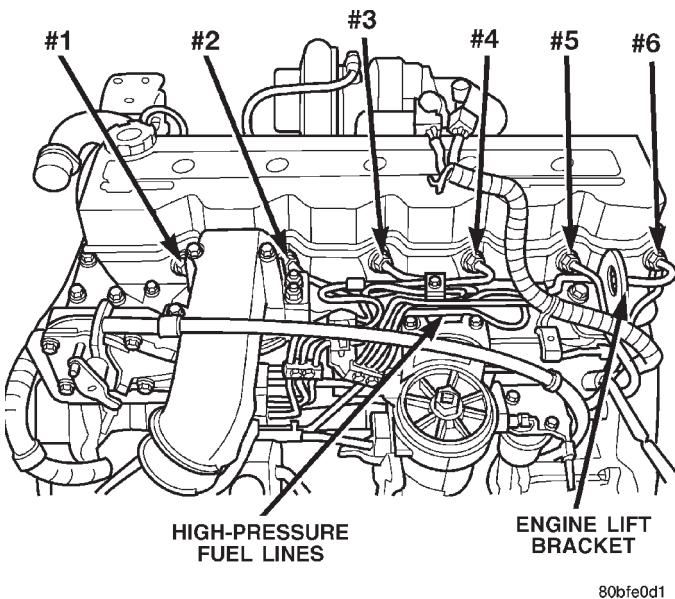


## FUEL LINES (Continued)

the fuel injection pump and the fuel injectors. Also refer to High-Pressure Fuel Lines Description/Operation.

**DESCRIPTION—HIGH PRESSURE FUEL LINES**

The high-pressure fuel lines are the 6 lines located between the fuel injection pump and the fuel injector connector tubes (Fig. 37). All other fuel lines are considered low-pressure lines.



*Fig. 37 High-Pressure Fuel Lines*

**OPERATION—HIGH PRESSURE FUEL LINES**

**CAUTION:** The high-pressure fuel lines must be held securely in place in their holders. The lines cannot contact each other or other components. Do not attempt to weld high-pressure fuel lines or to repair lines that are damaged. If lines are ever kinked or bent, they must be replaced. Use only the recommended lines when replacement of high-pressure fuel line is necessary.

High-pressure fuel lines deliver fuel under pressure of up to approximately 120,000 kPa (17,405 PSI) from the injection pump to the fuel injectors. The lines expand and contract from the high-pressure fuel pulses generated during the injection process. All high-pressure fuel lines are of the same length and inside diameter. Correct high-pressure fuel line usage and installation is critical to smooth engine operation.

**WARNING:** USE EXTREME CAUTION WHEN INSPECTING FOR HIGH-PRESSURE FUEL LEAKS. INSPECT FOR HIGH-PRESSURE FUEL LEAKS WITH A SHEET OF CARDBOARD. HIGH FUEL INJECTION

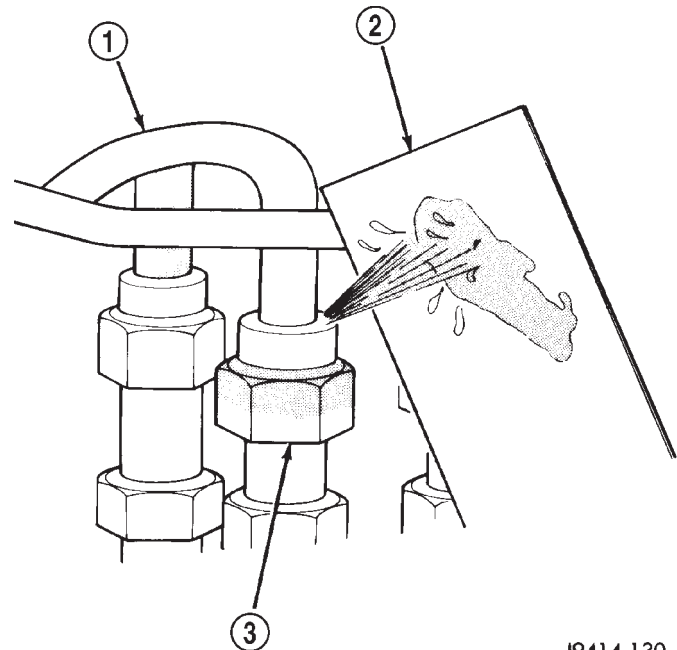
**PRESSURE CAN CAUSE PERSONAL INJURY IF CONTACT IS MADE WITH THE SKIN.**

**DIAGNOSIS AND TESTING - HIGH-PRESSURE FUEL LINE LEAKS**

High-pressure fuel line leaks can cause starting problems and poor engine performance.

**WARNING:** DUE TO EXTREME FUEL PRESSURES OF UP TO 120,000 kPa (17,400 PSI), USE EXTREME CAUTION WHEN INSPECTING FOR HIGH-PRESSURE FUEL LEAKS. DO NOT GET YOUR HAND NEAR A SUSPECTED LEAK. INSPECT FOR HIGH-PRESSURE FUEL LEAKS WITH A SHEET OF CARDBOARD. HIGH FUEL INJECTION PRESSURE CAN CAUSE PERSONAL INJURY IF CONTACT IS MADE WITH THE SKIN.

Start the engine. Move the cardboard over the high-pressure fuel lines and check for fuel spray onto the cardboard (Fig. 38). If a high-pressure line connection is leaking, bleed the system and tighten the connection. Refer to the Air Bleed Procedure in this group for procedures. Replace damaged, restricted or leaking high-pressure fuel lines with the correct replacement line.



J9414-130

*Fig. 38 Typical Test for Leaks with Cardboard*

- 1 - HIGH-PRESSURE LINE
- 2 - CARDBOARD
- 3 - FITTING

## FUEL LINES (Continued)

**CAUTION:** The high-pressure fuel lines must be clamped securely in place in the holders. The lines cannot contact each other or other components. Do not attempt to weld high-pressure fuel lines or to repair lines that are damaged. Only use the recommended lines when replacement of high-pressure fuel line is necessary.

## REMOVAL

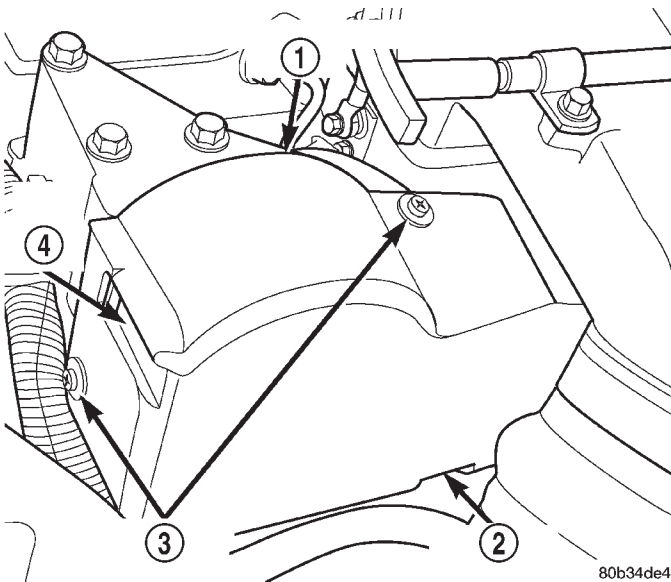
High-pressure lines are used between the fuel injection pump and the fuel injectors only. All high-pressure fuel lines are of the same length and inside diameter. Correct high-pressure fuel line usage and installation is critical to smooth engine operation.

**CAUTION:** Refer to Cleaning Fuel System Parts.

(1) Disconnect both negative battery cables from both batteries. Cover and isolate ends of cables.

(2) Thoroughly clean fuel lines at cylinder head and injection pump ends.

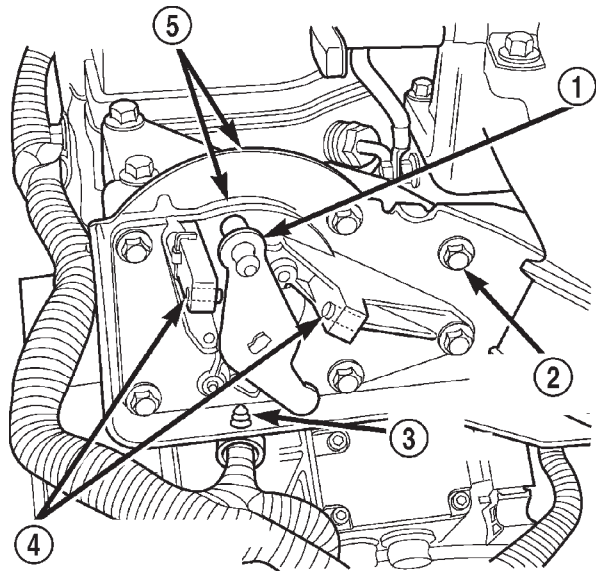
(3) Remove cable cover (Fig. 39). Cable cover is attached with 2 Phillips screws, 2 plastic retention clips and 2 push tabs (Fig. 39). Remove 2 Phillips screws and carefully pry out 2 retention clips. After clip removal, push rearward on front tab, and upward on lower tab for cover removal. **Do not remove any cables at lever.**



**Fig. 39 Cable/Lever/Throttle Linkage Cover**

- 1 - CABLE/LEVER/LINKAGE COVER
- 2 - PUSH UP LOWER TAB
- 3 - SCREWS/CLIPS (2)
- 4 - TAB PUSH HERE

(4) Disconnect wiring harness (clip) at bottom of Accelerator Pedal Position Sensor (APPS) mounting bracket (Fig. 40).

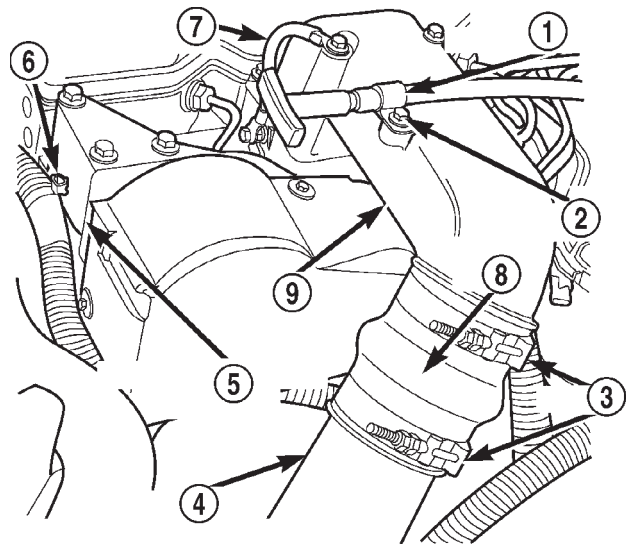


80b46b88

**Fig. 40 Wiring Clip at APPS**

- 1 - LEVER
- 2 - MOUNTING BOLTS (6)
- 3 - WIRE HARNESS CLIP
- 4 - CALIBRATION SCREWS (NO ADJUSTMENT)
- 5 - APPS ASSEMBLY

(5) Using 2 small screwdrivers, pry front wiring clip (Fig. 41) from cable bracket housing. Position wiring harness towards front of engine.



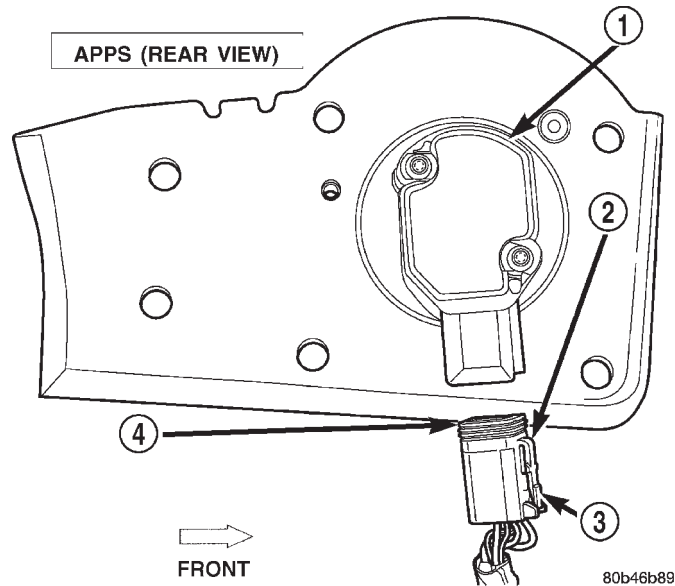
80b46b86

**Fig. 41 Air Tube (Typical)**

- 1 - ENGINE OIL DIPSTICK TUBE
- 2 - TUBE BOLT
- 3 - CLAMPS
- 4 - AIR TUBE (INTAKE MANIFOLD TO CHARGE AIR COOLER)
- 5 - CABLE BRACKET HOUSING
- 6 - FRONT WIRING CLIP
- 7 - GROUND CABLE
- 8 - RUBBER HOSE
- 9 - AIR INTAKE HOUSING

## FUEL LINES (Continued)

(6) Remove electrical connector from APPS by pushing connector tab rearward while pulling down on connector (Fig. 42).



**Fig. 42 Rear View of APPS**

- 1 - APPS
- 2 - TAB
- 3 - PUSH FOR REMOVAL
- 4 - APPS CONNECTOR

(7) Disconnect 2 electrical cables from cable mounting studs (Fig. 43) at intake air heater on top of intake manifold.

(8) Remove engine oil dipstick from engine.

(9) Remove engine oil dipstick tube support mounting bolt (Fig. 43) and position tube to side.

(10) Disconnect clamps and remove air tube (intake manifold-to-intercooler) (Fig. 41).

(11) Remove 4 air intake housing mounting bolts and remove housing (Fig. 44) and (Fig. 43). Position ground cable at top of air intake housing to front of engine.

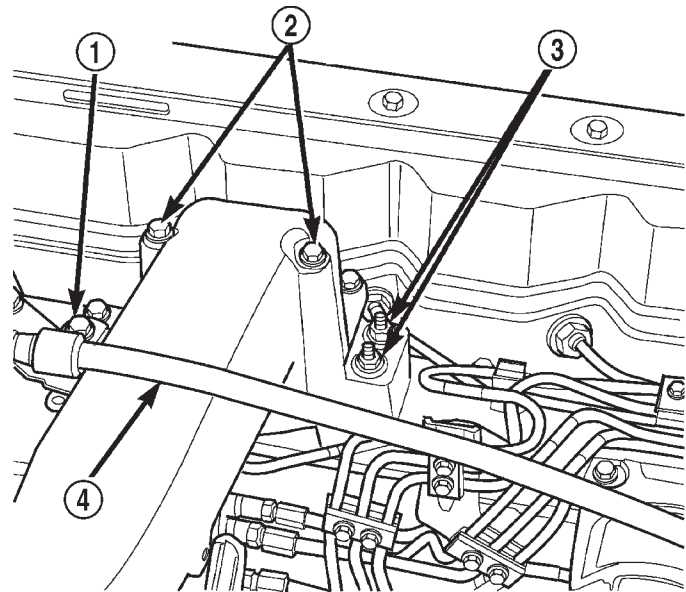
(12) Remove intake manifold air heater element block from engine (Fig. 45). Discard old upper and lower gaskets

(13) Remove 3 cable bracket housing mounting bolts (Fig. 44). Carefully position cable bracket and cable assembly to side of engine. **Leave cables connected to lever.**

(14) Remove engine lifting bracket at rear of intake manifold (2 bolts) (Fig. 46).

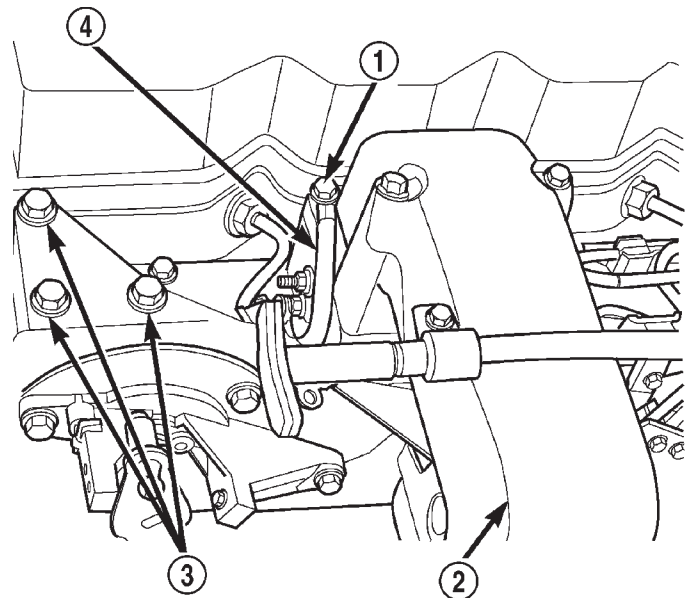
(15) Remove bolts from all fuel injection line support brackets at intake manifold.

(16) Place shop towels around fuel lines at fuel injectors. Do not allow fuel to drip down side of engine.



**Fig. 43 Air Intake Housing (Rear View)**

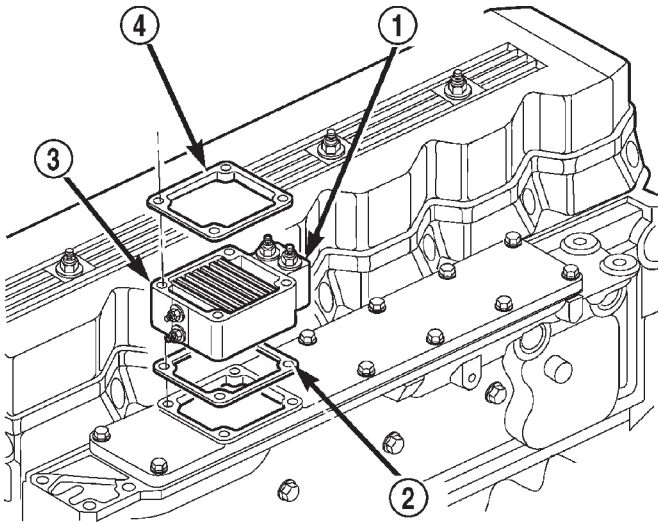
- 1 - TUBE MOUNTING BOLT
- 2 - HOUSING BOLTS (2)
- 3 - INTAKE HEATER CABLE MOUNTING STUDS (2)
- 4 - DIPSTICK TUBE



**Fig. 44 Air Intake Housing (Front View)**

- 1 - GROUND CABLE BOLT
- 2 - INTAKE AIR HOUSING
- 3 - CABLE BRACKET HOUSING BOLTS (3)
- 4 - GROUND CABLE

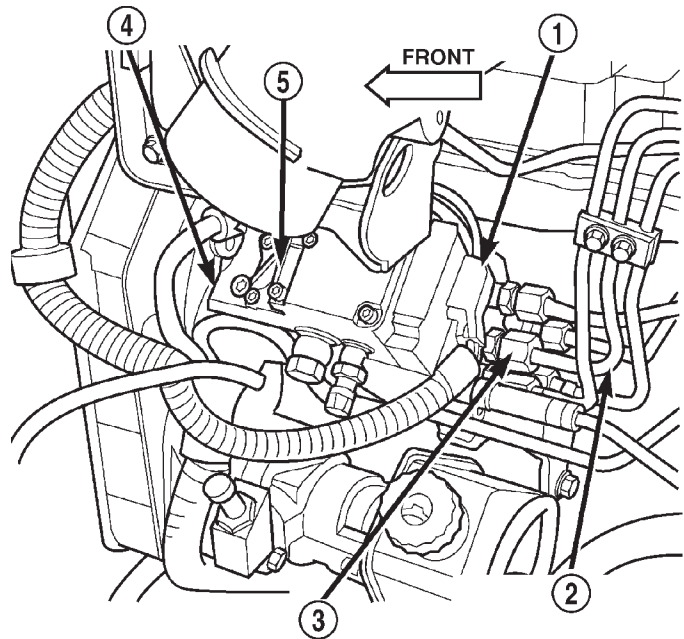
## FUEL LINES (Continued)



80b46b90

**Fig. 45 Intake Manifold Air Heater (Elements)**

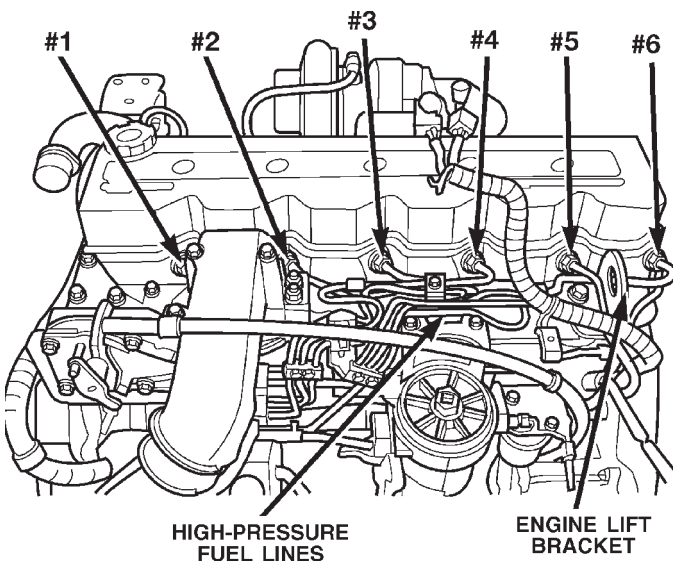
- 1 - AIR HEATER ELEMENTS
- 2 - LOWER GASKET
- 3 - BLOCK
- 4 - UPPER GASKET



80bfe0d0

**Fig. 47 High Pressure Lines at Fuel Injection Pump**

- 1 - FPCM ELECTRICAL CONNECTOR
- 2 - HIGH-PRESSURE FUEL LINES
- 3 - FITTINGS
- 4 - FUEL INJECTION PUMP
- 5 - FPCM



80bfe0d1

**Fig. 46 High-Pressure Fuel Lines**

**CAUTION: WHEN LOOSENING OR TIGHTENING HIGH-PRESSURE FITTINGS AT INJECTION PUMP, USE A BACK-UP WRENCH ON DELIVERY VALVE AT PUMP. DO NOT ALLOW DELIVERY VALVE TO ROTATE.**

(17) Loosen high-pressure line fittings at injection pump (Fig. 47) beginning with cylinders 1, 2 and 4.

(18) Loosen high-pressure lines at cylinder head for cylinders 1, 2 and 4 (Fig. 46).

(19) Carefully remove front line bundle from engine. **Do not bend lines while removing.** While removing front line bundle, note line position.

(20) Loosen high-pressure lines at injection pump beginning with cylinders 3, 5 and 6.

(21) Loosen high-pressure lines at cylinder head for cylinders 3, 5 and 6 (Fig. 46).

(22) Carefully remove rear line bundle from engine. **Do not bend lines while removing.** While removing rear line bundle, note line position.

## INSTALLATION

High-pressure lines are used between the fuel injection pump and the fuel injectors only. All high-pressure fuel lines are of the same length and inside diameter. Correct high-pressure fuel line usage and installation is critical to smooth engine operation.

**CAUTION: Be sure that the high-pressure fuel lines are installed in the same order that they were removed.**

(1) Lubricate threads of injector line fittings with clean engine oil.

(2) Loosen, but do not remove, all fuel line support bracket bolts.



## FUEL LINES (Continued)

(3) Install **rear** injection line bundle beginning with cylinder head (fuel injector) connections, followed by injection pump connections. Tighten all fittings finger tight.

(4) Tighten fittings at fuel injector ends for cylinders number 6 and 5 to 38 N·m (28 ft. lbs.) torque. **Do not tighten number 3 line at this time. It will be tightened during bleeding procedure.**

(5) Tighten 3 fittings at fuel injection pump ends to 24 N·m (18 ft. lbs.) torque.

(6) Install **front** injection line bundle beginning with cylinder head (fuel injector) connections, followed by injection pump connections. Tighten all fittings finger tight.

(7) Tighten fitting at fuel injector end for cylinder number 2 to 38 N·m (28 ft. lbs.) torque. **Do not tighten lines number 1 or 4 at this time. They will be tightened during bleeding procedure.**

(8) Tighten remaining 3 fittings at fuel injection pump ends to 24 N·m (18 ft. lbs.) torque.

(9) Install fuel line support bracket bolts to intake manifold and tighten to 24 N·m (18 ft. lbs.) torque.

**CAUTION: Be sure fuel lines are not contacting each other or any other component. Noise will result.**

(10) Install engine lifting bracket at rear of intake manifold. Tighten 2 bolts to 77 N·m (57 ft. lbs.) torque.

(11) Install cable bracket housing/cable assembly and tighten 3 mounting bolts to 24 N·m (18 ft. lbs.) torque.

(12) Clean any old gasket material below and above intake manifold air heater element block. Also clean mating areas at intake manifold and air intake housing.

(13) Using new gaskets, position intake manifold air heater element block to engine.

(14) Install air intake housing and position ground cable. Install 4 mounting bolts and tighten to 24 N·m (18 ft. lbs.) torque.

(15) Install air tube (intake manifold-to-charge air cooler) (Fig. 41). Tighten clamps to 8 N·m (72 in. lbs.) torque.

(16) Install engine oil dipstick tube support mounting bolt and tighten to 24 N·m (18 ft. lbs.) torque.

(17) Install engine oil dipstick to engine.

(18) Connect 2 electrical cables to cable mounting studs.

(19) Connect electrical connector to bottom of APPS by pushing connector upward until it snaps into position.

(20) Connect wiring harness (clip) at bottom of Accelerator Pedal Position Sensor (APPS) mounting bracket (Fig. 40).

(21) Connect front wiring clip (Fig. 41) to cable bracket housing.

(22) Install cable cover (Fig. 39).

(23) Connect both negative battery cables to both batteries.

(24) Bleed air from fuel system. Do this at fuel injector ends of lines. Use cylinders numbers 1, 3 and 4 for bleeding. (Refer to 14 - FUEL SYSTEM/FUEL DELIVERY - STANDARD PROCEDURE). After bleeding, tighten fittings to 38 N·m (28 ft. lbs.) torque.

(25) Check lines/fittings for leaks.

## FUEL TANK

## DESCRIPTION - DIESEL FUEL TANK

The fuel tank is similar to the tank used with gasoline powered models. The tank is equipped with a separate fuel return line and a different fuel tank module for diesel powered models. A fuel tank mounted, electric fuel pump is not used with diesel powered models. Refer to Fuel Tank Module for additional information.

For removal and installation procedures, refer to Fuel Tank - Gasoline Engines.

## FUEL TANK MODULE

## DESCRIPTION

An electric fuel pump is **not used** in the fuel tank module for diesel powered engines. Fuel is supplied by the engine mounted fuel transfer pump and the fuel injection pump.

The fuel tank module is installed in the top of the fuel tank (Fig. 48). The fuel tank module (Fig. 48) contains the following components:

- Fuel reservoir
- A separate in-tank fuel filter
- Rollover valve
- Fuel gauge sending unit (fuel level sensor)
- Fuel supply line connection
- Fuel return line connection
- Auxiliary non-pressurized fuel supply fitting

## OPERATION

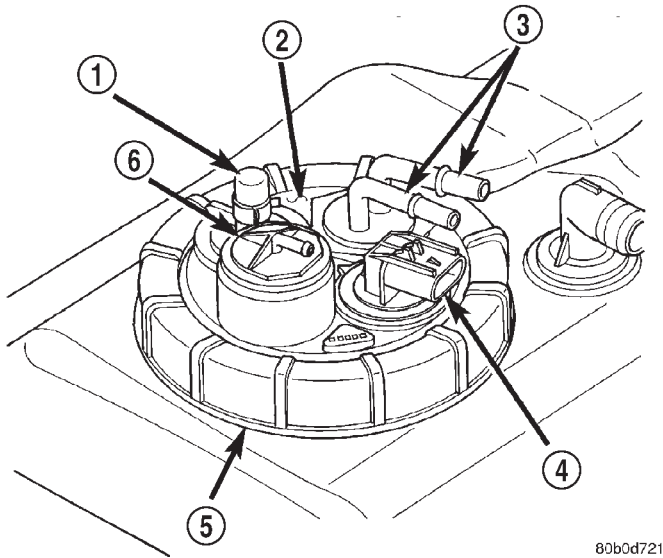
Refer to Fuel Gauge Sending Unit.

## REMOVAL

(1) Drain and remove fuel tank. Refer to Fuel Tank Removal/Installation.

(2) Thoroughly clean area around tank module at top of tank.

## FUEL TANK MODULE (Continued)



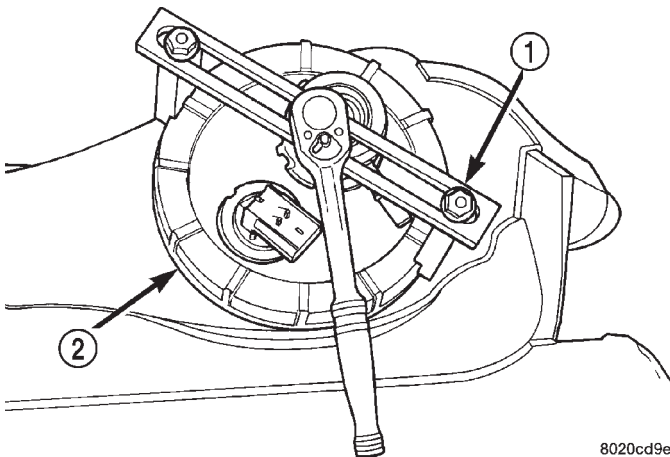
80b0d721

**Fig. 48 Top View of Fuel Tank Module—Diesel**

- 1 - AUXILIARY CAPPED FITTING
- 2 - FUEL PUMP MODULE
- 3 - FUEL SUPPLY/RETURN FITTINGS
- 4 - ELECTRICAL CONNECTOR
- 5 - LOCKNUT
- 6 - ROLLOVER VALVE

(3) The plastic fuel tank module locknut is threaded onto fuel tank (Fig. 39). Install Special Tool 6856 to locknut and remove locknut (Fig. 49). The fuel tank module will spring up when locknut is removed.

(4) Remove module from fuel tank.



8020cd9e

**Fig. 49 Locknut Removal/Installation—TYPICAL MODULE**

- 1 - SPECIAL TOOL 6856
- 2 - LOCKNUT

## INSTALLATION

**CAUTION:** Whenever the fuel tank module is serviced, the rubber gasket must be replaced.

(1) Thoroughly clean locknut and locknut threads at top of tank.

(2) Using new gasket, carefully position fuel tank module into opening in fuel tank.

(3) Position locknut over top of fuel tank module. Install locknut finger tight.

(4) When looking down at tank from drivers side of tank, the arrow at top of module should be aligned between two marks stamped into tank (approximately 2 o'clock position). The fuel line connectors, roll over valve and fuel gauge electrical connector should all be pointed to drivers side of vehicle. Rotate and align module/tank marks if necessary before tightening locknut. **This step must be performed to prevent the module's float from contacting side of fuel tank.**

(5) Tighten locknut to 24–44 N·m (18–32 ft. lbs.) torque.

(6) Install fuel tank. Refer to Fuel Tank Removal/Installation.

## FUEL TRANSFER PUMP

## DESCRIPTION

The fuel transfer pump (fuel lift pump) is located on the left-rear side of the engine cylinder block above the starter motor (Fig. 50). The 12-volt electric vane-type pump is operated and controlled by the Engine Control Module (ECM) (Fig. 51).

## OPERATION

The purpose of the fuel transfer pump is to supply (transfer) a low-pressure fuel source: **from** the fuel tank, **through** the fuel filter/water separator and **to** the fuel injection pump. Here, the low-pressure is raised to a high-pressure by the fuel injection pump for operation of the high-pressure fuel injectors. Check valves within the pump, control direction of fuel flow and prevent fuel bleed-back during engine shut down.

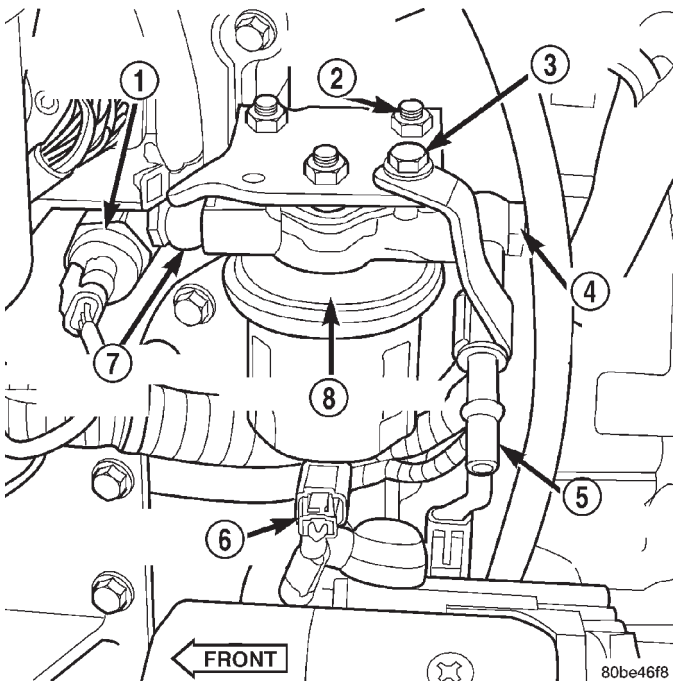
Normal current flow to the pump is 12 amperes.

With the engine running, the pump has 2 modes of operation: Mode 1: 100 percent duty-cycle with a minimum pressure of 10 psi **except when the engine is cranking**. Mode 2: 25 percent duty-cycle with minimum pressure of 7 psi **with the engine cranking**

The 25 percent duty-cycle is used to limit injection pump inlet pressure until the engine is running.



## FUEL TRANSFER PUMP (Continued)



**Fig. 50 Fuel Transfer Pump Location**

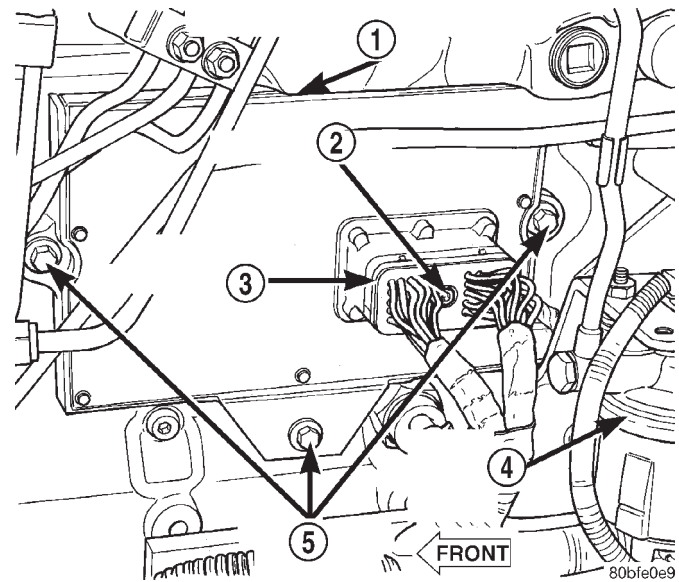
- 1 - OIL PRESSURE SENSOR
- 2 - PUMP BRACKET NUTS
- 3 - SUPPORT BRACKET BOLT
- 4 - BANJO BOLT (REAR)
- 5 - FUEL SUPPLY LINE
- 6 - ELECTRICAL CONNECTOR
- 7 - BANJO BOLT (FRONT)
- 8 - FUEL TRANSFER PUMP

The transfer pump is self-priming: When the key is first turned on (without cranking engine), the pump will operate for approximately 2 seconds and then shut off. The pump will also operate for up to 25 seconds after the starter is engaged, and then disengaged and the engine is not running. The pump shuts off immediately if the key is on and the engine stops running.

The fuel volume of the transfer pump will always provide more fuel than the fuel injection pump requires. Excess fuel is returned from the injection pump through an overflow valve. The valve is located on the side of the injection pump (Fig. 52). It is also used to connect the fuel return line to the side of the injection pump. This valve opens at approximately 97 kPa (14 psi) and returns fuel to the fuel tank through the fuel return line.

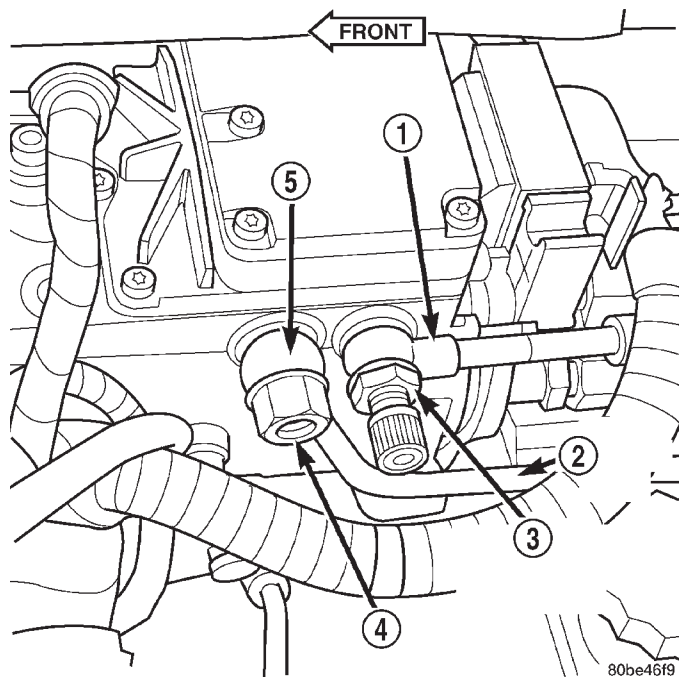
## DIAGNOSIS AND TESTING - FUEL TRANSFER PUMP PRESSURE

The following tests will include: pressures tests of fuel transfer pump (engine running and engine cranking), a pressure drop test of fuel filter, a test for supply side restrictions, and a test for air in fuel supply side.



**Fig. 51 Engine Control Module (ECM) Location**

- 1 - ENGINE CONTROL MODULE (ECM)
- 2 - HEX HEADED BOLT
- 3 - 50-WAY CONNECTOR
- 4 - FUEL TRANSFER PUMP
- 5 - MOUNTING BOLTS (3)



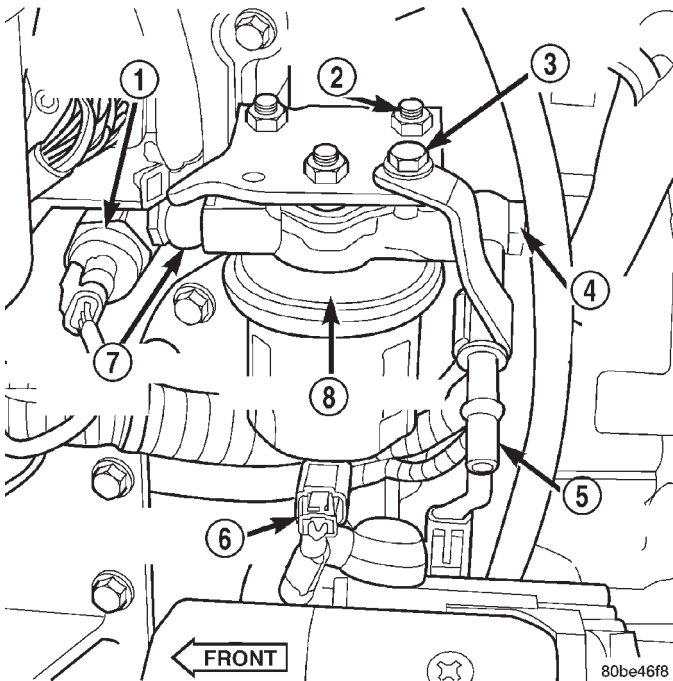
**Fig. 52 Injection Pump Overflow Valve Location**

- 1 - FUEL SUPPLY LINE
- 2 - FUEL RETURN LINE
- 3 - BANJO BOLT (TEST PORT FITTING)
- 4 - OVERFLOW VALVE
- 5 - BANJO FITTING

## FUEL TRANSFER PUMP (Continued)

Refer to Fuel Transfer Pump Description/Operation for an operational description of transfer pump.

The fuel transfer (lift) pump is located on left side of engine and above starter motor (Fig. 53).



**Fig. 53 Fuel Transfer Pump Location**

- 1 - OIL PRESSURE SENSOR
- 2 - PUMP BRACKET NUTS (3)
- 3 - SUPPORT BRACKET BOLT
- 4 - BANJO BOLT (REAR)
- 5 - FUEL SUPPLY LINE
- 6 - ELECTRICAL CONNECTOR
- 7 - BANJO BOLT (FRONT)
- 8 - FUEL TRANSFER PUMP

An improperly operating fuel transfer pump, a plugged or dirty fuel filter, or a defective overflow valve can cause low engine power, excessive white smoke and/or hard engine starting.

Before performing following tests, inspect fuel supply and return lines for restrictions, kinks or leaks.

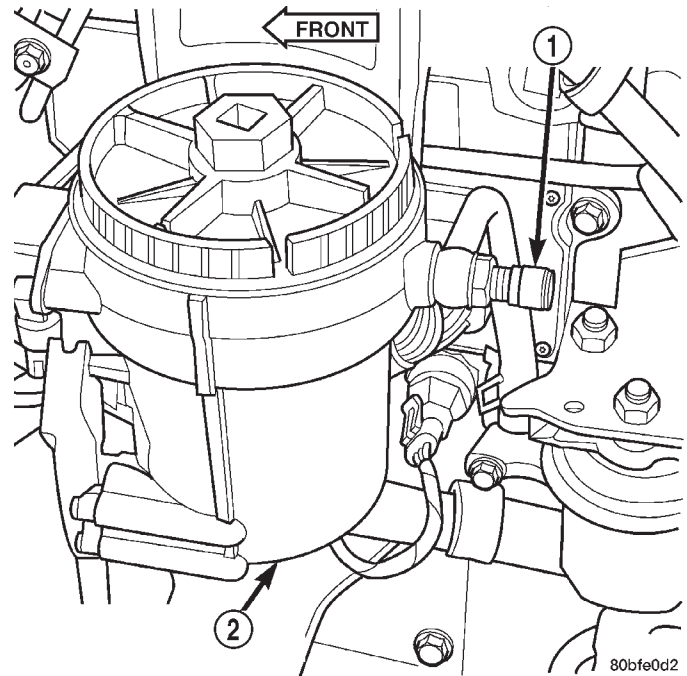
Fuel leaking from pump casing indicates a leaking pump which must be replaced.

**Pressure Test:** Because the transfer pump is operating at two different pressure cycles (engine running and engine cranking), two different pressure tests will be performed.

(1) Remove protective cap at inlet test port (Fig. 54). Clean area around cap/fitting before cap removal.

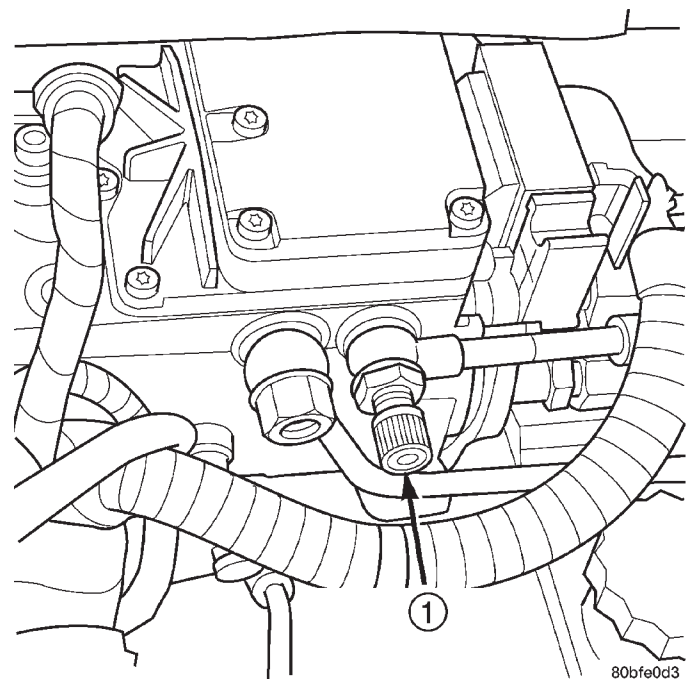
(2) Remove protective cap at outlet test port (Fig. 55). Clean area around cap/fitting before cap removal.

(3) Install Special Fuel Pressure Test Gauge 6828 (or equivalent) to fitting at inlet test port (Fig. 54).



**Fig. 54 Fuel Pressure Test Port Fitting (Inlet)**

- 1 - FUEL PRESSURE TEST PORT (INLET)
- 2 - FUEL FILTER/WATER SEPARATOR

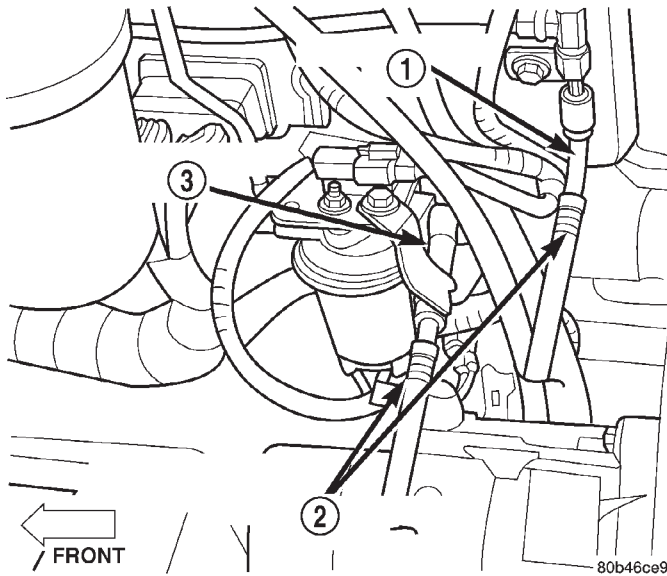


**Fig. 55 Fuel Pressure Test Port Fitting (Outlet)**

- 1 - FUEL PRESSURE TEST PORT (OUTLET)

(4) To prevent engine from starting, remove fuel system relay (fuel injection pump relay). Relay is located in Power Distribution Center (PDC). Refer to label under PDC cover for relay location.

## FUEL TRANSFER PUMP (Continued)



**Fig. 56 Fuel Return and Supply Line Quick-Connect Locations**

- 1 - FUEL RETURN LINE
- 2 - QUICK-CONNECT FITTINGS
- 3 - FUEL SUPPLY LINE

(5) Using key, crank engine over while observing gauge. Pressure should be 5–7 psi.

(6) Re-install fuel system relay to PDC.

(7) Start engine and record fuel pressure. Pressure should be a **minimum** of 69 kPa (10 psi) at idle speed.

(8) Because fuel pump relay was removed, a Diagnostic Trouble Code (DTC) may have been set. After testing is completed, and relay has been installed, use DRB scan tool to remove DTC.

#### Pressure Drop Test:

(9) Shut engine off and remove test gauge from inlet port test fitting. Re-attach 6828 test gauge to outlet port (Fig. 55). Start engine and record fuel pressure. Pressure should not be more than 34 kPa (5 psi) lower than inlet port pressure test. If so, replace fuel filter.

#### Fuel Supply Restriction Test:

Due to very small vacuum specifications, the DRB scan tool along with the Peripheral Expansion Port (PEP) Module and 0–15 psi transducer must be used.

(10) Verify transfer pump pressure is OK before performing restriction test.

(11) Locate and disconnect fuel supply line quick-connect fitting at left-rear of engine (Fig. 56). After disconnecting line, plastic clip will remain attached to metal fuel line at engine. Carefully remove clip from metal line. Snap same clip into fuel supply hose.

(12) Install Special Rubber Adapter Hose Tool 6631 (3/8") into ends of disconnected fuel supply line.

(13) Install transducer from PEP module to brass "T" fitting on tool 6631.

(14) Hook up DRB scan tool to transducer.

**WARNING: DO NOT STAND IN LINE WITH THE COOLING FAN FOR THE FOLLOWING STEPS.**

(15) Start engine and record vacuum reading with engine speed at high-idle (high-idle means engine speed is at 100 percent throttle and no load). The fuel restriction test **MUST** be done with engine speed at high-idle.

(16) If vacuum reading is **less** than 6 in/hg. (0–152 mm hg.), test is OK. If vacuum reading is **higher** than 6 in/hg. (152 mm hg.), restriction exists in fuel supply line or in fuel tank module. Check fuel supply line for damage, dents or kinking. If OK, remove module and check module and lines for blockage. Also check fuel pump inlet filter at bottom of module for obstructions.

#### Testing For Air Leaks in Fuel Supply Side:

(17) A 3-foot section of 3/8" I.D. clear tubing is required for this test.

(18) Using a tire core valve removal tool, carefully remove core valve from inlet fitting test port.

(19) Attach and clamp the 3/8" clear hose to fitting nipple.

(20) Place other end of hose into a large clear container. Allow hose to loop as high as possible **above** test port.

(21) The fuel transfer pump can be put into a 25 second run (test) mode if key is quickly turned to crank position and released back to run position without starting engine.

To prevent engine from starting in this test, first remove fuel system relay (fuel injection pump relay). Relay is located in Power Distribution Center (PDC). Refer to label under PDC cover for relay location.

Because fuel pump relay was removed, a Diagnostic Trouble Code (DTC) may have been set. After testing is completed, and relay has been installed, use DRB scan tool to remove DTC.

(22) Allow air to purge from empty hose before examining for air bubbles. Air bubbles should not be present.

(23) If bubbles are present, check for leaks in supply line to fuel tank.

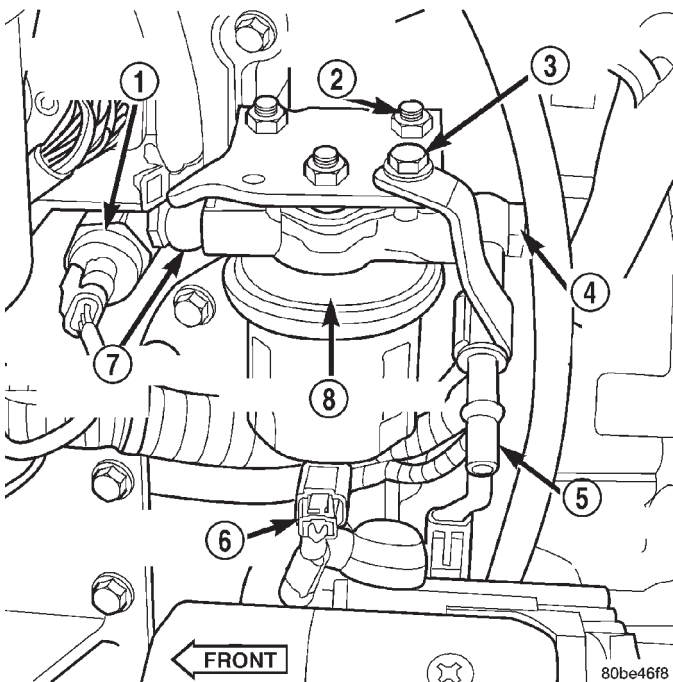
(24) If supply line is not leaking, remove fuel tank module and remove filter at bottom of module (filter snaps to module). Check for leaks between supply nipple at top of module, and filter opening at bottom of module. Replace module if necessary.

(25) After performing test, install core back into test fitting. Before installing protective cap, be sure fitting is not leaking.

## FUEL TRANSFER PUMP (Continued)

## REMOVAL

The fuel transfer pump (fuel lift pump) is located on left side of engine, below and rearward of fuel filter (Fig. 57).



**Fig. 57 Fuel Transfer Pump Location**

- 1 - OIL PRESSURE SENSOR
- 2 - PUMP BRACKET NUTS (3)
- 3 - SUPPORT BRACKET BOLT
- 4 - BANJO BOLT (REAR)
- 5 - FUEL SUPPLY LINE
- 6 - ELECTRICAL CONNECTOR
- 7 - BANJO BOLT (FRONT)
- 8 - FUEL TRANSFER PUMP

(1) Disconnect both negative battery cables at both batteries.

(2) Thoroughly clean area around transfer pump and fuel lines of any contamination.

(3) Remove starter motor. Refer to Starter Removal/Installation in 8, Starting System for procedures.

(4) Place a drain pan below the pump.

(5) Disconnect fuel line quick-connect fitting at fuel supply line (Fig. 57) at rear of pump.

(6) Remove support bracket bolt at top of pump (Fig. 57).

(7) Remove front and rear banjo bolts at pump (Fig. 57).

(8) Disconnect electrical connector at side of pump (Fig. 57).

(9) Remove three pump bracket nuts (Fig. 57) and remove pump from vehicle.

## INSTALLATION

The fuel transfer pump (fuel lift pump) is located on left side of engine, below and rearward of fuel filter (Fig. 57).

(1) Install new gaskets to fuel supply line/support bracket and banjo bolt at rear of pump. Install line and banjo bolt to pump. **Do not** tighten banjo bolt at this time.

(2) Install new gaskets to fuel line and banjo bolt at front of pump.

(3) Position 3 pump studs into pump mounting bracket and install 3 nuts. **Do not** tighten nuts at this time.

(4) Install support bracket bolt (Fig. 57). **Do not** tighten bolt at this time.

(5) Tighten 3 pump nuts to 12 N·m (9 ft. lbs.) torque.

(6) Tighten both banjo bolts to 24 N·m (18 ft. lbs.) torque.

(7) Tighten support bracket bolt 12 N·m (9 ft. lbs.) torque.

(8) Connect electrical connector to pump (Fig. 57).

(9) Connect fuel line quick-connect fitting to fuel supply line at rear of pump.

(10) Install starter motor. Refer to Starter Removal/Installation in 8, Starting for procedures.

(11) Connect both negative battery cables at both batteries.

(12) Bleed air at fuel supply line at side of fuel injection pump. Refer to the Air Bleed Procedure.

(13) Start engine and check for leaks.

## OVERFLOW VALVE

## DESCRIPTION

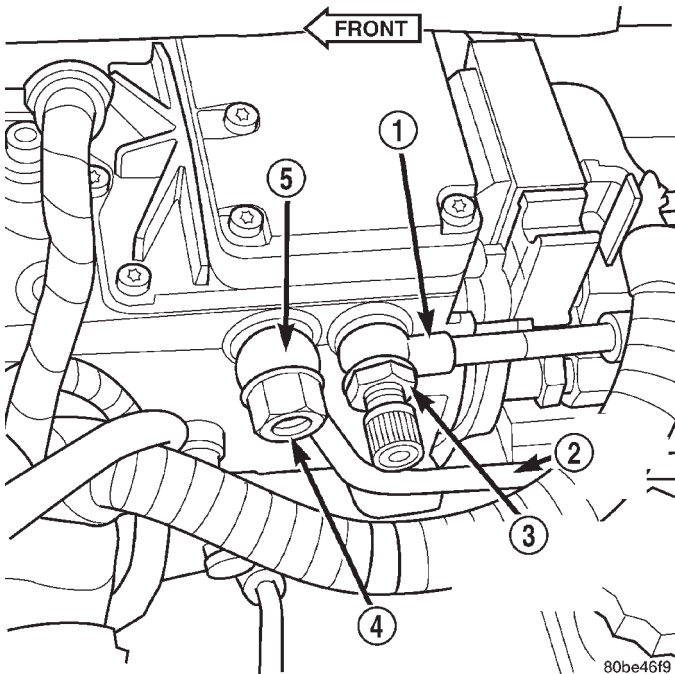
The overflow valve is located on the side of the injection pump (Fig. 58). It is also used to connect the fuel return line (banjo fitting) to the fuel injection pump.

## OPERATION

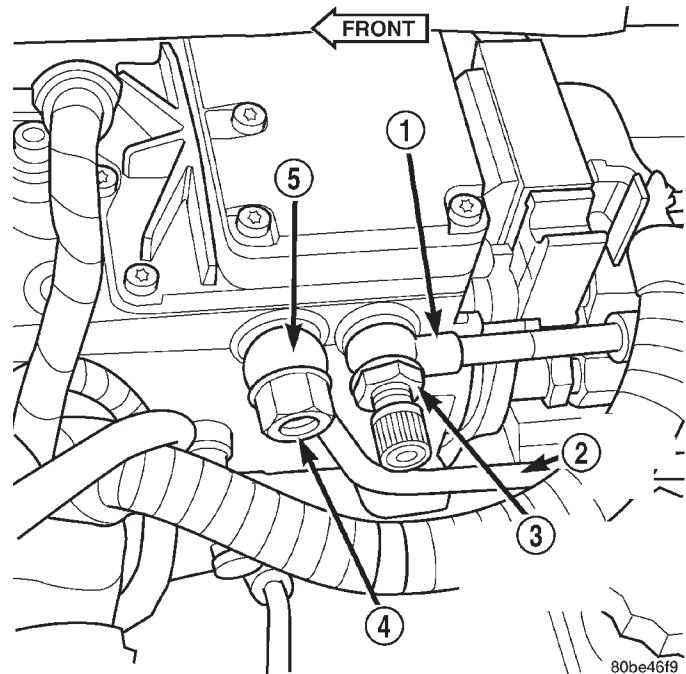
Fuel volume from the fuel transfer (lift) pump will always provide more fuel than the fuel injection pump requires. The overflow valve (a check valve) is used to route excess fuel through the fuel return line and back to the fuel tank. Approximately 70% of supplied fuel is returned to the fuel tank. The valve opens at approximately 97 kPa (14 psi). If the check valve within the assembly is sticking open, fuel drainage of the injection pump could cause hard starting.



## OVERFLOW VALVE (Continued)

**Fig. 58 Overflow Valve Location**

- 1 - FUEL SUPPLY LINE
- 2 - FUEL RETURN LINE
- 3 - BANJO BOLT (TEST PORT FITTING)
- 4 - OVERFLOW VALVE
- 5 - BANJO FITTING

**Fig. 59 Overflow Valve Location**

- 1 - FUEL SUPPLY LINE
- 2 - FUEL RETURN LINE
- 3 - BANJO BOLT (TEST PORT FITTING)
- 4 - OVERFLOW VALVE
- 5 - BANJO FITTING

If a Diagnostic Trouble Code (DTC) has been stored for “decreased engine performance due to high injection pump fuel temperature”, the overflow valve may be stuck in closed position.

**DIAGNOSIS AND TESTING - OVERFLOW VALVE**

Fuel volume from the fuel transfer (lift) pump will always provide more fuel than the fuel injection pump requires. The overflow valve (a check valve) is used to route excess fuel through the fuel return line and back to the fuel tank. Approximately 70% of supplied fuel is returned to the fuel tank. The valve is located on the side of the injection pump (Fig. 59). It is also used to connect the fuel return line (banjo fitting) to the fuel injection pump. The valve opens at approximately 97 kPa (14 psi). If the check valve within the assembly is sticking, low engine power or hard starting may result.

If a Diagnostic Trouble Code (DTC) has been stored for “decreased engine performance due to high injection pump fuel temperature”, the overflow valve may be stuck in closed position.

A rubber tipped blow gun with regulated air line pressure is needed for this test.

(1) Clean area around overflow valve and fuel return line at injection pump before removal.

(2) Remove valve from pump and banjo fitting.

(3) Discard old sealing gaskets.

(4) Set regulated air pressure to approximately 97 kPa (14–16 psi).

(5) Using blow gun, apply pressure to overflow valve inlet end (end that goes into injection pump).

(6) Internal check valve should release, and air should pass through valve at 97 kPa (14–16 psi). If not, replace valve.

(7) Reduce regulated air pressure to 10 psi and observe valve. Valve should stay shut. If not, replace valve.

(8) Install new sealing gaskets to valve.

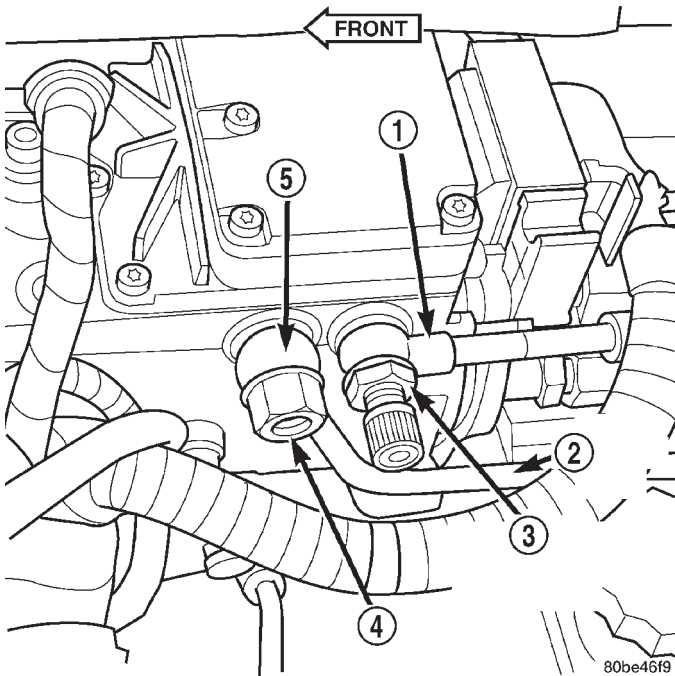
(9) Install valve through banjo fitting and into pump.

(10) Tighten to 30 N·m (24 ft. lbs.) torque.

**REMOVAL**

The overflow valve (pressure relief valve) is located at the outside of fuel injection pump (Fig. 60). It connects the fuel return line (banjo fitting) to the pump. The valve has no internal serviceable parts and must be replaced as an assembly. Two sealing gaskets are used. One gasket is located between pump and banjo fitting. The other is located between the banjo fitting and end of valve.

## OVERFLOW VALVE (Continued)



**Fig. 60 Overflow Valve Location**

- 1 - FUEL SUPPLY LINE
- 2 - FUEL RETURN LINE
- 3 - BANJO BOLT (TEST PORT FITTING)
- 4 - OVERFLOW VALVE
- 5 - BANJO FITTING

(1) Clean area around overflow valve and fuel return line at injection pump before removal.

(2) Remove valve from pump and banjo fitting.

(3) Discard old sealing gaskets.

## INSTALLATION

The overflow valve (pressure relief valve) is located at the outside of fuel injection pump (Fig. 60). It connects the fuel return line (banjo fitting) to the pump. The valve has no internal serviceable parts and must be replaced as an assembly. Two sealing gaskets are used. One gasket is located between pump and banjo fitting. The other is located between the banjo fitting and end of valve.

(1) Install new sealing gaskets to valve.

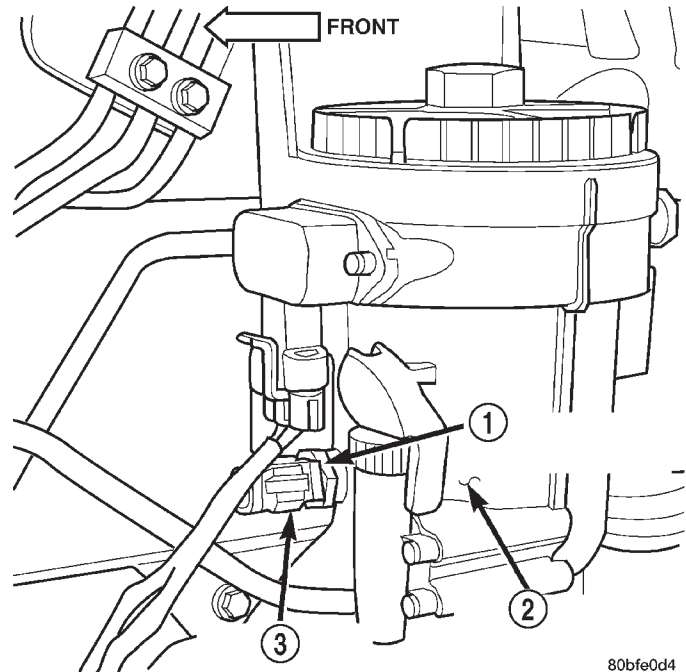
(2) Install valve through banjo fitting and into pump.

(3) Tighten to 30 N·m (24 ft. lbs.) torque.

## WATER IN FUEL SENSOR

### DESCRIPTION

The WIF sensor is located on the side of the fuel filter/water separator canister (Fig. 61).



**Fig. 61 Water-in-Fuel Sensor Location**

- 1 - WATER-IN-FUEL (WIF) SENSOR
- 2 - FUEL FILTER/WATER SEPARATOR
- 3 - WIF SENSOR CONNECTOR

## OPERATION

The sensor sends an input to the Engine Control Module (ECM) when it senses water in the fuel filter/water separator. As the water level in the filter/separator increases, the resistance across the WIF sensor decreases. This decrease in resistance is sent as a signal to the ECM and compared to a high water standard value. Once the value reaches 30 to 40 kilohms, the ECM will activate the water-in-fuel warning lamp through CCD bus circuits. This all takes place when the ignition key is initially put in the ON position. The ECM continues to monitor the input at the end of the intake manifold air heater post-heat cycle.

## REMOVAL

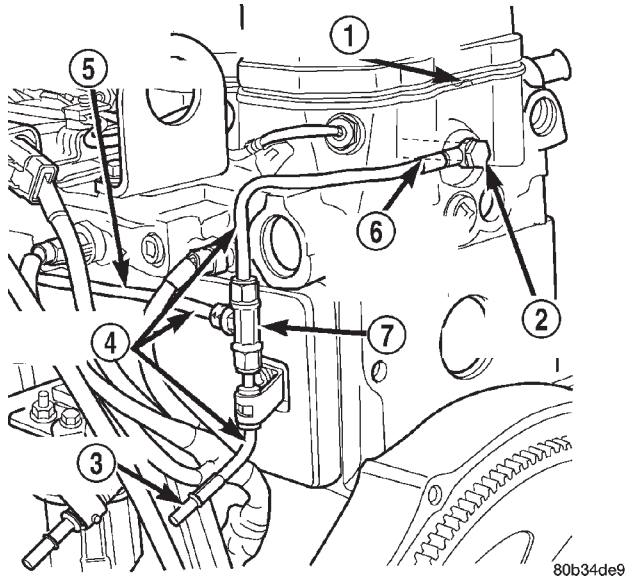
The Water-In-Fuel (WIF) sensor is located at the side of fuel filter/water separator canister. Refer to Fuel Filter/Water Separator Removal/Installation for WIF sensor removal/installation procedures.



## FUEL DRAIN MANIFOLD

### DESCRIPTION

The fuel drain manifold is actually a rifled passage within the cylinder head (Fig. 62).



**Fig. 62 Fuel Drain Manifold Passage**

- 1 - REAR OF CYLINDER HEAD
- 2 - BANJO FITTING/BOLT
- 3 - FUEL RETURN TO TANK
- 4 - FUEL RETURN LINES
- 5 - FUEL RETURN LINE FROM PUMP OVERFLOW VALVE
- 6 - FUEL DRAIN MANIFOLD PASSAGE
- 7 - "T"

### OPERATION

When the engine is running, and during injection, a small amount of fuel flows past the injector nozzle and is not injected into the combustion chamber. This fuel is used to lubricate the fuel injectors. Excess fuel drains into the fuel drain manifold (or passage). Fuel is drained from this passage into a line at the rear of the cylinder head (Fig. 62). After exiting the cylinder head, fuel is routed (returned) back to the fuel tank. A "T" is installed into the fuel return line (Fig. 62). This "T" is used to allow excess fuel from the injection pump to be returned into the fuel tank. A one-way check valve within the overflow valve prevents fuel (from the fuel drain manifold) from entering the fuel injection pump.

A **small** amount of fuel is returned from the fuel injectors, while a **large** amount (about 70% of supplied fuel) is returned from the fuel injection pump.

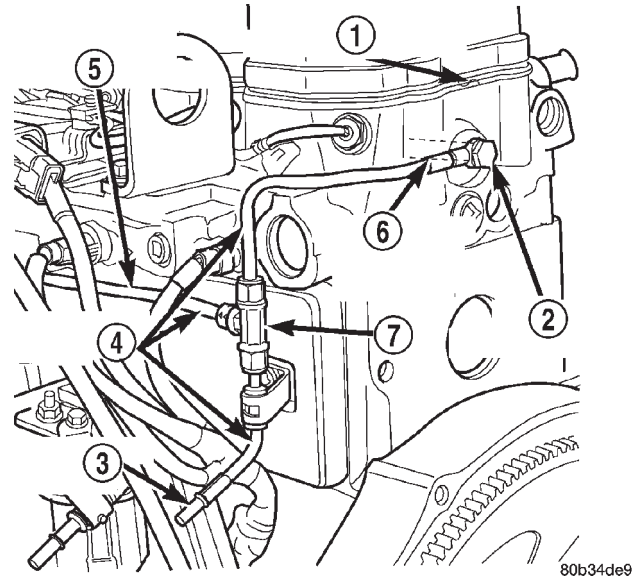
### REMOVAL

The fuel drain manifold (line) connects a fuel return passage within the cylinder head to a "T" fitting on the fuel return line. It is located at the rear of the cylinder head.

(1) Disconnect both negative battery cables at both batteries.

(2) Remove starter motor. Refer to Group 8B for procedures.

(3) Disconnect fitting at "T" (Fig. 63).



**Fig. 63 Fuel Return Line at Rear of Cylinder Head**

- 1 - REAR OF CYLINDER HEAD
- 2 - BANJO FITTING/BOLT
- 3 - FUEL RETURN TO TANK
- 4 - FUEL RETURN LINES
- 5 - FUEL RETURN LINE FROM PUMP OVERFLOW VALVE
- 6 - FUEL DRAIN MANIFOLD PASSAGE
- 7 - "T"

(4) Remove banjo bolt at rear of cylinder head. Discard old sealing washers.

(5) Remove fuel line from vehicle.

(6) Clean connection at rear of cylinder head before line installation.

### INSTALLATION

The fuel drain manifold (line) connects a fuel return passage within the cylinder head to a "T" fitting on the fuel return line. It is located at the rear of the cylinder head.

Servicing fuel return components will not require air bleeding.

(1) Using new sealing washers, assemble banjo bolt to fuel line.

(2) Position line to engine and loosely tighten fasteners.

(3) Tighten banjo bolt to 24 N·m (18 ft. lbs.) torque.

(4) Tighten fitting at "T" to 12 N·m (106 in. lbs.) torque.

(5) Install starter motor. Refer to 8, Starter for procedures.

(6) Connect both negative battery cables at both batteries.

## FUEL INJECTION - DIESEL

### TABLE OF CONTENTS

	page		page
<b>FUEL INJECTION - DIESEL</b>		<b>OPERATION</b> .....	100
DESCRIPTION.....	87	<b>REMOVAL</b> .....	100
<b>DIAGNOSIS AND TESTING</b> .....	89	<b>INSTALLATION</b> .....	101
<b>BOOST PRESSURE</b> .....	89	<b>INTAKE AIR HEATER RELAY</b>	
<b>SPECIFICATIONS</b> .....	90	DESCRIPTION.....	101
<b>ACCELERATOR PEDAL POSITION SENSOR</b>		OPERATION.....	102
DESCRIPTION.....	91	REMOVAL.....	102
OPERATION.....	91	INSTALLATION.....	102
REMOVAL.....	91	<b>INTAKE AIR TEMPERATURE SENSOR</b>	
INSTALLATION.....	93	DESCRIPTION.....	102
<b>FUEL INJECTOR</b>		OPERATION.....	102
DESCRIPTION.....	93	REMOVAL.....	103
OPERATION.....	94	INSTALLATION.....	103
<b>DIAGNOSIS AND TESTING</b> .....	95	<b>MAP SENSOR</b>	
<b>FUEL INJECTOR TEST</b> .....	95	DESCRIPTION.....	103
REMOVAL.....	96	OPERATION.....	103
INSTALLATION.....	98	REMOVAL.....	104
<b>FUEL INJECTION PUMP RELAY</b>		INSTALLATION.....	104
DESCRIPTION.....	99	<b>PTO SWITCH</b>	
OPERATION.....	99	DESCRIPTION.....	104
<b>FUEL TEMPERATURE SENSOR</b>		<b>THROTTLE CONTROL CABLE</b>	
DESCRIPTION.....	99	REMOVAL.....	104
OPERATION.....	100	INSTALLATION.....	105
<b>INTAKE AIR HEATER</b>			
DESCRIPTION.....	100		

## FUEL INJECTION - DIESEL

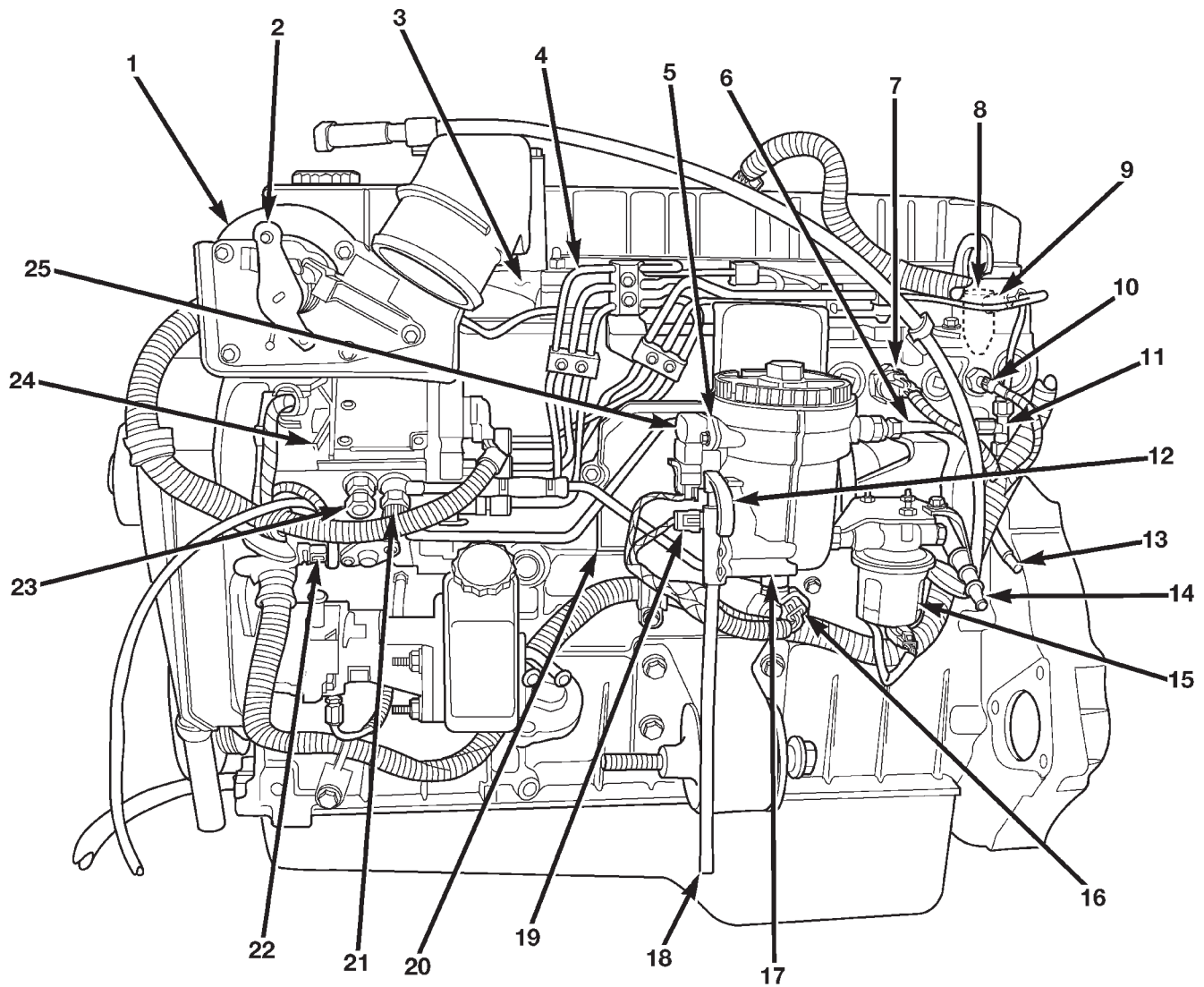
### DESCRIPTION - DIESEL FUEL INJECTION SYSTEM

The Engine Control Module (ECM) and Fuel Injection Pump Control Module (FPCM) are used primarily for fuel system control. The ECM is a separate replaceable component, while the FPCM is internal to the fuel injection pump and is a non-serviceable part. The ECM and FPCM are interconnected (wired together) for fuel injection control.

The Powertrain Control Module (PCM) is used to regulate or control the A/C, charging and speed control systems. It is also used to partially control certain electronic automatic transmission components. The PCM also has control over certain instrument panel components.

Refer to either Powertrain Control Module (PCM) or Engine Control Module (ECM) for additional information. Refer to (Fig. 1) for a partial list of fuel system components.

## FUEL INJECTION - DIESEL (Continued)



80a10a53

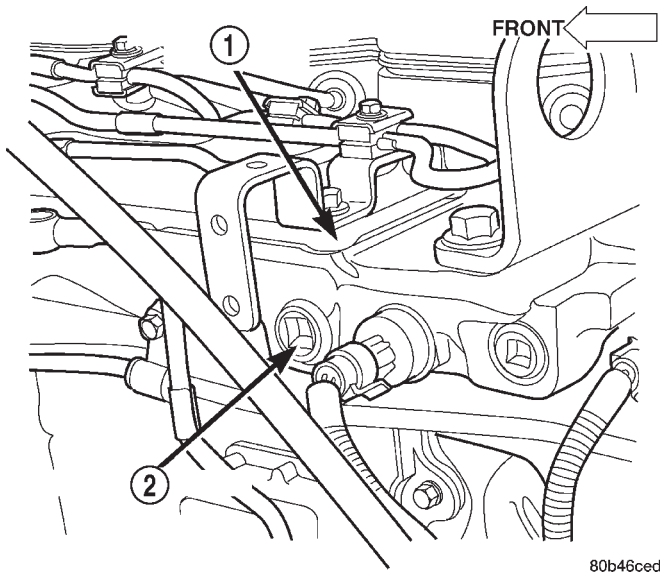
**Fig. 1 Fuel System Components - Diesel**

- |   |  |
|---|--|
| 1 - ENGINE COOLANT TEMPERATURE (ECT) SENSOR                               | 14 - FUEL SUPPLY LINE (LOW-PRESSURE, TO ENGINE)  |
| 2 - THROTTLE LEVER BELLCRANK AND APPS (ACCELERATOR PEDAL POSITION SENSOR) | 15 - FUEL TRANSFER (LIFT) PUMP                   |
| 3 - INTAKE MANIFOLD AIR HEATER/ELEMENTS                                   | 16 - OIL PRESSURE SENSOR                         |
| 4 - HIGH-PRESSURE FUEL LINES  | 17 - FUEL FILTER/WATER SEPARATOR                 |
| 5 - FUEL HEATER   | 18 - DRAIN TUBE                                  |
| 6 - FUEL PRESSURE TEST PORT   | 19 - WATER-IN-FUEL (WIF) SENSOR                  |
| 7 - MAP (BOOST) SENSOR  | 20 - ENGINE CONTROL MODULE (ECM)                 |
| 8 - FUEL INJECTORS  | 21 - FUEL PRESSURE TEST PORT                     |
| 9 - FUEL INJECTOR CONNECTOR   | 22 - CAMSHAFT POSITION SENSOR (CMP)              |
| 10 - INTAKE AIR TEMPERATURE (IAT) SENSOR                                  | 23 - OVERFLOW VALVE                              |
| 11 - FUEL DRAIN MANIFOLD  | 24 - FUEL INJECTION PUMP                         |
| 12 - DRAIN VALVE  | 25 - FUEL HEATER TEMPERATURE SENSOR (THERMOSTAT) |
| 13 - FUEL RETURN LINE (TO FUEL TANK)                                      |  |

## FUEL INJECTION - DIESEL (Continued)

**DIAGNOSIS AND TESTING - BOOST PRESSURE**

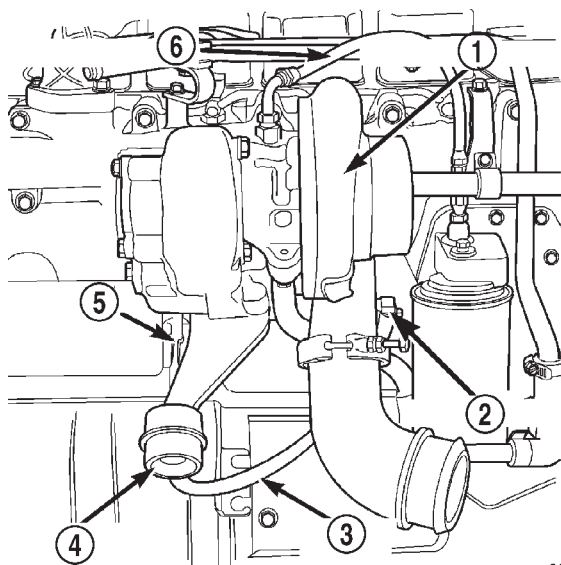
Two pressure gauges attached at two different points are required for this test.



80b46ced

**Fig. 2 Boost Pressure Test at Intake Manifold**

- 1 - REAR OF INTAKE MANIFOLD  
2 - 3/4" PIPE PLUG



80b46cee

**Fig. 3 Boost Pressure Test at Turbocharger**

- 1 - TURBOCHARGER  
2 - 1/8" FITTING  
3 - SIGNAL LINE  
4 - WASTEGATE ACTUATOR  
5 - CONTROL ROD  
6 - OIL SUPPLY LINE

(1) Obtain two 6828 fuel pressure test gauges (equivalent gauges are OK). **Gauge Consistency Test:** Connect the gauges together to a common pressure source and verify pressure consistency of both gauges. Do this consistency test at approximately 206 kPa (30 psi). If pressures are different, they can still be used for test. Note and record differences in pressures before testing. Make adjustments as necessary.

(2) Remove 3/4" pipe plug fitting at rear of intake manifold (Fig. 2). Temporarily replace this fitting with fitting reducer to adapt to pressure gauge. **Note: This pipe plug is located to front of MAP sensor. Do not remove plug to rear of MAP sensor. This is a COOLANT passage plug.**

(3) Loosen hose clamp and disconnect rubber signal line (Fig. 3) from 1/8" brass fitting at front of turbocharger.

(4) Remove 1/8" brass fitting (Fig. 3) from turbocharger. Temporarily replace this fitting with a 1/8" "T" fitting to adapt to pressure gauge.

(5) Reattach signal line to temporary "T".

(6) Attach first pressure gauge to intake manifold fitting.

(7) Attach second pressure gauge to "T" fitting at turbocharger.

Engine must be at rated RPM and full load for the test.

If gauge pressure differential is greater than 3 psi (6 in. Hg), check intercooler and associated piping for restrictions, plugging or damage.

Maximum pressure at intake manifold (rated rpm and load) is 36-37 in/hg  $\pm$  3 in/hg (17.7-18.2 psi  $\pm$  1.5 psi).

Wastegate should open at no higher than 38.7 in/hg (19 psi) at wide open throttle, full load. If wastegate is out of adjustment, a DTC may have been set. Refer to Wastegate Adjustment in Engines for adjustment procedures.

## FUEL INJECTION - DIESEL (Continued)

## SPECIFICATIONS

## TORQUE - DIESEL ENGINE

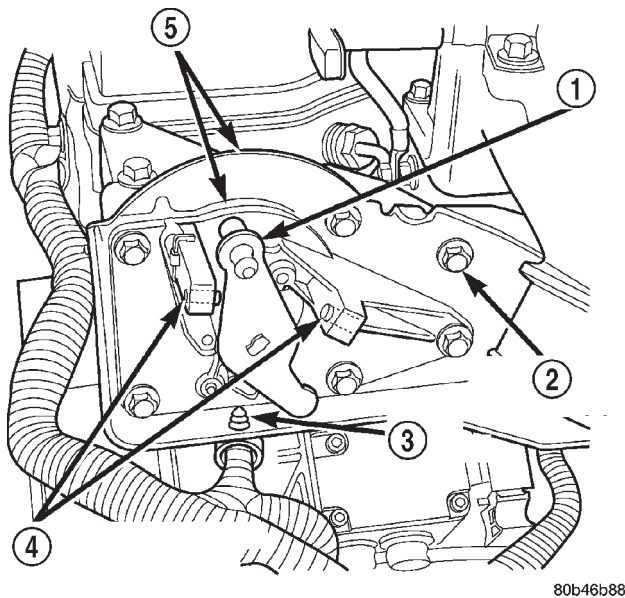
DESCRIPTION	N m	Ft. Lbs.	In. Lbs.
Accelerator Pedal Position Sensor Bracket Bolts	12		105
Air Intake Housing Bolts	24	18	
Banjo Fittings at top of Filter/Separator	24	18	
Banjo Fittings at Fuel Return Lines	24	18	
Banjo Fitting At Fuel Supply Line (Injector Pump)	24	18	
Camshaft Position Sensor (CMP) Bolt	20	15	
ECM Mounting Bolts	24	18	
Engine Coolant Temperature (ECT) Sensor	14	10	
Engine Lifting Bracket Bolts	77	57	
Fuel Drain Manifold "T" Fitting	12		106
Fuel Filter Canister Bracket Bolts	24	18	
Fuel Filter Canister Mounting Nut	14	10	
Fuel Filter Drain Valve Mounting Screws	3-5		30-40
Fuel Heater Screws	2-3		15-20
Fuel Injector Clamp Bolts	10		89
Fuel Pump Module Locknut	24-44	18-32	
Fuel Tank Mounting Nuts	41	30	
Fuel Transfer Pump Mounting Nuts	12	9	
High-Pressure Fuel Line Fittings (at Injectors)	38	28	
High-Pressure Fuel Line Fittings (at Pump)	24	18	
High-Pressure Fuel Line Clamps-to- Intake Manifold	24	18	
Hose Clamps at Intercooler Tube	8		72
Injection Pump-to-Injection Pump Gear Nut	170	125	
Injection Pump Mounting Nuts	43	32	
Intake Manifold Air Temperature (IAT) Sensor	14	10	
Intake Manifold Air Heater Relay Bolts	4.5		40
Manifold Air Pressure (MAP) Sensor	14	10	
PCM Mounting Bolts	4		35
Overflow Valve-to-Fuel Injection Pump	24	18	
Water-In-Fuel (WIF) Sensor	2-3		15-20



## ACCELERATOR PEDAL POSITION SENSOR

### DESCRIPTION

The APPS assembly is located at the top-left-front of the engine (Fig. 4). A plastic cover is used to cover the assembly. The actual sensor is located behind its mounting bracket (Fig. 5).



**Fig. 4 APPS Assembly Location**

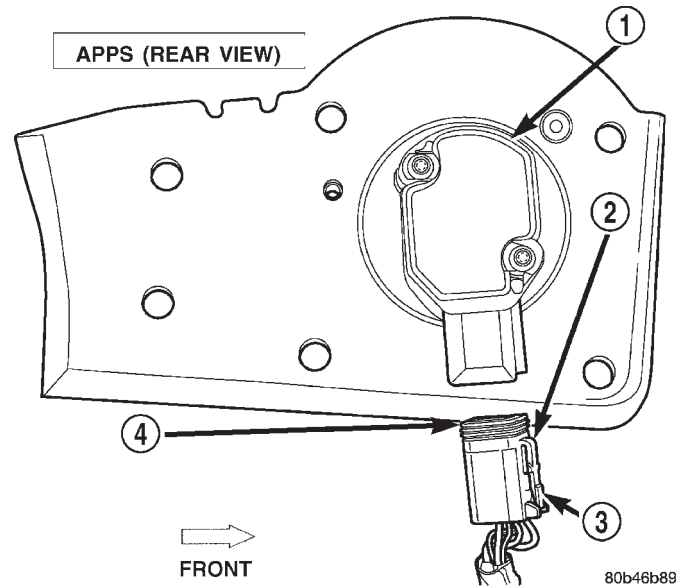
- 1 - LEVER
- 2 - MOUNTING BOLTS (6)
- 3 - WIRE HARNESS CLIP
- 4 - CALIBRATION SCREWS (NO ADJUSTMENT)
- 5 - APPS ASSEMBLY

### OPERATION

The Accelerator Pedal Position Sensor (APPS) is a linear potentiometer. It provides the Engine Control Module (ECM) with a DC voltage signal proportional to the angle, or position of the accelerator pedal. In previous model years, this part was known as the Throttle Position Sensor (TPS).

Diesel engines used in previous model years used a mechanical cable between the accelerator pedal and the TPS lever. Linkage and bellcranks between the TPS cable lever and the fuel injection pump were also used. Although the cable has been retained with the APPS, the linkage and bellcranks between the cable lever and the fuel injection pump are no longer used.

The APPS is serviced (replaced) as one assembly including the lever, brackets and sensor. The APPS is calibrated and permanently positioned to its mounting bracket.



**Fig. 5 APPS Sensor Location (Rear View)**

- 1 - APPS
- 2 - TAB
- 3 - PUSH FOR REMOVAL
- 4 - APPS CONNECTOR

**CAUTION:** Do not attempt to remove sensor from its mounting bracket as electronic calibration will be destroyed (sensor-to-bracket mounting screws are permanently attached). Two accelerator lever set screws (Fig. 4) are used to position lever. Do not attempt to alter positions of these set screws as electronic calibration will be destroyed.

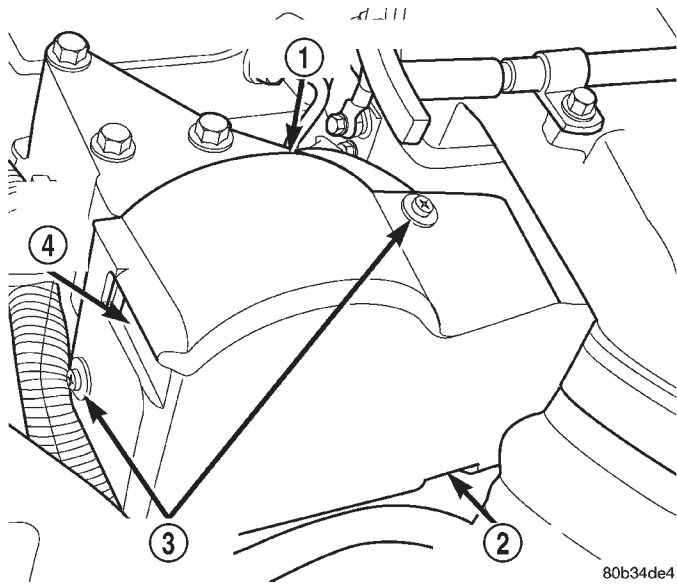
### REMOVAL

The APPS is serviced (replaced) as one assembly including the lever, brackets and sensor. The APPS is calibrated to its mounting bracket. The APPS assembly is located at left-front of engine below plastic cable/lever/linkage cover (Fig. 6).

**CAUTION:** Do not attempt to remove sensor from its mounting bracket as electronic calibration will be destroyed (sensor-to-bracket mounting screws are permanently attached). Two accelerator lever set screws (Fig. 8) are used to position lever. Do not attempt to alter positions of these set screws as electronic calibration will be destroyed.

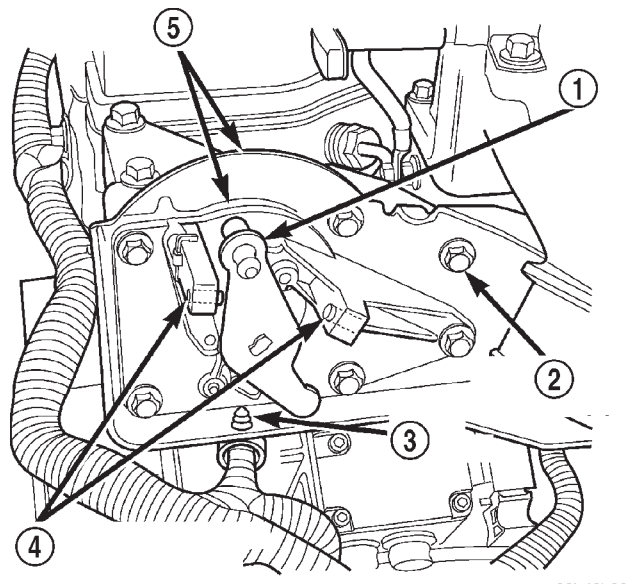


ACCELERATOR PEDAL POSITION SENSOR (Continued)



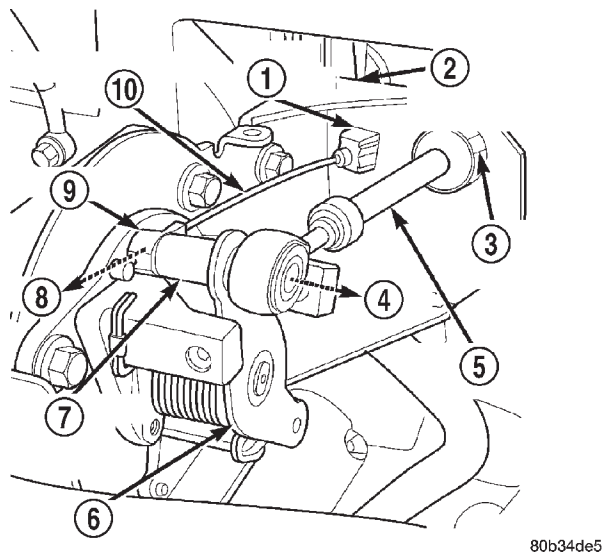
**Fig. 6 Cable/Lever/Linkage/Cover**

- 1 - CABLE/LEVER/LINKAGE COVER
- 2 - PUSH UP LOWER TAB
- 3 - SCREWS/CLIPS (2)
- 4 - TAB PUSH HERE



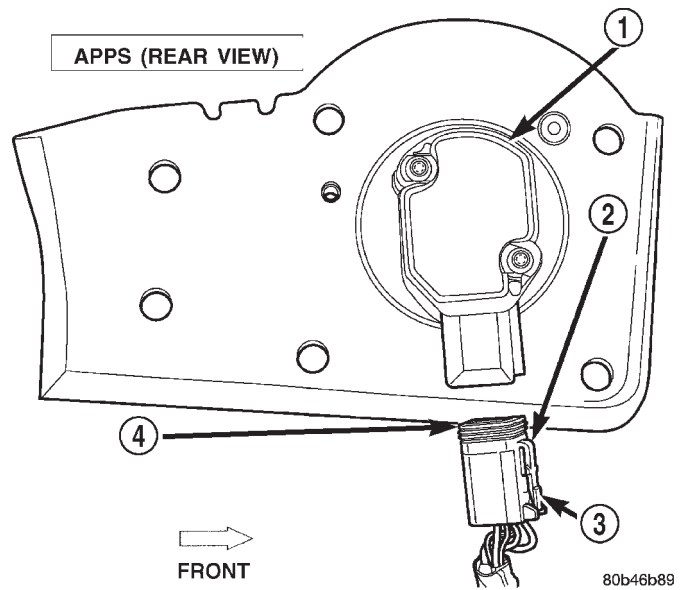
**Fig. 8 APPS Assembly**

- 1 - LEVER
- 2 - MOUNTING BOLTS (6)
- 3 - WIRE HARNESS CLIP
- 4 - CALIBRATION SCREWS (NO ADJUSTMENT)
- 5 - APPS ASSEMBLY



**Fig. 7 Cables at Throttle Lever**

- 1 - PINCH (2) TABS
- 2 - CABLE MOUNTING BRACKET
- 3 - PINCH TABS (2)
- 4 - OFF
- 5 - THROTTLE CABLE
- 6 - THROTTLE LEVER
- 7 - THROTTLE LEVER PIN
- 8 - OFF
- 9 - CONNECTOR
- 10 - SPEED CONTROL CABLE



**Fig. 9 Electrical Connector at Bottom of APPS**

- 1 - APPS
- 2 - TAB
- 3 - PUSH FOR REMOVAL
- 4 - APPS CONNECTOR

## ACCELERATOR PEDAL POSITION SENSOR (Continued)

(1) Disconnect both negative battery cables at both batteries.

(2) Remove cable cover (Fig. 6). Cable cover is attached with 2 Phillips screws, 2 plastic retention clips and 2 push tabs (Fig. 6). Remove 2 Phillips screws and carefully pry out 2 retention clips. After clip removal, push rearward on front tab, and upward on lower tab for cover removal.

(3) Using finger pressure only, disconnect end of speed control servo cable from throttle lever pin by pulling forward on connector while holding lever rearward (Fig. 7). **DO NOT try to pull connector off perpendicular to lever pin. Connector will be broken.**

(4) Using two small screwdrivers, pry throttle cable connector socket from throttle lever ball (Fig. 7). **Be very careful not to bend throttle lever arm.**

(5) Disconnect transmission control cable at lever arm (if equipped). Refer to 21, Transmission.

(6) Squeeze pinch tabs on speed control cable (Fig. 7) and pull cable rearward to remove from cable mounting bracket.

(7) Squeeze pinch tabs on throttle cable (Fig. 7) and pull cable rearward to remove from cable mounting bracket.

(8) If equipped with an automatic transmission, refer to 21, Transmission for transmission control cable removal procedures.

(9) Disconnect wiring harness clip (Fig. 8) at bottom of bracket.

(10) Remove 6 mounting bolts (Fig. 8) and partially remove APPS assembly from engine. After assembly is partially removed, disconnect electrical connector from bottom of sensor by pushing on connector tab (Fig. 9).

(11) Remove APPS assembly from engine.

## INSTALLATION

The APPS is serviced (replaced) as one assembly including the lever, brackets and sensor. The APPS is calibrated to its mounting bracket. The APPS assembly is located at left-front of engine below plastic cable/lever/linkage cover (Fig. 6).

(1) Snap electrical connector into bottom of sensor.

(2) Position APPS assembly to engine and install 6 bolts. Tighten bolts to 12 N-m (105 in. lbs.) torque.

(3) Connect wiring harness clip (Fig. 8) at bottom of bracket.

(4) If equipped with an automatic transmission, refer to Group 21, Transmission for transmission control cable installation procedures.

(5) Install speed control cable into mounting bracket. Be sure pinch tabs (Fig. 7) have secured cable.

(6) Install throttle cable into mounting bracket. Be sure pinch tabs (Fig. 7) have secured cable.

(7) Connect throttle cable at lever (snaps on).

(8) Connect speed control cable to lever by pushing cable connector rearward onto lever pin while holding lever forward.

(9) Install cable cover.

(10) Connect both negative battery cables to both batteries.

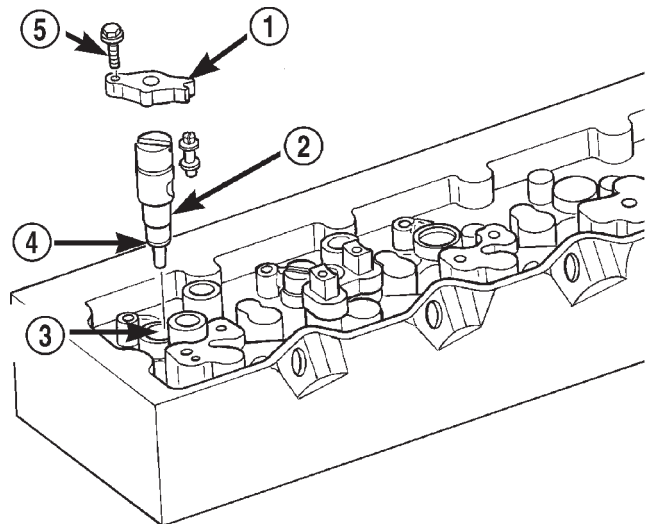
(11) **ECM Calibration:** Turn key to ON position. Without starting engine, slowly press throttle pedal to floor and then slowly release. This step must be done (one time) to ensure accelerator pedal position sensor calibration has been learned by ECM. If not done, possible DTC's may be set.

(12) Use DRB scan tool to erase any DTC's from ECM/PCM.

## FUEL INJECTOR

### DESCRIPTION

Six individual, high-pressure fuel injectors are used. The injectors are vertically mounted (Fig. 10) into a bored hole in the top of the cylinder head. This bored hole is located between the intake/exhaust valves.



80b46ce3

**Fig. 10 Fuel Injector Location**

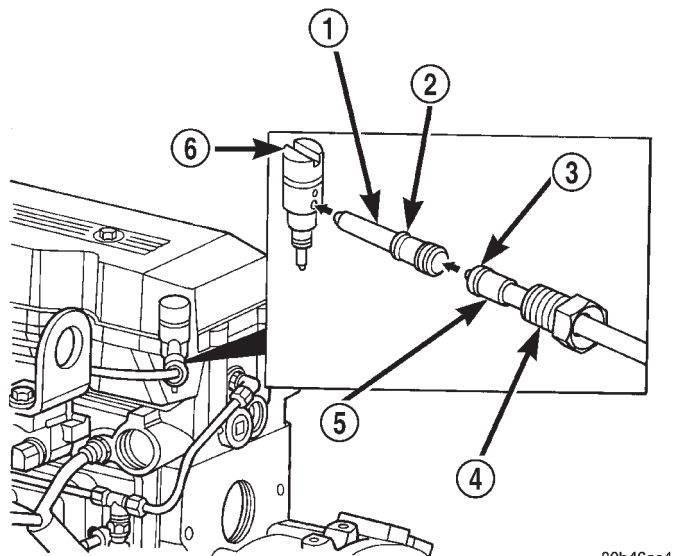
- 1 - CLAMP
- 2 - FUEL INJECTOR
- 3 - BORED HOLE
- 4 - SHIM
- 5 - BOLTS

## FUEL INJECTOR (Continued)

## OPERATION

High-pressure fuel is supplied from the injection pump, through a high-pressure fuel line, through a steel connector and into the fuel injector. When fuel pressure rises to approximately 31,026 kPa (4,500 psi), the needle valve spring tension is overcome. The needle valve rises and fuel flows through the spray holes in the nozzle tip into the combustion chamber. The pressure required to lift the needle valve is the nozzle opening pressure. This is sometimes referred to as the "pop" pressure setting.

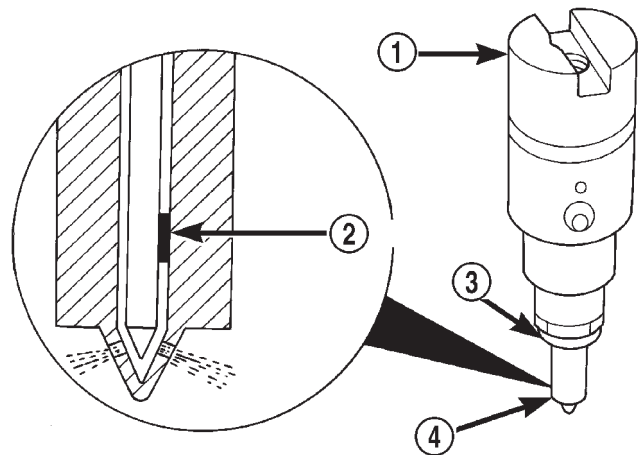
Each fuel injector is connected to each high-pressure fuel line with a steel connector (Fig. 11). This steel connector is positioned into the cylinder head and sealed with an o-ring. The connectors are sealed to the high-pressure fuel lines with fittings (Fig. 11). The ferrule (Fig. 11) on the end of the high-pressure fuel line pushes against the steel connector when the fuel line fitting is torqued into the cylinder head. This torquing force provides a sealing pressure between both the fuel line-to-connector and the fuel connector-to-fuel injector. **The fitting torque is very critical.** If the fitting is under torqued, the mating surfaces will not seal and a high-pressure fuel leak will result. If the fitting is over torqued, the connector and injector will deform and also cause a high-pressure fuel leak. This leak will be inside the cylinder head and will not be visible. The result will be a possible fuel injector miss-fire and low power.



80b46ce4

**Fig. 11 Fuel Injector Connections**

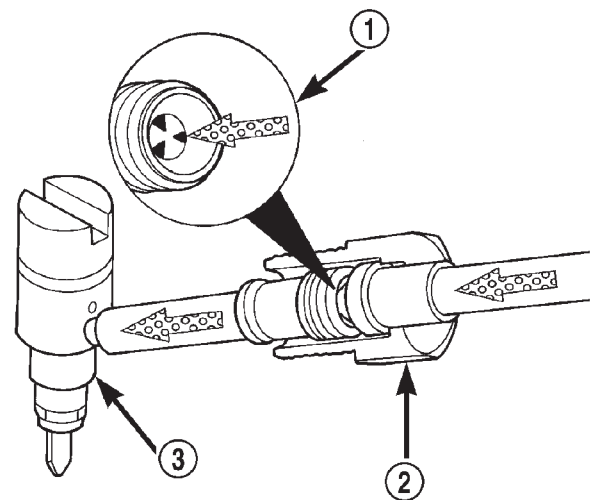
- 1 - CONNECTOR
- 2 - O-RING
- 3 - FERRULE
- 4 - FITTING
- 5 - FUEL LINE
- 6 - INJECTOR



80b46ce6

**Fig. 12 Fuel Injector Spray Pattern**

- 1 - INJECTOR
- 2 - CLEARANCE
- 3 - SHIM
- 4 - NOZZLE



80b46ce5

**Fig. 13 Fuel Injector Edge Filter**

- 1 - EDGE FILTER
- 2 - FITTING
- 3 - FUEL INJECTOR

The fuel injectors use hole type nozzles (Fig. 12). High-pressure flows into the side of the injector and causes the injector needle to lift and fuel to be injected. The clearances in the nozzle bore (Fig. 12) are extremely small and any sort of dirt or contaminants will cause the injector to stick. Because of this, it is very important to do a thorough cleaning of any lines before opening up any fuel system component.

## FUEL INJECTOR (Continued)

Always cover or cap any open fuel connections before a fuel system repair is performed.

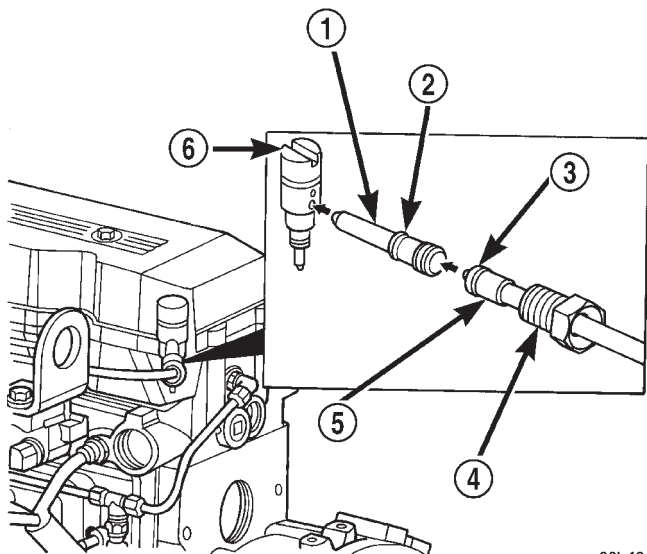
Each fuel injector connector tube contains an edge filter (Fig. 13) that breaks up small contaminants that enter the injector. The edge filter uses the injectors pulsating high-pressure to break up most particles so they are small enough to pass through the injector. **The edge filters are not a substitute for proper cleaning and covering of all fuel system components during repair.**

The bottom of each fuel injector is sealed to the cylinder head with a **1.5mm** thick copper shim (gasket) (Fig. 12). The correct thickness shim must always be re-installed after removing an injector.

Fuel pressure in the injector circuit decreases after injection. The injector needle valve is immediately closed by the needle valve spring and fuel flow into the combustion chamber is stopped. Exhaust gases are prevented from entering the injector nozzle by the needle valve.

## DIAGNOSIS AND TESTING—FUEL INJECTOR TEST

The fuel injectors are located in the top of the cylinder head between the intake/exhaust valves (Fig. 14).



**Fig. 14 Fuel Injector Connections**

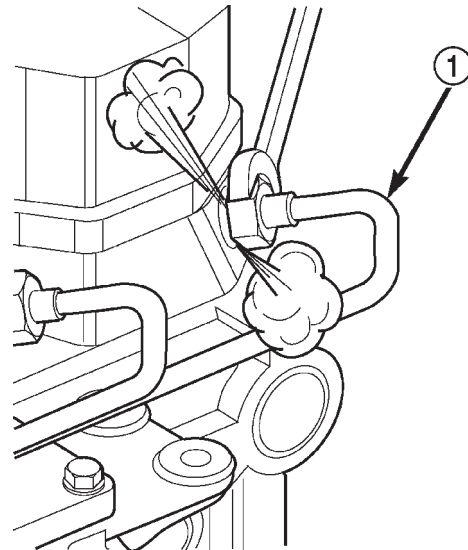
- 1 - CONNECTOR
- 2 - O-RING
- 3 - FERRULE
- 4 - FITTING
- 5 - FUEL LINE
- 6 - INJECTOR

A leaking fuel injector can cause fuel knock, poor performance, black smoke, poor fuel economy and rough engine idle. If fuel injector needle valve does not operate properly, engine may misfire and produce low power.

A leak in injection pump-to-injector high-pressure fuel line can cause many of same symptoms as malfunctioning injector. Inspect for leaks in high-pressure lines before checking for malfunctioning fuel injector.

**WARNING: THE INJECTION PUMP SUPPLIES HIGH-PRESSURE FUEL OF UP TO APPROXIMATELY 120,000 kPa (17,400 psi) TO EACH INDIVIDUAL INJECTOR THROUGH HIGH-PRESSURE LINES. FUEL UNDER THIS AMOUNT OF PRESSURE CAN PENETRATE SKIN AND CAUSE PERSONAL INJURY. WEAR SAFETY GOGGLES AND ADEQUATE PROTECTIVE CLOTHING. AVOID CONTACT WITH FUEL SPRAY WHEN BLEEDING HIGH-PRESSURE FUEL LINES.**

**WARNING: DO NOT BLEED AIR FROM FUEL SYSTEM OF A HOT ENGINE. DO NOT ALLOW FUEL TO SPRAY ONTO EXHAUST MANIFOLD WHEN BLEEDING AIR FROM FUEL SYSTEM.**



80b46b80

**Fig. 15 Inspecting Injector Operation**

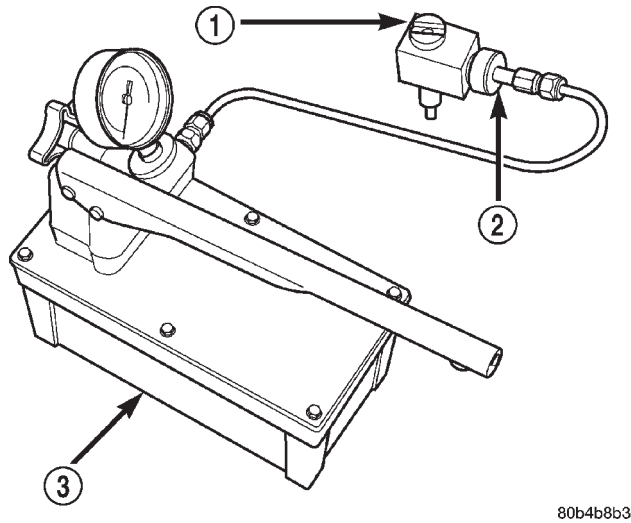
- 1 - HIGH-PRESSURE FUEL LINE

(1) To determine which fuel injector is malfunctioning, run engine and isolate each cylinder using DRB scan tool. **The DRB scan tool lists the injector firing order in both cylinder numerical order (1-2-3-4-5-6), and actual firing order (1-5-3-6-2-4).**

(2) Note RPM drop for each cylinder. As an alternative, loosen high-pressure fuel line fitting at fuel injector connector tube (Fig. 15). Listen for a change in engine speed. After testing, tighten line fitting to 40 N·m (30 ft. lbs.) torque. If engine speed drops, injector was operating normally. If engine speed remains same, injector may be malfunctioning. Test all injectors in same manner one at a time.

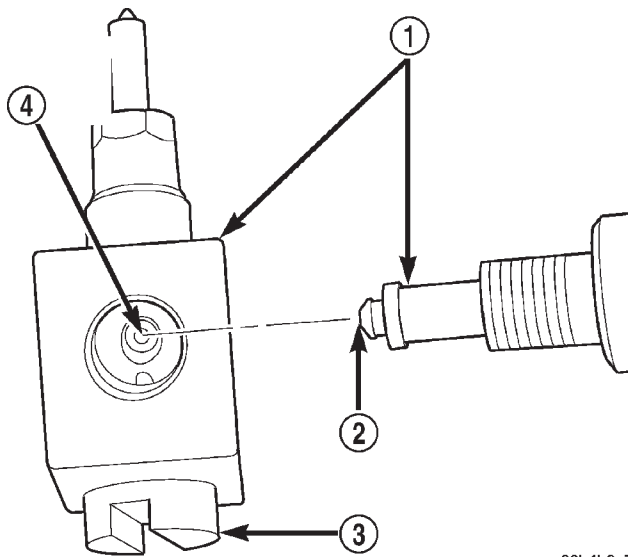


## FUEL INJECTOR (Continued)

**Fig. 16 Fuel**

- 1 - FUEL INJECTOR
- 2 - ADAPTOR TOOL 8301
- 3 - POP PRESSURE TESTER

80b4b8b3

**Fig. 17 Installing Injector to Adaptor Tool 8301**

- 1 - ADAPTOR TOOL 8301
- 2 - TIP
- 3 - FUEL INJECTOR
- 4 - INLET AT SIDE OF INJECTOR

80b4b8c7

(3) Once injector has been found to be malfunctioning, remove it from engine and test it. Refer to Fuel Injector Removal/Installation.

**WARNING: FUEL INJECTOR TESTERS CAN DEVELOP EXTREMELY HIGH PRESSURES. FUEL UNDER THIS AMOUNT OF PRESSURE CAN PENETRATE SKIN AND CAUSE PERSONAL INJURY. WEAR SAFETY GOGGLES AND ADEQUATE PRO-**

**TECTIVE CLOTHING. AVOID CONTACT WITH FUEL SPRAY WHEN OPERATING INJECTOR TESTOR.**

(4) After injector has been removed, obtain benchmark fuel injector tester OTC® (SPX®) part number 4210 (Fig. 16) (or equivalent). Install Special Tool number 8301 (Fuel Injector Adapter) to 4210 tester. Install fuel injector into 8301 adapter. Be sure tip of adapter tool 8301 is aligned to inlet hole at side of injector (Fig. 17) before tightening tool. Tighten tool 8301 to injector. Position container below injector before testing.

(5) Refer to operating instructions supplied with pressure tester for procedures.

(a) Check opening pressure or "pop" pressure. Pressure should be approximately 31,026 kPa (310 bars) or (4500 psi ± 250 psi). If fuel injector needle valve is opening (popping) too early or too late, replace injector.

(b) Perform a leak-down test on injector. Apply pressure with injector tester. The injector should not leak (drip) fuel with pressure at approximately 20 bars (291 psi) lower than pop pressure.

(c) Operate tester lever quickly several times to check injector spray pattern. Verify fuel is spraying from each injector nozzle hole. Injector should also spray evenly from each nozzle hole.

(d) Pay attention to size and shape of spray plumes. They should all be equal. If possible, compare spray pattern to that of a new fuel injector with same part number. Checking each plume for consistency is an excellent indicator of injector performance. Even if only one nozzle hole is plugged, significant performance problems could result.

(e) Look for burrs on injector inlet.

(f) Check nozzle holes for hole erosion or plugging.

(g) Inspect end of nozzle for burrs or rough machine marks.

(h) Look for cracks at nozzle end.

(i) Check nozzle color for signs of overheating. Overheating will cause nozzle to turn a dark yellow/tan or blue (depending on overheating temperature).

(j) Look at end of injector tube where it meets injector. A small, shiny band should be seen at this point. The band should have a consistent thickness. If not, injector could be leaking into fuel return.

(k) If any of these conditions occur, replace injector.

**REMOVAL**

The fuel injectors are located in the top of the cylinder head between the intake/exhaust valves (Fig. 18).

## FUEL INJECTOR (Continued)

**CAUTION: Refer to Cleaning Fuel System Parts.**

(1) Disconnect both negative battery cables from both batteries. Cover and isolate ends of cables.

Each fuel injector is connected to each high-pressure fuel line with a steel connector tube (Fig. 19). This steel connector is positioned into cylinder head and sealed with an o-ring. The connectors are connected to high-pressure fuel lines with fittings (Fig. 19).

(2) If injector at #1 or #2 cylinder is being removed, intake manifold air heater assembly must be removed. Refer to Intake Manifold Air Heater Removal/Installation.

(3) If injector at #5 cylinder is being removed, remove engine lifting bracket (2 bolts).

(4) Thoroughly clean area around injector and injector high-pressure lines before removal.

(5) Remove necessary high-pressure fuel lines. (Refer to 14 - FUEL SYSTEM/FUEL DELIVERY/FUEL LINES - REMOVAL). **Do not bend any high-pressure fuel line to gain access to fuel injector.** Cover or cap any open fuel connections.

(6) Remove valve cover (Refer to 9 - ENGINE/CYLINDER HEAD/CYLINDER HEAD COVER(S) - REMOVAL).

(7) Thread Special Tool 8324 (Fuel Injector Connector Tube Remover) onto end of injector connector tube (Fig. 20).

(8) Pull injector connector tube from cylinder head. **The injector connector tube must be removed before attempting to remove fuel injector or serious damage to fuel injector and tube will result.**

(9) Remove and discard old o-ring (Fig. 19) from injector connector tube.

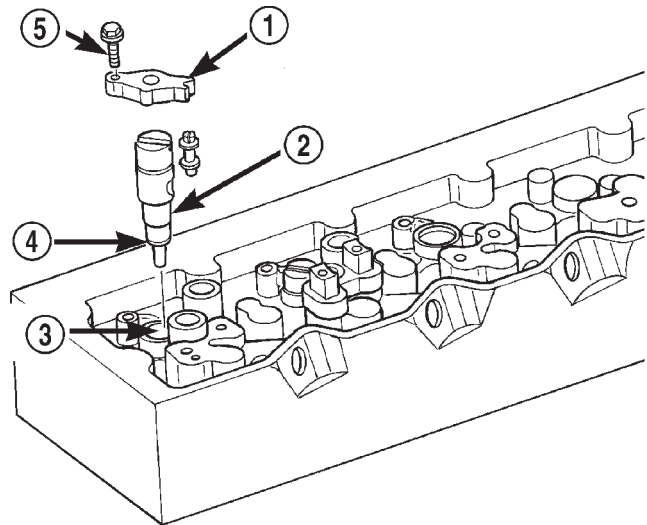
(10) Remove fuel injector hold down clamp bolt at front end of clamp (Fig. 18). **Do not loosen or remove special (2 shouldered) bolt at rear end of clamp.** Remove injector clamp by sliding it from shoulders on rear clamp bolt.

(11) Thread rod from Special Tool number 8318 (Fuel Injector Remover) into top of fuel injector (Fig. 21).

(12) Tighten nut on 8318 tool to pull (remove) fuel injector from cylinder head.

(13) Remove and discard old o-ring from fuel injector.

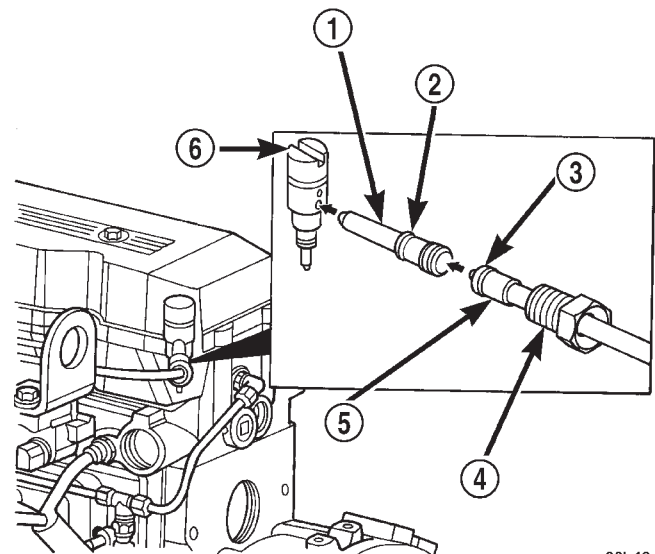
(14) Remove and discard copper sealing washer (shim) (Fig. 22) from bottom of injector. **If copper sealing washer has remained in cylinder head, it must be removed.**



80b46ce3

**Fig. 18 Fuel Injector Location**

- 1 - CLAMP
- 2 - FUEL INJECTOR
- 3 - BORED HOLE
- 4 - SHIM
- 5 - BOLTS



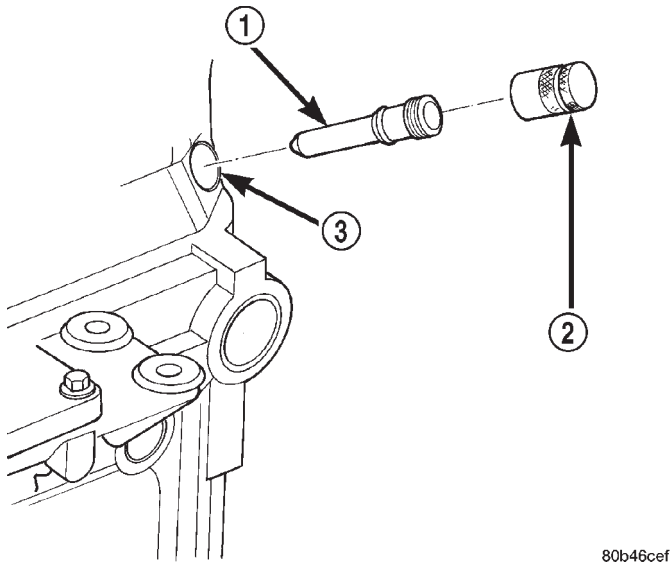
80b46ce4

**Fig. 19 Fuel Injector Connections**

- 1 - CONNECTOR
- 2 - O-RING
- 3 - FERRULE
- 4 - FITTING
- 5 - FUEL LINE
- 6 - INJECTOR



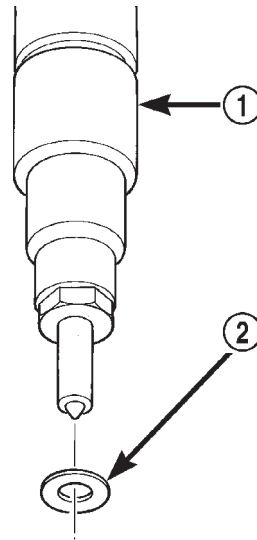
FUEL INJECTOR (Continued)



80b46cef

**Fig. 20 Fuel Injector Connector Tube Removal**

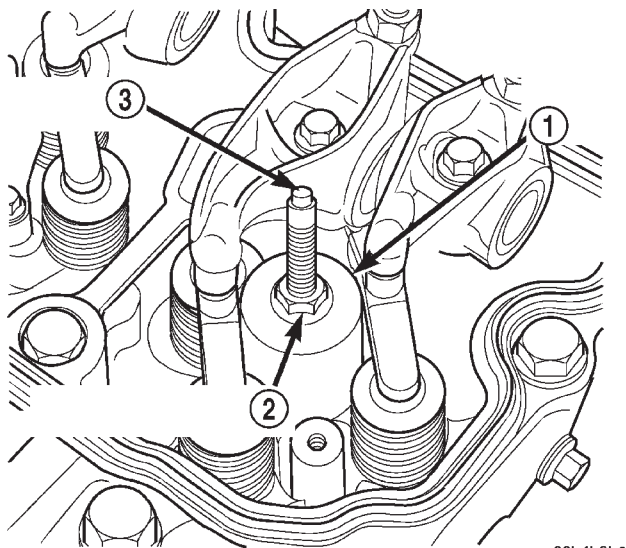
- 1 - FUEL INJECTOR CONNECTOR TUBE
- 2 - SPECIAL TOOL 8324
- 3 - CYLINDER HEAD



80b4b8b1

**Fig. 22 Fuel Injector Sealing Washer (Shim) Location**

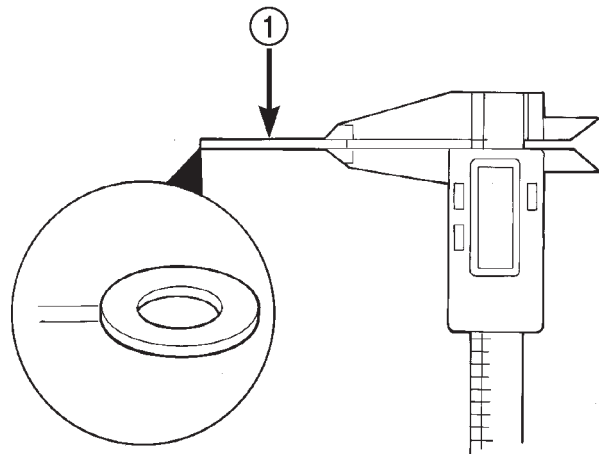
- 1 - FUEL INJECTOR
- 2 - COPPER SEALING WASHER (SHIM)



80b4b8b0

**Fig. 21 Fuel Injector Removal**

- 1 - FUEL INJECTOR REMOVAL TOOL 8318
- 2 - TIGHTEN NUT FOR INJECTOR TERMINAL
- 3 - THREAD INTO INJECTOR



80b4b8b2

**Fig. 23 Measuring Injector Sealing Washer (Shim)**

- 1 - SHIM

**INSTALLATION**

The fuel injectors are located in the top of the cylinder head between the intake/exhaust valves (Fig. 18).

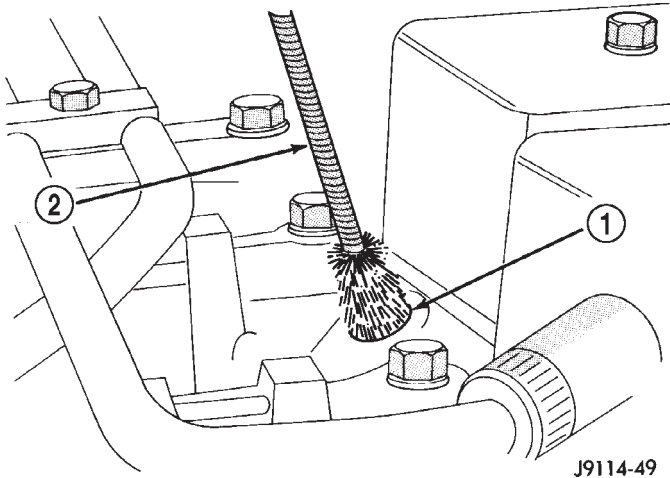
- (1) Inspect fuel injector.
  - (a) If necessary, perform pressure test of injector. Refer to Fuel Injector Testing.
  - (b) Look for burrs on injector inlet.

- (c) Check nozzle holes for hole erosion or plugging.
- (d) Inspect end of nozzle for burrs or rough machine marks.
- (e) Look for cracks at nozzle end.
- (f) Check nozzle color for signs of overheating. Overheating will cause nozzle to turn a dark yellow/tan or blue (depending on overheating temperature).

## FUEL INJECTOR (Continued)

(g) If any of these conditions occur, replace injector.

(2) Thoroughly clean fuel injector cylinder head bore with special Cummins wire brush tool or equivalent (Fig. 24). Blow out bore hole with compressed air.



**Fig. 24 Cleaning Cylinder Head Injector Bore—  
TYPICAL BORE**

1 - INJECTOR BORE  
2 - WIRE BRUSH

(3) The bottom of fuel injector is sealed to cylinder head bore with a copper sealing washer (shim) of a certain thickness. A new shim with correct thickness must always be re-installed after removing injector. Measure thickness of injector shim (Fig. 23). **Shim Thickness: 1.5 mm (.060")**

(4) Install new shim (washer) to bottom of injector (Fig. 22). Apply light coating of clean engine oil to washer. This will keep washer in place during installation.

(5) Install new o-ring to fuel injector. Apply small amount of clean engine oil to o-ring.

(6) Note fuel inlet hole on side of fuel injector. This hole must be positioned towards injector connector tube. Position injector into cylinder head bore being extremely careful not to allow injector tip to touch sides of bore. Press fuel injector into cylinder head with finger pressure only. **Do not use any tools to press fuel injector into position. Damage to machined surfaces may result.**

(7) Position fuel injector hold down clamp into shouldered bolt while aligning slot in top of injector into groove in bottom of clamp. Tighten opposite clamp bolt (Fig. 18) to 10 N·m (89 in. lbs.) torque.

(8) Install new o-ring to fuel injector connector tube. Apply small amount of clean engine oil to o-ring.

(9) Press injector connector tube into cylinder head with finger pressure only. **Do not use any tools to**

**press tube into position. Damage to machined surfaces may result.**

(10) Connect high-pressure fuel lines. Refer to High-Pressure Fuel Lines Removal/Installation. **The fuel line fitting torque is very critical.** If fitting is under torqued, the mating surfaces will not seal and a high-pressure fuel leak will result. If fitting is over torqued, the connector and injector will deform and also cause a high-pressure fuel leak. This leak will be inside cylinder head and will not be visible resulting in a possible fuel injector miss and low power.

(11) Install valve cover. (Refer to 9 - ENGINE/CYLINDER HEAD/CYLINDER HEAD COVER(S) - INSTALLATION).

(12) (If necessary) install intake manifold air heater assembly. Refer to Intake Manifold Air Heater Removal/Installation.

(13) (If necessary) install engine lifting bracket. Tighten 2 bolts to 77 N·m (57 ft. lbs.) torque.

(14) Connect negative battery cables to both batteries.

(15) Bleed air from high-pressure lines (Refer to 14 - FUEL SYSTEM/FUEL DELIVERY - STANDARD PROCEDURE).

## FUEL INJECTION PUMP RELAY

### DESCRIPTION

The fuel injection pump relay is located in the Power Distribution Center (PDC). Refer to label under PDC cover for relay location.

### OPERATION

The Engine Control Module (ECM) energizes the electric fuel injection pump through the fuel injection pump relay. Battery voltage is applied to the fuel injection pump relay at all times. When the key is turned ON, the relay is energized when a 12-volt signal is provided by the ECM. When energized, 12-volts is supplied to the Fuel Pump Control Module. The Fuel Pump Control Module is located on the top of the fuel injection pump and is non-servicable.

## FUEL TEMPERATURE SENSOR

### DESCRIPTION

Two different fuel temperature sensors are used. One of the sensors is located inside of the Bosch VP44 fuel injection pump and is a non-servicable part. The other fuel temperature sensor is located in the top of the fuel filter housing and is serviceable (serviceable if replacing the fuel heater).

## FUEL TEMPERATURE SENSOR (Continued)

## OPERATION

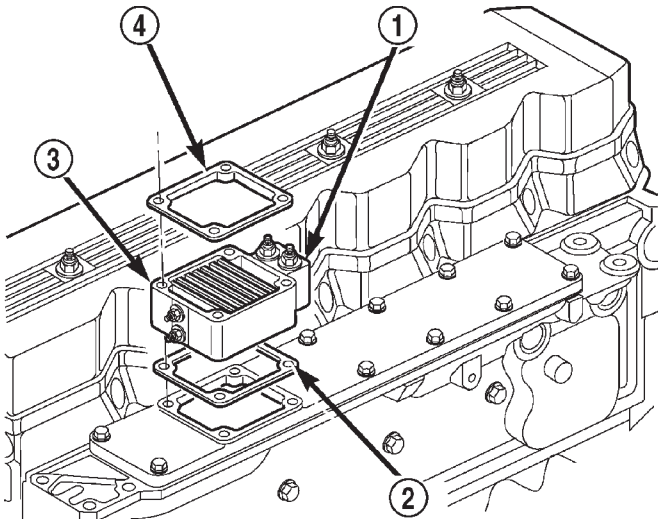
The sensor located in the Bosch VP44 fuel injection pump is used to check fuel temperature within the injection pump and to set a Diagnostic Trouble Code (DTC) if a specific high fuel temperature has been reached. If high temperature has been reached, engine power will be de-rated by the Engine Control Module (ECM).

The sensor located in the top of the fuel filter housing is used to control the fuel heater element. Refer to Fuel Heater Description and Operation for additional information.

## INTAKE AIR HEATER

## DESCRIPTION

The intake manifold air heater element assembly is located in the top of the intake manifold (Fig. 25).



80b46b90

**Fig. 25 Air Heater Elements Location**

- 1 - AIR HEATER ELEMENTS
- 2 - LOWER GASKET
- 3 - BLOCK
- 4 - UPPER GASKET

## OPERATION

The air heater elements are used to heat incoming air to the intake manifold. This is done to help engine starting and improve driveability with cool or cold outside temperatures.

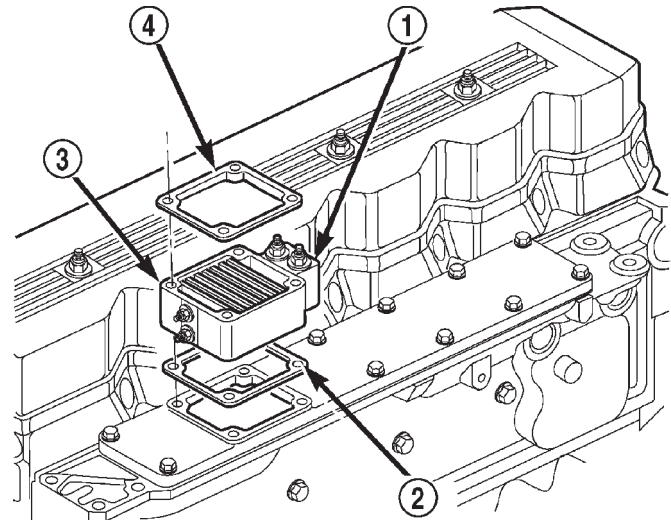
Electrical supply for the 2 air heater elements is controlled by the Engine Control Module (ECM) through the 2 air heater relays. Refer to Intake Manifold Air Heater Relays for more information.

Two heavy-duty cables connect the 2 air heater elements to the 2 air heater relays. Each of these cables will supply approximately 95 amps at 12 volts to an individual heating element within the heater block assembly.

Refer to the Powertrain Diagnostic Procedures manual for an electrical operation and complete description of the intake heaters, including pre-heat and post-heat cycles.

## REMOVAL

The 2 intake manifold air heater elements are attached to a metal block located at the top of the intake manifold (Fig. 26). If servicing either of the heater elements, the entire block/element assembly must be replaced.



80b46b90

**Fig. 26 Intake Manifold Air Heater Element Location**

- 1 - AIR HEATER ELEMENTS
- 2 - LOWER GASKET
- 3 - BLOCK
- 4 - UPPER GASKET

(1) Disconnect both negative battery cables at both batteries.

(2) Disconnect clamp from rubber hose at air intake housing.

(3) Disconnect rubber hose at air intake housing.

(4) Remove engine oil dipstick tube mounting bolt (Fig. 28). Position dipstick tube to the side.

(5) Disconnect heater electrical cables at cable mounting studs (Fig. 28).

(6) Disconnect ground cable bolt and ground cable from housing (Fig. 27).

(7) Remove 4 housing bolts (Fig. 28).

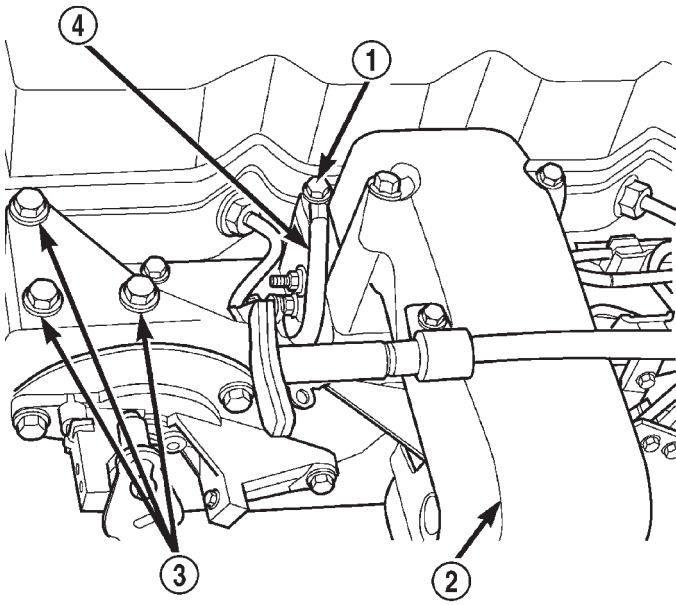
(8) Remove air intake housing from top of heater elements.

(9) Remove heater element assembly from intake manifold.

(10) Clean old gasket material from air intake housing and intake manifold.

(11) Clean old gasket material from both ends of heater block (Fig. 26).

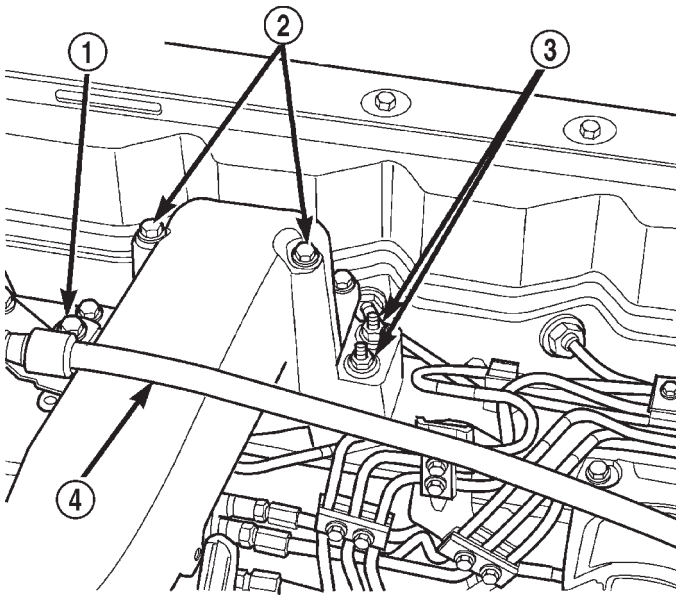
## INTAKE AIR HEATER (Continued)



80bfe0d7

**Fig. 27 Air Intake Housing (Front View)**

- 1 - GROUND CABLE BOLT
- 2 - INTAKE AIR HOUSING
- 3 - CABLE BRACKET HOUSING BOLTS (3)
- 4 - GROUND CABLE



80bfe0d8

**Fig. 28 Air Intake Housing (Rear View)**

- 1 - TUBE MOUNTING BOLT
- 2 - HOUSING BOLTS (2)
- 3 - INTAKE HEATER CABLE MOUNTING STUDS (2)
- 4 - DIPSTICK TUBE

**INSTALLATION**

The 2 intake manifold air heater elements are attached to a metal block located at the top of the

intake manifold (Fig. 26). If servicing either of the heater elements, the entire block/element assembly must be replaced.

(1) Using 2 new gaskets, position element assembly and air housing to intake manifold.

(2) Position ground cable (Fig. 27) to air housing.

(3) Install 4 housing bolts and tighten to 24 N-m (18 ft. lbs.) torque.

(4) Connect heater cables at cable mounting studs (Fig. 28). **Do not allow the cable eyelets to contact any other metal source other than the cable nuts/studs.**

(5) Install engine oil dipstick tube and mounting bolt.

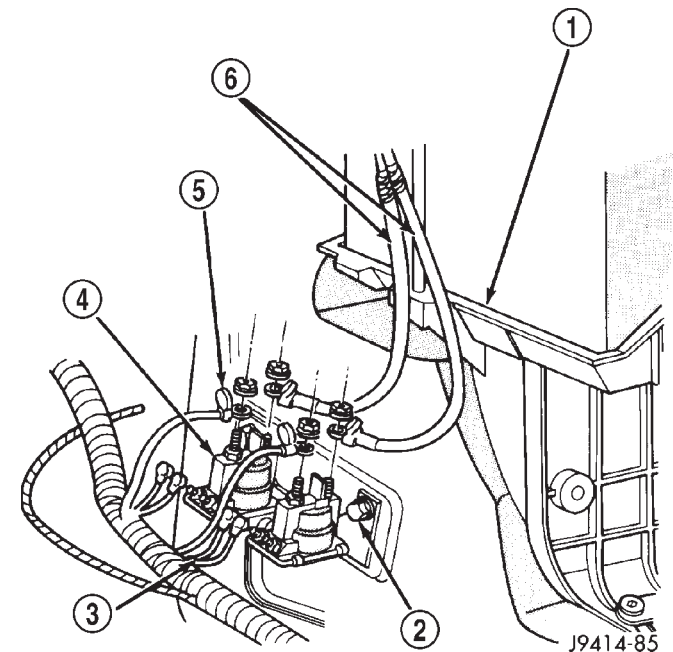
(6) Connect rubber hose to air intake housing.

(7) Connect clamp to rubber hose at air intake housing.

(8) Connect both negative battery cables at both batteries.

**INTAKE AIR HEATER RELAY****DESCRIPTION**

The 2 intake manifold air heater relays are located in the engine compartment, attached to the left inner fender below the left battery (Fig. 29).



J9414-85

**Fig. 29 Intake Manifold Air Heater Relays Location**

- 1 - BATTERY (LEFT SIDE)
- 2 - RELAY MOUNTING BOLTS (3)
- 3 - RELAY TRIGGER WIRES (4)
- 4 - INTAKE AIR HEATER RELAYS (2)
- 5 - RUBBER SHIELDS (4)
- 6 - CABLES TO BATTERY (+)



## INTAKE AIR HEATER RELAY (Continued)

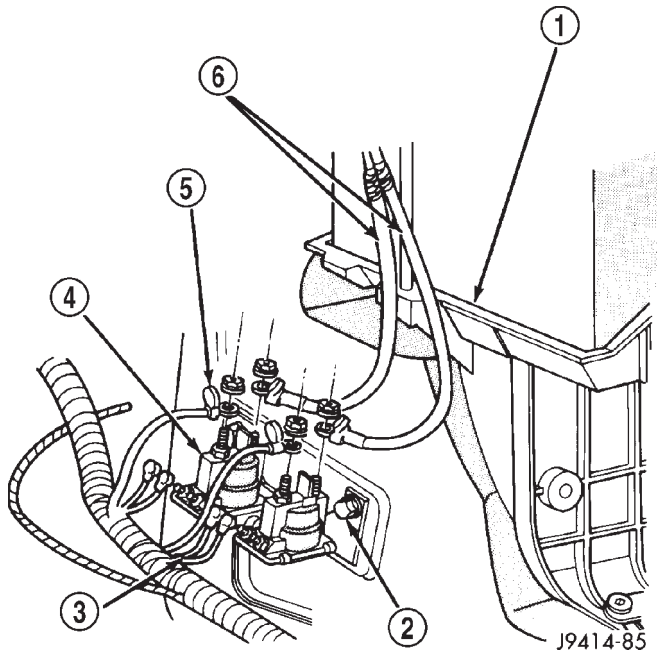
## OPERATION

The Engine Control Module (ECM) operates the 2 heating elements through the 2 intake manifold air heater relays.

Refer to Powertrain Diagnostic Procedures for an electrical operation and complete description of the intake heaters, including pre-heat and post-heat cycles.

## REMOVAL

The relays are located in engine compartment, bolted to left inner fender below left battery (Fig. 30).



**Fig. 30 Intake Manifold Air Heater Relays**

- 1 - BATTERY (LEFT SIDE)
- 2 - RELAY MOUNTING BOLTS (2)
- 3 - RELAY TRIGGER WIRES (4)
- 4 - INTAKE AIR HEATER RELAYS (2)
- 5 - RUBBER SHIELDS (4)
- 6 - CABLES TO BATTERY (+)

The mounting bracket and both relays are replaced as an assembly.

(1) Disconnect both negative battery cables at both batteries.

(2) Disconnect four relay trigger wires at both relays (Fig. 30). Note position of wiring before removing.

(3) Lift four rubber shields from all 4 cables (Fig. 30).

(4) Remove four nuts at cable connectors (Fig. 30). Note position of wiring before removing.

(5) Remove three relay mounting bracket bolts (Fig. 30) and remove relay assembly.

## INSTALLATION

The relays are located in engine compartment, bolted to left inner fender below left battery (Fig. 30).

(1) Install relay assembly to inner fender. Tighten mounting bolts to 4.5 N·m (40 in. lbs.) torque.

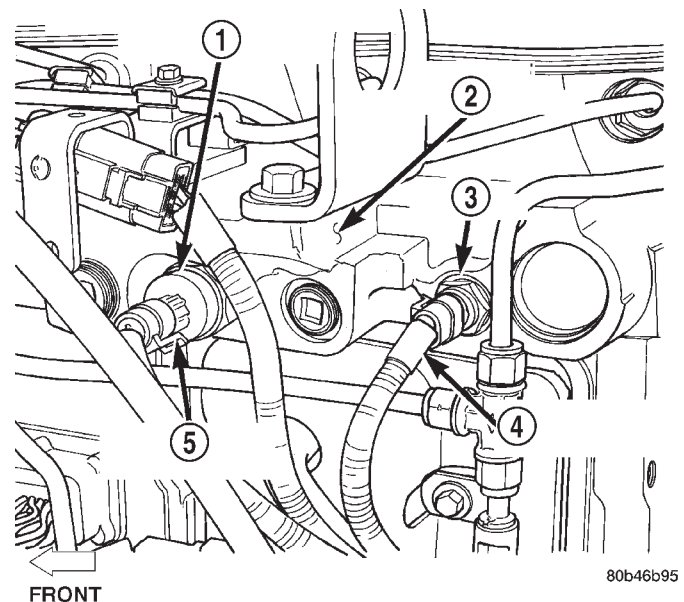
(2) Connect eight electrical connectors to relays.

(3) Connect battery cables to both batteries.

## INTAKE AIR TEMPERATURE SENSOR

## DESCRIPTION - DIESEL

The intake manifold air temperature sensor is installed into the rear of the intake manifold (Fig. 31) with the sensor element extending into the air stream.



**Fig. 31 Intake Manifold Air Temperature (IAT) Sensor Location**

- 1 - MANIFOLD AIR PRESSURE (MAP) SENSOR
- 2 - REAR OF CYLINDER HEAD
- 3 - IAT SENSOR
- 4 - ELECTRICAL CONNECTOR
- 5 - ELECTRICAL CONNECTOR

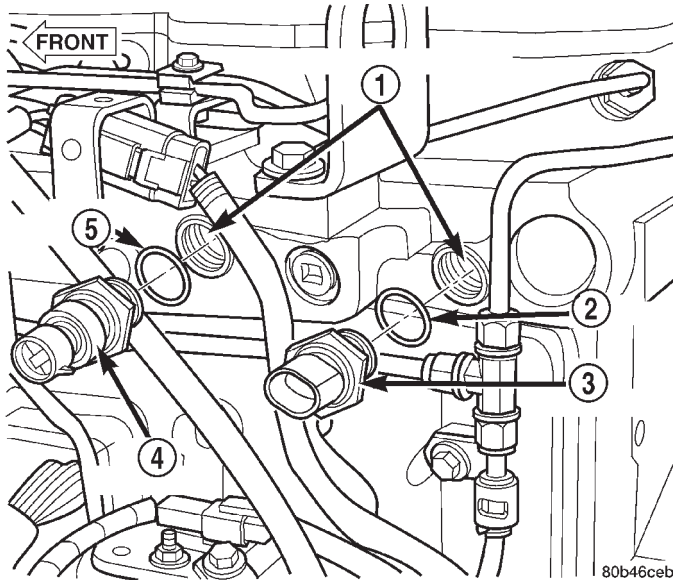
## OPERATION - DIESEL

The IAT provides an input voltage to the Engine Control Module (ECM) indicating intake manifold air temperature. The input is used along with inputs from other sensors for intake air heater element operation, for engine protection, fuel timing and fuel control. As the temperature of the air-fuel stream in the manifold varies, the sensor resistance changes. This results in a different input voltage to the ECM.

## INTAKE AIR TEMPERATURE SENSOR (Continued)

## REMOVAL - DIESEL

The IAT sensor is located in the left/rear side of the intake manifold (Fig. 32).



**Fig. 32 IAT Sensor**

- 1 - SENSOR MOUNTING HOLES
- 2 - O-RING
- 3 - IAT SENSOR
- 4 - MAP SENSOR
- 5 - O-RING

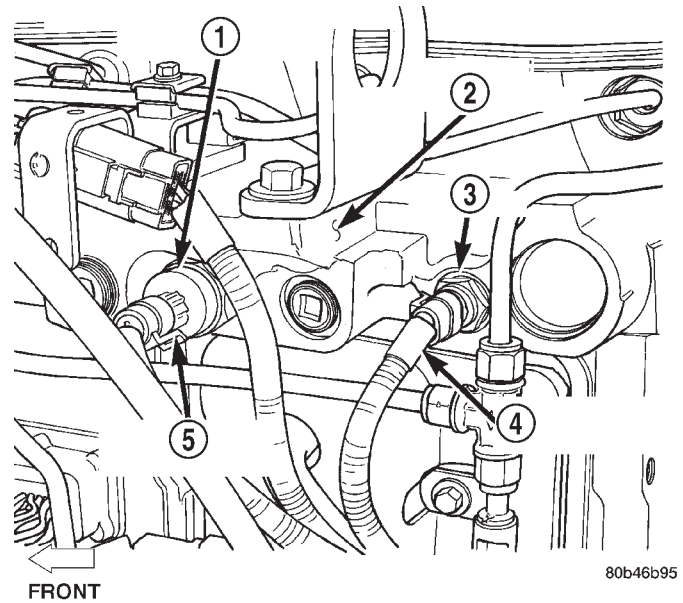
The IAT sensor is located in the left/rear side of the intake manifold (Fig. 32).

- (1) Disconnect electrical connector from IAT sensor (Fig. 32).
- (2) Remove IAT sensor from intake manifold (Fig. 33).
- (3) Discard sensor o-ring (Fig. 33).

## INSTALLATION - DIESEL

The IAT sensor is located in the left/rear side of the intake manifold (Fig. 32).

- (1) Clean sensor mounting hole (Fig. 33) of rust or contaminants.
- (2) Install new o-ring to sensor. Apply clean engine oil to sensor o-ring and sensor threads.
- (3) Install IAT sensor into intake manifold. Tighten to 14 N·m (10 ft. lbs.) torque.
- (4) Connect sensor electrical connector.



**Fig. 33 Intake Manifold Air Temperature (IAT) Sensor Location**

- 1 - MANIFOLD AIR PRESSURE (MAP) SENSOR
- 2 - REAR OF CYLINDER HEAD
- 3 - IAT SENSOR
- 4 - ELECTRICAL CONNECTOR
- 5 - ELECTRICAL CONNECTOR

## MAP SENSOR

## DESCRIPTION - DIESEL

The MAP sensor is installed into the rear of the intake manifold (Fig. 31).

## OPERATION - DIESEL

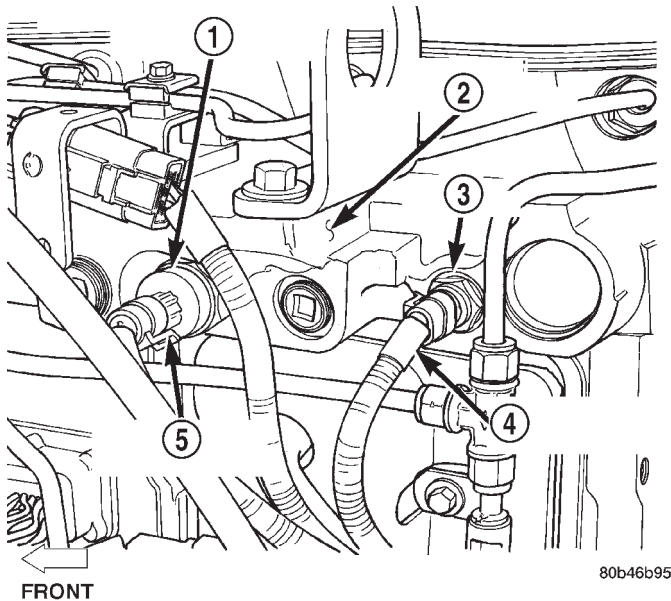
The MAP sensor reacts to air pressure changes in the intake manifold. It provides an input voltage to the Engine Control Module (ECM). As pressure changes, MAP sensor voltage will change. The change in MAP sensor voltage results in a different input voltage to the ECM. The ECM uses this input, along with inputs from other sensors to provide fuel timing, fuel control and engine protection. Engine protection is used to derate (drop power off) the engine if turbocharger pressure becomes too high.



## MAP SENSOR (Continued)

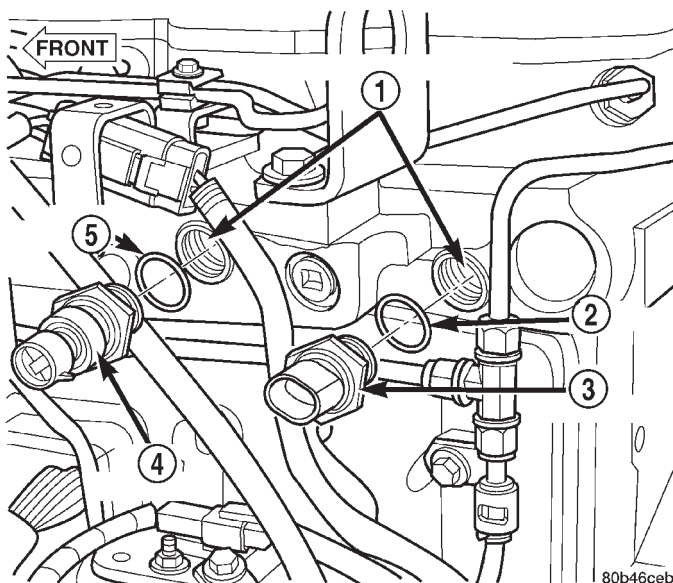
## REMOVAL - DIESEL

The MAP sensor is located in the left/rear side of the intake manifold (Fig. 34).



**Fig. 34 MAP Sensor Location**

- 1 - MANIFOLD AIR PRESSURE (MAP) SENSOR
- 2 - REAR OF CYLINDER HEAD
- 3 - IAT SENSOR
- 4 - ELECTRICAL CONNECTOR
- 5 - ELECTRICAL CONNECTOR



**Fig. 35 MAP Sensor Removal/Installation**

- 1 - SENSOR MOUNTING HOLES
- 2 - O-RING
- 3 - IAT SENSOR
- 4 - MAP SENSOR
- 5 - O-RING

The MAP sensor is located in the left/rear side of the intake manifold (Fig. 34).

- (1) Disconnect electrical connector from MAP sensor (Fig. 34).
- (2) Remove MAP sensor from intake manifold (Fig. 35).
- (3) Discard sensor o-ring (Fig. 35).

## INSTALLATION

The MAP sensor is located in the left/rear side of the intake manifold (Fig. 34).

- (1) Clean sensor mounting hole (Fig. 35) of rust or contaminants.
- (2) Install new o-ring to sensor. Apply clean engine oil to sensor o-ring and sensor threads.
- (3) Install MAP sensor into intake manifold. Tighten to 14 N·m (10 ft. lbs.) torque.
- (4) Connect sensor electrical connector.

## PTO SWITCH

## OPERATION

This Engine Control Module (ECM) input is used only on models equipped with aftermarket Power Take Off (PTO) units.

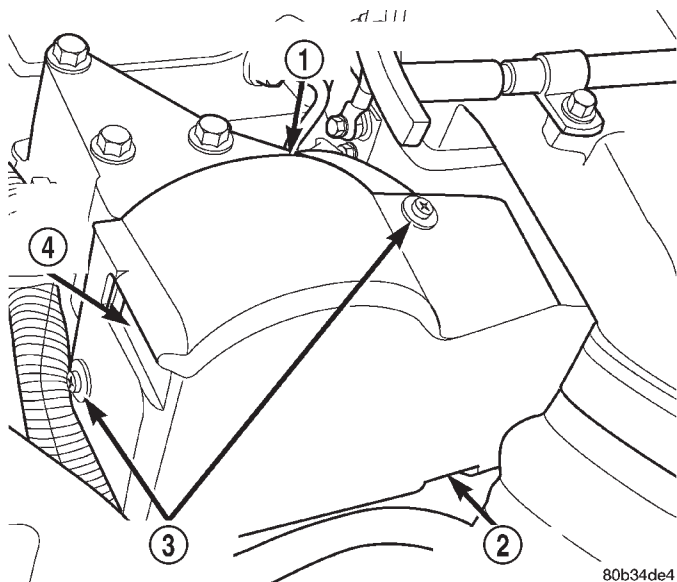
The input is used to tell the ECM that the PTO has been engaged. When engaged, the ECM will disable certain OBD II functions until the PTO has been turned off.

## THROTTLE CONTROL CABLE

## REMOVAL

- (1) Disconnect both negative battery cables at both batteries.
- (2) From inside vehicle, hold up accelerator pedal. Remove plastic cable retainer and throttle cable core wire from upper end of pedal arm (Fig. 21). The plastic cable retainer snaps into pedal arm.
- (3) Remove cable core wire at pedal arm.
- (4) From inside vehicle, pinch both sides of plastic cable housing retainer tabs at dash panel (Fig. 21).
- (5) Remove cable housing from dash panel and pull cable into engine compartment.
- (6) Remove cable cover (Fig. 36). Cable cover is attached with 2 Phillips screws, 2 plastic retention clips and 2 push tabs (Fig. 36). Remove 2 Phillips screws and carefully pry out 2 retention clips. After clip removal, push rearward on front tab, and upward on lower tab for cover removal.
- (7) Using 2 screwdrivers, pry cable connector socket from throttle lever ball (Fig. 37). **Be very careful not to bend throttle lever arm.**

## THROTTLE CONTROL CABLE (Continued)

**Fig. 36 Cable/Lever/Throttle Linkage Cover**

- 1 - CABLE/LEVER/LINKAGE COVER
- 2 - PUSH UP LOWER TAB
- 3 - SCREWS/CLIPS (2)
- 4 - TAB PUSH HERE

(8) Squeeze 2 pinch tabs on sides of throttle cable at mounting bracket (Fig. 37) and push cable rearward out of bracket .

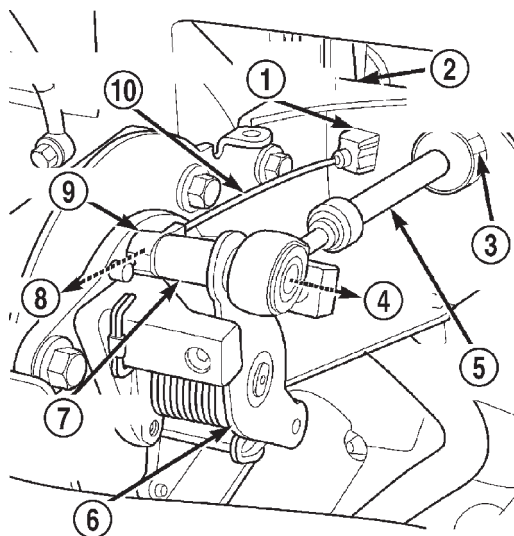
**INSTALLATION**

(1) Install cable through mounting hole on cable mounting bracket (Fig. 37). Cable snaps into bracket. Be sure 2 pinch tabs are secure.

(2) Using large pliers, connect cable end socket to throttle lever ball (snaps on).

(3) Install remaining cable housing end into and through dash panel opening (snaps into position). The two plastic pinch tabs (Fig. 21) should lock cable to dash panel.

(4) From inside vehicle, hold up accelerator pedal. Install throttle cable core wire and plastic cable

**Fig. 37 Throttle Cable at Throttle Lever**

- 1 - PINCH (2) TABS
- 2 - CABLE MOUNTING BRACKET
- 3 - PINCH TABS (2)
- 4 - OFF
- 5 - THROTTLE CABLE
- 6 - THROTTLE LEVER
- 7 - THROTTLE LEVER PIN
- 8 - OFF
- 9 - CONNECTOR
- 10 - SPEED CONTROL CABLE

retainer into and through upper end of pedal arm (the plastic retainer is snapped into pedal arm). When installing plastic retainer to accelerator pedal arm, note index tab on pedal arm (Fig. 21). Align index slot on plastic cable retainer to this index tab.

(5) Connect negative battery cables to both batteries.

(6) Before starting engine, operate accelerator pedal to check for any binding.

(7) Install cable/lever cover.



# STEERING

## TABLE OF CONTENTS

	page		page
<b>STEERING</b>		<b>COLUMN</b> .....	6
DESCRIPTION .....	1	<b>GEAR</b> .....	14
OPERATION .....	1	<b>PUMP</b> .....	31
DIAGNOSIS AND TESTING .....	2	<b>LINKAGE - 2WD</b> .....	38
POWER STEERING SYSTEM .....	2	<b>LINKAGE - 4WD</b> .....	40
POWER STEERING FLOW AND PRESSURE ...	4		

## STEERING

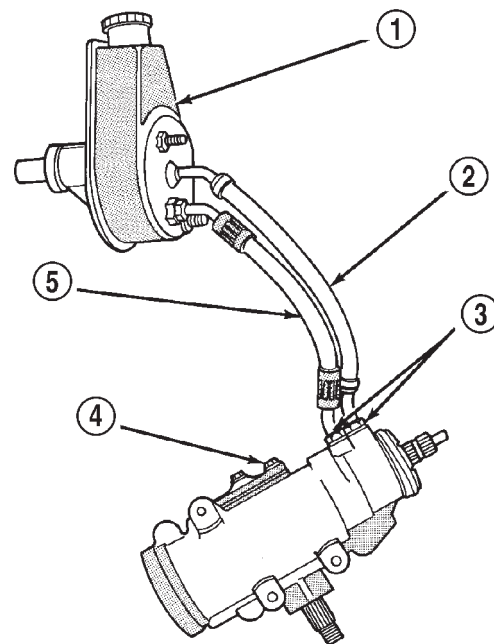
### DESCRIPTION

The power steering system consist of a steering column, steering gear and hydraulic pump. The gear is mounted to the frame rail and attaches to the steering linkage. The pump is a constant flow rate and displacement vane-type pump. The pump supplies hydraulic fluid pressure to the power steering gear (Fig. 1).

Vehicles equipped with trailer tow option have a power steering pump oil cooler.

### OPERATION

The gear acts as a rolling thread between the worm shaft and rack piston. The worm shaft is supported by a thrust bearing at the lower end and a bearing assembly at the upper end. When the worm shaft is turned from input from the steering column the rack piston moves. The rack piston teeth mesh with the pitman shaft. Turning the worm shaft, turns the pitman shaft, which turns the steering linkage.



J9219-65

**Fig. 1 Power Steering Gear & Pump**

- 1 - HYDRAULIC PUMP ASSEMBLY
- 2 - RETURN LINE HOSE ASSEMBLY
- 3 - FITTINGS
- 4 - STEERING GEAR ASSEMBLY (RECIRCULATING BALL GEAR SHOWN)
- 5 - PRESSURE HOSE ASSEMBLY

## STEERING (Continued)

**DIAGNOSIS AND TESTING - POWER STEERING SYSTEM**

There is some noise in all power steering systems. One of the most common is a hissing sound evident at a standstill parking. Or when the steering wheel is at the end of it's travel. Hiss is a high frequency noise similar to that of a water tap being closed slowly. The noise is present in all valves that have a high velocity fluid passing through an orifice. There is no relationship between this noise and steering performance.

*STEERING NOISE*

CONDITION	POSSIBLE CAUSES	CORRECTION
OBJECTIONAL HISS OR WHISTLE	<ol style="list-style-type: none"> <li>1. Steering intermediate shaft to dash panel seal.</li> <li>2. Noisy valve in power steering gear.</li> </ol>	<ol style="list-style-type: none"> <li>1. Check and repair seal at dash panel.</li> <li>2. Repair steering gear.</li> </ol>
RATTLE OR CLUNK	<ol style="list-style-type: none"> <li>1. Gear mounting bolts loose.</li> <li>2. Loose or damaged suspension components.</li> <li>3. Loose or damaged steering linkage.</li> <li>4. Internal gear noise.</li> <li>5. Pressure hose in contact with other components.</li> <li>6. Loose or damaged intermediate shaft or column.</li> </ol>	<ol style="list-style-type: none"> <li>1. Tighten bolts to specification.</li> <li>2. Inspect and repair suspension.</li> <li>3. Inspect and repair steering linkage.</li> <li>4. Repair steering gear.</li> <li>5. Reposition hose.</li> <li>6. Inspect and repair or replace.</li> </ol>
CHIRP OR SQUEAL	<ol style="list-style-type: none"> <li>1. Loose belt.</li> </ol>	<ol style="list-style-type: none"> <li>1. Adjust or replace.</li> </ol>
WHINE OR GROWL	<ol style="list-style-type: none"> <li>1. Low fluid level.</li> <li>2. Pressure hose in contact with other components.</li> <li>3. Internal pump noise.</li> </ol>	<ol style="list-style-type: none"> <li>1. Fill to proper level.</li> <li>2. Reposition hose.</li> <li>3. Replace pump.</li> </ol>
SUCKING AIR SOUND	<ol style="list-style-type: none"> <li>1. Loose return line clamp.</li> <li>2. O-ring missing or damaged on hose fitting.</li> <li>3. Low fluid level.</li> <li>4. Air leak between pump and reservoir.</li> <li>5. Reservoir cap not installed correctly.</li> </ol>	<ol style="list-style-type: none"> <li>1. Replace clamp.</li> <li>2. Replace o-ring.</li> <li>3. Fill to proper level.</li> <li>4. Repair as necessary.</li> <li>5. Install reservoir cap correctly.</li> </ol>
SCRUBBING OR KNOCKING	<ol style="list-style-type: none"> <li>1. Wrong tire size.</li> <li>2. Wrong gear.</li> </ol>	<ol style="list-style-type: none"> <li>1. Verify tire size.</li> <li>2. Verify gear.</li> </ol>

## STEERING (Continued)

*BINDING AND STICKING*

CONDITION	POSSIBLE CAUSE	CORRECTION
DIFFICULT TO TURN WHEEL STICKS OR BINDS	<ol style="list-style-type: none"> <li>1. Low fluid level.</li> <li>2. Tire pressure.</li> <li>3. Steering components (ball joints/tie rod ends).</li> <li>4. Loose belt.</li> <li>5. Low pump pressure.</li> <li>6. Column shaft coupler binding.</li> <li>7. Steering gear worn or out of adjustment.</li> </ol>	<ol style="list-style-type: none"> <li>1. Fill to proper level.</li> <li>2. Adjust tire pressure.</li> <li>3. Lube, inspect and repair as necessary.</li> <li>4. Adjust or replace.</li> <li>5. Pressure test and replace if necessary.</li> <li>6. Replace coupler.</li> <li>7. Repair or replace gear.</li> </ol>

*INSUFFICIENT ASST. OR POOR RETURN TO CENTER*

CONDITION	POSSIBLE CAUSE	CORRECTION
HARD TURNING OR MOMENTARY INCREASE IN TURNING EFFORT	<ol style="list-style-type: none"> <li>1. Tire pressure.</li> <li>2. Low fluid level.</li> <li>3. Loose belt.</li> <li>4. Lack of lubrication.</li> <li>5. Low pump pressure.</li> <li>6. Internal gear leak.</li> </ol>	<ol style="list-style-type: none"> <li>1. Adjust tire pressure.</li> <li>2. Fill to proper level.</li> <li>3. Adjust or replace.</li> <li>4. Inspect and lubricate steering and suspension compnents.</li> <li>5. Pressure test and repair as necessary.</li> <li>6. Pressure and flow test, and repair as necessary.</li> </ol>
STEERING WHEEL DOES NOT WANT TO RETURN TO CENTER POSITION	<ol style="list-style-type: none"> <li>1. Tire pressure.</li> <li>2. Wheel alignment.</li> <li>3. Lack of lubrication.</li> <li>4. High friction in steering gear.</li> </ol>	<ol style="list-style-type: none"> <li>1. Adjust tire pressure.</li> <li>2. Align front end.</li> <li>3. Inspect and lubricate steering and suspension compnents.</li> <li>4. Test and adjust gear as necessary.</li> </ol>

*LOOSE STEERING AND VEHICLE LEAD*

CONDITION	POSSIBLE CAUSE	CORRECTION
EXCESSIVE PLAY IN STEERING WHEEL	<ol style="list-style-type: none"> <li>1. Worn or loose suspension or steering components.</li> <li>2. Worn or loose wheel bearings.</li> <li>3. Steering gear mounting.</li> <li>4. Gear out of adjustment.</li> <li>5. Worn or loose steering coupler.</li> </ol>	<ol style="list-style-type: none"> <li>1. Inspect and repair as necessary.</li> <li>2. Inspect and repair or adjust bearings.</li> <li>3. Tighten gear mounting bolts to specification.</li> <li>4. Adjust gear to specification.</li> <li>5. Inspect and replace as necessary.</li> </ol>

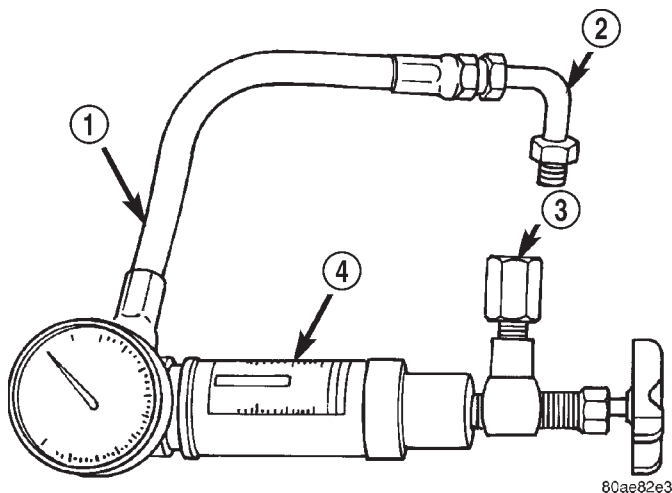


## STEERING (Continued)

CONDITION	POSSIBLE CAUSE	CORRECTION
VEHICLE PULLS OR LEADS TO ONE SIDE.	<ol style="list-style-type: none"> <li>1. Tire Pressure.</li> <li>2. Radial tire lead.</li> <li>3. Brakes dragging.</li> <li>4. Wheel alignment.</li> </ol>	<ol style="list-style-type: none"> <li>1. Adjust tire pressure.</li> <li>2. Rotate tires.</li> <li>3. Repair as necessary.</li> <li>4. Align front end.</li> </ol>

### DIAGNOSIS AND TESTING - POWER STEERING FLOW AND PRESSURE

The following procedure is used to test the operation of the power steering system on the vehicle. This test will provide the flow rate of the power steering pump along with the maximum relief pressure. Perform test any time a power steering system problem is present. This test will determine if the power steering pump or power steering gear is not functioning properly. The following pressure and flow test is performed using Power Steering Analyzer Tool kit 6815 (Fig. 2) and Adapter Kit 6893.



**Fig. 2 Pressure Test Gauge**

- 1 - GAUGE HOSE
- 2 - TUBE
- 3 - ADAPTER FITTINGS
- 4 - ANALYZER

### POWER STEERING ANALYZER INSTALLATION

#### WITHOUT HYDRAULIC BOOSTER

- (1) Remove the high pressure hose from the power steering pump.
- (2) Connect Tube 6844 into the pump hose fitting.

(3) Connect pressure gauge hose from the Power Steering Analyzer to Tube 6844.

(4) Connect Adapter 6826 to Power Steering Analyzer test valve end.

(5) Connect the power steering hose from the steering gear to Adapter 6826.

#### WITH HYDRAULIC BOOSTER

(1) Remove high pressure hose which goes to the steering gear from the tube coming out of the booster.

(2) Connect Adapter 6826 to the Power Steering Analyzer pressure gauge hose.

(3) Connect pressure gauge hose to the tube coming out of the booster.

(4) Connect Tube 6844 to the steering gear hose and Power Steering Analyzer test valve end.

#### FLOW AND PRESSURE TEST

- (1) Check belt condition and tension.
- (2) Open the test valve completely.
- (3) Start engine and let idle long enough to circulate power steering fluid through flow/pressure test gauge and to get air out of the fluid. Then shut off engine.
- (4) Check fluid level, add fluid as necessary. Start engine again and let idle.
- (5) Gauge should read below 1034 kPa (150 psi), if above, inspect the hoses for restrictions and repair as necessary. The initial pressure reading should be in the range of 345-552 kPa (50-80 psi).
- (6) Increase the engine speed to 1500 RPM and read the flow meter. If the flow rate (GPM) is below specification (Refer to pump specification chart for GPM) the pump should be replaced.

**CAUTION:** The following test procedure involves testing maximum pump pressure output and flow control valve operation. Do not leave valve closed for more than three seconds as the pump could be damaged.

## STEERING (Continued)

(7) Close valve fully three times and record highest pressure indicated each time. **All three readings must be above specifications and within 345 kPa (50 psi) of each other.**

- Pressures above specifications but not within 345 kPa (50 psi) of each other, replace pump.

- Pressures within 345 kPa (50 psi) of each other but below specifications, replace pump.

(8) Open the test valve and turn the steering wheel to the extreme left and right positions three times against the stops. Record the highest pressure reading at each position. Compare the readings to the pump specifications chart. If pressures readings are not within 50 psi of each other, the gear is leaking internally and must be repaired.

**CAUTION:** Do not force the pump to operate against the stops for more than 2 to 3 seconds at a time because, pump damage will result.

## PUMP SPECIFICATION

ENGINE	RELIEF PRESSURE (P.S.I.)	FLOW (G.P.M.) at 1500 RPM
3.9L	1450 to 1550	2.7 to 3.1
5.2L	1450 to 1550	2.7 to 3.1
5.9L	1450 to 1550	2.7 to 3.1
8.0L	1450 to 1550	2.7 to 3.1
5.9L Diesel	1450 to 1550	3.1 to 3.5
All With Hydraulic Booster	1450 to 1550	3.1 to 3.5

**NOTE:** After performing test and removing Power Steering Analyzer, check power steering fluid level.

# COLUMN

## TABLE OF CONTENTS

	page		page
<b>COLUMN</b>		<b>IGNITION SWITCH</b>	
DESCRIPTION.....	6	DESCRIPTION.....	11
OPERATION.....	6	OPERATION.....	11
REMOVAL.....	7	DIAGNOSIS AND TESTING.....	11
INSTALLATION.....	8	IGNITION SWITCH.....	11
SPECIFICATIONS.....	9	REMOVAL.....	12
<b>KEY-IN IGNITION SWITCH</b>		INSTALLATION.....	12
DESCRIPTION.....	9	<b>GEAR SHIFT LEVER</b>	
DIAGNOSIS AND TESTING.....	10	REMOVAL.....	13
IGNITION SWITCH AND KEY LOCK		INSTALLATION.....	13
CYLINDER.....	10	<b>STEERING WHEEL</b>	
<b>LOCK CYLINDER HOUSING</b>		REMOVAL.....	13
REMOVAL.....	10	INSTALLATION.....	13
INSTALLATION.....	11		

## COLUMN

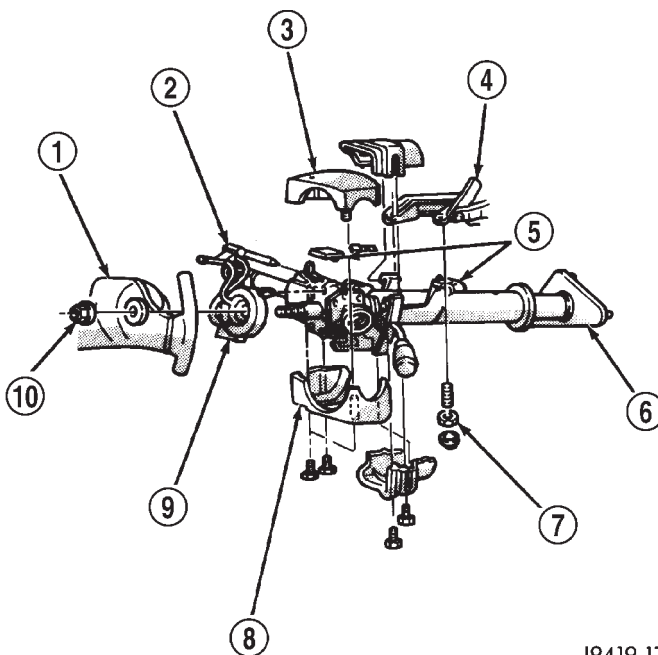
### DESCRIPTION

The tilt and standard column (Fig. 1) has been designed to be serviced as an assembly; less wiring, switches, shrouds, steering wheel, etc. Most steering column components can be serviced without removing the steering column from the vehicle.

### SERVICE PRECAUTIONS

Safety goggles should be worn at all times when working on steering columns.

To service the steering wheel, switches or the air-bag, refer to the WARNINGS and CAUTIONS below.



J9419-17

**Fig. 1 Steering Column**

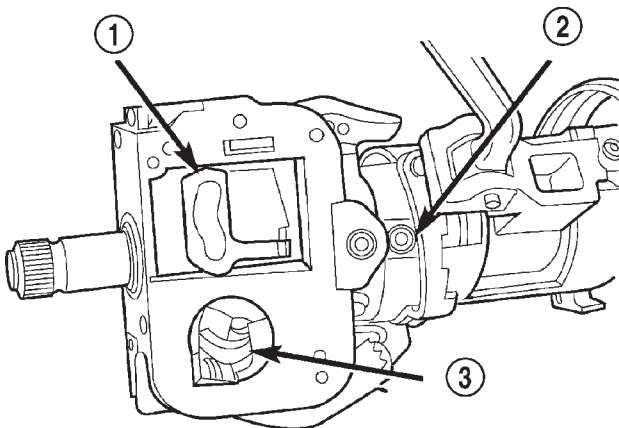
- 1 - STEERING WHEEL
- 2 - TILT LEVER
- 3 - UPPER SHROUD
- 4 - PANEL BRACKET
- 5 - SPACER
- 6 - TOE PLATE
- 7 - NUT
- 8 - LOWER SHROUD
- 9 - CLOCK SPRING
- 10 - NUT

## COLUMN (Continued)

**WARNING: THE AIRBAG SYSTEM IS A SENSITIVE, COMPLEX ELECTRO-MECHANICAL UNIT. BEFORE ATTEMPTING TO DIAGNOSE, REMOVE OR INSTALL THE AIRBAG SYSTEM COMPONENTS YOU MUST FIRST DISCONNECT AND ISOLATE THE BATTERY NEGATIVE (GROUND) CABLE. THEN WAIT TWO MINUTES FOR THE SYSTEM CAPACITOR TO DISCHARGE. FAILURE TO DO SO COULD RESULT IN ACCIDENTAL DEPLOYMENT OF THE AIRBAG AND POSSIBLE PERSONAL INJURY. THE FASTENERS, SCREWS, AND BOLTS, ORIGINALLY USED FOR THE AIRBAG COMPONENTS, HAVE SPECIAL COATINGS AND ARE SPECIFICALLY DESIGNED FOR THE AIRBAG SYSTEM. THEY MUST NEVER BE REPLACED WITH ANY SUBSTITUTES. ANYTIME A NEW FASTENER IS NEEDED, REPLACE WITH THE CORRECT FASTENERS PROVIDED IN THE SERVICE PACKAGE OR FASTENERS LISTED IN THE PARTS BOOKS.**

**CAUTION: Do not hammer on steering column shaft or shift tube. This may cause the shaft/shift tube to collapse or damage the bearing.**

**CAUTION: Do not attempt to remove the pivot pins to disassemble the tilting mechanism. Do not remove shaft lock plate, plate retainer, park lock link or slider. This will damage the column (Fig. 2) and (Fig. 3) .**



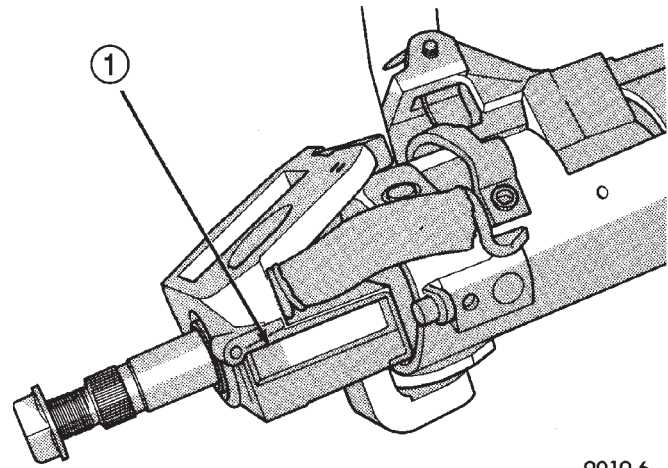
80bfe13f

**Fig. 2 Observe Cautions**

- 1 - CAUTION: NEVER REMOVE IGNITION LOCKING LINK
- 2 - CAUTION: NEVER REMOVE PARK LOCK SLIDER
- 3 - CAUTION: NEVER REMOVE SHAFT LOCK PLATE

## REMOVAL

- (1) Position the front wheels straight ahead.
- (2) Disconnect the negative (ground) cable from the battery.



9019-6

**Fig. 3 Observe Cautions**

- 1 - CAUTION: NEVER REMOVE SHAFT LOCK PLATE RETAINER

(3) Remove the airbag, (Refer to 8 - ELECTRICAL/RESTRAINTS/DRIVER AIRBAG - REMOVAL).

(4) Remove the steering wheel with an appropriate puller, (Refer to 19 - STEERING/COLUMN/STEERING WHEEL - REMOVAL).

**CAUTION: Ensure the puller bolts are fully engaged into the steering wheel and not into the clock-spring, before attempting to remove the wheel. Failure to do so may damage the steering wheel.**

(5) Remove the shift link rod in the engine compartment (if equipped). Pry the rod out from the grommet in the shift lever.

(6) Scribe or paint reference mark on the column shaft-to-coupler. This will aid in column shaft installation alignment. Remove the steering column shaft-to-coupler bolt (Fig. 4).

(7) Remove the steering column opening cover/knee blocker, (Refer to 23 - BODY/INSTRUMENT PANEL/STEERING COLUMN OPENING COVER - REMOVAL).

(8) Remove the PRNDL cable on column shift vehicles. Put the shift lever in **Park** position. Pull the cable and twist to remove from the position arm. Push the tab up on bottom of the cable retainer, then squeeze sides to remove retainer from the column (Fig. 5).

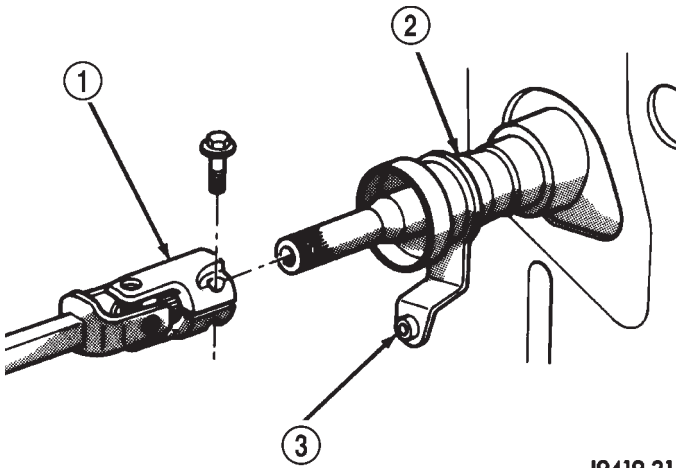
(9) Remove the tilt lever (if equipped) from the column.

(10) Remove the upper and lower lock housing shroud and remove the lower fixed shroud.

(11) Remove the turn signal multi-function switch connector with a 7mm socket (Fig. 6).

(12) Loosen the upper Support Bracket nuts to allow some slack. This will aid in removal of the upper fixed shroud.

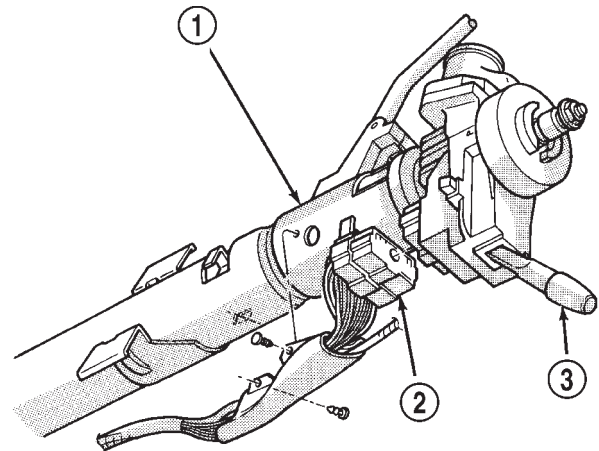
## COLUMN (Continued)



J9419-21

**Fig. 4 Steering Coupler-Typical**

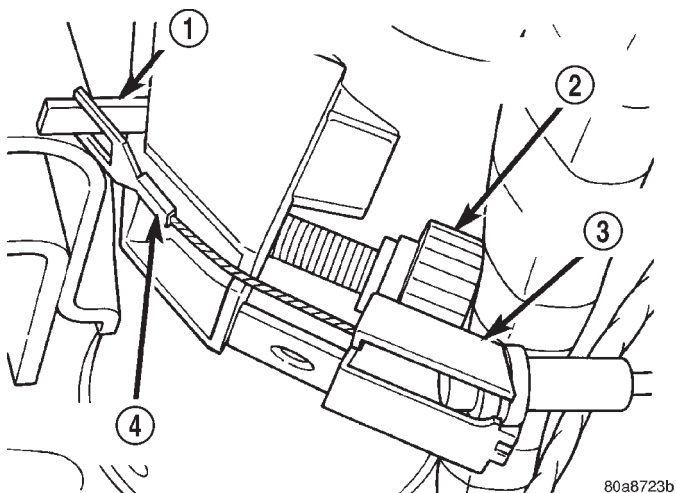
- 1 - STEERING COUPLER
- 2 - STEERING COLUMN
- 3 - SHIFT LEVER



J918J-1

**Fig. 6 Multi-function Switch**

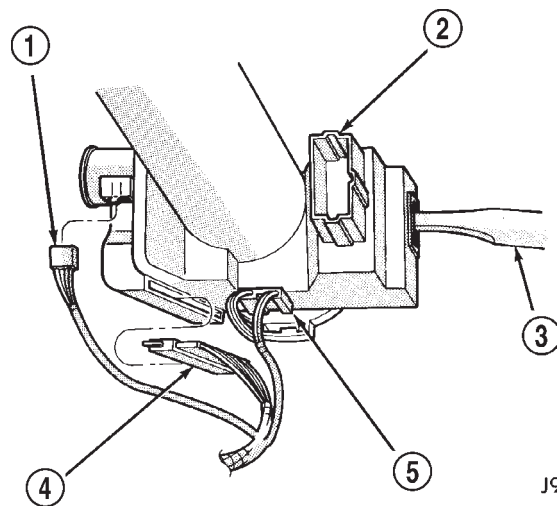
- 1 - STEERING COLUMN ASSY.
- 2 - MULTI-FUNCTION SWITCH CONNECTOR
- 3 - TURN SIGNAL SWITCH AND LEVER



80a8723b

**Fig. 5 PRNDL Drive**

- 1 - PRNDL LEVER
- 2 - THUMB SCREW
- 3 - CABLE RETAINER
- 4 - PRNDL CABLE



J918J-2

**Fig. 7 Steering Column Wiring**

- 1 - KEY-IN SWITCH & HALO LIGHT
- 2 - MULTI-FUNCTION SWITCH
- 3 - TURN SIGNAL SWITCH & LEVER
- 4 - IGNITION SWITCH
- 5 - SPEED CONTROL

(13) Remove the electrical connections from Key-in light, Ignition Switch, Horn, Overdrive Switch and Clock Spring (Speed Control) (Fig. 7).

(14) Remove the wiring harness from the column by prying out the plastic retainer buttons.

(15) Remove the toe plate fasteners.

(16) Remove the column from vehicle.

(17) Remove the Ignition and Multi-Function Switch, then remove the Clock Spring and tape the Clock Spring to prevent it from turning, (Refer to 8 - ELECTRICAL/RESTRAINTS/CLOCKSPRING REMOVAL).

**INSTALLATION**

(1) Install the clock spring and switches, (Refer to 8 - ELECTRICAL/RESTRAINTS/CLOCKSPRING - INSTALLATION).

**NOTE:** Turn the Ignition Switch to the on position and verify the gear shifter moves. If the shifter does not move ensure the Ignition Switch is installed properly.

(2) Column shift vehicles, install a new grommet. Use multi-purpose lubricant, or equivalent, to aid installation of the grommet.



## COLUMN (Continued)

**NOTE: A new grommet should be used when ever the rod is disconnected from the lever.**

- (3) Remove the shipping lock pin if necessary.
- (4) Install the column through the floor pan.
- (5) Position the column bracket breakaway capsules on the mounting studs. Install, but **loose assemble** the two upper bracket nuts.
- (6) With the front wheels in the straight-ahead position. Align steering column shaft to the coupler. Install a **new** pinch bolt and tighten to 49 N·m (36 ft. lbs.).
- (7) Clip the wiring harness on the steering column. Connect the multi- function switch wiring and tighten with 7mm socket.
- (8) Install the upper fixed shroud.
- (9) Be sure both breakaway capsules are fully seated in the slots in the column support bracket. Pull the column rearward then tighten upper bracket nuts to 12 N·m (105 in. lbs.).
- (10) Tighten the toe plate to floor pan attaching nuts to 22.5 N·m (200 in. lbs.).
- (11) Install the wiring connections to the column. Install the lower fixed shroud.

(12) Column shift vehicles, install the PRNDL driver cable. Place shifter in Park position. If indicator needs adjusting, turn thumb screw on cable retainer to adjust cable.

(13) Install the lock housing shrouds. Install the tilt lever (if equipped).

(14) Install the knee blocker and steering column opening cover, (Refer to 23 - BODY/INSTRUMENT PANEL/STEERING COLUMN OPENING COVER - INSTALLATION).

(15) Install steering wheel and tighten nut to 61 N·m (45 ft. lbs.), (Refer to 19 - STEERING/COLUMN/STEERING WHEEL - INSTALLATION).

(16) Install the airbag, (Refer to 8 - ELECTRICAL/RESTRAINTS/DRIVER AIRBAG - INSTALLATION).

(17) Column shift vehicles, connect the shift link rod to the transmission shift lever. Use multi-purpose lubricant, or an equivalent product, to aid the installation.

(18) Install the battery ground (negative) cable.

(19) Verify operation of the automatic transmission shift linkage and adjust as necessary, (Refer to 21 - TRANSMISSION/TRANSAXLE/AUTOMATIC - 44RE/GEAR SHIFT CABLE - ADJUSTMENTS).

## SPECIFICATIONS

## TORQUE CHART

## TORQUE SPECIFICATIONS

DESCRIPTION	N·m	Ft. Lbs.	In. Lbs.
Steering Wheel Nut	61	45	—
Steering Coupler Bolt	49	36	—
Steering Column Upper Bracket	12	—	105
Steering Column Toe Plate	23	—	200

## KEY-IN IGNITION SWITCH

## DESCRIPTION

The key-in ignition switch is integral to the ignition switch, which is mounted on the right side of the steering column. It closes a path to ground for the Central Timer Module (CTM) when the ignition key is inserted in the ignition lock cylinder and the

driver door ajar switch is closed (driver door is open). The key-in ignition switch opens the ground path when the key is removed from the ignition lock cylinder. The ground path is also opened when the driver door ajar switch is open (driver door is closed).

The key-in ignition switch cannot be repaired and, if faulty or damaged, the entire ignition switch must be replaced.(Refer to 19 - STEERING/COLUMN/IGNITION SWITCH - REMOVAL).



## KEY-IN IGNITION SWITCH (Continued)

## DIAGNOSIS AND TESTING - IGNITION SWITCH AND KEY LOCK CYLINDER

## ELECTRICAL DIAGNOSIS

For ignition switch electrical schematics, refer to Ignition Switch in the appropriate section of Electrical Wiring Diagrams.

## MECHANICAL DIAGNOSIS (KEY DIFFICULT TO ROTATE)

**Vehicles equipped with an automatic transmission and a floor mounted shifter:** a cable is used to connect the interlock device in the steering column assembly, to the transmission floor shift lever. This interlock device is used to lock the transmission shifter in the PARK position when the key lock cylinder is rotated to the LOCKED or ACCESSORY position. The interlock device within the steering column is not serviceable. If repair is necessary, the steering column assembly must be replaced. (Refer to 19 - STEERING/COLUMN - REMOVAL).

If the ignition key is difficult to rotate to or from the LOCK or ACCESSORY position, it may not be the fault of the key cylinder or the steering column components. The brake transmission shift interlock cable may be out of adjustment. Refer to Brake Transmission Shift Interlock Cable Adjustment in Transmissions for adjustment procedures.

**Vehicles equipped with an automatic transmission and a steering column mounted shifter:** an interlock device is located within the steering column. This interlock device is used to lock the transmission shifter in the PARK position when the key lock cylinder is in the LOCKED or ACCESSORY position. If it is difficult to rotate the key to or from the LOCK or ACCESSORY position, the interlock device within the steering column may be defective. This device is not serviceable. If repair is necessary, the steering column assembly must be replaced. (Refer to 19 - STEERING/COLUMN - REMOVAL).

**Vehicles equipped with a manual transmission and a floor mounted shifter:** on certain models, a lever is located on the steering column behind the ignition key lock cylinder. The lever must be manually operated to allow rotation of the ignition key lock cylinder to the LOCK or ACCESSORY position. If it is difficult to rotate the key to the LOCK or ACCESSORY position, the lever mechanism may be defective. This mechanism is not serviceable. If repair is necessary, the steering column assembly must be replaced. (Refer to 19 - STEERING/COLUMN - REMOVAL).

On other models, the ignition key cylinder must be depressed to allow it to be rotated into the LOCK or ACCESSORY position. If it is difficult to rotate the key to the LOCK or ACCESSORY position, the lock

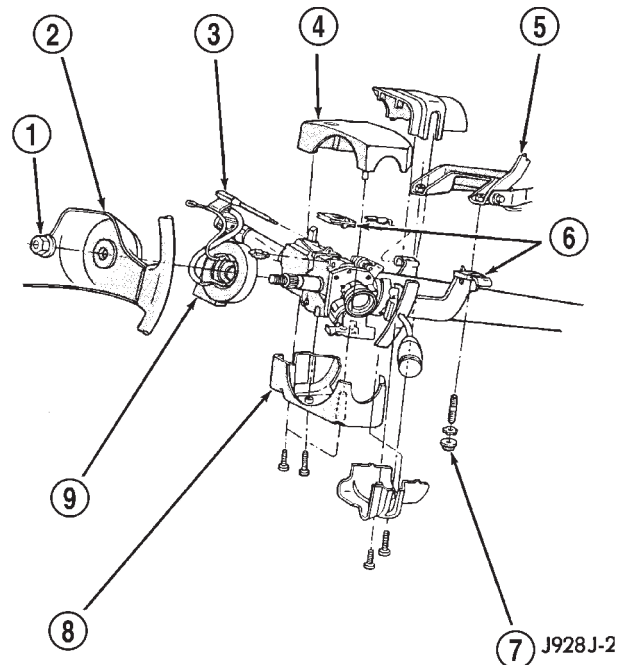
mechanism within the steering column may be defective. This mechanism is not serviceable. If repair is necessary, the steering column assembly must be replaced. (Refer to 19 - STEERING/COLUMN - REMOVAL).

## LOCK CYLINDER HOUSING

## REMOVAL

The ignition key must be in the key cylinder for cylinder removal.

- (1) Disconnect negative cable from battery.
- (2) If equipped with tilt column, remove tilt lever by turning it counterclockwise.
- (3) Remove upper and lower covers (shrouds) from steering column (Fig. 8).



**Fig. 8 Shroud Removal/Installation—Typical**

- 1 - NUT
- 2 - STEERING WHEEL
- 3 - TILT LEVER
- 4 - UPPER SHROUD
- 5 - PANEL BRACKET
- 6 - SPACER
- 7 - NUT
- 8 - LOWER SHROUD
- 9 - CLOCK SPRING

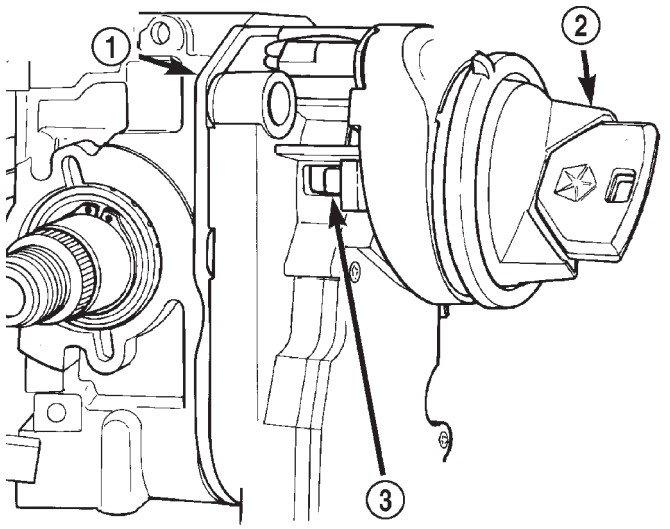
(4) If equipped with automatic transmission, place shifter in PARK position.

(5) A retaining pin (Fig. 9) is located at side of key cylinder assembly.

- (a) Rotate key to RUN position.

## LOCK CYLINDER HOUSING (Continued)

(b) Press in on retaining pin while pulling key cylinder from ignition switch.



80a592b6

**Fig. 9 Retaining Pin**

- 1 - IGNITION SWITCH
- 2 - KEY/KEY CYLINDER (RUN POSITION)
- 3 - RETAINING PIN

## INSTALLATION

The ignition key must be in the key cylinder for cylinder installation.

(1) Install the lock cylinder into the housing using care to align the end of the lock cylinder with the ignition switch.

(2) Push the lock cylinder in until it clicks.

## IGNITION SWITCH

### DESCRIPTION

The electrical ignition switch is located on the steering column. It is used as the main on/off switching device for most electrical components. The mechanical key lock cylinder is used to engage/disengage the electrical ignition switch.

### OPERATION

**Vehicles equipped with an automatic transmission and a floor mounted shifter:** a cable is used to connect the interlock device in the steering column assembly, to the transmission floor shift lever. This interlock device is used to lock the transmission shifter in the PARK position when the key lock cylinder is rotated to the LOCKED or ACCESSORY position. The interlock device within the steering column is not serviceable. If repair is necessary, the steering column assembly must be replaced. (Refer to 19 - STEERING/COLUMN - REMOVAL).

If the ignition key is difficult to rotate to or from the LOCK or ACCESSORY position, it may not be the fault of the key cylinder or the steering column components. The brake transmission shift interlock cable may be out of adjustment. Refer to Brake Transmission Shift Interlock Cable Adjustment in Group 21, Transmissions for adjustment procedures.

**Vehicles equipped with an automatic transmission and a steering column mounted shifter:** an interlock device is located within the steering column. This interlock device is used to lock the transmission shifter in the PARK position when the key lock cylinder is in the LOCKED or ACCESSORY position. If it is difficult to rotate the key to or from the LOCK or ACCESSORY position, the interlock device within the steering column may be defective. This device is not serviceable. If repair is necessary, the steering column assembly must be replaced. (Refer to 19 - STEERING/COLUMN - REMOVAL).

**Vehicles equipped with a manual transmission and a floor mounted shifter:** on certain models, a lever is located on the steering column behind the ignition key lock cylinder. The lever must be manually operated to allow rotation of the ignition key lock cylinder to the LOCK or ACCESSORY position. If it is difficult to rotate the key to the LOCK or ACCESSORY position, the lever mechanism may be defective. This mechanism is not serviceable. If repair is necessary, the steering column assembly must be replaced. (Refer to 19 - STEERING/COLUMN - REMOVAL).

On other models, the ignition key cylinder must be depressed to allow it to be rotated into the LOCK or ACCESSORY position. If it is difficult to rotate the key to the LOCK or ACCESSORY position, the lock mechanism within the steering column may be defective. This mechanism is not serviceable. If repair is necessary, the steering column assembly must be replaced. (Refer to 19 - STEERING/COLUMN - REMOVAL).

## DIAGNOSIS AND TESTING - IGNITION SWITCH

### TEST AND REPAIR

If the key removal effort is excessive on a vehicle with a automatic transmission first adjust the shift linkage, (Refer to 21 - TRANSMISSION/TRAN-SAXLE/AUTOMATIC - 42RE/GEAR SHIFT CABLE - ADJUSTMENTS).

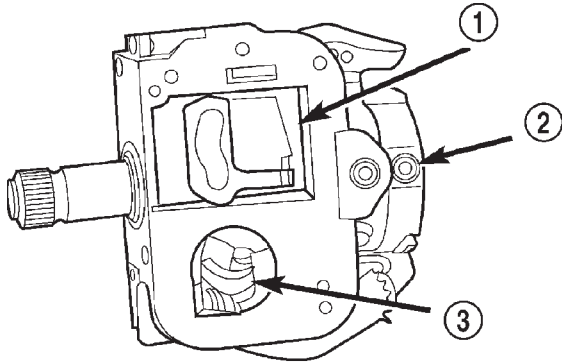
If the ignition switch effort is excessive remove the ignition key cylinder from the steering column. (Refer to 19 - STEERING/COLUMN/LOCK CYLINDER HOUSING - INSTALLATION). Check the turning effort of the key cylinder. If the ignition key cylinder effort is excessive replace the key cylinder. If the

## IGNITION SWITCH (Continued)

ignition key cylinder operates properly look for the following conditions.

(1) Look for rough areas or flash in the casting and if found remove with a file (Fig. 10).

(2) Grease the lock plate actuator, lock plate, slider and locking link.



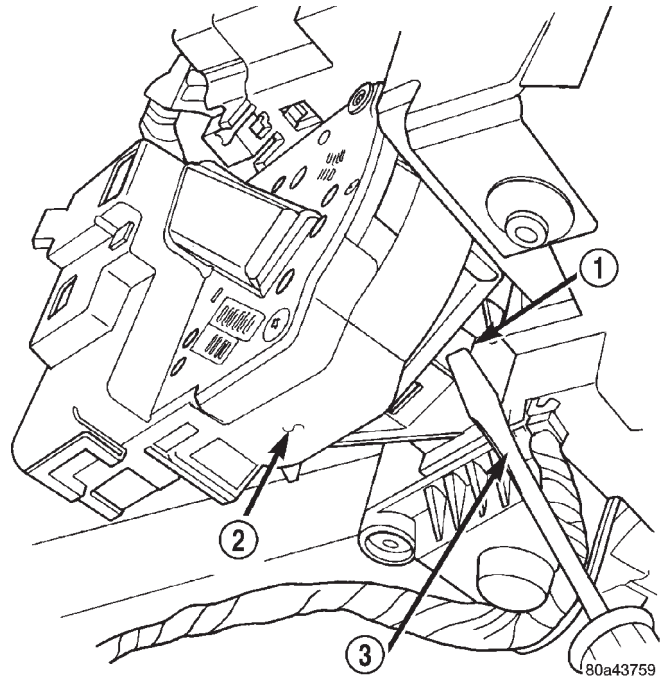
80bfe145

**Fig. 10 Steering Column Flash Removal**

1 - FILE THIS AREA TO REMOVE FLASHING AND PROVIDE CLEARANCE TO ELIMINATE BINDING

2 - PARK LOCK SLIDER

3 - CAUTION: NEVER REMOVE SHAFT LOCK PLATE



80a43759

**Fig. 11 Ignition Switch Lock Tab**

1 - LOCK TAB

2 - IGNITION SWITCH

3 - SCREWDRIVER

## REMOVAL

The ignition key must be in the key cylinder for cylinder removal. The key cylinder must be removed first before removing ignition switch.

(1) Remove key cylinder, (Refer to 19 - STEERING/COLUMN/LOCK CYLINDER HOUSING - REMOVAL).

(2) Remove lower steering column cover screws and remove cover (Fig. 8).

(3) Remove ignition switch mounting screw (Fig. 13). Use tamper proof torx bit to remove the screw.

(4) Using a small screwdriver, push on locking tab (Fig. 11) and remove switch from steering column.

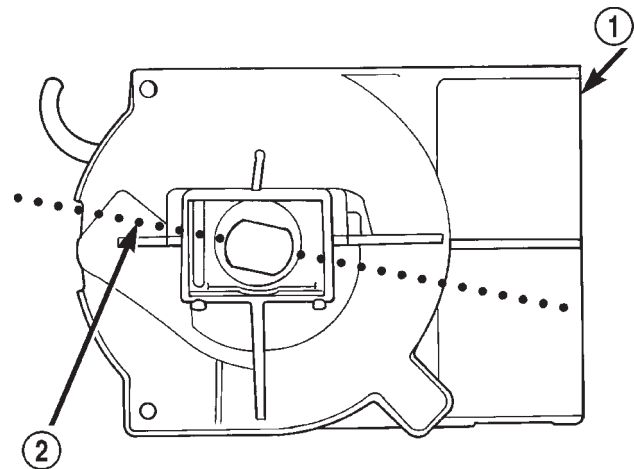
(5) Disconnect two electrical connectors at rear of ignition switch (Fig. 13).

## INSTALLATION

The ignition key must be in the key cylinder for cylinder removal. The key cylinder must be removed first before removing ignition switch.

(1) Before installing ignition switch, rotate the slot in the switch to the ON position (Fig. 12).

(2) Connect two electrical connectors to rear of ignition switch. Make sure that locking tabs are fully seated into wiring connectors.



80a43850

**Fig. 12 Switch In ON Position**

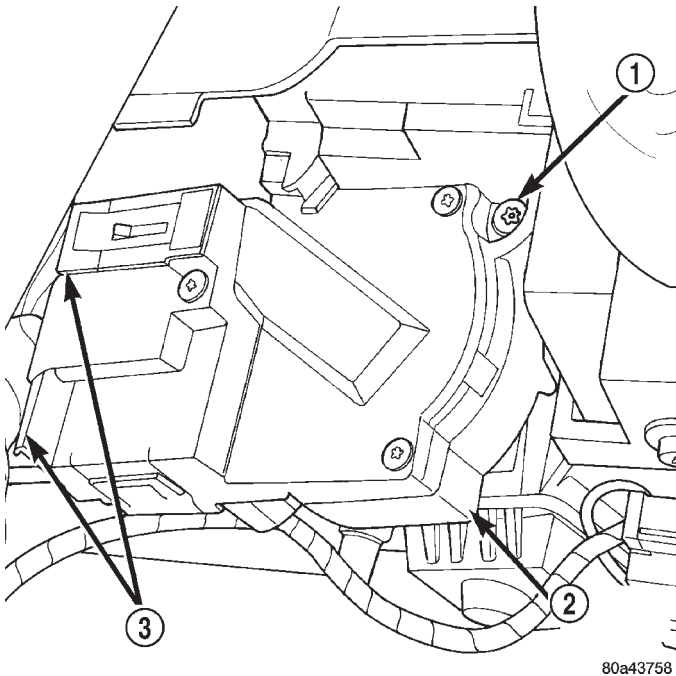
1 - IGNITION SWITCH

2 - ROTATE TO ON POSITION

(3) Position switch to column and install tamper proof screw. Tighten screw to 3 N·m (26 in. lbs.).

(4) Install steering column lower cover.

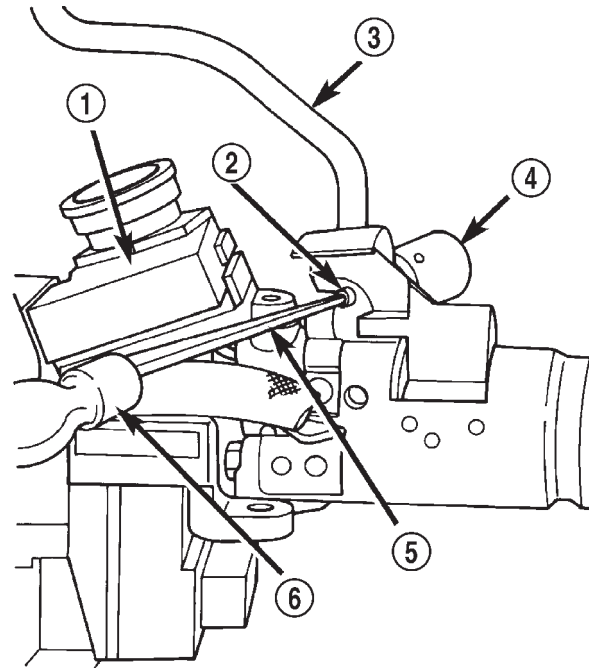
## IGNITION SWITCH (Continued)



80a43758

**Fig. 13 Ignition Switch Removal/Installation**

- 1 - TAMPER PROOF SCREW
- 2 - IGNITION SWITCH
- 3 - ELECTRICAL CONNECTORS



80bfe146

**Fig. 14 Gear Shift Lever Removal**

- 1 - IGNITION SWITCH
- 2 - KNURLED PIN
- 3 - GEARSHIFT LEVER
- 4 - SOCKET
- 5 - DRIFT
- 6 - HAMMER

## GEAR SHIFT LEVER

**REMOVAL**

(1) Support the steering column assembly as shown in (Fig. 14) using a suitable size socket and back-up support.

(2) Disconnect over drive switch wiring.

(3) Using a drift of the appropriate size drive the knurled pin out of the steering column and gear shift lever. Remove the gear shift lever from the steering column assembly.

**CAUTION:** The pin can only be removed from the direction shown (Fig. 14).

**INSTALLATION**

(1) Support the steering column using a suitable size socket and back-up support.

(2) Install the gear shift lever into the steering column assembly. Align the pin holes in the gear shift lever and the steering column assembly.

**CAUTION:** The pin must be installed in the original direction.

(3) Carefully Install the pin into the steering column assembly and through the shift lever. If the pin binds check the alignment on the holes. Be sure pin is fully installed into the steering column assembly.

(4) Connect over drive switch wiring.

## STEERING WHEEL

**REMOVAL**

For steering wheel removal procedure,(Refer to 8 - ELECTRICAL/RESTRAINTS/CLOCKSPRING REMOVAL) .

**INSTALLATION**

For steering wheel installation procedure,(Refer to 8 - ELECTRICAL/RESTRAINTS/CLOCKSPRING INSTALLATION).

# GEAR

## TABLE OF CONTENTS

	page		page
<b>GEAR</b>		<b>INSTALLATION</b> .....	23
DESCRIPTION.....	14	<b>PITMAN SHAFT SEAL</b>	
OPERATION.....	14	REMOVAL.....	23
DIAGNOSIS AND TESTING.....	14	INSTALLATION.....	24
POWER STEERING GEAR LEAKAGE.....	14	<b>SPOOL VALVE</b>	
REMOVAL.....	16	REMOVAL.....	24
INSTALLATION.....	16	INSTALLATION.....	26
ADJUSTMENTS.....	16	<b>STEERING GEAR HOUSING PLUG</b>	
SPECIFICATIONS.....	19	REMOVAL.....	27
SPECIAL TOOLS.....	20	INSTALLATION.....	27
<b>PITMAN BEARING</b>		<b>WORM SHAFT</b>	
REMOVAL.....	20	REMOVAL.....	27
INSTALLATION.....	21	INSTALLATION.....	29
<b>PITMAN SHAFT</b>			
REMOVAL.....	22		

## GEAR

### DESCRIPTION

The power steering gear is a recirculating ball type gear (Fig. 1). The gear ratio's used are 17.5:1 and 14:1.

### OPERATION

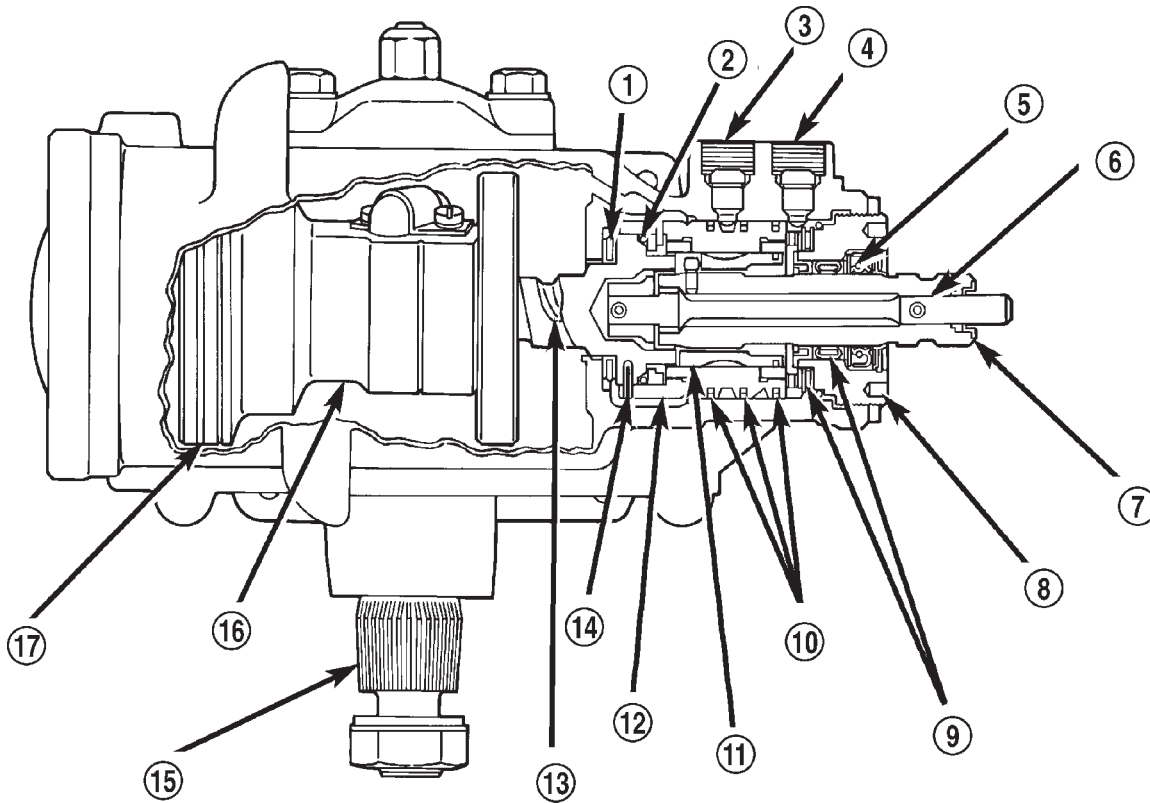
The gear acts as a rolling thread between the worm shaft and rack piston. The worm shaft is supported by a thrust bearing at the lower end and a

bearing assembly at the upper end. When the worm shaft is turned from input from the steering column the rack piston moves. The rack piston teeth mesh with the pitman shaft. Turning the worm shaft, turns the pitman shaft, which turns the steering linkage.

### DIAGNOSIS AND TESTING - POWER STEERING GEAR LEAKAGE

(1) Possible power steering gear leakage areas. (Fig. 2).

## GEAR (Continued)



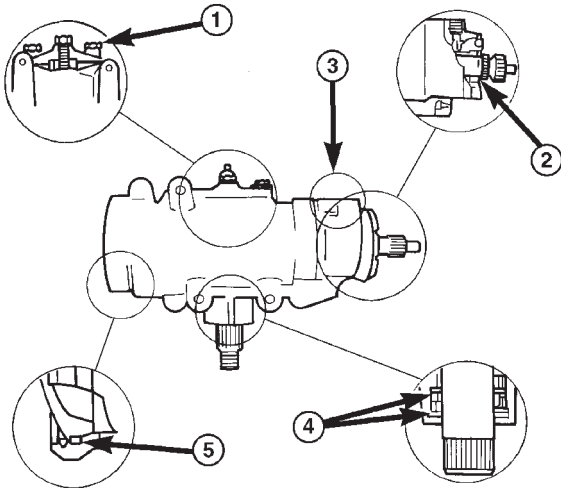
80be477b

**Fig. 1 Power Steering Gear**

- |                    |                   |
|--------------------|-------------------|
| 1 - THRUST BEARING | 10 - TEFLON SEALS |
| 2 - O-RING SEAL    | 11 - SPOOL VALVE  |
| 3 - INLET          | 12 - VALVE BODY   |
| 4 - OUTLET         | 13 - WORMSHAFT    |
| 5 - SEAL           | 14 - PIN          |
| 6 - TORSION BAR    | 15 - PITMAN SHAFT |
| 7 - STUB SHAFT     | 16 - RACK PISTON  |
| 8 - ADJUSTER PLUG  | 17 - TEFLON RING  |
| 9 - THRUST BEARING |                   |



GEAR (Continued)



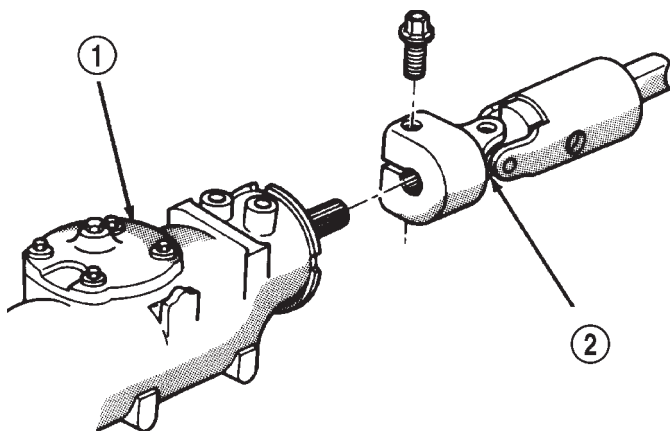
- 1. SIDE COVER LEAK - TORQUE SIDE COVER BOLTS TO SPECIFICATION. REPLACE THE SIDE COVER SEAL IF THE LEAKAGE PERSISTS.
- 2. ADJUSTER PLUG SEAL - REPLACE THE ADJUSTER PLUG SEALS.
- 3. PRESSURE LINE FITTING - TORQUE THE HOSE FITTING NUT TO SPECIFICATIONS. IF LEAKAGE PERSISTS, REPLACE THE SEAL.
- 4. PITMAN SHAFT SEALS - REPLACE THE SEALS.
- 5. TOP COVER SEAL - REPLACE THE SEAL.

80a1c3c2

**Fig. 2 STEERING GEAR**

**REMOVAL**

- (1) Place the front wheels in a straight-ahead position.
- (2) Disconnect and cap the fluid hoses from steering gear.
- (3) Remove coupler pinch bolt at the steering gear and slide shaft off gear (Fig. 3).

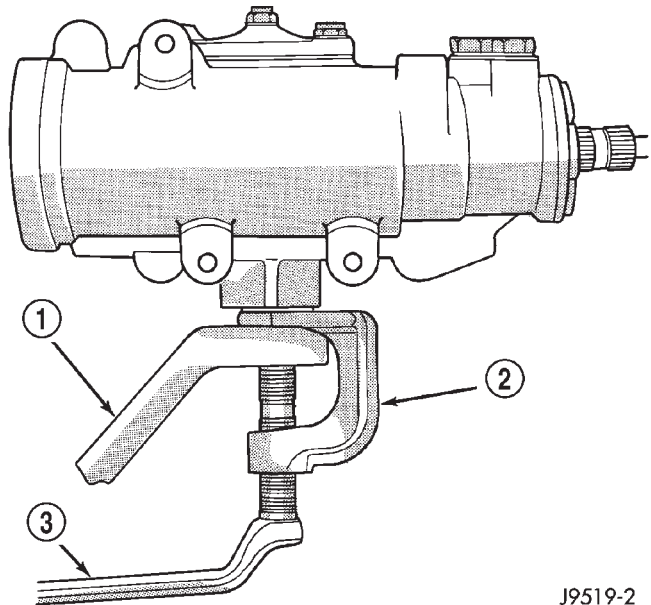


J9419-20

**Fig. 3 Column Shaft**

- 1 - STEERING GEAR
- 2 - STEERING COUPLER

- (4) Mark the pitman shaft and pitman arm for installation reference. Remove the pitman arm from the shaft with Puller C-4150A (Fig. 4).



J9519-2

**Fig. 4 Pitman Arm**

- 1 - PITMAN ARM
- 2 - SPECIAL TOOL C-4150-A
- 3 - WRENCH

- (5) Remove steering gear retaining bolts and nuts. Remove the steering gear from the vehicle.

**INSTALLATION**

- (1) Position the steering gear on the frame rail and install the bolts. Tighten mounting bolts to specifications.
- (2) Align steering coupler on gear shaft. Install pinch bolt and tighten to 49 N-m (36 ft. lbs.) torque.
- (3) Align and install the pitman arm.
- (4) Install the washer and retaining nut on the pitman shaft. Tighten the nut to 251 N-m (185 ft. lbs.).
- (5) Connect fluid hoses to steering gear, tighten to 31 N-m (23 ft. lbs.). Add fluid, (Refer to 19 - STEERING/PUMP - STANDARD PROCEDURE).

**ADJUSTMENTS**

**CAUTION:** Steering gear must be adjusted in the proper order. If adjustments are not performed in order, gear damage and improper steering response may result.

**NOTE:** Adjusting the steering gear in the vehicle is not recommended. Remove gear from the vehicle and drain the fluid. Then mount gear in a vise to perform adjustments.

## GEAR (Continued)

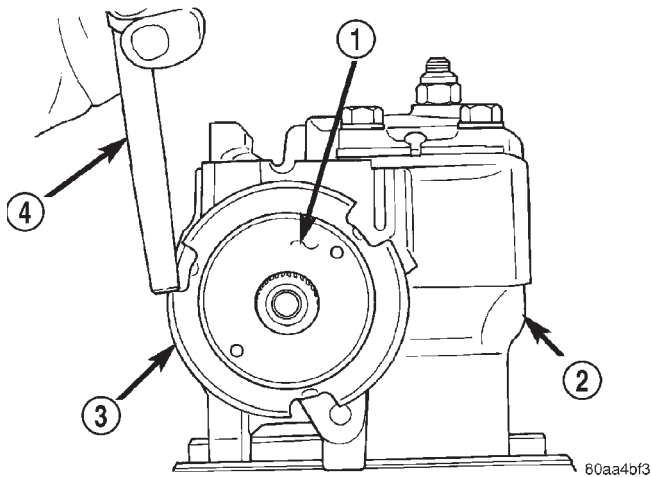
**WORM THRUST BEARING PRELOAD**

(1) Mount the gear carefully into a vise.

**CAUTION:** Do not overtighten the vise on the gear case. This may affect the adjustment

(2) Remove adjuster plug locknut (Fig. 5) .

(3) Rotate the stub shaft back and forth with a 12 point socket to drain the remaining fluid.



**Fig. 5 Adjuster Lock Nut**

- 1 - ADJUSTER NUT
- 2 - STEERING GEAR
- 3 - LOCK NUT
- 4 - PUNCH

(4) Turn the adjuster in with Spanner Wrench C-4381. Tighten the plug and thrust bearing in the housing until firmly bottomed in the housing about 28-31 N·m (20-23 ft. lbs.).

(5) Place an index mark on the housing even with one of the holes in adjuster plug (Fig. 6) .

(6) Measure back (counterclockwise) 18 mm (0.70 in) and mark the housing (Fig. 7) .

(7) Rotate adjustment cap back (counterclockwise) with spanner wrench until hole is aligned with the second mark (Fig. 8) .

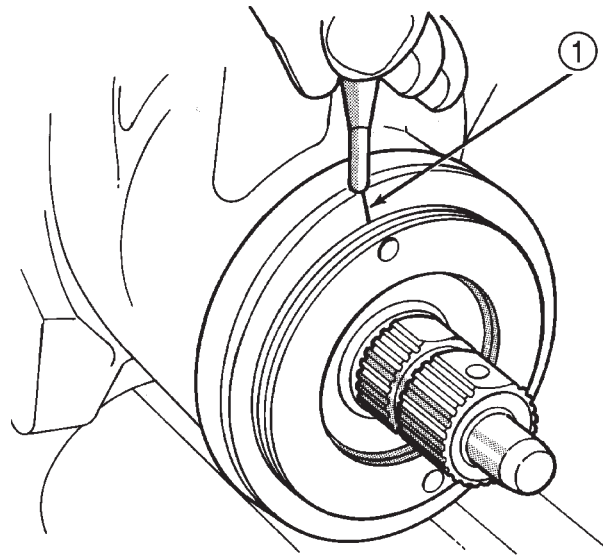
(8) Install and tighten lock nut to 108 N·m (80 ft. lbs.). Be sure adjustment cap does not turn while tightening the lock nut.

**PITMAN SHAFT OVER-CENTER PRELOAD**

**NOTE:** Before performing this procedure, the worm bearing preload adjustment must be performed.

(1) Rotate the stub shaft with a 12 point socket from stop to stop and count the number of turns.

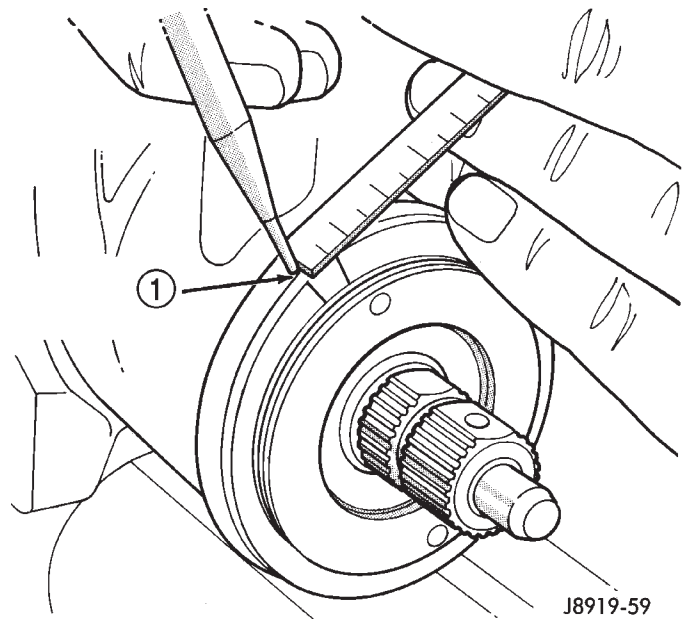
(2) Starting at either stop, turn the stub shaft back 1/2 the total number of turns. This is the center of the gear travel (Fig. 9) .



J8919-58

**Fig. 6 Alignment Marking On Housing**

1 - INDEX



J8919-59

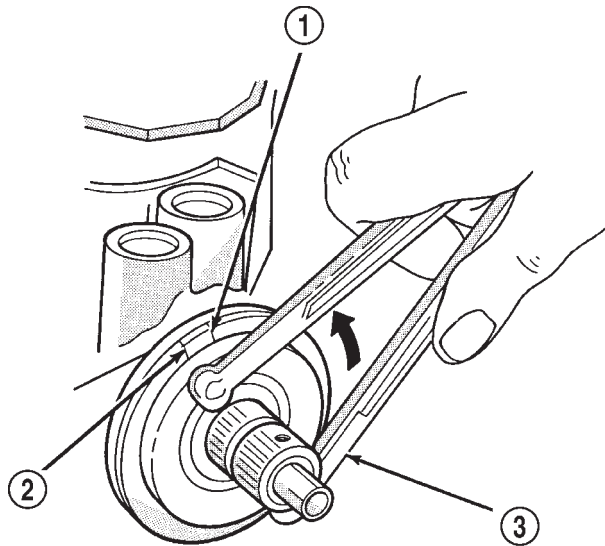
**Fig. 7 Second Marking On Housing**

1 - REFERENCE MARK

(3) Place the torque wrench in the vertical position on the stub shaft. Rotate the wrench 45 degrees each side of the center and record the highest rotational torque in this range (Fig. 10) . This is the Over-Center Rotating Torque.

**NOTE:** The stub shaft must rotate smoothly without sticking or binding.

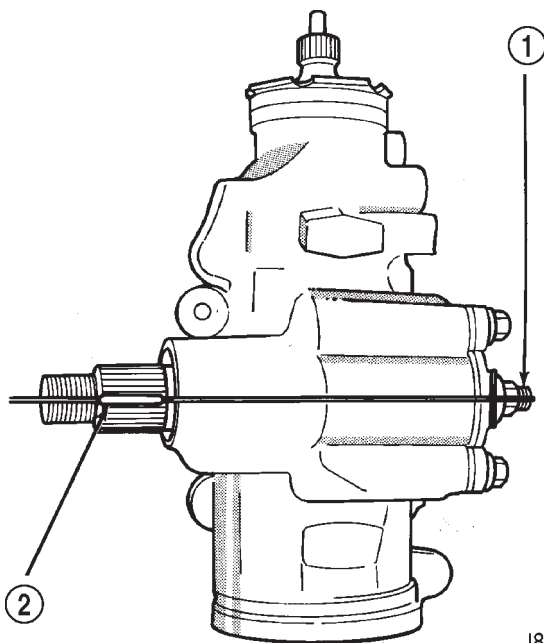
GEAR (Continued)



J9219-30

**Fig. 8 Aligning To The Second Mark**

- 1 - FIRST MARK
- 2 - SECOND MARK
- 3 - SPANNER WRENCH



J8919-62

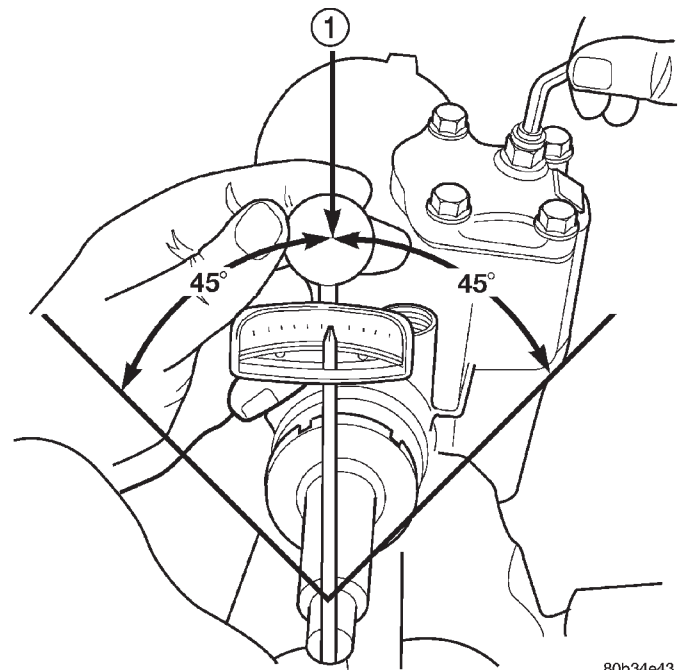
**Fig. 9 Steering Gear Centered**

- 1 - ADJUSTMENT SCREW
- 2 - MASTER SPLINE

(4) Rotate the stud shaft between 180° and 270° to the left of center and record the left off-center preload. Repeat this to the right of center and record the right off-center preload. The average of these two recorded readings is the Preload Rotating Torque.

(5) The Over-Center Rotating Torque should be 0.23-0.68 N-m (2-6 in. lbs.) **higher** than the Preload Rotating Torque.

(6) If an adjustment to the Over-Center Rotating Torque is necessary, first loosen the adjuster lock nut. Then turn the pitman shaft adjuster screw back (COUNTERCLOCKWISE) until fully extended, then turn back in (CLOCKWISE) one full turn.



80b34e43

**Fig. 10 Checking Over-center Rotation Torque**

- 1 - CENTER

(7) Remeasure Over-Center Rotating Torque. If necessary turn the adjuster screw and repeat measurement until correct Over-Center Rotating Torque is reached.

**NOTE: To increase the Over-Center Rotating Torque turn the screw CLOCKWISE.**

(8) Prevent the adjuster screw from turning while tightening adjuster lock nut. Tighten the adjuster lock nut to 49 N-m (36 ft. lbs.).

## SPECIFICATIONS

## POWER STEERING GEAR

## SPECIFICATIONS

DESCRIPTION	SPECIFICATION
Steering Gear Type	Recirculating Ball

DESCRIPTION	SPECIFICATION
Gear Code & Ratio AM	17.5:1
Gear Code & Ratio HC/FW	14:1
Gear Code & Ratio JZ	16-13:1

## TORQUE SPECIFICATIONS

DESCRIPTION	N-m	Ft. Lbs.	In. Lbs.
Wormshaft Bearing Preload	0.85-1.64	—	7.5-14.5
Pitman Shaft Overcenter Drag New Gear (under 400 miles)	0.23-0.68	—	2-6 + Wormshaft Preload

## TORQUE CHART

## TORQUE SPECIFICATIONS

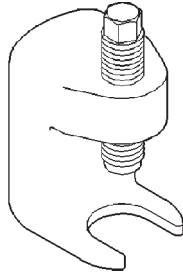
DESCRIPTION	N-m	Ft. Lbs.	In. Lbs.
Steering Gear Mounting Frame Bolts	176	130	—
Line Fittings Pressure	31	23	—
Line Fittings Return	31	23	—
Steering Gear Adjustment Cap Locknut	108	80	—
Steering Gear Adjustment Screw Locknut	49	36	—
Steering Gear Pitman Shaft Nut	251	185	—
Steering Gear Rack Piston Plug	150	111	—
Steering Gear Side Cover Bolts	60	44	—
Steering Gear Return Guide Clamp Bolt	4.8	—	43

## SPECIAL TOOLS

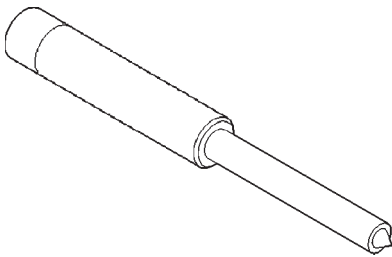
## POWER STEERING GEAR



*Remover/Installer, Steering Plug C-4381*



*Remover, Pitman Arm C-4150A*



*Remover/Installer Steering Rack Piston C-4175*

## PITMAN BEARING

## REMOVAL

(1) Clean exposed end of pitman shaft and housing with a wire brush.

(2) Remove preload adjuster nut (Fig. 11).

(3) Rotate the stub shaft with a 12 point socket from stop to stop and count the number of turns.

(4) Center the stub shaft by rotating it from the stop 1/2 of the total amount of turns.

(5) Remove side cover bolts and remove side cover, gasket and pitman shaft as an assembly (Fig. 11).

**NOTE:** The pitman shaft will not clear the housing if it is not centered.

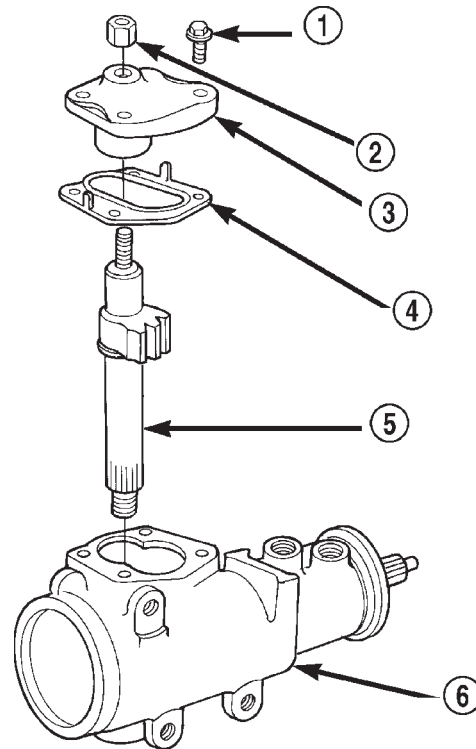
(6) Remove pitman shaft from the side cover.

(7) Remove dust seal from the housing with a seal pick (Fig. 12).

**CAUTION:** Use care not to score the housing bore when prying out seals and washer.

(8) Remove retaining ring with snap ring pliers.

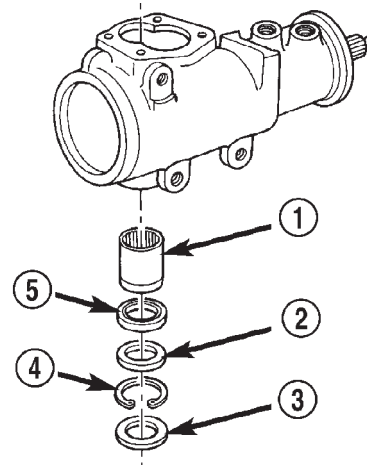
(9) Remove washer from the housing.



80a3543f

**Fig. 11 Side Cover and Pitman Shaft**

- 1 - SIDE COVER BOLTS
- 2 - PRELOAD ADJUSTER NUT
- 3 - SIDE COVER
- 4 - GASKET SEAL
- 5 - PITMAN SHAFT GEAR
- 6 - HOUSING ASSEMBLY



80aa4b10

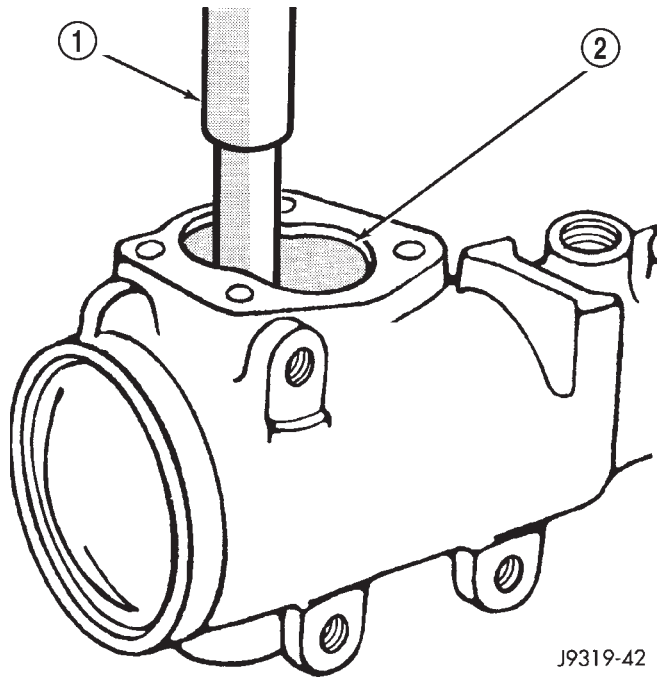
**Fig. 12 Pitman Shaft Seals & Bearing**

- 1 - BEARING
- 2 - WASHER
- 3 - DUST SEAL
- 4 - RETAINER
- 5 - OIL SEAL

## PITMAN BEARING (Continued)

(10) Remove oil seal from the housing with a seal pick.

(11) Remove pitman shaft bearing from housing with a bearing driver and handle (Fig. 13).



**Fig. 13 Needle Bearing Removal**

- 1 - REMOVER  
2 - SIDE COVER AREA

## INSTALLATION

(1) Install upper pitman shaft bearing, with Driver 8294 and Handle C-4171 (Fig. 14). Drive bearing into housing until the driver bottoms out.

**NOTE:** Install upper pitman shaft bearing with the part number/letters facing the driver.

(2) Install lower pitman shaft bearing with the other side Driver 8294 and Handle C-4171 (Fig. 15). Drive bearing into housing until the bearing shoulder is seated against the housing.

(3) Coat the oil seal and backup washers with **special greases** supplied with the new seal.

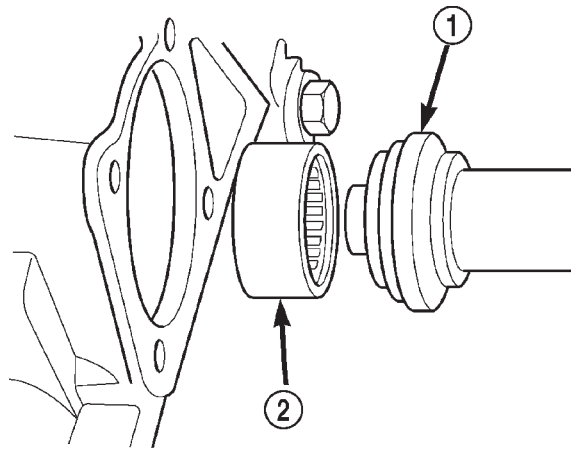
(4) Install the oil seal with Driver 8294 and Handle C-4171.

(5) Install plastic backup washer.

**NOTE:** The plastic backup washer has a lip on the inside diameter that faces down towards the oil seal.

(6) Install metal backup washer.

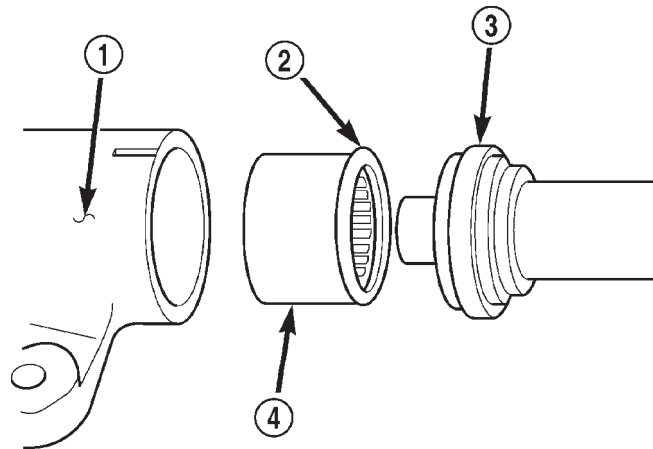
(7) Install the retainer ring with snap ring pliers.



80b6b1a5

**Fig. 14 Upper Pitman**

- 1 - DRIVER  
2 - UPPER BEARING



80b6b1a6

**Fig. 15 Lower Pitman Shaft Bearing**

- 1 - STEERING GEAR  
2 - BEARING SHOULDER  
3 - DRIVER  
4 - LOWER BEARING

(8) Coat the dust seal with **special grease** supplied with the new seal.

(9) Install dust seal with Driver 8294 and Handle C-4171.

(10) Install new pitman shaft cover o-ring.

(11) Install pitman shaft assembly into the housing.

(12) Install cover bolts and tighten to 62 N-m (46 ft. lbs.).

(13) Perform over-center rotation torque adjustment, (Refer to 19 - STEERING/GEAR - DIAGNOSIS AND TESTING).

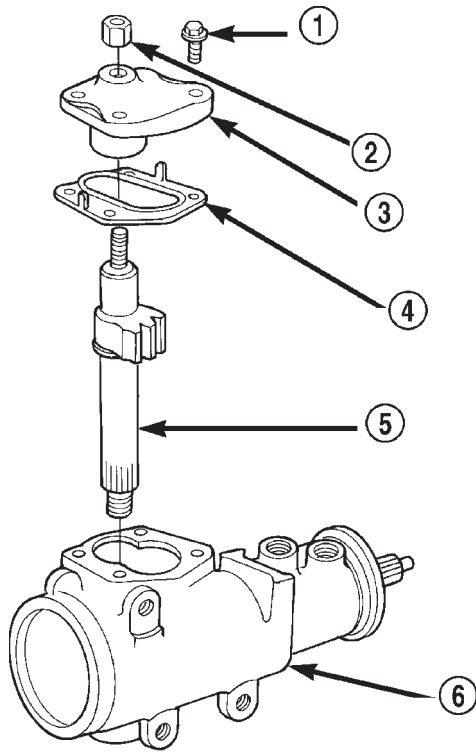


## PITMAN SHAFT

### REMOVAL

- (1) Clean exposed end of pitman shaft and housing with a wire brush.
- (2) Remove preload adjuster nut (Fig. 16).
- (3) Rotate the stub shaft with a 12 point socket from stop to stop and count the number of turns.
- (4) Center the stub shaft by rotating it from the stop 1/2 of the total amount of turns.
- (5) Remove side cover bolts and remove side cover, gasket and pitman shaft as an assembly (Fig. 16).

**NOTE:** The pitman shaft will not clear the housing if it is not centered.



80a3543f

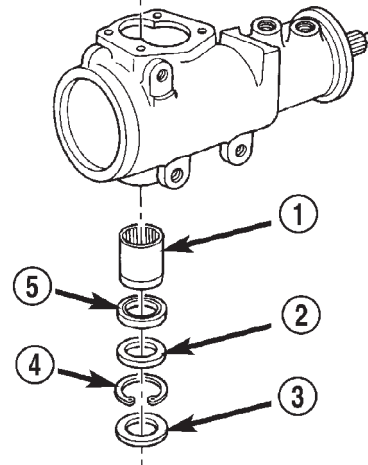
**Fig. 16 Side Cover and Pitman Shaft**

- 1 - SIDE COVER BOLTS
- 2 - PRELOAD ADJUSTER NUT
- 3 - SIDE COVER
- 4 - GASKET SEAL
- 5 - PITMAN SHAFT GEAR
- 6 - HOUSING ASSEMBLY

- (6) Remove pitman shaft from the side cover.
- (7) Remove dust seal from the housing with a seal pick (Fig. 17).

**CAUTION:** Use care not to score the housing bore when prying out seals and washer.

- (8) Remove retaining ring with snap ring pliers.

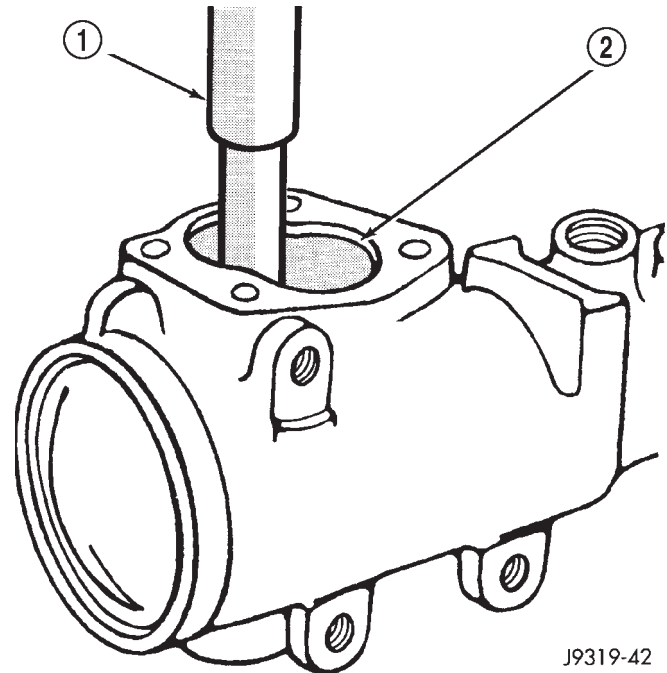


80aa4bf0

**Fig. 17 Pitman Shaft Seals & Bearing**

- 1 - BEARING
- 2 - WASHER
- 3 - DUST SEAL
- 4 - RETAINER
- 5 - OIL SEAL

- (9) Remove washer from the housing.
- (10) Remove oil seal from the housing with a seal pick.
- (11) Remove pitman shaft bearing from housing with a bearing driver and handle (Fig. 18).



J9319-42

**Fig. 18 Needle Bearing Removal**

- 1 - REMOVER
- 2 - SIDE COVER AREA

## PITMAN SHAFT (Continued)

## INSTALLATION

(1) Install pitman shaft bearing into housing with a bearing driver and handle.

(2) Coat the oil seal and washer with **special grease** supplied with the new seal.

(3) Install the oil seal with a driver and handle.

(4) Install backup washer.

(5) Install the retainer ring with snap ring pliers.

(6) Coat the dust seal with **special grease** supplied with the new seal.

(7) Install dust seal with a driver and handle.

(8) Install pitman shaft to side cover by screwing shaft in until it fully seats to side cover.

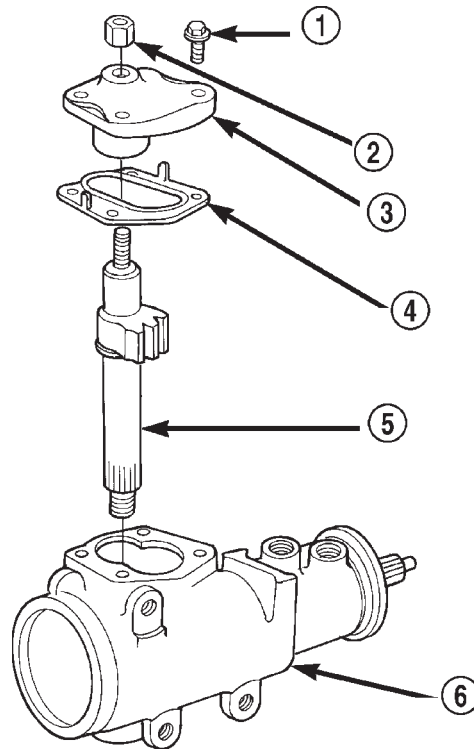
(9) Install preload adjuster nut. **Do not tighten nut until after Over-Center Rotation Torque adjustment has been made.**

(10) Install gasket to side cover and bend tabs around edges of side cover (Fig. 11).

(11) Install pitman shaft assembly and side cover to housing.

(12) Install side cover bolts and tighten to 60 N·m (44 ft. lbs.).

(13) Perform over-center rotation torque adjustment, (Refer to 19 - STEERING/GEAR - ADJUSTMENTS).



80a3543f

**Fig. 19 Side Cover and Pitman Shaft**

- 1 - SIDE COVER BOLTS
- 2 - PRELOAD ADJUSTER NUT
- 3 - SIDE COVER
- 4 - GASKET SEAL
- 5 - PITMAN SHAFT GEAR
- 6 - HOUSING ASSEMBLY

## PITMAN SHAFT SEAL

## REMOVAL

(1) Clean exposed end of pitman shaft and housing with a wire brush.

(2) Remove preload adjuster nut (Fig. 19).

(3) Rotate the stub shaft with a 12 point socket from stop to stop and count the number of turns.

(4) Center the stub shaft by rotating it from the stop 1/2 of the total amount of turns.

(5) Remove side cover bolts and remove side cover, gasket and pitman shaft as an assembly (Fig. 19).

**NOTE:** The pitman shaft will not clear the housing if it is not centered.

(6) Remove pitman shaft from the side cover.

(7) Remove dust seal from the housing with a seal pick (Fig. 20).

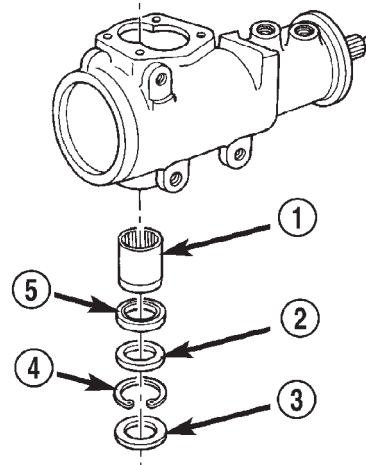
**CAUTION:** Use care not to score the housing bore when prying out seals and washer.

(8) Remove retaining ring with snap ring pliers.

(9) Remove washer from the housing.

(10) Remove oil seal from the housing with a seal pick.

(11) Remove pitman shaft bearing from housing with a bearing driver and handle (Fig. 21).

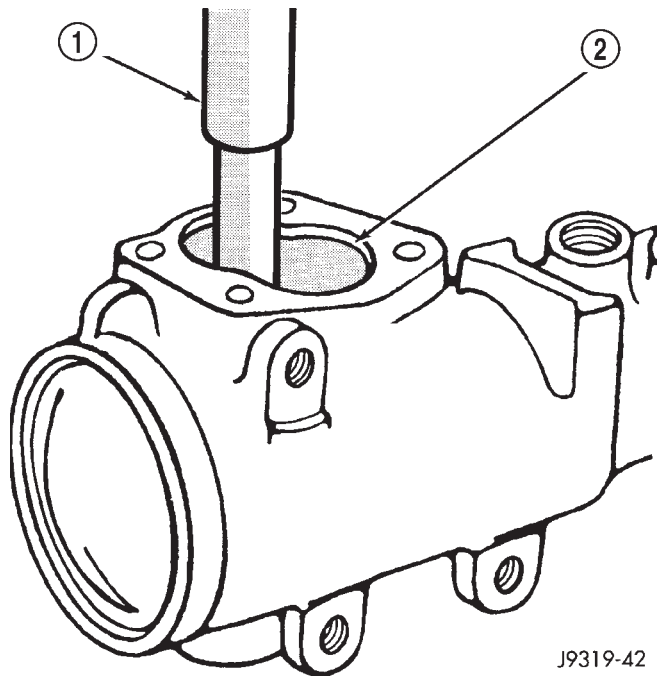


80aa4b10

**Fig. 20 Pitman Shaft Seals & Bearing**

- 1 - BEARING
- 2 - WASHER
- 3 - DUST SEAL
- 4 - RETAINER
- 5 - OIL SEAL

## PITMAN SHAFT SEAL (Continued)



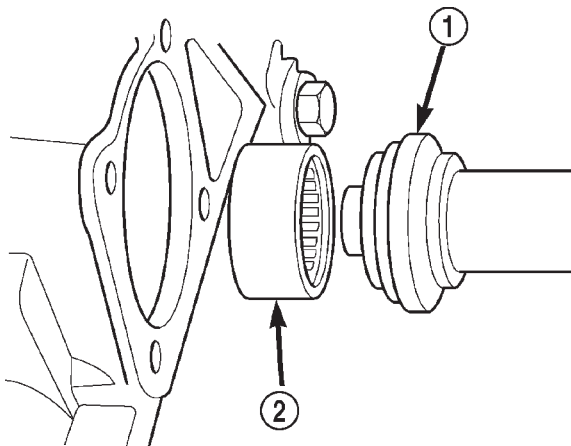
**Fig. 21 Needle Bearing Removal**

- 1 - REMOVER  
2 - SIDE COVER AREA

## INSTALLATION

(1) Install upper pitman shaft bearing, with Driver 8294 and Handle C-4171 (Fig. 22). Drive bearing into housing until the driver bottoms out.

**NOTE:** Install upper pitman shaft bearing with the part number/letters facing the driver.

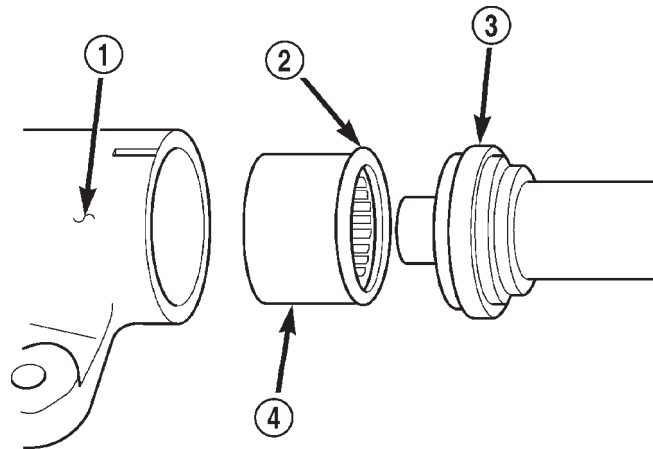


**Fig. 22 Upper Pitman Shaft Bearing**

- 1 - DRIVER  
2 - UPPER BEARING

(2) Install lower pitman shaft bearing with the other side Driver 8294 and Handle C-4171 (Fig. 23).

Drive bearing into housing until the bearing shoulder is seated against the housing.



**Fig. 23 Lower Pitman Shaft Bearing**

- 1 - STEERING GEAR  
2 - BEARING SHOULDER  
3 - DRIVER  
4 - LOWER BEARING

80b6b1a6

(3) Coat the oil seal and backup washers with **special greases** supplied with the new seal.

(4) Install the oil seal with Driver 8294 and Handle C-4171.

(5) Install plastic backup washer.

**NOTE:** The plastic backup washer has a lip on the inside diameter that faces down towards the oil seal.

(6) Install metal backup washer.

(7) Install the retainer ring with snap ring pliers.

(8) Coat the dust seal with **special grease** supplied with the new seal.

(9) Install dust seal with Driver 8294 and Handle C-4171.

(10) Install new pitman shaft cover o-ring.

(11) Install pitman shaft assembly into the housing.

(12) Install cover bolts and tighten to 62 N·m (46 ft. lbs.).

(13) Perform over-center rotation torque adjustment, (Refer to 19 - STEERING/GEAR - ADJUSTMENTS).

## SPOOL VALVE

### REMOVAL

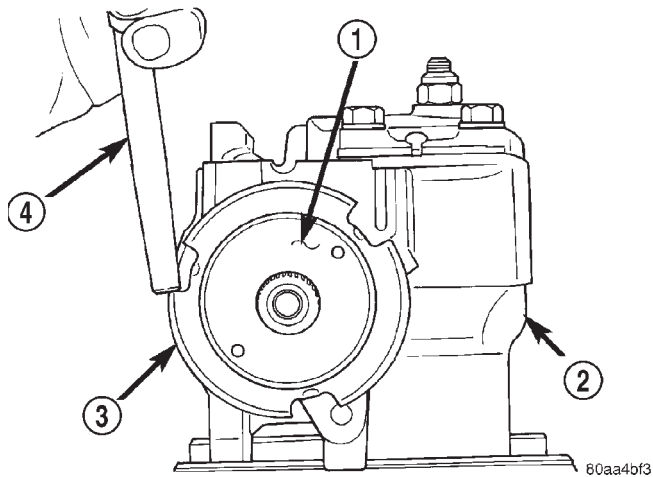
(1) Remove lock nut (Fig. 24).

(2) Remove adjuster nut with Spanner Wrench C-4381.

## SPOOL VALVE (Continued)

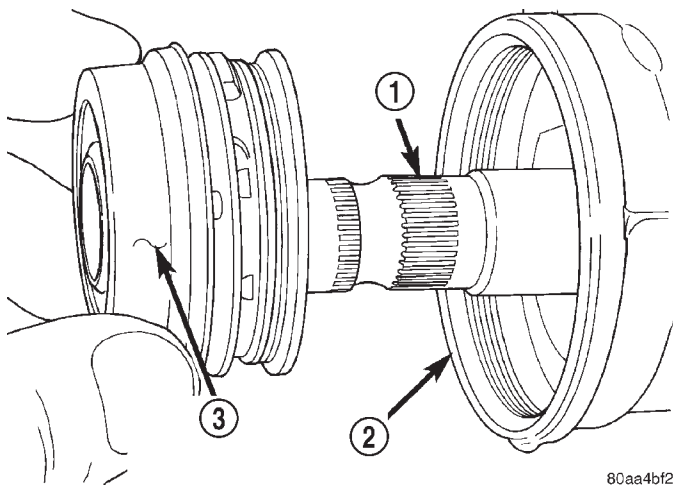
(3) Remove thrust support assembly out of the housing (Fig. 25).

(4) Pull stub shaft and valve assembly from the housing (Fig. 26).



**Fig. 24 Lock Nut and Adjuster Nut**

- 1 - ADJUSTER NUT
- 2 - STEERING GEAR
- 3 - LOCK NUT
- 4 - PUNCH

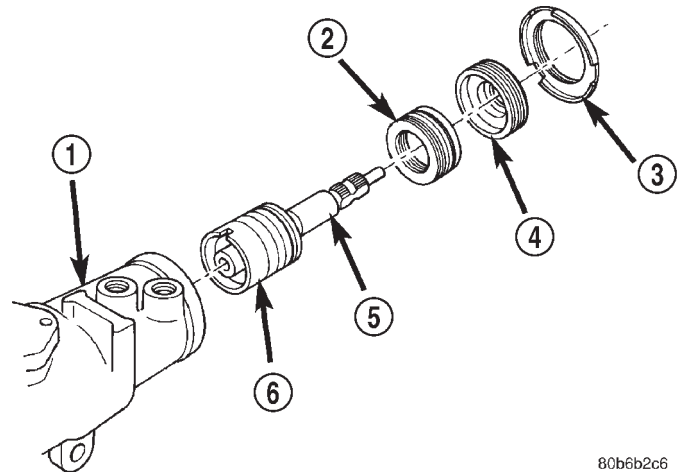


**Fig. 25 Thrust Support Assembly**

- 1 - STUB SHAFT
- 2 - HOUSING
- 3 - THRUST SUPPORT ASSEMBLY

(5) Remove stub shaft from valve assembly by lightly tapping shaft on a block of wood to loosen shaft. Then disengage stub shaft pin from hole in spool valve and separate the valve assembly from stub shaft (Fig. 27).

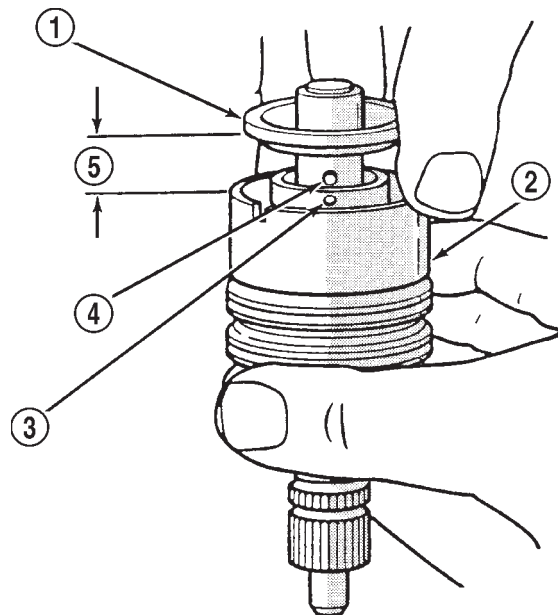
(6) Remove spool valve from valve body by pulling and rotating the spool valve from the valve body (Fig. 28).



80b6b2c6

**Fig. 26 Valve Assembly With Stub Shaft**

- 1 - GEAR
- 2 - THRUST SUPPORT
- 3 - LOCK NUT
- 4 - ADJUSTER NUT
- 5 - STUB SHAFT
- 6 - VALVE ASSEMBLY



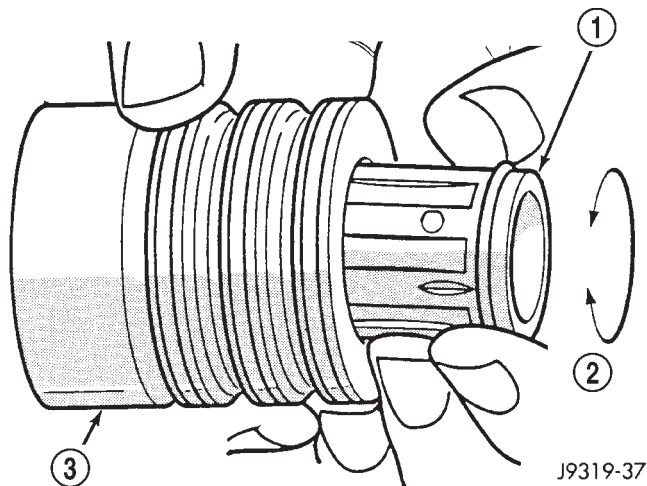
J9319-36

**Fig. 27 Stub Shaft**

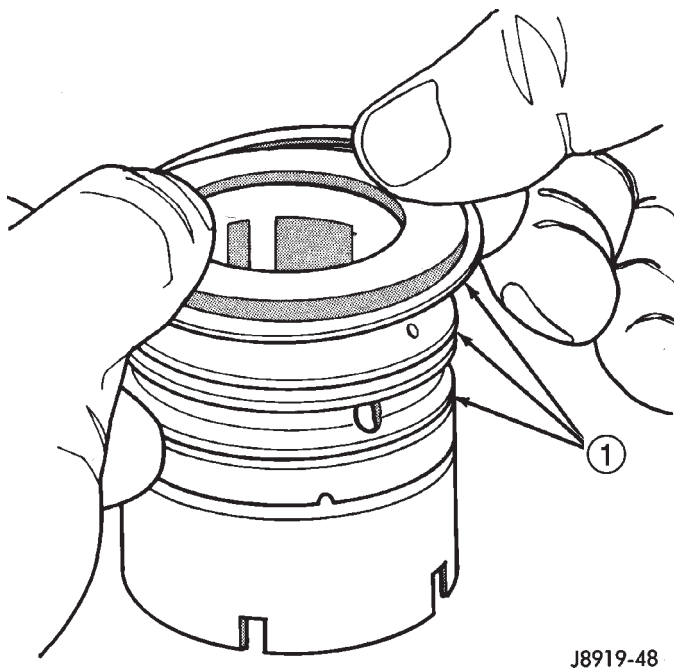
- 1 - STUB SHAFT
- 2 - VALVE BODY
- 3 - HOLE IN SPOOL
- 4 - SHAFT PIN
- 5 - 6mm (1/4")

(7) Remove spool valve O-ring and valve body teflon rings and O-rings underneath the teflon rings (Fig. 29).

## SPOOL VALVE (Continued)

**Fig. 28 Spool Valve**

- 1 - SPOOL VALVE  
2 - ROTATE VALVE TO REMOVE  
3 - VALVE BODY

**Fig. 29 Valve Seals**

- 1 - O-RING SEALS

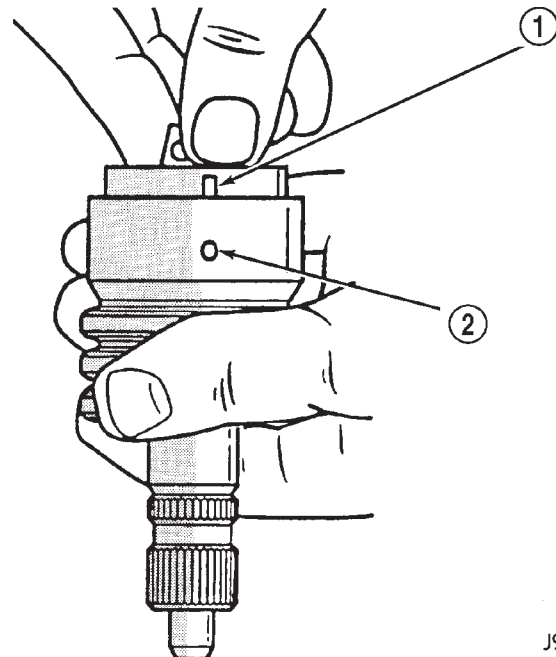
(8) Remove the O-ring between the worm shaft and the stub shaft.

**INSTALLATION**

**NOTE:** Clean and dry all components, then lubricate with power steering fluid.

- (1) Install spool valve spool O-ring.
- (2) Install spool valve in valve body by pushing and rotating. Hole in spool valve for stub shaft pin must be accessible from opposite end of valve body.
- (3) Install stub shaft in valve spool and engage locating pin on stub shaft into spool valve hole (Fig. 30).

**NOTE:** Notch in stub shaft cap must fully engage valve body pin and seat against valve body shoulder.

**Fig. 30 Stub Shaft Installation**

- 1 - NOTCH IN CAP  
2 - VALVE BODY PIN

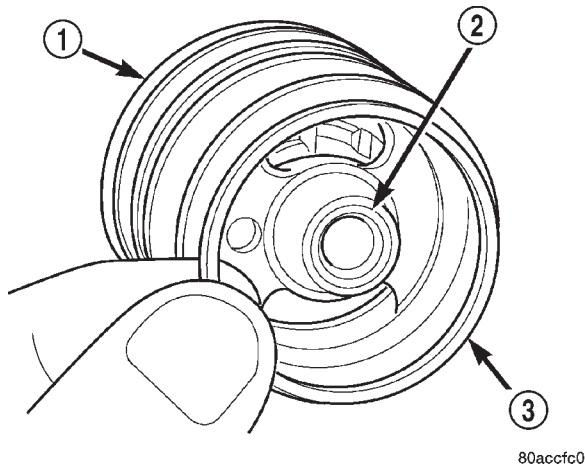
- (4) Install O-rings and teflon rings over the O-rings on valve body.
- (5) Install O-ring into the back of the stub shaft cap (Fig. 31).
- (6) Install stub shaft and valve assembly in the housing. Line up worm shaft to slots in the valve assembly.
- (7) Install thrust support assembly.

**NOTE:** The thrust support is serviced as an assembly. If any component of the thrust support is damaged the assembly must be replaced.

- (8) Install adjuster nut and lock nut.
- (9) Adjust Thrust Bearing Preload and Over-Center Rotating Torque, (Refer to 19 - STEERING/GEAR - ADJUSTMENTS).



## SPOOL VALVE (Continued)

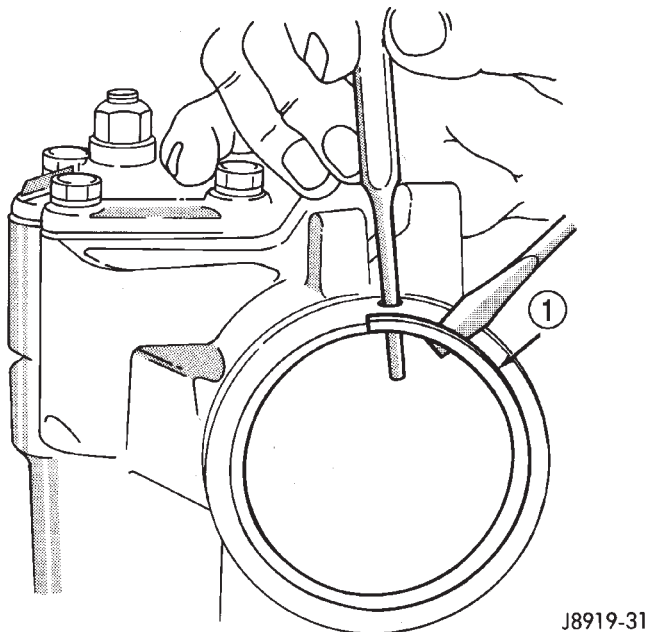
**Fig. 31 Stub Shaft Cap O-Ring**

- 1 - VALVE BODY
- 2 - STUB SHAFT CAP
- 3 - O-RING

STEERING GEAR HOUSING  
PLUG

## REMOVAL

(1) Unseat and remove retaining ring from groove with a punch through the hole in the end of the housing (Fig. 32).

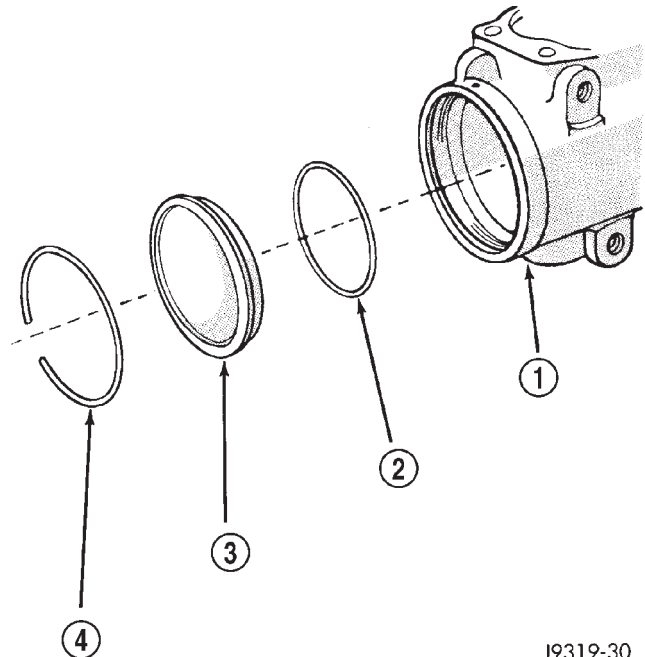
**Fig. 32 End Plug Retaining Ring**

- 1 - RETAINING RING

(2) Slowly rotate stub shaft with 12 point socket COUNTER-CLOCKWISE to force the end plug out from housing.

**CAUTION:** Do not turn stub shaft any further than necessary. The rack piston balls will drop out of the rack piston circuit if the stub shaft is turned too far.

(3) Remove O-ring from the housing (Fig. 33).

**Fig. 33 End Plug Components**

- 1 - HOUSING ASSEMBLY
- 2 - HOUSING END PLUG O-RING SEAL
- 3 - HOUSING END PLUG
- 4 - RETAINING RING

## INSTALLATION

(1) Lubricate O-ring with power steering fluid and install into the housing.

(2) Install end plug by tapping the plug lightly with a plastic mallet into the housing.

(3) Install retaining ring so one end of the ring covers the housing access hole (Fig. 34).

## WORM SHAFT

## REMOVAL

(1) Remove housing end plug, (Refer to 19 - STEERING/GEAR/STEERING GEAR HOUSING PLUG - REMOVAL).

(2) Remove rack piston plug (Fig. 35).

(3) Remove side cover and pitman shaft.

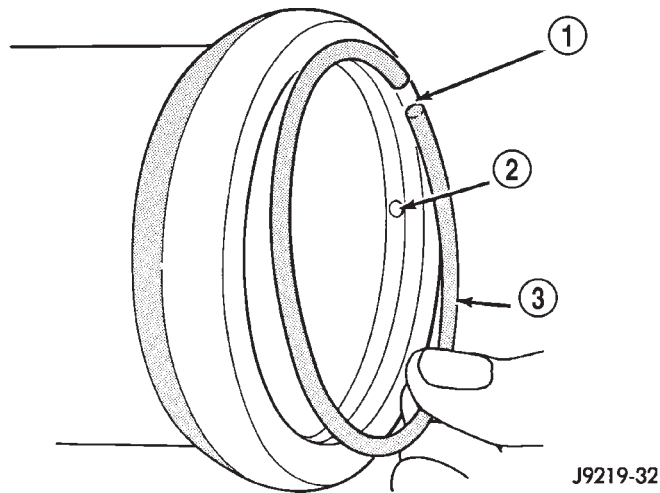
(4) Turn stub shaft COUNTERCLOCKWISE until the rack piston begins to come out of the housing.

(5) Insert Arbor C-4175 into bore of rack piston (Fig. 36) and hold tool tightly against worm shaft.

(6) Turn the stub shaft with a 12 point socket COUNTERCLOCKWISE, this will force the rack pis-

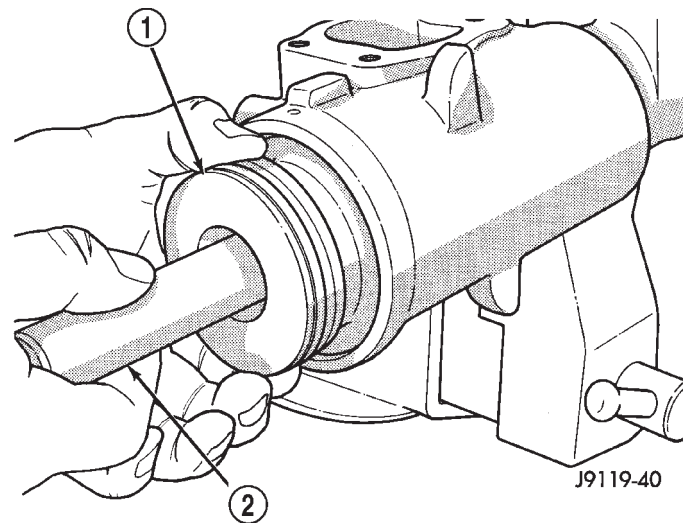


WORM SHAFT (Continued)



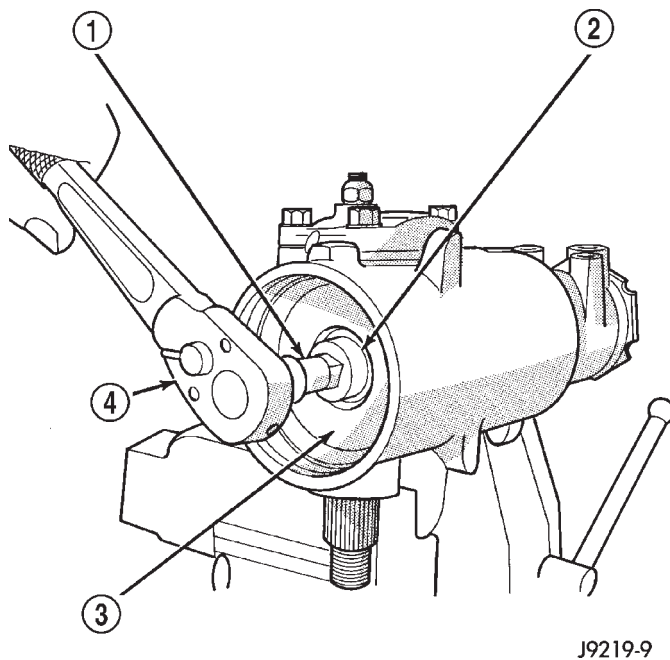
**Fig. 34 Installing The**

- 1 - RING CAP
- 2 - PUNCH ACCESS HOLE
- 3 - RETAINER RING



**Fig. 36 Rack Piston with Arbor**

- 1 - RACK PISTON
- 2 - SPECIAL TOOL C-4175



**Fig. 35 Rack Piston End Plug**

- 1 - EXTENSION
- 2 - END PLUG
- 3 - RACK PISTON
- 4 - RATCHET

ton onto the tool and hold the rack piston balls in place.

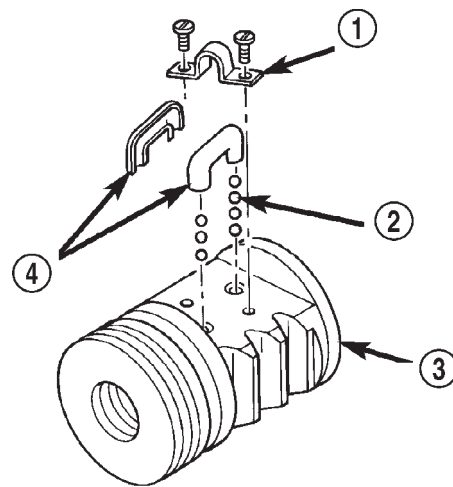
(7) Remove the rack piston and tool together from housing.

(8) Remove tool from rack piston.

(9) Remove rack piston balls.

(10) Remove clamp bolts, clamp and ball guide (Fig. 37).

(11) Remove teflon ring and O-ring from the rack piston (Fig. 38).



**Fig. 37 Rack Piston**

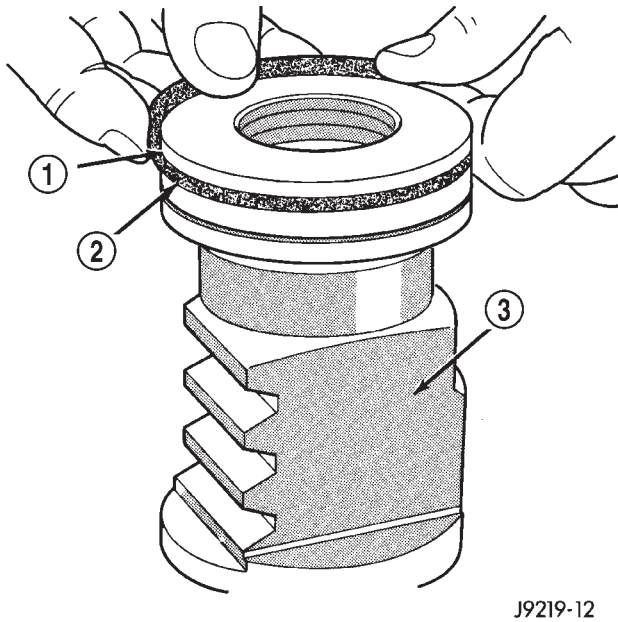
- 1 - CLAMP
- 2 - BALLS
- 3 - RACK PISTON
- 4 - BALL GUIDE

(12) Remove the adjuster lock nut and adjuster nut from the stub shaft.

(13) Pull the stub shaft with the spool valve and thrust support assembly out of the housing.

(14) Remove the worm shaft from the housing (Fig. 39).

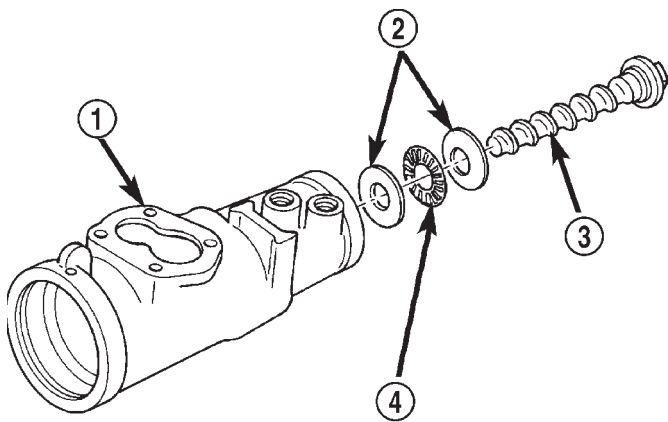
## WORM SHAFT (Continued)



J9219-12

**Fig. 38 Rack Piston Teflon Ring and O-Ring**

- 1 - TEFLON SEAL
- 2 - BACK-UP O-RING MUST BE INSTALLED UNDER PISTON RING
- 3 - RACK PISTON NUT



80aa4bf5

**Fig. 39 Worm Shaft**

- 1 - GEAR HOUSING
- 2 - BEARING RACE
- 3 - WORM SHAFT
- 4 - BEARING

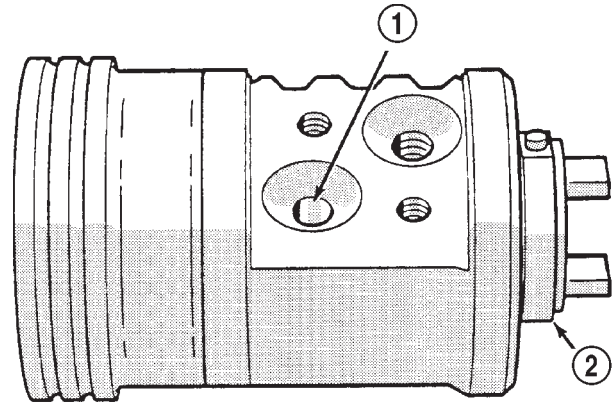
**INSTALLATION**

**NOTE:** Clean and dry all components and lubricate with power steering fluid.

(1) Check for scores, nicks or burrs on the rack piston finished surface. Slight wear is normal on the worm gear surfaces.

(2) Install O-ring and teflon ring on the rack piston.

(3) Install worm shaft in the rack piston and align worm shaft spiral groove with rack piston ball guide hole (Fig. 40).



J9319-39

**Fig. 40 Installing Balls in Rack Piston**

- 1 - INSTALL BALLS IN THIS HOLE WHILE SLOWLY ROTATING WORM COUNTER CLOCKWISE
- 2 - WORM FLANGE

**CAUTION:** The rack piston balls must be installed alternately into the rack piston and ball guide. This maintains worm shaft preload. There are 12 black balls and 12 silver (Chrome) balls. The black balls are smaller than the silver balls.

(4) Lubricate and install rack piston balls through return guide hole while turning worm shaft COUNTERCLOCKWISE (Fig. 40).

(5) Install remaining balls in guide using grease to hold the balls in place (Fig. 41).

(6) Install the guide onto rack piston and install clamp and clamp bolts. Tighten bolts to 4.8 N-m (43 in. lbs.).

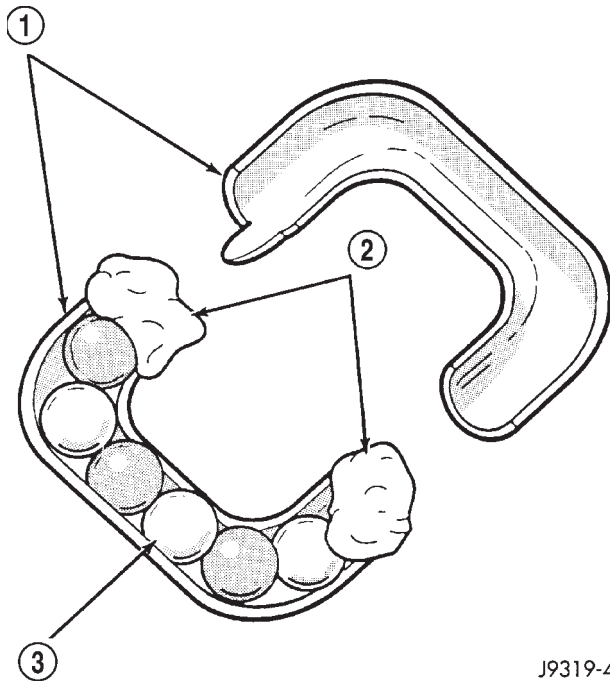
(7) Insert Arbor C-4175 into bore of rack piston and hold tool tightly against worm shaft.

(8) Turn the worm shaft COUNTERCLOCKWISE while pushing on the arbor. This will force the rack piston onto the arbor and hold the rack piston balls in place.

(9) Install the races and thrust bearing on the worm shaft and install shaft in the housing (Fig. 39).

(10) Install the stub shaft with spool valve, thrust support assembly and adjuster nut in the housing.

## WORM SHAFT (Continued)



J9319-40

**Fig. 41 Balls in the Return Guide**

- 1 - GUIDE
- 2 - PETROLEUM JELLY
- 3 - BALLS

(11) Install the rack piston and arbor tool into the housing.

(12) Hold arbor tightly against worm shaft and turn stub shaft **CLOCKWISE** until rack piston is seated on worm shaft.

(13) Install pitman shaft and side cover in the housing.

(14) Install rack piston plug and tighten to 150 N·m (111 ft. lbs.).

(15) Install housing end plug, (Refer to 19 - STEERING/GEAR/STEERING GEAR HOUSING PLUG - INSTALLATION).

(16) Adjust worm shaft thrust bearing preload and over-center rotating torque, (Refer to 19 - STEERING/GEAR - ADJUSTMENTS).

# PUMP

## TABLE OF CONTENTS

	page		page
<b>PUMP</b>		<b>SPECIAL TOOLS</b> . . . . .	36
DESCRIPTION . . . . .	31	<b>PULLEY</b>	
OPERATION . . . . .	31	REMOVAL . . . . .	36
DIAGNOSIS AND TESTING . . . . .	31	INSTALLATION . . . . .	36
PUMP LEAKAGE . . . . .	31	<b>HOSES - PRESSURE</b>	
STANDARD PROCEDURE . . . . .	31	DESCRIPTION . . . . .	37
POWER STEERING PUMP - INITIAL		OPERATION . . . . .	37
OPERATION . . . . .	31	<b>HOSES - RETURN</b>	
FLUSHING POWER STEERING SYSTEM . . . . .	32	DESCRIPTION . . . . .	37
REMOVAL . . . . .	33	OPERATION . . . . .	37
INSTALLATION . . . . .	35		

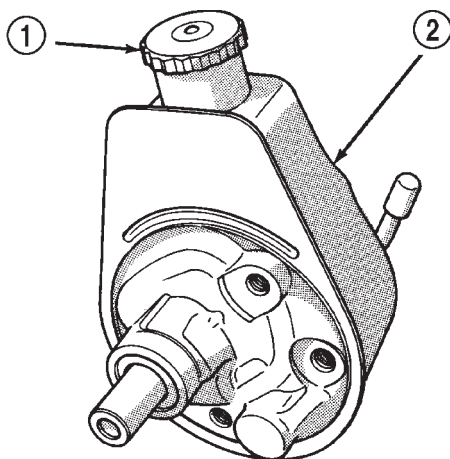
## PUMP

### DESCRIPTION

The P-Series pump is used on these vehicles (Fig. 1). The pump shaft has a pressed-on pulley that is belt driven by the crankshaft pulley on gasoline engines. The pump is driven off the back of the vacuum pump on the diesel engine.

Trailer tow option vehicles are equipped with a power steering pump oil cooler. The oil cooler is mounted to the front crossmember.

**NOTE:** Power steering pumps are not interchangeable with pumps installed on other vehicles.



**Fig. 1 P-Series—Pump**

1 - RESERVOIR CAP AND DIPSTICK  
2 - RESERVOIR

RH13

### OPERATION

Hydraulic pressure is provided by the pump for the power steering gear. The power steering pump is a constant flow rate and displacement, vane-type pump. The pump is connected to the steering gear via the pressure hose and the return hose. On vehicles equipped with a hydraulic booster, the pump supplies the hydraulic pressure for the booster.

### DIAGNOSIS AND TESTING - PUMP LEAKAGE

(1) Possible pump leakage areas. (Fig. 2).

### STANDARD PROCEDURE - POWER STEERING PUMP - INITIAL OPERATION

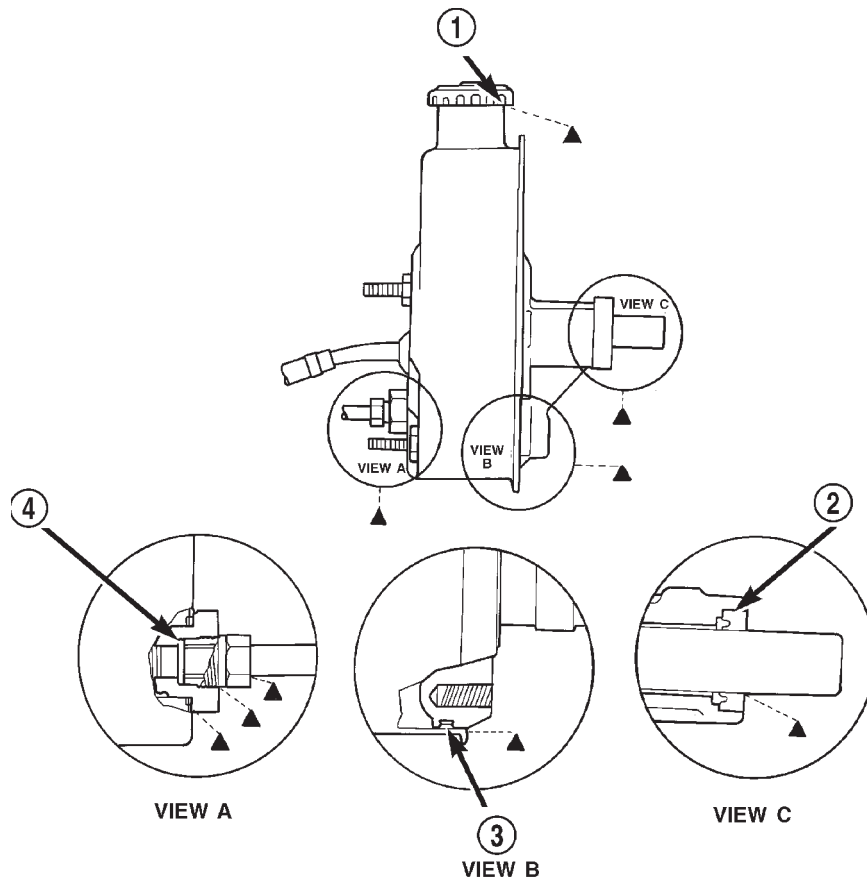
**WARNING:** THE FLUID LEVEL SHOULD BE CHECKED WITH ENGINE OFF TO PREVENT INJURY FROM MOVING COMPONENTS.

**CAUTION:** Use MOPAR Power Steering Fluid or equivalent. Do not use automatic transmission fluid and do not overfill.

Wipe filler cap clean, then check the fluid level. The dipstick should indicate **COLD** when the fluid is at normal temperature.

- (1) Turn steering wheel all the way to the left
- (2) Fill the pump fluid reservoir to the proper level and let the fluid settle for at least two (2) minutes.
- (3) Raise the front wheels off the ground.
- (4) Slowly turn the steering wheel lock-to-lock 20 times with the engine off while checking the fluid level.

## PUMP (Continued)



**Fig. 2 Power Steering Pump**

80abfe6a

1 - CHECK OIL LEVEL; IF LEAKAGE PERSISTS WITH THE CORRECT LEVEL AND CAP TIGHT, REPLACE THE CAP  
2 - SHAFT SEAL

3 - RESERVOIR O-RING  
4 - O-RING SEAL

**NOTE:** Vehicles with long return lines or oil coolers turn wheel 40 times.

(5) Start the engine. With the engine idling maintain the fluid level.

(6) Lower the front wheels and let the engine idle for two minutes.

(7) Turn the steering wheel in both direction and verify power assist and quit operation of the pump.

If the fluid is extremely foamy or milky looking, allow the vehicle to stand a few minutes and repeat the procedure.

**CAUTION:** Do not run a vehicle with foamy fluid for an extended period. This may cause pump damage.

### STANDARD PROCEDURE - FLUSHING POWER STEERING SYSTEM

Flushing is required when the power steering/hydraulic booster system fluid has become contaminated. Contaminated fluid in the steering/booster system can cause seal deterioration and affect steering gear/booster spool valve operation.

(1) Raise the front end of the vehicle off the ground until the wheels are free to turn.

(2) Remove the return line from the pump.

**NOTE:** If vehicle is equipped with a hydraulic booster remove both return lines from the pump.

(3) Plug the return line port/ports at the pump.

(4) Position the return line/lines into a large container to catch the fluid.

(5) While an assistant is filling the pump reservoir start the engine.

(6) With the engine running at idle turn the wheel back and forth.

**NOTE:** Do not contact or hold the wheel against the steering stops.

(7) Run a quart of fluid through the system then stop the engine and install the return line/lines.



## PUMP (Continued)

(8) Fill the system with fluid and perform Steering Pump Initial Operation, (Refer to 19 - STEERING/PUMP - STANDARD PROCEDURE).

(9) Start the engine and run it for fifteen minutes then stop the engine.

(10) Remove the return line/lines from the pump and plug the pump port/ports.

(11) Pour fresh fluid into the reservoir and check the draining fluid for contamination. If the fluid is still contaminated, disassemble and clean the steering gear and flush the system again.

(12) Install the return line/lines and perform Steering Pump Initial Operation, (Refer to 19 - STEERING/PUMP - STANDARD PROCEDURE).

**REMOVAL - GASOLINE ENGINE**

(1) Remove the serpentine drive belt, (Refer to 7 - COOLING/ACCESSORY DRIVE/DRIVE BELTS - REMOVAL) OR (Refer to 7 - COOLING/ACCESSORY DRIVE/DRIVE BELTS - REMOVAL).

(2) Remove the hoses from the power steering pump and cap the fittings.

(3) Remove battery ground cable and unthread stud from cylinder head, do not remove from bracket.

(4) Loosen upper bracket bolt and remove the lower bracket to engine block bolts.

(5) Pivot the pump assembly past the coolant tube.

(6) Remove the upper stud and remove upper bolt from cylinder head.

(7) Remove steering pump and mounting bracket from engine as an assembly.

(8) Remove the pump pulley with Puller C-4333, to access pump attaching bolts, (Refer to 19 - STEERING/PUMP/PULLEY - REMOVAL).

(9) Remove the front pump bracket (Fig. 3). On 8.0L engine remove rear pump bracket (Fig. 4).

**REMOVAL - DIESEL ENGINE**

(1) Remove and cap steering pump hoses and vacuum pump vacuum line.

(2) Remove the sender unit from engine block and plug hole in block (Fig. 5).

(3) Remove the serpentine belt, (Refer to 7 - COOLING/ACCESSORY DRIVE/DRIVE BELTS - REMOVAL).

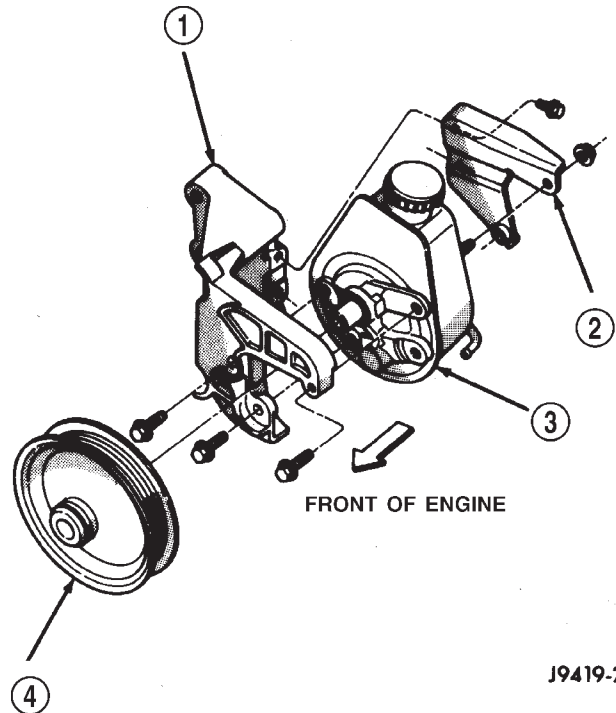
(4) Remove and cap the oil feed line from the bottom of the vacuum pump (Fig. 6).

(5) Remove the lower bolt that attaches the vacuum/steering pump assembly to the engine block. Remove the nut from the steering pump attaching bracket (Fig. 6).

(6) Remove upper bolt from the pump assembly (Fig. 7) and remove the assembly.

(7) Remove the mounting gasket.

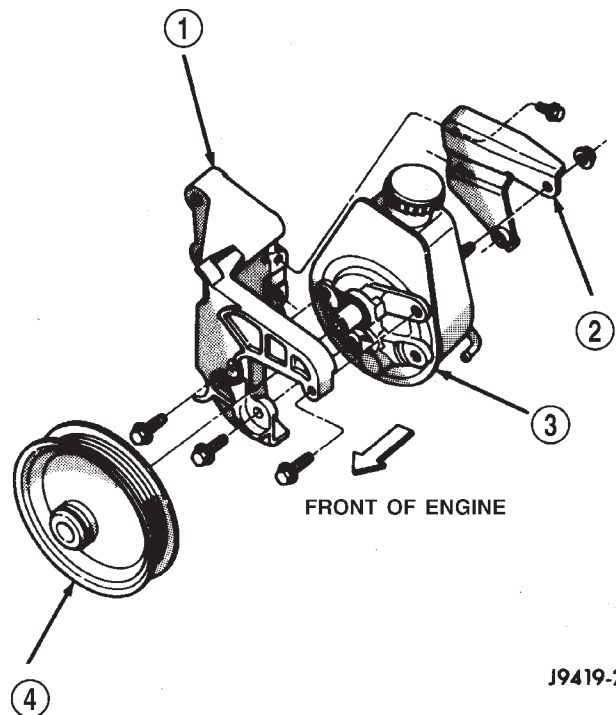
(8) Remove the steering pump to vacuum pump bracket attaching nuts (Fig. 8).



J9419-27

**Fig. 3 Pump Mounting 8.0L**

- 1 - FRONT BRACKET
- 2 - REAR BRACKET
- 3 - STEERING PUMP
- 4 - PULLEY



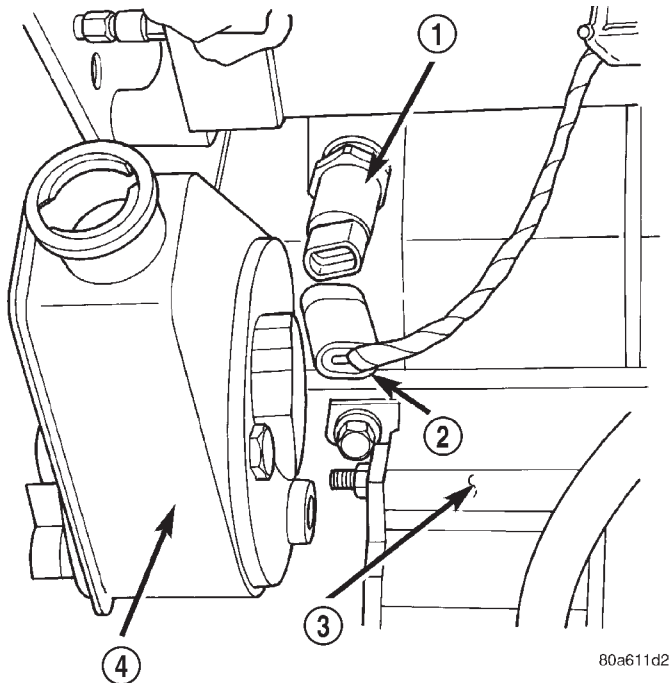
J9419-27

**Fig. 4 Pump Mounting 8.0L**

- 1 - FRONT BRACKET
- 2 - REAR BRACKET
- 3 - STEERING PUMP
- 4 - PULLEY



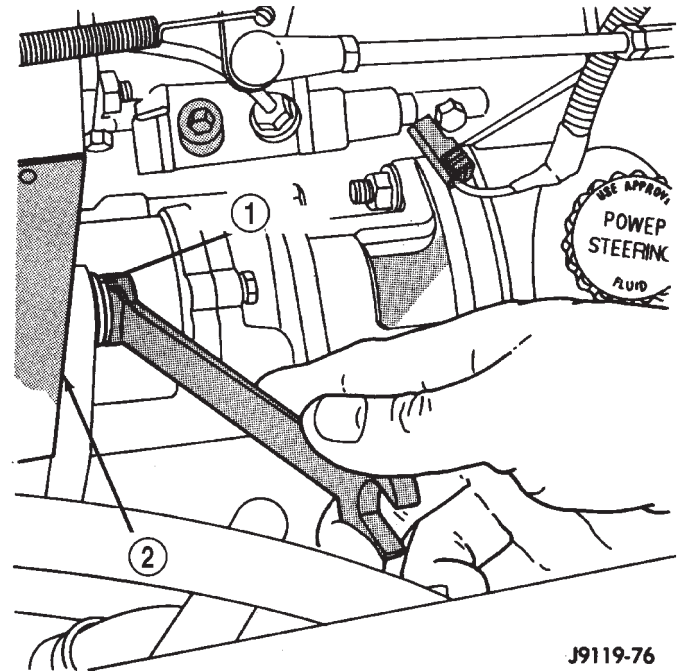
PUMP (Continued)



80a611d2

**Fig. 5 Oil Pressure Sending Unit**

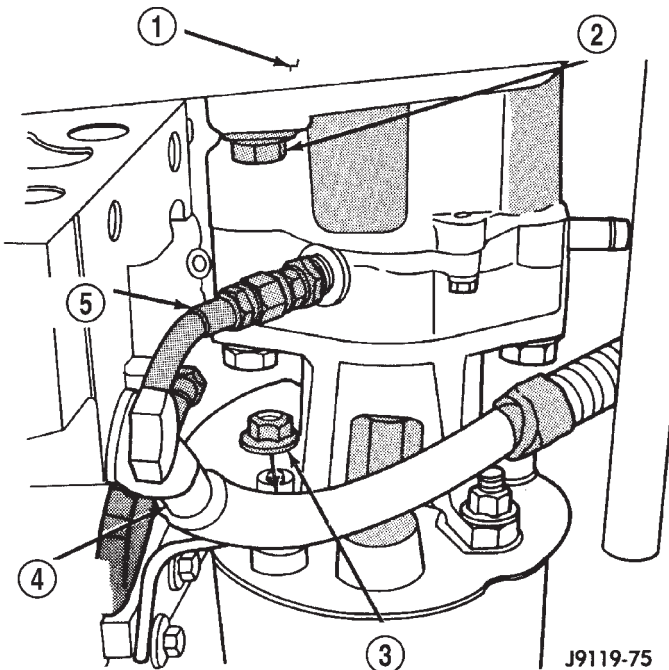
- 1 - OIL PRESSURE SENDER UNIT
- 2 - ELECTRICAL CONNECTOR
- 3 - ENGINE BLOCK
- 4 - STEERING PUMP



J9119-76

**Fig. 7 Pump Assembly Upper Bolt**

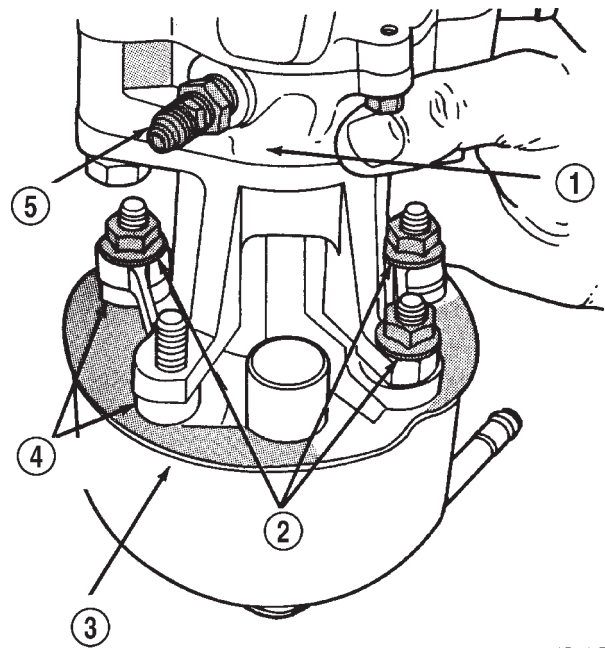
- 1 - PUMP UPPER BOLT
- 2 - DRIVE COVER



J9119-75

**Fig. 6 Oil**

- 1 - ENGINE BLOCK
- 2 - LOWER PUMP ASSEMBLY BOLT
- 3 - STEERING PUMP BRACKET ATTACHING NUT
- 4 - BATTERY GROUND CABLE
- 5 - OIL FEED LINE



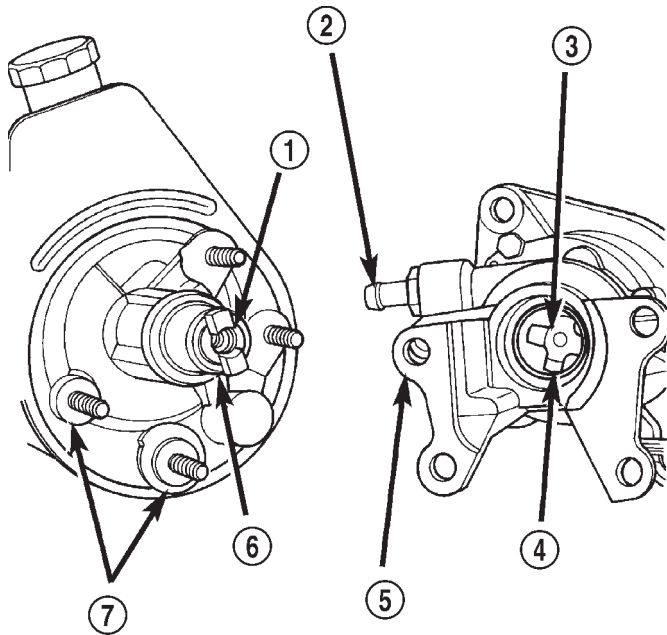
J9119-78

**Fig. 8 Bracket Mounting Nuts**

- 1 - VACUUM PUMP
- 2 - ATTACHING NUTS
- 3 - STEERING PUMP
- 4 - PUMP SPACERS
- 5 - OIL FEED FITTING

## PUMP (Continued)

(9) Slide the steering pump from the bracket. Use care not to damage the internal oil seal in the vacuum pump (Fig. 9).



80a611d1

**Fig. 9 Steering Pump & Vacuum Pump**

- 1 - PUMP SHAFT
- 2 - VACUUM FITTING
- 3 - VACUUM PUMP DRIVE
- 4 - OIL SEAL
- 5 - MOUNTING BRACKET
- 6 - DRIVE DOG
- 7 - PUMP SPACERS

(10) Remove the two pump body spacers.

### INSTALLATION - GASOLINE ENGINE

(1) Install the front pump bracket and tighten bolts to 47 N·m (35 ft. lbs.). On 8.0L engine install rear pump bracket and tighten nut to 47 N·m (35 ft. lbs.), tighten bolts to 24 N·m (18 ft. lbs.).

(2) Install the pump pulley with Installer C-4063-B, (Refer to 19 - STEERING/PUMP/PULLEY - INSTALLATION).

(3) Install steering pump assembly on the engine block. Install the upper stud and bolt in bracket.

(4) Pivot the pump down past the coolant tube and install the lower bolts in bracket.

(5) Tighten the bolts and nut to 41 N·m (30 ft. lbs.).

(6) Connect the hoses to the pump.

(7) Install the serpentine drive belt, (Refer to 7 - COOLING/ACCESSORY DRIVE/DRIVE BELTS - INSTALLATION), (Refer to 7 - COOLING/ACCESSORY DRIVE/DRIVE BELTS - INSTALLATION).

(8) Fill the reservoir with power steering fluid, (Refer to 19 - STEERING/PUMP - STANDARD PROCEDURE).

### INSTALLATION - DIESEL ENGINE

(1) Install the two pump body spacers.

(2) Rotate the drive gear until the steering pump and vacuum pump drive dogs align. Install the steering pump onto the vacuum pump bracket. Use care to avoid damaging the oil seal in the vacuum pump during installation. **The steering pump housing and spacers must mate completely with the vacuum pump bracket.**

(3) Install the vacuum pump bracket to steering pump nuts and tighten to 24 N·m (18 ft. lbs.).

(4) Position new gasket on vacuum pump assembly. Use sealer if necessary to retain the gasket.

(5) Align and install the pump assembly on the engine. Ensure the steering pump stud is inserted into the block bracket. Tighten the pump-to-engine block attaching bolts to 77 N·m (57 ft. lbs.).

(6) Install the steering pump to attaching bracket nut and tighten to 24 N·m (18 ft. lbs.).

(7) Remove plug and install the oil pressure sending unit and electrical connector.

(8) Install the oil feed line to the vacuum pump. Tighten the oil line connection to 7 N·m (60 in. lbs./ 5 ft. lbs.).

(9) Install the fluid hoses to the power steering pump. Tighten the pressure fitting at the pump to 31 N·m (23 ft. lbs.).

(10) Install and clamp the hose on the vacuum pump.

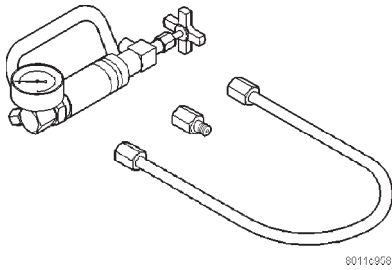
(11) Install the serpentine belt, (Refer to 7 - COOLING/ACCESSORY DRIVE/DRIVE BELTS - INSTALLATION).

(12) Fill the reservoir with power steering fluid, (Refer to 19 - STEERING/PUMP - STANDARD PROCEDURE).

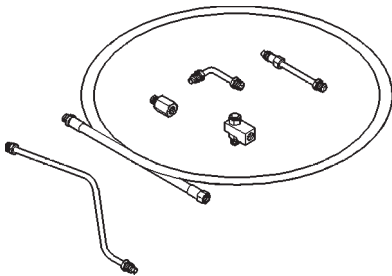
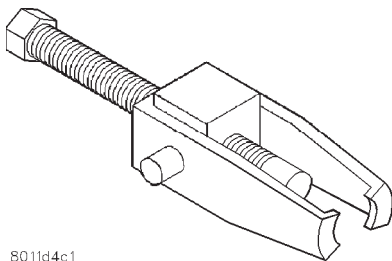
(13) Start the engine and check the operation of the brakes.

## SPECIAL TOOLS

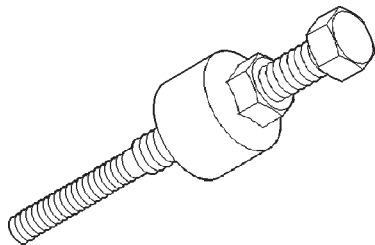
## POWER STEERING PUMP



8011c998

**Analyzer Set, Power Steering Flow/Pressure 6815****Adapters, Power Steering Flow/Pressure Tester 6893**

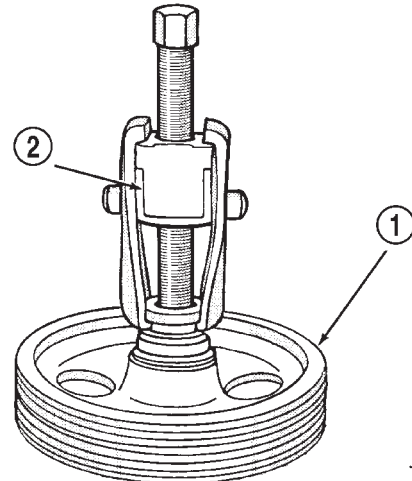
8011d4c1

**Puller C-4333****Installer, Power Steering Pulley C-4063-B**

## PULLEY

## REMOVAL

- (1) Remove pump assembly.
- (2) Remove pulley from pump with Puller C-4333 (Fig. 10).



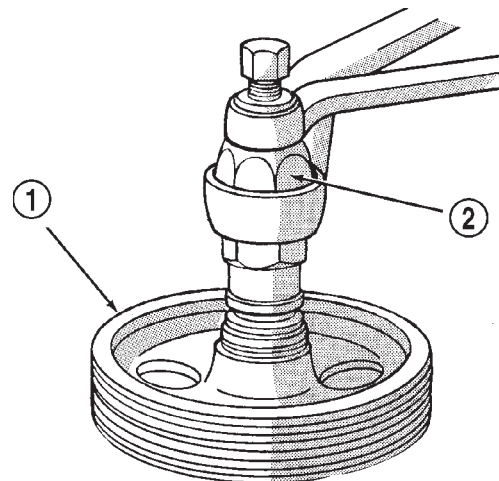
J9319-45

**Fig. 10 Pulley Removal**

- 1 - POWER STEERING PUMP DRIVE PULLEY
- 2 - SPECIAL TOOL C-4333

## INSTALLATION

- (1) Replace pulley if bent, cracked, or loose.
- (2) Install pulley on pump with Installer C-4063-B (Fig. 11) flush with the end of the shaft. Ensure the tool and pulley remain aligned with the pump shaft.



J9519-1

**Fig. 11 Pulley Installation**

- 1 - POWER STEERING PUMP DRIVE PULLEY
- 2 - SPECIAL TOOL C-4063-B

- (3) Install pump assembly.
- (4) With Serpentine Belts; Run engine until warm (5 min.) and note any belt chirp. If chirp exists, move pulley outward approximately 0.5 mm (0.020 in.). If noise increases, press on 1.0 mm (0.040 in.). **Be careful that pulley does not contact mounting bolts.**

## HOSES - PRESSURE

### DESCRIPTION

The hose consists of two metal ends and rubber center section that contains a tuning cable.

### OPERATION

Power steering pressure line, is used to transfer high pressure power steering fluid, from the power steering pump to the power steering gear.

## HOSES - RETURN

### DESCRIPTION

Power steering return line is a hose which is clamped at the pump and the gear.

### OPERATION

Power steering return line, is used to transfer low pressure power steering fluid, from the power steering gear to the power steering pump.

# LINKAGE - 2WD

## TABLE OF CONTENTS

	page		page
<b>LINKAGE - 2WD</b>		<b>REMOVAL</b> . . . . .	38
DESCRIPTION . . . . .	38	INSTALLATION . . . . .	39
STANDARD PROCEDURE . . . . .	38	SPECIFICATIONS . . . . .	39
LUBRICATION . . . . .	38	SPECIAL TOOLS . . . . .	39

## LINKAGE - 2WD

### DESCRIPTION

Light duty (LD) and heavy duty (HD) steering linkage is used with IFS suspensions. The linkage is comprised of a idler arm, pitman arm, center link and tie rod ends. Heavy duty linkage is used on 8800 and 10500 lb. GVW vehicles.

**CAUTION:** If any steering components are replaced or serviced an alignment must be performed.

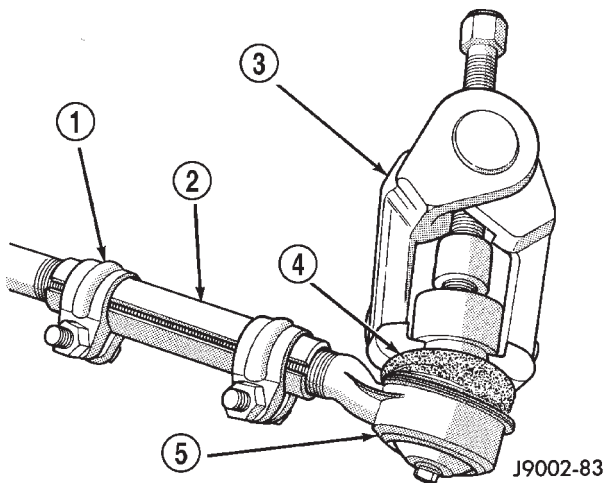
**NOTE:** When servicing the steering linkage, use care to avoid damaging ball stud seals. Use Puller C-3894-A or an appropriate puller to remove tie rod ends (Fig. 1).

### STANDARD PROCEDURE - LUBRICATION

Periodic lubrication of the idler arm is required. Refer to Lubrication And Maintenance for the recommended maintenance schedule.

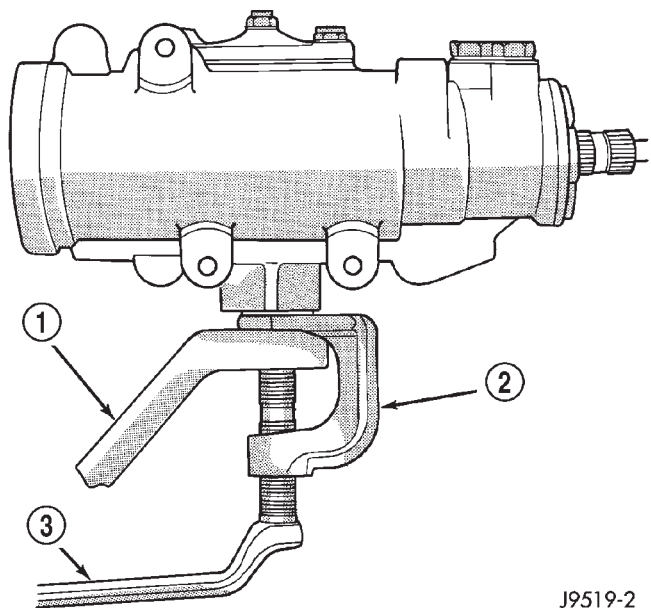
### REMOVAL

- (1) Remove the nut from the tie-rod.
- (2) Remove the tie-rod end ball studs from the steering knuckles with an appropriate puller.
- (3) Remove inner tie-rod ends from center link .
- (4) Remove idler arm stud from center link with an appropriate puller. Remove the idler arm bolt from frame bracket.
- (5) Remove pitman arm ball stud from center link.
- (6) Mark the pitman arm and shaft positions for installation reference. Remove pitman arm with Puller C-4150A (Fig. 2).



**Fig. 1 Tie Rod End**

- 1 - CLAMP
- 2 - ADJUSTMENT SLEEVE
- 3 - PULLER TOOL C-3894-A
- 4 - SEAL
- 5 - TIE-ROD END



**Fig. 2 Pitman Arm**

- 1 - PITMAN ARM
- 2 - SPECIAL TOOL C-4150-A
- 3 - WRENCH

## LINKAGE - 2WD (Continued)

**INSTALLATION**

(1) Position idler arm on the frame bracket and tighten the bolt to specification.

(2) Center steering gear to alignment marks and install pitman arm.

(3) Install the lock washer and retaining nut on the pitman shaft. Tighten the nut to 251 N·m (185 ft. lbs.).

(4) Install center link to ball studs and tighten retaining nuts to specification.

(5) Install tie-rod ends into center link and tighten the nuts to 88 N·m (65 ft. lbs.). Install new nuts.

(6) Install tie-rod ends into steering knuckles and tighten nuts to 108 N·m (80 ft. lbs.).

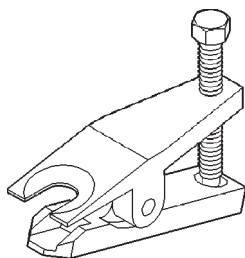
(7) Remove the supports and lower the vehicle to the surface. Center steering wheel and adjust toe, (Refer to 2 - SUSPENSION/WHEEL ALIGNMENT - STANDARD PROCEDURE).

**NOTE:** Position the clamp on the sleeve so retaining bolt is located on the bottom side of the sleeve.

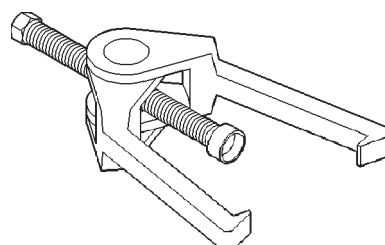
(8) After adjustment, tighten the tie-rod adjustment sleeve clamp bolt to 61 N·m (45 ft. lbs.).

**SPECIFICATIONS****TORQUE CHART***TORQUE SPECIFICATIONS*

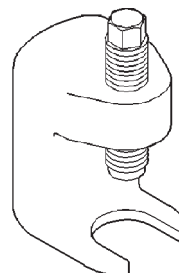
<b>DESCRIPTION</b>	<b>N·m</b>	<b>Ft. Lbs.</b>	<b>In. Lbs.</b>
Pitman Arm Gear Nut	250	185	—
Pitman Arm Center Link Nut	115	85	—
Idler Arm Mounting Bolts	271	200	—
Idler Arm Center Link Nut	88	65	—
Tie Rod Knuckle Nut	108	80	—
Tie Rod Center Link Nut	88	65	—
Tie Rod Adjuster Clamp	61	45	—

**SPECIAL TOOLS****STEERING LINKAGE**

**Remover Ball Stud MB-991113**



**Puller Tie Rod C-3894-A**



**Remover Pitman C-4150A**



# LINKAGE - 4WD

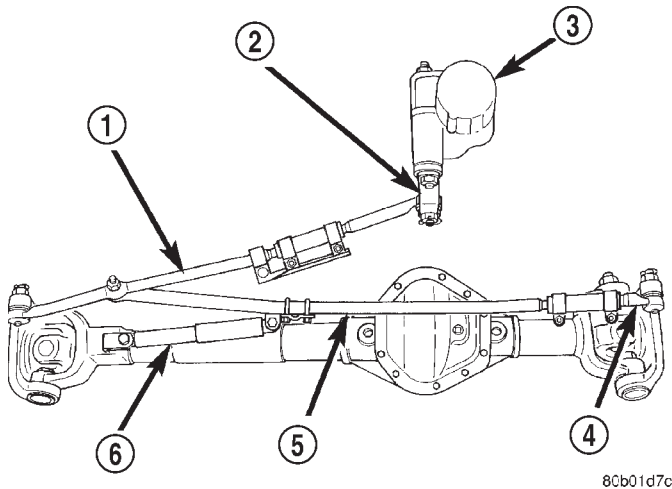
## TABLE OF CONTENTS

	page		page
<b>LINKAGE - 4WD</b>		<b>REMOVAL</b> .....	40
DESCRIPTION .....	40	<b>INSTALLATION</b> .....	41
STANDARD PROCEDURE .....	40	<b>SPECIFICATIONS</b> .....	41
LUBRICATION .....	40	<b>SPECIAL TOOLS</b> .....	42

## LINKAGE - 4WD

### DESCRIPTION

The steering linkage is comprised of a tie rod end, tie rod, drag link, steering damper and pitman arm (Fig. 1).

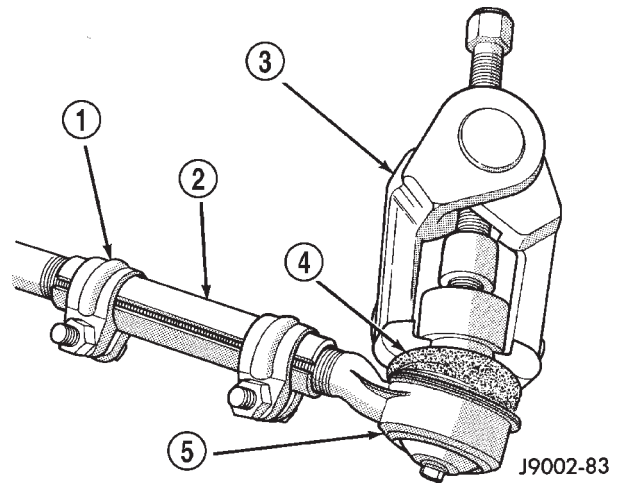


**Fig. 1 Steering Linkage**

- 1 - DRAG LINK
- 2 - PITMAN ARM
- 3 - STEERING GEAR
- 4 - TIE ROD END
- 5 - TIE ROD
- 6 - DAMPER

**CAUTION:** If any steering components are replaced or serviced an alignment must be performed.

**NOTE:** To avoid damaging ball stud seals, use Puller C-3894-A or an appropriate puller to remove tie rod ends (Fig. 2).



**Fig. 2 Tie Rod End**

- 1 - CLAMP
- 2 - ADJUSTMENT SLEEVE
- 3 - PULLER TOOL C-3894-A
- 4 - SEAL
- 5 - TIE-ROD END

### STANDARD PROCEDURE - LUBRICATION

Periodic lubrication of the steering system components is required. Refer to Lubrication And Maintenance for the recommended maintenance schedule.

The following components must be lubricated:

- Tie rod
- Tie rod end
- Drag link

### REMOVAL

- (1) Remove steering damper mounting nuts and bolts and remove damper.
- (2) Remove tie rod nuts.
- (3) Remove tie rod from drag link and left knuckle with Puller C-4150A.
- (4) Remove drag and nuts.
- (5) Remove drag link from right knuckle and pitman arm with Puller C-4150A.
- (6) Mark the pitman arm and shaft positions for installation reference. Remove the nut and washer from the pitman arm. Remove the pitman arm with Puller C-4150A.

## LINKAGE - 4WD (Continued)

**INSTALLATION**

- (1) Align reference marks and install pitman arm.
- (2) Install the lock washer and retaining nut on the pitman shaft and tighten nut to 251 N·m (185 ft. lbs.).
- (3) Install drag link to the pitman arm. Install the nut and tighten to 108 N·m (80 ft. lbs.).
- (4) Install drag link to the right steering knuckle. Install the nut and tighten to 88 N·m (65 ft. lbs.).
- (5) Install tie rod to the left steering knuckle and drag link. Install the nuts and tighten to 108 N·m (80 ft. lbs.).

(6) Install steering damper on the axle. Tighten nut to 95 N·m (75 ft. lbs.).

(7) Install steering damper on the tie rod. Tighten nut to 81 N·m (60 ft. lbs.).

(8) Remove the supports and lower the vehicle to the surface. Center steering wheel and adjust toe, refer to Group 2 Suspension.

(9) After adjustment tighten tie rod adjustment sleeve clamp bolts to 61 N·m (45 ft. lbs.).

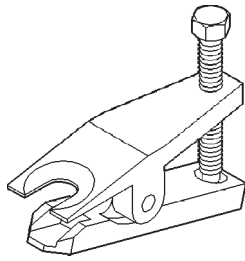
**NOTE: Position the clamp on the sleeve so retaining bolt is located on the bottom side of the sleeve.**

**SPECIFICATIONS****TORQUE CHART***TORQUE SPECIFICATIONS*

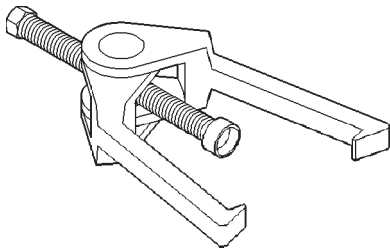
<b>DESCRIPTION</b>	<b>N·m</b>	<b>Ft. Lbs.</b>	<b>In. Lbs.</b>
Pitman Arm Gear Shaft	251	185	—
Drag Link Pitman Arm	108	80	—
Drag Link Tie Rod	88	65	—
Drag Link Adjuster Clamp	61	45	—
Tie Rod End Knuckle	108	80	—
Tie Rod End Adjuster Clamp	61	45	—
Steering Damper Axle	95	70	—
Steering Damper Tie Rod	81	60	—

SPECIAL TOOLS

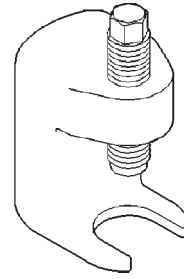
STEERING LINKAGE



***Remover Ball Stud MB-991113***



***Puller Tie Rod C-3894-A***



***Remover Pitman C-4150A***

# TRANSMISSION AND TRANSFER CASE

## TABLE OF CONTENTS

	page		page
<b>MANUAL - NV3500</b> .....	1	<b>AUTOMATIC TRANSMISSION - 46RE</b> .....	477
<b>MANUAL - NV4500</b> .....	44	<b>AUTOMATIC TRANSMISSION - 47RE</b> .....	648
<b>MANUAL - NV5600</b> .....	91	<b>TRANSFER CASE - NV231HD</b> .....	820
<b>AUTOMATIC TRANSMISSION - 42RE</b> .....	134	<b>TRANSFER CASE - NV241LD</b> .....	855
<b>AUTOMATIC TRANSMISSION - 44RE</b> .....	305	<b>TRANSFER CASE - NV241HD</b> .....	890

## MANUAL - NV3500

### TABLE OF CONTENTS

	page		page
<b>MANUAL - NV3500</b>		<b>CLEANING</b> .....	15
DESCRIPTION .....	1	<b>INSPECTION</b> .....	15
OPERATION .....	1	<b>ASSEMBLY</b> .....	17
DIAGNOSIS AND TESTING .....	3	<b>INSTALLATION</b> .....	40
MANUAL TRANSMISSION .....	3	<b>SPECIFICATIONS</b> .....	41
REMOVAL .....	3	<b>SPECIAL TOOLS</b> .....	41
DISASSEMBLY .....	5		

## MANUAL - NV3500

### DESCRIPTION

The NV3500 is a medium-duty 5-speed, constant mesh fully synchronized manual transmission. Fifth gear is an overdrive range with a ratio of 0.73:1. The NV3500 is available in two and four-wheel drive configurations.

The transmission gear case consists of two aluminum housings (Fig. 1). The clutch housing is not a removable component. It is an integral part of the transmission front housing.

A combination of roller and ball bearings are used to support the transmission shafts in the two housings. The transmission gears all rotate on caged type needle bearings. A roller bearing is used between the input and output shaft.

The transmission has a single shaft shift mechanism with three shift forks all mounted on the shaft. The shaft is supported in the front and rear housings by bushings and one linear ball bearing. Internal shift components consist of the forks, shaft, shift lever socket, and detent components

### GEAR RATIOS

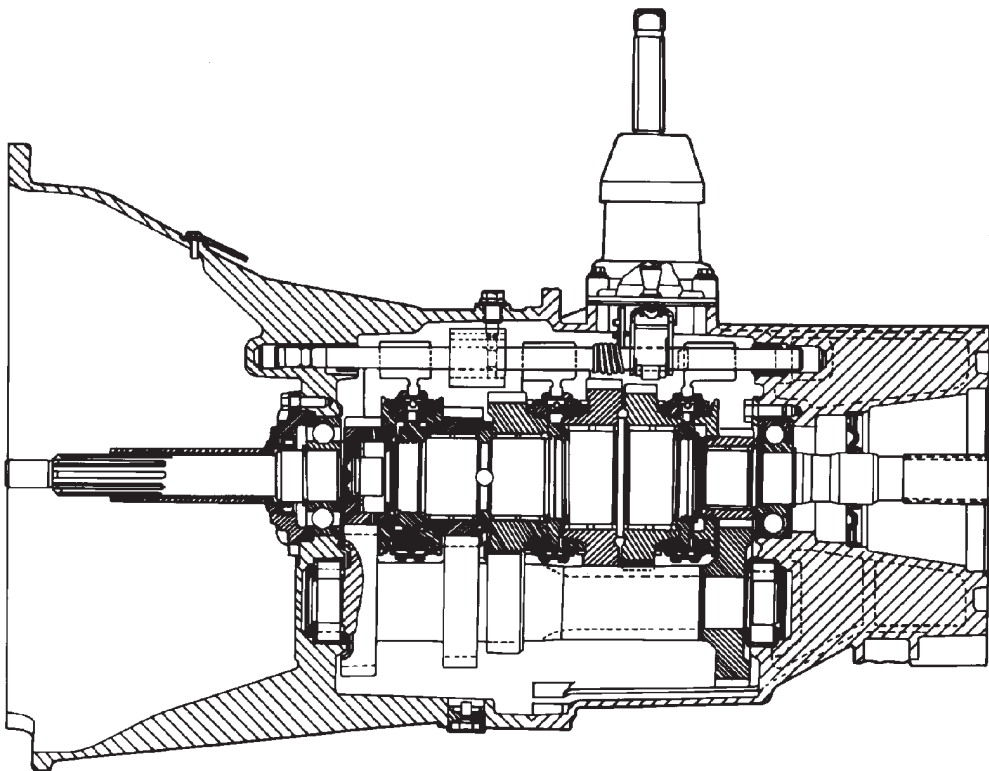
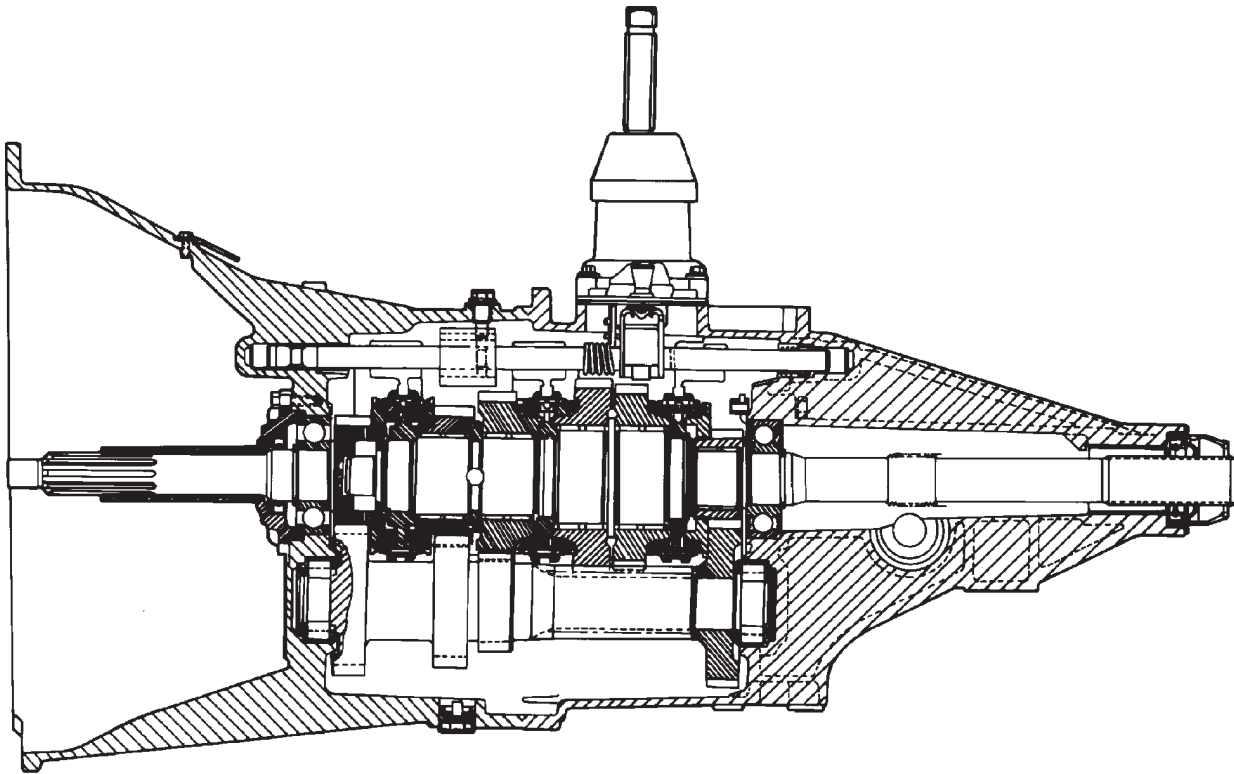
Gear ratios is as follows:

GEAR	RATIO
FIRST	4.02:1
SECOND	2.32:1
THIRD	1.40:1
FOURTH	1:1
FIFTH	0.73:1
REVERSE	3.55:1

### OPERATION

The manual transmission receives power through the clutch assembly from the engine. The clutch disc is splined to the transmission input shaft and is turned at engine speed at all times that the clutch is engaged. The input shaft is connected to the transmission countershaft through the mesh of fourth speed gear on the input shaft and the fourth countershaft gear. At this point, all the transmission gears are spinning.

MANUAL - NV3500 (Continued)



*Fig. 1 NV3500 Manual Transmission*

## MANUAL - NV3500 (Continued)

The driver selects a particular gear by moving the shift lever to the desired gear position. This movement moves the internal transmission shift components to begin the shift sequence. As the shift lever moves the selected shift rail, the shift fork attached to that rail begins to move. The fork is positioned in a groove in the outer circumference of the synchronizer sleeve. As the shift fork moves the synchronizer sleeve, the synchronizer begins to speed-up or slow down the selected gear (depending on whether we are up-shifting or down-shifting). The synchronizer does this by having the synchronizer hub splined to the mainshaft, or the countershaft in some cases, and moving the blocker ring into contact with the gear's friction cone. As the blocker ring and friction cone come together, the gear speed is brought up or down to the speed of the synchronizer. As the two speeds match, the splines on the inside of the synchronizer sleeve become aligned with the teeth on the blocker ring and the friction cone and eventually will slide over the teeth, locking the gear to the mainshaft, or countershaft, through the synchronizer.

## DIAGNOSIS AND TESTING - MANUAL TRANSMISSION

### LOW LUBRICANT LEVEL

A low transmission lubricant level is generally the result of a leak, inadequate lubricant fill or an incorrect lubricant level check.

Leaks can occur at the mating surfaces of the gear case, adaptor or extension housing, or from the front/rear seals. A suspected leak could also be the result of an overfill condition.

Leaks at the rear of the extension or adapter housing will be from the housing oil seals. Leaks at component mating surfaces will probably be the result of inadequate sealer, gaps in the sealer, incorrect bolt tightening or use of a non-recommended sealer.

A leak at the front of the transmission will be from either the front bearing retainer or retainer seal. Lubricant may be seen dripping from the clutch housing after extended operation. If the leak is severe, it may also contaminate the clutch disc causing the disc to slip, grab and or chatter.

A correct lubricant level check can only be made when the vehicle is level. Also allow the lubricant to settle for a minute or so before checking. These recommendations will ensure an accurate check and avoid an underfill or overfill condition. Always check the lubricant level after any addition of fluid to avoid an incorrect lubricant level condition.

### HARD SHIFTING

Hard shifting is usually caused by a low lubricant level, improper or contaminated lubricants. The con-

sequence of using non-recommended lubricants is noise, excessive wear, internal bind and hard shifting. Substantial lubricant leaks can result in gear, shift rail, synchro, and bearing damage. If a leak goes undetected for an extended period, the first indications of component damage are usually hard shifting and noise.

Component damage, incorrect clutch adjustment or damaged clutch pressure plate or disc are additional probable causes of increased shift effort. Incorrect adjustment or a worn/damaged pressure plate or disc can cause incorrect release. If clutch problem is advanced, gear clash during shifts can result. Worn or damaged synchro rings can cause gear clash when shifting into any forward gear. In some new or rebuilt transmissions, new synchro rings may tend to stick slightly causing hard or noisy shifts. In most cases this condition will decline as the rings wear-in.

### TRANSMISSION NOISE

Most manual transmissions make some noise during normal operation. Rotating gears generate a mild whine that is audible, but generally only at extreme speeds.

Severe highly audible transmission noise is generally the initial indicator of a lubricant problem. Insufficient, improper or contaminated lubricant will promote rapid wear of gears, synchros, shift rails, forks and bearings. The overheating caused by a lubricant problem, can also lead to gear breakage.

### REMOVAL

- (1) Disconnect battery negative cable.
- (2) Shift transmission into Neutral.
- (3) Remove shift boot bezel screws and slide boot upward on shift lever extension.
- (4) Remove shift lever extension from the shift tower and lever assembly.
- (5) Remove bolts attaching shift tower and lever assembly to rear case. Then remove shift tower and lever assembly.
- (6) Raise vehicle on hoist.
- (7) Remove crankshaft position sensor. Retain sensor attaching bolts.
- (8) Remove skid plate, if equipped.
- (9) Drain transmission lubricant if transmission will be disassembled for service.
- (10) Mark propeller shaft/shafts and yoke/yokes for installation reference and remove propeller shaft/shafts.
- (11) Disengage harness from clips on transmission housing.
- (12) Support engine with adjustable jack stand and wood block.
- (13) Drain transmission lubricant if transmission will be disassembled for service.



## MANUAL - NV3500 (Continued)

**TWO WHEEL DRIVE**

(1) Remove nuts attaching rear mount to crossmember (Fig. 2). Then remove insulator from extension housing if necessary.

(2) Remove bolts and nuts attaching crossmember to frame rails. Rotate crossmember diagonally and remove crossmember.

(3) Disconnect exhaust as necessary.

(4) Remove slave cylinder attaching nuts and remove cylinder from clutch housing.

(5) Remove starter motor.

(6) Support and secure transmission with safety chains to a transmission jack.

(7) Remove nuts/bolts attaching transmission front housing to engine.

(8) Remove transmission dust shield.

(9) Move transmission rearward until input shaft is clear of clutch disc and cover. Then lower jack and remove transmission from under vehicle.

**FOUR WHEEL DRIVE**

(1) Disconnect transfer case shift linkage at transfer case range lever.

(2) Remove bolts attaching shift linkage bracket to transfer case and move linkage and bracket aside.

(3) Support transfer case with transmission jack.

(4) Remove nuts attaching transfer case to transmission adapter housing.

(5) Remove transfer case with aid of helper.

(6) Support engine with a jack stand and a wood block.

(7) Remove nuts and bolts attaching support bracket and cushions to fixed crossmember.

(8) Remove nuts and bolts attaching removable crossmember to frame rails.

(9) Remove crossmember.

(10) Disconnect exhaust as necessary.

(11) Remove slave cylinder attaching nuts and remove cylinder from clutch housing. Move cylinder aside for working clearance.

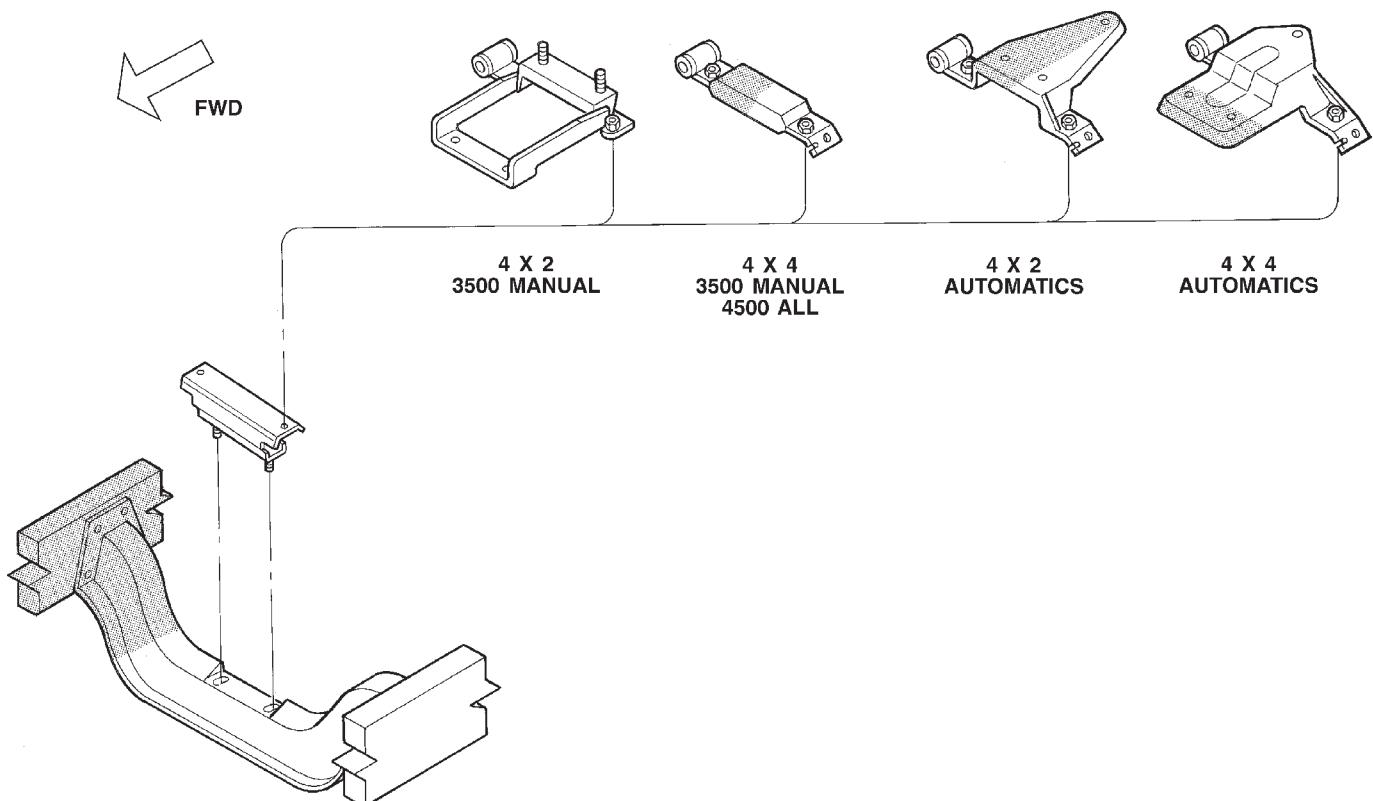
(12) Remove clutch housing dust cover.

(13) On some models, it may be necessary to remove front axle struts and oil filter for access and removal clearance. Remove these components if necessary.

(14) Support transmission with transmission jack. Secure transmission to jack with safety chains.

(15) Remove bolts attaching transmission clutch housing to engine block.

(16) Move transmission rearward until transmission input shaft is clear of clutch disc and cover. Then lower jack and remove transmission from under vehicle.



J9509-126

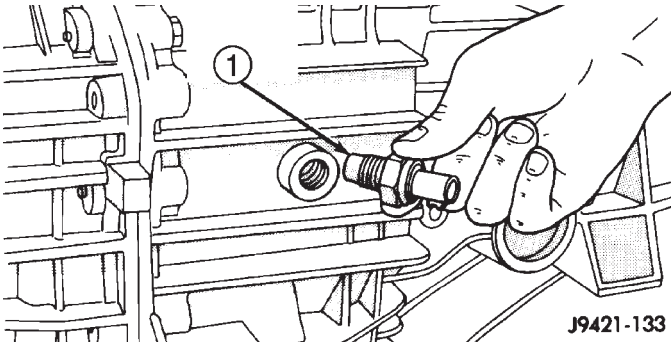
**Fig. 2 Transmission Rear Support Brackets**

## MANUAL - NV3500 (Continued)

## DISASSEMBLY

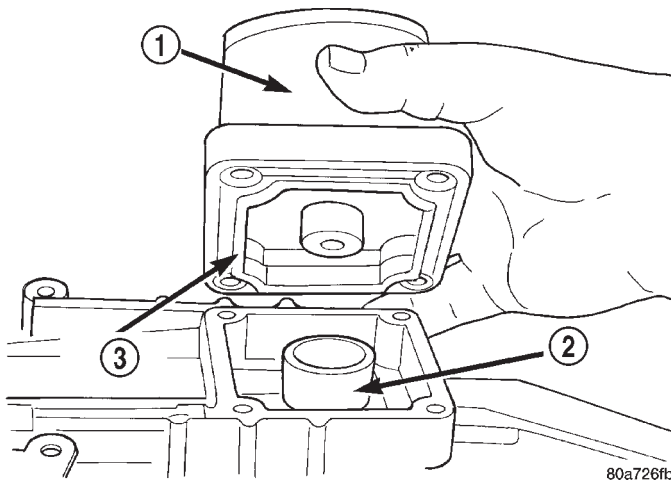
## FRONT HOUSING

- (1) Shift transmission into Neutral.
- (2) If lubricant was not drained out of transmission during removal, remove drain plug and drain lubricant.
- (3) Inspect drain plug magnet for debris.
- (4) Remove backup light switch located on passenger side of rear housing (Fig. 3).

**Fig. 3 Backup Light Switch**

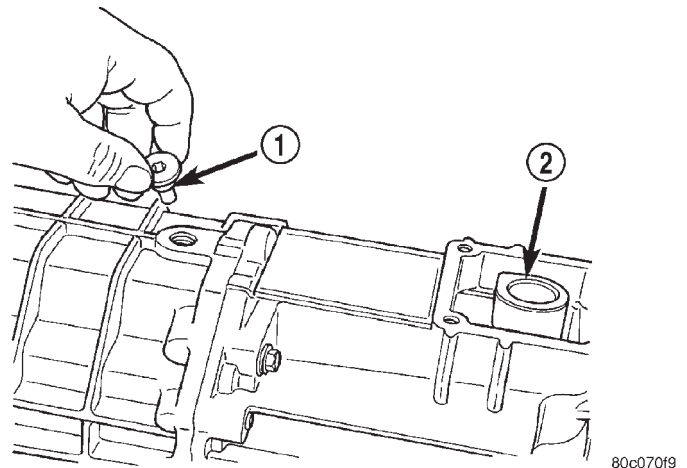
1 - BACKUP LIGHT SWITCH

- (5) Remove shift tower bolts and remove tower and lever assembly (Fig. 4).

**Fig. 4 Shift Tower**

1 - SHIFT TOWER AND LEVER ASSEMBLY  
 2 - SHIFT SOCKET  
 3 - SEAL

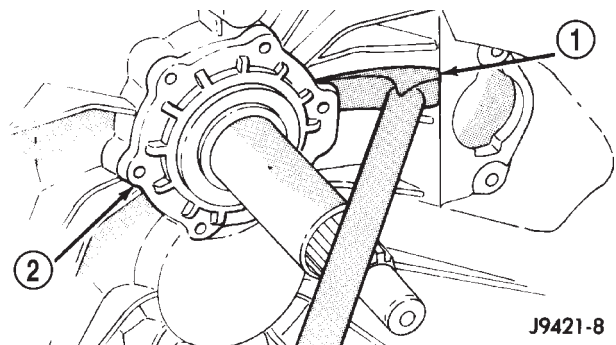
- (6) Remove shift shaft lock bolt (Fig. 5). Bolt is located at top of front housing just forward of shift tower. Bolt is a shoulder bolt that secures the shift shaft bushing and lever.

**Fig. 5 Shift Shaft Lock Bolt**

1 - SHIFT SHAFT LOCK BOLT  
 2 - SHAFT SOCKET

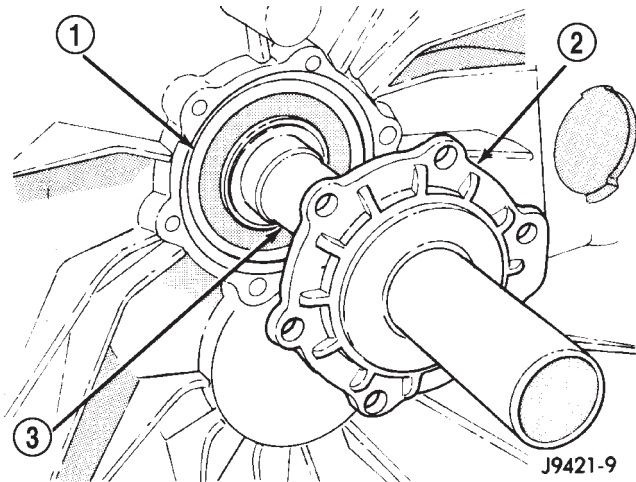
- (7) Remove bolts attaching input shaft bearing retainer to front housing and remove retainer.

**NOTE:** Use pry tool to carefully lift retainer and break sealer bead (Fig. 6).

**Fig. 6 Loosening Bearing**

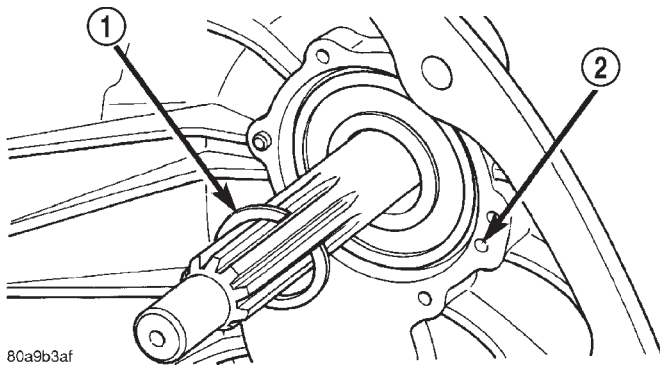
1 - PRY TOOL  
 2 - INPUT SHAFT BEARING RETAINER

- (8) Remove bearing retainer from input shaft (Fig. 7).
- (9) Remove snap ring that secures input shaft in front bearing (Fig. 8).



**Fig. 7 Input Shaft Bearing Retainer**

- 1 - SHAFT BEARING
- 2 - BEARING RETAINER
- 3 - INPUT SHAFT



**Fig. 8 Input Shaft**

- 1 - INPUT SHAFT SNAP RING
- 2 - OIL FEED

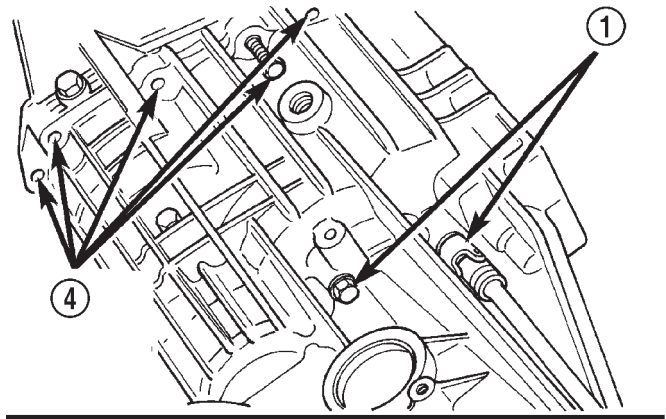
(10) Remove shift shaft detent plug with Remover 8117A. Attach fingers of the remover to the detent plug and push the cup down till it contacts the trans. Then tighten the nut till it pulls the plug from the case.

(11) Remove shift shaft detent plunger and spring with a pencil magnet.

(12) Remove bolts that attach front housing to rear housing (Fig. 9). Three bolts at extreme rear of housing are actually for the output shaft bearing retainer. It is not necessary to remove all three bolts at this time. Leave at least one bolt in place until geartrain is ready to be removed from case.

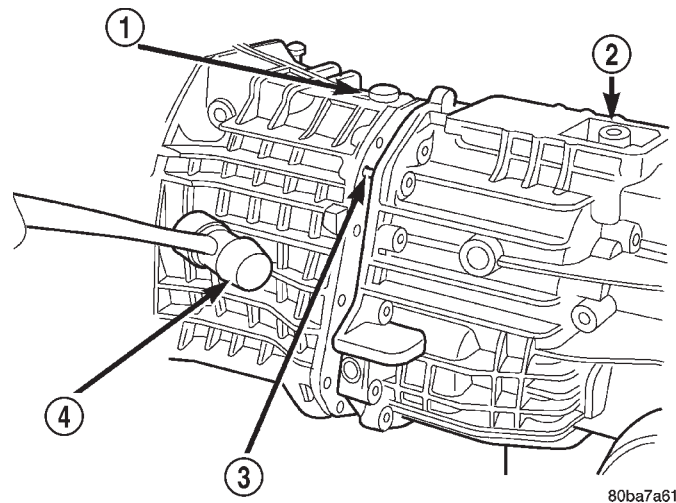
(13) Separate front housing from rear housing (Fig. 10). Use plastic hammer to tap front housing off alignment dowels.

(14) Remove and inspect input shaft bearing. Inspect countershaft front bearing race (Fig. 11).



**Fig. 9 Housing And Bearing Retainer Bolt**

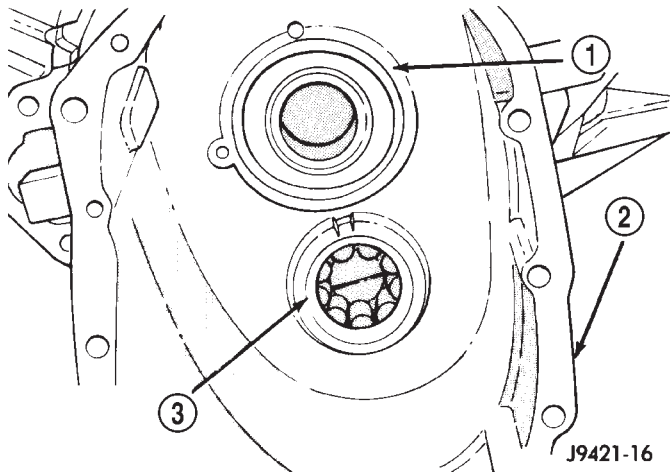
- 1 - RETAINER BOLTS
- 2 - HOUSING BOLTS
- 3 - RETAINER BOLT
- 4 - HOUSING BOLT LOCATIONS



**Fig. 10 Front Housing**

- 1 - FRONT HOUSING
- 2 - REAR HOUSING
- 3 - DOWELS (2)
- 4 - PLASTIC MALLETT

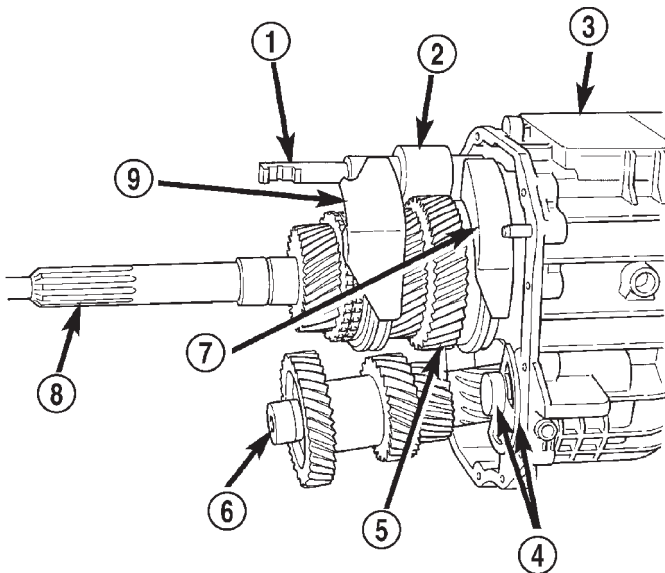
## MANUAL - NV3500 (Continued)



**Fig. 11 Input Shaft Bearing and Countershaft Front Bearing Race**

- 1 - INPUT SHAFT BEARING
- 2 - FRONT HOUSING
- 3 - COUNTERSHAFT FRONT BEARING

(15) Note position of input shaft, shift shaft and forks, and geartrain components in housing (Fig. 12).



**Fig. 12 Geartrain And Shift Components**

- 1 - SHIFT SHAFT
- 2 - BUSHING
- 3 - REAR HOUSING
- 4 - REVERSE IDLER AND SUPPORT
- 5 - OUTPUT SHAFT AND GEARS
- 6 - COUNTERSHAFT
- 7 - 1-2 FORK
- 8 - INPUT SHAFT
- 9 - 3-4 FORK

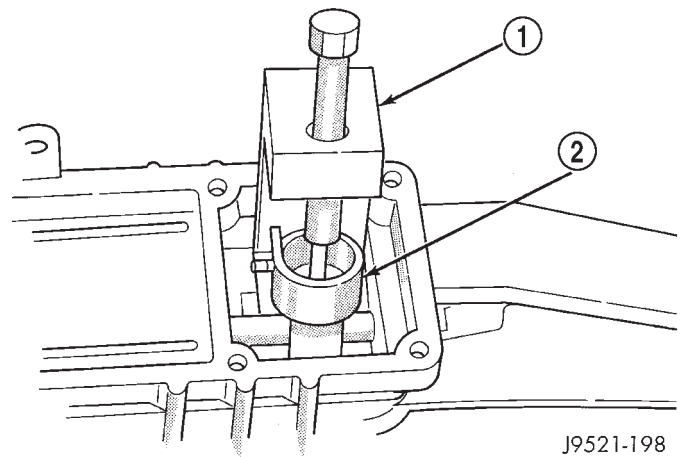
### SHIFT/FORK SHAFTS AND REVERSE IDLER SEGMENT

(1) Unseat shift socket roll pin with Remover 6858. Position remover on shift shaft and center tool over the roll pin. Verify tool legs are firmly seated on the shift socket (Fig. 13).

(2) Tilt socket toward the side of the case to avoid trapping the pin between the gear teeth.

(3) Tighten remover to press the roll pin downward and out of the shift socket (Fig. 13).

**NOTE:** Roll pin does not have to be completely removed, the pin must only be clear of the shift shaft. Be careful not to push the pin into the geartrain.



**Fig. 13 Shift Socket**

- 1 - REMOVER 6858
- 2 - SHIFT SOCKET

(4) Drive out shift bushing and lever roll pint with a hammer and punch (Fig. 14).

**NOTE:** Use proper size punch to avoid bending the shift shaft.

(5) Pull shift shaft straight out of rear housing, shift socket, fifth-reverse fork and 1-2 fork (Fig. 15).

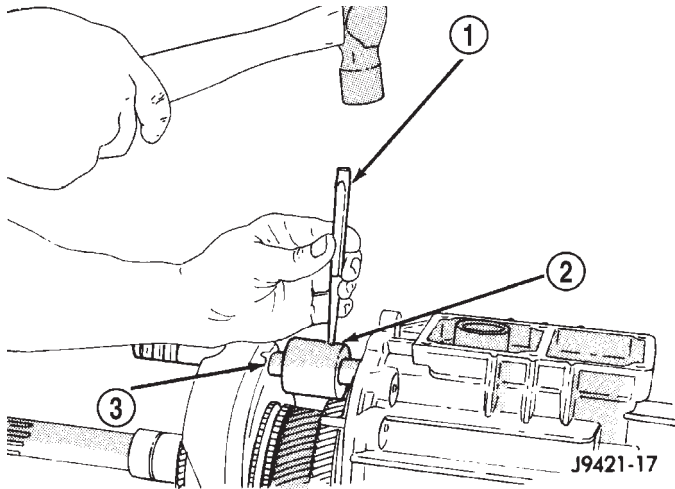
(6) Remove shift socket from rear housing (Fig. 16).

(7) Remove lever and bushing (Fig. 17).

(8) Remove 3-4 fork. Rotate 3-4 fork around synchro sleeve until fork clears shift arms on 1-2 and fifth-reverse forks. Then remove 3-4 fork (Fig. 18).

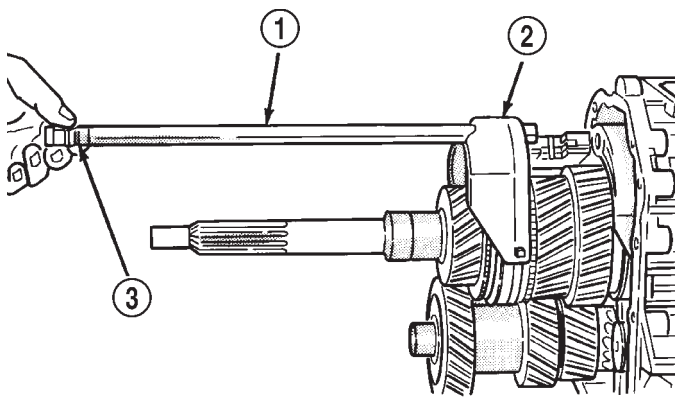


MANUAL - NV3500 (Continued)



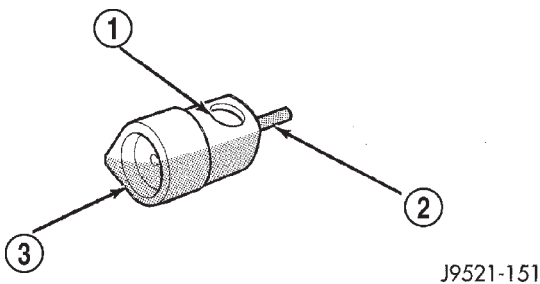
**Fig. 14 Shift Shaft Lever And Bushing Roll Pin**

- 1 - PIN PUNCH
- 2 - BUSHING AND LEVER
- 3 - SHIFT SHAFT



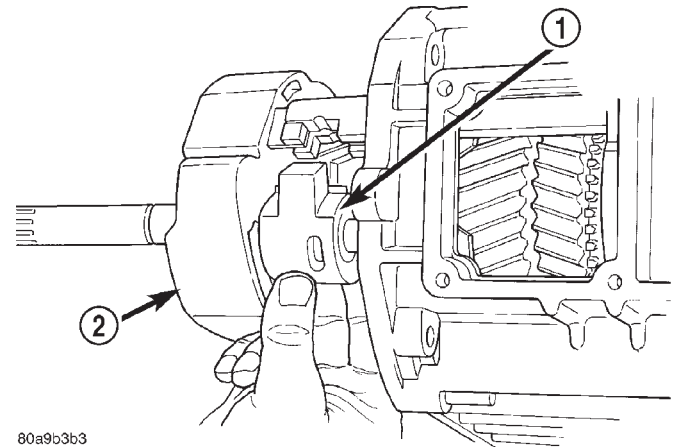
**Fig. 15 Shift Shaft**

- 1 - SHIFT SHAFT
- 2 - 3-4 FORK
- 3 - SHAFT DETENT NOTCHES



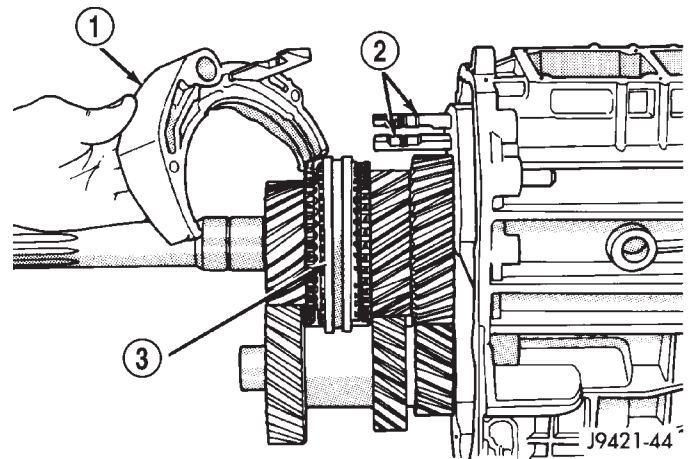
**Fig. 16 Shift Socket And Roll**

- 1 - SHAFT BORE
- 2 - ROLL PIN
- 3 - SHIFT SOCKET



**Fig. 17 Shift Shaft Lever And Bushing**

- 1 - SHAFT LEVER AND BUSHING
- 2 - 3-4 FORK



**Fig. 18 3-4 Shift Fork**

- 1 - 3-4 FORK
- 2 - 1-2 AND 5TH-REVERSE FORK ARMS
- 3 - 3-4 SYNCHRO SLEEVE

(9) Remove the reverse idler shaft support bolt (front bolt) (Fig. 19).

(10) Loosen rear reverse idler shaft bolt (rear bolt) (Fig. 19).

(11) Remove reverse idler shaft support segment by sliding it straight out of housing.

(12) Support geartrain and rear housing on Fixture 6747 as follows:

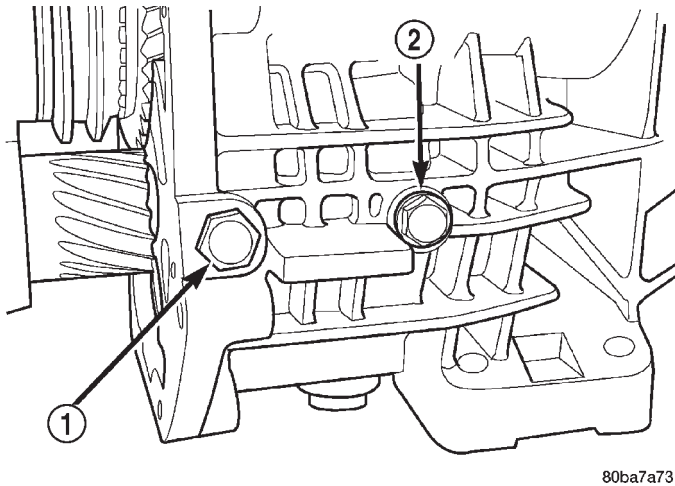
(a) Adjust height of reverse idler pedestal rod until the reverse idle shaft bottoms in Cup 8115.

(b) Position Adapters 6747-1A and 6747-2B on Fixture 6747.

(c) Slide fixture tool onto input shaft, countershaft and idler gear (Fig. 20).

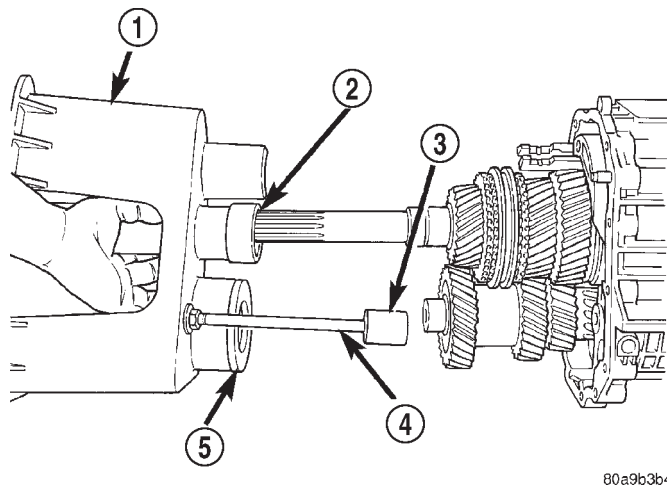
(d) Stand geartrain and rear housing upright on fixture (Fig. 21). Have helper hold fixture tool in place while housing and geartrain is being rotated into upright position.

## MANUAL - NV3500 (Continued)



**Fig. 19 Reverse Idler Shaft/Support**

- 1 - SUPPORT BOLT  
2 - SHAFT BOLT



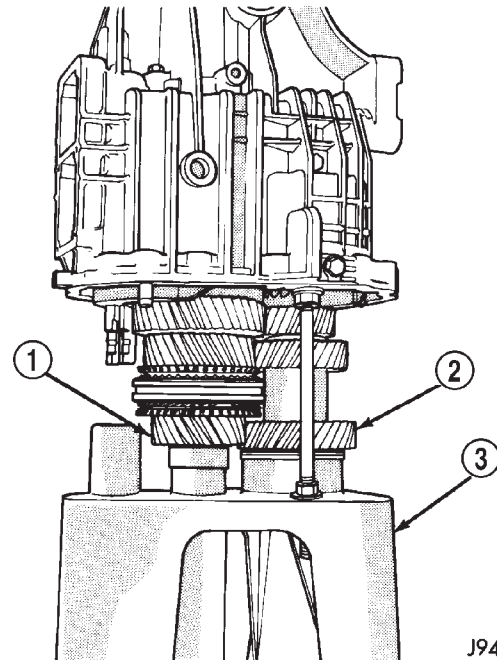
**Fig. 20 Fixture Assembly**

- 1 - FIXTURE 6747  
2 - ADAPTER 6747-1A  
3 - CUP 8115  
4 - REVERSE IDLER PEDESTAL  
5 - ADAPTER 6747-2B

(13) Remove rear bolt holding reverse idler shaft in housing.

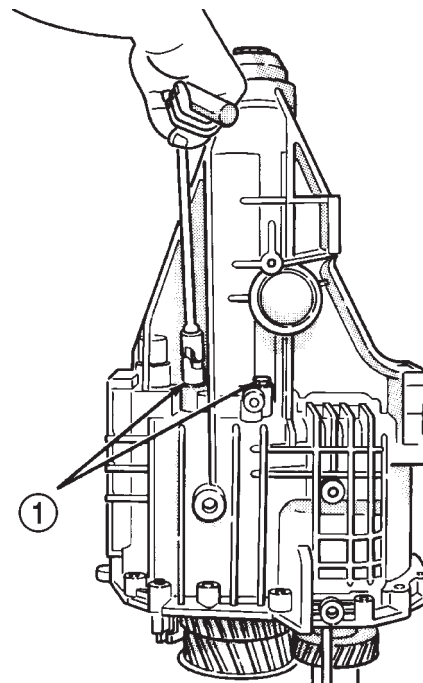
### REAR HOUSING - 2WD

(1) On 2-wheel drive transmission, remove three bolts that attach output shaft bearing retainer to rear case (Fig. 22). Bolts are rear of shift tower opening.



**Fig. 21 Geartrain And Housing Mounted On Fixture**

- 1 - INPUT SHAFT  
2 - COUNTERSHAFT  
3 - FIXTURE 6747



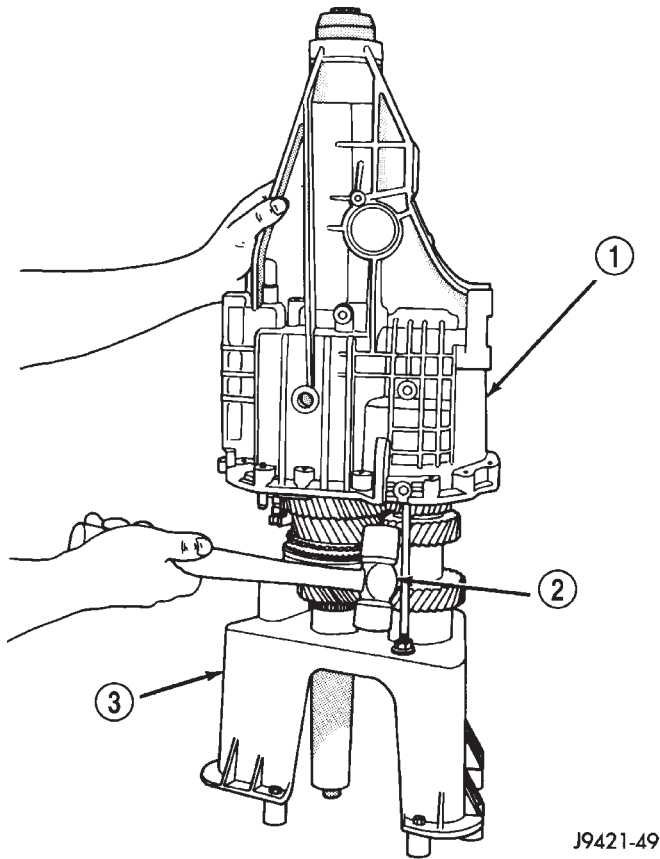
**Fig. 22 Output Shaft**

- 1 - OUTPUT SHAFT BEARING RETAINER BOLTS (THIRD BOLT IS AT OPPOSITE SIDE OF CASE)



MANUAL - NV3500 (Continued)

(2) Unseat output shaft bearing from bearing bore in rear housing. With a plastic/rawhide hammer tap rear housing upward and off output shaft bearing (Fig. 23).



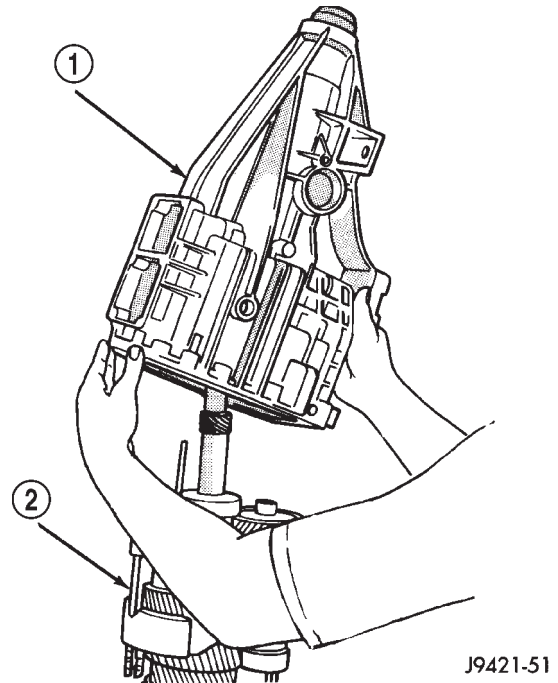
J9421-49

**Fig. 23 Separate Rear Housing From Output Shaft Bearing - 2WD**

- 1 - REAR HOUSING
- 2 - PLASTIC OR RAWHIDE MALLET
- 3 - FIXTURE 6747

(3) Lift rear housing up and off geartrain (Fig. 24).  
 (4) Remove countershaft rear bearing from countershaft (Fig. 25).

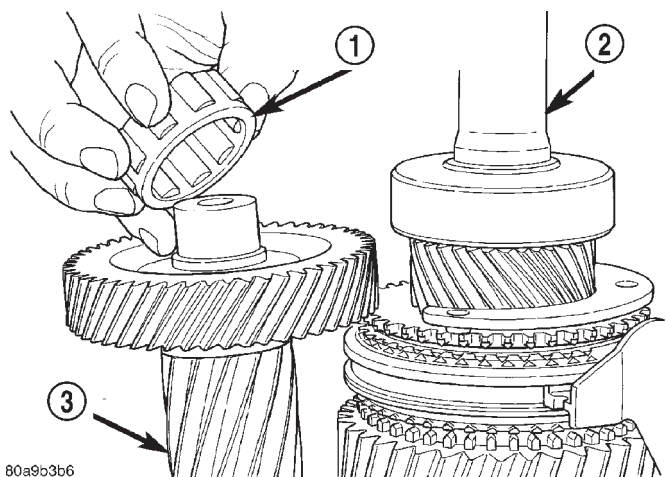
(5) Examine condition of bearing bore and idler shaft notch in rear housing . Replace housing if any of these components are damaged.



J9421-51

**Fig. 24 Rear Housing - 2WD**

- 1 - REAR HOUSING
- 2 - SHIFT FORKS AND GEARTRAIN



80a9b3b6

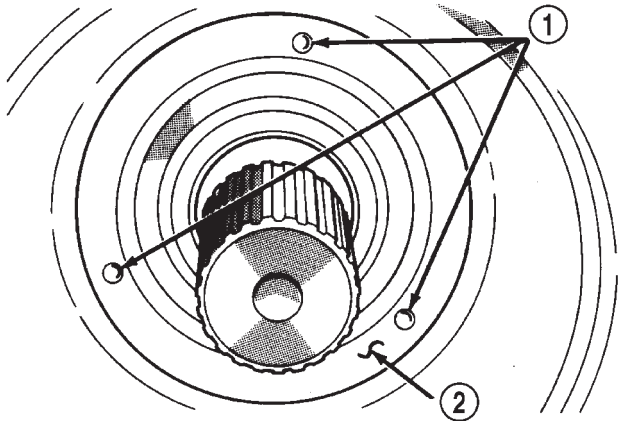
**Fig. 25 Countershaft Rear Bearing**

- 1 - COUNTERSHAFT REAR BEARING
- 2 - OUTPUT SHAFT
- 3 - COUNTER SHAFT

## MANUAL - NV3500 (Continued)

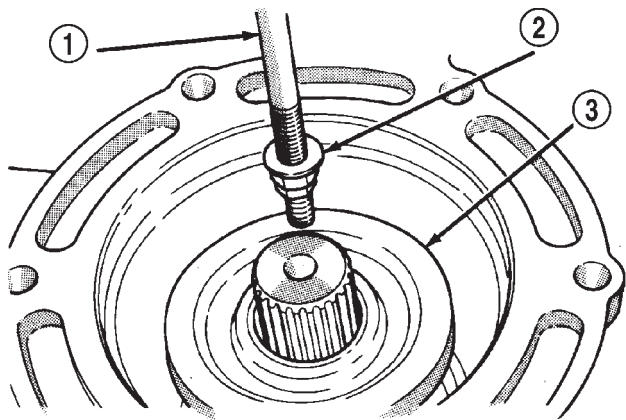
**REAR ADAPTER HOUSING - 4WD**

(1) Locate dimples in face of rear seal (Fig. 26). With a slide hammer mounted screw remove seal by inserting screw into seal at dimple locations (Fig. 27).



**Fig. 26 Dimples In Seal Face - 4WD**

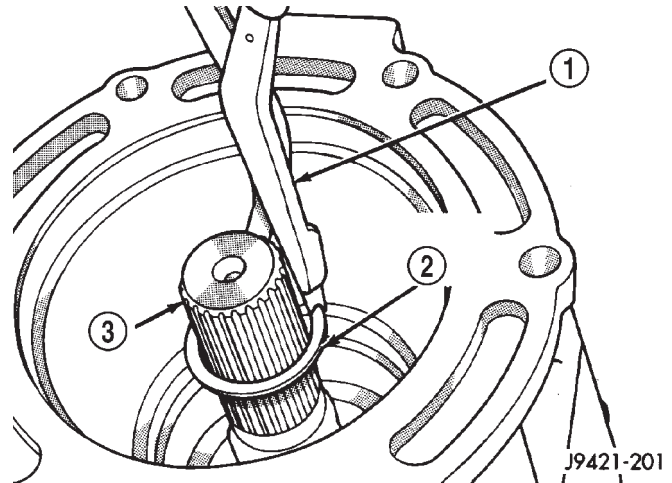
- 1 - LOCATION OF DIMPLES  
2 - SEAL FACE



**Fig. 27 Rear Seal - 4WD**

- 1 - SLIDE HAMMER  
2 - REMOVER TOOL  
3 - REAR SEAL

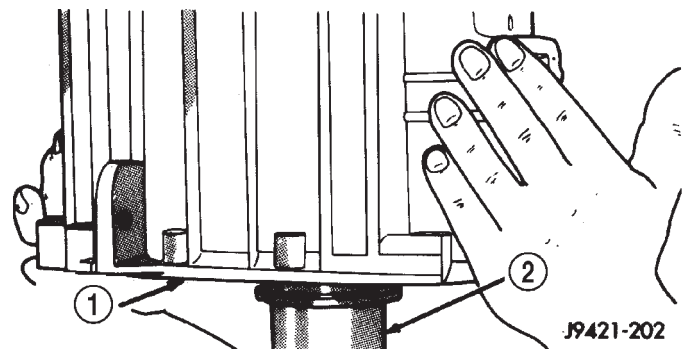
(2) Remove rear bearing snap ring from output shaft with snap ring pliers (Fig. 28).



**Fig. 28 Rear Bearing Snap Ring - 4WD**

- 1 - HEAVY DUTY SNAP RING PLIERS  
2 - REAR BEARING SNAP RING  
3 - OUTPUT SHAFT

(3) Lift rear adapter housing upward and off geartrain (Fig. 29).



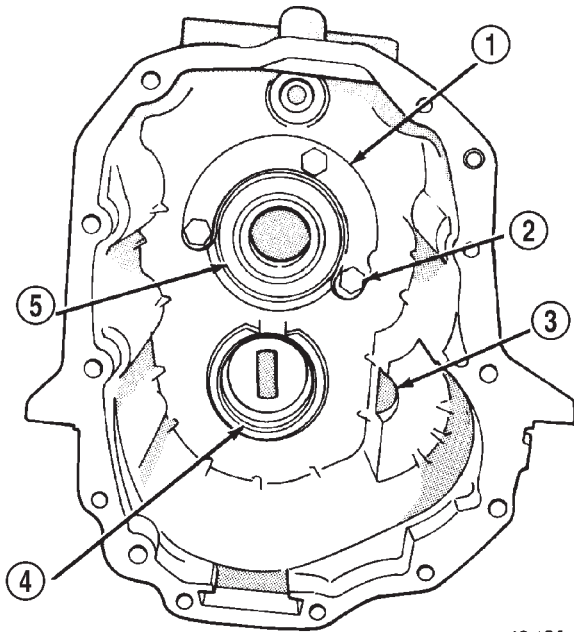
**Fig. 29 Rear Adapter Housing**

- 1 - REAR ADAPTER HOUSING  
2 - OUTPUT SHAFT

(4) Remove bearing retainer bolts and remove rear bearing retainer and rear bearing (Fig. 30). Use hammer handle to push or tap bearing out of housing if needed.

(5) Examine condition of bearing bore, counter-shaft rear bearing race and idler shaft notch in rear housing. Replace housing if race, bore or notch are worn or damaged.

MANUAL - NV3500 (Continued)



J9421-203

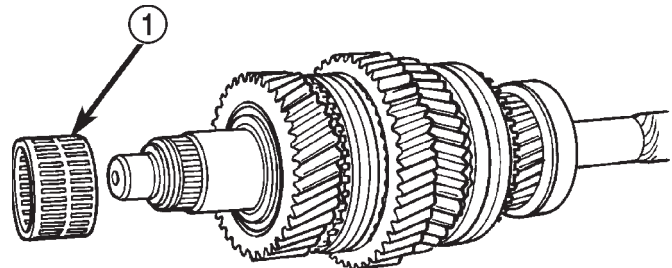
**Fig. 30 Rear Adapter Housing Components**

- 1 - BEARING RETAINER
- 2 - RETAINER BOLTS (3)
- 3 - IDLER SHAFT NOTCH
- 4 - COUNTERSHAFT REAR BEARING RACE
- 5 - REAR BEARING

(1) Remove snap ring that secures 3-4 synchro hub on output shaft.

(2) Remove 3-4 synchro assembly, third gear synchro ring and third gear with shop press and Bearing Splitter 1130. Position splitter between second and third gears.

(3) Remove third gear needle bearing (Fig. 31).



80a9b3b7

**Fig. 31 Third Gear Needle Bearing**

- 1 - THIRD GEAR NEEDLE BEARING

(4) Remove retaining ring that secures two-piece thrust washer on shaft with a small pry tool (Fig. 32).

## GEARTRAIN FROM FIXTURE

(1) Remove reverse idler gear assembly from assembly fixture cup.

(2) Remove 1-2 and fifth-reverse forks from synchro sleeves.

(3) Slide countershaft out of fixture tool.

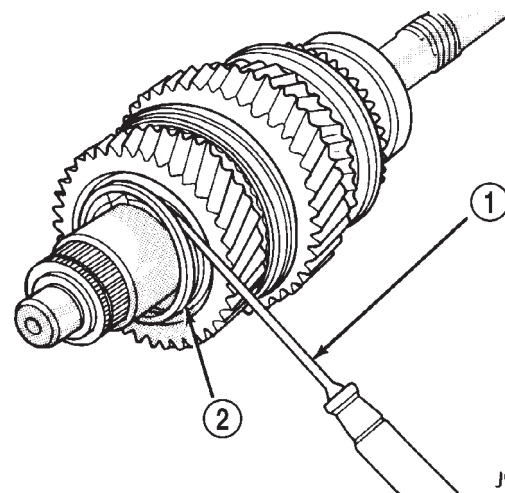
(4) Remove output shaft bearing retainer from rear surface of fifth gear (retainer will drop onto gear after bolts are removed).

(5) Lift and remove output shaft and gears off input shaft.

(6) Lift and remove input shaft, pilot bearing and fourth gear synchro ring from assembly fixture tool.

## OUTPUT SHAFT

**NOTE:** The synchronizer hubs and sleeves are different and must not be intermixed. Remove each synchronizer unit as an assembly to avoid intermixing parts. Mark each synchro hub and sleeve with a scribe or paint for correct assembly reference.



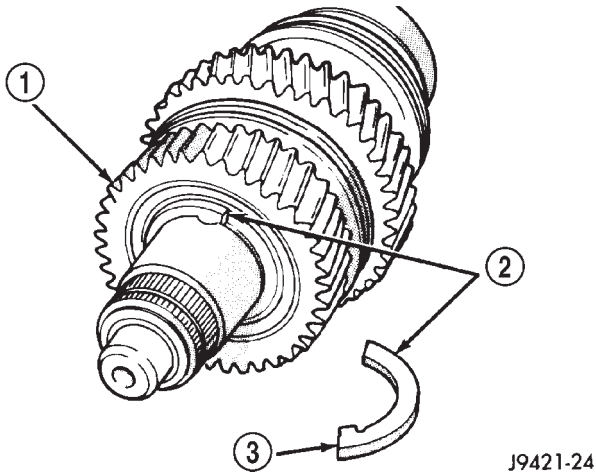
J9421-23

**Fig. 32 Thrust Washer**

- 1 - PRY TOOL
- 2 - THRUST WASHER RETAINING RING

## MANUAL - NV3500 (Continued)

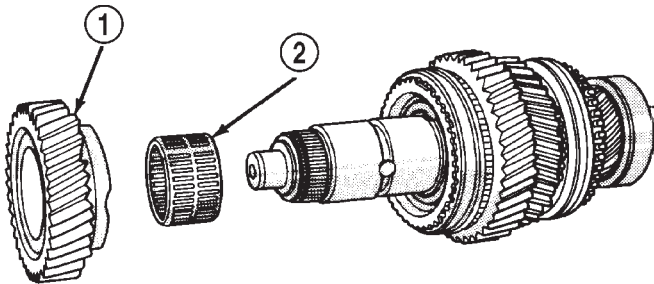
(5) Remove two-piece thrust washer (Fig. 33). Note position of washer locating lugs in shaft notches for installation reference.



**Fig. 33 Two-Piece Thrust Washer**

- 1 - SECOND GEAR
- 2 - THRUST WASHER (2-PIECE)
- 3 - WASHER LOCATING LUG

(6) Remove second gear and needle bearing (Fig. 34).



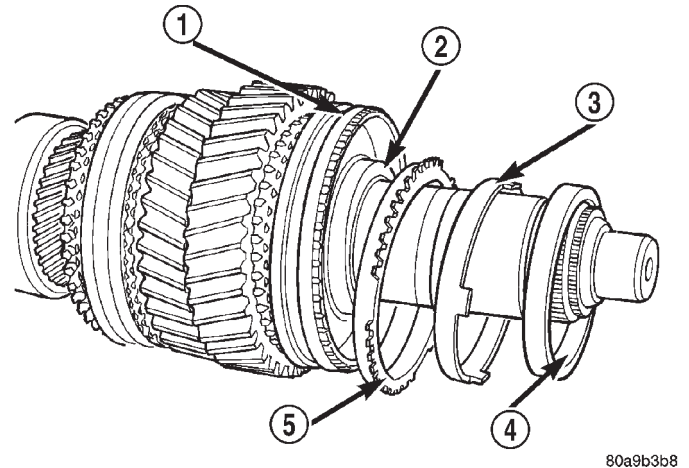
**Fig. 34 Second Gear**

- 1 - SECOND GEAR
- 2 - SECOND GEAR NEEDLE BEARING

(7) Remove second gear synchro ring, synchro friction cone, and synchro cone (Fig. 35).

(8) Remove interm ring.

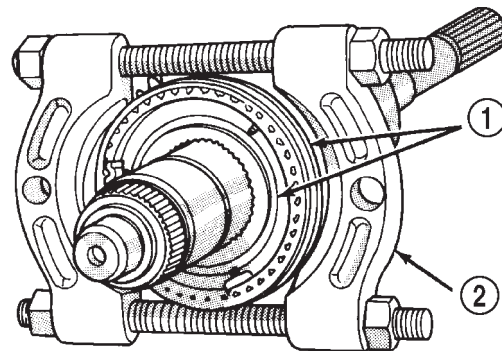
(9) Remove 1-2 synchro hub snap ring.



**Fig. 35 Second Gear Synchro Ring And Cones**

- 1 - 1-2 SYNCHRO HUB AND SLEEVE
- 2 - INTERM RING
- 3 - SYNCHRO FRICTION CONE
- 4 - SYNCHRO CONE
- 5 - SYNCHRO RING

(10) Remove 1-2 synchro hub and sleeve and first gear from output shaft with shop press and Bearing Splitter 1130 (Fig. 36). Position splitter between first and reverse gears.

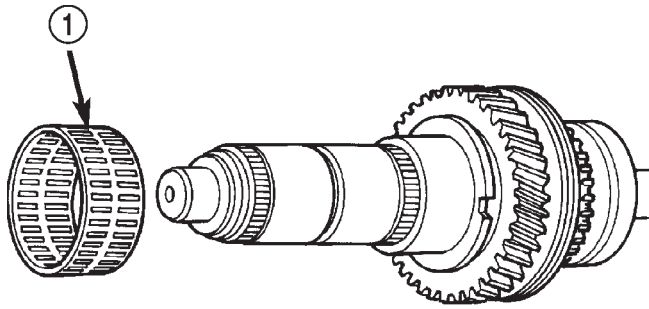


**Fig. 36 Hub Sleeve And 1-2 Synchro**

- 1 - 1-2 SYNCHRO HUB AND SLEEVE
- 2 - SPLITTER 1130

MANUAL - NV3500 (Continued)

(11) Remove first gear needle bearing (Fig. 37).

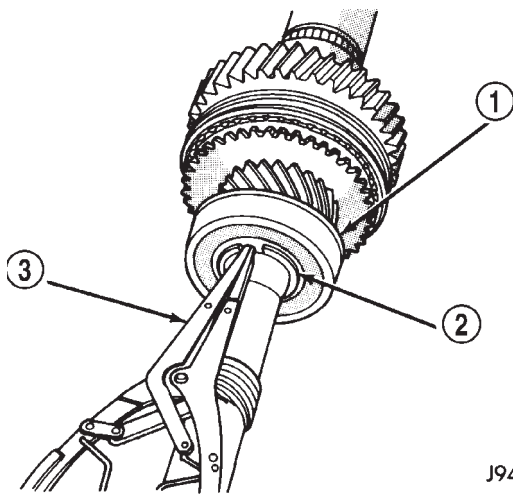


80a9b3b9

**Fig. 37 First Gear Needle Bearing**

1 - FIRST GEAR NEEDLE BEARING

(12) Remove output shaft bearing snap ring (Fig. 38).



J9421-29

**Fig. 38 Output Shaft Bearing Snap Ring**

1 - OUTPUT SHAFT BEARING  
2 - BEARING SNAP RING  
3 - SNAP RING PLIERS

(13) On 2-wheel drive models, remove output shaft bearing.

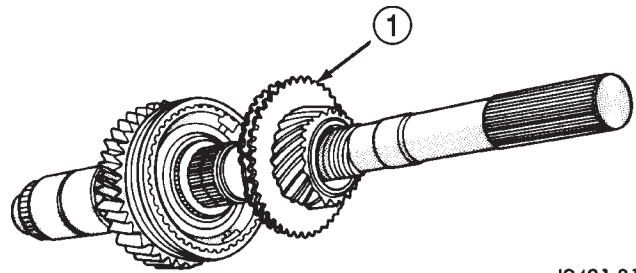
(14) Remove fifth gear (Fig. 39).

(15) Remove fifth gear needle bearing, spreading bearing apart just enough to clear shoulder on output shaft (Fig. 40).

(16) Remove fifth-reverse synchro hub snap ring (Fig. 41).

(17) Remove fifth-reverse synchro hub and sleeve with shop press (Fig. 42).

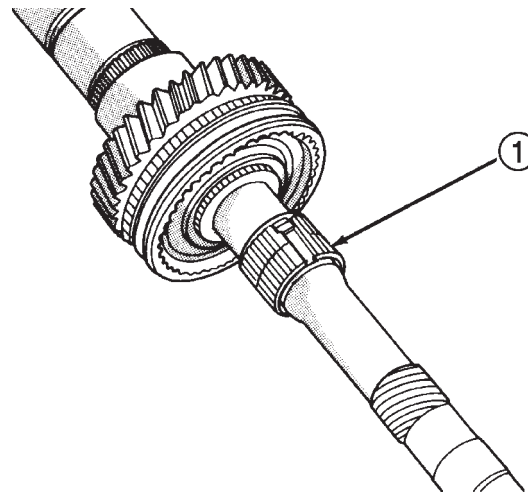
(18) Remove reverse gear and needle bearing (Fig. 43).



J9421-31

**Fig. 39 Fifth Gear**

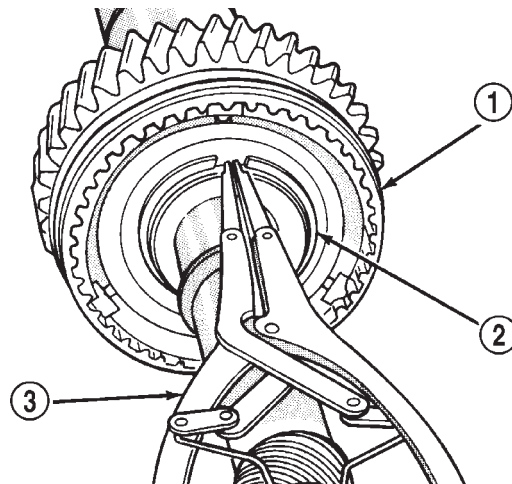
1 - FIFTH GEAR AND SYNCHRO RING



J9421-32

**Fig. 40 Fifth Gear Needle**

1 - FIFTH GEAR NEEDLE BEARING



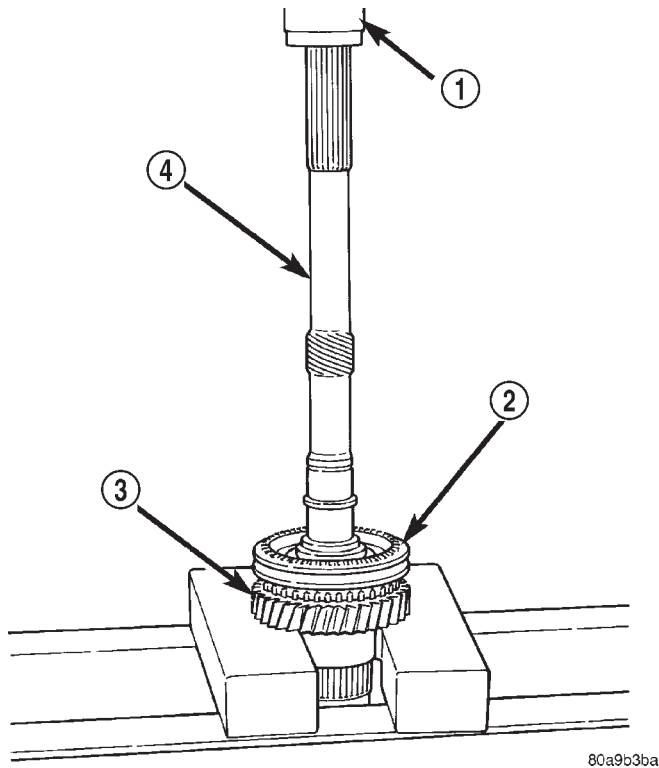
J9421-33

**Fig. 41 Fifth-Reverse**

1 - FIFTH-REVERSE SYNCHRO HUB AND SLEEVE  
2 - SYNCHRO HUB SNAP RING  
3 - SNAP RING PLIERS

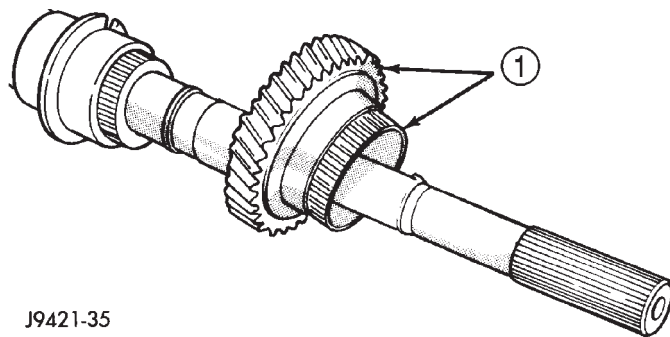


## MANUAL - NV3500 (Continued)



**Fig. 42 Fifth-Reverse Synchro**

- 1 - PRESS
- 2 - FIFTH-REVERSE SYNCHRO HUB AND SLEEVE
- 3 - REVERSE GEAR
- 4 - OUTPUT SHAFT



**Fig. 43 Reverse Gear And Needle Bearing**

- 1 - REVERSE GEAR AND NEEDLE BEARING

### REVERSE IDLER

- (1) Remove idler gear snap rings (Fig. 44).
- (2) Remove thrust washer, wave washer, thrust plate and idler gear from shaft.
- (3) Remove idler gear needle bearing from shaft.

### CLEANING

Clean the gears, shafts, shift components and transmission housings with a standard parts cleaning solvent. Do not use acid or corrosive base solvents. Dry all parts except bearings with compressed air.

Clean the shaft bearings with a mild solvent such as Mopar® degreasing solvent, Gunk, or similar solvents. Do not dry the bearings with compressed air. Allow the bearings to either air dry, or wipe them dry with clean shop towels.

### INSPECTION

#### SHIFT LEVER ASSEMBLY

The shift lever assembly is not serviceable. Replace the lever and shift tower as an assembly if the tower, lever, lever ball, or internal components are worn, or damaged.

#### SHIFT SHAFT AND FORKS

Inspect the shift fork interlock arms and synchro sleeve contact surfaces (Fig. 45). Replace any fork exhibiting wear or damage in these areas. Do not attempt to salvage shift forks.

Check condition of the shift shaft detent plunger and spring. The plunger should be smooth and free of nicks, or scores. The plunger spring should be straight and not collapsed, or distorted. Minor scratches, or nicks on the plunger can be smoothed with 320/400 grit emery soaked in oil. Replace the plunger and spring if in doubt about condition. Check condition of detent plunger bushings. Replace if damaged.

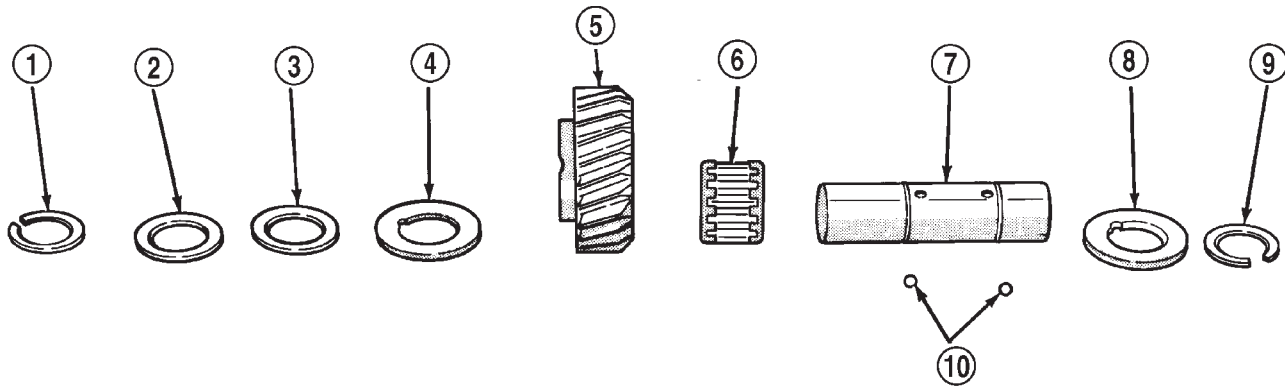
Inspect the shift shaft, shift shaft bushing and bearing, the shaft lever, and the lever bushing that fits over the lever. Replace the shaft if bent, cracked, or severely scored. Minor burrs, nicks, or scratches can be smoothed off with 320/400 grit emery cloth followed by polishing with crocus cloth. Replace the shift shaft bushing or bearing if damaged.

Replace the shaft lever and bushing if either part is deformed, or worn. Do not attempt to salvage these parts as shift fork binding will occur. Replace the roll pin that secures the lever to the shaft.

#### FRONT/REAR HOUSINGS AND BEARING RETAINERS

Inspect the housings carefully. Look for cracks, stripped threads, scored mating surfaces, damaged bearing bores, or worn dowel pin holes. Minor nicks on mating surfaces can be dressed off with a fine file, or emery cloth. Damaged threads can be renewed by either re-tapping or installing Helicoil inserts.



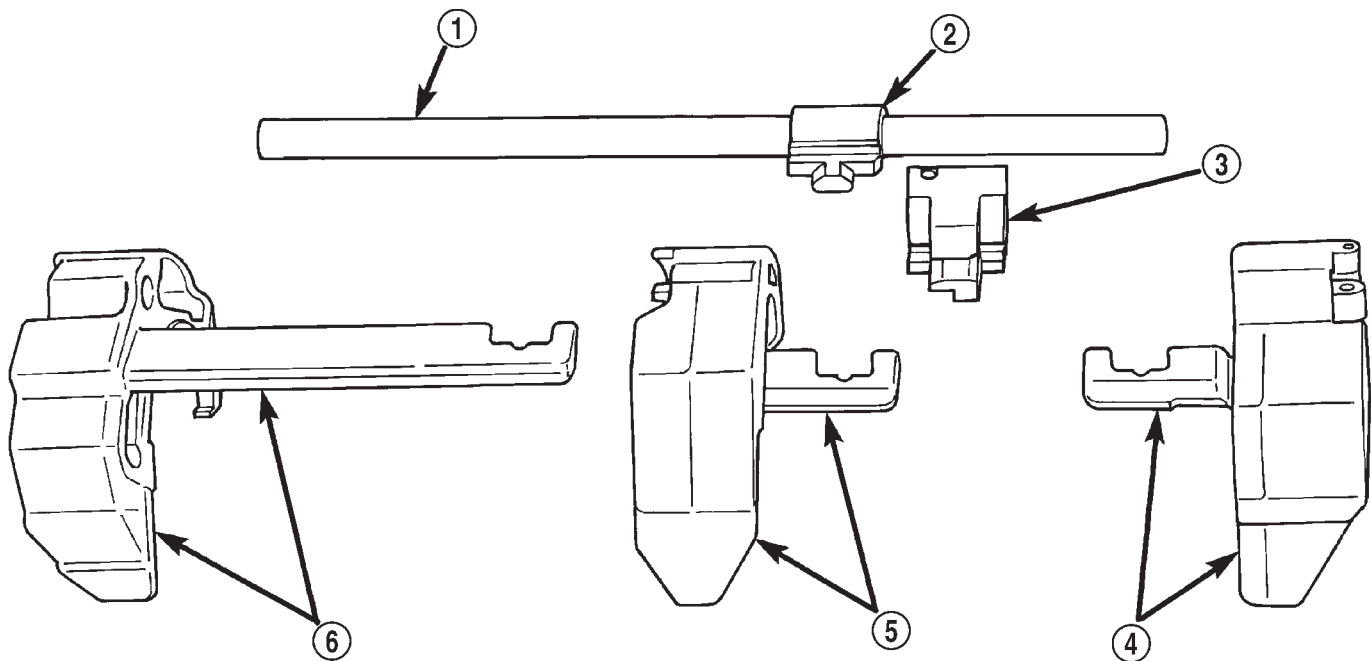


J9421-53

**Fig. 44 Reverse Idler Components**

- 1 - SNAP RING
- 2 - FLAT WASHER
- 3 - WAVE WASHER
- 4 - THRUST WASHER
- 5 - REVERSE IDLER GEAR

- 6 - IDLER GEAR BEARING
- 7 - IDLER SHAFT
- 8 - THRUST WASHER
- 9 - SNAP RING
- 10 - THRUST WASHER LOCKBALLS



80c070ff

**Fig. 45 Shift Forks And Shaft**

- 1 - SHIFT SHAFT
- 2 - SHAFT LEVER
- 3 - SHAFT LEVER BUSHING

- 4 - 3-4 SHIFT FORK
- 5 - 1-2 SHIFT FORK
- 6 - FIFTH-REVERSE SHIFT FORK

**NOTE:** The front housing contains the countershaft front bearing race. The rear housing contains the countershaft rear bearing race. Be advised that these components are NOT serviceable items. The front housing will have to be replaced if the coun-

tershaft bearing race is loose, worn, or damaged. The rear housing will have to be replaced if the countershaft rear bearing race is loose, worn, or damaged.

## MANUAL - NV3500 (Continued)

Inspect the input shaft bearing retainer. Be sure the release bearing slide surface of the retainer is in good condition. Minor nicks on the surface can be smoothed off with 320/420 grit emery cloth and final polished with oil coated crocus cloth. Replace the retainer seal if necessary.

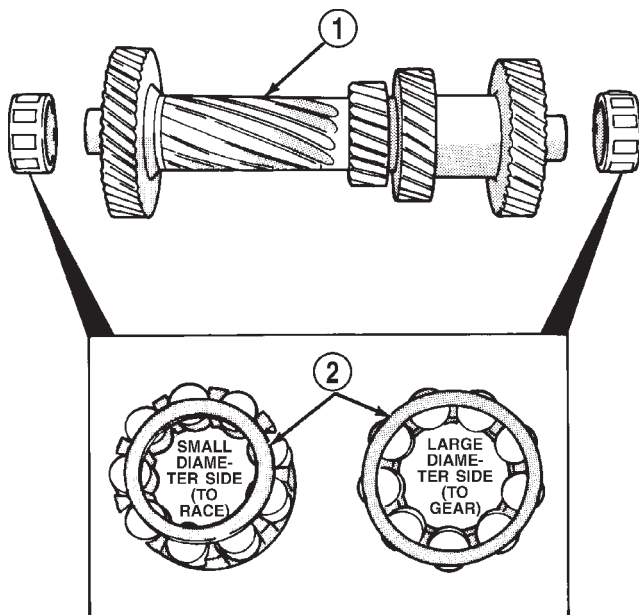
Inspect the output shaft bearing retainer. Be sure the U-shaped retainer is flat and free of distortion. Replace the retainer if the threads are damaged, or if the retainer is bent, or cracked.

### COUNTERSHAFT BEARINGS AND RACES

The countershaft bearings and races are machine lapped during manufacture to form matched sets. The bearings and races should not be interchanged.

**NOTE: The bearing races are a permanent press fit in the housings and are NOT serviceable. If a bearing race becomes damaged, it will be necessary to replace the front or rear housing as necessary. A new countershaft bearing will be supplied with each new housing for service use.**

The countershaft bearings can be installed backwards if care is not exercised. The bearing roller cage is a different diameter on each side. Be sure the bearing is installed so the large diameter side of the cage is facing the countershaft gear (Fig. 46). The small diameter side goes in the bearing race.



J9421-55

**Fig. 46 Countershaft Bearings**

- 1 - COUNTERSHAFT  
2 - BEARING CAGE

### REVERSE IDLER COMPONENTS

Inspect the idler gear, bearing, shaft, thrust washer, wave washer and thrust plate. Replace the bearing if any of the needle bearing rollers are worn, chipped, cracked, flat-spotted, or brinnelled. Also replace the bearing if the plastic bearing cage is damaged or distorted.

Replace the thrust washer, wave washer, or thrust plate if cracked, chipped, or worn. Replace the idler gear if the teeth are chipped, cracked or worn thin. Replace the shaft if worn, scored, or the bolt threads are damaged beyond repair. Replace the support segment if cracked, or chipped and replace the idler attaching bolts if the threads are damaged.

### Shift Socket

Inspect the shift socket for wear or damage. replace the socket if the roll pin, or shift shaft bores are damaged. Minor nicks in the shift lever ball seat in the socket can be smoothed down with 400 grit emery or wet/dry paper. Replace the socket if the ball seat is worn, or cracked. Do not reuse the original shift socket roll pin. Install a new pin during reassembly. The socket roll pin is approximately is approximately 33 mm (1-1/4 in.) long.

### Output Shaft And Geartrain

Inspect all of the gears for worn, cracked, chipped, or broken teeth. Also check condition of the bearing bore in each gear. The bores should be smooth and free of surface damage. Discoloration of the gear bores is a normal occurrence and is not a reason for replacement. Replace gears only when tooth damage has occurred, or if the bores are brinnelled or severely scored.

Inspect the shaft splines and bearings surfaces. Minor nicks on the bearing surfaces can be smoothed with 320/420 grit emery and final polished with crocus cloth. Replace the shaft if the splines are damaged or bearing surfaces are deeply scored, worn, or brinnelled.

### ASSEMBLY

Gaskets are not used in this transmission. Sealers are used at all case joints. Recommended sealers are Mopar Gasket Maker for all case joints and Mopar silicone sealer, or equivalent, for the input shaft bearing retainer. Apply these products as indicated in the assembly procedures.

**NOTE: The transmission shift components must be in Neutral position during assembly. This prevents damaging to the synchro and shift components when the housings are installed.**

## MANUAL - NV3500 (Continued)

The 3-4, 1-2 and fifth-reverse synchro hub snap rings can be fitted selectively. New snap rings are available in 0.05 mm (0.0019 in.) thickness increments. Use thickest snap ring that will fit in each snap ring groove.

**SYNCHRONIZER**

To assemble each synchro install the springs, struts and detent balls one at a time as follows:

(1) Slide sleeve part way onto the hub. Leave enough room to install the spring in the hub and the strut in the hub groove.

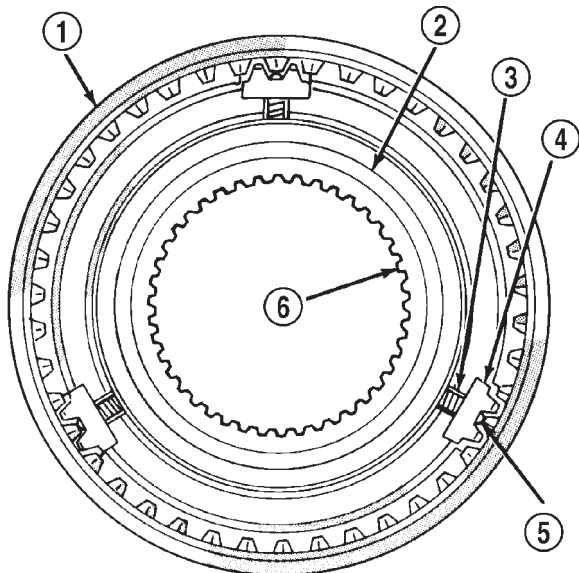
(2) Install first spring in the hub, then install a strut over the spring. Verify spring is seated in the spring bore in the strut.

(3) Slide sleeve onto the hub just far enough to hold the first strut and spring in place.

(4) Place detent ball in the top of the strut, then carefully work the sleeve over the ball to hold it in place. A small flat blade screwdriver can be used to press the ball into place while moving the sleeve over it.

(5) Repeat procedure for the remaining springs, struts and balls. Tape or a rubber band can be used to temporarily secure each strut and ball as they are installed.

(6) Verify the synchro three springs, struts and detent balls are all in place (Fig. 47).



J9421-57

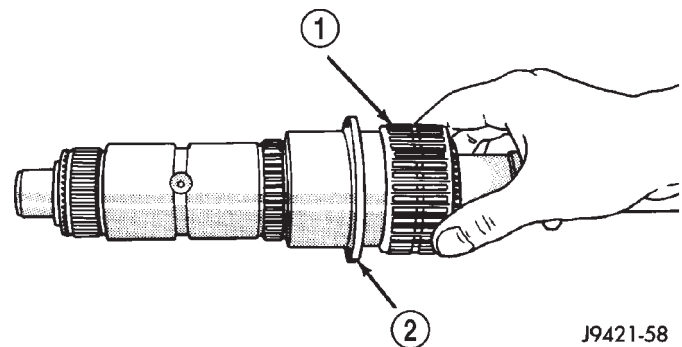
**Fig. 47 Synchronizer Components**

- 1 - SLEEVE
- 2 - HUB SHOULDER
- 3 - SPRING (3)
- 4 - STRUT (3)
- 5 - DETENT BALL (3)
- 6 - HUB

**OUTPUT SHAFT**

**NOTE:** Lubricate shaft, gears and bearings with recommended lubricant during assembly. Petroleum jelly can be used to hold parts in place. Immerse each synchro ring in lubricant before installation.

(1) Lubricate and install reverse gear needle bearing on shaft (Fig. 48). Slide bearing up against shoulder on output shaft.

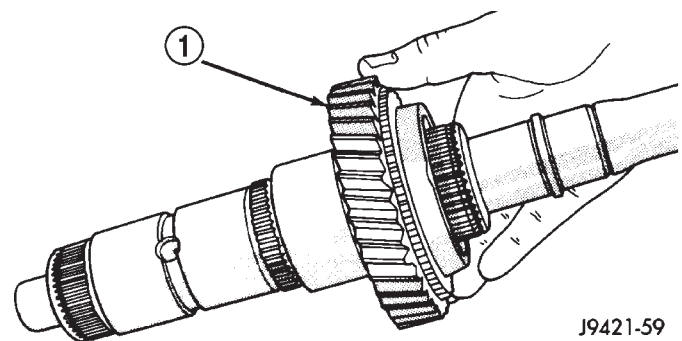


J9421-58

**Fig. 48 Reverse Gear Bearing**

- 1 - REVERSE GEAR BEARING
- 2 - SHOULDER

(2) Install reverse gear over needle bearing (Fig. 49).



J9421-59

**Fig. 49 Reverse Gear**

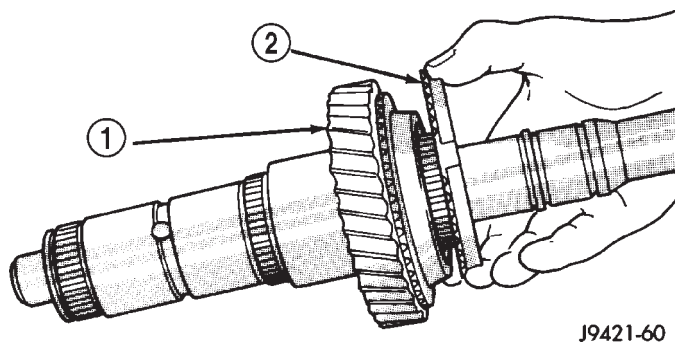
- 1 - REVERSE GEAR

(3) Install brass synchro ring on reverse gear (Fig. 50).

(4) Assemble fifth-reverse synchro hub, sleeve, struts, springs and detent balls, if not previously done.

**CAUTION:** One side of the hub has shoulders around the hub bore, this side of the hub faces the front of the shaft. One side of the sleeve is tapered the tapered side faces the front of the shaft.

## MANUAL - NV3500 (Continued)

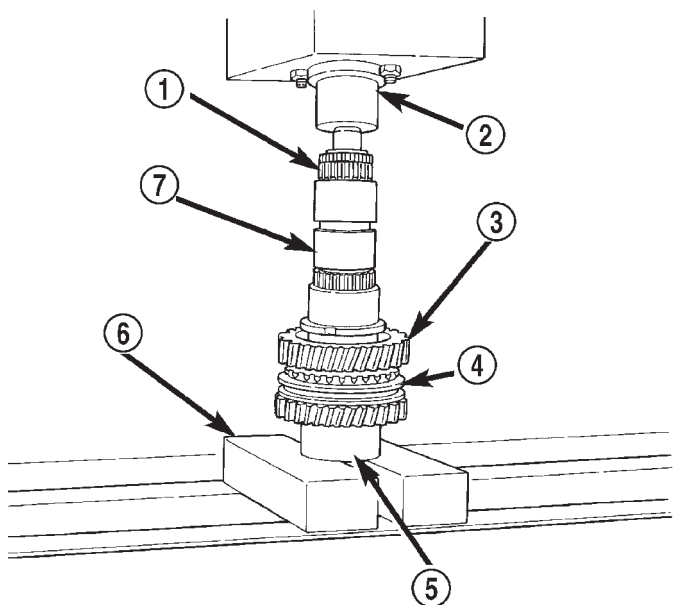


J9421-60

**Fig. 50 Reverse Gear Synchro**

- 1 - REVERSE GEAR
- 2 - SYNCHRO RING

(5) Start fifth-reverse synchro assembly on output shaft splines by hand. Then seat synchro onto shaft with shop press and Remover 6310-1 (Fig. 51).



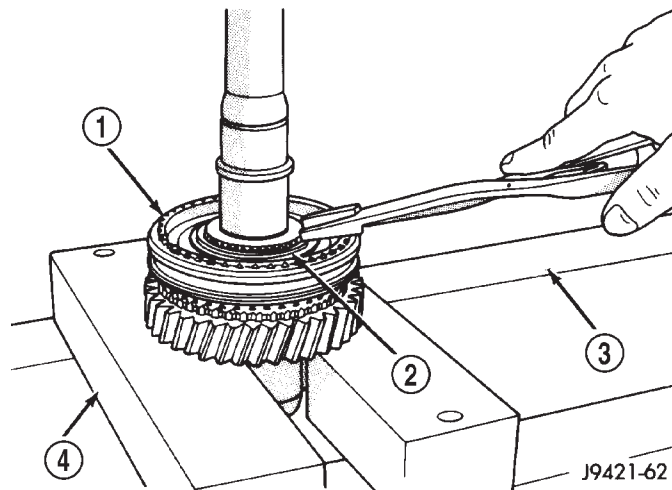
80a9b3bb

**Fig. 51 Fifth-Reverse Synchro Assembly**

- 1 - SPACER
- 2 - PRESS RAM
- 3 - REVERSE GEAR
- 4 - FIFTH-REVERSE SYNCHRO ASSEMBLY
- 5 - REMOVER 6310-1
- 6 - PRESS BLOCKS
- 7 - OUTPUT SHAFT

(6) Install the thickest **new** fifth-reverse hub snap ring (Fig. 52) that will fit in shaft groove. Verify snap ring is seated in the groove.

**NOTE:** Snap rings are available in thicknesses from 2.00 mm to 2.20 mm (0.078 to 0.086 in.).

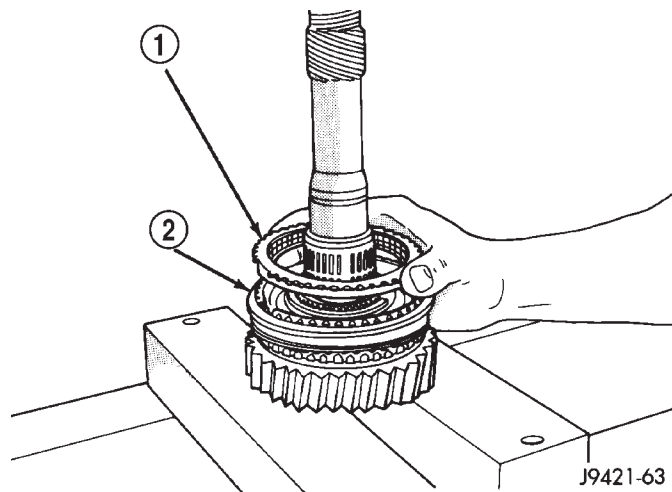


J9421-62

**Fig. 52 Fifth-Reverse Synchro Hub Snap Ring**

- 1 - FIFTH-REVERSE SYNCHRO ASSEMBLY
- 2 - SNAP RING
- 3 - PRESS BED
- 4 - PRESS BLOCKS

(7) Install fifth gear synchro ring in synchro hub and sleeve (Fig. 53).



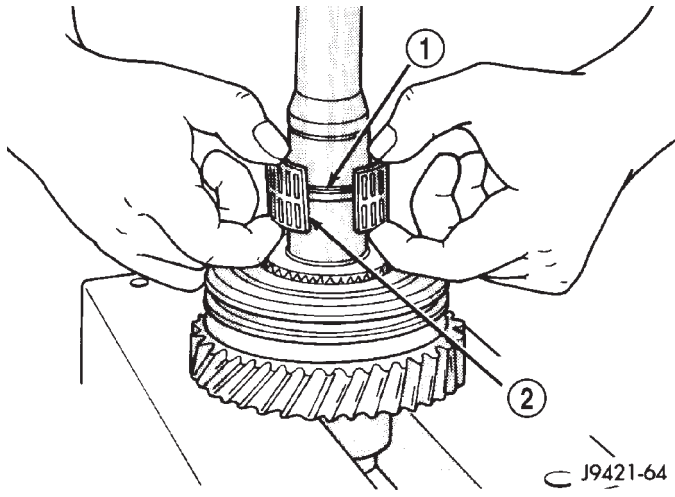
J9421-63

**Fig. 53 Fifth Gear Synchro Ring**

- 1 - FIFTH-SPEED SYNCHRO RING
- 2 - FIFTH-REVERSE SYNCHRO ASSEMBLY

MANUAL - NV3500 (Continued)

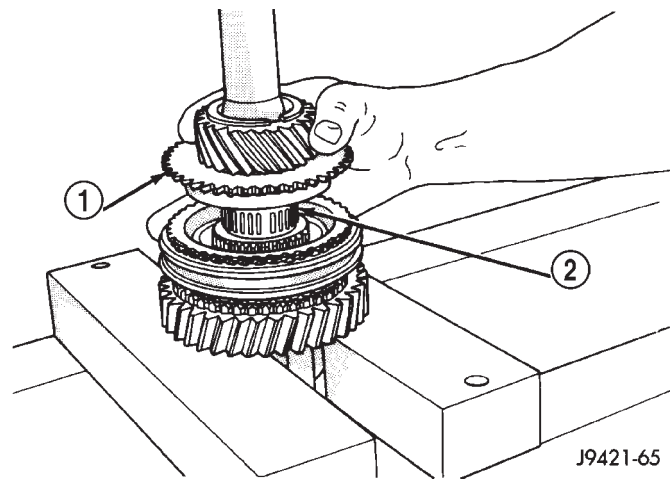
(8) Install fifth gear bearing. Spread bearing only enough to clear shoulder on output shaft (Fig. 54). Verify bearing is properly seated.



**Fig. 54 Fifth Gear Bearing**

- 1 - SHAFT SHOULDER
- 2 - FIFTH GEAR BEARING

(9) Install fifth gear on shaft and onto bearing (Fig. 55).

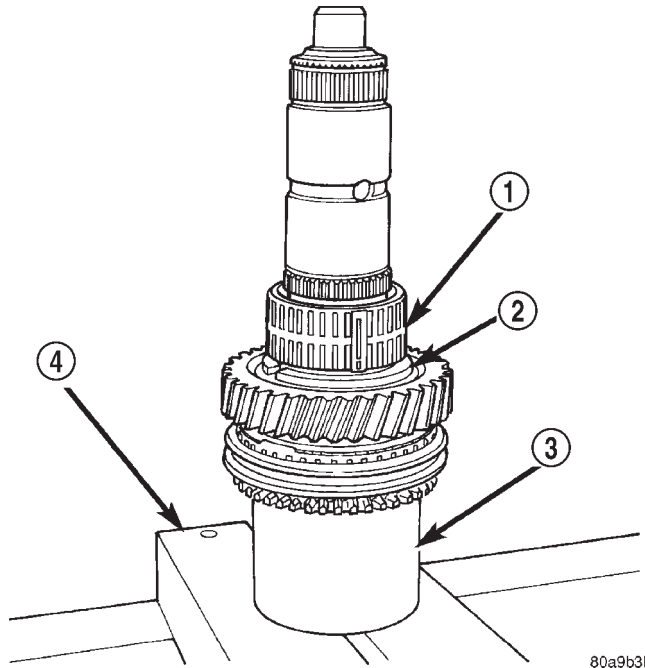


**Fig. 55 Fifth Gear**

- 1 - FIFTH GEAR
- 2 - BEARING

(10) Invert output shaft and set the shaft in Special Tool 6310-1 so that fifth gear is seated on the tool (Fig. 56).

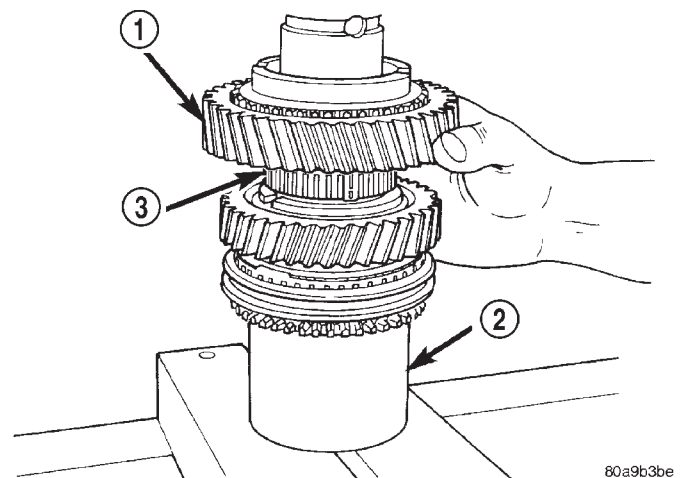
(11) Install first gear bearing on output shaft (Fig. 56). Verify bearing is seated on shaft shoulder and is properly joined.



**Fig. 56 First Gear**

- 1 - FIRST GEAR BEARING
- 2 - SHAFT SHOULDER
- 3 - SPECIAL TOOL 6310-1
- 4 - PRESS BLOCKS

(12) Install first gear on shaft and over bearing (Fig. 57). Verify bearing synchro cone is facing up as shown.



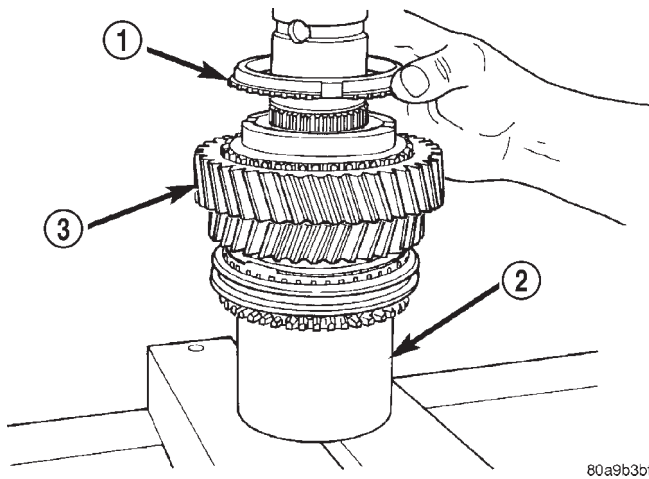
**Fig. 57 First Gear**

- 1 - FIRST GEAR
- 2 - SPECIAL TOOL 6310-1
- 3 - BEARING



## MANUAL - NV3500 (Continued)

(13) Install first gear synchro ring (Fig. 58).



80a9b3bf

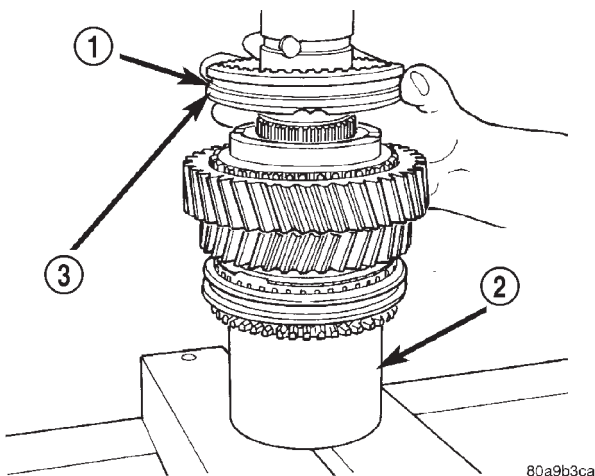
**Fig. 58 First Gear Synchro Ring**

- 1 - FIRST GEAR SYNCHRO RING
- 2 - SPECIAL TOOL 6310-1
- 3 - FIRST GEAR

(14) Assemble 1-2 synchro hub sleeve, springs, struts and detent balls.

**CAUTION:** One side of the synchro sleeve is marked First Gear Side. This side of the sleeve must face first gear after installation.

(15) Start 1-2 synchro assembly on shaft by hand (Fig. 59). Verify synchro sleeve is properly positioned.



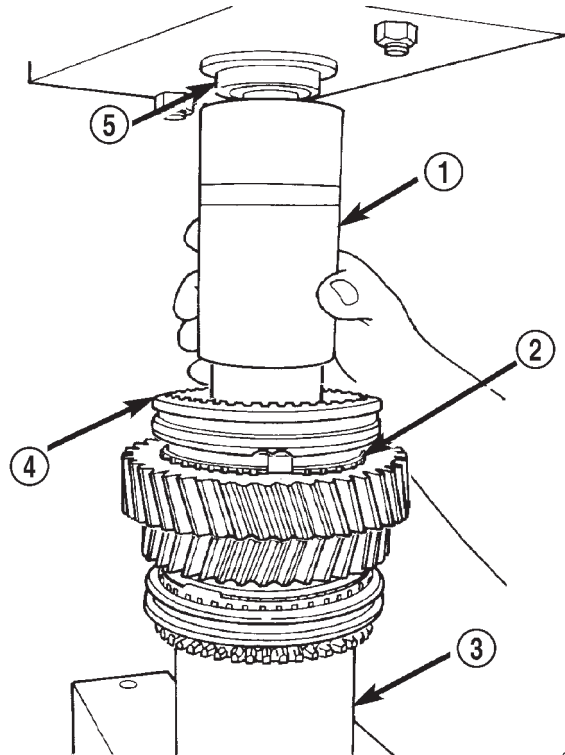
80a9b3ca

**Fig. 59 Starting 1-2 Synchro**

- 1 - 1-2 SYNCHRO ASSEMBLY
- 2 - SPECIAL TOOL 6310-1
- 3 - FIRST GEAR SIDE

(16) Press 1-2 synchro onto output shaft using suitable size pipe and shop press (Fig. 60).

**CAUTION:** Carefully align the synchro ring and sleeve as the hub is being pressed onto the shaft. The synchro ring can be cracked if it becomes misaligned.



80a9b3cb

**Fig. 60 Press 1-2 Synchro On Output Shaft**

- 1 - PIPE TOOL
- 2 - SYNCHRO RING
- 3 - SPECIAL TOOL 6310-1
- 4 - 1-2 SYNCHRO ASSEMBLY
- 5 - PRESS RAM

(17) Install interm ring.

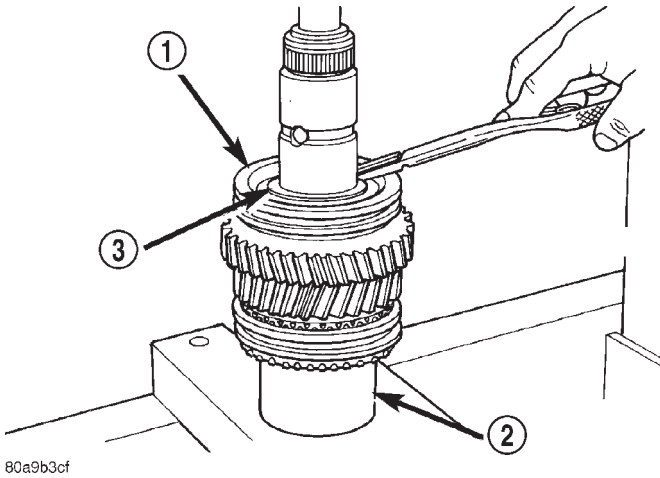
(18) Install thickest **new** 1-2 synchro hub snap ring (Fig. 61) that will fit in shaft groove. Verify snap ring is seated in shaft groove.

**NOTE:** Snap rings are available in thicknesses from 1.80 mm to 2.00 mm (0.070 to 0.078 in.).

(19) Install second gear synchro ring in 1-2 synchro hub and sleeve (Fig. 62). Verify synchro ring is seated in sleeve.

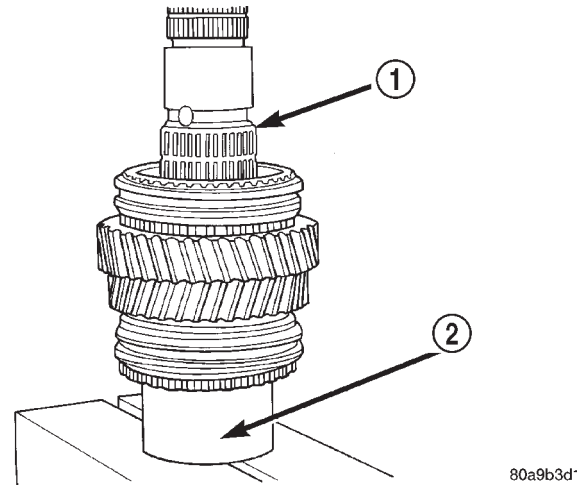
(20) Install synchro friction cone and synchro cone in synchro ring.





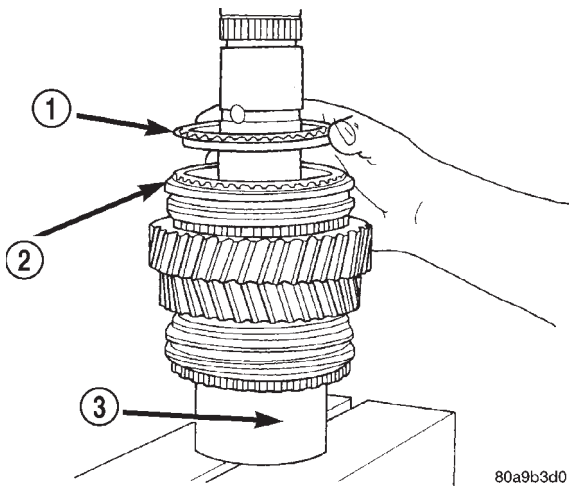
**Fig. 61 1-2 Synchro Hub Snap Ring**

- 1 - 1-2 SYNCHRO
- 2 - SPECIAL TOOL 6310-1
- 3 - SYNCHRO SNAP RING



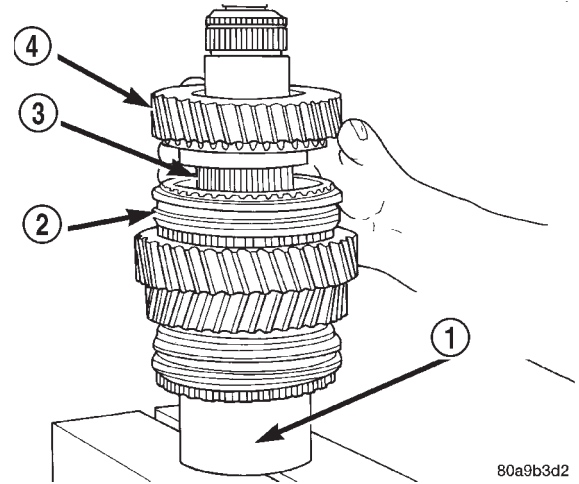
**Fig. 63 Second Gear Bearing**

- 1 - SECOND GEAR BEARING
- 2 - SPECIAL TOOL 6310-1



**Fig. 62 Second Gear Synchro Ring**

- 1 - SECOND GEAR SYNCHRO RING
- 2 - 1-2 SYNCHRO
- 3 - SPECIAL TOOL 6310-1



**Fig. 64 Second Gear**

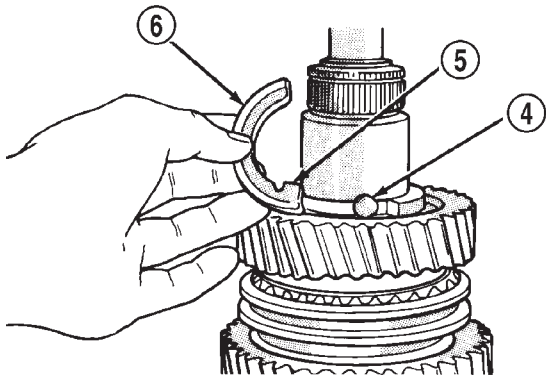
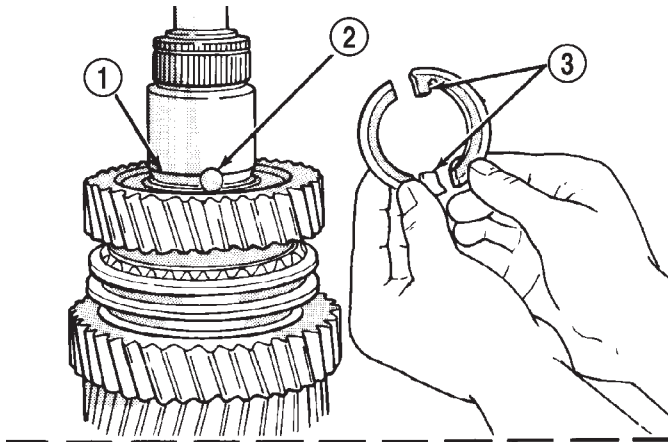
- 1 - SPECIAL TOOL 6310-1
- 2 - 1-2 SYNCHRO ASSEMBLY
- 3 - BEARING
- 4 - SECOND GEAR

(21) Install second gear needle bearing on shaft (Fig. 63).

(22) Install second gear onto shaft and bearing (Fig. 64). Verify second gear is seated on synchro components.

(23) Install two-piece thrust washer with halves seated in the shaft groove and washer lugs seated in shaft lug bores (Fig. 65). Verify i.d. grooves and markings noted during removal are facing the correct direction.

## MANUAL - NV3500 (Continued)



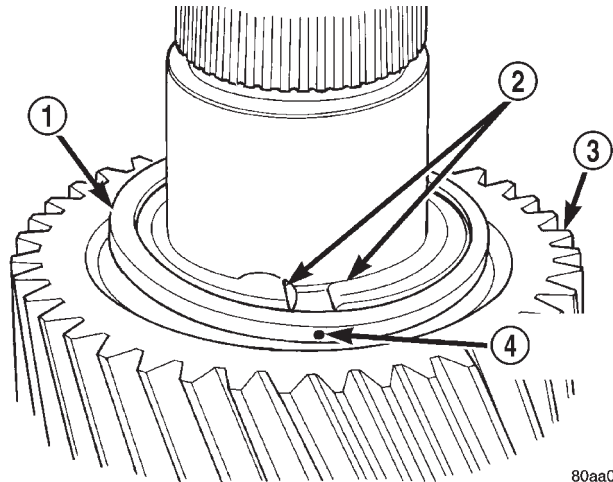
J9421-77

**Fig. 65 Two-Piece Thrust**

- 1 - WASHER GROOVE IN SHAFT
- 2 - LUG BORE
- 3 - THRUST WASHER LUGS
- 4 - LUG BORE
- 5 - LUG
- 6 - WASHER HALF

(24) Start retaining ring around two-piece thrust washer (Fig. 66). Verify locating dimple is between thrust washer halves.

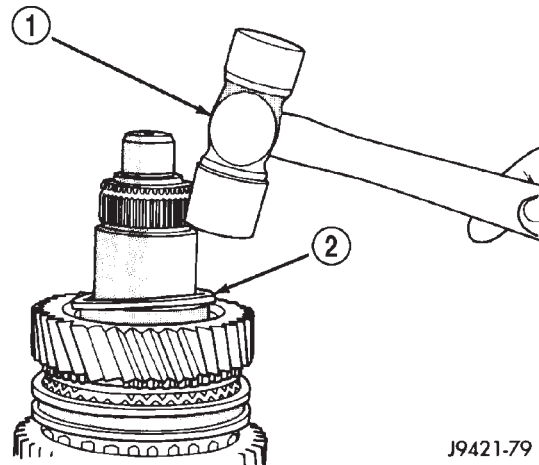
(25) Seat thrust washer retaining ring with plastic mallet (Fig. 67).



80aa0ea8

**Fig. 66 Retaining Ring**

- 1 - THRUST WASHER RETAINING RING
- 2 - THRUST WASHER HALVES
- 3 - SECOND GEAR
- 4 - LOCATING DIMPLE



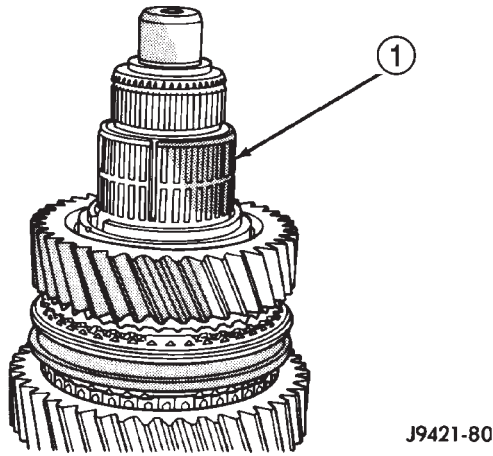
J9421-79

**Fig. 67 Thrust Retainer**

- 1 - PLASTIC MALLETT
- 2 - THRUST WASHER RETAINING RING

MANUAL - NV3500 (Continued)

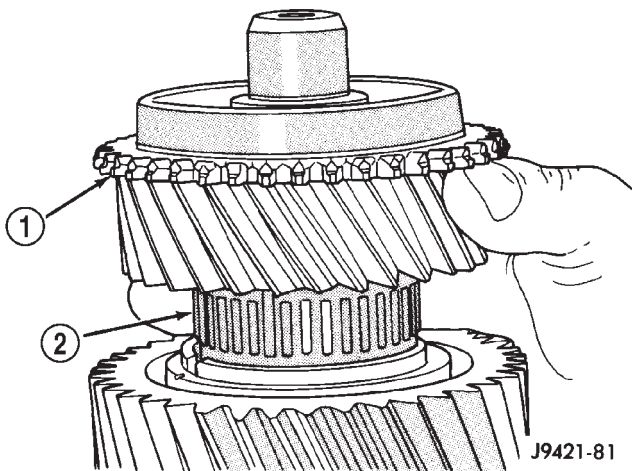
(26) Install third gear needle bearing on shaft (Fig. 68).



**Fig. 68 Third Gear Bearing**

1 - THIRD GEAR BEARING

(27) Install third gear on shaft and bearing (Fig. 69).

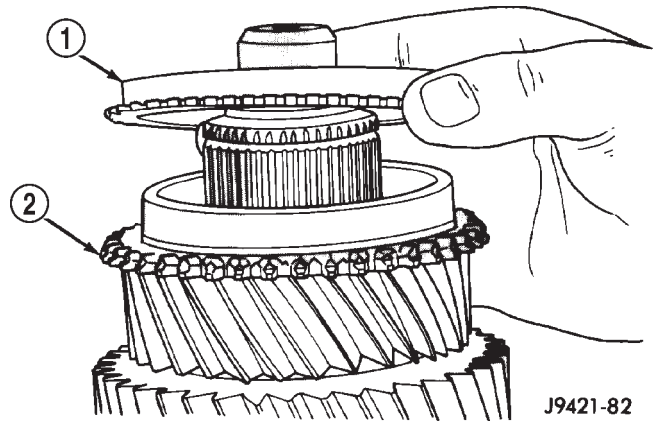


**Fig. 69 Third Gear**

1 - THIRD GEAR  
2 - BEARING

(28) Install third speed synchro ring on third gear (Fig. 70).

(29) Assemble 3-4 synchro hub, sleeve, springs, struts and detent balls.

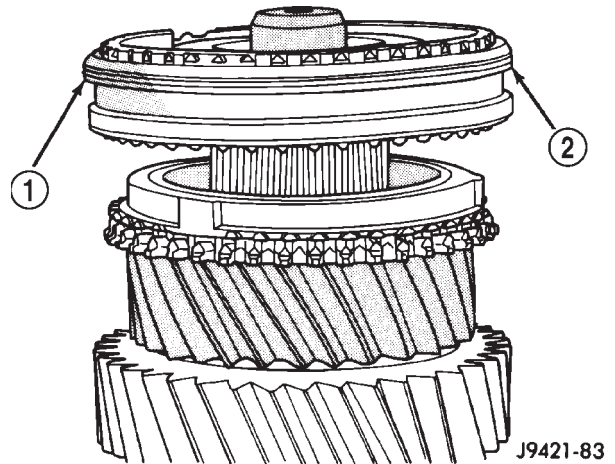


**Fig. 70 Third Gear Synchro Ring**

1 - THIRD SPEED SYNCHRO RING  
2 - THIRD GEAR

**CAUTION:** The 3-4 synchro hub and sleeve can be installed backwards if care is not exercised. One side of the sleeve has grooves in it, this side of sleeve faces the front of the shaft.

(30) Start 3-4 synchro hub on output shaft splines by hand (Fig. 71).

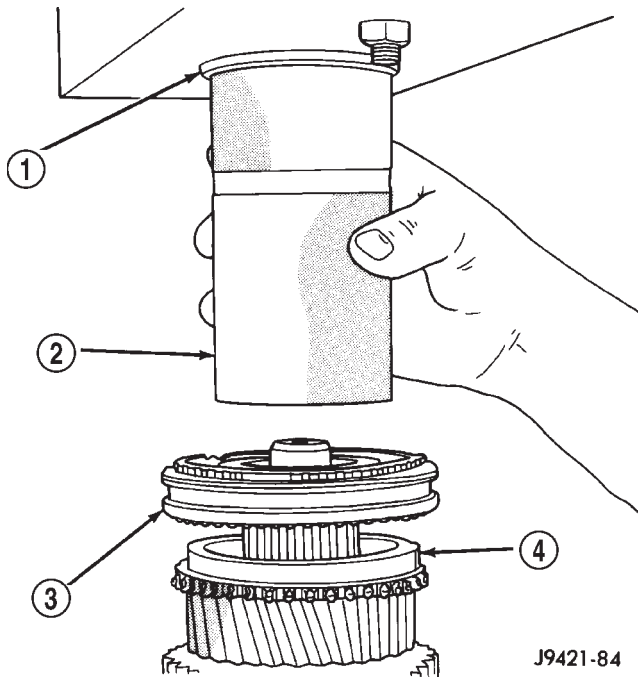


**Fig. 71 3-4 Synchro Hub On Output Shaft**

1 - GROOVED SIDE OF SLEEVE  
2 - 3-4 SYNCHRO ASSEMBLY

## MANUAL - NV3500 (Continued)

(31) Press 3-4 synchro assembly onto output shaft with shop press and suitable size pipe (Fig. 72). Verify tool presses on hub as close to output shaft as possible but does not contact the shaft splines.

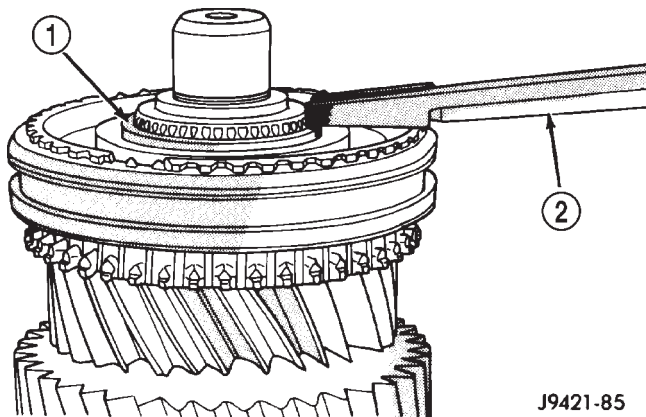


**Fig. 72 Press 3-4 Synchro On Output Shaft**

- 1 - PRESS RAM
- 2 - PIPE TOOL
- 3 - 3-4 SYNCHRO
- 4 - THIRD SPEED SYNCHRO RING

(32) Install thickest **new** 3-4 synchro hub snap ring (Fig. 73) that will fit in shaft groove. Verify snap ring is seated in groove.

**NOTE:** Snap rings are available in thicknesses from 2.00 - 2.30 mm (0.078 - 0.090 in.).



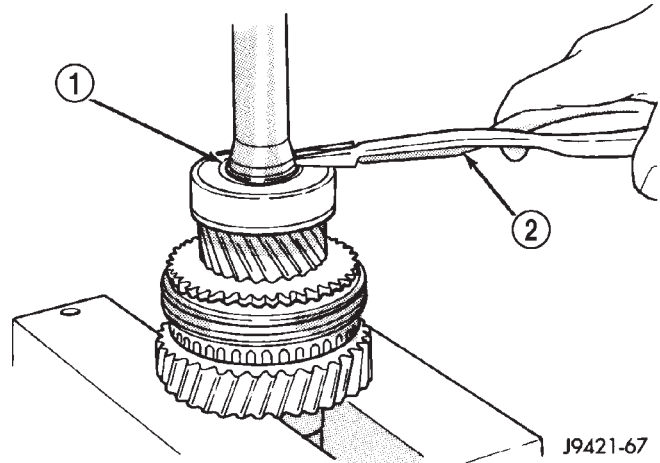
**Fig. 73 3-4 Synchro Hub Snap Ring**

- 1 - 3-4 SYNCHRO HUB SNAP RING
- 2 - HEAVY DUTY SNAP RING PLIERS

(33) Install output shaft bearing.

(34) Install output shaft bearing snap ring with heavy duty snap ring pliers (Fig. 74). Verify snap ring is seated in shaft groove.

**NOTE:** Spread snap ring only enough to install it.



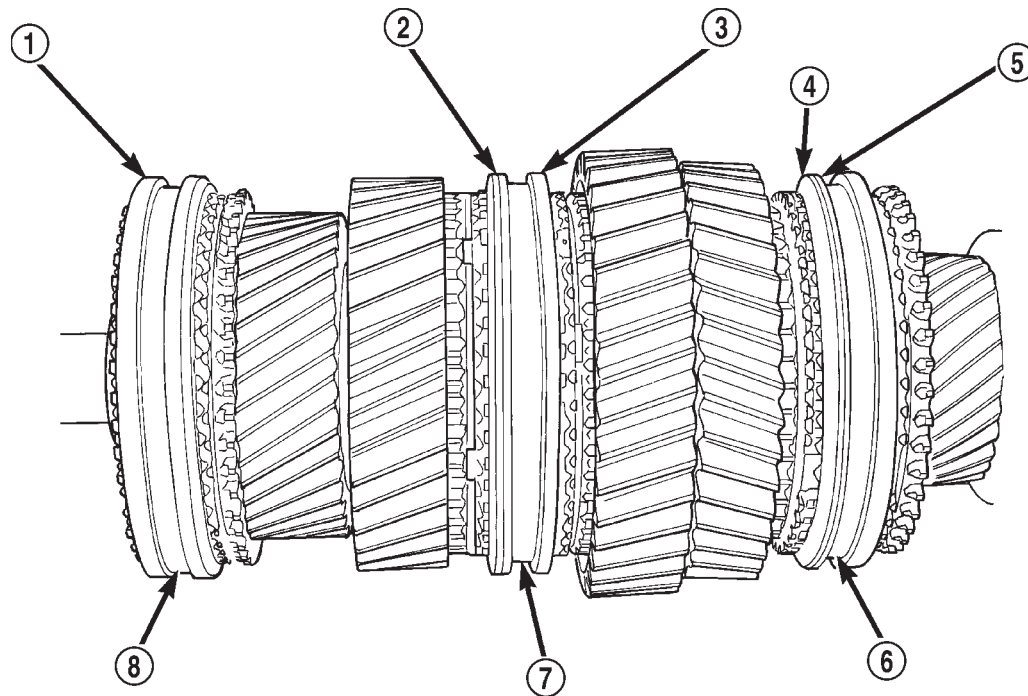
**Fig. 74 Output Shaft Bearing Snap**

- 1 - BEARING SNAP RING
- 2 - HEAVY DUTY SNAP RING PLIERS

(35) Verify position of synchro sleeves before proceeding (Fig. 75). Grooved side of 3-4 sleeve must be facing forward. First gear side of 1-2 sleeve must be facing first gear. Tapered side of fifth-reverse sleeve must be facing forward.

### REVERSE IDLER ASSEMBLY

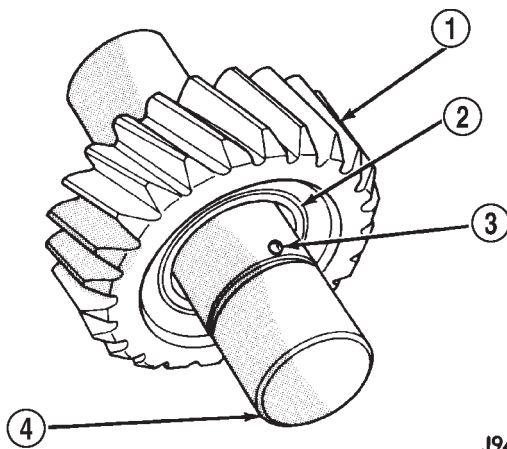
- (1) Lubricate idler components with gear lube.
- (2) Slide idler gear bearing on shaft (Fig. 76). Bearing fits either way on shaft.
- (3) Slide gear onto shaft. Side of gear with recess goes to rear (Fig. 76).
- (4) Place first lock ball in dimple at rear end of idler shaft (Fig. 76). Petroleum jelly can be used to hold ball in place if desired.
- (5) Slide thrust rear thrust washer onto shaft and over lock ball (Fig. 77).
- (6) Install snap ring in groove at rear of shaft (Fig. 77).
- (7) Install lock ball in dimple at front of shaft. Hold ball in place with petroleum jelly if desired.



80aa0ea9

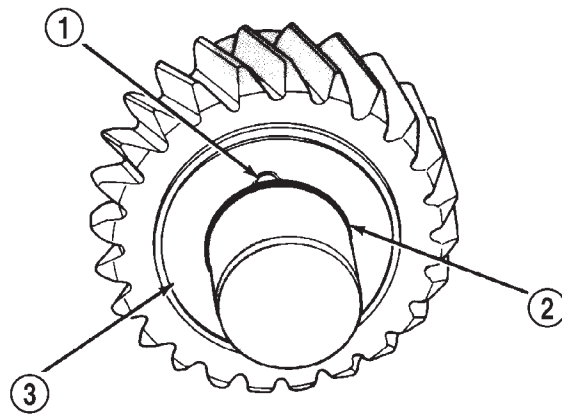
**Fig. 75 Synchro Sleeve Locations**

- |   |                            |
|---|----------------------------|
| 1 - DOUBLE GROOVE FORWARD                     | 5 - GROOVE FORWARD         |
| 2 - GROOVE FORWARD                            | 6 - 5TH-REV SYNCHRO SLEEVE |
| 3 - FIRST GEAR SIDE MARKING TOWARD FIRST GEAR | 7 - 1-2 SYNCHRO SLEEVE     |
| 4 - TAPER FORWARD                             | 8 - 3-4 SYNCHRO SLEEVE     |



**Fig. 76 Idler Gear And Bearing**

- 1 - IDLER GEAR
- 2 - BEARING
- 3 - LOCK BALL
- 4 - REAR OF SHAFT



**Fig. 77 Idler Gear Rear Thrust Washer**

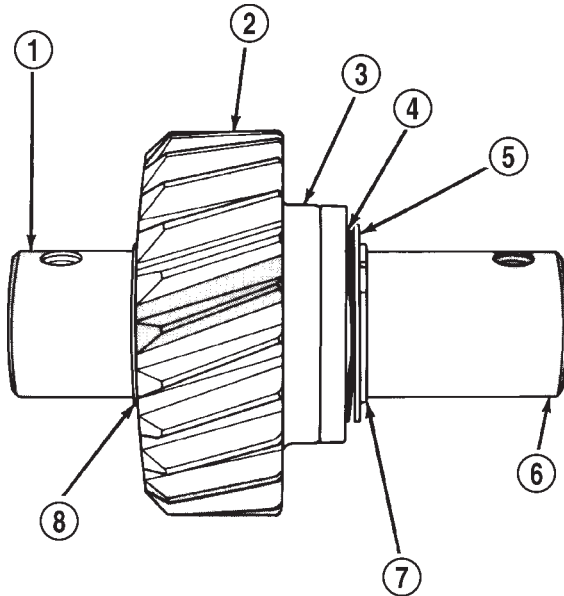
- 1 - LOCK BALL
- 2 - SNAP RING GROOVE
- 3 - THRUST WASHER



## MANUAL - NV3500 (Continued)

(8) Install front thrust washer on shaft and slide washer up against gear and over lock ball (Fig. 78).

(9) Install wave washer, flat washer and remaining snap ring on idler shaft (Fig. 78). Verify snap ring is seated.



J9421-90

**Fig. 78 Idler Gear And Shaft Assembly**

- 1 - REAR OF SHAFT
- 2 - GEAR
- 3 - THRUST WASHER AND BALL
- 4 - WAVE WASHER
- 5 - FLAT WASHER
- 6 - FRONT OF SHAFT
- 7 - SNAP RING
- 8 - SNAP RING

## SHIFT SHAFT AND DETENT PLUNGER BUSHINGS/ BEARINGS

(1) Inspect shift shaft bushing and bearing for damage.

(2) If necessary, the shift shaft bushing can be replaced as follows:

(a) Locate a bolt that will thread into the bushing without great effort.

(b) Thread the bolt into the bushing, allowing the bolt to make its own threads in the bushing.

(c) Attach a slide hammer or suitable puller to the bolt and remove bushing.

(d) Use the short end of Installer 8119 to install the new bushing.

(e) Bushing is correctly installed if flush with the transmission case.

(3) If necessary, the shift shaft bearing can be replaced as follows:

(a) Locate a bolt that will thread into the bearing without great effort.

(b) Thread the bolt into the bearing as much as possible.

(c) Attach a slide hammer or suitable puller to the bolt and remove the bearing.

(d) Use the short end of Installer 8119 to install the new bearing.

(e) Bearing is correctly installed if flush with the transmission case.

(4) Inspect detent plunger bushings for damage.

**NOTE:** The detent plunger bushings are installed to a specific depth. The space between the two bushings when correctly installed contain an oil feed hole. Do not attempt to install the bushings with anything other than the specified tool or this oil hole may become restricted.

(5) If necessary, the detent plunger bushings can be replaced as follows:

(a) Using the long end of Installer 8119, drive the detent bushings through the outer case and into the shift shaft bore.

(b) Remove the bushings from the shift shaft bore.

(c) Install a new detent plunger bushing on the long end of Installer 8118.

(d) Start bushing in the detent plunger bore in the case.

(e) Drive bushing into the bore until the tool contacts the transmission case.

(f) Install a new detent plunger bushing on the short end of Installer 8118.

(g) Start the bushing in the detent plunger bore in the case.

(h) Drive bushing into the bore until the tool contacts the transmission case.

## GEARTRAIN ASSEMBLY

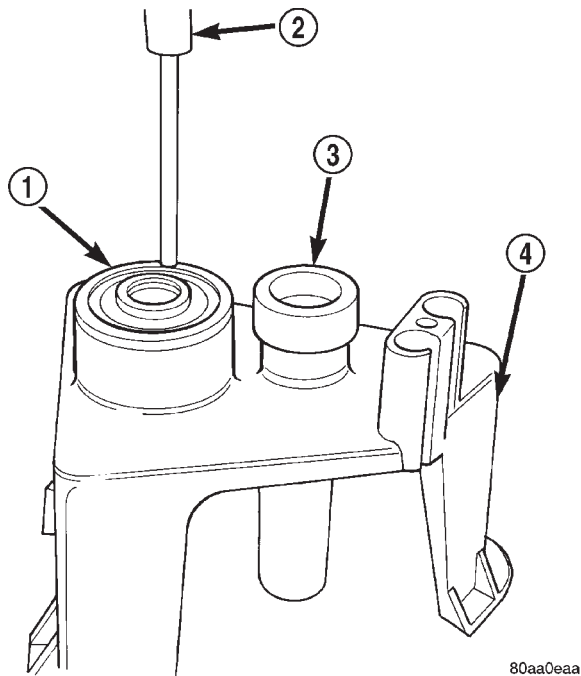
(1) Install Adapter 6747-1A on input shaft hub of Fixture 6747 (Fig. 79). Then install Adapter 6747-2B on front bearing hub of countershaft. Be sure the shoulder is seated against the countershaft.

(2) Install input shaft in fixture tool. Make sure Adapter Tool 6747-1A is positioned under shaft as shown (Fig. 80).

(3) Install pilot bearing in input shaft (Fig. 80).

**NOTE:** The side of the pilot bearing with the small diameter goes toward the input shaft.

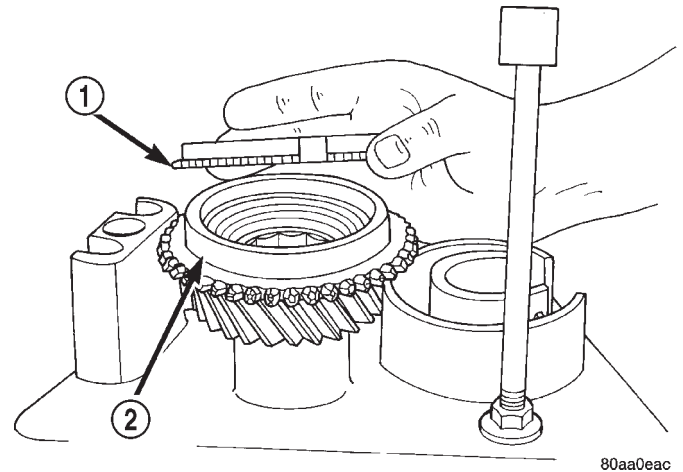




**Fig. 79 Fixture For Geartrain Build-up**

- 1 - ADAPTER 6747-2B
- 2 - CUP 8115
- 3 - ADAPTER 6747-1A
- 4 - FIXTURE 6747

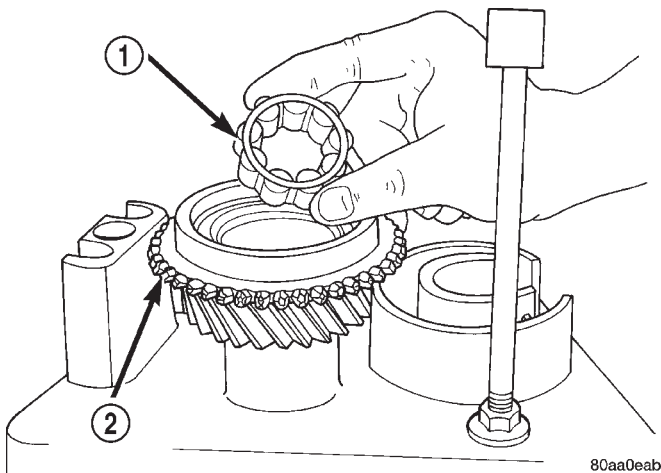
(4) Install fourth gear synchro ring on input shaft (Fig. 81).



**Fig. 81 Fourth Gear Synchro**

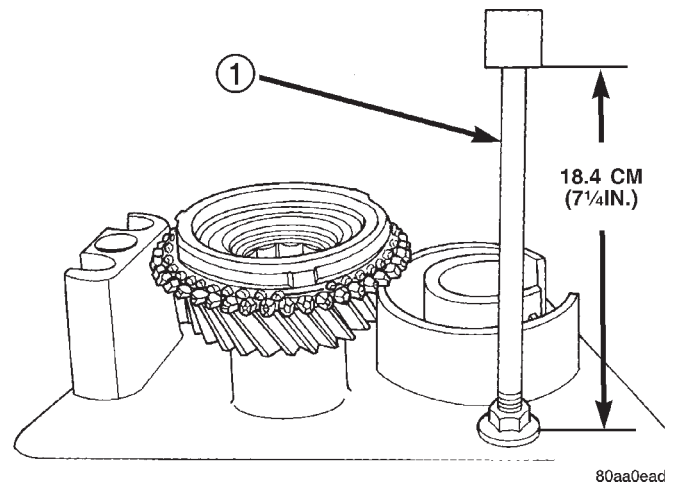
- 1 - FOURTH GEAR SYNCHRO RING
- 2 - INPUT SHAFT

(5) Adjust height of idler gear pedestal on assembly fixture (Fig. 82). Start with a basic height of 18.4 cm (7-1/4 in.). Final adjustment can be made after gear is positioned on pedestal.



**Fig. 80 Pilot Bearing And Input Shaft**

- 1 - PILOT BEARING
- 2 - INPUT SHAFT

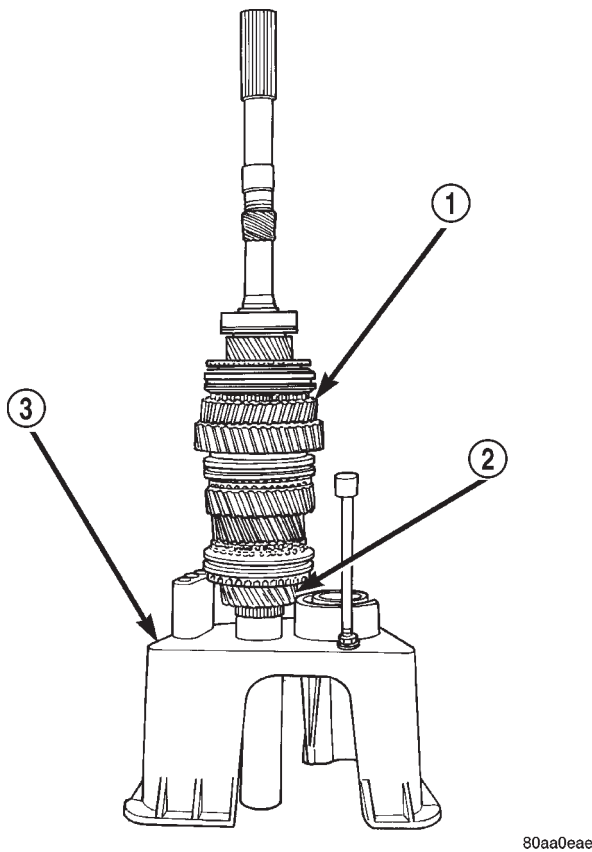


**Fig. 82 Idler Pedestal Base Height**

- 1 - REVERSE IDLER PEDESTAL

## MANUAL - NV3500 (Continued)

(6) Install assembled output shaft and geartrain in input shaft (Fig. 83). Carefully rotate output shaft until the 3-4 synchro ring seats in synchro hub and sleeve.



80aa0eae

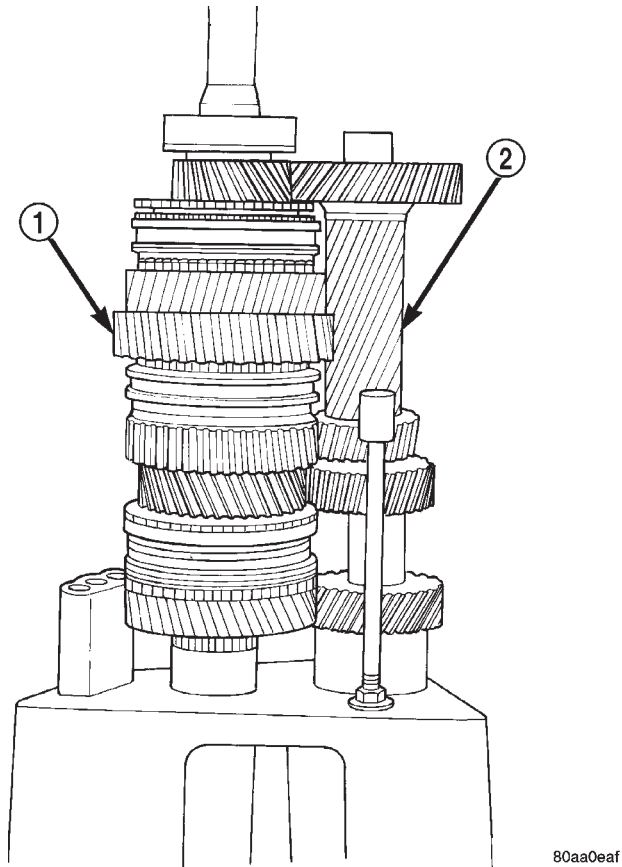
**Fig. 83 Output Shaft And Geartrain Installed In Input**

- 1 - OUTPUT SHAFT AND GEARTRAIN
- 2 - INPUT SHAFT
- 3 - FIXTURE 6747

(7) Install Adapter 6747-2B on front bearing hub of countershaft, if not previously done. The shoulder goes toward the countershaft.

(8) Slide countershaft (and adapter) into fixture slot. Verify countershaft and output shaft gears are fully meshed with the mainshaft gears before proceeding (Fig. 84).

(9) Check alignment of countershaft and output shaft gear teeth. Gears may not align perfectly a difference in height of 1.57 to 3.18 mm (1/16 to 1/8 in.) will probably exist. This difference will not interfere with assembly. If difference is greater than this, the countershaft adapter tool is probably upside down. Remove countershaft, reverse adapter tool, reinstall countershaft and check alignment again.

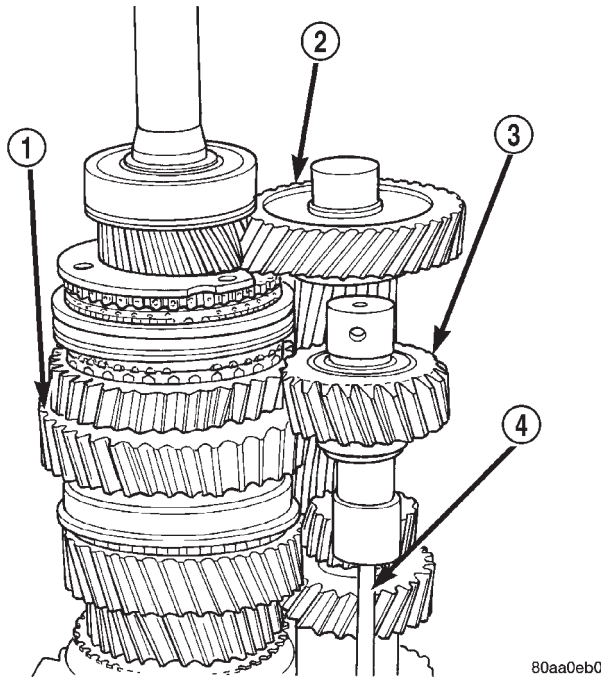


80aa0eaf

**Fig. 84 Countershaft On Fixture Tool**

- 1 - OUTPUT SHAFT AND GEARTRAIN
- 2 - COUNTERSHAFT (SLIDE INTO PLACE ON FIXTURE TOOL)

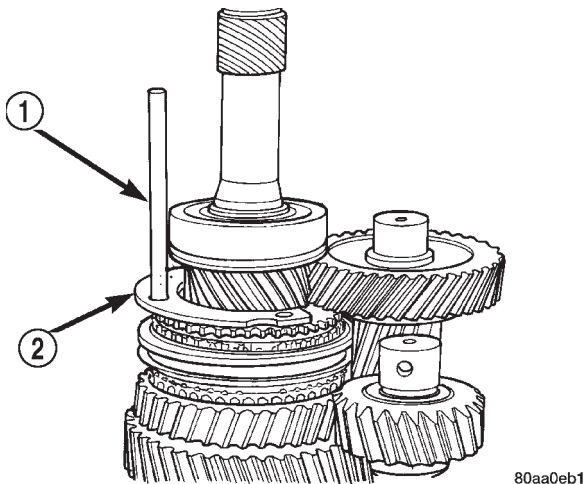
(10) Position reverse idler in support cup of assembly fixture (Fig. 85). Verify idler gear is properly meshed and aligned with shaft gear teeth and that bolt holes are facing out from the geartrain. Adjust pedestal up or down if necessary and verify short end of idler shaft is facing up as shown.



**Fig. 85 Reverse Idler Assembly On Assembly Fixture Tool**

- 1 - OUTPUT SHAFT AND GEARTRAIN
- 2 - COUNTERSHAFT
- 3 - REVERSE IDLER ASSEMBLY
- 4 - TOOL PEDESTAL

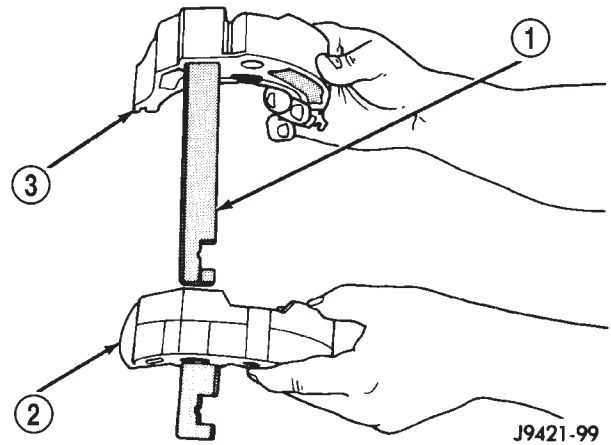
(11) On 2-wheel drive transmission, thread one Alignment Pin 8120 in center or passenger side hole of output shaft bearing retainer. Then position retainer on fifth gear as shown (Fig. 86).



**Fig. 86 Positioning Output Shaft Bearing Retainer**

- 1 - PIN 8120
- 2 - OUTPUT SHAFT BEARING RETAINER

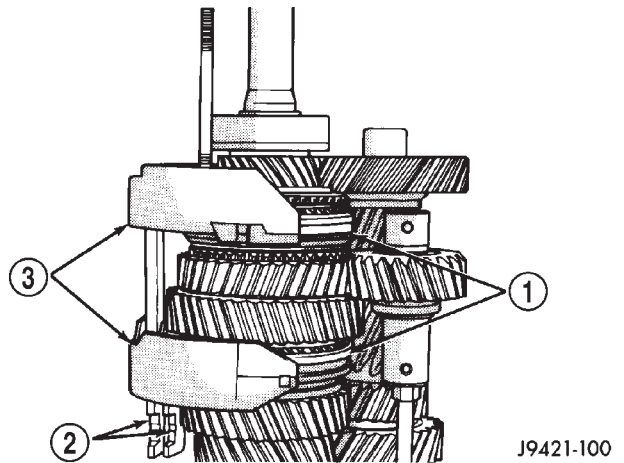
(12) Assemble 1-2 and fifth reverse-shift forks (Fig. 87). Arm of fifth-reverse fork goes through slot in 1-2 fork.



**Fig. 87 1-2 And Fifth-Reverse Shift Forks**

- 1 - INSERT ARM THROUGH 1-2 FORK
- 2 - 1-2 FORK
- 3 - FIFTH-REVERSE FORK

(13) Install assembled shift forks in synchro sleeves and verify forks are seated in sleeves (Fig. 88).



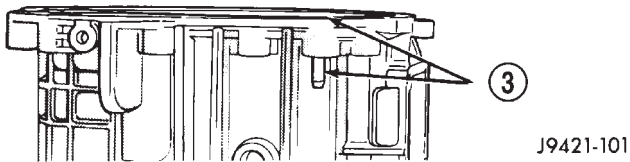
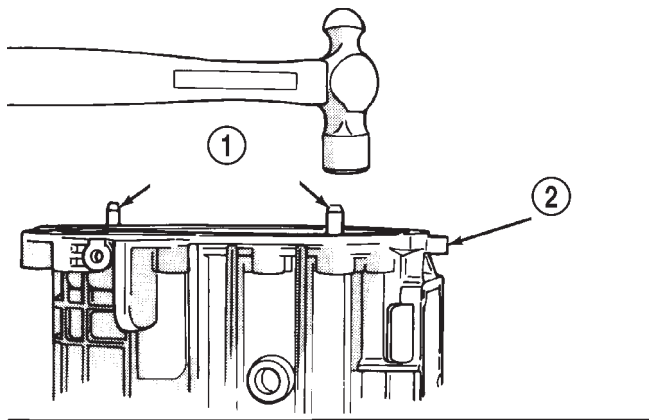
**Fig. 88 Shift Forks In Synchro**

- 1 - SYNCHRO SLEEVES
- 2 - FORK ARMS
- 3 - SHIFT FORKS

## MANUAL - NV3500 (Continued)

**REAR HOUSING - 2WD**

(1) Drive adapter housing alignment dowels back into housing until dowels are flush with mounting surface (Fig. 89).



**Fig. 89 Rear Housing Dowels**

- 1 - HOUSING ALIGNMENT DOWELS
- 2 - REAR HOUSING
- 3 - DOWEL FLUSH WITH SURFACE

(2) Apply liberal quantity of petroleum jelly to countershaft rear bearing and bearing race.

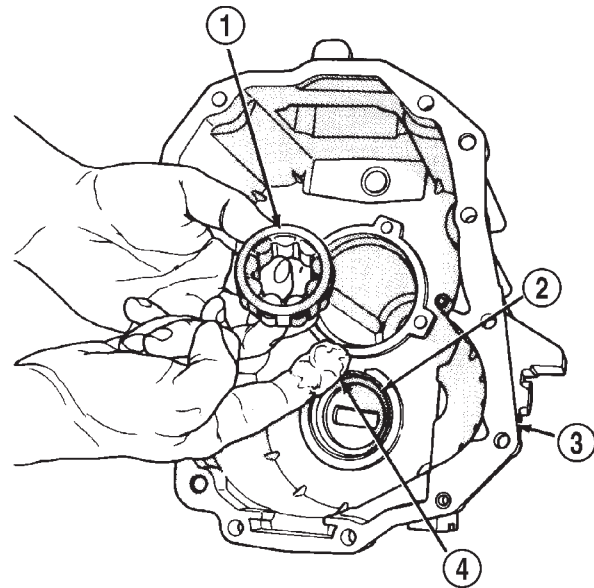
(3) Install countershaft rear bearing in bearing race (Fig. 90).

**NOTE:** Large diameter side of the roller retainer faces the countershaft and the small diameter side faces the race and housing (Fig. 91).

(4) Apply extra petroleum jelly to hold countershaft rear bearing in place when housing is installed.

(5) Apply light coat of petroleum jelly to shift shaft bushing/bearing in rear housing (Fig. 91).

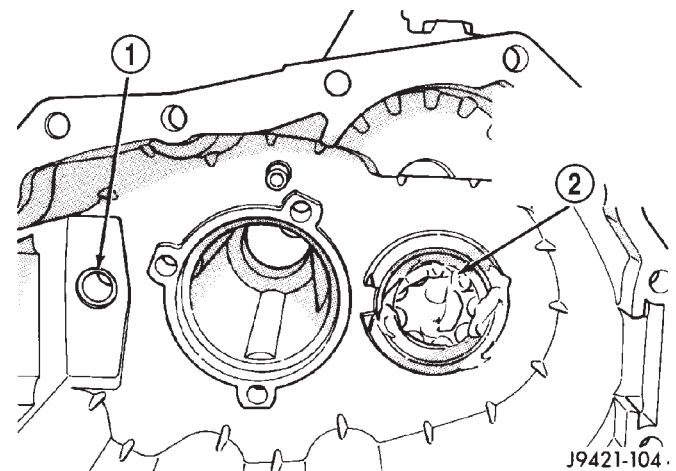
(6) Reach into countershaft rear bearing with finger and push each bearing roller outward against the race. Then apply extra petroleum jelly to hold rollers in place during housing installation.



J9421-103

**Fig. 90 Countershaft Rear**

- 1 - COUNTERSHAFT REAR BEARING
- 2 - REAR BEARING RACE
- 3 - REAR HOUSING
- 4 - PETROLEUM JELLY (APPLY TO BEARING AND RACE)



J9421-104

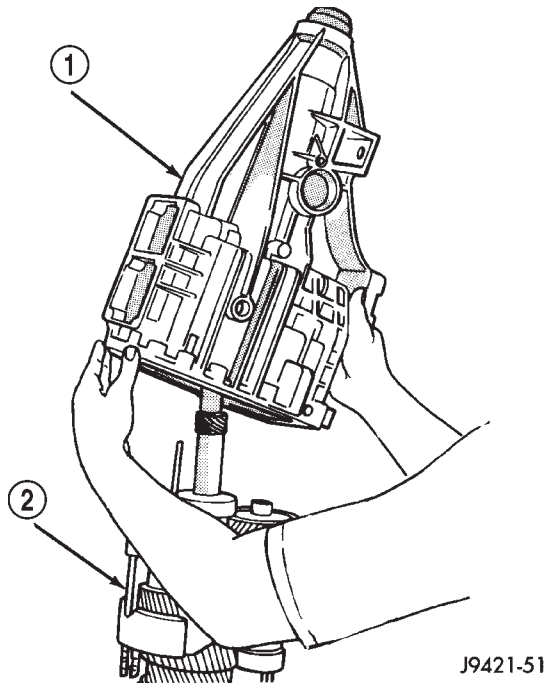
**Fig. 91 Countershaft Bearing**

- 1 - SHIFT SHAFT BUSHING/BEARING
- 2 - COUNTERSHAFT REAR BEARING (SEATED IN RACE)

## MANUAL - NV3500 (Continued)

(7) Install rear housing onto geartrain (Fig. 92) and verify bearing retainer pilot stud is in correct bolt hole in housing. Be sure countershaft and output shaft bearings are aligned in housing and on countershaft.

**NOTE:** It may be necessary to lift upward on countershaft slightly to ensure that the countershaft rear bearing engages to the countershaft before the rear output shaft bearing engages the housing.



**Fig. 92 Rear Housing - 2WD**

- 1 - REAR HOUSING
- 2 - SHIFT FORKS AND GEARTRAIN

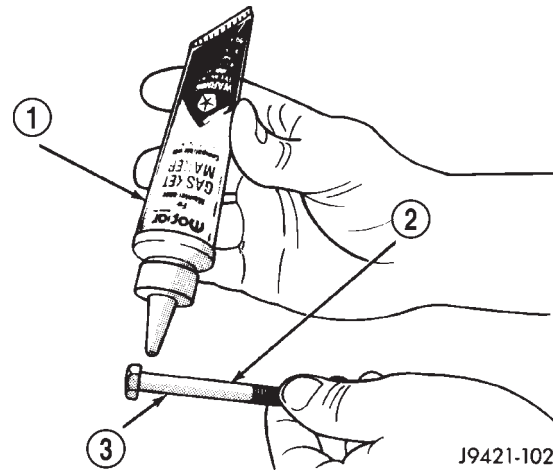
(8) Seat rear housing on output shaft rear bearing and countershaft. Use plastic or rawhide mallet to tap housing into place.

(9) Apply Mopar Gasket Maker or equivalent to housing bolt threads, bolt shanks and under bolt heads (Fig. 93).

(10) Start first two bolts in retainer (Fig. 94). It may be necessary to move retainer rearward (with pilot stud) in order to start bolts in retainer.

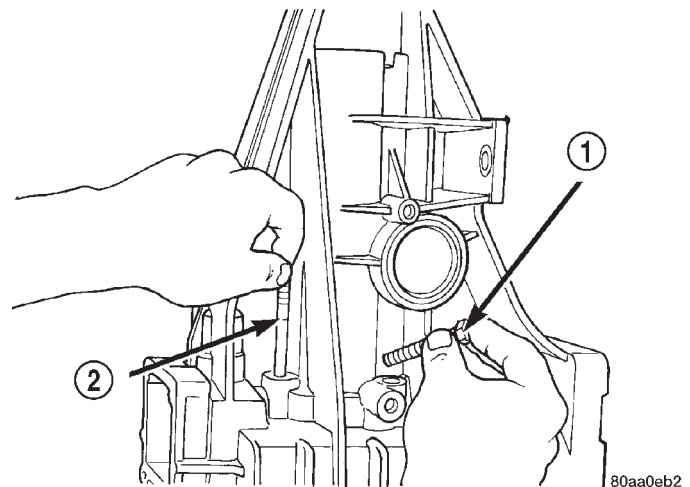
(11) Remove Alignment Pin 8120 and install last retainer bolt (Fig. 94).

(12) Tighten all three retainer bolts to 30-35 N·m (22-26 ft. lbs.).



**Fig. 93 Housing Bolts**

- 1 - MOPAR GASKET MAKER (OR LOCTITE 518)
- 2 - RETAINER AND HOUSING BOLTS
- 3 - APPLY SEALER TO UNDERSIDE OF BOLT HEAD, SHANK AND THREADS



**Fig. 94 Pilot Stud Tool And Retainer Bolts - 2WD**

- 1 - BEARING RETAINER BOLT
- 2 - PIN 8120

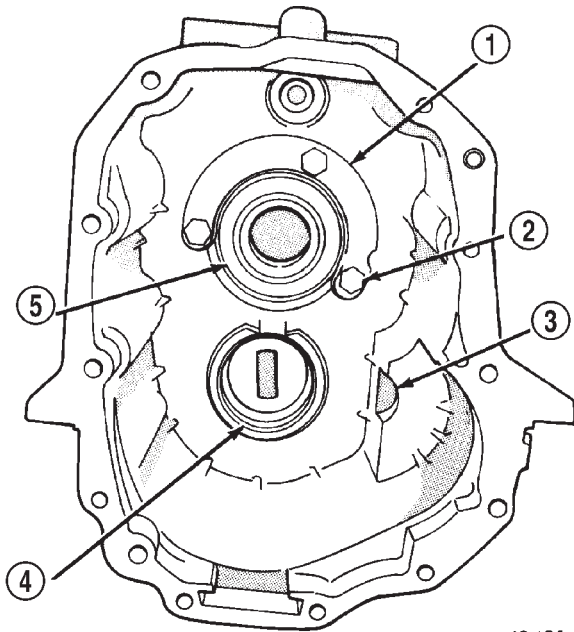
### ADAPTER HOUSING - 4WD

(1) Install rear bearing in adapter housing. Use wood hammer handle or wood dowel to tap bearing into place.

(2) Position rear bearing retainer in adapter housing (Fig. 95).



## MANUAL - NV3500 (Continued)



J9421-203

**Fig. 95 Adapter Housing - 4WD**

- 1 - BEARING RETAINER
- 2 - RETAINER BOLT
- 3 - IDLER SHAFT NOTCH
- 4 - COUNTERSHAFT BEARING RACE
- 5 - REAR BEARING

(3) Apply Mopar Gasket Maker or equivalent to threads, bolt shanks and under hex heads of bearing retainer bolts (Fig. 93).

(4) Apply liberal quantity of petroleum jelly to countershaft rear bearing and bearing race.

(5) Install countershaft rear bearing in bearing race (Fig. 91).

**NOTE:** Large diameter side of the roller retainer faces the countershaft and the small diameter side faces the race and housing (Fig. 91).

(6) Apply extra petroleum jelly to hold countershaft rear bearing in place when housing is installed.

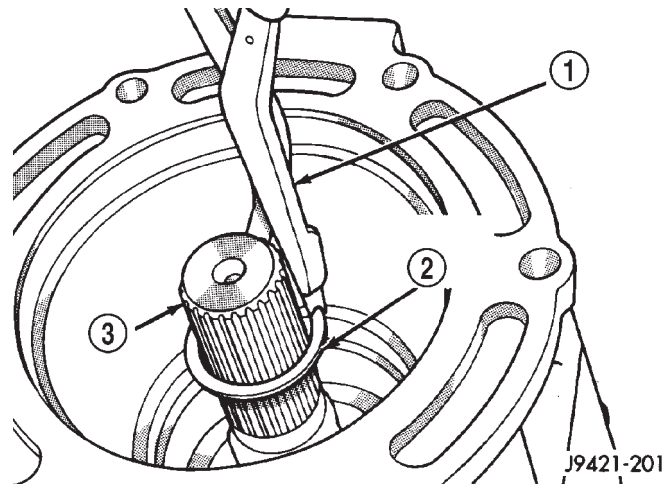
(7) Apply light coat of petroleum jelly to shift shaft bushing/bearing in adapter housing (Fig. 91).

(8) Install adapter housing on geartrain.

(9) Install rear bearing snap ring on output shaft (Fig. 96).

(10) Lubricate lip of new rear seal (Fig. 97) with Mopar® Door Ease, or transmission fluid.

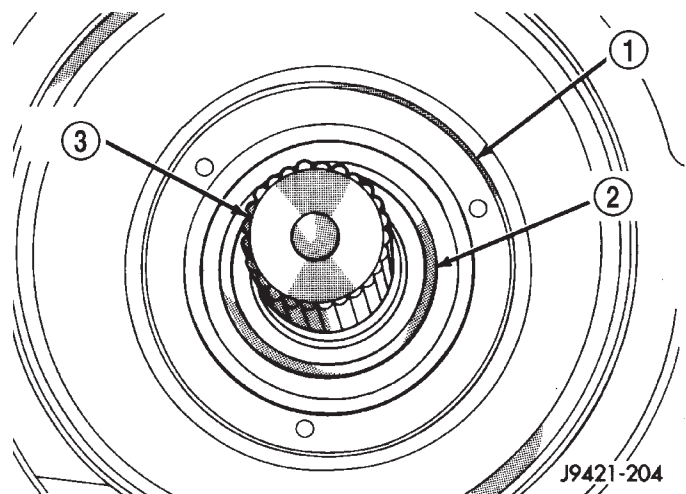
(11) Install **new** rear seal in adapter housing bore with Installer C-3860-A. Verify seal is seated in housing bore (Fig. 97).



J9421-201

**Fig. 96 Rear Bearing Snap Ring - 4WD**

- 1 - SNAP RING PLIERS
- 2 - SNAP RING
- 3 - OUTPUT SHAFT



J9421-204

**Fig. 97 Rear Seal**

- 1 - REAR SEAL
- 2 - SEAL LIP
- 3 - OUTPUT SHAFT

### SHIFT SHAFT, SHAFT LEVER AND BUSHING AND SHIFT SOCKET

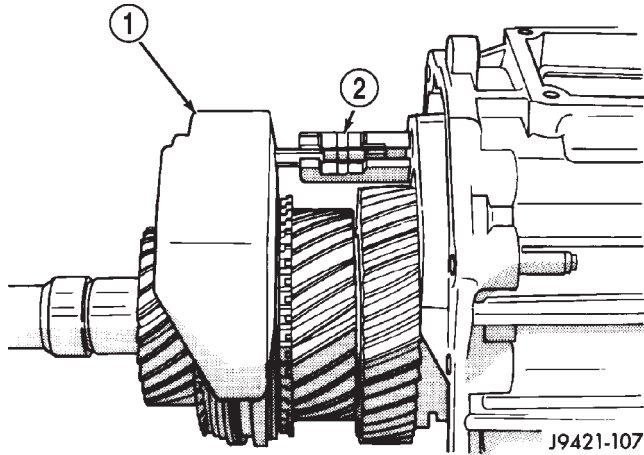
(1) Verify that all synchro sleeves are in Neutral position (centered on hub).

**CAUTION:** Transmission synchros must all be in Neutral position for reassembly. Otherwise the housings, shift forks and gears can be damaged during installation of the two housings.



MANUAL - NV3500 (Continued)

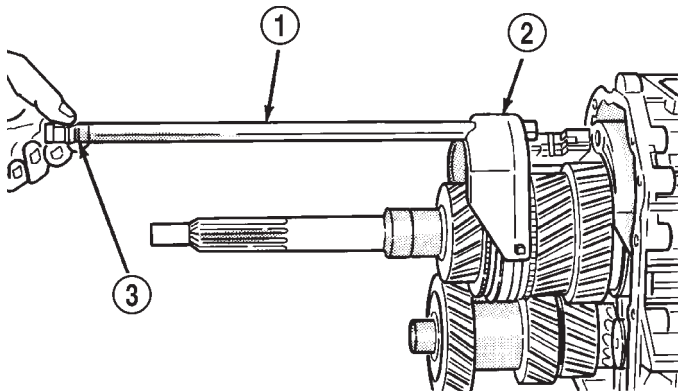
(2) Install 3-4 shift fork in synchro sleeve (Fig. 98). Verify groove in fork arm is aligned with grooves in 1-2 and fifth-reverse fork arms as shown.



**Fig. 98 3-4 Shift Fork**

- 1 - 3-4 FORK
- 2 - ALIGN GROOVES IN FORK ARMS

(3) Slide shift shaft through 3-4 shift fork (Fig. 99) with shaft detent notches to the rear.

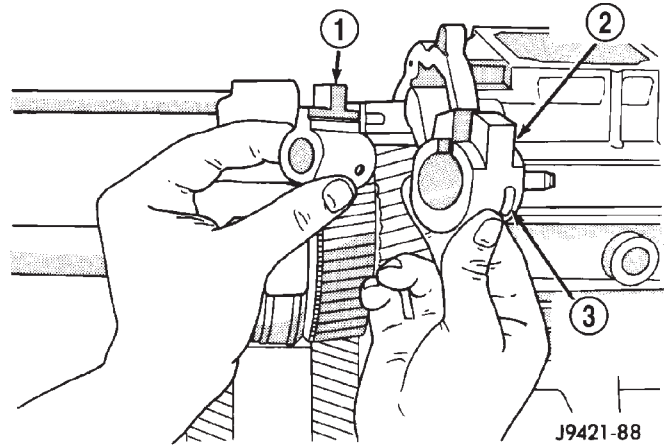


**Fig. 99 Shift Shaft**

- 1 - SHIFT SHAFT
- 2 - 3-4 FORK
- 3 - SHAFT DETENT NOTCHES

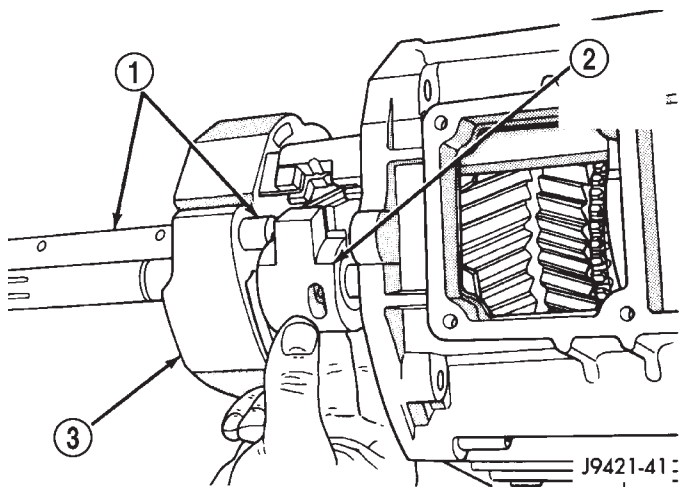
(4) Assemble shift shaft shift lever and bushing (Fig. 100). Verify slot in bushing is facing up and roll pin hole for lever is aligned with hole in shaft.

(5) Install assembled lever and bushing on shift shaft (Fig. 101).



**Fig. 100 Shift Shaft Lever And Bushing**

- 1 - SHAFT LEVER
- 2 - LEVER BUSHING
- 3 - BUSHING LOCK PIN SLOT



**Fig. 101 Install Shift Shaft Lever And Bushing**

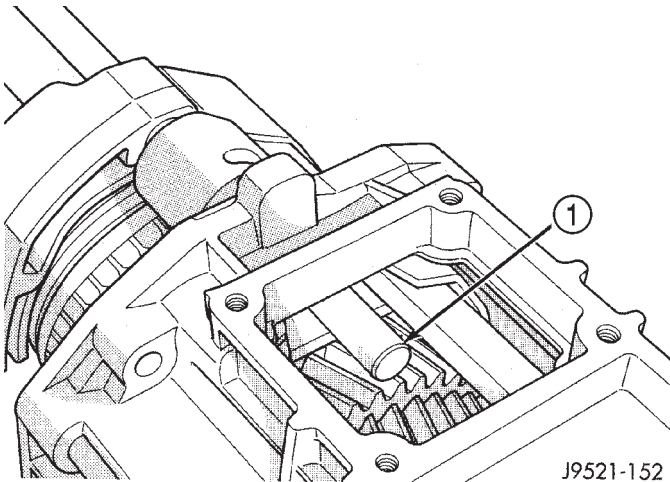
- 1 - SHIFT SHAFT
- 2 - SHAFT LEVER AND BUSHING
- 3 - 3-4 FORK

(6) Slide shift shaft through 1-2 and fifth-reverse fork and into shift lever opening in rear housing (Fig. 102).

(7) Align shift socket with shaft and slide shaft through socket and into shift shaft bearing in rear housing (Fig. 103).

(8) Rotate shift shaft so detent notches in shaft are facing the TOP of the transmission housing.

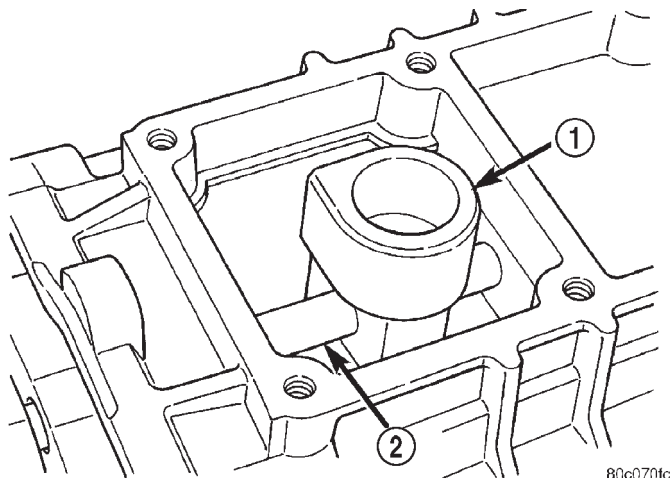
## MANUAL - NV3500 (Continued)



J9521-152

**Fig. 102 Inserting Shaft Into Lever Opening**

1 - SHIFT SHAFT



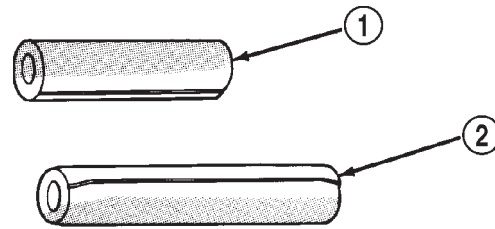
80c070fc

**Fig. 103 Shift Socket**1 - SHIFT SOCKET  
2 - SHIFT SHAFT

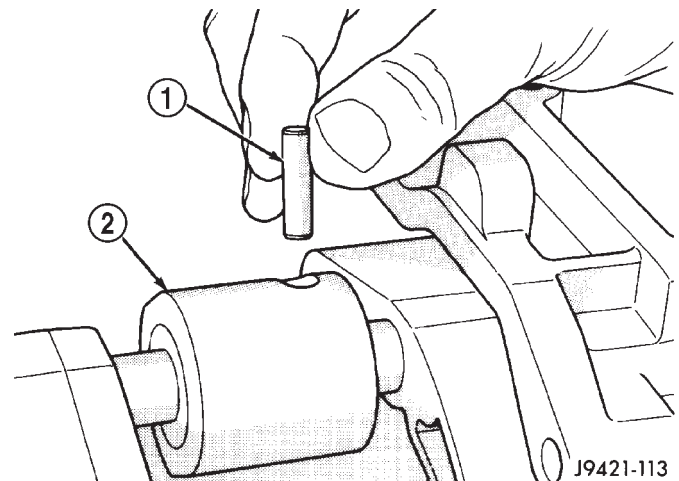
**CAUTION:** Both shaft roll pins can be installed when the shaft is 180° off. If this occurs, the transmission will have to be disassembled again to correct shaft alignment.

(9) Select correct **new** roll pin for shift shaft lever (Fig. 104). Shaft lever roll pin is approximately 22 mm (7/8 in.) long. Shift socket roll pin is approximately 33 mm (1-1/4 in.) long.

(10) Align roll pin holes in shift shaft, lever and bushing. Then start roll pin into shaft lever by hand (Fig. 105).



J9421-86

**Fig. 104 Roll Pin Identification**1 - SHAFT LEVER ROLL PIN  
2 - SHIFT SOCKET ROLL PIN

J9421-113

**Fig. 105 Roll Pin In Shift Socket**1 - SHAFT LEVER ROLL PIN  
2 - LEVER AND BUSHING

(11) Seat shaft lever roll pin with pin punch (Fig. 106).

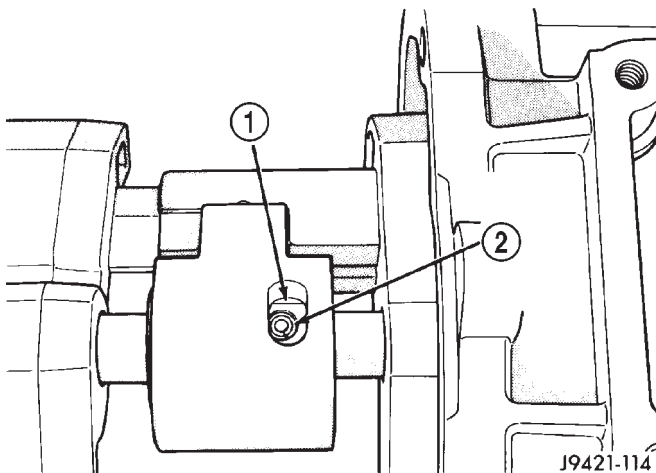
**CAUTION:** Shaft lever roll pin must be flush with the surface of the lever. The lever bushing will bind on the roll pin if the pin is not seated flush.

(12) Verify that lock pin slot in lever bushing is positioned as shown (Fig. 106).

(13) Align roll pin holes in shift socket and shift shaft. Then start roll pin into shift shaft by hand (Fig. 107).

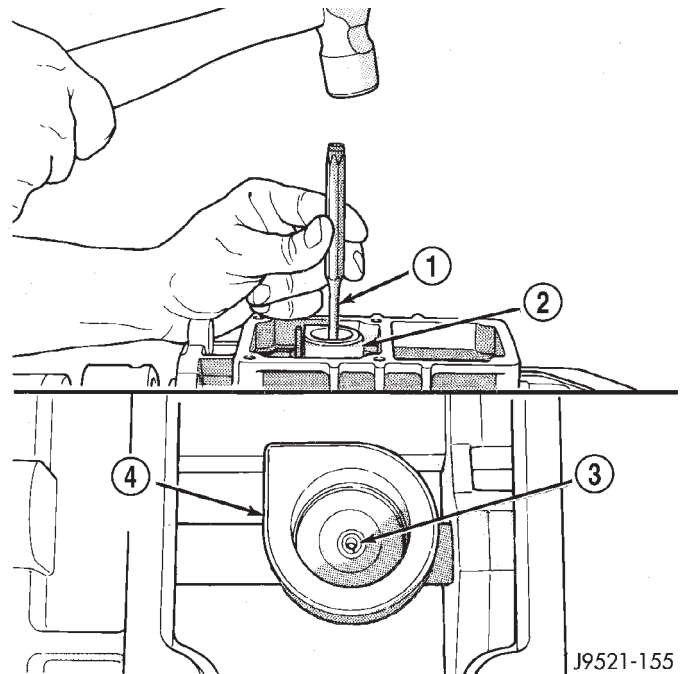
(14) Seat roll pin in shift socket with pin punch. Roll pin must be flush with socket after installation (Fig. 108).

(15) Verify that notches in shift fork arms are aligned. Realign arms if necessary.



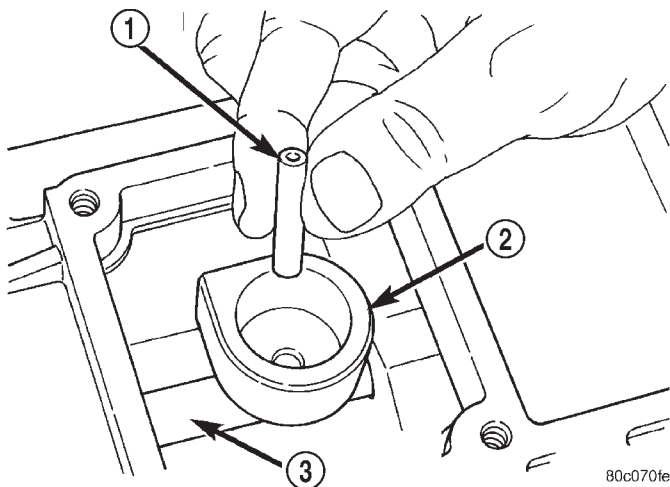
**Fig. 106 Shift Shaft Lever Roll**

- 1 - BUSHING LOCK PIN SLOT
- 2 - SEAT ROLL PIN FLUSH WITH LEVER



**Fig. 108 Seat Shift Socket**

- 1 - PIN PUNCH
- 2 - SHIFT SOCKET
- 3 - SEAT ROLL PIN FLUSH
- 4 - SHIFT SOCKET



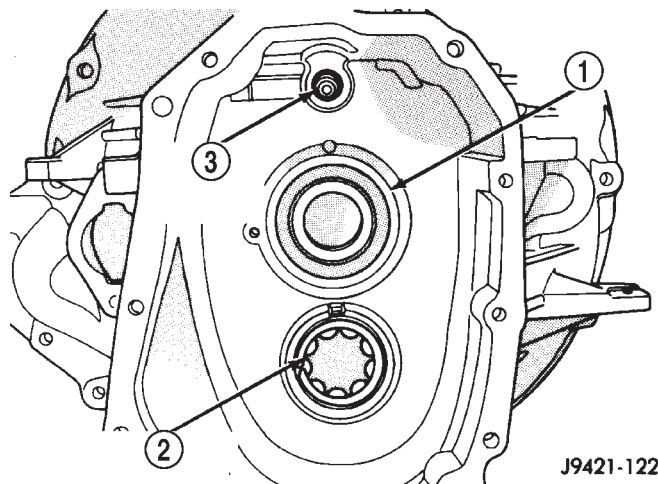
**Fig. 107 Roll Pin In Shift Socket**

- 1 - ROLL PIN
- 2 - SHIFT SOCKET
- 3 - SHIFT SHAFT

**FRONT HOUSING AND INPUT SHAFT BEARING RETAINER**

(1) If previously removed, install input shaft bearing in front housing bore (Fig. 109). Install snap ring and use plastic mallet to seat bearing. Bearing goes in from front side of housing only.

(2) Apply liberal quantity of petroleum jelly to countershaft front bearing. Then insert bearing in front housing race (Fig. 109). Large diameter side of bearing cage goes toward countershaft (Fig. 110). Small diameter side goes toward bearing race in housing.



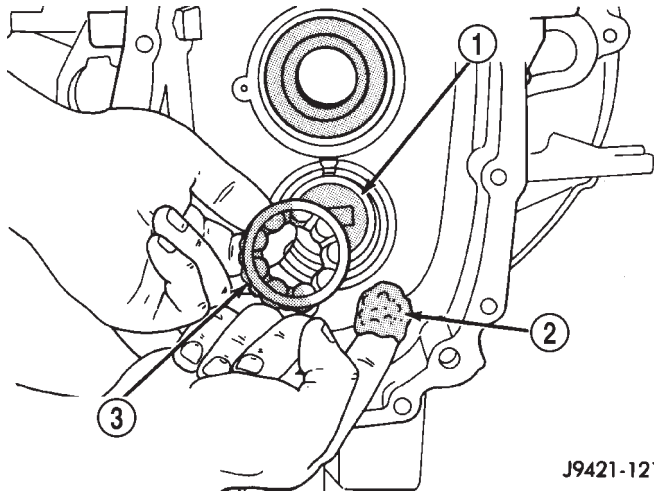
**Fig. 109 Input Shaft Bearing And Countershaft Front Bearing**

- 1 - INPUT SHAFT BEARING
- 2 - COUNTERSHAFT FRONT BEARING
- 3 - SHIFT SHAFT BUSHING

(3) Reach into countershaft front bearing with finger and push each bearing roller outward against race. Then apply extra petroleum jelly to hold rollers in place during housing installation.

(4) Apply small amount of petroleum jelly to shift shaft bushing in front housing.

## MANUAL - NV3500 (Continued)

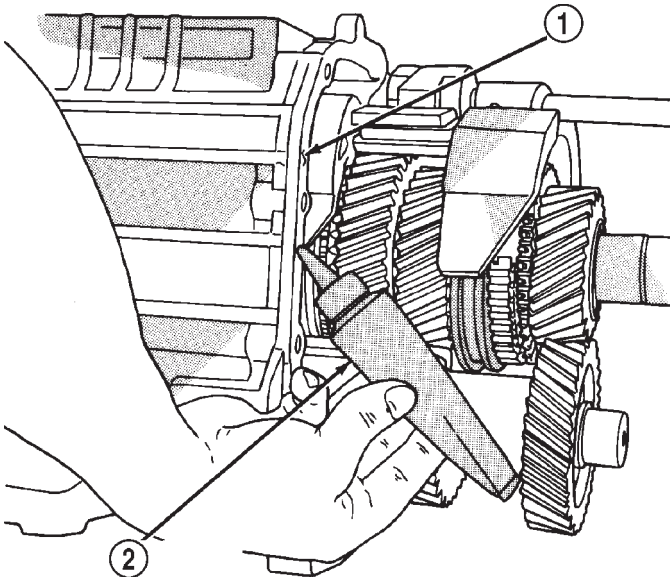


J9421-121

**Fig. 110 Countershaft Front Bearing**

- 1 - BEARING RACE
- 2 - PETROLEUM JELLY
- 3 - COUNTERSHAFT FRONT BEARING

(5) Apply 1/8 in. wide bead of Mopar® Gasket Maker or equivalent to mating surfaces of front and rear housings (Fig. 111).



J9421-123

**Fig. 111 Seal Front/Rear Housings**

- 1 - HOUSING FLANGE SURFACE
- 2 - MOPAR GASKET MAKER (OR LOCTITE 518)

(6) Have helper hold rear housing and geartrain in upright position. Then install front housing on rear housing and geartrain.

(7) Work front housing downward onto geartrain until seated on rear housing.

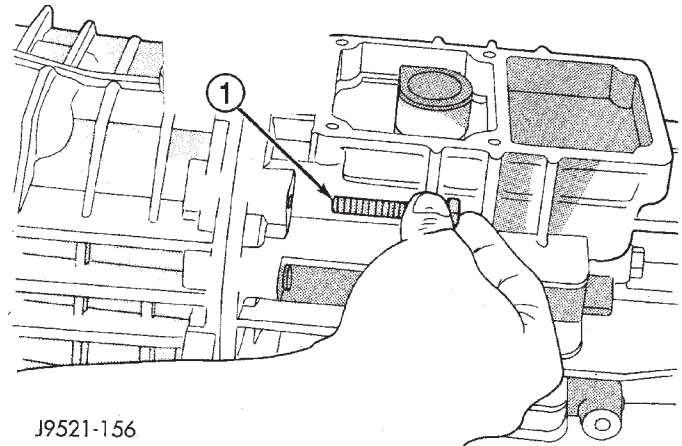
**CAUTION:** Front housings will not seat if shift components are not in Neutral or one or more components are misaligned. Do not force the front housing into place.

(8) Tap rear housing alignment dowels back into place with hammer and pin punch. Both dowels should be flush fit in each housing. Have helper hold transmission upright while dowels are tapped back into place.

(9) Place transmission in horizontal position.

(10) Apply Mopar® Gasket Maker or equivalent, to housing attaching bolts. Apply sealer material sealer to underside of bolt heads and to bolt shanks and threads (Fig. 112).

(11) Install and start housing attaching bolts by hand (Fig. 112). Then tighten bolts to 34 N·m (25 ft. lbs.).



J9521-156

**Fig. 112 Housing Bolts**

- 1 - HOUSING ATTACHING BOLTS (APPLY SEALER BEFOREHAND)

(12) Install shift shaft bushing lock bolt (Fig. 113). Apply Mopar Gasket Maker or equivalent to bolt threads, shank and underside of bolt head before installation.

**CAUTION:** If lock bolt cannot be fully installed the shift shaft is not in Neutral, or the shaft bushing (or lever) is misaligned.

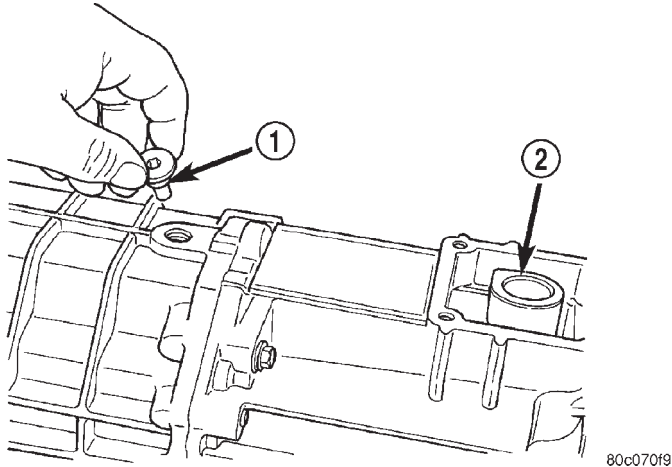
(13) Lubricate then install shift shaft detent plunger in housing bore (Fig. 114). Lubricate plunger with petroleum jelly or gear lubricant. Verify plunger is fully seated in detent notch in shift shaft.

(14) Install detent spring inside plunger (Fig. 114).

(15) Install detent plug in end of Installer 8123. Position plug on detent spring and compress spring until detent plug pilots in detent plunger bore. Drive detent plug into transmission case until plug seats.

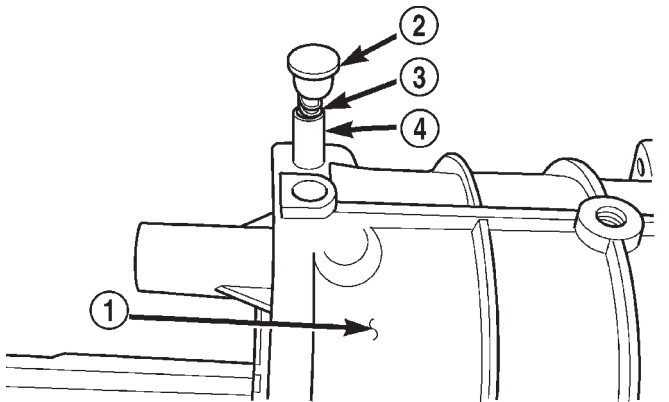
(16) Install backup light switch (Fig. 115).





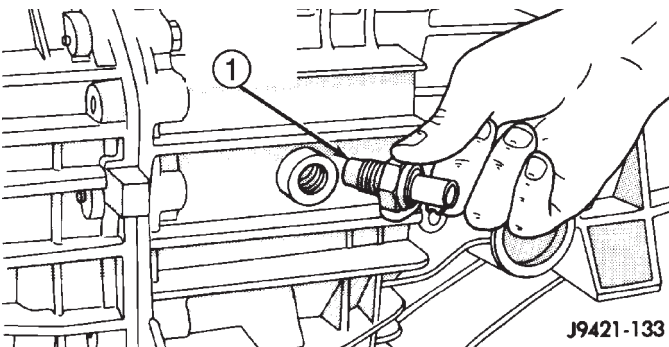
**Fig. 113 Shift Shaft Bushing Lock Bolt**

- 1 - SHIFT SHAFT LOCK BOLT
- 2 - SHAFT SOCKET



**Fig. 114 Shift Shaft Detent Plunger**

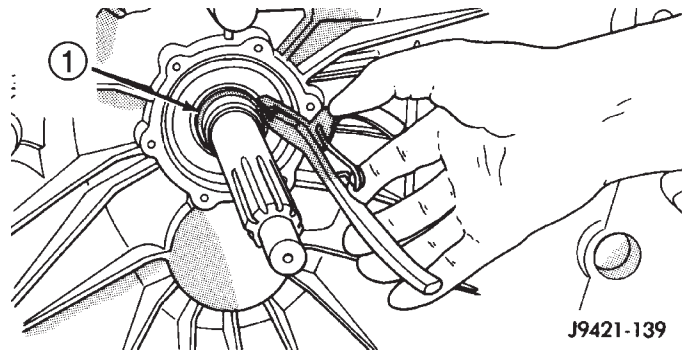
- 1 - FRONT HOUSING
- 2 - PLUG
- 3 - SPRING
- 4 - PLUNGER



**Fig. 115 Backup Light Switch**

- 1 - BACKUP LIGHT SWITCH

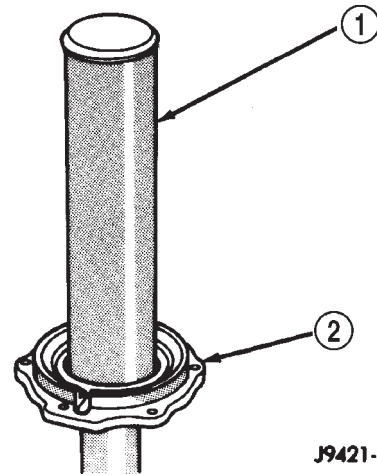
(17) Install input shaft snap ring (Fig. 116).



**Fig. 116 Shaft Snap Ring - Typical**

- 1 - INPUT SHAFT SNAP RING

(18) Install **new** oil seal in front bearing retainer with Installer 6448 (Fig. 117).



**Fig. 117 Oil Seal In Front Bearing Retainer**

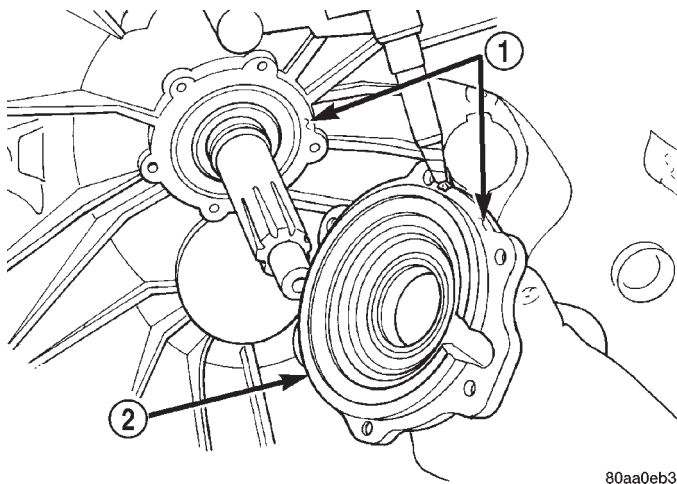
- 1 - INSTALLER 6448
- 2 - FRONT BEARING RETAINER

(19) Apply bead of Mopar silicone sealer or equivalent to flange surface of front bearing retainer (Fig. 118).

(20) Align and install front bearing retainer over input shaft and onto housing mounting surface (Fig. 119). Verify bolt holes are aligned before seating retainer.

**CAUTION:** Be sure sealer does not get into the oil feed hole in the transmission case or bearing retainer.

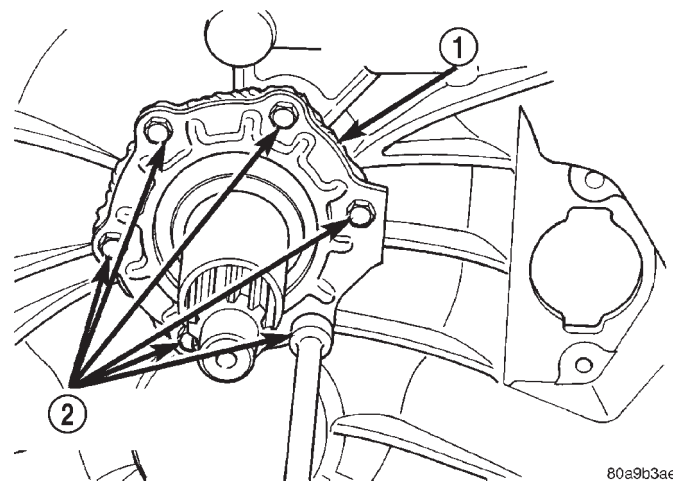
## MANUAL - NV3500 (Continued)



80aa0eb3

**Fig. 118 Seal Bearing Retainer And Housing - Typical**

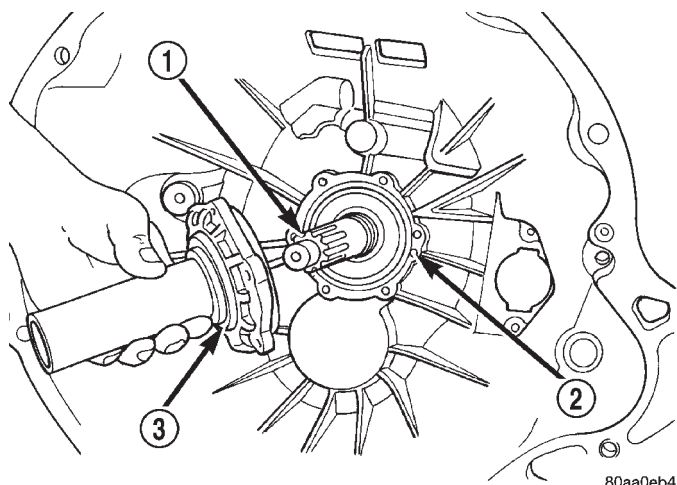
- 1 - APPLY SEALER BEAD  
2 - INPUT SHAFT BEARING RETAINER



80a9b3ae

**Fig. 120 Input Shaft Bearing Retainer Bolts - Typical**

- 1 - RETAINER BOLTS

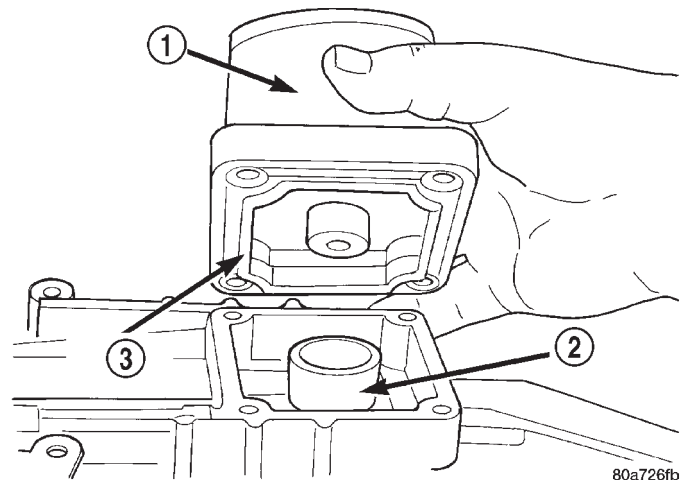


80aa0eb4

**Fig. 119 Input Shaft Bearing Retainer**

- 1 - INPUT SHAFT  
2 - OIL FEED  
3 - BEARING RETAINER

(21) Install and tighten bearing retainer bolts to 7-10 N·m (5-7 ft. lbs.) (Fig. 120).



80a726fb

**Fig. 121 Shift Tower**

- 1 - SHIFT TOWER

### SHIFT TOWER AND LEVER

(1) Apply petroleum jelly to ball end of shift lever and interior of shift socket.

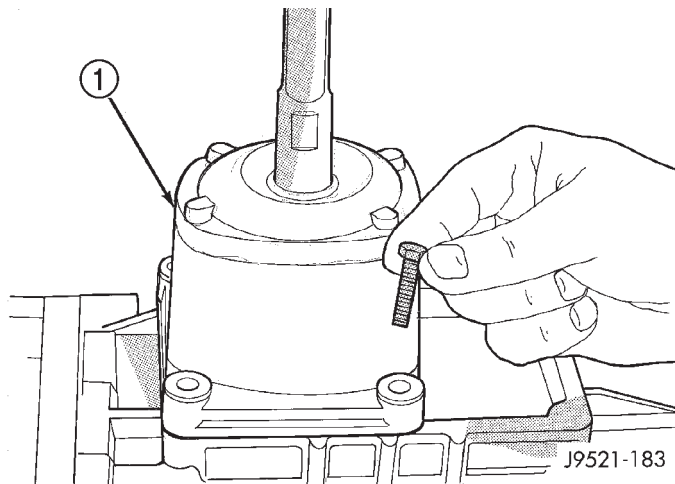
(2) Shift the transmission into third gear.

(3) Align and install shift tower and lever assembly (Fig. 121). Be sure shift ball is seated in socket and the offset in the tower is toward the passenger side of the vehicle before installing tower bolts.

(4) Install shift tower bolts (Fig. 122) and tighten bolts to 8.5 N·m (75.2 in. lbs.).



## MANUAL - NV3500 (Continued)



**Fig. 122 Shift Tower Bolts**

1 - SHIFT TOWER AND LEVER ASSEMBLY

(5) Fill transmission to bottom edge of fill plug hole with Mopar Transmission Lubricant.

(6) Install and tighten fill plug to 34 N·m (25 ft. lbs.).

(7) Check transmission vent. Be sure vent is open and not restricted.

## INSTALLATION

**NOTE:** If a new transmission is being installed, be sure to use all components supplied with the new transmission. For example, if a new shift tower is supplied with the new transmission, do not re-use the original shift tower.

Make sure transmission front housing mounting surface is clean. Before installation apply light coat of Mopar high temperature bearing grease to contact surfaces of following components:

- input shaft splines.
- release bearing slide surface of front retainer.
- release bearing bore.
- release fork.
- release fork ball stud.
- propeller shaft slip yoke.

(1) Support and secure transmission to jack with safety chains.

(2) Raise and align transmission input shaft with clutch disc, then slide transmission into place.

(3) Install and tighten transmission bolts to 54-61 N·m (40-45 ft. lbs.). Be sure front housing is fully seated before tightening bolts. Install front dust cover after all bolts are tightened.

(4) Fill transmission with Mopar lubricant. Correct fill level is to bottom edge of fill plug hole.

(5) Connect backup lamp switch wires.

(6) Connect transmission harnesses to clips on case.

(7) Install crossmember. Tighten crossmember-to-frame bolts to 68 N·m (50 ft. lbs.).

(8) Tighten crossmember-to-transmission insulator nuts to 68 N·m (50 ft. lbs.).

(9) Install slave cylinder. Tighten cylinder nuts to 23 N·m (200 in. lbs.).

(10) Remove jack used to support transmission.

(11) Install strut bolts/nuts, if removed. Also install oil filter if removal was necessary.

(12) Install and connect exhaust system. Align exhaust components before tightening clamp and bracket bolts and nuts. Be sure exhaust components are clear of all chassis and driveline components.

## TWO WHEEL DRIVE

(1) Align and install propeller shaft.

(2) Verify that all linkage components, hoses and electrical wires have been connected.

(3) Remove any remaining support stands and lower vehicle.

(4) Install crankshaft position sensor.

(5) Connect battery negative cable.

(6) Install shift tower and lever assembly. Tighten shift tower bolts to 7-10 N·m (5-7 ft. lbs.).

(7) Install the shift lever extension onto the shift tower and lever assembly.

(8) Install shift boot and bezel.

## FOUR WHEEL DRIVE

(1) Install transfer case. Align and position transfer case with transmission jack or aid of helper.

(2) Install and tighten transfer case attaching nuts to 47 N·m (35 ft. lbs.).

(3) Install and connect transfer case shift linkage.

(4) Align and install front and rear propeller shafts.

(5) Verify that all linkage components, hoses and electrical wires have been connected.

(6) Check transfer case fluid level. Add Mopar Dexron II, or ATF Plus if necessary. Correct level is to edge of fill plug hole. Be sure transfer case is level before checking or adding fluid.

(7) Check and adjust transfer case shift linkage if necessary.

(8) Install transfer case skid plate, if equipped.

(9) Install crankshaft position sensor.

(10) Remove any remaining support stands and lower vehicle.

(11) Connect battery negative cable.

(12) Install shift tower and lever assembly. Tighten shift tower bolts to 7-10 N·m (5-7 ft. lbs.).

(13) Install the shift lever extension onto the shift tower and lever assembly.

(14) Install shift boot and bezel.

MANUAL - NV3500 (Continued)

SPECIFICATIONS

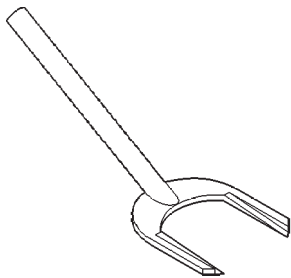
MANUAL - NV3500

TORQUE SPECIFICATIONS

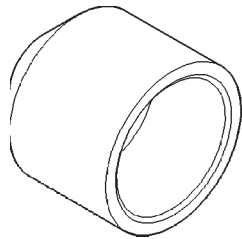
DESCRIPTION	N·m	Ft. Lbs.	In. Lbs.
Clutch Housing Bolts	54-61	40-45	-
Crossmember To Frame Bolts	61-75	44-55	-
Crossmember To Insulator Nuts	54-61	40-45	-
Drain/Fill Plug	9-27	14-20	-
Front To Rear Housing Bolts	30-35	22-26	-
Front Bearing Retainer Bolts	7-10	5-7	62-88
Idler Shaft Bolts	19-25	14-18	-
Rear Bearing Retainer Bolts	30-35	22-26	-
Shift Tower Bolts	7-10	5-7	62-88
Slave Cylinder Nuts	23	17	-
Transfer Case Nuts	47	35	-
U-Joint Clamp Bolts	19	14	-

SPECIAL TOOLS

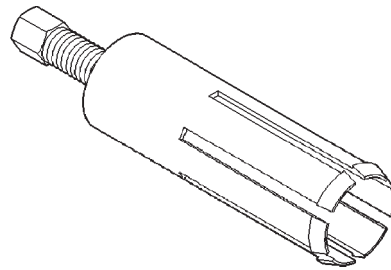
MANUAL - NV3500



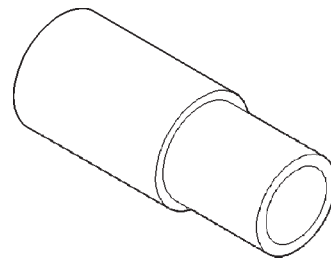
**Remover C-3985-B**



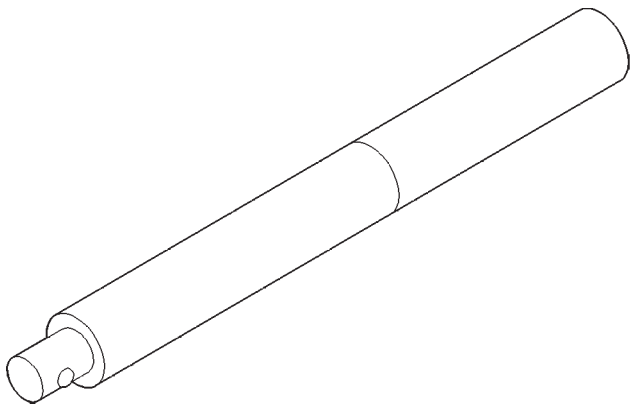
**Installer C-3972-A**



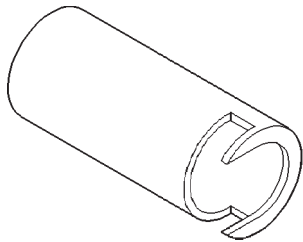
**Remover 6957**



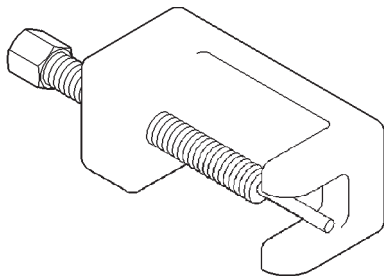
**Installer 6951**



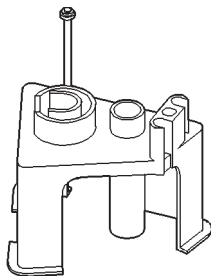
**Handle C-4171**



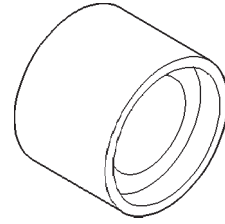
**Remover 8117**



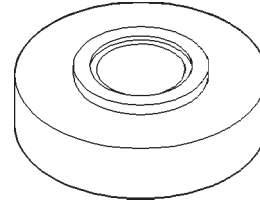
**Remover/Installer 6858**



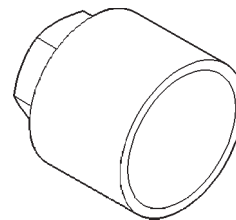
**Fixture 6747**



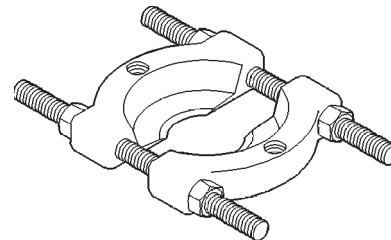
**Adapter 6747-1A**



**Adapter 6747-2B**

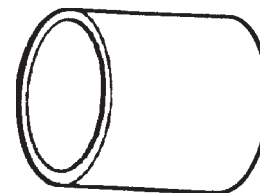


**Cup 8115**



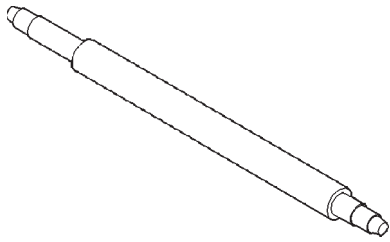
1130-00109ac3

**Splitter 1130**

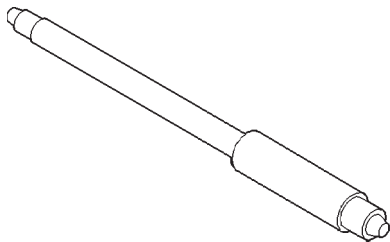


**Tube 6310-1**

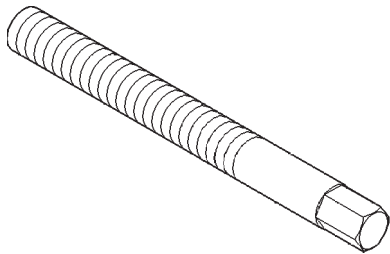
MANUAL - NV3500 (Continued)



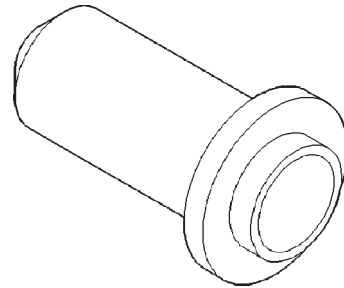
**Installer 8118**



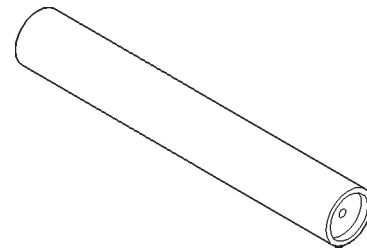
**Remover/Installer 8119**



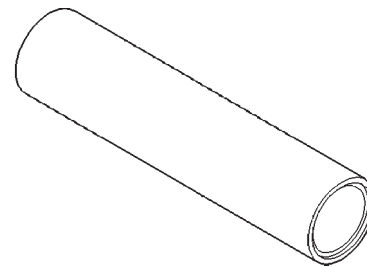
**Stud, Alignment 8120**



**Installer C-3860-A**



**Installer 8123**



**Installer 6448**

# MANUAL - NV4500

## TABLE OF CONTENTS

	page		page
<b>MANUAL - NV4500</b>		<b>ADAPTER HOUSING SEAL</b>	
DESCRIPTION . . . . .	44	REMOVAL . . . . .	87
OPERATION . . . . .	46	INSTALLATION . . . . .	87
DIAGNOSIS AND TESTING . . . . .	46	<b>EXTENSION HOUSING SEAL</b>	
MANUAL TRANSMISSION . . . . .	46	REMOVAL . . . . .	87
REMOVAL . . . . .	47	INSTALLATION . . . . .	87
DISASSEMBLY . . . . .	48	<b>SHIFT MECHANISM</b>	
CLEANING . . . . .	64	REMOVAL . . . . .	88
INSPECTION . . . . .	64	INSTALLATION . . . . .	89
ASSEMBLY . . . . .	65	<b>SHIFT COVER</b>	
INSTALLATION . . . . .	82	REMOVAL . . . . .	90
SPECIFICATIONS . . . . .	83	INSTALLATION . . . . .	90
SPECIAL TOOLS . . . . .	83		

## MANUAL - NV4500

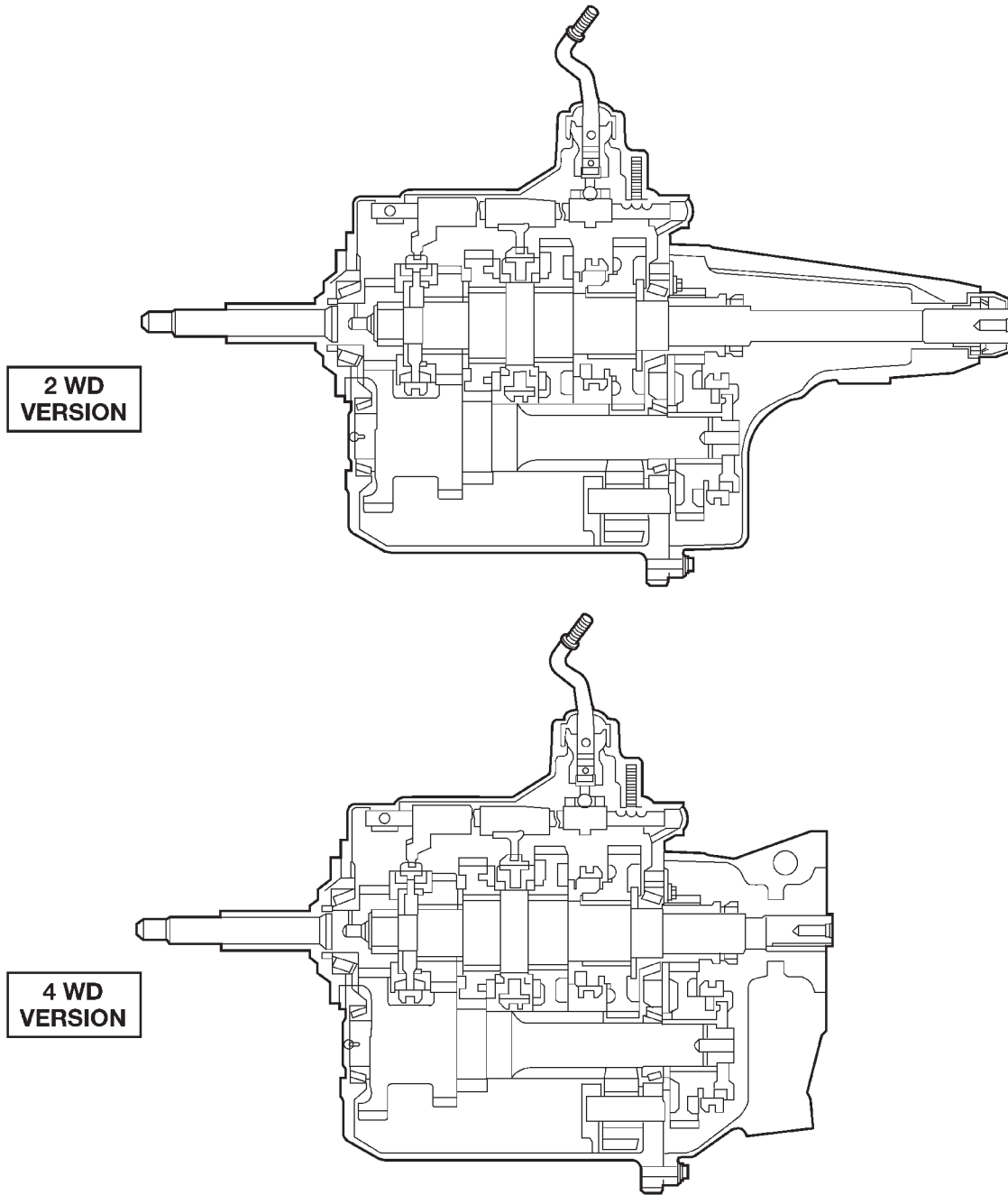
### DESCRIPTION

The NV4500 is a five speed constant mesh manual transmission (Fig. 1). All gear ranges including reverse are synchronized. Fifth gear is an overdrive range. The transmission has a cast iron gear case and aluminum shift cover.

Two versions are used, a standard duty for 5.9L applications and a heavy duty for V10 and Cummins diesel applications. Main differences are the larger diameter input shaft, output shaft, and mainshaft fifth gear in the heavy duty model.

Tapered roller bearings support the drive gear, mainshaft and countershaft in the gear case. Roller bearings in the drive gear support the forward end of the mainshaft. The mainshaft gears are all supported on caged type roller bearings. Drive gear thrust reaction is controlled by a needle type thrust bearing. The bearing is located at the forward end of the mainshaft.

The transmission is a top loader style. The shift lever is located in a shifter tower which is bolted to the shift cover and operates the shift forks and rails directly. The shift forks and rails are all located within the aluminum cover which is bolted to the top of the gear case.



**Fig. 1 NV4500 Manual Transmissions**

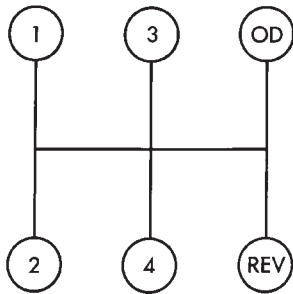
80b171e7



## MANUAL - NV4500 (Continued)

**SHIFT PATTERN**

The shift pattern is in a modified H pattern (Fig. 2). Overdrive fifth and reverse gears are in line and outboard of the first through fourth gear positions.



J9221-13

**Fig. 2 NV4500****GEAR RATIOS**

GEAR	RATIO
FIRST	5.61:1
SECOND	3.04:1
THIRD	1.67:1
FOURTH	1.00:1
FIFTH	0.75:1
REVERSE	5.04:1

**IDENTIFICATION**

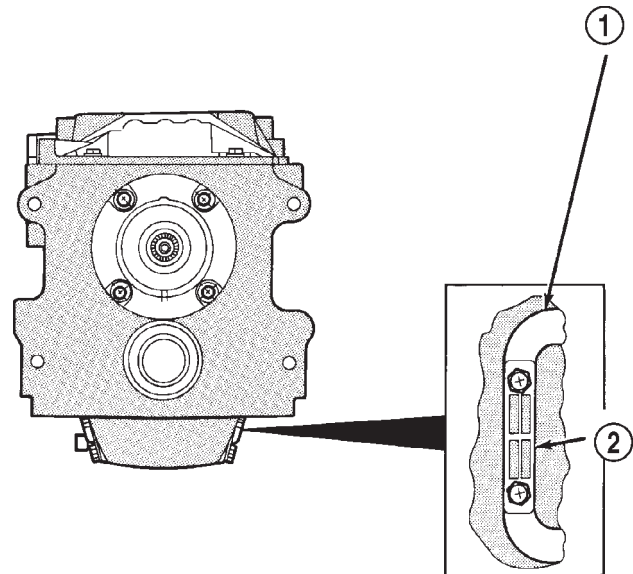
The transmission identification tag is attached to the driver side PTO cover (Fig. 3).

The tag provides the transmission model number, build date and part number. Be sure to reinstall the I.D. tag if removed during service. The information on the tag is essential to correct parts ordering.

**OPERATION**

The manual transmission receives power through the clutch assembly from the engine. The clutch disc is splined to the transmission input shaft and is turned at engine speed at all times that the clutch is engaged. The input shaft is connected to the transmission countershaft through the mesh of fourth speed gear on the input shaft and the fourth countershaft gear. At this point, all the transmission gears are spinning.

The driver selects a particular gear by moving the shift lever to the desired gear position. This movement moves the internal transmission shift components to begin the shift sequence. As the shift lever moves the selected shift rail, the shift fork attached to that rail begins to move. The fork is positioned in a groove in the outer circumference of the synchronizer sleeve. As the shift fork moves the synchronizer sleeve, the synchronizer begins to speed-up or slow



J9221-14

**Fig. 3 Identification Tag Location**

- 1 - PTO COVER
- 2 - I.D. TAG

down the selected gear (depending on whether we are up-shifting or down-shifting). The synchronizer does this by having the synchronizer hub splined to the mainshaft, or the countershaft in some cases, and moving the blocker ring into contact with the gear's friction cone. As the blocker ring and friction cone come together, the gear speed is brought up or down to the speed of the synchronizer. As the two speeds match, the splines on the inside of the synchronizer sleeve become aligned with the teeth on the blocker ring and the friction cone and eventually will slide over the teeth, locking the gear to the mainshaft, or countershaft, through the synchronizer.

**DIAGNOSIS AND TESTING - MANUAL TRANSMISSION****LOW LUBRICANT LEVEL**

A low transmission lubricant level is generally the result of a leak, inadequate lubricant fill or an incorrect lubricant level check.

Leaks can occur at the mating surfaces of the gear case, adaptor or extension housing, or from the front/rear seals. A suspected leak could also be the result of an overfill condition.

Leaks at the rear of the extension or adapter housing will be from the housing oil seals. Leaks at component mating surfaces will probably be the result of inadequate sealer, gaps in the sealer, incorrect bolt tightening or use of a non-recommended sealer.

## MANUAL - NV4500 (Continued)

A leak at the front of the transmission will be from either the front bearing retainer or retainer seal. Lubricant may be seen dripping from the clutch housing after extended operation. If the leak is severe, it may also contaminate the clutch disc causing the disc to slip, grab and or chatter.

A correct lubricant level check can only be made when the vehicle is level. Also allow the lubricant to settle for a minute or so before checking. These recommendations will ensure an accurate check and avoid an underfill or overfill condition. Always check the lubricant level after any addition of fluid to avoid an incorrect lubricant level condition.

**HARD SHIFTING**

Hard shifting is usually caused by a low lubricant level, improper or contaminated lubricants. The consequence of using non-recommended lubricants is noise, excessive wear, internal bind and hard shifting. Substantial lubricant leaks can result in gear, shift rail, synchro, and bearing damage. If a leak goes undetected for an extended period, the first indications of component damage are usually hard shifting and noise.

Component damage, incorrect clutch adjustment or damaged clutch pressure plate or disc are additional probable causes of increased shift effort. Incorrect adjustment or a worn/damaged pressure plate or disc can cause incorrect release. If clutch problem is advanced, gear clash during shifts can result. Worn or damaged synchro rings can cause gear clash when shifting into any forward gear. In some new or rebuilt transmissions, new synchro rings may tend to stick slightly causing hard or noisy shifts. In most cases this condition will decline as the rings wear-in.

**TRANSMISSION NOISE**

Most manual transmissions make some noise during normal operation. Rotating gears generate a mild whine that is audible, but generally only at extreme speeds.

Severe highly audible transmission noise is generally the initial indicator of a lubricant problem. Insufficient, improper or contaminated lubricant will promote rapid wear of gears, synchros, shift rails, forks and bearings. The overheating caused by a lubricant problem, can also lead to gear breakage.

**REMOVAL**

- (1) Disconnect battery negative cable.
- (2) Shift transmission into Neutral.
- (3) Remove shift boot screws from floorpan and slide boot upward on the shift lever.
- (4) Remove shift lever extension from shift tower and lever assembly.

(5) Remove shift tower bolts holding tower to isolator plate and transmission shift cover.

(6) Remove shift tower and isolator plate from transmission shift cover.

(7) Raise and support vehicle.

(8) Remove skid plate, if equipped.

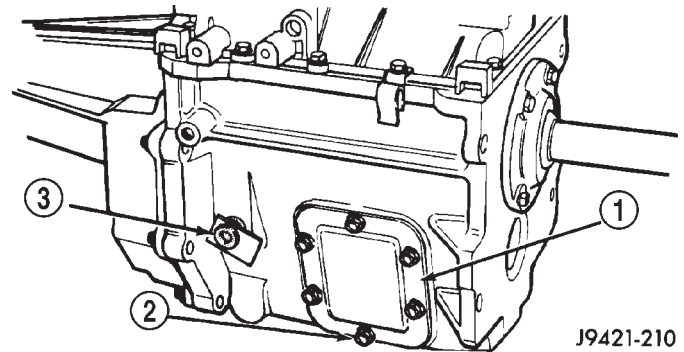
(9) Mark propeller shaft and axle yokes for installation reference and remove shaft/shafts.

(10) Remove exhaust system Y-pipe.

(11) Disconnect speed sensor and backup light switch connectors.

(12) Support engine with safety stand and a wood block.

(13) If transmission is to be disassembled for, remove drain bolt at bottom of PTO cover and drain lubricant (Fig. 4).



J9421-210

**Fig. 4 NV4500 Drain Bolt**

- 1 - PTO COVER
- 2 - DRAIN BOLT
- 3 - FILL PLUG

**TWO WHEEL DRIVE**

(1) Remove nuts/bolts attaching transmission to rear mount.

(2) Support and secure transmission with safety chains to a transmission jack.

(3) Remove rear crossmember.

(4) Remove clutch slave cylinder bolts and move cylinder aside for clearance.

(5) Remove transmission harness wires from clips on transmission shift cover.

(6) Remove transmission to clutch housing bolts.

(7) Slide transmission and jack rearward until input shaft clears clutch housing.

(8) Lower transmission jack and remove transmission from under vehicle.

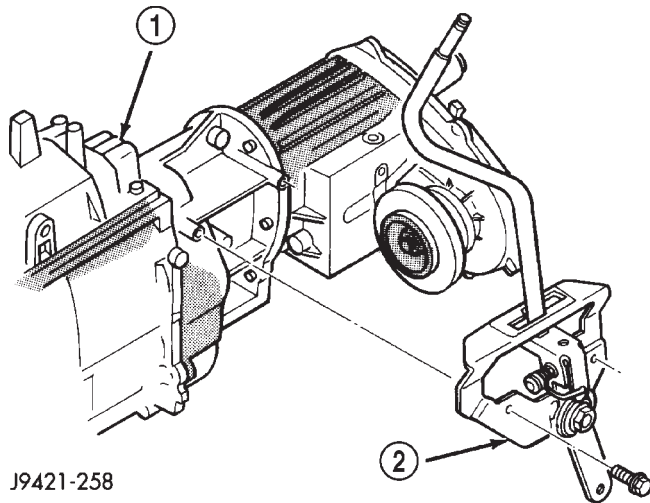
**FOUR WHEEL DRIVE**

(1) Disconnect transfer case shift linkage at transfer case range lever. Then remove transfer case shift mechanism from transmission (Fig. 5).

(2) Support and secure transfer case to transmission jack with safety chains.

(3) Remove transfer case mounting nuts.

MANUAL - NV4500 (Continued)



J9421-258

**Fig. 5 Transfer Case Shift Mechanism-Typical**

- 1 - TRANSMISSION  
2 - TRANSFER CASE SHIFT MECHANISM

(4) Move transfer case rearward until input gear clears transmission mainshaft.

(5) Lower transfer case assembly and move it from under vehicle.

(6) Support and secure transmission with safety chains to a transmission jack.

(7) Remove transmission harness from retaining clips on transmission shift cover.

(8) Remove bolts/nuts attaching transmission mount to rear crossmember.

(9) Remove rear crossmember.

(10) Remove clutch slave cylinder splash shield, if equipped.

(11) Loosen clutch slave cylinder attaching nuts until cylinder piston rod is clear of release lever. This reduces pressure on lever and release bearing making transmission removal/installation easier. Cylinder does not have to be removed completely.

(12) Remove transmission bolts from clutch housing.

(13) Move transmission rearward until input shaft clears clutch disc and release bearing.

(14) Lower transmission and remove it from under vehicle.

## DISASSEMBLY

### EXTENSION/ADAPTER HOUSING

(1) Raise and support vehicle.

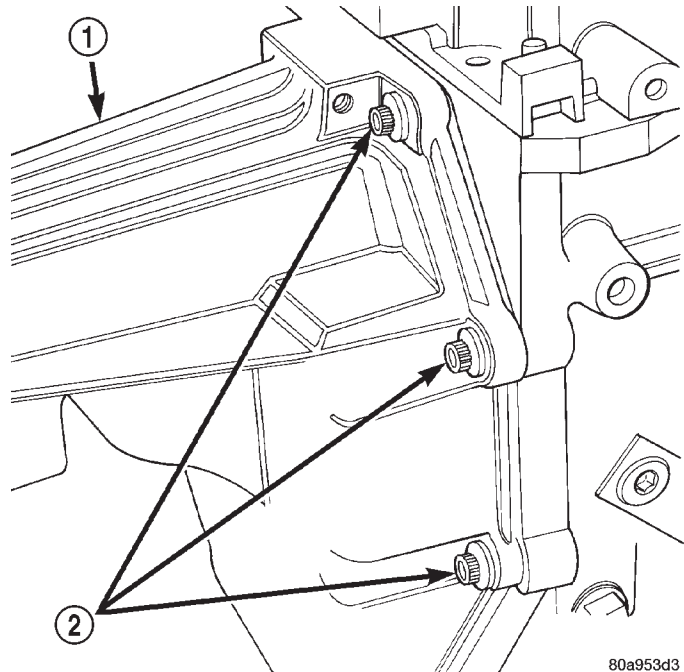
(2) Remove rear propeller shaft.

(3) Support transmission with a transmission jack.

(4) Remove engine rear support. Refer to 9 Engine for procedures.

(5) Remove transfer case, if equipped.

(6) Remove bolts attaching extension/adapter housing to gear case (Fig. 6).



80a953d3

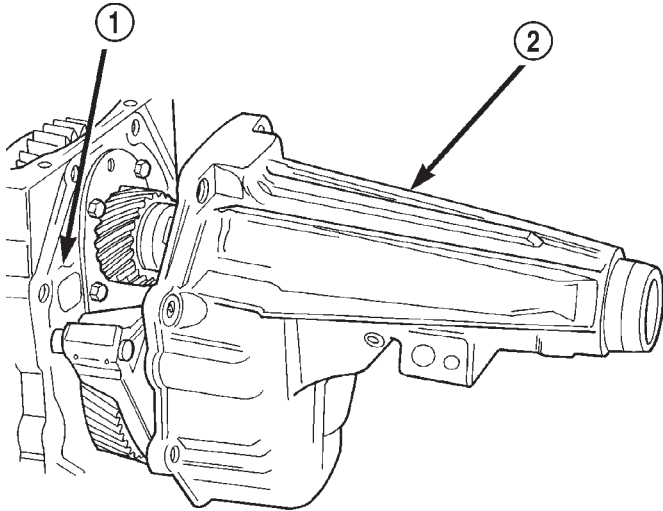
**Fig. 6 Extension/Adapter Housing Bolts**

- 1 - EXTENSION HOUSING  
2 - BOLTS

(7) Remove extension/adapter housing (Fig. 7). There is one alignment dowel in the gear case and one in the extension/adapter housing.

(8) Remove rubber spline seal from end of mainshaft (Fig. 8). The seal is used to prevent lubricant loss during shipping and does not have to be replaced if damaged.

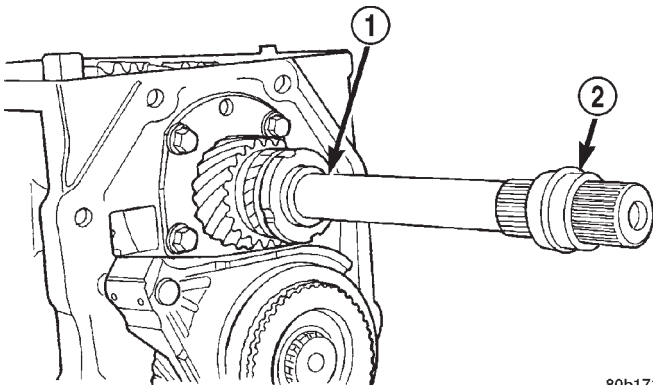
## MANUAL - NV4500 (Continued)



80b171f5

**Fig. 7 Extension/Adapter Housing**

- 1 - GEAR CASE  
2 - EXTENSION HOUSING



80b171f6

**Fig. 8 Mainshaft Spline Seal**

- 1 - MAINSHAFT  
2 - RUBBER SPLINE SEAL

**FIFTH GEAR NUT**

- (1) Remove extension/adapter housing.
- (2) Loosen fifth gear clamp nut clamping screw approximately 1 1/2 turns.
- (3) Install nut Wrench 6743 on fifth gear nut (Fig. 9).

**NOTE: Wrench only fits one way on nut. Be sure wrench is fully engaged in nut slots and is not cocked.**

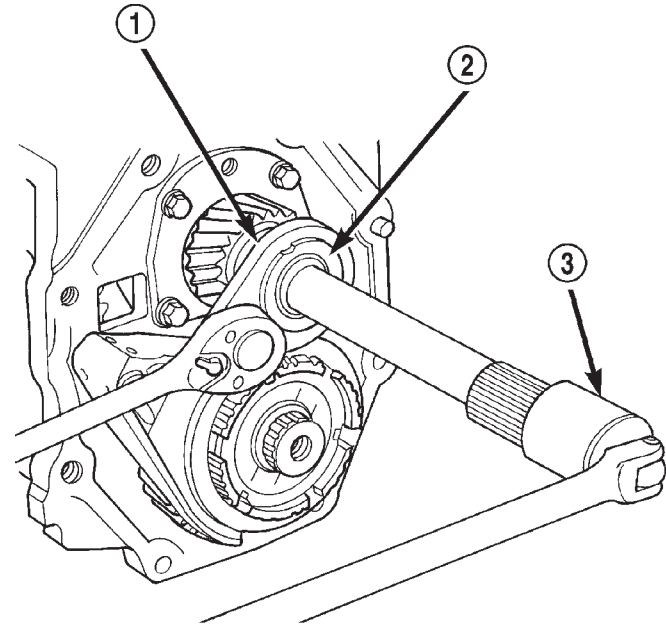
- (4) Install splined Socket 6993 4X2 Socket 6984 4X4 to retain mainshaft while removing the fifth gear nut.

- (5) Install breaker bar in socket wrench (Fig. 9)

**NOTE: Wedge breaker bar handle against work-bench. Purpose of socket wrench and breaker bar**

**is to prevent mainshaft from turning while nut is loosened.**

- (6) Remove fifth gear nut, then remove belleville washer from mainshaft.



80b171f8

**Fig. 9 Fifth Gear Nut**

- 1 - WRENCH 6443/6743  
2 - FIFTH GEAR NUT  
3 - SOCKET 6993/6984

**FIFTH GEAR**

- (1) Remove roll pins that secure countershaft fifth gear shift fork to shift rail with pin punch (Fig. 10). Roll pins are driven out from bottom of fork and not from top.

- (2) Remove snap ring that secures fifth gear clutch hub and gear on countershaft (Fig. 11).

- (3) Remove countershaft fifth gear clutch gear and stop ring.

- (4) Remove fifth gear shift fork and gear assembly. Remove assembly by tapping fork off rail with plastic mallet.

- (5) Remove fifth gear shift fork from sleeve.

- (6) Remove sleeve, struts, and strut springs from countershaft fifth gear hub, if necessary.

- (7) Remove countershaft fifth gear needle bearing assembly (Fig. 12).

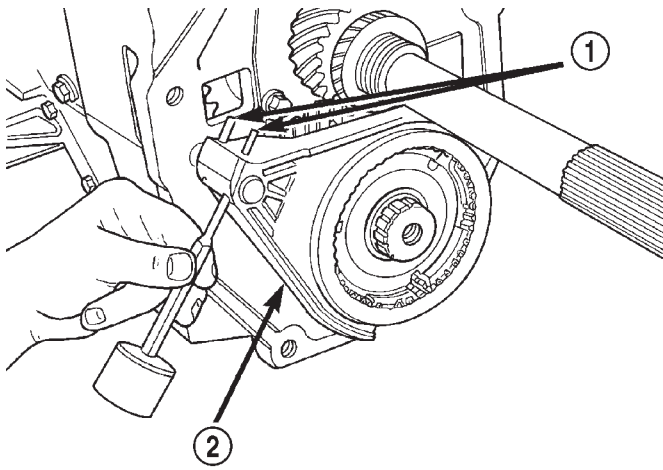
- (8) Remove cone shaped rear bearing thrust washer from end of countershaft (Fig. 13). Note position of washer for assembly reference. Also note that washer bore has notch for locating pin.

- (9) Remove and retain thrust washer locating pin from countershaft.

- (10) Remove mainshaft overdrive fifth gear with Puller Tool Set 6444.



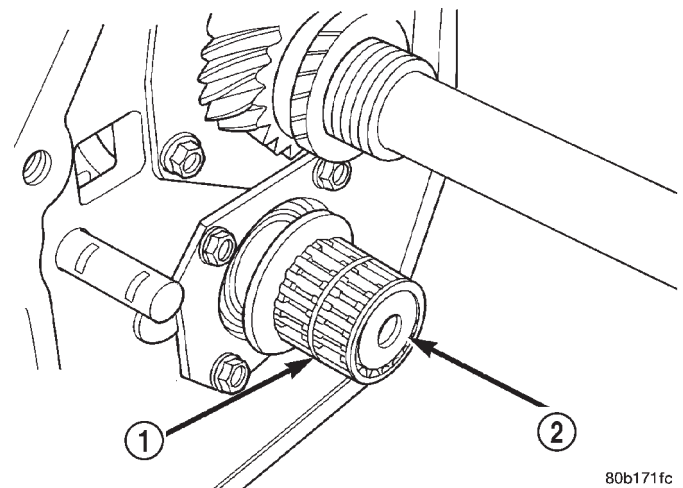
## MANUAL - NV4500 (Continued)



80b171fa

**Fig. 10 Fifth Gear Shift Fork Roll Pins**

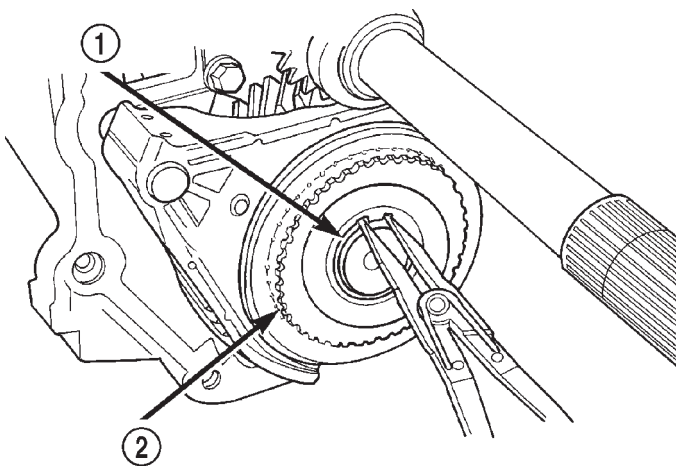
- 1 - FORK ROLL PINS  
2 - FIFTH GEAR SHIFT FORK



80b171fc

**Fig. 12 Countershaft Fifth Gear Needle Bearing**

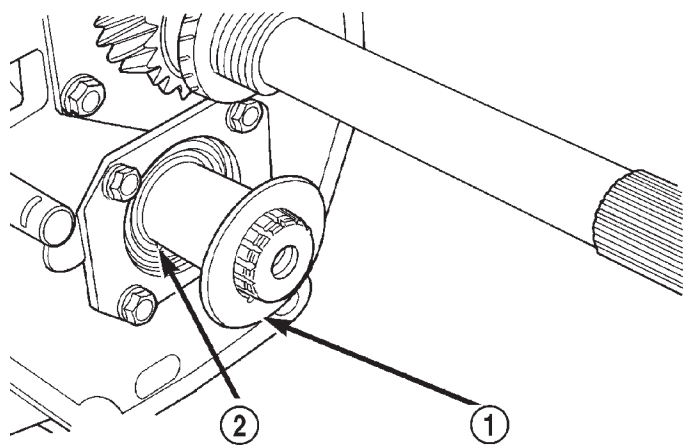
- 1 - FIFTH GEAR NEEDLE BEARING ASSEMBLY  
2 - COUNTERSHAFT



80b171fb

**Fig. 11 Countershaft Fifth Gear Clutch Gear Snap Ring**

- 1 - CLUTCH GEAR RING  
2 - FIFTH SYNCHRO CLUTCH GEAR



80b1b2a7

**Fig. 13 Countershaft Rear Bearing Thrust Washer**

- 1 - THRUST WASHER (CONE SHAPED)  
2 - THRUST WASHER PIN

(11) Position first Puller Jaw 6459 or 6820 on gear (Fig. 14).

(12) Assemble Puller Flange 6444-1 and Puller Rods 6444-3 4X2 vehicles or 6444-4 4X4 vehicles (Fig. 15).

(13) Slide assembled puller flange and rods onto output shaft. Then seat flange in notch of puller jaw (Fig. 15).

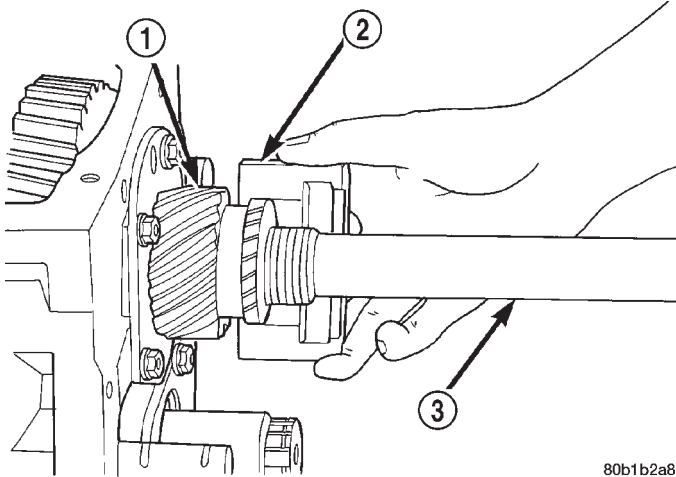
(14) Position second puller jaw on gear and in notch of puller flange (Fig. 16).

(15) Slide Retaining Collar 6444-8 over puller jaws to hold them in place (Fig. 16).

(16) Install Puller and Bolt 6444 on puller rods. Then secure puller to rods with retaining nuts (Fig. 17).

(17) Tighten puller bolt to remove gear from shaft splines (Fig. 17).

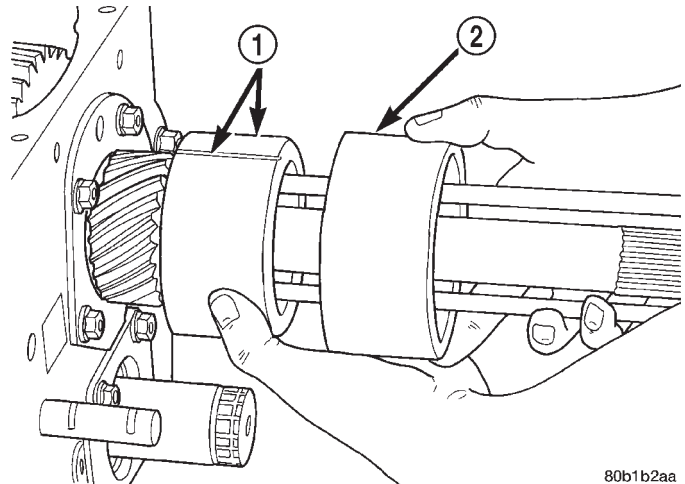
## MANUAL - NV4500 (Continued)



80b1b2a8

**Fig. 14 First Puller Jaw On Mainshaft Fifth (Overdrive) Gear**

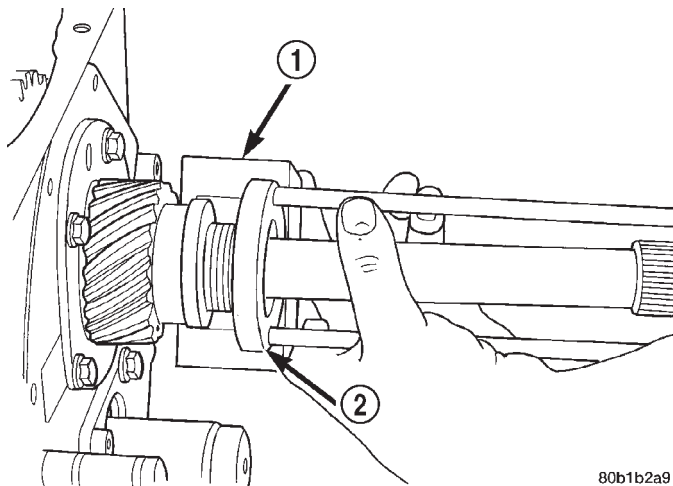
- 1 - MAINSHAFT FIFTH GEAR
- 2 - JAWS 6459 OR HD JAWS 6820
- 3 - MAINSHAFT



80b1b2aa

**Fig. 16 Retaining Collar Over Puller Jaws**

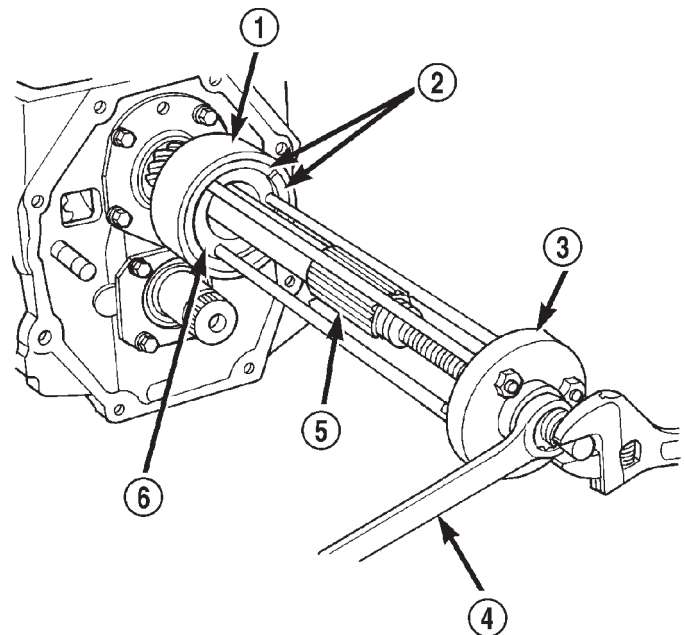
- 1 - JAWS
- 2 - COLLAR 6444-8



80b1b2a9

**Fig. 15 Seating Puller Flange In First Puller**

- 1 - JAWS
- 2 - PULLER FLANGE 6444-1



80b1b2ab

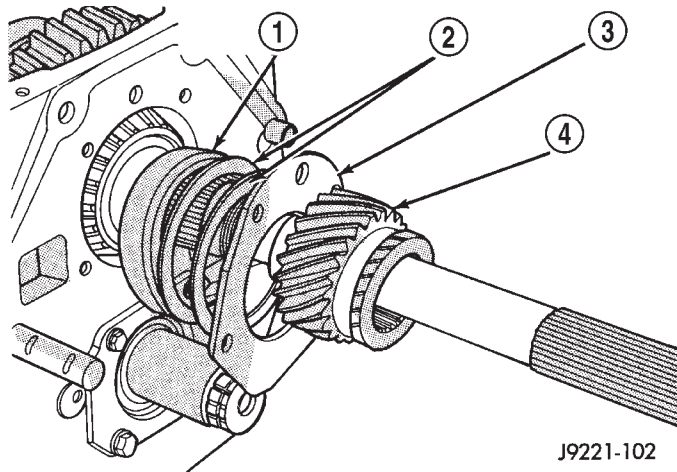
**Fig. 17 Fifth Gear From Mainshaft Splines**

- 1 - COLLAR 6444-8
- 2 - JAWS 6459 OR 6820
- 3 - BOLT 6444
- 4 - WRENCH
- 5 - MAINSHAFT
- 6 - PULLER FLANGE 6444-1



MANUAL - NV4500 (Continued)

(18) Remove bolts attaching mainshaft rear bearing plate to gear case and remove fifth gear plate end play shims and bearing cup (Fig. 18).

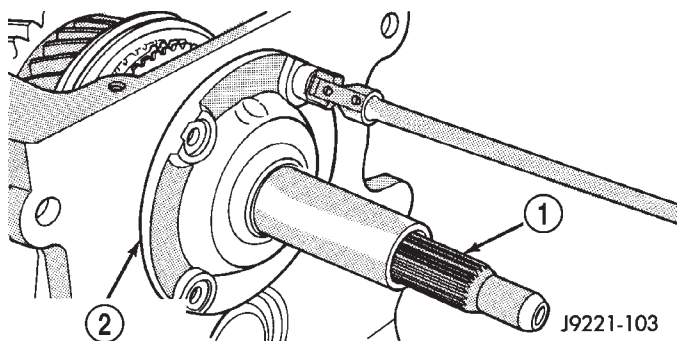


**Fig. 18 Mainshaft Fifth Gear Bearing Plate, Bearing Shims, And Rear Bearing Cup**

- 1 - MAINSHAFT REAR BEARING CUP
- 2 - BEARING SHIMS
- 3 - BEARING PLATE
- 4 - FIFTH GEAR

**FRONT RETAINER**

(1) Remove front retainer bolts (Fig. 19). Discard retainer bolts. They should not be reused.



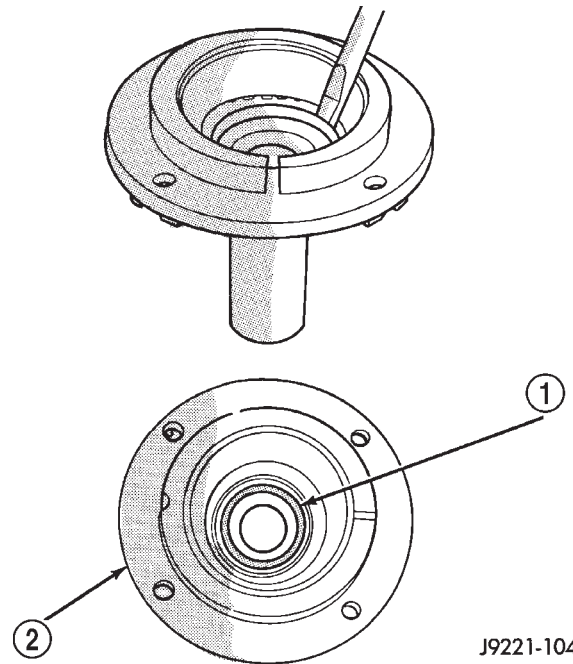
**Fig. 19 Front Bearing Retainer**

- 1 - DRIVE GEAR
- 2 - FRONT BEARING RETAINER

(2) Remove retainer by lightly tapping it back and forth with plastic mallet. Then rock retainer back and forth by hand to work it out of gear case.

**NOTE: Retainer flange extends into transmission case and is a snug fit.**

(3) Remove seal from front retainer (Fig. 20). Collapse one side of seal then pry it out with pry tool.

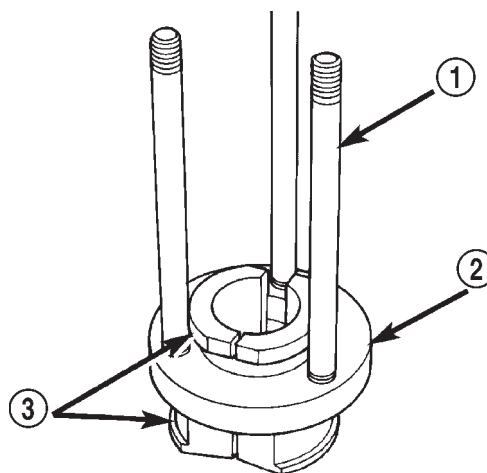


**Fig. 20 Bearing Retainer Seal**

- 1 - SEAL
- 2 - FRONT BEARING RETAINER

(4) To remove front retainer bearing cup, assemble Puller Flange 6444-1 and Puller Rods 6444-4 (Fig. 21).

(5) Insert Puller Jaws 6453-1 in puller flange (Fig. 21). Narrow lip of puller jaws will go under bearing cup.



**Fig. 21 Puller Rods, Flange And Jaws**

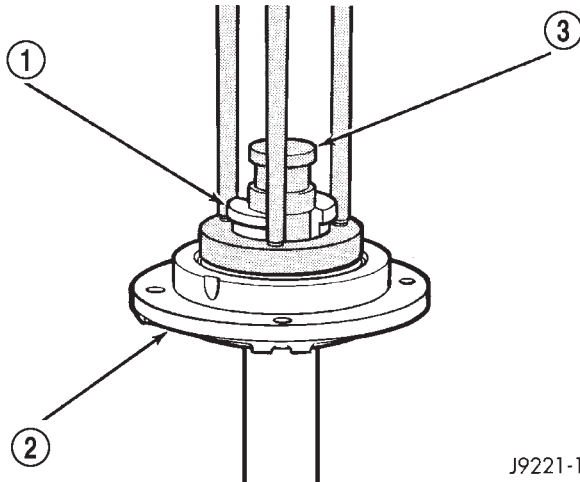
- 1 - RODS 6444-4
- 2 - FLANGE 6444-1
- 3 - JAWS 6453-1

(6) Install Disc C-4487-1 into bearing retainer on heavy duty transmissions for Insert 6453-2 to rest upon.

## MANUAL - NV4500 (Continued)

(7) Install assembled tools in front retainer (Fig. 22). Be sure puller jaws are seated under bearing cup.

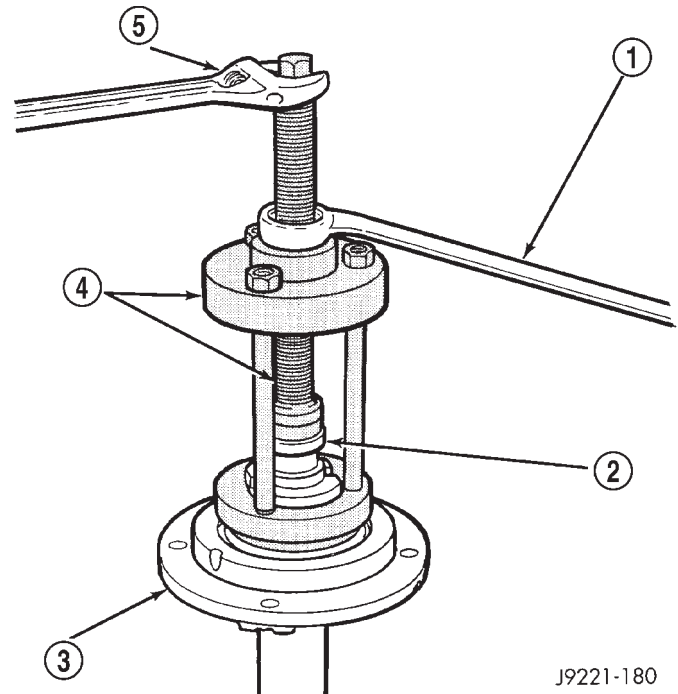
(8) Place Insert Tool 6453-2 in center of puller jaws (Fig. 22). Insert tool is used to hold puller jaws in place.



J9221-179

**Fig. 22 Puller Tools In Front Retainer**

- 1 - INSERT 6453-2
- 2 - FRONT RETAINER
- 3 - JAWS 6453-1



J9221-180

**Fig. 23 Bearing Cup Puller**

- 1 - WRENCH
- 2 - INSERT 6453-2
- 3 - FRONT RETAINER
- 4 - PULLER 6444
- 5 - WRENCH

(9) Install Puller 6444 on puller rods (Fig. 23). Then install retaining nuts on puller rods.

(10) Tighten puller bolt to draw bearing cup out of retainer (Fig. 23).

#### DRIVE GEAR

(1) Remove drive gear (Fig. 24).

(2) Remove pilot bearing from drive gear (Fig. 25).

(3) To remove tapered bearing from drive gear, assemble Puller Flange 6444-1 and Puller Rods 6444-6 (Fig. 26). Then position first Puller Jaw 6447 on bearing

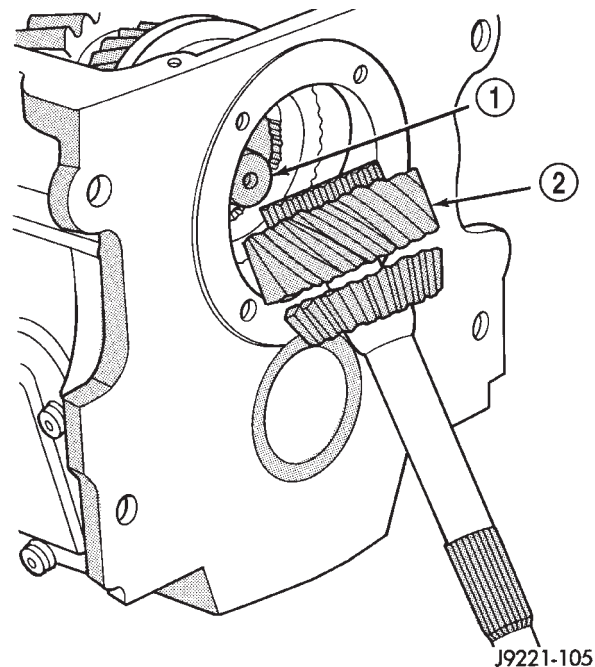
(4) Slide assembled puller flange and rod tools onto input shaft. Then seat flange in notch of puller jaw.

(5) Position second Puller Jaw 6447 on gear and in notch of puller flange.

(6) Slide Retaining Collar 6444-8 over puller jaws to hold them in place.

(7) Install Puller 6444 on puller rods then install retaining nuts.

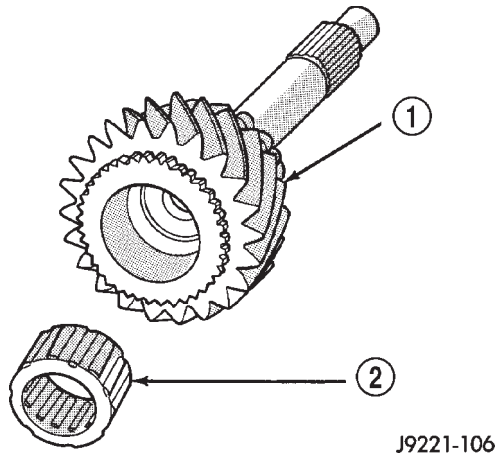
(8) Tighten puller bolt to remove bearing cone from drive gear.



J9221-105

**Fig. 24 Drive Gear**

- 1 - MAINSHAFT
- 2 - DRIVE GEAR

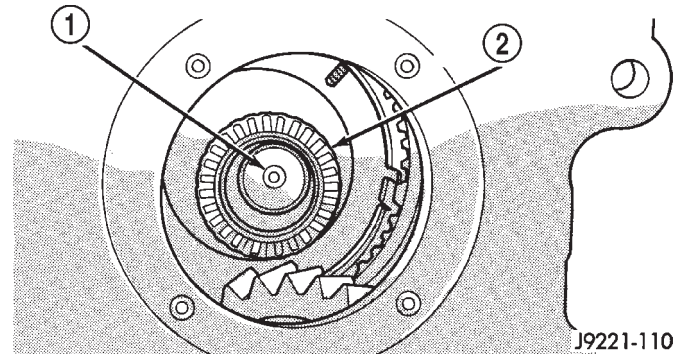


**Fig. 25 Pilot Bearing**

- 1 - DRIVE GEAR
- 2 - MAINSHAFT PILOT BEARING

**MAINSHAFT AND GEARTRAIN**

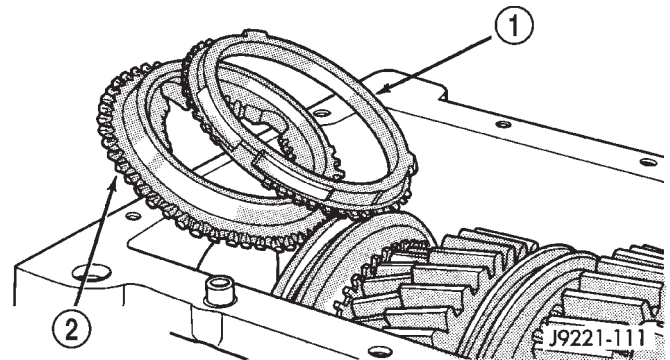
- (1) Move 1-2 and 3-4 synchro sleeves into neutral.
- (2) Remove drive gear thrust bearing from forward end of mainshaft (Fig. 27).



**Fig. 27 Drive Gear Thrust Bearing**

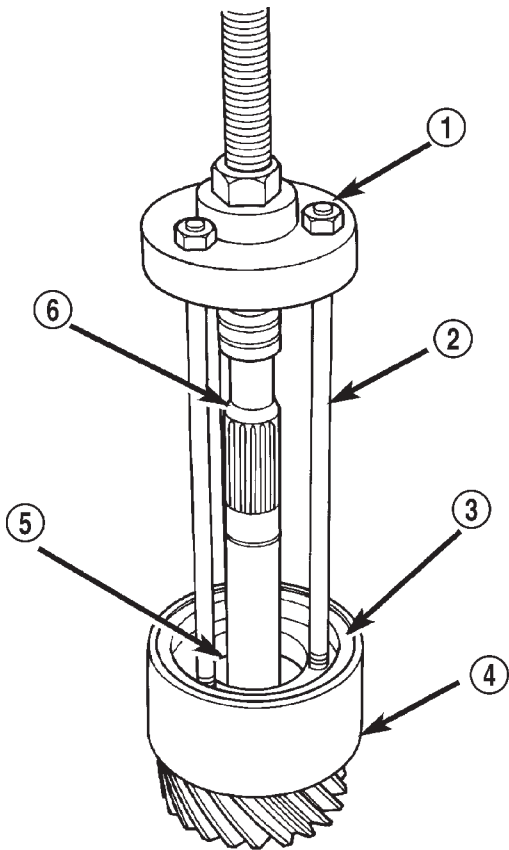
- 1 - MAINSHAFT
- 2 - DRIVE GEAR THRUST BEARING

- (3) Remove fourth gear clutch gear and synchro stop ring from mainshaft (Fig. 28).



**Fig. 28 Fourth Gear Clutch Gear Stop Ring**

- 1 - FOURTH GEAR SYNCHRO STOP RING
- 2 - FOURTH SPEED CLUTCH GEAR



**Fig. 26 Front Bearing Puller**

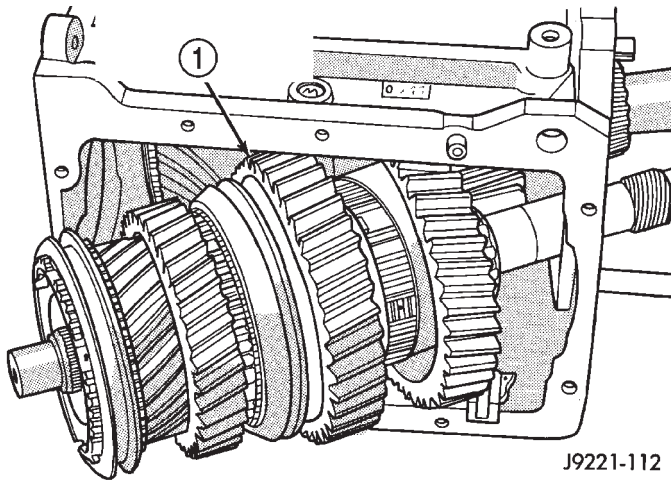
- 1 - PULLER 6444
- 2 - RODS 6444-6
- 3 - JAWS 6447
- 4 - COLLAR 6444-8
- 5 - FLANGE 6444-1
- 6 - DRIVE GEAR

- (4) Roll gear case onto left side (Fig. 29).
- (5) To remove mainshaft assembly (Fig. 29) lift front end of mainshaft slightly.

**NOTE: Handling mainshaft carefully because gears are loose on the mainshaft.**

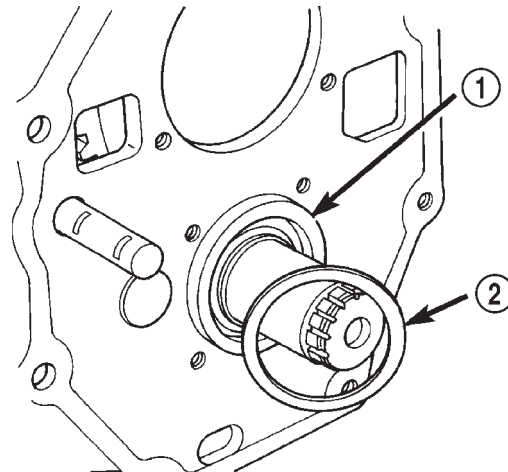
- (6) Grasp mainshaft rear splines, then turn spline end of mainshaft counterclockwise to rotate shaft and geartrain out of case. Tilt mainshaft outward and removed from case.

## MANUAL - NV4500 (Continued)



**Fig. 29 Mainshaft And Geartrain**

1 - MAINSHAFT AND CASE

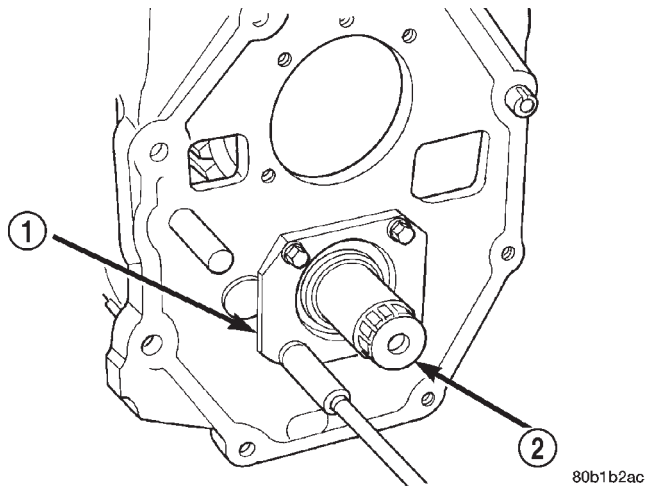


**Fig. 31 Countershaft End Play Shim And Rear Bearing Cup**

1 - COUNTERSHAFT REAR BEARING CUP  
2 - END PLAY SHIM

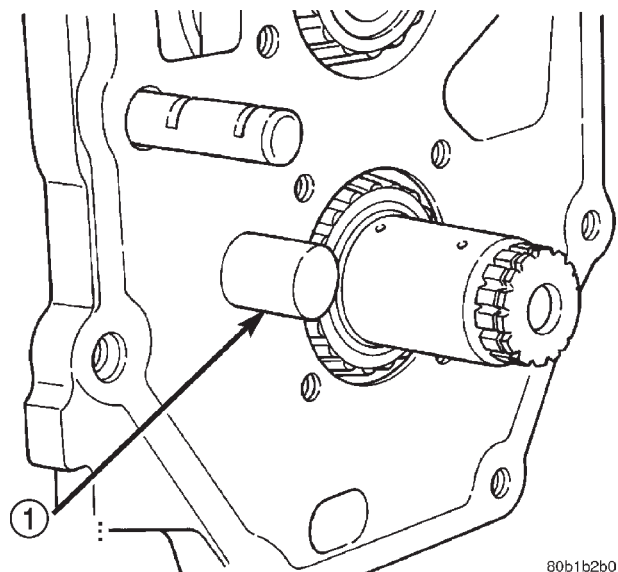
## REVERSE IDLER AND COUNTERSHAFT

(1) Remove countershaft rear bearing plate (Fig. 30).



**Fig. 30 Countershaft Rear Bearing Plate**

1 - REAR BEARING PLATE  
2 - COUNTERSHAFT



**Fig. 32 Reverse Idler Shaft**

1 - REVERSE IDLER SHAFT

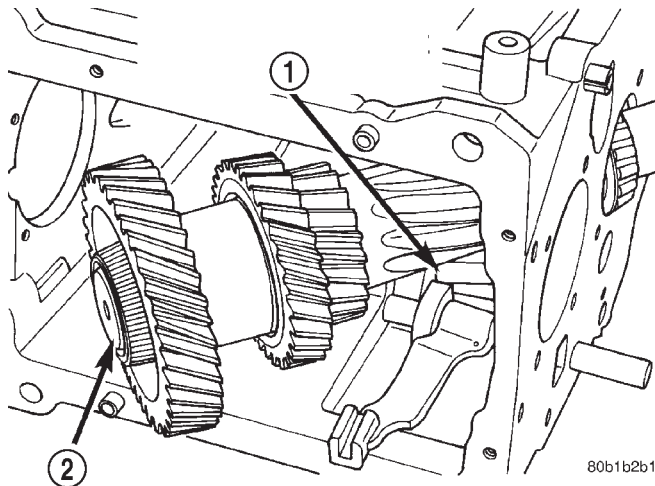
(2) Remove countershaft end play shim and rear bearing cup (Fig. 31).

(3) Remove reverse idler shaft (Fig. 32).

(4) Rotate countershaft outward and push reverse idler gear away from countershaft and toward front of case (Fig. 33).

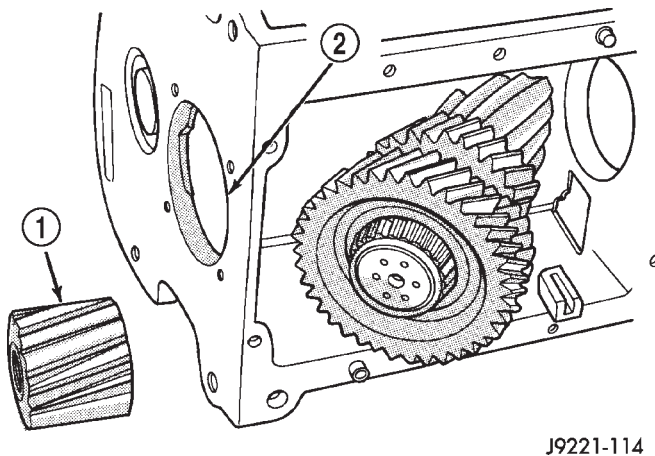
(5) Remove idler gear (Fig. 34).





**Fig. 33 Idler Gear Moved Away From Countershaft**

- 1 - REVERSE IDLER GEAR
- 2 - COUNTERSHAFT



**Fig. 34 Reverse Idler Gear**

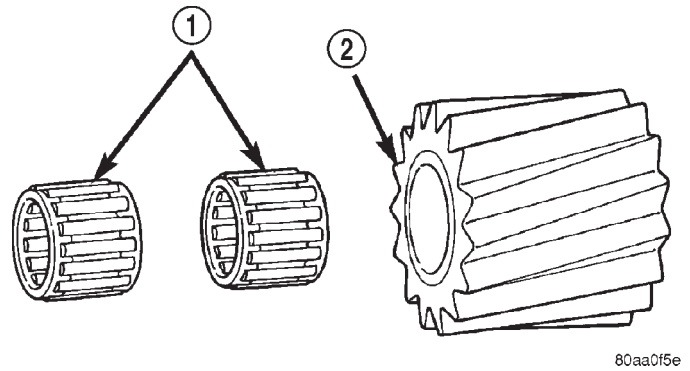
- 1 - REVERSE IDLER GEAR
- 2 - DRIVE GEAR BORE

(6) Keep reverse idler gear bearings and spacer together for cleaning and inspection (Fig. 35). Insert idler shaft through gear and bearings to keep them in place.

(7) Remove idler gear thrust washers from gear case. Install washers on idler shaft to keep them together for cleaning and inspection.

(8) To remove countershaft rear bearing, assemble Puller Flange 6444-1 and Puller Rods 6444-4 (Fig. 36).

**NOTE:** Shaft cannot be removed from case until rear bearing has been removed.



**Fig. 35 Idler Gear Components**

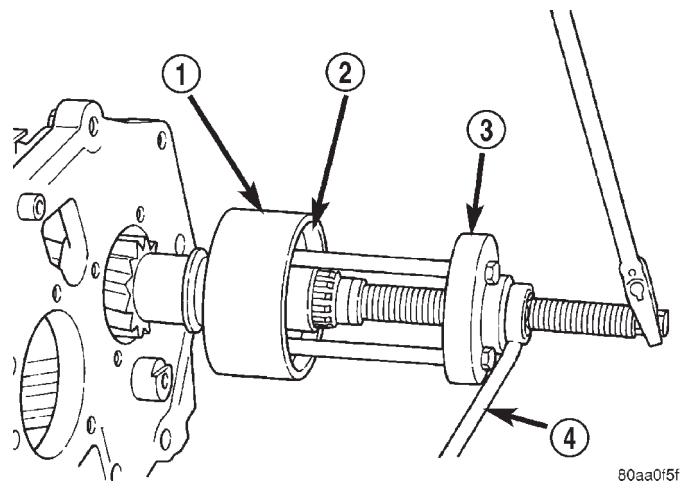
- 1 - BEARINGS
- 2 - REVERSE IDLER GEAR

- (9) Position first Puller Jaw 6449 on bearing cone
- (10) Seat puller flange in notch of puller jaw just installed on bearing cone
- (11) Install second Puller Jaw 6449 on bearing and in notch of puller flange
- (12) Slide Retaining Collar 6444-8 over puller jaws to hold them in place

**NOTE:** Retaining collar has small lip on one end and only fits one way over jaws.

(13) Install Puller 6444 on puller rods, then secure puller to rods with retaining nuts

(14) Tighten puller bolt to remove bearing from shaft. If bearing is exceptionally tight, tap end of puller bolt with copper mallet to help loosen bearing.

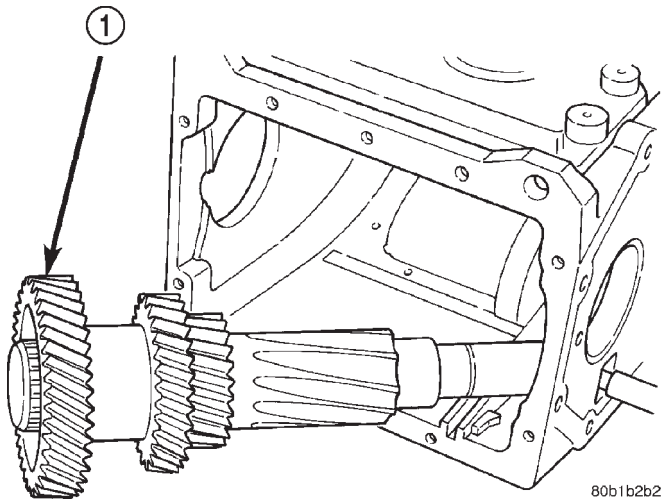


**Fig. 36 Countershaft Rear Bearing**

- 1 - COLLAR 6444-8
- 2 - JAWS 6449
- 3 - PULLER 6444
- 4 - WRENCH

## MANUAL - NV4500 (Continued)

(15) Remove bearing puller tools then rotate countershaft out of gear case (Fig. 37).



**Fig. 37 Countershaft And Case**

1 - COUNTERSHAFT

(16) To Remove countershaft front bearing, assemble Puller Flange 6444-1 and Puller Bolts 6444-4 (Fig. 38).

(17) Position first Puller Jaw 6451 on bearing.

(18) Seat puller flange in notch of puller jaw.

(19) Install second Puller Jaw 6451 on bearing and in notch of puller flange.

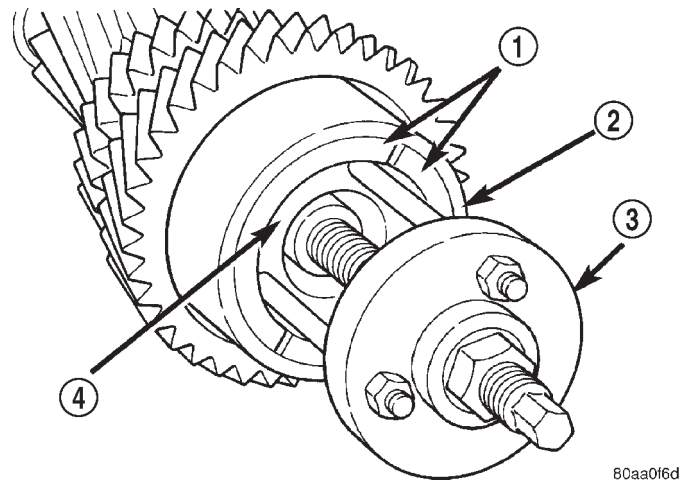
(20) Slide Retaining Collar 6444-8 over puller jaws to hold them in place

**NOTE:** Retaining collar has small lip on one end and only fits one way over jaws.

(21) Install puller bridge and bolt assembly 6444 on puller bolts and install retaining nuts

(22) Tighten puller bolt to remove bearing from shaft. If bearing is exceptionally tight, tap end of puller bolt with mallet to help loosen bearing.

(23) Remove bearing puller tools.

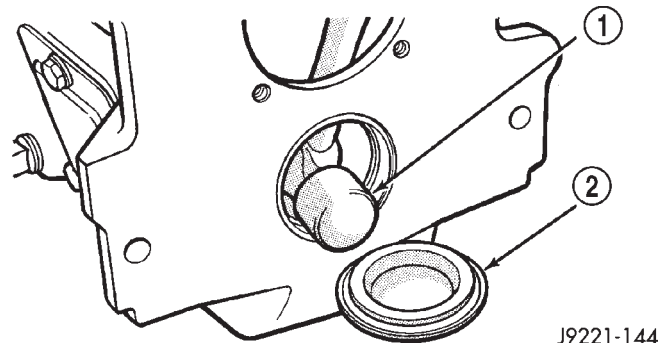


**Fig. 38 Countershaft Front Bearing**

1 - JAWS 6451  
2 - COLLAR 6444-8  
3 - PULLER 6444  
4 - FLANGE 6444-1

#### GEAR CASE

(1) Remove countershaft front bearing cap with mallet or hammer (Fig. 39).



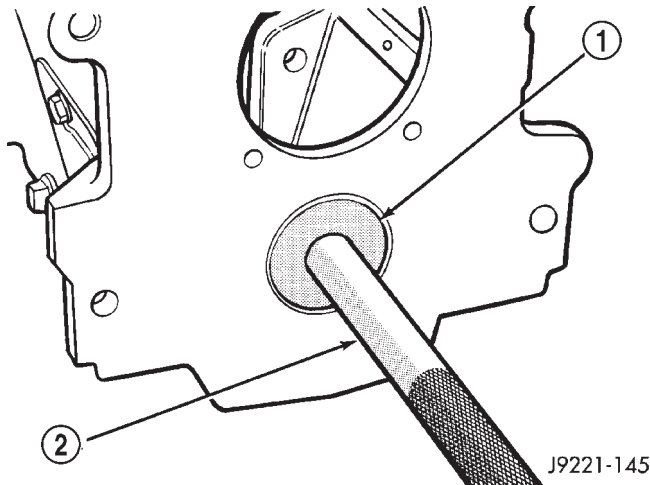
**Fig. 39 Countershaft Front Bearing Cap**

1 - HAMMER  
2 - BEARING CAP



MANUAL - NV4500 (Continued)

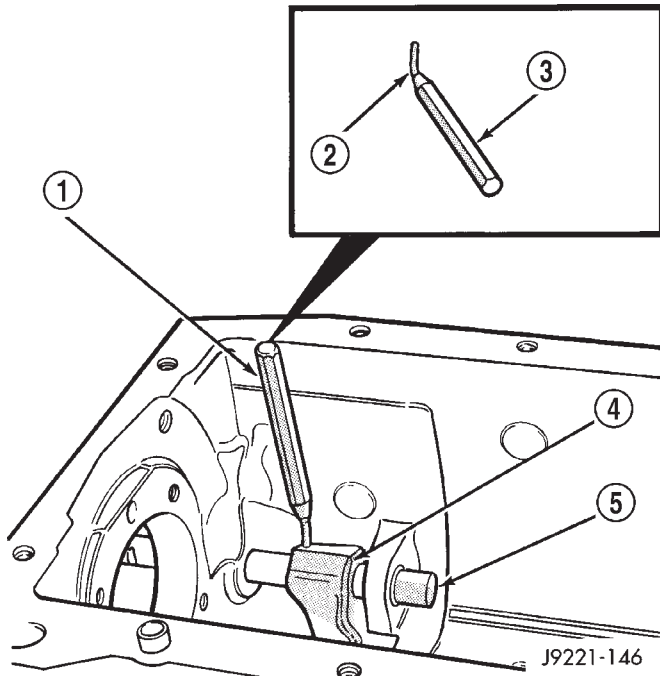
(2) Remove countershaft front bearing cup with Remover 6454 and Handle C-4171 (Fig. 40).



**Fig. 40 Countershaft Front Bearing Cup**

- 1 - REMOVER 6454
- 2 - HANDLE C-4171

(3) Remove roll pin that secures shift lug on shift rail in case (Fig. 41). A small pin punch can be modified by putting a slight bend in it to drive pin completely out of shift rail (Fig. 41).



**Fig. 41 Shift Lug Roll Pin**

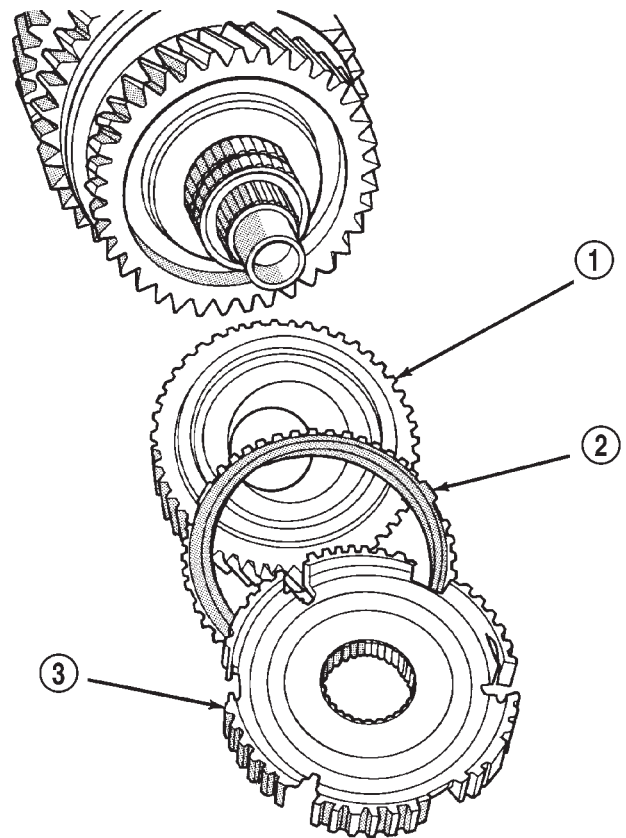
- 1 - PUNCH
- 2 - 30° BEND
- 3 - PIN PUNCH MODIFICATION
- 4 - SHIFT LUG
- 5 - SHIFT RAIL

(4) Remove shift lug rail.

**MAINSHAFT**

**NOTE:** Not all of the mainshaft gear and synchro components are a one-way fit. Some gear and synchro components can be installed backwards. Paint or scribe gear and synchro components for installation reference. Then stack geartrain parts in order of removal to avoid incorrect assembly.

(1) Remove drive gear thrust bearing from end of mainshaft, if not previously removed.  
 (2) Remove 3-4 synchro hub, third gear stop ring and third gear as an assembly (Fig. 42).

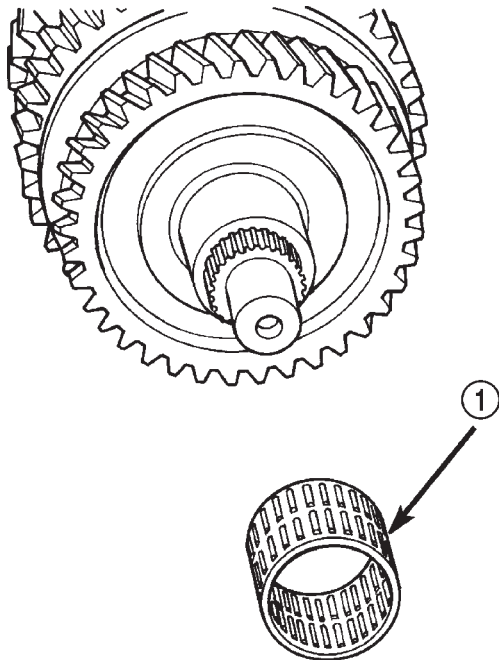


**Fig. 42 Third Gear, Stop Ring, And 3-4 Hub**

- 1 - THIRD GEAR
- 2 - THIRD GEAR STOP RING
- 3 - 3-4 SYNCHRO HUB

## MANUAL - NV4500 (Continued)

(3) Remove third gear bearing from mainshaft (Fig. 43).

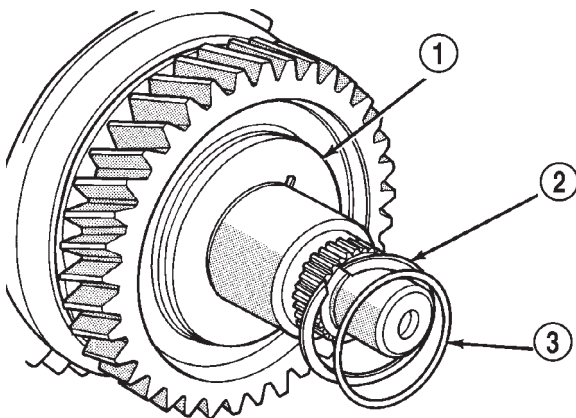


80aa016e

**Fig. 43 Third Gear Bearing**

1 - THIRD GEAR NEEDLE BEARING

(4) Remove third gear bearing spacer (Fig. 44).  
 (5) Remove second gear thrust washer snap ring from mainshaft (Fig. 44).



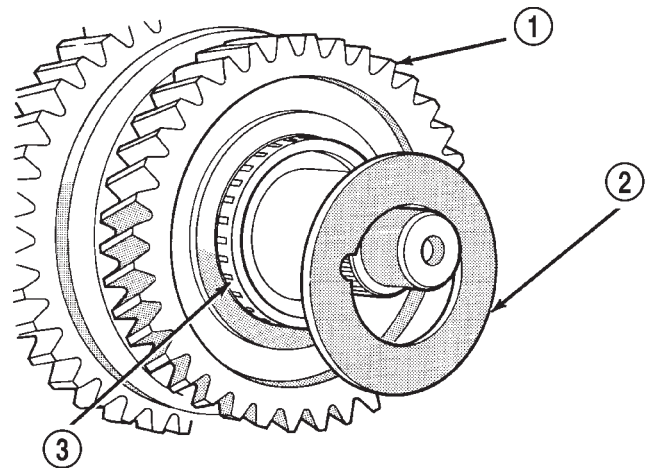
J9221-122

**Fig. 44 Snap Ring And Third Gear Bearing Spacer**

1 - SECOND GEAR THRUST WASHER  
 2 - THRUST WASHER SNAP RING  
 3 - THIRD GEAR BEARING SPACER

(6) Remove second gear thrust washer (Fig. 45). Note that washer is notched for locating pin.

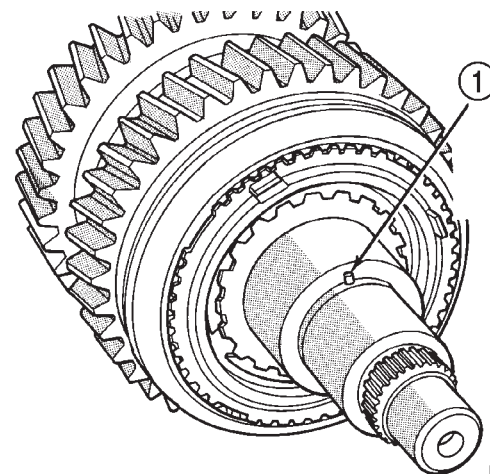
(7) Remove thrust washer locating pin (Fig. 46). Use needle nose pliers to remove pin.



J9221-123

**Fig. 45 Second Gear Thrust Washer**

1 - SECOND GEAR  
 2 - THRUST WASHER  
 3 - SECOND GEAR BEARING



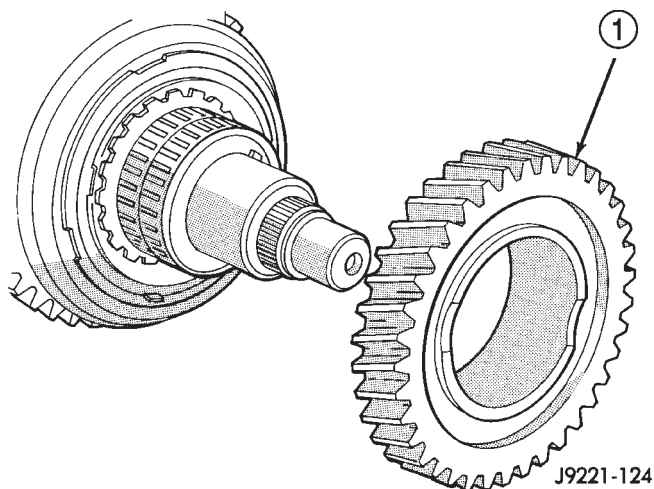
J9221-126

**Fig. 46 Thrust Washer Locating Pin**

1 - THRUST WASHER LOCATING PIN

MANUAL - NV4500 (Continued)

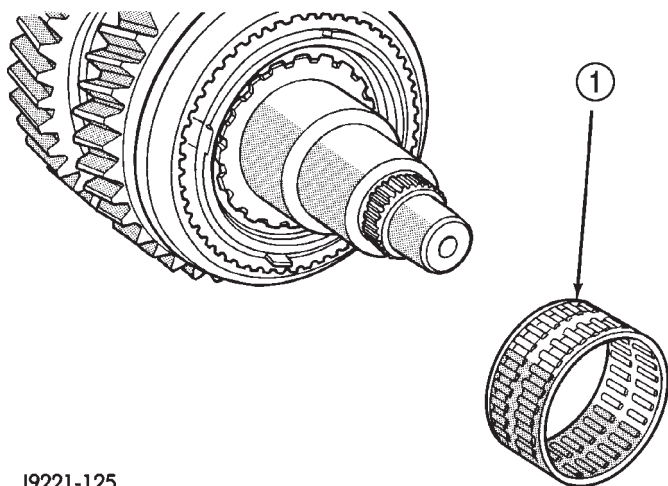
(8) Remove second gear (Fig. 47).



**Fig. 47 Second Gear**

1 - SECOND GEAR

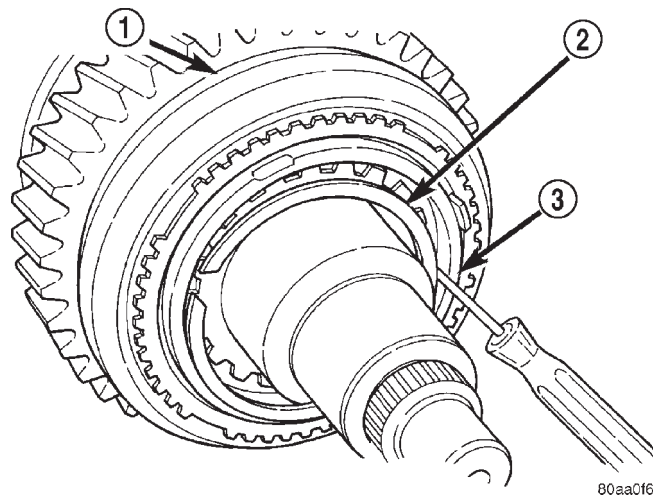
(9) Remove second gear bearing (Fig. 48).



**Fig. 48 Second Gear Bearing**

1 - SECOND GEAR NEEDLE BEARING

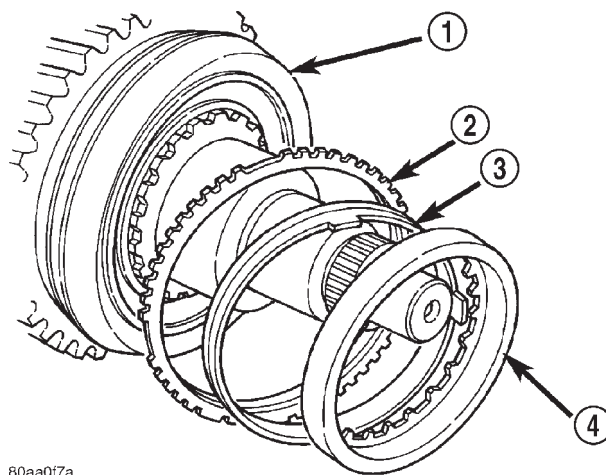
(10) Remove second gear clutch cone snap ring (Fig. 49). Snap ring is seated in mainshaft synchro hub groove.



**Fig. 49 Second Gear Clutch Cone Snap Ring**

1 - 1-2 SLEEVE  
2 - SNAP RING  
3 - SECOND GEAR CLUTCH CONE

(11) Remove second gear clutch cone, synchro clutch ring and synchro stop ring (Fig. 50).

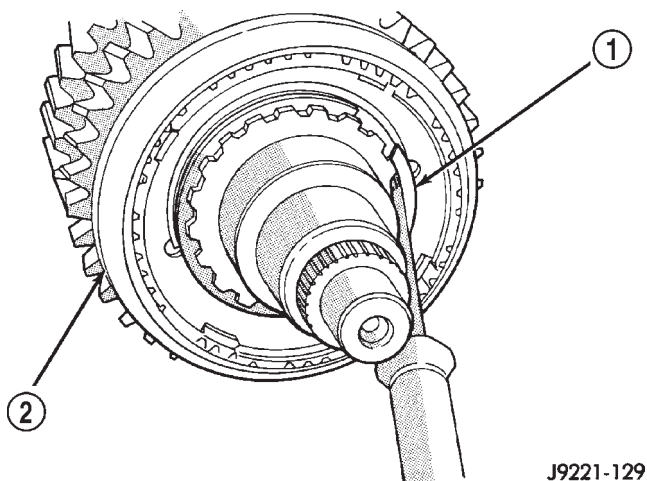


**Fig. 50 Second Gear Clutch Cone And Ring**

1 - 1-2 SLEEVE AND HUB  
2 - SYNCHRO STOP RING  
3 - CLUTCH RING  
4 - SECOND GEAR CLUTCH CONE

## MANUAL - NV4500 (Continued)

(12) Remove 1-2 synchro hub snap ring (Fig. 51).

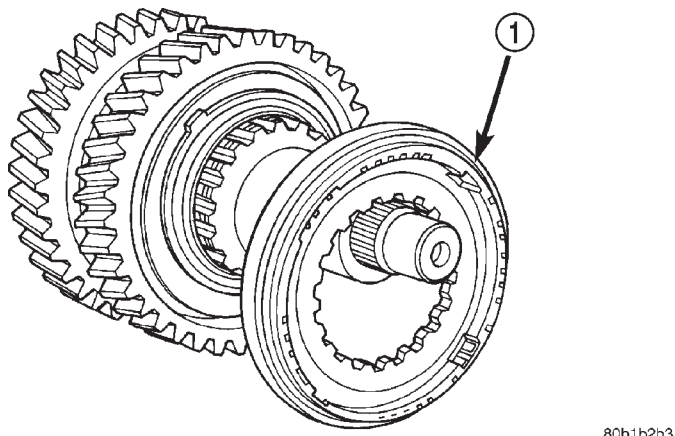


J9221-129

**Fig. 51 1-2 Sleeve And Hub Snap Ring**

- 1 - 1-2 HUB SNAP RING  
2 - 1-2 SLEEVE AND HUB

(13) Remove 1-2 synchro sleeve, hub, struts and springs as an assembly (Fig. 52). Note that tapered side of sleeve also goes toward front. Do not disassemble synchro components unless worn or damaged.

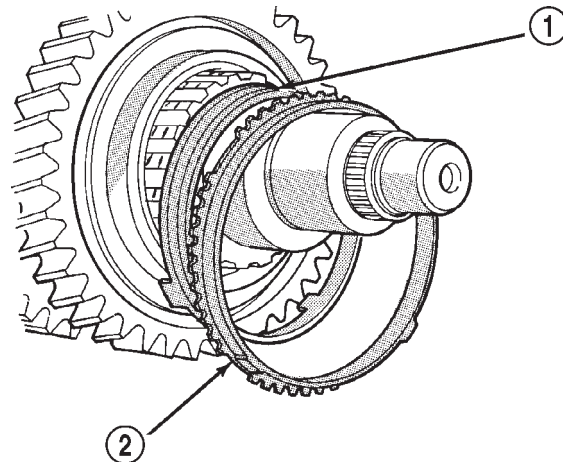


80b1b2b3

**Fig. 52 1-2 Synchro Sleeve And Hub**

- 1 - 1-2 SLEEVE AND HUB

(14) Remove first gear synchro stop ring and clutch ring (Fig. 53).

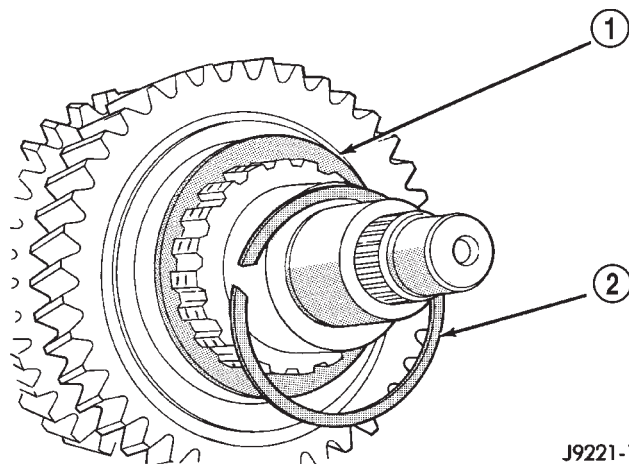


J9221-131

**Fig. 53 First Gear Stop And Clutch Ring**

- 1 - FIRST GEAR CLUTCH RING  
2 - FIRST GEAR STOP RING

(15) Remove first gear clutch cone front snap ring from mainshaft hub (Fig. 54).



J9221-132

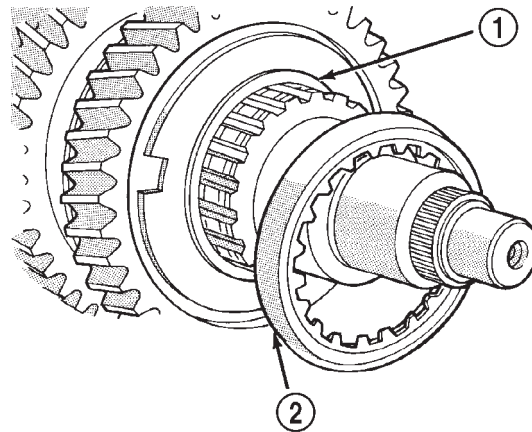
**Fig. 54 First Gear Clutch Gear Front Snap Ring**

- 1 - FIRST SPEED CLUTCH GEAR  
2 - CLUTCH GEAR SNAP RING (FRONT)



MANUAL - NV4500 (Continued)

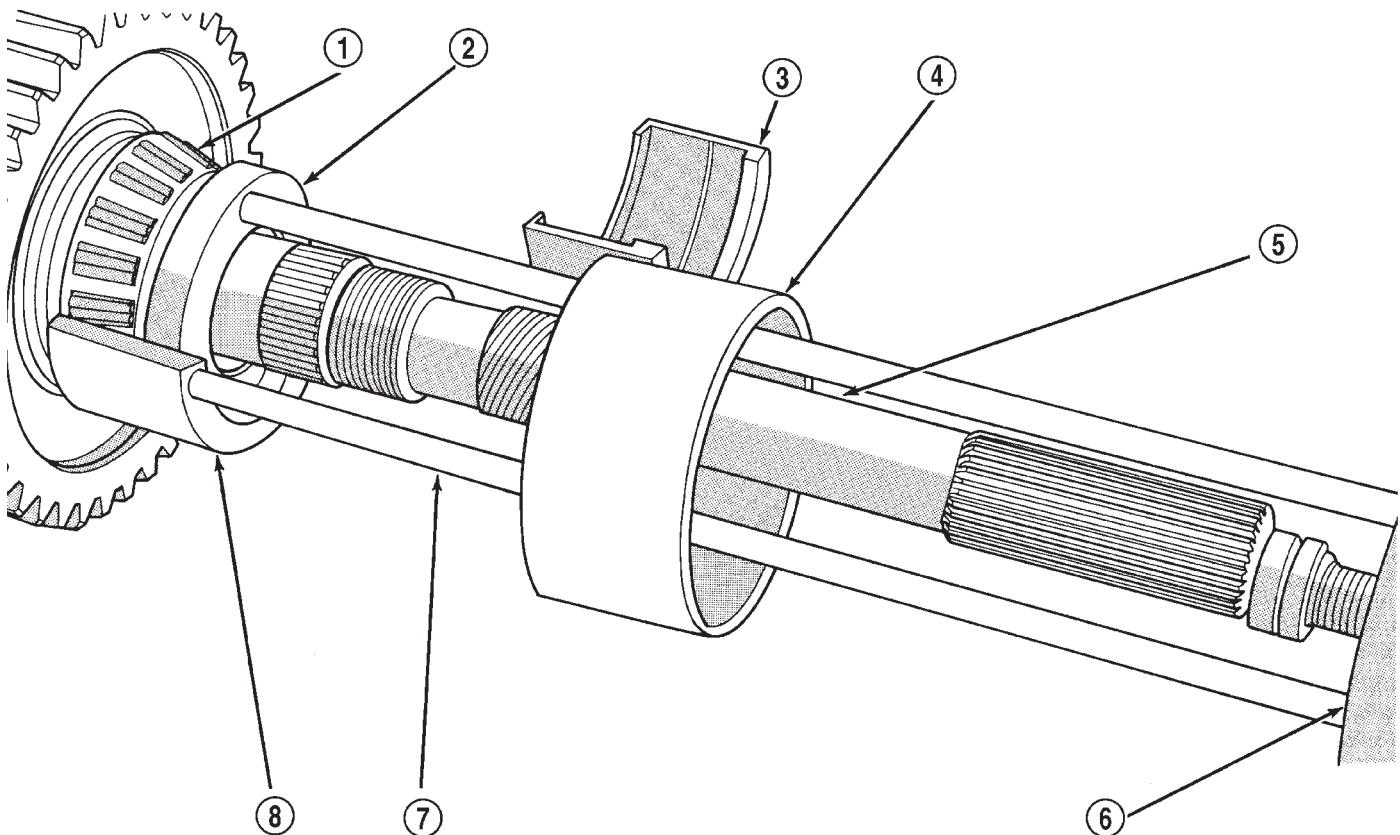
- (16) Remove first gear clutch cone (Fig. 55).
- (17) Remove first gear clutch gear rear snap ring from mainshaft hub (Fig. 55). Do not remove this snap ring unless mainshaft is to be replaced.
- (18) To remove mainshaft rear bearing, assemble Puller Flange 6444-1 and Puller Rods 6444-3 for 4X2 or 6444-4 for 4X4 (Fig. 56).
- (19) Position the first Puller Jaw 6445 on the bearing cone.
- (20) Seat Puller Flange 6444-1 in notch of first puller jaw.
- (21) Install the second Puller Jaw 6445 on the bearing cone and puller flange.
- (22) Install Puller 6444 on the puller rods and secure with nuts.
- (23) Hold hex portion of Puller 6444 a wrench (Fig. 57) and tighten screw.
- (24) Remove bearing puller tools and rear mainshaft bearing from output shaft.



J9221-133

**Fig. 55 First Gear Clutch Gear**

- 1 - CLUTCH GEAR SNAP RING (REAR)
- 2 - FIRST SPEED CLUTCH GEAR

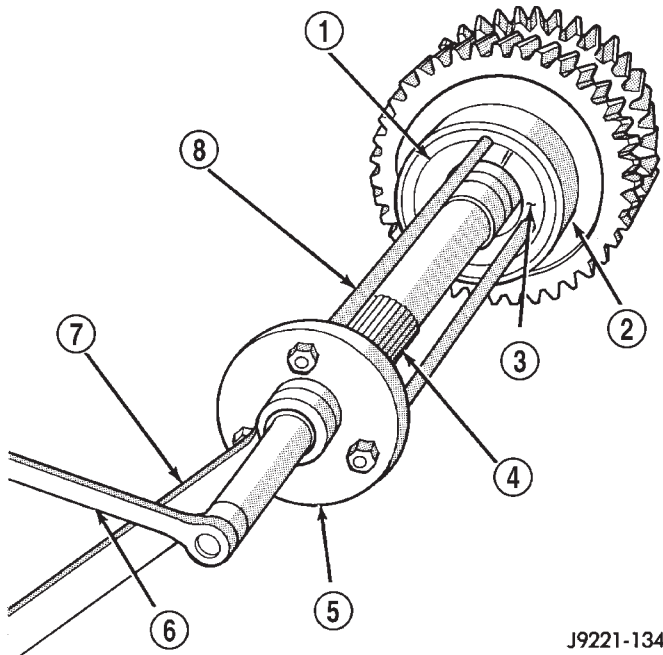


J9221-138

**Fig. 56 Mainshaft Rear Bearing Puller**

- |                   |                           |
|-------------------|---------------------------|
| 1 - REAR BEARING  | 5 - MAINSHAFT             |
| 2 - FLANGE 6444-1 | 6 - PULLER 6444           |
| 3 - JAW 6445      | 7 - RODS 6443-3 OR 6444-4 |
| 4 - COLLAR 6444-8 | 8 - JAW 6445              |

## MANUAL - NV4500 (Continued)

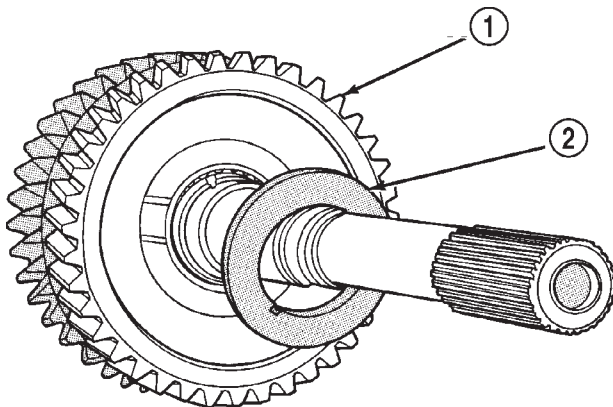


J9221-134

**Fig. 57 Mainshaft Rear Bearing**

- 1 - JAWS 6445
- 2 - COLLAR 6444-8
- 3 - FLANGE 6444-1
- 4 - MAINSHAFT
- 5 - PULLER 6444
- 6 - TIGHTENING WRENCH
- 7 - HOLDING WRENCH
- 8 - RODS 6444-3 OR 6444-4

(25) Remove reverse gear thrust washer (Fig. 58).



J9221-135

**Fig. 58 Reverse Gear Thrust Washer**

- 1 - REVERSE GEAR
- 2 - THRUST WASHER

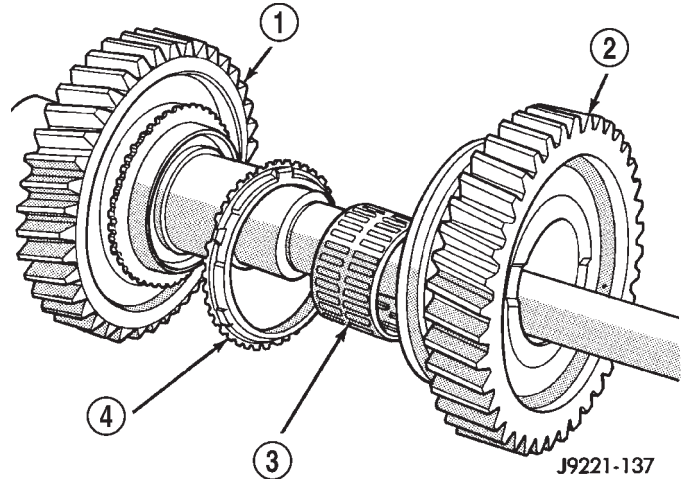
(26) Remove reverse gear and synchro components as assembly (Fig. 59). Do not disassemble synchro components unless they are damaged. If synchro sleeve or struts require service, mark position of

sleeve on hub before removal. Correct sleeve position is important as sleeve can be installed backwards causing shift problems.

(27) Remove reverse gear bearing assembly from mainshaft (Fig. 59).

(28) Remove reverse gear bearing spacer from mainshaft (Fig. 60).

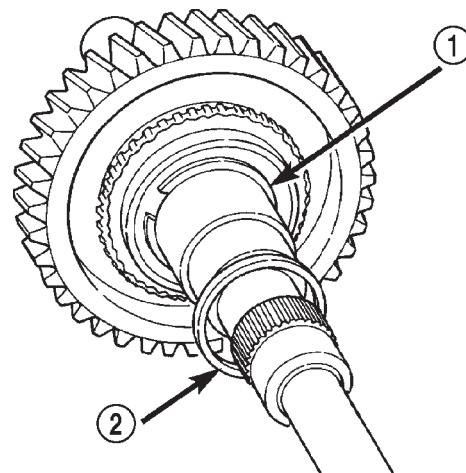
(29) Remove reverse clutch gear snap ring (Fig. 60). Tension of this snap ring is considerable. Heavy duty snap ring pliers will be required to spread the ring far enough to remove it.



J9221-137

**Fig. 59 Reverse Gear, Bearing, And Stop Ring**

- 1 - FIRST GEAR
- 2 - REVERSE GEAR ASSEMBLY
- 3 - BEARING ASSEMBLY
- 4 - STOP RING



80b1b2b4

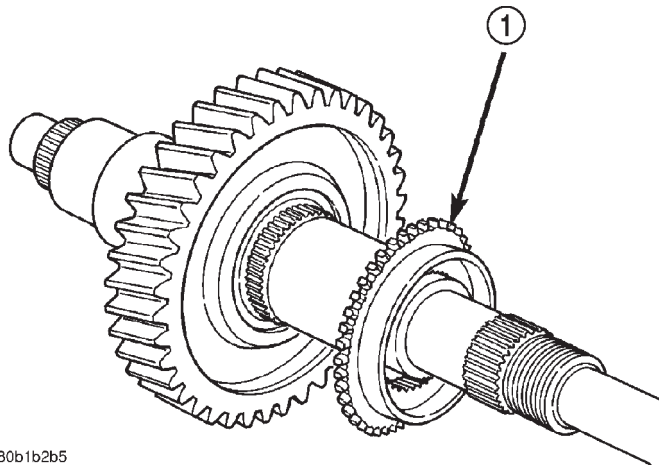
**Fig. 60 Reverse Gear Bearing Spacer And First Gear Snap Ring**

- 1 - CLUTCH GEAR SNAP RING
- 2 - REVERSE GEAR BEARING SPACER

(30) Remove reverse clutch gear (Fig. 61).



MANUAL - NV4500 (Continued)

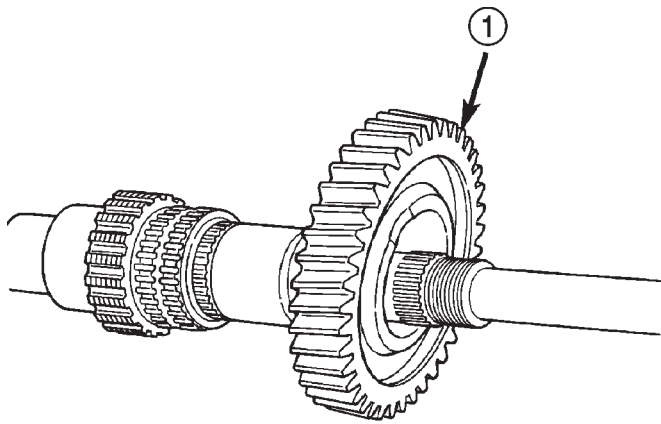


80b1b2b5

**Fig. 61 Reverse Clutch Gear**

1 - REVERSE CLUTCH GEAR

(31) Remove first gear from bearing and mainshaft (Fig. 62).

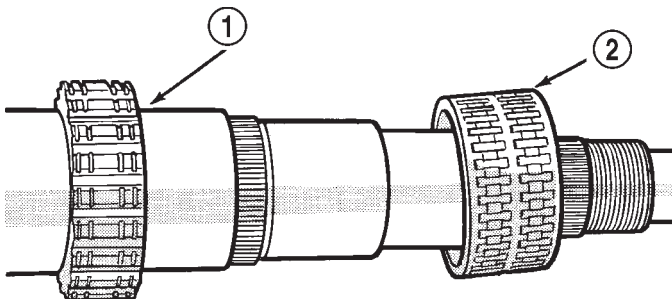


80b1b2b6

**Fig. 62 First Gear**

1 - FIRST GEAR

(32) Remove first gear bearing from mainshaft (Fig. 63).



J9221-153

**Fig. 63 First Gear Bearing**

1 - MAINSHAFT

2 - FIRST GEAR BEARING

## CLEANING

Clean the gears, shafts, shift components and transmission housings with a standard parts cleaning solvent. Do not use acid or corrosive base solvents. Dry all parts except bearings with compressed air.

Clean the shaft bearings with a mild solvent such as Mopar® degreasing solvent, Gunk, or similar solvents. Do not dry the bearings with compressed air. Allow the bearings to either air dry, or wipe them dry with clean shop towels.

## INSPECTION - TRANSMISSION

Inspect the reverse idler gear, bearings, shaft and thrust washers. Replace the bearings if the rollers are worn, chipped, cracked, flat-spotted or brinnelled. Or if the bearing cage is damaged or distorted. Replace the thrust washers if cracked, chipped or worn. Replace the gear if the teeth are chipped, cracked or worn thin.

Inspect the drive gear and bearings. Minor scratches and burrs on the gear surfaces can be reduced with an oil stone and 400 grit paper wetted with oil. Replace either bearing if worn, or damaged. Replace the gear if any teeth, splines, or bearing surfaces are also worn or damaged.

Inspect the front bearing retainer and bearing cup. Replace the bearing cup if scored, cracked, brinnelled or rough. Check the release bearing slide surface of the retainer carefully. Minor corrosion, nicks, or pitting can be smoothed with 400 grit emery and polished out with crocus cloth. Wet the abrasive paper and crocus cloth with oil when smoothing/polishing. Replace the retainer if worn or damaged in any way. Do not reuse original retainer bolts. Install new bolts during assembly.

Inspect the countershaft and bearings. Replace the bearings if worn, rough, flat spotted or heat checked. Check the countershaft gear teeth carefully. Small nicks, scratches or burrs can be removed with an oil stone and 400 grit paper wetted with oil. Replace the shaft if any of the teeth are worn, cracked, broken or severely chipped.

Be sure to check condition of the countershaft bearing cups. Replace either bearings cup if worn, or damaged.

Check condition of the mainshaft. Inspect all the bearing surfaces, splines and threads. Also check condition of the snap ring grooves in the hub area and the speedometer drive gear teeth. Minor scratches or burrs can be removed with an oil stone and polished with crocus cloth. However, replace the shaft if any surfaces exhibit considerable wear or damage.

Check condition of the gear case and extension or adapter housing. Be sure the alignment dowels in the

## MANUAL - NV4500 (Continued)

case top surface and in the housing/adaptor are tight and in good condition.

Run a tap through the gear case bolt holes if the threads need minor cleanup. Helicoil inserts can be used to repair seriously damaged threaded holes if necessary.

Be sure all case and housing/adaptor sealing and mating surfaces are free of burrs and nicks. This is especially important as gaskets are not used in the transmission. Minor nicks and scratches on the sealing surfaces can be dressed off with a fine tooth file or oil stone.

Replace the gear case or housing/adaptor if cracked or broken. Do not attempt to repair this type of damage by welding or brazing.

Check condition of the countershaft fifth gear components. This includes the shift lug and rail located in the gear case and the rail bushings.

Inspect the gear and hub assembly. Minor burrs can be cleaned up with an oil stone. However, the gear and hub assembly should be replaced if the teeth or splines are excessively worn, or damaged. The synchro sleeve should also be replaced if worn or damaged in any way. Do not reuse synchro struts that are worn or springs that are collapsed or severely distorted. Replace worn distorted synchro parts to avoid shift problems after assembly and installation.

The shift fork should be inspected for evidence of wear and distortion. Check fit of the sleeve in the fork to be sure the two parts fit and work smoothly. Replace the fork if the roll pin holes are worn over-size or damaged. Do not attempt to salvage a worn fork. It will cause shift problems later on. Replace shift fork roll pins if necessary or if doubt exists about their condition.

The bearings should be examined carefully for wear, roughness, flat spots, pitting or other damage. Replace the bearings if necessary.

Inspect the blocker ring and clutch gear. replace either part if worn or damaged in any way. Also be sure replacement parts fit properly before proceeding with assembly.

Examine the 1-2 synchro hub and sleeve for wear or damage. Replace sleeve and hub if the splines are worn, chipped or damaged.

Replace the synchro struts if worn, or chipped. Also replace the springs if collapsed, distorted or broken.

Inspect the mainshaft geartrain components. Check teeth on all gears, hubs, clutch gears, stop rings and clutch rings. The teeth must be in good condition and not worn, cracked or chipped. Replace any component that exhibits wear or damage.

Examine the synchro stop rings, clutch rings and clutch gears. Replace any part that exhibits wear,

distortion or damage. Replace the clutch rings if the friction material is burned, flaking off or worn.

Inspect all of the thrust washers and locating pins. Replace the pins if bent or worn. Replace the washers if worn or the locating pin notches are distorted.

Check condition of the synchro struts and springs. Replace these parts if worn, cracked or distorted.

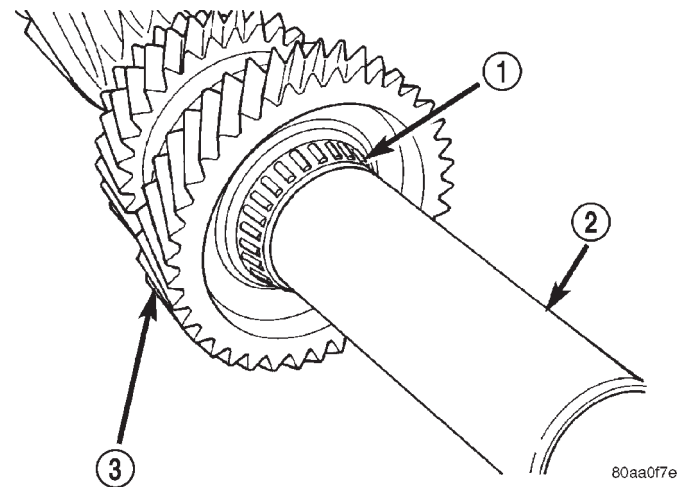
## ASSEMBLY

**NOTE: Gaskets are not used in the NV4500 transmission. Use Mopar® Silicone Sealer or equivalent on all gear case and extension housing sealing surfaces.**

## COUNTERSHAFT AND REVERSE IDLER GEAR

(1) Install countershaft front bearing cup in case with Handle C-4171 and Installer 6061-1.

(2) Install front bearing on countershaft with Installer C-4340 (Fig. 64).



**Fig. 64 Countershaft Front Bearing**

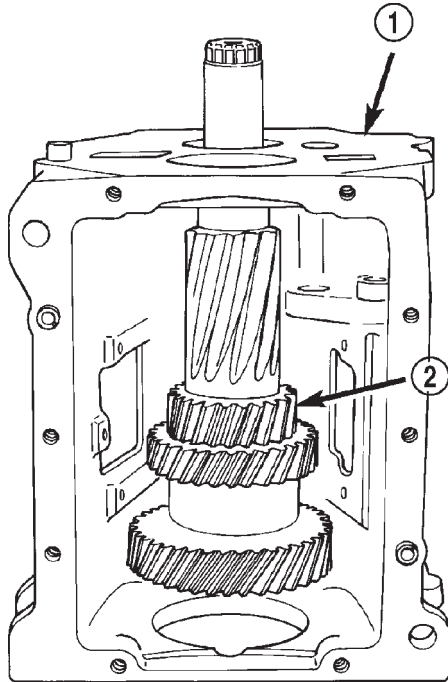
- 1 - FRONT BEARING
- 2 - INSTALLER C-4340
- 3 - COUNTERSHAFT

(3) Lubricate countershaft front bearing cup and cone with petroleum jelly.

(4) Position gear case on end with rear of case facing up (Fig. 65).

(5) Install countershaft in gear case (Fig. 65).

**NOTE: Do not install rear countershaft bearing on countershaft at this time.**



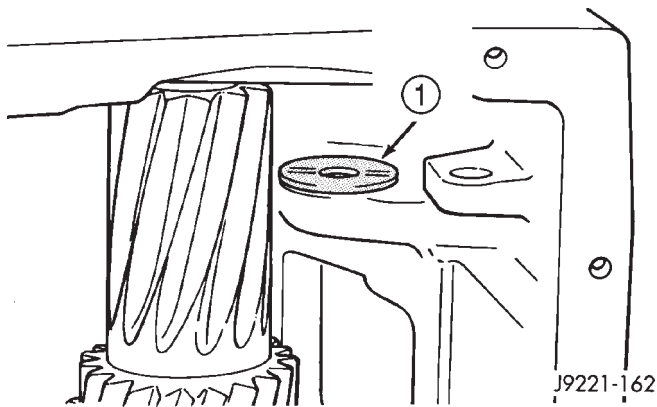
80b1b2b7

**Fig. 65 Countershaft In Gear Case**

- 1 - GEAR CASE
- 2 - COUNTERSHAFT

(6) Lubricate reverse idler gear bearings with petroleum jelly and install first bearing and second bearing (Fig. 66).

(7) Install idler gear front thrust washer on boss in gear case (Fig. 66). Coat thrust washer with liberal quantity of petroleum jelly to hold it in place.

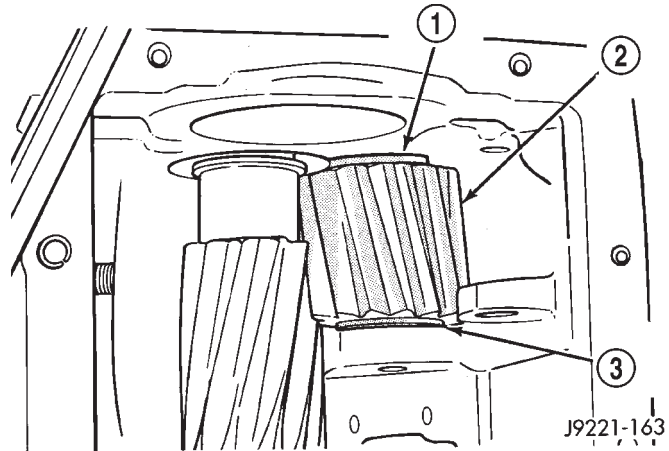


J9221-162

**Fig. 66 Idler Gear Front Thrust Washer**

- 1 - POSITION IDLER GEAR FRONT THRUST WASHER ON BOSS

- (8) Install reverse idler gear in case (Fig. 67).
- (9) Install idler gear rear thrust washer between idler gear and case boss (Fig. 67).



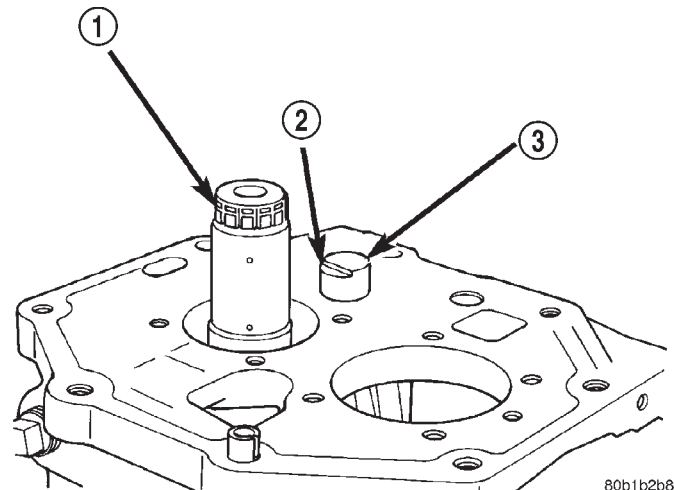
J9221-163

**Fig. 67 Idler Gear**

- 1 - REAR THRUST WASHER
- 2 - REVERSE IDLER GEAR
- 3 - FRONT THRUST WASHER

(10) Align idler gear bearings and thrust washers with a drift.

(11) Install reverse idler shaft with notched end of shaft facing countershaft (Fig. 68).



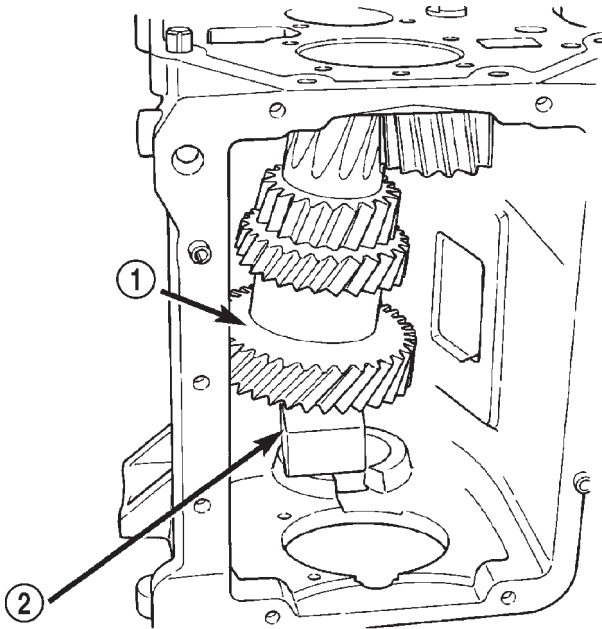
80b1b2b8

**Fig. 68 Reverse Idler Shaft**

- 1 - COUNTERSHAFT
- 2 - SHAFT NOTCH MUST FACE COUNTERSHAFT
- 3 - REVERSE IDLER SHAFT

## MANUAL - NV4500 (Continued)

(12) Lift countershaft upward and position wood block between front of shaft and case (Fig. 69).

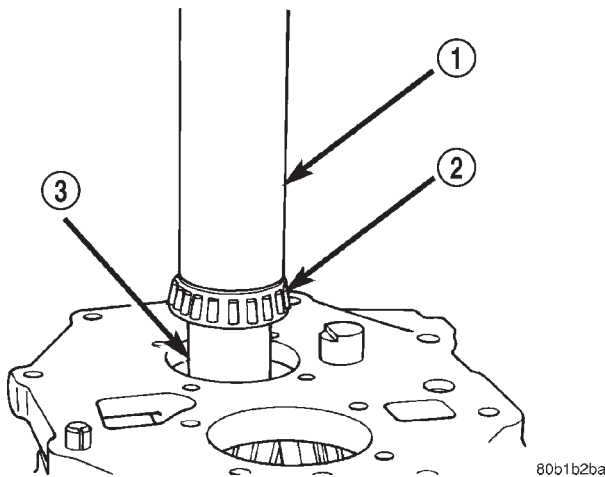


80b1b2b9

**Fig. 69 Supporting Countershaft With Wood Block**

- 1 - COUNTERSHAFT  
2 - WOOD BLOCK

(13) Install rear bearing cone on countershaft with Installer C-4040 (Fig. 70).



80b1b2ba

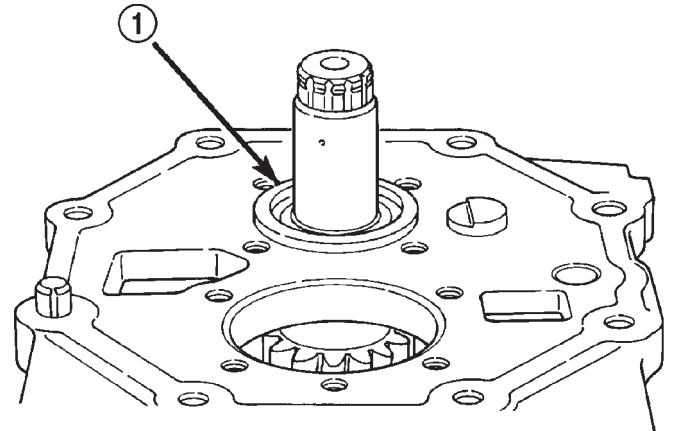
**Fig. 70 Countershaft Rear Bearing**

- 1 - INSTALLER C-4040  
2 - REAR BEARING  
3 - COUNTERSHAFT

(14) Remove wood block from under countershaft and lower countershaft front bearing into front bearing cup.

(15) Lubricate countershaft rear bearing cup and cone with petroleum jelly.

(16) Install countershaft rear bearing cup in gear case and over rear bearing (Fig. 71). Tap cup into place with plastic mallet if necessary.



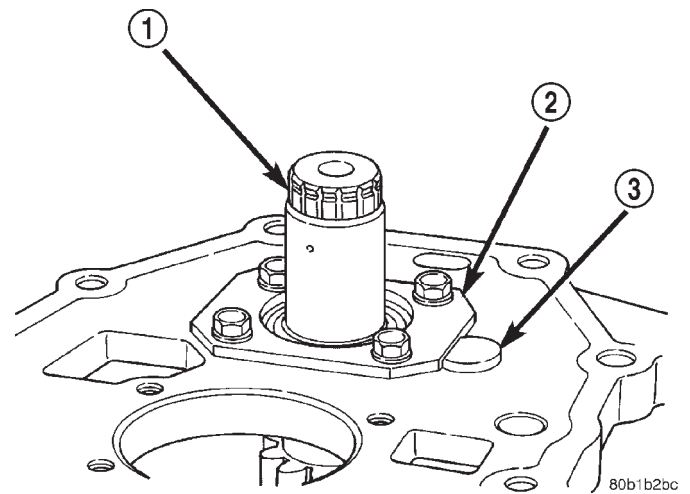
80b1b2bb

**Fig. 71 Countershaft Rear Bearing Cup**

- 1 - COUNTERSHAFT REAR BEARING CUP

(17) Install countershaft rear bearing plate (Fig. 72).

**NOTE:** Verify plate is seated in notch in reverse idler shaft before tightening bearing plate bolts.



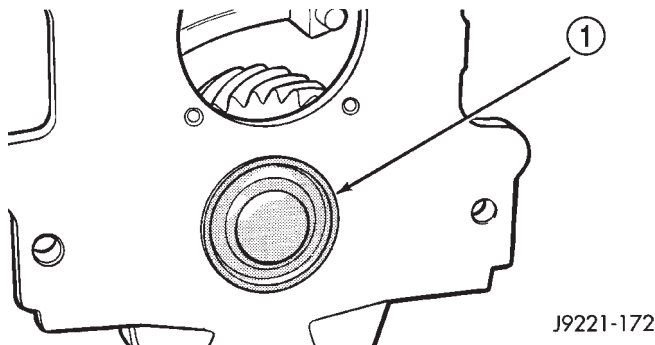
80b1b2bc

**Fig. 72 Countershaft Rear Bearing Plate**

- 1 - COUNTERSHAFT  
2 - REAR BEARING PLATE  
3 - IDLER SHAFT

## MANUAL - NV4500 (Continued)

(18) Apply Mopar® silicone adhesive/sealer to flange and lip of new cap. Install **new** front bearing cap in gear case (Fig. 73) with Handle C-4171 and Installer C-3972-A.

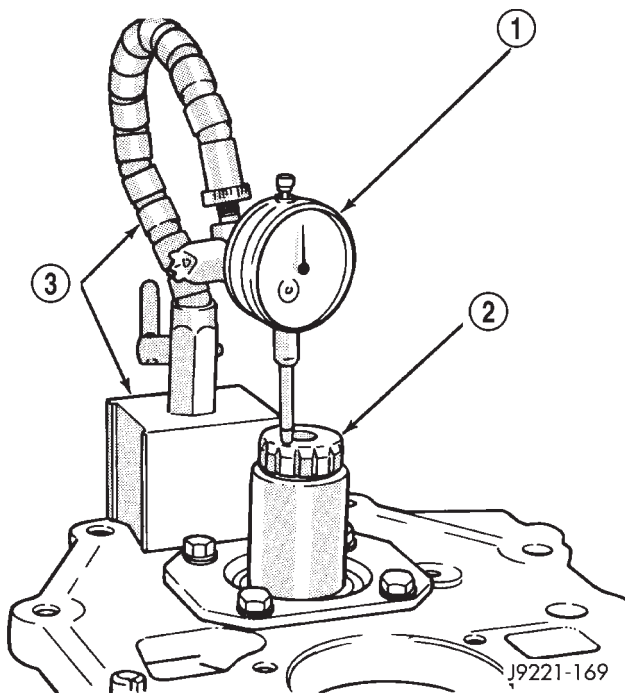


**Fig. 73 Countershaft Front Bearing Cap**

1 - FRONT BEARING CAP (SEAT WITH WOOD BLOCK)

## COUNTERSHAFT END PLAY

- (1) Rotate countershaft 4-5 times to seat bearings.
- (2) Mount dial indicator on case. Then position indicator plunger on end of countershaft and zero dial indicator (Fig. 74).
- (3) Raise countershaft with screwdriver and note end play reading on dial indicator. End play should be 0.051 - 0.15 mm (0.002 - 0.006 in.).

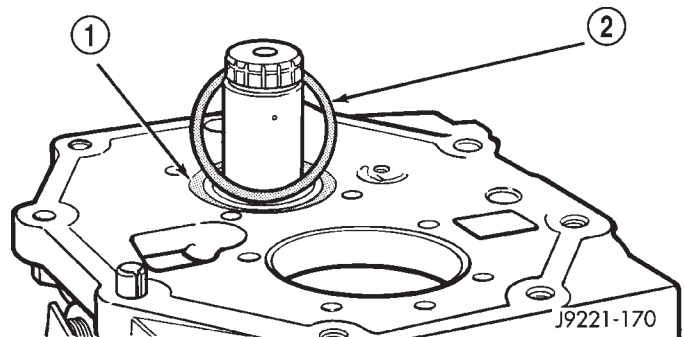


**Fig. 74 Measuring Countershaft End Play**

1 - DIAL INDICATOR  
2 - COUNTER SHAFT  
3 - INDICATOR MOUNTING ARM AND BASE

(4) Remove countershaft rear bearing plate.

(5) Install a end play shim that will provide minimum countershaft end play. Position shim on rear bearing cup (Fig. 75).



**Fig. 75 Countershaft End Play Shim**

1 - REAR BEARING CUP  
2 - END PLAY SHIM (SELECTIVE)

(6) Install countershaft rear bearing plate (Fig. 72).

**NOTE:** Verify plate is seated in reverse idler shaft notch and end play shims are still in position before installing bolts.

(7) Apply 1-2 drops Mopar® Loc N' Seal or equivalent to threads of rear bearing plate bolts. Then install and tighten bearing plate bolts to 23 N·m (200 in. lbs.).

## SHIFT LUG AND RAIL

- (1) Lubricate shift lug and rail with Castrol® Syntorq.
- (2) Insert shift lug rail part way into case.
- (3) Install shift lug on rail.
- (4) Position shift rail so roll pin notches are toward outside of case (Fig. 76).
- (5) Install roll pin that secures lug to rail (Fig. 76).

## MAINSHAFT AND GEARTRAIN

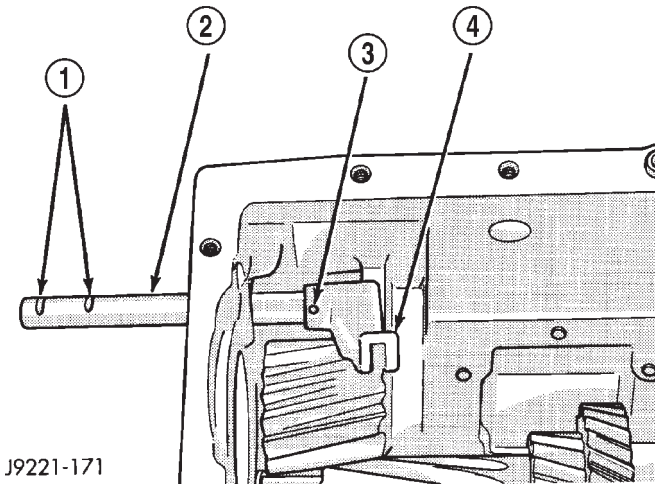
**CAUTION:** The reverse, 1-2 and 3-4 synchro components can be assembled and installed incorrectly. Follow assembly procedures for component identification and location.

Lubricate mainshaft bearing surfaces and all bearing assemblies with Castrol Syntorq or with petroleum jelly.

(1) Install first snap ring in rear most groove of mainshaft hub (Fig. 77). This snap ring locates first gear clutch gear on shaft.



## MANUAL - NV4500 (Continued)

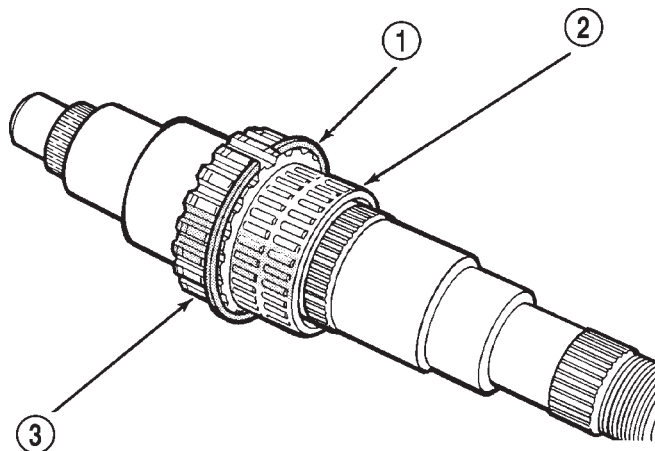


J9221-171

**Fig. 76 Shift Lug And Rail**

- 1 - NOTCHES (FOR 5TH GEAR SHIFT FORK ROLL PINS)
- 2 - LUG RAIL
- 3 - ROLL PIN HOLE
- 4 - SHIFT LUG

**NOTE:** Four of these snap rings are used to secure various components on the mainshaft 1-2 synchro hub. The snap rings are all the same size and are interchangeable.



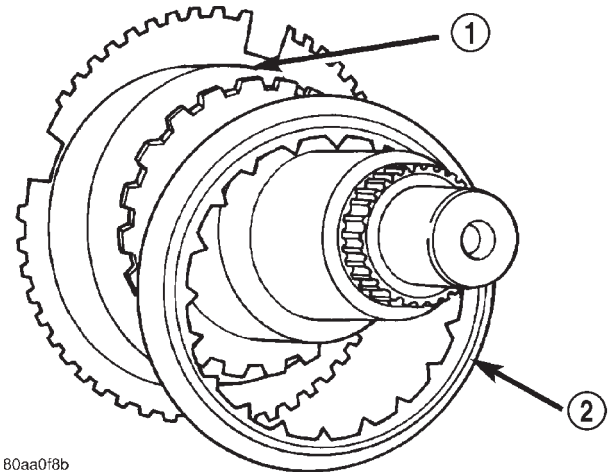
J9221-176

**Fig. 77 First Gear Bearing and Snap Ring**

- 1 - SNAP RING
- 2 - FIRST GEAR BEARING
- 3 - MAINSHAFT SYNCHRO HUB

(2) Install first gear clutch cone on mainshaft 1-2 synchro hub with recessed side of cone facing front (Fig. 78). Verify cone is seated against snap ring on hub.

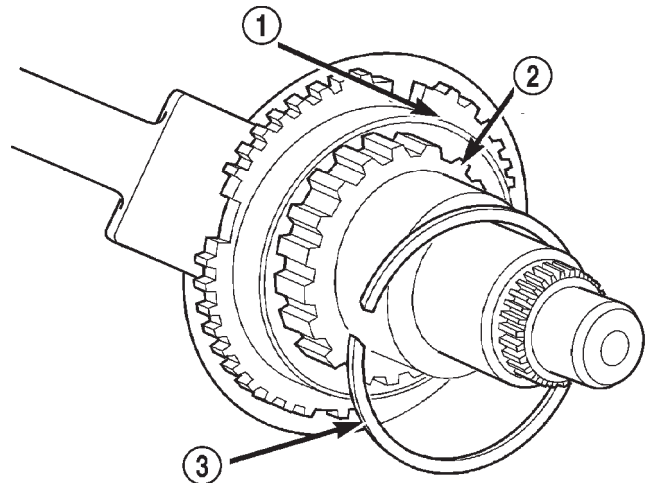
(3) Install snap ring on mainshaft 1-2 synchro hub to secure clutch cone (Fig. 79). Verify snap ring is seated in hub groove and against clutch cone.



80aa0f8b

**Fig. 78 First Gear Clutch Cone**

- 1 - MAINSHAFT 1-2 SYNCHRO HUB
- 2 - FIRST GEAR CLUTCH CONE



80aa0f8c

**Fig. 79 First Gear Clutch Cone Snap Ring**

- 1 - FIRST GEAR CLUTCH CONE
- 2 - MAINSHAFT 1-2 SYNCHRO HUB
- 3 - CLUTCH CONE SNAP RING

(4) Support mainshaft in upright position to install remaining gears, snap rings and synchro components. Shaft can be supported in gear case or hole can be cut in workbench to support shaft.

(5) If 1-2 synchro hub and sleeve were disassembled for service, reassemble hub, sleeve, struts and springs as follows:

(a) Align and install sleeve on hub. Rotate sleeve until it slides onto hub. Sleeve only fits one way and will easily slide onto hub when long slot in sleeve, aligns with long shoulder on hub (Fig. 80).

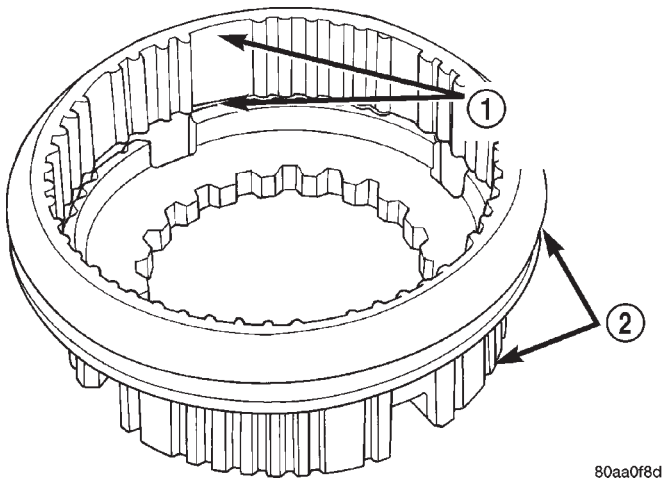
(b) Place wood blocks under hub that will raise hub about 3.5 cm (1.375 in.) above surface of workbench. Then allow sleeve to drop down on hub (Fig. 81).



MANUAL - NV4500 (Continued)

(c) Install springs and struts in hub (Fig. 81). Use lots of petroleum jelly to hold them in place. Then compress struts with your fingers and move sleeve upward until struts are started in sleeve. Verify that struts are engaged in sleeve before proceeding.

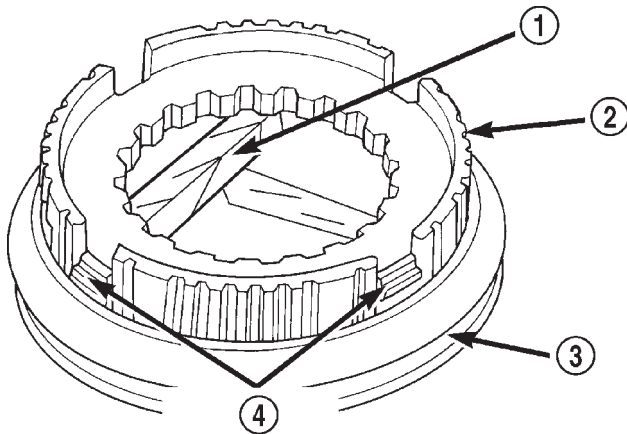
(d) Turn synchro assembly upright. Then move sleeve into neutral position on hub and work struts into sleeve at same time. Be sure struts are seated and springs are not displaced during assembly.



80aa0f8d

**Fig. 80 1-2 Synchro Sleeve On Hub**

- 1 - ALIGN WIDE SLOT IN SLEEVE WITH WIDE SPLINE OF HUB
- 2 - 1-2 SLEEVE AND HUB

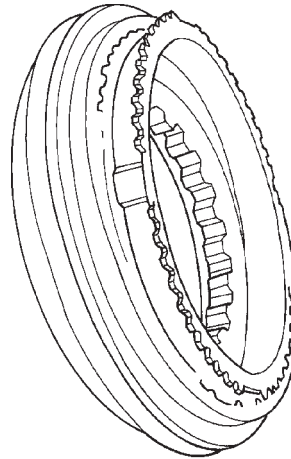


80aa0f8e

**Fig. 81 1-2 Synchro Struts And Springs**

- 1 - WOOD BLOCKS
- 2 - HUB
- 3 - SLEEVE
- 4 - STRUTS AND SPRINGS (4 EACH)

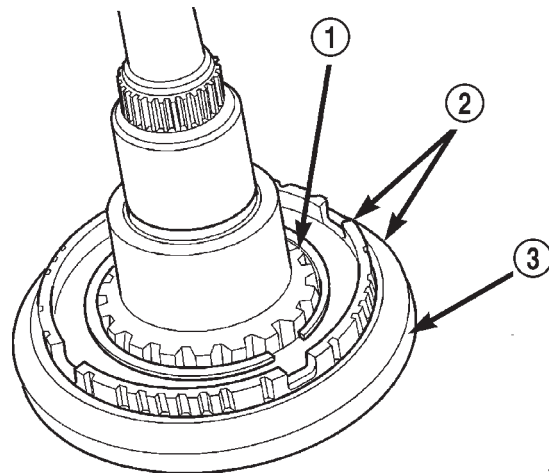
(6) Install first gear stop ring in 1-2 synchro hub and sleeve (Fig. 82). Verify stop ring is seated and engaged in hub and sleeve.



80aa0f8f

**Fig. 82 First Gear Stop Ring In Synchro Hub**

(7) Install 1-2 synchro assembly and stop ring on mainshaft with the taper on the sleeve facing forward. (Fig. 83).



80aa0f9a

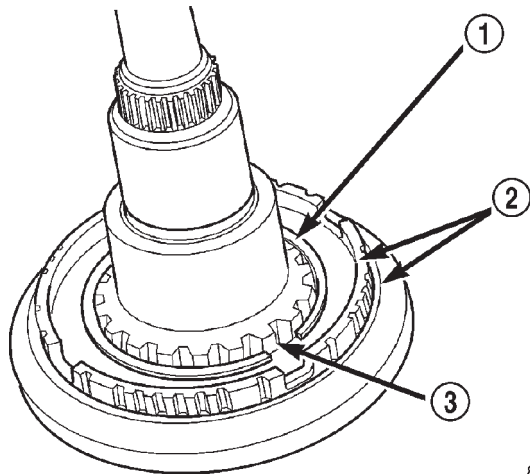
**Fig. 83 1-2 Synchro**

- 1 - MAINSHAFT HUB
- 2 - 1-2 SYNCHRO ASSEMBLY
- 3 - TAPERED SIDE OF SLEEVE

(8) Install snap ring that secures 1-2 synchro on mainshaft hub (Fig. 84). Verify snap ring is seated in groove in mainshaft hub.

(9) Assemble second gear clutch cone, clutch ring and stop ring (Fig. 85).

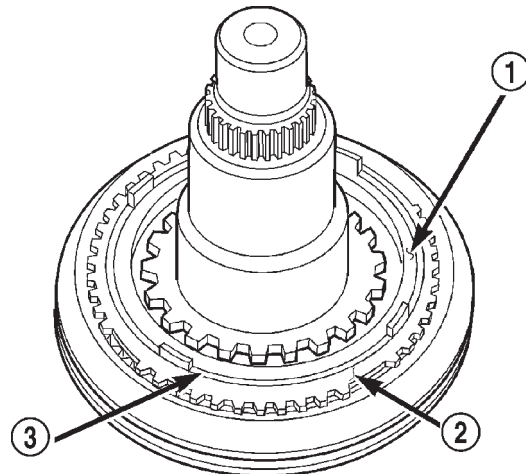
## MANUAL - NV4500 (Continued)



80aa0f9b

**Fig. 84 1-2 Synchro Snap Ring**

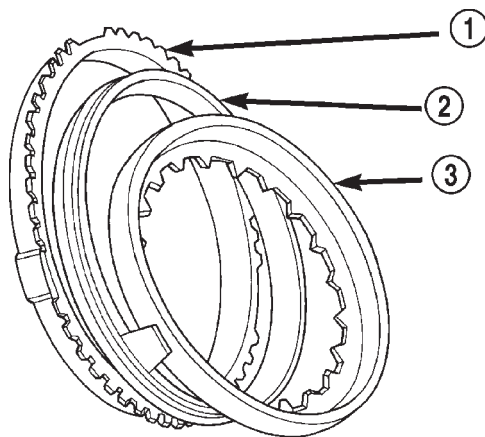
- 1 - SYNCHRO SNAP RING
- 2 - 1-2 SYNCHRO ASSEMBLY
- 3 - MAINSHAFT HUB



80aa0fbe

**Fig. 86 Second Gear Clutch Cone, Clutch Ring And Stop Ring**

- 1 - CLUTCH CONE
- 2 - STOP RING
- 3 - CLUTCH RING



80aa0f9c

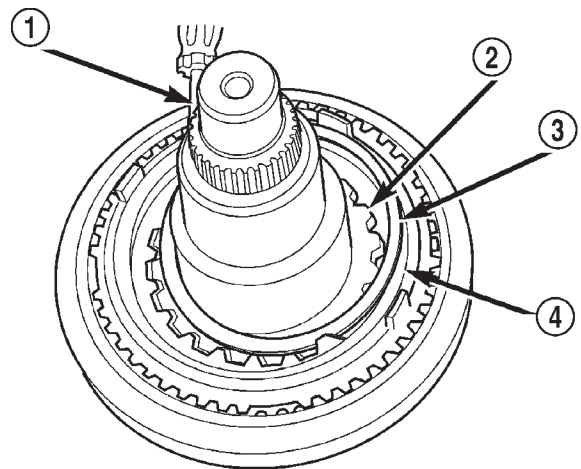
**Fig. 85 Second Gear Clutch Cone, Clutch Ring And Stop Ring**

- 1 - STOP RING
- 2 - CLUTCH RING
- 3 - CLUTCH CONE

(10) Install assembled second gear clutch cone and rings on mainshaft and in 1-2 synchro hub (Fig. 86).

(11) Install snap ring that secures second gear clutch cone on mainshaft (Fig. 87). Use narrow blade screwdriver to work snap ring into hub groove as shown. Verify snap ring is seated in mainshaft groove.

**NOTE:** If snap ring will not fit in groove, clutch cone is slightly misaligned.



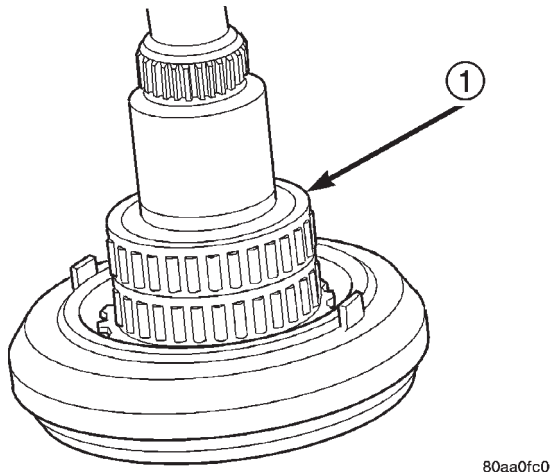
80aa0fbf

**Fig. 87 Second Gear Clutch Cone Snap Ring**

- 1 - SCREWDRIVER
- 2 - MAINSHAFT HUB
- 3 - SNAP RING
- 4 - SECOND GEAR CLUTCH CONE

## MANUAL - NV4500 (Continued)

(12) Install second gear bearing on mainshaft (Fig. 88).

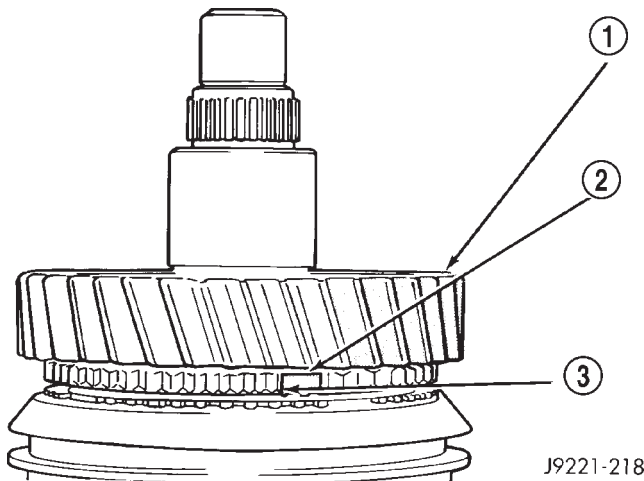


80aa0fc0

**Fig. 88 Second Gear Bearing**

1 - SECOND GEAR BEARING

(13) Install second gear on mainshaft and bearing. Rotate gear until tabs of second gear clutch ring are seated in tab slots in gear (Fig. 89).

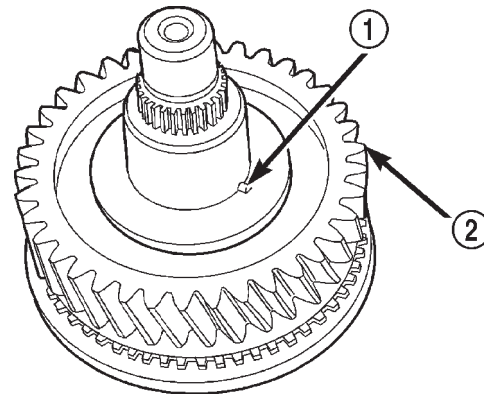


J9221-218

**Fig. 89 Second Gear**

1 - SECOND GEAR  
2 - CLUTCH RING TABS  
3 - TAB SLOTS (IN GEAR)

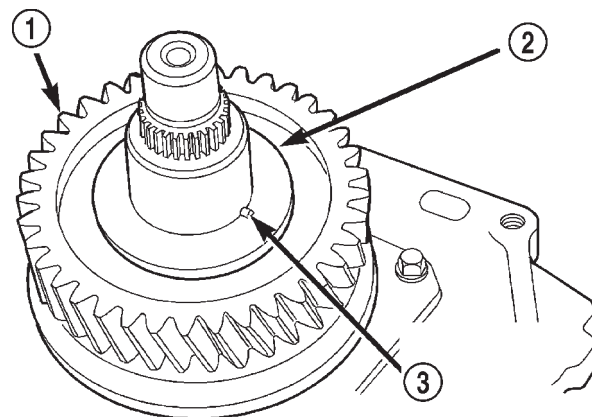
- (14) Install thrust washer pin in shaft (Fig. 90).  
 (15) Install second gear thrust washer. Verify washer is seated on gear and pin (Fig. 91).  
 (16) Install second gear thrust washer snap ring (Fig. 92). Verify snap ring is seated in mainshaft groove.  
 (17) Install third gear bearing spacer on shaft and seat it against thrust washer snap ring (Fig. 92).  
 (18) Install third gear bearing on mainshaft (Fig. 93). Bearing should be flush with mainshaft hub.



80aa0fc1

**Fig. 90 Thrust Washer Pin**

1 - THRUST WASHER PIN  
2 - SECOND GEAR



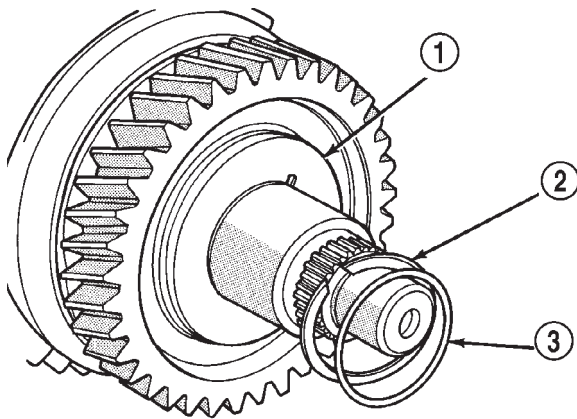
80aa0fc2

**Fig. 91 Second Gear Thrust Washer**

1 - SECOND GEAR  
2 - SECOND GEAR THRUST WASHER  
3 - LOCATING PIN IN WASHER NOTCH

**NOTE:** If bearing is not flush with hub, the bearing spacer or snap ring was not installed.

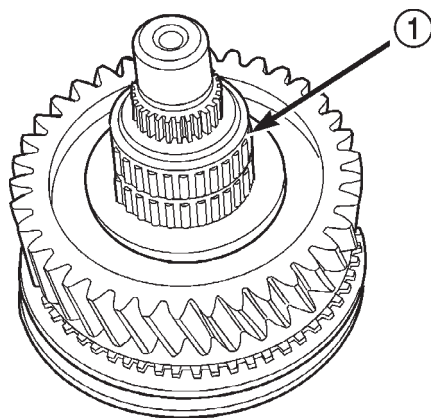
- (19) Install third gear over bearing and onto mainshaft (Fig. 94).  
 (20) Install synchro stop ring on third gear (Fig. 95). Verify stop ring is seated on cone taper.  
 (21) If 3-4 synchro was disassembled for service, reassemble synchro components as follows:  
 (a) Align and install synchro sleeve on hub (Fig. 96). **Front side of hub has a narrow groove machined in it.**  
 (b) Insert all three synchro struts in slots machined in sleeve and hub (Fig. 96).  
 (c) Install and seat synchro springs (Fig. 96). Use flat blade or Phillips screwdriver to compress springs and seat them in struts and hub as shown.



J9221-122

**Fig. 92 Snap Ring And Third**

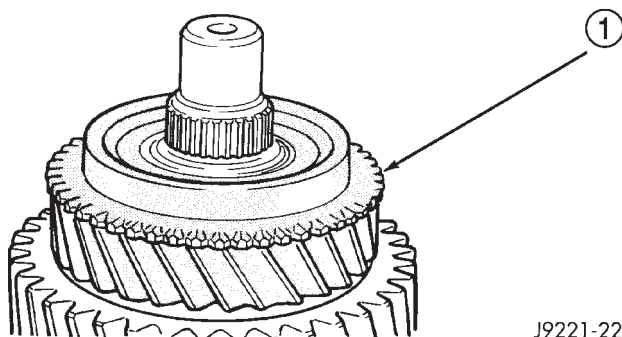
- 1 - SECOND GEAR THRUST WASHER
- 2 - THRUST WASHER SNAP RING
- 3 - THIRD GEAR BEARING SPACER



80aa0fc3

**Fig. 93 Third Gear Bearing**

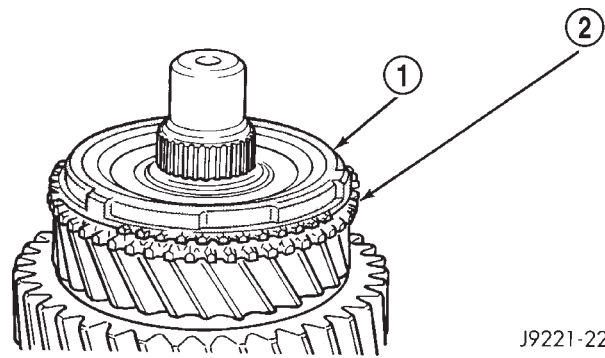
- 1 - THIRD GEAR BEARING



J9221-226

**Fig. 94 Third Gear**

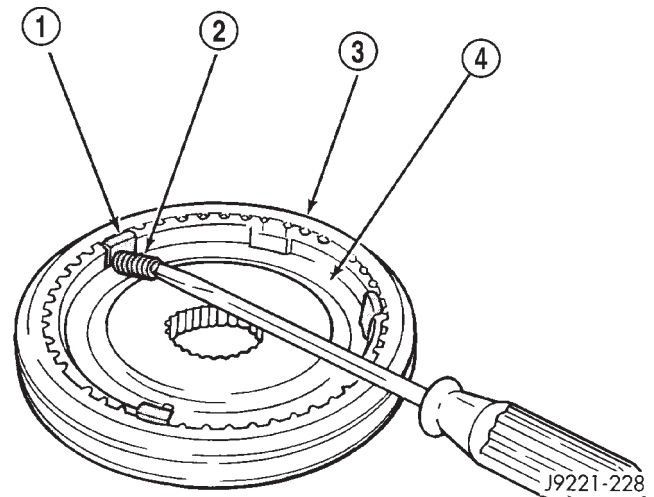
- 1 - THIRD GEAR



J9221-227

**Fig. 95 Third Gear Stop Ring**

- 1 - SYNCHRO STOP RING
- 2 - THIRD GEAR



J9221-228

**Fig. 96 Synchro Assembly (3-4)**

- 1 - STRUT (3)
- 2 - SPRING (3)
- 3 - 3-4 SLEEVE
- 4 - 3-4 HUB

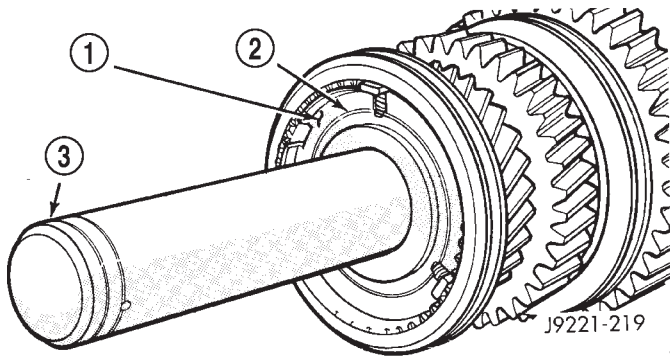
(22) Start 3-4 synchro assembly on mainshaft with the hub groove and sleeve groove both facing forward. Tap assembly onto shaft splines until hub is about 3 mm (0.125 in.) away from third gear stop ring. Then align stop ring with synchro sleeve and hub and seat synchro assembly with Installer C-4040 (Fig. 97).

(23) Verify 3-4 synchro hub is seated on shaft with approximately 3 mm (0.125 in.) of shaft spline visible.

**NOTE:** If hub is not seated, stop ring lugs are misaligned. Rotate ring until lugs are engaged in 3-4 hub slots.

(24) Verify that second and third gear rotate freely at this point. If not, determine the cause and correct.

(25) Invert mainshaft in case or bench.



**Fig. 97 Seating 3-4 Synchro Assembly On Mainshaft**

- 1 - 3-4 SYNCHRO HUB
- 2 - HUB GROOVE
- 3 - INSTALLER C-4040

(26) Install first gear bearing on mainshaft.

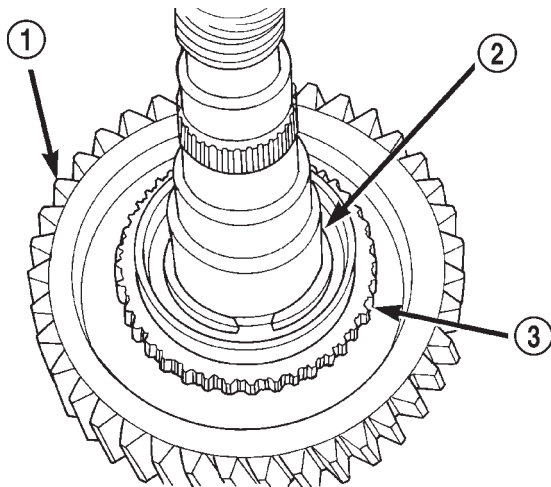
(27) Install first gear on shaft with clutch hub side of gear facing the front of shaft (Fig. 98). Verify tabs on clutch ring are aligned and seated in first gear hub.

**NOTE:** 1-2 synchro hub will not seat properly if clutch ring tabs are misaligned.

(28) Install reverse clutch gear on first gear (Fig. 98). Verify clutch gear is seated on shaft splines.

(29) Install reverse clutch gear snap ring with heavy duty snap ring pliers (Fig. 98). Verify snap ring is seated in groove.

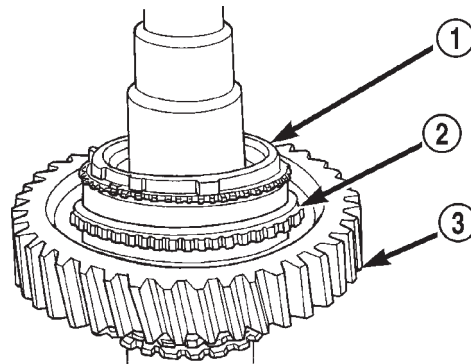
**NOTE:** Reverse gear will not fit properly if snap ring is not seated.



**Fig. 98 First Gear And Clutch Gear**

- 1 - FIRST GEAR
- 2 - REVERSE CLUTCH GEAR SNAP RING
- 3 - REVERSE CLUTCH GEAR

(30) Install stop ring on clutch cone (Fig. 99). Verify stop ring is seated on cone taper.

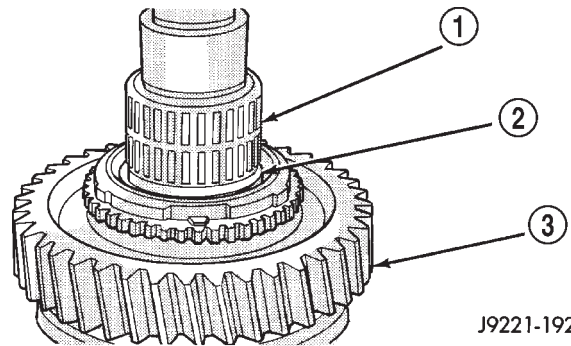


**Fig. 99 Clutch Gear Stop Ring**

- 1 - REVERSE GEAR STOP RING
- 2 - CLUTCH GEAR
- 3 - FIRST GEAR

(31) Install reverse gear bearing spacer on mainshaft and seat against reverse clutch gear snap ring (Fig. 100).

(32) Install reverse gear bearing on mainshaft (Fig. 100).



**Fig. 100 Reverse Gear Bearing And Spacer**

- 1 - REVERSE GEAR BEARING
- 2 - BEARING SPACER
- 3 - FIRST GEAR

(33) If reverse gear sleeve and struts were disassembled for service, reassemble sleeve, struts and springs as follows:

**CAUTION:** The reverse sleeve will fit either way on the hub. Verify tapered side of the sleeve faces rearward.

(a) Position sleeve on hub so tapered side of sleeve faces rearward. (Fig. 101).

(b) Rotate sleeve to align teeth on sleeve and hub. Sleeve will slide easily into place on hub when properly aligned.



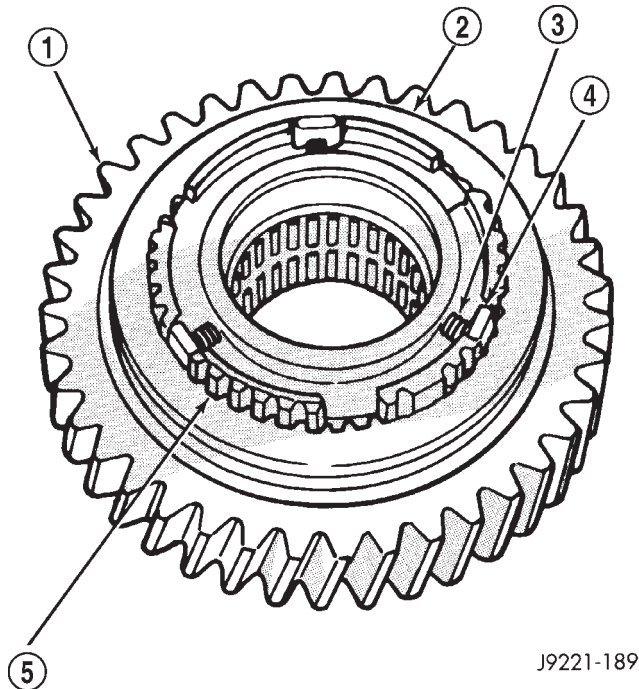
## MANUAL - NV4500 (Continued)

(c) Install springs in gear hub (Fig. 101). Use petroleum jelly to hold springs in place if desired.

(d) Compress first spring with flat blade screwdriver and slide strut into position in hub slot. Then work spring into seat in strut with small hooked tool or screwdriver.

(e) Install second and third struts in same manner as described in step (d).

(f) Work sleeve upward on hub until struts are centered and seated in sleeve. Sleeve should be in neutral position after seating struts.



J9221-189

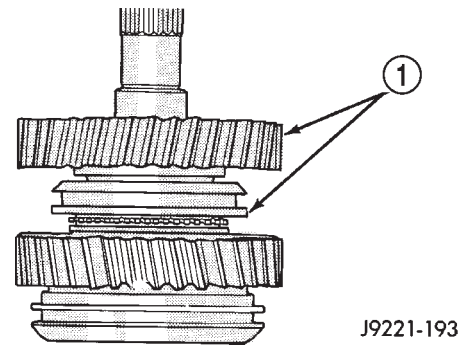
**Fig. 101 Reverse Gear Synchro Assembly**

- 1 - REVERSE GEAR
- 2 - SLEEVE
- 3 - SPRING (3)
- 4 - STRUT (3)
- 5 - HUB

(34) Install reverse gear and synchro assembly on mainshaft (Fig. 102). Rotate assembly until stop ring lugs engage in hub slots and gear drops into seated position.

(35) Install reverse gear thrust washer (Fig. 103).

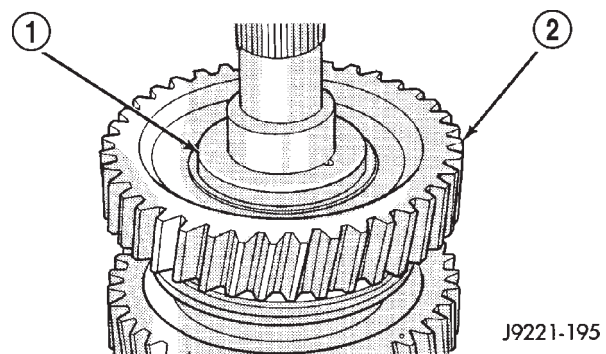
(36) Install rear bearing on mainshaft with Installer 6446. Seat bearing on output shaft and against thrust washer (Fig. 104).



J9221-193

**Fig. 102 Reverse Gear**

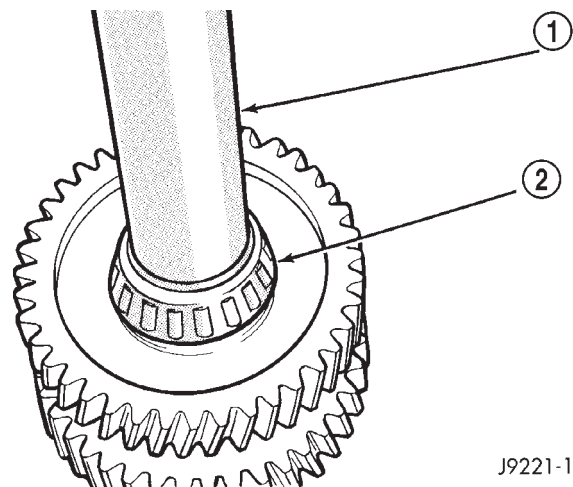
- 1 - REVERSE GEAR AND SYNCHRO ASSEMBLY



J9221-195

**Fig. 103 Reverse Gear Thrust Washer**

- 1 - THRUST WASHER
- 2 - REVERSE GEAR



J9221-175

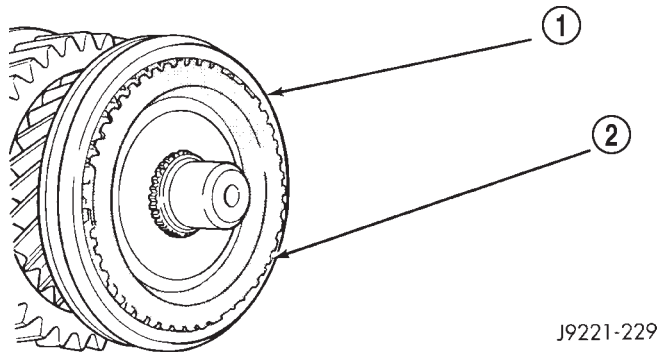
**Fig. 104 Mainshaft Rear Bearing**

- 1 - INSTALLER 6446
- 2 - MAINSHAFT REAR BEARING



## MANUAL - NV4500 (Continued)

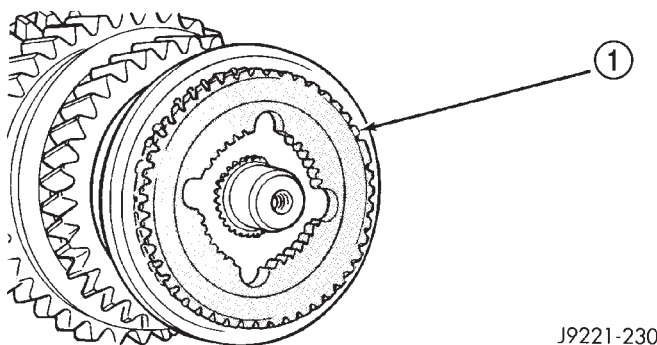
(37) Install fourth gear stop ring in 3-4 synchro sleeve (Fig. 105).



**Fig. 105 Fourth gear Stop Ring**

- 1 - 3-4 SYNCHRO SLEEVE  
2 - FOURTH SPEED STOP RING

(38) Install fourth gear clutch gear in stop ring (Fig. 106).



**Fig. 106 Fourth gear Clutch Gear**

- 1 - FOURTH SPEED CLUTCH GEAR

(39) Roll gear case onto its left side.

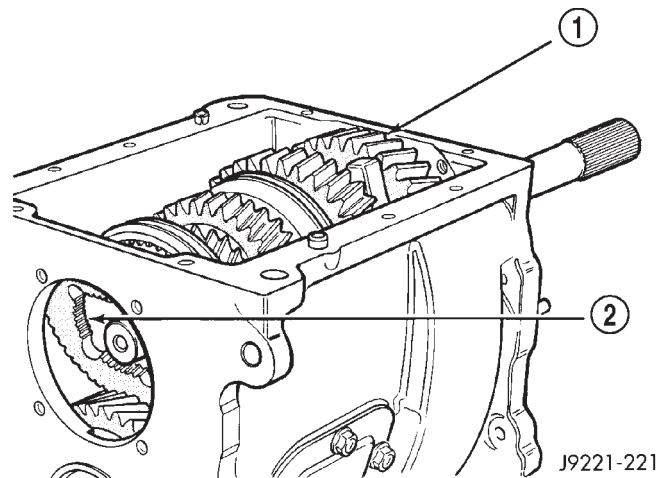
(40) Grip mainshaft at pilot bearing hub and just behind reverse gear. Then lift assembly and guide rear of shaft through bearing bore at rear of case.

(41) Continue holding front of shaft but switch grip at rear to shaft output splines. Lift mainshaft assembly slightly, align gears and seat assembly in case.

(42) Set transmission case upright (Fig. 107).

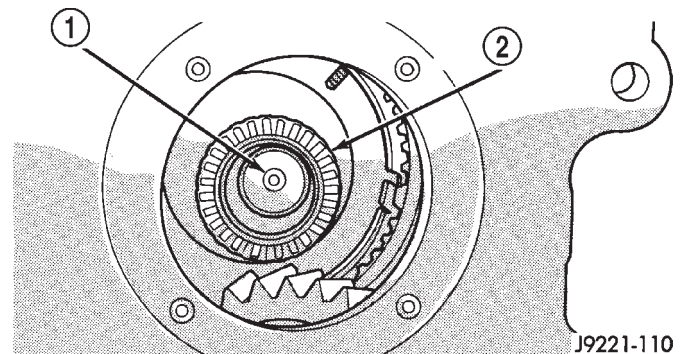
(43) Install drive gear thrust bearing on mainshaft (Fig. 108). Use plenty of petroleum jelly to hold bearing in place.

(44) Check alignment and mesh of mainshaft gears. If gears are not aligned, roll case on side and realign shaft and gears in case.



**Fig. 107 Mainshaft And Geartrain In Case**

- 1 - MAINSHAFT AND GEARTRAIN ASSEMBLY  
2 - FOURTH SPEED CLUTCH GEAR



**Fig. 108 Drive Gear Thrust Bearing**

- 1 - MAINSHAFT  
2 - DRIVE GEAR THRUST BEARING

#### DRIVE GEAR AND RETAINER

(1) Install bearing on drive gear with Installer 6448 (Fig. 109).

(2) Lubricate pilot bearing with petroleum jelly and install it in drive gear bore.

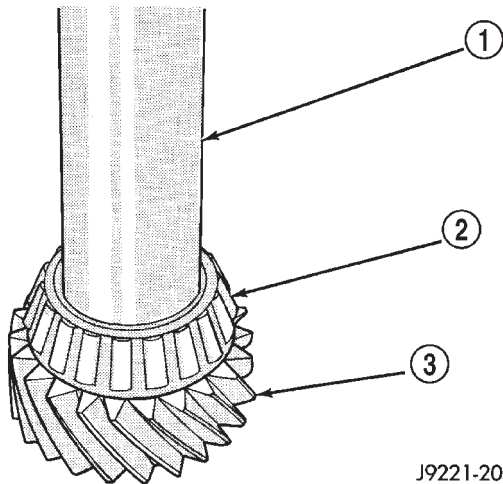
(3) Install drive gear on mainshaft. Work gear rearward until mainshaft hub is seated in pilot bearing.

(4) Install bearing cup in front retainer with Handle C-4171 and Installer C-4308 (Fig. 110).

(5) Install new oil seal in front bearing retainer with Installer 6052 (Fig. 111). Use one or two wood blocks to support retainer as shown. Lubricate seal lip with petroleum jelly after installation.

(6) Clean contact surfaces of gear case and front bearing retainer with a wax and grease remover.

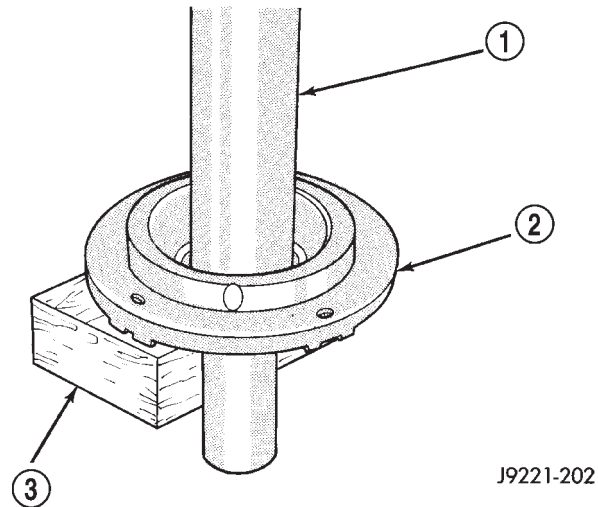
## MANUAL - NV4500 (Continued)



J9221-204

**Fig. 109 Front Bearing On Drive Gear**

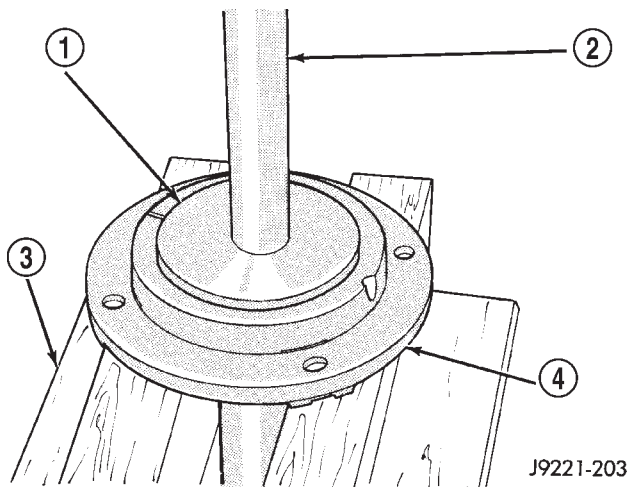
- 1 - INSTALLER 6448
- 2 - BEARING
- 3 - DRIVE GEAR



J9221-202

**Fig. 111 Bearing Retainer Oil Seal**

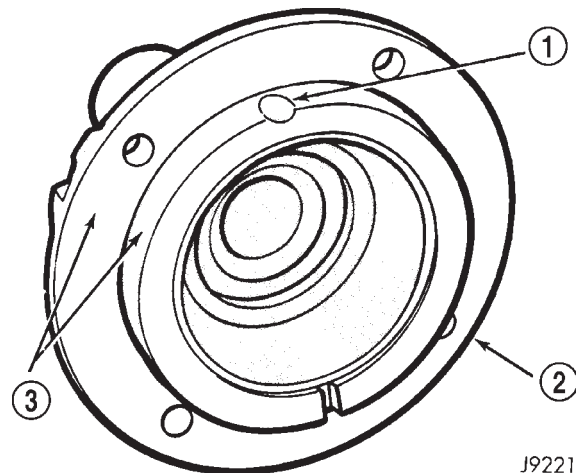
- 1 - INSTALLER 6052
- 2 - RETAINER
- 3 - WOOD BLOCK



J9221-203

**Fig. 110 Front Bearing Cup In Retainer**

- 1 - INSTALLER C-4308
- 2 - HANDLE C-4171
- 3 - WOOD BLOCKS
- 4 - RETAINER



J9221-231

**Fig. 112 Location Of Front Retainer Lube Channel**

- 1 - LUBE CHANNEL
- 2 - FRONT RETAINER
- 3 - APPLY GASKET MAKER HERE

(7) Apply Mopar® Silicone Sealer or equivalent to flange surface of front bearing retainer (Fig. 112).

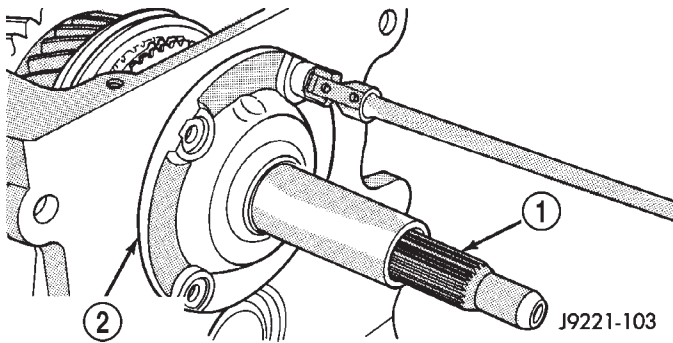
(8) Install front bearing retainer over drive gear and start it into case.

(9) Start front bearing retainer in gear case. Verify retainer lube channel is at the top-center (**12 O'clock**) position (Fig. 112).

(10) Align front bearing retainer bolt holes and tap retainer into place with plastic mallet. Install **new** retainer bolts and tighten to 30 N·m (22 ft. lbs.) (Fig. 113).

**NOTE: Never reuse the old bolts.**

MANUAL - NV4500 (Continued)

**Fig. 113 Front Bearing Retainer**

- 1 - DRIVE GEAR  
2 - FRONT BEARING RETAINER

**MAINSHAFT END PLAY**

(1) Install mainshaft rear bearing cup in case and over bearing. Tap bearing cup into place with plastic mallet.

(2) Install rear bearing plate to hold mainshaft and rear bearing in position (Fig. 114).

**NOTE: Do not install any end play shims at this time.**

(3) Tighten rear bearing plate bolts securely.

(4) Place gear case in upright position on bench. Either cut hole in bench to accept drive gear and front retainer or use C-clamps to secure transmission on bench.

**NOTE: Do not leave transmission unsupported.**

(5) Install Extension Rod 8161 into a suitable threaded hole in rear of case.

(6) Mount dial indicator on extension rod and position indicator plunger against end of mainshaft.

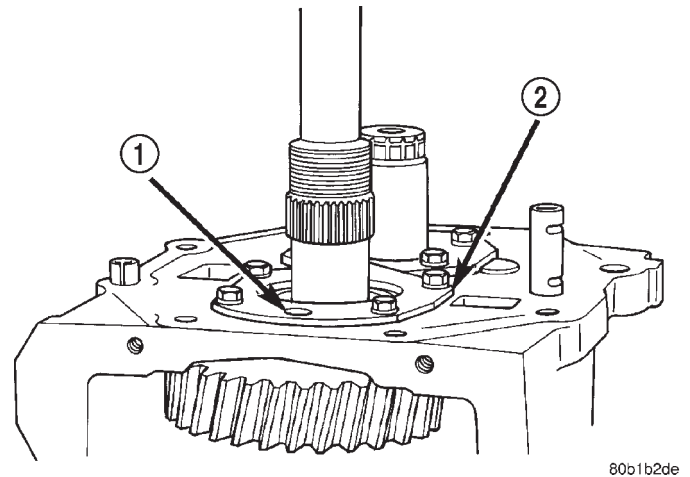
(7) Move mainshaft forward to remove all play then zero dial indicator.

(8) Move mainshaft upward and record dial indicator reading. Move mainshaft with pry tool positioned between drive gear and case.

(9) End play should be 0.051-0.15 mm (0.002-0.006 in.). Select fit shims are available to adjust end play. If end play adjustment is required, remove bearing plate and install necessary shim.

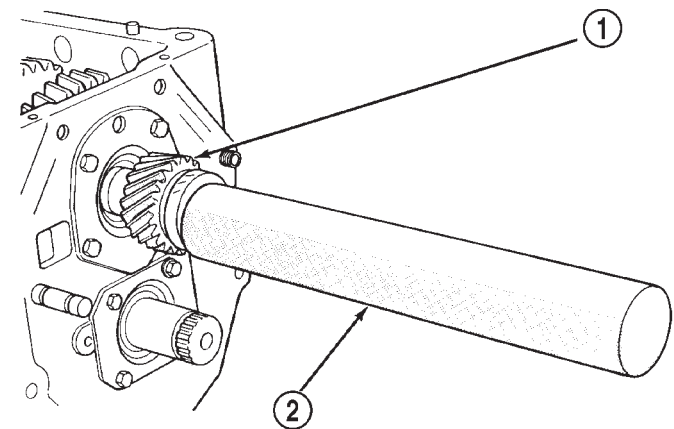
(10) Reinstall rear bearing plate with oil hole in bearing plate at the top (Fig. 114).

(11) Apply Mopar® Lock N' Seal or equivalent to bearing plate bolt threads. Install and tighten bolts to 23 N-m (200 in. lbs.).

**Fig. 114 Rear Bearing Plate**

- 1 - BEARING PLATE OIL HOLE (AT TOP)  
2 - MAINSHAFT REAR BEARING PLATE

(12) Install mainshaft fifth gear with Installer 6446 (Fig. 115). Gear is seated when it contacts rear bearing.

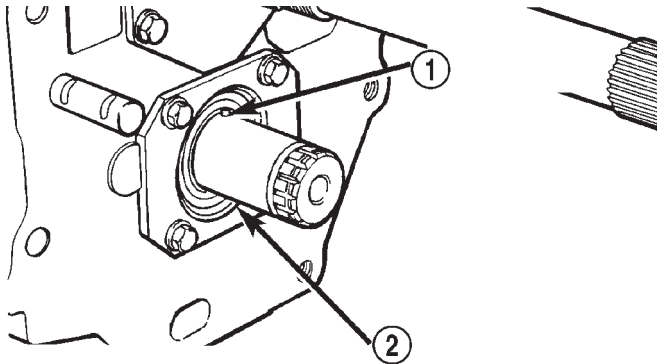
**Fig. 115 Mainshaft Fifth Gear**

- 1 - MAINSHAFT FIFTH GEAR  
2 - INSTALLER 6446

## MANUAL - NV4500 (Continued)

## COUNTERSHAFT FIFTH GEAR SYNCHRO

(1) Install thrust washer pin in countershaft (Fig. 116).



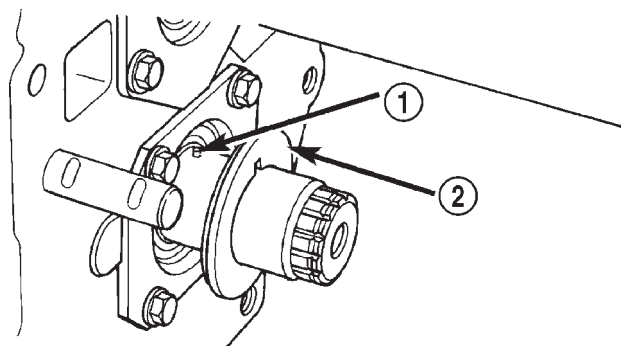
80b1b2df

**Fig. 116 Fifth Gear Thrust Washer Pin**

- 1 - THRUST WASHER PIN  
2 - COUNTERSHAFT

(2) Install thrust washer on countershaft. Turn washer until pin engages in washer notch (Fig. 117).

**NOTE:** The flat side of washer faces the rear and cone side faces the front.



80b1b2e1

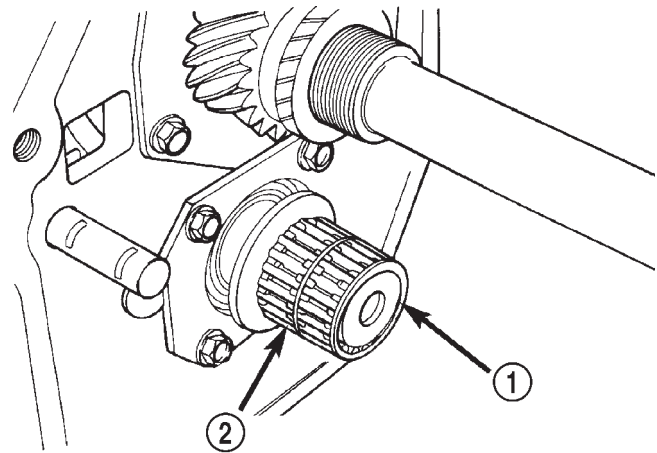
**Fig. 117 Fifth Gear Thrust Washer**

- 1 - PIN  
2 - THRUST WASHER

(3) Lubricate and install fifth gear bearing on countershaft (Fig. 118).

(4) Install synchro sleeve on hub of countershaft fifth gear with tapered side of sleeve facing front and the flat side facing rear (Fig. 119).

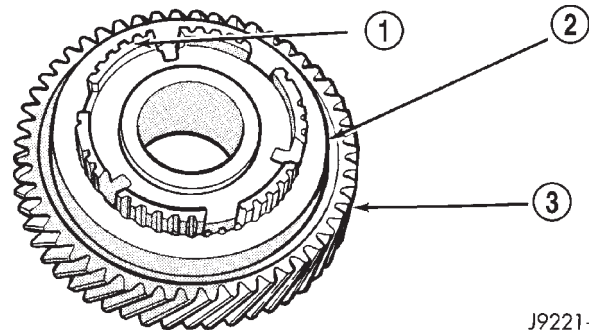
(5) Install shift fork in synchro sleeve (Fig. 120).



80b1b2e3

**Fig. 118 Countershaft Fifth Gear Bearing**

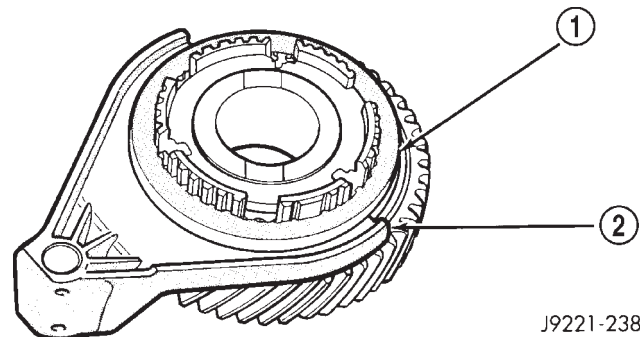
- 1 - COUNTERSHAFT  
2 - FIFTH GEAR NEEDLE BEARING



J9221-237

**Fig. 119 Synchro Sleeve On Countershaft Fifth**

- 1 - GEAR HUB  
2 - SYNCHRO SLEEVE  
3 - COUNTERSHAFT FIFTH GEAR



J9221-238

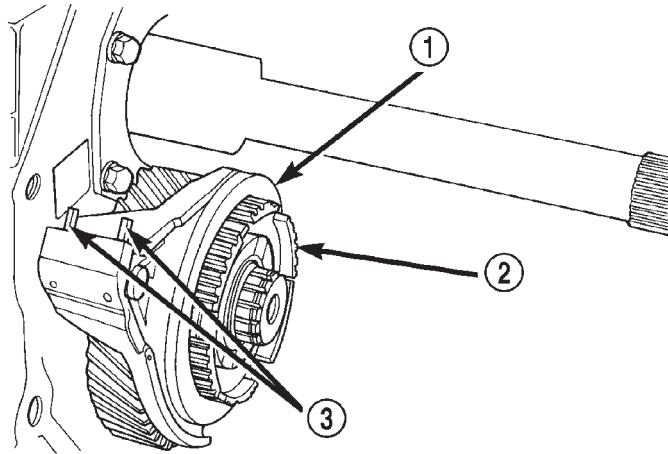
**Fig. 120 Fifth Gear Shift Fork In Synchro Sleeve**

- 1 - SYNCHRO SLEEVE  
2 - SHIFT FORK



## MANUAL - NV4500 (Continued)

(6) Install assembled fifth gear, synchro sleeve and shift fork (Fig. 121). Align fork with shift lug rail and align gear with bearings and countershaft. Start components onto shaft and rail, then tap gear and fork into place with plastic or rawhide mallet.

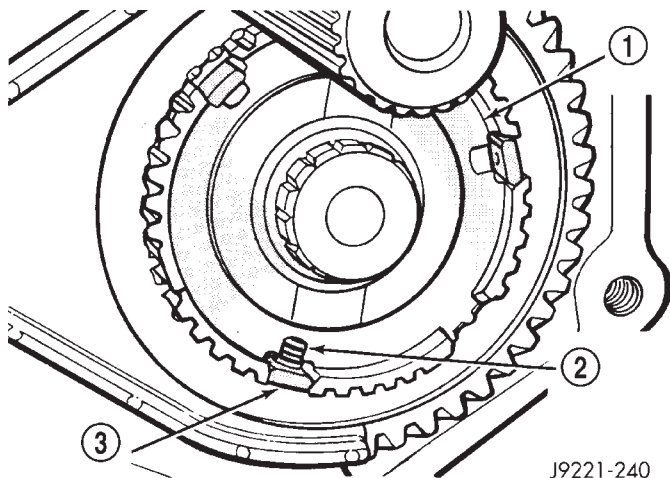


80b1b2e4

**Fig. 121 Countershaft Fifth Gear, Shift Fork And Synchro Sleeve**

- 1 - SHIFT FORK AND SLEEVE
- 2 - FIFTH GEAR HUB
- 3 - SHIFT FORK ROLL PINS

(7) Install fifth gear synchro struts and springs (Fig. 122).

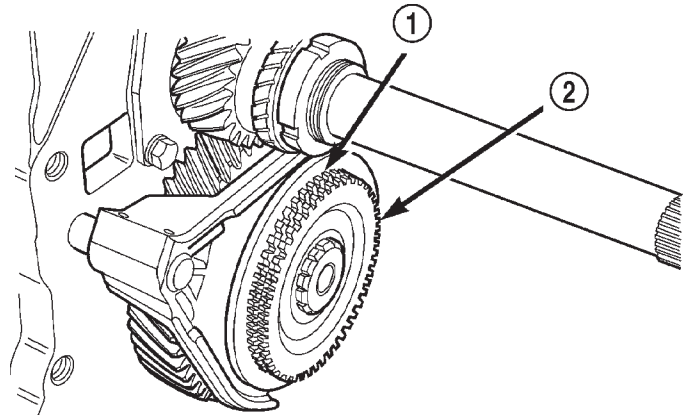


J9221-240

**Fig. 122 Fifth Gear Synchro Struts And Springs**

- 1 - FIFTH GEAR HUB
- 2 - SYNCHRO SPRING (3)
- 3 - SYNCHRO STRUT (3)

(8) Assemble and install fifth synchro clutch gear and stop ring in fifth gear hub (Fig. 123). Verify parts are seated in fifth gear hub.

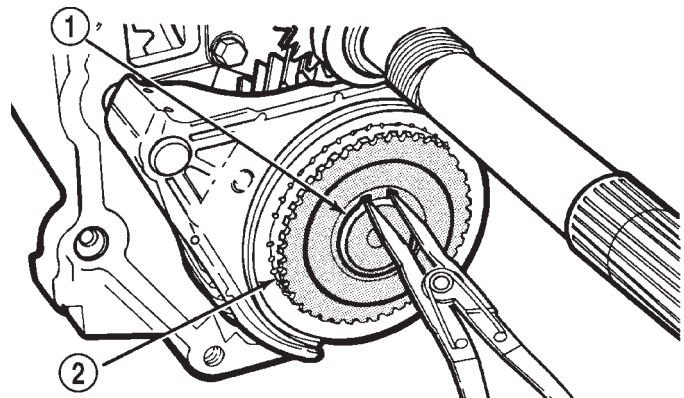


80b1b2e5

**Fig. 123 Fifth Synchro Clutch Gear And Stop Ring**

- 1 - STOP RING
- 2 - CLUTCH GEAR

(9) Install clutch gear snap ring (Fig. 124).



J9221-89

**Fig. 124 Fifth Synchro Clutch Snap Ring**

- 1 - CLUTCH GEAR RING
- 2 - FIFTH SYNCHRO CLUTCH GEAR

(10) Align roll pin holes in shift fork with notches in shift lug rail. Then install roll pins from top side of fork (Fig. 121).

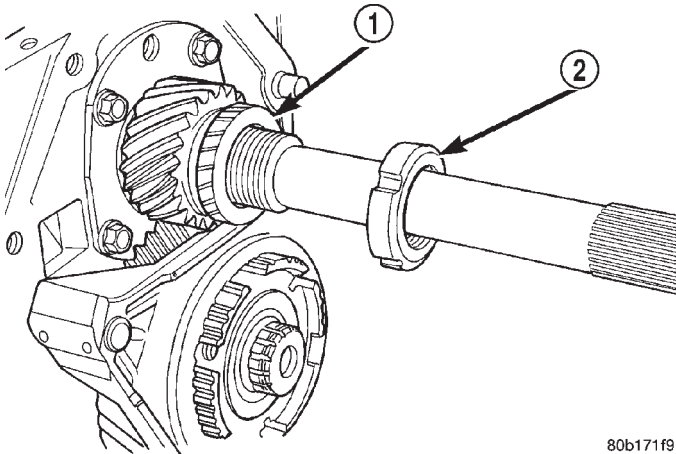
**NOTE:** Roll pins only fit one way due to small shoulder at one end of each pin.

#### FIFTH GEAR NUT

- (1) Install belleville washer onto the mainshaft.
- (2) Install fifth gear nut over the mainshaft.
- (3) Tighten the clamp bolt until the gap in the clamp nut assembly is closed.

## MANUAL - NV4500 (Continued)

- (4) Back the clamp bolt off one full turn.
- (5) Place 10-15 drops of Loctite™ 272 onto the mainshaft threads where the fifth gear nut will be engaged.
- (6) Install fifth gear nut on mainshaft (Fig. 125).



80b171f9

**Fig. 125 Fifth Gear Nut**

- 1 - FIFTH GEAR
- 2 - FIFTH GEAR NUT

(7) There are two splined sockets available to retain the mainshaft while installing the fifth gear nut.

- 4X2 mainshafts Socket 6993
- 4X4 mainshafts Socket 6984

(8) Tighten fifth gear nut as much as possible with Nut Wrench 6743, long handle ratchet, breaker bar and applicable socket wrench (Fig. 126).

(9) Lock mainshaft gears by shifting all synchro sleeves into engaged position.

(10) Tighten fifth gear nut with Nut Wrench 6743 and high capacity torque wrench. Tighten nut to 366-380 N·m (270-280 ft. lbs.). Have helper hold transmission steady if necessary.

(11) Torque the fifth gear clamp nut clamping bolt to 13.5 N·m (10 ft. lbs.).

(12) Unlock the mainshaft gears by shifting all synchro sleeves out of the engaged position.

**EXTENSION/ADAPTER HOUSING**

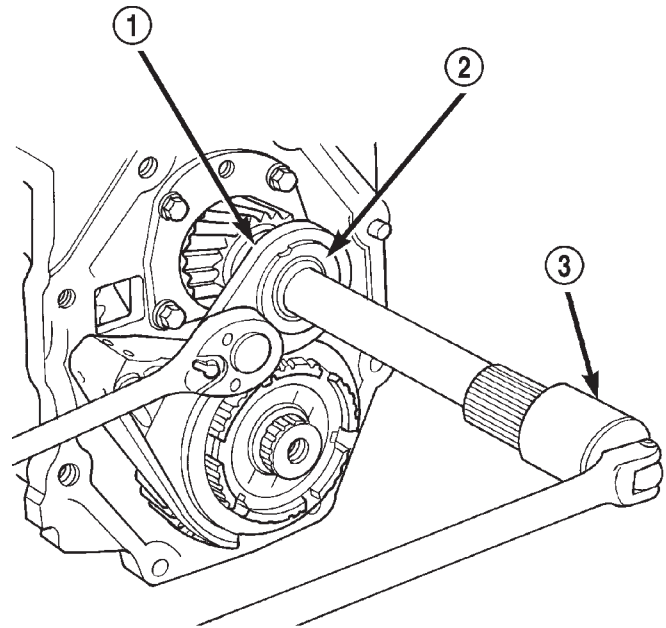
(1) Clean mating surfaces of extension/adaptor housing and gear case with a wax and grease remover.

(2) Check alignment dowels in gear case and housing or adapter. Be sure dowels are in position and seated.

(3) Apply Mopar® Silicone Sealer or equivalent to gear case and housing mating surfaces.

(4) Align and install extension/adaptor housing on gear case (Fig. 127).

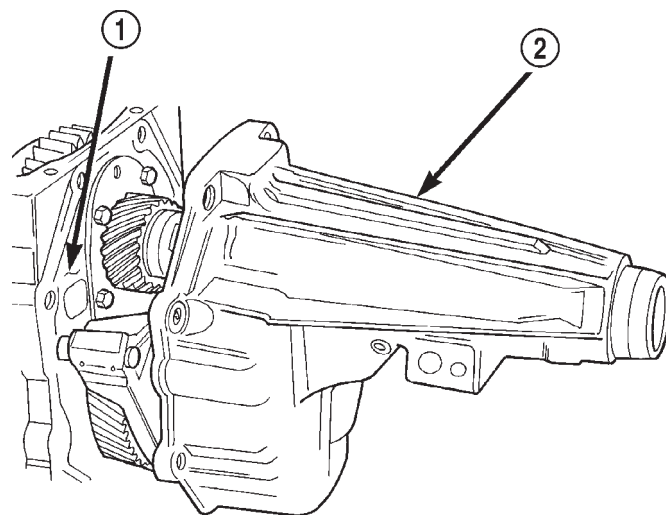
(5) Apply Mopar® Lock N' Seal or equivalent to threads of extension/adaptor housing bolts.



80b171f8

**Fig. 126 Fifth Gear Nut**

- 1 - WRENCH 6443 OR 6743
- 2 - FIFTH GEAR NUT
- 3 - SOCKET 6443 OR 6743



80b171f5

**Fig. 127 Extension/Adapter Housing**

- 1 - GEAR CASE
- 2 - EXTENSION HOUSING

(6) Install and tighten housing bolts to 54 N·m (40 ft. lbs.).

(7) Install transfer case, if equipped.

(8) Install engine rear support. Refer to 9 Engine for procedures.

(9) Install propeller shaft(s).

(10) Remove transmission support stand and lower vehicle.



MANUAL - NV4500 (Continued)

## INSTALLATION

**NOTE:** If a new transmission is being installed, be sure to use all components supplied with the new transmission. For example, if a new shift tower is supplied with the new transmission, do not re-use the original shift tower.

Before installation apply light coat of Mopar high temperature bearing grease to contact surfaces of following components:

- input shaft splines.
- release bearing slide surface of front retainer.
- release bearing bore.
- release fork.
- release fork ball stud.
- propeller shaft slip yoke.

(1) Apply sealer to threads of bottom PTO cover bolt and install bolt in case.

(2) Mount transmission on jack and position transmission under vehicle.

(3) Raise transmission until input shaft is centered in release bearing and clutch disc hub.

(4) Move transmission forward and start input shaft in release bearing, clutch disc and pilot bushing.

(5) Work transmission forward until seated against clutch housing. Do not allow transmission to remain unsupported after input shaft has entered clutch disc.

(6) Install and tighten transmission-to-clutch housing bolts to 108 N·m (80 ft. lbs.).

(7) Install transmission mount on transmission or rear crossmember.

(8) Install rear crossmember.

(9) Remove transmission jack and engine support fixture.

(10) Position transmission harness wires in clips on shift cover.

(11) Install clutch slave cylinder and install slave cylinder shield, if equipped.

(12) Connect speed sensor and backup light switch wires.

## TWO WHEEL DRIVE

(1) Fill transmission with recommended lubricant. Correct fill level is bottom edge of fill plug hole.

(2) Align and install propeller shaft.

(3) Lower vehicle.

(4) Clean the mating surfaces of shift tower, isolator plate, and shift cover with suitable wax and grease remover.

(5) Apply Mopar Gasket Maker, or equivalent, to the sealing surface of the shift cover. Do not over apply sealant.

(6) Install the isolator plate onto the shift cover, metal side down.

(7) Install the shift tower onto the isolator plate. No sealant is necessary between the shift tower and the isolator plate.

(8) Verify that the shift tower, isolator plate, and the shift tower bushings are properly aligned.

(9) Install the bolts to hold the shift tower to the isolator plate and the shift cover. Tighten the shift tower bolts to 10.2–11.25 N·m (7.5–8.3 ft. lbs.).

(10) Install the shift lever extension onto the shift tower and lever assembly.

(11) Install shift boot and bezel.

(12) Connect battery negative cable.

## FOUR WHEEL DRIVE

(1) Install transfer case shift mechanism on transmission.

(2) Install transfer case on transmission jack. Secure transfer case to jack with safety chains.

(3) Raise jack and align transfer case input gear with transmission mainshaft.

(4) Move transfer case forward and seat it on adapter.

(5) Install and tighten transfer case attaching nuts. Tighten nuts to 41-47 N·m (30-35 ft. lbs.) if case has 3/8 studs, or 30-41 N·m (22-30 ft. lbs.) if case has 5/16 studs.

(6) Install transfer case shift mechanism to side of transfer case.

(7) Connect transfer case shift lever to range lever on transfer case.

(8) Align and connect propeller shafts.

(9) Fill transmission with required lubricant. Check lubricant level in transfer case and add lubricant if necessary.

(10) Install transfer case skid plate, if equipped, and crossmember. Tighten attaching bolts/nuts to 41 N·m (30 ft. lbs.) torque.

(11) Install exhaust system components.

(12) Lower vehicle.

(13) Clean the mating surfaces of shift tower, isolator plate, and shift cover with suitable wax and grease remover.

(14) Apply Mopar Gasket Maker, or equivalent, to the sealing surface of the shift cover. Do not over apply sealant.

(15) Install the isolator plate onto the shift cover, metal side down.

(16) Install the shift tower onto the isolator plate. No sealant is necessary between the shift tower and the isolator plate.

(17) Verify that the shift tower, isolator plate, and the shift tower bushings are properly aligned.

MANUAL - NV4500 (Continued)

(18) Install the bolts to hold the shift tower to the isolator plate and the shift cover. Tighten the shift tower bolts to 10.2–11.25 N·m (7.5–8.3 ft. lbs.).

(19) Install the shift lever extension onto the shift tower and lever assembly.

(20) Install shift lever boot and bezel.

(21) Connect battery negative cable.

SPECIFICATIONS

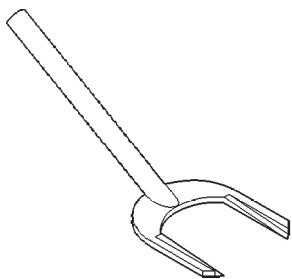
SPECIFICATIONS - NV4500

TORQUE SPECIFICATIONS

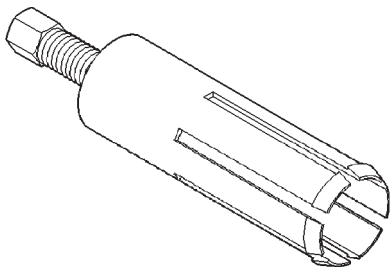
DESCRIPTION	N·m	Ft. Lbs.	In. Lbs.
Switch, Back-up Lamp	22-34	16-25	-
Countershaft Bearing Plate Bolts	19-26	14-19	170-230
Fifth Gear Nut	366-380	270-280	-
Fifth Gear Nut Clamp Bolt	13.5	10	-
Drain and Fill Plug	34-47	25-35	-
Front Bearing Retainer Bolts	27-34	20-25	235-305
Mainshaft Bearing Plate Bolts	19-26	14-19	170-230
PTO Cover Bolts	27-54	20-40	-
Extension/Adapter Housing Bolts	41-68	30-50	-
Shift Cover Bolt	27-31	20-23	-

SPECIAL TOOLS

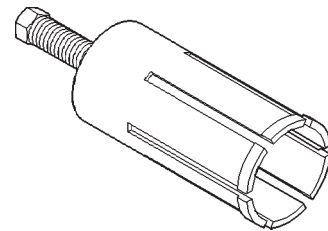
MANUAL - NV4500



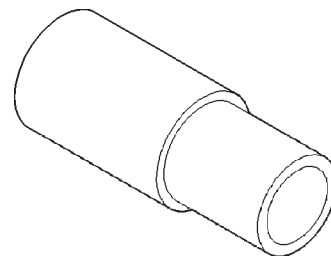
**Remover Seal C-3985-B**



**Remover Bushing 6957**

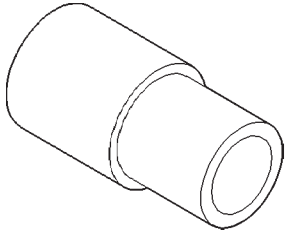


**Remover, Bushing—8155**

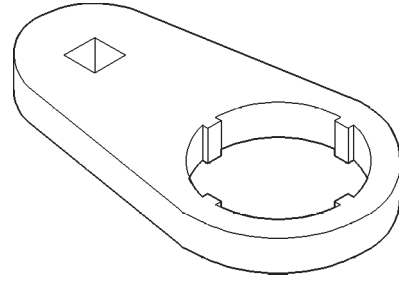


**Installer Bushing 6951**

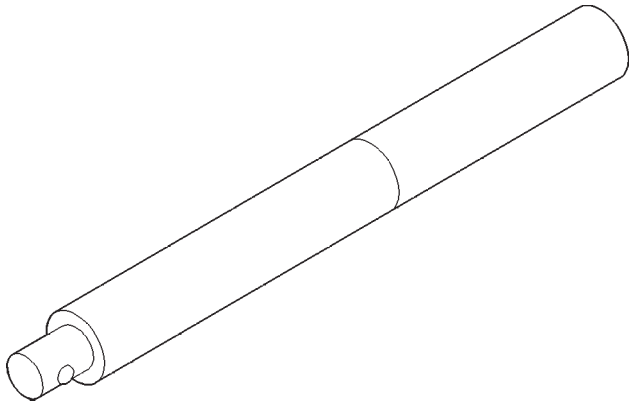
MANUAL - NV4500 (Continued)



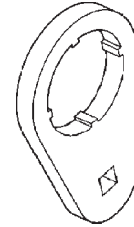
**Installer Bushing 8156**



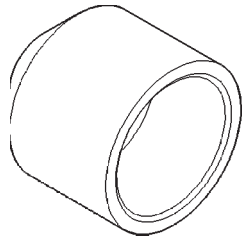
**Wrench 6443**



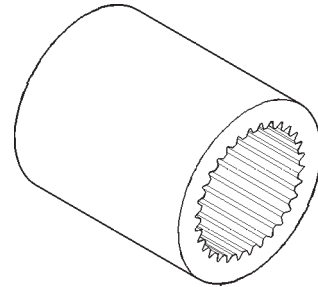
**Handle C-4171**



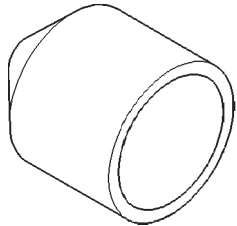
**Wrench 6743**



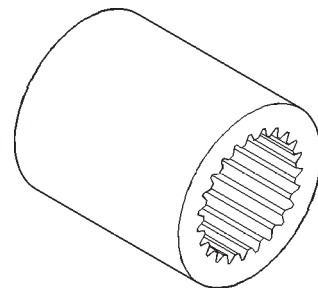
**Installer Seal C-3972-A**



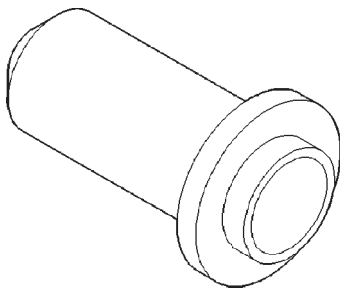
**Socket 6441**



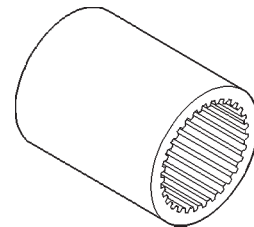
**Installer Seal 8154**



**Socket 6442**

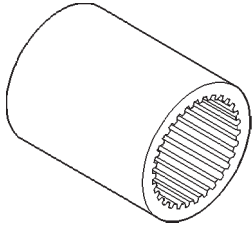


**Installer Seal C-3860-A**

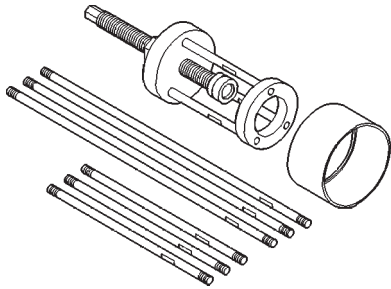


**Socket 6993**

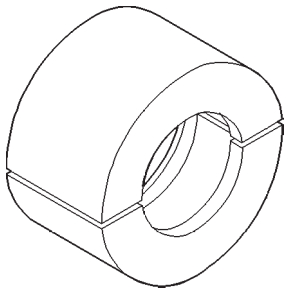
MANUAL - NV4500 (Continued)



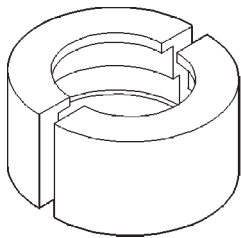
**Socket 6984**



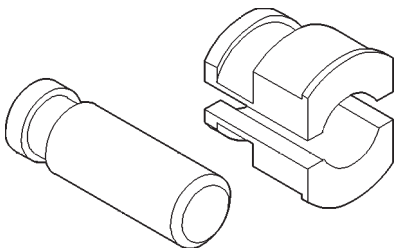
**Puller 6444**



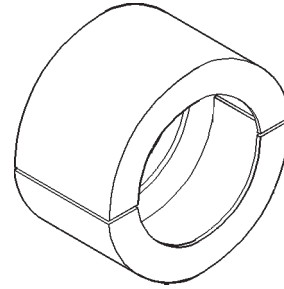
**Jaws 6459**



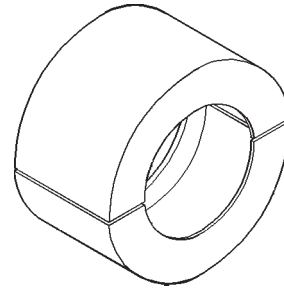
**Jaws 6820**



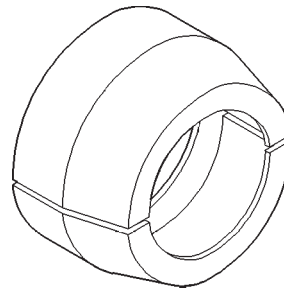
**Jaws and Insert 6453**



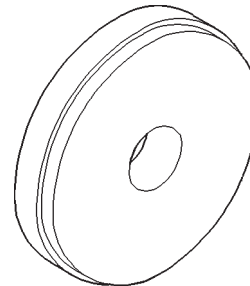
**Jaws 6447**



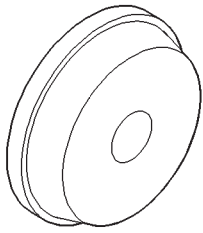
**Jaws 6449**



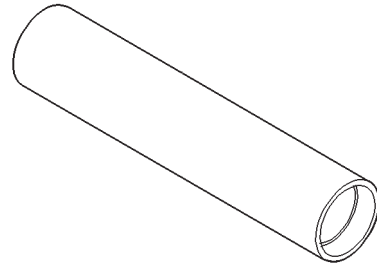
**Jaws 6451**



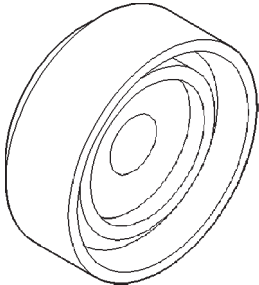
**Remover 6454**



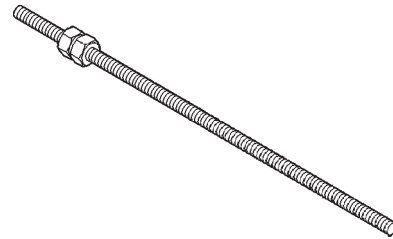
**Installer 6061**



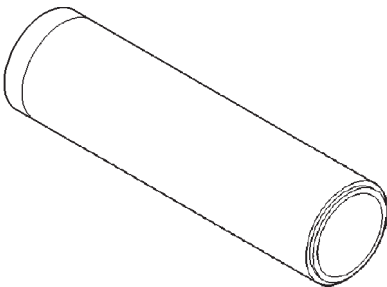
**Installer 6052**



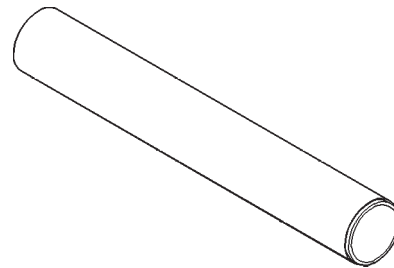
**Installer C-4340**



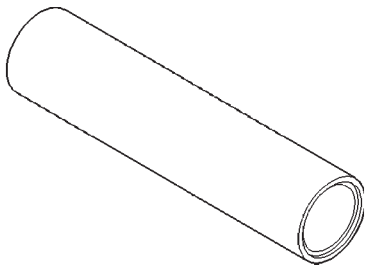
**Rod Extension 8161**



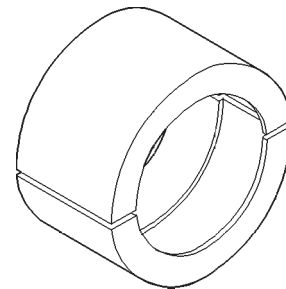
**Installer C-4040**



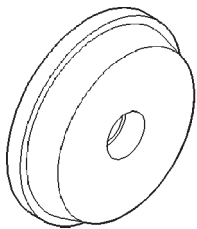
**Installer 6446**



**Installer 6448**



**Jaws 6445**

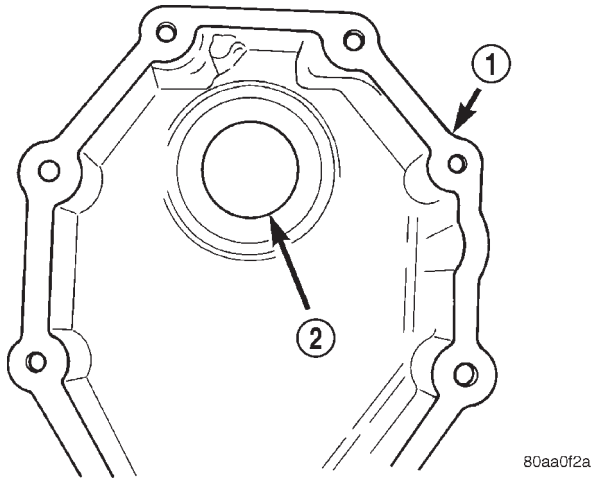


**Installer C-4308**

## ADAPTER HOUSING SEAL

### REMOVAL

- (1) Raise and support vehicle.
- (2) Mark the propeller shafts and yokes for installation reference and remove the shafts.
- (3) Support transmission with a transmission jack.
- (4) Remove engine rear support. Refer to Group 9 Engine for procedures.
- (5) Remove transfer case.
- (6) Remove adapter housing seal with a pry tool or slide hammer mounted screw (Fig. 128).



**Fig. 128 Adapter Housing - 4WD**

- 1 - ADAPTER HOUSING
- 2 - SEAL

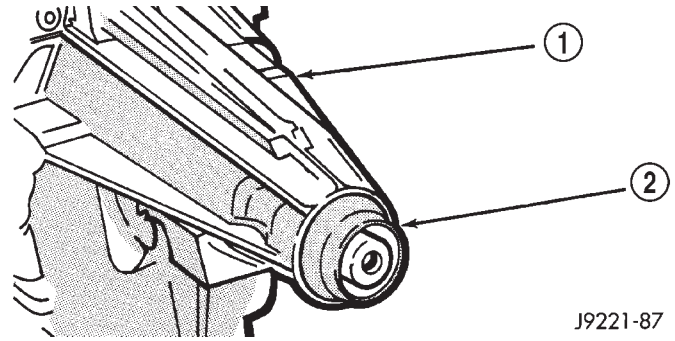
### INSTALLATION

- (1) Install adapter housing seal with Installer C-3860-A and Handle C-4171.
- (2) Install transfer case.
- (3) Install propeller shafts with reference marks aligned.
- (4) Fill transfer case and transmission to proper level.
- (5) Remove support and lower vehicle.

## EXTENSION HOUSING SEAL

### REMOVAL

- (1) Raise and support the vehicle.
- (2) Mark the propeller shaft and yoke for installation reference.
- (3) Remove the propeller shaft.
- (4) On light duty 4X2 vehicles, remove extension housing seal (Fig. 129) using Remover C-3985-B.
- (5) On heavy duty 4X2 vehicles, remove extension housing seal with a pry tool or a slide hammer mounted screw.



**Fig. 129 Extension Housing - 2WD**

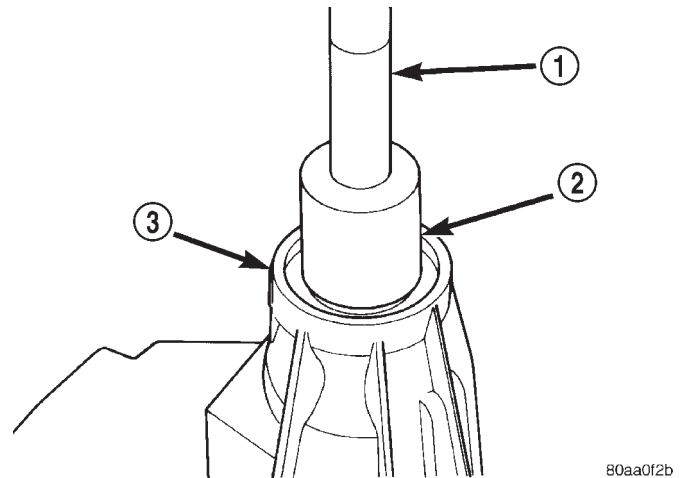
- 1 - EXTENSION HOUSING
- 2 - SEAL

- (6) On light duty transmissions, remove the extension housing bushing with Remover 6957.

- (7) On heavy duty transmissions, remove the extension housing bushing with Remover 8155.

### INSTALLATION

- (1) On light duty transmissions, install housing bushing with Installer 6951 and Handle C-4171 (Fig. 130).



**Fig. 130 Extension Housing Bushing**

- 1 - HANDLE
- 2 - INSTALLER
- 3 - EXTENSION HOUSING

- (2) On heavy duty transmissions, install housing bushing with Installer 8156 and Handle C-4171.

- (3) On light duty transmissions, install housing seal with Installer C-3972-A and Handle C-4171 (Fig. 131).

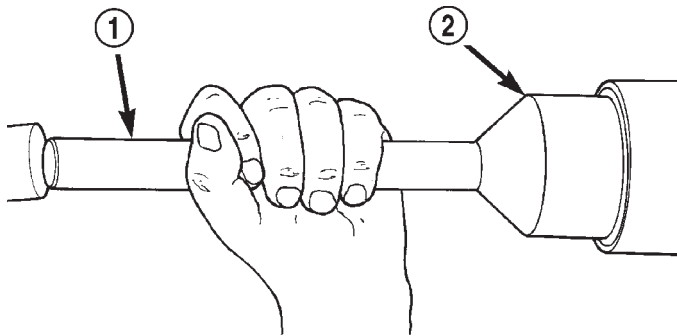
- (4) On heavy duty transmissions, install housing seal with Installer 8154 and Handle C-4171.

- (5) Install propeller shaft with reference marks aligned.

- (6) Check and fill transmission.



EXTENSION HOUSING SEAL (Continued)



80a7e2be

**Fig. 131 Extension Housing Seal**

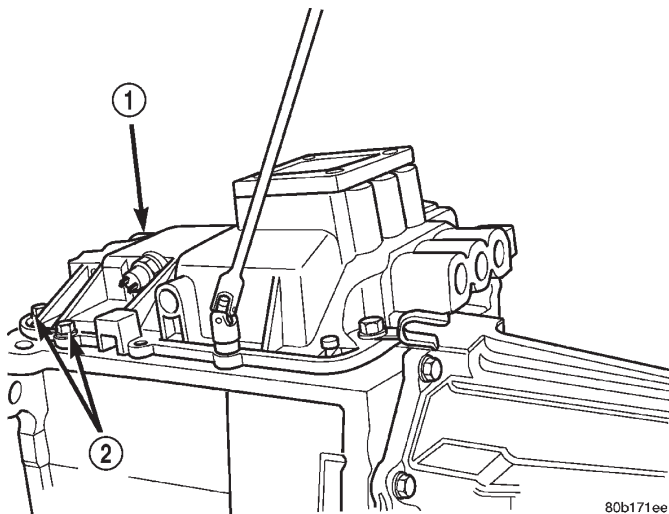
- 1 - HANDLE
- 2 - INSTALLER

(7) Remove support and lower vehicle.

SHIFT MECHANISM

REMOVAL

- (1) Remove transmission from vehicle.
- (2) Remove shift cover bolts (Fig. 132).



80b171ee

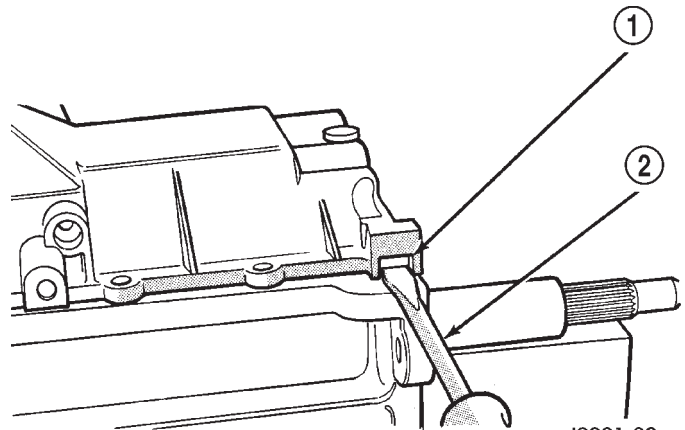
**Fig. 132 Shift Cover Bolts**

- 1 - SHIFT COVER
- 2 - BOLTS (10)

(3) Loosen shift cover with pry tool. To avoid damaging cover seal surface, insert pry tool only in slots provided in cover (Fig. 133).

(4) Raise cover enough to disengage it from alignment dowels in gear case (Fig. 134).

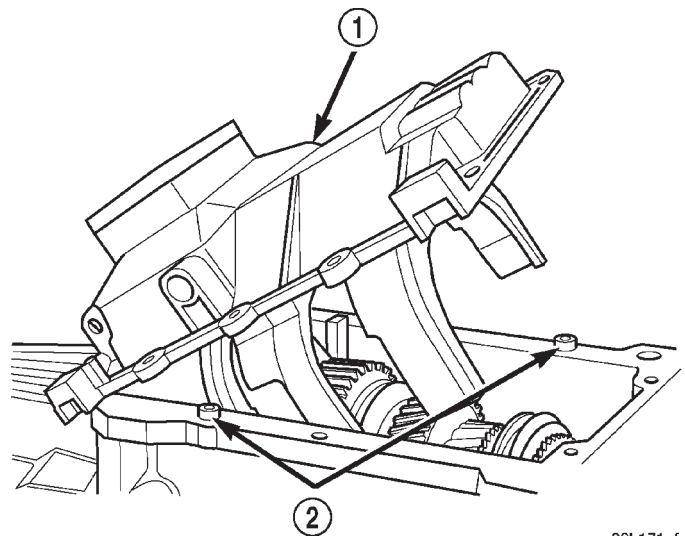
(5) Raise front of shift cover and lift cover up and off gear case (Fig. 134).



J9221-82

**Fig. 133 Loosening Shift Cover**

- 1 - SHIFT COVER SLOT
- 2 - PRY TOOL



80b171ef

**Fig. 134 Shift Cover**

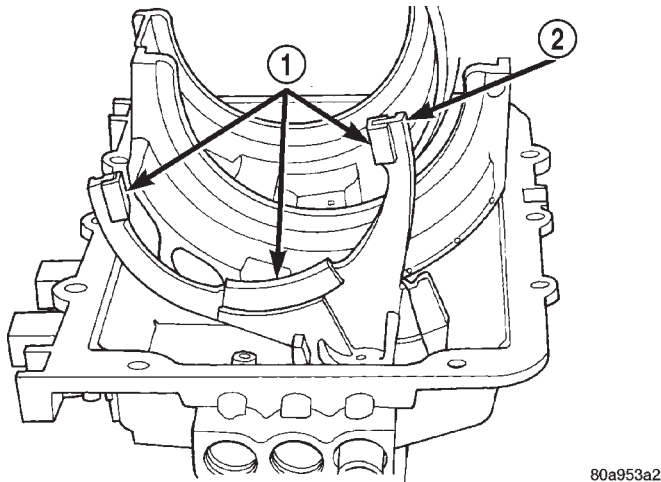
- 1 - SHIFT COVER
- 2 - ALIGNMENT DOWELS

FIFTH-REVERSE SHIFT FORK PADS

The plastic shift fork pads are held in place by a combination of tension and a small locating tang. Three pads are used on the fork (Fig. 135).

The pads can be removed either by hand or with a narrow blade screwdriver. To remove the pads by hand, grasp each pad and tilt it out and off the fork. If the pads prove difficult to remove by hand, insert a screwdriver blade between the pad and fork and pry the pad off.

## SHIFT MECHANISM (Continued)



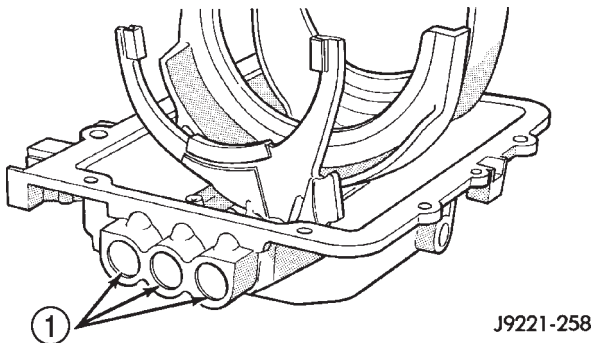
80a953a2

**Fig. 135 Shift Fork Pad Locations**

- 1 - SHIFT FORK PADS  
2 - FIFTH-REVERSE FORK

**EXPANSION PLUG**

The expansion plugs at the rear of the shift rail bores (Fig. 136) can be replaced if loose and/or leaking.



J9221-258

**Fig. 136 Expansion Plug Location**

- 1 - EXPANSION PLUGS

- (1) Drill 6 mm (1/4 in.) diameter hole in center of each plug to be removed.
- (2) Pry plug out of cover with tapered punch.
- (3) Clean all chips from shift cover and plug bores. Then clean plug bores with solvent and dry with clean shop towel.

**INSTALLATION****EXPANSION PLUG**

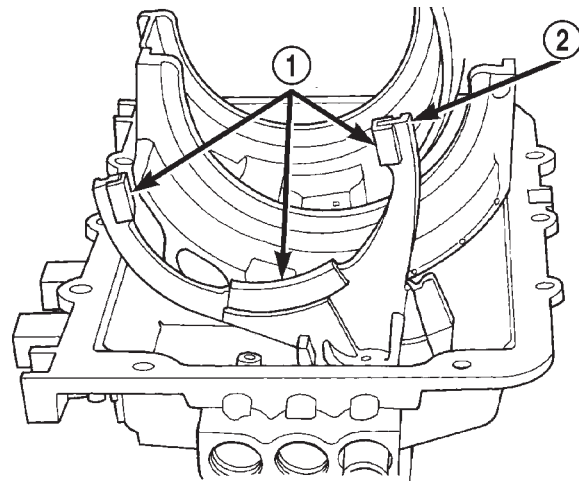
- (1) Apply small bead of sealer to outer edge of each new plug. Use Mopar® silicone adhesive/sealer, or equivalent.
- (2) Position each new plug in bore and tap into place with hammer and suitable size punch or socket.

**FIFTH-REVERSE SHIFT FORK PADS**

- (1) Align pad locating tab.
- (2) Snap pads into place and verify locating tabs are locked-in.

**SHIFT COVER**

- (1) Clean mating surfaces of shift cover and gear case with wax and grease remover.
- (2) Apply Mopar® Silicone Sealer, or equivalent, to sealing surface of shift cover or gear case. Do not over-apply sealer material. Excess can be squeezed into gear case and could block lubricant feed holes in time.
- (3) Lubricate synchro sleeves with Castrol Syntorq gear lubricant. Then apply light coat of petroleum jelly to shift fork contact surfaces.
- (4) Verify that the shift fork pads (Fig. 137) are properly and securely positioned on the fifth-reverse fork



80a953a2

**Fig. 137 Fifth-Reverse Shift Fork Pads**

- 1 - SHIFT FORK PADS  
2 - FIFTH-REVERSE FORK

- (5) Verify that 1-2 and 3-4 synchro sleeves are in neutral position. Also verify that forks in shift cover are in neutral position.
- (6) Align and install shift cover. If cover will not seat, it is either not aligned on gear case dowels, or shift forks are not aligned with sleeves and shift lug.
- (7) Apply Mopar® Lock N' Seal, or equivalent, to threads of shift cover bolts.
- (8) Install and tighten shift cover bolts to 27-31 N·m (216-276 in. lbs.).
- (9) Install backup lamp switch and gasket in cover. Apply sealer to switch threads before installation and tighten switch to 22-34 N·m (193-265 in. lbs.).
- (10) Install vent assembly, if removed. Apply an adhesive/sealer to vent tube to help secure it in cover.
- (11) Install transmission.

## SHIFT COVER

### REMOVAL

- (1) Shift transmission into Neutral.
- (2) Unscrew and remove the shift lever extension from the shift
- (3) Remove screws attaching shift boot to floorpan. Then slide boot upward on the shift lever.
- (4) Remove the bolts holding the shift tower to the isolator plate and transmission shift cover.
- (5) Remove the shift tower and isolator plate from the transmission shift cover.

### INSTALLATION

- (1) Clean the mating surfaces of shift tower, isolator plate, and shift cover with suitable wax and grease remover.

(2) Apply Mopar® Gasket Maker, or equivalent, to the sealing surface of the shift cover. Do not over apply sealant.

(3) Install the isolator plate onto the shift cover, metal side down.

(4) Install the shift tower onto the isolator plate. No sealant is necessary between the shift tower and the isolator plate.

(5) Verify that the shift tower, isolator plate, and the shift tower bushings are properly aligned.

(6) Install the bolts to hold the shift tower to the isolator plate and the shift cover. Tighten the shift tower bolts to 10.2–11.25 N·m (7.5–8.3 ft. lbs.).

(7) Install the shift lever extension, shift boot, and bezel.

# MANUAL - NV5600

## TABLE OF CONTENTS

	page		page
<b>MANUAL - NV5600</b>		<b>SPECIFICATIONS</b> .....	126
DESCRIPTION.....	91	SPECIAL TOOLS.....	127
OPERATION.....	93	<b>ADAPTER HOUSING SEAL</b>	
DIAGNOSIS AND TESTING.....	93	REMOVAL.....	132
MANUAL TRANSMISSION.....	93	INSTALLATION.....	132
REMOVAL.....	94	<b>EXTENSION HOUSING SEAL</b>	
DISASSEMBLY.....	95	REMOVAL.....	132
CLEANING.....	109	INSTALLATION.....	132
INSPECTION.....	109	<b>SHIFT COVER</b>	
ASSEMBLY.....	110	REMOVAL.....	132
INSTALLATION.....	125	INSTALLATION.....	133

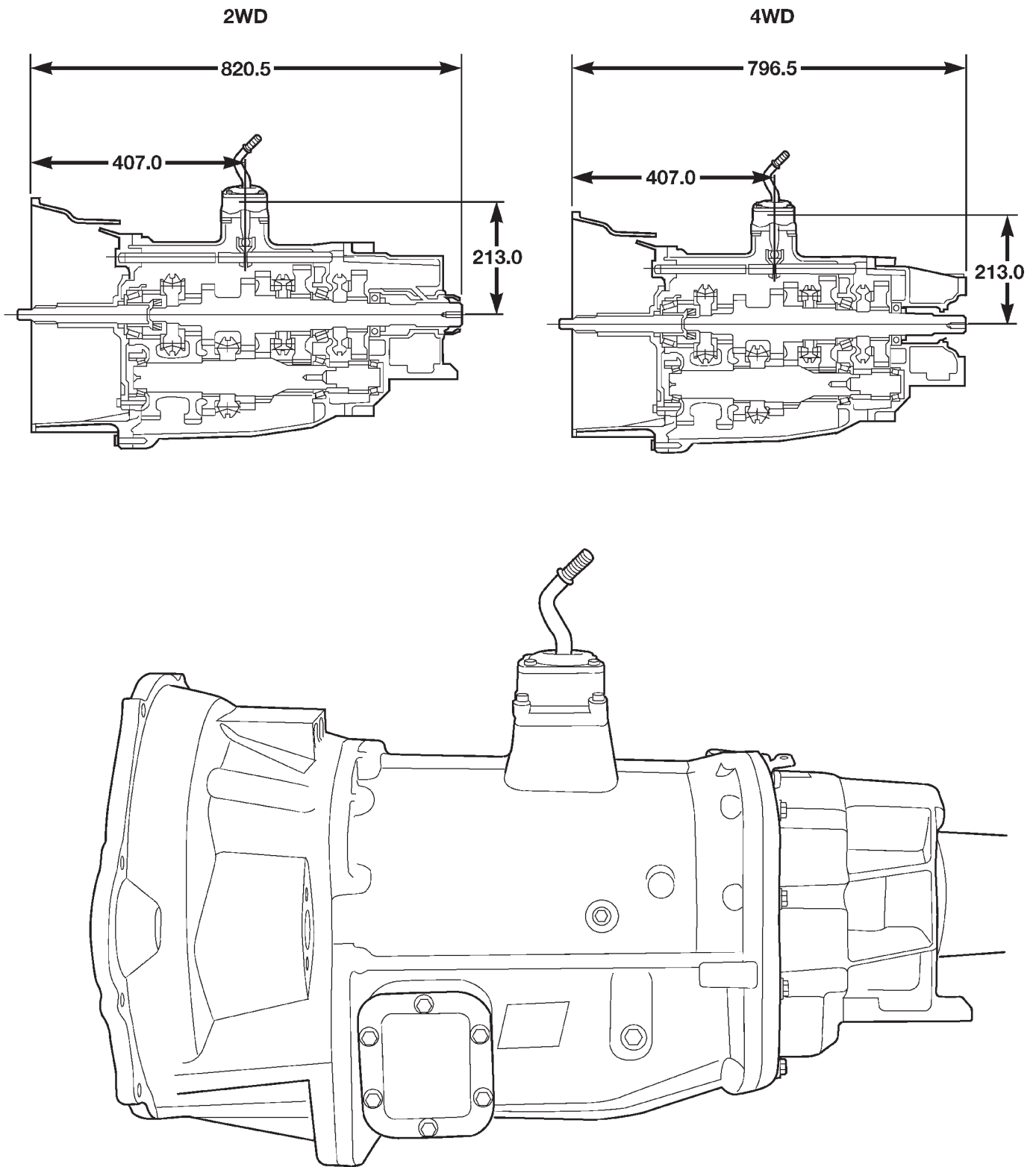
## MANUAL - NV5600

### DESCRIPTION

The NV5600 is a six speed constant mesh manual transmission (Fig. 1). All gear ranges including reverse are synchronized. First and second gears utilize dual cone synchronizers in order to aid shifting.

Sixth gear is an overdrive range. The transmission uses cast iron for the gear case and extension/adaptor housing and aluminum for the clutch housing.

The transmission is a end loader transmission. The shift lever is located in a shifter tower which is bolted to the gear case and operates the shift shaft.

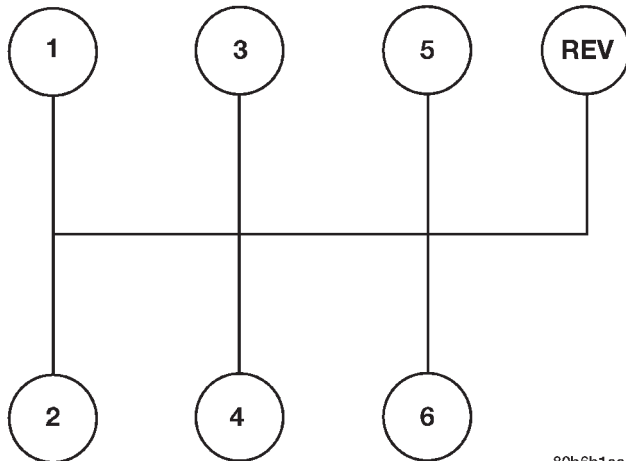


**Fig. 1 NV5600 Manual Transmission**

## MANUAL - NV5600 (Continued)

**SHIFT PATTERN**

The shift pattern is in a modified H pattern (Fig. 2). Overdrive fifth and sixth gears are in line and outboard of the first through fourth gear positions. Reverse gear is to the right of fifth and sixth and forward of the neutral gate.



80b6b1aa

**Fig. 2 Shift Pattern****GEAR RATIOS**

GEAR	RATIO
FIRST	5.63:1
SECOND	3.38:1
THIRD	2.04:1
FOURTH	1.39:1
FIFTH	1.00:1
SIXTH	0.73:1
REVERSE	5.63:1

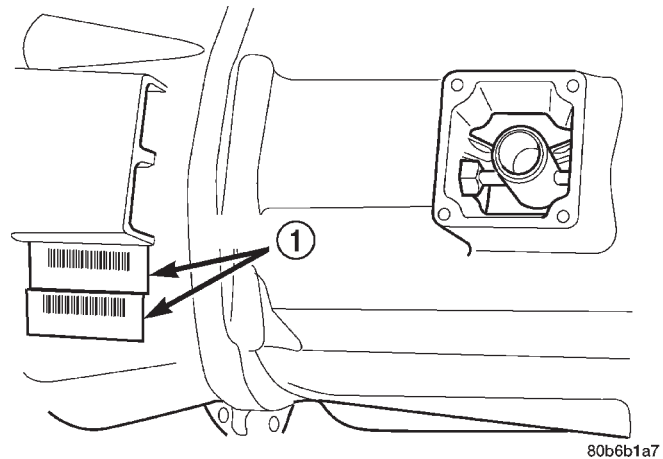
**IDENTIFICATION**

The transmission has two identification tags attached to the driver side upper clutch housing (Fig. 3).

One tag provides the transmission part number. The second tag provides sequencing and build date information. The information on the tags are essential to correct parts ordering.

**OPERATION**

The manual transmission receives power through the clutch assembly from the engine. The clutch disc is splined to the transmission input shaft and is turned at engine speed at all times that the clutch is engaged. The input shaft is connected to the transmission countershaft through the mesh of fourth speed gear on the input shaft and the fourth countershaft gear. At this point, all the transmission gears are spinning.



80b6b1a7

**Fig. 3 Identification Tag Location**

1 - IDENTIFICATION TAGS

The driver selects a particular gear by moving the shift lever to the desired gear position. This movement moves the internal transmission shift components to begin the shift sequence. As the shift lever moves the selected shift rail, the shift fork attached to that rail begins to move. The fork is positioned in a groove in the outer circumference of the synchronizer sleeve. As the shift fork moves the synchronizer sleeve, the synchronizer begins to speed-up or slow down the selected gear (depending on whether we are up-shifting or down-shifting). The synchronizer does this by having the synchronizer hub splined to the mainshaft, or the countershaft in some cases, and moving the blocker ring into contact with the gear's friction cone. As the blocker ring and friction cone come together, the gear speed is brought up or down to the speed of the synchronizer. As the two speeds match, the splines on the inside of the synchronizer sleeve become aligned with the teeth on the blocker ring and the friction cone and eventually will slide over the teeth, locking the gear to the mainshaft, or countershaft, through the synchronizer.

**DIAGNOSIS AND TESTING - MANUAL TRANSMISSION****LOW LUBRICANT LEVEL**

A low transmission lubricant level is generally the result of a leak, inadequate lubricant fill or an incorrect lubricant level check.

Leaks can occur at the mating surfaces of the gear case, adaptor or extension housing, or from the front/rear seals. A suspected leak could also be the result of an overfill condition.

Leaks at the rear of the extension or adapter housing will be from the housing oil seals. Leaks at component mating surfaces will probably be the result of inadequate sealer, gaps in the sealer, incorrect bolt tightening or use of a non-recommended sealer.



## MANUAL - NV5600 (Continued)

A leak at the front of the transmission will be from either the front bearing retainer or retainer seal. Lubricant may be seen dripping from the clutch housing after extended operation. If the leak is severe, it may also contaminate the clutch disc causing the disc to slip, grab and or chatter.

A correct lubricant level check can only be made when the vehicle is level. Also allow the lubricant to settle for a minute or so before checking. These recommendations will ensure an accurate check and avoid an underfill or overfill condition. Always check the lubricant level after any addition of fluid to avoid an incorrect lubricant level condition.

### HARD SHIFTING

Hard shifting is usually caused by a low lubricant level, improper or contaminated lubricants. The consequence of using non-recommended lubricants is noise, excessive wear, internal bind and hard shifting. Substantial lubricant leaks can result in gear, shift rail, synchro, and bearing damage. If a leak goes undetected for an extended period, the first indications of component damage are usually hard shifting and noise.

Component damage, incorrect clutch adjustment or damaged clutch pressure plate or disc are additional probable causes of increased shift effort. Incorrect adjustment or a worn/damaged pressure plate or disc can cause incorrect release. If clutch problem is advanced, gear clash during shifts can result. Worn or damaged synchro rings can cause gear clash when shifting into any forward gear. In some new or rebuilt transmissions, new synchro rings may tend to stick slightly causing hard or noisy shifts. In most cases this condition will decline as the rings wear-in.

### TRANSMISSION NOISE

Most manual transmissions make some noise during normal operation. Rotating gears generate a mild whine that is audible, but generally only at extreme speeds.

Severe highly audible transmission noise is generally the initial indicator of a lubricant problem. Insufficient, improper or contaminated lubricant will promote rapid wear of gears, synchros, shift rails, forks and bearings. The overheating caused by a lubricant problem, can also lead to gear breakage.

### REMOVAL

**NOTE:** Use a heavy duty scissors style transmission jack for remove of the transmission.

- (1) Disconnect battery negative cable.
- (2) Shift transmission into Neutral.
- (3) Remove screws attaching shift boot to floorpan. Then slide boot upward on the shift lever.

(4) Remove the bolts holding the shift tower to the isolator plate and transmission gear case.

(5) Remove the shift tower and isolator plate from the transmission gear case.

(6) Raise and support vehicle.

(7) Remove skid plate, if equipped.

(8) Mark propeller shaft/shafts and axle yokes for installation reference.

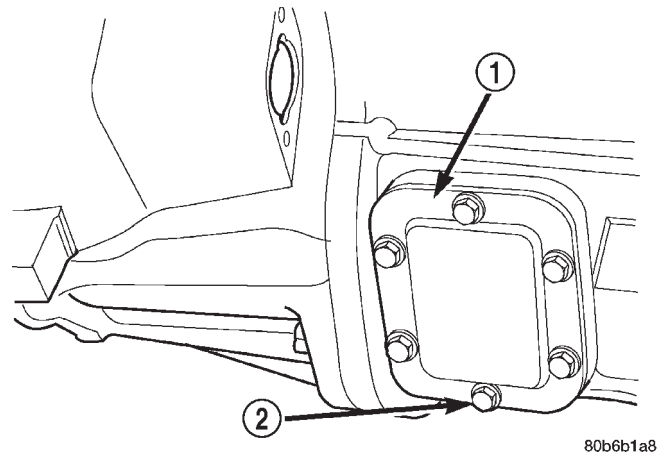
(9) Remove propeller shaft.

(10) Disconnect and remove exhaust system as necessary.

(11) Disconnect wires at backup light switch.

(12) Support engine with adjustable safety stand and wood block.

(13) If transmission is to be disassembled for repair, remove drain bolt at bottom of PTO cover and drain lubricant from transmission (Fig. 4).



**Fig. 4 NV5600 Drain Bolt**

1 - PTO COVER

2 - DRAIN BOLT

(14) Remove clutch slave cylinder splash shield, if equipped.

(15) Remove clutch slave cylinder bolts and move cylinder aside for clearance.

(16) Remove wire harness from clips on transmission.

### TWO WHEEL DRIVE

(1) Remove bolts/nuts mounting transmission to the rear mount.

(2) Support and secure transmission with safety chains to a transmission jack.

(3) Remove rear crossmember.

(4) Remove transmission clutch housing bolts at the engine block.

(5) Slide transmission and jack rearward until input shaft clears clutch disc and pressure plate.

(6) Lower transmission jack and remove transmission from under vehicle.

## MANUAL - NV5600 (Continued)

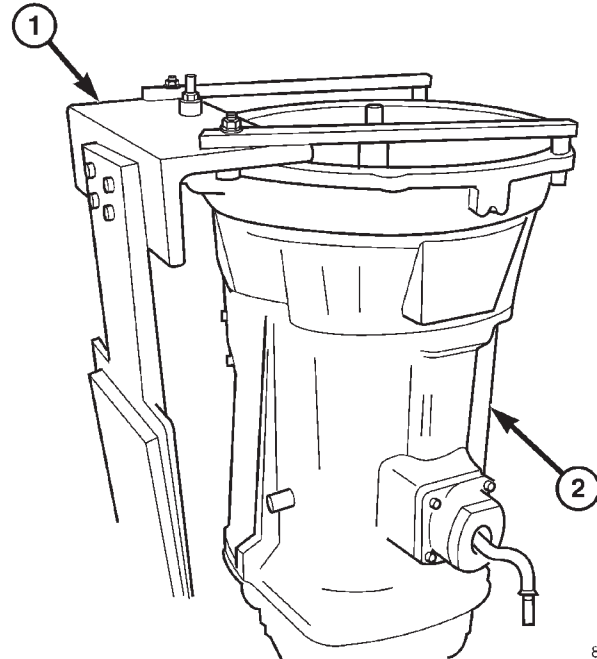
**FOUR WHEEL DRIVE**

- (1) Disconnect transfer case shift linkage at transfer case range lever.
- (2) Support and secure transfer case with safety chains to a transmission jack.
- (3) Remove transfer case mounting nuts.
- (4) Move transfer case rearward until input gear clears transmission mainshaft.
- (5) Lower transfer case assembly and move it from under vehicle.
- (6) Support and secure transmission with safety chains to a transmission jack.
- (7) Remove bolts/nuts attaching transmission mount to rear crossmember.
- (8) Remove rear crossmember.
- (9) Remove transmission clutch housing bolts at the engine block.
- (10) Move transmission rearward until input shaft clears clutch disc.
- (11) Lower transmission and remove it from under vehicle.

**DISASSEMBLY**

**NOTE:** The use of Fixture 8241 for moving and handling the NV5600 is required. The fixture supports the transmission at the center of gravity in order to ease mounting the transmission into the build fixture.

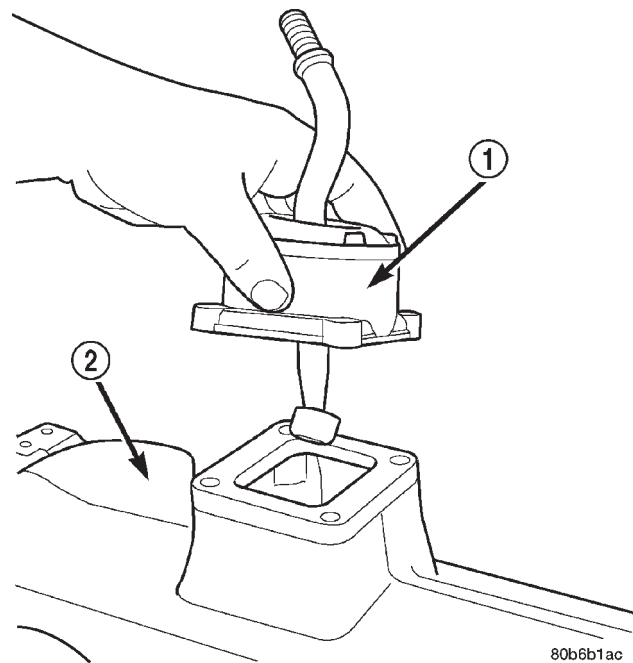
- (1) Using Fixture 8241, mount the transmission into the Build Fixture 8230 (Fig. 5).
- (2) Rotate the transmission to the horizontal position, if necessary.
- (3) Remove the shift tower (Fig. 6) and isolator plate (Fig. 7).
- (4) Remove primary shift rail detent plug (Fig. 8).
- (5) Remove primary shift rail detent spring (Fig. 9).
- (6) Remove primary shift rail detent plunger (Fig. 10).
- (7) Remove clutch housing bolts (10) (Fig. 11) from inside the housing.
- (8) Remove shift rail blocker bolt (Fig. 12) from the side of the transmission gear case.



80a2e751

**Fig. 5 TRANSMISSION BUILD FIXTURE**

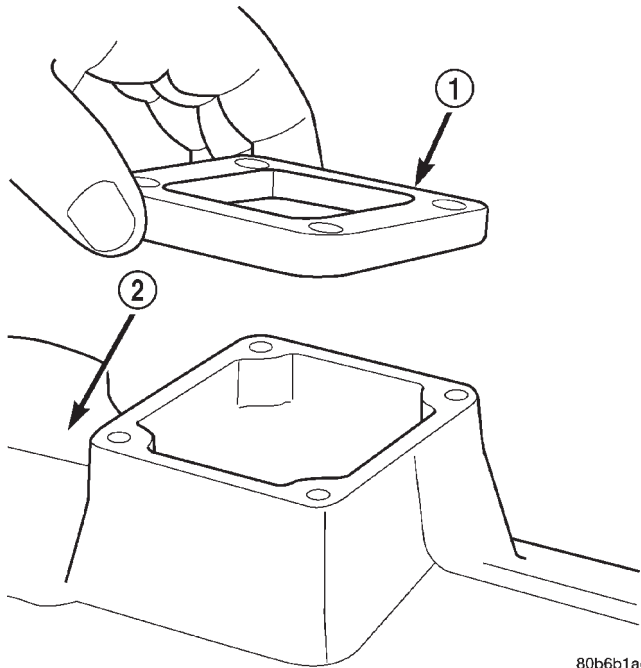
- 1 - FIXTURE
- 2 - TRANSMISSION



80b6b1ac

**Fig. 6 Shift Tower**

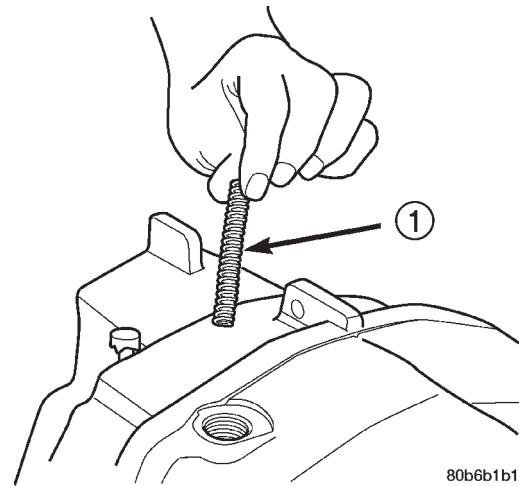
- 1 - SHIFT TOWER
- 2 - TRANSMISSION



80b6b1ad

**Fig. 7 Isolator Plate**

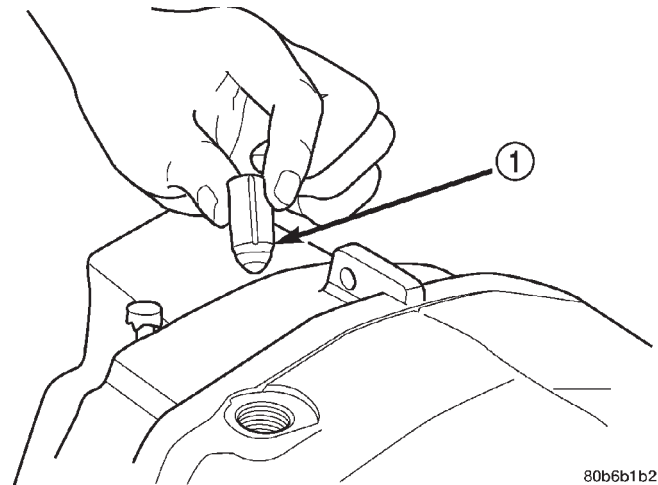
- 1 - ISOLATOR PLATE
- 2 - TRANSMISSION



80b6b1b1

**Fig. 9 PRIMARY SHIFT RAIL DETENT**

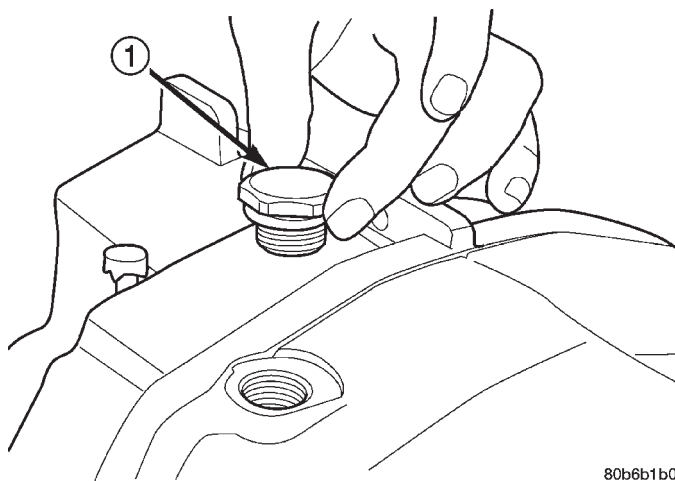
- 1 - PRIMARY SHFT RAIL DETENT SPRING



80b6b1b2

**Fig. 10 PRIMARY SHIFT RAIL DETENT**

- 1 - PRIMARY SHFT RAIL DETENT PLUNGER

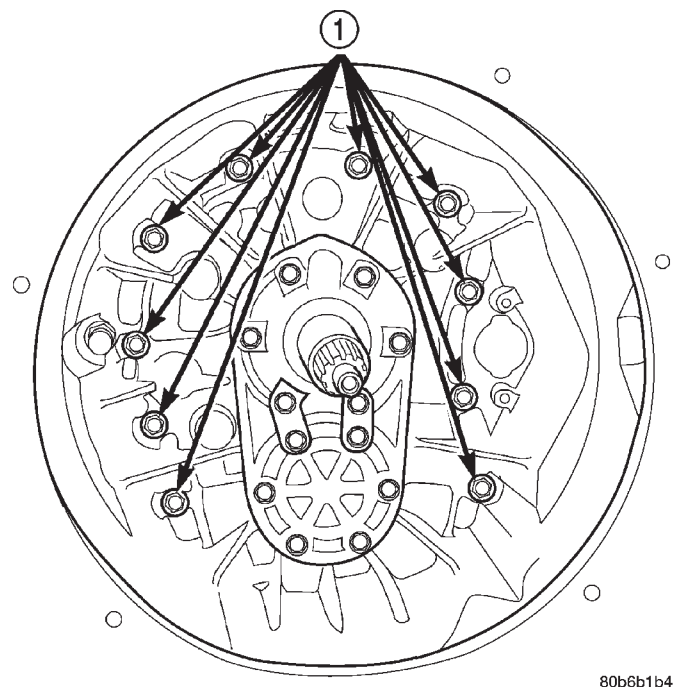


80b6b1b0

**Fig. 8 PRIMARY SHIFT RAIL DETENT**

- 1 - PRIMARY SHFT RAIL DETENT PLUG

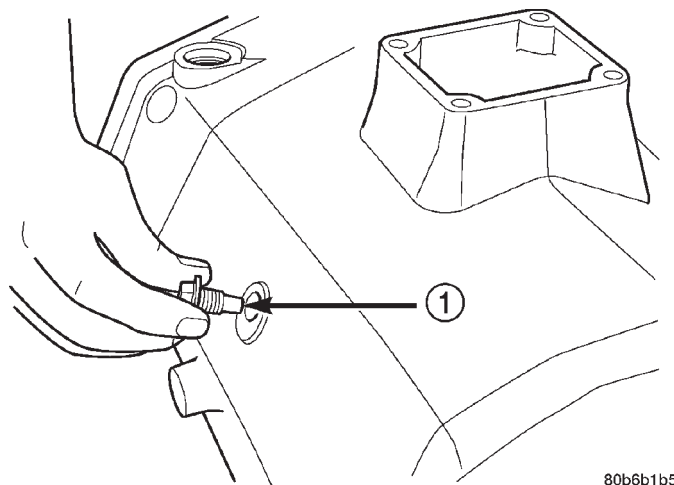
## MANUAL - NV5600 (Continued)



80b6b1b4

**Fig. 11 CLUTCH HOUSING BOLTS**

1 - BOLTS (10)



80b6b1b5

**Fig. 12 SHIFT RAIL BLOCKER BOLT**

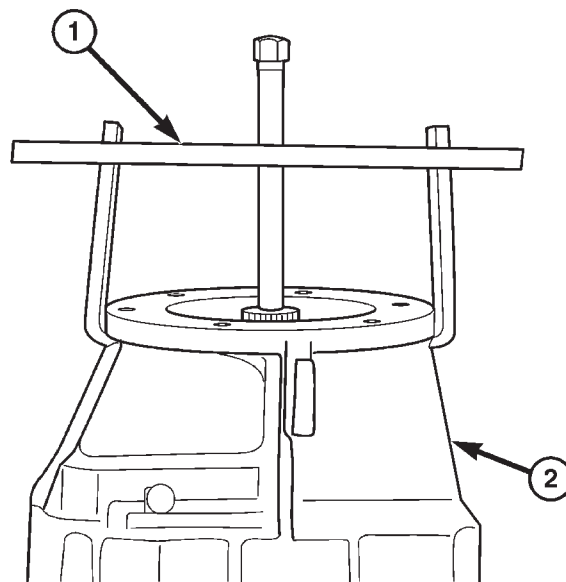
1 - SHIFT RAIL BLOCKER BOLT

**EXTENSION/ADAPTER HOUSING**

(1) Remove bolts holding the extension/adapter housing onto the transmission gear case.

(2) Remove extension/adapter housing from the transmission gear case with Puller 8244 (Fig. 13).

**NOTE:** It may be necessary to straighten the housing during removal due to the tendency for the reverse idler shaft to bind into one side of the housing.



80a2e76a

**Fig. 13 Trans Case Puller**

1 - PULLER

2 - EXTENSION/ADAPTER HOUSING

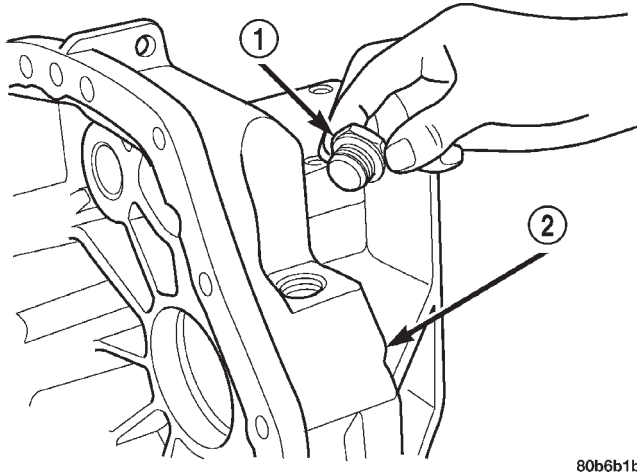
(3) Remove crossover detent plug, spring and plunger from the extension/adapter housing (Fig. 14).

(4) Remove bolt and washer holding the crossover cam to the extension/adapter housing (Fig. 15).

(5) Remove crossover cam from the extension/adapter housing.

(6) Remove back-up lamp switch and gasket from the extension/adapter housing.

(7) Remove countershaft rear bearing race from the extension/adapter housing with Remover L-4518 (Fig. 16).



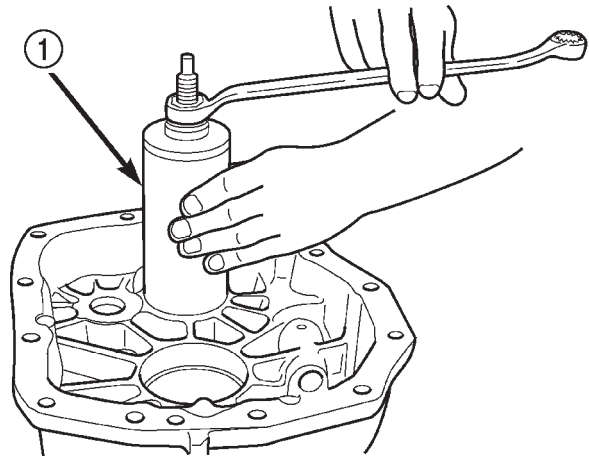
80b6b1b8

**Fig. 14 Crossover Cam Detent Plug**

- 1 - DETENT PLUG
- 2 - EXTENSION HOUSING

**NOTE:** Tag all countershaft pre-load shims from between the bearing race and the housing (Fig. 17).

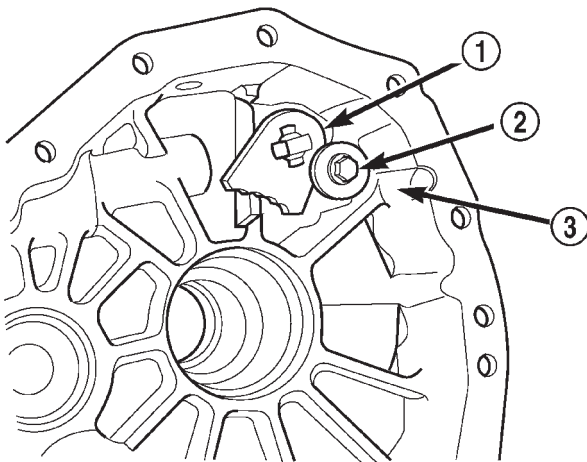
(8) Remove crossover cam bushing from the extension/adaptor housing with Remover 8240.



80b6b1bb

**Fig. 16 Countershaft Rear Bearing Race**

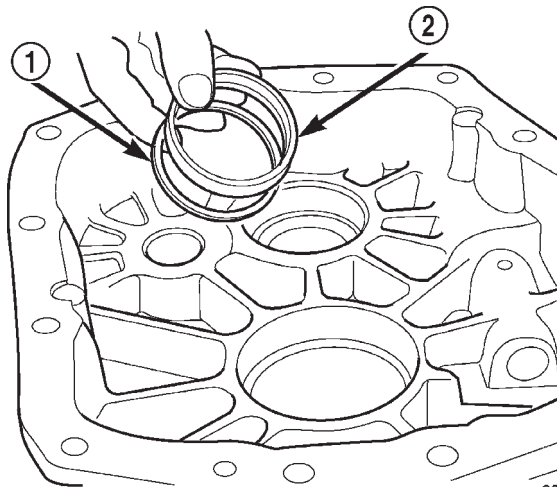
- 1 - REMOVER L-4518



80c07138

**Fig. 15 Crossover Cam Bolt**

- 1 - CROSSOVER CAM
- 2 - BOLT
- 3 - EXTENSION HOUSING



80b6b1bc

**Fig. 17 Countershaft Rear Bearing Race and Shim**

- 1 - PRE-LOAD SHIM
- 2 - BEARING RACE

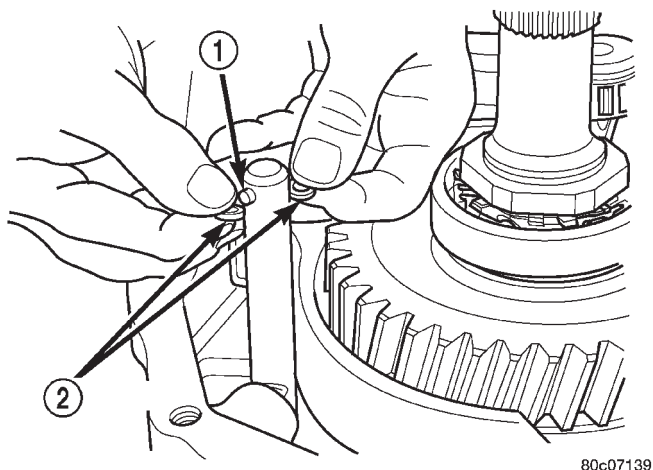
(9) On 4X2 vehicles, remove extension housing seal with a pry tool or a slide hammer mounted screw.

(10) On 4X4 vehicles, remove adapter housing seal with a pry tool or a slide hammer mounted screw.

## MANUAL - NV5600 (Continued)

## REVERSE GEAR

(1) Remove crossover cam rollers and pin (Fig. 18).



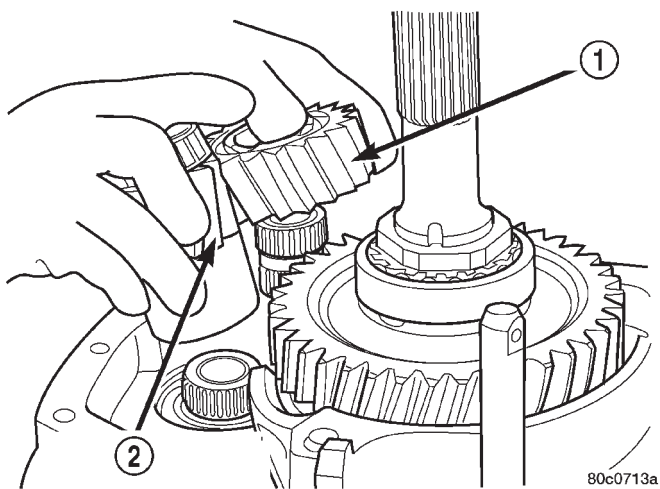
80c07139

**Fig. 18 CROSSOVER CAM ROLLERS**

- 1 - CROSSOVER CAM PIN  
2 - CROSSOVER CAM ROLLERS

(2) Remove reverse idler thrust washer from the reverse idler.

(3) Remove reverse idler and reverse countershaft gears together (Fig. 19).



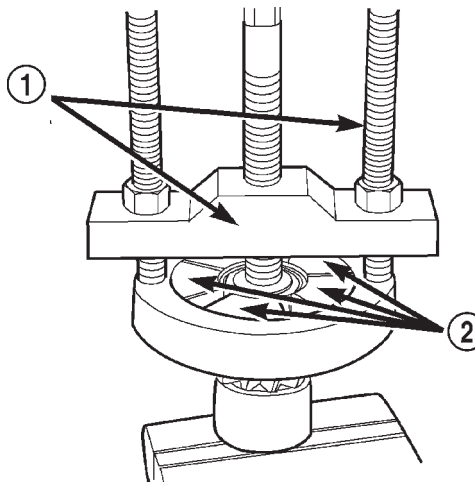
80c0713a

**Fig. 19 REVERSE IDLER AND COUNTERSHAFT**

- 1 - REVERSE IDLER GEAR  
2 - COUNTERSHAFT REVERSE GEAR

(4) Remove reverse idler gear rear bearing, bearing spacer, front bearing and front thrust washer from the idler gear shaft.

(5) Remove reverse countershaft rear bearing from the countershaft reverse gear assembly with Puller C-293-PA and Adapters C-293-52 (Fig. 20).

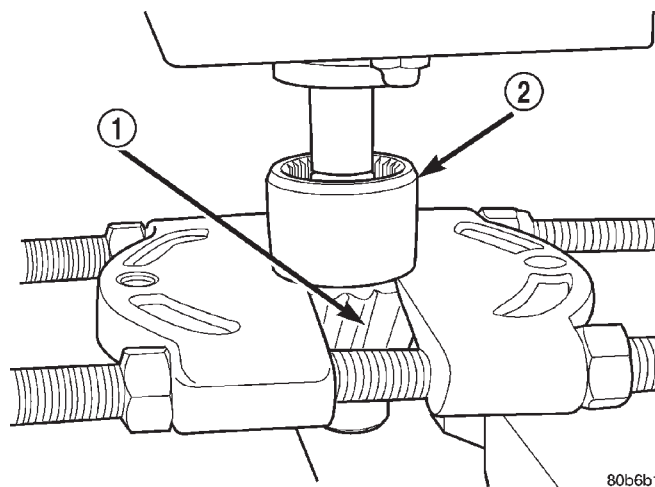


80b6b1c0

**Fig. 20 COUNTERSHAFT REAR BEARING**

- 1 - PULLER C-293-PA  
2 - ADAPTERS C-293-52

(6) With a bearing splitter and shop press separate the countershaft reverse gear and sleeve (Fig. 21).



80b6b1c1

**Fig. 21 Reverse Countershaft**

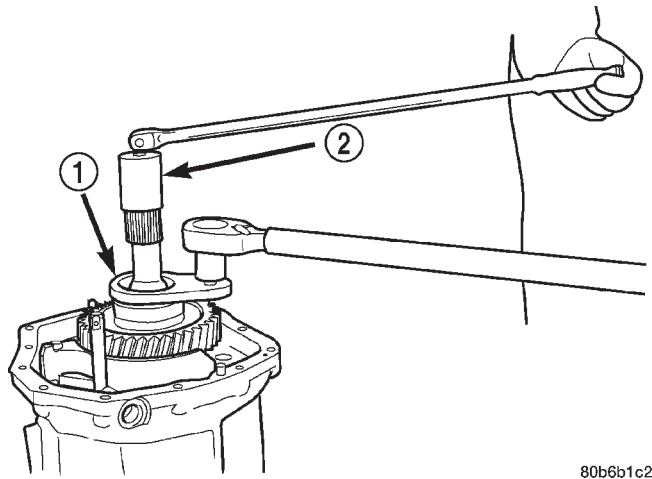
- 1 - COUNTERSHAFT REVERSE GEAR  
2 - SLEEVE



## MANUAL - NV5600 (Continued)

(7) Remove output shaft nut with Wrench 8226 on the shaft nut and Socket 6993 or 6984 to hold the shaft (Fig. 22). Discard output shaft nut from the output shaft.

**NOTE:** If necessary strike the flat side area of Wrench 8226 with a hammer to break the nut loose.

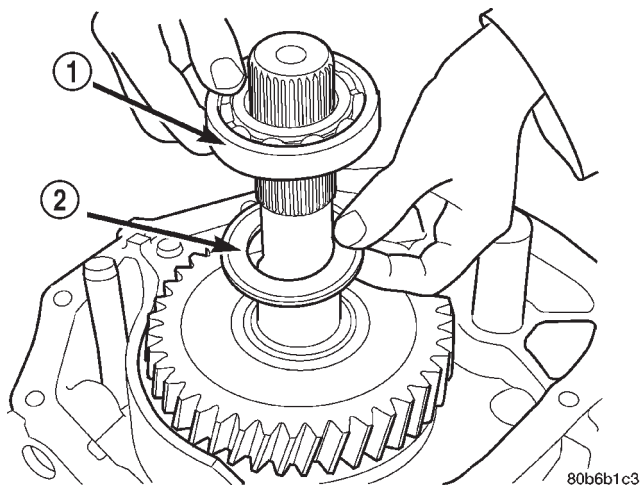


80b6b1c2

**Fig. 22 Output Shaft Nut**

- 1 - WRENCH 8226  
2 - SOCKET 6993

(8) Remove output shaft ball bearing assembly and reverse thrust washer from the output shaft (Fig. 23).

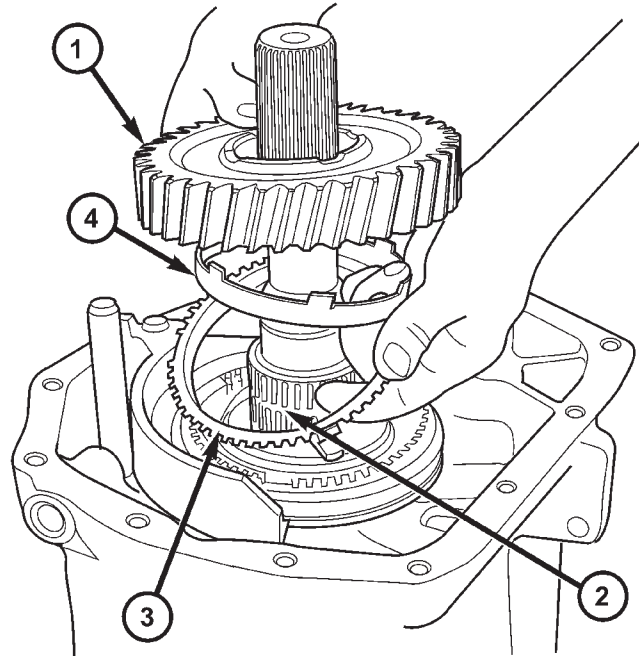


80b6b1c3

**Fig. 23 INSTALL OUTPUT SHAFT BEARING**

- 1 - OUTPUT SHAFT BALL BEARING  
2 - THRUST WASHER

(9) Remove reverse gear, reverse gear synchronizer cone, reverse gear outer blocker ring and reverse gear bearing (Fig. 24).



809f4ceb

**Fig. 24 REVERSE GEAR COMPONENTS**

- 1 - REVERSE GEAR  
2 - REVERSE BEARING  
3 - BLOCKER RING  
4 - FRICTION CONE

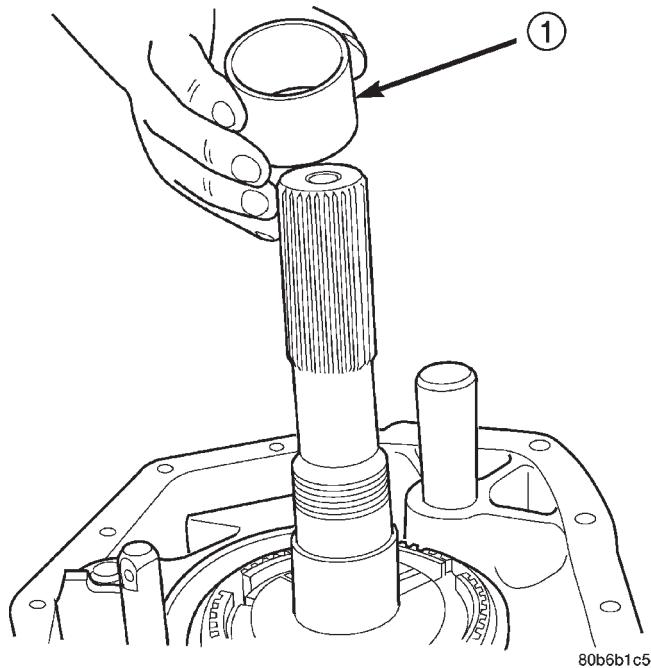
(10) Remove reverse gear bearing sleeve from the output shaft (Fig. 25).

**NOTE:** If necessary heat the sleeve slightly with a heat gun. Do not use a torch to heat the sleeve or damage to the output shaft may occur.

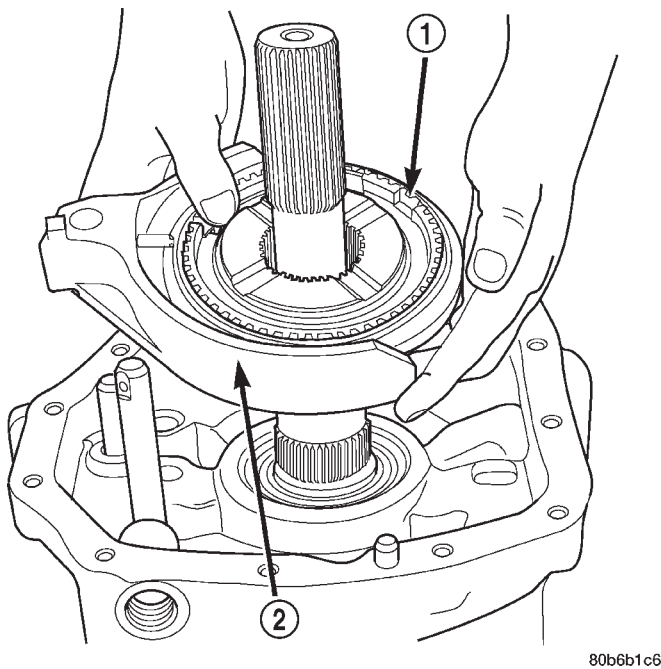
(11) Remove roll-pin securing the reverse shift fork to the reverse shift rail. Use a 6mm (7/32 inch) punch and hammer.

(12) Remove reverse shift fork and synchronizer as an assembly from the reverse shift rail and the output shaft (Fig. 26).

## MANUAL - NV5600 (Continued)

**Fig. 25 REVERSE BEARING SLEEVE**

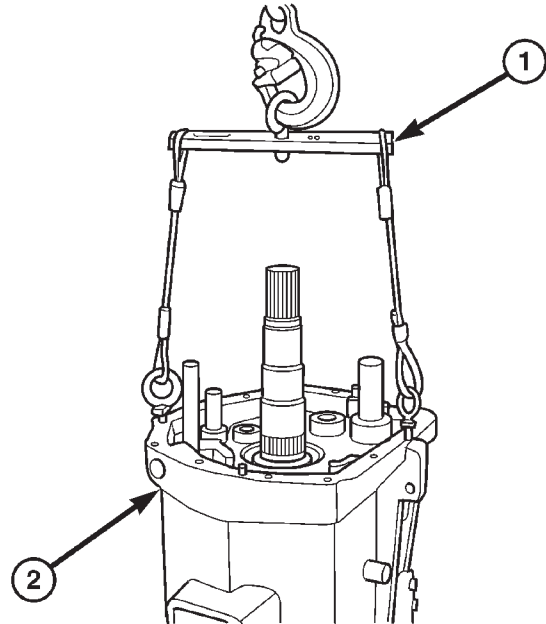
1 - REVERSE GEAR BEARING SLEEVE

**Fig. 26 REVERSE SHIFT FORK**1 - REVERSE SYNCHRO  
2 - REVERSE SHIFT FORK**TRANSMISSION GEAR CASE**

- (1) Remove remaining bolts holding the transmission gear case to the clutch housing.
- (2) Remove the shift socket roll pin with a 6mm (7/32 inch) punch and hammer.

(3) Install Fixture 8232 to the transmission gear case.

(4) Attach an engine crane or equivalent to Fixture 8232 and remove the transmission gear case from the clutch housing (Fig. 27).

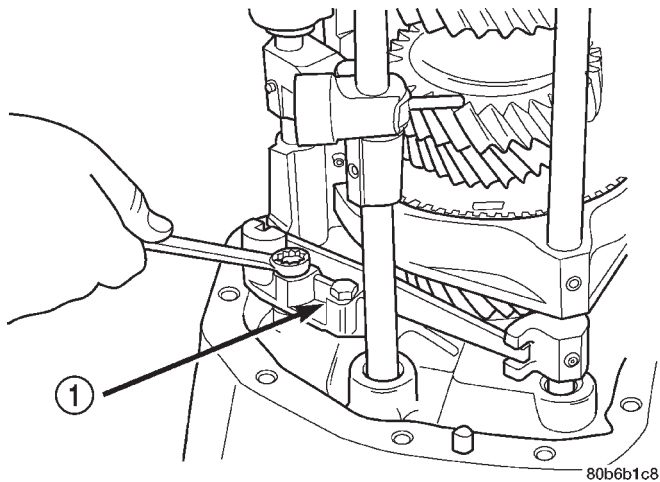
**Fig. 27 TRANSMISSION LIFT**1 - FIXTURE 8232  
2 - TRANSMISSION CASE

(5) Remove rear output shaft and countershaft bearing races from the transmission gear case with a brass drift and hammer.

**GEARTRAIN**

- (1) Remove bolts holding the 5-6 crossover bracket to the clutch housing (Fig. 28).
- (2) Attach Fixture 8232 to the output shaft and countershaft (Fig. 29).
- (3) Attach an engine crane or equivalent to Fixture 8232 and raise the geartrain approximately 1/4 in. from the clutch housing.
- (4) Remove 5-6 crossover bracket from the clutch housing.
- (5) Lower the geartrain back into the clutch housing.
- (6) Install Holding Tool 8242 (Fig. 30) onto the 5-6 synchro and tighten the screw to hold the 5-6 synchro together during the removal operation.

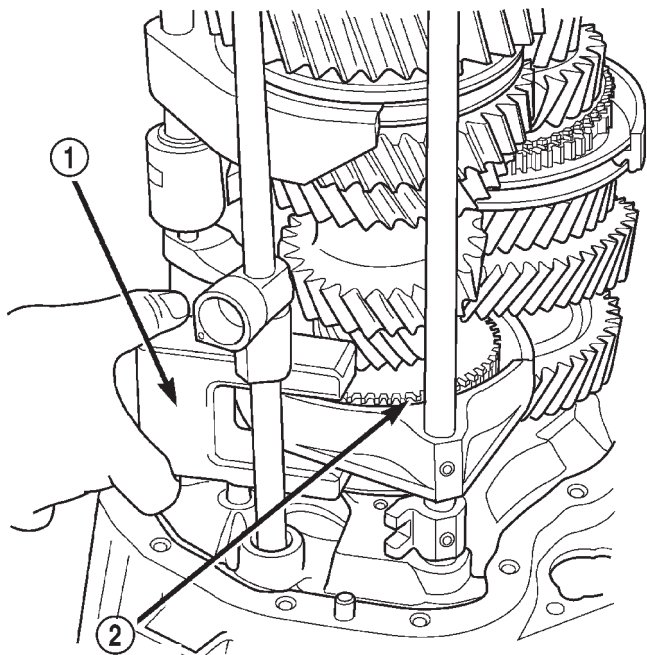
**NOTE:** Pay attention to the order of the shift fork arms at the primary shift rail when they are in the Neutral position.



80b6b1c8

**Fig. 28 5-6 CROSSOVER**

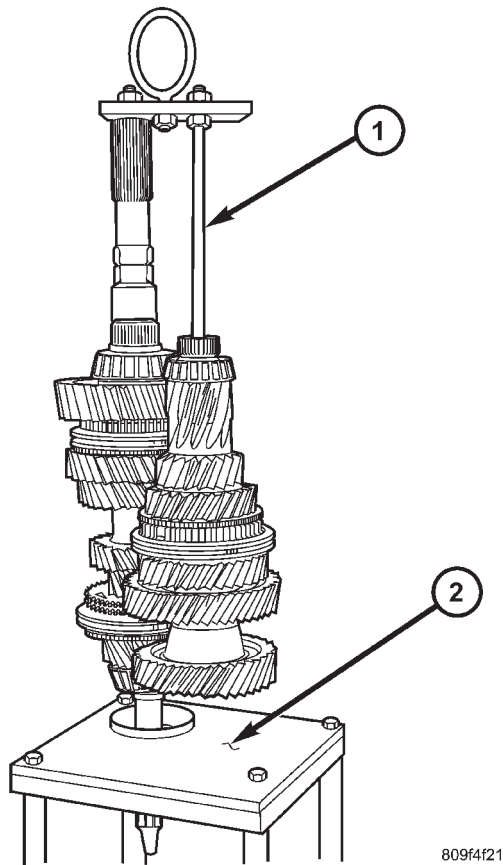
1 - 5-6 CROSSOVER BRACKET



80b6b1c9

**Fig. 30 HOLDING TOOL 8242**

1 - HOLDING TOOL 8242  
2 - 5-6 SYNCHRO

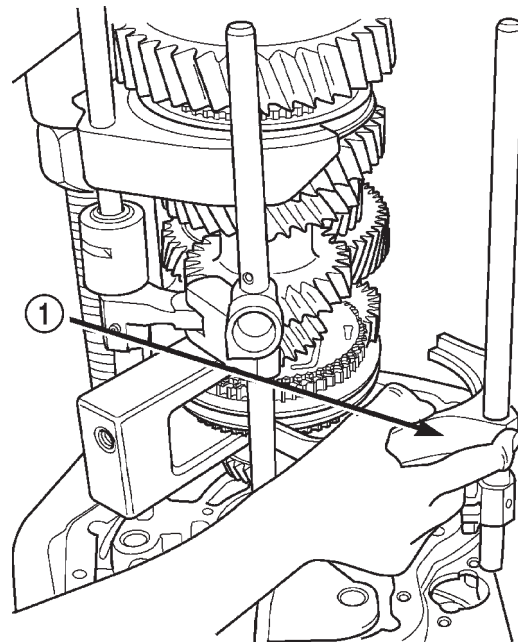


809f4f21

**Fig. 29 ATTACH FIXTURE 8232**

1 - FIXTURE 8232

(7) Raise geartrain and shift rails until all the shift rails clear the clutch housing.



80b6b32f

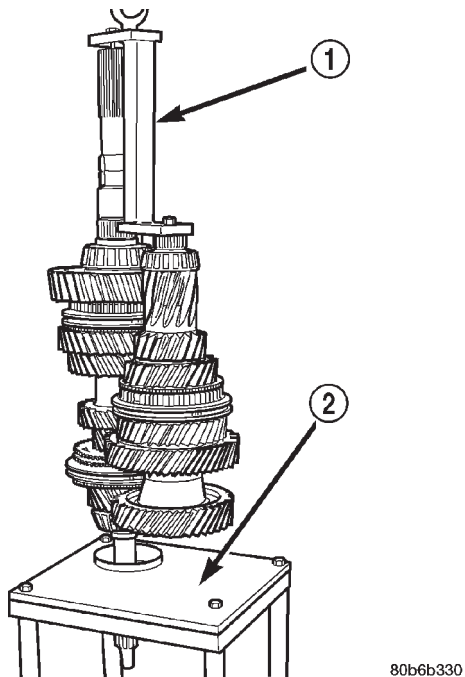
**Fig. 31 SHIFT RAILS**

1 - SHIFT RAILS

(9) Raise the geartrain until the input shaft is clear of the clutch housing.

## MANUAL - NV5600 (Continued)

(10) Remove geartrain from the clutch housing and install the geartrain into Support Stand 8246 (Fig. 32).



80b6b330

**Fig. 32 LIFT GEARTRAIN WITH ENGINE CRANE**

1 - FIXTURE 8232  
2 - SUPPORT STAND 8246

(11) Remove Fixture 8232 from the output shaft and the countershaft.

(12) Separate the countershaft from the output shaft.

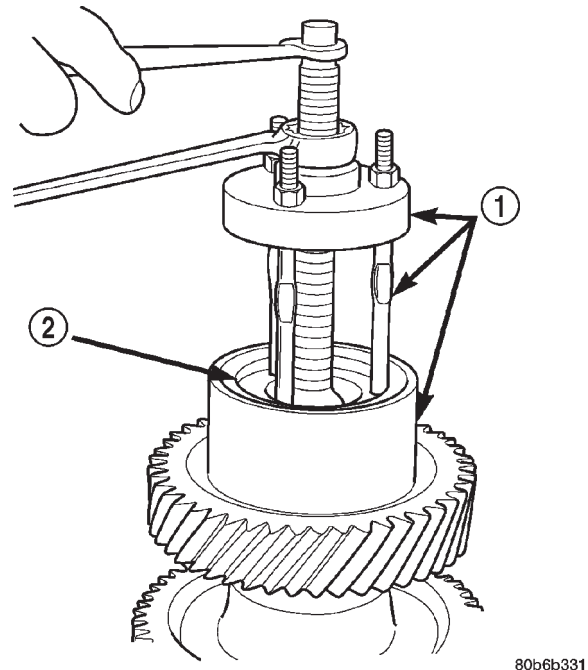
(13) Separate the output shaft from the input shaft. Hold the 5-6 synchro together while removing the output shaft to prevent the synchro sleeve from being dislodged from the synchro hub.

#### COUNTERSHAFT BEARINGS

(1) Remove snap-ring holding the front countershaft bearing onto the countershaft.

(2) Remove front countershaft bearing with Sleeve 6444-8, Adapters 6451, Puller Rods 6444-4 and Puller 6444 (Fig. 33).

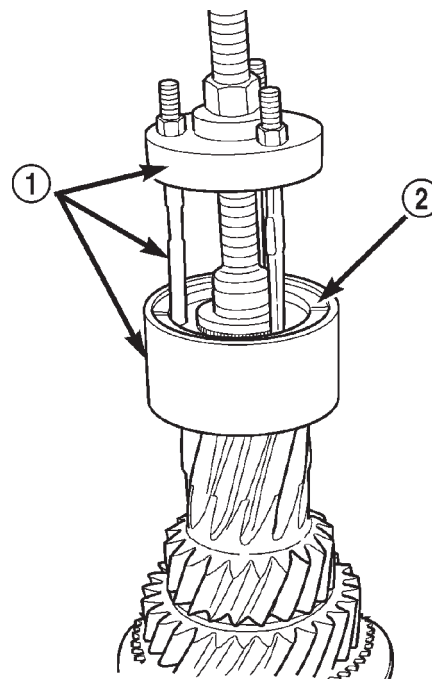
(3) Remove rear countershaft bearing with Sleeve 6444-8, Adapters 6447, Puller Rods 6444-4, Puller 6444 and suitable press button (Fig. 34).



80b6b331

**Fig. 33 FRONT COUNTERSHAFT BEARING**

1 - PULLER 6444  
2 - ADAPTERS 6451



80b6b334

**Fig. 34 REAR COUNTERSHAFT BEARING**

1 - PULLER 6444  
2 - ADAPTERS 6447

## MANUAL - NV5600 (Continued)

## OUTPUT SHAFT BEARINGS

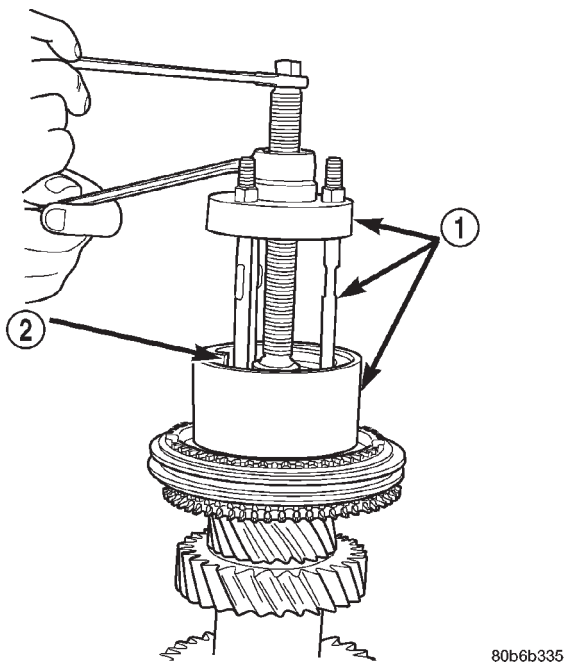
(1) Remove snap-ring holding the pocket bearing onto the output shaft.

(2) Remove pocket bearing from the output shaft with Sleeve 6444-8, Adapters 8234, Puller Rods 6444-4 and the remainder of Puller 6444 (Fig. 35).

(3) Remove snap-ring holding the rear output shaft bearing onto the output shaft.

(4) Use Sleeve 6444-8, Adapters 8271 and Puller Rods 6444-3 for 4X2 vehicles or Puller Rods 6444-4 for 4X4 vehicles with the remainder of Puller 6444 to remove the rear output shaft bearing from the output shaft.

(5) Remove rear output shaft thrust washer from the output shaft.



80b6b335

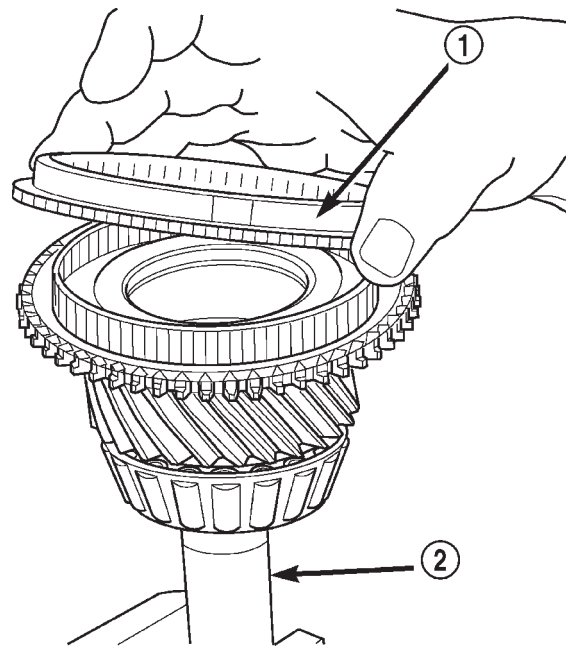
**Fig. 35 OUTPUT SHAFT POCKET BEARING**

- 1 - PULLER 6444  
2 - ADAPTERS 8234

## INPUT SHAFT

(1) Remove fifth gear blocker ring from the input shaft (Fig. 36).

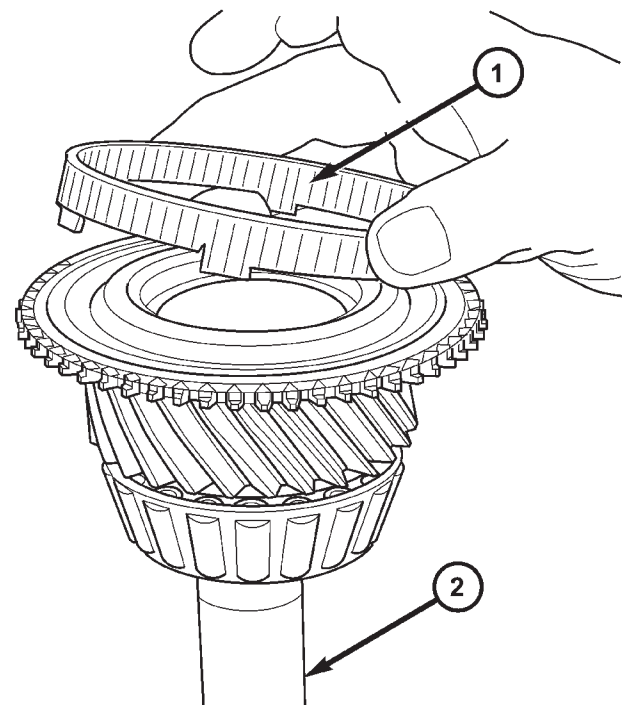
(2) Remove fifth gear friction cone from the input shaft (Fig. 37).



80b6b336

**Fig. 36 FIFTH GEAR BLOCKER RING**

- 1 - FIFTH GEAR BLOCKER RING  
2 - INPUT SHAFT



809f507a

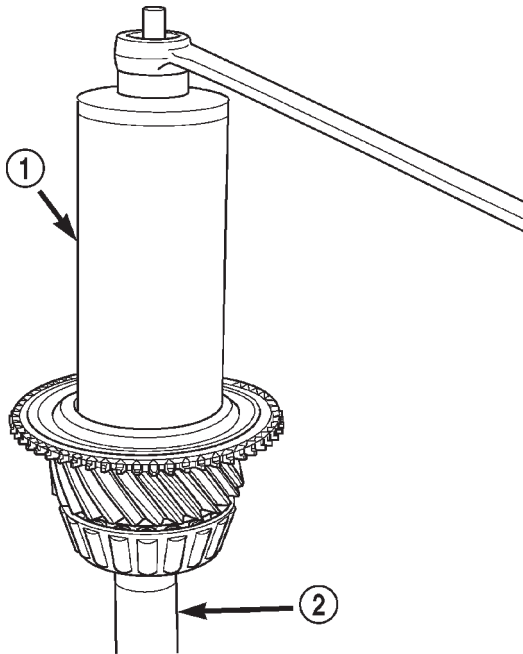
**Fig. 37 FIFTH GEAR FRICTION CONE**

- 1 - FIFTH GEAR FRICTION CONE  
2 - INPUT SHAFT



## MANUAL - NV5600 (Continued)

(3) Remove output shaft pocket bearing race from the input shaft with Puller L-4518 (Fig. 38).



80b6b339

**Fig. 38 OUTPUT SHAFT POCKET BEARING**

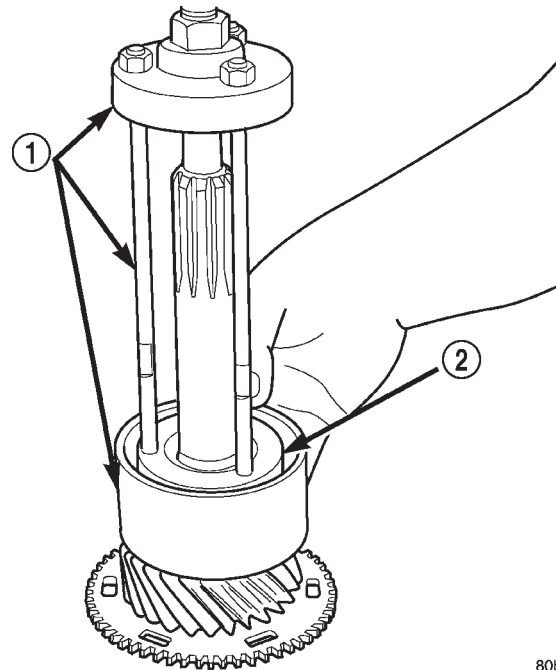
- 1 - PULLER L-4518  
2 - INPUT SHAFT

(4) Remove input shaft bearing and oil guide from the input shaft with Sleeve 6444-8, Adapters 8243, Puller Rods 6444-6 and the remainder of Puller 6444 (Fig. 39).

## OUTPUT SHAFT

**NOTE:** Some gear and synchro components can be installed backwards. To avoid assembly problems, mark the gears, clutch gears, synchro hubs, and sleeves for reference during teardown. Use paint or a scribe for marking purposes. Then stack the geartrain parts in order of removal. This practice will help avoid incorrect assembly.

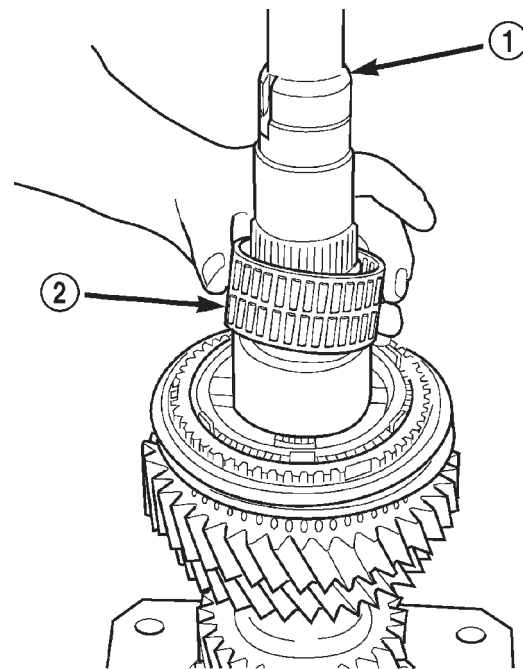
- (1) Remove first gear from the output shaft.
- (2) Remove first gear bearing from the output shaft (Fig. 40).
- (3) Remove first gear blocker rings (2) and cones from the 1-2 synchro assembly (Fig. 41).
- (4) Install the remainder of the output shaft into Fixture 8227 with press blocks under second gear.
- (5) Install shaft and Fixture assembly into a shop press (Fig. 42).
- (6) Press second gear, 1-2 synchro assembly and first gear bearing sleeve from the output shaft.
- (7) Remove second gear bearing from the output shaft.



80b6b33a

**Fig. 39 INPUT SHAFT BEARING**

- 1 - PULLER 6444  
2 - ADAPTERS 8243



80b6b33b

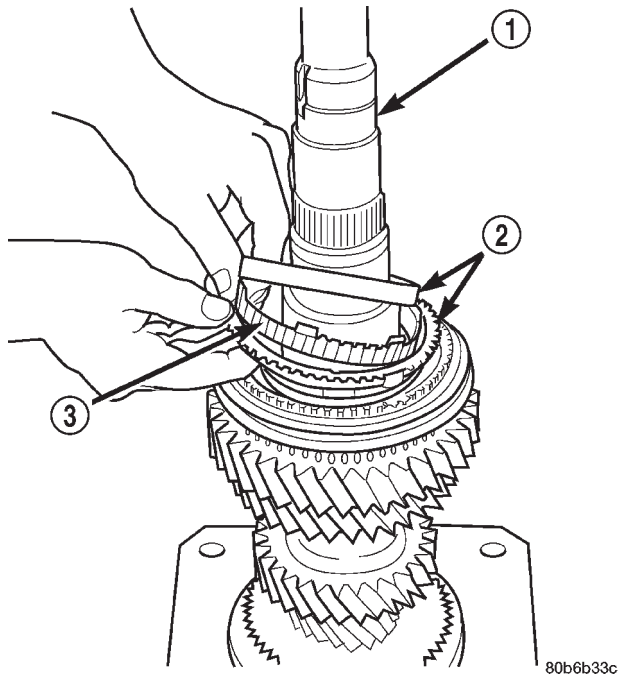
**Fig. 40 FIRST GEAR BEARING**

- 1 - OUTPUT SHAFT  
2 - FIRST GEAR BEARING

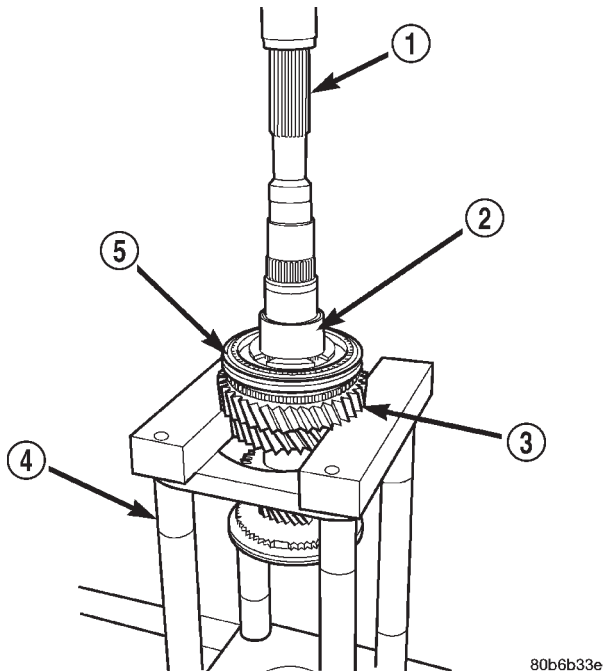
(8) Reverse output shaft in the Fixture 8227 with press blocks positioned under the 5-6 synchro assembly.



MANUAL - NV5600 (Continued)

**Fig. 41 FIRST GEAR BLOCKER RINGS**

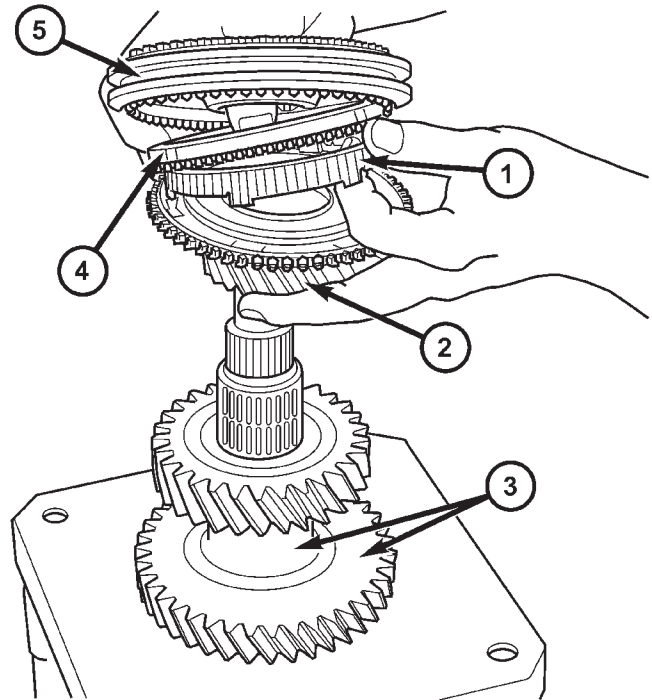
- 1 - OUTPUT SHAFT
- 2 - FIRST GEAR BLOCKER RINGS
- 3 - FIRST GEAR FRICTION CONE

**Fig. 42 SECOND GEAR 1-2 SYNCRO**

- 1 - OUTPUT SHAFT
- 2 - FIRST GEAR BEARING SLEEVE
- 3 - SECOND GEAR
- 4 - FIXTURE
- 5 - 1-2 SYNCRO 8227

(9) Press the 5-6 synchro assembly from the output shaft.

(10) Remove sixth gear and the sixth gear bearing from the output shaft (Fig. 43).

**Fig. 43 SIXTH GEAR COMPONENTS**

- 1 - SIXTH GEAR FRICTION CONE
- 2 - SIXTH GEAR
- 3 - OUTPUT SHAFT
- 4 - SIXTH GEAR BLOCKER RING
- 5 - 5-6 SYNCRO

**COUNTERSHAFT**

(1) Install the countershaft into Fixture 8227 with press blocks located under the fifth countershaft gear.

(2) Place the assembly into a shop press.

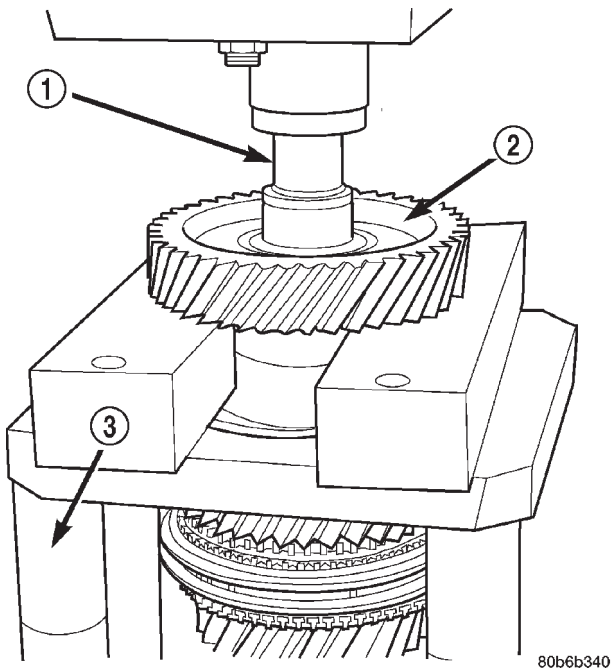
(3) Use Guide 8235 on end of countershaft and press the countershaft fifth gear from the countershaft (Fig. 44).

(4) Place countershaft in Fixture 8227 with press blocks placed under the sixth countershaft gear.

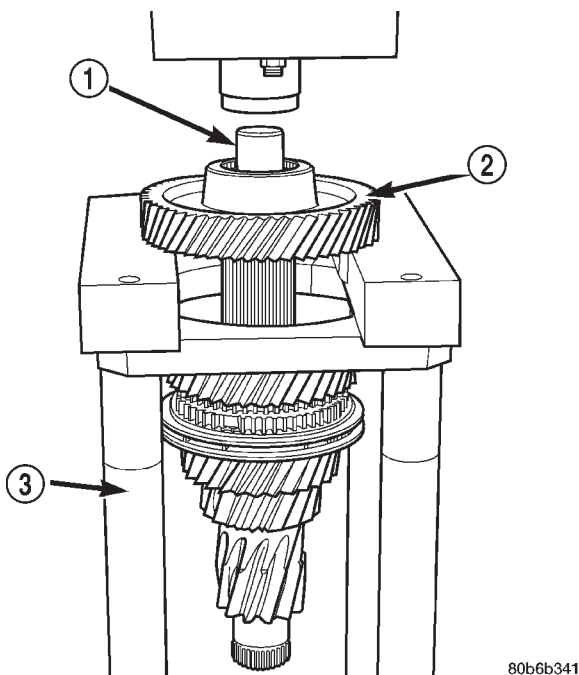
(5) Use Guide 8235 on end of countershaft and press the countershaft sixth gear from the countershaft (Fig. 45).

(6) Remove countershaft from the press and Fixture 8227.

## MANUAL - NV5600 (Continued)

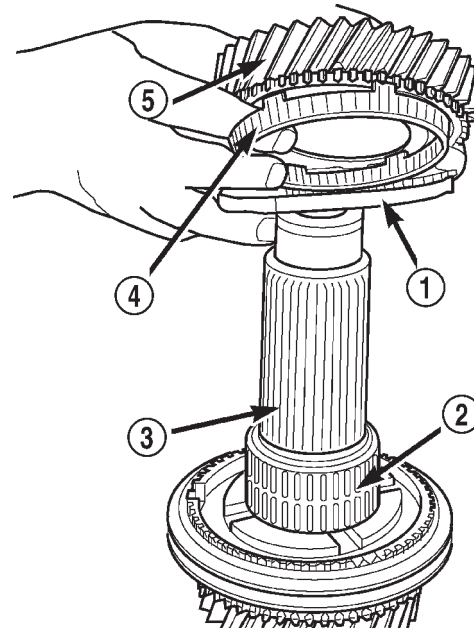
**Fig. 44 FIFTH COUNTERSHAFT GEAR**

- 1 - GUIDE 8235
- 2 - FIFTH COUNTER SHAFT GEAR
- 3 - FIXTURE 8227

**Fig. 45 SIXTH COUNTERSHAFT GEAR**

- 1 - GUIDE 8235
- 2 - SIXTH COUNTER SHAFT GEAR
- 3 - FIXTURE 8227

(7) Remove fourth countershaft gear, friction cone, blocker ring and bearing from the countershaft (Fig. 46).

**Fig. 46 FOURTH COUNTERSHAFT GEAR**

- 1 - FOURTH GEAR BLOCKER RING
- 2 - FOURTH GEAR BEARING
- 3 - COUNTERSHAFT
- 4 - FOURTH GEAR FRICTION CONE
- 5 - FOURTH COUNTERSHAFT GEAR

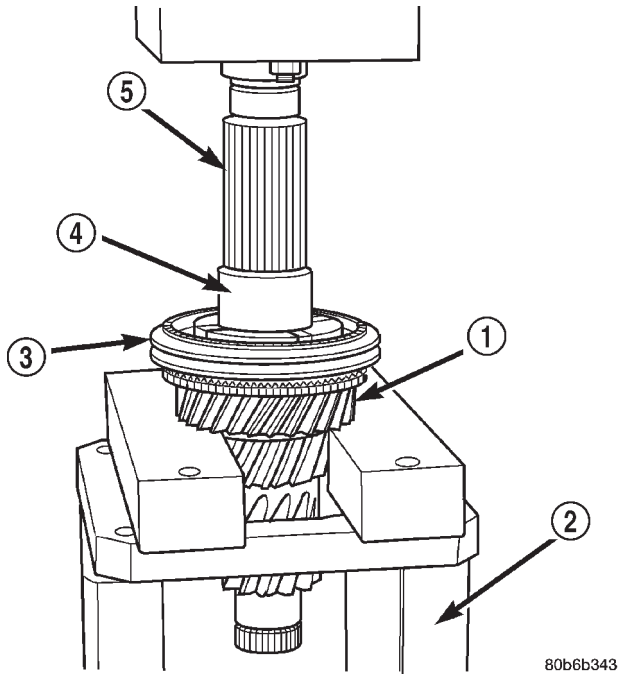
(8) Install countershaft into Fixture 8227 with press blocks located under the third countershaft gear

(9) Place assembly into a shop press and press third countershaft gear, 3-4 synchro, and fourth countershaft gear bearing sleeve from the countershaft (Fig. 47).

(10) Remove countershaft from the press and Fixture 8227.

(11) Remove third countershaft gear bearing from the countershaft (Fig. 48).

(12) The 2-3 thrust washer should not normally need to be removed from the countershaft. If necessary slid 2-3 thrust washer off countershaft.



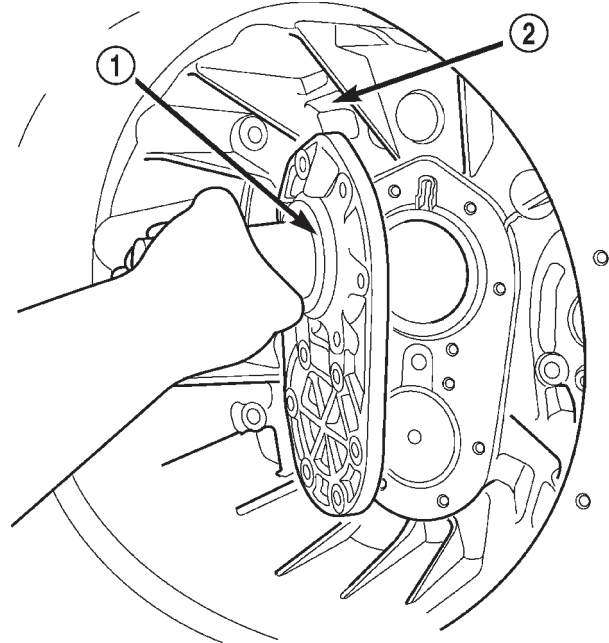
80b6b343

**Fig. 47 THIRD COUNTERSHAFT GEAR**

- 1 - THIRD COUNTERSHAFT GEAR
- 2 - FIXTURE 8227
- 3 - 3-4 SYNCHRO
- 4 - BEARING SLEEVE
- 5 - COUNTERSHAFT

**CLUTCH HOUSING**

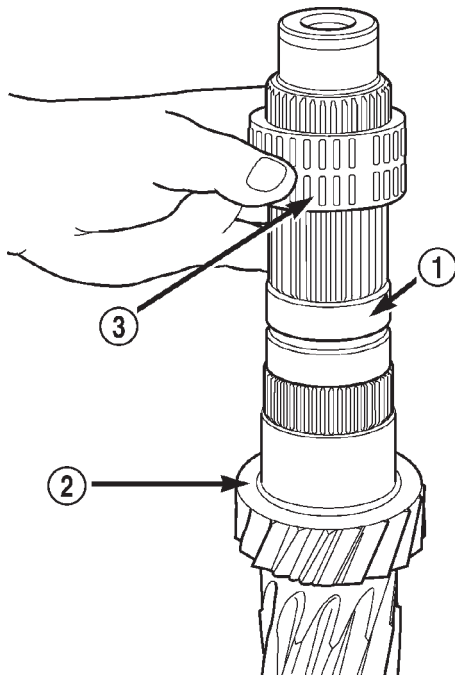
(1) Remove input shaft retainer bolts from the clutch housing and remove retainer (Fig. 49).



80b6b345

**Fig. 49 INPUT SHAFT RETAINER**

- 1 - INPUT SHAFT RETAINER
- 2 - CLUTCH HOUSING



80b6b344

**Fig. 48 THIRD GEAR BEARING**

- 1 - COUNTERSHAFT
- 2 - 2-3 THRUST WASHER
- 3 - THIRD COUNTERSHAFT GEAR BEARING

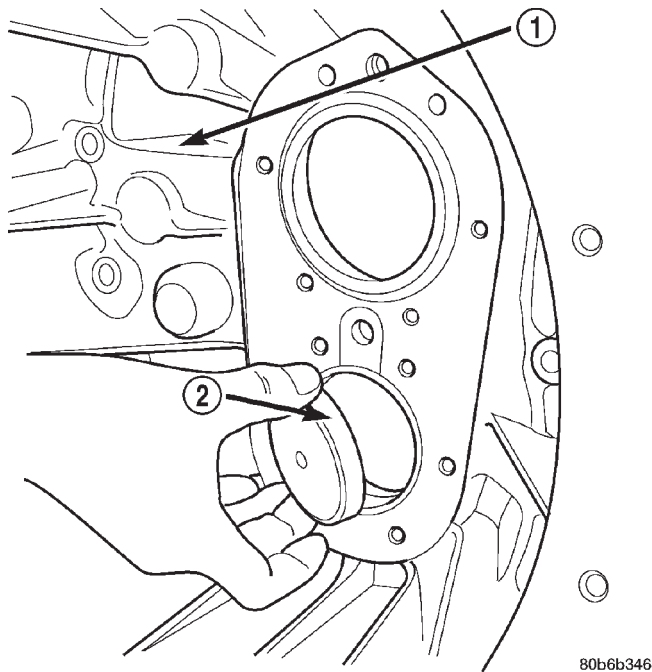
(2) Remove countershaft oil guide from the countershaft front bearing bore in the clutch housing (Fig. 50).

(3) Remove countershaft front bearing race, end-play shims, and spacer from the clutch housing with Remover 6061-1 and Handle C-4171 (Fig. 51).

(4) Remove input shaft bearing race with Remover/Installer 8237 and Handle C-4171.

(5) Remove input shaft oil guide and retainer seal (Fig. 52).

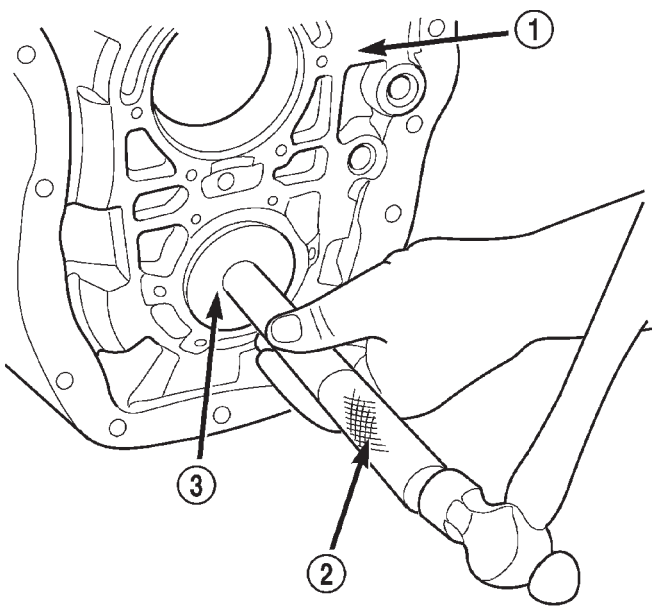
## MANUAL - NV5600 (Continued)



80b6b346

**Fig. 50 COUNTERSHAFT OIL GUIDE**

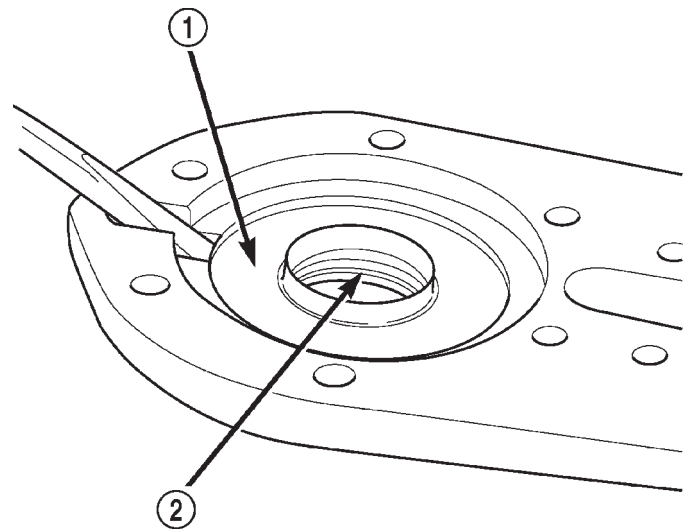
- 1 - CLUTCH HOUSING
- 2 - COUNTERSHAFT OIL GUIDE



80b6b347

**Fig. 51 FRONT COUNTERSHAFT BEARING**

- 1 - CLUTCH HOUSING
- 2 - HANDLE C-4171
- 3 - REMOVER 6061-1



80b6b348

**Fig. 52 OIL GUIDE AND SEAL**

- 1 - INPUT SHAFT OIL GUIDE
- 2 - INPUT SHAFT OIL SEAL

**CLEANING - TRANSMISSION**

Clean the gears, bearings shafts, extension/adaptor housing and gear case with solvent. Dry all parts except the bearings with compressed air. Allow the bearings to either air dry or wipe them dry with clean shop towels.

Run a tap through the gear case bolt holes if the threads need minor cleanup. Helicoil inserts can be used to repair seriously damaged threaded holes if necessary.

**INSPECTION - TRANSMISSION**

Inspect the reverse idler gear, bearings, shaft and thrust washers. Replace the bearings if the rollers are worn, chipped, cracked, flat-spotted or brinnelled. Or if the bearing cage is damaged or distorted. Replace the thrust washers if cracked, chipped or worn. Replace the gear if the teeth are chipped, cracked or worn thin.

Inspect the drive gear and bearings. Minor scratches and burrs on the gear surfaces can be reduced with an oil stone and 400 grit paper wetted with oil. Replace either bearing if worn, or damaged. Replace the gear if any teeth, splines, or bearing surfaces are also worn or damaged.

Inspect the front bearing retainer and bearing cup. Replace the bearing cup if scored, cracked, brinnelled or rough. Check the release bearing slide surface of the retainer carefully. Minor corrosion, nicks, or pitting can be smoothed with 400 grit emery and polished out with crocus cloth. Wet the abrasive paper

## MANUAL - NV5600 (Continued)

and crocus cloth with oil when smoothing/polishing. Replace the retainer if worn or damaged in any way. Do not reuse original retainer bolts. Install new bolts during assembly.

Inspect the countershaft and bearings. Replace the bearings if worn, rough, flat spotted or heat checked. Check the countershaft gear teeth carefully. Small nicks, scratches or burrs can be removed with an oil stone and 400 grit paper wetted with oil. Replace the shaft if any of the teeth are worn, cracked, broken or severely chipped.

Be sure to check condition of the countershaft bearing cups. Replace either bearings cup if worn, or damaged.

Check condition of the mainshaft. Inspect all the bearing surfaces, splines and threads. Also check condition of the snap ring grooves in the hub area and the speedometer drive gear teeth. Minor scratches or burrs can be removed with an oil stone and polished with crocus cloth. However, replace the shaft if any surfaces exhibit considerable wear or damage.

Check condition of the gear case and extension or adapter housing. Be sure the alignment dowels in the case top surface and in the housing/adapter are tight and in good condition.

Run a tap through the gear case bolt holes if the threads need minor cleanup. Helicoil inserts can be used to repair seriously damaged threaded holes if necessary.

Be sure all case and housing/adapter sealing and mating surfaces are free of burrs and nicks. This is especially important as gaskets are not used in the transmission. Minor nicks and scratches on the sealing surfaces can be dressed off with a fine tooth file or oil stone.

Replace the gear case or housing/adapter if cracked or broken. Do not attempt to repair this type of damage by welding or brazing.

Check condition of the countershaft fifth gear components. This includes the shift lug and rail located in the gear case and the rail bushings.

Inspect the gear and hub assembly. Minor burrs can be cleaned up with an oil stone. However, the gear and hub assembly should be replaced if the teeth or splines are excessively worn, or damaged. The synchro sleeve should also be replaced if worn or damaged in any way. Do not reuse synchro struts that are worn or springs that are collapsed or severely distorted. Replace worn distorted synchro parts to avoid shift problems after assembly and installation.

The shift fork should be inspected for evidence of wear and distortion. Check fit of the sleeve in the fork to be sure the two parts fit and work smoothly. Replace the fork if the roll pin holes are worn over-size or damaged. Do not attempt to salvage a worn

fork. It will cause shift problems later on. Replace shift fork roll pins if necessary or if doubt exists about their condition.

The bearings should be examined carefully for wear, roughness, flat spots, pitting or other damage. Replace the bearings if necessary.

Inspect the blocker ring and clutch gear. replace either part if worn or damaged in any way. Also be sure replacement parts fit properly before proceeding with assembly.

Examine the 1-2 synchro hub and sleeve for wear or damage. Replace sleeve and hub if the splines are worn, chipped or damaged.

Replace the synchro struts if worn, or chipped. Also replace the springs if collapsed, distorted or broken.

Inspect the mainshaft geartrain components. Check teeth on all gears, hubs, clutch gears, stop rings and clutch rings. The teeth must be in good condition and not worn, cracked or chipped. Replace any component that exhibits wear or damage.

Examine the synchro stop rings, clutch rings and clutch gears. Replace any part that exhibits wear, distortion or damage. Replace the clutch rings if the friction material is burned, flaking off or worn.

Inspect all of the thrust washers and locating pins. Replace the pins if bent or worn. Replace the washers if worn or the locating pin notches are distorted.

Check condition of the synchro struts and springs. Replace these parts if worn, cracked or distorted.

## ASSEMBLY

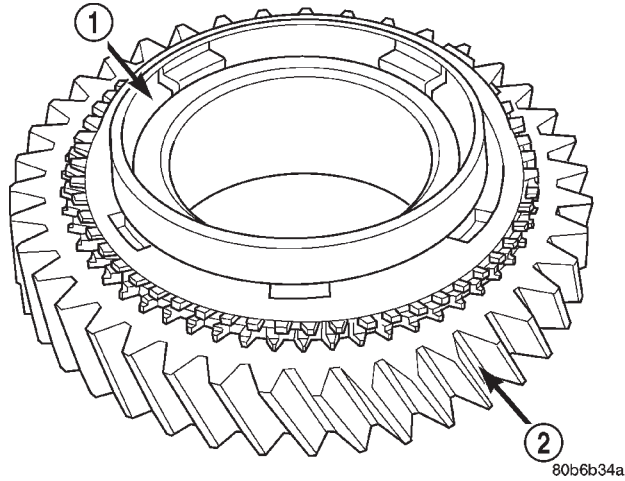
**NOTE: Gaskets are not used in the transmission. Use Mopar® Gasket Maker or equivalent on all gear case and extension housing sealing surfaces.**

### OUTPUT SHAFT

- (1) Place second gear on bench with the synchro clutch ring up.
- (2) Install second gear synchro inner blocker ring onto second gear (Fig. 53).
- (3) Install second gear synchro friction cone over the blocker ring and onto second gear (Fig. 54).
- (4) Install second gear synchro outer blocker ring over the second gear synchro friction cone. Align one of the lugs on the outer ring with a lug on the inner ring (Fig. 55).
- (5) Install 1-2 synchro assembly onto the second gear assembly (Fig. 56).
- (6) Reverse assembly on the bench.

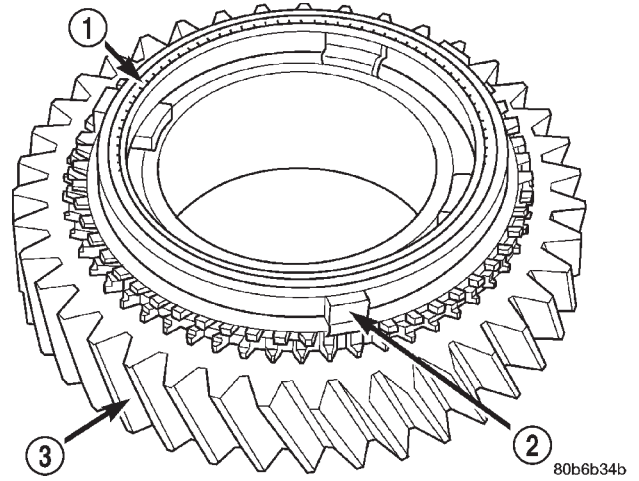


MANUAL - NV5600 (Continued)



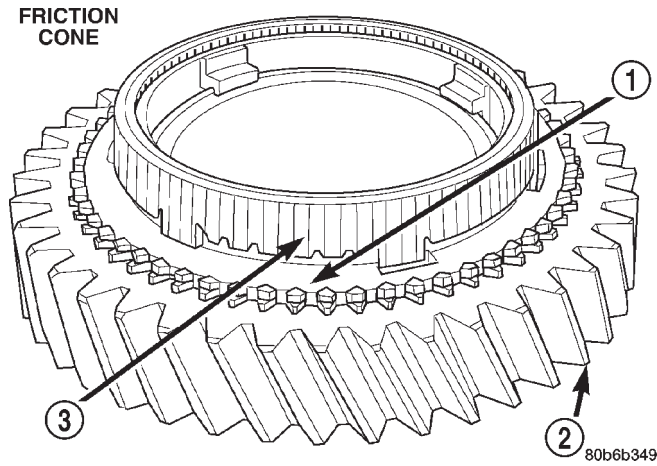
**Fig. 53 Inner Blocker Ring**

- 1 - INNER BLOCKER RING
- 2 - GEAR



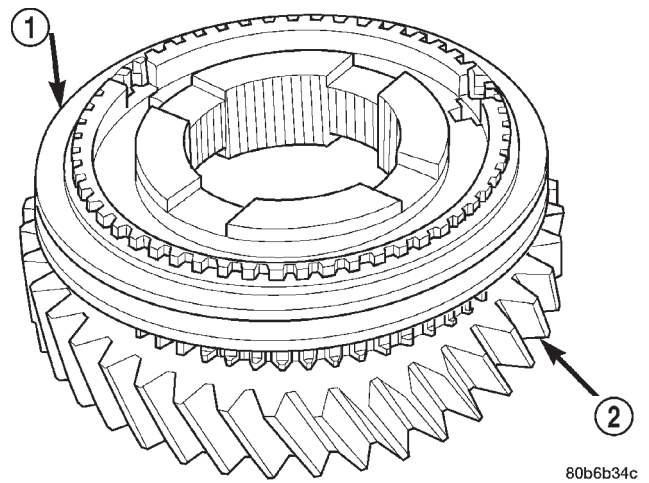
**Fig. 55 Outer Blocker Ring**

- 1 - OUTER BLOCKER RING
- 2 - LUG
- 3 - GEAR



**Fig. 54 Friction Cone**

- 1 - LOW AREA
- 2 - GEAR
- 3 - HIGH AREA



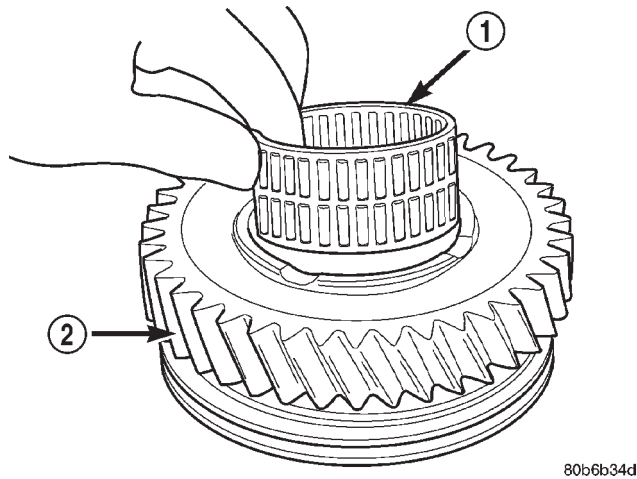
**Fig. 56 3-4 Synchro Assembly**

- 1 - SYNCHRO
- 2 - GEAR



## MANUAL - NV5600 (Continued)

(7) Install second gear bearing into second gear (Fig. 57).



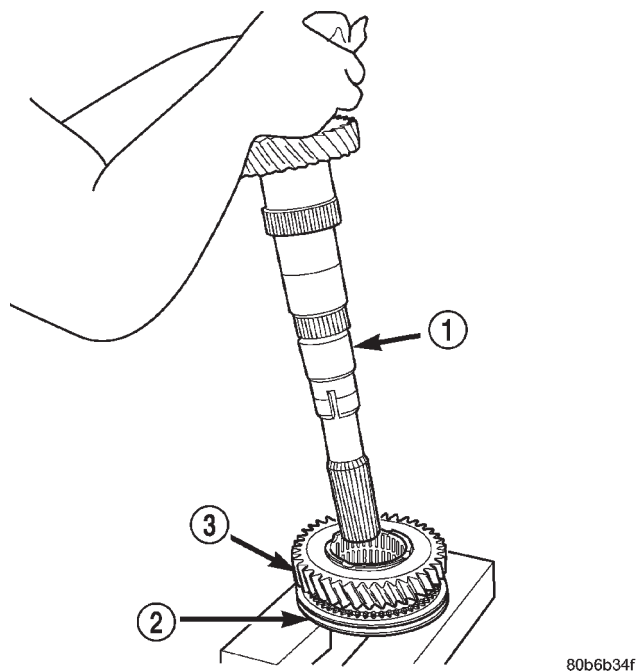
**Fig. 57 Second Gear Bearing**

1 - BEARING  
2 - GEAR

(8) Place completed 1-2 synchro, second gear and second gear bearing to a shop press with second gear facing upward.

(9) Install output shaft into the second gear 1-2 synchro assembly with the front of the output shaft facing upward (Fig. 58).

(10) Press the output shaft into position.



**Fig. 58 Output Shaft Into 1-2 Synchro**

1 - OUTPUT SHAFT  
2 - 1-2 SYNCHRO  
3 - SECOND GEAR

(11) Place first gear on bench with the synchro clutch ring up.

(12) Install first gear synchro inner blocker ring onto first gear (Fig. 53).

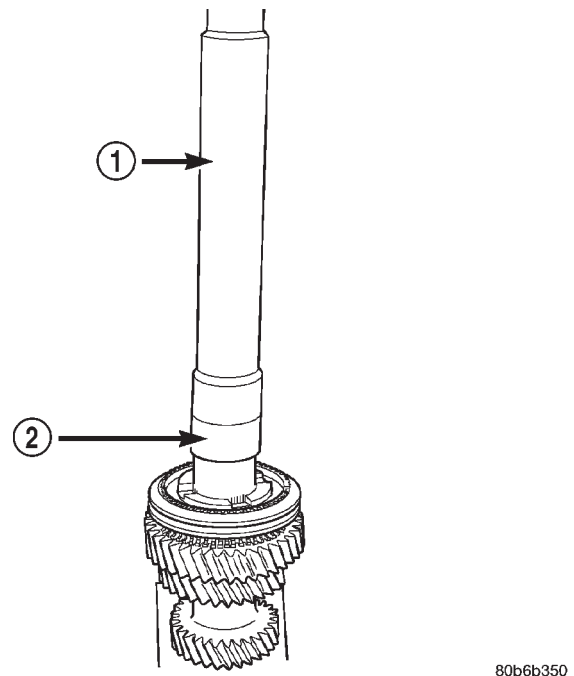
(13) Install first gear synchro friction cone over the blocker ring and onto first gear (Fig. 54).

(14) Install first gear synchro outer blocker ring over the first gear synchro friction cone. Align one of the lugs on the outer ring with a lug on the inner ring (Fig. 55).

(15) Reverse the output shaft in the press.

(16) Install first gear bearing sleeve onto the output shaft.

(17) Install first gear bearing sleeve the remainder of the way onto the output shaft using Installer 8228 and a shop press (Fig. 59).



**Fig. 59 First Gear Bearing Sleeve**

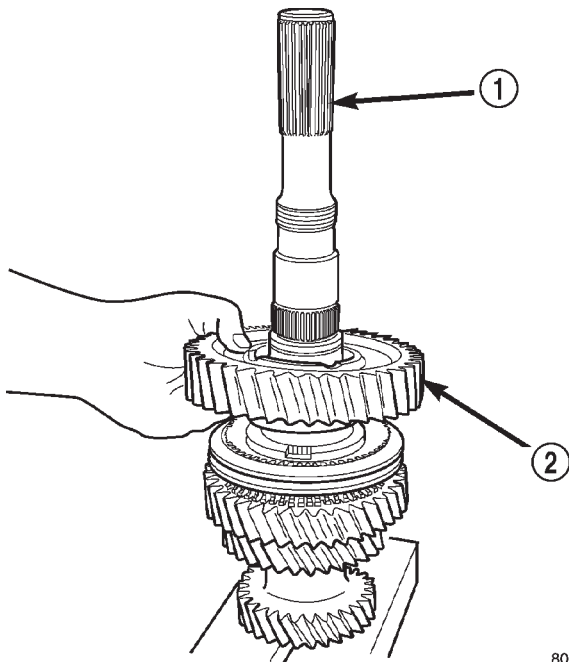
1 - INSTALLER 8228  
2 - FIRST GEAR BEARING SLEEVE

(18) Install first gear and blocker assembly onto the output shaft (Fig. 60).

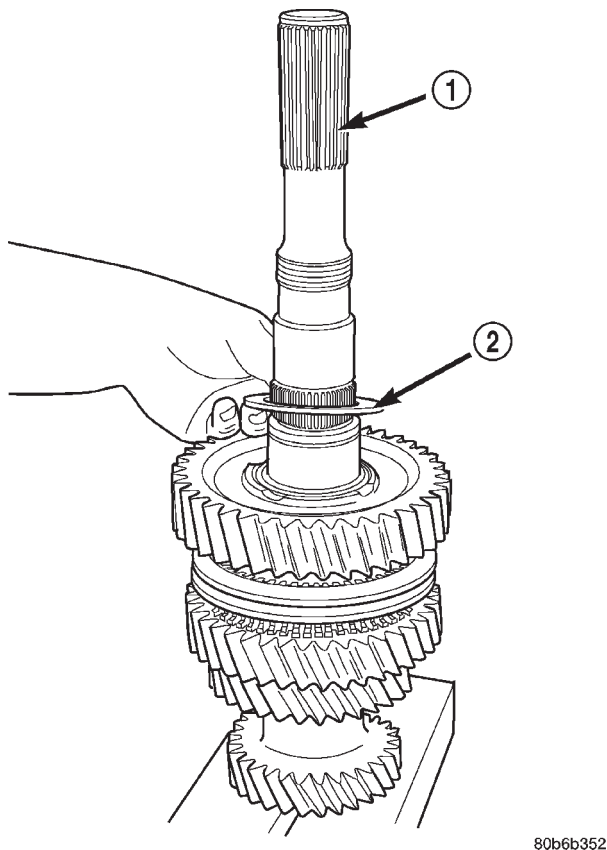
(19) Install first gear bearing over the output shaft and into first gear.

(20) Install output shaft thrust washer onto the output shaft (Fig. 61).

## MANUAL - NV5600 (Continued)

**Fig. 60 First Gear And Blocker Assembly**

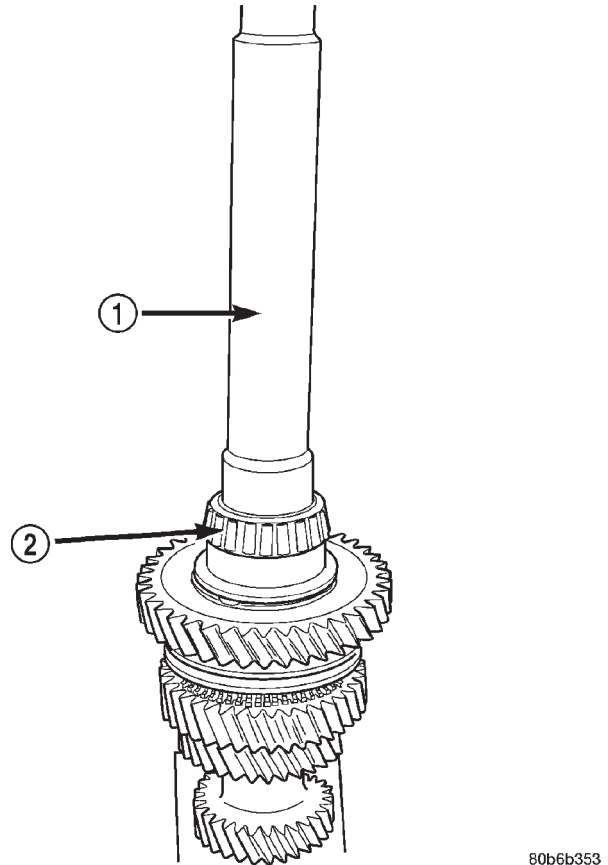
- 1 - OUTPUT SHAFT  
2 - 1ST GEAR AND BLOCKER ASSEMBLY

**Fig. 61 Output Shaft Thrust Washer**

- 1 - OUTPUT SHAFT  
2 - OUTPUT SHAFT THRUST WASHER

(21) Install rear output shaft bearing onto the output shaft with Installer 8228 and a shop press (Fig. 62).

(22) Install a **new** snap-ring to hold the rear output bearing onto the output shaft. Select and install the thickest snap-ring which will fit into the groove.

**Fig. 62 Rear Output Shaft Bearing**

- 1 - INSTALLER 8228  
2 - REAR OUTPUT SHAFT BEARING

(23) Reverse output shaft in the Fixture 8227 and support the shaft with press blocks under first gear.

(24) Install sixth gear bearing onto the output shaft.

(25) Install sixth gear onto the output shaft and over the sixth gear bearing (Fig. 63).

(26) Install the sixth gear friction cone onto sixth gear.

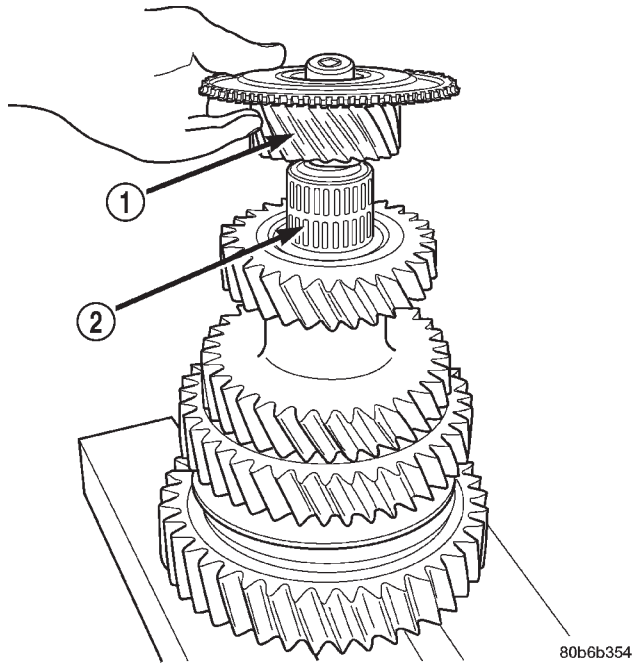
(27) Install sixth gear blocker ring over the sixth gear friction cone (Fig. 64).

(28) Install Guide 8235 onto the end of the output shaft (Fig. 65).

(29) Install 5-6 synchro over Guide 8235 and onto the output shaft (Fig. 66).

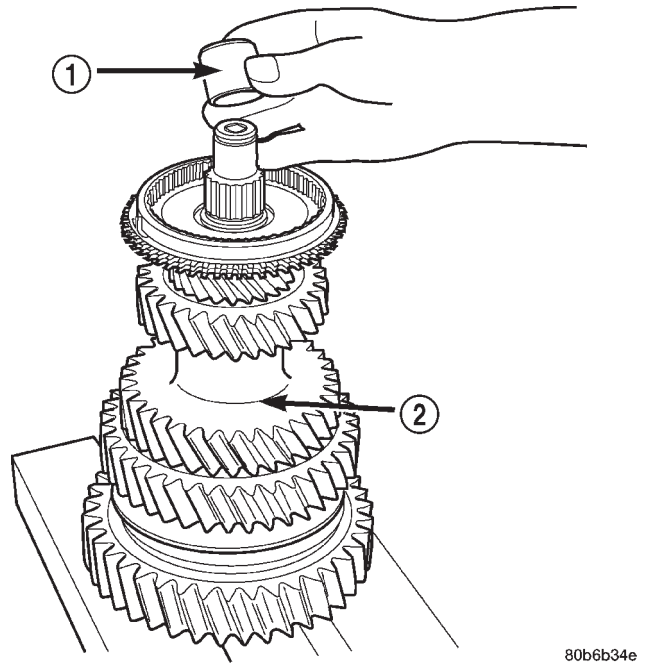
(30) Press 5-6 synchro onto the output shaft with Installer 8156 and a shop press.

(31) Install output shaft pocket bearing onto the output shaft.



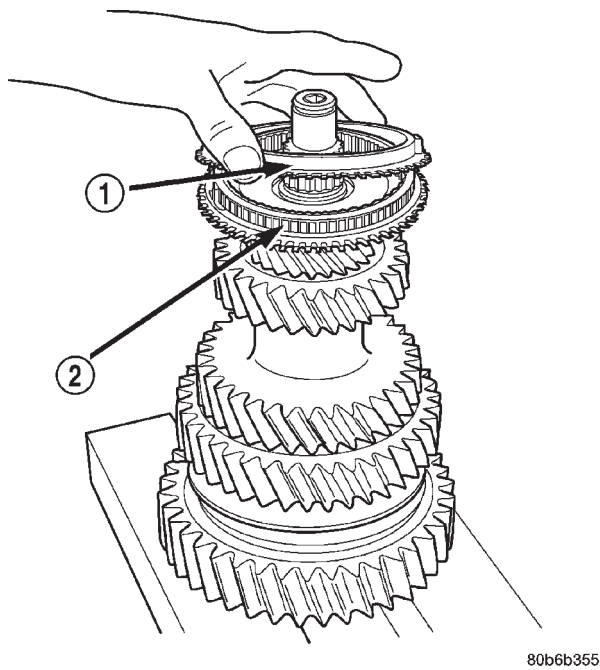
**Fig. 63 Sixth Gear**

- 1 - 6TH GEAR
- 2 - 6TH GEAR BEARING



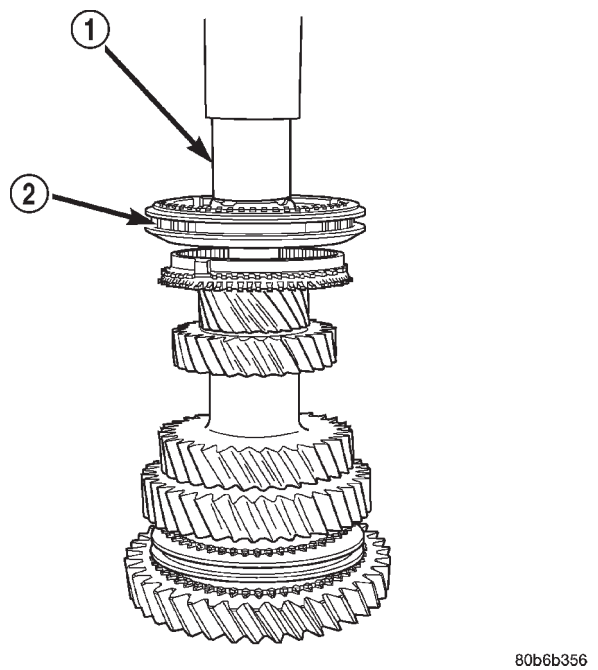
**Fig. 65 Output Shaft Guide**

- 1 - GUIDE 8235
- 2 - OUTPUT SHAFT



**Fig. 64 Sixth Gear Blocker Ring**

- 1 - 6TH GEAR BLOCKER RING
- 2 - 6TH GEAR FRICTION CONE

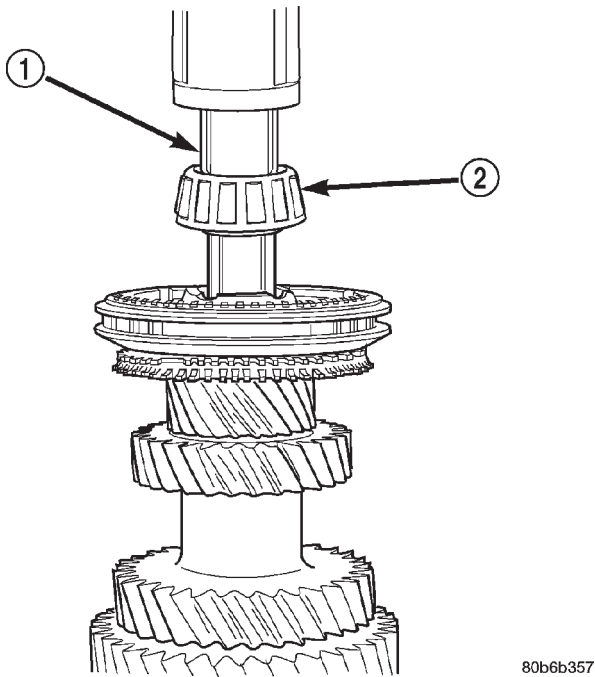


**Fig. 66 5-6 Synchro**

- 1 - INSTALLER 8156
- 2 - 5-6 SYNCHRO

## MANUAL - NV5600 (Continued)

(32) Press pocket bearing the remainder of the way onto the output shaft using Guide 8235 and a shop press (Fig. 67).



**Fig. 67 Output Shaft Pocket Bearing**

- 1 - GUIDE 8235  
2 - POCKET BEARING

(33) Install a **new** snap-ring to hold the output shaft pocket bearing onto the output shaft.

## COUNTERSHAFT

(1) Place third countershaft gear on the bench with the synchro clutch ring up.

(2) Install third countershaft gear friction cone onto third gear (Fig. 68).

(3) Install third countershaft gear blocker ring onto the friction cone (Fig. 69).

(4) Install 3-4 synchro assembly onto the blocker ring/gear assembly (Fig. 70).

(5) Reverse the assembly on the bench.

(6) Install third countershaft gear bearing into the third countershaft gear.

(7) Install 2-3 thrust washer onto the countershaft.

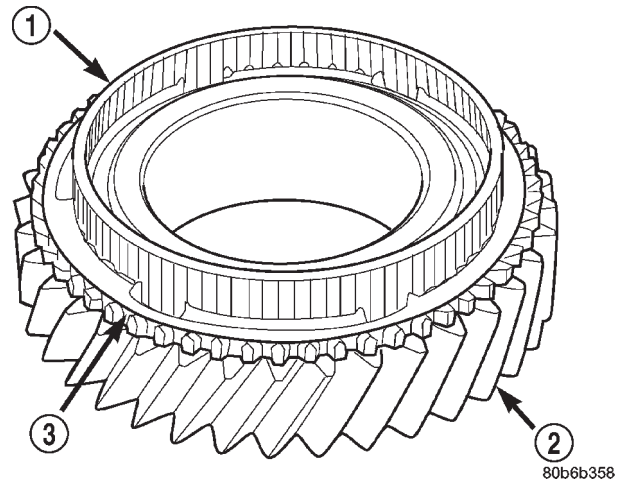
(8) Place third gear/3-4 synchro assembly in a shop press.

(9) Install countershaft through the third gear/3-4 synchro assembly.

(10) Press countershaft into the 3-4 synchro assembly (Fig. 71).

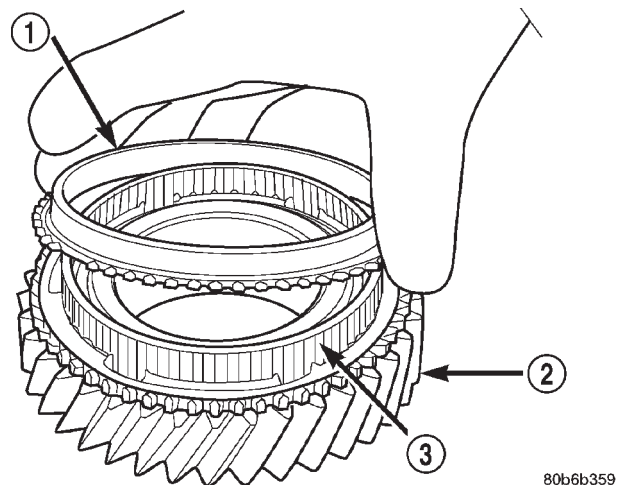
(11) Install fourth countershaft gear bearing sleeve onto the output shaft.

(12) Press fourth countershaft bearing sleeve onto the countershaft with Installer 8228 and a shop press.



**Fig. 68 Friction Cone Onto Gear**

- 1 - FRICTION CONE  
2 - GEAR  
3 - CLUTCH RING



**Fig. 69 Blocker Ring Onto Friction Cone**

- 1 - BLOCKER RING  
2 - GEAR  
3 - FRICTION CONE

(13) Place fourth countershaft gear on the bench with the synchro clutch ring up.

(14) Install fourth countershaft gear friction cone onto fourth countershaft gear (Fig. 68).

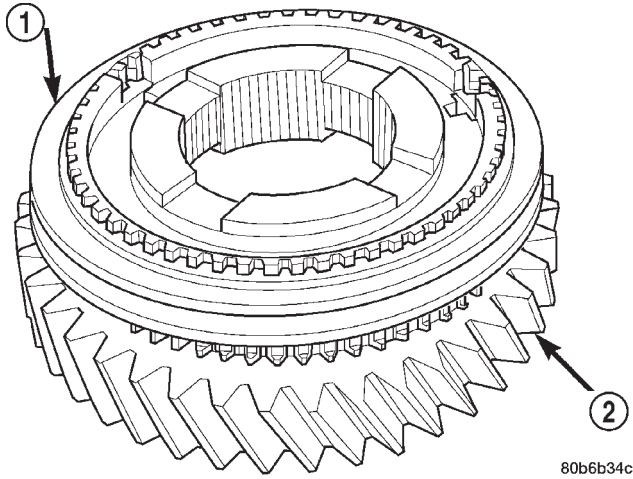
(15) Install fourth countershaft gear blocker ring onto the friction cone (Fig. 69).

(16) Install fourth countershaft gear bearing into the fourth countershaft gear.

(17) Place sixth countershaft gear in the shop press.

(18) Position fourth countershaft gear assembly onto the sixth countershaft gear (Fig. 72).

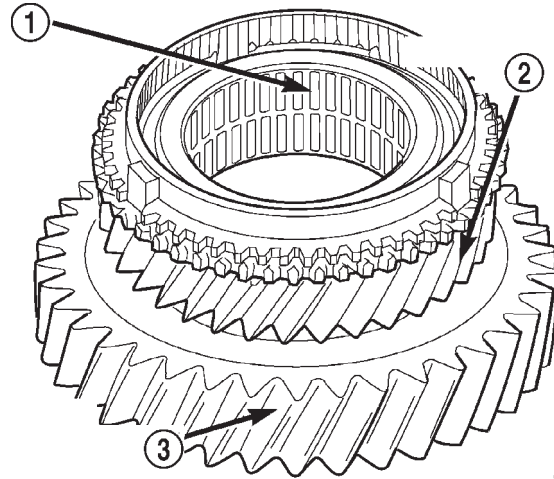
(19) Install countershaft into the fourth/sixth countershaft gear assembly in the shop press.



80b6b34c

**Fig. 70 3-4 Synchro Assembly**

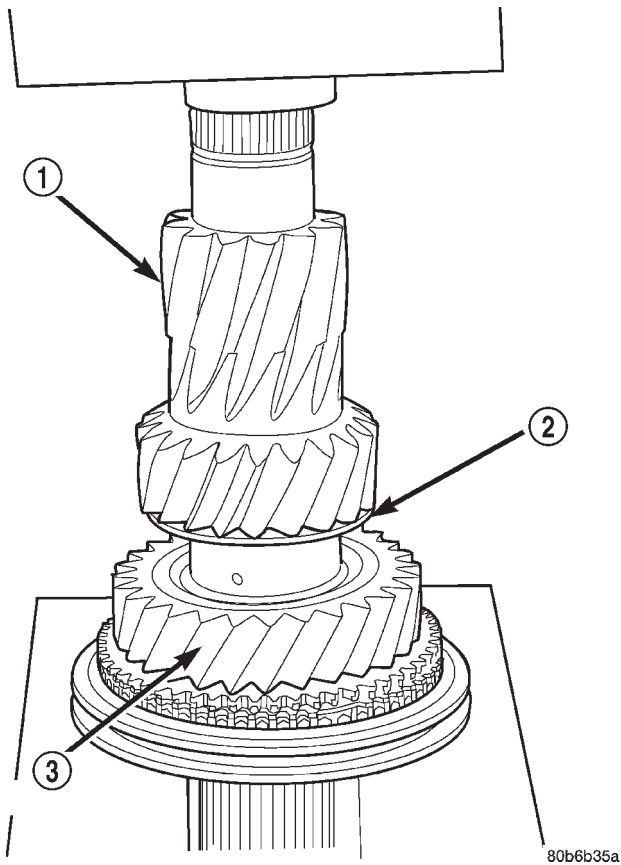
- 1 - SYNCHRO
- 2 - GEAR



80b6b35b

**Fig. 72 Fourth Countershaft onto Sixth Countershaft Gear**

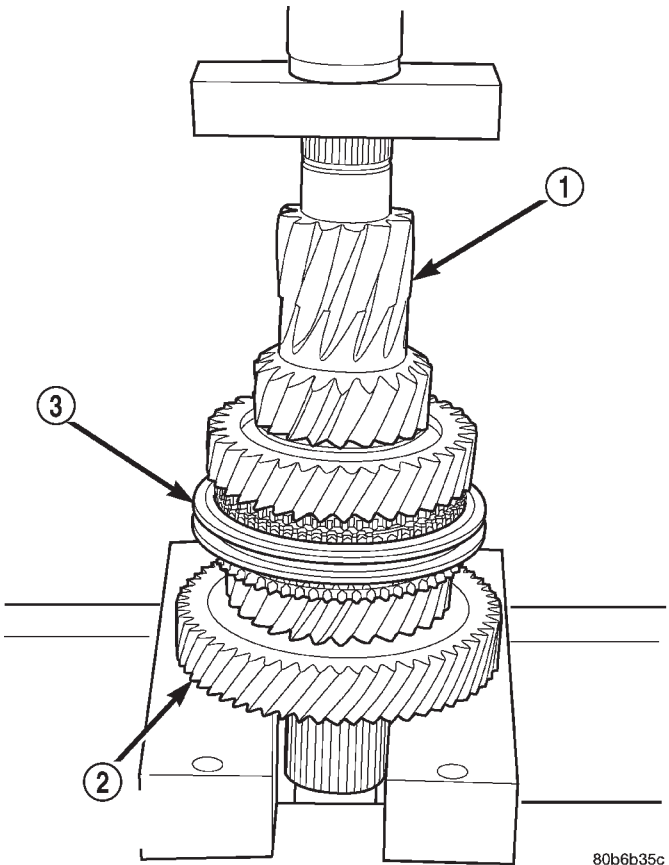
- 1 - 4TH BEARING
- 2 - 4TH COUNTERSHAFT GEAR
- 3 - 6TH COUNTERSHAFT GEAR



80b6b35a

**Fig. 71 Countershaft into 3-4 Synchro**

- 1 - COUNTERSHAFT
- 2 - 2-3 THRUST WASHER
- 3 - THIRD COUNTERSHAFT GEAR



80b6b35c

**Fig. 73 Countershaft To Sixth Countershaft Gear**

- 1 - COUNTERSHAFT
- 2 - 6TH COUNTERSHAFT GEAR
- 3 - 3-4 SYNCHRO

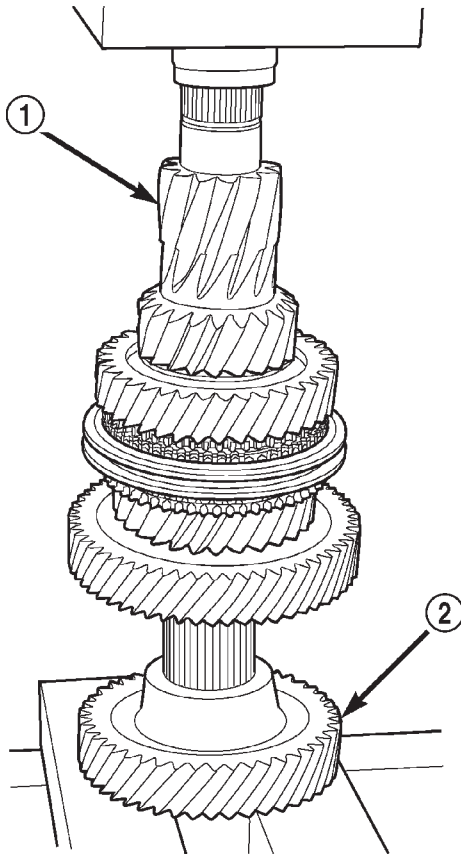
(20) Press countershaft into sixth gear (Fig. 73).  
 (21) Place fifth countershaft gear into the shop press.



## MANUAL - NV5600 (Continued)

(22) Install countershaft into the fifth countershaft gear and press countershaft into fifth gear (Fig. 74).

**CAUTION:** Gear and shaft must be aligned while pressing or the gear will bind on the shaft.



80b6b35e

**Fig. 74 Countershaft to Fifth Countershaft Gear**

1 - COUNTERSHAFT  
2 - 5TH COUNTERSHAFT GEAR

(23) Place front countershaft bearing onto the countershaft.

(24) Install front countershaft bearing onto the countershaft with Installer 8236 and Handle C-4171.

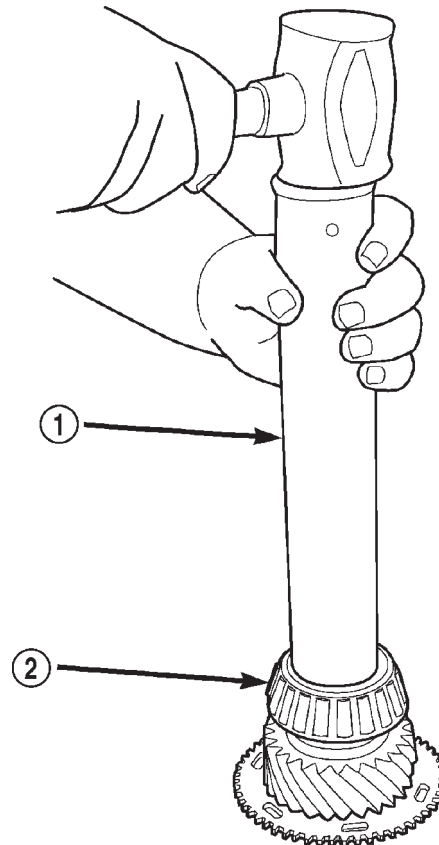
(25) Install a **new** snap-ring to hold the front countershaft bearing onto the countershaft.

(26) Place rear countershaft bearing onto the countershaft.

## INPUT SHAFT

(1) Place the input shaft bearing onto the input shaft.

(2) Install input shaft bearing with Installer MD998805 (Fig. 75).



80b6b360

**Fig. 75 Input Shaft Bearing**

1 - INSTALLER MD998805  
2 - INPUT SHAFT BEARING

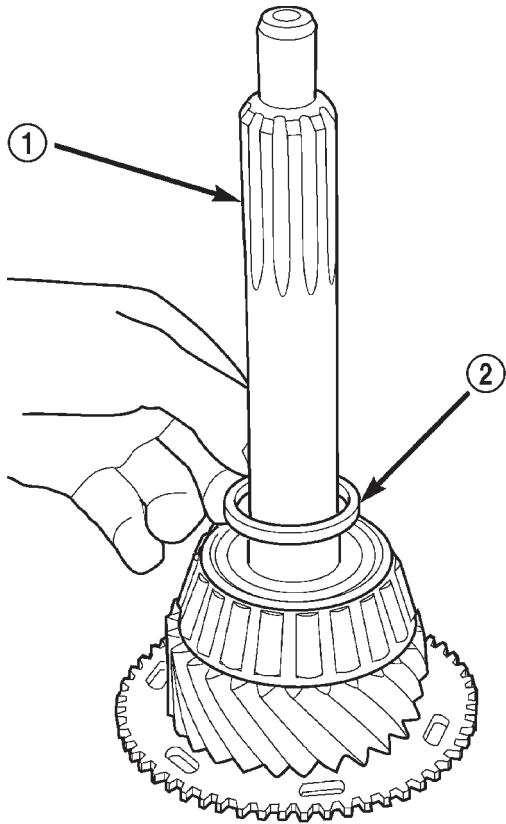
(3) Position the input shaft bearing oil guide on the input shaft (Fig. 76).

(4) Install input shaft bearing oil guide with Installer MD998805.

(5) Place the output shaft pocket bearing race in the input shaft.

(6) Install output shaft pocket bearing race into the input shaft with Installer C-4628 and Handle C-4171 (Fig. 77).





80b6b361

**Fig. 76 Input Shaft Oil Guide**

- 1 - INPUT SHAFT
- 2 - INPUT SHAFT OIL GUIDE

**CLUTCH HOUSING**

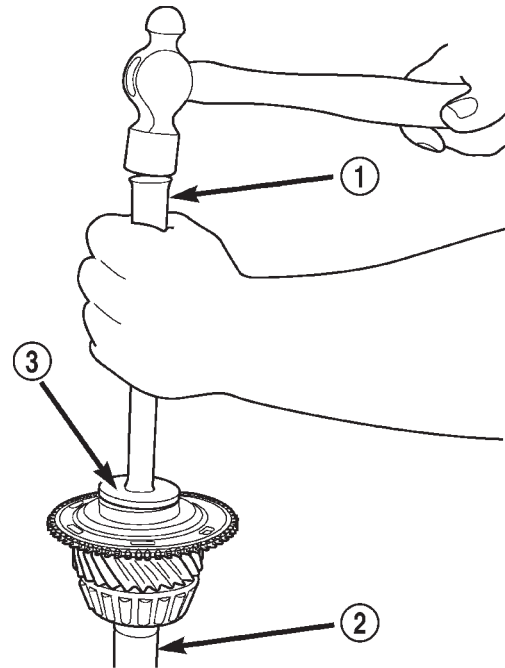
(1) Install input shaft bearing race so that the bearing race protrudes 0.3 in. above the front surface of the clutch housing. Install bearing race with Remover/Installer 8237 and Handle C-4171.

(2) Install countershaft front bearing race into the clutch housing so that the bearing race protrudes 0.4 in. above the front surface of the clutch housing. Install bearing race with Remover 6061-1 and Handle C-4171.

(3) Install countershaft oil guide and spacer into the countershaft front bearing bore in the clutch housing (Fig. 78).

(4) Clean all old sealer from the input shaft retainer and the clutch housing but **DO NOT** apply new sealer at this time. New sealer will be applied after all the preload measurements are made and end-play shims are installed.

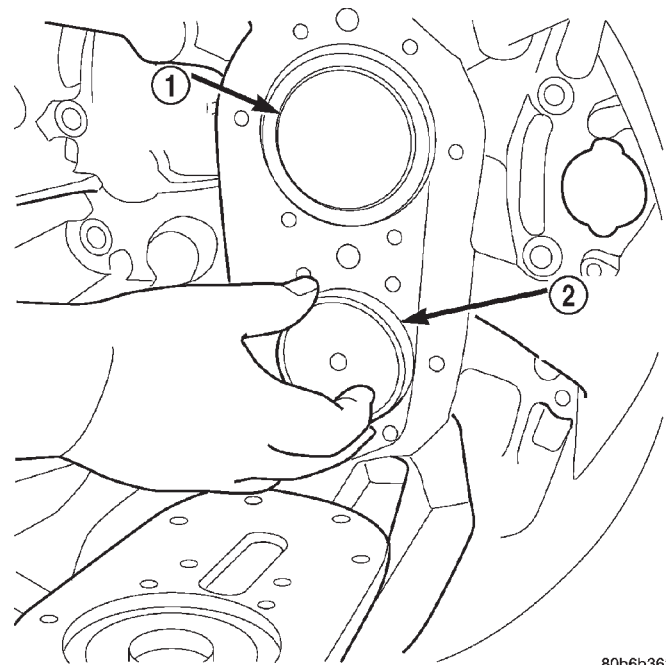
**NOTE:** Do not replace the input shaft seal at this time. A new seal will be installed after all the preload measurements are made and endplay shims are installed.



80b6b35f

**Fig. 77 Output Shaft Pocket Bearing Race**

- 1 - HANDLE C-4171
- 2 - INPUT SHAFT
- 3 - INSTALLER C-4628



80b6b362

**Fig. 78 Oil Guide and Spacer**

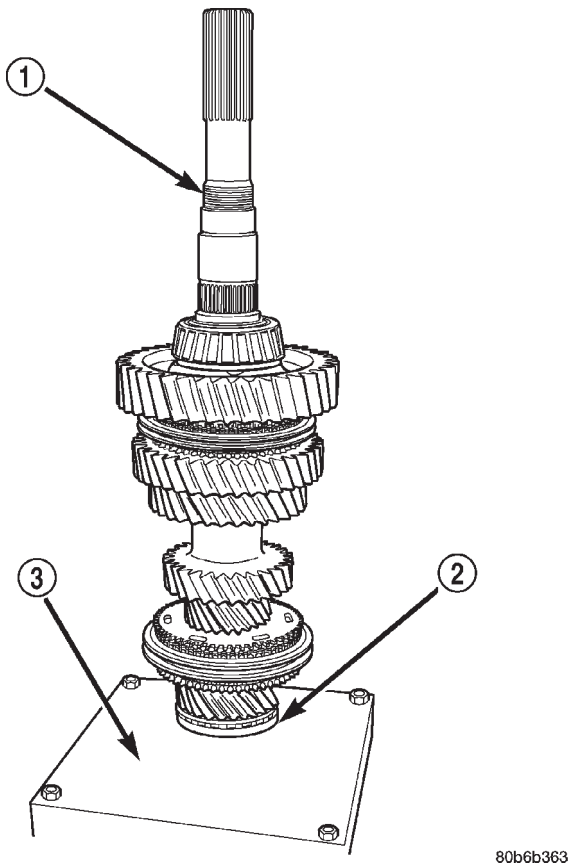
- 1 - 0.3 IN BEYOND FLUSH
- 2 - 0.4 IN BEYOND FLUSH

(5) Install input shaft retainer onto the clutch housing and install bolts to hold the input shaft retainer.

## MANUAL - NV5600 (Continued)

## GEARTRAIN

- (1) Install input shaft into Support Stand 8246.
- (2) Install fifth gear friction cone onto the input shaft.
- (3) Install fifth gear blocker ring onto the fifth gear friction cone.
- (4) Install output shaft into the input shaft (Fig. 79).



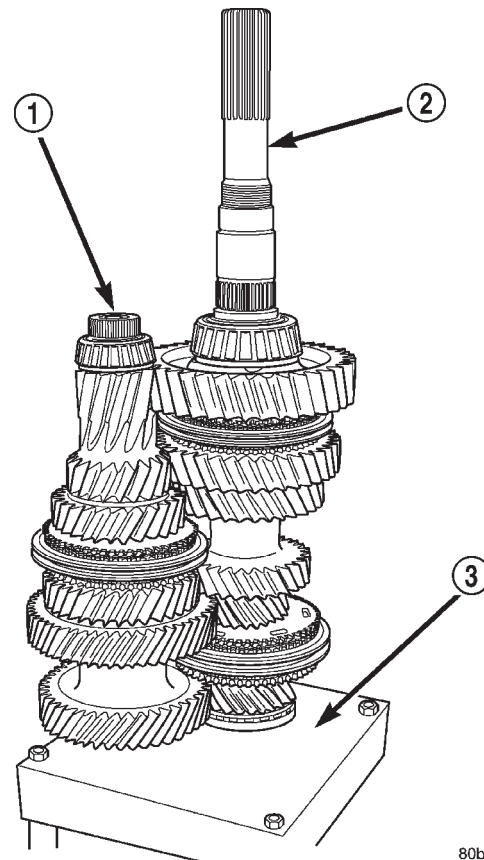
**Fig. 79 Install Output Shaft to Input Shaft**

- 1 - OUTPUT SHAFT
- 2 - INPUT SHAFT
- 3 - SUPPORT STAND 8246

(5) Install countershaft into the Support Stand 8246 and verify that all gears are meshed with their mates on the mainshaft (Fig. 80).

(6) Install Fixture 8232 to the output shaft and the countershaft.

(7) Install Holding Tool 8242 onto the 5-6 synchro and tighten the screw to hold the 5-6 synchro together during the remainder of the installation procedure.



**Fig. 80 Countershaft to Mainshaft**

- 1 - COUNTERSHAFT
- 2 - OUTPUT SHAFT
- 3 - SUPPORT STAND 8246

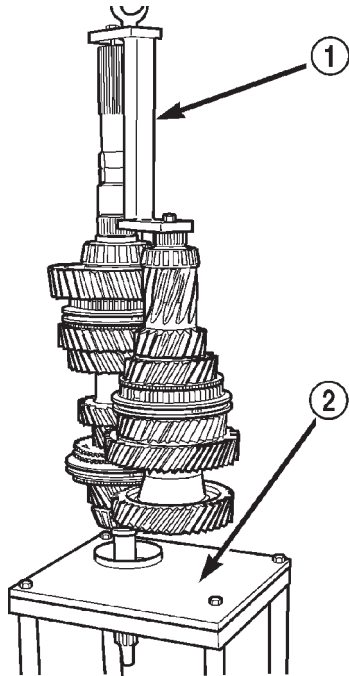
(8) Attach an engine crane or equivalent to Fixture 8232 and move the geartrain from the Support Stand 8246 to the clutch housing (Fig. 81).

(9) Install shift forks and rails onto the geartrain (Fig. 82).

**NOTE:** The closest shift arm to the geartrain is for Reverse. The next is 5-6, then 3-4 and then 1-2 when moving out from the geartrain.

(10) Install geartrain and shift rails into the clutch housing. Lower the geartrain and rails into the housing slowly while guiding input shaft through input shaft seal. Avoid any binds on the shift rails, forks and synchros as the rails enter their bushings.

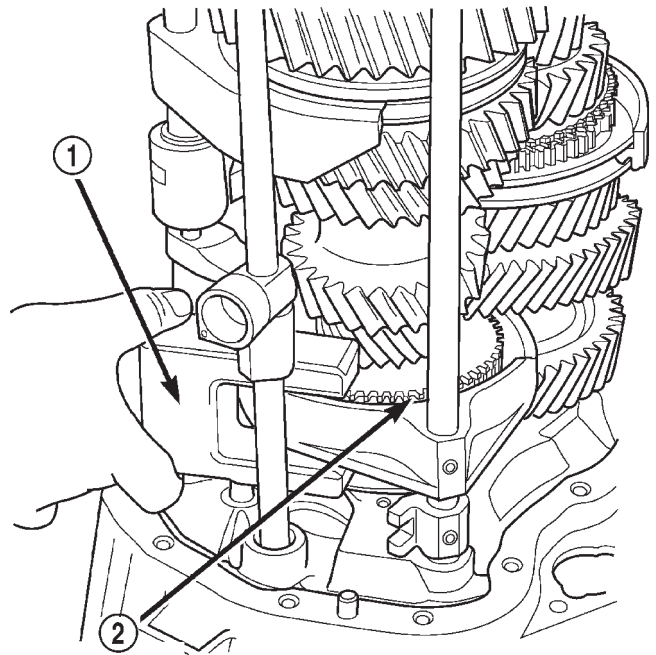
**CAUTION:** Do not damage input shaft seal with the input shaft splines.



80b6b330

**Fig. 81 Lift Geartrain with Engine Crane**

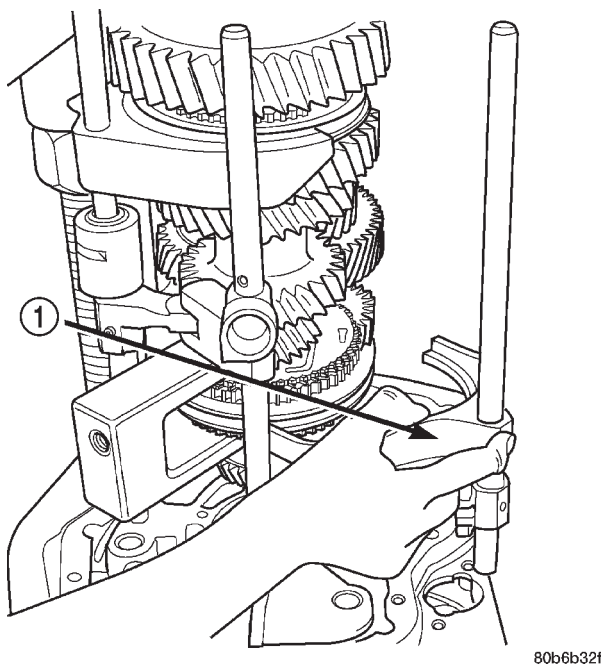
- 1 - FIXTURE 8232
- 2 - SUPPORT STAND 8246



80b6b1c9

**Fig. 83 Holding Tool 8242**

- 1 - HOLDING TOOL 8242
- 2 - 5-6 SYNCHRO



80b6b32f

**Fig. 82 Install Shift Rails**

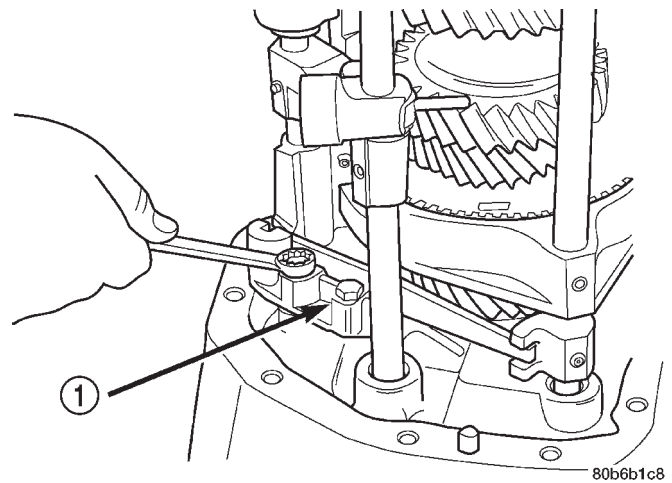
- 1 - SHIFT RAILS

(11) With the geartrain approximately 1/4 in. from the clutch housing, remove Holding Tool 8242 from the 5-6 synchro (Fig. 83).

(12) Install 5-6 crossover bracket and arm to the shift rails and the clutch housing.

(13) Lower geartrain the remainder of the way into the clutch housing.

(14) Install the 5-6 crossover bracket bolts (Fig. 84).



80b6b1c8

**Fig. 84 5-6 Crossover Bracket Bolts**

- 1 - 5-6 CROSSOVER BRACKET

(15) Remove engine crane and Fixture 8232 from the output shaft and the countershaft.

## MANUAL - NV5600 (Continued)

## TRANSMISSION GEAR CASE

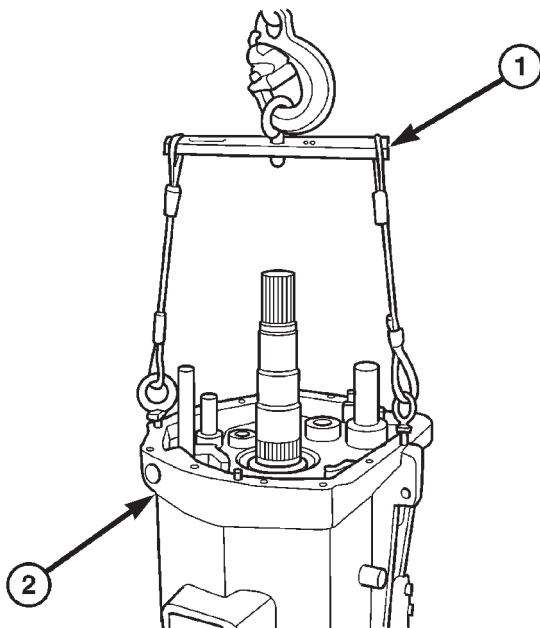
(1) Install rear output shaft bearing race into the transmission gear case with Installer C-4308 and Handle C-4171.

(2) Install rear countershaft bearing race into the transmission gear case with Installer 8153 and Handle C-4171.

(3) Install Fixture 8232 to the transmission gear case.

**NOTE:** Shift socket must be loose on the shift shaft and is rotated a minimum of 90° from its normal position. This will ensure enough clearance to install the transmission gear case.

(4) Attach an engine crane or equivalent to Fixture 8232 and install the transmission gear case onto the clutch housing (Fig. 85).



80a2e762

**Fig. 85 Transmission Gear Case**

- 1 - FIXTURE 8232  
2 - TRANSMISSION CASE

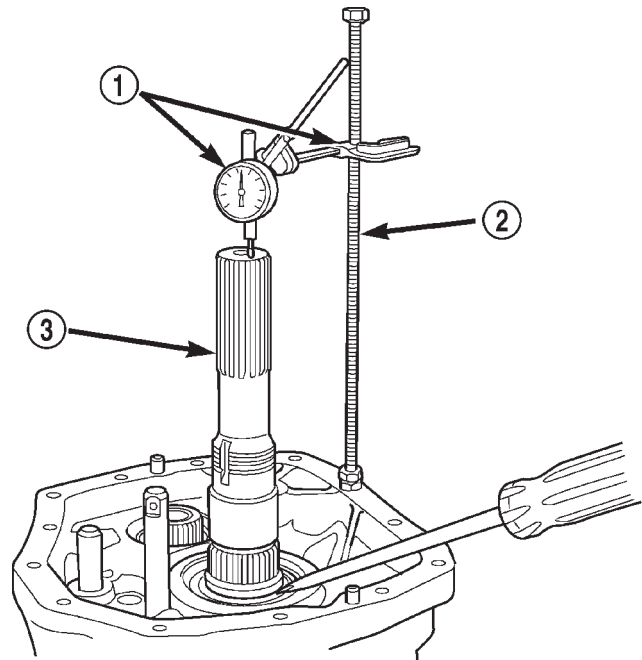
(5) Install clutch housing bolts and tighten to 48 N·m (35 ft.lbs.).

(6) Install shift socket roll pin with a suitable 6mm (7/32 inch) punch and hammer.

## MAINSHAFT AND COUNTERSHAFT ENDPLAY

(1) With transmission in vertical position, use Socket 6993 to rotate the shafts and seat the bearings.

(2) Measure mainshaft endplay with Dial Indicator Set C-3339 and Extension Rod 8161 installed onto the rear of the transmission gear case (Fig. 86).



80b6b365

**Fig. 86 Measure Mainshaft End-Play**

- 1 - DIAL INDICATOR C-3339  
2 - EXTENSION ROD 8161  
3 - MAIN SHAFT

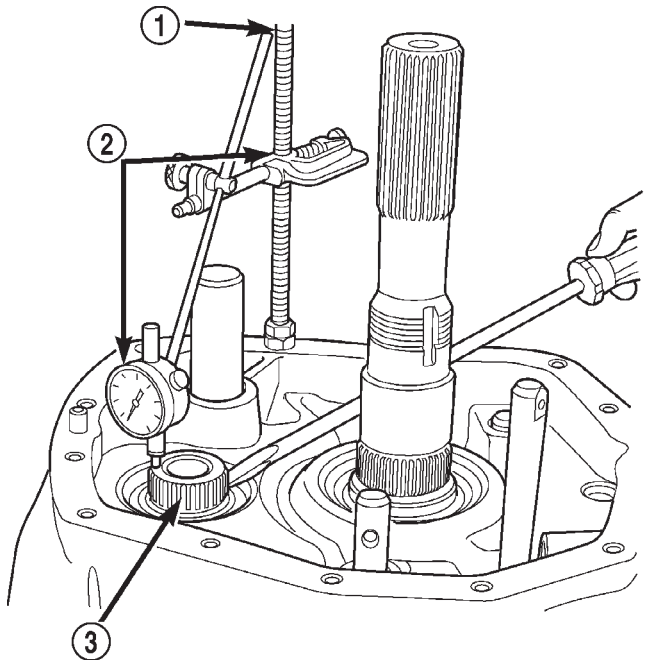
(3) Measure countershaft end-play with Dial Indicator Set C-3339 and Extension Rod 8161 installed onto the rear of the transmission gear case (Fig. 87).

(4) Rotate transmission into a horizontal position and remove the input shaft retainer.

(5) Install shims necessary to achieve an end-play of 0.051-0.15 mm (0.002-0.006 in.) for the mainshaft and countershaft.

**NOTE:** Countershaft shims go between the bearing race and spacer. Mainshaft shims go into the input shaft retainer.

## MANUAL - NV5600 (Continued)



80b6b366

**Fig. 87 Measure Countershaft End-Play**

- 1 - EXTENSION ROD 8161
- 2 - DIAL INDICATOR C-3339
- 3 - COUNTERSHAFT

(6) Install a **new** input shaft seal into the input shaft retainer with Installer C-4965.

(7) Install input shaft oil guide with C-3972-A and Handle C-4171.

(8) Apply sealer to the input shaft retainer and install retainer onto the clutch housing. Install bolts and tighten to 28 N·m (20 ft.lbs.).

**REVERSE GEAR**

(1) Install reverse shift fork and synchronizer as an assembly onto the reverse shift rail and output shaft (Fig. 88).

**NOTE:** Raised square shoulder and snap-ring on the synchro face the case.

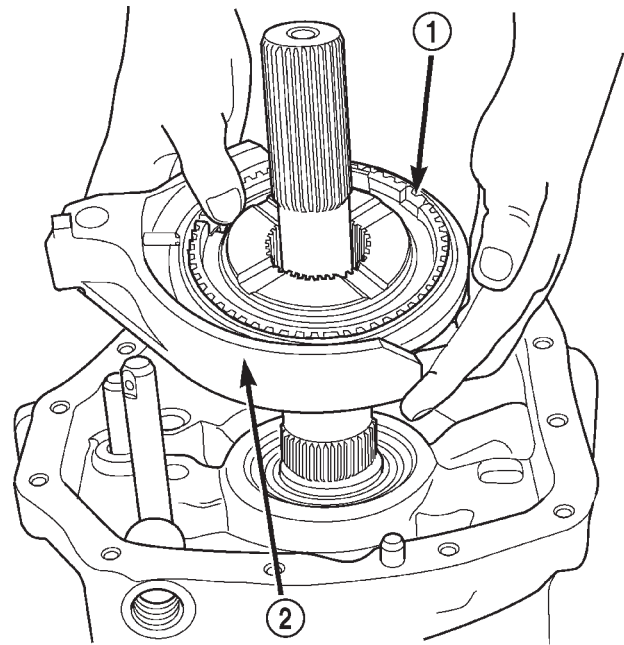
(2) Install roll-pin securing the reverse shift fork to the reverse shift rail with 6mm (7/32 in) punch and a hammer.

(3) Install reverse gear bearing sleeve onto the output shaft with Installer 6446 if necessary (Fig. 89).

(4) Install reverse gear, reverse gear synchronizer cone, reverse gear outer blocker ring, and reverse gear bearing (Fig. 90).

(5) Install output shaft ball bearing assembly and reverse thrust washer onto the output shaft (Fig. 91).

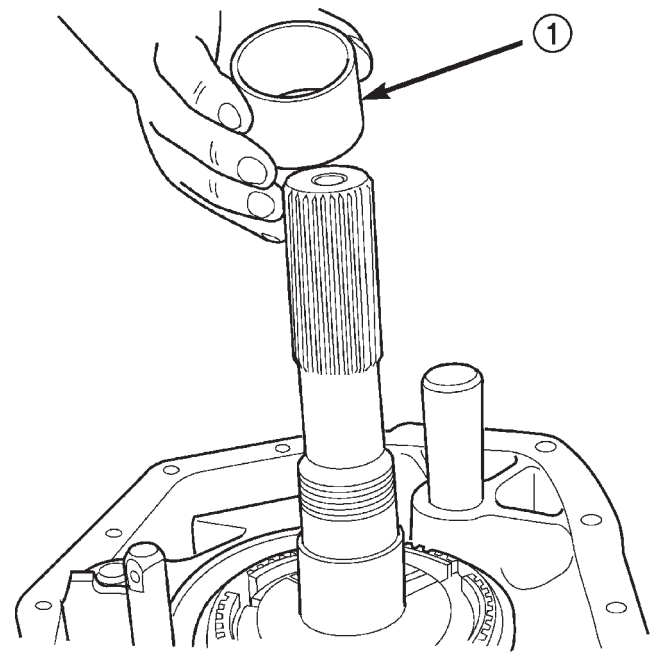
**NOTE:** Raised shoulder on thrust washer faces away from the reverse gear.



80b6b1c6

**Fig. 88 Reverse Shift Fork and Synchro**

- 1 - REVERSE SYNCHRO
- 2 - REVERSE SHIFT FORK



80b6b1c5

**Fig. 89 Reverse Bearing Sleeve**

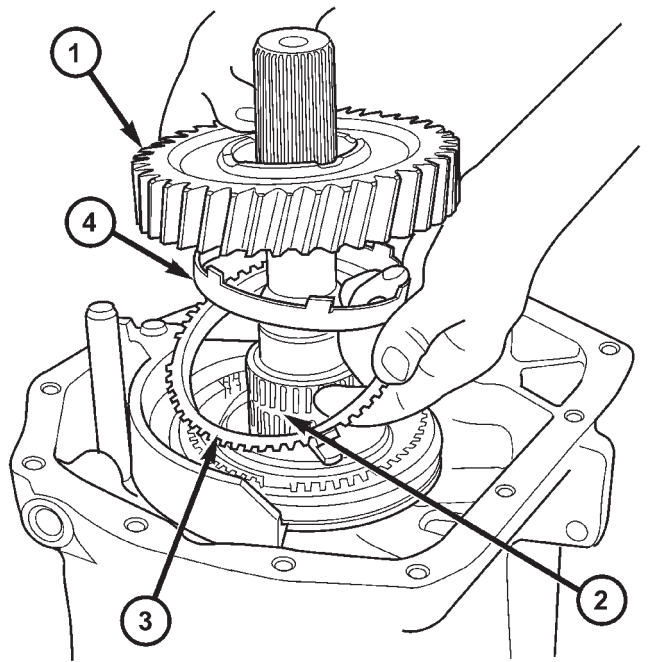
- 1 - REVERSE GEAR BEARING SLEEVE

(6) Install a **new** output shaft nut onto the output shaft.

(7) With Wrench 8226 on the output shaft nut and Socket 6993 or 6984 holding the output shaft, tighten the nut to 339 N·m (250 ft.lbs.).



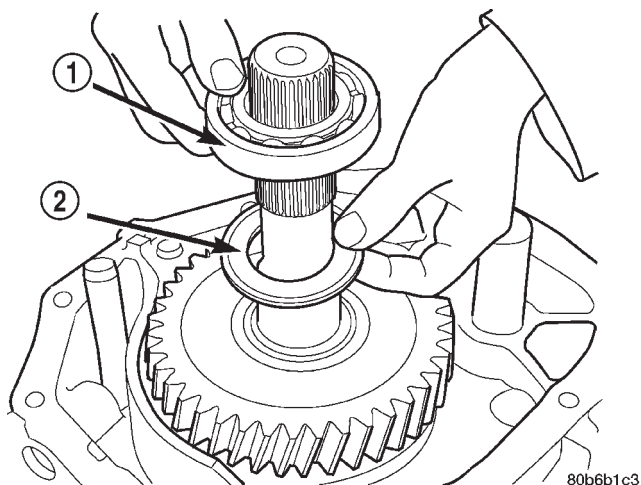
## MANUAL - NV5600 (Continued)



809f4ceb

**Fig. 90 Reverse Gear Components**

- 1 - REVERSE GEAR
- 2 - REVERSE BEARING
- 3 - BLOCKER RING
- 4 - FRICTION CONE



80b6b1c3

**Fig. 91 Output Shaft Bearing and Thrust Washer**

- 1 - OUTPUT SHAFT BALL BEARING
- 2 - THRUST WASHER

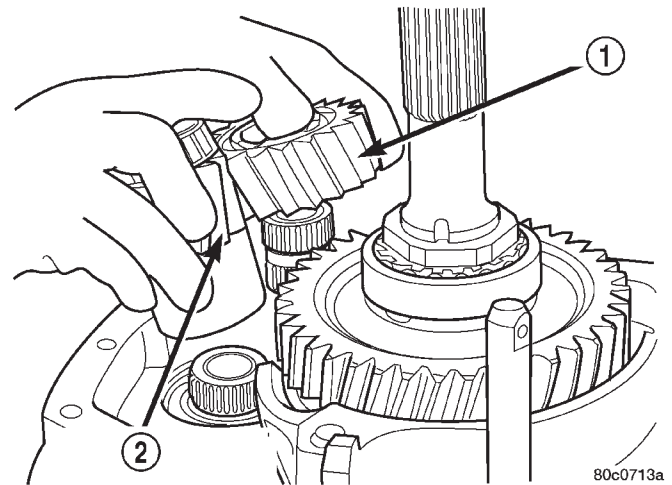
(8) Stake nut into the slot in the output shaft with a 9mm (5/16 in.) punch.

(9) Press countershaft reverse gear into the sleeve with a shop press.

(10) Install reverse countershaft rear bearing onto the countershaft reverse gear assembly with Installer C-4652 and Handle C-4171.

(11) Install reverse idler gear rear bearing, bearing spacer, front bearing, and front thrust washer onto the idler gear shaft.

(12) Install idler and reverse countershaft gears together (Fig. 92).



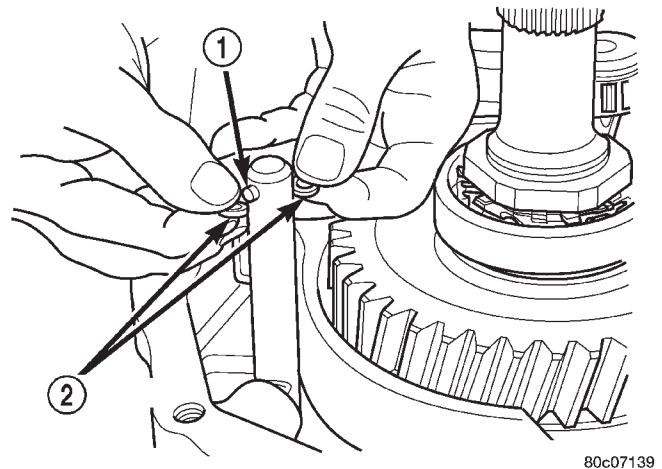
80c0713a

**Fig. 92 Reverse Idler and Countershaft Gears**

- 1 - REVERSE IDLER GEAR
- 2 - COUNTERSHAFT REVERSE GEAR

(13) Install reverse idler thrust washer from the reverse idler.

(14) Install crossover cam rollers and pin (Fig. 93).



80c07139

**Fig. 93 Crossover Cam Rollers and Pin**

- 1 - CROSSOVER CAM PIN
- 2 - CROSSOVER CAM ROLLERS



## MANUAL - NV5600 (Continued)

## EXTENSION/ADAPTER HOUSING

(1) Install extension housing bushing with Installer 8156 and Handle C-4171, if necessary. The oil feed hole must be at the 12 o'clock position when installed.

(2) On 4X2 vehicles, install extension housing seal with Installer 8154 and Handle C-4171, with the weep hole at the bottom.

**NOTE:** Drain hole located in the dust boot portion of the seal must face downward ( toward the ground) when installed.

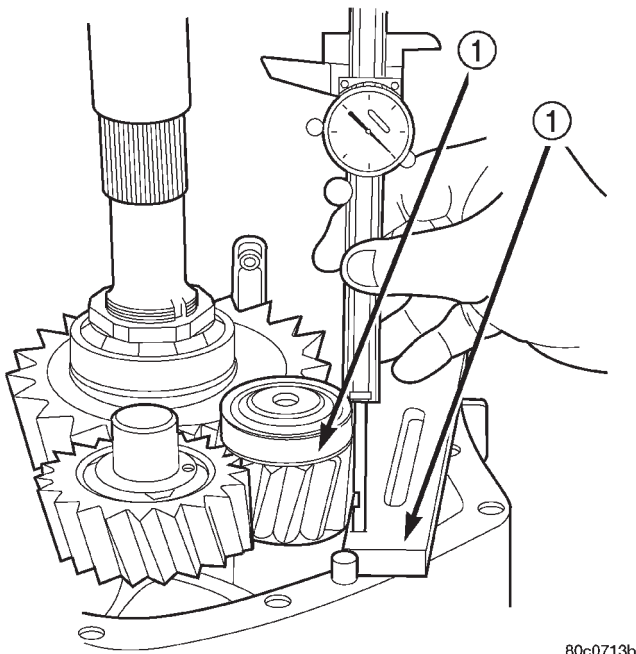
(3) On 4X4 vehicles, install adapter housing seal with Installer C-3860-A and Handle C-4171.

(4) Install the crossover cam bushing into the extension/adapter housing with Installer 8239 and Handle C-4171.

(5) Clean the rear of the transmission case of all sealer.

(6) Install reverse countershaft gear bearing race onto the reverse countershaft gear bearing.

(7) Measure the distance from the back of the bearing race to Gauge Bar 6311 (Fig. 94).



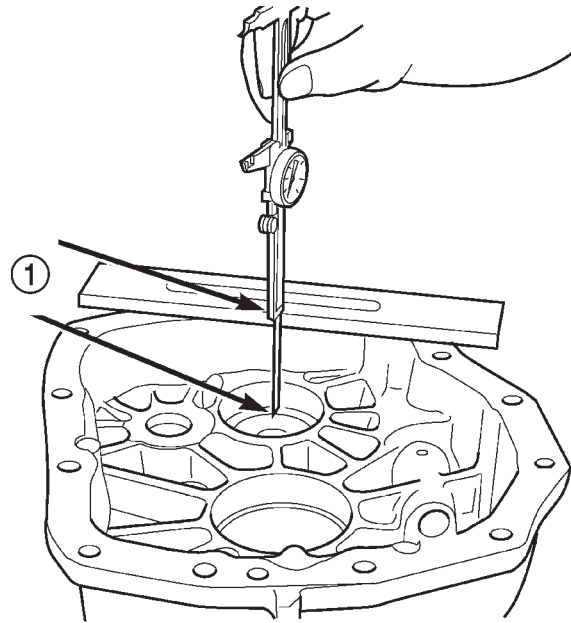
**Fig. 94 Measure Height of Reverse Countershaft**

1 - MEASURE DISTANCE FROM RACE TO GAUGE BAR 6311

(8) Measure thickness of the gauge bar and record the total of the two measurements.

(9) Clean all the sealer from the extension/adapter housing.

(10) Place Gauge Bar 6311 across the housing face. Measure the distance from the top of the bar to the bottom of the reverse countershaft bearing race bore (Fig. 95).



80ba77f2

**Fig. 95 Reverse Countershaft Gear Bearing Race Bore**

1 - GAUGE BAR 6311 TO BEARING RACE BORE MEASUREMENT

(11) Subtract thickness of the gauge bar from the measurement and record the result.

(12) The difference between the two measurements is the end-play for the reverse countershaft gear assembly.

(13) Install shims to achieve 0.15-0.25 mm (0.006-0.010 in.) end-play for the reverse countershaft gear assembly into the reverse countershaft bearing race bore.

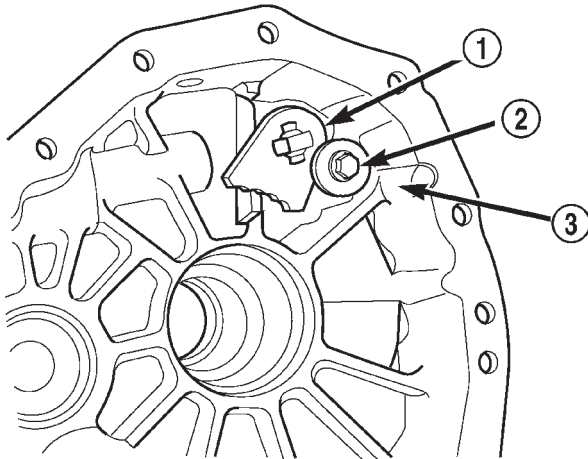
(14) Use Installer to install the reverse countershaft bearing race into the extension/adapter housing.

(15) Install back-up lamp switch and a new gasket into the extension/adapter housing. Tighten switch to 28 N·m (20 ft.lbs.).

(16) Install crossover cam into the extension/adapter housing.

(17) Install bolt to hold the crossover cam to the extension/adapter housing (Fig. 96).

## MANUAL - NV5600 (Continued)

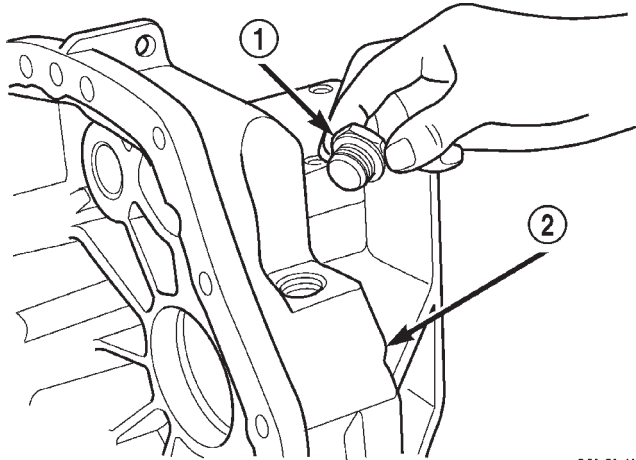


80c07138

**Fig. 96 Crossover Cam**

- 1 - CROSSOVER CAM
- 2 - BOLT
- 3 - EXTENSION HOUSING

(18) Install crossover detent plunger, spring and plug into the extension/adaptor housing. Tighten the plug to 47.5 N·m (35 ft.lbs.) (Fig. 97).



80b6b1b8

**Fig. 97 Crossover Cam Detent Plug**

- 1 - DETENT PLUG
- 2 - EXTENSION HOUSING

(19) Apply sealer to the surface of the transmission case.

(20) Install extension/adaptor housing onto the transmission case.

(21) Install bolts to hold the extension/adaptor housing onto the transmission gear case. Tighten bolts to 48 N·m (35 ft.lbs.).

(22) Install shift rail blocker bolt and tighten bolt to 55 N·m (41 ft.lbs.).

(23) Install primary shift rail detent plunger, spring and plug into the transmission case. Tighten detent plug to 47.5 N·m (35 ft.lbs.).

(24) Install shift tower onto the transmission case and tighten bolts to 9 N·m (7 ft.lbs.).

**INSTALLATION**

**NOTE:** If a new transmission is being installed, be sure to use all components supplied with the new transmission. For example, if a new shift tower is supplied with the new transmission, do not re-use the original shift tower.

**NOTE:** Use a heavy duty scissors style transmission jack to install the transmission.

Before installation apply light coat of Mopar high temperature bearing grease to contact surfaces of following components:

- input shaft splines.
- release bearing slide surface of front retainer.
- release bearing bore.
- release fork.
- release fork ball stud.
- propeller shaft slip yoke.

(1) Apply sealer to threads of bottom PTO cover bolt and install bolt in case.

(2) Mount transmission on jack and position transmission under vehicle.

(3) Raise transmission until input shaft is centered in clutch disc hub.

(4) Move transmission forward and start input shaft in clutch disc and pilot bushing/bearing.

(5) Work transmission forward until seated against engine block. Do not allow transmission to remain unsupported after input shaft has entered clutch disc.

(6) Install and tighten transmission-to-engine block bolts.

(7) Install clutch slave cylinder.

(8) Connect backup light switch wires.

(9) Fill transmission with recommended lubricant.

Correct fill level is bottom edge of fill plug hole.

(10) Position transmission harness wires in clips on transmission.

(11) Install transmission mount on transmission or rear crossmember.

(12) Install rear crossmember.

(13) Remove transmission jack and engine support fixture.

**TWO WHEEL DRIVE**

(1) Install propeller shaft with reference marks aligned.

(2) Install exhaust system components.

(3) Remove support and lower vehicle.

(4) Shift transmission into third gear.

## MANUAL - NV5600 (Continued)

(5) Clean the mating surfaces of shift tower and isolator plate with suitable wax and grease remover.

(6) Apply Mopar Gasket Maker or equivalent to sealing surface of the transmission case. Do not over apply sealant.

(7) Install isolator plate onto the transmission case metal side down.

(8) Install shift tower onto the isolator plate. No sealant is necessary between the shift tower and top of isolator plate.

(9) Verify that the shift tower, isolator plate and the shift socket are properly aligned.

(10) Install bolts to hold the shift tower to the isolator plate and the transmission case. Tighten bolts to 10.2–11.25 N·m (7.5–8.3 ft. lbs.).

(11) Install shift boot and bezel.

(12) Connect battery negative cable.

**FOUR WHEEL DRIVE**

(1) Install and secure transfer case on the transmission jack.

(2) Raise and align transfer case input gear with transmission mainshaft.

(3) Move transfer case forward and seat it on adapter.

(4) Install and tighten transfer case mounting nuts to 41-47 N·m (30-35 ft. lbs.) if case has 3/8 studs. If case has 5/16 studs tighten to 30-41 N·m (22-30 ft. lbs.).

(5) Connect transfer case shift lever to range lever on transfer case.

(6) Install propeller shafts with reference marks aligned.

(7) Fill transmission with required lubricant. Check lubricant level in transfer case and add lubricant if necessary.

(8) Install transfer case skid plate, if equipped, and crossmember. Tighten attaching bolts/nuts to 41 N·m (30 ft. lbs.).

(9) Install exhaust system components.

(10) Remove support and lower vehicle.

(11) Shift transmission into third gear.

(12) Clean the mating surfaces of shift tower, isolator plate, and transmission case with suitable wax and grease remover.

(13) Apply Mopar Gasket Maker or equivalent to the sealing surface of the transmission case. Do not over apply sealant.

(14) Install isolator plate onto the transmission case, metal side down.

(15) Install shift tower onto the isolator plate. No sealant is necessary between the shift tower and top of isolator plate.

(16) Verify that the shift tower, isolator plate and the shift tower bushings are properly aligned.

(17) Install the bolts to hold the shift tower to the isolator plate and the transmission case. Tighten the shift tower bolts to 10.2–11.25 N·m (7.5–8.3 ft. lbs.).

(18) Install shift lever boot and bezel.

(19) Connect battery negative cable.

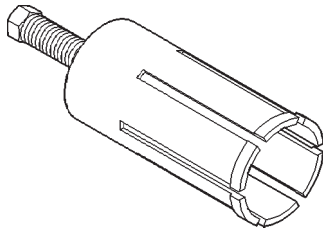
**SPECIFICATIONS****SPECIFICATIONS - NV5600***TORQUE SPECIFICATIONS*

DESCRIPTION	N·m	Ft. Lbs.	In. Lbs.
Plug, Crossover Cam and Detent	48	35	-
Bolt, Input Retainer	28	20	-
Bolt, 5-6 Crossover Bracket	28	20	-
Bolt, Clutch Housing	48	35	-
Bolt, Extension/Adapter Housing	48	35	-
Bolt, Shift Tower	9	7	80
Switch, Back-up Lamp	28	20	-
Bolt, Shift Blocker	55	41	-
Bolt, PTO Cover	40	30	-
Pivot, Clutch Release Lever	22	16	-
Plug, Fill	30	22	-
Nut, Output Shaft	339	250	-

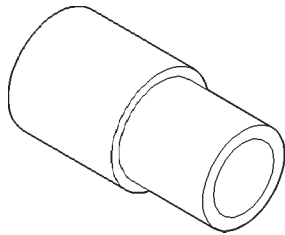
MANUAL - NV5600 (Continued)

SPECIAL TOOLS

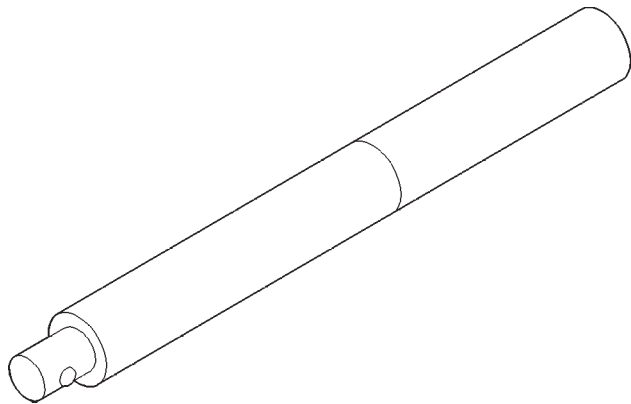
NV5600 MANUAL TRANSMISSION



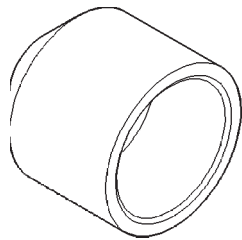
**Remover, Bushing—8155**



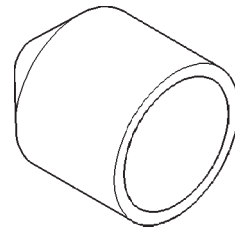
**Installer, Bushing—8156**



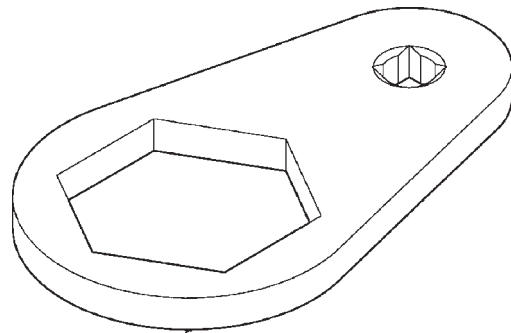
**Handle Universal—C-4171**



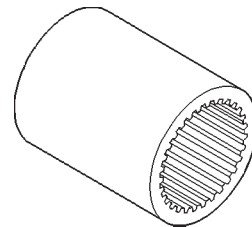
**Installer, Seal—C-3972-A**



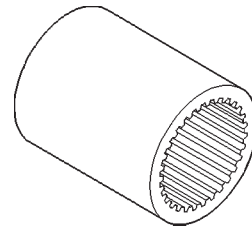
**Installer, Seal—8154**



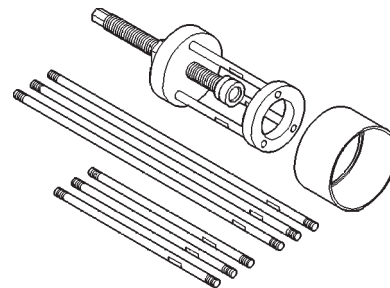
**Wrench, Output Shaft—8226**



**Wrench, Splined Socket—6984**

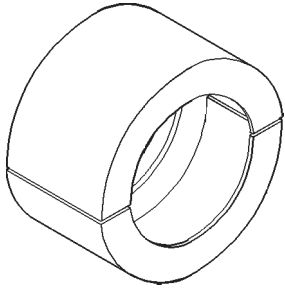


**Wrench, Splined Socket—6984**

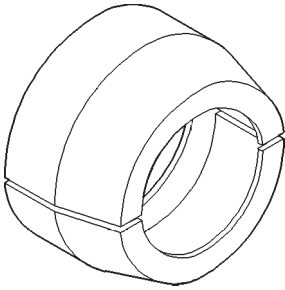


**Puller, Bearing and Gear—6444**

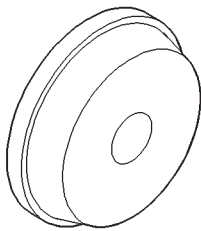
MANUAL - NV5600 (Continued)



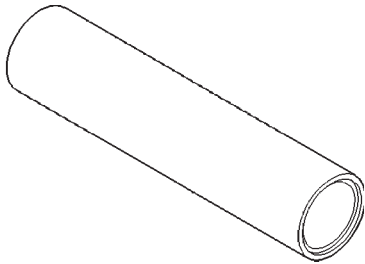
**Jaws, Bearing Cone (For Puller 6444)—6447**



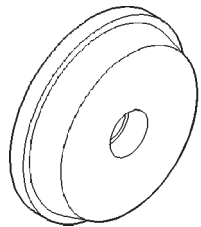
**Jaws, Bearing Cone (For Puller 6444)—6451**



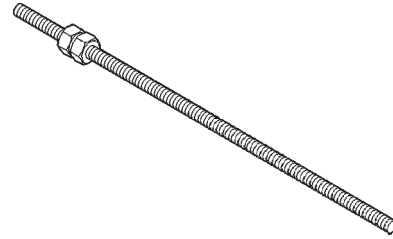
**Installer—6061**



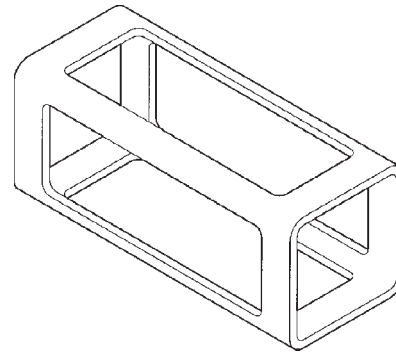
**Installer, Bearing Cone—6448**



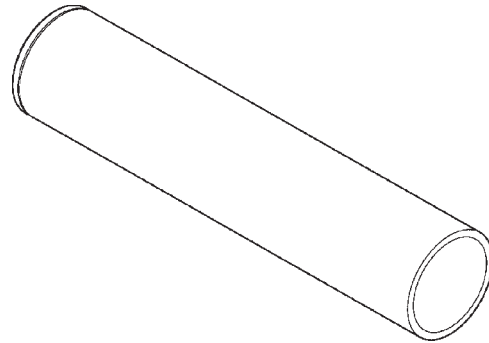
**Installer, Bearing Cup—C-4308**



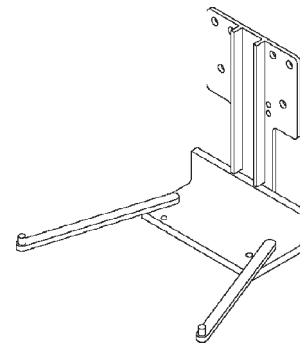
**Rod, Extension—8161**



**Fixture—8227**

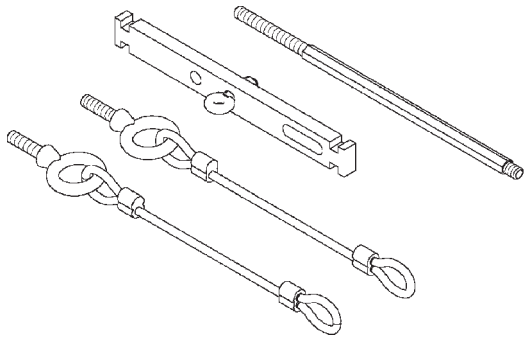


**Installer—8228**

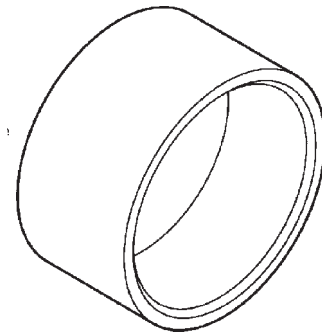


**Fixture—8230**

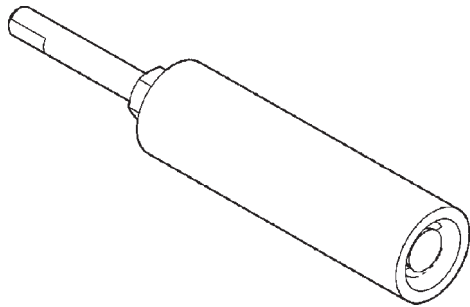
MANUAL - NV5600 (Continued)



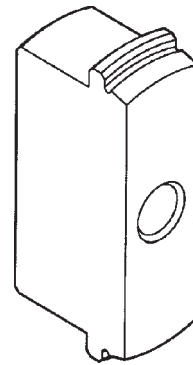
**Adapter—8232**



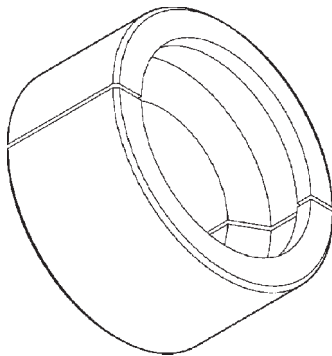
**Installer—8236**



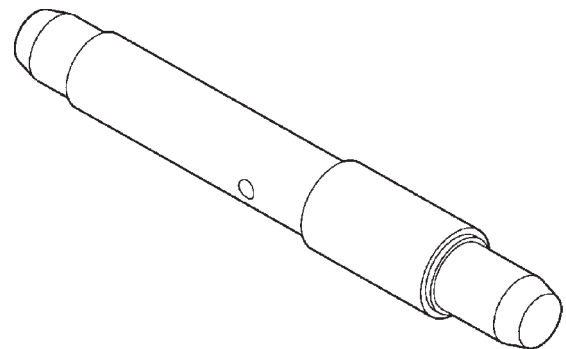
**Remover—8233**



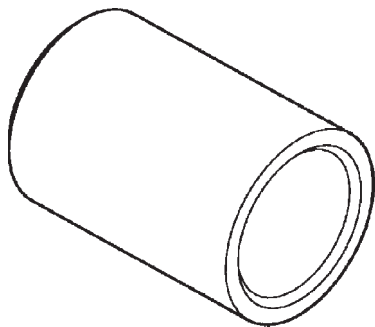
**Installer/Remover—8237**



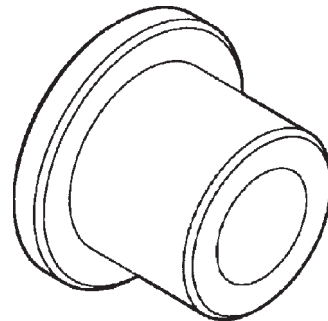
**Remover—8234**



**Installer/Remover—8238**



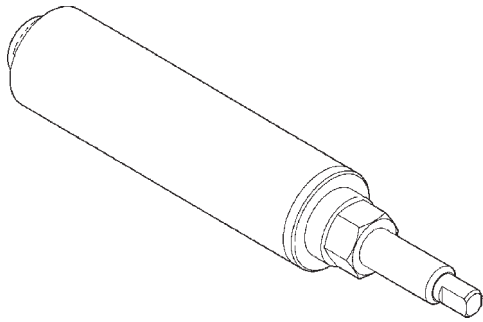
**Guide—8235**



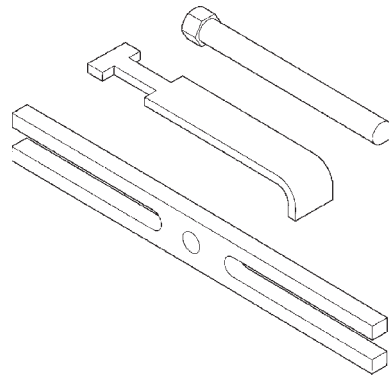
**Installer—8239**



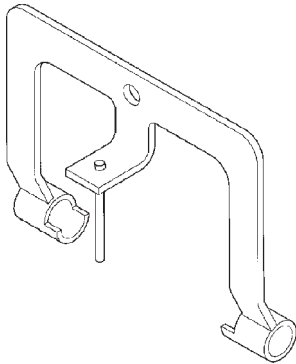
MANUAL - NV5600 (Continued)



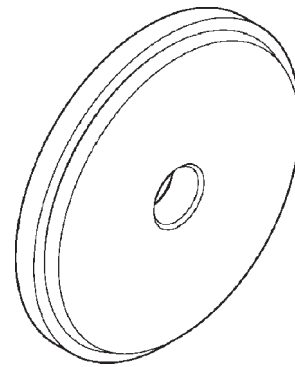
**Remover—8240**



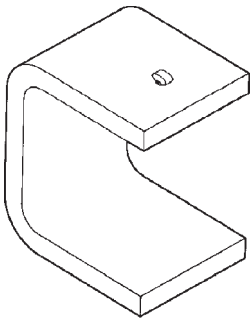
**Puller—8244**



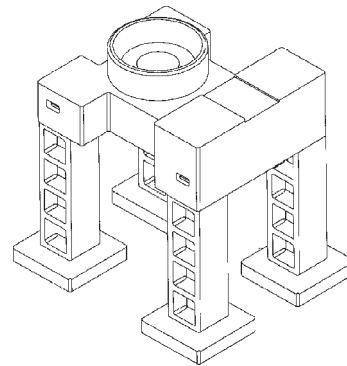
**Transport Fixture—8241**



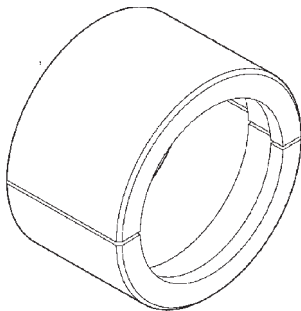
**Remover—8245**



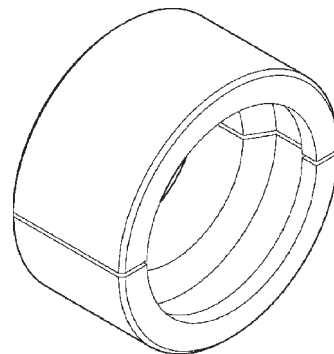
**Holding Tool—8242**



**Support Stand—8246**

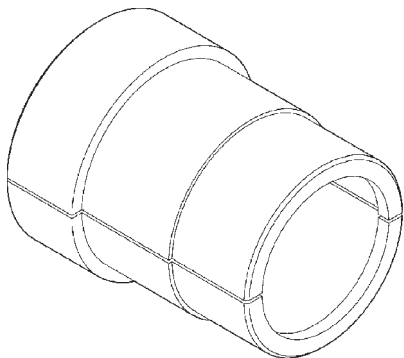


**Remover—8243**

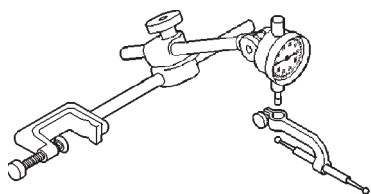


**Remover—8262**

MANUAL - NV5600 (Continued)



**Remover—8271**

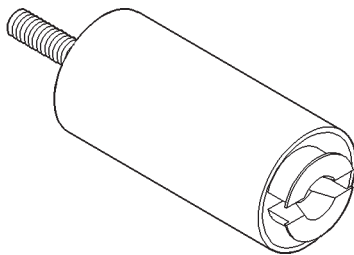


8011d42b

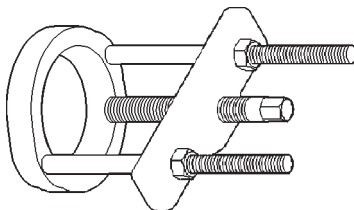
**Dial Indicator Set—C-3339**



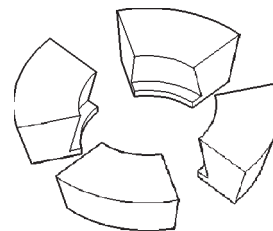
**Installer, Bearing—C-4965**



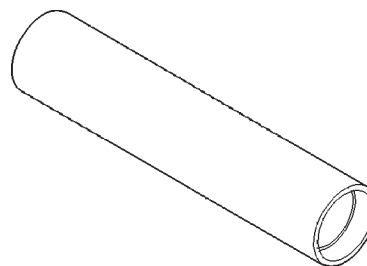
**Remover—L-4518**



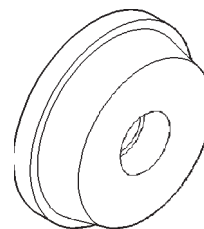
**Puller, Bearing—C-293-PA**



**Adapter, Bearing Puller—C-293-52**



**Installer—MD998805**



**Installer,**

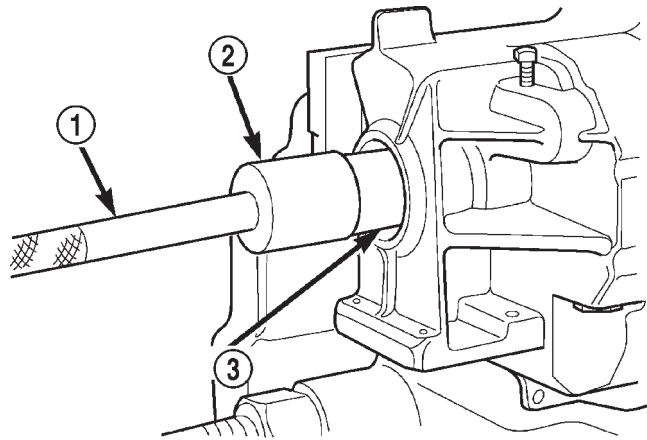
## ADAPTER HOUSING SEAL

### REMOVAL

- (1) Remove the propeller shaft.
- (2) Remove the transfer case.
- (3) Remove adapter housing seal with a pry tool or a slide hammer mounted screw.

### INSTALLATION

- (1) Install extension housing seal with Installer 8154 and Handle C-4171.
- (2) Install propeller shaft with reference marks aligned.



80b6b1ae

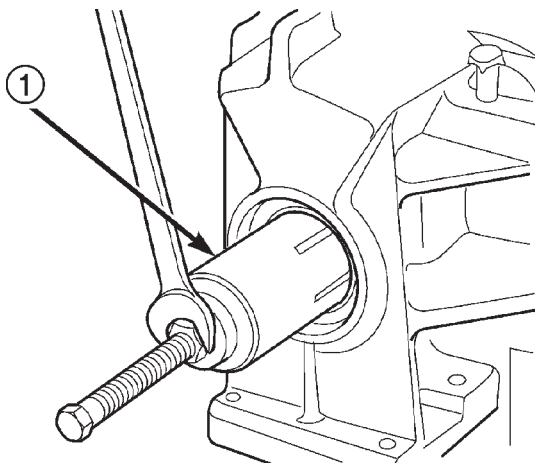
**Fig. 99 Extension Housing Bushing Installer**

- 1 - HANDLE
- 2 - INSTALLER
- 3 - BUSHING

## EXTENSION HOUSING SEAL

### REMOVAL

- (1) Raise and support vehicle.
- (2) Mark propeller shaft and pinion yoke for installation reference and remove the propeller shaft.
- (3) Remove the extension housing seal with a suitable pry tool or a slide hammer mounted screw.
- (4) Remove the extension housing bushing with Remover 8155 (Fig. 98).



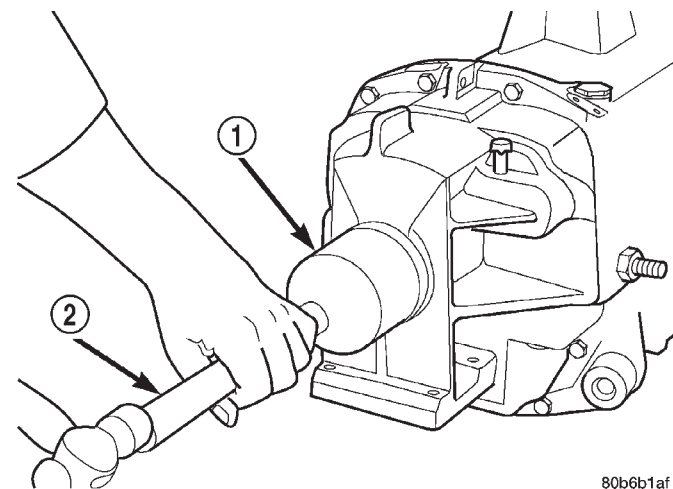
80b6b1ba

**Fig. 98 Extension Housing**

- 1 - REMOVER

### INSTALLATION

- (1) Install extension housing bushing with Installer 8156 (Fig. 99) and Handle C-4171.
- (2) Install adapter housing seal with Installer 8154 and Handle C-4171 (Fig. 100).
- (3) Install transfer case and propeller shaft(s).
- (4) Check and fill transmission.
- (5) Remove support and lower vehicle.



80b6b1af

**Fig. 100 Extension Housing Seal Installer**

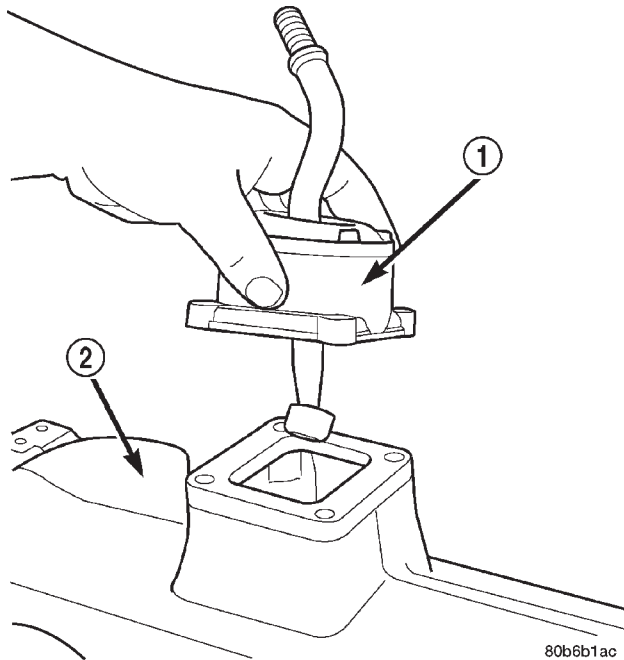
- 1 - INSTALLER
- 2 - HANDLE

## SHIFT COVER

### REMOVAL

- (1) Shift transmission into Neutral.
- (2) Unscrew and remove the shift lever extension from the shift
- (3) Remove screws attaching shift boot to floorpan. Then slide boot upward on the shift lever.
- (4) Remove the bolts holding the shift tower to the isolator plate and transmission gear case.
- (5) Remove the shift tower (Fig. 101) and isolator plate (Fig. 102) from the transmission.

## SHIFT COVER (Continued)

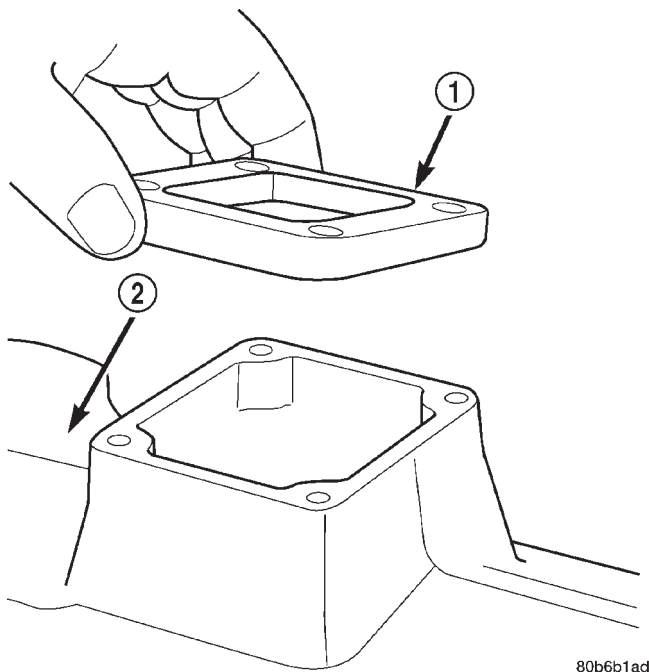


**Fig. 101 Remove Shift Tower**

- 1 - SHIFT TOWER
- 2 - TRANSMISSION

**INSTALLATION**

- (1) Shift transmission into third gear.
- (2) Clean the mating surfaces of shift tower, isolator plate, and transmission gear case with suitable wax and grease remover.
- (3) Apply Mopar® Gasket Maker, or equivalent, to the sealing surface of the transmission. Do not over apply sealant.
- (4) Install the isolator plate onto the transmission, metal side down.
- (5) Install the shift tower onto the isolator plate. No sealant is necessary between the shift tower and top of the isolator plate.
- (6) Verify that the shift tower, isolator plate, and the shift tower bushings are properly aligned.
- (7) Install the bolts to hold the shift tower to the isolator plate and the transmission gear case. Tighten the shift tower bolts to 8–10 N·m (7–9 ft. lbs.).
- (8) Install the shift lever extension, shift boot, and bezel.



**Fig. 102 Remove Shift Tower Isolator Plate**

- 1 - ISOLATOR PLATE
- 2 - TRANSMISSION

## AUTOMATIC TRANSMISSION - 42RE

## TABLE OF CONTENTS

	page		page
<b>AUTOMATIC TRANSMISSION - 42RE</b>		<b>FLUID AND FILTER REPLACEMENT</b> . . . . .	201
DESCRIPTION . . . . .	135	TRANSMISSION FILL . . . . .	201
OPERATION . . . . .	137	<b>FRONT CLUTCH</b>	
DIAGNOSIS AND TESTING . . . . .	143	DESCRIPTION . . . . .	202
AUTOMATIC TRANSMISSION . . . . .	143	OPERATION . . . . .	202
PRELIMINARY . . . . .	143	DISASSEMBLY . . . . .	202
ROAD TESTING . . . . .	143	INSPECTION . . . . .	205
HYDRAULIC PRESSURE TEST . . . . .	144	ASSEMBLY . . . . .	206
AIR CHECKING TRANSMISSION CLUTCH AND BAND OPERATION . . . . .	147	<b>FRONT SERVO</b>	
CONVERTER HOUSING FLUID LEAK . . . . .	148	DESCRIPTION . . . . .	206
DIAGNOSIS CHARTS . . . . .	149	OPERATION . . . . .	207
STANDARD PROCEDURE . . . . .	159	DISASSEMBLY . . . . .	207
ALUMINUM THREAD REPAIR . . . . .	159	CLEANING . . . . .	207
REMOVAL . . . . .	159	INSPECTION . . . . .	207
DISASSEMBLY . . . . .	160	ASSEMBLY . . . . .	208
CLEANING . . . . .	165	<b>OIL PUMP</b>	
INSPECTION . . . . .	165	DESCRIPTION . . . . .	208
ASSEMBLY . . . . .	166	OPERATION . . . . .	208
INSTALLATION . . . . .	173	STANDARD PROCEDURE . . . . .	209
SCHEMATICS AND DIAGRAMS . . . . .	174	OIL PUMP VOLUME CHECK . . . . .	209
SPECIFICATIONS . . . . .	186	DISASSEMBLY . . . . .	209
SPECIAL TOOLS . . . . .	188	CLEANING . . . . .	211
<b>ACCUMULATOR</b>		INSPECTION . . . . .	211
DESCRIPTION . . . . .	191	ASSEMBLY . . . . .	212
OPERATION . . . . .	191	<b>OUTPUT SHAFT FRONT BEARING</b>	
INSPECTION . . . . .	192	REMOVAL . . . . .	213
<b>BANDS</b>		INSTALLATION . . . . .	213
DESCRIPTION . . . . .	192	<b>OUTPUT SHAFT REAR BEARING</b>	
OPERATION . . . . .	192	REMOVAL . . . . .	213
ADJUSTMENTS . . . . .	193	INSTALLATION . . . . .	213
<b>ELECTRONIC GOVERNOR</b>		<b>OVERDRIVE CLUTCH</b>	
DESCRIPTION . . . . .	194	DESCRIPTION . . . . .	214
OPERATION . . . . .	194	OPERATION . . . . .	214
REMOVAL . . . . .	196	<b>OVERDRIVE OFF SWITCH</b>	
INSTALLATION . . . . .	197	DESCRIPTION . . . . .	215
<b>EXTENSION HOUSING BUSHING</b>		OPERATION . . . . .	215
REMOVAL . . . . .	198	DIAGNOSIS AND TESTING . . . . .	215
INSTALLATION . . . . .	198	OVERDRIVE ELECTRICAL CONTROLS . . . . .	215
<b>EXTENSION HOUSING SEAL</b>		REMOVAL . . . . .	215
REMOVAL . . . . .	198	INSTALLATION . . . . .	215
INSTALLATION . . . . .	198	<b>OVERDRIVE UNIT</b>	
<b>FLUID AND FILTER</b>		REMOVAL . . . . .	216
DIAGNOSIS AND TESTING . . . . .	199	DISASSEMBLY . . . . .	217
EFFECTS OF INCORRECT FLUID LEVEL . . . . .	199	CLEANING . . . . .	224
CAUSES OF BURNT FLUID . . . . .	199	INSPECTION . . . . .	224
FLUID CONTAMINATION . . . . .	199	ASSEMBLY . . . . .	225
STANDARD PROCEDURE . . . . .	199	INSTALLATION . . . . .	234
FLUID LEVEL CHECK . . . . .	199		

**OVERRUNNING CLUTCH CAM/OVERDRIVE****PISTON RETAINER**

DESCRIPTION . . . . .	235
OPERATION . . . . .	235
DISASSEMBLY . . . . .	235
CLEANING . . . . .	236
INSPECTION . . . . .	236
ASSEMBLY . . . . .	236

**PARK/NEUTRAL POSITION SWITCH**

DIAGNOSIS AND TESTING . . . . .	237
PARK/NEUTRAL POSITION SWITCH . . . . .	237
REMOVAL . . . . .	238
INSTALLATION . . . . .	238

**PISTONS**

DESCRIPTION . . . . .	238
OPERATION . . . . .	238

**PLANETARY GEARTRAIN/OUTPUT SHAFT**

DESCRIPTION . . . . .	240
OPERATION . . . . .	240
DISASSEMBLY . . . . .	240
INSPECTION . . . . .	241
ASSEMBLY . . . . .	241

**REAR CLUTCH**

DESCRIPTION . . . . .	246
OPERATION . . . . .	246
DISASSEMBLY . . . . .	247
CLEANING . . . . .	247
INSPECTION . . . . .	248
ASSEMBLY . . . . .	248

**REAR SERVO**

DESCRIPTION . . . . .	250
OPERATION . . . . .	250
DISASSEMBLY . . . . .	251
CLEANING . . . . .	251
ASSEMBLY . . . . .	251

**SHIFT MECHANISM**

DESCRIPTION . . . . .	251
-----------------------	-----

## AUTOMATIC TRANSMISSION - 42RE

**DESCRIPTION**

The 42RE is a four speed fully automatic transmission (Fig. 1) with an electronic governor. The 42RE is equipped with a lock-up clutch in the torque converter. First through third gear ranges are provided by the clutches, bands, overrunning clutch, and planetary gear sets in the transmission. Fourth gear range is provided by the overdrive unit that contains an overdrive clutch, direct clutch, planetary gear set, and overrunning clutch.

The transmission contains a front, rear, and direct clutch which function as the input driving components. It also contains the kickdown (front) and the

OPERATION . . . . .	251
ADJUSTMENTS . . . . .	252

**SOLENOID**

DESCRIPTION . . . . .	252
OPERATION . . . . .	253

**SPEED SENSOR**

DESCRIPTION . . . . .	253
OPERATION . . . . .	253

**THROTTLE VALVE CABLE**

DESCRIPTION . . . . .	253
ADJUSTMENTS . . . . .	254

**TORQUE CONVERTER**

DESCRIPTION . . . . .	256
OPERATION . . . . .	260
REMOVAL . . . . .	261
INSTALLATION . . . . .	261

**TORQUE CONVERTER DRAINBACK VALVE**

DESCRIPTION . . . . .	262
OPERATION . . . . .	262
STANDARD PROCEDURE . . . . .	262
TORQUE CONVERTER DRAINBACK VALVE . . . . .	262

**TRANSMISSION TEMPERATURE SENSOR**

DESCRIPTION . . . . .	262
OPERATION . . . . .	262

**VALVE BODY**

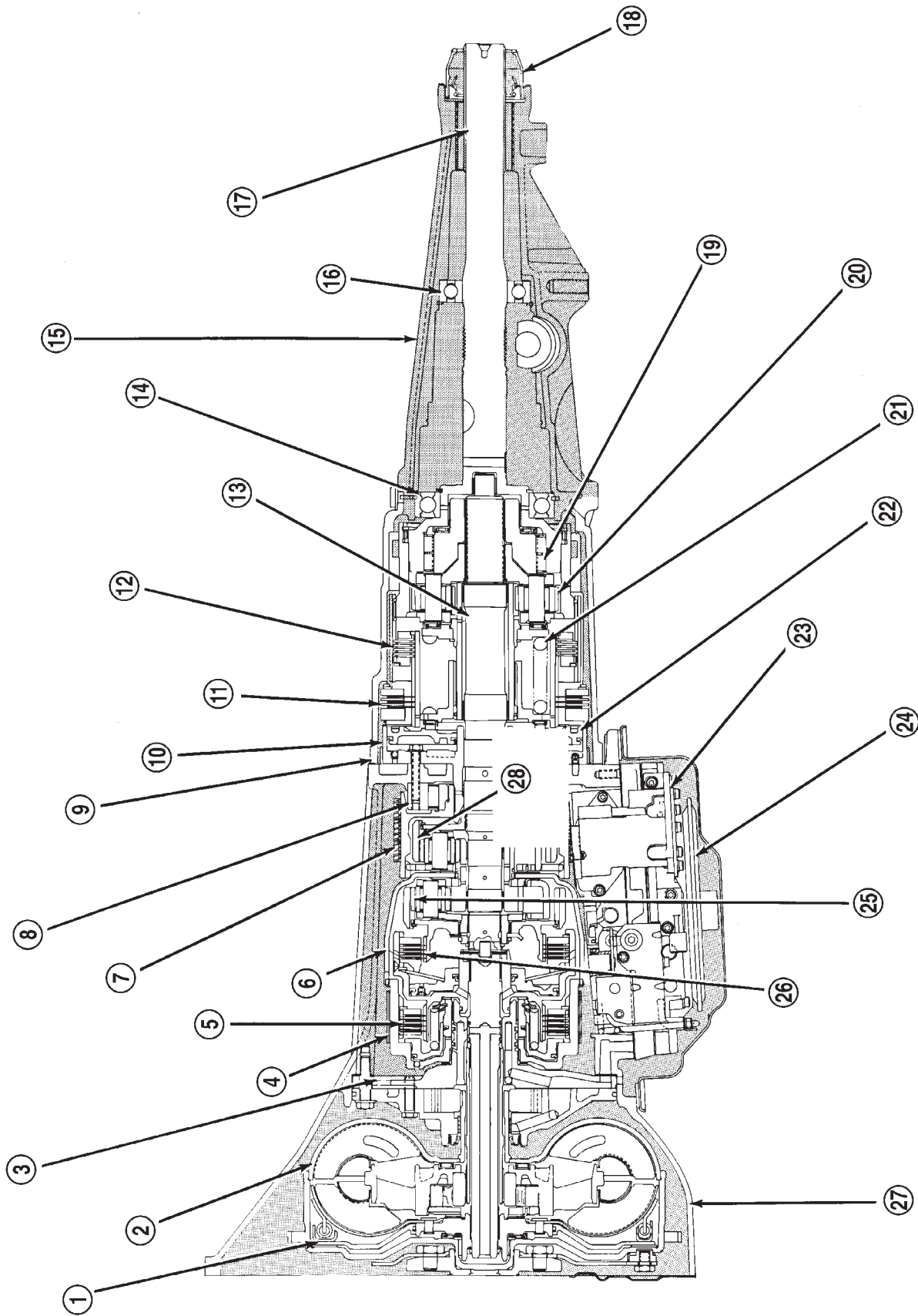
DESCRIPTION . . . . .	263
OPERATION . . . . .	267
REMOVAL . . . . .	281
DISASSEMBLY . . . . .	282
CLEANING . . . . .	293
INSPECTION . . . . .	293
ASSEMBLY . . . . .	294
INSTALLATION . . . . .	303
ADJUSTMENTS . . . . .	304

low/reverse (rear) bands which, along with the overrunning clutch and overdrive clutch, serve as the holding components. The driving and holding components combine to select the necessary planetary gear components, in the front, rear, or overdrive planetary gear set, transfer the engine power from the input shaft through to the output shaft.

The valve body is mounted to the lower side of the transmission and contains the valves to control pressure regulation, fluid flow control, and clutch/band application. The oil pump is mounted at the front of the transmission and is driven by the torque converter hub. The pump supplies the oil pressure necessary for clutch/band actuation and transmission lubrication.



AUTOMATIC TRANSMISSION - 42RE (Continued)



J9321-407

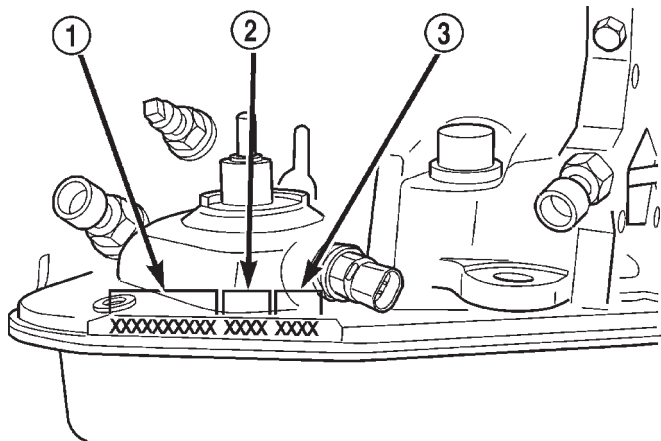
Fig. 1 42RE Transmission

AUTOMATIC TRANSMISSION - 42RE (Continued)

- |  |                                   |
|--|-----------------------------------|
| 1 - CONVERTER CLUTCH                             | 15 - HOUSING                      |
| 2 - TORQUE CONVERTER                             | 16 - REAR BEARING                 |
| 3 - OIL PUMP AND REACTION SHAFT SUPPORT ASSEMBLY | 17 - OUTPUT SHAFT                 |
| 4 - FRONT BAND                                   | 18 - SEAL                         |
| 5 - FRONT CLUTCH                                 | 19 - OVERDRIVE OVERRUNNING CLUTCH |
| 6 - DRIVING SHELL                                | 20 - OVERDRIVE PLANETARY GEAR     |
| 7 - REAR BAND                                    | 21 - DIRECT CLUTCH SPRING         |
| 8 - TRANSMISSION OVERRUNNING CLUTCH              | 22 - OVERDRIVE CLUTCH PISTON      |
| 9 - OVERDRIVE UNIT                               | 23 - VALVE BODY ASSEMBLY          |
| 10 - PISTON RETAINER                             | 24 - FILTER                       |
| 11 - OVERDRIVE CLUTCH                            | 25 - FRONT PLANETARY GEAR         |
| 12 - DIRECT CLUTCH                               | 26 - REAR CLUTCH                  |
| 13 - INTERMEDIATE SHAFT                          | 27 - TRANSMISSION                 |
| 14 - FRONT BEARING                               | 28 - REAR PLANETARY GEAR          |

**IDENTIFICATION**

Transmission identification numbers are stamped on the left side of the case just above the oil pan gasket surface (Fig. 2). Refer to this information when ordering replacement parts.



80b11960

**Fig. 2 Transmission Part And Serial Number Location**

- 1 - PART NUMBER
- 2 - BUILD DATE
- 3 - SERIAL NUMBER

**GEAR RATIOS** The 42RE gear ratios are:

<b>1st</b> .....	2.74:1
<b>2nd</b> .....	1.54:1
<b>3rd</b> .....	1.00:1
<b>4th</b> .....	0.69:1
<b>Rev.</b> .....	2.21:1

**OPERATION**

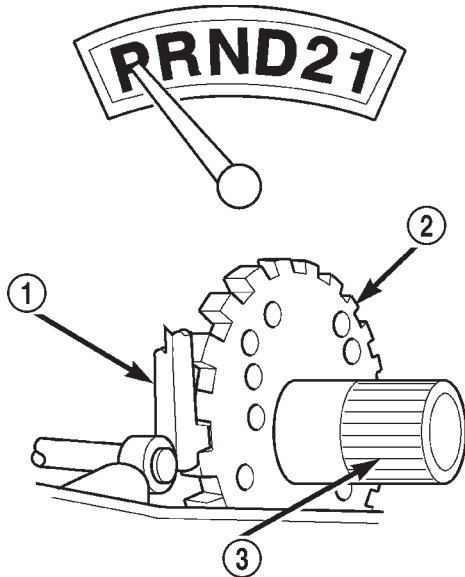
The application of each driving or holding component is controlled by the valve body based upon the manual lever position, throttle pressure, and governor pressure. The governor pressure is a variable pressure input to the valve body and is one of the signals that a shift is necessary. First through fourth gear are obtained by selectively applying and releasing the different clutches and bands. Engine power is thereby routed to the various planetary gear assemblies which combine with the overrunning clutch assemblies to generate the different gear ratios. The torque converter clutch is hydraulically applied and is released when fluid is vented from the hydraulic circuit by the torque converter control (TCC) solenoid on the valve body. The torque converter clutch is controlled by the Powertrain Control Module (PCM). The torque converter clutch engages in fourth gear, and in third gear under various conditions, such as when the O/D switch is OFF, when the vehicle is cruising on a level surface after the vehicle has warmed up. The torque converter clutch will disengage momentarily when an increase in engine load is sensed by the PCM, such as when the vehicle begins to go uphill or the throttle pressure is increased. The torque converter clutch feature increases fuel economy and reduces the transmission fluid temperature.

Since the overdrive clutch is applied in fourth gear only and the direct clutch is applied in all ranges except fourth gear, the transmission operation for park, neutral, and first through third gear will be described first. Once these powerflows are described, the third to fourth shift sequence will be described.

AUTOMATIC TRANSMISSION - 42RE (Continued)

**PARK POWERFLOW**

As the engine is running and the crankshaft is rotating, the flexplate and torque converter, which are also bolted to it, are all rotating in a clockwise direction as viewed from the front of the engine. The notched hub of the torque converter is connected to the oil pump's internal gear, supplying the transmission with oil pressure. As the converter turns, it turns the input shaft in a clockwise direction. As the input shaft is rotating, the front clutch hub-rear clutch retainer and all their associated parts are also rotating, all being directly connected to the input shaft. The power flow from the engine through the front clutch hub and rear clutch retainer stops at the rear clutch retainer. Therefore, no power flow to the output shaft occurs because no clutches are applied. The only mechanism in use at this time is the parking sprag (Fig. 3), which locks the parking gear on the output shaft to the transmission case.



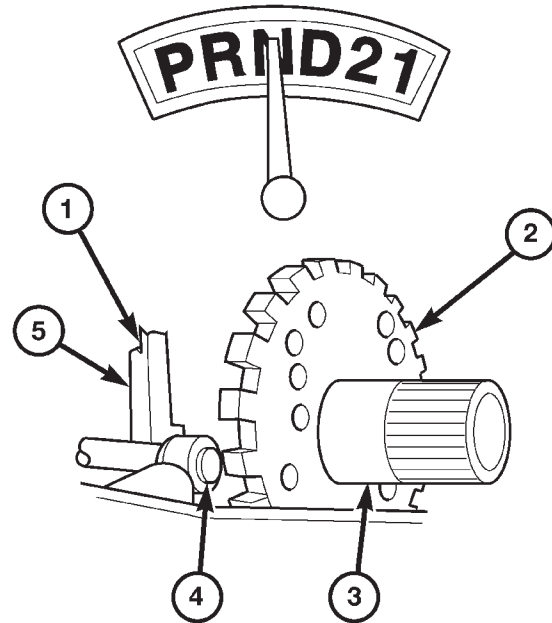
80c070a6

**Fig. 3 Park Powerflow**

- 1 - PAWL ENGAGED FOR PARK
- 2 - PARK SPRAG
- 3 - OUTPUT SHAFT

**NEUTRAL POWERFLOW**

With the gear selector in the NEUTRAL position (Fig. 4), the power flow of the transmission is essentially the same as in the park position. The only operational difference is that the parking sprag has been disengaged, unlocking the output shaft from the transmission case and allowing it to move freely.



80a06c8f

**Fig. 4 Neutral Powerflow**

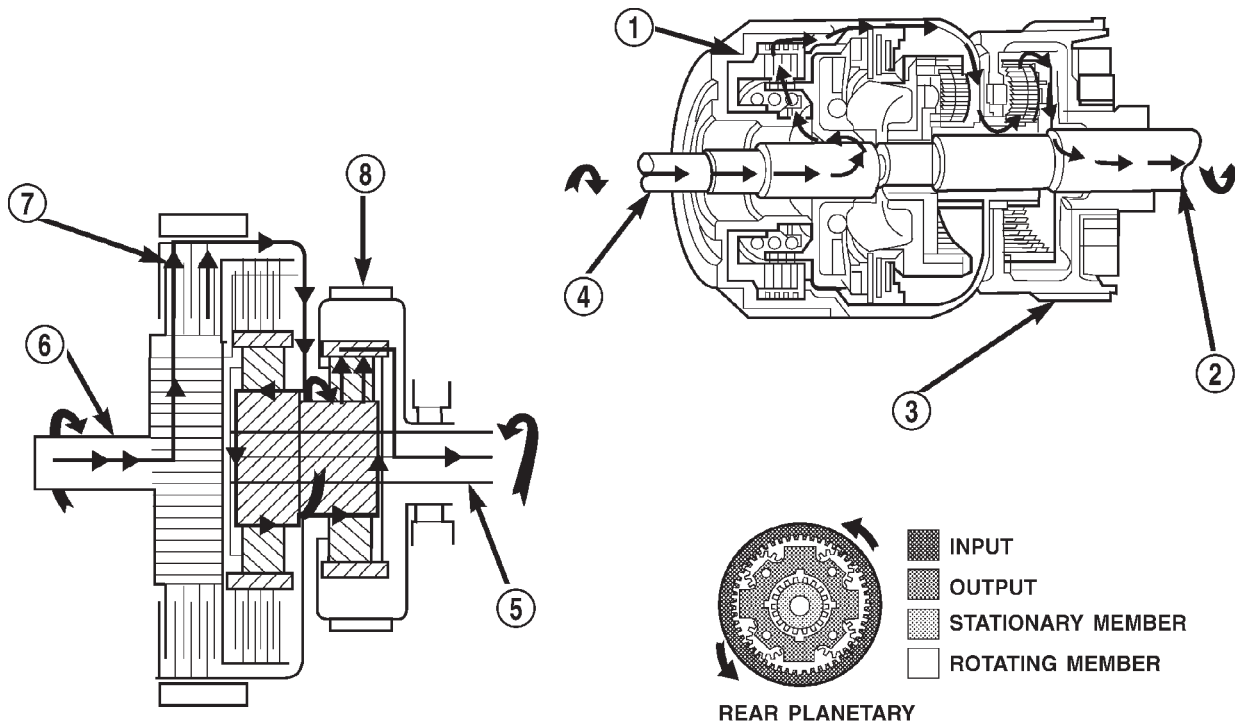
- 1 - PAWL DISENGAGED FOR NEUTRAL
- 2 - PARK SPRAG
- 3 - OUTPUT SHAFT
- 4 - CAM
- 5 - PAWL

AUTOMATIC TRANSMISSION - 42RE (Continued)

**REVERSE POWERFLOW**

When the gear selector is moved into the REVERSE position (Fig. 5), the front clutch and the rear band are applied. With the application of the front clutch, engine torque is applied to the sun gear, turning it in a clockwise direction. The clockwise rotation of the sun gear causes the rear planet pinions to rotate against engine rotation in a counterclockwise direction. The rear band is holding the low reverse drum, which is splined to the rear carrier. Since the rear carrier is being held, the torque from

the planet pinions is transferred to the rear annulus gear, which is splined to the output shaft. The output shaft in turn rotates with the annulus gear in a counterclockwise direction giving a reverse gear output. The entire transmission of torque is applied to the rear planetary gearset only. Although there is torque input to the front gearset through the sun gear, no other member of the gearset is being held. During the entire reverse stage of operation, the front planetary gears are in an idling condition.



80c070a8

**Fig. 5 Reverse Powerflow**

- 1 - FRONT CLUTCH ENGAGED
- 2 - OUTPUT SHAFT
- 3 - LOW/REVERSE BAND APPLIED
- 4 - INPUT SHAFT

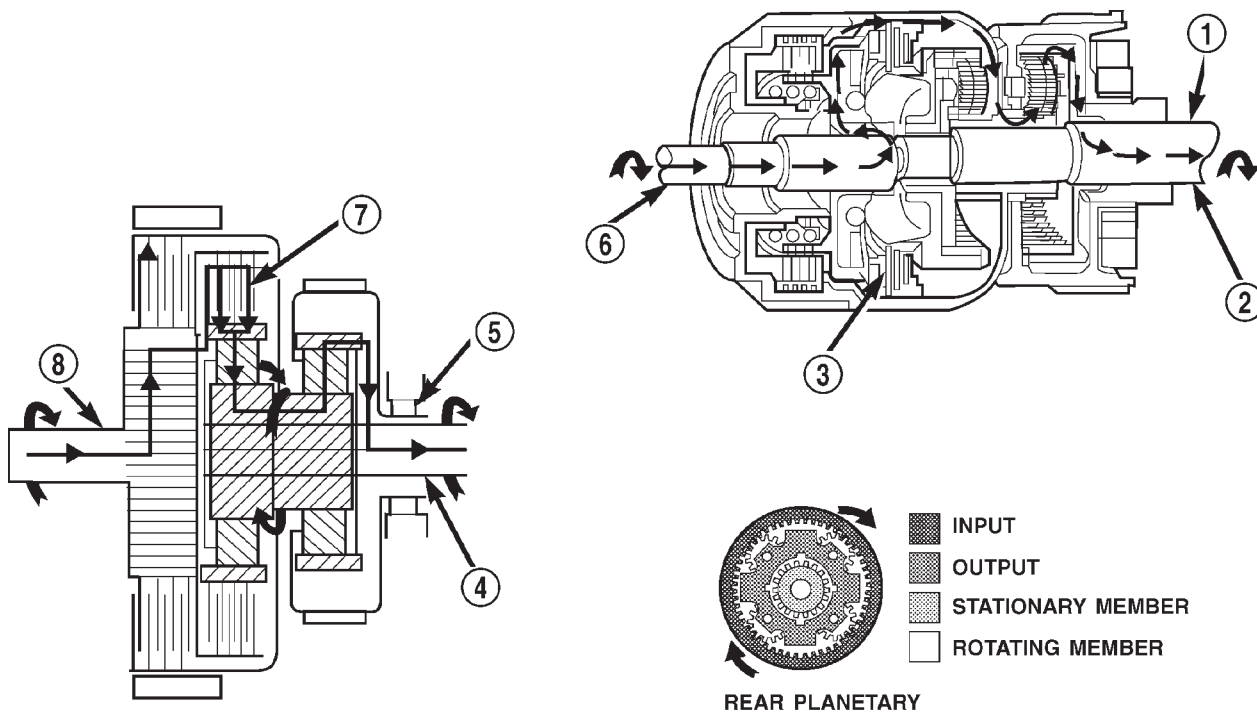
- 5 - OUTPUT SHAFT
- 6 - INPUT SHAFT
- 7 - FRONT CLUTCH ENGAGED
- 8 - LOW/REVERSE BAND APPLIED

AUTOMATIC TRANSMISSION - 42RE (Continued)

**FIRST GEAR POWERFLOW**

When the gearshift lever is moved into the DRIVE position the transmission goes into first gear (Fig. 6). As soon as the transmission is shifted from PARK or NEUTRAL to DRIVE, the rear clutch applies, applying the rear clutch pack to the front annulus gear. Engine torque is now applied to the front annulus gear turning it in a clockwise direction. With the front annulus gear turning in a clockwise direction, it causes the front planets to turn in a clockwise direction. The rotation of the front planets cause the sun to revolve in a counterclockwise direction. The sun gear now transfers its counterclockwise rotation to

the rear planets which rotate back in a clockwise direction. With the rear annulus gear stationary, the rear planet rotation on the annulus gear causes the rear planet carrier to revolve in a counterclockwise direction. The rear planet carrier is splined into the low-reverse drum, and the low reverse drum is splined to the inner race of the over-running clutch. With the over-running clutch locked, the planet carrier is held, and the resulting torque provided by the planet pinions is transferred to the rear annulus gear. The rear annulus gear is splined to the output shaft and rotated along with it (clockwise) in an underdrive gear reduction mode.



80c070a9

**Fig. 6 First Gear Powerflow**

- 1 - OUTPUT SHAFT
- 2 - OVER-RUNNING CLUTCH HOLDING
- 3 - REAR CLUTCH APPLIED
- 4 - OUTPUT SHAFT

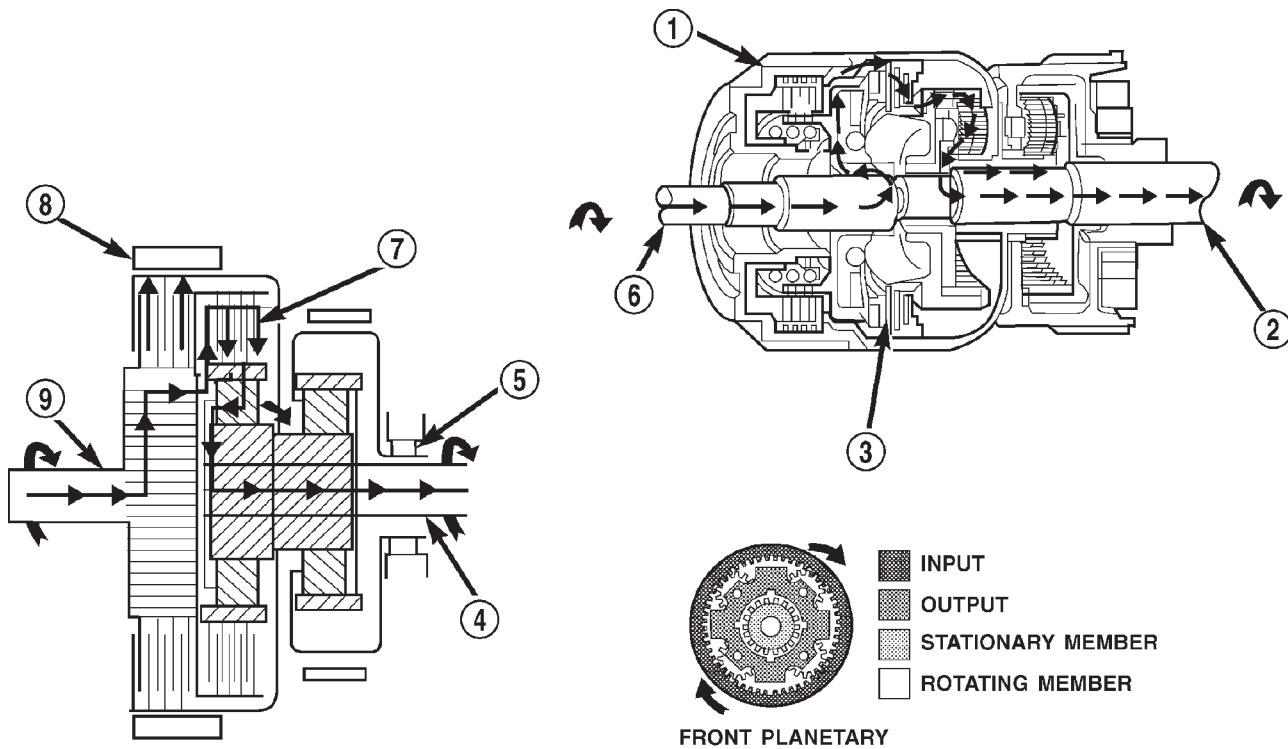
- 5 - OVER-RUNNING CLUTCH HOLDING
- 6 - INPUT SHAFT
- 7 - REAR CLUTCH APPLIED
- 8 - INPUT SHAFT

AUTOMATIC TRANSMISSION - 42RE (Continued)

**SECOND GEAR POWERFLOW**

In DRIVE-SECOND (Fig. 7), the same elements are applied as in MANUAL-SECOND. Therefore, the power flow will be the same, and both gears will be discussed as one in the same. In DRIVE-SECOND, the transmission has proceeded from first gear to its shift point, and is shifting from first gear to second. The second gear shift is obtained by keeping the rear clutch applied and applying the front (kickdown) band. The front band holds the front clutch retainer that is locked to the sun gear driving shell. With the rear clutch still applied, the input is still on the front annulus gear turning it clockwise at engine speed.

Now that the front band is holding the sun gear stationary, the annulus rotation causes the front planets to rotate in a clockwise direction. The front carrier is then also made to rotate in a clockwise direction but at a reduced speed. This will transmit the torque to the output shaft, which is directly connected to the front planet carrier. The rear planetary annulus gear will also be turning because it is directly splined to the output shaft. All power flow has occurred in the front planetary gear set during the drive-second stage of operation, and now the over-running clutch, in the rear of the transmission, is disengaged and freewheeling on its hub.



**Fig. 7 Second Gear Powerflow**

- 1 - KICKDOWN BAND APPLIED
- 2 - OUTPUT SHAFT
- 3 - REAR CLUTCH ENGAGED
- 4 - OUTPUT SHAFT
- 5 - OVER-RUNNING CLUTCH FREE-WHEELING
- 6 - INPUT SHAFT
- 7 - REAR CLUTCH APPLIED
- 8 - KICKDOWN BAND APPLIED
- 9 - INPUT SHAFT

80c070aa

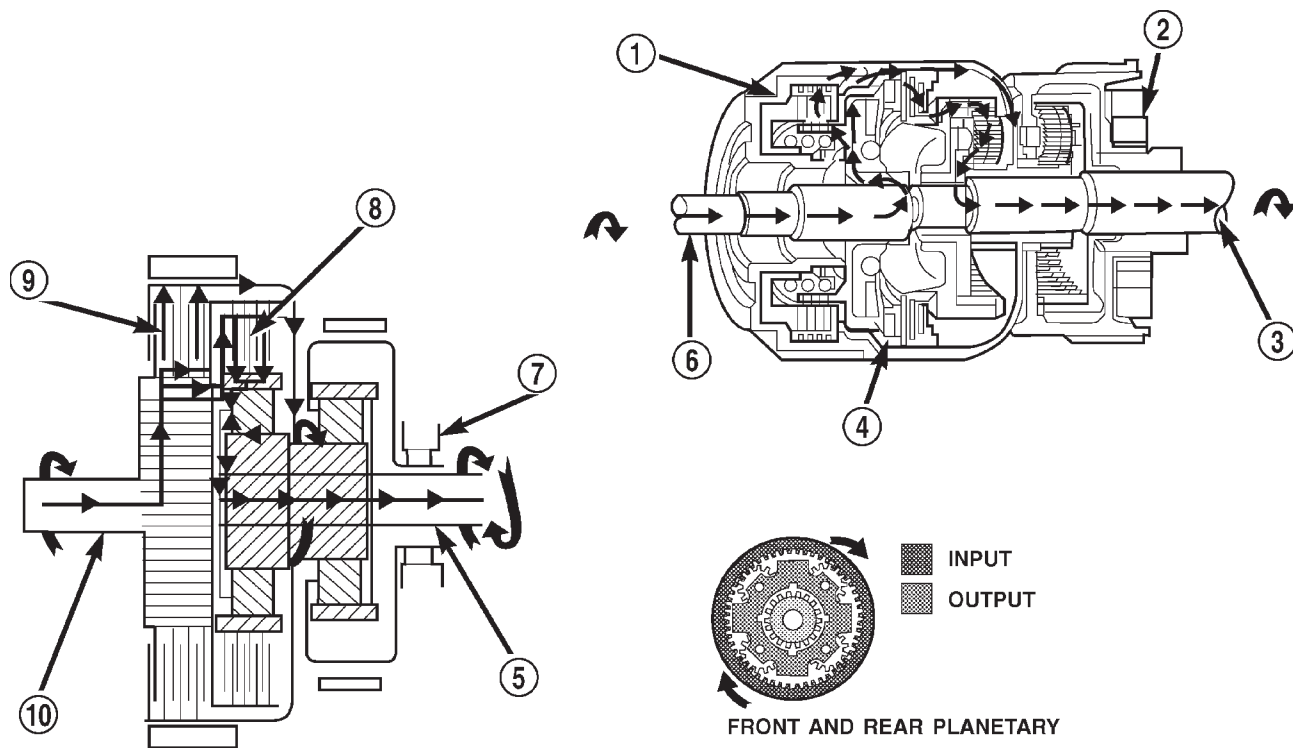


AUTOMATIC TRANSMISSION - 42RE (Continued)

**DIRECT DRIVE POWERFLOW**

The vehicle has accelerated and reached the shift point for the 2-3 upshift into direct drive (Fig. 8). When the shift takes place, the front band is released, and the front clutch is applied. The rear clutch stays applied as it has been in all the forward gears. With the front clutch now applied, engine torque is now on the front clutch retainer, which is locked to the sun gear driving shell. This means that the sun gear is now turning in engine rotation (clockwise) and at engine speed. The rear clutch is still applied so engine torque is also still on the front

annulus gear. If two members of the same planetary set are driven, direct drive results. Therefore, when two members are rotating at the same speed and in the same direction, it is the same as being locked up. The rear planetary set is also locked up, given the sun gear is still the input, and the rear annulus gear must turn with the output shaft. Both gears are turning in the same direction and at the same speed. The front and rear planet pinions do not turn at all in direct drive. The only rotation is the input from the engine to the connected parts, which are acting as one common unit, to the output shaft.



80c070ab

**Fig. 8 Direct Drive Powerflow**

- 1 - FRONT CLUTCH APPLIED
- 2 - OVER-RUNNING CLUTCH FREE-WHEELING
- 3 - OUTPUT SHAFT
- 4 - REAR CLUTCH APPLIED
- 5 - OUTPUT SHAFT

- 6 - INPUT SHAFT
- 7 - OVER-RUNNING CLUTCH FREE-WHEELING
- 8 - REAR CLUTCH APPLIED
- 9 - FRONT CLUTCH APPLIED
- 10 - INPUT SHAFT

## AUTOMATIC TRANSMISSION - 42RE (Continued)

**FOURTH GEAR POWERFLOW**

Fourth gear overdrive range is electronically controlled and hydraulically activated. Various sensor inputs are supplied to the powertrain control module to operate the overdrive solenoid on the valve body. The solenoid contains a check ball that opens and closes a vent port in the 3-4 shift valve feed passage. The overdrive solenoid (and check ball) are not energized in first, second, third, or reverse gear. The vent port remains open, diverting line pressure from the 2-3 shift valve away from the 3-4 shift valve. The overdrive control switch must be in the ON position to transmit overdrive status to the PCM. A 3-4 upshift occurs only when the overdrive solenoid is energized by the PCM. The PCM energizes the overdrive solenoid during the 3-4 upshift. This causes the solenoid check ball to close the vent port allowing line pressure from the 2-3 shift valve to act directly on the 3-4 upshift valve. Line pressure on the 3-4 shift valve overcomes valve spring pressure moving the valve to the upshift position. This action exposes the feed passages to the 3-4 timing valve, 3-4 quick fill valve, 3-4 accumulator, and ultimately to the overdrive piston. Line pressure through the timing valve moves the overdrive piston into contact with the overdrive clutch. The direct clutch is disengaged before the overdrive clutch is engaged. The boost valve provides increased fluid apply pressure to the overdrive clutch during 3-4 upshifts, and when accelerating in fourth gear. The 3-4 accumulator cushions overdrive clutch engagement to smooth 3-4 upshifts. The accumulator is charged at the same time as apply pressure acts against the overdrive piston.

**DIAGNOSIS AND TESTING - AUTOMATIC TRANSMISSION**

Automatic transmission problems can be a result of poor engine performance, incorrect fluid level, incorrect linkage or cable adjustment, band or hydraulic control pressure adjustments, hydraulic system malfunctions or electrical/mechanical component malfunctions. Begin diagnosis by checking the easily accessible items such as: fluid level and condition, linkage adjustments and electrical connections. A road test will determine if further diagnosis is necessary.

**DIAGNOSIS AND TESTING - PRELIMINARY**

Two basic procedures are required. One procedure for vehicles that are drivable and an alternate procedure for disabled vehicles (will not back up or move forward).

**VEHICLE IS DRIVEABLE**

(1) Check for transmission fault codes using DRB® scan tool.

(2) Check fluid level and condition.

(3) Adjust throttle and gearshift linkage if complaint was based on delayed, erratic, or harsh shifts.

(4) Road test and note how transmission upshifts, downshifts, and engages.

(5) Perform hydraulic pressure test if shift problems were noted during road test.

(6) Perform air-pressure test to check clutch-band operation.

**VEHICLE IS DISABLED**

(1) Check fluid level and condition.

(2) Check for broken or disconnected gearshift or throttle linkage.

(3) Check for cracked, leaking cooler lines, or loose or missing pressure-port plugs.

(4) Raise and support vehicle on safety stands, start engine, shift transmission into gear, and note following:

(a) If propeller shaft turns but wheels do not, problem is with differential or axle shafts.

(b) If propeller shaft does not turn and transmission is noisy, stop engine. Remove oil pan, and check for debris. If pan is clear, remove transmission and check for damaged drive plate, converter, oil pump, or input shaft.

(c) If propeller shaft does not turn and transmission is not noisy, perform hydraulic-pressure test to determine if problem is hydraulic or mechanical.

**DIAGNOSIS AND TESTING - ROAD TESTING**

Before road testing, be sure the fluid level and control cable adjustments have been checked and adjusted if necessary. Verify that diagnostic trouble codes have been resolved.

Observe engine performance during the road test. A poorly tuned engine will not allow accurate analysis of transmission operation.

Operate the transmission in all gear ranges. Check for shift variations and engine flare which indicates slippage. Note if shifts are harsh, spongy, delayed, early, or if part throttle downshifts are sensitive.

Slippage indicated by engine flare, usually means clutch, band or overrunning clutch problems. If the condition is advanced, an overhaul will be necessary to restore normal operation.

A slipping clutch or band can often be determined by comparing which internal units are applied in the various gear ranges. The Clutch and Band Application chart provides a basis for analyzing road test results.

## AUTOMATIC TRANSMISSION - 42RE (Continued)

## CLUTCH AND BAND APPLICATION CHART

SHIFT LEVER POSITION	TRANSMISSION CLUTCHES AND BANDS					OVERDRIVE CLUTCHES		
	FRONT CLUTCH	FRONT BAND	REAR CLUTCH	REAR BAND	OVER-RUNNING CLUTCH	OVER-DRIVE CLUTCH	DIRECT CLUTCH	OVER-RUNNING CLUTCH
Reverse	X			X			X	
Drive - First			X		X		X	X
Drive - Second		X	X				X	X
Drive - Third	X		X				X	X
Drive - Fourth	X		X			X		
Manual Second		X	X		X		X	X
Manual First			X	X	X		X	X

Note that the rear clutch is applied in all forward ranges (D, 2, 1). The transmission overrunning clutch is applied in first gear (D, 2 and 1 ranges) only. The rear band is applied in 1 and R range only.

Note that the overdrive clutch is applied only in fourth gear and the overdrive direct clutch and overrunning clutch are applied in all ranges except fourth gear.

For example: If slippage occurs in first gear in D and 2 range but not in 1 range, the transmission overrunning clutch is faulty. Similarly, if slippage occurs in any two forward gears, the rear clutch is slipping.

Applying the same method of analysis, note that the front and rear clutches are applied simultaneously only in D range third and fourth gear. If the transmission slips in third gear, either the front clutch or the rear clutch is slipping.

If the transmission slips in fourth gear but not in third gear, the overdrive clutch is slipping. By selecting another gear which does not use these clutches, the slipping unit can be determined. For example, if the transmission also slips in Reverse, the front clutch is slipping. If the transmission does not slip in Reverse, the rear clutch is slipping.

If slippage occurs during the 3-4 shift or only in fourth gear, the overdrive clutch is slipping. Similarly, if the direct clutch were to fail, the transmission would lose both reverse gear and overrunning braking in 2 position (manual second gear).

If the transmission will not shift to fourth gear, the control switch, overdrive solenoid or related wiring may also be the problem cause.

This process of elimination can be used to identify a slipping unit and check operation. Proper use of the Clutch and Band Application Chart is the key.

Although road test analysis will help determine the slipping unit, the actual cause of a malfunction usually cannot be determined until hydraulic and air pressure tests are performed. Practically any condition can be caused by leaking hydraulic circuits or sticking valves.

Unless a malfunction is obvious, such as no drive in D range first gear, do not disassemble the transmission. Perform the hydraulic and air pressure tests to help determine the probable cause.

## DIAGNOSIS AND TESTING - HYDRAULIC PRESSURE TEST

Hydraulic test pressures range from a low of one psi (6.895 kPa) governor pressure, to 300 psi (2068 kPa) at the rear servo pressure port in reverse.

An accurate tachometer and pressure test gauges are required. Test Gauge C-3292 has a 100 psi range and is used at the accumulator, governor, and front servo ports. Test Gauge C-3293-SP has a 300 psi range and is used at the rear servo and overdrive ports where pressures exceed 100 psi.

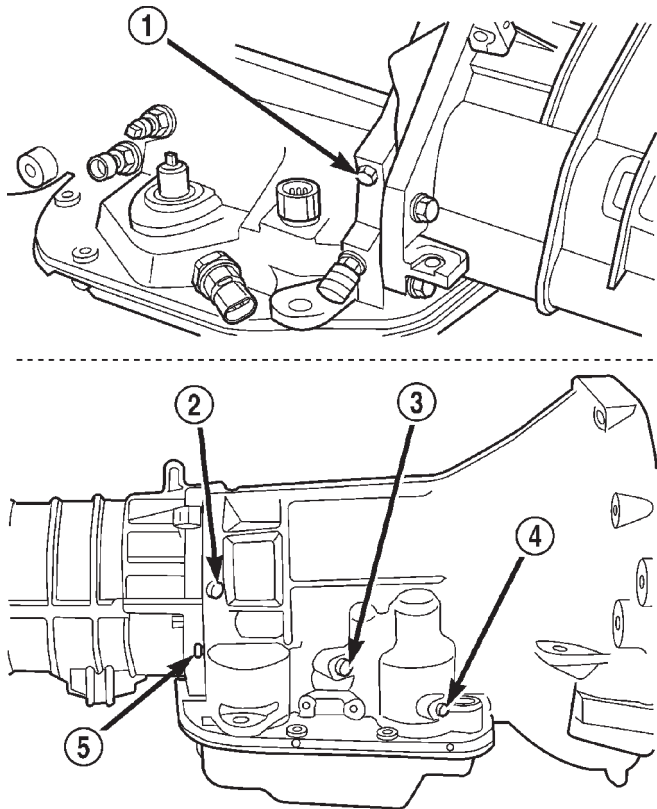
## AUTOMATIC TRANSMISSION - 42RE (Continued)

**Pressure Test Port Locations**

Test ports are located at both sides of the transmission case (Fig. 9).

Line pressure is checked at the accumulator port on the right side of the case. The front servo pressure port is at the right side of the case just behind the filler tube opening.

The rear servo and governor pressure ports are at the right rear of the transmission case. The overdrive clutch pressure port is at the left rear of the case.



80b170e6

**Fig. 9 Pressure Test Port Locations**

- 1 - OVERDRIVE CLUTCH TEST PORT
- 2 - GOVERNOR TEST PORT
- 3 - ACCUMULATOR TEST PORT
- 4 - FRONT SERVO TEST PORT
- 5 - REAR SERVO TEST PORT

**Test One - Transmission In Manual Low**

**NOTE:** This test checks pump output, pressure regulation, and condition of the rear clutch and servo circuit. Both test gauges are required for this test.

(1) Connect tachometer to engine. Position tachometer so it can be observed from driver seat if helper will be operating engine. Raise vehicle on hoist that will allow rear wheels to rotate freely.

(2) Connect 100 psi Gauge C-3292 to accumulator port. Then connect 300 psi Gauge C-3293-SP to rear servo port.

(3) Disconnect throttle and gearshift cables from levers on transmission valve body manual shaft.

(4) Have helper start and run engine at 1000 rpm.

(5) Move transmission shift lever fully forward into 1 range.

(6) Gradually move transmission throttle lever from full forward to full rearward position and note pressures on both gauges:

- Line pressure at accumulator port should be 54-60 psi (372-414 kPa) with throttle lever forward and gradually increase to 90-96 psi (621-662 kPa) as throttle lever is moved rearward.

- Rear servo pressure should be same as line pressure within 3 psi (20.68 kPa).

**Test Two - Transmission In 2 Range**

**NOTE:** This test checks pump output, line pressure and pressure regulation. Use 100 psi Test Gauge C-3292 for this test.

(1) Leave vehicle in place on hoist and leave Test Gauge C-3292 connected to accumulator port.

(2) Have helper start and run engine at 1000 rpm.

(3) Move transmission shift lever one detent rearward from full forward position. This is 2 range.

(4) Move transmission throttle lever from full forward to full rearward position and read pressure on gauge.

(5) Line pressure should be 54-60 psi (372-414 kPa) with throttle lever forward and gradually increase to 90-96 psi (621-662 kPa) as lever is moved rearward.

**Test Three - Transmission In D Range Third Gear**

**NOTE:** This test checks pressure regulation and condition of the clutch circuits. Both test gauges are required for this test.

(1) Turn OD switch off.

(2) Leave vehicle on hoist and leave Gauge C-3292 in place at accumulator port.

(3) Move Gauge C-3293-SP over to front servo port for this test.

(4) Have helper start and run engine at 1600 rpm for this test.

(5) Move transmission shift lever two detents rearward from full forward position. This is D range.

(6) Read pressures on both gauges as transmission throttle lever is gradually moved from full forward to full rearward position:

- Line pressure at accumulator in D range third gear, should be 54-60 psi (372-414 kPa) with throttle

## AUTOMATIC TRANSMISSION - 42RE (Continued)

lever forward and increase as lever is moved rearward.

- Front servo pressure in D range third gear, should be within 3 psi (21 kPa) of line pressure up to kickdown point.

## Test Four - Transmission In Reverse

**NOTE: This test checks pump output, pressure regulation and the front clutch and rear servo circuits. Use 300 psi Test Gauge C-3293-SP for this test.**

- (1) Leave vehicle on hoist and leave gauge C-3292 in place at accumulator port.
- (2) Move 300 psi Gauge C-3293-SP back to rear servo port.
- (3) Have helper start and run engine at 1600 rpm for test.
- (4) Move transmission shift lever four detents rearward from full forward position. This is Reverse range.
- (5) Move transmission throttle lever fully forward then fully rearward and note reading at Gauge C-3293-SP.
- (6) Pressure should be 145 - 175 psi (1000-1207 kPa) with throttle lever forward and increase to 230 - 280 psi (1586-1931 kPa) as lever is gradually moved rearward.

## Test Five - Governor Pressure

**NOTE: This test checks governor operation by measuring governor pressure response to changes in vehicle speed. It is usually not necessary to check governor operation unless shift speeds are incorrect or if the transmission will not downshift. The test should be performed on the road or on a hoist that will allow the rear wheels to rotate freely.**

- (1) Move 100 psi Test Gauge C-3292 to governor pressure port.
- (2) Move transmission shift lever two detents rearward from full forward position. This is D range.
- (3) Have helper start and run engine at curb idle speed. Then firmly apply service brakes so wheels will not rotate.

(4) Note governor pressure:

- Governor pressure should be no more than 20.6 kPa (3 psi) at curb idle speed and wheels not rotating.

- If pressure exceeds 20.6 kPa (3 psi), a fault exists in governor pressure control system.

(5) Release brakes, slowly increase engine speed, and observe speedometer and pressure test gauge (do not exceed 30 mph on speedometer). Governor pressure should increase in proportion to vehicle speed. Or approximately 6.89 kPa (1 psi) for every 1 mph.

(6) Governor pressure rise should be smooth and drop back to no more than 20.6 kPa (3 psi), after engine returns to curb idle and brakes are applied to prevent wheels from rotating.

(7) Compare results of pressure test with analysis chart.

## Test Six - Transmission In Overdrive Fourth Gear

**NOTE: This test checks line pressure at the overdrive clutch in fourth gear range. Use 300 psi Test Gauge C-3293-SP for this test. The test should be performed on the road or on a chassis dyno.**

- (1) Remove tachometer; it is not needed for this test.
- (2) Move 300 psi Gauge to overdrive clutch pressure test port. Then remove other gauge and reinstall test port plug.
- (3) Lower vehicle.
- (4) Turn OD switch on.
- (5) Secure test gauge so it can be viewed from drivers seat.
- (6) Start engine and shift into D range.
- (7) Increase vehicle speed gradually until 3-4 shift occurs and note gauge pressure.
- (8) Pressure should be 469-496 kPa (68-72 psi) with closed throttle and increase to 620-827 kPa (90-120 psi) at 1/2 to 3/4 throttle. Note that pressure can increase to around 896 kPa (130 psi) at full throttle.
- (9) Return to shop or move vehicle off chassis dyno.



AUTOMATIC TRANSMISSION - 42RE (Continued)

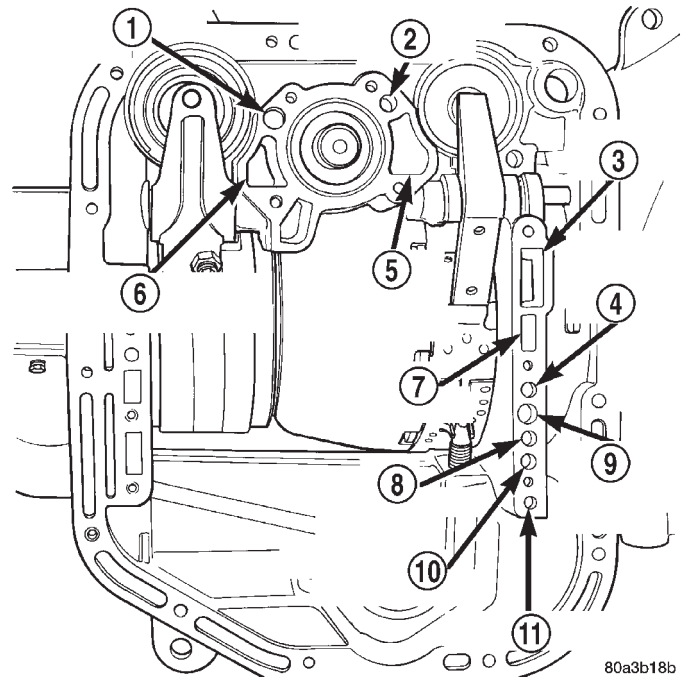
PRESSURE TEST ANALYSIS CHART

TEST CONDITION	INDICATION
Line pressure OK during any one test	Pump and regulator valve OK
Line pressure OK in R but low in D, 2, 1	Leakage in rear clutch area (seal rings, clutch seals)
Pressure low in D Fourth Gear Range	Overdrive clutch piston seal, or check ball problem
Pressure OK in 1, 2 but low in D3 and R	Leakage in front clutch area
Pressure OK in 2 but low in R and 1	Leakage in rear servo
Front servo pressure in 2	Leakage in servo; broken servo ring or cracked servo piston
Pressure low in all positions	Clogged filter, stuck regulator valve, worn or faulty pump, low oil level
Governor pressure too high at idle speed	Governor pressure solenoid valve system fault. Refer to diagnostic book.
Governor pressure low at all mph figures	Faulty governor pressure solenoid, transmission control module, or governor pressure sensor
Lubrication pressure low at all throttle positions	Clogged fluid cooler or lines, seal rings leaking, worn pump bushings, pump, clutch retainer, or clogged filter.
Line pressure high	Output shaft plugged, sticky regulator valve
Line pressure low	Sticky regulator valve, clogged filter, worn pump

**DIAGNOSIS AND TESTING - AIR CHECKING TRANSMISSION CLUTCH AND BAND OPERATION**

Air-pressure testing can be used to check transmission front/rear clutch and band operation. The test can be conducted with the transmission either in the vehicle or on the work bench, as a final check, after overhaul.

Air-pressure testing requires that the oil pan and valve body be removed from the transmission. The servo and clutch apply passages are shown (Fig. 10).



**Fig. 10 Air Pressure Test Passages**

- 1 - REAR SERVO APPLY
- 2 - FRONT SERVO APPLY
- 3 - PUMP SUCTION
- 4 - FRONT CLUTCH APPLY
- 5 - FRONT SERVO RELEASE
- 6 - LINE PRESSURE TO ACCUMULATOR
- 7 - PUMP PRESSURE
- 8 - TO CONVERTER
- 9 - REAR CLUTCH APPLY
- 10 - FROM CONVERTER
- 11 - TO COOLER

**Front Clutch Air Test**

Place one or two fingers on the clutch housing and apply air pressure through front clutch apply passage. Piston movement can be felt and a soft thump heard as the clutch applies.

**Rear Clutch Air Test**

Place one or two fingers on the clutch housing and apply air pressure through rear clutch apply passage.



## AUTOMATIC TRANSMISSION - 42RE (Continued)

Piston movement can be felt and a soft thump heard as the clutch applies.

**Front Servo Apply Air Test**

Apply air pressure to the front servo apply passage. The servo rod should extend and cause the band to tighten around the drum. Spring pressure should release the servo when air pressure is removed.

**Rear Servo Air Test**

Apply air pressure to the rear servo apply passage. The servo rod should extend and cause the band to tighten around the drum. Spring pressure should release the servo when air pressure is removed.

**DIAGNOSIS AND TESTING - CONVERTER HOUSING FLUID LEAK**

When diagnosing converter housing fluid leaks, two items must be established before repair.

- (1) Verify that a leak condition actually exists.
- (2) Determined the true source of the leak.

Some suspected converter housing fluid leaks may not be leaks at all. They may only be the result of residual fluid in the converter housing, or excess fluid spilled during factory fill or fill after repair. Converter housing leaks have several potential sources. Through careful observation, a leak source can be identified before removing the transmission for repair. Pump seal leaks tend to move along the drive hub and onto the rear of the converter. Pump body leaks follow the same path as a seal leak (Fig. 11). Pump vent or pump attaching bolt leaks are generally deposited on the inside of the converter housing and not on the converter itself (Fig. 11). Pump o-ring or gasket leaks usually travel down the inside of the converter housing. Front band lever pin plug leaks are generally deposited on the housing and not on the converter.

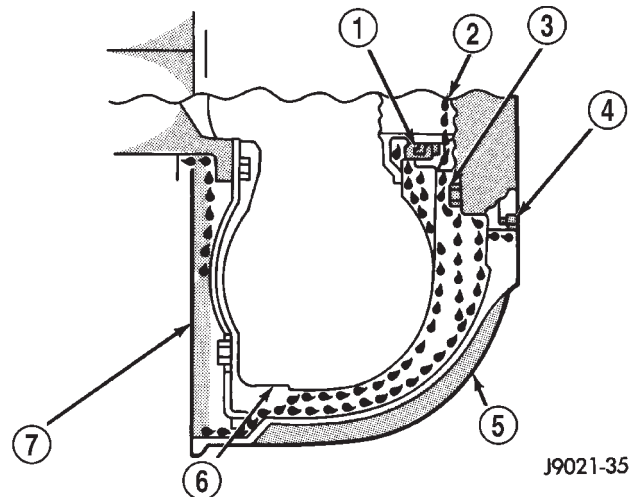
**TORQUE CONVERTER LEAK POINTS**

Possible sources of converter leaks are:

- (1) Leaks at the weld joint around the outside diameter weld (Fig. 12).
- (2) Leaks at the converter hub weld (Fig. 12).

**CONVERTER HOUSING AREA LEAK CORRECTION**

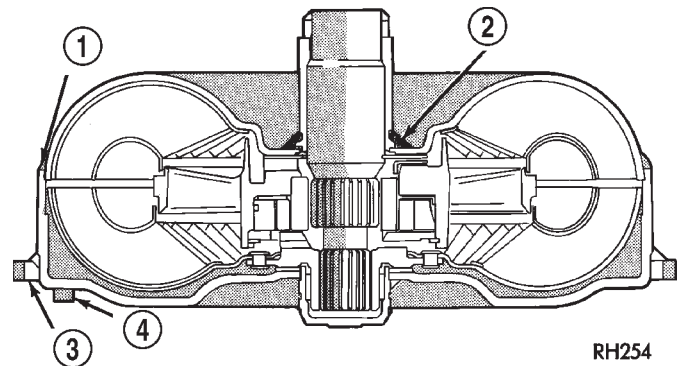
- (1) Remove converter.
- (2) Tighten front band adjusting screw until band is tight around front clutch retainer. This prevents front/rear clutches from coming out when oil pump is removed.
- (3) Remove oil pump and remove pump seal. Inspect pump housing drainback and vent holes for obstructions. Clear holes with solvent and wire.



J9021-35

**Fig. 11 Converter Housing Leak Paths**

- 1 - PUMP SEAL
- 2 - PUMP VENT
- 3 - PUMP BOLT
- 4 - PUMP GASKET
- 5 - CONVERTER HOUSING
- 6 - CONVERTER
- 7 - REAR MAIN SEAL LEAK



RH254

**Fig. 12 Converter Leak Points - Typical**

- 1 - OUTSIDE DIAMETER WELD
- 2 - TORQUE CONVERTER HUB WELD
- 3 - STARTER RING GEAR
- 4 - LUG

(4) Inspect pump bushing and converter hub. If bushing is scored, replace it. If converter hub is scored, either polish it with crocus cloth or replace converter.

(5) Install new pump seal, O-ring, and gasket. Replace oil pump if cracked, porous or damaged in any way. Be sure to loosen the front band before installing the oil pump, damage to the oil pump seal may occur if the band is still tightened to the front clutch retainer.

(6) Loosen kickdown lever pin access plug three turns. Apply Loctite™ 592, or Permatex® No. 2 to

## AUTOMATIC TRANSMISSION - 42RE (Continued)

plug threads and tighten plug to 17 N·m (150 in. lbs.) torque.

(7) Adjust front band.

(8) Lubricate pump seal and converter hub with transmission fluid or petroleum jelly and install converter.

(9) Install transmission and converter housing dust shield.

(10) Lower vehicle.

provide general information on a variety of transmission, overdrive unit and converter clutch fault conditions.

The hydraulic flow charts in the Schematics and Diagrams section of this group, outline fluid flow and hydraulic circuitry. Circuit operation is provided for PARK, NEUTRAL, FIRST, SECOND, THIRD, FOURTH, MANUAL FIRST, MANUAL SECOND, and REVERSE gear ranges. Normal working pressures are also supplied for each of the gear ranges.

## DIAGNOSIS AND TESTING - DIAGNOSIS CHARTS

The diagnosis charts provide additional reference when diagnosing a transmission fault. The charts

### DIAGNOSIS CHARTS

CONDITION	POSSIBLE CAUSES	CORRECTION
HARSH ENGAGEMENT (FROM NEUTRAL TO DRIVE OR REVERSE)	1. Fluid Level Low.	1. Add Fluid
	2. Throttle Linkage Mis-adjusted.	2. Adjust linkage - setting may be too long.
	3. Mount and Driveline Bolts Loose.	3. Check engine mount, transmission mount, propeller shaft, rear spring to body bolts, rear control arms, crossmember and axle bolt torque. Tighten loose bolts and replace missing bolts.
	4. U-Joint Worn/Broken.	4. Remove propeller shaft and replace U-Joint.
	5. Axle Backlash Incorrect.	5. Check per Service Manual. Correct as needed.
	6. Hydraulic Pressure Incorrect.	6. Check pressure. Remove, overhaul or adjust valve body as needed.
	7. Band Mis-adjusted.	7. Adjust rear band.
	8. Valve Body Check Balls Missing.	8. Inspect valve body for proper check ball installation.
	9. Axle Pinion Flange Loose.	9. Replace nut and check pinion threads before installing new nut. Replace pinion gear if threads are damaged.
	10. Clutch, band or planetary component damaged.	10. Remove, disassemble and repair transmission as necessary.
	11. Converter Clutch Faulty.	11. Replace converter and flush cooler and line before installing new converter.

## AUTOMATIC TRANSMISSION - 42RE (Continued)

CONDITION	POSSIBLE CAUSES	CORRECTION
DELAYED ENGAGEMENT (FROM NEUTRAL TO DRIVE OR REVERSE)	1. Fluid Level Low.	1. Correct level and check for leaks.
	2. Filter Clogged.	2. Change filter.
	3. Gearshift Linkage Mis-adjusted.	3. Adjust linkage and repair linkage if worn or damaged.
	4. Torque Converter Drain Back (Oil drains from torque converter into transmission sump).	4. If vehicle moves normally after 5 seconds after shifting into gear, no repair is necessary. If longer, inspect pump bushing for wear. Replace pump house.
	5. Rear Band Mis-adjusted.	5. Adjust band.
	6. Valve Body Filter Plugged.	6. Replace fluid and filter. If oil pan and old fluid were full of clutch disc material and/or metal particles, overhaul will be necessary.
	7. Oil Pump Gears Worn/Damaged.	7. Remove transmission and replace oil pump.
	8. Governor Circuit and Solenoid Valve Electrical Fault.	8. Test with DRB® scan tool and repair as required.
	9. Hydraulic Pressure Incorrect.	9. Perform pressure test, remove transmission and repair as needed.
	10. Reaction Shaft Seal Rings Worn/Broken.	10. Remove transmission, remove oil pump and replace seal rings.
	11. Rear Clutch/Input Shaft, Rear Clutch Seal Rings Damaged.	11. Remove and disassemble transmission and repair as necessary.
	12. Regulator Valve Stuck.	12. Clean.
	13. Cooler Plugged.	13. Transfer case failure can plug cooler.
NO DRIVE RANGE (REVERSE OK)	1. Fluid Level Low.	1. Add fluid and check for leaks if drive is restored.
	2. Gearshift Linkage/Cable Loose/Misadjusted.	2. Repair or replace linkage components.
	3. Rear Clutch Burnt.	3. Remove and disassemble transmission and rear clutch and seals. Repair/replace worn or damaged parts as needed.
	4. Valve Body Malfunction.	4. Remove and disassemble valve body. Replace assembly if any valves or bores are damaged.
	5. Transmission Overrunning Clutch Broken.	5. Remove and disassemble transmission. Replace overrunning clutch.
	6. Input Shaft Seal Rings Worn/Damaged.	6. Remove and disassemble transmission. Replace seal rings and any other worn or damaged parts.
	7. Front Planetary Failed Broken.	7. Remove and repair.

## AUTOMATIC TRANSMISSION - 42RE (Continued)

CONDITION	POSSIBLE CAUSES	CORRECTION
NO DRIVE OR REVERSE (VEHICLE WILL NOT MOVE)	1. Fluid Level Low.	1. Add fluid and check for leaks if drive is restored.
	2. Gearshift Linkage/Cable Loose/Misadjusted.	2. Inspect, adjust and reassemble linkage as needed. Replace worn/damaged parts.
	3. U-Joint/Axle/Transfer Case Broken.	3. Perform preliminary inspection procedure for vehicle that will not move. Refer to procedure in diagnosis section.
	4. Filter Plugged.	4. Remove and disassemble transmission. Repair or replace failed components as needed. Replace filter. If filter and fluid contained clutch material or metal particles, an overhaul may be necessary. Perform lube flow test. Flush oil. Replace cooler as necessary.
	5. Oil Pump Damaged.	5. Perform pressure test to confirm low pressure. Replace pump body assembly if necessary.
	6. Valve Body Malfunctioned.	6. Check and inspect valve body. Replace valve body (as assembly) if any valve or bore is damaged. Clean and reassemble correctly if all parts are in good condition.
	7. Transmission Internal Component Damaged.	7. Remove and disassemble transmission. Repair or replace failed components as needed.
	8. Park Sprag not Releasing - Check Stall Speed, Worn/Damaged/Stuck.	8. Remove, disassemble, repair.
	9. Torque Converter Damage.	9. Inspect and replace as required.
SHIFTS DELAYED OR ERRATIC (SHIFTS ALSO HARSH AT TIMES)	1. Fluid Level Low/High.	1. Correct fluid level and check for leaks if low.
	2. Fluid Filter Clogged.	2. Replace filter. If filter and fluid contained clutch material or metal particles, an overhaul may be necessary. Perform lube flow test.
	3. Throttle Linkage Mis-adjusted.	3. Adjust linkage as described in service section.
	4. Throttle Linkage Binding.	4. Check cable for binding. Check for return to closed throttle at transmission.
	5. Gearshift Linkage/Cable Mis-adjusted.	5. Adjust linkage/cable as described in service section.
	6. Clutch or Servo Failure.	6. Remove valve body and air test clutch, and band servo operation. Disassemble and repair transmission as needed.
	7. Governor Circuit Electrical Fault.	7. Test using DRB® scan tool and repair as required.
	8. Front Band Mis-adjusted.	8. Adjust band.
	9. Pump Suction Passage Leak.	9. Check for excessive foam on dipstick after normal driving. Check for loose pump bolts, defective gasket. Replace pump assembly if needed.

## AUTOMATIC TRANSMISSION - 42RE (Continued)

CONDITION	POSSIBLE CAUSES	CORRECTION
NO REVERSE (D RANGES OK)	1. Gearshift Linkage/Cable Mis-adjusted/Damaged.	1. Repair or replace linkage parts as needed.
	2. Park Sprag Sticking.	2. Replace overdrive annulus gear.
	3. Rear Band Mis-adjusted/Worn.	3. Adjust band; replace.
	4. Valve Body Malfunction.	4. Remove and service valve body. Replace valve body if any valves or valve bores are worn or damaged.
	5. Rear Servo Malfunction.	5. Remove and disassemble transmission. Replace worn/damaged servo parts as necessary.
	6. Direct Clutch in Overdrive Worn.	6. Disassemble overdrive. Replace worn or damaged parts.
	7. Front Clutch Burnt.	7. Remove and disassemble transmission. Replace worn, damaged clutch parts as required.
HAS FIRST/REVERSE ONLY (NO 1-2 OR 2-3 UPSHIFT)	1. Governor Circuit Electrical Fault.	1. Test using DRB® scan tool and repair as required.
	2. Valve Body Malfunction.	2. Repair stuck 1-2 shift valve or governor plug.
	3. Front Servo/Kickdown Band Damaged/Burned.	3. Repair/replace.
MOVES IN 2ND OR 3RD GEAR, ABRUPTLY DOWNSHIFTS TO LOW	1. Valve Body Malfunction.	1. Remove, clean and inspect. Look for stuck 1-2 valve or governor plug.
NO LOW GEAR (MOVES IN 2ND OR 3RD GEAR ONLY)	1. Governor Circuit Electrical Fault.	1. Test with DRB® scan tool and repair as required.
	2. Valve Body Malfunction.	2. Remove, clean and inspect. Look for sticking 1-2 shift valve, 2-3 shift valve, governor plug or broken springs.
	3. Front Servo Piston Cocked in Bore.	3. Inspect servo and repair as required.
	4. Front Band Linkage Malfunction	4. Inspect linkage and look for bind in linkage.
NO KICKDOWN OR NORMAL DOWNSHIFT	1. Throttle Linkage Mis-adjusted.	1. Adjust linkage.
	2. Accelerator Pedal Travel Restricted.	2. Verify floor mat is not under pedal, repair worn accelerator cable or bent brackets.
	3. Valve Body Hydraulic Pressures Too High or Too Low Due to Valve Body Malfunction or Incorrect Hydraulic Control Pressure Adjustments.	3. Perform hydraulic pressure tests to determine cause and repair as required. Correct valve body pressure adjustments as required.
	4. Governor Circuit Electrical Fault.	4. Test with DRB® scan tool and repair as required.
	5. Valve Body Malfunction.	5. Perform hydraulic pressure tests to determine cause and repair as required. Correct valve body pressure adjustments as required.

## AUTOMATIC TRANSMISSION - 42RE (Continued)

CONDITION	POSSIBLE CAUSES	CORRECTION
	6. TPS Malfunction.	6. Replace sensor, check with DRB® scan tool.
	7. PCM Malfunction.	7. Check with DRB® scan tool and replace if required.
	8. Valve Body Malfunction.	8. Repair sticking 1-2, 2-3 shift valves, governor plugs, 3-4 solenoid, 3-4 shift valve, 3-4 timing valve.
STUCK IN LOW GEAR (WILL NOT UPSHIFT)	1. Throttle Linkage Mis-adjusted/ Stuck.	1. Adjust linkage and repair linkage if worn or damaged. Check for binding cable or missing return spring.
	2. Gearshift Linkage Mis-adjusted.	2. Adjust linkage and repair linkage if worn or damaged.
	3. Governor Component Electrical Fault.	3. Check operating pressures and test with DRB® scan tool, repair faulty component.
	4. Front Band Out of Adjustment.	4. Adjust Band.
	5. Clutch or Servo Malfunction.	5. Air pressure check operation of clutches and bands. Repair faulty component.
CREEPS IN NEUTRAL	1. Gearshift Linkage Mis-adjusted.	1. Adjust linkage.
	2. Rear Clutch Dragging/Warped.	2. Disassemble and repair.
	3. Valve Body Malfunction.	3. Perform hydraulic pressure test to determine cause and repair as required.
BUZZING NOISE	1. Fluid Level Low	1. Add fluid and check for leaks.
	2. Shift Cable Mis-assembled.	2. Route cable away from engine and bell housing.
	3. Valve Body Mis-assembled.	3. Remove, disassemble, inspect valve body. Reassemble correctly if necessary. Replace assembly if valves or springs are damaged. Check for loose bolts or screws.
	4. Pump Passages Leaking.	4. Check pump for porous casting, scores on mating surfaces and excess rotor clearance. Repair as required. Loose pump bolts.
	5. Cooling System Cooler Plugged.	5. Flow check cooler circuit. Repair as needed.
	6. Overrunning Clutch Damaged.	6. Replace clutch.
SLIPS IN REVERSE ONLY	1. Fluid Level Low.	1. Add fluid and check for leaks.
	2. Gearshift Linkage Mis-adjusted.	2. Adjust linkage.
	3. Rear Band Mis-adjusted.	3. Adjust band.
	4. Rear Band Worn.	4. Replace as required.
	5. Overdrive Direct Clutch Worn.	5. Disassemble overdrive. Repair as needed.
	6. Hydraulic Pressure Too Low.	6. Perform hydraulic pressure tests to determine cause.
	7. Rear Servo Leaking.	7. Air pressure check clutch-servo operation and repair as required.
	8. Band Linkage Binding.	8. Inspect and repair as required.



## AUTOMATIC TRANSMISSION - 42RE (Continued)

CONDITION	POSSIBLE CAUSES	CORRECTION
SLIPS IN FORWARD DRIVE RANGES	1. Fluid Level Low.	1. Add fluid and check for leaks.
	2. Fluid Foaming.	2. Check for high oil level, bad pump gasket or seals, dirt between pump halves and loose pump bolts. Replace pump if necessary.
	3. Throttle Linkage Mis-adjusted.	3. Adjust linkage.
	4. Gearshift Linkage Mis-adjusted.	4. Adjust linkage.
	5. Rear Clutch Worn.	5. Inspect and replace as needed.
	6. Low Hydraulic Pressure Due to Worn Pump, Incorrect Control Pressure Adjustments, Valve Body Warpage or Malfunction, Sticking, Leaking Seal Rings, Clutch Seals Leaking, Servo Leaks, Clogged Filter or Cooler Lines.	6. Perform hydraulic and air pressure tests to determine cause.
	7. Rear Clutch Malfunction, Leaking Seals or Worn Plates.	7. Air pressure check clutch-servo operation and repair as required.
	8. Overrunning Clutch Worn, Not Holding (Slips in 1 Only).	8. Replace Clutch.
SLIPS IN LOW GEAR "D" ONLY, BUT NOT IN MANUAL 1 POSITION	Overrunning Clutch Faulty.	Replace overrunning clutch.
GROWLING, GRATING OR SCRAPING NOISES	1. Drive Plate Broken.	1. Replace.
	2. Torque Converter Bolts Hitting Dust Shield.	2. Dust shield bent. Replace or repair.
	3. Planetary Gear Set Broken/ Seized.	3. Check for debris in oil pan and repair as required.
	4. Overrunning Clutch Worn/Broken.	4. Inspect and check for debris in oil pan. Repair as required.
	5. Oil Pump Components Scored/ Binding.	5. Remove, inspect and repair as required.
	6. Output Shaft Bearing or Bushing Damaged.	6. Remove, inspect and repair as required.
	7. Clutch Operation Faulty.	7. Perform air pressure check and repair as required.
	8. Front and Rear Bands Mis-adjusted.	8. Adjust bands.

## AUTOMATIC TRANSMISSION - 42RE (Continued)

CONDITION	POSSIBLE CAUSES	CORRECTION
DRAGS OR LOCKS UP	1. Fluid Level Low.	1. Check and adjust level.
	2. Clutch Dragging/Failed	2. Air pressure check clutch operation and repair as required.
	3. Front or Rear Band Mis-adjusted.	3. Adjust bands.
	4. Case Leaks Internally.	4. Check for leakage between passages in case.
	5. Servo Band or Linkage Malfunction.	5. Air pressure check servo operation and repair as required.
	6. Overrunning Clutch Worn.	6. Remove and inspect clutch. Repair as required.
	7. Planetary Gears Broken.	7. Remove, inspect and repair as required (look for debris in oil pan).
	8. Converter Clutch Dragging.	8. Check for plugged cooler. Perform flow check. Inspect pump for excessive side clearance. Replace pump as required.
NO 4-3 DOWNSHIFT	1. Circuit Wiring and/or Connectors Shorted.	1. Test wiring and connectors with test lamp and volt/ohmmeter. Repair wiring as necessary. Replace connectors and/or harnesses as required.
	2. PCM Malfunction.	2. Check PCM operation with DRB® scan tool. Replace PCM only if faulty.
	3. TPS Malfunction	3. Check TPS with DRB® scan tool at PCM.
	4. Lockup Solenoid Not Venting.	4. Remove valve body and replace solenoid assembly if plugged or shorted.
	5. Overdrive Solenoid Not Venting.	5. Remove valve body and replace solenoid if plugged or shorted.
	6. Valve Body Valve Sticking.	6. Repair stuck 3-4 shift valve or lockup timing valve.
NO 4-3 DOWNSHIFT WHEN CONTROL SWITCH IS TURNED OFF	1. Control Switch Open/Shorted.	1. Test and replace switch if faulty.
	2. Overdrive Solenoid Connector Shorted.	2. Test solenoids and replace if seized or shorted.
	3. PCM Malfunction.	3. Test with DRB® scan tool. Replace PCM if faulty.
	4. Valve Body Stuck Valves.	4. Repair stuck 3-4, lockup or lockup timing valve.
CLUNK NOISE FROM DRIVELINE ON CLOSED THROTTLE 4-3 DOWNSHIFT	1. Transmission Fluid Low.	1. Add Fluid.
	2. Throttle Cable Mis-adjusted.	2. Adjust cable.
	3. Overdrive Clutch Select Spacer Wrong Spacer.	3. Replace overdrive piston thrust plate spacer.

## AUTOMATIC TRANSMISSION - 42RE (Continued)

CONDITION	POSSIBLE CAUSES	CORRECTION
3-4 UPSHIFT OCCURS IMMEDIATELY AFTER 2-3 SHIFT	1. Overdrive Solenoid Connector or Wiring Shorted.	1. Test connector and wiring for loose connections, shorts or ground and repair as needed.
	2. TPS Malfunction.	2. Test TPS and replace as necessary. Check with DRB® scan tool.
	3. PCM Malfunction.	3. Test PCM with DRB® scan tool and replace controller if faulty.
	4. Overdrive Solenoid Malfunction.	4. Replace solenoid.
	5. Valve Body Malfunction.	5. Remove, disassemble, clean and inspect valve body components. Make sure all valves and plugs slide freely in bores. Polish valves with crocus cloth if needed.
WHINE/NOISE RELATED TO ENGINE SPEED	1. Fluid Level Low.	1. Add fluid and check for leaks.
	2. Shift Cable Incorrect Routing.	2. Check shift cable for correct routing. Should not touch engine or bell housing.
NO 3-4 UPSHIFT	1. O/D Switch In OFF Position.	1. Turn control switch to ON position.
	2. Overdrive Circuit Fuse Blown.	2. Replace fuse. Determine why fuse failed and repair as necessary (i.e., shorts or grounds in circuit).
	3. O/D Switch Wire Shorted/Open Cut.	3. Check wires/connections with 12V test lamp and voltmeter. Repair damaged or loose wire/connection as necessary.
	4. Distance or Coolant Sensor Malfunction.	4. Check with DRB® scan tool and repair or replace as necessary.
	5. TPS Malfunction.	5. Check with DRB® scan tool and replace if necessary.
	6. Neutral Sense to PCM Wire Shorted/Cut.	6. Test switch/sensor as described in service section and replace if necessary. Engine no start.
	7. PCM Malfunction.	7. Check with DRB® scan tool and replace if necessary.
	8. Overdrive Solenoid Shorted/Open.	8. Replace solenoid if shorted or open and repair loose or damaged wires (DRB® scan tool).
	9. Solenoid Feed Orifice in Valve Body Blocked.	9. Remove, disassemble, and clean valve body thoroughly. Check feed orifice.
	10. Overdrive Clutch Failed.	10. Disassemble overdrive and repair as needed.
	11. Hydraulic Pressure Low.	11. Pressure test transmission to determine cause.
	12. Valve Body Valve Stuck.	12. Repair stuck 3-4 shift valve, 3-4 timing valve.
	13. O/D Piston Incorrect Spacer.	13. Remove unit, check end play and install correct spacer.
	14. Overdrive Piston Seal Failure.	14. Replace both seals.
	15. O/D Check Valve/Orifice Failed.	15. Check for free movement and secure assembly (in piston retainer). Check ball bleed orifice.

## AUTOMATIC TRANSMISSION - 42RE (Continued)

CONDITION	POSSIBLE CAUSES	CORRECTION
SLIPS IN OVERDRIVE FOURTH GEAR	1. Fluid Level Low.	1. Add fluid and check for leaks.
	2. Overdrive Clutch Pack Worn.	2. Remove overdrive unit and rebuild clutch pack.
	3. Overdrive Piston Retainer Bleed Orifice Blown Out.	3. Disassemble transmission, remove retainer and replace orifice.
	4. Overdrive Piston or Seal Malfunction.	4. Remove overdrive unit. Replace seals if worn. Replace piston if damaged. If piston retainer is damaged, remove and disassemble the transmission.
	5. 3-4 Shift Valve, Timing Valve or Accumulator Malfunction.	5. Remove and overhaul valve body. Replace accumulator seals. Make sure all valves operate freely in bores and do not bind or stick. Make sure valve body screws are correctly tightened and separator plates are properly positioned.
	6. Overdrive Unit Thrust Bearing Failure.	6. Disassemble overdrive unit and replace thrust bearing (NO. 1 thrust bearing is between overdrive piston and clutch hub; NO. 2 thrust bearing is between the planetary gear and the direct clutch spring plate; NO. 3 thrust bearing is between overrunning clutch hub and output shaft).
	7. O/D Check Valve/Bleed Orifice Failure.	7. Check for function/secure orifice insert in O/D piston retainer.
DELAYED 3-4 UPSHIFT (SLOW TO ENGAGE)	1. Fluid Level Low.	1. Add fluid and check for leaks.
	2. Throttle Valve Cable Mis-adjusted.	2. Adjust throttle valve cable.
	3. Overdrive Clutch Pack Worn/ Burnt.	3. Remove unit and rebuild clutch pack.
	4. TPS Faulty.	4. Test with DRB® scan tool and replace as necessary
	5. Overdrive Clutch Bleed Orifice Plugged.	5. Disassemble transmission and replace orifice.
	6. Overdrive Solenoid or Wiring Shorted/Open.	6. Test solenoid and check wiring for loose/corroded connections or shorts/grounds. Replace solenoid if faulty and repair wiring if necessary.
	7. Overdrive Excess Clearance.	7. Remove unit. Measure end play and select proper spacer.
	8. O/D Check Valve Missing or Stuck.	8. Check for presence of check valve. Repair or replace as required.
TORQUE CONVERTER LOCKS UP IN SECOND AND/OR THIRD GEAR	Lockup Solenoid, Relay or Wiring Shorted/Open.	Test solenoid, relay and wiring for continuity, shorts or grounds. Replace solenoid and relay if faulty. Repair wiring and connectors as necessary.
HARSH 1-2, 2-3, 3-4 OR 3-2 SHIFTS	Lockup Solenoid Malfunction.	Remove valve body and replace solenoid assembly.

## AUTOMATIC TRANSMISSION - 42RE (Continued)

CONDITION	POSSIBLE CAUSES	CORRECTION
NO START IN PARK OR NEUTRAL	1. Gearshift Linkage/Cable Mis-adjusted.	1. Adjust linkage/cable.
	2. Neutral Sense Wire Open/Cut.	2. Check continuity with test lamp. Repair as required.
	3. Park/Neutral Switch, or Transmission Range Sensor Faulty.	3. Refer to service section for test and replacement procedure.
	4. Park/Neutral Switch, or Transmission Range Sensor Connection Faulty.	4. Connectors spread open. Repair.
	5. Valve Body Manual Lever Assembly Bent/Worn/Broken.	5. Inspect lever assembly and replace if damaged.
NO REVERSE (OR SLIPS IN REVERSE)	1. Direct Clutch Pack (front clutch) Worn.	1. Disassemble unit and rebuild clutch pack.
	2. Rear Band Mis-adjusted.	2. Adjust band.
	3. Front Clutch Malfunctioned/ Burned.	3. Air-pressure test clutch operation. Remove and rebuild if necessary.
	4. Overdrive Thrust Bearing Failure.	4. Disassemble geartrain and replace bearings.
	5. Direct Clutch Spring Collapsed/ Broken.	5. Remove and disassemble unit. Check clutch position and replace spring.
OIL LEAKS.	1. Fluid Lines and Fittings Loose/ Leaks/Damaged.	1. Tighten fittings. If leaks persist, replace fittings and lines if necessary.
	2. Fill Tube (where tube enters case) Leaks/Damaged.	2. Replace tube seal. Inspect tube for cracks in fill tube.
	3. Pressure Port Plug Loose Loose/Damaged.	3. Tighten to correct torque. Replace plug or reseal if leak persists.
	4. Pan Gasket Leaks.	4. Tighten pan screws (150 in. lbs.). If leaks persist, replace gasket.
	5. Valve Body Manual Lever Shaft Seal Leaks/Worn.	5. Replace shaft seal.
	6. Rear Bearing Access Plate Leaks.	6. Replace gasket. Tighten screws.
	7. Gasket Damaged or Bolts are Loose.	7. Replace bolts or gasket or tighten both.
	8. Adapter/Extension Gasket Damaged Leaks/Damaged.	8. Replace gasket.
	9. Park/Neutral Switch, or Transmission Range Sensor Leaks/Damaged.	9. Replace switch and gasket.
	10. Converter Housing Area Leaks.	10. Check for leaks at seal caused by worn seal or burr on converter hub (cutting seal), worn bushing, missing oil return, oil in front pump housing or hole plugged. Check for leaks past O-ring seal on pump or past pump-to-case bolts; pump housing porous, oil coming out vent due to overfill or leak past front band shaft access plug.

## AUTOMATIC TRANSMISSION - 42RE (Continued)

CONDITION	POSSIBLE CAUSES	CORRECTION
	11. Pump Seal Leaks/Worn/Damaged.	11. Replace seal.
	12. Torque Converter Weld Leak/Cracked Hub.	12. Replace converter.
	13. Case Porosity Leaks.	13. Replace case.
NOISY OPERATION IN FOURTH GEAR ONLY	1. Overdrive Clutch Discs, Plates or Snap Rings Damaged.	1. Remove unit and rebuild clutch pack.
	2. Overdrive Piston or Planetary Thrust Bearing Damaged.	2. Remove and disassemble unit. Replace either thrust bearing if damaged.
	3. Output Shaft Bearings Scored/Damaged.	3. Remove and disassemble unit. Replace either bearing if damaged.
	4. Planetary Gears Worn/Chipped.	4. Remove and overhaul overdrive unit.
	5. Overdrive Unit Overrunning Clutch Rollers Worn/Scored.	5. Remove and overhaul overdrive unit.

### STANDARD PROCEDURE - ALUMINUM THREAD REPAIR

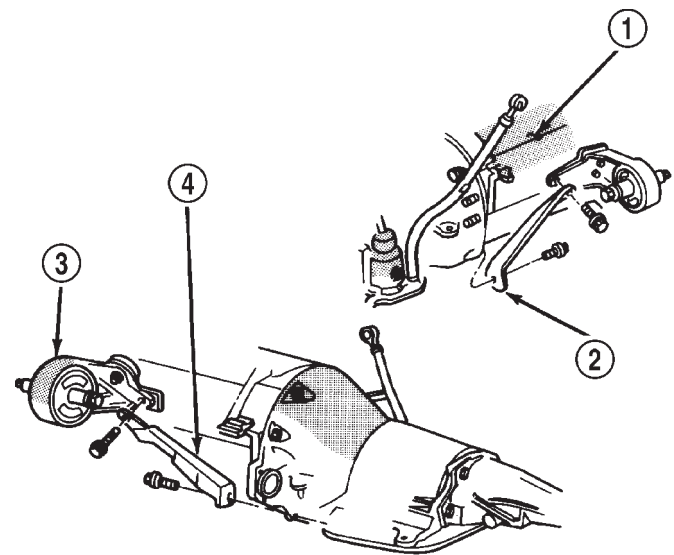
Damaged or worn threads in the aluminum transmission case and valve body can be repaired by the use of Heli-Coils™, or equivalent. This repair consists of drilling out the worn-out damaged threads. Then tap the hole with a special Heli-Coil™ tap, or equivalent, and installing a Heli-Coil™ insert, or equivalent, into the hole. This brings the hole back to its original thread size.

Heli-Coil™, or equivalent, tools and inserts are readily available from most automotive parts suppliers.

### REMOVAL

The overdrive unit can be removed and serviced separately. It is not necessary to remove the entire transmission assembly to perform overdrive unit repairs.

- (1) Disconnect battery negative cable.
- (2) Disconnect and lower or remove necessary exhaust components.
- (3) Remove engine-to-transmission struts, if equipped (Fig. 13).
- (4) Disconnect fluid cooler lines at transmission.
- (5) Remove starter motor. (Refer to 8 - ELECTRICAL/STARTING/STARTER MOTOR - REMOVAL)
- (6) Disconnect and remove the crankshaft position sensor. (Refer to 14 - FUEL SYSTEM/FUEL INJECTION/CRANKSHAFT POSITION SENSOR - REMOVAL) Retain the sensor attaching bolts.
- (7) Remove torque converter access cover.
- (8) If transmission is being removed for overhaul, remove transmission oil pan, drain fluid and reinstall pan.
- (9) Remove fill tube bracket bolts and pull tube out of transmission. Retain fill tube seal (Fig. 13). On 4 x 4 models, it will also be necessary to remove bolt



J9421-255

**Fig. 13 Transmission-To-Engine Strut Attachment**

- 1 - ENGINE BLOCK
- 2 - STRUT (PASSENGER SIDE)
- 3 - ENGINE MOUNT
- 4 - STRUT (DRIVER SIDE)

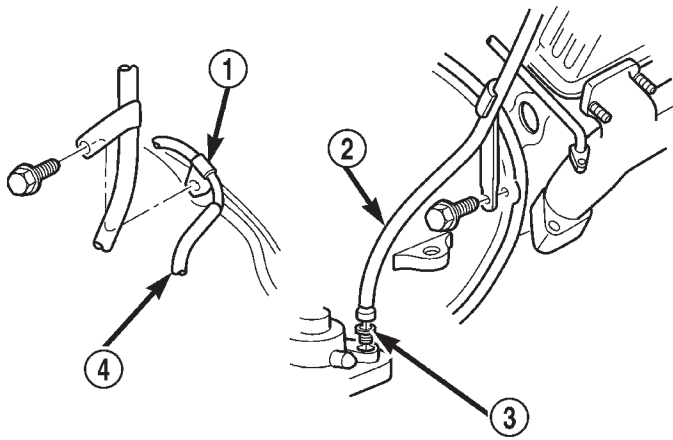
attaching transfer case vent tube to converter housing (Fig. 14).

(10) Rotate crankshaft in clockwise direction until converter bolts are accessible. Then remove bolts one at a time. Rotate crankshaft with socket wrench on dampener bolt.

(11) Mark propeller shaft and axle yokes for assembly alignment. Then disconnect and remove propeller shaft. On 4 x 4 models, remove both propeller shafts. (Refer to 3 - DIFFERENTIAL & DRIV-

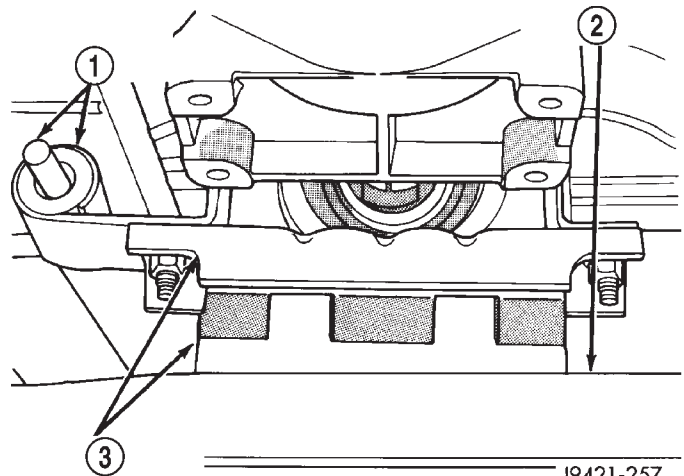


## AUTOMATIC TRANSMISSION - 42RE (Continued)

**Fig. 14 Fill Tube Attachment**

80b170f3

- 1 - TRANSFER CASE VENT TUBE
- 2 - FILL TUBE (V8)
- 3 - TUBE SEAL
- 4 - FILL TUBE (V6)

**Fig. 15 Rear Support Cushion**

J9421-257

- 1 - EXHAUST PIPE ARM AND BRACKET
- 2 - CROSSMEMBER
- 3 - REAR SUPPORT AND CUSHION

**ELINE/PROPELLER SHAFT/PROPELLER SHAFT - REMOVAL)**

(12) Disconnect wires from park/neutral position switch and transmission solenoid.

(13) Disconnect gearshift rod and torque shaft assembly from transmission.

(14) Disconnect throttle valve cable from transmission bracket and throttle valve lever.

(15) On 4 x 4 models, disconnect shift rod from transfer case shift lever.

(16) Support rear of engine with safety stand or jack.

(17) Raise transmission slightly with service jack to relieve load on crossmember and supports.

(18) Remove bolts securing rear support and cushion to transmission and crossmember. Raise transmission slightly, slide exhaust hanger arm from bracket (Fig. 15) and remove rear support.

(19) Remove bolts attaching crossmember to frame and remove crossmember.

(20) On 4 x 4 models, remove transfer case with transmission jack or aid of helper.

(21) Remove all converter housing bolts.

(22) Carefully work transmission and torque converter assembly rearward off engine block dowels.

(23) Lower transmission and remove assembly from under the vehicle.

(24) To remove torque converter, remove C-clamp from edge of bell housing and carefully slide torque converter out of the transmission.

**DISASSEMBLY**

(1) Clean transmission exterior with steam gun or with solvent. Wear eye protection during cleaning operations.

(2) Place transmission in a vertical position.

(3) Measure input shaft end play as follows (Fig. 16).

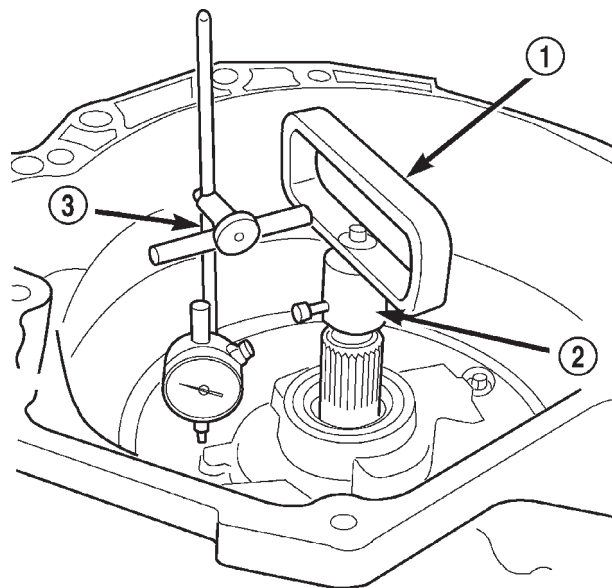
(a) Attach Adapter 8266-6 to Handle 8266-8.

(b) Attach dial indicator C-3339 to Handle 8266-8.

(c) Install the assembled tool onto the input shaft of the transmission and tighten the retaining screw on Adapter 8266-6 to secure it to the input shaft.

(d) Position the dial indicator plunger against a flat spot on the oil pump and zero the dial indicator.

(e) Move the input shaft in and out. Record the maximum travel for assembly reference.

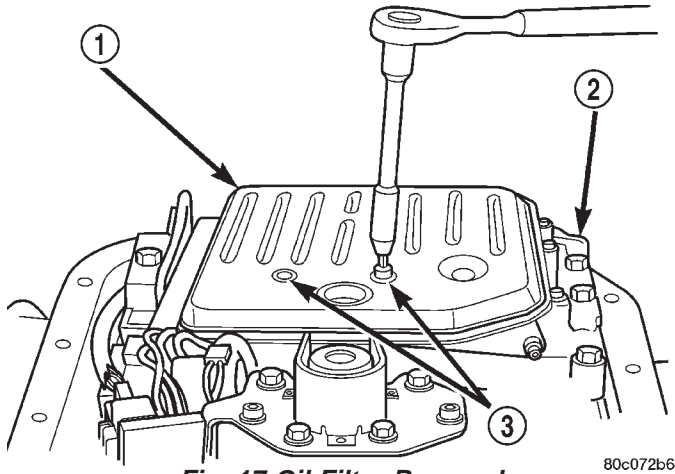
**Fig. 16 Checking Input Shaft End Play**

80c070b5

- 1 - TOOL 8266-8
- 2 - TOOL 8266-6
- 3 - TOOL C-3339

AUTOMATIC TRANSMISSION - 42RE (Continued)

- (4) Remove shift and throttle levers from valve body manual lever shaft.
- (5) Place transmission in horizontal position.
- (6) Remove transmission oil pan and gasket.
- (7) Remove filter from valve body (Fig. 17). Keep filter screws separate from other valve body screws. Filter screws are longer and should be kept with filter.

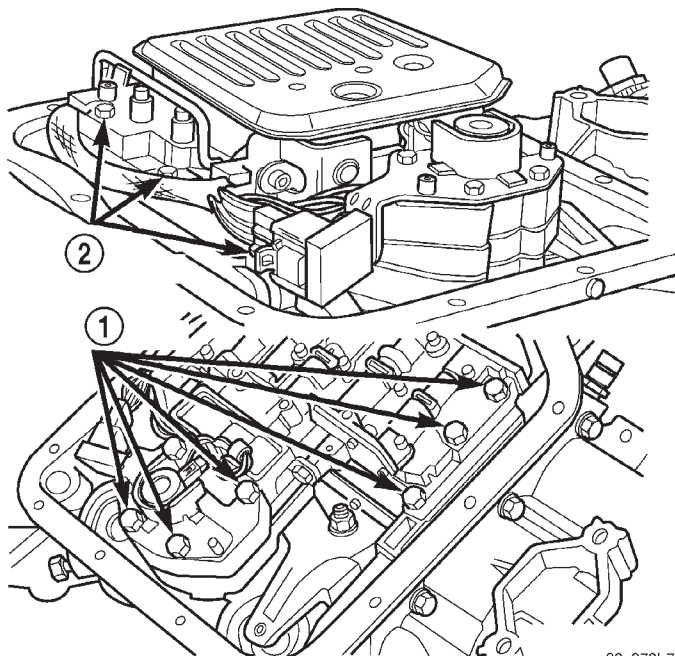


**Fig. 17 Oil Filter Removal**

80c072b6

- 1 - OIL FILTER
- 2 - VALVE BODY
- 3 - FILTER SCREWS (2)

- (8) Remove park/neutral position switch.
- (9) Remove hex head bolts attaching valve body to transmission case (Fig. 18). A total of 10 bolts are used. Note different bolt lengths for assembly reference.



**Fig. 18 Valve Body Bolt Locations**

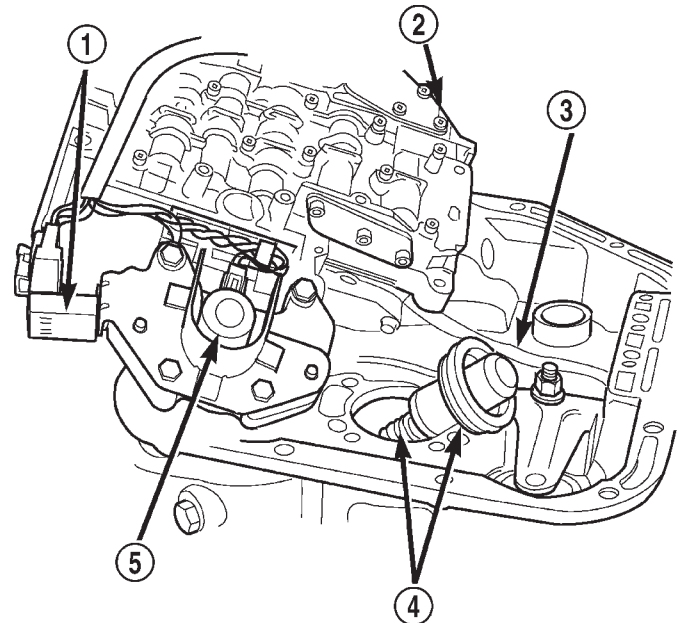
80c072b7

- 1 - VALVE BODY BOLTS
- 2 - VALVE BODY BOLTS

- (10) Remove valve body assembly. Push valve body harness connector out of case. Then work park rod and valve body out of case (Fig. 19).

- (11) Remove accumulator piston and inner and outer springs (Fig. 20).

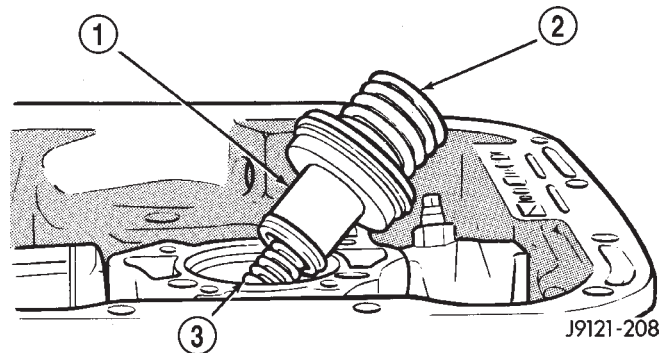
- (12) Remove pump oil seal with suitable pry tool or slide-hammer mounted screw.



**Fig. 19 Valve Body Removal**

80c072b8

- 1 - GOVERNOR PRESSURE SENSOR
- 2 - VALVE BODY
- 3 - PARK ROD
- 4 - ACCUMULATOR PISTON
- 5 - GOVERNOR PRESSURE SOLENOID



**Fig. 20 Accumulator Piston And Springs**

J9121-208

- 1 - ACCUMULATOR PISTON
- 2 - OUTER SPRING
- 3 - INNER SPRING

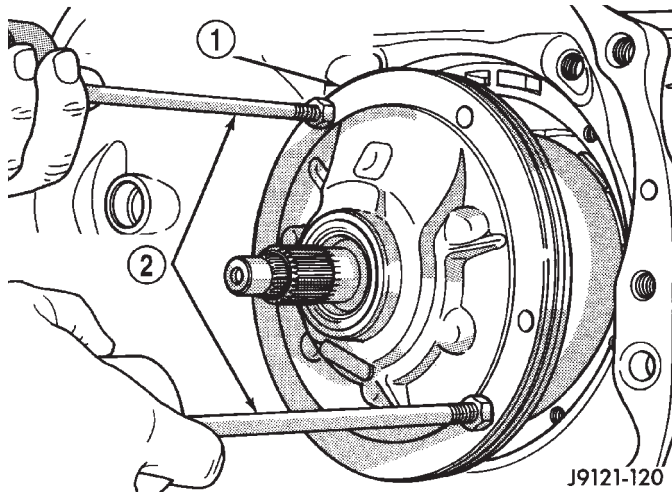
## AUTOMATIC TRANSMISSION - 42RE (Continued)

(13) Loosen front band adjusting screw locknut 4-5 turns. Then tighten band adjusting screw until band is tight around front clutch retainer. This prevents front/rear clutches from coming out with pump and possibly damaging clutch or pump components.

(14) Remove oil pump bolts.

(15) Thread bolts of Slide Hammer Tools C-3752 into threaded holes in pump body flange (Fig. 21).

(16) Bump slide hammer weights outward to remove pump and reaction shaft support assembly from case (Fig. 21).



**Fig. 21 Removing Oil Pump And Reaction Shaft Support Assembly**

- 1 - OIL PUMP AND REACTION SHAFT SUPPORT ASSEMBLY
- 2 - SLIDE HAMMER TOOLS C-3752

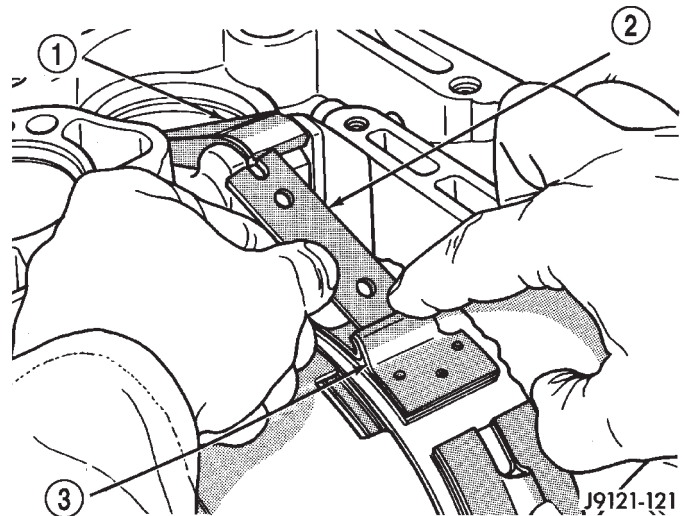
(17) Loosen front band adjusting screw until band is completely loose.

(18) Squeeze front band together and remove band strut (Fig. 22).

(19) Remove front band lever (Fig. 23).

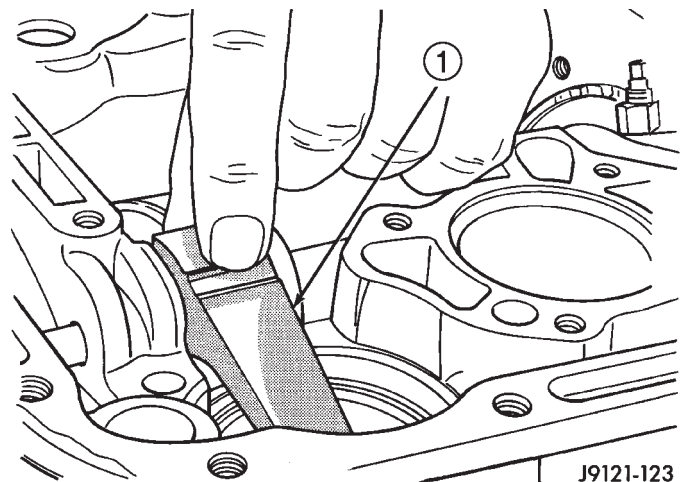
(20) Remove front band lever shaft plug, if necessary, from converter housing.

(21) Remove front band lever shaft.



**Fig. 22 Removing Front Band Strut**

- 1 - BAND LEVER
- 2 - BAND STRUT
- 3 - FRONT BAND



**Fig. 23 Removing Front Band Lever**

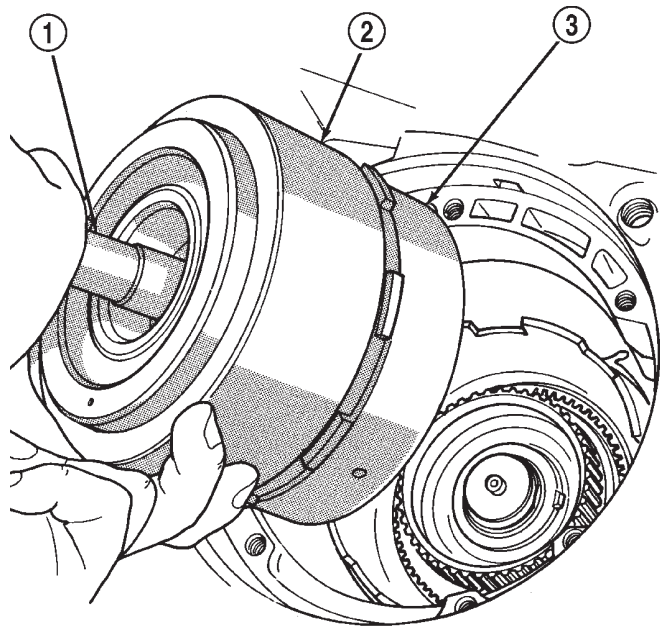
- 1 - FRONT BAND LEVER



AUTOMATIC TRANSMISSION - 42RE (Continued)

(22) Remove front and rear clutch units as assembly. Grasp input shaft, hold clutch units together and remove them from case (Fig. 24).

(23) Lift front clutch off rear clutch (Fig. 25). Set clutch units aside for overhaul.



J9121-124

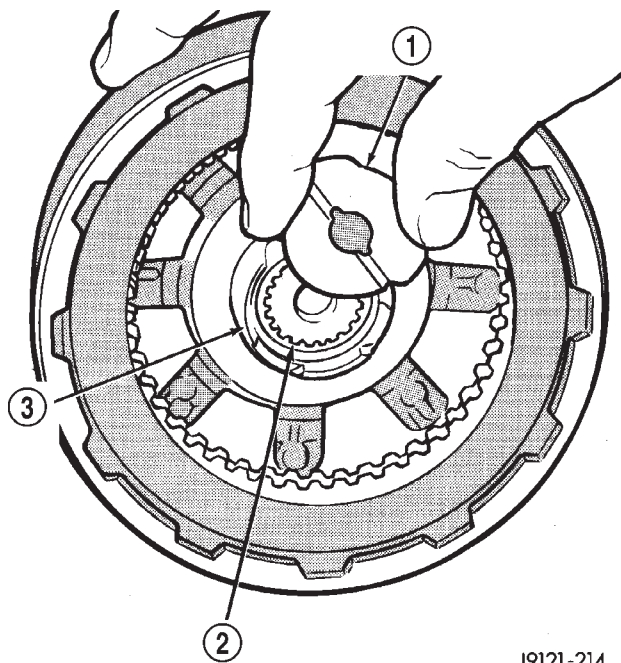
**Fig. 24 Removing Front/Rear Clutch Assemblies**

- 1 - INPUT SHAFT
- 2 - FRONT CLUTCH
- 3 - REAR CLUTCH

(24) Remove intermediate shaft thrust washer from front end of shaft or from rear clutch hub (Fig. 26).

(25) Remove output shaft thrust plate from intermediate shaft hub (Fig. 27).

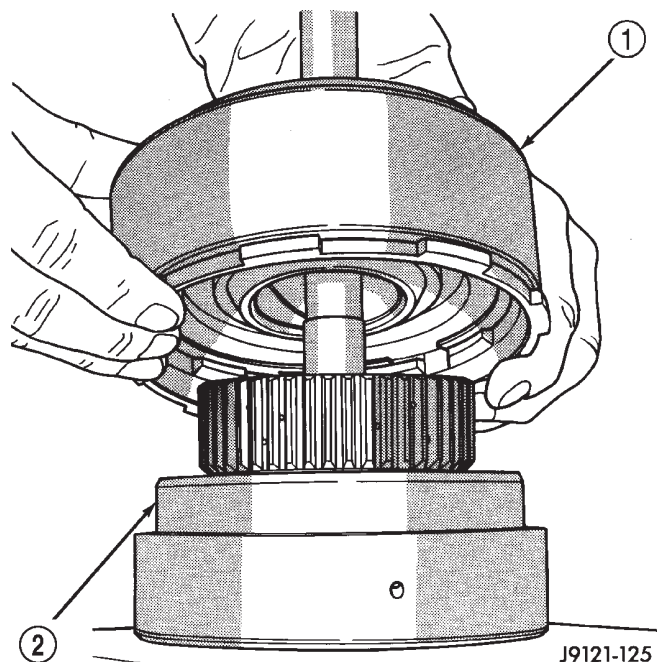
(26) Slide front band off driving shell (Fig. 28) and remove band from case.



J9121-214

**Fig. 26 Removing Intermediate Shaft Thrust Washer**

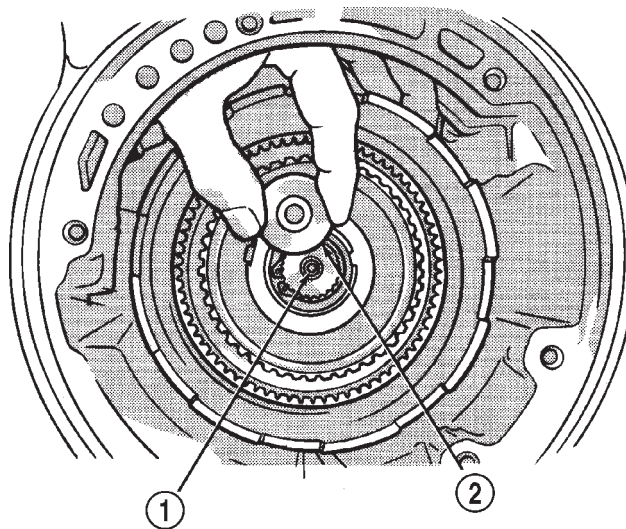
- 1 - INTERMEDIATE SHAFT THRUST WASHER
- 2 - INPUT SHAFT
- 3 - REAR CLUTCH RETAINER HUB



J9121-125

**Fig. 25 Separating Front/Rear Clutch Assemblies**

- 1 - FRONT CLUTCH
- 2 - REAR CLUTCH

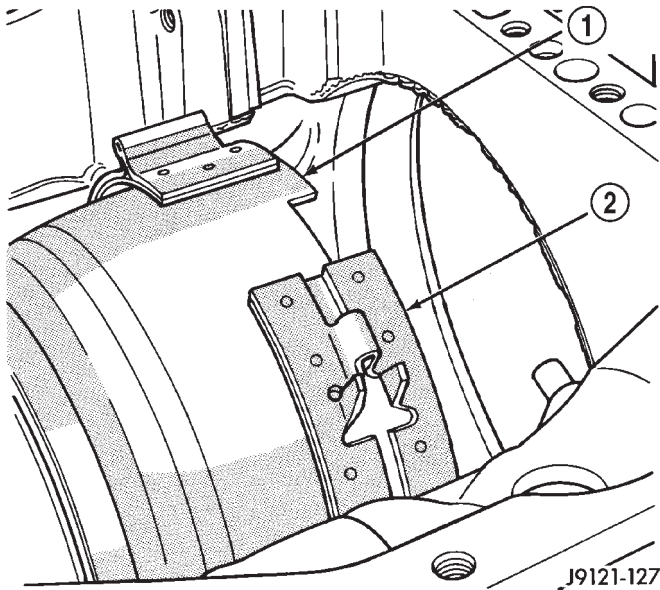


J9121-215

**Fig. 27 Removing Intermediate Shaft Thrust Plate**

- 1 - INTERMEDIATE SHAFT HUB
- 2 - INTERMEDIATE SHAFT THRUST PLATE

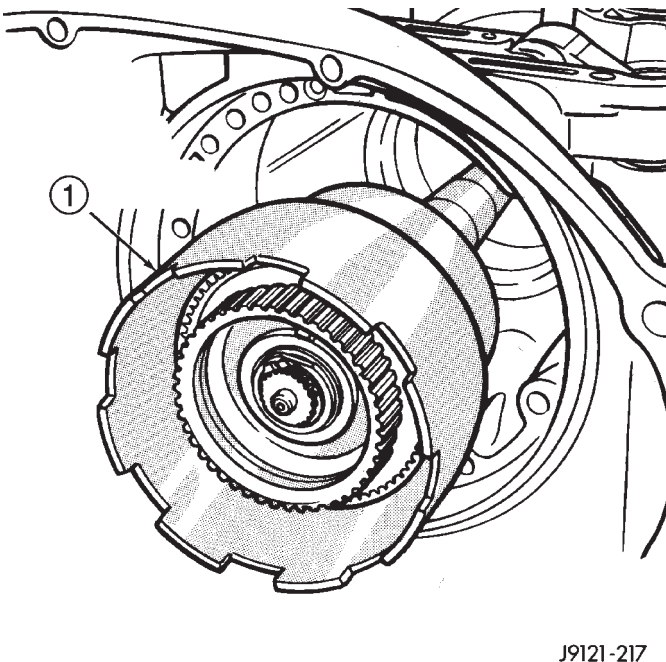
AUTOMATIC TRANSMISSION - 42RE (Continued)



**Fig. 28 Front Band Removal**

- 1 - DRIVING SHELL
- 2 - FRONT BAND

(27) Remove planetary geartrain as assembly (Fig. 29). Support geartrain with both hands during removal. Do not allow machined surfaces on intermediate shaft or overdrive piston retainer to become nicked or scratched.



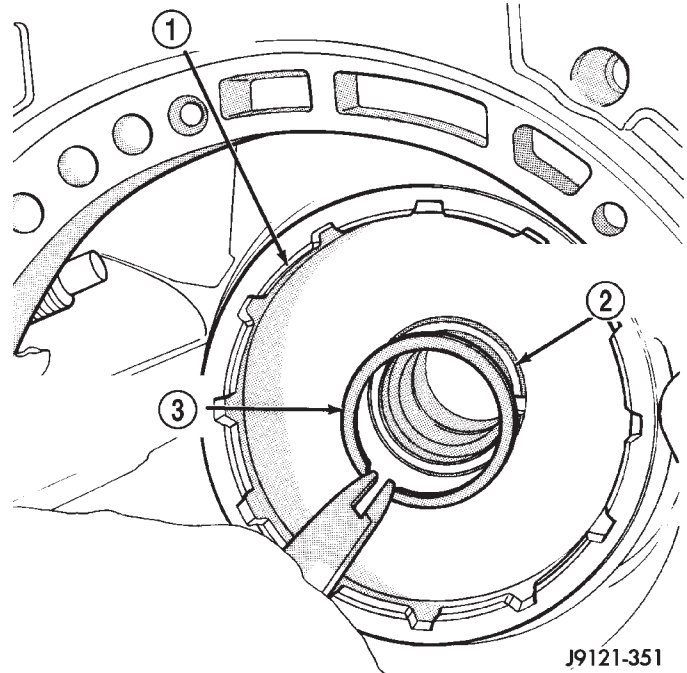
**Fig. 29 Removing Planetary Geartrain And Intermediate Shaft Assembly**

- 1 - PLANETARY GEARTRAIN AND INTERMEDIATE SHAFT ASSEMBLY

(28) If overdrive unit is not to be serviced, install Alignment Shaft 6227-2 into the overdrive unit to prevent misalignment of the overdrive clutches during service of main transmission components.

(29) Loosen rear band adjusting screw 4-5 turns.

(30) Remove low-reverse drum snap-ring (Fig. 30).

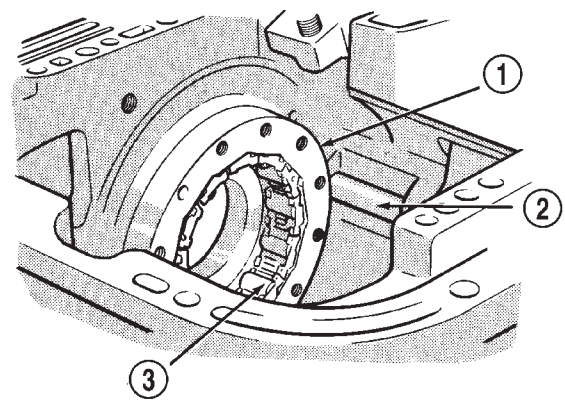


**Fig. 30 Removing Low-Reverse Drum Snap-Ring**

- 1 - LOW-REVERSE DRUM
- 2 - HUB OF OVERDRIVE PISTON RETAINER
- 3 - LOW-REVERSE DRUM SNAP-RING

(31) Remove low-reverse drum and reverse band.

(32) Remove overrunning clutch roller and spring assembly as a unit (Fig. 31).



**Fig. 31 Overrunning Clutch Assembly Removal**

- 1 - OVERRUNNING CLUTCH CAM
- 2 - REAR BAND REACTION PIN
- 3 - OVERRUNNING CLUTCH ASSEMBLY

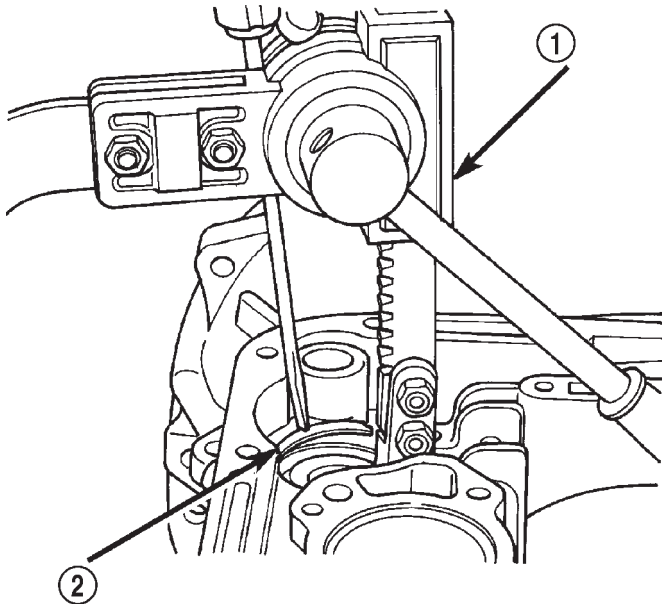


## AUTOMATIC TRANSMISSION - 42RE (Continued)

(33) Compress front servo rod guide about 1/8 inch with Valve Spring Compressor C-3422-B (Fig. 32).

(34) Remove front servo rod guide snap-ring. Exercise caution when removing snap-ring. Servo bore can be scratched or nicked if care is not exercised.

(35) Remove compressor tools and remove front servo rod guide, spring and servo piston.



80be44b7

**Fig. 32 Compressing Front Servo Rod Guide**

- 1 - SPRING COMPRESSOR TOOL C-3422-B  
2 - ROD GUIDE SNAP-RING

(36) Compress rear servo spring retainer about 1/16 inch with Valve Spring Compressor C-3422-B (Fig. 33).

(37) Remove rear servo spring retainer snap-ring. Then remove compressor tools and remove rear servo spring and piston.

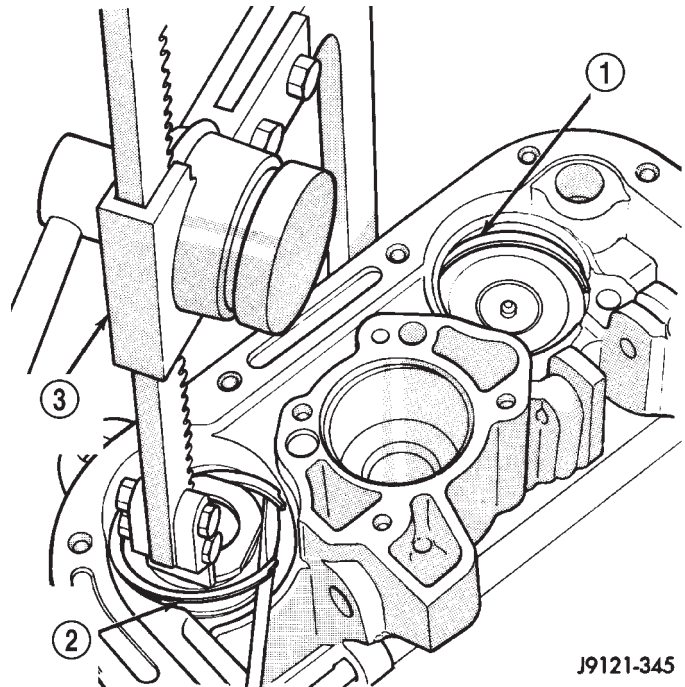
(38) Inspect transmission components.

**NOTE: To Service the overrunning clutch cam or overdrive piston retainer, refer to the Overrunning Clutch Cam service procedure in this section.**

## CLEANING

Clean the case in a solvent tank. Flush the case bores and fluid passages thoroughly with solvent. Dry the case and all fluid passages with compressed air. Be sure all solvent is removed from the case and that all fluid passages are clear.

**NOTE: Do not use shop towels or rags to dry the case (or any other transmission component) unless they are made from lint-free materials. Lint will stick to case surfaces and transmission components and**



J9121-345

**Fig. 33 Compressing Rear Servo Spring**

- 1 - FRONT SERVO SNAP-RING  
2 - REAR SERVO SNAP-RING  
3 - SPECIAL TOOL

circulate throughout the transmission after assembly. A sufficient quantity of lint can block fluid passages and interfere with valve body operation.

Lubricate transmission parts with Mopar® ATF +4, type 9602, transmission fluid during overhaul and assembly. Use petroleum jelly, Mopar® Door Ease, or Ru-Glyde™ to prelubricate seals, O-rings, and thrust washers. Petroleum jelly can also be used to hold parts in place during reassembly.

## INSPECTION

Inspect the case for cracks, porous spots, worn bores, or damaged threads. Damaged threads can be repaired with Helicoil thread inserts. However, the case will have to be replaced if it exhibits any type of damage or wear.

Lubricate the front band adjusting screw threads with petroleum jelly and thread the screw part-way into the case. Be sure the screw turns freely.

Inspect the transmission bushings during overhaul. Bushing condition is important as worn, scored bushings contribute to low pressures, clutch slip and accelerated wear of other components. However, do not replace bushings as a matter of course. Replace bushings only when they are actually worn, or scored.

Use recommended tools to replace bushings. The tools are sized and designed to remove, install, and



## AUTOMATIC TRANSMISSION - 42RE (Continued)

seat bushings correctly. The bushing replacement tools are included in Bushing Tool Set C-3887-B.

Pre-sized service bushings are available for replacement purposes. Only the sun gear bushings are not serviced.

The use of crocus cloth is permissible where necessary, providing it is used carefully. When used on shafts, or valves, use extreme care to avoid rounding off sharp edges. Sharp edges are vital as they prevent foreign matter from getting between the valve and valve bore.

Do not reuse oil seals, gaskets, seal rings, or O-rings during overhaul. Replace these parts as a matter of course. Also do not reuse snap rings or E-clips that are bent or distorted. Replace these parts as well.

### ASSEMBLY

Do not allow dirt, grease, or foreign material to enter the case or transmission components during assembly. Keep the transmission case and components clean. Also make sure the tools and workbench area used for assembly operations are equally clean.

Shop towels used for wiping off tools and hands must be made from **lint free** material. Lint will stick to transmission parts and could interfere with valve operation, or even restrict fluid passages.

Lubricate the transmission components with Mopar® transmission fluid during reassembly. Use Mopar® Door Ease, or Ru-Glyde™ on seals and O-rings to ease installation.

Petroleum jelly can also be used to hold thrust washers, thrust plates and gaskets in position during assembly. However, **do not** use chassis grease, bearing grease, white grease, or similar lubricants on any transmission part. These types of lubricants can eventually block or restrict fluid passages and interfere with valve operation. Use petroleum jelly only.

Do not force parts into place. The transmission components and subassemblies are easily installed by hand when properly aligned.

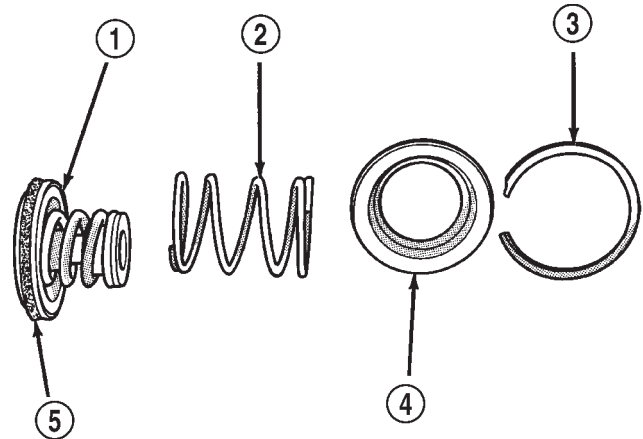
If a part seems extremely difficult to install, it is either misaligned or incorrectly assembled. Also verify that thrust washers, thrust plates and seal rings are correctly positioned before assembly. These parts can interfere with proper assembly if mis-positioned.

The planetary geartrain, front/rear clutch assemblies and oil pump are all much easier to install when the transmission case is upright.

(1) Install rear servo piston, spring and retainer (Fig. 34). Install spring on top of servo piston and install retainer on top of spring.

(2) Install front servo piston assembly, servo spring and rod guide (Fig. 35).

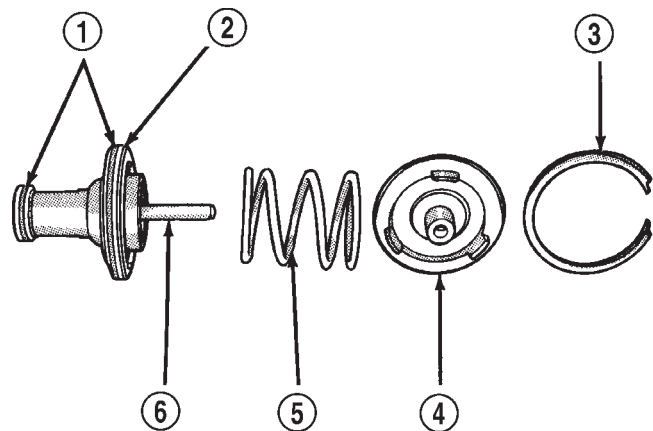
(3) Compress front/rear servo springs with Valve Spring Compressor C-3422-B and install each servo snap-ring (Fig. 36).



J9121-343

**Fig. 34 Rear Servo Components**

- 1 - SERVO PISTON
- 2 - PISTON SPRING
- 3 - SNAP-RING
- 4 - RETAINER
- 5 - PISTON SEAL

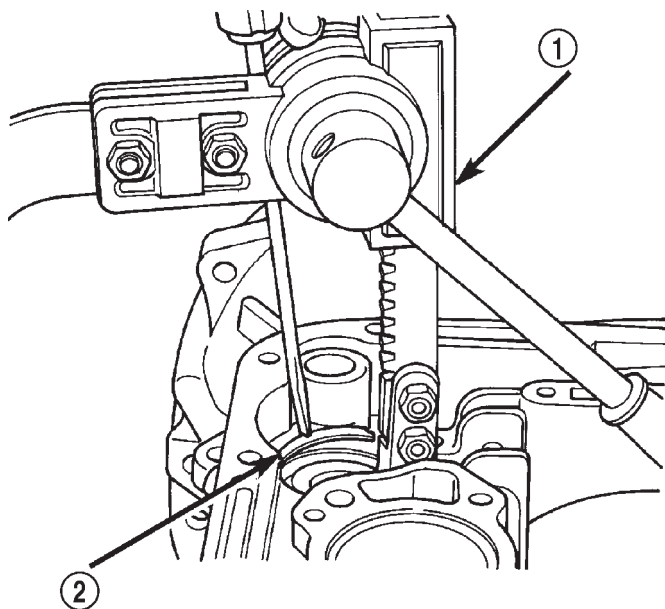


J9121-344

**Fig. 35 Front Servo Components**

- 1 - PISTON SEAL RINGS
- 2 - SERVO PISTON
- 3 - SNAP-RING
- 4 - ROD GUIDE
- 5 - SPRING
- 6 - ROD

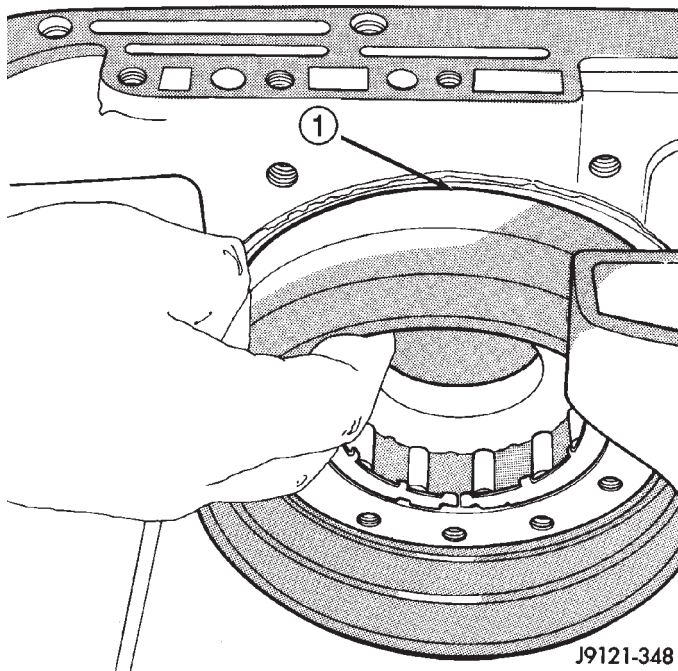
## AUTOMATIC TRANSMISSION - 42RE (Continued)

**Fig. 36 Compressing Front/Rear Servo Springs**

- 1 - SPRING COMPRESSOR TOOL C-3422-B  
2 - ROD GUIDE SNAP-RING

(4) Lubricate clutch cam rollers with transmission fluid.

(5) Install rear band in case (Fig. 37). Be sure twin lugs on band are seated against reaction pin.

**Fig. 37 Rear Band Installation**

- 1 - REAR BAND

(6) Install low-reverse drum and check overrunning clutch operation as follows:

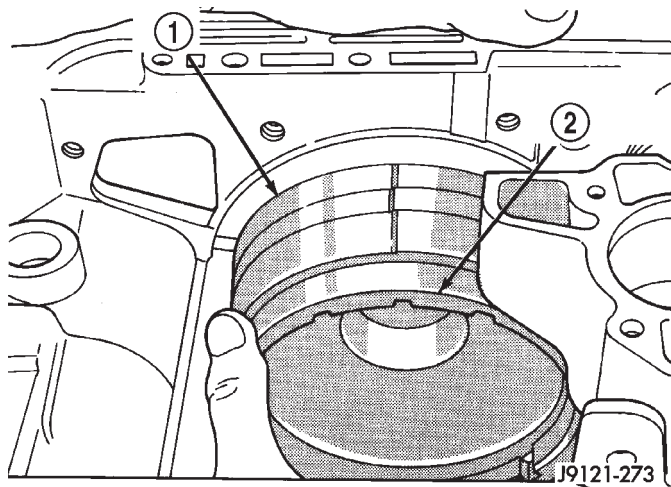
(a) Lubricate overrunning clutch race (on drum hub) with transmission fluid.

(b) Guide drum through rear band.

(c) Tilt drum slightly and start race (on drum hub) into overrunning clutch rollers.

(d) Press drum rearward and turn it in clockwise direction until drum seats in overrunning clutch (Fig. 38).

(e) Turn drum back and forth. Drum should rotate freely in clockwise direction and lock in counterclockwise direction (as viewed from front of case).

**Fig. 38 Installing Low-Reverse Drum**

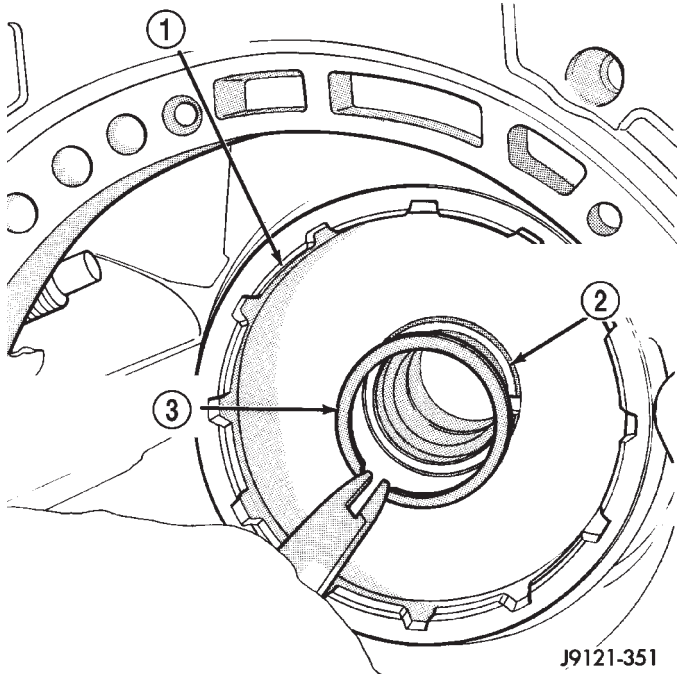
- 1 - REAR BAND  
2 - LOW-REVERSE DRUM

AUTOMATIC TRANSMISSION - 42RE (Continued)

(7) Install snap-ring that secures low-reverse drum to hub of overdrive piston retainer (Fig. 39).

(8) Install rear band lever and pivot pin (Fig. 40). Align lever with pin bores in case and push pivot pin into place.

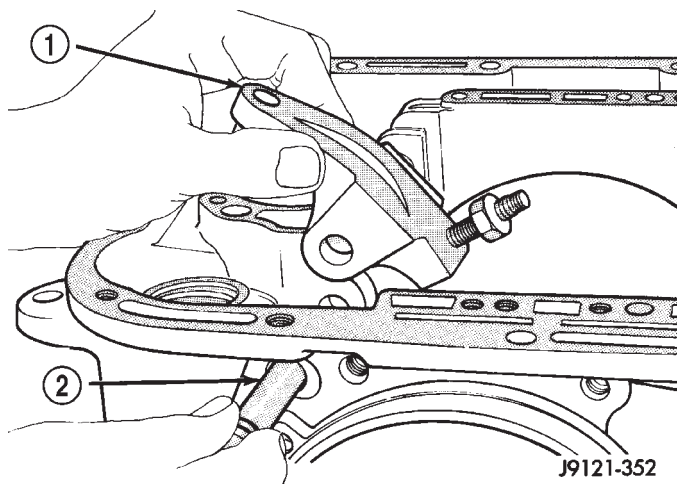
(9) Install planetary geartrain assembly (Fig. 41).



J9121-351

**Fig. 39 Installing Low-Reverse Drum Retaining Snap-Ring**

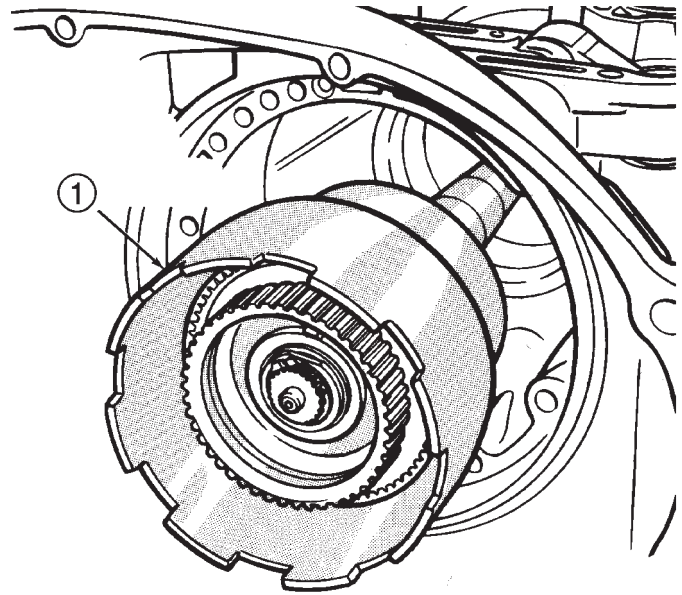
- 1 - LOW-REVERSE DRUM
- 2 - HUB OF OVERDRIVE PISTON RETAINER
- 3 - LOW-REVERSE DRUM SNAP-RING



J9121-352

**Fig. 40 Rear Band Lever And Pivot Pin Installation**

- 1 - REAR BAND LEVER
- 2 - LEVER PIVOT PIN

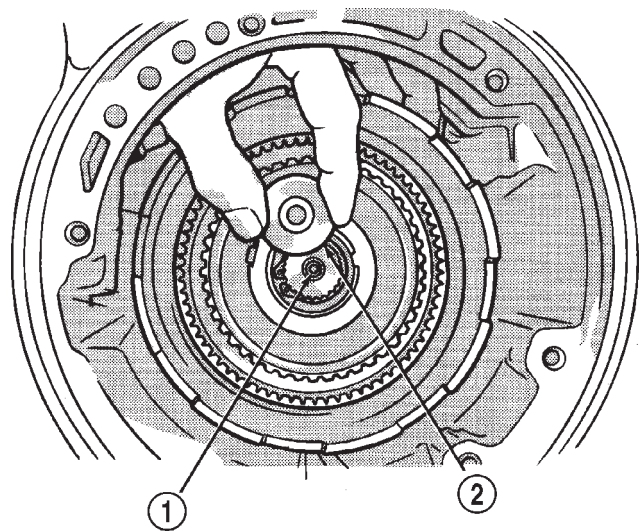


J9121-217

**Fig. 41 Installing Planetary Geartrain**

- 1 - PLANETARY GEARTRAIN AND INTERMEDIATE SHAFT ASSEMBLY

(10) Install thrust plate on intermediate shaft hub (Fig. 42). Use petroleum jelly to hold thrust plate in place.



J9121-215

**Fig. 42 Installing Intermediate Shaft Thrust Plate**

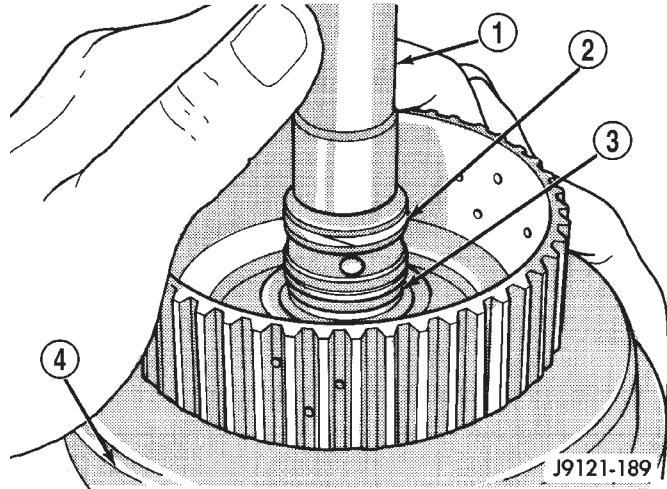
- 1 - INTERMEDIATE SHAFT HUB
- 2 - INTERMEDIATE SHAFT THRUST PLATE



AUTOMATIC TRANSMISSION - 42RE (Continued)

(11) Check seal ring on rear clutch retainer hub and seal rings on input shaft (Fig. 43). Also verify that shaft seal rings are installed in sequence shown.

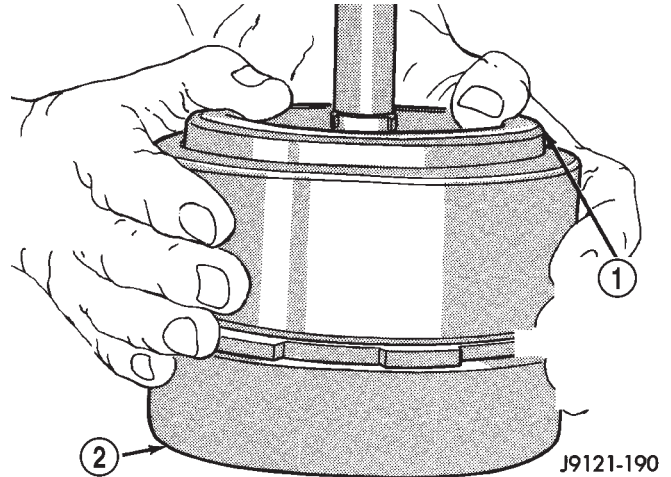
(12) Install rear clutch thrust washer (Fig. 44). Use additional petroleum jelly to hold washer in place if necessary.



**Fig. 43 Input Shaft Seal Ring Location**

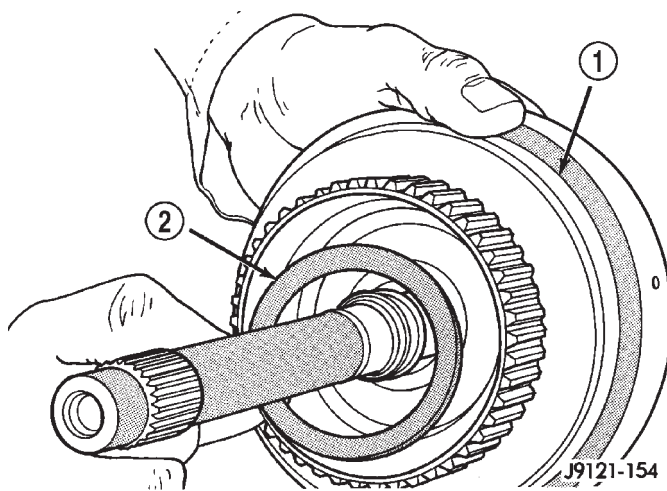
- 1 - INPUT SHAFT
- 2 - TEFLON SEAL RING
- 3 - PLASTIC SEAL RING
- 4 - REAR CLUTCH RETAINER

washer in place. Be sure grooved side of washer faces rearward (toward output shaft) as shown. Also note that washer only fits one way in clutch hub. Note thickness of this washer. It is a select fit part and is used to control transmission end play.



**Fig. 45 Assembling Front And Rear Clutch Units**

- 1 - TURN FRONT CLUTCH BACK & FORTH UNTIL SEATED
- 2 - REAR CLUTCH ASSEMBLY

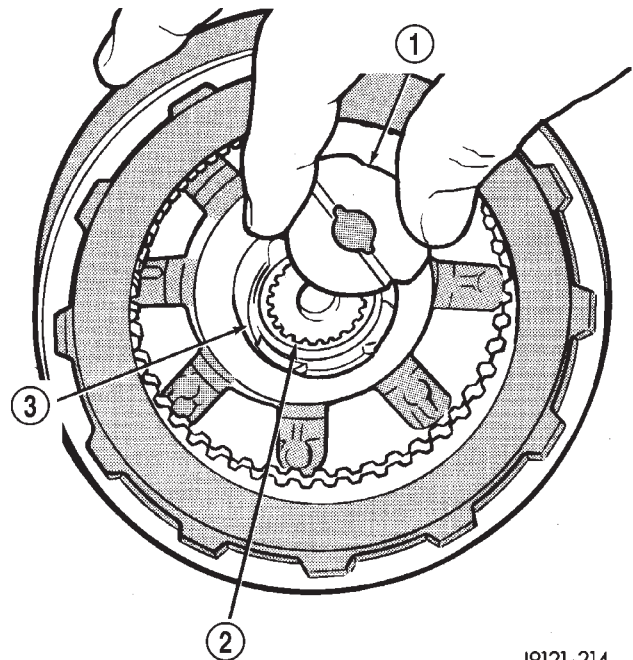


**Fig. 44 Installing Rear Clutch Thrust Washer**

- 1 - REAR CLUTCH RETAINER
- 2 - REAR CLUTCH THRUST WASHER (FIBER)

(13) Align clutch discs in front clutch and install front clutch on rear clutch (Fig. 45). Rotate front clutch retainer back and forth until completely seated on rear clutch retainer.

(14) Coat intermediate shaft thrust washer with petroleum jelly. Then install washer in rear clutch hub (Fig. 46). Use enough petroleum jelly to hold



**Fig. 46 Installing Intermediate Shaft Thrust Plate**

- 1 - INTERMEDIATE SHAFT THRUST WASHER
- 2 - INPUT SHAFT
- 3 - REAR CLUTCH RETAINER HUB

## AUTOMATIC TRANSMISSION - 42RE (Continued)

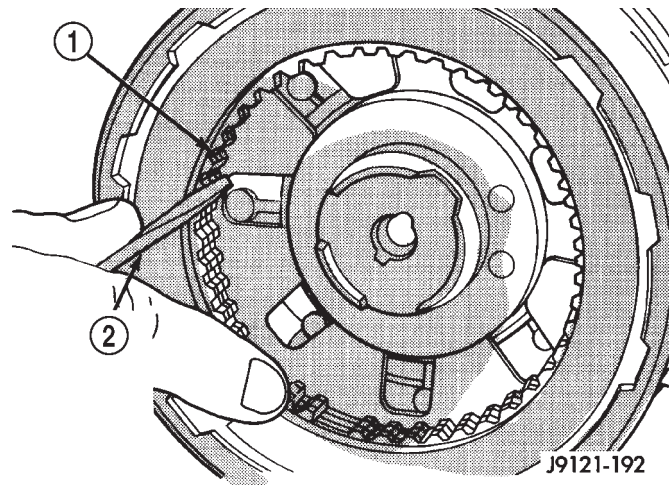
(15) Align drive teeth on rear clutch discs with small screwdriver (Fig. 47). This makes installation on front planetary easier.

(16) Raise front end of transmission upward as far as possible and support case with wood blocks. Front/rear clutch and oil pump assemblies are easier to install if transmission is as close to upright position as possible.

(17) Slide front band into case.

(18) Install front and rear clutch units as assembly (Fig. 48). Align rear clutch with front annulus gear and install assembly in driving shell. Be sure output shaft thrust washer and thrust plate are not displaced during installation.

(19) Carefully work assembled clutches back and forth to engage and seat rear clutch discs on front annulus gear. Also be sure front clutch drive lugs are fully engaged in slots of driving shell after installation.



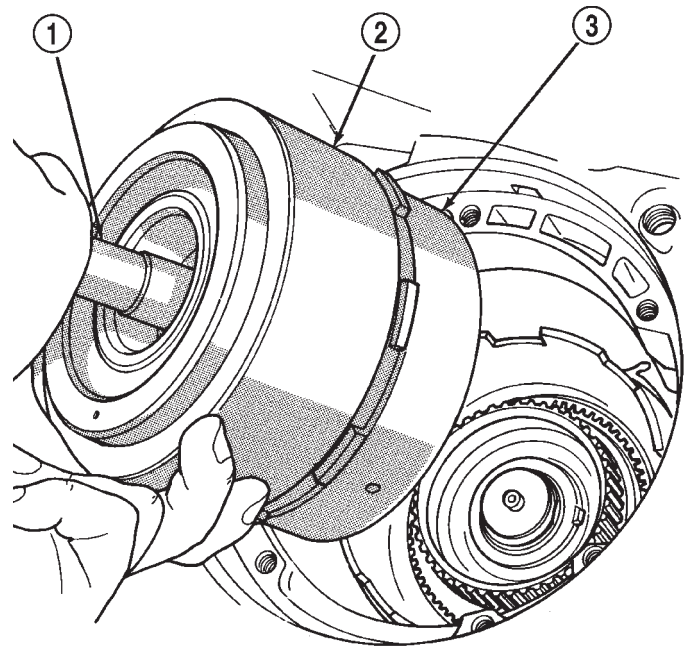
**Fig. 47 Aligning Rear Clutch Disc Lugs**

- 1 - REAR CLUTCH DISCS
- 2 - USE SMALL SCREWDRIVER TO ALIGN CLUTCH DISC TEETH

(20) Assemble front band strut.

(21) Install front band adjuster, strut and adjusting screw (Fig. 49).

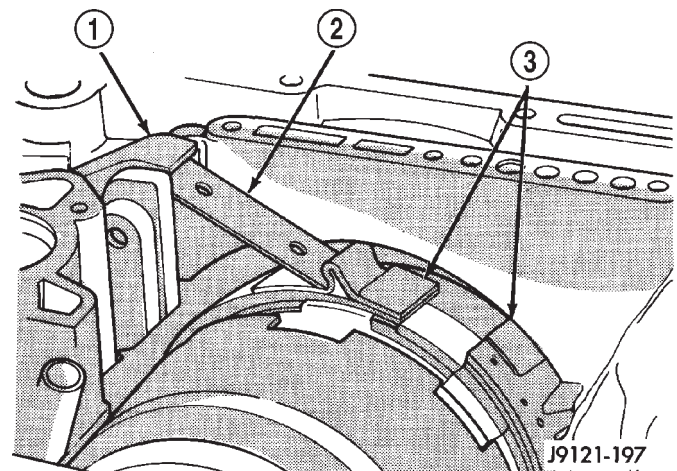
(22) Tighten band adjusting screw until band just grips clutch retainer. Verify that front/rear clutches are still seated before continuing.



J9121-124

**Fig. 48 Installing Front/Rear Clutch Assemblies**

- 1 - INPUT SHAFT
- 2 - FRONT CLUTCH
- 3 - REAR CLUTCH



J9121-197

**Fig. 49 Front Band Linkage Installation**

- 1 - BAND LEVER
- 2 - BAND STRUT
- 3 - FRONT BAND



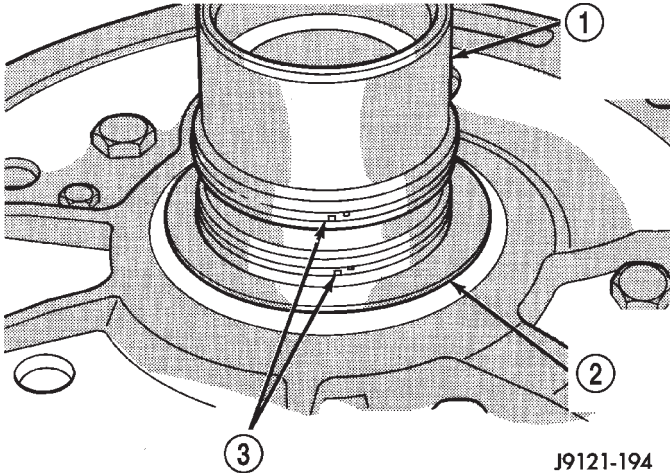
## AUTOMATIC TRANSMISSION - 42RE (Continued)

(23) Check seal rings on reaction shaft support hub. Verify that seal rings are hooked together and that front clutch thrust washer is properly positioned (Fig. 50). Use petroleum jelly to hold thrust washer in place if necessary.

(24) Lubricate oil pump body seal with petroleum jelly. Lubricate pump shaft seal lip with petroleum jelly.

(25) Thread two Pilot Stud Tools C-3288-B into bolt holes in oil pump bore flange (Fig. 51).

(26) Align and install oil pump gasket (Fig. 51).

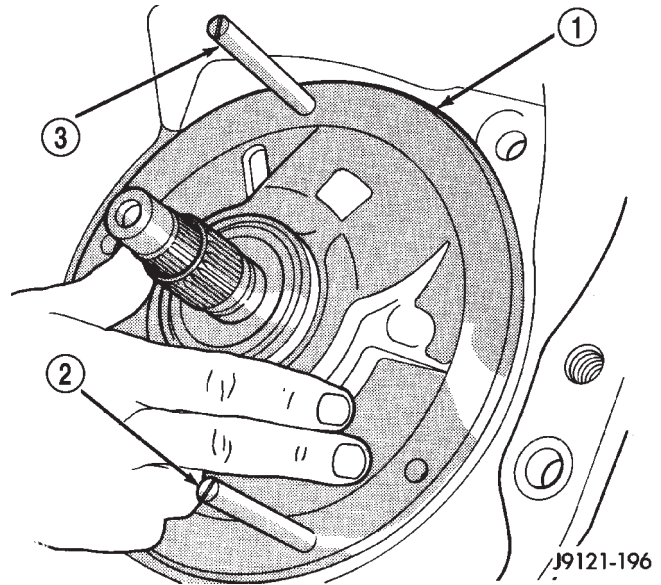


**Fig. 50 Reaction Shaft Support Seal Rings And Front Clutch Thrust Washer**

- 1 - REACTION SHAFT SUPPORT HUB
- 2 - FRONT CLUTCH THRUST WASHER
- 3 - SEAL RINGS

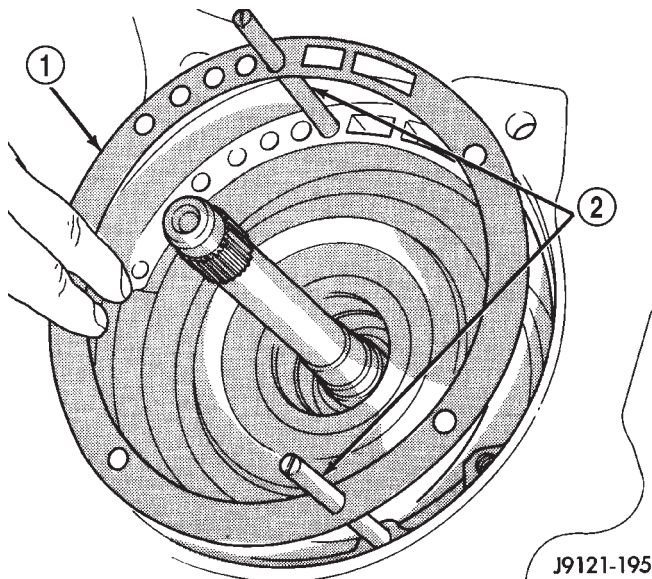
(27) Install oil pump (Fig. 52). Align and position pump on pilot studs. Slide pump down studs and work it into front clutch hub and case by hand. Then install 2 or 3 pump bolts to hold pump in place.

(28) Remove pilot stud tools and install remaining oil pump bolts. Tighten bolts alternately in diagonal pattern to 20 N·m (15 ft. lbs.).



**Fig. 52 Installing Oil Pump**

- 1 - OIL PUMP
- 2 - PILOT STUD TOOL
- 3 - PILOT STUD TOOL



**Fig. 51 Installing Pilot Studs And Oil Pump Gasket**

- 1 - OIL PUMP GASKET
- 2 - PILOT STUD TOOLS C-3288-B

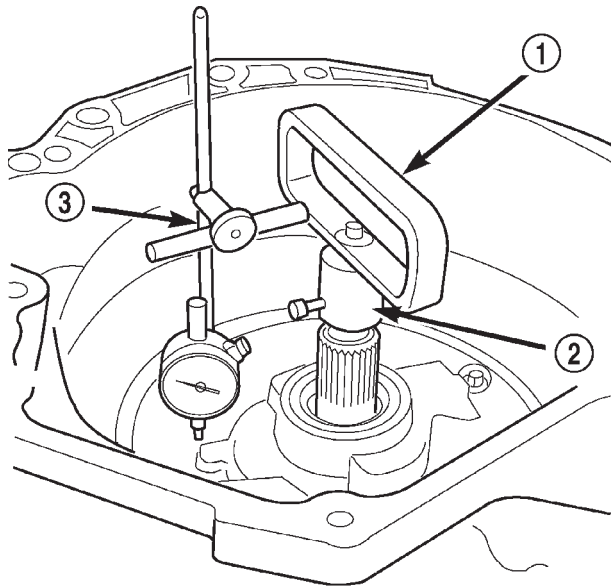
(29) Measure input shaft end play (Fig. 53).

**NOTE:** If end play is incorrect, transmission is incorrectly assembled, or the intermediate shaft thrust washer is incorrect. The intermediate shaft thrust washer is selective.

- (a) Attach Adapter 8266-6 to Handle 8266-8.
  - (b) Attach dial indicator C-3339 to Handle 8266-8.
  - (c) Install the assembled tool onto the input shaft of the transmission and tighten the retaining screw on Adapter 8266-6 to secure it to the input shaft.
  - (d) Position the dial indicator plunger against a flat spot on the oil pump and zero the dial indicator.
  - (e) Move input shaft in and out and record reading. End play should be 0.56-2.31 mm (0.022-0.091 in.). Adjust as necessary.
- (30) Install accumulator piston and inner and outer springs (Fig. 54).
- (31) Verify that valve body solenoid harness is secured in 3-4 accumulator housing cover plate.
- (32) Install valve body as follows:



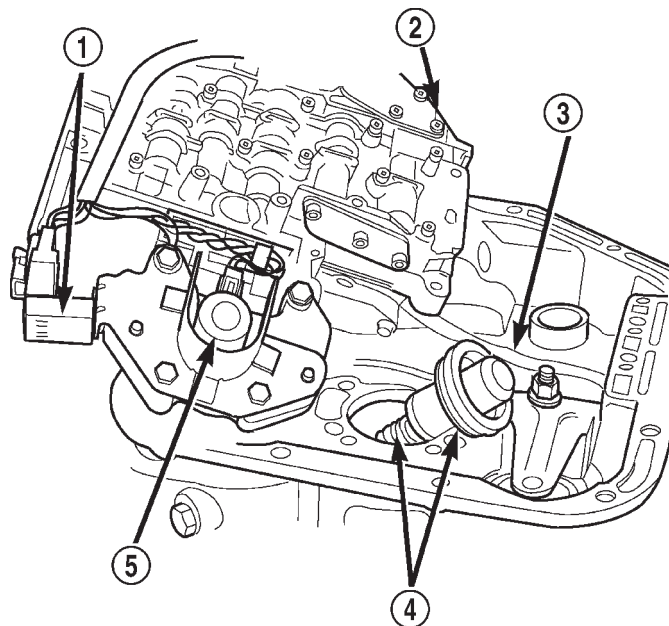
## AUTOMATIC TRANSMISSION - 42RE (Continued)



80c070b5

**Fig. 53 Checking Input Shaft End Play**

- 1 - TOOL 8266-8
- 2 - TOOL 8266-6
- 3 - TOOL C-3339



80c072b8

**Fig. 54 Accumulator Piston And Springs**

- 1 - GOVERNOR PRESSURE SENSOR
- 2 - VALVE BODY
- 3 - PARK ROD
- 4 - ACCUMULATOR PISTON
- 5 - GOVERNOR PRESSURE SOLENOID

(a) Align and carefully insert park rod into pawl. Rod will make click noise as it enters pawl. Move rod slightly to check engagement.

(b) Align and seat valve body on case. Be sure manual lever shaft and overdrive connector are fully seated in case. Also be sure valve body wiring is not pinched or kinked.

(c) Install and start all valve body attaching bolts by hand. Then tighten bolts evenly, in a diagonal pattern to 12 N·m (105 in. lbs.) torque. Do not overtighten valve body bolts. This could result in distortion and cross leakage after installation.

**CAUTION:** It is possible for the park rod to displace into a cavity just above the pawl sprag during installation. Make sure the rod is actually engaged in the pawl and has not displaced into the cavity.

(33) Install new filter on valve body. Tighten filter screws to 4 N·m (35 in. lbs.).

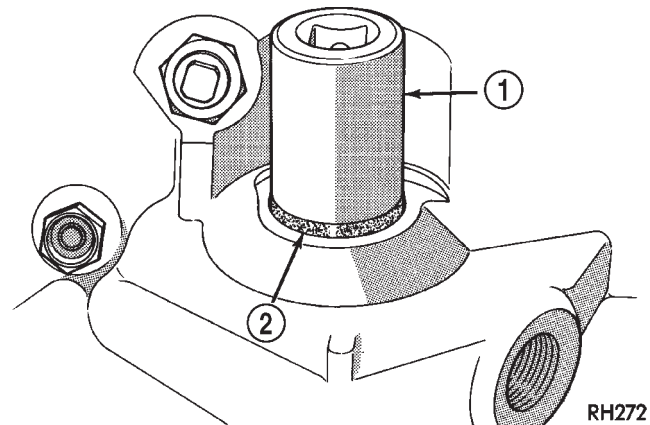
(34) Adjust front and rear bands.

(35) Install seal on park/neutral position switch. Then install and tighten switch to 34 N·m (25 ft. lbs.).

(36) Install magnet in oil pan. Magnet goes on small protrusion at corner of pan.

(37) Position new oil pan gasket on case and install oil pan. Tighten pan bolts to 17 N·m (13 ft. lbs.).

(38) Install new valve body manual shaft seal in case (Fig. 55). Lubricate seal lip and manual shaft with petroleum jelly. Start seal over shaft and into case. Seat seal with 15/16 inch, deep well socket.



RH272

**Fig. 55 Installing Manual Lever Shaft Seal**

- 1 - 15/16" SOCKET
- 2 - SEAL

(39) Install throttle valve and shift selector levers on valve body manual lever shaft.

## AUTOMATIC TRANSMISSION - 42RE (Continued)

**INSTALLATION**

(1) Check torque converter hub and hub drive notches for sharp edges burrs, scratches, or nicks. Polish the hub and notches with 320/400 grit paper and crocus cloth if necessary. The hub must be smooth to avoid damaging pump seal at installation.

(2) Lubricate pocket in the rear oil pump seal lip with transmission fluid.

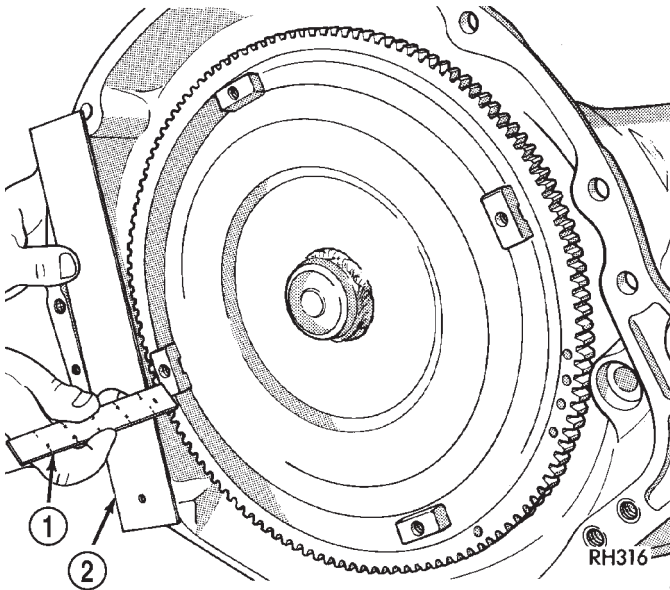
(3) Lubricate converter pilot hub of the crankshaft with a light coating of Mopar® High Temp Grease.

(4) Align and install converter in oil pump.

(5) Carefully insert converter in oil pump. Then rotate converter back and forth until fully seated in pump gears.

(6) Check converter seating with steel scale and straightedge (Fig. 56). Surface of converter lugs should be 1/2 in. to rear of straightedge when converter is fully seated.

(7) Temporarily secure converter with C-clamp.



**Fig. 56 Checking Converter Seating - Typical**

- 1 - SCALE  
2 - STRAIGHTEDGE

(8) Position transmission on jack and secure it with chains.

(9) Check condition of converter driveplate. Replace the plate if cracked, distorted or damaged. **Also be sure transmission dowel pins are seated in engine block and protrude far enough to hold transmission in alignment.**

(10) Raise transmission and align converter with drive plate and converter housing with engine block.

(11) Move transmission forward. Then raise, lower or tilt transmission to align converter housing with engine block dowels.

(12) Carefully work transmission forward and over engine block dowels until converter hub is seated in crankshaft.

(13) Install bolts attaching converter housing to engine.

(14) Install rear support. Then lower transmission onto crossmember and install bolts attaching transmission mount to crossmember.

(15) Remove engine support fixture.

(16) Install crankshaft position sensor. (Refer to 14 - FUEL SYSTEM/FUEL INJECTION/CRANKSHAFT POSITION SENSOR - INSTALLATION)

(17) Install new plastic retainer grommet on any shift linkage rod or lever that was disconnected. Grommets should not be reused. Use pry tool to remove rod from grommet and cut away old grommet. Use pliers to snap new grommet into lever and to snap rod into grommet at assembly.

(18) Connect gearshift and throttle cable to transmission.

(19) Connect wires to park/neutral position switch, transmission solenoid(s) and oxygen sensor. Be sure transmission harnesses are properly routed.

**CAUTION: It is essential that correct length bolts be used to attach the converter to the driveplate. Bolts that are too long will damage the clutch surface inside the converter.**

(20) Install torque converter-to-driveplate bolts. On models with 10.75 in. converter, tighten bolts to 31 N·m (270 in. lbs.). On models with 12.2 in. converter, tighten bolts to 47 N·m (35 ft. lbs.).

(21) Install converter housing access cover.

(22) Install starter motor and cooler line bracket. (Refer to 8 - ELECTRICAL/STARTING/STARTER MOTOR - INSTALLATION)

(23) Connect cooler lines to transmission.

(24) Install transmission fill tube. Install new seal on tube before installation.

(25) Install exhaust components.

(26) Align and connect propeller shaft. (Refer to 3 - DIFFERENTIAL & DRIVELINE/PROPELLER SHAFT/PROPELLER SHAFT - INSTALLATION)

(27) Adjust gearshift linkage and throttle valve cable if necessary.

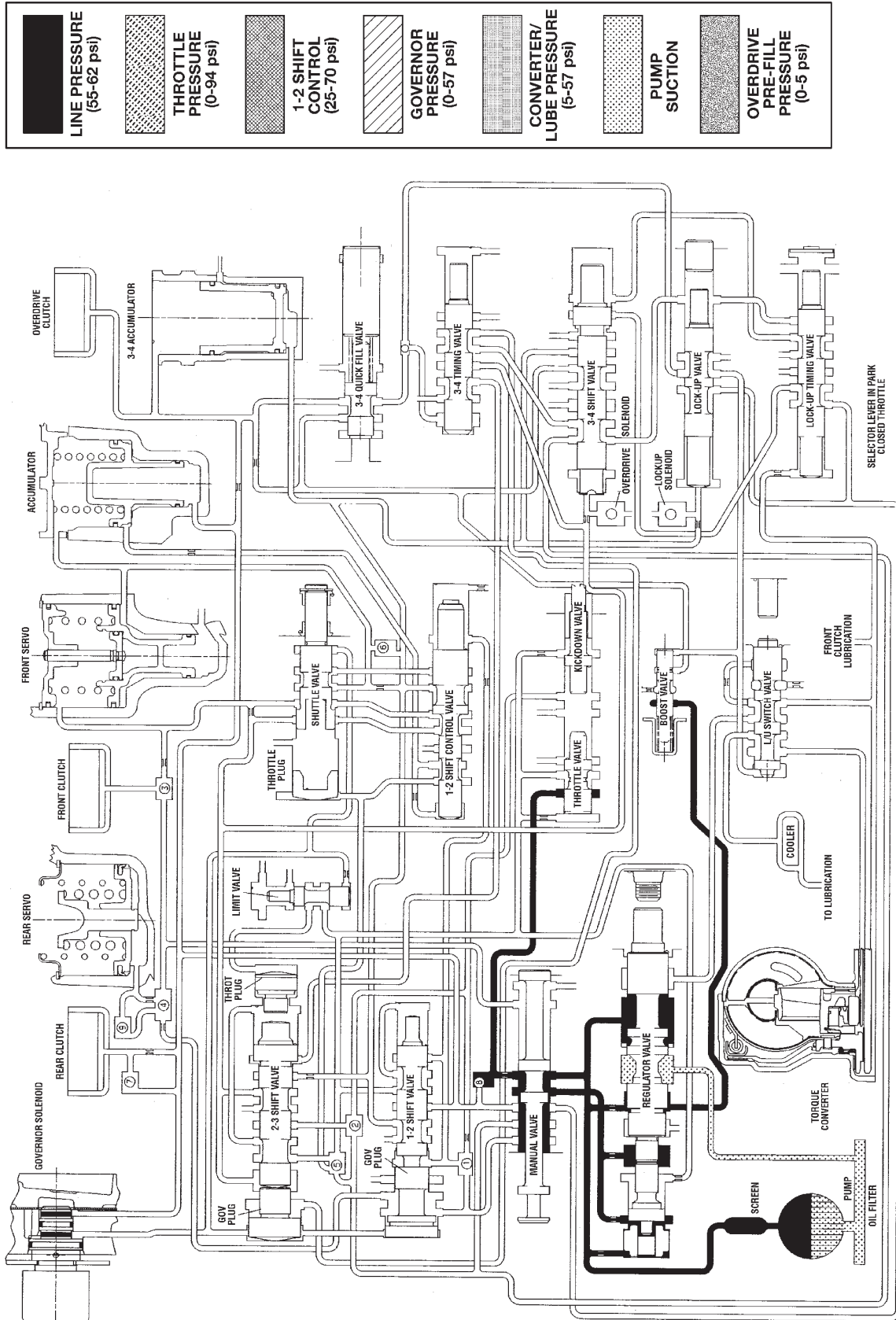
(28) Lower vehicle.

(29) Fill transmission with Mopar® ATF +4, type 9602, Automatic Transmission fluid.

AUTOMATIC TRANSMISSION - 42RE (Continued)

SCHEMATICS AND DIAGRAMS

HYDRAULIC SCHEMATICS

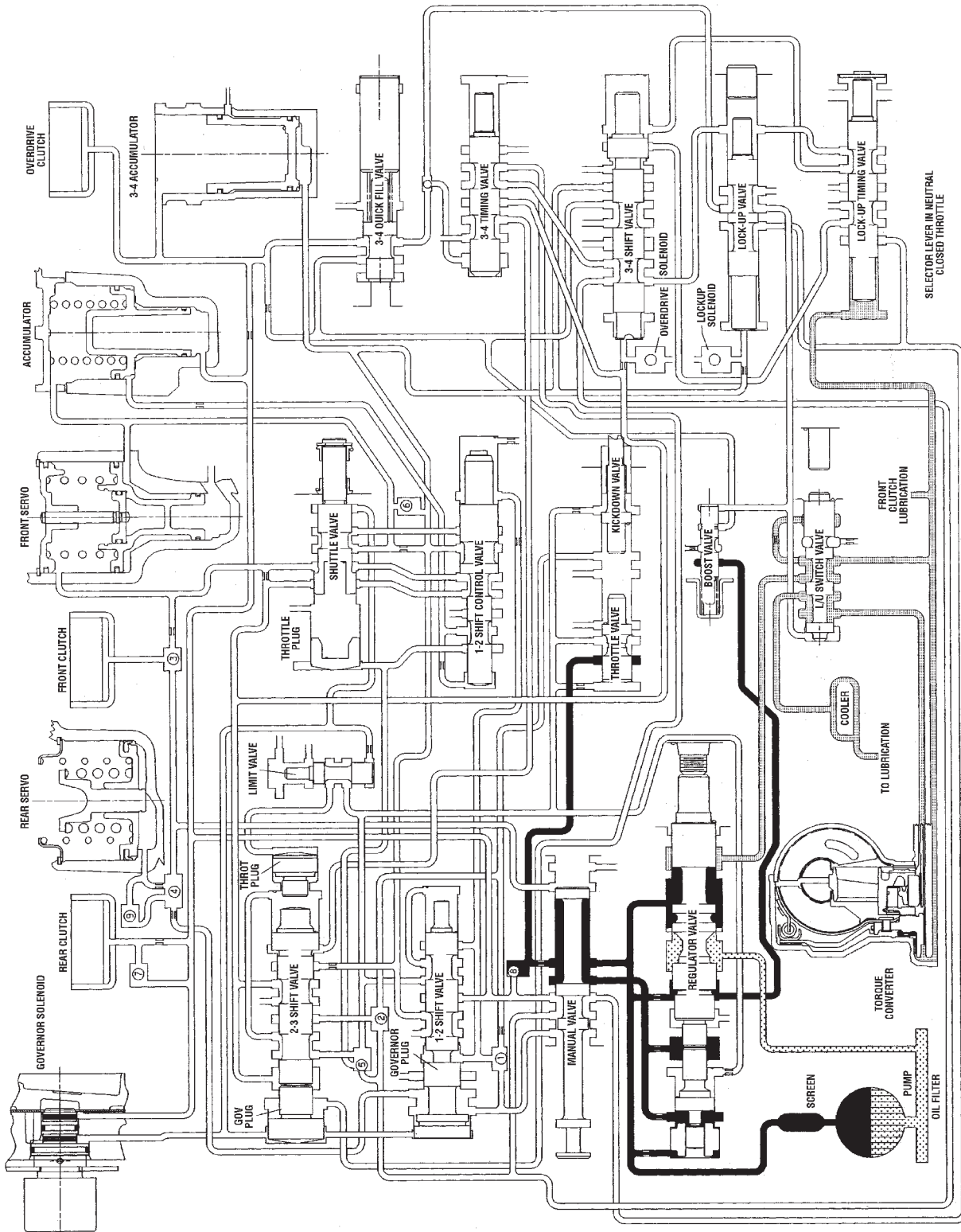
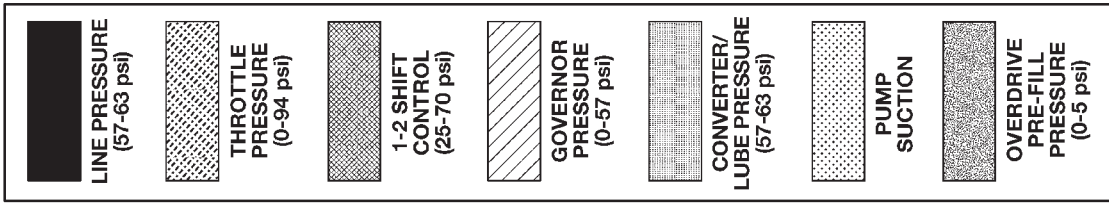


80880583

HYDRAULIC FLOW IN PARK

AUTOMATIC TRANSMISSION - 42RE (Continued)

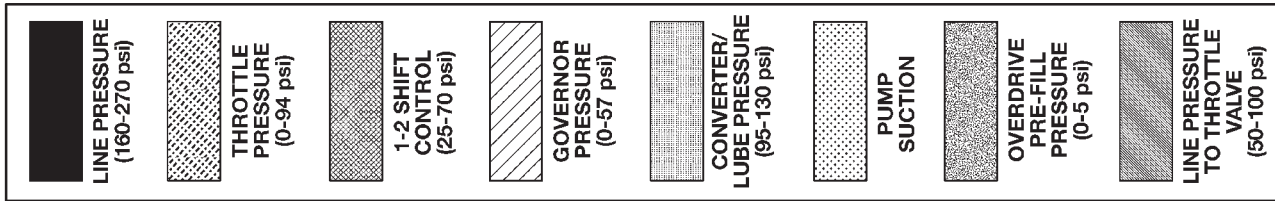
80860594



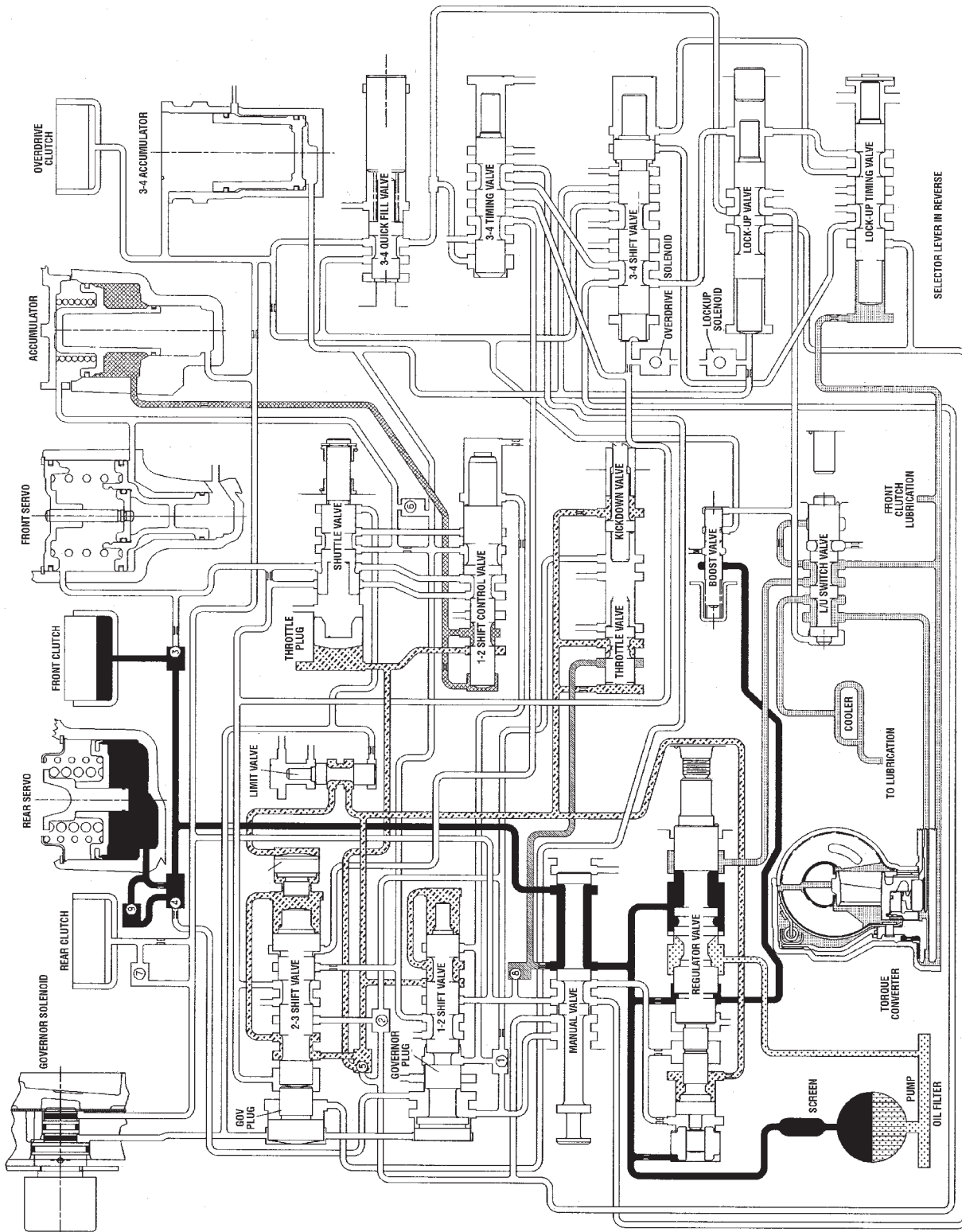
HYDRAULIC FLOW IN NEUTRAL



AUTOMATIC TRANSMISSION - 42RE (Continued)



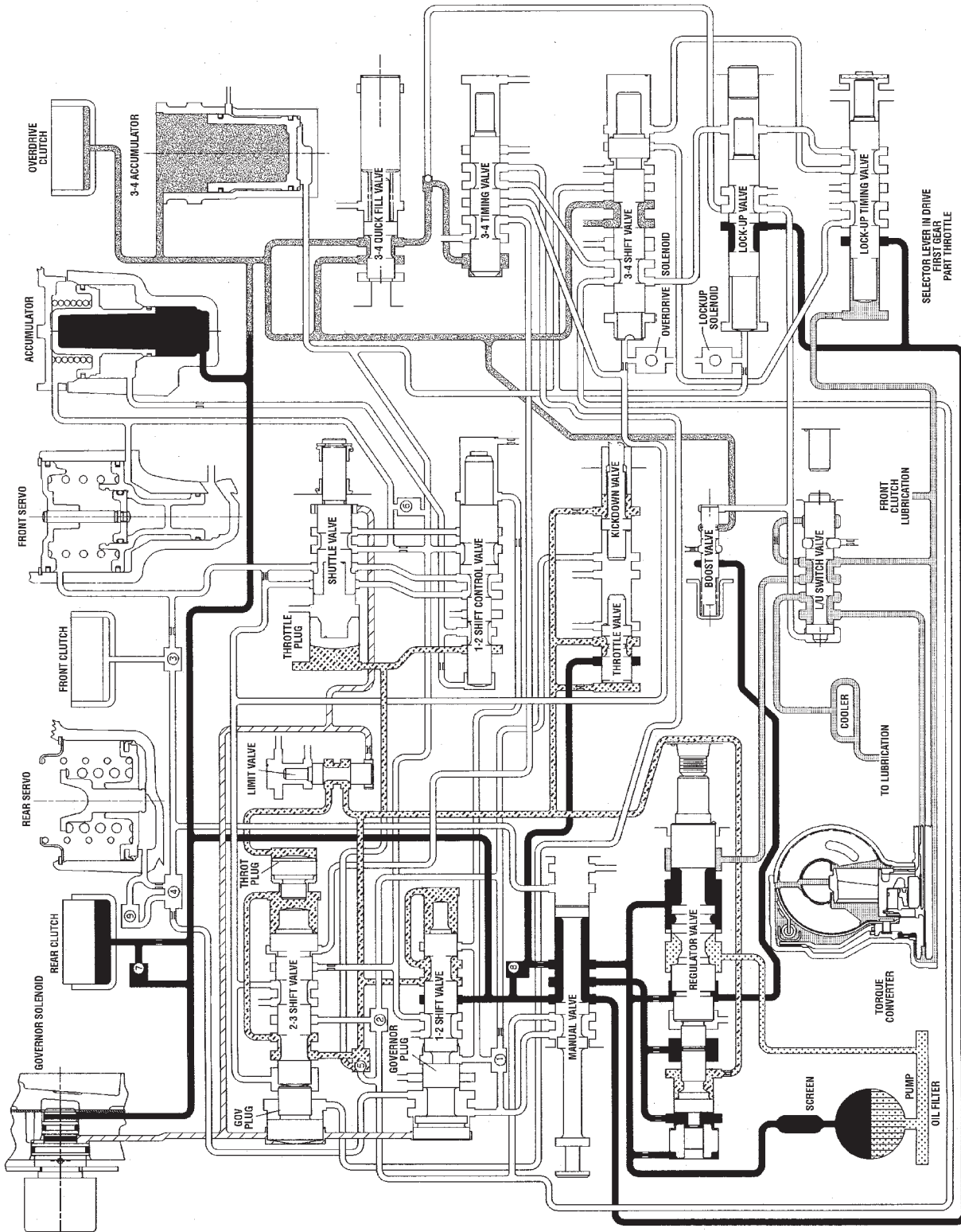
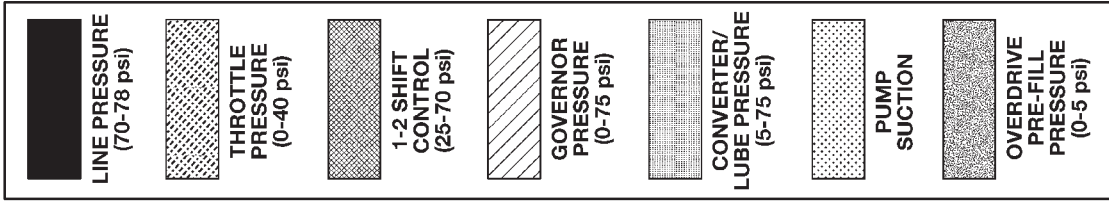
80880595



HYDRAULIC FLOW IN REVERSE

AUTOMATIC TRANSMISSION - 42RE (Continued)

80880596

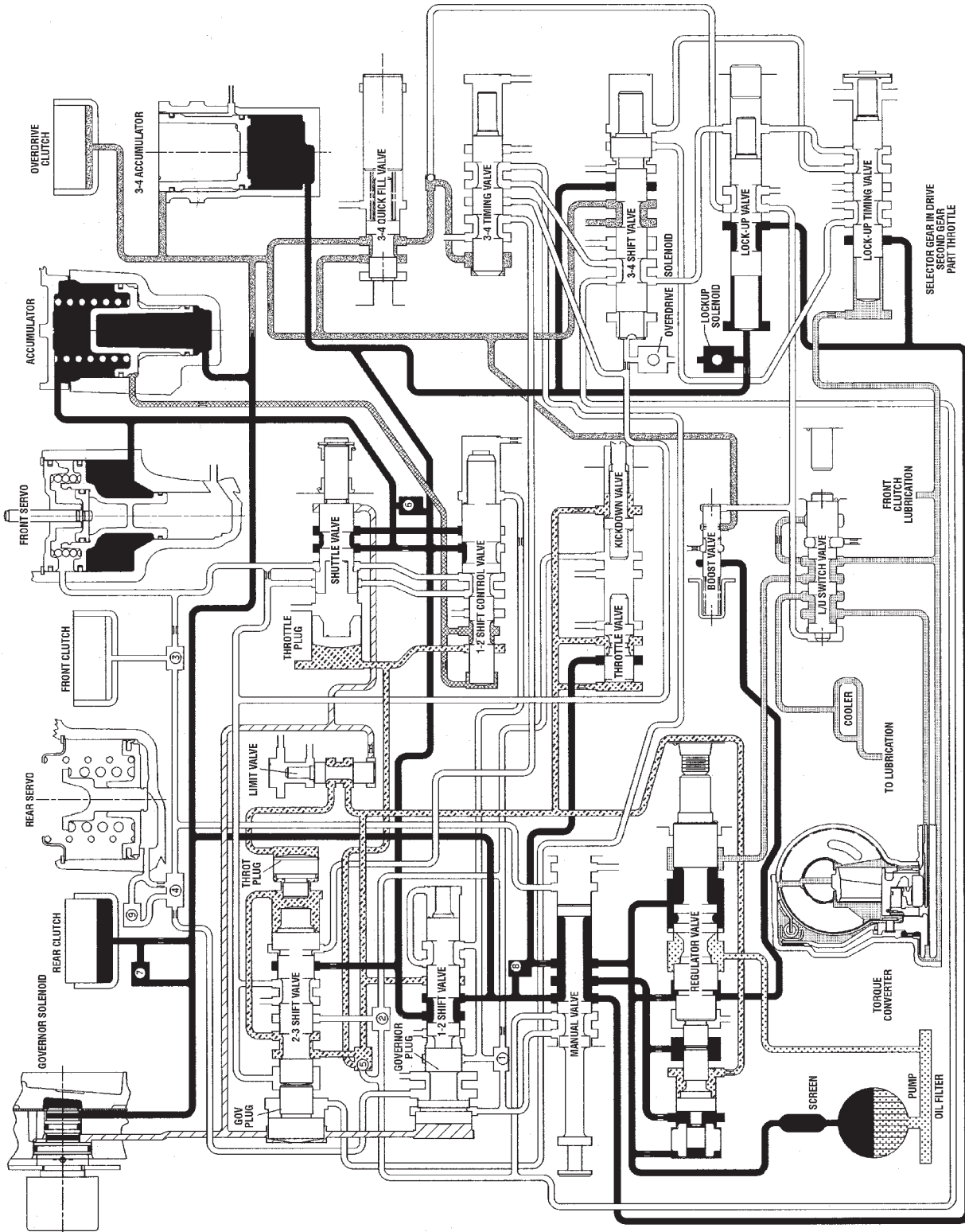
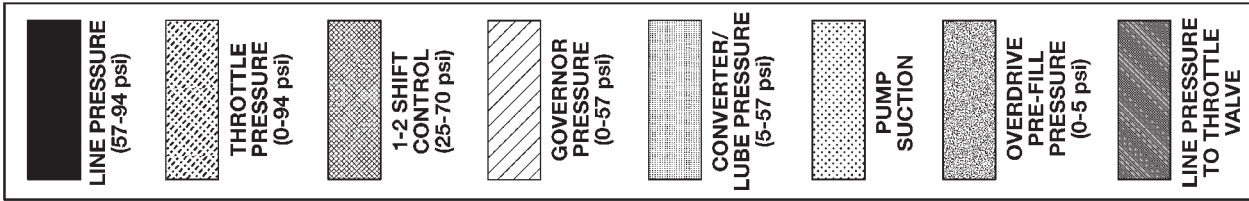


HYDRAULIC FLOW IN DRIVE FIRST GEAR



AUTOMATIC TRANSMISSION - 42RE (Continued)

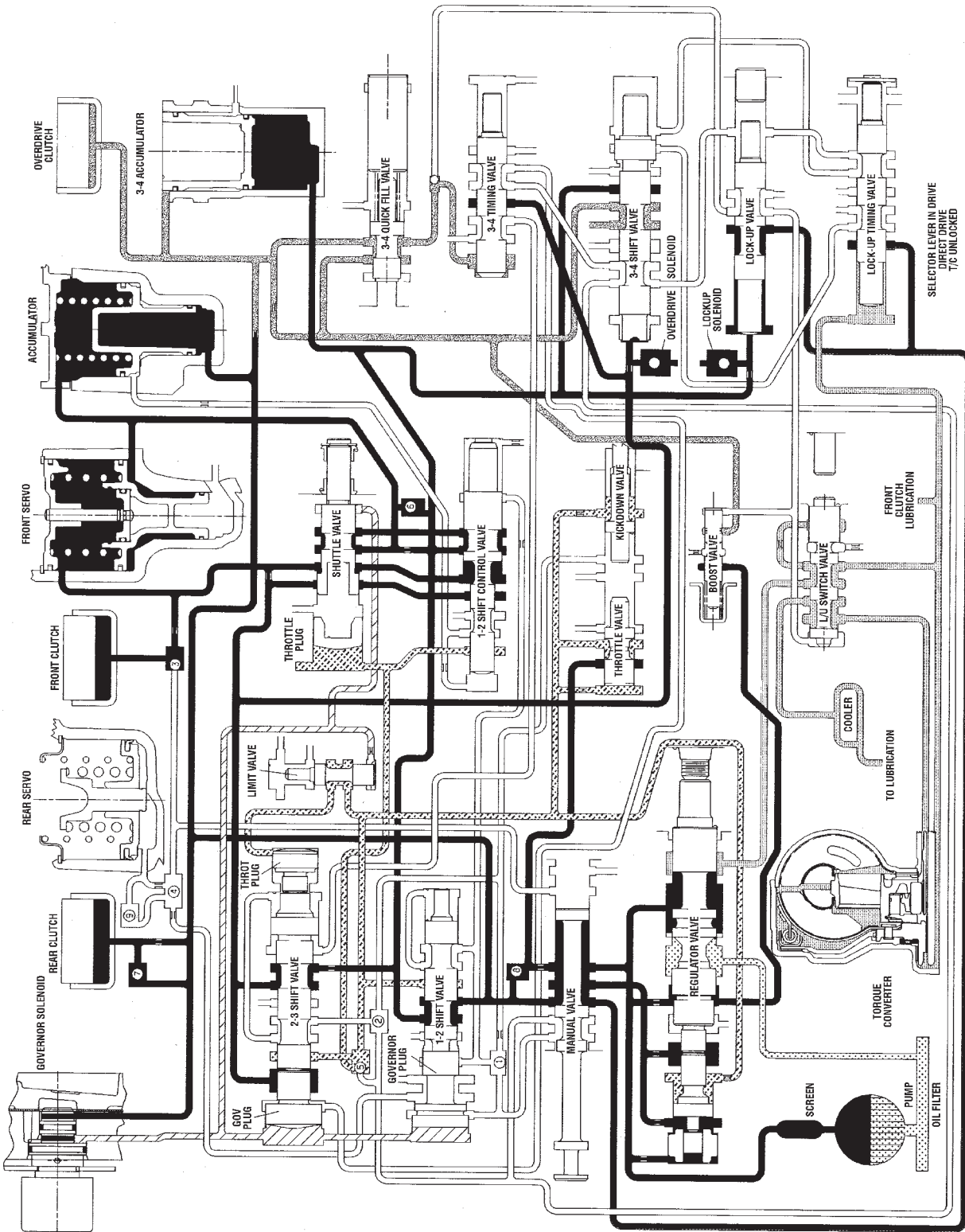
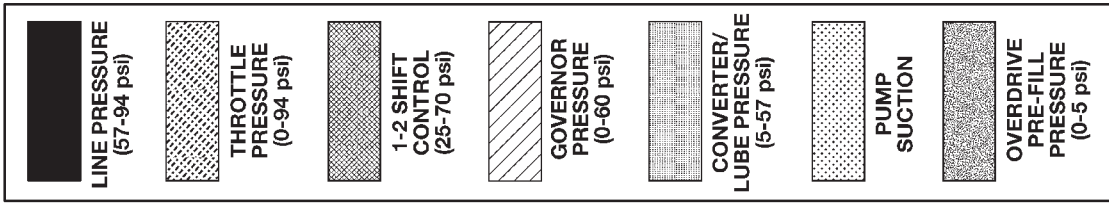
80880697



HYDRAULIC FLOW IN DRIVE SECOND GEAR

AUTOMATIC TRANSMISSION - 42RE (Continued)

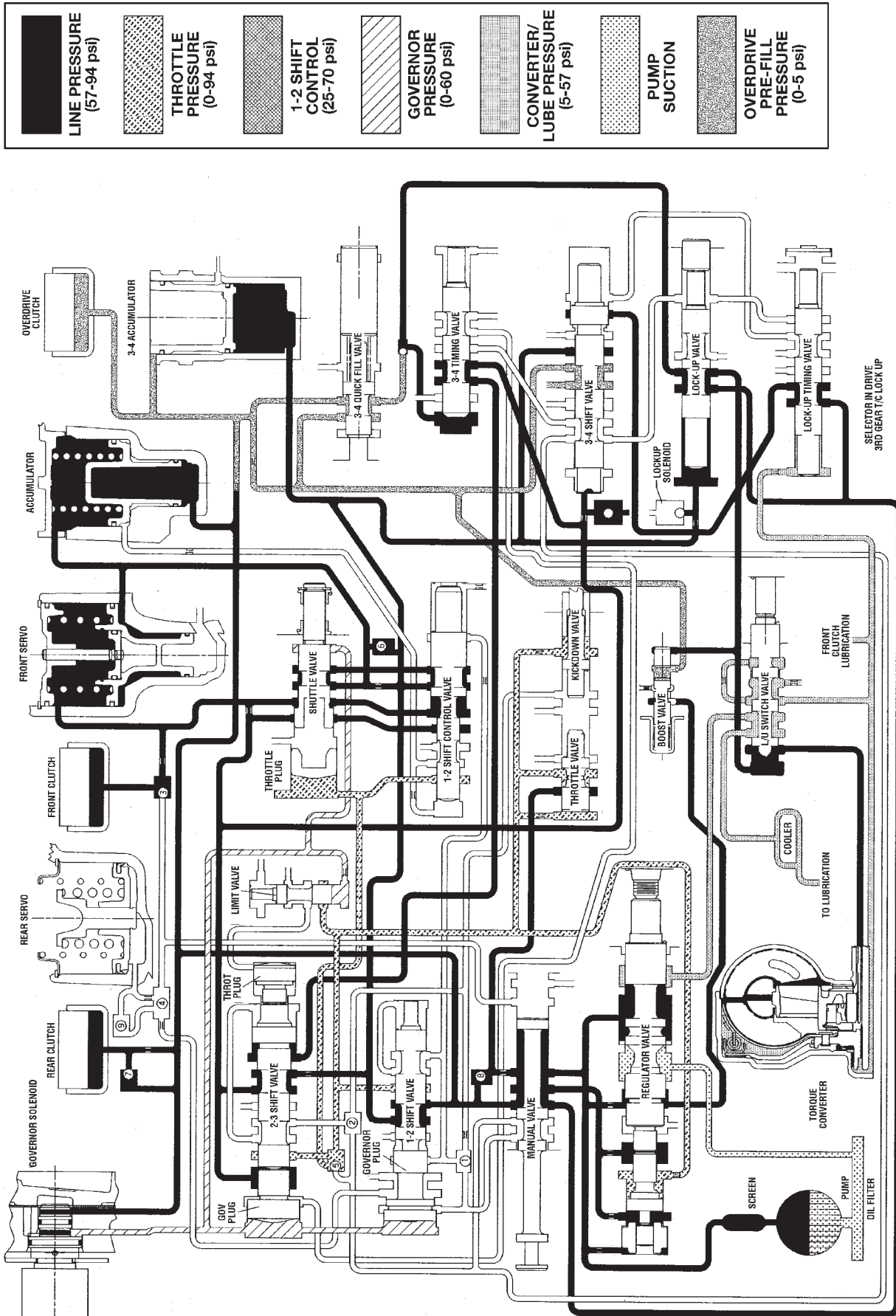
80860598



HYDRAULIC FLOW IN DRIVE THIRD GEAR (CONVERTER CLUTCH NOT APPLIED)

AUTOMATIC TRANSMISSION - 42RE (Continued)

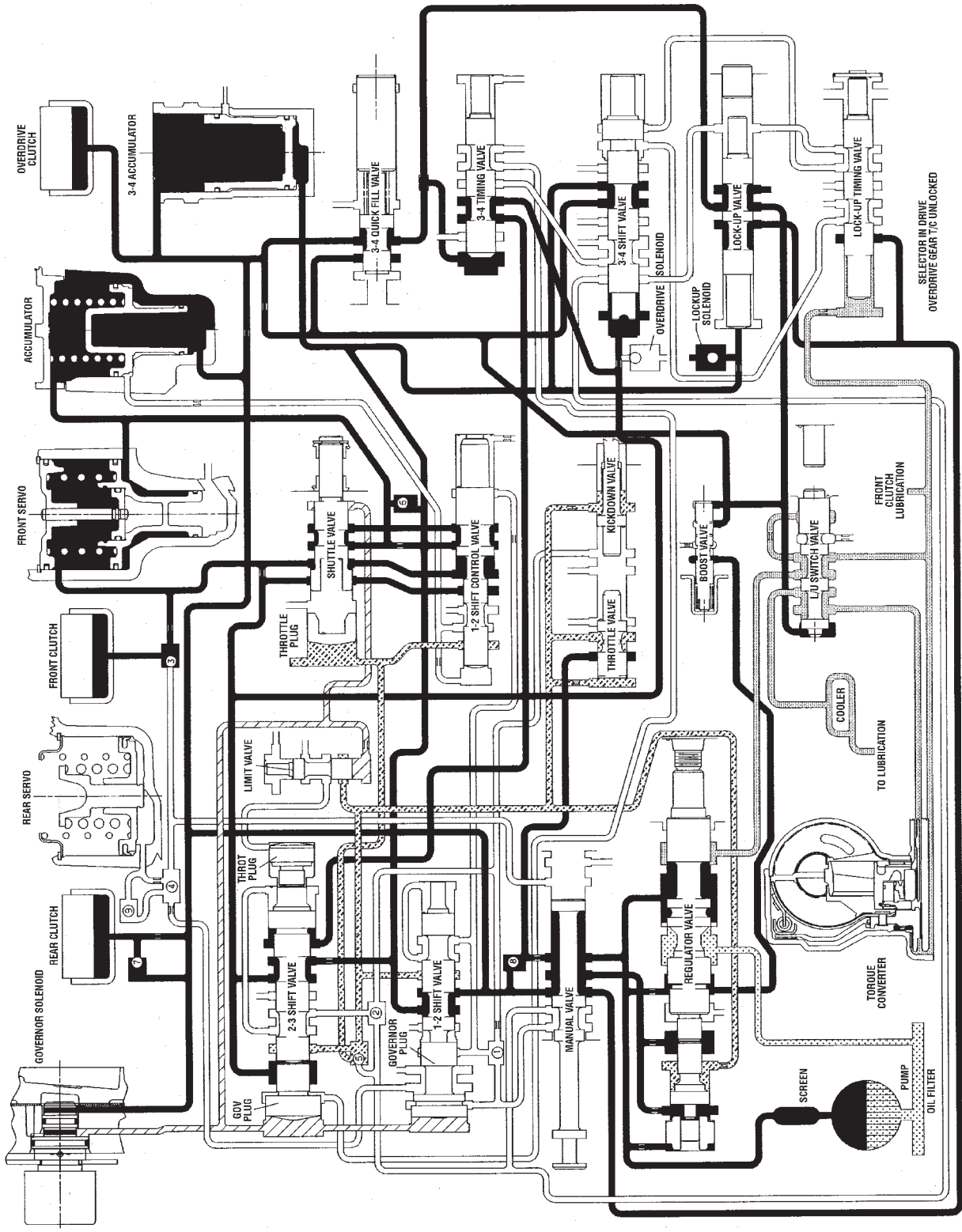
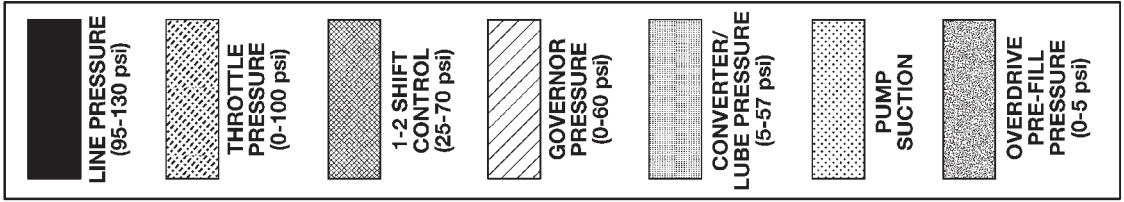
80860599



HYDRAULIC FLOW IN DRIVE THIRD GEAR (CONVERTER CLUTCH APPLIED)

AUTOMATIC TRANSMISSION - 42RE (Continued)

8086059b

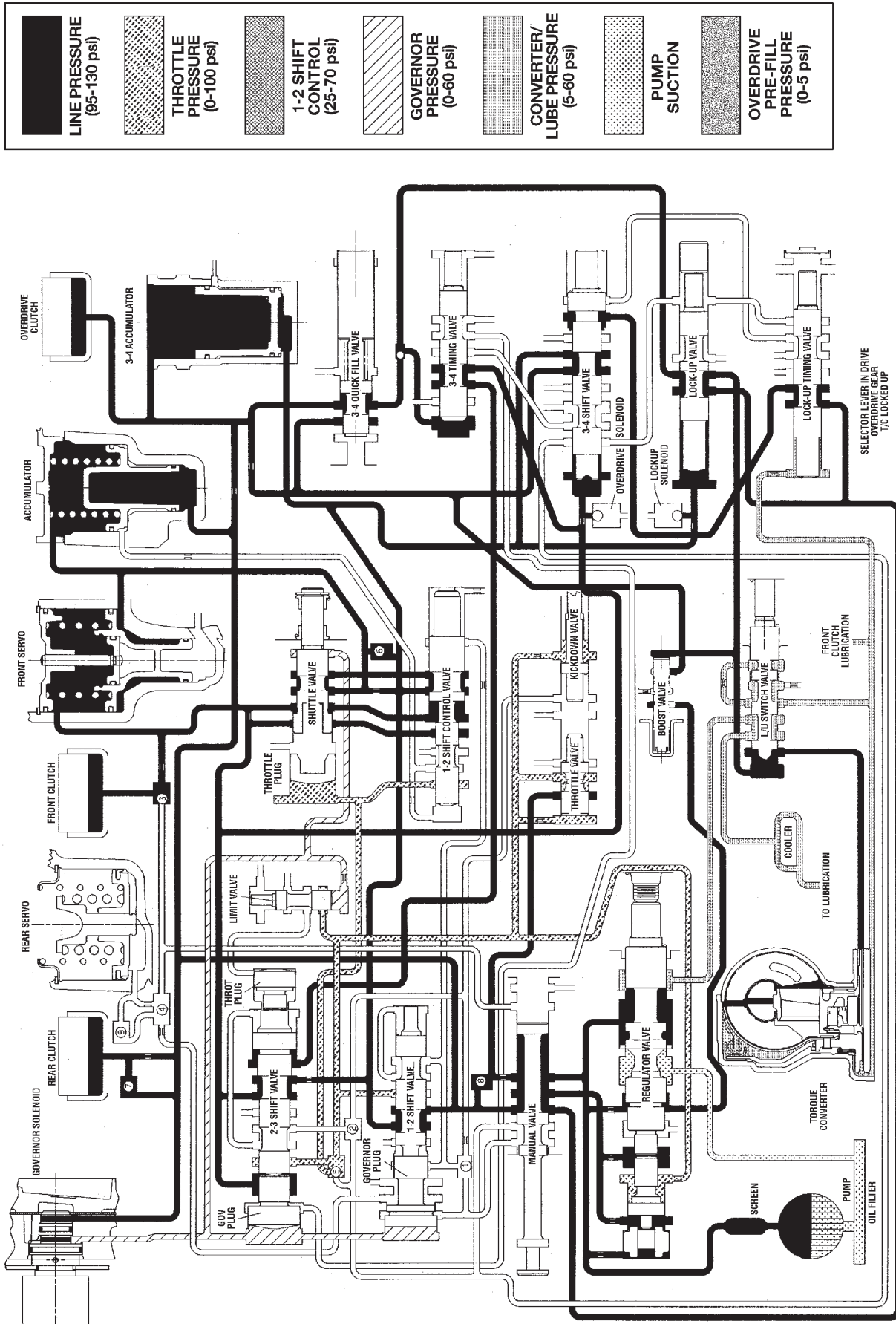


HYDRAULIC FLOW IN DRIVE FOURTH GEAR (CONVERTER CLUTCH NOT APPLIED)



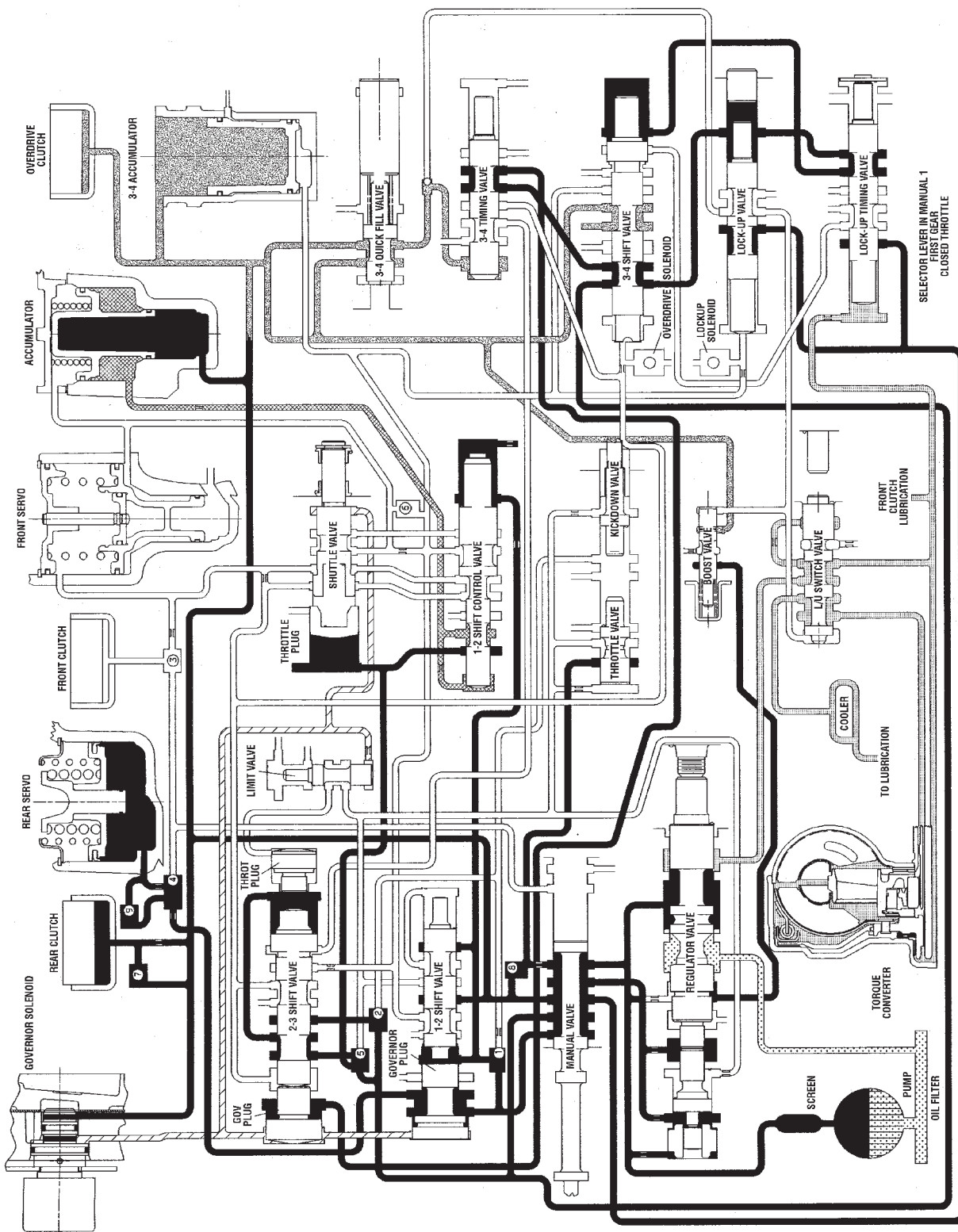
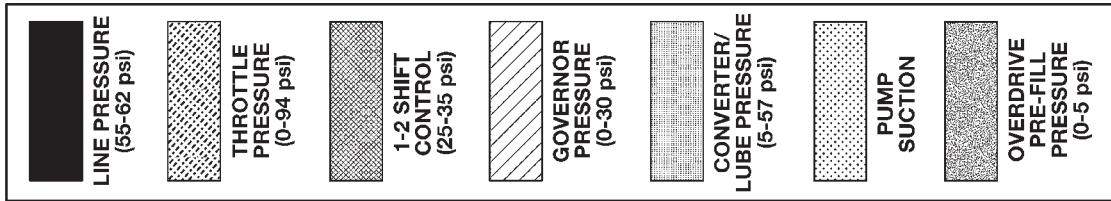
AUTOMATIC TRANSMISSION - 42RE (Continued)

8086059c



HYDRAULIC FLOW IN DRIVE FOURTH GEAR (CONVERTER CLUTCH APPLIED)

AUTOMATIC TRANSMISSION - 42RE (Continued)



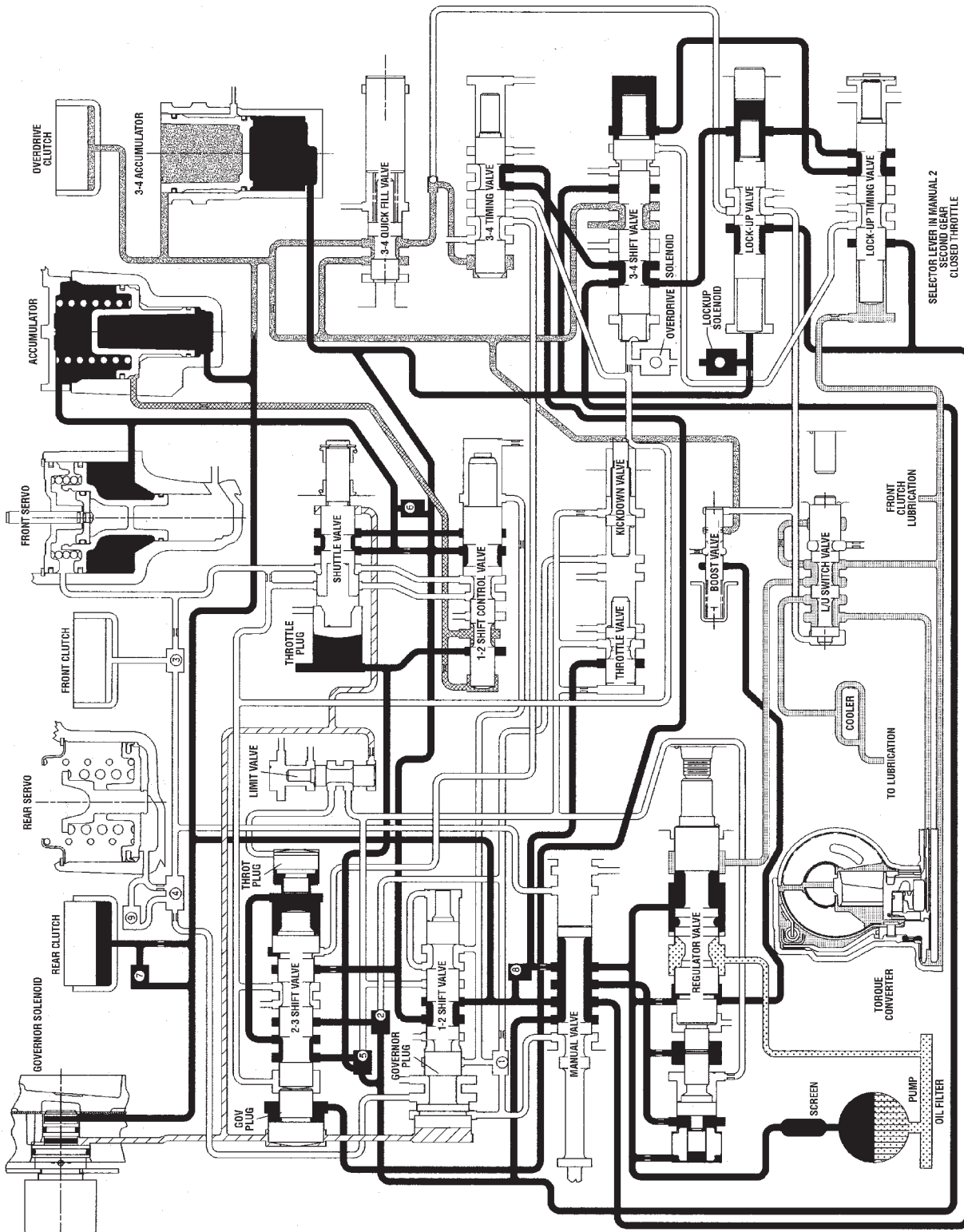
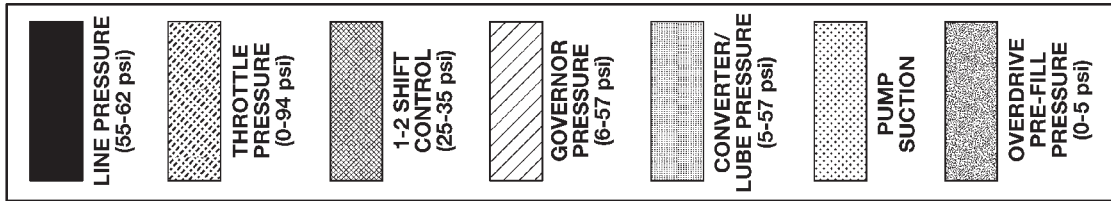
8086059e

HYDRAULIC FLOW IN MANUAL LOW (1)



AUTOMATIC TRANSMISSION - 42RE (Continued)

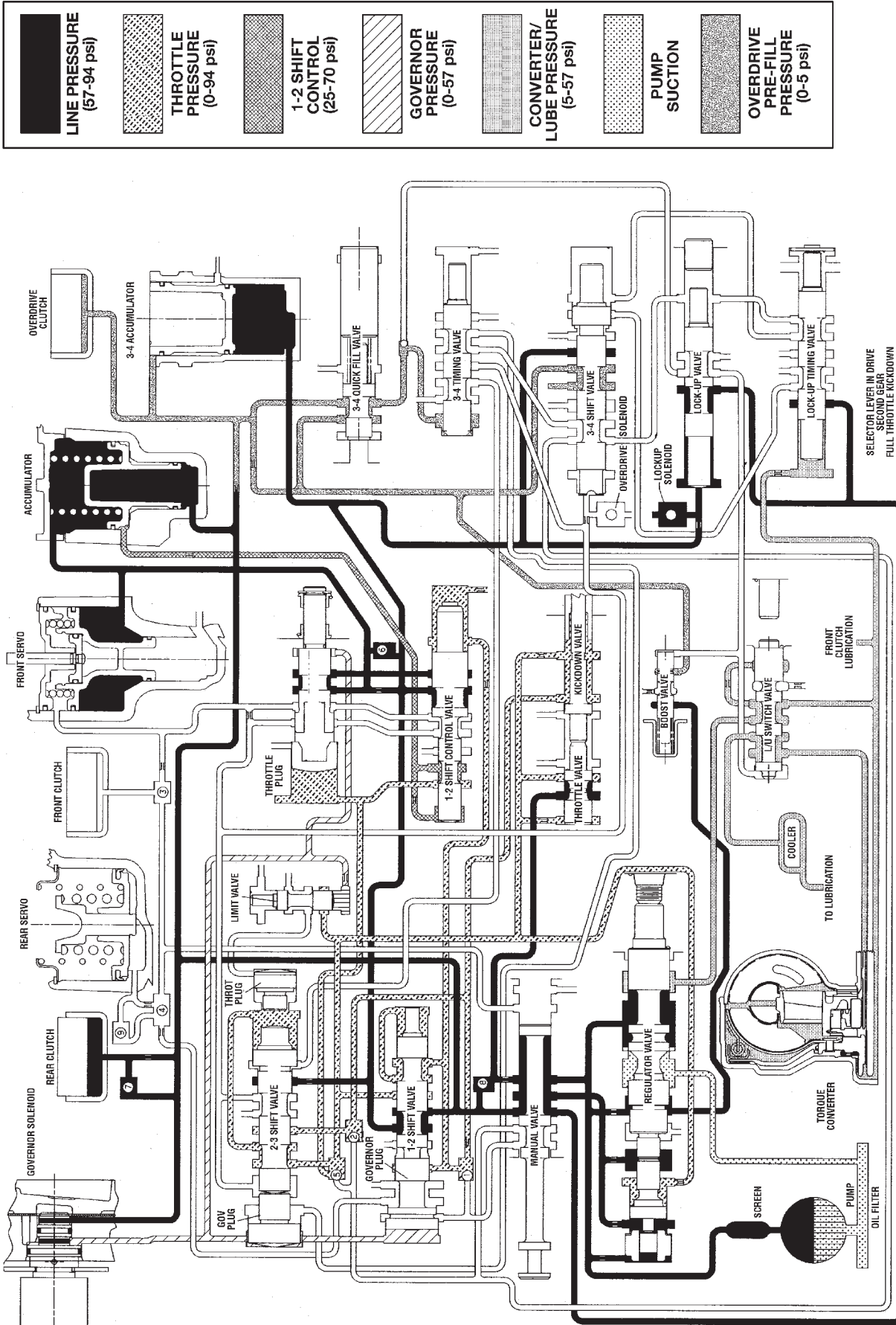
808805a1



HYDRAULIC FLOW IN MANUAL SECOND (2)

AUTOMATIC TRANSMISSION - 42RE (Continued)

808805e2



HYDRAULIC FLOW DURING FULL THROTTLE 3-2 DOWNSHIFT (PASSING)

## AUTOMATIC TRANSMISSION - 42RE (Continued)

## SPECIFICATIONS

## TRANSMISSION

## GENERAL

Component	Metric	Inch
Planetary end play	0.127-1.22 mm	0.005-0.048 in.
Input shaft end play	0.56-2.31 mm	0.022-0.091 in.
Clutch pack clearance/ Front.	1.70- 3.40mm	0.067-0.134 in.
Clutch pack clearance/ Rear.	0.559-0.914 mm	0.022-0.036 in.
Front clutch	4 discs	
Rear clutch	4 discs	
Overdrive clutch	3 discs	
Direct clutch	6 discs	
Band adjustment from 72 in. lbs.		
Front band	Back off 3 turns	
Rear band	Back off 4 turns	
Recommended fluid	Mopar® ATF +4, type 9602	

## GEAR RATIOS

1ST GEAR	2.74:1
2ND GEAR	1.54:1
3RD GEAR	1.0:1
4TH GEAR	0.69:1
REVERSE	2.21:1

## THRUST WASHER/SPACER/SNAP-RING DIMENSIONS

Component	Metric	Inch
Front clutch thrust washer (reaction shaft support hub)	1.55 mm	0.061 in.
Rear clutch thrust washer (clutch retainer)	1.55 mm	0.061 in.
Intermediate shaft thrust plate (shaft hub pilot)	Select fit to set end play	
Output shaft thrust washer (rear clutch hub)	1.5-1.6 mm	0.060-0.063 in.
Rear clutch pack snap-ring	1.5 mm	0.060 in.
	1.95 mm	0.076 in.
	2.45 mm	0.098 in.
Planetary geartrain snap-ring (at front of output shaft)	Select fit (three thicknesses available)	
Overdrive piston thrust plate	Thrust plate and spacer are select fit. Refer to size charts and selection procedures in Overdrive Unit D&A procedures	
Intermediate shaft spacer		

## AUTOMATIC TRANSMISSION - 42RE (Continued)

**PRESSURE TEST**

Overdrive clutch	Fourth gear only	Pressure should be 469-496 kPa (68-72 psi) with closed throttle and increase to 620-896 kPa (90-130 psi) at 1/2 to 3/4 throttle.
Line pressure (at accumulator)	Closed throttle	372-414 kPa (54-60 psi).
Front servo	Third gear only	No more than 21 kPa (3 psi) lower than line pressure.
Rear servo	1 range R range	No more than 21 kPa (3 psi) lower than line pressure. 1103 kPa (160 psi) at idle, builds to 1862 kPa (270 psi) at 1600 rpm.
Governor	D range closed throttle	Pressure should respond smoothly to changes in mph and return to 0-7 kPa (0-1.5 psi) when stopped with transmission in D, 1, 2. Pressure above 7 kPa (1.5 psi) at stand still will prevent transmission from downshifting.

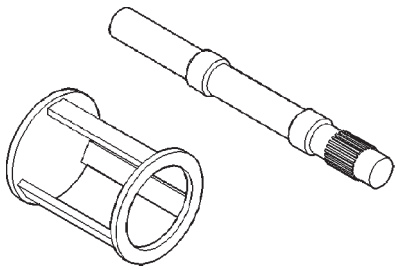
*TORQUE SPECIFICATIONS*

<b>DESCRIPTION</b>	<b>N-m</b>	<b>Ft. Lbs.</b>	<b>In. Lbs.</b>
Fitting, cooler line at trans	18	13	-
Bolt, torque convertor	31	-	270
Bolt, clevis bracket to crossmember	47	35	-
Bolt, clevis bracket to rear support	68	50	-
Bolt, driveplate to crankshaft	75	55	-
Plug, front band reaction	17	13	-
Locknut, front band adj.	34	25	-
Switch, park/neutral	34	25	-
Bolt, fluid pan	17	13	-
Screws, fluid filter	4	-	35
Bolt, oil pump	20	15	-
Bolt, overrunning clutch cam	17	13	-
Bolt, O/D to trans.	34	25	-
Bolt, O/D piston retainer	17	13	-
Plug, pressure test port	14	10	-
Bolt, reaction shaft support	20	15	-
Locknut, rear band	41	30	-
Bolt, valve body to case	12	-	100
Sensor, trans speed	27	20	-
Screw, solenoid wiring connector	4	-	35
Screw, solenoid to transfer plate	4	-	35

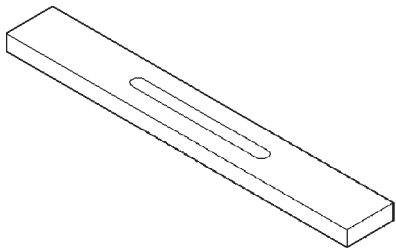
AUTOMATIC TRANSMISSION - 42RE (Continued)

SPECIAL TOOLS

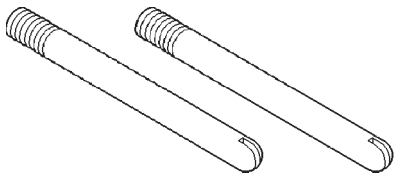
RE TRANSMISSIONS



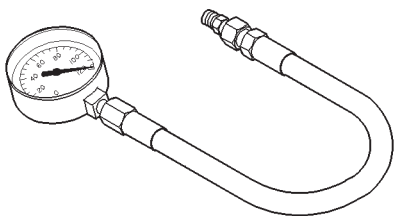
**Shaft, Spring Compressor and Alignment - 6227**



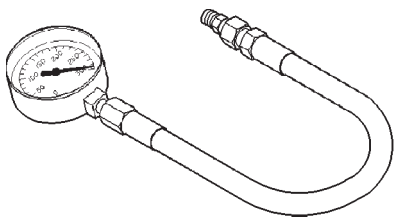
**Bar, Gauge - 6311**



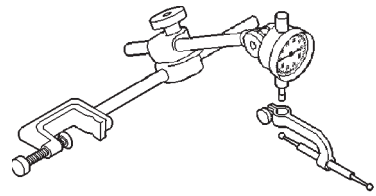
**Pilot, Extension Housing - C-3288-B**



**Gauge, Oil Pressure - C-3292**

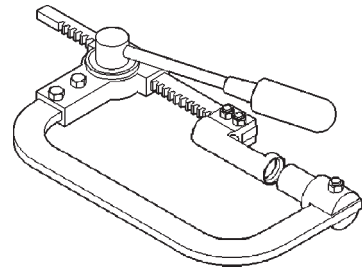


**Gauge, Oil Pressure - C-3293SP**

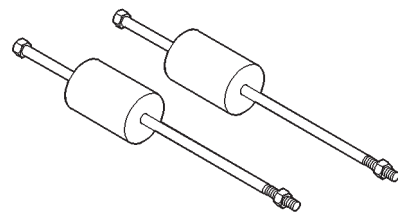


8011d42b

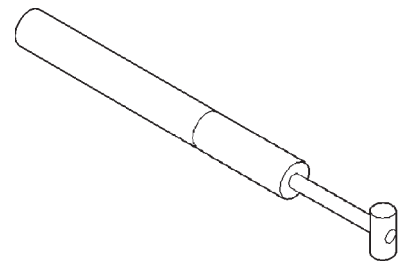
**Dial Indicator - C-3339**



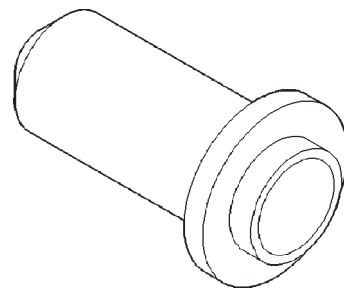
**Compressor, Spring - C-3422-C**



**Puller, Slide Hammer - C-3752**

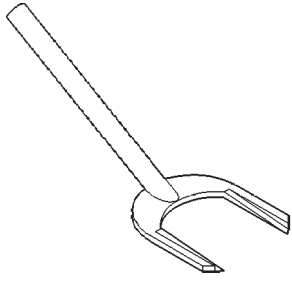


**Gauge, Throttle Setting - C-3763**

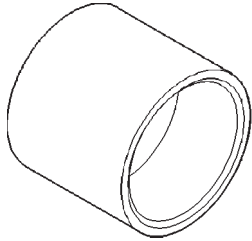


**Installer, Seal - C-3860-A**

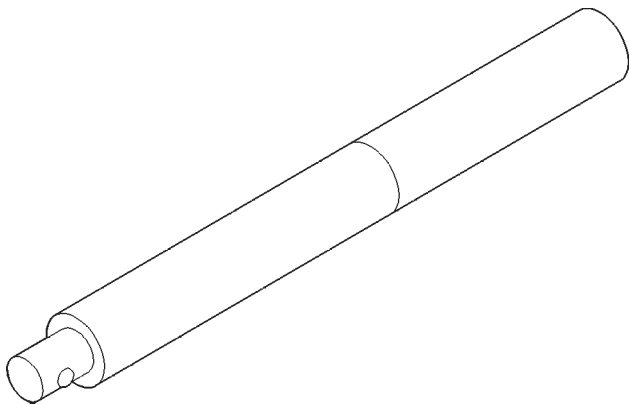
AUTOMATIC TRANSMISSION - 42RE (Continued)



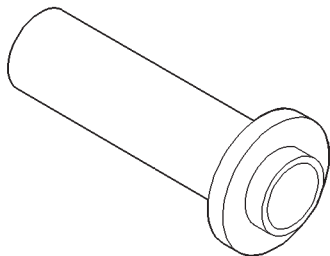
**Remover, Seal - C-3985-B**



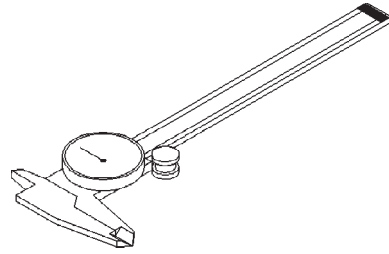
**Installer, Seal - C-3995-A**



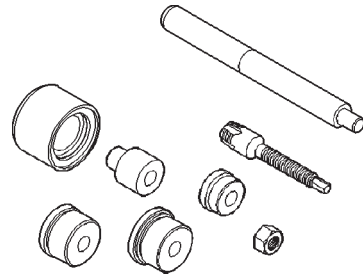
**Handle, Universal - C-4171**



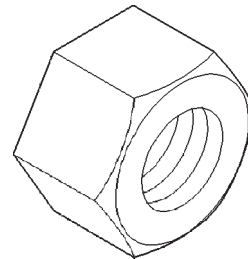
**Installer, Seal - C-4193-A**



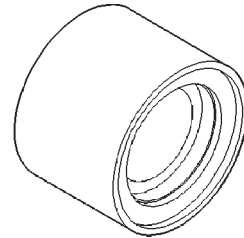
**Dial Caliper - C-4962**



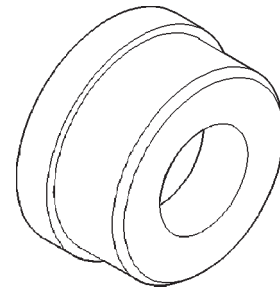
**Kit, Bushing Remover/Installer - C-3887-J**



**Nut, Bushing Remover - SP-1191, From kit C-3887-J**



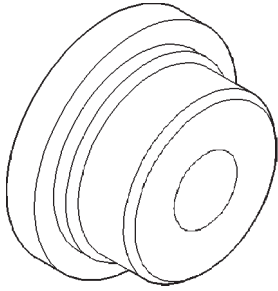
**Cup, Bushing Remover - SP-3633, From kit C-3887-J**



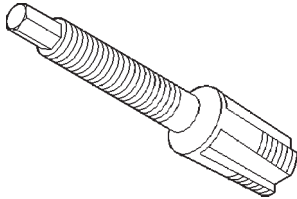
**Remover, Bushing - SP-3551**



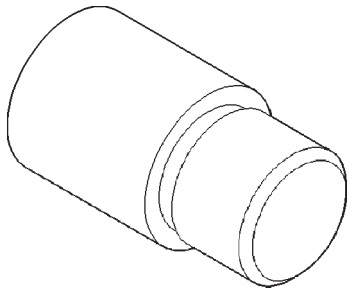
AUTOMATIC TRANSMISSION - 42RE (Continued)



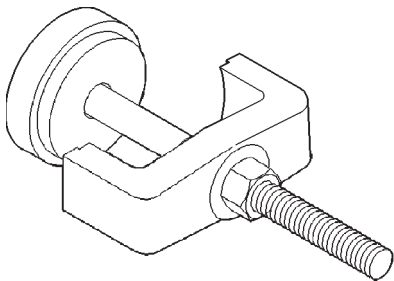
**Installer, Bushing - SP-5117**



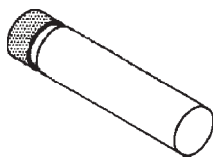
**Remover, Bushing - SP-5324**



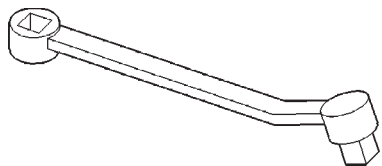
**Installer, Bushing - SP-5325**



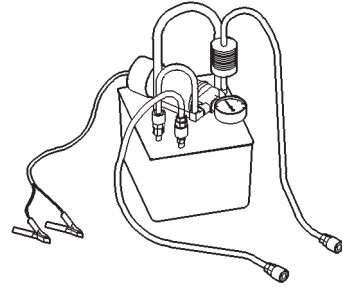
**Compressor, Spring - C-3575-A**



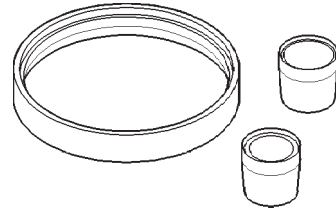
**Gauge - 6312**



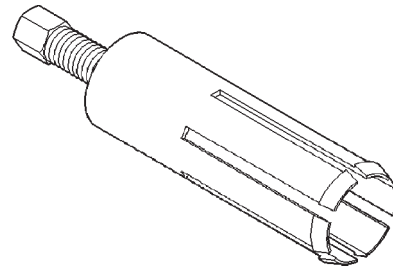
**Adapter, Band Adjuster - C-3705**



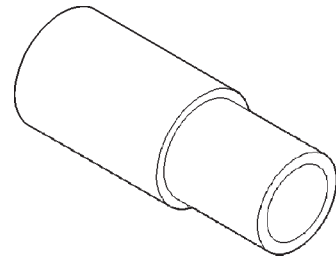
**Flusher, Oil Cooler - 6906-B**



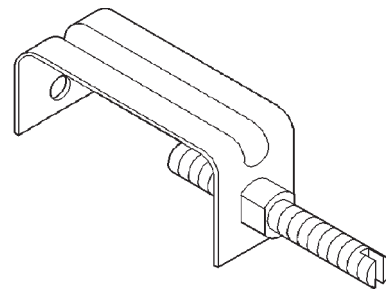
**Installer, Piston - 8114**



**Remover, Bushing - 6957**



**Installer, Bushing - 6951**

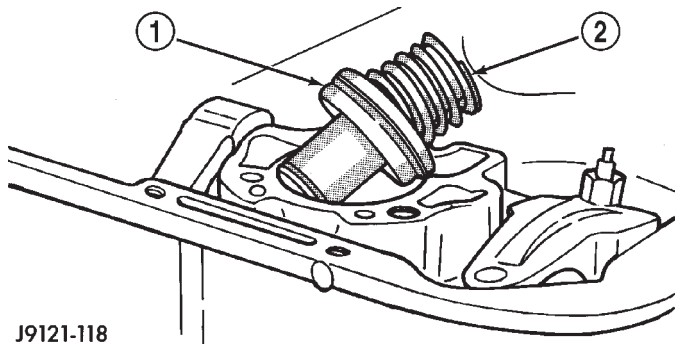


**Retainer, Detent Ball and Spring - 6583**

## ACCUMULATOR

### DESCRIPTION

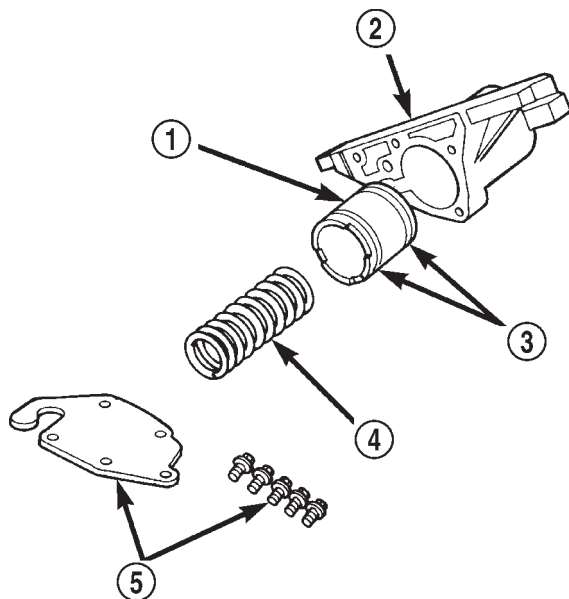
The accumulator (Fig. 57) is a hydraulic device that has the sole purpose of cushioning the application of a band or clutch. The accumulator consists of a dual-land piston and a spring located in a bore in the transmission case. The 3-4 accumulator is located in a housing attached to the side of the valve body (Fig. 58).



J9121-118

**Fig. 57 Accumulator**

- 1 - ACCUMULATOR PISTON
- 2 - PISTON SPRING



804d8eb9

**Fig. 58 3-4 Accumulator and Housing**

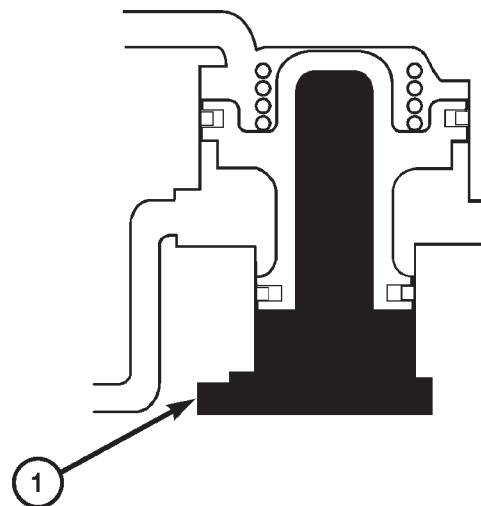
- 1 - ACCUMULATOR PISTON
- 2 - 3-4 ACCUMULATOR HOUSING
- 3 - TEFLON SEALS
- 4 - PISTON SPRING
- 5 - COVER PLATE AND SCREWS

### OPERATION

Both the accumulator and the 3-4 accumulator function the same. Line pressure is directed to the small end of the piston when the transmission is placed into a DRIVE position (Fig. 59), bottoming it against the accumulator plate. When the 1-2 upshift occurs (Fig. 60), line pressure is directed to the large end of the piston and then to the kickdown servo. As the line pressure reaches the accumulator, the combination of spring pressure and line pressure forces the piston away from the accumulator plate. This causes a balanced pressure situation, which results in a cushioned band application. After the kickdown servo has become immovable, line pressure will finish pushing the accumulator up into its bore. When the large end of the accumulator piston is seated in its bore, the band or clutch is fully applied.

**NOTE:** The accumulator is shown in the inverted position for illustrative purposes.

### BOTTOMED AGAINST ACCUMULATOR PLATE

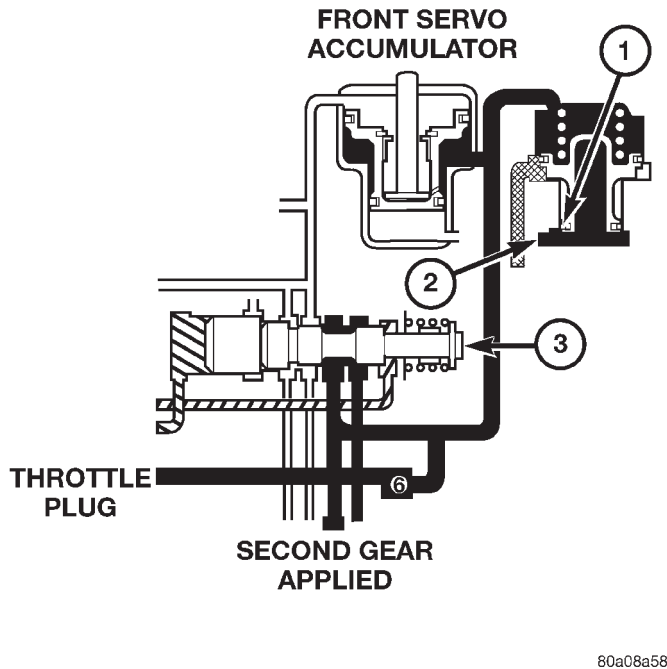


80a08a54

**Fig. 59 Accumulator in DRIVE - FIRST GEAR POSITION**

- 1 - LINE PRESSURE

ACCUMULATOR (Continued)



80a08a58

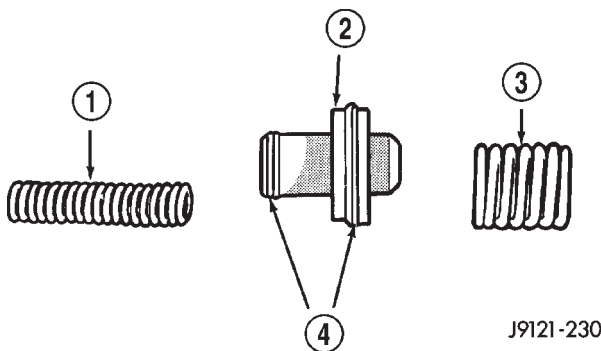
**Fig. 60 Accumulator in SECOND Gear Position**

- 1 - BOTTOM OF BORE
- 2 - LINE PRESSURE
- 3 - SHUTTLE VALVE

**INSPECTION**

Inspect the accumulator piston and seal rings (Fig. 61). Replace the seal rings if worn or cut. Replace the piston if chipped or cracked.

Check condition of the accumulator inner and outer springs (Fig. 61). Replace the springs if the coils are cracked, distorted or collapsed.



J9121-230

**Fig. 61 Accumulator Components**

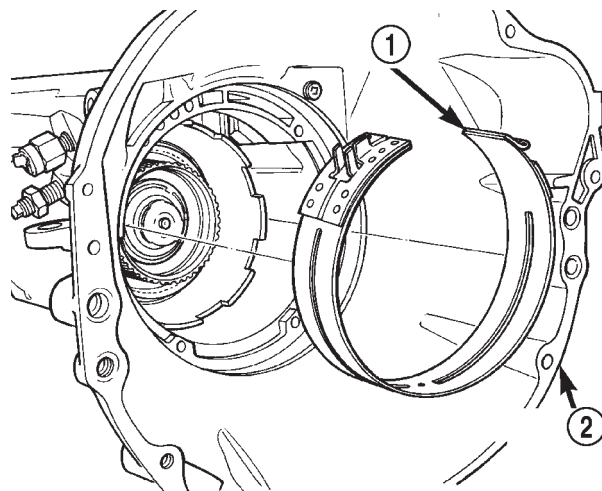
- 1 - INNER SPRING
- 2 - ACCUMULATOR PISTON
- 3 - OUTER SPRING
- 4 - SEAL RINGS

**BANDS**

**DESCRIPTION**

**KICKDOWN (FRONT) BAND**

The kickdown, or "front", band (Fig. 62) holds the common sun gear of the planetary gear sets. The front (kickdown) band is made of steel, and faced on its inner circumference with a friction-type lining. One end of the band is anchored to the transmission case, and the other is acted on with a pushing force by a servo piston. The front band is a single-wrap design (the band does not completely encompass/wrap the drum that it holds).



80a3b192

**Fig. 62 Front Band**

- 1 - FRONT BAND
- 2 - TRANSMISSION HOUSING

**LOW/REVERSE (REAR) BAND**

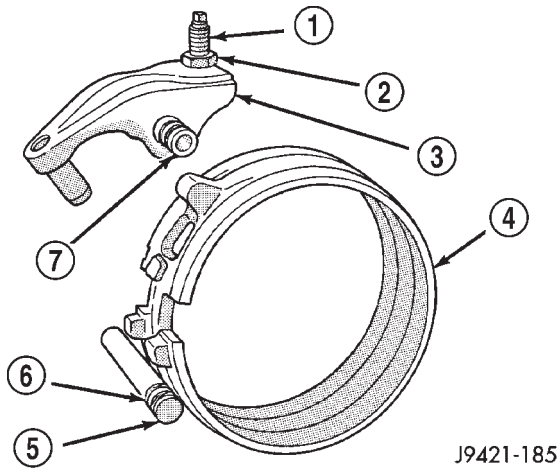
The low/reverse band, or "rear", band (Fig. 63) is similar in appearance and operation to the front band. The rear band is slightly different in that it does not use a link bar, but is acted directly on by the apply lever. This is referred to as a double-wrap band design (the drum is completely encompassed/wrapped by the band). The double-wrap band provides a greater holding power in comparison to the single-wrap design.

**OPERATION**

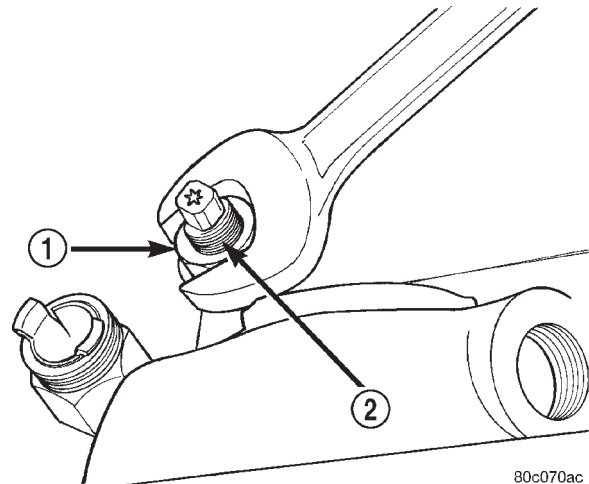
**KICKDOWN (FRONT) BAND**

The kickdown band holds the common sun gear of the planetary gear sets by applying and holding the front clutch retainer, which is splined to the sun gear driving shell, and in turn splined directly to the sun gear. The application of the band by the servo is typically done by an apply lever and link bar.

## BANDS (Continued)

**Fig. 63 Rear Band**

- 1 - ADJUSTING SCREW
- 2 - LOCKNUT
- 3 - LEVER
- 4 - REAR BAND
- 5 - REACTION PIN
- 6 - O-RINGS
- 7 - PIVOT PIN

**Fig. 64 Front Band Adjustment Screw Location**

- 1 - LOCK-NUT
- 2 - FRONT BAND ADJUSTER

**LOW/REVERSE (REAR) BAND**

The rear band holds the rear planet carrier stationary by being mounted around and applied to the low/reverse drum.

**ADJUSTMENT - BANDS****FRONT BAND**

The front (kickdown) band adjusting screw is located on the left side of the transmission case above the manual valve and throttle valve levers.

- (1) Raise vehicle.
- (2) Loosen band adjusting screw locknut (Fig. 64). Then back locknut off 3-5 turns. Be sure adjusting screw turns freely in case. Apply lubricant to screw threads if necessary.
- (3) Tighten band adjusting screw to 8 N·m (72 in. lbs.) torque with Inch Pound Torque Wrench C-3380-A, a 3-in. extension and appropriate Torx™ socket.

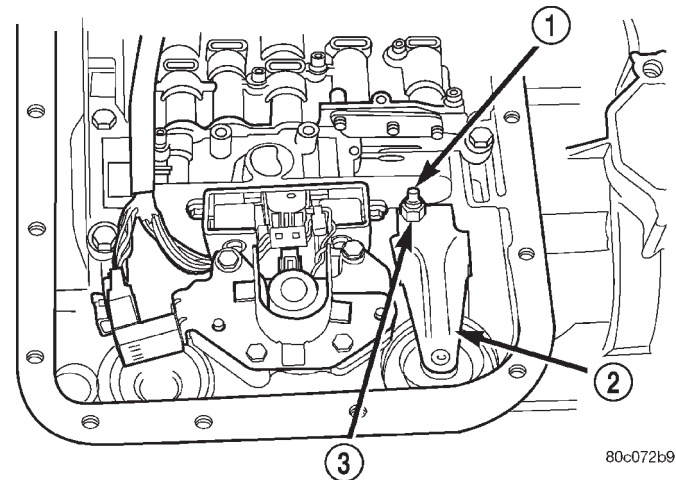
**CAUTION:** If Adapter C-3705 is needed to reach the adjusting screw, tighten the screw to only 5 N·m (47-50 in. lbs.) torque.

- (4) Back off front band adjusting screw 3 turns.
- (5) Hold adjuster screw in position and tighten locknut to 41 N·m (30 ft. lbs.) torque.
- (6) Lower vehicle.

**REAR BAND**

The transmission oil pan must be removed for access to the rear band adjusting screw.

- (1) Raise vehicle.
- (2) Remove transmission oil pan and drain fluid.
- (3) Loosen band adjusting screw locknut 5-6 turns (Fig. 65). Be sure adjusting screw turns freely in lever.
- (4) Tighten adjusting screw to 8 N·m (72 in. lbs.) torque.

**Fig. 65 Rear Band Adjusting Screw Location**

- 1 - ADJUSTING SCREW
- 2 - REAR BAND LEVER
- 3 - LOCKNUT

- (5) Back off adjusting screw 4 turns.
- (6) Hold adjusting screw in place and tighten locknut to 34 N·m (25 ft. lbs.) torque.

## BANDS (Continued)

(7) Position new gasket on oil pan and install pan on transmission. Tighten pan bolts to 17 N·m (13 ft. lbs.) torque.

(8) Lower vehicle and refill transmission with Mopar® ATF +4, type 9602, fluid.

## ELECTRONIC GOVERNOR

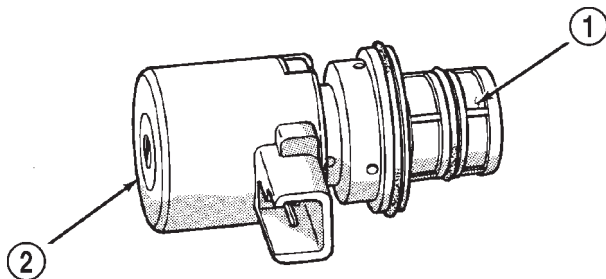
## DESCRIPTION

Governor pressure is controlled electronically. Components used for governor pressure control include:

- Governor body
- Valve body transfer plate
- Governor pressure solenoid valve
- Governor pressure sensor
- Fluid temperature thermistor
- Throttle position sensor (TPS)
- Transmission speed sensor
- Powertrain control module (PCM)

## GOVERNOR PRESSURE SOLENOID VALVE

The solenoid valve is a duty-cycle solenoid which regulates the governor pressure needed for upshifts and downshifts. It is an electro-hydraulic device located in the governor body on the valve body transfer plate (Fig. 66).



J9321-408A

**Fig. 66 Governor Pressure Solenoid Valve**

- 1 - SOLENOID FILTER  
2 - GOVERNOR PRESSURE SOLENOID

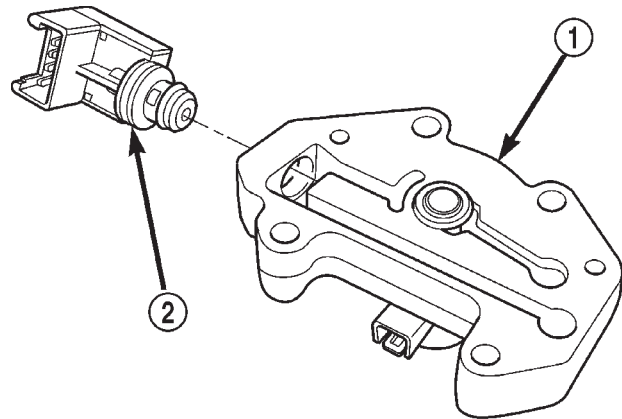
## GOVERNOR PRESSURE SENSOR

The governor pressure sensor measures output pressure of the governor pressure solenoid valve (Fig. 67).

## GOVERNOR BODY AND TRANSFER PLATE

The transfer plate is designed to supply transmission line pressure to the governor pressure solenoid valve and to return governor pressure.

The governor pressure solenoid valve is mounted in the governor body. The body is bolted to the lower side of the transfer plate (Fig. 67).



80c072af

**Fig. 67 Governor Pressure Sensor**

- 1 - GOVERNOR BODY  
2 - GOVERNOR PRESSURE SENSOR/TRANSMISSION FLUID TEMPERATURE THERMISTOR

## GOVERNOR PRESSURE CURVES

There are four governor pressure curves programmed into the transmission control module. The different curves allow the control module to adjust governor pressure for varying conditions. One curve is used for operation when fluid temperature is at, or below,  $-1^{\circ}\text{C}$  ( $30^{\circ}\text{F}$ ). A second curve is used when fluid temperature is at, or above,  $10^{\circ}\text{C}$  ( $50^{\circ}\text{F}$ ) during normal city or highway driving. A third curve is used during wide-open throttle operation. The fourth curve is used when driving with the transfer case in low range.

## OPERATION

Compensation is required for performance variations of two of the input devices. Though the slope of the transfer functions is tightly controlled, offset may vary due to various environmental factors or manufacturing tolerances.

The pressure transducer is affected by barometric pressure as well as temperature. Calibration of the zero pressure offset is required to compensate for shifting output due to these factors.

Normal calibration will be performed when sump temperature is above 50 degrees F, or in the absence of sump temperature data, after the first 10 minutes of vehicle operation. Calibration of the pressure transducer offset occurs each time the output shaft speed falls below 200 RPM. Calibration shall be repeated each 3 seconds the output shaft speed is below 200 RPM. A 0.5 second pulse of 95% duty cycle is applied to the governor pressure solenoid valve and the transducer output is read during this pulse. Averaging of the transducer signal is necessary to reject electrical noise.



## ELECTRONIC GOVERNOR (Continued)

Under cold conditions (below 50 degrees F sump), the governor pressure solenoid valve response may be too slow to guarantee 0 psi during the 0.5 second calibration pulse. Calibration pulses are continued during this period, however the transducer output valves are discarded. Transducer offset must be read at key-on, under conditions which promote a stable reading. This value is retained and becomes the offset during the "cold" period of operation.

### GOVERNOR PRESSURE SOLENOID VALVE

The inlet side of the solenoid valve is exposed to normal transmission line pressure. The outlet side of the valve leads to the valve body governor circuit.

The solenoid valve regulates line pressure to produce governor pressure. The average current supplied to the solenoid controls governor pressure. One amp current produces zero kPa/psi governor pressure. Zero amps sets the maximum governor pressure.

The powertrain control module (PCM) turns on the trans control relay which supplies electrical power to the solenoid valve. Operating voltage is 12 volts (DC). The PCM controls the ground side of the solenoid using the governor pressure solenoid control circuit.

### GOVERNOR PRESSURE SENSOR

The sensor output signal provides the necessary feedback to the PCM. This feedback is needed to adequately control governor pressure.

### GOVERNOR BODY AND TRANSFER PLATE

The transfer plate channels line pressure to the solenoid valve through the governor body. It also channels governor pressure from the solenoid valve to the governor circuit. It is the solenoid valve that develops the necessary governor pressure.

### GOVERNOR PRESSURE CURVES

#### LOW TRANSMISSION FLUID TEMPERATURE

When the transmission fluid is cold the conventional governor can delay shifts, resulting in higher than normal shift speeds and harsh shifts. The electronically controlled low temperature governor pressure curve is higher than normal to make the transmission shift at normal speeds and sooner. The PCM uses a temperature sensor in the transmission oil sump to determine when low temperature governor pressure is needed.

### NORMAL OPERATION

Normal operation is refined through the increased computing power of the PCM and through access to data on engine operating conditions provided by the PCM that were not available with the previous stand-alone electronic module. This facilitated the development of a load adaptive shift strategy - the ability to alter the shift schedule in response to vehicle load condition. One manifestation of this capability is grade "hunting" prevention - the ability of the transmission logic to delay an upshift on a grade if the engine does not have sufficient power to maintain speed in the higher gear. The 3-2 downshift and the potential for hunting between gears occurs with a heavily loaded vehicle or on steep grades. When hunting occurs, it is very objectionable because shifts are frequent and accompanied by large changes in noise and acceleration.

### WIDE OPEN THROTTLE OPERATION

In wide-open throttle (WOT) mode, adaptive memory in the PCM assures that up-shifts occur at the preprogrammed optimum speed. WOT operation is determined from the throttle position sensor, which is also a part of the emission control system. The initial setting for the WOT upshift is below the optimum engine speed. As WOT shifts are repeated, the PCM learns the time required to complete the shifts by comparing the engine speed when the shifts occur to the optimum speed. After each shift, the PCM adjusts the shift point until the optimum speed is reached. The PCM also considers vehicle loading, grade and engine performance changes due to high altitude in determining when to make WOT shifts. It does this by measuring vehicle and engine acceleration and then factoring in the shift time.

### TRANSFER CASE LOW RANGE OPERATION

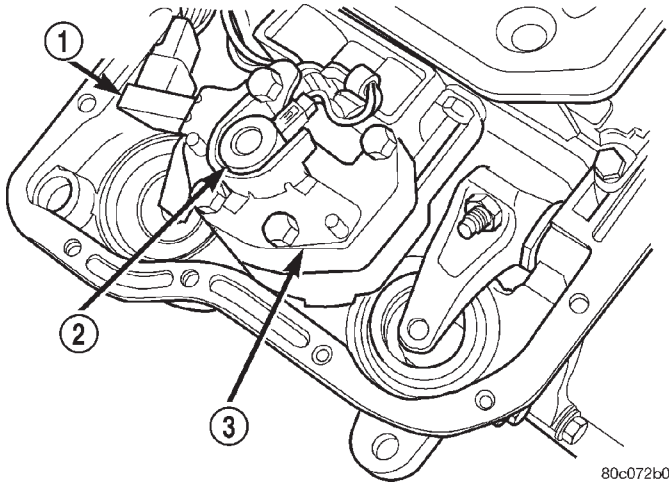
On four-wheel drive vehicles operating in low range, the engine can accelerate to its peak more rapidly than in Normal range, resulting in delayed shifts and undesirable engine "flare." The low range governor pressure curve is also higher than normal to initiate upshifts sooner. The PCM compares electronic vehicle speed signal used by the speedometer to the transmission output shaft speed signal to determine when the transfer case is in low range.



ELECTRONIC GOVERNOR (Continued)

**REMOVAL**

- (1) Hoist and support vehicle on safety stands.
- (2) Remove transmission fluid pan and filter.
- (3) Disengage wire connectors from pressure sensor and solenoid (Fig. 68).

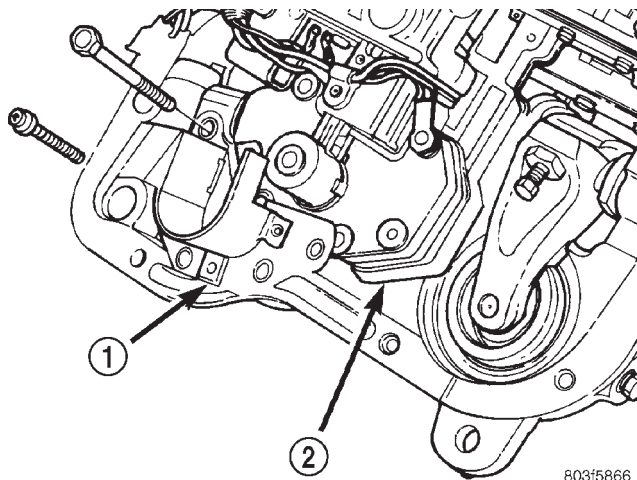


80c072b0

**Fig. 68 Governor Solenoid And Pressure Sensor**

- 1 - PRESSURE SENSOR
- 2 - PRESSURE SOLENOID
- 3 - GOVERNOR

- (4) Remove screws holding pressure solenoid retainer to governor body.
- (5) Separate solenoid retainer from governor (Fig. 69).

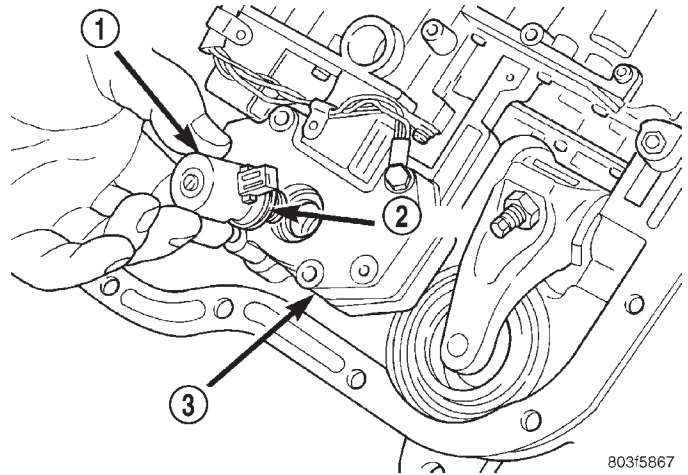


803f5866

**Fig. 69 Pressure Solenoid Retainer**

- 1 - PRESSURE SOLENOID RETAINER
- 2 - GOVERNOR

- (6) Pull solenoid from governor body (Fig. 70).
- (7) Pull pressure sensor from governor body.
- (8) Remove bolts holding governor body to valve body.

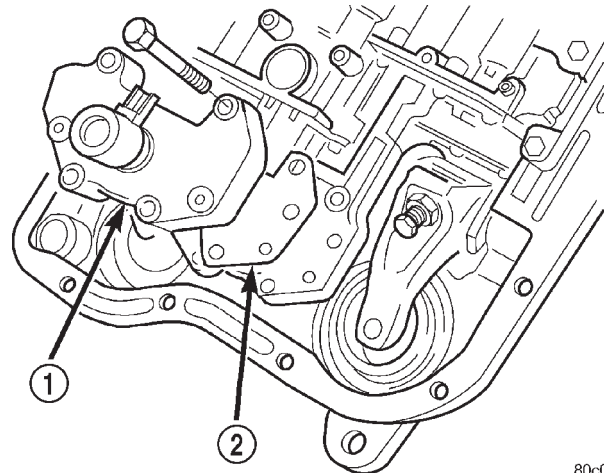


803f5867

**Fig. 70 Pressure Solenoid and O-ring**

- 1 - PRESSURE SOLENOID
- 2 - O-RING
- 3 - GOVERNOR

- (9) Separate governor body from valve body (Fig. 71).
- (10) Remove governor body gasket.



80c072b1

**Fig. 71 Governor Body and Gasket**

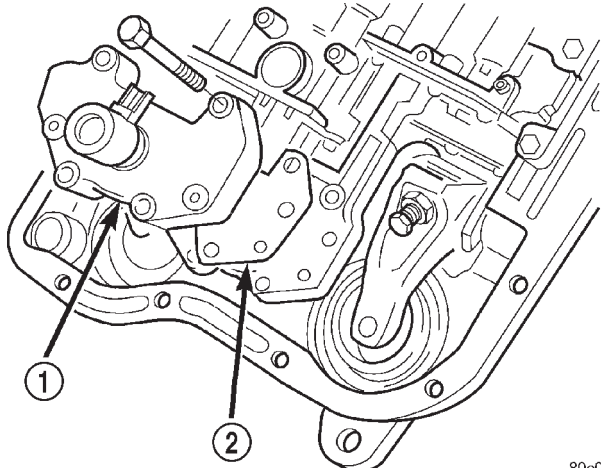
- 1 - GOVERNOR BODY
- 2 - GASKET

## ELECTRONIC GOVERNOR (Continued)

**INSTALLATION**

Before installing the pressure sensor and solenoid in the governor body, replace o-ring seals, clean the gasket surfaces and replace gasket.

- (1) Place gasket in position on back of governor body (Fig. 72).
- (2) Place governor body in position on valve body.
- (3) Install bolts to hold governor body to valve body.



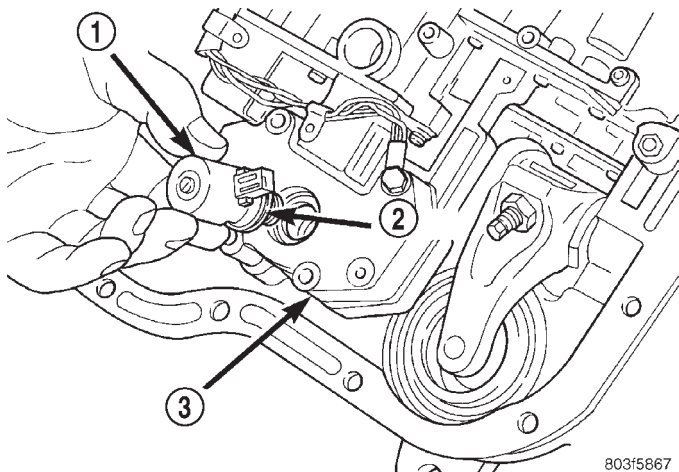
**Fig. 72 Governor Body and Gasket**

80c072b1

- 1 - GOVERNOR BODY
- 2 - GASKET

(4) Lubricate o-ring on pressure sensor with transmission fluid.

- (5) Align pressure sensor to bore in governor body.
- (6) Push pressure sensor into governor body.
- (7) Lubricate o-ring, on pressure solenoid, with transmission fluid.
- (8) Align pressure solenoid to bore in governor body (Fig. 73).

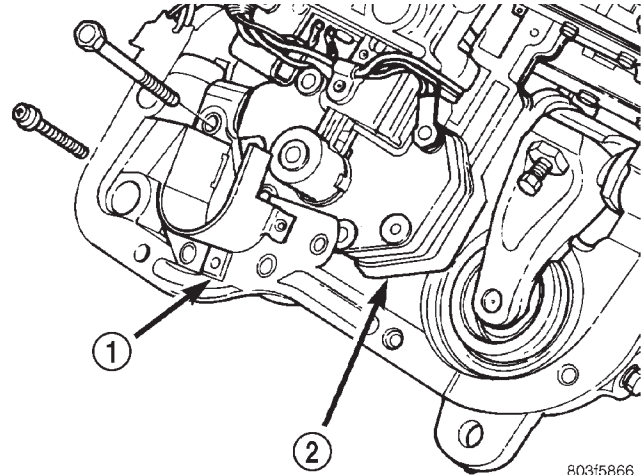


**Fig. 73 Pressure Solenoid and O-ring**

803f5867

- 1 - PRESSURE SOLENOID
- 2 - O-RING
- 3 - GOVERNOR

- (9) Push solenoid into governor body.
- (10) Place solenoid retainer in position on governor (Fig. 74).
- (11) Install screws to hold pressure solenoid retainer to governor body.



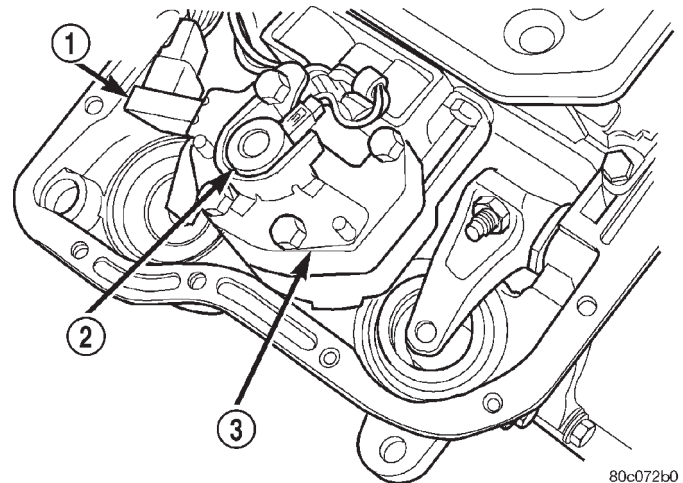
803f5866

**Fig. 74 Pressure Solenoid Retainer**

- 1 - PRESSURE SOLENOID RETAINER
- 2 - GOVERNOR

(12) Engage wire connectors into pressure sensor and solenoid (Fig. 75).

- (13) Install transmission fluid pan and (new) filter.
- (14) Lower vehicle and road test to verify repair.



80c072b0

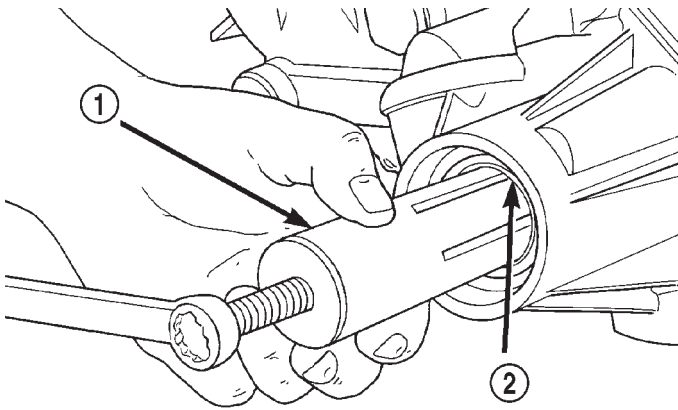
**Fig. 75 Governor Solenoid And Pressure Sensor**

- 1 - PRESSURE SENSOR
- 2 - PRESSURE SOLENOID
- 3 - GOVERNOR

## EXTENSION HOUSING BUSHING

### REMOVAL

- (1) Remove extension housing yoke seal.
- (2) Insert Remover 6957 into the extension housing. Tighten tool to bushing and remove bushing (Fig. 76).



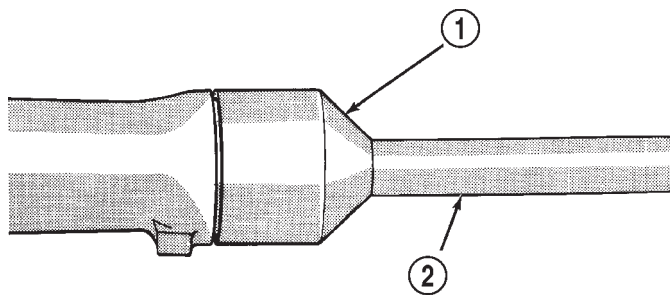
80a11095

**Fig. 76 Bushing Removal - Typical**

- 1 - REMOVER
- 2 - EXTENSION HOUSING BUSHING

### INSTALLATION

- (1) Align bushing oil hole with oil slot in extension housing.
- (2) Tap bushing into place with Installer 6951 and Handle C-4171.
- (3) Install new oil seal in housing using Seal Installer C-3995-A (Fig. 77).



J9521-58

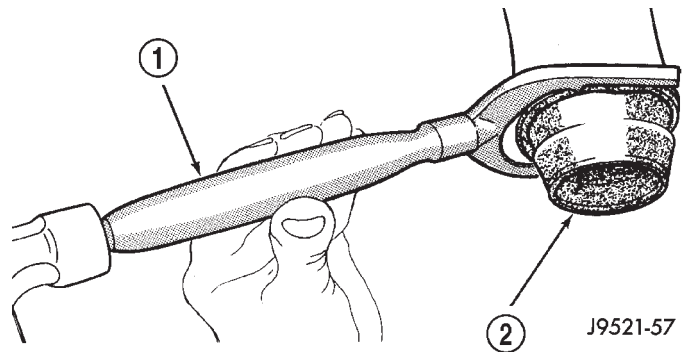
**Fig. 77 Extension Housing Seal Installation**

- 1 - SPECIAL TOOL C-3995-A OR C-3972-A
- 2 - SPECIAL TOOL C-4471

## EXTENSION HOUSING SEAL

### REMOVAL

- (1) Raise vehicle.
- (2) Mark propeller shaft and axle yoke for alignment reference.
- (3) Disconnect and remove propeller shaft.
- (4) Remove old seal with Seal Remover C-3985-B (Fig. 78) from overdrive housing.



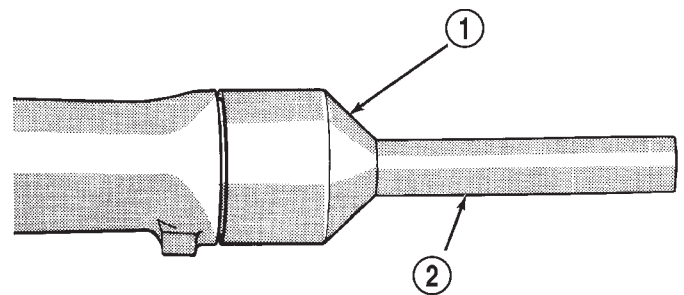
J9521-57

**Fig. 78 Removing Overdrive Housing Yoke Seal**

- 1 - SPECIAL TOOL C-3985-B
- 2 - SEAL

### INSTALLATION

- (1) Place seal in position on overdrive housing.
- (2) Drive seal into overdrive housing with Seal Installer C-3995-A (Fig. 79).
- (3) Carefully guide propeller shaft slip yoke into housing and onto output shaft splines. Align marks made at removal and connect propeller shaft to rear axle pinion yoke.



J9521-58

**Fig. 79 Installing Overdrive Housing Seal**

- 1 - SPECIAL TOOL C-3995-A OR C-3972-A
- 2 - SPECIAL TOOL C-4471

## FLUID AND FILTER

### DIAGNOSIS AND TESTING - EFFECTS OF INCORRECT FLUID LEVEL

A low fluid level allows the pump to take in air along with the fluid. Air in the fluid will cause fluid pressures to be low and develop slower than normal. If the transmission is overfilled, the gears churn the fluid into foam. This aerates the fluid and causing the same conditions occurring with a low level. In either case, air bubbles cause fluid overheating, oxidation and varnish buildup which interferes with valve and clutch operation. Foaming also causes fluid expansion which can result in fluid overflow from the transmission vent or fill tube. Fluid overflow can easily be mistaken for a leak if inspection is not careful.

### DIAGNOSIS AND TESTING - CAUSES OF BURNT FLUID

Burnt, discolored fluid is a result of overheating which has two primary causes.

(1) A result of restricted fluid flow through the main and/or auxiliary cooler. This condition is usually the result of a faulty or improperly installed drainback valve, a damaged main cooler, or severe restrictions in the coolers and lines caused by debris or kinked lines.

(2) Heavy duty operation with a vehicle not properly equipped for this type of operation. Trailer towing or similar high load operation will overheat the transmission fluid if the vehicle is improperly equipped. Such vehicles should have an auxiliary transmission fluid cooler, a heavy duty cooling system, and the engine/axle ratio combination needed to handle heavy loads.

### DIAGNOSIS AND TESTING - FLUID CONTAMINATION

Transmission fluid contamination is generally a result of:

- adding incorrect fluid
- failure to clean dipstick and fill tube when checking level
- engine coolant entering the fluid
- internal failure that generates debris
- overheat that generates sludge (fluid breakdown)
- failure to reverse flush cooler and lines after repair
- failure to replace contaminated converter after repair

The use of non-recommended fluids can result in transmission failure. The usual results are erratic shifts, slippage, abnormal wear and eventual failure due to fluid breakdown and sludge formation. Avoid this condition by using recommended fluids only.

The dipstick cap and fill tube should be wiped clean before checking fluid level. Dirt, grease and other foreign material on the cap and tube could fall into the tube if not removed beforehand. Take the time to wipe the cap and tube clean before withdrawing the dipstick.

Engine coolant in the transmission fluid is generally caused by a cooler malfunction. The only remedy is to replace the radiator as the cooler in the radiator is not a serviceable part. If coolant has circulated through the transmission, an overhaul is necessary.

The transmission cooler and lines should be reverse flushed whenever a malfunction generates sludge and/or debris. The torque converter should also be replaced at the same time.

Failure to flush the cooler and lines will result in recontamination. Flushing applies to auxiliary coolers as well. The torque converter should also be replaced whenever a failure generates sludge and debris. This is necessary because normal converter flushing procedures will not remove all contaminants.

### STANDARD PROCEDURE - FLUID LEVEL CHECK

Low fluid level can cause a variety of conditions because it allows the pump to take in air along with the fluid. As in any hydraulic system, air bubbles make the fluid spongy, therefore, pressures will be low and build up slowly.

Improper filling can also raise the fluid level too high. When the transmission has too much fluid, the geartrain churns up foam and cause the same conditions which occur with a low fluid level.

In either case, air bubbles can cause overheating and/or fluid oxidation, and varnishing. This can interfere with normal valve, clutch, and accumulator operation. Foaming can also result in fluid escaping from the transmission vent where it may be mistaken for a leak.

Along with fluid level, it is important to check the condition of the fluid. When the fluid smells burned, and is contaminated with metal or friction material particles, a complete transmission recondition is needed. Be sure to examine the fluid on the dipstick closely. If there is any doubt about its condition, drain out a sample for a double check.

After the fluid has been checked, seat the dipstick fully to seal out water and dirt.

The transmission has a dipstick to check oil level. It is located on the right side of the engine. Be sure to wipe all dirt from dipstick handle before removing.

Fluid level is checked with the engine running at curb idle speed, the transmission in NEUTRAL and the transmission fluid at normal operating temperature. **The engine should be running at idle speed for at least one minute, with the vehicle on level ground.**

The transmission fluid level can be checked two ways.



FLUID AND FILTER (Continued)

**PROCEDURE ONE**

(1) Transmission fluid must be at normal operating temperature for accurate fluid level check. Drive vehicle if necessary to bring fluid temperature up to normal hot operating temperature of 82°C (180°F).

(2) Position vehicle on level surface.

(3) Start and run engine at curb idle speed.

(4) Apply parking brakes.

(5) Shift transmission momentarily into all gear ranges. Then shift transmission back to NEUTRAL.

(6) Clean top of filler tube and dipstick to keep dirt from entering tube.

(7) Remove dipstick (Fig. 80) and check fluid level as follows:

(a) Correct acceptable level is in crosshatch area.

(b) Correct maximum level is to MAX arrow mark.

(c) Incorrect level is at or below MIN line.

(d) If fluid is low, add only enough Mopar® ATF +4, type 9602, to restore correct level. Do not over-fill.

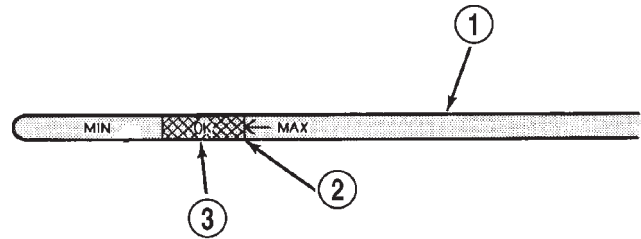
**PROCEDURE TWO**

(1) Start engine and apply parking brake.

(2) Shift the transmission into DRIVE for approximately 2 seconds.

(3) Shift the transmission into REVERSE for approximately 2 seconds.

(4) Shift the transmission into PARK.



804d8ede

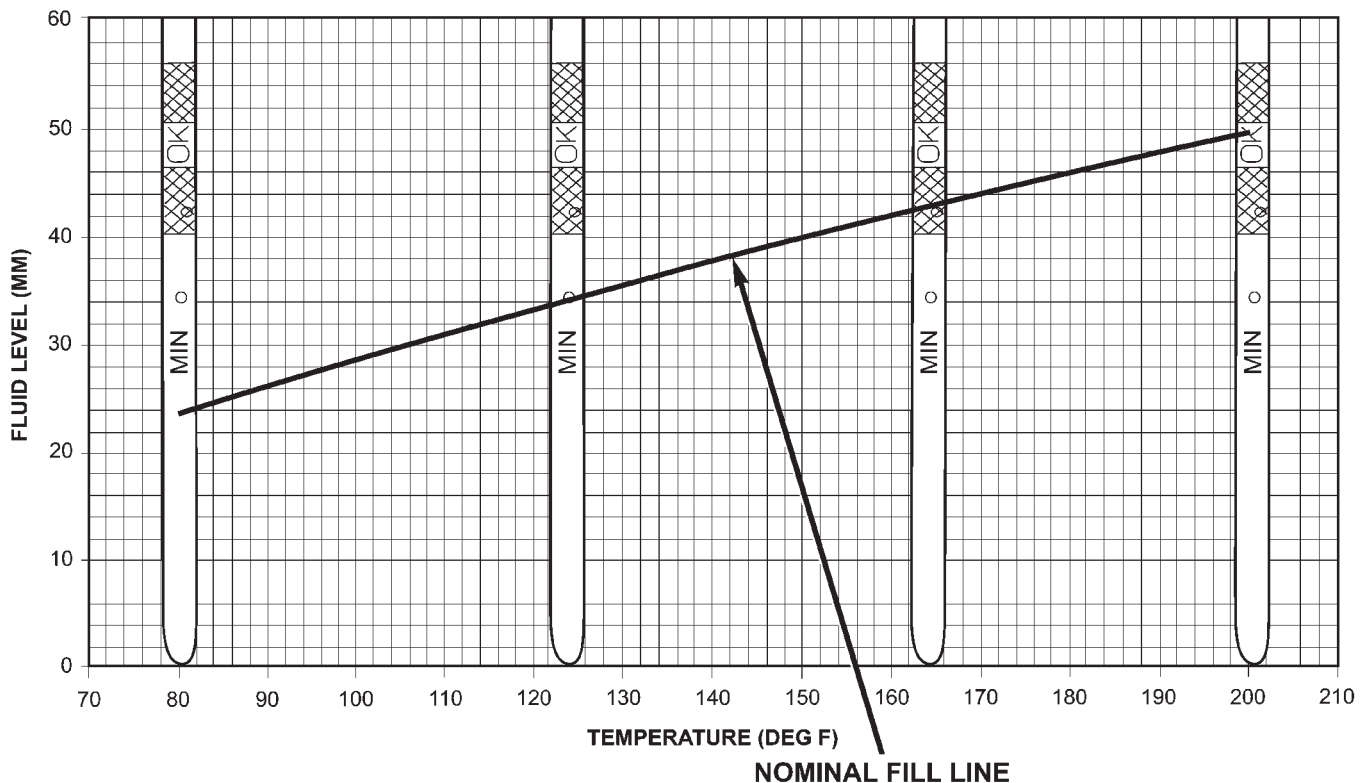
**Fig. 80 Dipstick Fluid Level Marks - Typical**

- 1 - DIPSTICK
- 2 - MAXIMUM CORRECT FLUID LEVEL
- 3 - ACCEPTABLE FLUID LEVEL

- (5) Hook up DRB® scan tool and select engine.
- (6) Select sensors.
- (7) Read the transmission temperature value.
- (8) Compare the fluid temperature value with the figure. (Fig. 81)
- (9) Adjust transmission fluid level shown on the dipstick according to the figure.

**NOTE:** After adding any fluid to the transmission, wait a minimum of 2 minutes for the oil to fully drain from the fill tube into the transmission before rechecking the fluid level.

(10) Check transmission for leaks.



**Fig. 81 42/44RE Fluid Fill Graph**

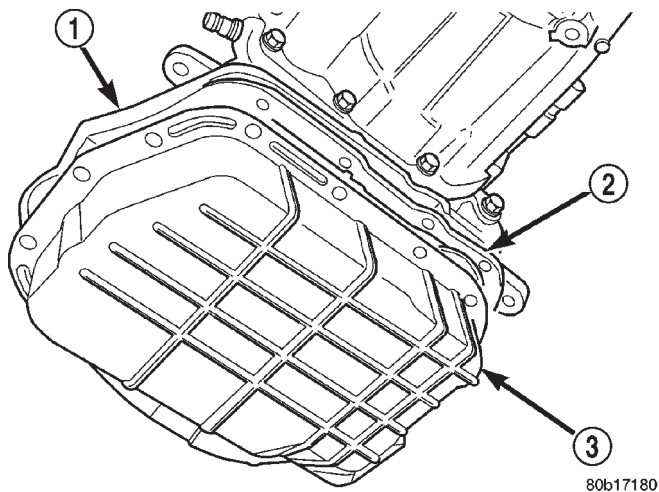
80a3fbfa

## FLUID AND FILTER (Continued)

**STANDARD PROCEDURE - FLUID AND FILTER REPLACEMENT**

For proper service intervals (Refer to LUBRICATION & MAINTENANCE/MAINTENANCE SCHEDULES - DESCRIPTION). The service fluid fill after a filter change is approximately 3.8 liters (4.0 quarts).

- (1) Hoist and support vehicle on safety stands.
- (2) Place a large diameter shallow drain pan beneath the transmission pan.
- (3) Remove bolts holding front and sides of pan to transmission (Fig. 82).
- (4) Loosen bolts holding rear of pan to transmission.
- (5) Slowly separate front of pan away from transmission allowing the fluid to drain into drain pan.
- (6) Hold up pan and remove remaining bolt holding pan to transmission.
- (7) While holding pan level, lower pan away from transmission.
- (8) Pour remaining fluid in pan into drain pan.
- (9) Remove screws holding filter to valve body (Fig. 83).
- (10) Separate filter from valve body and pour fluid in filter into drain pan.
- (11) Dispose of used trans fluid and filter properly.

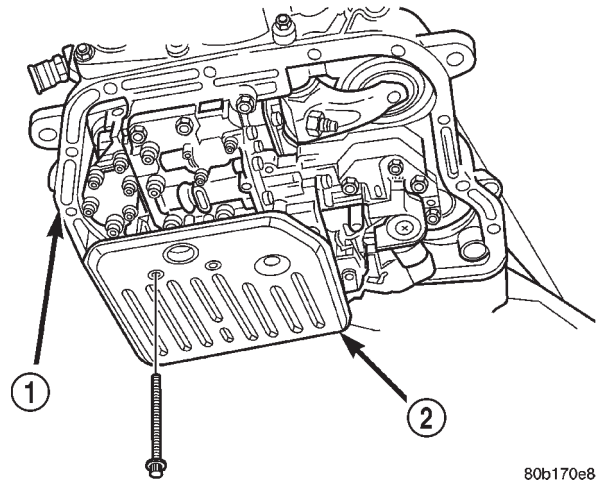
**Fig. 82 Transmission Pan**

- 1 - TRANSMISSION  
2 - GASKET  
3 - PAN

**STANDARD PROCEDURE - TRANSMISSION FILL**

To avoid overfilling transmission after a fluid change or overhaul, perform the following procedure:

- (1) Remove dipstick and insert clean funnel in transmission fill tube.
- (2) Add following initial quantity of Mopar® ATF +4, type 9602, to transmission:



80b170e8

**Fig. 83 Transmission Filter**

- 1 - TRANSMISSION  
2 - FILTER

(a) If only fluid and filter were changed, add **3 pints (1-1/2 quarts)** of ATF +4 to transmission.

(b) If transmission was completely overhauled, torque converter was replaced or drained, and cooler was flushed, add **12 pints (6 quarts)** of ATF +4 to transmission.

- (3) Apply parking brakes.
- (4) Start and run engine at normal curb idle speed.
- (5) Apply service brakes, shift transmission through all gear ranges then back to NEUTRAL, set parking brake, and leave engine running at curb idle speed.
- (6) Remove funnel, insert dipstick and check fluid level. If level is low, **add fluid to bring level to MIN mark on dipstick**. Check to see if the oil level is equal on both sides of the dipstick. If one side is noticeably higher than the other, the dipstick has picked up some oil from the dipstick tube. Allow the oil to drain down the dipstick tube and re-check.
- (7) Drive vehicle until transmission fluid is at normal operating temperature.
- (8) With the engine running at curb idle speed, the gear selector in NEUTRAL, and the parking brake applied, check the transmission fluid level.

**CAUTION: Do not overfill transmission, fluid foaming and shifting problems can result.**

(9) Add fluid to bring level up to MAX arrow mark.

When fluid level is correct, shut engine off, release park brake, remove funnel, and install dipstick in fill tube.



## FRONT CLUTCH

### DESCRIPTION

The front clutch assembly (Fig. 84) is composed of the front clutch retainer, pressure plate, clutch plates, driving discs, piston, piston return spring, return spring retainer, and snap-rings. The front clutch is the forward-most component in the transmission geartrain and is directly behind the oil pump and is considered a driving component.

**NOTE:** The number of discs and plates may vary with each engine and vehicle combination.

### OPERATION

To apply the clutch, pressure is applied between the clutch retainer and piston. The fluid pressure is provided by the oil pump, transferred through the control valves and passageways, and enters the clutch through the hub of the reaction shaft support. With pressure applied between the clutch retainer and piston, the piston moves away from the clutch retainer and compresses the clutch pack. This action applies the clutch pack, allowing torque to flow through the input shaft into the driving discs, and into the clutch plates and pressure plate that are lugged to the clutch retainer. The waved snap-ring is used to cushion the application of the clutch pack.

When pressure is released from the piston, the spring returns the piston to its fully released position and disengages the clutch. The release spring also helps to cushion the application of the clutch assembly. When the clutch is in the process of being released by the release spring, fluid flows through a vent and one-way ball-check-valve located in the clutch retainer. The check-valve is needed to eliminate the possibility of plate drag caused by centrifugal force acting on the residual fluid trapped in the clutch piston retainer.

### DISASSEMBLY

(1) Remove waved snap-ring and remove pressure plate, clutch plates and clutch discs (Fig. 85).

(2) Compress clutch piston spring with Compressor Tool C-3575-A (Fig. 86). Be sure legs of tool are seated squarely on spring retainer before compressing spring.

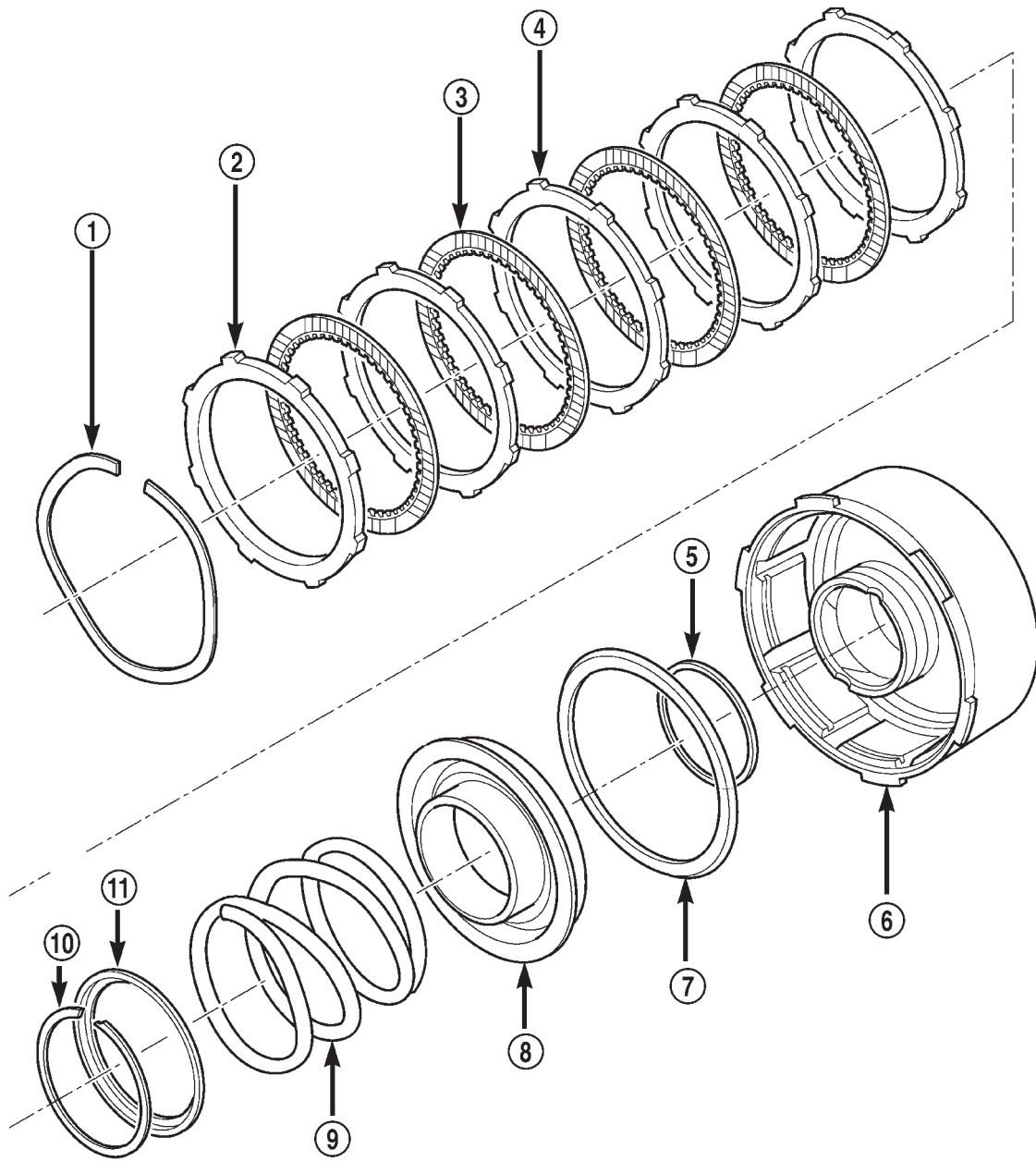
(3) Remove retainer snap-ring and remove compressor tool.

(4) Remove spring retainer and clutch spring. Note position of retainer on spring for assembly reference.

(5) Remove clutch piston from clutch retainer. Remove piston by rotating it up and out of retainer.

(6) Remove seals from clutch retainer piston bore and clutch retainer hub. Discard both seals as they are not reusable.

FRONT CLUTCH (Continued)



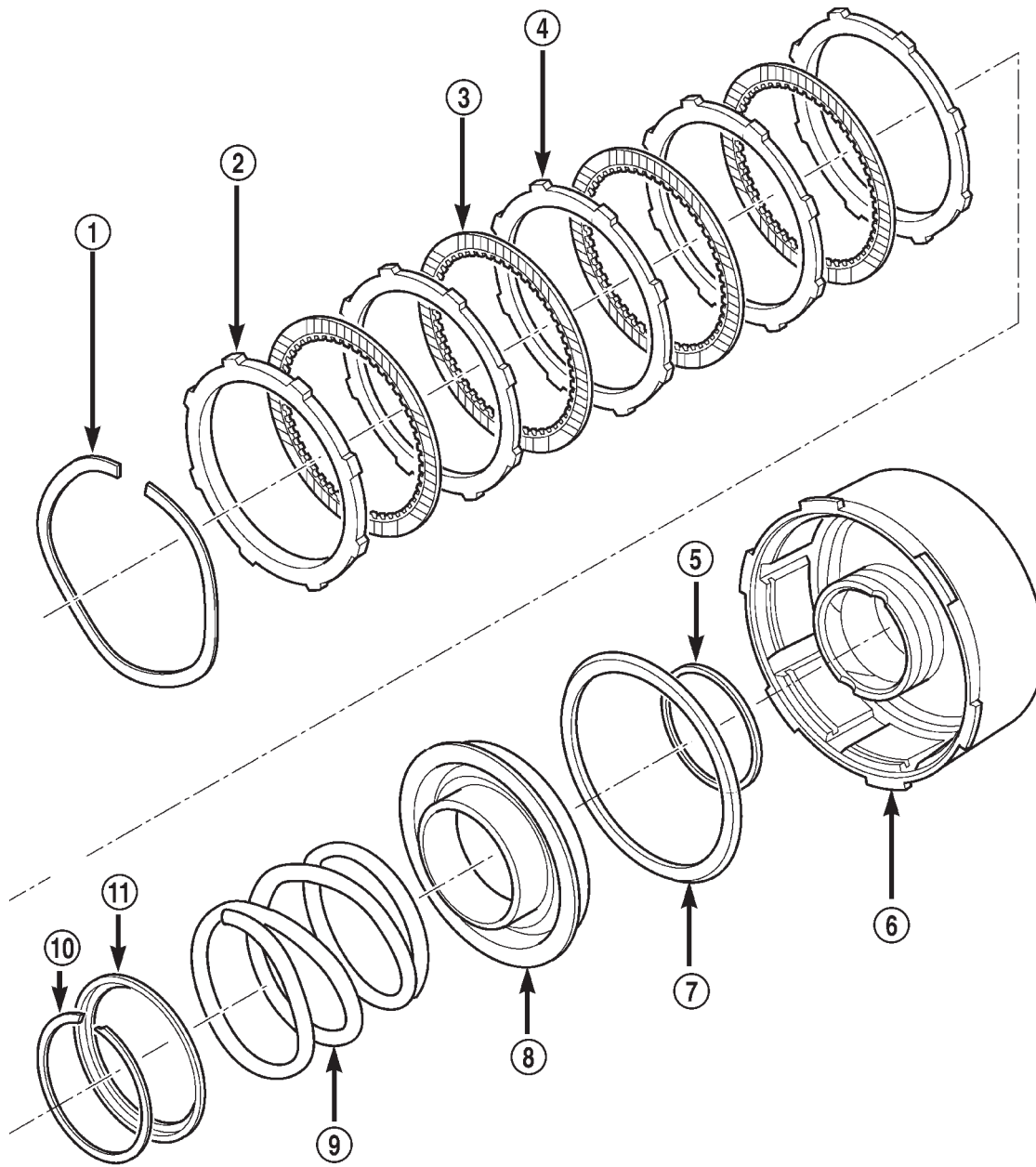
80bdbd40

**Fig. 84 Front Clutch Components**

- 1 - SNAP-RING (WAVE)
- 2 - REACTION PLATE
- 3 - CLUTCH DISC
- 4 - CLUTCH PLATE
- 5 - SEAL
- 6 - CLUTCH RETAINER

- 7 - SEAL
- 8 - PISTON
- 9 - SPRING
- 10 - SNAP-RING
- 11 - SPRING RETAINER

FRONT CLUTCH (Continued)



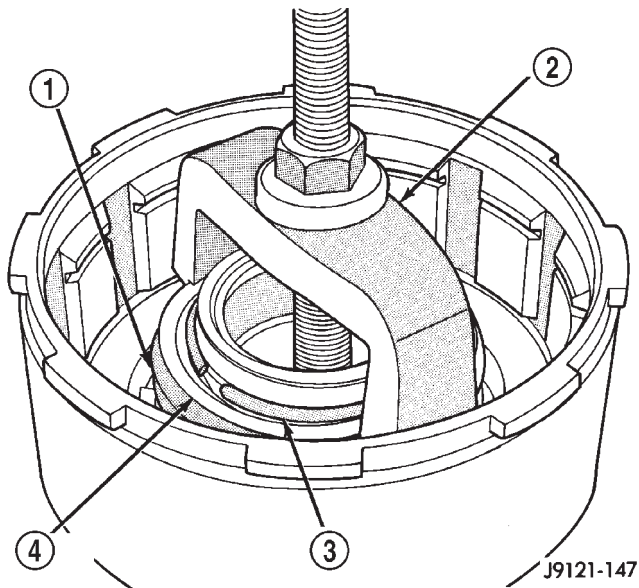
80bdbd40

**Fig. 85 42RE Front Clutch Components**

- 1 - SNAP-RING (WAVE)
- 2 - REACTION PLATE
- 3 - CLUTCH DISC
- 4 - CLUTCH PLATE
- 5 - SEAL
- 6 - CLUTCH RETAINER

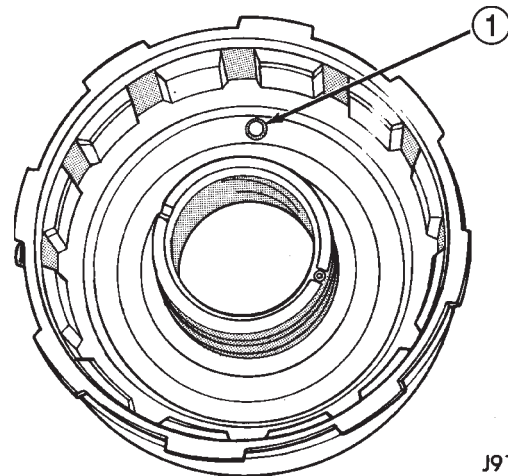
- 7 - SEAL
- 8 - PISTON
- 9 - SPRING
- 10 - SNAP-RING
- 11 - SPRING RETAINER

## FRONT CLUTCH (Continued)



**Fig. 86 Compressing Front Clutch Piston Spring**

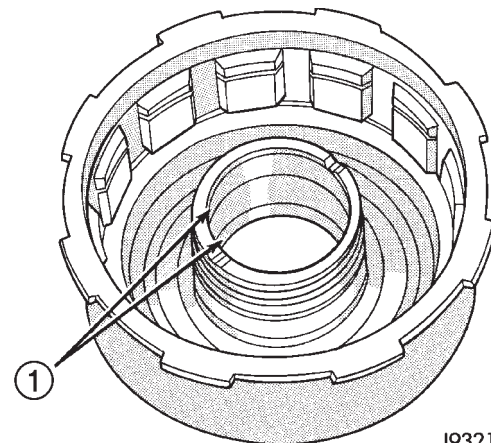
- 1 - FRONT CLUTCH SPRING
- 2 - COMPRESSOR TOOL C-3575-A
- 3 - RETAINER SNAP-RING
- 4 - SPRING RETAINER



J9121-368

**Fig. 87 Front Clutch Piston Retainer Check Ball Location**

- 1 - RETAINER CHECK BALL



J9321-223

**Fig. 88 Retainer Bushing Location/Inspection**

- 1 - FRONT CLUTCH RETAINER BUSHINGS (NON-SERVICEABLE)

## INSPECTION

Inspect the front clutch components. Replace the clutch discs if warped, worn, scored, burned or charred, or if the facing is flaking off. Replace the steel plates if heavily scored, warped, or broken. Be sure the driving lugs on the plates are in good condition. The lugs must not be bent, cracked or damaged in any way.

Replace the clutch spring and spring retainer if either is distorted, warped or broken.

Check the lug grooves in the clutch retainer. The steel plates should slide freely in the slots. Replace the retainer if the grooves are worn or damaged.

Check action of the check ball in the retainer (Fig. 87). The ball must move freely and not stick.

**NOTE:** Inspect the clutch retainer bushings carefully (Fig. 88). The retainer bushings are **NOT** serviceable. It will be necessary to replace the retainer if either bushing is scored, or worn.

Inspect the piston and retainer seal surfaces for nicks or scratches. Minor scratches can be removed with crocus cloth. However, replace the piston and/or retainer if the seal surfaces are seriously scored.

## FRONT CLUTCH (Continued)

## ASSEMBLY

**NOTE:** The 42RE transmission uses four plates and discs for the front clutch.

(1) Soak clutch discs in transmission fluid while assembling other clutch parts.

(2) Install new seals in the clutch retainer lower groove and on outer diameter of the retainer hub. Be sure lip of each seal faces interior of clutch retainer.

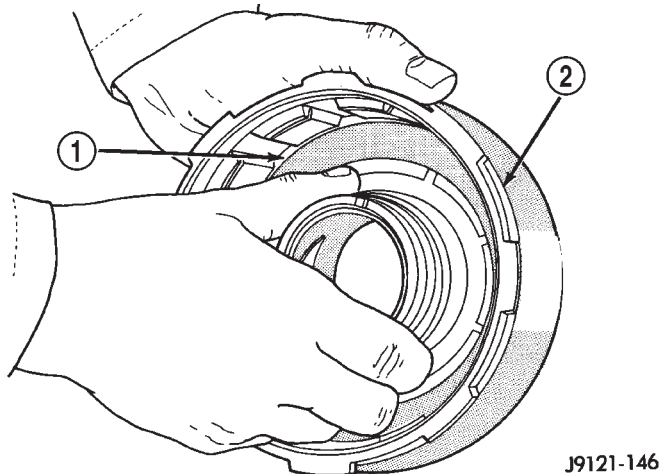
(3) Lubricate lips of the retainer seals with liberal quantity of Mopar® Door Ease. Then lubricate retainer hub, bore and piston with light coat of transmission fluid.

(4) Install clutch piston in retainer (Fig. 89). Use twisting motion to seat piston in bottom of retainer.

**CAUTION:** Never push the clutch piston straight in. This will fold the seals over causing leakage and clutch slip.

(5) Position spring in clutch piston (Fig. 90).

(6) Position spring retainer on top of piston spring. Make sure retainer is properly installed (Fig. 85).



J9121-146

**Fig. 89 Front Clutch Piston Installation**

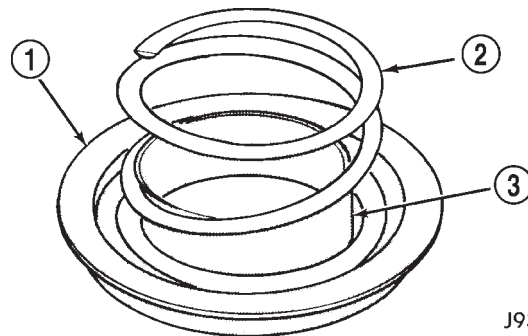
- 1 - CLUTCH PISTON
- 2 - FRONT CLUTCH RETAINER

(7) Compress piston spring and retainer with Compressor Tool C-3575-A (Fig. 86). Then install new snap-ring to secure spring retainer and spring.

(8) Install clutch plates and discs (Fig. 85). Install steel plate then disc until all plates and discs are installed. The front clutch uses 4 clutch discs and plates in a 42RE transmission.

(9) Install pressure plate and waved snap-ring (Fig. 85).

Clearance should be 1.70 to 3.40 mm (0.067 to 0.134 in.). If clearance is incorrect, clutch discs,



J9321-466

**Fig. 90 Clutch Piston Spring Installation**

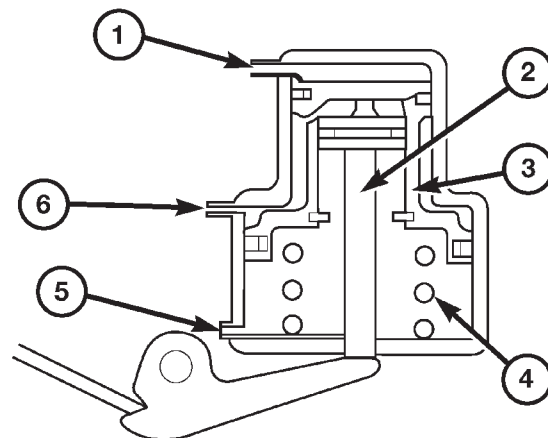
- 1 - RETAINER
- 2 - CLUTCH SPRING
- 3 - PISTON

plates, pressure plates and snap-ring may have to be changed.

## FRONT SERVO

## DESCRIPTION

The kickdown servo (Fig. 91) consists of a two-land piston with an inner piston, a piston rod and guide, and a return spring. The dual-land piston uses seal rings on its outer diameters and an O-ring for the inner piston.



80a08c99

**Fig. 91 Front Servo**

- 1 - VENT
- 2 - PISTON ROD
- 3 - PISTON
- 4 - SPRING
- 5 - RELEASE PRESSURE
- 6 - APPLY PRESSURE

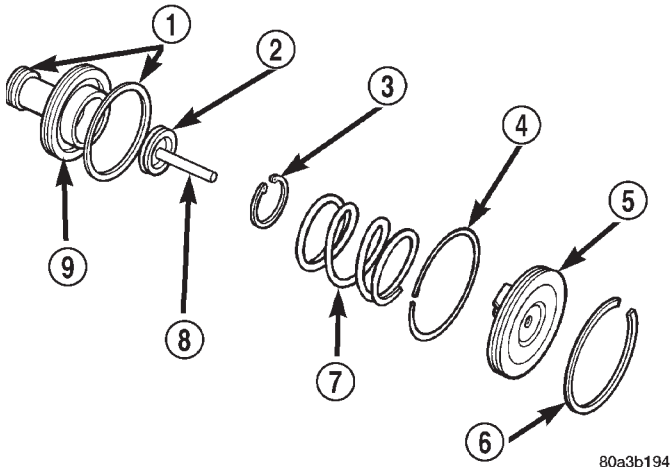
## FRONT SERVO (Continued)

**OPERATION**

The application of the piston is accomplished by applying pressure between the two lands of the piston. The pressure acts against the larger lower land to push the piston downward, allowing the piston rod to extend through its guide against the apply lever. Release of the servo at the 2-3 upshift is accomplished by a combination of spring and line pressure, acting on the bottom of the larger land of the piston. The small piston is used to cushion the application of the band by bleeding oil through a small orifice in the larger piston. The release timing of the kickdown servo is very important to obtain a smooth but firm shift. The release has to be very quick, just as the front clutch application is taking place. Otherwise, engine runaway or a shift hesitation will occur. To accomplish this, the band retains its holding capacity until the front clutch is applied, giving a small amount of overlap between them.

**DISASSEMBLY**

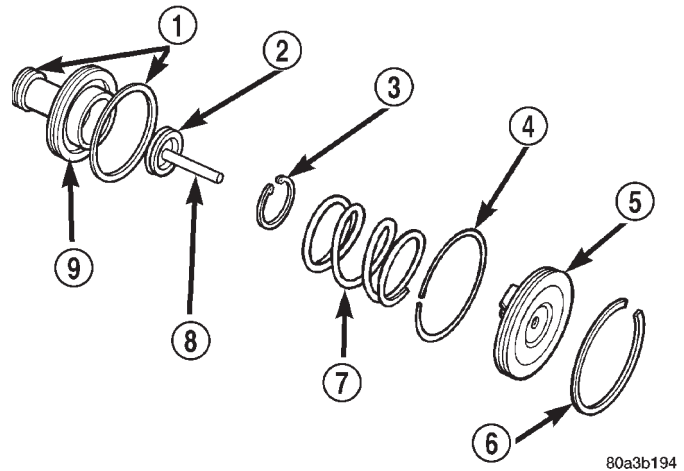
- (1) Remove seal ring from rod guide (Fig. 92).
- (2) Remove small snap-ring from servo piston rod. Then remove piston rod, spring and washer from piston.
- (3) Remove and discard servo component o-ring and seal rings.

**Fig. 92 Front Servo**

- 1 - PISTON RINGS
- 2 - O-RING
- 3 - SNAP-RING
- 4 - SEAL RING
- 5 - PISTON ROD GUIDE
- 6 - SNAP-RING
- 7 - SERVO SPRING
- 8 - PISTON ROD
- 9 - SERVO PISTON

**CLEANING**

Clean the servo piston components (Fig. 93) with solvent and dry them with compressed air.

**Fig. 93 Front Servo Piston**

- 1 - PISTON RINGS
- 2 - O-RING
- 3 - SNAP-RING
- 4 - SEAL RING
- 5 - PISTON ROD GUIDE
- 6 - SNAP-RING
- 7 - SERVO SPRING
- 8 - PISTON ROD
- 9 - SERVO PISTON

**INSPECTION**

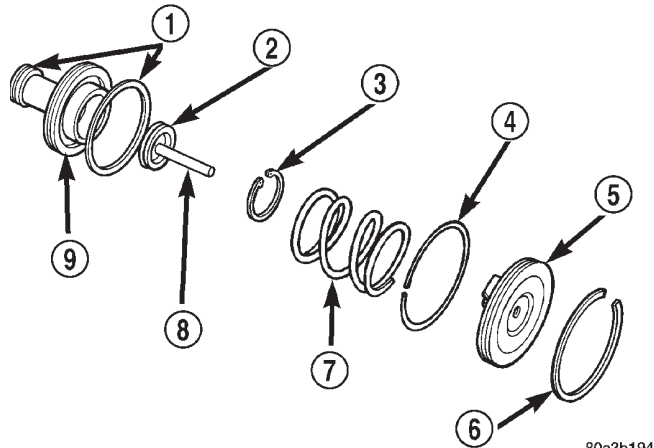
Inspect the servo components (Fig. 94). Replace the springs if collapsed, distorted or broken. Replace the guide, rod and piston if cracked, bent, or worn. Discard the servo snap-ring if distorted or warped.

Check the servo piston bore for wear. If the bore is severely scored, or damaged, it will be necessary to replace the case.

Replace any servo component if doubt exists about condition. Do not reuse suspect parts.



FRONT SERVO (Continued)



**Fig. 94 Front Servo Piston**

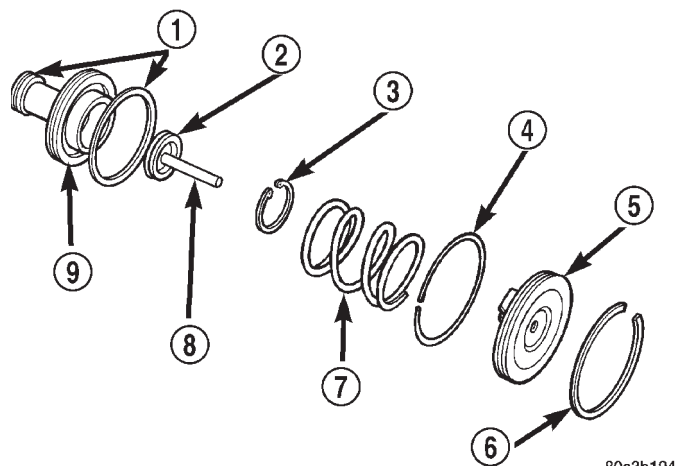
80a3b194

- 1 - PISTON RINGS
- 2 - O-RING
- 3 - SNAP-RING
- 4 - SEAL RING
- 5 - PISTON ROD GUIDE
- 6 - SNAP-RING
- 7 - SERVO SPRING
- 8 - PISTON ROD
- 9 - SERVO PISTON

**ASSEMBLY**

Clean and inspect front servo components.

- (1) Lubricate new o-ring and seal rings with petroleum jelly and install them on piston, guide and rod.
- (2) Install rod in piston. Install spring and washer on rod. Compress spring and install snap-ring (Fig. 95).



**Fig. 95 Front Servo**

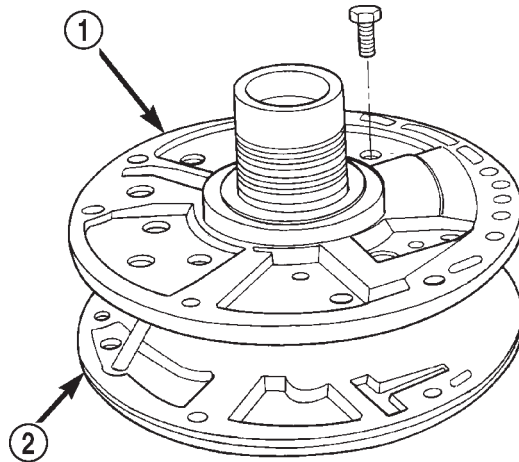
80a3b194

- 1 - PISTON RINGS
- 2 - O-RING
- 3 - SNAP-RING
- 4 - SEAL RING
- 5 - PISTON ROD GUIDE
- 6 - SNAP-RING
- 7 - SERVO SPRING
- 8 - PISTON ROD
- 9 - SERVO PISTON

**OIL PUMP**

**DESCRIPTION**

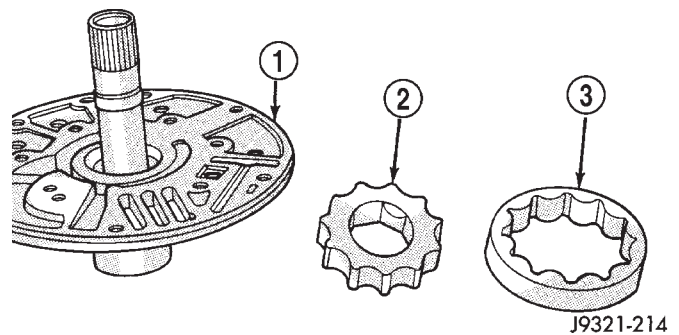
The oil pump (Fig. 96) is located in the pump housing inside the bell housing of the transmission case. The oil pump consists of an inner and outer gear (Fig. 97), a housing, and a cover that also serves as the reaction shaft support.



80a483e7

**Fig. 96 Oil Pump and Reaction Shaft Support**

- 1 - REACTION SHAFT SUPPORT
- 2 - PUMP



J9321-214

**Fig. 97 Pump Gear Removal**

- 1 - REACTION SHAFT SUPPORT
- 2 - INNER GEAR
- 3 - OUTER GEAR

**OPERATION**

As the torque converter rotates, the converter hub rotates the inner and outer gears. As the gears rotate, the clearance between the gear teeth increases in the crescent area, and creates a suction at the inlet side of the pump. This suction draws fluid through the pump inlet from the oil pan. As the clearance between the gear teeth in the crescent area decreases, it forces pressurized fluid into the pump outlet and to the valve body.

## OIL PUMP (Continued)

**STANDARD PROCEDURE - OIL PUMP VOLUME CHECK**

Measuring the oil pump output volume will determine if sufficient oil flow to the transmission oil cooler exists, and whether or not an internal transmission failure is present.

Verify that the transmission fluid is at the proper level. Refer to the Fluid Level Check procedure in this section. If necessary, fill the transmission to the proper level with Mopar® ATF +4, type 9602, Automatic Transmission Fluid.

(1) Disconnect the **To cooler** line at the cooler inlet and place a collecting container under the disconnected line.

**CAUTION:** With the fluid set at the proper level, fluid collection should not exceed (1) quart or internal damage to the transmission may occur.

(2) Run the engine **at curb idle speed**, with the shift selector in neutral.

(3) If one quart of transmission fluid is collected in the container in 20 seconds or less, oil pump flow volume is within acceptable limits. If fluid flow is intermittent, or it takes more than 20 seconds to collect one quart of fluid, refer to the Hydraulic Pressure tests in this section for further diagnosis.

(4) Re-connect the **To cooler** line to the transmission cooler inlet.

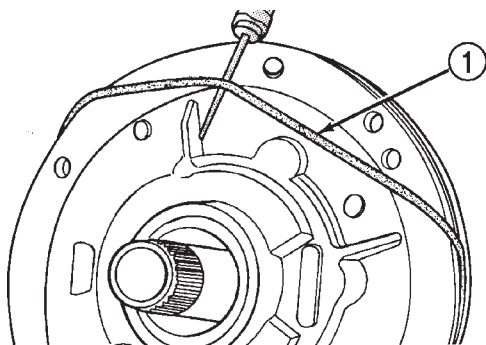
(5) Refill the transmission to proper level.

**DISASSEMBLY**

(1) Remove seal ring from housing and reaction shaft support (Fig. 98).

(2) Mark pump housing and support assembly for alignment reference.

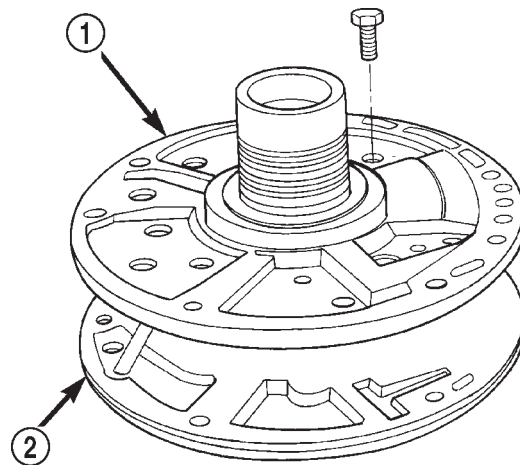
(3) Remove bolts attaching pump body to support (Fig. 99).



J9321-211

**Fig. 98 Removing Pump Seal Ring**

1 - PUMP HOUSING SEAL RING



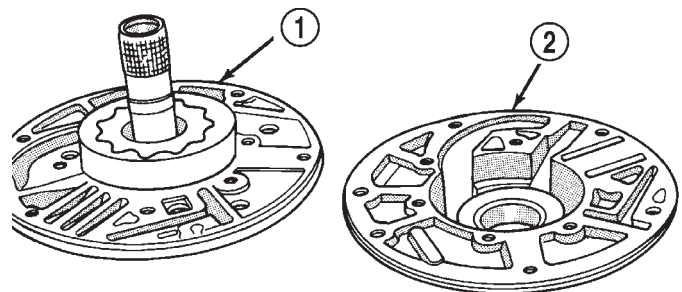
80a483e7

**Fig. 99 Pump Support Bolts**

1 - REACTION SHAFT SUPPORT

2 - PUMP

(4) Separate support from pump housing (Fig. 100).



J9321-213

**Fig. 100 Separating Pump Housing From Reaction Shaft Support**

1 - REACTION SHAFT SUPPORT

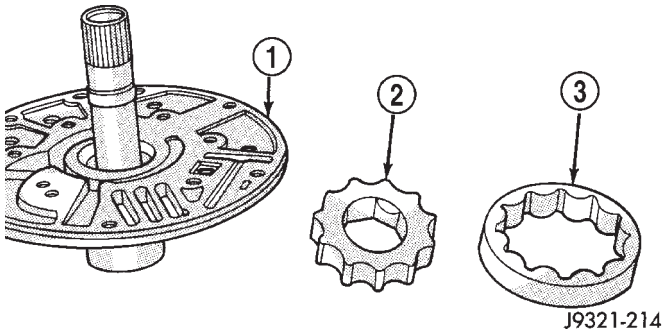
2 - PUMP HOUSING

OIL PUMP (Continued)

(5) Remove inner and outer gears from reaction shaft support (Fig. 101).

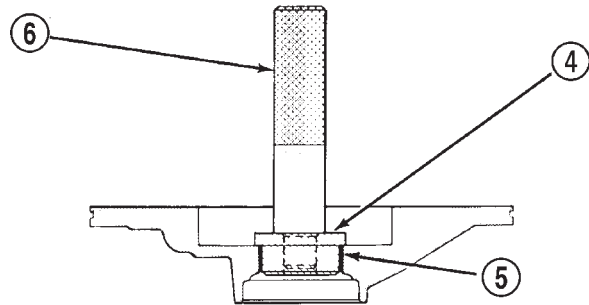
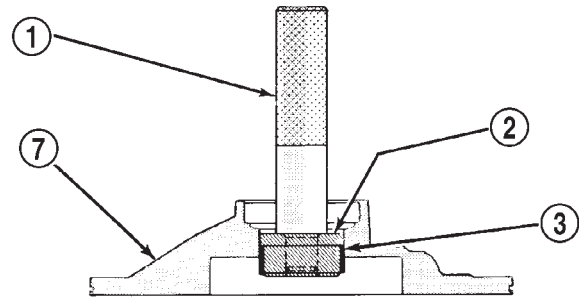
(6) If pump seal was not removed during transmission disassembly, remove seal with punch and hammer.

(7) Remove front clutch thrust washer from support hub (Fig. 102).



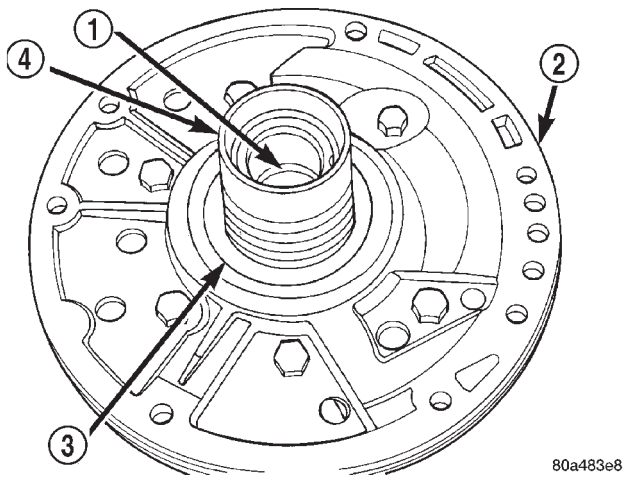
**Fig. 101 Pump Gear Removal**

- 1 - REACTION SHAFT SUPPORT
- 2 - INNER GEAR
- 3 - OUTER GEAR



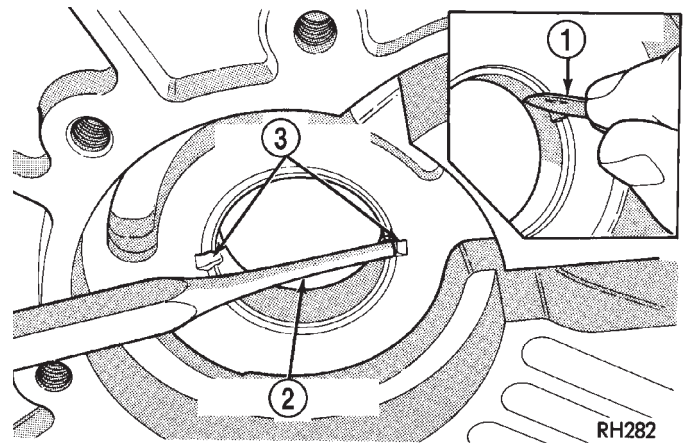
**Fig. 103 Removing Oil Pump Bushing**

- 1 - SPECIAL TOOL C-4171
- 2 - SPECIAL TOOL SP-3551
- 3 - BUSHING
- 4 - SPECIAL TOOL SP-5117
- 5 - BUSHING
- 6 - SPECIAL TOOL C-4171
- 7 - PUMP HOUSING



**Fig. 102 Support Hub Thrust Washer**

- 1 - BUSHING
- 2 - REACTION SHAFT SUPPORT
- 3 - THRUST WASHER
- 4 - HUB



**Fig. 104 Staking Oil Pump Bushing**

- 1 - NARROW BLADE
- 2 - BLUNT PUNCH
- 3 - TWO STAKES

**OIL PUMP BUSHING REPLACEMENT**

(1) Remove pump bushing with Tool Handle C-4171 and Bushing Remover SP-3551 from Tool Set C-3887-J (Fig. 103).

(2) Install new pump bushing with Tool Handle C-4171 and Bushing Installer SP-5117 (Fig. 103). Bushing should be flush with pump housing bore.

(3) Stake new pump bushing in two places with blunt punch (Fig. 104). Remove burrs from stake points with knife blade afterward.

## OIL PUMP (Continued)

**REACTION SHAFT SUPPORT BUSHING REMOVAL**

(1) Assemble Bushing Remover Tools SP-1191, 3633 and 5324 (Fig. 105). Do not clamp any part of reaction shaft or support in vise.

(2) Hold Cup Tool SP-3633 firmly against reaction shaft and thread remover SP-5324 into bushing as far as possible by hand. Then thread remover tool 3-4 additional turns into bushing with a wrench.

(3) Turn remover tool hex nut down against remover cup to pull bushing from shaft. Clean all chips from shaft after bushing removal.

(4) Lightly grip old bushing in vise or with pliers and back remover tool out of bushing.

(5) Assemble Bushing Installer Tools C-4171 and SP-5325 (Fig. 105).

(6) Slide new bushing onto Installer Tool SP-5325.

(7) Position reaction shaft support upright on a clean smooth surface.

(8) Align bushing in bore. Then tap bushing into place until Bushing Installer SP-5325 bottoms.

(9) Clean reaction shaft support thoroughly after installing bushing.

**CLEANING**

Clean pump and support components with solvent and dry them with compressed air.

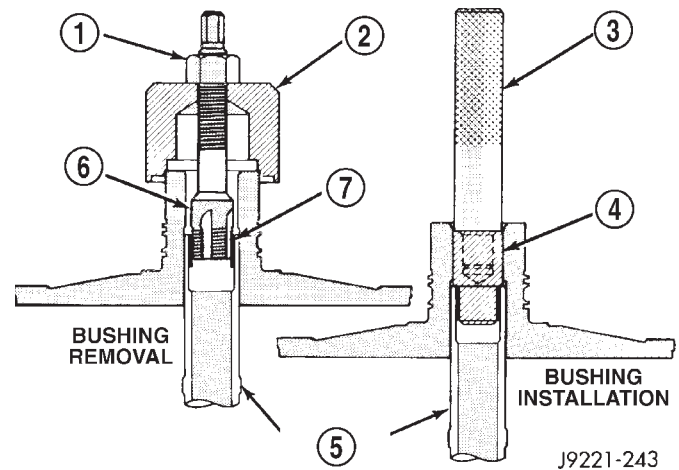
**INSPECTION**

Check condition of the seal rings and thrust washer on the reaction shaft support. The seal rings do not need to be replaced unless cracked, broken, or severely worn.

Inspect the pump and support components. Replace the pump or support if the seal ring grooves or machined surfaces are worn, scored, pitted, or damaged. Replace the pump gears if pitted, worn chipped, or damaged.

Inspect the pump bushing. Then check the reaction shaft support bushing. Replace either bushing only if heavily worn, scored or damaged. It is not necessary to replace the bushings unless they are actually damaged.

Clearance between outer gear and reaction shaft housing should be 0.010 to 0.063 mm (0.0004 to 0.0025 in.). Clearance between inner gear and reac-



**Fig. 105 Replacing Reaction Shaft Support Bushing**

- 1 - SPECIAL TOOL SP-1191
- 2 - SPECIAL TOOL SP-3633
- 3 - SPECIAL TOOL C-4171
- 4 - SPECIAL TOOL SP-5325
- 5 - REACTION SHAFT
- 6 - SPECIAL TOOL SP-5324
- 7 - BUSHING

tion shaft housing should be 0.010 to 0.063 mm (0.0004 to 0.0025 in.). Both clearances can be measured at the same time by installing the gears in the pump body and measure pump component clearances as follows:

(1) Position an appropriate piece of Plastigage™ across both gears.

(2) Align the plastigage to a flat area on the reaction shaft housing.

(3) Install the reaction shaft to the pump housing.

(4) Separate the reaction shaft housing from the pump housing and measure the Plastigage™ following the instructions supplied with it.

Clearance between inner gear tooth and outer gear should be 0.08 to 0.19 mm (0.0035 to 0.0075 in.). Measure clearance with an appropriate feeler gauge.

Clearance between outer gear and pump housing should be 0.10 to 0.19 mm (0.004 to 0.0075 in.). Measure clearance with an appropriate feeler gauge.

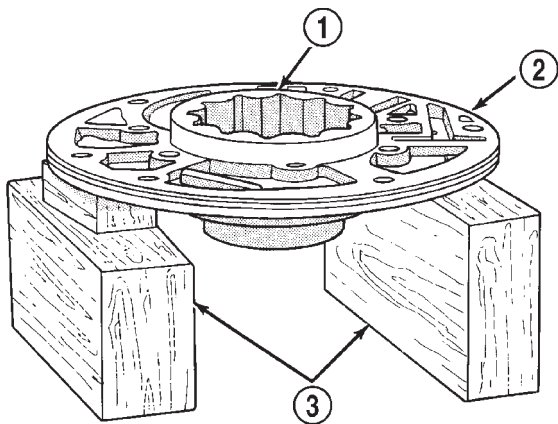


OIL PUMP (Continued)

**ASSEMBLY**

- (1) Lubricate gear bore in pump housing with transmission fluid.
- (2) Lubricate pump gears with transmission fluid.
- (3) Support pump housing on wood blocks (Fig. 106).
- (4) Install outer gear in pump housing (Fig. 106). Gear can be installed either way (it is not a one-way fit).
- (5) Install pump inner gear (Fig. 107).

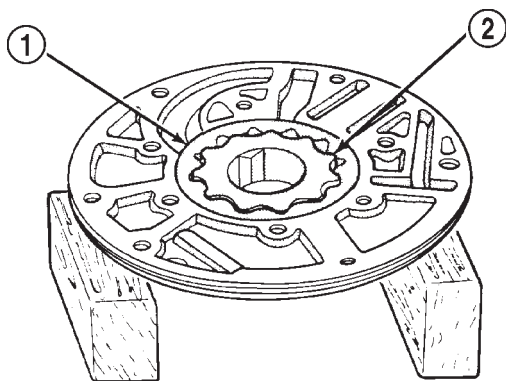
**CAUTION:** The pump inner gear is a one way fit. The bore on one side of the gear inside diameter (I.D.) is chamfered. Be sure the chamfered side faces forward (to front of pump).



J9321-219

**Fig. 106 Supporting Pump And Installing Outer Gear**

- 1 - OUTER GEAR
- 2 - PUMP HOUSING
- 3 - WOOD BLOCKS



J9321-465

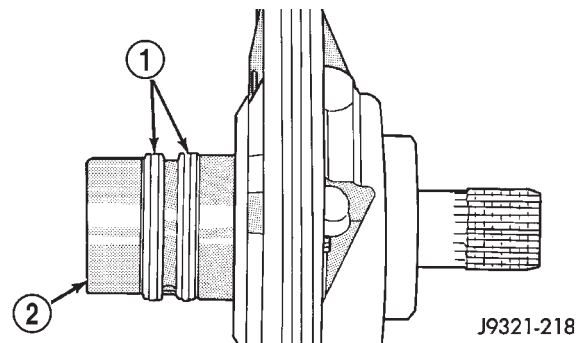
**Fig. 107 Pump Inner Gear Installation**

- 1 - OUTER GEAR
- 2 - INNER GEAR

(6) Install new thrust washer on hub of reaction shaft support. Lubricate washer with transmission fluid or petroleum jelly.

(7) If reaction shaft seal rings are being replaced, install new seal rings on support hub (Fig. 108). Lubricate seal rings with transmission fluid or petroleum jelly after installation. Squeeze each ring until ring ends are securely hooked together.

**CAUTION:** The reaction shaft support seal rings will break if overspread, or twisted. If new rings are being installed, spread them only enough for installation. Also be very sure the ring ends are securely hooked together after installation. Otherwise, the rings will either prevent pump installation, or break during installation.



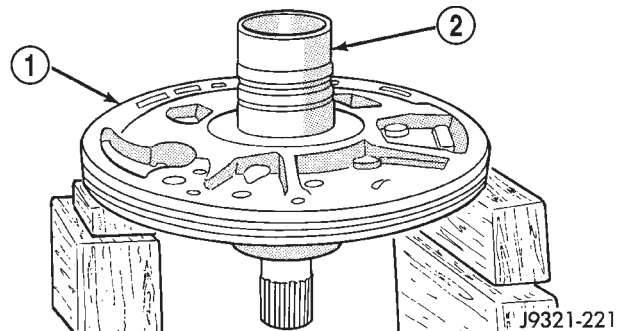
J9321-218

**Fig. 108 Hub Seal Ring Position**

- 1 - SEAL RINGS
- 2 - SUPPORT HUB

(8) Install reaction shaft support on pump housing (Fig. 109).

(9) Align reaction support on pump housing. Use alignment marks made at disassembly. Or, rotate support until bolt holes in support and pump housing are all aligned (holes are offset for one-way fit).



J9321-221

**Fig. 109 Assembling Reaction Shaft Support And Pump Housing**

- 1 - PUMP HOUSING
- 2 - REACTION SHAFT SUPPORT

## OIL PUMP (Continued)

(10) Install all bolts that attach support to pump housing. Then tighten bolts finger tight.

(11) Tighten support-to-pump bolts to required torque as follows:

(a) Reverse pump assembly and install it in transmission case. Position pump so bolts are facing out and are accessible.

(b) Secure pump assembly in case with 2 or 3 bolts, or with pilot studs.

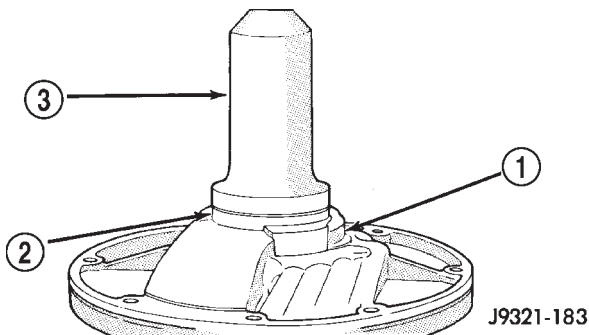
(c) Tighten support-to-pump bolts to 20 N·m (15 ft. lbs.).

(d) Remove pump assembly from transmission case.

(12) Install new oil seal in pump with Special Tool C-4193 and Tool Handle C-4171 (Fig. 110). Be sure seal lip faces inward.

(13) Install new seal ring around pump housing. Be sure seal is properly seated in groove.

(14) Lubricate lip of pump oil seal and O-ring seal with transmission fluid.



**Fig. 110 Pump Oil Seal Installation**

- 1 - PUMP BODY
- 2 - PUMP SEAL
- 3 - SPECIAL TOOL C-4193

## OUTPUT SHAFT FRONT BEARING

### REMOVAL

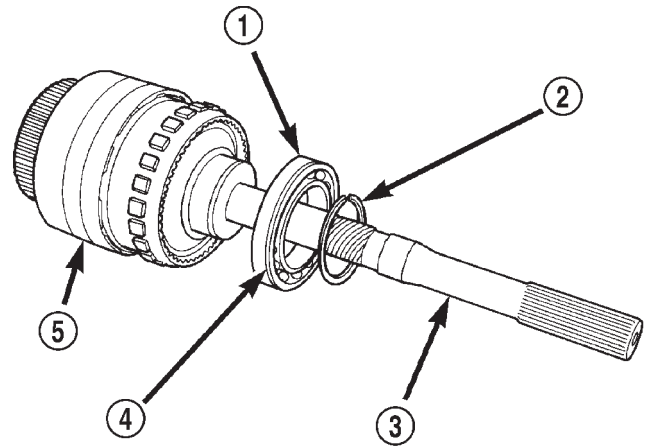
- (1) Remove overdrive unit from the vehicle.
- (2) Remove overdrive geartrain from housing.
- (3) Remove snap-ring holding output shaft front bearing to overdrive geartrain. (Fig. 111).
- (4) Pull bearing from output shaft.

### INSTALLATION

(1) Place replacement bearing in position on geartrain with locating retainer groove toward the rear.

(2) Push bearing onto shaft until the snap-ring groove is visible.

(3) Install snap-ring to hold bearing onto output shaft.



**Fig. 111 Output Shaft Front Bearing**

- 1 - OUTPUT SHAFT FRONT BEARING
- 2 - SNAP-RING
- 3 - OUTPUT SHAFT
- 4 - GROOVE TO REAR
- 5 - OVERDRIVE GEARTRAIN

- (4) Install overdrive geartrain into housing.
- (5) Install overdrive unit in vehicle.

## OUTPUT SHAFT REAR BEARING

### REMOVAL

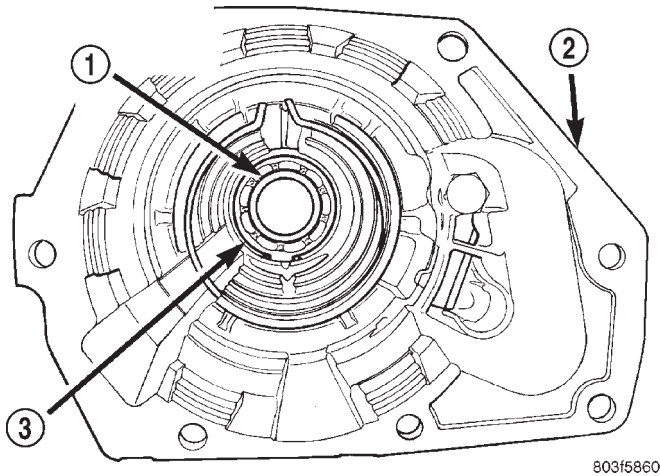
- (1) Remove overdrive unit from the vehicle. (Refer to 21 - TRANSMISSION/TRANSAXLE/AUTOMATIC/OVERDRIVE - REMOVAL)
- (2) Remove overdrive geartrain from housing.
- (3) Remove snap-ring holding output shaft rear bearing into overdrive housing (Fig. 112).
- (4) Using a suitable driver inserted through the rear end of housing, drive bearing from housing.

### INSTALLATION

- (1) Place replacement bearing in position in housing.
- (2) Using a suitable driver, drive bearing into housing until the snap-ring groove is visible.
- (3) Install snap-ring to hold bearing into housing (Fig. 112).
- (4) Install overdrive geartrain into housing.
- (5) Install overdrive unit in vehicle.



OUTPUT SHAFT REAR BEARING (Continued)



803f5860

**Fig. 112 Output Shaft Rear Bearing**

- 1 - OUTPUT SHAFT REAR BEARING
- 2 - OVERDRIVE HOUSING
- 3 - SNAP-RING

piston, and piston spacer are located on the rear of the main transmission case.

**NOTE:** The number of discs and plates may vary with each engine and vehicle combination.

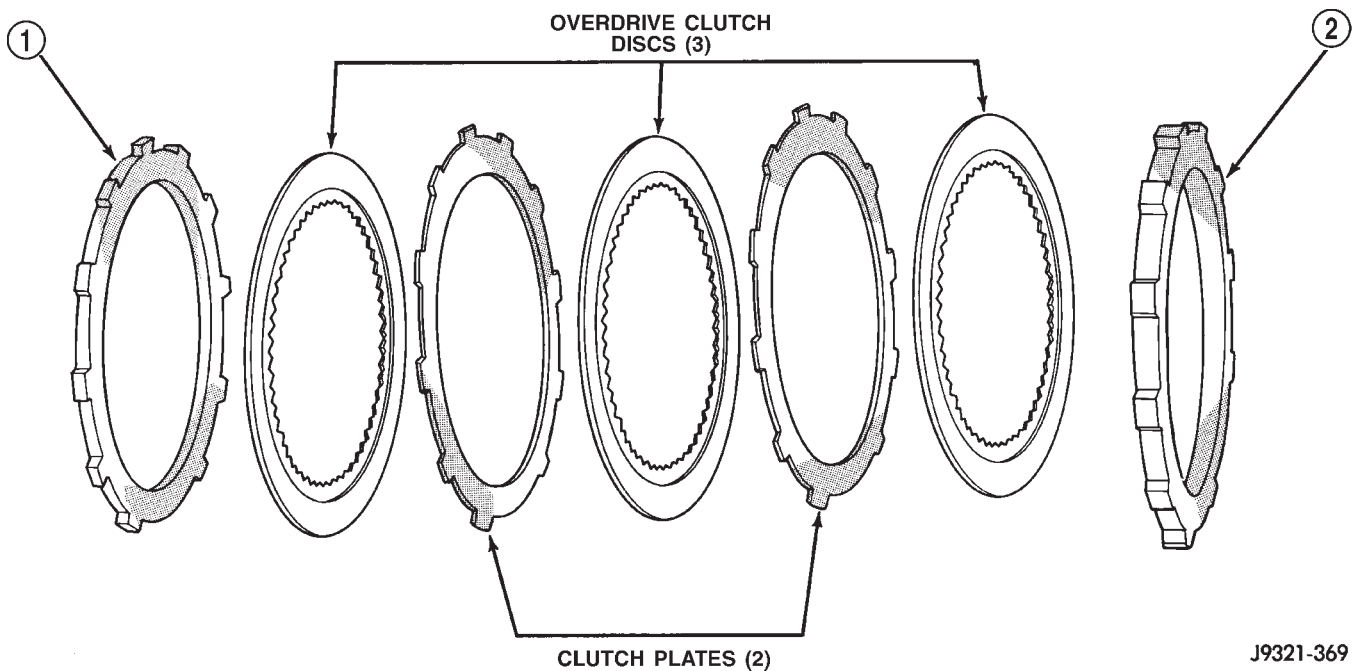
**OPERATION**

To apply the clutch, pressure is applied between the piston retainer and piston. The fluid pressure is provided by the oil pump, transferred through the control valves and passageways, and enters the clutch through passages at the lower rear portion of the valve body area. With pressure applied between the piston retainer and piston, the piston moves away from the piston retainer and compresses the clutch pack. This action applies the clutch pack, allowing torque to flow through the intermediate shaft into the overdrive planetary gear set. The overdrive clutch discs are attached to the overdrive clutch hub while the overdrive clutch plates, reaction plate, and pressure plate are lugged to the overdrive housing. This allows the intermediate shaft to transfer the engine torque to the planetary gear and overrunning clutch. This drives the planetary gear inside the annulus, which is attached to the overdrive clutch drum and output shaft, creating the desired gear ratio. The waved snap-ring is used to cushion the application of the clutch pack.

**OVERDRIVE CLUTCH**

**DESCRIPTION**

The overdrive clutch (Fig. 113) is composed of the pressure plate, clutch plates, holding discs, overdrive piston retainer, piston, piston spacer, and snap-rings. The overdrive clutch is the forwardmost component in the transmission overdrive unit and is considered a holding component. The overdrive piston retainer,



J9321-369

**Fig. 113 Overdrive Clutch**

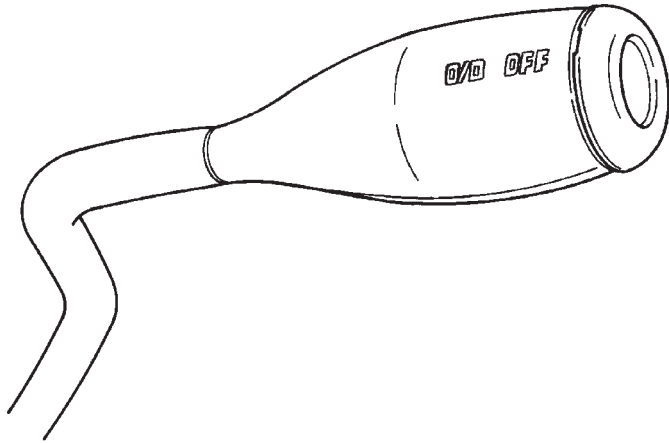
- 1 - REACTION PLATE

- 2 - PRESSURE PLATE

## OVERDRIVE OFF SWITCH

### DESCRIPTION

The overdrive OFF (control) switch is located in the shift lever arm (Fig. 114). The switch is a momentary contact device that signals the PCM to toggle current status of the overdrive function.



80a8e1c1

**Fig. 114 Overdrive Off Switch**

### OPERATION

At key-on, overdrive operation is allowed. Pressing the switch once causes the overdrive OFF mode to be entered and the overdrive OFF switch lamp to be illuminated. Pressing the switch a second time causes normal overdrive operation to be restored and the overdrive lamp to be turned off. The overdrive OFF mode defaults to ON after the ignition switch is cycled OFF and ON. The normal position for the control switch is the ON position. The switch must be in this position to energize the solenoid and allow a 3-4 upshift. The control switch indicator light illuminates only when the overdrive switch is turned to the OFF position, or when illuminated by the transmission control module.

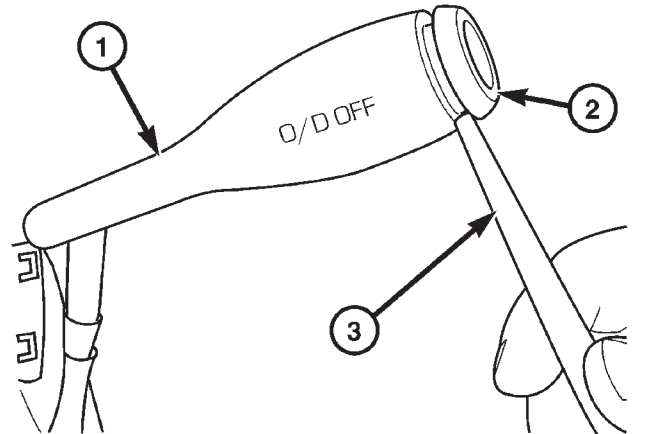
### DIAGNOSIS AND TESTING - OVERDRIVE ELECTRICAL CONTROLS

The overdrive off switch, valve body solenoid, case connectors and related wiring can all be tested with a 12 volt test lamp or a volt/ohmmeter. Check continuity of each component when diagnosis indicates this is necessary.

Switch and solenoid continuity should be checked whenever the transmission fails to shift into fourth gear range.

### REMOVAL

(1) Using a plastic trim tool, remove the overdrive off switch retainer from the shift lever (Fig. 115).

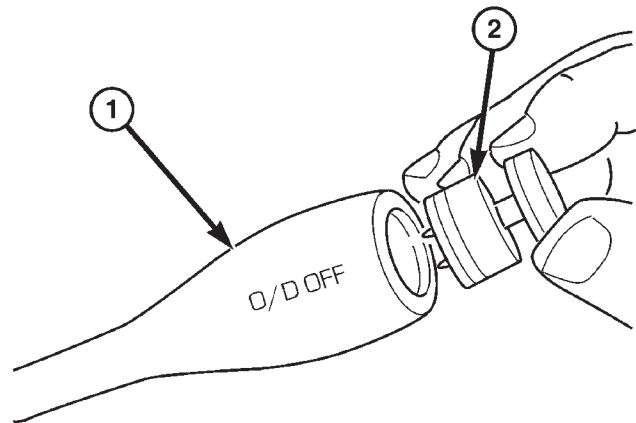


80a8ea93

**Fig. 115 Overdrive Off Switch Retainer**

- 1 - GEAR SHIFT LEVER
- 2 - OVERDRIVE OFF SWITCH RETAINER
- 3 - PLASTIC TRIM TOOL

(2) Pull the switch outwards to release it from the connector in the lever (Fig. 116)



80a8ed2b

**Fig. 116 Remove the Overdrive Off Switch**

- 1 - GEAR SHIFT LEVER
- 2 - OVERDRIVE OFF SWITCH

### INSTALLATION

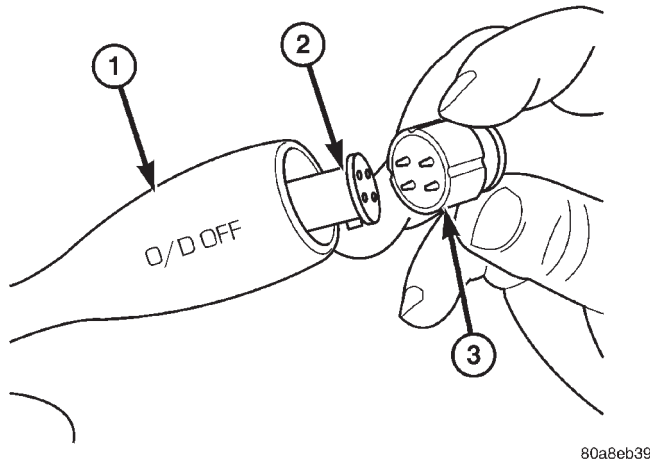
**NOTE:** There is enough slack in the wire to pull out the connector from the lever.

(1) Pull the connector out of the lever just enough to grasp it.

**CAUTION:** Be careful not to bend the pins on the overdrive off switch. Use care when installing the switch, as it is not indexed, and can be accidentally installed incorrectly.

## OVERDRIVE OFF SWITCH (Continued)

(2) Install the overdrive off switch into the connector (Fig. 117)



**Fig. 117 Install the Overdrive Off Switch**

- 1 - GEAR SHIFT LEVER  
2 - OVERDRIVE OFF SWITCH WIRING CONNECTOR  
3 - OVERDRIVE OFF SWITCH

(3) Push the overdrive off switch and wiring into the shift lever.

(4) Install the overdrive off switch retainer onto the shift lever.

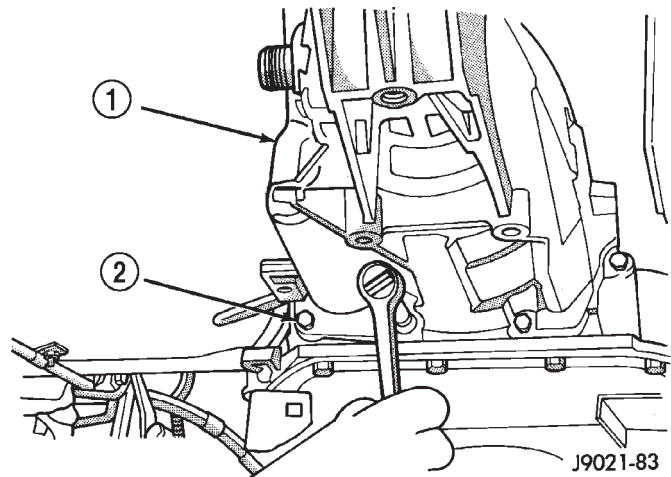
## OVERDRIVE UNIT

## REMOVAL

- (1) Shift transmission into PARK.
- (2) Raise vehicle.
- (3) Remove transfer case, if equipped.
- (4) Mark propeller shaft universal joint(s) and axle pinion yoke, or the companion flange and flange yoke, for alignment reference at installation, if necessary.
- (5) Disconnect and remove the rear propeller shaft, if necessary. (Refer to 3 - DIFFERENTIAL & DRIVE/PROPELLER SHAFT/PROPELLER SHAFT - REMOVAL)
- (6) Remove transmission oil pan, remove gasket, drain oil and reinstall pan.
- (7) If overdrive unit had malfunctioned, or if fluid is contaminated, remove entire transmission. If diagnosis indicated overdrive problems only, remove just the overdrive unit.

- (8) Support transmission with transmission jack.
- (9) Remove bolts attaching overdrive unit to transmission (Fig. 118).

**CAUTION:** Support the overdrive unit with a jack before moving it rearward. This is necessary to prevent damaging the intermediate shaft. Do not allow the shaft to support the entire weight of the overdrive unit.



**Fig. 118 Overdrive Unit Bolts**

- 1 - OVERDRIVE UNIT  
2 - ATTACHING BOLTS (7)

(10) Carefully work overdrive unit off intermediate shaft. Do not tilt unit during removal. Keep it as level as possible.

(11) If overdrive unit does not require service, immediately insert Alignment Tool 6227-2 in splines of planetary gear and overrunning clutch to prevent splines from rotating out of alignment. If misalignment occurs, overdrive unit will have to be disassembled in order to realign splines.

(12) Remove and retain overdrive piston thrust bearing. Bearing may remain on piston or in clutch hub during removal.

(13) Position drain pan on workbench.

(14) Place overdrive unit over drain pan. Tilt unit to drain residual fluid from case.

(15) Examine fluid for clutch material or metal fragments. If fluid contains these items, overhaul will be necessary.

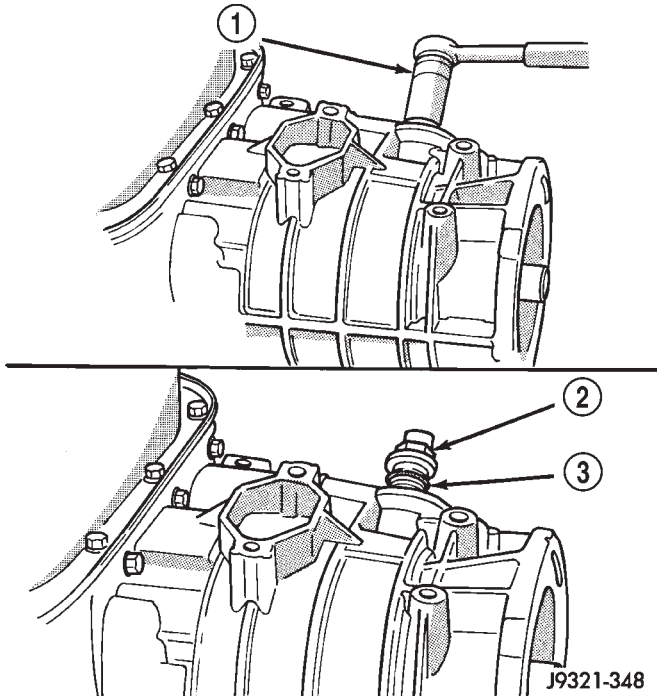
(16) If overdrive unit does not require any service, leave alignment tool in position. Tool will prevent accidental misalignment of planetary gear and overrunning clutch splines.

## OVERDRIVE UNIT (Continued)

## DISASSEMBLY

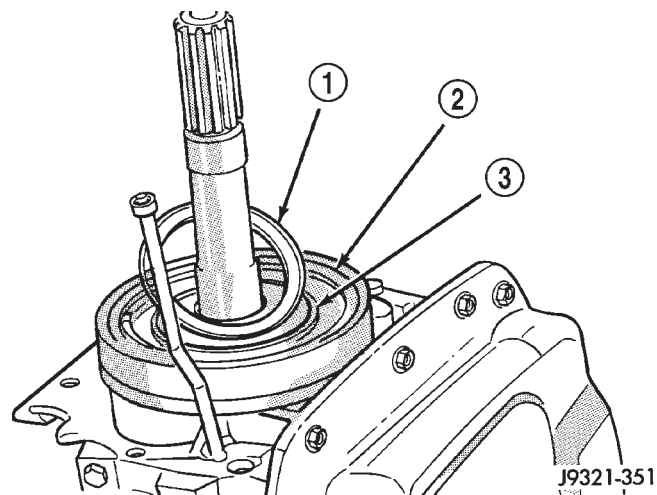
(1) Remove transmission speed sensor and O-ring seal from overdrive case (Fig. 119).

(2) Remove overdrive piston thrust bearing (Fig. 120).



**Fig. 119 Transmission Speed Sensor Removal**

- 1 - SOCKET AND WRENCH
- 2 - SPEED SENSOR
- 3 - O-RING

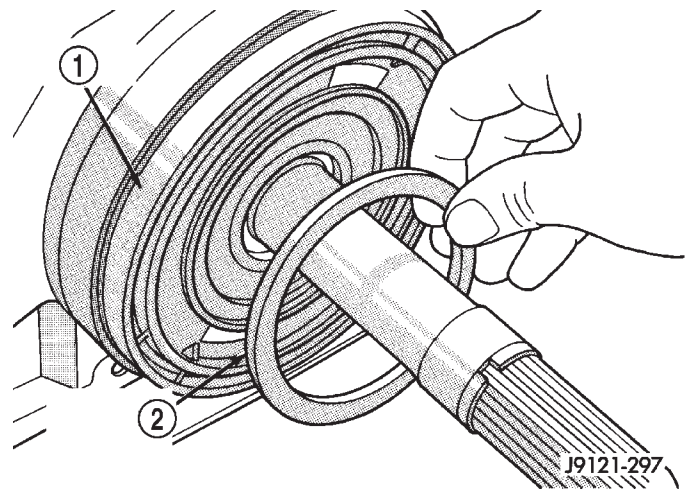


**Fig. 120 Overdrive Piston Thrust Bearing Removal**

- 1 - THRUST BEARING
- 2 - OVERDRIVE PISTON
- 3 - THRUST PLATE

## OVERDRIVE PISTON

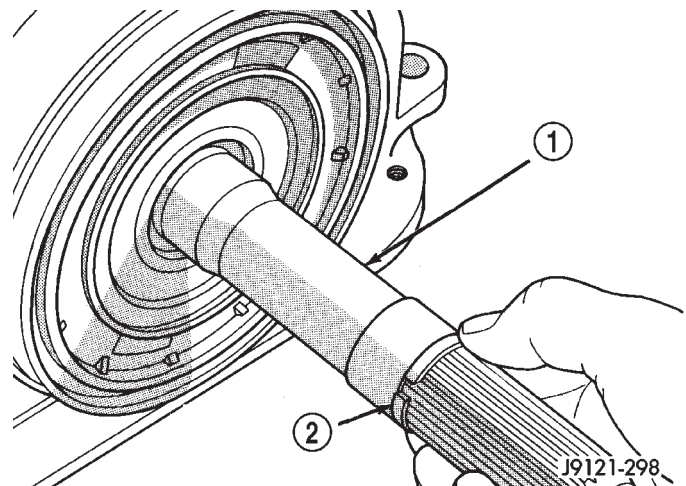
(1) Remove overdrive piston thrust plate (Fig. 121). Retain thrust plate. It is a select fit part and may possibly be reused.



**Fig. 121 Overdrive Piston Thrust Plate Removal**

- 1 - OVERDRIVE PISTON
- 2 - OVERDRIVE PISTON SPACER (SELECT FIT)

(2) Remove intermediate shaft spacer (Fig. 122). Retain spacer. It is a select fit part and may possibly be reused.



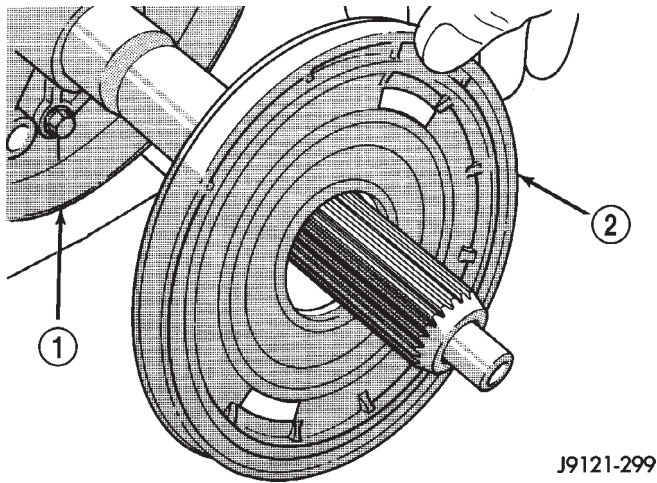
**Fig. 122 Intermediate Shaft Spacer Location**

- 1 - INTERMEDIATE SHAFT
- 2 - INTERMEDIATE SHAFT SPACER (SELECT FIT)



OVERDRIVE UNIT (Continued)

(3) Remove overdrive piston from retainer (Fig. 123).



**Fig. 123 Overdrive Piston Removal**

- 1 - PISTON RETAINER
- 2 - OVERDRIVE PISTON

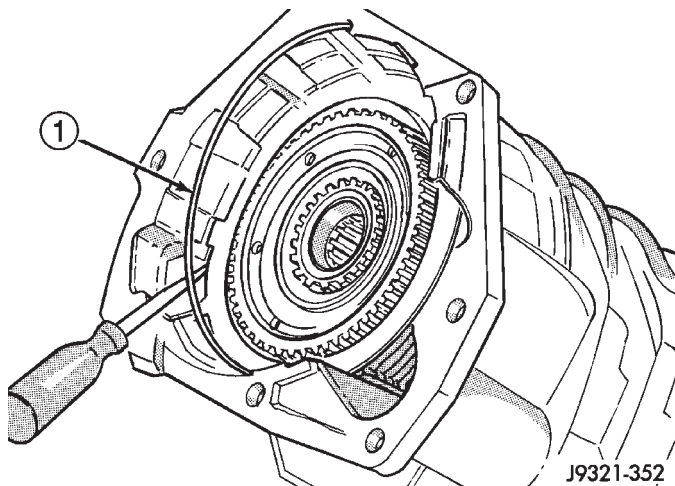
**OVERDRIVE CLUTCH PACK**

(1) Remove overdrive clutch pack wire retaining ring (Fig. 124).

(2) Remove overdrive clutch pack (Fig. 125).

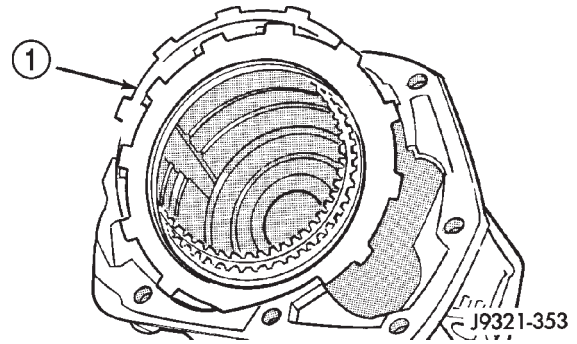
**NOTE:** The 42RE transmission has three clutch discs and two clutch plates.

(3) Note position of clutch pack components for assembly reference (Fig. 126).



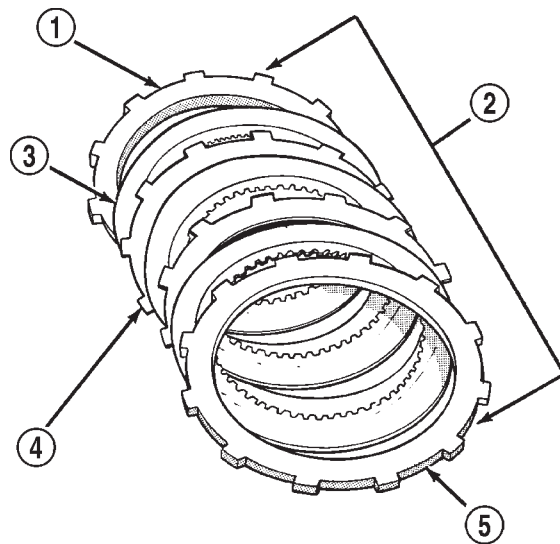
**Fig. 124 Removing Overdrive Clutch Pack Retaining Ring**

- 1 - OVERDRIVE CLUTCH PACK RETAINING RING



**Fig. 125 Overdrive Clutch Pack Removal**

- 1 - OVERDRIVE CLUTCH PACK



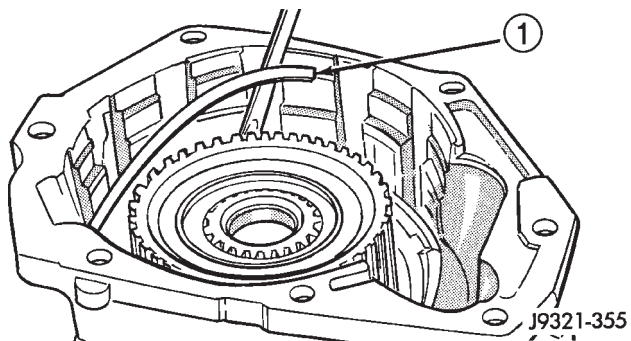
**Fig. 126 42RE Overdrive Clutch Component Position**

- 1 - PRESSURE PLATE (TO FRONT)
- 2 - OVERDRIVE CLUTCH PACK
- 3 - CLUTCH DISC (3)
- 4 - CLUTCH PLATE (2)
- 5 - REACTION PLATE (TO REAR)

OVERDRIVE UNIT (Continued)

OVERDRIVE GEARTRAIN

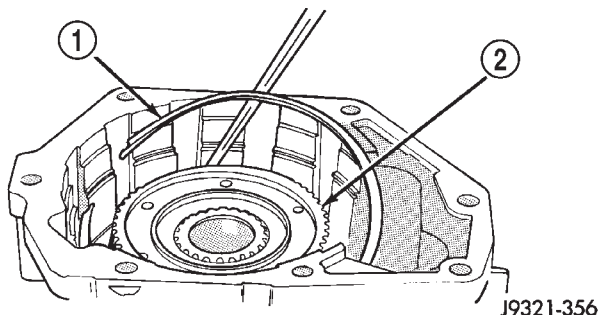
(1) Remove overdrive clutch wave spring (Fig. 127).



**Fig. 127 Overdrive Clutch Wave**

- 1 - WAVE SPRING

(2) Remove overdrive clutch reaction snap-ring (Fig. 128). Note that snap-ring is located in same groove as wave spring.



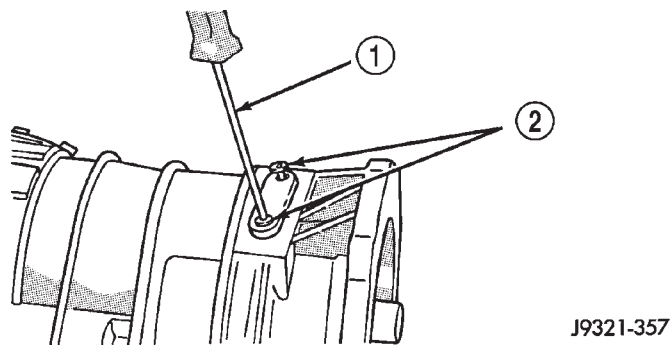
**Fig. 128 Overdrive Clutch Reaction Snap-Ring Removal**

- 1 - REACTION RING
- 2 - CLUTCH HUB

(3) Remove Torx™ head screws that attach access cover and gasket to overdrive case (Fig. 129).

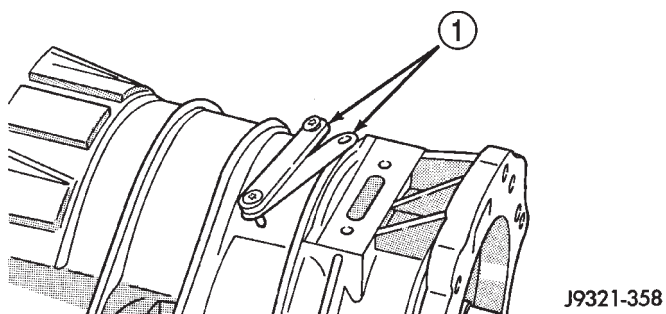
(4) Remove access cover and gasket (Fig. 130).

(5) Expand output shaft bearing snap-ring with expanding-type snap-ring pliers. Then push output shaft forward to release shaft bearing from locating ring (Fig. 131).



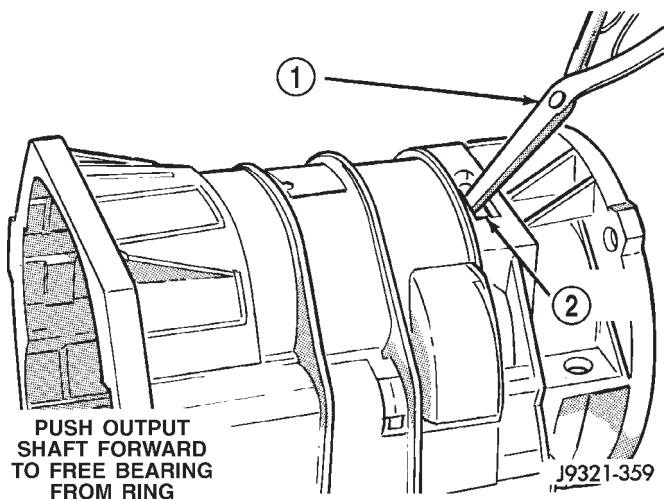
**Fig. 129 Access Cover Screw Removal**

- 1 - TORX SCREWDRIVER (T25)
- 2 - ACCESS COVER SCREWS



**Fig. 130 Access Cover And Gasket Removal**

- 1 - ACCESS COVER AND GASKET



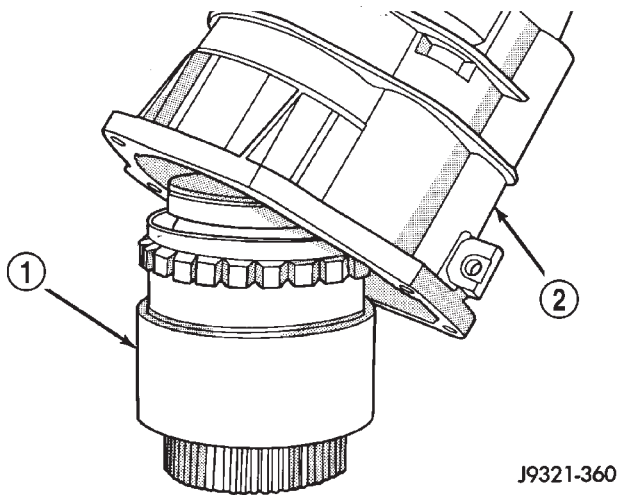
**Fig. 131 Releasing Bearing From Locating Ring**

- 1 - EXPAND BEARING LOCATING RING WITH SNAP-RING PLIERS
- 2 - ACCESS HOLE



OVERDRIVE UNIT (Continued)

(6) Lift gear case up and off geartrain assembly (Fig. 132).



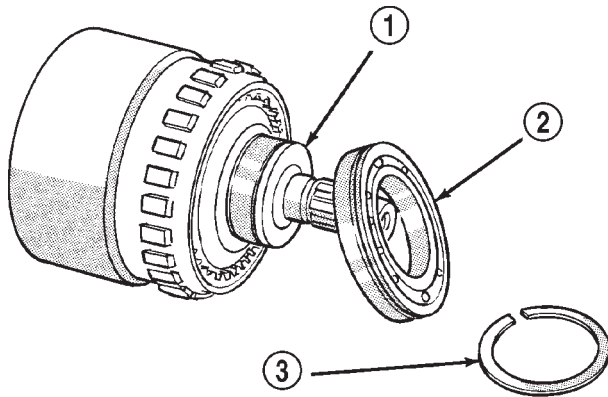
J9321-360

**Fig. 132 Removing Gear Case From Geartrain Assembly**

- 1 - GEARTRAIN ASSEMBLY
- 2 - GEAR CASE

(7) Remove snap-ring that retains rear bearing on output shaft.

(8) Remove rear bearing from output shaft (Fig. 133).



J9321-362

**Fig. 133 Rear Bearing Removal**

- 1 - OUTPUT SHAFT
- 2 - REAR BEARING
- 3 - SNAP-RING

**DIRECT CLUTCH, HUB AND SPRING**

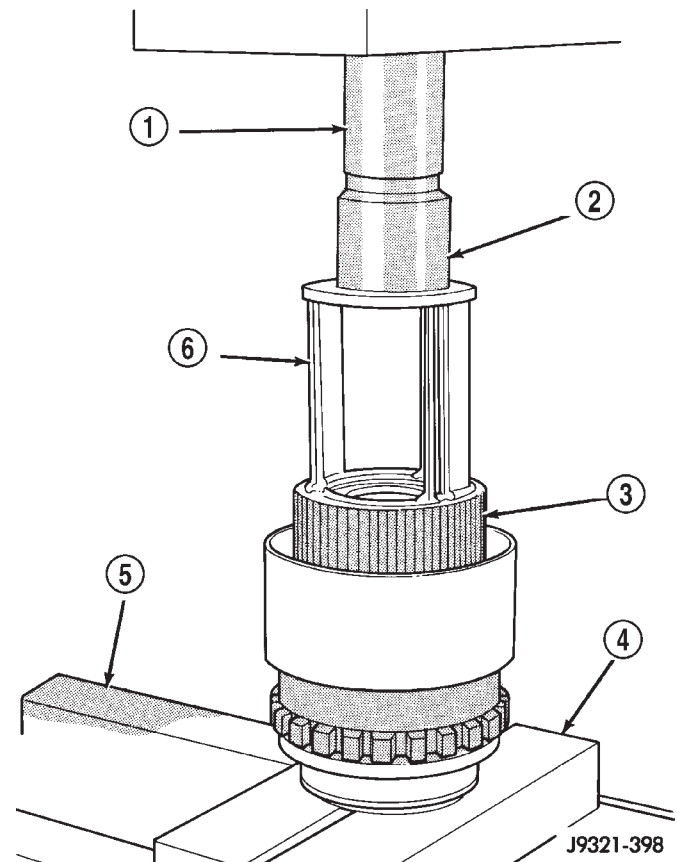
**WARNING: THE NEXT STEP IN DISASSEMBLY INVOLVES COMPRESSING THE DIRECT CLUTCH SPRING. IT IS EXTREMELY IMPORTANT THAT PROPER EQUIPMENT BE USED TO COMPRESS THE SPRING AS SPRING FORCE IS APPROXIMATELY 830 POUNDS. USE SPRING COMPRESSOR**

**TOOL 6227-1 AND A HYDRAULIC SHOP PRESS WITH A MINIMUM RAM TRAVEL OF 5-6 INCHES. THE PRESS MUST ALSO HAVE A BED THAT CAN BE ADJUSTED UP OR DOWN AS REQUIRED. RELEASE CLUTCH SPRING TENSION SLOWLY AND COMPLETELY TO AVOID PERSONAL INJURY.**

(1) Mount geartrain assembly in shop press (Fig. 134).

(2) Position Compressor Tool 6227-1 on clutch hub (Fig. 134). Support output shaft flange with steel press plates as shown and center assembly under press ram.

(3) Apply press pressure slowly. Compress hub and spring far enough to expose clutch hub retaining ring and relieve spring pressure on clutch pack snap-ring (Fig. 134).



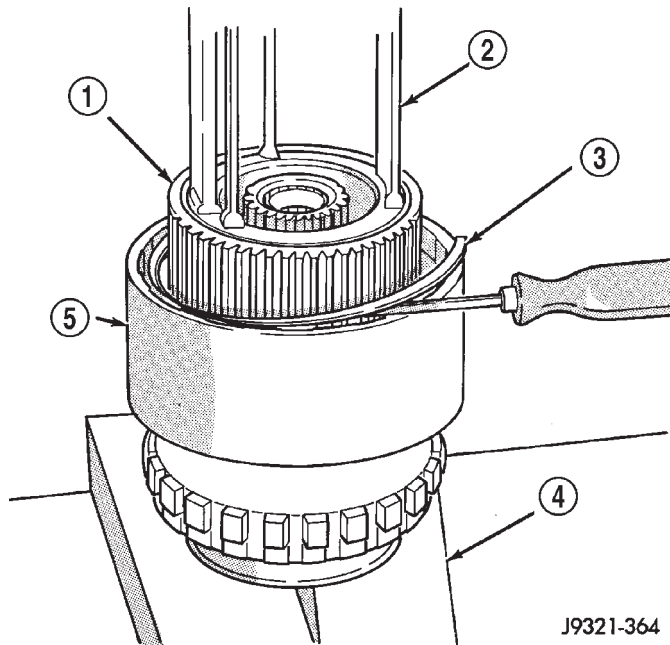
J9321-398

**Fig. 134 Geartrain Mounted In Shop Press**

- 1 - PRESS RAM
- 2 - SPECIAL TOOL C-3995-A (OR SIMILAR TOOL)
- 3 - CLUTCH HUB
- 4 - PLATES
- 5 - PRESS BED
- 6 - SPECIAL TOOL 6227-1

## OVERDRIVE UNIT (Continued)

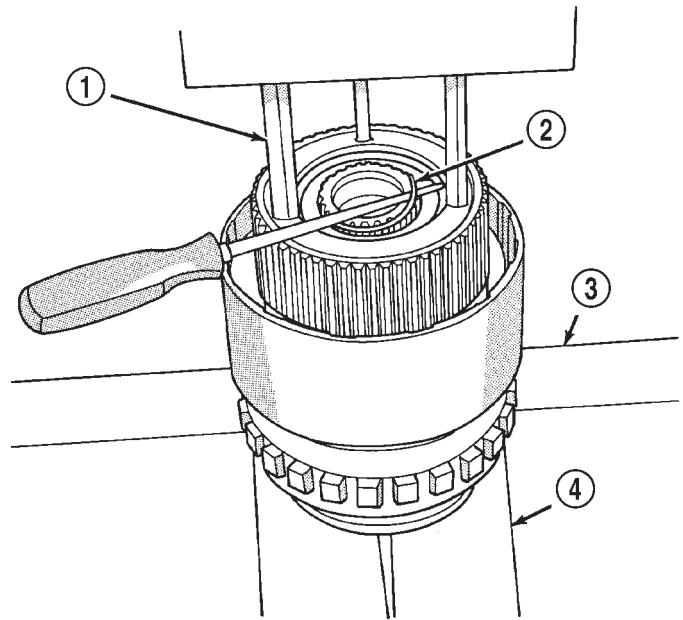
- (4) Remove direct clutch pack snap-ring (Fig. 135).
- (5) Remove direct clutch hub retaining ring (Fig. 136).
- (6) Release press load slowly and completely (Fig. 137).
- (7) Remove Special Tool 6227-1. Then remove clutch pack from hub (Fig. 137).



J9321-364

**Fig. 135 Direct Clutch Pack Snap-Ring Removal**

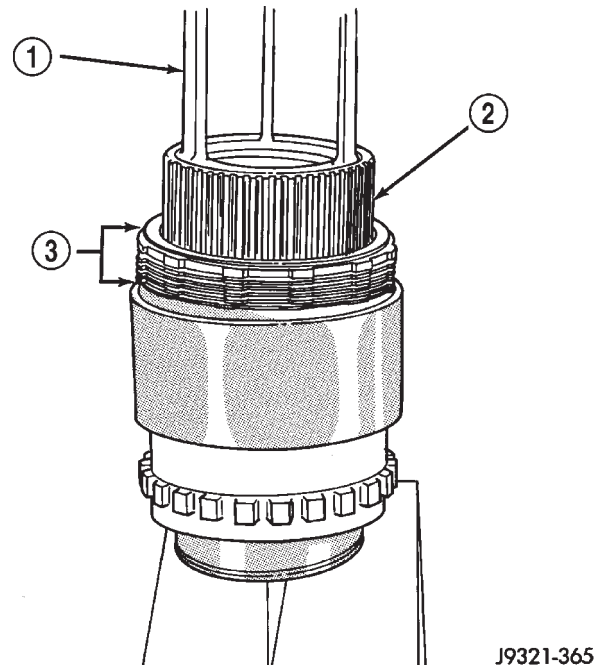
- 1 - CLUTCH HUB
- 2 - SPECIAL TOOL 6227-1
- 3 - DIRECT CLUTCH PACK SNAP-RING
- 4 - PRESS PLATES
- 5 - CLUTCH DRUM



J9321-363

**Fig. 136 Direct Clutch Hub Retaining Ring Removal**

- 1 - SPECIAL TOOL 6227-1
- 2 - CLUTCH HUB RETAINING RING
- 3 - PRESS BED
- 4 - PRESS PLATES



J9321-365

**Fig. 137 Direct Clutch Pack Removal**

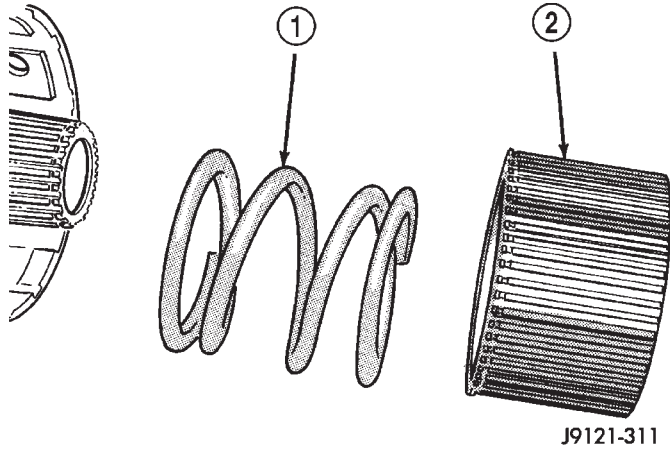
- 1 - SPECIAL TOOL 6227-1
- 2 - DIRECT CLUTCH HUB
- 3 - DIRECT CLUTCH PACK

OVERDRIVE UNIT (Continued)

**GEARTRAIN**

(1) Remove direct clutch hub and spring (Fig. 138).

(2) Remove sun gear and spring plate. Then remove planetary thrust bearing and planetary gear (Fig. 139).



J9121-311

**Fig. 138 Direct Clutch Hub And Spring Removal**

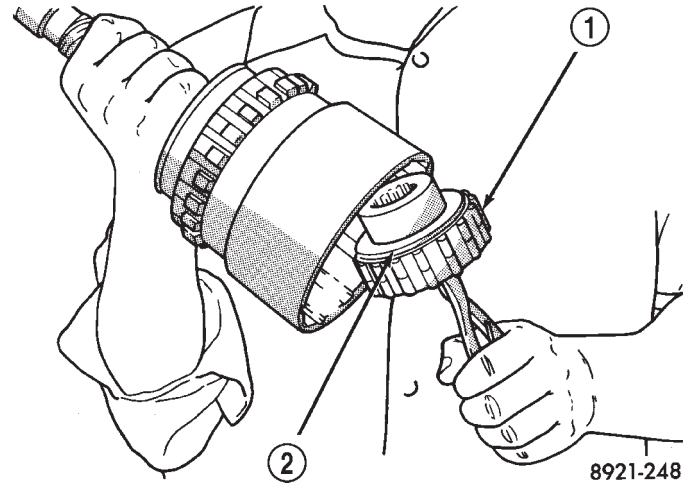
- 1 - DIRECT CLUTCH SPRING
- 2 - DIRECT CLUTCH HUB

(3) Remove overrunning clutch assembly with expanding type snap-ring pliers (Fig. 140). Insert pliers into clutch hub. Expand pliers to grip hub splines and remove clutch with counterclockwise, twisting motion.

(4) Remove thrust bearing from overrunning clutch hub.

(5) Remove overrunning clutch from hub.

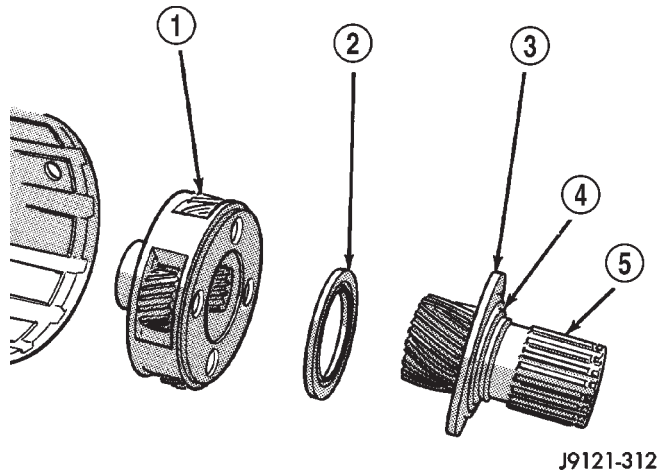
(6) Mark position of annulus gear and direct clutch drum for assembly alignment reference (Fig. 141). Use small center punch or scribe to make alignment marks.



8921-248

**Fig. 140 Overrunning Clutch**

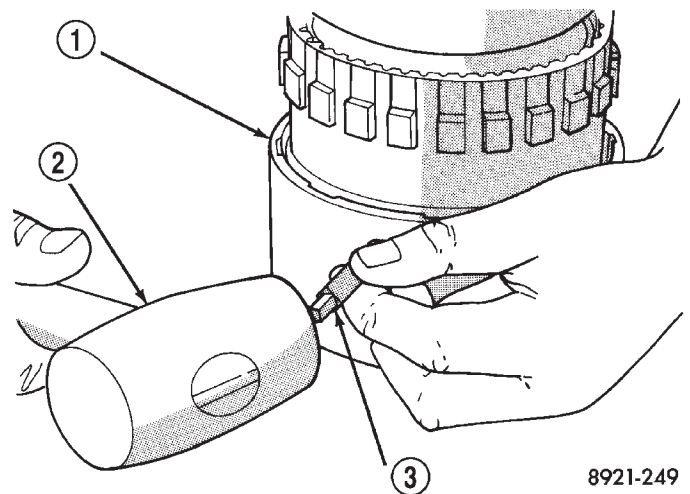
- 1 - OVERRUNNING CLUTCH
- 2 - NEEDLE BEARING



J9121-312

**Fig. 139 Removing Sun Gear, Thrust Bearing And Planetary Gear**

- 1 - PLANETARY GEAR
- 2 - PLANETARY THRUST BEARING
- 3 - CLUTCH SPRING PLATE
- 4 - SPRING PLATE SNAP-RING
- 5 - SUN GEAR



8921-249

**Fig. 141 Marking Direct Clutch Drum And Annulus Gear For Assembly Alignment**

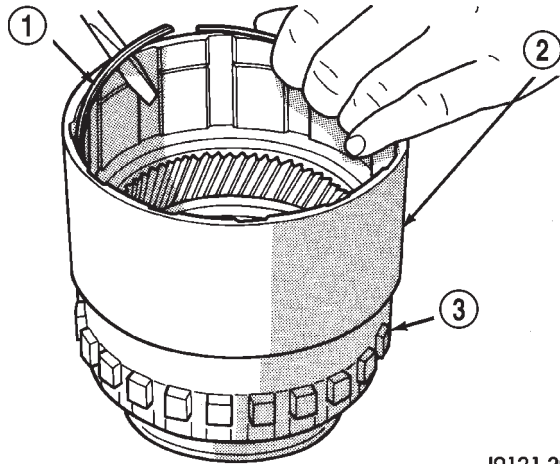
- 1 - DIRECT CLUTCH DRUM
- 2 - HAMMER
- 3 - PUNCH

## OVERDRIVE UNIT (Continued)

(7) Remove direct clutch drum rear retaining ring (Fig. 142).

(8) Remove direct clutch drum outer retaining ring (Fig. 143).

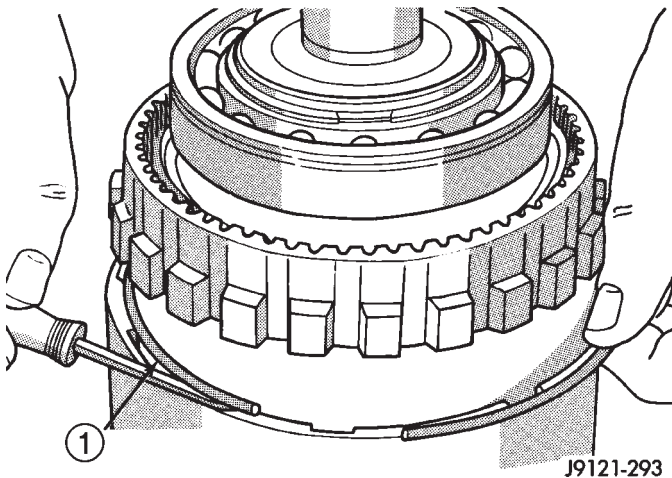
(9) Mark annulus gear and output shaft for assembly alignment reference (Fig. 144). Use punch or scriber to mark gear and shaft.



J9121-292

**Fig. 142 Clutch Drum Inner Retaining Ring Removal**

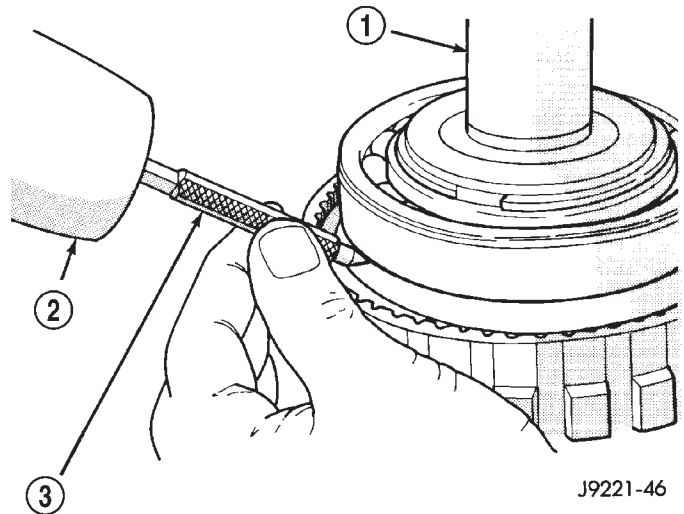
- 1 - INNER RETAINING RING
- 2 - DIRECT CLUTCH DRUM
- 3 - ANNULUS GEAR



J9121-293

**Fig. 143 Clutch Drum Outer Retaining Ring Removal**

- 1 - OUTER RETAINING RING



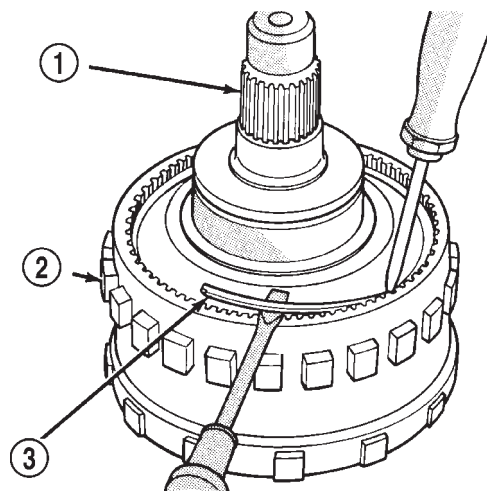
J9221-46

**Fig. 144 Marking Annulus Gear And Output Shaft For Assembly Alignment**

- 1 - OUTPUT SHAFT
- 2 - HAMMER
- 3 - PUNCH

(10) Remove snap-ring that secures annulus gear on output shaft (Fig. 145). Use two screwdrivers to unseat and work snap-ring out of groove as shown.

(11) Remove annulus gear from output shaft (Fig. 146). Use rawhide or plastic mallet to tap gear off shaft.



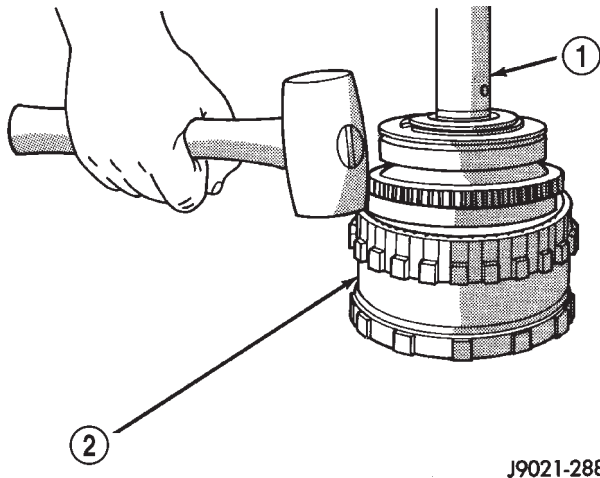
J9321-448

**Fig. 145 Annulus Gear Snap-Ring Removal**

- 1 - OUTPUT SHAFT
- 2 - ANNULUS GEAR
- 3 - SNAP-RING



## OVERDRIVE UNIT (Continued)



J9021-288

**Fig. 146 Annulus Gear Removal**

- 1 - OUTPUT SHAFT  
2 - ANNULUS GEAR

**GEAR CASE AND PARK LOCK**

- (1) Remove locating ring from gear case.
- (2) Remove park pawl shaft retaining bolt and remove shaft, pawl and spring.
- (3) Remove reaction plug snap-ring and remove reaction plug.
- (4) Remove output shaft seal.

**CLEANING**

Clean the geartrain and case components with solvent. Dry all parts except the bearings with compressed air. Allow bearings to air dry.

Do not use shop towels for wiping parts dry unless the towels are made from a lint-free material. A sufficient quantity of lint (from shop towels, cloths, rags, etc.) could plug the transmission filter and fluid passages.

Discard the old case gasket and seals. Do not attempt to salvage these parts. They are not reusable. Replace any of the overdrive unit snap-rings if distorted or damaged.

Minor nicks or scratches on components can be smoothed with crocus cloth. However, do not attempt to reduce severe scoring on any components with abrasive materials. Replace severely scored components; do not try to salvage them.

**INSPECTION**

Check condition of the park lock components and the overdrive case.

Check the bushings in the overdrive case. Replace the bushings if severely scored or worn. Also replace the case seal if loose, distorted, or damaged.

Examine the overdrive and direct clutch discs and plates. Replace the discs if the facing is worn, severely scored, or burned and flaking off. Replace the clutch plates if worn, heavily scored, or cracked. Check the lugs on the clutch plates for wear. The plates should slide freely in the drum. Replace the plates or drum if binding occurs.

Check condition of the annulus gear, direct clutch hub, clutch drum and clutch spring. Replace the gear, hub and drum if worn or damaged. Replace the spring if collapsed, distorted, or cracked.

Be sure the splines and lugs on the gear, drum and hub are in good condition. The clutch plates and discs should slide freely in these components.

Inspect the thrust bearings and spring plate. Replace the plate if worn or scored. Replace the bearings if rough, noisy, brinnelled, or worn.

Inspect the planetary gear assembly and the sun gear and bushings. If either the sun gear or the bushings are damaged, replace the gear and bushings as an assembly. The gear and bushings are not serviced separately.

The planetary carrier and pinions must be in good condition. Also be sure the pinion pins are secure and in good condition. Replace the carrier if worn or damaged.

Inspect the overrunning clutch and race. The race surface should be smooth and free of scores. Replace the overrunning clutch assembly or the race if either assembly is worn or damaged in any way.

Replace the shaft pilot bushing and inner bushing if damaged. Replace either shaft bearing if rough or noisy. Replace the bearing snap-rings if distorted or cracked.

Check the machined surfaces on the output shaft. These surfaces should be clean and smooth. Very minor nicks or scratches can be smoothed with crocus cloth. Replace the shaft if worn, scored or damaged in any way.

Inspect the output shaft bushings. The small bushing is the intermediate shaft pilot bushing. The large bushing is the overrunning clutch hub bushing. Replace either bushing if scored, pitted, cracked, or worn.

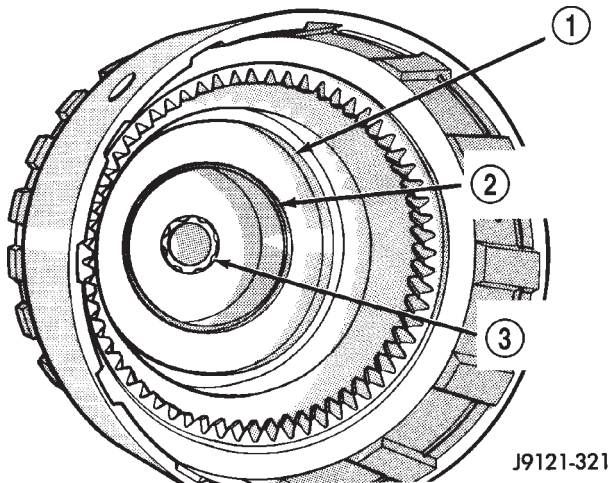
## OVERDRIVE UNIT (Continued)

## ASSEMBLY

## GEARTRAIN AND DIRECT CLUTCH

(1) Soak direct clutch and overdrive clutch discs in Mopar® ATF +4, type 9602, transmission fluid. Allow discs to soak for 10-20 minutes.

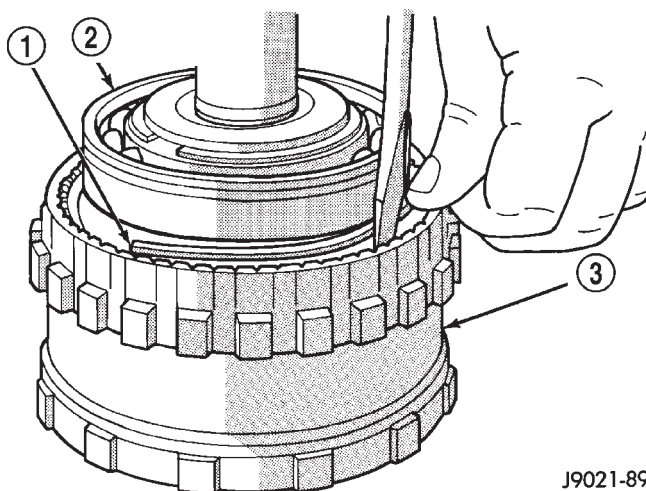
(2) Install new pilot bushing and clutch hub bushing in output shaft if necessary (Fig. 147). Lubricate bushings with petroleum jelly, or transmission fluid.



**Fig. 147 Output Shaft Pilot Bushing**

- 1 - OUTPUT SHAFT HUB
- 2 - OVERRUNNING CLUTCH HUB BUSHING
- 3 - INTERMEDIATE SHAFT PILOT BUSHING

(3) Install annulus gear on output shaft, if removed. Then install annulus gear retaining snap-ring (Fig. 148).

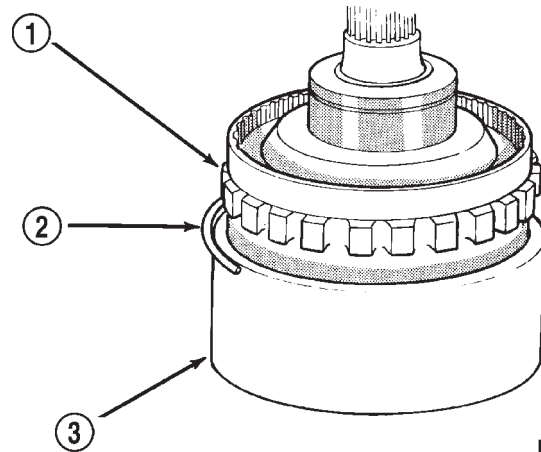


**Fig. 148 Annulus Gear Installation**

- 1 - SNAP-RING
- 2 - OUTPUT SHAFT FRONT BEARING
- 3 - ANNULUS GEAR

(4) Align and install clutch drum on annulus gear (Fig. 149). Be sure drum is engaged in annulus gear lugs.

(5) Install clutch drum outer retaining ring (Fig. 149).

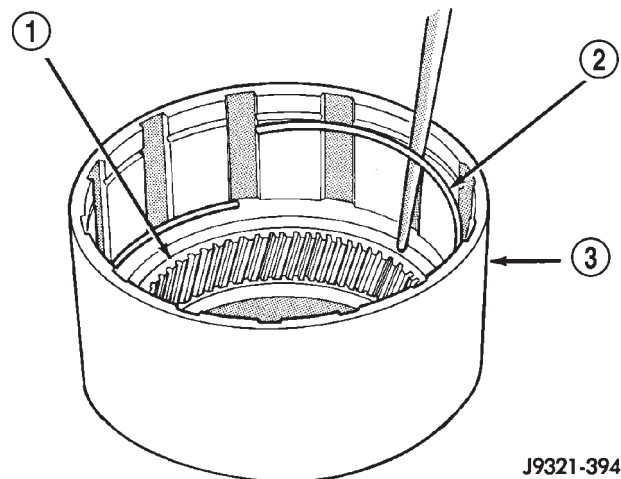


**Fig. 149 Clutch Drum And Outer Retaining Ring Installation**

- 1 - ANNULUS GEAR
- 2 - OUTER SNAP-RING
- 3 - CLUTCH DRUM

(6) Slide clutch drum forward and install inner retaining ring (Fig. 150).

(7) Install rear bearing and snap-ring on output shaft (Fig. 151). Be sure locating ring groove in bearing is toward rear.

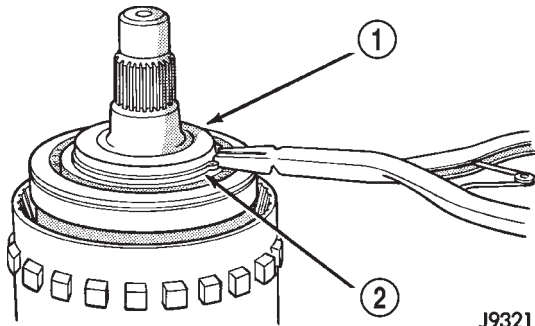


**Fig. 150 Clutch Drum Inner Retaining Ring Installation**

- 1 - ANNULUS GEAR
- 2 - INNER SNAP-RING
- 3 - CLUTCH DRUM



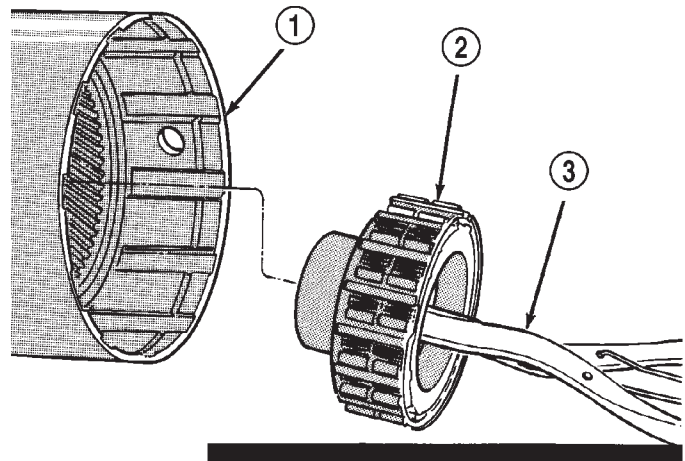
## OVERDRIVE UNIT (Continued)



J9321-370

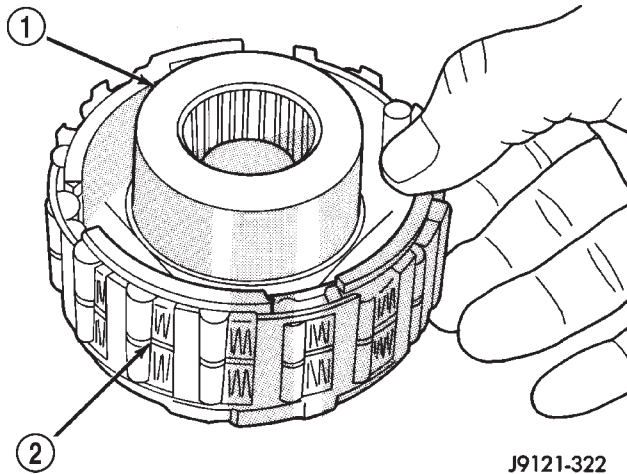
**Fig. 151 Rear Bearing And Snap-Ring Installation**

- 1 - REAR BEARING
- 2 - SNAP-RING



(8) Install overrunning clutch on hub (Fig. 152). Note that clutch only fits one-way. Shoulder on clutch should seat in small recess at edge of hub.

(9) Install thrust bearing on overrunning clutch hub. Use generous amount of petroleum jelly to hold bearing in place for installation. Bearing fits one-way only. Be sure bearing is seated squarely against hub. Reinstall bearing if it does not seat squarely.



J9121-322

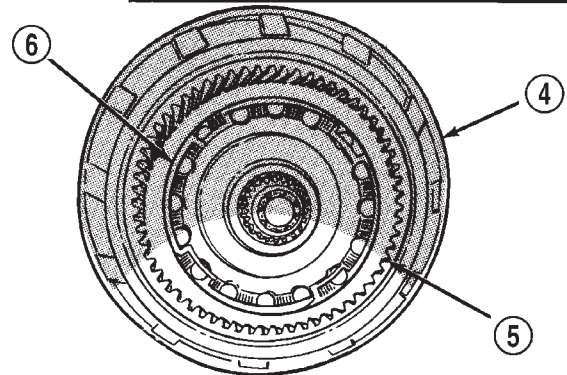
**Fig. 152 Assembling Overrunning Clutch And Hub**

- 1 - CLUTCH HUB
- 2 - OVERRUNNING CLUTCH

(10) Install overrunning clutch in output shaft (Fig. 153). Insert snap-ring pliers in hub splines. Expand pliers to grip hub. Then install assembly with counterclockwise, twisting motion.

(11) Install planetary gear in annulus gear (Fig. 154). Be sure planetary pinions are fully seated in annulus gear before proceeding.

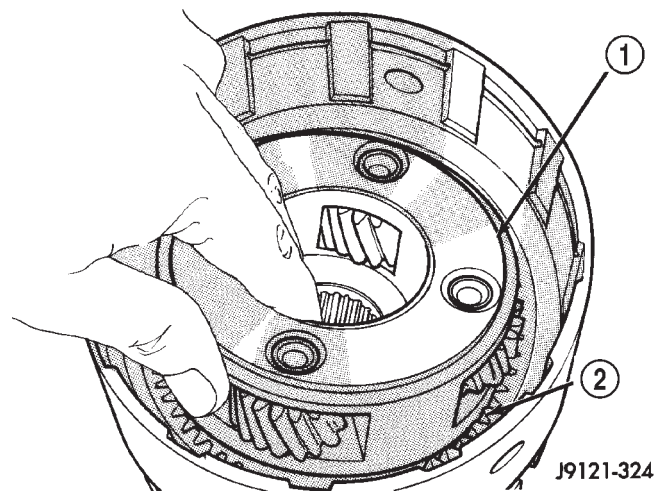
(12) Coat planetary thrust bearing and bearing contact surface of spring plate with generous amount of petroleum jelly. This will help hold bearing in place during installation.



J9121-314

**Fig. 153 Overrunning Clutch Installation**

- 1 - CLUTCH DRUM
- 2 - OVERRUNNING CLUTCH ASSEMBLY
- 3 - EXPANDING-TYPE SNAP-RING PLIERS
- 4 - CLUTCH DRUM
- 5 - ANNULUS GEAR
- 6 - OVERRUNNING CLUTCH ASSEMBLY SEATED IN OUTPUT SHAFT



J9121-324

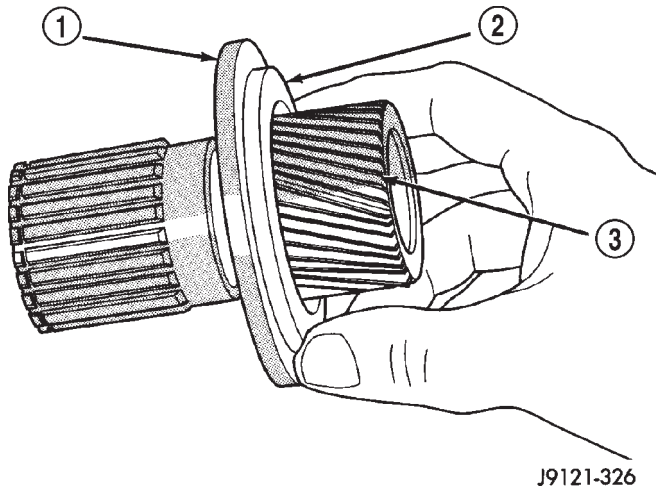
**Fig. 154 Planetary Gear Installation**

- 1 - PLANETARY GEAR
- 2 - ANNULUS GEAR

## OVERDRIVE UNIT (Continued)

(13) Install planetary thrust bearing on sun gear (Fig. 155). Slide bearing onto gear and seat it against spring plate as shown. Bearing fits one-way only. If it does not seat squarely against spring plate, remove and reposition bearing.

(14) Install assembled sun gear, spring plate and thrust bearing (Fig. 156). Be sure sun gear and thrust bearing are fully seated before proceeding.

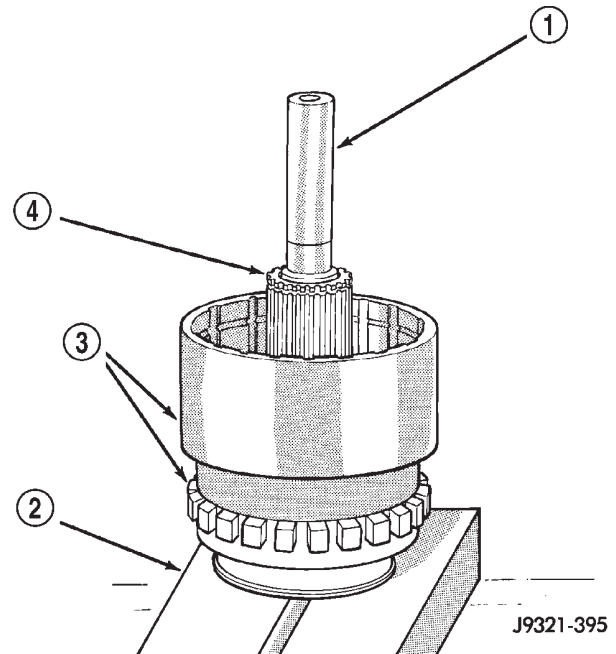


J9121-326

**Fig. 155 Planetary Thrust Bearing Installation**

- 1 - SPRING PLATE
- 2 - PLANETARY THRUST BEARING
- 3 - SUN GEAR

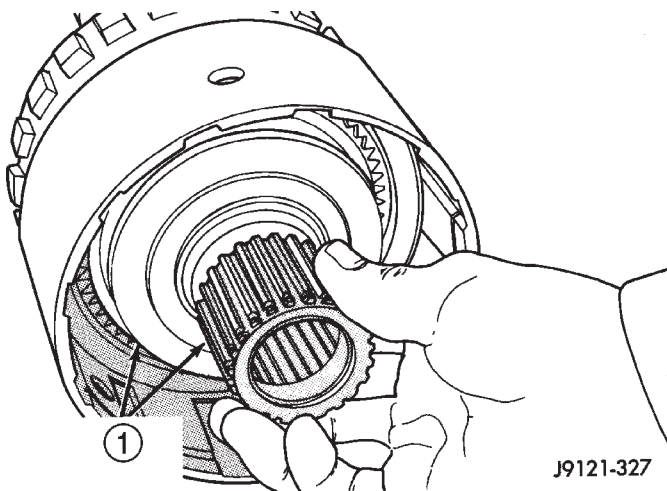
(17) Install direct clutch spring (Fig. 158). Be sure spring is properly seated on spring plate.



J9321-395

**Fig. 157 Alignment Tool Installation**

- 1 - SPECIAL TOOL 6227-2
- 2 - PRESS PLATES
- 3 - ASSEMBLED DRUM AND ANNULUS GEAR
- 4 - SUN GEAR



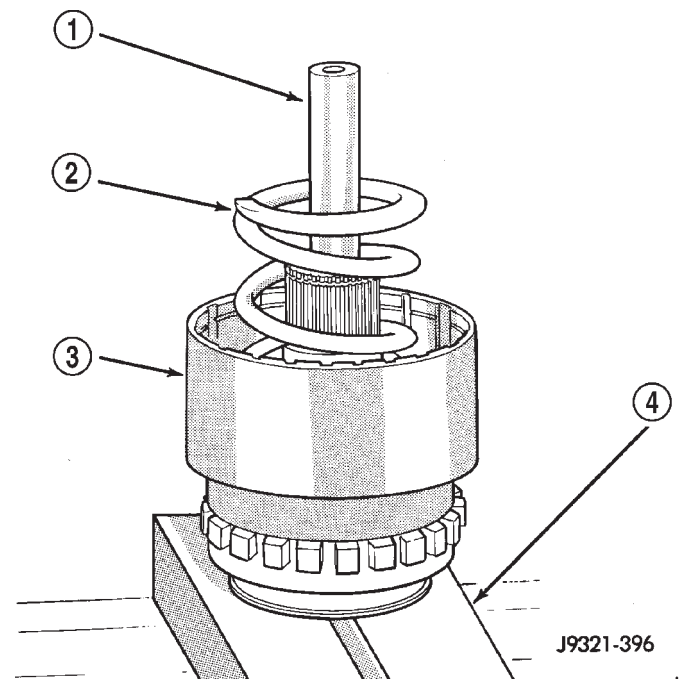
J9121-327

**Fig. 156 Sun Gear Installation**

- 1 - SUN GEAR AND SPRING PLATE ASSEMBLY

(15) Mount assembled output shaft, annulus gear, and clutch drum in shop press. Direct clutch spring, hub and clutch pack are easier to install with assembly mounted in press.

(16) Align splines in hubs of planetary gear and overrunning clutch with Alignment tool 6227-2 (Fig. 157). Insert tool through sun gear and into splines of both hubs. Be sure alignment tool is fully seated before proceeding.



J9321-396

**Fig. 158 Direct Clutch Spring Installation**

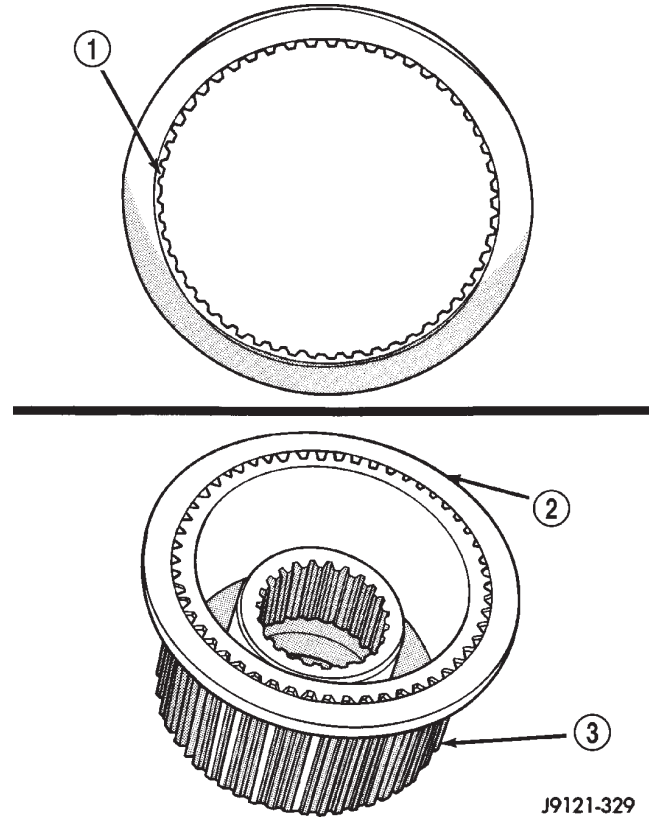
- 1 - SPECIAL TOOL 6227-2
- 2 - DIRECT CLUTCH SPRING
- 3 - CLUTCH HUB
- 4 - PRESS PLATES

OVERDRIVE UNIT (Continued)

**NOTE:** The 42RE transmission has 6 direct clutch discs and 5 clutch plates.

(18) Assemble and install direct clutch pack on hub as follows:

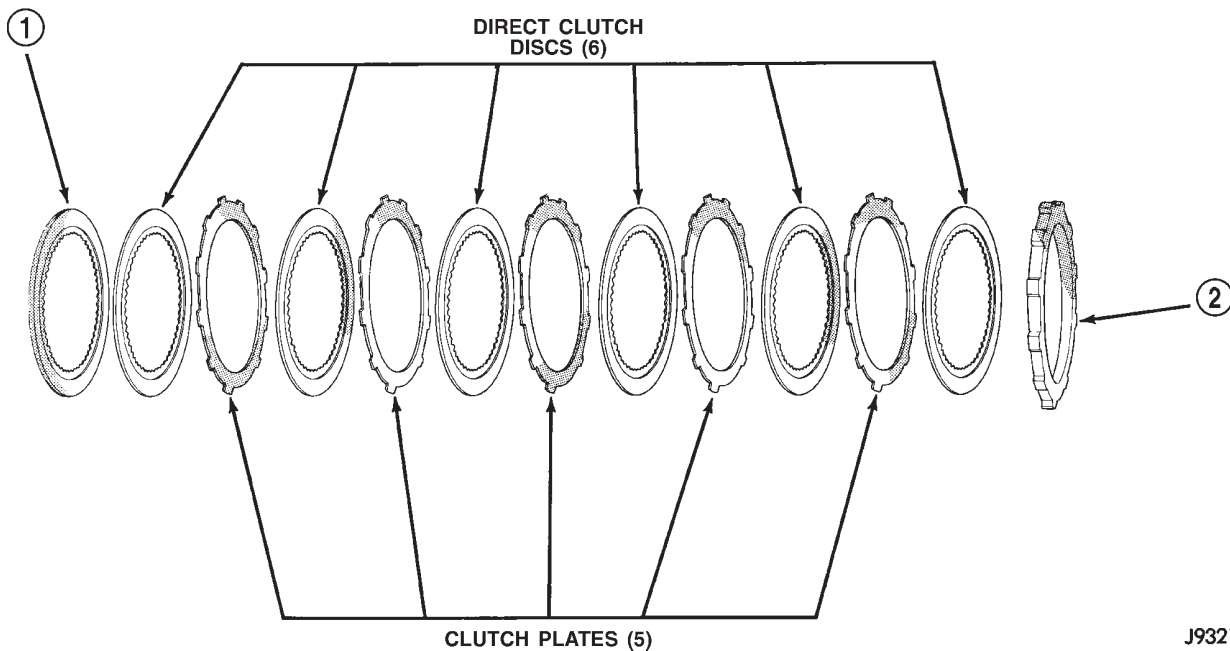
- (a) Assemble clutch pack components (Fig. 159).
- (b) Install direct clutch reaction plate on clutch hub first. Note that one side of reaction plate is counterbored. Be sure this side faces rearward. Splines at rear of hub are raised slightly. Counterbore in plate fits over raised splines. Plate should be flush with this end of hub (Fig. 160).
- (c) Install first clutch disc followed by a steel plate until all discs and plates have been installed.
- (d) Install pressure plate. This is last clutch pack item to be installed. Be sure plate is installed with shoulder side facing upward (Fig. 161).



J9121-329

**Fig. 160 Correct Position Of Direct Clutch Reaction Plate**

- 1 - REACTION PLATE COUNTERBORE
- 2 - DIRECT CLUTCH REACTION PLATE (FLUSH WITH END OF HUB)
- 3 - CLUTCH HUB



J9321-368

**Fig. 159 42RE Direct Clutch Pack Components**

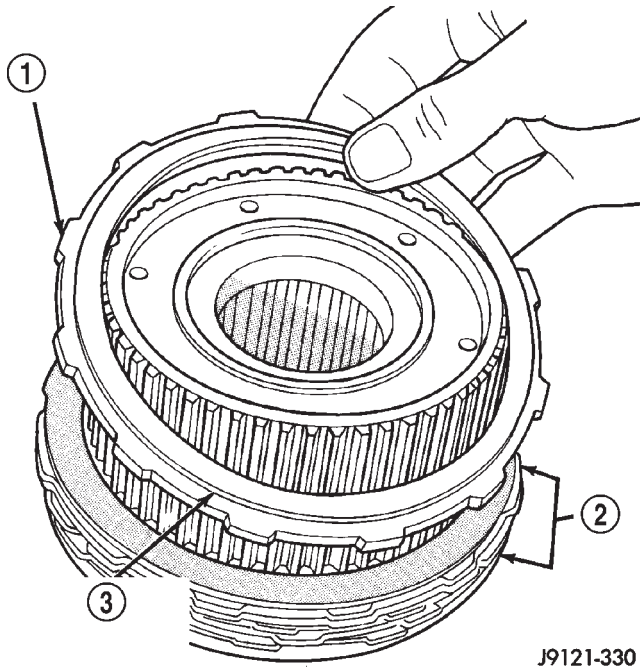
1 - REACTION PLATE

2 - PRESSURE PLATE



## OVERDRIVE UNIT (Continued)

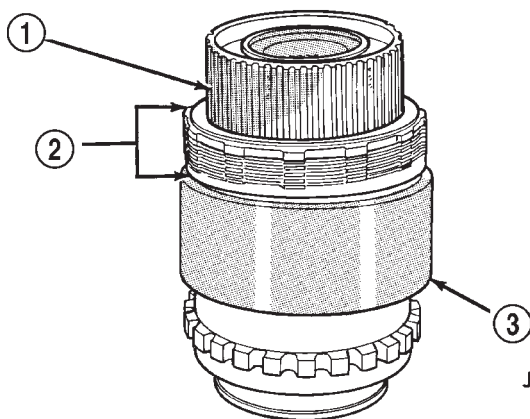
(19) Install clutch hub and clutch pack on direct clutch spring (Fig. 162). Be sure hub is started on sun gear splines before proceeding.



J9121-330

**Fig. 161 Correct Position Of Direct Clutch Pressure Plate**

- 1 - DIRECT CLUTCH PRESSURE PLATE
- 2 - CLUTCH PACK
- 3 - BE SURE SHOULDER SIDE OF PLATE FACES UPWARD



J9321-397

**Fig. 162 Direct Clutch**

- 1 - CLUTCH HUB
- 2 - DIRECT CLUTCH PACK
- 3 - CLUTCH DRUM

**WARNING: THE NEXT STEP IN GEARTRAIN ASSEMBLY INVOLVES COMPRESSING THE DIRECT CLUTCH HUB AND SPRING. IT IS EXTREMELY IMPORTANT THAT PROPER EQUIPMENT BE USED TO COMPRESS THE SPRING AS SPRING FORCE IS APPROXIMATELY 830 POUNDS. USE COMPRESSOR TOOL C-6227-1 AND A HYDRAULIC-TYPE SHOP PRESS WITH A MINIMUM RAM TRAVEL OF 6 INCHES. THE PRESS MUST ALSO HAVE A BED THAT CAN BE ADJUSTED UP OR DOWN AS REQUIRED. RELEASE CLUTCH SPRING TENSION SLOWLY AND COMPLETELY TO AVOID PERSONAL INJURY.**

(20) Position Compressor Tool 6227-1 on clutch hub.

(21) Compress clutch hub and spring just enough to place tension on hub and hold it in place.

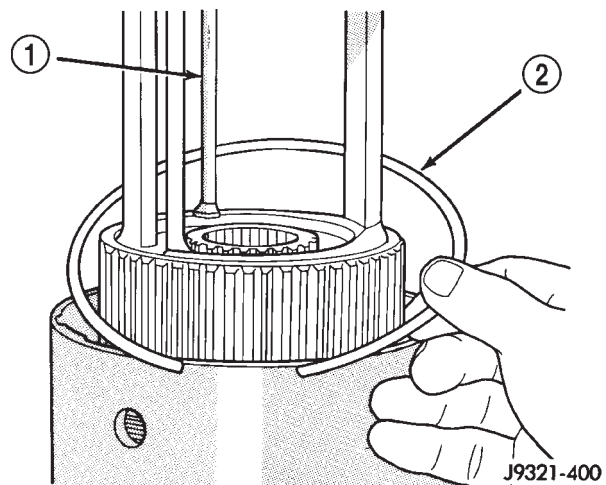
(22) Slowly compress clutch hub and spring. Compress spring and hub only enough to expose ring grooves for clutch pack snap ring and clutch hub retaining ring.

(23) Realign clutch pack on hub and seat clutch discs and plates in clutch drum.

(24) Install direct clutch pack snap-ring (Fig. 163). Be very sure snap-ring is fully seated in clutch drum ring groove.

(25) Install clutch hub retaining ring (Fig. 164). Be very sure retaining ring is fully seated in sun gear ring groove.

(26) Slowly release press ram, remove compressor tools and remove geartrain assembly.

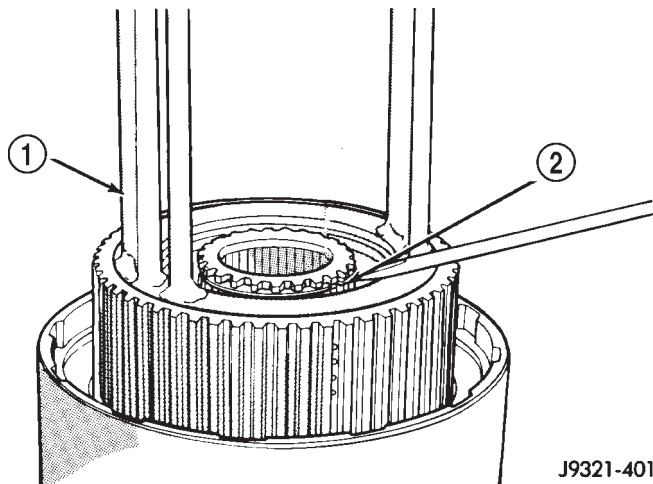


J9321-400

**Fig. 163 Direct Clutch Pack Snap-Ring Installation**

- 1 - SPECIAL TOOL 6227-1
- 2 - DIRECT CLUTCH PACK SNAP-RING

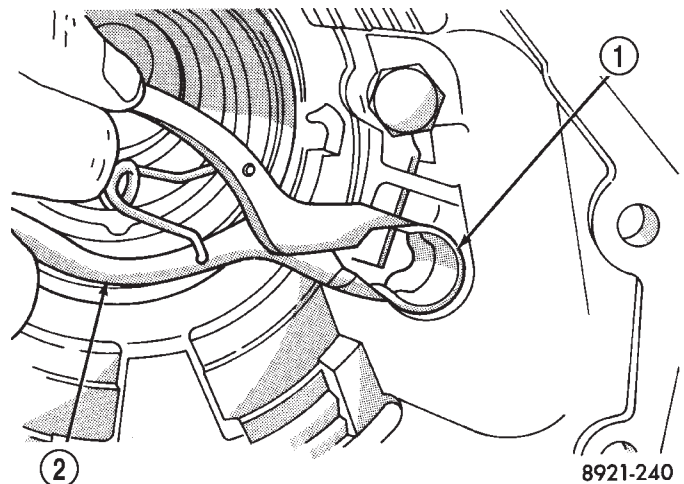
OVERDRIVE UNIT (Continued)



J9321-401

**Fig. 164 Clutch Hub Retaining Ring Installation**

- 1 - SPECIAL TOOL 6227-1
- 2 - CLUTCH HUB RETAINING RING



8921-240

**Fig. 166 Reaction Plug And Snap-Ring Installation**

- 1 - REACTION PLUG SNAP-RING
- 2 - SNAP-RING PLIERS

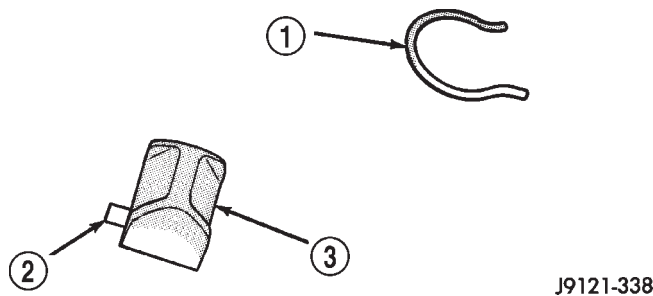
**GEAR CASE**

(1) Position park pawl and spring in case and install park pawl shaft. Verify that end of spring with 90° bend is hooked to pawl and straight end of spring is seated against case.

(2) Install pawl shaft retaining bolt. Tighten bolt to 27 N·m (20 ft. lbs.) torque.

(3) Install park lock reaction plug. Note that plug has locating pin at rear (Fig. 165). Be sure pin is seated in hole in case before installing snap-ring.

(4) Install reaction plug snap-ring (Fig. 166). Compress snap ring only enough for installation; do not distort it.



J9121-338

**Fig. 165 Reaction Plug Locating Pin And Snap-Ring**

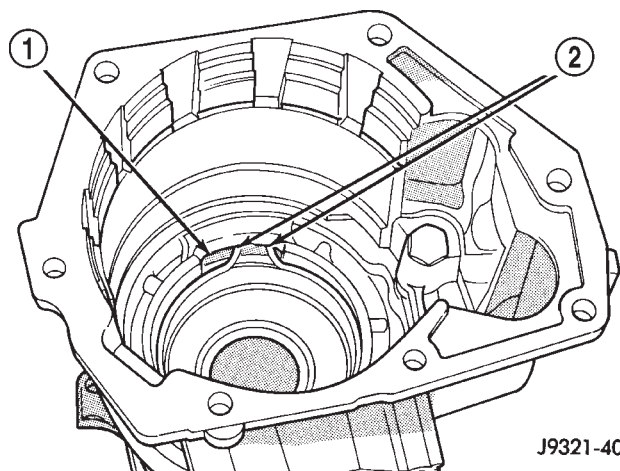
- 1 - REACTION PLUG SNAP-RING (DO NOT OVERCOMPRESS TO INSTALL)
- 2 - LOCATING PIN
- 3 - PARK LOCK REACTION PLUG

(5) Install new seal in gear case. On 4x4 gear case, use Tool Handle C-4171 and Installer C-3860-A to seat seal in case. On 4 x 2 gear case, use same Handle C-4171 and Installer C-3995-A to seat seal in case.

(6) Verify that tab ends of rear bearing locating ring extend into access hole in gear case (Fig. 167).

(7) Support geartrain on Tool 6227-1 (Fig. 168). Be sure tool is securely seated in clutch hub.

(8) Install overdrive gear case on geartrain (Fig. 168).

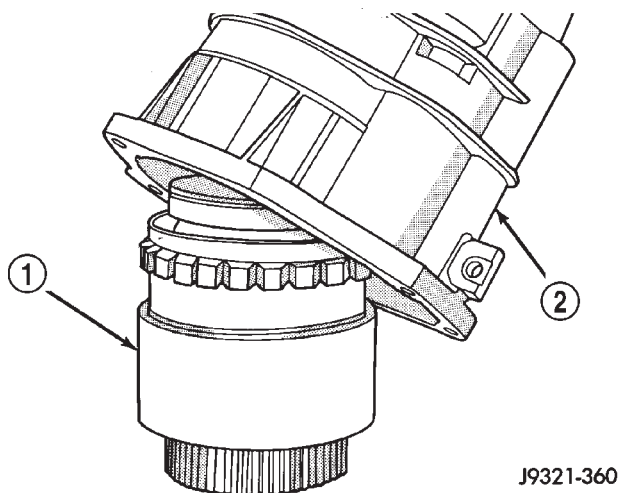


J9321-403

**Fig. 167 Correct Rear Bearing Locating Ring Position**

- 1 - CASE ACCESS HOLE
- 2 - TAB ENDS OF LOCATING RING

## OVERDRIVE UNIT (Continued)



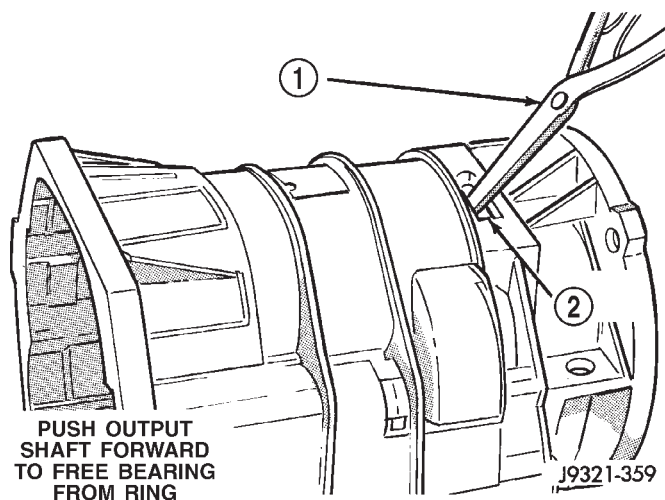
J9321-360

**Fig. 168 Overdrive Gear Case Installation**

- 1 - GEARTRAIN ASSEMBLY  
2 - GEAR CASE

(9) Expand front bearing locating ring with snapping pliers (Fig. 169). Then slide case downward until locating ring locks in bearing groove and release snap-ring.

(10) Install locating ring access cover and gasket in overdrive unit case (Fig. 170).



J9321-359

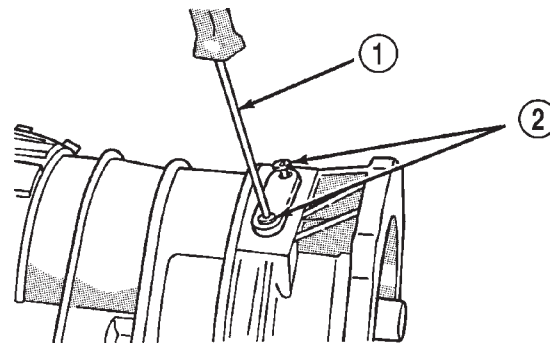
**Fig. 169 Seating Locating Ring In Rear Bearing**

- 1 - EXPAND BEARING LOCATING RING WITH SNAP-RING PLIERS  
2 - ACCESS HOLE

**OVERDRIVE CLUTCH**

(1) Install overdrive clutch reaction ring first. Reaction ring is flat with notched ends (Fig. 171).

(2) Install wave spring on top of reaction ring (Fig. 172). Reaction ring and wave ring both fit in same ring groove. Use screwdriver to seat each ring securely in groove. Also ensure that the ends of the two rings are offset from each other.



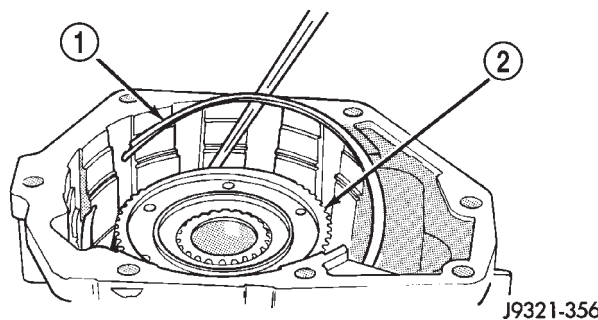
J9321-357

**Fig. 170 Locating Ring Access Cover And Gasket Installation**

- 1 - TORX SCREWDRIVER (T25)  
2 - ACCESS COVER SCREWS

**NOTE:** The 42RE transmission has 3 overdrive clutch discs and 2 plates.

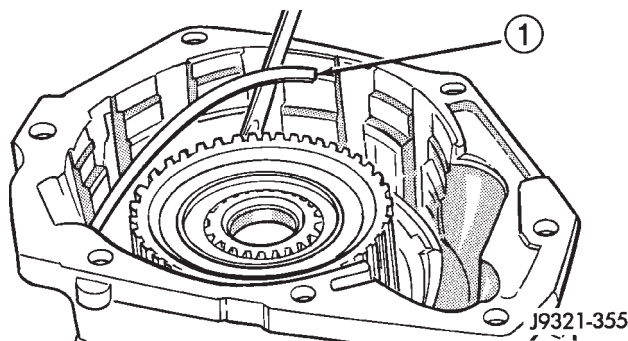
(3) Assemble overdrive clutch pack (Fig. 173).



J9321-356

**Fig. 171 Overdrive Clutch Reaction Ring Installation**

- 1 - REACTION RING  
2 - CLUTCH HUB



J9321-355

**Fig. 172 Overdrive Clutch Wave Spring Installation**

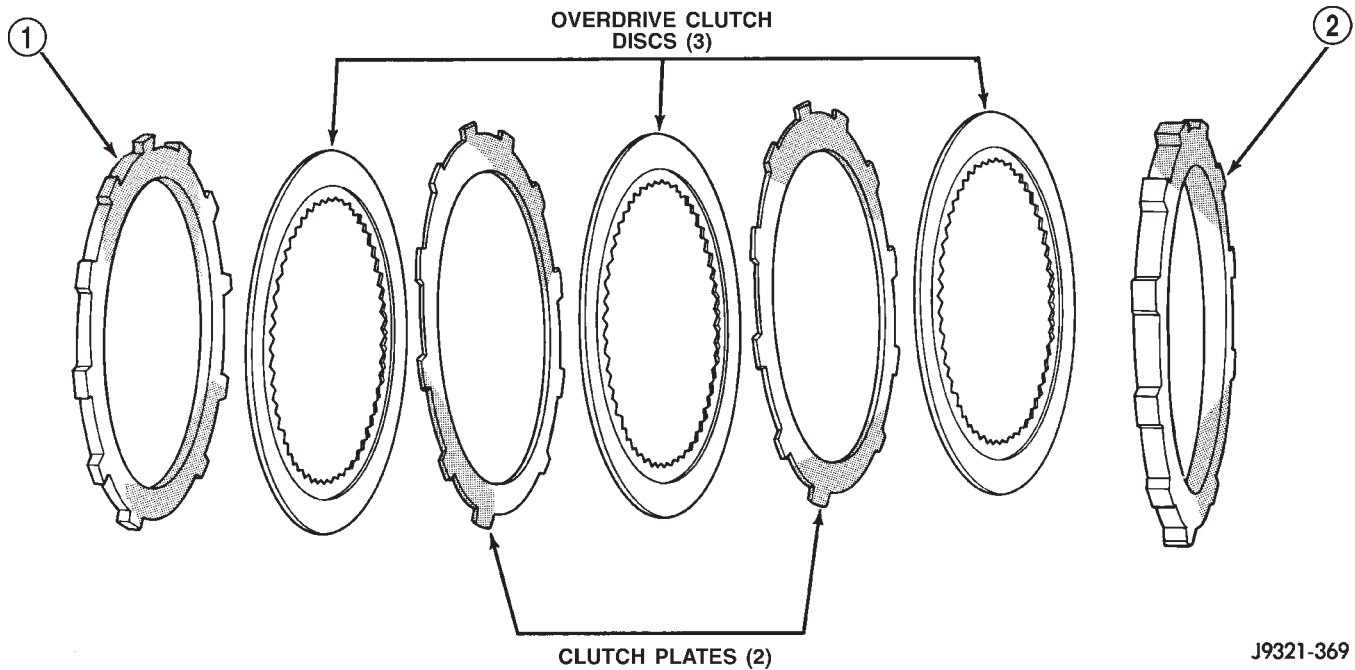
- 1 - WAVE SPRING

(4) Install overdrive clutch reaction plate first.

**NOTE:** The reaction plate is thinner than the pressure plate in a 42RE transmission.



## OVERDRIVE UNIT (Continued)



**Fig. 173 42RE Overdrive Clutch Components**

1 - REACTION PLATE

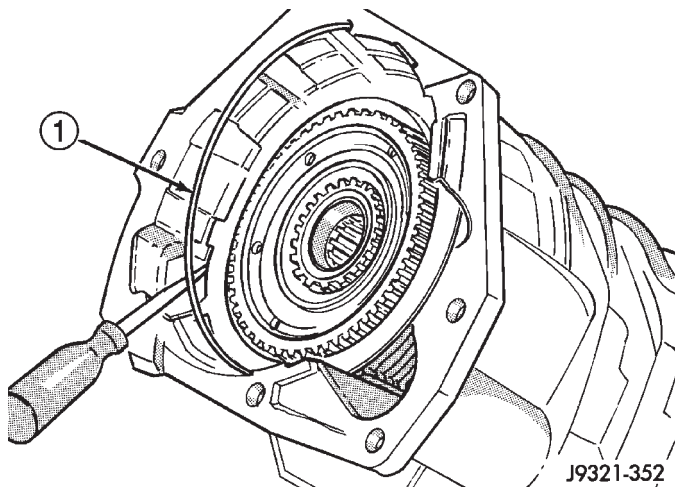
2 - PRESSURE PLATE

J9321-369

(5) Install first clutch disc followed by first clutch plate. Then install remaining clutch discs and plates in same order.

(6) Install clutch pack pressure plate.

(7) Install clutch pack wire-type retaining ring (Fig. 174).



J9321-352

**Fig. 174 Overdrive Clutch Pack Retaining Ring Installation**

1 - OVERDRIVE CLUTCH PACK RETAINING RING

### INTERMEDIATE SHAFT SPACER SELECTION

(1) Place overdrive unit in vertical position. Mount it on blocks, or in workbench with appropriate size mounting hole cut into it. Be sure unit is facing upward for access to direct clutch hub. Also be sure output shaft is not loaded and internal components are moved rearward for accurate measurement.

(2) Determine correct thickness intermediate shaft spacer as follows:

(a) Insert Special Tool 6312 through sun gear, planetary gear and into pilot bushing in output shaft. Be sure tool bottoms against planetary shoulder.

(b) Position Gauge Tool 6311 across face of overdrive case (Fig. 175). Then position Dial Caliper C-4962 over gauge tool.

(c) Extend sliding scale of dial caliper downward through gauge tool slot until scale contacts end of Gauge Alignment Tool 6312. Lock scale in place. Remove dial caliper tool and note distance measured (Fig. 175).

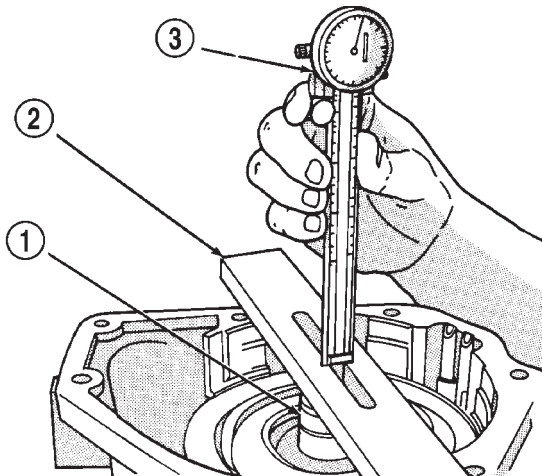
(d) Select proper thickness end play spacer from spacer chart based on distance measured (Fig. 176).

(e) Remove Gauge Alignment Tool 6312.

### OD THRUST PLATE SELECTION

(1) Place overdrive unit in vertical position. Mount it on blocks, or in workbench with appropriate size

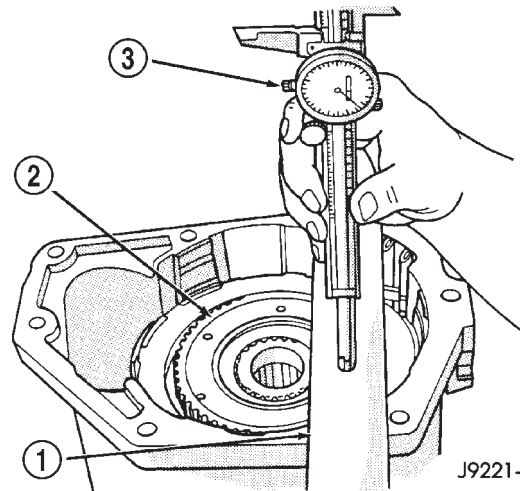
## OVERDRIVE UNIT (Continued)



J9221-47

**Fig. 175 Shaft End Play Measurement**

- 1 - SPECIAL TOOL 6312
- 2 - SPECIAL TOOL 6311
- 3 - SPECIAL TOOL C-4962



J9221-48

**Fig. 177 Overdrive Piston Thrust Plate Measurement**

- 1 - SPECIAL TOOL 6311
- 2 - DIRECT CLUTCH HUB THRUST BEARING SEAT
- 3 - SPECIAL TOOL C-4962

End Play Measurement (Inches)	Spacer Thickness (Inches)
.7336 - .7505	.158 - .159
.7506 - .7675	.175 - .176
.7676 - .7855	.193 - .194
.7856 - .8011	.211 - .212

J9121-341

**Fig. 176 Intermediate Shaft End Play Spacer Selection**

mounting hole cut into it. Be sure unit is facing upward for access to direct clutch hub. Also be sure output shaft is not loaded and internal components are moved rearward for accurate measurement.

(2) Determine correct thickness overdrive piston thrust plate as follows:

(a) Position Gauge Tool 6311 across face of overdrive case. Then position Dial Caliper C-4962 over gauge tool (Fig. 177).

(b) Measure distance to clutch hub thrust bearing seat at four points 90° apart. Then average measurements by adding them and dividing by 4.

(c) Select and install required thrust plate from information in thrust plate chart (Fig. 178).

(3) Leave Alignment Tool 6227-2 in place. Tool will keep planetary and clutch hub splines in alignment until overdrive unit is ready for installation on transmission.

(4) Transmission speed sensor can be installed at this time if desired. However, it is recommended that sensor not be installed until after overdrive unit is secured to transmission.

End Play Measurement (Inches)	Spacer Thickness (Inches)
1.7500 - 1.7649	.108 - .110
1.7650 - 1.7799	.123 - .125
1.7800 - 1.7949	.138 - .140
1.7950 - 1.8099	.153 - .155
1.8100 - 1.8249	.168 - .170
1.8250 - 1.8399	.183 - .185
1.8400 - 1.8549	.198 - .200
1.8550 - 1.8699	.213 - .215
1.8700 - 1.8849	.228 - .230
1.8850 - 1.8999	.243 - .245

J9121-342

**Fig. 178 Overdrive Piston Thrust Plate Selection****OVERDRIVE PISTON**

(1) Install new seals on over drive piston.

(2) Stand transmission case upright on bellhousing.

(3) Position Guide Ring 8114-1 on outer edge of overdrive piston retainer.

(4) Position Seal Guide 8114-2 on inner edge of overdrive piston retainer.

(5) Install overdrive piston in overdrive piston retainer by: aligning locating lugs on overdrive piston to the two mating holes in retainer.

(a) Aligning locating lugs on overdrive piston to the two mating holes in retainer.

(b) Lubricate overdrive piston seals with Mopar® Door Ease, or equivalent.

(c) Install piston over Seal Guide 8114-2 and inside Guide Ring 8114-1.

## OVERDRIVE UNIT (Continued)

(d) Push overdrive piston into position in retainer.

(e) Verify that the locating lugs entered the lug bores in the retainer.

(6) Install intermediate shaft spacer on intermediate shaft.

(7) Install overdrive piston thrust plate on overdrive piston.

(8) Install overdrive piston thrust bearing on overdrive piston.

(9) Install transmission speed sensor and O-ring seal in overdrive case (Fig. 119).

## INSTALLATION

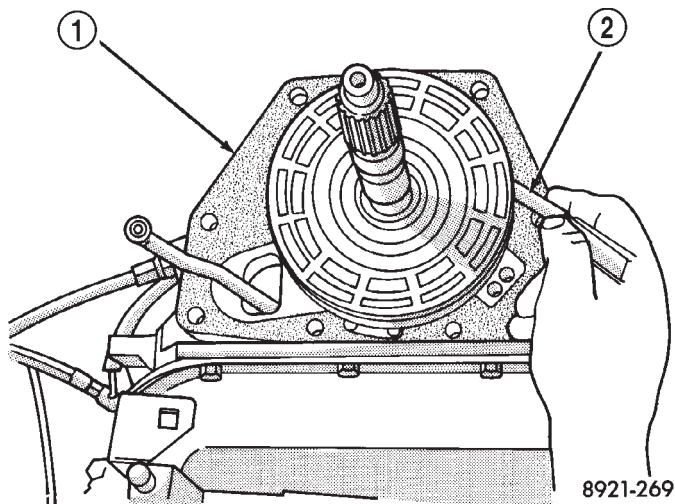
(1) Be sure overdrive unit Alignment Tool 6227-2 is fully seated before moving unit. If tool is not seated and gear splines rotate out of alignment, overdrive unit will have to be disassembled in order to realign splines.

(2) If overdrive piston retainer was not removed during service and original case gasket is no longer reusable, prepare new gasket by trimming it.

(3) Cut out old case gasket around piston retainer with razor knife (Fig. 179).

(4) Use old gasket as template and trim new gasket to fit.

(5) Position new gasket over piston retainer and on transmission case. Use petroleum jelly to hold gasket in place if necessary. Do not use any type of sealer to secure gasket. Use petroleum jelly only.

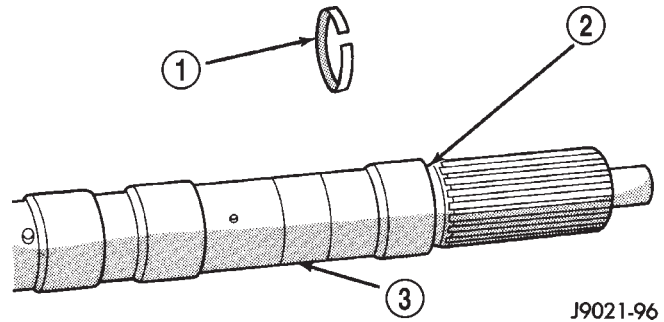


**Fig. 179 Trimming Overdrive Case Gasket**

- 1 - GASKET  
2 - SHARP KNIFE

(6) Install selective spacer on intermediate shaft, if removed. Spacer goes in groove just rearward of shaft rear splines (Fig. 180).

(7) Install thrust bearing in overdrive unit sliding hub. Use petroleum jelly to hold bearing in position.



**Fig. 180 Intermediate Shaft Selective Spacer Location**

- 1 - SELECTIVE SPACER  
2 - SPACER GROOVE  
3 - INTERMEDIATE SHAFT

**CAUTION:** Be sure the shoulder on the inside diameter of the bearing is facing forward.

(8) Verify that splines in overdrive planetary gear and overrunning clutch hub are aligned with Alignment Tool 6227-2. Overdrive unit cannot be installed if splines are not aligned. If splines have rotated out of alignment, unit will have to be disassembled to realign splines.

(9) Carefully slide Alignment Tool 6227-2 out of overdrive planetary gear and overrunning clutch splines.

(10) Raise overdrive unit and carefully slide it straight onto intermediate shaft. Insert park rod into park lock reaction plug at same time. Avoid tilting overdrive during installation as this could cause planetary gear and overrunning clutch splines to rotate out of alignment. If this occurs, it will be necessary to remove and disassemble overdrive unit to realign splines.

(11) Work overdrive unit forward on intermediate shaft until seated against transmission case.

(12) Install bolts attaching overdrive unit to transmission unit. Tighten bolts in diagonal pattern to 34 N·m (25 ft-lbs).

(13) Connect the transmission speed sensor and overdrive wiring connectors.

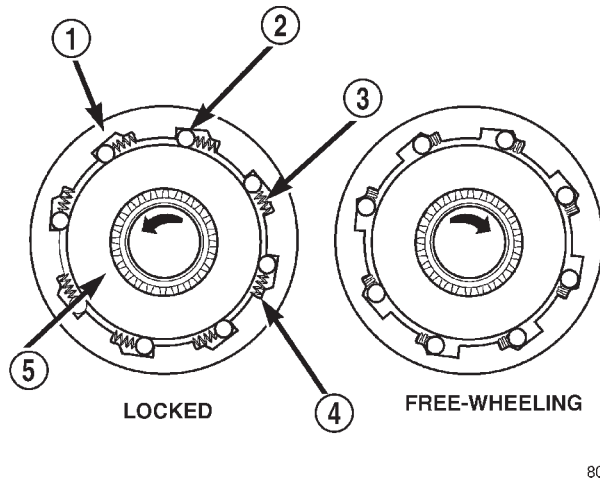
(14) Install the transfer case, if equipped.

(15) Align and install rear propeller shaft, if necessary. (Refer to 3 - DIFFERENTIAL & DRIVELINE/ PROPELLER SHAFT/PROPELLER SHAFT - INSTALLATION)

## OVERRUNNING CLUTCH CAM/OVERDRIVE PISTON RETAINER

### DESCRIPTION

The overrunning clutch (Fig. 181) consists of an inner race, an outer race (or cam), rollers and springs, and the spring retainer. The number of rollers and springs depends on what transmission and which overrunning clutch is being dealt with.



**Fig. 181 Overrunning Clutch**

- 1 - OUTER RACE (CAM)
- 2 - ROLLER
- 3 - SPRING
- 4 - SPRING RETAINER
- 5 - INNER RACE (HUB)

### OPERATION

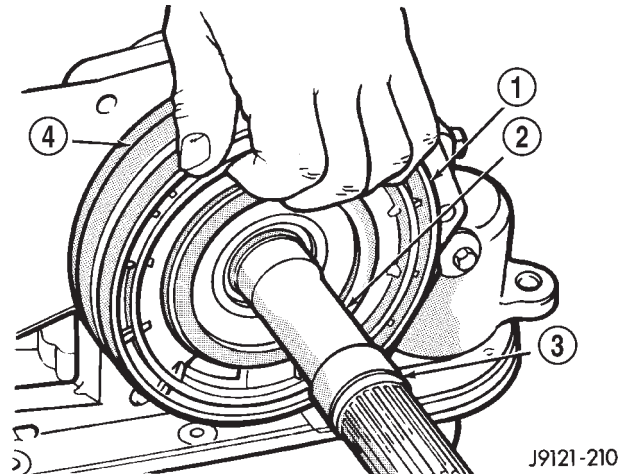
As the inner race is rotated in a clockwise direction (as viewed from the front of the transmission), the race causes the rollers to roll toward the springs, causing them to compress against their retainer. The compression of the springs increases the clearance between the rollers and cam. This increased clearance between the rollers and cam results in a free-wheeling condition. When the inner race attempts to rotate counterclockwise, the action causes the rollers to roll in the same direction as the race, aided by the pushing of the springs. As the rollers try to move in the same direction as the inner race, they are wedged between the inner and outer races due to the design of the cam. In this condition, the clutch is locked and acts as one unit.

### DISASSEMBLY

**NOTE:** To service the overrunning clutch cam and the overdrive piston retainer, the transmission

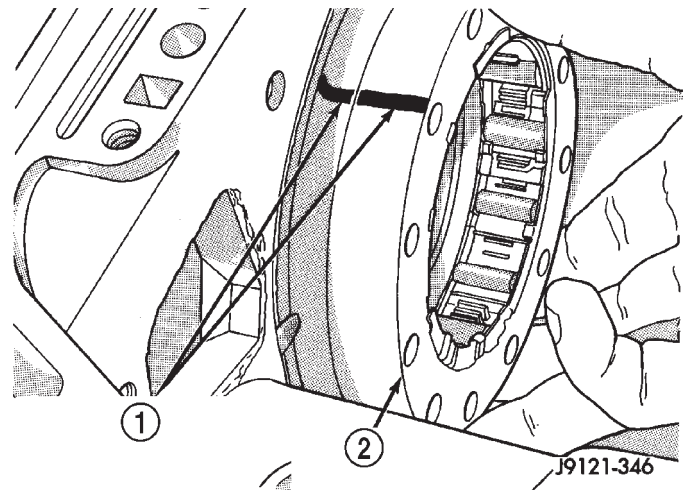
geartrain and the overdrive unit must be removed from the transmission.

- (1) Remove the overdrive piston (Fig. 182).
- (2) Remove the overdrive piston retainer bolts.
- (3) Remove overdrive piston retainer.
- (4) Remove case gasket.
- (5) Mark the position of the overrunning clutch cam in the case (Fig. 183).
- (6) Remove the overrunning clutch cam bolts.
- (7) Remove the overrunning clutch cam.



**Fig. 182 Overdrive Piston Removal**

- 1 - OVERDRIVE CLUTCH PISTON
- 2 - INTERMEDIATE SHAFT
- 3 - SELECTIVE SPACER
- 4 - PISTON RETAINER



**Fig. 183 Overrunning Clutch Cam Removal**

- 1 - ALIGN MARKS IDENTIFYING NON-THREADED HOLE IN CAM AND CASE
- 2 - OVERRUNNING CLUTCH ASSEMBLY



## OVERRUNNING CLUTCH CAM/OVERDRIVE PISTON RETAINER (Continued)

## CLEANING

Clean the overrunning clutch assembly, clutch cam, low-reverse drum, and overdrive piston retainer in solvent. Dry them with compressed air after cleaning.

## INSPECTION

Inspect condition of each clutch part after cleaning. Replace the overrunning clutch roller and spring assembly if any rollers or springs are worn or damaged, or if the roller cage is distorted, or damaged. Replace the cam if worn, cracked or damaged.

Replace the low-reverse drum if the clutch race, roller surface or inside diameter is scored, worn or damaged. **Do not remove the clutch race from the low-reverse drum under any circumstances. Replace the drum and race as an assembly if either component is damaged.**

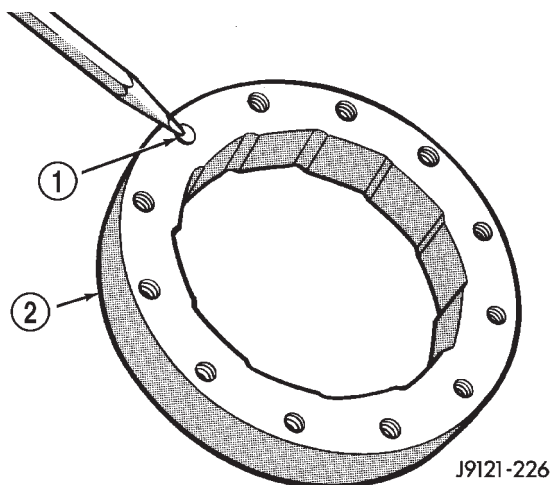
Examine the overdrive piston retainer carefully for wear, cracks, scoring or other damage. Be sure the retainer hub is a snug fit in the case and drum. Replace the retainer if worn or damaged.

## ASSEMBLY

(1) Examine bolt holes in overrunning clutch cam. Note that one hole is **not threaded** (Fig. 184). This hole must align with blank area in clutch cam bolt circle (Fig. 185). Mark hole location on clutch cam and blank area in case with grease pencil, paint stripe, or scribe mark for assembly reference.

(2) Mark location of non-threaded hole in clutch cam and blank area in bolt circle with grease pencil.

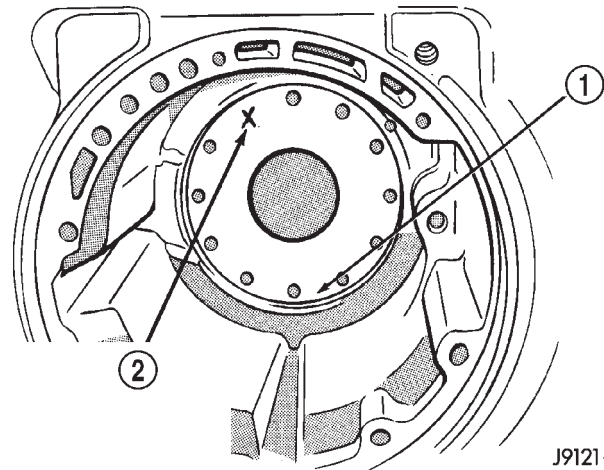
(3) Align and install overrunning clutch and cam in case (Fig. 186). Be sure cam is correctly installed. Bolt holes in cam are slightly countersunk on one



**Fig. 184 Location Of Non-Threaded Hole In Clutch Cam**

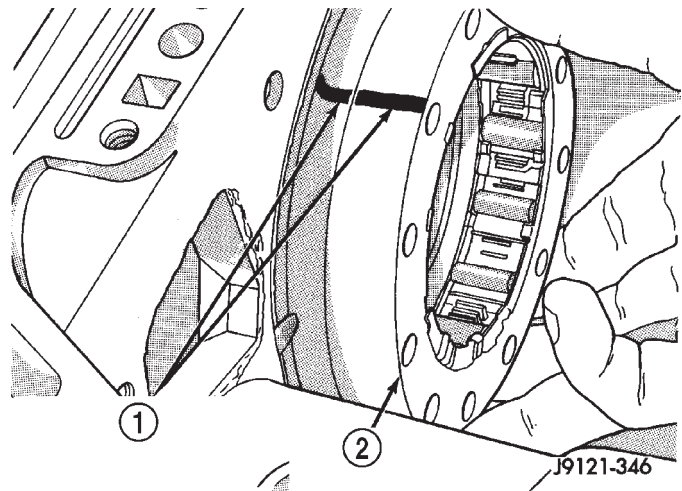
- 1 - NON-THREADED HOLE  
2 - OVERRUNNING CLUTCH CAM

side. Be sure this side of cam faces rearward (toward piston retainer).



**Fig. 185 Location Of Blank Area In Clutch Cam Bolt Circle**

- 1 - OVERRUNNING CLUTCH CAM SEAT IN CASE  
2 - NON-THREADED HOLE IN CLUTCH CAM ALIGNS HERE (BLANK AREA) OF SEAT



**Fig. 186 Overrunning Clutch Installation**

- 1 - ALIGN MARKS IDENTIFYING NON-THREADED HOLE IN CAM AND CASE  
2 - OVERRUNNING CLUTCH ASSEMBLY

(4) Verify that non-threaded hole in clutch cam is properly aligned. Check alignment by threading a bolt into each bolt hole. Adjust clutch cam position if necessary.

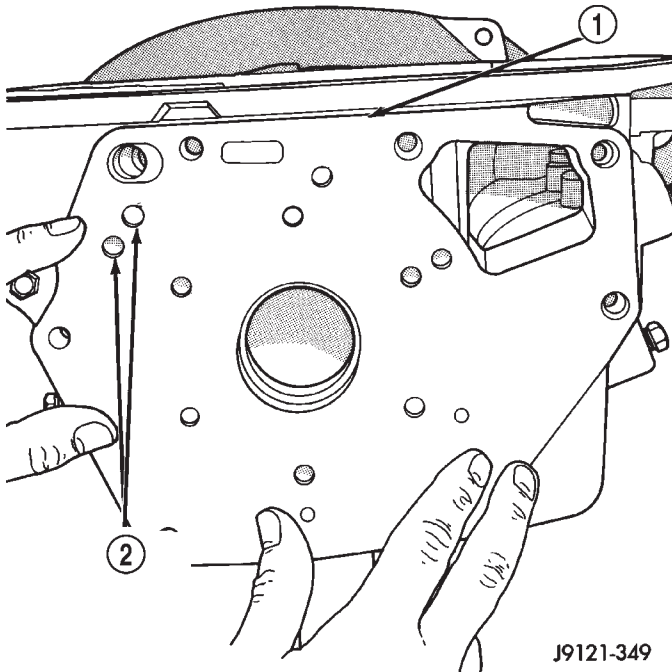
(5) Install and tighten overrunning clutch cam bolts to 17 N·m (13 ft. lbs.) torque. Note that clutch cam bolts are shorter than piston retainer bolts.

(6) Install new gasket at rear of transmission case. Use petroleum jelly to hold gasket in place. Be sure to align governor feed holes in gasket with feed passages in case (Fig. 187). Also install gasket before

## OVERRUNNING CLUTCH CAM/OVERDRIVE PISTON RETAINER (Continued)

overdrive piston retainer. Center hole in gasket is smaller than retainer and cannot be installed over retainer.

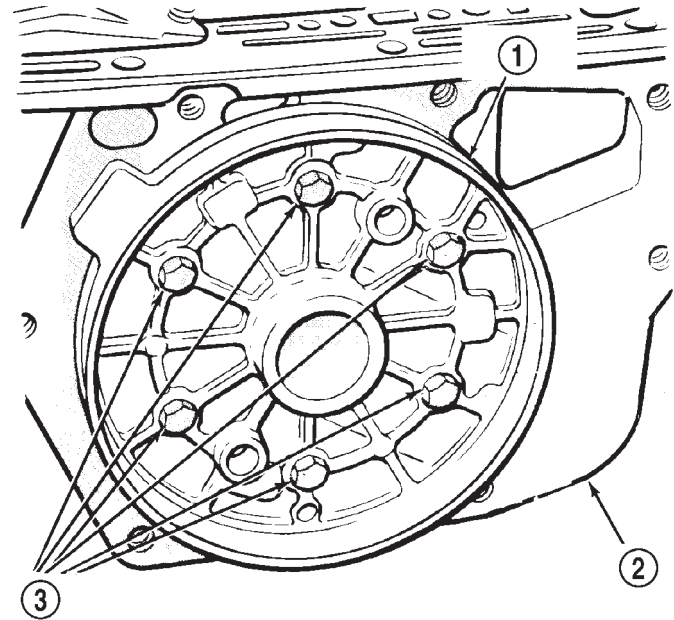
(7) Position overdrive piston retainer on transmission case and align bolt holes in retainer, gasket and case (Fig. 188). Then install and tighten retainer bolts to 17 N·m (13 ft. lbs.) torque.



**Fig. 187 Installing/Aligning Case Gasket**

- 1 - CASE GASKET
- 2 - BE SURE GOVERNOR TUBE FEED HOLES IN CASE AND GASKET ARE ALIGNED

- (8) Install new seals on over drive piston.
- (9) Stand transmission case upright on bellhousing.
- (10) Position Guide Ring 8114-1 on outer edge of overdrive piston retainer.
- (11) Position Seal Guide 8114-2 on inner edge of overdrive piston retainer.
- (12) Install overdrive piston in overdrive piston retainer by: aligning locating lugs on overdrive piston to the two mating holes in retainer.
  - (a) Aligning locating lugs on overdrive piston to the two mating holes in retainer.
  - (b) Lubricate overdrive piston seals with Mopar® Door Ease, or equivalent.
  - (c) Install piston over Seal Guide 8114-2 and inside Guide Ring 8114-1.
  - (d) Push overdrive piston into position in retainer.
  - (e) Verify that the locating lugs entered the lug bores in the retainer.



J9321-464

**Fig. 188 Aligning Overdrive Piston Retainer**

- 1 - PISTON RETAINER
- 2 - GASKET
- 3 - RETAINER BOLTS

**NOTE:** Install the remaining transmission components and the overdrive unit.

## PARK/NEUTRAL POSITION SWITCH

### DIAGNOSIS AND TESTING - PARK/NEUTRAL POSITION SWITCH

The center terminal of the park/neutral position switch is the starter-circuit terminal. It provides the ground for the starter solenoid circuit through the selector lever in PARK and NEUTRAL positions only. The outer terminals on the switch are for the backup lamp circuit.

#### SWITCH TEST

To test the switch, remove the wiring connector. Test for continuity between the center terminal and the transmission case. Continuity should exist only when the transmission is in PARK or NEUTRAL.

Shift the transmission into REVERSE and test continuity at the switch outer terminals. Continuity should exist only when the transmission is in REVERSE. Continuity should not exist between the outer terminals and the case.

Check gearshift linkage adjustment before replacing a switch that tests faulty.



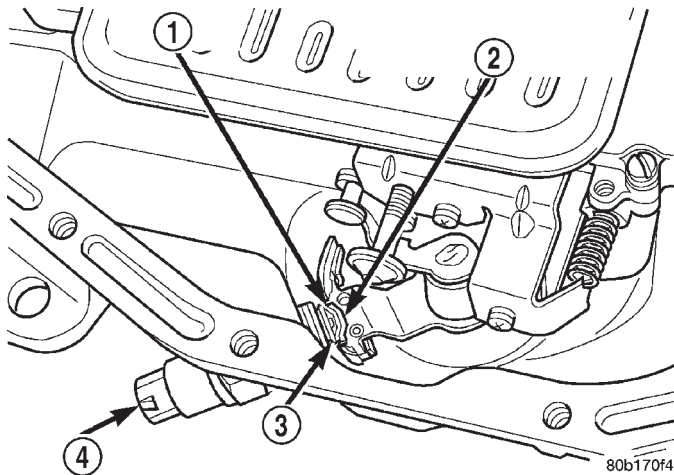
PARK/NEUTRAL POSITION SWITCH (Continued)

**REMOVAL**

- (1) Raise vehicle and position drain pan under switch.
- (2) Disconnect switch wires.
- (3) Remove switch from case.

**INSTALLATION**

- (1) Move shift lever to PARK and NEUTRAL positions. Verify that switch operating lever fingers are centered in switch opening in case (Fig. 189).



**Fig. 189 Park/Neutral Position Switch**

- 1 - NEUTRAL CONTACT
- 2 - MANUAL LEVER AND SWITCH PLUNGER IN REVERSE POSITION
- 3 - PARK CONTACT
- 4 - SWITCH

- (2) Install new seal on switch and install switch in case. Tighten switch to 34 N·m (25 ft. lbs.) torque.
- (3) Test continuity of new switch with 12V test lamp.
- (4) Connect switch wires and lower vehicle.
- (5) Top off transmission fluid level.

**PISTONS**

**DESCRIPTION**

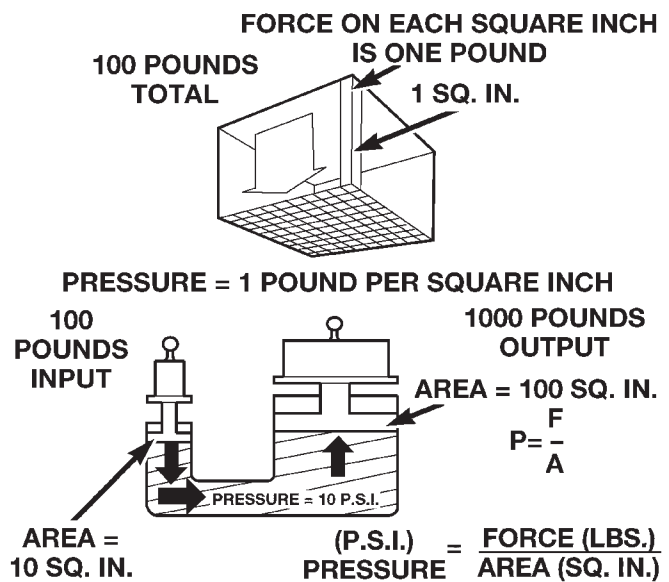
There are several sizes and types of pistons used in an automatic transmission. Some pistons are used to apply clutches, while others are used to apply bands. They all have in common the fact that they are round or circular in shape, located within a smooth walled cylinder, which is closed at one end and converts fluid pressure into mechanical movement. The fluid pressure exerted on the piston is contained within the system through the use of piston rings or seals.

**OPERATION**

The principal which makes this operation possible is known as Pascal's Law. Pascal's Law can be stated as: "Pressure on a confined fluid is transmitted equally in all directions and acts with equal force on equal areas."

**PRESSURE**

Pressure (Fig. 190) is nothing more than force (lbs.) divided by area (in or ft.), or force per unit area. Given a 100 lb. block and an area of 100 sq. in. on the floor, the pressure exerted by the block is: 100 lbs. 100 in or 1 pound per square inch, or PSI as it is commonly referred to.



**FORCE ON LARGE PISTON = 1000 LBS.**

80bfe272

**Fig. 190 Force and Pressure Relationship**

**PRESSURE ON A CONFINED FLUID**

Pressure is exerted on a confined fluid (Fig. 191) by applying a force to some given area in contact with the fluid. A good example of this is a cylinder filled with fluid and equipped with a piston that is closely fitted to the cylinder wall. If a force is applied to the piston, pressure will be developed in the fluid. Of course, no pressure will be created if the fluid is not confined. It will simply "leak" past the piston. There must be a resistance to flow in order to create pressure. Piston sealing is extremely important in hydraulic operation. Several kinds of seals are used to accomplish this within a transmission. These include but are not limited to O-rings, D-rings, lip seals, sealing rings, or extremely close tolerances between the piston and the cylinder wall. The force exerted is downward (gravity), however, the principle remains the same no matter which direction is taken.

PISTONS (Continued)

The pressure created in the fluid is equal to the force applied, divided by the piston area. If the force is 100 lbs., and the piston area is 10 sq. in., then the pressure created equals 10 PSI. Another interpretation of Pascal's Law is that regardless of container shape or size, the pressure will be maintained throughout, as long as the fluid is confined. In other words, the pressure in the fluid is the same everywhere within the container.

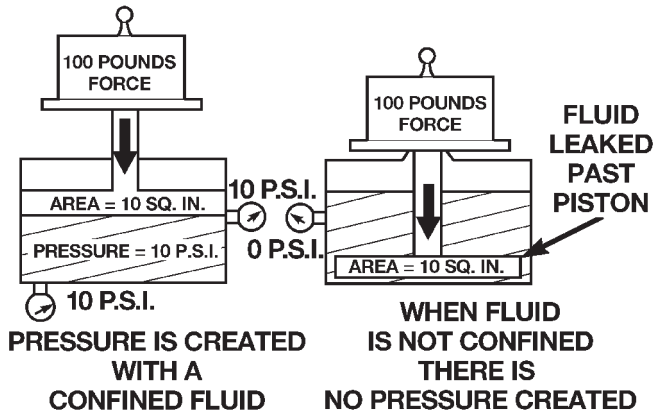


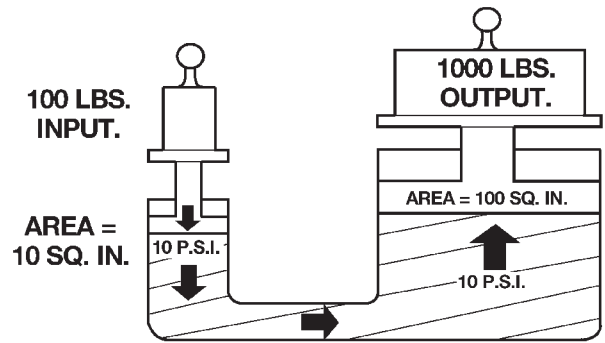
Fig. 191 Pressure on a Confined Fluid

FORCE MULTIPLICATION

Using the 10 PSI example used in the illustration (Fig. 192), a force of 1000 lbs. can be moved with a force of only 100 lbs. The secret of force multiplication in hydraulic systems is the total fluid contact area employed. The illustration, (Fig. 192), shows an area that is ten times larger than the original area. The pressure created with the smaller 100 lb. input is 10 PSI. The concept "pressure is the same everywhere" means that the pressure underneath the larger piston is also 10 PSI. Pressure is equal to the force applied divided by the contact area. Therefore, by means of simple algebra, the output force may be found. This concept is extremely important, as it is also used in the design and operation of all shift valves and limiting valves in the valve body, as well as the pistons, of the transmission, which activate the clutches and bands. It is nothing more than using a difference of area to create a difference in pressure to move an object.

PISTON TRAVEL

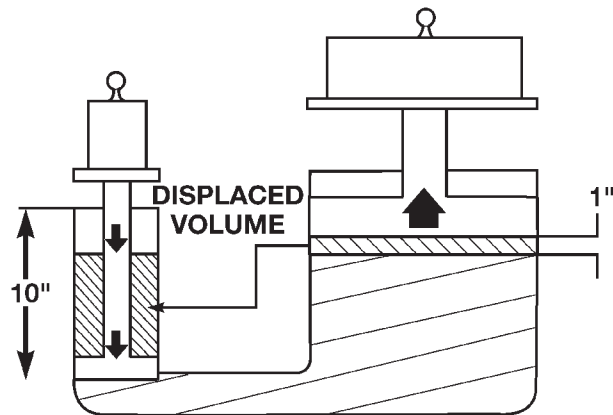
The relationship between hydraulic lever and a mechanical lever is the same. With a mechanical lever it's a weight-to-distance output rather than a pressure-to-area output. Using the same forces and areas as in the previous example, the smaller piston (Fig. 193) has to move ten times the distance required to move the larger piston one inch. There-



80bfe274

Fig. 192 Force Multiplication

fore, for every inch the larger piston moves, the smaller piston moves ten inches. This principle is true in other instances also. A common garage floor jack is a good example. To raise a car weighing 2000 lbs., an effort of only 100 lbs. may be required. For every inch the car moves upward, the input piston at the jack handle must move 20 inches downward.



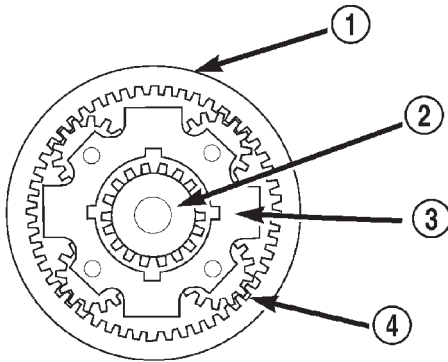
80bfe275

Fig. 193 Piston Travel

## PLANETARY GEARTRAIN/ OUTPUT SHAFT

### DESCRIPTION

The planetary gearsets (Fig. 194) are designated as the front, rear, and overdrive planetary gear assemblies and located in such order. A simple planetary gearset consists of three main members:



**Fig. 194 Planetary Gearset**

- 1 - ANNULUS GEAR
- 2 - SUN GEAR
- 3 - PLANET CARRIER
- 4 - PLANET PINIONS (4)

- The sun gear which is at the center of the system.

- The planet carrier with planet pinion gears which are free to rotate on their own shafts and are in mesh with the sun gear.

- The annulus gear, which rotates around and is in mesh with the planet pinion gears.

**NOTE:** The number of pinion gears does not affect the gear ratio, only the duty rating.

### OPERATION

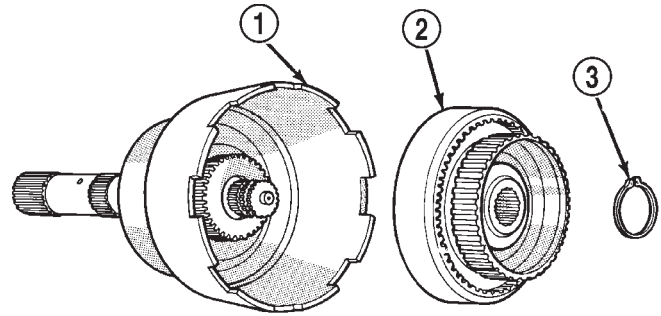
With any given planetary gearset, several conditions must be met for power to be able to flow:

- One member must be held.
- Another member must be driven or used as an input.
- The third member may be used as an output for power flow.
- For direct drive to occur, two gear members in the front planetary gearset must be driven.

**NOTE:** Gear ratios are dependent on the number of teeth on the annulus and sun gears.

### DISASSEMBLY

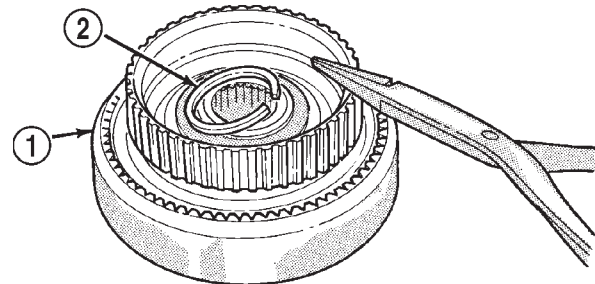
- (1) Remove planetary snap-ring (Fig. 195).
- (2) Remove front annulus and planetary assembly from driving shell (Fig. 195).
- (3) Remove snap-ring that retains front planetary gear in annulus gear (Fig. 196).



J9421-175

**Fig. 195 Front Annulus And Planetary Assembly Removal**

- 1 - DRIVING SHELL
- 2 - FRONT ANNULUS AND PLANETARY ASSEMBLY
- 3 - PLANETARY SNAP-RING



J9421-176

**Fig. 196 Front Planetary Snap-Ring Removal**

- 1 - FRONT ANNULUS GEAR
- 2 - PLANETARY SNAP-RING

## PLANETARY GEARTRAIN/OUTPUT SHAFT (Continued)

(4) Remove tabbed thrust washer and tabbed thrust plate from hub of front annulus (Fig. 197).

(5) Separate front annulus and planetary gears (Fig. 197).

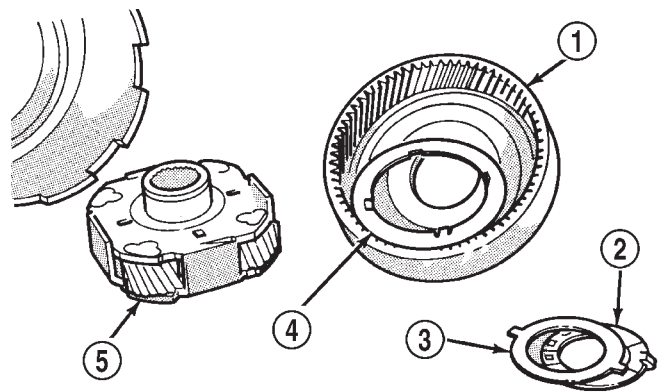
(6) Remove front planetary gear front thrust washer from annulus gear hub.

(7) Separate and remove driving shell, rear planetary and rear annulus from output shaft (Fig. 198).

(8) Remove front planetary rear thrust washer from driving shell.

(9) Remove tabbed thrust washers from rear planetary gear.

(10) Remove lock ring that retains sun gear in driving shell. Then remove sun gear, spacer and thrust plates.



J9421-177

**Fig. 197 Front Planetary And Annulus Gear Disassembly**

- 1 - FRONT ANNULUS
- 2 - THRUST WASHER
- 3 - THRUST PLATE
- 4 - FRONT THRUST WASHER
- 5 - FRONT PLANETARY

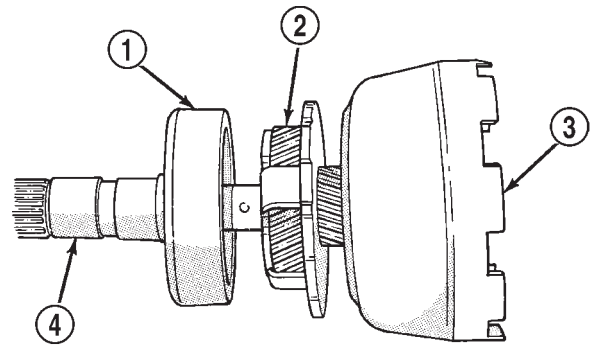
## INSPECTION

Check sun gear and driving shell condition. Replace the gear if damaged or if the bushings are scored or worn. The bushings are not serviceable. Replace the driving shell if worn, cracked or damaged.

Replace planetary gear sets if gears, pinion pins, or carrier are damaged in any way. Replace the annulus gears and supports if either component is worn or damaged.

Inspect the geartrain spacers, thrust plates, snap-rings, and thrust washers. Replace any of these parts that are worn, distorted or damaged. Do not attempt to reuse these parts.

The planetary gear thrust washers are different sizes. The large diameter washers go on the front planetary and the smaller washers go on the rear planetary. All the washers have four locating tabs on



J9421-178

**Fig. 198 Removing Driving Shell, Rear Planetary And Rear Annulus**

- 1 - REAR ANNULUS
- 2 - REAR PLANETARY
- 3 - DRIVING SHELL
- 4 - OUTPUT SHAFT

them. These tabs fit in the holes or slots provided in each planetary gear.

Inspect the output shaft carefully. Pay particular attention to the machined bushing/bearing surfaces on the shaft and the governor valve shaft bore at the shaft rear.

Replace the output shaft if the machined surfaces are scored, pitted, or damaged in any way. Also replace the shaft if the splines are damaged, or exhibits cracks at any location (especially at the governor valve shaft bore).

The annulus gears can be removed from their supports if necessary. Just remove the snap-rings and separate the two parts when replacement is necessary. In addition, the annulus gear bushings can be replaced if severely worn, or scored. However it is not necessary to replace the bushings if they only exhibit normal wear. Check bushing fit on the output shaft to be sure.

## ASSEMBLY

(1) Lubricate output shaft and planetary components with transmission fluid. Use petroleum jelly to lubricate and hold thrust washers and plates in position.

(2) Assemble rear annulus gear and support if disassembled. Be sure support snap-ring is seated and that shoulder-side of support faces rearward (Fig. 199).

(3) Install rear thrust washer on rear planetary gear. Use enough petroleum jelly to hold washer in place. Also be sure all four washer tabs are properly engaged in gear slots.

(4) Install rear annulus over and onto rear planetary gear (Fig. 199).



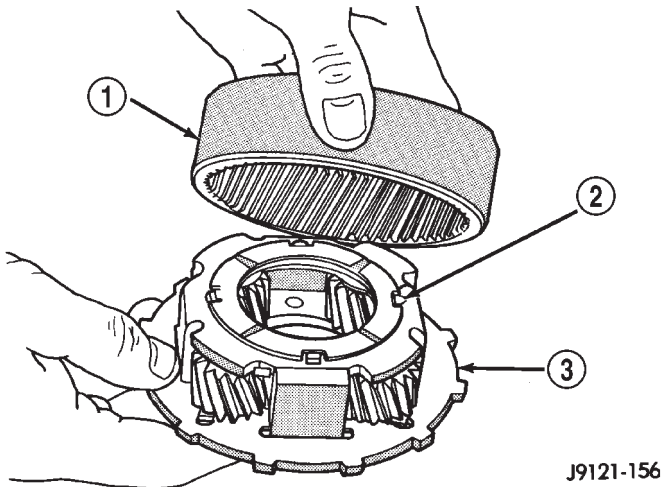
PLANETARY GEARTRAIN/OUTPUT SHAFT (Continued)

(5) Install assembled rear planetary and annulus gear on output shaft (Fig. 200). Verify that assembly is fully seated on shaft.

(6) Install front thrust washer on rear planetary gear (Fig. 201). Use enough petroleum jelly to hold washer on gear. Be sure all four washer tabs are seated in slots.

(7) Install spacer on sun gear (Fig. 202).

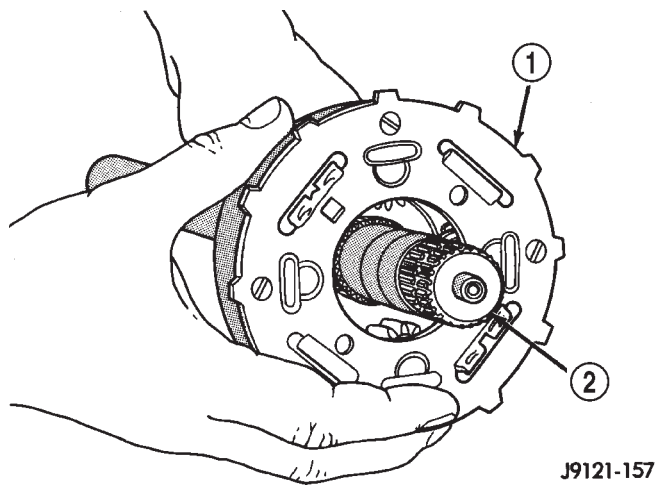
(8) Install thrust plate on sun gear (Fig. 203). Note that driving shell thrust plates are interchangeable. Use either plate on sun gear and at front/rear of shell.



J9121-156

**Fig. 199 Assembling Rear Annulus And Planetary Gear**

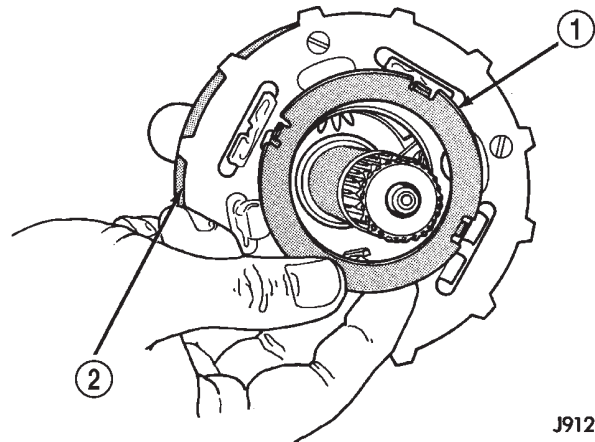
- 1 - REAR ANNULUS GEAR
- 2 - TABBED THRUST WASHER
- 3 - REAR PLANETARY



J9121-157

**Fig. 200 Installing Rear Annulus And Planetary On Output Shaft**

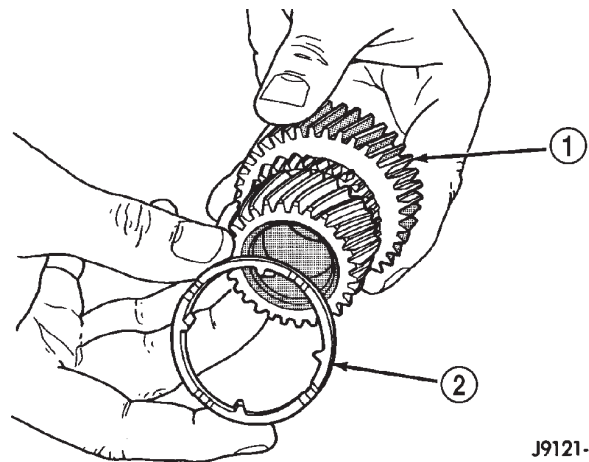
- 1 - REAR ANNULUS AND PLANETARY GEAR ASSEMBLY
- 2 - OUTPUT SHAFT



J9121-158

**Fig. 201 Installing Rear Planetary Front Thrust Washer**

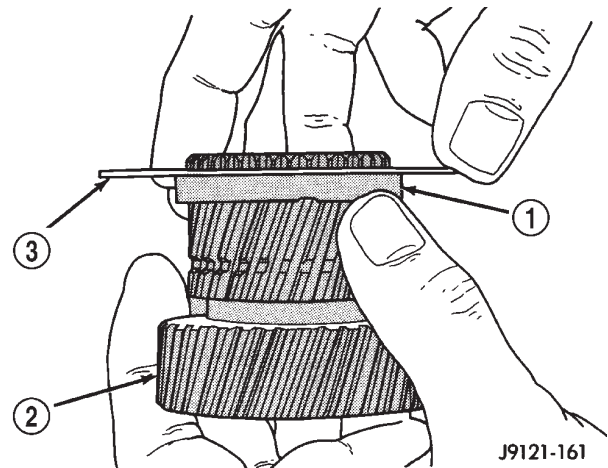
- 1 - FRONT TABBED THRUST WASHER
- 2 - REAR PLANETARY GEAR



J9121-159

**Fig. 202 Installing Spacer On Sun Gear**

- 1 - SUN GEAR
- 2 - SUN GEAR SPACER



J9121-161

**Fig. 203 Installing Driving Shell Front Thrust Plate On Sun Gear**

- 1 - SPACER
- 2 - SUN GEAR
- 3 - THRUST PLATE

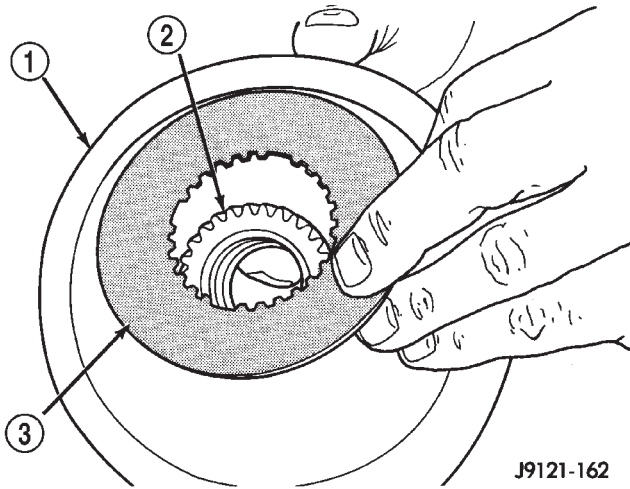
PLANETARY GEARTRAIN/OUTPUT SHAFT (Continued)

(9) Hold sun gear in place and install thrust plate over sun gear at rear of driving shell (Fig. 204).

(10) Position wood block on bench and support sun gear on block (Fig. 205). This makes it easier to align and install sun gear lock ring. Keep wood block handy as it will also be used for geartrain end play check.

(11) Align rear thrust plate on driving shell and install sun gear lock ring. Be sure ring is fully seated in sun gear ring groove (Fig. 206).

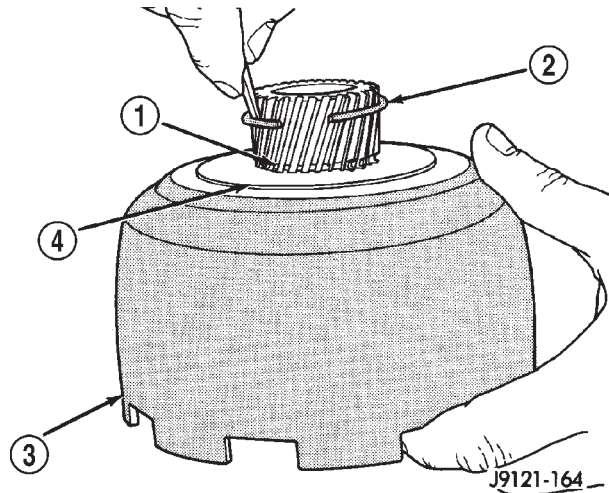
(12) Install assembled driving shell and sun gear on output shaft (Fig. 207).



J9121-162

**Fig. 204 Installing Driving Shell Rear Thrust Plate**

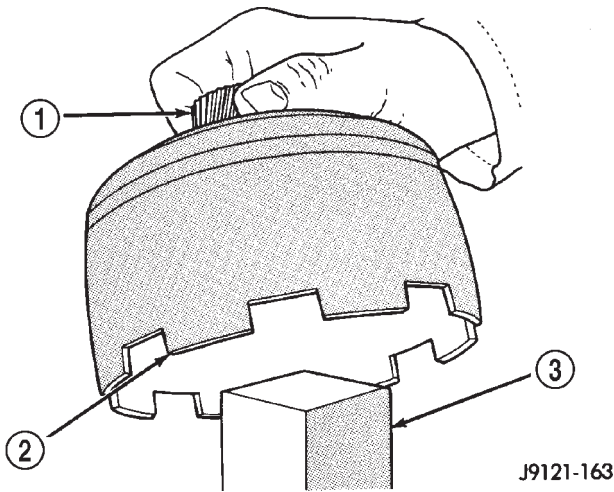
- 1 - DRIVING SHELL
- 2 - SUN GEAR
- 3 - REAR THRUST PLATE



J9121-164

**Fig. 206 Installing Sun Gear Lock Ring**

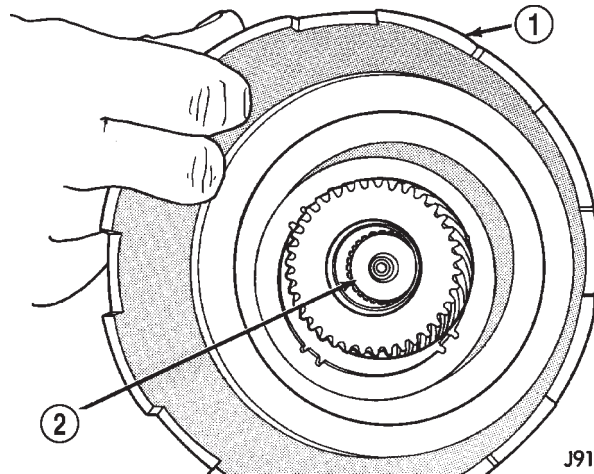
- 1 - LOCK RING GROOVE
- 2 - SUN GEAR LOCK RING
- 3 - DRIVING SHELL
- 4 - REAR THRUST PLATE



J9121-163

**Fig. 205 Supporting Sun Gear On Wood Block**

- 1 - SUN GEAR
- 2 - DRIVING SHELL
- 3 - WOOD BLOCK



J9121-165

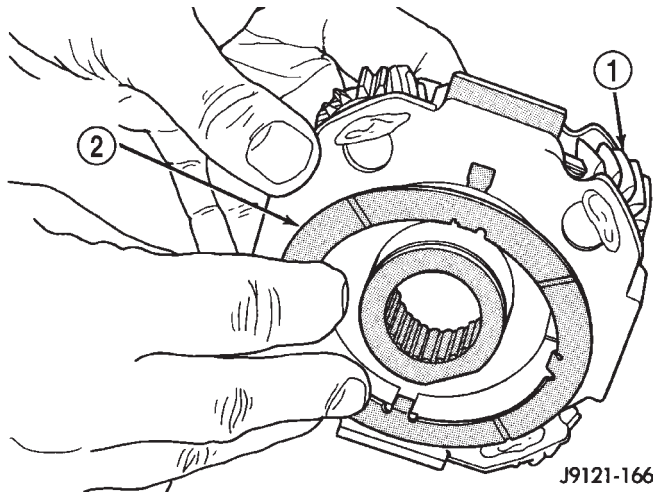
**Fig. 207 Installing Assembled Sun Gear And Driving Shell On Output Shaft**

- 1 - SUN GEAR/DRIVING SHELL ASSEMBLY
- 2 - OUTPUT SHAFT



PLANETARY GEARTRAIN/OUTPUT SHAFT (Continued)

(13) Install rear thrust washer on front planetary gear (Fig. 208). Use enough petroleum jelly to hold washer in place and be sure all four washer tabs are seated.



J9121-166

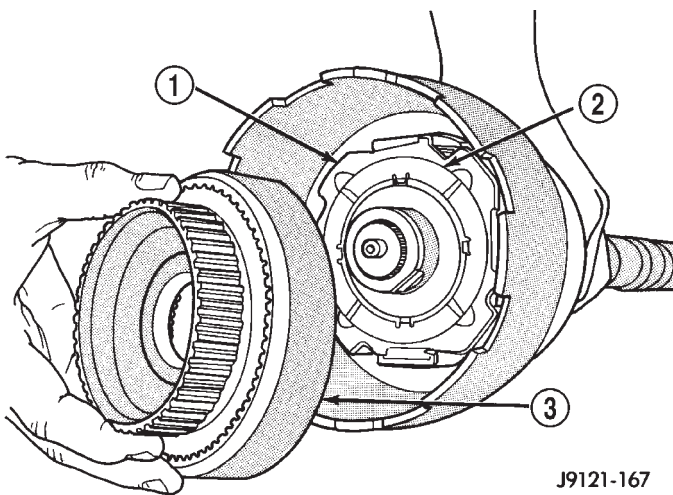
**Fig. 208 Installing Rear Thrust Washer On Front Planetary Gear**

- 1 - FRONT PLANETARY GEAR
- 2 - REAR TABBED THRUST WASHER

(14) Install front planetary gear on output shaft and in driving shell (Fig. 209).

(15) Install front thrust washer on front planetary gear. Use enough petroleum jelly to hold washer in place and be sure all four washer tabs are seated.

(16) Assemble front annulus gear and support, if necessary. Be sure support snap-ring is seated.



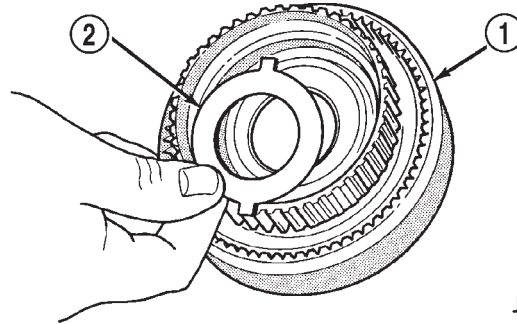
J9121-167

**Fig. 209 Installing Front Planetary And Annulus Gears**

- 1 - FRONT PLANETARY GEAR
- 2 - FRONT THRUST WASHER
- 3 - FRONT ANNULUS GEAR

(17) Install front annulus on front planetary (Fig. 209).

(18) Position thrust plate on front annulus gear support (Fig. 210). Note that plate has two tabs on it. These tabs fit in notches of annulus hub.

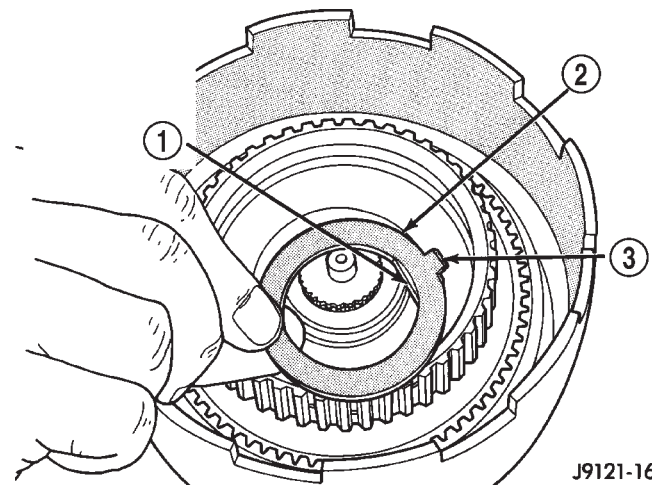


J9421-179

**Fig. 210 Positioning Thrust Plate On Front Annulus Support**

- 1 - FRONT ANNULUS
- 2 - THRUST PLATE

(19) Install thrust washer in front annulus (Fig. 211). Align flat on washer with flat on planetary hub. Also be sure washer tab is facing up.



J9121-168

**Fig. 211 Installing Front Annulus Thrust Washer**

- 1 - WASHER FLAT ALIGNS WITH FLAT ON PLANETARY HUB
- 2 - FRONT ANNULUS THRUST WASHER
- 3 - TAB FACES FRONT

PLANETARY GEARTRAIN/OUTPUT SHAFT (Continued)

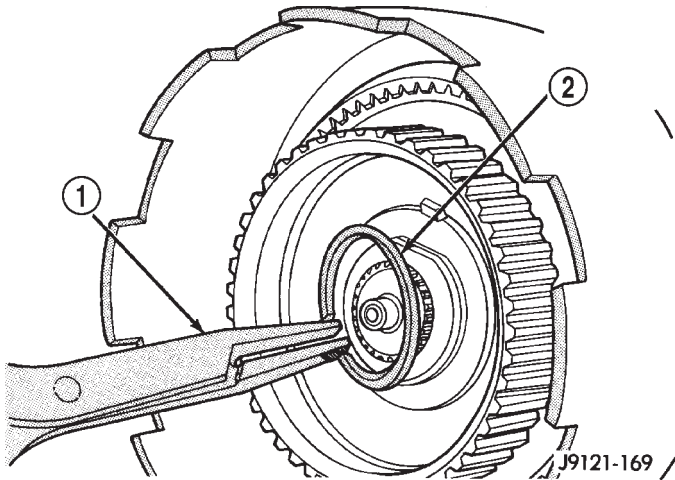
(20) Install front annulus snap-ring (Fig. 212). Use snap-ring pliers to avoid distorting ring during installation. Also be sure ring is fully seated.

(21) Install planetary selective snap-ring with snap-ring pliers (Fig. 213). Be sure ring is fully seated.

(22) Turn planetary geartrain assembly over so driving shell is facing workbench. Then support geartrain on wood block positioned under forward end of output shaft. This allows geartrain components to move forward for accurate end play check.

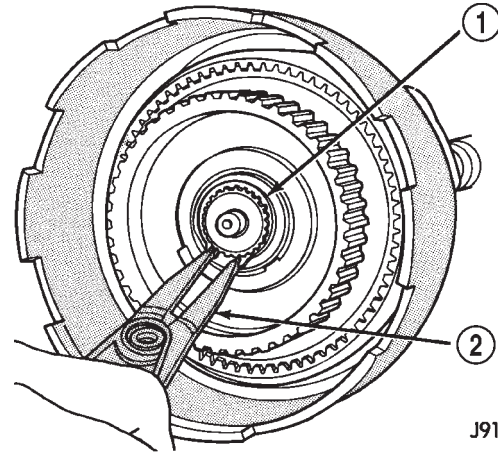
(23) Check planetary geartrain end play with feeler gauge (Fig. 214). Gauge goes between shoulder on output shaft and end of rear annulus support.

(24) Geartrain end play should be 0.12 to 1.22 mm (0.005 to 0.048 in.). If end play is incorrect, snap-ring (or thrust washers) may have to be replaced. Snap-rings are available in three different thicknesses for adjustment purposes.



**Fig. 212 Installing Front Annulus Snap-Ring**

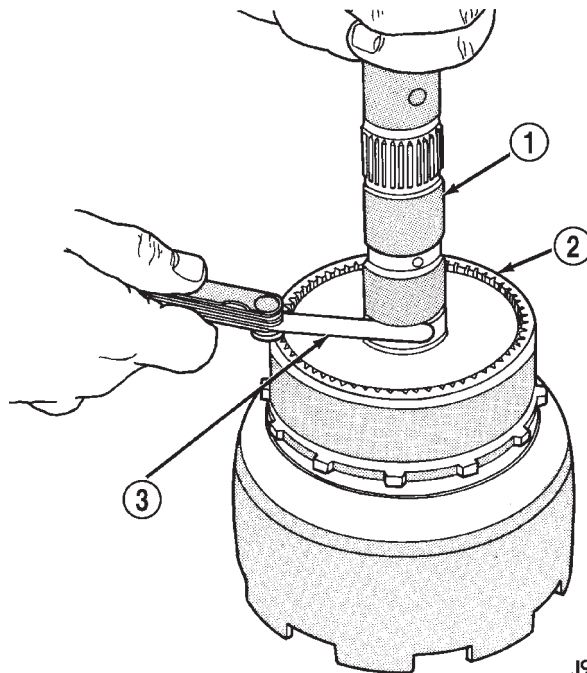
- 1 - SNAP-RING PLIERS
- 2 - FRONT ANNULUS SNAP-RING



J9121-170

**Fig. 213 Installing Planetary Selective Snap-Ring**

- 1 - SELECTIVE SNAP-RING
- 2 - SNAP-RING PLIERS



J9121-171

**Fig. 214 Checking Planetary Geartrain End Play**

- 1 - OUTPUT SHAFT
- 2 - REAR ANNULUS GEAR
- 3 - FEELER GAUGE

## REAR CLUTCH

### DESCRIPTION

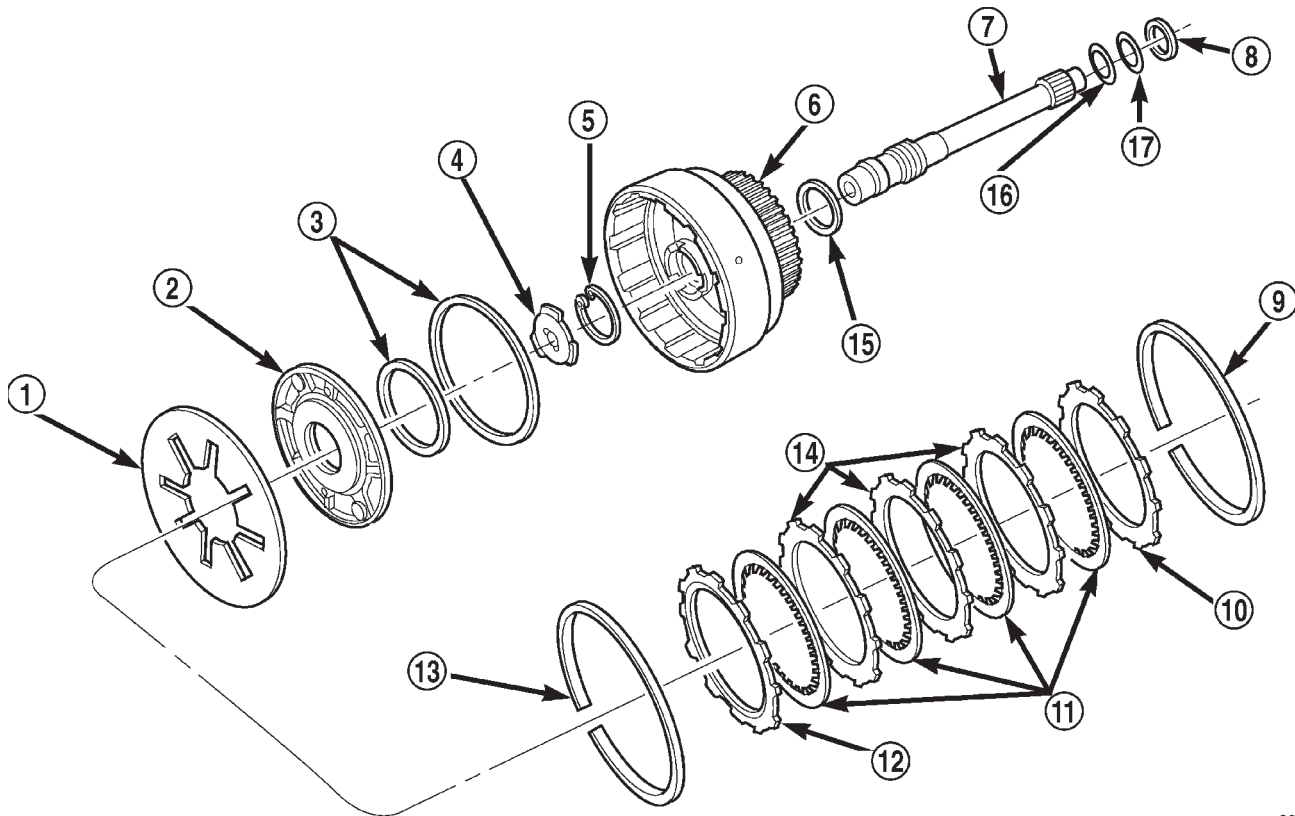
The rear clutch assembly (Fig. 215) is composed of the rear clutch retainer, pressure plate, clutch plates, driving discs, piston, Belleville spring, and snap-rings. The Belleville spring acts as a lever to multiply the force applied on to it by the apply piston. The increased apply force on the rear clutch pack, in comparison to the front clutch pack, is needed to hold against the greater torque load imposed onto the rear pack. The rear clutch is directly behind the front clutch and is considered a driving component.

**NOTE: The number of discs and plates may vary with each engine and vehicle combination.**

### OPERATION

To apply the clutch, pressure is applied between the clutch retainer and piston. The fluid pressure is provided by the oil pump, transferred through the control valves and passageways, and enters the clutch through the hub of the reaction shaft support. With pressure applied between the clutch retainer and piston, the piston moves away from the clutch retainer and compresses the clutch pack. This action applies the clutch pack, allowing torque to flow through the input shaft into the driving discs, and into the clutch plates and pressure plate that are lugged to the clutch retainer. The waved spring is used to cushion the application of the clutch pack. The snap-ring is selective and used to adjust clutch pack clearance.

When pressure is released from the piston, the spring returns the piston to its fully released position



80c070a4

**Fig. 215 Rear Clutch**

- |  |                                     |
|--|-------------------------------------|
| 1 - PISTON SPRING                      | 10 - TOP PRESSURE PLATE             |
| 2 - REAR CLUTCH PISTON                 | 11 - CLUTCH DISCS (4)               |
| 3 - CLUTCH PISTON SEALS                | 12 - BOTTOM PRESSURE PLATE          |
| 4 - OUTPUT SHAFT THRUST WASHER (METAL) | 13 - WAVE SPRING                    |
| 5 - INPUT SHAFT SNAP-RING              | 14 - CLUTCH PLATES (3)              |
| 6 - REAR CLUTCH RETAINER               | 15 - RETAINER SEAL RING             |
| 7 - INPUT SHAFT                        | 16 - SHAFT REAR SEAL RING (PLASTIC) |
| 8 - REAR CLUTCH THRUST WASHER (FIBER)  | 17 - SHAFT FRONT SEAL RING (TEFLON) |
| 9 - CLUTCH PACK SNAP-RING (SELECTIVE)  |                                     |

## REAR CLUTCH (Continued)

and disengages the clutch. The release spring also helps to cushion the application of the clutch assembly. When the clutch is in the process of being released by the release spring, fluid flows through a vent and one-way ball-check-valve located in the piston. The check-valve is needed to eliminate the possibility of plate drag caused by centrifugal force acting on the residual fluid trapped in the clutch piston retainer.

**DISASSEMBLY**

- (1) Remove fiber thrust washer from forward side of clutch retainer.
- (2) Remove input shaft front/rear seal rings.
- (3) Remove selective clutch pack snap-ring (Fig. 216).

(4) Remove top pressure plate, clutch discs, steel plates, bottom pressure plate and wave snap-ring and wave spring (Fig. 216).

(5) Remove clutch piston with rotating motion.

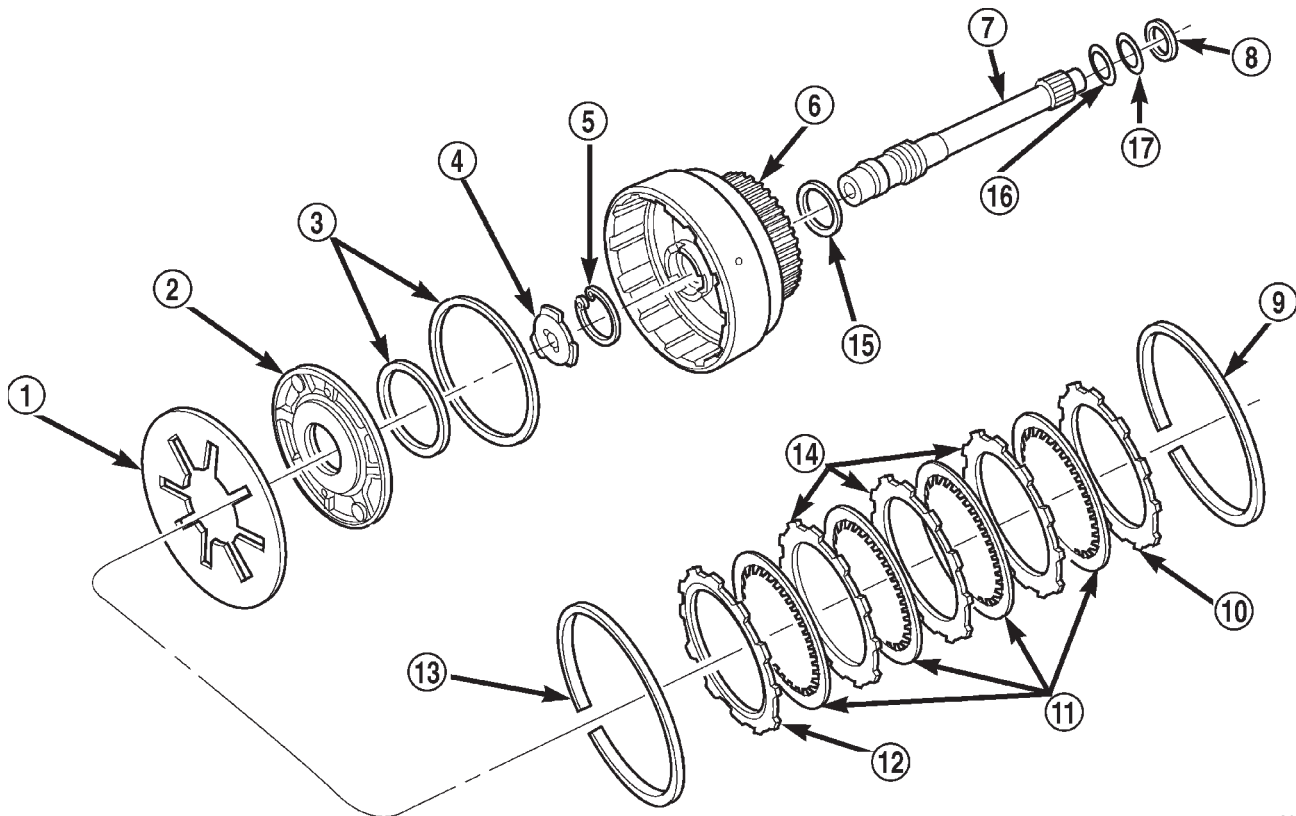
(6) Remove and discard piston seals.

(7) Remove input shaft snap-ring (Fig. 217). It may be necessary to press the input shaft in slightly to relieve tension on the snap-ring

(8) Press input shaft out of retainer with shop press and suitable size press tool. Use a suitably sized press tool to support the retainer as close to the input shaft as possible.

**CLEANING**

Clean the clutch components with solvent and dry them with compressed air. Do not use rags or shop towels to dry any of the clutch parts. Lint from such



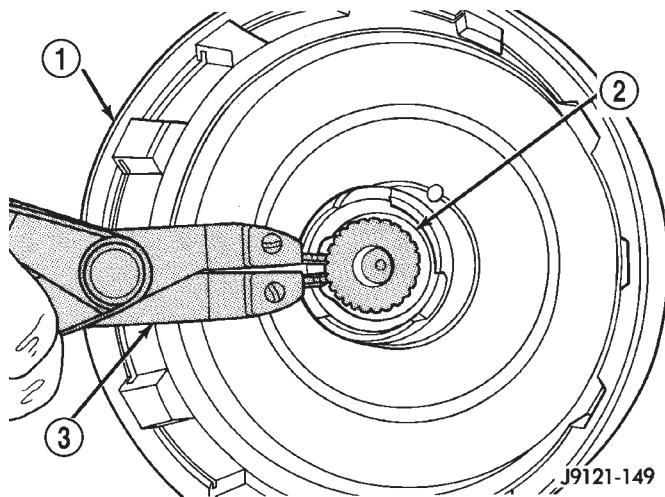
80c070a4

**Fig. 216 Rear Clutch Components**

- |  |                                     |
|--|-------------------------------------|
| 1 - PISTON SPRING                      | 10 - TOP PRESSURE PLATE             |
| 2 - REAR CLUTCH PISTON                 | 11 - CLUTCH DISCS (4)               |
| 3 - CLUTCH PISTON SEALS                | 12 - BOTTOM PRESSURE PLATE          |
| 4 - OUTPUT SHAFT THRUST WASHER (METAL) | 13 - WAVE SPRING                    |
| 5 - INPUT SHAFT SNAP-RING              | 14 - CLUTCH PLATES (3)              |
| 6 - REAR CLUTCH RETAINER               | 15 - RETAINER SEAL RING             |
| 7 - INPUT SHAFT                        | 16 - SHAFT REAR SEAL RING (PLASTIC) |
| 8 - REAR CLUTCH THRUST WASHER (FIBER)  | 17 - SHAFT FRONT SEAL RING (TEFLON) |
| 9 - CLUTCH PACK SNAP-RING (SELECTIVE)  |                                     |



## REAR CLUTCH (Continued)



**Fig. 217 Removing Input Shaft Snap-Ring**

- 1 - REAR CLUTCH RETAINER
- 2 - INPUT SHAFT SNAP-RING
- 3 - SNAP-RING PLIERS

materials will adhere to component surfaces and could restrict or block fluid passages after assembly.

## INSPECTION

Replace the clutch discs if warped, worn, scored, burned/charred, the lugs are damaged, or if the facing is flaking off. Replace the top and bottom pressure plates if scored, warped, or cracked. Be sure the driving lugs on the pressure and clutch plates are also in good condition. The lugs must not be bent, cracked or damaged in any way.

Replace the piston spring and wave spring if either part is distorted, warped or broken.

Check the lug grooves in the clutch retainer. The clutch and pressure plates should slide freely in the slots. Replace the retainer if the grooves are worn or damaged. Also check action of the check balls in the retainer and piston. Each check ball must move freely and not stick.

Replace the retainer bushing if worn, scored, or doubt exists about bushing condition.

Inspect the piston and retainer seal surfaces for nicks or scratches. Minor scratches can be removed with crocus cloth. However, replace the piston and/or retainer if the seal surfaces are seriously scored.

Check condition of the fiber thrust washer and metal output shaft thrust washer. Replace either washer if worn or damaged.

Check condition of the seal rings on the input shaft and clutch retainer hub. Replace the seal rings only if worn, distorted, or damaged. The input shaft front seal ring is teflon with chamfered ends. The rear ring is metal with interlocking ends.

Check the input shaft for wear, or damage. Replace the shaft if worn, scored or damaged in any way.

## ASSEMBLY

(1) Soak clutch discs in transmission fluid while assembling other clutch parts.

(2) Install new seal rings on clutch retainer hub and input shaft, if necessary, (Fig. 218) and (Fig. 219).

(a) Be sure clutch hub seal ring is fully seated in groove and is not twisted.

(3) Lubricate splined end of input shaft and clutch retainer with transmission fluid. Then press input shaft into retainer (Fig. 220). Use a suitably sized press tool to support retainer as close to input shaft as possible.

(4) Install input shaft snap-ring (Fig. 217).

(5) Invert retainer and press input shaft in opposite direction until snap-ring is seated.

(6) Install new seals on clutch piston. Be sure lip of each seal faces interior of clutch retainer.

(7) Lubricate lip of piston seals with generous quantity of Mopar® Door Ease. Then lubricate retainer hub and bore with light coat of transmission fluid.

(8) Install clutch piston in retainer. Use twisting motion to seat piston in bottom of retainer. A thin strip of plastic (about 0.020" thick), can be used to guide seals into place if necessary.

**CAUTION: Never push the clutch piston straight in. This will fold the seals over causing leakage and clutch slip. In addition, never use any type of metal tool to help ease the piston seals into place. Metal tools will cut, shave, or score the seals.**

(9) Install piston spring in retainer and on top of piston (Fig. 221). Concave side of spring faces downward (toward piston).

(10) Install wave spring in retainer (Fig. 221). Be sure spring is completely seated in retainer groove.

(11) Install bottom pressure plate (Fig. 216). Ridged side of plate faces downward (toward piston) and flat side toward clutch pack.

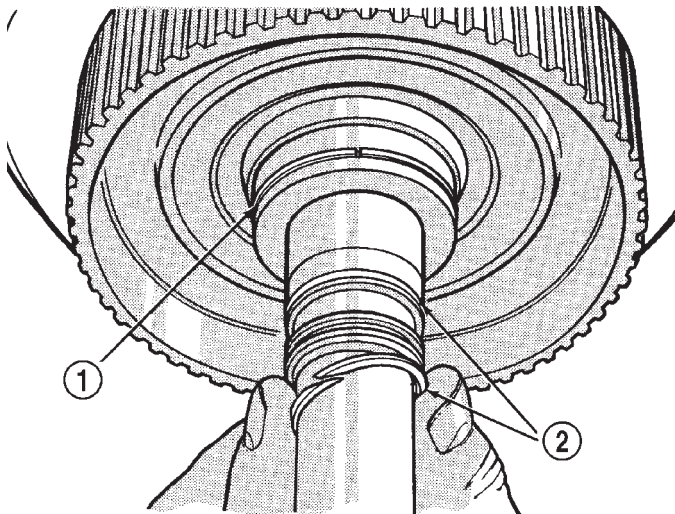
(12) Install first clutch disc in retainer on top of bottom pressure plate. Then install a clutch plate followed by a clutch disc until entire clutch pack is installed (4 discs and 3 plates are required) (Fig. 216).

(13) Install top pressure plate.

(14) Install selective snap-ring. Be sure snap-ring is fully seated in retainer groove.



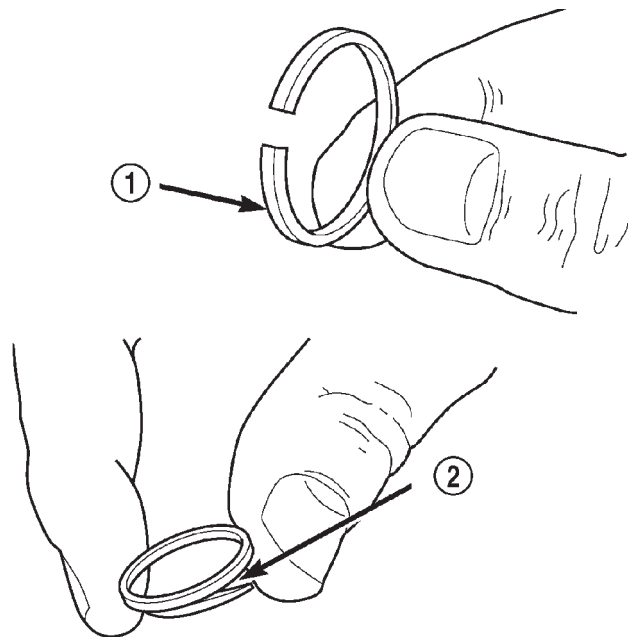
## REAR CLUTCH (Continued)



J9121-538

**Fig. 218 Rear Clutch Retainer And Input Shaft Seal Ring Installation**

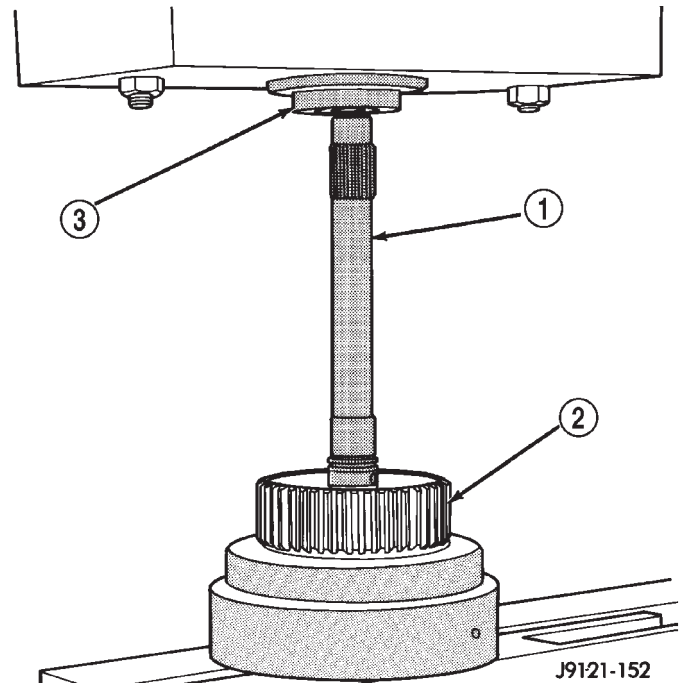
- 1 - REAR CLUTCH RETAINER HUB SEAL RING  
2 - INPUT SHAFT SEAL RINGS



80c070a5

**Fig. 219 Input Shaft Seal Ring Identification**

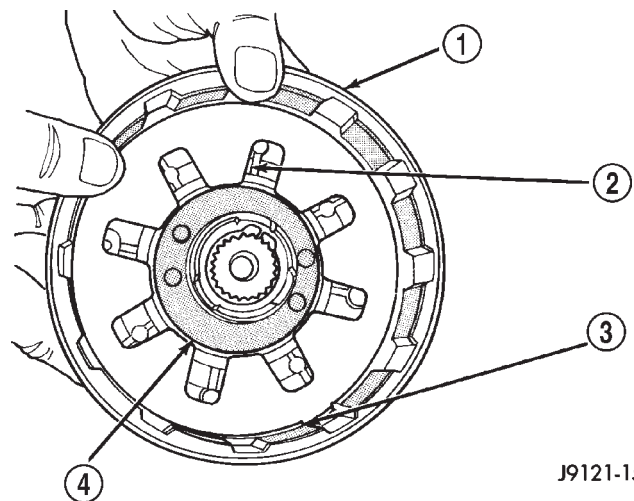
- 1 - PLASTIC REAR SEAL RING  
2 - TEFLON FRONT SEAL RING (SQUEEZE RING TOGETHER SLIGHTLY BEFORE INSTALLATION FOR BETTER FIT)



J9121-152

**Fig. 220 Pressing Input Shaft Into Rear Clutch Retainer**

- 1 - INPUT SHAFT  
2 - REAR CLUTCH RETAINER  
3 - PRESS RAM



J9121-153

**Fig. 221 Piston Spring/Wave Spring Position**

- 1 - REAR CLUTCH RETAINER  
2 - PISTON SPRING  
3 - WAVE SPRING  
4 - CLUTCH PISTON

## REAR CLUTCH (Continued)

(15) Using a suitable gauge bar and dial indicator, measure clutch pack clearance (Fig. 222).

(a) Position gauge bar across the clutch drum with the dial indicator pointer on the pressure plate (Fig. 222).

(b) Using two small screw drivers, lift the pressure plate and release it.

(c) Zero the dial indicator.

(d) Lift the pressure plate until it contacts the snap-ring and record the dial indicator reading.

Clearance should be 0.559 - 0.914 mm (0.022 - 0.036 in.). If clearance is incorrect, steel plates, discs, selective snap ring and pressure plates may have to be changed.

The selective snap-ring thicknesses are:

- 0.107-0.109 in.
- 0.098-0.100 in.
- 0.095-0.097 in.
- 0.083-0.085 in.
- 0.076-0.078 in.
- 0.071-0.073 in.
- 0.060-0.062 in.

(16) Coat rear clutch thrust washer with petroleum jelly and install washer over input shaft and into clutch retainer (Fig. 223). Use enough petroleum jelly to hold washer in place.

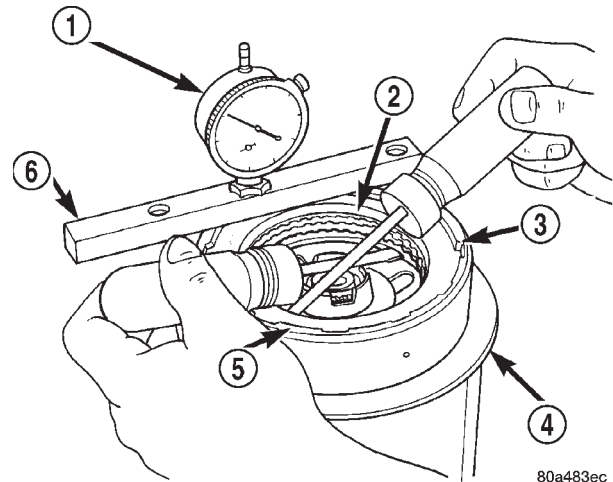
## REAR SERVO

## DESCRIPTION

The rear (low/reverse) servo consists of a single stage or diameter piston and a spring loaded plug. The spring is used to cushion the application of the rear (low/reverse) band.

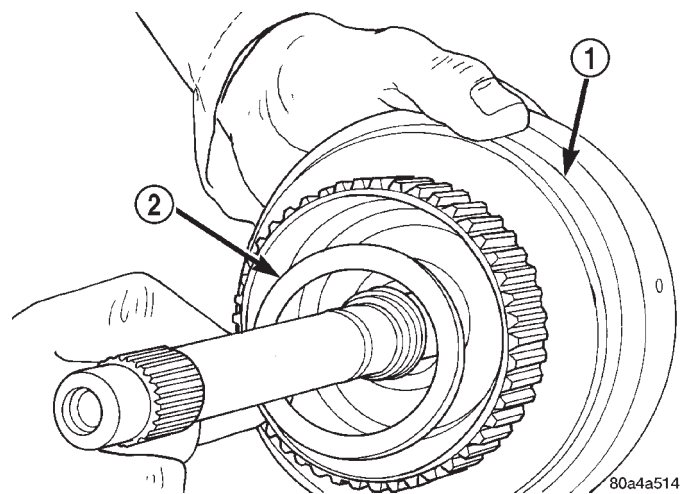
## OPERATION

While in the de-energized state (no pressure applied), the piston is held up in its bore by the piston spring. The plug is held down in its bore, in the piston, by the plug spring. When pressure is applied to the top of the piston, the plug is forced down in its bore, taking up any clearance. As the piston moves, it causes the plug spring to compress, and the piston moves down over the plug. The piston continues to move down until it hits the shoulder of the plug and fully applies the band. The period of time from the initial application, until the piston is against the



**Fig. 222 Checking Rear Clutch Pack Clearance**

- 1 - DIAL INDICATOR
- 2 - PRESSURE PLATE
- 3 - SNAP-RING
- 4 - STAND
- 5 - REAR CLUTCH
- 6 - GAUGE BAR



**Fig. 223 Installing Rear Clutch Thrust Washer**

- 1 - REAR CLUTCH RETAINER
- 2 - REAR CLUTCH THRUST WASHER

shoulder of the plug, represents a reduced shocking of the band that cushions the shift.

## REAR SERVO (Continued)

## DISASSEMBLY

- (1) Remove small snap-ring and remove plug and spring from servo piston (Fig. 224).
- (2) Remove and discard servo piston seal ring.

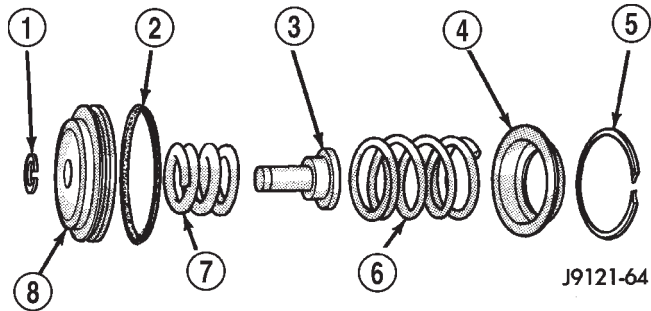


Fig. 224 Rear Servo Components

- 1 - SNAP-RING
- 2 - PISTON SEAL
- 3 - PISTON PLUG
- 4 - SPRING RETAINER
- 5 - SNAP-RING
- 6 - PISTON SPRING
- 7 - CUSHION SPRING
- 8 - PISTON

## CLEANING

Remove and discard the servo piston seal ring (Fig. 225). Then clean the servo components with solvent and dry with compressed air. Replace either spring if collapsed, distorted or broken. Replace the plug and piston if cracked, bent, or worn. Discard the servo snap-rings and use new ones at assembly.

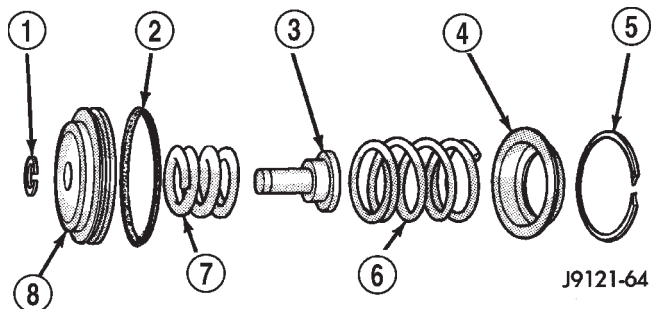


Fig. 225 Rear Servo Components

- 1 - SNAP-RING
- 2 - PISTON SEAL
- 3 - PISTON PLUG
- 4 - SPRING RETAINER
- 5 - SNAP-RING
- 6 - PISTON SPRING
- 7 - CUSHION SPRING
- 8 - PISTON

## ASSEMBLY

- (1) Lubricate piston and guide seals (Fig. 226) with petroleum jelly. Lubricate other servo parts with Mopar® ATF +4, type 9602, transmission fluid.
- (2) Install new seal ring on servo piston.
- (3) Assemble piston, plug, spring and new snap-ring.
- (4) Lubricate piston seal lip with petroleum jelly.

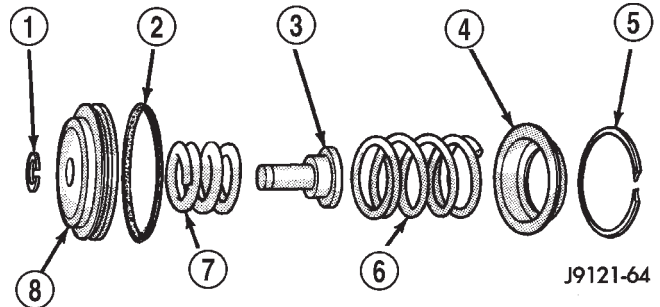


Fig. 226 Rear Servo Components

- 1 - SNAP-RING
- 2 - PISTON SEAL
- 3 - PISTON PLUG
- 4 - SPRING RETAINER
- 5 - SNAP-RING
- 6 - PISTON SPRING
- 7 - CUSHION SPRING
- 8 - PISTON

## SHIFT MECHANISM

## DESCRIPTION

The gear shift mechanism provides six shift positions which are:

- PARK (P)
- REVERSE (R)
- NEUTRAL (N)
- DRIVE (D)
- Manual SECOND (2)
- Manual LOW (1)

## OPERATION

Manual LOW (1) range provides first gear only. Overrun braking is also provided in this range. Manual SECOND (2) range provides first and second gear only.

DRIVE range provides first, second third and overdrive fourth gear ranges. The shift into overdrive fourth gear range occurs only after the transmission has completed the shift into D third gear range. No further movement of the shift mechanism is required to complete the 3-4 shift.

The fourth gear upshift occurs automatically when the overdrive selector switch is in the ON position.

## SHIFT MECHANISM (Continued)

No upshift to fourth gear will occur if any of the following are true:

- The transmission fluid temperature is below 10° C (50° F) or above 121° C (250° F).
- The shift to third is not yet complete.
- Vehicle speed is too low for the 3-4 shift to occur.
- Battery temperature is below -5° C (23° F).

## ADJUSTMENT

Check linkage adjustment by starting engine in PARK and NEUTRAL. Adjustment is acceptable if the engine starts in only these two positions. Adjustment is incorrect if the engine starts in one position but not both positions.

If the engine starts in any other position, or if the engine will not start in any position, the park/neutral switch is probably faulty.

## LINKAGE ADJUSTMENT

Check condition of the shift linkage (Fig. 227). Do not attempt adjustment if any component is loose, worn, or bent. Replace any suspect components.

Replace the grommet securing the shift rod or torque rod in place if either rod was removed from the grommet. Remove the old grommet as necessary and use suitable pliers to install the new grommet.

- (1) Shift transmission into PARK.
- (2) Raise and support vehicle.
- (3) Loosen lock bolt in front shift rod adjusting swivel (Fig. 227).
- (4) Ensure that the shift rod slides freely in the swivel. Lube rod and swivel as necessary.
- (5) Move transmission shift lever fully rearward to the Park detent.
- (6) Center adjusting swivel on shift rod.
- (7) Tighten swivel lock bolt to 10 N·m (90 in. lbs.).
- (8) Lower vehicle and verify proper adjustment.

## SOLENOID

## DESCRIPTION

The typical electrical solenoid used in automotive applications is a linear actuator. It is a device that produces motion in a straight line. This straight line motion can be either forward or backward in direction, and short or long distance.

A solenoid is an electromechanical device that uses a magnetic force to perform work. It consists of a coil of wire, wrapped around a magnetic core made from steel or iron, and a spring loaded, movable plunger, which performs the work, or straight line motion.

The solenoids used in transmission applications are attached to valves which can be classified as **normally open** or **normally closed**. The **normally open** solenoid valve is defined as a valve which

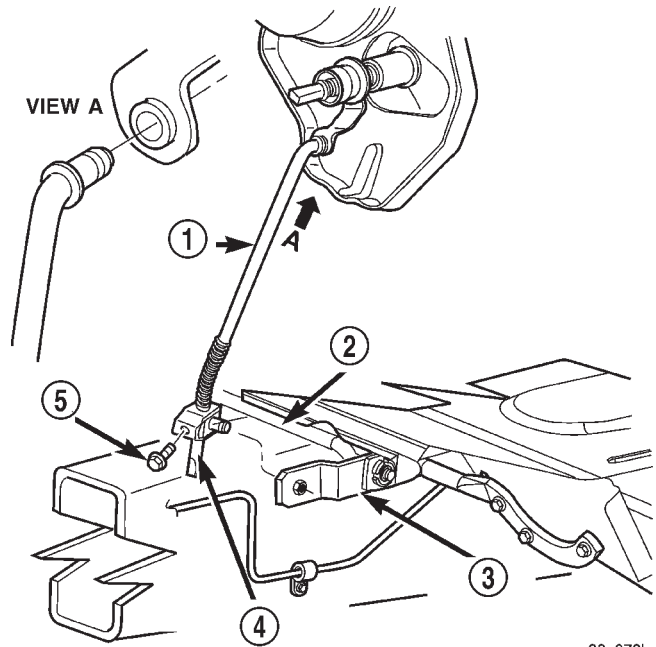


Fig. 227 Linkage Adjustment Components

- 1 - FRONT SHIFT ROD
- 2 - TORQUE SHAFT ASSEMBLY
- 3 - TORQUE SHAFT ARM
- 4 - ADJUSTING SWIVEL
- 5 - LOCK BOLT

allows hydraulic flow when no current or voltage is applied to the solenoid. The **normally closed** solenoid valve is defined as a valve which does not allow hydraulic flow when no current or voltage is applied to the solenoid. These valves perform hydraulic control functions for the transmission and must therefore be durable and tolerant of dirt particles. For these reasons, the valves have hardened steel poppets and ball valves. The solenoids operate the valves directly, which means that the solenoids must have very high outputs to close the valves against the sizable flow areas and line pressures found in current transmissions. Fast response time is also necessary to ensure accurate control of the transmission.

The strength of the magnetic field is the primary force that determines the speed of operation in a particular solenoid design. A stronger magnetic field will cause the plunger to move at a greater speed than a weaker one. There are basically two ways to increase the force of the magnetic field:

- Increase the amount of current applied to the coil or
- Increase the number of turns of wire in the coil.

The most common practice is to increase the number of turns by using thin wire that can completely fill the available space within the solenoid housing. The strength of the spring and the length of the



## SOLENOID (Continued)

plunger also contribute to the response speed possible by a particular solenoid design.

A solenoid can also be described by the method by which it is controlled. Some of the possibilities include variable force, pulse-width modulated, constant ON, or duty cycle. The variable force and pulse-width modulated versions utilize similar methods to control the current flow through the solenoid to position the solenoid plunger at a desired position somewhere between full ON and full OFF. The constant ON and duty cycled versions control the voltage across the solenoid to allow either full flow or no flow through the solenoid's valve.

## OPERATION

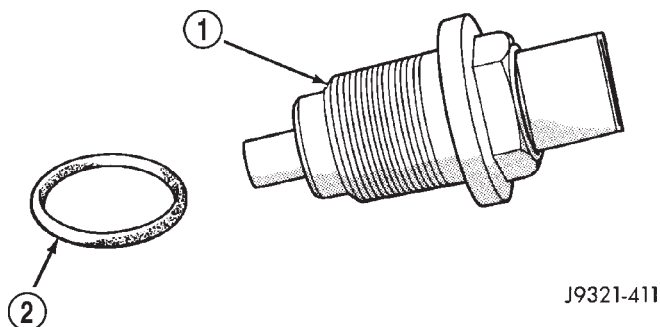
When an electrical current is applied to the solenoid coil, a magnetic field is created which produces an attraction to the plunger, causing the plunger to move and work against the spring pressure and the load applied by the fluid the valve is controlling. The plunger is normally directly attached to the valve which it is to operate. When the current is removed from the coil, the attraction is removed and the plunger will return to its original position due to spring pressure.

The plunger is made of a conductive material and accomplishes this movement by providing a path for the magnetic field to flow. By keeping the air gap between the plunger and the coil to the minimum necessary to allow free movement of the plunger, the magnetic field is maximized.

## SPEED SENSOR

## DESCRIPTION

The speed sensor (Fig. 228) is located in the over-drive gear case. The sensor is positioned over the park gear and monitors transmission output shaft rotating speed.



**Fig. 228 Transmission Output Speed Sensor**

- 1 - TRANSMISSION OUTPUT SHAFT SPEED SENSOR
- 2 - SEAL

## OPERATION

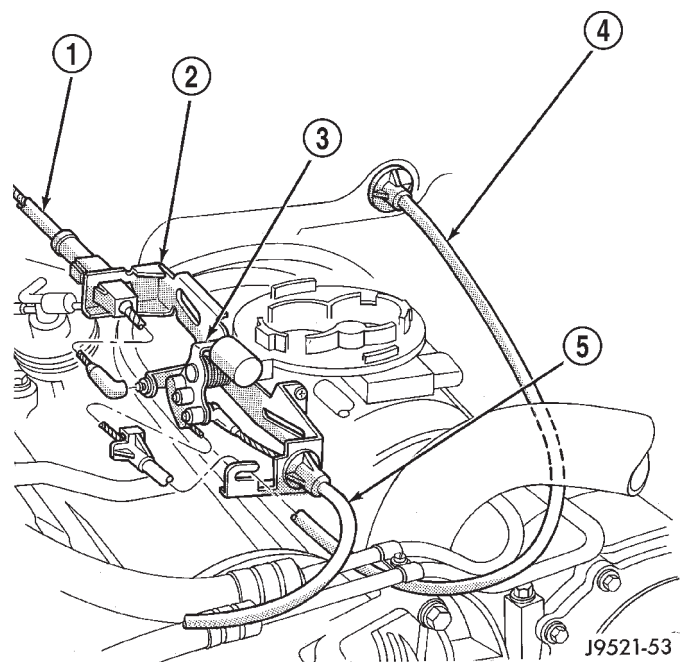
Speed sensor signals are triggered by the park gear lugs as they rotate past the sensor pickup face. Input signals from the sensor are sent to the transmission control module for processing. Signals from this sensor are shared with the powertrain control module.

## THROTTLE VALVE CABLE

## DESCRIPTION

Transmission throttle valve cable (Fig. 229) adjustment is extremely important to proper operation. This adjustment positions the throttle valve, which controls shift speed, quality, and part-throttle downshift sensitivity.

If cable setting is too loose, early shifts and slippage between shifts may occur. If the setting is too tight, shifts may be delayed and part throttle downshifts may be very sensitive.



**Fig. 229 Throttle Valve Cable Attachment - At Engine**

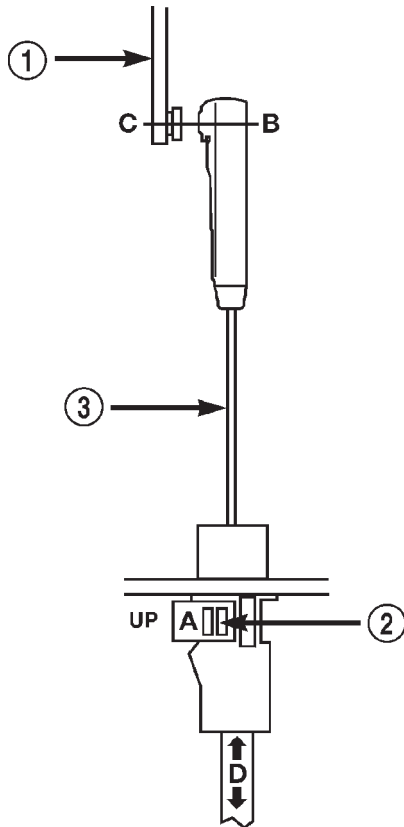
- 1 - THROTTLE VALVE CABLE
- 2 - CABLE BRACKET
- 3 - THROTTLE BODY LEVER
- 4 - ACCELERATOR CABLE
- 5 - SPEED CONTROL CABLE

The transmission throttle valve is operated by a cam on the throttle lever. The throttle lever is operated by an adjustable cable (Fig. 230). The cable is attached to an arm mounted on the throttle lever shaft. A retaining clip at the engine-end of the cable



## THROTTLE VALVE CABLE (Continued)

is removed to provide for cable adjustment. The retaining clip is then installed back onto the throttle valve cable to lock in the adjustment.



80bce9fb

**Fig. 230 Throttle Valve Cable at Throttle Linkage**

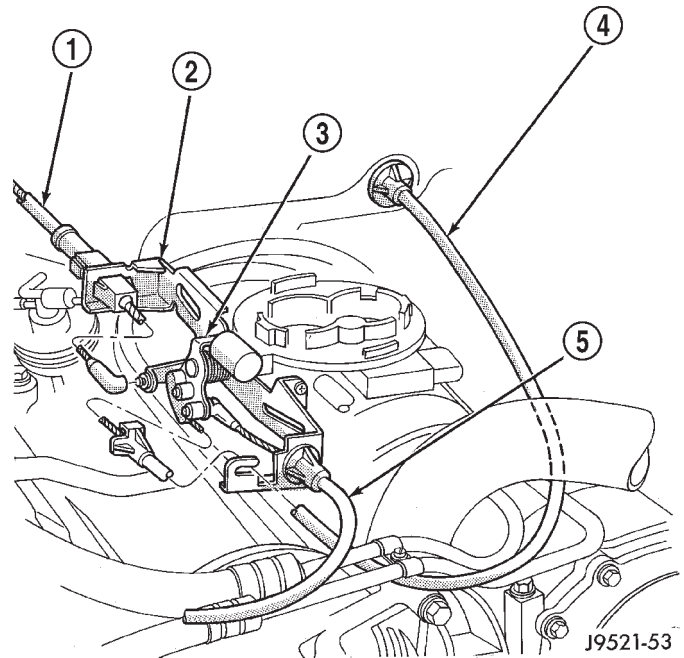
- 1 - THROTTLE LINKAGE
- 2 - THROTTLE VALVE CABLE LOCKING CLIP
- 3 - THROTTLE VALVE CABLE

## ADJUSTMENTS - TRANSMISSION THROTTLE VALVE CABLE

A correctly adjusted throttle valve cable will cause the throttle lever on the transmission to move simultaneously with the throttle body lever from the idle position. Proper adjustment will allow simultaneous movement without causing the transmission throttle lever to either move ahead of, or lag behind the lever on the throttle body.

### ADJUSTMENT VERIFICATION

- (1) Turn ignition key to OFF position.
- (2) Remove air cleaner.
- (3) Verify that lever on throttle body is at curb idle position (Fig. 231). Then verify that the transmission throttle lever (Fig. 232) is also at idle (fully forward) position.
- (4) Slide cable off attachment stud on throttle body lever.



**Fig. 231 Throttle Valve Cable Attachment - At Engine**

- 1 - THROTTLE VALVE CABLE
- 2 - CABLE BRACKET
- 3 - THROTTLE BODY LEVER
- 4 - ACCELERATOR CABLE
- 5 - SPEED CONTROL CABLE

(5) Compare position of cable end to attachment stud on throttle body lever:

- Cable end and attachment stud should be aligned (or centered on one another) to within 1 mm (0.039 in.) in either direction (Fig. 233).

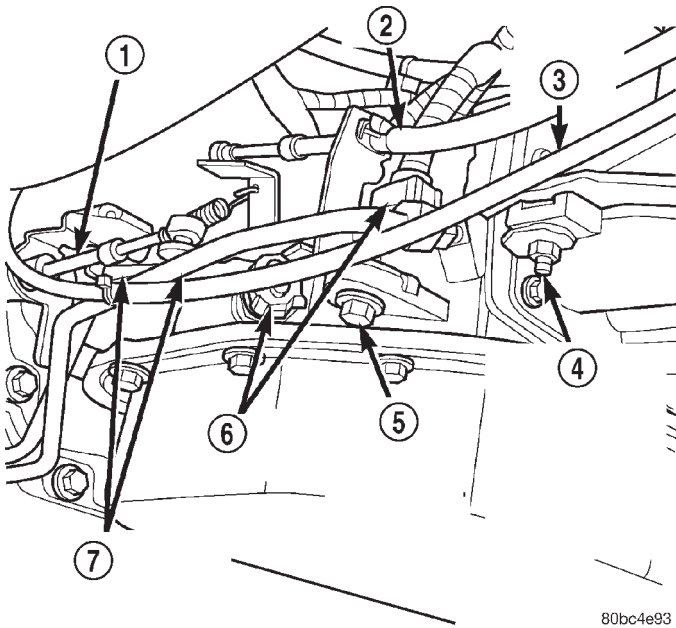
- If cable end and attachment stud are misaligned (off center), cable will have to be adjusted as described in Throttle Valve Cable Adjustment procedure.

(6) Reconnect cable end to attachment stud. Then with aid of a helper, observe movement of transmission throttle lever and lever on throttle body.

- If both levers move simultaneously from idle to half-throttle and back to idle position, adjustment is correct.

- If transmission throttle lever moves ahead of, or lags behind throttle body lever, cable adjustment will be necessary. Or, if throttle body lever prevents transmission lever from returning to closed position, cable adjustment will be necessary.

## THROTTLE VALVE CABLE (Continued)



80bc4e93

**Fig. 232 Throttle Valve Cable at Transmission**

- 1 - TRANSMISSION SHIFTER CABLE
- 2 - THROTTLE VALVE CABLE
- 3 - TRANSFER CASE SHIFTER CABLE
- 4 - TRANSFER CASE SHIFTER CABLE BRACKET RETAINING BOLT (1 OR 2)
- 5 - THROTTLE VALVE CABLE BRACKET RETAINING BOLT
- 6 - ELECTRICAL CONNECTORS
- 7 - TRANSMISSION FLUID LINES

## ADJUSTMENT PROCEDURE

- (1) Turn ignition switch to OFF position.
- (2) Remove air cleaner if necessary.
- (3) Disconnect cable end from attachment stud.

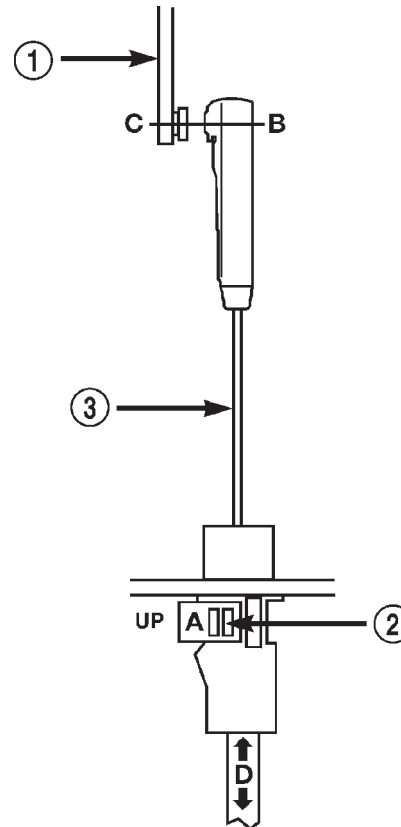
**Carefully slide cable off stud. Do not pry or pull cable off.**

(4) Verify that transmission throttle lever is in fully closed position. Then be sure lever on throttle body is at curb idle position.

(5) Pry the T.V. cable lock (A) into the UP position (Fig. 233). This will unlock the cable and allow for readjustment.

(6) Apply just enough tension on the T.V. cable (B) to remove any slack in the cable. **Pulling too tight will cause the T.V. lever on the transmission to move out of its idle position, which will result in an incorrect T.V. cable adjustment.** Slide the sheath of the T.V. cable (D) back and forth until the centerlines of the T.V. cable end (B) and the throttle bell crank lever (C) are aligned within one millimeter (1mm) (Fig. 233).

(7) While holding the T.V. cable in the set position push the T.V. cable lock (A) into the down position (Fig. 233). This will lock the present T.V. cable adjustment.



80bce9fb

**Fig. 233 Throttle Valve Cable at Throttle Linkage**

- 1 - THROTTLE LINKAGE
- 2 - THROTTLE VALVE CABLE LOCKING CLIP
- 3 - THROTTLE VALVE CABLE

**NOTE:** Be sure that as the cable is pulled forward and centered on the throttle lever stud, the cable housing moves smoothly with the cable. Due to the angle at which the cable housing enters the spring housing, the cable housing may bind slightly and create an incorrect adjustment.

(8) Reconnect the T.V. cable (B) to the throttle bellcrank lever (C).

(9) Check cable adjustment. Verify transmission throttle lever and lever on throttle body move simultaneously.

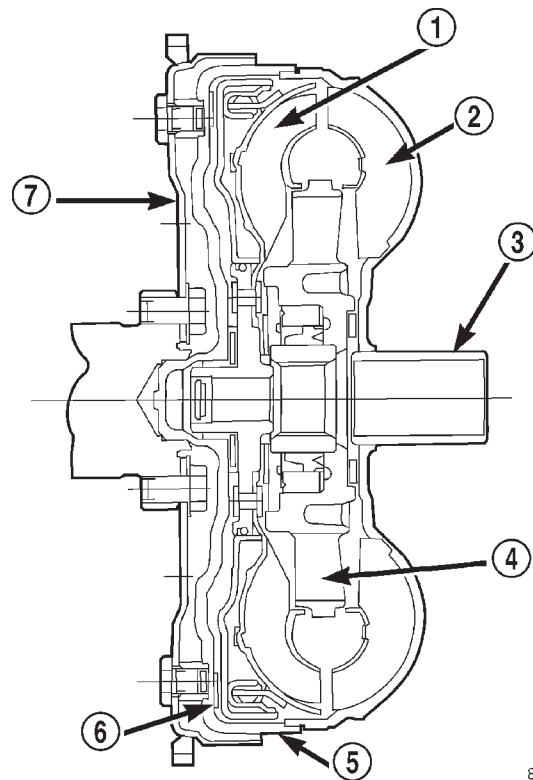
## TORQUE CONVERTER

### DESCRIPTION

The torque converter (Fig. 234) is a hydraulic device that couples the engine crankshaft to the transmission. The torque converter consists of an outer shell with an internal turbine, a stator, an overrunning clutch, an impeller and an electronically applied converter clutch. The converter clutch provides reduced engine speed and greater fuel economy when engaged. Clutch engagement also provides reduced transmission fluid temperatures. The torque converter hub drives the transmission oil (fluid) pump.

The torque converter is a sealed, welded unit that is not repairable and is serviced as an assembly.

**CAUTION:** The torque converter must be replaced if a transmission failure resulted in large amounts of metal or fiber contamination in the fluid. If the fluid is contaminated, flush the all transmission fluid cooler(s) and lines.



80c07135

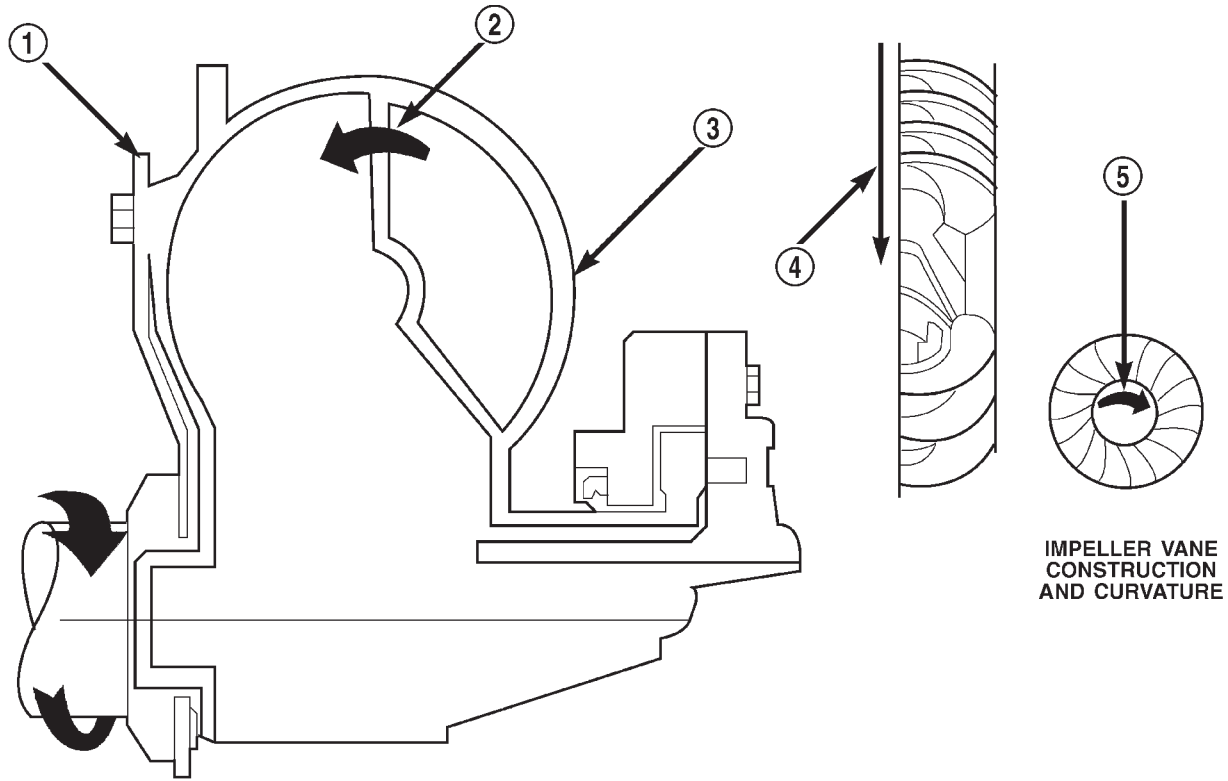
**Fig. 234 Torque Converter Assembly**

- 1 - TURBINE
- 2 - IMPELLER
- 3 - HUB
- 4 - STATOR
- 5 - FRONT COVER
- 6 - CONVERTER CLUTCH DISC
- 7 - DRIVE PLATE

TORQUE CONVERTER (Continued)

**IMPELLER**

The impeller (Fig. 235) is an integral part of the converter housing. The impeller consists of curved blades placed radially along the inside of the housing on the transmission side of the converter. As the converter housing is rotated by the engine, so is the impeller, because they are one and the same and are the driving members of the system.



**IMPELLER VANE  
CONSTRUCTION  
AND CURVATURE**

80bfe26a

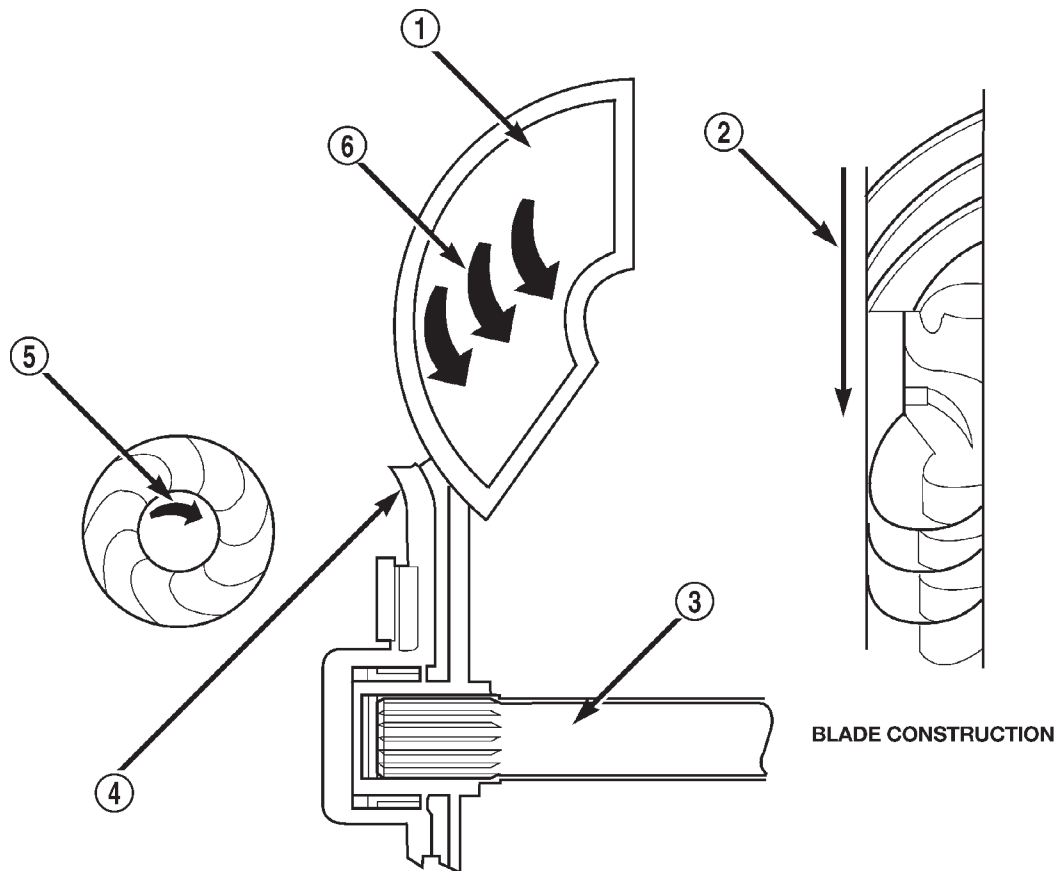
**Fig. 235 Impeller**

- |   |                     |
|---|---------------------|
| 1 - ENGINE FLEXPLATE                                    | 4 - ENGINE ROTATION |
| 2 - OIL FLOW FROM IMPELLER SECTION INTO TURBINE SECTION | 5 - ENGINE ROTATION |
| 3 - IMPELLER VANES AND COVER ARE INTEGRAL               |                     |

## TORQUE CONVERTER (Continued)

**TURBINE**

The turbine (Fig. 236) is the output, or driven, member of the converter. The turbine is mounted within the housing opposite the impeller, but is not attached to the housing. The input shaft is inserted through the center of the impeller and splined into the turbine. The design of the turbine is similar to the impeller, except the blades of the turbine are curved in the opposite direction.



80bfe26b

**Fig. 236 Turbine**

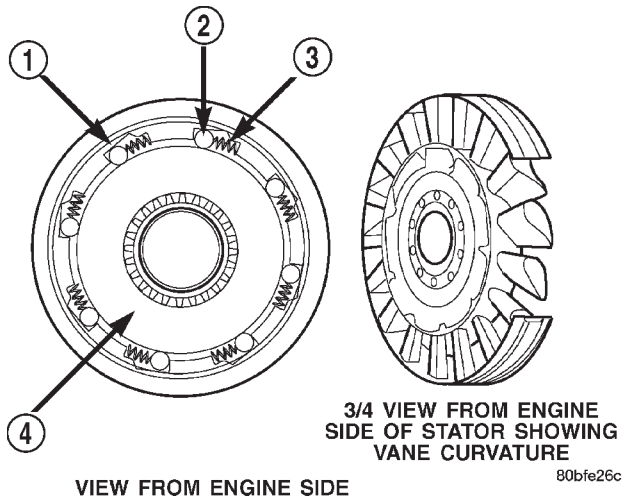
- |                     |                                       |
|---------------------|---------------------------------------|
| 1 - TURBINE VANE    | 4 - PORTION OF TORQUE CONVERTER COVER |
| 2 - ENGINE ROTATION | 5 - ENGINE ROTATION                   |
| 3 - INPUT SHAFT     | 6 - OIL FLOW WITHIN TURBINE SECTION   |



## TORQUE CONVERTER (Continued)

## STATOR

The stator assembly (Fig. 237) is mounted on a stationary shaft which is an integral part of the oil pump. The stator is located between the impeller and turbine within the torque converter case (Fig. 238). The stator contains an over-running clutch, which allows the stator to rotate only in a clockwise direction. When the stator is locked against the over-running clutch, the torque multiplication feature of the torque converter is operational.

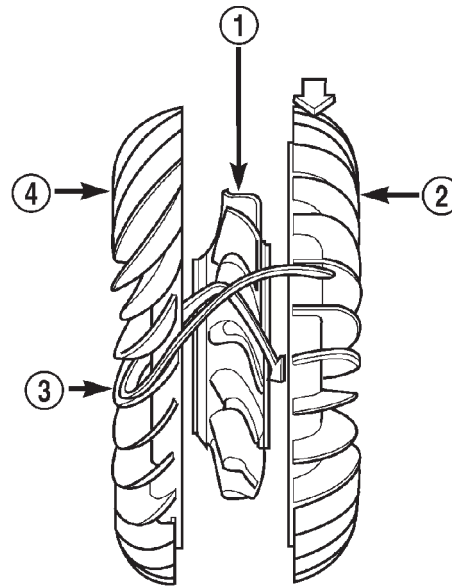


**Fig. 237 Stator Components**

- 1 - CAM (OUTER RACE)
- 2 - ROLLER
- 3 - SPRING
- 4 - INNER RACE

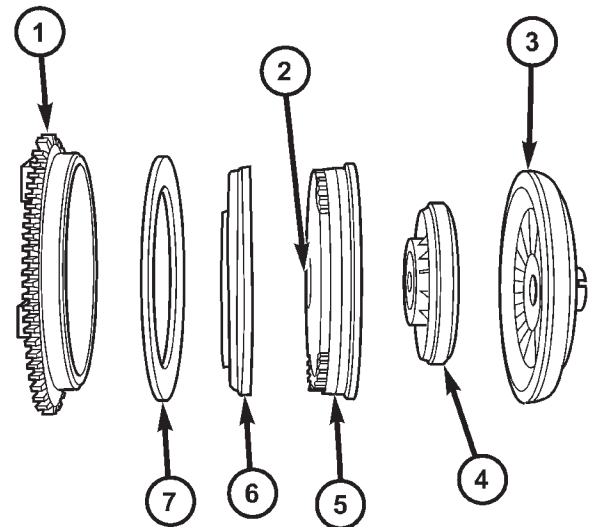
## TORQUE CONVERTER CLUTCH (TCC)

The TCC (Fig. 239) was installed to improve the efficiency of the torque converter that is lost to the slippage of the fluid coupling. Although the fluid coupling provides smooth, shock-free power transfer, it is natural for all fluid couplings to slip. If the impeller and turbine were mechanically locked together, a zero slippage condition could be obtained. A hydraulic piston was added to the turbine, and a friction material was added to the inside of the front cover to provide this mechanical lock-up.



**Fig. 238 Stator Location**

- 1 - STATOR
- 2 - IMPELLER
- 3 - FLUID FLOW
- 4 - TURBINE



**Fig. 239 Torque Converter Clutch (TCC)**

- 1 - IMPELLER FRONT COVER
- 2 - THRUST WASHER ASSEMBLY
- 3 - IMPELLER
- 4 - STATOR
- 5 - TURBINE
- 6 - PISTON
- 7 - FRICTION DISC

## TORQUE CONVERTER (Continued)

## OPERATION

The converter impeller (Fig. 240) (driving member), which is integral to the converter housing and bolted to the engine drive plate, rotates at engine speed. The converter turbine (driven member), which reacts from fluid pressure generated by the impeller, rotates and turns the transmission input shaft.

## TURBINE

As the fluid that was put into motion by the impeller blades strikes the blades of the turbine, some of the energy and rotational force is transferred into the turbine and the input shaft. This causes both of them (turbine and input shaft) to rotate in a clockwise direction following the impeller. As the fluid is leaving the trailing edges of the turbine's blades it continues in a "hindering" direction back toward the impeller. If the fluid is not redirected before it strikes the impeller, it will strike the impeller in such a direction that it would tend to slow it down.

## STATOR

Torque multiplication is achieved by locking the stator's over-running clutch to its shaft (Fig. 241). Under stall conditions (the turbine is stationary), the oil leaving the turbine blades strikes the face of the stator blades and tries to rotate them in a counter-

clockwise direction. When this happens the overrunning clutch of the stator locks and holds the stator from rotating. With the stator locked, the oil strikes the stator blades and is redirected into a "helping" direction before it enters the impeller. This circulation of oil from impeller to turbine, turbine to stator, and stator to impeller, can produce a maximum torque multiplication of about 2.4:1. As the turbine begins to match the speed of the impeller, the fluid that was hitting the stator in such a way as to cause it to lock-up is no longer doing so. In this condition of operation, the stator begins to free wheel and the converter acts as a fluid coupling.

## TORQUE CONVERTER CLUTCH (TCC)

The torque converter clutch is hydraulically applied and is released when fluid is vented from the hydraulic circuit by the torque converter control (TCC) solenoid on the valve body. The torque converter clutch is controlled by the Powertrain Control Module (PCM). The torque converter clutch engages in fourth gear, and in third gear under various conditions, such as when the O/D switch is OFF, when the vehicle is cruising on a level surface after the vehicle has warmed up. The torque converter clutch will disengage momentarily when an increase in engine load is sensed by the PCM, such as when the

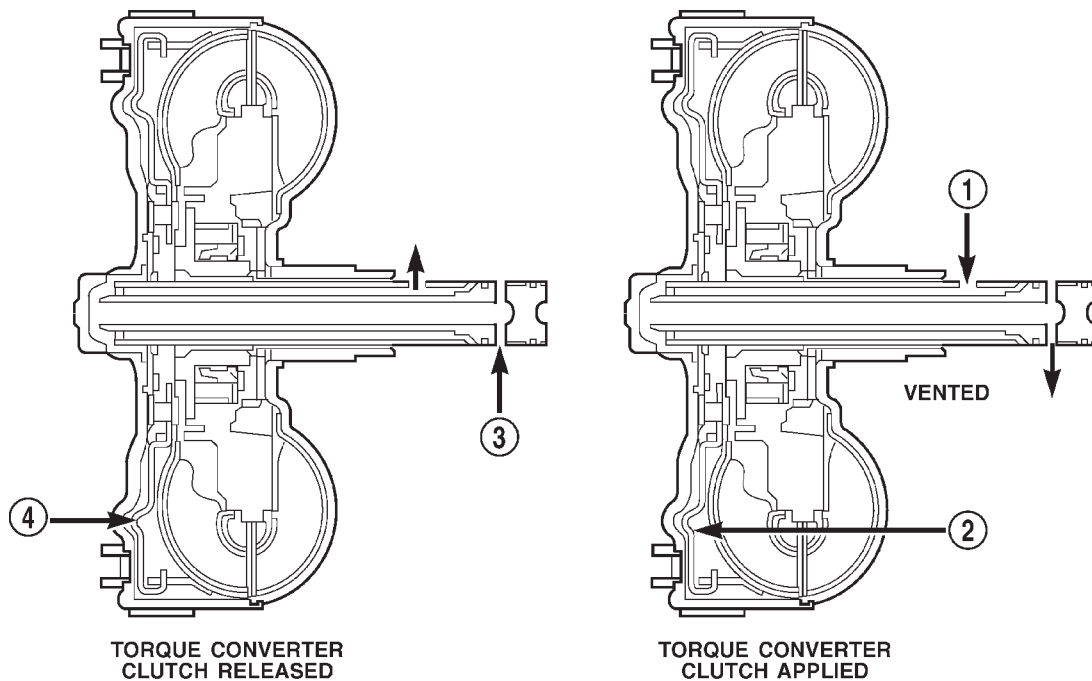


Fig. 240 Torque Converter Fluid Operation

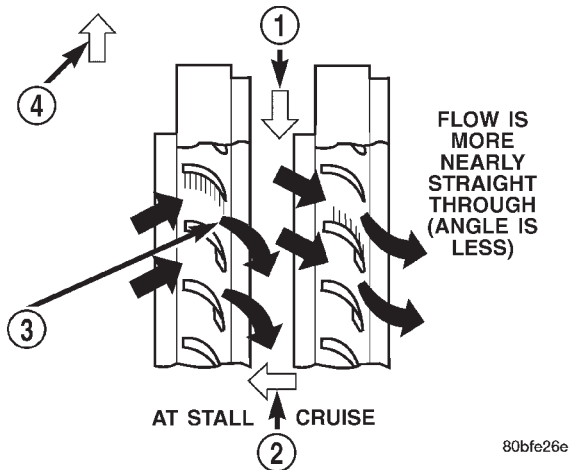
1 - APPLY PRESSURE

2 - THE PISTON MOVES SLIGHTLY FORWARD

3 - RELEASE PRESSURE

4 - THE PISTON MOVES SLIGHTLY REARWARD

## TORQUE CONVERTER (Continued)

**Fig. 241 Stator Operation**

- 1 - DIRECTION STATOR WILL FREE WHEEL DUE TO OIL PUSHING ON BACKSIDE OF VANES
- 2 - FRONT OF ENGINE
- 3 - INCREASED ANGLE AS OIL STRIKES VANES
- 4 - DIRECTION STATOR IS LOCKED UP DUE TO OIL PUSHING AGAINST STATOR VANES

vehicle begins to go uphill or the throttle pressure is increased.

**REMOVAL**

- (1) Remove transmission and torque converter from vehicle.
- (2) Place a suitable drain pan under the converter housing end of the transmission.

**CAUTION:** Verify that transmission is secure on the lifting device or work surface, the center of gravity of the transmission will shift when the torque converter is removed creating an unstable condition. The torque converter is a heavy unit. Use caution when separating the torque converter from the transmission.

- (3) Pull the torque converter forward until the center hub clears the oil pump seal.
- (4) Separate the torque converter from the transmission.

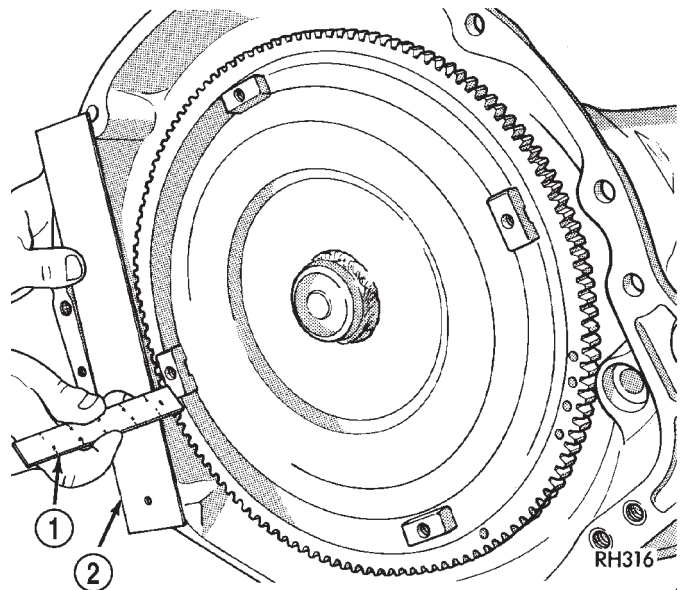
**INSTALLATION**

Check converter hub and drive notches for sharp edges, burrs, scratches, or nicks. Polish the hub and notches with 320/400 grit paper or crocus cloth if necessary. The hub must be smooth to avoid damaging the pump seal at installation.

- (1) Lubricate oil pump seal lip with transmission fluid.
- (2) Place torque converter in position on transmission.

**CAUTION:** Do not damage oil pump seal or bushing while inserting torque converter into the front of the transmission.

- (3) Align torque converter to oil pump seal opening.
- (4) Insert torque converter hub into oil pump.
- (5) While pushing torque converter inward, rotate converter until converter is fully seated in the oil pump gears.
- (6) Check converter seating with a scale and straightedge (Fig. 242). Surface of converter lugs should be 1/2 in. to rear of straightedge when converter is fully seated.
- (7) If necessary, temporarily secure converter with C-clamp attached to the converter housing.
- (8) Install the transmission in the vehicle.
- (9) Fill the transmission with the recommended fluid.

**Fig. 242 Checking Torque Converter Seating - Typical**

- 1 - SCALE
- 2 - STRAIGHTEDGE

## TORQUE CONVERTER DRAINBACK VALVE

### DESCRIPTION

The drainback valve is located in the transmission cooler outlet (pressure) line.

### OPERATION

The valve prevents fluid from draining from the converter into the cooler and lines when the vehicle is shut down for lengthy periods. Production valves have a hose nipple at one end, while the opposite end is threaded for a flare fitting. All valves have an arrow (or similar mark) to indicate direction of flow through the valve.

### STANDARD PROCEDURE - TORQUE CONVERTER DRAINBACK VALVE

The converter drainback check valve is located in the cooler outlet (pressure) line near the radiator tank. The valve prevents fluid drainback when the vehicle is parked for lengthy periods. The valve check ball is spring loaded and has an opening pressure of approximately 2 psi.

The valve is serviced as an assembly; it is not repairable. Do not clean the valve if restricted, or contaminated by sludge, or debris. If the valve fails, or if a transmission malfunction occurs that generates significant amounts of sludge and/or clutch particles and metal shavings, the valve must be replaced.

The valve must be removed whenever the cooler and lines are reverse flushed. The valve can be flow tested when necessary. The procedure is exactly the same as for flow testing a cooler.

If the valve is restricted, installed backwards, or in the wrong line, it will cause an overheating condition and possible transmission failure.

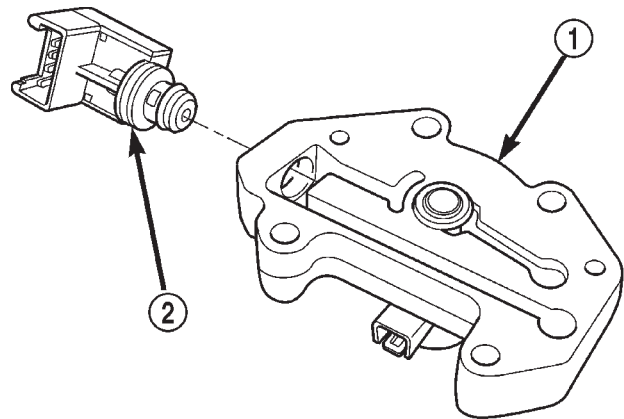
**CAUTION:** The drainback valve is a one-way flow device. It must be properly oriented in terms of flow direction for the cooler to function properly. The valve must be installed in the pressure line. Otherwise flow will be blocked and would cause an overheating condition and eventual transmission failure.

## TRANSMISSION TEMPERATURE SENSOR

### DESCRIPTION

Transmission fluid temperature readings are supplied to the transmission control module by the thermistor (Fig. 243). The temperature readings are used to control engagement of the fourth gear overdrive clutch, the converter clutch, and governor pressure. Normal resistance value for the thermistor at room temperature is approximately 1000 ohms.

The thermistor is part of the governor pressure sensor assembly and is immersed in transmission fluid at all times.



80c072af

**Fig. 243 Governor Pressure Sensor**

1 - GOVERNOR BODY

2 - GOVERNOR PRESSURE SENSOR/TRANSMISSION FLUID TEMPERATURE THERMISTOR

### OPERATION

The PCM prevents engagement of the converter clutch and overdrive clutch, when fluid temperature is below approximately 10°C (50°F).

If fluid temperature exceeds 126°C (260°F), the PCM causes a 4-3 downshift and engage the converter clutch. Engagement is according to the third gear converter clutch engagement schedule.

The overdrive OFF lamp in the instrument panel illuminates when the shift back to third occurs. The transmission will not allow fourth gear operation until fluid temperature decreases to approximately 110°C (230°F).

## VALVE BODY

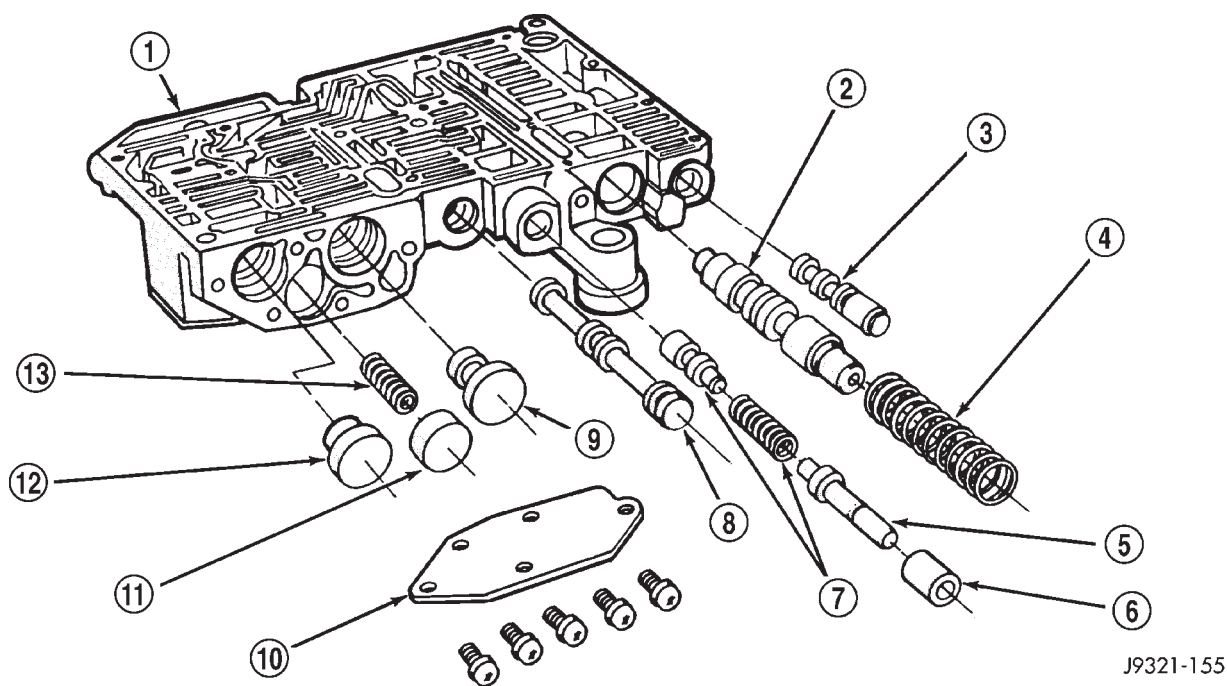
### DESCRIPTION

The valve body consists of a cast aluminum valve body, a separator plate, and transfer plate. The valve body contains valves and check balls that control fluid delivery to the torque converter clutch, bands, and frictional clutches. The valve body contains the following components (Fig. 244), (Fig. 245), (Fig. 246), and (Fig. 247):

- Regulator valve
- Regulator valve throttle pressure plug
- Line pressure plug and sleeve
- Kickdown valve
- Kickdown limit valve
- 1-2 shift valve
- 1-2 control valve
- 2-3 shift valve

- 2-3 governor plug
- 3-4 shift valve
- 3-4 timing valve
- 3-4 quick fill valve
- 3-4 accumulator
- Throttle valve
- Throttle pressure plug
- Switch valve
- Manual valve
- Converter clutch lock-up valve
- Converter clutch lock-up timing Valve
- Shuttle valve
- Shuttle valve throttle plug
- Boost Valve
- 10 check balls

By adjusting the spring pressure acting on the regulator valve, transmission line pressure can be adjusted.



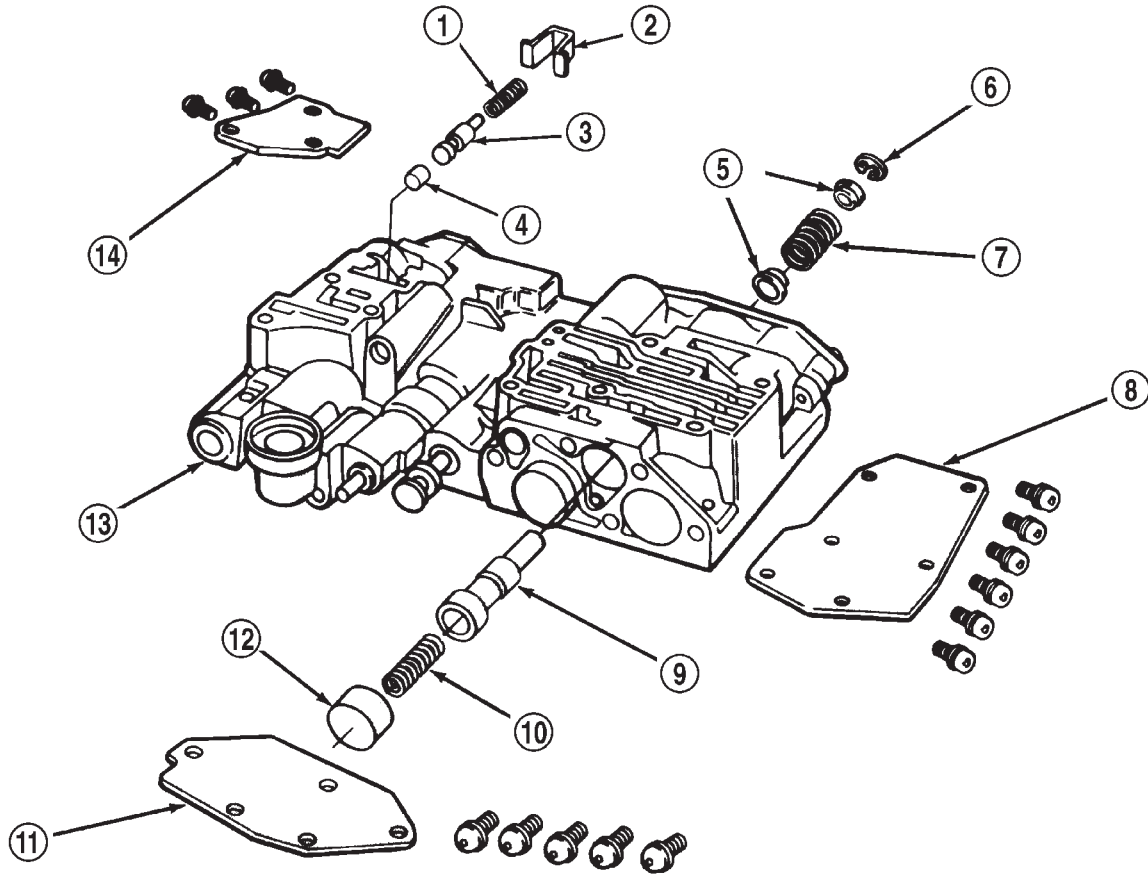
J9321-155

**Fig. 244 Upper Housing Control Valve Locations**

- |                               |                                   |
|-------------------------------|-----------------------------------|
| 1 - UPPER HOUSING             | 8 - MANUAL VALVE                  |
| 2 - REGULATOR VALVE           | 9 - 1-2 GOVERNOR PLUG             |
| 3 - SWITCH VALVE              | 10 - GOVERNOR PLUG COVER          |
| 4 - REGULATOR VALVE SPRING    | 11 - THROTTLE PLUG                |
| 5 - KICKDOWN VALVE            | 12 - 2-3 GOVERNOR PLUG            |
| 6 - KICKDOWN DETENT           | 13 - SHUTTLE VALVE PRIMARY SPRING |
| 7 - THROTTLE VALVE AND SPRING |                                   |



VALVE BODY (Continued)

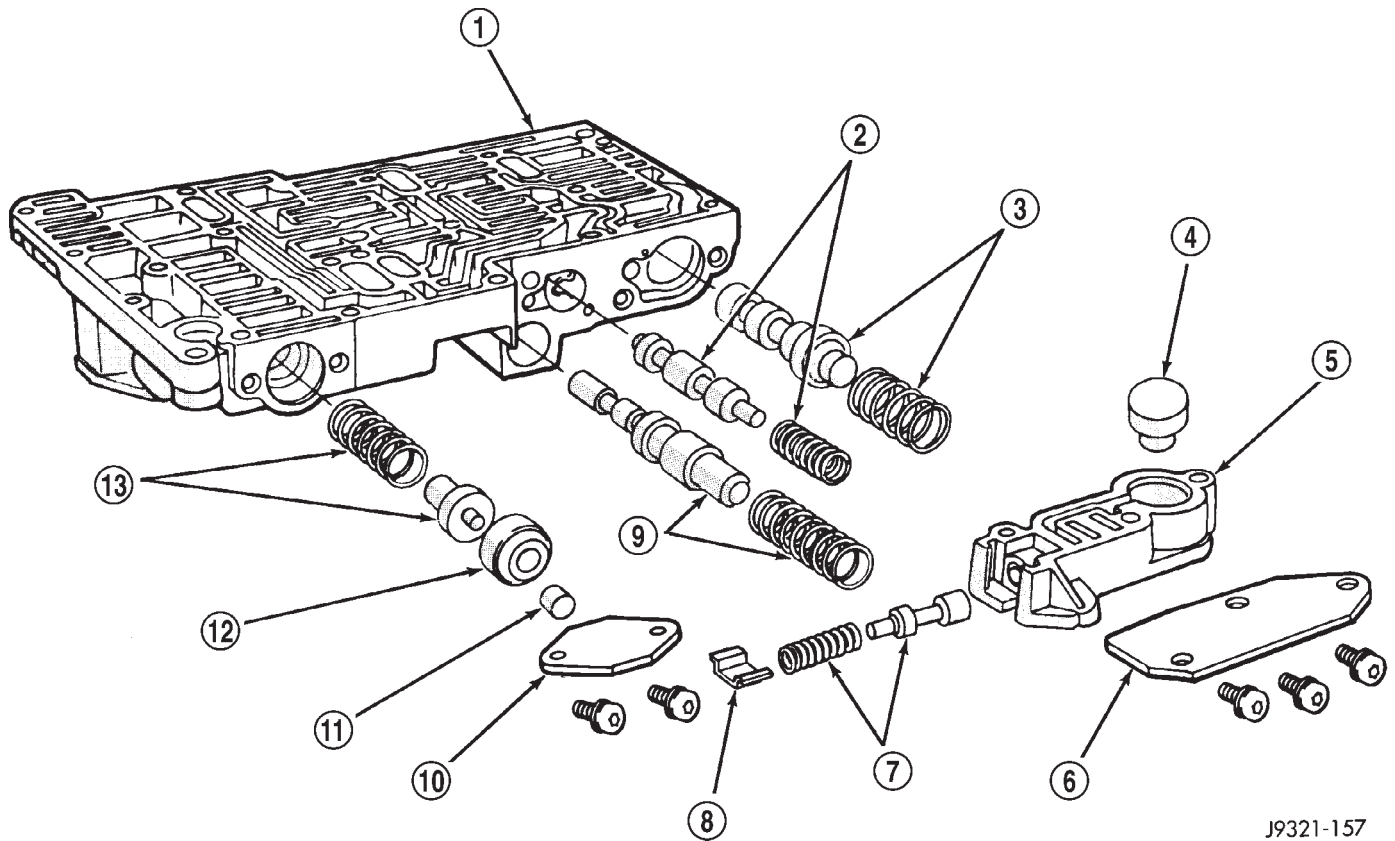


J9421-217

**Fig. 245 Shuttle and Boost Valve Locations**

- |                                    |                                   |
|------------------------------------|-----------------------------------|
| 1 - SPRING                         | 8 - SHUTTLE VALVE COVER           |
| 2 - RETAINER                       | 9 - SHUTTLE VALVE                 |
| 3 - BOOST VALVE                    | 10 - SHUTTLE VALVE PRIMARY SPRING |
| 4 - BOOST VALVE PLUG               | 11 - GOVERNOR PLUG COVER          |
| 5 - SPRING GUIDES                  | 12 - THROTTLE PLUG                |
| 6 - E-CLIP                         | 13 - UPPER HOUSING                |
| 7 - SHUTTLE VALVE SECONDARY SPRING | 14 - BOOST VALVE COVER            |

VALVE BODY (Continued)

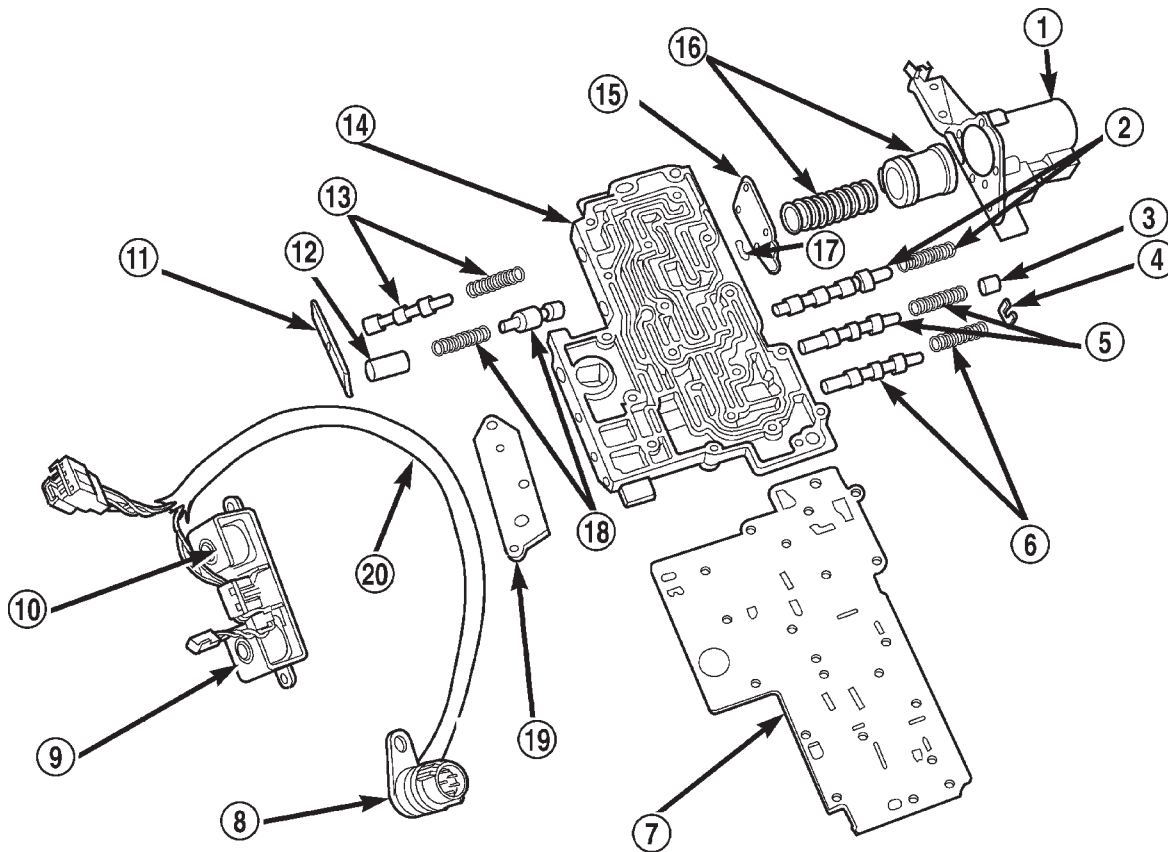


J9321-157

**Fig. 246 Upper Housing Shift Valve and Pressure Plug Locations**

- |                                |  |
|--------------------------------|--|
| 1 - UPPER HOUSING              | 8 - RETAINER                           |
| 2 - 1-2 SHIFT VALVE AND SPRING | 9 - 1-2 SHIFT CONTROL VALVE AND SPRING |
| 3 - 2-3 SHIFT VALVE AND SPRING | 10 - PRESSURE PLUG COVER               |
| 4 - 2-3 THROTTLE PLUG          | 11 - LINE PRESSURE PLUG                |
| 5 - LIMIT VALVE HOUSING        | 12 - PLUG SLEEVE                       |
| 6 - LIMIT VALVE COVER          | 13 - THROTTLE PRESSURE SPRING AND PLUG |
| 7 - LIMIT VALVE AND SPRING     |  |

## VALVE BODY (Continued)



80c072b5

**Fig. 247 Lower Housing Shift Valves and Springs**

- |  |  |
|--|--|
| 1 - 3-4 ACCUMULATOR HOUSING                  | 11 - TIMING VALVE COVER                |
| 2 - 3-4 SHIFT VALVE AND SPRING               | 12 - PLUG                              |
| 3 - PLUG                                     | 13 - 3-4 TIMING VALVE AND SPRING       |
| 4 - SPRING RETAINER                          | 14 - LOWER HOUSING                     |
| 5 - CONVERTER CLUTCH VALVE AND SPRING        | 15 - ACCUMULATOR END PLATE             |
| 6 - CONVERTER CLUTCH TIMING VALVE AND SPRING | 16 - 3-4 ACCUMULATOR PISTON AND SPRING |
| 7 - OVERDRIVE SEPARATOR PLATE                | 17 - E-CLIP                            |
| 8 - CASE CONNECTOR                           | 18 - 3-4 QUICK FILL SPRING AND VALVE   |
| 9 - CONVERTER CLUTCH SOLENOID                | 19 - SOLENOID GASKET                   |
| 10 - OVERDRIVE SOLENOID                      | 20 - HARNESS                           |

## VALVE BODY (Continued)

## OPERATION

**NOTE:** Refer to the Hydraulic Schematics for a visual aid in determining valve location, operation and design.

## CHECK BALLS

CHECK BALL NUMBER	DESCRIPTION
1	Allows either the manual valve to put line pressure on the 1-2 governor plug or the KD Valve to put WOT line pressure on the 1-2 governor plug.
2	Allows either the manual valve to put line pressure on the 2-3 governor plug or the KD Valve to put WOT line pressure on the 2-3 governor plug.
3	Allows either the Reverse circuit or the 3rd gear circuit to pressurize the front clutch.
4	Allows either the Manual Low circuit from the Manual Valve or the Reverse from the Manual Valve circuit to pressurize the rear servo.
5	Directs line pressure to the spring end of the 2-3 shift valve in either Manual Low or Manual 2nd, forcing the downshift to 2nd gear regardless of governor pressure.
6	Provides a by-pass around the front servo orifice so that the servo can release quickly.
7	Provides a by-pass around the rear clutch orifice so that the clutch can release quickly.
8	Directs reverse line pressure through an orifice to the throttle valve eliminating the extra leakage and insuring that Reverse line pressure pressure will be sufficient.
9	Provides a by-pass around the rear servo orifice so that the servo can release quickly.
ECE (10)	Allows the lockup clutch to used at WOT in 3rd gear by putting line pressure from the 3-4 Timing Valve on the interlock area of the 2-3 shift valve, thereby preventing a 3rd gear Lock-up to 2nd gear kickdown.

## VALVE BODY (Continued)

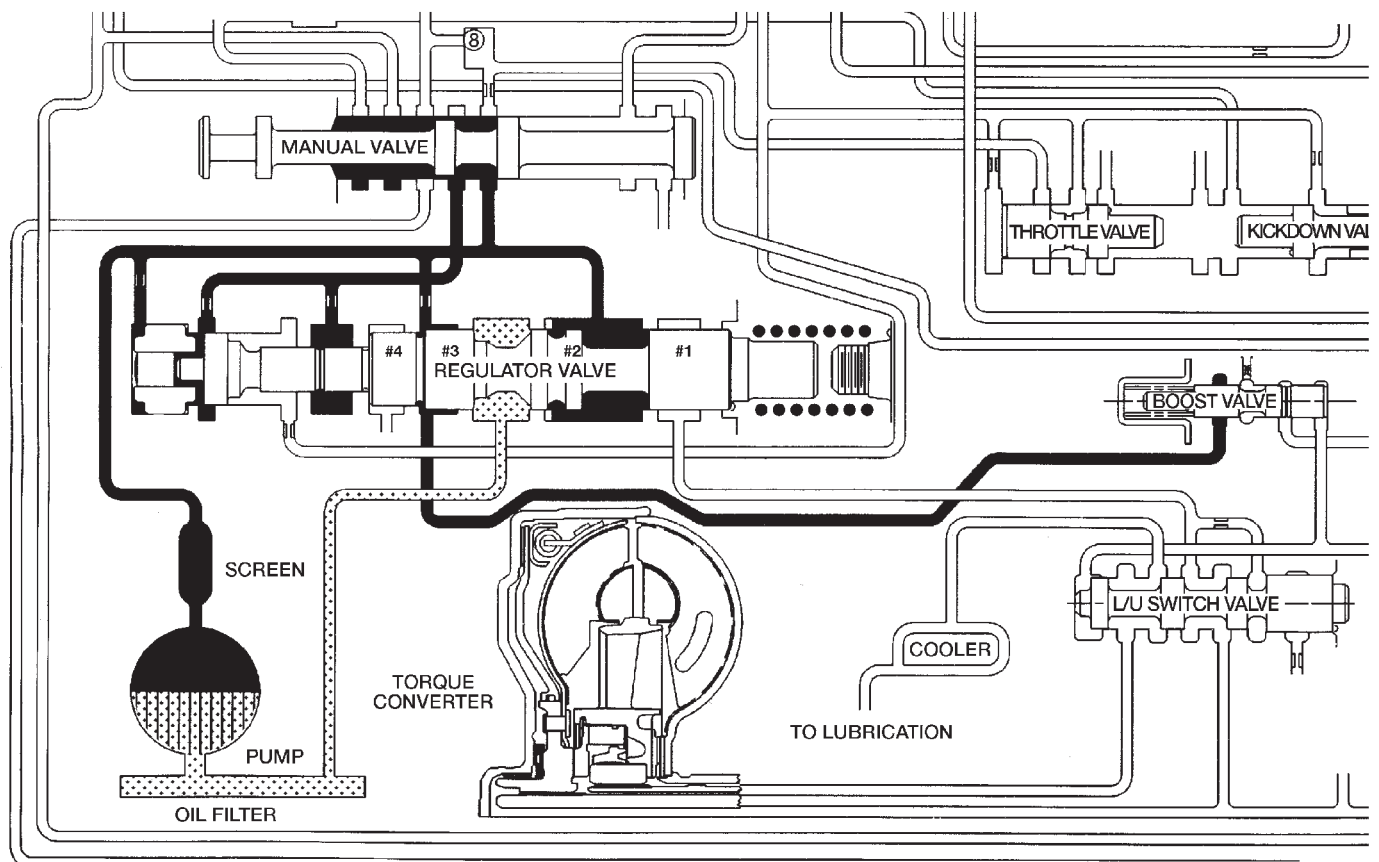
## REGULATOR VALVE

The pressure regulator valve is needed to control the hydraulic pressure within the system and reduce the amount of heat produced in the fluid. The pressure regulator valve is located in the valve body near the manual valve. The pressure regulator valve train controls the maximum pressure in the lines by metering the dumping of fluid back into the sump. Regulated pressure is referred to as "line pressure."

The regulator valve (Fig. 248) has a spring on one end that pushes the valve to the left. This closes a dump (vent) that is used to lower pressure. The closing of the dump will cause the oil pressure to increase. Oil pressure on the opposite end of the valve pushes the valve to the right, opening the dump and lowering oil pressure. The result is spring pressure working against oil pressure to maintain the oil at specific pressures. With the engine running, fluid flows from the pump to the pressure regulator valve, manual valve, and the interconnected circuits. As fluid is sent through passages to the regulator valve, the pressure pushes the valve to the right against the large spring. It is also sent to the reaction areas on the left side of the throttle pressure plug and the line pressure plug. With the gear selector in the PARK position, fluid recirculates through the regulator and manual valves back to the sump.

Meanwhile, the torque converter is filled slowly. In all other gear positions (Fig. 249), fluid flows between two right side lands to the switch valve and torque converter. At low pump speeds, the flow is controlled by the pressure valve groove to reduce pressure to the torque converter. After the torque converter and switch valve fill with fluid, the switch valve becomes the controlling metering device for torque converter pressure. The regulator valve then begins to control the line pressure for the other transmission circuits. The balance of the fluid pressure pushing the valve to the right and the spring pressure pushing to the left determines the size of the metering passage at land #2 (land #1 being at the far right of the valve in the diagram). As fluid leaks past the land, it moves into a groove connected to the filter or sump. As the land meters the fluid to the sump, it causes the pressure to reduce and the spring decreases the size of the metering passage. When the size of the metering passage is reduced, the pressure rises again and the size of the land is increased again. Pressure is regulated by this constant balance of hydraulic and spring pressure.

The metering at land #2 establishes the line pressure throughout the transmission. It is varied according to changes in throttle position and the transmission's internal condition within a range of

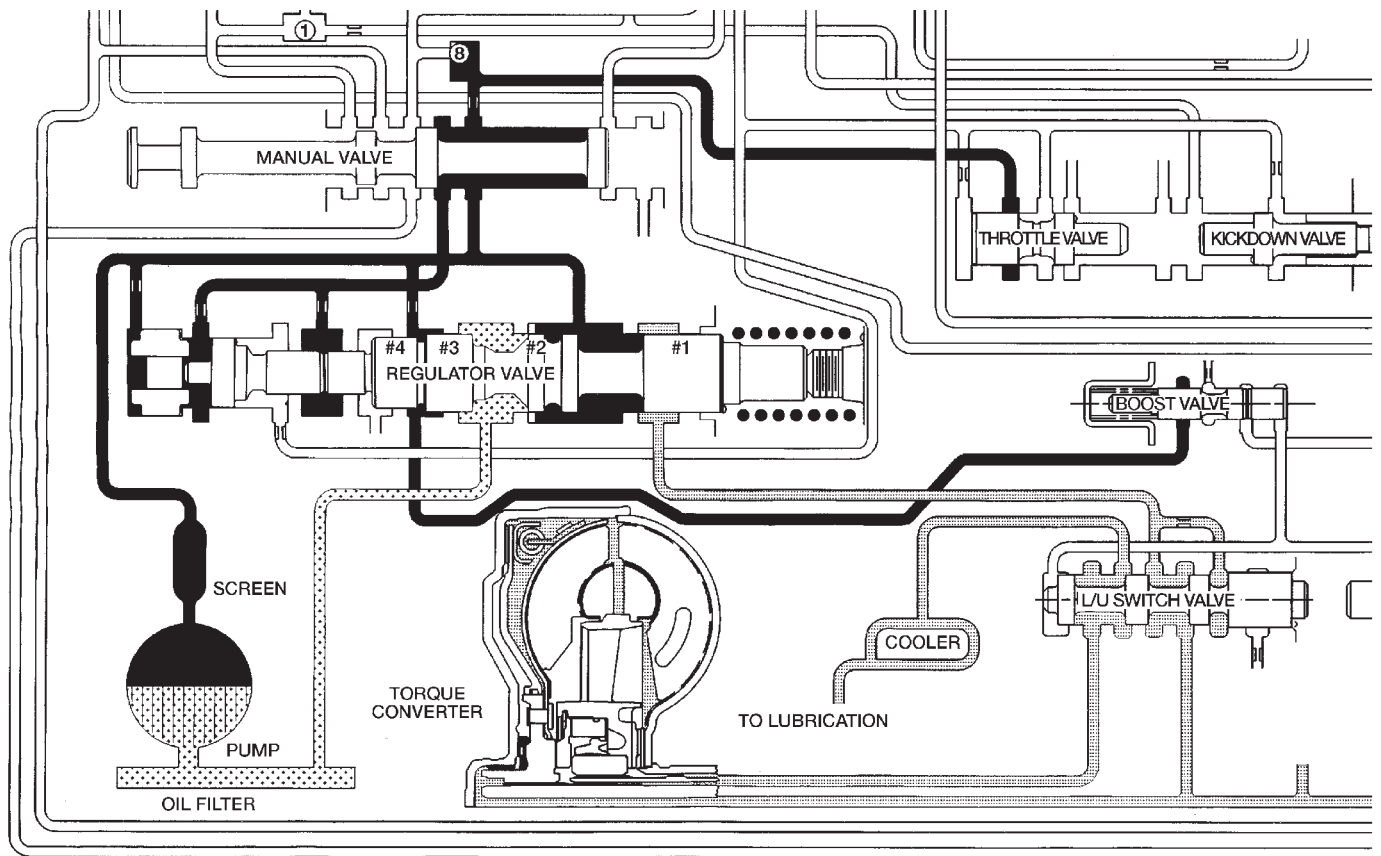


80c0713c

Fig. 248 Regulator Valve in PARK Position



## VALVE BODY (Continued)



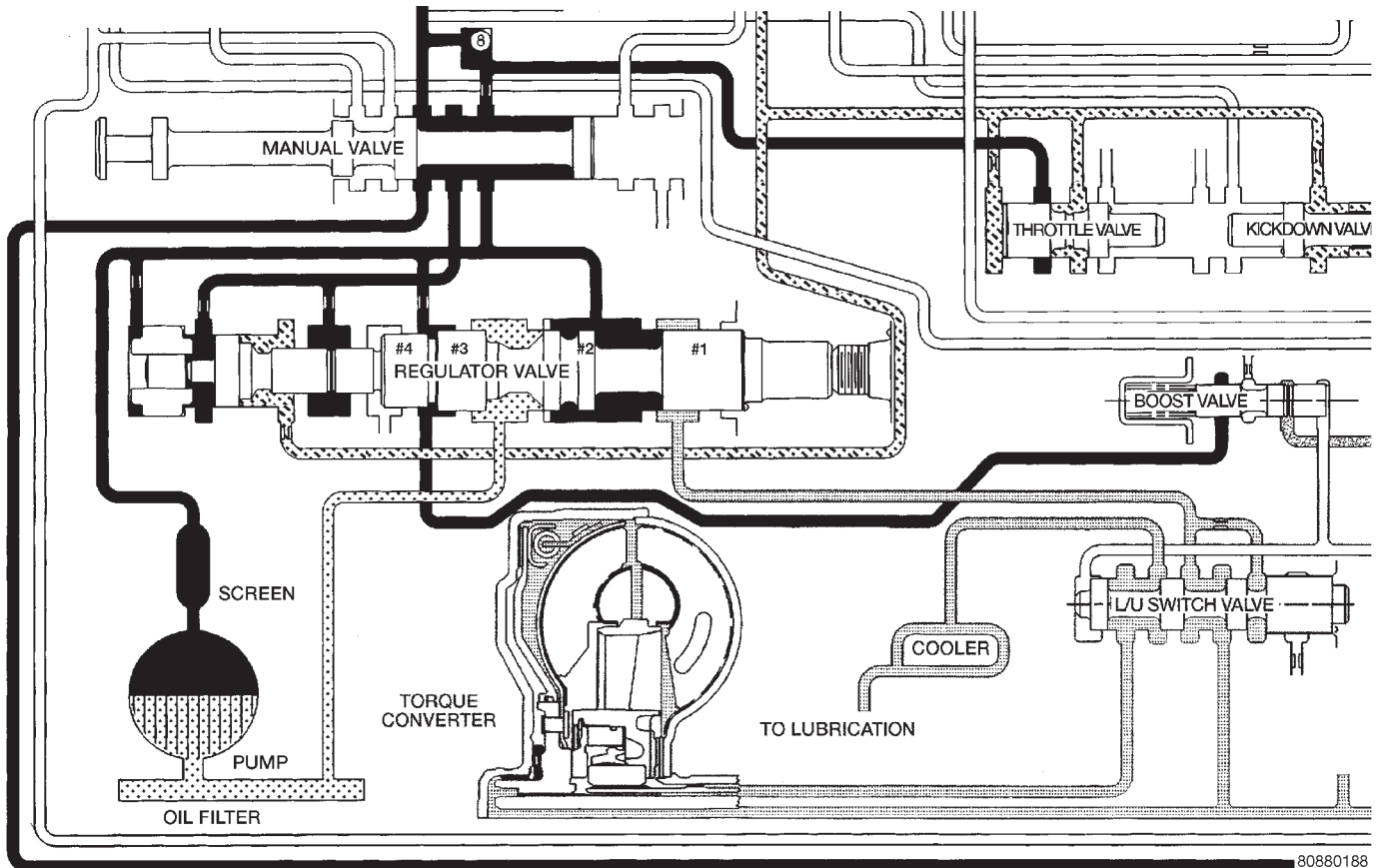
80880187

**Fig. 249 Regulator Valve in NEUTRAL Position**

57-94 psi (except in REVERSE) (Fig. 250). The regulated line pressure in REVERSE (Fig. 251) is held at much higher pressures than in the other gear positions: 145-280 psi. The higher pressure for REVERSE is achieved by the manual valve blocking the supply of line pressure to the reaction area left of

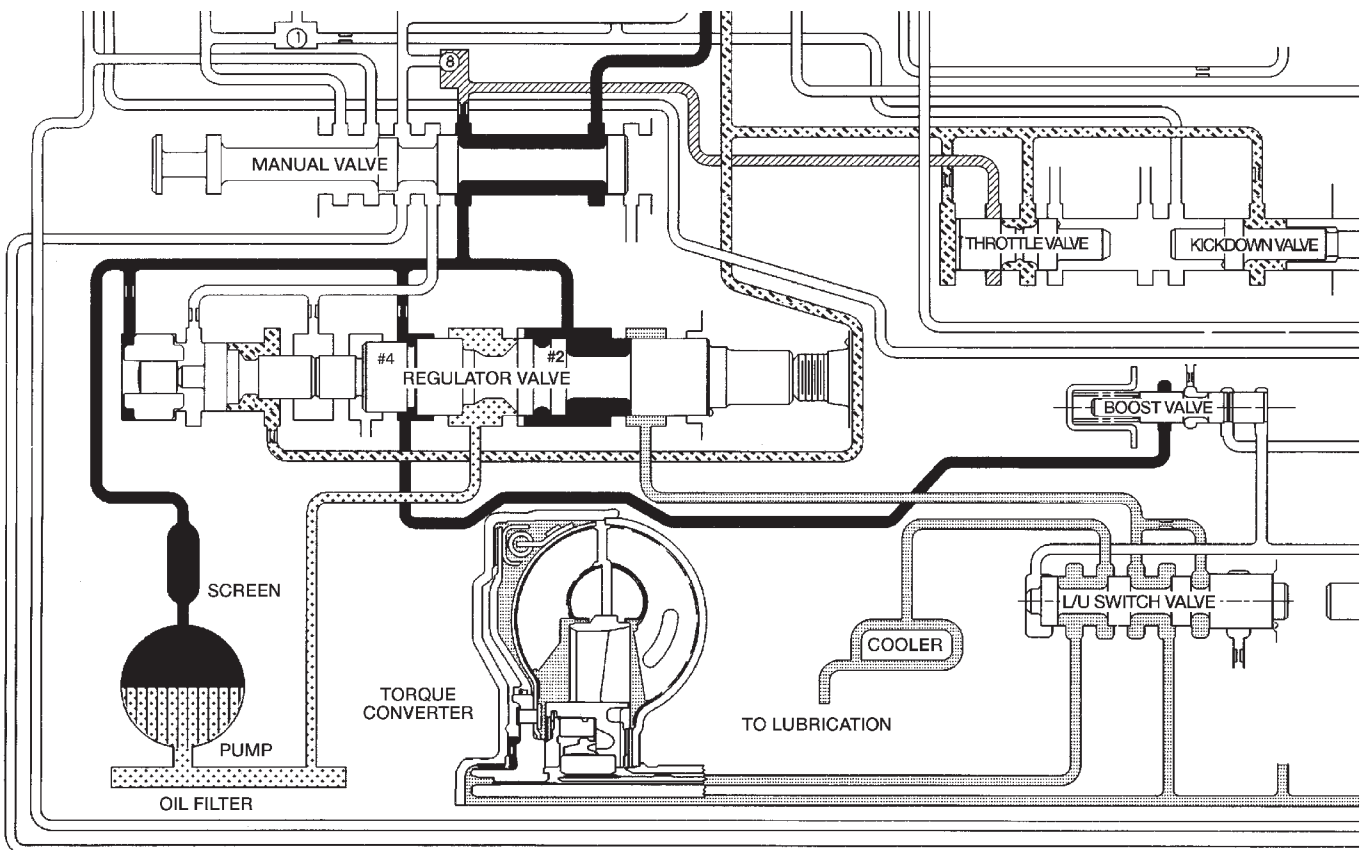
land #4. With this pressure blocked, there is less area for pressure to act on to balance the force of the spring on the right. This allows line pressure to push the valve train to the right, reducing the amount of fluid returned to the pump's inlet, increasing line pressure.

VALVE BODY (Continued)



80880188

Fig. 250 Regulator Valve in DRIVE Position



80c07140

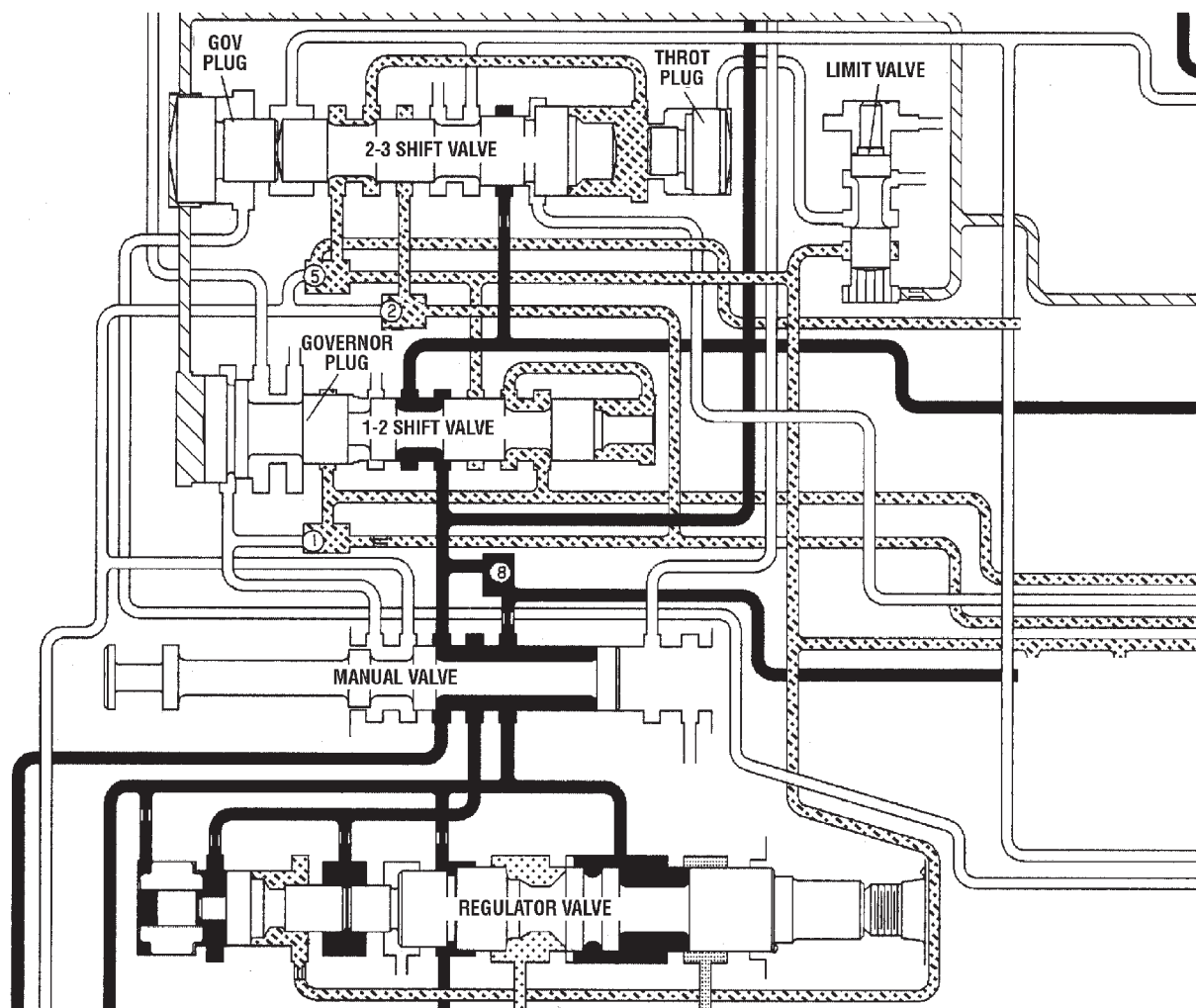
Fig. 251 Regulator Valve in REVERSE Position

## VALVE BODY (Continued)

**KICKDOWN VALVE**

When the throttle valve is as far over to the left as it can go, the maximum line pressure possible will enter the throttle pressure circuit. In this case, throttle pressure will equal line pressure. With the kickdown valve (Fig. 252) pushed into the bore as far as it will go, fluid initially flows through the annular groove of the 2-3 shift valve (which will be in the direct drive position to the right).

After passing the annular groove, the fluid is routed to the spring end of the 2-3 shift valve. Fluid pressure reacting on the area of land #1 overcomes governor pressure, downshifting the 2-3 shift valve into the kickdown, or second gear stage of operation. The valve is held in the kickdown position by throttle pressure routed from a seated check ball (#2). Again, if vehicle speed is low enough, throttle pressure will also push the 1-2 shift valve left to seat its governor plug, and downshift to drive breakaway.



8088018a

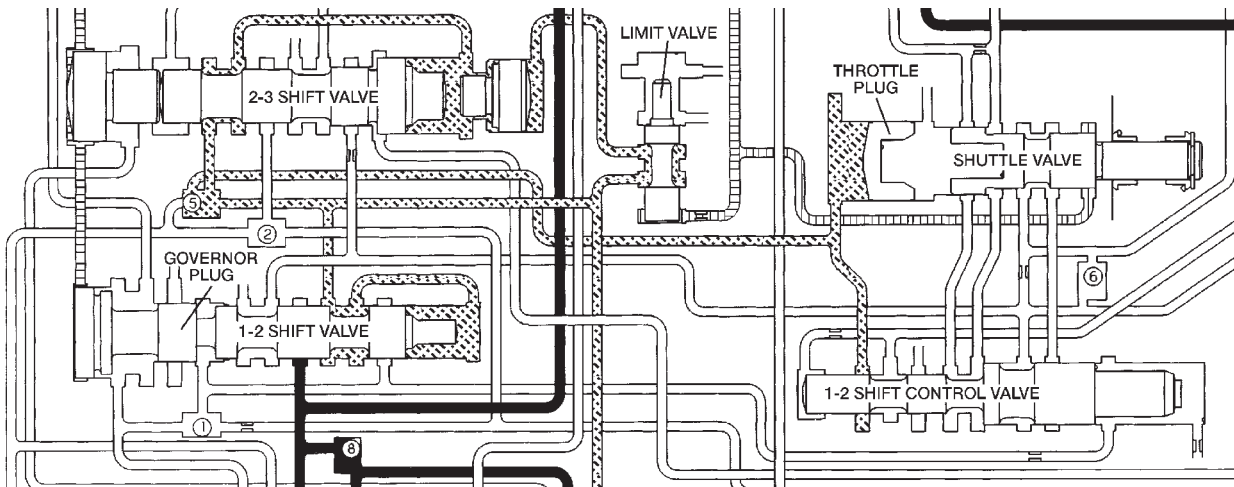
**Fig. 252 Kickdown Valve-Wide Open Throttle**

VALVE BODY (Continued)

**KICKDOWN LIMIT VALVE**

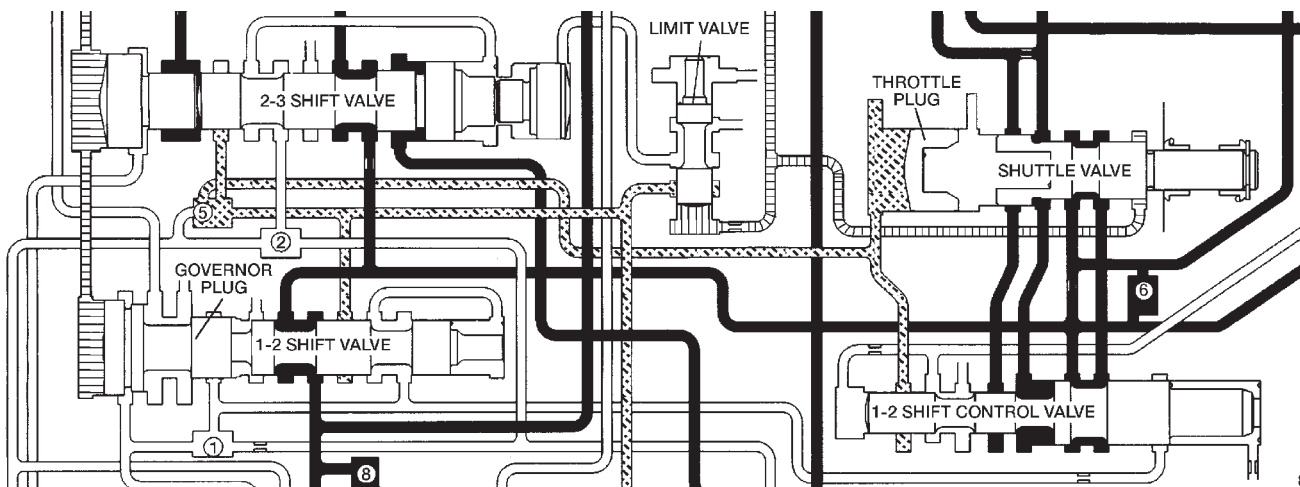
The purpose of the limit valve is to prevent a 3-2 downshift at higher speeds when a part-throttle downshift is not desirable. At these higher speeds only a full throttle 3-2 downshift will occur. At low road speeds (Fig. 253) the limit valve does not come into play and does not affect the downshifts. As the vehicle's speed increases (Fig. 254), the governor pressure also increases. The increased governor pressure acts on the reaction area of the bottom land of

the limit valve overcoming the spring force trying to push the valve toward the bottom of its bore. This pushes the valve upward against the spring and bottoms the valve against the top of the housing. With the valve bottomed against the housing, the throttle pressure supplied to the valve will be closed off by the bottom land of the limit valve. When the supply of throttle pressure has been shut off, the 3-2 part throttle downshift plug becomes inoperative, because no pressure is acting on its reaction area.



80c07142

**Fig. 253 Kickdown Limit Valve-Low Speeds**



80c07143

**Fig. 254 Kickdown Limit Valve-High Speeds**

## VALVE BODY (Continued)

**1-2 SHIFT VALVE**

The 1-2 shift valve assembly (Fig. 255), or mechanism, consists of: the 1-2 shift valve, governor plug, and a spring on the end of the valve. After the manual valve has been placed into a forward gear range, line pressure is directed to the 1-2 shift valve. As the throttle is depressed, throttle pressure is applied to the right side of the 1-2 shift valve assembly. With throttle pressure applied to the right side of the valve, there is now both spring pressure and throttle pressure acting on the valve, holding it against the governor plug. As the vehicle begins to move and build speed, governor pressure is created and is applied to the left of the valve at the governor plug.

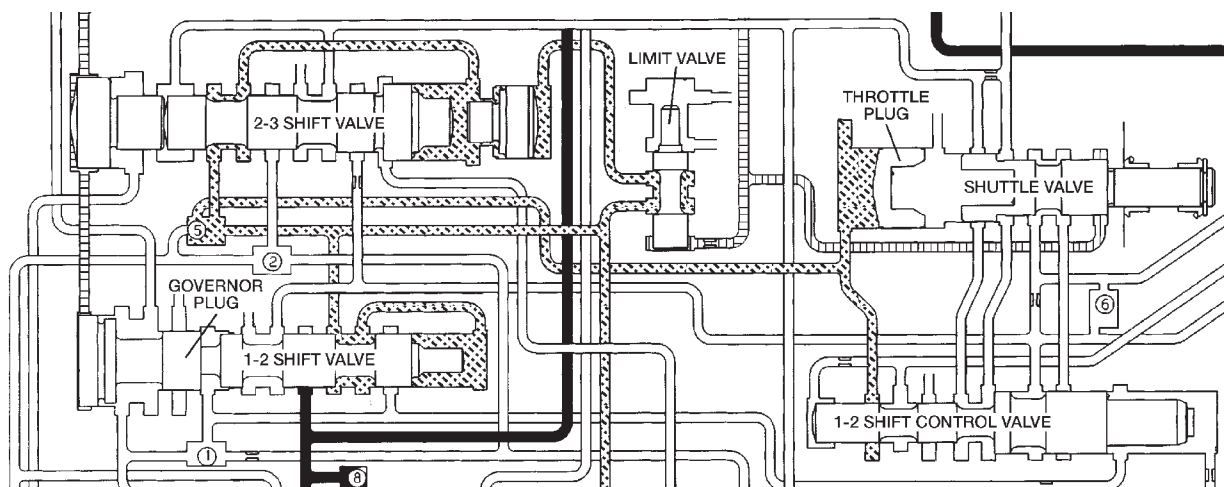
When governor pressure builds to a point where it can overcome the combined force of the spring and throttle pressure on the other side of the valve, the valve will begin to move over to the right. As the valve moves to the right, the middle land of the valve will close off the circuit supplying the throttle pressure to the right side of the valve. When the throttle

pressure is closed off, the valve will move even farther to the right, allowing line pressure to enter another circuit and energize the front servo, applying the front band (Fig. 256).

The governor plug serves a dual purpose:

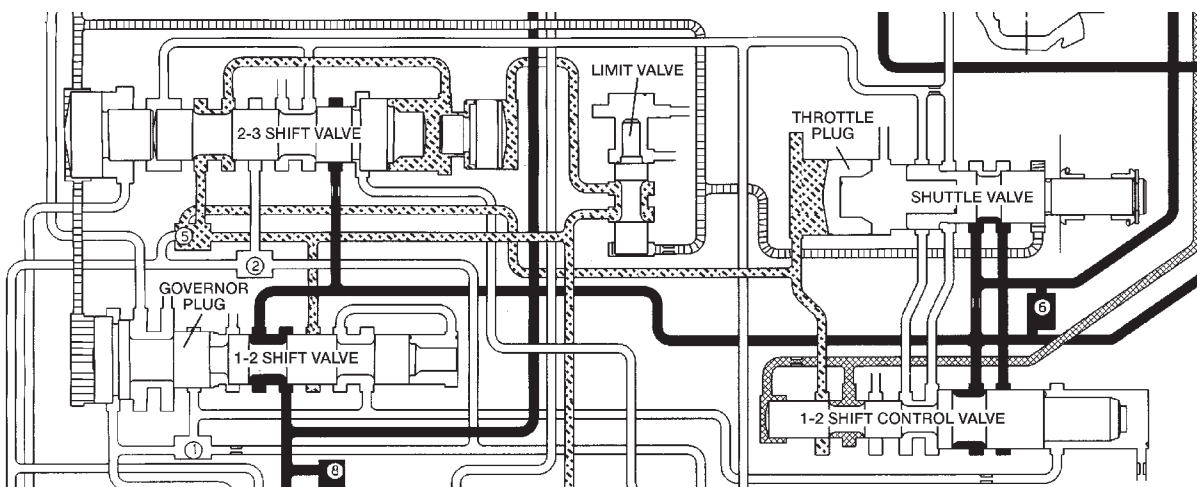
- It allows the shift valves to move either left or right, allowing both upshifts and downshifts.
- When in a manual selection position, it will be hydraulically "blocked" into position so no upshift can occur.

The physical blocking of the upshift while in the manual "1" position is accomplished by the directing of line pressure between both lands of the governor plug, pushing the plug back against the end plate overcoming governor pressure. With the combination of the line pressure and spring pressure, the valve cannot move, preventing any upshift.



80c07144

**Fig. 255 1-2 Shift Valve-Before Shift**



80c07145

**Fig. 256 1-2 Shift Valve-After Shift**



## VALVE BODY (Continued)

**1-2 SHIFT CONTROL VALVE**

It contains a valve with four lands and a spring. It is used as both a "relay" and "balanced" valve.

The valve has two specific operations (Fig. 257):

- Aid in quality of the 1-2 upshift.
- Aid in the quality and timing of the 3-2 kick-down ranges.

When the manual valve is set to the DRIVE position and the transmission is in the first or second gear range, 1-2 shift control or "modulated throttle pressure" is supplied to the middle of the accumulator piston by the 1-2 shift control valve. During the 1-2 upshift, this pressure is used to control the kickdown servo apply pressure that is needed to apply the kickdown and accumulator pistons. Thus, the 1-2 shift point is "cushioned" and the quality is improved. During a WOT kickdown, kickdown pressure is applied between the kickdown valve and the 1-2 shift control valve. This additional pressure is directed to the 1-2 shift control's spring cavity, adding to the spring load on the valve. The result of this increased "modulated" throttle pressure is a firmer WOT upshift.

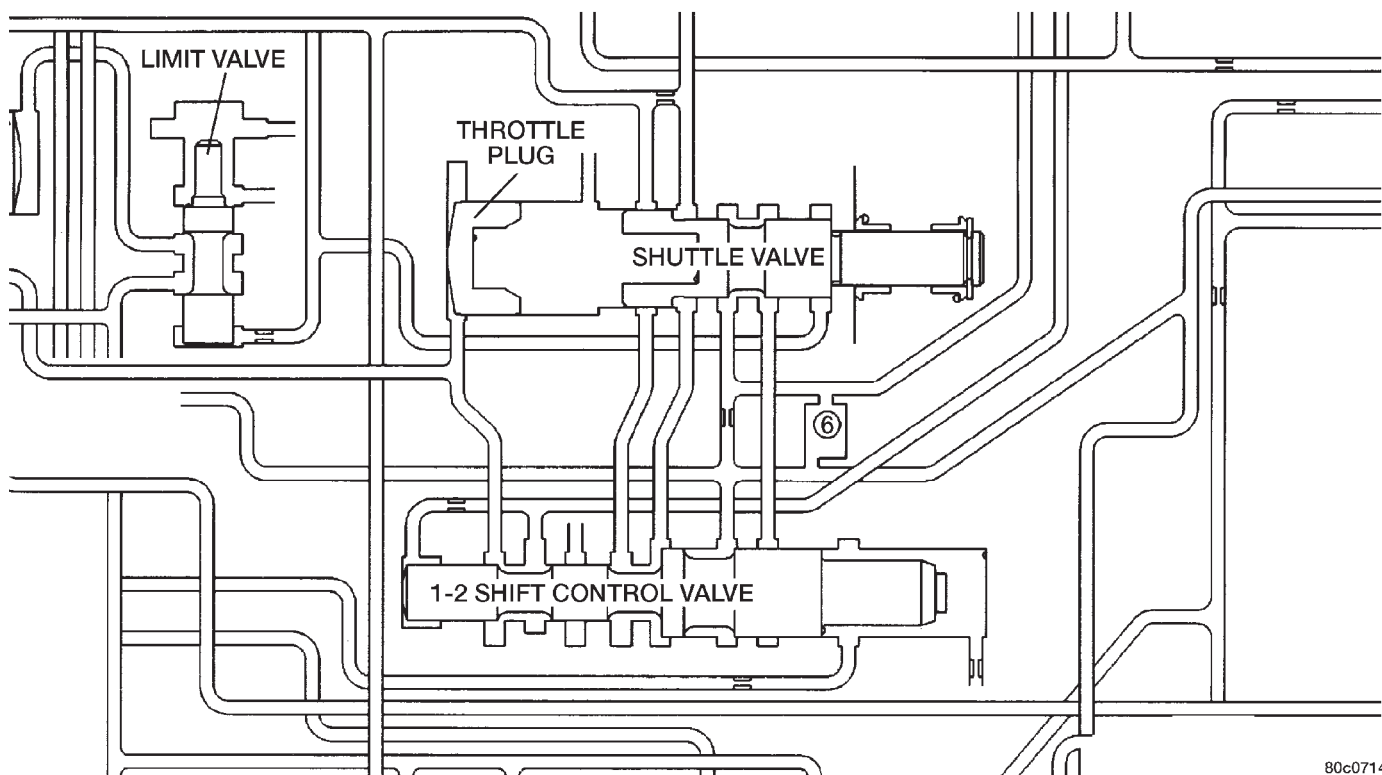
**2-3 SHIFT VALVE**

The 2-3 shift valve mechanism (Fig. 258) consists of the 2-3 shift valve, governor plug and spring, and a throttle plug. After the 1-2 shift valve has completed its operation and applied the front band, line pressure is directed to the 2-3 shift valve through the connecting passages from the 1-2 shift valve. The line pressure will then dead-end at land #2 until the 2-3 valve is ready to make its shift. Now that the vehicle is in motion and

under acceleration, there is throttle pressure being applied to the spring side of the valve and between lands #3 and #4.

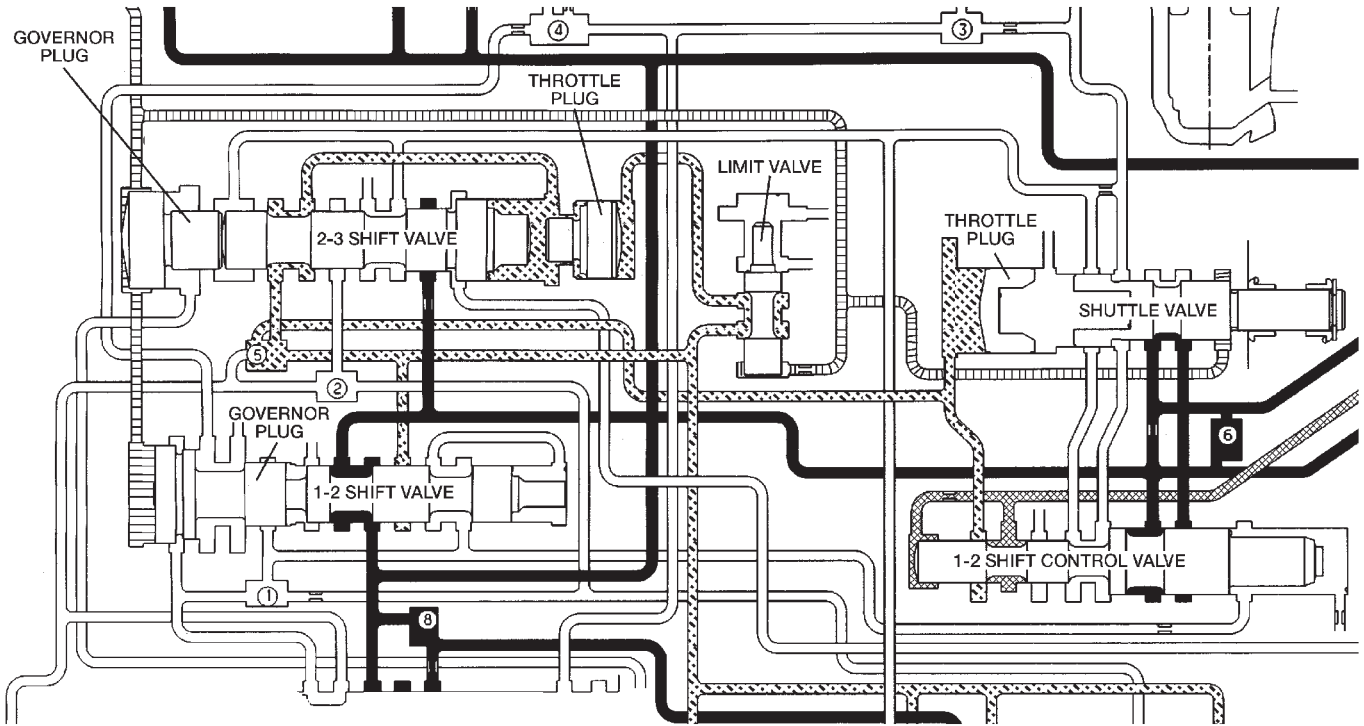
As vehicle speed increases, governor pressure increases proportionately, until it becomes great enough to overcome the combined throttle and spring pressure on the right side of the valve. Since the throttle pressure end of the 2-3 shift valve is larger in diameter than the 1-2 shift valve, the 2-3 shift will always happen at a greater speed than the 1-2 shift. When this happens, the governor plug is forced against the shift valve moving it to the right. The shift valve causes land #4 to close the passage supplying throttle pressure to the 2-3 shift valve. Without throttle pressure present in the circuit now, the governor plug will push the valve over far enough to bottom the valve in its bore. This allows land #2 to direct line pressure to the front clutch.

After the shift (Fig. 259), line pressure is directed to the land between the shift valve and the governor plug, and to the release side of the kickdown servo. This releases the front band and applies the front clutch, shifting into third gear or direct drive. The rear clutch remains applied, as it has been in the other gears. During a manual "1" or manual "2" gear selection, line pressure is sent between the two lands of the 2-3 governor plug. This line pressure at the governor plug locks the shift valve into the second gear position, preventing an upshift into direct drive. The theory for the blocking of the valve is the same as that of the 1-2 shift valve.



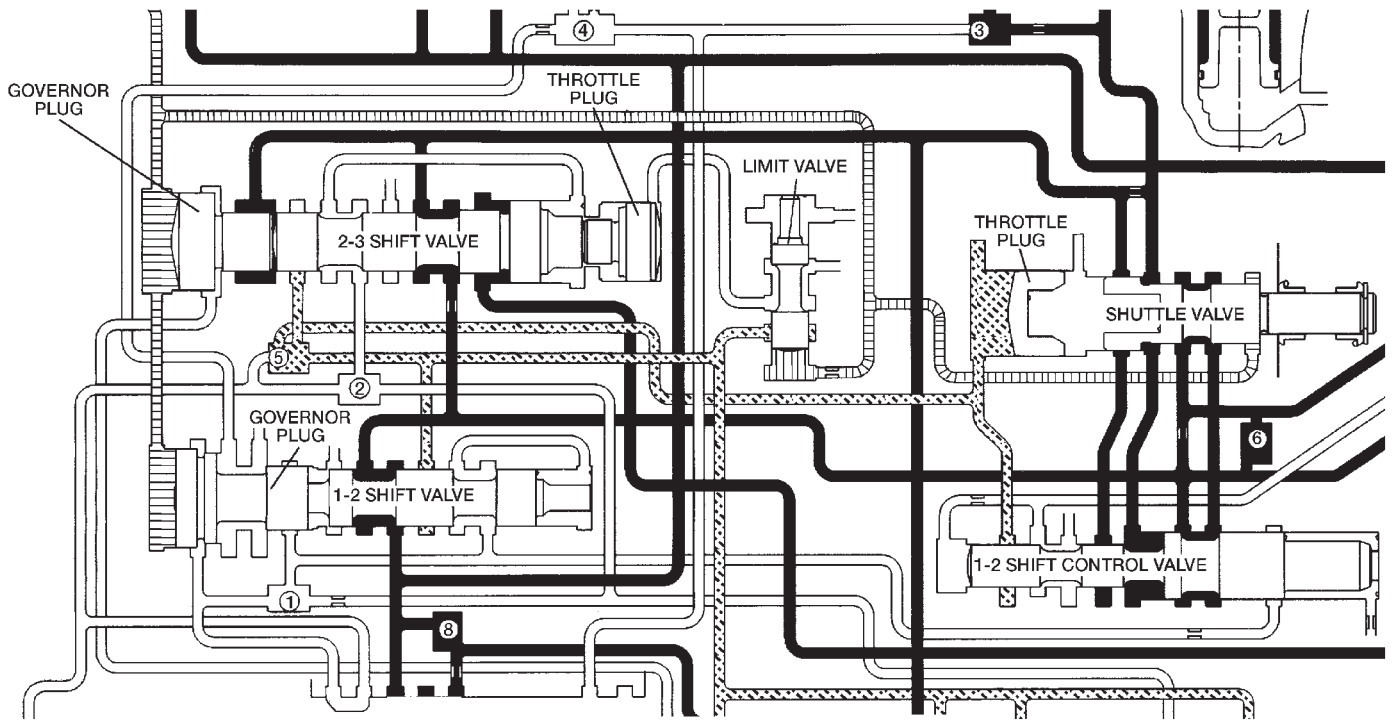
**Fig. 257 1-2 Shift Control Valve**

VALVE BODY (Continued)



80c07147

**Fig. 258 2-3 Shift Valve-Before Shift**



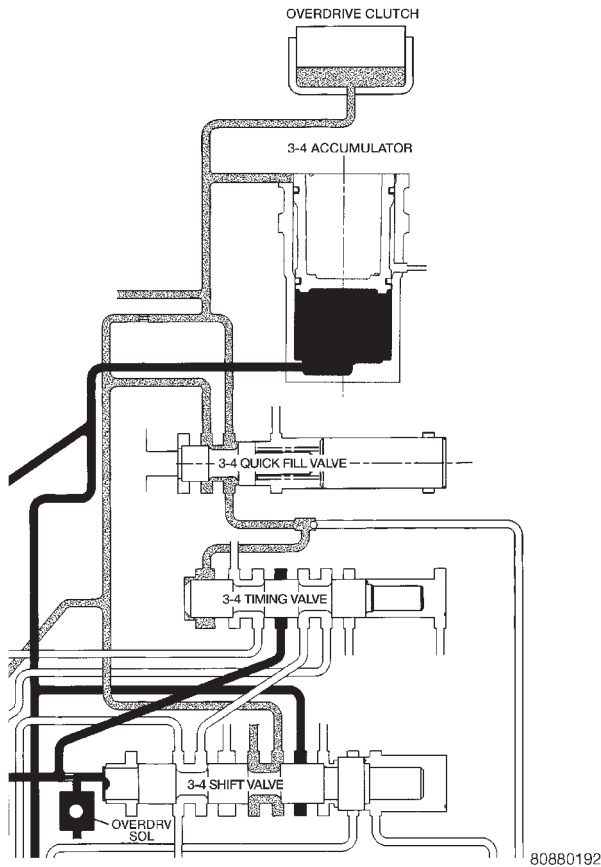
80c07148

**Fig. 259 2-3 Shift Valve-After Shift**

## VALVE BODY (Continued)

**3-4 SHIFT VALVE**

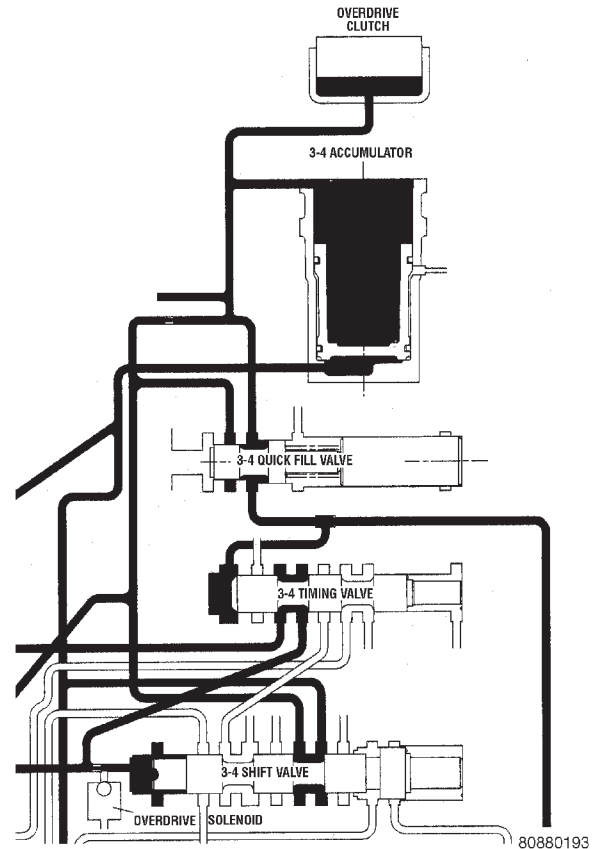
The PCM energizes the overdrive solenoid during the 3-4 upshift (Fig. 260). This causes the solenoid check ball to close the vent port allowing line pressure from the 2-3 shift valve to act directly on the 3-4 upshift valve. Line pressure on the 3-4 shift valve overcomes valve spring pressure moving the valve to the upshift position (Fig. 261). This action exposes the feed passages to the 3-4 timing valve, 3-4 quick fill valve, 3-4 accumulator, and ultimately to the overdrive piston.



**Fig. 260 3-4 Shift Valve Before Shift**

**3-4 TIMING VALVE**

The 3-4 timing valve is moved by line pressure coming through the 3-4 shift valve (Fig. 261). After the shift, the timing valve holds the 2-3 shift valve in an upshift position. The purpose is to prevent the 2-3 valve from downshifting before the 3-4 valve (Fig. 260).



**Fig. 261 3-4 Shift Valve After Shift**

**3-4 QUICK FILL VALVE**

The 3-4 quick fill valve provides faster engagement of the overdrive clutch during 3-4 upshifts. The valve temporarily bypasses the clutch piston feed orifice at the start of a 3-4 upshift (Fig. 260). This exposes a larger passage into the piston retainer resulting in a much faster clutch fill and apply sequence. The quick fill valve does not bypass the regular clutch feed orifice throughout the 3-4 upshift. Instead, once a pre-determined pressure develops within the clutch, the valve closes the bypass (Fig. 261). Clutch fill is then completed through the regular feed orifice.

## VALVE BODY (Continued)

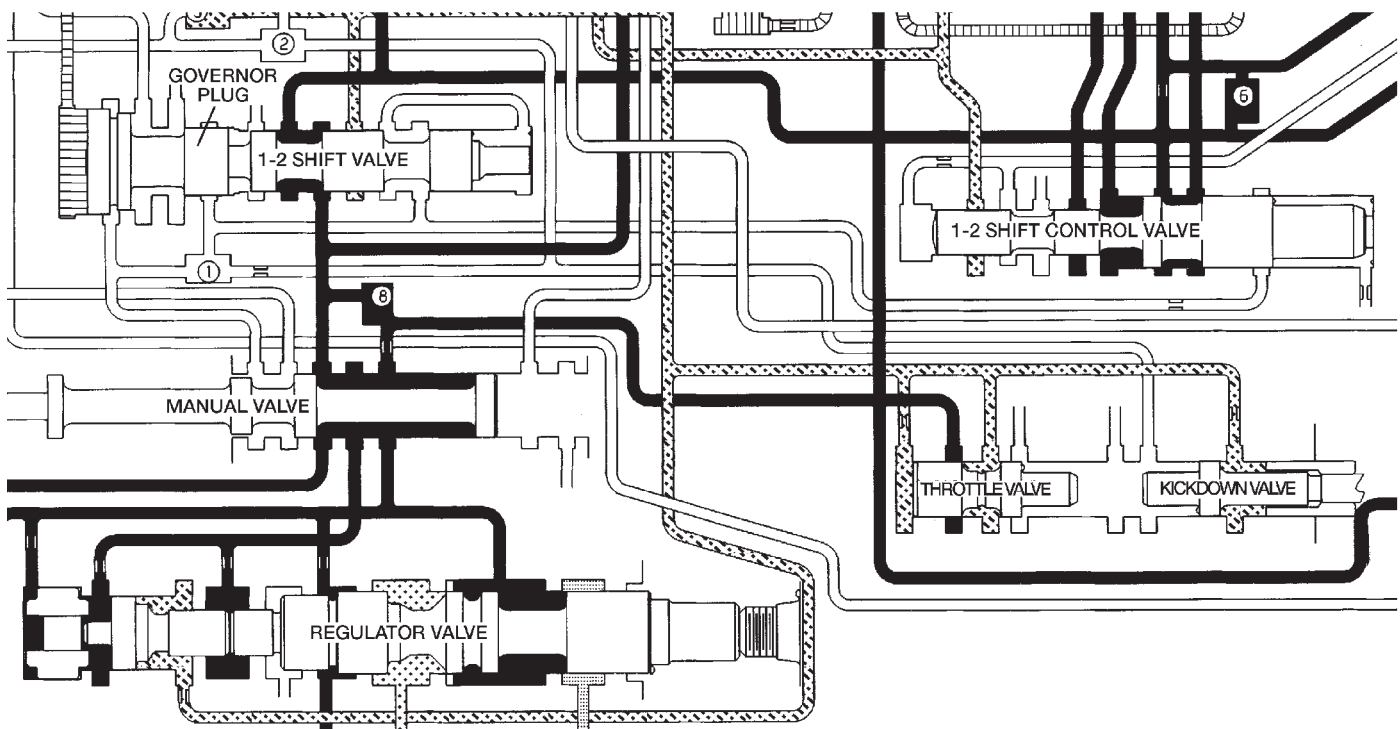
## THROTTLE VALVE

In all gear positions the throttle valve (Fig. 262) is being supplied with line pressure. The throttle valve meters and reduces the line pressure that now becomes throttle pressure. The throttle valve is moved by a spring and the kickdown valve, which is mechanically connected to the throttle. The larger the throttle opening, the higher the throttle pressure (to a maximum of line pressure). The smaller the throttle opening, the lower the throttle pressure (to a minimum of zero at idle). As engine speed increases, the increase in pump speed increases pump output. The increase in pressure and volume must be regulated to maintain the balance within the transmission. To do this, throttle pressure is routed to the reaction area on the right side of the throttle pressure plug (in the regulator valve).

The higher engine speed and line pressure would open the vent too far and reduce line pressure too much. Throttle pressure, which increases with engine speed (throttle opening), is used to oppose the movement of the pressure valve to help control the metering passage at the vent. The throttle pressure is combined with spring pressure to reduce the force of the throttle pressure plug on the pressure valve. The larger spring at the right closes the regulator valve passage and maintains or increases line pressure. The increased line pressure works against the reaction area of the line pressure plug and the reaction

area left of land #3 simultaneously moves the regulator valve train to the right and controls the metering passage.

The kickdown valve, along with the throttle valve, serve to delay upshifts until the correct vehicle speed has been reached. It also controls downshifts upon driver demand, or increased engine load. If these valves were not in place, the shift points would be at the same speed for all throttle positions. The kickdown valve is actuated by a cam connected to the throttle. This is accomplished through either a linkage or a cable. The cam forces the kickdown valve toward the throttle valve compressing the spring between them and moving the throttle valve. As the throttle valve land starts to uncover its port, line pressure is "metered" out into the circuits and viewed as throttle pressure. This increased throttle pressure is metered out into the circuits it is applied to: the 1-2 and 2-3 shift valves. When the throttle pressure is high enough, a 3-2 downshift will occur. If the vehicle speed is low enough, a 2-1 downshift will occur.



80c07149

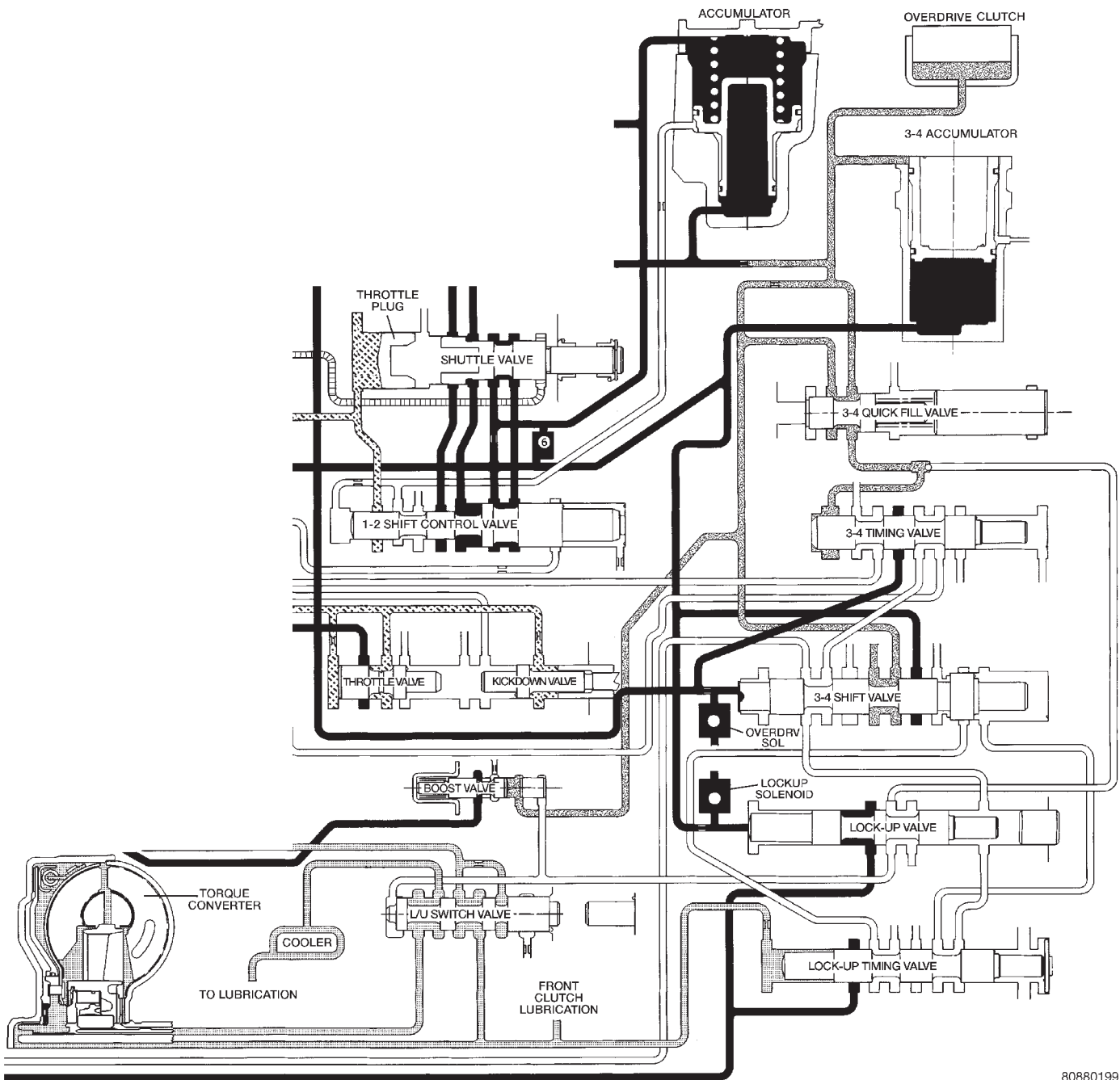
Fig. 262 Throttle Valve

VALVE BODY (Continued)

**SWITCH VALVE**

When the transmission is in Drive Second before the TCC application occurs (Fig. 263), the pressure regulator valve is supplying torque converter pressure to the switch valve. The switch valve directs this pressure through the transmission input shaft, into the converter, through the converter, back out between the input shaft and the reaction shaft, and back up to the switch valve. From the switch valve, the fluid pressure is directed to the transmission cooler, and lubrication pressure returns from the cooler to lubricate different portions of the transmission.

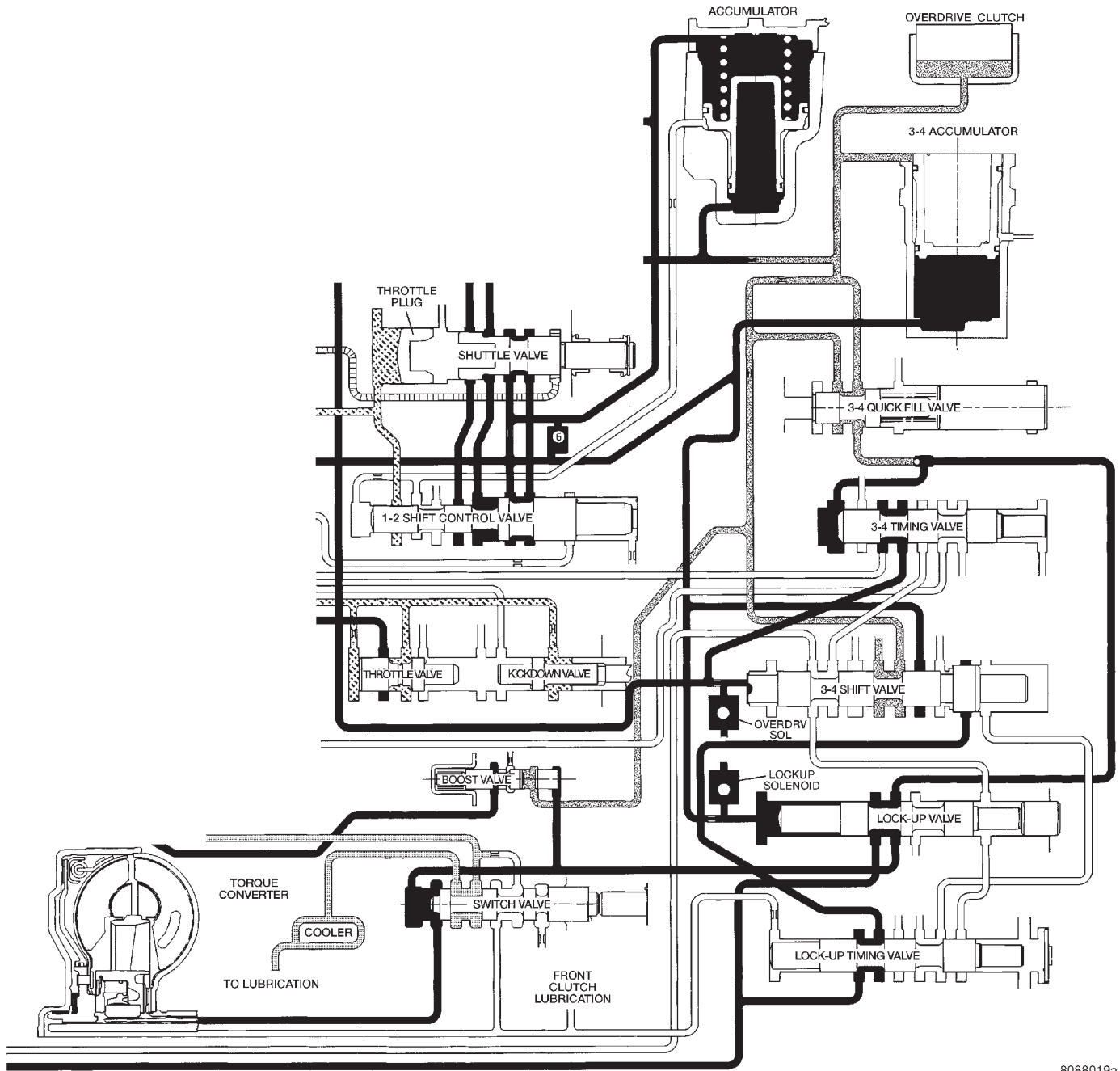
Once the TCC control valve has moved to the right (Fig. 264), line pressure is directed to the tip of the switch valve, forcing the valve to the right. The switch valve now vents oil from the front of the piston in the torque converter, and supplies line pressure to the (rear) apply side of the torque converter piston. This pressure differential causes the piston to apply against the friction material, cutting off any further flow of line pressure oil. After the switch valve is shuttled right allowing line pressure to engage the TCC, torque converter pressure is directed past the switch valve into the transmission cooler and lubrication circuits.



**Fig. 263 Switch Valve-Torque Converter Unlocked**



VALVE BODY (Continued)



8088019a

**Fig. 264 Switch Valve-Torque Converter Locked**

VALVE BODY (Continued)

**MANUAL VALVE**

The manual valve (Fig. 265) is a relay valve. The purpose of the manual valve is to direct fluid to the correct circuit needed for a specific gear or driving range. The manual valve, as the name implies, is manually operated by the driver with a lever located on the side of the valve body. The valve is connected mechanically by either a cable or linkage to the gear-shift mechanism. The valve is held in each of its positions by a spring-loaded roller or ball that engages the "roostercomb" of the manual valve lever.

**CONVERTER CLUTCH LOCK-UP VALVE**

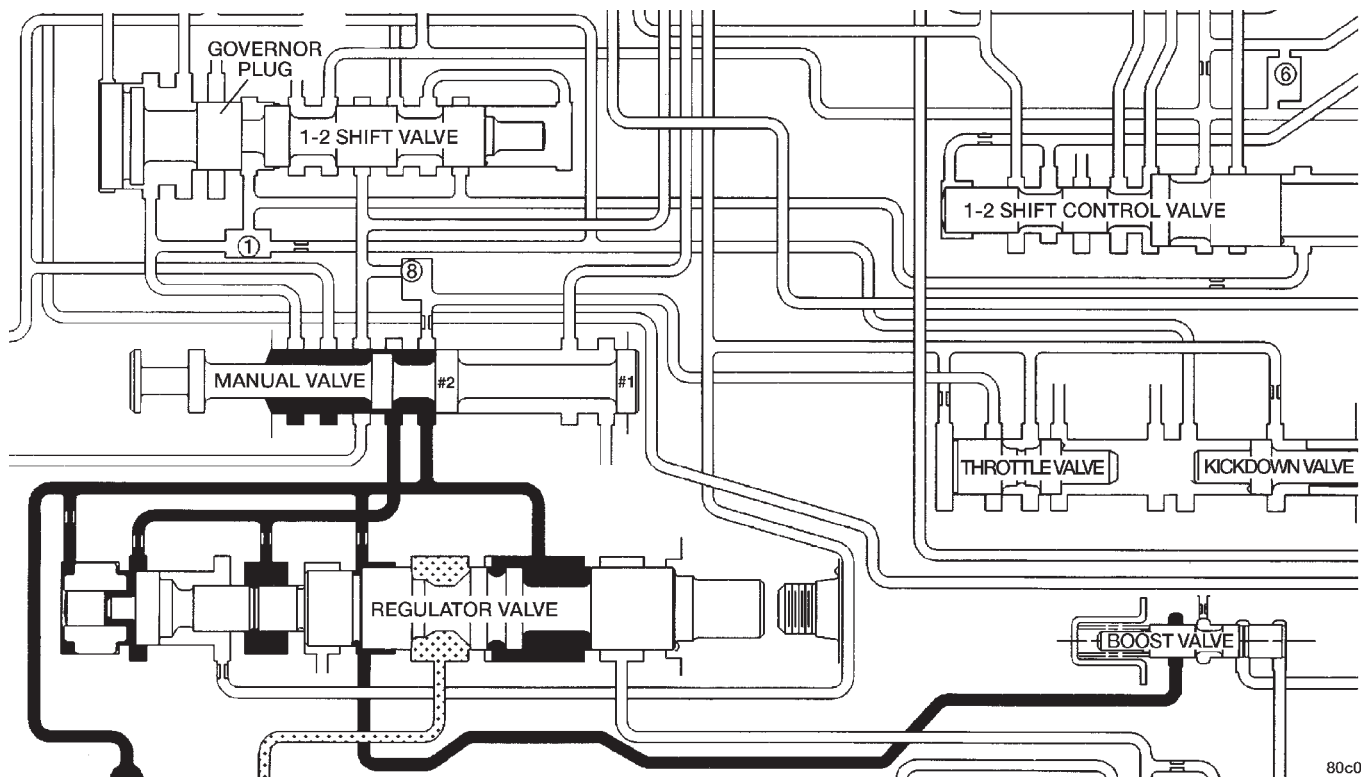
The torque converter clutch (TCC) lock-up valve controls the back (ON) side of the torque converter clutch. When the PCM energizes the TCC solenoid to engage the converter clutch piston, pressure is applied to the TCC lock-up valve which moves to the right and applies pressure to the torque converter clutch.

**CONVERTER CLUTCH LOCK-UP TIMING VALVE**

The torque converter clutch (TCC) lock-up timing valve is there to block any 4-3 downshift until the TCC is completely unlocked and the clutch is disengaged.

**SHUTTLE VALVE**

The assembly is contained in a bore in the valve body above the shift valves. When the manual valve is positioned in the Drive range, throttle pressure acts on the throttle plug of the shuttle valve (Fig. 257) to move it against a spring, increasing the spring force on the shuttle valve. During a part or full throttle 1-2 upshift, the throttle plug is bottomed by throttle pressure, holding the shuttle valve to the right against governor pressure, and opening a by-pass circuit. The shuttle valve controls the quality of the kickdown shift by restricting the rate of fluid discharge from the front clutch and servo release circuits. During a 3-2 kickdown, fluid discharges through the shuttle by-pass circuit. When the shuttle valve closes the by-pass circuit, fluid discharge is restricted and controlled for the application of the front band. During a 2-3 "lift foot" upshift, the shuttle valve by-passes the restriction to allow full fluid flow through the by-pass groove for a faster release of the band.



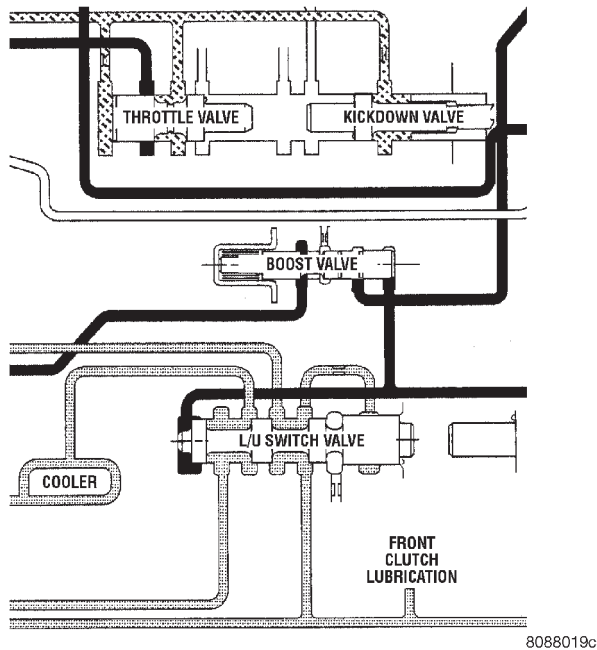
80c0714c

Fig. 265 Manual Valve

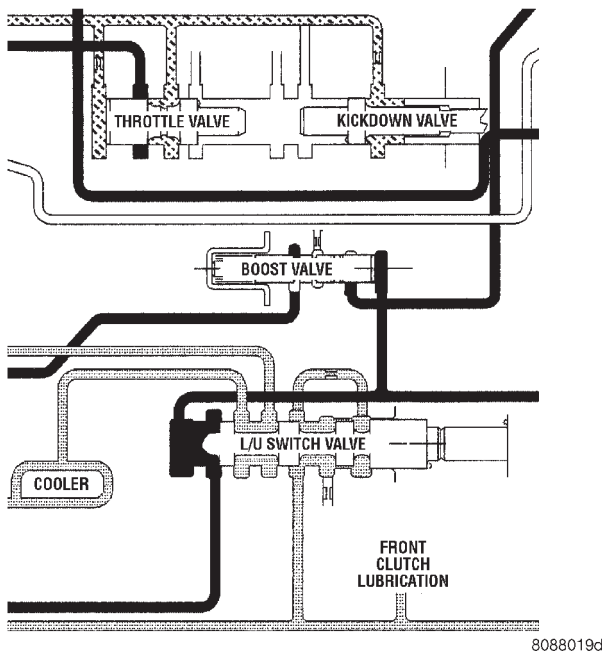
## VALVE BODY (Continued)

**BOOST VALVE**

The boost valve (Fig. 266) provides increased fluid apply pressure to the overdrive clutch during 3-4 upshifts (Fig. 267), and when accelerating in fourth gear. The boost valve also serves to increase line pressure during torque converter lock-up.



**Fig. 266 Boost Valve Before Lock-up**



**Fig. 267 Boost Valve After Lock-up**

**REMOVAL**

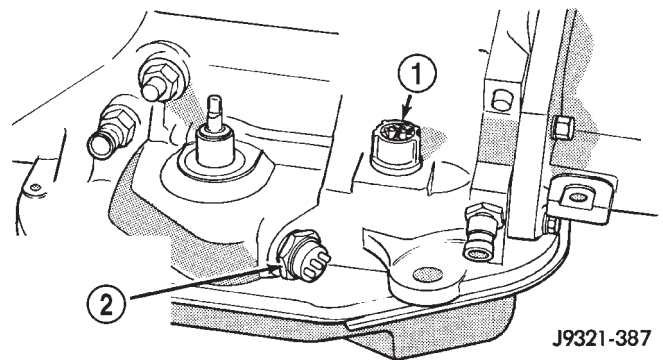
The valve body can be removed for service without having to remove the transmission assembly.

The valve body can be disassembled for cleaning and inspection of the individual components.

The only replaceable valve body components are:

- Manual lever.
- Manual lever washer, seal, E-clip, and shaft seal.
- Manual lever detent ball.
- Throttle lever.
- Fluid filter.
- Pressure adjusting screw bracket.
- Governor pressure solenoid.
- Governor pressure sensor (includes transmission temperature thermistor).
- Converter clutch/overdrive solenoid assembly and harness .
- Governor housing gasket.
- Solenoid case connector O-rings.

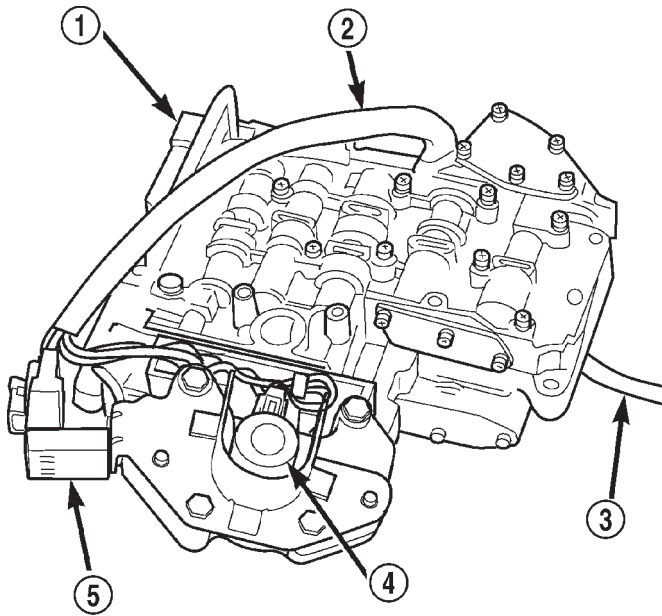
- (1) Shift transmission into NEUTRAL.
- (2) Raise vehicle.
- (3) Remove gearshift and throttle levers from shaft of valve body manual lever.
- (4) Disconnect wires at solenoid case connector (Fig. 268).
- (5) Position drain pan under transmission oil pan.
- (6) Remove transmission oil pan and gasket.
- (7) Remove fluid filter from valve body.
- (8) Remove bolts attaching valve body to transmission case.
- (9) Lower valve body enough to remove accumulator piston and springs.
- (10) Work manual lever shaft and electrical connector out of transmission case.
- (11) Lower valve body, rotate valve body away from case, pull park rod out of sprag, and remove valve body (Fig. 269).



**Fig. 268 Transmission Case Connector**

- 1 - SOLENOID CASE CONNECTOR
- 2 - PARK/NEUTRAL POSITION SWITCH

## VALVE BODY (Continued)



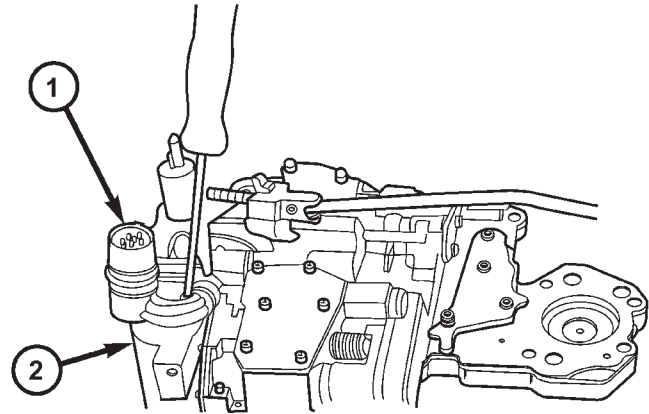
80c072b2

**Fig. 269 Valve Body**

- 1 - VALVE BODY
- 2 - WIRE HARNESS
- 3 - PARK ROD
- 4 - GOVERNOR PRESSURE SOLENOID
- 5 - GOVERNOR PRESSURE SENSOR

(6) Remove small shoulder bolt that secures solenoid harness case connector to 3-4 accumulator housing (Fig. 270). Retain shoulder bolt. Either tape it to harness or thread it back into accumulator housing after connector removal.

(7) Unhook overdrive/converter solenoid harness from 3-4 accumulator cover plate (Fig. 271).



808803a3

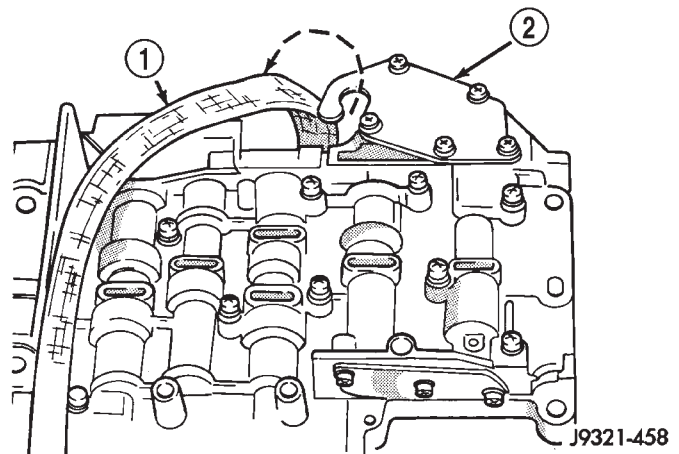
**Fig. 270 Solenoid Harness Case Connector Shoulder Bolt**

- 1 - SOLENOID HARNESS CASE CONNECTOR
- 2 - 3-4 ACCUMULATOR HOUSING

## DISASSEMBLY

**CAUTION:** Do not clamp any valve body component in a vise. This practice can damage the component resulting in unsatisfactory operation after assembly and installation. Do not use pliers to remove any of the valves, plugs or springs and do not force any of the components out or into place. The valves and valve body housings will be damaged if force is used. Tag or mark the valve body springs for reference as they are removed. Do not allow them to become intermixed.

- (1) Disconnect wires from governor pressure sensor and solenoid.
- (2) Remove screws attaching governor body and retainer plate to transfer plate.
- (3) Remove retainer plate, governor body and gasket from transfer plate.
- (4) Remove governor pressure sensor from governor body.
- (5) Remove governor pressure solenoid by pulling it straight out of bore in governor body. Remove and discard solenoid O-rings if worn, cut, or torn.



J9321-458

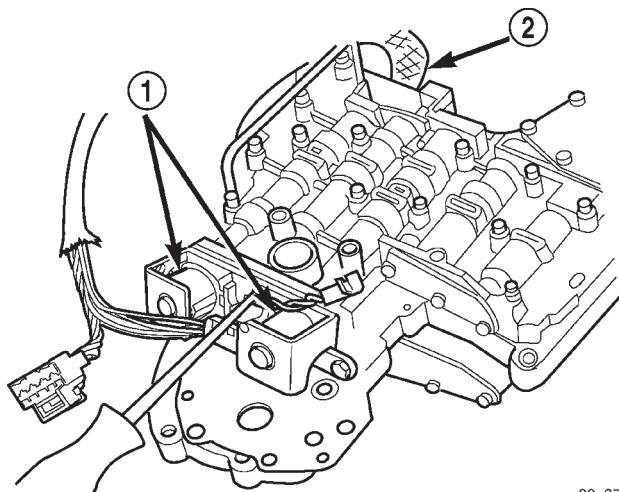
**Fig. 271 Unhooking Solenoid Harness From Accumulator Cover Plate**

- 1 - OVERDRIVE/CONVERTER SOLENOID WIRE HARNESS
- 2 - 3-4 ACCUMULATOR COVER PLATE

## VALVE BODY (Continued)

(8) Turn valve body over and remove screws that attach overdrive/converter solenoid assembly to valve body (Fig. 272).

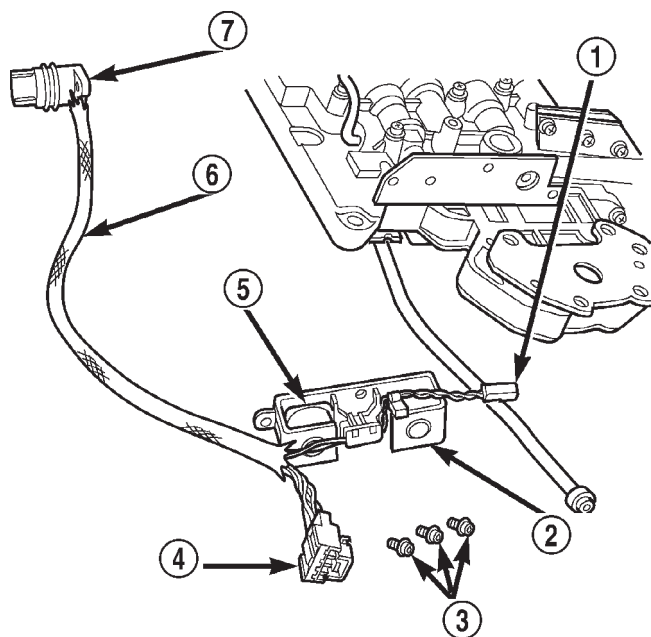
(9) Remove solenoid and harness assembly from valve body (Fig. 273).



80c072b3

**Fig. 272 Solenoid Assembly Screws**

- 1 - OVERDRIVE/CONVERTER CLUTCH SOLENOID ASSEMBLY  
2 - HARNESS



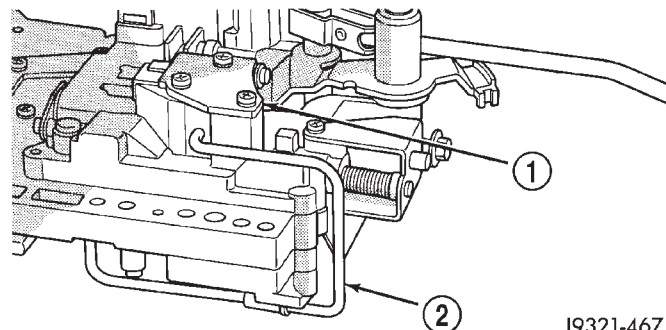
80c072b4

**Fig. 273 Solenoid Assembly**

- 1 - GOVERNOR SOLENOID WIRES  
2 - CONVERTER CLUTCH SOLENOID  
3 - SOLENOID SCREWS  
4 - GOVERNOR SENSOR WIRES  
5 - OVERDRIVE SOLENOID  
6 - HARNESS  
7 - CASE CONNECTOR

(10) Remove boost valve cover (Fig. 274).

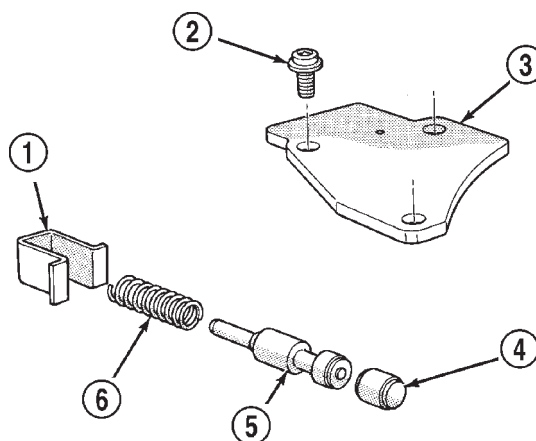
(11) Remove boost valve retainer, valve spring and boost valve (Fig. 275).



J9321-467

**Fig. 274 Boost Valve**

- 1 - BOOST VALVE HOUSING AND COVER  
2 - BOOST VALVE TUBE



J9321-468

**Fig. 275 Boost Valve Components**

- 1 - SPRING AND VALVE RETAINER  
2 - COVER SCREWS  
3 - BOOST VALVE COVER  
4 - BOOST VALVE PLUG  
5 - BOOST VALVE  
6 - BOOST VALVE SPRING



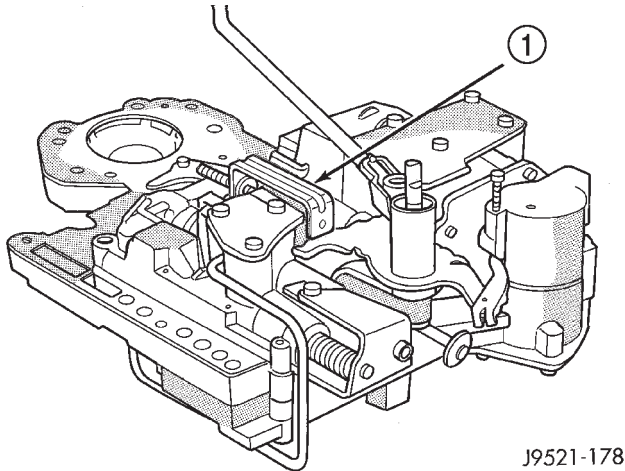
VALVE BODY (Continued)

(12) Secure detent ball and spring with Retainer Tool 6583 (Fig. 276).

(13) Remove park rod E-clip and separate rod from manual lever (Fig. 277).

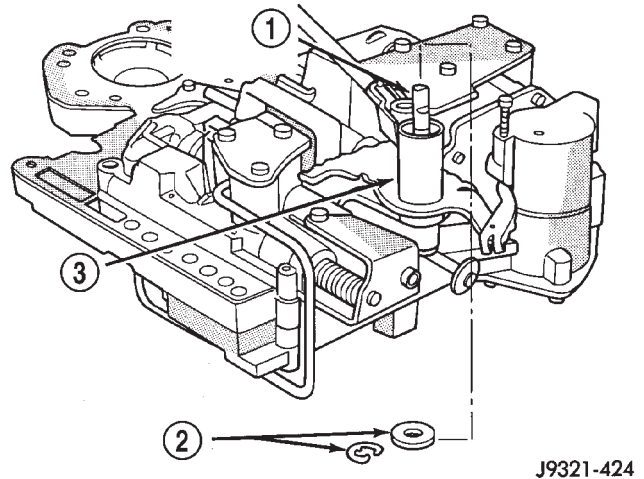
(14) Remove E-clip and washer that retains throttle lever shaft in manual lever (Fig. 278).

(15) Remove manual lever and throttle lever (Fig. 279). Rotate and lift manual lever off valve body and throttle lever shaft. Then slide throttle lever out of valve body.



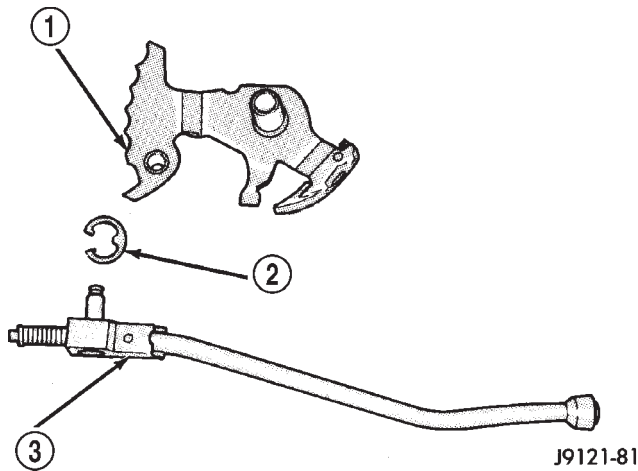
**Fig. 276 Detent Ball And Spring**

1 - SPECIAL TOOL 6583 POSITIONED ON DETENT HOUSING



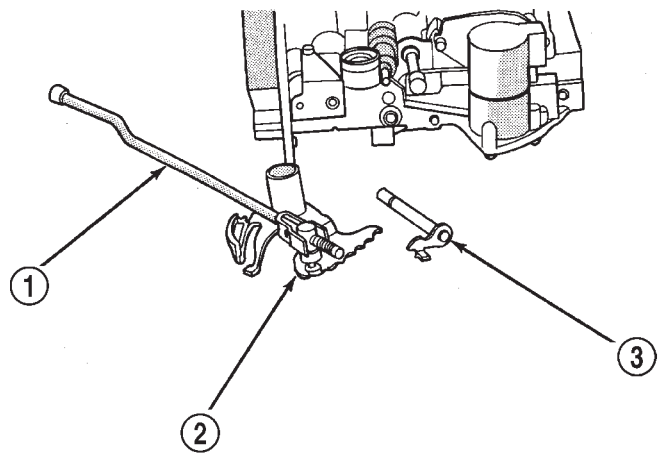
**Fig. 278 Throttle Lever E-Clip And Washer**

1 - THROTTLE LEVER SHAFT  
2 - E-CLIP AND WASHER  
3 - MANUAL SHAFT



**Fig. 277 Park Rod**

1 - MANUAL LEVER  
2 - E-CLIP  
3 - PARK ROD



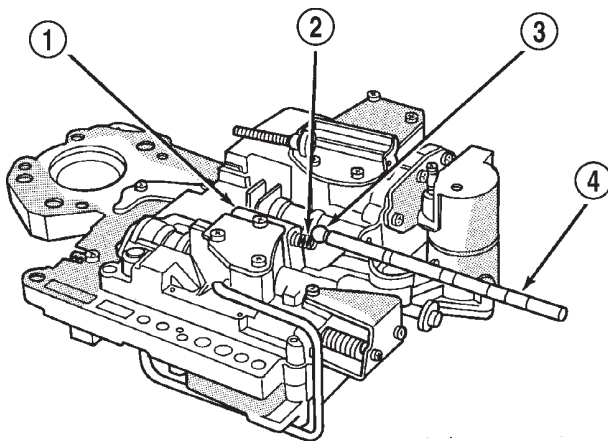
**Fig. 279 Manual And Throttle Lever**

1 - PARK ROD  
2 - MANUAL LEVER ASSEMBLY  
3 - THROTTLE LEVER

## VALVE BODY (Continued)

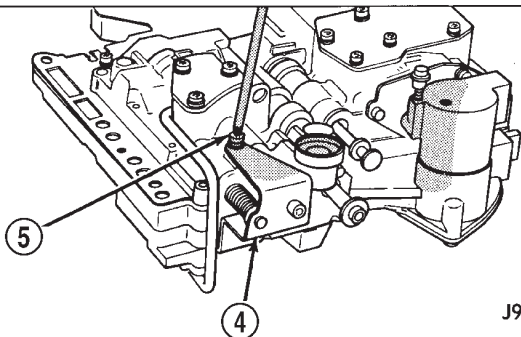
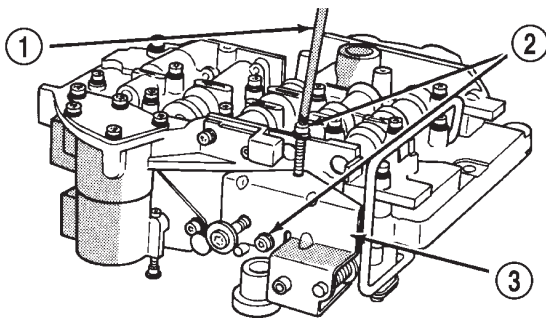
(16) Position pencil magnet next to detent housing to catch detent ball and spring. Then carefully remove Retainer Tool 6583 and remove detent ball and spring (Fig. 280).

(17) Remove screws attaching pressure adjusting screw bracket to valve body and transfer plate (Fig. 281). Hold bracket firmly against spring tension while removing last screw.



**Fig. 280 Detent Ball And Spring** J9321-426

- 1 - DETENT HOUSING
- 2 - DETENT SPRING
- 3 - DETENT BALL
- 4 - PENCIL MAGNET



**Fig. 281 Adjusting Screw Bracket Fastener** J9321-430

- 1 - T25 TORX™ BIT
- 2 - REMOVE THESE SCREWS FIRST
- 3 - BRACKET
- 4 - BRACKET
- 5 - REMOVE THIS SCREW LAST

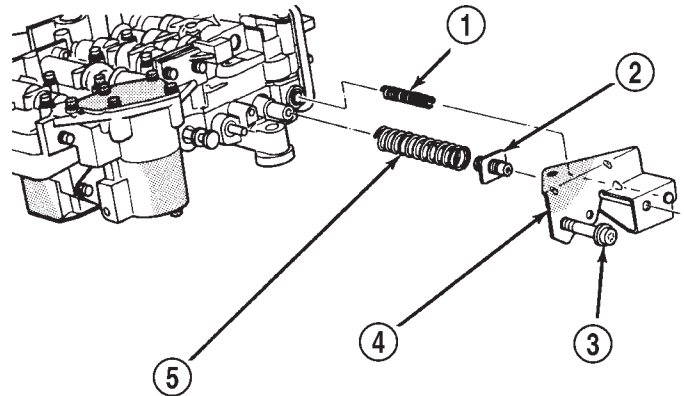
(18) Remove adjusting screw bracket, line pressure adjusting screw, pressure regulator valve spring and switch valve spring (Fig. 282). Do not remove throttle pressure adjusting screw from bracket and do not disturb setting of either adjusting screw during removal.

(19) Turn upper housing over and remove switch valve, regulator valve and spring, and manual valve (Fig. 283).

(20) Remove kickdown detent, kickdown valve, and throttle valve and spring (Fig. 283).

(21) Loosen left-side 3-4 accumulator housing attaching screw about 2-3 threads. Then remove center and right-side housing attaching screws (Fig. 284).

(22) Carefully rotate 3-4 accumulator housing upward and remove 3-4 shift valve spring and converter clutch valve plug and spring (Fig. 285).

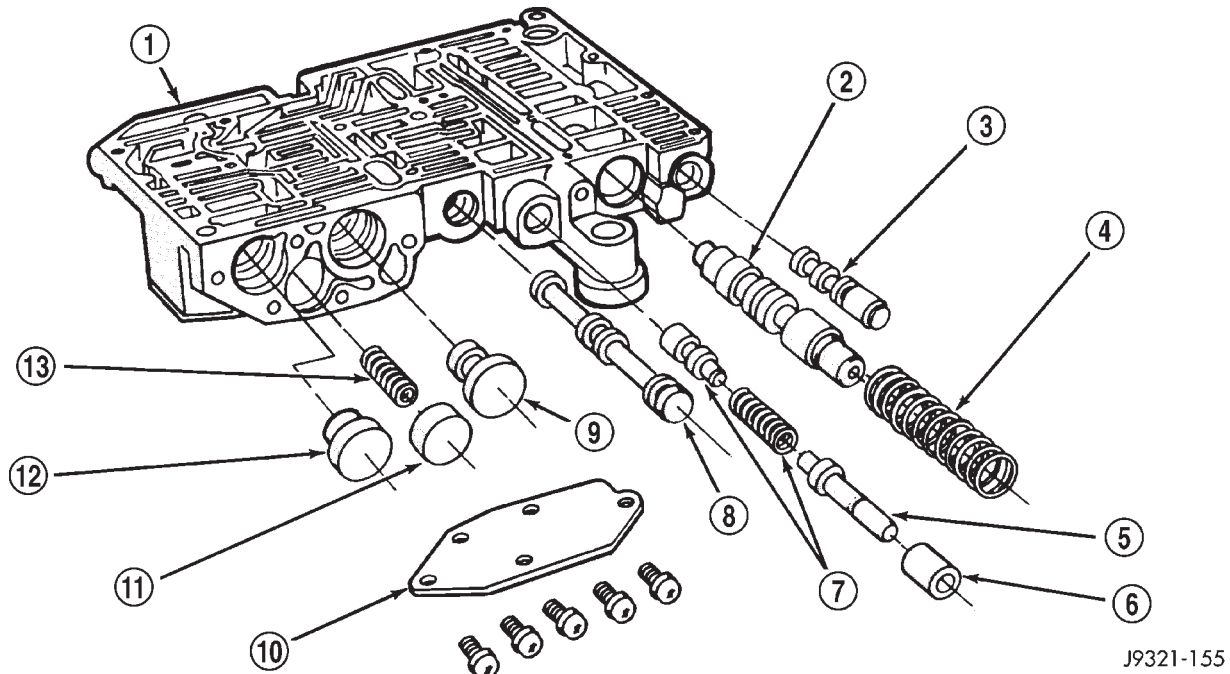


J9321-431

**Fig. 282 Adjusting Screw Bracket And Spring**

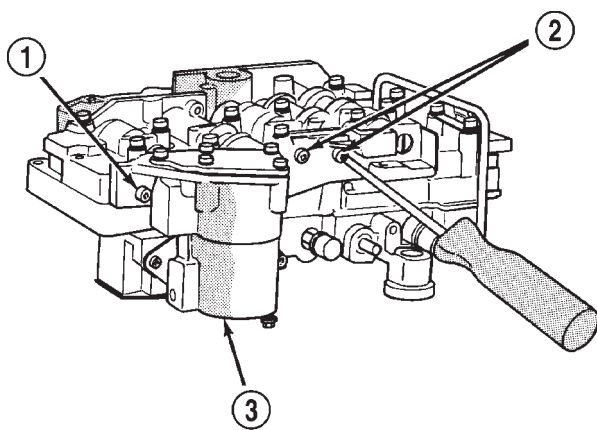
- 1 - SWITCH VALVE SPRING
- 2 - LINE PRESSURE SCREW
- 3 - THROTTLE PRESSURE ADJUSTING SCREW
- 4 - ADJUSTING SCREW BRACKET
- 5 - PRESSURE REGULATOR VALVE SPRING

VALVE BODY (Continued)



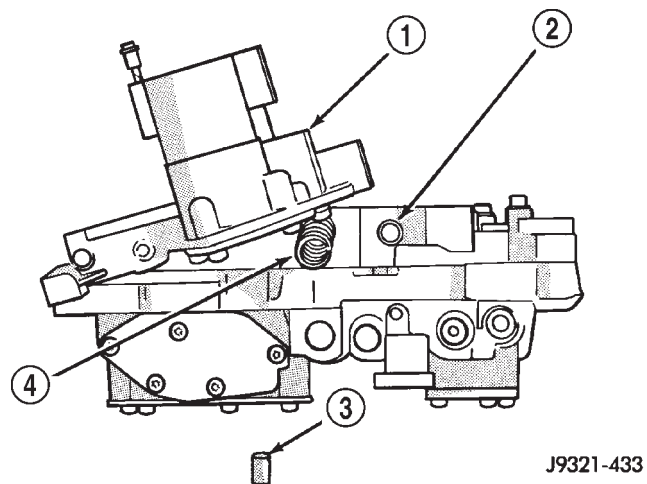
**Fig. 283 Upper Housing Control Valve Locations**

- |                               |                                   |
|-------------------------------|-----------------------------------|
| 1 - UPPER HOUSING             | 8 - MANUAL VALVE                  |
| 2 - REGULATOR VALVE           | 9 - 1-2 GOVERNOR PLUG             |
| 3 - SWITCH VALVE              | 10 - GOVERNOR PLUG COVER          |
| 4 - REGULATOR VALVE SPRING    | 11 - THROTTLE PLUG                |
| 5 - KICKDOWN VALVE            | 12 - 2-3 GOVERNOR PLUG            |
| 6 - KICKDOWN DETENT           | 13 - SHUTTLE VALVE PRIMARY SPRING |
| 7 - THROTTLE VALVE AND SPRING |                                   |



**Fig. 284 Accumulator Housing Screw Locations**

- 1 - LOOSEN THIS SCREW
- 2 - REMOVE THESE SCREWS
- 3 - 3-4 ACCUMULATOR HOUSING



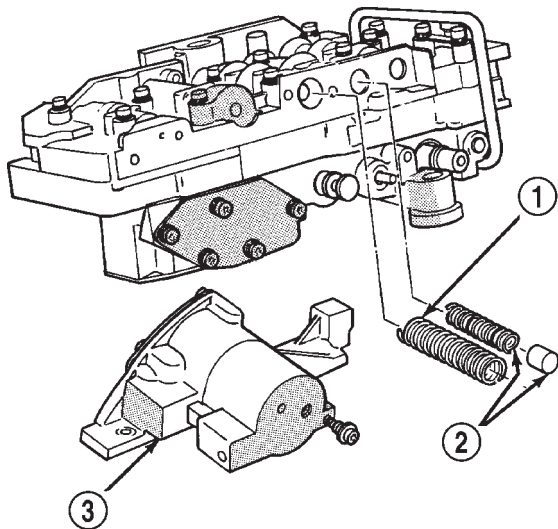
**Fig. 285 3-4 Shift And Converter Clutch Valve Springs And Plug**

- 1 - ACCUMULATOR HOUSING
- 2 - CONVERTER CLUTCH VALVE SPRING
- 3 - CLUTCH VALVE PLUG
- 4 - 3-4 SHIFT VALVE SPRING

## VALVE BODY (Continued)

(23) Remove left-side screw and remove 3-4 accumulator housing from valve body (Fig. 286).

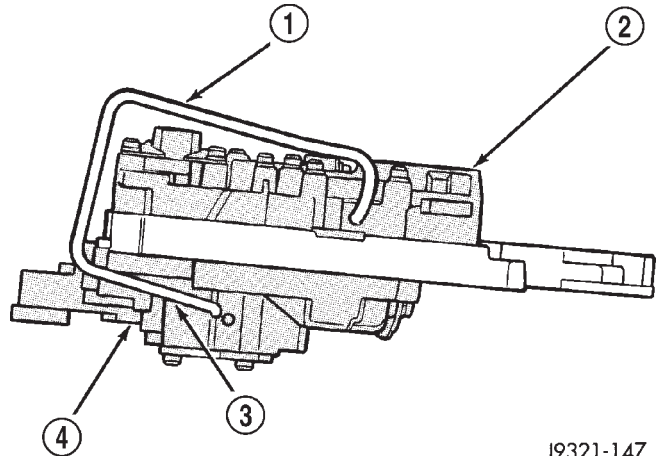
(24) Bend back tabs on boost valve tube brace (Fig. 287).



J9321-434

**Fig. 286 Accumulator Housing, Valve Springs And Plug**

- 1 - 3-4 SHIFT VALVE SPRING
- 2 - CONVERTER CLUTCH VALVE SPRING AND PLUG
- 3 - 3-4 ACCUMULATOR HOUSING



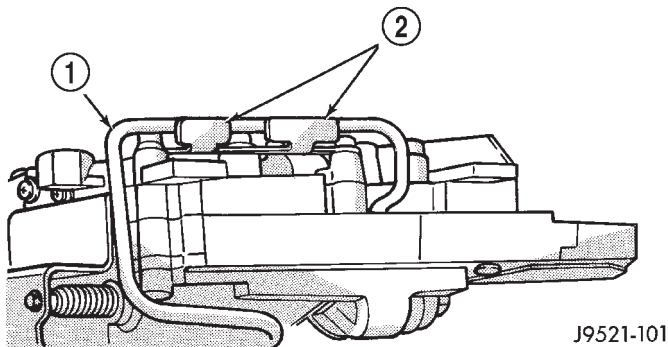
J9321-147

**Fig. 288 Boost Valve Tube**

- 1 - BOOST VALVE TUBE
- 2 - LOWER HOUSING
- 3 - DISENGAGE THIS END OF TUBE FIRST
- 4 - UPPER HOUSING

(27) Remove screws attaching valve body lower housing to upper housing and transfer plate (Fig. 289). Note position of boost valve tube brace for assembly reference.

(28) Remove lower housing and overdrive separator plate from transfer plate (Fig. 289).



J9521-101

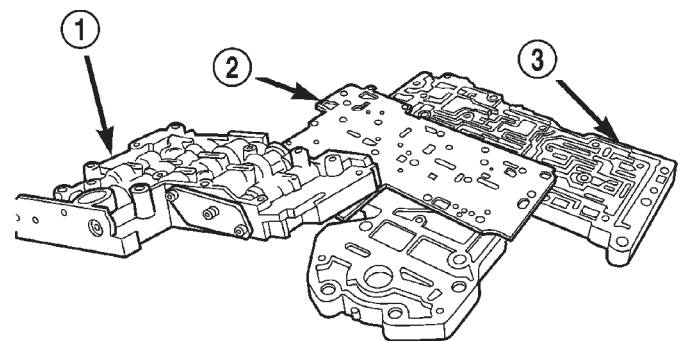
**Fig. 287 Boost Valve Tube Brace**

- 1 - BOOST VALVE TUBE
- 2 - TUBE BRACE (DOUBLE TAB)

(25) Remove boost valve connecting tube (Fig. 288). Disengage tube from upper housing port first. Then rock opposite end of tube back and forth to work it out of lower housing.

**CAUTION:** Do not use tools to loosen or pry the connecting tube out of the valve body housings. Loosen and remove the tube by hand only.

(26) Turn valve body over so lower housing is facing upward (Fig. 289). In this position, the two check balls in upper housing will remain in place and not fall out when lower housing and separator plate are removed.



80b170f8

**Fig. 289 Lower Housing**

- 1 - LOWER HOUSING
- 2 - OVERDRIVE SEPARATOR PLATE
- 3 - TRANSFER PLATE AND UPPER HOUSING



VALVE BODY (Continued)

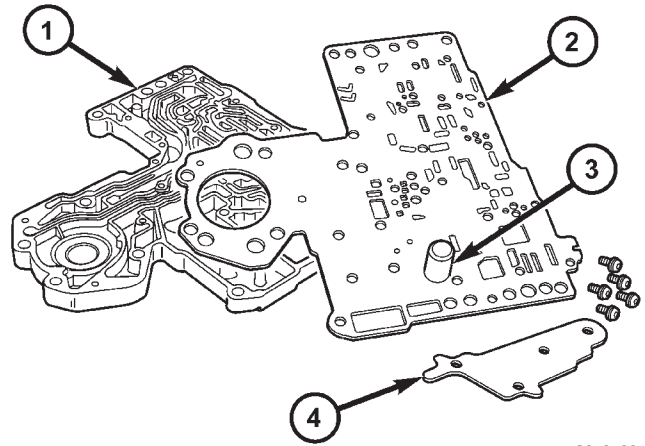
(29) Remove the ECE check ball from the transfer plate (Fig. 290). The ECE check ball is approximately 4.8 mm (3/16 in.) in diameter.

(30) Remove transfer plate from upper housing (Fig. 291).

(31) Turn transfer plate over so upper housing separator plate is facing upward.

(32) Remove upper housing separator plate from transfer plate (Fig. 292). Note position of filter in separator plate for assembly reference.

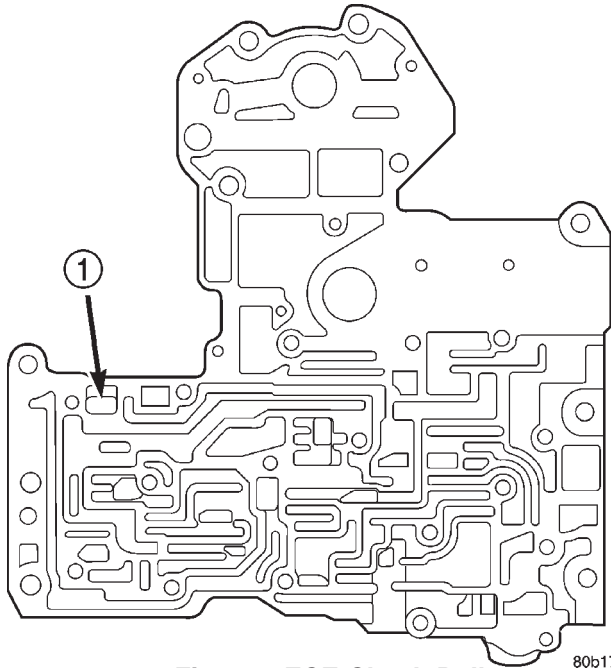
(33) Remove rear clutch and rear servo check balls from transfer plate. Note check ball location for assembly reference (Fig. 293).



80a3e08a

**Fig. 292 Upper Housing Separator Plate**

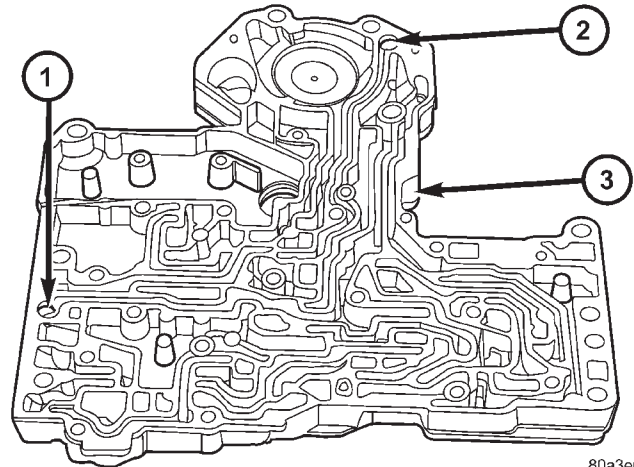
- 1 - TRANSFER PLATE
- 2 - UPPER HOUSING SEPARATOR PLATE
- 3 - FILTER SCREEN
- 4 - BRACE



80b17125

**Fig. 290 ECE Check Ball**

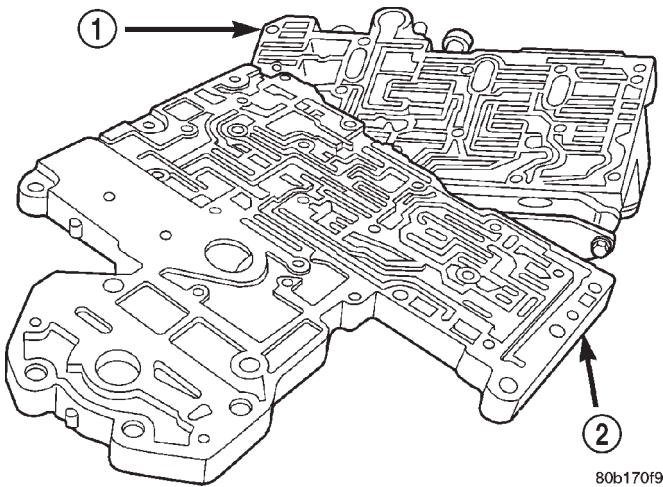
- 1 - ECE CHECK BALL (3/16")



80a3e0c1

**Fig. 293 Rear Clutch And Rear Servo Check Ball**

- 1 - REAR CLUTCH CHECK BALL
- 2 - REAR SERVO CHECK BALL
- 3 - TRANSFER PLATE



80b170f9

**Fig. 291 Transfer Plate**

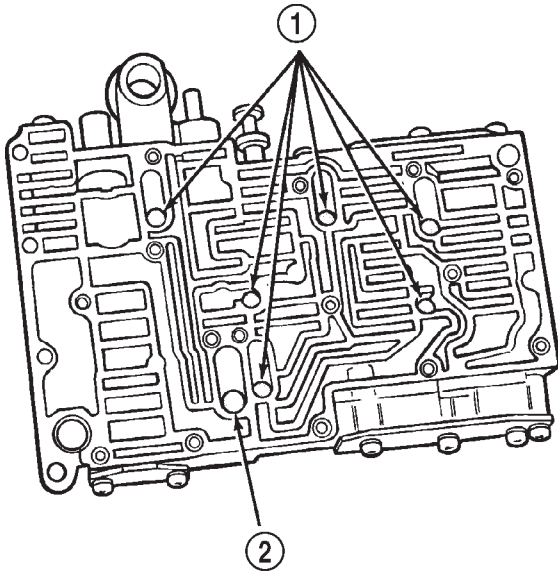
- 1 - UPPER HOUSING
- 2 - TRANSFER PLATE



## VALVE BODY (Continued)

## VALVE BODY UPPER HOUSING

(1) Note location of check balls in valve body upper housing (Fig. 294). Then remove the one large diameter and the six smaller diameter check balls.



J9321-154

**Fig. 294 Check Ball Locations In Upper Housing**

- 1 - SMALL DIAMETER CHECK BALLS (6)  
2 - LARGE DIAMETER CHECK BALL (1)

(2) Remove governor plug and shuttle valve covers (Fig. 296).

(3) Remove E-clip that secures shuttle valve secondary spring on valve stem (Fig. 295).

(4) Remove throttle plug, primary spring, shuttle valve, secondary spring, and spring guides (Fig. 296).

(5) Remove boost valve retainer, spring and valve if not previously removed.

(6) Remove throttle plug and 1-2 and 2-3 governor plugs (Fig. 283).

(7) Turn upper housing around and remove limit valve and shift valve covers (Fig. 297).

(8) Remove limit valve housing. Then remove retainer, spring, limit valve, and 2-3 throttle plug from limit valve housing (Fig. 297).

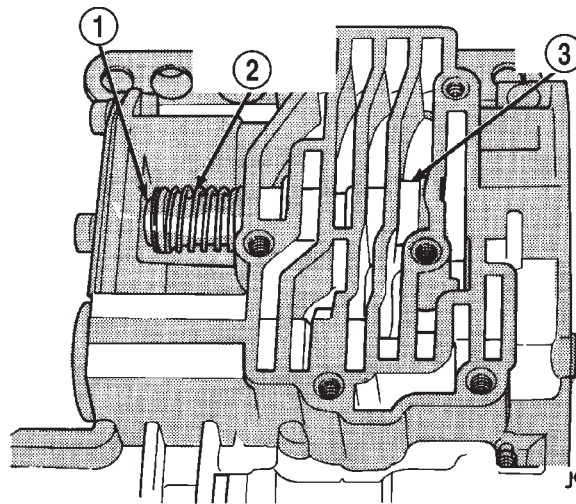
(9) Remove 1-2 shift control valve and spring (Fig. 297).

(10) Remove 1-2 shift valve and spring (Fig. 297).

(11) Remove 2-3 shift valve and spring from valve body (Fig. 297).

(12) Remove pressure plug cover (Fig. 297).

(13) Remove line pressure plug, sleeve, throttle pressure plug and spring (Fig. 297).

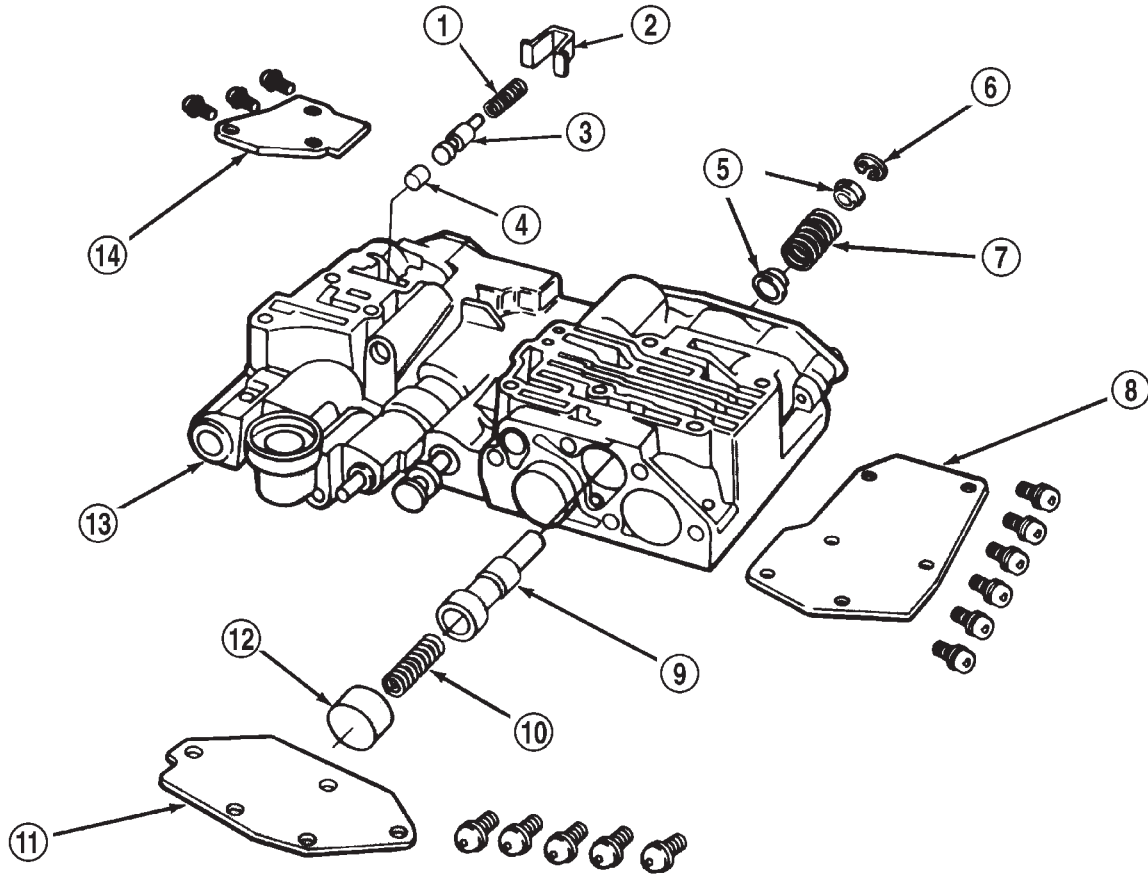


J9121-179

**Fig. 295 Shuttle Valve E-Clip And Secondary Spring Location**

- 1 - E-CLIP  
2 - SECONDARY SPRING AND GUIDES  
3 - SHUTTLE VALVE

## VALVE BODY (Continued)

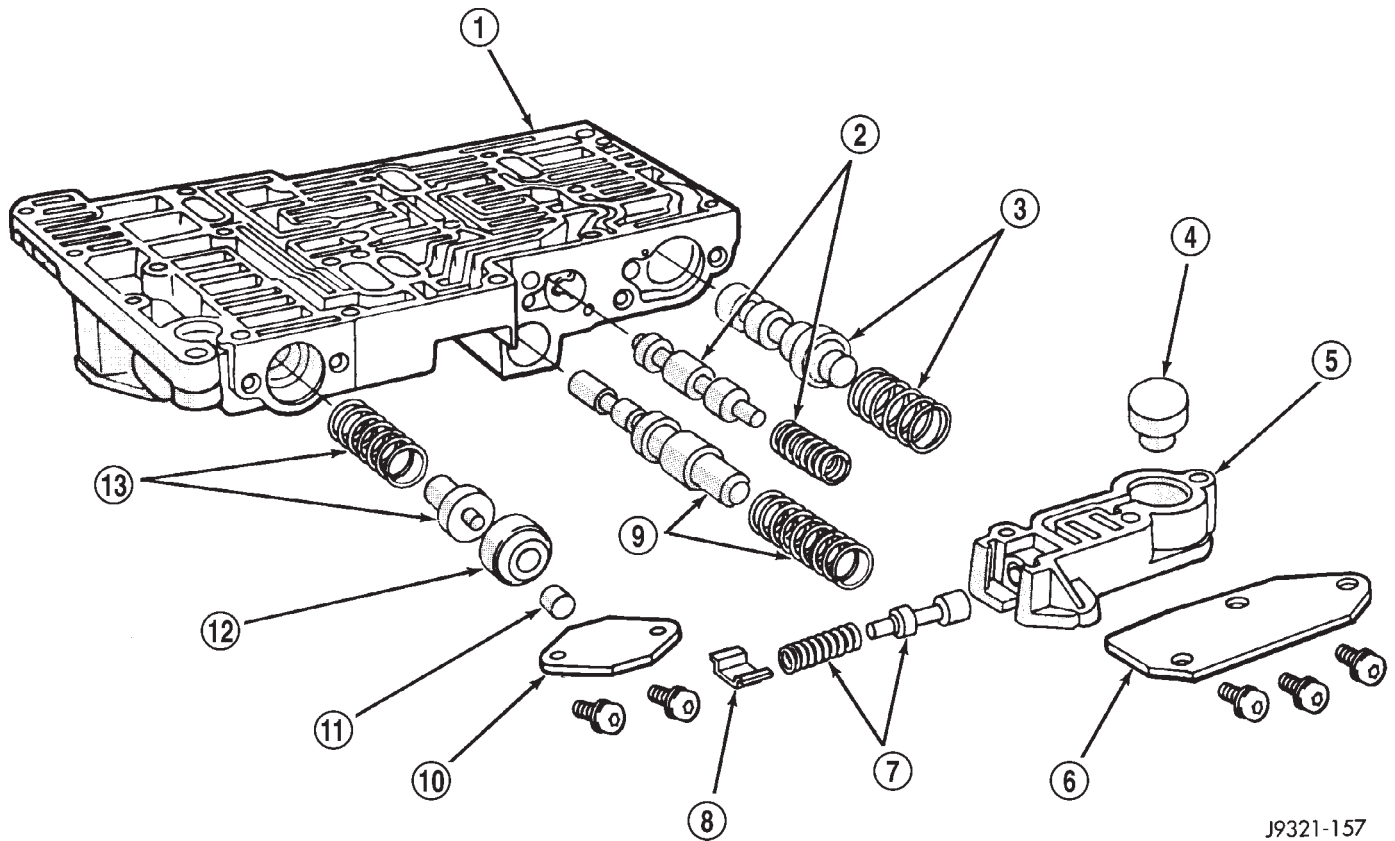


J9421-217

**Fig. 296 Shuttle And Boost Valve Components**

- |                                    |                                   |
|------------------------------------|-----------------------------------|
| 1 - SPRING                         | 8 - SHUTTLE VALVE COVER           |
| 2 - RETAINER                       | 9 - SHUTTLE VALVE                 |
| 3 - BOOST VALVE                    | 10 - SHUTTLE VALVE PRIMARY SPRING |
| 4 - BOOST VALVE PLUG               | 11 - GOVERNOR PLUG COVER          |
| 5 - SPRING GUIDES                  | 12 - THROTTLE PLUG                |
| 6 - E-CLIP                         | 13 - UPPER HOUSING                |
| 7 - SHUTTLE VALVE SECONDARY SPRING | 14 - BOOST VALVE COVER            |

VALVE BODY (Continued)



J9321-157

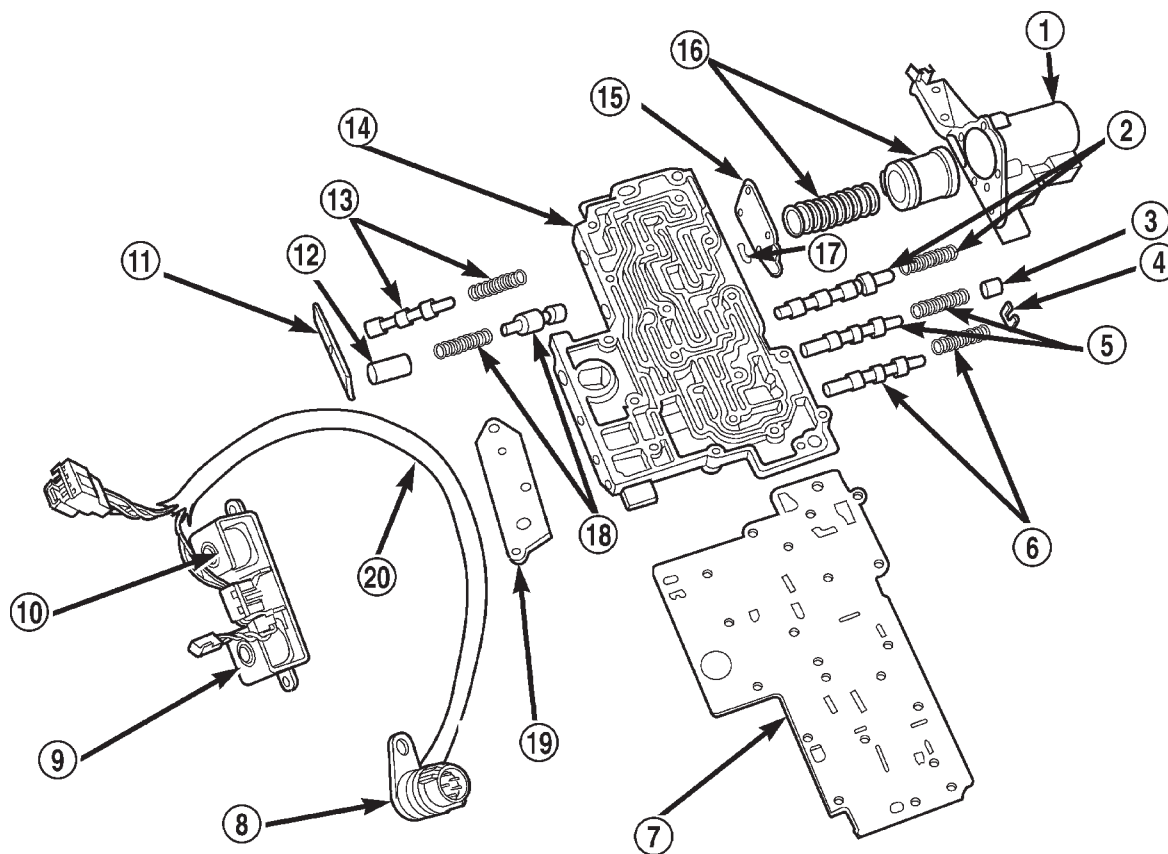
**Fig. 297 Upper Housing Shift Valve And Pressure Plug Locations**

- |                                |  |
|--------------------------------|--|
| 1 - UPPER HOUSING              | 8 - RETAINER                           |
| 2 - 1-2 SHIFT VALVE AND SPRING | 9 - 1-2 SHIFT CONTROL VALVE AND SPRING |
| 3 - 2-3 SHIFT VALVE AND SPRING | 10 - PRESSURE PLUG COVER               |
| 4 - 2-3 THROTTLE PLUG          | 11 - LINE PRESSURE PLUG                |
| 5 - LIMIT VALVE HOUSING        | 12 - PLUG SLEEVE                       |
| 6 - LIMIT VALVE COVER          | 13 - THROTTLE PRESSURE SPRING AND PLUG |
| 7 - LIMIT VALVE AND SPRING     |  |

## VALVE BODY (Continued)

## VALVE BODY LOWER HOUSING

- (1) Remove timing valve cover.
  - (2) Remove 3-4 timing valve and spring.
  - (3) Remove 3-4 quick fill valve, spring and plug.
  - (4) Remove 3-4 shift valve and spring.
  - (5) Remove converter clutch valve, spring and plug
- (Fig. 298).
- (6) Remove converter clutch timing valve, retainer and valve spring.



80c072b5

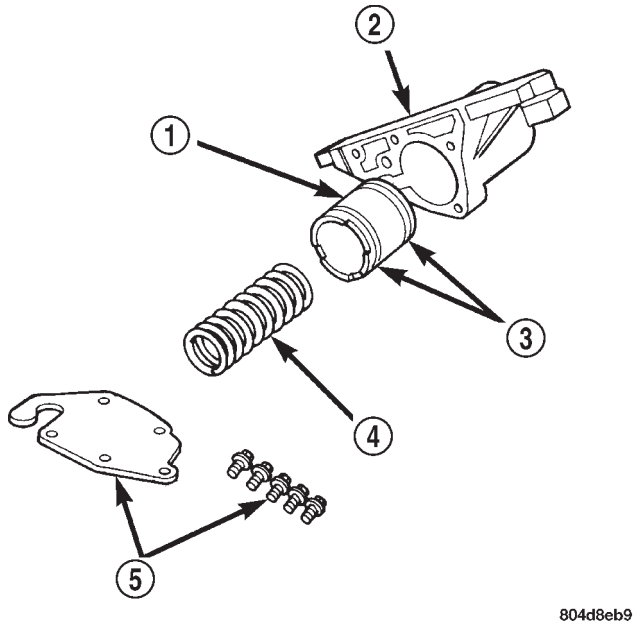
**Fig. 298 Lower Housing Shift Valves and Springs**

- |  |  |
|--|--|
| 1 - 3-4 ACCUMULATOR HOUSING                  | 11 - TIMING VALVE COVER                |
| 2 - 3-4 SHIFT VALVE AND SPRING               | 12 - PLUG                              |
| 3 - PLUG                                     | 13 - 3-4 TIMING VALVE AND SPRING       |
| 4 - SPRING RETAINER                          | 14 - LOWER HOUSING                     |
| 5 - CONVERTER CLUTCH VALVE AND SPRING        | 15 - ACCUMULATOR END PLATE             |
| 6 - CONVERTER CLUTCH TIMING VALVE AND SPRING | 16 - 3-4 ACCUMULATOR PISTON AND SPRING |
| 7 - OVERDRIVE SEPARATOR PLATE                | 17 - E-CLIP                            |
| 8 - CASE CONNECTOR                           | 18 - 3-4 QUICK FILL SPRING AND VALVE   |
| 9 - CONVERTER CLUTCH SOLENOID                | 19 - SOLENOID GASKET                   |
| 10 - OVERDRIVE SOLENOID                      | 20 - HARNESS                           |

## VALVE BODY (Continued)

**3-4 ACCUMULATOR HOUSING**

- (1) Remove end plate from housing.
- (2) Remove piston spring.
- (3) Remove piston. Remove and discard piston seals (Fig. 299).



804d8eb9

**Fig. 299 Accumulator Housing Components**

- 1 - ACCUMULATOR PISTON
- 2 - 3-4 ACCUMULATOR HOUSING
- 3 - TEFLON SEALS
- 4 - PISTON SPRING
- 5 - COVER PLATE AND SCREWS

**CLEANING**

Clean the valve housings, valves, plugs, springs, and separator plates with a standard parts cleaning solution only. Do not use gasoline, kerosene, or any type of caustic solution.

Do not immerse any of the electrical components in cleaning solution. Clean the governor solenoid and sensor and the dual solenoid and harness assembly by wiping them off with dry shop towels only.

Dry all except the electrical parts with compressed air. Make sure all passages are clean and free from obstructions. **Do not use rags or shop towels to dry or wipe off valve body components. Lint from these materials can stick to valve body parts, interfere with valve operation, and clog filters and fluid passages.**

Wipe the governor pressure sensor and solenoid valve with dry, lint free shop towels only. The O-rings on the sensor and solenoid valve are the only serviceable components. Be sure the vent ports in the solenoid valve are open and not blocked by dirt or debris. Replace the valve and/or sensor only when DRB scan tool diagnosis indicates this is necessary. Or, if either

part has sustained physical damage (dented, deformed, broken, etc.).

**CAUTION:** Do not turn the small screw at the end of the solenoid valve for any reason. Turning the screw in either direction will ruin solenoid calibration and result in solenoid failure. In addition, the filter on the solenoid valve is **NOT** serviceable. Do not try to remove the filter as this will damage the valve housing.

**INSPECTION**

Inspect the throttle and manual valve levers and shafts. Do not attempt to straighten a bent shaft or correct a loose lever. Replace these components if worn, bent, loose or damaged in any way.

Inspect all of the valve body mating surfaces for scratches, nicks, burrs, or distortion. Use a straight-edge to check surface flatness. Minor scratches may be removed with crocus cloth using only very light pressure.

Minor distortion of a valve body mating surface may be corrected by smoothing the surface with a sheet of crocus cloth. Position the crocus cloth on a surface plate, sheet of plate glass or equally flat surface. If distortion is severe or any surfaces are heavily scored, the valve body will have to be replaced.

**CAUTION:** Many of the valves and plugs, such as the throttle valve, shuttle valve plug, 1-2 shift valve and 1-2 governor plug, are made of coated aluminum. Aluminum components are identified by the dark color of the special coating applied to the surface (or by testing with a magnet). Do not sand aluminum valves or plugs under any circumstances. This practice could damage the special coating causing the valves/plugs to stick and bind.

Inspect the valves and plugs for scratches, burrs, nicks, or scores. Minor surface scratches on steel valves and plugs can be removed with crocus cloth but **do not round off the edges of the valve or plug lands.** Maintaining sharpness of these edges is vitally important. The edges prevent foreign matter from lodging between the valves and plugs and the bore.

Inspect all the valve and plug bores in the valve body. Use a penlight to view the bore interiors. Replace the valve body if any bores are distorted or scored. Inspect all of the valve body springs. The springs must be free of distortion, warpage or broken coils.

Check the two separator plates for distortion or damage of any kind. Inspect the upper housing, lower housing, 3-4 accumulator housing, and transfer



## VALVE BODY (Continued)

plate carefully. Be sure all fluid passages are clean and clear. Check condition of the upper housing and transfer plate check balls as well. The check balls and ball seats must not be worn or damaged.

Trial fit each valve and plug in its bore to check freedom of operation. When clean and dry, the valves and plugs should drop freely into the bores.

Valve body bores do not change dimensionally with use. If the valve body functioned correctly when new, it will continue to operate properly after cleaning and inspection. It should not be necessary to replace a valve body assembly unless it is damaged in handling.

The only serviceable valve body components are listed below. The remaining valve body components are serviced only as part of a complete valve body assembly. Serviceable parts are:

- dual solenoid and harness assembly
- solenoid gasket
- solenoid case connector O-rings and shoulder bolt
- switch valve and spring
- pressure adjusting screw and bracket assembly
- throttle lever
- manual lever and shaft seal
- throttle lever shaft seal, washer, and E-clip
- fluid filter and screws
- detent ball and spring
- valve body screws
- governor pressure solenoid
- governor pressure sensor and retaining clip
- park lock rod and E-clip

## ASSEMBLY

**CAUTION:** Do not force valves or plugs into place during reassembly. If the valve body bores, valves and plugs are free of distortion or burrs, the valve body components should all slide into place easily. In addition, do not overtighten the transfer plate and valve body screws during reassembly. Overtightening can distort the housings resulting in valve sticking, cross leakage and unsatisfactory operation. Tighten valve body screws to recommended torque only.

## LOWER HOUSING

(1) Lubricate valves, springs, and the housing valve and plug bores with clean transmission fluid (Fig. 298).

(2) Install 3-4 timing valve spring and valve in lower housing.

(3) Install 3-4 quick fill valve in lower housing.

(4) Install 3-4 quick fill valve spring and plug in housing.

(5) Install timing valve end plate. Tighten end plate screws to 4 N·m (35 in. lbs.) torque.

## 3-4 ACCUMULATOR

(1) Lubricate accumulator piston, seals and housing piston bore with clean transmission fluid (Fig. 299).

(2) Install new seal rings on accumulator piston.

(3) Install piston and spring in housing.

(4) Install end plate on housing.

## TRANSFER PLATE

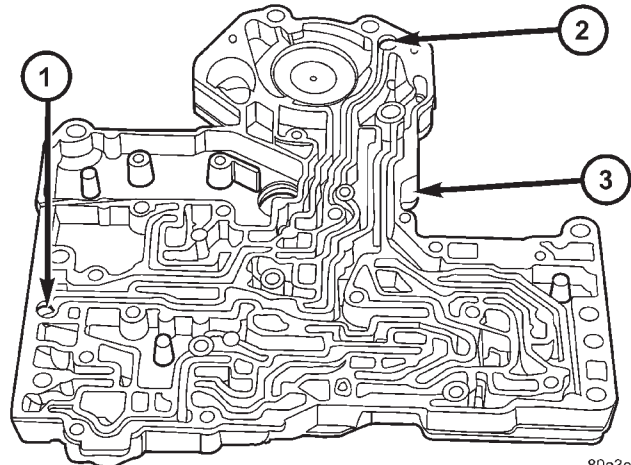
(1) Install rear clutch and rear servo check balls in transfer plate (Fig. 300).

(2) Install filter screen in upper housing separator plate (Fig. 301).

(3) Align and position upper housing separator plate on transfer plate (Fig. 302).

(4) Install brace plate (Fig. 302). Tighten brace attaching screws to 4 N·m (35 in. lbs.) torque.

(5) Install remaining separator plate attaching screws. Tighten screws to 4 N·m (35 in. lbs.) torque.

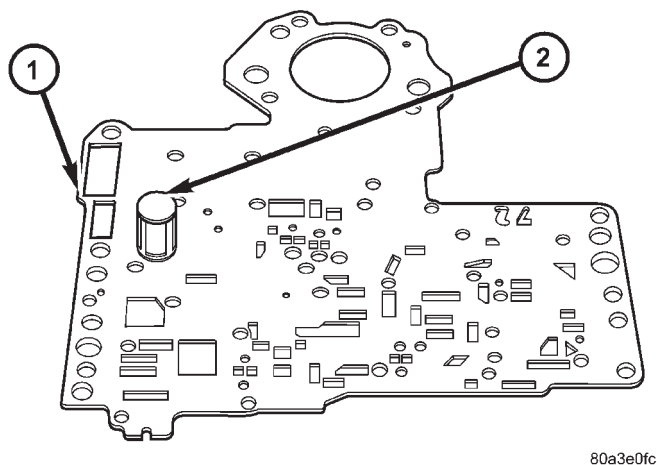


80a3e0c1

**Fig. 300 Rear Clutch And Rear Servo Check Ball Locations**

- 1 - REAR CLUTCH CHECK BALL
- 2 - REAR SERVO CHECK BALL
- 3 - TRANSFER PLATE

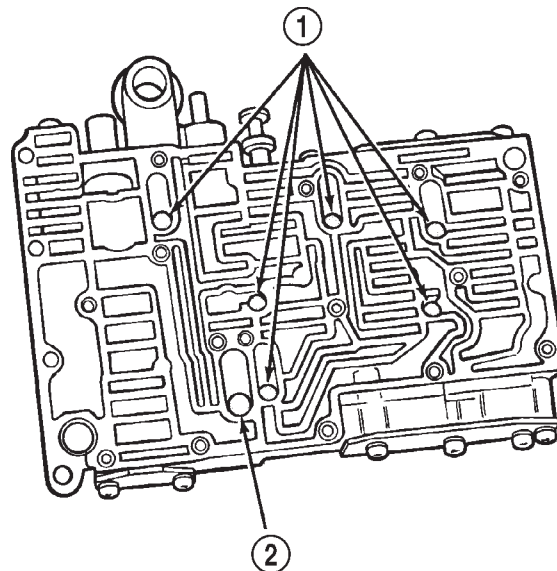
VALVE BODY (Continued)



80a3e0fc

**Fig. 301 Separator Plate Filter Screen Installation**

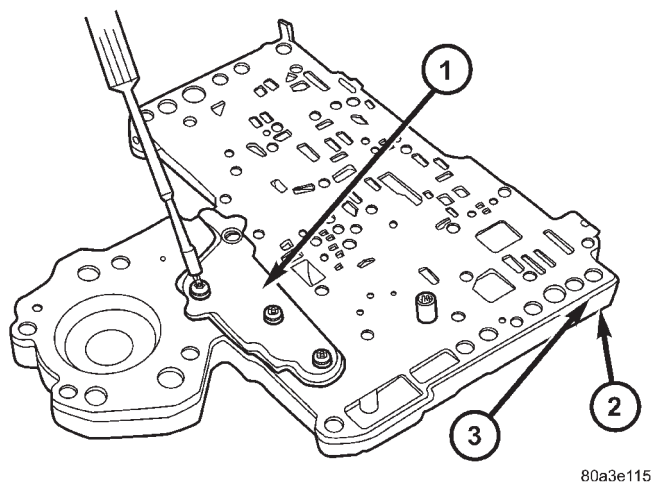
- 1 - UPPER HOUSING SEPARATOR PLATE
- 2 - FILTER SCREEN



J9321-154

**Fig. 303 Check Ball Locations In Upper Housing**

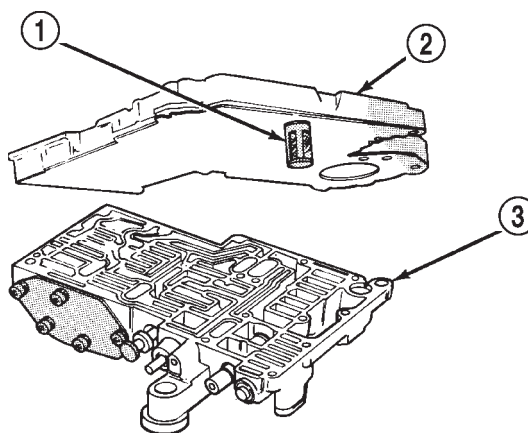
- 1 - SMALL DIAMETER CHECK BALLS (6)
- 2 - LARGE DIAMETER CHECK BALL (1)



80a3e115

**Fig. 302 Brace Plate**

- 1 - BRACE
- 2 - TRANSFER PLATE
- 3 - SEPARATOR PLATE



J9321-439

**Fig. 304 Installing Transfer Plate On Upper Housing**

- 1 - FILTER SCREEN
- 2 - TRANSFER PLATE/SEPARATOR PLATE ASSEMBLY
- 3 - UPPER HOUSING

**UPPER AND LOWER HOUSING**

(1) Position upper housing so internal passages and check ball seats are facing upward. Then install check balls in housing (Fig. 303). Eight check balls are used. The single large check ball is approximately 8.7 mm (11/32 in.) diameter. The single small check ball is approximately 4.8 mm (3/16 in.) in diameter. The remaining 6 check balls are approximately 6.3 mm (1/4 in.) in diameter.

(2) Position assembled transfer plate and upper housing separator plate on upper housing (Fig. 304). Be sure filter screen is seated in proper housing recess.

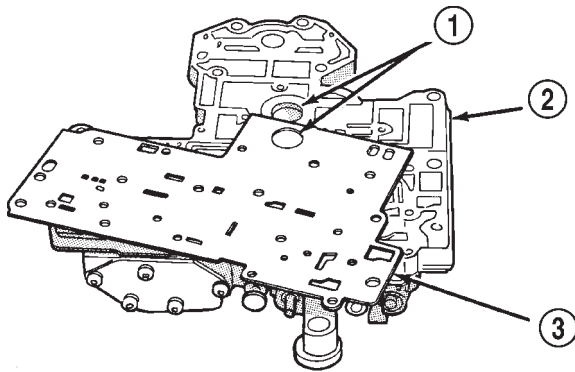
## VALVE BODY (Continued)

(3) Install the ECE check ball into the transfer plate (Fig. 290). The ECE check ball is approximately 4.8 mm (3/16 in.) in diameter.

(4) Position lower housing separator plate on transfer plate (Fig. 305).

(5) Install lower housing on assembled transfer plate and upper housing (Fig. 306).

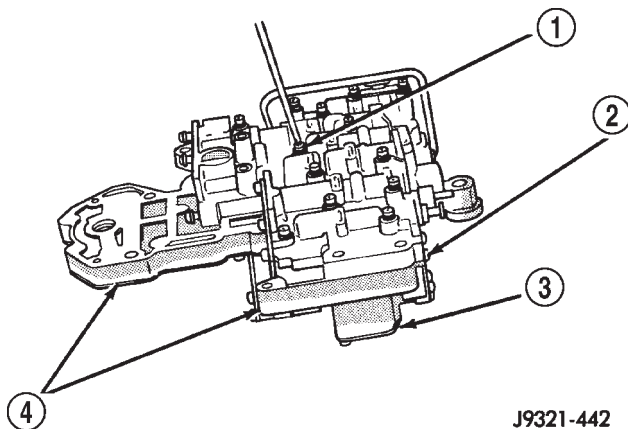
(6) Install and start all valve body screws by hand except for the screws to hold the boost valve tube brace. Save those screws for later installation. Then tighten screws evenly to 4 N·m (35 in. lbs.) torque. Start at center and work out to sides when tightening screws (Fig. 306).



J9321-441

**Fig. 305 Lower Housing Separator Plate**

- 1 - BE SURE TO ALIGN BORES
- 2 - TRANSFER PLATE
- 3 - LOWER HOUSING (OVERDRIVE) SEPARATOR PLATE



J9321-442

**Fig. 306 Installing Lower Housing On Transfer Plate And Upper Housing**

- 1 - VALVE BODY SCREWS (13)
- 2 - LOWER HOUSING
- 3 - UPPER HOUSING
- 4 - TRANSFER PLATE

## UPPER HOUSING VALVE AND PLUG

Refer to (Fig. 307), (Fig. 308) and (Fig. 309) to perform the following steps.

(1) Lubricate valves, plugs, springs with clean transmission fluid.

(2) Assemble regulator valve line pressure plug, sleeve, throttle plug and spring. Insert assembly in upper housing and install cover plate. Tighten cover plate screws to 4 N·m (35 in. lbs.) torque.

(3) Install 1-2 and 2-3 shift valves and springs.

(4) Install 1-2 shift control valve and spring.

(5) Install retainer, spring, limit valve, and 2-3 throttle plug from limit valve housing.

(6) Install limit valve housing and cover plate. Tighten screws to 4 N·m (35 in. lbs.).

(7) Install shuttle valve as follows:

(a) Insert plastic guides in shuttle valve secondary spring and install spring on end of valve.

(b) Install shuttle valve into housing.

(c) Hold shuttle valve in place.

(d) Compress secondary spring and install E-clip in groove at end of shuttle valve.

(e) Verify that spring and E-clip are properly seated before proceeding.

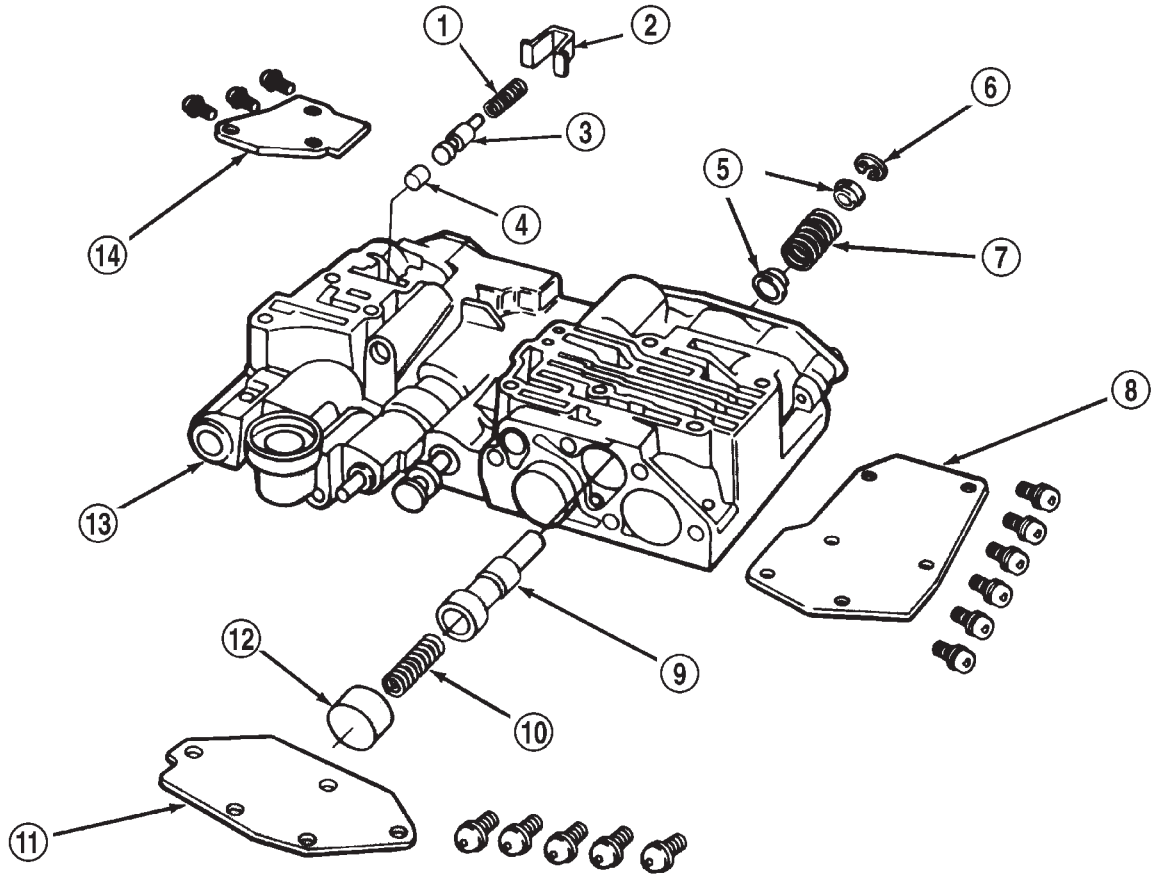
(8) Install shuttle valve cover plate. Tighten cover plate screws to 4 N·m (35 in. lbs.) torque.

(9) Install 1-2 and 2-3 valve governor plugs in valve body.

(10) Install shuttle valve primary spring and throttle plug.

(11) Align and install governor plug cover. Tighten cover screws to 4 N·m (35 in. lbs.) torque.

VALVE BODY (Continued)

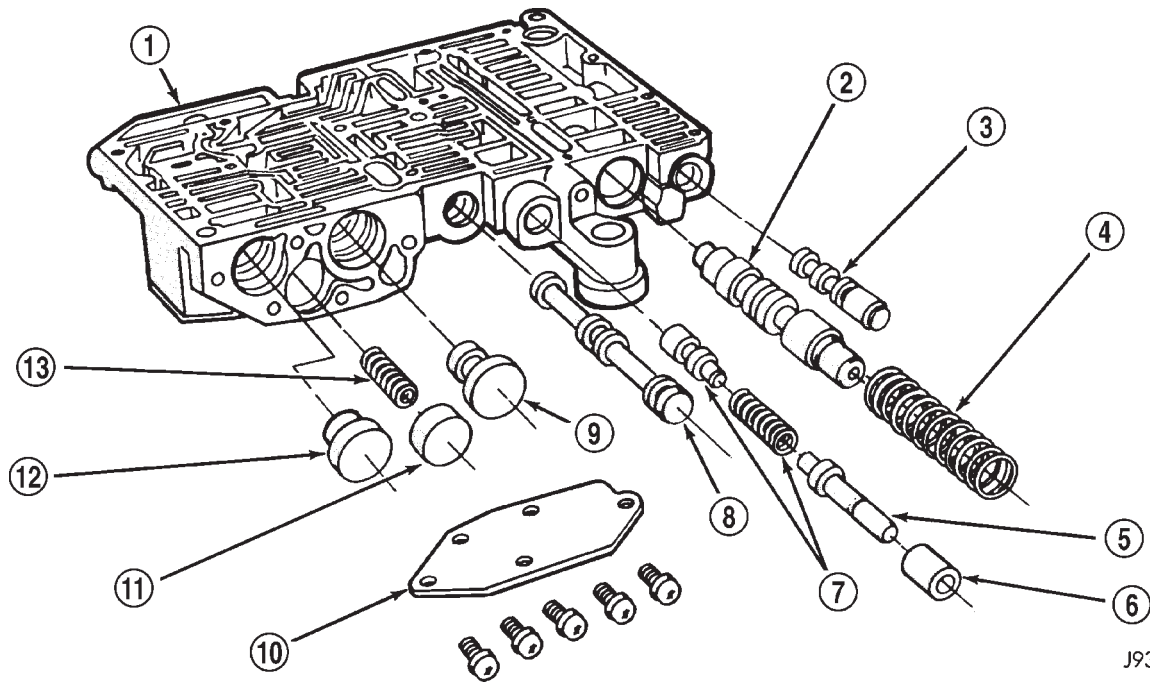


J9421-217

**Fig. 307 Shuttle And Boost Valve Components**

- |                                    |                                   |
|------------------------------------|-----------------------------------|
| 1 - SPRING                         | 8 - SHUTTLE VALVE COVER           |
| 2 - RETAINER                       | 9 - SHUTTLE VALVE                 |
| 3 - BOOST VALVE                    | 10 - SHUTTLE VALVE PRIMARY SPRING |
| 4 - BOOST VALVE PLUG               | 11 - GOVERNOR PLUG COVER          |
| 5 - SPRING GUIDES                  | 12 - THROTTLE PLUG                |
| 6 - E-CLIP                         | 13 - UPPER HOUSING                |
| 7 - SHUTTLE VALVE SECONDARY SPRING | 14 - BOOST VALVE COVER            |

VALVE BODY (Continued)



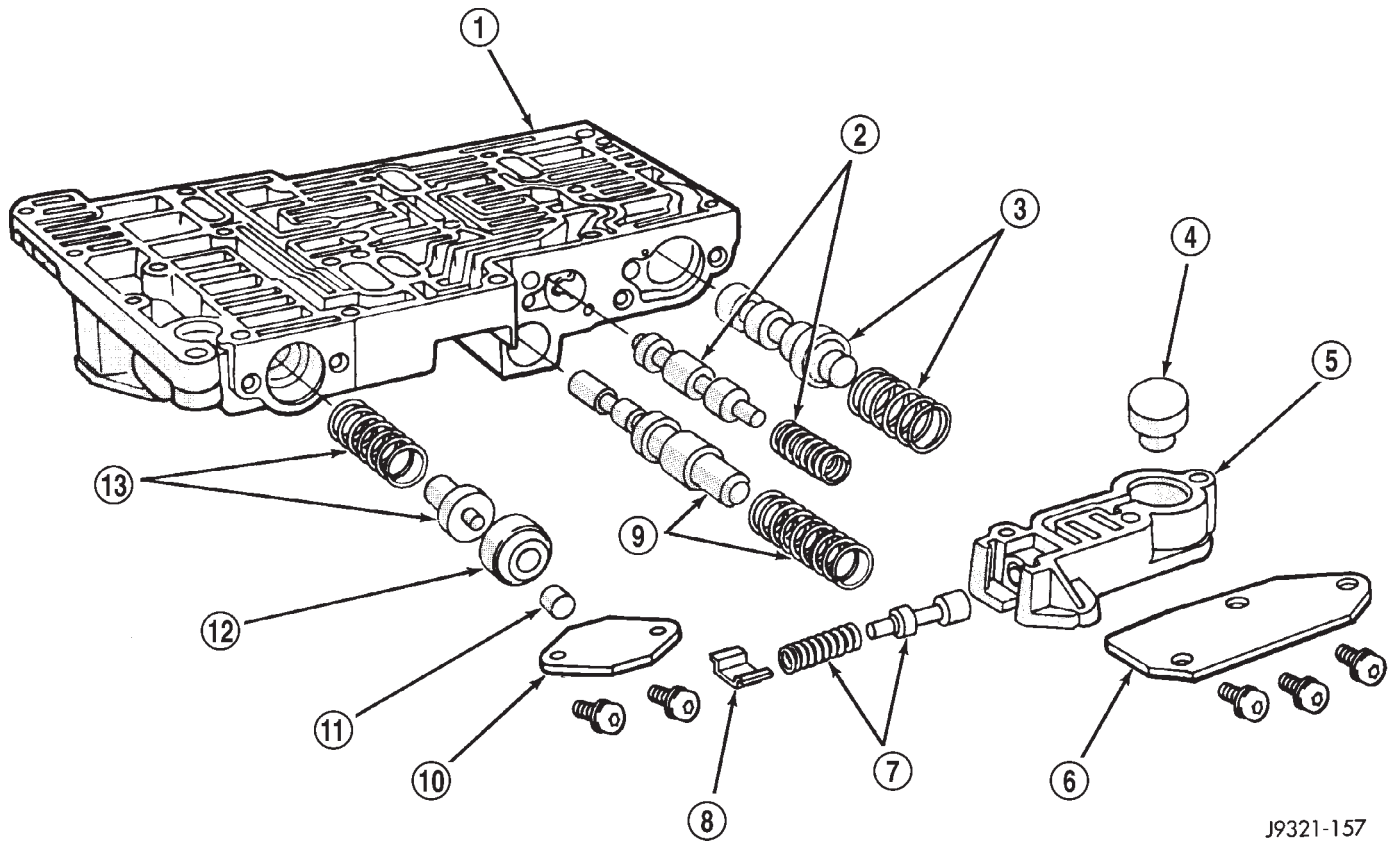
J9321-155

**Fig. 308 Upper Housing Control Valve Locations**

- |                               |                                   |
|-------------------------------|-----------------------------------|
| 1 - UPPER HOUSING             | 8 - MANUAL VALVE                  |
| 2 - REGULATOR VALVE           | 9 - 1-2 GOVERNOR PLUG             |
| 3 - SWITCH VALVE              | 10 - GOVERNOR PLUG COVER          |
| 4 - REGULATOR VALVE SPRING    | 11 - THROTTLE PLUG                |
| 5 - KICKDOWN VALVE            | 12 - 2-3 GOVERNOR PLUG            |
| 6 - KICKDOWN DETENT           | 13 - SHUTTLE VALVE PRIMARY SPRING |
| 7 - THROTTLE VALVE AND SPRING |                                   |



VALVE BODY (Continued)



J9321-157

**Fig. 309 Upper Housing Shift Valve And Pressure Plug Locations**

- |                                |  |
|--------------------------------|--|
| 1 - UPPER HOUSING              | 8 - RETAINER                           |
| 2 - 1-2 SHIFT VALVE AND SPRING | 9 - 1-2 SHIFT CONTROL VALVE AND SPRING |
| 3 - 2-3 SHIFT VALVE AND SPRING | 10 - PRESSURE PLUG COVER               |
| 4 - 2-3 THROTTLE PLUG          | 11 - LINE PRESSURE PLUG                |
| 5 - LIMIT VALVE HOUSING        | 12 - PLUG SLEEVE                       |
| 6 - LIMIT VALVE COVER          | 13 - THROTTLE PRESSURE SPRING AND PLUG |
| 7 - LIMIT VALVE AND SPRING     |  |

## VALVE BODY (Continued)

**BOOST VALVE TUBE AND BRACE**

(1) Position valve body assembly so lower housing is facing upward (Fig. 310).

(2) Lubricate tube ends and housing ports with transmission fluid or petroleum jelly.

(3) Start tube in lower housing port first. Then swing tube downward and work opposite end of tube into upper housing port (Fig. 310).

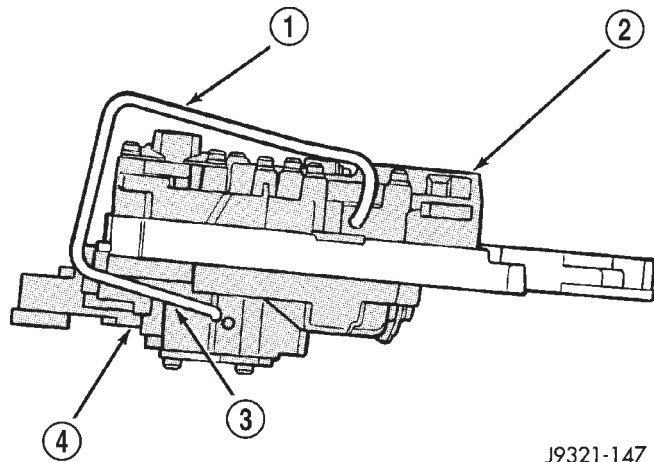
(4) Insert and seat each end of tube in housings.

(5) Slide tube brace under tube and into alignment with valve body screw holes (Fig. 311).

(6) Install and finger tighten three screws that secure tube brace to valve body housings (Fig. 311).

(7) Bend tube brace tabs up and against tube to hold it in position (Fig. 312).

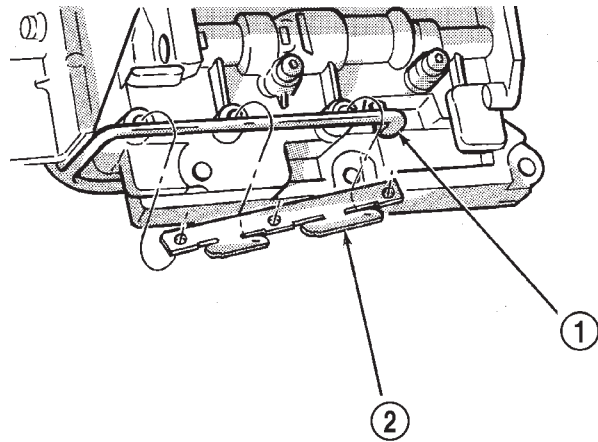
(8) Tighten all valve body housing screws to 4 N·m (35 in. lbs.) torque after tube and brace are installed. Tighten screws in diagonal pattern starting at center and working outward.



J9321-147

**Fig. 310 Boost Valve Tube**

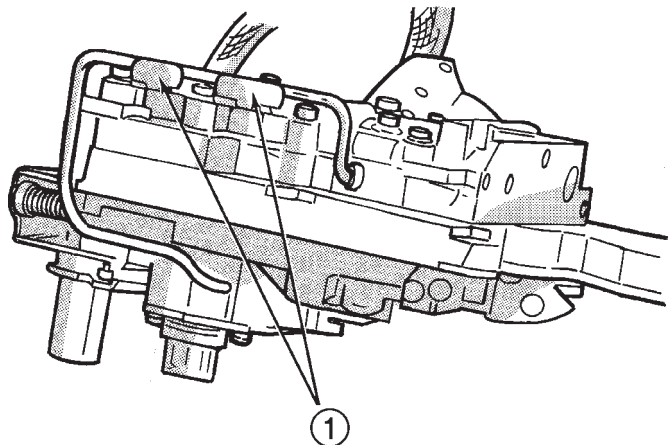
- 1 - BOOST VALVE TUBE
- 2 - LOWER HOUSING
- 3 - DISENGAGE THIS END OF TUBE FIRST
- 4 - UPPER HOUSING



J9521-107

**Fig. 311 Boost Valve Tube And Brace**

- 1 - BOOST VALVE TUBE
- 2 - TUBE BRACE



J9521-108

**Fig. 312 Securing Boost Valve Tube With Brace Tabs**

- 1 - BEND TABS UP AGAINST TUBE AS SHOWN

## VALVE BODY (Continued)

**3-4 ACCUMULATOR**

(1) Position converter clutch valve and 3-4 shift valve springs in housing (Fig. 313).

(2) Loosely attach accumulator housing with right-side screw (Fig. 313). Install only one screw at this time as accumulator must be free to pivot upward for ease of installation.

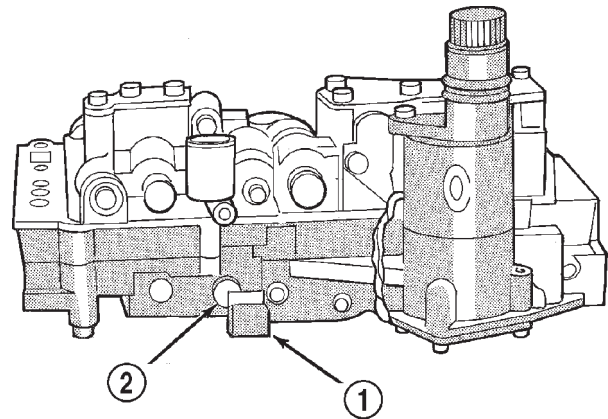
(3) Install 3-4 shift valve and spring.

(4) Install converter clutch timing valve and spring.

(5) Position plug on end of converter clutch valve spring. Then compress and hold springs and plug in place with fingers of one hand.

(6) Swing accumulator housing upward over valve springs and plug.

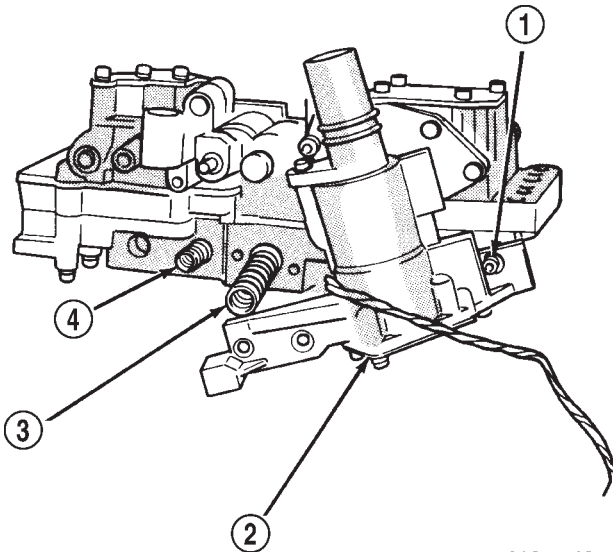
(7) Hold accumulator housing firmly in place and install remaining two attaching screws. Be sure springs and clutch valve plug are properly seated (Fig. 314). Tighten screws to 4 N·m (35 in. lbs.).



J9521-180

**Fig. 314 Seating 3-4 Accumulator On Lower Housing**

- 1 - ACCUMULATOR BOX  
2 - CONVERTER CLUTCH VALVE PLUG



J9321-160

**Fig. 313 Converter Clutch And 3-4 Shift Valve Springs**

- 1 - RIGHT-SIDE SCREW  
2 - 3-4 ACCUMULATOR  
3 - 3-4 SHIFT VALVE SPRING  
4 - CONVERTER CLUTCH VALVE SPRING

**VALVE BODY FINAL**

(1) Install boost valve, valve spring, retainer and cover plate. Tighten cover plate screws to 4 N·m (35 in. lbs.) torque.

(2) Insert manual lever detent spring in upper housing.

(3) Position detent ball on end of spring. Then hold detent ball and spring in detent housing with Retainer Tool 6583 (Fig. 315).

(4) Install throttle lever in upper housing. Then install manual lever over throttle lever and start manual lever into housing.

(5) Align manual lever with detent ball and manual valve. Hold throttle lever upward. Then press down on manual lever until fully seated. Remove detent ball retainer tool after lever is seated.

(6) Then install manual lever seal, washer and E-clip.

(7) Verify that throttle lever is aligned with end of kickdown valve stem and that manual lever arm is engaged in manual valve (Fig. 316).

(8) Position line pressure adjusting screw in adjusting screw bracket.

(9) Install spring on end of line pressure regulator valve.

(10) Install switch valve spring on tang at end of adjusting screw bracket.

(11) Install manual valve.

(12) Install throttle valve and spring.

(13) Install kickdown valve and detent.

(14) Install pressure regulator valve.

(15) Install switch valve.

(16) Position adjusting screw bracket on valve body. Align valve springs and press bracket into place. Install short, upper bracket screws first and long bottom screw last. Verify that valve springs and bracket are properly aligned. Then tighten all three bracket screws to 4 N·m (35 in. lbs.) torque.

(17) Perform Line Pressure and Throttle Pressure adjustments. (Refer to 21 - TRANSMISSION/TRAN-SAXLE/AUTOMATIC/VALVE BODY - ADJUSTMENTS)

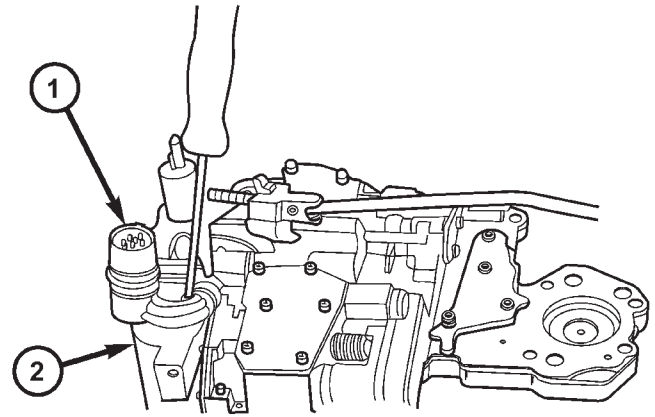
(18) Lubricate solenoid case connector O-rings and shaft of manual lever with light coat of petroleum jelly.

VALVE BODY (Continued)

(19) Attach solenoid case connector to 3-4 accumulator with shoulder-type screw. Connector has small locating tang that fits in dimple at top of accumulator housing (Fig. 317). Seat tang in dimple before tightening connector screw.

(20) Install solenoid assembly and gasket. Tighten solenoid attaching screws to 8 N·m (72 in. lbs.) torque.

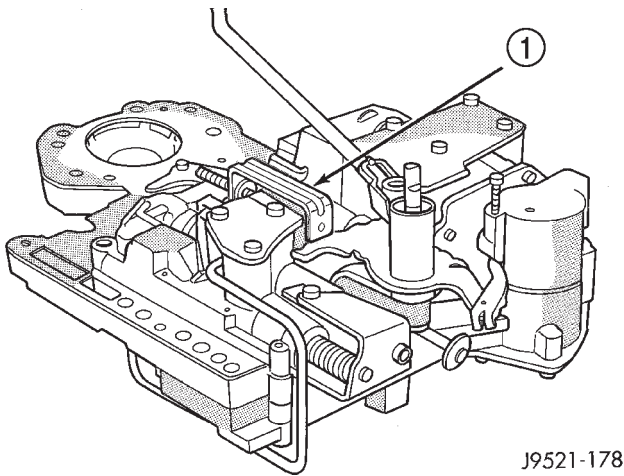
(21) Verify that solenoid wire harness is properly routed (Fig. 318). Solenoid harness must be clear of manual lever and park rod and not be pinched between accumulator housing and cover.



808803a3

**Fig. 317 Solenoid Harness Case Connector Shoulder Bolt**

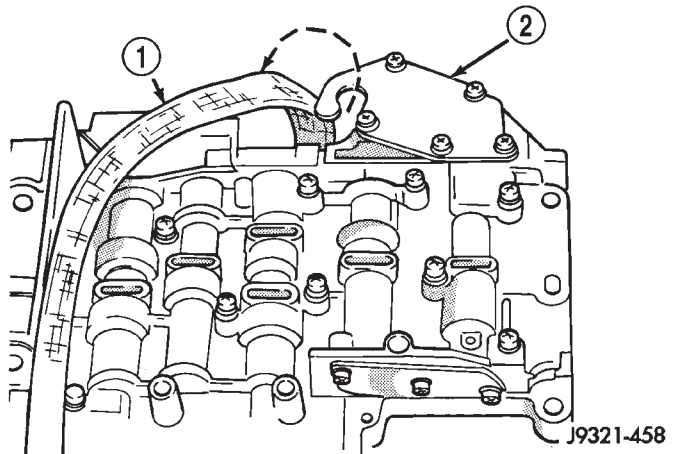
- 1 - SOLENOID HARNESS CASE CONNECTOR
- 2 - 3-4 ACCUMULATOR HOUSING



J9521-178

**Fig. 315 Detent Ball Spring**

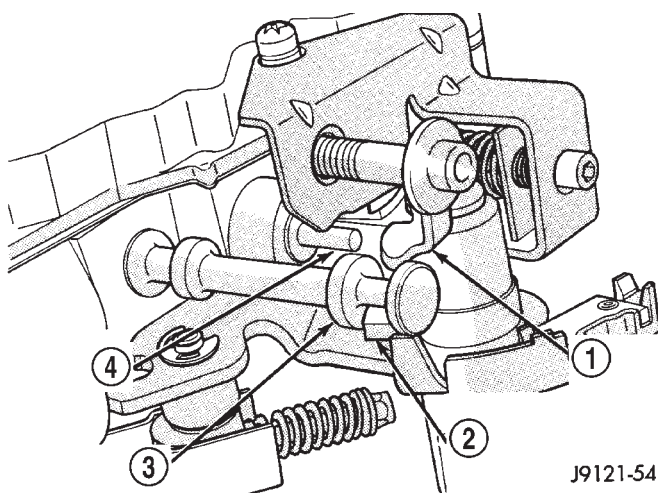
- 1 - SPECIAL TOOL 6583 POSITIONED ON DETENT HOUSING



J9321-458

**Fig. 318 Solenoid Harness Routing**

- 1 - OVERDRIVE/CONVERTER SOLENOID WIRE HARNESS
- 2 - 3-4 ACCUMULATOR COVER PLATE



J9121-54

**Fig. 316 Manual And Throttle Lever Alignment**

- 1 - THROTTLE LEVER
- 2 - MANUAL LEVER VALVE ARM
- 3 - MANUAL VALVE
- 4 - KICKDOWN VALVE

**GOVERNOR BODY, SENSOR AND SOLENOID**

(1) Turn valve body assembly over so accumulator side of transfer plate is facing down.

(2) Install new O-rings on governor pressure solenoid and sensor.

(3) Lubricate solenoid and sensor O-rings with clean transmission fluid.

(4) Install governor pressure sensor in governor body.

(5) Install governor pressure solenoid in governor body. Push solenoid in until it snaps into place in body.

(6) Position governor body gasket on transfer plate.



## VALVE BODY (Continued)

(7) Install retainer plate on governor body and around solenoid. Be sure solenoid connector is positioned in retainer cutout.

(8) Align screw holes in governor body and transfer plate. Then install and tighten governor body screws to 4 N·m (35 in. lbs.) torque.

(9) Connect harness wires to governor pressure solenoid and governor pressure sensor.

(10) Install fluid filter and pan.

(11) Lower vehicle.

(12) Fill transmission with recommended fluid and road test vehicle to verify repair.

## INSTALLATION

(1) Check condition of O-ring seals on valve body harness connector (Fig. 319). Replace seals on connector body if cut or worn.

(2) Check condition of manual lever shaft seal in transmission case. Replace seal if lip is cut or worn. Install new seal with 15/16 deep well socket (Fig. 320).

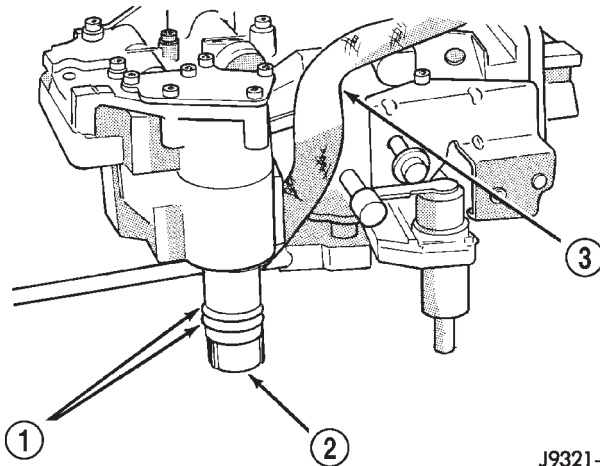
(3) Check condition of seals on accumulator piston (Fig. 321). Install new piston seals, if necessary.

(4) Place valve body manual lever in low (1 position) so ball on park lock rod will be easier to install in sprag.

(5) Lubricate shaft of manual lever with petroleum jelly. This will ease inserting shaft through seal in case.

(6) Lubricate seal rings on valve body harness connector with petroleum jelly.

(7) Position valve body in case and work end of park lock rod into and through pawl sprag. Turn propeller shaft to align sprag and park lock teeth if necessary. The rod will click as it enters pawl. Move rod to check engagement.



J9321-389

**Fig. 319 Valve Body Harness Connector O-Ring Seal**

- 1 - CONNECTOR O-RINGS
- 2 - VALVE BODY HARNESS CONNECTOR
- 3 - HARNESS

**CAUTION:** It is possible for the park rod to displace into a cavity just above the pawl sprag during installation. Make sure the rod is actually engaged in the pawl and has not displaced into this cavity.

(8) Install accumulator springs and piston into case. Then swing valve body over piston and outer spring to hold it in place.

(9) Align accumulator piston and outer spring, manual lever shaft and electrical connector in case.

(10) Then seat valve body in case and install one or two bolts to hold valve body in place.

(11) Tighten valve body bolts alternately and evenly to 11 N·m (100 in. lbs.) torque.

(12) Install new fluid filter on valve body. Tighten filter screws to 4 N·m (35 in. lbs.) torque.

(13) Install throttle and gearshift levers on valve body manual lever shaft.

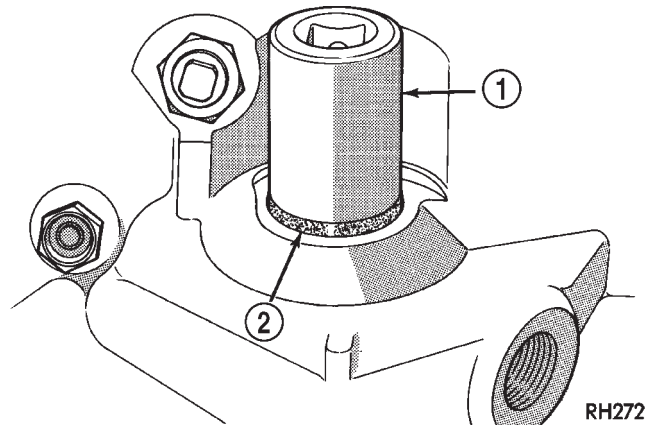
(14) Check and adjust front and rear bands if necessary.

(15) Connect solenoid case connector wires.

(16) Install oil pan and new gasket. Tighten pan bolts to 17 N·m (13 ft. lbs.) torque.

(17) Lower vehicle and fill transmission with Mopar® ATF +4, type 9602, fluid.

(18) Check and adjust gearshift and throttle valve cables, if necessary.

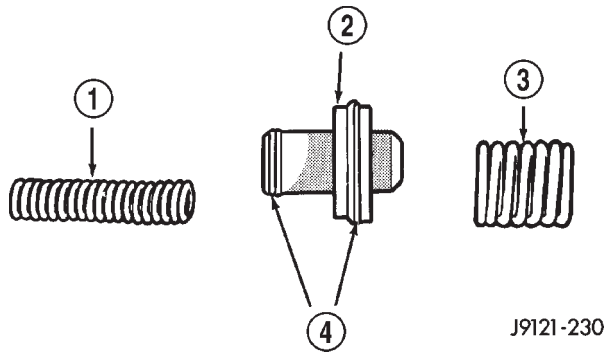


**Fig. 320 Manual Lever Shaft Seal**

- 1 - 15/16" SOCKET
- 2 - SEAL



## VALVE BODY (Continued)

**Fig. 321 Accumulator Piston Components**

- 1 - INNER SPRING
- 2 - ACCUMULATOR PISTON
- 3 - OUTER SPRING
- 4 - SEAL RINGS

## ADJUSTMENTS - VALVE BODY

## CONTROL PRESSURE ADJUSTMENTS

There are two control pressure adjustments on the valve body;

- Line Pressure
- Throttle Pressure

Line and throttle pressures are interdependent because each affects shift quality and timing. As a result, both adjustments must be performed properly and in the correct sequence. Adjust line pressure first and throttle pressure last.

## LINE PRESSURE ADJUSTMENT

Measure distance from the valve body to the inner edge of the adjusting screw with an accurate steel scale (Fig. 322).

Distance should be 33.4 mm (1-5/16 in.).

If adjustment is required, turn the adjusting screw in, or out, to obtain required distance setting.

**NOTE:** The 33.4 mm (1-5/16 in.) setting is an approximate setting. Manufacturing tolerances may make it necessary to vary from this dimension to obtain desired pressure.

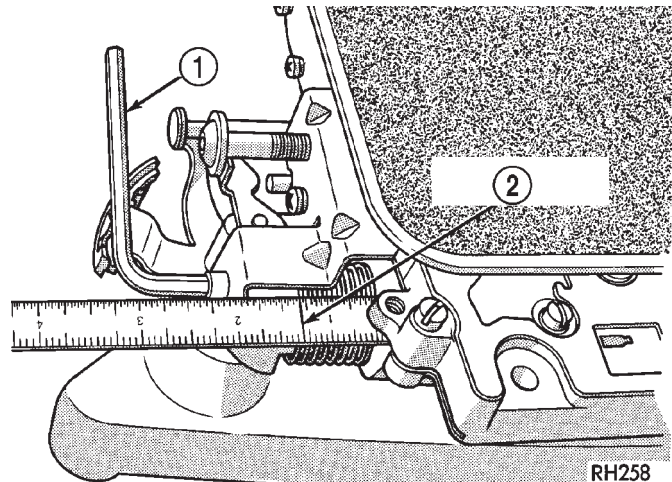
One complete turn of the adjusting screw changes line pressure approximately 1-2/3 psi (9 kPa).

Turning the adjusting screw counterclockwise increases pressure while turning the screw clockwise decreases pressure.

## THROTTLE PRESSURE ADJUSTMENT

Insert Gauge Tool C-3763 between the throttle lever cam and the kickdown valve stem (Fig. 323).

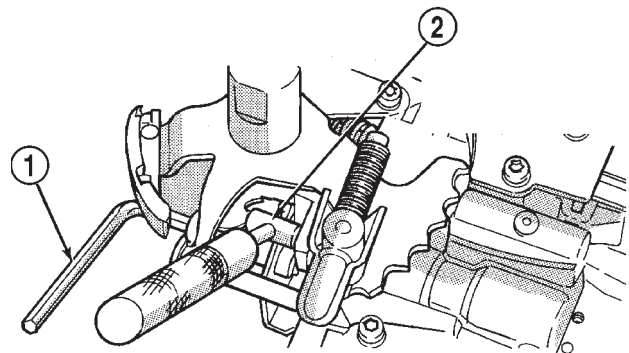
Push the gauge tool inward to compress the kickdown valve against the spring and bottom the throttle valve.

**Fig. 322 Line Pressure Adjustment**

- 1 - WRENCH
- 2 - 1-5/16 INCH

Maintain pressure against kickdown valve spring. Turn throttle lever stop screw until the screw head touches throttle lever tang and the throttle lever cam touches gauge tool.

**NOTE:** The kickdown valve spring must be fully compressed and the kickdown valve completely bottomed to obtain correct adjustment.



J9521-109

**Fig. 323 Throttle Pressure Adjustment**

- 1 - HEX WRENCH (IN THROTTLE LEVER ADJUSTING SCREW)
- 2 - SPECIAL TOOL C-3763 (POSITIONED BETWEEN THROTTLE LEVER AND KICKDOWN VALVE)

## AUTOMATIC TRANSMISSION - 44RE

## TABLE OF CONTENTS

	page		page
<b>AUTOMATIC TRANSMISSION - 44RE</b>		<b>FLUID AND FILTER REPLACEMENT</b> . . . . .	372
DESCRIPTION . . . . .	306	TRANSMISSION FILL . . . . .	372
OPERATION . . . . .	308	<b>FRONT CLUTCH</b>	
DIAGNOSIS AND TESTING . . . . .	314	DESCRIPTION . . . . .	373
AUTOMATIC TRANSMISSION . . . . .	314	OPERATION . . . . .	373
PRELIMINARY . . . . .	314	DISASSEMBLY . . . . .	373
ROAD TESTING . . . . .	314	INSPECTION . . . . .	376
HYDRAULIC PRESSURE TEST . . . . .	315	ASSEMBLY . . . . .	376
AIR CHECKING TRANSMISSION CLUTCH AND BAND OPERATION . . . . .	318	<b>FRONT SERVO</b>	
CONVERTER HOUSING FLUID LEAK DIAGNOSIS CHARTS . . . . .	319	DESCRIPTION . . . . .	377
STANDARD PROCEDURE . . . . .	320	OPERATION . . . . .	377
ALUMINUM THREAD REPAIR . . . . .	320	DISASSEMBLY . . . . .	378
REMOVAL . . . . .	330	CLEANING . . . . .	378
DISASSEMBLY . . . . .	330	INSPECTION . . . . .	378
CLEANING . . . . .	331	ASSEMBLY . . . . .	379
INSPECTION . . . . .	336	<b>OIL PUMP</b>	
ASSEMBLY . . . . .	337	DESCRIPTION . . . . .	379
INSTALLATION . . . . .	337	OPERATION . . . . .	379
SCHEMATICS AND DIAGRAMS . . . . .	344	STANDARD PROCEDURE . . . . .	379
SPECIFICATIONS . . . . .	345	OIL PUMP VOLUME CHECK . . . . .	379
SPECIAL TOOLS . . . . .	345	DISASSEMBLY . . . . .	380
<b>ACCUMULATOR</b>		CLEANING . . . . .	381
DESCRIPTION . . . . .	362	INSPECTION . . . . .	382
OPERATION . . . . .	362	ASSEMBLY . . . . .	382
INSPECTION . . . . .	363	<b>OUTPUT SHAFT FRONT BEARING</b>	
<b>BANDS</b>		REMOVAL . . . . .	384
DESCRIPTION . . . . .	363	INSTALLATION . . . . .	384
OPERATION . . . . .	364	<b>OUTPUT SHAFT REAR BEARING</b>	
ADJUSTMENTS . . . . .	364	REMOVAL . . . . .	384
<b>ELECTRONIC GOVERNOR</b>		INSTALLATION . . . . .	384
DESCRIPTION . . . . .	365	<b>OVERDRIVE CLUTCH</b>	
OPERATION . . . . .	365	DESCRIPTION . . . . .	385
REMOVAL . . . . .	367	OPERATION . . . . .	385
INSTALLATION . . . . .	367	<b>OVERDRIVE SWITCH</b>	
<b>EXTENSION HOUSING BUSHING</b>		DESCRIPTION . . . . .	385
REMOVAL . . . . .	369	OPERATION . . . . .	385
INSTALLATION . . . . .	369	DIAGNOSIS AND TESTING . . . . .	386
<b>EXTENSION HOUSING SEAL</b>		OVERDRIVE ELECTRICAL CONTROLS . . . . .	386
REMOVAL . . . . .	369	REMOVAL . . . . .	386
INSTALLATION . . . . .	369	INSTALLATION . . . . .	386
<b>FLUID AND FILTER</b>		<b>OVERDRIVE UNIT</b>	
DIAGNOSIS AND TESTING . . . . .	370	REMOVAL . . . . .	387
EFFECTS OF INCORRECT FLUID LEVEL . . . . .	370	DISASSEMBLY . . . . .	387
CAUSES OF BURNT FLUID . . . . .	370	CLEANING . . . . .	394
FLUID CONTAMINATION . . . . .	370	INSPECTION . . . . .	394
STANDARD PROCEDURE . . . . .	370	ASSEMBLY . . . . .	395
FLUID LEVEL CHECK . . . . .	370	INSTALLATION . . . . .	404

<b>OVERRUNNING CLUTCH CAM/OVERDRIVE</b>	
<b>PISTON RETAINER</b>	
DESCRIPTION . . . . .	405
OPERATION . . . . .	405
DISASSEMBLY . . . . .	405
CLEANING . . . . .	406
INSPECTION . . . . .	406
ASSEMBLY . . . . .	406
<b>PARK/NEUTRAL POSITION SWITCH</b>	
DIAGNOSIS AND TESTING . . . . .	408
PARK/NEUTRAL POSITION SWITCH . . . . .	408
REMOVAL . . . . .	408
INSTALLATION . . . . .	408
<b>PISTONS</b>	
DESCRIPTION . . . . .	408
OPERATION . . . . .	409
<b>PLANETARY GEARTRAIN/OUTPUT SHAFT</b>	
DESCRIPTION . . . . .	410
OPERATION . . . . .	410
DISASSEMBLY . . . . .	411
INSPECTION . . . . .	411
ASSEMBLY . . . . .	412
<b>REAR CLUTCH</b>	
DESCRIPTION . . . . .	417
OPERATION . . . . .	417
DISASSEMBLY . . . . .	418
CLEANING . . . . .	418
INSPECTION . . . . .	419
ASSEMBLY . . . . .	419
<b>REAR SERVO</b>	
DESCRIPTION . . . . .	421
OPERATION . . . . .	421
DISASSEMBLY . . . . .	421
CLEANING . . . . .	422
ASSEMBLY . . . . .	422
<b>SHIFT MECHANISM</b>	
DESCRIPTION . . . . .	422

## AUTOMATIC TRANSMISSION - 44RE

### DESCRIPTION

The 44RE is a four speed fully automatic transmission (Fig. 1) with an electronic governor. The 44RE is equipped with a lock-up clutch in the torque converter. First through third gear ranges are provided by the clutches, bands, overrunning clutch, and planetary gear sets in the transmission. Fourth gear range is provided by the overdrive unit that contains an overdrive clutch, direct clutch, planetary gear set, and overrunning clutch.

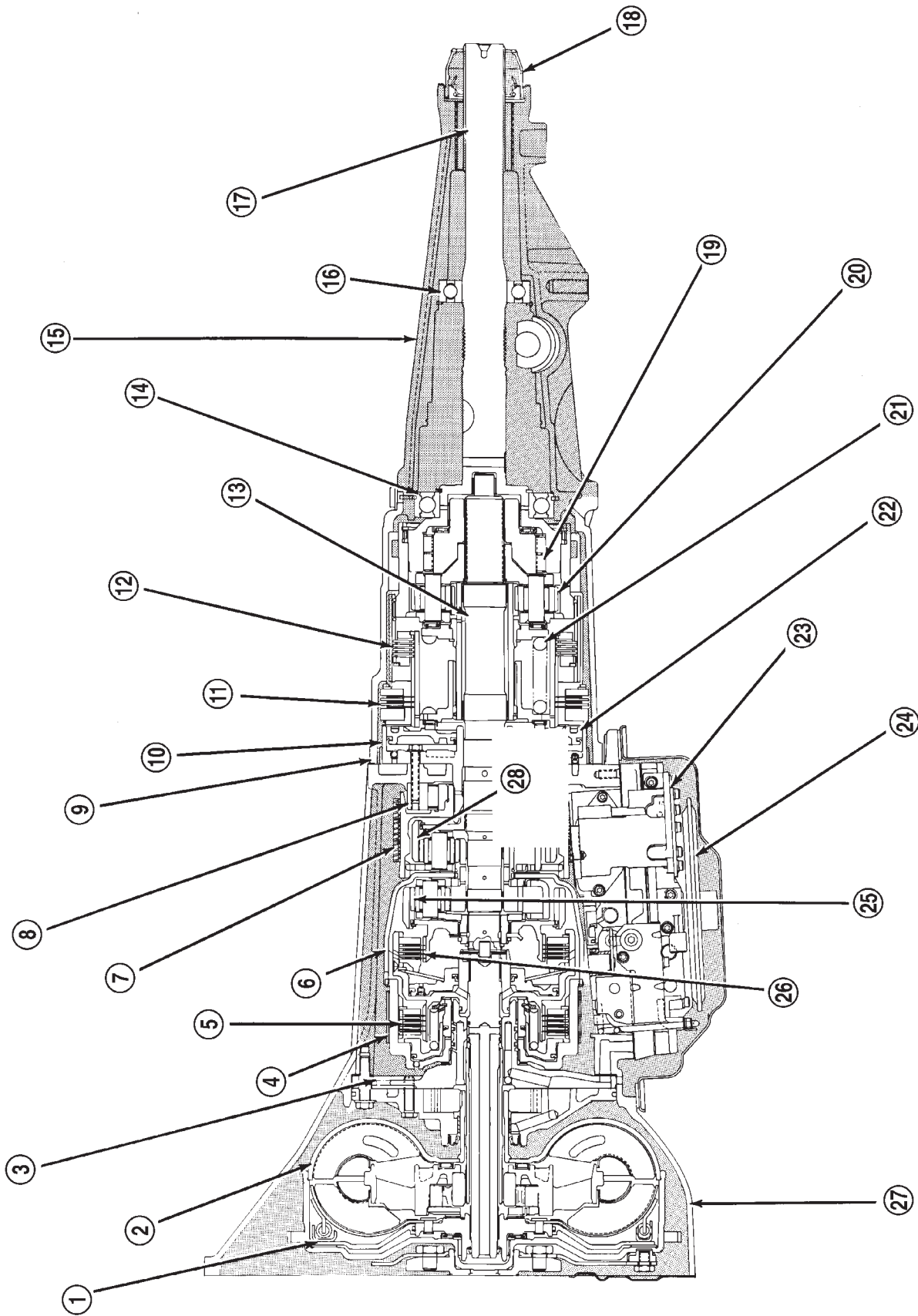
The transmission contains a front, rear, and direct clutch which function as the input driving components. It also contains the kickdown (front) and the

OPERATION . . . . .	422
ADJUSTMENTS . . . . .	423
<b>SOLENOID</b>	
DESCRIPTION . . . . .	423
OPERATION . . . . .	424
<b>SPEED SENSOR</b>	
DESCRIPTION . . . . .	424
OPERATION . . . . .	424
<b>THROTTLE VALVE CABLE</b>	
DESCRIPTION . . . . .	424
ADJUSTMENTS . . . . .	425
<b>TORQUE CONVERTER</b>	
DESCRIPTION . . . . .	427
OPERATION . . . . .	430
REMOVAL . . . . .	432
INSTALLATION . . . . .	432
<b>TORQUE CONVERTER DRAINBACK VALVE</b>	
DESCRIPTION . . . . .	432
OPERATION . . . . .	432
STANDARD PROCEDURE . . . . .	432
TORQUE CONVERTER DRAINBACK VALVE . . . . .	432
<b>TRANSMISSION TEMPERATURE SENSOR</b>	
DESCRIPTION . . . . .	433
OPERATION . . . . .	433
<b>VALVE BODY</b>	
DESCRIPTION . . . . .	433
OPERATION . . . . .	438
REMOVAL . . . . .	452
DISASSEMBLY . . . . .	453
CLEANING . . . . .	465
INSPECTION . . . . .	465
ASSEMBLY . . . . .	466
INSTALLATION . . . . .	475
ADJUSTMENTS . . . . .	476

low/reverse (rear) bands which, along with the overrunning clutch and overdrive clutch, serve as the holding components. The driving and holding components combine to select the necessary planetary gear components, in the front, rear, or overdrive planetary gear set, transfer the engine power from the input shaft through to the output shaft.

The valve body is mounted to the lower side of the transmission and contains the valves to control pressure regulation, fluid flow control, and clutch/band application. The oil pump is mounted at the front of the transmission and is driven by the torque converter hub. The pump supplies the oil pressure necessary for clutch/band actuation and transmission lubrication.

AUTOMATIC TRANSMISSION - 44RE (Continued)



J9321-407

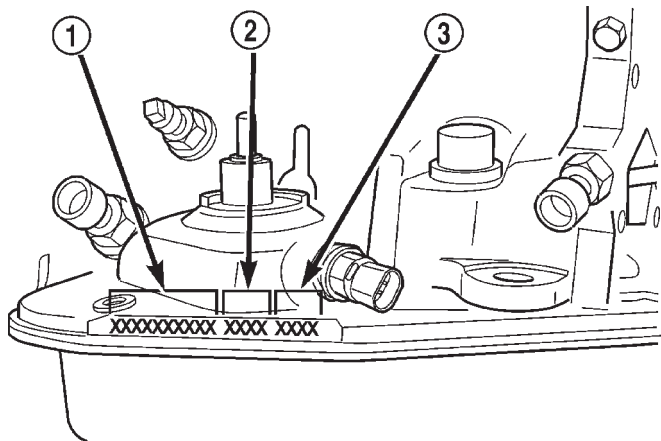
Fig. 1 44RE Transmission

AUTOMATIC TRANSMISSION - 44RE (Continued)

- 1 - CONVERTER CLUTCH
- 2 - TORQUE CONVERTER
- 3 - OIL PUMP AND REACTION SHAFT SUPPORT ASSEMBLY
- 4 - FRONT BAND
- 5 - FRONT CLUTCH
- 6 - DRIVING SHELL
- 7 - REAR BAND
- 8 - TRANSMISSION OVERRUNNING CLUTCH
- 9 - OVERDRIVE UNIT
- 10 - PISTON RETAINER
- 11 - OVERDRIVE CLUTCH
- 12 - DIRECT CLUTCH
- 13 - INTERMEDIATE SHAFT
- 14 - FRONT BEARING
- 15 - HOUSING
- 16 - REAR BEARING
- 17 - OUTPUT SHAFT
- 18 - SEAL
- 19 - OVERDRIVE OVERRUNNING CLUTCH
- 20 - OVERDRIVE PLANETARY GEAR
- 21 - DIRECT CLUTCH SPRING
- 22 - OVERDRIVE CLUTCH PISTON
- 23 - VALVE BODY ASSEMBLY
- 24 - FILTER
- 25 - FRONT PLANETARY GEAR
- 26 - REAR CLUTCH
- 27 - TRANSMISSION
- 28 - REAR PLANETARY GEAR

**IDENTIFICATION**

Transmission identification numbers are stamped on the left side of the case just above the oil pan gasket surface (Fig. 2). Refer to this information when ordering replacement parts.



80b11960

**Fig. 2 Transmission Part And Serial Number Location**

- 1 - PART NUMBER
- 2 - BUILD DATE
- 3 - SERIAL NUMBER

**GEAR RATIOS** The 44RE gear ratios are:

<b>1st</b> .....	2.74:1
<b>2nd</b> .....	1.54:1
<b>3rd</b> .....	1.00:1
<b>4th</b> .....	0.69:1
<b>Rev.</b> .....	2.21:1

**OPERATION**

The application of each driving or holding component is controlled by the valve body based upon the manual lever position, throttle pressure, and governor pressure. The governor pressure is a variable pressure input to the valve body and is one of the signals that a shift is necessary. First through fourth gear are obtained by selectively applying and releasing the different clutches and bands. Engine power is thereby routed to the various planetary gear assemblies which combine with the overrunning clutch assemblies to generate the different gear ratios. The torque converter clutch is hydraulically applied and is released when fluid is vented from the hydraulic circuit by the torque converter control (TCC) solenoid on the valve body. The torque converter clutch is controlled by the Powertrain Control Module (PCM). The torque converter clutch engages in fourth gear, and in third gear under various conditions, such as when the O/D switch is OFF, when the vehicle is cruising on a level surface after the vehicle has warmed up. The torque converter clutch will disengage momentarily when an increase in engine load is sensed by the PCM, such as when the vehicle begins to go uphill or the throttle pressure is increased. The torque converter clutch feature increases fuel economy and reduces the transmission fluid temperature.

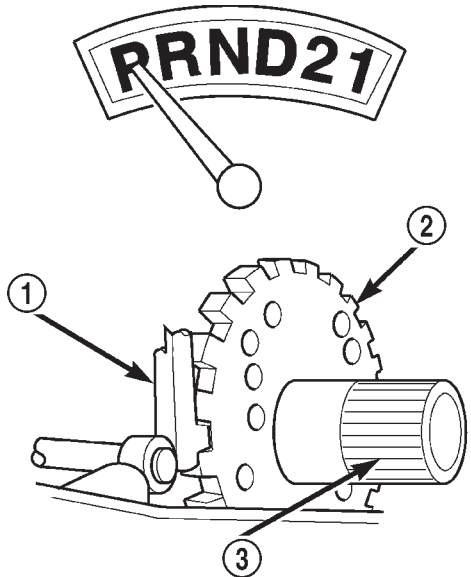
Since the overdrive clutch is applied in fourth gear only and the direct clutch is applied in all ranges except fourth gear, the transmission operation for park, neutral, and first through third gear will be described first. Once these powerflows are described, the third to fourth shift sequence will be described.



AUTOMATIC TRANSMISSION - 44RE (Continued)

**PARK POWERFLOW**

As the engine is running and the crankshaft is rotating, the flexplate and torque converter, which are also bolted to it, are all rotating in a clockwise direction as viewed from the front of the engine. The notched hub of the torque converter is connected to the oil pump's internal gear, supplying the transmission with oil pressure. As the converter turns, it turns the input shaft in a clockwise direction. As the input shaft is rotating, the front clutch hub-rear clutch retainer and all their associated parts are also rotating, all being directly connected to the input shaft. The power flow from the engine through the front clutch hub and rear clutch retainer stops at the rear clutch retainer. Therefore, no power flow to the output shaft occurs because no clutches are applied. The only mechanism in use at this time is the parking sprag (Fig. 3), which locks the parking gear on the output shaft to the transmission case.



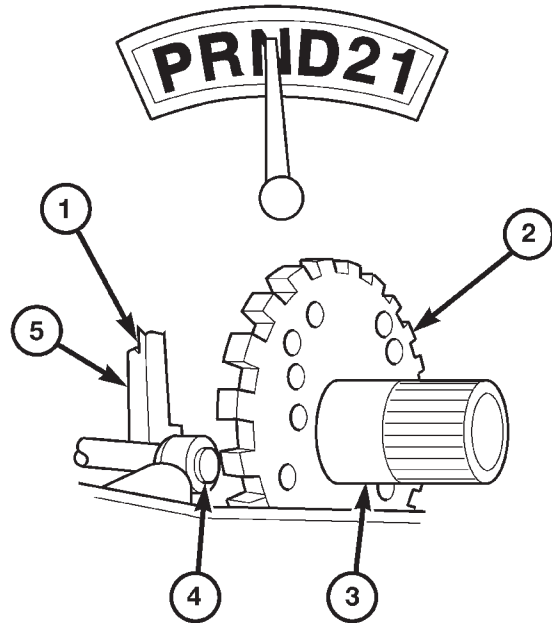
80c070a6

**Fig. 3 Park Powerflow**

- 1 - PAWL ENGAGED FOR PARK
- 2 - PARK SPRAG
- 3 - OUTPUT SHAFT

**NEUTRAL POWERFLOW**

With the gear selector in the NEUTRAL position (Fig. 4), the power flow of the transmission is essentially the same as in the park position. The only operational difference is that the parking sprag has been disengaged, unlocking the output shaft from the transmission case and allowing it to move freely.



80a06c8f

**Fig. 4 Neutral Powerflow**

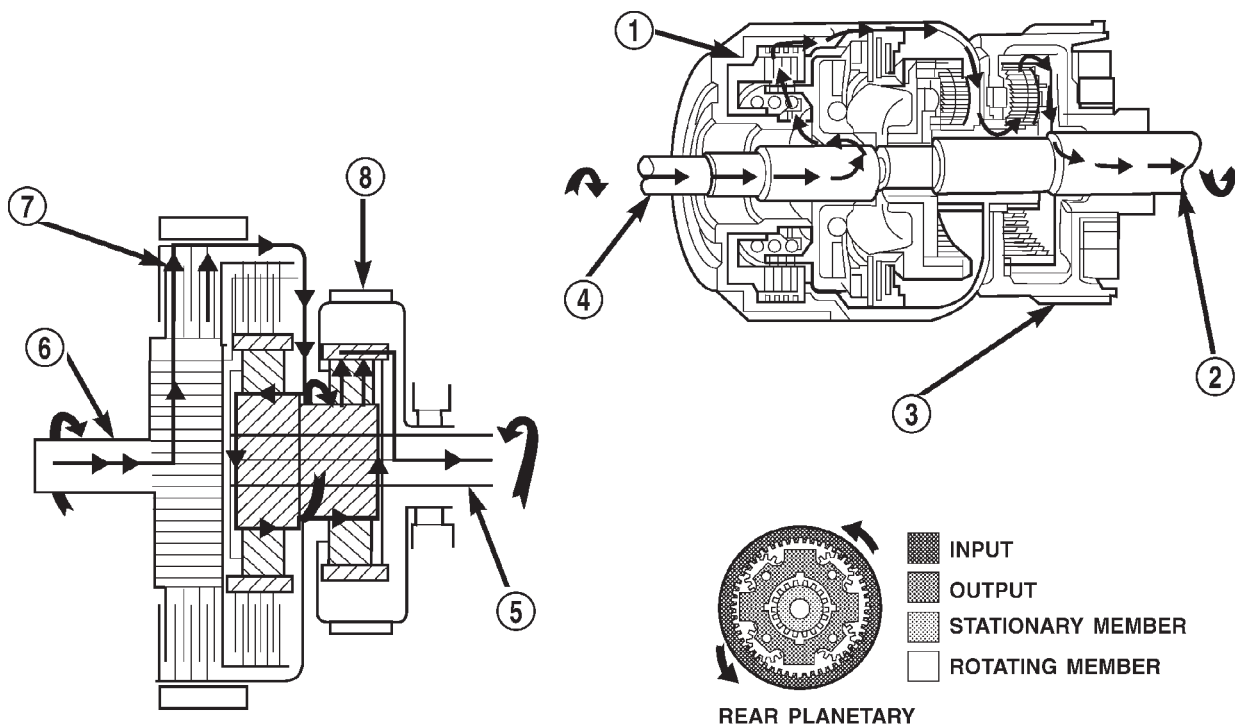
- 1 - PAWL DISENGAGED FOR NEUTRAL
- 2 - PARK SPRAG
- 3 - OUTPUT SHAFT
- 4 - CAM
- 5 - PAWL

AUTOMATIC TRANSMISSION - 44RE (Continued)

**REVERSE POWERFLOW**

When the gear selector is moved into the REVERSE position (Fig. 5), the front clutch and the rear band are applied. With the application of the front clutch, engine torque is applied to the sun gear, turning it in a clockwise direction. The clockwise rotation of the sun gear causes the rear planet pinions to rotate against engine rotation in a counterclockwise direction. The rear band is holding the low reverse drum, which is splined to the rear carrier. Since the rear carrier is being held, the torque from

the planet pinions is transferred to the rear annulus gear, which is splined to the output shaft. The output shaft in turn rotates with the annulus gear in a counterclockwise direction giving a reverse gear output. The entire transmission of torque is applied to the rear planetary gearset only. Although there is torque input to the front gearset through the sun gear, no other member of the gearset is being held. During the entire reverse stage of operation, the front planetary gears are in an idling condition.



**Fig. 5 Reverse Powerflow**

- 1 - FRONT CLUTCH ENGAGED
- 2 - OUTPUT SHAFT
- 3 - LOW/REVERSE BAND APPLIED
- 4 - INPUT SHAFT

- 5 - OUTPUT SHAFT
- 6 - INPUT SHAFT
- 7 - FRONT CLUTCH ENGAGED
- 8 - LOW/REVERSE BAND APPLIED

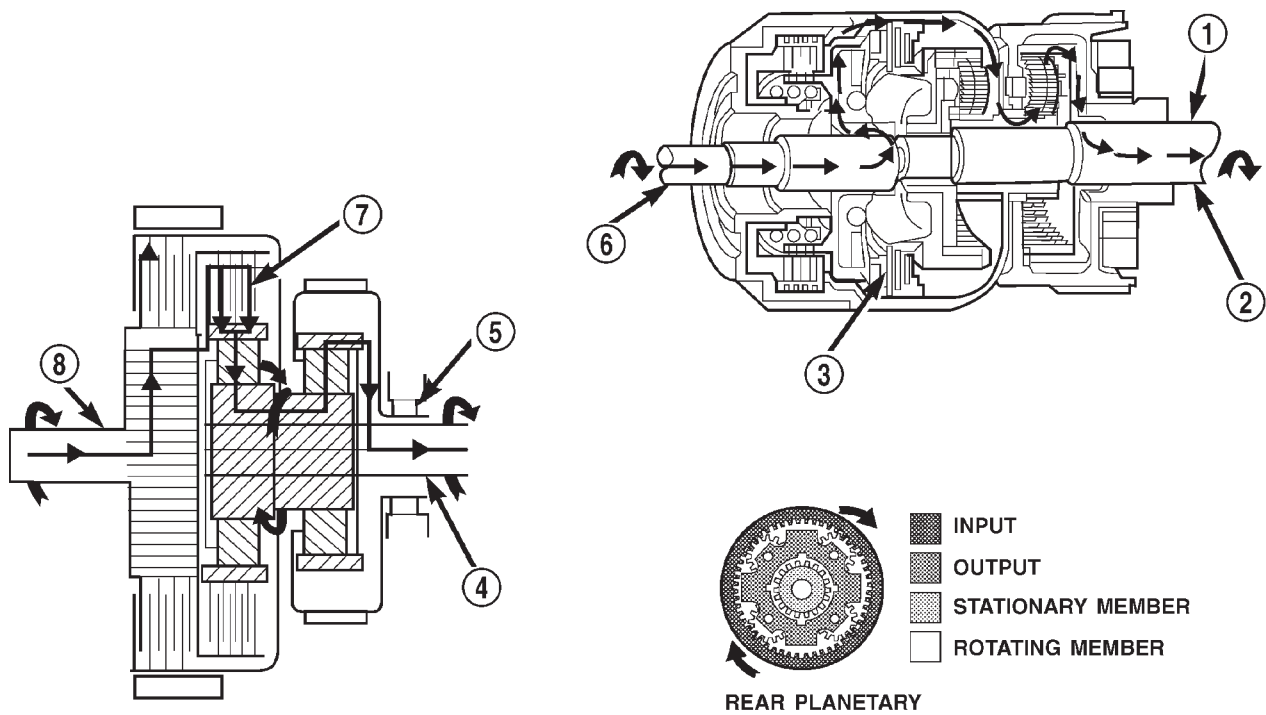
80c070a8

AUTOMATIC TRANSMISSION - 44RE (Continued)

**FIRST GEAR POWERFLOW**

When the gearshift lever is moved into the DRIVE position the transmission goes into first gear (Fig. 6). As soon as the transmission is shifted from PARK or NEUTRAL to DRIVE, the rear clutch applies, applying the rear clutch pack to the front annulus gear. Engine torque is now applied to the front annulus gear turning it in a clockwise direction. With the front annulus gear turning in a clockwise direction, it causes the front planets to turn in a clockwise direction. The rotation of the front planets cause the sun to revolve in a counterclockwise direction. The sun gear now transfers its counterclockwise rotation to

the rear planets which rotate back in a clockwise direction. With the rear annulus gear stationary, the rear planet rotation on the annulus gear causes the rear planet carrier to revolve in a counterclockwise direction. The rear planet carrier is splined into the low-reverse drum, and the low reverse drum is splined to the inner race of the over-running clutch. With the over-running clutch locked, the planet carrier is held, and the resulting torque provided by the planet pinions is transferred to the rear annulus gear. The rear annulus gear is splined to the output shaft and rotated along with it (clockwise) in an underdrive gear reduction mode.



**Fig. 6 First Gear Powerflow**

- 1 - OUTPUT SHAFT
- 2 - OVER-RUNNING CLUTCH HOLDING
- 3 - REAR CLUTCH APPLIED
- 4 - OUTPUT SHAFT

- 5 - OVER-RUNNING CLUTCH HOLDING
- 6 - INPUT SHAFT
- 7 - REAR CLUTCH APPLIED
- 8 - INPUT SHAFT

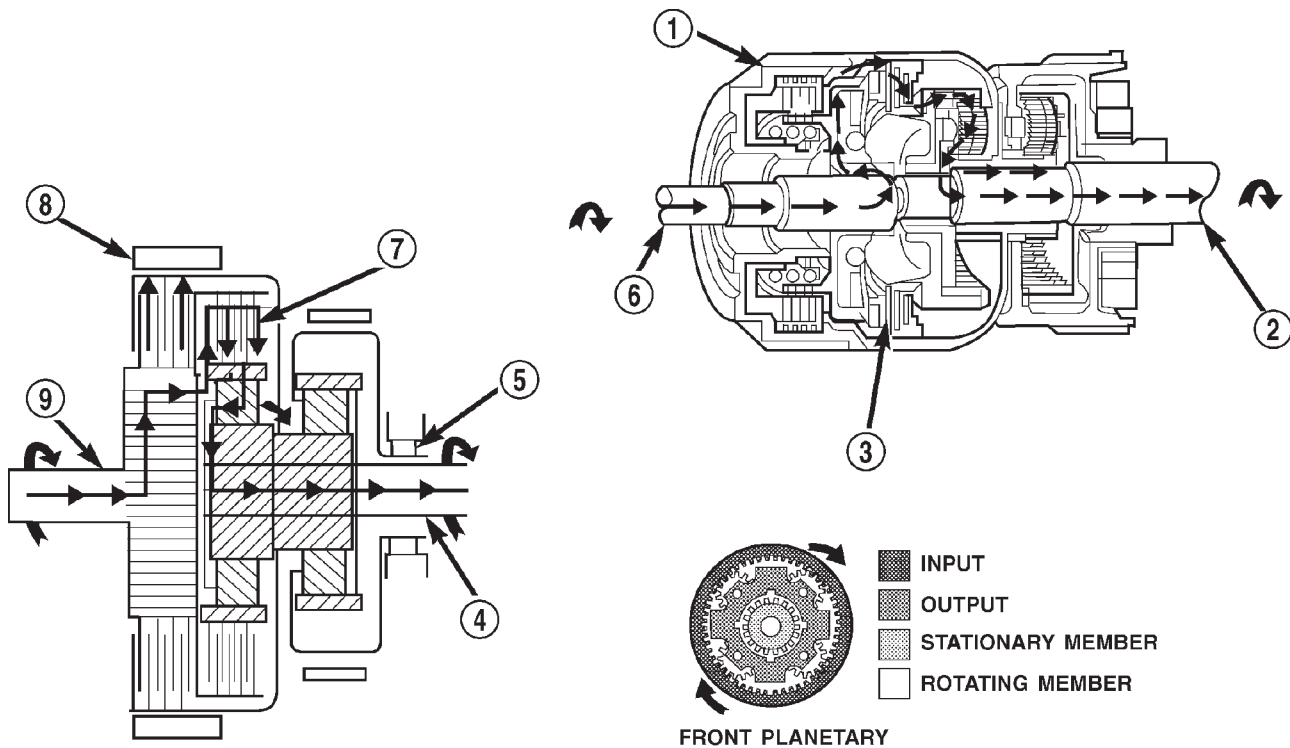
80c070a9

AUTOMATIC TRANSMISSION - 44RE (Continued)

**SECOND GEAR POWERFLOW**

In DRIVE-SECOND (Fig. 7), the same elements are applied as in MANUAL-SECOND. Therefore, the power flow will be the same, and both gears will be discussed as one in the same. In DRIVE-SECOND, the transmission has proceeded from first gear to its shift point, and is shifting from first gear to second. The second gear shift is obtained by keeping the rear clutch applied and applying the front (kickdown) band. The front band holds the front clutch retainer that is locked to the sun gear driving shell. With the rear clutch still applied, the input is still on the front annulus gear turning it clockwise at engine speed.

Now that the front band is holding the sun gear stationary, the annulus rotation causes the front planets to rotate in a clockwise direction. The front carrier is then also made to rotate in a clockwise direction but at a reduced speed. This will transmit the torque to the output shaft, which is directly connected to the front planet carrier. The rear planetary annulus gear will also be turning because it is directly splined to the output shaft. All power flow has occurred in the front planetary gear set during the drive-second stage of operation, and now the over-running clutch, in the rear of the transmission, is disengaged and freewheeling on its hub.



80c070aa

**Fig. 7 Second Gear Powerflow**

- 1 - KICKDOWN BAND APPLIED
- 2 - OUTPUT SHAFT
- 3 - REAR CLUTCH ENGAGED
- 4 - OUTPUT SHAFT
- 5 - OVER-RUNNING CLUTCH FREE-WHEELING

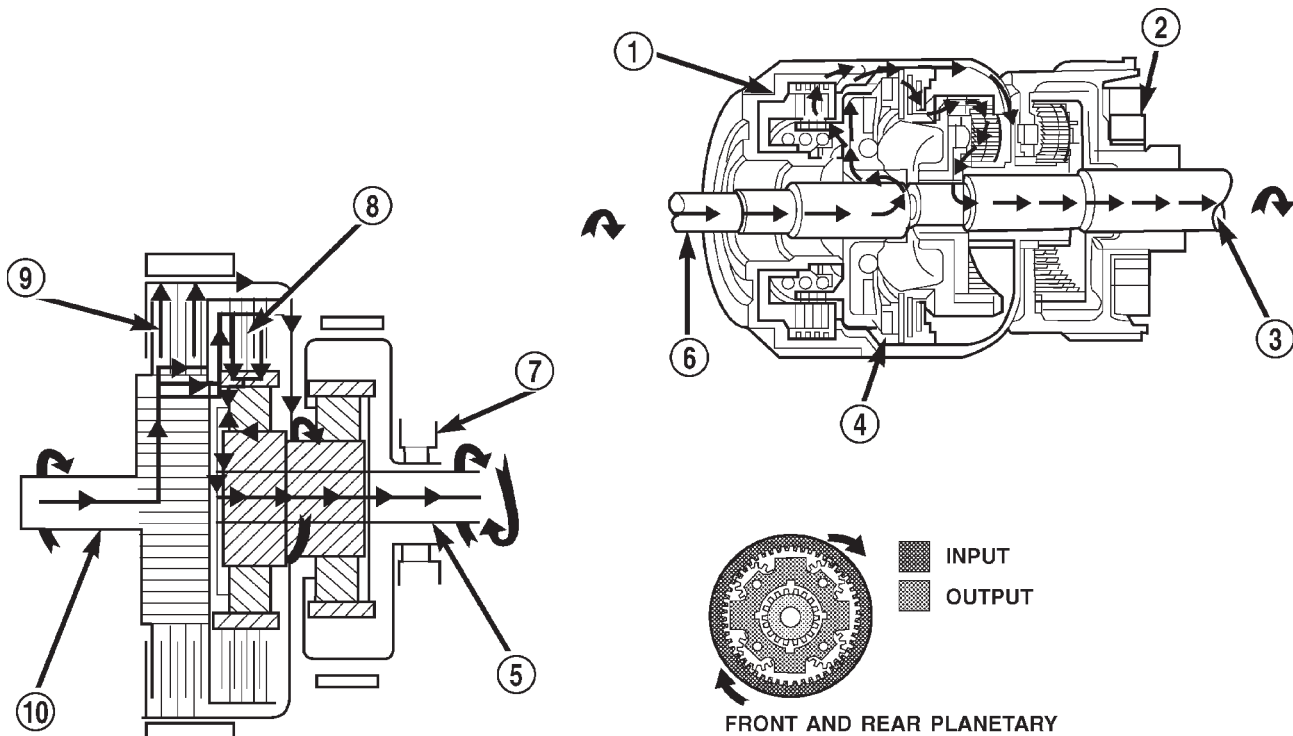
- 6 - INPUT SHAFT
- 7 - REAR CLUTCH APPLIED
- 8 - KICKDOWN BAND APPLIED
- 9 - INPUT SHAFT

AUTOMATIC TRANSMISSION - 44RE (Continued)

**DIRECT DRIVE POWERFLOW**

The vehicle has accelerated and reached the shift point for the 2-3 upshift into direct drive (Fig. 8). When the shift takes place, the front band is released, and the front clutch is applied. The rear clutch stays applied as it has been in all the forward gears. With the front clutch now applied, engine torque is now on the front clutch retainer, which is locked to the sun gear driving shell. This means that the sun gear is now turning in engine rotation (clockwise) and at engine speed. The rear clutch is still applied so engine torque is also still on the front annulus gear. If two members of the same planetary

set are driven, direct drive results. Therefore, when two members are rotating at the same speed and in the same direction, it is the same as being locked up. The rear planetary set is also locked up, given the sun gear is still the input, and the rear annulus gear must turn with the output shaft. Both gears are turning in the same direction and at the same speed. The front and rear planet pinions do not turn at all in direct drive. The only rotation is the input from the engine to the connected parts, which are acting as one common unit, to the output shaft.



**Fig. 8 Direct Drive Powerflow**

- 1 - FRONT CLUTCH APPLIED
- 2 - OVER-RUNNING CLUTCH FREE-WHEELING
- 3 - OUTPUT SHAFT
- 4 - REAR CLUTCH APPLIED
- 5 - OUTPUT SHAFT

- 6 - INPUT SHAFT
- 7 - OVER-RUNNING CLUTCH FREE-WHEELING
- 8 - REAR CLUTCH APPLIED
- 9 - FRONT CLUTCH APPLIED
- 10 - INPUT SHAFT

80c070ab



## AUTOMATIC TRANSMISSION - 44RE (Continued)

**FOURTH GEAR POWERFLOW**

Fourth gear overdrive range is electronically controlled and hydraulically activated. Various sensor inputs are supplied to the powertrain control module to operate the overdrive solenoid on the valve body. The solenoid contains a check ball that opens and closes a vent port in the 3-4 shift valve feed passage. The overdrive solenoid (and check ball) are not energized in first, second, third, or reverse gear. The vent port remains open, diverting line pressure from the 2-3 shift valve away from the 3-4 shift valve. The overdrive control switch must be in the ON position to transmit overdrive status to the PCM. A 3-4 upshift occurs only when the overdrive solenoid is energized by the PCM. The PCM energizes the overdrive solenoid during the 3-4 upshift. This causes the solenoid check ball to close the vent port allowing line pressure from the 2-3 shift valve to act directly on the 3-4 upshift valve. Line pressure on the 3-4 shift valve overcomes valve spring pressure moving the valve to the upshift position. This action exposes the feed passages to the 3-4 timing valve, 3-4 quick fill valve, 3-4 accumulator, and ultimately to the overdrive piston. Line pressure through the timing valve moves the overdrive piston into contact with the overdrive clutch. The direct clutch is disengaged before the overdrive clutch is engaged. The boost valve provides increased fluid apply pressure to the overdrive clutch during 3-4 upshifts, and when accelerating in fourth gear. The 3-4 accumulator cushions overdrive clutch engagement to smooth 3-4 upshifts. The accumulator is charged at the same time as apply pressure acts against the overdrive piston.

**DIAGNOSIS AND TESTING - AUTOMATIC TRANSMISSION**

Automatic transmission problems can be a result of poor engine performance, incorrect fluid level, incorrect linkage or cable adjustment, band or hydraulic control pressure adjustments, hydraulic system malfunctions or electrical/mechanical component malfunctions. Begin diagnosis by checking the easily accessible items such as: fluid level and condition, linkage adjustments and electrical connections. A road test will determine if further diagnosis is necessary.

**DIAGNOSIS AND TESTING - PRELIMINARY**

Two basic procedures are required. One procedure for vehicles that are drivable and an alternate procedure for disabled vehicles (will not back up or move forward).

**VEHICLE IS DRIVEABLE**

(1) Check for transmission fault codes using DRB® scan tool.

(2) Check fluid level and condition.

(3) Adjust throttle and gearshift linkage if complaint was based on delayed, erratic, or harsh shifts.

(4) Road test and note how transmission upshifts, downshifts, and engages.

(5) Perform hydraulic pressure test if shift problems were noted during road test.

(6) Perform air-pressure test to check clutch-band operation.

**VEHICLE IS DISABLED**

(1) Check fluid level and condition.

(2) Check for broken or disconnected gearshift or throttle linkage.

(3) Check for cracked, leaking cooler lines, or loose or missing pressure-port plugs.

(4) Raise and support vehicle on safety stands, start engine, shift transmission into gear, and note following:

(a) If propeller shaft turns but wheels do not, problem is with differential or axle shafts.

(b) If propeller shaft does not turn and transmission is noisy, stop engine. Remove oil pan, and check for debris. If pan is clear, remove transmission and check for damaged drive plate, converter, oil pump, or input shaft.

(c) If propeller shaft does not turn and transmission is not noisy, perform hydraulic-pressure test to determine if problem is hydraulic or mechanical.

**DIAGNOSIS AND TESTING - ROAD TESTING**

Before road testing, be sure the fluid level and control cable adjustments have been checked and adjusted if necessary. Verify that diagnostic trouble codes have been resolved.

Observe engine performance during the road test. A poorly tuned engine will not allow accurate analysis of transmission operation.

Operate the transmission in all gear ranges. Check for shift variations and engine flare which indicates slippage. Note if shifts are harsh, spongy, delayed, early, or if part throttle downshifts are sensitive.

Slippage indicated by engine flare, usually means clutch, band or overrunning clutch problems. If the condition is advanced, an overhaul will be necessary to restore normal operation.

A slipping clutch or band can often be determined by comparing which internal units are applied in the various gear ranges. The Clutch and Band Application chart provides a basis for analyzing road test results.

## AUTOMATIC TRANSMISSION - 44RE (Continued)

## CLUTCH AND BAND APPLICATION CHART

SHIFT LEVER POSITION	TRANSMISSION CLUTCHES AND BANDS					OVERDRIVE CLUTCHES		
	FRONT CLUTCH	FRONT BAND	REAR CLUTCH	REAR BAND	OVER-RUNNING CLUTCH	OVER-DRIVE CLUTCH	DIRECT CLUTCH	OVER-RUNNING CLUTCH
Reverse	X			X			X	
Drive - First			X		X		X	X
Drive - Second		X	X				X	X
Drive - Third	X		X				X	X
Drive - Fourth	X		X			X		
Manual Second		X	X		X		X	X
Manual First			X	X	X		X	X

Note that the rear clutch is applied in all forward ranges (D, 2, 1). The transmission overrunning clutch is applied in first gear (D, 2 and 1 ranges) only. The rear band is applied in 1 and R range only.

Note that the overdrive clutch is applied only in fourth gear and the overdrive direct clutch and overrunning clutch are applied in all ranges except fourth gear.

For example: If slippage occurs in first gear in D and 2 range but not in 1 range, the transmission overrunning clutch is faulty. Similarly, if slippage occurs in any two forward gears, the rear clutch is slipping.

Applying the same method of analysis, note that the front and rear clutches are applied simultaneously only in D range third and fourth gear. If the transmission slips in third gear, either the front clutch or the rear clutch is slipping.

If the transmission slips in fourth gear but not in third gear, the overdrive clutch is slipping. By selecting another gear which does not use these clutches, the slipping unit can be determined. For example, if the transmission also slips in Reverse, the front clutch is slipping. If the transmission does not slip in Reverse, the rear clutch is slipping.

If slippage occurs during the 3-4 shift or only in fourth gear, the overdrive clutch is slipping. Similarly, if the direct clutch were to fail, the transmission would lose both reverse gear and overrunning braking in 2 position (manual second gear).

If the transmission will not shift to fourth gear, the control switch, overdrive solenoid or related wiring may also be the problem cause.

This process of elimination can be used to identify a slipping unit and check operation. Proper use of the Clutch and Band Application Chart is the key.

Although road test analysis will help determine the slipping unit, the actual cause of a malfunction usually cannot be determined until hydraulic and air pressure tests are performed. Practically any condition can be caused by leaking hydraulic circuits or sticking valves.

Unless a malfunction is obvious, such as no drive in D range first gear, do not disassemble the transmission. Perform the hydraulic and air pressure tests to help determine the probable cause.

## DIAGNOSIS AND TESTING - HYDRAULIC PRESSURE TEST

Hydraulic test pressures range from a low of one psi (6.895 kPa) governor pressure, to 300 psi (2068 kPa) at the rear servo pressure port in reverse.

An accurate tachometer and pressure test gauges are required. Test Gauge C-3292 has a 100 psi range and is used at the accumulator, governor, and front servo ports. Test Gauge C-3293-SP has a 300 psi range and is used at the rear servo and overdrive ports where pressures exceed 100 psi.

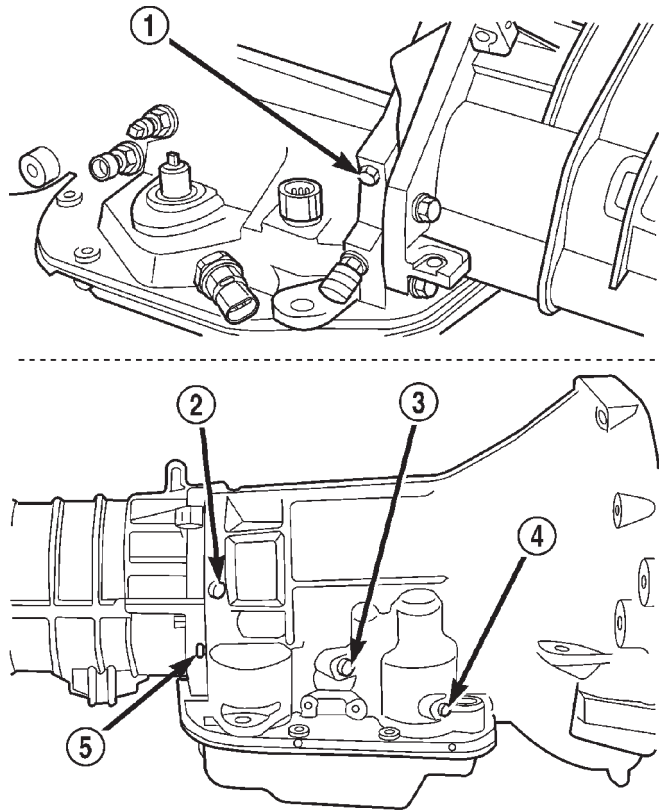
### Pressure Test Port Locations

Test ports are located at both sides of the transmission case (Fig. 9).

Line pressure is checked at the accumulator port on the right side of the case. The front servo pressure port is at the right side of the case just behind the filler tube opening.

## AUTOMATIC TRANSMISSION - 44RE (Continued)

The rear servo and governor pressure ports are at the right rear of the transmission case. The overdrive clutch pressure port is at the left rear of the case.



80b170e6

**Fig. 9 Pressure Test Port Locations**

- 1 - OVERDRIVE CLUTCH TEST PORT
- 2 - GOVERNOR TEST PORT
- 3 - ACCUMULATOR TEST PORT
- 4 - FRONT SERVO TEST PORT
- 5 - REAR SERVO TEST PORT

#### Test One - Transmission In Manual Low

**NOTE:** This test checks pump output, pressure regulation, and condition of the rear clutch and servo circuit. Both test gauges are required for this test.

- (1) Connect tachometer to engine. Position tachometer so it can be observed from driver seat if helper will be operating engine. Raise vehicle on hoist that will allow rear wheels to rotate freely.
- (2) Connect 100 psi Gauge C-3292 to accumulator port. Then connect 300 psi Gauge C-3293-SP to rear servo port.
- (3) Disconnect throttle and gearshift cables from levers on transmission valve body manual shaft.
- (4) Have helper start and run engine at 1000 rpm.
- (5) Move transmission shift lever fully forward into 1 range.

(6) Gradually move transmission throttle lever from full forward to full rearward position and note pressures on both gauges:

- Line pressure at accumulator port should be 54-60 psi (372-414 kPa) with throttle lever forward and gradually increase to 90-96 psi (621-662 kPa) as throttle lever is moved rearward.
- Rear servo pressure should be same as line pressure within 3 psi (20.68 kPa).

#### Test Two - Transmission In 2 Range

**NOTE:** This test checks pump output, line pressure and pressure regulation. Use 100 psi Test Gauge C-3292 for this test.

- (1) Leave vehicle in place on hoist and leave Test Gauge C-3292 connected to accumulator port.
- (2) Have helper start and run engine at 1000 rpm.
- (3) Move transmission shift lever one detent rearward from full forward position. This is 2 range.
- (4) Move transmission throttle lever from full forward to full rearward position and read pressure on gauge.
- (5) Line pressure should be 54-60 psi (372-414 kPa) with throttle lever forward and gradually increase to 90-96 psi (621-662 kPa) as lever is moved rearward.

#### Test Three - Transmission In D Range Third Gear

**NOTE:** This test checks pressure regulation and condition of the clutch circuits. Both test gauges are required for this test.

- (1) Turn OD switch off.
- (2) Leave vehicle on hoist and leave Gauge C-3292 in place at accumulator port.
- (3) Move Gauge C-3293-SP over to front servo port for this test.
- (4) Have helper start and run engine at 1600 rpm for this test.
- (5) Move transmission shift lever two detents rearward from full forward position. This is D range.
- (6) Read pressures on both gauges as transmission throttle lever is gradually moved from full forward to full rearward position:
  - Line pressure at accumulator in D range third gear, should be 54-60 psi (372-414 kPa) with throttle lever forward and increase as lever is moved rearward.
  - Front servo pressure in D range third gear, should be within 3 psi (21 kPa) of line pressure up to kickdown point.

## AUTOMATIC TRANSMISSION - 44RE (Continued)

## Test Four - Transmission In Reverse

**NOTE: This test checks pump output, pressure regulation and the front clutch and rear servo circuits. Use 300 psi Test Gauge C-3293-SP for this test.**

- (1) Leave vehicle on hoist and leave gauge C-3292 in place at accumulator port.
- (2) Move 300 psi Gauge C-3293-SP back to rear servo port.
- (3) Have helper start and run engine at 1600 rpm for test.
- (4) Move transmission shift lever four detents rearward from full forward position. This is Reverse range.
- (5) Move transmission throttle lever fully forward then fully rearward and note reading at Gauge C-3293-SP.
- (6) Pressure should be 145 - 175 psi (1000-1207 kPa) with throttle lever forward and increase to 230 - 280 psi (1586-1931 kPa) as lever is gradually moved rearward.

## Test Five - Governor Pressure

**NOTE: This test checks governor operation by measuring governor pressure response to changes in vehicle speed. It is usually not necessary to check governor operation unless shift speeds are incorrect or if the transmission will not downshift. The test should be performed on the road or on a hoist that will allow the rear wheels to rotate freely.**

- (1) Move 100 psi Test Gauge C-3292 to governor pressure port.
- (2) Move transmission shift lever two detents rearward from full forward position. This is D range.
- (3) Have helper start and run engine at curb idle speed. Then firmly apply service brakes so wheels will not rotate.
- (4) Note governor pressure:
  - Governor pressure should be no more than 20.6 kPa (3 psi) at curb idle speed and wheels not rotating.

- If pressure exceeds 20.6 kPa (3 psi), a fault exists in governor pressure control system.

(5) Release brakes, slowly increase engine speed, and observe speedometer and pressure test gauge (do not exceed 30 mph on speedometer). Governor pressure should increase in proportion to vehicle speed. Or approximately 6.89 kPa (1 psi) for every 1 mph.

(6) Governor pressure rise should be smooth and drop back to no more than 20.6 kPa (3 psi), after engine returns to curb idle and brakes are applied to prevent wheels from rotating.

(7) Compare results of pressure test with analysis chart.

## Test Six - Transmission In Overdrive Fourth Gear

**NOTE: This test checks line pressure at the overdrive clutch in fourth gear range. Use 300 psi Test Gauge C-3293-SP for this test. The test should be performed on the road or on a chassis dyno.**

- (1) Remove tachometer; it is not needed for this test.
- (2) Move 300 psi Gauge to overdrive clutch pressure test port. Then remove other gauge and reinstall test port plug.
- (3) Lower vehicle.
- (4) Turn OD switch on.
- (5) Secure test gauge so it can be viewed from drivers seat.
- (6) Start engine and shift into D range.
- (7) Increase vehicle speed gradually until 3-4 shift occurs and note gauge pressure.
- (8) Pressure should be 469-496 kPa (68-72 psi) with closed throttle and increase to 620-827 kPa (90-120 psi) at 1/2 to 3/4 throttle. Note that pressure can increase to around 896 kPa (130 psi) at full throttle.
- (9) Return to shop or move vehicle off chassis dyno.



AUTOMATIC TRANSMISSION - 44RE (Continued)

PRESSURE TEST ANALYSIS CHART

TEST CONDITION	INDICATION
Line pressure OK during any one test	Pump and regulator valve OK
Line pressure OK in R but low in D, 2, 1	Leakage in rear clutch area (seal rings, clutch seals)
Pressure low in D Fourth Gear Range	Overdrive clutch piston seal, or check ball problem
Pressure OK in 1, 2 but low in D3 and R	Leakage in front clutch area
Pressure OK in 2 but low in R and 1	Leakage in rear servo
Front servo pressure in 2	Leakage in servo; broken servo ring or cracked servo piston
Pressure low in all positions	Clogged filter, stuck regulator valve, worn or faulty pump, low oil level
Governor pressure too high at idle speed	Governor pressure solenoid valve system fault. Refer to diagnostic book.
Governor pressure low at all mph figures	Faulty governor pressure solenoid, transmission control module, or governor pressure sensor
Lubrication pressure low at all throttle positions	Clogged fluid cooler or lines, seal rings leaking, worn pump bushings, pump, clutch retainer, or clogged filter.
Line pressure high	Output shaft plugged, sticky regulator valve
Line pressure low	Sticky regulator valve, clogged filter, worn pump

DIAGNOSIS AND TESTING - AIR CHECKING TRANSMISSION CLUTCH AND BAND OPERATION

Air-pressure testing can be used to check transmission front/rear clutch and band operation. The test can be conducted with the transmission either in the vehicle or on the work bench, as a final check, after overhaul.

Air-pressure testing requires that the oil pan and valve body be removed from the transmission. The servo and clutch apply passages are shown (Fig. 10).

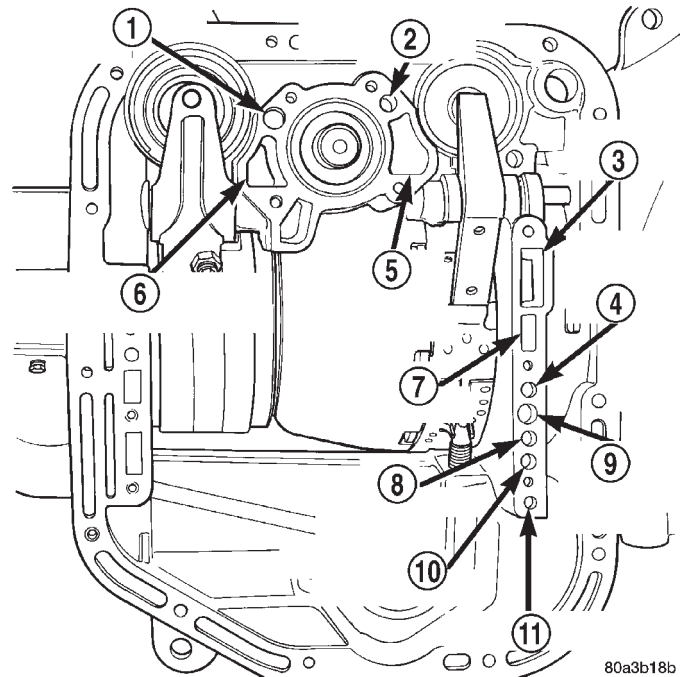


Fig. 10 Air Pressure Test Passages

- 1 - REAR SERVO APPLY
- 2 - FRONT SERVO APPLY
- 3 - PUMP SUCTION
- 4 - FRONT CLUTCH APPLY
- 5 - FRONT SERVO RELEASE
- 6 - LINE PRESSURE TO ACCUMULATOR
- 7 - PUMP PRESSURE
- 8 - TO CONVERTER
- 9 - REAR CLUTCH APPLY
- 10 - FROM CONVERTER
- 11 - TO COOLER

Front Clutch Air Test

Place one or two fingers on the clutch housing and apply air pressure through front clutch apply passage. Piston movement can be felt and a soft thump heard as the clutch applies.

Rear Clutch Air Test

Place one or two fingers on the clutch housing and apply air pressure through rear clutch apply passage.



AUTOMATIC TRANSMISSION - 44RE (Continued)

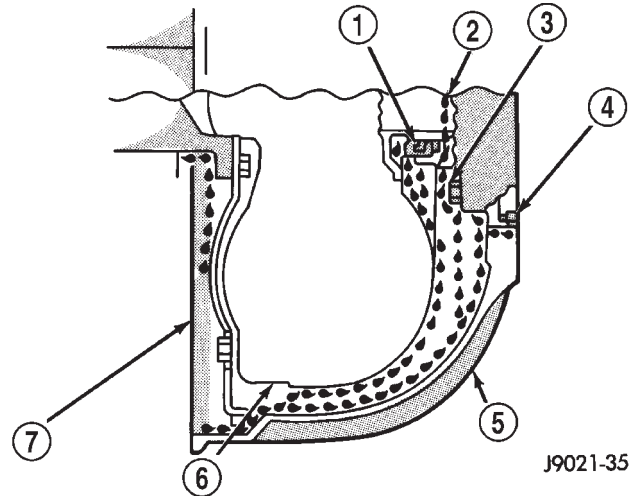
Piston movement can be felt and a soft thump heard as the clutch applies.

**Front Servo Apply Air Test**

Apply air pressure to the front servo apply passage. The servo rod should extend and cause the band to tighten around the drum. Spring pressure should release the servo when air pressure is removed.

**Rear Servo Air Test**

Apply air pressure to the rear servo apply passage. The servo rod should extend and cause the band to tighten around the drum. Spring pressure should release the servo when air pressure is removed.



**Fig. 11 Converter Housing Leak Paths**

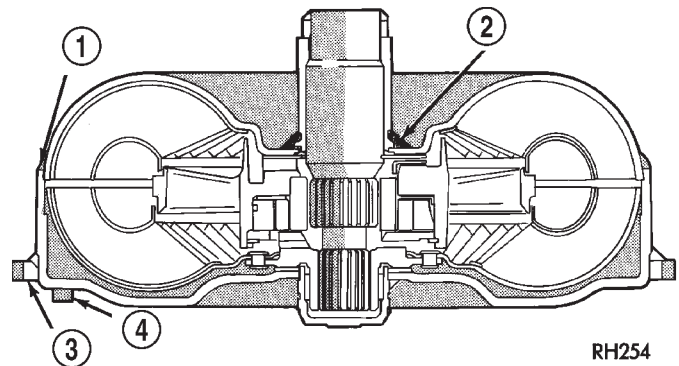
- 1 - PUMP SEAL
- 2 - PUMP VENT
- 3 - PUMP BOLT
- 4 - PUMP GASKET
- 5 - CONVERTER HOUSING
- 6 - CONVERTER
- 7 - REAR MAIN SEAL LEAK

**DIAGNOSIS AND TESTING - CONVERTER HOUSING FLUID LEAK**

When diagnosing converter housing fluid leaks, two items must be established before repair.

- (1) Verify that a leak condition actually exists.
- (2) Determined the true source of the leak.

Some suspected converter housing fluid leaks may not be leaks at all. They may only be the result of residual fluid in the converter housing, or excess fluid spilled during factory fill or fill after repair. Converter housing leaks have several potential sources. Through careful observation, a leak source can be identified before removing the transmission for repair. Pump seal leaks tend to move along the drive hub and onto the rear of the converter. Pump body leaks follow the same path as a seal leak (Fig. 11). Pump vent or pump attaching bolt leaks are generally deposited on the inside of the converter housing and not on the converter itself (Fig. 11). Pump o-ring or gasket leaks usually travel down the inside of the converter housing. Front band lever pin plug leaks are generally deposited on the housing and not on the converter.



**Fig. 12 Converter Leak Points - Typical**

- 1 - OUTSIDE DIAMETER WELD
- 2 - TORQUE CONVERTER HUB WELD
- 3 - STARTER RING GEAR
- 4 - LUG

**TORQUE CONVERTER LEAK POINTS**

Possible sources of converter leaks are:

- (1) Leaks at the weld joint around the outside diameter weld (Fig. 12).
- (2) Leaks at the converter hub weld (Fig. 12).

**CONVERTER HOUSING AREA LEAK CORRECTION**

- (1) Remove converter.
- (2) Tighten front band adjusting screw until band is tight around front clutch retainer. This prevents front/rear clutches from coming out when oil pump is removed.
- (3) Remove oil pump and remove pump seal. Inspect pump housing drainback and vent holes for obstructions. Clear holes with solvent and wire.

(4) Inspect pump bushing and converter hub. If bushing is scored, replace it. If converter hub is scored, either polish it with crocus cloth or replace converter.

(5) Install new pump seal, O-ring, and gasket. Replace oil pump if cracked, porous or damaged in any way. Be sure to loosen the front band before installing the oil pump, damage to the oil pump seal may occur if the band is still tightened to the front clutch retainer.

(6) Loosen kickdown lever pin access plug three turns. Apply Loctite™ 592, or Permatex® No. 2 to

## AUTOMATIC TRANSMISSION - 44RE (Continued)

plug threads and tighten plug to 17 N·m (150 in. lbs.) torque.

(7) Adjust front band.

(8) Lubricate pump seal and converter hub with transmission fluid or petroleum jelly and install converter.

(9) Install transmission and converter housing dust shield.

(10) Lower vehicle.

provide general information on a variety of transmission, overdrive unit and converter clutch fault conditions.

The hydraulic flow charts in the Schematics and Diagrams section of this group, outline fluid flow and hydraulic circuitry. Circuit operation is provided for PARK, NEUTRAL, FIRST, SECOND, THIRD, FOURTH, MANUAL FIRST, MANUAL SECOND, and REVERSE gear ranges. Normal working pressures are also supplied for each of the gear ranges.

## DIAGNOSIS AND TESTING - DIAGNOSIS CHARTS

The diagnosis charts provide additional reference when diagnosing a transmission fault. The charts

### DIAGNOSIS CHARTS

CONDITION	POSSIBLE CAUSES	CORRECTION
HARSH ENGAGEMENT (FROM NEUTRAL TO DRIVE OR REVERSE)	1. Fluid Level Low.	1. Add Fluid
	2. Throttle Linkage Mis-adjusted.	2. Adjust linkage - setting may be too long.
	3. Mount and Driveline Bolts Loose.	3. Check engine mount, transmission mount, propeller shaft, rear spring to body bolts, rear control arms, crossmember and axle bolt torque. Tighten loose bolts and replace missing bolts.
	4. U-Joint Worn/Broken.	4. Remove propeller shaft and replace U-Joint.
	5. Axle Backlash Incorrect.	5. Check per Service Manual. Correct as needed.
	6. Hydraulic Pressure Incorrect.	6. Check pressure. Remove, overhaul or adjust valve body as needed.
	7. Band Mis-adjusted.	7. Adjust rear band.
	8. Valve Body Check Balls Missing.	8. Inspect valve body for proper check ball installation.
	9. Axle Pinion Flange Loose.	9. Replace nut and check pinion threads before installing new nut. Replace pinion gear if threads are damaged.
	10. Clutch, band or planetary component damaged.	10. Remove, disassemble and repair transmission as necessary.
	11. Converter Clutch Faulty.	11. Replace converter and flush cooler and line before installing new converter.

## AUTOMATIC TRANSMISSION - 44RE (Continued)

CONDITION	POSSIBLE CAUSES	CORRECTION
DELAYED ENGAGEMENT (FROM NEUTRAL TO DRIVE OR REVERSE)	1. Fluid Level Low.	1. Correct level and check for leaks.
	2. Filter Clogged.	2. Change filter.
	3. Gearshift Linkage Mis-adjusted.	3. Adjust linkage and repair linkage if worn or damaged.
	4. Torque Converter Drain Back (Oil drains from torque converter into transmission sump).	4. If vehicle moves normally after 5 seconds after shifting into gear, no repair is necessary. If longer, inspect pump bushing for wear. Replace pump house.
	5. Rear Band Mis-adjusted.	5. Adjust band.
	6. Valve Body Filter Plugged.	6. Replace fluid and filter. If oil pan and old fluid were full of clutch disc material and/or metal particles, overhaul will be necessary.
	7. Oil Pump Gears Worn/Damaged.	7. Remove transmission and replace oil pump.
	8. Governor Circuit and Solenoid Valve Electrical Fault.	8. Test with DRB <sup>®</sup> scan tool and repair as required.
	9. Hydraulic Pressure Incorrect.	9. Perform pressure test, remove transmission and repair as needed.
	10. Reaction Shaft Seal Rings Worn/Broken.	10. Remove transmission, remove oil pump and replace seal rings.
	11. Rear Clutch/Input Shaft, Rear Clutch Seal Rings Damaged.	11. Remove and disassemble transmission and repair as necessary.
	12. Regulator Valve Stuck.	12. Clean.
	13. Cooler Plugged.	13. Transfer case failure can plug cooler.
NO DRIVE RANGE (REVERSE OK)	1. Fluid Level Low.	1. Add fluid and check for leaks if drive is restored.
	2. Gearshift Linkage/Cable Loose/Misadjusted.	2. Repair or replace linkage components.
	3. Rear Clutch Burnt.	3. Remove and disassemble transmission and rear clutch and seals. Repair/replace worn or damaged parts as needed.
	4. Valve Body Malfunction.	4. Remove and disassemble valve body. Replace assembly if any valves or bores are damaged.
	5. Transmission Overrunning Clutch Broken.	5. Remove and disassemble transmission. Replace overrunning clutch.
	6. Input Shaft Seal Rings Worn/Damaged.	6. Remove and disassemble transmission. Replace seal rings and any other worn or damaged parts.
	7. Front Planetary Failed Broken.	7. Remove and repair.

## AUTOMATIC TRANSMISSION - 44RE (Continued)

CONDITION	POSSIBLE CAUSES	CORRECTION
NO DRIVE OR REVERSE (VEHICLE WILL NOT MOVE)	1. Fluid Level Low.	1. Add fluid and check for leaks if drive is restored.
	2. Gearshift Linkage/Cable Loose/Misadjusted.	2. Inspect, adjust and reassemble linkage as needed. Replace worn/damaged parts.
	3. U-Joint/Axle/Transfer Case Broken.	3. Perform preliminary inspection procedure for vehicle that will not move. Refer to procedure in diagnosis section.
	4. Filter Plugged.	4. Remove and disassemble transmission. Repair or replace failed components as needed. Replace filter. If filter and fluid contained clutch material or metal particles, an overhaul may be necessary. Perform lube flow test. Flush oil. Replace cooler as necessary.
	5. Oil Pump Damaged.	5. Perform pressure test to confirm low pressure. Replace pump body assembly if necessary.
	6. Valve Body Malfunctioned.	6. Check and inspect valve body. Replace valve body (as assembly) if any valve or bore is damaged. Clean and reassemble correctly if all parts are in good condition.
	7. Transmission Internal Component Damaged.	7. Remove and disassemble transmission. Repair or replace failed components as needed.
	8. Park Sprag not Releasing - Check Stall Speed, Worn/Damaged/Stuck.	8. Remove, disassemble, repair.
	9. Torque Converter Damage.	9. Inspect and replace as required.
SHIFTS DELAYED OR ERRATIC (SHIFTS ALSO HARSH AT TIMES)	1. Fluid Level Low/High.	1. Correct fluid level and check for leaks if low.
	2. Fluid Filter Clogged.	2. Replace filter. If filter and fluid contained clutch material or metal particles, an overhaul may be necessary. Perform lube flow test.
	3. Throttle Linkage Mis-adjusted.	3. Adjust linkage as described in service section.
	4. Throttle Linkage Binding.	4. Check cable for binding. Check for return to closed throttle at transmission.
	5. Gearshift Linkage/Cable Mis-adjusted.	5. Adjust linkage/cable as described in service section.
	6. Clutch or Servo Failure.	6. Remove valve body and air test clutch, and band servo operation. Disassemble and repair transmission as needed.
	7. Governor Circuit Electrical Fault.	7. Test using DRB® scan tool and repair as required.
	8. Front Band Mis-adjusted.	8. Adjust band.
	9. Pump Suction Passage Leak.	9. Check for excessive foam on dipstick after normal driving. Check for loose pump bolts, defective gasket. Replace pump assembly if needed.

## AUTOMATIC TRANSMISSION - 44RE (Continued)

CONDITION	POSSIBLE CAUSES	CORRECTION
NO REVERSE (D RANGES OK)	1. Gearshift Linkage/Cable Mis-adjusted/Damaged.	1. Repair or replace linkage parts as needed.
	2. Park Sprag Sticking.	2. Replace overdrive annulus gear.
	3. Rear Band Mis-adjusted/Worn.	3. Adjust band; replace.
	4. Valve Body Malfunction.	4. Remove and service valve body. Replace valve body if any valves or valve bores are worn or damaged.
	5. Rear Servo Malfunction.	5. Remove and disassemble transmission. Replace worn/damaged servo parts as necessary.
	6. Direct Clutch in Overdrive Worn.	6. Disassemble overdrive. Replace worn or damaged parts.
	7. Front Clutch Burnt.	7. Remove and disassemble transmission. Replace worn, damaged clutch parts as required.
HAS FIRST/REVERSE ONLY (NO 1-2 OR 2-3 UPSHIFT)	1. Governor Circuit Electrical Fault.	1. Test using DRB® scan tool and repair as required.
	2. Valve Body Malfunction.	2. Repair stuck 1-2 shift valve or governor plug.
	3. Front Servo/Kickdown Band Damaged/Burned.	3. Repair/replace.
MOVES IN 2ND OR 3RD GEAR, ABRUPTLY DOWNSHIFTS TO LOW	1. Valve Body Malfunction.	1. Remove, clean and inspect. Look for stuck 1-2 valve or governor plug.
NO LOW GEAR (MOVES IN 2ND OR 3RD GEAR ONLY)	1. Governor Circuit Electrical Fault.	1. Test with DRB® scan tool and repair as required.
	2. Valve Body Malfunction.	2. Remove, clean and inspect. Look for sticking 1-2 shift valve, 2-3 shift valve, governor plug or broken springs.
	3. Front Servo Piston Cocked in Bore.	3. Inspect servo and repair as required.
	4. Front Band Linkage Malfunction	4. Inspect linkage and look for bind in linkage.
NO KICKDOWN OR NORMAL DOWNSHIFT	1. Throttle Linkage Mis-adjusted.	1. Adjust linkage.
	2. Accelerator Pedal Travel Restricted.	2. Verify floor mat is not under pedal, repair worn accelerator cable or bent brackets.
	3. Valve Body Hydraulic Pressures Too High or Too Low Due to Valve Body Malfunction or Incorrect Hydraulic Control Pressure Adjustments.	3. Perform hydraulic pressure tests to determine cause and repair as required. Correct valve body pressure adjustments as required.
	4. Governor Circuit Electrical Fault.	4. Test with DRB® scan tool and repair as required.
	5. Valve Body Malfunction.	5. Perform hydraulic pressure tests to determine cause and repair as required. Correct valve body pressure adjustments as required.



## AUTOMATIC TRANSMISSION - 44RE (Continued)

CONDITION	POSSIBLE CAUSES	CORRECTION
	6. TPS Malfunction.	6. Replace sensor, check with DRB® scan tool.
	7. PCM Malfunction.	7. Check with DRB® scan tool and replace if required.
	8. Valve Body Malfunction.	8. Repair sticking 1-2, 2-3 shift valves, governor plugs, 3-4 solenoid, 3-4 shift valve, 3-4 timing valve.
STUCK IN LOW GEAR (WILL NOT UPSHIFT)	1. Throttle Linkage Mis-adjusted/ Stuck.	1. Adjust linkage and repair linkage if worn or damaged. Check for binding cable or missing return spring.
	2. Gearshift Linkage Mis-adjusted.	2. Adjust linkage and repair linkage if worn or damaged.
	3. Governor Component Electrical Fault.	3. Check operating pressures and test with DRB® scan tool, repair faulty component.
	4. Front Band Out of Adjustment.	4. Adjust Band.
	5. Clutch or Servo Malfunction.	5. Air pressure check operation of clutches and bands. Repair faulty component.
CREEPS IN NEUTRAL	1. Gearshift Linkage Mis-adjusted.	1. Adjust linkage.
	2. Rear Clutch Dragging/Warped.	2. Disassemble and repair.
	3. Valve Body Malfunction.	3. Perform hydraulic pressure test to determine cause and repair as required.
BUZZING NOISE	1. Fluid Level Low	1. Add fluid and check for leaks.
	2. Shift Cable Mis-assembled.	2. Route cable away from engine and bell housing.
	3. Valve Body Mis-assembled.	3. Remove, disassemble, inspect valve body. Reassemble correctly if necessary. Replace assembly if valves or springs are damaged. Check for loose bolts or screws.
	4. Pump Passages Leaking.	4. Check pump for porous casting, scores on mating surfaces and excess rotor clearance. Repair as required. Loose pump bolts.
	5. Cooling System Cooler Plugged.	5. Flow check cooler circuit. Repair as needed.
	6. Overrunning Clutch Damaged.	6. Replace clutch.
SLIPS IN REVERSE ONLY	1. Fluid Level Low.	1. Add fluid and check for leaks.
	2. Gearshift Linkage Mis-adjusted.	2. Adjust linkage.
	3. Rear Band Mis-adjusted.	3. Adjust band.
	4. Rear Band Worn.	4. Replace as required.
	5. Overdrive Direct Clutch Worn.	5. Disassemble overdrive. Repair as needed.
	6. Hydraulic Pressure Too Low.	6. Perform hydraulic pressure tests to determine cause.
	7. Rear Servo Leaking.	7. Air pressure check clutch-servo operation and repair as required.
	8. Band Linkage Binding.	8. Inspect and repair as required.

## AUTOMATIC TRANSMISSION - 44RE (Continued)

CONDITION	POSSIBLE CAUSES	CORRECTION
SLIPS IN FORWARD DRIVE RANGES	1. Fluid Level Low.	1. Add fluid and check for leaks.
	2. Fluid Foaming.	2. Check for high oil level, bad pump gasket or seals, dirt between pump halves and loose pump bolts. Replace pump if necessary.
	3. Throttle Linkage Mis-adjusted.	3. Adjust linkage.
	4. Gearshift Linkage Mis-adjusted.	4. Adjust linkage.
	5. Rear Clutch Worn.	5. Inspect and replace as needed.
	6. Low Hydraulic Pressure Due to Worn Pump, Incorrect Control Pressure Adjustments, Valve Body Warpage or Malfunction, Sticking, Leaking Seal Rings, Clutch Seals Leaking, Servo Leaks, Clogged Filter or Cooler Lines.	6. Perform hydraulic and air pressure tests to determine cause.
	7. Rear Clutch Malfunction, Leaking Seals or Worn Plates.	7. Air pressure check clutch-servo operation and repair as required.
	8. Overrunning Clutch Worn, Not Holding (Slips in 1 Only).	8. Replace Clutch.
SLIPS IN LOW GEAR "D" ONLY, BUT NOT IN MANUAL 1 POSITION	Overrunning Clutch Faulty.	Replace overrunning clutch.
GROWLING, GRATING OR SCRAPING NOISES	1. Drive Plate Broken.	1. Replace.
	2. Torque Converter Bolts Hitting Dust Shield.	2. Dust shield bent. Replace or repair.
	3. Planetary Gear Set Broken/ Seized.	3. Check for debris in oil pan and repair as required.
	4. Overrunning Clutch Worn/Broken.	4. Inspect and check for debris in oil pan. Repair as required.
	5. Oil Pump Components Scored/ Binding.	5. Remove, inspect and repair as required.
	6. Output Shaft Bearing or Bushing Damaged.	6. Remove, inspect and repair as required.
	7. Clutch Operation Faulty.	7. Perform air pressure check and repair as required.
	8. Front and Rear Bands Mis-adjusted.	8. Adjust bands.
DRAGS OR LOCKS UP	1. Fluid Level Low.	1. Check and adjust level.
	2. Clutch Dragging/Failed	2. Air pressure check clutch operation and repair as required.
	3. Front or Rear Band Mis-adjusted.	3. Adjust bands.
	4. Case Leaks Internally.	4. Check for leakage between passages in case.
	5. Servo Band or Linkage Malfunction.	5. Air pressure check servo operation and repair as required.

## AUTOMATIC TRANSMISSION - 44RE (Continued)

CONDITION	POSSIBLE CAUSES	CORRECTION
	6. Overrunning Clutch Worn.	6. Remove and inspect clutch. Repair as required.
	7. Planetary Gears Broken.	7. Remove, inspect and repair as required (look for debris in oil pan).
	8. Converter Clutch Dragging.	8. Check for plugged cooler. Perform flow check. Inspect pump for excessive side clearance. Replace pump as required.
NO 4-3 DOWNSHIFT	1. Circuit Wiring and/or Connectors Shorted.	1. Test wiring and connectors with test lamp and volt/ohmmeter. Repair wiring as necessary. Replace connectors and/or harnesses as required.
	2. PCM Malfunction.	2. Check PCM operation with DRB® scan tool. Replace PCM only if faulty.
	3. TPS Malfunction	3. Check TPS with DRB® scan tool at PCM.
	4. Lockup Solenoid Not Venting.	4. Remove valve body and replace solenoid assembly if plugged or shorted.
	5. Overdrive Solenoid Not Venting.	5. Remove valve body and replace solenoid if plugged or shorted.
	6. Valve Body Valve Sticking.	6. Repair stuck 3-4 shift valve or lockup timing valve.
NO 4-3 DOWNSHIFT WHEN CONTROL SWITCH IS TURNED OFF	1. Control Switch Open/Shorted.	1. Test and replace switch if faulty.
	2. Overdrive Solenoid Connector Shorted.	2. Test solenoids and replace if seized or shorted.
	3. PCM Malfunction.	3. Test with DRB® scan tool. Replace PCM if faulty.
	4. Valve Body Stuck Valves.	4. Repair stuck 3-4, lockup or lockup timing valve.
CLUNK NOISE FROM DRIVELINE ON CLOSED THROTTLE 4-3 DOWNSHIFT	1. Transmission Fluid Low.	1. Add Fluid.
	2. Throttle Cable Mis-adjusted.	2. Adjust cable.
	3. Overdrive Clutch Select Spacer Wrong Spacer.	3. Replace overdrive piston thrust plate spacer.
3-4 UPSHIFT OCCURS IMMEDIATELY AFTER 2-3 SHIFT	1. Overdrive Solenoid Connector or Wiring Shorted.	1. Test connector and wiring for loose connections, shorts or ground and repair as needed.
	2. TPS Malfunction.	2. Test TPS and replace as necessary. Check with DRB® scan tool.
	3. PCM Malfunction.	3. Test PCM with DRB® scan tool and replace controller if faulty.
	4. Overdrive Solenoid Malfunction.	4. Replace solenoid.
	5. Valve Body Malfunction.	5. Remove, disassemble, clean and inspect valve body components. Make sure all valves and plugs slide freely in bores. Polish valves with crocus cloth if needed.
WHINE/NOISE RELATED TO ENGINE SPEED	1. Fluid Level Low.	1. Add fluid and check for leaks.
	2. Shift Cable Incorrect Routing.	2. Check shift cable for correct routing. Should not touch engine or bell housing.

## AUTOMATIC TRANSMISSION - 44RE (Continued)

CONDITION	POSSIBLE CAUSES	CORRECTION
NO 3-4 UPSHIFT	1. O/D Switch In OFF Position.	1. Turn control switch to ON position.
	2. Overdrive Circuit Fuse Blown.	2. Replace fuse. Determine why fuse failed and repair as necessary (i.e., shorts or grounds in circuit).
	3. O/D Switch Wire Shorted/Open Cut.	3. Check wires/connections with 12V test lamp and voltmeter. Repair damaged or loose wire/connection as necessary.
	4. Distance or Coolant Sensor Malfunction.	4. Check with DRB® scan tool and repair or replace as necessary.
	5. TPS Malfunction.	5. Check with DRB® scan tool and replace if necessary.
	6. Neutral Sense to PCM Wire Shorted/Cut.	6. Test switch/sensor as described in service section and replace if necessary. Engine no start.
	7. PCM Malfunction.	7. Check with DRB® scan tool and replace if necessary.
	8. Overdrive Solenoid Shorted/Open.	8. Replace solenoid if shorted or open and repair loose or damaged wires (DRB® scan tool).
	9. Solenoid Feed Orifice in Valve Body Blocked.	9. Remove, disassemble, and clean valve body thoroughly. Check feed orifice.
	10. Overdrive Clutch Failed.	10. Disassemble overdrive and repair as needed.
	11. Hydraulic Pressure Low.	11. Pressure test transmission to determine cause.
	12. Valve Body Valve Stuck.	12. Repair stuck 3-4 shift valve, 3-4 timing valve.
	13. O/D Piston Incorrect Spacer.	13. Remove unit, check end play and install correct spacer.
	14. Overdrive Piston Seal Failure.	14. Replace both seals.
	15. O/D Check Valve/Orifice Failed.	15. Check for free movement and secure assembly (in piston retainer). Check ball bleed orifice.
SLIPS IN OVERDRIVE FOURTH GEAR	1. Fluid Level Low.	1. Add fluid and check for leaks.
	2. Overdrive Clutch Pack Worn.	2. Remove overdrive unit and rebuild clutch pack.
	3. Overdrive Piston Retainer Bleed Orifice Blown Out.	3. Disassemble transmission, remove retainer and replace orifice.
	4. Overdrive Piston or Seal Malfunction.	4. Remove overdrive unit. Replace seals if worn. Replace piston if damaged. If piston retainer is damaged, remove and disassemble the transmission.
	5. 3-4 Shift Valve, Timing Valve or Accumulator Malfunction.	5. Remove and overhaul valve body. Replace accumulator seals. Make sure all valves operate freely in bores and do not bind or stick. Make sure valve body screws are correctly tightened and separator plates are properly positioned.

## AUTOMATIC TRANSMISSION - 44RE (Continued)

CONDITION	POSSIBLE CAUSES	CORRECTION
	6. Overdrive Unit Thrust Bearing Failure.	6. Disassemble overdrive unit and replace thrust bearing (NO. 1 thrust bearing is between overdrive piston and clutch hub; NO. 2 thrust bearing is between the planetary gear and the direct clutch spring plate; NO. 3 thrust bearing is between overrunning clutch hub and output shaft).
	7. O/D Check Valve/Bleed Orifice Failure.	7. Check for function/secure orifice insert in O/D piston retainer.
DELAYED 3-4 UPSHIFT (SLOW TO ENGAGE)	1. Fluid Level Low.	1. Add fluid and check for leaks.
	2. Throttle Valve Cable Mis-adjusted.	2. Adjust throttle valve cable.
	3. Overdrive Clutch Pack Worn/ Burnt.	3. Remove unit and rebuild clutch pack.
	4. TPS Faulty.	4. Test with DRB® scan tool and replace as necessary
	5. Overdrive Clutch Bleed Orifice Plugged.	5. Disassemble transmission and replace orifice.
	6. Overdrive Solenoid or Wiring Shorted/Open.	6. Test solenoid and check wiring for loose/corroded connections or shorts/grounds. Replace solenoid if faulty and repair wiring if necessary.
	7. Overdrive Excess Clearance.	7. Remove unit. Measure end play and select proper spacer.
	8. O/D Check Valve Missing or Stuck.	8. Check for presence of check valve. Repair or replace as required.
TORQUE CONVERTER LOCKS UP IN SECOND AND/OR THIRD GEAR	Lockup Solenoid, Relay or Wiring Shorted/Open.	Test solenoid, relay and wiring for continuity, shorts or grounds. Replace solenoid and relay if faulty. Repair wiring and connectors as necessary.
HARSH 1-2, 2-3, 3-4 OR 3-2 SHIFTS	Lockup Solenoid Malfunction.	Remove valve body and replace solenoid assembly.
NO START IN PARK OR NEUTRAL	1. Gearshift Linkage/Cable Mis-adjusted.	1. Adjust linkage/cable.
	2. Neutral Sense Wire Open/Cut.	2. Check continuity with test lamp. Repair as required.
	3. Park/Neutral Switch, or Transmission Range Sensor Faulty.	3. Refer to service section for test and replacement procedure.
	4. Park/Neutral Switch, or Transmission Range Sensor Connection Faulty.	4. Connectors spread open. Repair.
	5. Valve Body Manual Lever Assembly Bent/Worn/Broken.	5. Inspect lever assembly and replace if damaged.



## AUTOMATIC TRANSMISSION - 44RE (Continued)

CONDITION	POSSIBLE CAUSES	CORRECTION
NO REVERSE (OR SLIPS IN REVERSE)	1. Direct Clutch Pack (front clutch) Worn.	1. Disassemble unit and rebuild clutch pack.
	2. Rear Band Mis-adjusted.	2. Adjust band.
	3. Front Clutch Malfunctioned/ Burned.	3. Air-pressure test clutch operation. Remove and rebuild if necessary.
	4. Overdrive Thrust Bearing Failure.	4. Disassemble geartrain and replace bearings.
	5. Direct Clutch Spring Collapsed/ Broken.	5. Remove and disassemble unit. Check clutch position and replace spring.
OIL LEAKS.	1. Fluid Lines and Fittings Loose/ Leaks/Damaged.	1. Tighten fittings. If leaks persist, replace fittings and lines if necessary.
	2. Fill Tube (where tube enters case) Leaks/Damaged.	2. Replace tube seal. Inspect tube for cracks in fill tube.
	3. Pressure Port Plug Loose Loose/Damaged.	3. Tighten to correct torque. Replace plug or reseal if leak persists.
	4. Pan Gasket Leaks.	4. Tighten pan screws (150 in. lbs.). If leaks persist, replace gasket.
	5. Valve Body Manual Lever Shaft Seal Leaks/Worn.	5. Replace shaft seal.
	6. Rear Bearing Access Plate Leaks.	6. Replace gasket. Tighten screws.
	7. Gasket Damaged or Bolts are Loose.	7. Replace bolts or gasket or tighten both.
	8. Adapter/Extension Gasket Damaged Leaks/Damaged.	8. Replace gasket.
	9. Park/Neutral Switch, or Transmission Range Sensor Leaks/ Damaged.	9. Replace switch and gasket.
	10. Converter Housing Area Leaks.	10. Check for leaks at seal caused by worn seal or burr on converter hub (cutting seal), worn bushing, missing oil return, oil in front pump housing or hole plugged. Check for leaks past O-ring seal on pump or past pump-to-case bolts; pump housing porous, oil coming out vent due to overfill or leak past front band shaft access plug.
	11. Pump Seal Leaks/Worn/Damaged.	11. Replace seal.
	12. Torque Converter Weld Leak/ Cracked Hub.	12. Replace converter.
	13. Case Porosity Leaks.	13. Replace case.
NOISY OPERATION IN FOURTH GEAR ONLY	1. Overdrive Clutch Discs, Plates or Snap Rings Damaged.	1. Remove unit and rebuild clutch pack.
	2. Overdrive Piston or Planetary Thrust Bearing Damaged.	2. Remove and disassemble unit. Replace either thrust bearing if damaged.
	3. Output Shaft Bearings Scored/ Damaged.	3. Remove and disassemble unit. Replace either bearing if damaged.
	4. Planetary Gears Worn/Chipped.	4. Remove and overhaul overdrive unit.
	5. Overdrive Unit Overrunning Clutch Rollers Worn/Scored.	5. Remove and overhaul overdrive unit.

## AUTOMATIC TRANSMISSION - 44RE (Continued)

**STANDARD PROCEDURE - ALUMINUM  
THREAD REPAIR**

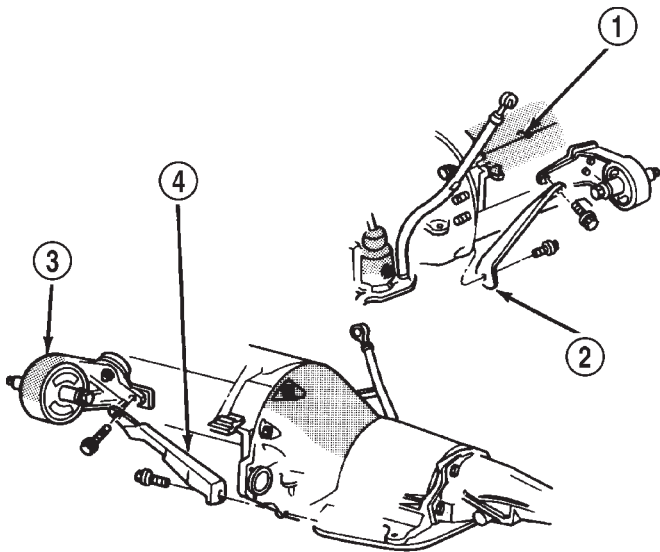
Damaged or worn threads in the aluminum transmission case and valve body can be repaired by the use of Heli-Coils™, or equivalent. This repair consists of drilling out the worn-out damaged threads. Then tap the hole with a special Heli-Coil™ tap, or equivalent, and installing a Heli-Coil™ insert, or equivalent, into the hole. This brings the hole back to its original thread size.

Heli-Coil™, or equivalent, tools and inserts are readily available from most automotive parts suppliers.

**REMOVAL**

The overdrive unit can be removed and serviced separately. It is not necessary to remove the entire transmission assembly to perform overdrive unit repairs.

- (1) Disconnect battery negative cable.
- (2) Disconnect and lower or remove necessary exhaust components.
- (3) Remove engine-to-transmission struts, if equipped (Fig. 13).



J9421-255

**Fig. 13 Transmission-To-Engine Strut Attachment**

- 1 - ENGINE BLOCK
- 2 - STRUT (PASSENGER SIDE)
- 3 - ENGINE MOUNT
- 4 - STRUT (DRIVER SIDE)

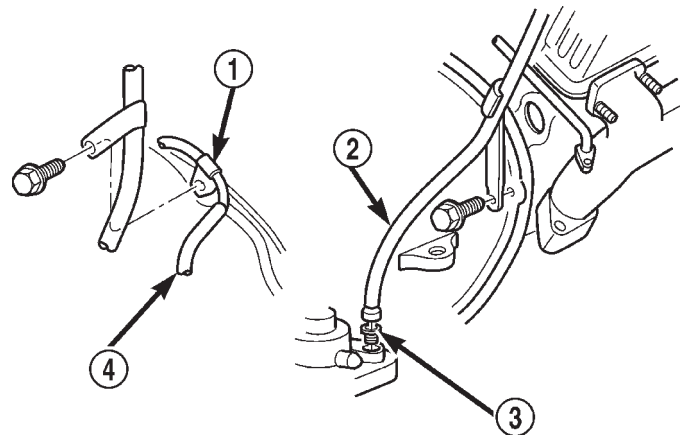
- (4) Disconnect fluid cooler lines at transmission.
- (5) Remove starter motor. (Refer to 8 - ELECTRICAL/STARTING/STARTER MOTOR - REMOVAL)

(6) Disconnect and remove the crankshaft position sensor. (Refer to 14 - FUEL SYSTEM/FUEL INJECTION/CRANKSHAFT POSITION SENSOR - REMOVAL) Retain the sensor attaching bolts.

(7) Remove torque converter access cover.

(8) If transmission is being removed for overhaul, remove transmission oil pan, drain fluid and reinstall pan.

(9) Remove fill tube bracket bolts and pull tube out of transmission. Retain fill tube seal (Fig. 13). On 4 x 4 models, it will also be necessary to remove bolt attaching transfer case vent tube to converter housing (Fig. 14).



80b170f3

**Fig. 14 Fill Tube Attachment**

- 1 - TRANSFER CASE VENT TUBE
- 2 - FILL TUBE (V8)
- 3 - TUBE SEAL
- 4 - FILL TUBE (V6)

(10) Rotate crankshaft in clockwise direction until converter bolts are accessible. Then remove bolts one at a time. Rotate crankshaft with socket wrench on dampener bolt.

(11) Mark propeller shaft and axle yokes for assembly alignment. Then disconnect and remove propeller shaft. On 4 x 4 models, remove both propeller shafts. (Refer to 3 - DIFFERENTIAL & DRIVELINE/PROPELLER SHAFT/PROPELLER SHAFT - REMOVAL)

(12) Disconnect wires from park/neutral position switch and transmission solenoid.

(13) Disconnect gearshift rod and torque shaft assembly from transmission.

(14) Disconnect throttle valve cable from transmission bracket and throttle valve lever.

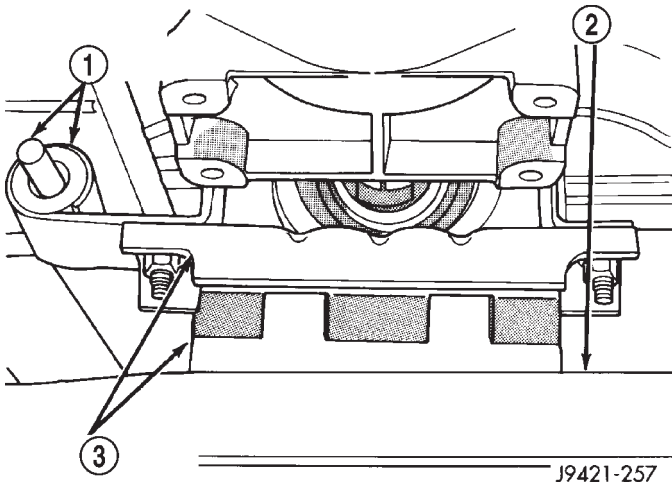
(15) On 4 x 4 models, disconnect shift rod from transfer case shift lever.

(16) Support rear of engine with safety stand or jack.

## AUTOMATIC TRANSMISSION - 44RE (Continued)

(17) Raise transmission slightly with service jack to relieve load on crossmember and supports.

(18) Remove bolts securing rear support and cushion to transmission and crossmember. Raise transmission slightly, slide exhaust hanger arm from bracket (Fig. 15) and remove rear support.



**Fig. 15 Rear Support Cushion**

- 1 - EXHAUST PIPE ARM AND BRACKET
- 2 - CROSSMEMBER
- 3 - REAR SUPPORT AND CUSHION

(19) Remove bolts attaching crossmember to frame and remove crossmember.

(20) On 4 x 4 models, remove transfer case with transmission jack or aid of helper.

(21) Remove all converter housing bolts.

(22) Carefully work transmission and torque converter assembly rearward off engine block dowels.

(23) Lower transmission and remove assembly from under the vehicle.

(24) To remove torque converter, remove C-clamp from edge of bell housing and carefully slide torque converter out of the transmission.

## DISASSEMBLY

(1) Clean transmission exterior with steam gun or with solvent. Wear eye protection during cleaning operations.

(2) Place transmission in a vertical position.

(3) Measure input shaft end play as follows (Fig. 16).

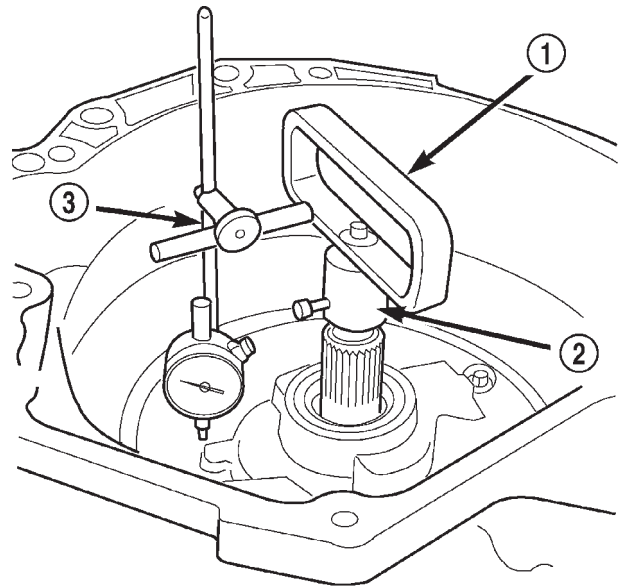
(a) Attach Adapter 8266-6 to Handle 8266-8.

(b) Attach dial indicator C-3339 to Handle 8266-8.

(c) Install the assembled tool onto the input shaft of the transmission and tighten the retaining screw on Adapter 8266-6 to secure it to the input shaft.

(d) Position the dial indicator plunger against a flat spot on the oil pump and zero the dial indicator.

(e) Move the input shaft in and out. Record the maximum travel for assembly reference.



**Fig. 16 Checking Input Shaft End Play**

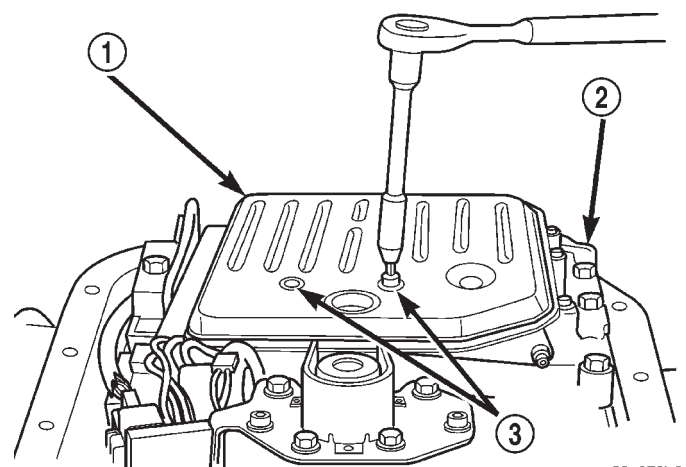
- 1 - TOOL 8266-8
- 2 - TOOL 8266-6
- 3 - TOOL C-3339

(4) Remove shift and throttle levers from valve body manual lever shaft.

(5) Place transmission in horizontal position.

(6) Remove transmission oil pan and gasket.

(7) Remove filter from valve body (Fig. 17). Keep filter screws separate from other valve body screws. Filter screws are longer and should be kept with filter.



**Fig. 17 Oil Filter Removal**

- 1 - OIL FILTER
- 2 - VALVE BODY
- 3 - FILTER SCREWS (2)

AUTOMATIC TRANSMISSION - 44RE (Continued)

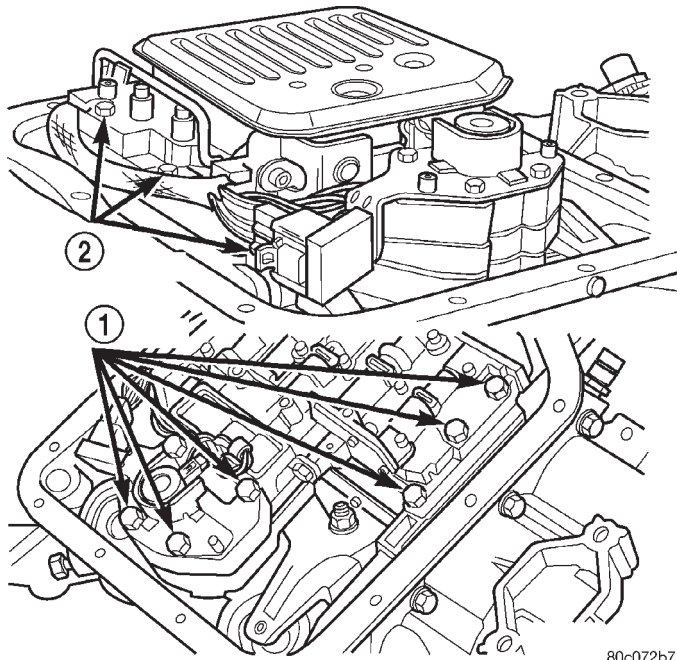
(8) Remove park/neutral position switch.

(9) Remove hex head bolts attaching valve body to transmission case (Fig. 18). A total of 10 bolts are used. Note different bolt lengths for assembly reference.

(10) Remove valve body assembly. Push valve body harness connector out of case. Then work park rod and valve body out of case (Fig. 19).

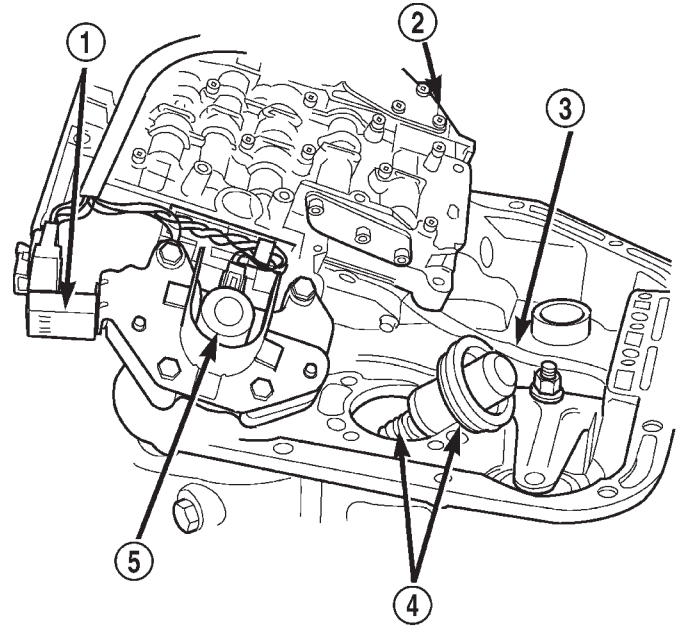
(11) Remove accumulator piston and inner and outer springs (Fig. 20).

(12) Remove pump oil seal with suitable pry tool or slide-hammer mounted screw.



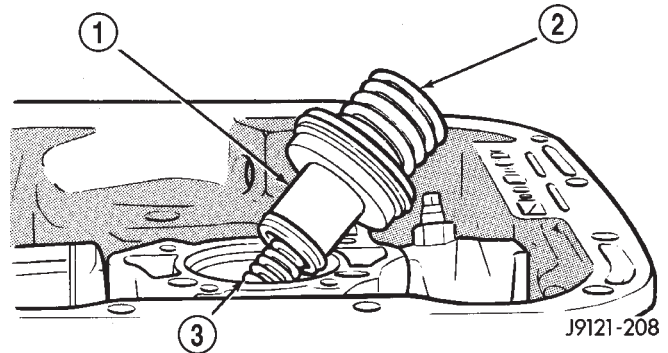
**Fig. 18 Valve Body Bolt Locations**

- 1 - VALVE BODY BOLTS
- 2 - VALVE BODY BOLTS



**Fig. 19 Valve Body Removal**

- 1 - GOVERNOR PRESSURE SENSOR
- 2 - VALVE BODY
- 3 - PARK ROD
- 4 - ACCUMULATOR PISTON
- 5 - GOVERNOR PRESSURE SOLENOID



**Fig. 20 Accumulator Piston And Springs**

- 1 - ACCUMULATOR PISTON
- 2 - OUTER SPRING
- 3 - INNER SPRING



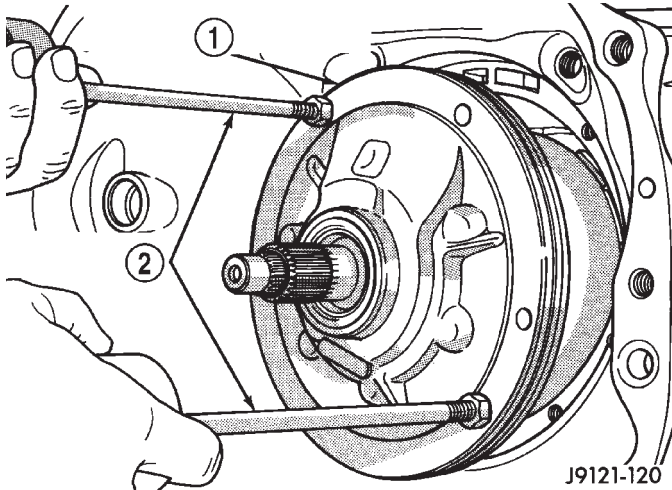
AUTOMATIC TRANSMISSION - 44RE (Continued)

(13) Loosen front band adjusting screw locknut 4-5 turns. Then tighten band adjusting screw until band is tight around front clutch retainer. This prevents front/rear clutches from coming out with pump and possibly damaging clutch or pump components.

(14) Remove oil pump bolts.

(15) Thread bolts of Slide Hammer Tools C-3752 into threaded holes in pump body flange (Fig. 21).

(16) Bump slide hammer weights outward to remove pump and reaction shaft support assembly from case (Fig. 21).



**Fig. 21 Removing Oil Pump And Reaction Shaft Support Assembly**

- 1 - OIL PUMP AND REACTION SHAFT SUPPORT ASSEMBLY
- 2 - SLIDE HAMMER TOOLS C-3752

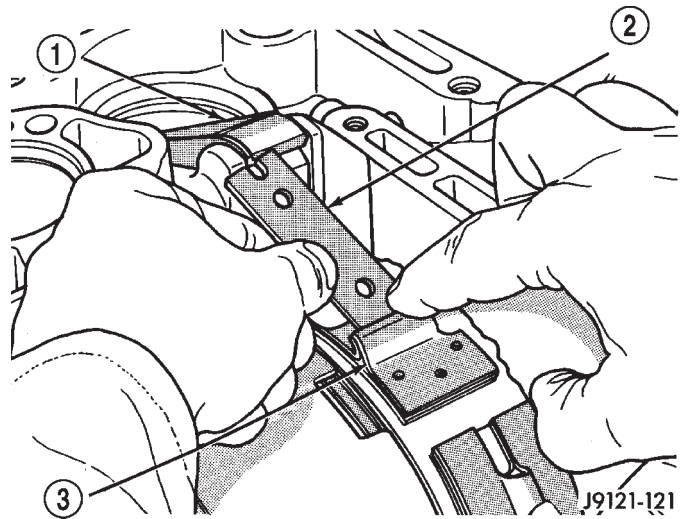
(17) Loosen front band adjusting screw until band is completely loose.

(18) Squeeze front band together and remove band strut (Fig. 22).

(19) Remove front band lever (Fig. 23).

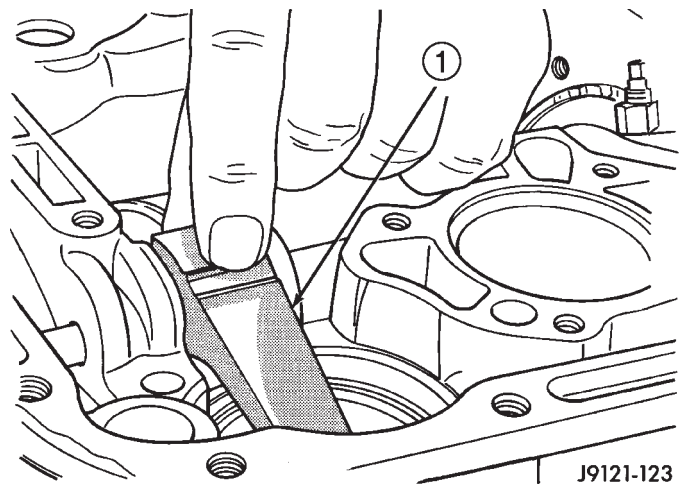
(20) Remove front band lever shaft plug, if necessary, from converter housing.

(21) Remove front band lever shaft.



**Fig. 22 Removing Front Band Strut**

- 1 - BAND LEVER
- 2 - BAND STRUT
- 3 - FRONT BAND



**Fig. 23 Removing Front Band Lever**

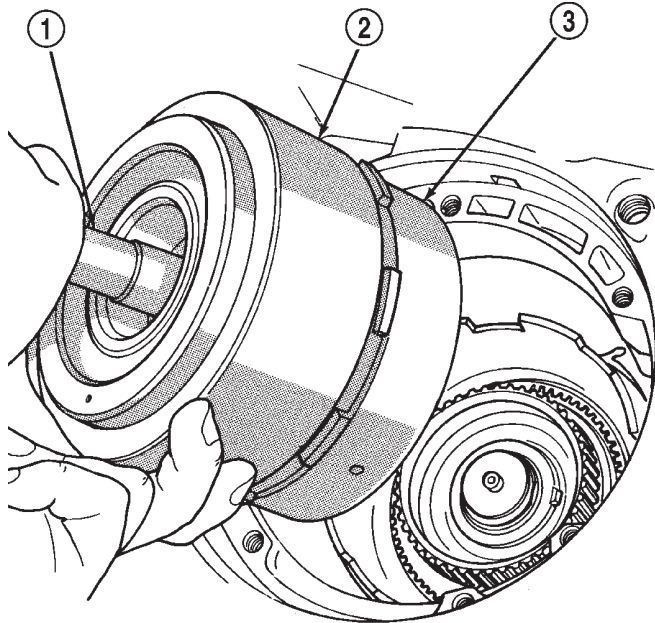
- 1 - FRONT BAND LEVER



AUTOMATIC TRANSMISSION - 44RE (Continued)

(22) Remove front and rear clutch units as assembly. Grasp input shaft, hold clutch units together and remove them from case (Fig. 24).

(23) Lift front clutch off rear clutch (Fig. 25). Set clutch units aside for overhaul.



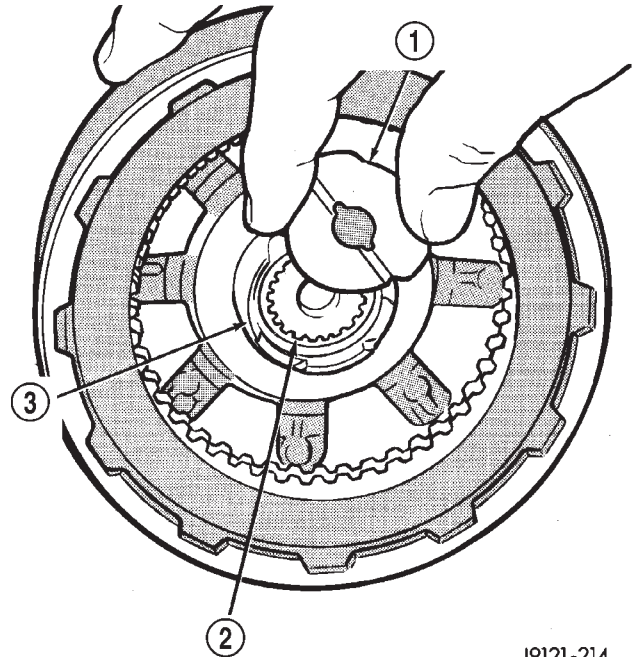
J9121-124

**Fig. 24 Removing Front/Rear Clutch Assemblies**

- 1 - INPUT SHAFT
- 2 - FRONT CLUTCH
- 3 - REAR CLUTCH

(24) Remove intermediate shaft thrust washer from front end of shaft or from rear clutch hub (Fig. 26).

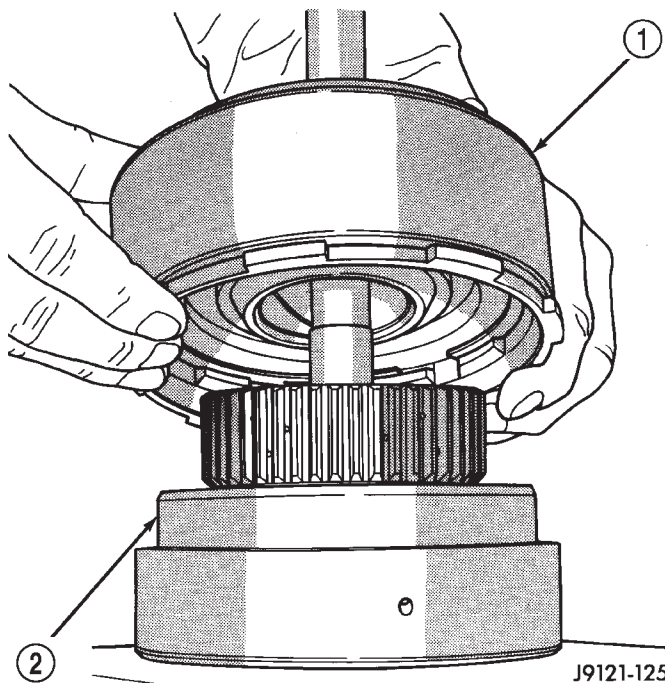
(25) Remove output shaft thrust plate from intermediate shaft hub (Fig. 27).



J9121-214

**Fig. 26 Removing Intermediate Shaft Thrust Washer**

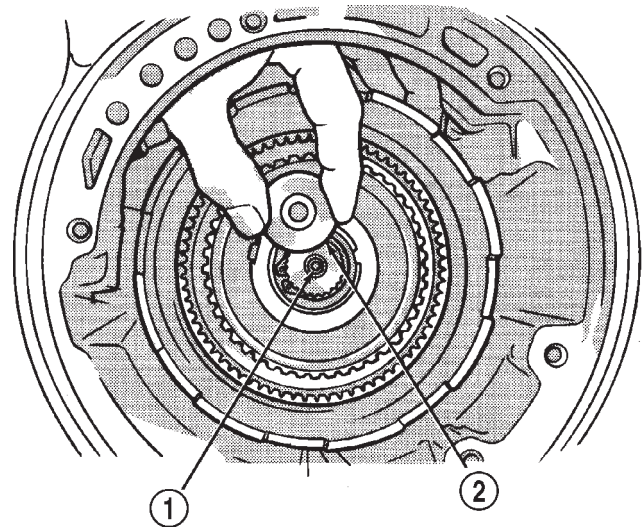
- 1 - INTERMEDIATE SHAFT THRUST WASHER
- 2 - INPUT SHAFT
- 3 - REAR CLUTCH RETAINER HUB



J9121-125

**Fig. 25 Separating Front/Rear Clutch Assemblies**

- 1 - FRONT CLUTCH
- 2 - REAR CLUTCH



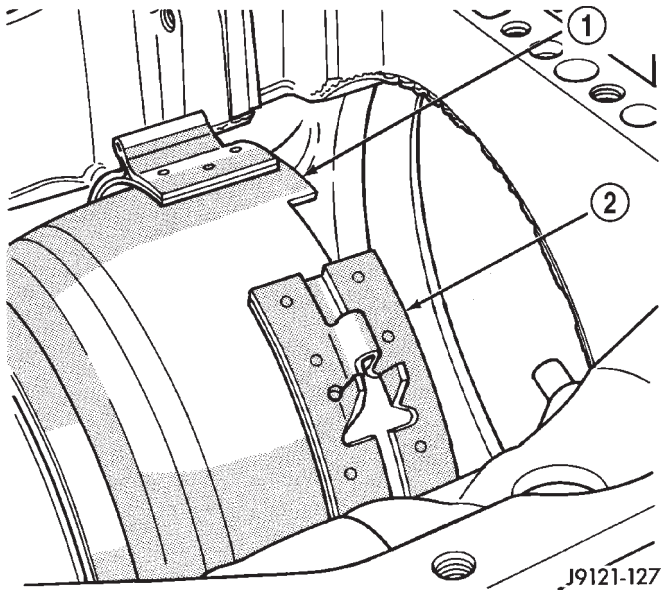
J9121-215

**Fig. 27 Removing Intermediate Shaft Thrust Plate**

- 1 - INTERMEDIATE SHAFT HUB
- 2 - INTERMEDIATE SHAFT THRUST PLATE

## AUTOMATIC TRANSMISSION - 44RE (Continued)

(26) Slide front band off driving shell (Fig. 28) and remove band from case.



**Fig. 28 Front Band Removal**

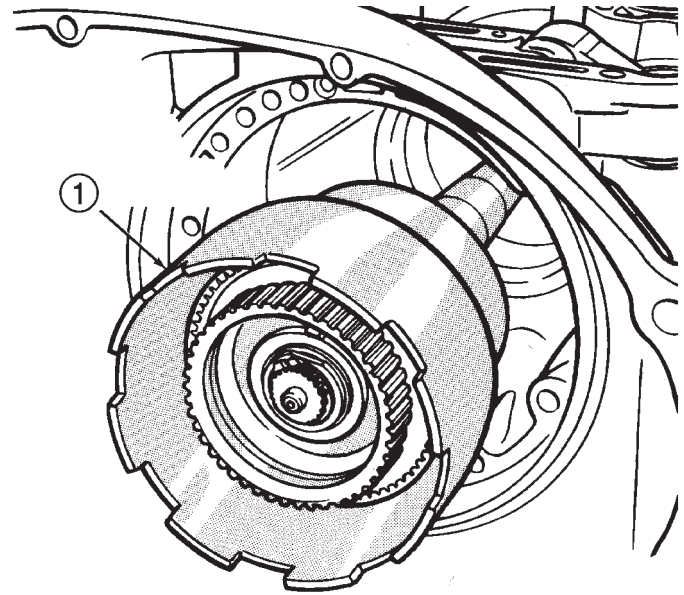
- 1 - DRIVING SHELL
- 2 - FRONT BAND

(27) Remove planetary geartrain as assembly (Fig. 29). Support geartrain with both hands during removal. Do not allow machined surfaces on intermediate shaft or overdrive piston retainer to become nicked or scratched.

(28) If overdrive unit is not to be serviced, install Alignment Shaft 6227-2 into the overdrive unit to prevent misalignment of the overdrive clutches during service of main transmission components.

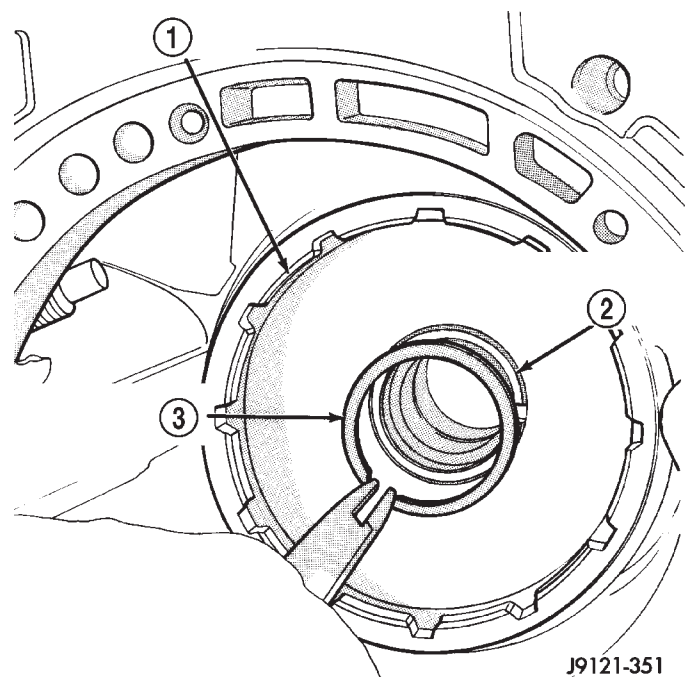
(29) Loosen rear band adjusting screw 4-5 turns.

(30) Remove low-reverse drum snap-ring (Fig. 30).



**Fig. 29 Removing Planetary Geartrain And Intermediate Shaft Assembly**

- 1 - PLANETARY GEARTRAIN AND INTERMEDIATE SHAFT ASSEMBLY

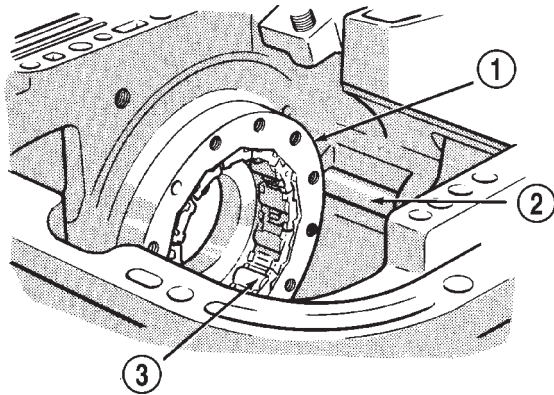


**Fig. 30 Removing Low-Reverse Drum Snap-Ring**

- 1 - LOW-REVERSE DRUM
- 2 - HUB OF OVERDRIVE PISTON RETAINER
- 3 - LOW-REVERSE DRUM SNAP-RING

## AUTOMATIC TRANSMISSION - 44RE (Continued)

- (31) Remove low-reverse drum and reverse band.  
 (32) Remove overrunning clutch roller and spring assembly as a unit (Fig. 31).  
 (33) Compress front servo rod guide about 1/8 inch with Valve Spring Compressor C-3422-B (Fig. 32).  
 (34) Remove front servo rod guide snap-ring. Exercise caution when removing snap-ring. Servo bore can be scratched or nicked if care is not exercised.  
 (35) Remove compressor tools and remove front servo rod guide, spring and servo piston.



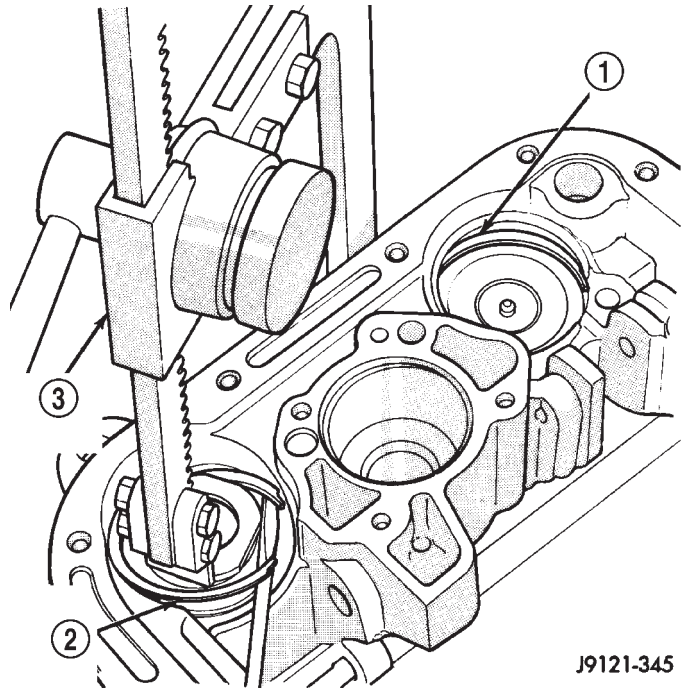
J9121-222

**Fig. 31 Overrunning Clutch Assembly Removal**

- 1 - OVERRUNNING CLUTCH CAM  
 2 - REAR BAND REACTION PIN  
 3 - OVERRUNNING CLUTCH ASSEMBLY

- (36) Compress rear servo spring retainer about 1/16 inch with Valve Spring Compressor C-3422-B (Fig. 33).  
 (37) Remove rear servo spring retainer snap-ring. Then remove compressor tools and remove rear servo spring and piston.  
 (38) Inspect transmission components.

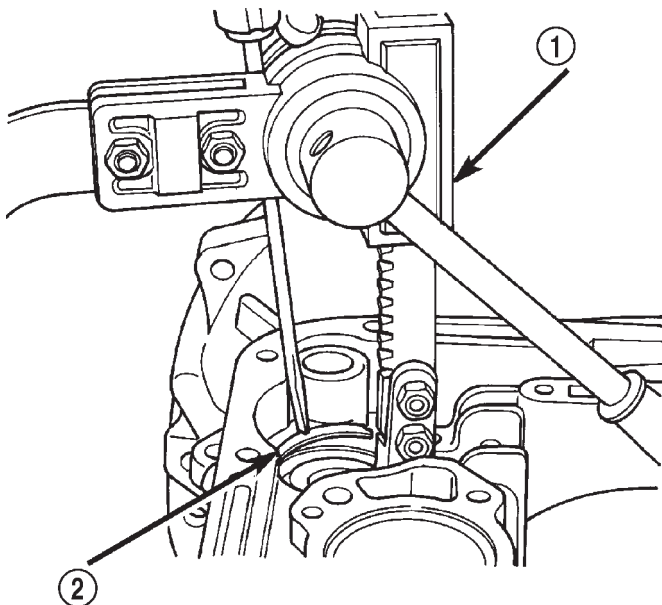
**NOTE:** To Service the overrunning clutch cam or overdrive piston retainer, refer to the Overrunning Clutch Cam service procedure in this section.



J9121-345

**Fig. 33 Compressing Rear Servo Spring**

- 1 - FRONT SERVO SNAP-RING  
 2 - REAR SERVO SNAP-RING  
 3 - SPECIAL TOOL



80be44b7

**Fig. 32 Compressing Front Servo Rod Guide**

- 1 - SPRING COMPRESSOR TOOL C-3422-B  
 2 - ROD GUIDE SNAP-RING

## CLEANING

Clean the case in a solvent tank. Flush the case bores and fluid passages thoroughly with solvent. Dry the case and all fluid passages with compressed air. Be sure all solvent is removed from the case and that all fluid passages are clear.

**NOTE:** Do not use shop towels or rags to dry the case (or any other transmission component) unless they are made from lint-free materials. Lint will stick to case surfaces and transmission components and circulate throughout the transmission after assembly. A sufficient quantity of lint can block fluid passages and interfere with valve body operation.

Lubricate transmission parts with Mopar® ATF +4, type 9602, transmission fluid during overhaul and



## AUTOMATIC TRANSMISSION - 44RE (Continued)

assembly. Use petroleum jelly, Mopar® Door Ease, or Ru-Glyde™ to prelubricate seals, O-rings, and thrust washers. Petroleum jelly can also be used to hold parts in place during reassembly.

### INSPECTION

Inspect the case for cracks, porous spots, worn bores, or damaged threads. Damaged threads can be repaired with Helicoil thread inserts. However, the case will have to be replaced if it exhibits any type of damage or wear.

Lubricate the front band adjusting screw threads with petroleum jelly and thread the screw part-way into the case. Be sure the screw turns freely.

Inspect the transmission bushings during overhaul. Bushing condition is important as worn, scored bushings contribute to low pressures, clutch slip and accelerated wear of other components. However, do not replace bushings as a matter of course. Replace bushings only when they are actually worn, or scored.

Use recommended tools to replace bushings. The tools are sized and designed to remove, install, and seat bushings correctly. The bushing replacement tools are included in Bushing Tool Set C-3887-B.

Pre-sized service bushings are available for replacement purposes. Only the sun gear bushings are not serviced.

The use of crocus cloth is permissible where necessary, providing it is used carefully. When used on shafts, or valves, use extreme care to avoid rounding off sharp edges. Sharp edges are vital as they prevent foreign matter from getting between the valve and valve bore.

Do not reuse oil seals, gaskets, seal rings, or O-rings during overhaul. Replace these parts as a matter of course. Also do not reuse snap rings or E-clips that are bent or distorted. Replace these parts as well.

### ASSEMBLY

Do not allow dirt, grease, or foreign material to enter the case or transmission components during assembly. Keep the transmission case and components clean. Also make sure the tools and workbench area used for assembly operations are equally clean.

Shop towels used for wiping off tools and hands must be made from **lint free** material. Lint will stick to transmission parts and could interfere with valve operation, or even restrict fluid passages.

Lubricate the transmission components with Mopar® transmission fluid during reassembly. Use Mopar® Door Ease, or Ru-Glyde™ on seals and O-rings to ease installation.

Petroleum jelly can also be used to hold thrust washers, thrust plates and gaskets in position during

assembly. However, **do not** use chassis grease, bearing grease, white grease, or similar lubricants on any transmission part. These types of lubricants can eventually block or restrict fluid passages and interfere with valve operation. Use petroleum jelly only.

Do not force parts into place. The transmission components and subassemblies are easily installed by hand when properly aligned.

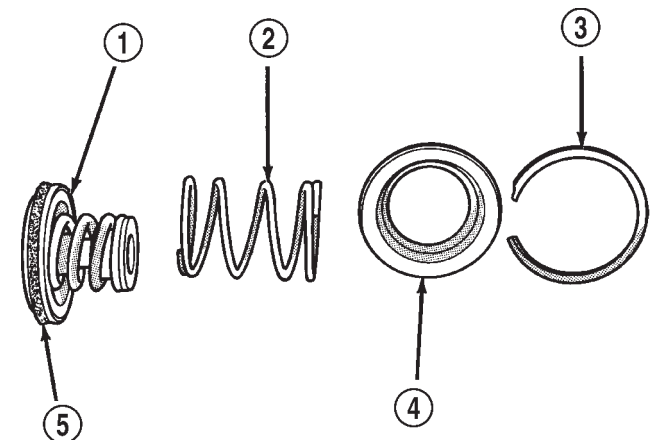
If a part seems extremely difficult to install, it is either misaligned or incorrectly assembled. Also verify that thrust washers, thrust plates and seal rings are correctly positioned before assembly. These parts can interfere with proper assembly if mis-positioned.

The planetary geartrain, front/rear clutch assemblies and oil pump are all much easier to install when the transmission case is upright.

(1) Install rear servo piston, spring and retainer (Fig. 34). Install spring on top of servo piston and install retainer on top of spring.

(2) Install front servo piston assembly, servo spring and rod guide (Fig. 35).

(3) Compress front/rear servo springs with Valve Spring Compressor C-3422-B and install each servo snap-ring (Fig. 36).

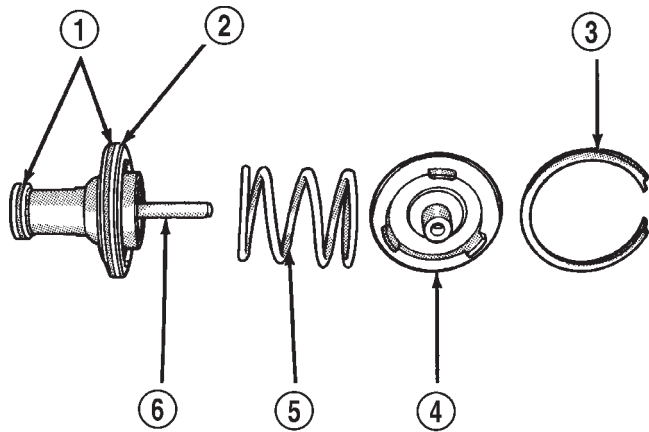


J9121-343

**Fig. 34 Rear Servo Components**

- 1 - SERVO PISTON
- 2 - PISTON SPRING
- 3 - SNAP-RING
- 4 - RETAINER
- 5 - PISTON SEAL

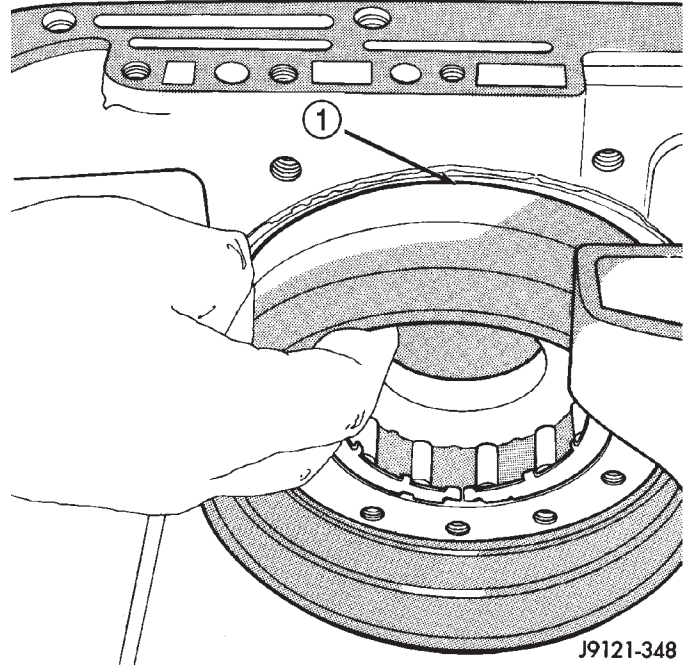
AUTOMATIC TRANSMISSION - 44RE (Continued)



J9121-344

**Fig. 35 Front Servo Components**

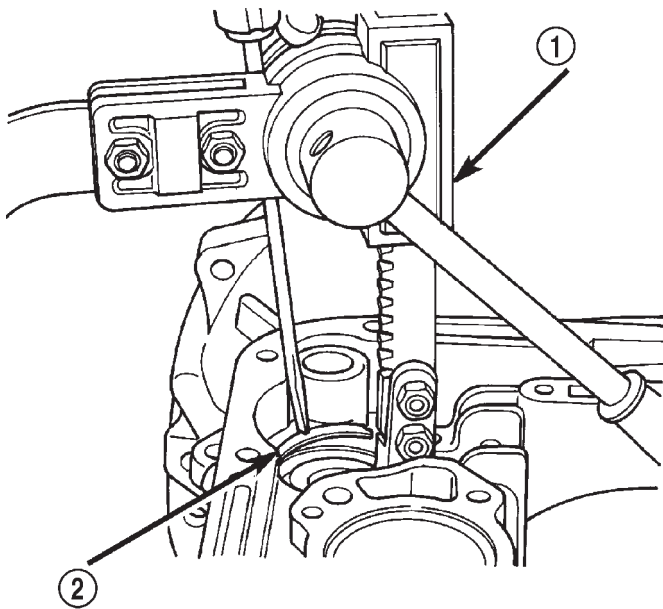
- 1 - PISTON SEAL RINGS
- 2 - SERVO PISTON
- 3 - SNAP-RING
- 4 - ROD GUIDE
- 5 - SPRING
- 6 - ROD



J9121-348

**Fig. 37 Rear Band Installation**

- 1 - REAR BAND



80be44b7

**Fig. 36 Compressing Front/Rear Servo Springs**

- 1 - SPRING COMPRESSOR TOOL C-3422-B
- 2 - ROD GUIDE SNAP-RING

(4) Lubricate clutch cam rollers with transmission fluid.

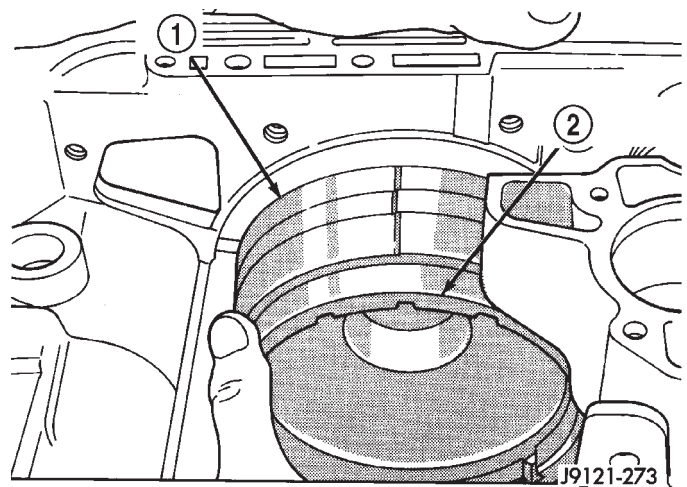
(5) Install rear band in case (Fig. 37). Be sure twin lugs on band are seated against reaction pin.

(6) Install low-reverse drum and check overrunning clutch operation as follows:

(a) Lubricate overrunning clutch race (on drum hub) with transmission fluid.

- (b) Guide drum through rear band.
- (c) Tilt drum slightly and start race (on drum hub) into overrunning clutch rollers.
- (d) Press drum rearward and turn it in clockwise direction until drum seats in overrunning clutch (Fig. 38).

(e) Turn drum back and forth. Drum should rotate freely in clockwise direction and lock in counterclockwise direction (as viewed from front of case).



J9121-273

**Fig. 38 Installing Low-Reverse Drum**

- 1 - REAR BAND
- 2 - LOW-REVERSE DRUM

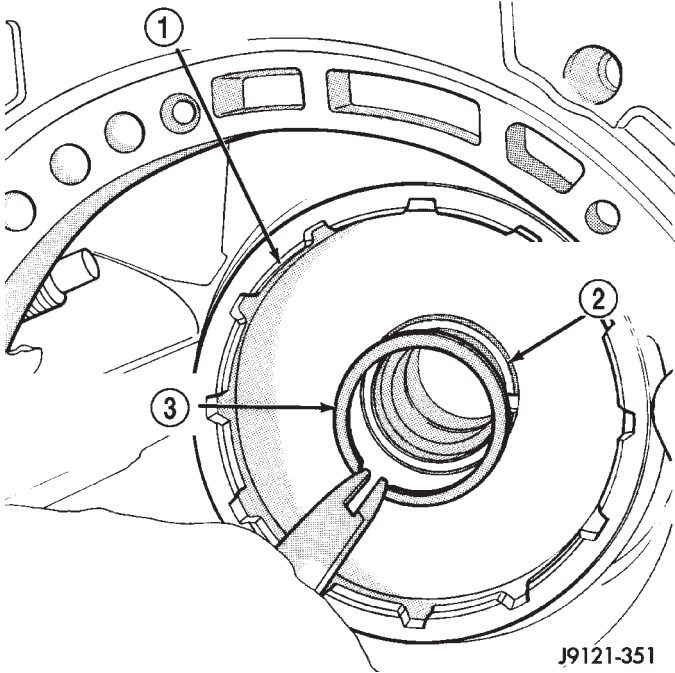


AUTOMATIC TRANSMISSION - 44RE (Continued)

(7) Install snap-ring that secures low-reverse drum to hub of overdrive piston retainer (Fig. 39).

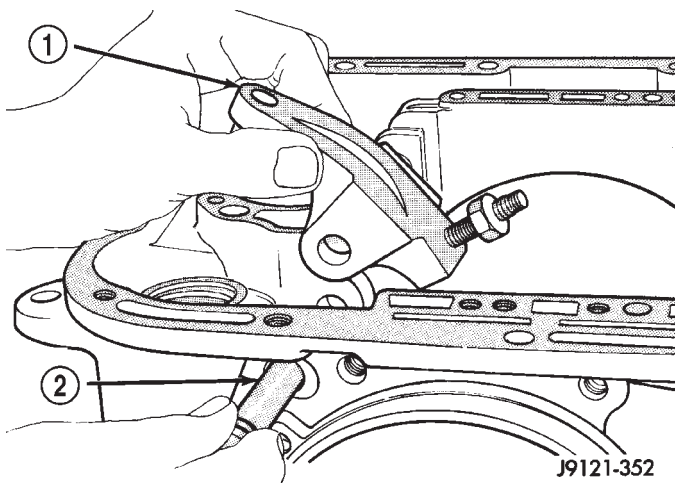
(8) Install rear band lever and pivot pin (Fig. 40). Align lever with pin bores in case and push pivot pin into place.

(9) Install planetary geartrain assembly (Fig. 41).



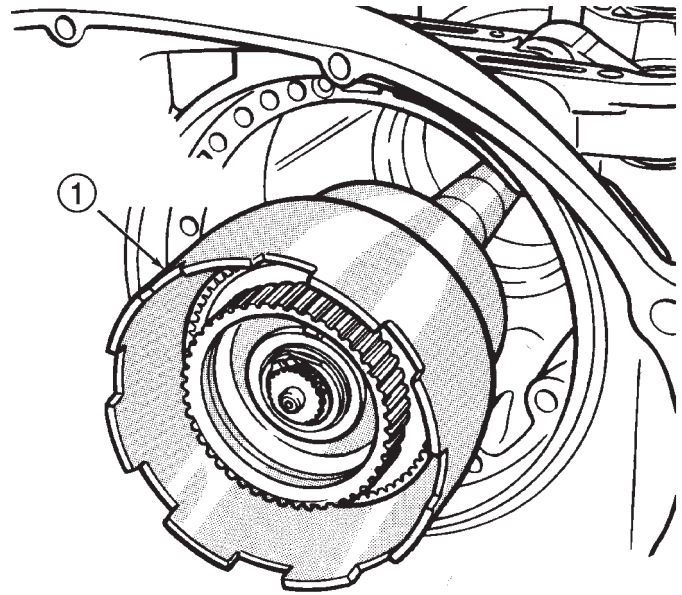
**Fig. 39 Installing Low-Reverse Drum Retaining Snap-Ring**

- 1 - LOW-REVERSE DRUM
- 2 - HUB OF OVERDRIVE PISTON RETAINER
- 3 - LOW-REVERSE DRUM SNAP-RING



**Fig. 40 Rear Band Lever And Pivot Pin Installation**

- 1 - REAR BAND LEVER
- 2 - LEVER PIVOT PIN

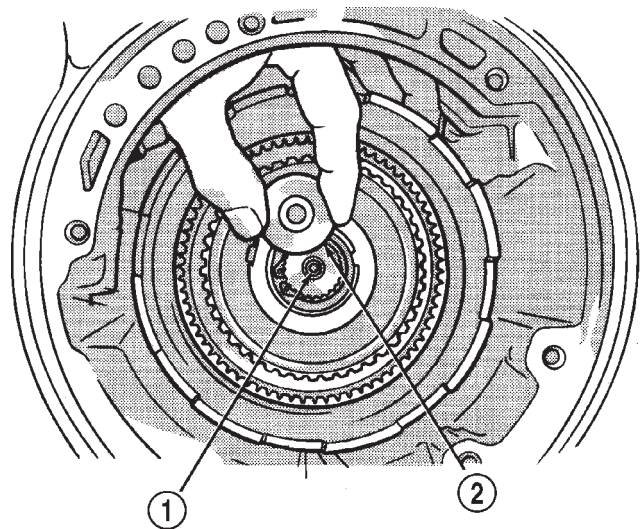


J9121-217

**Fig. 41 Installing Planetary Geartrain**

- 1 - PLANETARY GEARTRAIN AND INTERMEDIATE SHAFT ASSEMBLY

(10) Install thrust plate on intermediate shaft hub (Fig. 42). Use petroleum jelly to hold thrust plate in place.



J9121-215

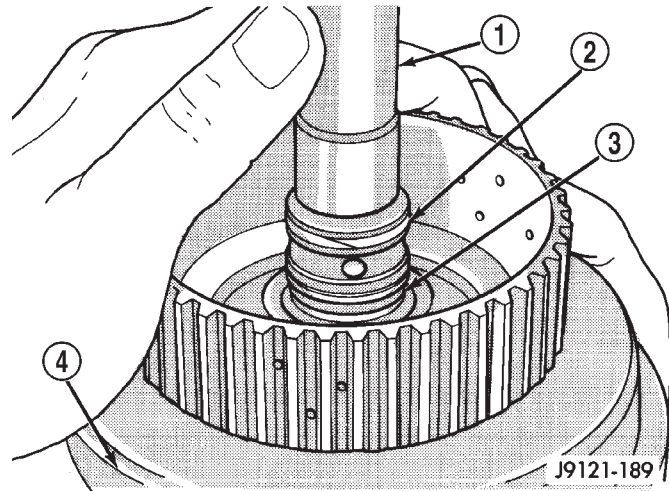
**Fig. 42 Installing Intermediate Shaft Thrust Plate**

- 1 - INTERMEDIATE SHAFT HUB
- 2 - INTERMEDIATE SHAFT THRUST PLATE

AUTOMATIC TRANSMISSION - 44RE (Continued)

(11) Check seal ring on rear clutch retainer hub and seal rings on input shaft (Fig. 43). Also verify that shaft seal rings are installed in sequence shown.

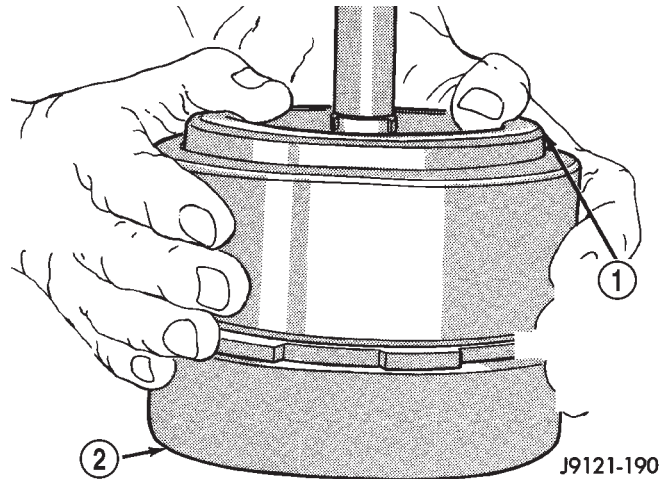
(12) Install rear clutch thrust washer (Fig. 44). Use additional petroleum jelly to hold washer in place if necessary.



**Fig. 43 Input Shaft Seal Ring Location**

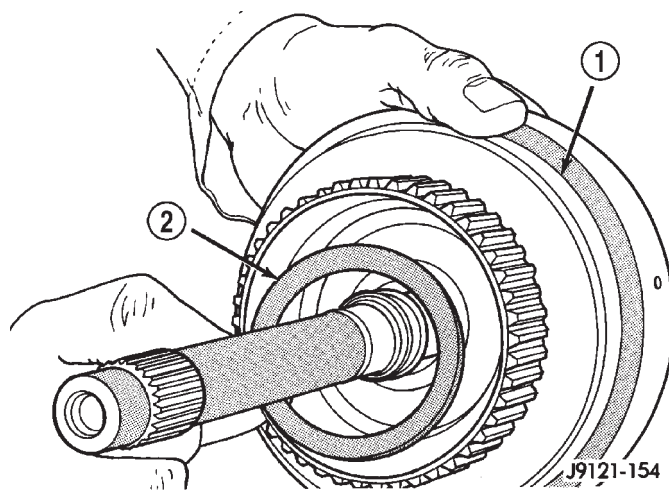
- 1 - INPUT SHAFT
- 2 - TEFLON SEAL RING
- 3 - PLASTIC SEAL RING
- 4 - REAR CLUTCH RETAINER

washer in place. Be sure grooved side of washer faces rearward (toward output shaft) as shown. Also note that washer only fits one way in clutch hub. Note thickness of this washer. It is a select fit part and is used to control transmission end play.



**Fig. 45 Assembling Front And Rear Clutch Units**

- 1 - TURN FRONT CLUTCH BACK & FORTH UNTIL SEATED
- 2 - REAR CLUTCH ASSEMBLY

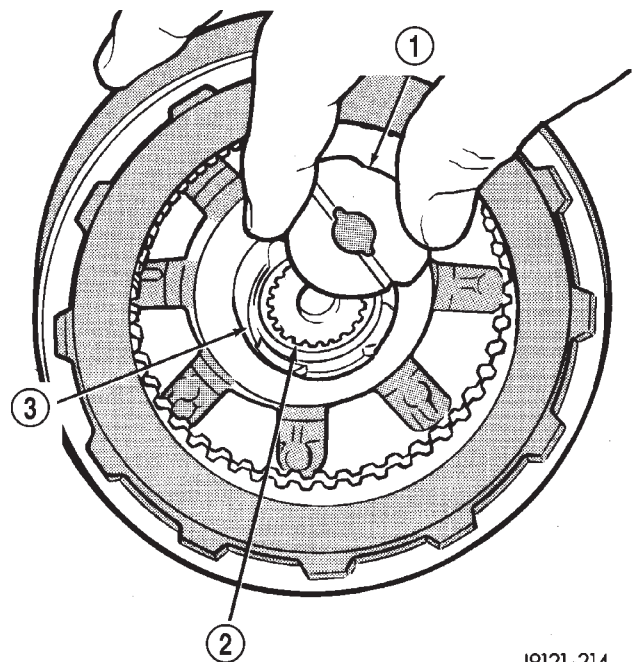


**Fig. 44 Installing Rear Clutch Thrust Washer**

- 1 - REAR CLUTCH RETAINER
- 2 - REAR CLUTCH THRUST WASHER (FIBER)

(13) Align clutch discs in front clutch and install front clutch on rear clutch (Fig. 45). Rotate front clutch retainer back and forth until completely seated on rear clutch retainer.

(14) Coat intermediate shaft thrust washer with petroleum jelly. Then install washer in rear clutch hub (Fig. 46). Use enough petroleum jelly to hold



**Fig. 46 Installing Intermediate Shaft Thrust Plate**

- 1 - INTERMEDIATE SHAFT THRUST WASHER
- 2 - INPUT SHAFT
- 3 - REAR CLUTCH RETAINER HUB



## AUTOMATIC TRANSMISSION - 44RE (Continued)

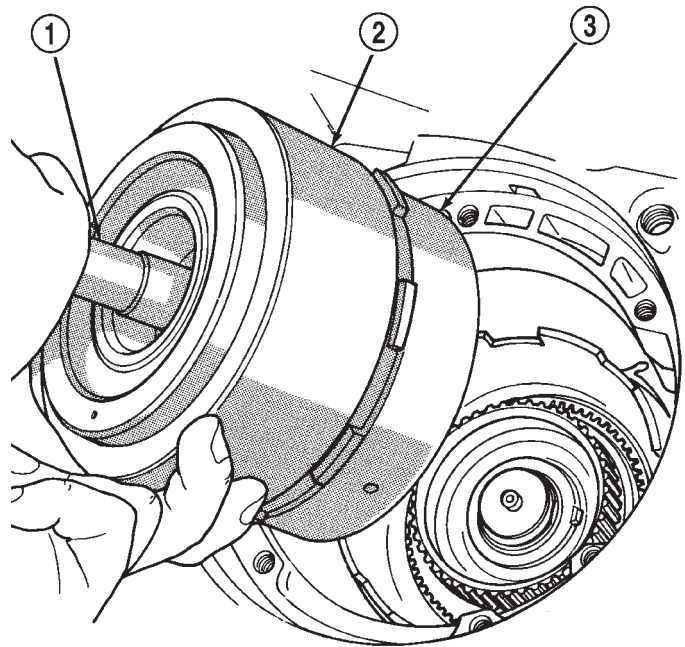
(15) Align drive teeth on rear clutch discs with small screwdriver (Fig. 47). This makes installation on front planetary easier.

(16) Raise front end of transmission upward as far as possible and support case with wood blocks. Front/rear clutch and oil pump assemblies are easier to install if transmission is as close to upright position as possible.

(17) Slide front band into case.

(18) Install front and rear clutch units as assembly (Fig. 48). Align rear clutch with front annulus gear and install assembly in driving shell. Be sure output shaft thrust washer and thrust plate are not displaced during installation.

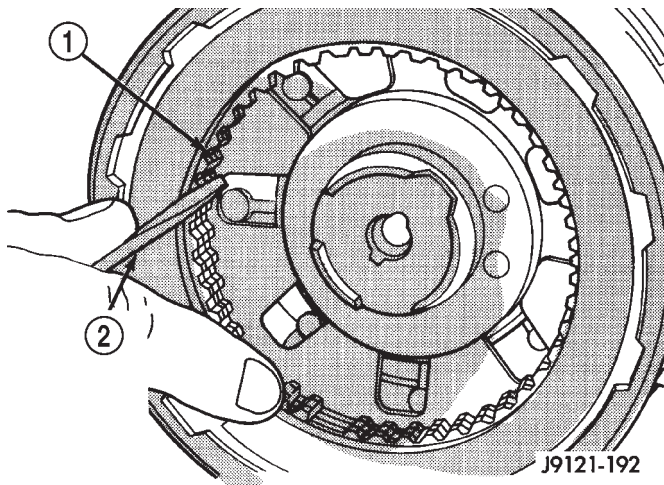
(19) Carefully work assembled clutches back and forth to engage and seat rear clutch discs on front annulus gear. Also be sure front clutch drive lugs are fully engaged in slots of driving shell after installation.



J9121-124

**Fig. 48 Installing Front/Rear Clutch Assemblies**

- 1 - INPUT SHAFT
- 2 - FRONT CLUTCH
- 3 - REAR CLUTCH



J9121-192

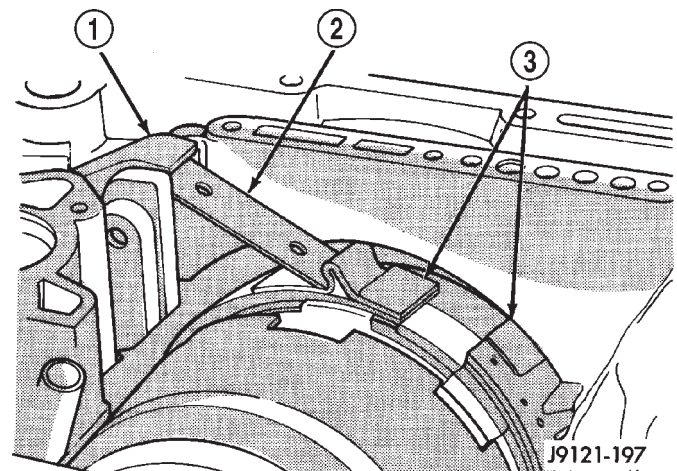
**Fig. 47 Aligning Rear Clutch Disc Lugs**

- 1 - REAR CLUTCH DISCS
- 2 - USE SMALL SCREWDRIVER TO ALIGN CLUTCH DISC TEETH

(20) Assemble front band strut.

(21) Install front band adjuster, strut and adjusting screw (Fig. 49).

(22) Tighten band adjusting screw until band just grips clutch retainer. Verify that front/rear clutches are still seated before continuing.



J9121-197

**Fig. 49 Front Band Linkage Installation**

- 1 - BAND LEVER
- 2 - BAND STRUT
- 3 - FRONT BAND

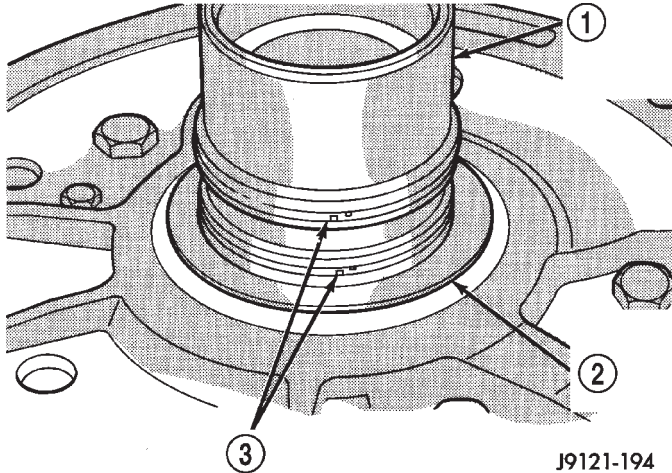
## AUTOMATIC TRANSMISSION - 44RE (Continued)

(23) Check seal rings on reaction shaft support hub. Verify that seal rings are hooked together and that front clutch thrust washer is properly positioned (Fig. 50). Use petroleum jelly to hold thrust washer in place if necessary.

(24) Lubricate oil pump body seal with petroleum jelly. Lubricate pump shaft seal lip with petroleum jelly.

(25) Thread two Pilot Stud Tools C-3288-B into bolt holes in oil pump bore flange (Fig. 51).

(26) Align and install oil pump gasket (Fig. 51).

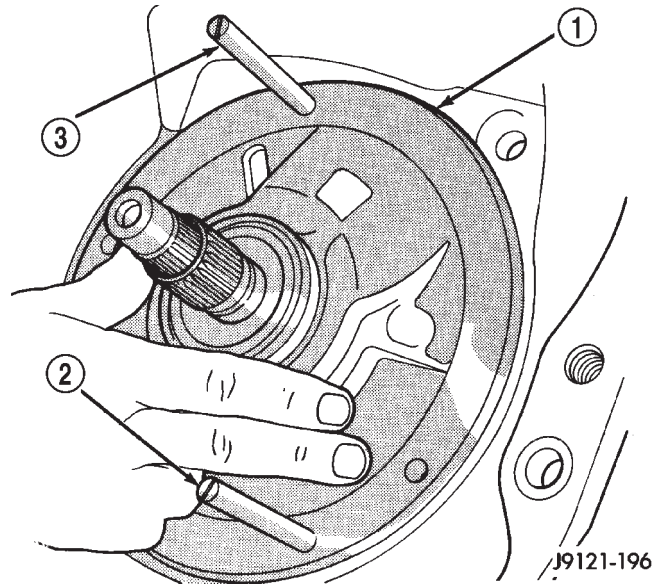


**Fig. 50 Reaction Shaft Support Seal Rings And Front Clutch Thrust Washer**

- 1 - REACTION SHAFT SUPPORT HUB
- 2 - FRONT CLUTCH THRUST WASHER
- 3 - SEAL RINGS

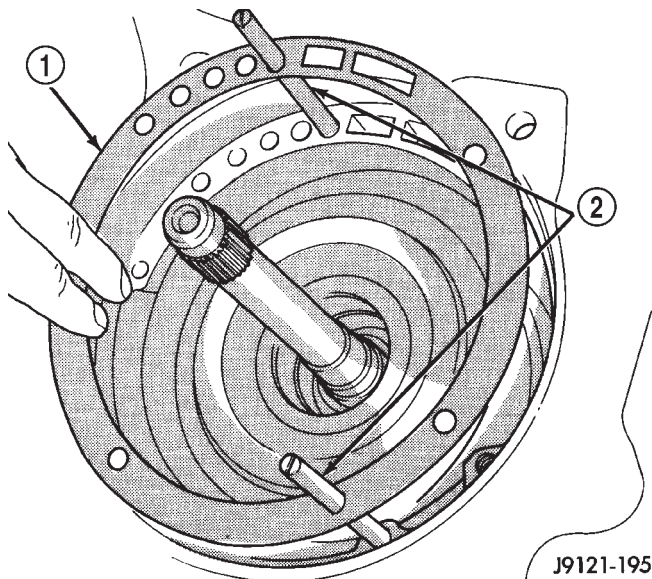
(27) Install oil pump (Fig. 52). Align and position pump on pilot studs. Slide pump down studs and work it into front clutch hub and case by hand. Then install 2 or 3 pump bolts to hold pump in place.

(28) Remove pilot stud tools and install remaining oil pump bolts. Tighten bolts alternately in diagonal pattern to 20 N·m (15 ft. lbs.).



**Fig. 52 Installing Oil Pump**

- 1 - OIL PUMP
- 2 - PILOT STUD TOOL
- 3 - PILOT STUD TOOL



**Fig. 51 Installing Pilot Studs And Oil Pump Gasket**

- 1 - OIL PUMP GASKET
- 2 - PILOT STUD TOOLS C-3288-B

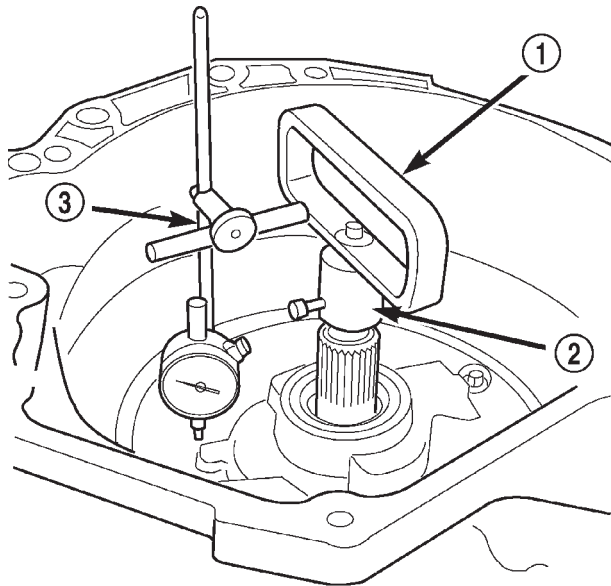
(29) Measure input shaft end play (Fig. 53).

**NOTE:** If end play is incorrect, transmission is incorrectly assembled, or the intermediate shaft thrust washer is incorrect. The intermediate shaft thrust washer is selective.

- (a) Attach Adapter 8266-6 to Handle 8266-8.
  - (b) Attach dial indicator C-3339 to Handle 8266-8.
  - (c) Install the assembled tool onto the input shaft of the transmission and tighten the retaining screw on Adapter 8266-6 to secure it to the input shaft.
  - (d) Position the dial indicator plunger against a flat spot on the oil pump and zero the dial indicator.
  - (e) Move input shaft in and out and record reading. End play should be 0.56-2.31 mm (0.022-0.091 in.). Adjust as necessary.
- (30) Install accumulator piston and inner and outer springs (Fig. 54).
- (31) Verify that valve body solenoid harness is secured in 3-4 accumulator housing cover plate.
- (32) Install valve body as follows:



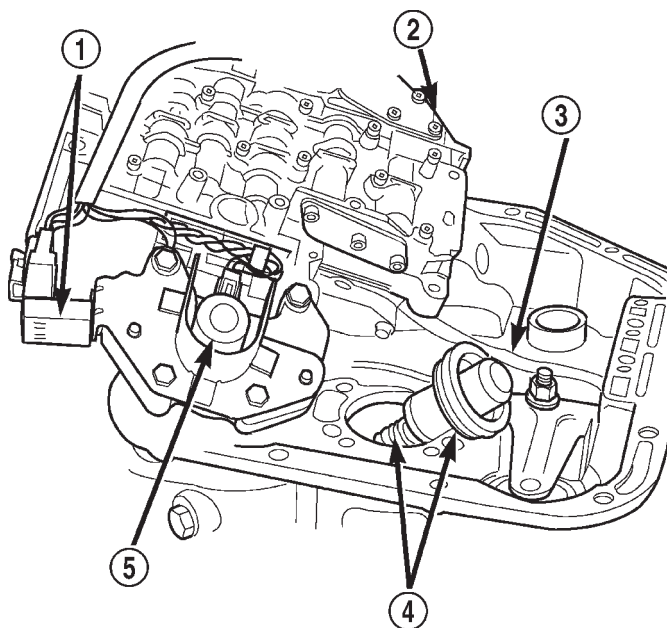
## AUTOMATIC TRANSMISSION - 44RE (Continued)



80c070b5

**Fig. 53 Checking Input Shaft End Play**

- 1 - TOOL 8266-8
- 2 - TOOL 8266-6
- 3 - TOOL C-3339



80c072b8

**Fig. 54 Accumulator Piston And Springs**

- 1 - GOVERNOR PRESSURE SENSOR
- 2 - VALVE BODY
- 3 - PARK ROD
- 4 - ACCUMULATOR PISTON
- 5 - GOVERNOR PRESSURE SOLENOID

(a) Align and carefully insert park rod into pawl. Rod will make click noise as it enters pawl. Move rod slightly to check engagement.

(b) Align and seat valve body on case. Be sure manual lever shaft and overdrive connector are fully seated in case. Also be sure valve body wiring is not pinched or kinked.

(c) Install and start all valve body attaching bolts by hand. Then tighten bolts evenly, in a diagonal pattern to 12 N·m (105 in. lbs.) torque. Do not overtighten valve body bolts. This could result in distortion and cross leakage after installation.

**CAUTION:** It is possible for the park rod to displace into a cavity just above the pawl sprag during installation. Make sure the rod is actually engaged in the pawl and has not displaced into the cavity.

(33) Install new filter on valve body. Tighten filter screws to 4 N·m (35 in. lbs.).

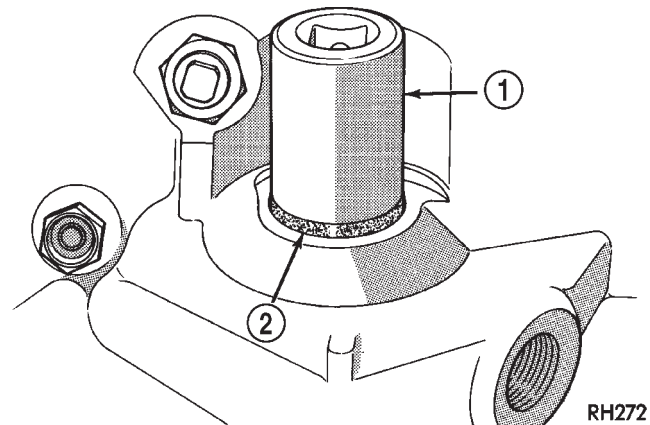
(34) Adjust front and rear bands.

(35) Install seal on park/neutral position switch. Then install and tighten switch to 34 N·m (25 ft. lbs.).

(36) Install magnet in oil pan. Magnet goes on small protrusion at corner of pan.

(37) Position new oil pan gasket on case and install oil pan. Tighten pan bolts to 17 N·m (13 ft. lbs.).

(38) Install new valve body manual shaft seal in case (Fig. 55). Lubricate seal lip and manual shaft with petroleum jelly. Start seal over shaft and into case. Seat seal with 15/16 inch, deep well socket.



RH272

**Fig. 55 Installing Manual Lever Shaft Seal**

- 1 - 15/16" SOCKET
- 2 - SEAL

(39) Install throttle valve and shift selector levers on valve body manual lever shaft.



## AUTOMATIC TRANSMISSION - 44RE (Continued)

## INSTALLATION

(1) Check torque converter hub and hub drive notches for sharp edges burrs, scratches, or nicks. Polish the hub and notches with 320/400 grit paper and crocus cloth if necessary. The hub must be smooth to avoid damaging pump seal at installation.

(2) Lubricate pocket in the rear oil pump seal lip with transmission fluid.

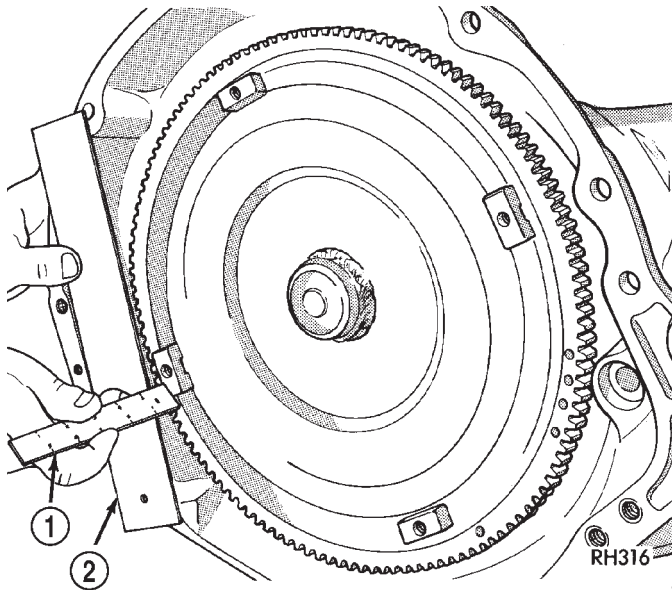
(3) Lubricate converter pilot hub of the crankshaft with a light coating of Mopar® High Temp Grease.

(4) Align and install converter in oil pump.

(5) Carefully insert converter in oil pump. Then rotate converter back and forth until fully seated in pump gears.

(6) Check converter seating with steel scale and straightedge (Fig. 56). Surface of converter lugs should be 1/2 in. to rear of straightedge when converter is fully seated.

(7) Temporarily secure converter with C-clamp.



**Fig. 56 Checking Converter Seating - Typical**

1 - SCALE

2 - STRAIGHTEDGE

(8) Position transmission on jack and secure it with chains.

(9) Check condition of converter driveplate. Replace the plate if cracked, distorted or damaged. **Also be sure transmission dowel pins are seated in engine block and protrude far enough to hold transmission in alignment.**

(10) Raise transmission and align converter with drive plate and converter housing with engine block.

(11) Move transmission forward. Then raise, lower or tilt transmission to align converter housing with engine block dowels.

(12) Carefully work transmission forward and over engine block dowels until converter hub is seated in crankshaft.

(13) Install bolts attaching converter housing to engine.

(14) Install rear support. Then lower transmission onto crossmember and install bolts attaching transmission mount to crossmember.

(15) Remove engine support fixture.

(16) Install crankshaft position sensor. (Refer to 14 - FUEL SYSTEM/FUEL INJECTION/CRANKSHAFT POSITION SENSOR - INSTALLATION)

(17) Install new plastic retainer grommet on any shift linkage rod or lever that was disconnected. Grommets should not be reused. Use pry tool to remove rod from grommet and cut away old grommet. Use pliers to snap new grommet into lever and to snap rod into grommet at assembly.

(18) Connect gearshift and throttle cable to transmission.

(19) Connect wires to park/neutral position switch, transmission solenoid(s) and oxygen sensor. Be sure transmission harnesses are properly routed.

**CAUTION: It is essential that correct length bolts be used to attach the converter to the driveplate. Bolts that are too long will damage the clutch surface inside the converter.**

(20) Install torque converter-to-driveplate bolts. On models with 10.75 in. converter, tighten bolts to 31 N·m (270 in. lbs.). On models with 12.2 in. converter, tighten bolts to 47 N·m (35 ft. lbs.).

(21) Install converter housing access cover.

(22) Install starter motor and cooler line bracket. (Refer to 8 - ELECTRICAL/STARTING/STARTER MOTOR - INSTALLATION)

(23) Connect cooler lines to transmission.

(24) Install transmission fill tube. Install new seal on tube before installation.

(25) Install exhaust components.

(26) Align and connect propeller shaft. (Refer to 3 - DIFFERENTIAL & DRIVELINE/PROPELLER SHAFT/PROPELLER SHAFT - INSTALLATION)

(27) Adjust gearshift linkage and throttle valve cable if necessary.

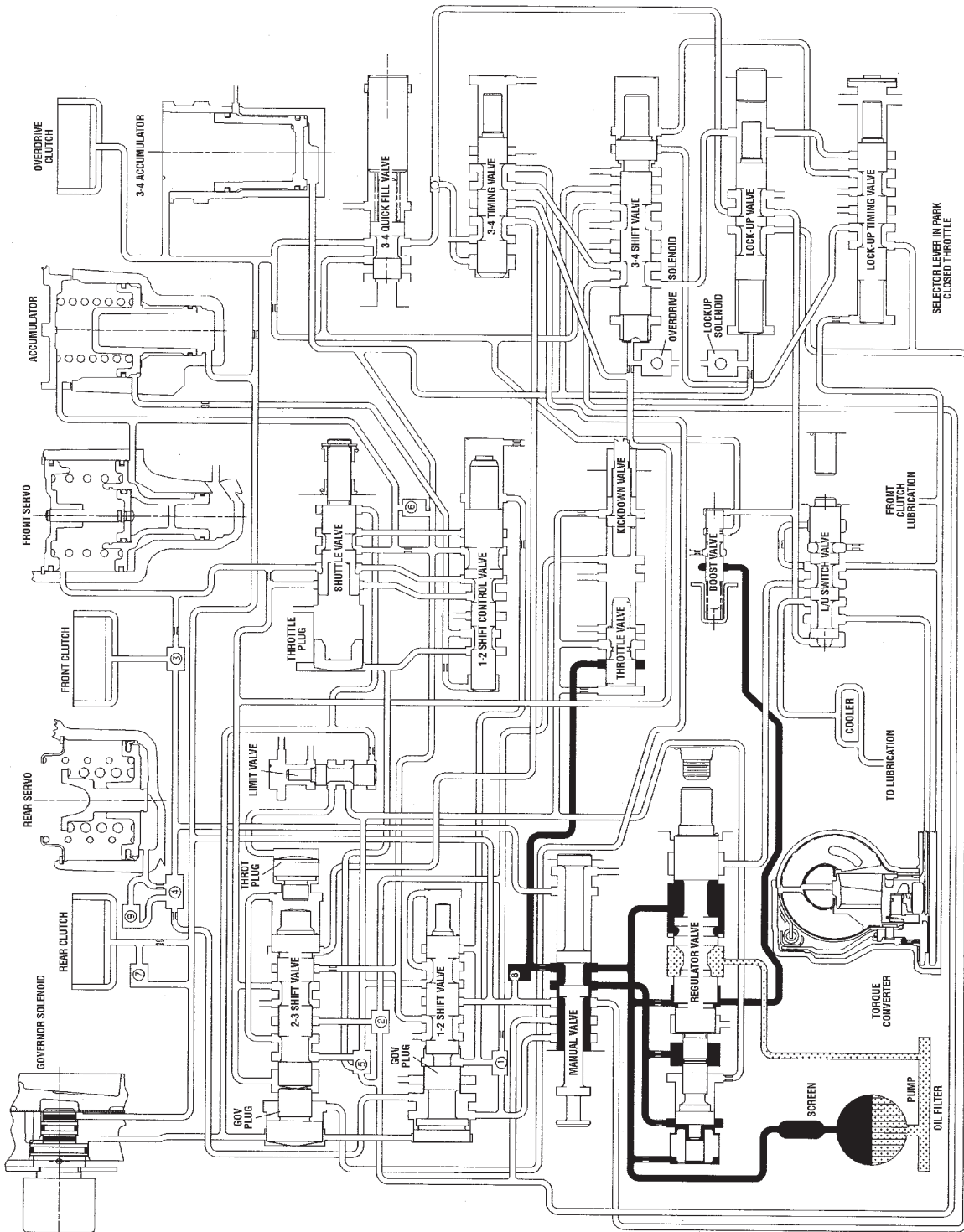
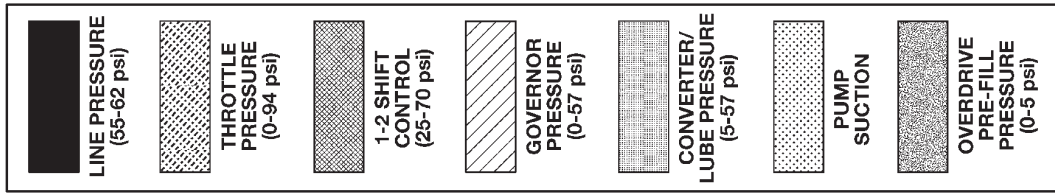
(28) Lower vehicle.

(29) Fill transmission with Mopar® ATF +4, type 9602, Automatic Transmission fluid.

AUTOMATIC TRANSMISSION - 44RE (Continued)

SCHEMATICS AND DIAGRAMS

HYDRAULIC SCHEMATICS

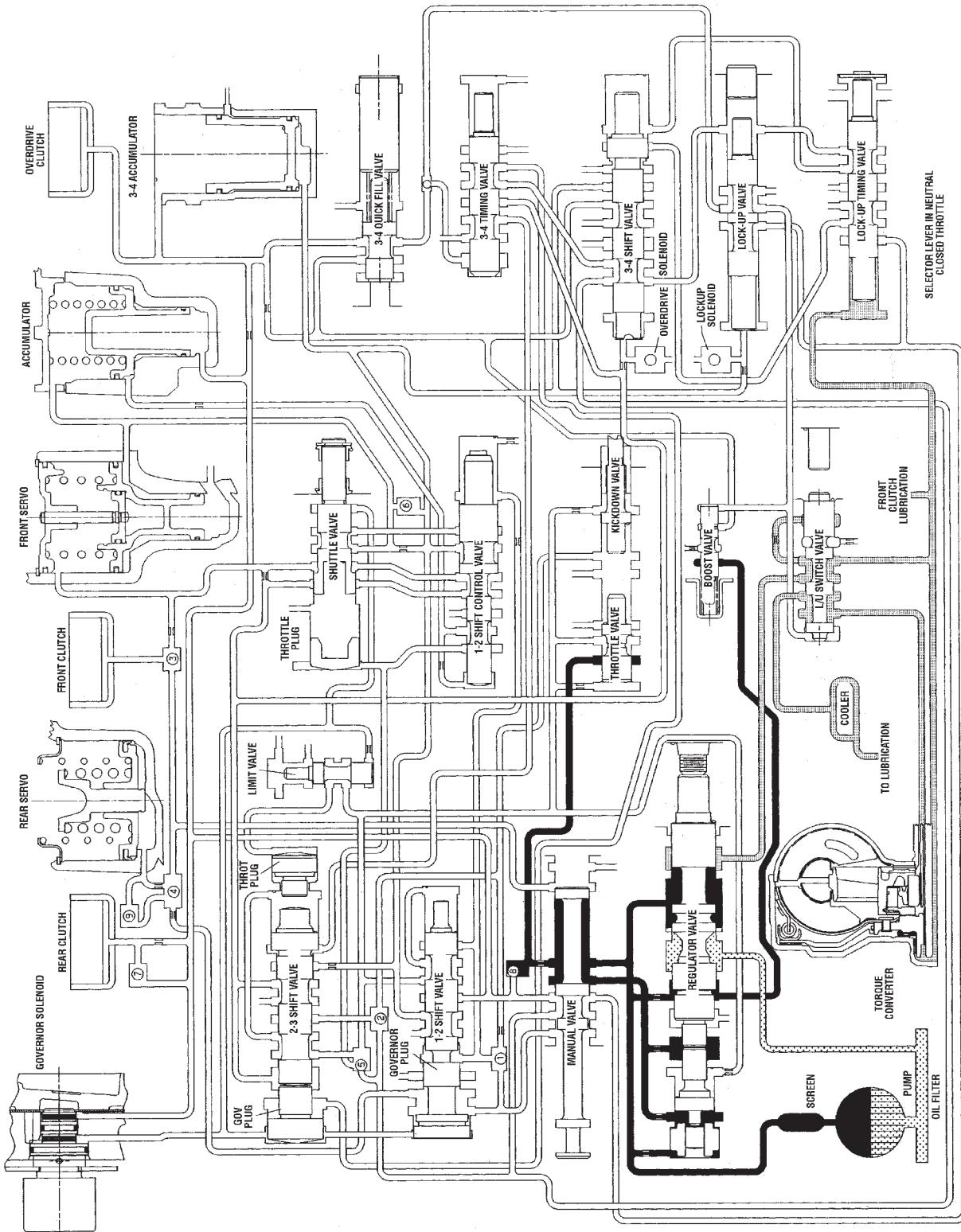
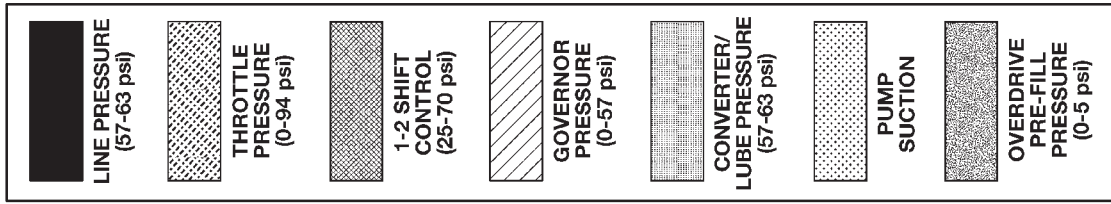


8080593

HYDRAULIC FLOW IN PARK

AUTOMATIC TRANSMISSION - 44RE (Continued)

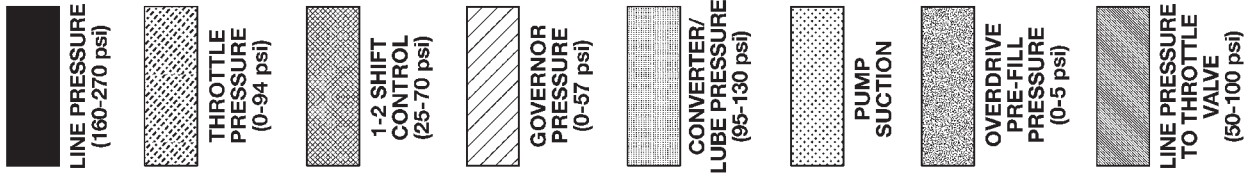
80860594



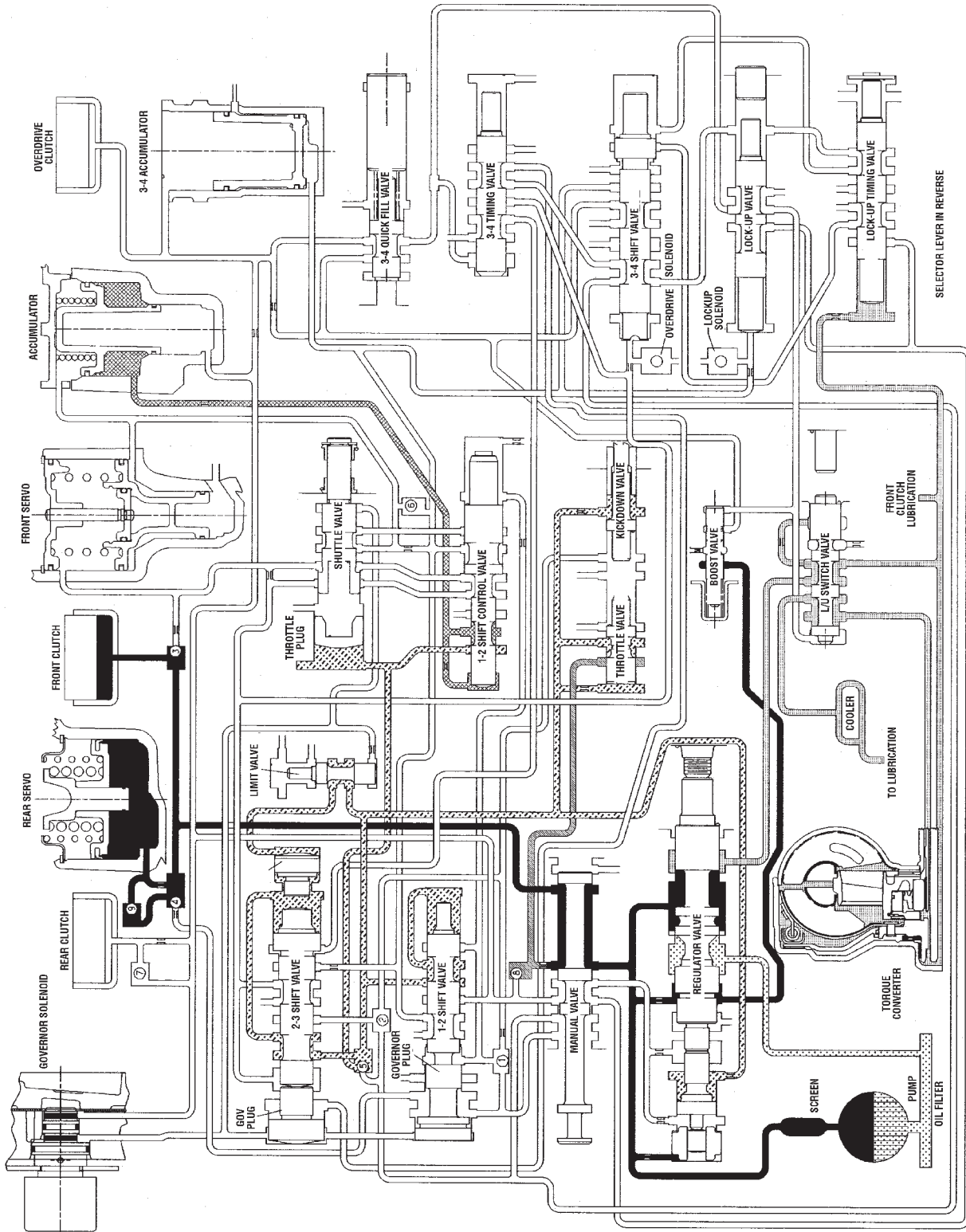
HYDRAULIC FLOW IN NEUTRAL

SELECTOR LEVER IN NEUTRAL  
CLOSED THROTTLE

AUTOMATIC TRANSMISSION - 44RE (Continued)



60860595

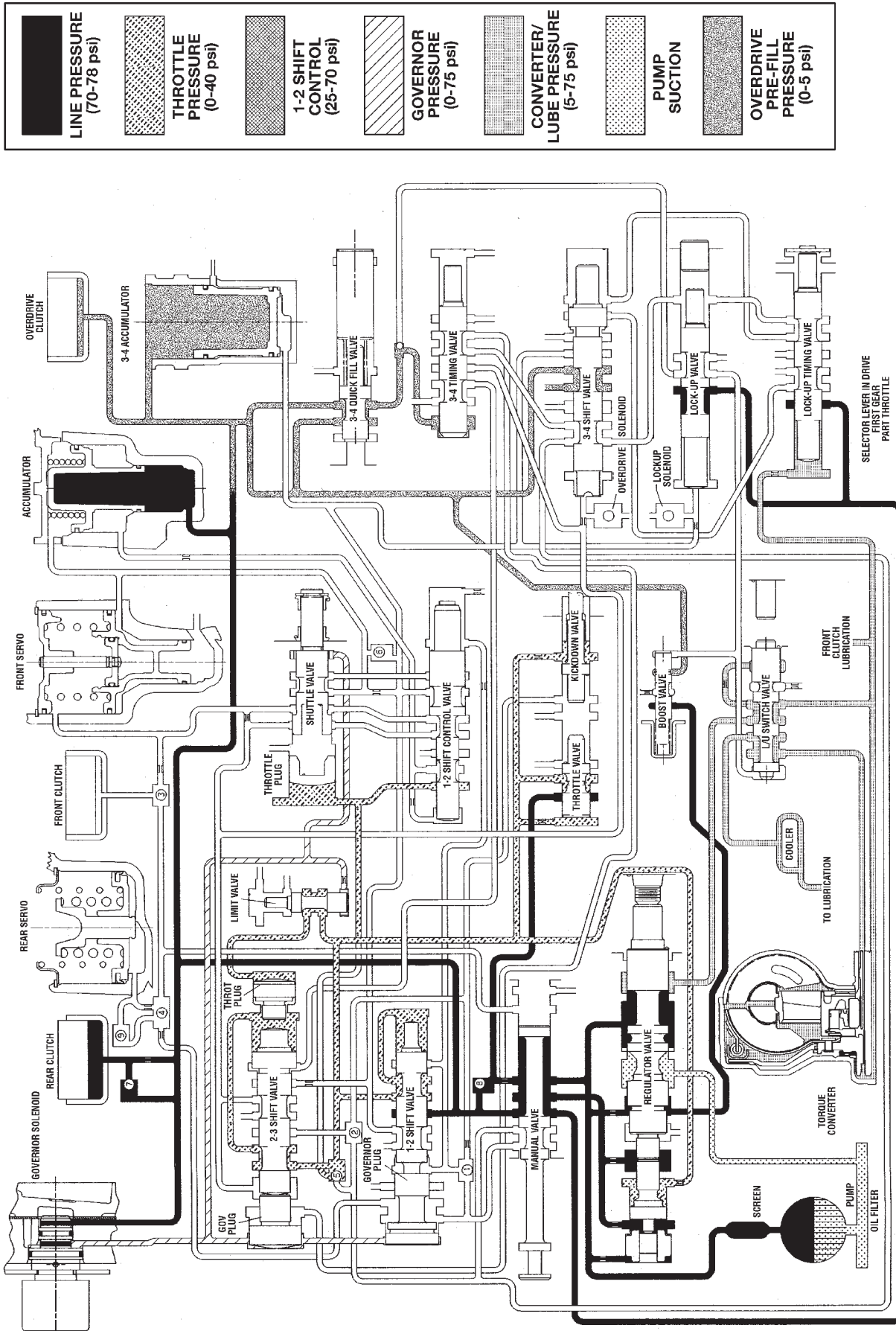


HYDRAULIC FLOW IN REVERSE



AUTOMATIC TRANSMISSION - 44RE (Continued)

80880596

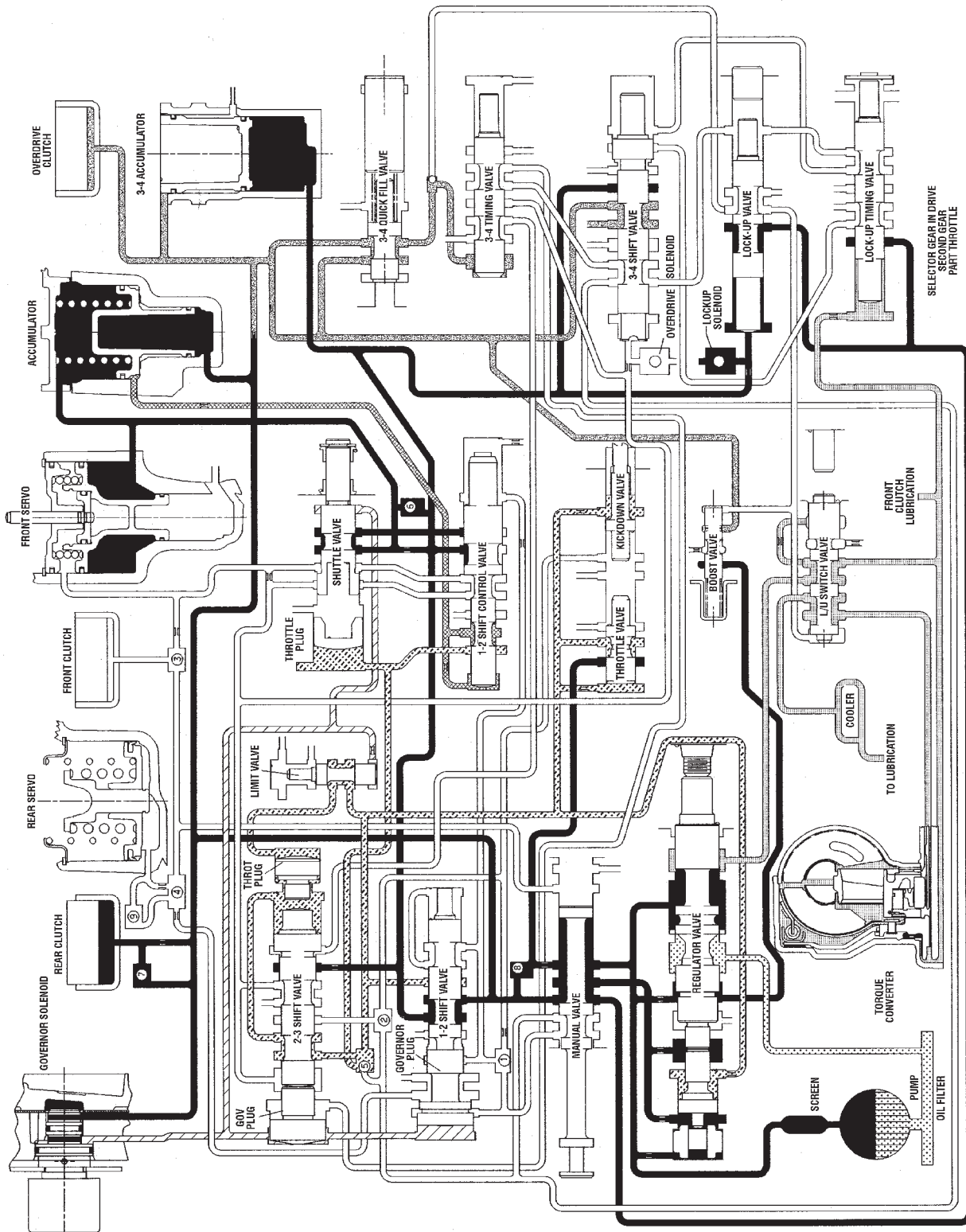
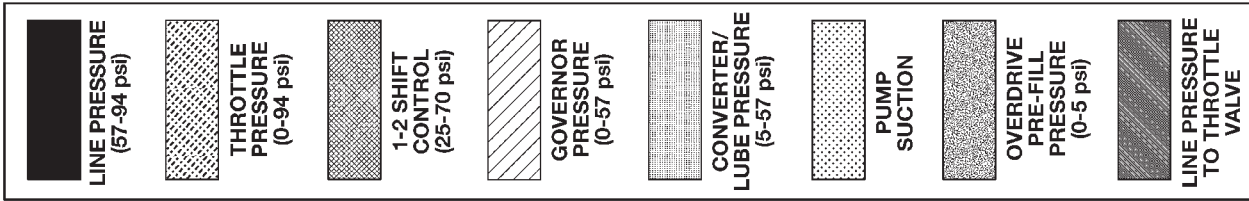


HYDRAULIC FLOW IN DRIVE FIRST GEAR



AUTOMATIC TRANSMISSION - 44RE (Continued)

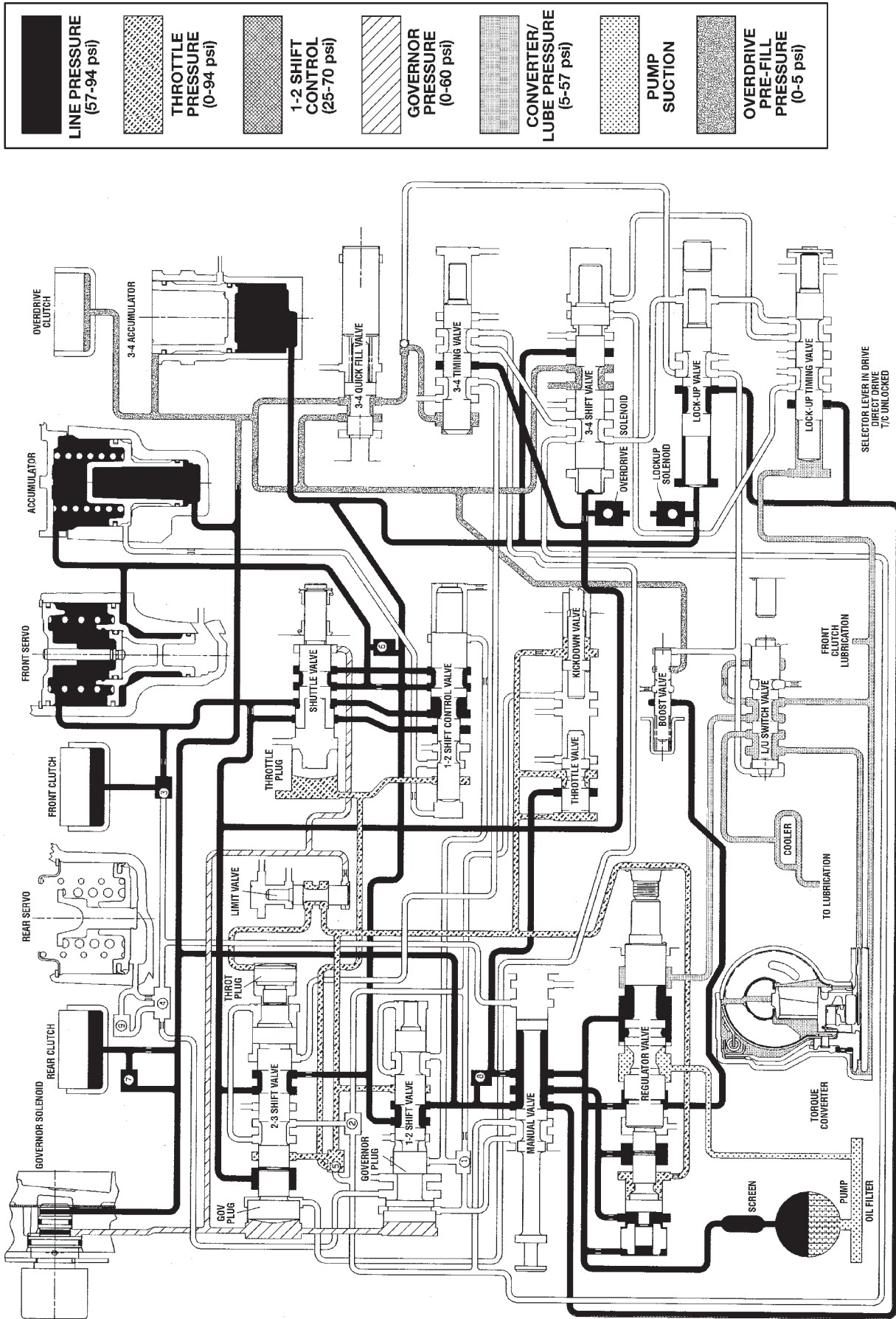
80880697



HYDRAULIC FLOW IN DRIVE SECOND GEAR

AUTOMATIC TRANSMISSION - 44RE (Continued)

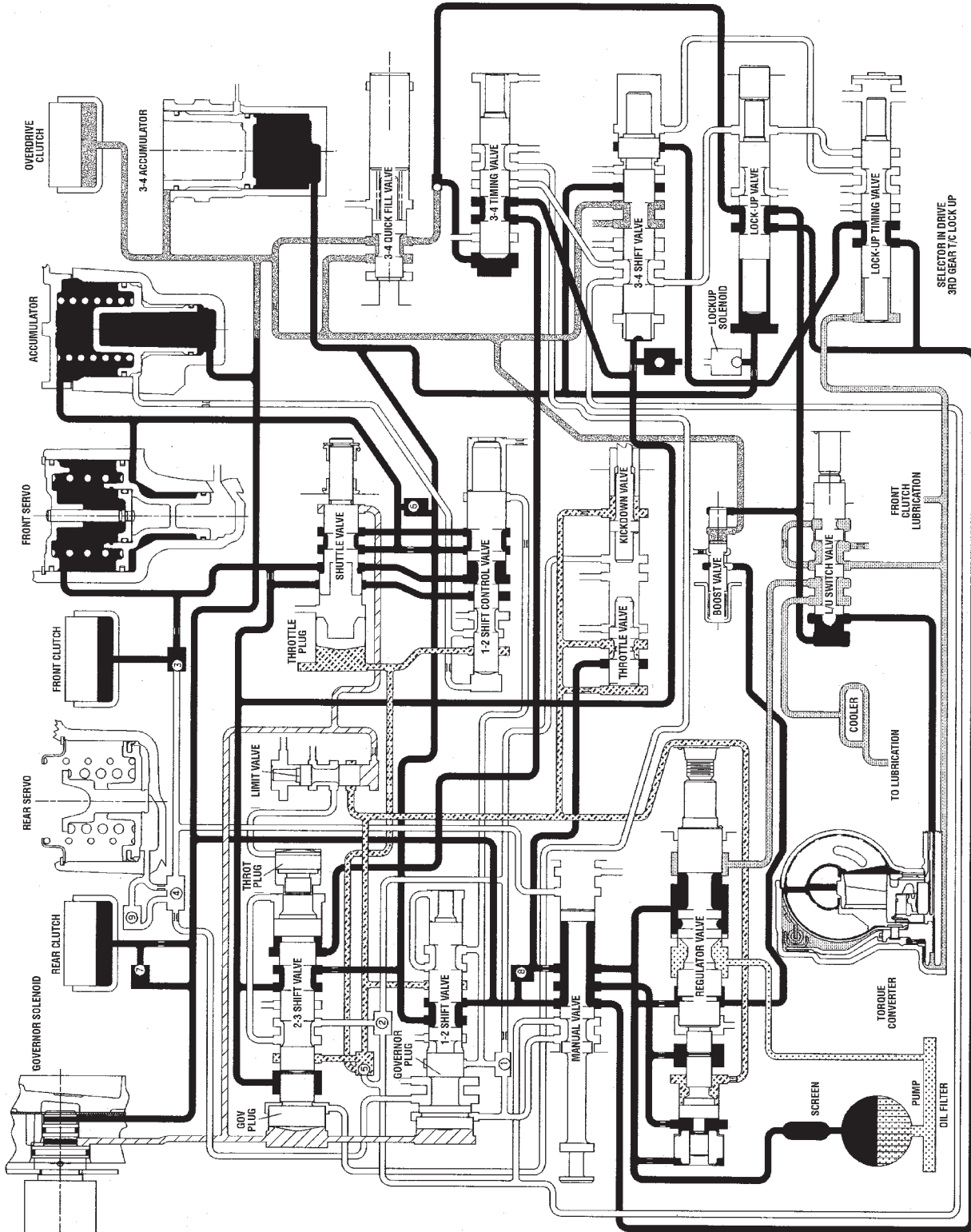
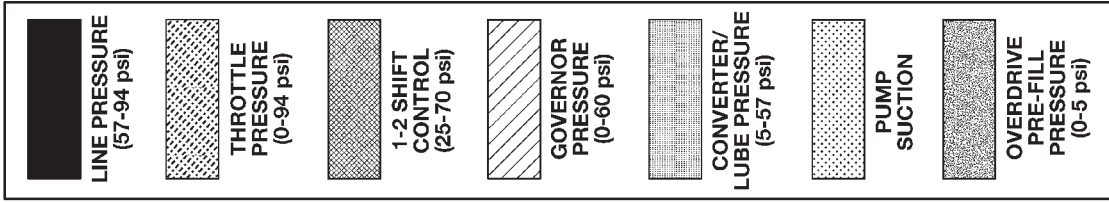
80860598



HYDRAULIC FLOW IN DRIVE THIRD GEAR (CONVERTER CLUTCH NOT APPLIED)

AUTOMATIC TRANSMISSION - 44RE (Continued)

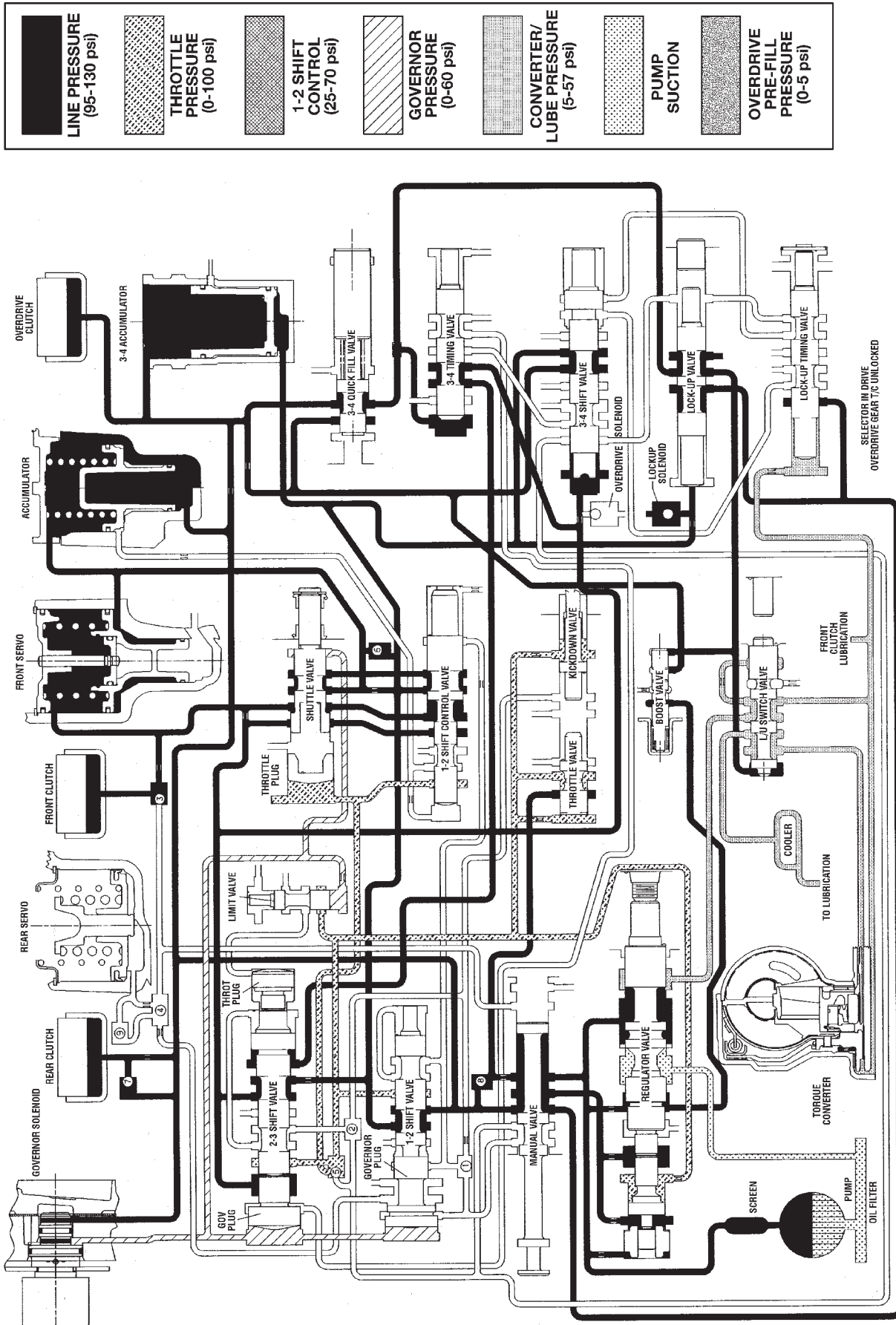
80860599



HYDRAULIC FLOW IN DRIVE THIRD GEAR (CONVERTER CLUTCH APPLIED)

AUTOMATIC TRANSMISSION - 44RE (Continued)

8088059b

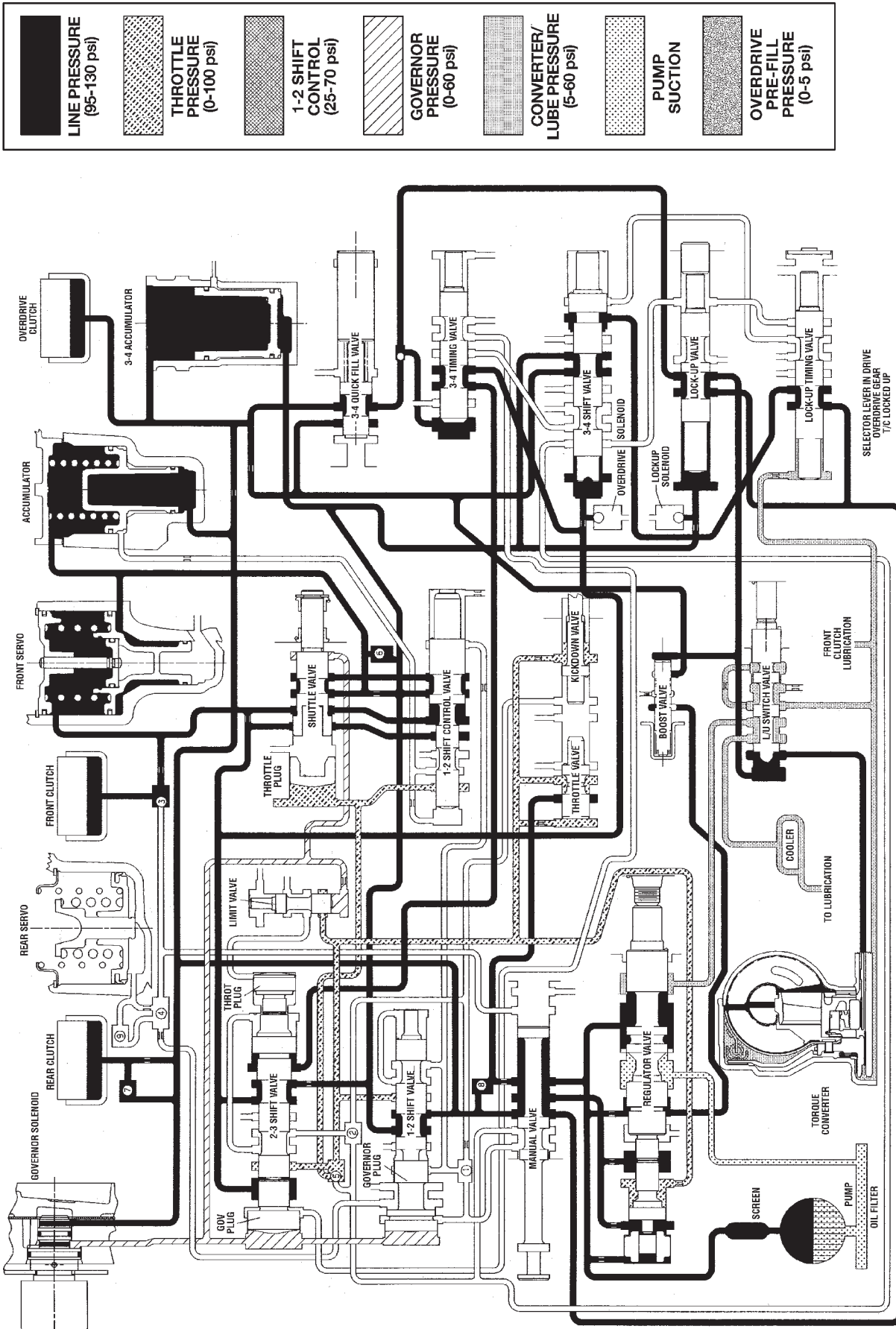


HYDRAULIC FLOW IN DRIVE FOURTH GEAR (CONVERTER CLUTCH NOT APPLIED)



AUTOMATIC TRANSMISSION - 44RE (Continued)

8086059c

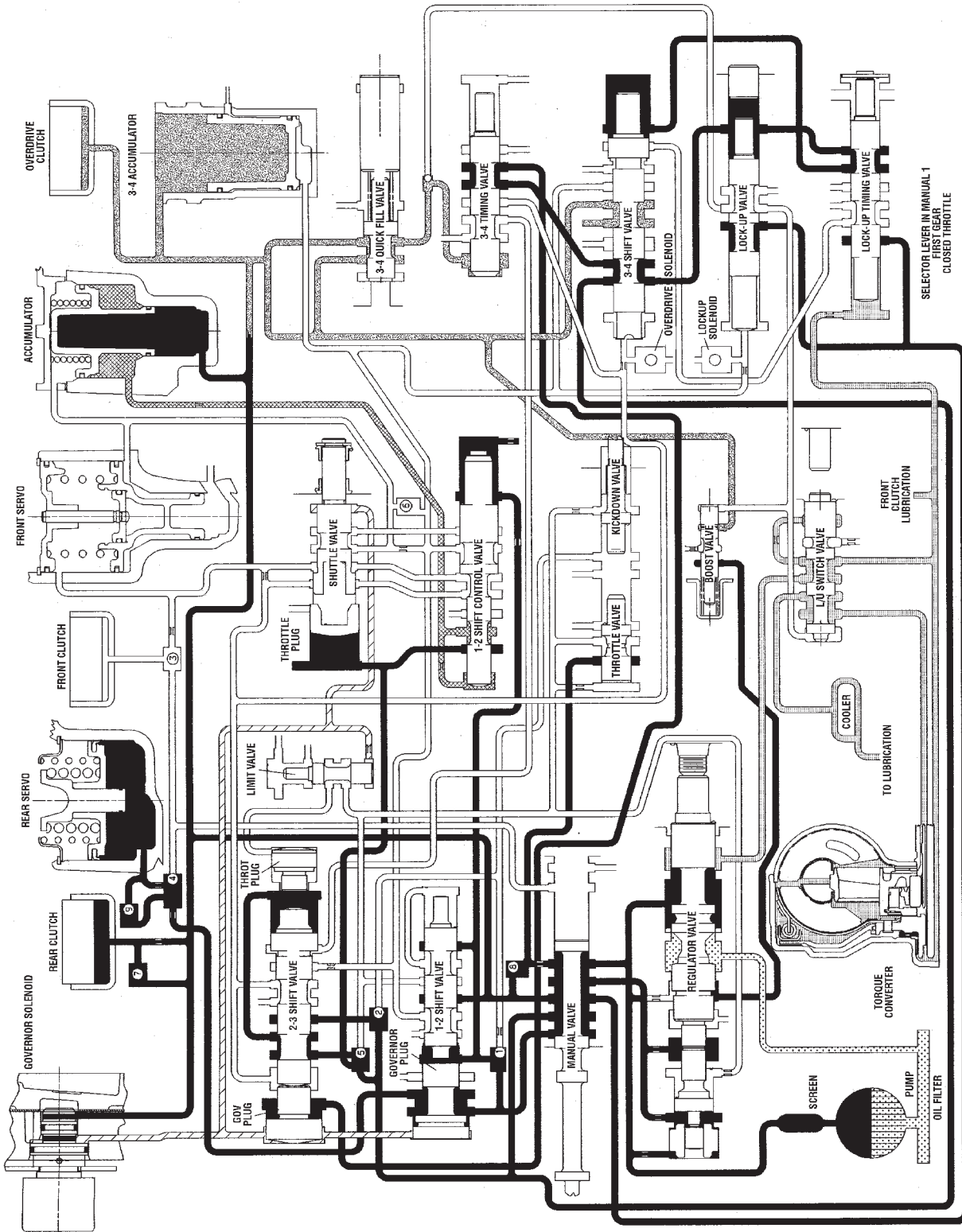
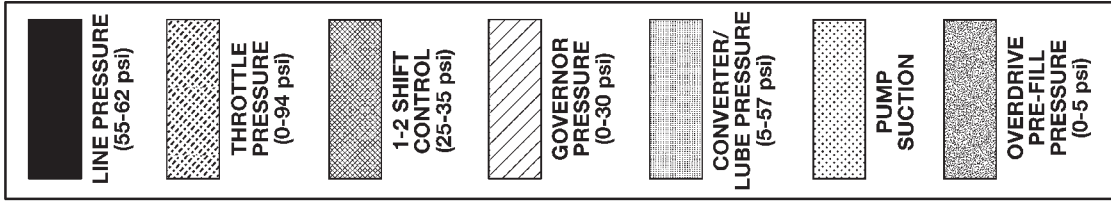


HYDRAULIC FLOW IN DRIVE FOURTH GEAR (CONVERTER CLUTCH APPLIED)



AUTOMATIC TRANSMISSION - 44RE (Continued)

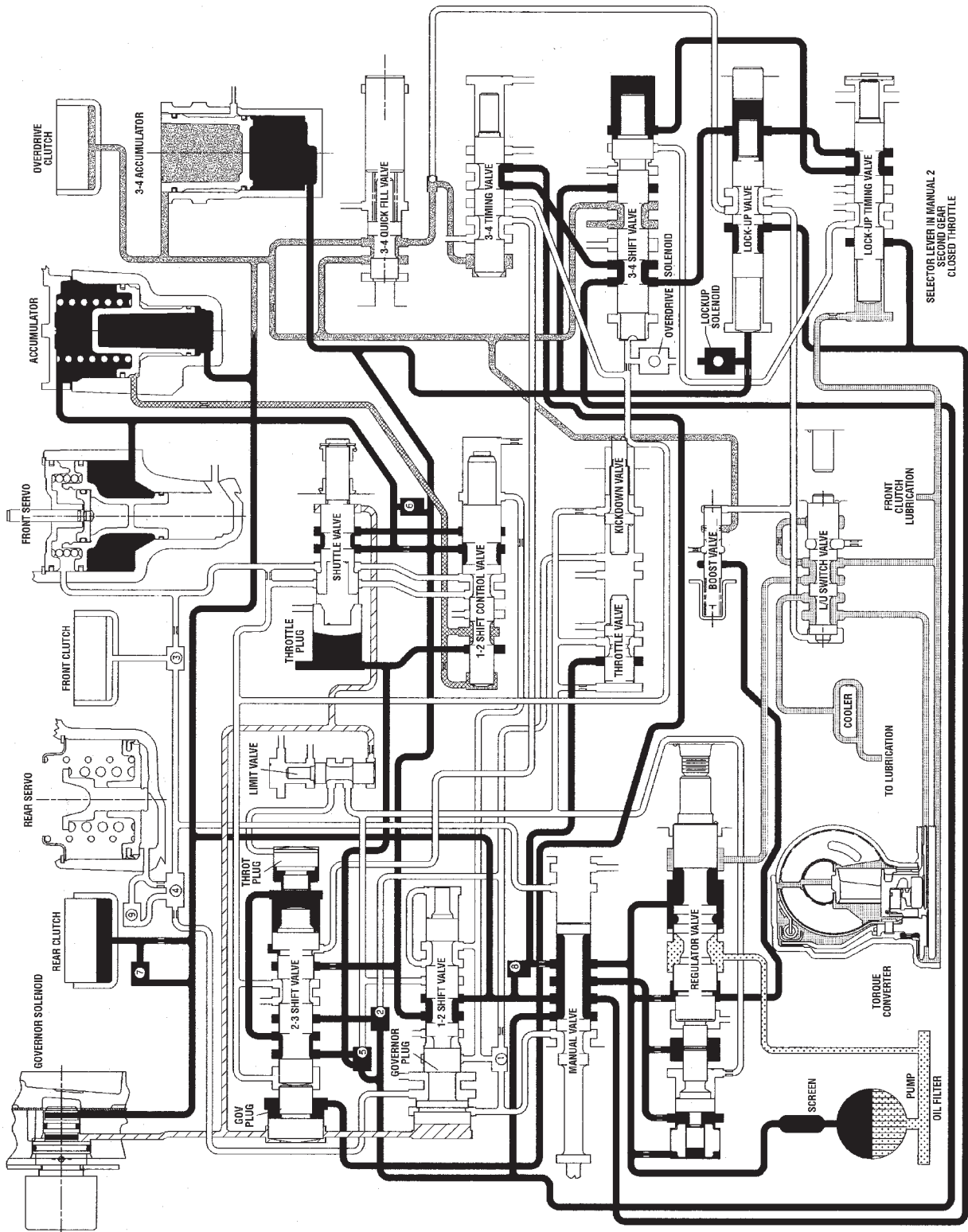
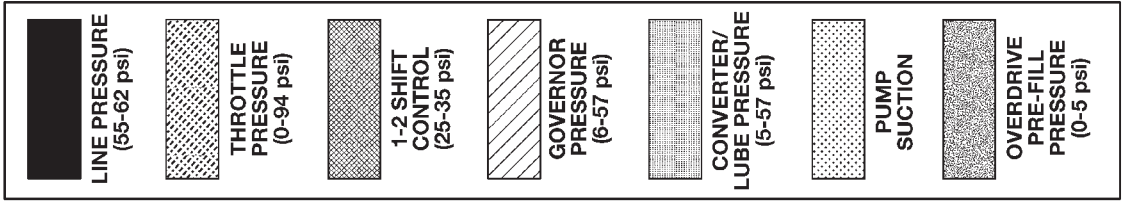
8088059c



HYDRAULIC FLOW IN MANUAL LOW (1)

AUTOMATIC TRANSMISSION - 44RE (Continued)

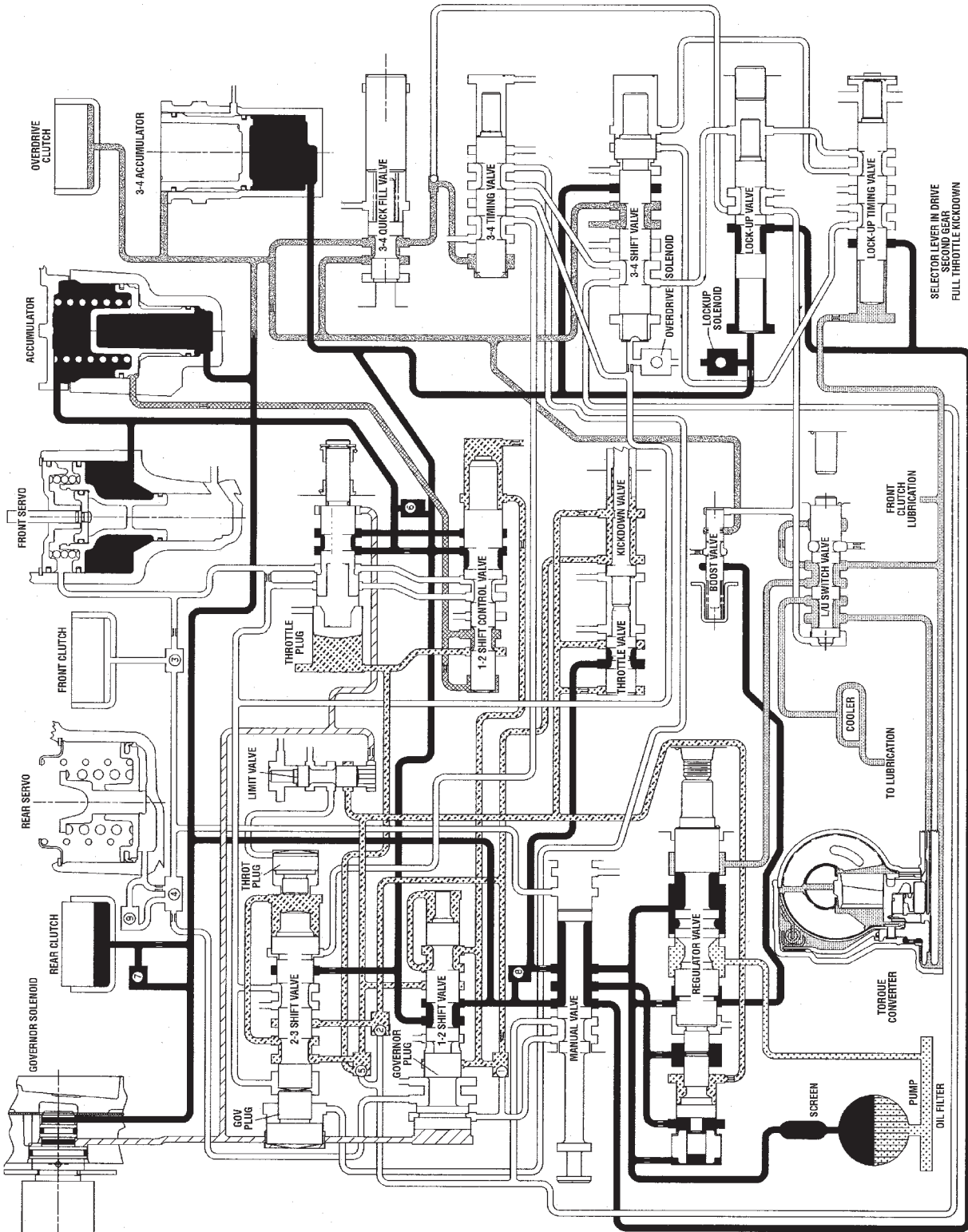
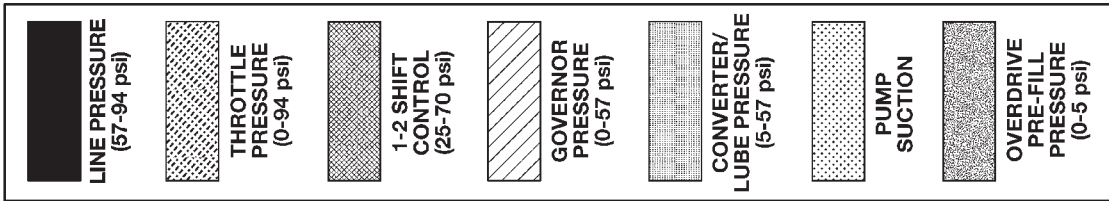
808805a1



HYDRAULIC FLOW IN MANUAL SECOND (2)

AUTOMATIC TRANSMISSION - 44RE (Continued)

808805e2



HYDRAULIC FLOW DURING FULL THROTTLE 3-2 DOWNSHIFT (PASSING)

## AUTOMATIC TRANSMISSION - 44RE (Continued)

## SPECIFICATIONS

## SPECIFICATIONS

## GENERAL

Component	Metric	Inch
Planetary end play	0.127-1.22 mm	0.005-0.048 in.
Input shaft end play	0.56-2.31 mm	0.022-0.091 in.
Clutch pack clearance/ Front.	1.70- 3.40mm	0.067-0.134 in.
Clutch pack clearance/ Rear.	0.559-0.914 mm	0.022-0.036 in.
Front clutch	5 discs	
Rear clutch	4 discs	
Overdrive clutch	4 discs	
Direct clutch	8 discs	
44RE Band adjustment from 72 in. lbs.		
Front band	Back off 1 7/8 turns	
Rear band	Back off 4 turns	
Recommended fluid	Mopar® ATF Plus 4, type 9602	

## GEAR RATIOS

1ST GEAR	2.74:1
2ND GEAR	1.54:1
3RD GEAR	1.0:1
4TH GEAR	0.69:1
REVERSE	2.21:1

## THRUST WASHER/SPACER/SNAP-RING DIMENSIONS

Component	Metric	Inch
Front clutch thrust washer (reaction shaft support hub)	1.55 mm	0.061 in.
Rear clutch thrust washer (clutch retainer)	1.55 mm	0.061 in.
Intermediate shaft thrust plate (shaft hub pilot)	1.5-1.6 mm	0.060-0.063 in.
Output shaft thrust washer (rear clutch hub)	Select fit to set end play	
Rear clutch pack snap-ring	1.5 mm	0.060 in.
	1.95 mm	0.076 in.
	2.45 mm	0.098 in.
Planetary geartrain snap-ring (at front of output shaft)	Select fit (three thicknesses available)	
Overdrive piston thrust plate	Thrust plate and spacer are select fit. Refer to size charts and selection procedures in Overdrive Unit D&A procedures	
Intermediate shaft spacer		

## AUTOMATIC TRANSMISSION - 44RE (Continued)

**PRESSURE TEST**

Overdrive clutch	Fourth gear only	Pressure should be 469-496 kPa (68-72 psi) with closed throttle and increase to 620-896 kPa (90-130 psi) at 1/2 to 3/4 throttle.
Line pressure (at accumulator)	Closed throttle	372-414 kPa (54-60 psi).
Front servo	Third or Fourth gear only	No more than 21 kPa (3 psi) lower than line pressure.
Rear servo	1 range R range	No more than 21 kPa (3 psi) lower than line pressure. 1103 kPa (160 psi) at idle, builds to 1862 kPa (270 psi) at 1600 rpm.
Governor	D range closed throttle	Pressure should respond smoothly to changes in mph and return to 0-7 kPa (0-1.5 psi) when stopped with transmission in D, 1, 2. Pressure above 7 kPa (1.5 psi) at stand still will prevent transmission from downshifting.

*TORQUE SPECIFICATIONS*

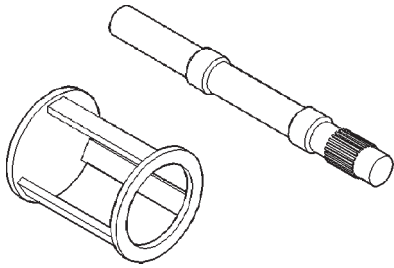
<b>DESCRIPTION</b>	<b>N-m</b>	<b>Ft. Lbs.</b>	<b>In. Lbs.</b>
Fitting, cooler line at trans	18	13	
Bolt, torque convertor	31		270
Bolt, clevis bracket to crossmember	47	35	
Bolt, clevis bracket to rear support	68	50	
Bolt, driveplate to crankshaft	75	55	
Plug, front band reaction	17	13	
Locknut, front band adj.	34	25	
Bolt, fluid pan	17	13	
Screws, fluid filter	4		35
Bolt, oil pump	20	15	
Bolt, overrunning clutch cam	17	13	
Bolt, O/D to trans.	34	25	
Bolt, O/D piston retainer	17	13	
Plug, pressure test port	14	10	
Bolt, reaction shaft support	20	15	
Locknut, rear band	41	30	
Bolt, valve body to case	12		100
Sensor, trans speed	27	20	
Screw, solenoid wiring connector	4		35
Screw, solenoid to transfer plate	4		35
Bracket, transmission range sensor mounting	34		300
Screw, transmission range sensor to mounting bracket	3.4		30



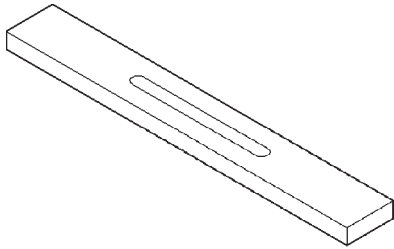
AUTOMATIC TRANSMISSION - 44RE (Continued)

SPECIAL TOOLS

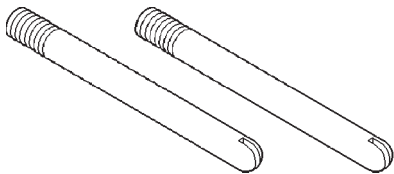
RE TRANSMISSIONS



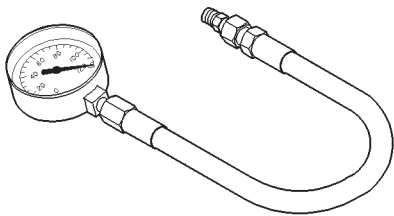
**Shaft, Spring Compressor and Alignment - 6227**



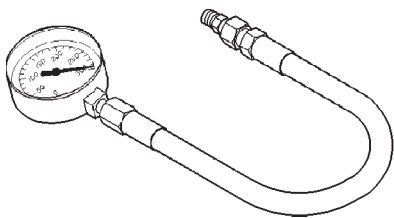
**Bar, Gauge - 6311**



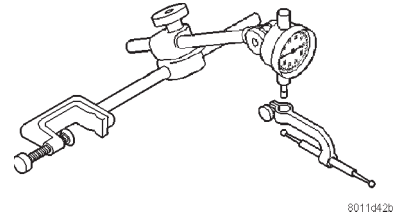
**Pilot, Extension Housing - C-3288-B**



**Gauge, Oil Pressure - C-3292**

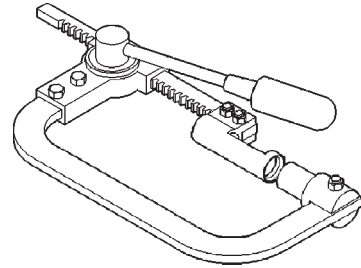


**Gauge, Oil Pressure - C-3293SP**

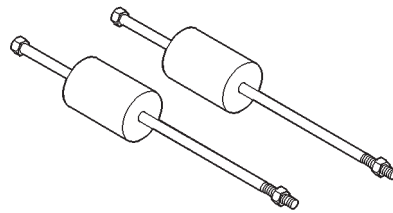


8011d42b

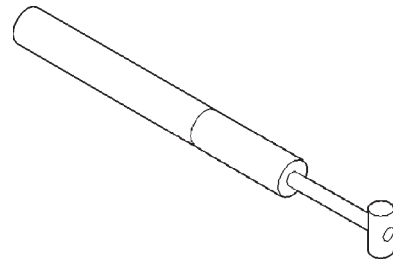
**Dial Indicator - C-3339**



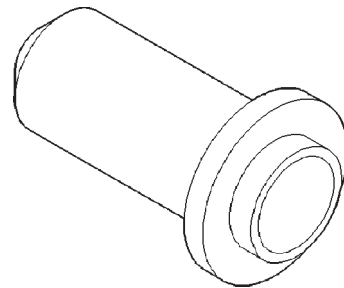
**Compressor, Spring - C-3422-C**



**Puller, Slide Hammer - C-3752**

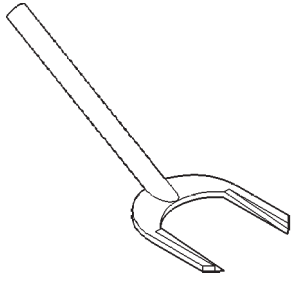


**Gauge, Throttle Setting - C-3763**

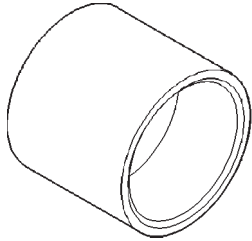


**Installer, Seal - C-3860-A**

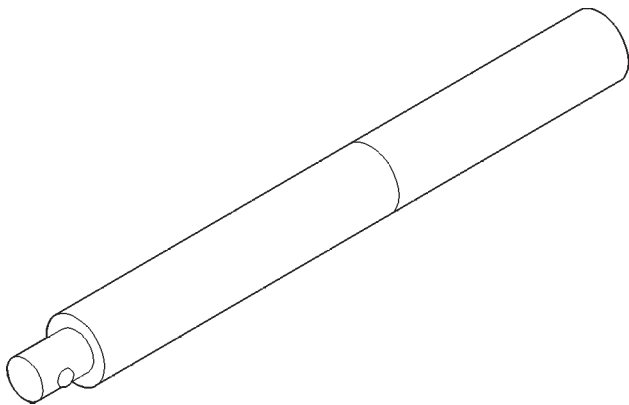
AUTOMATIC TRANSMISSION - 44RE (Continued)



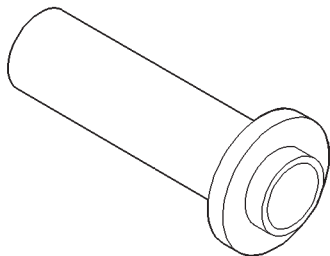
**Remover, Seal - C-3985-B**



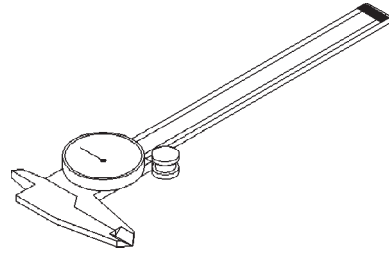
**Installer, Seal - C-3995-A**



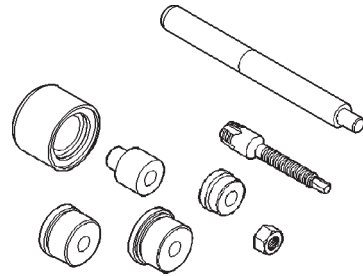
**Handle, Universal - C-4171**



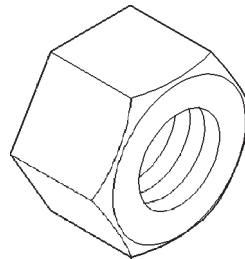
**Installer, Seal - C-4193-A**



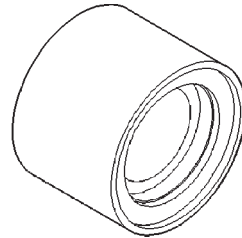
**Dial Caliper - C-4962**



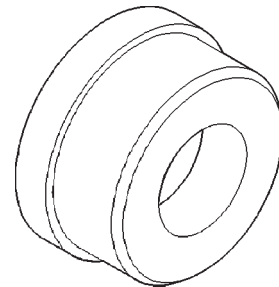
**Kit, Bushing Remover/Installer - C-3887-J**



**Nut, Bushing Remover - SP-1191, From kit C-3887-J**

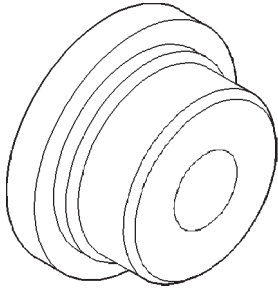


**Cup, Bushing Remover - SP-3633, From kit C-3887-J**

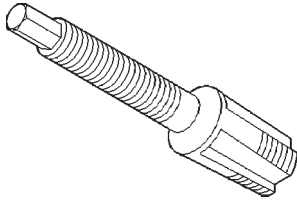


**Remover, Bushing - SP-3551**

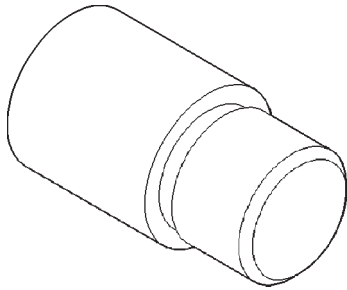
AUTOMATIC TRANSMISSION - 44RE (Continued)



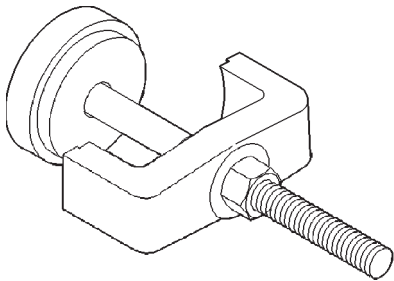
**Installer, Bushing - SP-5117**



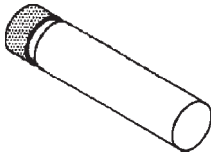
**Remover, Bushing - SP-5324**



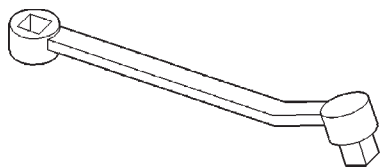
**Installer, Bushing - SP-5325**



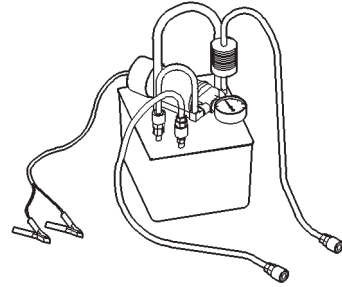
**Compressor, Spring - C-3575-A**



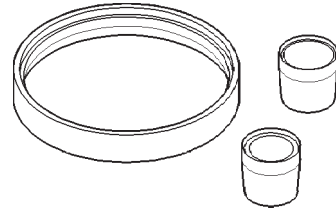
**Gauge - 6312**



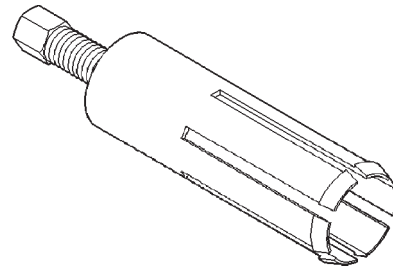
**Adapter, Band Adjuster - C-3705**



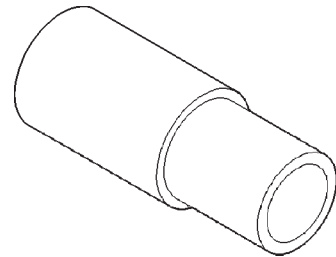
**Flusher, Oil Cooler - 6906-B**



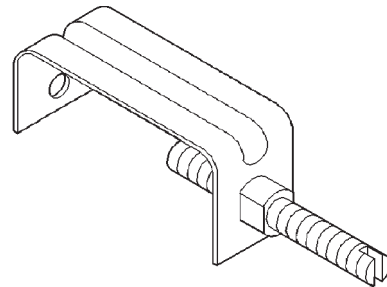
**Installer, Piston - 8114**



**Remover, Bushing - 6957**



**Installer, Bushing - 6951**

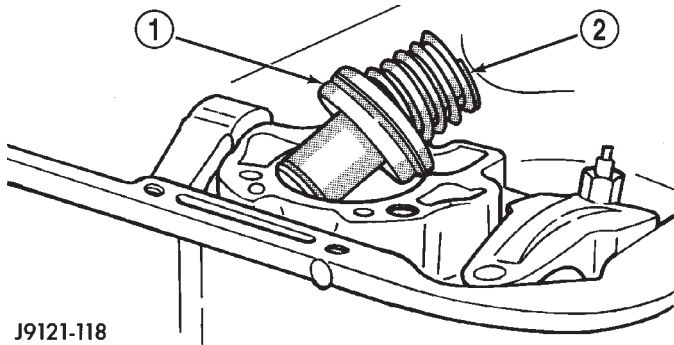


**Retainer, Detent Ball and Spring - 6583**

# ACCUMULATOR

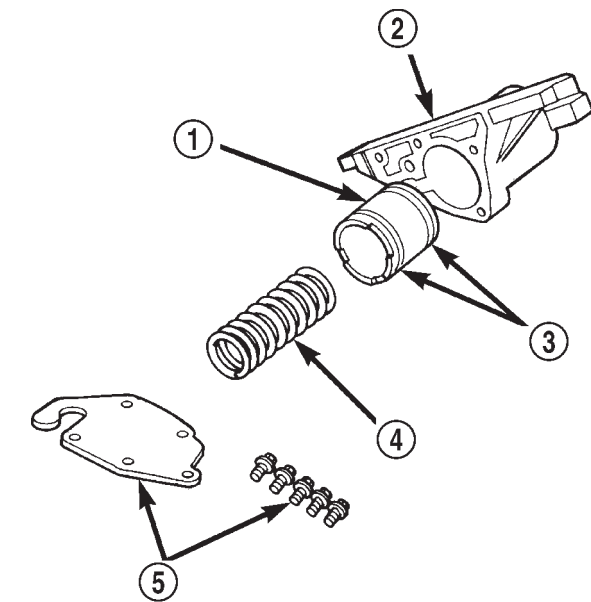
## DESCRIPTION

The accumulator (Fig. 57) is a hydraulic device that has the sole purpose of cushioning the application of a band or clutch. The accumulator consists of a dual-land piston and a spring located in a bore in the transmission case. The 3-4 accumulator is located in a housing attached to the side of the valve body (Fig. 58).



**Fig. 57 Accumulator**

- 1 - ACCUMULATOR PISTON
- 2 - PISTON SPRING



**Fig. 58 3-4 Accumulator and Housing**

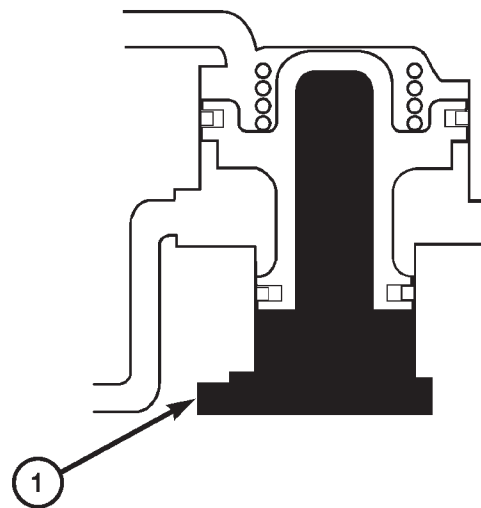
- 1 - ACCUMULATOR PISTON
- 2 - 3-4 ACCUMULATOR HOUSING
- 3 - TEFLON SEALS
- 4 - PISTON SPRING
- 5 - COVER PLATE AND SCREWS

## OPERATION

Both the accumulator and the 3-4 accumulator function the same. Line pressure is directed to the small end of the piston when the transmission is placed into a DRIVE position (Fig. 59), bottoming it against the accumulator plate. When the 1-2 upshift occurs (Fig. 60), line pressure is directed to the large end of the piston and then to the kickdown servo. As the line pressure reaches the accumulator, the combination of spring pressure and line pressure forces the piston away from the accumulator plate. This causes a balanced pressure situation, which results in a cushioned band application. After the kickdown servo has become immovable, line pressure will finish pushing the accumulator up into its bore. When the large end of the accumulator piston is seated in its bore, the band or clutch is fully applied.

**NOTE:** The accumulator is shown in the inverted position for illustrative purposes.

### BOTTOMED AGAINST ACCUMULATOR PLATE



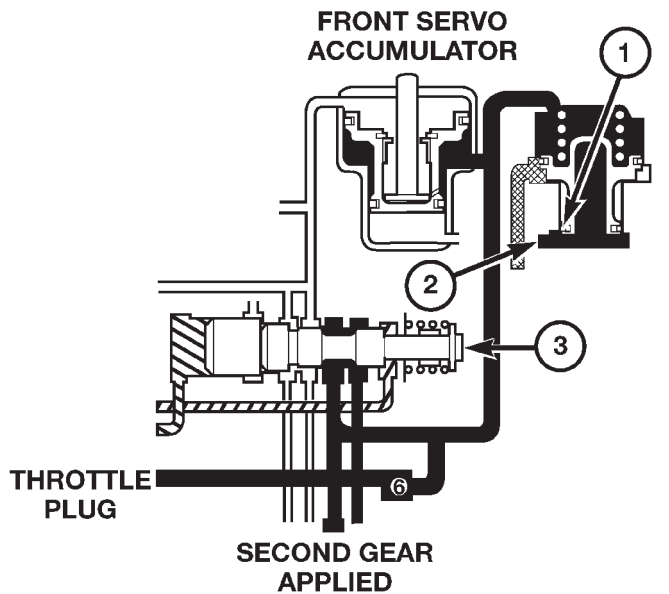
**Fig. 59 Accumulator in DRIVE - FIRST GEAR POSITION**

- 1 - LINE PRESSURE

80a08a54

804d8eb9

## ACCUMULATOR (Continued)



80a08a58

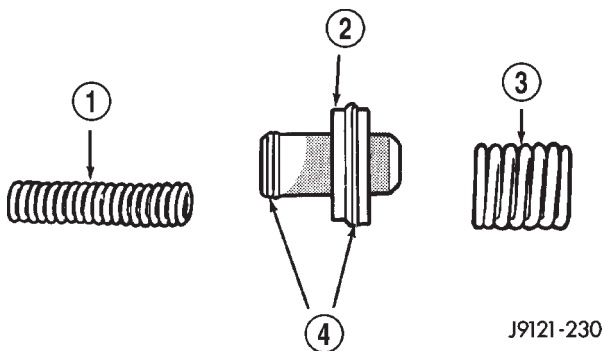
**Fig. 60 Accumulator in SECOND Gear Position**

- 1 - BOTTOM OF BORE
- 2 - LINE PRESSURE
- 3 - SHUTTLE VALVE

## INSPECTION

Inspect the accumulator piston and seal rings (Fig. 61). Replace the seal rings if worn or cut. Replace the piston if chipped or cracked.

Check condition of the accumulator inner and outer springs (Fig. 61). Replace the springs if the coils are cracked, distorted or collapsed.



J9121-230

**Fig. 61 Accumulator Components**

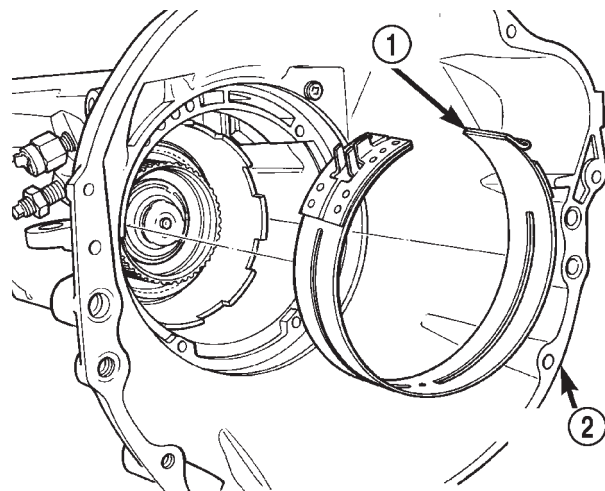
- 1 - INNER SPRING
- 2 - ACCUMULATOR PISTON
- 3 - OUTER SPRING
- 4 - SEAL RINGS

## BANDS

## DESCRIPTION

## KICKDOWN (FRONT) BAND

The kickdown, or "front", band (Fig. 62) holds the common sun gear of the planetary gear sets. The front (kickdown) band is made of steel, and faced on its inner circumference with a friction-type lining. One end of the band is anchored to the transmission case, and the other is acted on with a pushing force by a servo piston. The front band is a single-wrap design (the band does not completely encompass/wrap the drum that it holds).



80a3b192

**Fig. 62 Front Band**

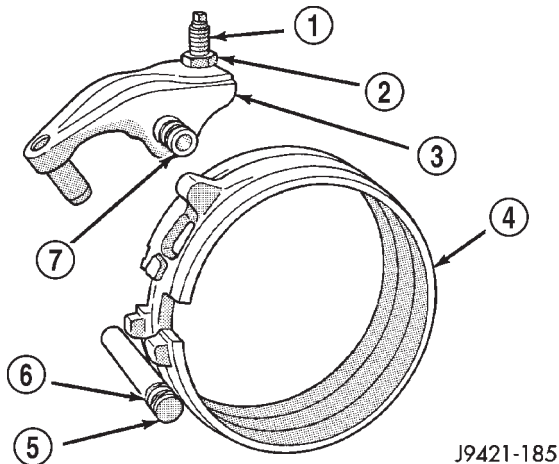
- 1 - FRONT BAND
- 2 - TRANSMISSION HOUSING



## BANDS (Continued)

**LOW/REVERSE (REAR) BAND**

The low/reverse band, or "rear", band (Fig. 63) is similar in appearance and operation to the front band. The rear band is slightly different in that it does not use a link bar, but is acted directly on by the apply lever. This is referred to as a double-wrap band design (the drum is completely encompassed/wrapped by the band). The double-wrap band provides a greater holding power in comparison to the single-wrap design.

**Fig. 63 Rear Band**

- 1 - ADJUSTING SCREW
- 2 - LOCKNUT
- 3 - LEVER
- 4 - REAR BAND
- 5 - REACTION PIN
- 6 - O-RINGS
- 7 - PIVOT PIN

**OPERATION****KICKDOWN (FRONT) BAND**

The kickdown band holds the common sun gear of the planetary gear sets by applying and holding the front clutch retainer, which is splined to the sun gear driving shell, and in turn splined directly to the sun gear. The application of the band by the servo is typically done by an apply lever and link bar.

**LOW/REVERSE (REAR) BAND**

The rear band holds the rear planet carrier stationary by being mounted around and applied to the low/reverse drum.

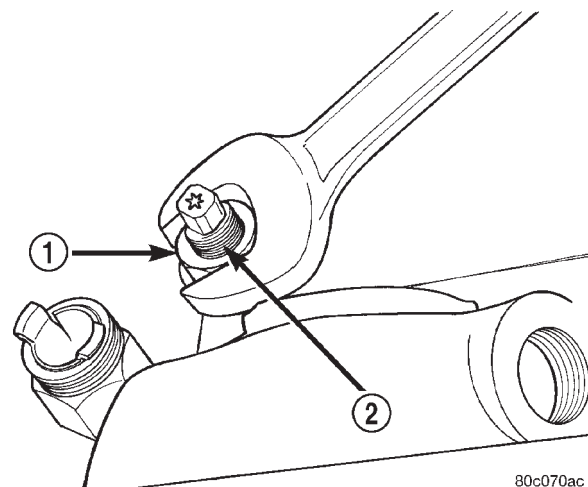
**ADJUSTMENT - BANDS****FRONT BAND**

The front (kickdown) band adjusting screw is located on the left side of the transmission case above the manual valve and throttle valve levers.

- (1) Raise vehicle.
- (2) Loosen band adjusting screw locknut (Fig. 64). Then back locknut off 3-5 turns. Be sure adjusting screw turns freely in case. Apply lubricant to screw threads if necessary.
- (3) Tighten band adjusting screw to 8 N·m (72 in. lbs.) torque with Inch Pound Torque Wrench C-3380-A, a 3-in. extension and appropriate Torx™ socket.

**CAUTION:** If Adapter C-3705 is needed to reach the adjusting screw, tighten the screw to only 5 N·m (47-50 in. lbs.) torque.

- (4) Back off front band adjusting screw 1 7/8 turns.
- (5) Hold adjuster screw in position and tighten locknut to 41 N·m (30 ft. lbs.) torque.
- (6) Lower vehicle.

**Fig. 64 Front Band Adjustment Screw Location**

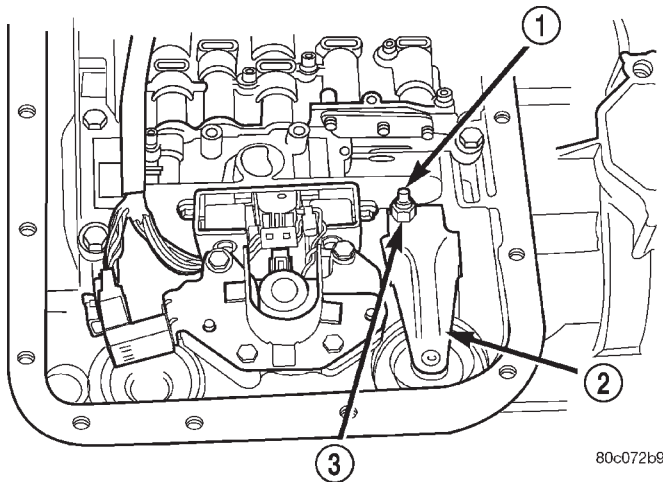
- 1 - LOCK-NUT
- 2 - FRONT BAND ADJUSTER

**REAR BAND**

The transmission oil pan must be removed for access to the rear band adjusting screw.

- (1) Raise vehicle.
- (2) Remove transmission oil pan and drain fluid.
- (3) Loosen band adjusting screw locknut 5-6 turns (Fig. 65). Be sure adjusting screw turns freely in lever.
- (4) Tighten adjusting screw to 8 N·m (72 in. lbs.) torque.
- (5) Back off adjusting screw 4 turns.
- (6) Hold adjusting screw in place and tighten locknut to 34 N·m (25 ft. lbs.) torque.
- (7) Position new gasket on oil pan and install pan on transmission. Tighten pan bolts to 17 N·m (13 ft. lbs.) torque.

## BANDS (Continued)



**Fig. 65 Rear Band Adjusting Screw Location**

- 1 - ADJUSTING SCREW
- 2 - REAR BAND LEVER
- 3 - LOCKNUT

(8) Lower vehicle and refill transmission with Mopar® ATF Plus 4, Type 9602 fluid.

## ELECTRONIC GOVERNOR

## DESCRIPTION

Governor pressure is controlled electronically. Components used for governor pressure control include:

- Governor body
- Valve body transfer plate
- Governor pressure solenoid valve
- Governor pressure sensor
- Fluid temperature thermistor
- Throttle position sensor (TPS)
- Transmission speed sensor
- Powertrain control module (PCM)

## GOVERNOR PRESSURE SOLENOID VALVE

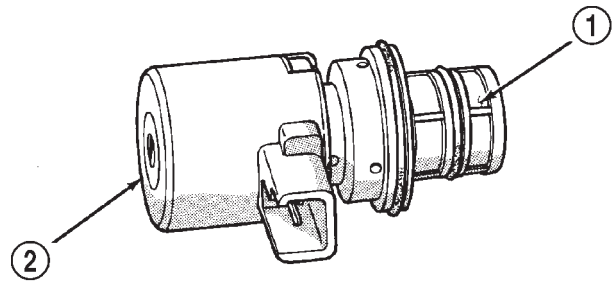
The solenoid valve is a duty-cycle solenoid which regulates the governor pressure needed for upshifts and downshifts. It is an electro-hydraulic device located in the governor body on the valve body transfer plate (Fig. 66).

## GOVERNOR PRESSURE SENSOR

The governor pressure sensor measures output pressure of the governor pressure solenoid valve (Fig. 67).

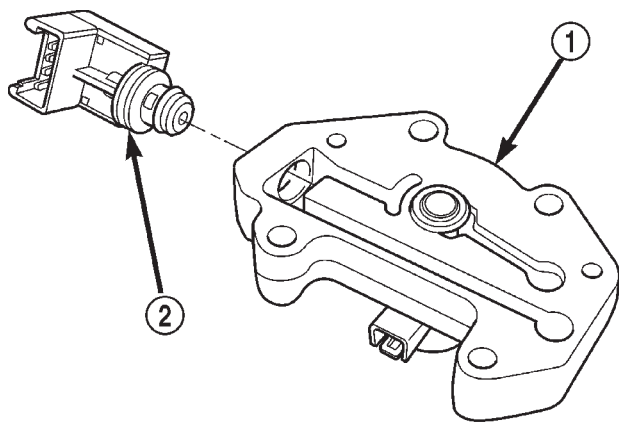
## GOVERNOR BODY AND TRANSFER PLATE

The transfer plate is designed to supply transmission line pressure to the governor pressure solenoid valve and to return governor pressure.



**Fig. 66 Governor Pressure Solenoid Valve**

- 1 - SOLENOID FILTER
- 2 - GOVERNOR PRESSURE SOLENOID



**Fig. 67 Governor Pressure Sensor**

- 1 - GOVERNOR BODY
- 2 - GOVERNOR PRESSURE SENSOR/TRANSMISSION FLUID TEMPERATURE THERMISTOR

The governor pressure solenoid valve is mounted in the governor body. The body is bolted to the lower side of the transfer plate (Fig. 67).

## GOVERNOR PRESSURE CURVES

There are four governor pressure curves programmed into the transmission control module. The different curves allow the control module to adjust governor pressure for varying conditions. One curve is used for operation when fluid temperature is at, or below,  $-1^{\circ}\text{C}$  ( $30^{\circ}\text{F}$ ). A second curve is used when fluid temperature is at, or above,  $10^{\circ}\text{C}$  ( $50^{\circ}\text{F}$ ) during normal city or highway driving. A third curve is used during wide-open throttle operation. The fourth curve is used when driving with the transfer case in low range.

## OPERATION

Compensation is required for performance variations of two of the input devices. Though the slope of the transfer functions is tightly controlled, offset may

## ELECTRONIC GOVERNOR (Continued)

vary due to various environmental factors or manufacturing tolerances.

The pressure transducer is affected by barometric pressure as well as temperature. Calibration of the zero pressure offset is required to compensate for shifting output due to these factors.

Normal calibration will be performed when sump temperature is above 50 degrees F, or in the absence of sump temperature data, after the first 10 minutes of vehicle operation. Calibration of the pressure transducer offset occurs each time the output shaft speed falls below 200 RPM. Calibration shall be repeated each 3 seconds the output shaft speed is below 200 RPM. A 0.5 second pulse of 95% duty cycle is applied to the governor pressure solenoid valve and the transducer output is read during this pulse. Averaging of the transducer signal is necessary to reject electrical noise.

Under cold conditions (below 50 degrees F sump), the governor pressure solenoid valve response may be too slow to guarantee 0 psi during the 0.5 second calibration pulse. Calibration pulses are continued during this period, however the transducer output values are discarded. Transducer offset must be read at key-on, under conditions which promote a stable reading. This value is retained and becomes the offset during the "cold" period of operation.

### GOVERNOR PRESSURE SOLENOID VALVE

The inlet side of the solenoid valve is exposed to normal transmission line pressure. The outlet side of the valve leads to the valve body governor circuit.

The solenoid valve regulates line pressure to produce governor pressure. The average current supplied to the solenoid controls governor pressure. One amp current produces zero kPa/psi governor pressure. Zero amps sets the maximum governor pressure.

The powertrain control module (PCM) turns on the trans control relay which supplies electrical power to the solenoid valve. Operating voltage is 12 volts (DC). The PCM controls the ground side of the solenoid using the governor pressure solenoid control circuit.

### GOVERNOR PRESSURE SENSOR

The sensor output signal provides the necessary feedback to the PCM. This feedback is needed to adequately control governor pressure.

### GOVERNOR BODY AND TRANSFER PLATE

The transfer plate channels line pressure to the solenoid valve through the governor body. It also channels governor pressure from the solenoid valve to the governor circuit. It is the solenoid valve that develops the necessary governor pressure.

## GOVERNOR PRESSURE CURVES

### LOW TRANSMISSION FLUID TEMPERATURE

When the transmission fluid is cold the conventional governor can delay shifts, resulting in higher than normal shift speeds and harsh shifts. The electronically controlled low temperature governor pressure curve is higher than normal to make the transmission shift at normal speeds and sooner. The PCM uses a temperature sensor in the transmission oil sump to determine when low temperature governor pressure is needed.

### NORMAL OPERATION

Normal operation is refined through the increased computing power of the PCM and through access to data on engine operating conditions provided by the PCM that were not available with the previous stand-alone electronic module. This facilitated the development of a load adaptive shift strategy - the ability to alter the shift schedule in response to vehicle load condition. One manifestation of this capability is grade "hunting" prevention - the ability of the transmission logic to delay an upshift on a grade if the engine does not have sufficient power to maintain speed in the higher gear. The 3-2 downshift and the potential for hunting between gears occurs with a heavily loaded vehicle or on steep grades. When hunting occurs, it is very objectionable because shifts are frequent and accompanied by large changes in noise and acceleration.

### WIDE OPEN THROTTLE OPERATION

In wide-open throttle (WOT) mode, adaptive memory in the PCM assures that up-shifts occur at the preprogrammed optimum speed. WOT operation is determined from the throttle position sensor, which is also a part of the emission control system. The initial setting for the WOT upshift is below the optimum engine speed. As WOT shifts are repeated, the PCM learns the time required to complete the shifts by comparing the engine speed when the shifts occur to the optimum speed. After each shift, the PCM adjusts the shift point until the optimum speed is reached. The PCM also considers vehicle loading, grade and engine performance changes due to high altitude in determining when to make WOT shifts. It does this by measuring vehicle and engine acceleration and then factoring in the shift time.

### TRANSFER CASE LOW RANGE OPERATION

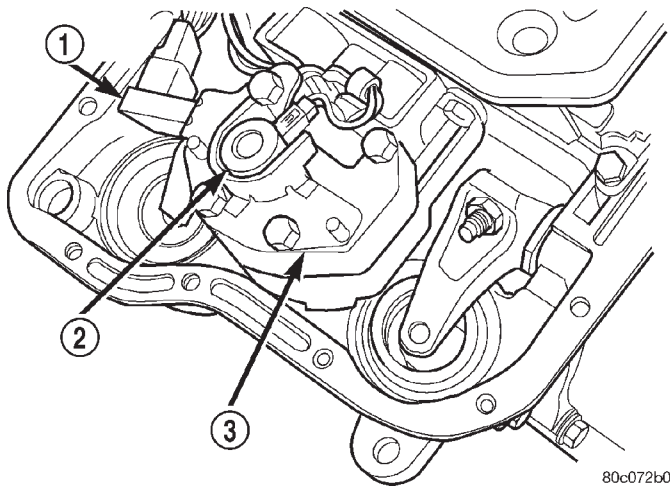
On four-wheel drive vehicles operating in low range, the engine can accelerate to its peak more rapidly than in Normal range, resulting in delayed shifts and undesirable engine "flare." The low range governor pressure curve is also higher than normal

## ELECTRONIC GOVERNOR (Continued)

to initiate upshifts sooner. The PCM compares electronic vehicle speed signal used by the speedometer to the transmission output shaft speed signal to determine when the transfer case is in low range.

**REMOVAL**

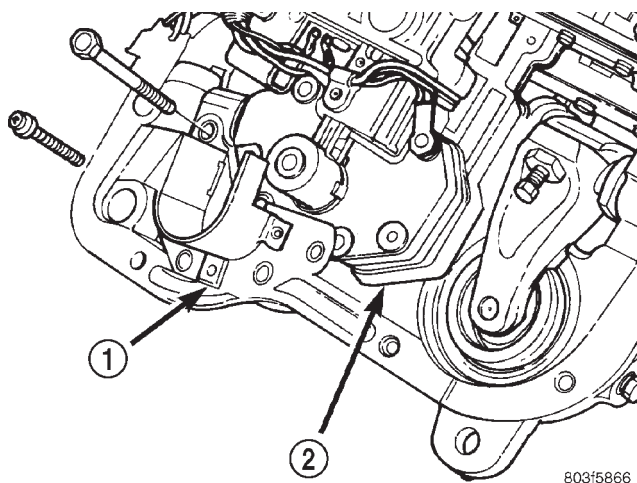
- (1) Hoist and support vehicle on safety stands.
- (2) Remove transmission fluid pan and filter.
- (3) Disengage wire connectors from pressure sensor and solenoid (Fig. 68).



**Fig. 68 Governor Solenoid And Pressure Sensor**

- 1 - PRESSURE SENSOR
- 2 - PRESSURE SOLENOID
- 3 - GOVERNOR

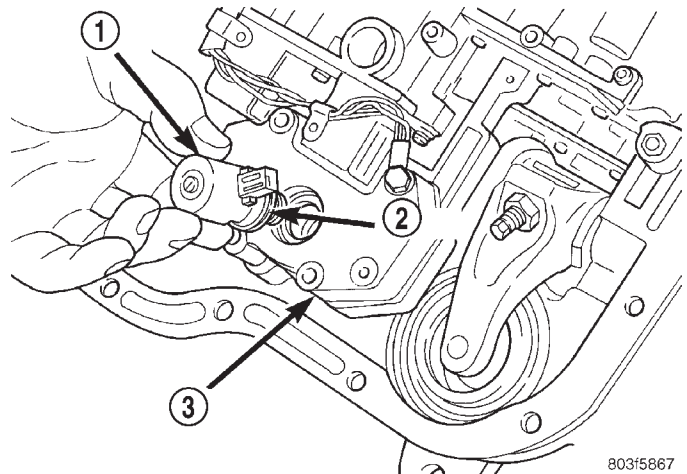
- (4) Remove screws holding pressure solenoid retainer to governor body.
- (5) Separate solenoid retainer from governor (Fig. 69).



**Fig. 69 Pressure Solenoid Retainer**

- 1 - PRESSURE SOLENOID RETAINER
- 2 - GOVERNOR

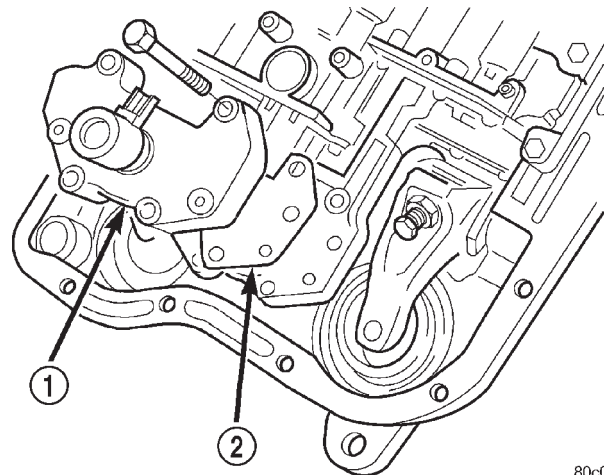
- (6) Pull solenoid from governor body (Fig. 70).
- (7) Pull pressure sensor from governor body.
- (8) Remove bolts holding governor body to valve body.



**Fig. 70 Pressure Solenoid and O-ring**

- 1 - PRESSURE SOLENOID
- 2 - O-RING
- 3 - GOVERNOR

- (9) Separate governor body from valve body (Fig. 71).
- (10) Remove governor body gasket.



**Fig. 71 Governor Body and Gasket**

- 1 - GOVERNOR BODY
- 2 - GASKET

**INSTALLATION**

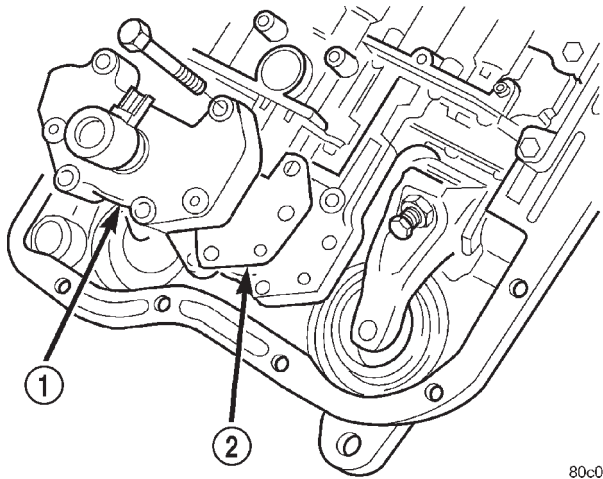
Before installing the pressure sensor and solenoid in the governor body, replace o-ring seals, clean the gasket surfaces and replace gasket.

- (1) Place gasket in position on back of governor body (Fig. 72).
- (2) Place governor body in position on valve body.



ELECTRONIC GOVERNOR (Continued)

(3) Install bolts to hold governor body to valve body.



80c072b1

**Fig. 72 Governor Body and Gasket**

- 1 - GOVERNOR BODY
- 2 - GASKET

(4) Lubricate o-ring on pressure sensor with transmission fluid.

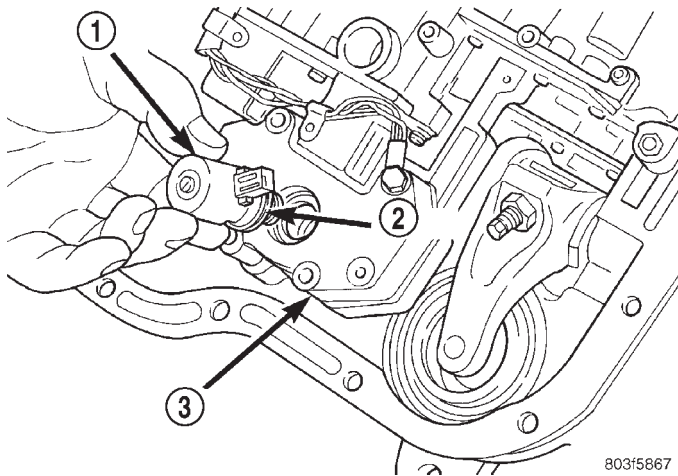
(5) Align pressure sensor to bore in governor body.

(6) Push pressure sensor into governor body.

(7) Lubricate o-ring, on pressure solenoid, with transmission fluid.

(8) Align pressure solenoid to bore in governor body (Fig. 73).

(9) Push solenoid into governor body.



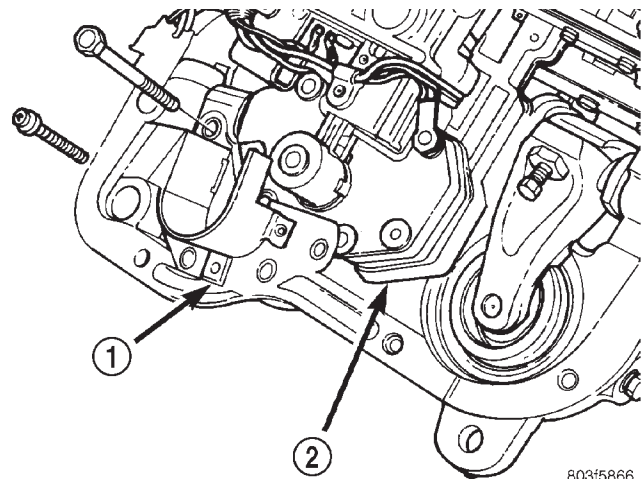
803f5867

**Fig. 73 Pressure Solenoid and O-ring**

- 1 - PRESSURE SOLENOID
- 2 - O-RING
- 3 - GOVERNOR

(10) Place solenoid retainer in position on governor (Fig. 74).

(11) Install screws to hold pressure solenoid retainer to governor body.



803f5866

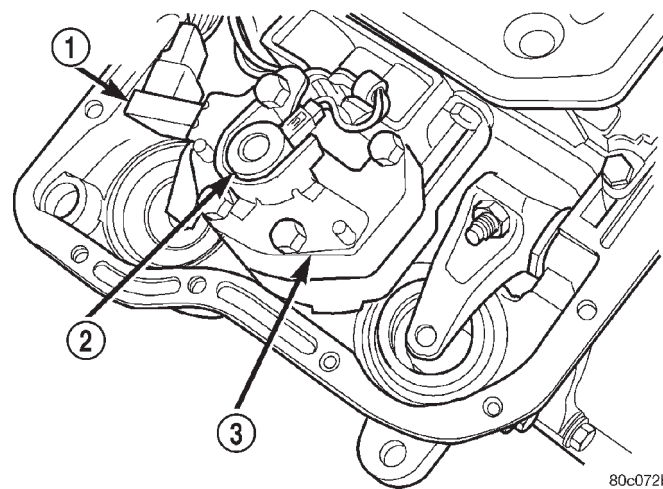
**Fig. 74 Pressure Solenoid Retainer**

- 1 - PRESSURE SOLENOID RETAINER
- 2 - GOVERNOR

(12) Engage wire connectors into pressure sensor and solenoid (Fig. 75).

(13) Install transmission fluid pan and (new) filter.

(14) Lower vehicle and road test to verify repair.



80c072b0

**Fig. 75 Governor Solenoid And Pressure Sensor**

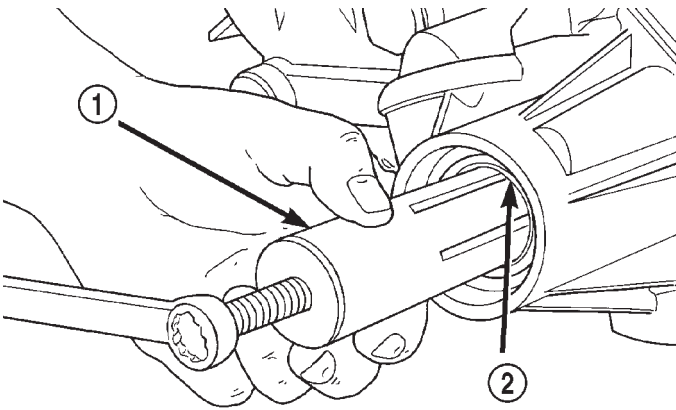
- 1 - PRESSURE SENSOR
- 2 - PRESSURE SOLENOID
- 3 - GOVERNOR



## EXTENSION HOUSING BUSHING

### REMOVAL

- (1) Remove extension housing yoke seal.
- (2) Insert Remover 6957 into the extension housing. Tighten tool to bushing and remove bushing (Fig. 76).



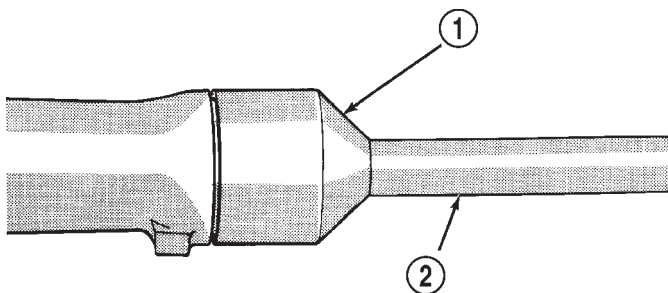
80a11095

**Fig. 76 Bushing Removal - Typical**

- 1 - REMOVER
- 2 - EXTENSION HOUSING BUSHING

### INSTALLATION

- (1) Align bushing oil hole with oil slot in extension housing.
- (2) Tap bushing into place with Installer 6951 and Handle C-4171.
- (3) Install new oil seal in housing using Seal Installer C-3995-A (Fig. 77).



J9521-58

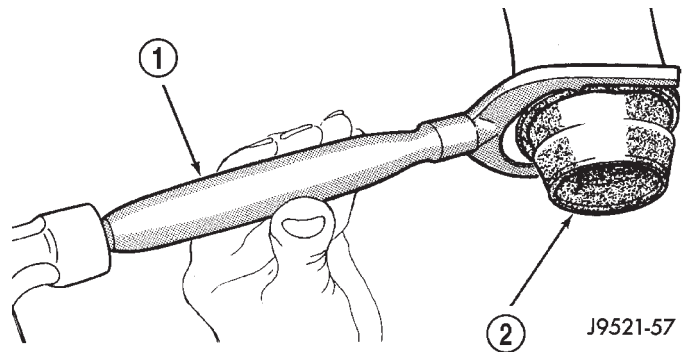
**Fig. 77 Extension Housing Seal Installation**

- 1 - SPECIAL TOOL C-3995-A OR C-3972-A
- 2 - SPECIAL TOOL C-4471

## EXTENSION HOUSING SEAL

### REMOVAL

- (1) Raise vehicle.
- (2) Mark propeller shaft and axle yoke for alignment reference.
- (3) Disconnect and remove propeller shaft.
- (4) Remove old seal with Seal Remover C-3985-B (Fig. 78) from overdrive housing.



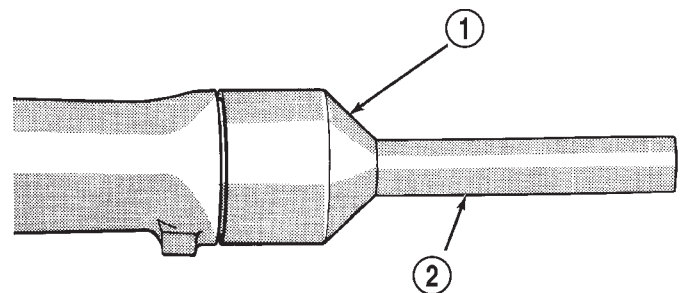
J9521-57

**Fig. 78 Removing Overdrive Housing Yoke Seal**

- 1 - SPECIAL TOOL C-3985-B
- 2 - SEAL

### INSTALLATION

- (1) Place seal in position on overdrive housing.
- (2) Drive seal into overdrive housing with Seal Installer C-3995-A (Fig. 79).
- (3) Carefully guide propeller shaft slip yoke into housing and onto output shaft splines. Align marks made at removal and connect propeller shaft to rear axle pinion yoke.



J9521-58

**Fig. 79 Installing Overdrive Housing Seal**

- 1 - SPECIAL TOOL C-3995-A OR C-3972-A
- 2 - SPECIAL TOOL C-4471

## FLUID AND FILTER

### DIAGNOSIS AND TESTING - EFFECTS OF INCORRECT FLUID LEVEL

A low fluid level allows the pump to take in air along with the fluid. Air in the fluid will cause fluid pressures to be low and develop slower than normal. If the transmission is overfilled, the gears churn the fluid into foam. This aerates the fluid and causing the same conditions occurring with a low level. In either case, air bubbles cause fluid overheating, oxidation and varnish buildup which interferes with valve and clutch operation. Foaming also causes fluid expansion which can result in fluid overflow from the transmission vent or fill tube. Fluid overflow can easily be mistaken for a leak if inspection is not careful.

### DIAGNOSIS AND TESTING - CAUSES OF BURNT FLUID

Burnt, discolored fluid is a result of overheating which has two primary causes.

(1) A result of restricted fluid flow through the main and/or auxiliary cooler. This condition is usually the result of a faulty or improperly installed drainback valve, a damaged main cooler, or severe restrictions in the coolers and lines caused by debris or kinked lines.

(2) Heavy duty operation with a vehicle not properly equipped for this type of operation. Trailer towing or similar high load operation will overheat the transmission fluid if the vehicle is improperly equipped. Such vehicles should have an auxiliary transmission fluid cooler, a heavy duty cooling system, and the engine/axle ratio combination needed to handle heavy loads.

### DIAGNOSIS AND TESTING - FLUID CONTAMINATION

Transmission fluid contamination is generally a result of:

- adding incorrect fluid
- failure to clean dipstick and fill tube when checking level
- engine coolant entering the fluid
- internal failure that generates debris
- overheat that generates sludge (fluid breakdown)
- failure to reverse flush cooler and lines after repair
- failure to replace contaminated converter after repair

The use of non-recommended fluids can result in transmission failure. The usual results are erratic shifts, slippage, abnormal wear and eventual failure due to fluid breakdown and sludge formation. Avoid this condition by using recommended fluids only.

The dipstick cap and fill tube should be wiped clean before checking fluid level. Dirt, grease and

other foreign material on the cap and tube could fall into the tube if not removed beforehand. Take the time to wipe the cap and tube clean before withdrawing the dipstick.

Engine coolant in the transmission fluid is generally caused by a cooler malfunction. The only remedy is to replace the radiator as the cooler in the radiator is not a serviceable part. If coolant has circulated through the transmission, an overhaul is necessary.

The transmission cooler and lines should be reverse flushed whenever a malfunction generates sludge and/or debris. The torque converter should also be replaced at the same time.

Failure to flush the cooler and lines will result in recontamination. Flushing applies to auxiliary coolers as well. The torque converter should also be replaced whenever a failure generates sludge and debris. This is necessary because normal converter flushing procedures will not remove all contaminants.

### STANDARD PROCEDURE - FLUID LEVEL CHECK

Low fluid level can cause a variety of conditions because it allows the pump to take in air along with the fluid. As in any hydraulic system, air bubbles make the fluid spongy, therefore, pressures will be low and build up slowly.

Improper filling can also raise the fluid level too high. When the transmission has too much fluid, the geartrain churns up foam and cause the same conditions which occur with a low fluid level.

In either case, air bubbles can cause overheating and/or fluid oxidation, and varnishing. This can interfere with normal valve, clutch, and accumulator operation. Foaming can also result in fluid escaping from the transmission vent where it may be mistaken for a leak.

Along with fluid level, it is important to check the condition of the fluid. When the fluid smells burned, and is contaminated with metal or friction material particles, a complete transmission recondition is needed. Be sure to examine the fluid on the dipstick closely. If there is any doubt about its condition, drain out a sample for a double check.

After the fluid has been checked, seat the dipstick fully to seal out water and dirt.

The transmission has a dipstick to check oil level. It is located on the right side of the engine. Be sure to wipe all dirt from dipstick handle before removing.

Fluid level is checked with the engine running at curb idle speed, the transmission in NEUTRAL and the transmission fluid at normal operating temperature. **The engine should be running at idle speed for at least one minute, with the vehicle on level ground.**

The transmission fluid level can be checked two ways.

## FLUID AND FILTER (Continued)

## PROCEDURE ONE

(1) Transmission fluid must be at normal operating temperature for accurate fluid level check. Drive vehicle if necessary to bring fluid temperature up to normal hot operating temperature of 82°C (180°F).

(2) Position vehicle on level surface.

(3) Start and run engine at curb idle speed.

(4) Apply parking brakes.

(5) Shift transmission momentarily into all gear ranges. Then shift transmission back to NEUTRAL.

(6) Clean top of filler tube and dipstick to keep dirt from entering tube.

(7) Remove dipstick (Fig. 80) and check fluid level as follows:

(a) Correct acceptable level is in crosshatch area.

(b) Correct maximum level is to MAX arrow mark.

(c) Incorrect level is at or below MIN line.

(d) If fluid is low, add only enough Mopar® ATF +4, type 9602, to restore correct level. Do not overfill.

## PROCEDURE TWO

(1) Start engine and apply parking brake.

(2) Shift the transmission into DRIVE for approximately 2 seconds.

(3) Shift the transmission into REVERSE for approximately 2 seconds.

(4) Shift the transmission into PARK.

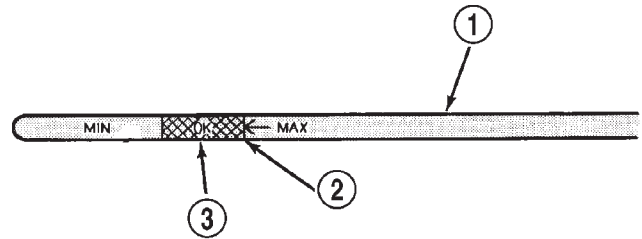


Fig. 80 Dipstick Fluid Level Marks - Typical

1 - DIPSTICK

2 - MAXIMUM CORRECT FLUID LEVEL

3 - ACCEPTABLE FLUID LEVEL

(5) Hook up DRB® scan tool and select engine.

(6) Select sensors.

(7) Read the transmission temperature value.

(8) Compare the fluid temperature value with the figure. (Fig. 81)

(9) Adjust transmission fluid level shown on the dipstick according to the figure.

**NOTE:** After adding any fluid to the transmission, wait a minimum of 2 minutes for the oil to fully drain from the fill tube into the transmission before rechecking the fluid level.

(10) Check transmission for leaks.

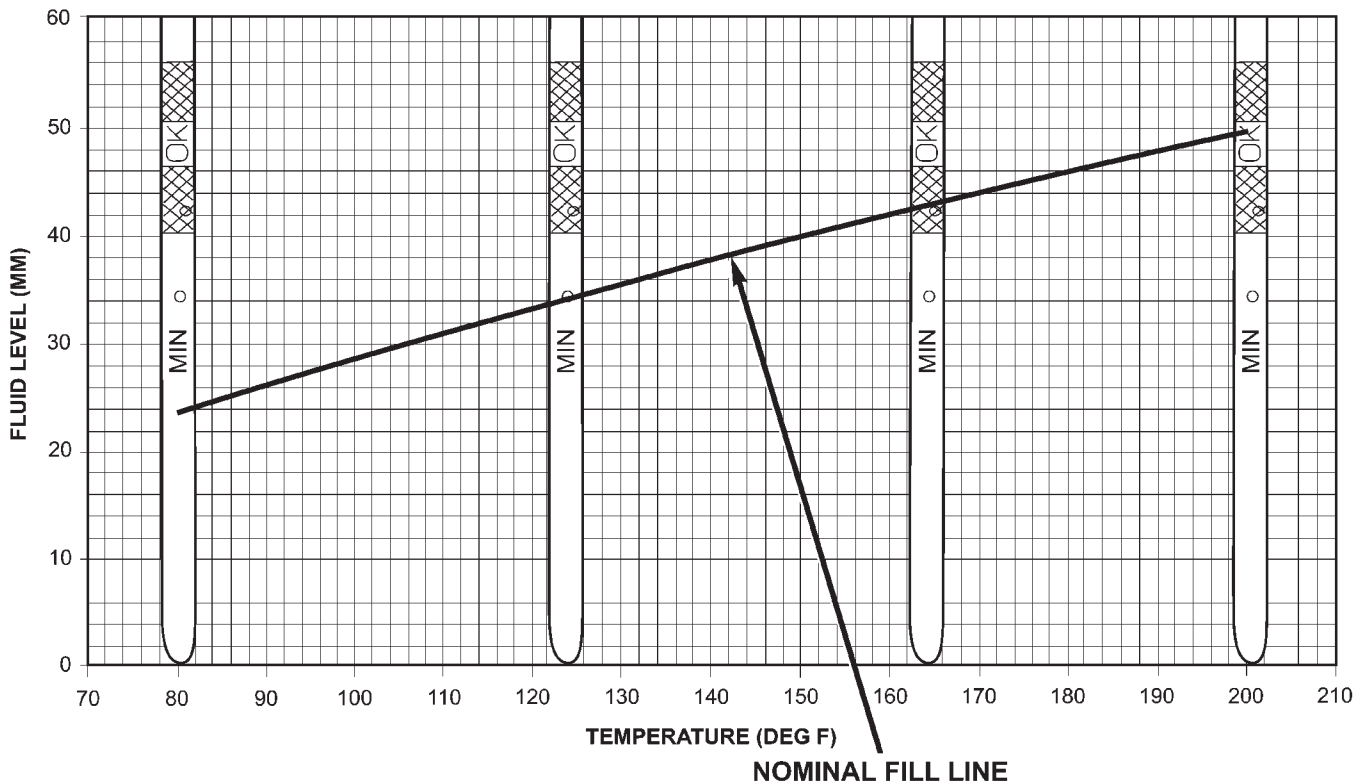


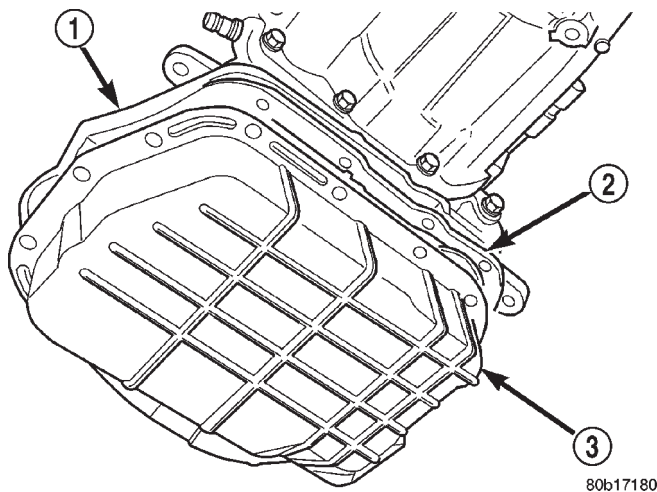
Fig. 81 42/44RE Fluid Fill Graph

## FLUID AND FILTER (Continued)

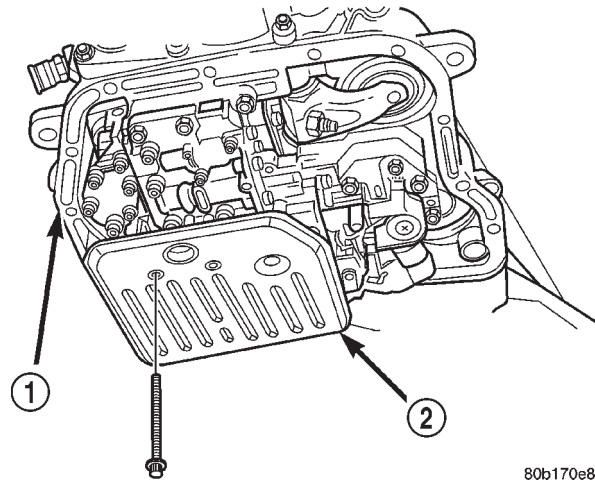
**STANDARD PROCEDURE - FLUID AND FILTER REPLACEMENT**

For proper service intervals (Refer to LUBRICATION & MAINTENANCE/MAINTENANCE SCHEDULES - DESCRIPTION). The service fluid fill after a filter change is approximately 3.8 liters (4.0 quarts).

- (1) Hoist and support vehicle on safety stands.
- (2) Place a large diameter shallow drain pan beneath the transmission pan.
- (3) Remove bolts holding front and sides of pan to transmission (Fig. 82).
- (4) Loosen bolts holding rear of pan to transmission.
- (5) Slowly separate front of pan away from transmission allowing the fluid to drain into drain pan.
- (6) Hold up pan and remove remaining bolt holding pan to transmission.
- (7) While holding pan level, lower pan away from transmission.
- (8) Pour remaining fluid in pan into drain pan.
- (9) Remove screws holding filter to valve body (Fig. 83).
- (10) Separate filter from valve body and pour fluid in filter into drain pan.
- (11) Dispose of used trans fluid and filter properly.

**Fig. 82 Transmission Pan**

- 1 - TRANSMISSION
- 2 - GASKET
- 3 - PAN



80b170e8

**Fig. 83 Transmission Filter**

- 1 - TRANSMISSION
- 2 - FILTER

- (a) If only fluid and filter were changed, add **3 pints (1-1/2 quarts)** of ATF +4 to transmission.
- (b) If transmission was completely overhauled, torque converter was replaced or drained, and cooler was flushed, add **12 pints (6 quarts)** of ATF +4 to transmission.
- (3) Apply parking brakes.
- (4) Start and run engine at normal curb idle speed.
- (5) Apply service brakes, shift transmission through all gear ranges then back to NEUTRAL, set parking brake, and leave engine running at curb idle speed.
- (6) Remove funnel, insert dipstick and check fluid level. If level is low, **add fluid to bring level to MIN mark on dipstick**. Check to see if the oil level is equal on both sides of the dipstick. If one side is noticeably higher than the other, the dipstick has picked up some oil from the dipstick tube. Allow the oil to drain down the dipstick tube and re-check.
- (7) Drive vehicle until transmission fluid is at normal operating temperature.
- (8) With the engine running at curb idle speed, the gear selector in NEUTRAL, and the parking brake applied, check the transmission fluid level.

**CAUTION: Do not overfill transmission, fluid foaming and shifting problems can result.**

- (9) Add fluid to bring level up to MAX arrow mark.

When fluid level is correct, shut engine off, release park brake, remove funnel, and install dipstick in fill tube.

**STANDARD PROCEDURE - TRANSMISSION FILL**

To avoid overfilling transmission after a fluid change or overhaul, perform the following procedure:

- (1) Remove dipstick and insert clean funnel in transmission fill tube.
- (2) Add following initial quantity of Mopar® ATF +4, type 9602, to transmission:

## FRONT CLUTCH

### DESCRIPTION

The front clutch assembly (Fig. 84) is composed of the front clutch retainer, pressure plate, clutch plates, driving discs, piston, piston return spring, return spring retainer, and snap-rings. The front clutch is the forward-most component in the transmission geartrain and is directly behind the oil pump and is considered a driving component.

**NOTE: The number of discs and plates may vary with each engine and vehicle combination.**

### OPERATION

To apply the clutch, pressure is applied between the clutch retainer and piston. The fluid pressure is provided by the oil pump, transferred through the control valves and passageways, and enters the clutch through the hub of the reaction shaft support. With pressure applied between the clutch retainer

and piston, the piston moves away from the clutch retainer and compresses the clutch pack. This action applies the clutch pack, allowing torque to flow through the input shaft into the driving discs, and into the clutch plates and pressure plate that are lugged to the clutch retainer. The waved snap-ring is used to cushion the application of the clutch pack.

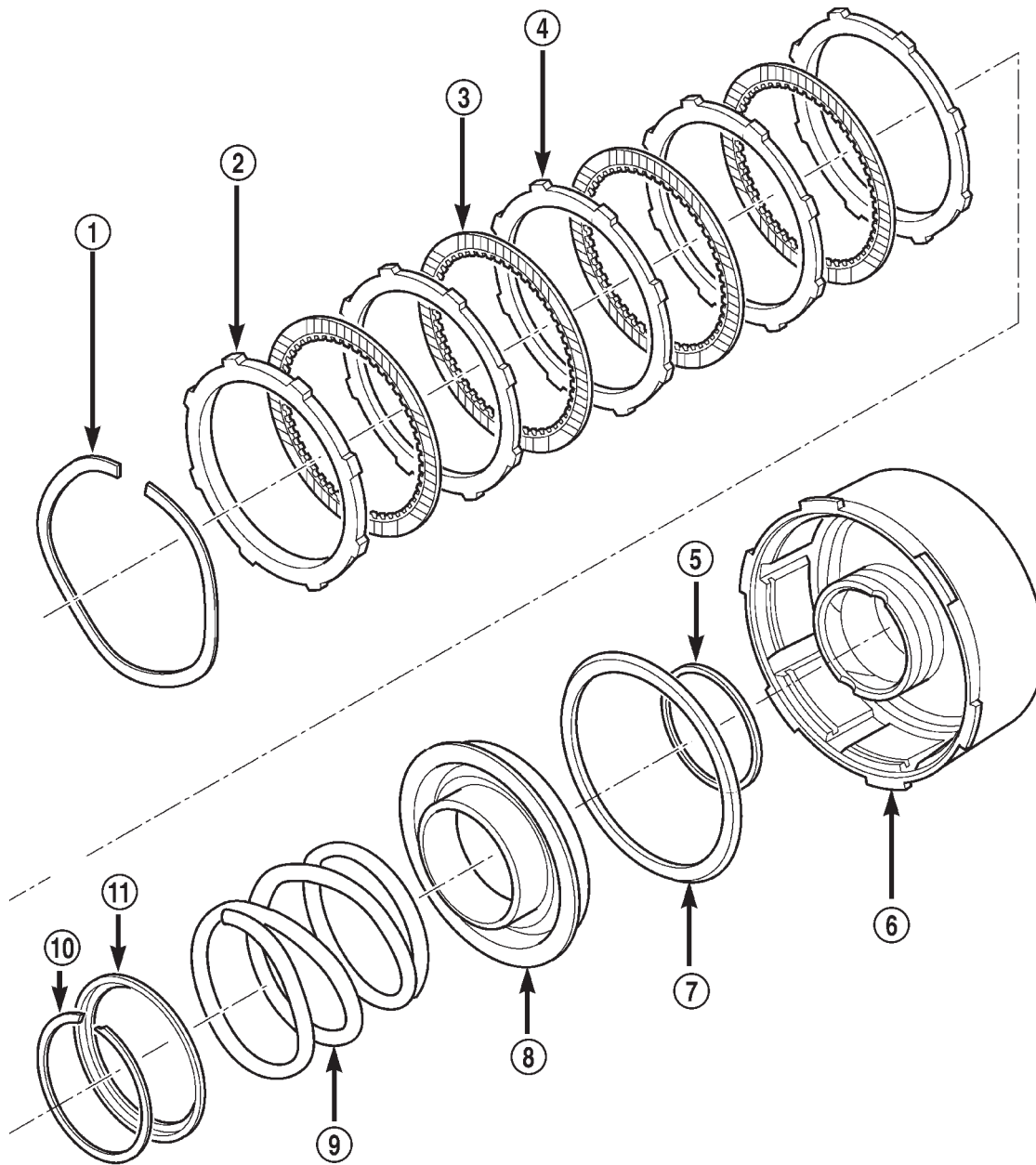
When pressure is released from the piston, the spring returns the piston to its fully released position and disengages the clutch. The release spring also helps to cushion the application of the clutch assembly. When the clutch is in the process of being released by the release spring, fluid flows through a vent and one-way ball-check-valve located in the clutch retainer. The check-valve is needed to eliminate the possibility of plate drag caused by centrifugal force acting on the residual fluid trapped in the clutch piston retainer.

### DISASSEMBLY

(1) Remove waved snap-ring and remove pressure plate, clutch plates and clutch discs (Fig. 85).



FRONT CLUTCH (Continued)



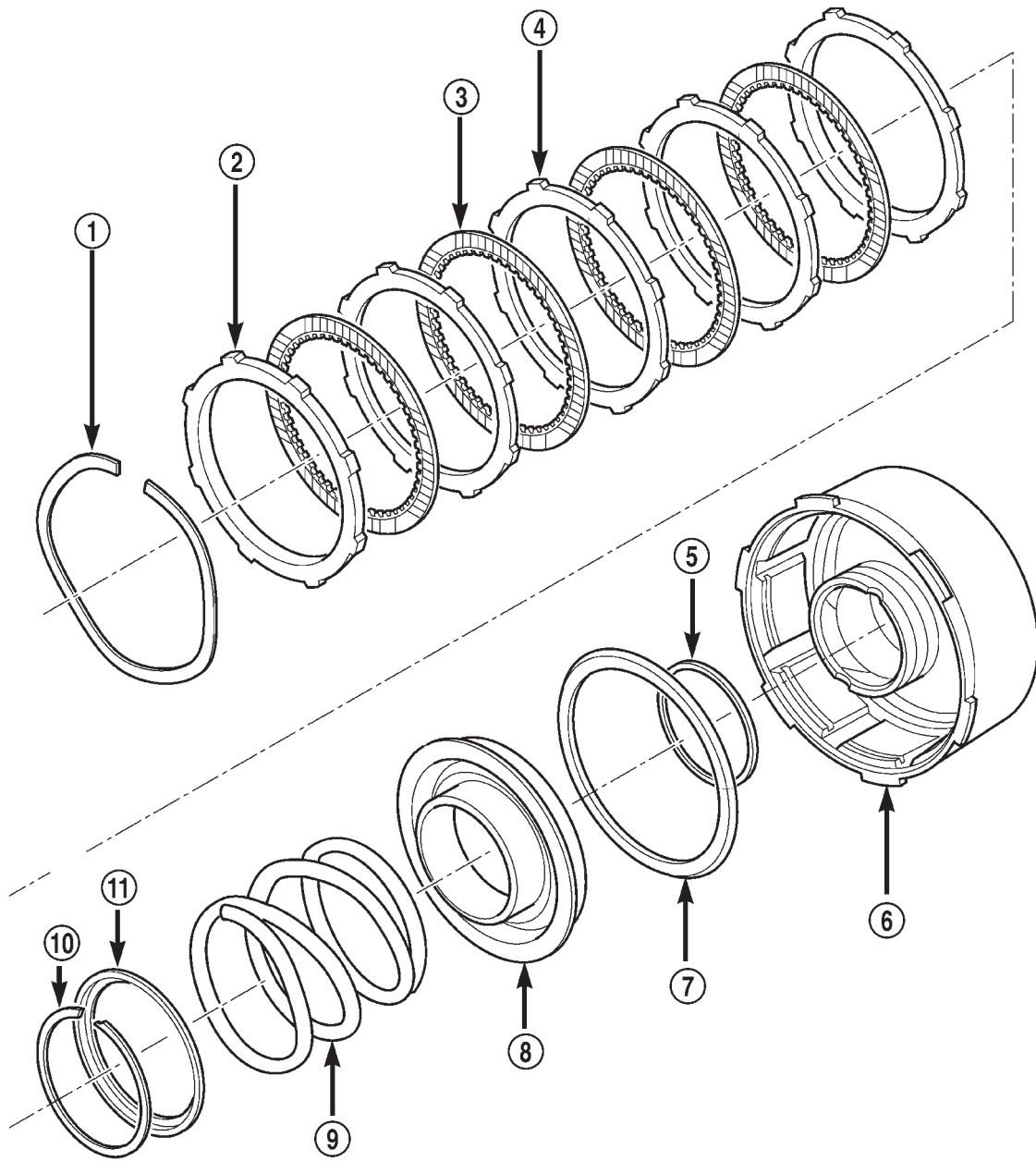
80bdbd40

**Fig. 84 Front Clutch Components**

- 1 - SNAP-RING (WAVE)
- 2 - REACTION PLATE
- 3 - CLUTCH DISC
- 4 - CLUTCH PLATE
- 5 - SEAL
- 6 - CLUTCH RETAINER

- 7 - SEAL
- 8 - PISTON
- 9 - SPRING
- 10 - SNAP-RING
- 11 - SPRING RETAINER

FRONT CLUTCH (Continued)



80bdbd40

**Fig. 85 Front Clutch Components - Typical**

- 1 - SNAP-RING (WAVE)
- 2 - REACTION PLATE
- 3 - CLUTCH DISC
- 4 - CLUTCH PLATE
- 5 - SEAL
- 6 - CLUTCH RETAINER

- 7 - SEAL
- 8 - PISTON
- 9 - SPRING
- 10 - SNAP-RING
- 11 - SPRING RETAINER

## FRONT CLUTCH (Continued)

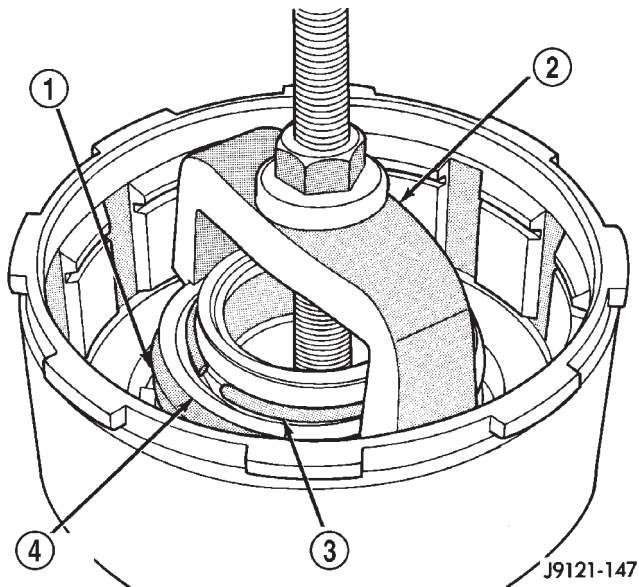
(2) Compress clutch piston spring with Compressor Tool C-3575-A (Fig. 86). Be sure legs of tool are seated squarely on spring retainer before compressing spring.

(3) Remove retainer snap-ring and remove compressor tool.

(4) Remove spring retainer and clutch spring. Note position of retainer on spring for assembly reference.

(5) Remove clutch piston from clutch retainer. Remove piston by rotating it up and out of retainer.

(6) Remove seals from clutch retainer piston bore and clutch retainer hub. Discard both seals as they are not reusable.



**Fig. 86 Compressing Front Clutch Piston Spring**

- 1 - FRONT CLUTCH SPRING
- 2 - COMPRESSOR TOOL C-3575-A
- 3 - RETAINER SNAP-RING
- 4 - SPRING RETAINER

## INSPECTION

Inspect the front clutch components. Replace the clutch discs if warped, worn, scored, burned or charred, or if the facing is flaking off. Replace the steel plates if heavily scored, warped, or broken. Be sure the driving lugs on the plates are in good condition. The lugs must not be bent, cracked or damaged in any way.

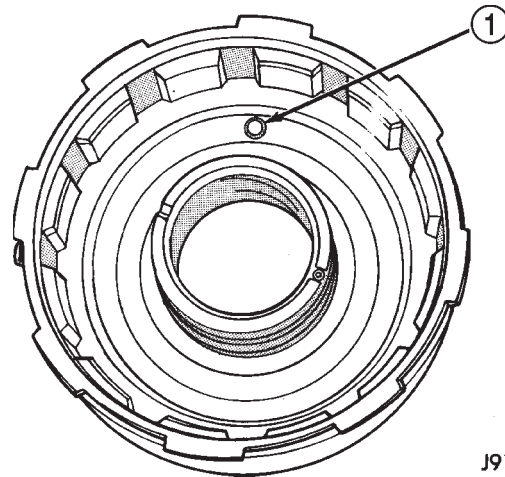
Replace the clutch spring and spring retainer if either is distorted, warped or broken.

Check the lug grooves in the clutch retainer. The steel plates should slide freely in the slots. Replace the retainer if the grooves are worn or damaged.

Check action of the check ball in the retainer (Fig. 87). The ball must move freely and not stick.

**NOTE:** Inspect the clutch retainer bushings carefully (Fig. 88). The retainer bushings are NOT serviceable. It will be necessary to replace the retainer if either bushing is scored, or worn.

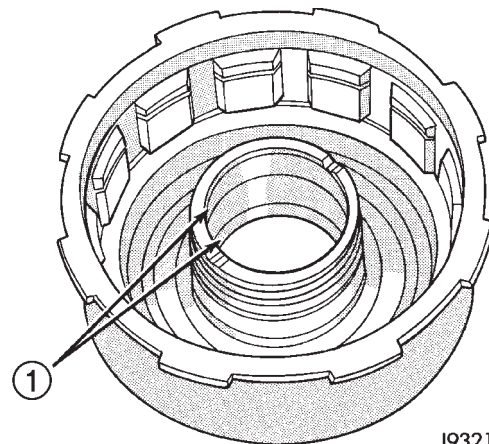
Inspect the piston and retainer seal surfaces for nicks or scratches. Minor scratches can be removed with crocus cloth. However, replace the piston and/or retainer if the seal surfaces are seriously scored.



J9121-368

**Fig. 87 Front Clutch Piston Retainer Check Ball Location**

- 1 - RETAINER CHECK BALL



J9321-223

**Fig. 88 Retainer Bushing Location/Inspection**

- 1 - FRONT CLUTCH RETAINER BUSHINGS (NON-SERVICEABLE)

## ASSEMBLY

**NOTE:** The 44RE transmission uses five (5) plates and discs for the front clutch.

(1) Soak clutch discs in transmission fluid while assembling other clutch parts.

## FRONT CLUTCH (Continued)

(2) Install new seals in the clutch retainer lower groove and on the outer diameter of the retainer hub. Be sure lip of each seal faces interior of clutch retainer.

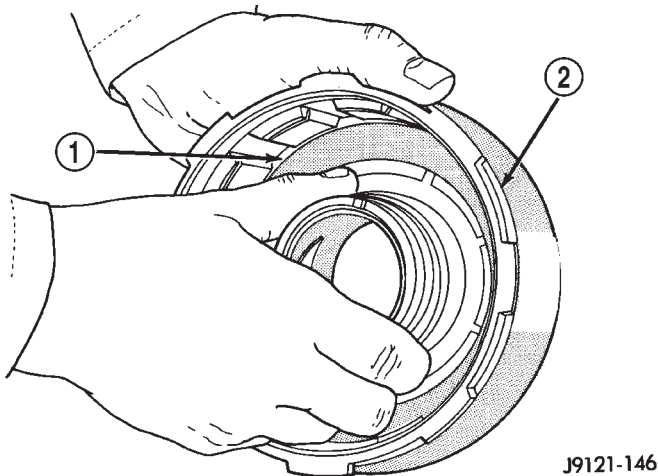
(3) Lubricate lips of the retainer seals with liberal quantity of Mopar® Door Ease. Then lubricate retainer hub, bore, and piston with light coat of transmission fluid.

(4) Install clutch piston in retainer (Fig. 89). Use twisting motion to seat piston in bottom of retainer.

**CAUTION: Never push the clutch piston straight in. This will fold the seals over causing leakage and clutch slip.**

(5) Position spring in clutch piston (Fig. 90).

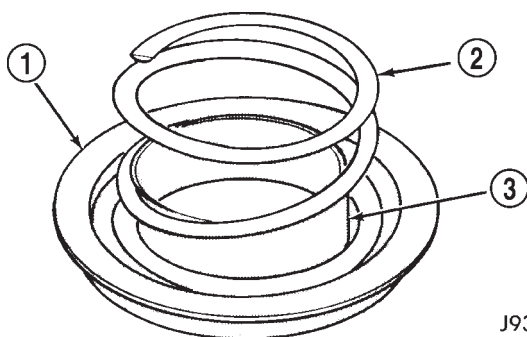
(6) Position spring retainer on top of piston spring. Make sure retainer is properly installed (Fig. 85).



J9121-146

**Fig. 89 Front Clutch Piston Installation**

- 1 - CLUTCH PISTON  
2 - FRONT CLUTCH RETAINER



J9321-466

**Fig. 90 Clutch Piston Spring Installation**

- 1 - RETAINER  
2 - CLUTCH SPRING  
3 - PISTON

(7) Compress piston spring and retainer with Compressor Tool C-3575-A (Fig. 86). Then install new snap ring to secure spring retainer and spring.

(8) Install clutch plates and discs. Install steel plate then disc until all plates and discs are installed. The front clutch uses 5 clutch discs and plates in a 44RE transmission.

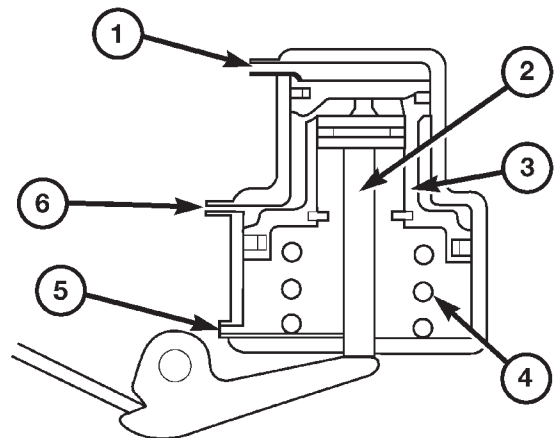
(9) Install pressure plate and waved snap-ring.

Clearance should be 1.70 to 3.40 mm (0.067 to 0.134 in.). If clearance is incorrect, clutch discs, plates, pressure plates and snap ring may have to be changed.

## FRONT SERVO

## DESCRIPTION

The kickdown servo (Fig. 91) consists of a two-land piston with an inner piston, a piston rod and guide, and a return spring. The dual-land piston uses seal rings on its outer diameters and an O-ring for the inner piston.



80a08c99

**Fig. 91 Front Servo**

- 1 - VENT  
2 - PISTON ROD  
3 - PISTON  
4 - SPRING  
5 - RELEASE PRESSURE  
6 - APPLY PRESSURE

## OPERATION

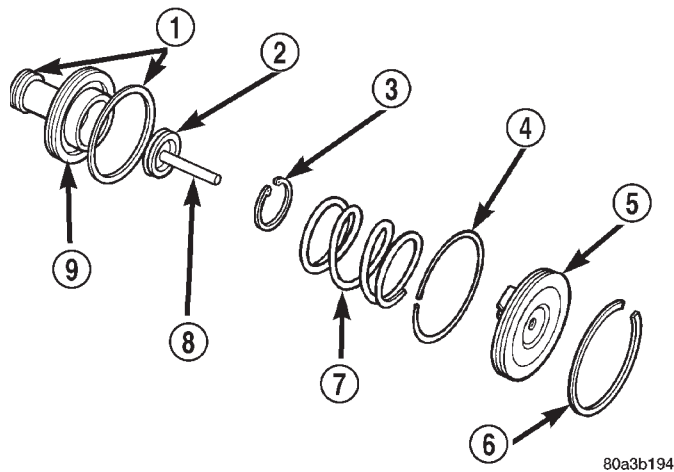
The application of the piston is accomplished by applying pressure between the two lands of the piston. The pressure acts against the larger lower land to push the piston downward, allowing the piston rod to extend through its guide against the apply lever. Release of the servo at the 2-3 upshift is accomplished by a combination of spring and line pressure, acting on the bottom of the larger land of the piston.

FRONT SERVO (Continued)

The small piston is used to cushion the application of the band by bleeding oil through a small orifice in the larger piston. The release timing of the kickdown servo is very important to obtain a smooth but firm shift. The release has to be very quick, just as the front clutch application is taking place. Otherwise, engine runaway or a shift hesitation will occur. To accomplish this, the band retains its holding capacity until the front clutch is applied, giving a small amount of overlap between them.

**DISASSEMBLY**

- (1) Remove seal ring from rod guide (Fig. 92).
- (2) Remove small snap-ring from servo piston rod. Then remove piston rod, spring and washer from piston.
- (3) Remove and discard servo component o-ring and seal rings.



**Fig. 92 Front Servo**

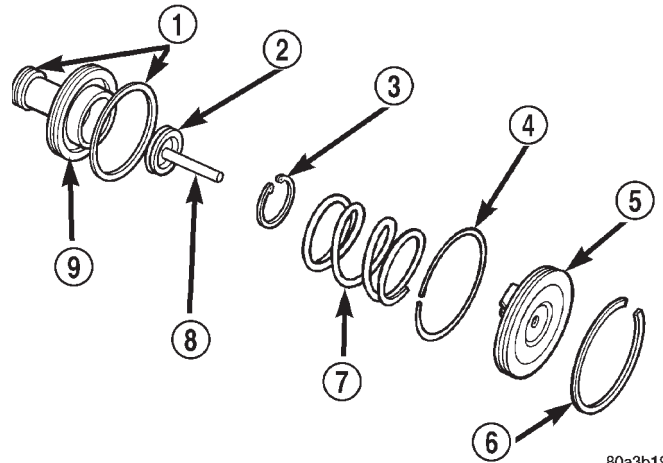
- 1 - PISTON RINGS
- 2 - O-RING
- 3 - SNAP-RING
- 4 - SEAL RING
- 5 - PISTON ROD GUIDE
- 6 - SNAP-RING
- 7 - SERVO SPRING
- 8 - PISTON ROD
- 9 - SERVO PISTON

**CLEANING**

Clean the servo piston components (Fig. 93) with solvent and dry them with compressed air.

**INSPECTION**

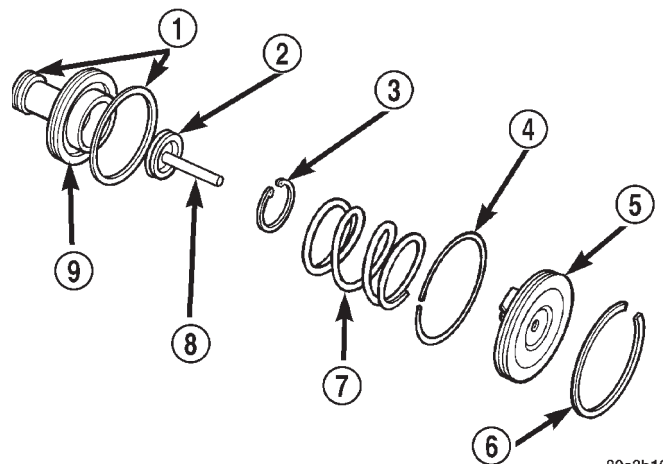
Inspect the servo components (Fig. 94). Replace the springs if collapsed, distorted or broken. Replace the guide, rod and piston if cracked, bent, or worn. Discard the servo snap-ring if distorted or warped.



80a3b194

**Fig. 93 Front Servo Piston**

- 1 - PISTON RINGS
- 2 - O-RING
- 3 - SNAP-RING
- 4 - SEAL RING
- 5 - PISTON ROD GUIDE
- 6 - SNAP-RING
- 7 - SERVO SPRING
- 8 - PISTON ROD
- 9 - SERVO PISTON



80a3b194

**Fig. 94 Front Servo Piston**

- 1 - PISTON RINGS
- 2 - O-RING
- 3 - SNAP-RING
- 4 - SEAL RING
- 5 - PISTON ROD GUIDE
- 6 - SNAP-RING
- 7 - SERVO SPRING
- 8 - PISTON ROD
- 9 - SERVO PISTON

Check the servo piston bore for wear. If the bore is severely scored, or damaged, it will be necessary to replace the case.



## FRONT SERVO (Continued)

Replace any servo component if doubt exists about condition. Do not reuse suspect parts.

## ASSEMBLY

Clean and inspect front servo components.

(1) Lubricate new o-ring and seal rings with petroleum jelly and install them on piston, guide and rod.

(2) Install rod in piston. Install spring and washer on rod. Compress spring and install snap-ring (Fig. 95).

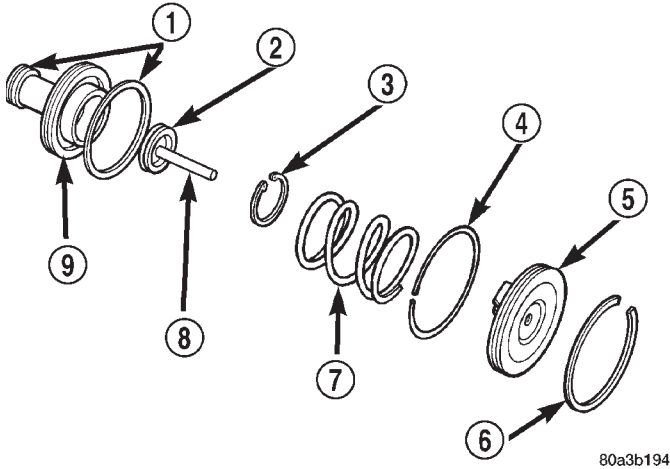
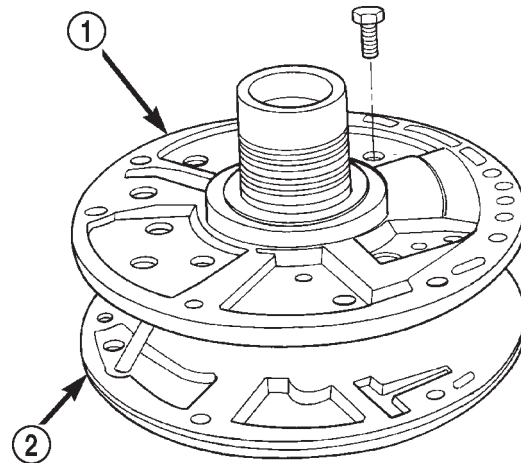


Fig. 95 Front Servo

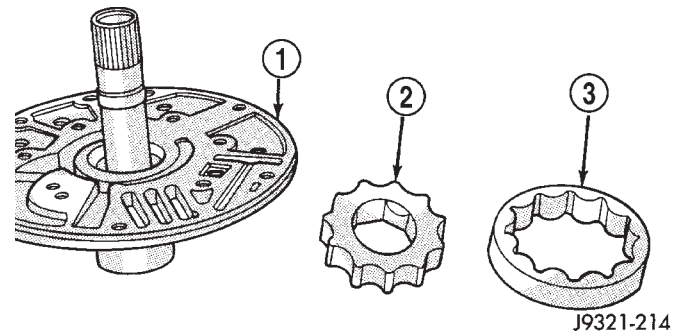
- 1 - PISTON RINGS
- 2 - O-RING
- 3 - SNAP-RING
- 4 - SEAL RING
- 5 - PISTON ROD GUIDE
- 6 - SNAP-RING
- 7 - SERVO SPRING
- 8 - PISTON ROD
- 9 - SERVO PISTON



80a483e7

Fig. 96 Oil Pump and Reaction Shaft Support

- 1 - REACTION SHAFT SUPPORT
- 2 - PUMP



J9321-214

Fig. 97 Pump Gear Removal

- 1 - REACTION SHAFT SUPPORT
- 2 - INNER GEAR
- 3 - OUTER GEAR

## OIL PUMP

## DESCRIPTION

The oil pump (Fig. 96) is located in the pump housing inside the bell housing of the transmission case. The oil pump consists of an inner and outer gear (Fig. 97), a housing, and a cover that also serves as the reaction shaft support.

## OPERATION

As the torque converter rotates, the converter hub rotates the inner and outer gears. As the gears rotate, the clearance between the gear teeth increases in the crescent area, and creates a suction at the inlet side of the pump. This suction draws fluid through the pump inlet from the oil pan. As the clearance between the gear teeth in the crescent area

decreases, it forces pressurized fluid into the pump outlet and to the valve body.

## STANDARD PROCEDURE - OIL PUMP VOLUME CHECK

Measuring the oil pump output volume will determine if sufficient oil flow to the transmission oil cooler exists, and whether or not an internal transmission failure is present.

Verify that the transmission fluid is at the proper level. Refer to the Fluid Level Check procedure in this section. If necessary, fill the transmission to the proper level with Mopar® ATF +4, type 9602, Automatic Transmission Fluid.

(1) Disconnect the **To cooler** line at the cooler inlet and place a collecting container under the disconnected line.

OIL PUMP (Continued)

**CAUTION:** With the fluid set at the proper level, fluid collection should not exceed (1) quart or internal damage to the transmission may occur.

(2) Run the engine **at curb idle speed**, with the shift selector in neutral.

(3) If one quart of transmission fluid is collected in the container in 20 seconds or less, oil pump flow volume is within acceptable limits. If fluid flow is intermittent, or it takes more than 20 seconds to collect one quart of fluid, refer to the Hydraulic Pressure tests in this section for further diagnosis.

(4) Re-connect the **To cooler** line to the transmission cooler inlet.

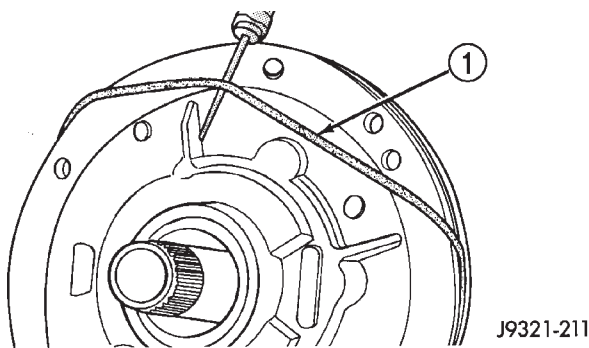
(5) Refill the transmission to proper level.

**DISASSEMBLY**

(1) Remove seal ring from housing and reaction shaft support (Fig. 98).

(2) Mark pump housing and support assembly for alignment reference.

(3) Remove bolts attaching pump body to support (Fig. 99).



J9321-211

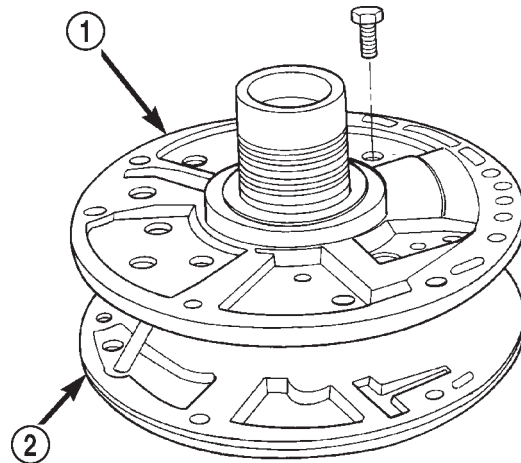
**Fig. 98 Removing Pump Seal Ring**

1 - PUMP HOUSING SEAL RING

(4) Separate support from pump housing (Fig. 100).

(5) Remove inner and outer gears from reaction shaft support (Fig. 101).

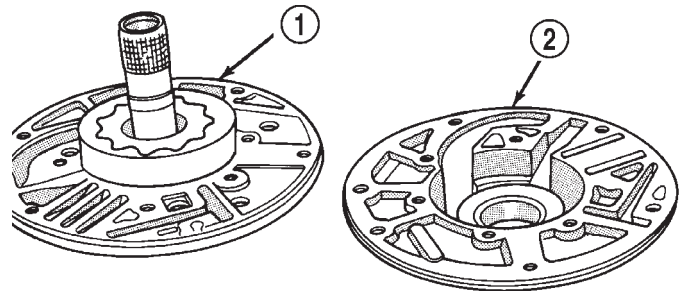
(6) If pump seal was not removed during transmission disassembly, remove seal with punch and hammer.



80a483e7

**Fig. 99 Pump Support Bolts**

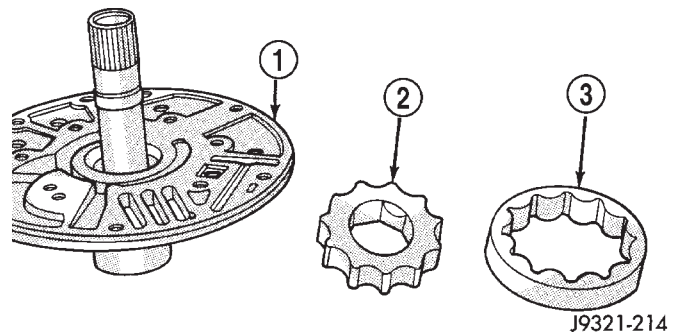
1 - REACTION SHAFT SUPPORT  
2 - PUMP



J9321-213

**Fig. 100 Separating Pump Housing From Reaction Shaft Support**

1 - REACTION SHAFT SUPPORT  
2 - PUMP HOUSING



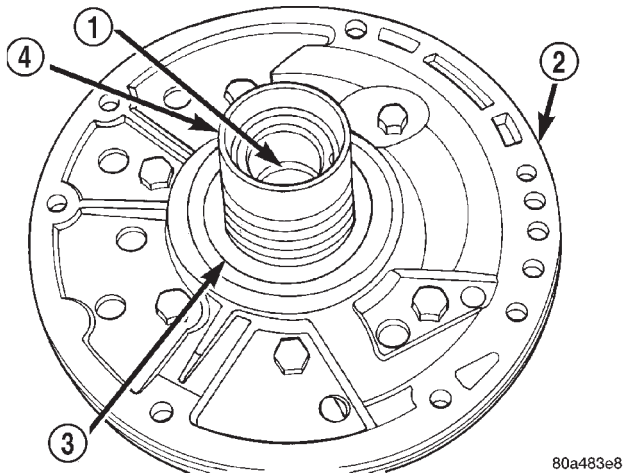
J9321-214

**Fig. 101 Pump Gear Removal**

1 - REACTION SHAFT SUPPORT  
2 - INNER GEAR  
3 - OUTER GEAR

## OIL PUMP (Continued)

(7) Remove front clutch thrust washer from support hub (Fig. 102).



**Fig. 102 Support Hub Thrust Washer**

- 1 - BUSHING
- 2 - REACTION SHAFT SUPPORT
- 3 - THRUST WASHER
- 4 - HUB

## OIL PUMP BUSHING REPLACEMENT

(1) Remove pump bushing with Tool Handle C-4171 and Bushing Remover SP-3551 from Tool Set C-3887-J (Fig. 103).

(2) Install new pump bushing with Tool Handle C-4171 and Bushing Installer SP-5117 (Fig. 103). Bushing should be flush with pump housing bore.

(3) Stake new pump bushing in two places with blunt punch (Fig. 104). Remove burrs from stake points with knife blade afterward.

## REACTION SHAFT SUPPORT BUSHING REMOVAL

(1) Assemble Bushing Remover Tools SP-1191, 3633 and 5324 (Fig. 105). Do not clamp any part of reaction shaft or support in vise.

(2) Hold Cup Tool SP-3633 firmly against reaction shaft and thread remover SP-5324 into bushing as far as possible by hand. Then thread remover tool 3-4 additional turns into bushing with a wrench.

(3) Turn remover tool hex nut down against remover cup to pull bushing from shaft. Clean all chips from shaft after bushing removal.

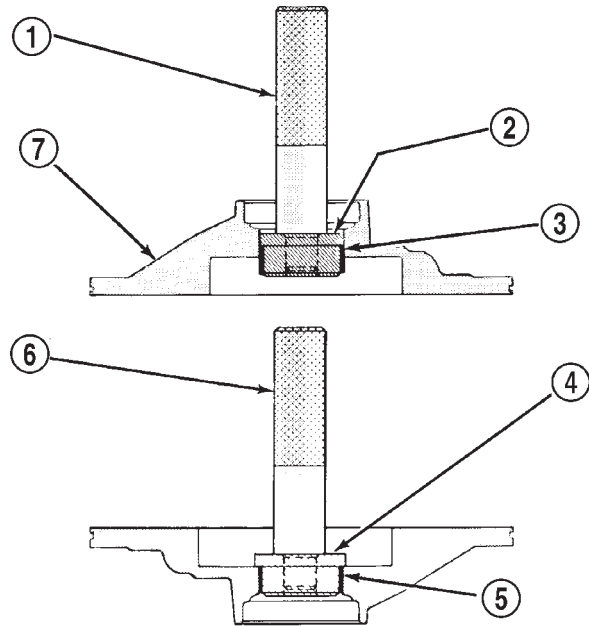
(4) Lightly grip old bushing in vise or with pliers and back remover tool out of bushing.

(5) Assemble Bushing Installer Tools C-4171 and SP-5325 (Fig. 105).

(6) Slide new bushing onto Installer Tool SP-5325.

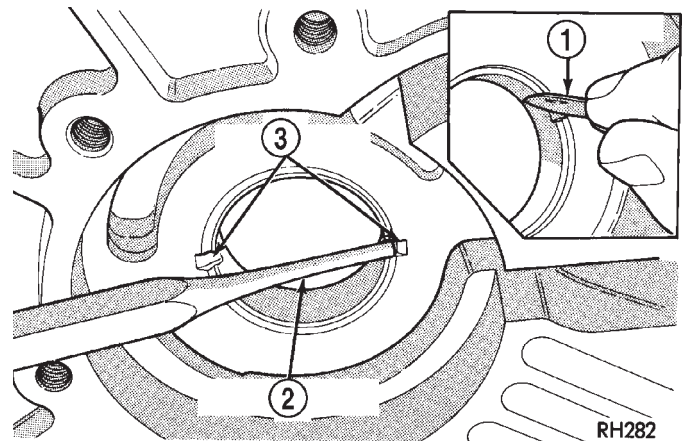
(7) Position reaction shaft support upright on a clean smooth surface.

(8) Align bushing in bore. Then tap bushing into place until Bushing Installer SP-5325 bottoms.



**Fig. 103 Removing Oil Pump Bushing**

- 1 - SPECIAL TOOL C-4171
- 2 - SPECIAL TOOL SP-3551
- 3 - BUSHING
- 4 - SPECIAL TOOL SP-5117
- 5 - BUSHING
- 6 - SPECIAL TOOL C-4171
- 7 - PUMP HOUSING



**Fig. 104 Staking Oil Pump Bushing**

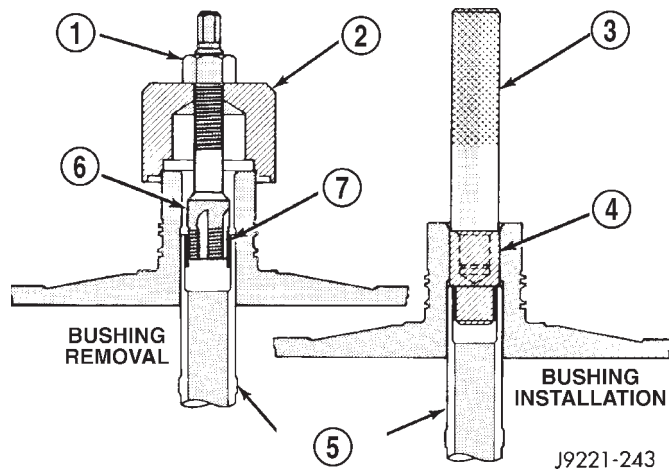
- 1 - NARROW BLADE
- 2 - BLUNT PUNCH
- 3 - TWO STAKES

(9) Clean reaction shaft support thoroughly after installing bushing.

## CLEANING

Clean pump and support components with solvent and dry them with compressed air.

## OIL PUMP (Continued)



**Fig. 105 Replacing Reaction Shaft Support Bushing**

- 1 - SPECIAL TOOL SP-1191
- 2 - SPECIAL TOOL SP-3633
- 3 - SPECIAL TOOL C-4171
- 4 - SPECIAL TOOL SP-5325
- 5 - REACTION SHAFT
- 6 - SPECIAL TOOL SP-5324
- 7 - BUSHING

## INSPECTION

Check condition of the seal rings and thrust washer on the reaction shaft support. The seal rings do not need to be replaced unless cracked, broken, or severely worn.

Inspect the pump and support components. Replace the pump or support if the seal ring grooves or machined surfaces are worn, scored, pitted, or damaged. Replace the pump gears if pitted, worn chipped, or damaged.

Inspect the pump bushing. Then check the reaction shaft support bushing. Replace either bushing only if heavily worn, scored or damaged. It is not necessary to replace the bushings unless they are actually damaged.

Clearance between outer gear and reaction shaft housing should be 0.010 to 0.063 mm (0.0004 to 0.0025 in.). Clearance between inner gear and reaction shaft housing should be 0.010 to 0.063 mm (0.0004 to 0.0025 in.). Both clearances can be measured at the same time by installing the gears in the pump body and measure pump component clearances as follows:

- (1) Position an appropriate piece of Plastigage™ across both gears.
- (2) Align the plastigage to a flat area on the reaction shaft housing.
- (3) Install the reaction shaft to the pump housing.
- (4) Separate the reaction shaft housing from the pump housing and measure the Plastigage™ following the instructions supplied with it.

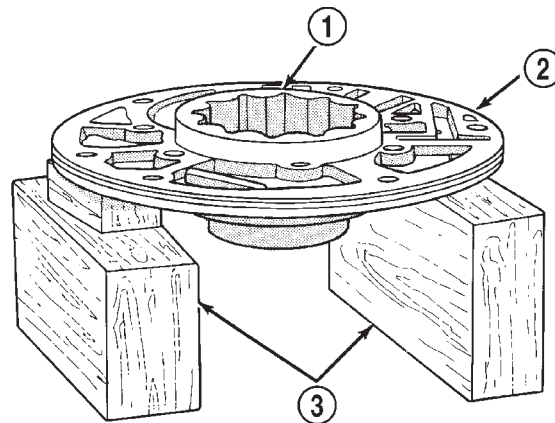
Clearance between inner gear tooth and outer gear should be 0.08 to 0.19 mm (0.0035 to 0.0075 in.). Measure clearance with an appropriate feeler gauge.

Clearance between outer gear and pump housing should be 0.10 to 0.19 mm (0.004 to 0.0075 in.). Measure clearance with an appropriate feeler gauge.

## ASSEMBLY

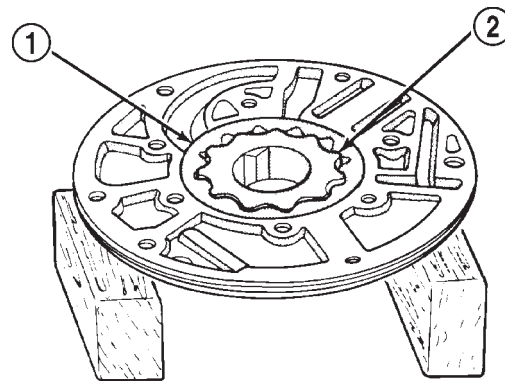
- (1) Lubricate gear bore in pump housing with transmission fluid.
- (2) Lubricate pump gears with transmission fluid.
- (3) Support pump housing on wood blocks (Fig. 106).
- (4) Install outer gear in pump housing (Fig. 106). Gear can be installed either way (it is not a one-way fit).
- (5) Install pump inner gear (Fig. 107).

**CAUTION:** The pump inner gear is a one way fit. The bore on one side of the gear inside diameter (I.D.) is chamfered. Be sure the chamfered side faces forward (to front of pump).



**Fig. 106 Supporting Pump And Installing Outer Gear**

- 1 - OUTER GEAR
- 2 - PUMP HOUSING
- 3 - WOOD BLOCKS



**Fig. 107 Pump Inner Gear Installation**

- 1 - OUTER GEAR
- 2 - INNER GEAR

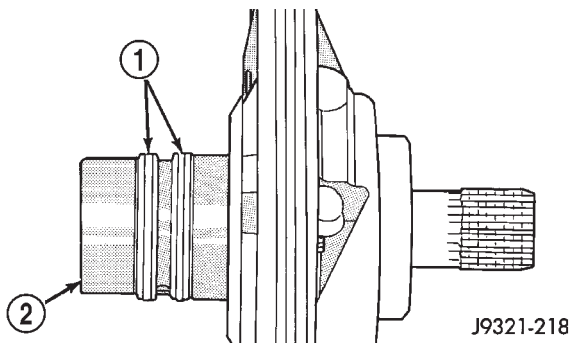


## OIL PUMP (Continued)

(6) Install new thrust washer on hub of reaction shaft support. Lubricate washer with transmission fluid or petroleum jelly.

(7) If reaction shaft seal rings are being replaced, install new seal rings on support hub (Fig. 108). Lubricate seal rings with transmission fluid or petroleum jelly after installation. Squeeze each ring until ring ends are securely hooked together.

**CAUTION:** The reaction shaft support seal rings will break if overspread, or twisted. If new rings are being installed, spread them only enough for installation. Also be very sure the ring ends are securely hooked together after installation. Otherwise, the rings will either prevent pump installation, or break during installation.

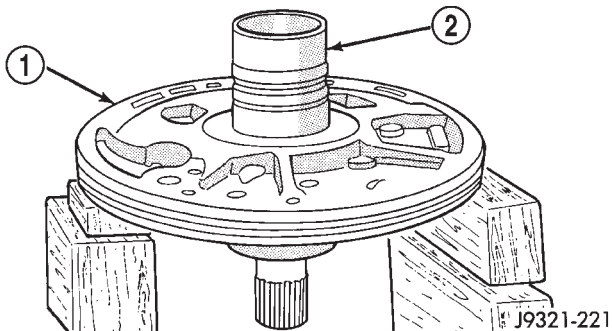


**Fig. 108 Hub Seal Ring Position**

- 1 - SEAL RINGS
- 2 - SUPPORT HUB

(8) Install reaction shaft support on pump housing (Fig. 109).

(9) Align reaction support on pump housing. Use alignment marks made at disassembly. Or, rotate support until bolt holes in support and pump housing are all aligned (holes are offset for one-way fit).



**Fig. 109 Assembling Reaction Shaft Support And Pump Housing**

- 1 - PUMP HOUSING
- 2 - REACTION SHAFT SUPPORT

(10) Install all bolts that attach support to pump housing. Then tighten bolts finger tight.

(11) Tighten support-to-pump bolts to required torque as follows:

(a) Reverse pump assembly and install it in transmission case. Position pump so bolts are facing out and are accessible.

(b) Secure pump assembly in case with 2 or 3 bolts, or with pilot studs.

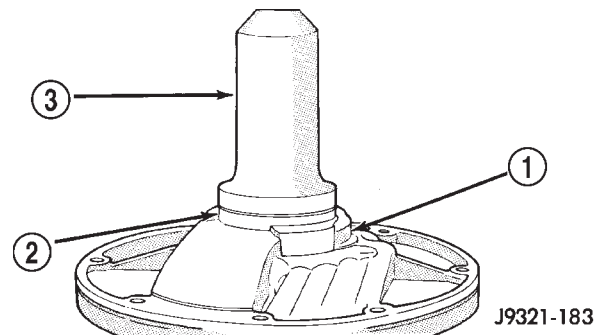
(c) Tighten support-to-pump bolts to 20 N·m (15 ft. lbs.).

(d) Remove pump assembly from transmission case.

(12) Install new oil seal in pump with Special Tool C-4193 and Tool Handle C-4171 (Fig. 110). Be sure seal lip faces inward.

(13) Install new seal ring around pump housing. Be sure seal is properly seated in groove.

(14) Lubricate lip of pump oil seal and O-ring seal with transmission fluid.



**Fig. 110 Pump Oil Seal Installation**

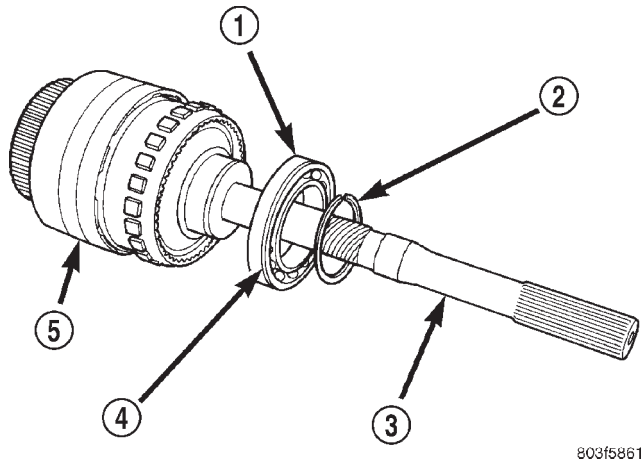
- 1 - PUMP BODY
- 2 - PUMP SEAL
- 3 - SPECIAL TOOL C-4193



## OUTPUT SHAFT FRONT BEARING

### REMOVAL

- (1) Remove overdrive unit from the vehicle.
- (2) Remove overdrive geartrain from housing.
- (3) Remove snap-ring holding output shaft front bearing to overdrive geartrain. (Fig. 111).
- (4) Pull bearing from output shaft.



803f5861

**Fig. 111 Output Shaft Front Bearing**

- 1 - OUTPUT SHAFT FRONT BEARING
- 2 - SNAP-RING
- 3 - OUTPUT SHAFT
- 4 - GROOVE TO REAR
- 5 - OVERDRIVE GEARTRAIN

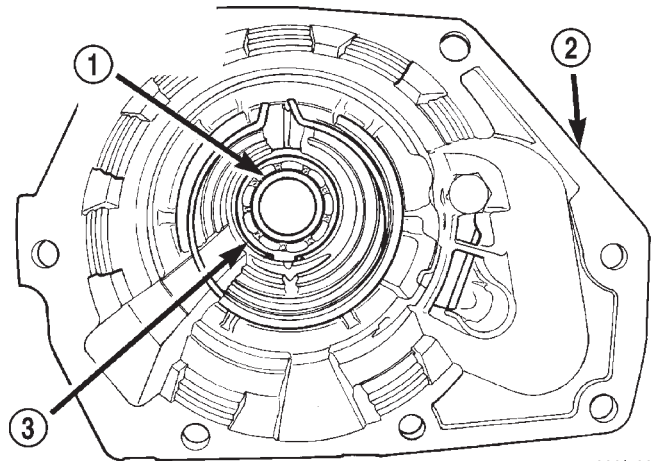
### INSTALLATION

- (1) Place replacement bearing in position on geartrain with locating retainer groove toward the rear.
- (2) Push bearing onto shaft until the snap-ring groove is visible.
- (3) Install snap-ring to hold bearing onto output shaft.
- (4) Install overdrive geartrain into housing.
- (5) Install overdrive unit in vehicle.

## OUTPUT SHAFT REAR BEARING

### REMOVAL

- (1) Remove overdrive unit from the vehicle. (Refer to 21 - TRANSMISSION/TRANSAXLE/AUTOMATIC/OVERDRIVE - REMOVAL)
- (2) Remove overdrive geartrain from housing.
- (3) Remove snap-ring holding output shaft rear bearing into overdrive housing (Fig. 112).
- (4) Using a suitable driver inserted through the rear end of housing, drive bearing from housing.



803f5860

**Fig. 112 Output Shaft Rear Bearing**

- 1 - OUTPUT SHAFT REAR BEARING
- 2 - OVERDRIVE HOUSING
- 3 - SNAP-RING

### INSTALLATION

- (1) Place replacement bearing in position in housing.
- (2) Using a suitable driver, drive bearing into housing until the snap-ring groove is visible.
- (3) Install snap-ring to hold bearing into housing (Fig. 112).
- (4) Install overdrive geartrain into housing.
- (5) Install overdrive unit in vehicle.

## OVERDRIVE CLUTCH

### DESCRIPTION

The overdrive clutch (Fig. 113) is composed of the pressure plate, clutch plates, holding discs, overdrive piston retainer, piston, piston spacer, and snap-rings. The overdrive clutch is the forwardmost component in the transmission overdrive unit and is considered a holding component. The overdrive piston retainer, piston, and piston spacer are located on the rear of the main transmission case.

**NOTE: The number of discs and plates may vary with each engine and vehicle combination.**

### OPERATION

To apply the clutch, pressure is applied between the piston retainer and piston. The fluid pressure is provided by the oil pump, transferred through the control valves and passageways, and enters the clutch through passages at the lower rear portion of the valve body area. With pressure applied between the piston retainer and piston, the piston moves away from the piston retainer and compresses the clutch pack. This action applies the clutch pack, allowing torque to flow through the intermediate shaft into the overdrive planetary gear set. The overdrive clutch discs are attached to the overdrive clutch hub while the overdrive clutch plates, reaction plate, and pressure plate are lugged to the overdrive housing. This allows the intermediate shaft to

transfer the engine torque to the planetary gear and overrunning clutch. This drives the planetary gear inside the annulus, which is attached to the overdrive clutch drum and output shaft, creating the desired gear ratio. The waved snap-ring is used to cushion the application of the clutch pack.

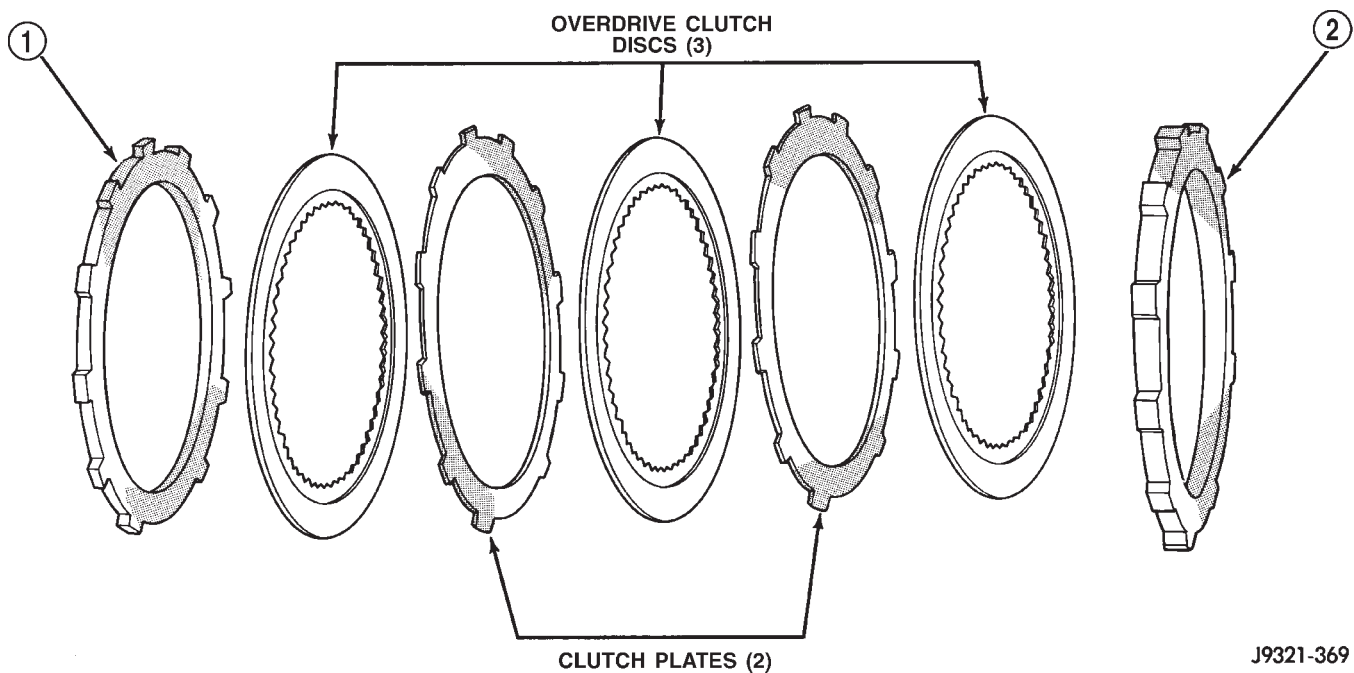
## OVERDRIVE SWITCH

### DESCRIPTION

The overdrive OFF (control) switch is located in the shift lever arm (Fig. 114). The switch is a momentary contact device that signals the PCM to toggle current status of the overdrive function.

### OPERATION

At key-on, overdrive operation is allowed. Pressing the switch once causes the overdrive OFF mode to be entered and the overdrive OFF switch lamp to be illuminated. Pressing the switch a second time causes normal overdrive operation to be restored and the overdrive lamp to be turned off. The overdrive OFF mode defaults to ON after the ignition switch is cycled OFF and ON. The normal position for the control switch is the ON position. The switch must be in this position to energize the solenoid and allow a 3-4 upshift. The control switch indicator light illuminates only when the overdrive switch is turned to the OFF position, or when illuminated by the transmission control module.



**Fig. 113 Overdrive Clutch**

J9321-369

OVERDRIVE SWITCH (Continued)

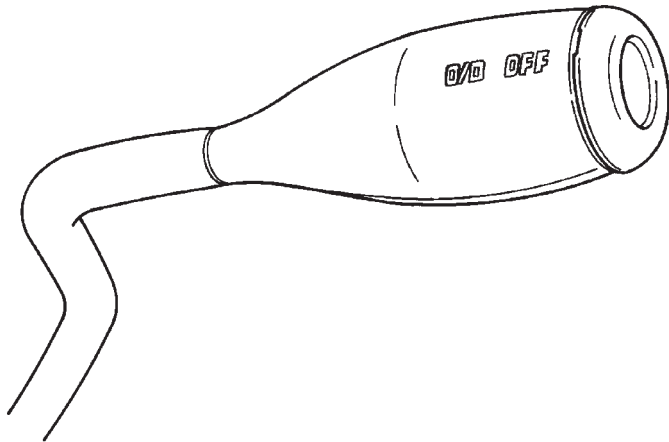


Fig. 114 Overdrive Off Switch

80a8e1c1

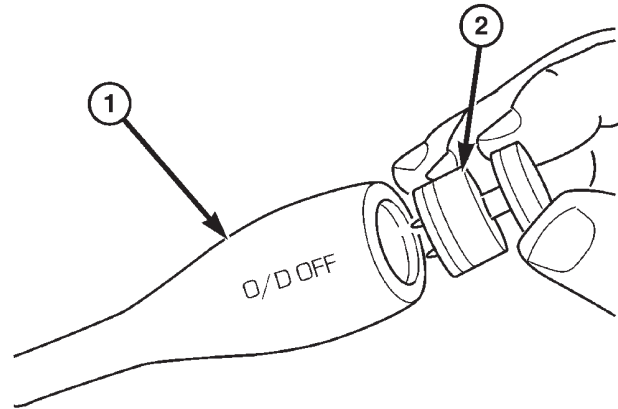


Fig. 116 Remove the Overdrive Off Switch

80a8ed2b

- 1 - GEAR SHIFT LEVER
- 2 - OVERDRIVE OFF SWITCH

DIAGNOSIS AND TESTING - OVERDRIVE ELECTRICAL CONTROLS

The overdrive off switch, valve body solenoid, case connectors and related wiring can all be tested with a 12 volt test lamp or a volt/ohmmeter. Check continuity of each component when diagnosis indicates this is necessary.

Switch and solenoid continuity should be checked whenever the transmission fails to shift into fourth gear range.

REMOVAL

(1) Using a plastic trim tool, remove the overdrive off switch retainer from the shift lever (Fig. 115).

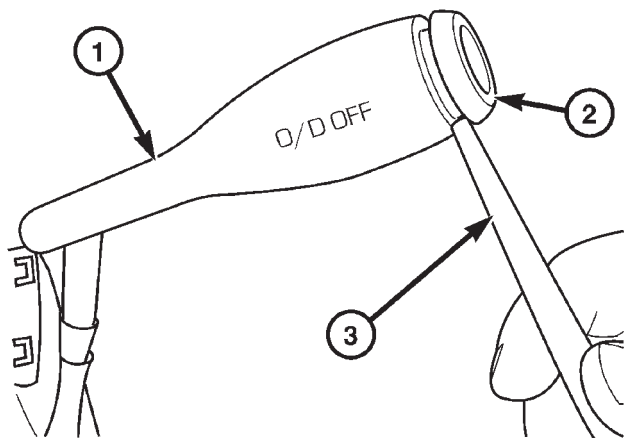


Fig. 115 Overdrive Off Switch Retainer

80a8ea93

- 1 - GEAR SHIFT LEVER
- 2 - OVERDRIVE OFF SWITCH RETAINER
- 3 - PLASTIC TRIM TOOL

(2) Pull the switch outwards to release it from the connector in the lever (Fig. 116)

INSTALLATION

**NOTE:** There is enough slack in the wire to pull out the connector from the lever.

(1) Pull the connector out of the lever just enough to grasp it.

**CAUTION:** Be careful not to bend the pins on the overdrive off switch. Use care when installing the switch, as it is not indexed, and can be accidentally installed incorrectly.

(2) Install the overdrive off switch into the connector (Fig. 117)

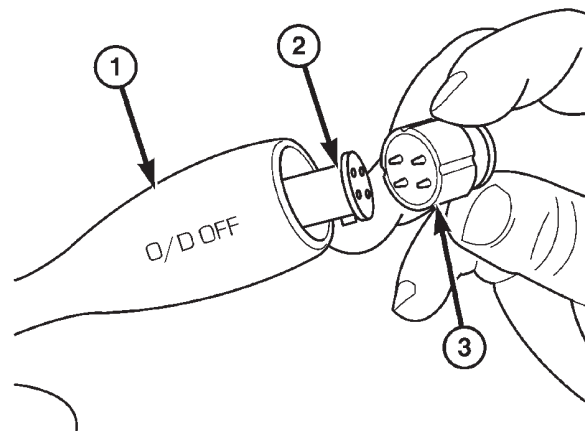


Fig. 117 Install the Overdrive Off Switch

80a8eb39

- 1 - GEAR SHIFT LEVER
- 2 - OVERDRIVE OFF SWITCH WIRING CONNECTOR
- 3 - OVERDRIVE OFF SWITCH

(3) Push the overdrive off switch and wiring into the shift lever.

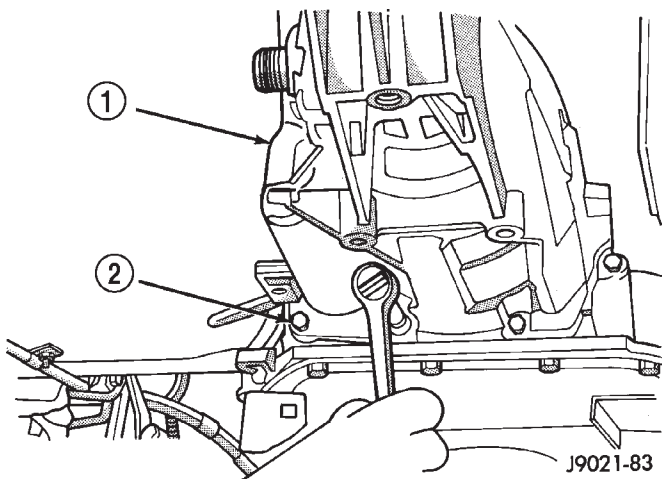
(4) Install the overdrive off switch retainer onto the shift lever.

## OVERDRIVE UNIT

### REMOVAL

- (1) Shift transmission into PARK.
- (2) Raise vehicle.
- (3) Remove transfer case, if equipped.
- (4) Mark propeller shaft universal joint(s) and axle pinion yoke, or the companion flange and flange yoke, for alignment reference at installation, if necessary.
- (5) Disconnect and remove the rear propeller shaft, if necessary. (Refer to 3 - DIFFERENTIAL & DRIVELINE/PROPELLER SHAFT/PROPELLER SHAFT - REMOVAL)
- (6) Remove transmission oil pan, remove gasket, drain oil and reinstall pan.
- (7) If overdrive unit had malfunctioned, or if fluid is contaminated, remove entire transmission. If diagnosis indicated overdrive problems only, remove just the overdrive unit.
- (8) Support transmission with transmission jack.
- (9) Remove bolts attaching overdrive unit to transmission (Fig. 118).

**CAUTION:** Support the overdrive unit with a jack before moving it rearward. This is necessary to prevent damaging the intermediate shaft. Do not allow the shaft to support the entire weight of the overdrive unit.



**Fig. 118 Overdrive Unit Bolts**

- 1 - OVERDRIVE UNIT
- 2 - ATTACHING BOLTS (7)

(10) Carefully work overdrive unit off intermediate shaft. Do not tilt unit during removal. Keep it as level as possible.

(11) If overdrive unit does not require service, immediately insert Alignment Tool 6227-2 in splines of planetary gear and overrunning clutch to prevent

splines from rotating out of alignment. If misalignment occurs, overdrive unit will have to be disassembled in order to realign splines.

(12) Remove and retain overdrive piston thrust bearing. Bearing may remain on piston or in clutch hub during removal.

(13) Position drain pan on workbench.

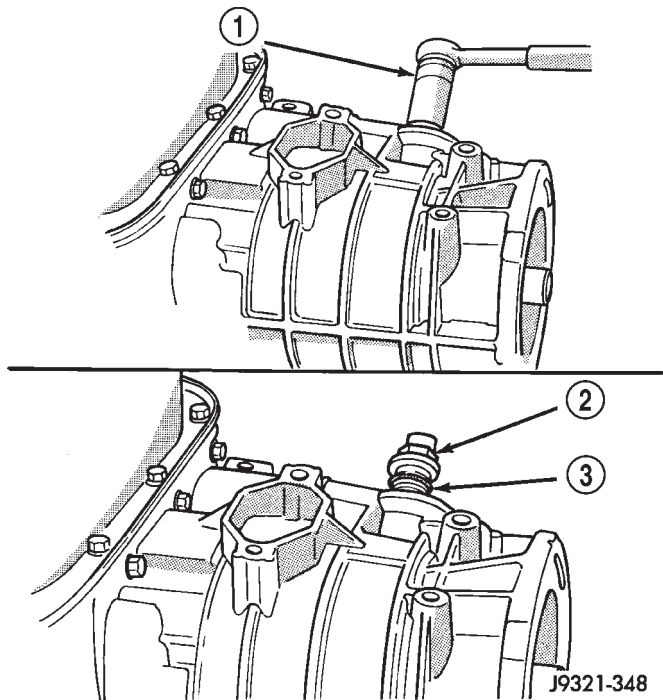
(14) Place overdrive unit over drain pan. Tilt unit to drain residual fluid from case.

(15) Examine fluid for clutch material or metal fragments. If fluid contains these items, overhaul will be necessary.

(16) If overdrive unit does not require any service, leave alignment tool in position. Tool will prevent accidental misalignment of planetary gear and overrunning clutch splines.

### DISASSEMBLY

- (1) Remove transmission speed sensor and O-ring seal from overdrive case (Fig. 119).
- (2) Remove overdrive piston thrust bearing (Fig. 120).

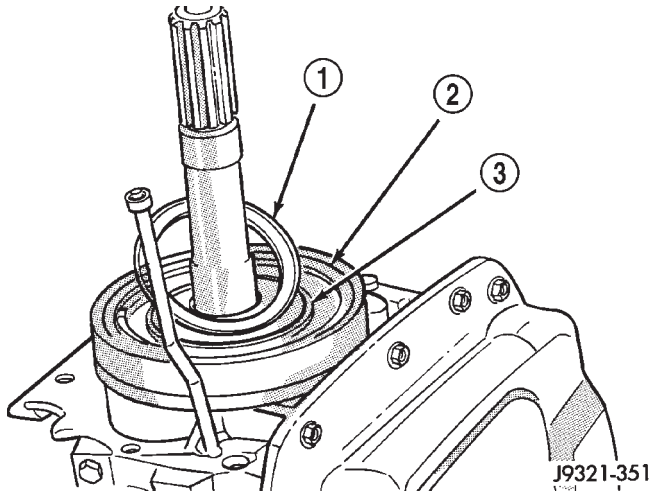


**Fig. 119 Transmission Speed Sensor Removal**

- 1 - SOCKET AND WRENCH
- 2 - SPEED SENSOR
- 3 - O-RING



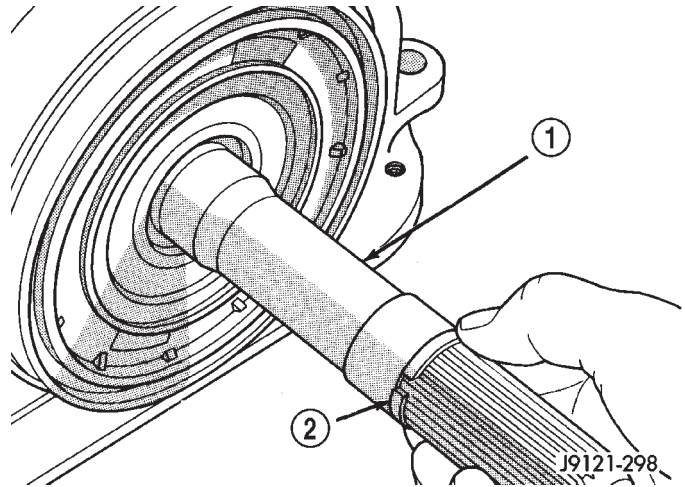
OVERDRIVE UNIT (Continued)



**Fig. 120 Overdrive Piston Thrust Bearing Removal**

- 1 - THRUST BEARING
- 2 - OVERDRIVE PISTON
- 3 - THRUST PLATE

(2) Remove intermediate shaft spacer (Fig. 122). Retain spacer. It is a select fit part and may possibly be reused.

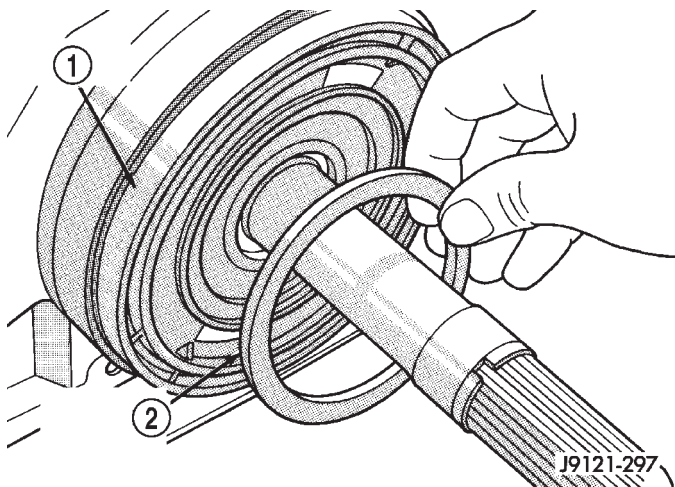


**Fig. 122 Intermediate Shaft Spacer Location**

- 1 - INTERMEDIATE SHAFT
- 2 - INTERMEDIATE SHAFT SPACER (SELECT FIT)

**OVERDRIVE PISTON**

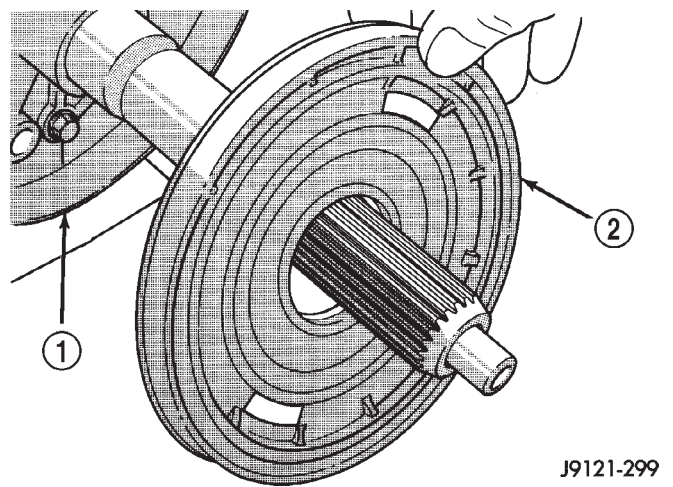
(1) Remove overdrive piston thrust plate (Fig. 121). Retain thrust plate. It is a select fit part and may possibly be reused.



**Fig. 121 Overdrive Piston Thrust Plate Removal**

- 1 - OVERDRIVE PISTON
- 2 - OVERDRIVE PISTON SPACER (SELECT FIT)

(3) Remove overdrive piston from retainer (Fig. 123).



**Fig. 123 Overdrive Piston Removal**

- 1 - PISTON RETAINER
- 2 - OVERDRIVE PISTON



## OVERDRIVE UNIT (Continued)

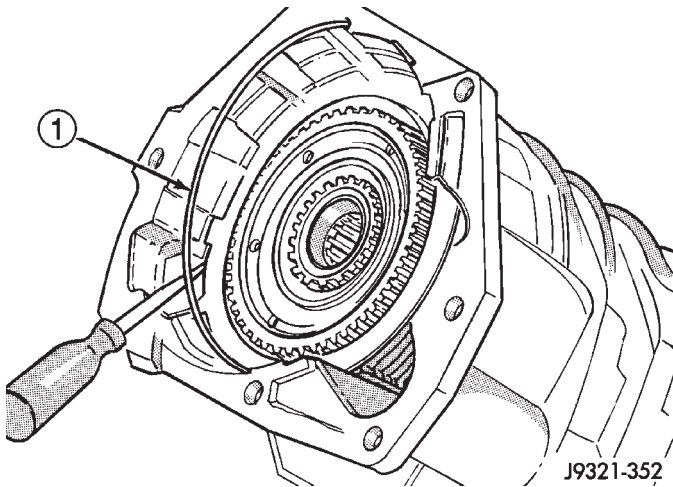
## OVERDRIVE CLUTCH PACK

(1) Remove overdrive clutch pack wire retaining ring (Fig. 124).

(2) Remove overdrive clutch pack (Fig. 125).

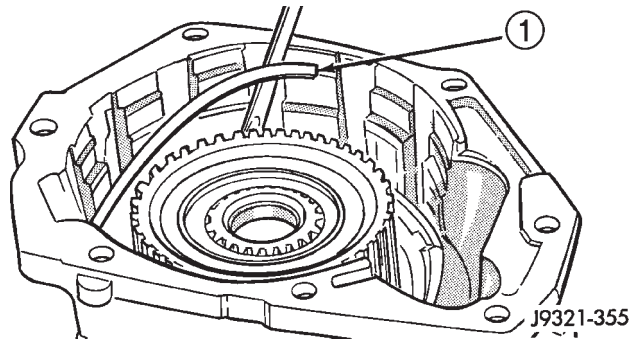
**NOTE:** The 44RE transmission has four(4) clutch discs and three(3) clutch plates.

(3) Note position of clutch pack components for assembly reference.



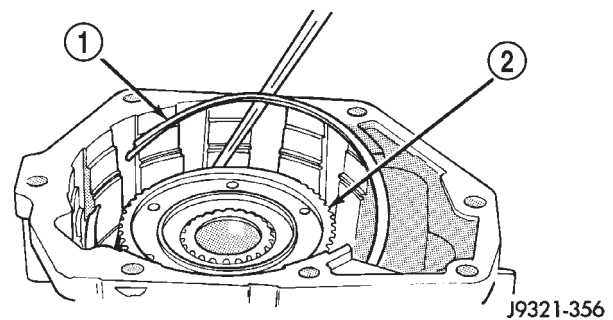
**Fig. 124 Removing Overdrive Clutch Pack Retaining Ring**

1 - OVERDRIVE CLUTCH PACK RETAINING RING



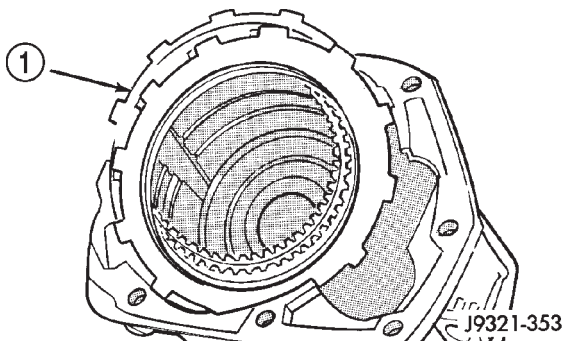
**Fig. 126 Overdrive Clutch Wave**

1 - WAVE SPRING



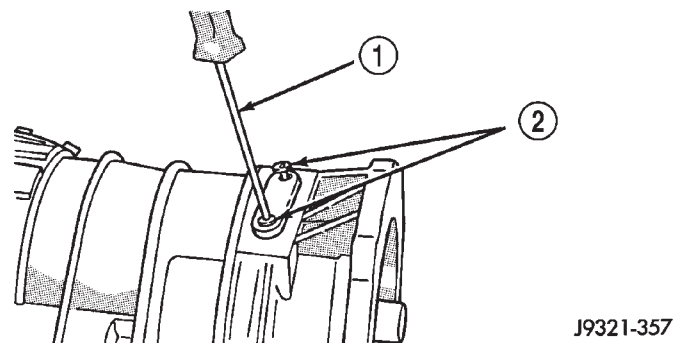
**Fig. 127 Overdrive Clutch Reaction Snap-Ring Removal**

1 - REACTION RING  
2 - CLUTCH HUB



**Fig. 125 Overdrive Clutch Pack Removal**

1 - OVERDRIVE CLUTCH PACK



**Fig. 128 Access Cover Screw Removal**

1 - TORX™ SCREWDRIVER (T25)  
2 - ACCESS COVER SCREWS

## OVERDRIVE GEARTRAIN

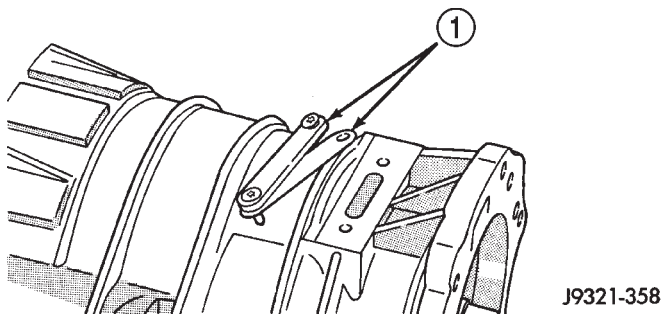
(1) Remove overdrive clutch wave spring (Fig. 126).

(2) Remove overdrive clutch reaction snap-ring (Fig. 127). Note that snap-ring is located in same groove as wave spring.

(3) Remove Torx™ head screws that attach access cover and gasket to overdrive case (Fig. 128).

OVERDRIVE UNIT (Continued)

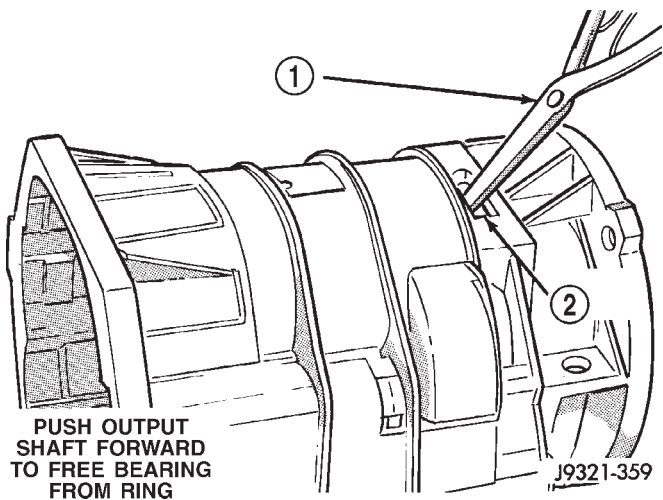
(4) Remove access cover and gasket (Fig. 129).



**Fig. 129 Access Cover And Gasket Removal**

1 - ACCESS COVER AND GASKET

(5) Expand output shaft bearing snap-ring with expanding-type snap-ring pliers. Then push output shaft forward to release shaft bearing from locating ring (Fig. 130).



**Fig. 130 Releasing Bearing From Locating Ring**

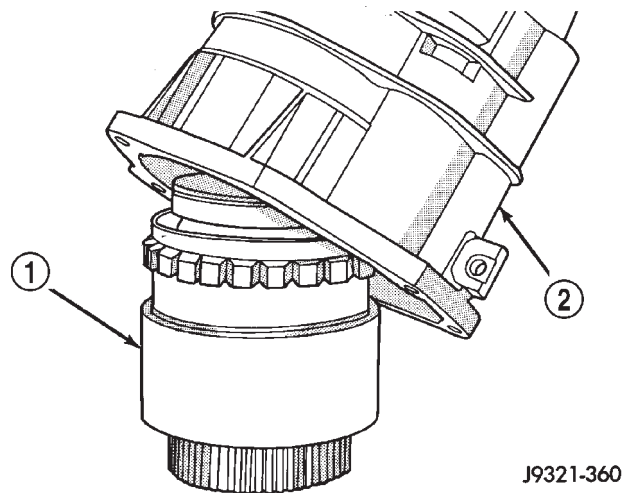
1 - EXPAND BEARING LOCATING RING WITH SNAP-RING PLIERS

2 - ACCESS HOLE

(6) Lift gear case up and off geartrain assembly (Fig. 131).

(7) Remove snap-ring that retains rear bearing on output shaft.

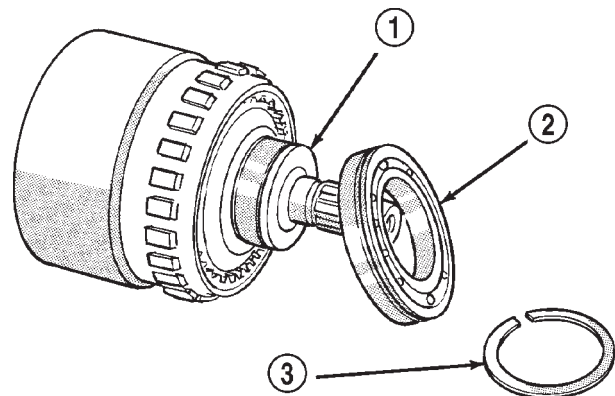
(8) Remove rear bearing from output shaft (Fig. 132).



**Fig. 131 Removing Gear Case From Geartrain Assembly**

1 - GEARTRAIN ASSEMBLY

2 - GEAR CASE



**Fig. 132 Rear Bearing Removal**

1 - OUTPUT SHAFT

2 - REAR BEARING

3 - SNAP-RING

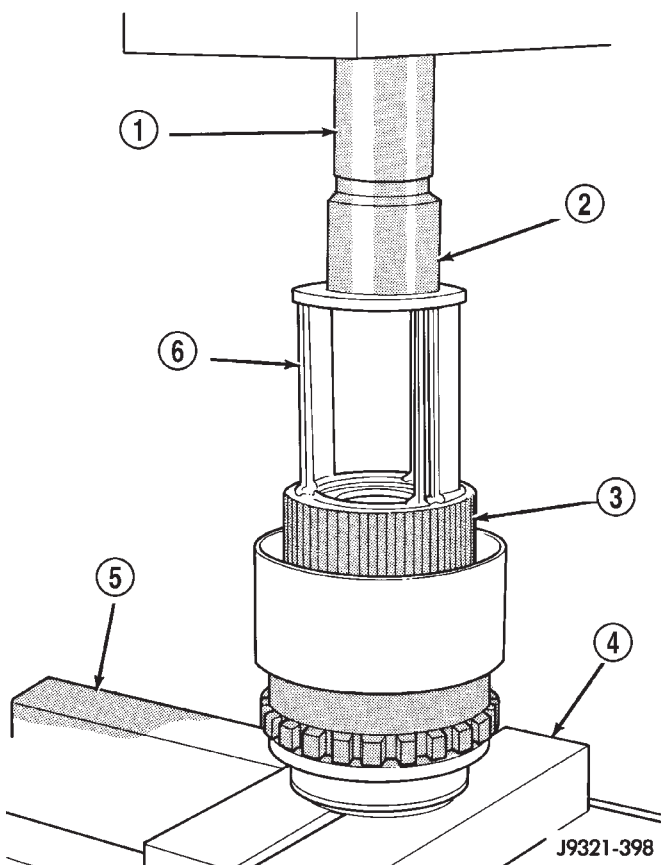
## OVERDRIVE UNIT (Continued)

## DIRECT CLUTCH, HUB AND SPRING

**WARNING: THE NEXT STEP IN DISASSEMBLY INVOLVES COMPRESSING THE DIRECT CLUTCH SPRING. IT IS EXTREMELY IMPORTANT THAT PROPER EQUIPMENT BE USED TO COMPRESS THE SPRING AS SPRING FORCE IS APPROXIMATELY 830 POUNDS. USE SPRING COMPRESSOR TOOL 6227-1 AND A HYDRAULIC SHOP PRESS WITH A MINIMUM RAM TRAVEL OF 5-6 INCHES. THE PRESS MUST ALSO HAVE A BED THAT CAN BE ADJUSTED UP OR DOWN AS REQUIRED. RELEASE CLUTCH SPRING TENSION SLOWLY AND COMPLETELY TO AVOID PERSONAL INJURY.**

(1) Mount geartrain assembly in shop press (Fig. 133).

(2) Position Compressor Tool 6227-1 on clutch hub (Fig. 133). Support output shaft flange with steel press plates as shown and center assembly under press ram.



**Fig. 133 Geartrain Mounted In Shop Press**

- 1 - PRESS RAM
- 2 - SPECIAL TOOL C-3995-A (OR SIMILAR TOOL)
- 3 - CLUTCH HUB
- 4 - PLATES
- 5 - PRESS BED
- 6 - SPECIAL TOOL 6227-1

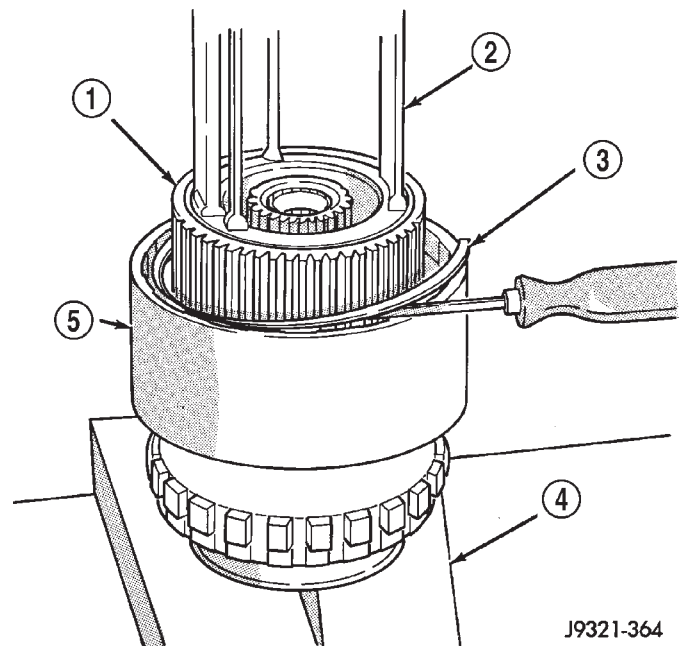
(3) Apply press pressure slowly. Compress hub and spring far enough to expose clutch hub retaining ring and relieve spring pressure on clutch pack snap-ring (Fig. 133).

(4) Remove direct clutch pack snap-ring (Fig. 134).

(5) Remove direct clutch hub retaining ring (Fig. 135).

(6) Release press load slowly and completely (Fig. 136).

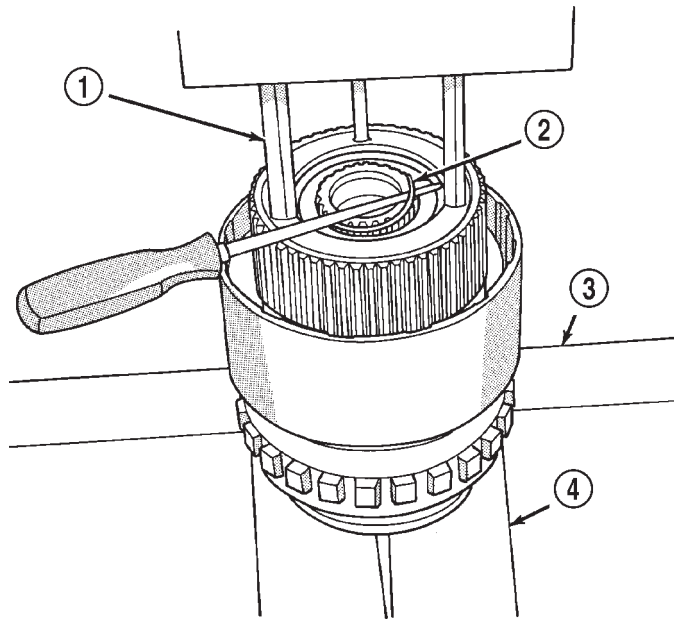
(7) Remove Special Tool 6227-1. Then remove clutch pack from hub (Fig. 136).



**Fig. 134 Direct Clutch Pack Snap-Ring Removal**

- 1 - CLUTCH HUB
- 2 - SPECIAL TOOL 6227-1
- 3 - DIRECT CLUTCH PACK SNAP-RING
- 4 - PRESS PLATES
- 5 - CLUTCH DRUM

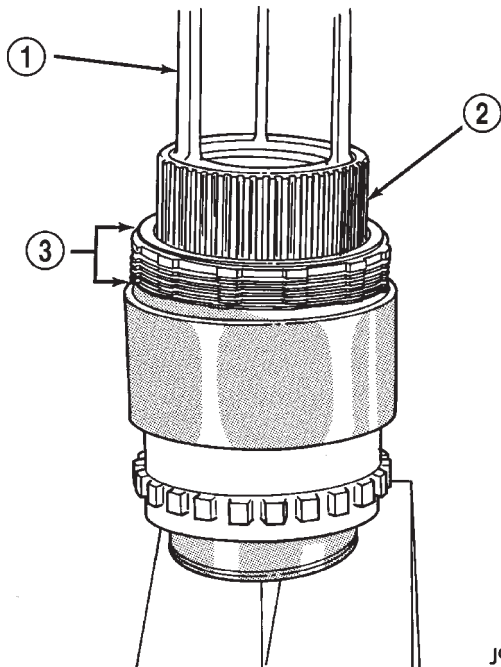
OVERDRIVE UNIT (Continued)



J9321-363

**Fig. 135 Direct Clutch Hub Retaining Ring Removal**

- 1 - SPECIAL TOOL 6227-1
- 2 - CLUTCH HUB RETAINING RING
- 3 - PRESS BED
- 4 - PRESS PLATES



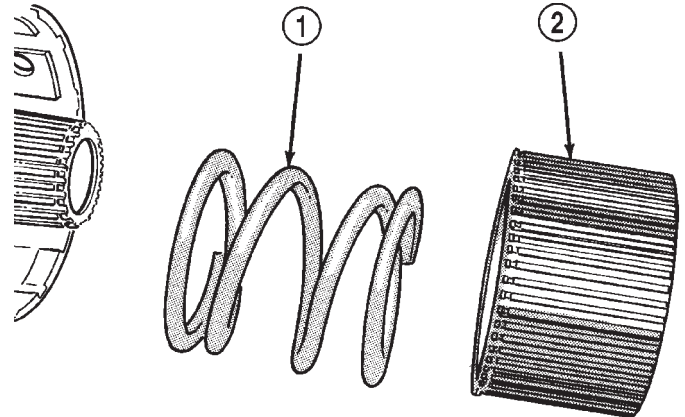
J9321-365

**Fig. 136 Direct Clutch Pack Removal**

- 1 - SPECIAL TOOL 6227-1
- 2 - DIRECT CLUTCH HUB
- 3 - DIRECT CLUTCH PACK

**GEARTRAIN**

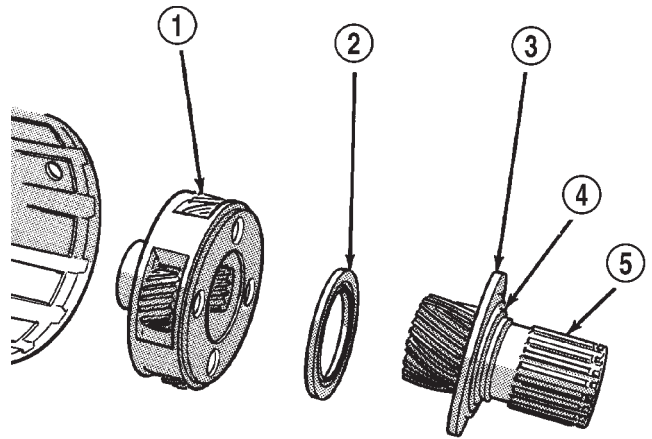
- (1) Remove direct clutch hub and spring (Fig. 137).
- (2) Remove sun gear and spring plate. Then remove planetary thrust bearing and planetary gear (Fig. 138).



J9121-311

**Fig. 137 Direct Clutch Hub And Spring Removal**

- 1 - DIRECT CLUTCH SPRING
- 2 - DIRECT CLUTCH HUB



J9121-312

**Fig. 138 Removing Sun Gear, Thrust Bearing And Planetary Gear**

- 1 - PLANETARY GEAR
- 2 - PLANETARY THRUST BEARING
- 3 - CLUTCH SPRING PLATE
- 4 - SPRING PLATE SNAP-RING
- 5 - SUN GEAR



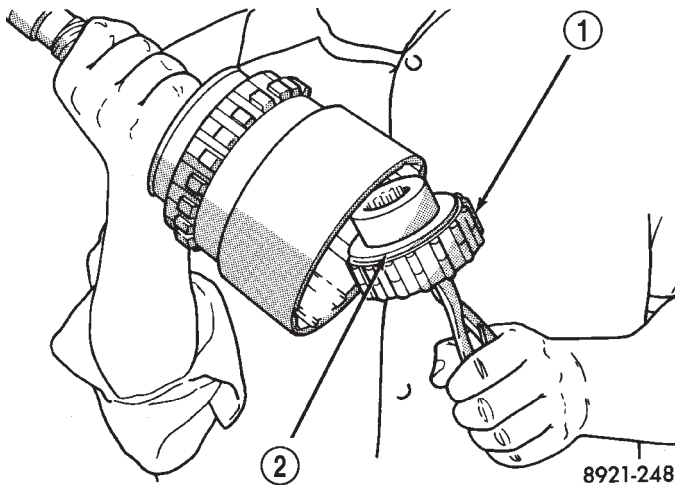
## OVERDRIVE UNIT (Continued)

(3) Remove overrunning clutch assembly with expanding type snap-ring pliers (Fig. 139). Insert pliers into clutch hub. Expand pliers to grip hub splines and remove clutch with counterclockwise, twisting motion.

(4) Remove thrust bearing from overrunning clutch hub.

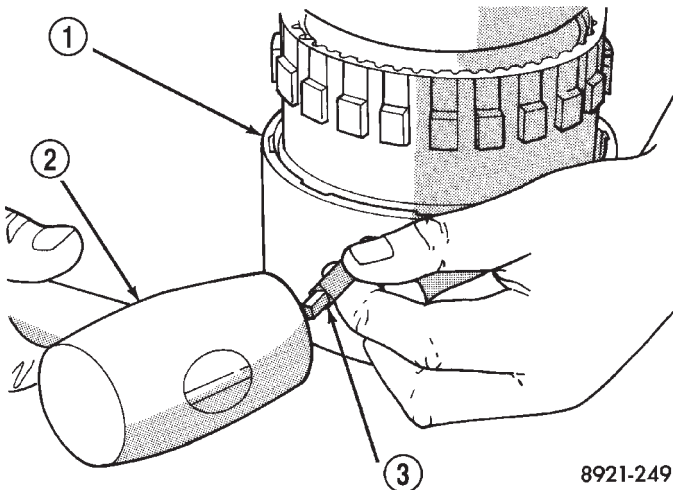
(5) Remove overrunning clutch from hub.

(6) Mark position of annulus gear and direct clutch drum for assembly alignment reference (Fig. 140). Use small center punch or scribe to make alignment marks.



**Fig. 139 Overrunning Clutch**

- 1 - OVERRUNNING CLUTCH  
2 - NEEDLE BEARING

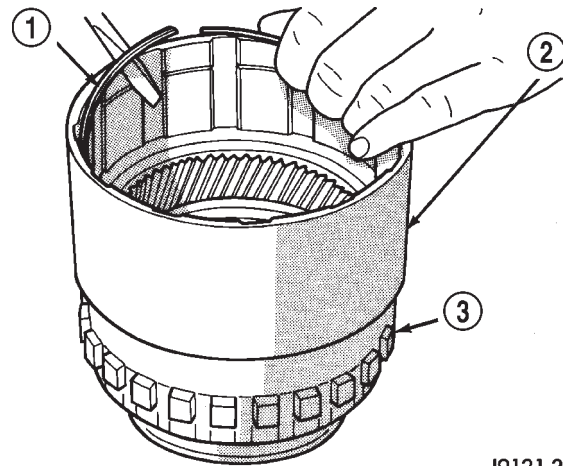


**Fig. 140 Marking Direct Clutch Drum And Annulus Gear For Assembly Alignment**

- 1 - DIRECT CLUTCH DRUM  
2 - HAMMER  
3 - PUNCH

(7) Remove direct clutch drum rear retaining ring (Fig. 141).

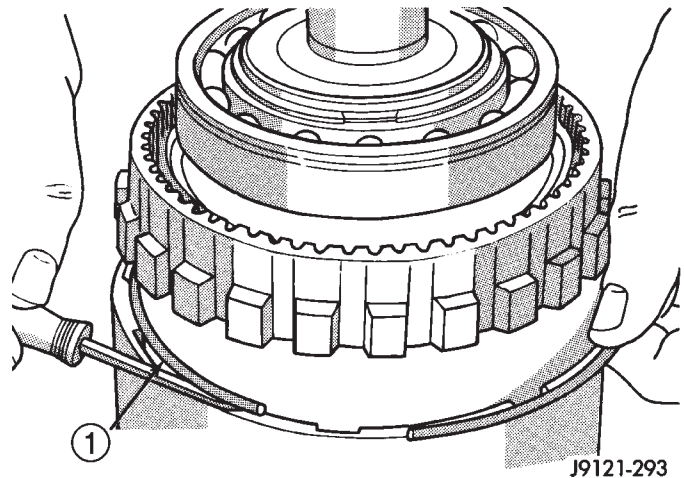
(8) Remove direct clutch drum outer retaining ring (Fig. 142).



J9121-292

**Fig. 141 Clutch Drum Inner Retaining Ring Removal**

- 1 - INNER RETAINING RING  
2 - DIRECT CLUTCH DRUM  
3 - ANNULUS GEAR



J9121-293

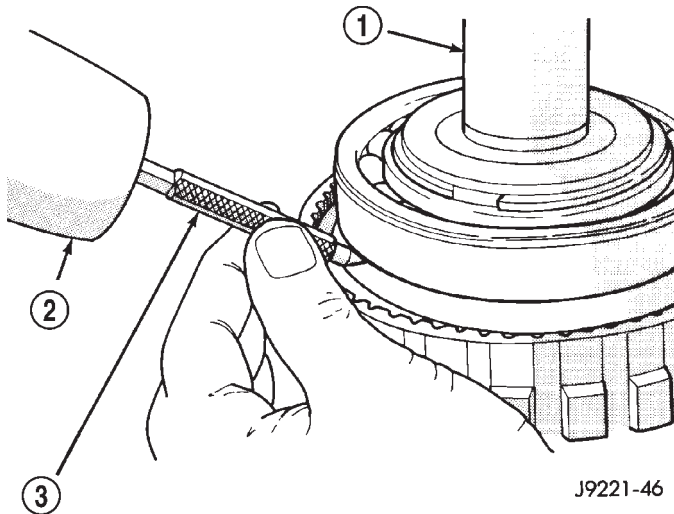
**Fig. 142 Clutch Drum Outer Retaining Ring Removal**

- 1 - OUTER RETAINING RING



## OVERDRIVE UNIT (Continued)

(9) Mark annulus gear and output shaft for assembly alignment reference (Fig. 143). Use punch or scriber to mark gear and shaft.



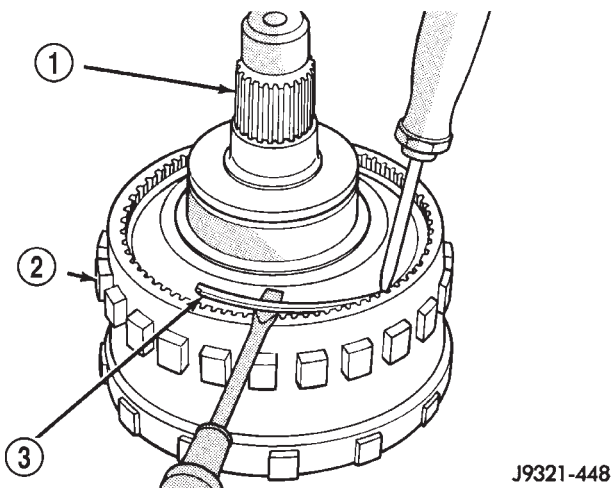
J9221-46

**Fig. 143 Marking Annulus Gear And Output Shaft For Assembly Alignment**

- 1 - OUTPUT SHAFT
- 2 - HAMMER
- 3 - PUNCH

(10) Remove snap-ring that secures annulus gear on output shaft (Fig. 144). Use two screwdrivers to unseat and work snap-ring out of groove as shown.

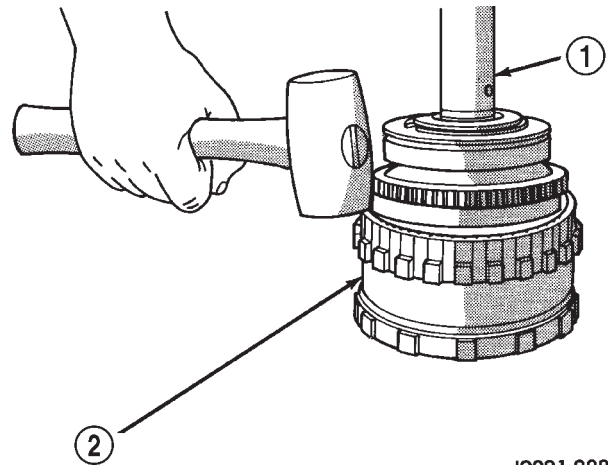
(11) Remove annulus gear from output shaft (Fig. 145). Use rawhide or plastic mallet to tap gear off shaft.



J9321-448

**Fig. 144 Annulus Gear Snap-Ring Removal**

- 1 - OUTPUT SHAFT
- 2 - ANNULUS GEAR
- 3 - SNAP-RING



J9021-288

**Fig. 145 Annulus Gear Removal**

- 1 - OUTPUT SHAFT
- 2 - ANNULUS GEAR

## GEAR CASE AND PARK LOCK

- (1) Remove locating ring from gear case.
- (2) Remove park pawl shaft retaining bolt and remove shaft, pawl and spring.
- (3) Remove reaction plug snap-ring and remove reaction plug.
- (4) Remove output shaft seal.

## CLEANING

Clean the geartrain and case components with solvent. Dry all parts except the bearings with compressed air. Allow bearings to air dry.

Do not use shop towels for wiping parts dry unless the towels are made from a lint-free material. A sufficient quantity of lint (from shop towels, cloths, rags, etc.) could plug the transmission filter and fluid passages.

Discard the old case gasket and seals. Do not attempt to salvage these parts. They are not reusable. Replace any of the overdrive unit snap-rings if distorted or damaged.

Minor nicks or scratches on components can be smoothed with crocus cloth. However, do not attempt to reduce severe scoring on any components with abrasive materials. Replace severely scored components; do not try to salvage them.

## INSPECTION

Check condition of the park lock components and the overdrive case.

Check the bushings in the overdrive case. Replace the bushings if severely scored or worn. Also replace the case seal if loose, distorted, or damaged.

Examine the overdrive and direct clutch discs and plates. Replace the discs if the facing is worn, severely scored, or burned and flaking off. Replace

## OVERDRIVE UNIT (Continued)

the clutch plates if worn, heavily scored, or cracked. Check the lugs on the clutch plates for wear. The plates should slide freely in the drum. Replace the plates or drum if binding occurs.

Check condition of the annulus gear, direct clutch hub, clutch drum and clutch spring. Replace the gear, hub and drum if worn or damaged. Replace the spring if collapsed, distorted, or cracked.

Be sure the splines and lugs on the gear, drum and hub are in good condition. The clutch plates and discs should slide freely in these components.

Inspect the thrust bearings and spring plate. Replace the plate if worn or scored. Replace the bearings if rough, noisy, brinnelled, or worn.

Inspect the planetary gear assembly and the sun gear and bushings. If either the sun gear or the bushings are damaged, replace the gear and bushings as an assembly. The gear and bushings are not serviced separately.

The planetary carrier and pinions must be in good condition. Also be sure the pinion pins are secure and in good condition. Replace the carrier if worn or damaged.

Inspect the overrunning clutch and race. The race surface should be smooth and free of scores. Replace the overrunning clutch assembly or the race if either assembly is worn or damaged in any way.

Replace the shaft pilot bushing and inner bushing if damaged. Replace either shaft bearing if rough or noisy. Replace the bearing snap-rings if distorted or cracked.

Check the machined surfaces on the output shaft. These surfaces should be clean and smooth. Very minor nicks or scratches can be smoothed with crocus cloth. Replace the shaft if worn, scored or damaged in any way.

Inspect the output shaft bushings. The small bushing is the intermediate shaft pilot bushing. The large bushing is the overrunning clutch hub bushing. Replace either bushing if scored, pitted, cracked, or worn.

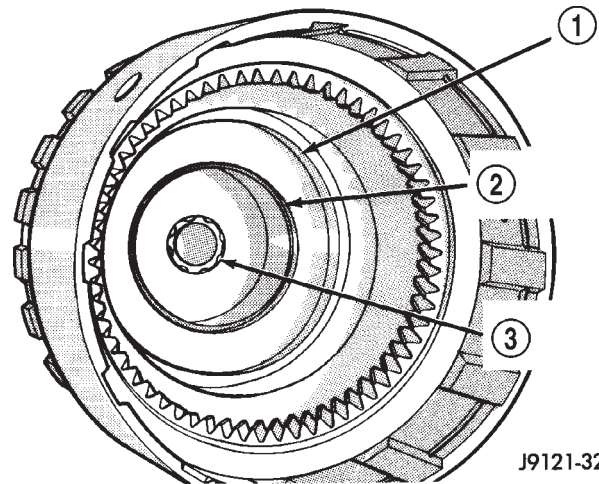
## ASSEMBLY

## GEARTRAIN AND DIRECT CLUTCH

(1) Soak direct clutch and overdrive clutch discs in Mopar® ATF +4, type 9602, transmission fluid. Allow discs to soak for 10-20 minutes.

(2) Install new pilot bushing and clutch hub bushing in output shaft if necessary (Fig. 146). Lubricate bushings with petroleum jelly, or transmission fluid.

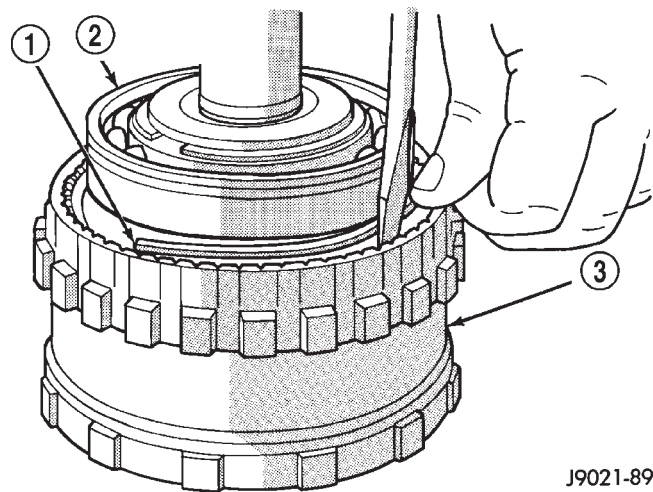
(3) Install annulus gear on output shaft, if removed. Then install annulus gear retaining snap-ring (Fig. 147).



J9121-321

**Fig. 146 Output Shaft Pilot Bushing**

- 1 - OUTPUT SHAFT HUB
- 2 - OVERRUNNING CLUTCH HUB BUSHING
- 3 - INTERMEDIATE SHAFT PILOT BUSHING



J9021-89

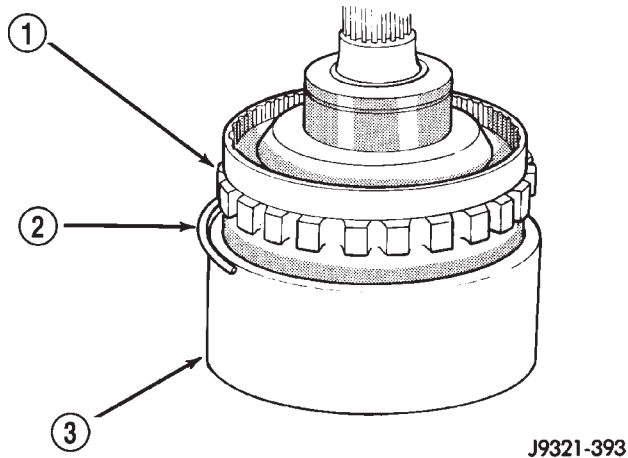
**Fig. 147 Annulus Gear Installation**

- 1 - SNAP-RING
- 2 - OUTPUT SHAFT FRONT BEARING
- 3 - ANNULUS GEAR

OVERDRIVE UNIT (Continued)

(4) Align and install clutch drum on annulus gear (Fig. 148). Be sure drum is engaged in annulus gear lugs.

(5) Install clutch drum outer retaining ring (Fig. 148).



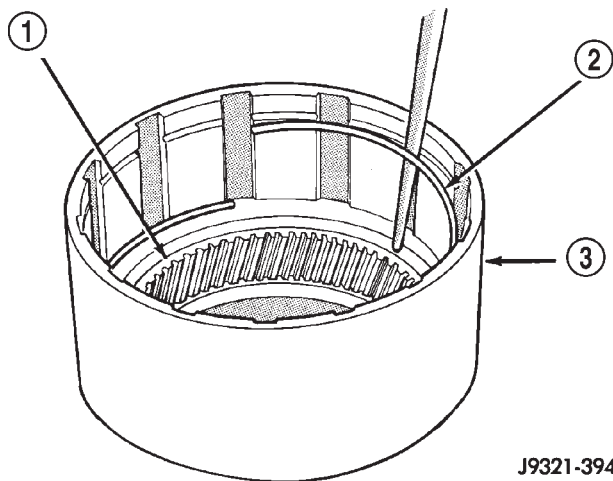
J9321-393

**Fig. 148 Clutch Drum And Outer Retaining Ring Installation**

- 1 - ANNULUS GEAR
- 2 - OUTER SNAP-RING
- 3 - CLUTCH DRUM

(6) Slide clutch drum forward and install inner retaining ring (Fig. 149).

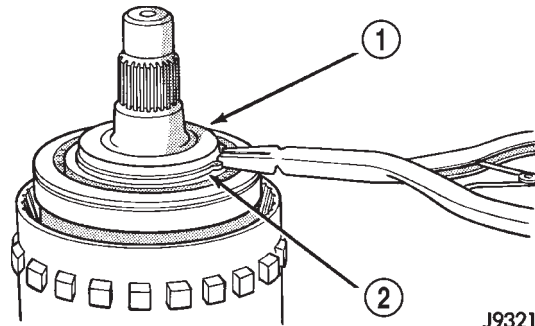
(7) Install rear bearing and snap-ring on output shaft (Fig. 150). Be sure locating ring groove in bearing is toward rear.



J9321-394

**Fig. 149 Clutch Drum Inner Retaining Ring Installation**

- 1 - ANNULUS GEAR
- 2 - INNER SNAP-RING
- 3 - CLUTCH DRUM



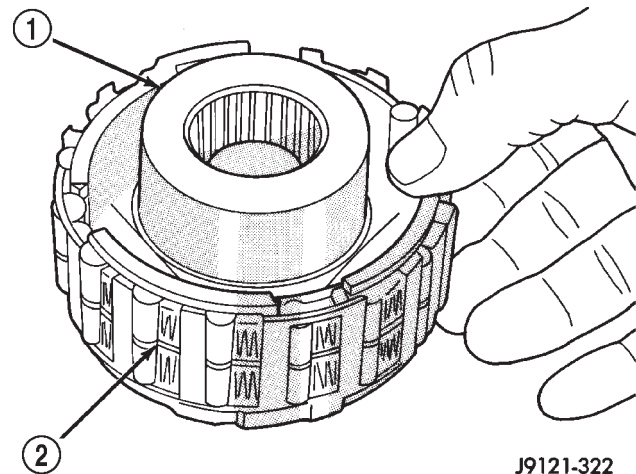
J9321-370

**Fig. 150 Rear Bearing And Snap-Ring Installation**

- 1 - REAR BEARING
- 2 - SNAP-RING

(8) Install overrunning clutch on hub (Fig. 151). Note that clutch only fits one-way. Shoulder on clutch should seat in small recess at edge of hub.

(9) Install thrust bearing on overrunning clutch hub. Use generous amount of petroleum jelly to hold bearing in place for installation. Bearing fits one-way only. Be sure bearing is seated squarely against hub. Reinstall bearing if it does not seat squarely.



J9121-322

**Fig. 151 Assembling Overrunning Clutch And Hub**

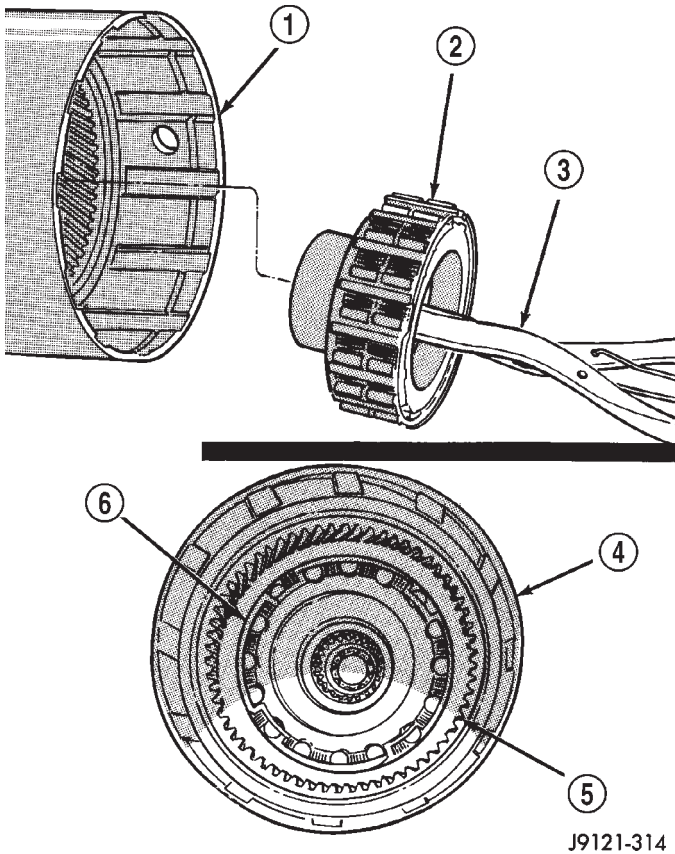
- 1 - CLUTCH HUB
- 2 - OVERRUNNING CLUTCH



## OVERDRIVE UNIT (Continued)

(10) Install overrunning clutch in output shaft (Fig. 152). Insert snap-ring pliers in hub splines. Expand pliers to grip hub. Then install assembly with counterclockwise, twisting motion.

(11) Install planetary gear in annulus gear (Fig. 153). Be sure planetary pinions are fully seated in annulus gear before proceeding.

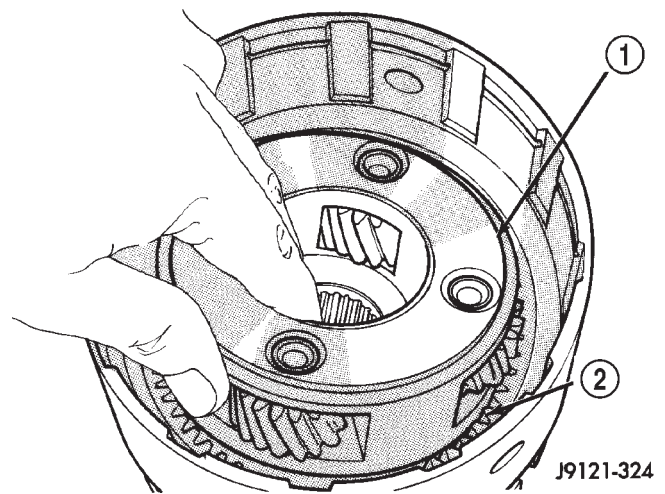


**Fig. 152 Overrunning Clutch Installation**

- 1 - CLUTCH DRUM
- 2 - OVERRUNNING CLUTCH ASSEMBLY
- 3 - EXPANDING-TYPE SNAP-RING PLIERS
- 4 - CLUTCH DRUM
- 5 - ANNULUS GEAR
- 6 - OVERRUNNING CLUTCH ASSEMBLY SEATED IN OUTPUT SHAFT

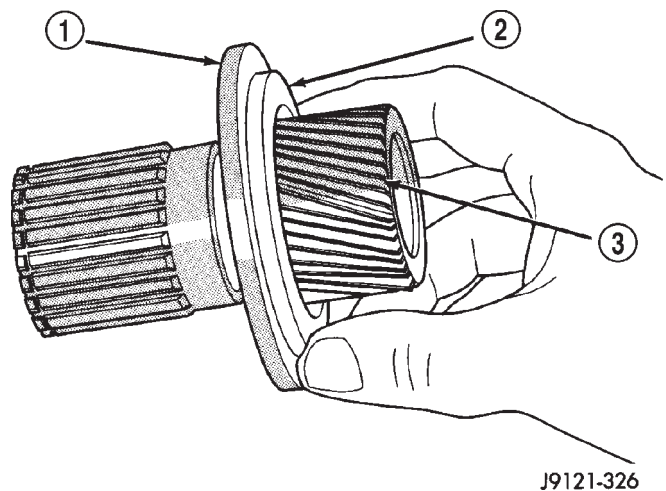
(12) Coat planetary thrust bearing and bearing contact surface of spring plate with generous amount of petroleum jelly. This will help hold bearing in place during installation.

(13) Install planetary thrust bearing on sun gear (Fig. 154). Slide bearing onto gear and seat it against spring plate as shown. Bearing fits one-way only. If it does not seat squarely against spring plate, remove and reposition bearing.



**Fig. 153 Planetary Gear Installation**

- 1 - PLANETARY GEAR
- 2 - ANNULUS GEAR

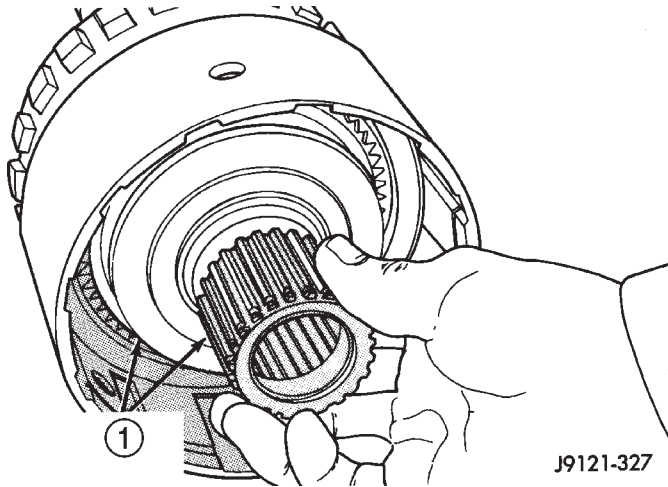


**Fig. 154 Planetary Thrust Bearing Installation**

- 1 - SPRING PLATE
- 2 - PLANETARY THRUST BEARING
- 3 - SUN GEAR

## OVERDRIVE UNIT (Continued)

(14) Install assembled sun gear, spring plate and thrust bearing (Fig. 155). Be sure sun gear and thrust bearing are fully seated before proceeding.



**Fig. 155 Sun Gear Installation**

1 - SUN GEAR AND SPRING PLATE ASSEMBLY

(15) Mount assembled output shaft, annulus gear, and clutch drum in shop press. Direct clutch spring, hub and clutch pack are easier to install with assembly mounted in press.

(16) Align splines in hubs of planetary gear and overrunning clutch with Alignment tool 6227-2 (Fig. 156). Insert tool through sun gear and into splines of both hubs. Be sure alignment tool is fully seated before proceeding.

(17) Install direct clutch spring (Fig. 157). Be sure spring is properly seated on spring plate.

**NOTE:** The 44RE transmission has 8 direct clutch discs and 7 clutch plates.

(18) Assemble and install direct clutch pack on hub as follows:

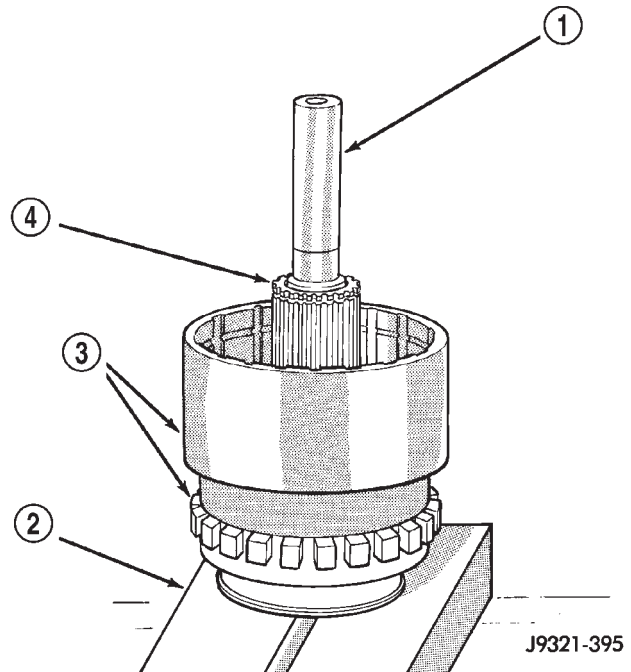
(a) Assemble clutch pack components (Fig. 158).

(b) Install direct clutch reaction plate on clutch hub first. Note that one side of reaction plate is counterbored. Be sure this side faces rearward. Splines at rear of hub are raised slightly. Counterbore in plate fits over raised splines. Plate should be flush with this end of hub (Fig. 159).

(c) Install first clutch disc followed by a steel plate until all discs and plates have been installed.

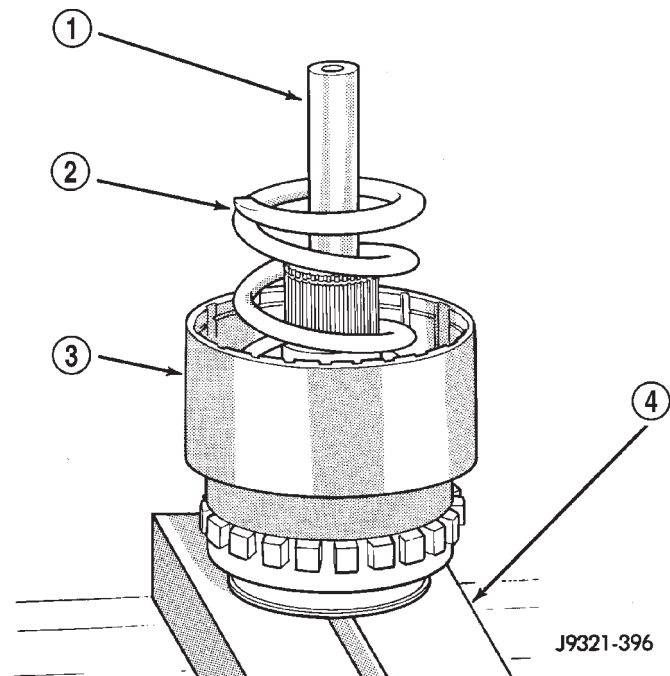
(d) Install pressure plate. This is last clutch pack item to be installed. Be sure plate is installed with shoulder side facing upward (Fig. 160).

(19) Install clutch hub and clutch pack on direct clutch spring (Fig. 161). Be sure hub is started on sun gear splines before proceeding.



**Fig. 156 Alignment Tool Installation**

- 1 - SPECIAL TOOL 6227-2
- 2 - PRESS PLATES
- 3 - ASSEMBLED DRUM AND ANNULUS GEAR
- 4 - SUN GEAR

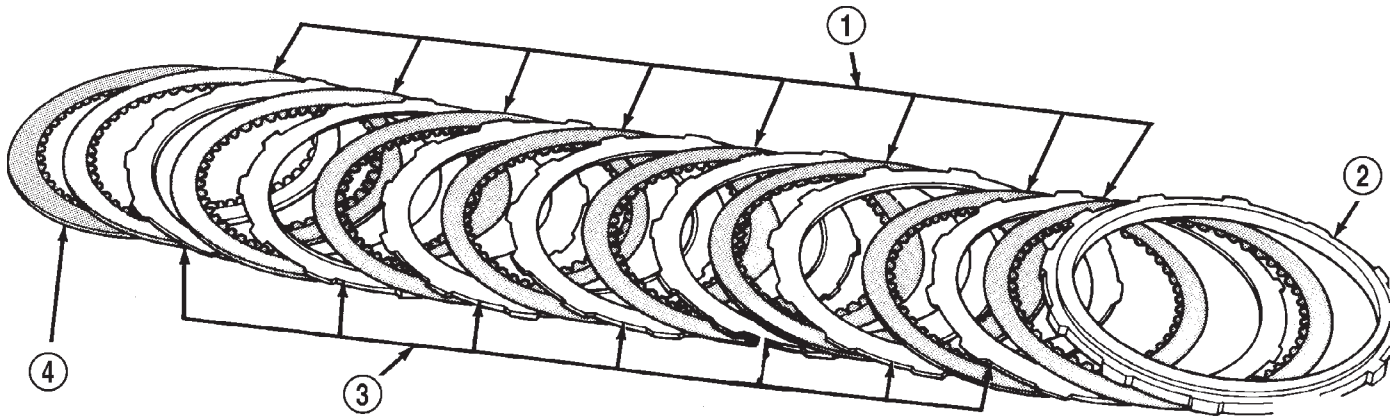


**Fig. 157 Direct Clutch Spring Installation**

- 1 - SPECIAL TOOL 6227-2
- 2 - DIRECT CLUTCH SPRING
- 3 - CLUTCH HUB
- 4 - PRESS PLATES



OVERDRIVE UNIT (Continued)

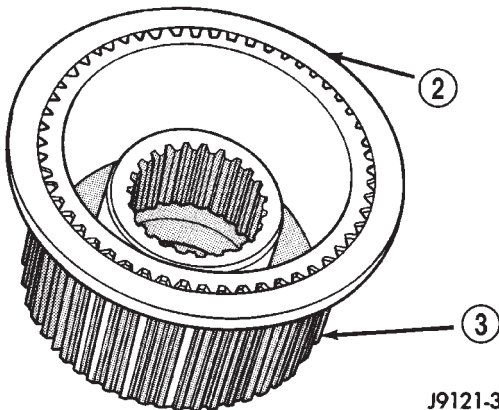
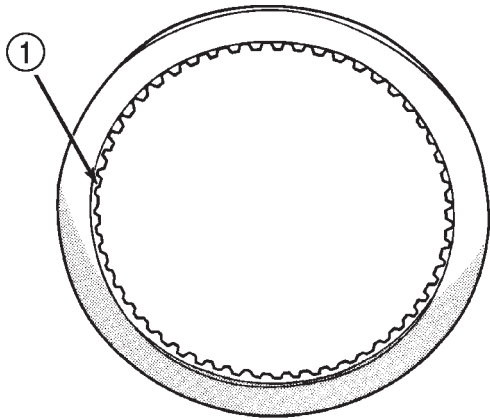


J9521-50

**Fig. 158 44RE Direct Clutch Pack Components**

- 1 - CLUTCH DISCS (8)
- 2 - PRESSURE PLATE

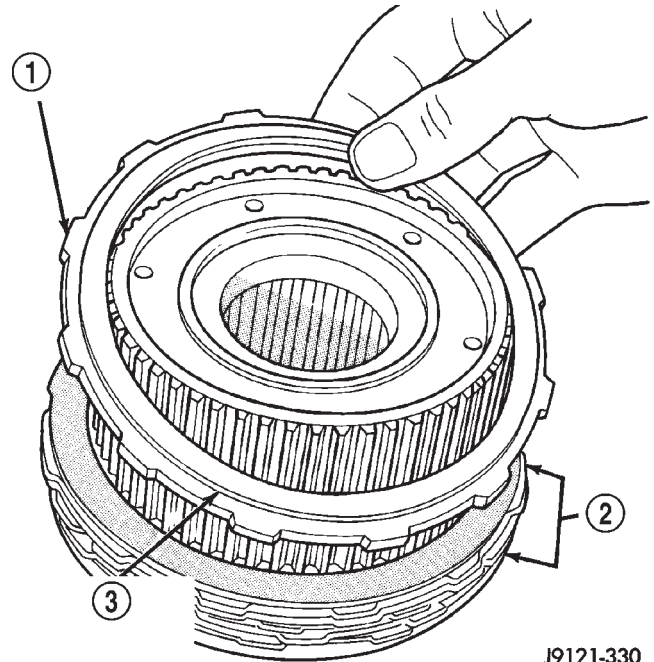
- 3 - CLUTCH PLATES (7)
- 4 - REACTION PLATE



J9121-329

**Fig. 159 Correct Position Of Direct Clutch Reaction Plate**

- 1 - REACTION PLATE COUNTERBORE
- 2 - DIRECT CLUTCH REACTION PLATE (FLUSH WITH END OF HUB)
- 3 - CLUTCH HUB

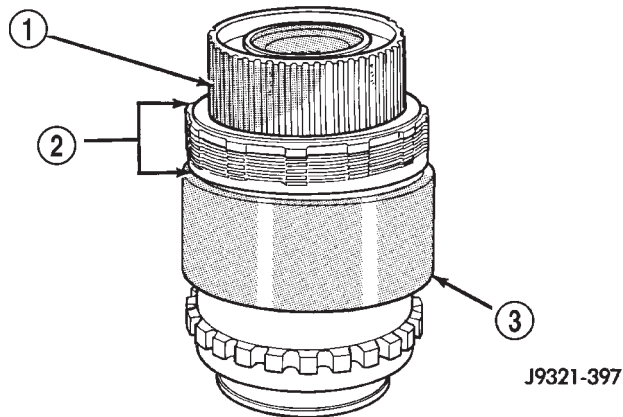


J9121-330

**Fig. 160 Correct Position Of Direct Clutch Pressure Plate**

- 1 - DIRECT CLUTCH PRESSURE PLATE
- 2 - CLUTCH PACK
- 3 - BE SURE SHOULDER SIDE OF PLATE FACES UPWARD

## OVERDRIVE UNIT (Continued)



**Fig. 161 Direct Clutch**

- 1 - CLUTCH HUB
- 2 - DIRECT CLUTCH PACK
- 3 - CLUTCH DRUM

**WARNING: THE NEXT STEP IN GEARTRAIN ASSEMBLY INVOLVES COMPRESSING THE DIRECT CLUTCH HUB AND SPRING. IT IS EXTREMELY IMPORTANT THAT PROPER EQUIPMENT BE USED TO COMPRESS THE SPRING AS SPRING FORCE IS APPROXIMATELY 830 POUNDS. USE COMPRESSOR TOOL C-6227-1 AND A HYDRAULIC-TYPE SHOP PRESS WITH A MINIMUM RAM TRAVEL OF 6 INCHES. THE PRESS MUST ALSO HAVE A BED THAT CAN BE ADJUSTED UP OR DOWN AS REQUIRED. RELEASE CLUTCH SPRING TENSION SLOWLY AND COMPLETELY TO AVOID PERSONAL INJURY.**

(20) Position Compressor Tool 6227-1 on clutch hub.

(21) Compress clutch hub and spring just enough to place tension on hub and hold it in place.

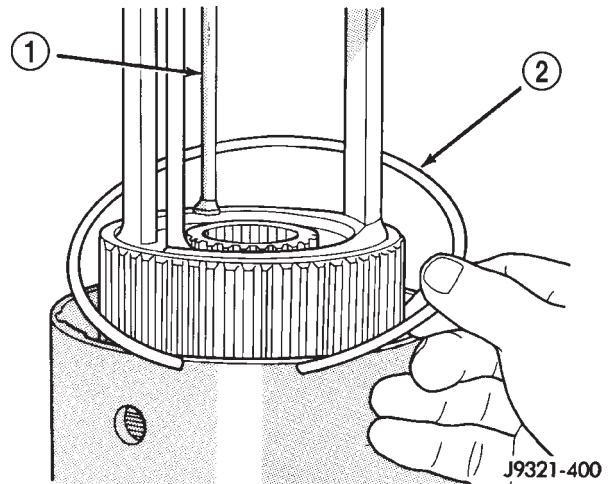
(22) Slowly compress clutch hub and spring. Compress spring and hub only enough to expose ring grooves for clutch pack snap ring and clutch hub retaining ring.

(23) Realign clutch pack on hub and seat clutch discs and plates in clutch drum.

(24) Install direct clutch pack snap-ring (Fig. 162). Be very sure snap-ring is fully seated in clutch drum ring groove.

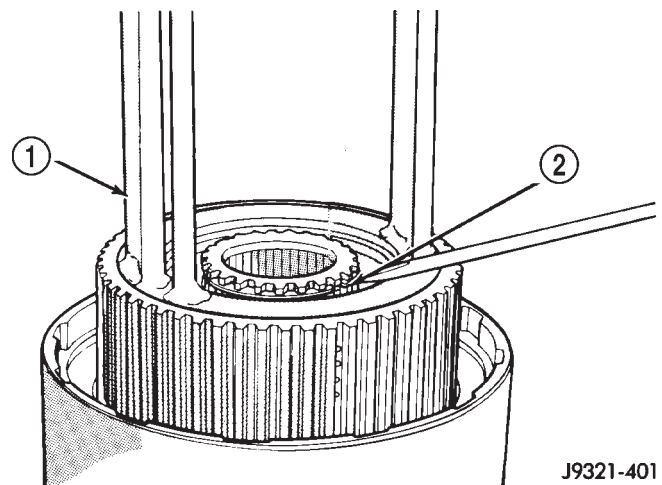
(25) Install clutch hub retaining ring (Fig. 163). Be very sure retaining ring is fully seated in sun gear ring groove.

(26) Slowly release press ram, remove compressor tools and remove geartrain assembly.



**Fig. 162 Direct Clutch Pack Snap-Ring Installation**

- 1 - SPECIAL TOOL 6227-1
- 2 - DIRECT CLUTCH PACK SNAP-RING



**Fig. 163 Clutch Hub Retaining Ring Installation**

- 1 - SPECIAL TOOL 6227-1
- 2 - CLUTCH HUB RETAINING RING

## OVERDRIVE UNIT (Continued)

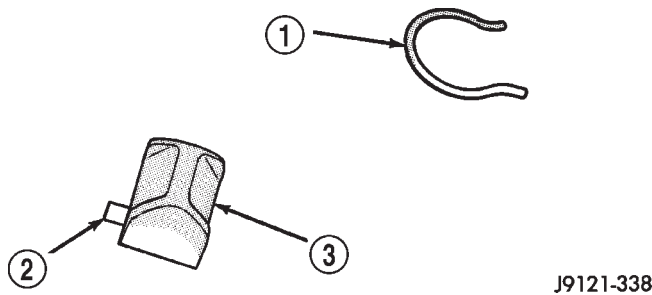
## GEAR CASE

(1) Position park pawl and spring in case and install park pawl shaft. Verify that end of spring with 90° bend is hooked to pawl and straight end of spring is seated against case.

(2) Install pawl shaft retaining bolt. Tighten bolt to 27 N·m (20 ft. lbs.) torque.

(3) Install park lock reaction plug. Note that plug has locating pin at rear (Fig. 164). Be sure pin is seated in hole in case before installing snap-ring.

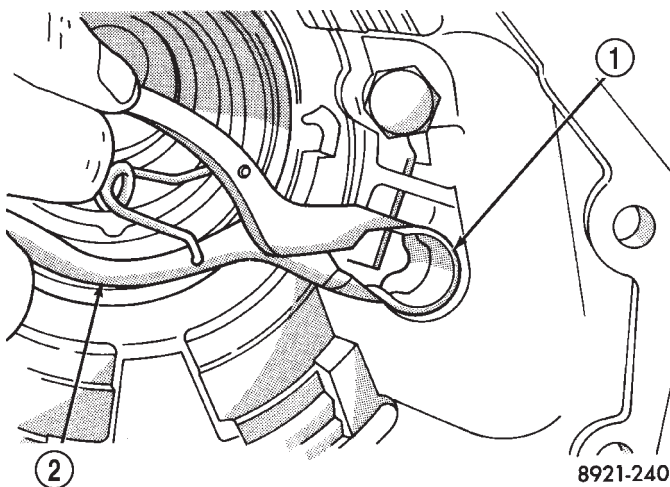
(4) Install reaction plug snap-ring (Fig. 165). Compress snap ring only enough for installation; do not distort it.



J9121-338

**Fig. 164 Reaction Plug Locating Pin And Snap-Ring**

- 1 - REACTION PLUG SNAP-RING (DO NOT OVERCOMPRESS TO INSTALL)  
 2 - LOCATING PIN  
 3 - PARK LOCK REACTION PLUG



8921-240

**Fig. 165 Reaction Plug And Snap-Ring Installation**

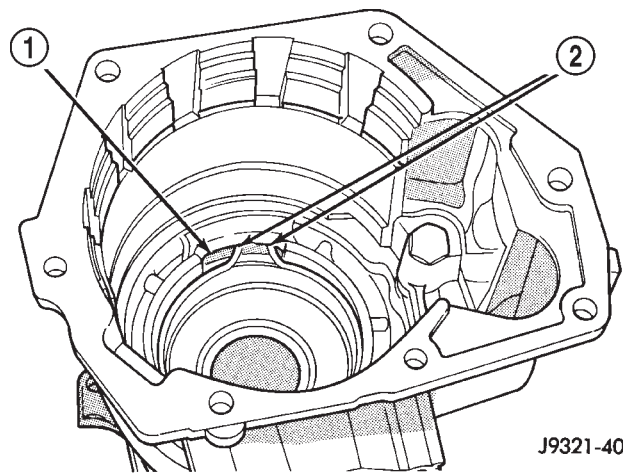
- 1 - REACTION PLUG SNAP-RING  
 2 - SNAP-RING PLIERS

(5) Install new seal in gear case. On 4x4 gear case, use Tool Handle C-4171 and Installer C-3860-A to seat seal in case. On 4 x 2 gear case, use same Handle C-4171 and Installer C-3995-A to seat seal in case.

(6) Verify that tab ends of rear bearing locating ring extend into access hole in gear case (Fig. 166).

(7) Support geartrain on Tool 6227-1 (Fig. 167). Be sure tool is securely seated in clutch hub.

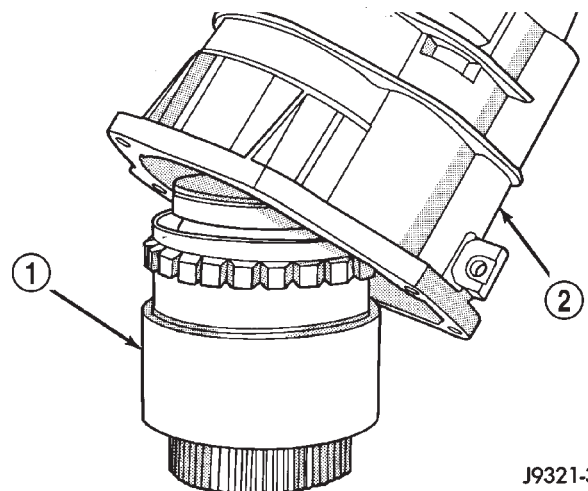
(8) Install overdrive gear case on geartrain (Fig. 167).



J9321-403

**Fig. 166 Correct Rear Bearing Locating Ring Position**

- 1 - CASE ACCESS HOLE  
 2 - TAB ENDS OF LOCATING RING



J9321-360

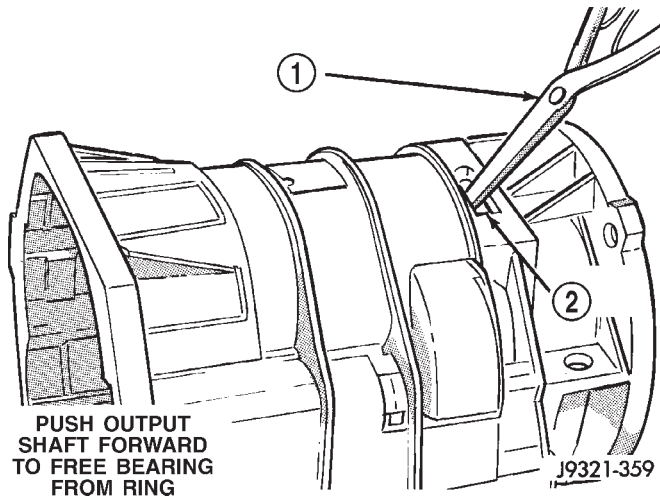
**Fig. 167 Overdrive Gear Case Installation**

- 1 - GEARTRAIN ASSEMBLY  
 2 - GEAR CASE

## OVERDRIVE UNIT (Continued)

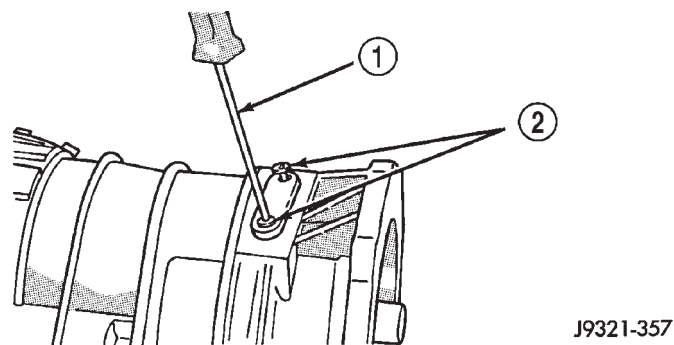
(9) Expand front bearing locating ring with snapping pliers (Fig. 168). Then slide case downward until locating ring locks in bearing groove and release snap-ring.

(10) Install locating ring access cover and gasket in overdrive unit case (Fig. 169).



**Fig. 168 Seating Locating Ring In Rear Bearing**

- 1 - EXPAND BEARING LOCATING RING WITH SNAP-RING PLIERS  
2 - ACCESS HOLE



**Fig. 169 Locating Ring Access Cover And Gasket Installation**

- 1 - TORX™ SCREWDRIVER (T25)  
2 - ACCESS COVER SCREWS

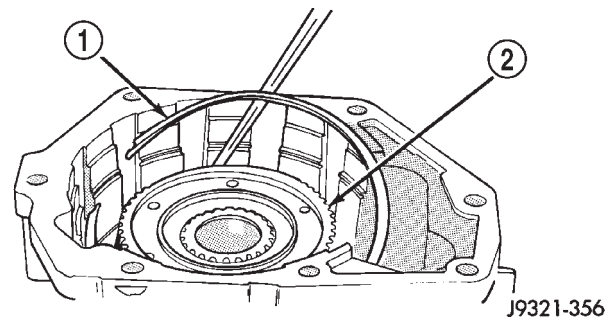
## OVERDRIVE CLUTCH

(1) Install overdrive clutch reaction ring first. Reaction ring is flat with notched ends (Fig. 170).

(2) Install wave spring on top of reaction ring (Fig. 171). Reaction ring and wave ring both fit in same ring groove. Use screwdriver to seat each ring securely in groove. Also ensure that the ends of the two rings are offset from each other.

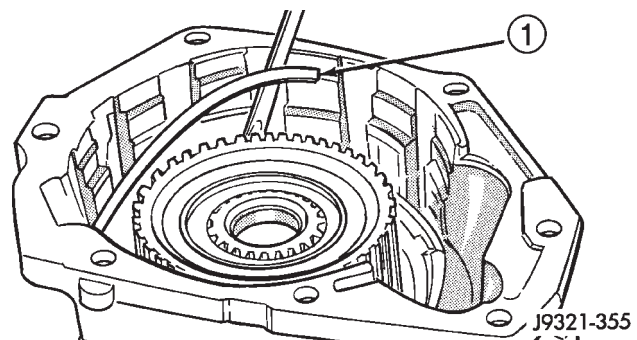
**NOTE:** The 44RE transmission has 4 overdrive clutch discs and 3 plates.

(3) Assemble overdrive clutch pack.



**Fig. 170 Overdrive Clutch Reaction Ring Installation**

- 1 - REACTION RING  
2 - CLUTCH HUB



**Fig. 171 Overdrive Clutch Wave Spring Installation**

- 1 - WAVE SPRING

(4) Install overdrive clutch reaction plate first.

**NOTE:** The reaction plate is the same thickness as the pressure plate in a 44RE transmission.

(5) Install first clutch disc followed by first clutch plate. Then install remaining clutch discs and plates in same order.

(6) Install clutch pack pressure plate.

(7) Install clutch pack wire-type retaining ring (Fig. 172).

## INTERMEDIATE SHAFT SPACER SELECTION

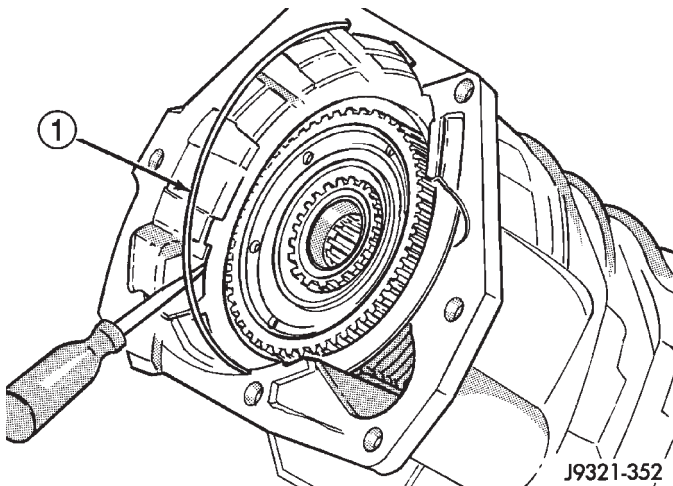
(1) Place overdrive unit in vertical position. Mount it on blocks, or in workbench with appropriate size mounting hole cut into it. Be sure unit is facing upward for access to direct clutch hub. Also be sure output shaft is not loaded and internal components are moved rearward for accurate measurement.

(2) Determine correct thickness intermediate shaft spacer as follows:

(a) Insert Special Tool 6312 through sun gear, planetary gear and into pilot bushing in output shaft. Be sure tool bottoms against planetary shoulder.



## OVERDRIVE UNIT (Continued)



**Fig. 172 Overdrive Clutch Pack Retaining Ring Installation**

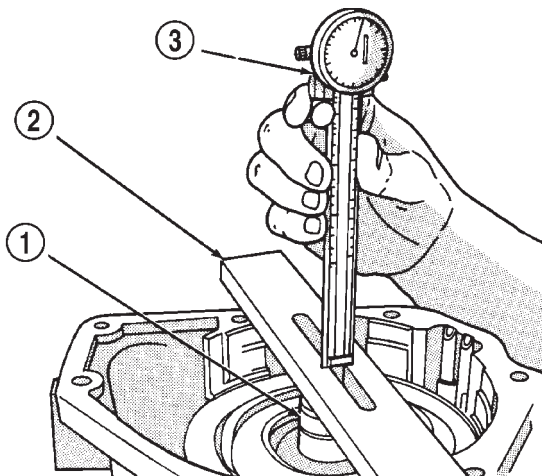
1 - OVERDRIVE CLUTCH PACK RETAINING RING

(b) Position Gauge Tool 6311 across face of overdrive case (Fig. 173). Then position Dial Caliper C-4962 over gauge tool.

(c) Extend sliding scale of dial caliper downward through gauge slot until scale contacts end of Gauge Alignment Tool 6312. Lock scale in place. Remove dial caliper tool and note distance measured (Fig. 173).

(d) Select proper thickness end play spacer from spacer chart based on distance measured (Fig. 174).

(e) Remove Gauge Alignment Tool 6312.



**Fig. 173 Shaft End Play Measurement**

1 - SPECIAL TOOL 6312  
2 - SPECIAL TOOL 6311  
3 - SPECIAL TOOL C-4962

End Play Measurement (Inches)	Spacer Thickness (Inches)
.7336 - .7505	.158 - .159
.7506 - .7675	.175 - .176
.7676 - .7855	.193 - .194
.7856 - .8011	.211 - .212

J9121-341

**Fig. 174 Intermediate Shaft End Play Spacer Selection**

### OD THRUST PLATE SELECTION

(1) Place overdrive unit in vertical position. Mount it on blocks, or in workbench with appropriate size mounting hole cut into it. Be sure unit is facing upward for access to direct clutch hub. Also be sure output shaft is not loaded and internal components are moved rearward for accurate measurement.

(2) Determine correct thickness overdrive piston thrust plate as follows:

(a) Position Gauge Tool 6311 across face of overdrive case. Then position Dial Caliper C-4962 over gauge tool (Fig. 175).

(b) Measure distance to clutch hub thrust bearing seat at four points 90° apart. Then average measurements by adding them and dividing by 4.

(c) Select and install required thrust plate from information in thrust plate chart (Fig. 176).

(3) Leave Alignment Tool 6227-2 in place. Tool will keep planetary and clutch hub splines in alignment until overdrive unit is ready for installation on transmission.

(4) Transmission speed sensor can be installed at this time if desired. However, it is recommended that sensor not be installed until after overdrive unit is secured to transmission.

### OVERDRIVE PISTON

(1) Install new seals on over drive piston.

(2) Stand transmission case upright on bellhousing.

(3) Position Guide Ring 8114-1 on outer edge of overdrive piston retainer.

(4) Position Seal Guide 8114-2 on inner edge of overdrive piston retainer.

(5) Install overdrive piston in overdrive piston retainer by: aligning locating lugs on overdrive piston to the two mating holes in retainer.

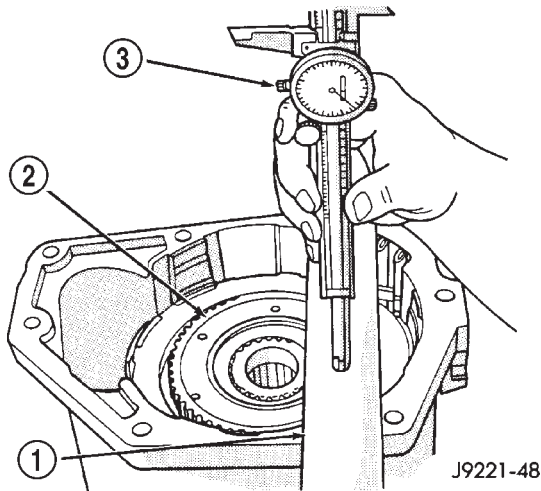
(a) Aligning locating lugs on overdrive piston to the two mating holes in retainer.

(b) Lubricate overdrive piston seals with Mopar® Door Ease, or equivalent.

(c) Install piston over Seal Guide 8114-2 and inside Guide Ring 8114-1.



OVERDRIVE UNIT (Continued)



**Fig. 175 Overdrive Piston Thrust Plate Measurement**

- 1 - SPECIAL TOOL 6311
- 2 - DIRECT CLUTCH HUB THRUST BEARING SEAT
- 3 - SPECIAL TOOL C-4962

End Play Measurement (Inches)	Spacer Thickness (Inches)
1.7500 - 1.7649	.108 - .110
1.7650 - 1.7799	.123 - .125
1.7800 - 1.7949	.138 - .140
1.7950 - 1.8099	.153 - .155
1.8100 - 1.8249	.168 - .170
1.8250 - 1.8399	.183 - .185
1.8400 - 1.8549	.198 - .200
1.8550 - 1.8699	.213 - .215
1.8700 - 1.8849	.228 - .230
1.8850 - 1.8999	.243 - .245

J9121-342

**Fig. 176 Overdrive Piston Thrust Plate Selection**

- (d) Push overdrive piston into position in retainer.
- (e) Verify that the locating lugs entered the lug bores in the retainer.
- (6) Install intermediate shaft spacer on intermediate shaft.
- (7) Install overdrive piston thrust plate on overdrive piston.
- (8) Install overdrive piston thrust bearing on overdrive piston.
- (9) Install transmission speed sensor and O-ring seal in overdrive case (Fig. 119).

**INSTALLATION**

(1) Be sure overdrive unit Alignment Tool 6227-2 is fully seated before moving unit. If tool is not seated and gear splines rotate out of alignment, over-

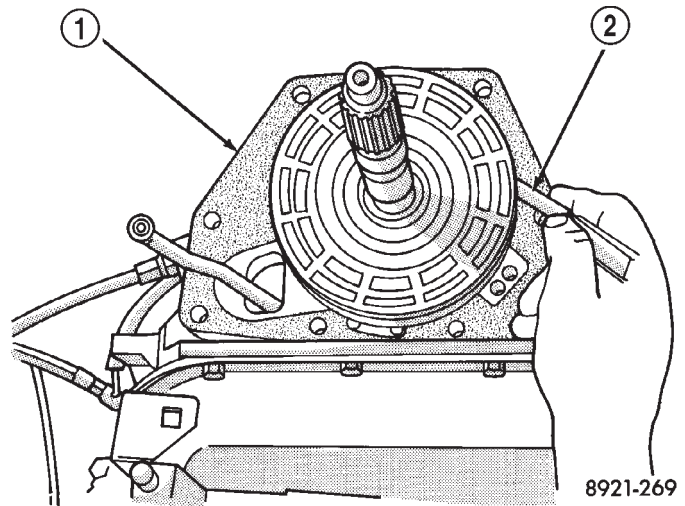
drive unit will have to be disassembled in order to realign splines.

(2) If overdrive piston retainer was not removed during service and original case gasket is no longer reusable, prepare new gasket by trimming it.

(3) Cut out old case gasket around piston retainer with razor knife (Fig. 177).

(4) Use old gasket as template and trim new gasket to fit.

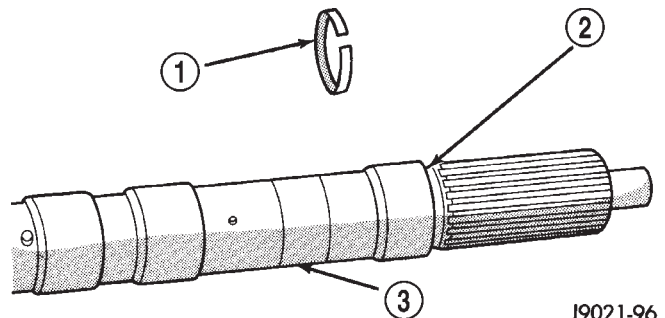
(5) Position new gasket over piston retainer and on transmission case. Use petroleum jelly to hold gasket in place if necessary. Do not use any type of sealer to secure gasket. Use petroleum jelly only.



**Fig. 177 Trimming Overdrive Case Gasket**

- 1 - GASKET
- 2 - SHARP KNIFE

(6) Install selective spacer on intermediate shaft, if removed. Spacer goes in groove just rearward of shaft rear splines (Fig. 178).



**Fig. 178 Intermediate Shaft Selective Spacer Location**

- 1 - SELECTIVE SPACER
- 2 - SPACER GROOVE
- 3 - INTERMEDIATE SHAFT

## OVERDRIVE UNIT (Continued)

(7) Install thrust bearing in overdrive unit sliding hub. Use petroleum jelly to hold bearing in position.

**CAUTION:** Be sure the shoulder on the inside diameter of the bearing is facing forward.

(8) Verify that splines in overdrive planetary gear and overrunning clutch hub are aligned with Alignment Tool 6227-2. Overdrive unit cannot be installed if splines are not aligned. If splines have rotated out of alignment, unit will have to be disassembled to realign splines.

(9) Carefully slide Alignment Tool 6227-2 out of overdrive planetary gear and overrunning clutch splines.

(10) Raise overdrive unit and carefully slide it straight onto intermediate shaft. Insert park rod into park lock reaction plug at same time. Avoid tilting overdrive during installation as this could cause planetary gear and overrunning clutch splines to rotate out of alignment. If this occurs, it will be necessary to remove and disassemble overdrive unit to realign splines.

(11) Work overdrive unit forward on intermediate shaft until seated against transmission case.

(12) Install bolts attaching overdrive unit to transmission unit. Tighten bolts in diagonal pattern to 34 N·m (25 ft-lbs).

(13) Connect the transmission speed sensor and overdrive wiring connectors.

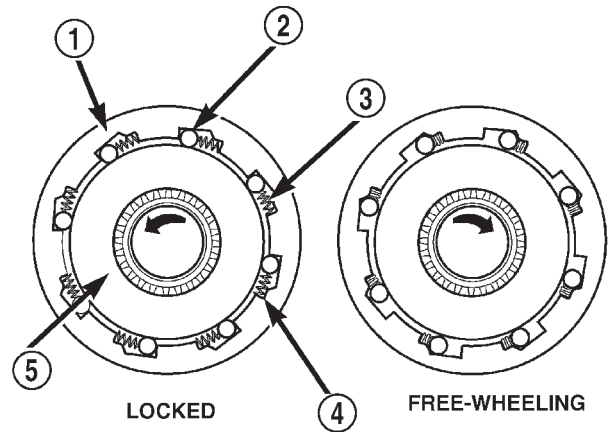
(14) Install the transfer case, if equipped.

(15) Align and install rear propeller shaft, if necessary. (Refer to 3 - DIFFERENTIAL & DRIVELINE/ PROPELLER SHAFT/PROPELLER SHAFT - INSTALLATION)

## OVERRUNNING CLUTCH CAM/OVERDRIVE PISTON RETAINER

### DESCRIPTION

The overrunning clutch (Fig. 179) consists of an inner race, an outer race (or cam), rollers and springs, and the spring retainer. The number of rollers and springs depends on what transmission and which overrunning clutch is being dealt with.



80be45f8

**Fig. 179 Overrunning Clutch**

- 1 - OUTER RACE (CAM)
- 2 - ROLLER
- 3 - SPRING
- 4 - SPRING RETAINER
- 5 - INNER RACE (HUB)

### OPERATION

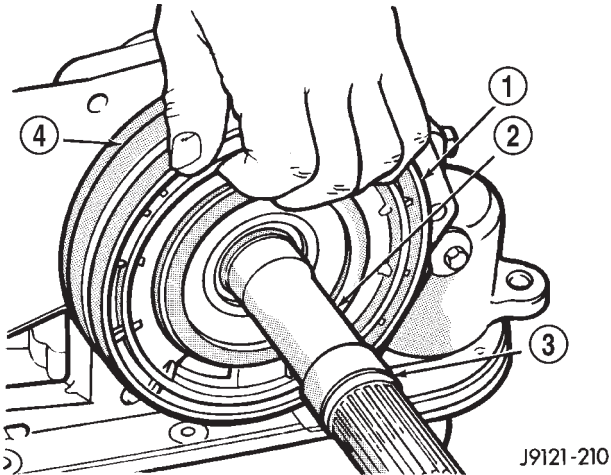
As the inner race is rotated in a clockwise direction (as viewed from the front of the transmission), the race causes the rollers to roll toward the springs, causing them to compress against their retainer. The compression of the springs increases the clearance between the rollers and cam. This increased clearance between the rollers and cam results in a free-wheeling condition. When the inner race attempts to rotate counterclockwise, the action causes the rollers to roll in the same direction as the race, aided by the pushing of the springs. As the rollers try to move in the same direction as the inner race, they are wedged between the inner and outer races due to the design of the cam. In this condition, the clutch is locked and acts as one unit.

### DISASSEMBLY

**NOTE:** To service the overrunning clutch cam and the overdrive piston retainer, the transmission geartrain and the overdrive unit must be removed from the transmission.

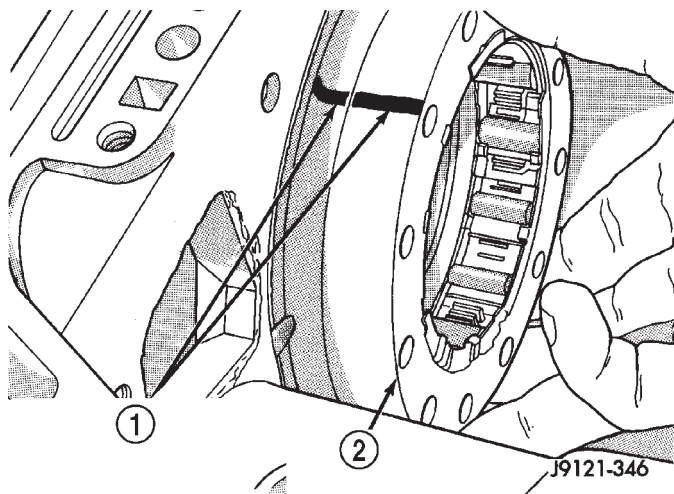
## OVERRUNNING CLUTCH CAM/OVERDRIVE PISTON RETAINER (Continued)

- (1) Remove the overdrive piston (Fig. 180).
- (2) Remove the overdrive piston retainer bolts.
- (3) Remove overdrive piston retainer.
- (4) Remove case gasket.
- (5) Mark the position of the overrunning clutch cam in the case (Fig. 181).
- (6) Remove the overrunning clutch cam bolts.
- (7) Remove the overrunning clutch cam.



**Fig. 180 Overdrive Piston Removal**

- 1 - OVERDRIVE CLUTCH PISTON
- 2 - INTERMEDIATE SHAFT
- 3 - SELECTIVE SPACER
- 4 - PISTON RETAINER



**Fig. 181 Overrunning Clutch Cam Removal**

- 1 - ALIGN MARKS IDENTIFYING NON-THREADED HOLE IN CAM AND CASE
- 2 - OVERRUNNING CLUTCH ASSEMBLY

## CLEANING

Clean the overrunning clutch assembly, clutch cam, low-reverse drum, and overdrive piston retainer in

solvent. Dry them with compressed air after cleaning.

## INSPECTION

Inspect condition of each clutch part after cleaning. Replace the overrunning clutch roller and spring assembly if any rollers or springs are worn or damaged, or if the roller cage is distorted, or damaged. Replace the cam if worn, cracked or damaged.

Replace the low-reverse drum if the clutch race, roller surface or inside diameter is scored, worn or damaged. **Do not remove the clutch race from the low-reverse drum under any circumstances. Replace the drum and race as an assembly if either component is damaged.**

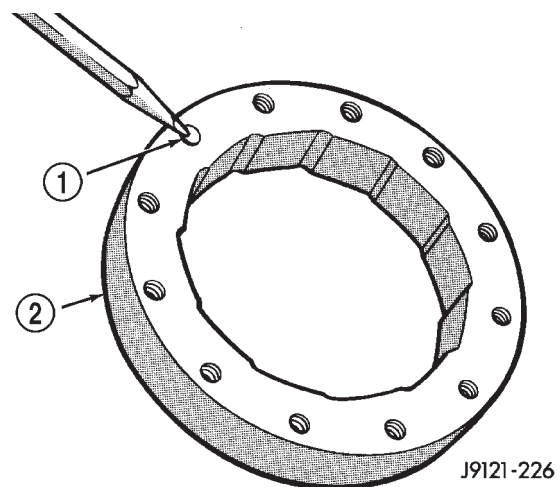
Examine the overdrive piston retainer carefully for wear, cracks, scoring or other damage. Be sure the retainer hub is a snug fit in the case and drum. Replace the retainer if worn or damaged.

## ASSEMBLY

(1) Examine bolt holes in overrunning clutch cam. Note that one hole is **not threaded** (Fig. 182). This hole must align with blank area in clutch cam bolt circle (Fig. 183). Mark hole location on clutch cam and blank area in case with grease pencil, paint stripe, or scribe mark for assembly reference.

(2) Mark location of non-threaded hole in clutch cam and blank area in bolt circle with grease pencil.

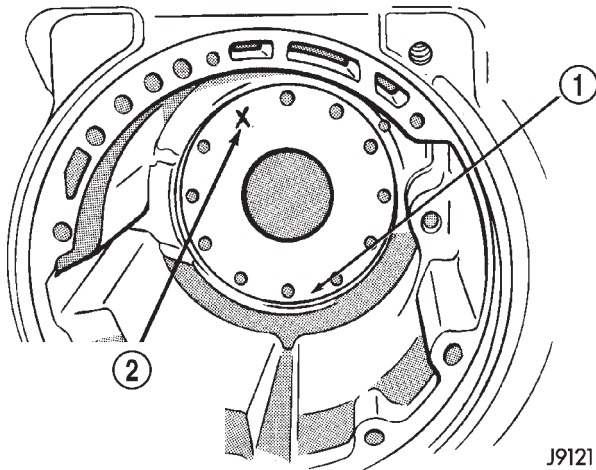
(3) Align and install overrunning clutch and cam in case (Fig. 184). Be sure cam is correctly installed. Bolt holes in cam are slightly countersunk on one side. Be sure this side of cam faces rearward (toward piston retainer).



**Fig. 182 Location Of Non-Threaded Hole In Clutch Cam**

- 1 - NON-THREADED HOLE
- 2 - OVERRUNNING CLUTCH CAM

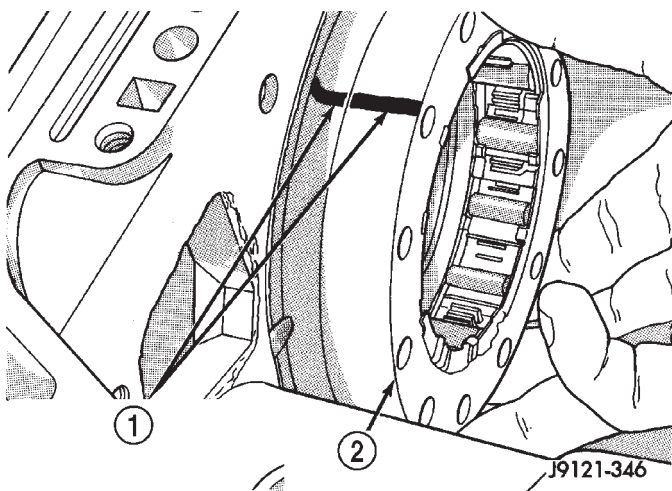
## OVERRUNNING CLUTCH CAM/OVERDRIVE PISTON RETAINER (Continued)



J9121-541

**Fig. 183 Location Of Blank Area In Clutch Cam Bolt Circle**

- 1 - OVERRUNNING CLUTCH CAM SEAT IN CASE  
2 - NON-THREADED HOLE IN CLUTCH CAM ALIGNS HERE (BLANK AREA) OF SEAT



J9121-346

**Fig. 184 Overrunning Clutch Installation**

- 1 - ALIGN MARKS IDENTIFYING NON-THREADED HOLE IN CAM AND CASE  
2 - OVERRUNNING CLUTCH ASSEMBLY

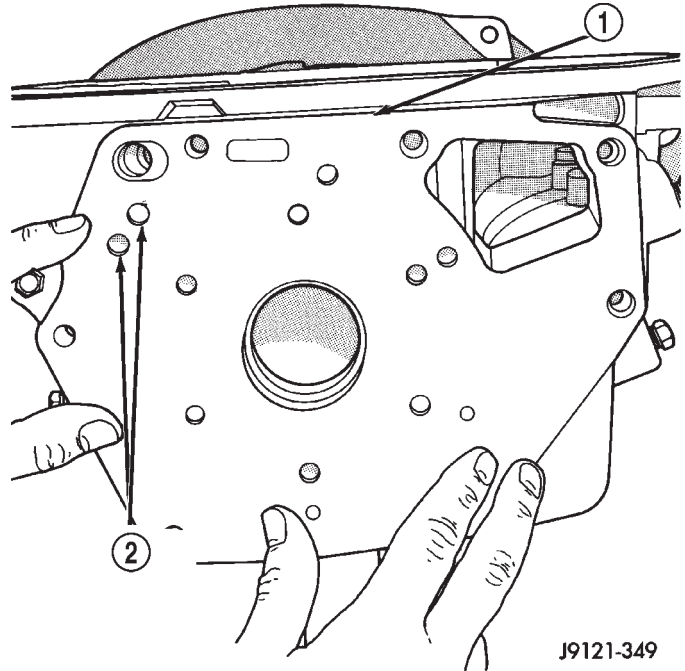
(4) Verify that non-threaded hole in clutch cam is properly aligned. Check alignment by threading a bolt into each bolt hole. Adjust clutch cam position if necessary.

(5) Install and tighten overrunning clutch cam bolts to 17 N·m (13 ft. lbs.) torque. Note that clutch cam bolts are shorter than piston retainer bolts.

(6) Install new gasket at rear of transmission case. Use petroleum jelly to hold gasket in place. Be sure to align governor feed holes in gasket with feed passages in case (Fig. 185). Also install gasket before overdrive piston retainer. Center hole in gasket is

smaller than retainer and cannot be installed over retainer.

(7) Position overdrive piston retainer on transmission case and align bolt holes in retainer, gasket and case (Fig. 186). Then install and tighten retainer bolts to 17 N·m (13 ft. lbs.) torque.



J9121-349

**Fig. 185 Installing/Aligning Case Gasket**

- 1 - CASE GASKET  
2 - BE SURE GOVERNOR TUBE FEED HOLES IN CASE AND GASKET ARE ALIGNED

(8) Install new seals on over drive piston.  
(9) Stand transmission case upright on bellhousing.

(10) Position Guide Ring 8114-1 on outer edge of overdrive piston retainer.

(11) Position Seal Guide 8114-2 on inner edge of overdrive piston retainer.

(12) Install overdrive piston in overdrive piston retainer by: aligning locating lugs on overdrive piston to the two mating holes in retainer.

(a) Aligning locating lugs on overdrive piston to the two mating holes in retainer.

(b) Lubricate overdrive piston seals with Mopar® Door Ease, or equivalent.

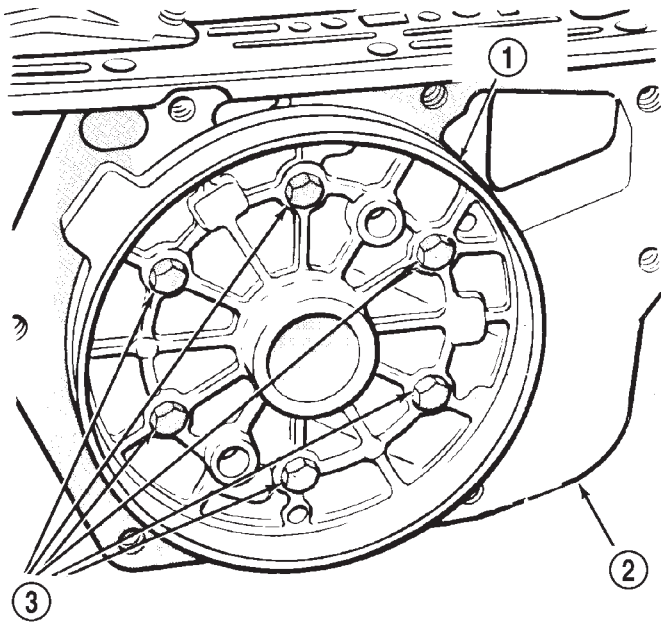
(c) Install piston over Seal Guide 8114-2 and inside Guide Ring 8114-1.

(d) Push overdrive piston into position in retainer.

(e) Verify that the locating lugs entered the lug bores in the retainer.



## OVERRUNNING CLUTCH CAM/OVERDRIVE PISTON RETAINER (Continued)



J9321-464

**Fig. 186** Aligning Overdrive Piston Retainer

- 1 - PISTON RETAINER
- 2 - GASKET
- 3 - RETAINER BOLTS

**NOTE:** Install the remaining transmission components and the overdrive unit.

## PARK/NEUTRAL POSITION SWITCH

### DIAGNOSIS AND TESTING - PARK/NEUTRAL POSITION SWITCH

The center terminal of the park/neutral position switch is the starter-circuit terminal. It provides the ground for the starter solenoid circuit through the selector lever in PARK and NEUTRAL positions only. The outer terminals on the switch are for the backup lamp circuit.

#### SWITCH TEST

To test the switch, remove the wiring connector. Test for continuity between the center terminal and the transmission case. Continuity should exist only when the transmission is in PARK or NEUTRAL.

Shift the transmission into REVERSE and test continuity at the switch outer terminals. Continuity should exist only when the transmission is in REVERSE. Continuity should not exist between the outer terminals and the case.

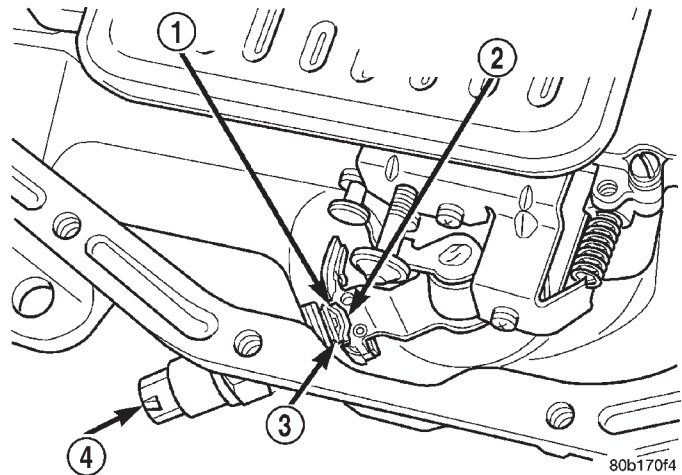
Check gearshift linkage adjustment before replacing a switch that tests faulty.

### REMOVAL

- (1) Raise vehicle and position drain pan under switch.
- (2) Disconnect switch wires.
- (3) Remove switch from case.

### INSTALLATION

- (1) Move shift lever to PARK and NEUTRAL positions. Verify that switch operating lever fingers are centered in switch opening in case (Fig. 187).

**Fig. 187** Park/Neutral Position Switch

- 1 - NEUTRAL CONTACT
- 2 - MANUAL LEVER AND SWITCH PLUNGER IN REVERSE POSITION
- 3 - PARK CONTACT
- 4 - SWITCH

- (2) Install new seal on switch and install switch in case. Tighten switch to 34 N·m (25 ft. lbs.) torque.
- (3) Test continuity of new switch with 12V test lamp.
- (4) Connect switch wires and lower vehicle.
- (5) Top off transmission fluid level.

## PISTONS

### DESCRIPTION

There are several sizes and types of pistons used in an automatic transmission. Some pistons are used to apply clutches, while others are used to apply bands. They all have in common the fact that they are round or circular in shape, located within a smooth walled cylinder, which is closed at one end and converts fluid pressure into mechanical movement. The fluid pressure exerted on the piston is contained within the system through the use of piston rings or seals.



## PISTONS (Continued)

## OPERATION

The principal which makes this operation possible is known as Pascal's Law. Pascal's Law can be stated as: "Pressure on a confined fluid is transmitted equally in all directions and acts with equal force on equal areas."

## PRESSURE

Pressure (Fig. 188) is nothing more than force (lbs.) divided by area (in or ft.), or force per unit area. Given a 100 lb. block and an area of 100 sq. in. on the floor, the pressure exerted by the block is: 100 lbs. 100 in or 1 pound per square inch, or PSI as it is commonly referred to.

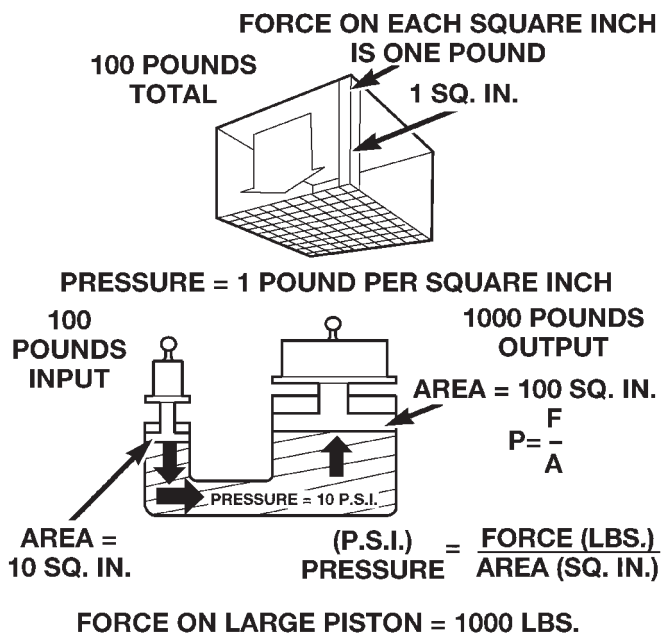
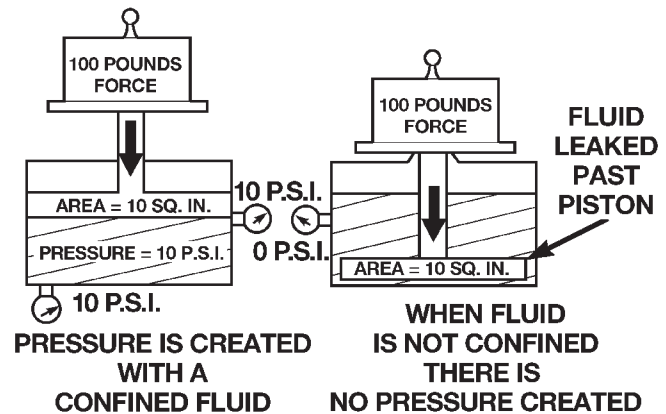


Fig. 188 Force and Pressure Relationship

## PRESSURE ON A CONFINED FLUID

Pressure is exerted on a confined fluid (Fig. 189) by applying a force to some given area in contact with the fluid. A good example of this is a cylinder filled with fluid and equipped with a piston that is closely fitted to the cylinder wall. If a force is applied to the piston, pressure will be developed in the fluid. Of course, no pressure will be created if the fluid is not confined. It will simply "leak" past the piston. There must be a resistance to flow in order to create pressure. Piston sealing is extremely important in hydraulic operation. Several kinds of seals are used to accomplish this within a transmission. These include but are not limited to O-rings, D-rings, lip seals, sealing rings, or extremely close tolerances between the piston and the cylinder wall. The force exerted is downward (gravity), however, the principle remains the same no matter which direction is taken.

The pressure created in the fluid is equal to the force applied, divided by the piston area. If the force is 100 lbs., and the piston area is 10 sq. in., then the pressure created equals 10 PSI. Another interpretation of Pascal's Law is that regardless of container shape or size, the pressure will be maintained throughout, as long as the fluid is confined. In other words, the pressure in the fluid is the same everywhere within the container.



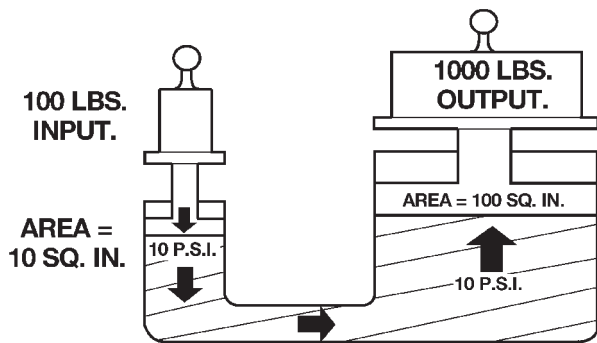
80bfe273

Fig. 189 Pressure on a Confined Fluid

## FORCE MULTIPLICATION

Using the 10 PSI example used in the illustration (Fig. 190), a force of 1000 lbs. can be moved with a force of only 100 lbs. The secret of force multiplication in hydraulic systems is the total fluid contact area employed. The illustration, (Fig. 190), shows an area that is ten times larger than the original area. The pressure created with the smaller 100 lb. input is 10 PSI. The concept "pressure is the same everywhere" means that the pressure underneath the larger piston is also 10 PSI. Pressure is equal to the force applied divided by the contact area. Therefore, by means of simple algebra, the output force may be found. This concept is extremely important, as it is also used in the design and operation of all shift valves and limiting valves in the valve body, as well as the pistons, of the transmission, which activate the clutches and bands. It is nothing more than using a difference of area to create a difference in pressure to move an object.

PISTONS (Continued)

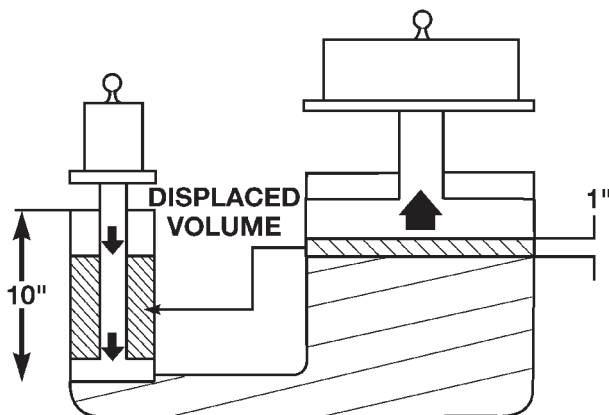


80bfe274

Fig. 190 Force Multiplication

PISTON TRAVEL

The relationship between hydraulic lever and a mechanical lever is the same. With a mechanical lever it's a weight-to-distance output rather than a pressure-to-area output. Using the same forces and areas as in the previous example, the smaller piston (Fig. 191) has to move ten times the distance required to move the larger piston one inch. Therefore, for every inch the larger piston moves, the smaller piston moves ten inches. This principle is true in other instances also. A common garage floor jack is a good example. To raise a car weighing 2000 lbs., an effort of only 100 lbs. may be required. For every inch the car moves upward, the input piston at the jack handle must move 20 inches downward.



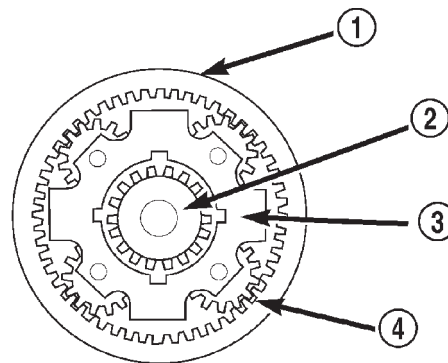
80bfe275

Fig. 191 Piston Travel

PLANETARY GEARTRAIN/  
OUTPUT SHAFT

DESCRIPTION

The planetary gearsets (Fig. 192) are designated as the front, rear, and overdrive planetary gear assemblies and located in such order. A simple planetary gearset consists of three main members:



80be45fe

Fig. 192 Planetary Gearset

- 1 - ANNULUS GEAR
- 2 - SUN GEAR
- 3 - PLANET CARRIER
- 4 - PLANET PINIONS (4)

- The sun gear which is at the center of the system.
- The planet carrier with planet pinion gears which are free to rotate on their own shafts and are in mesh with the sun gear.
- The annulus gear, which rotates around and is in mesh with the planet pinion gears.

**NOTE:** The number of pinion gears does not affect the gear ratio, only the duty rating.

OPERATION

With any given planetary gearset, several conditions must be met for power to be able to flow:

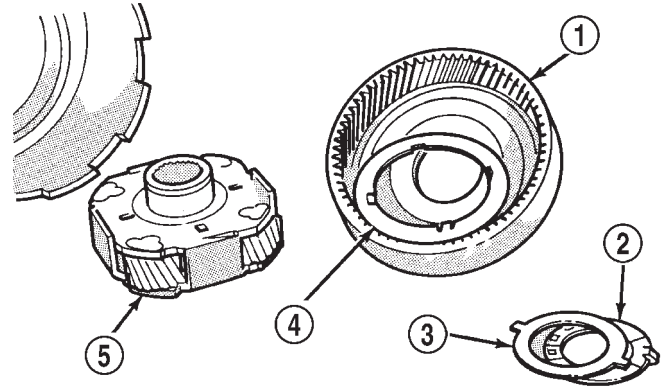
- One member must be held.
- Another member must be driven or used as an input.
- The third member may be used as an output for power flow.
- For direct drive to occur, two gear members in the front planetary gearset must be driven.

**NOTE:** Gear ratios are dependent on the number of teeth on the annulus and sun gears.

PLANETARY GEARTRAIN/OUTPUT SHAFT (Continued)

**DISASSEMBLY**

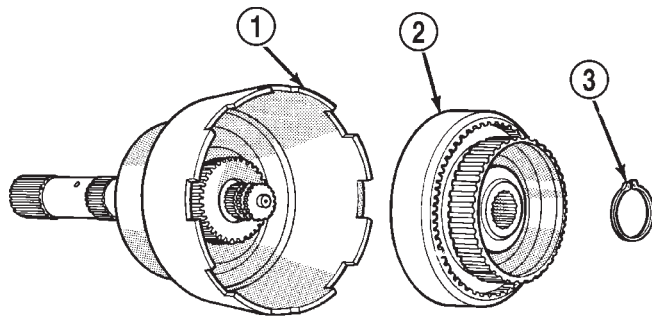
- (1) Remove planetary snap-ring (Fig. 193).
- (2) Remove front annulus and planetary assembly from driving shell (Fig. 193).
- (3) Remove snap-ring that retains front planetary gear in annulus gear (Fig. 194).
- (4) Remove tabbed thrust washer and tabbed thrust plate from hub of front annulus (Fig. 195).
- (5) Separate front annulus and planetary gears (Fig. 195).
- (6) Remove front planetary gear front thrust washer from annulus gear hub.
- (7) Separate and remove driving shell, rear planetary and rear annulus from output shaft (Fig. 196).
- (8) Remove front planetary rear thrust washer from driving shell.
- (9) Remove tabbed thrust washers from rear planetary gear.
- (10) Remove lock ring that retains sun gear in driving shell. Then remove sun gear, spacer and thrust plates.



J9421-177

**Fig. 195 Front Planetary And Annulus Gear Disassembly**

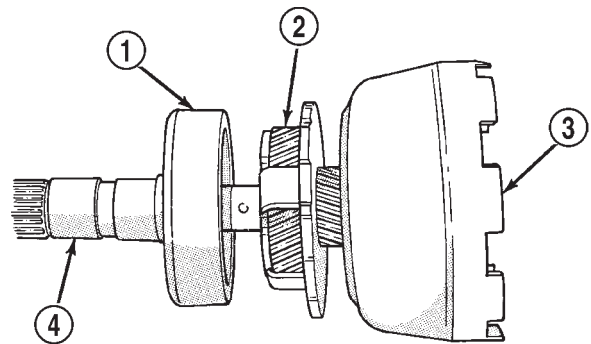
- 1 - FRONT ANNULUS
- 2 - THRUST WASHER
- 3 - THRUST PLATE
- 4 - FRONT THRUST WASHER
- 5 - FRONT PLANETARY



J9421-175

**Fig. 193 Front Annulus And Planetary Assembly Removal**

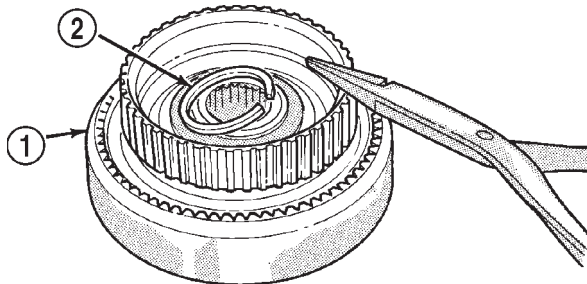
- 1 - DRIVING SHELL
- 2 - FRONT ANNULUS AND PLANETARY ASSEMBLY
- 3 - PLANETARY SNAP-RING



J9421-178

**Fig. 196 Removing Driving Shell, Rear Planetary And Rear Annulus**

- 1 - REAR ANNULUS
- 2 - REAR PLANETARY
- 3 - DRIVING SHELL
- 4 - OUTPUT SHAFT



J9421-176

**Fig. 194 Front Planetary Snap-Ring Removal**

- 1 - FRONT ANNULUS GEAR
- 2 - PLANETARY SNAP-RING

**INSPECTION**

Check sun gear and driving shell condition. Replace the gear if damaged or if the bushings are scored or worn. The bushings are not serviceable. Replace the driving shell if worn, cracked or damaged.

Replace planetary gear sets if gears, pinion pins, or carrier are damaged in any way. Replace the annulus gears and supports if either component is worn or damaged.

## PLANETARY GEARTRAIN/OUTPUT SHAFT (Continued)

Inspect the geartrain spacers, thrust plates, snap-rings, and thrust washers. Replace any of these parts that are worn, distorted or damaged. Do not attempt to reuse these parts.

The planetary gear thrust washers are different sizes. The large diameter washers go on the front planetary and the smaller washers go on the rear planetary. All the washers have four locating tabs on them. These tabs fit in the holes or slots provided in each planetary gear.

Inspect the output shaft carefully. Pay particular attention to the machined bushing/bearing surfaces on the shaft and the governor valve shaft bore at the shaft rear.

Replace the output shaft if the machined surfaces are scored, pitted, or damaged in any way. Also replace the shaft if the splines are damaged, or exhibits cracks at any location (especially at the governor valve shaft bore).

The annulus gears can be removed from their supports if necessary. Just remove the snap-rings and separate the two parts when replacement is necessary. In addition, the annulus gear bushings can be replaced if severely worn, or scored. However it is not necessary to replace the bushings if they only exhibit normal wear. Check bushing fit on the output shaft to be sure.

## ASSEMBLY

(1) Lubricate output shaft and planetary components with transmission fluid. Use petroleum jelly to lubricate and hold thrust washers and plates in position.

(2) Assemble rear annulus gear and support if disassembled. Be sure support snap-ring is seated and that shoulder-side of support faces rearward (Fig. 197).

(3) Install rear thrust washer on rear planetary gear. Use enough petroleum jelly to hold washer in place. Also be sure all four washer tabs are properly engaged in gear slots.

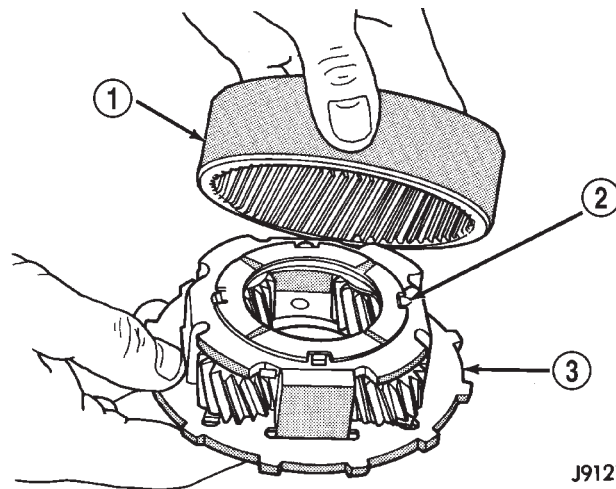
(4) Install rear annulus over and onto rear planetary gear (Fig. 197).

(5) Install assembled rear planetary and annulus gear on output shaft (Fig. 198). Verify that assembly is fully seated on shaft.

(6) Install front thrust washer on rear planetary gear (Fig. 199). Use enough petroleum jelly to hold washer on gear. Be sure all four washer tabs are seated in slots.

(7) Install spacer on sun gear (Fig. 200).

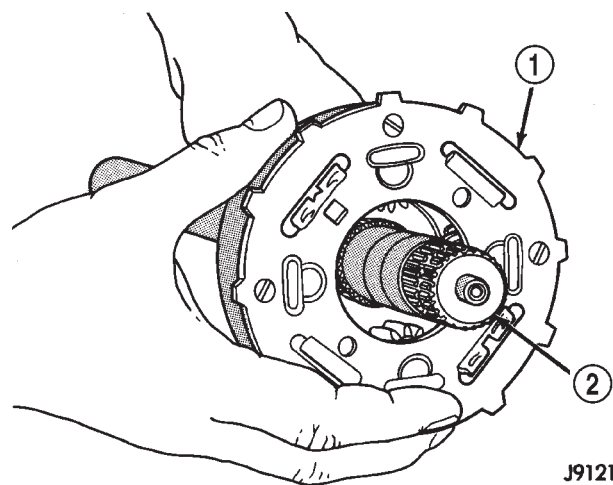
(8) Install thrust plate on sun gear (Fig. 201). Note that driving shell thrust plates are interchangeable. Use either plate on sun gear and at front/rear of shell.



J9121-156

**Fig. 197 Assembling Rear Annulus And Planetary Gear**

- 1 - REAR ANNULUS GEAR
- 2 - TABBED THRUST WASHER
- 3 - REAR PLANETARY

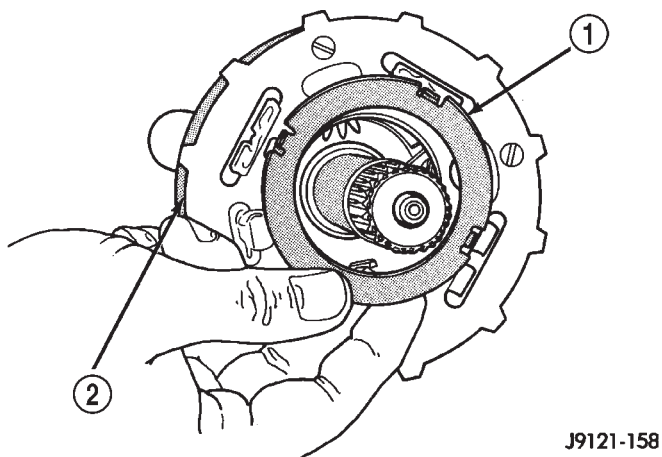


J9121-157

**Fig. 198 Installing Rear Annulus And Planetary On Output Shaft**

- 1 - REAR ANNULUS AND PLANETARY GEAR ASSEMBLY
- 2 - OUTPUT SHAFT

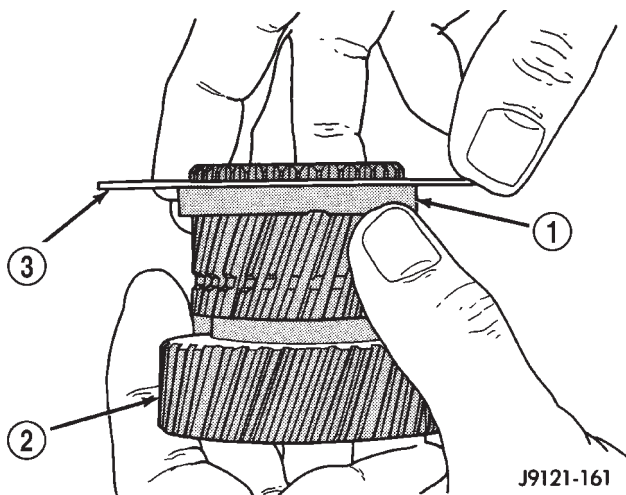
## PLANETARY GEARTRAIN/OUTPUT SHAFT (Continued)



J9121-158

**Fig. 199 Installing Rear Planetary Front Thrust Washer**

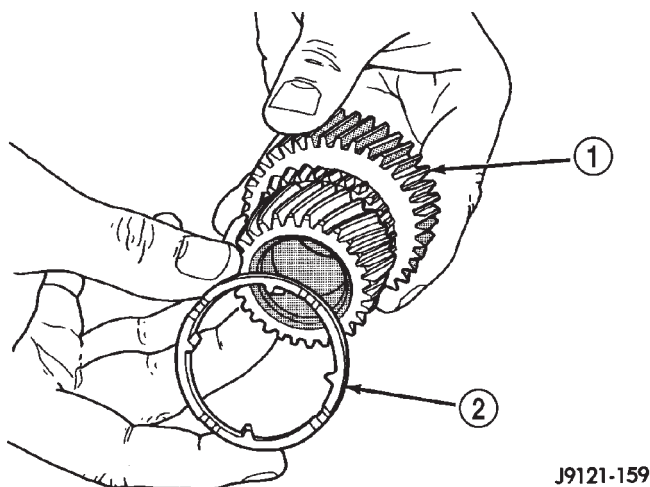
- 1 - FRONT TABBED THRUST WASHER  
2 - REAR PLANETARY GEAR



J9121-161

**Fig. 201 Installing Driving Shell Front Thrust Plate On Sun Gear**

- 1 - SPACER  
2 - SUN GEAR  
3 - THRUST PLATE



J9121-159

**Fig. 200 Installing Spacer On Sun Gear**

- 1 - SUN GEAR  
2 - SUN GEAR SPACER

(9) Hold sun gear in place and install thrust plate over sun gear at rear of driving shell (Fig. 202).

(10) Position wood block on bench and support sun gear on block (Fig. 203). This makes it easier to align and install sun gear lock ring. Keep wood block handy as it will also be used for geartrain end play check.

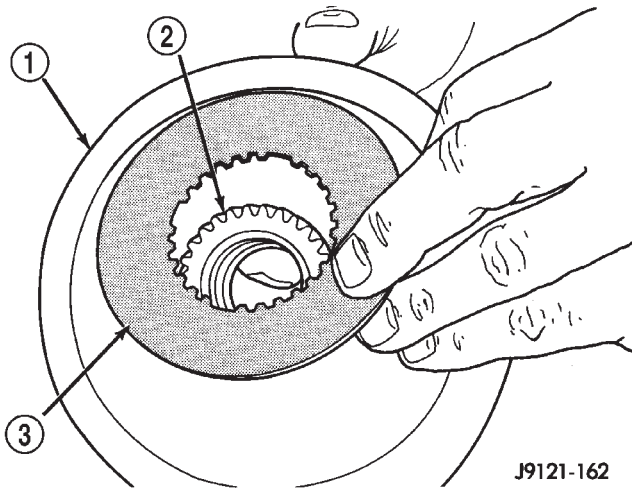
(11) Align rear thrust plate on driving shell and install sun gear lock ring. Be sure ring is fully seated in sun gear ring groove (Fig. 204).

(12) Install assembled driving shell and sun gear on output shaft (Fig. 205).

(13) Install rear thrust washer on front planetary gear (Fig. 206). Use enough petroleum jelly to hold washer in place and be sure all four washer tabs are seated.



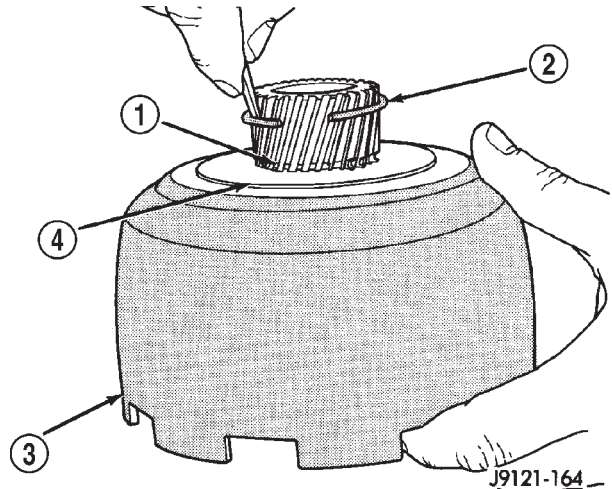
PLANETARY GEARTRAIN/OUTPUT SHAFT (Continued)



J9121-162

**Fig. 202 Installing Driving Shell Rear Thrust Plate**

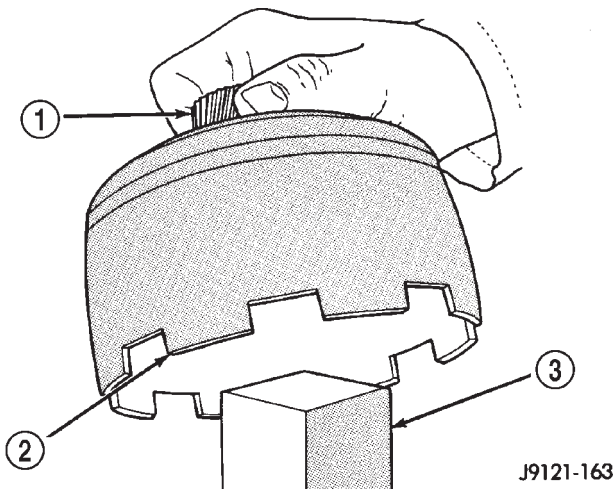
- 1 - DRIVING SHELL
- 2 - SUN GEAR
- 3 - REAR THRUST PLATE



J9121-164

**Fig. 204 Installing Sun Gear Lock Ring**

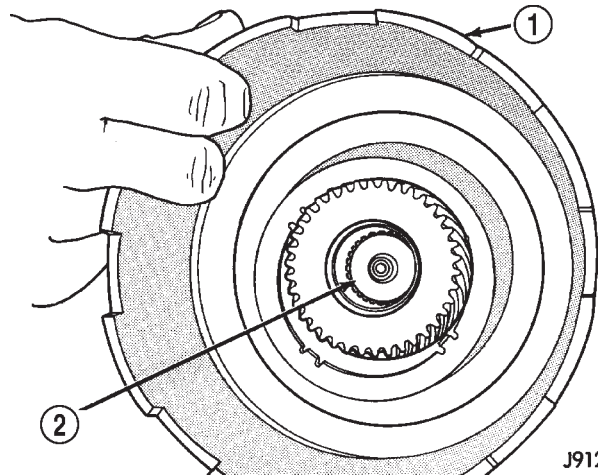
- 1 - LOCK RING GROOVE
- 2 - SUN GEAR LOCK RING
- 3 - DRIVING SHELL
- 4 - REAR THRUST PLATE



J9121-163

**Fig. 203 Supporting Sun Gear On Wood Block**

- 1 - SUN GEAR
- 2 - DRIVING SHELL
- 3 - WOOD BLOCK

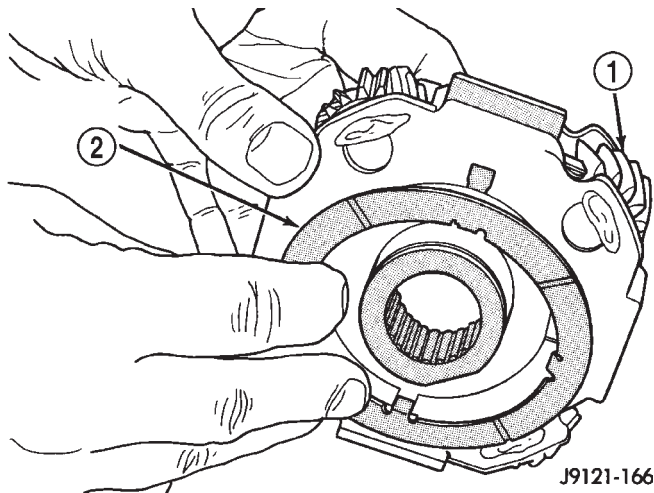


J9121-165

**Fig. 205 Installing Assembled Sun Gear And Driving Shell On Output Shaft**

- 1 - SUN GEAR/DRIVING SHELL ASSEMBLY
- 2 - OUTPUT SHAFT

## PLANETARY GEARTRAIN/OUTPUT SHAFT (Continued)



**Fig. 206 Installing Rear Thrust Washer On Front Planetary Gear**

- 1 - FRONT PLANETARY GEAR  
2 - REAR TABBED THRUST WASHER

(14) Install front planetary gear on output shaft and in driving shell (Fig. 207).

(15) Install front thrust washer on front planetary gear. Use enough petroleum jelly to hold washer in place and be sure all four washer tabs are seated.

(16) Assemble front annulus gear and support, if necessary. Be sure support snap-ring is seated.

(17) Install front annulus on front planetary (Fig. 207).

(18) Position thrust plate on front annulus gear support (Fig. 208). Note that plate has two tabs on it. These tabs fit in notches of annulus hub.

(19) Install thrust washer in front annulus (Fig. 209). Align flat on washer with flat on planetary hub. Also be sure washer tab is facing up.

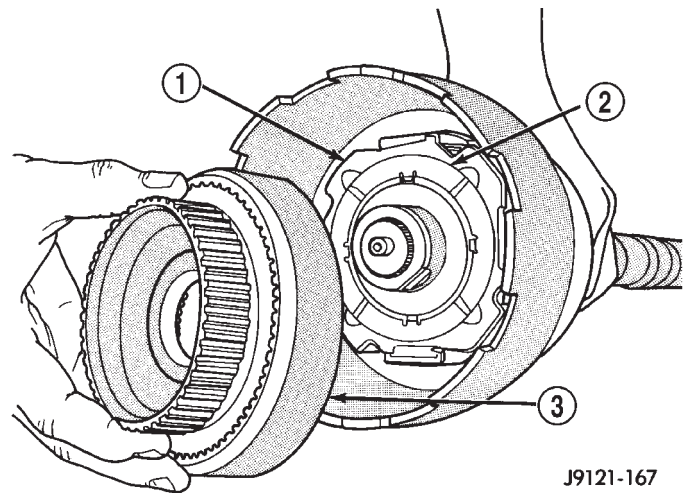
(20) Install front annulus snap-ring (Fig. 210). Use snap-ring pliers to avoid distorting ring during installation. Also be sure ring is fully seated.

(21) Install planetary selective snap-ring with snap-ring pliers (Fig. 211). Be sure ring is fully seated.

(22) Turn planetary geartrain assembly over so driving shell is facing workbench. Then support geartrain on wood block positioned under forward end of output shaft. This allows geartrain components to move forward for accurate end play check.

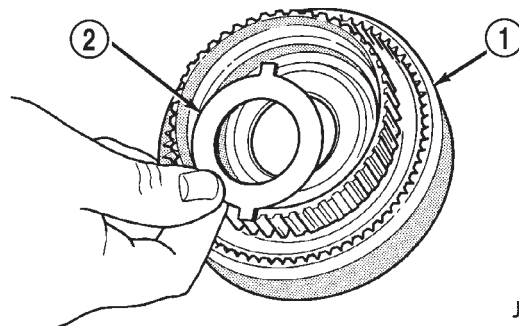
(23) Check planetary geartrain end play with feeler gauge (Fig. 212). Gauge goes between shoulder on output shaft and end of rear annulus support.

(24) Geartrain end play should be 0.12 to 1.22 mm (0.005 to 0.048 in.). If end play is incorrect, snap-ring (or thrust washers) may have to be replaced. Snap-rings are available in three different thicknesses for adjustment purposes.



**Fig. 207 Installing Front Planetary And Annulus Gears**

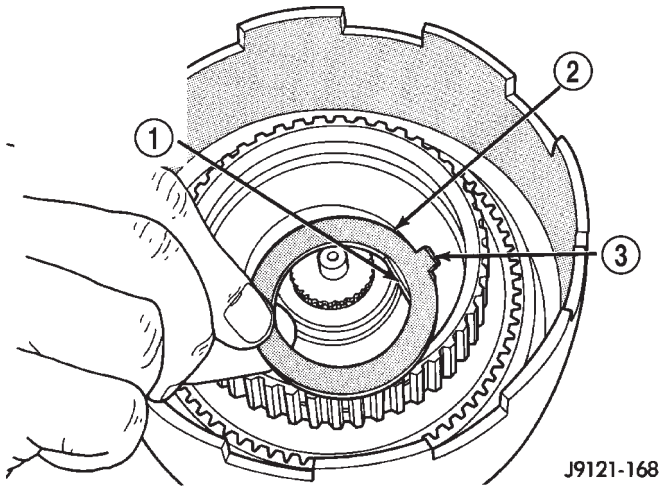
- 1 - FRONT PLANETARY GEAR  
2 - FRONT THRUST WASHER  
3 - FRONT ANNULUS GEAR



**Fig. 208 Positioning Thrust Plate On Front Annulus Support**

- 1 - FRONT ANNULUS  
2 - THRUST PLATE

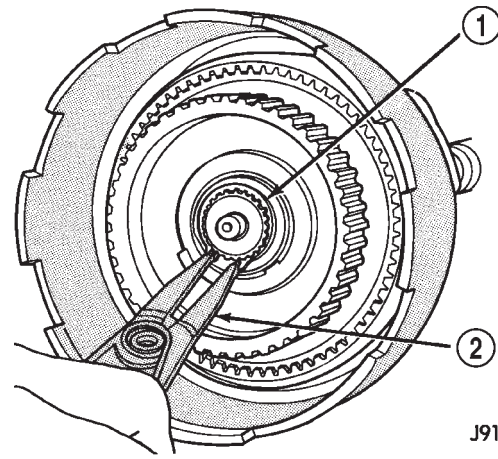
PLANETARY GEARTRAIN/OUTPUT SHAFT (Continued)



J9121-168

**Fig. 209 Installing Front Annulus Thrust Washer**

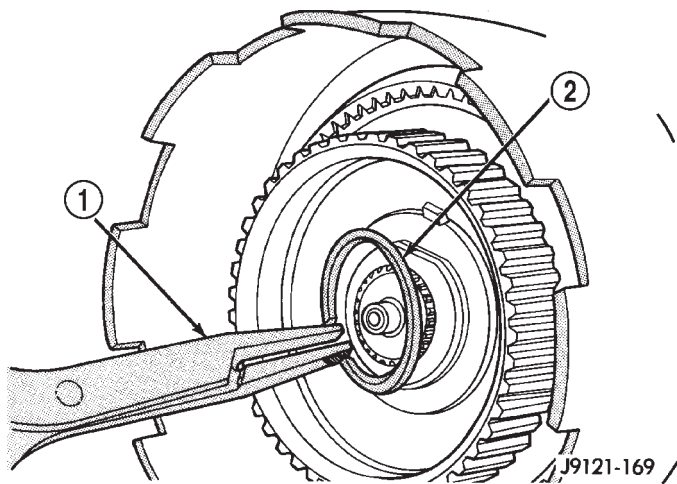
- 1 - WASHER FLAT ALIGNS WITH FLAT ON PLANETARY HUB
- 2 - FRONT ANNULUS THRUST WASHER
- 3 - TAB FACES FRONT



J9121-170

**Fig. 211 Installing Planetary Selective Snap-Ring**

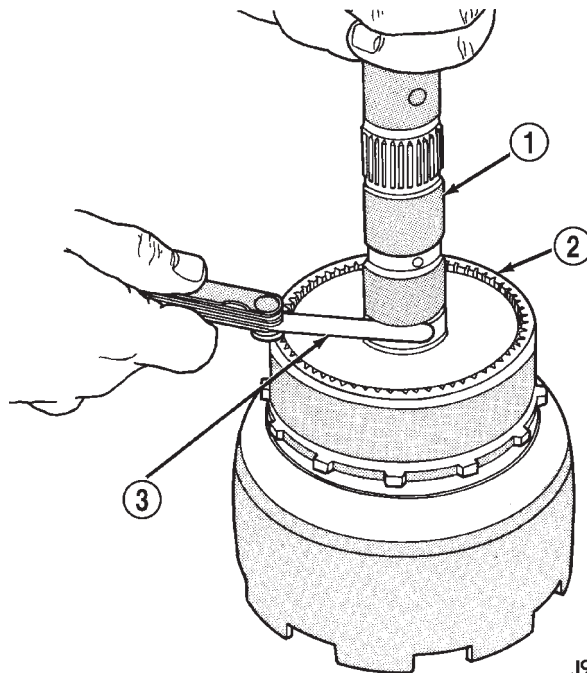
- 1 - SELECTIVE SNAP-RING
- 2 - SNAP-RING PLIERS



J9121-169

**Fig. 210 Installing Front Annulus Snap-Ring**

- 1 - SNAP-RING PLIERS
- 2 - FRONT ANNULUS SNAP-RING



J9121-171

**Fig. 212 Checking Planetary Geartrain End Play**

- 1 - OUTPUT SHAFT
- 2 - REAR ANNULUS GEAR
- 3 - FEELER GAUGE

## REAR CLUTCH

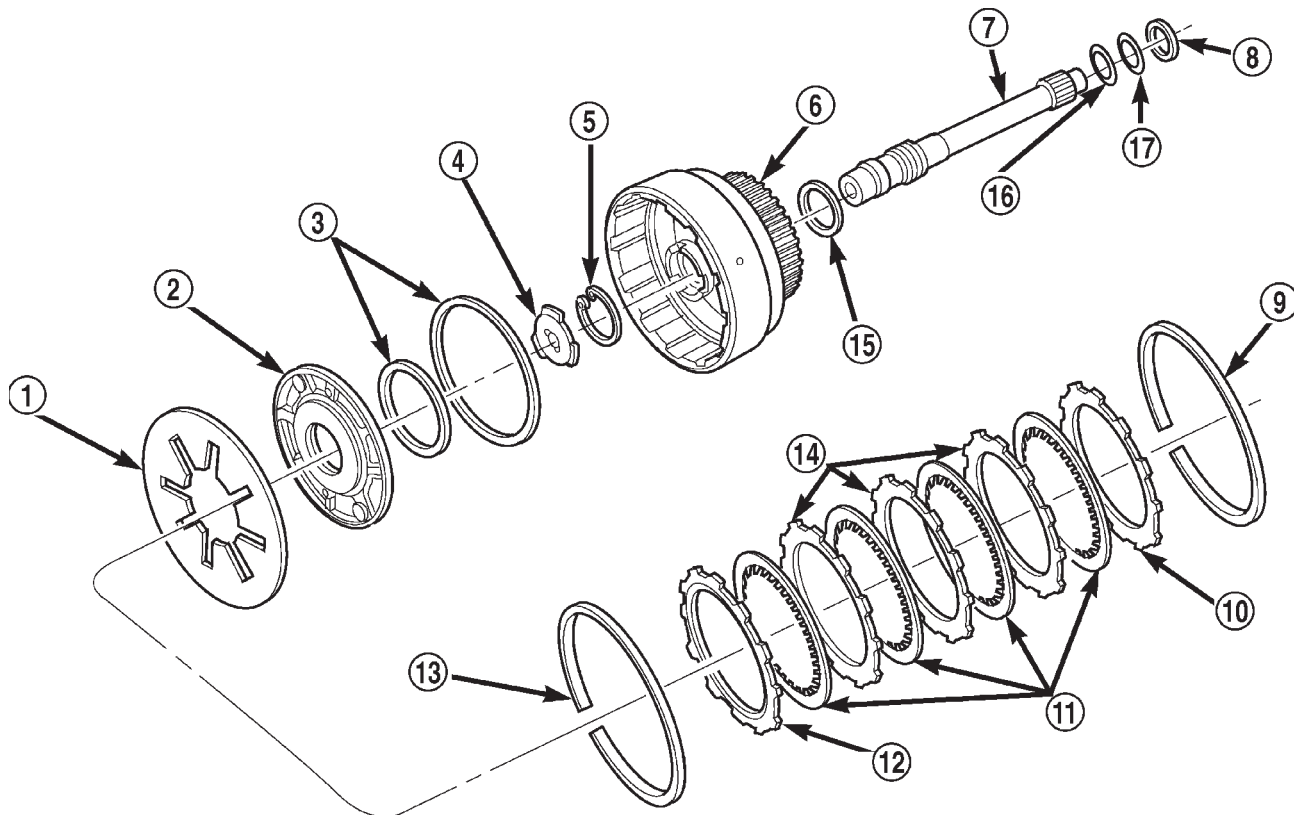
### DESCRIPTION

The rear clutch assembly (Fig. 213) is composed of the rear clutch retainer, pressure plate, clutch plates, driving discs, piston, Belleville spring, and snap-rings. The Belleville spring acts as a lever to multiply the force applied on to it by the apply piston. The increased apply force on the rear clutch pack, in comparison to the front clutch pack, is needed to hold against the greater torque load imposed onto the rear pack. The rear clutch is directly behind the front clutch and is considered a driving component.

**NOTE: The number of discs and plates may vary with each engine and vehicle combination.**

### OPERATION

To apply the clutch, pressure is applied between the clutch retainer and piston. The fluid pressure is provided by the oil pump, transferred through the control valves and passageways, and enters the clutch through the hub of the reaction shaft support. With pressure applied between the clutch retainer and piston, the piston moves away from the clutch retainer and compresses the clutch pack. This action applies the clutch pack, allowing torque to flow through the input shaft into the driving discs, and into the clutch plates and pressure plate that are lugged to the clutch retainer. The waved spring is used to cushion the application of the clutch pack. The snap-ring is selective and used to adjust clutch pack clearance.



80c070a4

**Fig. 213 Rear Clutch**

- |  |                                     |
|--|-------------------------------------|
| 1 - PISTON SPRING                      | 10 - TOP PRESSURE PLATE             |
| 2 - REAR CLUTCH PISTON                 | 11 - CLUTCH DISCS (4)               |
| 3 - CLUTCH PISTON SEALS                | 12 - BOTTOM PRESSURE PLATE          |
| 4 - OUTPUT SHAFT THRUST WASHER (METAL) | 13 - WAVE SPRING                    |
| 5 - INPUT SHAFT SNAP-RING              | 14 - CLUTCH PLATES (3)              |
| 6 - REAR CLUTCH RETAINER               | 15 - RETAINER SEAL RING             |
| 7 - INPUT SHAFT                        | 16 - SHAFT REAR SEAL RING (PLASTIC) |
| 8 - REAR CLUTCH THRUST WASHER (FIBER)  | 17 - SHAFT FRONT SEAL RING (TEFLON) |
| 9 - CLUTCH PACK SNAP-RING (SELECTIVE)  |                                     |



## REAR CLUTCH (Continued)

When pressure is released from the piston, the spring returns the piston to its fully released position and disengages the clutch. The release spring also helps to cushion the application of the clutch assembly. When the clutch is in the process of being released by the release spring, fluid flows through a vent and one-way ball-check-valve located in the piston. The check-valve is needed to eliminate the possibility of plate drag caused by centrifugal force acting on the residual fluid trapped in the clutch piston retainer.

**DISASSEMBLY**

- (1) Remove fiber thrust washer from forward side of clutch retainer.
- (2) Remove input shaft front/rear seal rings.
- (3) Remove selective clutch pack snap-ring (Fig. 214).

(4) Remove top pressure plate, clutch discs, steel plates, bottom pressure plate and wave snap-ring and wave spring (Fig. 214).

(5) Remove clutch piston with rotating motion.

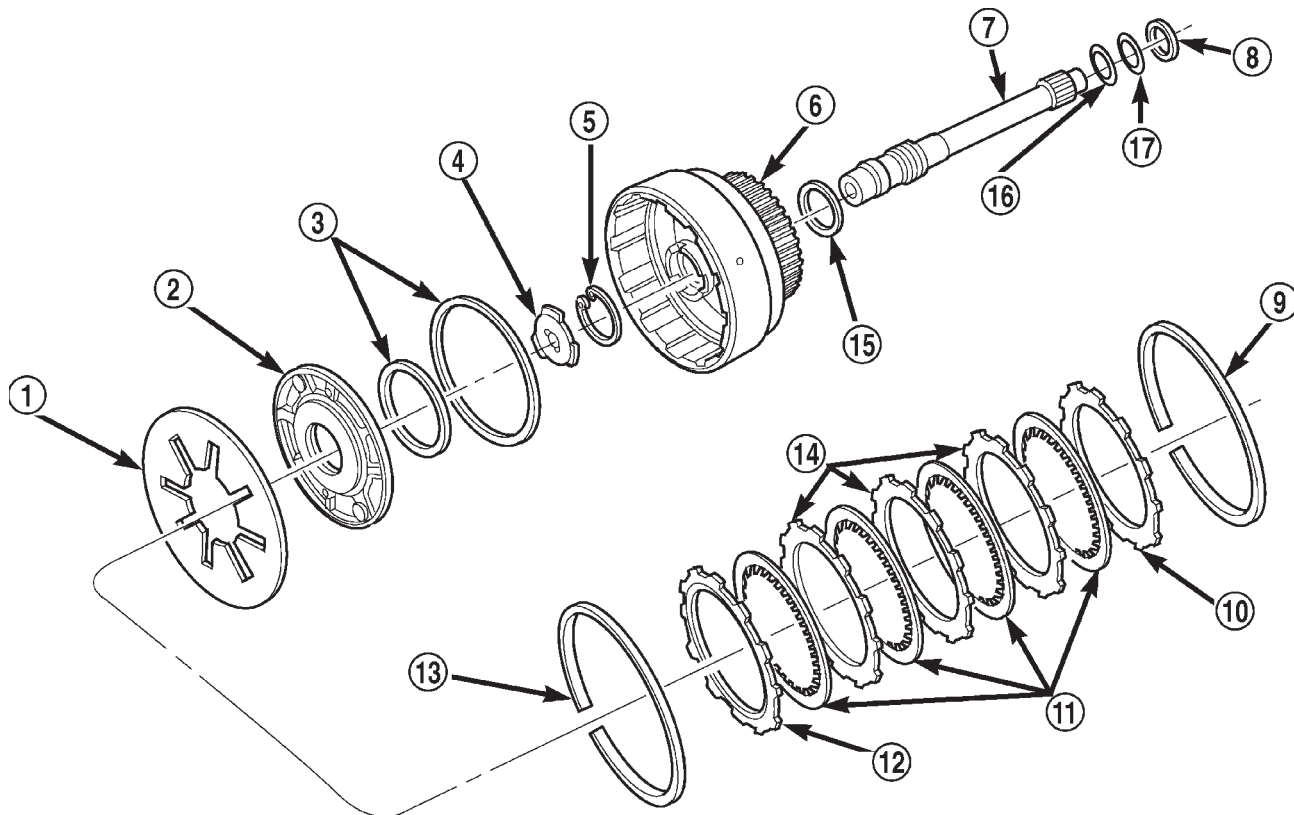
(6) Remove and discard piston seals.

(7) Remove input shaft snap-ring (Fig. 215). It may be necessary to press the input shaft in slightly to relieve tension on the snap-ring

(8) Press input shaft out of retainer with shop press and suitable size press tool. Use a suitably sized press tool to support the retainer as close to the input shaft as possible.

**CLEANING**

Clean the clutch components with solvent and dry them with compressed air. Do not use rags or shop towels to dry any of the clutch parts. Lint from such materials will adhere to component surfaces and could restrict or block fluid passages after assembly.



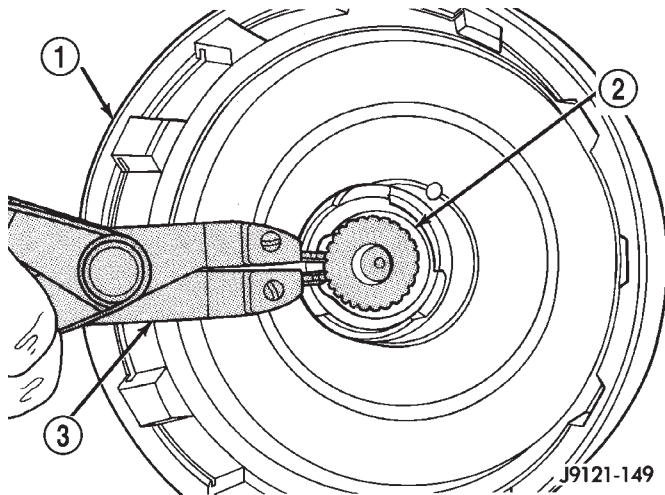
80c070a4

**Fig. 214 Rear Clutch Components**

- |  |                                     |
|--|-------------------------------------|
| 1 - PISTON SPRING                      | 10 - TOP PRESSURE PLATE             |
| 2 - REAR CLUTCH PISTON                 | 11 - CLUTCH DISCS (4)               |
| 3 - CLUTCH PISTON SEALS                | 12 - BOTTOM PRESSURE PLATE          |
| 4 - OUTPUT SHAFT THRUST WASHER (METAL) | 13 - WAVE SPRING                    |
| 5 - INPUT SHAFT SNAP-RING              | 14 - CLUTCH PLATES (3)              |
| 6 - REAR CLUTCH RETAINER               | 15 - RETAINER SEAL RING             |
| 7 - INPUT SHAFT                        | 16 - SHAFT REAR SEAL RING (PLASTIC) |
| 8 - REAR CLUTCH THRUST WASHER (FIBER)  | 17 - SHAFT FRONT SEAL RING (TEFLON) |
| 9 - CLUTCH PACK SNAP-RING (SELECTIVE)  |                                     |



## REAR CLUTCH (Continued)



**Fig. 215 Removing Input Shaft Snap-Ring**

- 1 - REAR CLUTCH RETAINER
- 2 - INPUT SHAFT SNAP-RING
- 3 - SNAP-RING PLIERS

## INSPECTION

Replace the clutch discs if warped, worn, scored, burned/charred, the lugs are damaged, or if the facing is flaking off. Replace the top and bottom pressure plates if scored, warped, or cracked. Be sure the driving lugs on the pressure and clutch plates are also in good condition. The lugs must not be bent, cracked or damaged in any way.

Replace the piston spring and wave spring if either part is distorted, warped or broken.

Check the lug grooves in the clutch retainer. The clutch and pressure plates should slide freely in the slots. Replace the retainer if the grooves are worn or damaged. Also check action of the check balls in the retainer and piston. Each check ball must move freely and not stick.

Replace the retainer bushing if worn, scored, or doubt exists about bushing condition.

Inspect the piston and retainer seal surfaces for nicks or scratches. Minor scratches can be removed with crocus cloth. However, replace the piston and/or retainer if the seal surfaces are seriously scored.

Check condition of the fiber thrust washer and metal output shaft thrust washer. Replace either washer if worn or damaged.

Check condition of the seal rings on the input shaft and clutch retainer hub. Replace the seal rings only if worn, distorted, or damaged. The input shaft front seal ring is teflon with chamfered ends. The rear ring is metal with interlocking ends.

Check the input shaft for wear, or damage. Replace the shaft if worn, scored or damaged in any way.

## ASSEMBLY

(1) Soak clutch discs in transmission fluid while assembling other clutch parts.

(2) Install new seal rings on clutch retainer hub and input shaft, if necessary, (Fig. 216) and (Fig. 217).

(a) Be sure clutch hub seal ring is fully seated in groove and is not twisted.

(3) Lubricate splined end of input shaft and clutch retainer with transmission fluid. Then press input shaft into retainer (Fig. 218). Use a suitably sized press tool to support retainer as close to input shaft as possible.

(4) Install input shaft snap-ring (Fig. 217).

(5) Invert retainer and press input shaft in opposite direction until snap-ring is seated.

(6) Install new seals on clutch piston. Be sure lip of each seal faces interior of clutch retainer.

(7) Lubricate lip of piston seals with generous quantity of Mopar® Door Ease. Then lubricate retainer hub and bore with light coat of transmission fluid.

(8) Install clutch piston in retainer. Use twisting motion to seat piston in bottom of retainer. A thin strip of plastic (about 0.020" thick), can be used to guide seals into place if necessary.

**CAUTION: Never push the clutch piston straight in. This will fold the seals over causing leakage and clutch slip. In addition, never use any type of metal tool to help ease the piston seals into place. Metal tools will cut, shave, or score the seals.**

(9) Install piston spring in retainer and on top of piston (Fig. 219). Concave side of spring faces downward (toward piston).

(10) Install wave spring in retainer (Fig. 219). Be sure spring is completely seated in retainer groove.

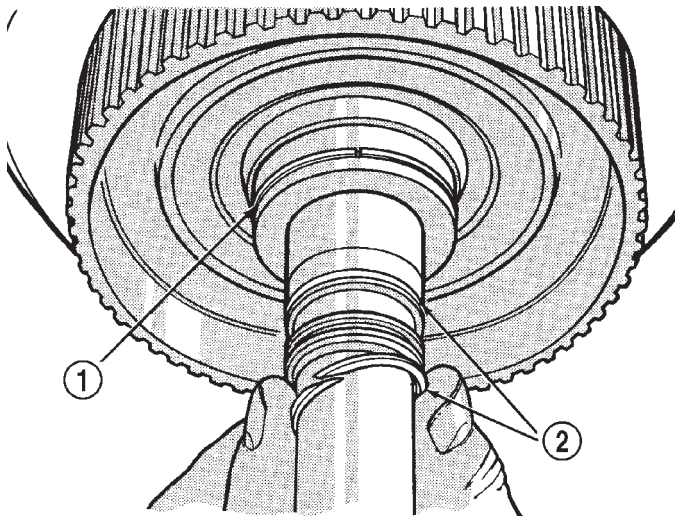
(11) Install bottom pressure plate (Fig. 216). Ridged side of plate faces downward (toward piston) and flat side toward clutch pack.

(12) Install first clutch disc in retainer on top of bottom pressure plate. Then install a clutch plate followed by a clutch disc until entire clutch pack is installed (4 discs and 3 plates are required) (Fig. 216).

(13) Install top pressure plate.

(14) Install selective snap-ring. Be sure snap-ring is fully seated in retainer groove.

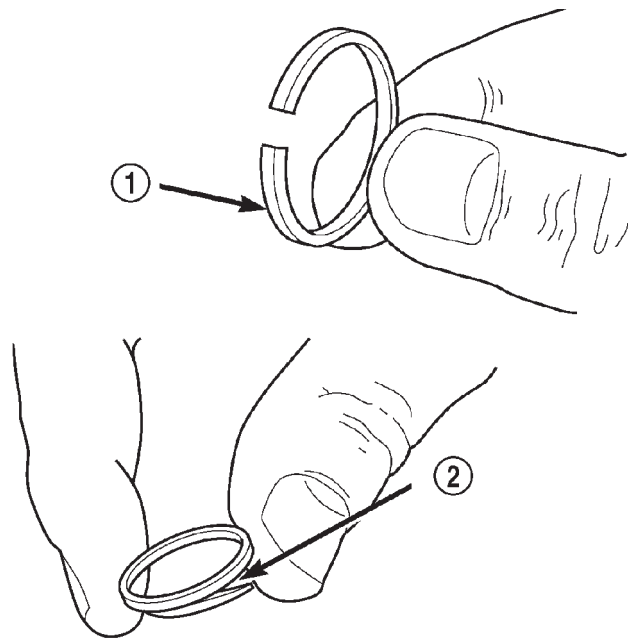
REAR CLUTCH (Continued)



J9121-538

**Fig. 216 Rear Clutch Retainer And Input Shaft Seal Ring Installation**

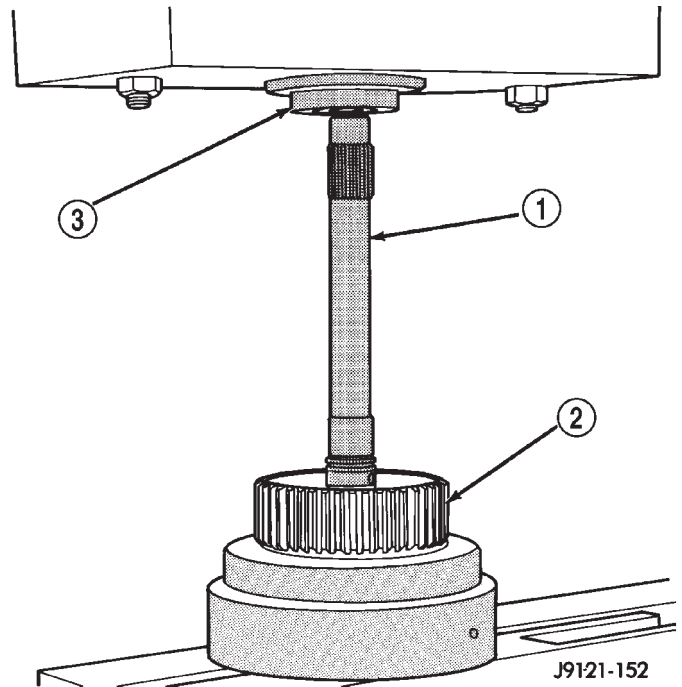
- 1 - REAR CLUTCH RETAINER HUB SEAL RING
- 2 - INPUT SHAFT SEAL RINGS



80c070a5

**Fig. 217 Input Shaft Seal Ring Identification**

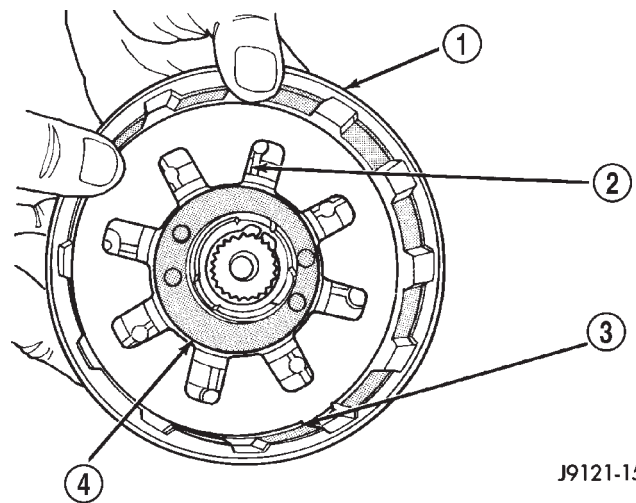
- 1 - PLASTIC REAR SEAL RING
- 2 - TEFLON FRONT SEAL RING (SQUEEZE RING TOGETHER SLIGHTLY BEFORE INSTALLATION FOR BETTER FIT)



J9121-152

**Fig. 218 Pressing Input Shaft Into Rear Clutch Retainer**

- 1 - INPUT SHAFT
- 2 - REAR CLUTCH RETAINER
- 3 - PRESS RAM



J9121-153

**Fig. 219 Piston Spring/Wave Spring Position**

- 1 - REAR CLUTCH RETAINER
- 2 - PISTON SPRING
- 3 - WAVE SPRING
- 4 - CLUTCH PISTON

## REAR CLUTCH (Continued)

(15) Using a suitable gauge bar and dial indicator, measure clutch pack clearance (Fig. 220).

(a) Position gauge bar across the clutch drum with the dial indicator pointer on the pressure plate (Fig. 220).

(b) Using two small screw drivers, lift the pressure plate and release it.

(c) Zero the dial indicator.

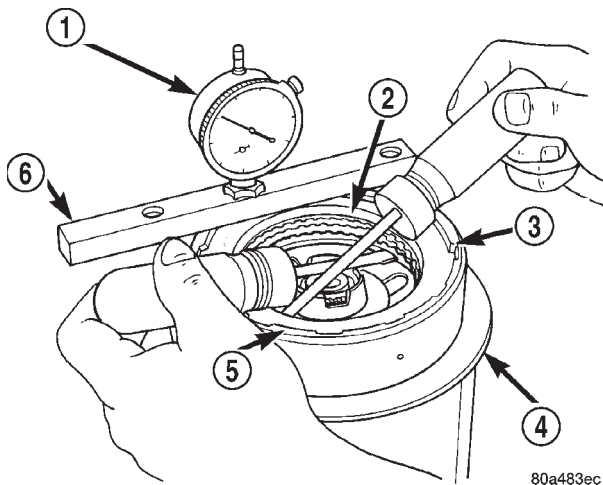
(d) Lift the pressure plate until it contacts the snap-ring and record the dial indicator reading.

Clearance should be 0.559 - 0.914 mm (0.022 - 0.036 in.). If clearance is incorrect, steel plates, discs, selective snap ring and pressure plates may have to be changed.

The selective snap-ring thicknesses are:

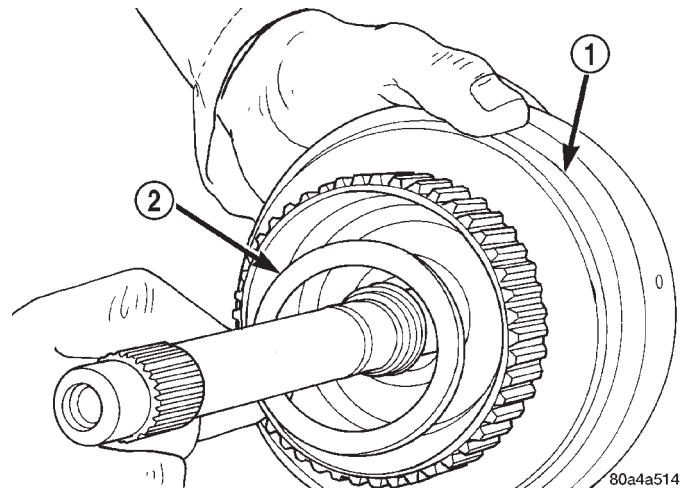
- 0.107-0.109 in.
- 0.098-0.100 in.
- 0.095-0.097 in.
- 0.083-0.085 in.
- 0.076-0.078 in.
- 0.071-0.073 in.
- 0.060-0.062 in.

(16) Coat rear clutch thrust washer with petroleum jelly and install washer over input shaft and into clutch retainer (Fig. 221). Use enough petroleum jelly to hold washer in place.



**Fig. 220 Checking Rear Clutch Pack Clearance**

- 1 - DIAL INDICATOR
- 2 - PRESSURE PLATE
- 3 - SNAP-RING
- 4 - STAND
- 5 - REAR CLUTCH
- 6 - GAUGE BAR



**Fig. 221 Installing Rear Clutch Thrust Washer**

- 1 - REAR CLUTCH RETAINER
- 2 - REAR CLUTCH THRUST WASHER

## REAR SERVO

## DESCRIPTION

The rear (low/reverse) servo consists of a single stage or diameter piston and a spring loaded plug. The spring is used to cushion the application of the rear (low/reverse) band.

## OPERATION

While in the de-energized state (no pressure applied), the piston is held up in its bore by the piston spring. The plug is held down in its bore, in the piston, by the plug spring. When pressure is applied to the top of the piston, the plug is forced down in its bore, taking up any clearance. As the piston moves, it causes the plug spring to compress, and the piston moves down until it hits the shoulder of the plug and fully applies the band. The period of time from the initial application, until the piston is against the shoulder of the plug, represents a reduced shocking of the band that cushions the shift.

## DISASSEMBLY

- (1) Remove small snap-ring and remove plug and spring from servo piston (Fig. 222).
- (2) Remove and discard servo piston seal ring.

## REAR SERVO (Continued)

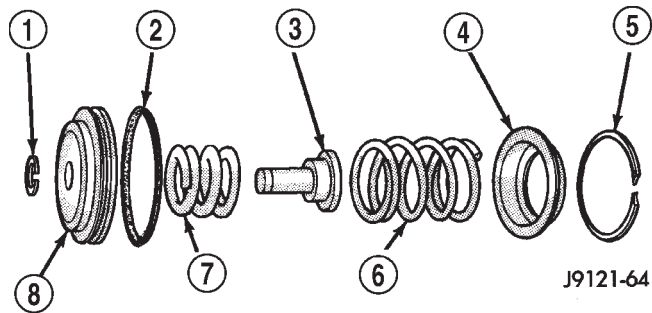


Fig. 222 Rear Servo Components

- 1 - SNAP-RING
- 2 - PISTON SEAL
- 3 - PISTON PLUG
- 4 - SPRING RETAINER
- 5 - SNAP-RING
- 6 - PISTON SPRING
- 7 - CUSHION SPRING
- 8 - PISTON

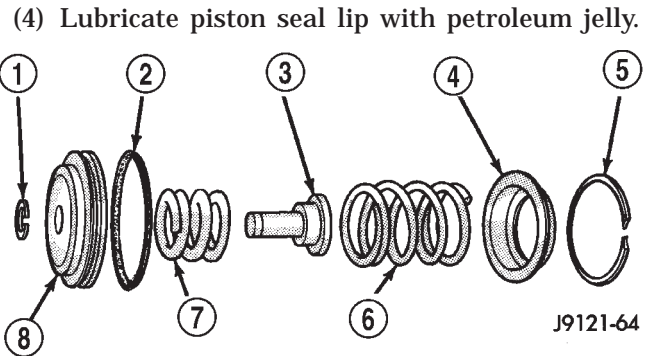


Fig. 224 Rear Servo Components

- 1 - SNAP-RING
- 2 - PISTON SEAL
- 3 - PISTON PLUG
- 4 - SPRING RETAINER
- 5 - SNAP-RING
- 6 - PISTON SPRING
- 7 - CUSHION SPRING
- 8 - PISTON

## CLEANING

Remove and discard the servo piston seal ring (Fig. 223). Then clean the servo components with solvent and dry with compressed air. Replace either spring if collapsed, distorted or broken. Replace the plug and piston if cracked, bent, or worn. Discard the servo snap-rings and use new ones at assembly.

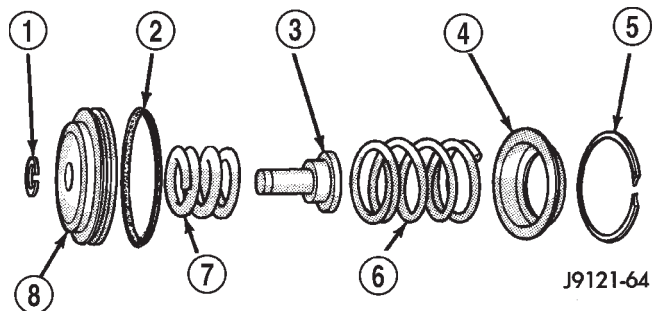


Fig. 223 Rear Servo Components

- 1 - SNAP-RING
- 2 - PISTON SEAL
- 3 - PISTON PLUG
- 4 - SPRING RETAINER
- 5 - SNAP-RING
- 6 - PISTON SPRING
- 7 - CUSHION SPRING
- 8 - PISTON

## ASSEMBLY

(1) Lubricate piston and guide seals (Fig. 224) with petroleum jelly. Lubricate other servo parts with Mopar® ATF +4, type 9602, transmission fluid.

(2) Install new seal ring on servo piston.

(3) Assemble piston, plug, spring and new snap-ring.

## SHIFT MECHANISM

## DESCRIPTION

The gear shift mechanism provides six shift positions which are:

- PARK (P)
- REVERSE (R)
- NEUTRAL (N)
- DRIVE (D)
- Manual SECOND (2)
- Manual LOW (1)

## OPERATION

Manual LOW (1) range provides first gear only. Overrun braking is also provided in this range. Manual SECOND (2) range provides first and second gear only.

DRIVE range provides first, second third and overdrive fourth gear ranges. The shift into overdrive fourth gear range occurs only after the transmission has completed the shift into D third gear range. No further movement of the shift mechanism is required to complete the 3-4 shift.

The fourth gear upshift occurs automatically when the overdrive selector switch is in the ON position. No upshift to fourth gear will occur if any of the following are true:

- The transmission fluid temperature is below 10° C (50° F) or above 121° C (250° F).
- The shift to third is not yet complete.
- Vehicle speed is too low for the 3-4 shift to occur.
- Battery temperature is below -5° C (23° F).



## SHIFT MECHANISM (Continued)

## ADJUSTMENT

Check linkage adjustment by starting engine in PARK and NEUTRAL. Adjustment is acceptable if the engine starts in only these two positions. Adjustment is incorrect if the engine starts in one position but not both positions.

If the engine starts in any other position, or if the engine will not start in any position, the park/neutral switch is probably faulty.

## LINKAGE ADJUSTMENT

Check condition of the shift linkage (Fig. 225). Do not attempt adjustment if any component is loose, worn, or bent. Replace any suspect components.

Replace the grommet securing the shift rod or torque rod in place if either rod was removed from the grommet. Remove the old grommet as necessary and use suitable pliers to install the new grommet.

- (1) Shift transmission into PARK.
- (2) Raise and support vehicle.
- (3) Loosen lock bolt in front shift rod adjusting swivel (Fig. 225).
- (4) Ensure that the shift rod slides freely in the swivel. Lube rod and swivel as necessary.
- (5) Move transmission shift lever fully rearward to the Park detent.
- (6) Center adjusting swivel on shift rod.
- (7) Tighten swivel lock bolt to 10 N·m (90 in. lbs.).
- (8) Lower vehicle and verify proper adjustment.

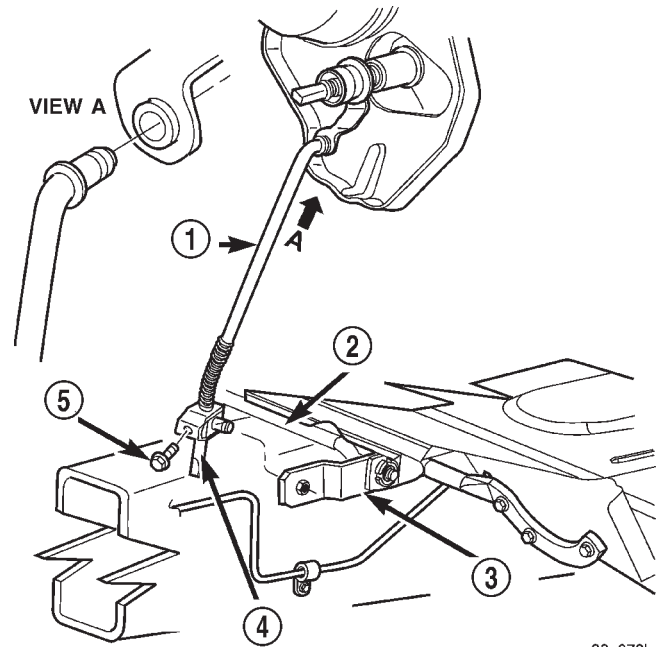
## SOLENOID

## DESCRIPTION

The typical electrical solenoid used in automotive applications is a linear actuator. It is a device that produces motion in a straight line. This straight line motion can be either forward or backward in direction, and short or long distance.

A solenoid is an electromechanical device that uses a magnetic force to perform work. It consists of a coil of wire, wrapped around a magnetic core made from steel or iron, and a spring loaded, movable plunger, which performs the work, or straight line motion.

The solenoids used in transmission applications are attached to valves which can be classified as **normally open** or **normally closed**. The **normally open** solenoid valve is defined as a valve which allows hydraulic flow when no current or voltage is applied to the solenoid. The **normally closed** solenoid valve is defined as a valve which does not allow hydraulic flow when no current or voltage is applied to the solenoid. These valves perform hydraulic control functions for the transmission and must therefore be durable and tolerant of dirt particles. For these reasons, the valves have hardened steel pop-



80c072ba

**Fig. 225 Linkage Adjustment Components**

- 1 - FRONT SHIFT ROD
- 2 - TORQUE SHAFT ASSEMBLY
- 3 - TORQUE SHAFT ARM
- 4 - ADJUSTING SWIVEL
- 5 - LOCK BOLT

pets and ball valves. The solenoids operate the valves directly, which means that the solenoids must have very high outputs to close the valves against the sizable flow areas and line pressures found in current transmissions. Fast response time is also necessary to ensure accurate control of the transmission.

The strength of the magnetic field is the primary force that determines the speed of operation in a particular solenoid design. A stronger magnetic field will cause the plunger to move at a greater speed than a weaker one. There are basically two ways to increase the force of the magnetic field:

- Increase the amount of current applied to the coil or
- Increase the number of turns of wire in the coil.

The most common practice is to increase the number of turns by using thin wire that can completely fill the available space within the solenoid housing. The strength of the spring and the length of the plunger also contribute to the response speed possible by a particular solenoid design.

A solenoid can also be described by the method by which it is controlled. Some of the possibilities include variable force, pulse-width modulated, constant ON, or duty cycle. The variable force and pulse-width modulated versions utilize similar methods to control the current flow through the solenoid to position the solenoid plunger at a desired position some-



## SOLENOID (Continued)

where between full ON and full OFF. The constant ON and duty cycled versions control the voltage across the solenoid to allow either full flow or no flow through the solenoid's valve.

## OPERATION

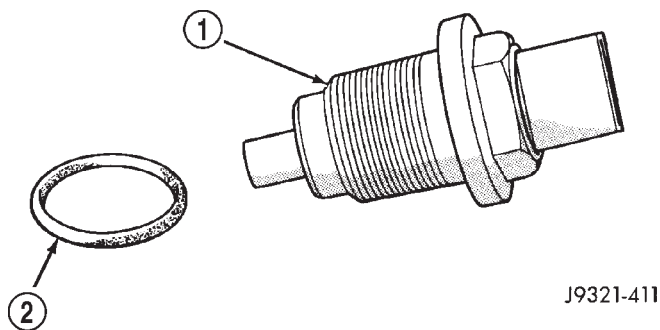
When an electrical current is applied to the solenoid coil, a magnetic field is created which produces an attraction to the plunger, causing the plunger to move and work against the spring pressure and the load applied by the fluid the valve is controlling. The plunger is normally directly attached to the valve which it is to operate. When the current is removed from the coil, the attraction is removed and the plunger will return to its original position due to spring pressure.

The plunger is made of a conductive material and accomplishes this movement by providing a path for the magnetic field to flow. By keeping the air gap between the plunger and the coil to the minimum necessary to allow free movement of the plunger, the magnetic field is maximized.

## SPEED SENSOR

## DESCRIPTION

The speed sensor (Fig. 226) is located in the over-drive gear case. The sensor is positioned over the park gear and monitors transmission output shaft rotating speed.



J9321-411

**Fig. 226 Transmission Output Speed Sensor**

- 1 - TRANSMISSION OUTPUT SHAFT SPEED SENSOR
- 2 - SEAL

## OPERATION

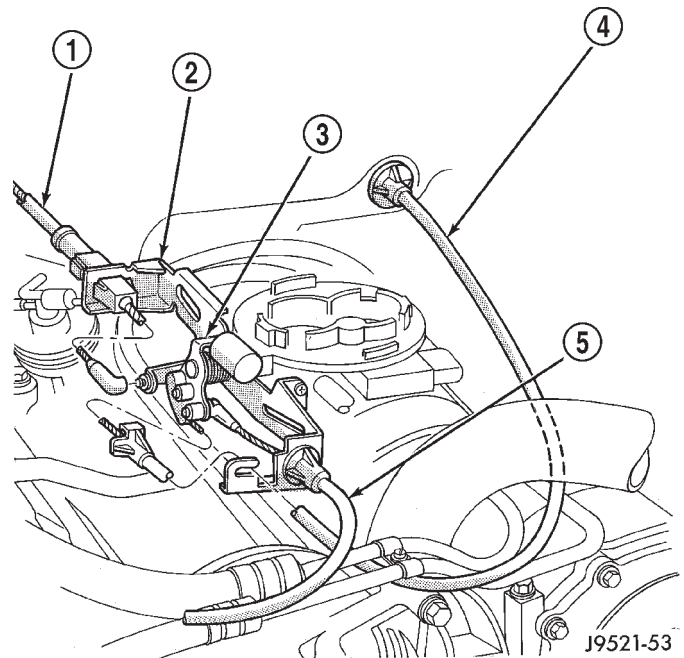
Speed sensor signals are triggered by the park gear lugs as they rotate past the sensor pickup face. Input signals from the sensor are sent to the transmission control module for processing. Signals from this sensor are shared with the powertrain control module.

## THROTTLE VALVE CABLE

## DESCRIPTION

Transmission throttle valve cable (Fig. 227) adjustment is extremely important to proper operation. This adjustment positions the throttle valve, which controls shift speed, quality, and part-throttle down-shift sensitivity.

If cable setting is too loose, early shifts and slippage between shifts may occur. If the setting is too tight, shifts may be delayed and part throttle down-shifts may be very sensitive.



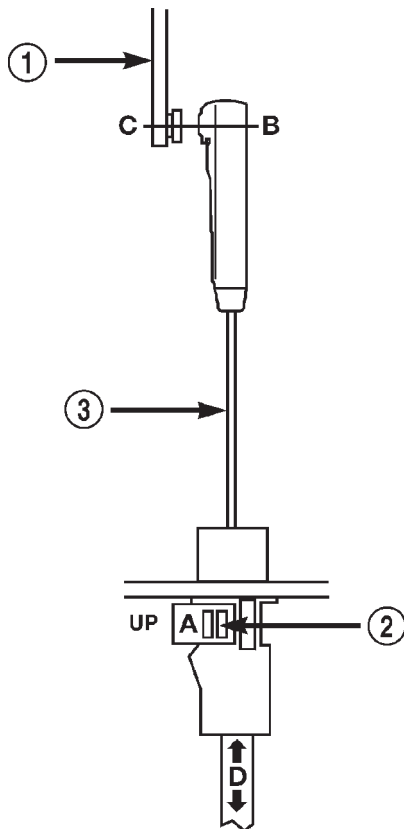
J9521-53

**Fig. 227 Throttle Valve Cable Attachment - At Engine**

- 1 - THROTTLE VALVE CABLE
- 2 - CABLE BRACKET
- 3 - THROTTLE BODY LEVER
- 4 - ACCELERATOR CABLE
- 5 - SPEED CONTROL CABLE

The transmission throttle valve is operated by a cam on the throttle lever. The throttle lever is operated by an adjustable cable (Fig. 228). The cable is attached to an arm mounted on the throttle lever shaft. A retaining clip at the engine-end of the cable is removed to provide for cable adjustment. The retaining clip is then installed back onto the throttle valve cable to lock in the adjustment.

## THROTTLE VALVE CABLE (Continued)



80bce9fb

**Fig. 228 Throttle Valve Cable at Throttle Linkage**

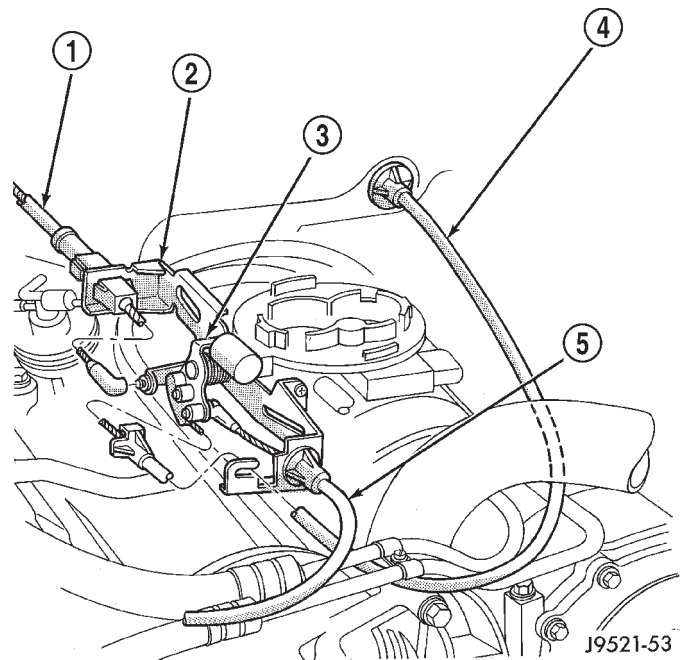
- 1 - THROTTLE LINKAGE
- 2 - THROTTLE VALVE CABLE LOCKING CLIP
- 3 - THROTTLE VALVE CABLE

## ADJUSTMENTS - TRANSMISSION THROTTLE VALVE CABLE

A correctly adjusted throttle valve cable will cause the throttle lever on the transmission to move simultaneously with the throttle body lever from the idle position. Proper adjustment will allow simultaneous movement without causing the transmission throttle lever to either move ahead of, or lag behind the lever on the throttle body.

### ADJUSTMENT VERIFICATION

- (1) Turn ignition key to OFF position.
- (2) Remove air cleaner.
- (3) Verify that lever on throttle body is at curb idle position (Fig. 229). Then verify that the transmission throttle lever (Fig. 230) is also at idle (fully forward) position.
- (4) Slide cable off attachment stud on throttle body lever.
- (5) Compare position of cable end to attachment stud on throttle body lever:



J9521-53

**Fig. 229 Throttle Valve Cable Attachment - At Engine**

- 1 - THROTTLE VALVE CABLE
- 2 - CABLE BRACKET
- 3 - THROTTLE BODY LEVER
- 4 - ACCELERATOR CABLE
- 5 - SPEED CONTROL CABLE

- Cable end and attachment stud should be aligned (or centered on one another) to within 1 mm (0.039 in.) in either direction (Fig. 231).

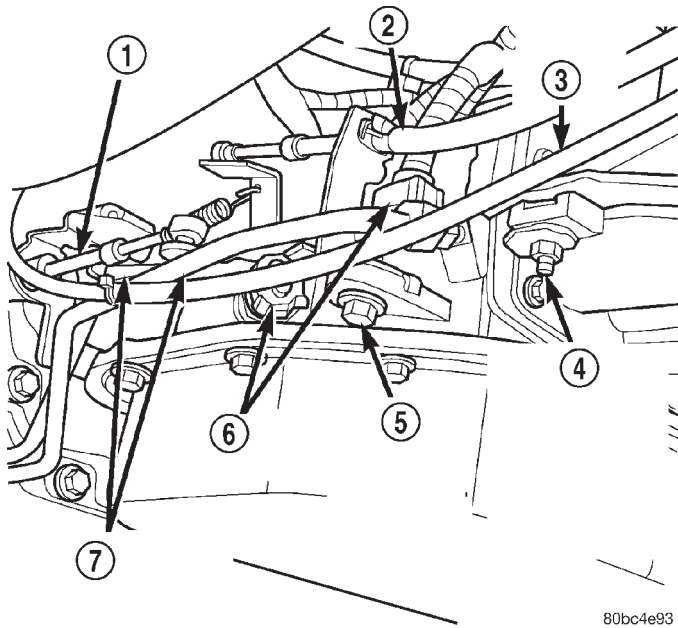
- If cable end and attachment stud are misaligned (off center), cable will have to be adjusted as described in Throttle Valve Cable Adjustment procedure.

(6) Reconnect cable end to attachment stud. Then with aid of a helper, observe movement of transmission throttle lever and lever on throttle body.

- If both levers move simultaneously from idle to half-throttle and back to idle position, adjustment is correct.

- If transmission throttle lever moves ahead of, or lags behind throttle body lever, cable adjustment will be necessary. Or, if throttle body lever prevents transmission lever from returning to closed position, cable adjustment will be necessary.

## THROTTLE VALVE CABLE (Continued)



80bc4e93

**Fig. 230 Throttle Valve Cable at Transmission**

- 1 - TRANSMISSION SHIFTER CABLE
- 2 - THROTTLE VALVE CABLE
- 3 - TRANSFER CASE SHIFTER CABLE
- 4 - TRANSFER CASE SHIFTER CABLE BRACKET RETAINING BOLT (1 OR 2)
- 5 - THROTTLE VALVE CABLE BRACKET RETAINING BOLT
- 6 - ELECTRICAL CONNECTORS
- 7 - TRANSMISSION FLUID LINES

### ADJUSTMENT PROCEDURE

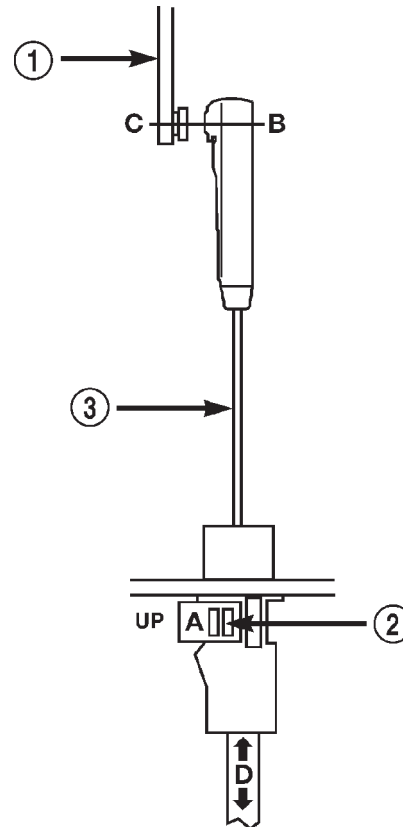
- (1) Turn ignition switch to OFF position.
- (2) Remove air cleaner if necessary.
- (3) Disconnect cable end from attachment stud.

**Carefully slide cable off stud. Do not pry or pull cable off.**

(4) Verify that transmission throttle lever is in fully closed position. Then be sure lever on throttle body is at curb idle position.

(5) Pry the T.V. cable lock (A) into the UP position (Fig. 231). This will unlock the cable and allow for readjustment.

(6) Apply just enough tension on the T.V. cable (B) to remove any slack in the cable. **Pulling too tight will cause the T.V. lever on the transmission to move out of its idle position, which will result in an incorrect T.V. cable adjustment.** Slide the sheath of the T.V. cable (D) back and forth until the centerlines of the T.V. cable end (B) and the throttle bell crank lever (C) are aligned within one millimeter (1mm) (Fig. 231).



80bce9fb

**Fig. 231 Throttle Valve Cable at Throttle Linkage**

- 1 - THROTTLE LINKAGE
- 2 - THROTTLE VALVE CABLE LOCKING CLIP
- 3 - THROTTLE VALVE CABLE

(7) While holding the T.V. cable in the set position push the T.V. cable lock (A) into the down position (Fig. 231). This will lock the present T.V. cable adjustment.

**NOTE:** Be sure that as the cable is pulled forward and centered on the throttle lever stud, the cable housing moves smoothly with the cable. Due to the angle at which the cable housing enters the spring housing, the cable housing may bind slightly and create an incorrect adjustment.

(8) Reconnect the T.V. cable (B) to the throttle bellcrank lever (C).

(9) Check cable adjustment. Verify transmission throttle lever and lever on throttle body move simultaneously.

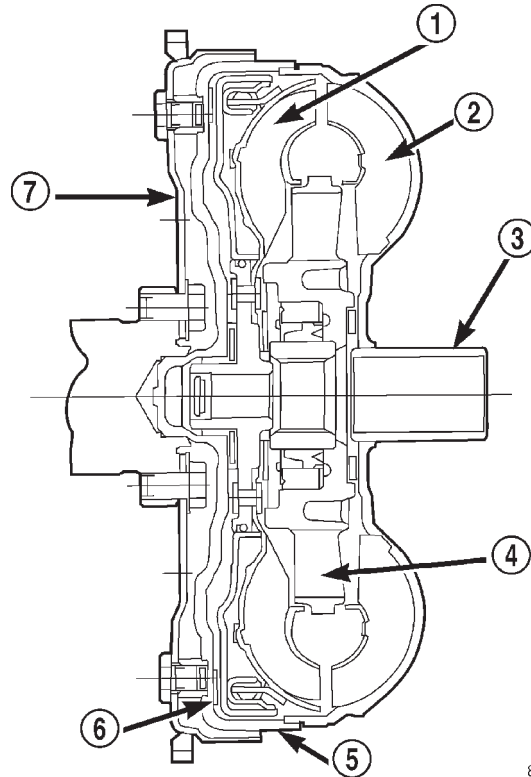
## TORQUE CONVERTER

### DESCRIPTION

The torque converter (Fig. 232) is a hydraulic device that couples the engine crankshaft to the transmission. The torque converter consists of an outer shell with an internal turbine, a stator, an overrunning clutch, an impeller and an electronically applied converter clutch. The converter clutch provides reduced engine speed and greater fuel economy when engaged. Clutch engagement also provides reduced transmission fluid temperatures. The torque converter hub drives the transmission oil (fluid) pump.

The torque converter is a sealed, welded unit that is not repairable and is serviced as an assembly.

**CAUTION:** The torque converter must be replaced if a transmission failure resulted in large amounts of metal or fiber contamination in the fluid. If the fluid is contaminated, flush the all transmission fluid cooler(s) and lines.

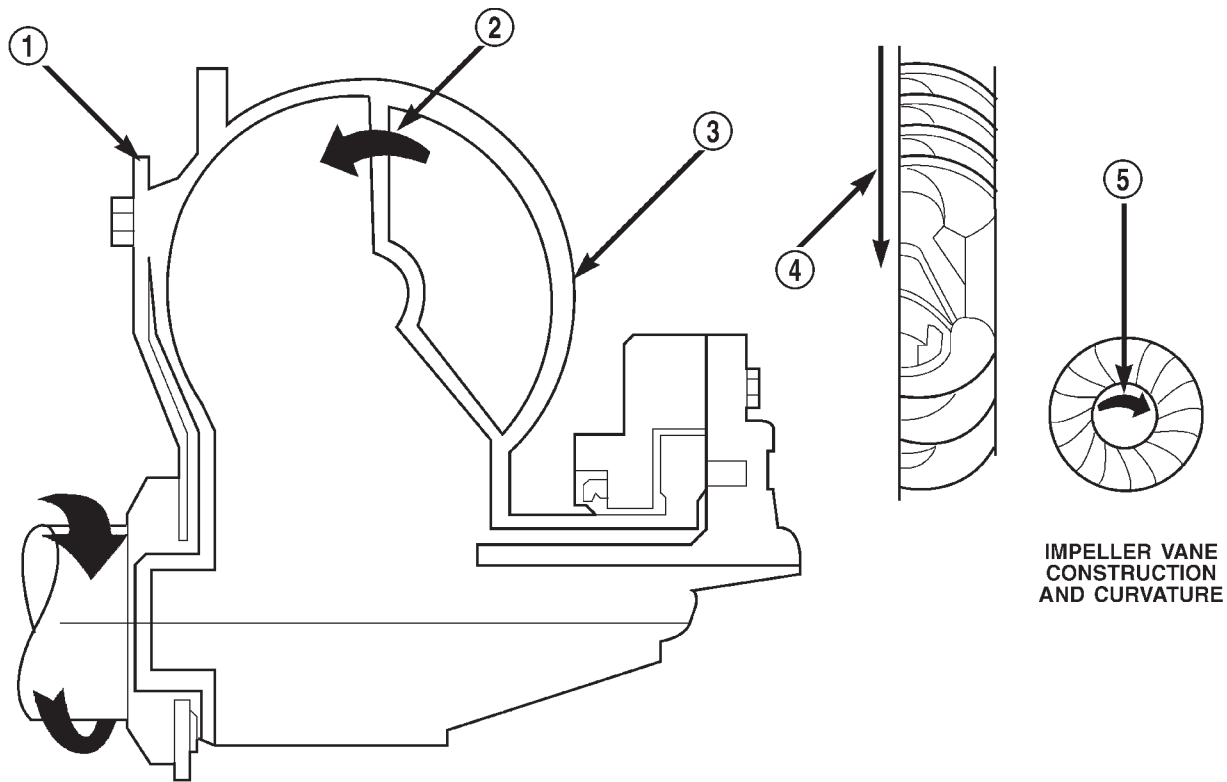


80c07135

**Fig. 232 Torque Converter Assembly**

- 1 - TURBINE
- 2 - IMPELLER
- 3 - HUB
- 4 - STATOR
- 5 - FRONT COVER
- 6 - CONVERTER CLUTCH DISC
- 7 - DRIVE PLATE

TORQUE CONVERTER (Continued)



**Fig. 233 Impeller**

80bfe26a

- 1 - ENGINE FLEXPATE
- 2 - OIL FLOW FROM IMPELLER SECTION INTO TURBINE SECTION
- 3 - IMPELLER VANES AND COVER ARE INTEGRAL

- 4 - ENGINE ROTATION
- 5 - ENGINE ROTATION

**IMPELLER**

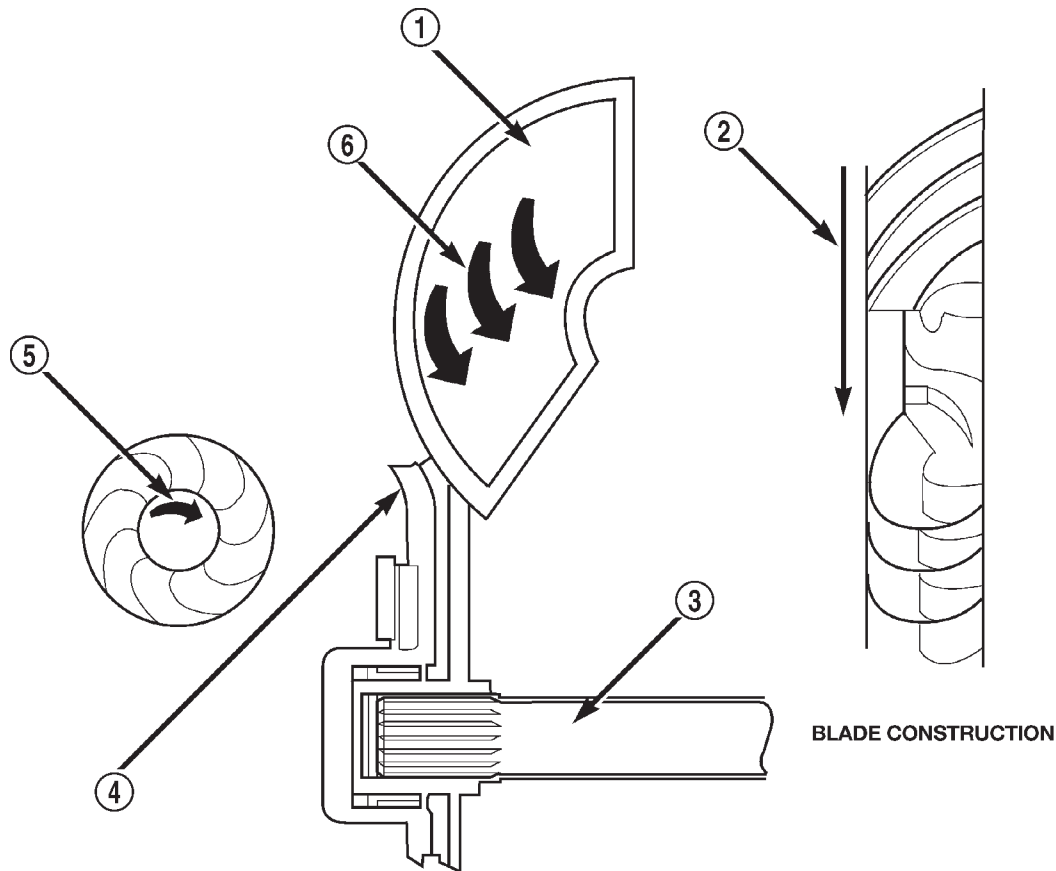
The impeller (Fig. 233) is an integral part of the converter housing. The impeller consists of curved blades placed radially along the inside of the housing on the transmission side of the converter. As the converter housing is rotated by the engine, so is the impeller, because they are one and the same and are the driving members of the system.

**TURBINE**

The turbine (Fig. 234) is the output, or driven, member of the converter. The turbine is mounted within the housing opposite the impeller, but is not attached to the housing. The input shaft is inserted through the center of the impeller and splined into the turbine. The design of the turbine is similar to the impeller, except the blades of the turbine are curved in the opposite direction.



TORQUE CONVERTER (Continued)



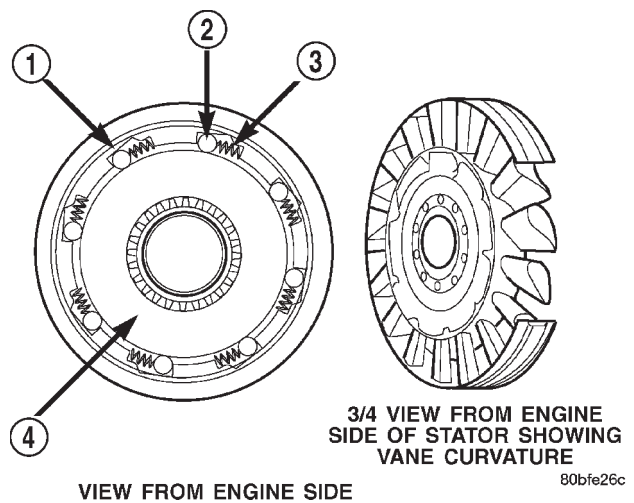
**Fig. 234 Turbine**

80bfe26b

- 1 - TURBINE VANE
- 2 - ENGINE ROTATION
- 3 - INPUT SHAFT
- 4 - PORTION OF TORQUE CONVERTER COVER
- 5 - ENGINE ROTATION
- 6 - OIL FLOW WITHIN TURBINE SECTION

**STATOR**

The stator assembly (Fig. 235) is mounted on a stationary shaft which is an integral part of the oil pump. The stator is located between the impeller and turbine within the torque converter case (Fig. 236). The stator contains an over-running clutch, which allows the stator to rotate only in a clockwise direction. When the stator is locked against the over-running clutch, the torque multiplication feature of the torque converter is operational.

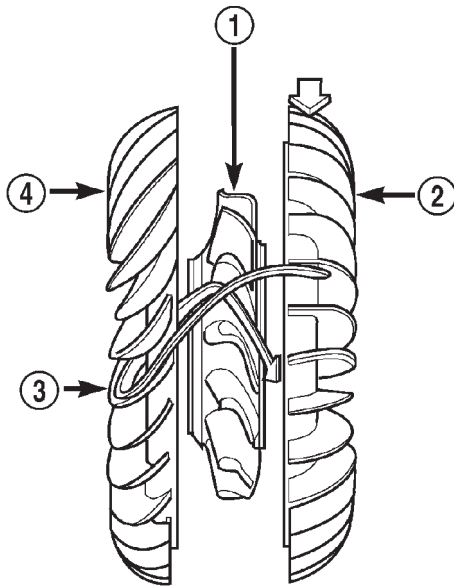


**Fig. 235 Stator Components**

- 1 - CAM (OUTER RACE)
- 2 - ROLLER
- 3 - SPRING
- 4 - INNER RACE

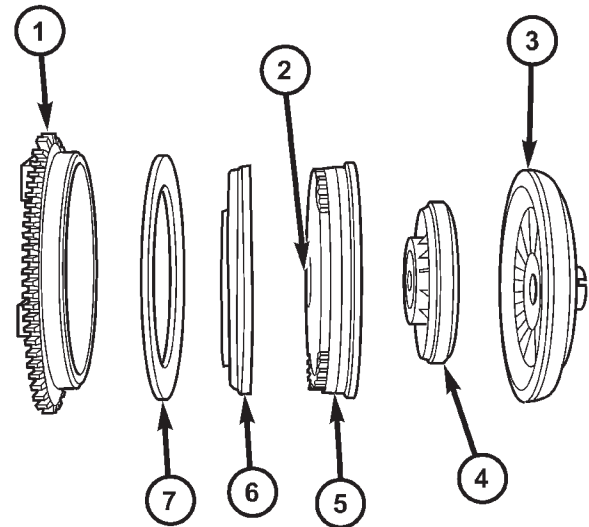
80bfe26c

## TORQUE CONVERTER (Continued)

**Fig. 236 Stator Location**

- 1 - STATOR
- 2 - IMPELLER
- 3 - FLUID FLOW
- 4 - TURBINE

80bfe26d



80870b2f

**Fig. 237 Torque Converter Clutch (TCC)**

- 1 - IMPELLER FRONT COVER
- 2 - THRUST WASHER ASSEMBLY
- 3 - IMPELLER
- 4 - STATOR
- 5 - TURBINE
- 6 - PISTON
- 7 - FRICTION DISC

**TORQUE CONVERTER CLUTCH (TCC)**

The TCC (Fig. 237) was installed to improve the efficiency of the torque converter that is lost to the slippage of the fluid coupling. Although the fluid coupling provides smooth, shock-free power transfer, it is natural for all fluid couplings to slip. If the impeller and turbine were mechanically locked together, a zero slippage condition could be obtained. A hydraulic piston was added to the turbine, and a friction material was added to the inside of the front cover to provide this mechanical lock-up.

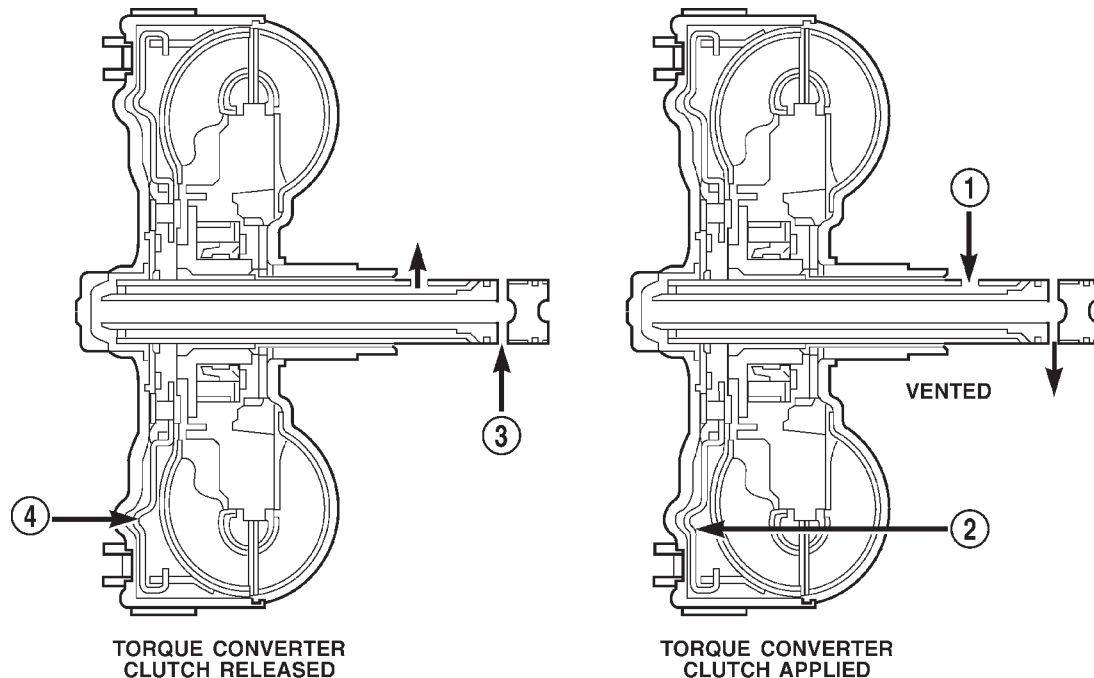
**OPERATION**

The converter impeller (Fig. 238) (driving member), which is integral to the converter housing and bolted to the engine drive plate, rotates at engine speed. The converter turbine (driven member), which reacts from fluid pressure generated by the impeller, rotates and turns the transmission input shaft.

**TURBINE**

As the fluid that was put into motion by the impeller blades strikes the blades of the turbine, some of the energy and rotational force is transferred into the turbine and the input shaft. This causes both of them (turbine and input shaft) to rotate in a clockwise direction following the impeller. As the fluid is leaving the trailing edges of the turbine's blades it continues in a "hindering" direction back toward the impeller. If the fluid is not redirected before it strikes the impeller, it will strike the impeller in such a direction that it would tend to slow it down.

## TORQUE CONVERTER (Continued)

**Fig. 238 Torque Converter Fluid Operation**

80bfe276

1 - APPLY PRESSURE

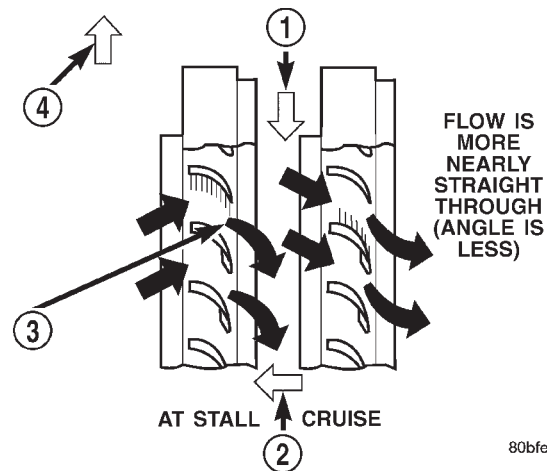
3 - RELEASE PRESSURE

2 - THE PISTON MOVES SLIGHTLY FORWARD

4 - THE PISTON MOVES SLIGHTLY REARWARD

**STATOR**

Torque multiplication is achieved by locking the stator's over-running clutch to its shaft (Fig. 239). Under stall conditions (the turbine is stationary), the oil leaving the turbine blades strikes the face of the stator blades and tries to rotate them in a counter-clockwise direction. When this happens the overrunning clutch of the stator locks and holds the stator from rotating. With the stator locked, the oil strikes the stator blades and is redirected into a "helping" direction before it enters the impeller. This circulation of oil from impeller to turbine, turbine to stator, and stator to impeller, can produce a maximum torque multiplication of about 2.4:1. As the turbine begins to match the speed of the impeller, the fluid that was hitting the stator in such a way as to cause it to lock-up is no longer doing so. In this condition of operation, the stator begins to free wheel and the converter acts as a fluid coupling.



80bfe26e

**Fig. 239 Stator Operation**

1 - DIRECTION STATOR WILL FREE WHEEL DUE TO OIL PUSHING ON BACKSIDE OF VANES

2 - FRONT OF ENGINE

3 - INCREASED ANGLE AS OIL STRIKES VANES

4 - DIRECTION STATOR IS LOCKED UP DUE TO OIL PUSHING AGAINST STATOR VANES

## TORQUE CONVERTER (Continued)

## TORQUE CONVERTER CLUTCH (TCC)

The torque converter clutch is hydraulically applied and is released when fluid is vented from the hydraulic circuit by the torque converter control (TCC) solenoid on the valve body. The torque converter clutch is controlled by the Powertrain Control Module (PCM). The torque converter clutch engages in fourth gear, and in third gear under various conditions, such as when the O/D switch is OFF, when the vehicle is cruising on a level surface after the vehicle has warmed up. The torque converter clutch will disengage momentarily when an increase in engine load is sensed by the PCM, such as when the vehicle begins to go uphill or the throttle pressure is increased.

## REMOVAL

- (1) Remove transmission and torque converter from vehicle.
- (2) Place a suitable drain pan under the converter housing end of the transmission.

**CAUTION:** Verify that transmission is secure on the lifting device or work surface, the center of gravity of the transmission will shift when the torque converter is removed creating an unstable condition. The torque converter is a heavy unit. Use caution when separating the torque converter from the transmission.

- (3) Pull the torque converter forward until the center hub clears the oil pump seal.

- (4) Separate the torque converter from the transmission.

## INSTALLATION

Check converter hub and drive notches for sharp edges, burrs, scratches, or nicks. Polish the hub and notches with 320/400 grit paper or crocus cloth if necessary. The hub must be smooth to avoid damaging the pump seal at installation.

- (1) Lubricate oil pump seal lip with transmission fluid.
- (2) Place torque converter in position on transmission.

**CAUTION:** Do not damage oil pump seal or bushing while inserting torque converter into the front of the transmission.

- (3) Align torque converter to oil pump seal opening.
- (4) Insert torque converter hub into oil pump.
- (5) While pushing torque converter inward, rotate converter until converter is fully seated in the oil pump gears.

- (6) Check converter seating with a scale and straightedge (Fig. 240). Surface of converter lugs should be 1/2 in. to rear of straightedge when converter is fully seated.

- (7) If necessary, temporarily secure converter with C-clamp attached to the converter housing.

- (8) Install the transmission in the vehicle.

- (9) Fill the transmission with the recommended fluid.

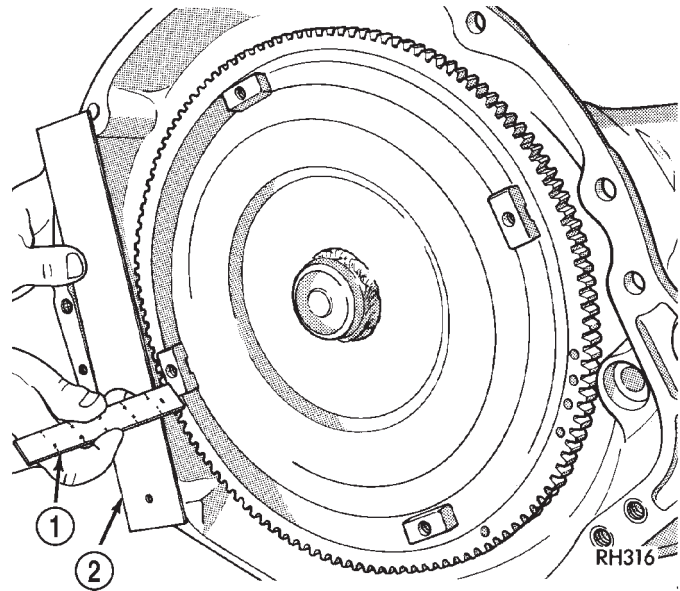


Fig. 240 Checking Torque Converter Seating - Typical

- 1 - SCALE
- 2 - STRAIGHTEDGE

## TORQUE CONVERTER DRAINBACK VALVE

## DESCRIPTION

The drainback valve is located in the transmission cooler outlet (pressure) line.

## OPERATION

The valve prevents fluid from draining from the converter into the cooler and lines when the vehicle is shut down for lengthy periods. Production valves have a hose nipple at one end, while the opposite end is threaded for a flare fitting. All valves have an arrow (or similar mark) to indicate direction of flow through the valve.

## STANDARD PROCEDURE - TORQUE CONVERTER DRAINBACK VALVE

The converter drainback check valve is located in the cooler outlet (pressure) line near the radiator tank. The valve prevents fluid drainback when the

## TORQUE CONVERTER DRAINBACK VALVE (Continued)

vehicle is parked for lengthy periods. The valve check ball is spring loaded and has an opening pressure of approximately 2 psi.

The valve is serviced as an assembly; it is not repairable. Do not clean the valve if restricted, or contaminated by sludge, or debris. If the valve fails, or if a transmission malfunction occurs that generates significant amounts of sludge and/or clutch particles and metal shavings, the valve must be replaced.

The valve must be removed whenever the cooler and lines are reverse flushed. The valve can be flow tested when necessary. The procedure is exactly the same as for flow testing a cooler.

If the valve is restricted, installed backwards, or in the wrong line, it will cause an overheating condition and possible transmission failure.

**CAUTION:** The drainback valve is a one-way flow device. It must be properly oriented in terms of flow direction for the cooler to function properly. The valve must be installed in the pressure line. Otherwise flow will be blocked and would cause an overheating condition and eventual transmission failure.

## TRANSMISSION TEMPERATURE SENSOR

### DESCRIPTION

Transmission fluid temperature readings are supplied to the transmission control module by the thermistor (Fig. 241). The temperature readings are used to control engagement of the fourth gear overdrive clutch, the converter clutch, and governor pressure. Normal resistance value for the thermistor at room temperature is approximately 1000 ohms.

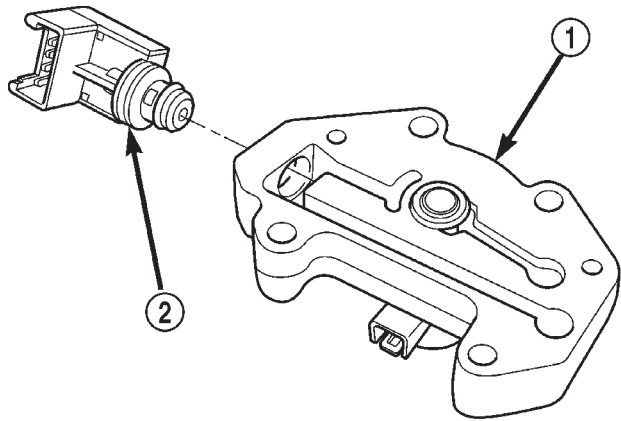
The thermistor is part of the governor pressure sensor assembly and is immersed in transmission fluid at all times.

### OPERATION

The PCM prevents engagement of the converter clutch and overdrive clutch, when fluid temperature is below approximately 10°C (50°F).

If fluid temperature exceeds 126°C (260°F), the PCM causes a 4-3 downshift and engage the converter clutch. Engagement is according to the third gear converter clutch engagement schedule.

The overdrive OFF lamp in the instrument panel illuminates when the shift back to third occurs. The transmission will not allow fourth gear operation until fluid temperature decreases to approximately 110°C (230°F).



80c072af

**Fig. 241 Governor Pressure Sensor**

- 1 - GOVERNOR BODY  
2 - GOVERNOR PRESSURE SENSOR/TRANSMISSION FLUID TEMPERATURE THERMISTOR

## VALVE BODY

### DESCRIPTION

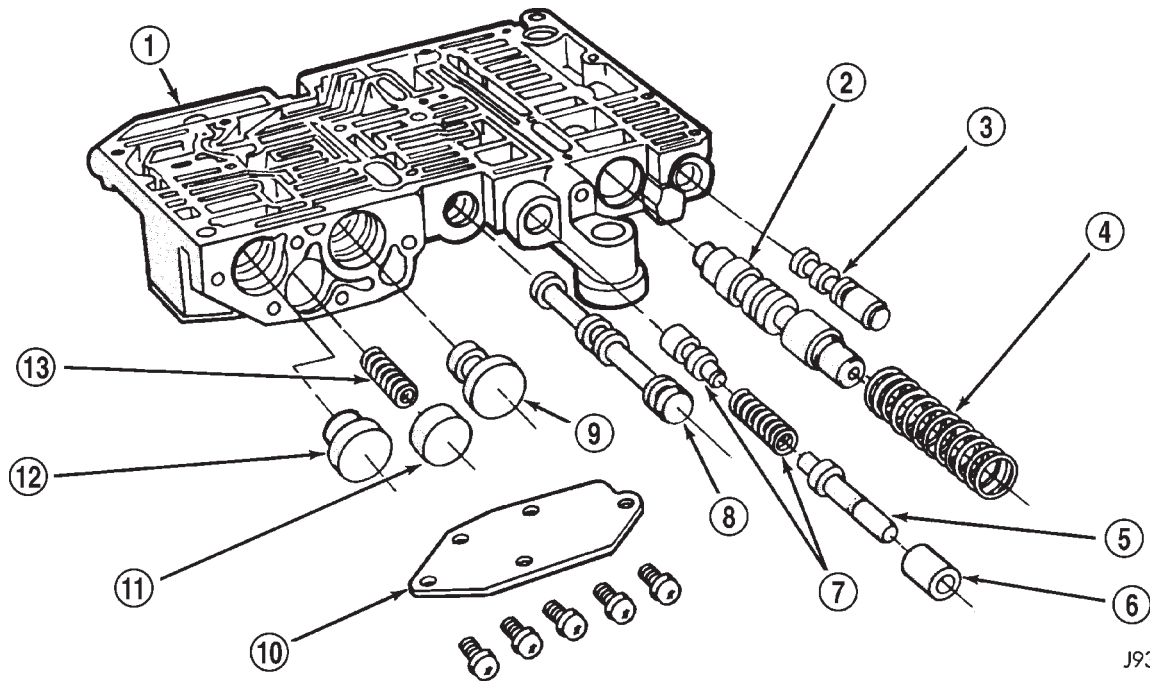
The valve body consists of a cast aluminum valve body, a separator plate, and transfer plate. The valve body contains valves and check balls that control fluid delivery to the torque converter clutch, bands, and frictional clutches. The valve body contains the following components (Fig. 242), (Fig. 243), (Fig. 244), and (Fig. 245):

- Regulator valve
- Regulator valve throttle pressure plug
- Line pressure plug and sleeve
- Kickdown valve
- Kickdown limit valve
- 1-2 shift valve
- 1-2 control valve
- 2-3 shift valve
- 2-3 governor plug
- 3-4 shift valve
- 3-4 timing valve
- 3-4 quick fill valve
- 3-4 accumulator
- Throttle valve
- Throttle pressure plug
- Switch valve
- Manual valve
- Converter clutch lock-up valve
- Converter clutch lock-up timing Valve
- Shuttle valve
- Shuttle valve throttle plug
- Boost Valve
- 10 check balls

By adjusting the spring pressure acting on the regulator valve, transmission line pressure can be adjusted.



VALVE BODY (Continued)

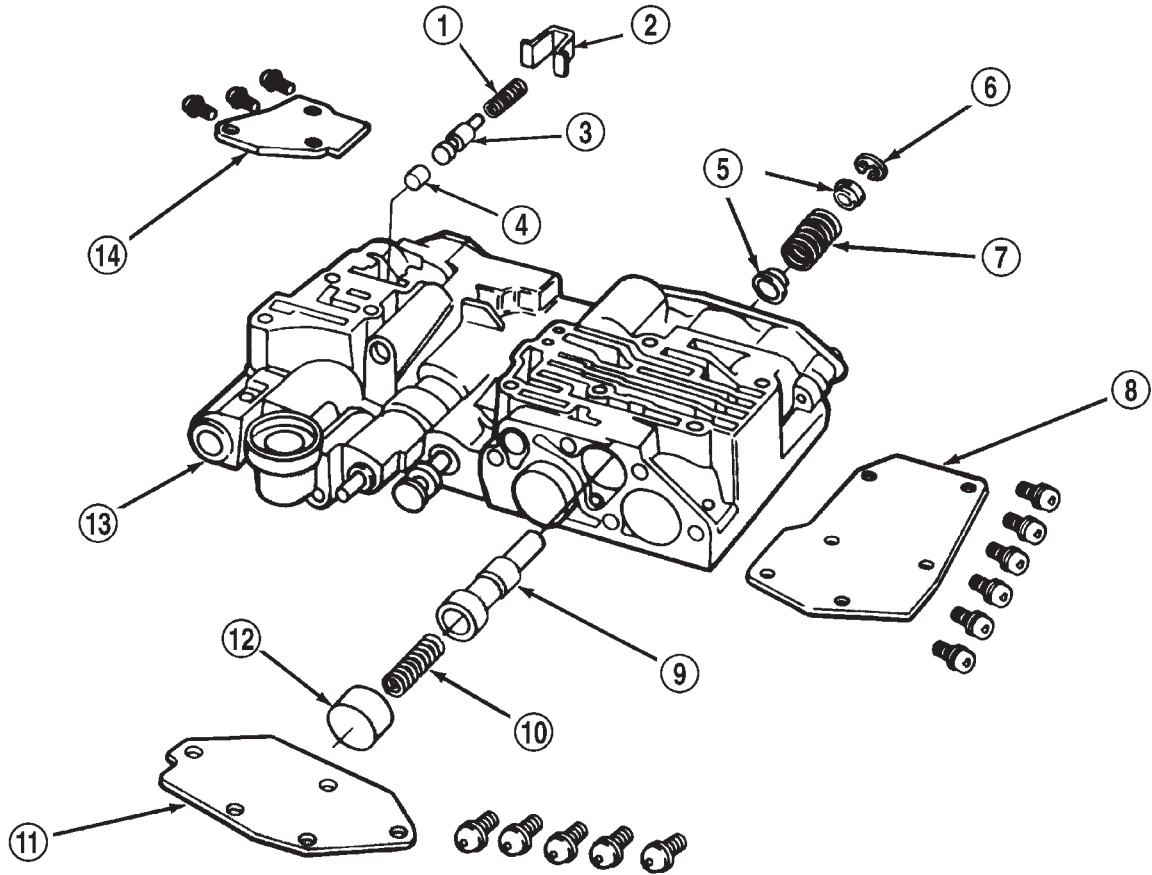


J9321-155

**Fig. 242 Upper Housing Control Valve Locations**

- |                               |                                   |
|-------------------------------|-----------------------------------|
| 1 - UPPER HOUSING             | 8 - MANUAL VALVE                  |
| 2 - REGULATOR VALVE           | 9 - 1-2 GOVERNOR PLUG             |
| 3 - SWITCH VALVE              | 10 - GOVERNOR PLUG COVER          |
| 4 - REGULATOR VALVE SPRING    | 11 - THROTTLE PLUG                |
| 5 - KICKDOWN VALVE            | 12 - 2-3 GOVERNOR PLUG            |
| 6 - KICKDOWN DETENT           | 13 - SHUTTLE VALVE PRIMARY SPRING |
| 7 - THROTTLE VALVE AND SPRING |                                   |

VALVE BODY (Continued)

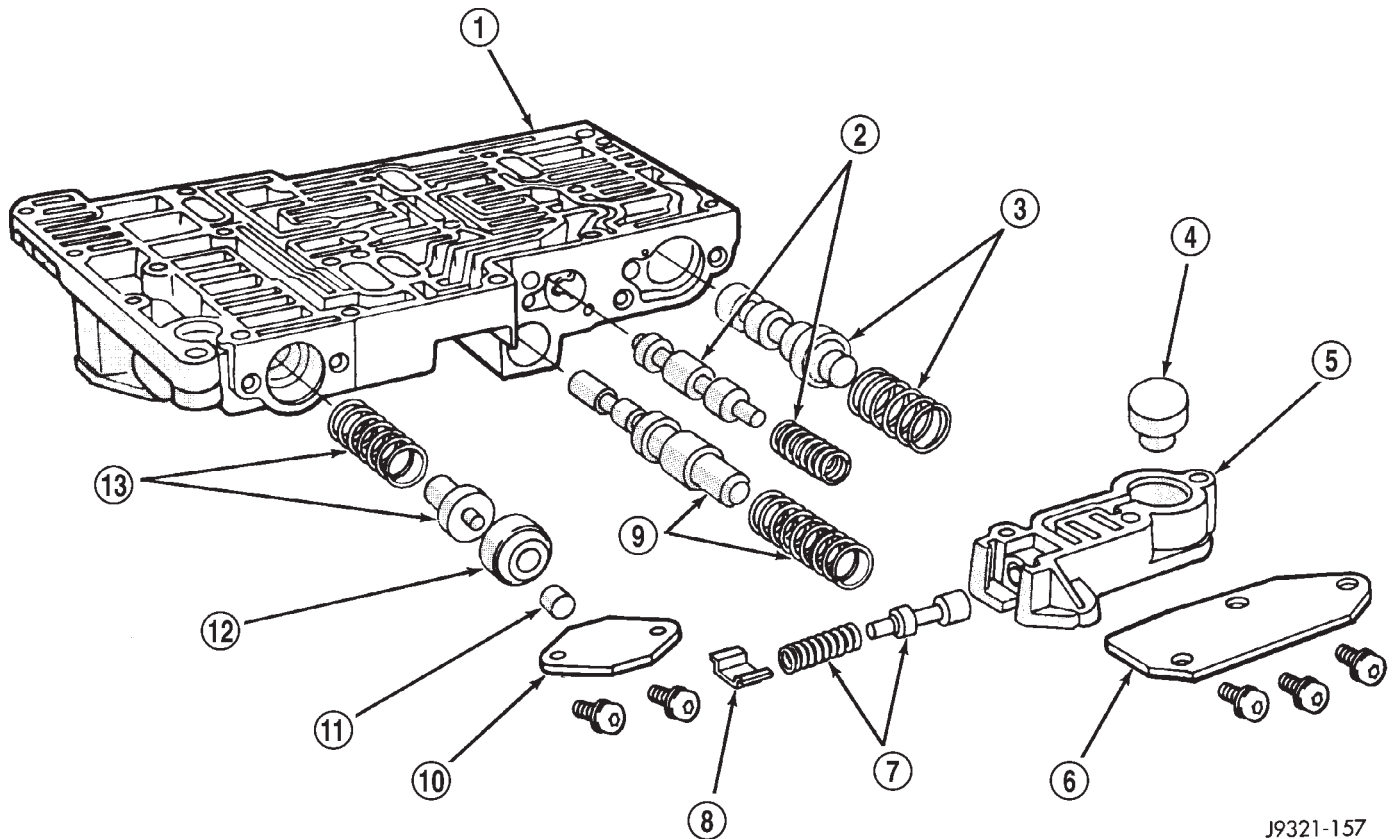


J9421-217

**Fig. 243 Shuttle and Boost Valve Locations**

- |                                    |                                   |
|------------------------------------|-----------------------------------|
| 1 - SPRING                         | 8 - SHUTTLE VALVE COVER           |
| 2 - RETAINER                       | 9 - SHUTTLE VALVE                 |
| 3 - BOOST VALVE                    | 10 - SHUTTLE VALVE PRIMARY SPRING |
| 4 - BOOST VALVE PLUG               | 11 - GOVERNOR PLUG COVER          |
| 5 - SPRING GUIDES                  | 12 - THROTTLE PLUG                |
| 6 - E-CLIP                         | 13 - UPPER HOUSING                |
| 7 - SHUTTLE VALVE SECONDARY SPRING | 14 - BOOST VALVE COVER            |

## VALVE BODY (Continued)

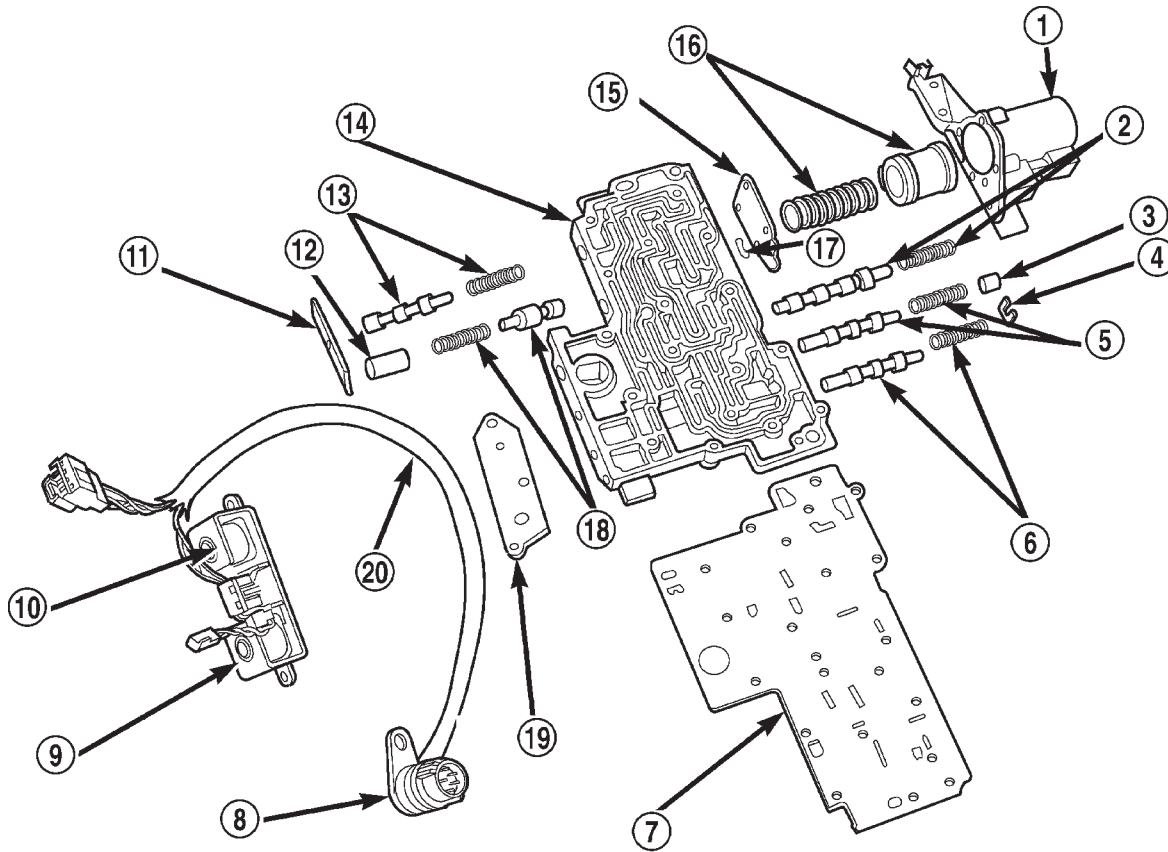


J9321-157

**Fig. 244 Upper Housing Shift Valve and Pressure Plug Locations**

- |                                |  |
|--------------------------------|--|
| 1 - UPPER HOUSING              | 8 - RETAINER                           |
| 2 - 1-2 SHIFT VALVE AND SPRING | 9 - 1-2 SHIFT CONTROL VALVE AND SPRING |
| 3 - 2-3 SHIFT VALVE AND SPRING | 10 - PRESSURE PLUG COVER               |
| 4 - 2-3 THROTTLE PLUG          | 11 - LINE PRESSURE PLUG                |
| 5 - LIMIT VALVE HOUSING        | 12 - PLUG SLEEVE                       |
| 6 - LIMIT VALVE COVER          | 13 - THROTTLE PRESSURE SPRING AND PLUG |
| 7 - LIMIT VALVE AND SPRING     |  |

VALVE BODY (Continued)



80c072b5

**Fig. 245 Lower Housing Shift Valves and Springs**

- |  |  |
|--|--|
| 1 - 3-4 ACCUMULATOR HOUSING                  | 11 - TIMING VALVE COVER                |
| 2 - 3-4 SHIFT VALVE AND SPRING               | 12 - PLUG                              |
| 3 - PLUG                                     | 13 - 3-4 TIMING VALVE AND SPRING       |
| 4 - SPRING RETAINER                          | 14 - LOWER HOUSING                     |
| 5 - CONVERTER CLUTCH VALVE AND SPRING        | 15 - ACCUMULATOR END PLATE             |
| 6 - CONVERTER CLUTCH TIMING VALVE AND SPRING | 16 - 3-4 ACCUMULATOR PISTON AND SPRING |
| 7 - OVERDRIVE SEPARATOR PLATE                | 17 - E-CLIP                            |
| 8 - CASE CONNECTOR                           | 18 - 3-4 QUICK FILL SPRING AND VALVE   |
| 9 - CONVERTER CLUTCH SOLENOID                | 19 - SOLENOID GASKET                   |
| 10 - OVERDRIVE SOLENOID                      | 20 - HARNESS                           |

## VALVE BODY (Continued)

## OPERATION

**NOTE:** Refer to the Hydraulic Schematics for a visual aid in determining valve location, operation and design.

## CHECK BALLS

CHECK BALL NUMBER	DESCRIPTION
1	Allows either the manual valve to put line pressure on the 1-2 governor plug or the KD Valve to put WOT line pressure on the 1-2 governor plug.
2	Allows either the manual valve to put line pressure on the 2-3 governor plug or the KD Valve to put WOT line pressure on the 2-3 governor plug.
3	Allows either the Reverse circuit or the 3rd gear circuit to pressurize the front clutch.
4	Allows either the Manual Low circuit from the Manual Valve or the Reverse from the Manual Valve circuit to pressurize the rear servo.
5	Directs line pressure to the spring end of the 2-3 shift valve in either Manual Low or Manual 2nd, forcing the downshift to 2nd gear regardless of governor pressure.
6	Provides a by-pass around the front servo orifice so that the servo can release quickly.
7	Provides a by-pass around the rear clutch orifice so that the clutch can release quickly.
8	Directs reverse line pressure through an orifice to the throttle valve eliminating the extra leakage and insuring that Reverse line pressure pressure will be sufficient.
9	Provides a by-pass around the rear servo orifice so that the servo can release quickly.
ECE (10)	Allows the lockup clutch to used at WOT in 3rd gear by putting line pressure from the 3-4 Timing Valve on the interlock area of the 2-3 shift valve, thereby preventing a 3rd gear Lock-up to 2nd gear kickdown.

## REGULATOR VALVE

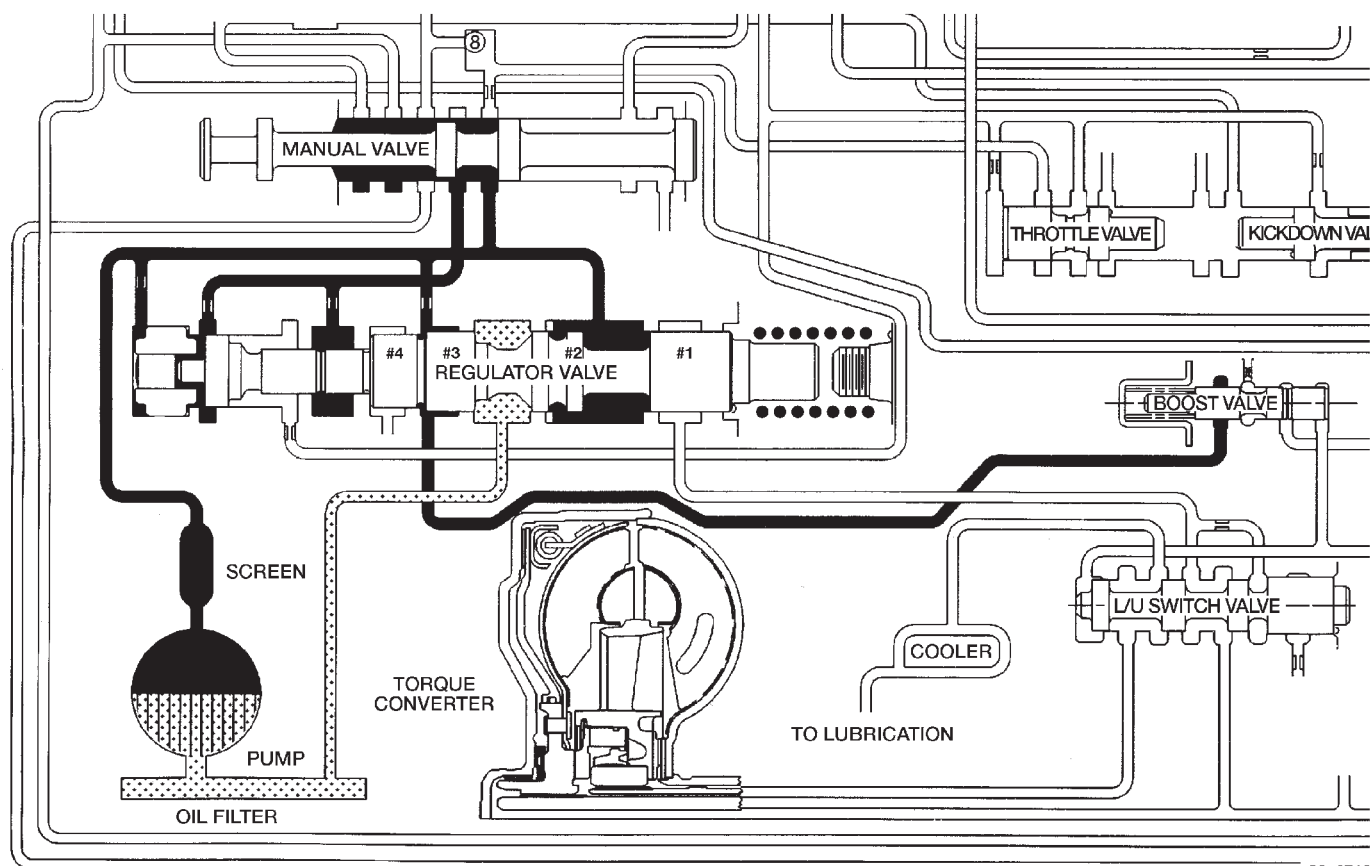
The pressure regulator valve is needed to control the hydraulic pressure within the system and reduce the amount of heat produced in the fluid. The pressure regulator valve is located in the valve body near the manual valve. The pressure regulator valve train controls the maximum pressure in the lines by metering the dumping of fluid back into the sump. Regulated pressure is referred to as "line pressure."

The regulator valve (Fig. 246) has a spring on one end that pushes the valve to the left. This closes a dump (vent) that is used to lower pressure. The closing of the dump will cause the oil pressure to increase. Oil pressure on the opposite end of the

valve pushes the valve to the right, opening the dump and lowering oil pressure. The result is spring pressure working against oil pressure to maintain the oil at specific pressures. With the engine running, fluid flows from the pump to the pressure regulator valve, manual valve, and the interconnected circuits. As fluid is sent through passages to the regulator valve, the pressure pushes the valve to the right against the large spring. It is also sent to the reaction areas on the left side of the throttle pressure plug and the line pressure plug. With the gear selector in the PARK position, fluid recirculates through the regulator and manual valves back to the sump.



## VALVE BODY (Continued)



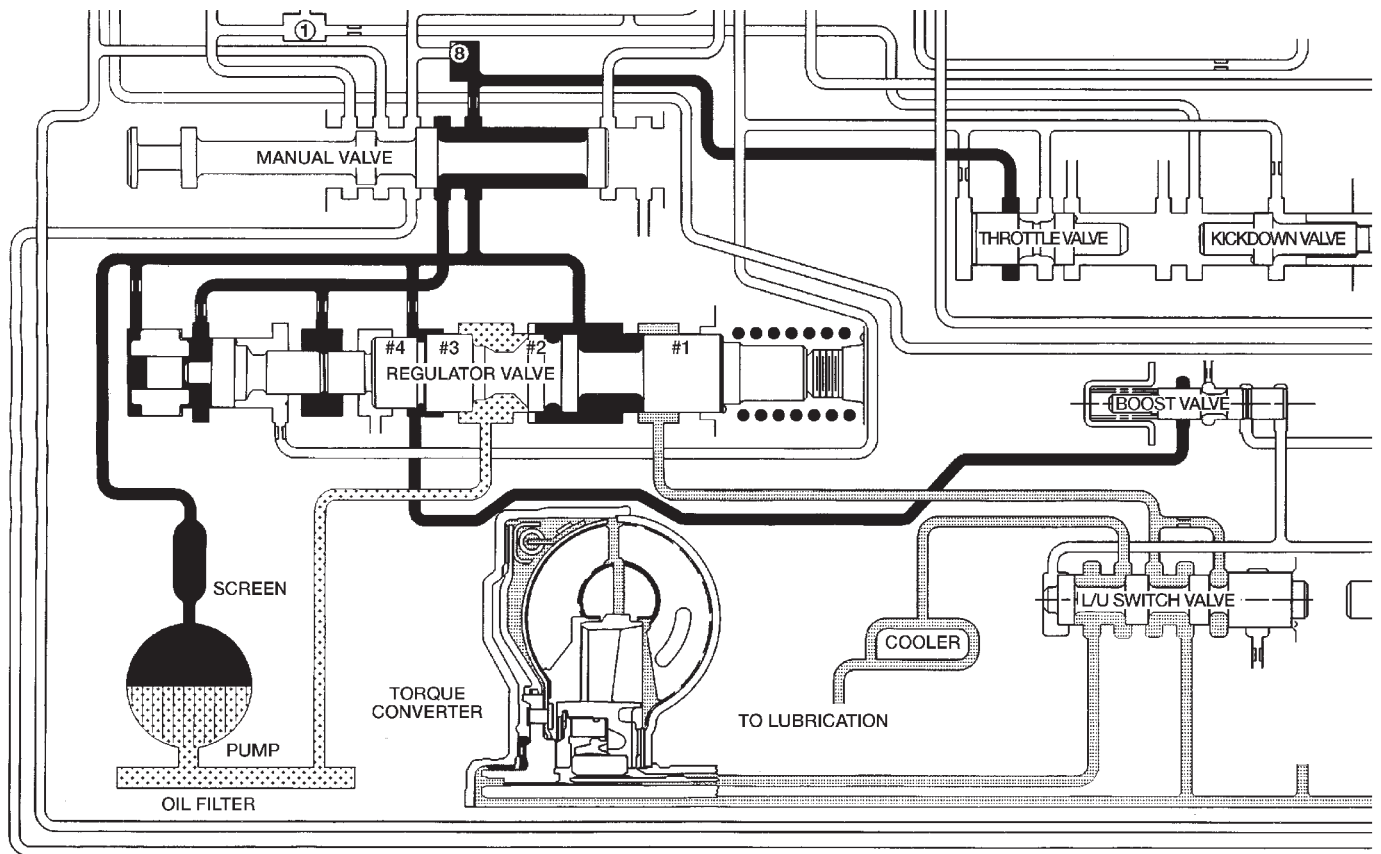
80c0713c

**Fig. 246 Regulator Valve in PARK Position**

Meanwhile, the torque converter is filled slowly. In all other gear positions (Fig. 247), fluid flows between two right side lands to the switch valve and torque converter. At low pump speeds, the flow is controlled by the pressure valve groove to reduce pressure to the torque converter. After the torque converter and switch valve fill with fluid, the switch valve becomes the controlling metering device for torque converter pressure. The regulator valve then begins to control the line pressure for the other transmission circuits. The balance of the fluid pressure pushing the valve to the right and the spring

pressure pushing to the left determines the size of the metering passage at land #2 (land #1 being at the far right of the valve in the diagram). As fluid leaks past the land, it moves into a groove connected to the filter or sump. As the land meters the fluid to the sump, it causes the pressure to reduce and the spring decreases the size of the metering passage. When the size of the metering passage is reduced, the pressure rises again and the size of the land is increased again. Pressure is regulated by this constant balance of hydraulic and spring pressure.

## VALVE BODY (Continued)



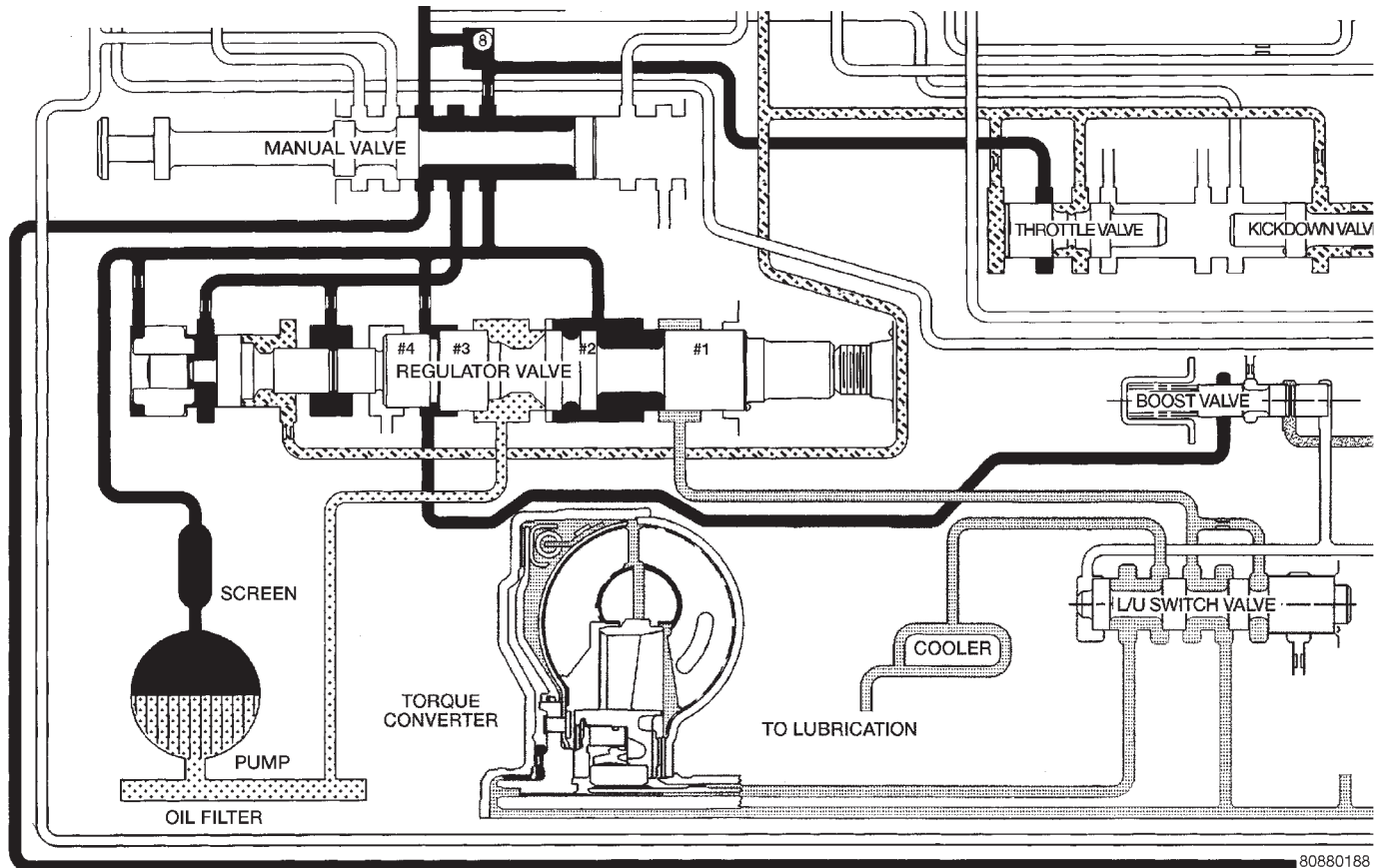
80880187

**Fig. 247 Regulator Valve in NEUTRAL Position**

The metering at land #2 establishes the line pressure throughout the transmission. It is varied according to changes in throttle position and the transmission's internal condition within a range of 57-94 psi (except in REVERSE) (Fig. 248). The regulated line pressure in REVERSE (Fig. 249) is held at much higher pressures than in the other gear positions: 145-280 psi. The higher pressure for

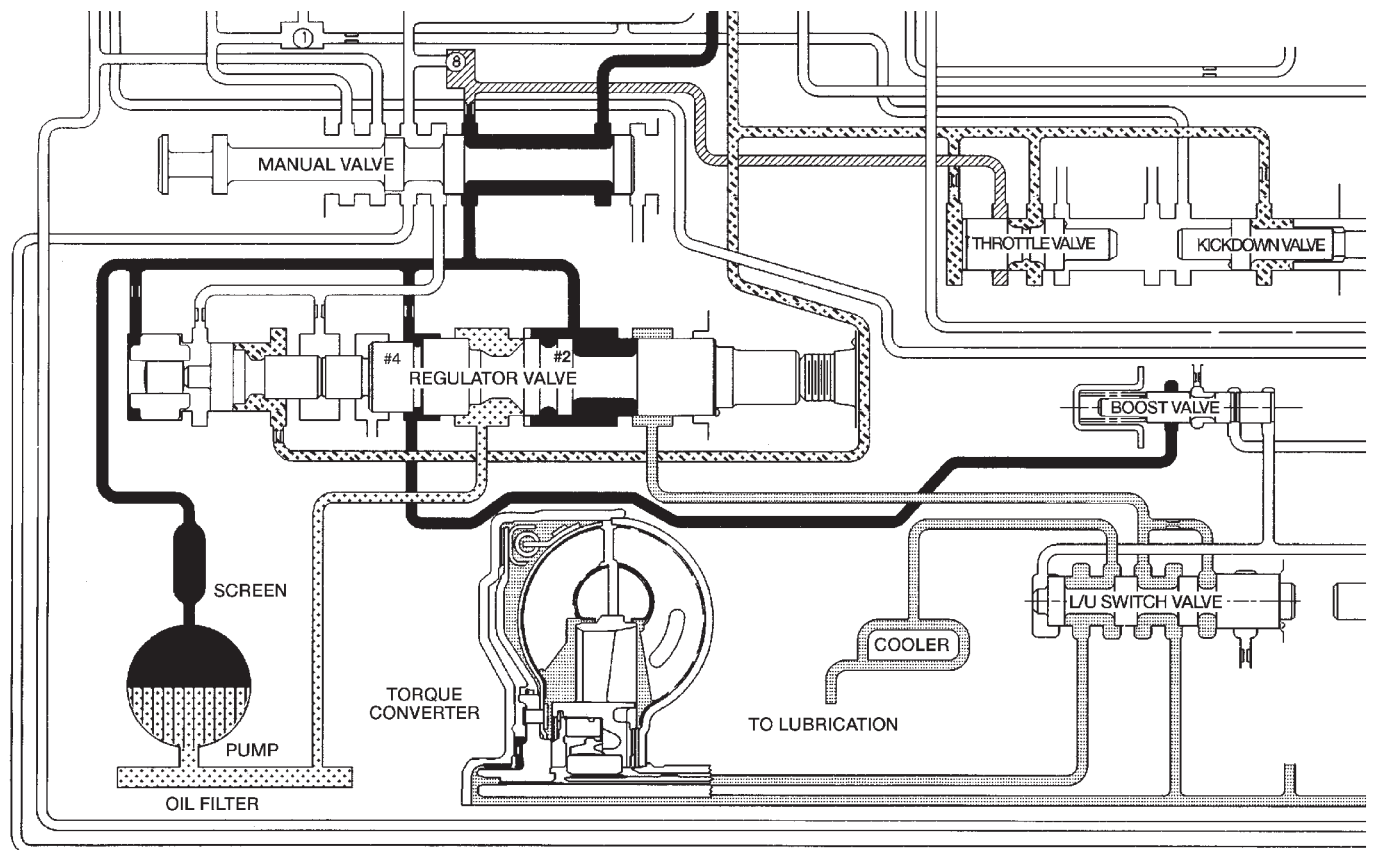
REVERSE is achieved by the manual valve blocking the supply of line pressure to the reaction area left of land #4. With this pressure blocked, there is less area for pressure to act on to balance the force of the spring on the right. This allows line pressure to push the valve train to the right, reducing the amount of fluid returned to the pump's inlet, increasing line pressure.

VALVE BODY (Continued)



80880188

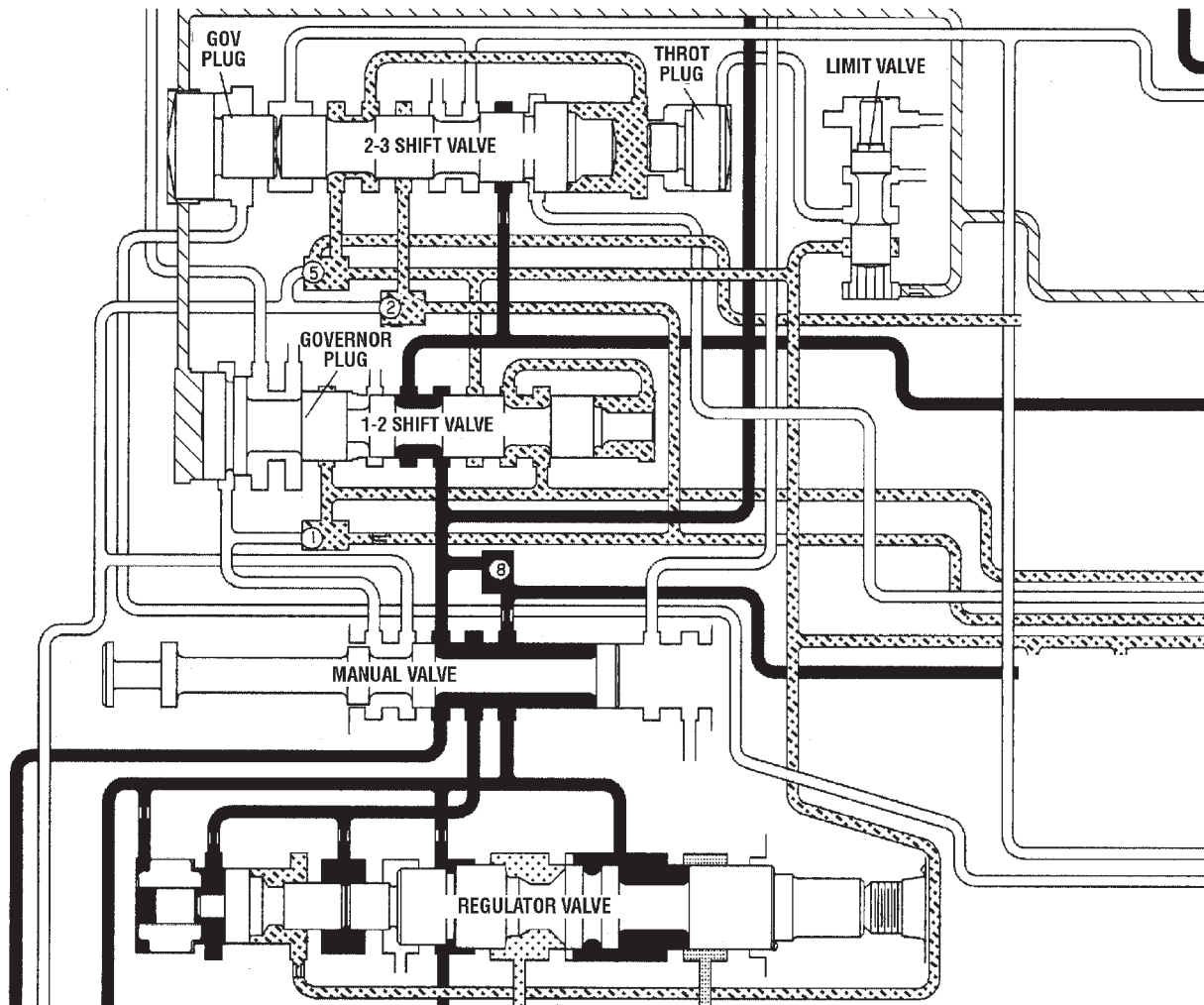
Fig. 248 Regulator Valve in DRIVE Position



80c07140

Fig. 249 Regulator Valve in REVERSE Position

## VALVE BODY (Continued)



8088018a

**Fig. 250 Kickdown Valve-Wide Open Throttle**

### KICKDOWN VALVE

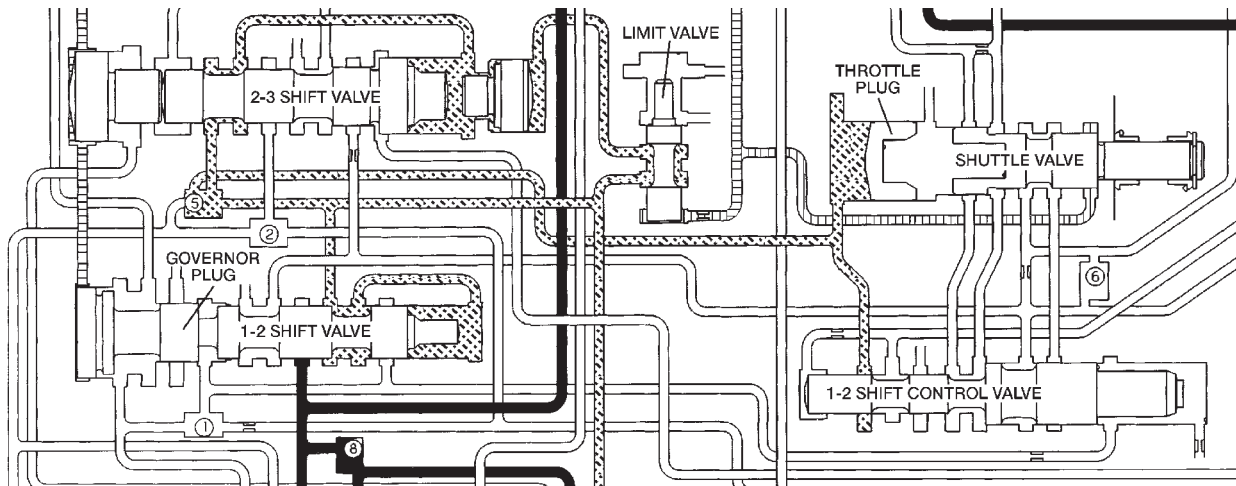
When the throttle valve is as far over to the left as it can go, the maximum line pressure possible will enter the throttle pressure circuit. In this case, throttle pressure will equal line pressure. With the kickdown valve (Fig. 250) pushed into the bore as far as it will go, fluid initially flows through the annular groove of the 2-3 shift valve (which will be in the direct drive position to the right).

After passing the annular groove, the fluid is routed to the spring end of the 2-3 shift valve. Fluid pressure reacting on the area of land #1 overcomes governor pressure, downshifting the 2-3 shift valve into the kickdown, or second gear stage of operation. The valve is held in the kickdown position by throttle pressure routed from a seated check ball (#2). Again, if vehicle speed is low enough, throttle pressure will also push the 1-2 shift valve left to seat its governor plug, and downshift to drive breakaway.

### KICKDOWN LIMIT VALVE

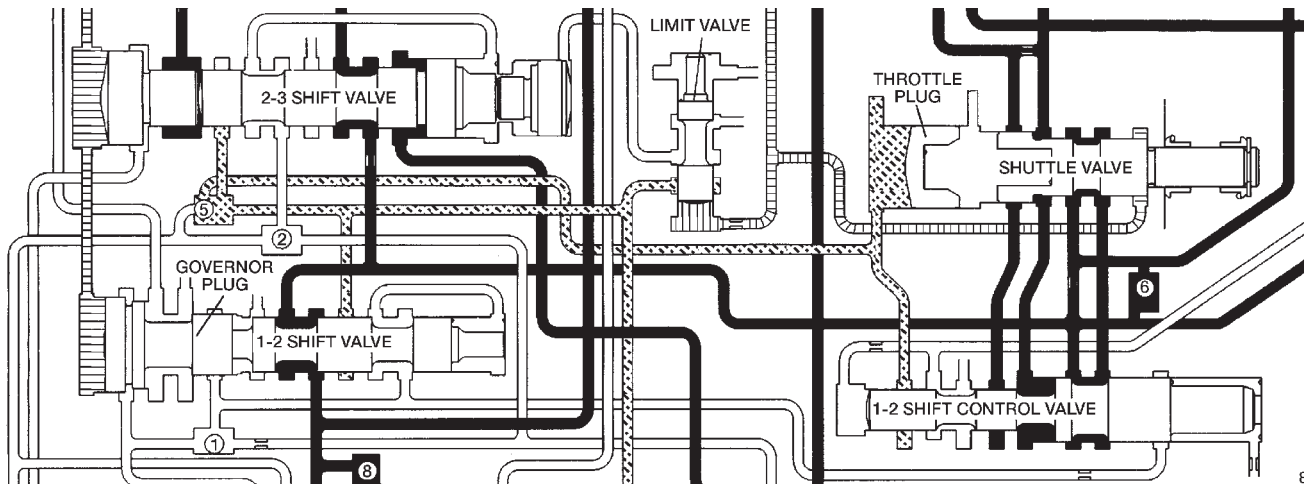
The purpose of the limit valve is to prevent a 3-2 downshift at higher speeds when a part-throttle downshift is not desirable. At these higher speeds only a full throttle 3-2 downshift will occur. At low road speeds (Fig. 251) the limit valve does not come into play and does not affect the downshifts. As the vehicle's speed increases (Fig. 252), the governor pressure also increases. The increased governor pressure acts on the reaction area of the bottom land of the limit valve overcoming the spring force trying to push the valve toward the bottom of its bore. This pushes the valve upward against the spring and bottoms the valve against the top of the housing. With the valve bottomed against the housing, the throttle pressure supplied to the valve will be closed off by the bottom land of the limit valve. When the supply of throttle pressure has been shut off, the 3-2 part throttle downshift plug becomes inoperative, because no pressure is acting on its reaction area.

## VALVE BODY (Continued)



80c07142

**Fig. 251 Kickdown Limit Valve-Low Speeds**



80c07143

**Fig. 252 Kickdown Limit Valve-High Speeds**

### 1-2 SHIFT VALVE

The 1-2 shift valve assembly (Fig. 253), or mechanism, consists of: the 1-2 shift valve, governor plug, and a spring on the end of the valve. After the manual valve has been placed into a forward gear range, line pressure is directed to the 1-2 shift valve. As the throttle is depressed, throttle pressure is applied to the right side of the 1-2 shift valve assembly. With throttle pressure applied to the right side of the valve, there is now both spring pressure and throttle pressure acting on the valve, holding it against the governor plug. As the vehicle begins to move and build speed, governor pressure is created and is applied to the left of the valve at the governor plug.

When governor pressure builds to a point where it can overcome the combined force of the spring and throttle pressure on the other side of the valve, the valve will begin to move over to the right. As the valve moves to the right, the middle land of the valve will close off the circuit supplying the throttle pressure to the right side of the valve. When the throttle

pressure is closed off, the valve will move even farther to the right, allowing line pressure to enter another circuit and energize the front servo, applying the front band (Fig. 254).

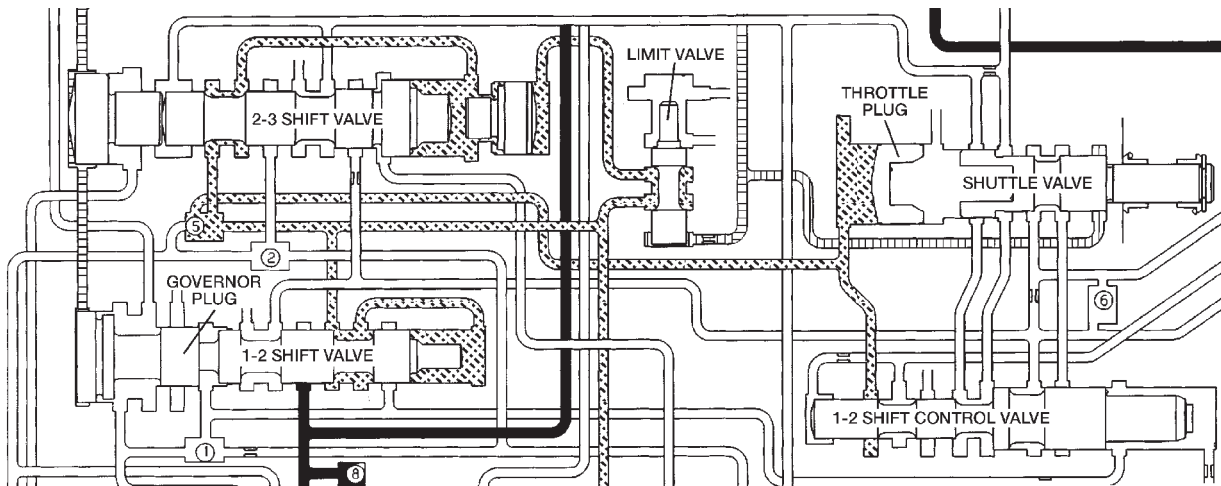
The governor plug serves a dual purpose:

- It allows the shift valves to move either left or right, allowing both upshifts and downshifts.
- When in a manual selection position, it will be hydraulically "blocked" into position so no upshift can occur.

The physical blocking of the upshift while in the manual "1" position is accomplished by the directing of line pressure between both lands of the governor plug. The line pressure reacts against the larger land of the plug, pushing the plug back against the end plate overcoming governor pressure. With the combination of the line pressure and spring pressure, the valve cannot move, preventing any upshift.

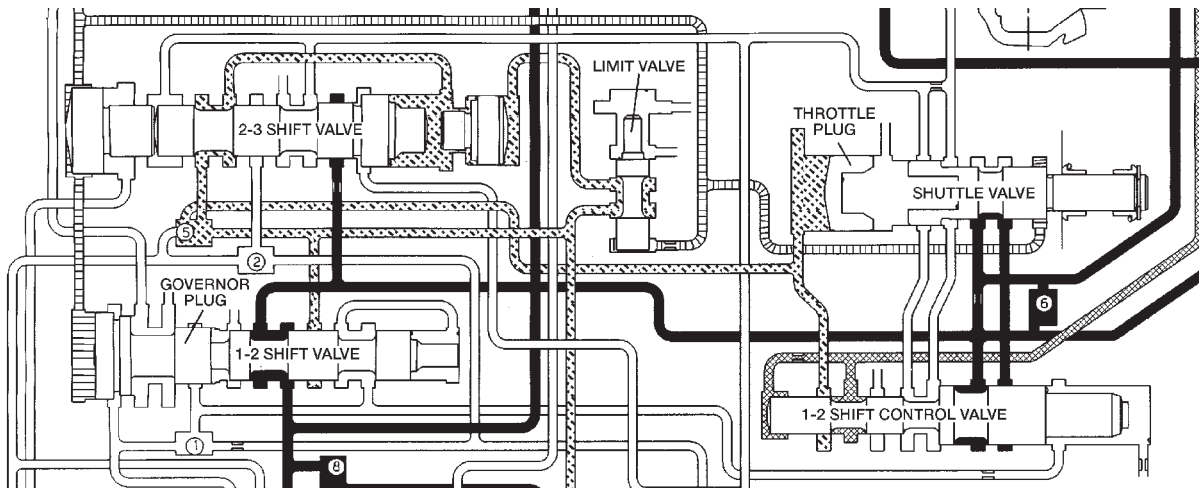


## VALVE BODY (Continued)



80c07144

Fig. 253 1-2 Shift Valve-Before Shift



80c07145

Fig. 254 1-2 Shift Valve-After Shift

**1-2 SHIFT CONTROL VALVE**

It contains a valve with four lands and a spring. It is used as both a "relay" and "balanced" valve.

The valve has two specific operations (Fig. 255):

- Aid in quality of the 1-2 upshift.
- Aid in the quality and timing of the 3-2 kick-down ranges.

When the manual valve is set to the DRIVE position and the transmission is in the first or second gear range, 1-2 shift control or "modulated throttle pressure" is supplied to the middle of the accumulator piston by the 1-2 shift control valve. During the 1-2 upshift, this pressure is used to control the kickdown servo apply pressure that is needed to apply the kickdown and accumulator pistons. Thus, the 1-2 shift point is "cushioned" and the quality is improved. During a WOT kickdown, kickdown pressure is applied between the kickdown valve and the 1-2 shift control valve. This additional pressure is directed to the 1-2 shift control's spring cavity, adding to the spring load on the valve. The result of this

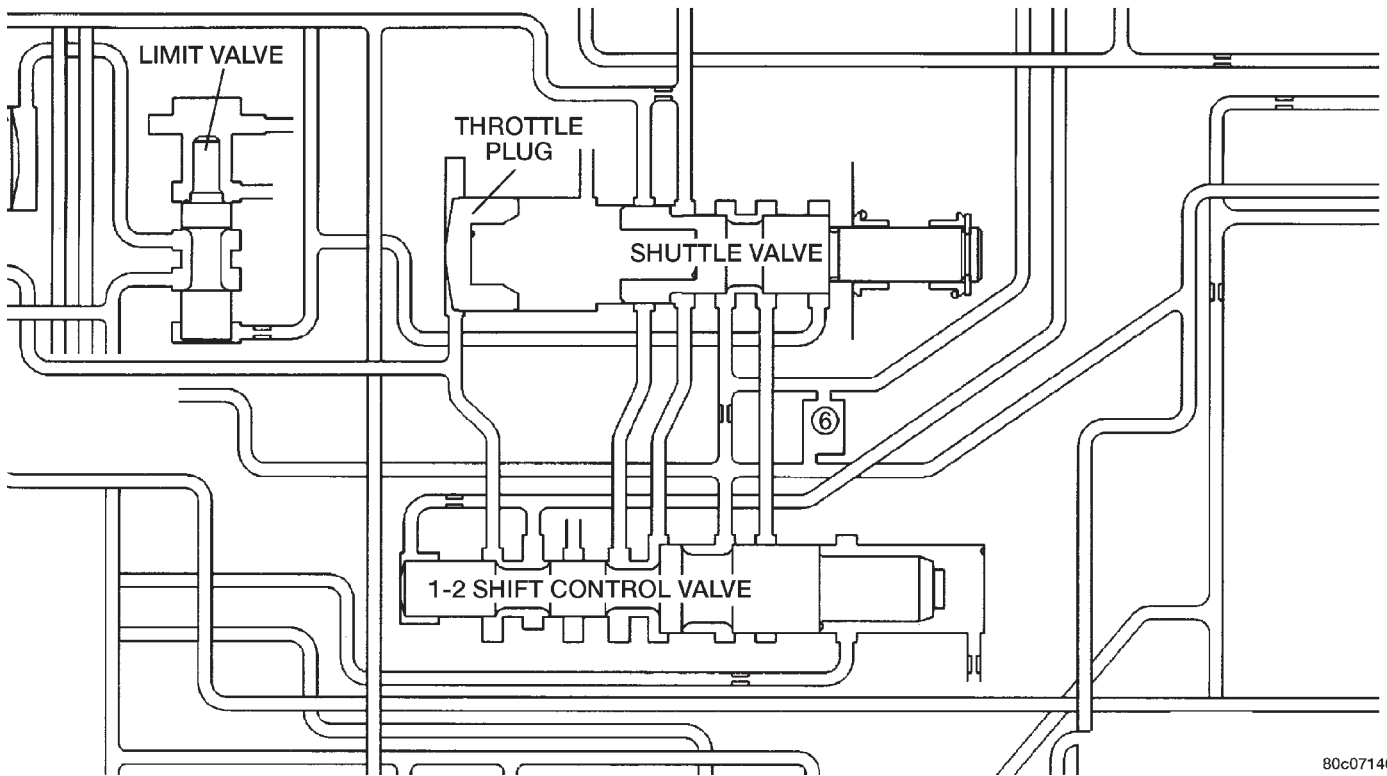
increased "modulated" throttle pressure is a firmer WOT upshift.

**2-3 SHIFT VALVE**

The 2-3 shift valve mechanism (Fig. 256) consists of the 2-3 shift valve, governor plug and spring, and a throttle plug. After the 1-2 shift valve has completed its operation and applied the front band, line pressure is directed to the 2-3 shift valve through the connecting passages from the 1-2 shift valve. The line pressure will then dead-end at land #2 until the 2-3 valve is ready to make its shift. Now that the vehicle is in motion and under acceleration, there is throttle pressure being applied to the spring side of the valve and between lands #3 and #4.

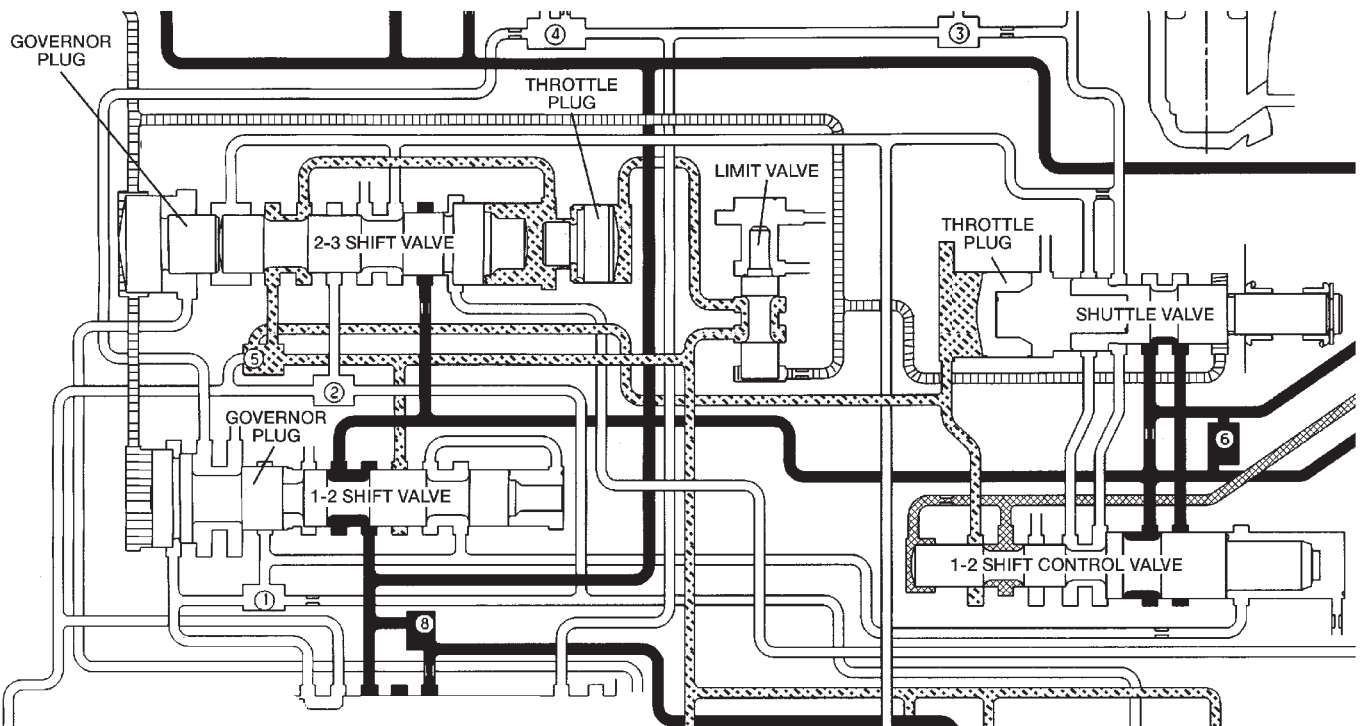
As vehicle speed increases, governor pressure increases proportionately, until it becomes great enough to overcome the combined throttle and spring pressure on the right side of the valve. Since the throttle pressure end of the 2-3 shift valve is larger in diameter than the 1-2 shift valve, the 2-3 shift will always happen at a greater speed than the 1-2 shift.

VALVE BODY (Continued)



80c07146

**Fig. 255 1-2 Shift Control Valve**



80c07147

**Fig. 256 2-3 Shift Valve-Before Shift**

When this happens, the governor plug is forced against the shift valve moving it to the right. The shift valve causes land #4 to close the passage supplying throttle pressure to the 2-3 shift valve. With-

out throttle pressure present in the circuit now, the governor plug will push the valve over far enough to bottom the valve in its bore. This allows land #2 to direct line pressure to the front clutch.

VALVE BODY (Continued)

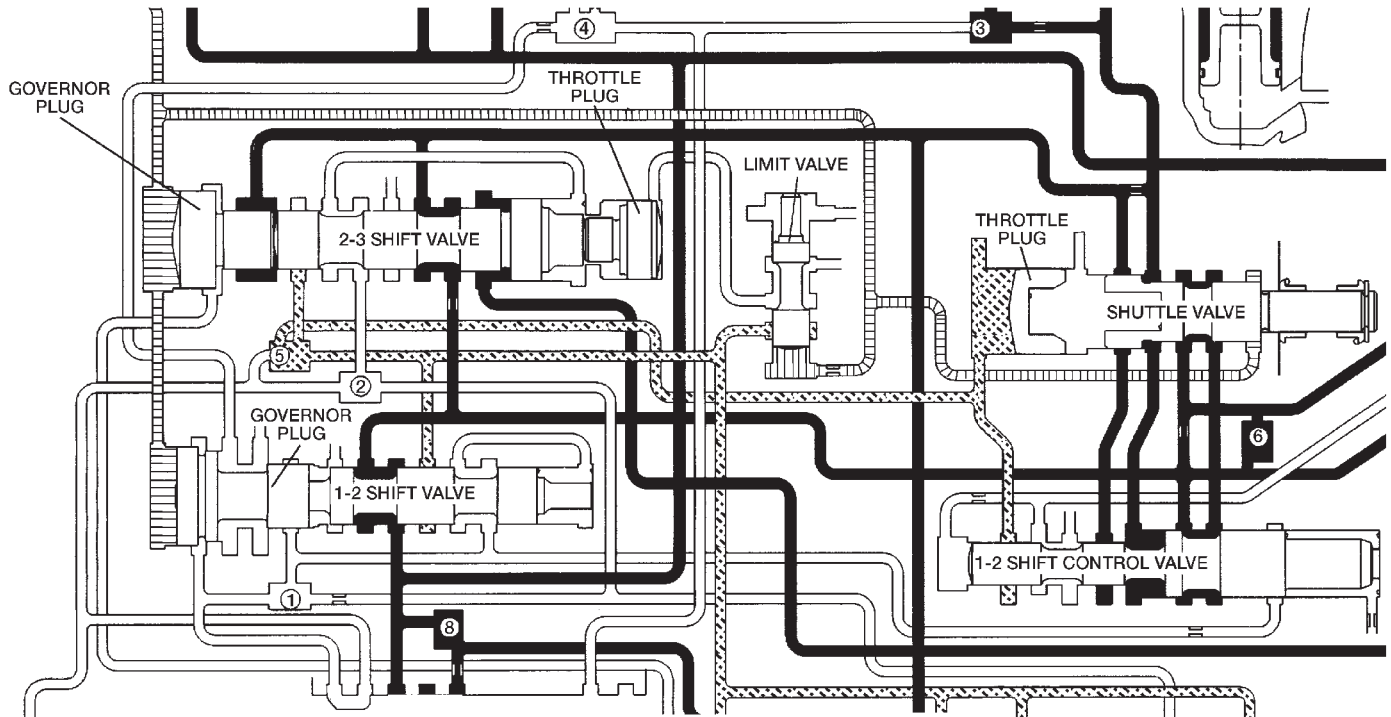


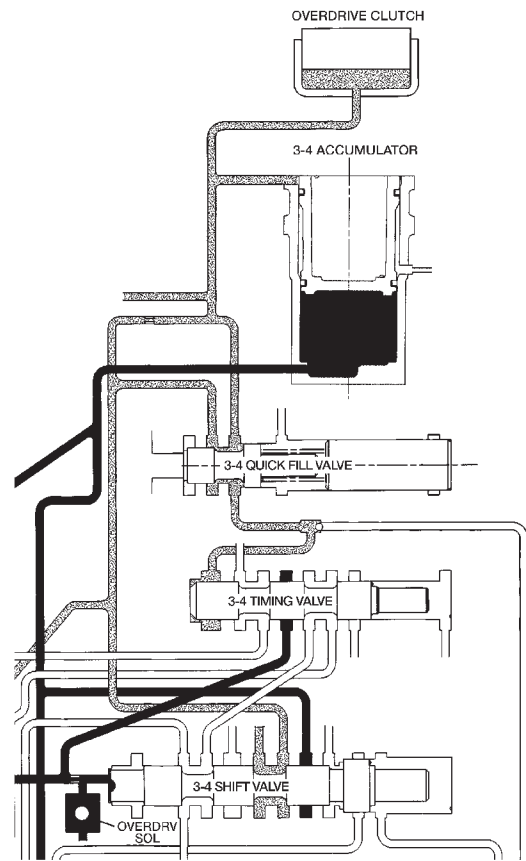
Fig. 257 2-3 Shift Valve-After Shift

80c07148

After the shift (Fig. 257), line pressure is directed to the land between the shift valve and the governor plug, and to the release side of the kickdown servo. This releases the front band and applies the front clutch, shifting into third gear or direct drive. The rear clutch remains applied, as it has been in the other gears. During a manual "1" or manual "2" gear selection, line pressure is sent between the two lands of the 2-3 governor plug. This line pressure at the governor plug locks the shift valve into the second gear position, preventing an upshift into direct drive. The theory for the blocking of the valve is the same as that of the 1-2 shift valve.

3-4 SHIFT VALVE

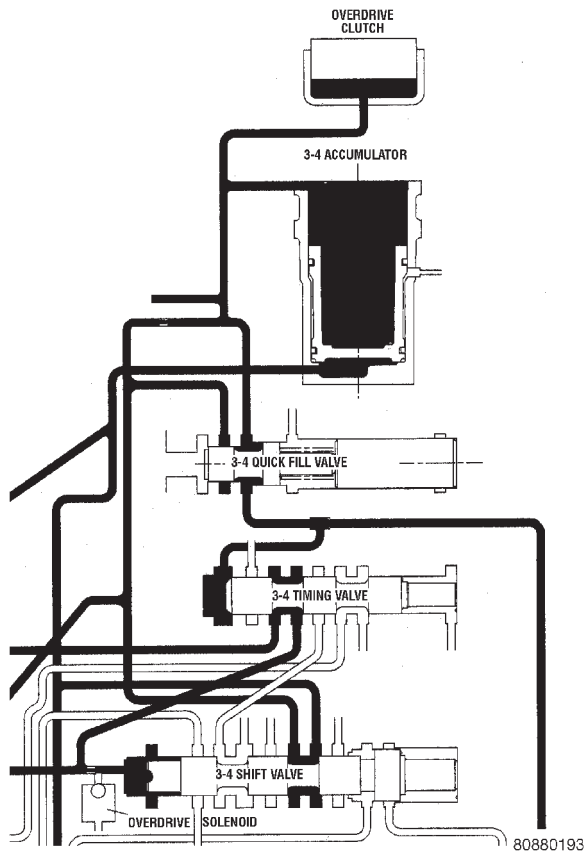
The PCM energizes the overdrive solenoid during the 3-4 upshift (Fig. 258). This causes the solenoid check ball to close the vent port allowing line pressure from the 2-3 shift valve to act directly on the 3-4 upshift valve. Line pressure on the 3-4 shift valve overcomes valve spring pressure moving the valve to the upshift position (Fig. 259). This action exposes the feed passages to the 3-4 timing valve, 3-4 quick fill valve, 3-4 accumulator, and ultimately to the overdrive piston.



80880192

Fig. 258 3-4 Shift Valve Before Shift

## VALVE BODY (Continued)



**Fig. 259 3-4 Shift Valve After Shift**

### 3-4 TIMING VALVE

The 3-4 timing valve is moved by line pressure coming through the 3-4 shift valve (Fig. 259). After the shift, the timing valve holds the 2-3 shift valve in an upshift position. The purpose is to prevent the 2-3 valve from downshifting before the 3-4 valve (Fig. 258).

### 3-4 QUICK FILL VALVE

The 3-4 quick fill valve provides faster engagement of the overdrive clutch during 3-4 upshifts. The valve temporarily bypasses the clutch piston feed orifice at the start of a 3-4 upshift (Fig. 258). This exposes a larger passage into the piston retainer resulting in a much faster clutch fill and apply sequence. The quick fill valve does not bypass the regular clutch feed orifice throughout the 3-4 upshift. Instead, once a predetermined pressure develops within the clutch, the valve closes the bypass (Fig. 259). Clutch fill is then completed through the regular feed orifice.

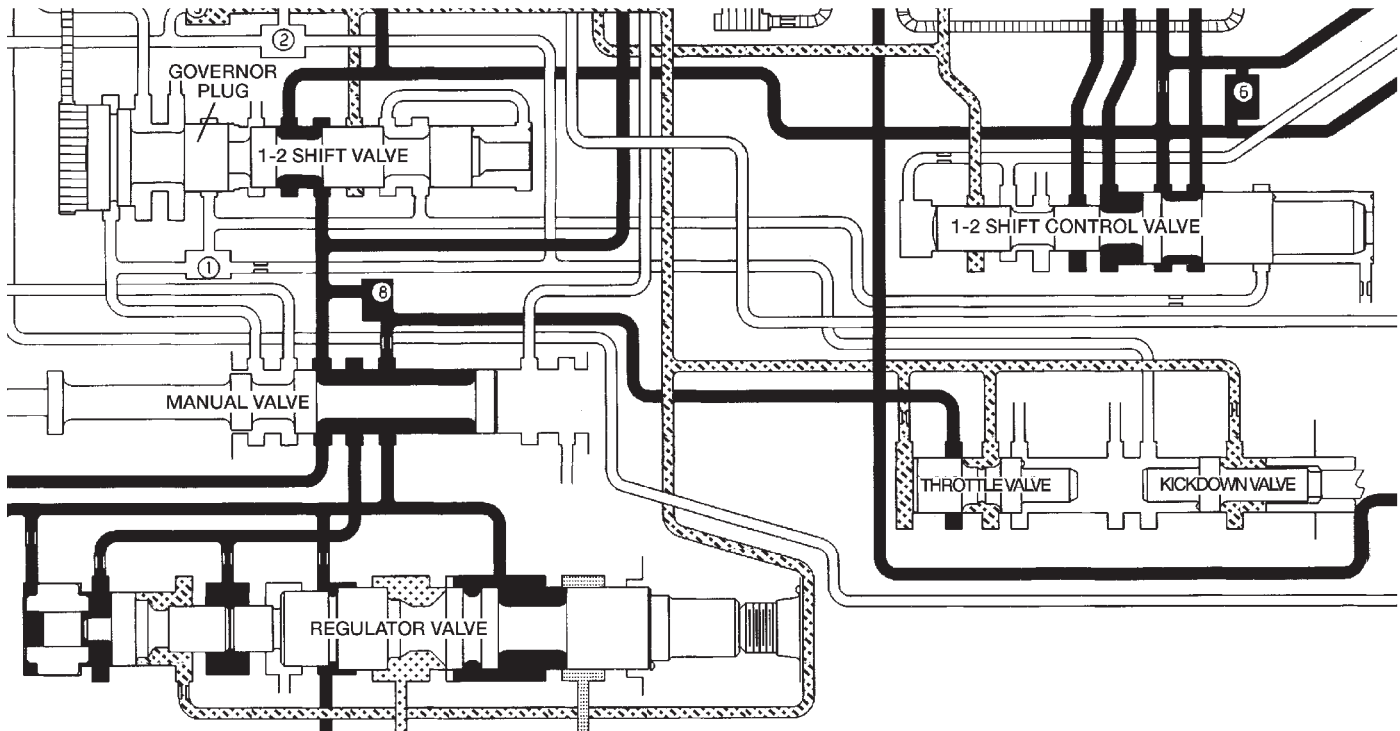
## THROTTLE VALVE

In all gear positions the throttle valve (Fig. 260) is being supplied with line pressure. The throttle valve meters and reduces the line pressure that now becomes throttle pressure. The throttle valve is moved by a spring and the kickdown valve, which is mechanically connected to the throttle. The larger the throttle opening, the higher the throttle pressure (to a maximum of line pressure). The smaller the throttle opening, the lower the throttle pressure (to a minimum of zero at idle). As engine speed increases, the increase in pump speed increases pump output. The increase in pressure and volume must be regulated to maintain the balance within the transmission. To do this, throttle pressure is routed to the reaction area on the right side of the throttle pressure plug (in the regulator valve).

The higher engine speed and line pressure would open the vent too far and reduce line pressure too much. Throttle pressure, which increases with engine speed (throttle opening), is used to oppose the movement of the pressure valve to help control the metering passage at the vent. The throttle pressure is combined with spring pressure to reduce the force of the throttle pressure plug on the pressure valve. The larger spring at the right closes the regulator valve passage and maintains or increases line pressure. The increased line pressure works against the reaction area of the line pressure plug and the reaction area left of land #3 simultaneously moves the regulator valve train to the right and controls the metering passage.

The kickdown valve, along with the throttle valve, serve to delay upshifts until the correct vehicle speed has been reached. It also controls downshifts upon driver demand, or increased engine load. If these valves were not in place, the shift points would be at the same speed for all throttle positions. The kickdown valve is actuated by a cam connected to the throttle. This is accomplished through either a linkage or a cable. The cam forces the kickdown valve toward the throttle valve compressing the spring between them and moving the throttle valve. As the throttle valve land starts to uncover its port, line pressure is "metered" out into the circuits and viewed as throttle pressure. This increased throttle pressure is metered out into the circuits it is applied to: the 1-2 and 2-3 shift valves. When the throttle pressure is high enough, a 3-2 downshift will occur. If the vehicle speed is low enough, a 2-1 downshift will occur.

## VALVE BODY (Continued)



80c07149

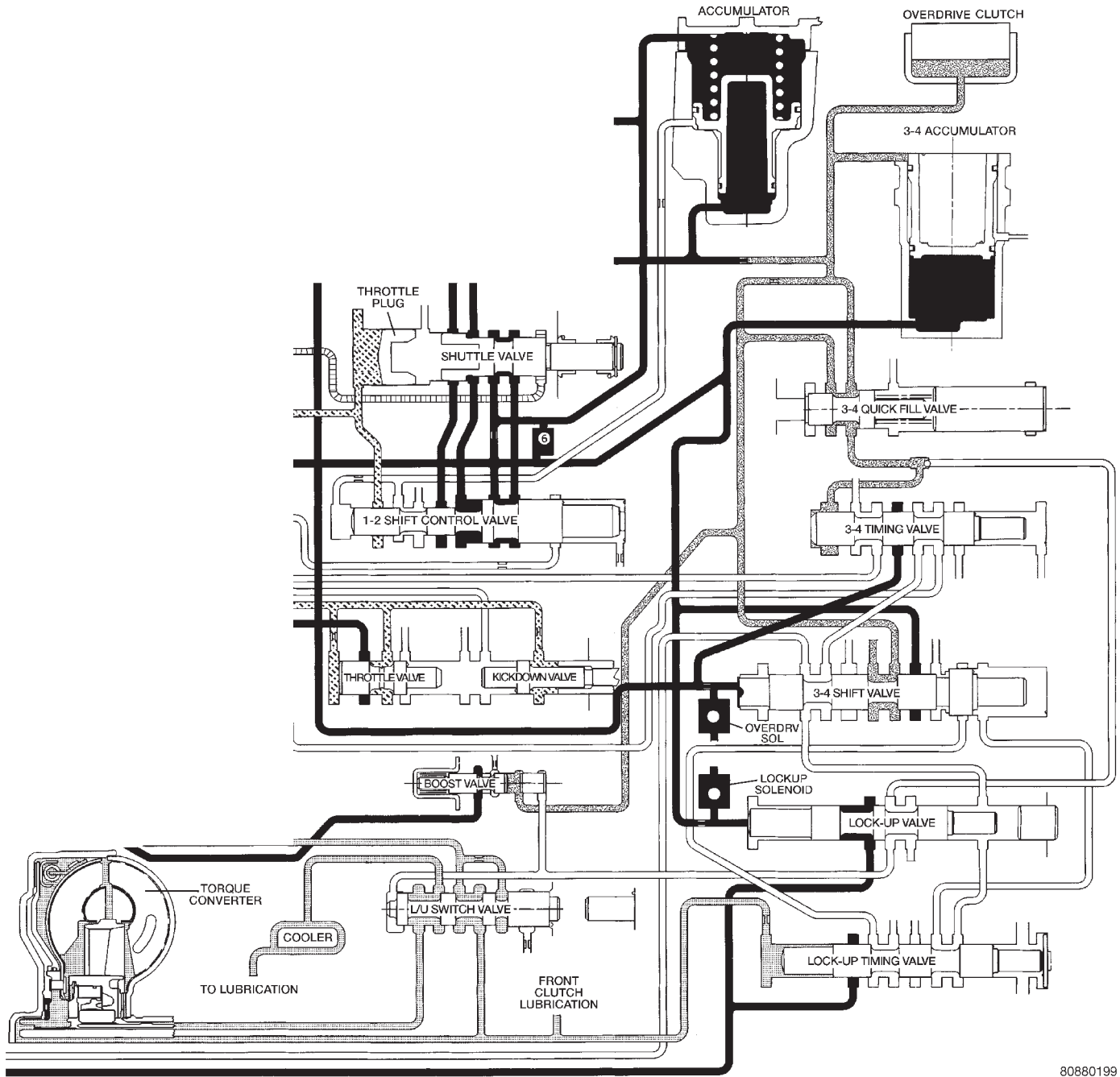
**Fig. 260 Throttle Valve****SWITCH VALVE**

When the transmission is in Drive Second before the TCC application occurs (Fig. 261), the pressure regulator valve is supplying torque converter pressure to the switch valve. The switch valve directs this pressure through the transmission input shaft, into the converter, through the converter, back out between the input shaft and the reaction shaft, and back up to the switch valve. From the switch valve, the fluid pressure is directed to the transmission cooler, and lubrication pressure returns from the cooler to lubricate different portions of the transmission.

Once the TCC control valve has moved to the right (Fig. 262), line pressure is directed to the tip of the switch valve, forcing the valve to the right. The switch valve now vents oil from the front of the piston in the torque converter, and supplies line pressure to the (rear) apply side of the torque converter piston. This pressure differential causes the piston to apply against the friction material, cutting off any further flow of line pressure oil. After the switch valve is shuttled right allowing line pressure to engage the TCC, torque converter pressure is directed past the switch valve into the transmission cooler and lubrication circuits.



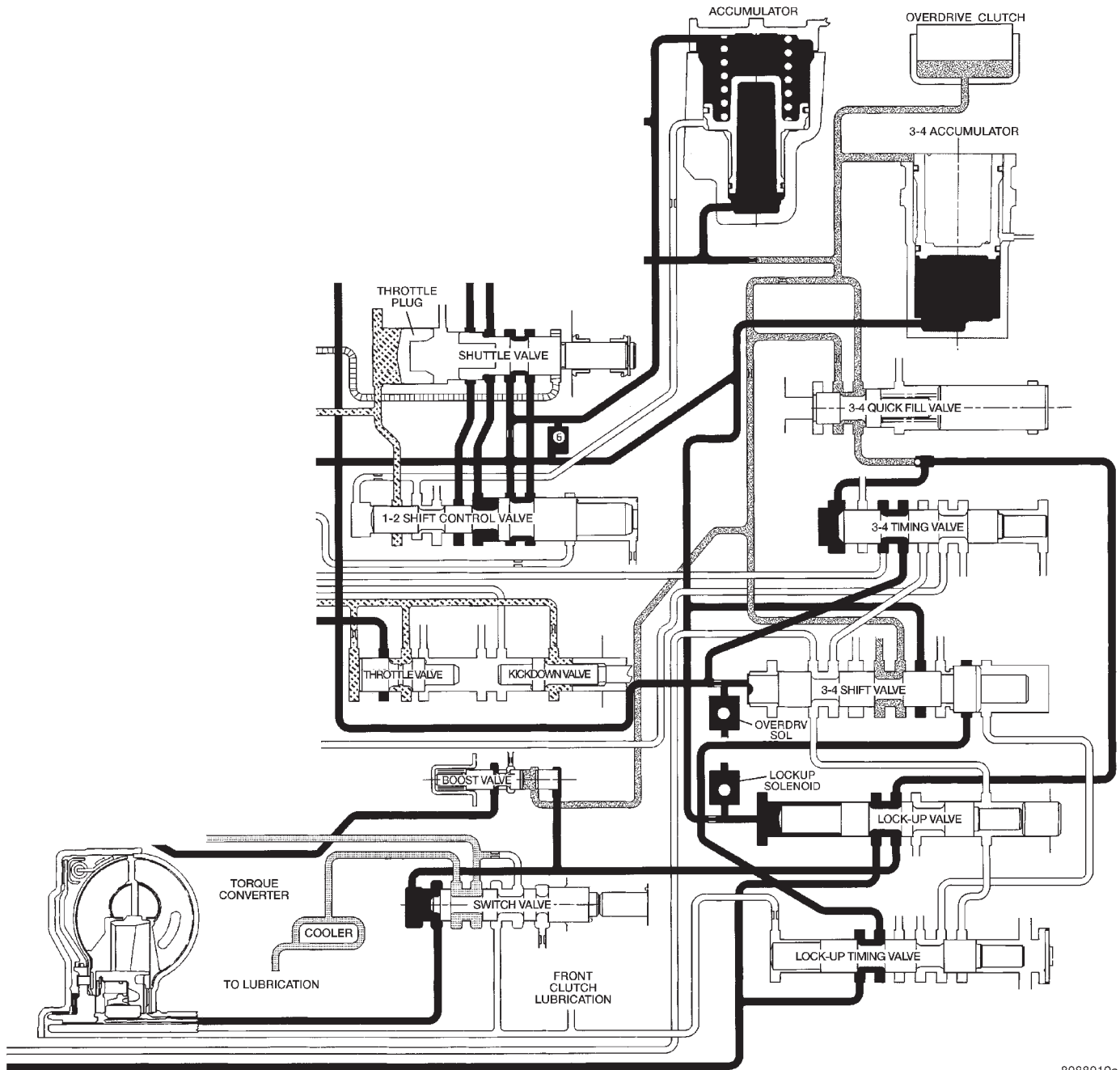
VALVE BODY (Continued)



80880199

**Fig. 261 Switch Valve-Torque Converter Unlocked**

## VALVE BODY (Continued)



8088019a

**Fig. 262 Switch Valve-Torque Converter Locked**

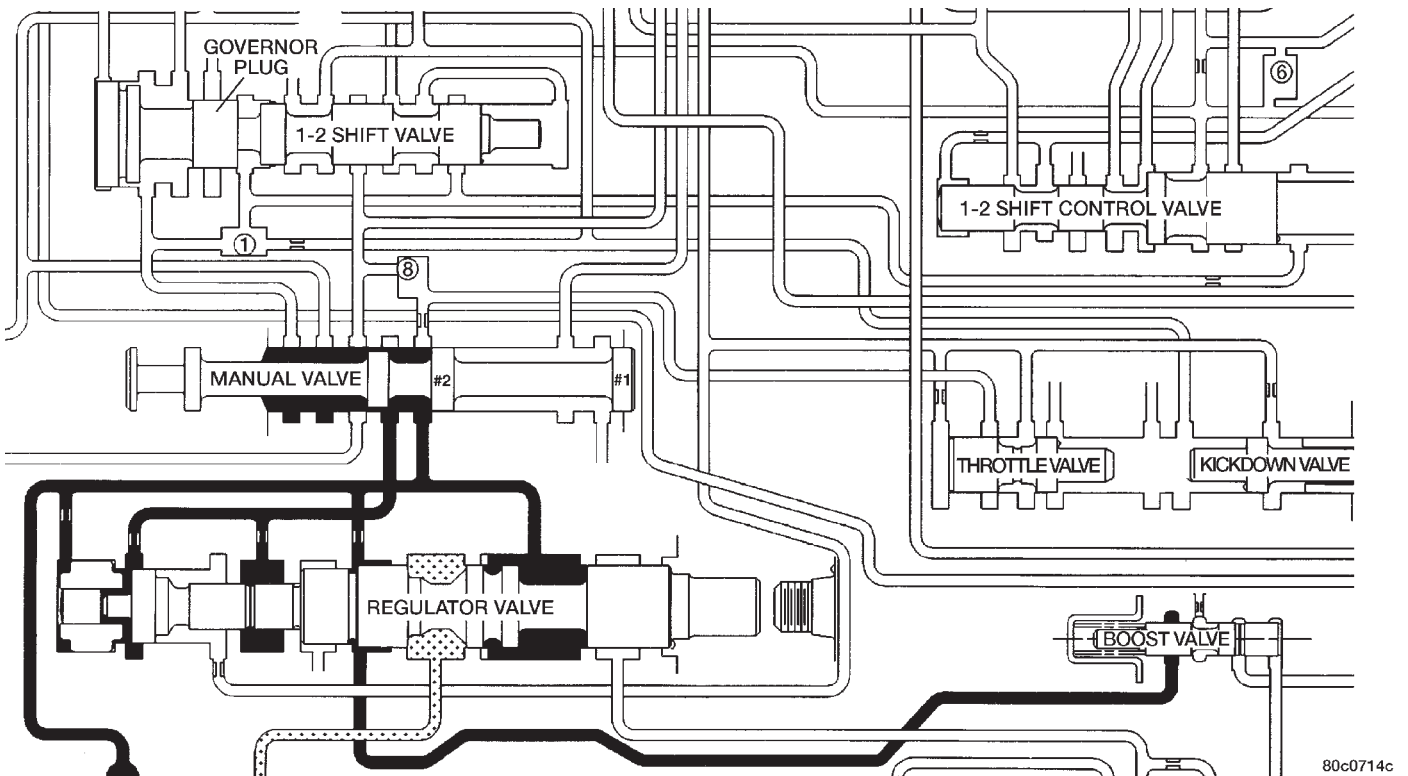
### MANUAL VALVE

The manual valve (Fig. 263) is a relay valve. The purpose of the manual valve is to direct fluid to the correct circuit needed for a specific gear or driving range. The manual valve, as the name implies, is manually operated by the driver with a lever located on the side of the valve body. The valve is connected mechanically by either a cable or linkage to the gear-shift mechanism. The valve is held in each of its positions by a spring-loaded roller or ball that engages the "roostercomb" of the manual valve lever.

### CONVERTER CLUTCH LOCK-UP VALVE

The torque converter clutch (TCC) lock-up valve controls the back (ON) side of the torque converter clutch. When the PCM energizes the TCC solenoid to engage the converter clutch piston, pressure is applied to the TCC lock-up valve which moves to the right and applies pressure to the torque converter clutch.

## VALVE BODY (Continued)



80c0714c

Fig. 263 Manual Valve

## CONVERTER CLUTCH LOCK-UP TIMING VALVE

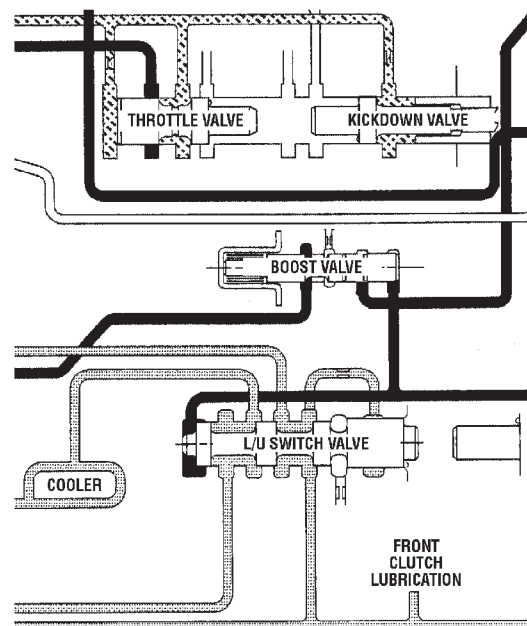
The torque converter clutch (TCC) lock-up timing valve is there to block any 4-3 downshift until the TCC is completely unlocked and the clutch is disengaged.

## SHUTTLE VALVE

The assembly is contained in a bore in the valve body above the shift valves. When the manual valve is positioned in the Drive range, throttle pressure acts on the throttle plug of the shuttle valve (Fig. 255) to move it against a spring, increasing the spring force on the shuttle valve. During a part or full throttle 1-2 upshift, the throttle plug is bottomed by throttle pressure, holding the shuttle valve to the right against governor pressure, and opening a by-pass circuit. The shuttle valve controls the quality of the kickdown shift by restricting the rate of fluid discharge from the front clutch and servo release circuits. During a 3-2 kickdown, fluid discharges through the shuttle by-pass circuit. When the shuttle valve closes the by-pass circuit, fluid discharge is restricted and controlled for the application of the front band. During a 2-3 "lift foot" upshift, the shuttle valve by-passes the restriction to allow full fluid flow through the by-pass groove for a faster release of the band.

## BOOST VALVE

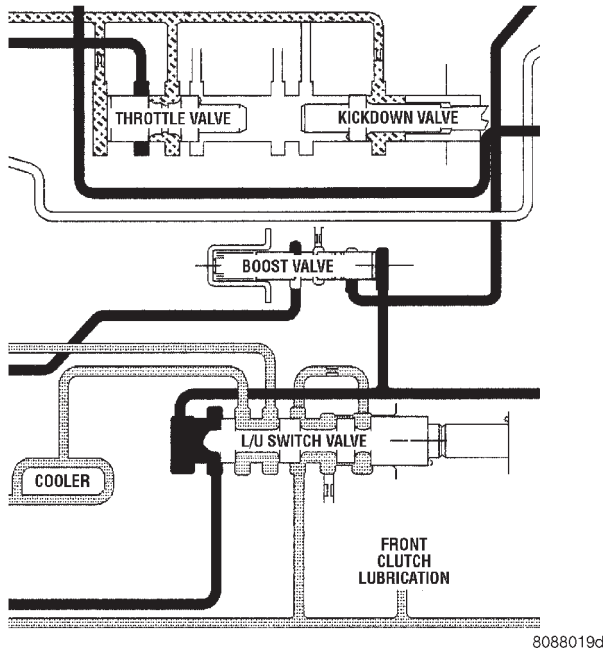
The boost valve (Fig. 264) provides increased fluid apply pressure to the overdrive clutch during 3-4 upshifts (Fig. 265), and when accelerating in fourth gear. The boost valve also serves to increase line pressure during torque converter lock-up.



8088019c

Fig. 264 Boost Valve Before Lock-up

## VALVE BODY (Continued)



8088019d

Fig. 265 Boost Valve After Lock-up

## REMOVAL

The valve body can be removed for service without having to remove the transmission assembly.

The valve body can be disassembled for cleaning and inspection of the individual components.

The only replaceable valve body components are:

- Manual lever.
- Manual lever washer, seal, E-clip, and shaft seal.
- Manual lever detent ball.
- Throttle lever.
- Fluid filter.
- Pressure adjusting screw bracket.
- Governor pressure solenoid.
- Governor pressure sensor (includes transmission temperature thermistor).
- Converter clutch/overdrive solenoid assembly and harness .
- Governor housing gasket.
- Solenoid case connector O-rings.

- (1) Shift transmission into NEUTRAL.
- (2) Raise vehicle.
- (3) Remove gearshift and throttle levers from shaft of valve body manual lever.
- (4) Disconnect wires at solenoid case connector (Fig. 266).
- (5) Position drain pan under transmission oil pan.
- (6) Remove transmission oil pan and gasket.
- (7) Remove fluid filter from valve body.
- (8) Remove bolts attaching valve body to transmission case.
- (9) Lower valve body enough to remove accumulator piston and springs.

(10) Work manual lever shaft and electrical connector out of transmission case.

(11) Lower valve body, rotate valve body away from case, pull park rod out of sprag, and remove valve body (Fig. 267).

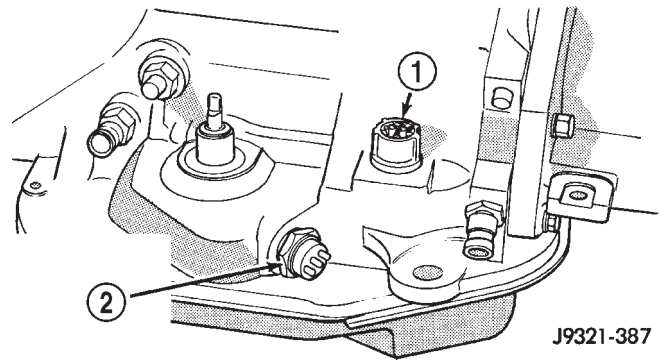
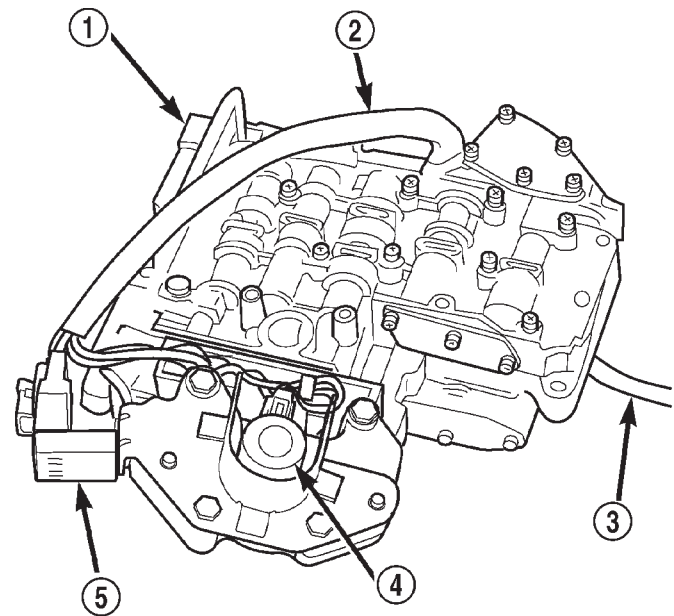


Fig. 266 Transmission Case Connector

- 1 - SOLENOID CASE CONNECTOR
- 2 - PARK/NEUTRAL POSITION SWITCH



80c072b2

Fig. 267 Valve Body

- 1 - VALVE BODY
- 2 - WIRE HARNESS
- 3 - PARK ROD
- 4 - GOVERNOR PRESSURE SOLENOID
- 5 - GOVERNOR PRESSURE SENSOR

## VALVE BODY (Continued)

## DISASSEMBLY

**CAUTION:** Do not clamp any valve body component in a vise. This practice can damage the component resulting in unsatisfactory operation after assembly and installation. Do not use pliers to remove any of the valves, plugs or springs and do not force any of the components out or into place. The valves and valve body housings will be damaged if force is used. Tag or mark the valve body springs for reference as they are removed. Do not allow them to become intermixed.

(1) Disconnect wires from governor pressure sensor and solenoid.

(2) Remove screws attaching governor body and retainer plate to transfer plate.

(3) Remove retainer plate, governor body and gasket from transfer plate.

(4) Remove governor pressure sensor from governor body.

(5) Remove governor pressure solenoid by pulling it straight out of bore in governor body. Remove and discard solenoid O-rings if worn, cut, or torn.

(6) Remove small shoulder bolt that secures solenoid harness case connector to 3-4 accumulator housing (Fig. 268). Retain shoulder bolt. Either tape it to harness or thread it back into accumulator housing after connector removal.

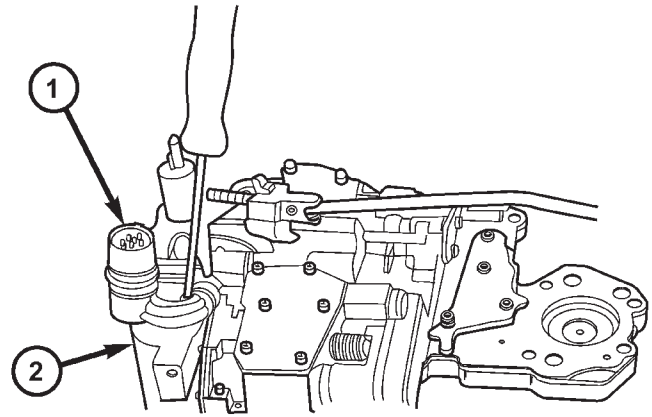
(7) Unhook overdrive/converter solenoid harness from 3-4 accumulator cover plate (Fig. 269).

(8) Turn valve body over and remove screws that attach overdrive/converter solenoid assembly to valve body (Fig. 270).

(9) Remove solenoid and harness assembly from valve body (Fig. 271).

(10) Remove boost valve cover (Fig. 272).

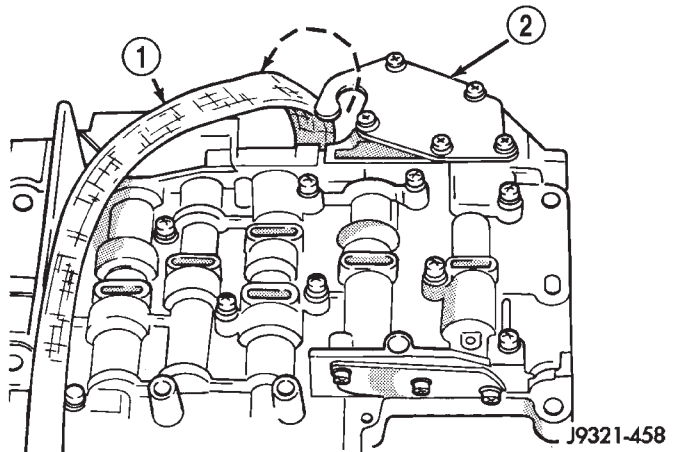
(11) Remove boost valve retainer, valve spring and boost valve (Fig. 273).



808803a3

**Fig. 268 Solenoid Harness Case Connector Shoulder Bolt**

- 1 - SOLENOID HARNESS CASE CONNECTOR  
2 - 3-4 ACCUMULATOR HOUSING



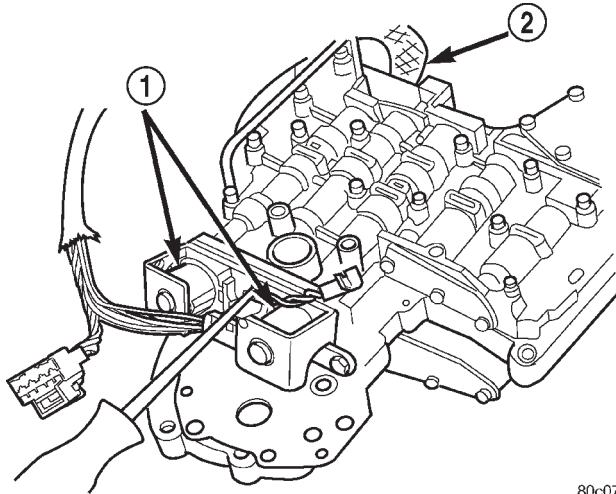
J9321-458

**Fig. 269 Unhooking Solenoid Harness From Accumulator Cover Plate**

- 1 - OVERDRIVE/CONVERTER SOLENOID WIRE HARNESS  
2 - 3-4 ACCUMULATOR COVER PLATE



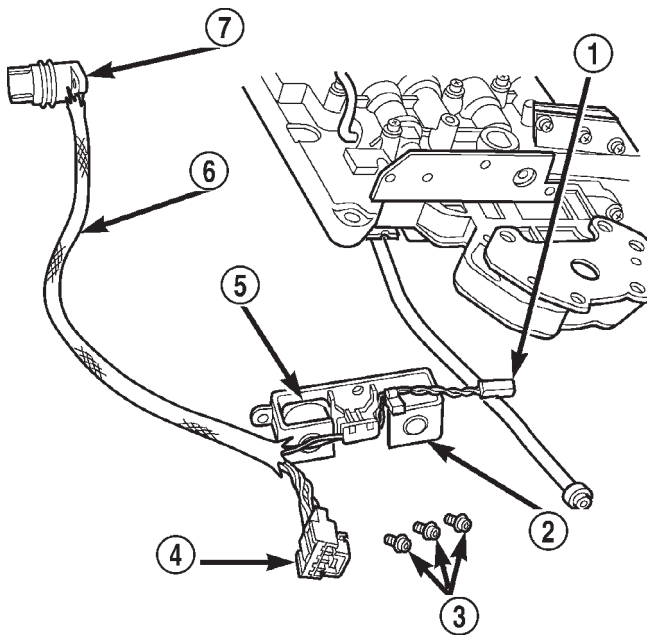
VALVE BODY (Continued)



80c072b3

**Fig. 270 Solenoid Assembly Screws**

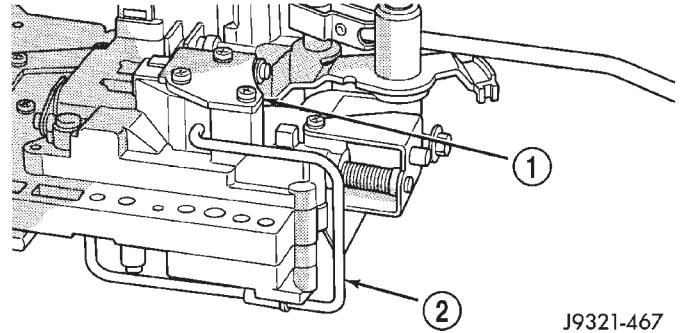
- 1 - OVERDRIVE/CONVERTER CLUTCH SOLENOID ASSEMBLY
- 2 - HARNESS



80c072b4

**Fig. 271 Solenoid Assembly**

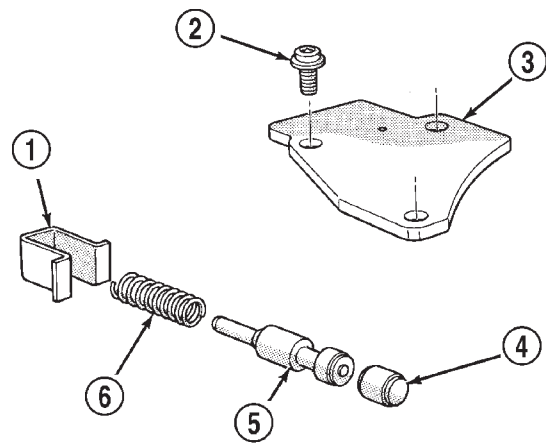
- 1 - GOVERNOR SOLENOID WIRES
- 2 - CONVERTER CLUTCH SOLENOID
- 3 - SOLENOID SCREWS
- 4 - GOVERNOR SENSOR WIRES
- 5 - OVERDRIVE SOLENOID
- 6 - HARNESS
- 7 - CASE CONNECTOR



J9321-467

**Fig. 272 Boost Valve**

- 1 - BOOST VALVE HOUSING AND COVER
- 2 - BOOST VALVE TUBE



J9321-468

**Fig. 273 Boost Valve Components**

- 1 - SPRING AND VALVE RETAINER
- 2 - COVER SCREWS
- 3 - BOOST VALVE COVER
- 4 - BOOST VALVE PLUG
- 5 - BOOST VALVE
- 6 - BOOST VALVE SPRING

## VALVE BODY (Continued)

(12) Secure detent ball and spring with Retainer Tool 6583 (Fig. 274).

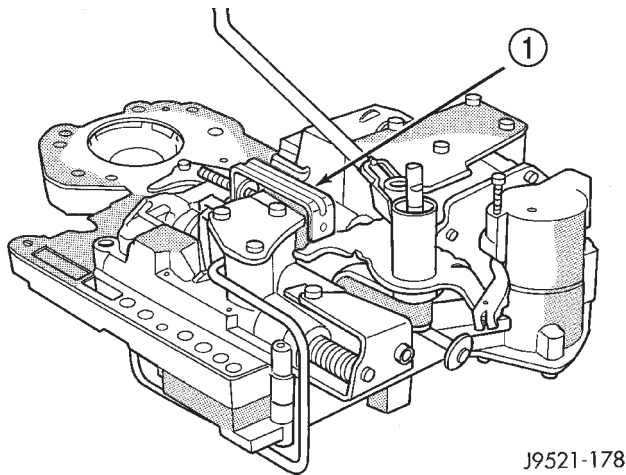
(13) Remove park rod E-clip and separate rod from manual lever (Fig. 275).

(14) Remove E-clip and washer that retains throttle lever shaft in manual lever (Fig. 276).

(15) Remove manual lever and throttle lever (Fig. 277). Rotate and lift manual lever off valve body and throttle lever shaft. Then slide throttle lever out of valve body.

(16) Position pencil magnet next to detent housing to catch detent ball and spring. Then carefully remove Retainer Tool 6583 and remove detent ball and spring (Fig. 278).

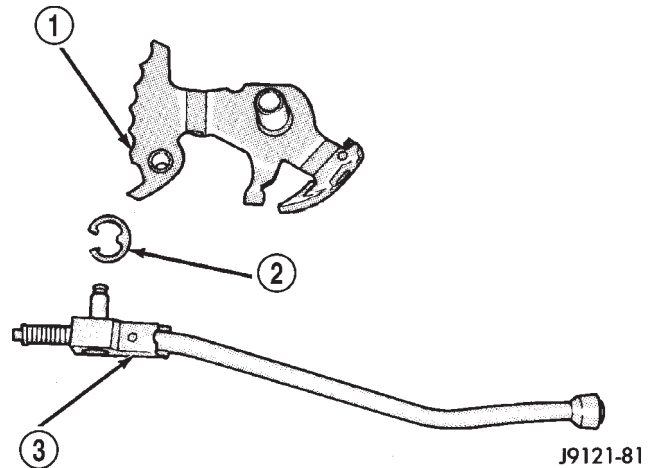
(17) Remove screws attaching pressure adjusting screw bracket to valve body and transfer plate (Fig. 279). Hold bracket firmly against spring tension while removing last screw.



J9521-178

**Fig. 274 Detent Ball And Spring**

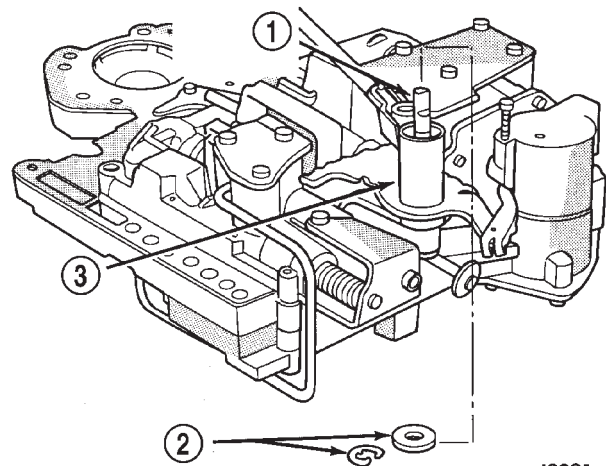
1 - SPECIAL TOOL 6583 POSITIONED ON DETENT HOUSING



J9121-81

**Fig. 275 Park Rod**

1 - MANUAL LEVER  
2 - E-CLIP  
3 - PARK ROD

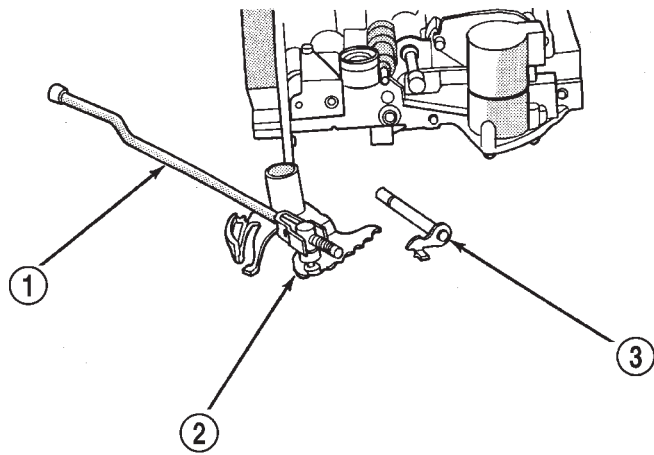


J9321-424

**Fig. 276 Throttle Lever E-Clip And Washer**

1 - THROTTLE LEVER SHAFT  
2 - E-CLIP AND WASHER  
3 - MANUAL SHAFT

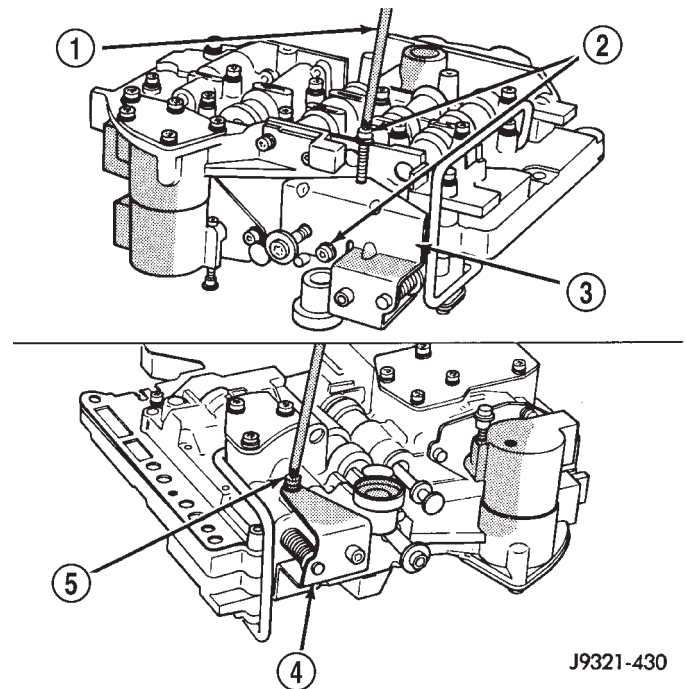
VALVE BODY (Continued)



J9321-425

**Fig. 277 Manual And Throttle Lever**

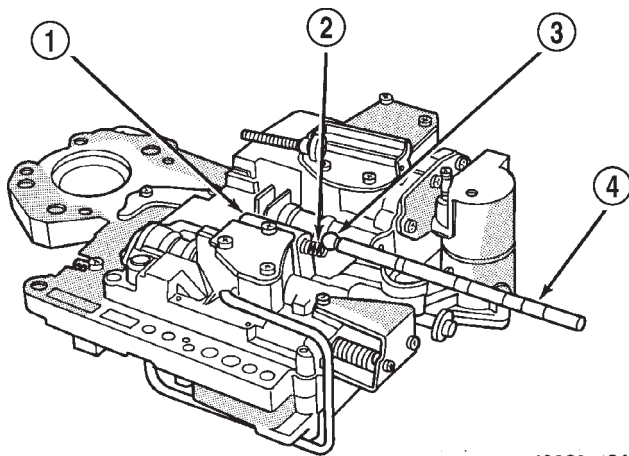
- 1 - PARK ROD
- 2 - MANUAL LEVER ASSEMBLY
- 3 - THROTTLE LEVER



J9321-430

**Fig. 279 Adjusting Screw Bracket Fastener**

- 1 - T25 TORX™ BIT
- 2 - REMOVE THESE SCREWS FIRST
- 3 - BRACKET
- 4 - BRACKET
- 5 - REMOVE THIS SCREW LAST



J9321-426

**Fig. 278 Detent Ball And Spring**

- 1 - DETENT HOUSING
- 2 - DETENT SPRING
- 3 - DETENT BALL
- 4 - PENCIL MAGNET

(18) Remove adjusting screw bracket, line pressure adjusting screw, pressure regulator valve spring and switch valve spring (Fig. 280). Do not remove throttle pressure adjusting screw from bracket and do not disturb setting of either adjusting screw during removal.

(19) Turn upper housing over and remove switch valve, regulator valve and spring, and manual valve (Fig. 281).

(20) Remove kickdown detent, kickdown valve, and throttle valve and spring (Fig. 281).

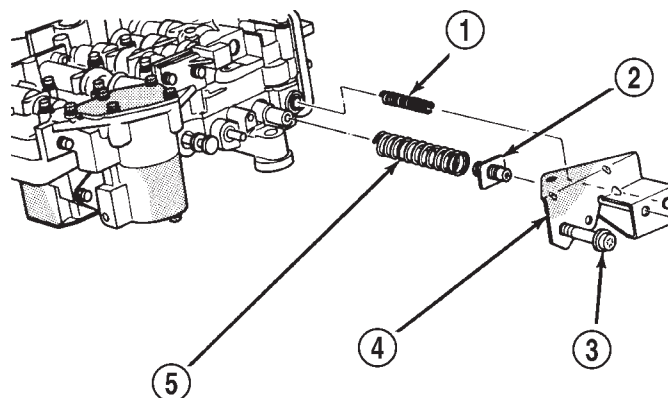
## VALVE BODY (Continued)

(21) Loosen left-side 3-4 accumulator housing attaching screw about 2-3 threads. Then remove center and right-side housing attaching screws (Fig. 282).

(22) Carefully rotate 3-4 accumulator housing upward and remove 3-4 shift valve spring and converter clutch valve plug and spring (Fig. 283).

(23) Remove left-side screw and remove 3-4 accumulator housing from valve body (Fig. 284).

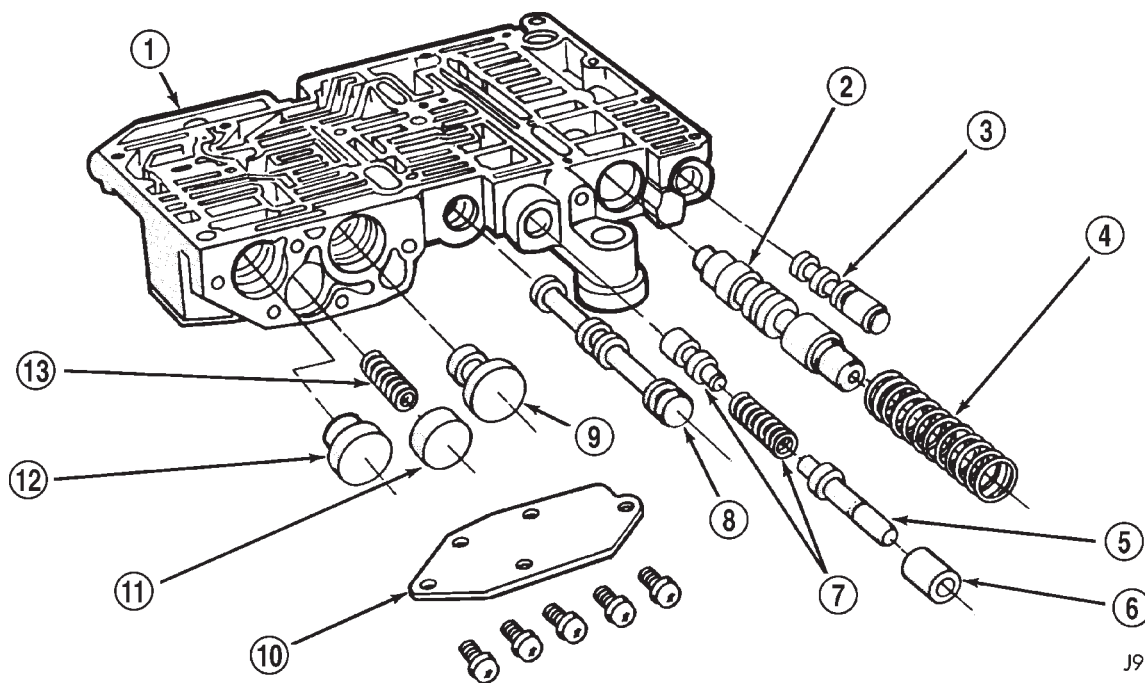
(24) Bend back tabs on boost valve tube brace (Fig. 285).



J9321-431

**Fig. 280 Adjusting Screw Bracket And Spring**

- 1 - SWITCH VALVE SPRING
- 2 - LINE PRESSURE SCREW
- 3 - THROTTLE PRESSURE ADJUSTING SCREW
- 4 - ADJUSTING SCREW BRACKET
- 5 - PRESSURE REGULATOR VALVE SPRING

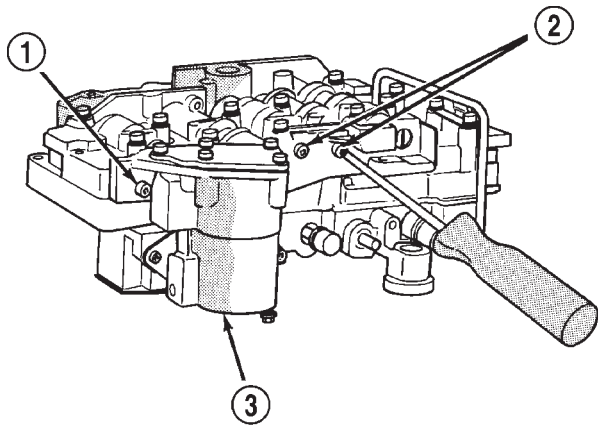


J9321-155

**Fig. 281 Upper Housing Control Valve Locations**

- 1 - UPPER HOUSING
- 2 - REGULATOR VALVE
- 3 - SWITCH VALVE
- 4 - REGULATOR VALVE SPRING
- 5 - KICKDOWN VALVE
- 6 - KICKDOWN DETENT
- 7 - THROTTLE VALVE AND SPRING
- 8 - MANUAL VALVE
- 9 - 1-2 GOVERNOR PLUG
- 10 - GOVERNOR PLUG COVER
- 11 - THROTTLE PLUG
- 12 - 2-3 GOVERNOR PLUG
- 13 - SHUTTLE VALVE PRIMARY SPRING

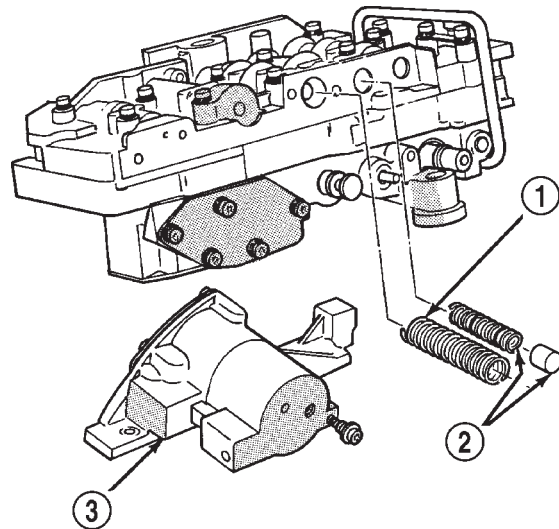
VALVE BODY (Continued)



J9321-432

**Fig. 282 Accumulator Housing Screw Locations**

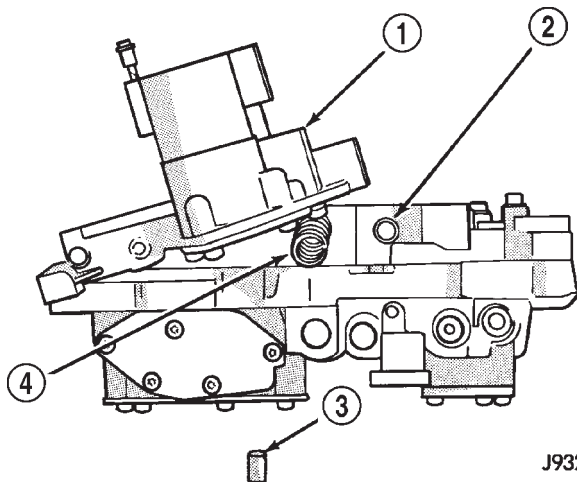
- 1 - LOOSEN THIS SCREW
- 2 - REMOVE THESE SCREWS
- 3 - 3-4 ACCUMULATOR HOUSING



J9321-434

**Fig. 284 Accumulator Housing, Valve Springs And Plug**

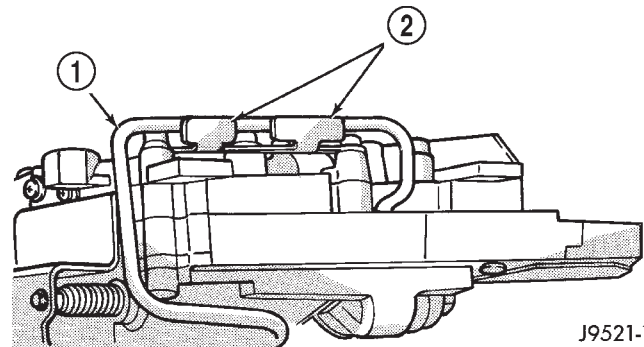
- 1 - 3-4 SHIFT VALVE SPRING
- 2 - CONVERTER CLUTCH VALVE SPRING AND PLUG
- 3 - 3-4 ACCUMULATOR HOUSING



J9321-433

**Fig. 283 3-4 Shift And Converter Clutch Valve Springs And Plug**

- 1 - ACCUMULATOR HOUSING
- 2 - CONVERTER CLUTCH VALVE SPRING
- 3 - CLUTCH VALVE PLUG
- 4 - 3-4 SHIFT VALVE SPRING



J9521-101

**Fig. 285 Boost Valve Tube Brace**

- 1 - BOOST VALVE TUBE
- 2 - TUBE BRACE (DOUBLE TAB)



## VALVE BODY (Continued)

(25) Remove boost valve connecting tube (Fig. 286). Disengage tube from upper housing port first. Then rock opposite end of tube back and forth to work it out of lower housing.

**CAUTION:** Do not use tools to loosen or pry the connecting tube out of the valve body housings. Loosen and remove the tube by hand only.

(26) Turn valve body over so lower housing is facing upward (Fig. 287). In this position, the two check balls in upper housing will remain in place and not fall out when lower housing and separator plate are removed.

(27) Remove screws attaching valve body lower housing to upper housing and transfer plate (Fig. 287). Note position of boost valve tube brace for assembly reference.

(28) Remove lower housing and overdrive separator plate from transfer plate (Fig. 287).

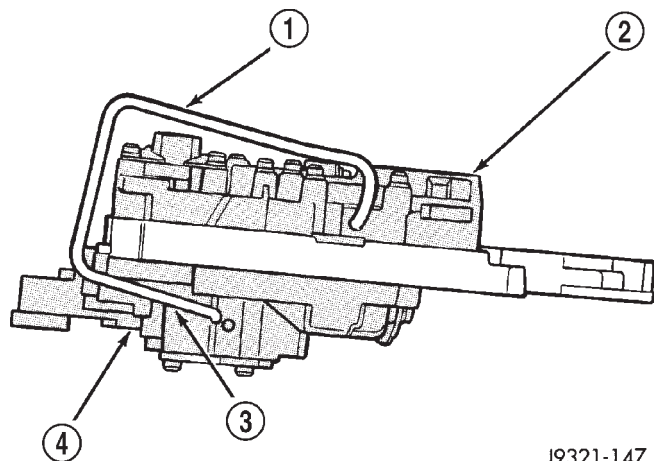
(29) Remove the ECE check ball from the transfer plate (Fig. 288). The ECE check ball is approximately 4.8 mm (3/16 in.) in diameter.

(30) Remove transfer plate from upper housing (Fig. 289).

(31) Turn transfer plate over so upper housing separator plate is facing upward.

(32) Remove upper housing separator plate from transfer plate (Fig. 290). Note position of filter in separator plate for assembly reference.

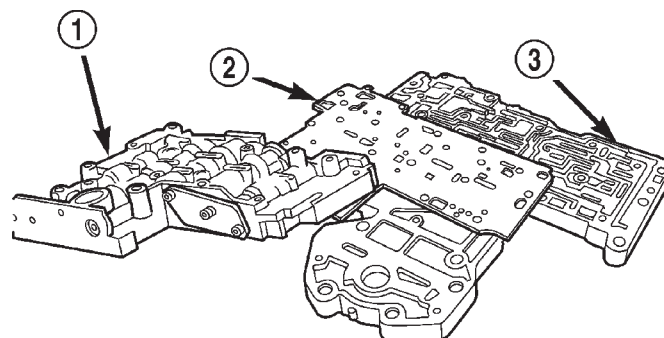
(33) Remove rear clutch and rear servo check balls from transfer plate. Note check ball location for assembly reference (Fig. 291).



J9321-147

**Fig. 286 Boost Valve Tube**

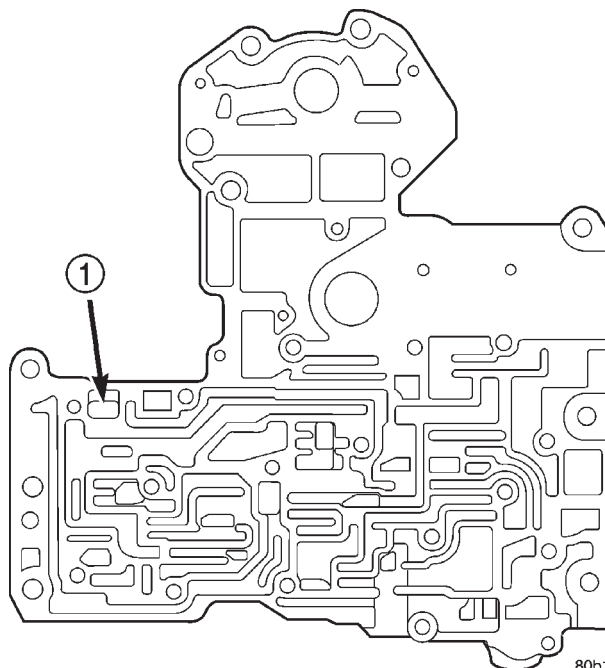
- 1 - BOOST VALVE TUBE
- 2 - LOWER HOUSING
- 3 - DISENGAGE THIS END OF TUBE FIRST
- 4 - UPPER HOUSING



80b170f8

**Fig. 287 Lower Housing**

- 1 - LOWER HOUSING
- 2 - OVERDRIVE SEPARATOR PLATE
- 3 - TRANSFER PLATE AND UPPER HOUSING

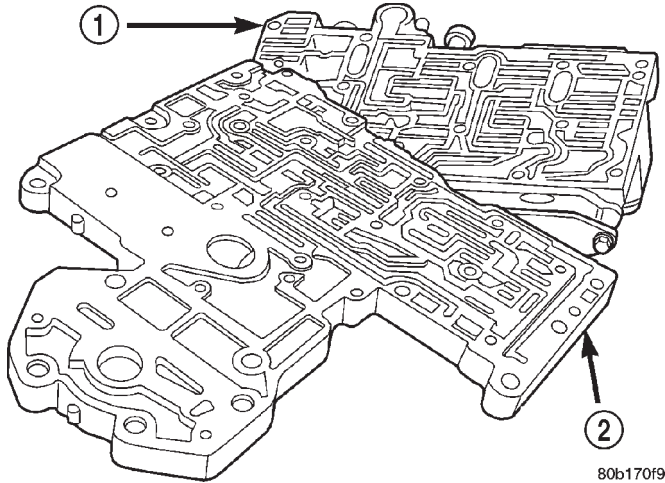


80b17125

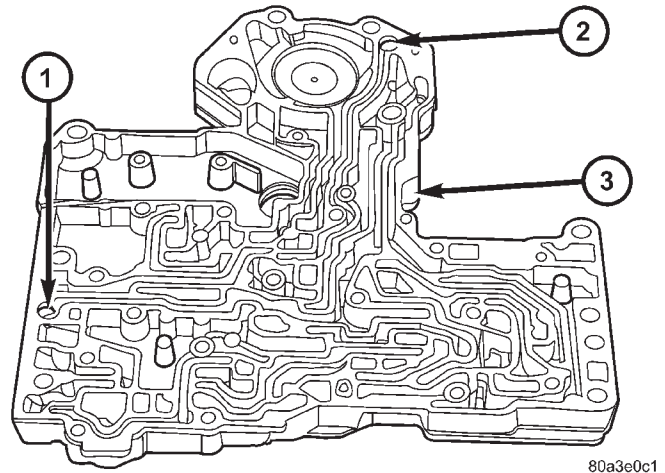
**Fig. 288 ECE Check Ball**

- 1 - ECE CHECK BALL (3/16")

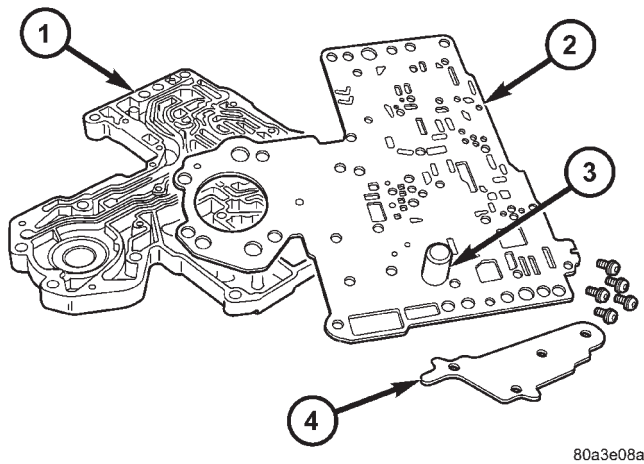
## VALVE BODY (Continued)

**Fig. 289 Transfer Plate**

- 1 - UPPER HOUSING  
2 - TRANSFER PLATE

**Fig. 291 Rear Clutch And Rear Servo Check Ball**

- 1 - REAR CLUTCH CHECK BALL  
2 - REAR SERVO CHECK BALL  
3 - TRANSFER PLATE

**Fig. 290 Upper Housing Separator Plate**

- 1 - TRANSFER PLATE  
2 - UPPER HOUSING SEPARATOR PLATE  
3 - FILTER SCREEN  
4 - BRACE

**VALVE BODY UPPER HOUSING**

(1) Note location of check balls in valve body upper housing (Fig. 292). Then remove the one large diameter and the six smaller diameter check balls.

(2) Remove governor plug and shuttle valve covers (Fig. 294).

(3) Remove E-clip that secures shuttle valve secondary spring on valve stem (Fig. 293).

(4) Remove throttle plug, primary spring, shuttle valve, secondary spring, and spring guides (Fig. 294).

(5) Remove boost valve retainer, spring and valve if not previously removed.

(6) Remove throttle plug and 1-2 and 2-3 governor plugs (Fig. 281).

(7) Turn upper housing around and remove limit valve and shift valve covers (Fig. 295).

(8) Remove limit valve housing. Then remove retainer, spring, limit valve, and 2-3 throttle plug from limit valve housing (Fig. 295).

(9) Remove 1-2 shift control valve and spring (Fig. 295).

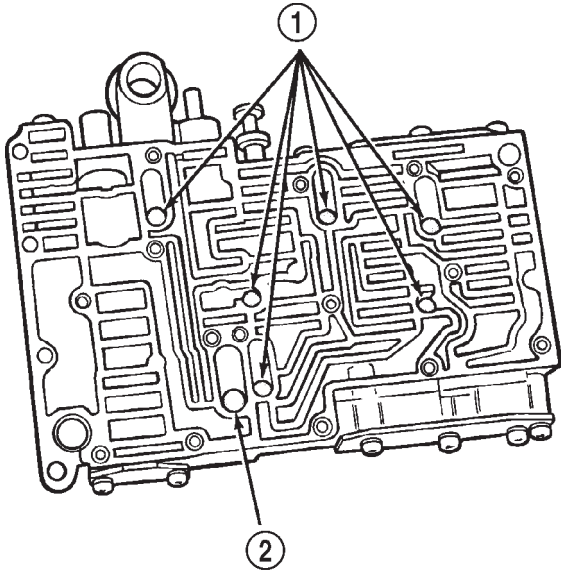
(10) Remove 1-2 shift valve and spring (Fig. 295).

(11) Remove 2-3 shift valve and spring from valve body (Fig. 295).

(12) Remove pressure plug cover (Fig. 295).

(13) Remove line pressure plug, sleeve, throttle pressure plug and spring (Fig. 295).

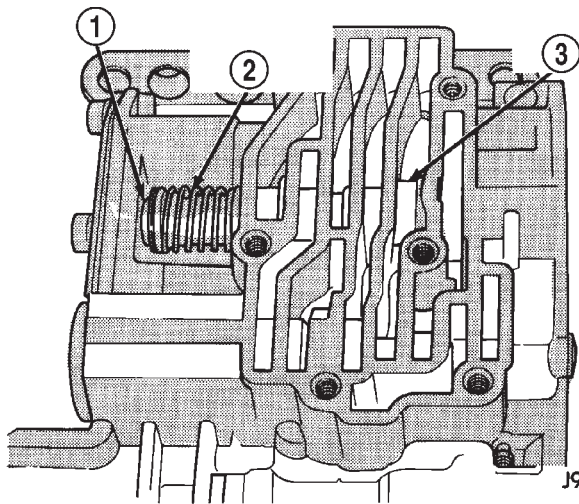
## VALVE BODY (Continued)



J9321-154

**Fig. 292 Check Ball Locations In Upper Housing**

- 1 - SMALL DIAMETER CHECK BALLS (6)
- 2 - LARGE DIAMETER CHECK BALL (1)

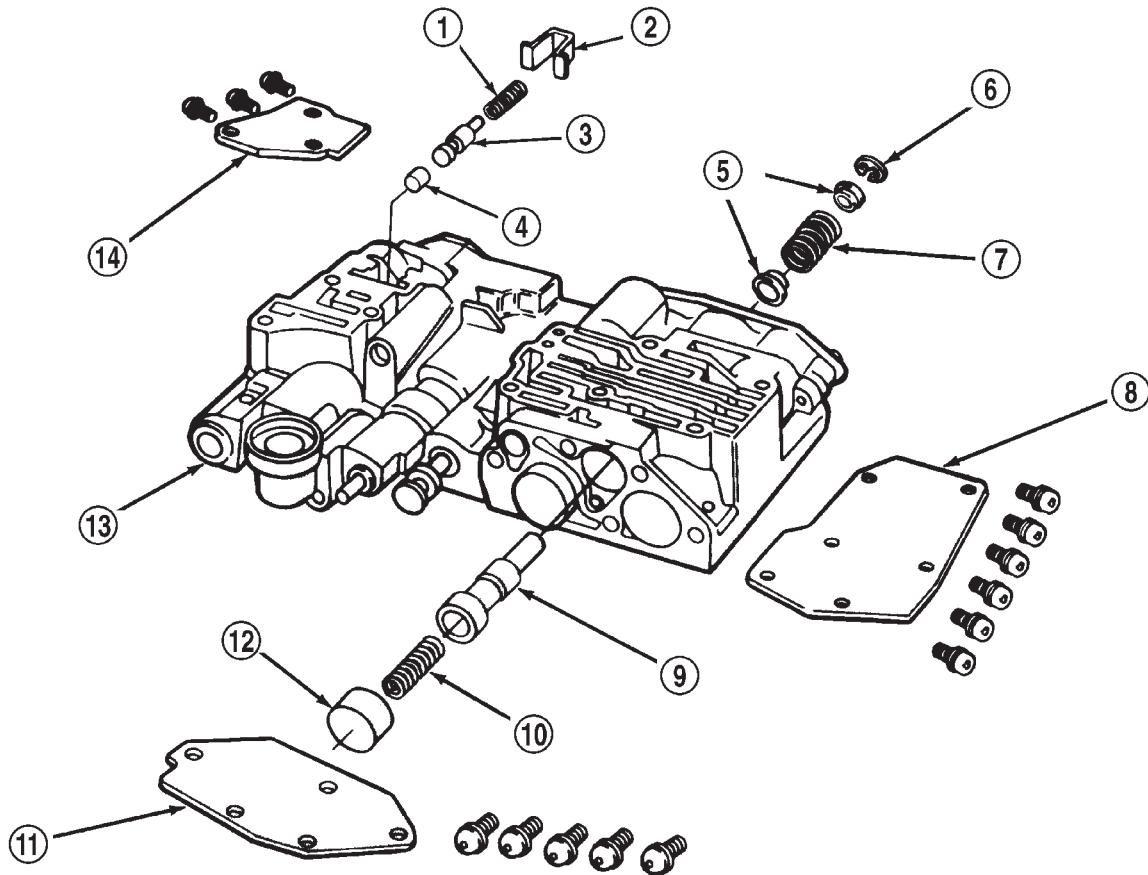


J9121-179

**Fig. 293 Shuttle Valve E-Clip And Secondary Spring Location**

- 1 - E-CLIP
- 2 - SECONDARY SPRING AND GUIDES
- 3 - SHUTTLE VALVE

## VALVE BODY (Continued)

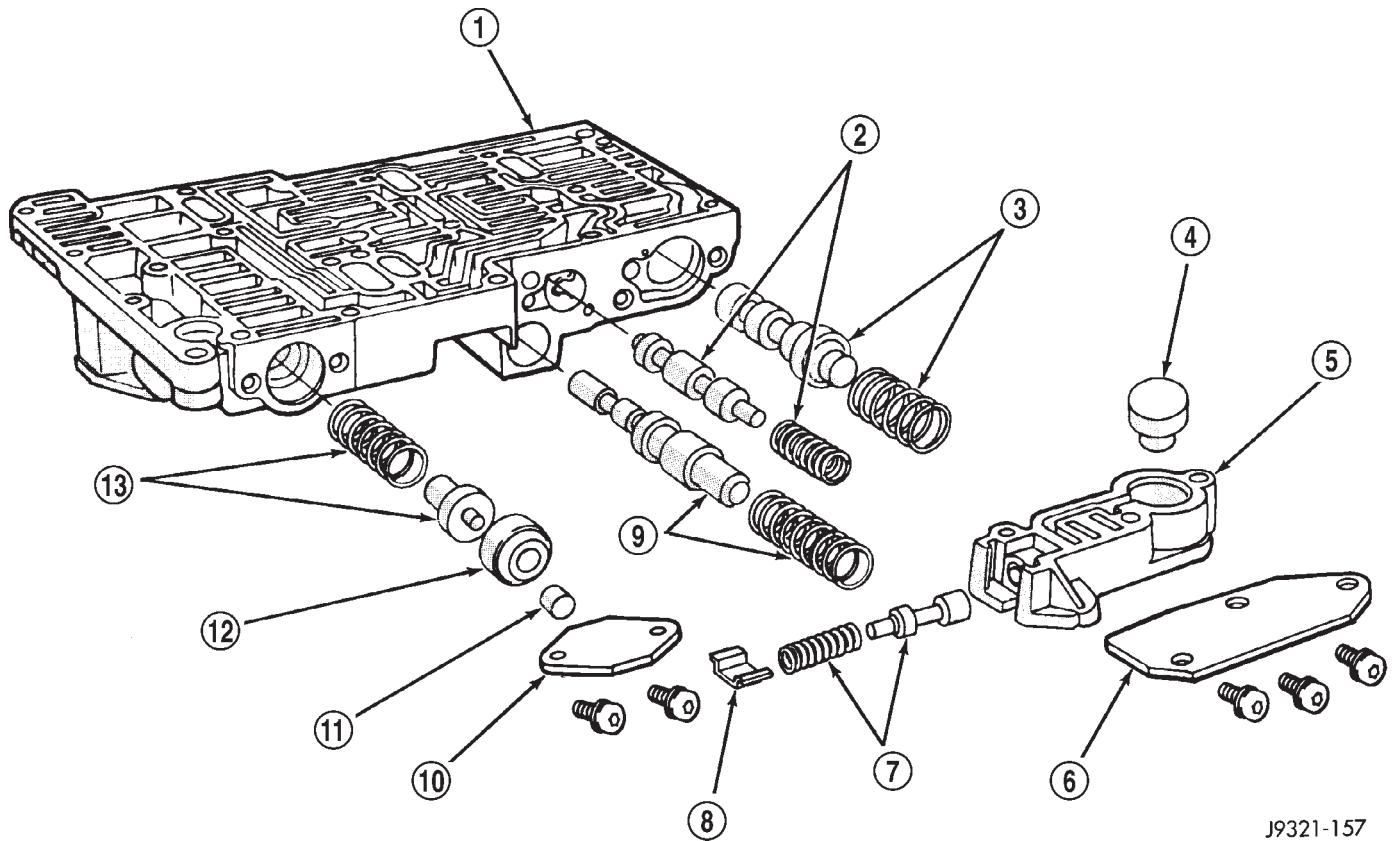


J9421-217

**Fig. 294 Shuttle And Boost Valve Components**

- |                                    |                                   |
|------------------------------------|-----------------------------------|
| 1 - SPRING                         | 8 - SHUTTLE VALVE COVER           |
| 2 - RETAINER                       | 9 - SHUTTLE VALVE                 |
| 3 - BOOST VALVE                    | 10 - SHUTTLE VALVE PRIMARY SPRING |
| 4 - BOOST VALVE PLUG               | 11 - GOVERNOR PLUG COVER          |
| 5 - SPRING GUIDES                  | 12 - THROTTLE PLUG                |
| 6 - E-CLIP                         | 13 - UPPER HOUSING                |
| 7 - SHUTTLE VALVE SECONDARY SPRING | 14 - BOOST VALVE COVER            |

VALVE BODY (Continued)



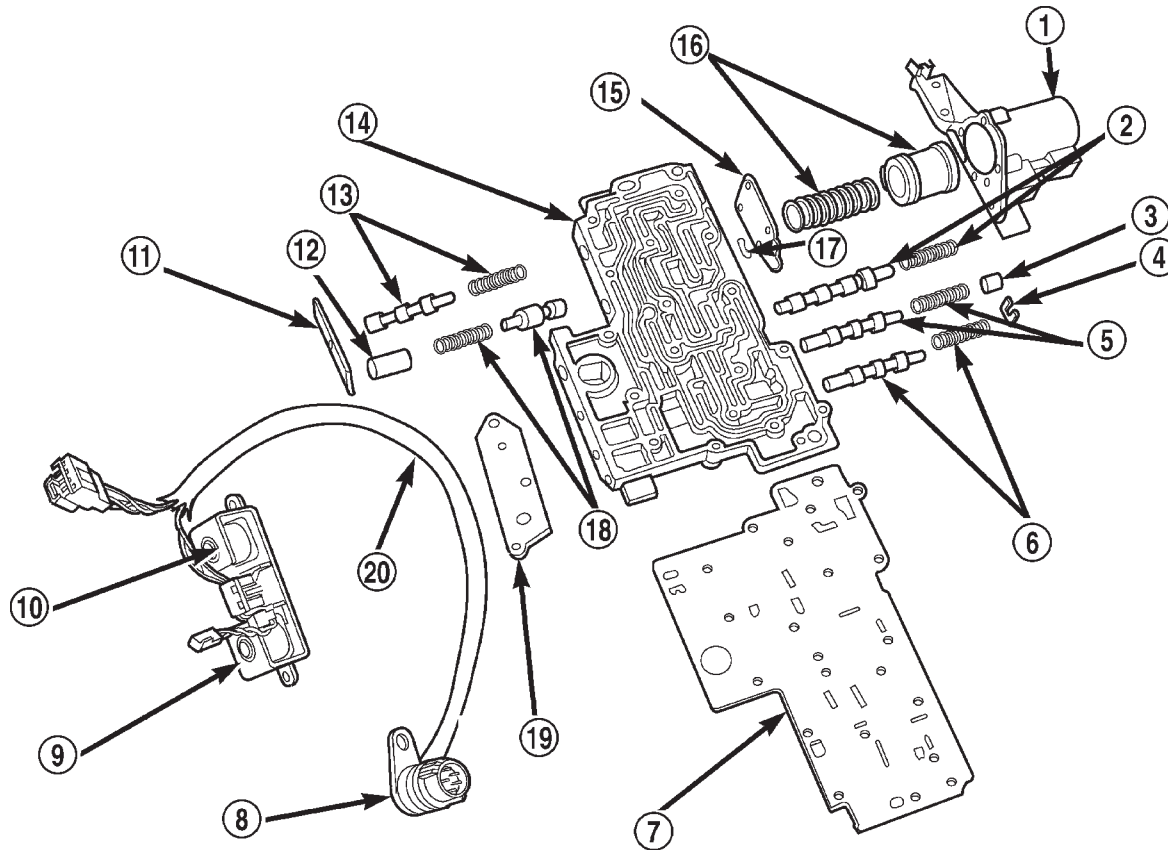
J9321-157

**Fig. 295 Upper Housing Shift Valve And Pressure Plug Locations**

- |                                |  |
|--------------------------------|--|
| 1 - UPPER HOUSING              | 8 - RETAINER                           |
| 2 - 1-2 SHIFT VALVE AND SPRING | 9 - 1-2 SHIFT CONTROL VALVE AND SPRING |
| 3 - 2-3 SHIFT VALVE AND SPRING | 10 - PRESSURE PLUG COVER               |
| 4 - 2-3 THROTTLE PLUG          | 11 - LINE PRESSURE PLUG                |
| 5 - LIMIT VALVE HOUSING        | 12 - PLUG SLEEVE                       |
| 6 - LIMIT VALVE COVER          | 13 - THROTTLE PRESSURE SPRING AND PLUG |
| 7 - LIMIT VALVE AND SPRING     |  |



## VALVE BODY (Continued)



80c072b5

**Fig. 296 Lower Housing Shift Valves and Springs**

- |  |  |
|--|--|
| 1 - 3-4 ACCUMULATOR HOUSING                  | 11 - TIMING VALVE COVER                |
| 2 - 3-4 SHIFT VALVE AND SPRING               | 12 - PLUG                              |
| 3 - PLUG                                     | 13 - 3-4 TIMING VALVE AND SPRING       |
| 4 - SPRING RETAINER                          | 14 - LOWER HOUSING                     |
| 5 - CONVERTER CLUTCH VALVE AND SPRING        | 15 - ACCUMULATOR END PLATE             |
| 6 - CONVERTER CLUTCH TIMING VALVE AND SPRING | 16 - 3-4 ACCUMULATOR PISTON AND SPRING |
| 7 - OVERDRIVE SEPARATOR PLATE                | 17 - E-CLIP                            |
| 8 - CASE CONNECTOR                           | 18 - 3-4 QUICK FILL SPRING AND VALVE   |
| 9 - CONVERTER CLUTCH SOLENOID                | 19 - SOLENOID GASKET                   |
| 10 - OVERDRIVE SOLENOID                      | 20 - HARNESS                           |

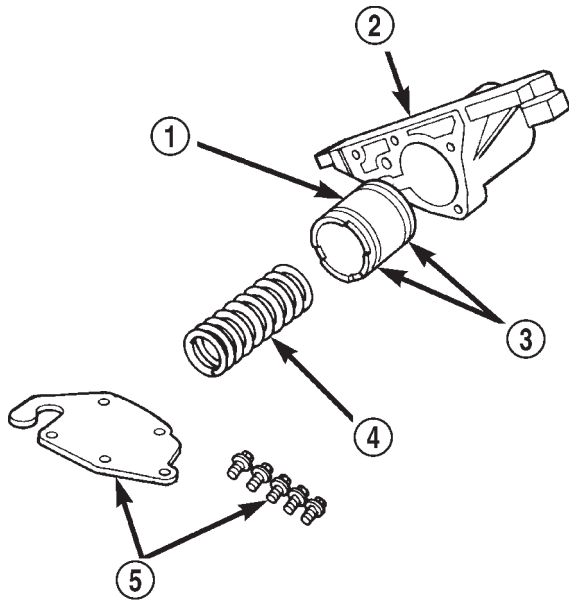
**VALVE BODY LOWER HOUSING**

- (1) Remove timing valve cover.
- (2) Remove 3-4 timing valve and spring.
- (3) Remove 3-4 quick fill valve, spring and plug.
- (4) Remove 3-4 shift valve and spring.
- (5) Remove converter clutch valve, spring and plug (Fig. 296).
- (6) Remove converter clutch timing valve, retainer and valve spring.

**3-4 ACCUMULATOR HOUSING**

- (1) Remove end plate from housing.
- (2) Remove piston spring.
- (3) Remove piston. Remove and discard piston seals (Fig. 297).

## VALVE BODY (Continued)



804d8eb9

**Fig. 297 Accumulator Housing Components**

- 1 - ACCUMULATOR PISTON
- 2 - 3-4 ACCUMULATOR HOUSING
- 3 - TEFLON SEALS
- 4 - PISTON SPRING
- 5 - COVER PLATE AND SCREWS

## CLEANING

Clean the valve housings, valves, plugs, springs, and separator plates with a standard parts cleaning solution only. Do not use gasoline, kerosene, or any type of caustic solution.

Do not immerse any of the electrical components in cleaning solution. Clean the governor solenoid and sensor and the dual solenoid and harness assembly by wiping them off with dry shop towels only.

Dry all except the electrical parts with compressed air. Make sure all passages are clean and free from obstructions. **Do not use rags or shop towels to dry or wipe off valve body components. Lint from these materials can stick to valve body parts, interfere with valve operation, and clog filters and fluid passages.**

Wipe the governor pressure sensor and solenoid valve with dry, lint free shop towels only. The O-rings on the sensor and solenoid valve are the only serviceable components. Be sure the vent ports in the solenoid valve are open and not blocked by dirt or debris. Replace the valve and/or sensor only when DRB scan tool diagnosis indicates this is necessary. Or, if either part has sustained physical damage (dented, deformed, broken, etc.)

**CAUTION:** Do not turn the small screw at the end of the solenoid valve for any reason. Turning the screw in either direction will ruin solenoid calibration and result in solenoid failure. In addition, the filter on the solenoid valve is **NOT** serviceable. Do not try to remove the filter as this will damage the valve housing.

## INSPECTION

Inspect the throttle and manual valve levers and shafts. Do not attempt to straighten a bent shaft or correct a loose lever. Replace these components if worn, bent, loose or damaged in any way.

Inspect all of the valve body mating surfaces for scratches, nicks, burrs, or distortion. Use a straight-edge to check surface flatness. Minor scratches may be removed with crocus cloth using only very light pressure.

Minor distortion of a valve body mating surface may be corrected by smoothing the surface with a sheet of crocus cloth. Position the crocus cloth on a surface plate, sheet of plate glass or equally flat surface. If distortion is severe or any surfaces are heavily scored, the valve body will have to be replaced.

**CAUTION:** Many of the valves and plugs, such as the throttle valve, shuttle valve plug, 1-2 shift valve and 1-2 governor plug, are made of coated aluminum. Aluminum components are identified by the dark color of the special coating applied to the surface (or by testing with a magnet). Do not sand aluminum valves or plugs under any circumstances. This practice could damage the special coating causing the valves/plugs to stick and bind.

Inspect the valves and plugs for scratches, burrs, nicks, or scores. Minor surface scratches on steel valves and plugs can be removed with crocus cloth but **do not round off the edges of the valve or plug lands.** Maintaining sharpness of these edges is vitally important. The edges prevent foreign matter from lodging between the valves and plugs and the bore.

Inspect all the valve and plug bores in the valve body. Use a penlight to view the bore interiors. Replace the valve body if any bores are distorted or scored. Inspect all of the valve body springs. The springs must be free of distortion, warpage or broken coils.

## VALVE BODY (Continued)

Check the two separator plates for distortion or damage of any kind. Inspect the upper housing, lower housing, 3-4 accumulator housing, and transfer plate carefully. Be sure all fluid passages are clean and clear. Check condition of the upper housing and transfer plate check balls as well. The check balls and ball seats must not be worn or damaged.

Trial fit each valve and plug in its bore to check freedom of operation. When clean and dry, the valves and plugs should drop freely into the bores.

Valve body bores do not change dimensionally with use. If the valve body functioned correctly when new, it will continue to operate properly after cleaning and inspection. It should not be necessary to replace a valve body assembly unless it is damaged in handling.

The only serviceable valve body components are listed below. The remaining valve body components are serviced only as part of a complete valve body assembly. Serviceable parts are:

- dual solenoid and harness assembly
- solenoid gasket
- solenoid case connector O-rings and shoulder bolt
- switch valve and spring
- pressure adjusting screw and bracket assembly
- throttle lever
- manual lever and shaft seal
- throttle lever shaft seal, washer, and E-clip
- fluid filter and screws
- detent ball and spring
- valve body screws
- governor pressure solenoid
- governor pressure sensor and retaining clip
- park lock rod and E-clip

## ASSEMBLY

**CAUTION:** Do not force valves or plugs into place during reassembly. If the valve body bores, valves and plugs are free of distortion or burrs, the valve body components should all slide into place easily. In addition, do not overtighten the transfer plate and valve body screws during reassembly. Overtightening can distort the housings resulting in valve sticking, cross leakage and unsatisfactory operation. Tighten valve body screws to recommended torque only.

## LOWER HOUSING

(1) Lubricate valves, springs, and the housing valve and plug bores with clean transmission fluid (Fig. 298).

(2) Install 3-4 timing valve spring and valve in lower housing.

(3) Install 3-4 quick fill valve in lower housing.

(4) Install 3-4 quick fill valve spring and plug in housing.

(5) Install timing valve end plate. Tighten end plate screws to 4 N·m (35 in. lbs.) torque.

## 3-4 ACCUMULATOR

(1) Lubricate accumulator piston, seals and housing piston bore with clean transmission fluid (Fig. 299).

(2) Install new seal rings on accumulator piston.

(3) Install piston and spring in housing.

(4) Install end plate on housing.

## TRANSFER PLATE

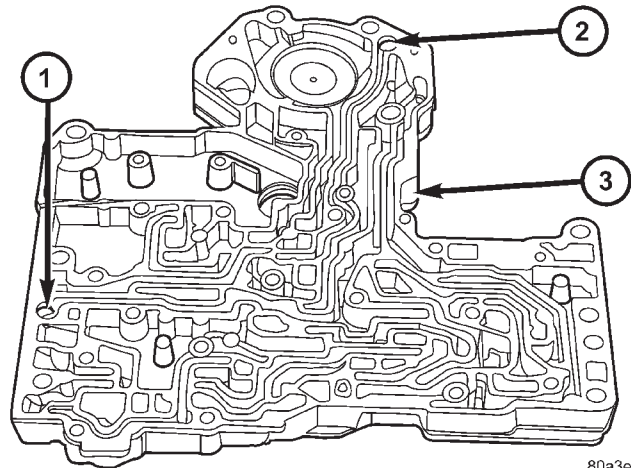
(1) Install rear clutch and rear servo check balls in transfer plate (Fig. 298).

(2) Install filter screen in upper housing separator plate (Fig. 299).

(3) Align and position upper housing separator plate on transfer plate (Fig. 300).

(4) Install brace plate (Fig. 300). Tighten brace attaching screws to 4 N·m (35 in. lbs.) torque.

(5) Install remaining separator plate attaching screws. Tighten screws to 4 N·m (35 in. lbs.) torque.

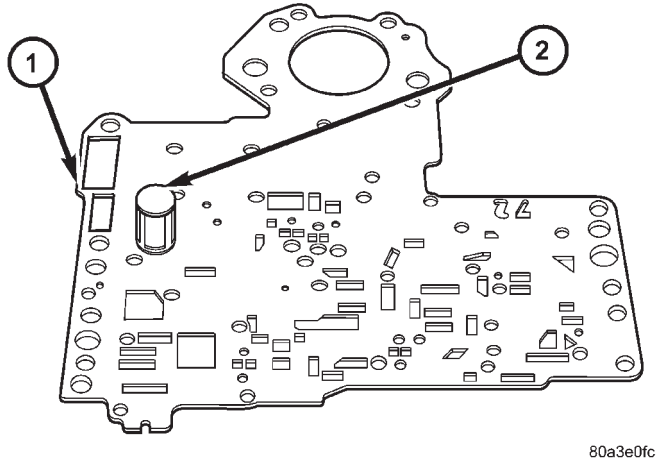


80a3e0c1

**Fig. 298 Rear Clutch And Rear Servo Check Ball Locations**

- 1 - REAR CLUTCH CHECK BALL
- 2 - REAR SERVO CHECK BALL
- 3 - TRANSFER PLATE

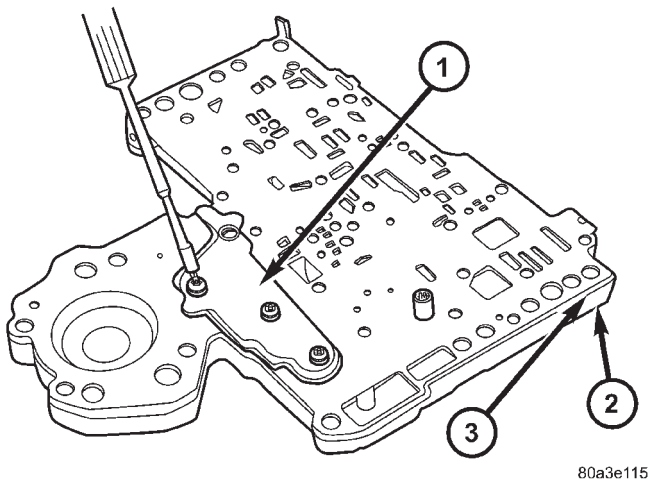
## VALVE BODY (Continued)



80a3e0fc

**Fig. 299 Separator Plate Filter Screen Installation**

- 1 - UPPER HOUSING SEPARATOR PLATE  
2 - FILTER SCREEN



80a3e115

**Fig. 300 Brace Plate**

- 1 - BRACE  
2 - TRANSFER PLATE  
3 - SEPARATOR PLATE

**UPPER AND LOWER HOUSING**

(1) Position upper housing so internal passages and check ball seats are facing upward. Then install check balls in housing (Fig. 301). Eight check balls are used. The single large check ball is approximately 8.7 mm (11/32 in.) diameter. The single small check ball is approximately 4.8 mm (3/16 in.) in diameter. The remaining 6 check balls are approximately 6.3 mm (1/4 in.) in diameter.

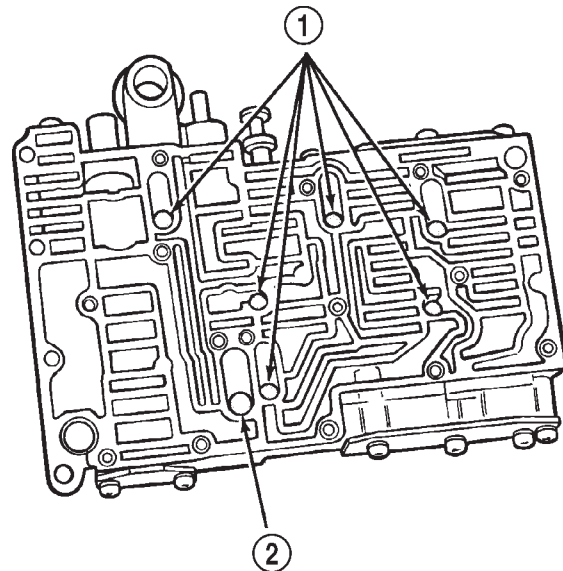
(2) Position assembled transfer plate and upper housing separator plate on upper housing (Fig. 302). Be sure filter screen is seated in proper housing recess.

(3) Install the ECE check ball into the transfer plate (Fig. 290). The ECE check ball is approximately 4.8 mm (3/16 in.) in diameter.

(4) Position lower housing separator plate on transfer plate (Fig. 303).

(5) Install lower housing on assembled transfer plate and upper housing (Fig. 304).

(6) Install and start all valve body screws by hand except for the screws to hold the boost valve tube brace. Save those screws for later installation. Then tighten screws evenly to 4 N·m (35 in. lbs.) torque. Start at center and work out to sides when tightening screws (Fig. 304).

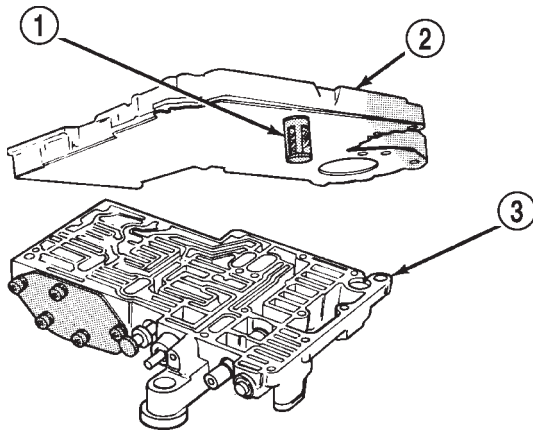


J9321-154

**Fig. 301 Check Ball Locations In Upper Housing**

- 1 - SMALL DIAMETER CHECK BALLS (6)  
2 - LARGE DIAMETER CHECK BALL (1)

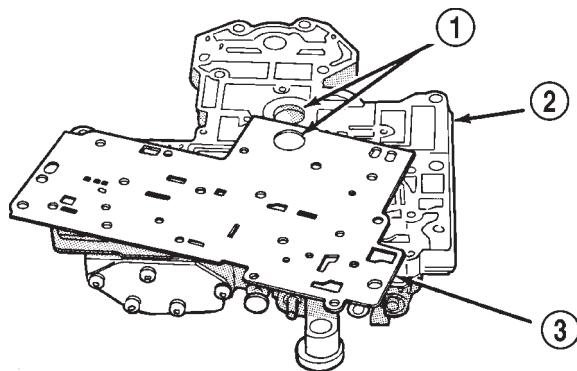
## VALVE BODY (Continued)



J9321-439

**Fig. 302 Installing Transfer Plate On Upper Housing**

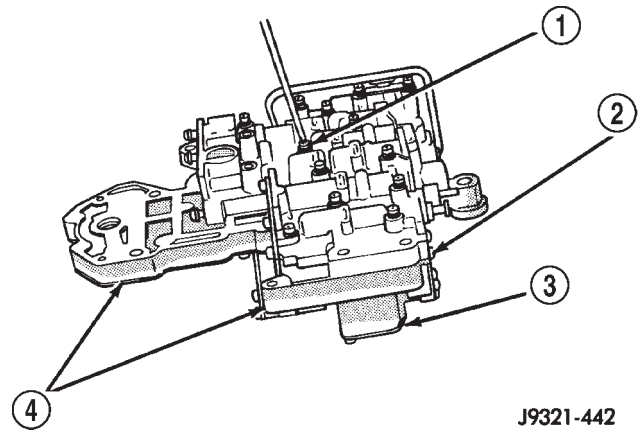
- 1 - FILTER SCREEN
- 2 - TRANSFER PLATE/SEPARATOR PLATE ASSEMBLY
- 3 - UPPER HOUSING



J9321-441

**Fig. 303 Lower Housing Separator Plate**

- 1 - BE SURE TO ALIGN BORES
- 2 - TRANSFER PLATE
- 3 - LOWER HOUSING (OVERDRIVE) SEPARATOR PLATE



J9321-442

**Fig. 304 Installing Lower Housing On Transfer Plate And Upper Housing**

- 1 - VALVE BODY SCREWS (13)
- 2 - LOWER HOUSING
- 3 - UPPER HOUSING
- 4 - TRANSFER PLATE

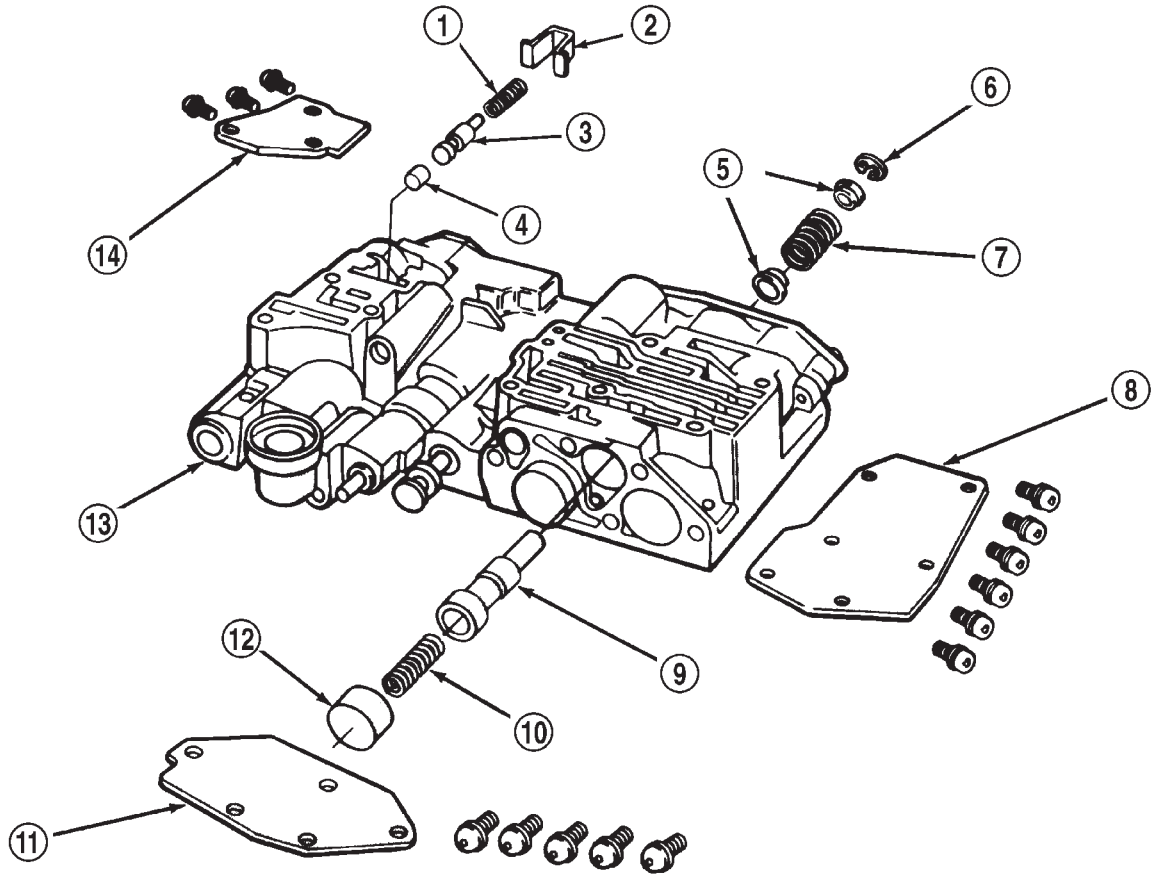
**UPPER HOUSING VALVE AND PLUG**

Refer to (Fig. 305), (Fig. 306) and (Fig. 307) to perform the following steps.

- (1) Lubricate valves, plugs, springs with clean transmission fluid.
- (2) Assemble regulator valve line pressure plug, sleeve, throttle plug and spring. Insert assembly in upper housing and install cover plate. Tighten cover plate screws to 4 N·m (35 in. lbs.) torque.
- (3) Install 1-2 and 2-3 shift valves and springs.
- (4) Install 1-2 shift control valve and spring.
- (5) Install retainer, spring, limit valve, and 2-3 throttle plug from limit valve housing.
- (6) Install limit valve housing and cover plate. Tighten screws to 4 N·m (35 in. lbs.).
- (7) Install shuttle valve as follows:
  - (a) Insert plastic guides in shuttle valve secondary spring and install spring on end of valve.
  - (b) Install shuttle valve into housing.
  - (c) Hold shuttle valve in place.
  - (d) Compress secondary spring and install E-clip in groove at end of shuttle valve.
  - (e) Verify that spring and E-clip are properly seated before proceeding.
- (8) Install shuttle valve cover plate. Tighten cover plate screws to 4 N·m (35 in. lbs.) torque.
- (9) Install 1-2 and 2-3 valve governor plugs in valve body.
- (10) Install shuttle valve primary spring and throttle plug.
- (11) Align and install governor plug cover. Tighten cover screws to 4 N·m (35 in. lbs.) torque.



VALVE BODY (Continued)

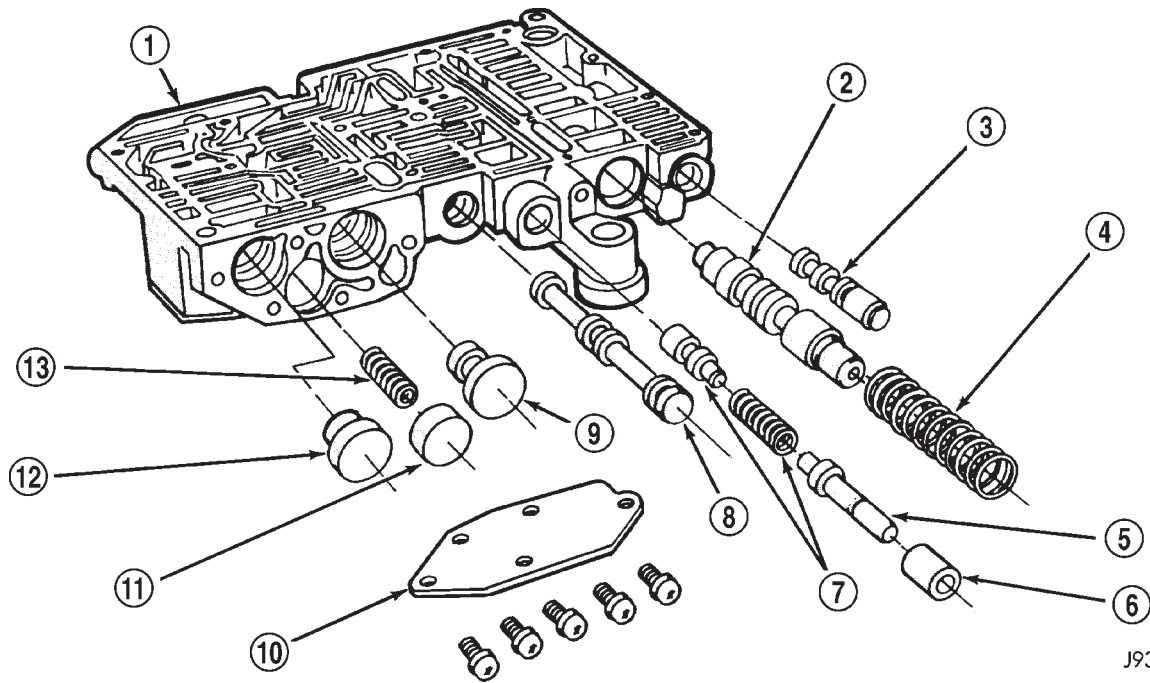


J9421-217

**Fig. 305 Shuttle And Boost Valve Components**

- |                                    |                                   |
|------------------------------------|-----------------------------------|
| 1 - SPRING                         | 8 - SHUTTLE VALVE COVER           |
| 2 - RETAINER                       | 9 - SHUTTLE VALVE                 |
| 3 - BOOST VALVE                    | 10 - SHUTTLE VALVE PRIMARY SPRING |
| 4 - BOOST VALVE PLUG               | 11 - GOVERNOR PLUG COVER          |
| 5 - SPRING GUIDES                  | 12 - THROTTLE PLUG                |
| 6 - E-CLIP                         | 13 - UPPER HOUSING                |
| 7 - SHUTTLE VALVE SECONDARY SPRING | 14 - BOOST VALVE COVER            |

VALVE BODY (Continued)

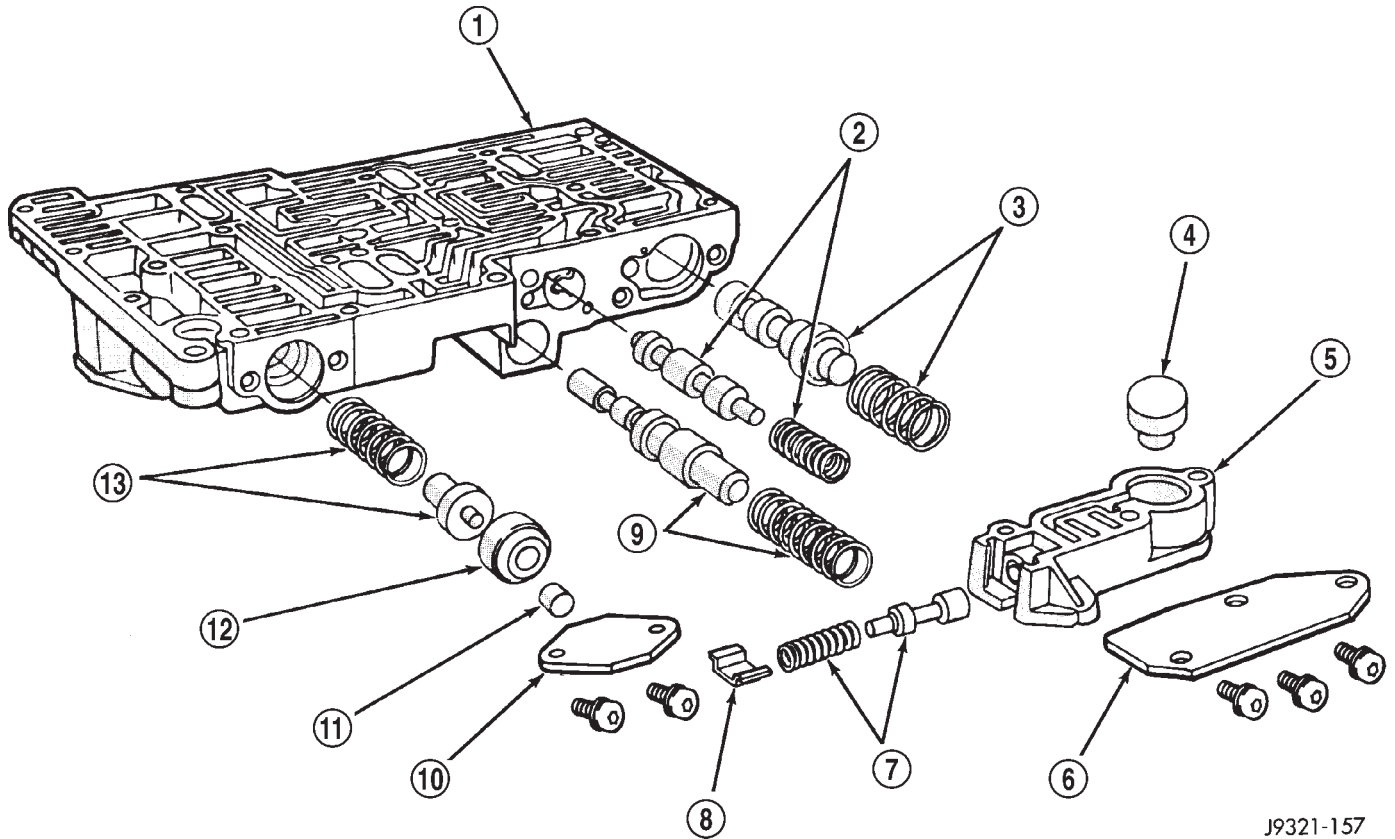


J9321-155

**Fig. 306 Upper Housing Control Valve Locations**

- |                               |                                   |
|-------------------------------|-----------------------------------|
| 1 - UPPER HOUSING             | 8 - MANUAL VALVE                  |
| 2 - REGULATOR VALVE           | 9 - 1-2 GOVERNOR PLUG             |
| 3 - SWITCH VALVE              | 10 - GOVERNOR PLUG COVER          |
| 4 - REGULATOR VALVE SPRING    | 11 - THROTTLE PLUG                |
| 5 - KICKDOWN VALVE            | 12 - 2-3 GOVERNOR PLUG            |
| 6 - KICKDOWN DETENT           | 13 - SHUTTLE VALVE PRIMARY SPRING |
| 7 - THROTTLE VALVE AND SPRING |                                   |

VALVE BODY (Continued)



J9321-157

**Fig. 307 Upper Housing Shift Valve And Pressure Plug Locations**

- |                                |  |
|--------------------------------|--|
| 1 - UPPER HOUSING              | 8 - RETAINER                           |
| 2 - 1-2 SHIFT VALVE AND SPRING | 9 - 1-2 SHIFT CONTROL VALVE AND SPRING |
| 3 - 2-3 SHIFT VALVE AND SPRING | 10 - PRESSURE PLUG COVER               |
| 4 - 2-3 THROTTLE PLUG          | 11 - LINE PRESSURE PLUG                |
| 5 - LIMIT VALVE HOUSING        | 12 - PLUG SLEEVE                       |
| 6 - LIMIT VALVE COVER          | 13 - THROTTLE PRESSURE SPRING AND PLUG |
| 7 - LIMIT VALVE AND SPRING     |  |

## VALVE BODY (Continued)

**BOOST VALVE TUBE AND BRACE**

(1) Position valve body assembly so lower housing is facing upward (Fig. 308).

(2) Lubricate tube ends and housing ports with transmission fluid or petroleum jelly.

(3) Start tube in lower housing port first. Then swing tube downward and work opposite end of tube into upper housing port (Fig. 308).

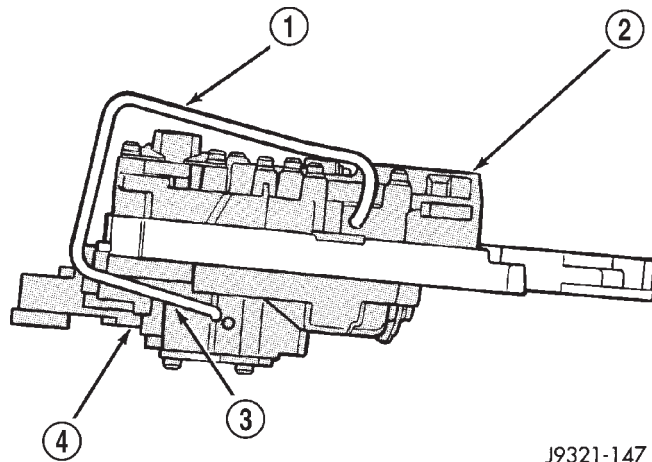
(4) Insert and seat each end of tube in housings.

(5) Slide tube brace under tube and into alignment with valve body screw holes (Fig. 309).

(6) Install and finger tighten three screws that secure tube brace to valve body housings (Fig. 309).

(7) Bend tube brace tabs up and against tube to hold it in position (Fig. 310).

(8) Tighten all valve body housing screws to 4 N·m (35 in. lbs.) torque after tube and brace are installed. Tighten screws in diagonal pattern starting at center and working outward.



J9321-147

**Fig. 308 Boost Valve Tube**

- 1 - BOOST VALVE TUBE
- 2 - LOWER HOUSING
- 3 - DISENGAGE THIS END OF TUBE FIRST
- 4 - UPPER HOUSING

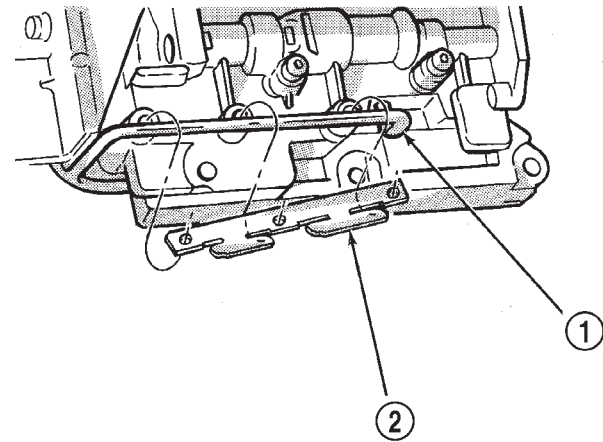
**3-4 ACCUMULATOR**

(1) Position converter clutch valve and 3-4 shift valve springs in housing (Fig. 311).

(2) Loosely attach accumulator housing with right-side screw (Fig. 311). Install only one screw at this time as accumulator must be free to pivot upward for ease of installation.

(3) Install 3-4 shift valve and spring.

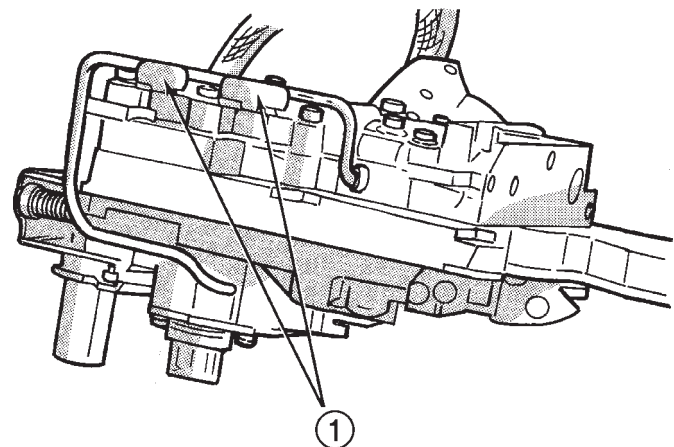
(4) Install converter clutch timing valve and spring.



J9521-107

**Fig. 309 Boost Valve Tube And Brace**

- 1 - BOOST VALVE TUBE
- 2 - TUBE BRACE



J9521-108

**Fig. 310 Securing Boost Valve Tube With Brace Tabs**

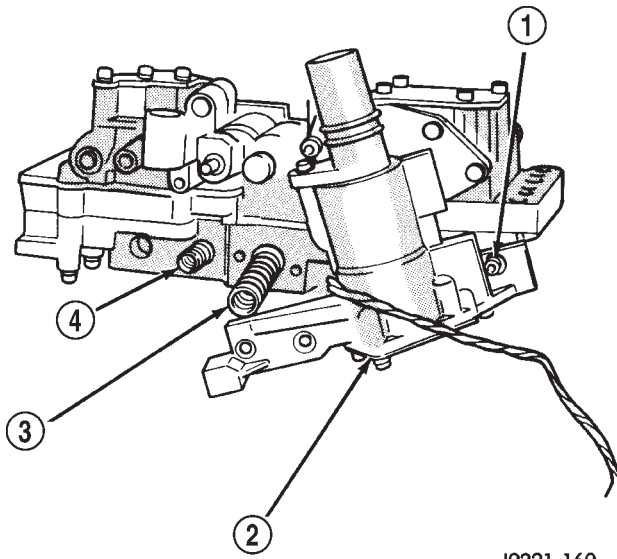
- 1 - BEND TABS UP AGAINST TUBE AS SHOWN

(5) Position plug on end of converter clutch valve spring. Then compress and hold springs and plug in place with fingers of one hand.

(6) Swing accumulator housing upward over valve springs and plug.

(7) Hold accumulator housing firmly in place and install remaining two attaching screws. Be sure springs and clutch valve plug are properly seated (Fig. 312). Tighten screws to 4 N·m (35 in. lbs.).

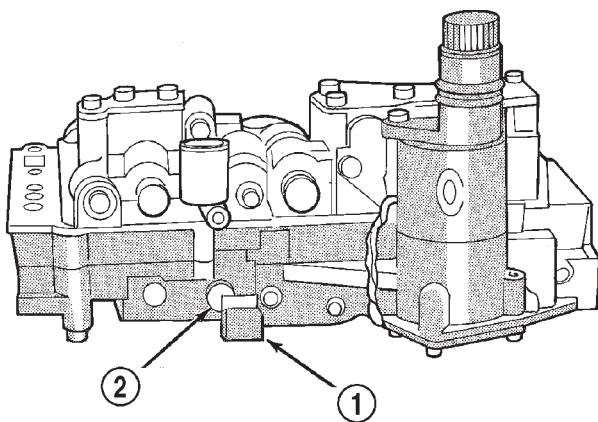
## VALVE BODY (Continued)



J9321-160

**Fig. 311 Converter Clutch And 3-4 Shift Valve Springs**

- 1 - RIGHT-SIDE SCREW
- 2 - 3-4 ACCUMULATOR
- 3 - 3-4 SHIFT VALVE SPRING
- 4 - CONVERTER CLUTCH VALVE SPRING



J9521-180

**Fig. 312 Seating 3-4 Accumulator On Lower Housing**

- 1 - ACCUMULATOR BOX
- 2 - CONVERTER CLUTCH VALVE PLUG

## VALVE BODY FINAL

(1) Install boost valve, valve spring, retainer and cover plate. Tighten cover plate screws to 4 N·m (35 in. lbs.) torque.

(2) Insert manual lever detent spring in upper housing.

(3) Position detent ball on end of spring. Then hold detent ball and spring in detent housing with Retainer Tool 6583 (Fig. 313).

(4) Install throttle lever in upper housing. Then install manual lever over throttle lever and start manual lever into housing.

(5) Align manual lever with detent ball and manual valve. Hold throttle lever upward. Then press down on manual lever until fully seated. Remove detent ball retainer tool after lever is seated.

(6) Then install manual lever seal, washer and E-clip.

(7) Verify that throttle lever is aligned with end of kickdown valve stem and that manual lever arm is engaged in manual valve (Fig. 314).

(8) Position line pressure adjusting screw in adjusting screw bracket.

(9) Install spring on end of line pressure regulator valve.

(10) Install switch valve spring on tang at end of adjusting screw bracket.

(11) Install manual valve.

(12) Install throttle valve and spring.

(13) Install kickdown valve and detent.

(14) Install pressure regulator valve.

(15) Install switch valve.

(16) Position adjusting screw bracket on valve body. Align valve springs and press bracket into place. Install short, upper bracket screws first and long bottom screw last. Verify that valve springs and bracket are properly aligned. Then tighten all three bracket screws to 4 N·m (35 in. lbs.) torque.

(17) Perform Line Pressure and Throttle Pressure adjustments. (Refer to 21 - TRANSMISSION/TRAN-SAXLE/AUTOMATIC/VALVE BODY - ADJUSTMENTS)

(18) Lubricate solenoid case connector O-rings and shaft of manual lever with light coat of petroleum jelly.

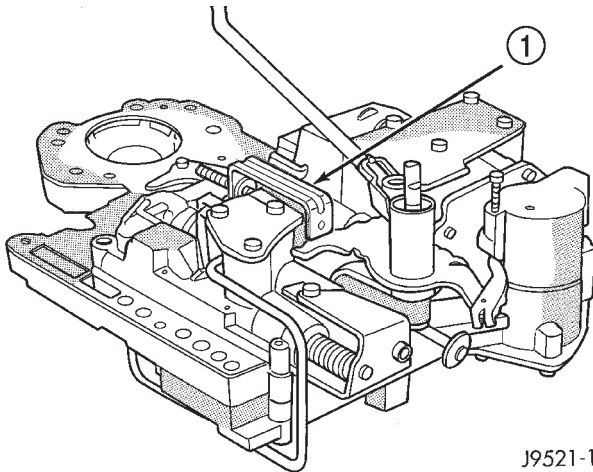
(19) Attach solenoid case connector to 3-4 accumulator with shoulder-type screw. Connector has small locating tang that fits in dimple at top of accumulator housing (Fig. 315). Seat tang in dimple before tightening connector screw.

(20) Install solenoid assembly and gasket. Tighten solenoid attaching screws to 8 N·m (72 in. lbs.) torque.

(21) Verify that solenoid wire harness is properly routed (Fig. 316). Solenoid harness must be clear of manual lever and park rod and not be pinched between accumulator housing and cover.



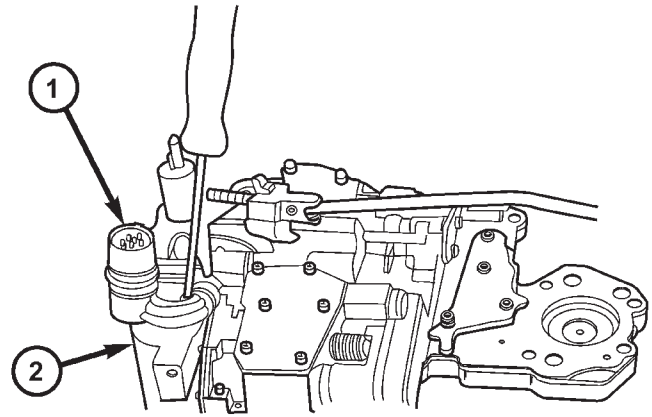
## VALVE BODY (Continued)



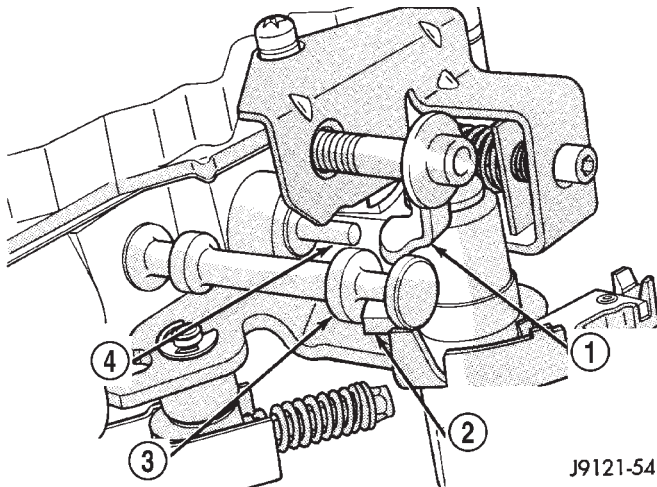
J9521-178

**Fig. 313 Detent Ball Spring**

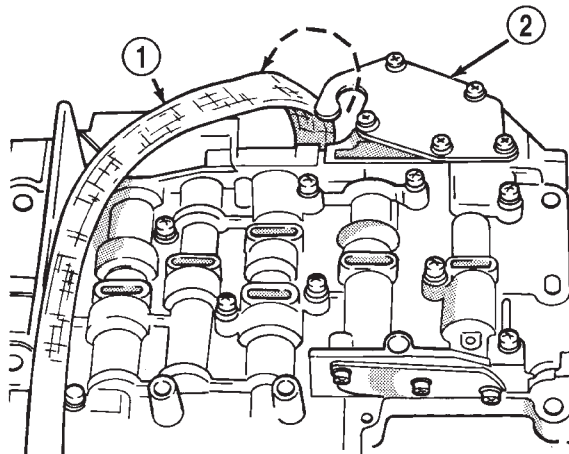
1 - SPECIAL TOOL 6583 POSITIONED ON DETENT HOUSING



808803a3

**Fig. 315 Solenoid Harness Case Connector Shoulder Bolt**1 - SOLENOID HARNESS CASE CONNECTOR  
2 - 3-4 ACCUMULATOR HOUSING

J9121-54

**Fig. 314 Manual And Throttle Lever Alignment**1 - THROTTLE LEVER  
2 - MANUAL LEVER VALVE ARM  
3 - MANUAL VALVE  
4 - KICKDOWN VALVE

J9321-458

**Fig. 316 Solenoid Harness Routing**1 - OVERDRIVE/CONVERTER SOLENOID WIRE HARNESS  
2 - 3-4 ACCUMULATOR COVER PLATE**GOVERNOR BODY, SENSOR AND SOLENOID**

(1) Turn valve body assembly over so accumulator side of transfer plate is facing down.

(2) Install new O-rings on governor pressure solenoid and sensor.

(3) Lubricate solenoid and sensor O-rings with clean transmission fluid.

(4) Install governor pressure sensor in governor body.

(5) Install governor pressure solenoid in governor body. Push solenoid in until it snaps into place in body.

(6) Position governor body gasket on transfer plate.

(7) Install retainer plate on governor body and around solenoid. Be sure solenoid connector is positioned in retainer cutout.

(8) Align screw holes in governor body and transfer plate. Then install and tighten governor body screws to 4 N·m (35 in. lbs.) torque.

(9) Connect harness wires to governor pressure solenoid and governor pressure sensor.

(10) Install fluid filter and pan.

(11) Lower vehicle.

(12) Fill transmission with recommended fluid and road test vehicle to verify repair.

## VALVE BODY (Continued)

## INSTALLATION

(1) Check condition of O-ring seals on valve body harness connector (Fig. 317). Replace seals on connector body if cut or worn.

(2) Check condition of manual lever shaft seal in transmission case. Replace seal if lip is cut or worn. Install new seal with 15/16 deep well socket (Fig. 318).

(3) Check condition of seals on accumulator piston (Fig. 319). Install new piston seals, if necessary.

(4) Place valve body manual lever in low (1 position) so ball on park lock rod will be easier to install in sprag.

(5) Lubricate shaft of manual lever with petroleum jelly. This will ease inserting shaft through seal in case.

(6) Lubricate seal rings on valve body harness connector with petroleum jelly.

(7) Position valve body in case and work end of park lock rod into and through pawl sprag. Turn propeller shaft to align sprag and park lock teeth if necessary. The rod will click as it enters pawl. Move rod to check engagement.

**CAUTION:** It is possible for the park rod to displace into a cavity just above the pawl sprag during installation. Make sure the rod is actually engaged in the pawl and has not displaced into this cavity.

(8) Install accumulator springs and piston into case. Then swing valve body over piston and outer spring to hold it in place.

(9) Align accumulator piston and outer spring, manual lever shaft and electrical connector in case.

(10) Then seat valve body in case and install one or two bolts to hold valve body in place.

(11) Tighten valve body bolts alternately and evenly to 11 N·m (100 in. lbs.) torque.

(12) Install new fluid filter on valve body. Tighten filter screws to 4 N·m (35 in. lbs.) torque.

(13) Install throttle and gearshift levers on valve body manual lever shaft.

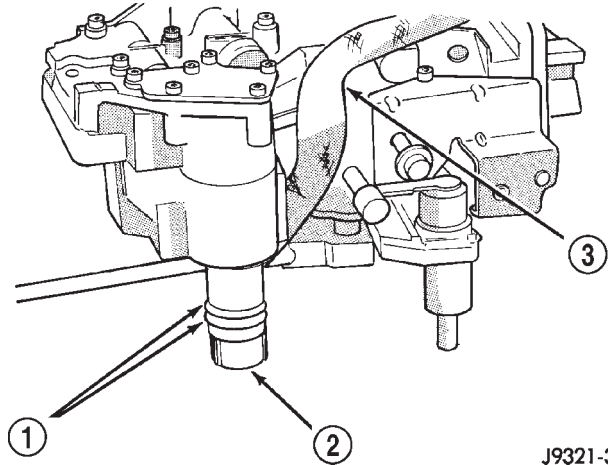
(14) Check and adjust front and rear bands if necessary.

(15) Connect solenoid case connector wires.

(16) Install oil pan and new gasket. Tighten pan bolts to 17 N·m (13 ft. lbs.) torque.

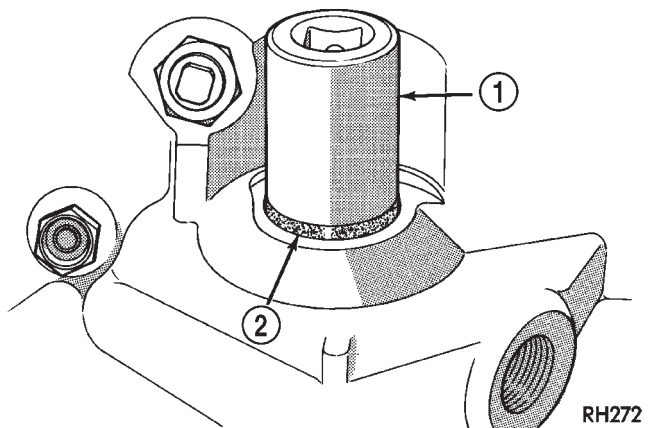
(17) Lower vehicle and fill transmission with Mopar® ATF +4, type 9602, fluid.

(18) Check and adjust gearshift and throttle valve cables, if necessary.



**Fig. 317 Valve Body Harness Connector O-Ring Seal**

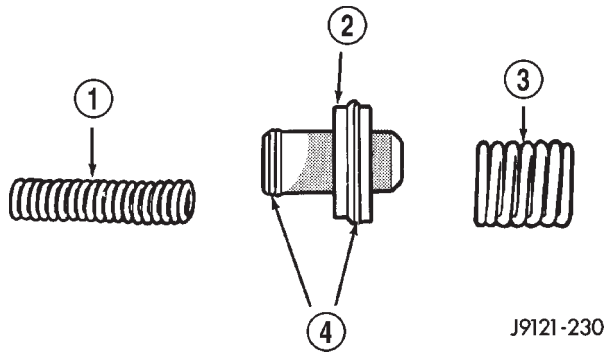
- 1 - CONNECTOR O-RINGS  
2 - VALVE BODY HARNESS CONNECTOR  
3 - HARNESS



**Fig. 318 Manual Lever Shaft Seal**

- 1 - 15/16" SOCKET  
2 - SEAL

## VALVE BODY (Continued)

**Fig. 319 Accumulator Piston Components**

- 1 - INNER SPRING
- 2 - ACCUMULATOR PISTON
- 3 - OUTER SPRING
- 4 - SEAL RINGS

## ADJUSTMENTS - VALVE BODY

## CONTROL PRESSURE ADJUSTMENTS

There are two control pressure adjustments on the valve body;

- Line Pressure
- Throttle Pressure

Line and throttle pressures are interdependent because each affects shift quality and timing. As a result, both adjustments must be performed properly and in the correct sequence. Adjust line pressure first and throttle pressure last.

## LINE PRESSURE ADJUSTMENT

Measure distance from the valve body to the inner edge of the adjusting screw with an accurate steel scale (Fig. 320).

Distance should be 33.4 mm (1-5/16 in.).

If adjustment is required, turn the adjusting screw in, or out, to obtain required distance setting.

**NOTE:** The 33.4 mm (1-5/16 in.) setting is an approximate setting. Manufacturing tolerances may make it necessary to vary from this dimension to obtain desired pressure.

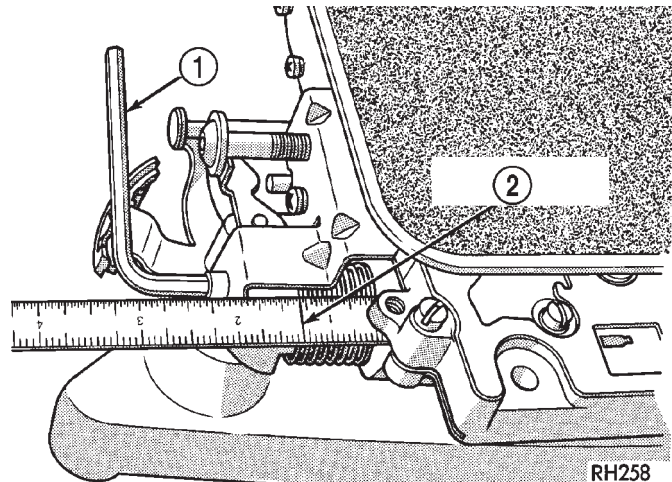
One complete turn of the adjusting screw changes line pressure approximately 1-2/3 psi (9 kPa).

Turning the adjusting screw counterclockwise increases pressure while turning the screw clockwise decreases pressure.

## THROTTLE PRESSURE ADJUSTMENT

Insert Gauge Tool C-3763 between the throttle lever cam and the kickdown valve stem (Fig. 321).

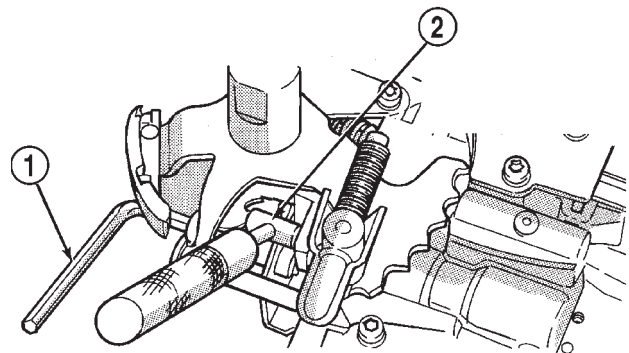
Push the gauge tool inward to compress the kickdown valve against the spring and bottom the throttle valve.

**Fig. 320 Line Pressure Adjustment**

- 1 - WRENCH
- 2 - 1-5/16 INCH

Maintain pressure against kickdown valve spring. Turn throttle lever stop screw until the screw head touches throttle lever tang and the throttle lever cam touches gauge tool.

**NOTE:** The kickdown valve spring must be fully compressed and the kickdown valve completely bottomed to obtain correct adjustment.



J9521-109

**Fig. 321 Throttle Pressure Adjustment**

- 1 - HEX WRENCH (IN THROTTLE LEVER ADJUSTING SCREW)
- 2 - SPECIAL TOOL C-3763 (POSITIONED BETWEEN THROTTLE LEVER AND KICKDOWN VALVE)

## AUTOMATIC TRANSMISSION - 46RE

## TABLE OF CONTENTS

	page		page
<b>AUTOMATIC TRANSMISSION - 46RE</b>		<b>FLUID AND FILTER REPLACEMENT</b> . . . . .	547
DESCRIPTION . . . . .	478	TRANSMISSION FILL . . . . .	547
OPERATION . . . . .	480	<b>FRONT CLUTCH</b>	
DIAGNOSIS AND TESTING . . . . .	486	DESCRIPTION . . . . .	548
AUTOMATIC TRANSMISSION . . . . .	486	OPERATION . . . . .	548
PRELIMINARY . . . . .	486	DISASSEMBLY . . . . .	549
ROAD TESTING . . . . .	486	INSPECTION . . . . .	550
HYDRAULIC PRESSURE TEST . . . . .	487	ASSEMBLY . . . . .	550
AIR TESTING TRANSMISSION CLUTCH AND BAND OPERATION . . . . .	490	<b>FRONT SERVO</b>	
CONVERTER HOUSING FLUID LEAK . . . . .	491	DESCRIPTION . . . . .	551
DIAGNOSIS CHARTS . . . . .	492	OPERATION . . . . .	552
STANDARD PROCEDURE . . . . .	502	DISASSEMBLY . . . . .	552
ALUMINUM THREAD REPAIR . . . . .	502	CLEANING . . . . .	552
REMOVAL . . . . .	502	INSPECTION . . . . .	553
DISASSEMBLY . . . . .	503	ASSEMBLY . . . . .	553
CLEANING . . . . .	509	<b>OIL PUMP</b>	
INSPECTION . . . . .	510	DESCRIPTION . . . . .	554
ASSEMBLY . . . . .	510	OPERATION . . . . .	554
INSTALLATION . . . . .	518	STANDARD PROCEDURE . . . . .	554
SCHEMATICS AND DIAGRAMS . . . . .	520	OIL PUMP VOLUME CHECK . . . . .	554
SPECIFICATIONS . . . . .	532	DISASSEMBLY . . . . .	555
SPECIAL TOOLS . . . . .	534	CLEANING . . . . .	557
<b>ACCUMULATOR</b>		INSPECTION . . . . .	557
DESCRIPTION . . . . .	537	ASSEMBLY . . . . .	558
OPERATION . . . . .	537	<b>OUTPUT SHAFT FRONT BEARING</b>	
INSPECTION . . . . .	538	REMOVAL . . . . .	559
<b>BANDS</b>		INSTALLATION . . . . .	560
DESCRIPTION . . . . .	538	<b>OUTPUT SHAFT REAR BEARING</b>	
OPERATION . . . . .	539	REMOVAL . . . . .	560
ADJUSTMENTS . . . . .	539	INSTALLATION . . . . .	560
<b>ELECTRONIC GOVERNOR</b>		<b>OVERDRIVE CLUTCH</b>	
DESCRIPTION . . . . .	540	DESCRIPTION . . . . .	560
OPERATION . . . . .	541	OPERATION . . . . .	560
REMOVAL . . . . .	542	<b>OVERDRIVE UNIT</b>	
INSTALLATION . . . . .	543	REMOVAL . . . . .	560
<b>EXTENSION HOUSING BUSHING</b>		DISASSEMBLY . . . . .	562
REMOVAL . . . . .	544	CLEANING . . . . .	568
INSTALLATION . . . . .	544	INSPECTION . . . . .	569
<b>EXTENSION HOUSING SEAL</b>		ASSEMBLY . . . . .	569
REMOVAL . . . . .	544	INSTALLATION . . . . .	577
INSTALLATION . . . . .	544	<b>OVERDRIVE SWITCH</b>	
<b>FLUID AND FILTER</b>		DESCRIPTION . . . . .	578
DIAGNOSIS AND TESTING . . . . .	545	OPERATION . . . . .	579
EFFECTS OF INCORRECT FLUID LEVEL . . . . .	545	DIAGNOSIS AND TESTING . . . . .	579
CAUSES OF BURNT FLUID . . . . .	545	OVERDRIVE ELECTRICAL CONTROLS . . . . .	579
FLUID CONTAMINATION . . . . .	545	REMOVAL . . . . .	579
STANDARD PROCEDURE . . . . .	545	INSTALLATION . . . . .	579
FLUID LEVEL CHECK . . . . .	545		



**OVERRUNNING CLUTCH CAM/OVERDRIVE**

**PISTON RETAINER**

DESCRIPTION . . . . . 580

OPERATION . . . . . 580

DISASSEMBLY . . . . . 580

CLEANING . . . . . 580

INSPECTION . . . . . 580

ASSEMBLY . . . . . 581

**PARK/NEUTRAL POSITION SWITCH**

DIAGNOSIS AND TESTING . . . . . 583

    PARK/NEUTRAL POSITION SWITCH . . . . . 583

REMOVAL . . . . . 583

INSTALLATION . . . . . 583

**PISTONS**

DESCRIPTION . . . . . 584

OPERATION . . . . . 584

**PLANETARY GEARTRAIN/OUTPUT SHAFT**

DESCRIPTION . . . . . 585

OPERATION . . . . . 585

DISASSEMBLY . . . . . 586

INSPECTION . . . . . 587

ASSEMBLY . . . . . 588

**REAR CLUTCH**

DESCRIPTION . . . . . 591

OPERATION . . . . . 592

DISASSEMBLY . . . . . 592

CLEANING . . . . . 593

INSPECTION . . . . . 593

ASSEMBLY . . . . . 593

**REAR SERVO**

DESCRIPTION . . . . . 594

OPERATION . . . . . 594

DISASSEMBLY . . . . . 594

CLEANING . . . . . 594

ASSEMBLY . . . . . 595

**SHIFT MECHANISM**

DESCRIPTION . . . . . 595

OPERATION . . . . . 595

ADJUSTMENTS . . . . . 596

**SOLENOID**

DESCRIPTION . . . . . 596

OPERATION . . . . . 597

**SPEED SENSOR**

DESCRIPTION . . . . . 597

OPERATION . . . . . 597

**THROTTLE VALVE CABLE**

DESCRIPTION . . . . . 597

ADJUSTMENTS . . . . . 598

**TORQUE CONVERTER**

DESCRIPTION . . . . . 600

OPERATION . . . . . 604

REMOVAL . . . . . 605

INSTALLATION . . . . . 605

**TORQUE CONVERTER DRAINBACK VALVE**

DESCRIPTION . . . . . 605

OPERATION . . . . . 605

STANDARD PROCEDURE . . . . . 606

    TORQUE CONVERTER DRAINBACK VALVE . 606

**TRANSMISSION TEMPERATURE SENSOR**

DESCRIPTION . . . . . 606

OPERATION . . . . . 606

**VALVE BODY**

DESCRIPTION . . . . . 607

OPERATION . . . . . 611

REMOVAL . . . . . 625

DISASSEMBLY . . . . . 626

CLEANING . . . . . 637

INSPECTION . . . . . 637

ASSEMBLY . . . . . 638

INSTALLATION . . . . . 645

ADJUSTMENTS . . . . . 646

## AUTOMATIC TRANSMISSION - 46RE

### DESCRIPTION

The 46RE (Fig. 1) is a four speed fully automatic transmissions with an electronic governor. The 46RE is equipped with a lock-up clutch in the torque converter. First through third gear ranges are provided by the clutches, bands, overrunning clutch, and planetary gear sets in the transmission. Fourth gear range is provided by the overdrive unit that contains an overdrive clutch, direct clutch, planetary gear set, and overrunning clutch.

The transmission contains a front, rear, and direct clutch which function as the input driving components. It also contains the kickdown (front) and the

low/reverse (rear) bands which, along with the overrunning clutch and overdrive clutch, serve as the holding components. The driving and holding components combine to select the necessary planetary gear components, in the front, rear, or overdrive planetary gear set, transfer the engine power from the input shaft through to the output shaft.

The valve body is mounted to the lower side of the transmission and contains the valves to control pressure regulation, fluid flow control, and clutch/band application. The oil pump is mounted at the front of the transmission and is driven by the torque converter hub. The pump supplies the oil pressure necessary for clutch/band actuation and transmission lubrication.



801834a2

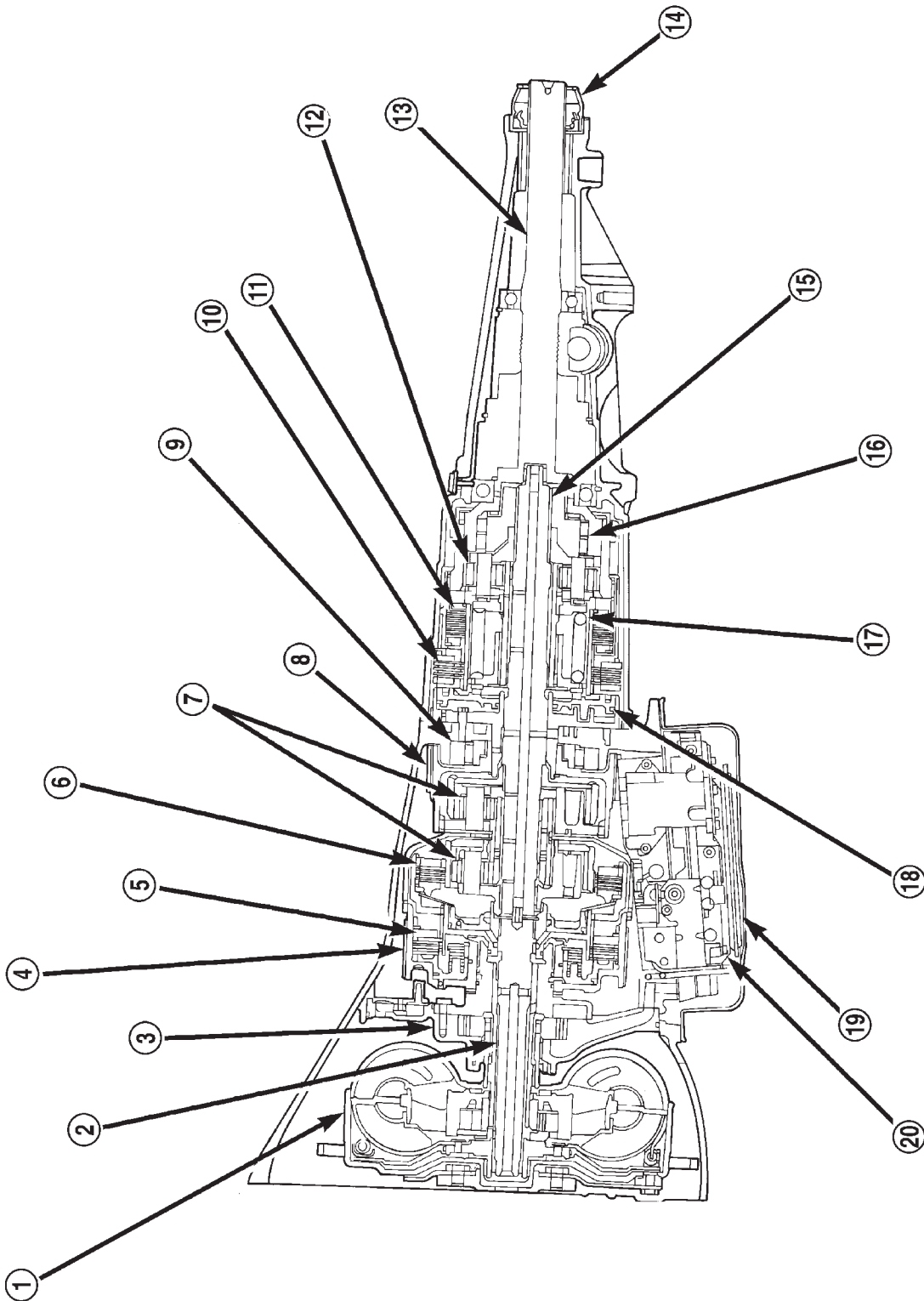


Fig. 1 46RE Transmission

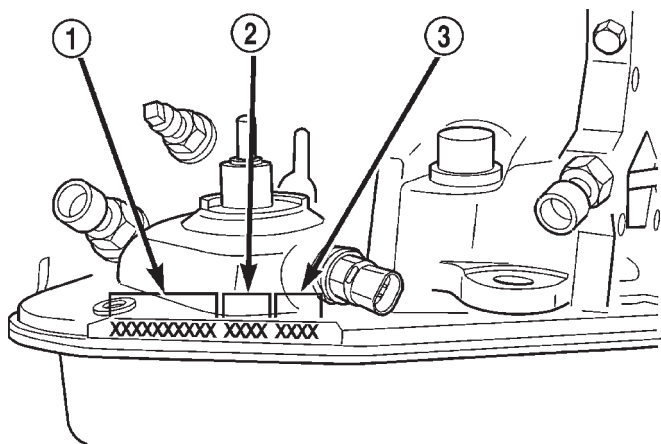
AUTOMATIC TRANSMISSION - 46RE (Continued)

- 1 - TORQUE CONVERTER
- 2 - INPUT SHAFT
- 3 - OIL PUMP
- 4 - FRONT BAND
- 5 - FRONT CLUTCH
- 6 - REAR CLUTCH
- 7 - PLANETARIES
- 8 - REAR BAND
- 9 - OVERRUNNING CLUTCH
- 10 - OVERDRIVE CLUTCH

- 11 - DIRECT CLUTCH
- 12 - PLANETARY GEAR
- 13 - OUTPUT SHAFT
- 14 - SEAL
- 15 - INTERMEDIATE SHAFT
- 16 - OVERDRIVE OVERRUNNING CLUTCH
- 17 - DIRECT CLUTCH SPRING
- 18 - OVERDRIVE PISTON RETAINER
- 19 - FILTER
- 20 - VALVE BODY

**IDENTIFICATION**

Transmission identification numbers are stamped on the left side of the case just above the oil pan gasket surface (Fig. 2). Refer to this information when ordering replacement parts.



80b11960

**Fig. 2 Transmission Part And Serial Number Location**

- 1 - PART NUMBER
- 2 - BUILD DATE
- 3 - SERIAL NUMBER

**GEAR RATIOS** The 46RE gear ratios are:

- 1st** ..... 2.45:1
- 2nd** ..... 1.45:1
- 3rd** ..... 1.00:1
- 4th** ..... 0.69:1

- 1st** ..... 2.45:1
- Rev.** ..... 2.21

**OPERATION**

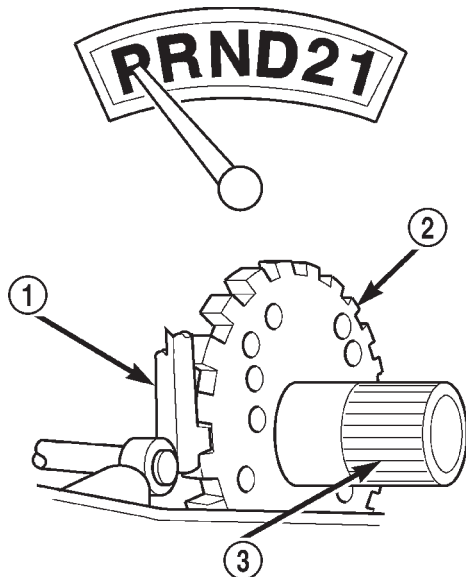
The application of each driving or holding component is controlled by the valve body based upon the manual lever position, throttle pressure, and governor pressure. The governor pressure is a variable pressure input to the valve body and is one of the signals that a shift is necessary. First through fourth gear are obtained by selectively applying and releasing the different clutches and bands. Engine power is thereby routed to the various planetary gear assemblies which combine with the overrunning clutch assemblies to generate the different gear ratios. The torque converter clutch is hydraulically applied and is released when fluid is vented from the hydraulic circuit by the torque converter control (TCC) solenoid on the valve body. The torque converter clutch is controlled by the Powertrain Control Module (PCM). The torque converter clutch engages in fourth gear, and in third gear under various conditions, such as when the O/D switch is OFF, when the vehicle is cruising on a level surface after the vehicle has warmed up. The torque converter clutch will disengage momentarily when an increase in engine load is sensed by the PCM, such as when the vehicle begins to go uphill or the throttle pressure is increased. The torque converter clutch feature increases fuel economy and reduces the transmission fluid temperature.

Since the overdrive clutch is applied in fourth gear only and the direct clutch is applied in all ranges except fourth gear, the transmission operation for park, neutral, and first through third gear will be described first. Once these powerflows are described, the third to fourth shift sequence will be described.

## AUTOMATIC TRANSMISSION - 46RE (Continued)

**PARK POWERFLOW**

As the engine is running and the crankshaft is rotating, the flexplate and torque converter, which are also bolted to it, are all rotating in a clockwise direction as viewed from the front of the engine. The notched hub of the torque converter is connected to the oil pump's internal gear, supplying the transmission with oil pressure. As the converter turns, it turns the input shaft in a clockwise direction. As the input shaft is rotating, the front clutch hub-rear clutch retainer and all their associated parts are also rotating, all being directly connected to the input shaft. The power flow from the engine through the front clutch hub and rear clutch retainer stops at the rear clutch retainer. Therefore, no power flow to the output shaft occurs because no clutches are applied. The only mechanism in use at this time is the parking sprag (Fig. 3), which locks the parking gear on the output shaft to the transmission case.

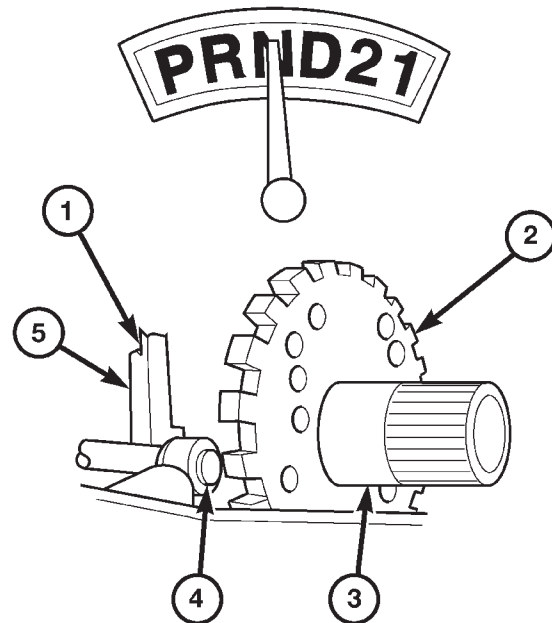
**Fig. 3 Park Powerflow**

- 1 - PAWL ENGAGED FOR PARK
- 2 - PARK SPRAG
- 3 - OUTPUT SHAFT

80c070a6

**NEUTRAL POWERFLOW**

With the gear selector in the NEUTRAL position (Fig. 4), the power flow of the transmission is essentially the same as in the park position. The only operational difference is that the parking sprag has been disengaged, unlocking the output shaft from the transmission case and allowing it to move freely.



80a06c8f

**Fig. 4 Neutral Powerflow**

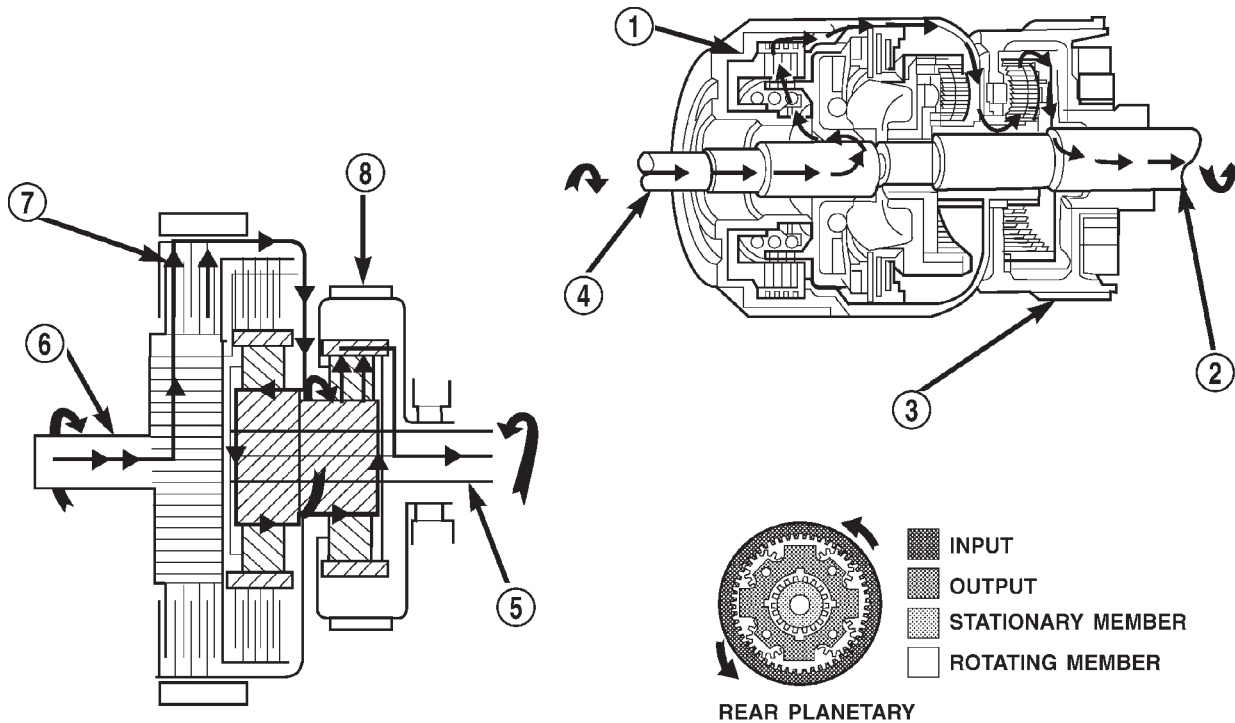
- 1 - PAWL DISENGAGED FOR NEUTRAL
- 2 - PARK SPRAG
- 3 - OUTPUT SHAFT
- 4 - CAM
- 5 - PAWL

AUTOMATIC TRANSMISSION - 46RE (Continued)

**REVERSE POWERFLOW**

When the gear selector is moved into the REVERSE position (Fig. 5), the front clutch and the rear band are applied. With the application of the front clutch, engine torque is applied to the sun gear, turning it in a clockwise direction. The clockwise rotation of the sun gear causes the rear planet pinions to rotate against engine rotation in a counterclockwise direction. The rear band is holding the low reverse drum, which is splined to the rear carrier. Since the rear carrier is being held, the torque from

the planet pinions is transferred to the rear annulus gear, which is splined to the output shaft. The output shaft in turn rotates with the annulus gear in a counterclockwise direction giving a reverse gear output. The entire transmission of torque is applied to the rear planetary gearset only. Although there is torque input to the front gearset through the sun gear, no other member of the gearset is being held. During the entire reverse stage of operation, the front planetary gears are in an idling condition.



80c070a8

**Fig. 5 Reverse Powerflow**

- 1 - FRONT CLUTCH ENGAGED
- 2 - OUTPUT SHAFT
- 3 - LOW/REVERSE BAND APPLIED
- 4 - INPUT SHAFT

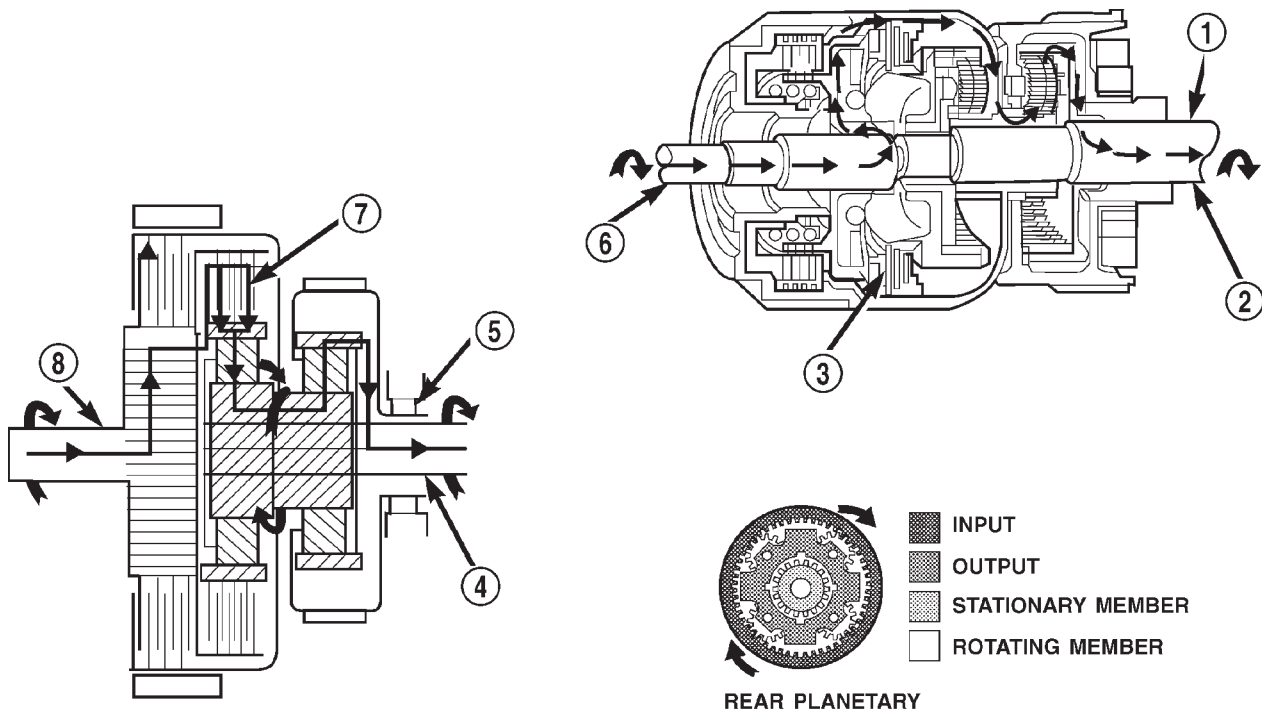
- 5 - OUTPUT SHAFT
- 6 - INPUT SHAFT
- 7 - FRONT CLUTCH ENGAGED
- 8 - LOW/REVERSE BAND APPLIED

AUTOMATIC TRANSMISSION - 46RE (Continued)

**FIRST GEAR POWERFLOW**

When the gearshift lever is moved into the DRIVE position the transmission goes into first gear (Fig. 6). As soon as the transmission is shifted from PARK or NEUTRAL to DRIVE, the rear clutch applies, applying the rear clutch pack to the front annulus gear. Engine torque is now applied to the front annulus gear turning it in a clockwise direction. With the front annulus gear turning in a clockwise direction, it causes the front planets to turn in a clockwise direction. The rotation of the front planets cause the sun to revolve in a counterclockwise direction. The sun gear now transfers its counterclockwise rotation to the rear planets which rotate back in a clockwise

direction. With the rear annulus gear stationary, the rear planet rotation on the annulus gear causes the rear planet carrier to revolve in a counterclockwise direction. The rear planet carrier is splined into the low-reverse drum, and the low reverse drum is splined to the inner race of the over-running clutch. With the over-running clutch locked, the planet carrier is held, and the resulting torque provided by the planet pinions is transferred to the rear annulus gear. The rear annulus gear is splined to the output shaft and rotated along with it (clockwise) in an underdrive gear reduction mode.



**Fig. 6 First Gear Powerflow**

- 1 - OUTPUT SHAFT
- 2 - OVER-RUNNING CLUTCH HOLDING
- 3 - REAR CLUTCH APPLIED
- 4 - OUTPUT SHAFT

- 5 - OVER-RUNNING CLUTCH HOLDING
- 6 - INPUT SHAFT
- 7 - REAR CLUTCH APPLIED
- 8 - INPUT SHAFT

80c070a9

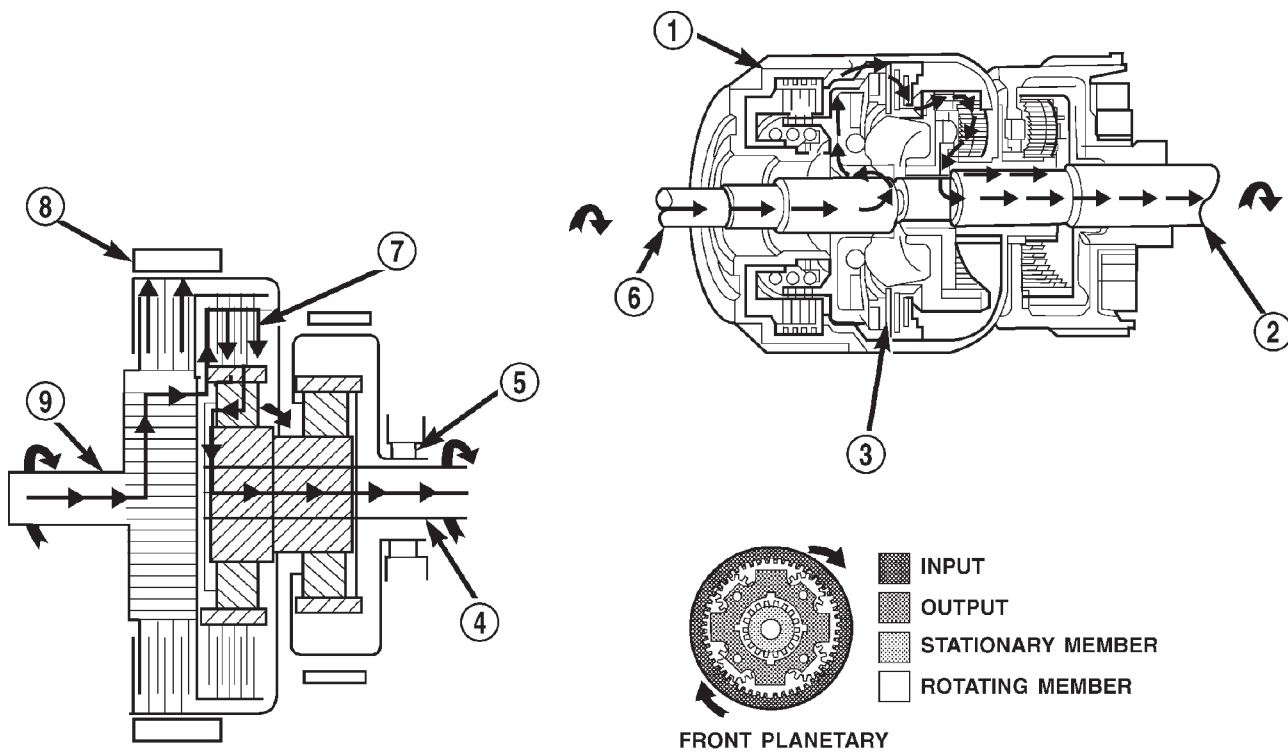


AUTOMATIC TRANSMISSION - 46RE (Continued)

**SECOND GEAR POWERFLOW**

In DRIVE-SECOND (Fig. 7), the same elements are applied as in MANUAL-SECOND. Therefore, the power flow will be the same, and both gears will be discussed as one in the same. In DRIVE-SECOND, the transmission has proceeded from first gear to its shift point, and is shifting from first gear to second. The second gear shift is obtained by keeping the rear clutch applied and applying the front (kickdown) band. The front band holds the front clutch retainer that is locked to the sun gear driving shell. With the rear clutch still applied, the input is still on the front annulus gear turning it clockwise at engine speed.

Now that the front band is holding the sun gear stationary, the annulus rotation causes the front planets to rotate in a clockwise direction. The front carrier is then also made to rotate in a clockwise direction but at a reduced speed. This will transmit the torque to the output shaft, which is directly connected to the front planet carrier. The rear planetary annulus gear will also be turning because it is directly splined to the output shaft. All power flow has occurred in the front planetary gear set during the drive-second stage of operation, and now the over-running clutch, in the rear of the transmission, is disengaged and freewheeling on its hub.



80c070aa

**Fig. 7 Second Gear Powerflow**

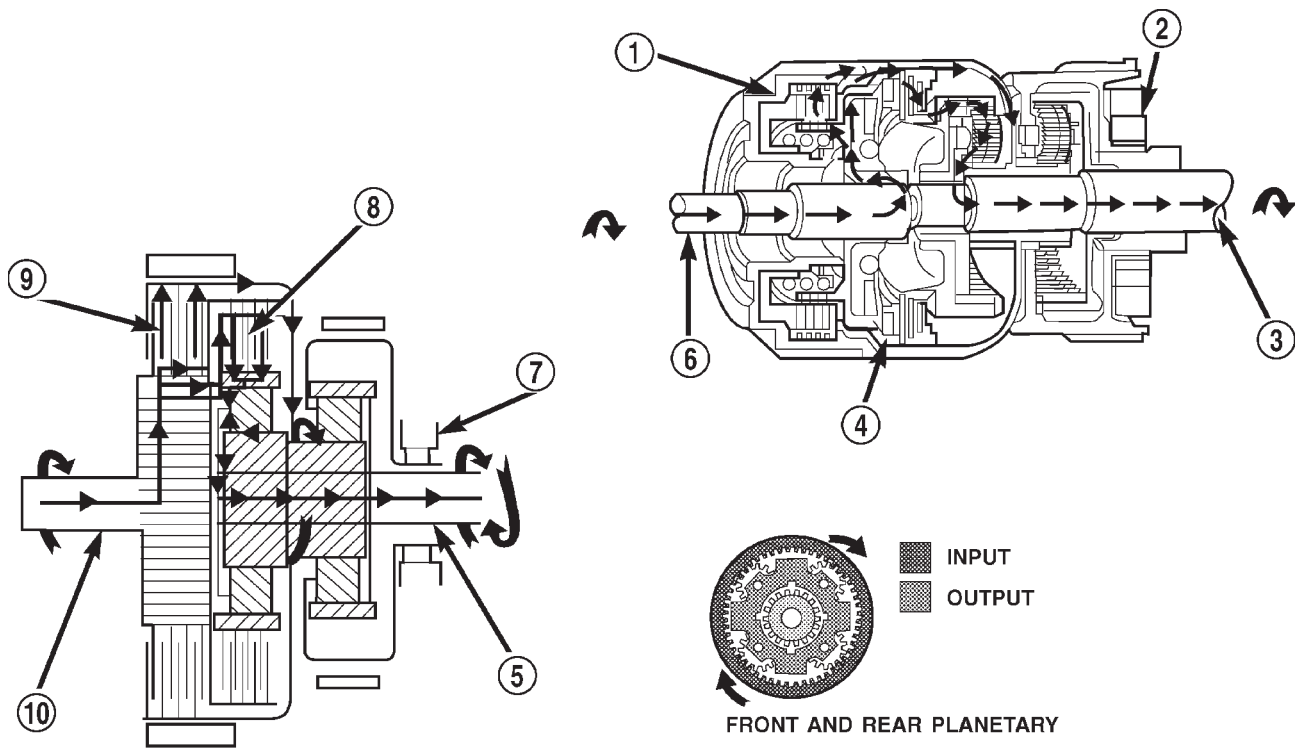
- 1 - KICKDOWN BAND APPLIED
- 2 - OUTPUT SHAFT
- 3 - REAR CLUTCH ENGAGED
- 4 - OUTPUT SHAFT
- 5 - OVER-RUNNING CLUTCH FREE-WHEELING
- 6 - INPUT SHAFT
- 7 - REAR CLUTCH APPLIED
- 8 - KICKDOWN BAND APPLIED
- 9 - INPUT SHAFT

AUTOMATIC TRANSMISSION - 46RE (Continued)

**DIRECT DRIVE POWERFLOW**

The vehicle has accelerated and reached the shift point for the 2-3 upshift into direct drive (Fig. 8). When the shift takes place, the front band is released, and the front clutch is applied. The rear clutch stays applied as it has been in all the forward gears. With the front clutch now applied, engine torque is now on the front clutch retainer, which is locked to the sun gear driving shell. This means that the sun gear is now turning in engine rotation (clockwise) and at engine speed. The rear clutch is still applied so engine torque is also still on the front

annulus gear. If two members of the same planetary set are driven, direct drive results. Therefore, when two members are rotating at the same speed and in the same direction, it is the same as being locked up. The rear planetary set is also locked up, given the sun gear is still the input, and the rear annulus gear must turn with the output shaft. Both gears are turning in the same direction and at the same speed. The front and rear planet pinions do not turn at all in direct drive. The only rotation is the input from the engine to the connected parts, which are acting as one common unit, to the output shaft.



**Fig. 8 Direct Drive Powerflow**

- 1 - FRONT CLUTCH APPLIED
- 2 - OVER-RUNNING CLUTCH FREE-WHEELING
- 3 - OUTPUT SHAFT
- 4 - REAR CLUTCH APPLIED
- 5 - OUTPUT SHAFT

- 6 - INPUT SHAFT
- 7 - OVER-RUNNING CLUTCH FREE-WHEELING
- 8 - REAR CLUTCH APPLIED
- 9 - FRONT CLUTCH APPLIED
- 10 - INPUT SHAFT

## AUTOMATIC TRANSMISSION - 46RE (Continued)

**FOURTH GEAR POWERFLOW**

Fourth gear overdrive range is electronically controlled and hydraulically activated. Various sensor inputs are supplied to the powertrain control module to operate the overdrive solenoid on the valve body. The solenoid contains a check ball that opens and closes a vent port in the 3-4 shift valve feed passage. The overdrive solenoid (and check ball) are not energized in first, second, third, or reverse gear. The vent port remains open, diverting line pressure from the 2-3 shift valve away from the 3-4 shift valve. The overdrive control switch must be in the ON position to transmit overdrive status to the PCM. A 3-4 upshift occurs only when the overdrive solenoid is energized by the PCM. The PCM energizes the overdrive solenoid during the 3-4 upshift. This causes the solenoid check ball to close the vent port allowing line pressure from the 2-3 shift valve to act directly on the 3-4 upshift valve. Line pressure on the 3-4 shift valve overcomes valve spring pressure moving the valve to the upshift position. This action exposes the feed passages to the 3-4 timing valve, 3-4 quick fill valve, 3-4 accumulator, and ultimately to the overdrive piston. Line pressure through the timing valve moves the overdrive piston into contact with the overdrive clutch. The direct clutch is disengaged before the overdrive clutch is engaged. The boost valve provides increased fluid apply pressure to the overdrive clutch during 3-4 upshifts, and when accelerating in fourth gear. The 3-4 accumulator cushions overdrive clutch engagement to smooth 3-4 upshifts. The accumulator is charged at the same time as apply pressure acts against the overdrive piston.

**DIAGNOSIS AND TESTING - AUTOMATIC TRANSMISSION**

Automatic transmission problems can be a result of poor engine performance, incorrect fluid level, incorrect linkage or cable adjustment, band or hydraulic control pressure adjustments, hydraulic system malfunctions or electrical/mechanical component malfunctions. Begin diagnosis by checking the easily accessible items such as: fluid level and condition, linkage adjustments and electrical connections. A road test will determine if further diagnosis is necessary.

**DIAGNOSIS AND TESTING - PRELIMINARY**

Two basic procedures are required. One procedure for vehicles that are drivable and an alternate procedure for disabled vehicles (will not back up or move forward).

**VEHICLE IS DRIVEABLE**

(1) Check for transmission fault codes using DRB® scan tool.

(2) Check fluid level and condition.

(3) Adjust throttle and gearshift linkage if complaint was based on delayed, erratic, or harsh shifts.

(4) Road test and note how transmission upshifts, downshifts, and engages.

(5) Perform hydraulic pressure test if shift problems were noted during road test.

(6) Perform air-pressure test to check clutch-band operation.

**VEHICLE IS DISABLED**

(1) Check fluid level and condition.

(2) Check for broken or disconnected gearshift or throttle linkage.

(3) Check for cracked, leaking cooler lines, or loose or missing pressure-port plugs.

(4) Raise and support vehicle on safety stands, start engine, shift transmission into gear, and note following:

(a) If propeller shaft turns but wheels do not, problem is with differential or axle shafts.

(b) If propeller shaft does not turn and transmission is noisy, stop engine. Remove oil pan, and check for debris. If pan is clear, remove transmission and check for damaged drive plate, converter, oil pump, or input shaft.

(c) If propeller shaft does not turn and transmission is not noisy, perform hydraulic-pressure test to determine if problem is hydraulic or mechanical.

**DIAGNOSIS AND TESTING - ROAD TESTING**

Before road testing, be sure the fluid level and control cable adjustments have been checked and adjusted if necessary. Verify that diagnostic trouble codes have been resolved.

Observe engine performance during the road test. A poorly tuned engine will not allow accurate analysis of transmission operation.

Operate the transmission in all gear ranges. Check for shift variations and engine flare which indicates slippage. Note if shifts are harsh, spongy, delayed, early, or if part throttle downshifts are sensitive.

Slippage indicated by engine flare, usually means clutch, band or overrunning clutch problems. If the condition is advanced, an overhaul will be necessary to restore normal operation.

A slipping clutch or band can often be determined by comparing which internal units are applied in the various gear ranges. The Clutch and Band Application chart provides a basis for analyzing road test results.

## AUTOMATIC TRANSMISSION - 46RE (Continued)

## CLUTCH AND BAND APPLICATION CHART

SHIFT LEVER POSITION	TRANSMISSION CLUTCHES AND BANDS					OVERDRIVE CLUTCHES		
	FRONT CLUTCH	FRONT BAND	REAR CLUTCH	REAR BAND	OVER-RUNNING CLUTCH	OVER-DRIVE CLUTCH	DIRECT CLUTCH	OVER-RUNNING CLUTCH
Reverse	X			X			X	
Drive - First			X		X		X	X
Drive - Second		X	X				X	X
Drive - Third	X		X				X	X
Drive - Fourth	X		X			X		
Manual Second		X	X		X		X	X
Manual First			X	X	X		X	X

Note that the rear clutch is applied in all forward ranges (D, 2, 1). The transmission overrunning clutch is applied in first gear (D, 2 and 1 ranges) only. The rear band is applied in 1 and R range only.

Note that the overdrive clutch is applied only in fourth gear and the overdrive direct clutch and overrunning clutch are applied in all ranges except fourth gear.

For example: If slippage occurs in first gear in D and 2 range but not in 1 range, the transmission overrunning clutch is faulty. Similarly, if slippage occurs in any two forward gears, the rear clutch is slipping.

Applying the same method of analysis, note that the front and rear clutches are applied simultaneously only in D range third and fourth gear. If the transmission slips in third gear, either the front clutch or the rear clutch is slipping.

If the transmission slips in fourth gear but not in third gear, the overdrive clutch is slipping. By selecting another gear which does not use these clutches, the slipping unit can be determined. For example, if the transmission also slips in Reverse, the front clutch is slipping. If the transmission does not slip in Reverse, the rear clutch is slipping.

If slippage occurs during the 3-4 shift or only in fourth gear, the overdrive clutch is slipping. Similarly, if the direct clutch were to fail, the transmission would lose both reverse gear and overrunning braking in 2 position (manual second gear).

If the transmission will not shift to fourth gear, the control switch, overdrive solenoid or related wiring may also be the problem cause.

This process of elimination can be used to identify a slipping unit and check operation. Proper use of the Clutch and Band Application Chart is the key.

Although road test analysis will help determine the slipping unit, the actual cause of a malfunction usually cannot be determined until hydraulic and air pressure tests are performed. Practically any condition can be caused by leaking hydraulic circuits or sticking valves.

Unless a malfunction is obvious, such as no drive in D range first gear, do not disassemble the transmission. Perform the hydraulic and air pressure tests to help determine the probable cause.

## DIAGNOSIS AND TESTING - HYDRAULIC PRESSURE TEST

Hydraulic test pressures range from a low of one psi (6.895 kPa) governor pressure, to 300 psi (2068 kPa) at the rear servo pressure port in reverse.

An accurate tachometer and pressure test gauges are required. Test Gauge C-3292 has a 100 psi range and is used at the accumulator, governor, and front servo ports. Test Gauge C-3293-SP has a 300 psi range and is used at the rear servo and overdrive ports where pressures exceed 100 psi.

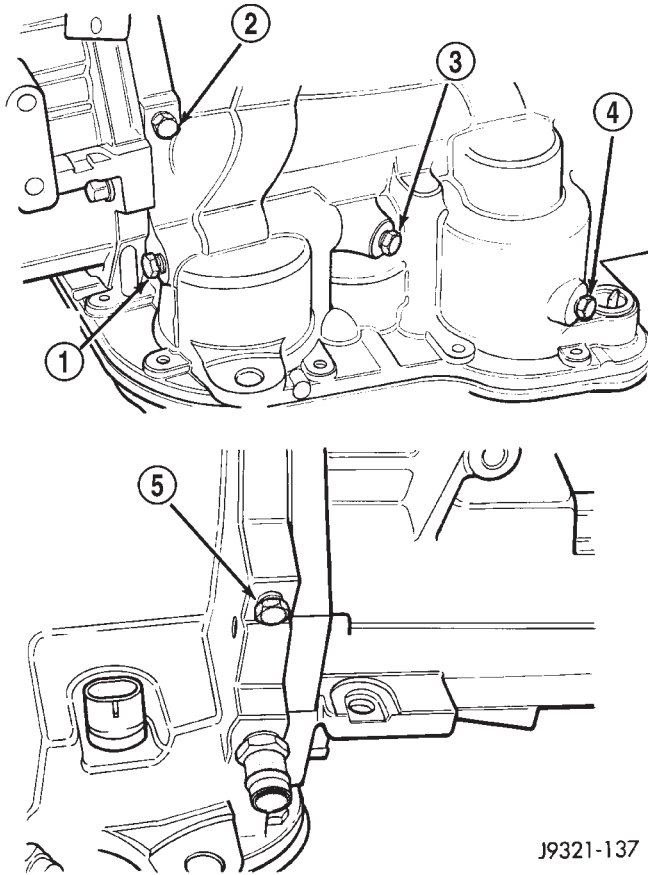
### Pressure Test Port Locations

Test ports are located at both sides of the transmission case (Fig. 9).

Line pressure is checked at the accumulator port on the right side of the case. The front servo pressure port is at the right side of the case just behind the filler tube opening.

## AUTOMATIC TRANSMISSION - 46RE (Continued)

The rear servo and governor pressure ports are at the right rear of the transmission case. The overdrive clutch pressure port is at the left rear of the case.



**Fig. 9 Pressure Test Port Locations**

- 1 - REAR SERVO TEST PORT
- 2 - GOVERNOR TEST PORT
- 3 - ACCUMULATOR TEST PORT
- 4 - FRONT SERVO TEST PORT
- 5 - OVERDRIVE CLUTCH TEST PORT

#### Test One - Transmission In Manual Low

**NOTE:** This test checks pump output, pressure regulation, and condition of the rear clutch and servo circuit. Both test gauges are required for this test.

- (1) Connect tachometer to engine. Position tachometer so it can be observed from driver seat if helper will be operating engine. Raise vehicle on hoist that will allow rear wheels to rotate freely.
- (2) Connect 100 psi Gauge C-3292 to accumulator port. Then connect 300 psi Gauge C-3293-SP to rear servo port.
- (3) Disconnect throttle and gearshift cables from levers on transmission valve body manual shaft.
- (4) Have helper start and run engine at 1000 rpm.
- (5) Move transmission shift lever fully forward into 1 range.

(6) Gradually move transmission throttle lever from full forward to full rearward position and note pressures on both gauges:

- Line pressure at accumulator port should be 54-60 psi (372-414 kPa) with throttle lever forward and gradually increase to 90-96 psi (621-662 kPa) as throttle lever is moved rearward.
- Rear servo pressure should be same as line pressure within 3 psi (20.68 kPa).

#### Test Two - Transmission In 2 Range

**NOTE:** This test checks pump output, line pressure and pressure regulation. Use 100 psi Test Gauge C-3292 for this test.

- (1) Leave vehicle in place on hoist and leave Test Gauge C-3292 connected to accumulator port.
- (2) Have helper start and run engine at 1000 rpm.
- (3) Move transmission shift lever one detent rearward from full forward position. This is 2 range.
- (4) Move transmission throttle lever from full forward to full rearward position and read pressure on gauge.
- (5) Line pressure should be 54-60 psi (372-414 kPa) with throttle lever forward and gradually increase to 90-96 psi (621-662 kPa) as lever is moved rearward.

#### Test Three - Transmission In D Range Third Gear

**NOTE:** This test checks pressure regulation and condition of the clutch circuits. Both test gauges are required for this test.

- (1) Turn OD switch off.
- (2) Leave vehicle on hoist and leave Gauge C-3292 in place at accumulator port.
- (3) Move Gauge C-3293-SP over to front servo port for this test.
- (4) Have helper start and run engine at 1600 rpm for this test.
- (5) Move transmission shift lever two detents rearward from full forward position. This is D range.
- (6) Read pressures on both gauges as transmission throttle lever is gradually moved from full forward to full rearward position:
  - Line pressure at accumulator in D range third gear, should be 54-60 psi (372-414 kPa) with throttle lever forward and increase as lever is moved rearward.
  - Front servo pressure in D range third gear, should be within 3 psi (21 kPa) of line pressure up to kickdown point.



## AUTOMATIC TRANSMISSION - 46RE (Continued)

## Test Four - Transmission In Reverse

**NOTE: This test checks pump output, pressure regulation and the front clutch and rear servo circuits. Use 300 psi Test Gauge C-3293-SP for this test.**

- (1) Leave vehicle on hoist and leave gauge C-3292 in place at accumulator port.
- (2) Move 300 psi Gauge C-3293-SP back to rear servo port.
- (3) Have helper start and run engine at 1600 rpm for test.
- (4) Move transmission shift lever four detents rearward from full forward position. This is Reverse range.
- (5) Move transmission throttle lever fully forward then fully rearward and note reading at Gauge C-3293-SP.
- (6) Pressure should be 145 - 175 psi (1000-1207 kPa) with throttle lever forward and increase to 230 - 280 psi (1586-1931 kPa) as lever is gradually moved rearward.

## Test Five - Governor Pressure

**NOTE: This test checks governor operation by measuring governor pressure response to changes in vehicle speed. It is usually not necessary to check governor operation unless shift speeds are incorrect or if the transmission will not downshift. The test should be performed on the road or on a hoist that will allow the rear wheels to rotate freely.**

- (1) Move 100 psi Test Gauge C-3292 to governor pressure port.
- (2) Move transmission shift lever two detents rearward from full forward position. This is D range.
- (3) Have helper start and run engine at curb idle speed. Then firmly apply service brakes so wheels will not rotate.
- (4) Note governor pressure:
  - Governor pressure should be no more than 20.6 kPa (3 psi) at curb idle speed and wheels not rotating.

- If pressure exceeds 20.6 kPa (3 psi), a fault exists in governor pressure control system.

- (5) Release brakes, slowly increase engine speed, and observe speedometer and pressure test gauge (do not exceed 30 mph on speedometer). Governor pressure should increase in proportion to vehicle speed. Or approximately 6.89 kPa (1 psi) for every 1 mph.
- (6) Governor pressure rise should be smooth and drop back to no more than 20.6 kPa (3 psi), after engine returns to curb idle and brakes are applied to prevent wheels from rotating.
- (7) Compare results of pressure test with analysis chart.

## Test Six - Transmission In Overdrive Fourth Gear

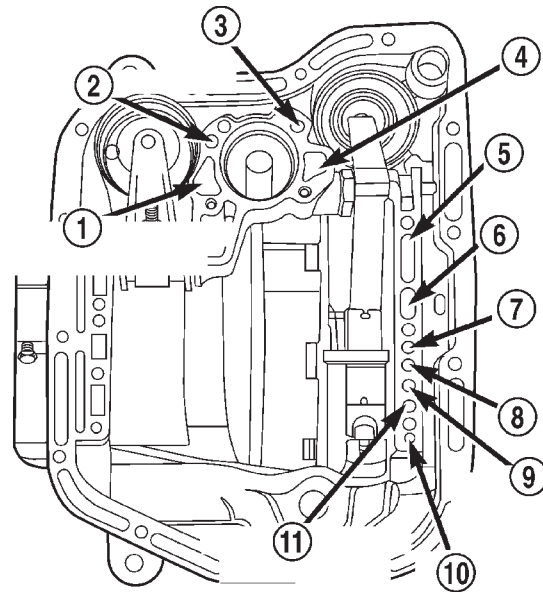
**NOTE: This test checks line pressure at the overdrive clutch in fourth gear range. Use 300 psi Test Gauge C-3293-SP for this test. The test should be performed on the road or on a chassis dyno.**

- (1) Remove tachometer; it is not needed for this test.
- (2) Move 300 psi Gauge to overdrive clutch pressure test port. Then remove other gauge and reinstall test port plug.
- (3) Lower vehicle.
- (4) Turn OD switch on.
- (5) Secure test gauge so it can be viewed from drivers seat.
- (6) Start engine and shift into D range.
- (7) Increase vehicle speed gradually until 3-4 shift occurs and note gauge pressure.
- (8) Pressure should be 469-496 kPa (68-72 psi) with closed throttle and increase to 620-827 kPa (90-120 psi) at 1/2 to 3/4 throttle. Note that pressure can increase to around 896 kPa (130 psi) at full throttle.
- (9) Return to shop or move vehicle off chassis dyno.

AUTOMATIC TRANSMISSION - 46RE (Continued)

PRESSURE TEST ANALYSIS CHART

TEST CONDITION	INDICATION
Line pressure OK during any one test	Pump and regulator valve OK
Line pressure OK in R but low in D, 2, 1	Leakage in rear clutch area (seal rings, clutch seals)
Pressure low in D Fourth Gear Range	Overdrive clutch piston seal, or check ball problem
Pressure OK in 1, 2 but low in D3 and R	Leakage in front clutch area
Pressure OK in 2 but low in R and 1	Leakage in rear servo
Front servo pressure in 2	Leakage in servo; broken servo ring or cracked servo piston
Pressure low in all positions	Clogged filter, stuck regulator valve, worn or faulty pump, low oil level
Governor pressure too high at idle speed	Governor pressure solenoid valve system fault. Refer to diagnostic book.
Governor pressure low at all mph figures	Faulty governor pressure solenoid, transmission control module, or governor pressure sensor
Lubrication pressure low at all throttle positions	Clogged fluid cooler or lines, seal rings leaking, worn pump bushings, pump, clutch retainer, or clogged filter.
Line pressure high	Output shaft plugged, sticky regulator valve
Line pressure low	Sticky regulator valve, clogged filter, worn pump



80b1717e

Fig. 10 Air Pressure Test Passages

- 1 - LINE PRESSURE TO ACCUMULATOR
- 2 - REAR SERVO APPLY
- 3 - FRONT SERVO APPLY
- 4 - FRONT SERVO RELEASE
- 5 - PUMP SUCTION
- 6 - PUMP PRESSURE
- 7 - FRONT CLUTCH APPLY
- 8 - REAR CLUTCH APPLY
- 9 - TO TORQUE CONVERTOR
- 10 - TO COOLER
- 11 - FROM TORQUE CONVERTER

Front Clutch Air Test

Place one or two fingers on the clutch housing and apply air pressure through front clutch apply passage. Piston movement can be felt and a soft thump heard as the clutch applies.

Rear Clutch Air Test

Place one or two fingers on the clutch housing and apply air pressure through rear clutch apply passage. Piston movement can be felt and a soft thump heard as the clutch applies.

Front Servo Air Test

Apply air pressure to the front servo apply passage. The servo rod should extend and cause the band to tighten around the drum. Spring pressure should release the servo when air pressure is removed.

Rear Servo Air Test

Apply air pressure to the rear servo apply passage. The servo rod should extend and cause the band to tighten around the drum. Spring pressure should release the servo when air pressure is removed.

DIAGNOSIS AND TESTING - AIR TESTING TRANSMISSION CLUTCH AND BAND OPERATION

Air-pressure testing can be used to check transmission front/rear clutch and band operation. The test can be conducted with the transmission either in the vehicle or on the work bench, as a final check, after overhaul.

Air-pressure testing requires that the oil pan and valve body be removed from the transmission. The servo and clutch apply passages are shown (Fig. 10).

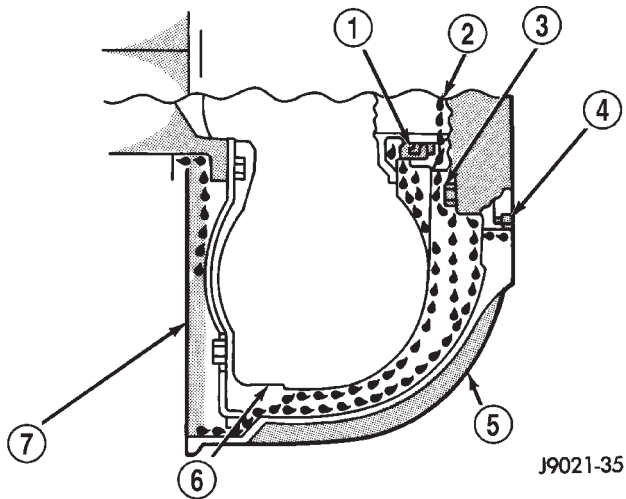
## AUTOMATIC TRANSMISSION - 46RE (Continued)

**DIAGNOSIS AND TESTING - CONVERTER HOUSING FLUID LEAK**

When diagnosing converter housing fluid leaks, two items must be established before repair.

- (1) Verify that a leak condition actually exists.
- (2) Determined the true source of the leak.

Some suspected converter housing fluid leaks may not be leaks at all. They may only be the result of residual fluid in the converter housing, or excess fluid spilled during factory fill or fill after repair. Converter housing leaks have several potential sources. Through careful observation, a leak source can be identified before removing the transmission for repair. Pump seal leaks tend to move along the drive hub and onto the rear of the converter. Pump body leaks follow the same path as a seal leak (Fig. 11). Pump vent or pump attaching bolt leaks are generally deposited on the inside of the converter housing and not on the converter itself (Fig. 11). Pump o-ring or gasket leaks usually travel down the inside of the converter housing. Front band lever pin plug leaks are generally deposited on the housing and not on the converter.



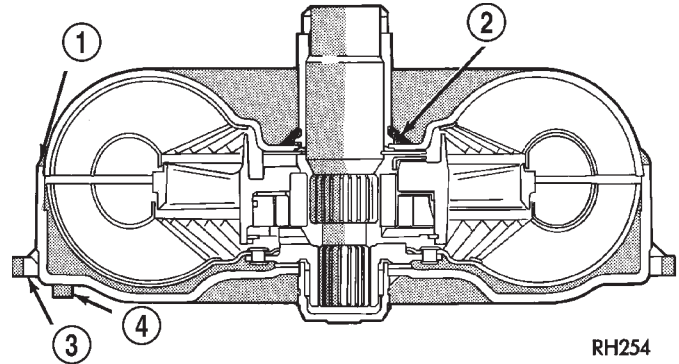
**Fig. 11 Converter Housing Leak Paths**

- 1 - PUMP SEAL
- 2 - PUMP VENT
- 3 - PUMP BOLT
- 4 - PUMP GASKET
- 5 - CONVERTER HOUSING
- 6 - CONVERTER
- 7 - REAR MAIN SEAL LEAK

**TORQUE CONVERTER LEAK POINTS**

Possible sources of converter leaks are:

- (1) Leaks at the weld joint around the outside diameter weld (Fig. 12).
- (2) Leaks at the converter hub weld (Fig. 12).



**Fig. 12 Converter Leak Points - Typical**

- 1 - OUTSIDE DIAMETER WELD
- 2 - TORQUE CONVERTER HUB WELD
- 3 - STARTER RING GEAR
- 4 - LUG

**CONVERTER HOUSING AREA LEAK CORRECTION**

- (1) Remove converter.
- (2) Tighten front band adjusting screw until band is tight around front clutch retainer. This prevents front/rear clutches from coming out when oil pump is removed.
- (3) Remove oil pump and remove pump seal. Inspect pump housing drainback and vent holes for obstructions. Clear holes with solvent and wire.
- (4) Inspect pump bushing and converter hub. If bushing is scored, replace it. If converter hub is scored, either polish it with crocus cloth or replace converter.
- (5) Install new pump seal, O-ring, and gasket. Replace oil pump if cracked, porous or damaged in any way. Be sure to loosen the front band before installing the oil pump, damage to the oil pump seal may occur if the band is still tightened to the front clutch retainer.
- (6) Loosen kickdown lever pin access plug three turns. Apply Loctite™ 592, or Permatex® No. 2 to plug threads and tighten plug to 17 N·m (150 in. lbs.) torque.
- (7) Adjust front band.
- (8) Lubricate pump seal and converter hub with transmission fluid or petroleum jelly and install converter.
- (9) Install transmission and converter housing dust shield.
- (10) Lower vehicle.

## AUTOMATIC TRANSMISSION - 46RE (Continued)

**DIAGNOSIS AND TESTING - DIAGNOSIS CHARTS**

The diagnosis charts provide additional reference when diagnosing a transmission fault. The charts provide general information on a variety of transmission, overdrive unit and converter clutch fault conditions.

The hydraulic flow charts in the Schematics and Diagrams section of this group, outline fluid flow and hydraulic circuitry. Circuit operation is provided for PARK, NEUTRAL, FIRST, SECOND, THIRD, FOURTH, MANUAL FIRST, MANUAL SECOND, and REVERSE gear ranges. Normal working pressures are also supplied for each of the gear ranges.

**DIAGNOSIS CHARTS**

<b>CONDITION</b>	<b>POSSIBLE CAUSES</b>	<b>CORRECTION</b>
HARSH ENGAGEMENT (FROM NEUTRAL TO DRIVE OR REVERSE)	1. Fluid Level Low.	1. Add Fluid
	2. Throttle Linkage Mis-adjusted.	2. Adjust linkage - setting may be too long.
	3. Mount and Driveline Bolts Loose.	3. Check engine mount, transmission mount, propeller shaft, rear spring to body bolts, rear control arms, crossmember and axle bolt torque. Tighten loose bolts and replace missing bolts.
	4. U-Joint Worn/Broken.	4. Remove propeller shaft and replace U-Joint.
	5. Axle Backlash Incorrect.	5. Check per Service Manual. Correct as needed.
	6. Hydraulic Pressure Incorrect.	6. Check pressure. Remove, overhaul or adjust valve body as needed.
	7. Band Mis-adjusted.	7. Adjust rear band.
	8. Valve Body Check Balls Missing.	8. Inspect valve body for proper check ball installation.
	9. Axle Pinion Flange Loose.	9. Replace nut and check pinion threads before installing new nut. Replace pinion gear if threads are damaged.
	10. Clutch, band or planetary component damaged.	10. Remove, disassemble and repair transmission as necessary.
	11. Converter Clutch Faulty.	11. Replace converter and flush cooler and line before installing new converter.
DELAYED ENGAGEMENT (FROM NEUTRAL TO DRIVE OR REVERSE)	1. Fluid Level Low.	1. Correct level and check for leaks.
	2. Filter Clogged.	2. Change filter.
	3. Gearshift Linkage Mis-adjusted.	3. Adjust linkage and repair linkage if worn or damaged.
	4. Torque Converter Drain Back (Oil drains from torque converter into transmission sump).	4. If vehicle moves normally after 5 seconds after shifting into gear, no repair is necessary. If longer, inspect pump bushing for wear. Replace pump house.
	5. Rear Band Mis-adjusted.	5. Adjust band.
	6. Valve Body Filter Plugged.	6. Replace fluid and filter. If oil pan and old fluid were full of clutch disc material and/or metal particles, overhaul will be necessary.
	7. Oil Pump Gears Worn/Damaged.	7. Remove transmission and replace oil pump.

## AUTOMATIC TRANSMISSION - 46RE (Continued)

CONDITION	POSSIBLE CAUSES	CORRECTION
	8. Governor Circuit and Solenoid Valve Electrical Fault.	8. Test with DRB® scan tool and repair as required.
	9. Hydraulic Pressure Incorrect.	9. Perform pressure test, remove transmission and repair as needed.
	10. Reaction Shaft Seal Rings Worn/Broken.	10. Remove transmission, remove oil pump and replace seal rings.
	11. Rear Clutch/Input Shaft, Rear Clutch Seal Rings Damaged.	11. Remove and disassemble transmission and repair as necessary.
	12. Regulator Valve Stuck.	12. Clean.
	13. Cooler Plugged.	13. Transfer case failure can plug cooler.
NO DRIVE RANGE (REVERSE OK)	1. Fluid Level Low.	1. Add fluid and check for leaks if drive is restored.
	2. Gearshift Linkage/Cable Loose/Misadjusted.	2. Repair or replace linkage components.
	3. Rear Clutch Burnt.	3. Remove and disassemble transmission and rear clutch and seals. Repair/replace worn or damaged parts as needed.
	4. Valve Body Malfunction.	4. Remove and disassemble valve body. Replace assembly if any valves or bores are damaged.
	5. Transmission Overrunning Clutch Broken.	5. Remove and disassemble transmission. Replace overrunning clutch.
	6. Input Shaft Seal Rings Worn/Damaged.	6. Remove and disassemble transmission. Replace seal rings and any other worn or damaged parts.
	7. Front Planetary Failed Broken.	7. Remove and repair.
NO DRIVE OR REVERSE (VEHICLE WILL NOT MOVE)	1. Fluid Level Low.	1. Add fluid and check for leaks if drive is restored.
	2. Gearshift Linkage/Cable Loose/Misadjusted.	2. Inspect, adjust and reassemble linkage as needed. Replace worn/damaged parts.
	3. U-Joint/Axle/Transfer Case Broken.	3. Perform preliminary inspection procedure for vehicle that will not move. Refer to procedure in diagnosis section.
	4. Filter Plugged.	4. Remove and disassemble transmission. Repair or replace failed components as needed. Replace filter. If filter and fluid contained clutch material or metal particles, an overhaul may be necessary. Perform lube flow test. Flush oil. Replace cooler as necessary.
	5. Oil Pump Damaged.	5. Perform pressure test to confirm low pressure. Replace pump body assembly if necessary.



## AUTOMATIC TRANSMISSION - 46RE (Continued)

CONDITION	POSSIBLE CAUSES	CORRECTION
	6. Valve Body Malfunctioned.	6. Check and inspect valve body. Replace valve body (as assembly) if any valve or bore is damaged. Clean and reassemble correctly if all parts are in good condition.
	7. Transmission Internal Component Damaged.	7. Remove and disassemble transmission. Repair or replace failed components as needed.
	8. Park Sprag not Releasing - Check Stall Speed, Worn/Damaged/Stuck.	8. Remove, disassemble, repair.
	9. Torque Converter Damage.	9. Inspect and replace as required.
SHIFTS DELAYED OR ERRATIC (SHIFTS ALSO HARSH AT TIMES)	1. Fluid Level Low/High.	1. Correct fluid level and check for leaks if low.
	2. Fluid Filter Clogged.	2. Replace filter. If filter and fluid contained clutch material or metal particles, an overhaul may be necessary. Perform lube flow test.
	3. Throttle Linkage Mis-adjusted.	3. Adjust linkage as described in service section.
	4. Throttle Linkage Binding.	4. Check cable for binding. Check for return to closed throttle at transmission.
	5. Gearshift Linkage/Cable Mis-adjusted.	5. Adjust linkage/cable as described in service section.
	6. Clutch or Servo Failure.	6. Remove valve body and air test clutch, and band servo operation. Disassemble and repair transmission as needed.
	7. Governor Circuit Electrical Fault.	7. Test using DRB® scan tool and repair as required.
	8. Front Band Mis-adjusted.	8. Adjust band.
	9. Pump Suction Passage Leak.	9. Check for excessive foam on dipstick after normal driving. Check for loose pump bolts, defective gasket. Replace pump assembly if needed.
NO REVERSE (D RANGES OK)	1. Gearshift Linkage/Cable Mis-adjusted/Damaged.	1. Repair or replace linkage parts as needed.
	2. Park Sprag Sticking.	2. Replace overdrive annulus gear.
	3. Rear Band Mis-adjusted/Worn.	3. Adjust band; replace.
	4. Valve Body Malfunction.	4. Remove and service valve body. Replace valve body if any valves or valve bores are worn or damaged.
	5. Rear Servo Malfunction.	5. Remove and disassemble transmission. Replace worn/damaged servo parts as necessary.
	6. Direct Clutch in Overdrive Worn.	6. Disassemble overdrive. Replace worn or damaged parts.
	7. Front Clutch Burnt.	7. Remove and disassemble transmission. Replace worn, damaged clutch parts as required.

## AUTOMATIC TRANSMISSION - 46RE (Continued)

CONDITION	POSSIBLE CAUSES	CORRECTION
HAS FIRST/REVERSE ONLY (NO 1-2 OR 2-3 UPSHIFT)	1. Governor Circuit Electrical Fault.	1. Test using DRB® scan tool and repair as required.
	2. Valve Body Malfunction.	2. Repair stuck 1-2 shift valve or governor plug.
	3. Front Servo/Kickdown Band Damaged/Burned.	3. Repair/replace.
MOVES IN 2ND OR 3RD GEAR, ABRUPTLY DOWNSHIFTS TO LOW	1. Valve Body Malfunction.	1. Remove, clean and inspect. Look for stuck 1-2 valve or governor plug.
NO LOW GEAR (MOVES IN 2ND OR 3RD GEAR ONLY)	1. Governor Circuit Electrical Fault.	1. Test with DRB® scan tool and repair as required.
	2. Valve Body Malfunction.	2. Remove, clean and inspect. Look for sticking 1-2 shift valve, 2-3 shift valve, governor plug or broken springs.
	3. Front Servo Piston Cocked in Bore.	3. Inspect servo and repair as required.
	4. Front Band Linkage Malfunction	4. Inspect linkage and look for bind in linkage.
NO KICKDOWN OR NORMAL DOWNSHIFT	1. Throttle Linkage Mis-adjusted.	1. Adjust linkage.
	2. Accelerator Pedal Travel Restricted.	2. Verify floor mat is not under pedal, repair worn accelerator cable or bent brackets.
	3. Valve Body Hydraulic Pressures Too High or Too Low Due to Valve Body Malfunction or Incorrect Hydraulic Control Pressure Adjustments.	3. Perform hydraulic pressure tests to determine cause and repair as required. Correct valve body pressure adjustments as required.
	4. Governor Circuit Electrical Fault.	4. Test with DRB® scan tool and repair as required.
	5. Valve Body Malfunction.	5. Perform hydraulic pressure tests to determine cause and repair as required. Correct valve body pressure adjustments as required.
	6. TPS Malfunction.	6. Replace sensor, check with DRB® scan tool.
	7. PCM Malfunction.	7. Check with DRB® scan tool and replace if required.
	8. Valve Body Malfunction.	8. Repair sticking 1-2, 2-3 shift valves, governor plugs, 3-4 solenoid, 3-4 shift valve, 3-4 timing valve.

## AUTOMATIC TRANSMISSION - 46RE (Continued)

CONDITION	POSSIBLE CAUSES	CORRECTION
STUCK IN LOW GEAR (WILL NOT UPSHIFT)	1. Throttle Linkage Mis-adjusted/ Stuck.	1. Adjust linkage and repair linkage if worn or damaged. Check for binding cable or missing return spring.
	2. Gearshift Linkage Mis-adjusted.	2. Adjust linkage and repair linkage if worn or damaged.
	3. Governor Component Electrical Fault.	3. Check operating pressures and test with DRB® scan tool, repair faulty component.
	4. Front Band Out of Adjustment.	4. Adjust Band.
	5. Clutch or Servo Malfunction.	5. Air pressure check operation of clutches and bands. Repair faulty component.
CREEPS IN NEUTRAL	1. Gearshift Linkage Mis-adjusted.	1. Adjust linkage.
	2. Rear Clutch Dragging/Warped.	2. Disassemble and repair.
	3. Valve Body Malfunction.	3. Perform hydraulic pressure test to determine cause and repair as required.
BUZZING NOISE	1. Fluid Level Low	1. Add fluid and check for leaks.
	2. Shift Cable Mis-assembled.	2. Route cable away from engine and bell housing.
	3. Valve Body Mis-assembled.	3. Remove, disassemble, inspect valve body. Reassemble correctly if necessary. Replace assembly if valves or springs are damaged. Check for loose bolts or screws.
	4. Pump Passages Leaking.	4. Check pump for porous casting, scores on mating surfaces and excess rotor clearance. Repair as required. Loose pump bolts.
	5. Cooling System Cooler Plugged.	5. Flow check cooler circuit. Repair as needed.
	6. Overrunning Clutch Damaged.	6. Replace clutch.
SLIPS IN REVERSE ONLY	1. Fluid Level Low.	1. Add fluid and check for leaks.
	2. Gearshift Linkage Mis-adjusted.	2. Adjust linkage.
	3. Rear Band Mis-adjusted.	3. Adjust band.
	4. Rear Band Worn.	4. Replace as required.
	5. Overdrive Direct Clutch Worn.	5. Disassemble overdrive. Repair as needed.
	6. Hydraulic Pressure Too Low.	6. Perform hydraulic pressure tests to determine cause.
	7. Rear Servo Leaking.	7. Air pressure check clutch-servo operation and repair as required.
	8. Band Linkage Binding.	8. Inspect and repair as required.

## AUTOMATIC TRANSMISSION - 46RE (Continued)

CONDITION	POSSIBLE CAUSES	CORRECTION
SLIPS IN FORWARD DRIVE RANGES	1. Fluid Level Low.	1. Add fluid and check for leaks.
	2. Fluid Foaming.	2. Check for high oil level, bad pump gasket or seals, dirt between pump halves and loose pump bolts. Replace pump if necessary.
	3. Throttle Linkage Mis-adjusted.	3. Adjust linkage.
	4. Gearshift Linkage Mis-adjusted.	4. Adjust linkage.
	5. Rear Clutch Worn.	5. Inspect and replace as needed.
	6. Low Hydraulic Pressure Due to Worn Pump, Incorrect Control Pressure Adjustments, Valve Body Warpage or Malfunction, Sticking, Leaking Seal Rings, Clutch Seals Leaking, Servo Leaks, Clogged Filter or Cooler Lines.	6. Perform hydraulic and air pressure tests to determine cause.
	7. Rear Clutch Malfunction, Leaking Seals or Worn Plates.	7. Air pressure check clutch-servo operation and repair as required.
	8. Overrunning Clutch Worn, Not Holding (Slips in 1 Only).	8. Replace Clutch.
SLIPS IN LOW GEAR "D" ONLY, BUT NOT IN MANUAL 1 POSITION	Overrunning Clutch Faulty.	Replace overrunning clutch.
GROWLING, GRATING OR SCRAPING NOISES	1. Drive Plate Broken.	1. Replace.
	2. Torque Converter Bolts Hitting Dust Shield.	2. Dust shield bent. Replace or repair.
	3. Planetary Gear Set Broken/ Seized.	3. Check for debris in oil pan and repair as required.
	4. Overrunning Clutch Worn/Broken.	4. Inspect and check for debris in oil pan. Repair as required.
	5. Oil Pump Components Scored/ Binding.	5. Remove, inspect and repair as required.
	6. Output Shaft Bearing or Bushing Damaged.	6. Remove, inspect and repair as required.
	7. Clutch Operation Faulty.	7. Perform air pressure check and repair as required.
	8. Front and Rear Bands Mis-adjusted.	8. Adjust bands.

## AUTOMATIC TRANSMISSION - 46RE (Continued)

CONDITION	POSSIBLE CAUSES	CORRECTION
DRAGS OR LOCKS UP	1. Fluid Level Low.	1. Check and adjust level.
	2. Clutch Dragging/Failed	2. Air pressure check clutch operation and repair as required.
	3. Front or Rear Band Mis-adjusted.	3. Adjust bands.
	4. Case Leaks Internally.	4. Check for leakage between passages in case.
	5. Servo Band or Linkage Malfunction.	5. Air pressure check servo operation and repair as required.
	6. Overrunning Clutch Worn.	6. Remove and inspect clutch. Repair as required.
	7. Planetary Gears Broken.	7. Remove, inspect and repair as required (look for debris in oil pan).
	8. Converter Clutch Dragging.	8. Check for plugged cooler. Perform flow check. Inspect pump for excessive side clearance. Replace pump as required.
NO 4-3 DOWNSHIFT	1. Circuit Wiring and/or Connectors Shorted.	1. Test wiring and connectors with test lamp and volt/ohmmeter. Repair wiring as necessary. Replace connectors and/or harnesses as required.
	2. PCM Malfunction.	2. Check PCM operation with DRB® scan tool. Replace PCM only if faulty.
	3. TPS Malfunction	3. Check TPS with DRB® scan tool at PCM.
	4. Lockup Solenoid Not Venting.	4. Remove valve body and replace solenoid assembly if plugged or shorted.
	5. Overdrive Solenoid Not Venting.	5. Remove valve body and replace solenoid if plugged or shorted.
	6. Valve Body Valve Sticking.	6. Repair stuck 3-4 shift valve or lockup timing valve.
NO 4-3 DOWNSHIFT WHEN CONTROL SWITCH IS TURNED OFF	1. Control Switch Open/Shorted.	1. Test and replace switch if faulty.
	2. Overdrive Solenoid Connector Shorted.	2. Test solenoids and replace if seized or shorted.
	3. PCM Malfunction.	3. Test with DRB® scan tool. Replace PCM if faulty.
	4. Valve Body Stuck Valves.	4. Repair stuck 3-4, lockup or lockup timing valve.
CLUNK NOISE FROM DRIVELINE ON CLOSED THROTTLE 4-3 DOWNSHIFT	1. Transmission Fluid Low.	1. Add Fluid.
	2. Throttle Cable Mis-adjusted.	2. Adjust cable.
	3. Overdrive Clutch Select Spacer Wrong Spacer.	3. Replace overdrive piston thrust plate spacer.



## AUTOMATIC TRANSMISSION - 46RE (Continued)

CONDITION	POSSIBLE CAUSES	CORRECTION
3-4 UPSHIFT OCCURS IMMEDIATELY AFTER 2-3 SHIFT	1. Overdrive Solenoid Connector or Wiring Shorted.	1. Test connector and wiring for loose connections, shorts or ground and repair as needed.
	2. TPS Malfunction.	2. Test TPS and replace as necessary. Check with DRB® scan tool.
	3. PCM Malfunction.	3. Test PCM with DRB® scan tool and replace controller if faulty.
	4. Overdrive Solenoid Malfunction.	4. Replace solenoid.
	5. Valve Body Malfunction.	5. Remove, disassemble, clean and inspect valve body components. Make sure all valves and plugs slide freely in bores. Polish valves with crocus cloth if needed.
WHINE/NOISE RELATED TO ENGINE SPEED	1. Fluid Level Low.	1. Add fluid and check for leaks.
	2. Shift Cable Incorrect Routing.	2. Check shift cable for correct routing. Should not touch engine or bell housing.
NO 3-4 UPSHIFT	1. O/D Switch In OFF Position.	1. Turn control switch to ON position.
	2. Overdrive Circuit Fuse Blown.	2. Replace fuse. Determine why fuse failed and repair as necessary (i.e., shorts or grounds in circuit).
	3. O/D Switch Wire Shorted/Open Cut.	3. Check wires/connections with 12V test lamp and voltmeter. Repair damaged or loose wire/connection as necessary.
	4. Distance or Coolant Sensor Malfunction.	4. Check with DRB® scan tool and repair or replace as necessary.
	5. TPS Malfunction.	5. Check with DRB® scan tool and replace if necessary.
	6. Neutral Sense to PCM Wire Shorted/Cut.	6. Test switch/sensor as described in service section and replace if necessary. Engine no start.
	7. PCM Malfunction.	7. Check with DRB® scan tool and replace if necessary.
	8. Overdrive Solenoid Shorted/Open.	8. Replace solenoid if shorted or open and repair loose or damaged wires (DRB® scan tool).
	9. Solenoid Feed Orifice in Valve Body Blocked.	9. Remove, disassemble, and clean valve body thoroughly. Check feed orifice.
	10. Overdrive Clutch Failed.	10. Disassemble overdrive and repair as needed.
	11. Hydraulic Pressure Low.	11. Pressure test transmission to determine cause.
	12. Valve Body Valve Stuck.	12. Repair stuck 3-4 shift valve, 3-4 timing valve.
	13. O/D Piston Incorrect Spacer.	13. Remove unit, check end play and install correct spacer.
	14. Overdrive Piston Seal Failure.	14. Replace both seals.
	15. O/D Check Valve/Orifice Failed.	15. Check for free movement and secure assembly (in piston retainer). Check ball bleed orifice.

## AUTOMATIC TRANSMISSION - 46RE (Continued)

CONDITION	POSSIBLE CAUSES	CORRECTION
SLIPS IN OVERDRIVE FOURTH GEAR	1. Fluid Level Low.	1. Add fluid and check for leaks.
	2. Overdrive Clutch Pack Worn.	2. Remove overdrive unit and rebuild clutch pack.
	3. Overdrive Piston Retainer Bleed Orifice Blown Out.	3. Disassemble transmission, remove retainer and replace orifice.
	4. Overdrive Piston or Seal Malfunction.	4. Remove overdrive unit. Replace seals if worn. Replace piston if damaged. If piston retainer is damaged, remove and disassemble the transmission.
	5. 3-4 Shift Valve, Timing Valve or Accumulator Malfunction.	5. Remove and overhaul valve body. Replace accumulator seals. Make sure all valves operate freely in bores and do not bind or stick. Make sure valve body screws are correctly tightened and separator plates are properly positioned.
	6. Overdrive Unit Thrust Bearing Failure.	6. Disassemble overdrive unit and replace thrust bearing (NO. 1 thrust bearing is between overdrive piston and clutch hub; NO. 2 thrust bearing is between the planetary gear and the direct clutch spring plate; NO. 3 thrust bearing is between overrunning clutch hub and output shaft).
	7. O/D Check Valve/Bleed Orifice Failure.	7. Check for function/secure orifice insert in O/D piston retainer.
DELAYED 3-4 UPSHIFT (SLOW TO ENGAGE)	1. Fluid Level Low.	1. Add fluid and check for leaks.
	2. Throttle Valve Cable Mis-adjusted.	2. Adjust throttle valve cable.
	3. Overdrive Clutch Pack Worn/ Burnt.	3. Remove unit and rebuild clutch pack.
	4. TPS Faulty.	4. Test with DRB® scan tool and replace as necessary
	5. Overdrive Clutch Bleed Orifice Plugged.	5. Disassemble transmission and replace orifice.
	6. Overdrive Solenoid or Wiring Shorted/Open.	6. Test solenoid and check wiring for loose/corroded connections or shorts/grounds. Replace solenoid if faulty and repair wiring if necessary.
	7. Overdrive Excess Clearance.	7. Remove unit. Measure end play and select proper spacer.
	8. O/D Check Valve Missing or Stuck.	8. Check for presence of check valve. Repair or replace as required.
TORQUE CONVERTER LOCKS UP IN SECOND AND/OR THIRD GEAR	Lockup Solenoid, Relay or Wiring Shorted/Open.	Test solenoid, relay and wiring for continuity, shorts or grounds. Replace solenoid and relay if faulty. Repair wiring and connectors as necessary.
HARSH 1-2, 2-3, 3-4 OR 3-2 SHIFTS	Lockup Solenoid Malfunction.	Remove valve body and replace solenoid assembly.

## AUTOMATIC TRANSMISSION - 46RE (Continued)

CONDITION	POSSIBLE CAUSES	CORRECTION
NO START IN PARK OR NEUTRAL	1. Gearshift Linkage/Cable Mis-adjusted.	1. Adjust linkage/cable.
	2. Neutral Sense Wire Open/Cut.	2. Check continuity with test lamp. Repair as required.
	3. Park/Neutral Switch, or Transmission Range Sensor Faulty.	3. Refer to service section for test and replacement procedure.
	4. Park/Neutral Switch, or Transmission Range Sensor Connection Faulty.	4. Connectors spread open. Repair.
	5. Valve Body Manual Lever Assembly Bent/Worn/Broken.	5. Inspect lever assembly and replace if damaged.
NO REVERSE (OR SLIPS IN REVERSE)	1. Direct Clutch Pack (front clutch) Worn.	1. Disassemble unit and rebuild clutch pack.
	2. Rear Band Mis-adjusted.	2. Adjust band.
	3. Front Clutch Malfunctioned/ Burned.	3. Air-pressure test clutch operation. Remove and rebuild if necessary.
	4. Overdrive Thrust Bearing Failure.	4. Disassemble geartrain and replace bearings.
	5. Direct Clutch Spring Collapsed/ Broken.	5. Remove and disassemble unit. Check clutch position and replace spring.
OIL LEAKS.	1. Fluid Lines and Fittings Loose/ Leaks/Damaged.	1. Tighten fittings. If leaks persist, replace fittings and lines if necessary.
	2. Fill Tube (where tube enters case) Leaks/Damaged.	2. Replace tube seal. Inspect tube for cracks in fill tube.
	3. Pressure Port Plug Loose Loose/Damaged.	3. Tighten to correct torque. Replace plug or reseal if leak persists.
	4. Pan Gasket Leaks.	4. Tighten pan screws (150 in. lbs.). If leaks persist, replace gasket.
	5. Valve Body Manual Lever Shaft Seal Leaks/Worn.	5. Replace shaft seal.
	6. Rear Bearing Access Plate Leaks.	6. Replace gasket. Tighten screws.
	7. Gasket Damaged or Bolts are Loose.	7. Replace bolts or gasket or tighten both.
	8. Adapter/Extension Gasket Damaged Leaks/Damaged.	8. Replace gasket.
	9. Park/Neutral Switch, or Transmission Range Sensor Leaks/Damaged.	9. Replace switch and gasket.
	10. Converter Housing Area Leaks.	10. Check for leaks at seal caused by worn seal or burr on converter hub (cutting seal), worn bushing, missing oil return, oil in front pump housing or hole plugged. Check for leaks past O-ring seal on pump or past pump-to-case bolts; pump housing porous, oil coming out vent due to overfill or leak past front band shaft access plug.

## AUTOMATIC TRANSMISSION - 46RE (Continued)

CONDITION	POSSIBLE CAUSES	CORRECTION
	11. Pump Seal Leaks/Worn/Damaged.	11. Replace seal.
	12. Torque Converter Weld Leak/Cracked Hub.	12. Replace converter.
	13. Case Porosity Leaks.	13. Replace case.
NOISY OPERATION IN FOURTH GEAR ONLY	1. Overdrive Clutch Discs, Plates or Snap Rings Damaged.	1. Remove unit and rebuild clutch pack.
	2. Overdrive Piston or Planetary Thrust Bearing Damaged.	2. Remove and disassemble unit. Replace either thrust bearing if damaged.
	3. Output Shaft Bearings Scored/Damaged.	3. Remove and disassemble unit. Replace either bearing if damaged.
	4. Planetary Gears Worn/Chipped.	4. Remove and overhaul overdrive unit.
	5. Overdrive Unit Overrunning Clutch Rollers Worn/Scored.	5. Remove and overhaul overdrive unit.

### STANDARD PROCEDURE - ALUMINUM THREAD REPAIR

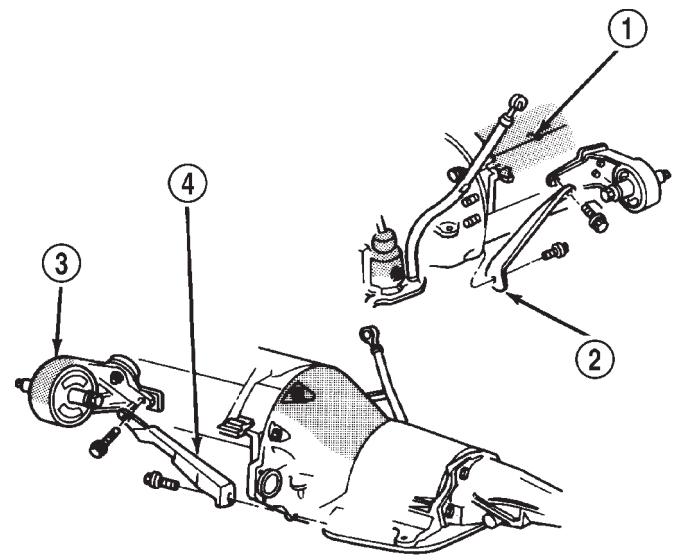
Damaged or worn threads in the aluminum transmission case and valve body can be repaired by the use of Heli-Coils™, or equivalent. This repair consists of drilling out the worn-out damaged threads. Then tap the hole with a special Heli-Coil™ tap, or equivalent, and installing a Heli-Coil™ insert, or equivalent, into the hole. This brings the hole back to its original thread size.

Heli-Coil™, or equivalent, tools and inserts are readily available from most automotive parts suppliers.

### REMOVAL

The overdrive unit can be removed and serviced separately. It is not necessary to remove the entire transmission assembly to perform overdrive unit repairs.

- (1) Disconnect battery negative cable.
- (2) Disconnect and lower or remove necessary exhaust components.
- (3) Remove engine-to-transmission struts, if equipped (Fig. 13).
- (4) Disconnect fluid cooler lines at transmission.
- (5) Remove starter motor. (Refer to 8 - ELECTRICAL/STARTING/STARTER MOTOR - REMOVAL)
- (6) Disconnect and remove the crankshaft position sensor. (Refer to 14 - FUEL SYSTEM/FUEL INJECTION/CRANKSHAFT POSITION SENSOR - REMOVAL) Retain the sensor attaching bolts.
- (7) Remove torque converter access cover.
- (8) If transmission is being removed for overhaul, remove transmission oil pan, drain fluid and reinstall pan.
- (9) Remove fill tube bracket bolts and pull tube out of transmission. Retain fill tube seal (Fig. 13). On 4 x 4 models, it will also be necessary to remove bolt attaching transfer case vent tube to converter housing (Fig. 14).



J9421-255

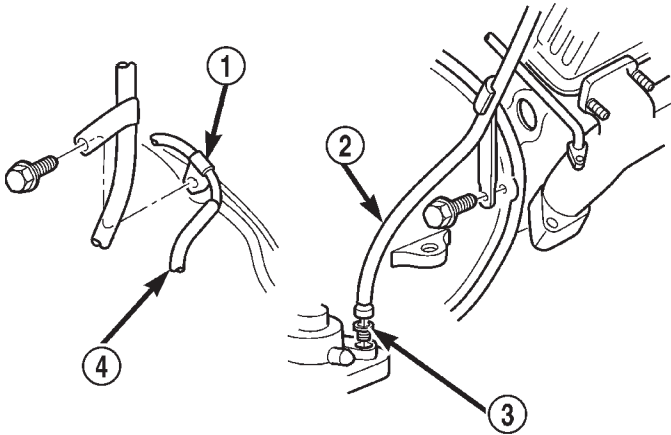
**Fig. 13 Transmission-To-Engine Strut Attachment**

- 1 - ENGINE BLOCK
- 2 - STRUT (PASSENGER SIDE)
- 3 - ENGINE MOUNT
- 4 - STRUT (DRIVER SIDE)

(10) Rotate crankshaft in clockwise direction until converter bolts are accessible. Then remove bolts one at a time. Rotate crankshaft with socket wrench on dampener bolt.

(11) Mark propeller shaft and axle yokes for assembly alignment. Then disconnect and remove propeller shaft. On 4 x 4 models, remove both propeller shafts. (Refer to 3 - DIFFERENTIAL & DRIVE/PROPPELLER SHAFT/PROPPELLER SHAFT - REMOVAL)

## AUTOMATIC TRANSMISSION - 46RE (Continued)

**Fig. 14 Fill Tube Attachment**

80b170f3

- 1 - TRANSFER CASE VENT TUBE
- 2 - FILL TUBE (V8)
- 3 - TUBE SEAL
- 4 - FILL TUBE (V6)

(12) Disconnect wires from park/neutral position switch and transmission solenoid.

(13) Disconnect gearshift rod and torque shaft assembly from transmission.

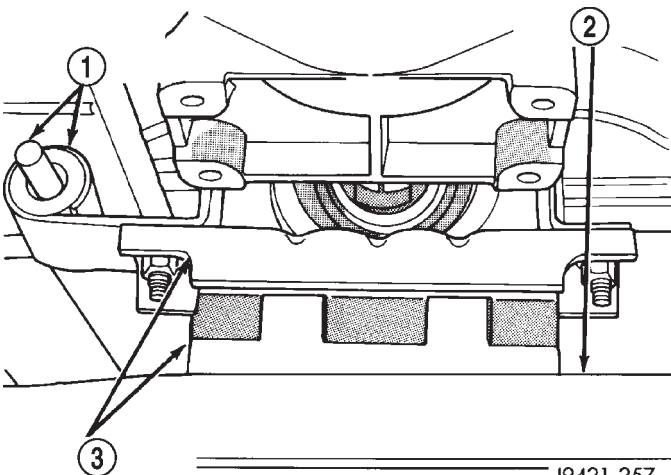
(14) Disconnect throttle valve cable from transmission bracket and throttle valve lever.

(15) On 4 x 4 models, disconnect shift rod from transfer case shift lever.

(16) Support rear of engine with safety stand or jack.

(17) Raise transmission slightly with service jack to relieve load on crossmember and supports.

(18) Remove bolts securing rear support and cushion to transmission and crossmember. Raise transmission slightly, slide exhaust hanger arm from bracket (Fig. 15) and remove rear support.

**Fig. 15 Rear Support Cushion**

J9421-257

- 1 - EXHAUST PIPE ARM AND BRACKET
- 2 - CROSSMEMBER
- 3 - REAR SUPPORT AND CUSHION

(19) Remove bolts attaching crossmember to frame and remove crossmember.

(20) On 4 x 4 models, remove transfer case with transmission jack or aid of helper.

(21) Remove all converter housing bolts.

(22) Carefully work transmission and torque converter assembly rearward off engine block dowels.

(23) Lower transmission and remove assembly from under the vehicle.

(24) To remove torque converter, remove C-clamp from edge of bell housing and carefully slide torque converter out of the transmission.

**DISASSEMBLY**

(1) Clean exterior of transmission with suitable solvent or pressure washer.

(2) Place transmission in vertical position.

(3) Measure the input shaft end play as follows (Fig. 16).

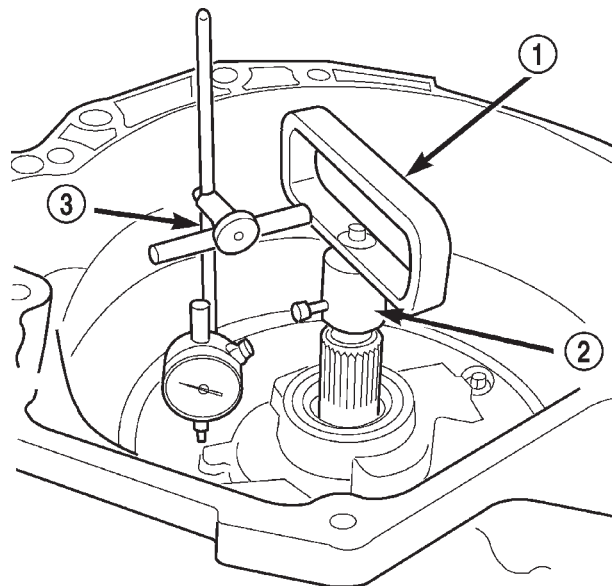
(a) Attach Adapter 8266-5 to Handle 8266-8.

(b) Attach dial indicator C-3339 to Handle 8266-8.

(c) Install the assembled tool onto the input shaft of the transmission and tighten the retaining screw on Adapter 8266-5 to secure it to the input shaft.

(d) Position the dial indicator plunger against a flat spot on the oil pump and zero the dial indicator.

(e) Move input shaft in and out and record reading. Record the maximum travel for assembly reference.

**Fig. 16 Checking Input Shaft End Play**

80c070b4

- 1 - TOOL 8266-8
- 2 - TOOL 8266-5
- 3 - TOOL C-3339

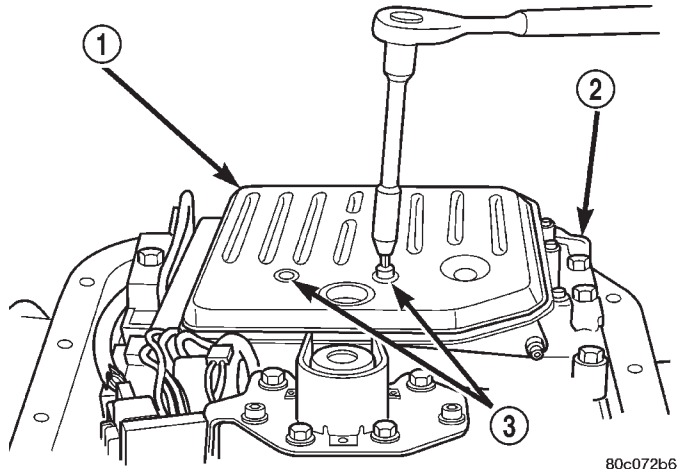


AUTOMATIC TRANSMISSION - 46RE (Continued)

(4) Remove throttle and shift levers from valve body manual shaft and throttle lever shaft.

(5) Remove transmission oil pan and gasket.

(6) Remove filter from valve body (Fig. 17). Keep filter screws separate from other valve body screws. Filter screws are longer and should be kept with filter.

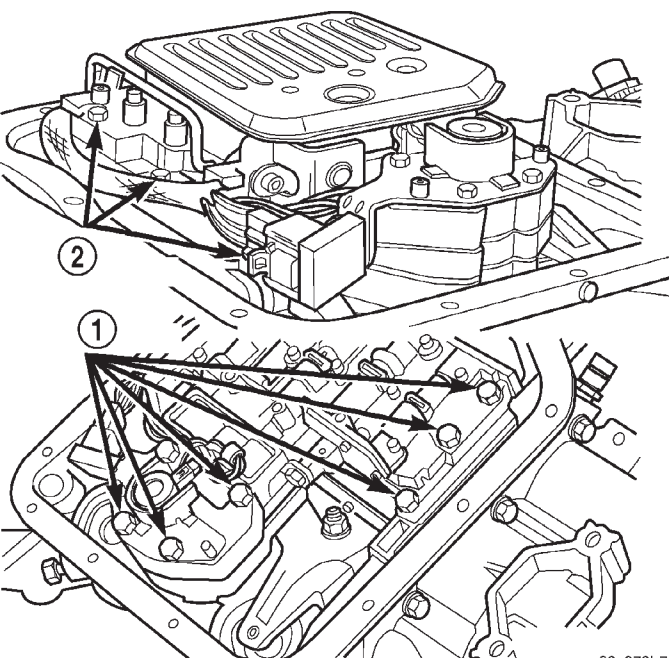


**Fig. 17 Oil Filter Removal**

80c072b6

- 1 - OIL FILTER
- 2 - VALVE BODY
- 3 - FILTER SCREWS (2)

(7) Remove park/neutral position switch and seal.  
 (8) Remove hex head bolts attaching valve body to transmission case (Fig. 18). A total of 10 bolts are used. Note different bolt lengths for assembly reference.

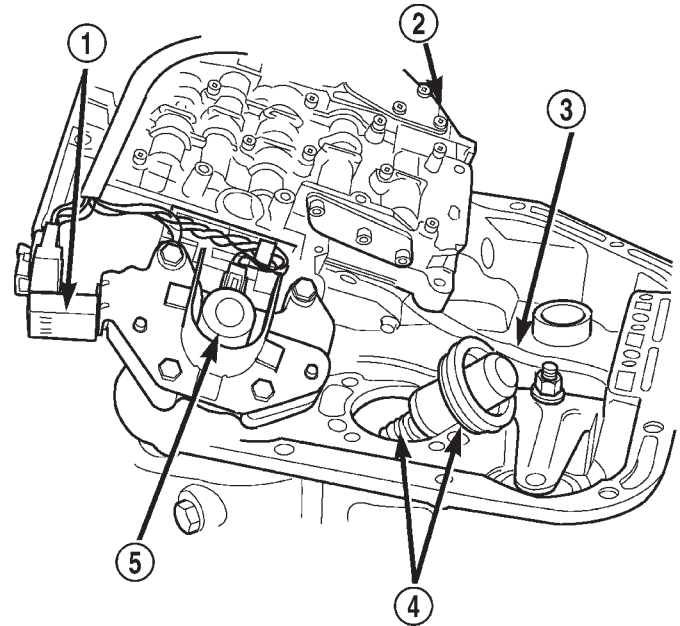


**Fig. 18 Valve Body Bolt Locations**

80c072b7

- 1 - VALVE BODY BOLTS
- 2 - VALVE BODY BOLTS

(9) Remove valve body assembly. Push valve body harness connector out of case. Then work park rod and valve body out of case (Fig. 19).



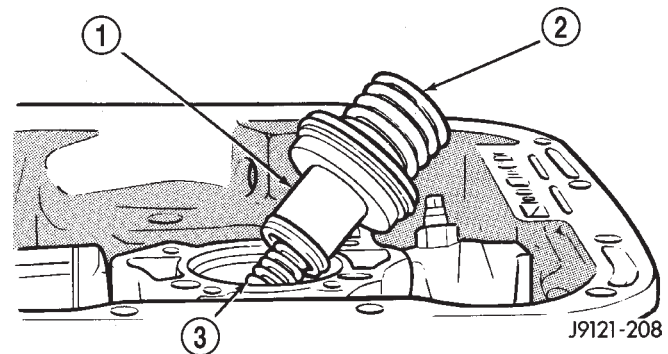
**Fig. 19 Valve Body Removal**

80c072b8

- 1 - GOVERNOR PRESSURE SENSOR
- 2 - VALVE BODY
- 3 - PARK ROD
- 4 - ACCUMULATOR PISTON
- 5 - GOVERNOR PRESSURE SOLENOID

(10) Remove accumulator outer spring, piston and inner spring (Fig. 20). Note position of piston and springs for assembly reference. Remove and discard piston seals if worn or cut.

(11) Remove pump oil seal with suitable pry tool or slide-hammer mounted screw.



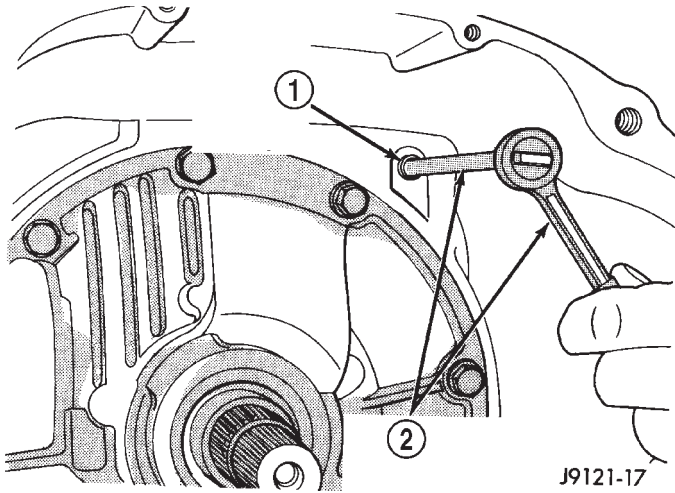
**Fig. 20 Accumulator Component Removal**

J9121-208

- 1 - ACCUMULATOR PISTON
- 2 - OUTER SPRING
- 3 - INNER SPRING

AUTOMATIC TRANSMISSION - 46RE (Continued)

(12) Remove front band lever pin access plug (Fig. 21). Use square end of 1/4 in. drive extension to remove plug as shown.



**Fig. 21 Front Band Lever Pin Access Plug**

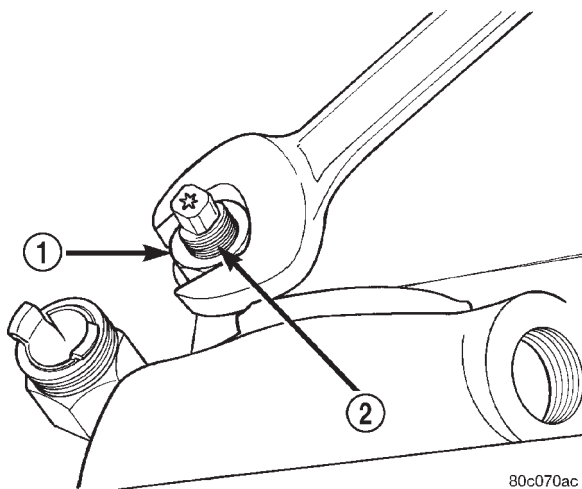
- 1 - FRONT BAND REACTION PIN ACCESS PLUG
- 2 - 1/4 DRIVE EXTENSION AND RATCHET

(13) Remove oil pump and reaction shaft support assembly as follows:

(a) Tighten front band adjusting screw until band is tight around front clutch retainer (Fig. 22). This will prevent retainer from coming out with pump and possibly damaging clutch or pump components.

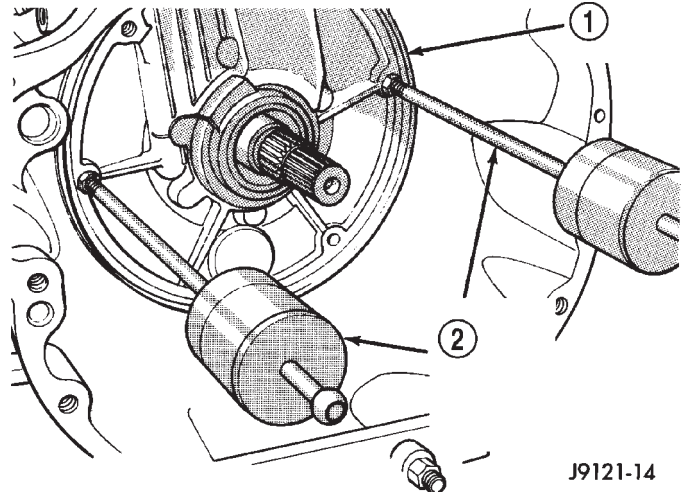
(b) Remove oil pump bolts.

(c) Thread Slide Hammer Tools C-3752 into threaded holes in flange of oil pump housing (Fig. 23).



**Fig. 22 Tightening Front Band To Hold Front Clutch In Place**

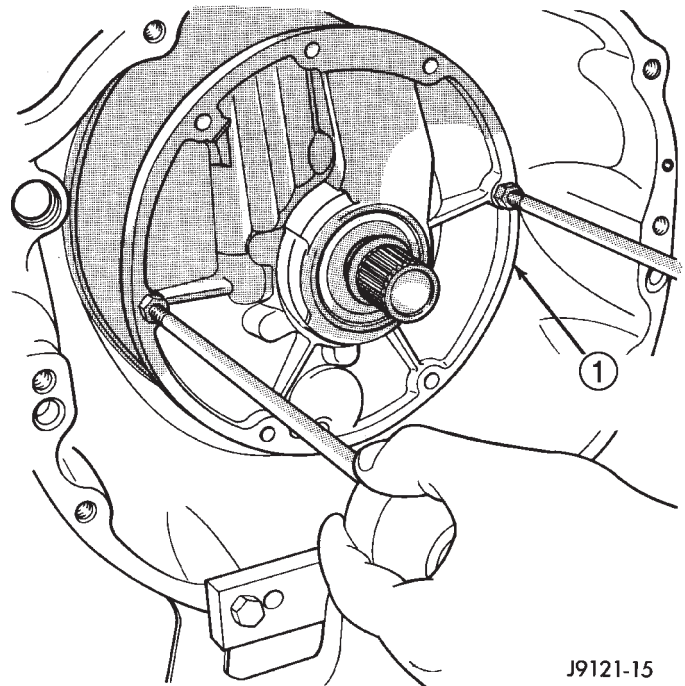
- 1 - LOCK-NUT
- 2 - FRONT BAND ADJUSTER



**Fig. 23 Oil Pump Removal Tools**

- 1 - PUMP HOUSING
- 2 - SLIDE HAMMER TOOLS (THREAD INTO PUMP HOUSING)

(d) Remove oil pump and reaction shaft support by bumping slide hammers outward alternately to pull pump from case (Fig. 24).



**Fig. 24 Oil Pump Removal**

- 1 - OIL PUMP AND REACTION SHAFT SUPPORT

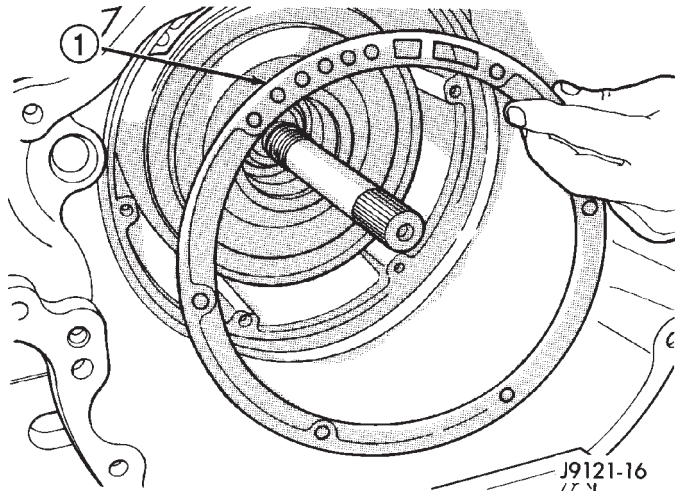
AUTOMATIC TRANSMISSION - 46RE (Continued)

(14) Remove oil pump gasket (Fig. 25). Note gasket position in case for assembly reference.

(15) Loosen front band adjusting screw until band is completely loose.

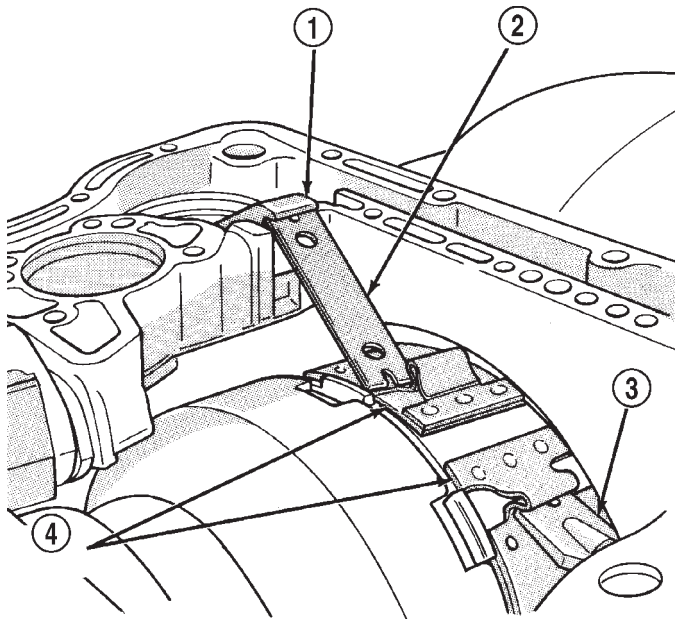
(16) Remove front band strut and anchor (Fig. 26).

(17) Squeeze front band together slightly and slide band over front clutch retainer and out of case (Fig. 27).



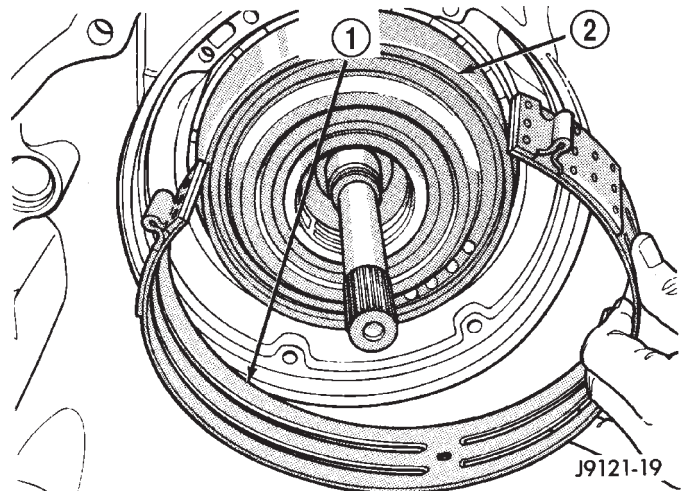
**Fig. 25 Oil Pump Gasket**

- 1 - OIL PUMP GASKET



**Fig. 26 Front Band Linkage**

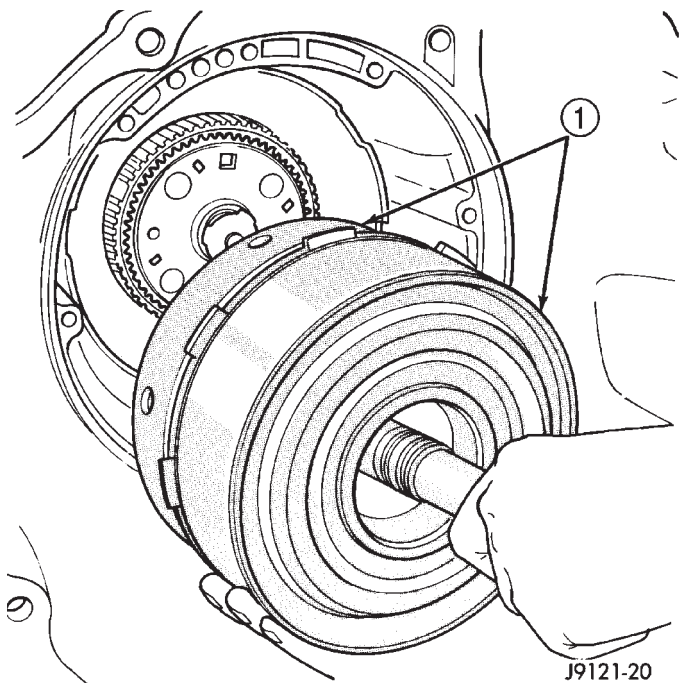
- 1 - LEVER
- 2 - STRUT
- 3 - ANCHOR
- 4 - FRONT BAND



**Fig. 27 Front Band Removal**

- 1 - FRONT BAND
- 2 - FRONT CLUTCH RETAINER

(18) Remove front and rear clutch assemblies as a unit (Fig. 28).



**Fig. 28 Removing Front/Rear Clutch Assemblies**

- 1 - FRONT AND REAR CLUTCH ASSEMBLIES



AUTOMATIC TRANSMISSION - 46RE (Continued)

(19) Remove front band reaction pin and lever. Start pin through lever and out of case bore with drift or punch. Then use pencil magnet to withdraw pin completely (Fig. 29).

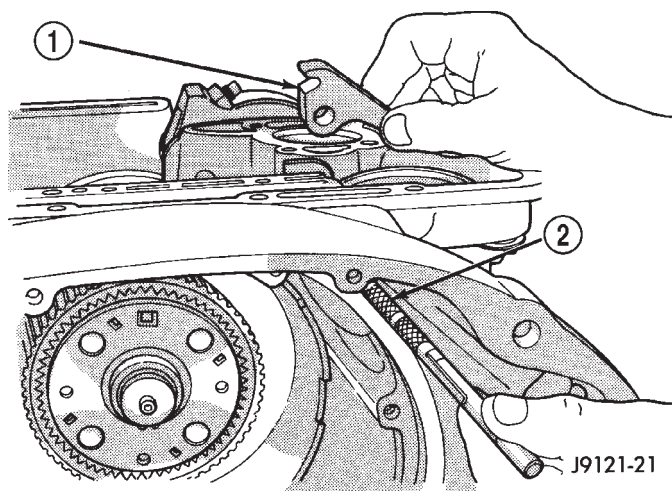
(20) Remove intermediate shaft thrust washer. Triangular shaped washer will either be on shaft pilot hub or in rear clutch retainer (Fig. 30).

(21) Remove thrust plate from intermediate shaft hub (Fig. 31).

(22) Remove intermediate shaft-planetary geartrain assembly (Fig. 32).

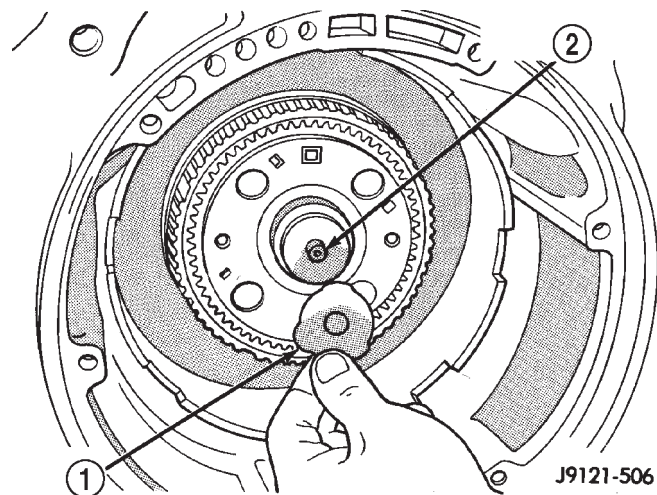
(23) If overdrive unit is not to be serviced, install Alignment Shaft 6227-2 into the overdrive unit to prevent misalignment of the overdrive clutches during service of main transmission components.

(24) Loosen rear band locknut and loosen adjusting screw 3-4 turns.



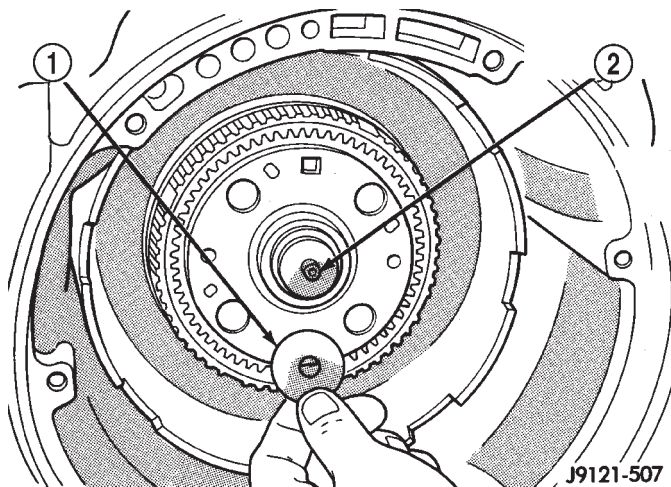
**Fig. 29 Front Band Lever And Pin**

- 1 - BAND LEVER
- 2 - USE PENCIL MAGNET TO REMOVE REACTION PIN



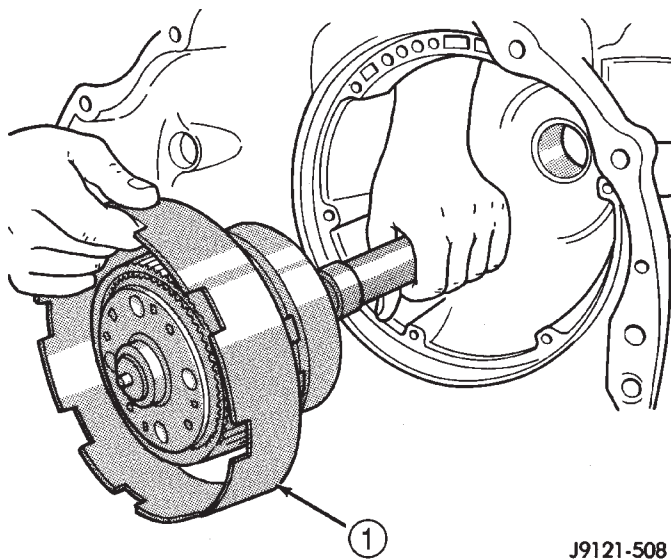
**Fig. 30 Intermediate Shaft Thrust Washer**

- 1 - THRUST WASHER
- 2 - INTERMEDIATE SHAFT PILOT HUB



**Fig. 31 Intermediate Shaft Thrust Plate**

- 1 - SHAFT THRUST PLATE
- 2 - INTERMEDIATE SHAFT PILOT HUB

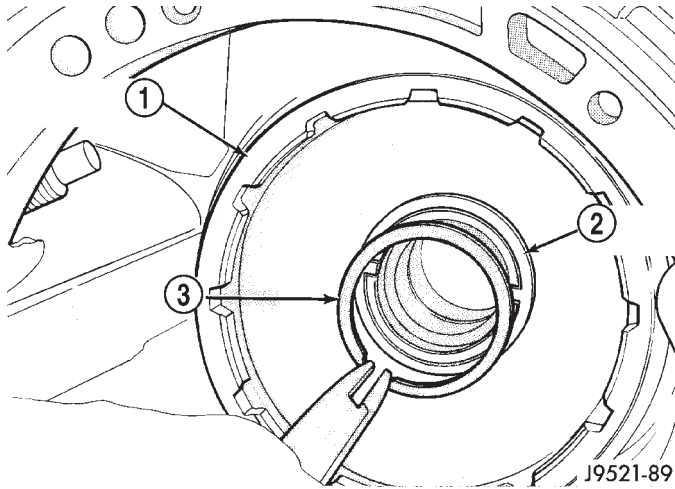


**Fig. 32 Intermediate Shaft And Planetary Geartrain**

- 1 - INTERMEDIATE SHAFT AND PLANETARY GEAR TRAIN ASSEMBLY

AUTOMATIC TRANSMISSION - 46RE (Continued)

(25) Remove snap-ring that retains low-reverse drum on overdrive piston retainer hub (Fig. 33).



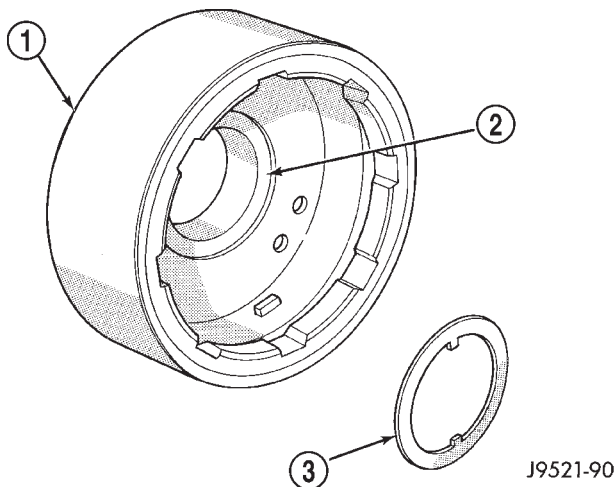
**Fig. 33 Low-Reverse Drum Snap-Ring**

- 1 - LOW-REVERSE DRUM
- 2 - TABBED WASHER
- 3 - SNAP-RING

(26) Slide low-reverse drum and thrust washer off piston retainer hub and out of rear band (Fig. 34).

(27) Note that overrunning clutch race will remain on splines of low-reverse drum after removal (Fig. 35). **The race is a permanent press fit on the hub splines. Do not attempt to remove the race.**

(28) Remove overrunning clutch assembly (Fig. 36). Assembly can be removed without displacing rollers and springs if care is exercised. Note position of rollers and springs for assembly reference.



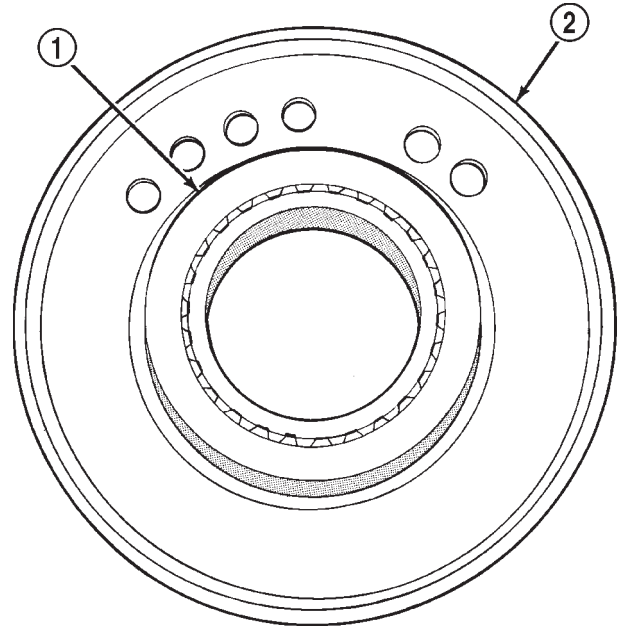
**Fig. 34 Low-Reverse Drum And Thrust Washer**

- 1 - LOW-REVERSE DRUM
- 2 - SPOTFACE FOR WASHER
- 3 - THRUST WASHER

(29) Remove rear band adjusting lever, reaction lever and pin (Fig. 37).

(30) Remove strut from rear band. Keep strut with levers and pin for cleaning, inspection and assembly reference.

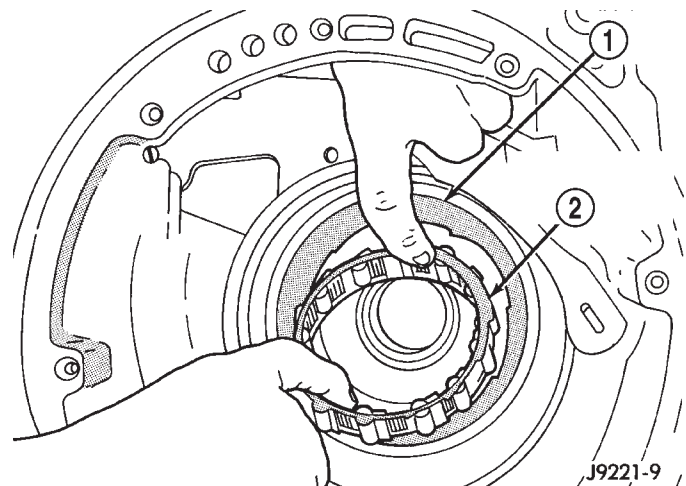
(31) Remove rear band and link (Fig. 38).



J9221-8

**Fig. 35 Overrunning Clutch Race Position On Low-Reverse Drum**

- 1 - OVERRUNNING CLUTCH RACE
- 2 - LOW-REVERSE DRUM



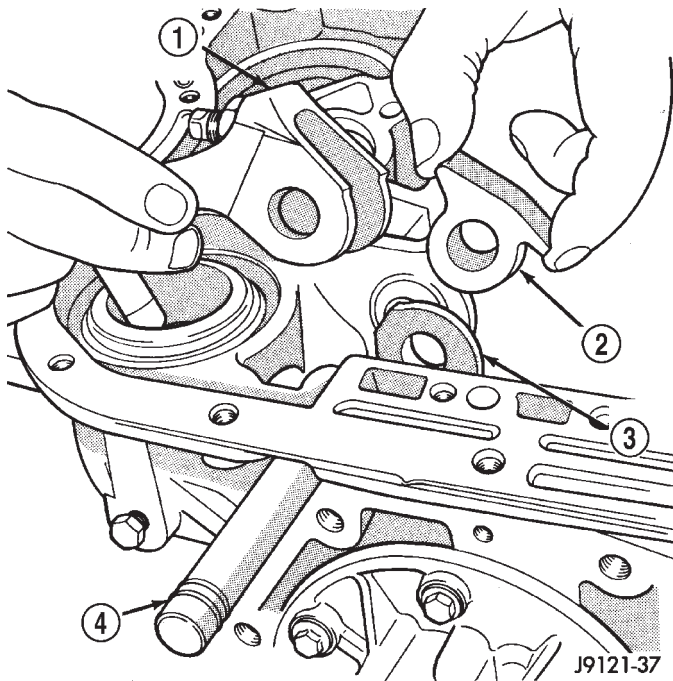
J9221-9

**Fig. 36 Overrunning Clutch Removal**

- 1 - CLUTCH CAM
- 2 - OVERRUNNING CLUTCH ASSEMBLY

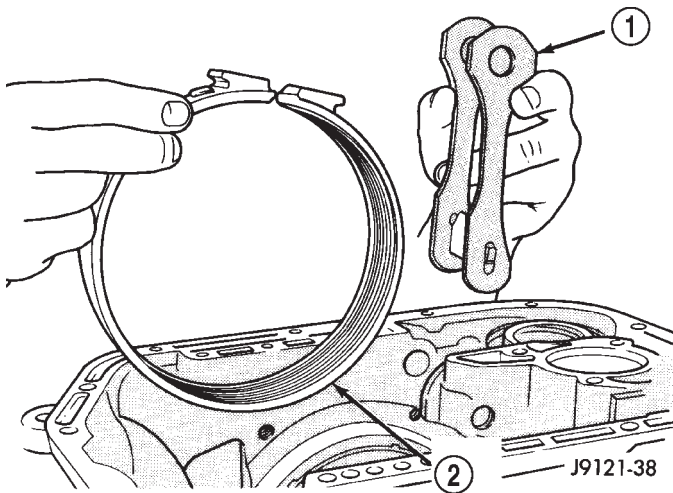


## AUTOMATIC TRANSMISSION - 46RE (Continued)



**Fig. 37 Rear Band Levers And Pins**

- 1 - REAR BAND ADJUSTING LEVER
- 2 - REACTION LEVER
- 3 - BAND LINK
- 4 - REAR BAND REACTION PIN



**Fig. 38 Rear Band And Link**

- 1 - BAND LINK
- 2 - REAR BAND

(32) Compress front servo rod guide with large C-clamp and Tool C-4470, or Compressor Tool C-3422-B (Fig. 39). Compress guide only enough to permit snap-ring removal (about 1/8 in.).

(33) Remove servo piston snap-ring (Fig. 39). Unseat one end of ring. Then carefully work removal tool around back of ring until free of ring groove.

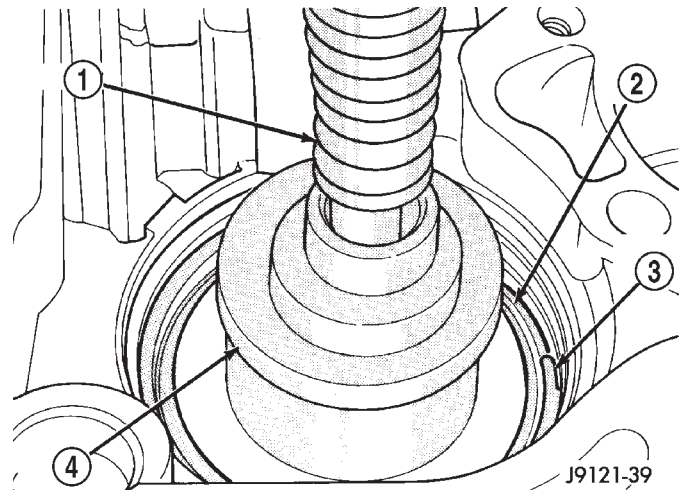
**Exercise caution when removing snap-ring. Servo bore can be scratched or nicked if care is not exercised.**

(34) Remove tools and remove servo piston and spring.

(35) Compress rear servo piston with C-clamp and Tool C-4470, or Valve Spring Compressor C-3422-B (Fig. 40). Compress servo spring retainer only enough to permit snap-ring removal.

(36) Remove servo piston snap-ring (Fig. 40). Start one end of ring out of bore. Then carefully work removal tool around back of snap-ring until free of ring groove. **Exercise caution when removing snap-ring. Servo bore can be scratched or nicked if care is not exercised.**

(37) Remove tools and remove rear servo retainer, spring and piston assembly.



**Fig. 39 Front Servo Retaining Snap-Ring**

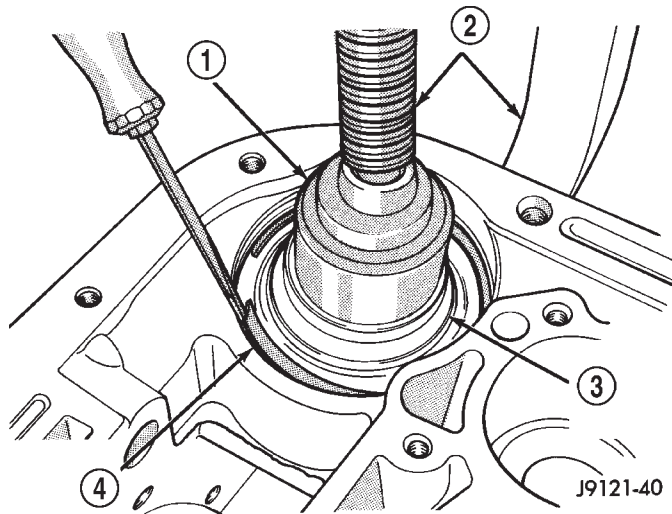
- 1 - C-CLAMP
- 2 - FRONT SERVO ROD GUIDE
- 3 - SNAP-RING
- 4 - TOOL C-4470

## CLEANING

Clean the case in a solvent tank. Flush the case bores and fluid passages thoroughly with solvent. Dry the case and all fluid passages with compressed air. Be sure all solvent is removed from the case and that all fluid passages are clear.

**NOTE: Do not use shop towels or rags to dry the case (or any other transmission component) unless they are made from lint-free materials. Lint will stick to case surfaces and transmission components and circulate throughout the transmission after assembly. A sufficient quantity of lint can block fluid passages and interfere with valve body operation.**

## AUTOMATIC TRANSMISSION - 46RE (Continued)



**Fig. 40 Rear Servo Retaining Snap-Ring**

- 1 - TOOL C-4470
- 2 - C-CLAMP
- 3 - REAR SERVO SPRING RETAINER
- 4 - RETAINER SNAP-RING

Lubricate transmission parts with Mopar® ATF +4, type 9602, transmission fluid during overhaul and assembly. Use petroleum jelly, Mopar® Door Ease, or Ru-Glyde™ to prelubricate seals, O-rings, and thrust washers. Petroleum jelly can also be used to hold parts in place during reassembly.

## INSPECTION

Inspect the case for cracks, porous spots, worn bores, or damaged threads. Damaged threads can be repaired with Helicoil thread inserts. However, the case will have to be replaced if it exhibits any type of damage or wear.

Lubricate the front band adjusting screw threads with petroleum jelly and thread the screw part-way into the case. Be sure the screw turns freely.

Inspect the transmission bushings during overhaul. Bushing condition is important as worn, scored bushings contribute to low pressures, clutch slip and accelerated wear of other components. However, do not replace bushings as a matter of course. Replace bushings only when they are actually worn, or scored.

Use recommended tools to replace bushings. The tools are sized and designed to remove, install, and seat bushings correctly. The bushing replacement tools are included in Bushing Tool Set C-3887-B.

Pre-sized service bushings are available for replacement purposes. Only the sun gear bushings are not serviced.

The use of crocus cloth is permissible where necessary, providing it is used carefully. When used on shafts, or valves, use extreme care to avoid rounding

off sharp edges. Sharp edges are vital as they prevent foreign matter from getting between the valve and valve bore.

Do not reuse oil seals, gaskets, seal rings, or O-rings during overhaul. Replace these parts as a matter of course. Also do not reuse snap rings or E-clips that are bent or distorted. Replace these parts as well.

## ASSEMBLY

Do not allow dirt, grease, or foreign material to enter the case or transmission components during assembly. Keep the transmission case and components clean. Also make sure the tools and workbench area used for reassembly operations are equally clean.

Shop towels used for wiping off tools and your hands must be made from **lint free** materials. Lint will stick to transmission parts and could interfere with valve operation or even restrict fluid passages.

Lubricate transmission clutch and gear components with Mopar® ATF +4, type 9602, during reassembly. Soak clutch discs in transmission fluid before installation.

Use Mopar® Door Ease, or Ru-Glyde™ on piston seals and O-rings to ease installation. Petroleum jelly can also be used to lubricate and hold thrust washers and plates in position during assembly.

**Do not use chassis grease, bearing grease, white grease, or similar lubricants on any part.** These types of lubricants can eventually block or restrict fluid passages and valve operation. Use petroleum jelly only.

Do not force parts into place. The transmission components and sub-assemblies are easily installed by hand when properly aligned. If a part seems difficult to install, it is either misaligned or incorrectly assembled. Verify that thrust washers, thrust plates and seal rings are correctly positioned.

The planetary geartrain, front/rear clutch assemblies and oil pump are all much easier to install when the transmission case is upright. Either tilt the case upward with wood blocks, or cut a hole in the bench large enough for the intermediate shaft and rear support. Then lower the shaft and support into the hole and support the rear of the case directly on the bench.

## FRONT/REAR SERVO

(1) Lubricate rear servo piston seal with Mopar® Door Ease or ATF +4. Lubricate servo bore in case with ATF +4.

(2) Install rear servo piston in case. Position piston at slight angle to bore and insert piston with twisting motion (Fig. 41).

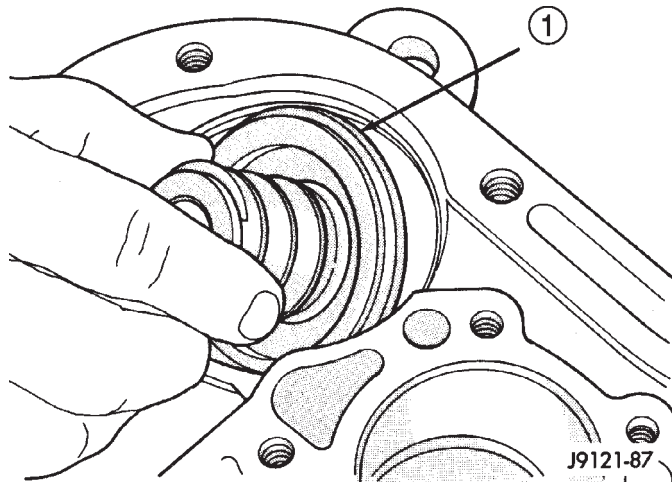
## AUTOMATIC TRANSMISSION - 46RE (Continued)

(3) Install rear servo spring and retainer in case bore (Fig. 42). Be sure spring is seated on piston.

(4) Compress rear servo piston with C-clamp or Valve Spring Compressor C-3422-B and install servo piston snap-ring (Fig. 43).

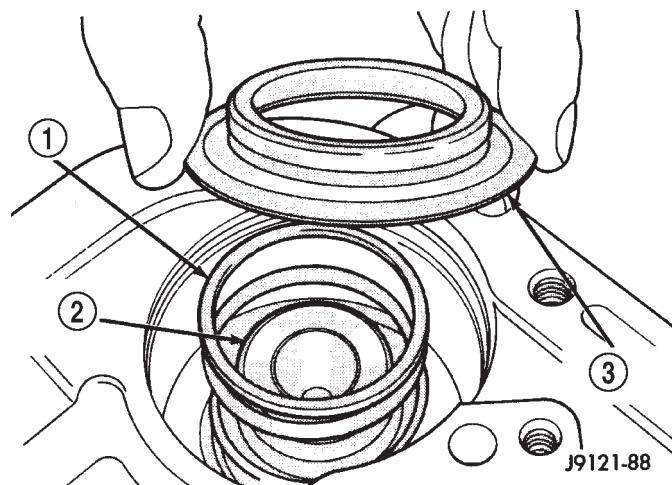
(5) Lubricate front servo piston components and servo bore in case with transmission fluid.

(6) Install front servo piston in bore. Carefully "run" small, suitable tool around piston ring to press it back into groove and ease installation (Fig. 44). Rotate piston into bore at same time. Rock piston slightly to ease piston ring past snap-ring groove and into bore.



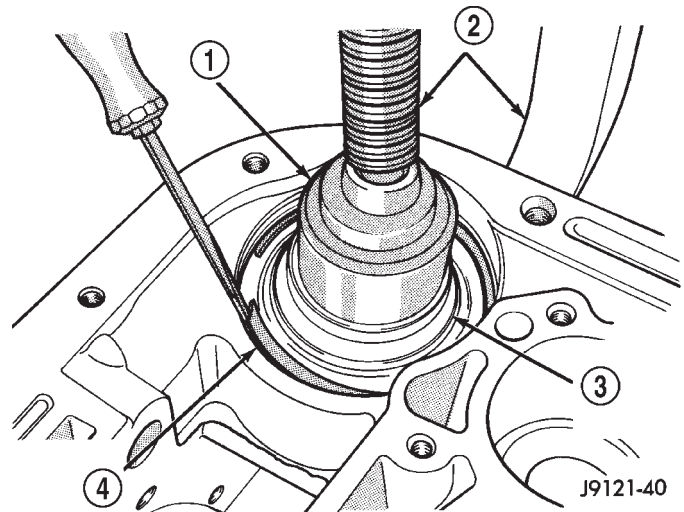
**Fig. 41 Rear Servo Piston**

1 - REAR SERVO PISTON



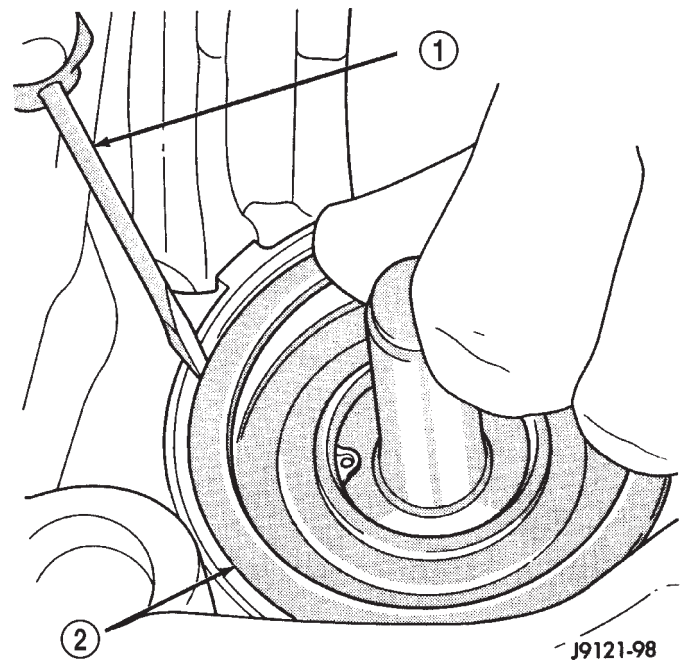
**Fig. 42 Rear Servo Piston Spring And Retainer**

1 - PISTON SPRING  
2 - REAR SERVO PISTON  
3 - SPRING RETAINER



**Fig. 43 Rear Servo Snap-Ring**

1 - TOOL C-4470  
2 - C-CLAMP  
3 - REAR SERVO SPRING RETAINER  
4 - RETAINER SNAP-RING



**Fig. 44 Front Servo Piston**

1 - USE SUITABLE TOOL TO HELP SEAT PISTON RING  
2 - FRONT SERVO PISTON



## AUTOMATIC TRANSMISSION - 46RE (Continued)

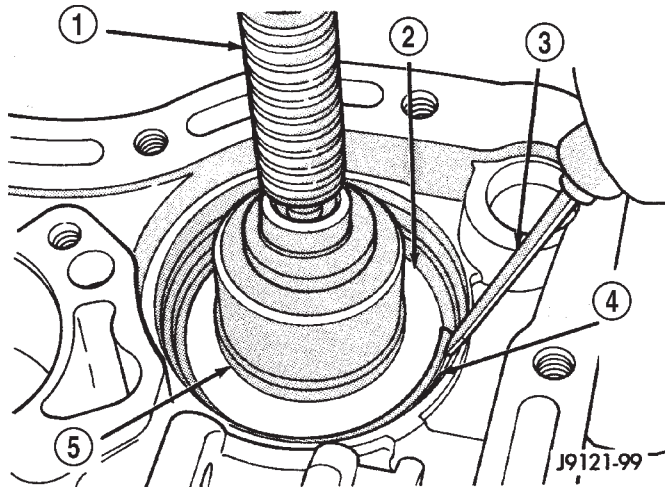
(7) Bottom front servo piston in bore and install servo spring.

(8) Install front servo piston rod guide as follows:

(a) Place Tool SP-5560 (or similar size tool) on guide and position C-clamp on tool and case (Fig. 45).

(b) Slowly compress rod guide while simultaneously easing seal ring into bore with suitable tool.

(9) Install rod guide snap-ring (Fig. 45).



**Fig. 45 Front Servo Rod Guide And Snap-Ring**

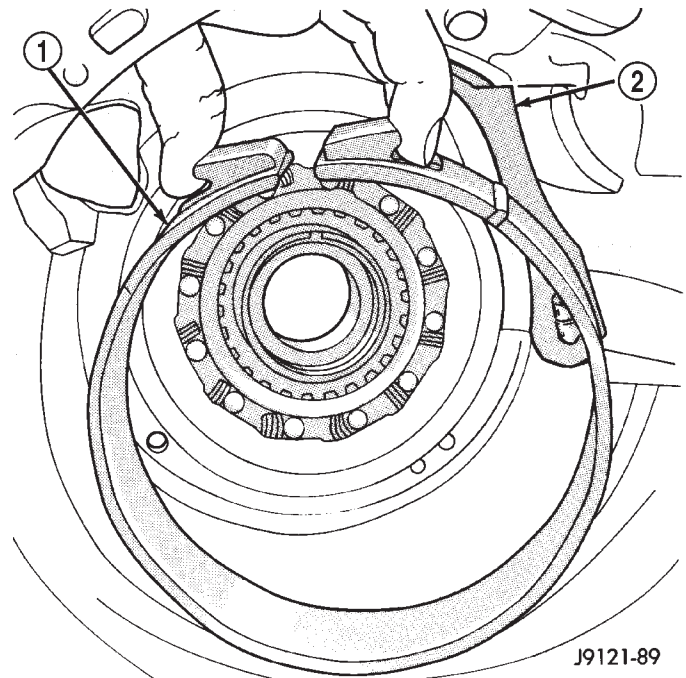
- 1 - C-CLAMP
- 2 - ROD GUIDE
- 3 - SMALL SCREWDRIVER
- 4 - ROD GUIDE SNAP-RING
- 5 - TOOL SP-5560

### OVERRUNNING CLUTCH, REAR BAND, AND LOW-REVERSE DRUM

(1) Install overrunning clutch components if not yet installed.

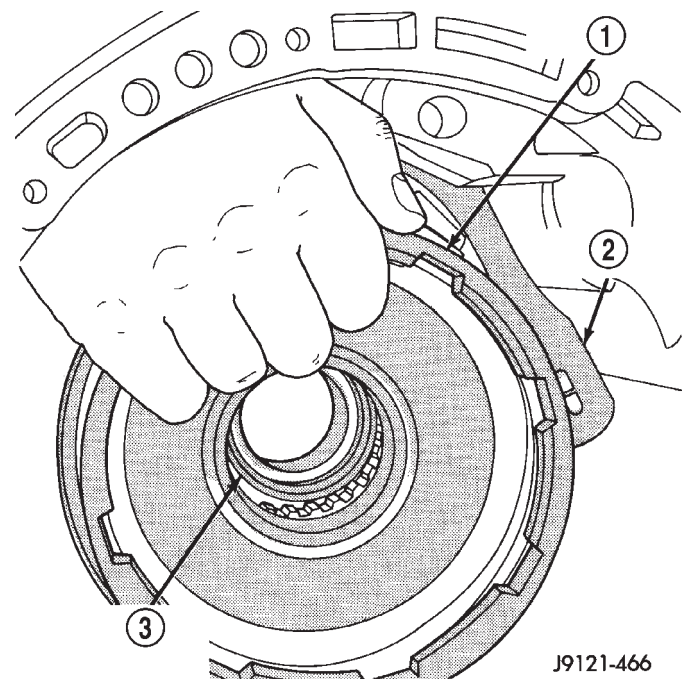
(2) Position rear band and link in case (Fig. 46).

(3) Install low-reverse drum (Fig. 47). Slide drum through rear band, onto piston retainer hub and into engagement with overrunning clutch and race.



**Fig. 46 Rear Band And Link**

- 1 - REAR BAND
- 2 - BAND LINK



**Fig. 47 Low-Reverse Drum**

- 1 - LOW-REVERSE DRUM
- 2 - REAR BAND LINK
- 3 - HUB OF OVERDRIVE PISTON RETAINER

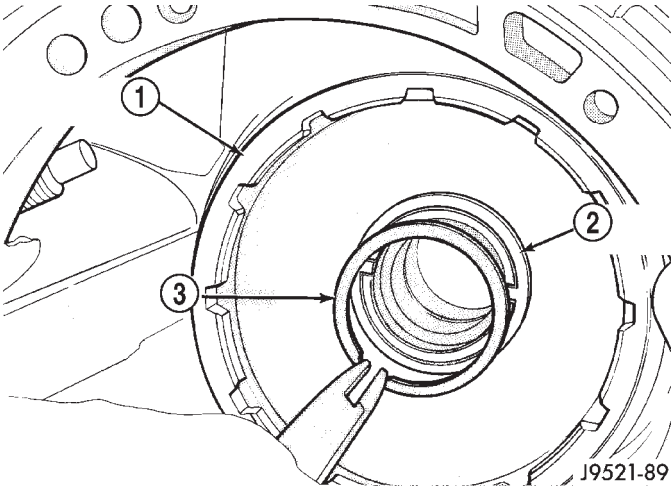
## AUTOMATIC TRANSMISSION - 46RE (Continued)

(4) Install thrust washer in low-reverse drum spot-face (Fig. 48). Use petroleum jelly to hold washer in place.

(5) Install snap-ring that secures low-reverse drum to piston retainer hub (Fig. 48).

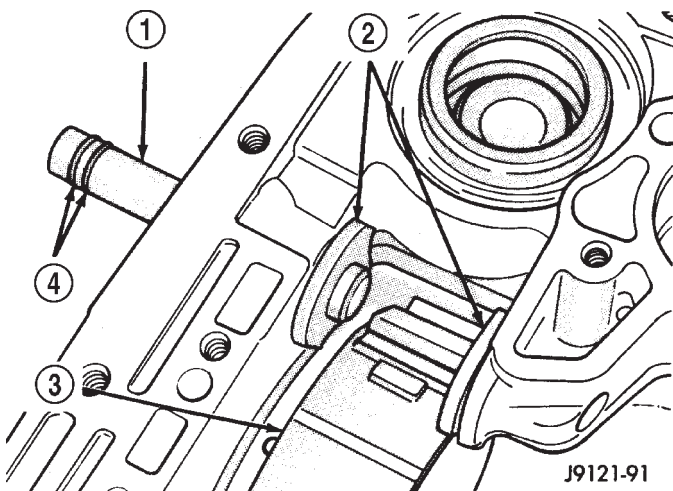
(6) Insert band reaction pin part way into case and band link (Fig. 49).

(7) Install rear band adjusting lever, reaction lever, and strut (Fig. 50). Be sure levers and strut are aligned and engaged before seating band reaction pin in case.



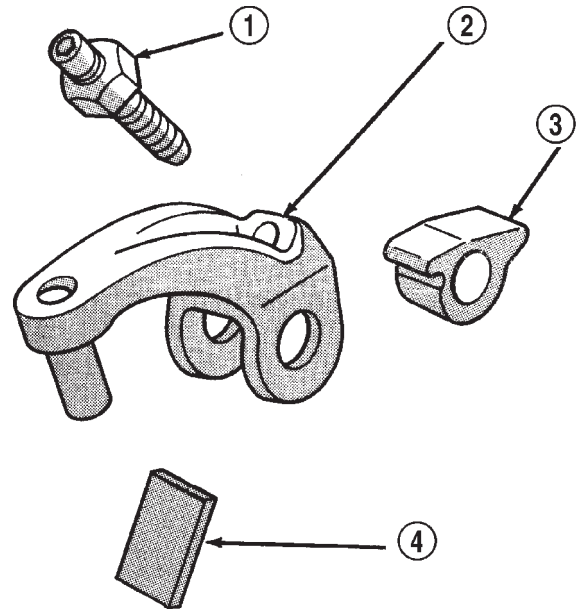
**Fig. 48 Low-Reverse Drum Snap-Ring**

- 1 - LOW-REVERSE DRUM
- 2 - TABBED WASHER
- 3 - SNAP-RING



**Fig. 49 Rear Band Reaction Pin**

- 1 - REACTION PIN
- 2 - BAND LINK
- 3 - REAR BAND
- 4 - O-RINGS



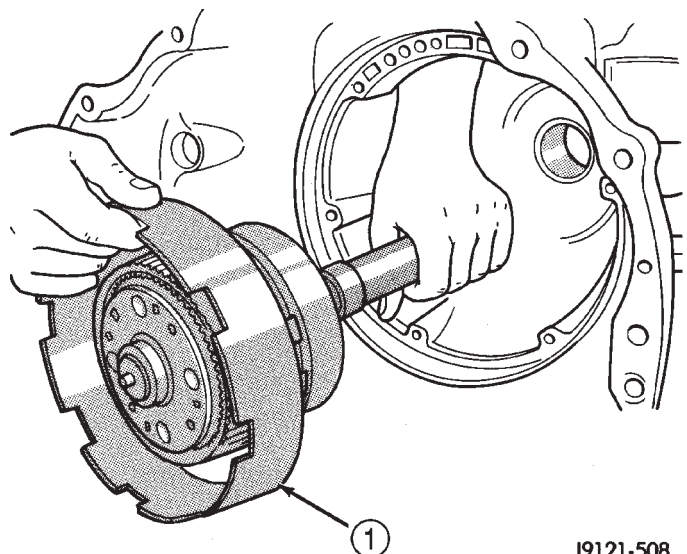
**Fig. 50 Rear Band Levers And Strut**

- 1 - ADJUSTING SCREW AND NUT
- 2 - ADJUSTING LEVER
- 3 - REACTION LEVER
- 4 - STRUT

### PLANETARY GEARTRAIN, FRONT/REAR CLUTCH, AND FRONT BAND

(1) Remove Alignment Shaft 6227-2, if installed previously.

(2) Install assembled intermediate shaft and planetary geartrain (Fig. 51). **Support shaft carefully during installation. Do not allow shaft bearing/bushing surfaces to become nicked or scratched.**



**Fig. 51 Intermediate Shaft And Planetary Geartrain**

- 1 - INTERMEDIATE SHAFT AND PLANETARY GEAR TRAIN ASSEMBLY

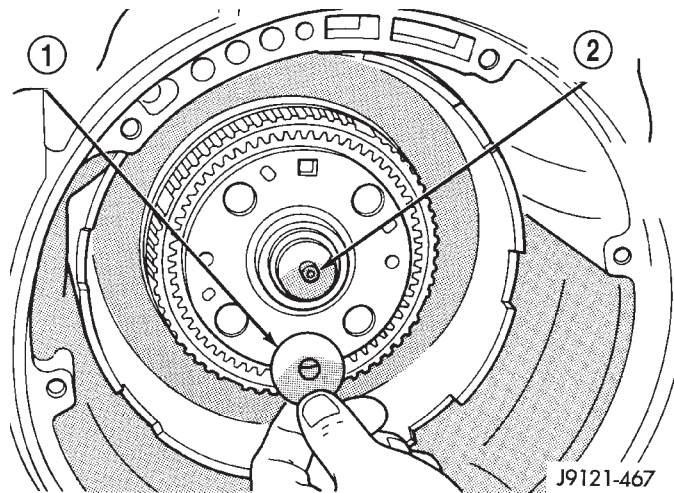


AUTOMATIC TRANSMISSION - 46RE (Continued)

(3) Lubricate intermediate shaft thrust plate with petroleum jelly and install plate on shaft pilot hub (Fig. 52).

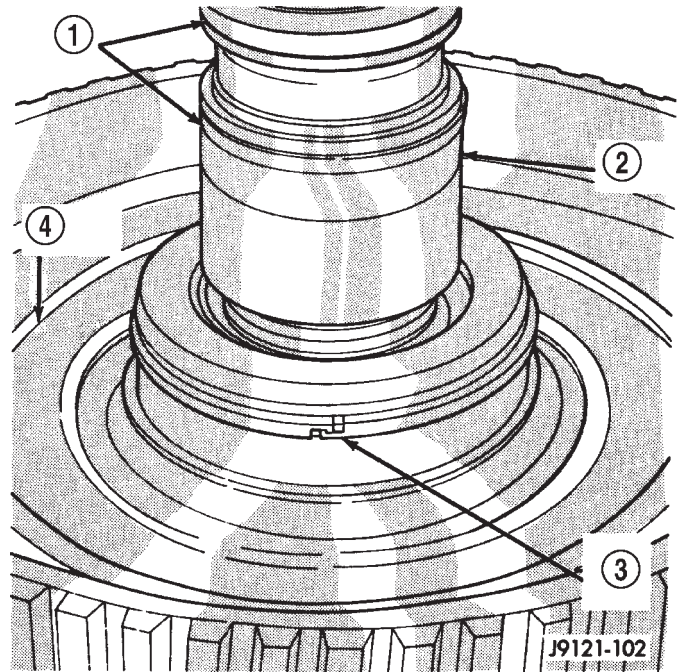
(4) Check input shaft front seal rings, fiber thrust washer and rear seal ring (Fig. 53). Be ends of rear seal ring are hooked together and diagonal cut ends of front seal rings are firmly seated against each other as shown. Lubricate seal rings with petroleum jelly after checking them.

(5) Assemble front and rear clutches (Fig. 54). Align lugs on front clutch discs. Mount front clutch on rear clutch. Turn front clutch retainer back and forth until front clutch discs are fully seated on rear clutch splined hub.



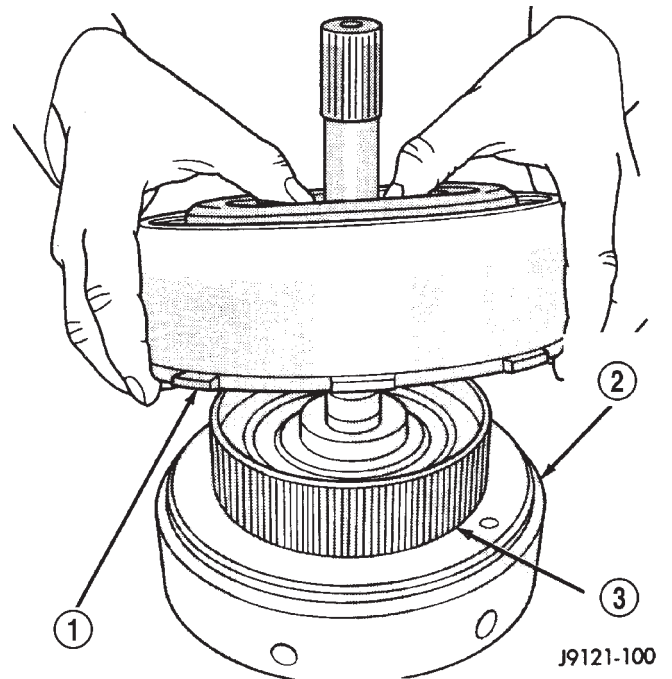
**Fig. 52 Intermediate Shaft Thrust Plate**

- 1 - SHAFT THRUST PLATE
- 2 - INTERMEDIATE SHAFT PILOT HUB



**Fig. 53 Input Shaft Seal Rings And Thrust Washer**

- 1 - TORLON® FRONT SEAL RINGS
- 2 - INPUT SHAFT
- 3 - REAR SEAL RING
- 4 - THRUST WASHER



**Fig. 54 Assembling Front And Rear Clutches**

- 1 - FRONT CLUTCH ASSEMBLY
- 2 - REAR CLUTCH ASSEMBLY
- 3 - REAR CLUTCH SPLINED HUB

## AUTOMATIC TRANSMISSION - 46RE (Continued)

(6) Install intermediate shaft thrust washer in hub of rear clutch retainer (Fig. 55). Use petroleum jelly to hold washer in place. Position washer so grooves are facing outward. **Washer only fits one way in clutch retainer hub.**

(7) Place transmission case in upright position, or place blocks under front end of transmission repair stand to tilt case rearward. This makes it easier to install front/rear clutch assembly.

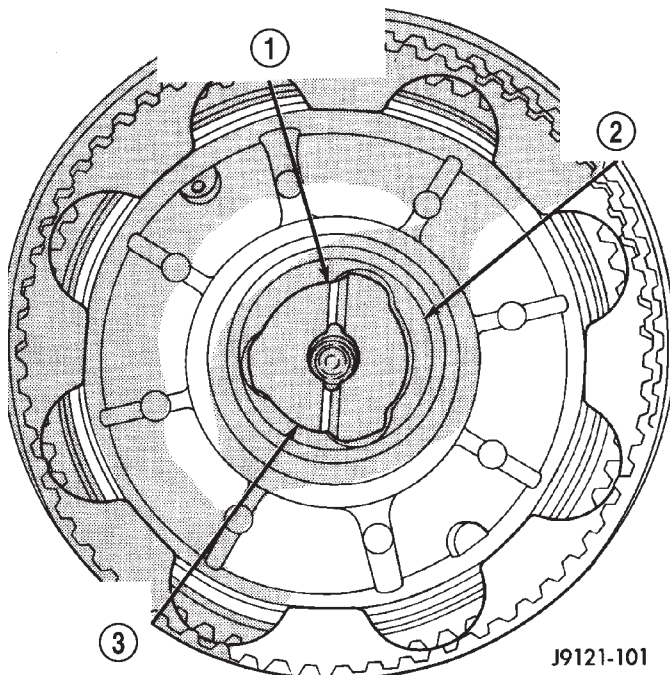
(8) Align discs in rear clutch. Then install and engage assembly in front planetary and driving shell (Fig. 56). Turn clutch retainers back and forth until both clutches are seated.

(9) Position front band lever in case and over servo rod guide. Then install front band lever pin in case and slide it through lever.

(10) Coat threads of front band pin access plug with sealer and install it in case. Tighten plug to 17 N-m (13 ft. lbs.) torque.

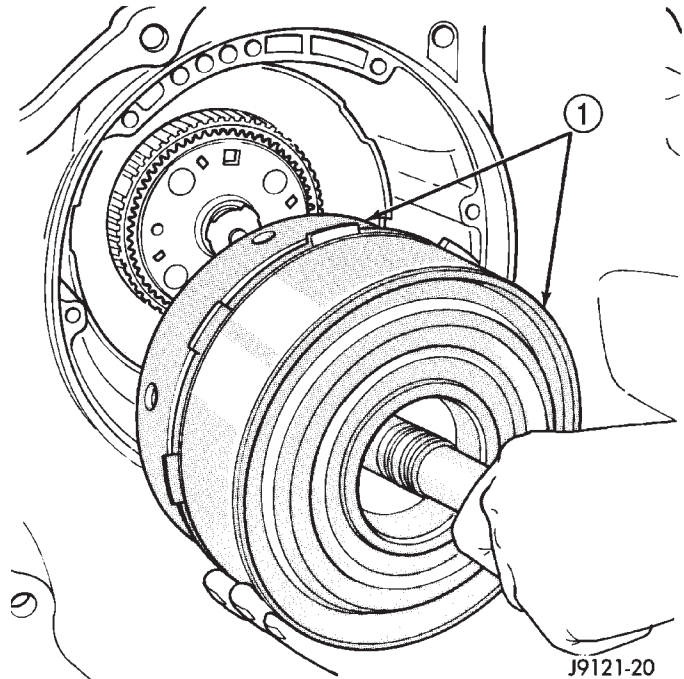
(11) Slide front band over front clutch retainer and install front band strut and anchor (Fig. 57).

(12) Tighten front band adjusting screw until band is tight on clutch retainer. This will hold clutches in place while oil pump is being installed. **Verify that front/rear clutch assembly is still properly seated before tightening band.**



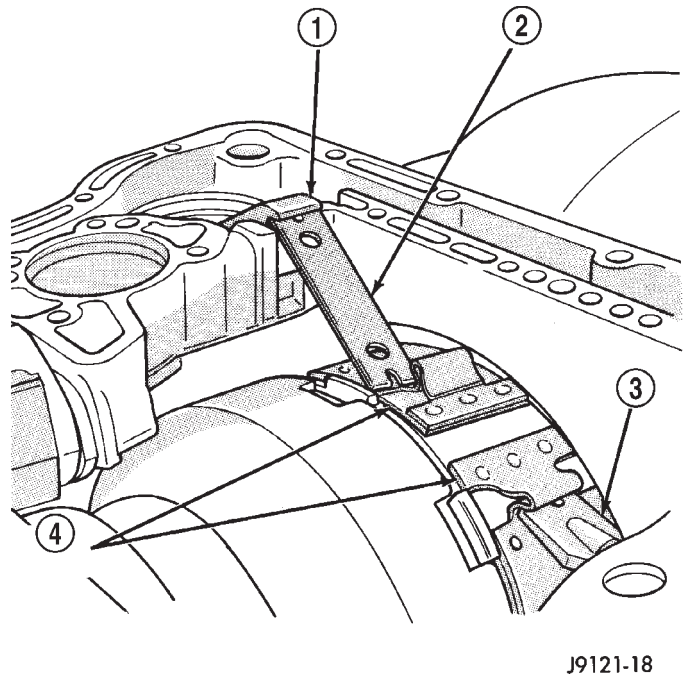
**Fig. 55 Intermediate Shaft Thrust Washer**

- 1 - BE SURE WASHER GROOVES FACE OUT AS SHOWN
- 2 - REAR CLUTCH RETAINER HUB
- 3 - OUTPUT SHAFT THRUST WASHER



**Fig. 56 Front/Rear Clutch Assemblies**

- 1 - FRONT AND REAR CLUTCH ASSEMBLIES



**Fig. 57 Front Band And Linkage**

- 1 - LEVER
- 2 - STRUT
- 3 - ANCHOR
- 4 - FRONT BAND

## AUTOMATIC TRANSMISSION - 46RE (Continued)

## OIL PUMP

(1) Install oil pump Pilot Studs C-3288-B in case (Fig. 58).

(2) Install new oil pump gasket on pilot studs and seat it in case. Be sure gasket is properly aligned with fluid passages in case (Fig. 58).

(3) Coat front clutch thrust washer with petroleum jelly to hold it in place. Then install washer over reaction shaft hub and seat it on pump (Fig. 59).

**CAUTION:** The thrust washer bore (I.D.), is chamfered on one side. Make sure the chamfered side is installed so it faces the pump.

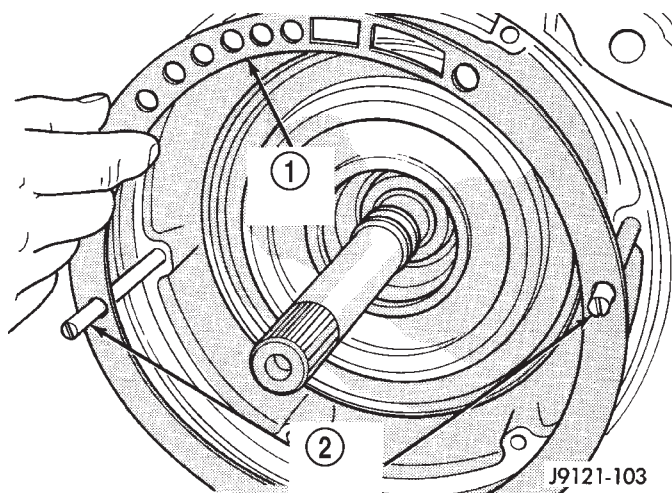
(4) Check seal rings on reaction shaft support. Be sure rings are hooked together correctly. Also be sure fiber thrust washer is in position (Fig. 60). Use extra petroleum jelly to hold washer in place if necessary.

(5) Lubricate oil pump seals with petroleum Mopar® ATF +4, type 9602.

(6) Mount oil pump on pilot studs and slide pump into case opening (Fig. 61). **Work pump into case by hand. Do not use a mallet or similar tools to seat pump.**

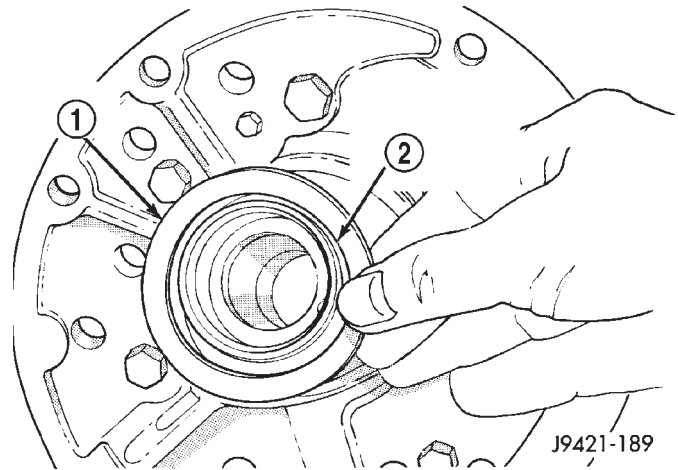
(7) Remove pilot studs and install oil pump bolts. Tighten pump bolts alternately and evenly to fully seat pump in case. Then final-tighten pump bolts to 20 N·m (15 ft. lbs.) torque.

(8) Verify correct installation. Rotate input and intermediate shafts and check for bind. If bind exists, components are either mis-assembled, or not seated. Disassemble and correct as necessary before proceeding.



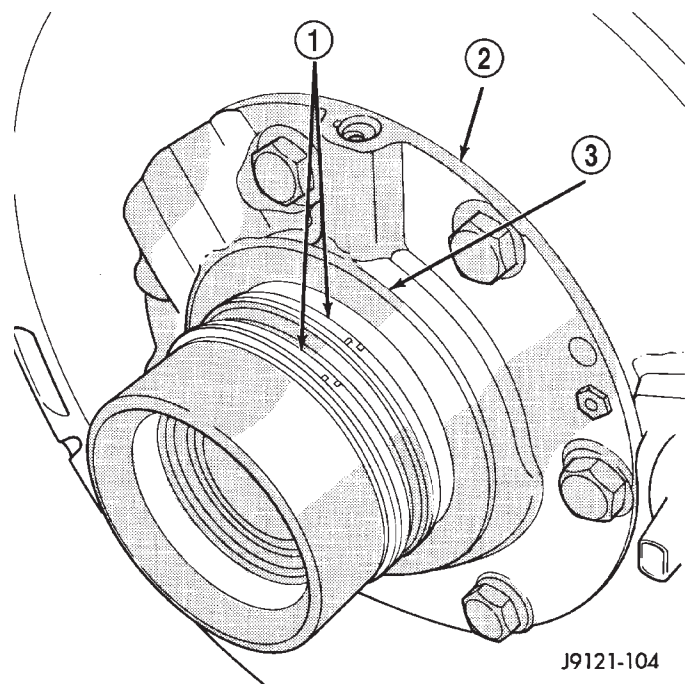
**Fig. 58 Oil Pump Gasket And Pilot Studs**

- 1 - OIL PUMP GASKET
- 2 - PILOT STUDS C-3288-B



**Fig. 59 Front Clutch Thrust Washer**

- 1 - THRUST WASHER
- 2 - CHAMFERED SIDE OF WASHER BORE GOES TOWARD PUMP

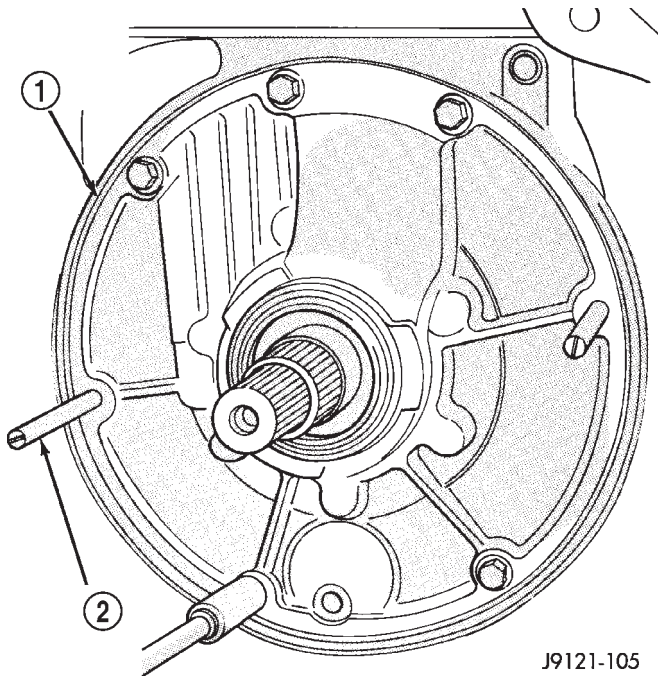


**Fig. 60 Reaction Shaft Seal Ring And Thrust Washer**

- 1 - SEAL RINGS
- 2 - REACTION SHAFT SUPPORT
- 3 - THRUST WASHER (FIBER)

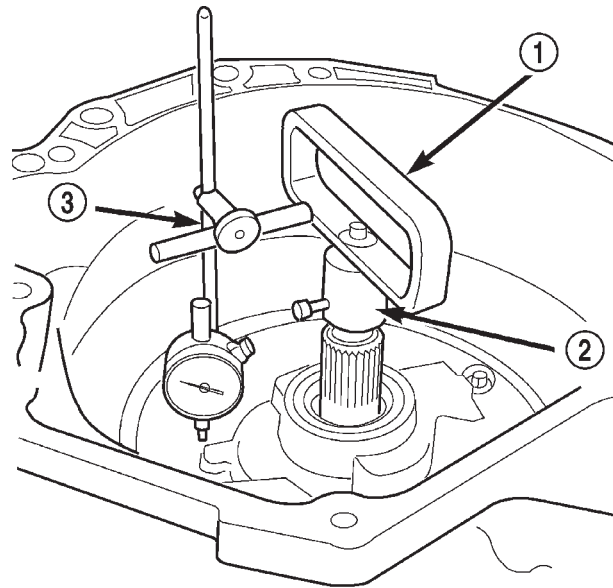


## AUTOMATIC TRANSMISSION - 46RE (Continued)

**Fig. 61 Oil Pump**

- 1 - SEAT OIL PUMP IN CASE BY HAND  
2 - REMOVE PILOT STUDS WHEN PUMP IS SEATED

J9121-105



80c070b4

**Fig. 62 Checking Input Shaft End Play**

- 1 - TOOL 8266-8  
2 - TOOL 8266-5  
3 - TOOL C-3339

**INPUT SHAFT END PLAY CHECK**

**NOTE:** Overdrive unit must be installed in order to correctly measure the input shaft end-play.

- (1) Measure input shaft end play (Fig. 62).

**NOTE:** If end play is incorrect, transmission is incorrectly assembled, or reaction shaft thrust washer is incorrect. The reaction shaft thrust washer is selective.

- (a) Attach Adapter 8266-5 to Handle 8266-8.
- (b) Attach dial indicator C-3339 to Handle 8266-8.
- (c) Install the assembled tool onto the input shaft of the transmission and tighten the retaining screw on Adapter 8266-5 to secure it to the input shaft.
- (d) Position the dial indicator plunger against a flat spot on the oil pump and zero the dial indicator.
- (e) Move input shaft in and out and record reading. End play should be 0.86-2.13 mm (0.034-0.084 in.). Adjust as necessary.

**ACCUMULATOR, VALVE BODY, OIL PAN, AND TORQUE CONVERTER**

- (1) Install accumulator inner spring, piston and outer spring (Fig. 63).

- (2) Verify that park/neutral position switch has **not** been installed in case. Valve body can not be installed if switch is in position.

- (3) Install new valve body manual shaft seal in case (Fig. 64). Lubricate seal lip and manual shaft with petroleum jelly. Start seal over shaft and into case. Seat seal with 15/16 inch, deep well socket.

- (4) Install valve body as follows:

- (a) Start park rod into park pawl. If rod will not slide past park pawl, pawl is engaged in park gear. Rotate overdrive output shaft with suitable size 12 point socket; this will free pawl and allow rod to engage.

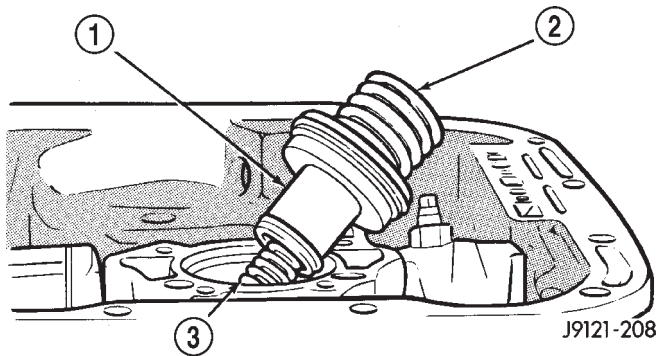
- (b) Align and seat valve body on case. Be sure manual lever shaft and overdrive connector are fully seated in case.

- (c) Install and start all valve body attaching bolts by hand. Then tighten bolts evenly, in a diagonal pattern to 12 N·m (105 in. lbs.) torque. **Do not overtighten valve body bolts. This could result in distortion and cross leakage after installation.**

- (5) Install new filter on valve body. Tighten filter screws to 4 N·m (35 in. lbs.).

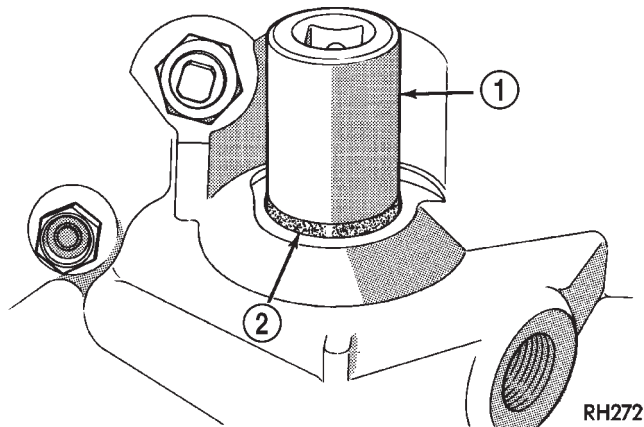
- (6) Install seal on park/neutral position switch. Then install and tighten switch to 34 N·m (25 ft. lbs.).

## AUTOMATIC TRANSMISSION - 46RE (Continued)



**Fig. 63 Accumulator Piston And Springs**

- 1 - ACCUMULATOR PISTON  
2 - OUTER SPRING  
3 - INNER SPRING



**Fig. 64 Manual Lever Shaft Seal**

- 1 - 15/16" SOCKET  
2 - SEAL

**CAUTION:** If the condition of the transmission before the overhaul procedure caused excessive metallic or fiber contamination in the fluid, replace the torque converter and reverse flush the cooler(s) and cooler lines. Fluid contamination and transmission failure can result if not done.

(7) Install torque converter. Use C-clamp or metal strap to hold converter in place for installation.

### BAND ADJUSTMENT AND FINAL

- (1) Adjust front and rear bands as follows:
  - (a) Loosen locknut on each band adjusting screw 4-5 turns.
  - (b) Tighten both adjusting screws to 8 N·m (72 in. lbs.).
  - (c) Back off front band adjusting screw 2-7/8 turns.
  - (d) Back off rear band adjusting screw 2 turns.
  - (e) Hold each adjusting screw in position and tighten locknut to 34 N·m (25 ft. lbs.) torque.

(2) Install magnet in oil pan. Magnet seats on small protrusion at corner of pan.

(3) Position new oil pan gasket on case and install oil pan. Tighten pan bolts to 17 N·m (13 ft. lbs.).

(4) Install throttle valve and shift selector levers on valve body manual lever shaft.

(5) Apply small quantity of dielectric grease to terminal pins of solenoid case connector and neutral switch.

(6) Fill transmission with recommended fluid. Refer to Service Procedures section of this group.

### INSTALLATION

(1) Check torque converter hub and hub drive notches for sharp edges burrs, scratches, or nicks. Polish the hub and notches with 320/400 grit paper and crocus cloth if necessary. The hub must be smooth to avoid damaging pump seal at installation.

(2) Lubricate pocket in the rear oil pump seal lip with transmission fluid.

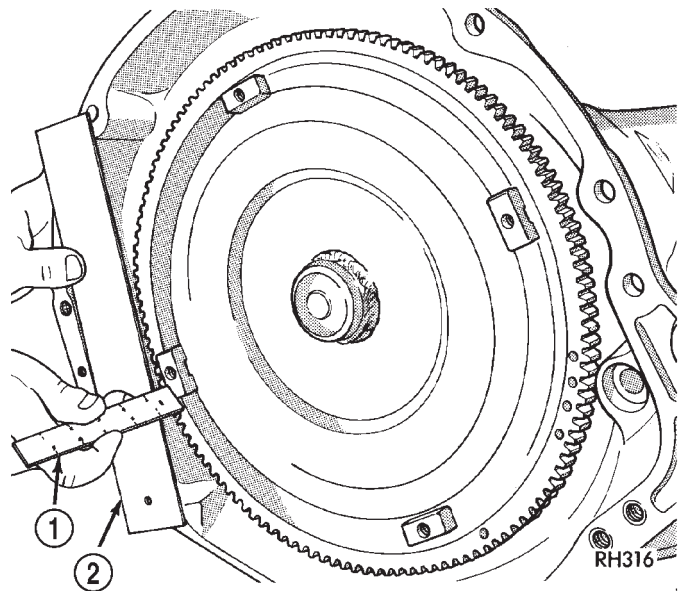
(3) Lubricate converter pilot hub of the crankshaft with a light coating of Mopar® High Temp Grease.

(4) Align and install converter in oil pump.

(5) Carefully insert converter in oil pump. Then rotate converter back and forth until fully seated in pump gears.

(6) Check converter seating with steel scale and straightedge (Fig. 65). Surface of converter lugs should be 1/2 in. to rear of straightedge when converter is fully seated.

(7) Temporarily secure converter with C-clamp.



**Fig. 65 Checking Converter Seating - Typical**

- 1 - SCALE  
2 - STRAIGHTEDGE



## AUTOMATIC TRANSMISSION - 46RE (Continued)

(8) Position transmission on jack and secure it with chains.

(9) Check condition of converter driveplate. Replace the plate if cracked, distorted or damaged. **Also be sure transmission dowel pins are seated in engine block and protrude far enough to hold transmission in alignment.**

(10) Raise transmission and align converter with drive plate and converter housing with engine block.

(11) Move transmission forward. Then raise, lower or tilt transmission to align converter housing with engine block dowels.

(12) Carefully work transmission forward and over engine block dowels until converter hub is seated in crankshaft.

(13) Install bolts attaching converter housing to engine.

(14) Install rear support. Then lower transmission onto crossmember and install bolts attaching transmission mount to crossmember.

(15) Remove engine support fixture.

(16) Install crankshaft position sensor. (Refer to 14 - FUEL SYSTEM/FUEL INJECTION/CRANKSHAFT POSITION SENSOR - INSTALLATION)

(17) Install new plastic retainer grommet on any shift linkage rod or lever that was disconnected. Grommets should not be reused. Use pry tool to remove rod from grommet and cut away old grommet. Use pliers to snap new grommet into lever and to snap rod into grommet at assembly.

(18) Connect gearshift and throttle cable to transmission.

(19) Connect wires to park/neutral position switch, transmission solenoid(s) and oxygen sensor. Be sure transmission harnesses are properly routed.

**CAUTION: It is essential that correct length bolts be used to attach the converter to the driveplate. Bolts that are too long will damage the clutch surface inside the converter.**

(20) Install torque converter-to-driveplate bolts. On models with 10.75 in. converter, tighten bolts to 31 N·m (270 in. lbs.). On models with 12.2 in. converter, tighten bolts to 47 N·m (35 ft. lbs.).

(21) Install converter housing access cover.

(22) Install starter motor and cooler line bracket. (Refer to 8 - ELECTRICAL/STARTING/STARTER MOTOR - INSTALLATION)

(23) Connect cooler lines to transmission.

(24) Install transmission fill tube. Install new seal on tube before installation.

(25) Install exhaust components.

(26) Align and connect propeller shaft. (Refer to 3 - DIFFERENTIAL & DRIVELINE/PROPELLER SHAFT/PROPELLER SHAFT - INSTALLATION)

(27) Adjust gearshift linkage and throttle valve cable if necessary.

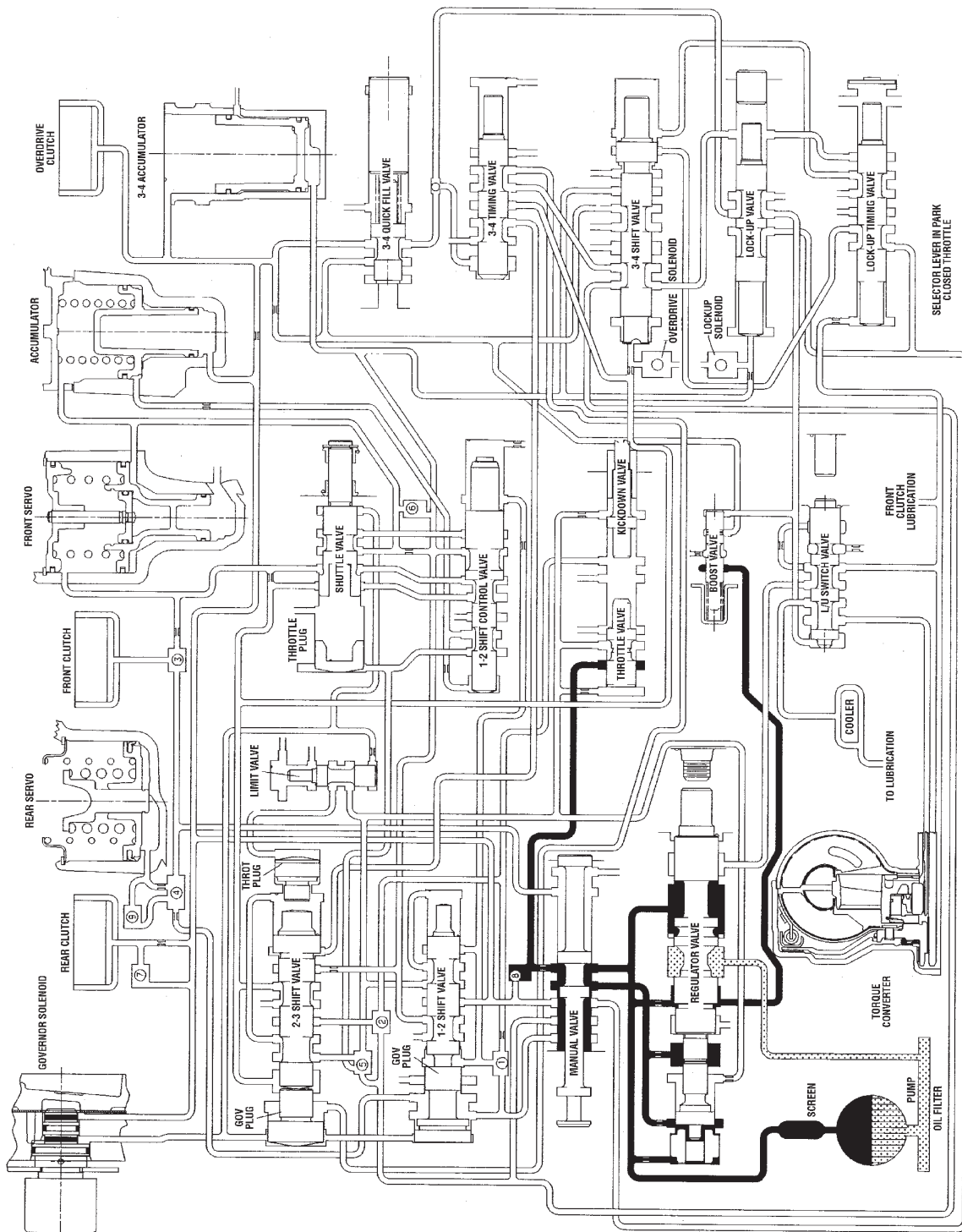
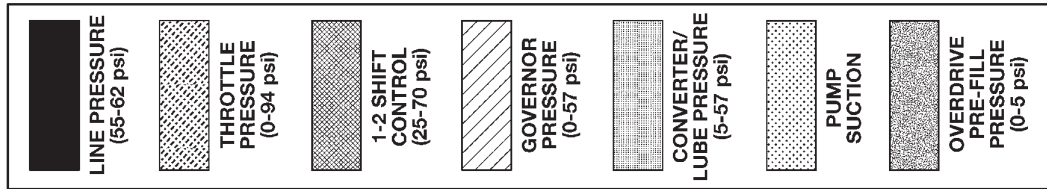
(28) Lower vehicle.

(29) Fill transmission with Mopar® ATF +4, type 9602, Automatic Transmission fluid.

AUTOMATIC TRANSMISSION - 46RE (Continued)

SCHEMATICS AND DIAGRAMS

HYDRAULIC SCHEMATICS

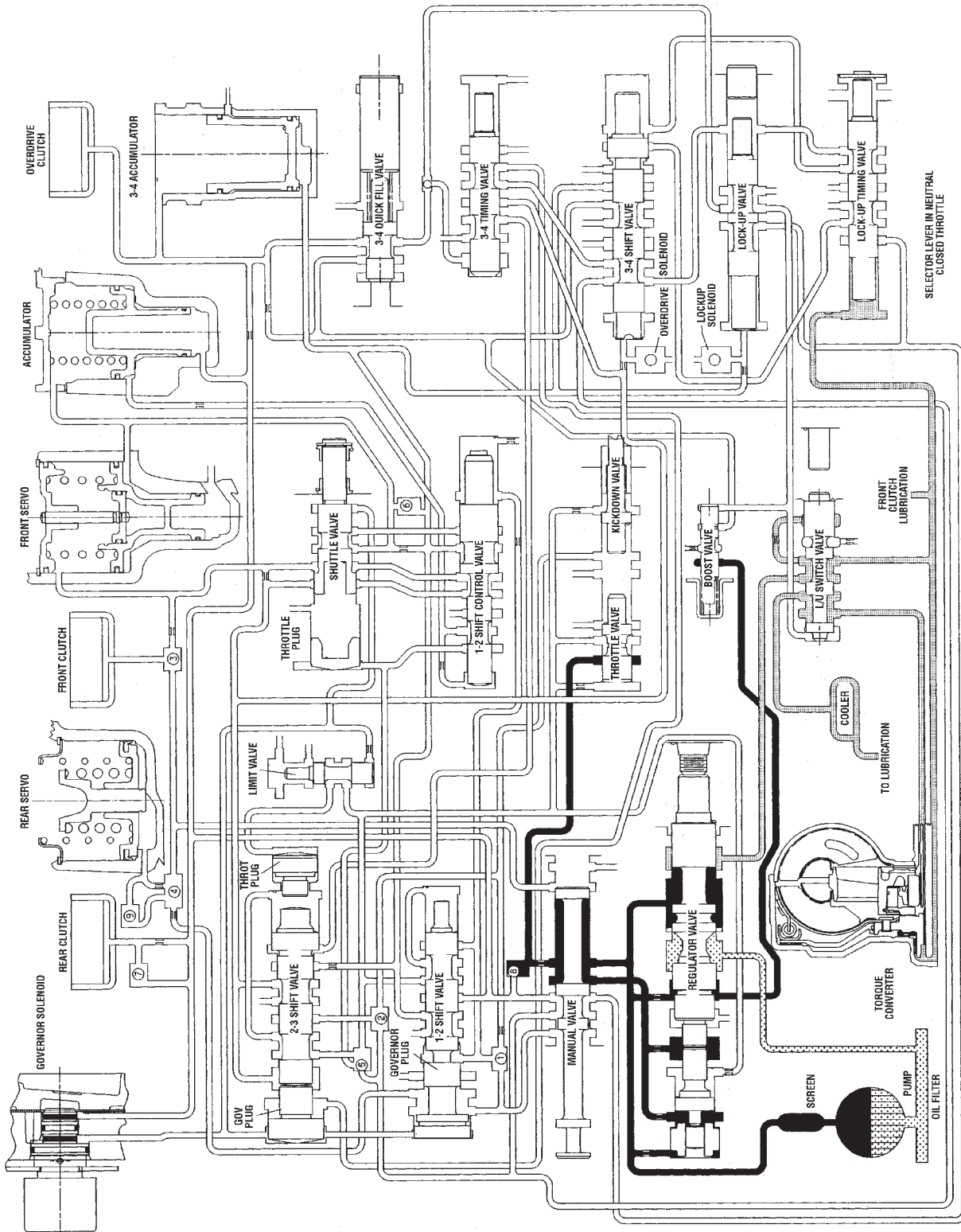
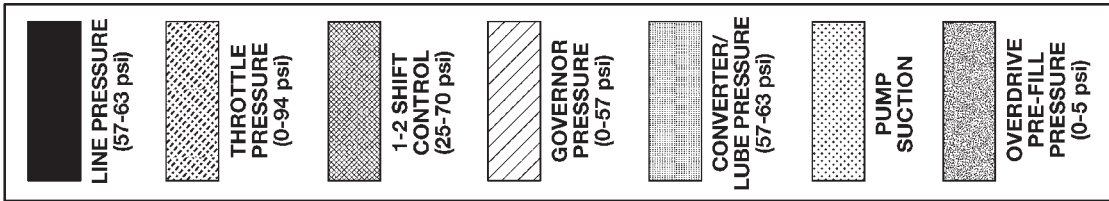


80580593

HYDRAULIC FLOW IN PARK

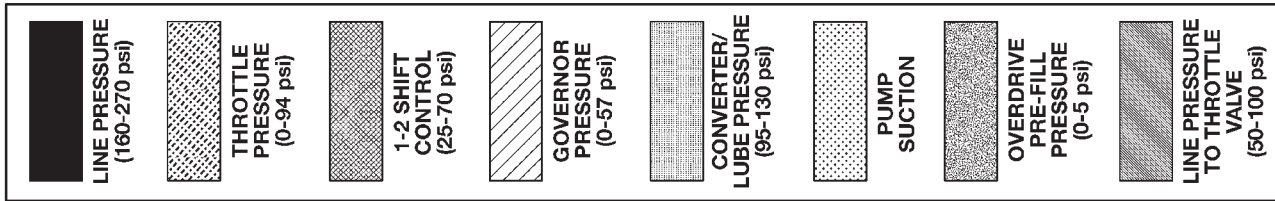
AUTOMATIC TRANSMISSION - 46RE (Continued)

80860594

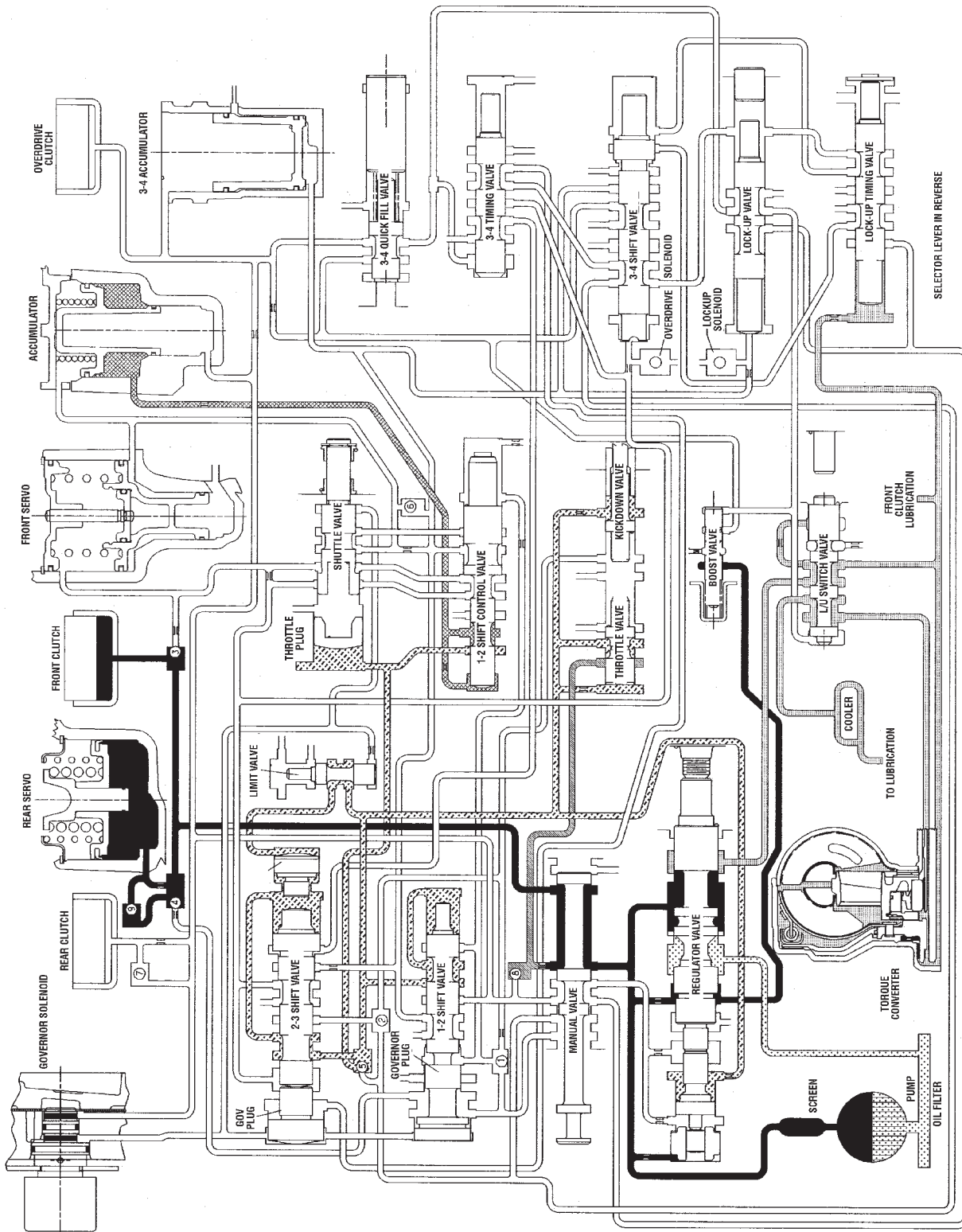


HYDRAULIC FLOW IN NEUTRAL

AUTOMATIC TRANSMISSION - 46RE (Continued)



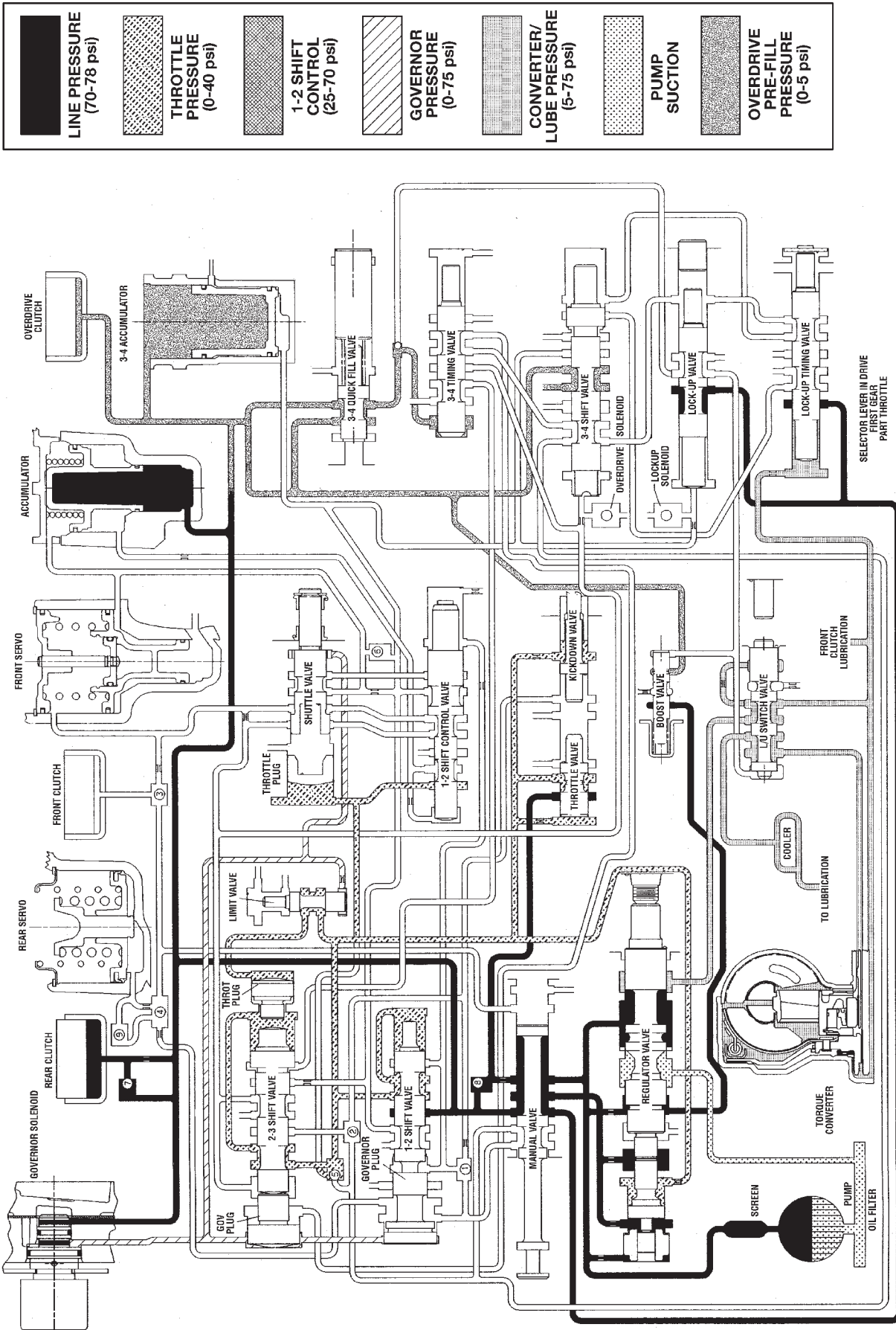
80880595



HYDRAULIC FLOW IN REVERSE

AUTOMATIC TRANSMISSION - 46RE (Continued)

80880596

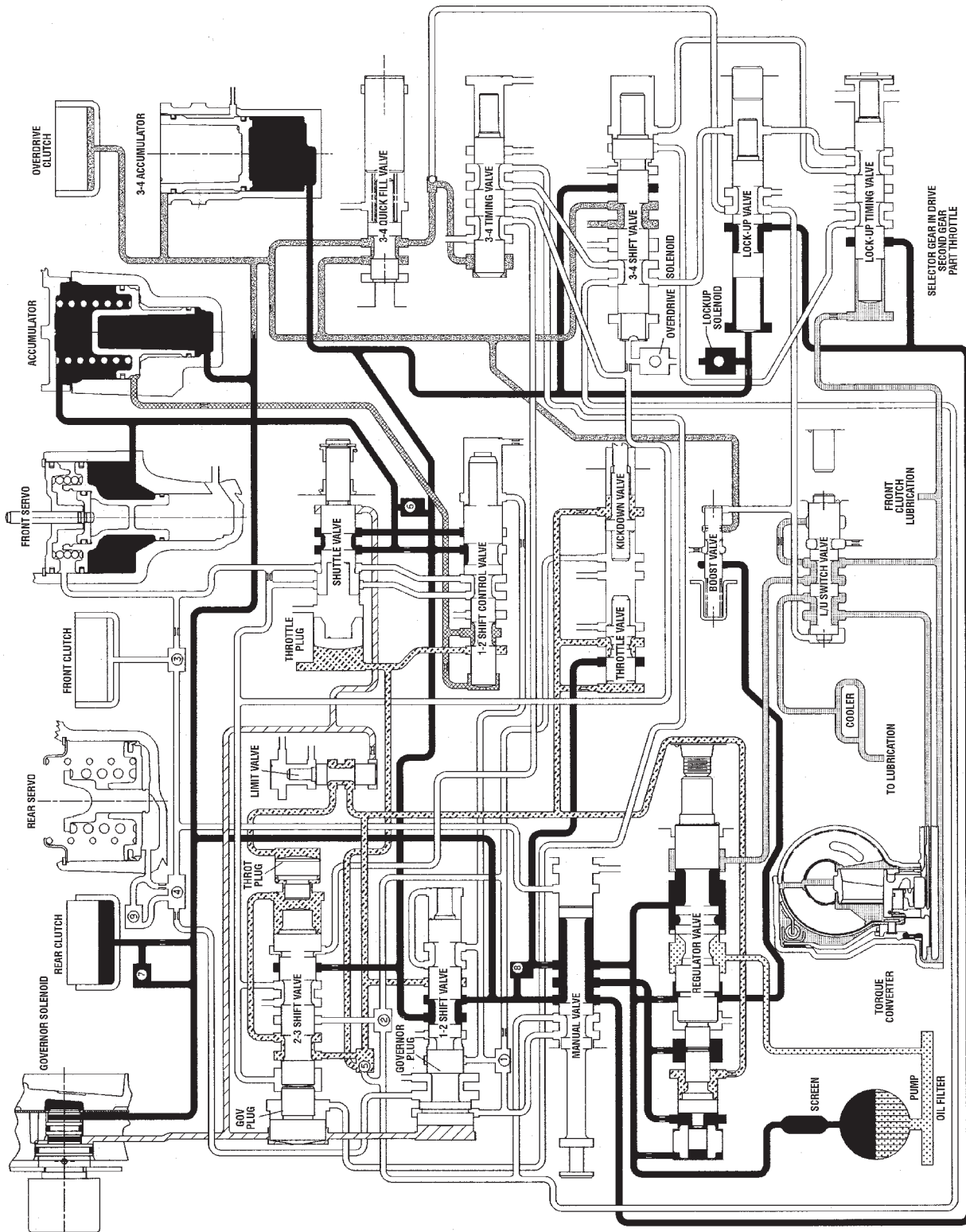
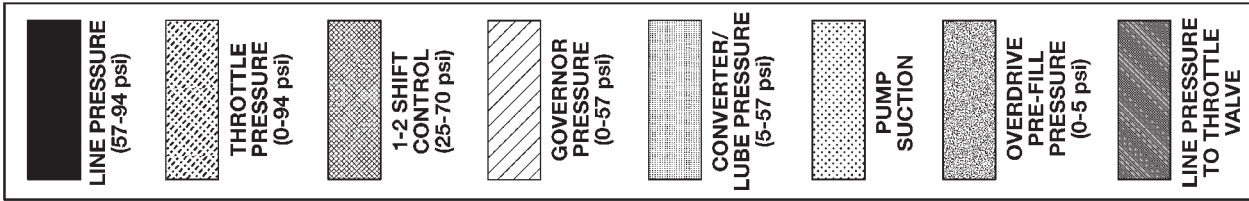


HYDRAULIC FLOW IN DRIVE FIRST GEAR



AUTOMATIC TRANSMISSION - 46RE (Continued)

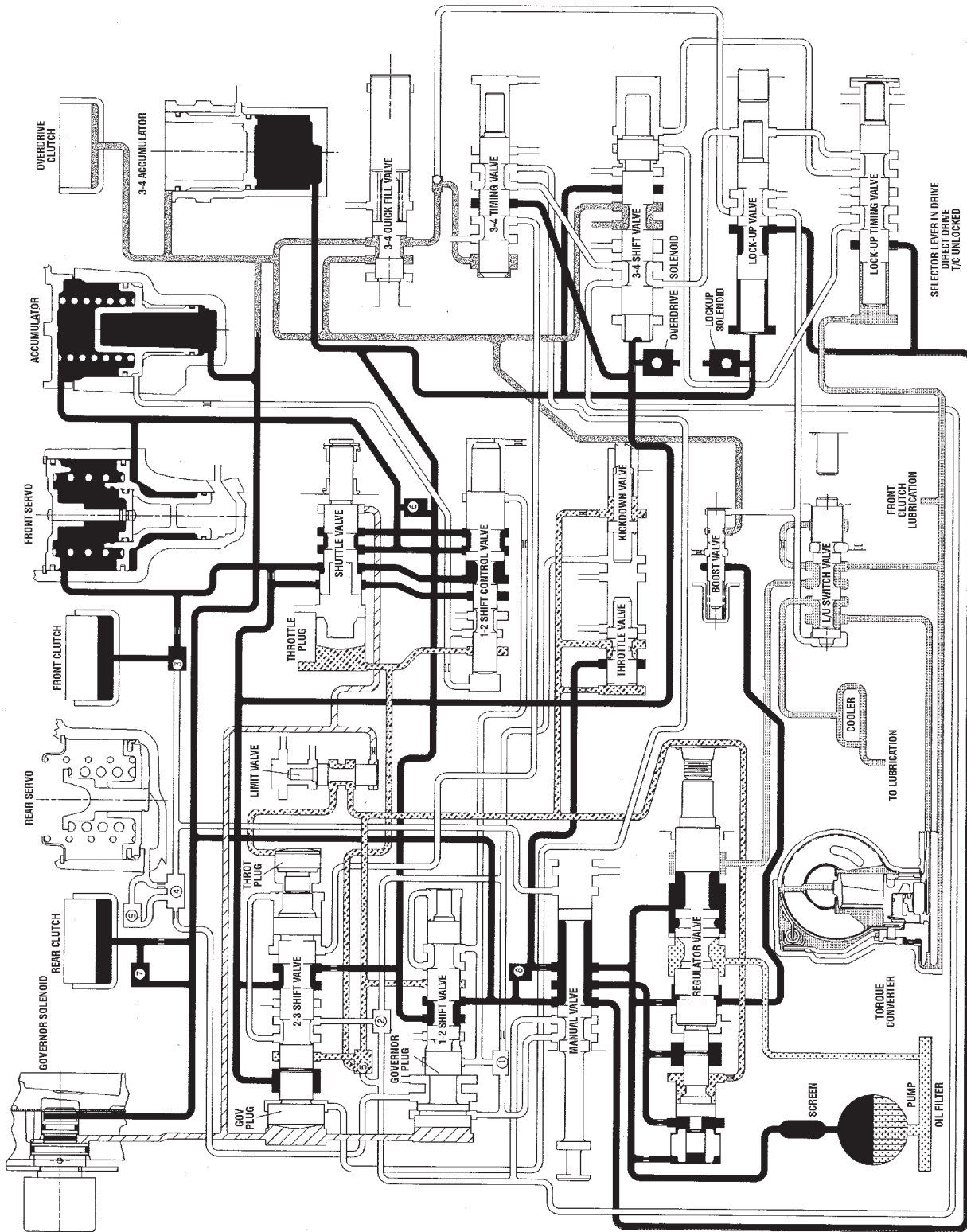
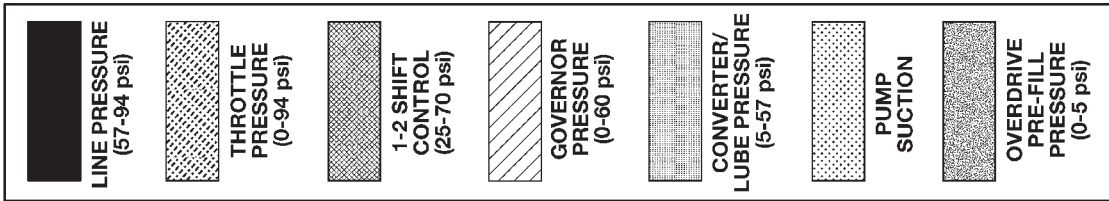
80880697



HYDRAULIC FLOW IN DRIVE SECOND GEAR

AUTOMATIC TRANSMISSION - 46RE (Continued)

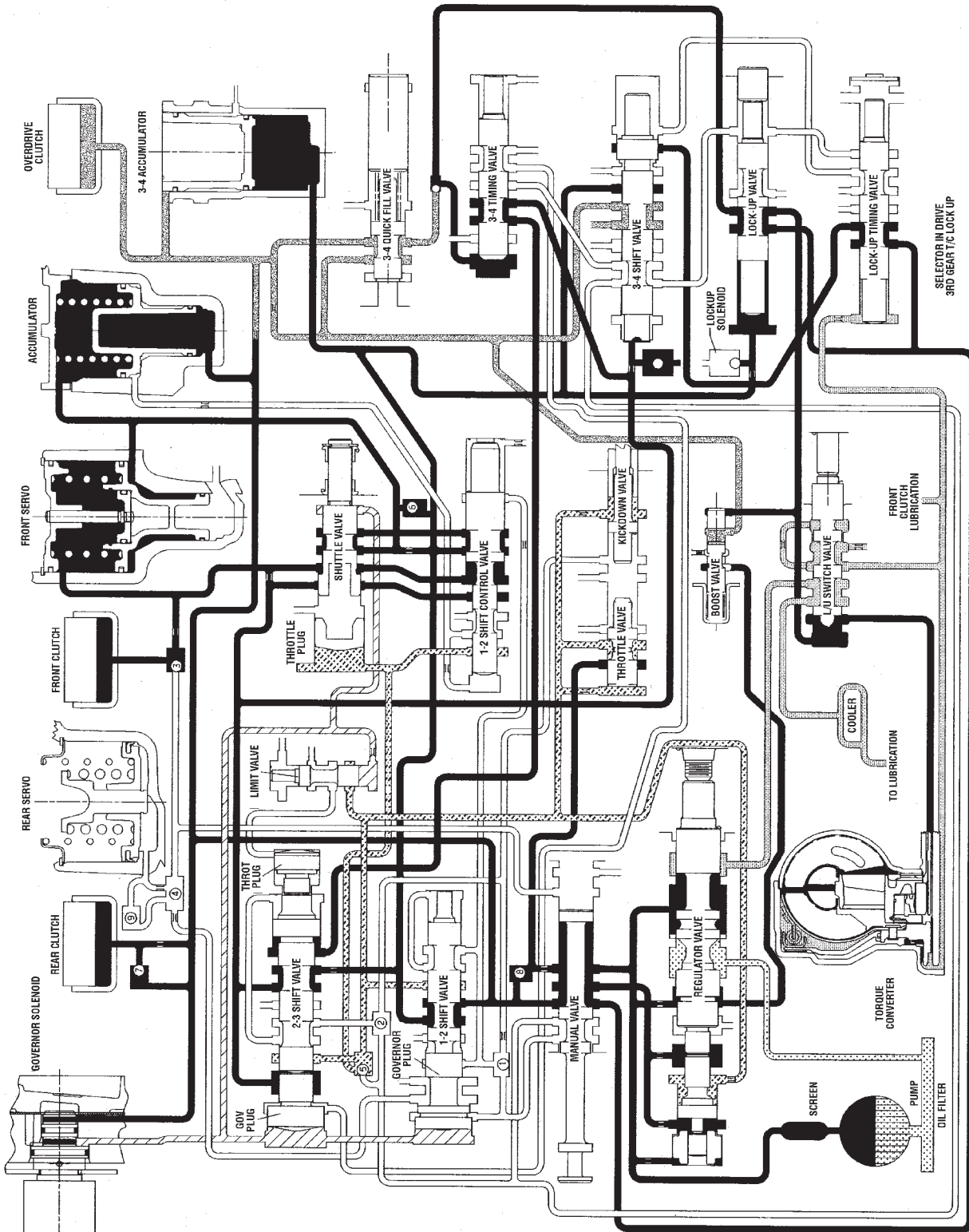
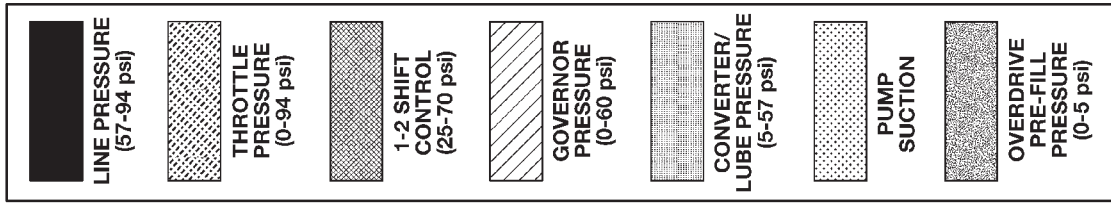
80860598



HYDRAULIC FLOW IN DRIVE THIRD GEAR (CONVERTER CLUTCH NOT APPLIED)

AUTOMATIC TRANSMISSION - 46RE (Continued)

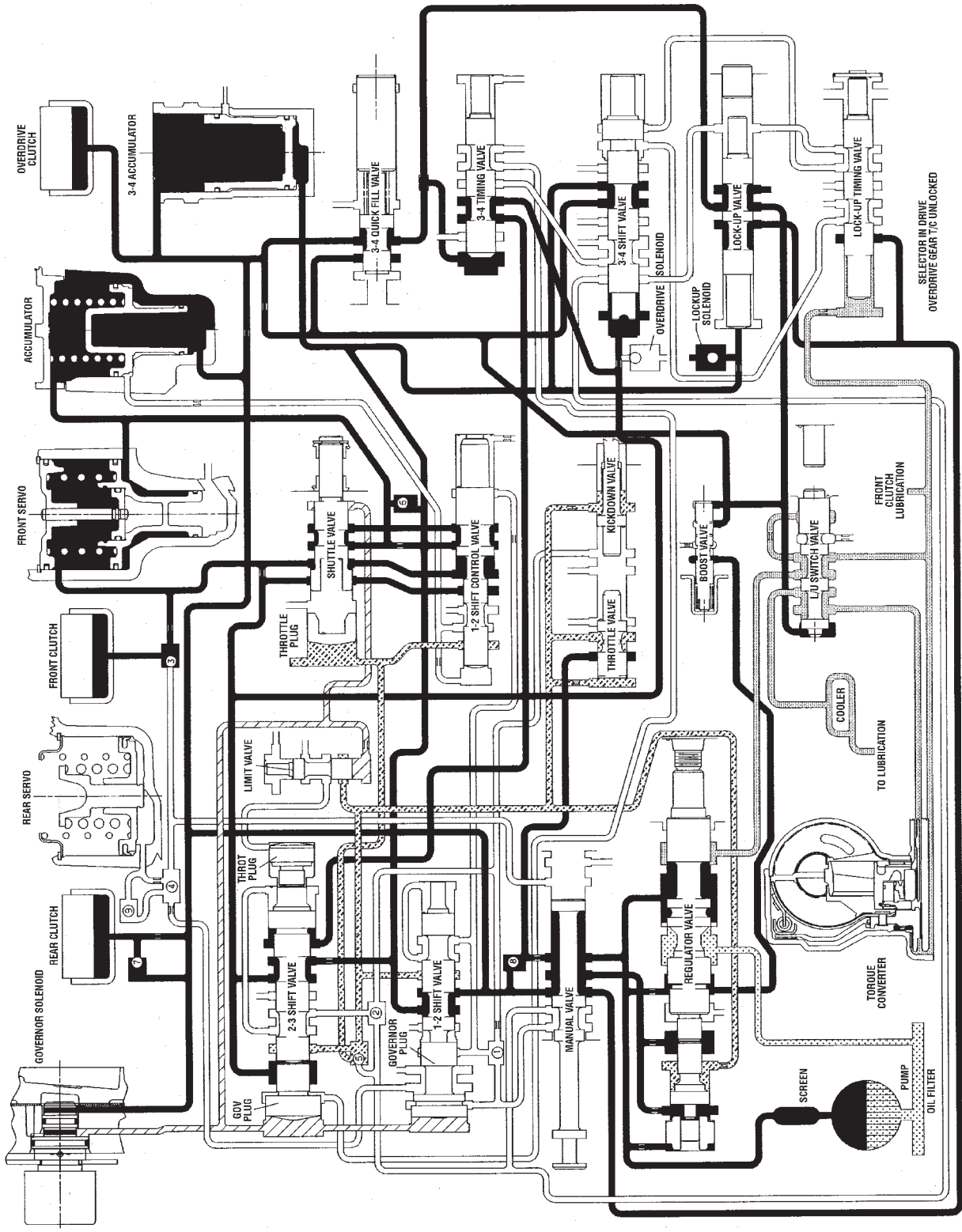
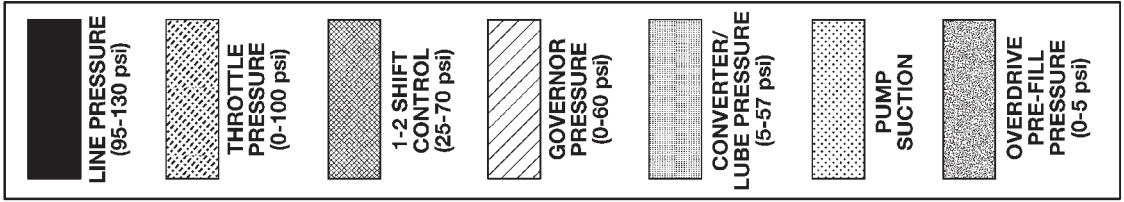
80860599



HYDRAULIC FLOW IN DRIVE THIRD GEAR (CONVERTER CLUTCH APPLIED)

AUTOMATIC TRANSMISSION - 46RE (Continued)

8088059b

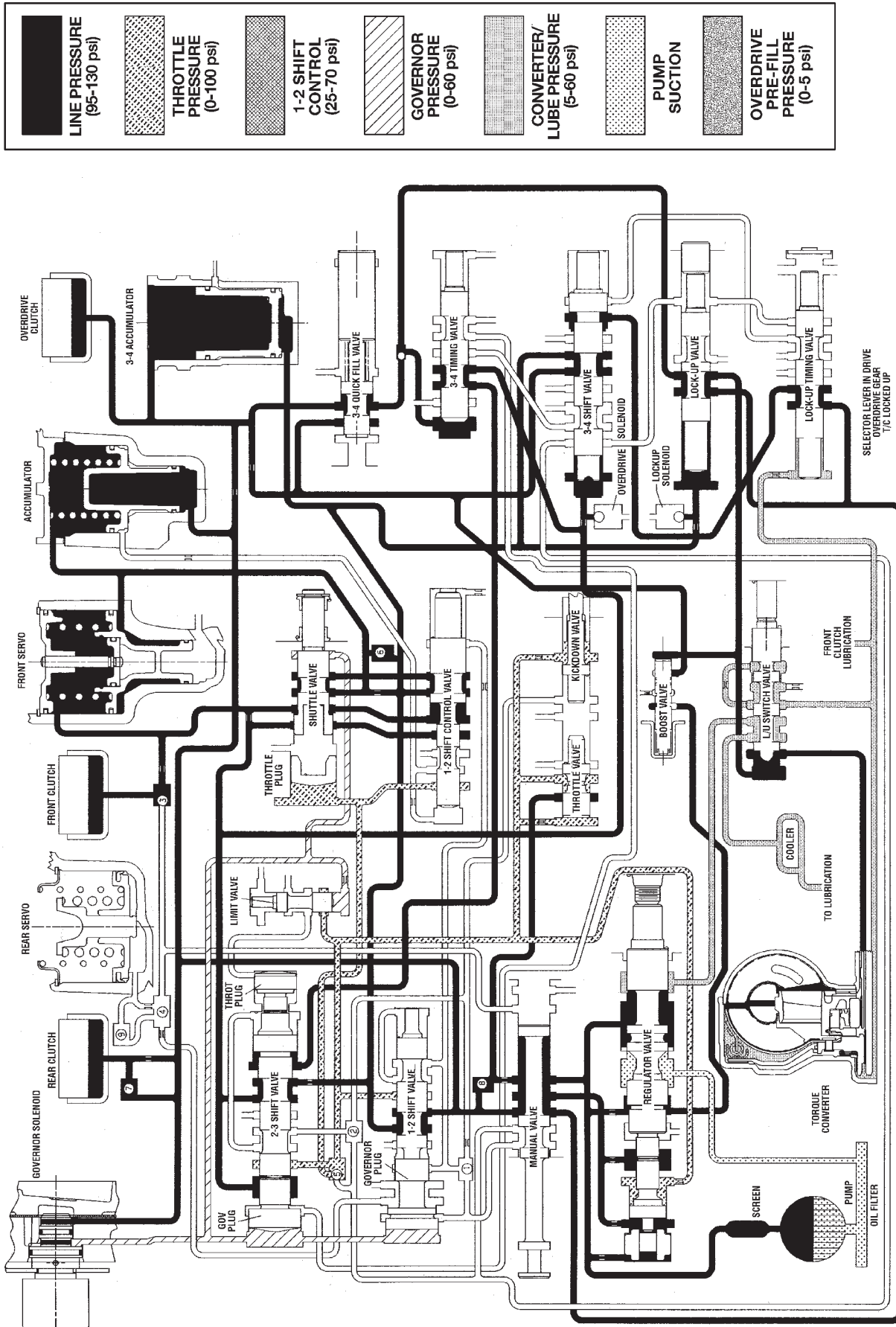


**HYDRAULIC FLOW IN DRIVE FOURTH GEAR (CONVERTER CLUTCH NOT APPLIED)**



AUTOMATIC TRANSMISSION - 46RE (Continued)

8086059c

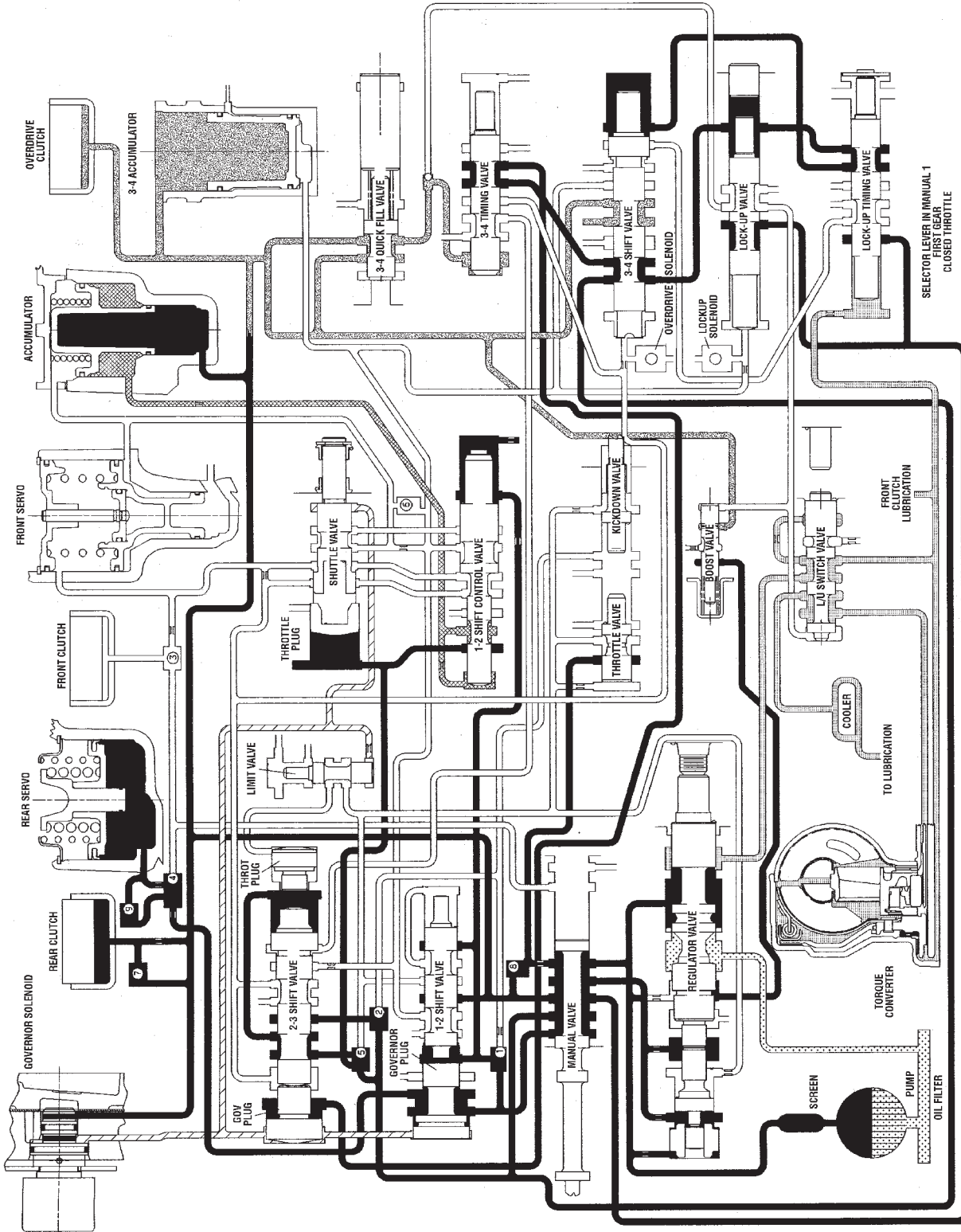
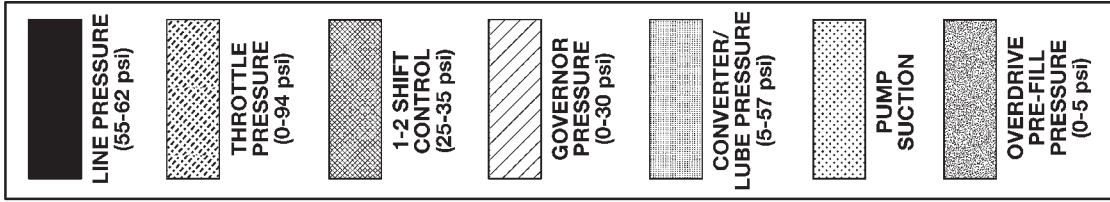


HYDRAULIC FLOW IN DRIVE FOURTH GEAR (CONVERTER CLUTCH APPLIED)



AUTOMATIC TRANSMISSION - 46RE (Continued)

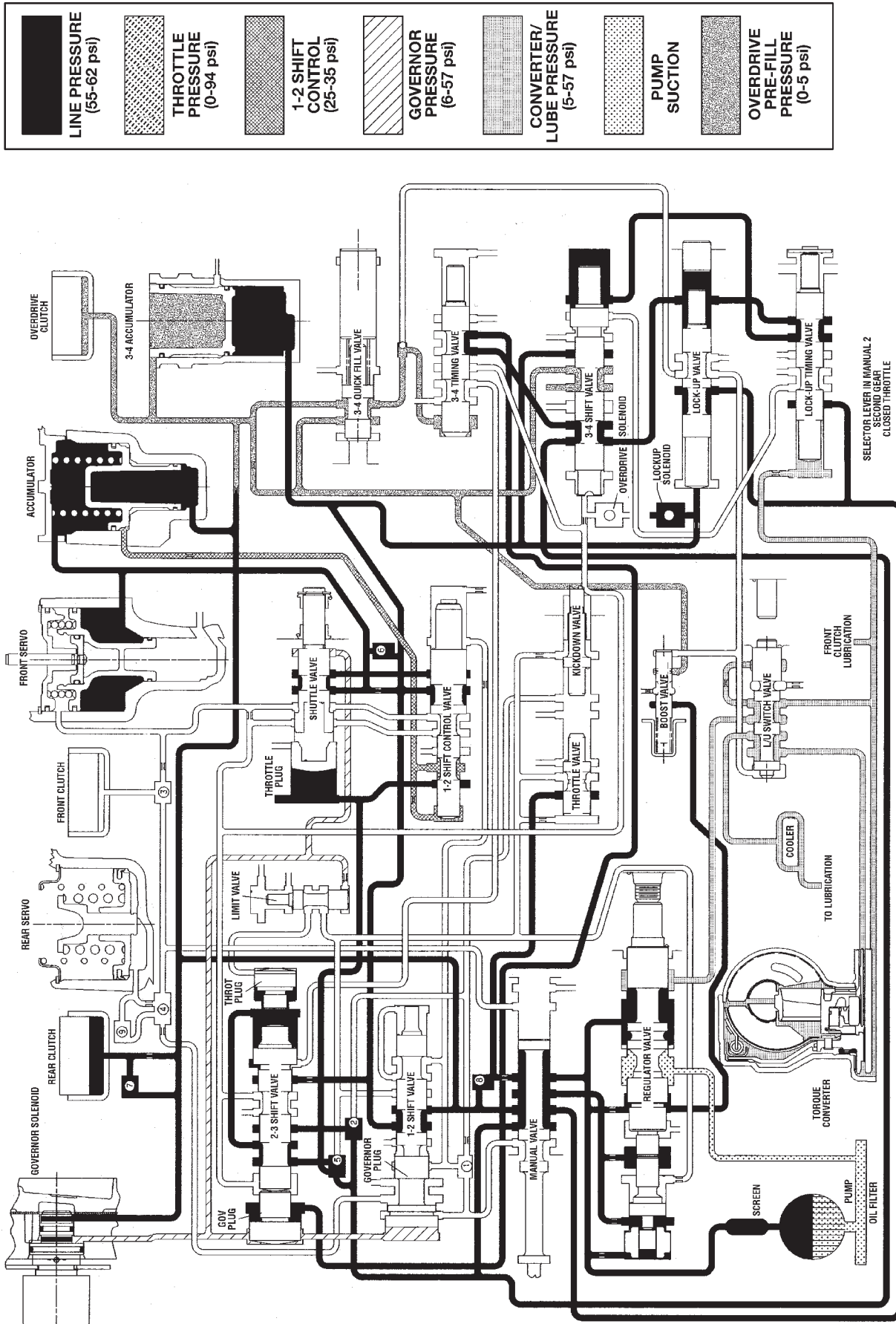
8088059c



HYDRAULIC FLOW IN MANUAL LOW (1)

AUTOMATIC TRANSMISSION - 46RE (Continued)

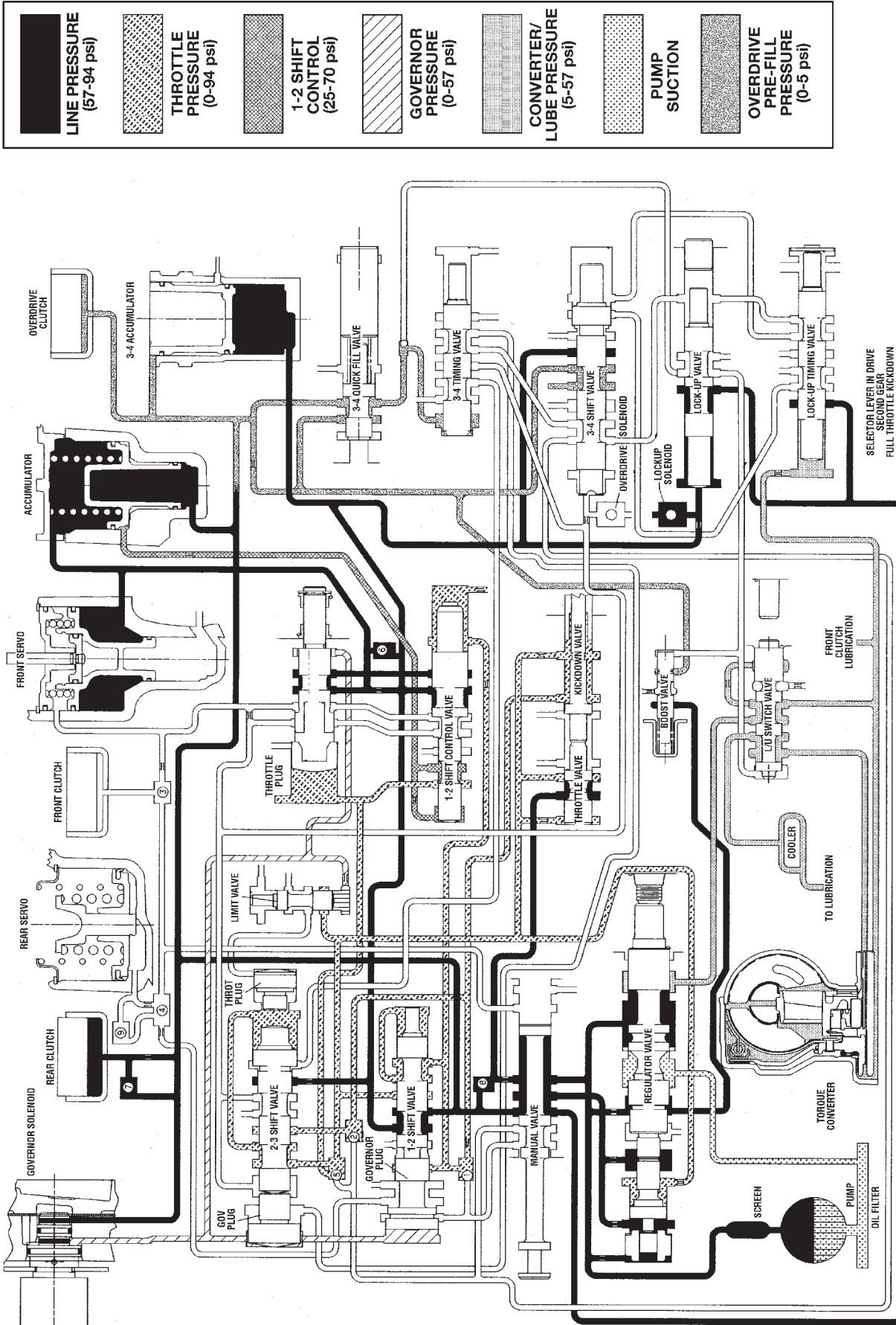
808805a1



HYDRAULIC FLOW IN MANUAL SECOND (2)

AUTOMATIC TRANSMISSION - 46RE (Continued)

808805e2



HYDRAULIC FLOW DURING FULL THROTTLE 3-2 DOWNSHIFT (PASSING)

## AUTOMATIC TRANSMISSION - 46RE (Continued)

## SPECIFICATIONS

## GEAR RATIOS

## TRANSMISSION

## GENERAL

Component	Metric	Inch
Planetary end play	0.150-1.22 mm	0.006-0.048 in.
Input shaft end play	0.86-2.13 mm	0.034-0.084 in.
Clutch pack clearance/ Front.	1.78-3.28 mm	0.070-0.129 in.
Clutch pack clearance/ Rear.	0.635-0.914 mm	0.025-0.036 in.
Front clutch	3 discs	
Rear clutch	4 discs	
Overdrive clutch	4 discs	
Direct clutch	8 discs	
Band adjustment from 72 in. lbs.		
Front band	Back off 2 7/8 turns	
Rear band	Back off 2 turns	
Recommended fluid	Mopar® ATF Plus 4, type 9602	

1ST GEAR	2.45:1
2ND GEAR	1.45:1
3RD GEAR	1.0:1
4TH GEAR	0.69:1
REVERSE	2.21:1

## THRUST WASHER/SPACER/SNAP-RING DIMENSIONS

Component	Metric	Inch
Front clutch thrust washer (reaction shaft support hub)	1.55 mm	0.061 in.
	2.15 mm	0.084 in.
	2.59 mm	0.102 in.
Rear clutch thrust washer (clutch retainer)	1.55 mm	0.061 in.
Intermediate shaft thrust plate (shaft hub pilot)	1.5-1.6 mm	0.060-0.063 in.
Output shaft thrust washer (rear clutch hub)	1.3-1.4 mm	0.052-0.054 in.
	1.75-1.8 mm	0.068-0.070 in.
	2.1-2.2 mm	0.083-0.085 in.
Rear clutch pack snap-ring	1.5-1.6 mm	0.060-0.062 in.
	1.9-1.95 mm	0.074-0.076 in.
Planetary geartrain snap-ring (at front of output shaft)	1.4-1.5 mm	0.055-0.059 in.
	1.6-1.7 mm	0.062-0.066 in.
Overdrive piston thrust plate	Thrust plate and spacer are select fit. Refer to size charts and selection procedures in Overdrive Unit D&A procedures	
Intermediate shaft spacer		

## AUTOMATIC TRANSMISSION - 46RE (Continued)

**PRESSURE TEST**

Overdrive clutch	Fourth gear only	Pressure should be 469-496 kPa (68-72 psi) with closed throttle and increase to 620-896 kPa (90-130 psi) at 1/2 to 3/4 throttle.
Line pressure (at accumulator)	Closed throttle	372-414 kPa (54-60 psi).
Front servo	Third gear only	No more than 21 kPa (3 psi) lower than line pressure.
Rear servo	1 range R range	No more than 21 kPa (3 psi) lower than line pressure. 1103 kPa (160 psi) at idle, builds to 1862 kPa (270 psi) at 1600 rpm.
Governor	D range closed throttle	Pressure should respond smoothly to changes in mph and return to 0-7 kPa (0-1.5 psi) when stopped with transmission in D, 1, 2. Pressure above 7 kPa (1.5 psi) at stand still will prevent transmission from downshifting.

*TORQUE SPECIFICATIONS*

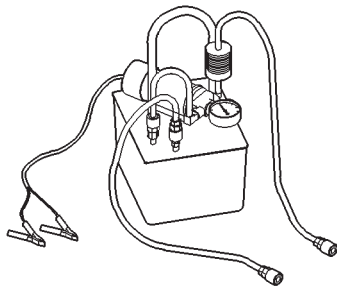
<b>DESCRIPTION</b>	<b>N-m</b>	<b>Ft. Lbs.</b>	<b>In. Lbs.</b>
Fitting, cooler line at trans	18	13	
Bolt, torque convertor	31	23	
Bolt, clevis bracket to crossmember	47	35	
Bolt, clevis bracket to rear support	68	50	
Bolt, driveplate to crankshaft	75	55	
Plug, front band reaction	17	13	
Locknut, front band adj.	34	25	
Switch, park/neutral	34	25	
Bolt, fluid pan	17	13	
Screws, fluid filter	4		35
Bolt, oil pump	20	15	
Bolt, overrunning clutch cam	17	13	
Bolt, O/D to trans.	34	25	
Bolt, O/D piston retainer	17	13	
Plug, pressure test port	14	10	
Bolt, reaction shaft support	20	15	
Locknut, rear band	41	30	
Bolt, valve body to case	12		100
Sensor, trans speed	27	20	
Screw, solenoid wiring connector	4		35
Screw, solenoid to transfer plate	4		35



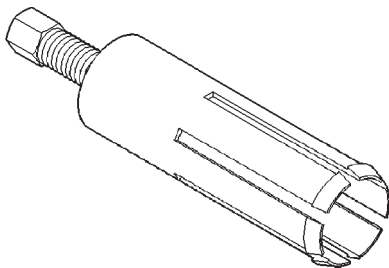
AUTOMATIC TRANSMISSION - 46RE (Continued)

SPECIAL TOOLS

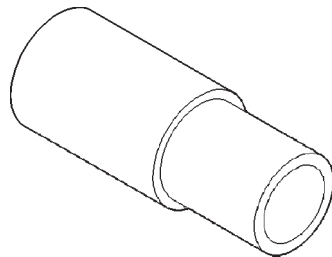
RE TRANSMISSION



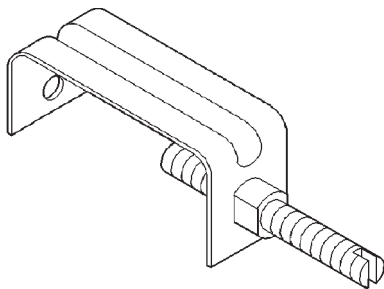
**Flusher, Oil Cooler - 6906**



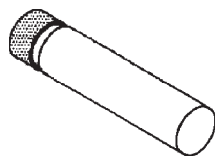
**Remover, Bushing - 6957**



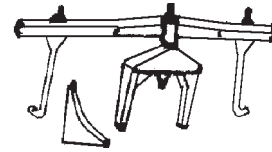
**Installer, Bushing - 6951**



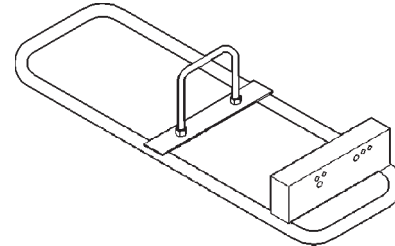
**Retainer, Detent Ball and Spring - 6583**



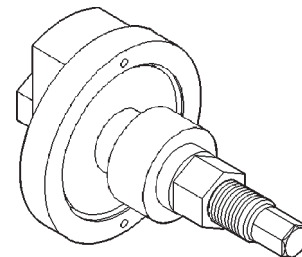
**Gauge, Block - 6312**



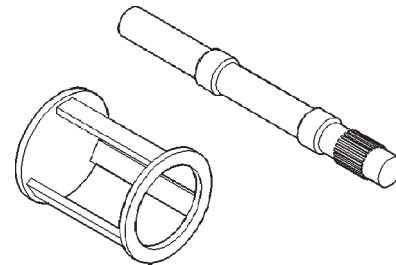
**Fixture, Engine Support - C-3487-A**



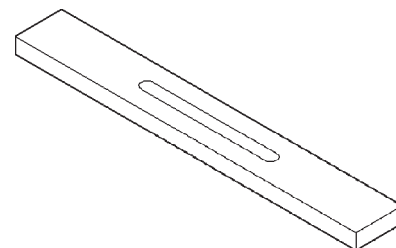
**Stand, Transmission Repair - C-3750-B**



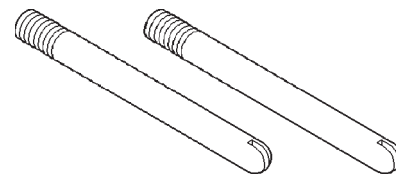
**Compressor, Spring - C-3863-A**



**Spring Compressor and Alignment Shaft - 6227**

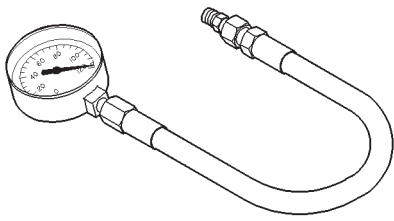


**Bar, Gauge - 6311**

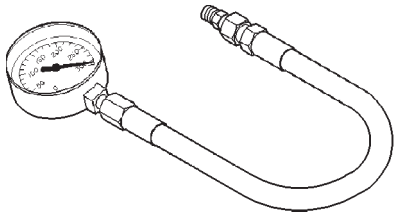


**Studs, Oil Pump Pilot - C-3288-B**

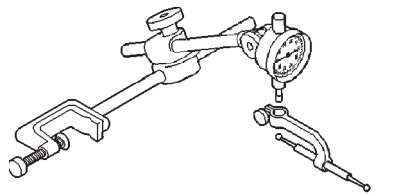
AUTOMATIC TRANSMISSION - 46RE (Continued)



**Gauge, Pressure - C-3292**

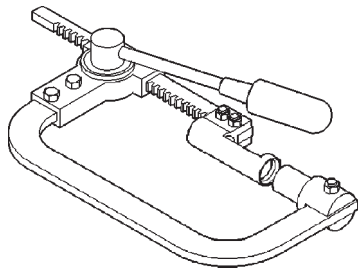


**Gauge, Pressure - C-3293SP**

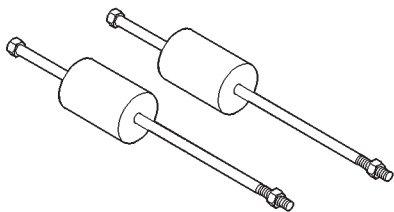


8011d42b

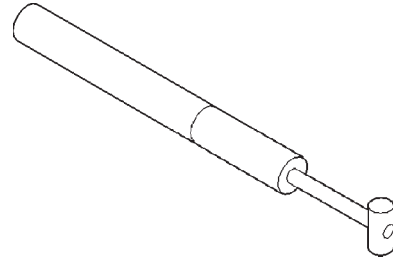
**Set, Dial Indicator - C-3339**



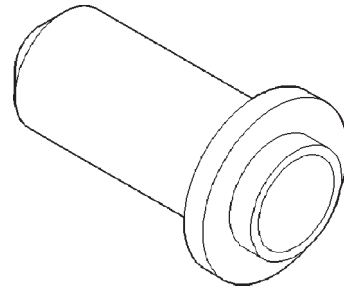
**Compressor, Spring - C-3422-B**



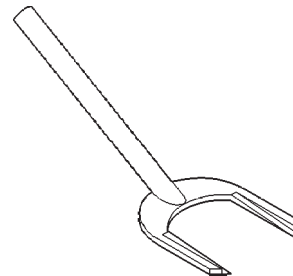
**Puller, Slide Hammer - C-3752**



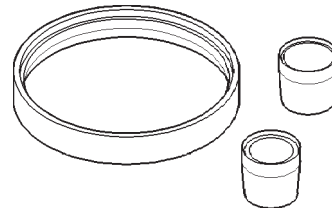
**Gauge, Throttle Setting - C-3763**



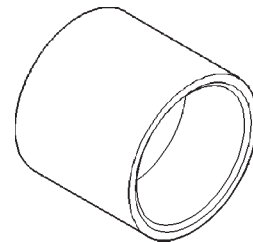
**Installer, Seal - C-3860-A**



**Remover, Seal - C-3985-B**

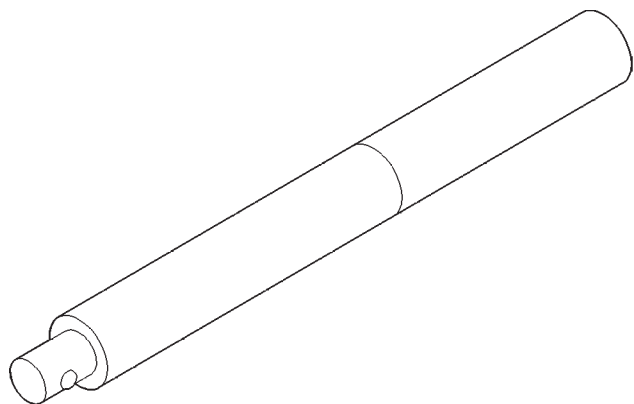


**Installer, Overdrive Piston Seal - 8114**

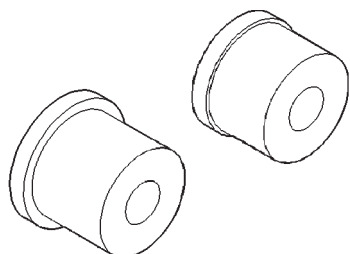


**Installer, Seal - C-3995-A**

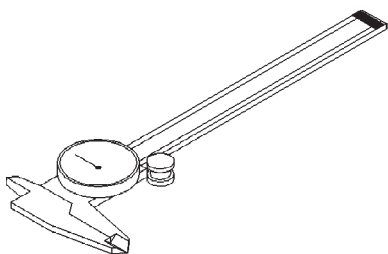
AUTOMATIC TRANSMISSION - 46RE (Continued)



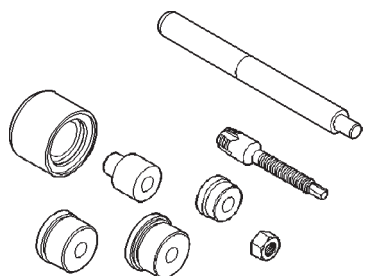
**Handle, Universal - C-4171**



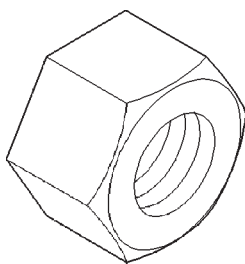
**Remover/Installer, Bushing - C-4470**



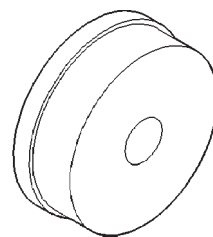
**Dial Caliper - C-4962**



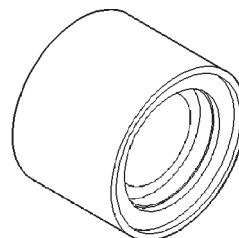
**Set, Bushing Remover/Installer - C-3887-J**



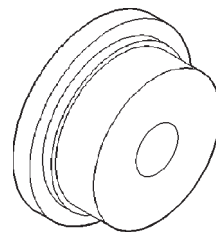
**Nut, Bushing Remover - SP-1191, From kit C-3887-J**



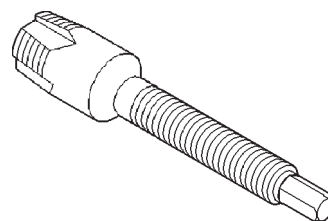
**Remover, Front Clutch Bushing - SP-3629, From kit C-3887-J**



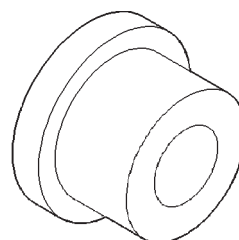
**Cup, Bushing Remover - SP-3633, From kit C-3887-J**



**Installer, Oil Pump Bushing - SP-5118, From kit C-3887-J**

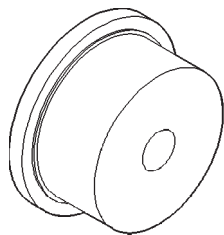


**Remover, Reaction Shaft Bushing - SP-5301, From Kit C-3887-J**

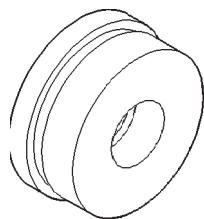


**Installer, Reaction Shaft Bushing - SP-5302, From kit C-3887-J**

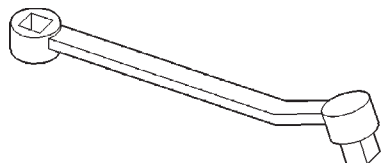
## AUTOMATIC TRANSMISSION - 46RE (Continued)



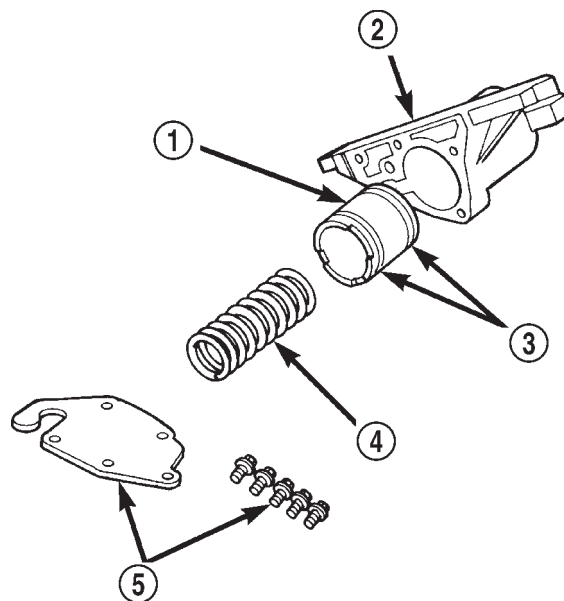
**Installer, Front Clutch Bushing - SP-5511, From kit C-3887-J**



**Remover, Bushing - SP-3550, From kit C-3887-J**



**Adapter, Band Adjuster - C-3705**



804d8eb9

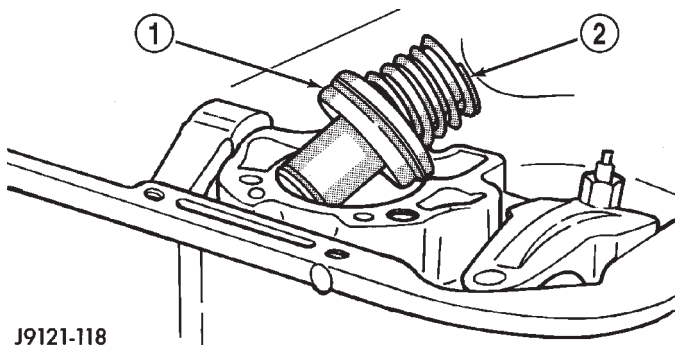
**Fig. 67 3-4 Accumulator and Housing**

- 1 - ACCUMULATOR PISTON
- 2 - 3-4 ACCUMULATOR HOUSING
- 3 - TEFLON SEALS
- 4 - PISTON SPRING
- 5 - COVER PLATE AND SCREWS

## ACCUMULATOR

### DESCRIPTION

The accumulator (Fig. 66) is a hydraulic device that has the sole purpose of cushioning the application of a band or clutch. The accumulator consists of a dual-land piston and a spring located in a bore in the transmission case. The 3-4 accumulator is located in a housing attached to the side of the valve body (Fig. 67).



J9121-118

**Fig. 66 Accumulator**

- 1 - ACCUMULATOR PISTON
- 2 - PISTON SPRING

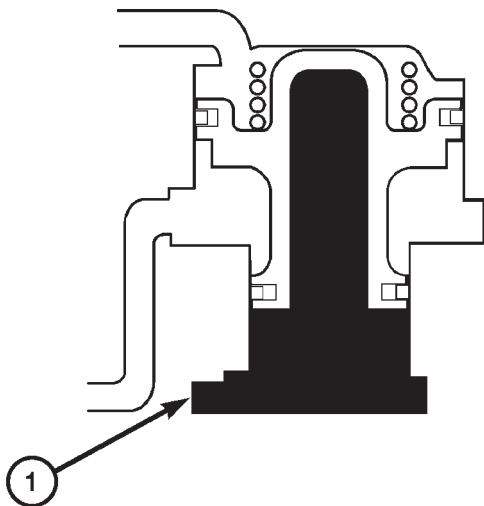
### OPERATION

Both the accumulator and the 3-4 accumulator function the same. Line pressure is directed to the small end of the piston when the transmission is placed into a DRIVE position (Fig. 68), bottoming it against the accumulator plate. When the 1-2 upshift occurs (Fig. 69), line pressure is directed to the large end of the piston and then to the kickdown servo. As the line pressure reaches the accumulator, the combination of spring pressure and line pressure forces the piston away from the accumulator plate. This causes a balanced pressure situation, which results in a cushioned band application. After the kickdown servo has become immovable, line pressure will finish pushing the accumulator up into its bore. When the large end of the accumulator piston is seated in its bore, the band or clutch is fully applied.

**NOTE:** The accumulator is shown in the inverted position for illustrative purposes.

ACCUMULATOR (Continued)

**BOTTOMED  
AGAINST ACCUMULATOR  
PLATE**



80a08a54

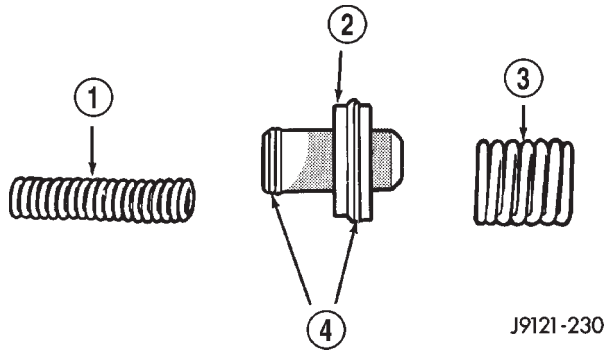
**Fig. 68 Accumulator in DRIVE - FIRST GEAR POSITION**

1 - LINE PRESSURE

**INSPECTION**

Inspect the accumulator piston and seal rings (Fig. 70). Replace the seal rings if worn or cut. Replace the piston if chipped or cracked.

Check condition of the accumulator inner and outer springs (Fig. 70). Replace the springs if the coils are cracked, distorted or collapsed.



**Fig. 70 Accumulator Components**

- 1 - INNER SPRING
- 2 - ACCUMULATOR PISTON
- 3 - OUTER SPRING
- 4 - SEAL RINGS

**BANDS**

**DESCRIPTION**

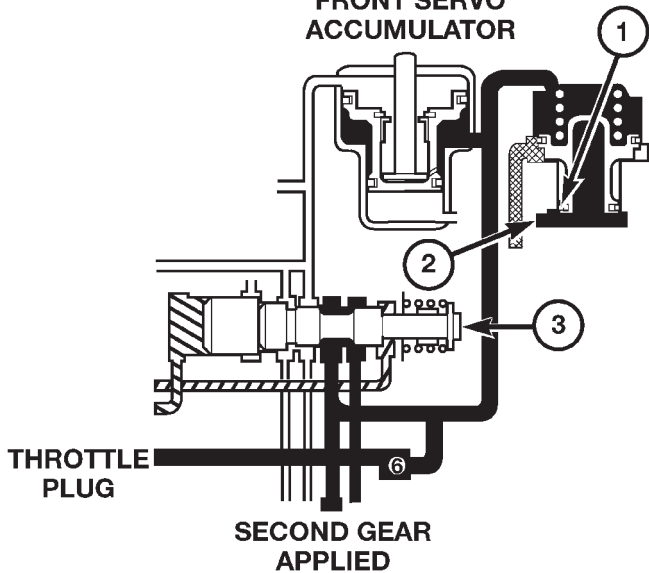
**KICKDOWN (FRONT) BAND**

The kickdown, or "front", band (Fig. 71) holds the common sun gear of the planetary gear sets. The front (kickdown) band is made of steel, and faced on its inner circumference with a friction-type lining. One end of the band is anchored to the transmission case, and the other is acted on with a pushing force by a servo piston. The front band is a single-wrap design (the band does not completely encompass/wrap the drum that it holds).

**LOW/REVERSE (REAR) BAND**

The low/reverse band, or "rear", band (Fig. 72) is similar in appearance and operation to the front band. The rear band is also a single-wrap design (the band does not completely encompass/wrap the drum that it holds).

**FRONT SERVO  
ACCUMULATOR**



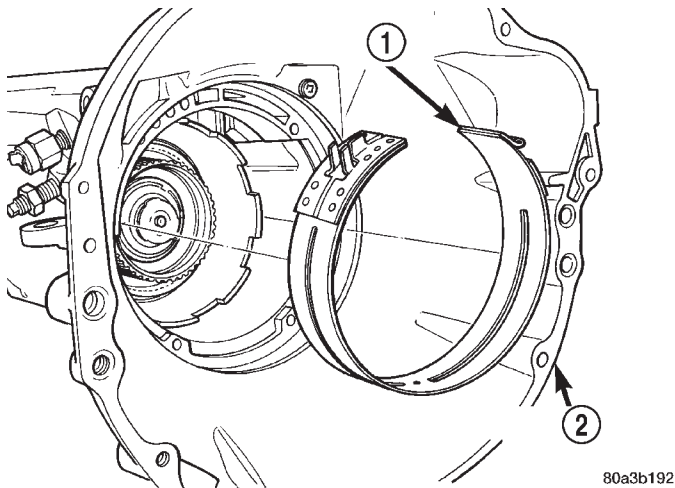
80a08a58

**Fig. 69 Accumulator in SECOND Gear Position**

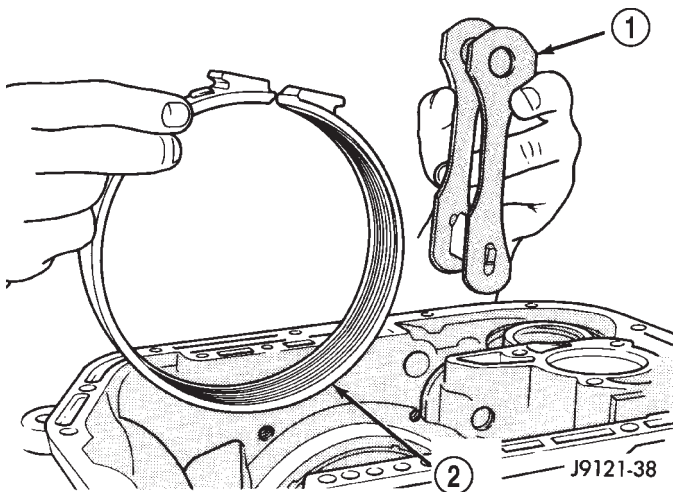
- 1 - BOTTOM OF BORE
- 2 - LINE PRESSURE
- 3 - SHUTTLE VALVE



## BANDS (Continued)

**Fig. 71 Front Band**

- 1 - FRONT BAND  
2 - TRANSMISSION HOUSING

**Fig. 72 Rear Band And Link**

- 1 - BAND LINK  
2 - REAR BAND

## OPERATION

## KICKDOWN (FRONT) BAND

The kickdown band holds the common sun gear of the planetary gear sets by applying and holding the front clutch retainer, which is splined to the sun gear driving shell, and in turn splined directly to the sun gear. The application of the band by the servo is typically done by an apply lever and link bar.

## LOW/REVERSE (REAR) BAND

The rear band holds the rear planet carrier stationary by being mounted around and applied to the low/reverse drum.

## ADJUSTMENT - BANDS

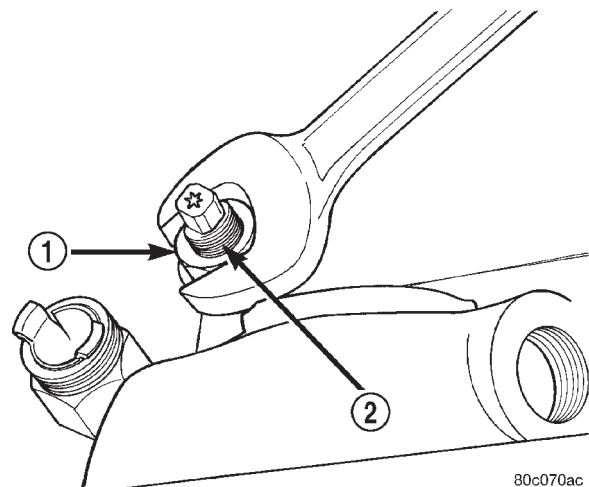
## FRONT BAND

The front (kickdown) band adjusting screw is located on the left side of the transmission case above the manual valve and throttle valve levers.

- (1) Raise vehicle.
- (2) Loosen band adjusting screw locknut (Fig. 73). Then back locknut off 3-5 turns. Be sure adjusting screw turns freely in case. Apply lubricant to screw threads if necessary.
- (3) Tighten band adjusting screw to 8 N·m (72 in. lbs.) torque with Inch Pound Torque Wrench C-3380-A, a 3-in. extension and an appropriate Torx™ socket.

**CAUTION:** If Adapter C-3705 is needed to reach the adjusting screw, tighten the screw to only 5 N·m (47-50 in. lbs.) torque.

- (4) Back off front band adjusting screw 2-7/8 turns.
- (5) Hold adjuster screw in position and tighten locknut to 41 N·m (30 ft. lbs.) torque.
- (6) Lower vehicle.

**Fig. 73 Front Band Adjustment Screw Location**

- 1 - LOCK-NUT  
2 - FRONT BAND ADJUSTER

## BANDS (Continued)

## REAR BAND

The transmission oil pan must be removed for access to the rear band adjusting screw.

- (1) Raise vehicle.
- (2) Remove transmission oil pan and drain fluid.
- (3) Loosen band adjusting screw locknut 5-6 turns.

Be sure adjusting screw turns freely in lever.

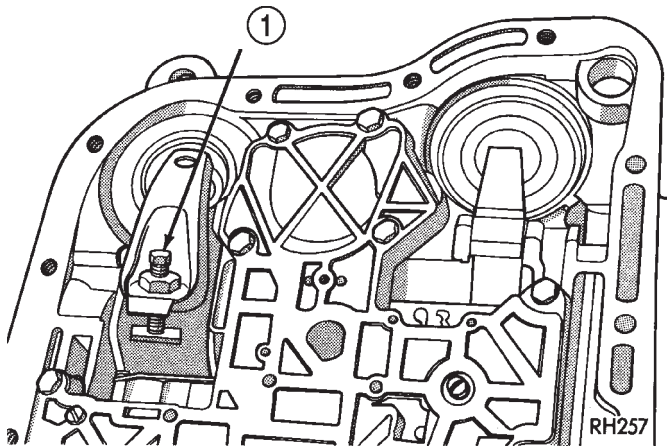
(4) Tighten adjusting screw to 8 N·m (72 in. lbs.) torque (Fig. 74).

(5) Back off adjusting screw 2 turns.

(6) Hold adjusting screw in place and tighten locknut to 34 N·m (25 ft. lbs.) torque.

(7) Position new gasket on oil pan and install pan on transmission. Tighten pan bolts to 17 N·m (13 ft. lbs.) torque.

(8) Lower vehicle and refill transmission with Mopar® ATF +4, Type 9602 fluid.



**Fig. 74 Rear Band Adjustment Screw Location**

1 - LOW-REVERSE BAND ADJUSTMENT

## ELECTRONIC GOVERNOR

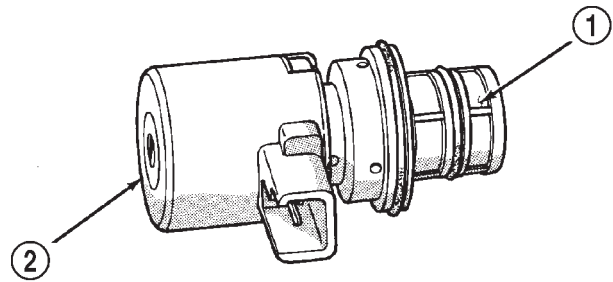
## DESCRIPTION

Governor pressure is controlled electronically. Components used for governor pressure control include:

- Governor body
- Valve body transfer plate
- Governor pressure solenoid valve
- Governor pressure sensor
- Fluid temperature thermistor
- Throttle position sensor (TPS)
- Transmission speed sensor
- Powertrain control module (PCM)

## GOVERNOR PRESSURE SOLENOID VALVE

The solenoid valve is a duty-cycle solenoid which regulates the governor pressure needed for upshifts and downshifts. It is an electro-hydraulic device located in the governor body on the valve body transfer plate (Fig. 75).



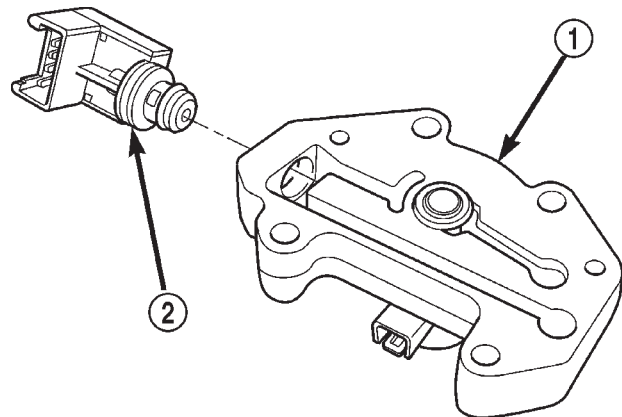
J9321-408A

**Fig. 75 Governor Pressure Solenoid Valve**

1 - SOLENOID FILTER  
2 - GOVERNOR PRESSURE SOLENOID

## GOVERNOR PRESSURE SENSOR

The governor pressure sensor measures output pressure of the governor pressure solenoid valve (Fig. 76).



80c072af

**Fig. 76 Governor Pressure Sensor**

1 - GOVERNOR BODY  
2 - GOVERNOR PRESSURE SENSOR/TRANSMISSION FLUID TEMPERATURE THERMISTOR

## GOVERNOR BODY AND TRANSFER PLATE

The transfer plate is designed to supply transmission line pressure to the governor pressure solenoid valve and to return governor pressure.

The governor pressure solenoid valve is mounted in the governor body. The body is bolted to the lower side of the transfer plate (Fig. 76).

## GOVERNOR PRESSURE CURVES

There are four governor pressure curves programmed into the transmission control module. The different curves allow the control module to adjust governor pressure for varying conditions. One curve is used for operation when fluid temperature is at, or below,  $-1^{\circ}\text{C}$  ( $30^{\circ}\text{F}$ ). A second curve is used when fluid temperature is at, or above,  $10^{\circ}\text{C}$  ( $50^{\circ}\text{F}$ ) during normal city or highway driving. A third curve is used

## ELECTRONIC GOVERNOR (Continued)

during wide-open throttle operation. The fourth curve is used when driving with the transfer case in low range.

### OPERATION

Compensation is required for performance variations of two of the input devices. Though the slope of the transfer functions is tightly controlled, offset may vary due to various environmental factors or manufacturing tolerances.

The pressure transducer is affected by barometric pressure as well as temperature. Calibration of the zero pressure offset is required to compensate for shifting output due to these factors.

Normal calibration will be performed when sump temperature is above 50 degrees F, or in the absence of sump temperature data, after the first 10 minutes of vehicle operation. Calibration of the pressure transducer offset occurs each time the output shaft speed falls below 200 RPM. Calibration shall be repeated each 3 seconds the output shaft speed is below 200 RPM. A 0.5 second pulse of 95% duty cycle is applied to the governor pressure solenoid valve and the transducer output is read during this pulse. Averaging of the transducer signal is necessary to reject electrical noise.

Under cold conditions (below 50 degrees F sump), the governor pressure solenoid valve response may be too slow to guarantee 0 psi during the 0.5 second calibration pulse. Calibration pulses are continued during this period, however the transducer output values are discarded. Transducer offset must be read at key-on, under conditions which promote a stable reading. This value is retained and becomes the offset during the "cold" period of operation.

### GOVERNOR PRESSURE SOLENOID VALVE

The inlet side of the solenoid valve is exposed to normal transmission line pressure. The outlet side of the valve leads to the valve body governor circuit.

The solenoid valve regulates line pressure to produce governor pressure. The average current supplied to the solenoid controls governor pressure. One amp current produces zero kPa/psi governor pressure. Zero amps sets the maximum governor pressure.

The powertrain control module (PCM) turns on the trans control relay which supplies electrical power to the solenoid valve. Operating voltage is 12 volts (DC). The PCM controls the ground side of the solenoid using the governor pressure solenoid control circuit.

### GOVERNOR PRESSURE SENSOR

The sensor output signal provides the necessary feedback to the PCM. This feedback is needed to adequately control governor pressure.

### GOVERNOR BODY AND TRANSFER PLATE

The transfer plate channels line pressure to the solenoid valve through the governor body. It also channels governor pressure from the solenoid valve to the governor circuit. It is the solenoid valve that develops the necessary governor pressure.

### GOVERNOR PRESSURE CURVES

#### LOW TRANSMISSION FLUID TEMPERATURE

When the transmission fluid is cold the conventional governor can delay shifts, resulting in higher than normal shift speeds and harsh shifts. The electronically controlled low temperature governor pressure curve is higher than normal to make the transmission shift at normal speeds and sooner. The PCM uses a temperature sensor in the transmission oil sump to determine when low temperature governor pressure is needed.

#### NORMAL OPERATION

Normal operation is refined through the increased computing power of the PCM and through access to data on engine operating conditions provided by the PCM that were not available with the previous stand-alone electronic module. This facilitated the development of a load adaptive shift strategy - the ability to alter the shift schedule in response to vehicle load condition. One manifestation of this capability is grade "hunting" prevention - the ability of the transmission logic to delay an upshift on a grade if the engine does not have sufficient power to maintain speed in the higher gear. The 3-2 downshift and the potential for hunting between gears occurs with a heavily loaded vehicle or on steep grades. When hunting occurs, it is very objectionable because shifts are frequent and accompanied by large changes in noise and acceleration.

#### WIDE OPEN THROTTLE OPERATION

In wide-open throttle (WOT) mode, adaptive memory in the PCM assures that up-shifts occur at the preprogrammed optimum speed. WOT operation is determined from the throttle position sensor, which is also a part of the emission control system. The initial setting for the WOT upshift is below the optimum engine speed. As WOT shifts are repeated, the PCM learns the time required to complete the shifts by comparing the engine speed when the shifts occur to the optimum speed. After each shift, the PCM adjusts the shift point until the optimum speed is

## ELECTRONIC GOVERNOR (Continued)

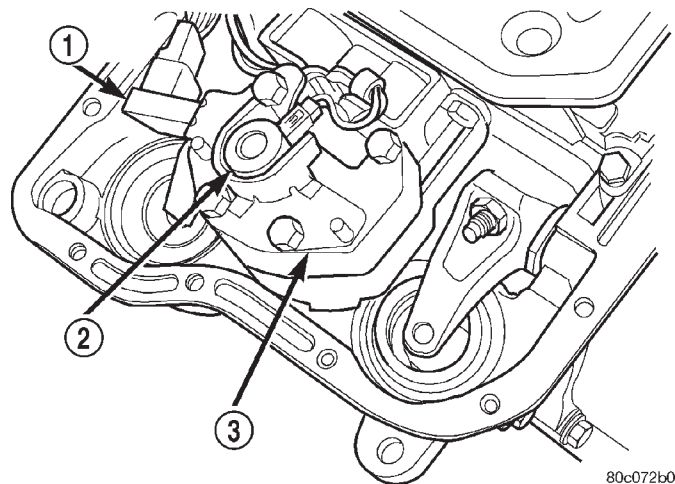
reached. The PCM also considers vehicle loading, grade and engine performance changes due to high altitude in determining when to make WOT shifts. It does this by measuring vehicle and engine acceleration and then factoring in the shift time.

## TRANSFER CASE LOW RANGE OPERATION

On four-wheel drive vehicles operating in low range, the engine can accelerate to its peak more rapidly than in Normal range, resulting in delayed shifts and undesirable engine "flare." The low range governor pressure curve is also higher than normal to initiate upshifts sooner. The PCM compares electronic vehicle speed signal used by the speedometer to the transmission output shaft speed signal to determine when the transfer case is in low range.

## REMOVAL

- (1) Hoist and support vehicle on safety stands.
- (2) Remove transmission fluid pan and filter.
- (3) Disengage wire connectors from pressure sensor and solenoid (Fig. 77).

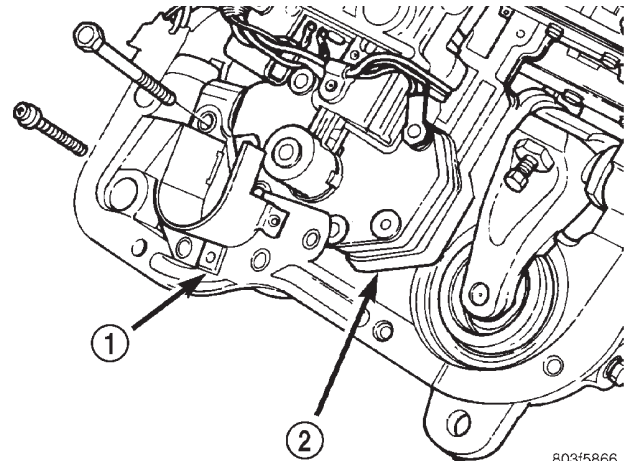


80c072b0

**Fig. 77 Governor Solenoid And Pressure Sensor**

- 1 - PRESSURE SENSOR
- 2 - PRESSURE SOLENOID
- 3 - GOVERNOR

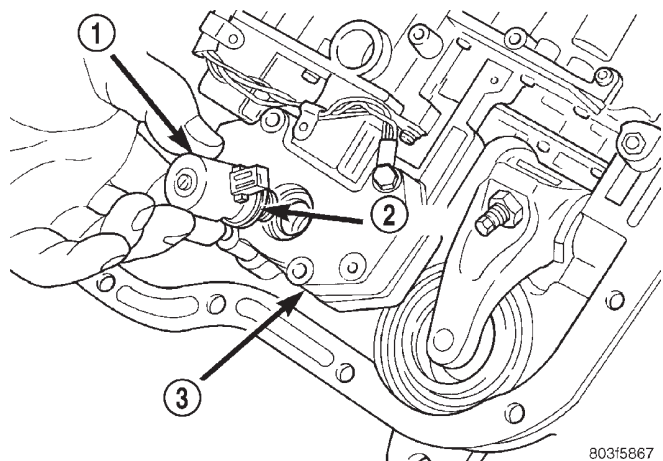
- (4) Remove screws holding pressure solenoid retainer to governor body.
- (5) Separate solenoid retainer from governor (Fig. 78).
- (6) Pull solenoid from governor body (Fig. 79).
- (7) Pull pressure sensor from governor body.
- (8) Remove bolts holding governor body to valve body.
- (9) Separate governor body from valve body (Fig. 80).
- (10) Remove governor body gasket.



803f5866

**Fig. 78 Pressure Solenoid Retainer**

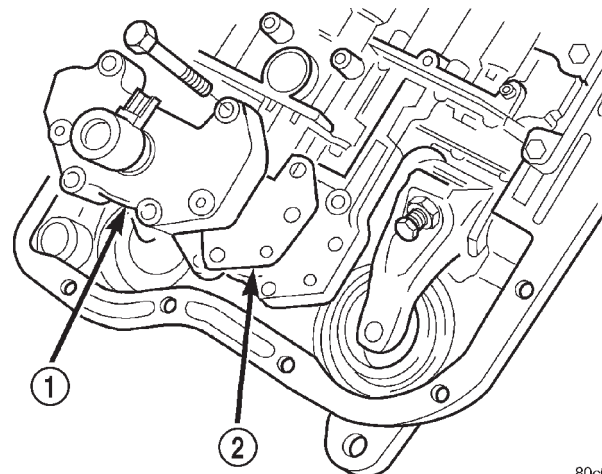
- 1 - PRESSURE SOLENOID RETAINER
- 2 - GOVERNOR



803f5867

**Fig. 79 Pressure Solenoid and O-ring**

- 1 - PRESSURE SOLENOID
- 2 - O-RING
- 3 - GOVERNOR



80c072b1

**Fig. 80 Governor Body and Gasket**

- 1 - GOVERNOR BODY
- 2 - GASKET

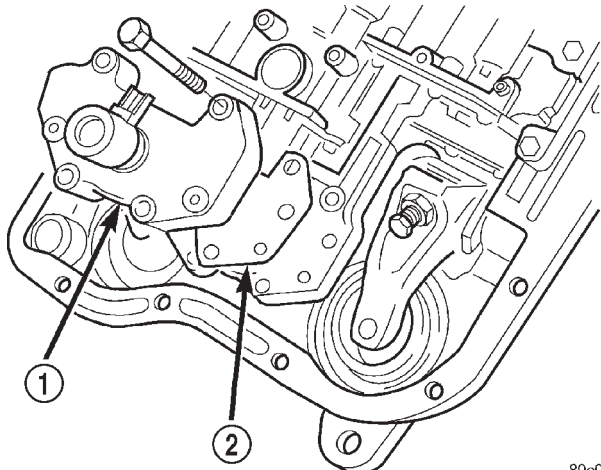


## ELECTRONIC GOVERNOR (Continued)

**INSTALLATION**

Before installing the pressure sensor and solenoid in the governor body, replace o-ring seals, clean the gasket surfaces and replace gasket.

- (1) Place gasket in position on back of governor body (Fig. 81).
- (2) Place governor body in position on valve body.
- (3) Install bolts to hold governor body to valve body.



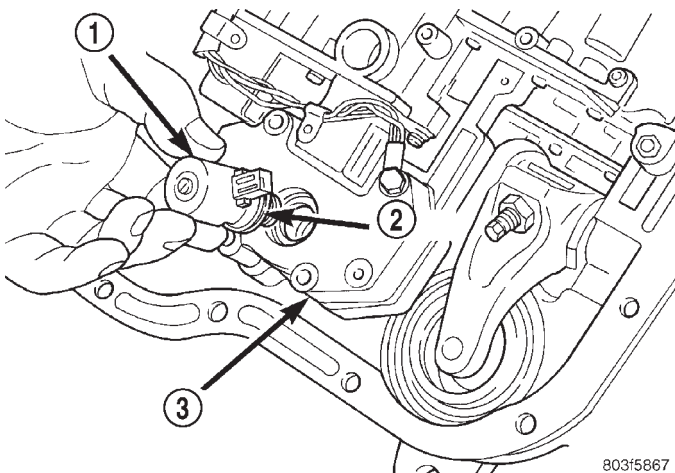
**Fig. 81 Governor Body and Gasket**

80c072b1

- 1 - GOVERNOR BODY
- 2 - GASKET

(4) Lubricate o-ring on pressure sensor with transmission fluid.

- (5) Align pressure sensor to bore in governor body.
- (6) Push pressure sensor into governor body.
- (7) Lubricate o-ring, on pressure solenoid, with transmission fluid.
- (8) Align pressure solenoid to bore in governor body (Fig. 82).

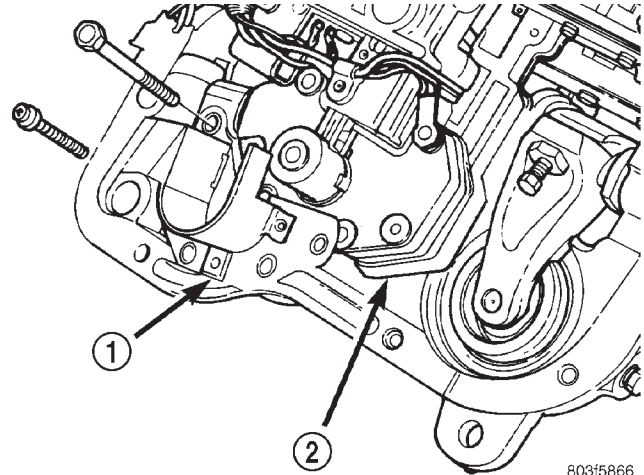


**Fig. 82 Pressure Solenoid and O-ring**

803f5867

- 1 - PRESSURE SOLENOID
- 2 - O-RING
- 3 - GOVERNOR

- (9) Push solenoid into governor body.
- (10) Place solenoid retainer in position on governor (Fig. 83).
- (11) Install screws to hold pressure solenoid retainer to governor body.



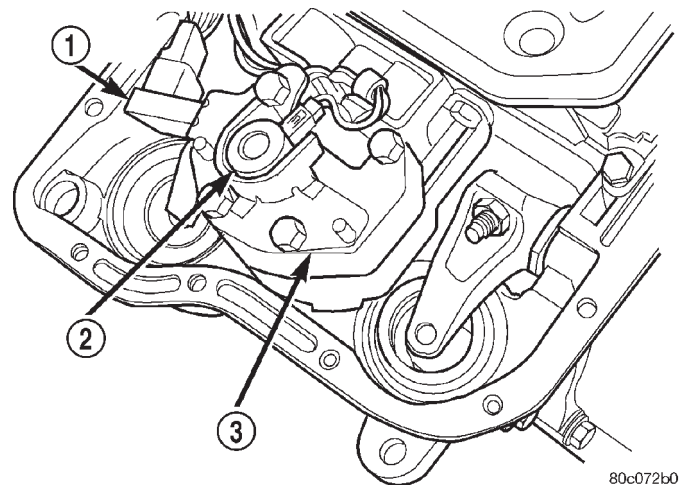
**Fig. 83 Pressure Solenoid Retainer**

803f5866

- 1 - PRESSURE SOLENOID RETAINER
- 2 - GOVERNOR

(12) Engage wire connectors into pressure sensor and solenoid (Fig. 84).

- (13) Install transmission fluid pan and (new) filter.
- (14) Lower vehicle and road test to verify repair.



**Fig. 84 Governor Solenoid And Pressure Sensor**

80c072b0

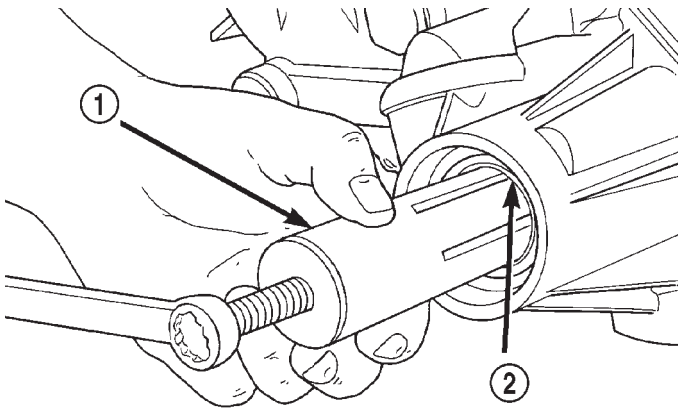
- 1 - PRESSURE SENSOR
- 2 - PRESSURE SOLENOID
- 3 - GOVERNOR



## EXTENSION HOUSING BUSHING

### REMOVAL

- (1) Remove extension housing yoke seal.
- (2) Insert Remover 6957 into the extension housing. Tighten tool to bushing and remove bushing (Fig. 85).



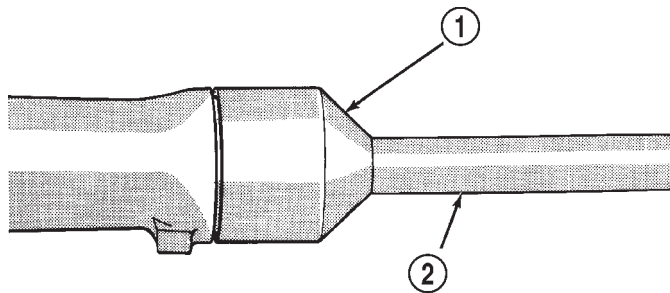
80a11095

**Fig. 85 Bushing Removal - Typical**

- 1 - REMOVER
- 2 - EXTENSION HOUSING BUSHING

### INSTALLATION

- (1) Align bushing oil hole with oil slot in extension housing.
- (2) Tap bushing into place with Installer 6951 and Handle C-4171.
- (3) Install new oil seal in housing using Seal Installer C-3995-A (Fig. 86).



J9521-58

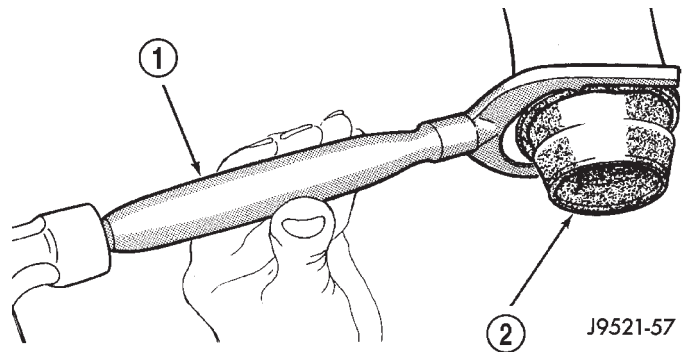
**Fig. 86 Extension Housing Seal Installation**

- 1 - SPECIAL TOOL C-3995-A OR C-3972-A
- 2 - SPECIAL TOOL C-4471

## EXTENSION HOUSING SEAL

### REMOVAL

- (1) Raise vehicle.
- (2) Mark propeller shaft and axle yoke for alignment reference.
- (3) Disconnect and remove propeller shaft.
- (4) Remove old seal with Seal Remover C-3985-B (Fig. 87) from overdrive housing.



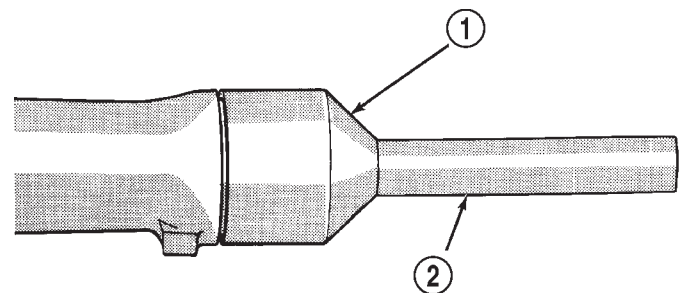
J9521-57

**Fig. 87 Removing Overdrive Housing Yoke Seal**

- 1 - SPECIAL TOOL C-3985-B
- 2 - SEAL

### INSTALLATION

- (1) Place seal in position on overdrive housing.
- (2) Drive seal into overdrive housing with Seal Installer C-3995-A (Fig. 88).
- (3) Carefully guide propeller shaft slip yoke into housing and onto output shaft splines. Align marks made at removal and connect propeller shaft to rear axle pinion yoke.



J9521-58

**Fig. 88 Installing Overdrive Housing Seal**

- 1 - SPECIAL TOOL C-3995-A OR C-3972-A
- 2 - SPECIAL TOOL C-4471

## FLUID AND FILTER

### DIAGNOSIS AND TESTING - EFFECTS OF INCORRECT FLUID LEVEL

A low fluid level allows the pump to take in air along with the fluid. Air in the fluid will cause fluid pressures to be low and develop slower than normal. If the transmission is overfilled, the gears churn the fluid into foam. This aerates the fluid and causing the same conditions occurring with a low level. In either case, air bubbles cause fluid overheating, oxidation and varnish buildup which interferes with valve and clutch operation. Foaming also causes fluid expansion which can result in fluid overflow from the transmission vent or fill tube. Fluid overflow can easily be mistaken for a leak if inspection is not careful.

### DIAGNOSIS AND TESTING - CAUSES OF BURNT FLUID

Burnt, discolored fluid is a result of overheating which has two primary causes.

(1) A result of restricted fluid flow through the main and/or auxiliary cooler. This condition is usually the result of a faulty or improperly installed drainback valve, a damaged main cooler, or severe restrictions in the coolers and lines caused by debris or kinked lines.

(2) Heavy duty operation with a vehicle not properly equipped for this type of operation. Trailer towing or similar high load operation will overheat the transmission fluid if the vehicle is improperly equipped. Such vehicles should have an auxiliary transmission fluid cooler, a heavy duty cooling system, and the engine/axle ratio combination needed to handle heavy loads.

### DIAGNOSIS AND TESTING - FLUID CONTAMINATION

Transmission fluid contamination is generally a result of:

- adding incorrect fluid
- failure to clean dipstick and fill tube when checking level
- engine coolant entering the fluid
- internal failure that generates debris
- overheat that generates sludge (fluid breakdown)
- failure to reverse flush cooler and lines after repair
- failure to replace contaminated converter after repair

The use of non-recommended fluids can result in transmission failure. The usual results are erratic shifts, slippage, abnormal wear and eventual failure due to fluid breakdown and sludge formation. Avoid this condition by using recommended fluids only.

The dipstick cap and fill tube should be wiped clean before checking fluid level. Dirt, grease and

other foreign material on the cap and tube could fall into the tube if not removed beforehand. Take the time to wipe the cap and tube clean before withdrawing the dipstick.

Engine coolant in the transmission fluid is generally caused by a cooler malfunction. The only remedy is to replace the radiator as the cooler in the radiator is not a serviceable part. If coolant has circulated through the transmission, an overhaul is necessary.

The transmission cooler and lines should be reverse flushed whenever a malfunction generates sludge and/or debris. The torque converter should also be replaced at the same time.

Failure to flush the cooler and lines will result in recontamination. Flushing applies to auxiliary coolers as well. The torque converter should also be replaced whenever a failure generates sludge and debris. This is necessary because normal converter flushing procedures will not remove all contaminants.

### STANDARD PROCEDURE - FLUID LEVEL CHECK

Low fluid level can cause a variety of conditions because it allows the pump to take in air along with the fluid. As in any hydraulic system, air bubbles make the fluid spongy, therefore, pressures will be low and build up slowly.

Improper filling can also raise the fluid level too high. When the transmission has too much fluid, the geartrain churns up foam and cause the same conditions which occur with a low fluid level.

In either case, air bubbles can cause overheating and/or fluid oxidation, and varnishing. This can interfere with normal valve, clutch, and accumulator operation. Foaming can also result in fluid escaping from the transmission vent where it may be mistaken for a leak.

Along with fluid level, it is important to check the condition of the fluid. When the fluid smells burned, and is contaminated with metal or friction material particles, a complete transmission recondition is needed. Be sure to examine the fluid on the dipstick closely. If there is any doubt about its condition, drain out a sample for a double check.

After the fluid has been checked, seat the dipstick fully to seal out water and dirt.

The transmission has a dipstick to check oil level. It is located on the right side of the engine. Be sure to wipe all dirt from dipstick handle before removing.

Fluid level is checked with the engine running at curb idle speed, the transmission in NEUTRAL and the transmission fluid at normal operating temperature. **The engine should be running at idle speed for at least one minute, with the vehicle on level ground.**

The transmission fluid level can be checked two ways.

FLUID AND FILTER (Continued)

**PROCEDURE ONE**

(1) Transmission fluid must be at normal operating temperature for accurate fluid level check. Drive vehicle if necessary to bring fluid temperature up to normal hot operating temperature of 82°C (180°F).

- (2) Position vehicle on level surface.
- (3) Start and run engine at curb idle speed.
- (4) Apply parking brakes.
- (5) Shift transmission momentarily into all gear ranges. Then shift transmission back to NEUTRAL.

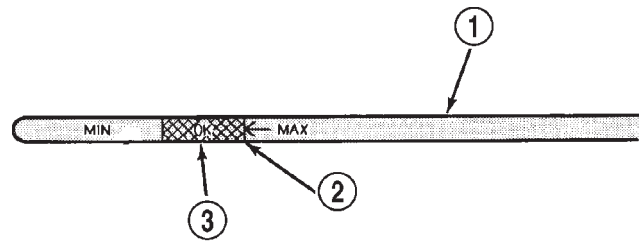
(6) Clean top of filler tube and dipstick to keep dirt from entering tube.

(7) Remove dipstick (Fig. 89) and check fluid level as follows:

- (a) Correct acceptable level is in crosshatch area.
- (b) Correct maximum level is to MAX arrow mark.
- (c) Incorrect level is at or below MIN line.
- (d) If fluid is low, add only enough Mopar® ATF +4, type 9602, to restore correct level. Do not overfill.

**PROCEDURE TWO**

- (1) Start engine and apply parking brake.
- (2) Shift the transmission into DRIVE for approximately 2 seconds.
- (3) Shift the transmission into REVERSE for approximately 2 seconds.
- (4) Shift the transmission into PARK.
- (5) Hook up DRB® scan tool and select engine.



804d8eee

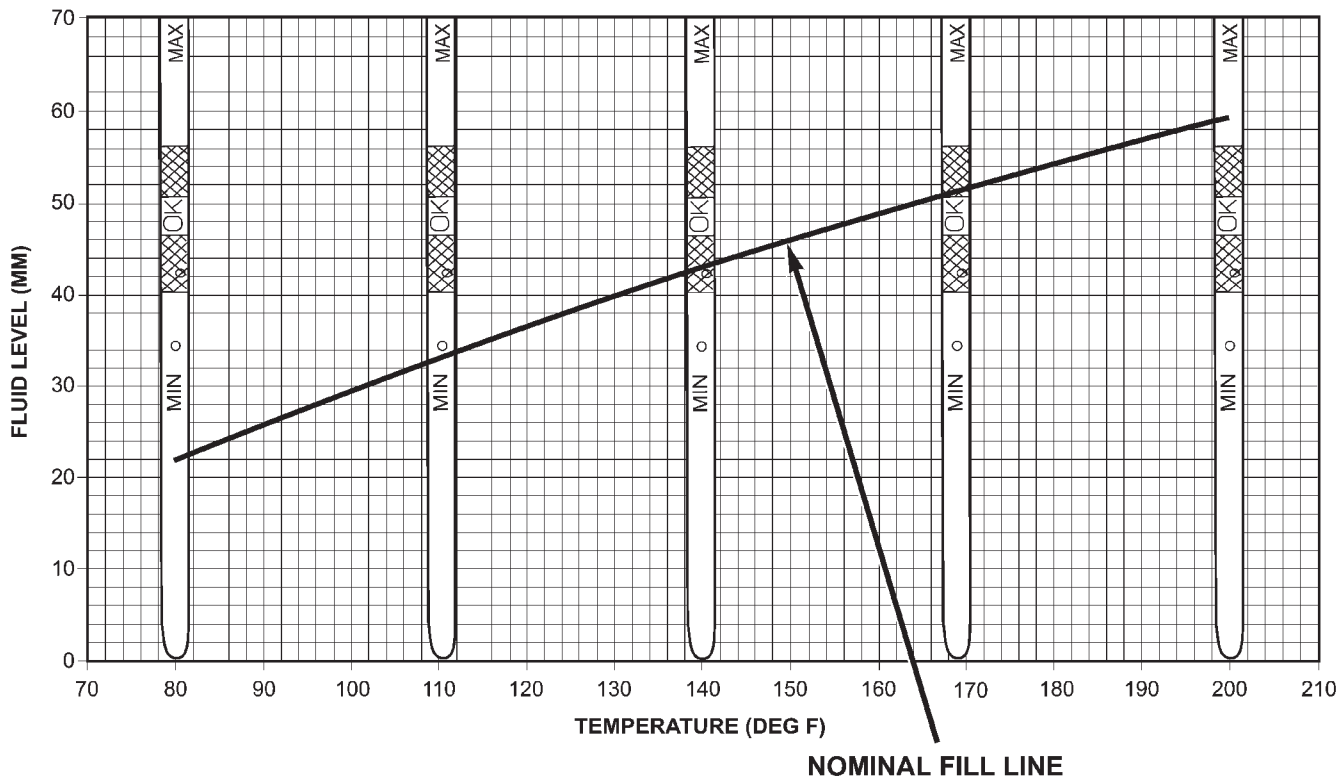
**Fig. 89 Dipstick Fluid Level Marks - Typical**

- 1 - DIPSTICK
- 2 - MAXIMUM CORRECT FLUID LEVEL
- 3 - ACCEPTABLE FLUID LEVEL

- (6) Select sensors.
- (7) Read the transmission temperature value.
- (8) Compare the fluid temperature value with the chart.
- (9) Adjust transmission fluid level shown on the dipstick according to the chart (Fig. 90).

**NOTE:** After adding any fluid to the transmission, wait a minimum of 2 minutes for the oil to fully drain from the fill tube into the transmission before rechecking the fluid level.

- (10) Check transmission for leaks.



**Fig. 90 46RE Fluid Fill Graph**

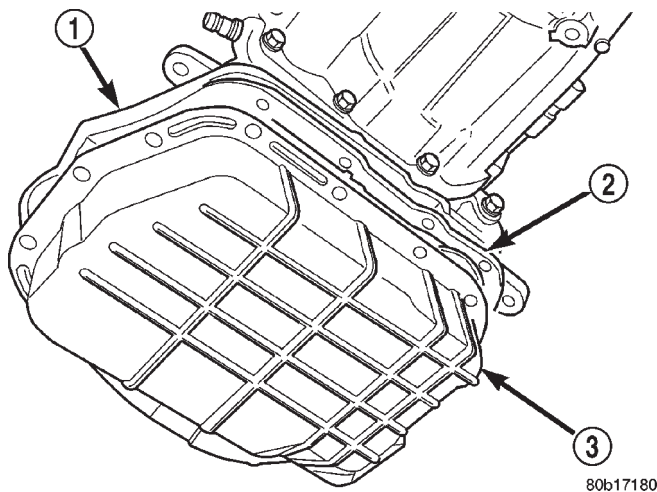
80a3cb22

## FLUID AND FILTER (Continued)

**STANDARD PROCEDURE - FLUID AND FILTER REPLACEMENT**

For proper service intervals (Refer to LUBRICATION & MAINTENANCE/MAINTENANCE SCHEDULES - DESCRIPTION). The service fluid fill after a filter change is approximately 3.8 liters (4.0 quarts).

- (1) Hoist and support vehicle on safety stands.
- (2) Place a large diameter shallow drain pan beneath the transmission pan.
- (3) Remove bolts holding front and sides of pan to transmission (Fig. 91).
- (4) Loosen bolts holding rear of pan to transmission.
- (5) Slowly separate front of pan away from transmission allowing the fluid to drain into drain pan.
- (6) Hold up pan and remove remaining bolt holding pan to transmission.
- (7) While holding pan level, lower pan away from transmission.
- (8) Pour remaining fluid in pan into drain pan.
- (9) Remove screws holding filter to valve body (Fig. 92).
- (10) Separate filter from valve body and pour fluid in filter into drain pan.
- (11) Dispose of used trans fluid and filter properly.

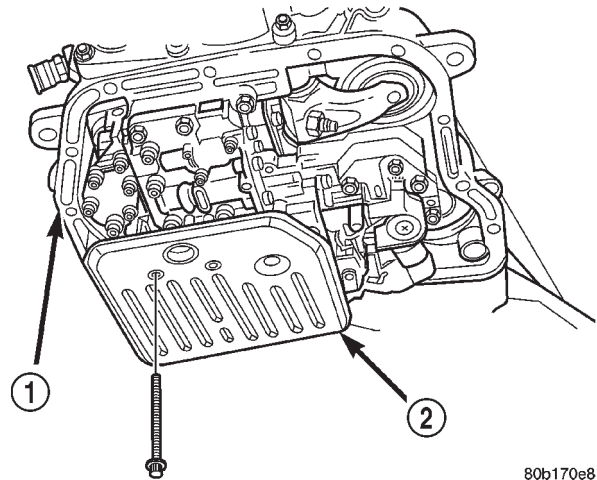
**Fig. 91 Transmission Pan**

- 1 - TRANSMISSION  
2 - GASKET  
3 - PAN

**STANDARD PROCEDURE - TRANSMISSION FILL**

To avoid overfilling transmission after a fluid change or overhaul, perform the following procedure:

- (1) Remove dipstick and insert clean funnel in transmission fill tube.
- (2) Add following initial quantity of Mopar® ATF +4, type 9602, to transmission:



80b170e8

**Fig. 92 Transmission Filter**

- 1 - TRANSMISSION  
2 - FILTER

(a) If only fluid and filter were changed, add **3 pints (1-1/2 quarts)** of ATF +4 to transmission.

(b) If transmission was completely overhauled, torque converter was replaced or drained, and cooler was flushed, add **12 pints (6 quarts)** of ATF +4 to transmission.

- (3) Apply parking brakes.
- (4) Start and run engine at normal curb idle speed.
- (5) Apply service brakes, shift transmission through all gear ranges then back to NEUTRAL, set parking brake, and leave engine running at curb idle speed.
- (6) Remove funnel, insert dipstick and check fluid level. If level is low, **add fluid to bring level to MIN mark on dipstick**. Check to see if the oil level is equal on both sides of the dipstick. If one side is noticeably higher than the other, the dipstick has picked up some oil from the dipstick tube. Allow the oil to drain down the dipstick tube and re-check.
- (7) Drive vehicle until transmission fluid is at normal operating temperature.
- (8) With the engine running at curb idle speed, the gear selector in NEUTRAL, and the parking brake applied, check the transmission fluid level.

**CAUTION: Do not overfill transmission, fluid foaming and shifting problems can result.**

(9) Add fluid to bring level up to MAX arrow mark.

When fluid level is correct, shut engine off, release park brake, remove funnel, and install dipstick in fill tube.



## FRONT CLUTCH

### DESCRIPTION

The front clutch assembly (Fig. 93) is composed of the front clutch retainer, pressure plate, clutch plates, driving discs, piston, piston return spring, return spring retainer, and snap-rings. The front clutch is the forward-most component in the transmission geartrain and is directly behind the oil pump and is considered a driving component.

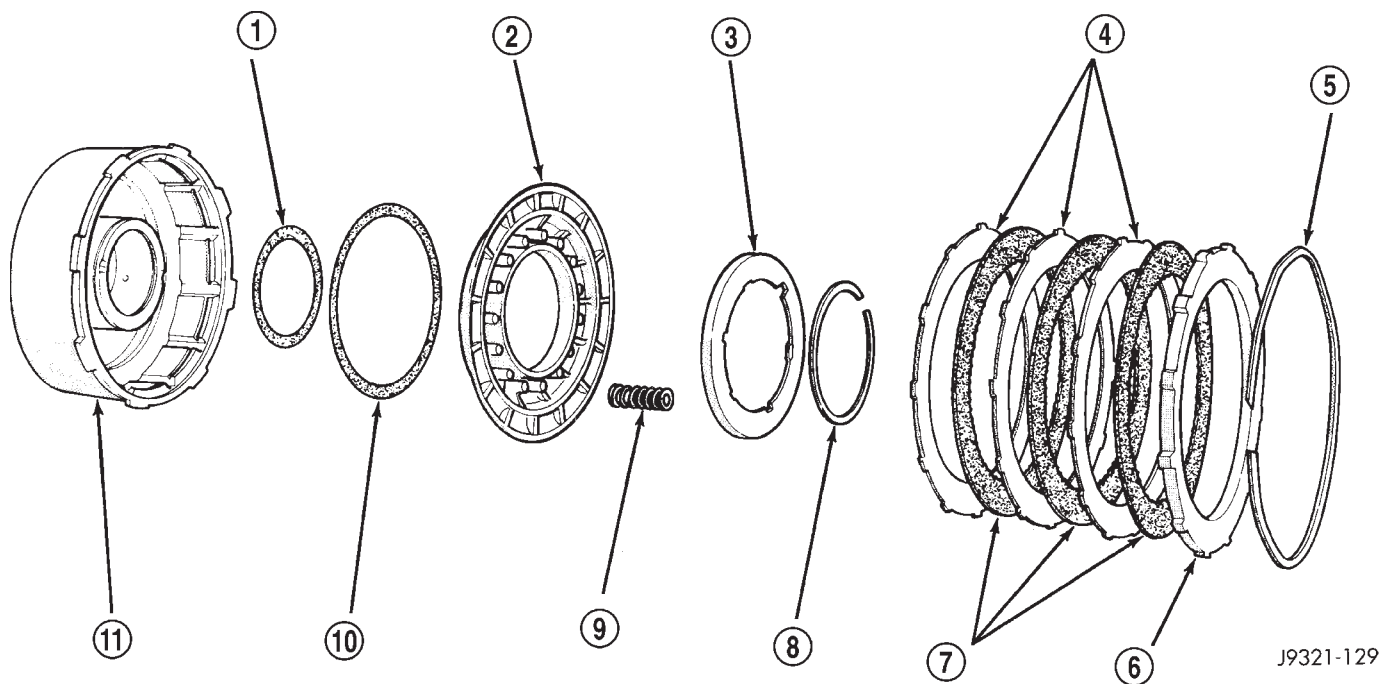
**NOTE: The number of discs and plates may vary with each engine and vehicle combination.**

### OPERATION

To apply the clutch, pressure is applied between the clutch retainer and piston. The fluid pressure is provided by the oil pump, transferred through the control valves and passageways, and enters the

clutch through the hub of the reaction shaft support. With pressure applied between the clutch retainer and piston, the piston moves away from the clutch retainer and compresses the clutch pack. This action applies the clutch pack, allowing torque to flow through the input shaft into the driving discs, and into the clutch plates and pressure plate that are lugged to the clutch retainer. The waved snap-ring is used to cushion the application of the clutch pack.

When pressure is released from the piston, the spring returns the piston to its fully released position and disengages the clutch. The release spring also helps to cushion the application of the clutch assembly. When the clutch is in the process of being released by the release spring, fluid flows through a vent and one-way ball-check-valve located in the clutch retainer. The check-valve is needed to eliminate the possibility of plate drag caused by centrifugal force acting on the residual fluid trapped in the clutch piston retainer.



J9321-129

**Fig. 93 Front Clutch Components**

- 1 - INNER PISTON SEAL
- 2 - CLUTCH PISTON
- 3 - CLUTCH PISTON SPRING RETAINER
- 4 - CLUTCH PLATES
- 5 - CLUTCH PACK SNAP-RING (WAVED)
- 6 - REACTION PLATE

- 7 - CLUTCH DISCS
- 8 - RETAINER SNAP-RING
- 9 - CLUTCH PISTON SPRINGS (9)
- 10 - OUTER PISTON SEAL
- 11 - FRONT CLUTCH RETAINER



## FRONT CLUTCH (Continued)

**DISASSEMBLY**

(1) Remove the waved snap-ring, reaction plate, clutch plates, and clutch discs.

(2) Compress clutch piston retainer and piston springs with Compressor Tool C-3863-A (Fig. 94).

(3) Remove retainer snap-ring and remove compressor tool.

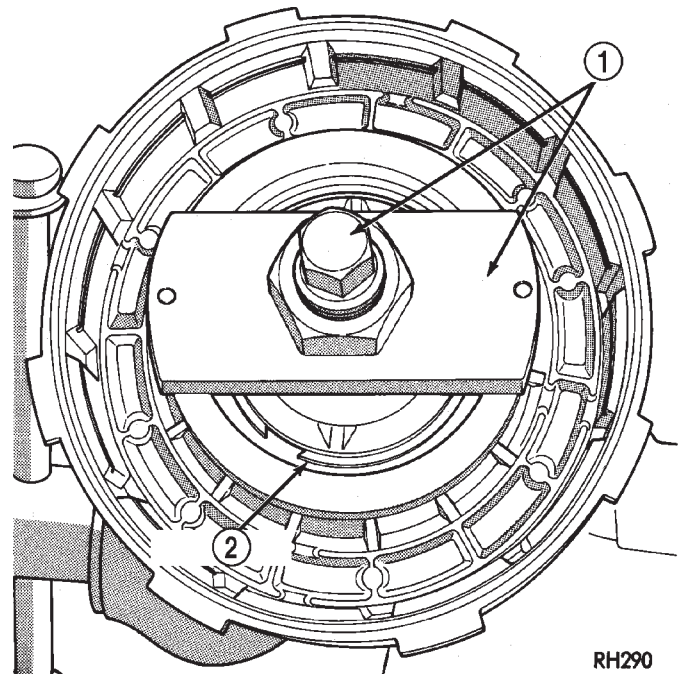
(4) Remove clutch piston springs (Fig. 95). Note position of piston springs for assembly reference.

(5) Remove clutch piston from retainer with a twisting motion.

(6) Remove and discard clutch piston inner and outer seals.

(7) Assemble Tool Handle C-4171 and Bushing Remover SP-3629 (Fig. 96).

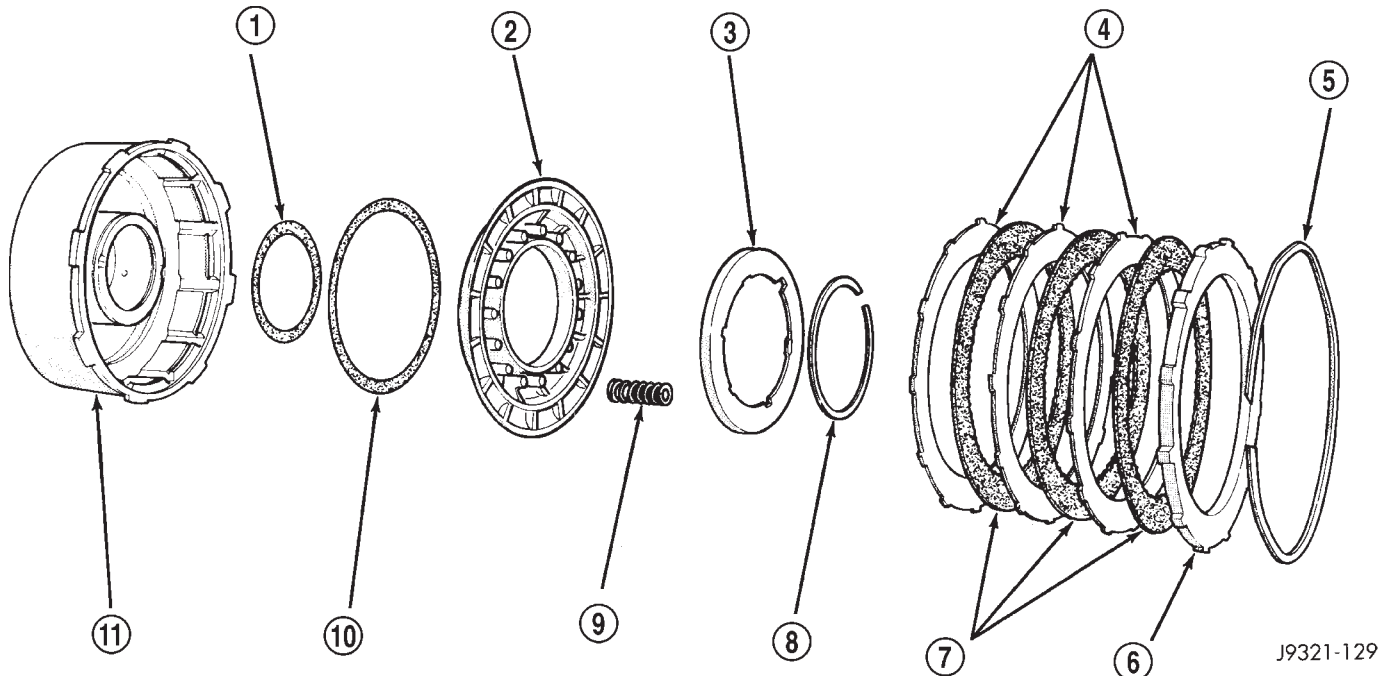
(8) Insert remover tool in bushing and drive bushing straight out of clutch retainer.



**Fig. 94 Removing Front Clutch Spring Retainer Snap-Ring**

1 - SPECIAL TOOL C-3863-A

2 - SNAP-RING



**Fig. 95 Front Clutch Components**

1 - INNER PISTON SEAL

2 - CLUTCH PISTON

3 - CLUTCH PISTON SPRING RETAINER

4 - CLUTCH PLATES

5 - CLUTCH PACK SNAP-RING (WAVED)

6 - REACTION PLATE

7 - CLUTCH DISCS

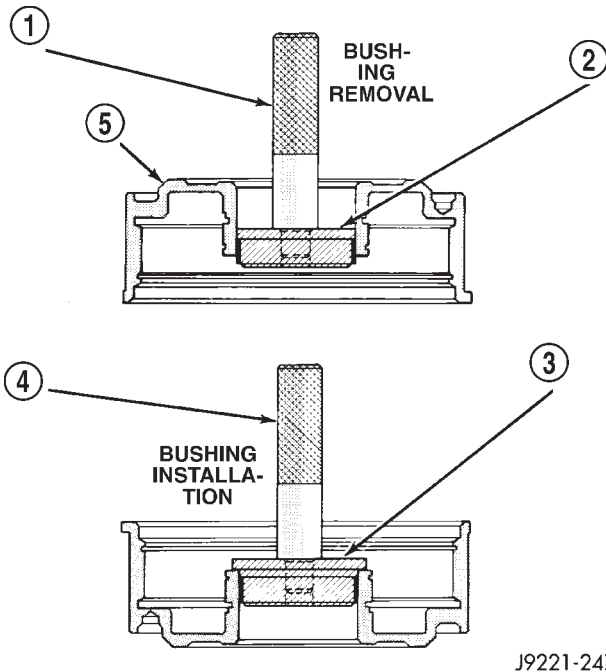
8 - RETAINER SNAP-RING

9 - CLUTCH PISTON SPRINGS (9)

10 - OUTER PISTON SEAL

11 - FRONT CLUTCH RETAINER

## FRONT CLUTCH (Continued)



J9221-247

**Fig. 96 Front Clutch Retainer Bushing Replacement Tools**

- 1 - SPECIAL TOOL C-4171
- 2 - SPECIAL TOOL SP-3629
- 3 - SPECIAL TOOL SP-5511
- 4 - SPECIAL TOOL C-4171
- 5 - FRONT CLUTCH RETAINER

## INSPECTION

Inspect the front clutch components. Replace the clutch discs if warped, worn, scored, burned or charred, the lugs are damaged, or if the facing is flaking off. Replace the steel plates and reaction plate if heavily scored, warped, or broken. Be sure the driving lugs on the discs and plate are also in good condition. The lugs must not be bent, cracked or damaged in any way.

Replace the piston springs and spring retainer if either are distorted, warped or broken.

Check the lug grooves in the clutch piston retainer. The steel plates should slide freely in the slots. Replace the piston retainer if the grooves are worn or damaged. Also check action of the check ball in the piston retainer. The ball must move freely and not stick.

Replace the retainer bushing if worn, scored, or there is any doubt about bushing condition.

Inspect the piston and retainer seal surfaces for nicks or scratches. Minor scratches can be removed with crocus cloth. However, replace the piston and/or retainer if the seal surfaces are seriously scored.

Check the clutch piston check ball. The ball should be securely in place. Replace the piston if the ball is missing, or seized in place.

## ASSEMBLY

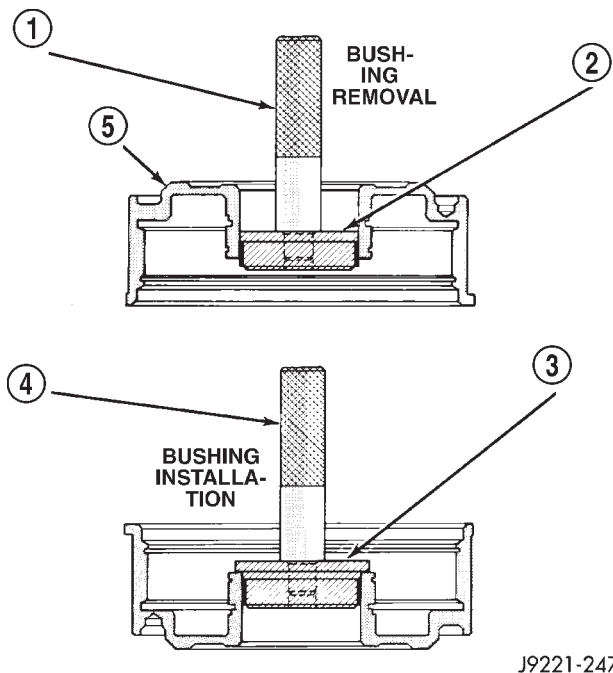
**NOTE:** The 46RE transmission uses three plates and discs for the front clutch.

(1) Mount Bushing Installer SP-5511 on tool handle (Fig. 97).

(2) Slide new bushing onto installer tool and start bushing into retainer.

(3) Tap new bushing into place until installer tool bottoms against clutch retainer.

(4) Remove installer tools and clean retainer thoroughly.



J9221-247

**Fig. 97 Front Clutch Retainer Bushing Replacement Tools**

- 1 - SPECIAL TOOL C-4171
- 2 - SPECIAL TOOL SP-3629
- 3 - SPECIAL TOOL SP-5511
- 4 - SPECIAL TOOL C-4171
- 5 - FRONT CLUTCH RETAINER

(5) Soak clutch discs in transmission fluid.  
 (6) Install new inner piston seal onto the outer diameter of the clutch retainer inner hub.

(7) Install new outer seal onto the clutch piston. Be sure seal lips of both seals face the interior of the retainer.

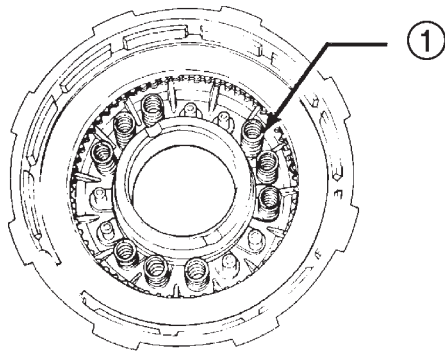
(8) Lubricate new inner and outer piston seals with Ru-Glyde™, or Mopar® Door Ease.

(9) Install clutch piston in retainer. Use twisting motion to seat piston in bottom of retainer. A thin strip of plastic (about 0.015 - 0.020 in. thick), can be used to guide seals into place if necessary.

## FRONT CLUTCH (Continued)

**CAUTION:** Never push the clutch piston straight in. This will fold the seals over causing leakage and clutch slip. In addition, never use any type of metal tool to help ease the piston seals into place. Metal tools will cut, shave, or score the seals.

(10) Install and position nine clutch piston springs (Fig. 98).



J9521-75

**Fig. 98 Front Clutch Spring Position**

1 - 9 SPRING CLUTCH

(11) Install spring retainer on top of piston springs.

(12) Compress spring retainer and piston springs with Tool C-3863-A.

(13) Install spring retainer snap-ring and remove compressor tool.

(14) Install clutch plates and discs (Fig. 95). Three clutch discs, three steel plates and one reaction plate are required.

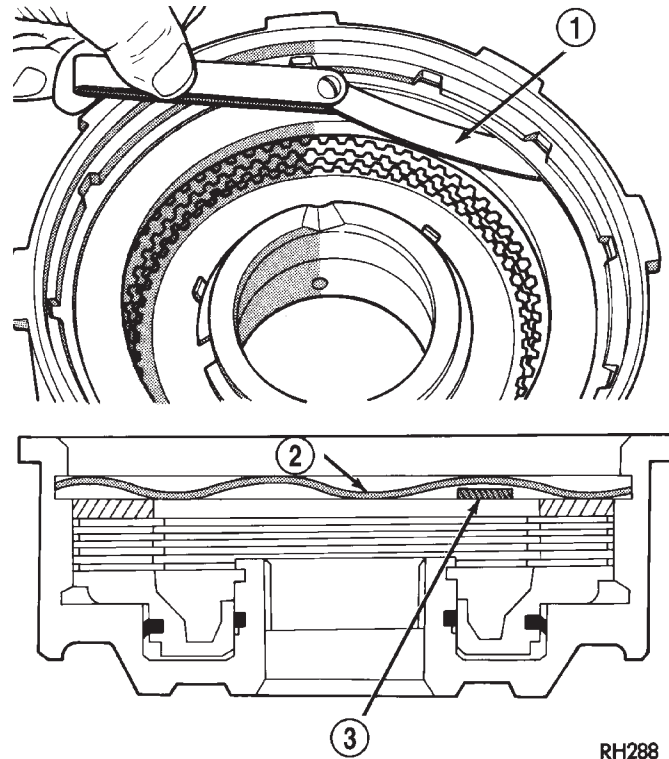
(15) Install reaction plate followed by waved snap-ring.

(16) Check clutch pack clearance with feeler gauge (Fig. 99). Clearance between waved spring and pressure plate should 1.78 - 3.28 mm (0.070 - 0.129 in.). If clearance is incorrect, clutch plates, clutch discs, snap-ring, or pressure plate may have to be changed.

## FRONT SERVO

## DESCRIPTION

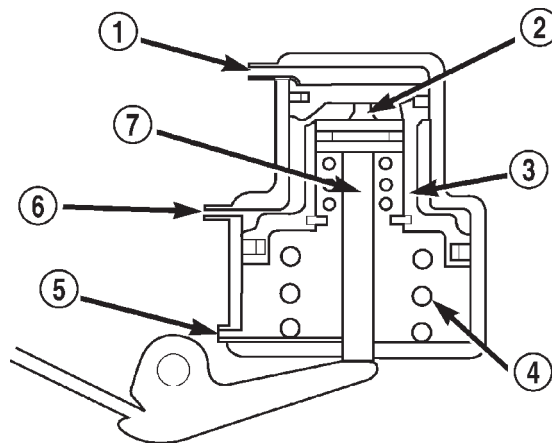
The kickdown servo (Fig. 100) consists of a two-land piston with an inner piston, a piston rod and guide, and a return spring. The dual-land piston uses seal rings on its outer diameters and an O-ring for the inner piston.



RH288

**Fig. 99 Typical Method Of Measuring Front Clutch Pack Clearance**

- 1 - FEELER GAUGE
- 2 - WAVED SNAP-RING
- 3 - FEELER GAUGE



80be45fa

**Fig. 100 Front Servo**

- 1 - VENT
- 2 - INNER PISTON
- 3 - PISTON
- 4 - SPRING
- 5 - RELEASE PRESSURE
- 6 - APPLY PRESSURE
- 7 - PISTON ROD

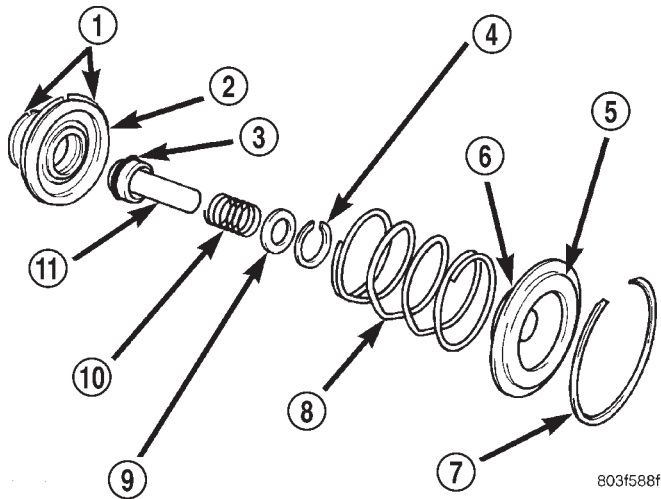
FRONT SERVO (Continued)

**OPERATION**

The application of the piston is accomplished by applying pressure between the two lands of the piston. The pressure acts against the larger lower land to push the piston downward, allowing the piston rod to extend through its guide against the apply lever. Release of the servo at the 2-3 upshift is accomplished by a combination of spring and line pressure, acting on the bottom of the larger land of the piston. The small piston is used to cushion the application of the band by bleeding oil through a small orifice in the larger piston. The release timing of the kickdown servo is very important to obtain a smooth but firm shift. The release has to be very quick, just as the front clutch application is taking place. Otherwise, engine runaway or a shift hesitation will occur. To accomplish this, the band retains its holding capacity until the front clutch is applied, giving a small amount of overlap between them.

**DISASSEMBLY**

- (1) Remove seal ring from rod guide (Fig. 101).
- (2) Remove small snap-ring from servo piston rod. Then remove piston rod, spring and washer from piston.
- (3) Remove and discard servo component O-ring and seal rings.

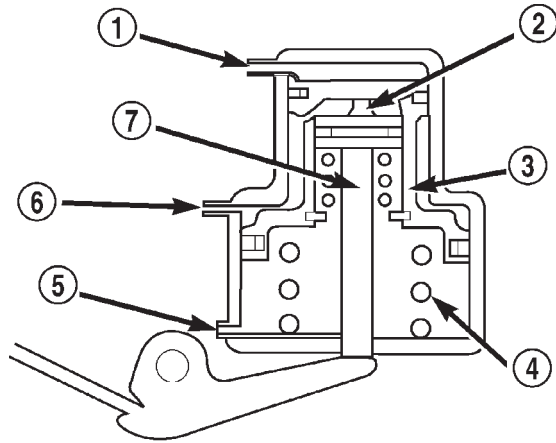


**Fig. 101 Front Servo**

- 1 - PISTON RINGS
- 2 - SERVO PISTON
- 3 - O-RING
- 4 - SNAP-RING
- 5 - PISTON ROD GUIDE
- 6 - SEAL RING
- 7 - SNAP-RING
- 8 - SERVO SPRING
- 9 - WASHER
- 10 - SPRING
- 11 - PISTON ROD

**CLEANING**

Clean the servo piston components (Fig. 102) with solvent and dry them with compressed air.



80be45fa

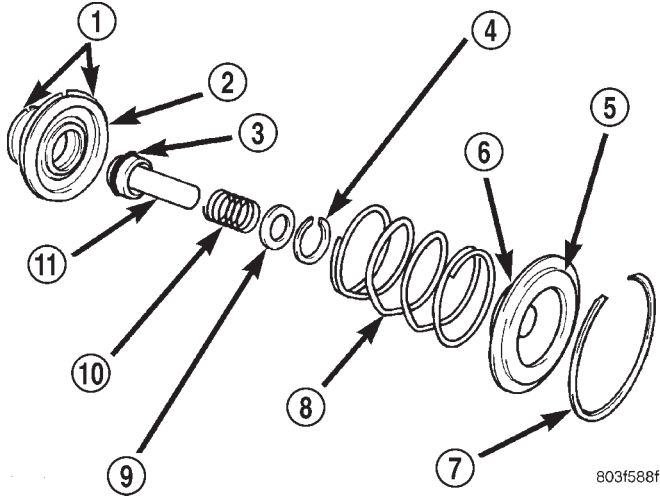
**Fig. 102 Front Servo**

- 1 - VENT
- 2 - INNER PISTON
- 3 - PISTON
- 4 - SPRING
- 5 - RELEASE PRESSURE
- 6 - APPLY PRESSURE
- 7 - PISTON ROD

FRONT SERVO (Continued)

**INSPECTION**

Inspect the servo components (Fig. 103). Replace the springs if collapsed, distorted or broken. Replace the guide, rod and piston if cracked, bent, or worn. Discard the servo snap-ring if distorted or warped.



**Fig. 103 Front Servo**

- 1 - PISTON RINGS
- 2 - SERVO PISTON
- 3 - O-RING
- 4 - SNAP-RING
- 5 - PISTON ROD GUIDE
- 6 - SEAL RING
- 7 - SNAP-RING
- 8 - SERVO SPRING
- 9 - WASHER
- 10 - SPRING
- 11 - PISTON ROD

Check the servo piston bore for wear. If the bore is severely scored, or damaged, it will be necessary to replace the case.

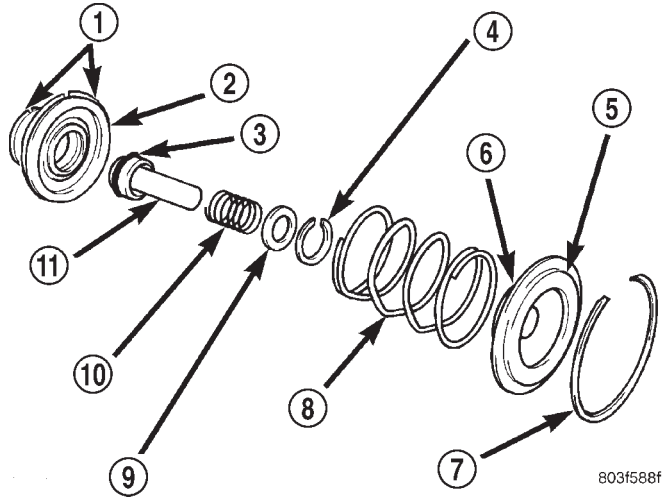
Replace any servo component if doubt exists about condition. Do not reuse suspect parts.

**ASSEMBLY**

Clean and inspect front servo components.

(1) Lubricate new o-ring and seal rings with petroleum jelly and install them on piston, guide and rod.

(2) Install rod in piston. Install spring and washer on rod. Compress spring and install snap-ring (Fig. 104).



**Fig. 104 Front Servo**

- 1 - PISTON RINGS
- 2 - SERVO PISTON
- 3 - O-RING
- 4 - SNAP-RING
- 5 - PISTON ROD GUIDE
- 6 - SEAL RING
- 7 - SNAP-RING
- 8 - SERVO SPRING
- 9 - WASHER
- 10 - SPRING
- 11 - PISTON ROD



## OIL PUMP

### DESCRIPTION

The oil pump (Fig. 105) is located in the pump housing inside the bell housing of the transmission case. The oil pump consists of an inner and outer gear, a housing, and a reaction shaft support.

### OPERATION

As the torque converter rotates, the converter hub rotates the inner and outer gears. As the gears rotate, the clearance between the gear teeth increases in the crescent area, and creates a suction at the inlet side of the pump. This suction draws fluid through the pump inlet from the oil pan. As the clearance between the gear teeth in the crescent area decreases, it forces pressurized fluid into the pump outlet and to the valve body.

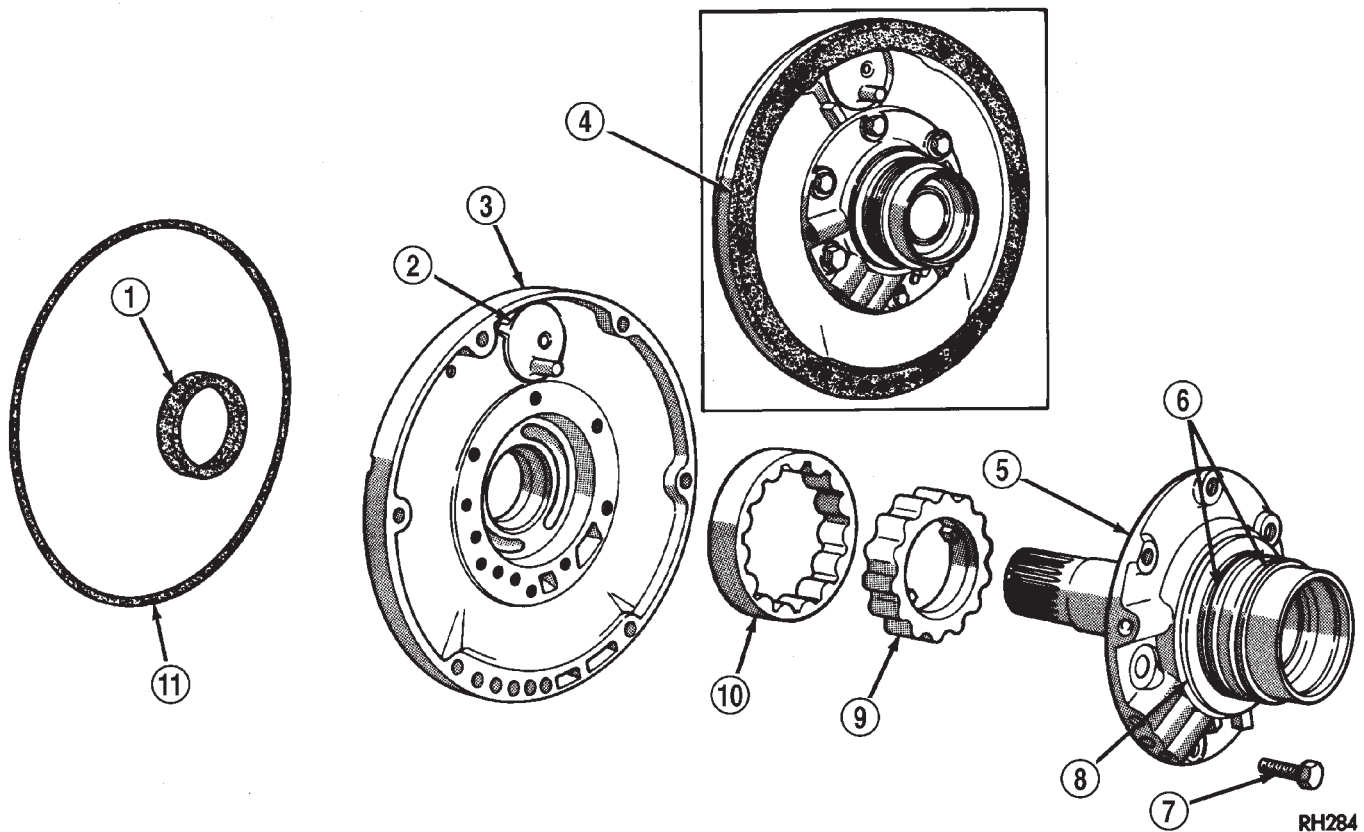
### STANDARD PROCEDURE - OIL PUMP VOLUME CHECK

Measuring the oil pump output volume will determine if sufficient oil flow to the transmission oil cooler exists, and whether or not an internal transmission failure is present.

Verify that the transmission fluid is at the proper level. Refer to the Fluid Level Check procedure in this section. If necessary, fill the transmission to the proper level with Mopar® ATF +4, type 9602, Automatic Transmission Fluid.

(1) Disconnect the **To cooler** line at the cooler inlet and place a collecting container under the disconnected line.

**CAUTION:** With the fluid set at the proper level, fluid collection should not exceed (1) quart or internal damage to the transmission may occur.



**Fig. 105 Oil Pump Assembly**

- 1 - OIL SEAL
- 2 - VENT BAFFLE
- 3 - OIL PUMP BODY
- 4 - GASKET
- 5 - REACTION SHAFT SUPPORT
- 6 - SEAL RINGS

- 7 - BOLTS (6)
- 8 - #1 THRUST WASHER (SELECTIVE)
- 9 - INNER GEAR
- 10 - OUTER GEAR
- 11 - "O" RING

RH284

OIL PUMP (Continued)

(2) Run the engine **at curb idle speed**, with the shift selector in neutral.

(3) If one quart of transmission fluid is collected in the container in 20 seconds or less, oil pump flow volume is within acceptable limits. If fluid flow is intermittent, or it takes more than 20 seconds to collect one quart of fluid, refer to the Hydraulic Pressure tests in this section for further diagnosis.

(4) Re-connect the **To cooler** line to the transmission cooler inlet.

(5) Refill the transmission to proper level.

**DISASSEMBLY**

(1) Mark position of support in oil pump body for assembly alignment reference. Use scribe or paint to make alignment marks.

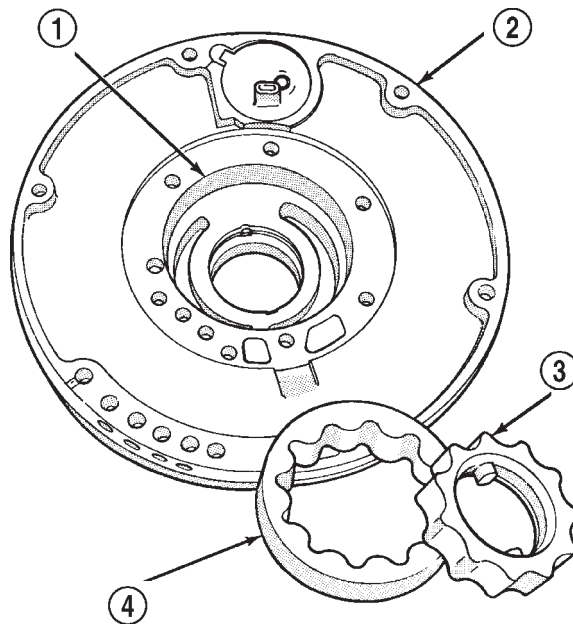
(2) Place pump body on two wood blocks.

(3) Remove reaction shaft support bolts and separate support from pump body (Fig. 106).

(4) Remove pump inner and outer gears (Fig. 107).

(5) Remove o-ring seal from pump body (Fig. 108). Discard seal after removal.

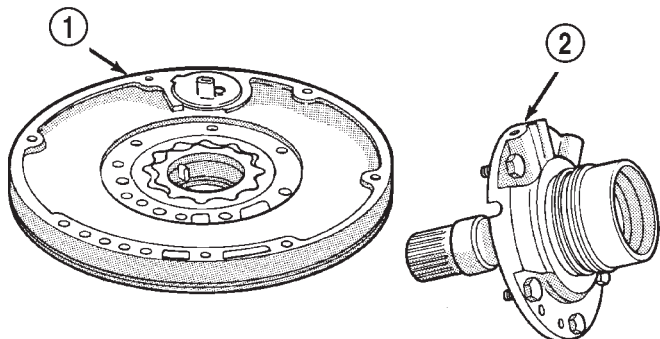
(6) Remove oil pump seal with Remover Tool C-3981. Discard seal after removal.



J9321-177

**Fig. 107 Pump Gears**

- 1 - GEAR BORE
- 2 - PUMP BODY
- 3 - INNER GEAR
- 4 - OUTER GEAR

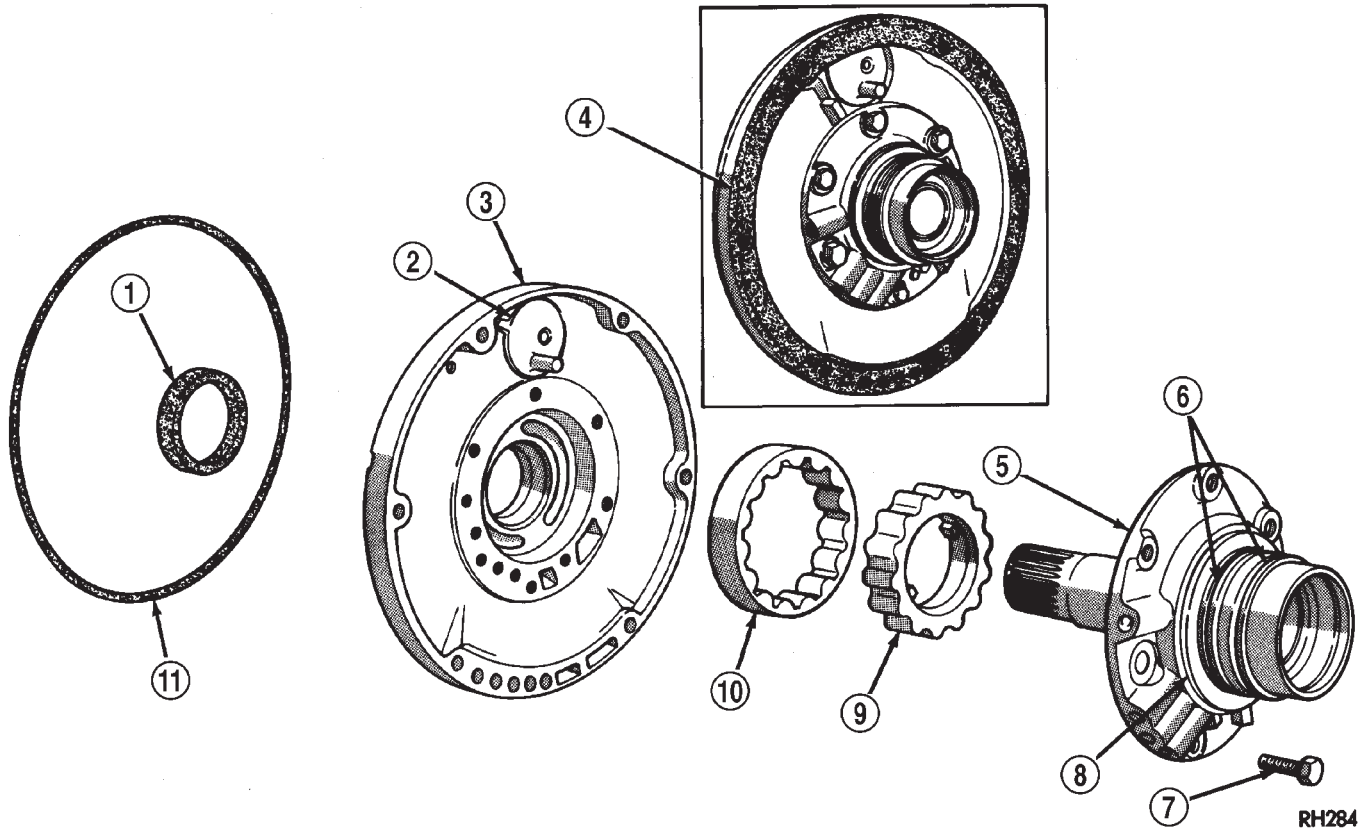


J9321-176

**Fig. 106 Reaction Shaft Support**

- 1 - OIL PUMP
- 2 - REACTION SHAFT SUPPORT

## OIL PUMP (Continued)

**Fig. 108 Oil Pump Assembly**

- 1 - OIL SEAL
- 2 - VENT BAFFLE
- 3 - OIL PUMP BODY
- 4 - GASKET
- 5 - REACTION SHAFT SUPPORT
- 6 - SEAL RINGS

- 7 - BOLTS (6)
- 8 - #1 THRUST WASHER (SELECTIVE)
- 9 - INNER GEAR
- 10 - OUTER GEAR
- 11 - "O" RING

RH284

## OIL PUMP (Continued)

## OIL PUMP BUSHING REMOVAL

(1) Position pump housing on clean, smooth surface with gear cavity facing down.

(2) Remove bushing with Tool Handle C-4171 and Bushing Remover SP-3550 (Fig. 109).

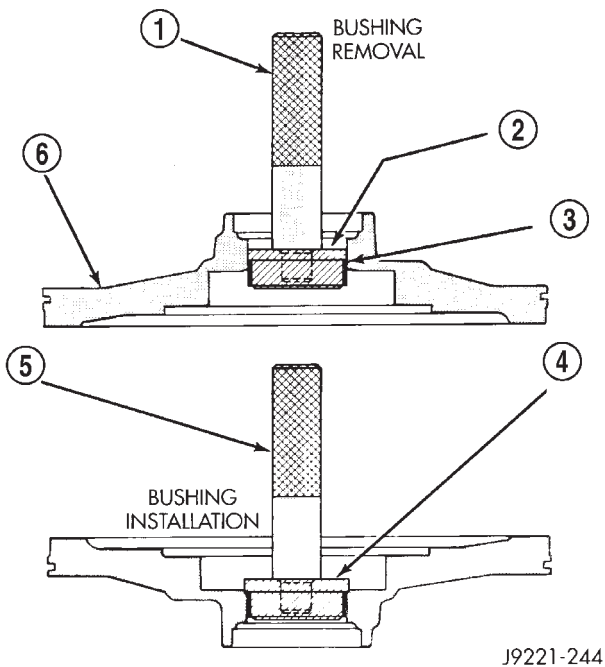
## REACTION SHAFT SUPPORT BUSHING REMOVAL

(1) Assemble Cup Tool SP-3633, Nut SP-1191 and Bushing Remover SP-5301 (Fig. 110).

(2) Hold cup tool firmly against reaction shaft. Thread remover tool into bushing as far as possible by hand.

(3) Using wrench, thread remover tool an additional 3-4 turns into bushing to firmly engage tool.

(4) Tighten tool hex nut against cup tool to pull bushing from shaft. Clean all chips from shaft and support after bushing removal.



J9221-244

**Fig. 109 Oil Pump Bushing**

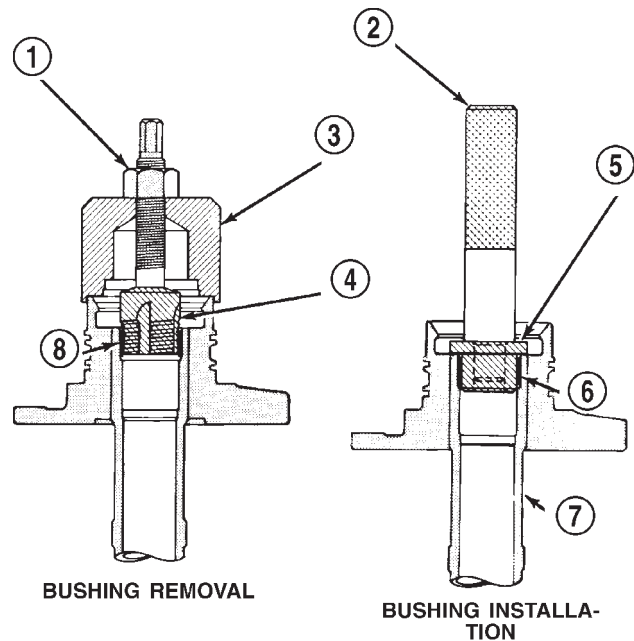
- 1 - SPECIAL TOOL C-4171
- 2 - SPECIAL TOOL SP-3550
- 3 - BUSHING
- 4 - SPECIAL TOOL SP-5118
- 5 - SPECIAL TOOL C-4171
- 6 - PUMP HOUSING

## CLEANING

Clean pump and support components with solvent and dry them with compressed air.

## INSPECTION

Check condition of the seal rings and thrust washer on the reaction shaft support. The seal rings



J9221-245

**Fig. 110 Reaction Shaft Bushing**

- 1 - SPECIAL TOOL SP-1191
- 2 - SPECIAL TOOL C-4171
- 3 - SPECIAL TOOL SP-3633
- 4 - SPECIAL TOOL SP-5301
- 5 - SPECIAL TOOL SP-5302
- 6 - BUSHING
- 7 - REACTION SHAFT
- 8 - BUSHING

do not need to be replaced unless cracked, broken, or severely worn.

Inspect the pump and support components. Replace the pump or support if the seal ring grooves or machined surfaces are worn, scored, pitted, or damaged. Replace the pump gears if pitted, worn chipped, or damaged.

Inspect the pump bushing. Then check the reaction shaft support bushing. Replace either bushing only if heavily worn, scored or damaged. It is not necessary to replace the bushings unless they are actually damaged.

Clearance between outer gear and reaction shaft housing should be 0.010 to 0.063 mm (0.0004 to 0.0025 in.). Clearance between inner gear and reaction shaft housing should be 0.010 to 0.063 mm (0.0004 to 0.0025 in.). Both clearances can be measured at the same time by installing the gears in the pump body and measure pump component clearances as follows:

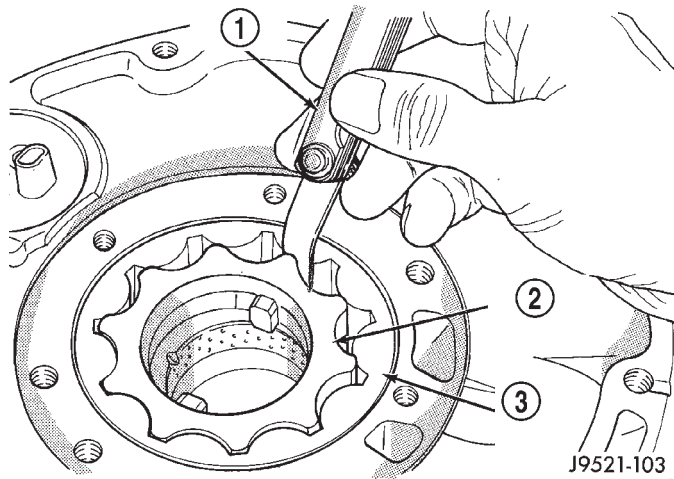
- (1) Position an appropriate piece of Plastigage™ across both gears.
- (2) Align the plastigage to a flat area on the reaction shaft housing.
- (3) Install the reaction shaft to the pump housing.

OIL PUMP (Continued)

(4) Separate the reaction shaft housing from the pump housing and measure the Plastigage™ following the instructions supplied with it.

Clearance between inner gear tooth and outer gear should be 0.08 to 0.19 mm (0.0035 to 0.0075 in.). Measure clearance with an appropriate feeler gauge (Fig. 111).

Clearance between outer gear and pump housing should be 0.10 to 0.19 mm (0.004 to 0.0075 in.). Measure clearance with an appropriate feeler gauge.



**Fig. 111 Checking Pump Gear Tip Clearance**

- 1 - FEELER GAUGE
- 2 - INNER GEAR
- 3 - OUTER GEAR

**ASSEMBLY**

**OIL PUMP BUSHING**

(1) Assemble Tool Handle C-4171 and Bushing Installer SP-5118 (Fig. 112).

(2) Place bushing on installer tool and start bushing into shaft.

(3) Tap bushing into place until Installer Tool SP-5118 bottoms in pump cavity. Keep tool and bushing square with bore. Do not allow bushing to become cocked during installation.

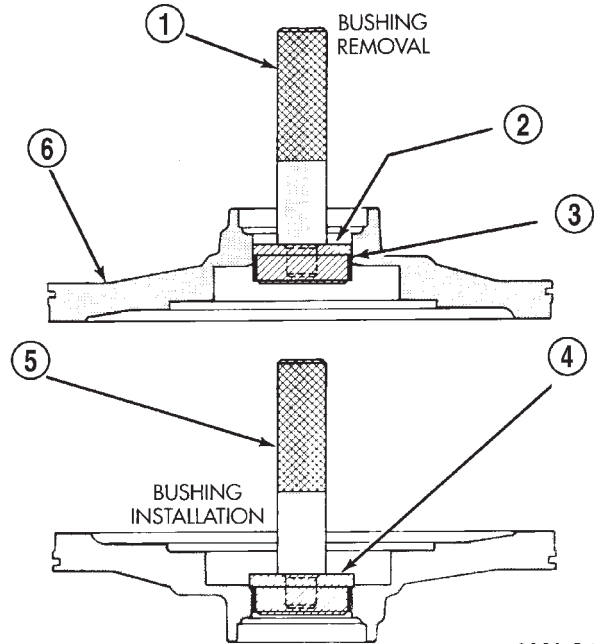
(4) Stake pump bushing in two places with blunt punch. Remove burrs from stake points with knife blade (Fig. 113).

**REACTION SHAFT SUPPORT BUSHING**

(1) Place reaction shaft support upright on a clean, smooth surface.

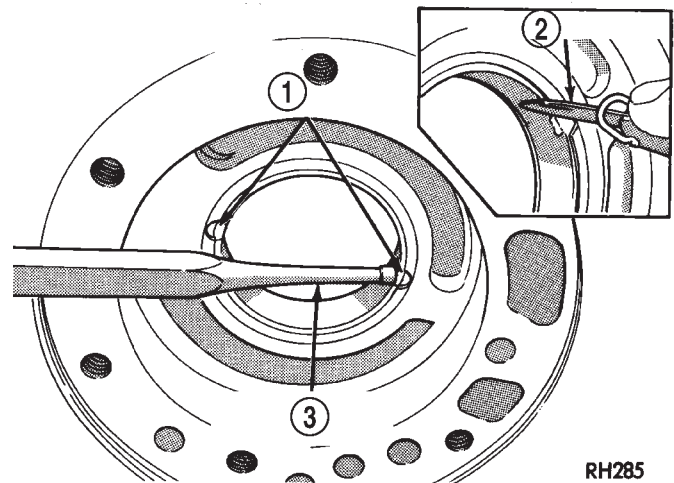
(2) Assemble Bushing Installer Tools C-4171 and SP-5302. Then slide new bushing onto installer tool (Fig. 114).

(3) Start bushing in shaft. Tap bushing into shaft until installer tool bottoms against support flange.



**Fig. 112 Oil Pump Bushing**

- 1 - SPECIAL TOOL C-4171
- 2 - SPECIAL TOOL SP-3550
- 3 - BUSHING
- 4 - SPECIAL TOOL SP-5118
- 5 - SPECIAL TOOL C-4171
- 6 - PUMP HOUSING



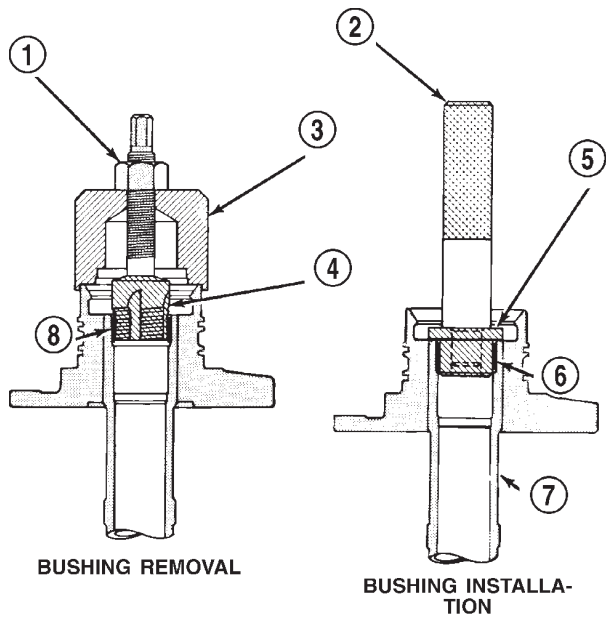
**Fig. 113 Staking-Deburring Oil Pump Bushing**

- 1 - TWO STAKES
- 2 - NARROW BLADE
- 3 - BLUNT PUNCH

(4) Clean reaction shaft support thoroughly after bushing replacement (to remove any chips).



## OIL PUMP (Continued)

**Fig. 114 Reaction Shaft Bushing**

J9221-245

- 1 - SPECIAL TOOL SP-1191
- 2 - SPECIAL TOOL C-4171
- 3 - SPECIAL TOOL SP-3633
- 4 - SPECIAL TOOL SP-5301
- 5 - SPECIAL TOOL SP-5302
- 6 - BUSHING
- 7 - REACTION SHAFT
- 8 - BUSHING

**OIL PUMP BODY**

(1) Lubricate pump gears with transmission fluid and install them in pump body.

(2) Install thrust washer on reaction shaft support hub. Lubricate washer with petroleum jelly or transmission fluid before installation.

(3) If reaction shaft seal rings are being replaced, install new seal rings on support hub. Lubricate seal rings with transmission fluid or petroleum jelly after installation. Squeeze each ring until ring ends are securely hooked together.

**CAUTION:** The reaction shaft support seal rings will break if overspread, or twisted. If new rings are being installed, spread them only enough for installation. Also be very sure the ring ends are securely hooked together after installation. Otherwise, the rings will either prevent pump installation, or break during installation.

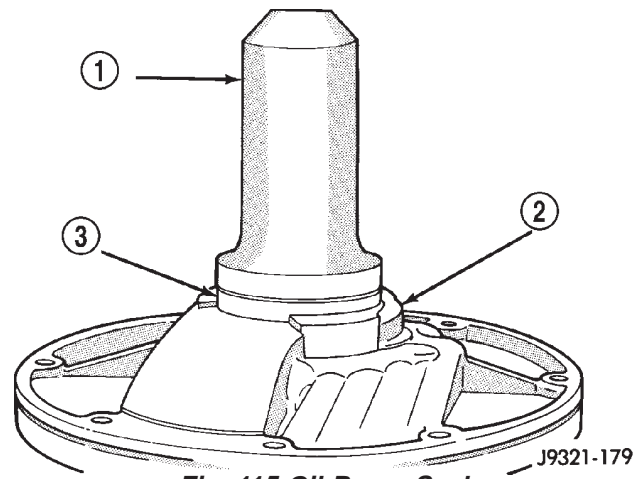
(4) Align and install reaction shaft support on pump body.

(5) Install bolts attaching reaction shaft support to pump. Tighten bolts to 20 N·m (175 in. lbs.) torque.

(6) Install new pump seal with Installer Tool C-3860-A (Fig. 115). Use hammer or mallet to tap seal into place.

(7) Install new o-ring on pump body. Lubricate oil seal and o-ring with petroleum jelly.

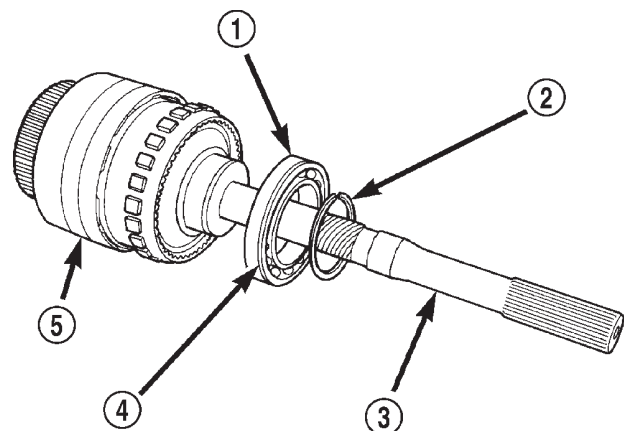
(8) Cover pump assembly to prevent dust entry and set aside for assembly installation.

**Fig. 115 Oil Pump Seal**

- 1 - SPECIAL TOOL C-3860-A
- 2 - PUMP BODY
- 3 - PUMP SEAL

**OUTPUT SHAFT FRONT BEARING****REMOVAL**

- (1) Remove overdrive unit from the vehicle.
- (2) Remove overdrive geartrain from housing.
- (3) Remove snap-ring holding output shaft front bearing to overdrive geartrain. (Fig. 116).
- (4) Pull bearing from output shaft.

**Fig. 116 Output Shaft Front Bearing**

803f5861

- 1 - OUTPUT SHAFT FRONT BEARING
- 2 - SNAP-RING
- 3 - OUTPUT SHAFT
- 4 - GROOVE TO REAR
- 5 - OVERDRIVE GEARTRAIN

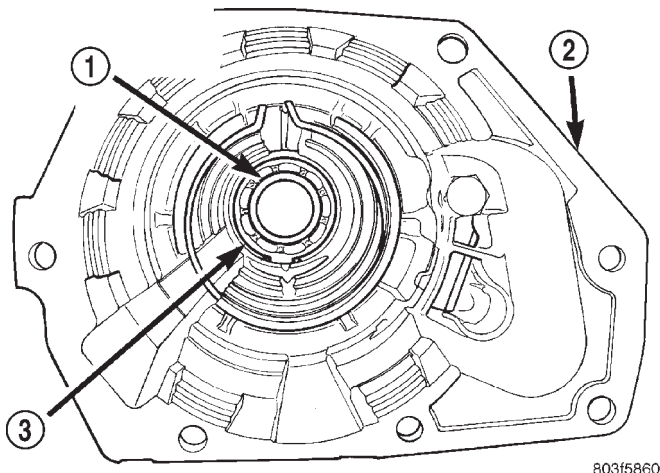
## OUTPUT SHAFT FRONT BEARING (Continued)

**INSTALLATION**

- (1) Place replacement bearing in position on geartrain with locating retainer groove toward the rear.
- (2) Push bearing onto shaft until the snap-ring groove is visible.
- (3) Install snap-ring to hold bearing onto output shaft.
- (4) Install overdrive geartrain into housing.
- (5) Install overdrive unit in vehicle.

**OUTPUT SHAFT REAR BEARING****REMOVAL**

- (1) Remove overdrive unit from the vehicle. (Refer to 21 - TRANSMISSION/TRANSAXLE/AUTOMATIC/OVERDRIVE - REMOVAL)
- (2) Remove overdrive geartrain from housing.
- (3) Remove snap-ring holding output shaft rear bearing into overdrive housing (Fig. 117).
- (4) Using a suitable driver inserted through the rear end of housing, drive bearing from housing.



803f5860

**Fig. 117 Output Shaft Rear Bearing**

- 1 - OUTPUT SHAFT REAR BEARING
- 2 - OVERDRIVE HOUSING
- 3 - SNAP-RING

**INSTALLATION**

- (1) Place replacement bearing in position in housing.
- (2) Using a suitable driver, drive bearing into housing until the snap-ring groove is visible.
- (3) Install snap-ring to hold bearing into housing (Fig. 112).
- (4) Install overdrive geartrain into housing.
- (5) Install overdrive unit in vehicle.

**OVERDRIVE CLUTCH****DESCRIPTION**

The overdrive clutch (Fig. 118) is composed of the pressure plate, clutch plates, holding discs, overdrive piston retainer, piston, piston spacer, and snap-rings. The overdrive clutch is the forwardmost component in the transmission overdrive unit and is considered a holding component. The overdrive piston retainer, piston, and piston spacer are located on the rear of the main transmission case.

**NOTE:** The number of discs and plates may vary with each engine and vehicle combination.

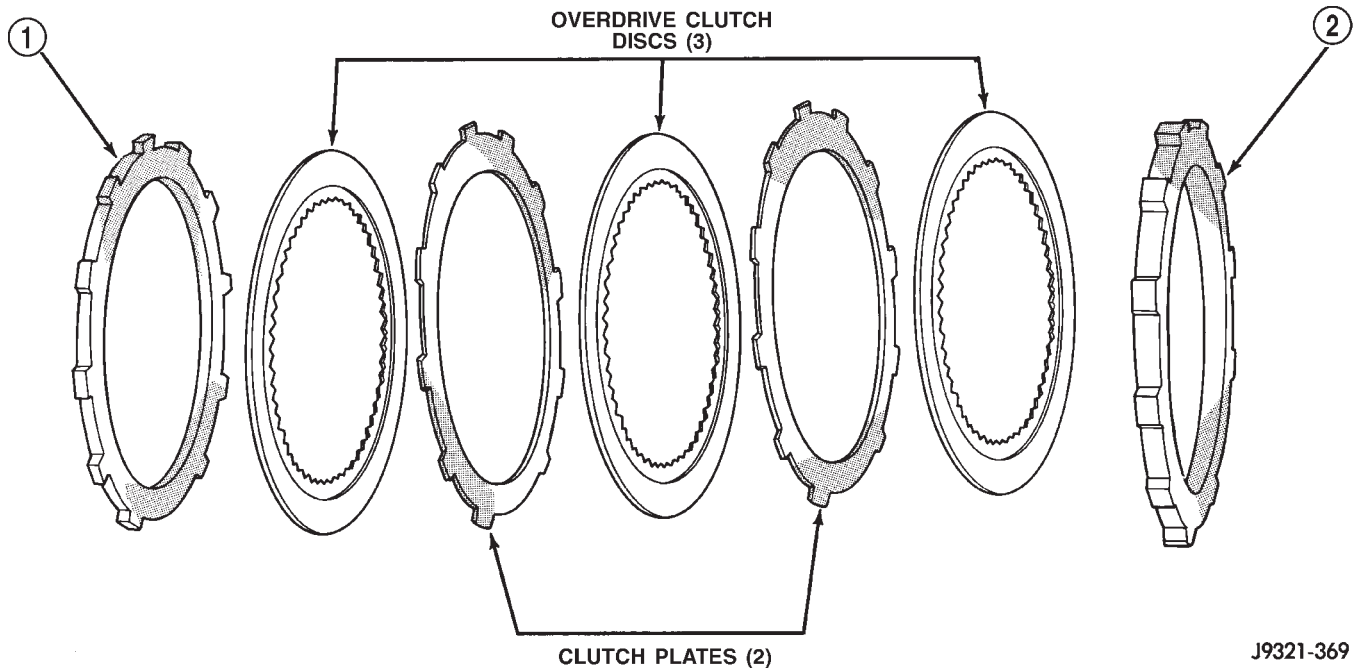
**OPERATION**

To apply the clutch, pressure is applied between the piston retainer and piston. The fluid pressure is provided by the oil pump, transferred through the control valves and passageways, and enters the clutch through passages at the lower rear portion of the valve body area. With pressure applied between the piston retainer and piston, the piston moves away from the piston retainer and compresses the clutch pack. This action applies the clutch pack, allowing torque to flow through the intermediate shaft into the overdrive planetary gear set. The overdrive clutch discs are attached to the overdrive clutch hub while the overdrive clutch plates, reaction plate, and pressure plate are lugged to the overdrive housing. This allows the intermediate shaft to transfer the engine torque to the planetary gear and overrunning clutch. This drives the planetary gear inside the annulus, which is attached to the overdrive clutch drum and output shaft, creating the desired gear ratio. The waved snap-ring is used to cushion the application of the clutch pack.

**OVERDRIVE UNIT****REMOVAL**

- (1) Shift transmission into PARK.
- (2) Raise vehicle.
- (3) Remove transfer case, if equipped.
- (4) Mark propeller shaft universal joint(s) and axle pinion yoke, or the companion flange and flange yoke, for alignment reference at installation, if necessary.
- (5) Disconnect and remove the rear propeller shaft, if necessary. (Refer to 3 - DIFFERENTIAL & DRIV-

## OVERDRIVE UNIT (Continued)



J9321-369

1 - REACTION PLATE

2 - PRESSURE PLATE

## ELINE/PROPELLER SHAFT/PROPELLER SHAFT - REMOVAL)

(6) Remove transmission oil pan, remove gasket, drain oil and reinstall pan.

(7) If overdrive unit had malfunctioned, or if fluid is contaminated, remove entire transmission. If diagnosis indicated overdrive problems only, remove just the overdrive unit.

(8) Support transmission with transmission jack.

(9) Remove bolts attaching overdrive unit to transmission (Fig. 119).

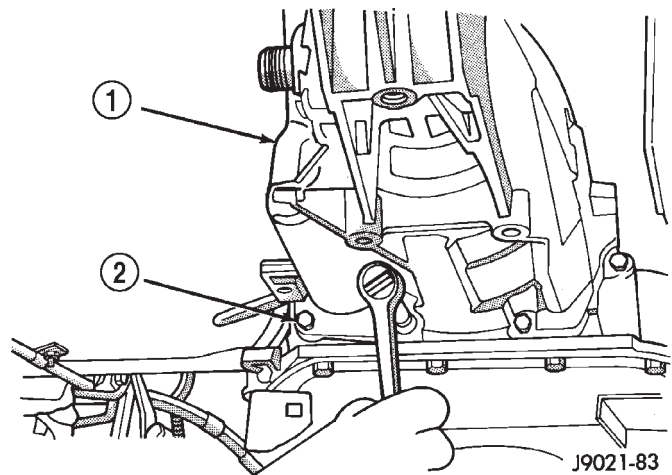
**CAUTION:** Support the overdrive unit with a jack before moving it rearward. This is necessary to prevent damaging the intermediate shaft. Do not allow the shaft to support the entire weight of the overdrive unit.

(10) Carefully work overdrive unit off intermediate shaft. Do not tilt unit during removal. Keep it as level as possible.

(11) If overdrive unit does not require service, immediately insert Alignment Tool 6227-2 in splines of planetary gear and overrunning clutch to prevent splines from rotating out of alignment. If misalignment occurs, overdrive unit will have to be disassembled in order to realign splines.

(12) Remove and retain overdrive piston thrust bearing. Bearing may remain on piston or in clutch hub during removal.

(13) Position drain pan on workbench.

**Fig. 119 Overdrive Unit Bolts**

1 - OVERDRIVE UNIT  
2 - ATTACHING BOLTS (7)

(14) Place overdrive unit over drain pan. Tilt unit to drain residual fluid from case.

(15) Examine fluid for clutch material or metal fragments. If fluid contains these items, overhaul will be necessary.

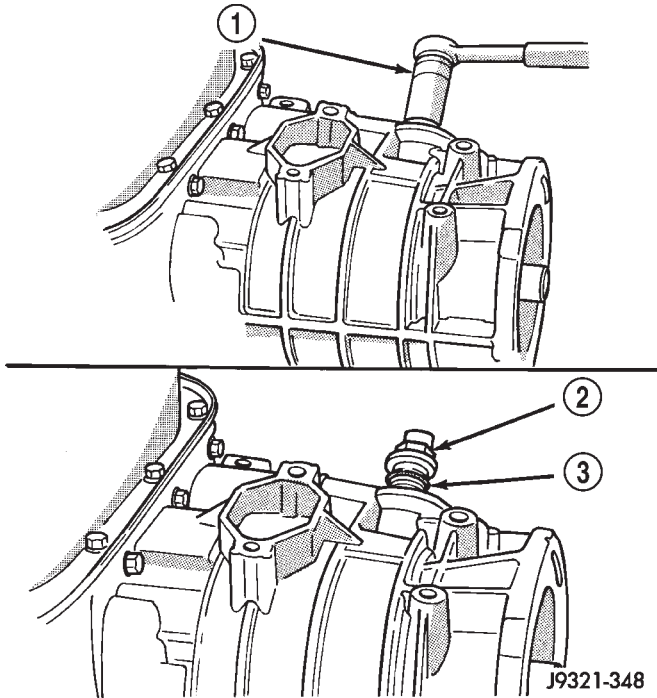
(16) If overdrive unit does not require any service, leave alignment tool in position. Tool will prevent accidental misalignment of planetary gear and overrunning clutch splines.

OVERDRIVE UNIT (Continued)

**DISASSEMBLY**

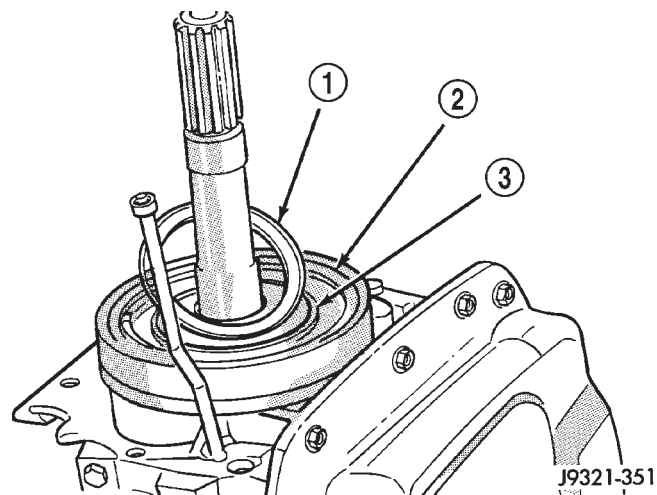
(1) Remove transmission speed sensor and o-ring seal from overdrive case (Fig. 120).

(2) Remove overdrive piston thrust bearing (Fig. 121).



**Fig. 120 Transmission Speed Sensor**

- 1 - SOCKET AND WRENCH
- 2 - SPEED SENSOR
- 3 - O-RING

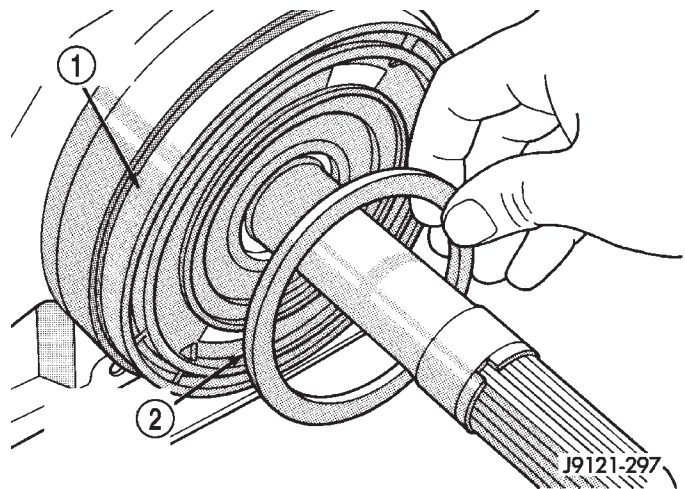


**Fig. 121 Overdrive Piston Thrust Bearing Removal/Installation**

- 1 - THRUST BEARING
- 2 - OVERDRIVE PISTON
- 3 - THRUST PLATE

**OVERDRIVE PISTON**

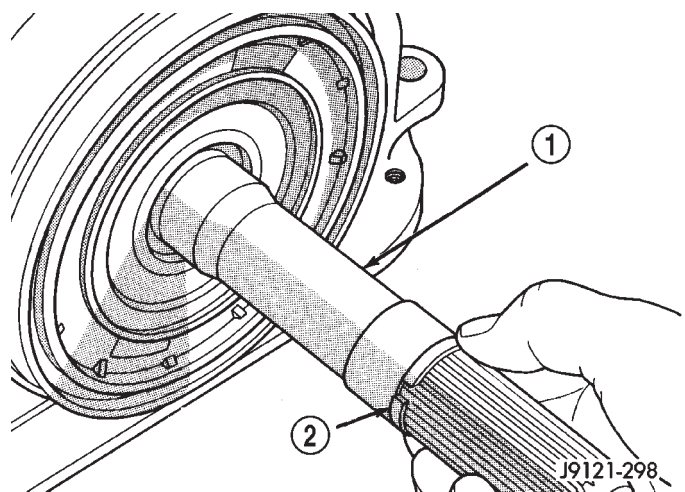
(1) Remove overdrive piston thrust plate (Fig. 122). Retain thrust plate. It is a select fit part and may possibly be reused.



**Fig. 122 Overdrive Piston Thrust Plate Removal/Installation**

- 1 - OVERDRIVE PISTON
- 2 - OVERDRIVE PISTON SPACER (SELECT FIT)

(2) Remove intermediate shaft spacer (Fig. 123). Retain spacer. It is a select fit part and may possibly be reused.



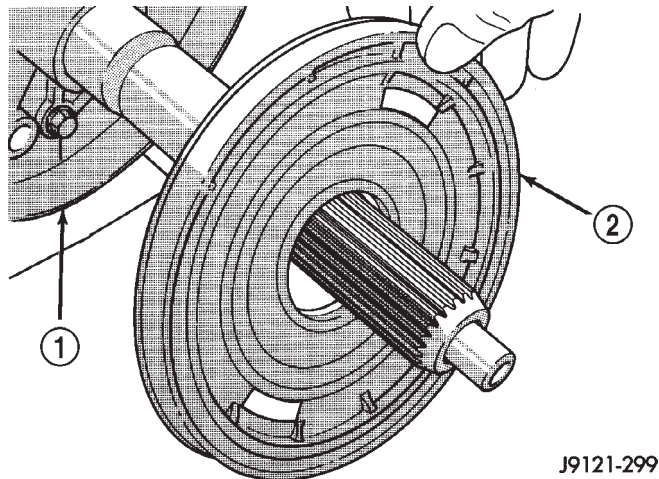
**Fig. 123 Intermediate Shaft Spacer Location**

- 1 - INTERMEDIATE SHAFT
- 2 - INTERMEDIATE SHAFT SPACER (SELECT FIT)



## OVERDRIVE UNIT (Continued)

(3) Remove overdrive piston from retainer (Fig. 124).



**Fig. 124 Overdrive Piston Removal**

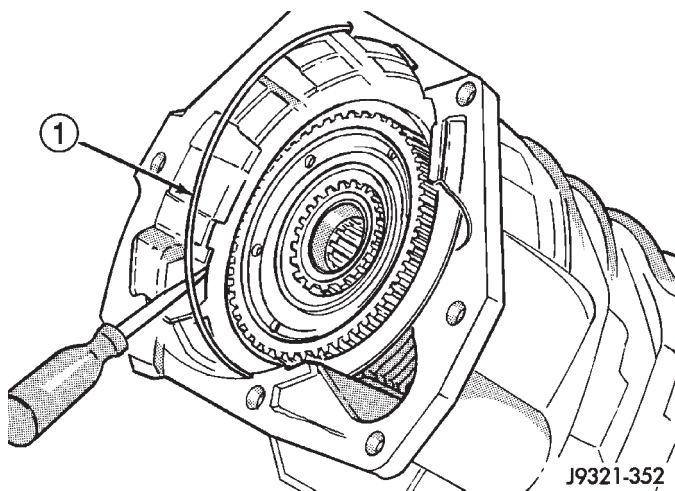
- 1 - PISTON RETAINER  
2 - OVERDRIVE PISTON

## OVERDRIVE CLUTCH PACK

(1) Remove overdrive clutch pack wire retaining ring (Fig. 125).

(2) Remove overdrive clutch pack (Fig. 126).

(3) Note position of clutch pack components for assembly reference (Fig. 127).

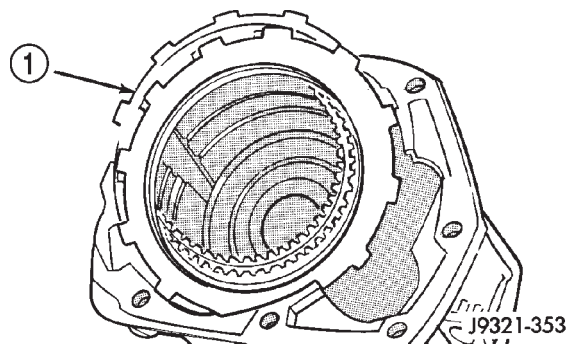


**Fig. 125 Removing Overdrive Clutch Pack Retaining Ring**

- 1 - OVERDRIVE CLUTCH PACK RETAINING RING

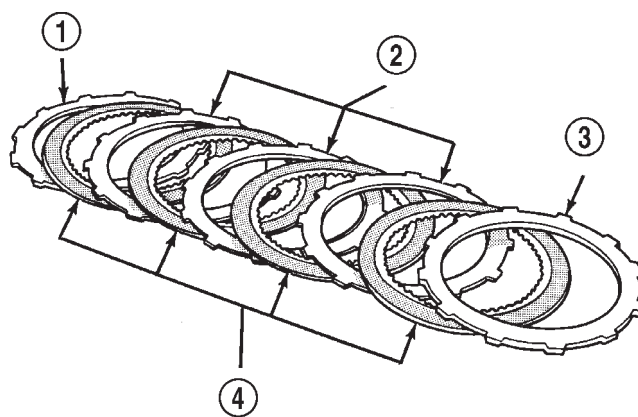
## OVERDRIVE GEARTRAIN

(1) Remove overdrive clutch wave spring (Fig. 128).



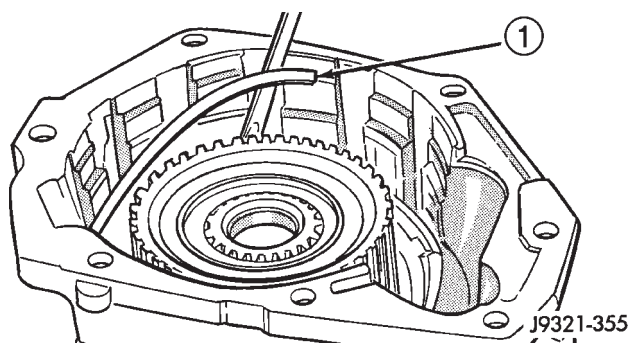
**Fig. 126 Overdrive Clutch Pack Removal**

- 1 - OVERDRIVE CLUTCH PACK



**Fig. 127 Overdrive Clutch Component Position - Typical**

- 1 - REACTION PLATE  
2 - CLUTCH PLATES (3)  
3 - PRESSURE PLATE  
4 - CLUTCH DISCS (4)



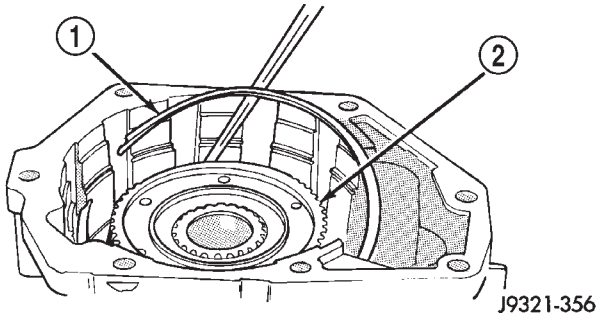
**Fig. 128 Overdrive Clutch Wave Spring Removal**

- 1 - WAVE SPRING



OVERDRIVE UNIT (Continued)

(2) Remove overdrive clutch reaction snap-ring (Fig. 129). Note that snap-ring is located in same groove as wave spring.

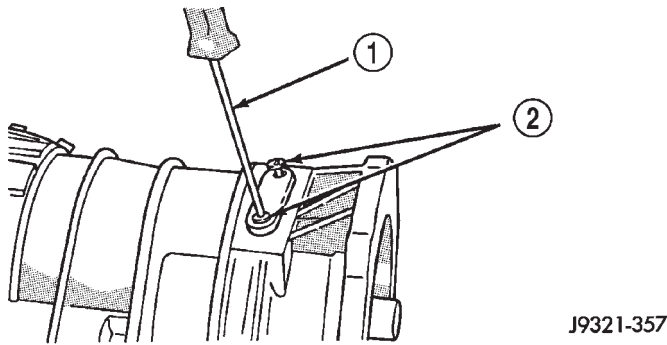


**Fig. 129 Overdrive Clutch Reaction Snap-Ring Removal**

- 1 - REACTION RING
- 2 - CLUTCH HUB

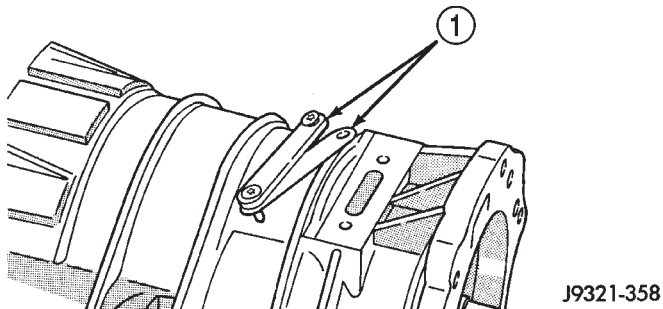
(3) Remove Torx™ head screws that attach access cover and gasket to overdrive case (Fig. 130).

(4) Remove access cover and gasket (Fig. 131).



**Fig. 130 Access Cover Screw Removal**

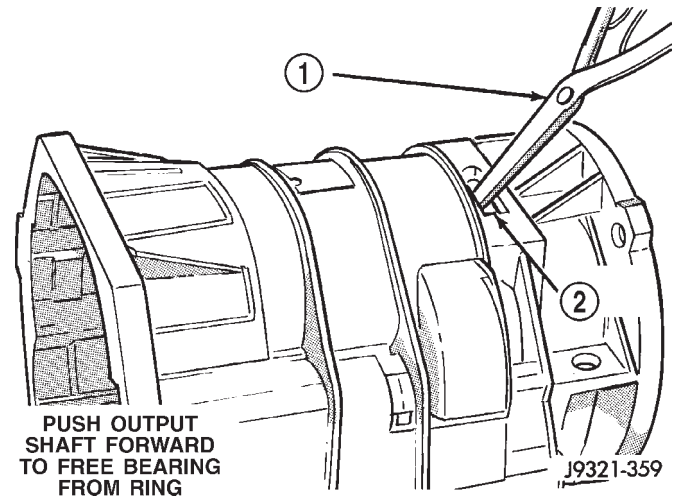
- 1 - TORX SCREWDRIVER (T25)
- 2 - ACCESS COVER SCREWS



**Fig. 131 Access Cover And Gasket Removal**

- 1 - ACCESS COVER AND GASKET

(5) Expand output shaft bearing snap-ring with expanding-type snap-ring pliers. Then push output shaft forward to release shaft bearing from locating ring (Fig. 132).

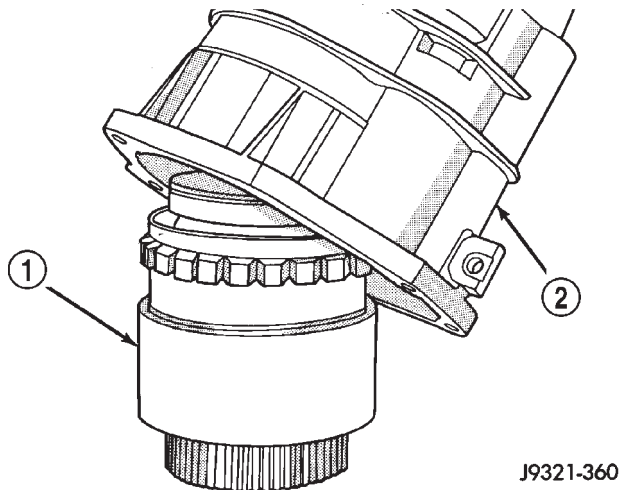


**PUSH OUTPUT SHAFT FORWARD TO FREE BEARING FROM RING**

**Fig. 132 Releasing Bearing From Locating Ring**

- 1 - EXPAND BEARING LOCATING RING WITH SNAP-RING PLIERS
- 2 - ACCESS HOLE

(6) Lift gear case up and off geartrain assembly (Fig. 133).



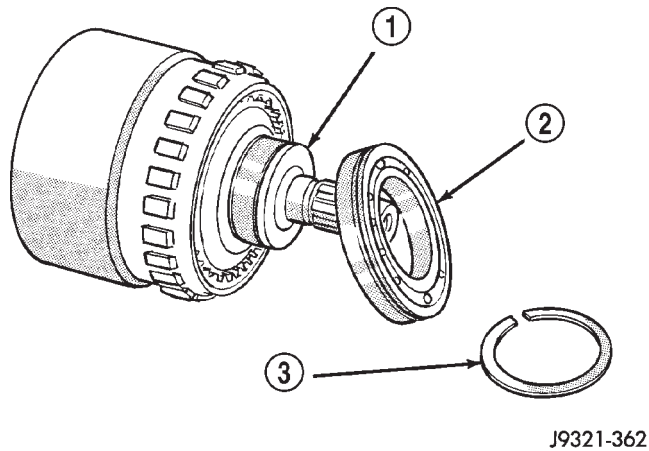
**Fig. 133 Removing Geartrain**

- 1 - GEARTRAIN ASSEMBLY
- 2 - GEAR CASE

## OVERDRIVE UNIT (Continued)

(7) Remove snap-ring that retains rear bearing on output shaft.

(8) Remove rear bearing from output shaft (Fig. 134).



**Fig. 134 Rear Bearing Removal**

- 1 - OUTPUT SHAFT
- 2 - REAR BEARING
- 3 - SNAP-RING

## DIRECT CLUTCH, HUB AND SPRING

**WARNING: THE NEXT STEP IN DISASSEMBLY INVOLVES COMPRESSING THE DIRECT CLUTCH SPRING. IT IS EXTREMELY IMPORTANT THAT PROPER EQUIPMENT BE USED TO COMPRESS THE SPRING AS SPRING FORCE IS APPROXIMATELY 830 POUNDS. USE SPRING COMPRESSOR TOOL 6227-1 AND A HYDRAULIC SHOP PRESS WITH A MINIMUM RAM TRAVEL OF 5-6 INCHES. THE PRESS MUST ALSO HAVE A BED THAT CAN BE ADJUSTED UP OR DOWN AS REQUIRED. RELEASE CLUTCH SPRING TENSION SLOWLY AND COMPLETELY TO AVOID PERSONAL INJURY.**

(1) Mount geartrain assembly in shop press (Fig. 135).

(2) Position Compressor Tool 6227-1 on clutch hub (Fig. 135). Support output shaft flange with steel press plates as shown and center assembly under press ram.

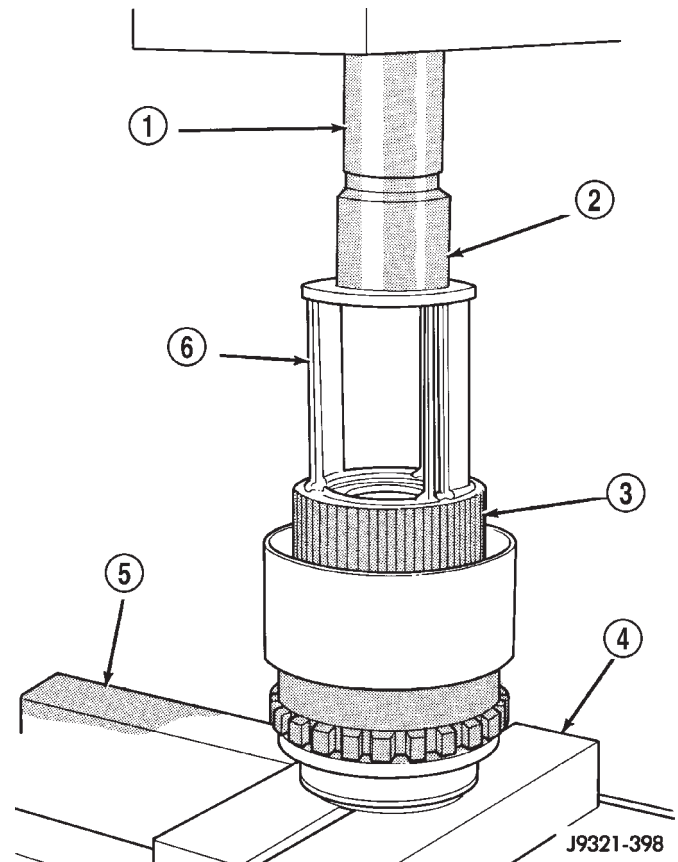
(3) Apply press pressure slowly. Compress hub and spring far enough to expose clutch hub retaining ring and relieve spring pressure on clutch pack snap-ring (Fig. 135).

(4) Remove direct clutch pack snap-ring (Fig. 136).

(5) Remove direct clutch hub retaining ring (Fig. 137).

(6) Release press load slowly and completely (Fig. 138).

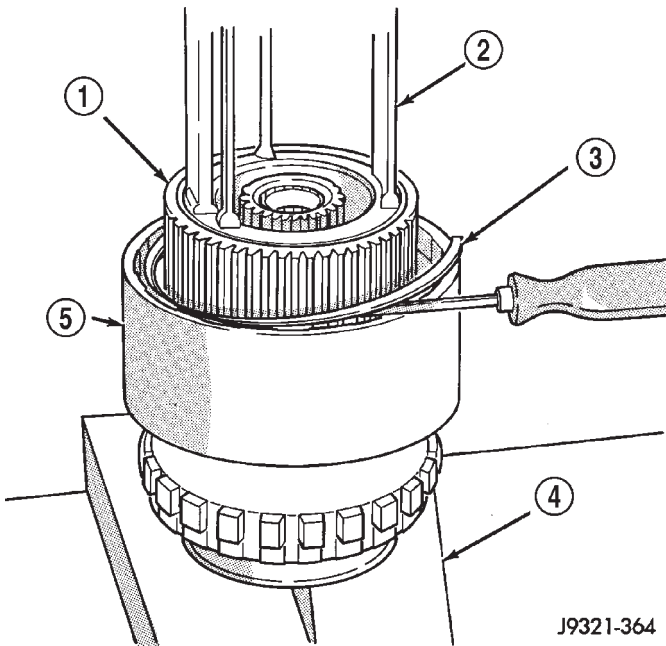
(7) Remove Special Tool 6227-1. Then remove clutch pack from hub (Fig. 138).



**Fig. 135 Geartrain Mounted In Shop Press**

- 1 - PRESS RAM
- 2 - SPECIAL TOOL C-3995-A (OR SIMILAR TOOL)
- 3 - CLUTCH HUB
- 4 - PLATES
- 5 - PRESS BED
- 6 - SPECIAL TOOL 6227-1

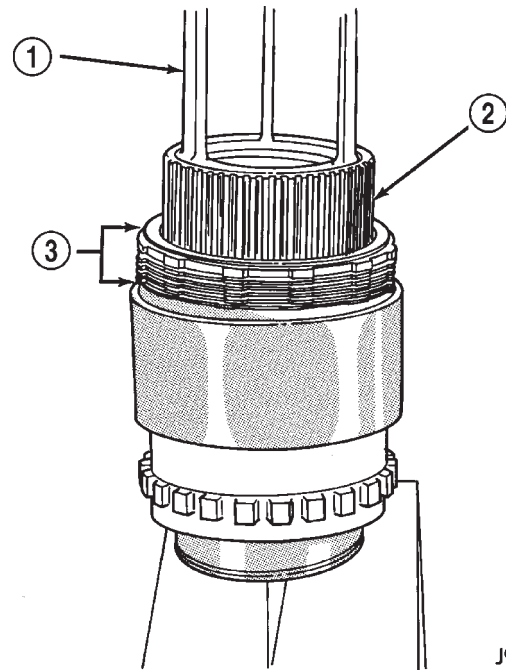
OVERDRIVE UNIT (Continued)



J9321-364

**Fig. 136 Direct Clutch Pack Snap-Ring Removal**

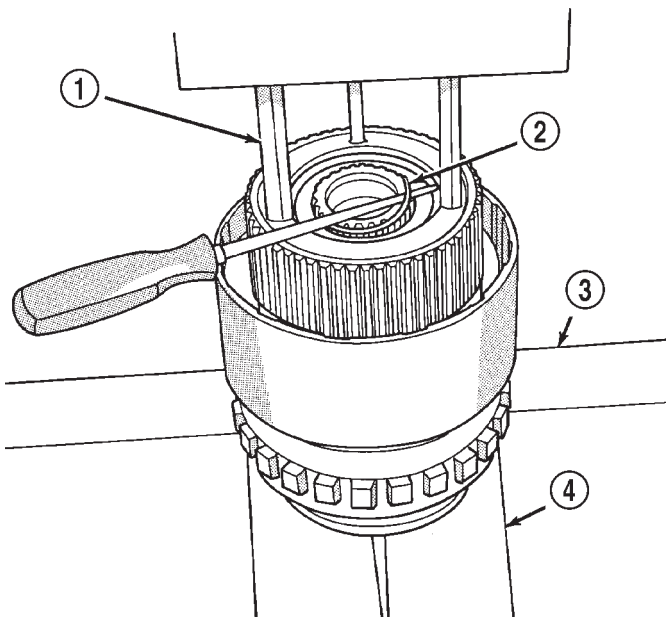
- 1 - CLUTCH HUB
- 2 - SPECIAL TOOL 6227-1
- 3 - DIRECT CLUTCH PACK SNAP-RING
- 4 - PRESS PLATES
- 5 - CLUTCH DRUM



J9321-365

**Fig. 138 Direct Clutch Pack Removal**

- 1 - SPECIAL TOOL 6227-1
- 2 - DIRECT CLUTCH HUB
- 3 - DIRECT CLUTCH PACK



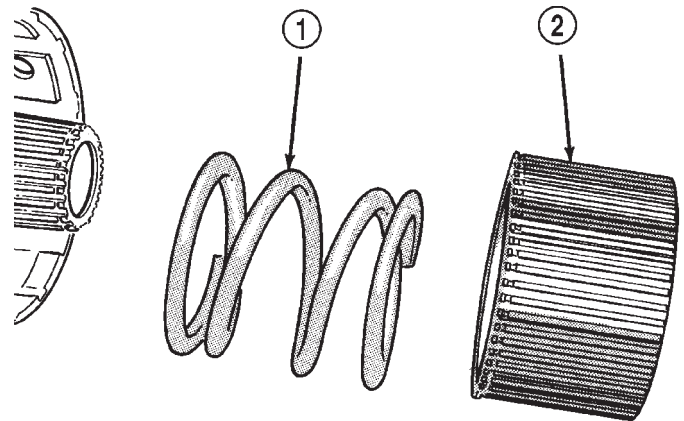
J9321-363

**Fig. 137 Direct Clutch Hub Retaining Ring Removal**

- 1 - SPECIAL TOOL 6227-1
- 2 - CLUTCH HUB RETAINING RING
- 3 - PRESS BED
- 4 - PRESS PLATES

**GEARTRAIN**

- (1) Remove direct clutch hub and spring (Fig. 139).
- (2) Remove sun gear and spring plate. Then remove planetary thrust bearing and planetary gear (Fig. 140).

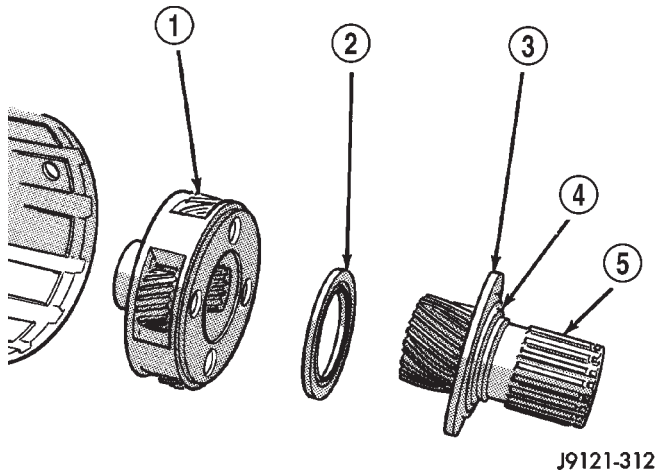


J9121-311

**Fig. 139 Direct Clutch Hub And Spring Removal**

- 1 - DIRECT CLUTCH SPRING
- 2 - DIRECT CLUTCH HUB

## OVERDRIVE UNIT (Continued)



J9121-312

**Fig. 140 Removing Sun Gear, Thrust Bearing And Planetary Gear**

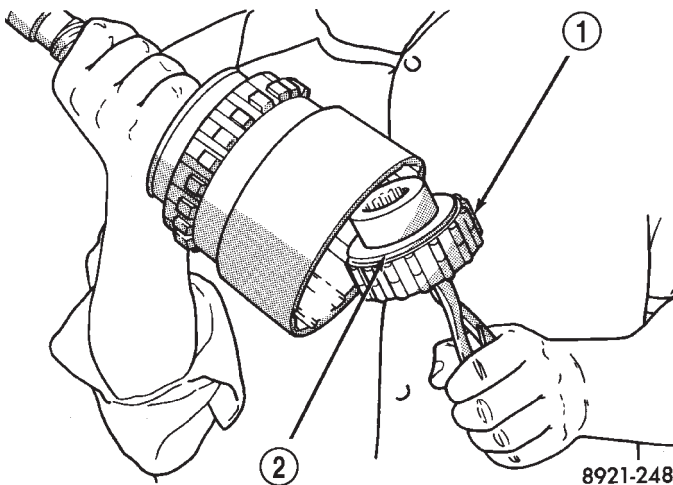
- 1 - PLANETARY GEAR
- 2 - PLANETARY THRUST BEARING
- 3 - CLUTCH SPRING PLATE
- 4 - SPRING PLATE SNAP-RING
- 5 - SUN GEAR

(3) Remove overrunning clutch assembly with expanding type snap-ring pliers (Fig. 141). Insert pliers into clutch hub. Expand pliers to grip hub splines and remove clutch with counterclockwise, twisting motion.

(4) Remove thrust bearing from overrunning clutch hub.

(5) Remove overrunning clutch from hub.

(6) Mark position of annulus gear and direct clutch drum for assembly alignment reference (Fig. 142).

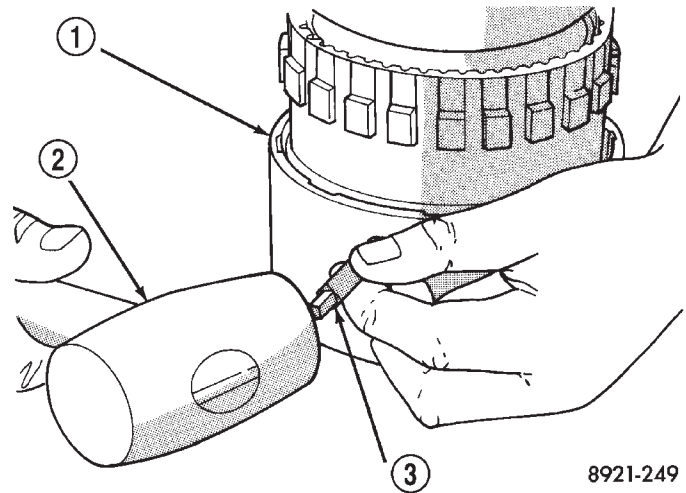


8921-248

**Fig. 141 Overrunning Clutch Assembly Removal/Installation**

- 1 - OVERRUNNING CLUTCH
- 2 - NEEDLE BEARING

Use small center punch or scribe to make alignment marks.



8921-249

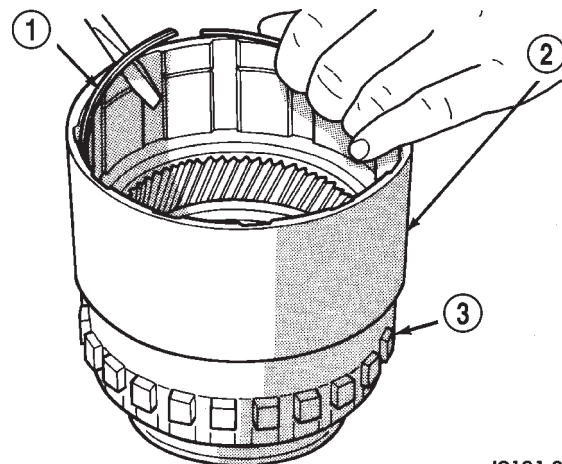
**Fig. 142 Marking Direct Clutch Drum And Annulus Gear For Assembly Alignment**

- 1 - DIRECT CLUTCH DRUM
- 2 - HAMMER
- 3 - PUNCH

(7) Remove direct clutch drum rear retaining ring (Fig. 143).

(8) Remove direct clutch drum outer retaining ring (Fig. 144).

(9) Mark annulus gear and output shaft for assembly alignment reference (Fig. 145). Use punch or scribe to mark gear and shaft.



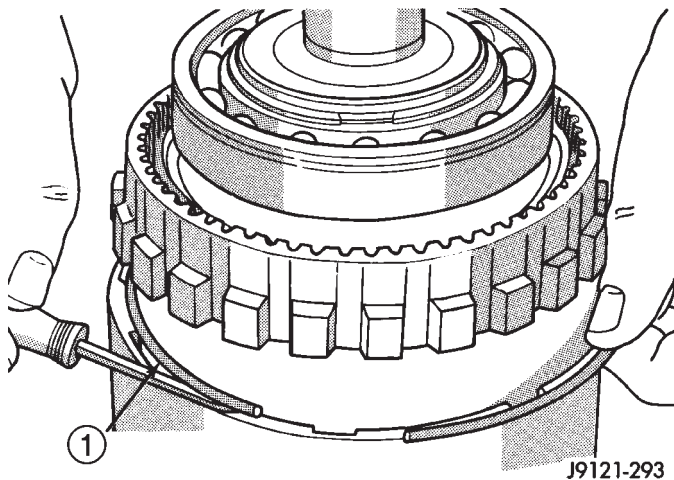
J9121-292

**Fig. 143 Clutch Drum Inner Retaining Ring Removal**

- 1 - INNER RETAINING RING
- 2 - DIRECT CLUTCH DRUM
- 3 - ANNULUS GEAR

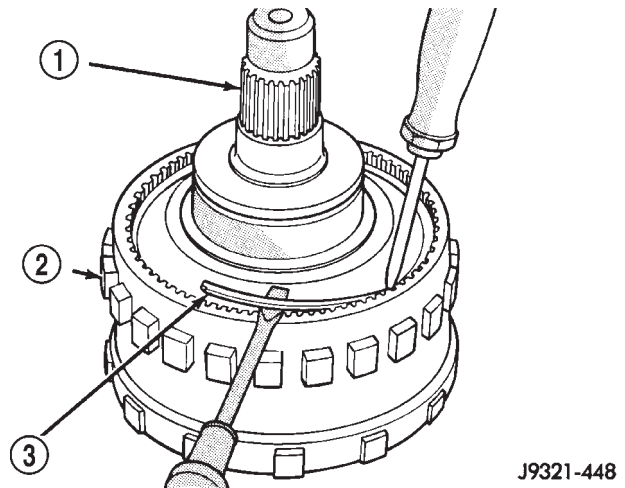


## OVERDRIVE UNIT (Continued)



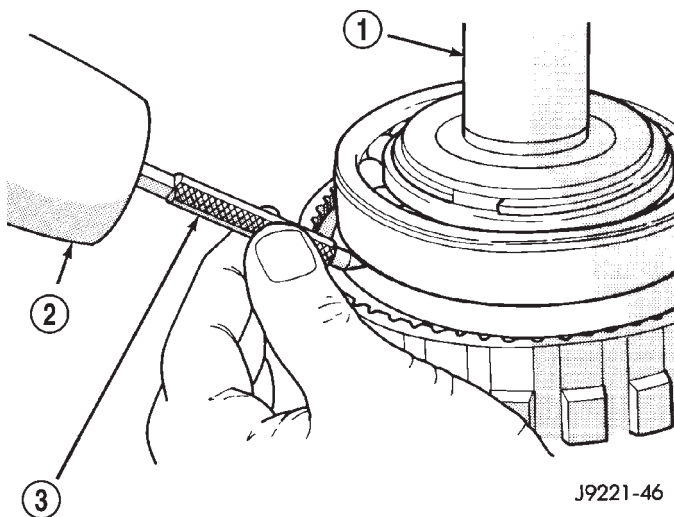
**Fig. 144 Clutch Drum Outer Retaining Ring Removal**

1 - OUTER RETAINING RING



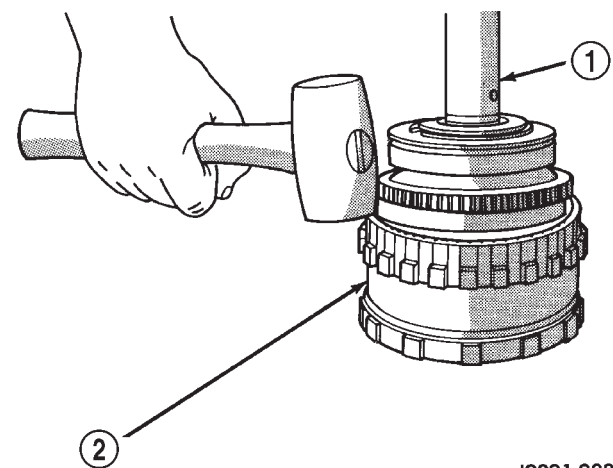
**Fig. 146 Annulus Gear Snap-Ring Removal**

1 - OUTPUT SHAFT  
2 - ANNULUS GEAR  
3 - SNAP-RING



**Fig. 145 Marking Annulus Gear And Output Shaft For Assembly Alignment**

1 - OUTPUT SHAFT  
2 - HAMMER  
3 - PUNCH



**Fig. 147 Annulus Gear Removal**

1 - OUTPUT SHAFT  
2 - ANNULUS GEAR

(10) Remove snap-ring that secures annulus gear on output shaft (Fig. 146). Use two screwdrivers to unseat and work snap-ring out of groove as shown.

(11) Remove annulus gear from output shaft (Fig. 147). Use rawhide or plastic mallet to tap gear off shaft.

### GEAR CASE AND PARK LOCK

- (1) Remove locating ring from gear case.
- (2) Remove park pawl shaft retaining bolt and remove shaft, pawl and spring.
- (3) Remove reaction plug snap-ring and remove reaction plug.
- (4) Remove output shaft seal.

### CLEANING

Clean the geartrain and case components with solvent. Dry all parts except the bearings with compressed air. Allow bearings to air dry.

Do not use shop towels for wiping parts dry unless the towels are made from a lint-free material. A sufficient quantity of lint (from shop towels, cloths, rags, etc.) could plug the transmission filter and fluid passages.

Discard the old case gasket and seals. Do not attempt to salvage these parts. They are not reusable. Replace any of the overdrive unit snap-rings if distorted or damaged.



## OVERDRIVE UNIT (Continued)

Minor nicks or scratches on components can be smoothed with crocus cloth. However, do not attempt to reduce severe scoring on any components with abrasive materials. Replace severely scored components; do not try to salvage them.

## INSPECTION

Check condition of the park lock components and the overdrive case.

Check the bushings in the overdrive case. Replace the bushings if severely scored or worn. Also replace the case seal if loose, distorted, or damaged.

Examine the overdrive and direct clutch discs and plates. Replace the discs if the facing is worn, severely scored, or burned and flaking off. Replace the clutch plates if worn, heavily scored, or cracked. Check the lugs on the clutch plates for wear. The plates should slide freely in the drum. Replace the plates or drum if binding occurs.

Check condition of the annulus gear, direct clutch hub, clutch drum and clutch spring. Replace the gear, hub and drum if worn or damaged. Replace the spring if collapsed, distorted, or cracked.

Be sure the splines and lugs on the gear, drum and hub are in good condition. The clutch plates and discs should slide freely in these components.

Inspect the thrust bearings and spring plate. Replace the plate if worn or scored. Replace the bearings if rough, noisy, brinnelled, or worn.

Inspect the planetary gear assembly and the sun gear and bushings. If either the sun gear or the bushings are damaged, replace the gear and bushings as an assembly. The gear and bushings are not serviced separately.

The planetary carrier and pinions must be in good condition. Also be sure the pinion pins are secure and in good condition. Replace the carrier if worn or damaged.

Inspect the overrunning clutch and race. The race surface should be smooth and free of scores. Replace the overrunning clutch assembly or the race if either assembly is worn or damaged in any way.

Replace the shaft pilot bushing and inner bushing if damaged. Replace either shaft bearing if rough or noisy. Replace the bearing snap-rings if distorted or cracked.

Check the machined surfaces on the output shaft. These surfaces should be clean and smooth. Very minor nicks or scratches can be smoothed with crocus cloth. Replace the shaft if worn, scored or damaged in any way.

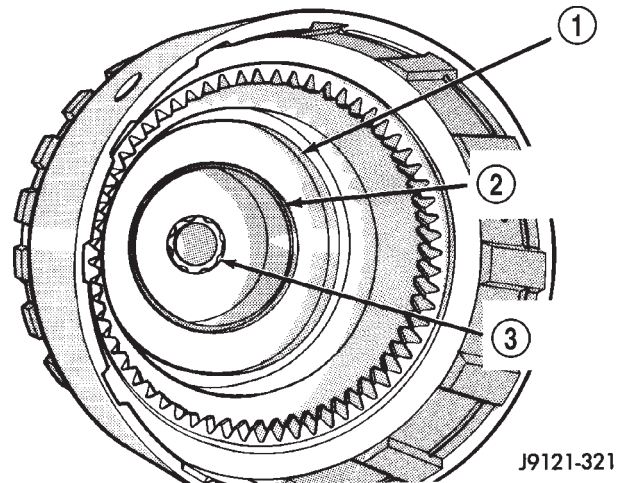
Inspect the output shaft bushings. The small bushing is the intermediate shaft pilot bushing. The large bushing is the overrunning clutch hub bushing. Replace either bushing if scored, pitted, cracked, or worn.

## ASSEMBLY

## GEARTRAIN AND DIRECT CLUTCH

(1) Soak direct clutch and overdrive clutch discs in Mopar® ATF +4, type 9602, transmission fluid. Allow discs to soak for 10-20 minutes.

(2) Install new pilot bushing and clutch hub bushing in output shaft if necessary (Fig. 148). Lubricate bushings with petroleum jelly, or transmission fluid.

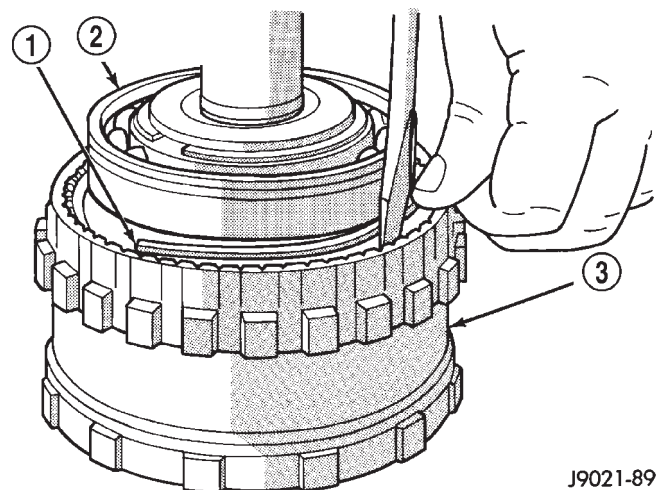


J9121-321

**Fig. 148 Output Shaft Pilot Bushing**

- 1 - OUTPUT SHAFT HUB
- 2 - OVERRUNNING CLUTCH HUB BUSHING
- 3 - INTERMEDIATE SHAFT PILOT BUSHING

(3) Install annulus gear on output shaft, if removed. Then install annulus gear retaining snap-ring (Fig. 149).



J9021-89

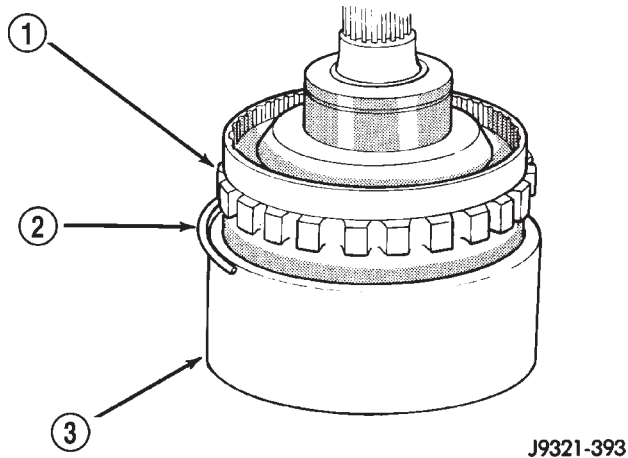
**Fig. 149 Annulus Gear Installation**

- 1 - SNAP-RING
- 2 - OUTPUT SHAFT FRONT BEARING
- 3 - ANNULUS GEAR

## OVERDRIVE UNIT (Continued)

(4) Align and install clutch drum on annulus gear (Fig. 150). Be sure drum is engaged in annulus gear lugs.

(5) Install clutch drum outer retaining ring (Fig. 150).



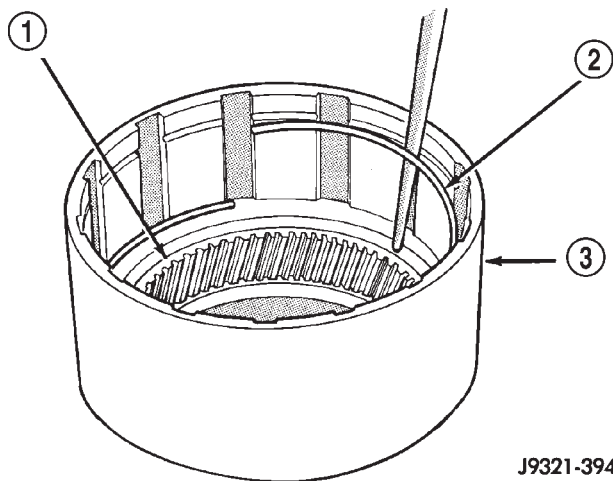
J9321-393

**Fig. 150 Clutch Drum And Outer Retaining Ring Installation**

- 1 - ANNULUS GEAR
- 2 - OUTER SNAP-RING
- 3 - CLUTCH DRUM

(6) Slide clutch drum forward and install inner retaining ring (Fig. 151).

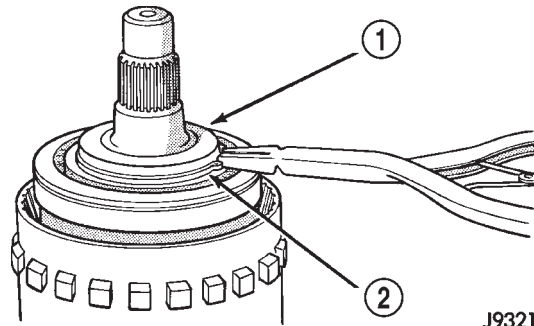
(7) Install rear bearing and snap ring on output shaft (Fig. 152). Be sure locating ring groove in bearing is toward rear.



J9321-394

**Fig. 151 Clutch Drum Inner Retaining Ring Installation**

- 1 - ANNULUS GEAR
- 2 - INNER SNAP-RING
- 3 - CLUTCH DRUM



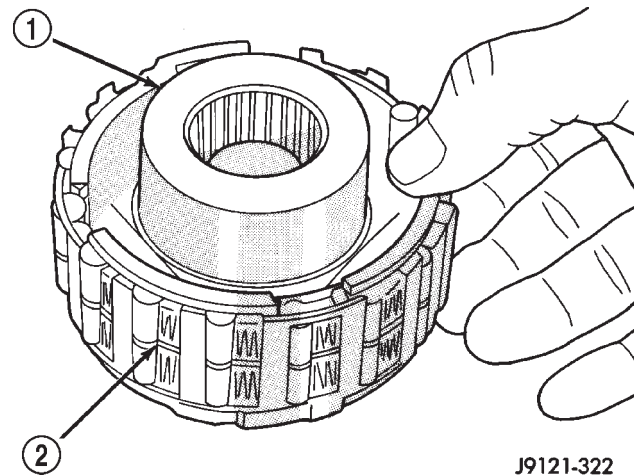
J9321-370

**Fig. 152 Rear Bearing And Snap-Ring Installation**

- 1 - REAR BEARING
- 2 - SNAP-RING

(8) Install overrunning clutch on hub (Fig. 153). Note that clutch only fits one way. Shoulder on clutch should seat in small recess at edge of hub.

(9) Install thrust bearing on overrunning clutch hub. Use generous amount of petroleum jelly to hold bearing in place for installation. Bearing fits one way only. Be sure bearing is seated squarely against hub. Reinstall bearing if it does not seat squarely.



J9121-322

**Fig. 153 Assembling Overrunning Clutch And Hub**

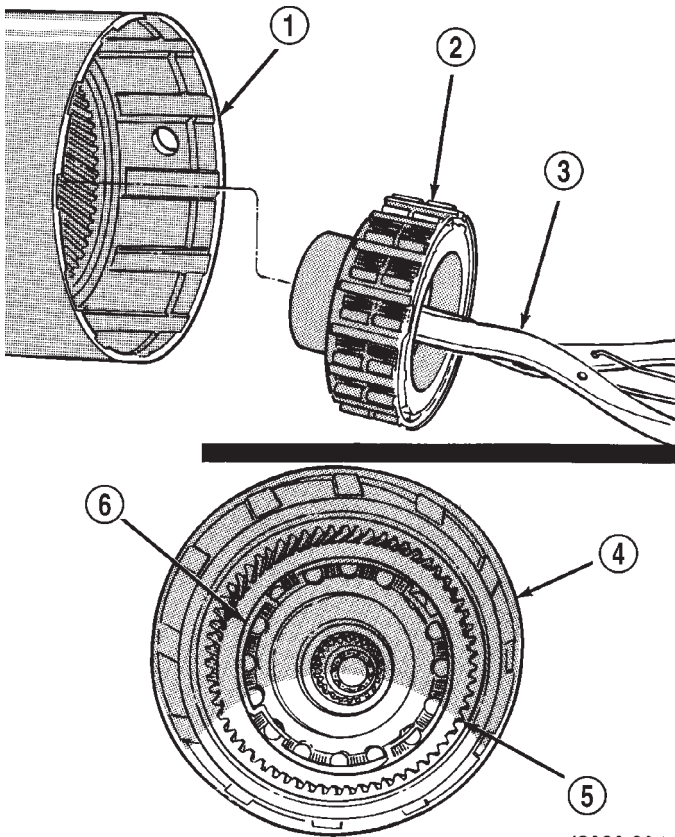
- 1 - CLUTCH HUB
- 2 - OVERRUNNING CLUTCH

(10) Install overrunning clutch in output shaft (Fig. 154). Insert snap ring pliers in hub splines. Expand pliers to grip hub. Then install assembly with counterclockwise, twisting motion.

(11) Install planetary gear in annulus gear (Fig. 155). Be sure planetary pinions are fully seated in annulus gear before proceeding.

(12) Coat planetary thrust bearing and bearing contact surface of spring plate with generous amount of petroleum jelly. This will help hold bearing in place during installation.

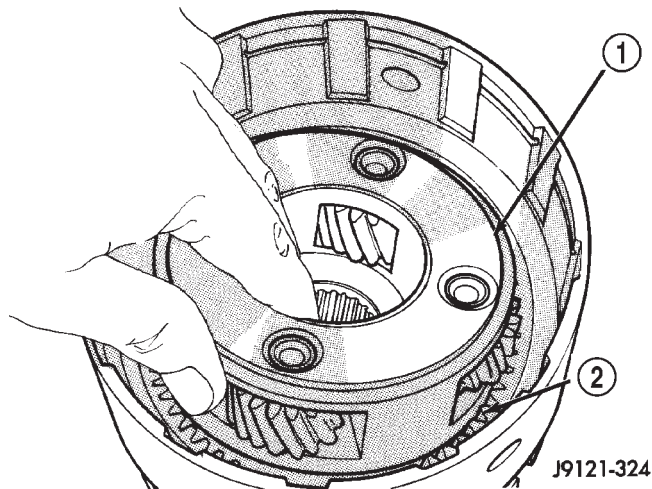
## OVERDRIVE UNIT (Continued)



J9121-314

**Fig. 154 Overrunning Clutch Installation**

- 1 - CLUTCH DRUM
- 2 - OVERRUNNING CLUTCH ASSEMBLY
- 3 - EXPANDING-TYPE SNAP-RING PLIERS
- 4 - CLUTCH DRUM
- 5 - ANNULUS GEAR
- 6 - OVERRUNNING CLUTCH ASSEMBLY SEATED IN OUTPUT SHAFT



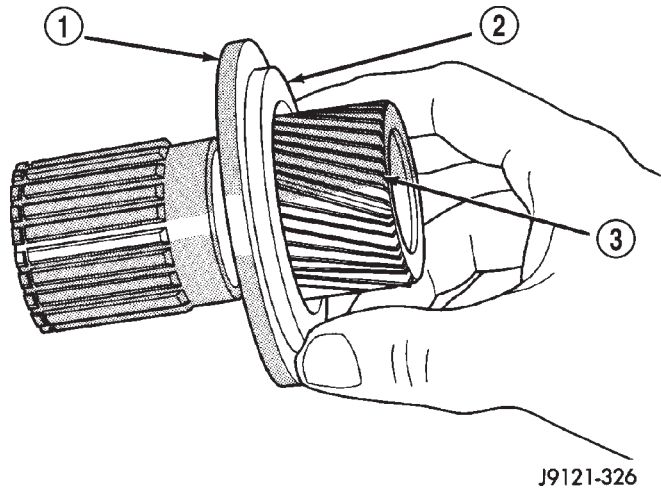
J9121-324

**Fig. 155 Planetary Gear Installation**

- 1 - PLANETARY GEAR
- 2 - ANNULUS GEAR

(13) Install planetary thrust bearing on sun gear (Fig. 156). Slide bearing onto gear and seat it against spring plate as shown. Bearing fits one way only. If it does not seat squarely against spring plate, remove and reposition bearing.

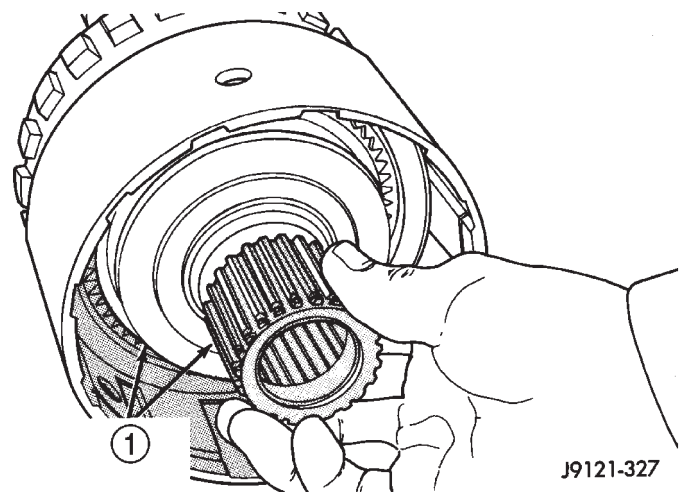
(14) Install assembled sun gear, spring plate and thrust bearing (Fig. 157). Be sure sun gear and thrust bearing are fully seated before proceeding.



J9121-326

**Fig. 156 Planetary Thrust Bearing Installation**

- 1 - SPRING PLATE
- 2 - PLANETARY THRUST BEARING
- 3 - SUN GEAR



J9121-327

**Fig. 157 Sun Gear Installation**

- 1 - SUN GEAR AND SPRING PLATE ASSEMBLY

(15) Mount assembled output shaft, annulus gear, and clutch drum in shop press. Direct clutch spring, hub and clutch pack are easier to install with assembly mounted in press.

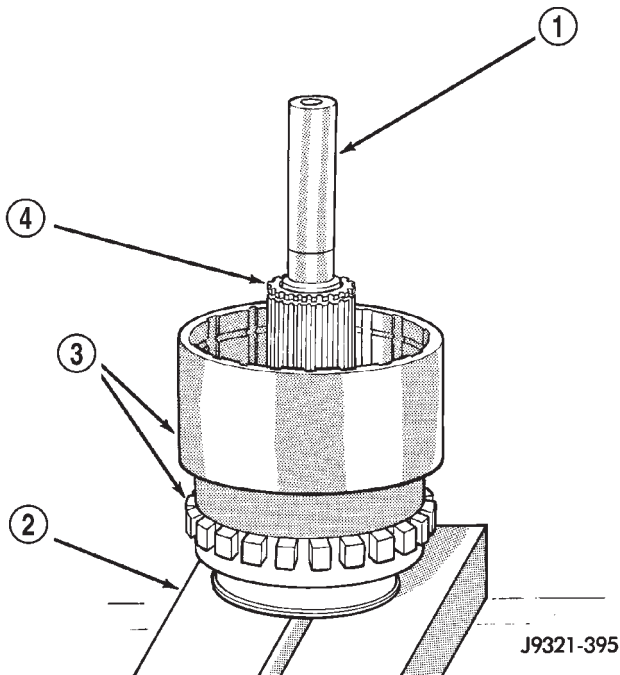
(16) Align splines in hubs of planetary gear and overrunning clutch with Alignment tool 6227-2 (Fig. 158). Insert tool through sun gear and into splines of



OVERDRIVE UNIT (Continued)

both hubs. Be sure alignment tool is fully seated before proceeding.

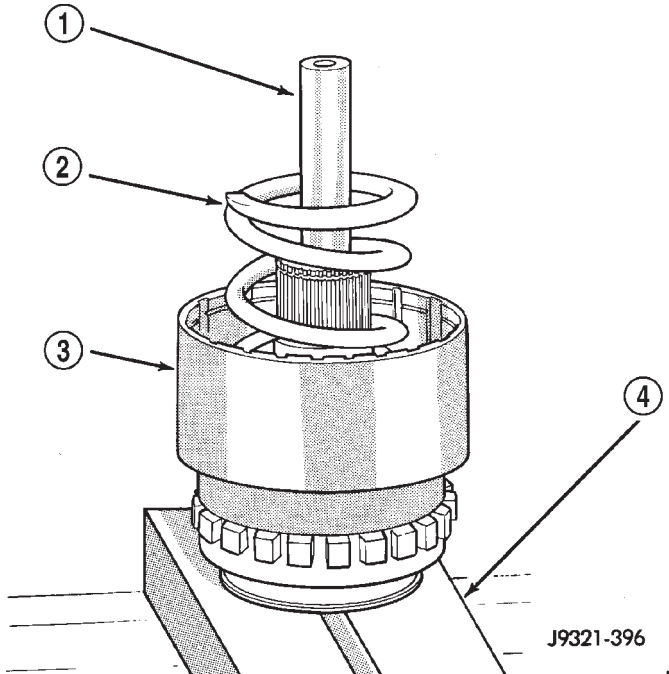
(17) Install direct clutch spring (Fig. 159). Be sure spring is properly seated on spring plate.



**Fig. 158 Alignment Tool Installation**

- 1 - SPECIAL TOOL 6227-2
- 2 - PRESS PLATES
- 3 - ASSEMBLED DRUM AND ANNULUS GEAR
- 4 - SUN GEAR

**NOTE:** The direct clutch in a 46RE transmission uses 8 clutch discs.

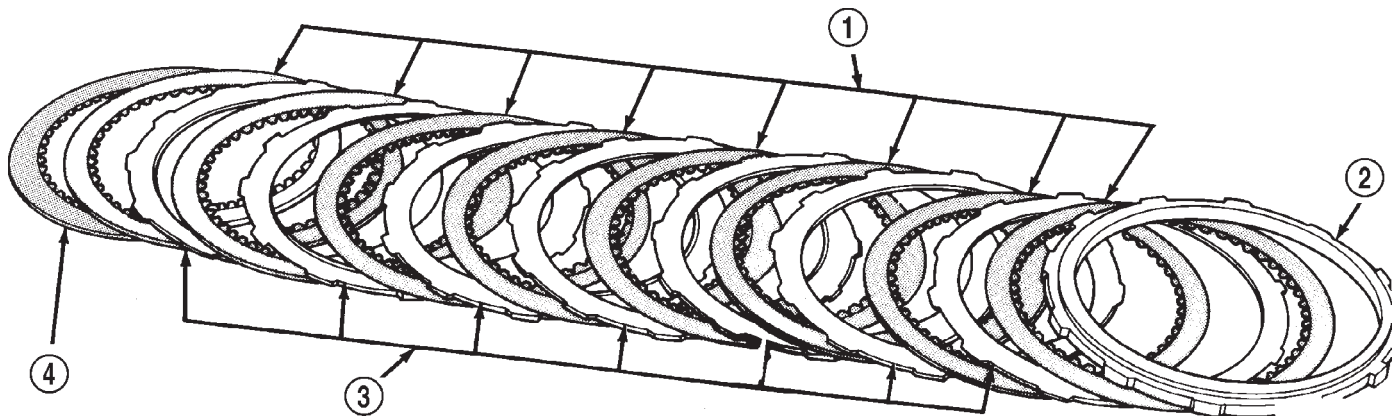


**Fig. 159 Direct Clutch Spring Installation**

- 1 - SPECIAL TOOL 6227-2
- 2 - DIRECT CLUTCH SPRING
- 3 - CLUTCH HUB
- 4 - PRESS PLATES

(18) Assemble and install direct clutch pack on hub as follows:

- (a) Assemble clutch pack components (Fig. 160).
- (b) Install direct clutch reaction plate on clutch hub first. Note that one side of reaction plate is counterbored. Be sure this side faces rearward. Splines at rear of hub are raised slightly. Counterbore in plate fits over raised splines. Plate should be flush with this end of hub (Fig. 161).



**Fig. 160 46RE Direct Clutch Pack Components**

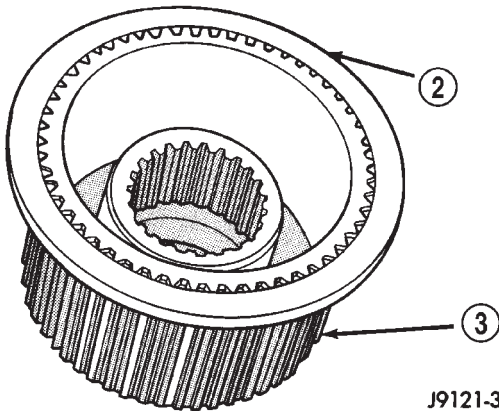
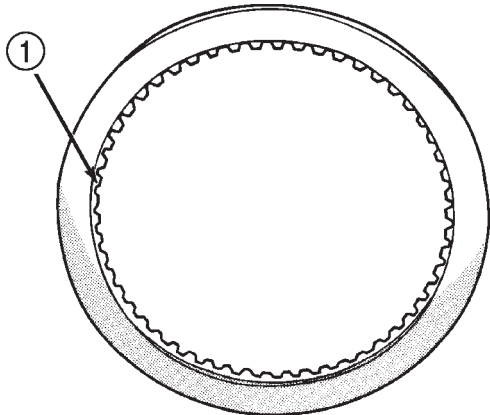
- 1 - CLUTCH DISCS (8)
- 2 - PRESSURE PLATE
- 3 - CLUTCH PLATES (7)
- 4 - REACTION PLATE

## OVERDRIVE UNIT (Continued)

(c) Install first clutch disc followed by a steel plate until all discs and plates have been installed.

(d) Install pressure plate. This is last clutch pack item to be installed. Be sure plate is installed with shoulder side facing upward (Fig. 162).

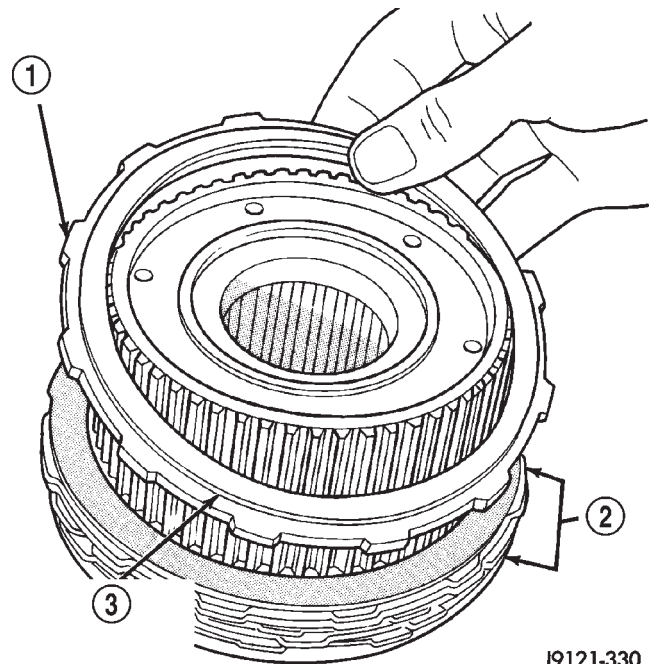
(19) Install clutch hub and clutch pack on direct clutch spring (Fig. 163). Be sure hub is started on sun gear splines before proceeding.



J9121-329

**Fig. 161 Correct Position Of Direct Clutch Reaction Plate**

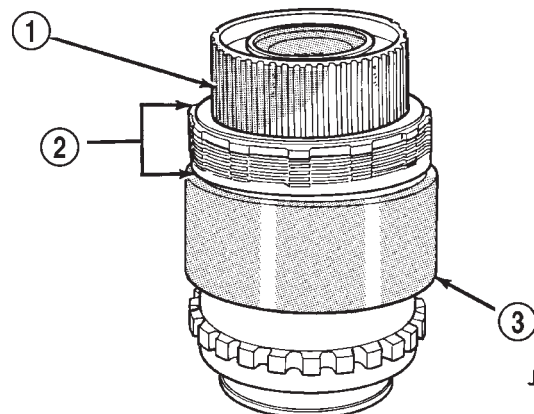
- 1 - REACTION PLATE COUNTERBORE
- 2 - DIRECT CLUTCH REACTION PLATE (FLUSH WITH END OF HUB)
- 3 - CLUTCH HUB



J9121-330

**Fig. 162 Correct Position Of Direct Clutch**

- 1 - DIRECT CLUTCH PRESSURE PLATE
- 2 - CLUTCH PACK
- 3 - BE SURE SHOULDER SIDE OF PLATE FACES UPWARD



J9321-397

**Fig. 163 Direct Clutch Pack And Clutch Hub Installation**

- 1 - CLUTCH HUB
- 2 - DIRECT CLUTCH PACK
- 3 - CLUTCH DRUM

**WARNING: THE NEXT STEP IN GEARTRAIN ASSEMBLY INVOLVES COMPRESSING THE DIRECT CLUTCH HUB AND SPRING. IT IS EXTREMELY IMPORTANT THAT PROPER EQUIPMENT BE USED TO COMPRESS THE SPRING AS SPRING FORCE IS APPROXIMATELY 830 POUNDS. USE COMPRESSOR TOOL C-6227-1 AND A HYDRAULIC-TYPE SHOP PRESS WITH A MINIMUM RAM TRAVEL OF 6 INCHES. THE PRESS MUST ALSO HAVE A BED THAT CAN BE ADJUSTED UP OR DOWN AS REQUIRED. RELEASE CLUTCH SPRING TENSION SLOWLY AND COMPLETELY TO AVOID PERSONAL INJURY.**

(20) Position Compressor Tool 6227-1 on clutch hub.

(21) Compress clutch hub and spring just enough to place tension on hub and hold it in place.

(22) Slowly compress clutch hub and spring. Compress spring and hub only enough to expose ring



## OVERDRIVE UNIT (Continued)

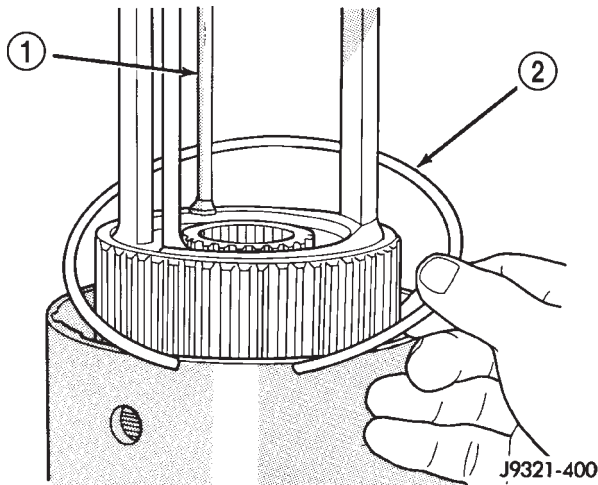
grooves for clutch pack snap ring and clutch hub retaining ring.

(23) Realign clutch pack on hub and seat clutch discs and plates in clutch drum.

(24) Install direct clutch pack snap ring (Fig. 164). Be very sure snap ring is fully seated in clutch drum ring groove.

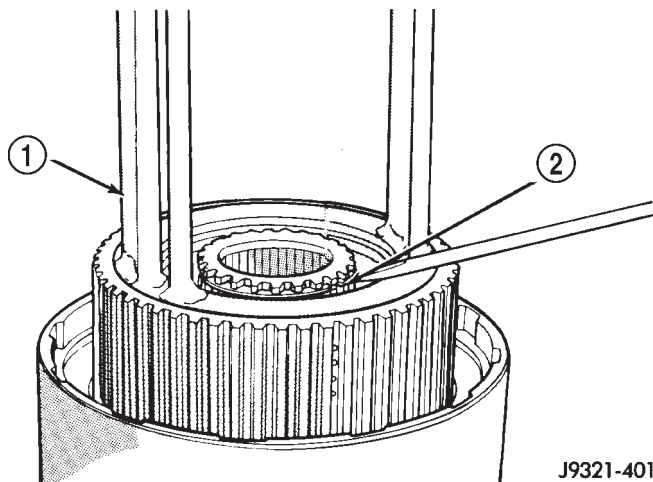
(25) Install clutch hub retaining ring (Fig. 165). Be very sure retaining ring is fully seated in sun gear ring groove.

(26) Slowly release press ram, remove compressor tools and remove geartrain assembly.



**Fig. 164 Direct Clutch Pack Snap-Ring Installation**

- 1 - SPECIAL TOOL 6227-1
- 2 - DIRECT CLUTCH PACK SNAP-RING



**Fig. 165 Clutch Hub Retaining Ring Installation**

- 1 - SPECIAL TOOL 6227-1
- 2 - CLUTCH HUB RETAINING RING

## GEAR CASE

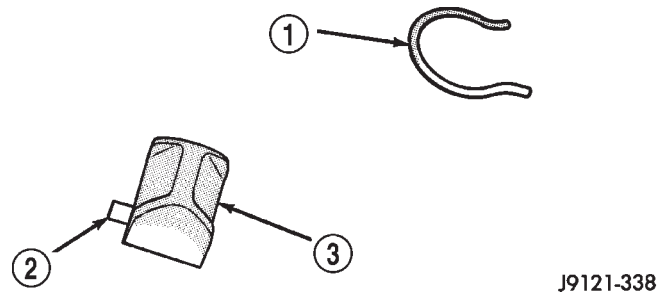
(1) Position park pawl and spring in case and install park pawl shaft. Verify that end of spring

with 90° bend is hooked to pawl and straight end of spring is seated against case.

(2) Install pawl shaft retaining bolt. Tighten bolt to 27 N·m (20 ft. lbs.) torque.

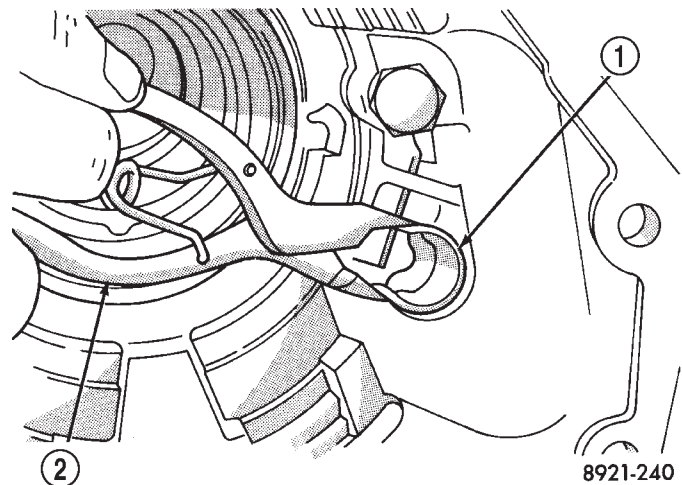
(3) Install park lock reaction plug. Note that plug has locating pin at rear (Fig. 166). Be sure pin is seated in hole in case before installing snap ring.

(4) Install reaction plug snap-ring (Fig. 167). Compress snap ring only enough for installation; do not distort it.



**Fig. 166 Reaction Plug Locating Pin And Snap-Ring**

- 1 - REACTION PLUG SNAP-RING (DO NOT OVERCOMPRESS TO INSTALL)
- 2 - LOCATING PIN
- 3 - PARK LOCK REACTION PLUG



**Fig. 167 Reaction Plug And Snap-Ring Installation**

- 1 - REACTION PLUG SNAP-RING
- 2 - SNAP-RING PLIERS

(5) Install new seal in gear case. Use Handle C-4171 and Installer C-3995-A to seat seal in case.

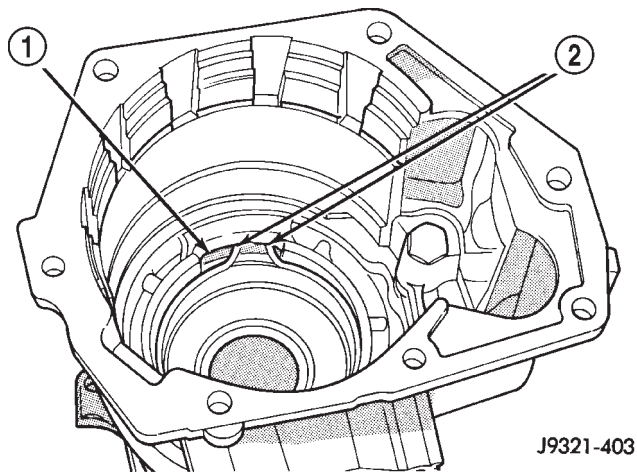
(6) Verify that tab ends of rear bearing locating ring extend into access hole in gear case (Fig. 168).

(7) Support geartrain on Tool 6227-1 (Fig. 169). Be sure tool is securely seated in clutch hub.

(8) Install overdrive gear case on geartrain (Fig. 169).

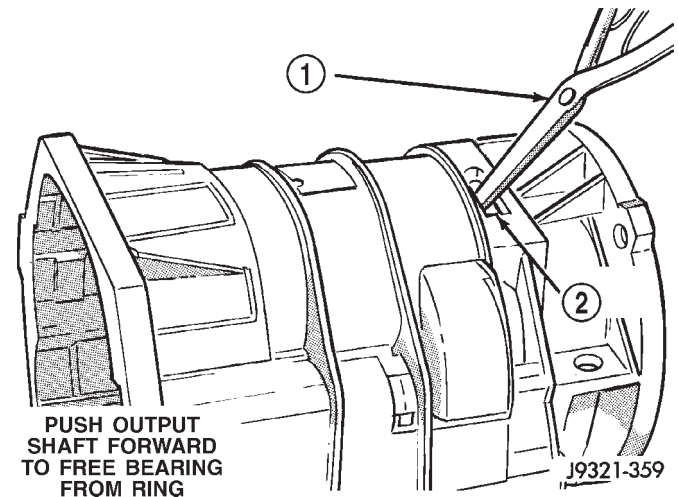
(9) Expand front bearing locating ring with snap ring pliers (Fig. 170). Then slide case downward until

## OVERDRIVE UNIT (Continued)



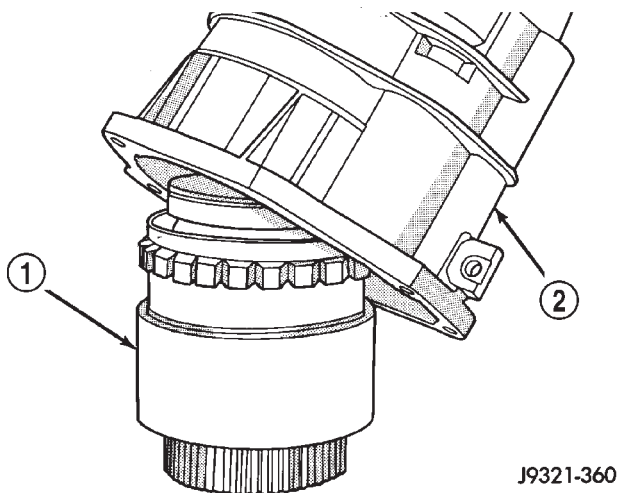
**Fig. 168 Correct Rear Bearing Locating Ring Position**

- 1 - CASE ACCESS HOLE  
2 - TAB ENDS OF LOCATING RING



**Fig. 170 Seating Locating Ring In Rear Bearing**

- 1 - EXPAND BEARING LOCATING RING WITH SNAP-RING PLIERS  
2 - ACCESS HOLE



**Fig. 169 Overdrive Gear Case Installation**

- 1 - GEARTRAIN ASSEMBLY  
2 - GEAR CASE

locating ring locks in bearing groove and release snap ring.

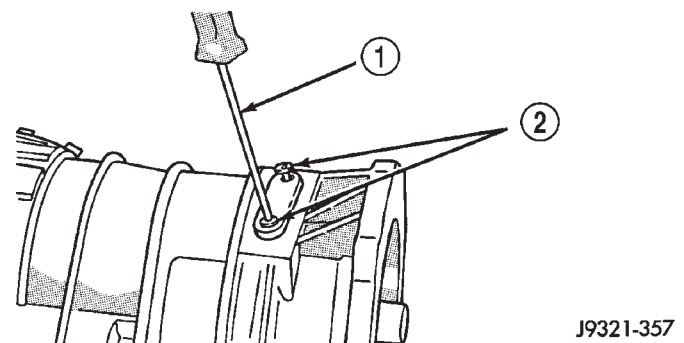
(10) Install locating ring access cover and gasket in overdrive unit case (Fig. 171).

## OVERDRIVE CLUTCH

**NOTE:** The overdrive clutch in a 46RE transmission uses 4 clutch discs.

(1) Install overdrive clutch reaction ring first. Reaction ring is flat with notched ends (Fig. 172).

(2) Install wave spring on top of reaction ring (Fig. 173). Reaction ring and wave ring both fit in same ring groove. Use screwdriver to seat each ring

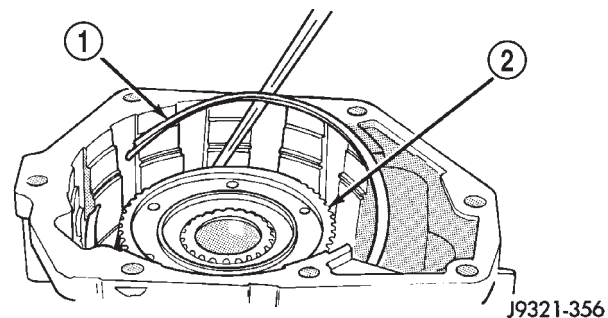


**Fig. 171 Locating Ring Access Cover And Gasket Installation**

- 1 - TORX SCREWDRIVER (T25)  
2 - ACCESS COVER SCREWS

securely in groove. Also ensure that the ends of the two rings are offset from each other.

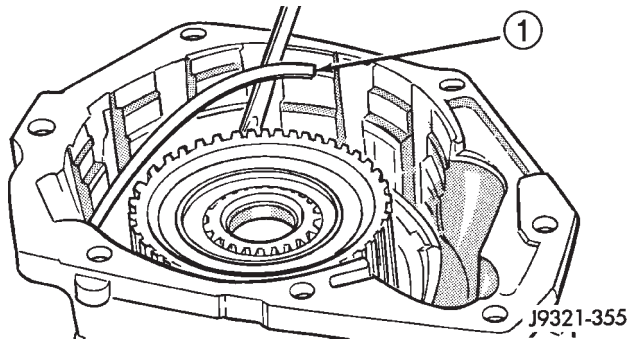
(3) Assemble overdrive clutch pack (Fig. 174).



**Fig. 172 Overdrive Clutch Reaction Ring Installation**

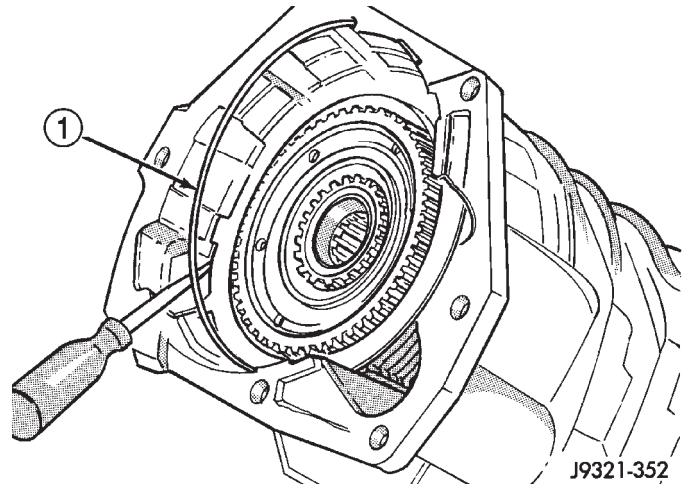
- 1 - REACTION RING  
2 - CLUTCH HUB

## OVERDRIVE UNIT (Continued)



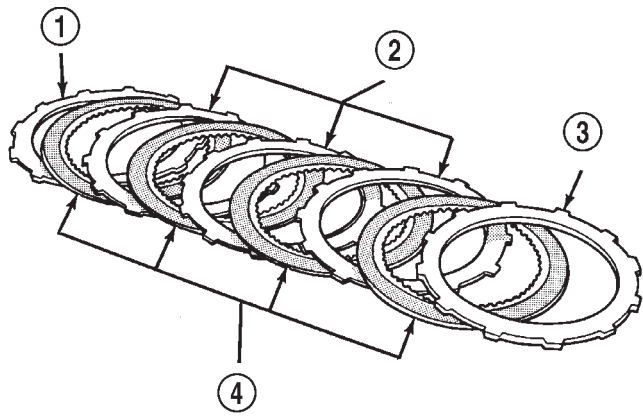
**Fig. 173 Overdrive Clutch Wave Spring Installation**

1 - WAVE SPRING



**Fig. 175 Overdrive Clutch Pack Retaining Ring Installation**

1 - OVERDRIVE CLUTCH PACK RETAINING RING



**Fig. 174 46RE Overdrive Clutch Components**

1 - REACTION PLATE  
2 - CLUTCH PLATES (3)  
3 - PRESSURE PLATE  
4 - CLUTCH DISCS (4)

(4) Install overdrive clutch reaction plate first.

**NOTE:** The reaction plate is the same thickness as the pressure plate in a 46RE transmission.

(5) Install first clutch disc followed by first clutch plate. Then install remaining clutch discs and plates in same order.

(6) Install clutch pack pressure plate.

(7) Install clutch pack wire-type retaining ring (Fig. 175).

### INTERMEDIATE SHAFT SPACER SELECTION

(1) Place overdrive unit in vertical position. Mount it on blocks, or in workbench with appropriate size mounting hole cut into it. Be sure unit is facing upward for access to direct clutch hub. Also be sure output shaft is not loaded and internal components are moved rearward for accurate measurement.

(2) Determine correct thickness intermediate shaft spacer as follows:

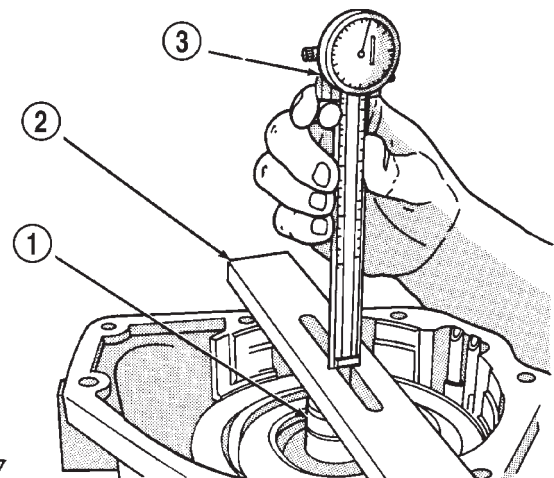
(a) Insert Special Tool 6312 through sun gear, planetary gear and into pilot bushing in output shaft. Be sure tool bottoms against planetary shoulder.

(b) Position Gauge Tool 6311 across face of overdrive case (Fig. 176). Then position Dial Caliper C-4962 over gauge tool.

(c) Extend sliding scale of dial caliper downward through gauge tool slot until scale contacts end of Gauge Alignment Tool 6312. Lock scale in place. Remove dial caliper tool and note distance measured (Fig. 176).

(d) Select proper thickness end play spacer from spacer chart based on distance measured (Fig. 177).

(e) Remove Gauge Alignment Tool 6312.



**Fig. 176 Shaft End Play Measurement**

1 - SPECIAL TOOL 6312  
2 - SPECIAL TOOL 6311  
3 - SPECIAL TOOL C-4962

## OVERDRIVE UNIT (Continued)

End Play Measurement (Inches)	Spacer Thickness (Inches)
.7336 - .7505	.158 - .159
.7506 - .7675	.175 - .176
.7676 - .7855	.193 - .194
.7856 - .8011	.211 - .212

J9121-341

**Fig. 177 Intermediate Shaft End Play Spacer Selection**

## OD THRUST PLATE SELECTION

(1) Place overdrive unit in vertical position. Mount it on blocks, or in workbench with appropriate size mounting hole cut into it. Be sure unit is facing upward for access to direct clutch hub. Also be sure output shaft is not loaded and internal components are moved rearward for accurate measurement.

(2) Determine correct thickness overdrive piston thrust plate as follows:

(a) Position Gauge Tool 6311 across face of overdrive case. Then position Dial Caliper C-4962 over gauge tool (Fig. 178).

(b) Measure distance to clutch hub thrust bearing seat at four points 90° apart. Then average measurements by adding them and dividing by 4.

(c) Select and install required thrust plate from information in thrust plate chart (Fig. 179).

(3) Leave Alignment Tool 6227-2 in place. Tool will keep planetary and clutch hub splines in alignment until overdrive unit is ready for installation on transmission.

(4) Transmission speed sensor can be installed at this time if desired. However, it is recommended that sensor not be installed until after overdrive unit is secured to transmission.

## OVERDRIVE PISTON

(1) Install new seals on overdrive piston.

(2) Stand transmission case upright on bellhousing.

(3) Position Guide Ring 8114-1 on outer edge of overdrive piston retainer.

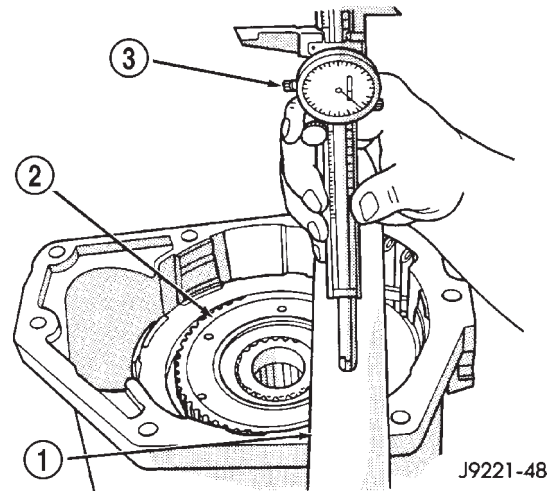
(4) Position Seal Guide 8114-3 on inner edge of overdrive piston retainer.

(5) Install overdrive piston in overdrive piston retainer by:

(a) Aligning locating lugs on overdrive piston to the two mating holes in retainer.

(b) Lubricate overdrive piston seals with Mopar® Door Ease, or equivalent.

(c) Install piston over Seal Guide 8114-3 and inside Guide Ring 8114-1.



J9221-48

**Fig. 178 Overdrive Piston Thrust Plate Measurement**

1 - SPECIAL TOOL 6311

2 - DIRECT CLUTCH HUB THRUST BEARING SEAT

3 - SPECIAL TOOL C-4962

End Play Measurement (Inches)	Spacer Thickness (Inches)
1.7500 - 1.7649	.108 - .110
1.7650 - 1.7799	.123 - .125
1.7800 - 1.7949	.138 - .140
1.7950 - 1.8099	.153 - .155
1.8100 - 1.8249	.168 - .170
1.8250 - 1.8399	.183 - .185
1.8400 - 1.8549	.198 - .200
1.8550 - 1.8699	.213 - .215
1.8700 - 1.8849	.228 - .230
1.8850 - 1.8999	.243 - .245

J9121-342

**Fig. 179 Overdrive Piston Thrust Plate Selection**

(d) Push overdrive piston into position in retainer.

(e) Verify that the locating lugs entered the lug bores in the retainer.

(6) Install intermediate shaft spacer on intermediate shaft.

(7) Install overdrive piston thrust plate on overdrive piston.

(8) Install overdrive piston thrust bearing on overdrive piston.

(9) Install transmission speed sensor and O-ring seal in overdrive case.

## INSTALLATION

(1) Be sure overdrive unit Alignment Tool 6227-2 is fully seated before moving unit. If tool is not



## OVERDRIVE UNIT (Continued)

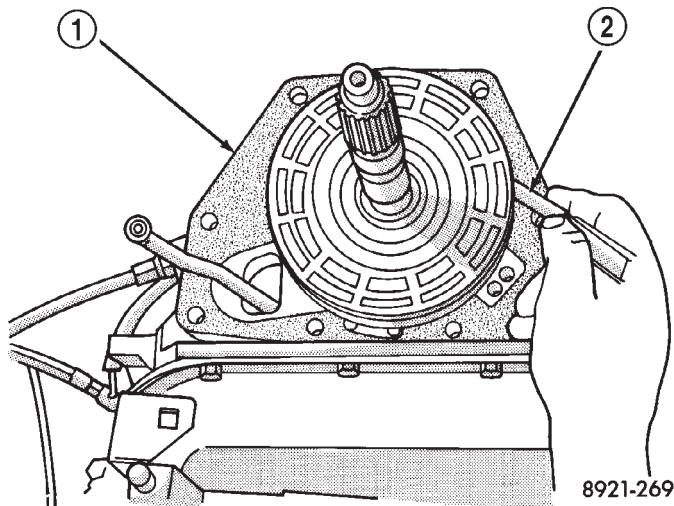
seated and gear splines rotate out of alignment, overdrive unit will have to be disassembled in order to realign splines.

(2) If overdrive piston retainer was not removed during service and original case gasket is no longer reusable, prepare new gasket by trimming it.

(3) Cut out old case gasket around piston retainer with razor knife (Fig. 180).

(4) Use old gasket as template and trim new gasket to fit.

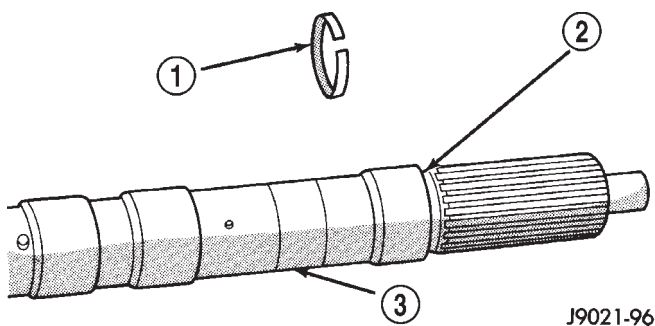
(5) Position new gasket over piston retainer and on transmission case. Use petroleum jelly to hold gasket in place if necessary. Do not use any type of sealer to secure gasket. Use petroleum jelly only.



**Fig. 180 Trimming Overdrive Case Gasket**

- 1 - GASKET  
2 - SHARP KNIFE

(6) Install selective spacer on intermediate shaft, if removed. Spacer goes in groove just rearward of shaft rear splines (Fig. 181).



**Fig. 181 Intermediate Shaft Selective Spacer Location**

- 1 - SELECTIVE SPACER  
2 - SPACER GROOVE  
3 - INTERMEDIATE SHAFT

(7) Install thrust bearing in overdrive unit sliding hub. Use petroleum jelly to hold bearing in position.

**CAUTION:** Be sure the shoulder on the inside diameter of the bearing is facing forward.

(8) Verify that splines in overdrive planetary gear and overrunning clutch hub are aligned with Alignment Tool 6227-2. Overdrive unit cannot be installed if splines are not aligned. If splines have rotated out of alignment, unit will have to be disassembled to realign splines.

(9) Carefully slide Alignment Tool 6227-2 out of overdrive planetary gear and overrunning clutch splines.

(10) Raise overdrive unit and carefully slide it straight onto intermediate shaft. Insert park rod into park lock reaction plug at same time. Avoid tilting overdrive during installation as this could cause planetary gear and overrunning clutch splines to rotate out of alignment. If this occurs, it will be necessary to remove and disassemble overdrive unit to realign splines.

(11) Work overdrive unit forward on intermediate shaft until seated against transmission case.

(12) Install bolts attaching overdrive unit to transmission unit. Tighten bolts in diagonal pattern to 34 N·m (25 ft-lbs).

(13) Connect the transmission speed sensor and overdrive wiring connectors.

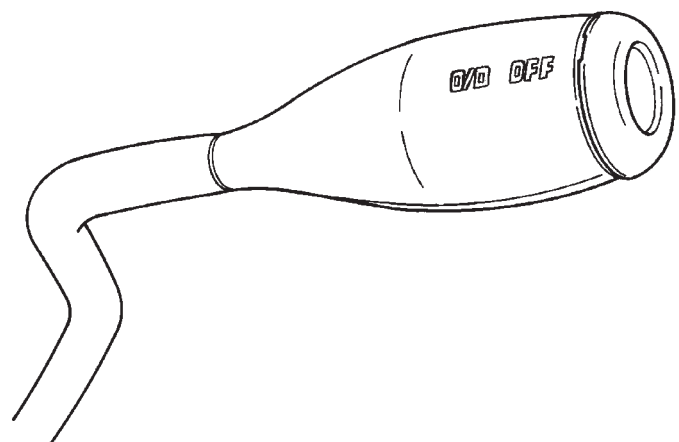
(14) Install the transfer case, if equipped.

(15) Align and install rear propeller shaft, if necessary. (Refer to 3 - DIFFERENTIAL & DRIVELINE/PROPELLER SHAFT/PROPELLER SHAFT - INSTALLATION)

## OVERDRIVE SWITCH

## DESCRIPTION

The overdrive OFF (control) switch is located in the shift lever arm (Fig. 182). The switch is a momentary contact device that signals the PCM to toggle current status of the overdrive function.



**Fig. 182 Overdrive Off Switch**

80a8e1c1



## OVERDRIVE SWITCH (Continued)

## OPERATION

At key-on, overdrive operation is allowed. Pressing the switch once causes the overdrive OFF mode to be entered and the overdrive OFF switch lamp to be illuminated. Pressing the switch a second time causes normal overdrive operation to be restored and the overdrive lamp to be turned off. The overdrive OFF mode defaults to ON after the ignition switch is cycled OFF and ON. The normal position for the control switch is the ON position. The switch must be in this position to energize the solenoid and allow a 3-4 upshift. The control switch indicator light illuminates only when the overdrive switch is turned to the OFF position, or when illuminated by the transmission control module.

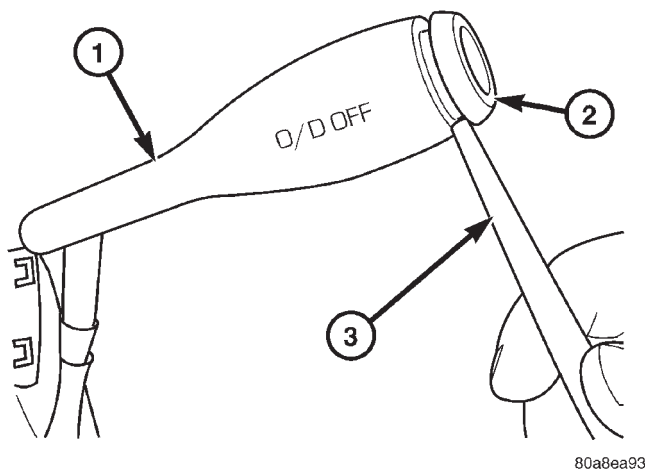
## DIAGNOSIS AND TESTING - OVERDRIVE ELECTRICAL CONTROLS

The overdrive off switch, valve body solenoid, case connectors and related wiring can all be tested with a 12 volt test lamp or a volt/ohmmeter. Check continuity of each component when diagnosis indicates this is necessary.

Switch and solenoid continuity should be checked whenever the transmission fails to shift into fourth gear range.

## REMOVAL

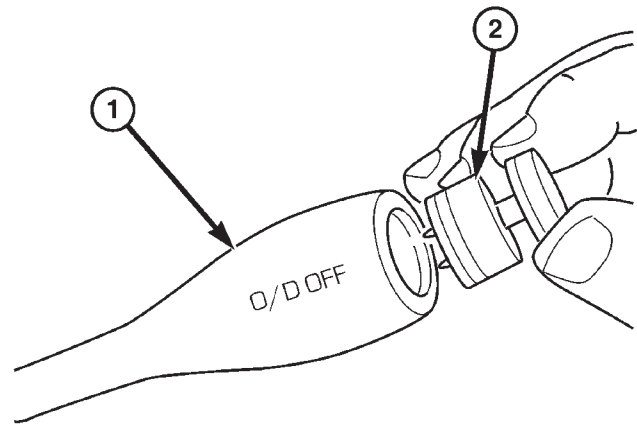
(1) Using a plastic trim tool, remove the overdrive off switch retainer from the shift lever (Fig. 183).



**Fig. 183 Overdrive Off Switch Retainer**

- 1 - GEAR SHIFT LEVER
- 2 - OVERDRIVE OFF SWITCH RETAINER
- 3 - PLASTIC TRIM TOOL

(2) Pull the switch outwards to release it from the connector in the lever (Fig. 184)



80a8ed2b

**Fig. 184 Remove the Overdrive Off Switch**

- 1 - GEAR SHIFT LEVER
- 2 - OVERDRIVE OFF SWITCH

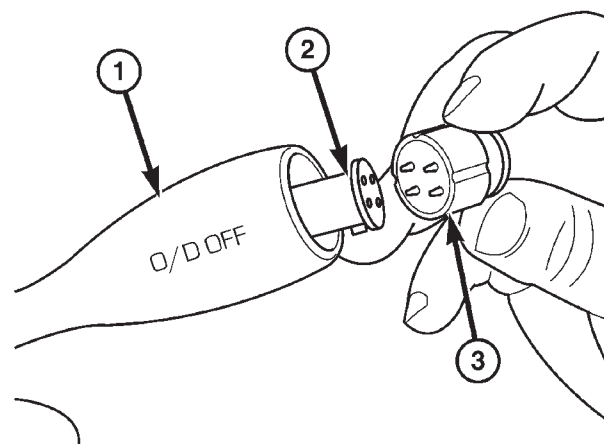
## INSTALLATION

**NOTE:** There is enough slack in the wire to pull out the connector from the lever.

(1) Pull the connector out of the lever just enough to grasp it.

**CAUTION:** Be careful not to bend the pins on the overdrive off switch. Use care when installing the switch, as it is not indexed, and can be accidentally installed incorrectly.

(2) Install the overdrive off switch into the connector (Fig. 185)



80a8eb39

**Fig. 185 Install the Overdrive Off Switch**

- 1 - GEAR SHIFT LEVER
- 2 - OVERDRIVE OFF SWITCH WIRING CONNECTOR
- 3 - OVERDRIVE OFF SWITCH

## OVERDRIVE SWITCH (Continued)

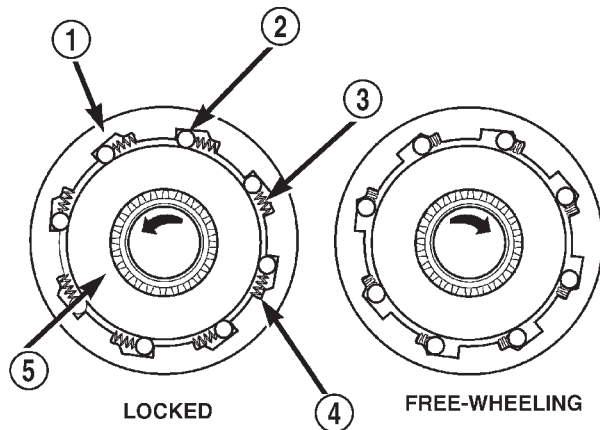
(3) Push the overdrive off switch and wiring into the shift lever.

(4) Install the overdrive off switch retainer onto the shift lever.

## OVERRUNNING CLUTCH CAM/OVERDRIVE PISTON RETAINER

## DESCRIPTION

The overrunning clutch (Fig. 186) consists of an inner race, an outer race (or cam), rollers and springs, and the spring retainer. The number of rollers and springs depends on what transmission and which overrunning clutch is being dealt with.



80be45f8

**Fig. 186 Overrunning Clutch**

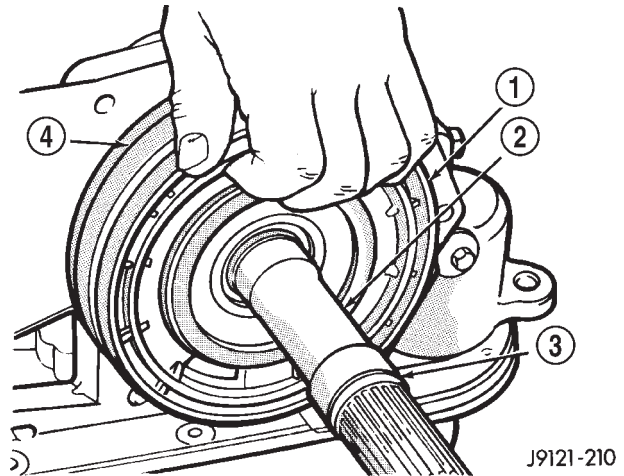
- 1 - OUTER RACE (CAM)
- 2 - ROLLER
- 3 - SPRING
- 4 - SPRING RETAINER
- 5 - INNER RACE (HUB)

## OPERATION

As the inner race is rotated in a clockwise direction (as viewed from the front of the transmission), the race causes the rollers to roll toward the springs, causing them to compress against their retainer. The compression of the springs increases the clearance between the rollers and cam. This increased clearance between the rollers and cam results in a free-wheeling condition. When the inner race attempts to rotate counterclockwise, the action causes the rollers to roll in the same direction as the race, aided by the pushing of the springs. As the rollers try to move in the same direction as the inner race, they are wedged between the inner and outer races due to the design of the cam. In this condition, the clutch is locked and acts as one unit.

## DISASSEMBLY

- (1) Remove the overdrive piston (Fig. 187).
- (2) Remove the overdrive piston retainer bolts.
- (3) Remove overdrive piston retainer.
- (4) Remove case gasket.
- (5) Tap old cam out of case with pin punch. Insert punch through bolt holes at rear of case (Fig. 188). Alternate position of punch to avoid cocking cam during removal.
- (6) Clean clutch cam bore and case. Be sure to remove all chips/shavings generated during cam removal.



J9121-210

**Fig. 187 Overdrive Piston Removal**

- 1 - OVERDRIVE CLUTCH PISTON
- 2 - INTERMEDIATE SHAFT
- 3 - SELECTIVE SPACER
- 4 - PISTON RETAINER

## CLEANING

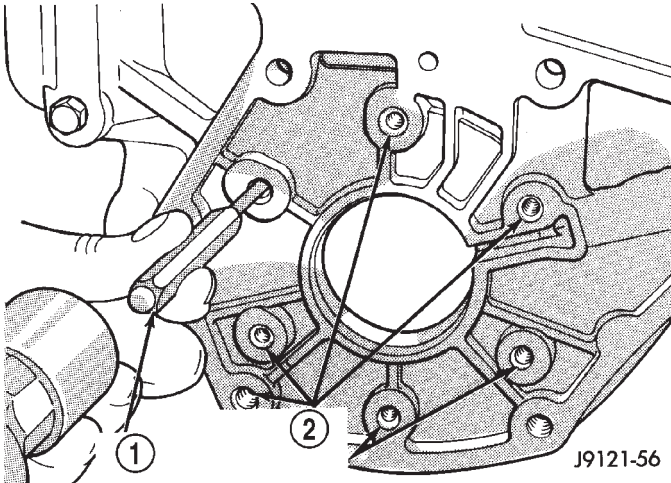
Clean the overrunning clutch assembly, clutch cam, low-reverse drum, and overdrive piston retainer in solvent. Dry them with compressed air after cleaning.

## INSPECTION

Inspect condition of each clutch part after cleaning. Replace the overrunning clutch roller and spring assembly if any rollers or springs are worn or damaged, or if the roller cage is distorted, or damaged. Replace the cam if worn, cracked or damaged.

Replace the low-reverse drum if the clutch race, roller surface or inside diameter is scored, worn or damaged. **Do not remove the clutch race from the low-reverse drum under any circumstances.**

## OVERRUNNING CLUTCH CAM/OVERDRIVE PISTON RETAINER (Continued)



**Fig. 188 Overrunning Clutch Cam**

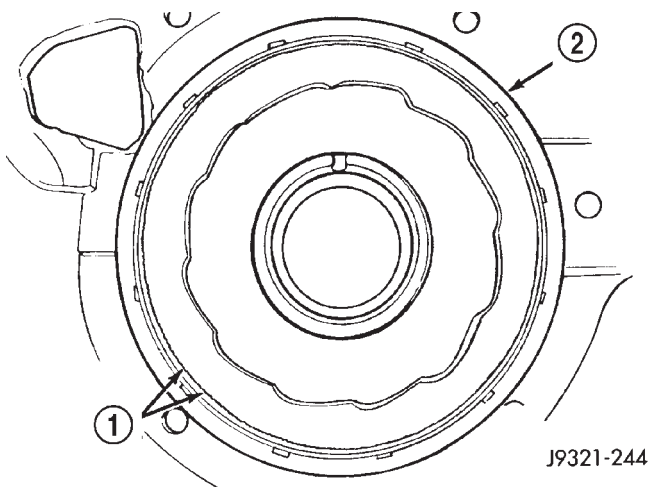
- 1 - PIN PUNCH  
2 - REAR SUPPORT BOLT HOLES

**Replace the drum and race as an assembly if either component is damaged.**

Examine the overdrive piston retainer carefully for wear, cracks, scoring or other damage. Be sure the retainer hub is a snug fit in the case and drum. Replace the retainer if worn or damaged.

**ASSEMBLY**

- (1) Temporarily install overdrive piston retainer in case. Use 3-4 bolts to secure retainer.
- (2) Align and start new clutch cam in the transmission case. Be sure serrations on cam and in case are aligned (Fig. 189). Then tap cam into case just enough to hold it in place.



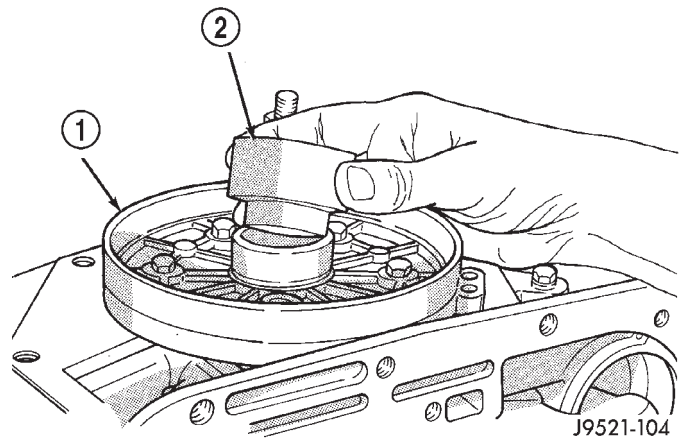
**Fig. 189 Positioning Replacement Clutch Cam In Case**

- 1 - ALIGN SERRATIONS ON CAM AND IN CASE  
2 - CLUTCH CAM

(3) Verify that cam is correctly positioned before proceeding any further. Narrow ends of cam ramps should be to left when cam is viewed from front end of case (Fig. 189).

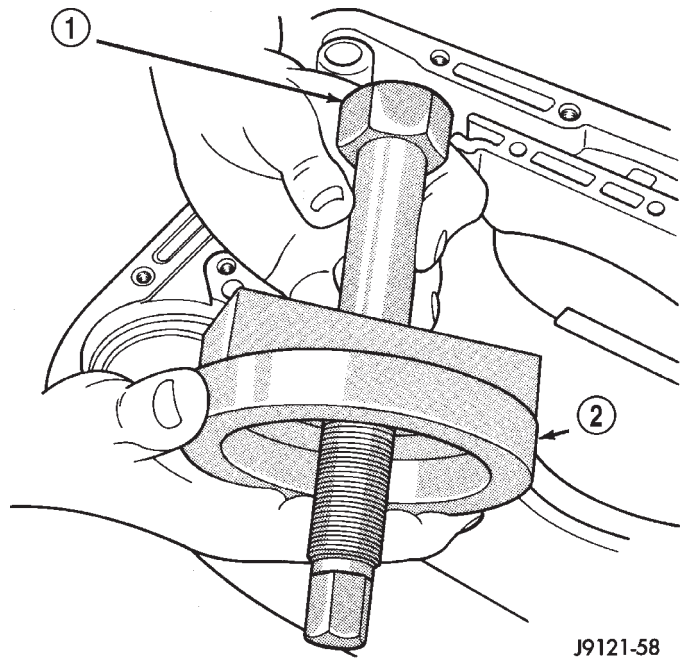
(4) Insert Adapter Tool SP-5124 into piston retainer (Fig. 190).

(5) Assemble Puller Bolt SP-3701 and Press Plate SP-3583-A (Fig. 191).



**Fig. 190 Positioning Adapter Tool In Overdrive Piston Retainer**

- 1 - PISTON RETAINER  
2 - SPECIAL TOOL SP-5124



**Fig. 191 Assembling Clutch Cam Puller Bolt And Press Plate**

- 1 - PULLER BOLT SP-3701  
2 - PRESS PLATE SP-3583-A

## OVERRUNNING CLUTCH CAM/OVERDRIVE PISTON RETAINER (Continued)

(6) Install assembled puller plate and bolt (Fig. 192). Insert bolt through cam, case and adapter tool. Be sure plate is seated squarely on cam.

(7) Hold puller plate and bolt in place and install puller nut SP-3701 on puller bolt (Fig. 193).

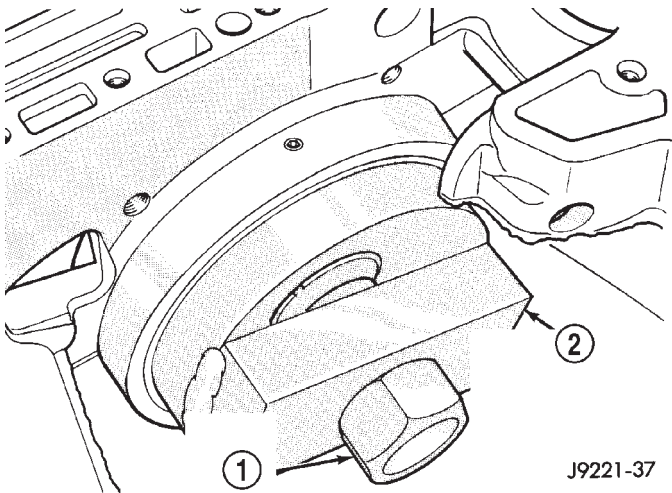
(8) Tighten puller nut to press clutch cam into case (Fig. 193). Be sure cam is pressed into case evenly and does not become cocked.

(9) Remove clutch cam installer tools.

(10) Stake case in 14 places around clutch cam to help secure cam in case. Use blunt punch or chisel to stake case.

(11) Remove piston retainer from case. Cover retainer with plastic sheeting, or paper to keep it dust free.

(12) Clean case and cam thoroughly. Be sure any chips/shavings generated during cam installation are removed from case.



**Fig. 192 Positioning Puller Plate On Clutch Cam**

- 1 - SPECIAL TOOL SP-3701
- 2 - BE SURE PLATE SP-3583-A IS SEATED SQUARELY ON CAM

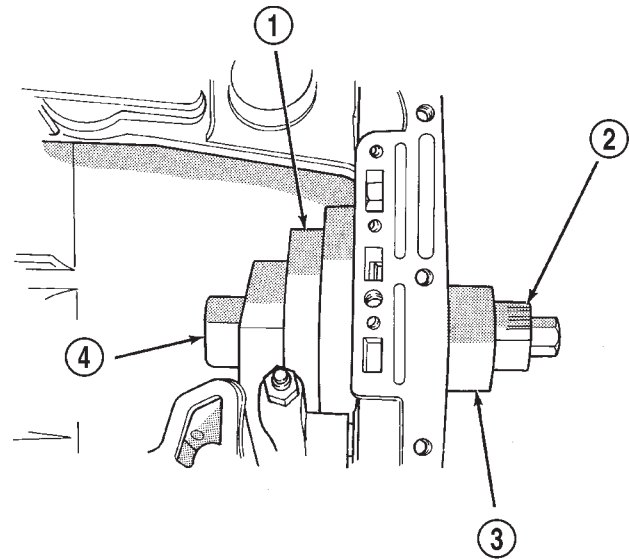
(13) Install new gasket at rear of transmission case. Use petroleum jelly to hold gasket in place. Be sure to align governor feed holes in gasket with feed passages in case (Fig. 194). Also install gasket before overdrive piston retainer. Center hole in gasket is smaller than retainer and cannot be installed over retainer.

(14) Position overdrive piston retainer on transmission case and align bolt holes in retainer, gasket and case (Fig. 195). Then install and tighten retainer bolts to 17 N·m (13 ft. lbs.) torque.

(15) Install new seals on overdrive piston.

(16) Stand transmission case upright on bellhousing.

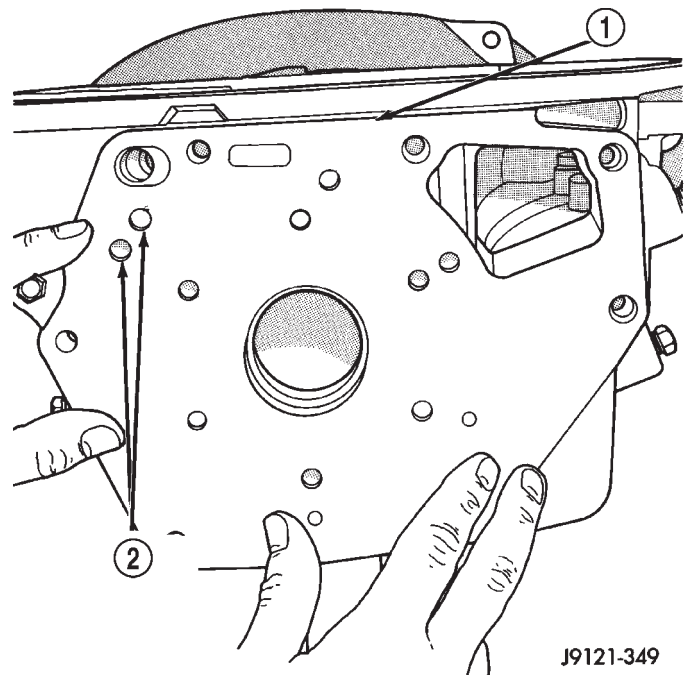
(17) Position Guide Ring 8114-1 on outer edge of overdrive piston retainer.



J9521-105

**Fig. 193 Pressing Overrunning Clutch Cam Into Case**

- 1 - SPECIAL TOOL SP-3583-A
- 2 - TIGHTEN NUT TO DRAW CAM INTO CASE (NUT IS PART OF BOLT SP-3701)
- 3 - SPECIAL TOOL SP-5124
- 4 - SPECIAL TOOL SP-3701



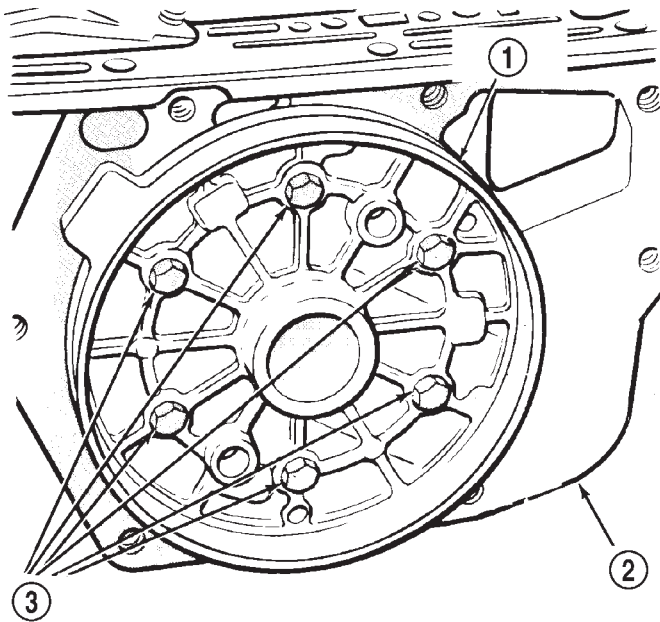
J9121-349

**Fig. 194 Installing/Aligning Case Gasket**

- 1 - CASE GASKET
- 2 - BE SURE GOVERNOR TUBE FEED HOLES IN CASE AND GASKET ARE ALIGNED



## OVERRUNNING CLUTCH CAM/OVERDRIVE PISTON RETAINER (Continued)



J9321-464

**Fig. 195 Aligning Overdrive Piston Retainer**

- 1 - PISTON RETAINER
- 2 - GASKET
- 3 - RETAINER BOLTS

(18) Position Seal Guide 8114-3 on inner edge of overdrive piston retainer.

(19) Install overdrive piston in overdrive piston retainer by: aligning locating lugs on overdrive piston to the two mating holes in retainer.

(a) Aligning locating lugs on overdrive piston to the two mating holes in retainer.

(b) Lubricate overdrive piston seals with Mopar® Door Ease, or equivalent.

(c) Install piston over Seal Guide 8114-3 and inside Guide Ring 8114-1.

(d) Push overdrive piston into position in retainer.

(e) Verify that the locating lugs entered the lug bores in the retainer.

## PARK/NEUTRAL POSITION SWITCH

### DIAGNOSIS AND TESTING - PARK/NEUTRAL POSITION SWITCH

The center terminal of the park/neutral position switch is the starter-circuit terminal. It provides the ground for the starter solenoid circuit through the selector lever in PARK and NEUTRAL positions only. The outer terminals on the switch are for the backup lamp circuit.

### SWITCH TEST

To test the switch, remove the wiring connector. Test for continuity between the center terminal and the transmission case. Continuity should exist only when the transmission is in PARK or NEUTRAL.

Shift the transmission into REVERSE and test continuity at the switch outer terminals. Continuity should exist only when the transmission is in REVERSE. Continuity should not exist between the outer terminals and the case.

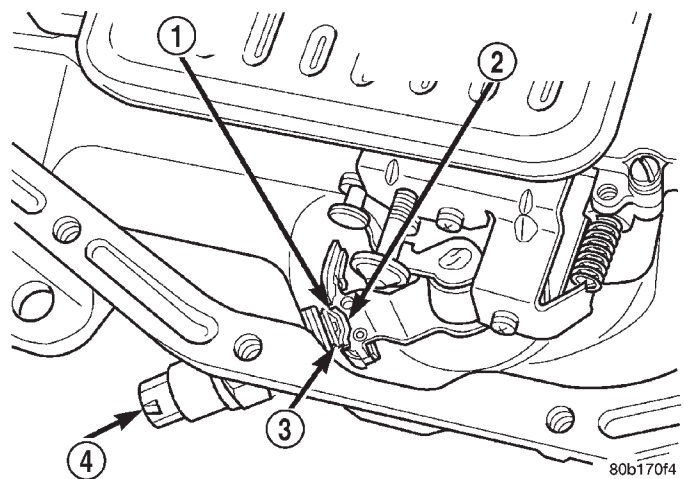
Check gearshift linkage adjustment before replacing a switch that tests faulty.

### REMOVAL

- (1) Raise vehicle and position drain pan under switch.
- (2) Disconnect switch wires.
- (3) Remove switch from case.

### INSTALLATION

- (1) Move shift lever to PARK and NEUTRAL positions. Verify that switch operating lever fingers are centered in switch opening in case (Fig. 196).

**Fig. 196 Park/Neutral Position Switch**

- 1 - NEUTRAL CONTACT
- 2 - MANUAL LEVER AND SWITCH PLUNGER IN REVERSE POSITION
- 3 - PARK CONTACT
- 4 - SWITCH

(2) Install new seal on switch and install switch in case. Tighten switch to 34 N·m (25 ft. lbs.) torque.

(3) Test continuity of new switch with 12V test lamp.

(4) Connect switch wires and lower vehicle.

(5) Top off transmission fluid level.



# PISTONS

## DESCRIPTION

There are several sizes and types of pistons used in an automatic transmission. Some pistons are used to apply clutches, while others are used to apply bands. They all have in common the fact that they are round or circular in shape, located within a smooth walled cylinder, which is closed at one end and converts fluid pressure into mechanical movement. The fluid pressure exerted on the piston is contained within the system through the use of piston rings or seals.

## OPERATION

The principal which makes this operation possible is known as Pascal's Law. Pascal's Law can be stated as: "Pressure on a confined fluid is transmitted equally in all directions and acts with equal force on equal areas."

## PRESSURE

Pressure (Fig. 197) is nothing more than force (lbs.) divided by area (in or ft.), or force per unit area. Given a 100 lb. block and an area of 100 sq. in. on the floor, the pressure exerted by the block is: 100 lbs. 100 in or 1 pound per square inch, or PSI as it is commonly referred to.

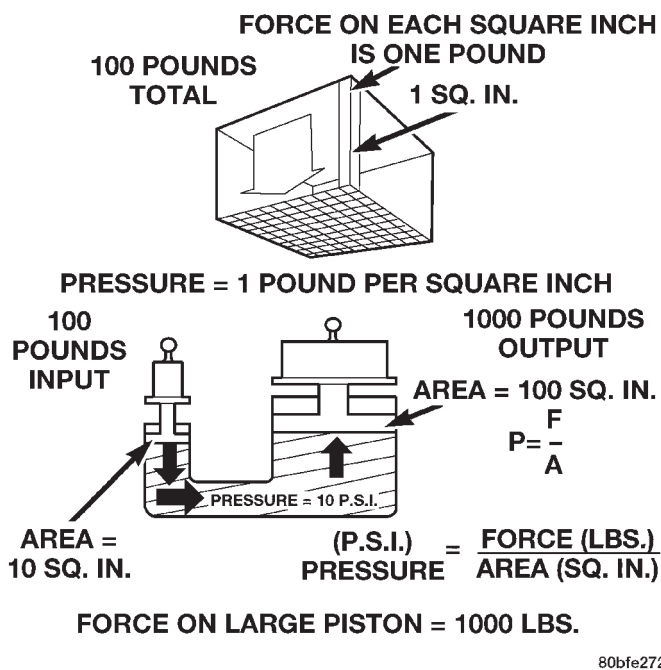
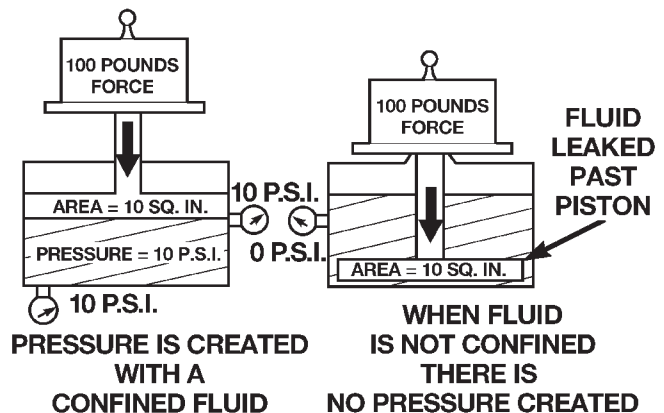


Fig. 197 Force and Pressure Relationship

## PRESSURE ON A CONFINED FLUID

Pressure is exerted on a confined fluid (Fig. 198) by applying a force to some given area in contact with the fluid. A good example of this is a cylinder

filled with fluid and equipped with a piston that is closely fitted to the cylinder wall. If a force is applied to the piston, pressure will be developed in the fluid. Of course, no pressure will be created if the fluid is not confined. It will simply "leak" past the piston. There must be a resistance to flow in order to create pressure. Piston sealing is extremely important in hydraulic operation. Several kinds of seals are used to accomplish this within a transmission. These include but are not limited to O-rings, D-rings, lip seals, sealing rings, or extremely close tolerances between the piston and the cylinder wall. The force exerted is downward (gravity), however, the principle remains the same no matter which direction is taken. The pressure created in the fluid is equal to the force applied, divided by the piston area. If the force is 100 lbs., and the piston area is 10 sq. in., then the pressure created equals 10 PSI. Another interpretation of Pascal's Law is that regardless of container shape or size, the pressure will be maintained throughout, as long as the fluid is confined. In other words, the pressure in the fluid is the same everywhere within the container.



80bfe273

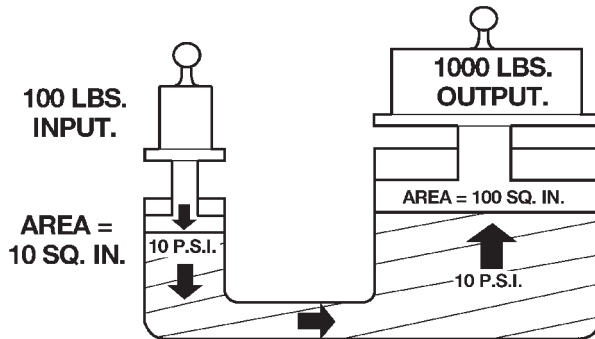
Fig. 198 Pressure on a Confined Fluid

## FORCE MULTIPLICATION

Using the 10 PSI example used in the illustration (Fig. 199), a force of 1000 lbs. can be moved with a force of only 100 lbs. The secret of force multiplication in hydraulic systems is the total fluid contact area employed. The illustration, (Fig. 199), shows an area that is ten times larger than the original area. The pressure created with the smaller 100 lb. input is 10 PSI. The concept "pressure is the same everywhere" means that the pressure underneath the larger piston is also 10 PSI. Pressure is equal to the force applied divided by the contact area. Therefore, by means of simple algebra, the output force may be found. This concept is extremely important, as it is also used in the design and operation of all shift

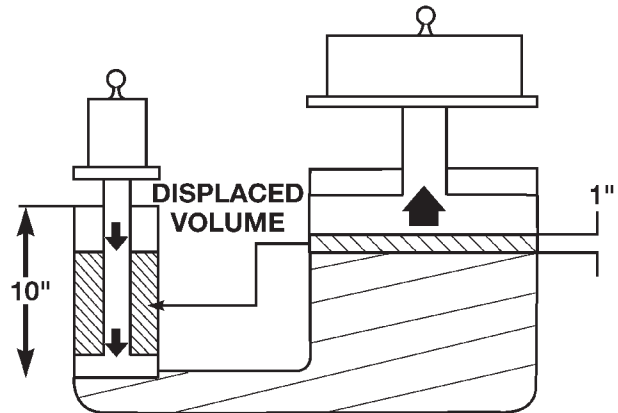
## PISTONS (Continued)

valves and limiting valves in the valve body, as well as the pistons, of the transmission, which activate the clutches and bands. It is nothing more than using a difference of area to create a difference in pressure to move an object.



80bfe274

Fig. 199 Force Multiplication

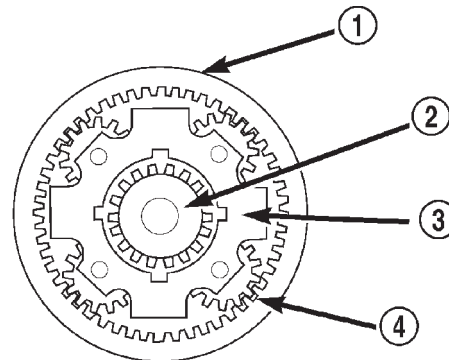


80bfe275

Fig. 200 Piston Travel

## PISTON TRAVEL

The relationship between hydraulic lever and a mechanical lever is the same. With a mechanical lever it's a weight-to-distance output rather than a pressure-to-area output. Using the same forces and areas as in the previous example, the smaller piston (Fig. 200) has to move ten times the distance required to move the larger piston one inch. Therefore, for every inch the larger piston moves, the smaller piston moves ten inches. This principle is true in other instances also. A common garage floor jack is a good example. To raise a car weighing 2000 lbs., an effort of only 100 lbs. may be required. For every inch the car moves upward, the input piston at the jack handle must move 20 inches downward.



80be45fe

Fig. 201 Planetary Gearset

- 1 - ANNULUS GEAR
- 2 - SUN GEAR
- 3 - PLANET CARRIER
- 4 - PLANET PINIONS (4)

PLANETARY GEARTRAIN/  
OUTPUT SHAFT

## DESCRIPTION

The planetary gearsets (Fig. 201) are designated as the front, rear, and overdrive planetary gear assemblies and located in such order. A simple planetary gearset consists of three main members:

- The sun gear which is at the center of the system.
- The planet carrier with planet pinion gears which are free to rotate on their own shafts and are in mesh with the sun gear.
- The annulus gear, which rotates around and is in mesh with the planet pinion gears.

**NOTE:** The number of pinion gears does not affect the gear ratio, only the duty rating.

## OPERATION

With any given planetary gearset, several conditions must be met for power to be able to flow:

- One member must be held.
- Another member must be driven or used as an input.
- The third member may be used as an output for power flow.

PLANETARY GEARTRAIN/OUTPUT SHAFT (Continued)

• For direct drive to occur, two gear members in the front planetary gearset must be driven.

**NOTE:** Gear ratios are dependent on the number of teeth on the annulus and sun gears.

**DISASSEMBLY**

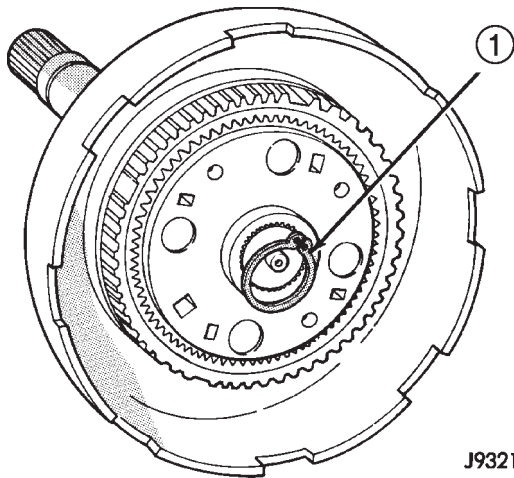
(1) Remove planetary snap-ring from intermediate shaft (Fig. 202). Discard snap-ring as it is not reusable.

(2) Remove front planetary gear and front annulus gear as assembly (Fig. 203).

(3) Remove front planetary gear and thrust washer from front annulus gear (Fig. 204). Note thrust washer position for assembly reference.

(4) Remove tabbed thrust washer from driving shell (Fig. 205). Note washer position for assembly reference.

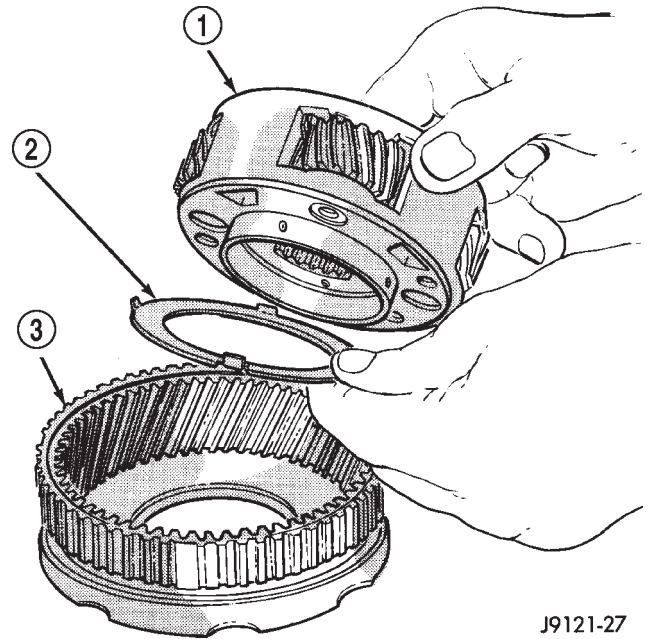
(5) Remove sun gear and driving shell as assembly (Fig. 206).



J9321-168

**Fig. 202 Removing Planetary Snap-Ring**

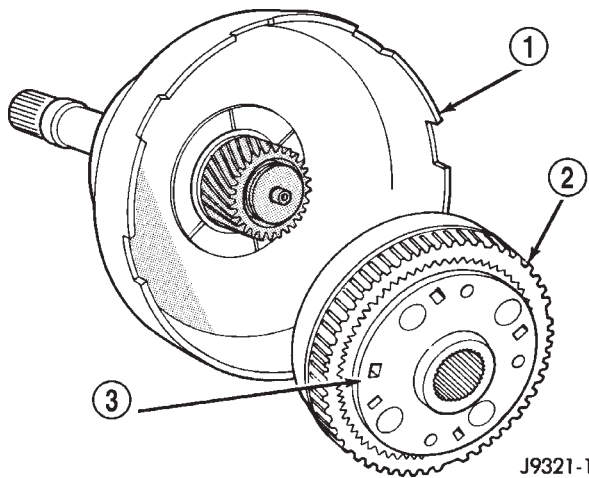
- 1 - PLANETARY SNAP-RING



J9121-27

**Fig. 204 Disassembling Front Planetary And Annulus Gears**

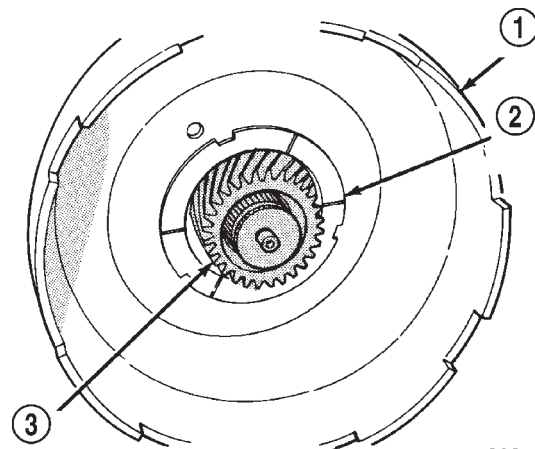
- 1 - FRONT PLANETARY GEAR
- 2 - TABBED THRUST WASHER
- 3 - FRONT ANNULUS GEAR



J9321-169

**Fig. 203 Removing Front Planetary And Annulus Gears**

- 1 - DRIVING SHELL
- 2 - FRONT ANNULUS GEAR
- 3 - FRONT PLANETARY GEAR

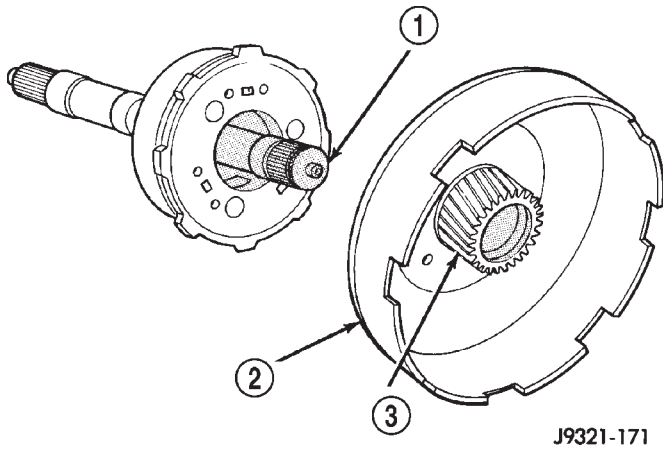


J9321-170

**Fig. 205 Driving Shell Thrust Washer Removal**

- 1 - DRIVING SHELL
- 2 - TABBED THRUST WASHER
- 3 - SUN GEAR

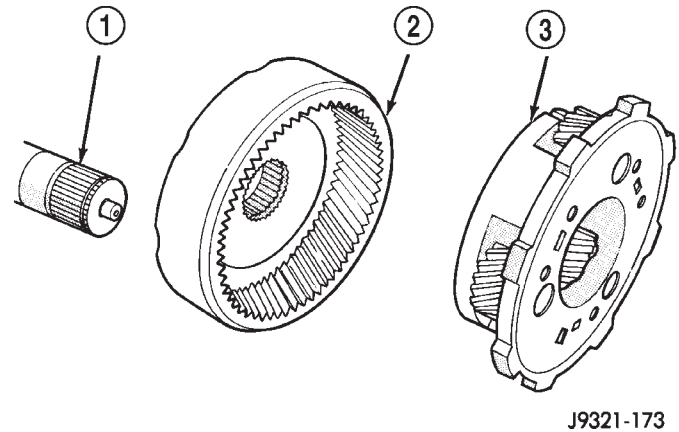
## PLANETARY GEARTRAIN/OUTPUT SHAFT (Continued)



J9321-171

**Fig. 206 Sun Gear And Driving Shell Removal**

- 1 - INTERMEDIATE SHAFT
- 2 - DRIVING SHELL
- 3 - SUN GEAR



J9321-173

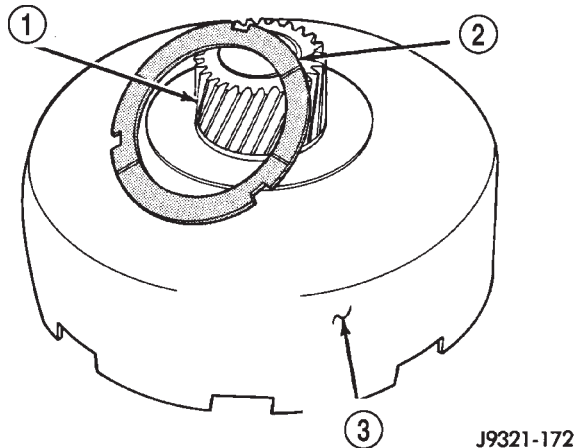
**Fig. 208 Rear Planetary And Annulus Gear Removal**

- 1 - INTERMEDIATE SHAFT
- 2 - REAR ANNULUS GEAR
- 3 - REAR PLANETARY GEAR

(6) Remove tabbed thrust washer from rear planetary gear (Fig. 207). Note washer position on gear for assembly reference.

(7) Remove rear planetary gear and rear annulus gear from intermediate shaft (Fig. 208).

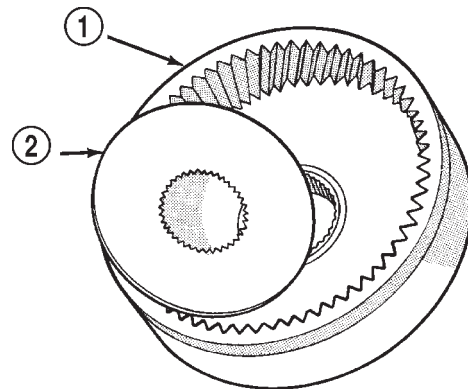
(8) Remove thrust plate from rear annulus gear (Fig. 209).



J9321-172

**Fig. 207 Rear Planetary Thrust Washer Removal**

- 1 - SUN GEAR
- 2 - REAR PLANETARY THRUST WASHER
- 3 - DRIVING SHELL



J9321-174

**Fig. 209 Rear Annulus Thrust Plate Removal**

- 1 - REAR ANNULUS GEAR
- 2 - THRUST PLATE

**INSPECTION**

Inspect the planetary gear sets and annulus gears. The planetary pinions, shafts, washers, and retaining pins are serviceable. However, if a pinion carrier is damaged, the entire planetary gear set must be replaced as an assembly.

Replace the annulus gears if the teeth are chipped, broken, or worn, or the gear is cracked. Replace the

planetary thrust plates and the tabbed thrust washers if cracked, scored or worn.

Inspect the machined surfaces of the intermediate shaft. Be sure the oil passages are open and clear. Replace the shaft if scored, pitted, or damaged.

Inspect the sun gear and driving shell. If either component is worn or damaged, remove the sun gear rear retaining ring and separate the sun gear and thrust plate from the driving shell. Then replace the necessary component.

Replace the sun gear as an assembly if the gear teeth are chipped or worn. Also replace the gear as an assembly if the bushings are scored or worn. The sun gear bushings are not serviceable. Replace the thrust plate if worn, or severely scored. Replace the driving shell if distorted, cracked, or damaged in any way.



PLANETARY GEARTRAIN/OUTPUT SHAFT (Continued)

Replace all snap-rings during geartrain assembly. Reusing snap-rings is not recommended.

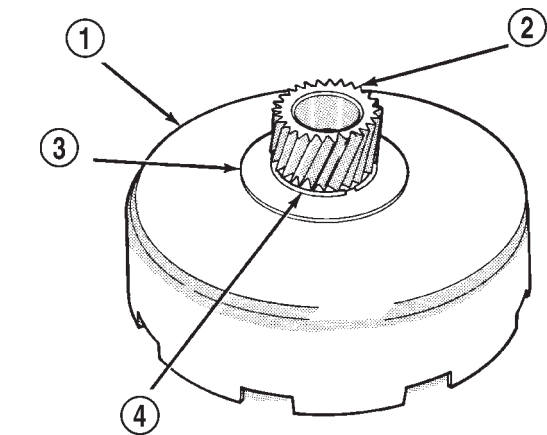
**ASSEMBLY**

(1) Lubricate sun gear and planetary gears with transmission fluid during assembly. Use petroleum jelly to lubricate intermediate shaft bushing surfaces, thrust washers and thrust plates and to hold these parts in place during assembly.

(2) Install front snap-ring on sun gear and install gear in driving shell. Then install thrust plate over sun gear and against rear side of driving shell (Fig. 210). Install rear snap-ring to secure sun gear and thrust plate in driving shell.

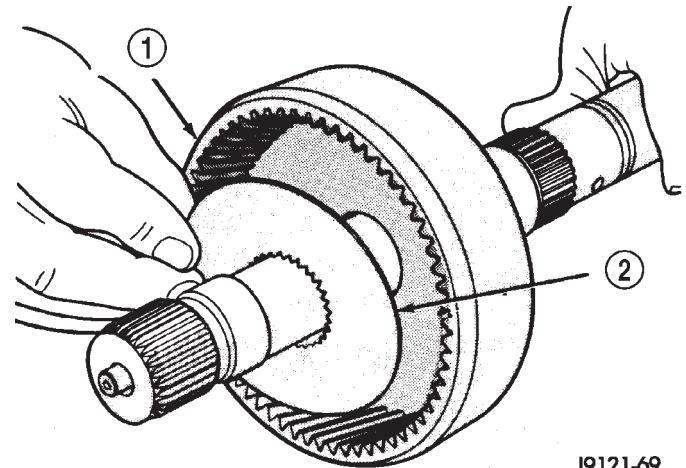
(3) Install rear annulus gear on intermediate shaft (Fig. 211).

(4) Install thrust plate in annulus gear (Fig. 212). Be sure plate is seated on shaft splines and against gear.



**Fig. 210 Sun Gear Installation** J9321-175

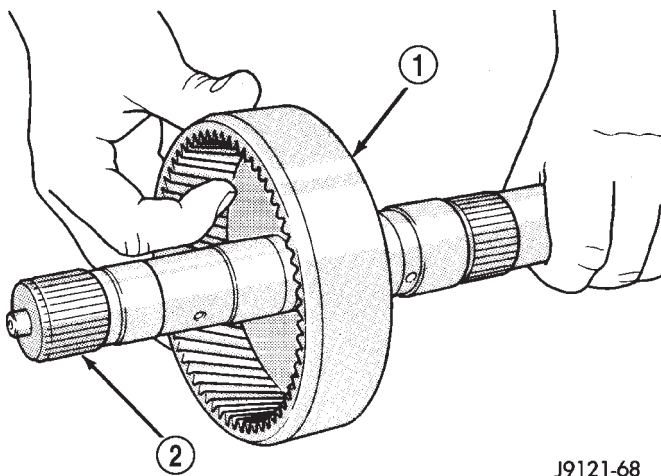
- 1 - DRIVING SHELL
- 2 - SUN GEAR
- 3 - THRUST PLATE
- 4 - SUN GEAR REAR RETAINING RING



**Fig. 212 Installing Rear Annulus Thrust Plate**

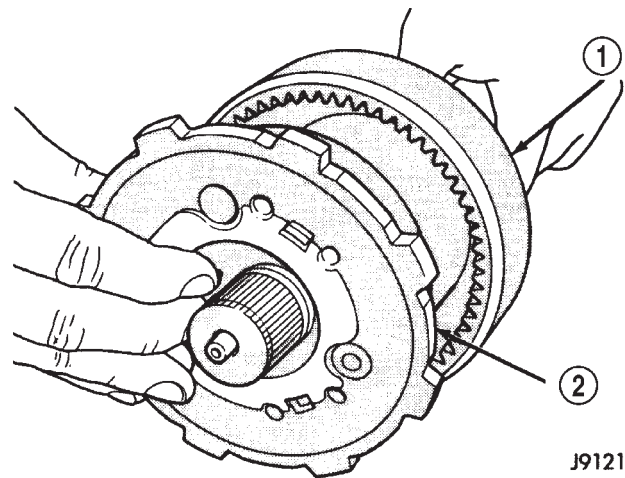
- 1 - REAR ANNULUS GEAR
- 2 - THRUST PLATE

(5) Install rear planetary gear in rear annulus gear (Fig. 213). Be sure planetary carrier is seated against annulus gear.



**Fig. 211 Installing Rear Annulus Gear On Intermediate Shaft** J9121-68

- 1 - REAR ANNULUS GEAR
- 2 - OUTPUT SHAFT



**Fig. 213 Installing Rear Planetary Gear**

- 1 - REAR ANNULUS GEAR
- 2 - REAR PLANETARY GEAR



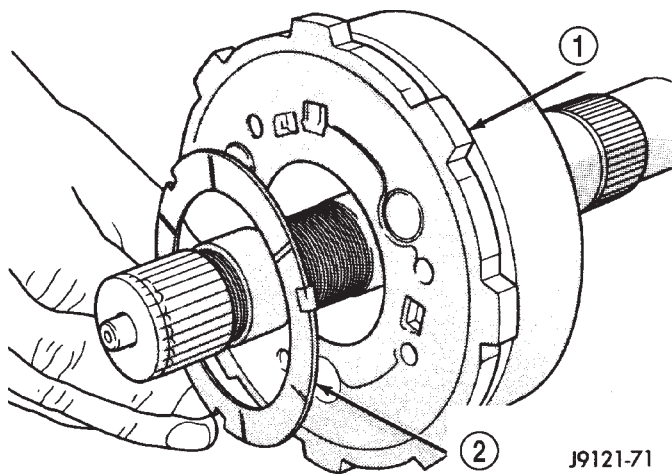
PLANETARY GEARTRAIN/OUTPUT SHAFT (Continued)

(6) Install tabbed thrust washer on front face of rear planetary gear (Fig. 214). Seat washer tabs in matching slots in face of gear carrier. Use extra petroleum jelly to hold washer in place if desired.

(7) Lubricate sun gear bushings with petroleum jelly or transmission fluid.

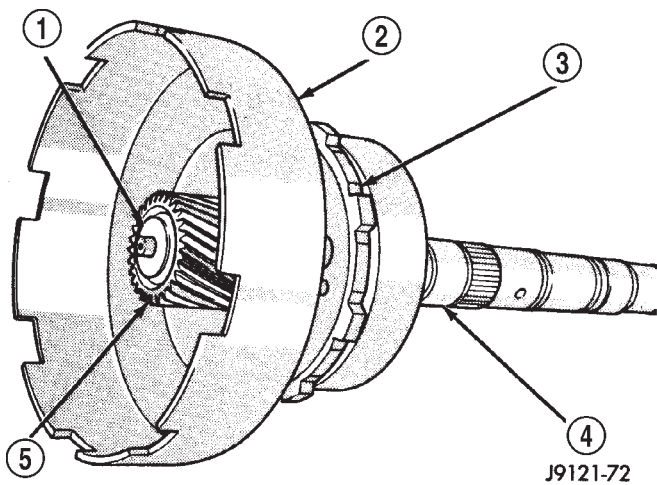
(8) Install sun gear and driving shell on intermediate shaft (Fig. 215). Seat shell against rear planetary gear. Verify that thrust washer on planetary gear was not displaced during installation.

(9) Install tabbed thrust washer in driving shell (Fig. 216), be sure washer tabs are seated in tab slots of driving shell. Use extra petroleum jelly to hold washer in place if desired.



**Fig. 214 Installing Rear Planetary Thrust Washer**

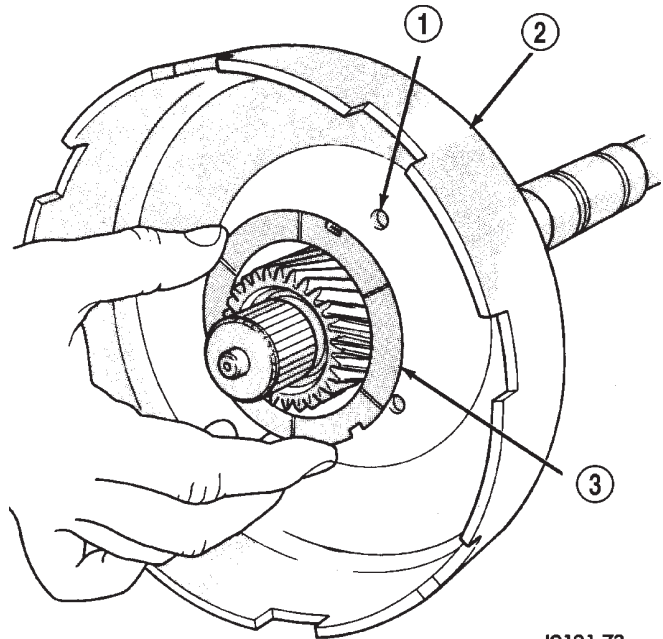
- 1 - REAR PLANETARY GEAR
- 2 - TABBED THRUST WASHER



**Fig. 215 Installing Sun Gear And Driving Shell**

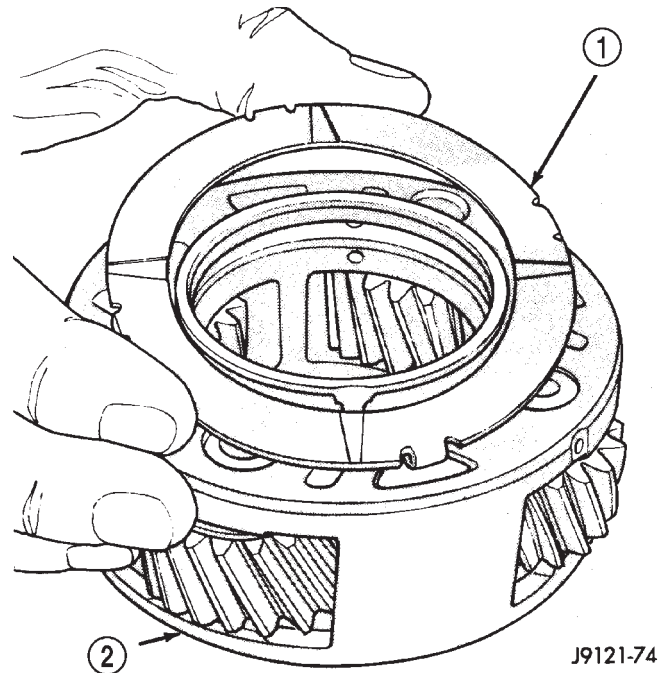
- 1 - OUTPUT SHAFT
- 2 - DRIVING SHELL
- 3 - REAR PLANETARY GEAR
- 4 - OUTPUT SHAFT
- 5 - SUN GEAR

(10) Install tabbed thrust washer on front planetary gear (Fig. 217). Seat washer tabs in matching slots in face of gear carrier. Use extra petroleum jelly to hold washer in place if desired.



**Fig. 216 Installing Driving Shell Thrust Washer**

- 1 - TAB SLOTS (3)
- 2 - DRIVING SHELL
- 3 - TABBED THRUST WASHER



**Fig. 217 Installing Thrust Washer On Front Planetary Gear**

- 1 - TABBED THRUST WASHER
- 2 - FRONT PLANETARY GEAR

## PLANETARY GEARTRAIN/OUTPUT SHAFT (Continued)

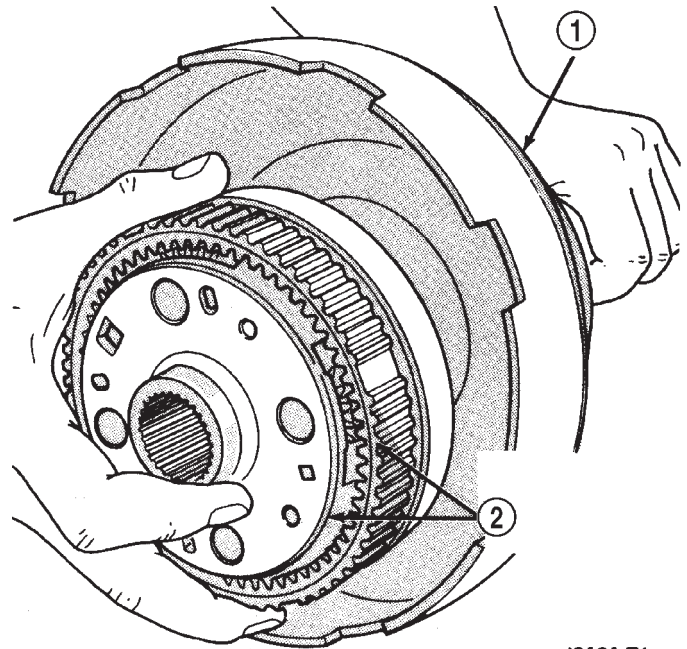
(11) Install front annulus gear over and onto front planetary gear (Fig. 218). Be sure gears are fully meshed and seated.

(12) Install front planetary and annulus gear assembly (Fig. 219). Hold gears together and slide them onto shaft. Be sure planetary pinions are seated on sun gear and that planetary carrier is seated on intermediate shaft.

(13) Place geartrain in upright position. Rotate gears to be sure all components are seated and properly assembled. Snap-ring groove at forward end of intermediate shaft will be completely exposed when components are assembled correctly.

(14) Install new planetary snap-ring in groove at end of intermediate shaft (Fig. 220).

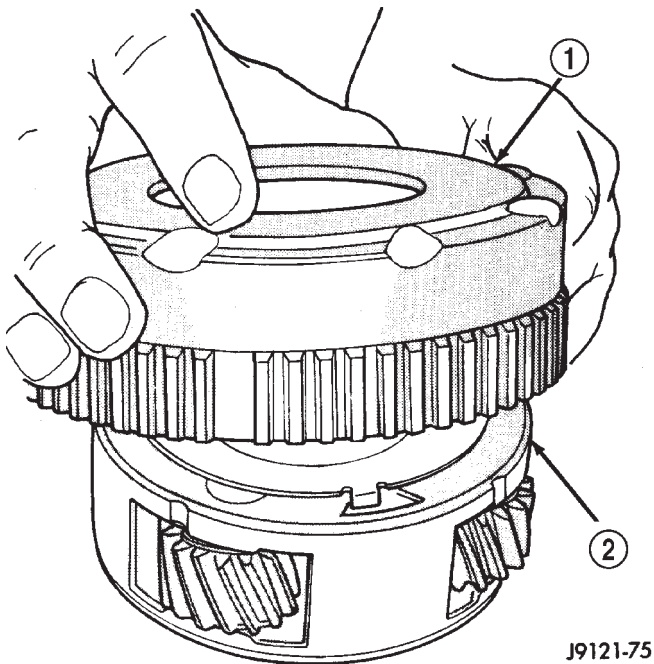
(15) Turn planetary geartrain over. Position wood block under front end of intermediate shaft and support geartrain on shaft. Be sure all geartrain parts have moved forward against planetary snap-ring. This is important for accurate end play check.



J9121-76

**Fig. 219 Installing Front Planetary And Annulus Gear Assembly**

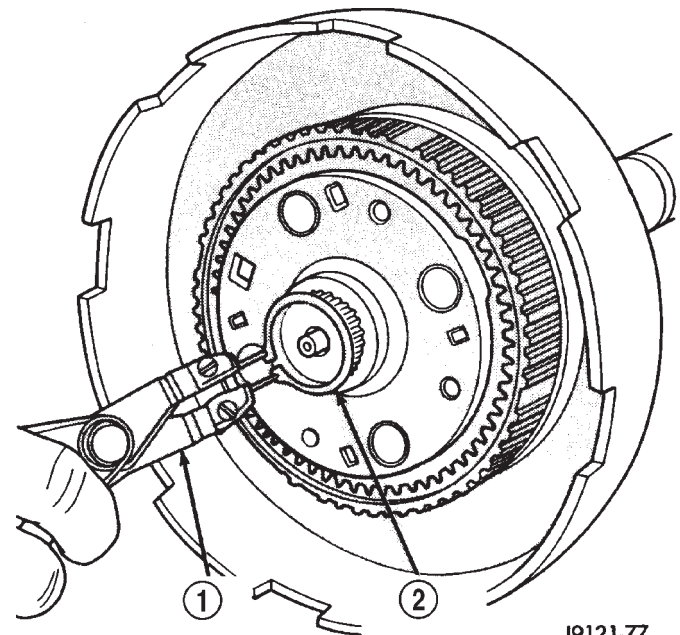
- 1 - DRIVING SHELL  
2 - ASSEMBLED FRONT PLANETARY AND ANNULUS GEARS



J9121-75

**Fig. 218 Assembling Front Planetary And Annulus Gears**

- 1 - FRONT ANNULUS GEAR  
2 - FRONT PLANETARY GEAR



J9121-77

**Fig. 220 Installing Planetary Snap-Ring**

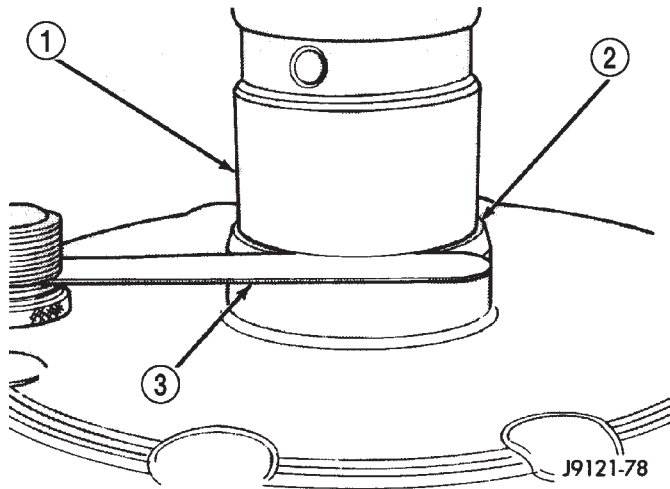
- 1 - SNAP-RING PLIERS  
2 - PLANETARY SNAP-RING

PLANETARY GEARTRAIN/OUTPUT SHAFT (Continued)

(16) Check planetary geartrain end play with feeler gauge (Fig. 221). Insert gauge between rear annulus gear and shoulder on intermediate shaft as

shown. End play should be 0.15 to 1.22 mm (0.006 to 0.048 in.).

(17) If end play is incorrect, install thinner/thicker planetary snap-ring as needed.



**Fig. 221 Checking Planetary Geartrain End Play**

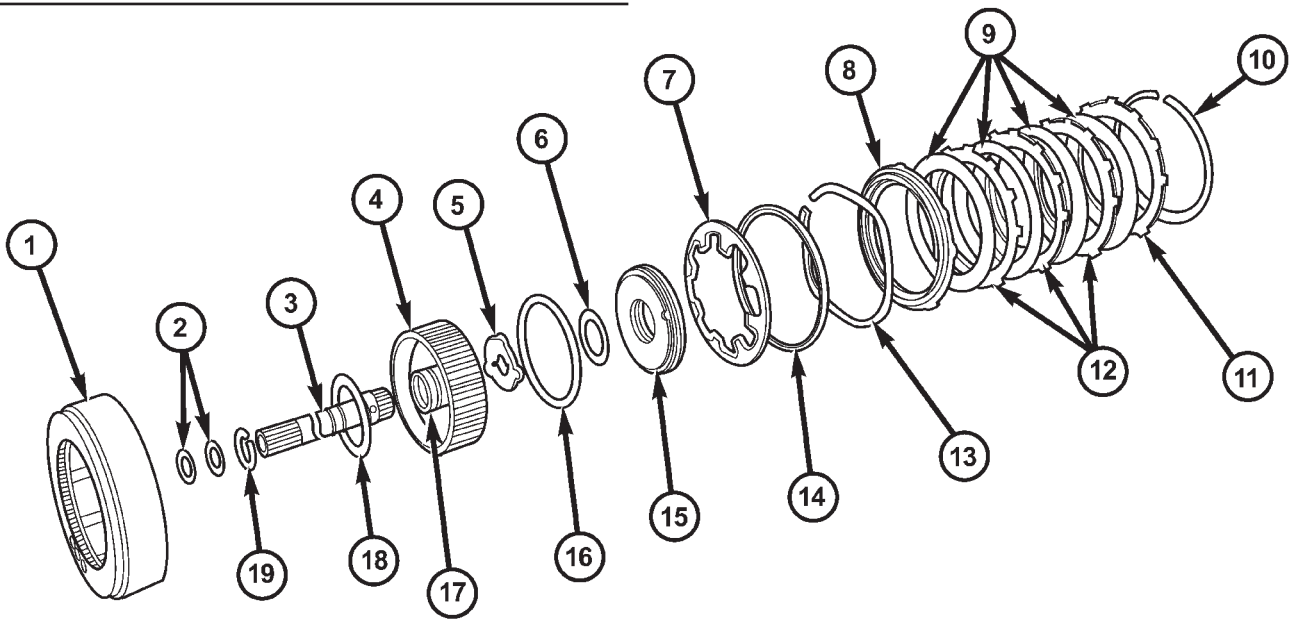
- 1 - OUTPUT SHAFT
- 2 - REAR ANNULUS GEAR
- 3 - FEELER GAUGE

REAR CLUTCH

DESCRIPTION

The rear clutch assembly (Fig. 222) is composed of the rear clutch retainer, pressure plate, clutch plates, driving discs, piston, Belleville spring, and snap-rings. The Belleville spring acts as a lever to multiply the force applied on to it by the apply piston. The increased apply force on the rear clutch pack, in comparison to the front clutch pack, is needed to hold against the greater torque load imposed onto the rear pack. The rear clutch is directly behind the front clutch and is considered a driving component.

**NOTE:** The number of discs and plates may vary with each engine and vehicle combination.



**Fig. 222 Rear Clutch Components**

- 1 - REAR CLUTCH RETAINER
- 2 - TORLON™ SEAL RINGS
- 3 - INPUT SHAFT
- 4 - PISTON RETAINER
- 5 - OUTPUT SHAFT THRUST WASHER
- 6 - INNER PISTON SEAL
- 7 - PISTON SPRING
- 8 - PRESSURE PLATE
- 9 - CLUTCH DISCS
- 10 - SNAP-RING (SELECTIVE)
- 11 - REACTION PLATE
- 12 - CLUTCH PLATES
- 13 - WAVE SPRING
- 14 - SPACER RING
- 15 - PISTON
- 16 - OUTER PISTON SEAL
- 17 - REAR SEAL RING
- 18 - FIBER THRUST WASHER
- 19 - RETAINING RING

## REAR CLUTCH (Continued)

**OPERATION**

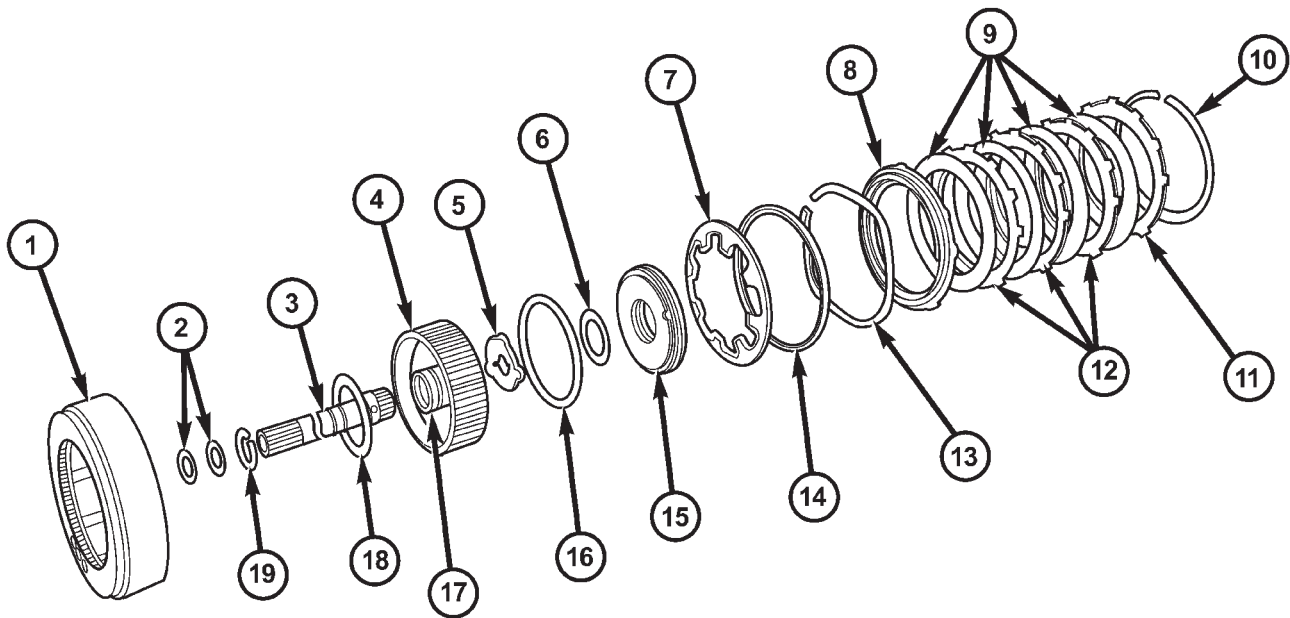
To apply the clutch, pressure is applied between the clutch retainer and piston. The fluid pressure is provided by the oil pump, transferred through the control valves and passageways, and enters the clutch through the hub of the reaction shaft support. With pressure applied between the clutch retainer and piston, the piston moves away from the clutch retainer and compresses the clutch pack. This action applies the clutch pack, allowing torque to flow through the input shaft into the driving discs, and into the clutch plates and pressure plate that are lugged to the clutch retainer. The waved spring is used to cushion the application of the clutch pack. The snap-ring is selective and used to adjust clutch pack clearance.

When pressure is released from the piston, the spring returns the piston to its fully released position and disengages the clutch. The release spring also helps to cushion the application of the clutch assembly. When the clutch is in the process of being released by the release spring, fluid flows through a vent and one-way ball-check-valve located in the pis-

ton. The check-valve is needed to eliminate the possibility of plate drag caused by centrifugal force acting on the residual fluid trapped in the clutch piston retainer.

**DISASSEMBLY**

- (1) Remove fiber thrust washer from forward side of clutch retainer.
- (2) Remove input shaft front and rear seal rings.
- (3) Remove selective clutch pack snap-ring (Fig. 223).
- (4) Remove the reaction plate, clutch discs, steel plates, pressure plate, wave spring, spacer ring, and piston spring (Fig. 223).
- (5) Remove clutch piston with rotating motion.
- (6) Remove and discard piston seals.
- (7) Remove input shaft retaining ring. It may be necessary to press the input shaft in slightly to relieve tension on the retaining ring
- (8) Press input shaft out of retainer with shop press and suitable size press tool. Use a suitably sized press tool to support the retainer as close to the input shaft as possible.



**Fig. 223 Rear Clutch Components**

- |                                |                          |
|--------------------------------|--------------------------|
| 1 - REAR CLUTCH RETAINER       | 11 - REACTION PLATE      |
| 2 - TORLON™ SEAL RINGS         | 12 - CLUTCH PLATES       |
| 3 - INPUT SHAFT                | 13 - WAVE SPRING         |
| 4 - PISTON RETAINER            | 14 - SPACER RING         |
| 5 - OUTPUT SHAFT THRUST WASHER | 15 - PISTON              |
| 6 - INNER PISTON SEAL          | 16 - OUTER PISTON SEAL   |
| 7 - PISTON SPRING              | 17 - REAR SEAL RING      |
| 8 - PRESSURE PLATE             | 18 - FIBER THRUST WASHER |
| 9 - CLUTCH DISCS               | 19 - RETAINING RING      |
| 10 - SNAP-RING (SELECTIVE)     |                          |



## REAR CLUTCH (Continued)

**CLEANING**

Clean the clutch components with solvent and dry them with compressed air. Do not use rags or shop towels to dry any of the clutch parts. Lint from such materials will adhere to component surfaces and could restrict or block fluid passages after assembly.

**INSPECTION**

Replace the clutch discs if warped, worn, scored, burned/charred, the lugs are damaged, or if the facing is flaking off. Replace the top and bottom pressure plates if scored, warped, or cracked. Be sure the driving lugs on the pressure and clutch plates are also in good condition. The lugs must not be bent, cracked or damaged in any way.

Replace the piston spring and wave spring if either part is distorted, warped or broken.

Check the lug grooves in the clutch retainer. The clutch and pressure plates should slide freely in the slots. Replace the retainer if the grooves are worn or damaged. Also check action of the check balls in the retainer and piston. Each check ball must move freely and not stick.

Replace the retainer bushing if worn, scored, or doubt exists about bushing condition.

Inspect the piston and retainer seal surfaces for nicks or scratches. Minor scratches can be removed with crocus cloth. However, replace the piston and/or retainer if the seal surfaces are seriously scored.

Check condition of the fiber thrust washer and metal output shaft thrust washer. Replace either washer if worn or damaged.

Check condition of the seal rings on the input shaft and clutch retainer hub. Replace the seal rings only if worn, distorted, or damaged. The input shaft front seal ring is teflon with chamfered ends. The rear ring is metal with interlocking ends.

Check the input shaft for wear, or damage. Replace the shaft if worn, scored or damaged in any way.

**ASSEMBLY**

(1) Soak clutch discs in transmission fluid while assembling other clutch parts.

(2) Install new seal rings on clutch retainer hub and input shaft if necessary.

(a) Be sure clutch hub seal ring is fully seated in groove and is not twisted.

(3) Lubricate splined end of input shaft and clutch retainer with transmission fluid. Then partially press input shaft into retainer (Fig. 224). Use a suitably sized press tool to support retainer as close to input shaft as possible.

(4) Install input shaft retaining ring.

(5) Press the input shaft the remainder of the way into the clutch retainer.

(6) Install new seals on clutch piston. Be sure lip of each seal faces interior of clutch retainer.

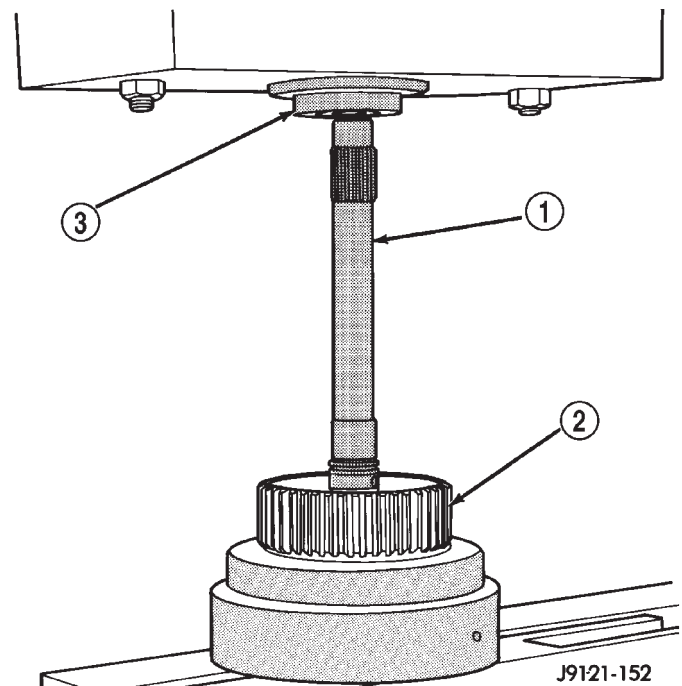
(7) Lubricate lip of piston seals with generous quantity of Mopar® Door Ease. Then lubricate retainer hub and bore with light coat of transmission fluid.

(8) Install clutch piston in retainer. Use twisting motion to seat piston in bottom of retainer. A thin strip of plastic (about 0.020" thick), can be used to guide seals into place if necessary.

**CAUTION: Never push the clutch piston straight in. This will fold the seals over causing leakage and clutch slip. In addition, never use any type of metal tool to help ease the piston seals into place. Metal tools will cut, shave, or score the seals.**

(9) Install piston spring in retainer and on top of piston. Concave side of spring faces downward (toward piston).

(10) Install the spacer ring and wave spring into the retainer. Be sure spring is completely seated in retainer groove.



**Fig. 224 Pressing Input Shaft Into Rear Clutch Retainer**

- 1 - INPUT SHAFT  
2 - REAR CLUTCH RETAINER  
3 - PRESS RAM

(11) Install pressure plate (Fig. 223). Ridged side of plate faces downward (toward piston) and flat side toward clutch pack.

(12) Install first clutch disc in retainer on top of pressure plate. Then install a clutch plate followed



## REAR CLUTCH (Continued)

by a clutch disc until entire clutch pack is installed (4 discs and 3 plates are required) (Fig. 223).

(13) Install the reaction plate.

(14) Install selective snap-ring. Be sure snap-ring is fully seated in retainer groove.

(15) Using a suitable gauge bar and dial indicator, measure clutch pack clearance (Fig. 225).

(a) Position gauge bar across the clutch drum with the dial indicator pointer on the pressure plate (Fig. 225).

(b) Using two small screw drivers, lift the pressure plate and release it.

(c) Zero the dial indicator.

(d) Lift the pressure plate until it contacts the snap-ring and record the dial indicator reading.

Clearance should be 0.635 - 0.914 mm (0.025 - 0.036 in.). If clearance is incorrect, steel plates, discs, selective snap ring and pressure plates may have to be changed.

The selective snap ring thicknesses are:

- 0.107 - 0.109 in.
- 0.098 - 0.100 in.
- 0.095 - 0.097 in.
- 0.083 - 0.085 in.
- 0.076 - 0.078 in.
- 0.071 - 0.073 in.
- 0.060 - 0.062 in.

(16) Coat rear clutch thrust washer with petroleum jelly and install washer over input shaft and into clutch retainer (Fig. 226). Use enough petroleum jelly to hold washer in place.

(17) Set rear clutch aside for installation during final assembly.

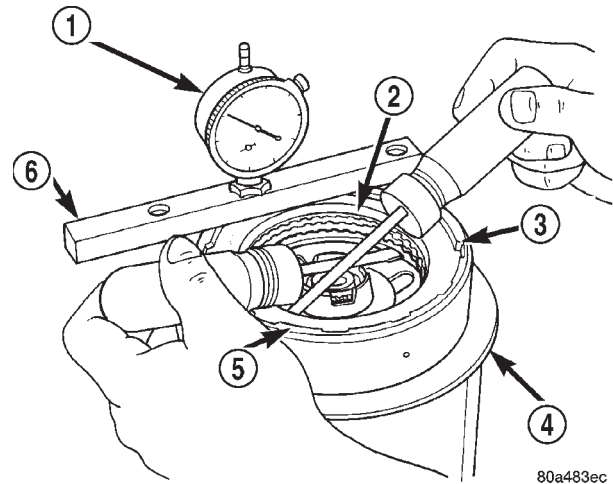
## REAR SERVO

## DESCRIPTION

The rear (low/reverse) servo consists of a single stage or diameter piston and a spring loaded plug. The spring is used to cushion the application of the rear (low/reverse) band.

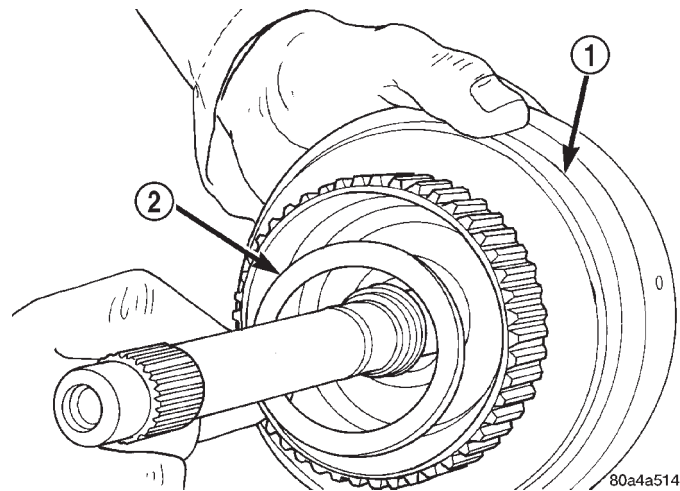
## OPERATION

While in the de-energized state (no pressure applied), the piston is held up in its bore by the piston spring. The plug is held down in its bore, in the piston, by the plug spring. When pressure is applied to the top of the piston, the plug is forced down in its bore, taking up any clearance. As the piston moves, it causes the plug spring to compress, and the piston moves down over the plug. The piston continues to move down until it hits the shoulder of the plug and fully applies the band. The period of time from the initial application, until the piston is against the



**Fig. 225 Checking Rear Clutch Pack Clearance**

- 1 - DIAL INDICATOR
- 2 - PRESSURE PLATE
- 3 - SNAP-RING
- 4 - STAND
- 5 - REAR CLUTCH
- 6 - GAUGE BAR



**Fig. 226 Installing Rear Clutch Thrust Washer**

- 1 - REAR CLUTCH RETAINER
- 2 - REAR CLUTCH THRUST WASHER

shoulder of the plug, represents a reduced shocking of the band that cushions the shift.

## DISASSEMBLY

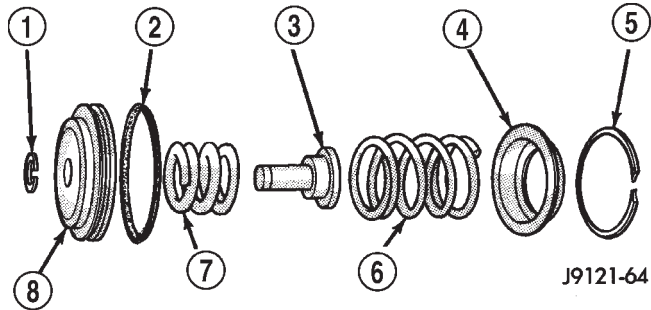
(1) Remove small snap-ring and remove plug and spring from servo piston (Fig. 227).

(2) Remove and discard servo piston seal ring.

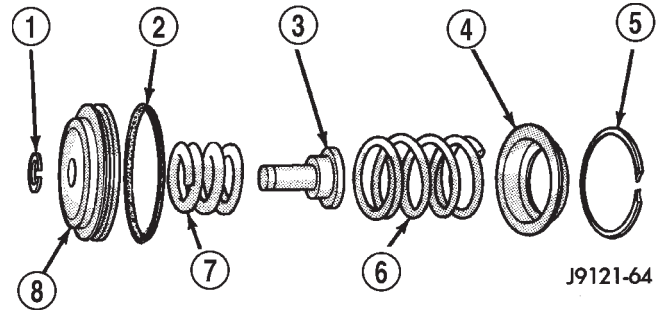
## CLEANING

Remove and discard the servo piston seal ring (Fig. 228). Then clean the servo components with solvent and dry with compressed air. Replace either spring if

## REAR SERVO (Continued)

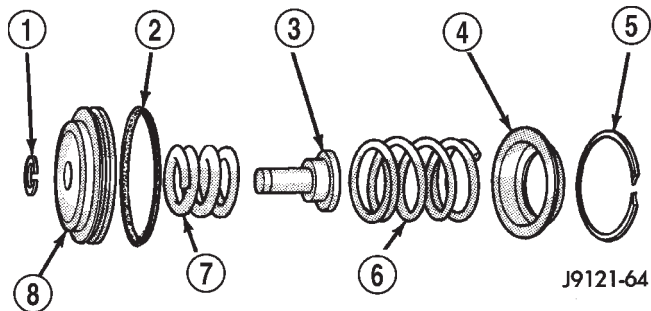
**Fig. 227 Rear Servo Components**

- 1 - SNAP-RING
- 2 - PISTON SEAL
- 3 - PISTON PLUG
- 4 - SPRING RETAINER
- 5 - SNAP-RING
- 6 - PISTON SPRING
- 7 - CUSHION SPRING
- 8 - PISTON

**Fig. 229 Rear Servo Components**

- 1 - SNAP-RING
- 2 - PISTON SEAL
- 3 - PISTON PLUG
- 4 - SPRING RETAINER
- 5 - SNAP-RING
- 6 - PISTON SPRING
- 7 - CUSHION SPRING
- 8 - PISTON

collapsed, distorted or broken. Replace the plug and piston if cracked, bent, or worn. Discard the servo snap-rings and use new ones at assembly.

**Fig. 228 Rear Servo Components**

- 1 - SNAP-RING
- 2 - PISTON SEAL
- 3 - PISTON PLUG
- 4 - SPRING RETAINER
- 5 - SNAP-RING
- 6 - PISTON SPRING
- 7 - CUSHION SPRING
- 8 - PISTON

**ASSEMBLY**

(1) Lubricate piston and guide seals (Fig. 229) with petroleum jelly. Lubricate other servo parts with Mopar® ATF +4, type 9602, transmission fluid.

(2) Install new seal ring on servo piston.

(3) Assemble piston, plug, spring and new snap-ring.

(4) Lubricate piston seal lip with petroleum jelly.

**SHIFT MECHANISM****DESCRIPTION**

The gear shift mechanism provides six shift positions which are:

- PARK (P)
- REVERSE (R)
- NEUTRAL (N)
- DRIVE (D)
- Manual SECOND (2)
- Manual LOW (1)

**OPERATION**

Manual LOW (1) range provides first gear only. Overrun braking is also provided in this range. Manual SECOND (2) range provides first and second gear only.

DRIVE range provides first, second third and overdrive fourth gear ranges. The shift into overdrive fourth gear range occurs only after the transmission has completed the shift into D third gear range. No further movement of the shift mechanism is required to complete the 3-4 shift.

The fourth gear upshift occurs automatically when the overdrive selector switch is in the ON position. No upshift to fourth gear will occur if any of the following are true:

- The transmission fluid temperature is below 10° C (50° F) or above 121° C (250° F).
- The shift to third is not yet complete.
- Vehicle speed is too low for the 3-4 shift to occur.
- Battery temperature is below -5° C (23° F).

## SHIFT MECHANISM (Continued)

## ADJUSTMENT

Check linkage adjustment by starting engine in PARK and NEUTRAL. Adjustment is acceptable if the engine starts in only these two positions. Adjustment is incorrect if the engine starts in one position but not both positions.

If the engine starts in any other position, or if the engine will not start in any position, the park/neutral switch is probably faulty.

## LINKAGE ADJUSTMENT

Check condition of the shift linkage (Fig. 230). Do not attempt adjustment if any component is loose, worn, or bent. Replace any suspect components.

Replace the grommet securing the shift rod or torque rod in place if either rod was removed from the grommet. Remove the old grommet as necessary and use suitable pliers to install the new grommet.

- (1) Shift transmission into PARK.
- (2) Raise and support vehicle.
- (3) Loosen lock bolt in front shift rod adjusting swivel (Fig. 230).
- (4) Ensure that the shift rod slides freely in the swivel. Lube rod and swivel as necessary.
- (5) Move transmission shift lever fully rearward to the Park detent.
- (6) Center adjusting swivel on shift rod.
- (7) Tighten swivel lock bolt to 10 N·m (90 in. lbs.).
- (8) Lower vehicle and verify proper adjustment.

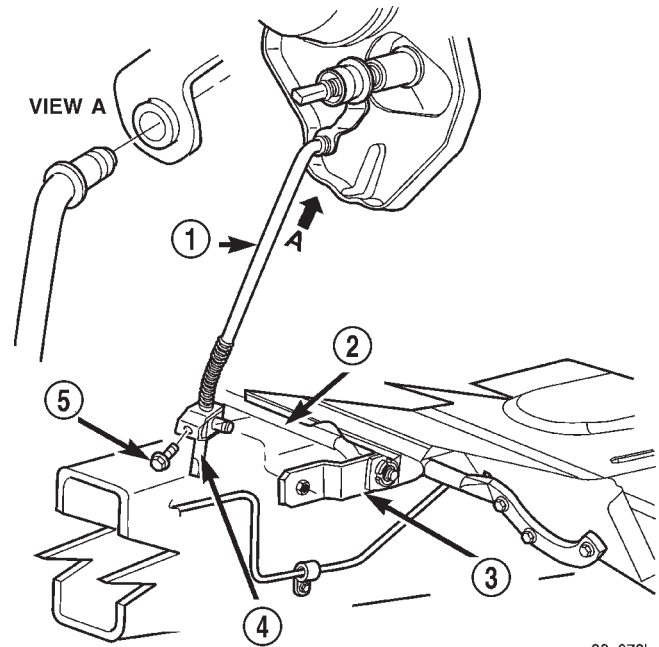
## SOLENOID

## DESCRIPTION

The typical electrical solenoid used in automotive applications is a linear actuator. It is a device that produces motion in a straight line. This straight line motion can be either forward or backward in direction, and short or long distance.

A solenoid is an electromechanical device that uses a magnetic force to perform work. It consists of a coil of wire, wrapped around a magnetic core made from steel or iron, and a spring loaded, movable plunger, which performs the work, or straight line motion.

The solenoids used in transmission applications are attached to valves which can be classified as **normally open** or **normally closed**. The **normally open** solenoid valve is defined as a valve which allows hydraulic flow when no current or voltage is applied to the solenoid. The **normally closed** solenoid valve is defined as a valve which does not allow hydraulic flow when no current or voltage is applied to the solenoid. These valves perform hydraulic control functions for the transmission and must therefore be durable and tolerant of dirt particles. For these reasons, the valves have hardened steel pop-



80c072ba

**Fig. 230 Linkage Adjustment Components**

- 1 - FRONT SHIFT ROD
- 2 - TORQUE SHAFT ASSEMBLY
- 3 - TORQUE SHAFT ARM
- 4 - ADJUSTING SWIVEL
- 5 - LOCK BOLT

pets and ball valves. The solenoids operate the valves directly, which means that the solenoids must have very high outputs to close the valves against the sizable flow areas and line pressures found in current transmissions. Fast response time is also necessary to ensure accurate control of the transmission.

The strength of the magnetic field is the primary force that determines the speed of operation in a particular solenoid design. A stronger magnetic field will cause the plunger to move at a greater speed than a weaker one. There are basically two ways to increase the force of the magnetic field:

- Increase the amount of current applied to the coil or
- Increase the number of turns of wire in the coil.

The most common practice is to increase the number of turns by using thin wire that can completely fill the available space within the solenoid housing. The strength of the spring and the length of the plunger also contribute to the response speed possible by a particular solenoid design.

A solenoid can also be described by the method by which it is controlled. Some of the possibilities include variable force, pulse-width modulated, constant ON, or duty cycle. The variable force and pulse-width modulated versions utilize similar methods to control the current flow through the solenoid to position the solenoid plunger at a desired position some-

## SOLENOID (Continued)

where between full ON and full OFF. The constant ON and duty cycled versions control the voltage across the solenoid to allow either full flow or no flow through the solenoid's valve.

## OPERATION

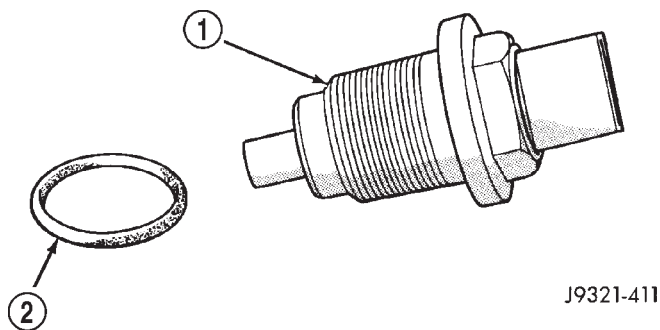
When an electrical current is applied to the solenoid coil, a magnetic field is created which produces an attraction to the plunger, causing the plunger to move and work against the spring pressure and the load applied by the fluid the valve is controlling. The plunger is normally directly attached to the valve which it is to operate. When the current is removed from the coil, the attraction is removed and the plunger will return to its original position due to spring pressure.

The plunger is made of a conductive material and accomplishes this movement by providing a path for the magnetic field to flow. By keeping the air gap between the plunger and the coil to the minimum necessary to allow free movement of the plunger, the magnetic field is maximized.

## SPEED SENSOR

## DESCRIPTION

The speed sensor (Fig. 231) is located in the over-drive gear case. The sensor is positioned over the park gear and monitors transmission output shaft rotating speed.



J9321-411

**Fig. 231 Transmission Output Speed Sensor**

- 1 - TRANSMISSION OUTPUT SHAFT SPEED SENSOR
- 2 - SEAL

## OPERATION

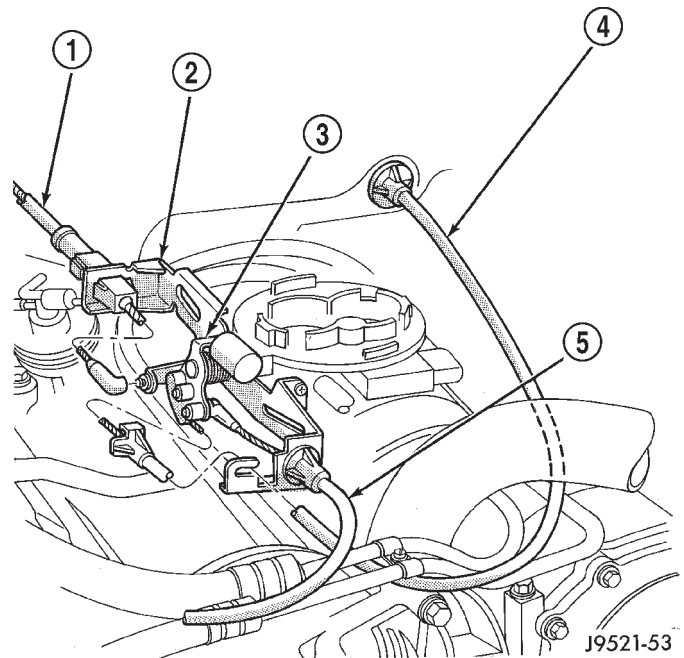
Speed sensor signals are triggered by the park gear lugs as they rotate past the sensor pickup face. Input signals from the sensor are sent to the transmission control module for processing. Signals from this sensor are shared with the powertrain control module.

## THROTTLE VALVE CABLE

## DESCRIPTION

Transmission throttle valve cable (Fig. 232) adjustment is extremely important to proper operation. This adjustment positions the throttle valve, which controls shift speed, quality, and part-throttle down-shift sensitivity.

If cable setting is too loose, early shifts and slippage between shifts may occur. If the setting is too tight, shifts may be delayed and part throttle down-shifts may be very sensitive.



J9521-53

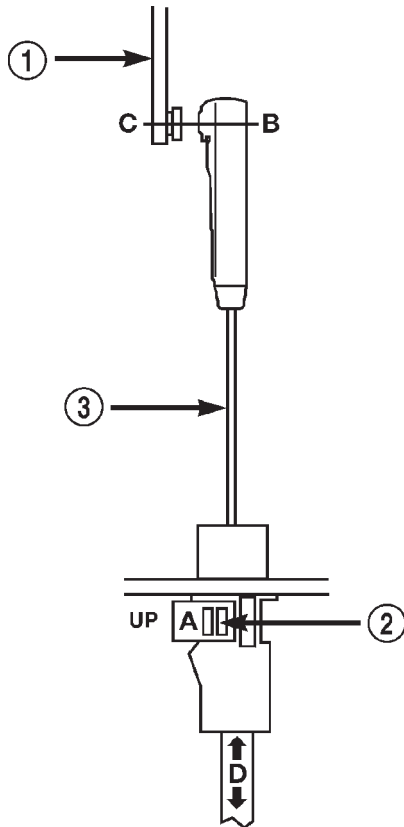
**Fig. 232 Throttle Valve Cable Attachment - At Engine**

- 1 - THROTTLE VALVE CABLE
- 2 - CABLE BRACKET
- 3 - THROTTLE BODY LEVER
- 4 - ACCELERATOR CABLE
- 5 - SPEED CONTROL CABLE



## THROTTLE VALVE CABLE (Continued)

The transmission throttle valve is operated by a cam on the throttle lever. The throttle lever is operated by an adjustable cable (Fig. 233). The cable is attached to an arm mounted on the throttle lever shaft. A retaining clip at the engine-end of the cable is removed to provide for cable adjustment. The retaining clip is then installed back onto the throttle valve cable to lock in the adjustment.



80bce9fb

**Fig. 233 Throttle Valve Cable at Throttle Linkage**

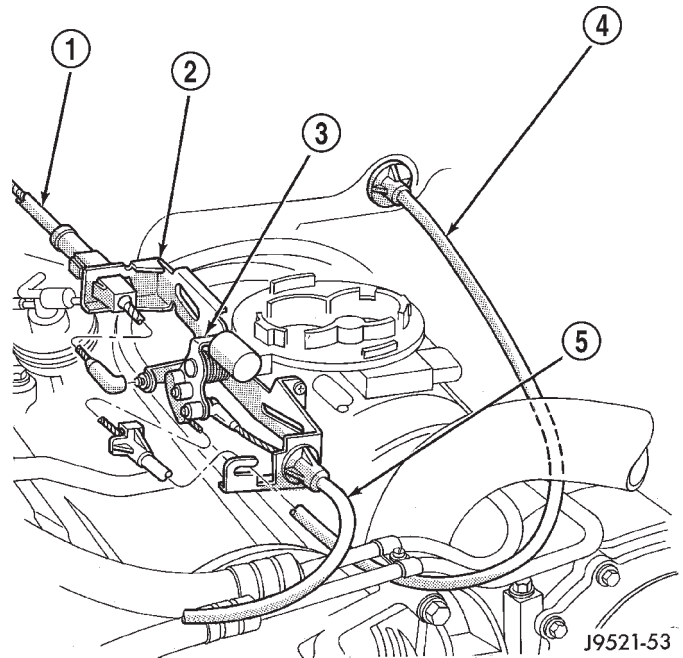
- 1 - THROTTLE LINKAGE
- 2 - THROTTLE VALVE CABLE LOCKING CLIP
- 3 - THROTTLE VALVE CABLE

## ADJUSTMENTS - TRANSMISSION THROTTLE VALVE CABLE

A correctly adjusted throttle valve cable will cause the throttle lever on the transmission to move simultaneously with the throttle body lever from the idle position. Proper adjustment will allow simultaneous movement without causing the transmission throttle lever to either move ahead of, or lag behind the lever on the throttle body.

### ADJUSTMENT VERIFICATION

- (1) Turn ignition key to OFF position.
- (2) Remove air cleaner.



J9521-53

**Fig. 234 Throttle Valve Cable Attachment - At Engine**

- 1 - THROTTLE VALVE CABLE
- 2 - CABLE BRACKET
- 3 - THROTTLE BODY LEVER
- 4 - ACCELERATOR CABLE
- 5 - SPEED CONTROL CABLE

(3) Verify that lever on throttle body is at curb idle position (Fig. 234). Then verify that the transmission throttle lever (Fig. 235) is also at idle (fully forward) position.

(4) Slide cable off attachment stud on throttle body lever.

(5) Compare position of cable end to attachment stud on throttle body lever:

- Cable end and attachment stud should be aligned (or centered on one another) to within 1 mm (0.039 in.) in either direction (Fig. 236).

- If cable end and attachment stud are misaligned (off center), cable will have to be adjusted as described in Throttle Valve Cable Adjustment procedure.

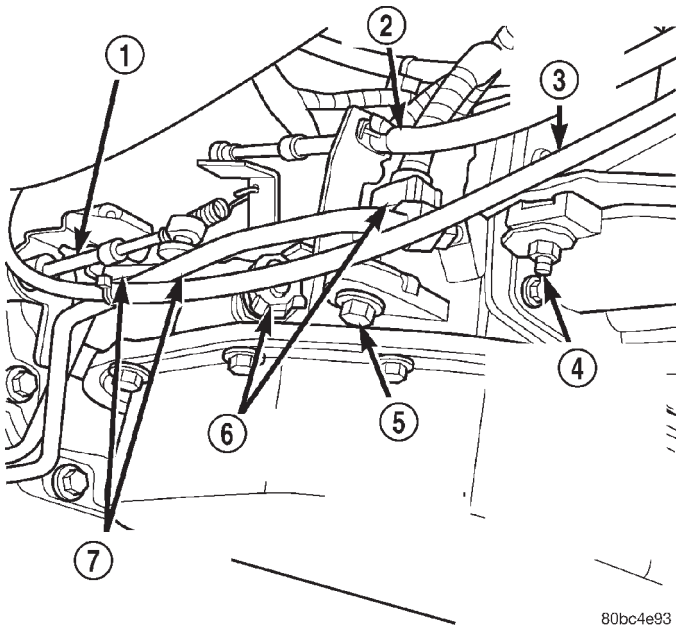
(6) Reconnect cable end to attachment stud. Then with aid of a helper, observe movement of transmission throttle lever and lever on throttle body.

- If both levers move simultaneously from idle to half-throttle and back to idle position, adjustment is correct.

- If transmission throttle lever moves ahead of, or lags behind throttle body lever, cable adjustment will be necessary. Or, if throttle body lever prevents transmission lever from returning to closed position, cable adjustment will be necessary.



## THROTTLE VALVE CABLE (Continued)



80bc4e93

**Fig. 235 Throttle Valve Cable at Transmission**

- 1 - TRANSMISSION SHIFTER CABLE
- 2 - THROTTLE VALVE CABLE
- 3 - TRANSFER CASE SHIFTER CABLE
- 4 - TRANSFER CASE SHIFTER CABLE BRACKET RETAINING BOLT (1 OR 2)
- 5 - THROTTLE VALVE CABLE BRACKET RETAINING BOLT
- 6 - ELECTRICAL CONNECTORS
- 7 - TRANSMISSION FLUID LINES

### ADJUSTMENT PROCEDURE

- (1) Turn ignition switch to OFF position.
- (2) Remove air cleaner if necessary.
- (3) Disconnect cable end from attachment stud.

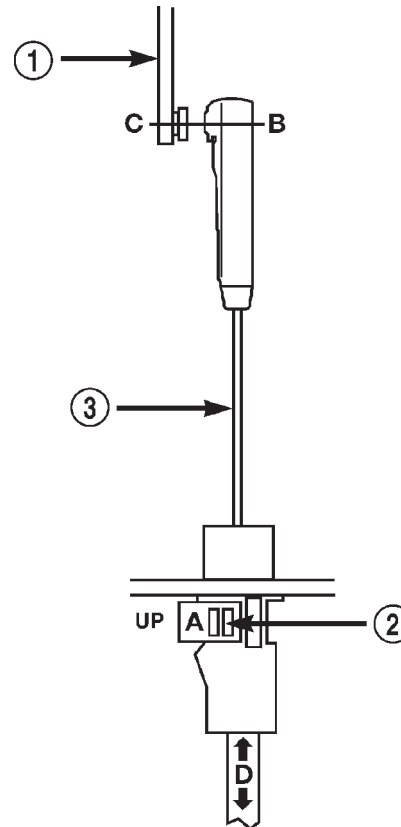
**Carefully slide cable off stud. Do not pry or pull cable off.**

(4) Verify that transmission throttle lever is in fully closed position. Then be sure lever on throttle body is at curb idle position.

(5) Pry the T.V. cable lock (A) into the UP position (Fig. 236). This will unlock the cable and allow for readjustment.

(6) Apply just enough tension on the T.V. cable (B) to remove any slack in the cable. **Pulling too tight will cause the T.V. lever on the transmission to move out of its idle position, which will result in an incorrect T.V. cable adjustment.** Slide the sheath of the T.V. cable (D) back and forth until the centerlines of the T.V. cable end (B) and the throttle bell crank lever (C) are aligned within one millimeter (1mm) (Fig. 236).

(7) While holding the T.V. cable in the set position push the T.V. cable lock (A) into the down position (Fig. 236). This will lock the present T.V. cable adjustment.



80bce9fb

**Fig. 236 Throttle Valve Cable at Throttle Linkage**

- 1 - THROTTLE LINKAGE
- 2 - THROTTLE VALVE CABLE LOCKING CLIP
- 3 - THROTTLE VALVE CABLE

**NOTE:** Be sure that as the cable is pulled forward and centered on the throttle lever stud, the cable housing moves smoothly with the cable. Due to the angle at which the cable housing enters the spring housing, the cable housing may bind slightly and create an incorrect adjustment.

(8) Reconnect the T.V. cable (B) to the throttle bellcrank lever (C).

(9) Check cable adjustment. Verify transmission throttle lever and lever on throttle body move simultaneously.

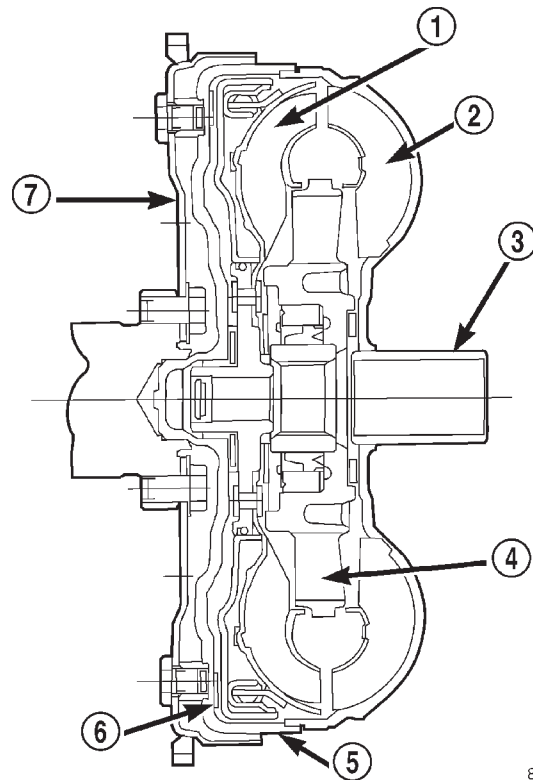
## TORQUE CONVERTER

### DESCRIPTION

The torque converter (Fig. 237) is a hydraulic device that couples the engine crankshaft to the transmission. The torque converter consists of an outer shell with an internal turbine, a stator, an overrunning clutch, an impeller and an electronically applied converter clutch. The converter clutch provides reduced engine speed and greater fuel economy when engaged. Clutch engagement also provides reduced transmission fluid temperatures. The torque converter hub drives the transmission oil (fluid) pump.

The torque converter is a sealed, welded unit that is not repairable and is serviced as an assembly.

**CAUTION:** The torque converter must be replaced if a transmission failure resulted in large amounts of metal or fiber contamination in the fluid. If the fluid is contaminated, flush the all transmission fluid cooler(s) and lines.



80c07135

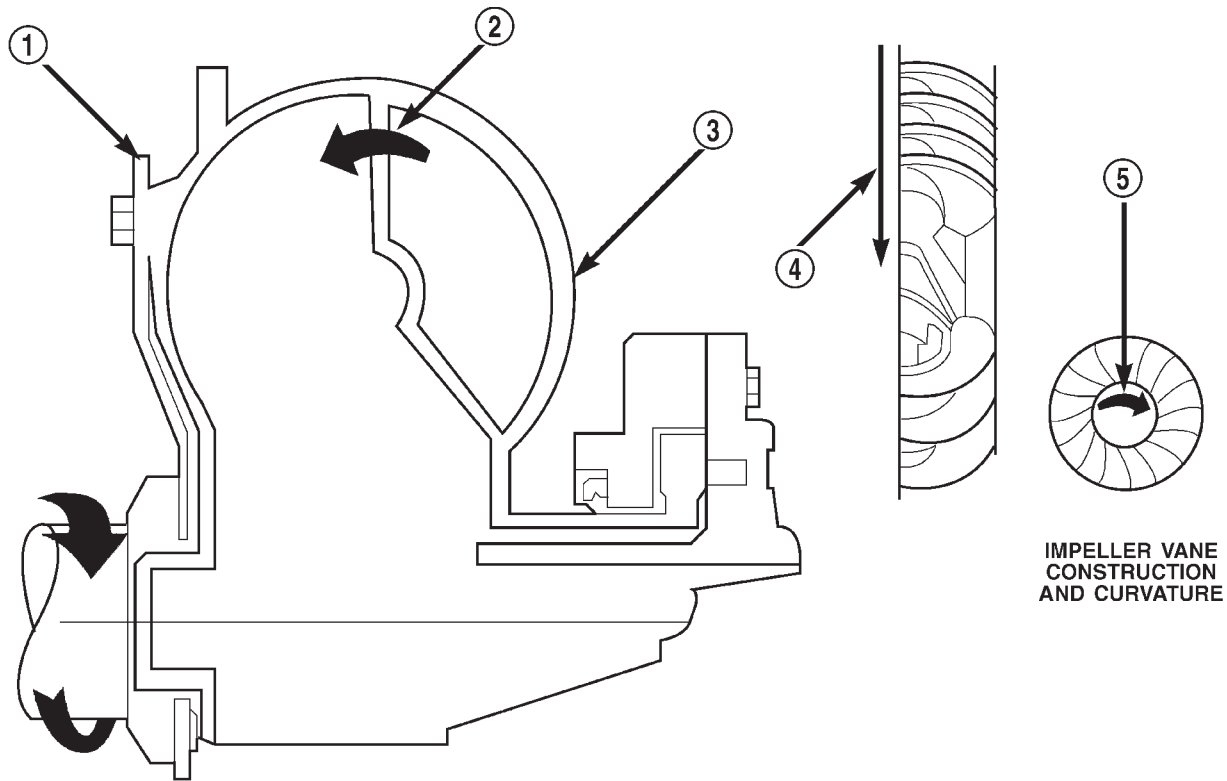
**Fig. 237 Torque Converter Assembly**

- 1 - TURBINE
- 2 - IMPELLER
- 3 - HUB
- 4 - STATOR
- 5 - FRONT COVER
- 6 - CONVERTER CLUTCH DISC
- 7 - DRIVE PLATE

TORQUE CONVERTER (Continued)

**IMPELLER**

The impeller (Fig. 238) is an integral part of the converter housing. The impeller consists of curved blades placed radially along the inside of the housing on the transmission side of the converter. As the converter housing is rotated by the engine, so is the impeller, because they are one and the same and are the driving members of the system.



**Fig. 238 Impeller**

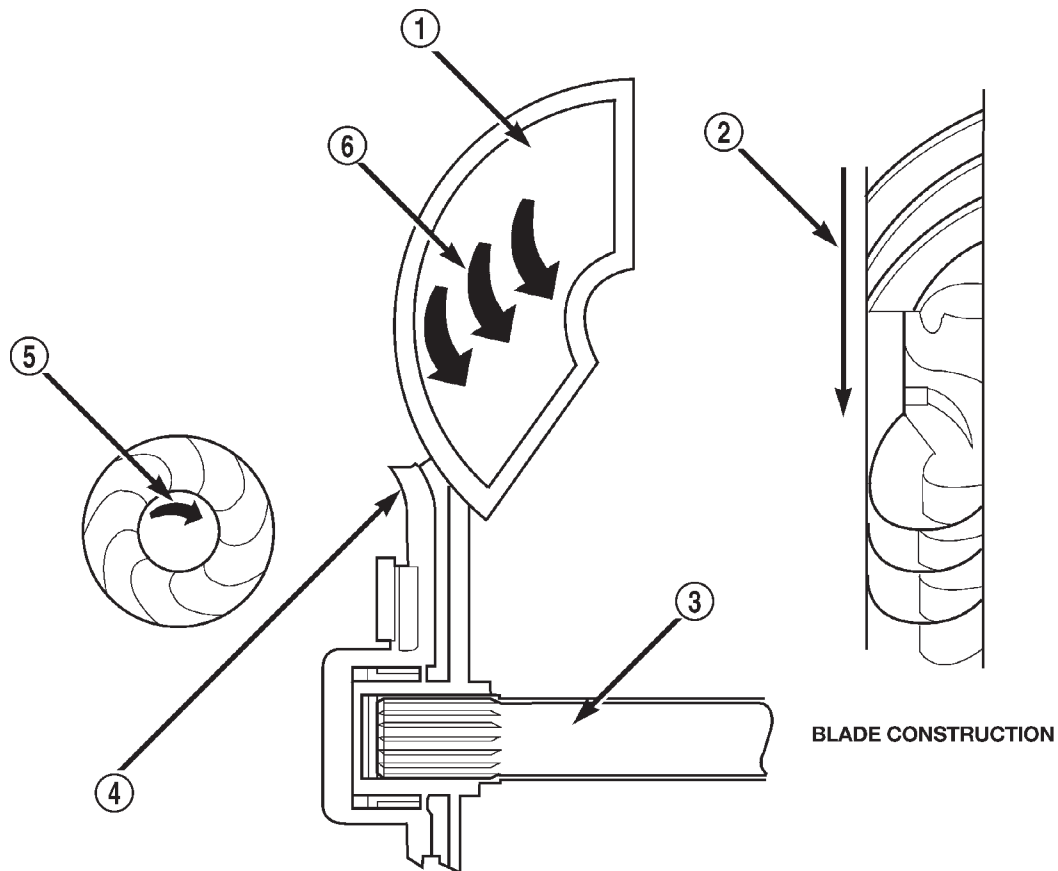
80bfe26a

- |   |                     |
|---|---------------------|
| 1 - ENGINE FLEXPLATE                                    | 4 - ENGINE ROTATION |
| 2 - OIL FLOW FROM IMPELLER SECTION INTO TURBINE SECTION | 5 - ENGINE ROTATION |
| 3 - IMPELLER VANES AND COVER ARE INTEGRAL               |                     |

## TORQUE CONVERTER (Continued)

## TURBINE

The turbine (Fig. 239) is the output, or driven, member of the converter. The turbine is mounted within the housing opposite the impeller, but is not attached to the housing. The input shaft is inserted through the center of the impeller and splined into the turbine. The design of the turbine is similar to the impeller, except the blades of the turbine are curved in the opposite direction.



80bfe26b

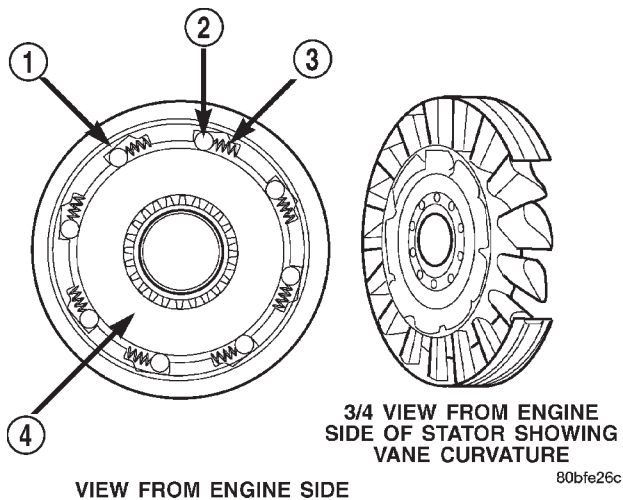
**Fig. 239 Turbine**

- |                     |                                       |
|---------------------|---------------------------------------|
| 1 - TURBINE VANE    | 4 - PORTION OF TORQUE CONVERTER COVER |
| 2 - ENGINE ROTATION | 5 - ENGINE ROTATION                   |
| 3 - INPUT SHAFT     | 6 - OIL FLOW WITHIN TURBINE SECTION   |

## TORQUE CONVERTER (Continued)

## STATOR

The stator assembly (Fig. 240) is mounted on a stationary shaft which is an integral part of the oil pump. The stator is located between the impeller and turbine within the torque converter case (Fig. 241). The stator contains an over-running clutch, which allows the stator to rotate only in a clockwise direction. When the stator is locked against the over-running clutch, the torque multiplication feature of the torque converter is operational.

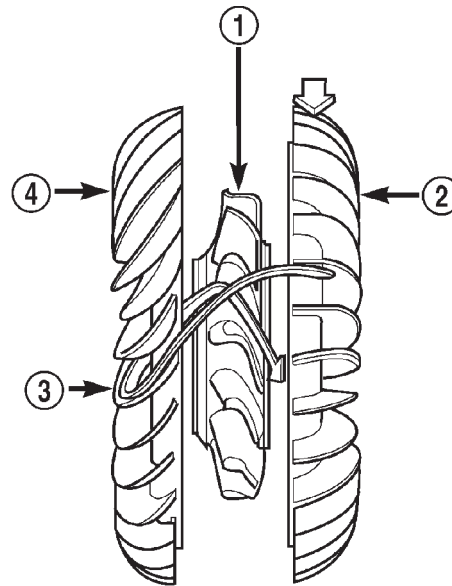


**Fig. 240 Stator Components**

- 1 - CAM (OUTER RACE)
- 2 - ROLLER
- 3 - SPRING
- 4 - INNER RACE

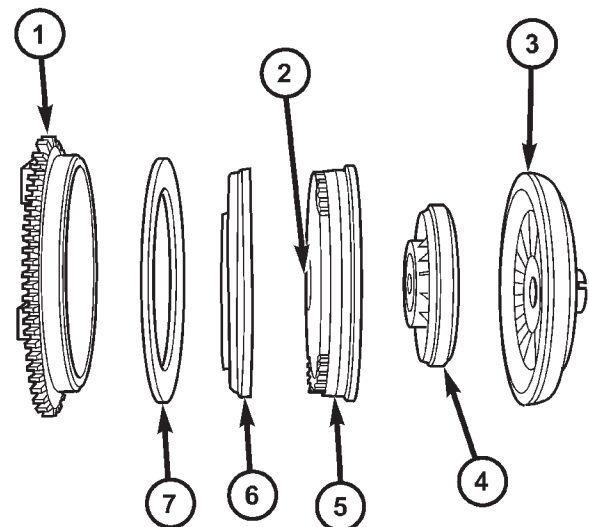
## TORQUE CONVERTER CLUTCH (TCC)

The TCC (Fig. 242) was installed to improve the efficiency of the torque converter that is lost to the slippage of the fluid coupling. Although the fluid coupling provides smooth, shock-free power transfer, it is natural for all fluid couplings to slip. If the impeller and turbine were mechanically locked together, a zero slippage condition could be obtained. A hydraulic piston was added to the turbine, and a friction material was added to the inside of the front cover to provide this mechanical lock-up.



**Fig. 241 Stator Location**

- 1 - STATOR
- 2 - IMPELLER
- 3 - FLUID FLOW
- 4 - TURBINE



**Fig. 242 Torque Converter Clutch (TCC)**

- 1 - IMPELLER FRONT COVER
- 2 - THRUST WASHER ASSEMBLY
- 3 - IMPELLER
- 4 - STATOR
- 5 - TURBINE
- 6 - PISTON
- 7 - FRICTION DISC



## TORQUE CONVERTER (Continued)

## OPERATION

The converter impeller (Fig. 243) (driving member), which is integral to the converter housing and bolted to the engine drive plate, rotates at engine speed. The converter turbine (driven member), which reacts from fluid pressure generated by the impeller, rotates and turns the transmission input shaft.

## TURBINE

As the fluid that was put into motion by the impeller blades strikes the blades of the turbine, some of the energy and rotational force is transferred into the turbine and the input shaft. This causes both of them (turbine and input shaft) to rotate in a clockwise direction following the impeller. As the fluid is leaving the trailing edges of the turbine's blades it continues in a "hindering" direction back toward the impeller. If the fluid is not redirected before it strikes the impeller, it will strike the impeller in such a direction that it would tend to slow it down.

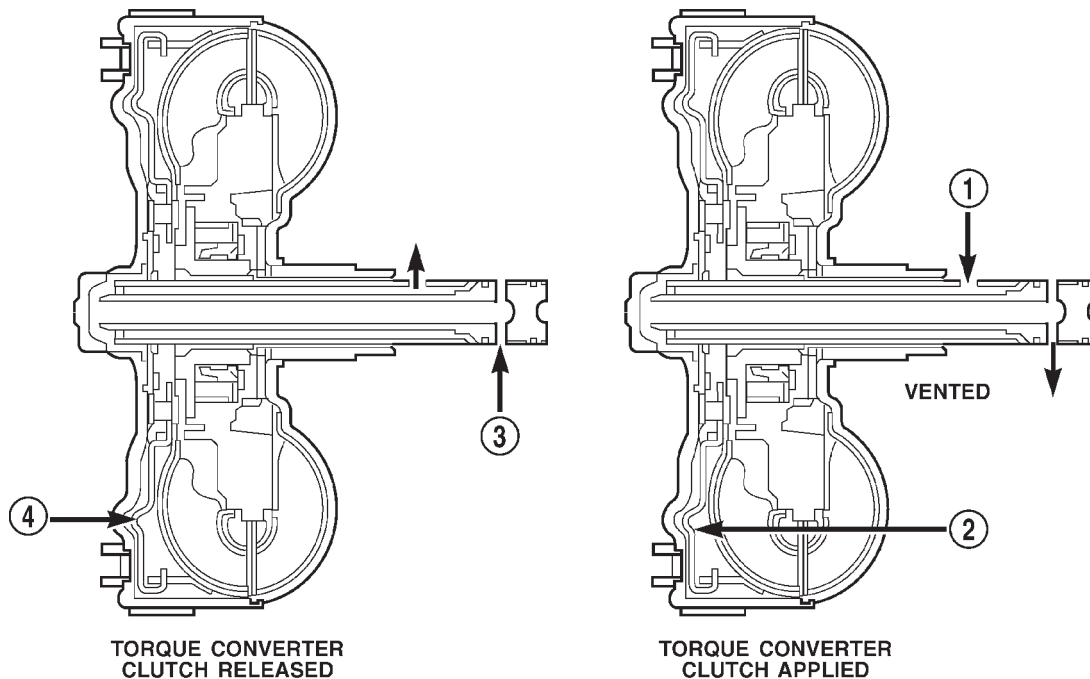
## STATOR

Torque multiplication is achieved by locking the stator's over-running clutch to its shaft (Fig. 244). Under stall conditions (the turbine is stationary), the oil leaving the turbine blades strikes the face of the stator blades and tries to rotate them in a counter-clockwise direction. When this happens the overrunning clutch of the stator locks and holds the stator

from rotating. With the stator locked, the oil strikes the stator blades and is redirected into a "helping" direction before it enters the impeller. This circulation of oil from impeller to turbine, turbine to stator, and stator to impeller, can produce a maximum torque multiplication of about 2.4:1. As the turbine begins to match the speed of the impeller, the fluid that was hitting the stator in such a way as to cause it to lock-up is no longer doing so. In this condition of operation, the stator begins to free wheel and the converter acts as a fluid coupling.

## TORQUE CONVERTER CLUTCH (TCC)

The torque converter clutch is hydraulically applied and is released when fluid is vented from the hydraulic circuit by the torque converter control (TCC) solenoid on the valve body. The torque converter clutch is controlled by the Powertrain Control Module (PCM). The torque converter clutch engages in fourth gear, and in third gear under various conditions, such as when the O/D switch is OFF, when the vehicle is cruising on a level surface after the vehicle has warmed up. The torque converter clutch will disengage momentarily when an increase in engine load is sensed by the PCM, such as when the vehicle begins to go uphill or the throttle pressure is increased.



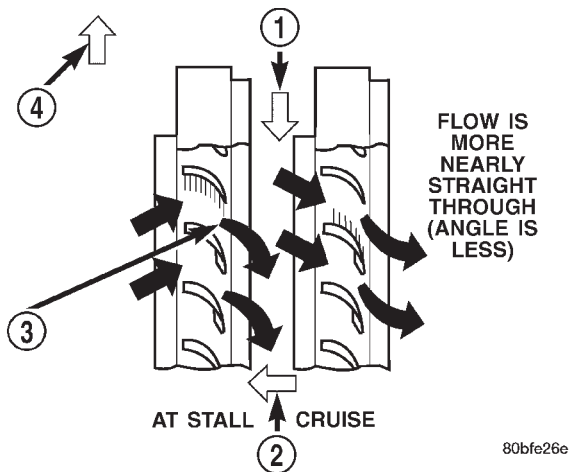
**Fig. 243 Torque Converter Fluid Operation**

80bfe276

- 1 - APPLY PRESSURE
- 2 - THE PISTON MOVES SLIGHTLY FORWARD

- 3 - RELEASE PRESSURE
- 4 - THE PISTON MOVES SLIGHTLY REARWARD

## TORQUE CONVERTER (Continued)

**Fig. 244 Stator Operation**

- 1 - DIRECTION STATOR WILL FREE WHEEL DUE TO OIL PUSHING ON BACKSIDE OF VANES
- 2 - FRONT OF ENGINE
- 3 - INCREASED ANGLE AS OIL STRIKES VANES
- 4 - DIRECTION STATOR IS LOCKED UP DUE TO OIL PUSHING AGAINST STATOR VANES

**REMOVAL**

- (1) Remove transmission and torque converter from vehicle.
- (2) Place a suitable drain pan under the converter housing end of the transmission.

**CAUTION:** Verify that transmission is secure on the lifting device or work surface, the center of gravity of the transmission will shift when the torque converter is removed creating an unstable condition. The torque converter is a heavy unit. Use caution when separating the torque converter from the transmission.

- (3) Pull the torque converter forward until the center hub clears the oil pump seal.

- (4) Separate the torque converter from the transmission.

**INSTALLATION**

Check converter hub and drive notches for sharp edges, burrs, scratches, or nicks. Polish the hub and notches with 320/400 grit paper or crocus cloth if necessary. The hub must be smooth to avoid damaging the pump seal at installation.

- (1) Lubricate oil pump seal lip with transmission fluid.

- (2) Place torque converter in position on transmission.

**CAUTION:** Do not damage oil pump seal or bushing while inserting torque converter into the front of the transmission.

- (3) Align torque converter to oil pump seal opening.

- (4) Insert torque converter hub into oil pump.

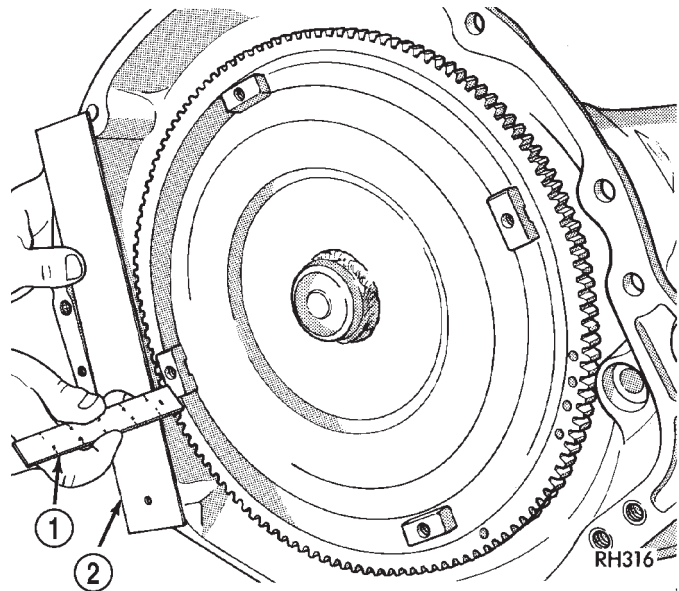
- (5) While pushing torque converter inward, rotate converter until converter is fully seated in the oil pump gears.

- (6) Check converter seating with a scale and straightedge (Fig. 245). Surface of converter lugs should be 1/2 in. to rear of straightedge when converter is fully seated.

- (7) If necessary, temporarily secure converter with C-clamp attached to the converter housing.

- (8) Install the transmission in the vehicle.

- (9) Fill the transmission with the recommended fluid.

**Fig. 245 Checking Torque Converter Seating - Typical**

- 1 - SCALE
- 2 - STRAIGHTEDGE

**TORQUE CONVERTER DRAINBACK VALVE****DESCRIPTION**

The drainback valve is located in the transmission cooler outlet (pressure) line.

**OPERATION**

The valve prevents fluid from draining from the converter into the cooler and lines when the vehicle is shut down for lengthy periods. Production valves have a hose nipple at one end, while the opposite end is threaded for a flare fitting. All valves have an arrow (or similar mark) to indicate direction of flow through the valve.

## TORQUE CONVERTER DRAINBACK VALVE (Continued)

**STANDARD PROCEDURE - TORQUE CONVERTER DRAINBACK VALVE**

The converter drainback check valve is located in the cooler outlet (pressure) line near the radiator tank. The valve prevents fluid drainback when the vehicle is parked for lengthy periods. The valve check ball is spring loaded and has an opening pressure of approximately 2 psi.

The valve is serviced as an assembly; it is not repairable. Do not clean the valve if restricted, or contaminated by sludge, or debris. If the valve fails, or if a transmission malfunction occurs that generates significant amounts of sludge and/or clutch particles and metal shavings, the valve must be replaced.

The valve must be removed whenever the cooler and lines are reverse flushed. The valve can be flow tested when necessary. The procedure is exactly the same as for flow testing a cooler.

If the valve is restricted, installed backwards, or in the wrong line, it will cause an overheating condition and possible transmission failure.

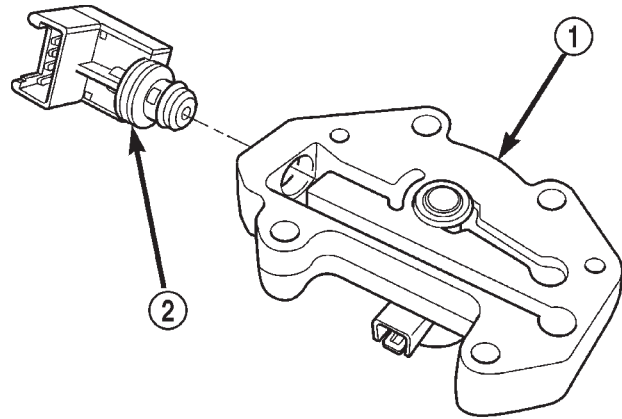
**CAUTION:** The drainback valve is a one-way flow device. It must be properly oriented in terms of flow direction for the cooler to function properly. The valve must be installed in the pressure line. Otherwise flow will be blocked and would cause an overheating condition and eventual transmission failure.

**TRANSMISSION TEMPERATURE SENSOR****DESCRIPTION**

Transmission fluid temperature readings are supplied to the transmission control module by the thermistor (Fig. 246). The temperature readings are used to control engagement of the fourth gear overdrive

clutch, the converter clutch, and governor pressure. Normal resistance value for the thermistor at room temperature is approximately 1000 ohms.

The thermistor is part of the governor pressure sensor assembly and is immersed in transmission fluid at all times.



80c072af

**Fig. 246 Governor Pressure Sensor**

- 1 - GOVERNOR BODY
- 2 - GOVERNOR PRESSURE SENSOR/TRANSMISSION FLUID TEMPERATURE THERMISTOR

**OPERATION**

The PCM prevents engagement of the converter clutch and overdrive clutch, when fluid temperature is below approximately 10°C (50°F).

If fluid temperature exceeds 126°C (260°F), the PCM causes a 4-3 downshift and engage the converter clutch. Engagement is according to the third gear converter clutch engagement schedule.

The overdrive OFF lamp in the instrument panel illuminates when the shift back to third occurs. The transmission will not allow fourth gear operation until fluid temperature decreases to approximately 110°C (230°F).

## VALVE BODY

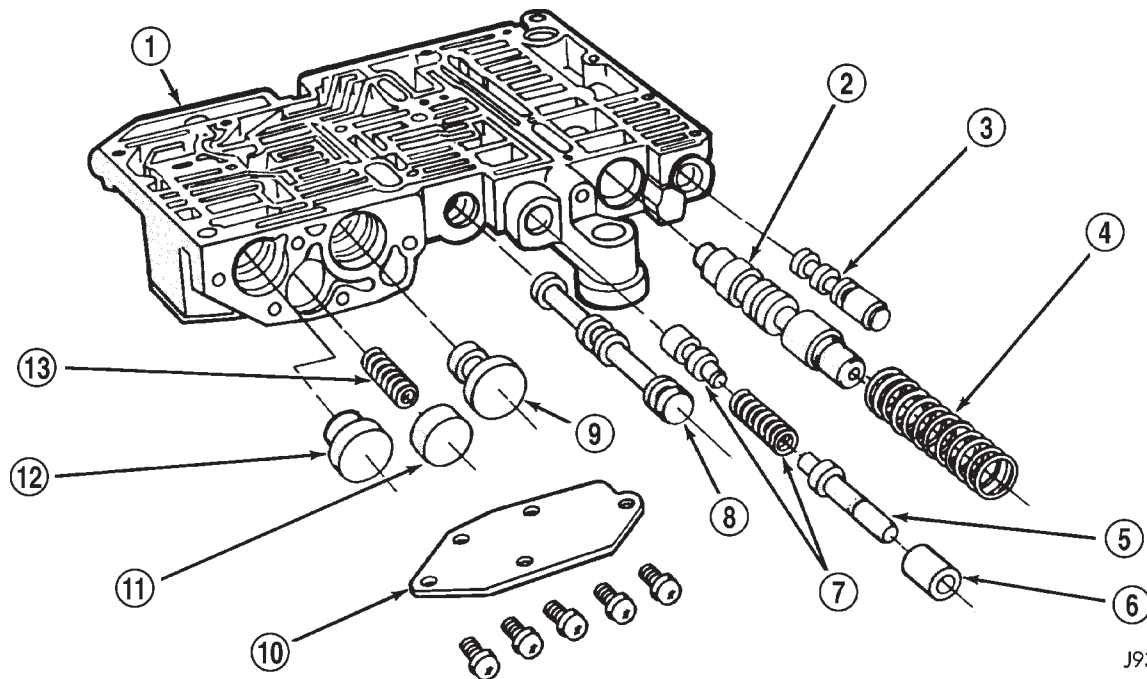
### DESCRIPTION

The valve body consists of a cast aluminum valve body, a separator plate, and transfer plate. The valve body contains valves and check balls that control fluid delivery to the torque converter clutch, bands, and frictional clutches. The valve body contains the following components (Fig. 247), (Fig. 248), (Fig. 249), and (Fig. 250):

- Regulator valve
- Regulator valve throttle pressure plug
- Line pressure plug and sleeve
- Kickdown valve
- Kickdown limit valve
- 1-2 shift valve
- 1-2 control valve
- 2-3 shift valve

- 2-3 governor plug
- 3-4 shift valve
- 3-4 timing valve
- 3-4 quick fill valve
- 3-4 accumulator
- Throttle valve
- Throttle pressure plug
- Switch valve
- Manual valve
- Converter clutch lock-up valve
- Converter clutch lock-up timing Valve
- Shuttle valve
- Shuttle valve throttle plug
- Boost Valve
- 10 check balls

By adjusting the spring pressure acting on the regulator valve, transmission line pressure can be adjusted.

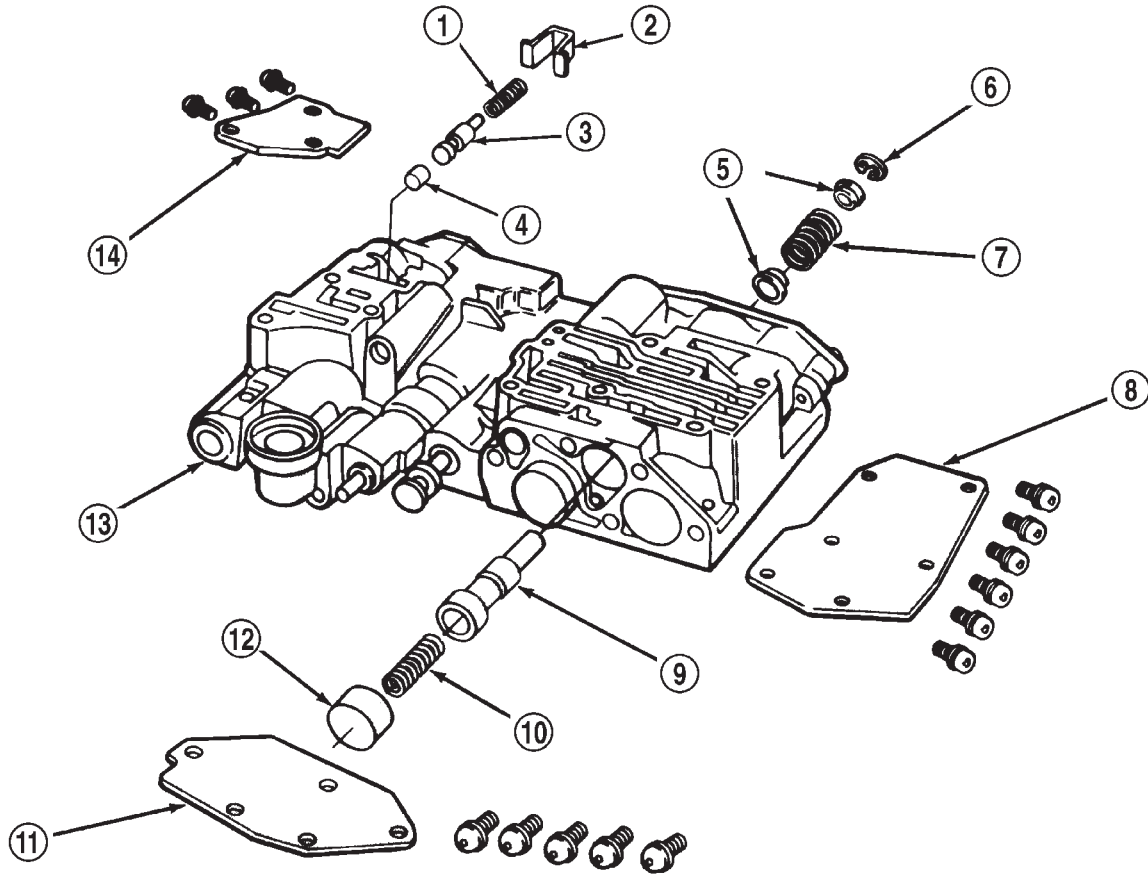


J9321-155

**Fig. 247 Upper Housing Control Valve Locations**

- |                               |                                   |
|-------------------------------|-----------------------------------|
| 1 - UPPER HOUSING             | 8 - MANUAL VALVE                  |
| 2 - REGULATOR VALVE           | 9 - 1-2 GOVERNOR PLUG             |
| 3 - SWITCH VALVE              | 10 - GOVERNOR PLUG COVER          |
| 4 - REGULATOR VALVE SPRING    | 11 - THROTTLE PLUG                |
| 5 - KICKDOWN VALVE            | 12 - 2-3 GOVERNOR PLUG            |
| 6 - KICKDOWN DETENT           | 13 - SHUTTLE VALVE PRIMARY SPRING |
| 7 - THROTTLE VALVE AND SPRING |                                   |

VALVE BODY (Continued)



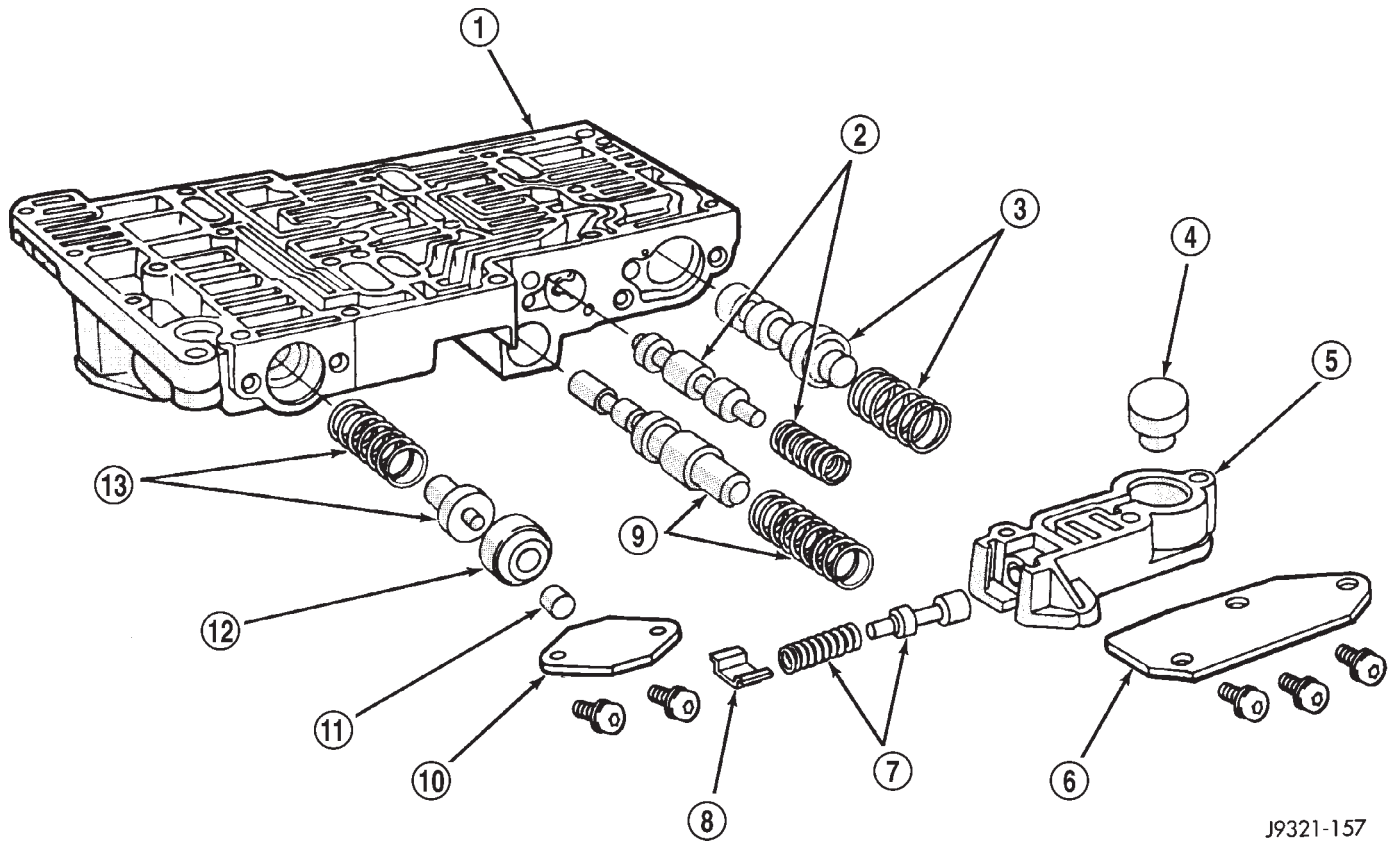
J9421-217

**Fig. 248 Shuttle and Boost Valve Locations**

- |                                    |                                   |
|------------------------------------|-----------------------------------|
| 1 - SPRING                         | 8 - SHUTTLE VALVE COVER           |
| 2 - RETAINER                       | 9 - SHUTTLE VALVE                 |
| 3 - BOOST VALVE                    | 10 - SHUTTLE VALVE PRIMARY SPRING |
| 4 - BOOST VALVE PLUG               | 11 - GOVERNOR PLUG COVER          |
| 5 - SPRING GUIDES                  | 12 - THROTTLE PLUG                |
| 6 - E-CLIP                         | 13 - UPPER HOUSING                |
| 7 - SHUTTLE VALVE SECONDARY SPRING | 14 - BOOST VALVE COVER            |



VALVE BODY (Continued)

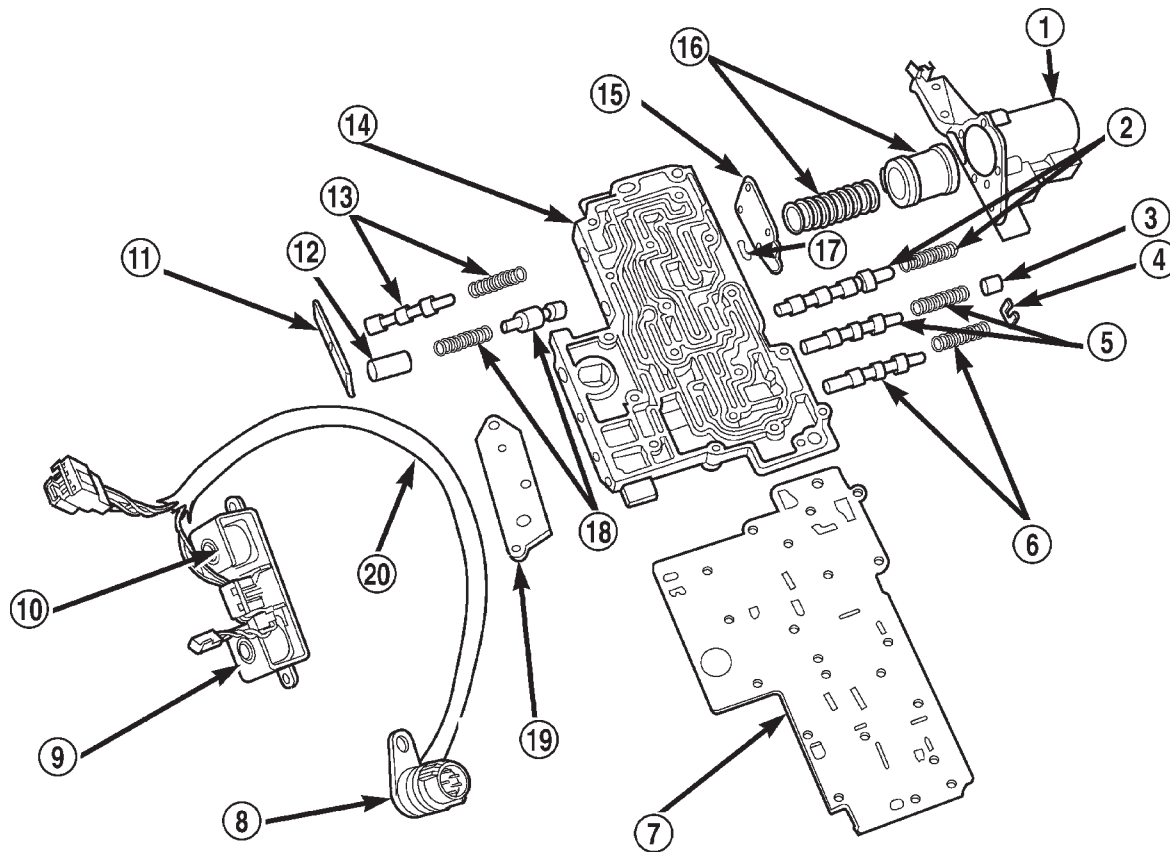


J9321-157

**Fig. 249 Upper Housing Shift Valve and Pressure Plug Locations**

- |                                |  |
|--------------------------------|--|
| 1 - UPPER HOUSING              | 8 - RETAINER                           |
| 2 - 1-2 SHIFT VALVE AND SPRING | 9 - 1-2 SHIFT CONTROL VALVE AND SPRING |
| 3 - 2-3 SHIFT VALVE AND SPRING | 10 - PRESSURE PLUG COVER               |
| 4 - 2-3 THROTTLE PLUG          | 11 - LINE PRESSURE PLUG                |
| 5 - LIMIT VALVE HOUSING        | 12 - PLUG SLEEVE                       |
| 6 - LIMIT VALVE COVER          | 13 - THROTTLE PRESSURE SPRING AND PLUG |
| 7 - LIMIT VALVE AND SPRING     |  |

## VALVE BODY (Continued)



80c072b5

**Fig. 250 Lower Housing Shift Valves and Springs**

- |  |  |
|--|--|
| 1 - 3-4 ACCUMULATOR HOUSING                  | 11 - TIMING VALVE COVER                |
| 2 - 3-4 SHIFT VALVE AND SPRING               | 12 - PLUG                              |
| 3 - PLUG                                     | 13 - 3-4 TIMING VALVE AND SPRING       |
| 4 - SPRING RETAINER                          | 14 - LOWER HOUSING                     |
| 5 - CONVERTER CLUTCH VALVE AND SPRING        | 15 - ACCUMULATOR END PLATE             |
| 6 - CONVERTER CLUTCH TIMING VALVE AND SPRING | 16 - 3-4 ACCUMULATOR PISTON AND SPRING |
| 7 - OVERDRIVE SEPARATOR PLATE                | 17 - E-CLIP                            |
| 8 - CASE CONNECTOR                           | 18 - 3-4 QUICK FILL SPRING AND VALVE   |
| 9 - CONVERTER CLUTCH SOLENOID                | 19 - SOLENOID GASKET                   |
| 10 - OVERDRIVE SOLENOID                      | 20 - HARNESS                           |

## VALVE BODY (Continued)

## OPERATION

**NOTE:** Refer to the Hydraulic Schematics for a visual aid in determining valve location, operation and design.

## CHECK BALLS

CHECK BALL NUMBER	DESCRIPTION
1	Allows either the manual valve to put line pressure on the 1-2 governor plug or the KD Valve to put WOT line pressure on the 1-2 governor plug.
2	Allows either the manual valve to put line pressure on the 2-3 governor plug or the KD Valve to put WOT line pressure on the 2-3 governor plug.
3	Allows either the Reverse circuit or the 3rd gear circuit to pressurize the front clutch.
4	Allows either the Manual Low circuit from the Manual Valve or the Reverse from the Manual Valve circuit to pressurize the rear servo.
5	Directs line pressure to the spring end of the 2-3 shift valve in either Manual Low or Manual 2nd, forcing the downshift to 2nd gear regardless of governor pressure.
6	Provides a by-pass around the front servo orifice so that the servo can release quickly.
7	Provides a by-pass around the rear clutch orifice so that the clutch can release quickly.
8	Directs reverse line pressure through an orifice to the throttle valve eliminating the extra leakage and insuring that Reverse line pressure pressure will be sufficient.
9	Provides a by-pass around the rear servo orifice so that the servo can release quickly.
ECE (10)	Allows the lockup clutch to used at WOT in 3rd gear by putting line pressure from the 3-4 Timing Valve on the interlock area of the 2-3 shift valve, thereby preventing a 3rd gear Lock-up to 2nd gear kickdown.

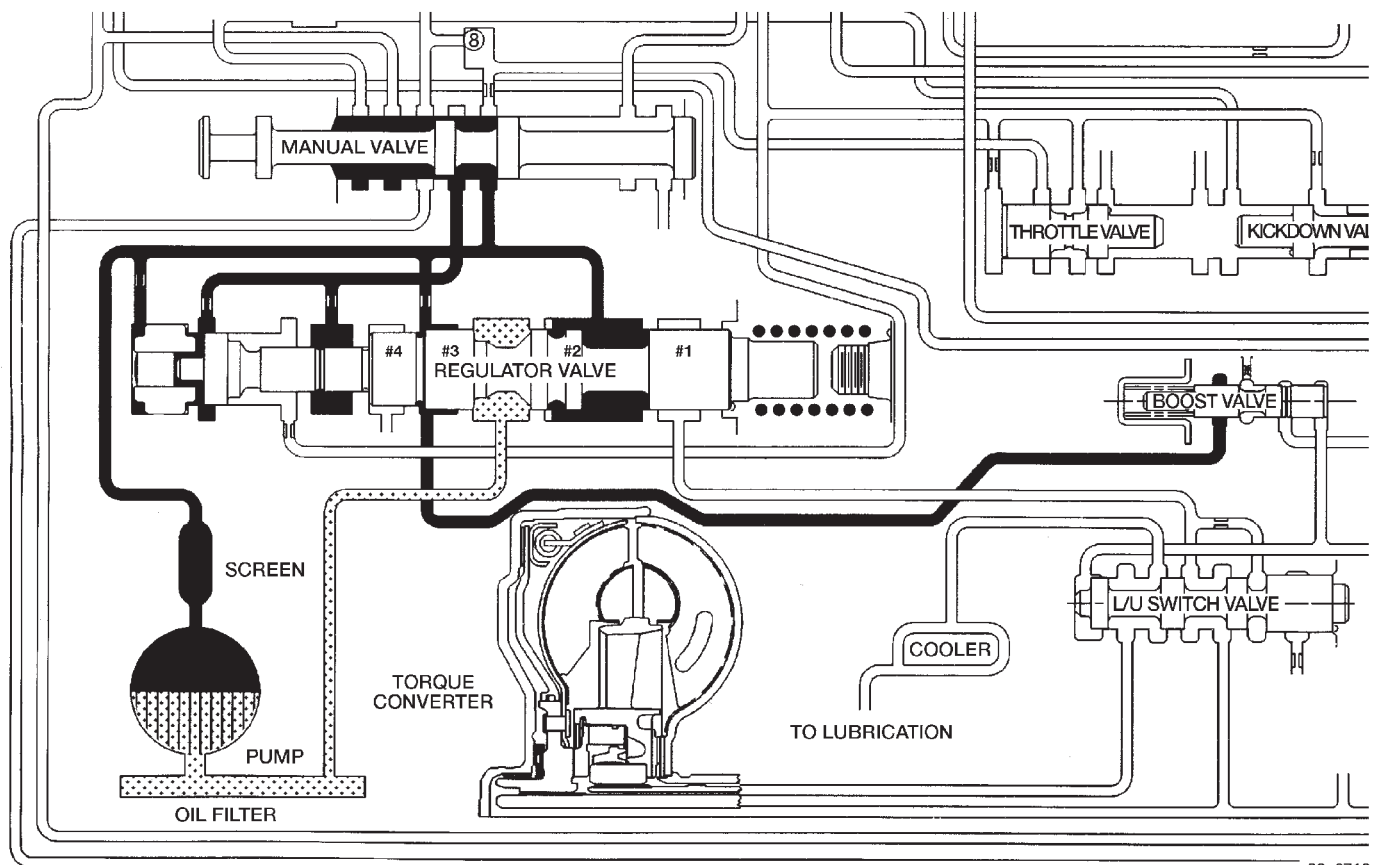
## VALVE BODY (Continued)

## REGULATOR VALVE

The pressure regulator valve is needed to control the hydraulic pressure within the system and reduce the amount of heat produced in the fluid. The pressure regulator valve is located in the valve body near the manual valve. The pressure regulator valve train controls the maximum pressure in the lines by metering the dumping of fluid back into the sump. Regulated pressure is referred to as "line pressure."

The regulator valve (Fig. 251) has a spring on one end that pushes the valve to the left. This closes a dump (vent) that is used to lower pressure. The closing of the dump will cause the oil pressure to increase. Oil pressure on the opposite end of the

valve pushes the valve to the right, opening the dump and lowering oil pressure. The result is spring pressure working against oil pressure to maintain the oil at specific pressures. With the engine running, fluid flows from the pump to the pressure regulator valve, manual valve, and the interconnected circuits. As fluid is sent through passages to the regulator valve, the pressure pushes the valve to the right against the large spring. It is also sent to the reaction areas on the left side of the throttle pressure plug and the line pressure plug. With the gear selector in the PARK position, fluid recirculates through the regulator and manual valves back to the sump.



80c0713c

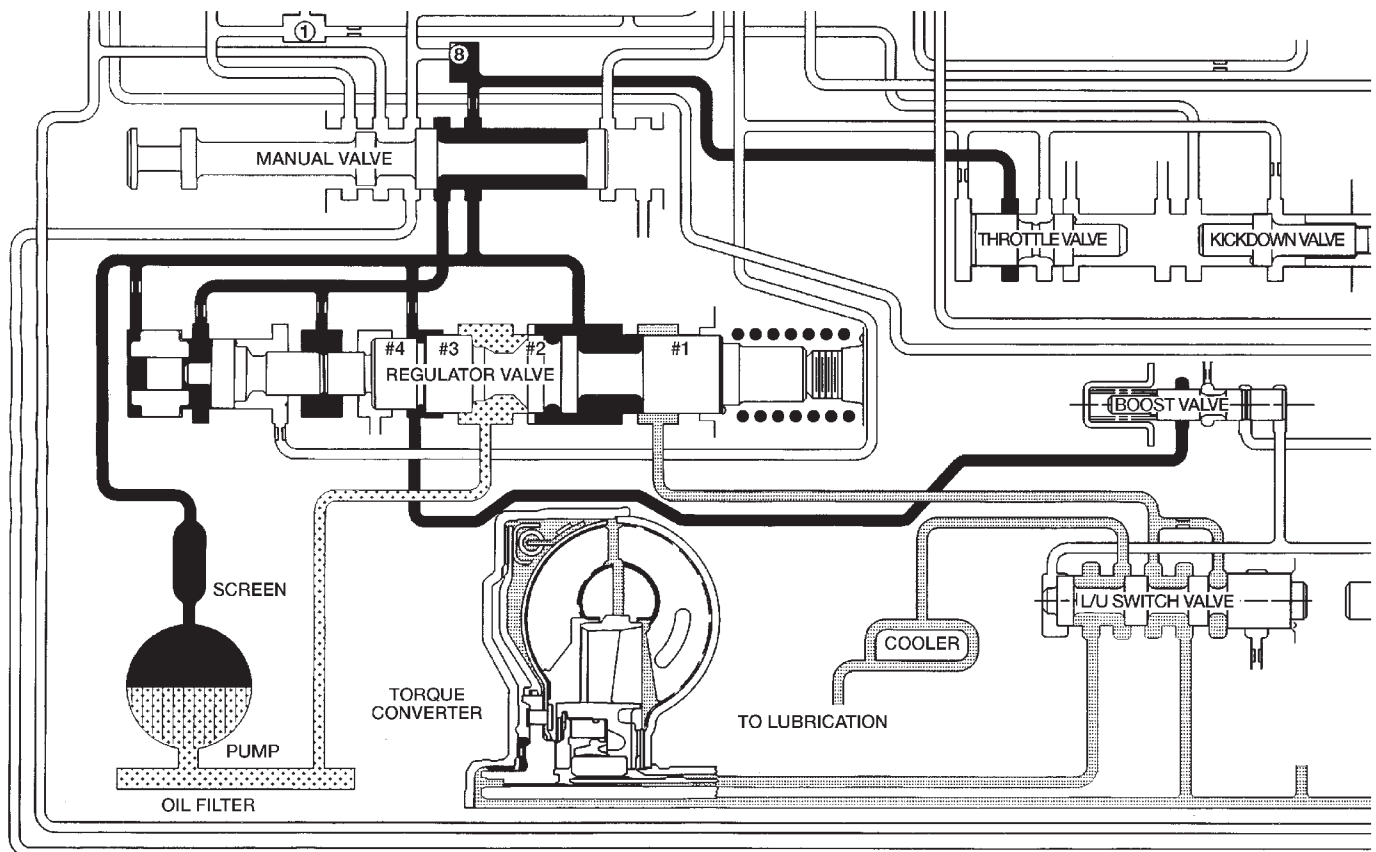
**Fig. 251 Regulator Valve in PARK Position**

## VALVE BODY (Continued)

Meanwhile, the torque converter is filled slowly. In all other gear positions (Fig. 252), fluid flows between two right side lands to the switch valve and torque converter. At low pump speeds, the flow is controlled by the pressure valve groove to reduce pressure to the torque converter. After the torque converter and switch valve fill with fluid, the switch valve becomes the controlling metering device for torque converter pressure. The regulator valve then begins to control the line pressure for the other transmission circuits. The balance of the fluid pressure pushing the valve to the right and the spring pressure pushing to the left determines the size of the metering passage at land #2 (land #1 being at the far right of the valve in the diagram). As fluid leaks past the land, it moves into a groove connected to the filter or sump. As the land meters the fluid to the sump, it causes the pressure to reduce and the spring decreases the size of the metering passage. When the size of the metering passage is reduced, the pressure rises again and the size of the land is increased again. Pressure is regulated by this constant balance of hydraulic and spring pressure.

The metering at land #2 establishes the line pressure throughout the transmission. It is varied according to changes in throttle position and the transmission's internal condition within a range of

57-94 psi (except in REVERSE) (Fig. 253). The regulated line pressure in REVERSE (Fig. 254) is held at much higher pressures than in the other gear positions: 145-280 psi. The higher pressure for REVERSE is achieved by the manual valve blocking the supply of line pressure to the reaction area left of land #4. With this pressure blocked, there is less area for pressure to act on to balance the force of the spring on the right. This allows line pressure to push the valve train to the right, reducing the amount of fluid returned to the pump's inlet, increasing line pressure.

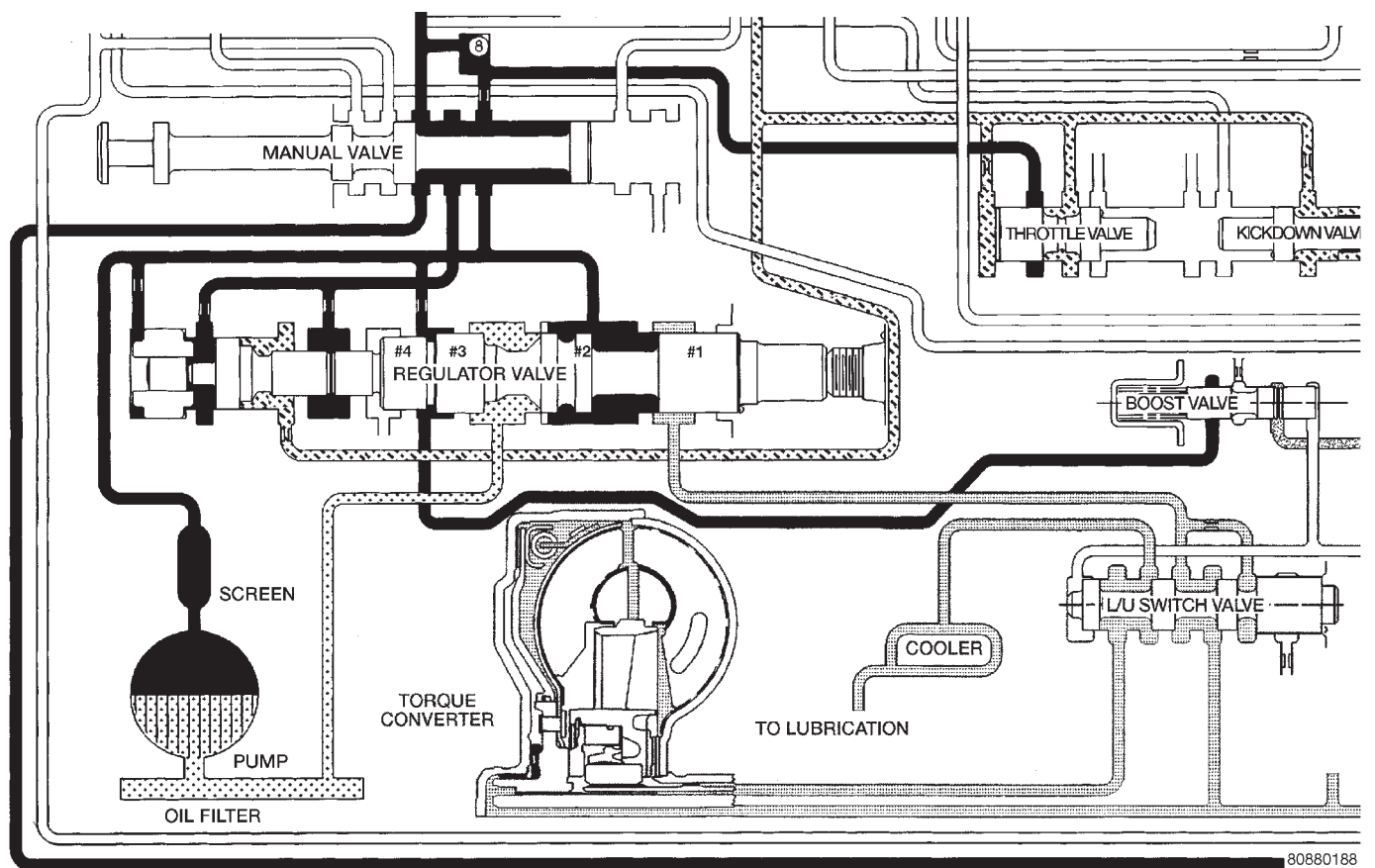


80880187

Fig. 252 Regulator Valve in NEUTRAL Position

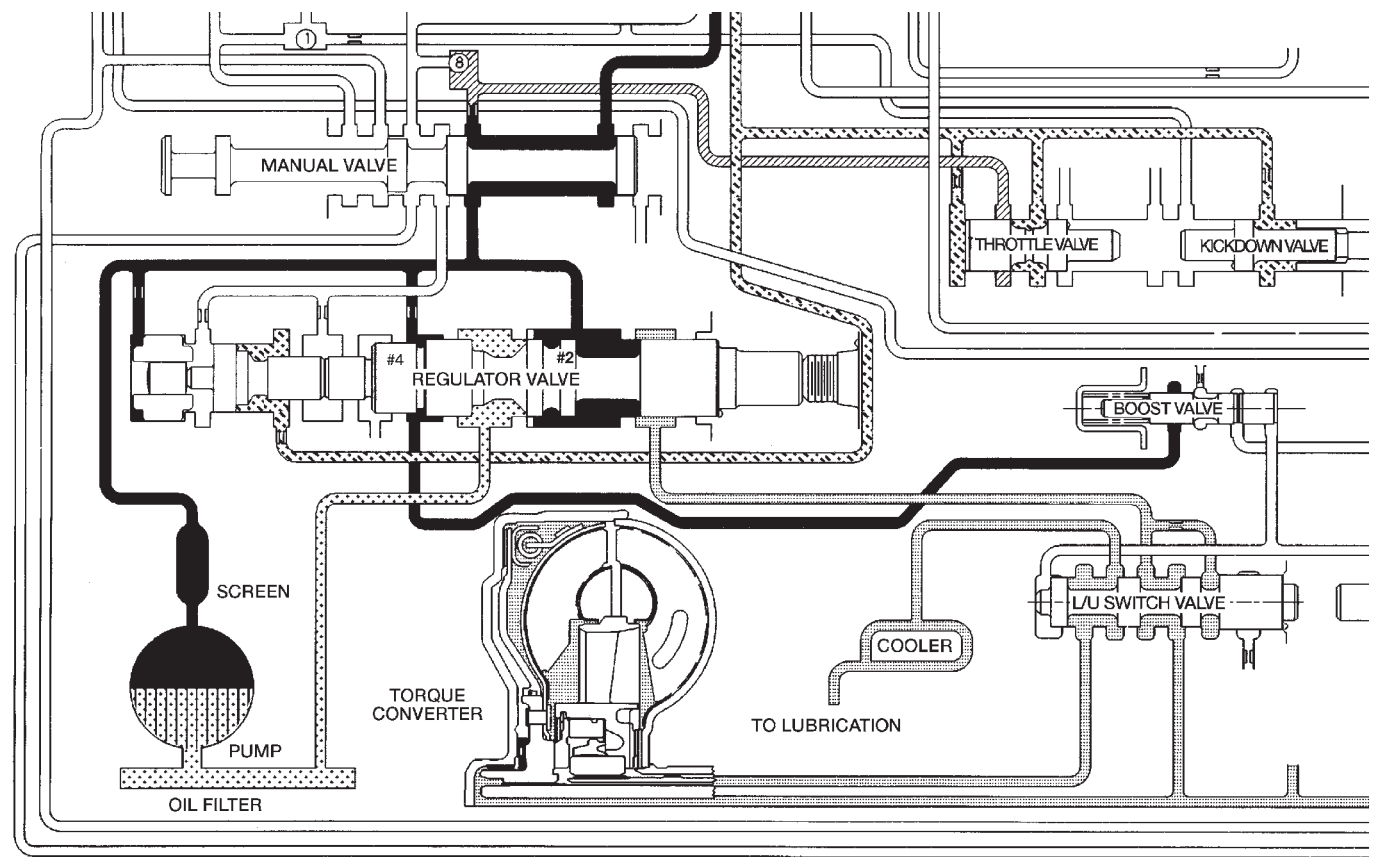


VALVE BODY (Continued)



80880188

Fig. 253 Regulator Valve in DRIVE Position



80c07140

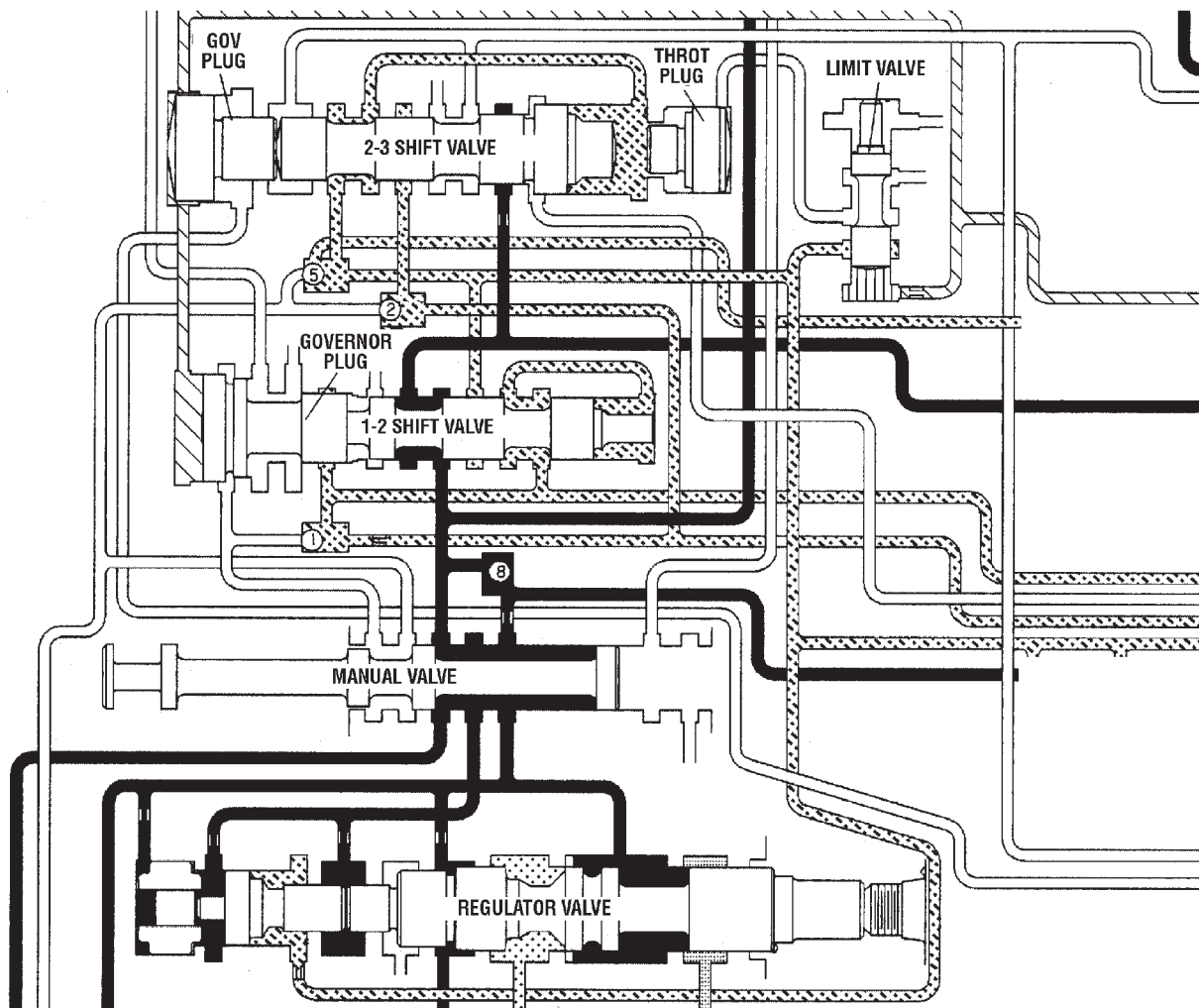
Fig. 254 Regulator Valve in REVERSE Position

## VALVE BODY (Continued)

**KICKDOWN VALVE**

When the throttle valve is as far over to the left as it can go, the maximum line pressure possible will enter the throttle pressure circuit. In this case, throttle pressure will equal line pressure. With the kickdown valve (Fig. 255) pushed into the bore as far as it will go, fluid initially flows through the annular groove of the 2-3 shift valve (which will be in the direct drive position to the right).

After passing the annular groove, the fluid is routed to the spring end of the 2-3 shift valve. Fluid pressure reacting on the area of land #1 overcomes governor pressure, downshifting the 2-3 shift valve into the kickdown, or second gear stage of operation. The valve is held in the kickdown position by throttle pressure routed from a seated check ball (#2). Again, if vehicle speed is low enough, throttle pressure will also push the 1-2 shift valve left to seat its governor plug, and downshift to drive breakaway.



8088018a

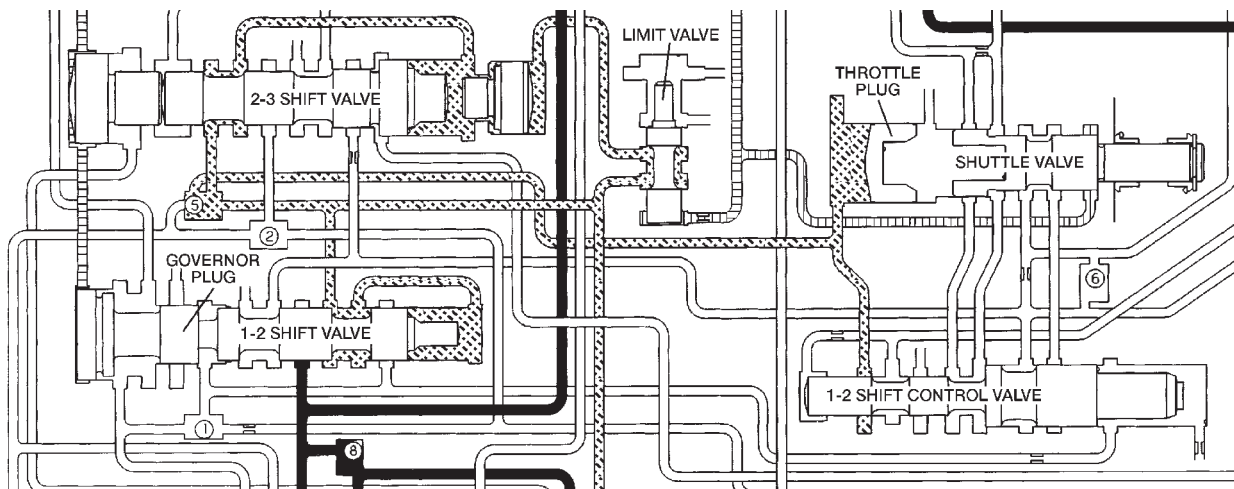
**Fig. 255 Kickdown Valve-Wide Open Throttle**

VALVE BODY (Continued)

**KICKDOWN LIMIT VALVE**

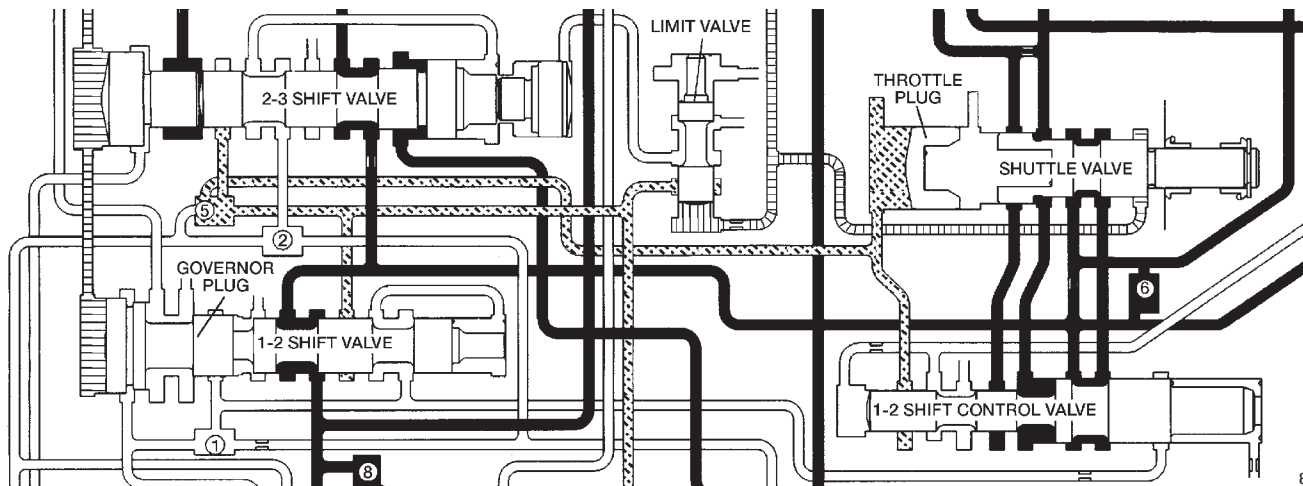
The purpose of the limit valve is to prevent a 3-2 downshift at higher speeds when a part-throttle downshift is not desirable. At these higher speeds only a full throttle 3-2 downshift will occur. At low road speeds (Fig. 256) the limit valve does not come into play and does not affect the downshifts. As the vehicle's speed increases (Fig. 257), the governor pressure also increases. The increased governor pressure acts on the reaction area of the bottom land of

the limit valve overcoming the spring force trying to push the valve toward the bottom of its bore. This pushes the valve upward against the spring and bottoms the valve against the top of the housing. With the valve bottomed against the housing, the throttle pressure supplied to the valve will be closed off by the bottom land of the limit valve. When the supply of throttle pressure has been shut off, the 3-2 part throttle downshift plug becomes inoperative, because no pressure is acting on its reaction area.



80c07142

**Fig. 256 Kickdown Limit Valve-Low Speeds**



80c07143

**Fig. 257 Kickdown Limit Valve-High Speeds**

## VALVE BODY (Continued)

**1-2 SHIFT VALVE**

The 1-2 shift valve assembly (Fig. 258), or mechanism, consists of: the 1-2 shift valve, governor plug, and a spring on the end of the valve. After the manual valve has been placed into a forward gear range, line pressure is directed to the 1-2 shift valve. As the throttle is depressed, throttle pressure is applied to the right side of the 1-2 shift valve assembly. With throttle pressure applied to the right side of the valve, there is now both spring pressure and throttle pressure acting on the valve, holding it against the governor plug. As the vehicle begins to move and build speed, governor pressure is created and is applied to the left of the valve at the governor plug.

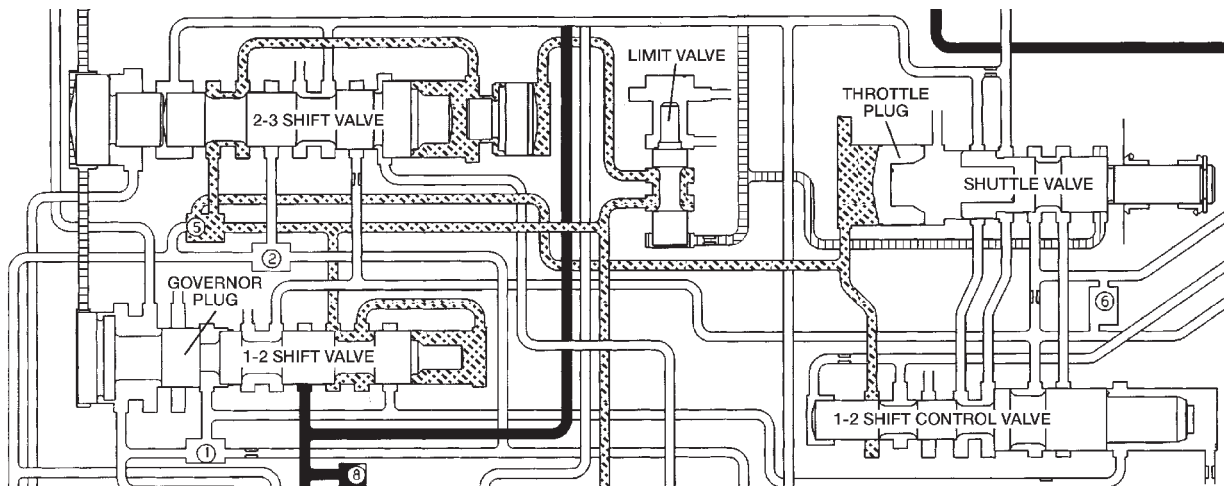
When governor pressure builds to a point where it can overcome the combined force of the spring and throttle pressure on the other side of the valve, the valve will begin to move over to the right. As the valve moves to the right, the middle land of the valve will close off the circuit supplying the throttle pressure to the right side of the valve. When the throttle

pressure is closed off, the valve will move even farther to the right, allowing line pressure to enter another circuit and energize the front servo, applying the front band (Fig. 259).

The governor plug serves a dual purpose:

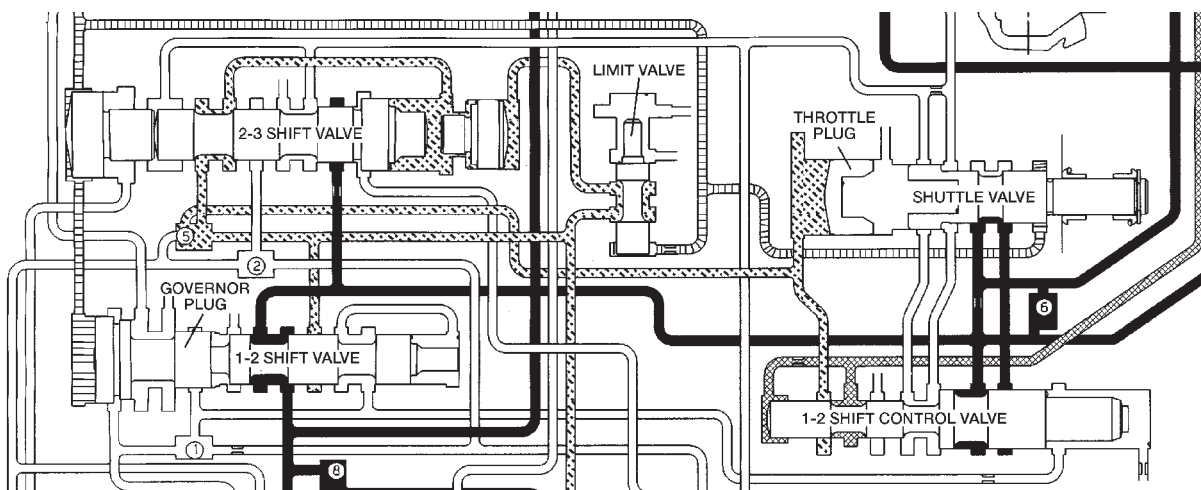
- It allows the shift valves to move either left or right, allowing both upshifts and downshifts.
- When in a manual selection position, it will be hydraulically "blocked" into position so no upshift can occur.

The physical blocking of the upshift while in the manual "1" position is accomplished by the directing of line pressure between both lands of the governor plug, pushing the plug back against the end plate overcoming governor pressure. With the combination of the line pressure and spring pressure, the valve cannot move, preventing any upshift.



80c07144

**Fig. 258 1-2 Shift Valve-Before Shift**



80c07145

**Fig. 259 1-2 Shift Valve-After Shift**

## VALVE BODY (Continued)

**1-2 SHIFT CONTROL VALVE**

It contains a valve with four lands and a spring. It is used as both a "relay" and "balanced" valve.

The valve has two specific operations (Fig. 260):

- Aid in quality of the 1-2 upshift.
- Aid in the quality and timing of the 3-2 kick-down ranges.

When the manual valve is set to the DRIVE position and the transmission is in the first or second gear range, 1-2 shift control or "modulated throttle pressure" is supplied to the middle of the accumulator piston by the 1-2 shift control valve. During the 1-2 upshift, this pressure is used to control the kick-down servo apply pressure that is needed to apply the kickdown and accumulator pistons. Thus, the 1-2 shift point is "cushioned" and the quality is improved. During a WOT kickdown, kickdown pressure is applied between the kickdown valve and the 1-2 shift control valve. This additional pressure is directed to the 1-2 shift control's spring cavity, adding to the spring load on the valve. The result of this increased "modulated" throttle pressure is a firmer WOT upshift.

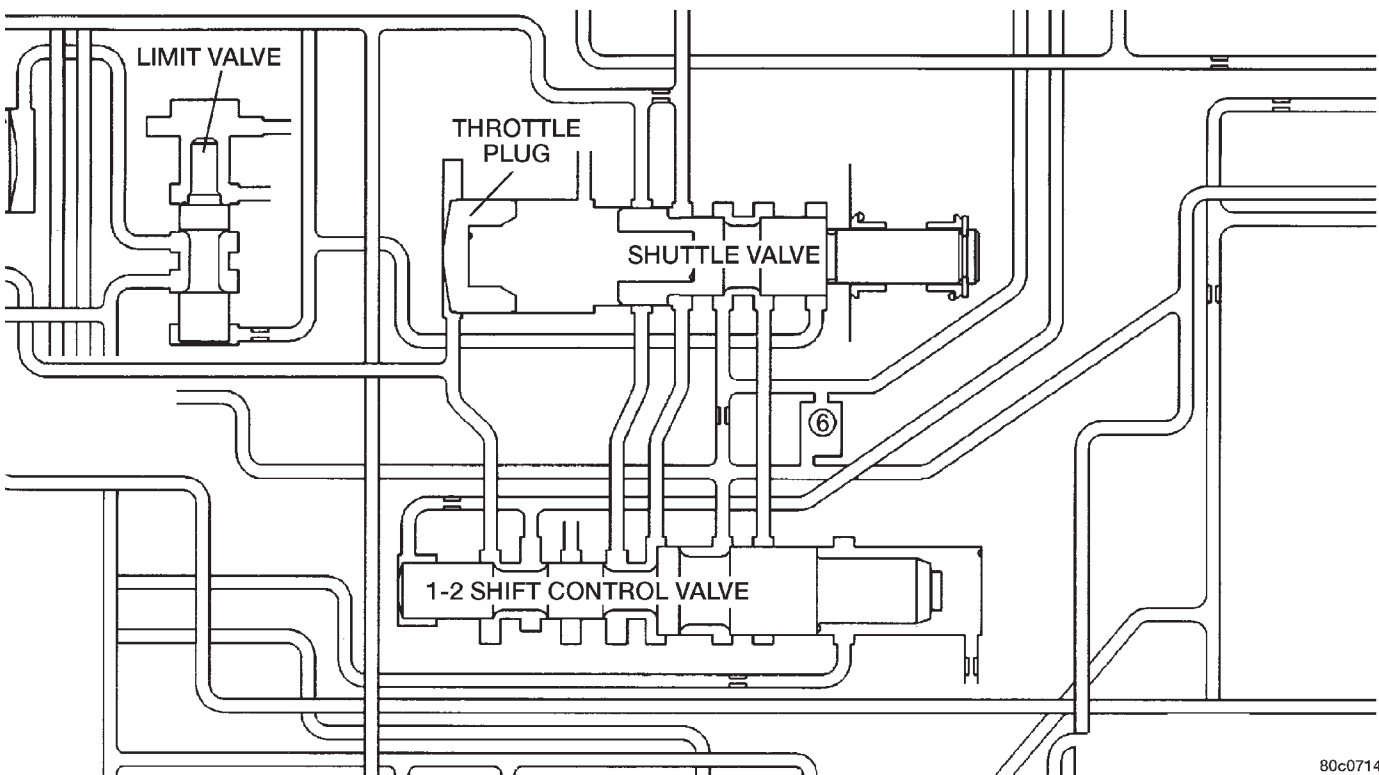
**2-3 SHIFT VALVE**

The 2-3 shift valve mechanism (Fig. 261) consists of the 2-3 shift valve, governor plug and spring, and a throttle plug. After the 1-2 shift valve has completed its operation and applied the front band, line pressure is directed to the 2-3 shift valve through the

connecting passages from the 1-2 shift valve. The line pressure will then dead-end at land #2 until the 2-3 valve is ready to make its shift. Now that the vehicle is in motion and under acceleration, there is throttle pressure being applied to the spring side of the valve and between lands #3 and #4.

As vehicle speed increases, governor pressure increases proportionately, until it becomes great enough to overcome the combined throttle and spring pressure on the right side of the valve. Since the throttle pressure end of the 2-3 shift valve is larger in diameter than the 1-2 shift valve, the 2-3 shift will always happen at a greater speed than the 1-2 shift. When this happens, the governor plug is forced against the shift valve moving it to the right. The shift valve causes land #4 to close the passage supplying throttle pressure to the 2-3 shift valve. Without throttle pressure present in the circuit now, the governor plug will push the valve over far enough to bottom the valve in its bore. This allows land #2 to direct line pressure to the front clutch.

After the shift (Fig. 262), line pressure is directed to the land between the shift valve and the governor plug, and to the release side of the kickdown servo. This releases the front band and applies the front clutch, shifting into third gear or direct drive. The rear clutch remains applied, as it has been in the other gears. During a manual "1" or manual "2" gear selection, line pressure is sent between the two lands of the 2-3 governor plug. This line pressure at the

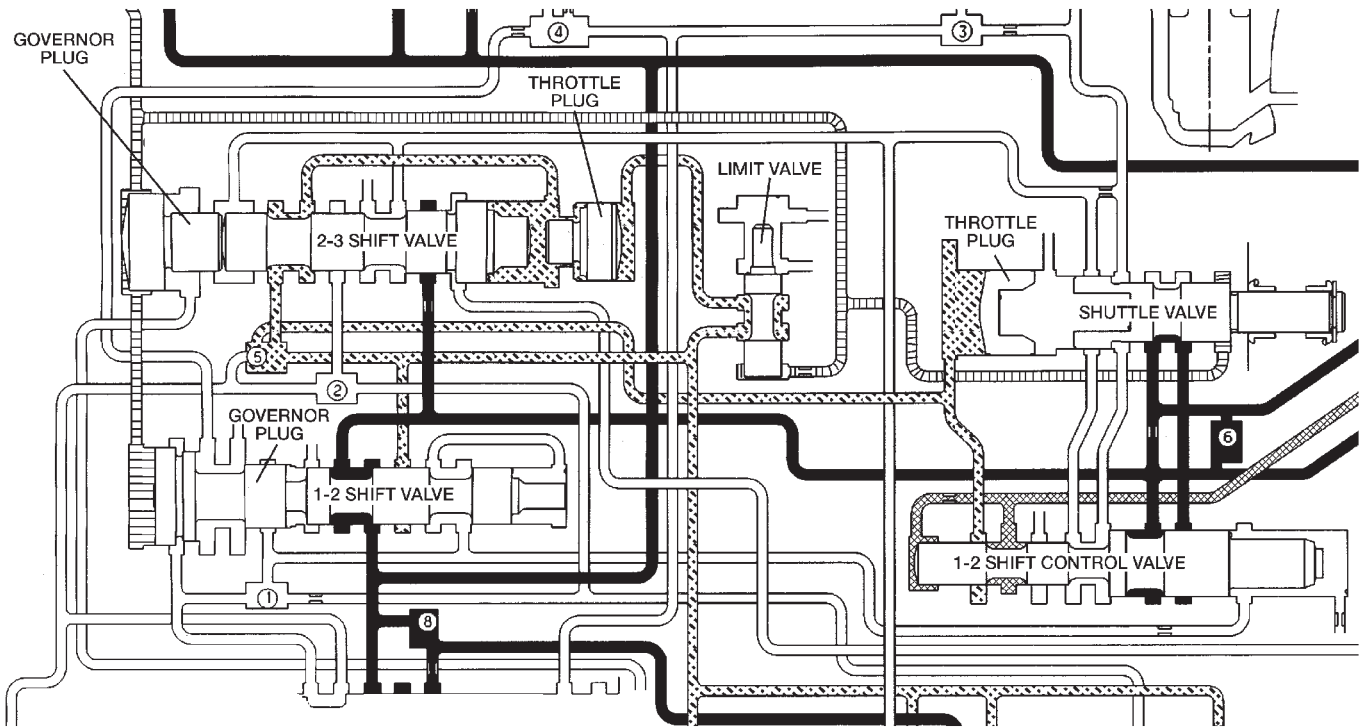


80c07146

**Fig. 260 1-2 Shift Control Valve**



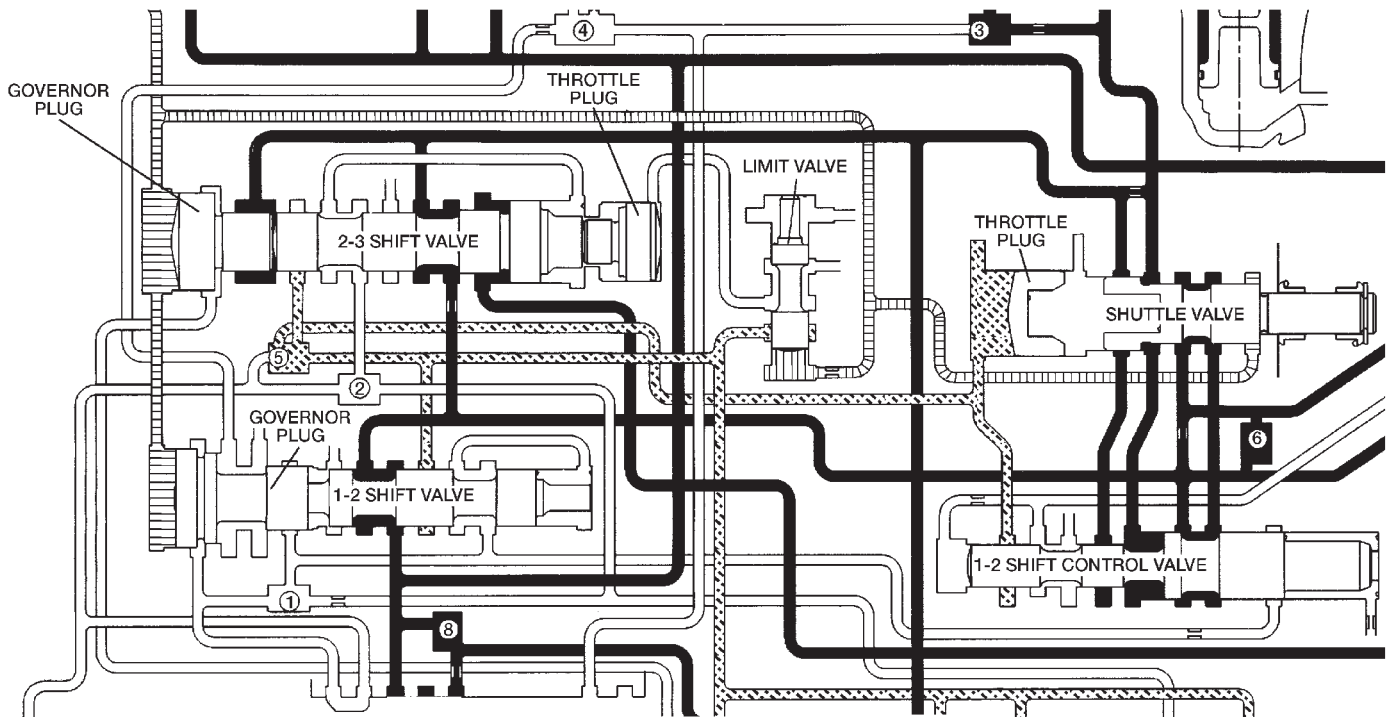
VALVE BODY (Continued)



80c07147

**Fig. 261 2-3 Shift Valve-Before Shift**

governor plug locks the shift valve into the second gear position, preventing an upshift into direct drive. The theory for the blocking of the valve is the same as that of the 1-2 shift valve.



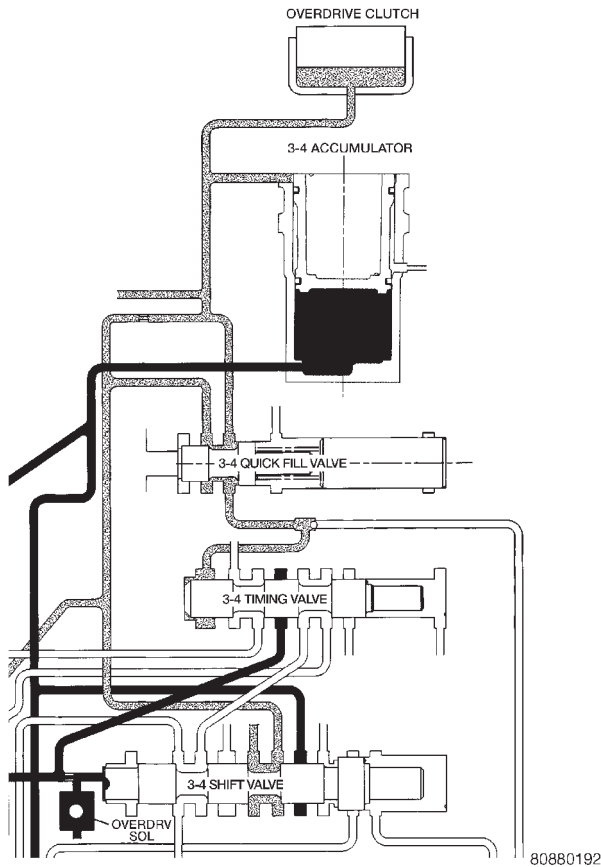
80c07148

**Fig. 262 2-3 Shift Valve-After Shift**

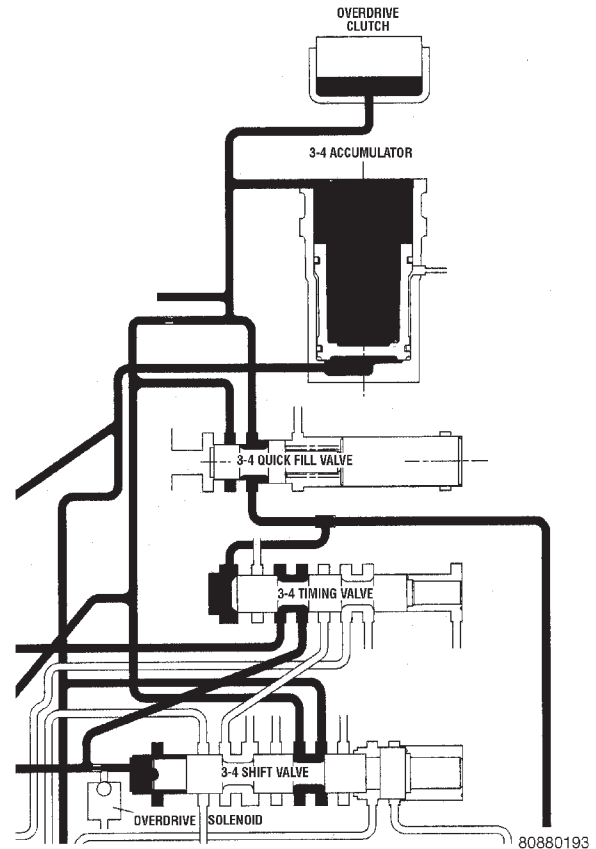
## VALVE BODY (Continued)

**3-4 SHIFT VALVE**

The PCM energizes the overdrive solenoid during the 3-4 upshift (Fig. 263). This causes the solenoid check ball to close the vent port allowing line pressure from the 2-3 shift valve to act directly on the 3-4 upshift valve. Line pressure on the 3-4 shift valve overcomes valve spring pressure moving the valve to the upshift position (Fig. 264). This action exposes the feed passages to the 3-4 timing valve, 3-4 quick fill valve, 3-4 accumulator, and ultimately to the overdrive piston.



**Fig. 263 3-4 Shift Valve Before Shift**



**Fig. 264 3-4 Shift Valve After Shift**

**3-4 TIMING VALVE**

The 3-4 timing valve is moved by line pressure coming through the 3-4 shift valve (Fig. 264). After the shift, the timing valve holds the 2-3 shift valve in an upshift position. The purpose is to prevent the 2-3 valve from downshifting before the 3-4 valve (Fig. 263).

**3-4 QUICK FILL VALVE**

The 3-4 quick fill valve provides faster engagement of the overdrive clutch during 3-4 upshifts. The valve temporarily bypasses the clutch piston feed orifice at the start of a 3-4 upshift (Fig. 263). This exposes a larger passage into the piston retainer resulting in a much faster clutch fill and apply sequence. The quick fill valve does not bypass the regular clutch feed orifice throughout the 3-4 upshift. Instead, once a predetermined pressure develops within the clutch, the valve closes the bypass (Fig. 264). Clutch fill is then completed through the regular feed orifice.

## VALVE BODY (Continued)

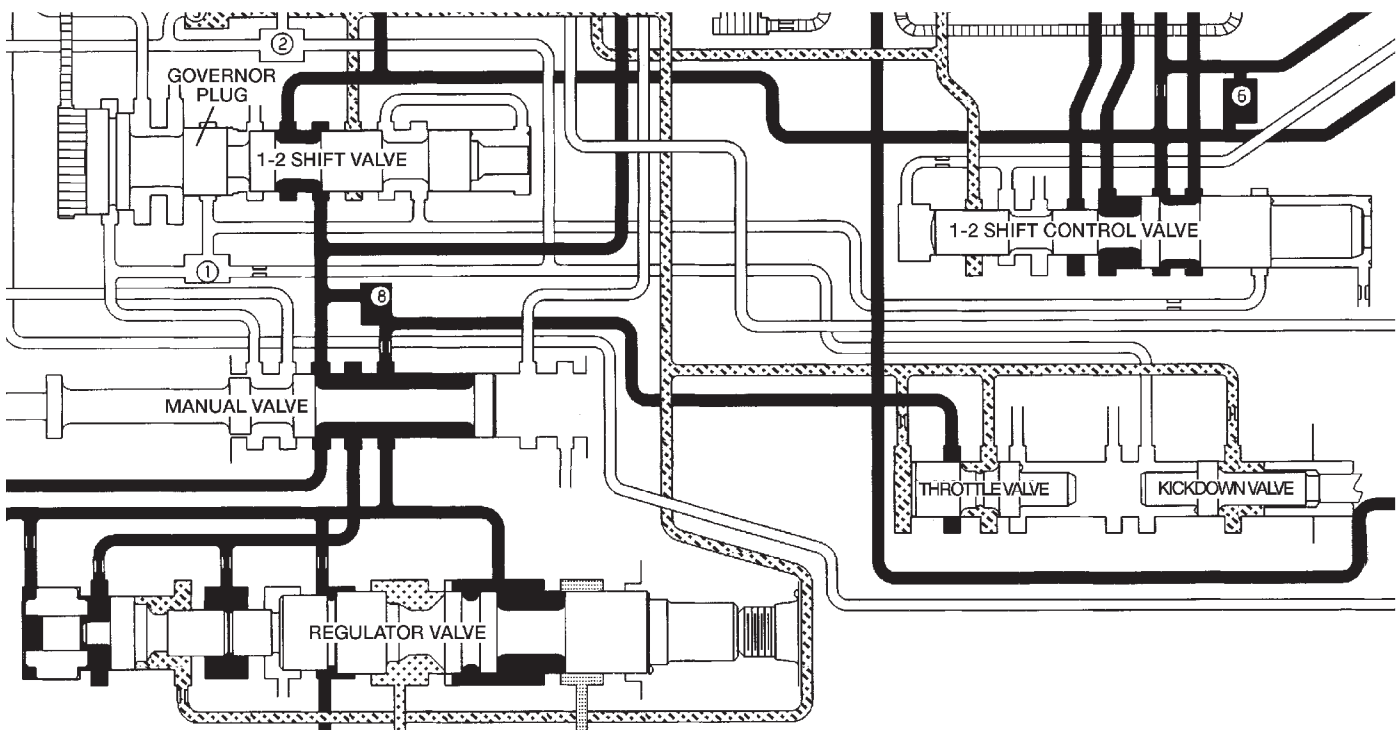
## THROTTLE VALVE

In all gear positions the throttle valve (Fig. 265) is being supplied with line pressure. The throttle valve meters and reduces the line pressure that now becomes throttle pressure. The throttle valve is moved by a spring and the kickdown valve, which is mechanically connected to the throttle. The larger the throttle opening, the higher the throttle pressure (to a maximum of line pressure). The smaller the throttle opening, the lower the throttle pressure (to a minimum of zero at idle). As engine speed increases, the increase in pump speed increases pump output. The increase in pressure and volume must be regulated to maintain the balance within the transmission. To do this, throttle pressure is routed to the reaction area on the right side of the throttle pressure plug (in the regulator valve).

The higher engine speed and line pressure would open the vent too far and reduce line pressure too much. Throttle pressure, which increases with engine speed (throttle opening), is used to oppose the movement of the pressure valve to help control the metering passage at the vent. The throttle pressure is combined with spring pressure to reduce the force of the throttle pressure plug on the pressure valve. The larger spring at the right closes the regulator valve

passage and maintains or increases line pressure. The increased line pressure works against the reaction area of the line pressure plug and the reaction area left of land #3 simultaneously moves the regulator valve train to the right and controls the metering passage.

The kickdown valve, along with the throttle valve, serve to delay upshifts until the correct vehicle speed has been reached. It also controls downshifts upon driver demand, or increased engine load. If these valves were not in place, the shift points would be at the same speed for all throttle positions. The kickdown valve is actuated by a cam connected to the throttle. This is accomplished through either a linkage or a cable. The cam forces the kickdown valve toward the throttle valve compressing the spring between them and moving the throttle valve. As the throttle valve land starts to uncover its port, line pressure is "metered" out into the circuits and viewed as throttle pressure. This increased throttle pressure is metered out into the circuits it is applied to: the 1-2 and 2-3 shift valves. When the throttle pressure is high enough, a 3-2 downshift will occur. If the vehicle speed is low enough, a 2-1 downshift will occur.



80c07149

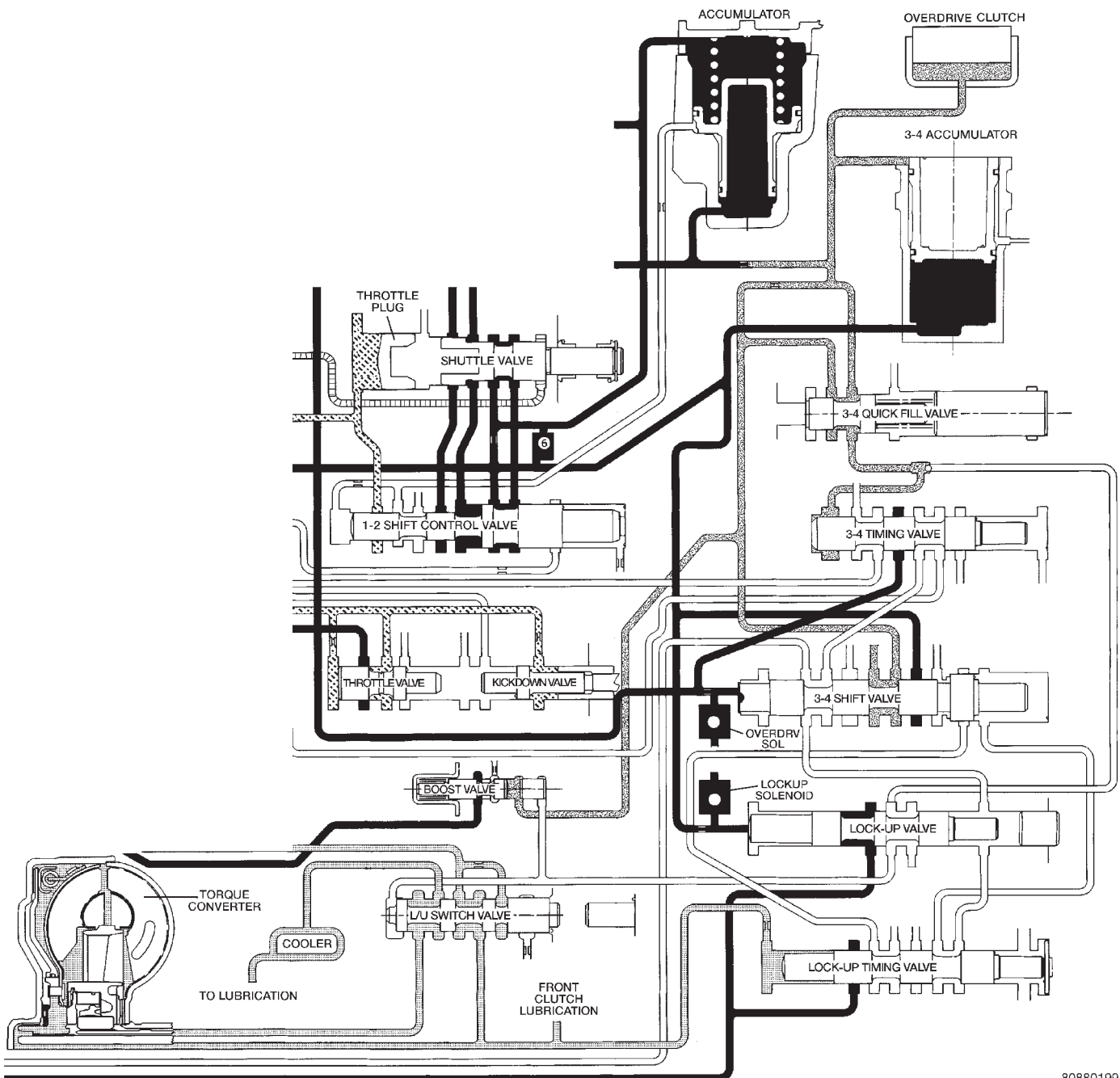
Fig. 265 Throttle Valve

VALVE BODY (Continued)

**SWITCH VALVE**

When the transmission is in Drive Second before the TCC application occurs (Fig. 266), the pressure regulator valve is supplying torque converter pressure to the switch valve. The switch valve directs this pressure through the transmission input shaft, into the converter, through the converter, back out

between the input shaft and the reaction shaft, and back up to the switch valve. From the switch valve, the fluid pressure is directed to the transmission cooler, and lubrication pressure returns from the cooler to lubricate different portions of the transmission.

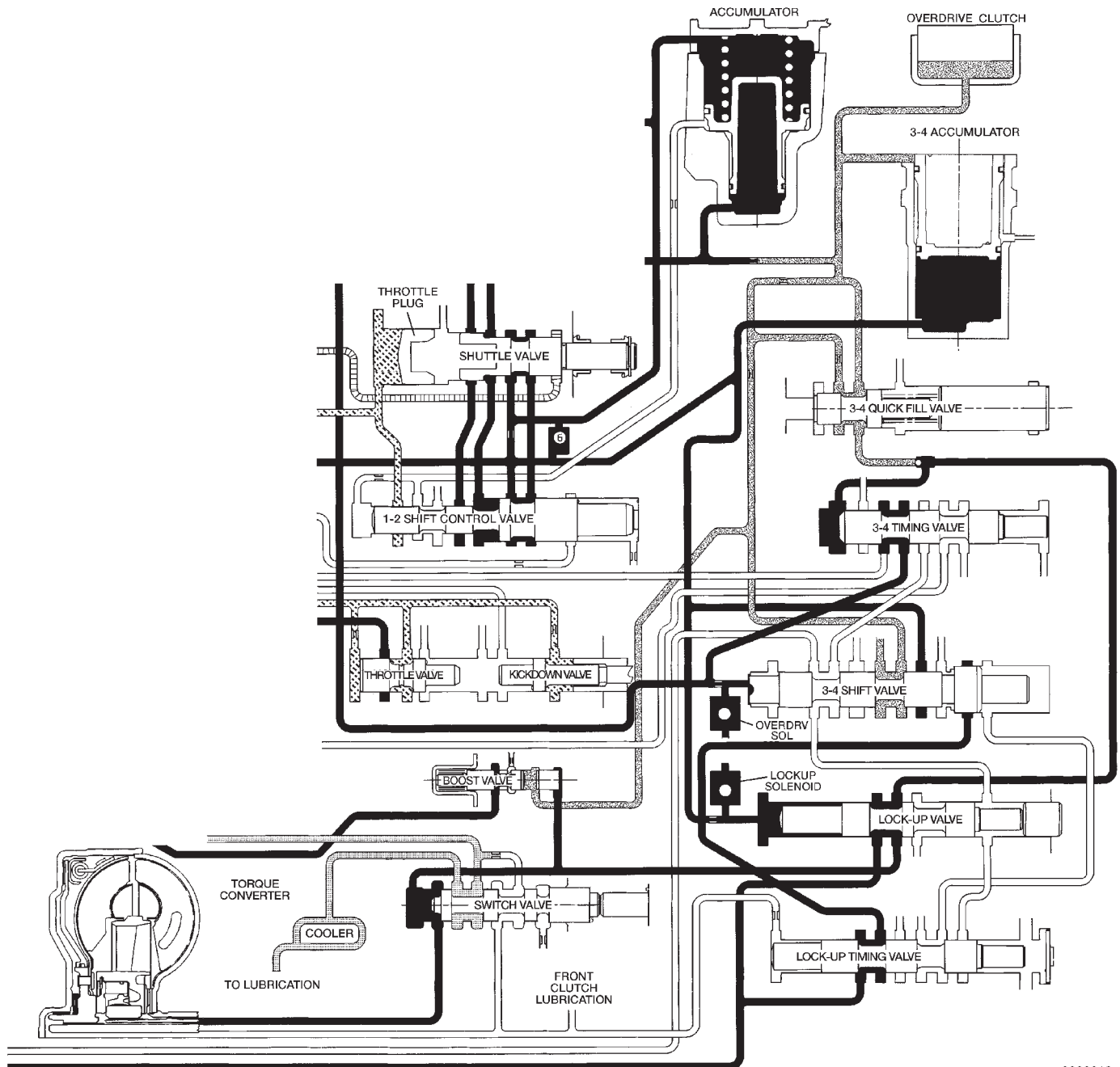


**Fig. 266 Switch Valve-Torque Converter Unlocked**

VALVE BODY (Continued)

Once the TCC control valve has moved to the right (Fig. 267), line pressure is directed to the tip of the switch valve, forcing the valve to the right. The switch valve now vents oil from the front of the piston in the torque converter, and supplies line pressure to the (rear) apply side of the torque converter piston. This pressure differential causes the piston to

apply against the friction material, cutting off any further flow of line pressure oil. After the switch valve is shuttled right allowing line pressure to engage the TCC, torque converter pressure is directed past the switch valve into the transmission cooler and lubrication circuits.



8088019a

**Fig. 267 Switch Valve-Torque Converter Locked**



## VALVE BODY (Continued)

**MANUAL VALVE**

The manual valve (Fig. 268) is a relay valve. The purpose of the manual valve is to direct fluid to the correct circuit needed for a specific gear or driving range. The manual valve, as the name implies, is manually operated by the driver with a lever located on the side of the valve body. The valve is connected mechanically by either a cable or linkage to the gear-shift mechanism. The valve is held in each of its positions by a spring-loaded roller or ball that engages the "roostercomb" of the manual valve lever.

**CONVERTER CLUTCH LOCK-UP VALVE**

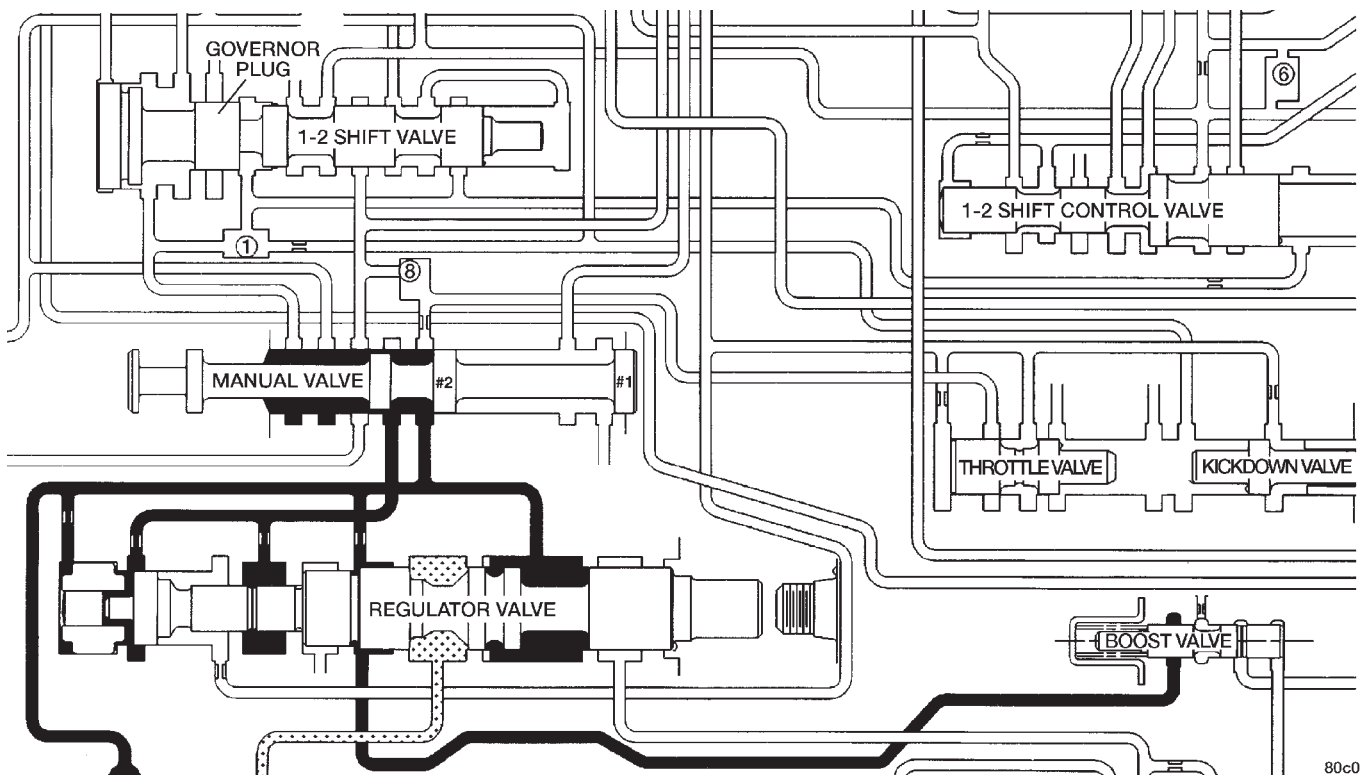
The torque converter clutch (TCC) lock-up valve controls the back (ON) side of the torque converter clutch. When the PCM energizes the TCC solenoid to engage the converter clutch piston, pressure is applied to the TCC lock-up valve which moves to the right and applies pressure to the torque converter clutch.

**CONVERTER CLUTCH LOCK-UP TIMING VALVE**

The torque converter clutch (TCC) lock-up timing valve is there to block any 4-3 downshift until the TCC is completely unlocked and the clutch is disengaged.

**SHUTTLE VALVE**

The assembly is contained in a bore in the valve body above the shift valves. When the manual valve is positioned in the Drive range, throttle pressure acts on the throttle plug of the shuttle valve (Fig. 260) to move it against a spring, increasing the spring force on the shuttle valve. During a part or full throttle 1-2 upshift, the throttle plug is bottomed by throttle pressure, holding the shuttle valve to the right against governor pressure, and opening a by-pass circuit. The shuttle valve controls the quality of the kickdown shift by restricting the rate of fluid discharge from the front clutch and servo release circuits. During a 3-2 kickdown, fluid discharges through the shuttle by-pass circuit. When the shuttle valve closes the by-pass circuit, fluid discharge is restricted and controlled for the application of the front band. During a 2-3 "lift foot" upshift, the shuttle valve by-passes the restriction to allow full fluid flow through the by-pass groove for a faster release of the band.



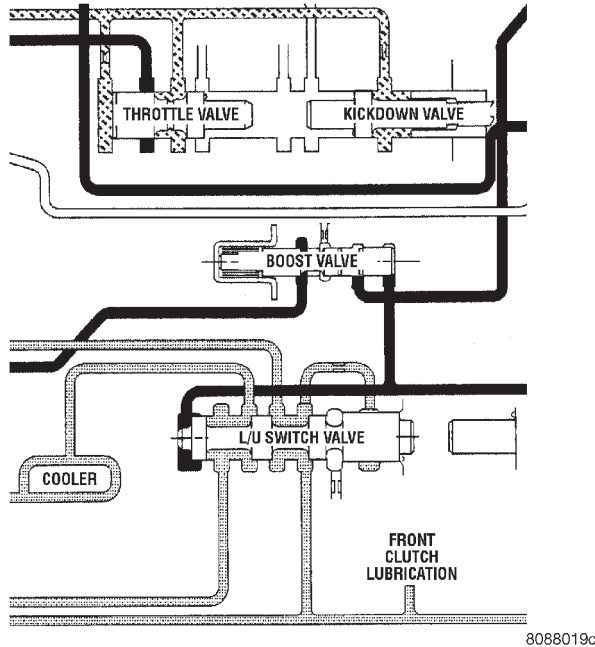
80c0714c

Fig. 268 Manual Valve

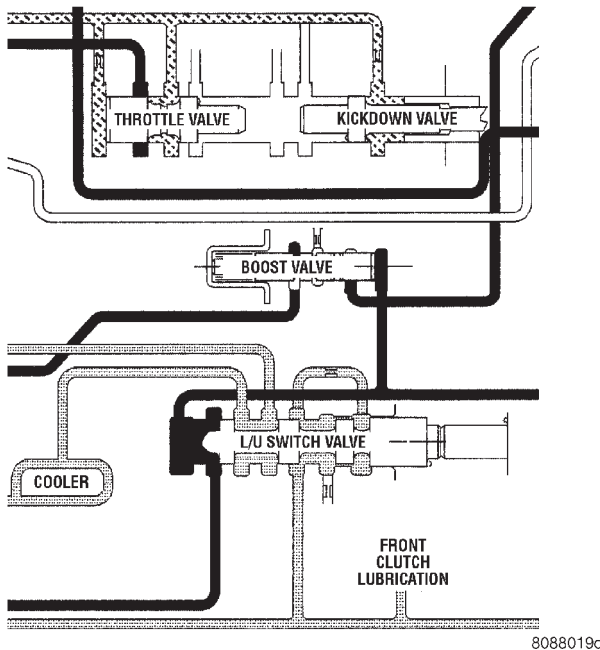
## VALVE BODY (Continued)

## BOOST VALVE

The boost valve (Fig. 269) provides increased fluid apply pressure to the overdrive clutch during 3-4 upshifts (Fig. 270), and when accelerating in fourth gear. The boost valve also serves to increase line pressure during torque converter lock-up.



**Fig. 269 Boost Valve Before Lock-up**



**Fig. 270 Boost Valve After Lock-up**

## REMOVAL

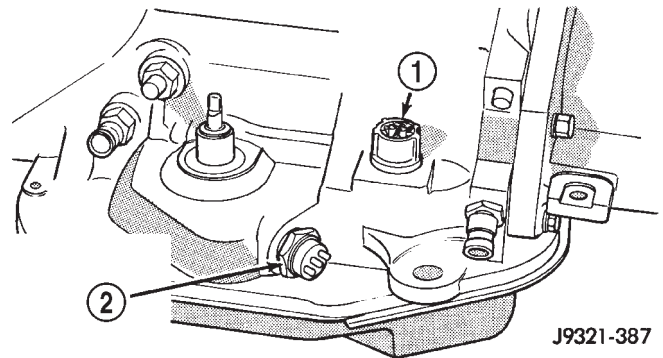
The valve body can be removed for service without having to remove the transmission assembly.

The valve body can be disassembled for cleaning and inspection of the individual components.

The only replaceable valve body components are:

- Manual lever.
- Manual lever washer, seal, E-clip, and shaft seal.
- Manual lever detent ball.
- Throttle lever.
- Fluid filter.
- Pressure adjusting screw bracket.
- Governor pressure solenoid.
- Governor pressure sensor (includes transmission temperature thermistor).
- Converter clutch/overdrive solenoid assembly and harness .
- Governor housing gasket.
- Solenoid case connector O-rings.

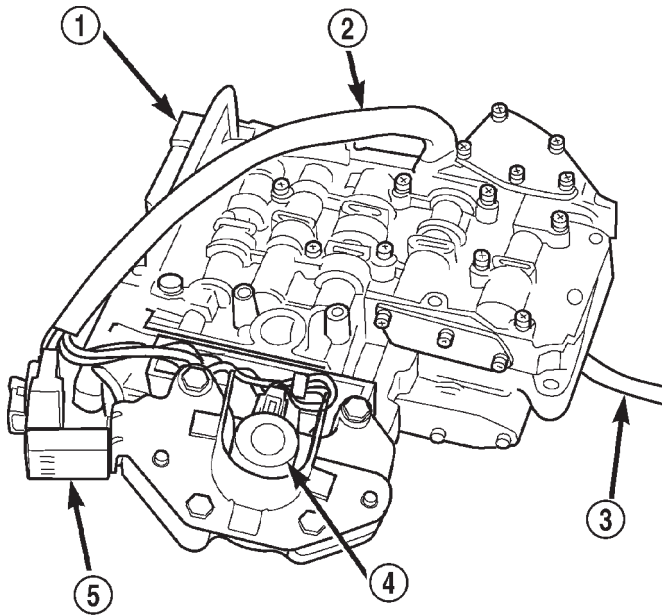
- (1) Shift transmission into NEUTRAL.
- (2) Raise vehicle.
- (3) Remove gearshift and throttle levers from shaft of valve body manual lever.
- (4) Disconnect wires at solenoid case connector (Fig. 271).
- (5) Position drain pan under transmission oil pan.
- (6) Remove transmission oil pan and gasket.
- (7) Remove fluid filter from valve body.
- (8) Remove bolts attaching valve body to transmission case.
- (9) Lower valve body enough to remove accumulator piston and springs.
- (10) Work manual lever shaft and electrical connector out of transmission case.
- (11) Lower valve body, rotate valve body away from case, pull park rod out of sprag, and remove valve body (Fig. 272).



**Fig. 271 Transmission Case Connector**

- 1 - SOLENOID CASE CONNECTOR
- 2 - PARK/NEUTRAL POSITION SWITCH

## VALVE BODY (Continued)



80c072b2

**Fig. 272 Valve Body**

- 1 - VALVE BODY
- 2 - WIRE HARNESS
- 3 - PARK ROD
- 4 - GOVERNOR PRESSURE SOLENOID
- 5 - GOVERNOR PRESSURE SENSOR

**DISASSEMBLY**

**CAUTION:** Do not clamp any valve body component in a vise. This practice can damage the component resulting in unsatisfactory operation after assembly and installation. Do not use pliers to remove any of the valves, plugs or springs and do not force any of the components out or into place. The valves and valve body housings will be damaged if force is used. Tag or mark the valve body springs for reference as they are removed. Do not allow them to become intermixed.

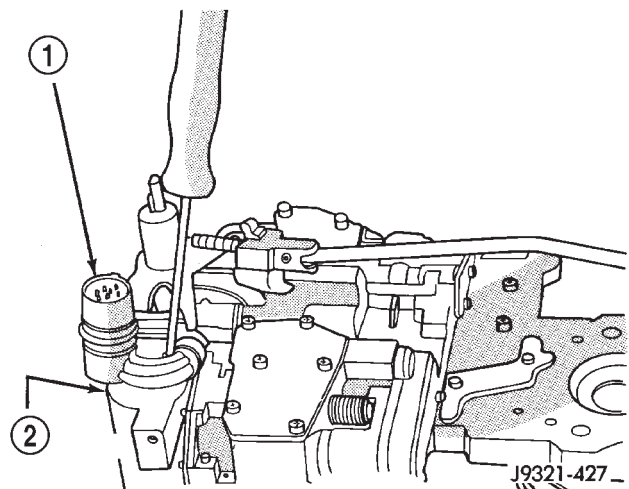
- (1) Disconnect wires from governor pressure sensor and solenoid.
- (2) Remove screws attaching governor body and retainer plate to transfer plate.
- (3) Remove retainer plate, governor body and gasket from transfer plate.

(4) Remove governor pressure sensor from governor body.

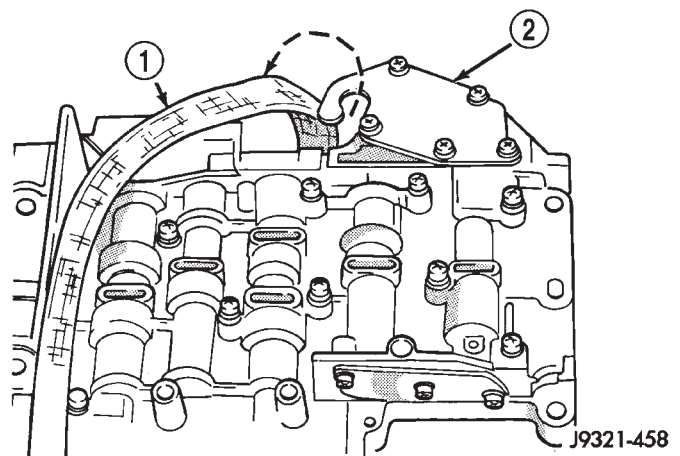
(5) Remove governor pressure solenoid by pulling it straight out of bore in governor body. Remove and discard solenoid O-rings if worn, cut, or torn.

(6) Remove small shoulder bolt that secures solenoid harness case connector to 3-4 accumulator housing (Fig. 273). Retain shoulder bolt. Either tape it to harness or thread it back into accumulator housing after connector removal.

(7) Unhook overdrive/converter solenoid harness from 3-4 accumulator cover plate (Fig. 274).

**Fig. 273 Solenoid Harness Case Connector Shoulder Bolt**

- 1 - SOLENOID HARNESS CASE CONNECTOR
- 2 - 3-4 ACCUMULATOR HOUSING

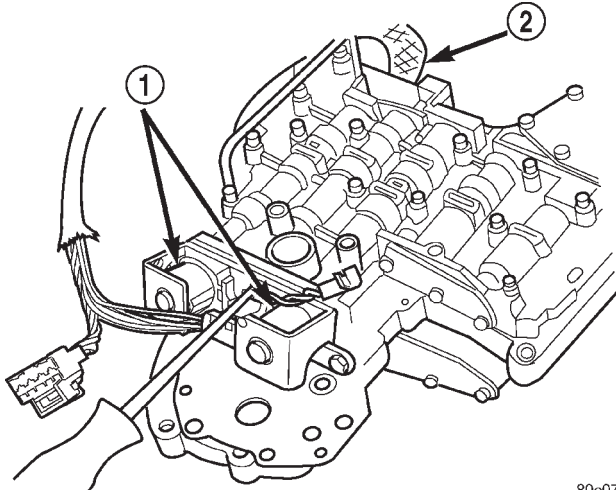
**Fig. 274 Solenoid Harness Routing**

- 1 - OVERDRIVE/CONVERTER SOLENOID WIRE HARNESS
- 2 - 3-4 ACCUMULATOR COVER PLATE

## VALVE BODY (Continued)

(8) Turn valve body over and remove screws that attach overdrive/converter solenoid assembly to valve body (Fig. 275).

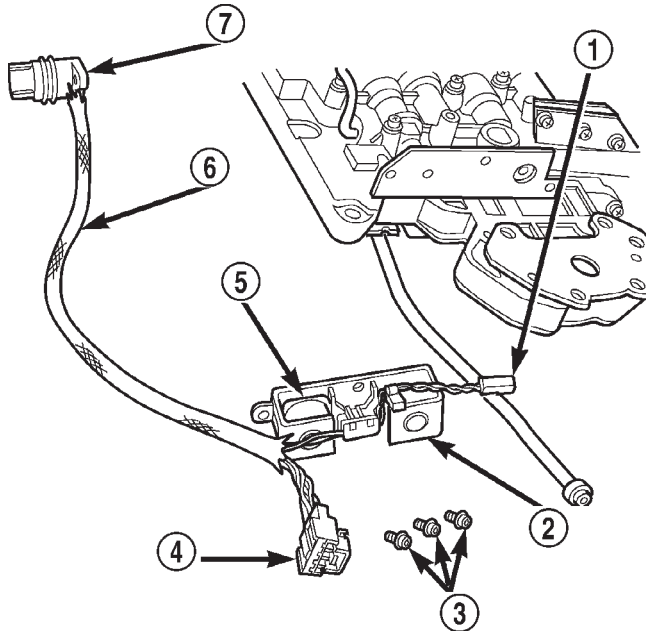
(9) Remove solenoid and harness assembly from valve body (Fig. 276).



80c072b3

**Fig. 275 Solenoid Assembly Screws**

- 1 - OVERDRIVE/CONVERTER CLUTCH SOLENOID ASSEMBLY  
2 - HARNESS



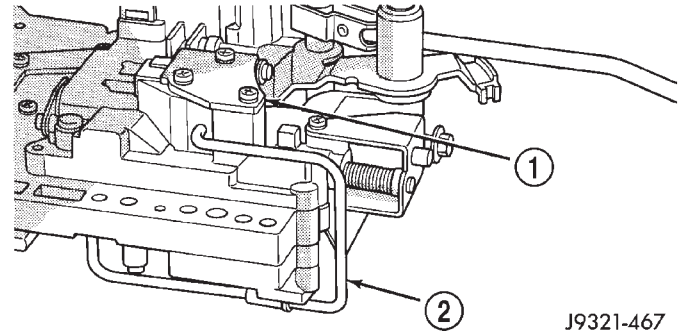
80c072b4

**Fig. 276 Solenoid Assembly**

- 1 - GOVERNOR SOLENOID WIRES  
2 - CONVERTER CLUTCH SOLENOID  
3 - SOLENOID SCREWS  
4 - GOVERNOR SENSOR WIRES  
5 - OVERDRIVE SOLENOID  
6 - HARNESS  
7 - CASE CONNECTOR

(10) Remove boost valve cover (Fig. 277).

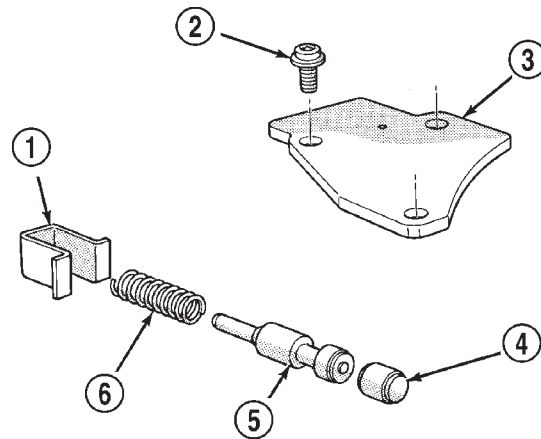
(11) Remove boost valve retainer, valve spring and boost valve (Fig. 278).



J9321-467

**Fig. 277 Boost Valve Cover Location**

- 1 - BOOST VALVE HOUSING AND COVER  
2 - BOOST VALVE TUBE



J9321-468

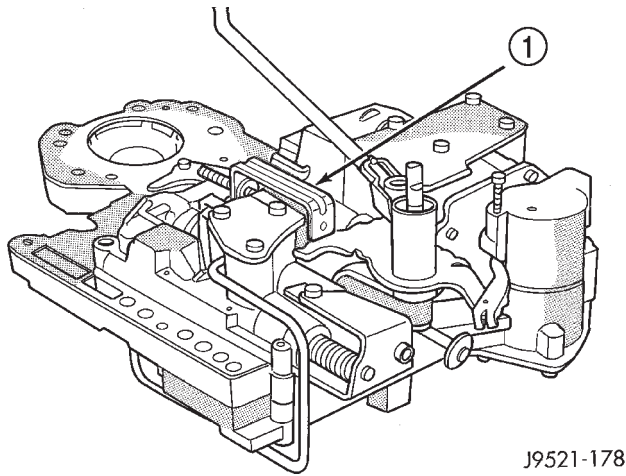
**Fig. 278 Boost Valve Components**

- 1 - SPRING AND VALVE RETAINER  
2 - COVER SCREWS  
3 - BOOST VALVE COVER  
4 - BOOST VALVE PLUG  
5 - BOOST VALVE  
6 - BOOST VALVE SPRING

VALVE BODY (Continued)

(12) Secure detent ball and spring with Retainer Tool 6583 (Fig. 279).

(13) Remove park rod E-clip and separate rod from manual lever (Fig. 280).



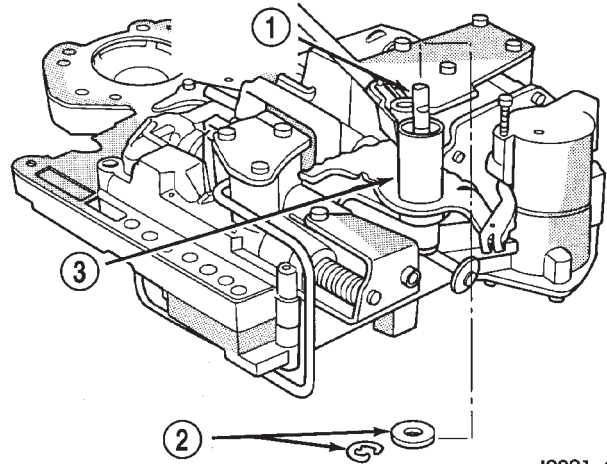
J9521-178

**Fig. 279 Detent Ball Spring**

1 - SPECIAL TOOL 6583 POSITIONED ON DETENT HOUSING

(14) Remove E-clip and washer that retains throttle lever shaft in manual lever (Fig. 281).

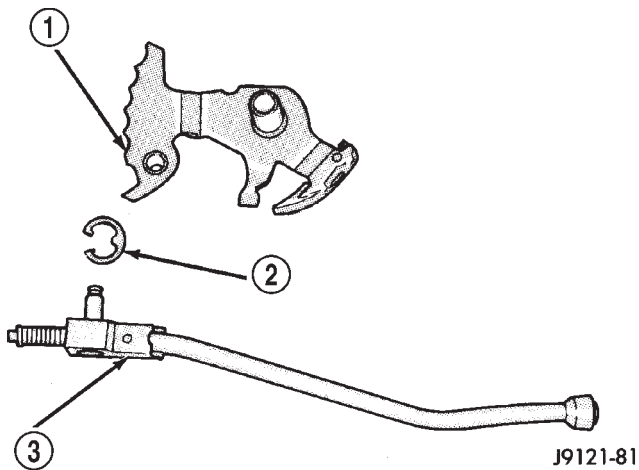
(15) Remove manual lever and throttle lever (Fig. 282). Rotate and lift manual lever off valve body and throttle lever shaft. Then slide throttle lever out of valve body.



J9321-424

**Fig. 281 Throttle Lever E-Clip And Washer**

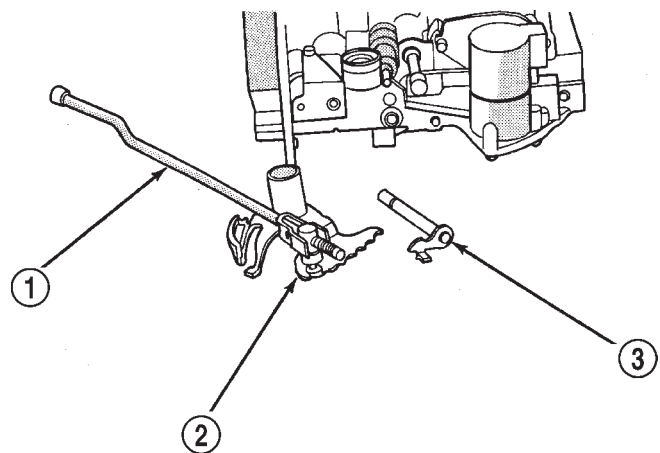
1 - THROTTLE LEVER SHAFT  
2 - E-CLIP AND WASHER  
3 - MANUAL SHAFT



J9121-81

**Fig. 280 Park Rod**

1 - MANUAL LEVER  
2 - E-CLIP  
3 - PARK ROD



J9321-425

**Fig. 282 Manual And Throttle Lever**

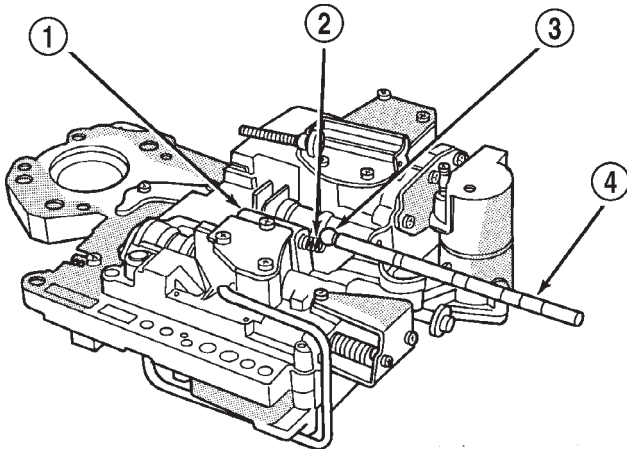
1 - PARK ROD  
2 - MANUAL LEVER ASSEMBLY  
3 - THROTTLE LEVER



## VALVE BODY (Continued)

(16) Position pencil magnet next to detent housing to catch detent ball and spring. Then carefully remove Retainer Tool 6583 and remove detent ball and spring (Fig. 283).

(17) Remove screws attaching pressure adjusting screw bracket to valve body and transfer plate (Fig. 284). Hold bracket firmly against spring tension while removing last screw.

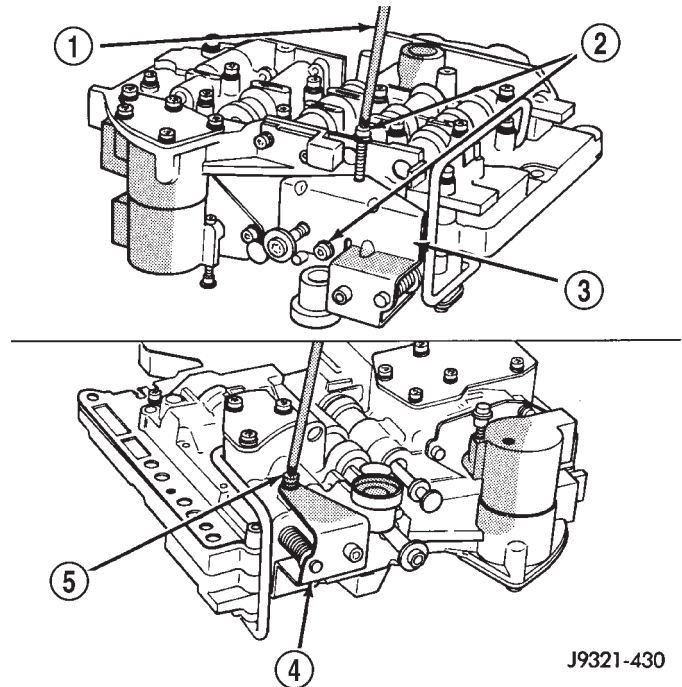


J9321-426

**Fig. 283 Detent Ball And Spring**

- 1 - DETENT HOUSING
- 2 - DETENT SPRING
- 3 - DETENT BALL
- 4 - PENCIL MAGNET

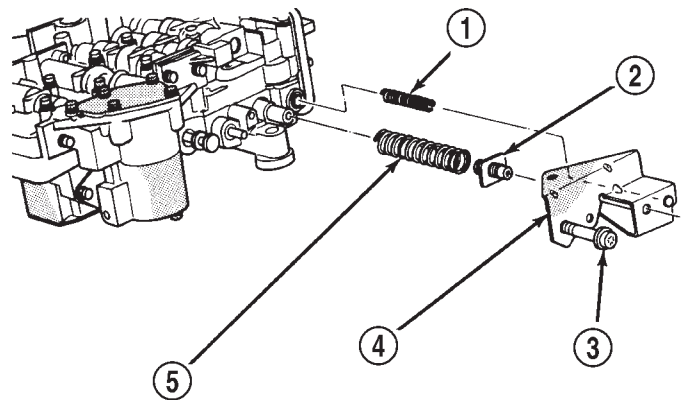
(18) Remove adjusting screw bracket, line pressure adjusting screw, pressure regulator valve spring and switch valve spring (Fig. 285). Do not remove throttle pressure adjusting screw from bracket and do not disturb setting of either adjusting screw during removal.



J9321-430

**Fig. 284 Adjusting Screw Bracket Fastener**

- 1 - T25 TORX™ BIT
- 2 - REMOVE THESE SCREWS FIRST
- 3 - BRACKET
- 4 - BRACKET
- 5 - REMOVE THIS SCREW LAST



J9321-431

**Fig. 285 Adjusting Screw Bracket**

- 1 - SWITCH VALVE SPRING
- 2 - LINE PRESSURE SCREW
- 3 - THROTTLE PRESSURE ADJUSTING SCREW
- 4 - ADJUSTING SCREW BRACKET
- 5 - PRESSURE REGULATOR VALVE SPRING

VALVE BODY (Continued)

(19) Turn upper housing over and remove switch valve, regulator valve and spring, and manual valve (Fig. 286).

(20) Remove kickdown detent, kickdown valve, and throttle valve and spring (Fig. 286).

(21) Loosen left-side 3-4 accumulator housing attaching screw about 2-3 threads. Then remove center and right-side housing attaching screws (Fig. 287).

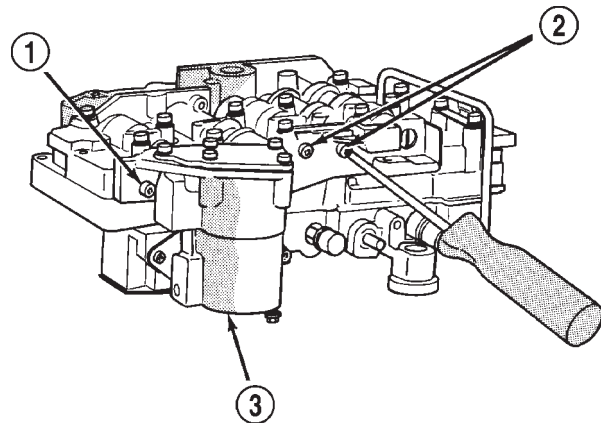
(22) Carefully rotate 3-4 accumulator housing upward and remove 3-4 shift valve spring and converter clutch valve plug and spring (Fig. 288).

(23) Remove left-side screw and remove 3-4 accumulator housing from valve body (Fig. 289).

(24) Bend back tabs on boost valve tube brace (Fig. 290).

(25) Remove boost valve connecting tube (Fig. 291). Disengage tube from upper housing port first. Then rock opposite end of tube back and forth to work it out of lower housing.

**CAUTION:** Do not use tools to loosen or pry the connecting tube out of the valve body housings. Loosen and remove the tube by hand only.

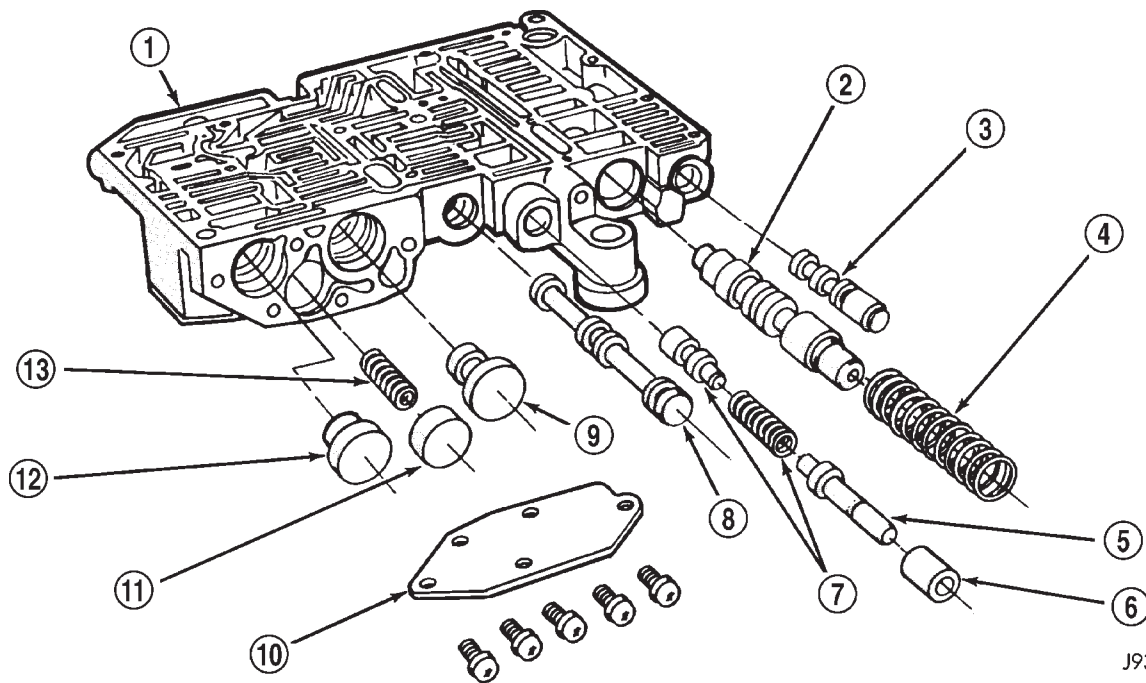


J9321-432

**Fig. 287 Accumulator Housing Screw Locations**

- 1 - LOOSEN THIS SCREW
- 2 - REMOVE THESE SCREWS
- 3 - 3-4 ACCUMULATOR HOUSING

(26) Turn valve body over so lower housing is facing upward (Fig. 292). In this position, the two check balls in upper housing will remain in place and not fall out when lower housing and separator plate are removed.

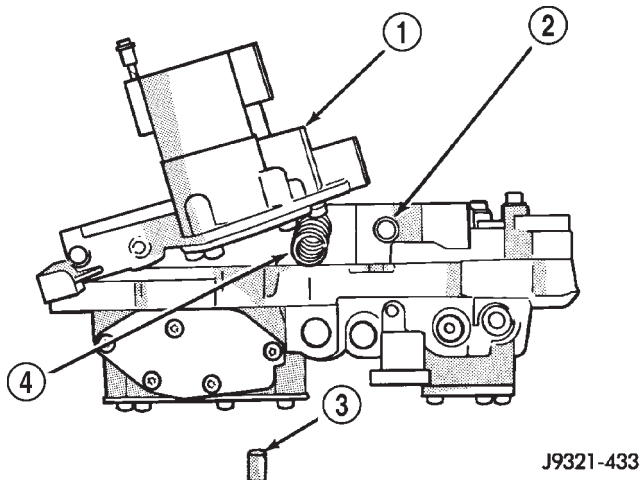


J9321-155

**Fig. 286 Upper Housing Control Valve Locations**

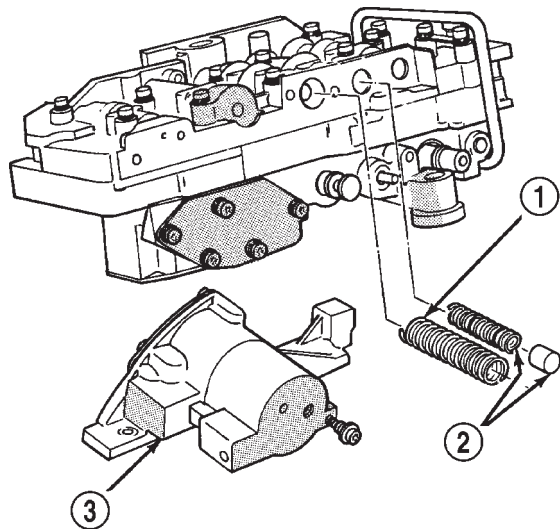
- 1 - UPPER HOUSING
- 2 - REGULATOR VALVE
- 3 - SWITCH VALVE
- 4 - REGULATOR VALVE SPRING
- 5 - KICKDOWN VALVE
- 6 - KICKDOWN DETENT
- 7 - THROTTLE VALVE AND SPRING
- 8 - MANUAL VALVE
- 9 - 1-2 GOVERNOR PLUG
- 10 - GOVERNOR PLUG COVER
- 11 - THROTTLE PLUG
- 12 - 2-3 GOVERNOR PLUG
- 13 - SHUTTLE VALVE PRIMARY SPRING

## VALVE BODY (Continued)



**Fig. 288 3-4 Shift And Converter Clutch Valve Springs and Plug**

- 1 - ACCUMULATOR HOUSING
- 2 - CONVERTER CLUTCH VALVE SPRING
- 3 - CLUTCH VALVE PLUG
- 4 - 3-4 SHIFT VALVE SPRING

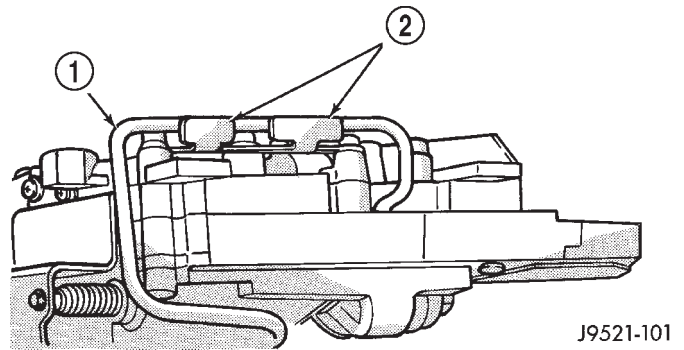


**Fig. 289 Accumulator Housing, Valve Springs, and Plug**

- 1 - 3-4 SHIFT VALVE SPRING
- 2 - CONVERTER CLUTCH VALVE SPRING AND PLUG
- 3 - 3-4 ACCUMULATOR HOUSING

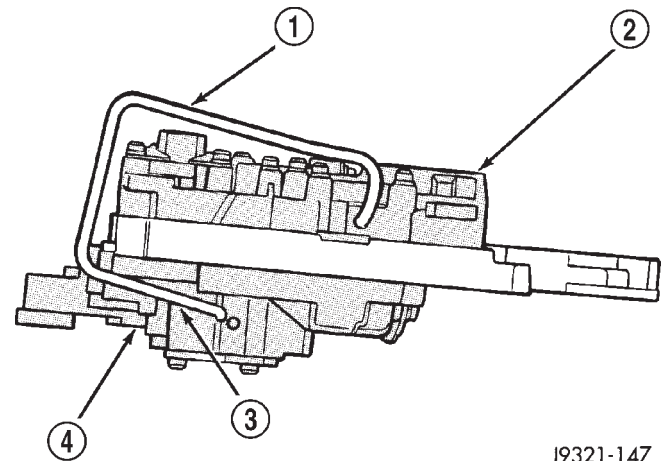
(27) Remove screws attaching valve body lower housing to upper housing and transfer plate (Fig. 292). Note position of boost valve tube brace for assembly reference.

(28) Remove lower housing and overdrive separator plate from transfer plate (Fig. 292).



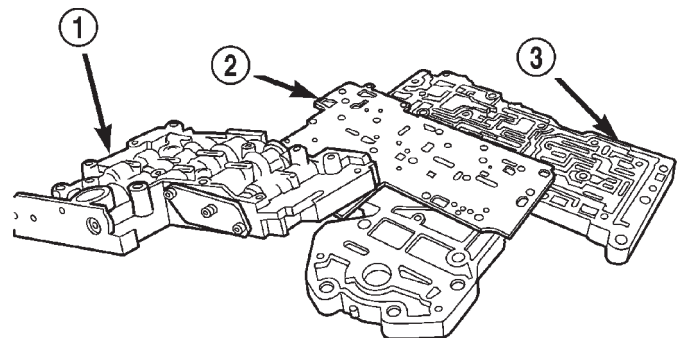
**Fig. 290 Boost Valve Tube Brace**

- 1 - BOOST VALVE TUBE
- 2 - TUBE BRACE (DOUBLE TAB)



**Fig. 291 Boost Valve Tube**

- 1 - BOOST VALVE TUBE
- 2 - LOWER HOUSING
- 3 - DISENGAGE THIS END OF TUBE FIRST
- 4 - UPPER HOUSING



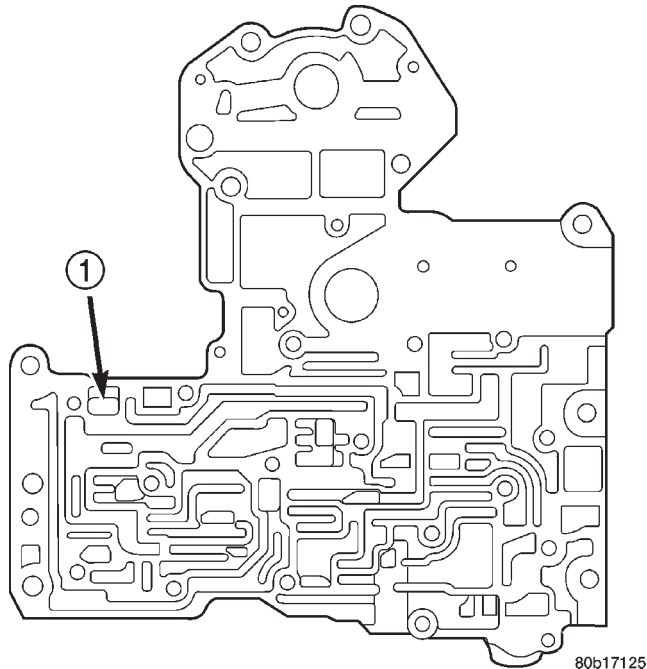
**Fig. 292 Lower Housing**

- 1 - LOWER HOUSING
- 2 - OVERDRIVE SEPARATOR PLATE
- 3 - TRANSFER PLATE AND UPPER HOUSING

VALVE BODY (Continued)

(29) Remove the ECE check ball from the transfer plate (Fig. 293). The ECE check ball is approximately 4.8 mm (3/16 in.) in diameter.

(30) Remove transfer plate from upper housing (Fig. 294).



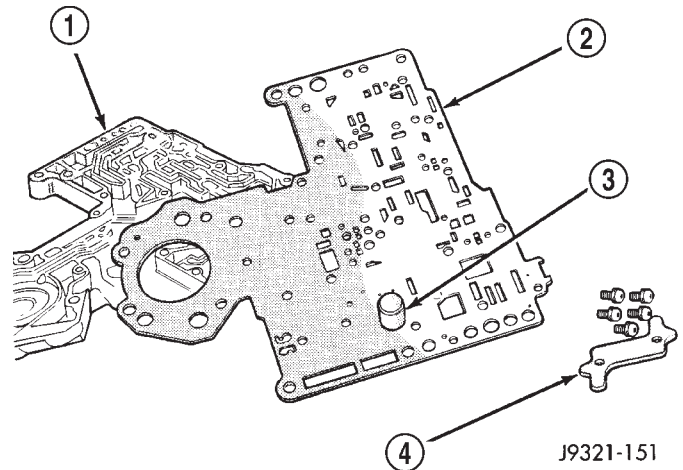
**Fig. 293 ECE Check Ball**

- 1 - ECE CHECK BALL (3/16")

(31) Turn transfer plate over so upper housing separator plate is facing upward.

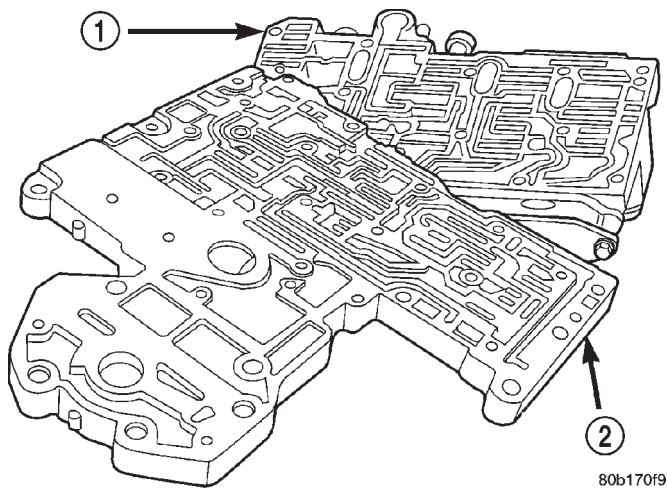
(32) Remove upper housing separator plate from transfer plate (Fig. 295). Note position of filter in separator plate for assembly reference.

(33) Remove rear clutch and rear servo check balls from transfer plate. Note check ball location for assembly reference (Fig. 296).



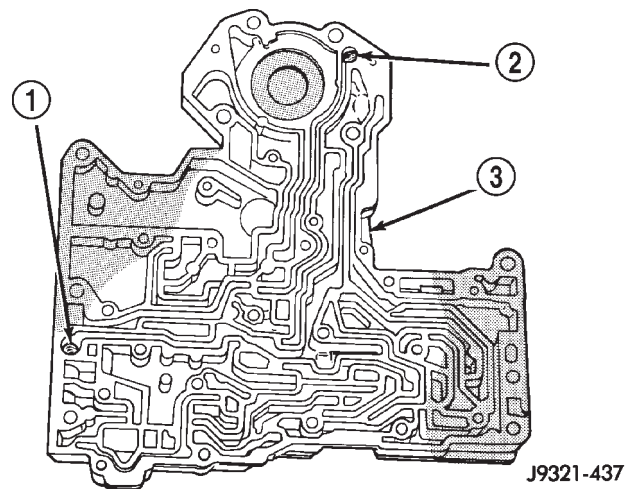
**Fig. 295 Upper Housing Separator Plate**

- 1 - TRANSFER PLATE
- 2 - UPPER HOUSING SEPARATOR PLATE
- 3 - FILTER SCREEN
- 4 - BRACE



**Fig. 294 Transfer Plate**

- 1 - UPPER HOUSING
- 2 - TRANSFER PLATE



**Fig. 296 Rear Clutch and Rear Servo Check Ball Locations**

- 1 - REAR CLUTCH CHECK BALL
- 2 - REAR SERVO CHECK BALL
- 3 - TRANSFER PLATE



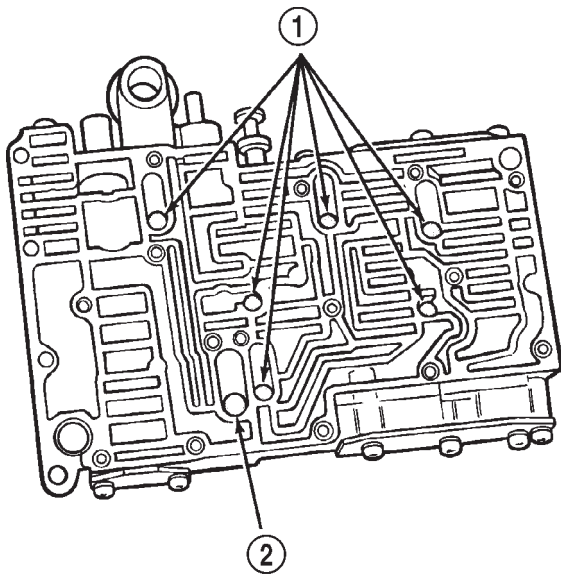
## VALVE BODY (Continued)

## VALVE BODY UPPER HOUSING

(1) Note location of check balls in valve body upper housing (Fig. 297). Then remove the one large diameter and the six smaller diameter check balls.

(2) Remove governor plug and shuttle valve covers (Fig. 299).

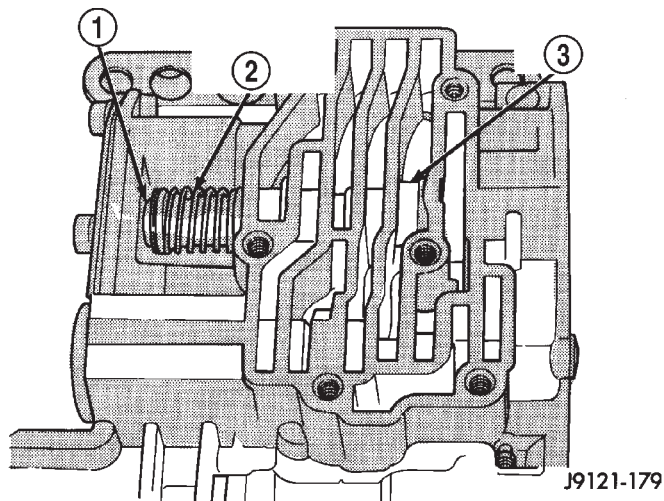
(3) Remove E-clip that secures shuttle valve secondary spring on valve stem (Fig. 298).



J9321-154

**Fig. 297 Check Ball Locations In Upper Housing**

- 1 - SMALL DIAMETER CHECK BALLS (6)  
2 - LARGE DIAMETER CHECK BALL (1)



J9121-179

**Fig. 298 Shuttle Valve E-Clip And Secondary Spring**

- 1 - E-CLIP  
2 - SECONDARY SPRING AND GUIDES  
3 - SHUTTLE VALVE

(4) Remove throttle plug, primary spring, shuttle valve, secondary spring, and spring guides (Fig. 299).

(5) Remove boost valve retainer, spring and valve if not previously removed.

(6) Remove throttle plug and 1-2 and 2-3 governor plugs (Fig. 286).

(7) Turn upper housing around and remove limit valve and shift valve covers (Fig. 300).

(8) Remove limit valve housing. Then remove retainer, spring, limit valve, and 2-3 throttle plug from limit valve housing (Fig. 300).

(9) Remove 1-2 shift control valve and spring (Fig. 300).

(10) Remove 1-2 shift valve and spring (Fig. 300).

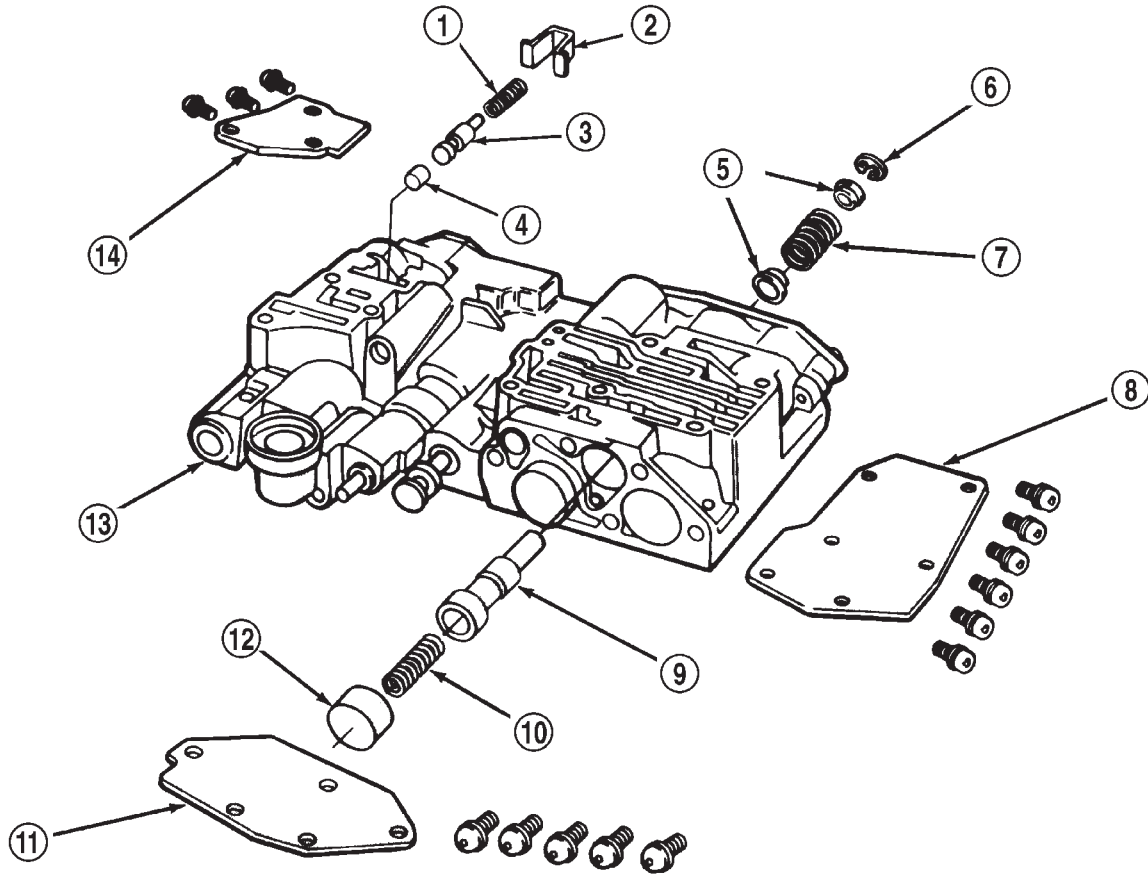
(11) Remove 2-3 shift valve and spring from valve body (Fig. 300).

(12) Remove pressure plug cover (Fig. 300).

(13) Remove line pressure plug, sleeve, throttle pressure plug and spring (Fig. 300).



VALVE BODY (Continued)

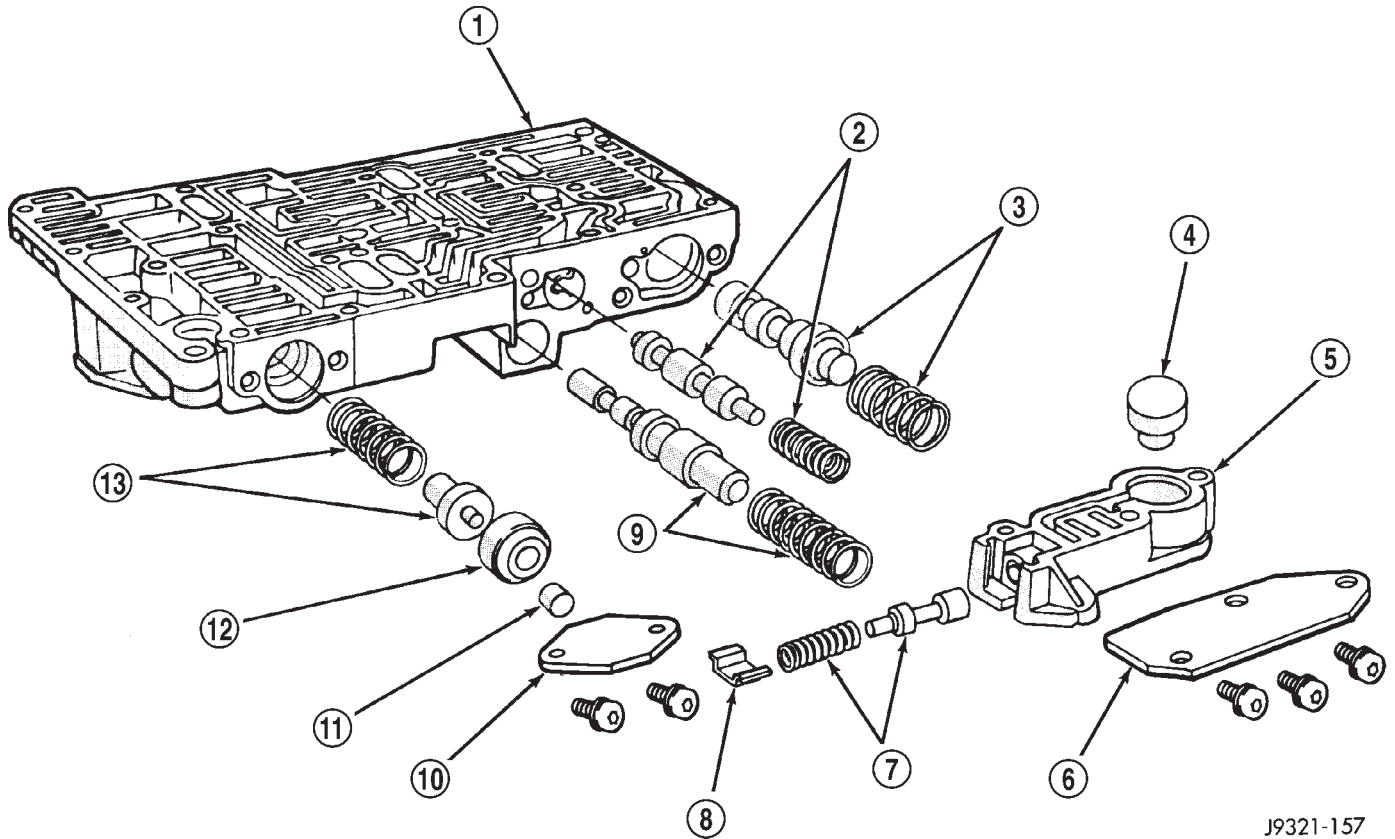


J9421-217

**Fig. 299 Shuttle and Boost Valve Location**

- |                                    |                                   |
|------------------------------------|-----------------------------------|
| 1 - SPRING                         | 8 - SHUTTLE VALVE COVER           |
| 2 - RETAINER                       | 9 - SHUTTLE VALVE                 |
| 3 - BOOST VALVE                    | 10 - SHUTTLE VALVE PRIMARY SPRING |
| 4 - BOOST VALVE PLUG               | 11 - GOVERNOR PLUG COVER          |
| 5 - SPRING GUIDES                  | 12 - THROTTLE PLUG                |
| 6 - E-CLIP                         | 13 - UPPER HOUSING                |
| 7 - SHUTTLE VALVE SECONDARY SPRING | 14 - BOOST VALVE COVER            |

VALVE BODY (Continued)



J9321-157

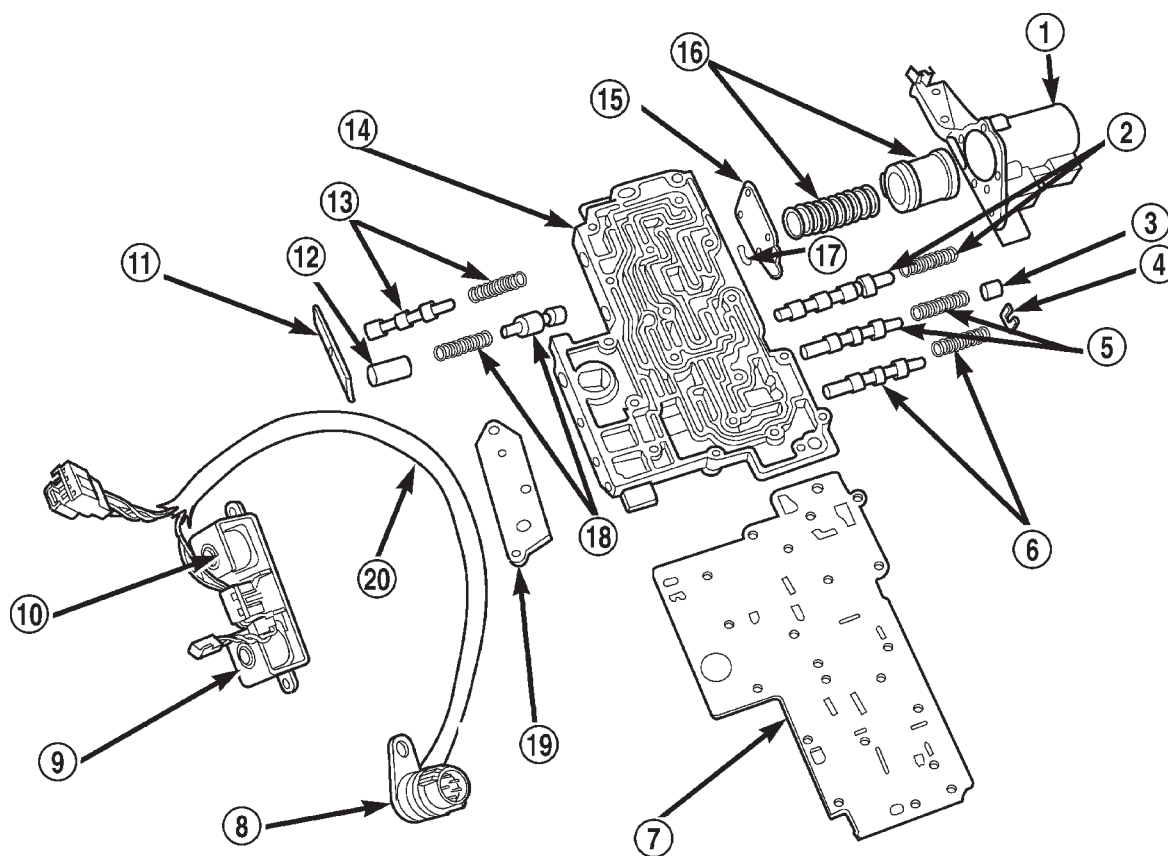
**Fig. 300 Upper Housing Shift Valve and Pressure Plug Locations**

- |                                |  |
|--------------------------------|--|
| 1 - UPPER HOUSING              | 8 - RETAINER                           |
| 2 - 1-2 SHIFT VALVE AND SPRING | 9 - 1-2 SHIFT CONTROL VALVE AND SPRING |
| 3 - 2-3 SHIFT VALVE AND SPRING | 10 - PRESSURE PLUG COVER               |
| 4 - 2-3 THROTTLE PLUG          | 11 - LINE PRESSURE PLUG                |
| 5 - LIMIT VALVE HOUSING        | 12 - PLUG SLEEVE                       |
| 6 - LIMIT VALVE COVER          | 13 - THROTTLE PRESSURE SPRING AND PLUG |
| 7 - LIMIT VALVE AND SPRING     |  |

## VALVE BODY (Continued)

## VALVE BODY LOWER HOUSING

- (1) Remove timing valve cover.
  - (2) Remove 3-4 timing valve and spring.
  - (3) Remove 3-4 quick fill valve, spring and plug.
  - (4) Remove 3-4 shift valve and spring.
  - (5) Remove converter clutch valve, spring and plug
- (Fig. 301).
- (6) Remove converter clutch timing valve, retainer and valve spring.



80c072b5

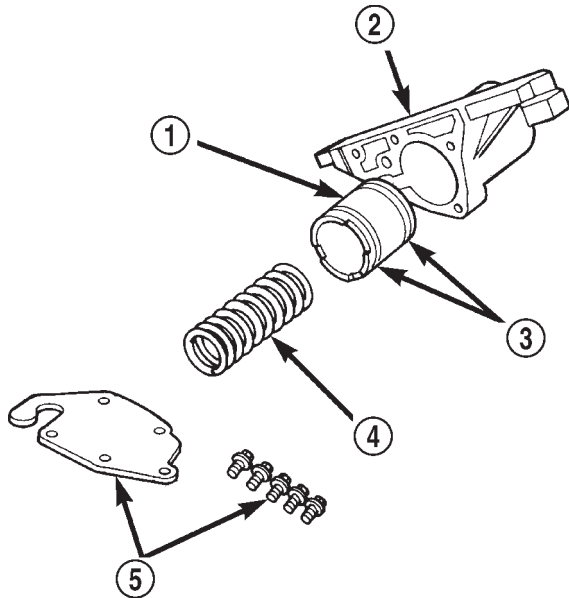
**Fig. 301 Lower Housing Shift Valves and Springs**

- |  |  |
|--|--|
| 1 - 3-4 ACCUMULATOR HOUSING                  | 11 - TIMING VALVE COVER                |
| 2 - 3-4 SHIFT VALVE AND SPRING               | 12 - PLUG                              |
| 3 - PLUG                                     | 13 - 3-4 TIMING VALVE AND SPRING       |
| 4 - SPRING RETAINER                          | 14 - LOWER HOUSING                     |
| 5 - CONVERTER CLUTCH VALVE AND SPRING        | 15 - ACCUMULATOR END PLATE             |
| 6 - CONVERTER CLUTCH TIMING VALVE AND SPRING | 16 - 3-4 ACCUMULATOR PISTON AND SPRING |
| 7 - OVERDRIVE SEPARATOR PLATE                | 17 - E-CLIP                            |
| 8 - CASE CONNECTOR                           | 18 - 3-4 QUICK FILL SPRING AND VALVE   |
| 9 - CONVERTER CLUTCH SOLENOID                | 19 - SOLENOID GASKET                   |
| 10 - OVERDRIVE SOLENOID                      | 20 - HARNESS                           |

## VALVE BODY (Continued)

**3-4 ACCUMULATOR HOUSING**

- (1) Remove end plate from housing.
- (2) Remove piston spring.
- (3) Remove piston. Remove and discard piston seals (Fig. 302).



804d8eb9

**Fig. 302 3-4 Accumulator and Housing**

- 1 - ACCUMULATOR PISTON
- 2 - 3-4 ACCUMULATOR HOUSING
- 3 - TEFLON SEALS
- 4 - PISTON SPRING
- 5 - COVER PLATE AND SCREWS

**CLEANING**

Clean the valve housings, valves, plugs, springs, and separator plates with a standard parts cleaning solution only. Do not use gasoline, kerosene, or any type of caustic solution.

Do not immerse any of the electrical components in cleaning solution. Clean the governor solenoid and sensor and the dual solenoid and harness assembly by wiping them off with dry shop towels only.

Dry all except the electrical parts with compressed air. Make sure all passages are clean and free from obstructions. **Do not use rags or shop towels to dry or wipe off valve body components. Lint from these materials can stick to valve body parts, interfere with valve operation, and clog filters and fluid passages.**

Wipe the governor pressure sensor and solenoid valve with dry, lint free shop towels only. The O-rings on the sensor and solenoid valve are the only serviceable components. Be sure the vent ports in the solenoid valve are open and not blocked by dirt or debris. Replace the valve and/or sensor only when DRB scan tool diagnosis indicates this is necessary. Or, if either

part has sustained physical damage (dented, deformed, broken, etc.).

**CAUTION:** Do not turn the small screw at the end of the solenoid valve for any reason. Turning the screw in either direction will ruin solenoid calibration and result in solenoid failure. In addition, the filter on the solenoid valve is **NOT** serviceable. Do not try to remove the filter as this will damage the valve housing.

**INSPECTION**

Inspect the throttle and manual valve levers and shafts. Do not attempt to straighten a bent shaft or correct a loose lever. Replace these components if worn, bent, loose or damaged in any way.

Inspect all of the valve body mating surfaces for scratches, nicks, burrs, or distortion. Use a straight-edge to check surface flatness. Minor scratches may be removed with crocus cloth using only very light pressure.

Minor distortion of a valve body mating surface may be corrected by smoothing the surface with a sheet of crocus cloth. Position the crocus cloth on a surface plate, sheet of plate glass or equally flat surface. If distortion is severe or any surfaces are heavily scored, the valve body will have to be replaced.

**CAUTION:** Many of the valves and plugs, such as the throttle valve, shuttle valve plug, 1-2 shift valve and 1-2 governor plug, are made of coated aluminum. Aluminum components are identified by the dark color of the special coating applied to the surface (or by testing with a magnet). Do not sand aluminum valves or plugs under any circumstances. This practice could damage the special coating causing the valves/plugs to stick and bind.

Inspect the valves and plugs for scratches, burrs, nicks, or scores. Minor surface scratches on steel valves and plugs can be removed with crocus cloth but **do not round off the edges of the valve or plug lands.** Maintaining sharpness of these edges is vitally important. The edges prevent foreign matter from lodging between the valves and plugs and the bore.

Inspect all the valve and plug bores in the valve body. Use a penlight to view the bore interiors. Replace the valve body if any bores are distorted or scored. Inspect all of the valve body springs. The springs must be free of distortion, warpage or broken coils.

Check the two separator plates for distortion or damage of any kind. Inspect the upper housing, lower housing, 3-4 accumulator housing, and transfer

## VALVE BODY (Continued)

plate carefully. Be sure all fluid passages are clean and clear. Check condition of the upper housing and transfer plate check balls as well. The check balls and ball seats must not be worn or damaged.

Trial fit each valve and plug in its bore to check freedom of operation. When clean and dry, the valves and plugs should drop freely into the bores.

Valve body bores do not change dimensionally with use. If the valve body functioned correctly when new, it will continue to operate properly after cleaning and inspection. It should not be necessary to replace a valve body assembly unless it is damaged in handling.

The only serviceable valve body components are listed below. The remaining valve body components are serviced only as part of a complete valve body assembly. Serviceable parts are:

- dual solenoid and harness assembly
- solenoid gasket
- solenoid case connector O-rings and shoulder bolt
- switch valve and spring
- pressure adjusting screw and bracket assembly
- throttle lever
- manual lever and shaft seal
- throttle lever shaft seal, washer, and E-clip
- fluid filter and screws
- detent ball and spring
- valve body screws
- governor pressure solenoid
- governor pressure sensor and retaining clip
- park lock rod and E-clip

## ASSEMBLY

**CAUTION:** Do not force valves or plugs into place during reassembly. If the valve body bores, valves and plugs are free of distortion or burrs, the valve body components should all slide into place easily. In addition, do not overtighten the transfer plate and valve body screws during reassembly. Overtightening can distort the housings resulting in valve sticking, cross leakage and unsatisfactory operation. Tighten valve body screws to recommended torque only.

## LOWER HOUSING

(1) Lubricate valves, springs, and the housing valve and plug bores with clean transmission fluid (Fig. 298).

(2) Install 3-4 timing valve spring and valve in lower housing.

(3) Install 3-4 quick fill valve in lower housing.

(4) Install 3-4 quick fill valve spring and plug in housing.

(5) Install timing valve end plate. Tighten end plate screws to 4 N·m (35 in. lbs.) torque.

## 3-4 ACCUMULATOR

(1) Lubricate accumulator piston, seals and housing piston bore with clean transmission fluid (Fig. 299).

(2) Install new seal rings on accumulator piston.

(3) Install piston and spring in housing.

(4) Install end plate on housing.

## TRANSFER PLATE

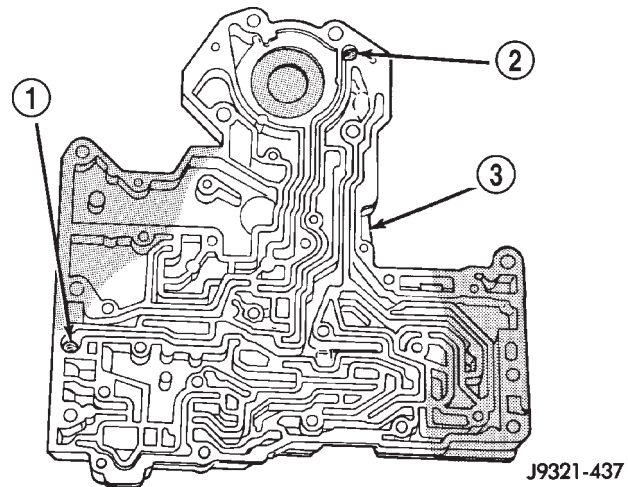
(1) Install rear clutch and rear servo check balls in transfer plate (Fig. 303).

(2) Install filter screen in upper housing separator plate (Fig. 304).

(3) Align and position upper housing separator plate on transfer plate (Fig. 305).

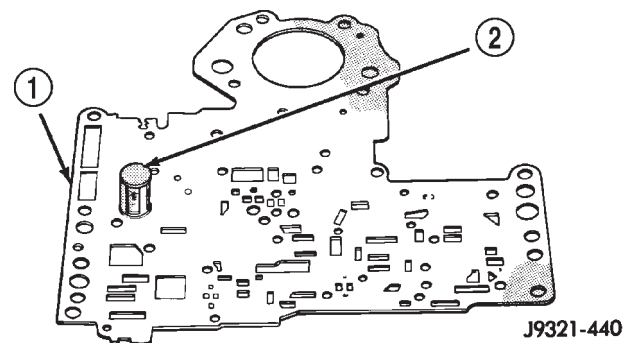
(4) Install brace plate (Fig. 305). Tighten brace attaching screws to 4 N·m (35 in. lbs.) torque.

(5) Install remaining separator plate attaching screws. Tighten screws to 4 N·m (35 in. lbs.) torque.



**Fig. 303 Rear Clutch And Rear Servo Check Ball Locations**

- 1 - REAR CLUTCH CHECK BALL
- 2 - REAR SERVO CHECK BALL
- 3 - TRANSFER PLATE

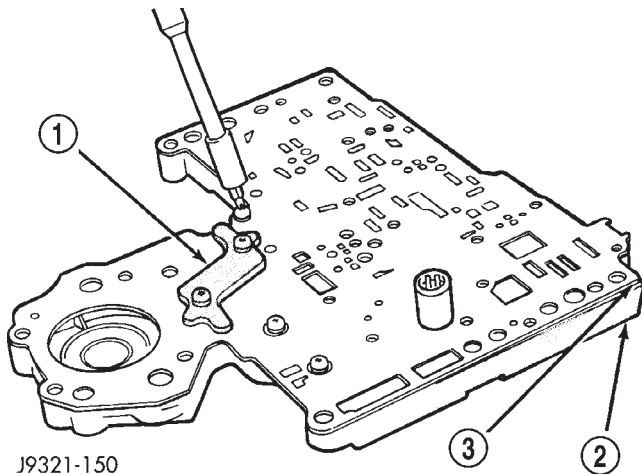


**Fig. 304 Separator Plate Filter Screen Installation**

- 1 - UPPER HOUSING SEPARATOR PLATE
- 2 - FILTER SCREEN



## VALVE BODY (Continued)



J9321-150

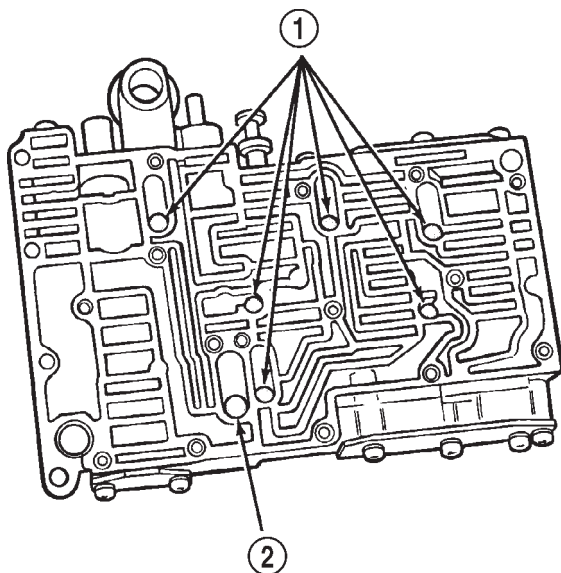
**Fig. 305 Brace Plate**

- 1 - BRACE
- 2 - TRANSFER PLATE
- 3 - SEPARATOR PLATE

## UPPER AND LOWER HOUSING

(1) Position upper housing so internal passages and check ball seats are facing upward. Then install check balls in housing (Fig. 306). Eight check balls are used. The single large check ball is approximately 8.7 mm (11/32 in.) diameter. The single small check ball is approximately 4.8 mm (3/16 in.) in diameter. The remaining 6 check balls are approximately 6.3 mm (1/4 in.) in diameter.

(2) Position assembled transfer plate and upper housing separator plate on upper housing (Fig. 307).



J9321-154

**Fig. 306 Check Ball Locations In Upper Housing**

- 1 - SMALL DIAMETER CHECK BALLS (6)
- 2 - LARGE DIAMETER CHECK BALL (1)

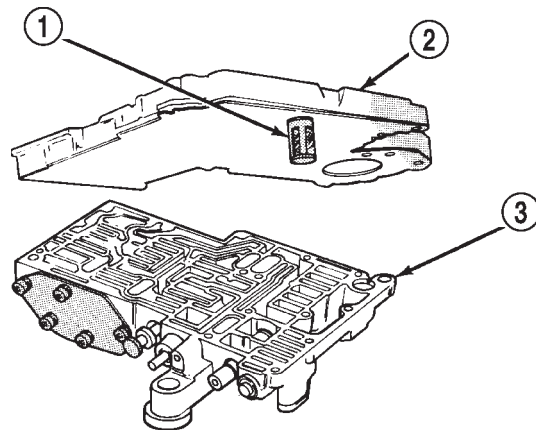
Be sure filter screen is seated in proper housing recess.

(3) Install the ECE check ball into the transfer plate (Fig. 290). The ECE check ball is approximately 4.8 mm (3/16 in.) in diameter.

(4) Position lower housing separator plate on transfer plate (Fig. 308).

(5) Install lower housing on assembled transfer plate and upper housing (Fig. 309).

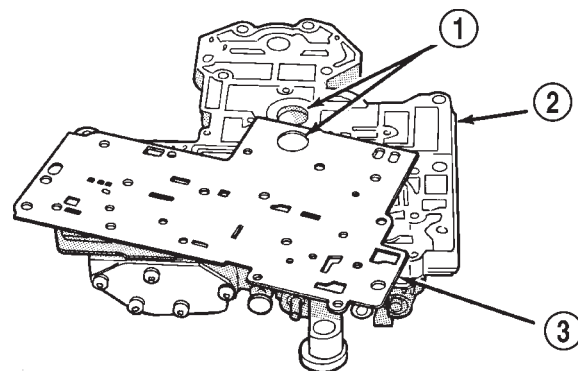
(6) Install and start all valve body screws by hand except for the screws to hold the boost valve tube brace. Save those screws for later installation. Then tighten screws evenly to 4 N·m (35 in. lbs.) torque. Start at center and work out to sides when tightening screws (Fig. 309).



J9321-439

**Fig. 307 Installing Transfer Plate On Upper Housing**

- 1 - FILTER SCREEN
- 2 - TRANSFER PLATE/SEPARATOR PLATE ASSEMBLY
- 3 - UPPER HOUSING

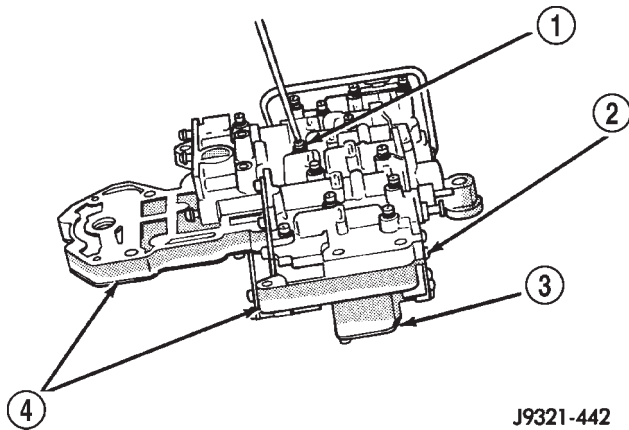


J9321-441

**Fig. 308 Lower Housing Separator Plate**

- 1 - BE SURE TO ALIGN BORES
- 2 - TRANSFER PLATE
- 3 - LOWER HOUSING (OVERDRIVE) SEPARATOR PLATE

VALVE BODY (Continued)



J9321-442

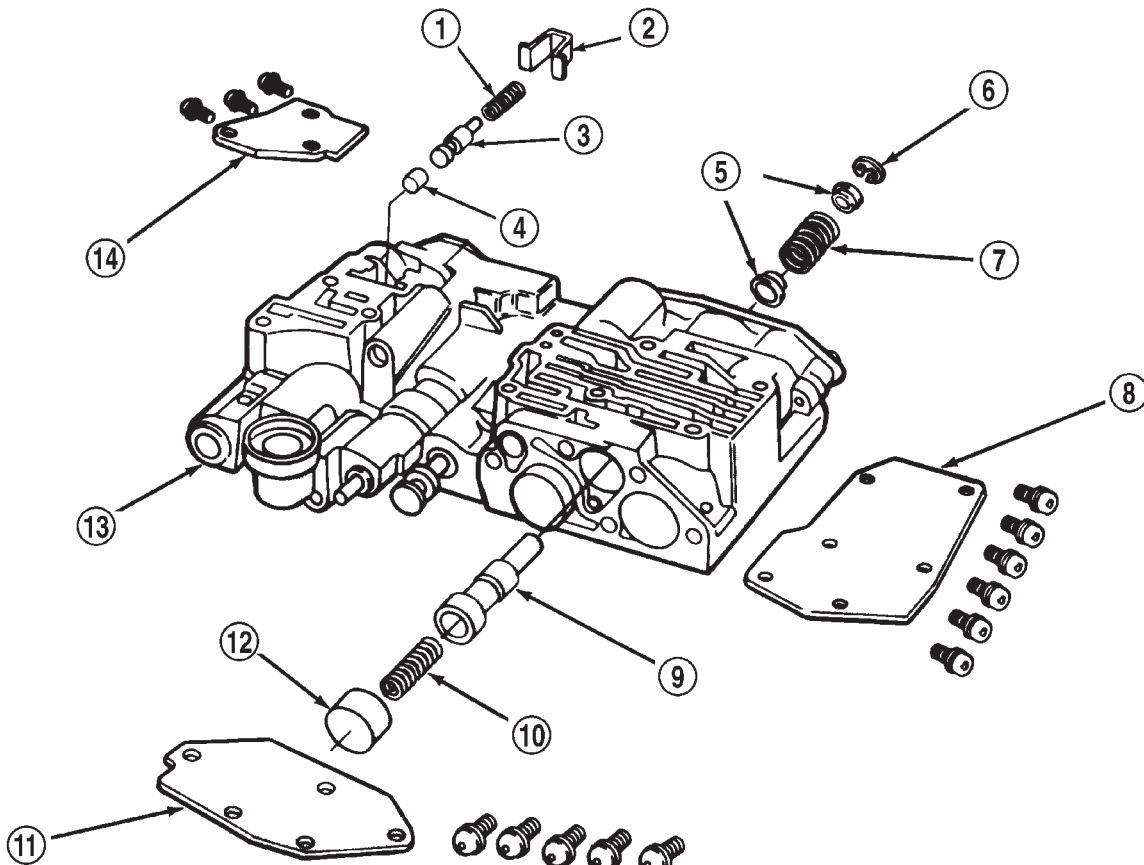
**Fig. 309 Installing Lower Housing On Transfer Plate And Upper Housing**

- 1 - VALVE BODY SCREWS (13)
- 2 - LOWER HOUSING
- 3 - UPPER HOUSING
- 4 - TRANSFER PLATE

**UPPER HOUSING VALVE AND PLUG**

Refer to (Fig. 310), (Fig. 311) and (Fig. 312) to perform the following steps.

- (1) Lubricate valves, plugs, springs with clean transmission fluid.
- (2) Assemble regulator valve line pressure plug, sleeve, throttle plug and spring. Insert assembly in upper housing and install cover plate. Tighten cover plate screws to 4 N·m (35 in. lbs.) torque.
- (3) Install 1-2 and 2-3 shift valves and springs.
- (4) Install 1-2 shift control valve and spring.
- (5) Install retainer, spring, limit valve, and 2-3 throttle plug from limit valve housing.
- (6) Install limit valve housing and cover plate. Tighten screws to 4 N·m (35 in. lbs.).
- (7) Install shuttle valve as follows:
  - (a) Insert plastic guides in shuttle valve secondary spring and install spring on end of valve.
  - (b) Install shuttle valve into housing.
  - (c) Hold shuttle valve in place.



**Fig. 310 Shuttle and Boost Valve Locations**

J9421-217

- 1 - SPRING
- 2 - RETAINER
- 3 - BOOST VALVE
- 4 - BOOST VALVE PLUG
- 5 - SPRING GUIDES
- 6 - E-CLIP
- 7 - SHUTTLE VALVE SECONDARY SPRING
- 8 - SHUTTLE VALVE COVER
- 9 - SHUTTLE VALVE
- 10 - SHUTTLE VALVE PRIMARY SPRING
- 11 - GOVERNOR PLUG COVER
- 12 - THROTTLE PLUG
- 13 - UPPER HOUSING
- 14 - BOOST VALVE COVER

## VALVE BODY (Continued)

(d) Compress secondary spring and install E-clip in groove at end of shuttle valve.

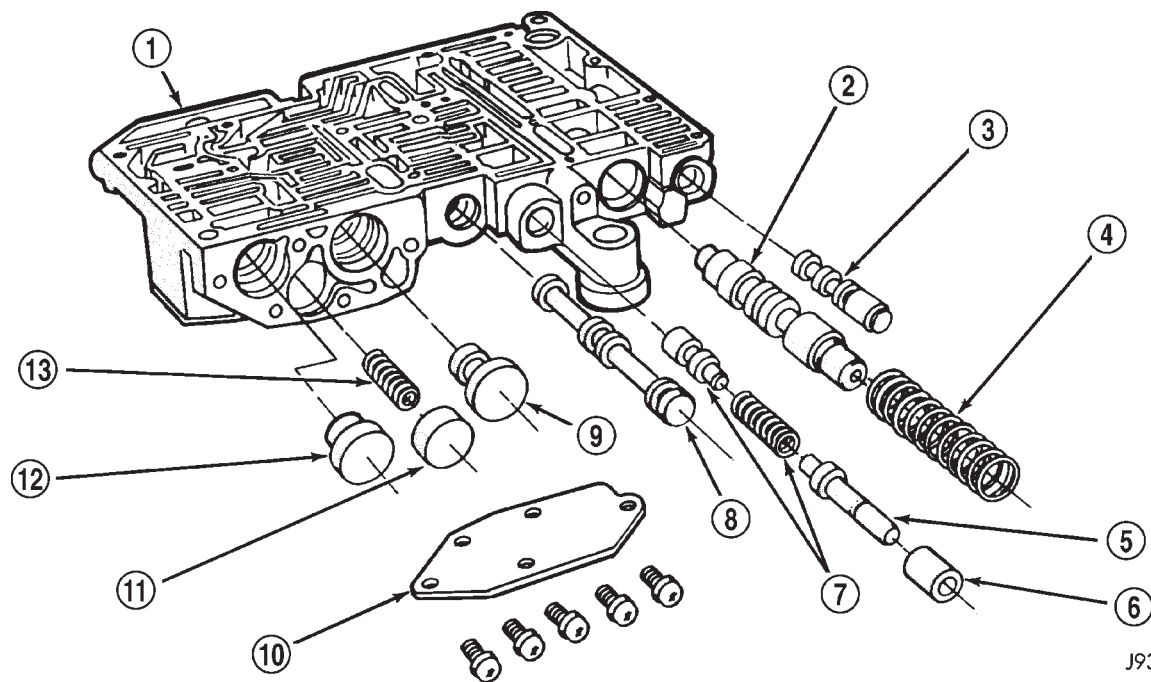
(e) Verify that spring and E-clip are properly seated before proceeding.

(8) Install shuttle valve cover plate. Tighten cover plate screws to 4 N·m (35 in. lbs.) torque.

(9) Install 1-2 and 2-3 valve governor plugs in valve body.

(10) Install shuttle valve primary spring and throttle plug.

(11) Align and install governor plug cover. Tighten cover screws to 4 N·m (35 in. lbs.) torque.



J9321-155

**Fig. 311 Upper Housing Control Valve Locations**

1 - UPPER HOUSING

2 - REGULATOR VALVE

3 - SWITCH VALVE

4 - REGULATOR VALVE SPRING

5 - KICKDOWN VALVE

6 - KICKDOWN DETENT

7 - THROTTLE VALVE AND SPRING

8 - MANUAL VALVE

9 - 1-2 GOVERNOR PLUG

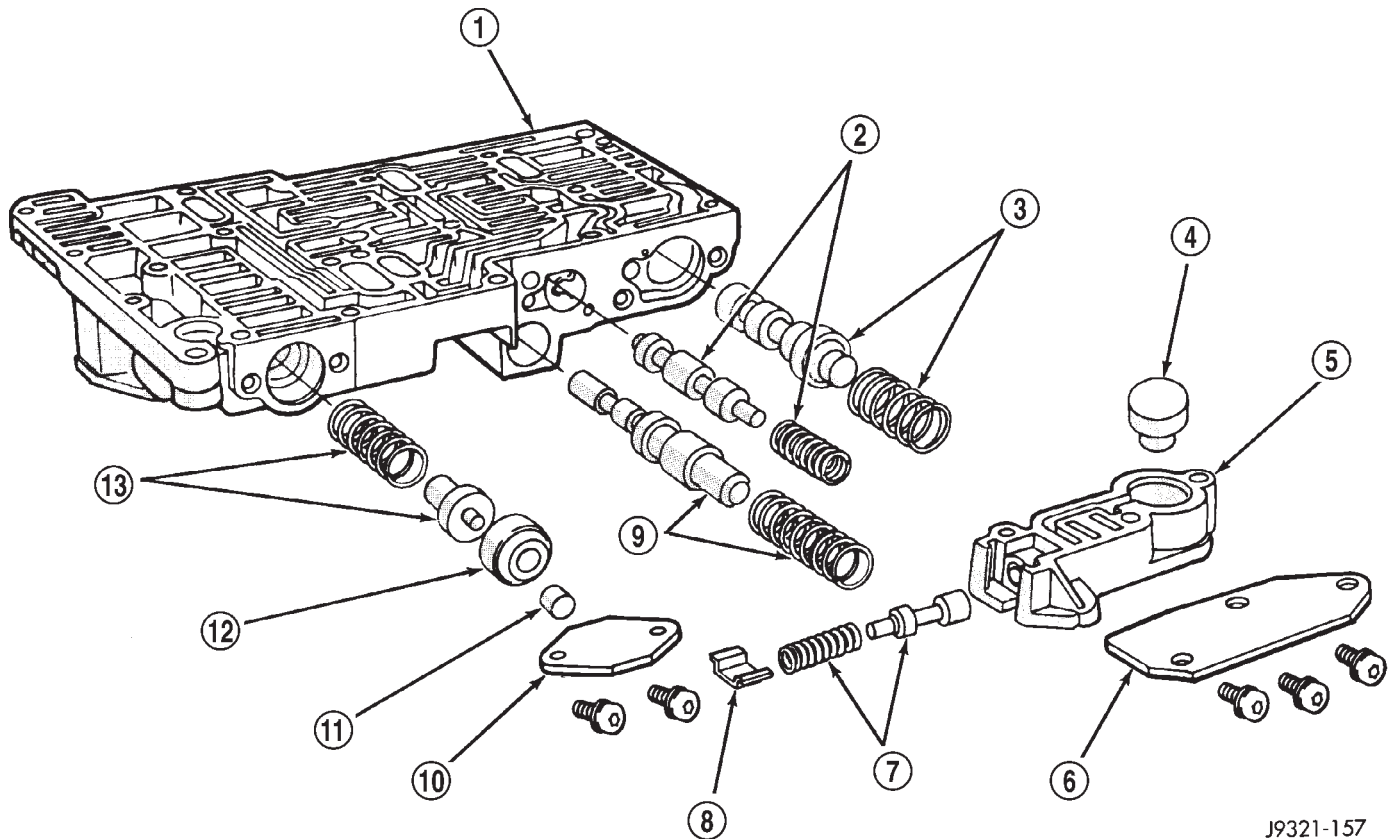
10 - GOVERNOR PLUG COVER

11 - THROTTLE PLUG

12 - 2-3 GOVERNOR PLUG

13 - SHUTTLE VALVE PRIMARY SPRING

## VALVE BODY (Continued)



J9321-157

**Fig. 312 Upper Housing Shift Valve and Pressure Plug Locations**

- |                                |  |
|--------------------------------|--|
| 1 - UPPER HOUSING              | 8 - RETAINER                           |
| 2 - 1-2 SHIFT VALVE AND SPRING | 9 - 1-2 SHIFT CONTROL VALVE AND SPRING |
| 3 - 2-3 SHIFT VALVE AND SPRING | 10 - PRESSURE PLUG COVER               |
| 4 - 2-3 THROTTLE PLUG          | 11 - LINE PRESSURE PLUG                |
| 5 - LIMIT VALVE HOUSING        | 12 - PLUG SLEEVE                       |
| 6 - LIMIT VALVE COVER          | 13 - THROTTLE PRESSURE SPRING AND PLUG |
| 7 - LIMIT VALVE AND SPRING     |  |

## VALVE BODY (Continued)

**BOOST VALVE TUBE AND BRACE**

(1) Position valve body assembly so lower housing is facing upward (Fig. 313).

(2) Lubricate tube ends and housing ports with transmission fluid or petroleum jelly.

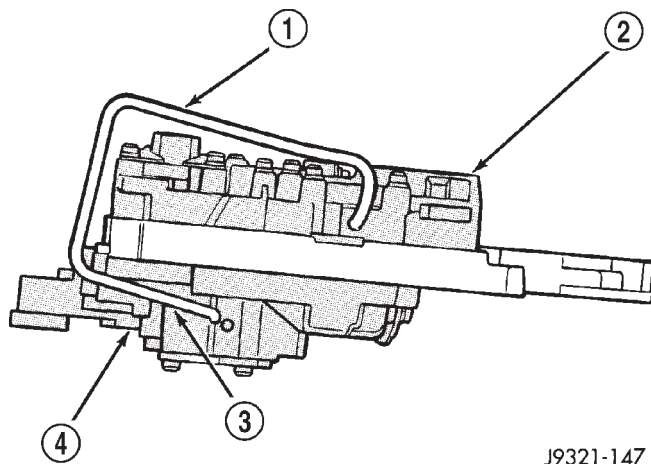
(3) Start tube in lower housing port first. Then swing tube downward and work opposite end of tube into upper housing port (Fig. 313).

(4) Insert and seat each end of tube in housings.

(5) Slide tube brace under tube and into alignment with valve body screw holes (Fig. 314).

(6) Install and finger tighten three screws that secure tube brace to valve body housings (Fig. 314).

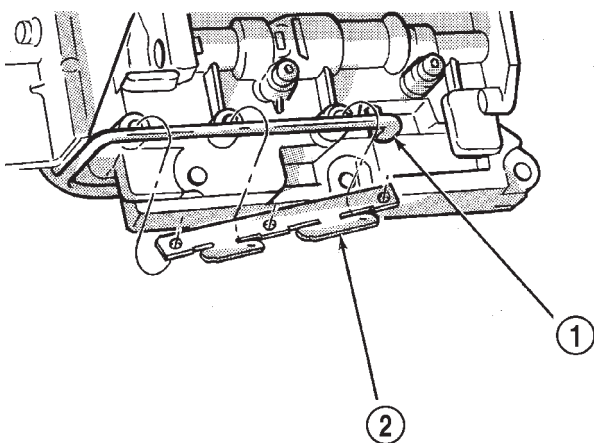
(7) Bend tube brace tabs up and against tube to hold it in position (Fig. 315).



J9321-147

**Fig. 313 Boost Valve Tube**

- 1 - BOOST VALVE TUBE
- 2 - LOWER HOUSING
- 3 - DISENGAGE THIS END OF TUBE FIRST
- 4 - UPPER HOUSING

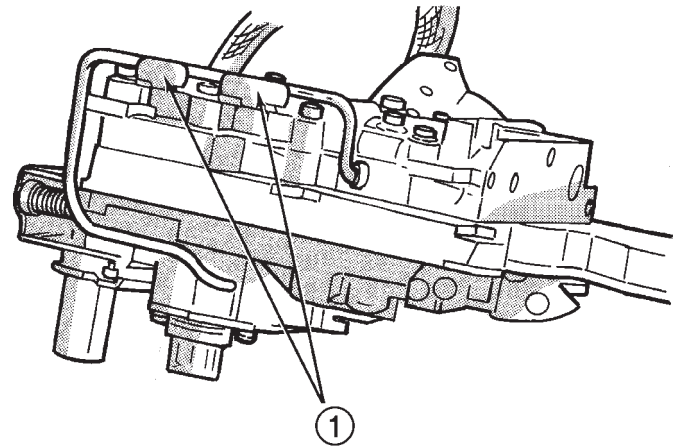


J9521-107

**Fig. 314 Boost Valve Tube And Brace**

- 1 - BOOST VALVE TUBE
- 2 - TUBE BRACE

(8) Tighten all valve body housing screws to 4 N-m (35 in. lbs.) torque after tube and brace are installed. Tighten screws in diagonal pattern starting at center and working outward.



J9521-108

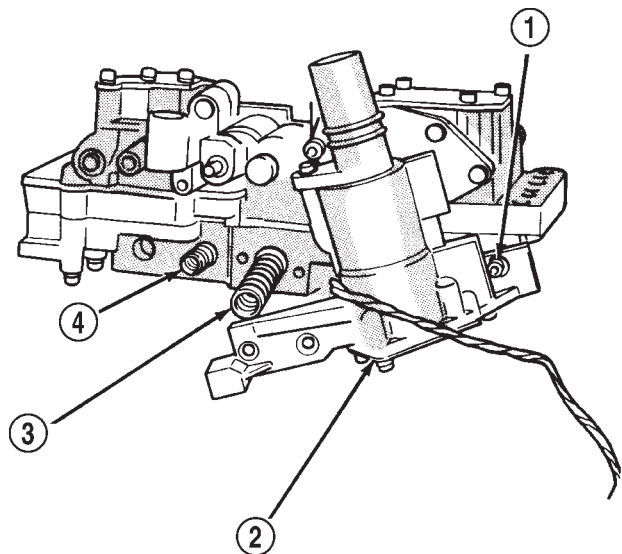
**Fig. 315 Securing Boost Valve Tube With Brace Tabs**

- 1 - BEND TABS UP AGAINST TUBE AS SHOWN

**3-4 ACCUMULATOR**

(1) Position converter clutch valve and 3-4 shift valve springs in housing (Fig. 316).

(2) Loosely attach accumulator housing with right-side screw (Fig. 316). Install only one screw at this time as accumulator must be free to pivot upward for ease of installation.



J9321-160

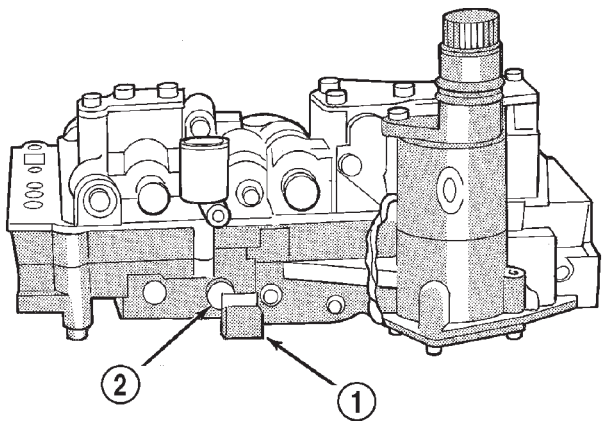
**Fig. 316 Converter Clutch And 3-4 Shift Valve Springs**

- 1 - RIGHT-SIDE SCREW
- 2 - 3-4 ACCUMULATOR
- 3 - 3-4 SHIFT VALVE SPRING
- 4 - CONVERTER CLUTCH VALVE SPRING



## VALVE BODY (Continued)

- (3) Install 3-4 shift valve and spring.
- (4) Install converter clutch timing valve and spring.
- (5) Position plug on end of converter clutch valve spring. Then compress and hold springs and plug in place with fingers of one hand.
- (6) Swing accumulator housing upward over valve springs and plug.
- (7) Hold accumulator housing firmly in place and install remaining two attaching screws. Be sure springs and clutch valve plug are properly seated (Fig. 317). Tighten screws to 4 N·m (35 in. lbs.).

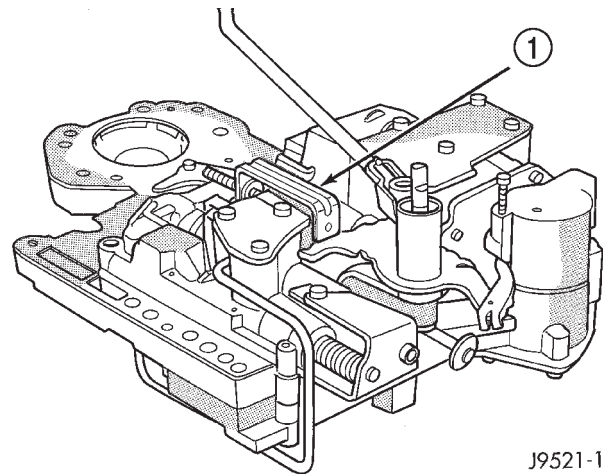


J9521-180

**Fig. 317 Seating 3-4 Accumulator On Lower Housing**

- 1 - ACCUMULATOR BOX  
2 - CONVERTER CLUTCH VALVE PLUG

- (9) Install spring on end of line pressure regulator valve.
- (10) Install switch valve spring on tang at end of adjusting screw bracket.
- (11) Install manual valve.
- (12) Install throttle valve and spring.
- (13) Install kickdown valve and detent.
- (14) Install pressure regulator valve.
- (15) Install switch valve.
- (16) Position adjusting screw bracket on valve body. Align valve springs and press bracket into place. Install short, upper bracket screws first and long bottom screw last. Verify that valve springs and bracket are properly aligned. Then tighten all three bracket screws to 4 N·m (35 in. lbs.) torque.



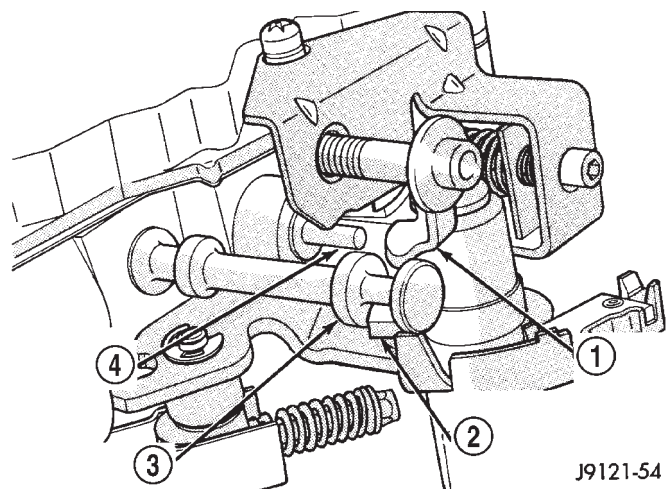
J9521-178

**Fig. 318 Detent Ball Spring**

- 1 - SPECIAL TOOL 6583 POSITIONED ON DETENT HOUSING

## VALVE BODY FINAL

- (1) Install boost valve, valve spring, retainer and cover plate. Tighten cover plate screws to 4 N·m (35 in. lbs.) torque.
- (2) Insert manual lever detent spring in upper housing.
- (3) Position detent ball on end of spring. Then hold detent ball and spring in detent housing with Retainer Tool 6583 (Fig. 318).
- (4) Install throttle lever in upper housing. Then install manual lever over throttle lever and start manual lever into housing.
- (5) Align manual lever with detent ball and manual valve. Hold throttle lever upward. Then press down on manual lever until fully seated. Remove detent ball retainer tool after lever is seated.
- (6) Then install manual lever seal, washer and E-clip.
- (7) Verify that throttle lever is aligned with end of kickdown valve stem and that manual lever arm is engaged in manual valve (Fig. 319).
- (8) Position line pressure adjusting screw in adjusting screw bracket.



J9121-54

**Fig. 319 Manual And Throttle Lever Alignment**

- 1 - THROTTLE LEVER  
2 - MANUAL LEVER VALVE ARM  
3 - MANUAL VALVE  
4 - KICKDOWN VALVE

## VALVE BODY (Continued)

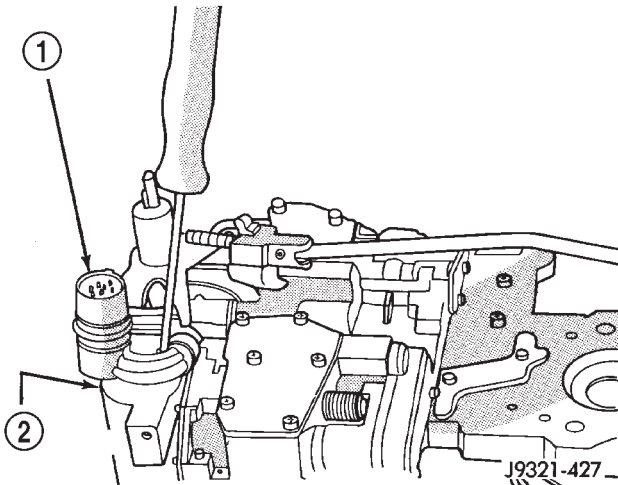
(17) Perform Line Pressure and Throttle Pressure adjustments. (Refer to 21 - TRANSMISSION/TRAN-SAXLE/AUTOMATIC/VALVE BODY - ADJUSTMENTS)

(18) Lubricate solenoid case connector O-rings and shaft of manual lever with light coat of petroleum jelly.

(19) Attach solenoid case connector to 3-4 accumulator with shoulder-type screw. Connector has small locating tang that fits in dimple at top of accumulator housing (Fig. 320). Seat tang in dimple before tightening connector screw.

(20) Install solenoid assembly and gasket. Tighten solenoid attaching screws to 8 N·m (72 in. lbs.) torque.

(21) Verify that solenoid wire harness is properly routed (Fig. 321). Solenoid harness must be clear of manual lever and park rod and not be pinched between accumulator housing and cover.



**Fig. 320 Solenoid Harness Case Connector Shoulder Bolt**

- 1 - SOLENOID HARNESS CASE CONNECTOR  
2 - 3-4 ACCUMULATOR HOUSING

## GOVERNOR BODY, SENSOR AND SOLENOID

(1) Turn valve body assembly over so accumulator side of transfer plate is facing down.

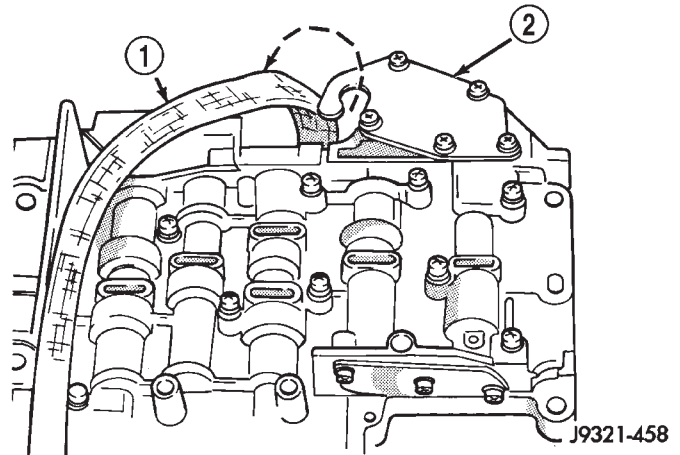
(2) Install new O-rings on governor pressure solenoid and sensor.

(3) Lubricate solenoid and sensor O-rings with clean transmission fluid.

(4) Install governor pressure sensor in governor body.

(5) Install governor pressure solenoid in governor body. Push solenoid in until it snaps into place in body.

(6) Position governor body gasket on transfer plate.



**Fig. 321 Solenoid Harness Routing**

- 1 - OVERDRIVE/CONVERTER SOLENOID WIRE HARNESS  
2 - 3-4 ACCUMULATOR COVER PLATE

(7) Install retainer plate on governor body and around solenoid. Be sure solenoid connector is positioned in retainer cutout.

(8) Align screw holes in governor body and transfer plate. Then install and tighten governor body screws to 4 N·m (35 in. lbs.) torque.

(9) Connect harness wires to governor pressure solenoid and governor pressure sensor.

(10) Install fluid filter and pan.

(11) Lower vehicle.

(12) Fill transmission with recommended fluid and road test vehicle to verify repair.

## INSTALLATION

(1) Check condition of O-ring seals on valve body harness connector (Fig. 322). Replace seals on connector body if cut or worn.

(2) Check condition of manual lever shaft seal in transmission case. Replace seal if lip is cut or worn. Install new seal with 15/16 deep well socket (Fig. 323).

(3) Check condition of seals on accumulator piston (Fig. 324). Install new piston seals, if necessary.

(4) Place valve body manual lever in low (1 position) so ball on park lock rod will be easier to install in sprag.

(5) Lubricate shaft of manual lever with petroleum jelly. This will ease inserting shaft through seal in case.

(6) Lubricate seal rings on valve body harness connector with petroleum jelly.

(7) Position valve body in case and work end of park lock rod into and through pawl sprag. Turn propeller shaft to align sprag and park lock teeth if necessary. The rod will click as it enters pawl. Move rod to check engagement.

## VALVE BODY (Continued)

**CAUTION:** It is possible for the park rod to displace into a cavity just above the pawl sprag during installation. Make sure the rod is actually engaged in the pawl and has not displaced into this cavity.

(8) Install accumulator springs and piston into case. Then swing valve body over piston and outer spring to hold it in place.

(9) Align accumulator piston and outer spring, manual lever shaft and electrical connector in case.

(10) Then seat valve body in case and install one or two bolts to hold valve body in place.

(11) Tighten valve body bolts alternately and evenly to 11 N·m (100 in. lbs.) torque.

(12) Install new fluid filter on valve body. Tighten filter screws to 4 N·m (35 in. lbs.) torque.

(13) Install throttle and gearshift levers on valve body manual lever shaft.

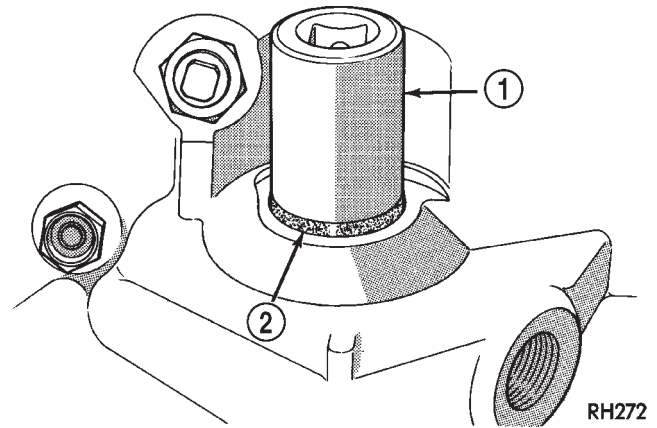
(14) Check and adjust front and rear bands if necessary.

(15) Connect solenoid case connector wires.

(16) Install oil pan and new gasket. Tighten pan bolts to 17 N·m (13 ft. lbs.) torque.

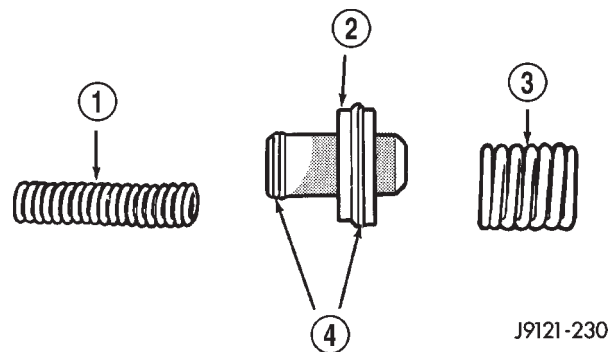
(17) Lower vehicle and fill transmission with Mopar® ATF +4, type 9602, fluid.

(18) Check and adjust gearshift and throttle valve cables, if necessary.



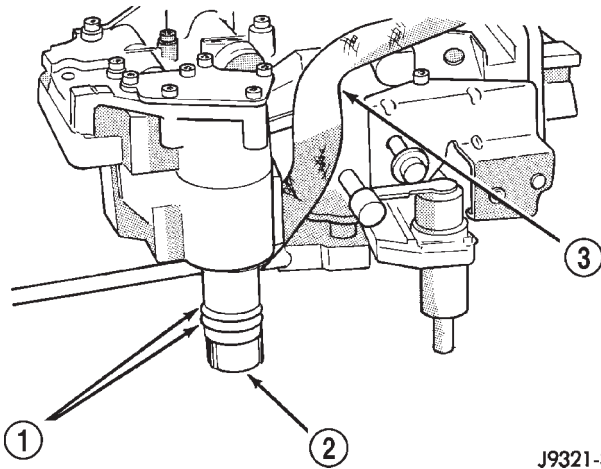
**Fig. 323 Manual Lever Shaft Seal**

- 1 - 15/16" SOCKET  
2 - SEAL



**Fig. 324 Accumulator Piston Components**

- 1 - INNER SPRING  
2 - ACCUMULATOR PISTON  
3 - OUTER SPRING  
4 - SEAL RINGS



**Fig. 322 Valve Body Harness Connector O-Ring Seal**

- 1 - CONNECTOR O-RINGS  
2 - VALVE BODY HARNESS CONNECTOR  
3 - HARNESS

## ADJUSTMENTS - VALVE BODY

## CONTROL PRESSURE ADJUSTMENTS

There are two control pressure adjustments on the valve body:

- Line Pressure
- Throttle Pressure

Line and throttle pressures are interdependent because each affects shift quality and timing. As a result, both adjustments must be performed properly and in the correct sequence. Adjust line pressure first and throttle pressure last.

## LINE PRESSURE ADJUSTMENT

Measure distance from the valve body to the inner edge of the adjusting screw with an accurate steel scale (Fig. 325).

Distance should be 33.4 mm (1-5/16 in.).

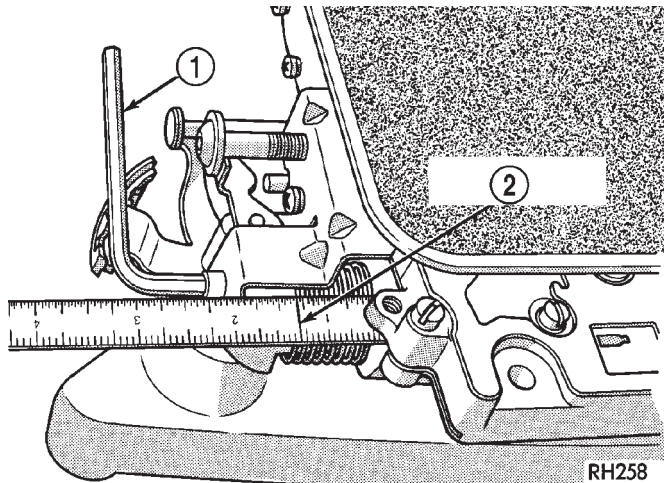
If adjustment is required, turn the adjusting screw in, or out, to obtain required distance setting.

**NOTE:** The 33.4 mm (1-5/16 in.) setting is an approximate setting. Manufacturing tolerances may make it necessary to vary from this dimension to obtain desired pressure.

## VALVE BODY (Continued)

One complete turn of the adjusting screw changes line pressure approximately 1-2/3 psi (9 kPa).

Turning the adjusting screw counterclockwise increases pressure while turning the screw clockwise decreases pressure.



**Fig. 325 Line Pressure Adjustment**

- 1 - WRENCH
- 2 - 1-5/16 INCH

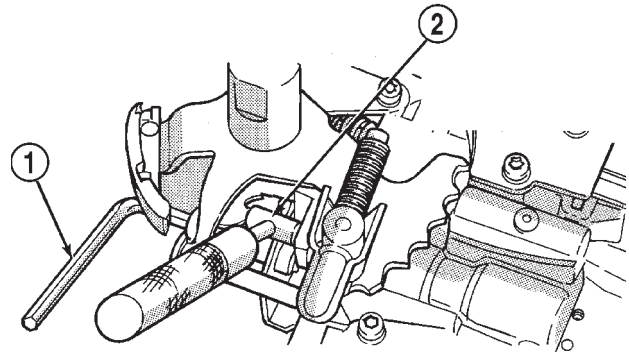
## THROTTLE PRESSURE ADJUSTMENT

Insert Gauge Tool C-3763 between the throttle lever cam and the kickdown valve stem (Fig. 326).

Push the gauge tool inward to compress the kickdown valve against the spring and bottom the throttle valve.

Maintain pressure against kickdown valve spring. Turn throttle lever stop screw until the screw head touches throttle lever tang and the throttle lever cam touches gauge tool.

**NOTE:** The kickdown valve spring must be fully compressed and the kickdown valve completely bottomed to obtain correct adjustment.



J9521-109

**Fig. 326 Throttle Pressure Adjustment**

- 1 - HEX WRENCH (IN THROTTLE LEVER ADJUSTING SCREW)
- 2 - SPECIAL TOOL C-3763 (POSITIONED BETWEEN THROTTLE LEVER AND KICKDOWN VALVE)



## AUTOMATIC TRANSMISSION - 47RE

## TABLE OF CONTENTS

	page		page
<b>AUTOMATIC TRANSMISSION - 47RE</b>		<b>FLUID AND FILTER REPLACEMENT</b> . . . . .	717
DESCRIPTION . . . . .	649	TRANSMISSION FILL . . . . .	718
OPERATION . . . . .	651	<b>FRONT CLUTCH</b>	
DIAGNOSIS AND TESTING . . . . .	657	DESCRIPTION . . . . .	718
AUTOMATIC TRANSMISSION . . . . .	657	OPERATION . . . . .	718
PRELIMINARY . . . . .	657	DISASSEMBLY . . . . .	719
ROAD TESTING . . . . .	657	INSPECTION . . . . .	721
HYDRAULIC PRESSURE TEST . . . . .	658	ASSEMBLY . . . . .	721
AIR TESTING TRANSMISSION CLUTCH AND BAND OPERATION . . . . .	661	<b>FRONT SERVO</b>	
CONVERTER HOUSING FLUID LEAK . . . . .	662	DESCRIPTION . . . . .	722
DIAGNOSIS CHARTS . . . . .	663	OPERATION . . . . .	723
STANDARD PROCEDURE . . . . .	673	DISASSEMBLY . . . . .	723
ALUMINUM THREAD REPAIR . . . . .	673	CLEANING . . . . .	723
REMOVAL . . . . .	673	INSPECTION . . . . .	723
DISASSEMBLY . . . . .	674	ASSEMBLY . . . . .	723
CLEANING . . . . .	680	<b>OIL PUMP</b>	
INSPECTION . . . . .	681	DESCRIPTION . . . . .	724
ASSEMBLY . . . . .	681	OPERATION . . . . .	724
INSTALLATION . . . . .	688	STANDARD PROCEDURE . . . . .	724
SCHEMATICS AND DIAGRAMS . . . . .	690	OIL PUMP VOLUME CHECK . . . . .	724
SPECIFICATIONS . . . . .	702	DISASSEMBLY . . . . .	726
SPECIAL TOOLS . . . . .	704	CLEANING . . . . .	728
<b>ACCUMULATOR</b>		INSPECTION . . . . .	728
DESCRIPTION . . . . .	707	ASSEMBLY . . . . .	729
OPERATION . . . . .	708	<b>OUTPUT SHAFT FRONT BEARING</b>	
INSPECTION . . . . .	708	REMOVAL . . . . .	730
<b>BANDS</b>		INSTALLATION . . . . .	730
DESCRIPTION . . . . .	709	<b>OUTPUT SHAFT REAR BEARING</b>	
OPERATION . . . . .	709	REMOVAL . . . . .	731
ADJUSTMENTS . . . . .	709	INSTALLATION . . . . .	731
<b>ELECTRONIC GOVERNOR</b>		<b>OVERDRIVE CLUTCH</b>	
DESCRIPTION . . . . .	710	DESCRIPTION . . . . .	731
OPERATION . . . . .	711	OPERATION . . . . .	731
REMOVAL . . . . .	712	<b>OVERDRIVE SWITCH</b>	
INSTALLATION . . . . .	713	DESCRIPTION . . . . .	732
<b>EXTENSION HOUSING BUSHING</b>		OPERATION . . . . .	732
REMOVAL . . . . .	714	DIAGNOSIS AND TESTING . . . . .	732
INSTALLATION . . . . .	714	OVERDRIVE ELECTRICAL CONTROLS . . . . .	732
<b>EXTENSION HOUSING SEAL</b>		REMOVAL . . . . .	733
REMOVAL . . . . .	714	INSTALLATION . . . . .	733
INSTALLATION . . . . .	715	<b>OVERDRIVE UNIT</b>	
<b>FLUID AND FILTER</b>		REMOVAL . . . . .	733
DIAGNOSIS AND TESTING . . . . .	715	DISASSEMBLY . . . . .	734
EFFECTS OF INCORRECT FLUID LEVEL . . . . .	715	CLEANING . . . . .	741
CAUSES OF BURNT FLUID . . . . .	715	INSPECTION . . . . .	741
FLUID CONTAMINATION . . . . .	715	ASSEMBLY . . . . .	742
STANDARD PROCEDURE . . . . .	715	INSTALLATION . . . . .	750
FLUID LEVEL CHECK . . . . .	715		



**OVERRUNNING CLUTCH CAM/OVERDRIVE****PISTON RETAINER**

DESCRIPTION . . . . .	751
OPERATION . . . . .	751
DISASSEMBLY . . . . .	751
CLEANING . . . . .	752
INSPECTION . . . . .	752
ASSEMBLY . . . . .	752

**PARK/NEUTRAL POSITION SWITCH**

DIAGNOSIS AND TESTING . . . . .	755
PARK/NEUTRAL POSITION SWITCH . . . . .	755
REMOVAL . . . . .	755
INSTALLATION . . . . .	755

**PISTONS**

DESCRIPTION . . . . .	755
OPERATION . . . . .	755

**PLANETARY GEARTRAIN/OUTPUT SHAFT**

DESCRIPTION . . . . .	757
OPERATION . . . . .	757
DISASSEMBLY . . . . .	757
INSPECTION . . . . .	760
ASSEMBLY . . . . .	760

**REAR CLUTCH**

DESCRIPTION . . . . .	764
OPERATION . . . . .	764
DISASSEMBLY . . . . .	765
CLEANING . . . . .	765
INSPECTION . . . . .	765
ASSEMBLY . . . . .	766

**REAR SERVO**

DESCRIPTION . . . . .	767
OPERATION . . . . .	767
DISASSEMBLY . . . . .	768
CLEANING . . . . .	768
ASSEMBLY . . . . .	768

**SHIFT MECHANISM**

DESCRIPTION . . . . .	768
-----------------------	-----

## AUTOMATIC TRANSMISSION - 47RE

**DESCRIPTION**

The 47RE (Fig. 1) is a four speed fully automatic transmissions with an electronic governor. The 47RE is equipped with a lock-up clutch in the torque converter. First through third gear ranges are provided by the clutches, bands, overrunning clutch, and planetary gear sets in the transmission. Fourth gear range is provided by the overdrive unit that contains an overdrive clutch, direct clutch, planetary gear set, and overrunning clutch.

The transmission contains a front, rear, and direct clutch which function as the input driving components. It also contains the kickdown (front) and the

OPERATION . . . . .	768
ADJUSTMENTS . . . . .	769

**SOLENOID**

DESCRIPTION . . . . .	769
OPERATION . . . . .	770

**SPEED SENSOR**

DESCRIPTION . . . . .	770
OPERATION . . . . .	770

**THROTTLE VALVE CABLE**

DESCRIPTION . . . . .	770
ADJUSTMENTS . . . . .	771

**TORQUE CONVERTER**

DESCRIPTION . . . . .	773
OPERATION . . . . .	777
REMOVAL . . . . .	778
INSTALLATION . . . . .	778

**TORQUE CONVERTER DRAINBACK VALVE**

DESCRIPTION . . . . .	778
OPERATION . . . . .	778
STANDARD PROCEDURE . . . . .	778
TORQUE CONVERTER DRAINBACK VALVE . . . . .	778

**TRANSMISSION TEMPERATURE SENSOR**

DESCRIPTION . . . . .	779
OPERATION . . . . .	779

**VALVE BODY**

DESCRIPTION . . . . .	780
OPERATION . . . . .	783
REMOVAL . . . . .	798
DISASSEMBLY . . . . .	799
CLEANING . . . . .	808
INSPECTION . . . . .	809
ASSEMBLY . . . . .	810
INSTALLATION . . . . .	818
ADJUSTMENTS . . . . .	818

low/reverse (rear) bands which, along with the overrunning clutch and overdrive clutch, serve as the holding components. The driving and holding components combine to select the necessary planetary gear components, in the front, rear, or overdrive planetary gear set, transfer the engine power from the input shaft through to the output shaft.

The valve body is mounted to the lower side of the transmission and contains the valves to control pressure regulation, fluid flow control, and clutch/band application. The oil pump is mounted at the front of the transmission and is driven by the torque converter hub. The pump supplies the oil pressure necessary for clutch/band actuation and transmission lubrication.

AUTOMATIC TRANSMISSION - 47RE (Continued)

805re50d

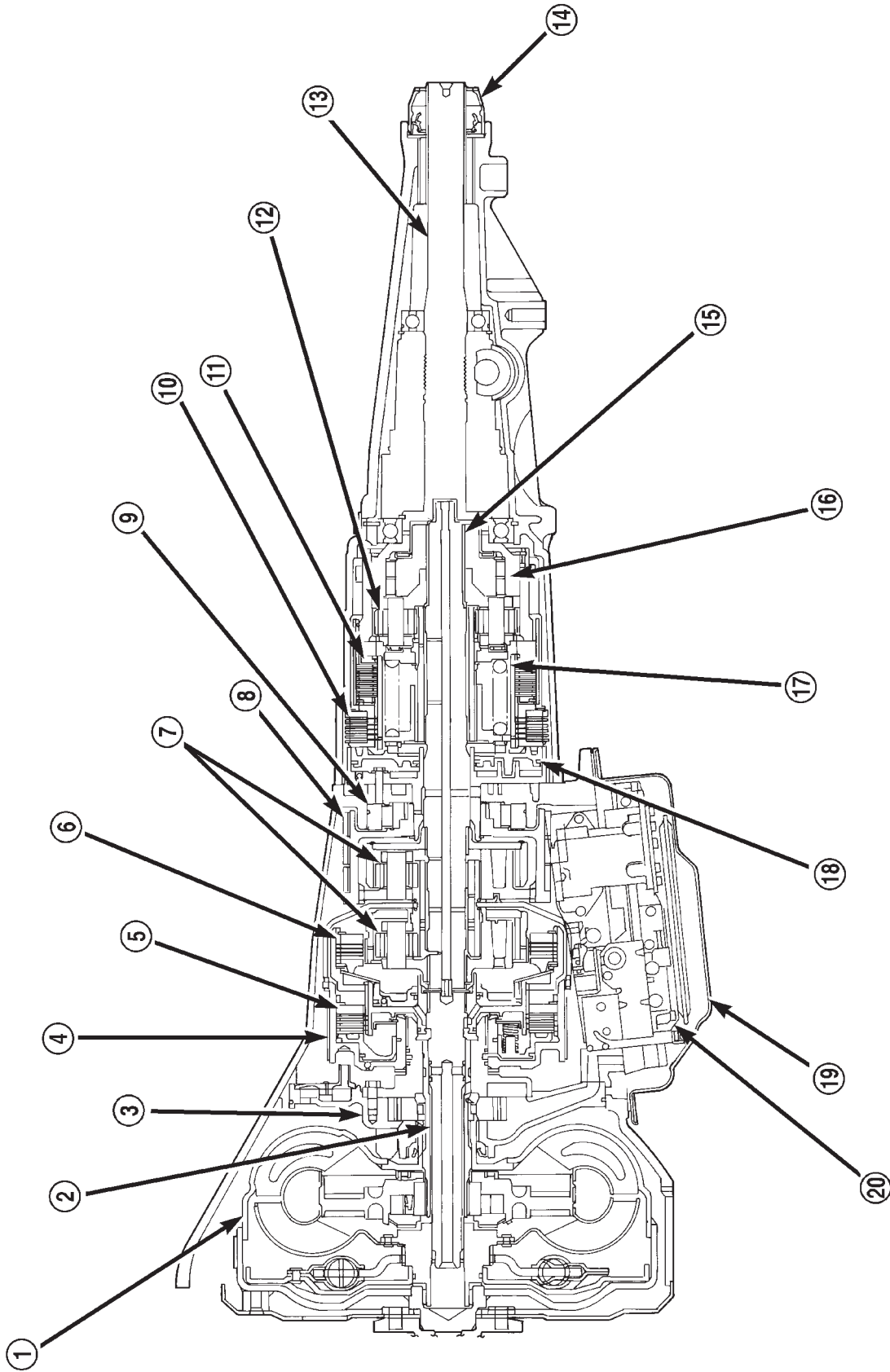


Fig. 1 47RE Transmission

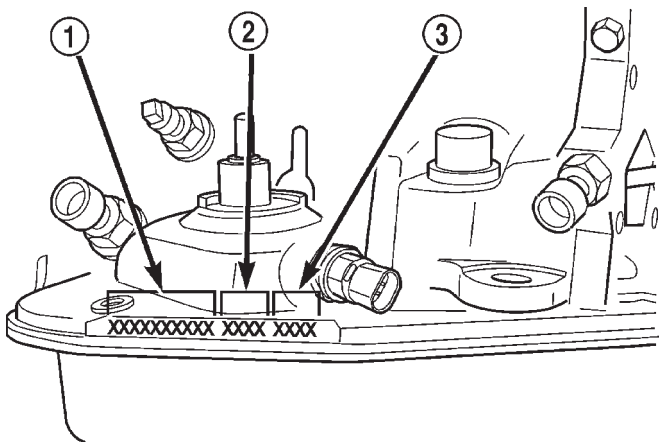
AUTOMATIC TRANSMISSION - 47RE (Continued)

- 1 - TORQUE CONVERTER
- 2 - INPUT SHAFT
- 3 - OIL PUMP
- 4 - FRONT BAND
- 5 - FRONT CLUTCH
- 6 - REAR CLUTCH
- 7 - PLANETARIES
- 8 - REAR BAND
- 9 - OVERRUNNING CLUTCH
- 10 - OVERDRIVE CLUTCH

- 11 - DIRECT CLUTCH
- 12 - PLANETARY GEAR
- 13 - OUTPUT SHAFT
- 14 - SEAL
- 15 - INTERMEDIATE SHAFT
- 16 - OVERDRIVE OVERRUNNING CLUTCH
- 17 - DIRECT CLUTCH SPRING
- 18 - OVERDRIVE PISTON RETAINER
- 19 - FILTER
- 20 - VALVE BODY

**IDENTIFICATION**

Transmission identification numbers are stamped on the left side of the case just above the oil pan gasket surface (Fig. 2). Refer to this information when ordering replacement parts.



80b11960

**Fig. 2 Transmission Part and Serial Number Location**

- 1 - PART NUMBER
- 2 - BUILD DATE
- 3 - SERIAL NUMBER

**GEAR RATIOS** The 47RE gear ratios are:

<b>1st</b> .....	2.45:1
<b>2nd</b> .....	1.45:1
<b>3rd</b> .....	1.00:1
<b>4th</b> .....	0.69:1
<b>Rev.</b> .....	2.21

**OPERATION**

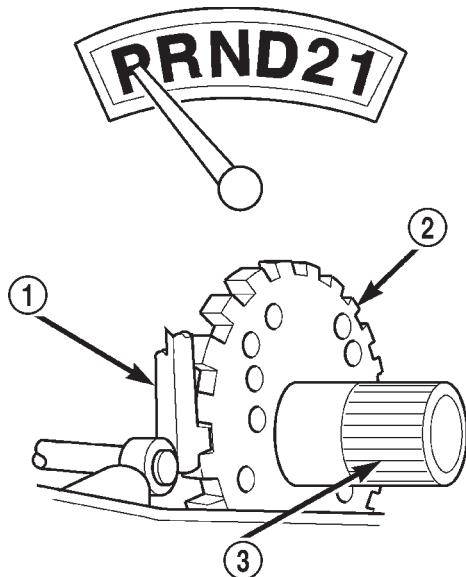
The application of each driving or holding component is controlled by the valve body based upon the manual lever position, throttle pressure, and governor pressure. The governor pressure is a variable pressure input to the valve body and is one of the signals that a shift is necessary. First through fourth gear are obtained by selectively applying and releasing the different clutches and bands. Engine power is thereby routed to the various planetary gear assemblies which combine with the overrunning clutch assemblies to generate the different gear ratios. The torque converter clutch is hydraulically applied and is released when fluid is vented from the hydraulic circuit by the torque converter control (TCC) solenoid on the valve body. The torque converter clutch is controlled by the Powertrain Control Module (PCM). The torque converter clutch engages in fourth gear, and in third gear under various conditions, such as when the O/D switch is OFF, when the vehicle is cruising on a level surface after the vehicle has warmed up. The torque converter clutch will disengage momentarily when an increase in engine load is sensed by the PCM, such as when the vehicle begins to go uphill or the throttle pressure is increased. The torque converter clutch feature increases fuel economy and reduces the transmission fluid temperature.

Since the overdrive clutch is applied in fourth gear only and the direct clutch is applied in all ranges except fourth gear, the transmission operation for park, neutral, and first through third gear will be described first. Once these powerflows are described, the third to fourth shift sequence will be described.

AUTOMATIC TRANSMISSION - 47RE (Continued)

**PARK POWERFLOW**

As the engine is running and the crankshaft is rotating, the flexplate and torque converter, which are also bolted to it, are all rotating in a clockwise direction as viewed from the front of the engine. The notched hub of the torque converter is connected to the oil pump's internal gear, supplying the transmission with oil pressure. As the converter turns, it turns the input shaft in a clockwise direction. As the input shaft is rotating, the front clutch hub-rear clutch retainer and all their associated parts are also rotating, all being directly connected to the input shaft. The power flow from the engine through the front clutch hub and rear clutch retainer stops at the rear clutch retainer. Therefore, no power flow to the output shaft occurs because no clutches are applied. The only mechanism in use at this time is the parking sprag (Fig. 3), which locks the parking gear on the output shaft to the transmission case.



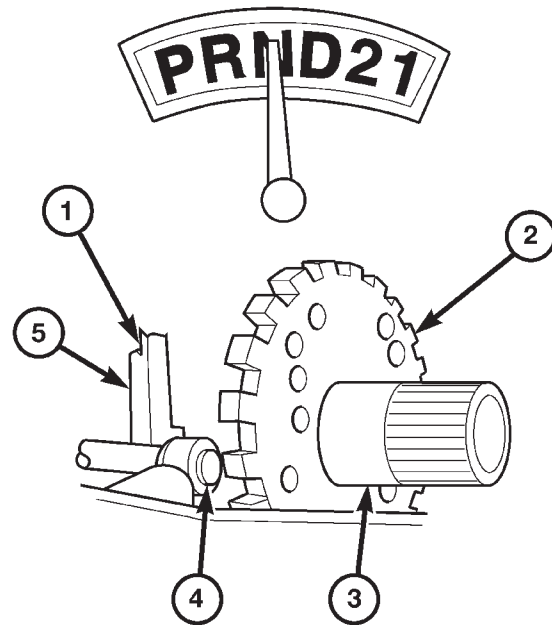
80c070a6

**Fig. 3 Park Powerflow**

- 1 - PAWL ENGAGED FOR PARK
- 2 - PARK SPRAG
- 3 - OUTPUT SHAFT

**NEUTRAL POWERFLOW**

With the gear selector in the NEUTRAL position (Fig. 4), the power flow of the transmission is essentially the same as in the park position. The only operational difference is that the parking sprag has been disengaged, unlocking the output shaft from the transmission case and allowing it to move freely.



80a06c8f

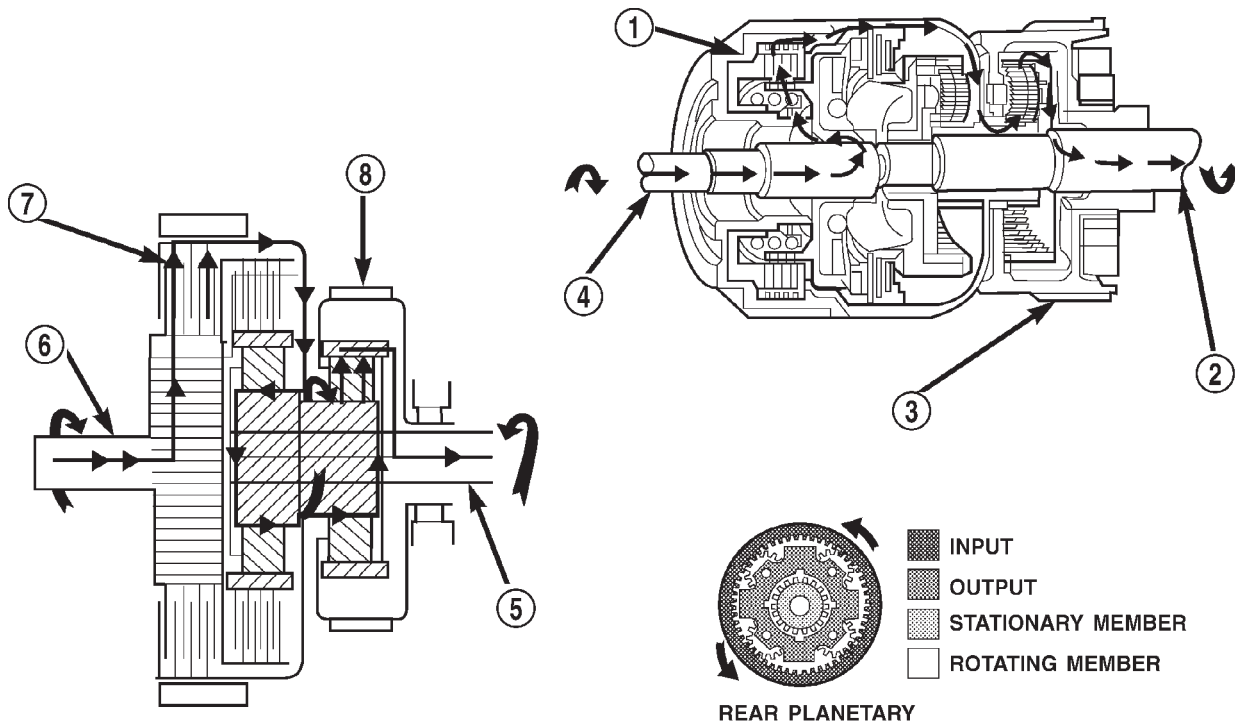
**Fig. 4 Neutral Powerflow**

- 1 - PAWL DISENGAGED FOR NEUTRAL
- 2 - PARK SPRAG
- 3 - OUTPUT SHAFT
- 4 - CAM
- 5 - PAWL

AUTOMATIC TRANSMISSION - 47RE (Continued)

**REVERSE POWERFLOW**

When the gear selector is moved into the REVERSE position (Fig. 5), the front clutch and the rear band are applied. With the application of the front clutch, engine torque is applied to the sun gear, turning it in a clockwise direction. The clockwise rotation of the sun gear causes the rear planet pinions to rotate against engine rotation in a counterclockwise direction. The rear band is holding the low reverse drum, which is splined to the rear carrier. Since the rear carrier is being held, the torque from the planet pinions is transferred to the rear annulus gear, which is splined to the output shaft. The output shaft in turn rotates with the annulus gear in a counterclockwise direction giving a reverse gear output. The entire transmission of torque is applied to the rear planetary gearset only. Although there is torque input to the front gearset through the sun gear, no other member of the gearset is being held. During the entire reverse stage of operation, the front planetary gears are in an idling condition.



80c070a8

**Fig. 5 Reverse Powerflow**

- 1 - FRONT CLUTCH ENGAGED
- 2 - OUTPUT SHAFT
- 3 - LOW/REVERSE BAND APPLIED
- 4 - INPUT SHAFT

- 5 - OUTPUT SHAFT
- 6 - INPUT SHAFT
- 7 - FRONT CLUTCH ENGAGED
- 8 - LOW/REVERSE BAND APPLIED

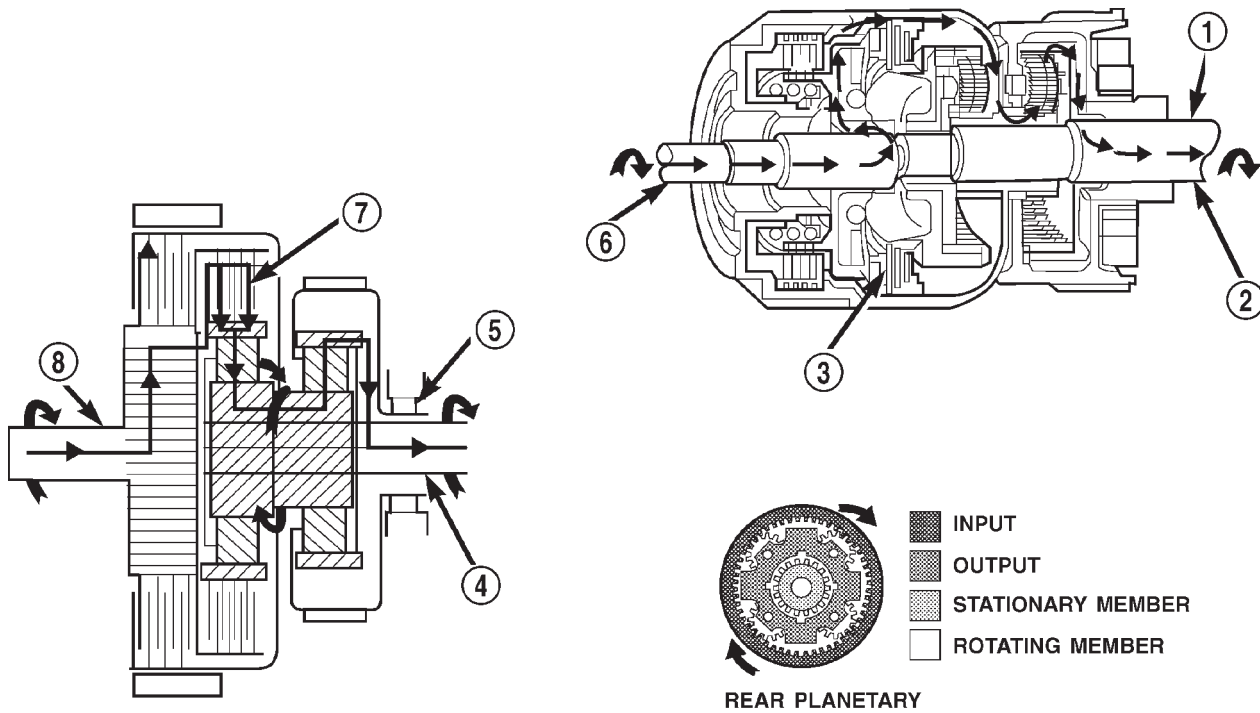


AUTOMATIC TRANSMISSION - 47RE (Continued)

**FIRST GEAR POWERFLOW**

When the gearshift lever is moved into the DRIVE position the transmission goes into first gear (Fig. 6). As soon as the transmission is shifted from PARK or NEUTRAL to DRIVE, the rear clutch applies, applying the rear clutch pack to the front annulus gear. Engine torque is now applied to the front annulus gear turning it in a clockwise direction. With the front annulus gear turning in a clockwise direction, it causes the front planets to turn in a clockwise direction. The rotation of the front planets cause the sun gear to revolve in a counterclockwise direction. The sun gear now transfers its counterclockwise rotation to the rear planets which rotate back in a clockwise direction. With the rear annulus gear stationary, the

rear planet rotation on the annulus gear causes the rear planet carrier to revolve in a counterclockwise direction. The rear planet carrier is splined into the low-reverse drum, and the low reverse drum is splined to the inner race of the over-running clutch. With the over-running clutch locked, the planet carrier is held, and the resulting torque provided by the planet pinions is transferred to the rear annulus gear. The rear annulus gear is splined to the output shaft and rotated along with it (clockwise) in an underdrive gear reduction mode.



80c070a9

**Fig. 6 First Gear Powerflow**

- 1 - OUTPUT SHAFT
- 2 - OVER-RUNNING CLUTCH HOLDING
- 3 - REAR CLUTCH APPLIED
- 4 - OUTPUT SHAFT

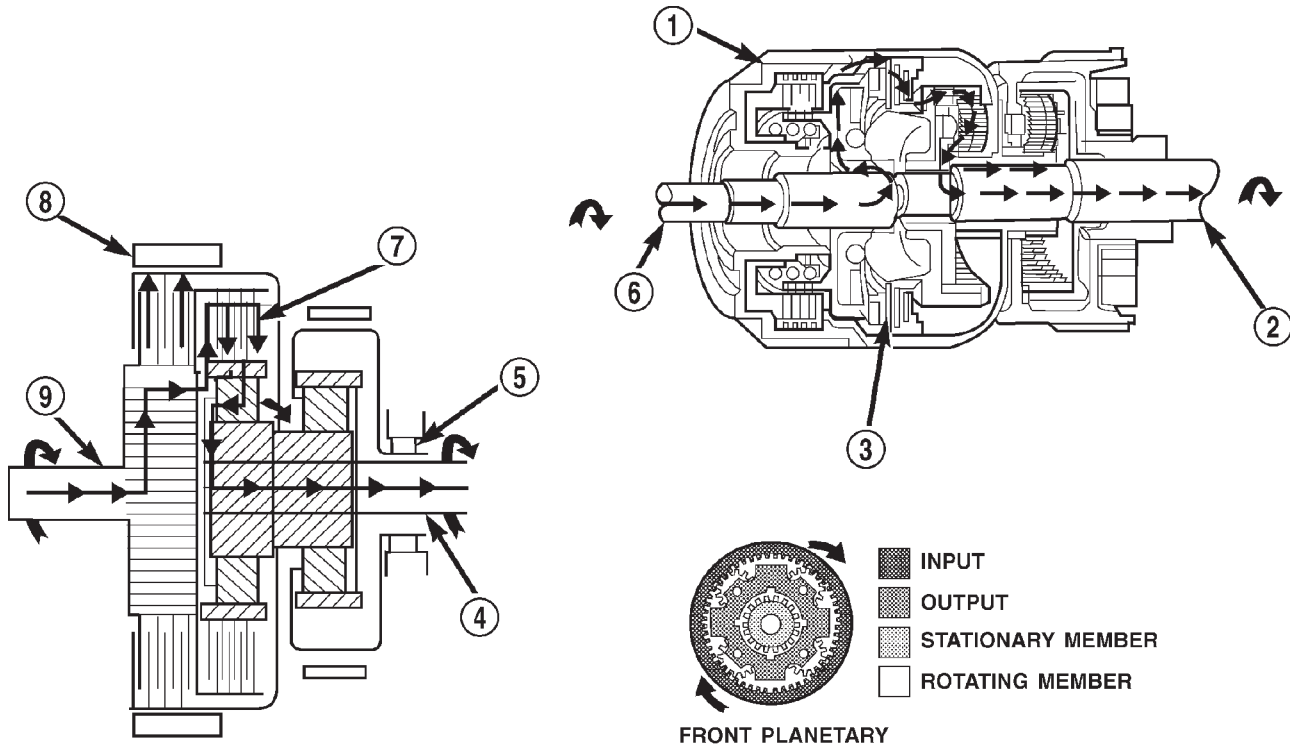
- 5 - OVER-RUNNING CLUTCH HOLDING
- 6 - INPUT SHAFT
- 7 - REAR CLUTCH APPLIED
- 8 - INPUT SHAFT

AUTOMATIC TRANSMISSION - 47RE (Continued)

**SECOND GEAR POWERFLOW**

In DRIVE-SECOND (Fig. 7), the same elements are applied as in MANUAL-SECOND. Therefore, the power flow will be the same, and both gears will be discussed as one in the same. In DRIVE-SECOND, the transmission has proceeded from first gear to its shift point, and is shifting from first gear to second. The second gear shift is obtained by keeping the rear clutch applied and applying the front (kickdown) band. The front band holds the front clutch retainer that is locked to the sun gear driving shell. With the rear clutch still applied, the input is still on the front annulus gear turning it clockwise at engine speed.

Now that the front band is holding the sun gear stationary, the annulus rotation causes the front planets to rotate in a clockwise direction. The front carrier is then also made to rotate in a clockwise direction but at a reduced speed. This will transmit the torque to the output shaft, which is directly connected to the front planet carrier. The rear planetary annulus gear will also be turning because it is directly splined to the output shaft. All power flow has occurred in the front planetary gear set during the drive-second stage of operation, and now the over-running clutch, in the rear of the transmission, is disengaged and freewheeling on its hub.



**Fig. 7 Second Gear Powerflow**

- 1 - KICKDOWN BAND APPLIED
- 2 - OUTPUT SHAFT
- 3 - REAR CLUTCH ENGAGED
- 4 - OUTPUT SHAFT
- 5 - OVER-RUNNING CLUTCH FREE-WHEELING
- 6 - INPUT SHAFT
- 7 - REAR CLUTCH APPLIED
- 8 - KICKDOWN BAND APPLIED
- 9 - INPUT SHAFT

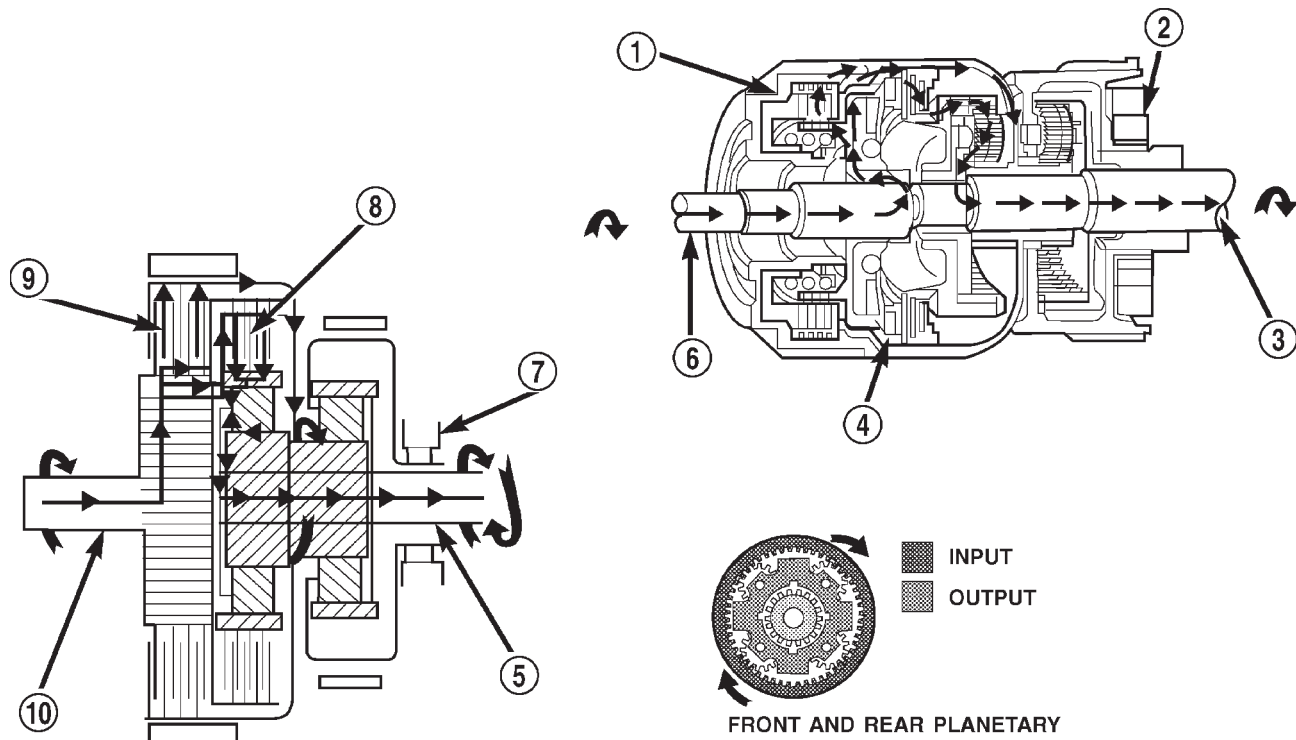
80c070aa

AUTOMATIC TRANSMISSION - 47RE (Continued)

**DIRECT DRIVE POWERFLOW**

The vehicle has accelerated and reached the shift point for the 2-3 upshift into direct drive (Fig. 8). When the shift takes place, the front band is released, and the front clutch is applied. The rear clutch stays applied as it has been in all the forward gears. With the front clutch now applied, engine torque is now on the front clutch retainer, which is locked to the sun gear driving shell. This means that the sun gear is now turning in engine rotation (clockwise) and at engine speed. The rear clutch is still applied so engine torque is also still on the front

annulus gear. If two members of the same planetary set are driven, direct drive results. Therefore, when two members are rotating at the same speed and in the same direction, it is the same as being locked up. The rear planetary set is also locked up, given the sun gear is still the input, and the rear annulus gear must turn with the output shaft. Both gears are turning in the same direction and at the same speed. The front and rear planet pinions do not turn at all in direct drive. The only rotation is the input from the engine to the connected parts, which are acting as one common unit, to the output shaft.



80c070ab

**Fig. 8 Direct Drive Powerflow**

- 1 - FRONT CLUTCH APPLIED
- 2 - OVER-RUNNING CLUTCH FREE-WHEELING
- 3 - OUTPUT SHAFT
- 4 - REAR CLUTCH APPLIED
- 5 - OUTPUT SHAFT

- 6 - INPUT SHAFT
- 7 - OVER-RUNNING CLUTCH FREE-WHEELING
- 8 - REAR CLUTCH APPLIED
- 9 - FRONT CLUTCH APPLIED
- 10 - INPUT SHAFT

## AUTOMATIC TRANSMISSION - 47RE (Continued)

**FOURTH GEAR POWERFLOW**

Fourth gear overdrive range is electronically controlled and hydraulically activated. Various sensor inputs are supplied to the powertrain control module to operate the overdrive solenoid on the valve body. The solenoid contains a check ball that opens and closes a vent port in the 3-4 shift valve feed passage. The overdrive solenoid (and check ball) are not energized in first, second, third, or reverse gear. The vent port remains open, diverting line pressure from the 2-3 shift valve away from the 3-4 shift valve. The overdrive control switch must be in the ON position to transmit overdrive status to the PCM. A 3-4 upshift occurs only when the overdrive solenoid is energized by the PCM. The PCM energizes the overdrive solenoid during the 3-4 upshift. This causes the solenoid check ball to close the vent port allowing line pressure from the 2-3 shift valve to act directly on the 3-4 upshift valve. Line pressure on the 3-4 shift valve overcomes valve spring pressure moving the valve to the upshift position. This action exposes the feed passages to the 3-4 timing valve, 3-4 quick fill valve, 3-4 accumulator, and ultimately to the overdrive piston. Line pressure through the timing valve moves the overdrive piston into contact with the overdrive clutch. The direct clutch is disengaged before the overdrive clutch is engaged. The boost valve provides increased fluid apply pressure to the overdrive clutch during 3-4 upshifts, and when accelerating in fourth gear. The 3-4 accumulator cushions overdrive clutch engagement to smooth 3-4 upshifts. The accumulator is charged at the same time as apply pressure acts against the overdrive piston.

**DIAGNOSIS AND TESTING - AUTOMATIC TRANSMISSION**

Automatic transmission problems can be a result of poor engine performance, incorrect fluid level, incorrect linkage or cable adjustment, band or hydraulic control pressure adjustments, hydraulic system malfunctions or electrical/mechanical component malfunctions. Begin diagnosis by checking the easily accessible items such as: fluid level and condition, linkage adjustments and electrical connections. A road test will determine if further diagnosis is necessary.

**DIAGNOSIS AND TESTING - PRELIMINARY**

Two basic procedures are required. One procedure for vehicles that are drivable and an alternate procedure for disabled vehicles (will not back up or move forward).

**VEHICLE IS DRIVEABLE**

- (1) Check for transmission fault codes using DRB® scan tool.
- (2) Check fluid level and condition.
- (3) Adjust throttle and gearshift linkage if complaint was based on delayed, erratic, or harsh shifts.
- (4) Road test and note how transmission upshifts, downshifts, and engages.
- (5) Perform hydraulic pressure test if shift problems were noted during road test.
- (6) Perform air-pressure test to check clutch-band operation.

**VEHICLE IS DISABLED**

- (1) Check fluid level and condition.
- (2) Check for broken or disconnected gearshift or throttle linkage.
- (3) Check for cracked, leaking cooler lines, or loose or missing pressure-port plugs.
- (4) Raise and support vehicle on safety stands, start engine, shift transmission into gear, and note following:
  - (a) If propeller shaft turns but wheels do not, problem is with differential or axle shafts.
  - (b) If propeller shaft does not turn and transmission is noisy, stop engine. Remove oil pan, and check for debris. If pan is clear, remove transmission and check for damaged drive plate, converter, oil pump, or input shaft.
  - (c) If propeller shaft does not turn and transmission is not noisy, perform hydraulic-pressure test to determine if problem is hydraulic or mechanical.

**DIAGNOSIS AND TESTING - ROAD TESTING**

Before road testing, be sure the fluid level and control cable adjustments have been checked and adjusted if necessary. Verify that diagnostic trouble codes have been resolved.

Observe engine performance during the road test. A poorly tuned engine will not allow accurate analysis of transmission operation.

Operate the transmission in all gear ranges. Check for shift variations and engine flare which indicates slippage. Note if shifts are harsh, spongy, delayed, early, or if part throttle downshifts are sensitive.

Slippage indicated by engine flare, usually means clutch, band or overrunning clutch problems. If the condition is advanced, an overhaul will be necessary to restore normal operation.

A slipping clutch or band can often be determined by comparing which internal units are applied in the various gear ranges. The Clutch and Band Application chart provides a basis for analyzing road test results.

## AUTOMATIC TRANSMISSION - 47RE (Continued)

## CLUTCH AND BAND APPLICATION CHART

SHIFT LEVER POSITION	TRANSMISSION CLUTCHES AND BANDS					OVERDRIVE CLUTCHES		
	FRONT CLUTCH	FRONT BAND	REAR CLUTCH	REAR BAND	OVER-RUNNING CLUTCH	OVER-DRIVE CLUTCH	DIRECT CLUTCH	OVER-RUNNING CLUTCH
Reverse	X			X			X	
Drive - First			X		X		X	X
Drive - Second		X	X				X	X
Drive - Third	X		X				X	X
Drive - Fourth	X		X			X		
Manual Second		X	X		X		X	X
Manual First			X	X	X		X	X

Note that the rear clutch is applied in all forward ranges (D, 2, 1). The transmission overrunning clutch is applied in first gear (D, 2 and 1 ranges) only. The rear band is applied in 1 and R range only.

Note that the overdrive clutch is applied only in fourth gear and the overdrive direct clutch and overrunning clutch are applied in all ranges except fourth gear.

For example: If slippage occurs in first gear in D and 2 range but not in 1 range, the transmission overrunning clutch is faulty. Similarly, if slippage occurs in any two forward gears, the rear clutch is slipping.

Applying the same method of analysis, note that the front and rear clutches are applied simultaneously only in D range third and fourth gear. If the transmission slips in third gear, either the front clutch or the rear clutch is slipping.

If the transmission slips in fourth gear but not in third gear, the overdrive clutch is slipping. By selecting another gear which does not use these clutches, the slipping unit can be determined. For example, if the transmission also slips in Reverse, the front clutch is slipping. If the transmission does not slip in Reverse, the rear clutch is slipping.

If slippage occurs during the 3-4 shift or only in fourth gear, the overdrive clutch is slipping. Similarly, if the direct clutch were to fail, the transmission would lose both reverse gear and overrunning braking in 2 position (manual second gear).

If the transmission will not shift to fourth gear, the control switch, overdrive solenoid or related wiring may also be the problem cause.

This process of elimination can be used to identify a slipping unit and check operation. Proper use of the Clutch and Band Application Chart is the key.

Although road test analysis will help determine the slipping unit, the actual cause of a malfunction usually cannot be determined until hydraulic and air pressure tests are performed. Practically any condition can be caused by leaking hydraulic circuits or sticking valves.

Unless a malfunction is obvious, such as no drive in D range first gear, do not disassemble the transmission. Perform the hydraulic and air pressure tests to help determine the probable cause.

## DIAGNOSIS AND TESTING - HYDRAULIC PRESSURE TEST

Hydraulic test pressures range from a low of one psi (6.895 kPa) governor pressure, to 300 psi (2068 kPa) at the rear servo pressure port in reverse.

An accurate tachometer and pressure test gauges are required. Test Gauge C-3292 has a 100 psi range and is used at the accumulator, governor, and front servo ports. Test Gauge C-3293-SP has a 300 psi range and is used at the rear servo and overdrive ports where pressures exceed 100 psi.

### Pressure Test Port Locations

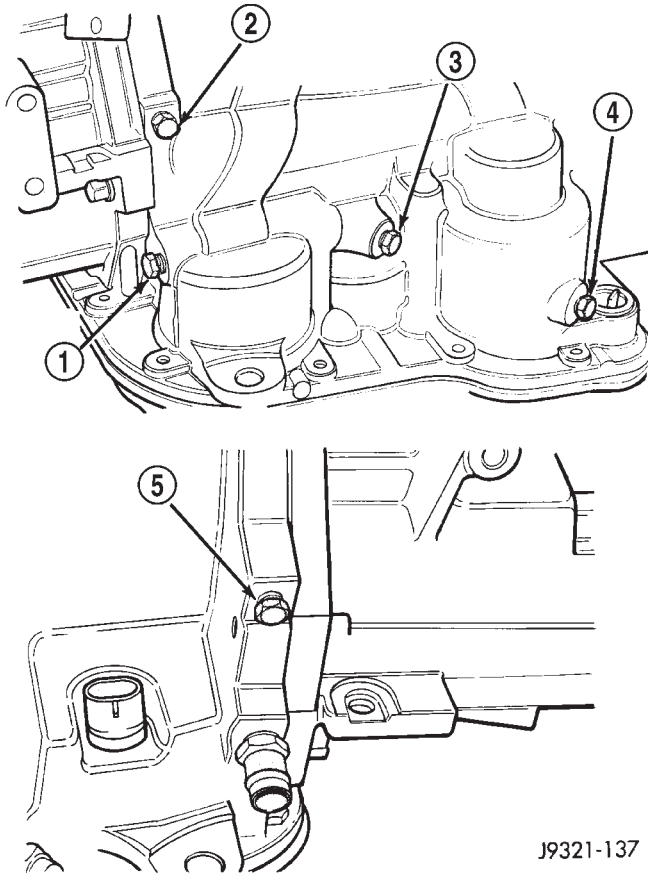
Test ports are located at both sides of the transmission case (Fig. 9).

Line pressure is checked at the accumulator port on the right side of the case. The front servo pressure port is at the right side of the case just behind the filler tube opening.



## AUTOMATIC TRANSMISSION - 47RE (Continued)

The rear servo and governor pressure ports are at the right rear of the transmission case. The overdrive clutch pressure port is at the left rear of the case.



**Fig. 9 Pressure Test Port Locations**

- 1 - REAR SERVO TEST PORT
- 2 - GOVERNOR TEST PORT
- 3 - ACCUMULATOR TEST PORT
- 4 - FRONT SERVO TEST PORT
- 5 - OVERDRIVE CLUTCH TEST PORT

#### Test One - Transmission In Manual Low

**NOTE:** This test checks pump output, pressure regulation, and condition of the rear clutch and servo circuit. Both test gauges are required for this test.

- (1) Connect tachometer to engine. Position tachometer so it can be observed from driver seat if helper will be operating engine. Raise vehicle on hoist that will allow rear wheels to rotate freely.
- (2) Connect 100 psi Gauge C-3292 to accumulator port. Then connect 300 psi Gauge C-3293-SP to rear servo port.
- (3) Disconnect throttle and gearshift cables from levers on transmission valve body manual shaft.
- (4) Have helper start and run engine at 1000 rpm.
- (5) Move transmission shift lever fully forward into 1 range.

(6) Gradually move transmission throttle lever from full forward to full rearward position and note pressures on both gauges:

- Line pressure at accumulator port should be 54-60 psi (372-414 kPa) with throttle lever forward and gradually increase to 90-96 psi (621-662 kPa) as throttle lever is moved rearward.
- Rear servo pressure should be same as line pressure within 3 psi (20.68 kPa).

#### Test Two - Transmission In 2 Range

**NOTE:** This test checks pump output, line pressure and pressure regulation. Use 100 psi Test Gauge C-3292 for this test.

- (1) Leave vehicle in place on hoist and leave Test Gauge C-3292 connected to accumulator port.
- (2) Have helper start and run engine at 1000 rpm.
- (3) Move transmission shift lever one detent rearward from full forward position. This is 2 range.
- (4) Move transmission throttle lever from full forward to full rearward position and read pressure on gauge.
- (5) Line pressure should be 54-60 psi (372-414 kPa) with throttle lever forward and gradually increase to 90-96 psi (621-662 kPa) as lever is moved rearward.

#### Test Three - Transmission In D Range Third Gear

**NOTE:** This test checks pressure regulation and condition of the clutch circuits. Both test gauges are required for this test.

- (1) Turn OD switch off.
- (2) Leave vehicle on hoist and leave Gauge C-3292 in place at accumulator port.
- (3) Move Gauge C-3293-SP over to front servo port for this test.
- (4) Have helper start and run engine at 1600 rpm for this test.
- (5) Move transmission shift lever two detents rearward from full forward position. This is D range.
- (6) Read pressures on both gauges as transmission throttle lever is gradually moved from full forward to full rearward position:
  - Line pressure at accumulator in D range third gear, should be 54-60 psi (372-414 kPa) with throttle lever forward and increase as lever is moved rearward.
  - Front servo pressure in D range third gear, should be within 3 psi (21 kPa) of line pressure up to kickdown point.

## AUTOMATIC TRANSMISSION - 47RE (Continued)

## Test Four - Transmission In Reverse

**NOTE: This test checks pump output, pressure regulation and the front clutch and rear servo circuits. Use 300 psi Test Gauge C-3293-SP for this test.**

- (1) Leave vehicle on hoist and leave gauge C-3292 in place at accumulator port.
- (2) Move 300 psi Gauge C-3293-SP back to rear servo port.
- (3) Have helper start and run engine at 1600 rpm for test.
- (4) Move transmission shift lever four detents rearward from full forward position. This is Reverse range.
- (5) Move transmission throttle lever fully forward then fully rearward and note reading at Gauge C-3293-SP.
- (6) Pressure should be 145 - 175 psi (1000-1207 kPa) with throttle lever forward and increase to 230 - 280 psi (1586-1931 kPa) as lever is gradually moved rearward.

## Test Five - Governor Pressure

**NOTE: This test checks governor operation by measuring governor pressure response to changes in vehicle speed. It is usually not necessary to check governor operation unless shift speeds are incorrect or if the transmission will not downshift. The test should be performed on the road or on a hoist that will allow the rear wheels to rotate freely.**

- (1) Move 100 psi Test Gauge C-3292 to governor pressure port.
- (2) Move transmission shift lever two detents rearward from full forward position. This is D range.
- (3) Have helper start and run engine at curb idle speed. Then firmly apply service brakes so wheels will not rotate.
- (4) Note governor pressure:
  - Governor pressure should be no more than 20.6 kPa (3 psi) at curb idle speed and wheels not rotating.

- If pressure exceeds 20.6 kPa (3 psi), a fault exists in governor pressure control system.

- (5) Release brakes, slowly increase engine speed, and observe speedometer and pressure test gauge (do not exceed 30 mph on speedometer). Governor pressure should increase in proportion to vehicle speed. Or approximately 6.89 kPa (1 psi) for every 1 mph.

- (6) Governor pressure rise should be smooth and drop back to no more than 20.6 kPa (3 psi), after engine returns to curb idle and brakes are applied to prevent wheels from rotating.

- (7) Compare results of pressure test with analysis chart.

## Test Six - Transmission In Overdrive Fourth Gear

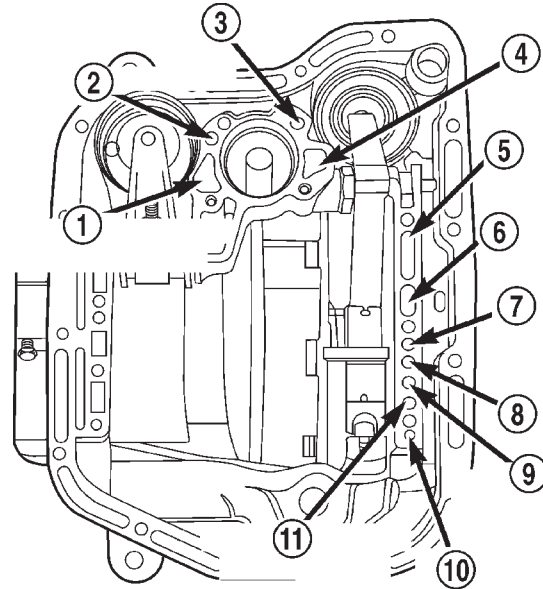
**NOTE: This test checks line pressure at the overdrive clutch in fourth gear range. Use 300 psi Test Gauge C-3293-SP for this test. The test should be performed on the road or on a chassis dyno.**

- (1) Remove tachometer; it is not needed for this test.
- (2) Move 300 psi Gauge to overdrive clutch pressure test port. Then remove other gauge and reinstall test port plug.
- (3) Lower vehicle.
- (4) Turn OD switch on.
- (5) Secure test gauge so it can be viewed from drivers seat.
- (6) Start engine and shift into D range.
- (7) Increase vehicle speed gradually until 3-4 shift occurs and note gauge pressure.
- (8) Pressure should be 469-496 kPa (68-72 psi) with closed throttle and increase to 620-827 kPa (90-120 psi) at 1/2 to 3/4 throttle. Note that pressure can increase to around 896 kPa (130 psi) at full throttle.
- (9) Return to shop or move vehicle off chassis dyno.

AUTOMATIC TRANSMISSION - 47RE (Continued)

PRESSURE TEST ANALYSIS CHART

TEST CONDITION	INDICATION
Line pressure OK during any one test	Pump and regulator valve OK
Line pressure OK in R but low in D, 2, 1	Leakage in rear clutch area (seal rings, clutch seals)
Pressure low in D Fourth Gear Range	Overdrive clutch piston seal, or check ball problem
Pressure OK in 1, 2 but low in D3 and R	Leakage in front clutch area
Pressure OK in 2 but low in R and 1	Leakage in rear servo
Front servo pressure in 2	Leakage in servo; broken servo ring or cracked servo piston
Pressure low in all positions	Clogged filter, stuck regulator valve, worn or faulty pump, low oil level
Governor pressure too high at idle speed	Governor pressure solenoid valve system fault. Refer to diagnostic book.
Governor pressure low at all mph figures	Faulty governor pressure solenoid, transmission control module, or governor pressure sensor
Lubrication pressure low at all throttle positions	Clogged fluid cooler or lines, seal rings leaking, worn pump bushings, pump, clutch retainer, or clogged filter.
Line pressure high	Output shaft plugged, sticky regulator valve
Line pressure low	Sticky regulator valve, clogged filter, worn pump



80b1717e

**Fig. 10 Air Pressure Test Passages**

- 1 - LINE PRESSURE TO ACCUMULATOR
- 2 - REAR SERVO APPLY
- 3 - FRONT SERVO APPLY
- 4 - FRONT SERVO RELEASE
- 5 - PUMP SUCTION
- 6 - PUMP PRESSURE
- 7 - FRONT CLUTCH APPLY
- 8 - REAR CLUTCH APPLY
- 9 - TO TORQUE CONVERTOR
- 10 - TO COOLER
- 11 - FROM TORQUE CONVERTER

**Front Clutch Air Test**

Place one or two fingers on the clutch housing and apply air pressure through front clutch apply passage. Piston movement can be felt and a soft thump heard as the clutch applies.

**Rear Clutch Air Test**

Place one or two fingers on the clutch housing and apply air pressure through rear clutch apply passage. Piston movement can be felt and a soft thump heard as the clutch applies.

**Front Servo Air Test**

Apply air pressure to the front servo apply passage. The servo rod should extend and cause the band to tighten around the drum. Spring pressure should release the servo when air pressure is removed.

**Rear Servo Air Test**

Apply air pressure to the rear servo apply passage. The servo rod should extend and cause the band to tighten around the drum. Spring pressure should release the servo when air pressure is removed.

**DIAGNOSIS AND TESTING - AIR TESTING TRANSMISSION CLUTCH AND BAND OPERATION**

Air-pressure testing can be used to check transmission front/rear clutch and band operation. The test can be conducted with the transmission either in the vehicle or on the work bench, as a final check, after overhaul.

Air-pressure testing requires that the oil pan and valve body be removed from the transmission. The servo and clutch apply passages are shown (Fig. 10).

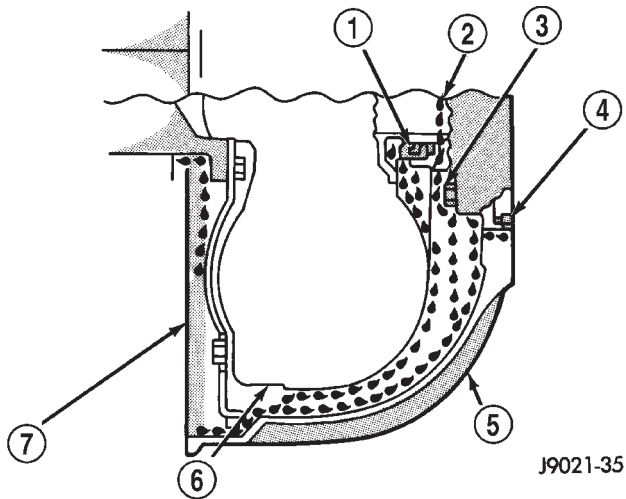
## AUTOMATIC TRANSMISSION - 47RE (Continued)

**DIAGNOSIS AND TESTING - CONVERTER HOUSING FLUID LEAK**

When diagnosing converter housing fluid leaks, two items must be established before repair.

- (1) Verify that a leak condition actually exists.
- (2) Determined the true source of the leak.

Some suspected converter housing fluid leaks may not be leaks at all. They may only be the result of residual fluid in the converter housing, or excess fluid spilled during factory fill or fill after repair. Converter housing leaks have several potential sources. Through careful observation, a leak source can be identified before removing the transmission for repair. Pump seal leaks tend to move along the drive hub and onto the rear of the converter. Pump body leaks follow the same path as a seal leak (Fig. 11). Pump vent or pump attaching bolt leaks are generally deposited on the inside of the converter housing and not on the converter itself (Fig. 11). Pump o-ring or gasket leaks usually travel down the inside of the converter housing. Front band lever pin plug leaks are generally deposited on the housing and not on the converter.



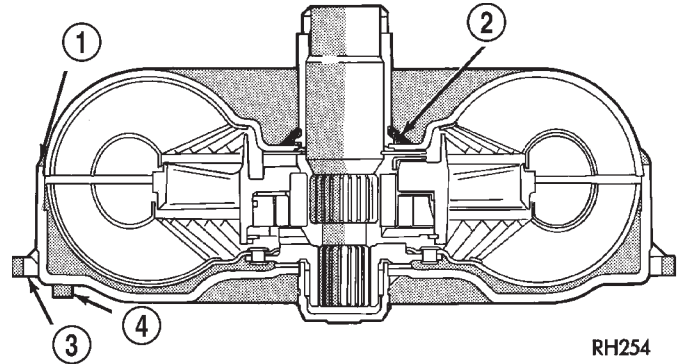
**Fig. 11 Converter Housing Leak Paths**

- 1 - PUMP SEAL
- 2 - PUMP VENT
- 3 - PUMP BOLT
- 4 - PUMP GASKET
- 5 - CONVERTER HOUSING
- 6 - CONVERTER
- 7 - REAR MAIN SEAL LEAK

**TORQUE CONVERTER LEAK POINTS**

Possible sources of converter leaks are:

- (1) Leaks at the weld joint around the outside diameter weld (Fig. 12).
- (2) Leaks at the converter hub weld (Fig. 12).



**Fig. 12 Converter Leak Points - Typical**

- 1 - OUTSIDE DIAMETER WELD
- 2 - TORQUE CONVERTER HUB WELD
- 3 - STARTER RING GEAR
- 4 - LUG

**CONVERTER HOUSING AREA LEAK CORRECTION**

- (1) Remove converter.
- (2) Tighten front band adjusting screw until band is tight around front clutch retainer. This prevents front/rear clutches from coming out when oil pump is removed.
- (3) Remove oil pump and remove pump seal. Inspect pump housing drainback and vent holes for obstructions. Clear holes with solvent and wire.
- (4) Inspect pump bushing and converter hub. If bushing is scored, replace it. If converter hub is scored, either polish it with crocus cloth or replace converter.
- (5) Install new pump seal, O-ring, and gasket. Replace oil pump if cracked, porous or damaged in any way. Be sure to loosen the front band before installing the oil pump, damage to the oil pump seal may occur if the band is still tightened to the front clutch retainer.
- (6) Loosen kickdown lever pin access plug three turns. Apply Loctite™ 592, or Permatex® No. 2 to plug threads and tighten plug to 17 N·m (150 in. lbs.) torque.
- (7) Adjust front band.
- (8) Lubricate pump seal and converter hub with transmission fluid or petroleum jelly and install converter.
- (9) Install transmission and converter housing dust shield.
- (10) Lower vehicle.

## AUTOMATIC TRANSMISSION - 47RE (Continued)

**DIAGNOSIS AND TESTING - DIAGNOSIS CHARTS**

The diagnosis charts provide additional reference when diagnosing a transmission fault. The charts provide general information on a variety of transmission, overdrive unit and converter clutch fault conditions.

The hydraulic flow charts in the Schematics and Diagrams section of this group, outline fluid flow and hydraulic circuitry. Circuit operation is provided for PARK, NEUTRAL, FIRST, SECOND, THIRD, FOURTH, MANUAL FIRST, MANUAL SECOND, and REVERSE gear ranges. Normal working pressures are also supplied for each of the gear ranges.

**DIAGNOSIS CHARTS**

<b>CONDITION</b>	<b>POSSIBLE CAUSES</b>	<b>CORRECTION</b>
HARSH ENGAGEMENT (FROM NEUTRAL TO DRIVE OR REVERSE)	1. Fluid Level Low.	1. Add Fluid
	2. Throttle Linkage Mis-adjusted.	2. Adjust linkage - setting may be too long.
	3. Mount and Driveline Bolts Loose.	3. Check engine mount, transmission mount, propeller shaft, rear spring to body bolts, rear control arms, crossmember and axle bolt torque. Tighten loose bolts and replace missing bolts.
	4. U-Joint Worn/Broken.	4. Remove propeller shaft and replace U-Joint.
	5. Axle Backlash Incorrect.	5. Check per Service Manual. Correct as needed.
	6. Hydraulic Pressure Incorrect.	6. Check pressure. Remove, overhaul or adjust valve body as needed.
	7. Band Mis-adjusted.	7. Adjust rear band.
	8. Valve Body Check Balls Missing.	8. Inspect valve body for proper check ball installation.
	9. Axle Pinion Flange Loose.	9. Replace nut and check pinion threads before installing new nut. Replace pinion gear if threads are damaged.
	10. Clutch, band or planetary component damaged.	10. Remove, disassemble and repair transmission as necessary.
	11. Converter Clutch Faulty.	11. Replace converter and flush cooler and line before installing new converter.
DELAYED ENGAGEMENT (FROM NEUTRAL TO DRIVE OR REVERSE)	1. Fluid Level Low.	1. Correct level and check for leaks.
	2. Filter Clogged.	2. Change filter.
	3. Gearshift Linkage Mis-adjusted.	3. Adjust linkage and repair linkage if worn or damaged.
	4. Torque Converter Drain Back (Oil drains from torque converter into transmission sump).	4. If vehicle moves normally after 5 seconds after shifting into gear, no repair is necessary. If longer, inspect pump bushing for wear. Replace pump house.
	5. Rear Band Mis-adjusted.	5. Adjust band.
	6. Valve Body Filter Plugged.	6. Replace fluid and filter. If oil pan and old fluid were full of clutch disc material and/or metal particles, overhaul will be necessary.



## AUTOMATIC TRANSMISSION - 47RE (Continued)

CONDITION	POSSIBLE CAUSES	CORRECTION
	7. Oil Pump Gears Worn/Damaged.	7. Remove transmission and replace oil pump.
	8. Governor Circuit and Solenoid Valve Electrical Fault.	8. Test with DRB® scan tool and repair as required.
	9. Hydraulic Pressure Incorrect.	9. Perform pressure test, remove transmission and repair as needed.
	10. Reaction Shaft Seal Rings Worn/Broken.	10. Remove transmission, remove oil pump and replace seal rings.
	11. Rear Clutch/Input Shaft, Rear Clutch Seal Rings Damaged.	11. Remove and disassemble transmission and repair as necessary.
	12. Regulator Valve Stuck.	12. Clean.
	13. Cooler Plugged.	13. Transfer case failure can plug cooler.
NO DRIVE RANGE (REVERSE OK)	1. Fluid Level Low.	1. Add fluid and check for leaks if drive is restored.
	2. Gearshift Linkage/Cable Loose/Misadjusted.	2. Repair or replace linkage components.
	3. Rear Clutch Burnt.	3. Remove and disassemble transmission and rear clutch and seals. Repair/replace worn or damaged parts as needed.
	4. Valve Body Malfunction.	4. Remove and disassemble valve body. Replace assembly if any valves or bores are damaged.
	5. Transmission Overrunning Clutch Broken.	5. Remove and disassemble transmission. Replace overrunning clutch.
	6. Input Shaft Seal Rings Worn/Damaged.	6. Remove and disassemble transmission. Replace seal rings and any other worn or damaged parts.
	7. Front Planetary Failed Broken.	7. Remove and repair.
NO DRIVE OR REVERSE (VEHICLE WILL NOT MOVE)	1. Fluid Level Low.	1. Add fluid and check for leaks if drive is restored.
	2. Gearshift Linkage/Cable Loose/Misadjusted.	2. Inspect, adjust and reassemble linkage as needed. Replace worn/damaged parts.
	3. U-Joint/Axle/Transfer Case Broken.	3. Perform preliminary inspection procedure for vehicle that will not move. Refer to procedure in diagnosis section.
	4. Filter Plugged.	4. Remove and disassemble transmission. Repair or replace failed components as needed. Replace filter. If filter and fluid contained clutch material or metal particles, an overhaul may be necessary. Perform lube flow test. Flush oil. Replace cooler as necessary.
	5. Oil Pump Damaged.	5. Perform pressure test to confirm low pressure. Replace pump body assembly if necessary.
	6. Valve Body Malfunctioned.	6. Check and inspect valve body. Replace valve body (as assembly) if any valve or bore is damaged. Clean and reassemble correctly if all parts are in good condition.

## AUTOMATIC TRANSMISSION - 47RE (Continued)

CONDITION	POSSIBLE CAUSES	CORRECTION
	7. Transmission Internal Component Damaged.	7. Remove and disassemble transmission. Repair or replace failed components as needed.
	8. Park Sprag not Releasing - Check Stall Speed, Worn/Damaged/Stuck.	8. Remove, disassemble, repair.
	9. Torque Converter Damage.	9. Inspect and replace as required.
SHIFTS DELAYED OR ERRATIC (SHIFTS ALSO HARSH AT TIMES)	1. Fluid Level Low/High.	1. Correct fluid level and check for leaks if low.
	2. Fluid Filter Clogged.	2. Replace filter. If filter and fluid contained clutch material or metal particles, an overhaul may be necessary. Perform lube flow test.
	3. Throttle Linkage Mis-adjusted.	3. Adjust linkage as described in service section.
	4. Throttle Linkage Binding.	4. Check cable for binding. Check for return to closed throttle at transmission.
	5. Gearshift Linkage/Cable Mis-adjusted.	5. Adjust linkage/cable as described in service section.
	6. Clutch or Servo Failure.	6. Remove valve body and air test clutch, and band servo operation. Disassemble and repair transmission as needed.
	7. Governor Circuit Electrical Fault.	7. Test using DRB® scan tool and repair as required.
	8. Front Band Mis-adjusted.	8. Adjust band.
	9. Pump Suction Passage Leak.	9. Check for excessive foam on dipstick after normal driving. Check for loose pump bolts, defective gasket. Replace pump assembly if needed.
NO REVERSE (D RANGES OK)	1. Gearshift Linkage/Cable Mis-adjusted/Damaged.	1. Repair or replace linkage parts as needed.
	2. Park Sprag Sticking.	2. Replace overdrive annulus gear.
	3. Rear Band Mis-adjusted/Worn.	3. Adjust band; replace.
	4. Valve Body Malfunction.	4. Remove and service valve body. Replace valve body if any valves or valve bores are worn or damaged.
	5. Rear Servo Malfunction.	5. Remove and disassemble transmission. Replace worn/damaged servo parts as necessary.
	6. Direct Clutch in Overdrive Worn.	6. Disassemble overdrive. Replace worn or damaged parts.
	7. Front Clutch Burnt.	7. Remove and disassemble transmission. Replace worn, damaged clutch parts as required.

## AUTOMATIC TRANSMISSION - 47RE (Continued)

CONDITION	POSSIBLE CAUSES	CORRECTION
HAS FIRST/REVERSE ONLY (NO 1-2 OR 2-3 UPSHIFT)	1. Governor Circuit Electrical Fault.	1. Test using DRB® scan tool and repair as required.
	2. Valve Body Malfunction.	2. Repair stuck 1-2 shift valve or governor plug.
	3. Front Servo/Kickdown Band Damaged/Burned.	3. Repair/replace.
MOVES IN 2ND OR 3RD GEAR, ABRUPTLY DOWNSHIFTS TO LOW	1. Valve Body Malfunction.	1. Remove, clean and inspect. Look for stuck 1-2 valve or governor plug.
NO LOW GEAR (MOVES IN 2ND OR 3RD GEAR ONLY)	1. Governor Circuit Electrical Fault.	1. Test with DRB® scan tool and repair as required.
	2. Valve Body Malfunction.	2. Remove, clean and inspect. Look for sticking 1-2 shift valve, 2-3 shift valve, governor plug or broken springs.
	3. Front Servo Piston Cocked in Bore.	3. Inspect servo and repair as required.
	4. Front Band Linkage Malfunction	4. Inspect linkage and look for bind in linkage.
NO KICKDOWN OR NORMAL DOWNSHIFT	1. Throttle Linkage Mis-adjusted.	1. Adjust linkage.
	2. Accelerator Pedal Travel Restricted.	2. Verify floor mat is not under pedal, repair worn accelerator cable or bent brackets.
	3. Valve Body Hydraulic Pressures Too High or Too Low Due to Valve Body Malfunction or Incorrect Hydraulic Control Pressure Adjustments.	3. Perform hydraulic pressure tests to determine cause and repair as required. Correct valve body pressure adjustments as required.
	4. Governor Circuit Electrical Fault.	4. Test with DRB® scan tool and repair as required.
	5. Valve Body Malfunction.	5. Perform hydraulic pressure tests to determine cause and repair as required. Correct valve body pressure adjustments as required.
	6. TPS Malfunction.	6. Replace sensor, check with DRB® scan tool.
	7. PCM Malfunction.	7. Check with DRB® scan tool and replace if required.
	8. Valve Body Malfunction.	8. Repair sticking 1-2, 2-3 shift valves, governor plugs, 3-4 solenoid, 3-4 shift valve, 3-4 timing valve.

## AUTOMATIC TRANSMISSION - 47RE (Continued)

CONDITION	POSSIBLE CAUSES	CORRECTION
STUCK IN LOW GEAR (WILL NOT UPSHIFT)	1. Throttle Linkage Mis-adjusted/ Stuck.	1. Adjust linkage and repair linkage if worn or damaged. Check for binding cable or missing return spring.
	2. Gearshift Linkage Mis-adjusted.	2. Adjust linkage and repair linkage if worn or damaged.
	3. Governor Component Electrical Fault.	3. Check operating pressures and test with DRB® scan tool, repair faulty component.
	4. Front Band Out of Adjustment.	4. Adjust Band.
	5. Clutch or Servo Malfunction.	5. Air pressure check operation of clutches and bands. Repair faulty component.
CREEPS IN NEUTRAL	1. Gearshift Linkage Mis-adjusted.	1. Adjust linkage.
	2. Rear Clutch Dragging/Warped.	2. Disassemble and repair.
	3. Valve Body Malfunction.	3. Perform hydraulic pressure test to determine cause and repair as required.
BUZZING NOISE	1. Fluid Level Low	1. Add fluid and check for leaks.
	2. Shift Cable Mis-assembled.	2. Route cable away from engine and bell housing.
	3. Valve Body Mis-assembled.	3. Remove, disassemble, inspect valve body. Reassemble correctly if necessary. Replace assembly if valves or springs are damaged. Check for loose bolts or screws.
	4. Pump Passages Leaking.	4. Check pump for porous casting, scores on mating surfaces and excess rotor clearance. Repair as required. Loose pump bolts.
	5. Cooling System Cooler Plugged.	5. Flow check cooler circuit. Repair as needed.
	6. Overrunning Clutch Damaged.	6. Replace clutch.
SLIPS IN REVERSE ONLY	1. Fluid Level Low.	1. Add fluid and check for leaks.
	2. Gearshift Linkage Mis-adjusted.	2. Adjust linkage.
	3. Rear Band Mis-adjusted.	3. Adjust band.
	4. Rear Band Worn.	4. Replace as required.
	5. Overdrive Direct Clutch Worn.	5. Disassemble overdrive. Repair as needed.
	6. Hydraulic Pressure Too Low.	6. Perform hydraulic pressure tests to determine cause.
	7. Rear Servo Leaking.	7. Air pressure check clutch-servo operation and repair as required.
	8. Band Linkage Binding.	8. Inspect and repair as required.

## AUTOMATIC TRANSMISSION - 47RE (Continued)

CONDITION	POSSIBLE CAUSES	CORRECTION
SLIPS IN FORWARD DRIVE RANGES	1. Fluid Level Low.	1. Add fluid and check for leaks.
	2. Fluid Foaming.	2. Check for high oil level, bad pump gasket or seals, dirt between pump halves and loose pump bolts. Replace pump if necessary.
	3. Throttle Linkage Mis-adjusted.	3. Adjust linkage.
	4. Gearshift Linkage Mis-adjusted.	4. Adjust linkage.
	5. Rear Clutch Worn.	5. Inspect and replace as needed.
	6. Low Hydraulic Pressure Due to Worn Pump, Incorrect Control Pressure Adjustments, Valve Body Warpage or Malfunction, Sticking, Leaking Seal Rings, Clutch Seals Leaking, Servo Leaks, Clogged Filter or Cooler Lines.	6. Perform hydraulic and air pressure tests to determine cause.
	7. Rear Clutch Malfunction, Leaking Seals or Worn Plates.	7. Air pressure check clutch-servo operation and repair as required.
	8. Overrunning Clutch Worn, Not Holding (Slips in 1 Only).	8. Replace Clutch.
SLIPS IN LOW GEAR "D" ONLY, BUT NOT IN MANUAL 1 POSITION	Overrunning Clutch Faulty.	Replace overrunning clutch.
GROWLING, GRATING OR SCRAPING NOISES	1. Drive Plate Broken.	1. Replace.
	2. Torque Converter Bolts Hitting Dust Shield.	2. Dust shield bent. Replace or repair.
	3. Planetary Gear Set Broken/ Seized.	3. Check for debris in oil pan and repair as required.
	4. Overrunning Clutch Worn/Broken.	4. Inspect and check for debris in oil pan. Repair as required.
	5. Oil Pump Components Scored/ Binding.	5. Remove, inspect and repair as required.
	6. Output Shaft Bearing or Bushing Damaged.	6. Remove, inspect and repair as required.
	7. Clutch Operation Faulty.	7. Perform air pressure check and repair as required.
	8. Front and Rear Bands Mis-adjusted.	8. Adjust bands.



## AUTOMATIC TRANSMISSION - 47RE (Continued)

CONDITION	POSSIBLE CAUSES	CORRECTION
DRAGS OR LOCKS UP	1. Fluid Level Low.	1. Check and adjust level.
	2. Clutch Dragging/Failed	2. Air pressure check clutch operation and repair as required.
	3. Front or Rear Band Mis-adjusted.	3. Adjust bands.
	4. Case Leaks Internally.	4. Check for leakage between passages in case.
	5. Servo Band or Linkage Malfunction.	5. Air pressure check servo operation and repair as required.
	6. Overrunning Clutch Worn.	6. Remove and inspect clutch. Repair as required.
	7. Planetary Gears Broken.	7. Remove, inspect and repair as required (look for debris in oil pan).
	8. Converter Clutch Dragging.	8. Check for plugged cooler. Perform flow check. Inspect pump for excessive side clearance. Replace pump as required.
NO 4-3 DOWNSHIFT	1. Circuit Wiring and/or Connectors Shorted.	1. Test wiring and connectors with test lamp and volt/ohmmeter. Repair wiring as necessary. Replace connectors and/or harnesses as required.
	2. PCM Malfunction.	2. Check PCM operation with DRB® scan tool. Replace PCM only if faulty.
	3. TPS Malfunction	3. Check TPS with DRB® scan tool at PCM.
	4. Lockup Solenoid Not Venting.	4. Remove valve body and replace solenoid assembly if plugged or shorted.
	5. Overdrive Solenoid Not Venting.	5. Remove valve body and replace solenoid if plugged or shorted.
	6. Valve Body Valve Sticking.	6. Repair stuck 3-4 shift valve or lockup timing valve.
NO 4-3 DOWNSHIFT WHEN CONTROL SWITCH IS TURNED OFF	1. Control Switch Open/Shorted.	1. Test and replace switch if faulty.
	2. Overdrive Solenoid Connector Shorted.	2. Test solenoids and replace if seized or shorted.
	3. PCM Malfunction.	3. Test with DRB® scan tool. Replace PCM if faulty.
	4. Valve Body Stuck Valves.	4. Repair stuck 3-4, lockup or lockup timing valve.
CLUNK NOISE FROM DRIVELINE ON CLOSED THROTTLE 4-3 DOWNSHIFT	1. Transmission Fluid Low.	1. Add Fluid.
	2. Throttle Cable Mis-adjusted.	2. Adjust cable.
	3. Overdrive Clutch Select Spacer Wrong Spacer.	3. Replace overdrive piston thrust plate spacer.

## AUTOMATIC TRANSMISSION - 47RE (Continued)

CONDITION	POSSIBLE CAUSES	CORRECTION
3-4 UPSHIFT OCCURS IMMEDIATELY AFTER 2-3 SHIFT	1. Overdrive Solenoid Connector or Wiring Shorted.	1. Test connector and wiring for loose connections, shorts or ground and repair as needed.
	2. TPS Malfunction.	2. Test TPS and replace as necessary. Check with DRB® scan tool.
	3. PCM Malfunction.	3. Test PCM with DRB® scan tool and replace controller if faulty.
	4. Overdrive Solenoid Malfunction.	4. Replace solenoid.
	5. Valve Body Malfunction.	5. Remove, disassemble, clean and inspect valve body components. Make sure all valves and plugs slide freely in bores. Polish valves with crocus cloth if needed.
WHINE/NOISE RELATED TO ENGINE SPEED	1. Fluid Level Low.	1. Add fluid and check for leaks.
	2. Shift Cable Incorrect Routing.	2. Check shift cable for correct routing. Should not touch engine or bell housing.
NO 3-4 UPSHIFT	1. O/D Switch In OFF Position.	1. Turn control switch to ON position.
	2. Overdrive Circuit Fuse Blown.	2. Replace fuse. Determine why fuse failed and repair as necessary (i.e., shorts or grounds in circuit).
	3. O/D Switch Wire Shorted/Open Cut.	3. Check wires/connections with 12V test lamp and voltmeter. Repair damaged or loose wire/connection as necessary.
	4. Distance or Coolant Sensor Malfunction.	4. Check with DRB® scan tool and repair or replace as necessary.
	5. TPS Malfunction.	5. Check with DRB® scan tool and replace if necessary.
	6. Neutral Sense to PCM Wire Shorted/Cut.	6. Test switch/sensor as described in service section and replace if necessary. Engine no start.
	7. PCM Malfunction.	7. Check with DRB® scan tool and replace if necessary.
	8. Overdrive Solenoid Shorted/Open.	8. Replace solenoid if shorted or open and repair loose or damaged wires (DRB® scan tool).
	9. Solenoid Feed Orifice in Valve Body Blocked.	9. Remove, disassemble, and clean valve body thoroughly. Check feed orifice.
	10. Overdrive Clutch Failed.	10. Disassemble overdrive and repair as needed.
	11. Hydraulic Pressure Low.	11. Pressure test transmission to determine cause.
	12. Valve Body Valve Stuck.	12. Repair stuck 3-4 shift valve, 3-4 timing valve.
	13. O/D Piston Incorrect Spacer.	13. Remove unit, check end play and install correct spacer.
	14. Overdrive Piston Seal Failure.	14. Replace both seals.
	15. O/D Check Valve/Orifice Failed.	15. Check for free movement and secure assembly (in piston retainer). Check ball bleed orifice.

## AUTOMATIC TRANSMISSION - 47RE (Continued)

CONDITION	POSSIBLE CAUSES	CORRECTION
SLIPS IN OVERDRIVE FOURTH GEAR	1. Fluid Level Low.	1. Add fluid and check for leaks.
	2. Overdrive Clutch Pack Worn.	2. Remove overdrive unit and rebuild clutch pack.
	3. Overdrive Piston Retainer Bleed Orifice Blown Out.	3. Disassemble transmission, remove retainer and replace orifice.
	4. Overdrive Piston or Seal Malfunction.	4. Remove overdrive unit. Replace seals if worn. Replace piston if damaged. If piston retainer is damaged, remove and disassemble the transmission.
	5. 3-4 Shift Valve, Timing Valve or Accumulator Malfunction.	5. Remove and overhaul valve body. Replace accumulator seals. Make sure all valves operate freely in bores and do not bind or stick. Make sure valve body screws are correctly tightened and separator plates are properly positioned.
	6. Overdrive Unit Thrust Bearing Failure.	6. Disassemble overdrive unit and replace thrust bearing (NO. 1 thrust bearing is between overdrive piston and clutch hub; NO. 2 thrust bearing is between the planetary gear and the direct clutch spring plate; NO. 3 thrust bearing is between overrunning clutch hub and output shaft).
	7. O/D Check Valve/Bleed Orifice Failure.	7. Check for function/secure orifice insert in O/D piston retainer.
DELAYED 3-4 UPSHIFT (SLOW TO ENGAGE)	1. Fluid Level Low.	1. Add fluid and check for leaks.
	2. Throttle Valve Cable Mis-adjusted.	2. Adjust throttle valve cable.
	3. Overdrive Clutch Pack Worn/ Burnt.	3. Remove unit and rebuild clutch pack.
	4. TPS Faulty.	4. Test with DRB® scan tool and replace as necessary
	5. Overdrive Clutch Bleed Orifice Plugged.	5. Disassemble transmission and replace orifice.
	6. Overdrive Solenoid or Wiring Shorted/Open.	6. Test solenoid and check wiring for loose/corroded connections or shorts/grounds. Replace solenoid if faulty and repair wiring if necessary.
	7. Overdrive Excess Clearance.	7. Remove unit. Measure end play and select proper spacer.
	8. O/D Check Valve Missing or Stuck.	8. Check for presence of check valve. Repair or replace as required.
TORQUE CONVERTER LOCKS UP IN SECOND AND/OR THIRD GEAR	Lockup Solenoid, Relay or Wiring Shorted/Open.	Test solenoid, relay and wiring for continuity, shorts or grounds. Replace solenoid and relay if faulty. Repair wiring and connectors as necessary.
HARSH 1-2, 2-3, 3-4 OR 3-2 SHIFTS	Lockup Solenoid Malfunction.	Remove valve body and replace solenoid assembly.

## AUTOMATIC TRANSMISSION - 47RE (Continued)

CONDITION	POSSIBLE CAUSES	CORRECTION
NO START IN PARK OR NEUTRAL	1. Gearshift Linkage/Cable Mis-adjusted.	1. Adjust linkage/cable.
	2. Neutral Sense Wire Open/Cut.	2. Check continuity with test lamp. Repair as required.
	3. Park/Neutral Switch, or Transmission Range Sensor Faulty.	3. Refer to service section for test and replacement procedure.
	4. Park/Neutral Switch, or Transmission Range Sensor Connection Faulty.	4. Connectors spread open. Repair.
	5. Valve Body Manual Lever Assembly Bent/Worn/Broken.	5. Inspect lever assembly and replace if damaged.
NO REVERSE (OR SLIPS IN REVERSE)	1. Direct Clutch Pack (front clutch) Worn.	1. Disassemble unit and rebuild clutch pack.
	2. Rear Band Mis-adjusted.	2. Adjust band.
	3. Front Clutch Malfunctioned/ Burned.	3. Air-pressure test clutch operation. Remove and rebuild if necessary.
	4. Overdrive Thrust Bearing Failure.	4. Disassemble geartrain and replace bearings.
	5. Direct Clutch Spring Collapsed/ Broken.	5. Remove and disassemble unit. Check clutch position and replace spring.
OIL LEAKS.	1. Fluid Lines and Fittings Loose/ Leaks/Damaged.	1. Tighten fittings. If leaks persist, replace fittings and lines if necessary.
	2. Fill Tube (where tube enters case) Leaks/Damaged.	2. Replace tube seal. Inspect tube for cracks in fill tube.
	3. Pressure Port Plug Loose Loose/Damaged.	3. Tighten to correct torque. Replace plug or reseal if leak persists.
	4. Pan Gasket Leaks.	4. Tighten pan screws (150 in. lbs.). If leaks persist, replace gasket.
	5. Valve Body Manual Lever Shaft Seal Leaks/Worn.	5. Replace shaft seal.
	6. Rear Bearing Access Plate Leaks.	6. Replace gasket. Tighten screws.
	7. Gasket Damaged or Bolts are Loose.	7. Replace bolts or gasket or tighten both.
	8. Adapter/Extension Gasket Damaged Leaks/Damaged.	8. Replace gasket.
	9. Park/Neutral Switch, or Transmission Range Sensor Leaks/Damaged.	9. Replace switch and gasket.
	10. Converter Housing Area Leaks.	10. Check for leaks at seal caused by worn seal or burr on converter hub (cutting seal), worn bushing, missing oil return, oil in front pump housing or hole plugged. Check for leaks past O-ring seal on pump or past pump-to-case bolts; pump housing porous, oil coming out vent due to overfill or leak past front band shaft access plug.

## AUTOMATIC TRANSMISSION - 47RE (Continued)

CONDITION	POSSIBLE CAUSES	CORRECTION
	11. Pump Seal Leaks/Worn/Damaged.	11. Replace seal.
	12. Torque Converter Weld Leak/Cracked Hub.	12. Replace converter.
	13. Case Porosity Leaks.	13. Replace case.
NOISY OPERATION IN FOURTH GEAR ONLY	1. Overdrive Clutch Discs, Plates or Snap Rings Damaged.	1. Remove unit and rebuild clutch pack.
	2. Overdrive Piston or Planetary Thrust Bearing Damaged.	2. Remove and disassemble unit. Replace either thrust bearing if damaged.
	3. Output Shaft Bearings Scored/Damaged.	3. Remove and disassemble unit. Replace either bearing if damaged.
	4. Planetary Gears Worn/Chipped.	4. Remove and overhaul overdrive unit.
	5. Overdrive Unit Overrunning Clutch Rollers Worn/Scored.	5. Remove and overhaul overdrive unit.

### STANDARD PROCEDURE - ALUMINUM THREAD REPAIR

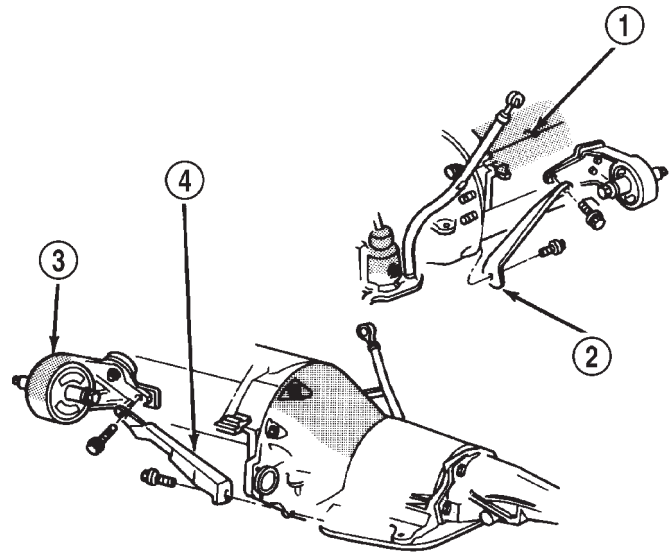
Damaged or worn threads in the aluminum transmission case and valve body can be repaired by the use of Heli-Coils™, or equivalent. This repair consists of drilling out the worn-out damaged threads. Then tap the hole with a special Heli-Coil™ tap, or equivalent, and installing a Heli-Coil™ insert, or equivalent, into the hole. This brings the hole back to its original thread size.

Heli-Coil™, or equivalent, tools and inserts are readily available from most automotive parts suppliers.

### REMOVAL

The overdrive unit can be removed and serviced separately. It is not necessary to remove the entire transmission assembly to perform overdrive unit repairs.

- (1) Disconnect battery negative cable.
- (2) Disconnect and lower or remove necessary exhaust components.
- (3) Remove engine-to-transmission struts, if equipped (Fig. 13).
- (4) Disconnect fluid cooler lines at transmission.
- (5) Remove starter motor. (Refer to 8 - ELECTRICAL/STARTING/STARTER MOTOR - REMOVAL)
- (6) Disconnect and remove the crankshaft position sensor. (Refer to 14 - FUEL SYSTEM/FUEL INJECTION/CRANKSHAFT POSITION SENSOR - REMOVAL) Retain the sensor attaching bolts.
- (7) Remove torque converter access cover.
- (8) If transmission is being removed for overhaul, remove transmission oil pan, drain fluid and reinstall pan.
- (9) Remove fill tube bracket bolts and pull tube out of transmission. Retain fill tube seal (Fig. 13). On 4 x 4 models, it will also be necessary to remove bolt



J9421-255

**Fig. 13 Transmission-To-Engine Strut Attachment**

- 1 - ENGINE BLOCK
- 2 - STRUT (PASSENGER SIDE)
- 3 - ENGINE MOUNT
- 4 - STRUT (DRIVER SIDE)

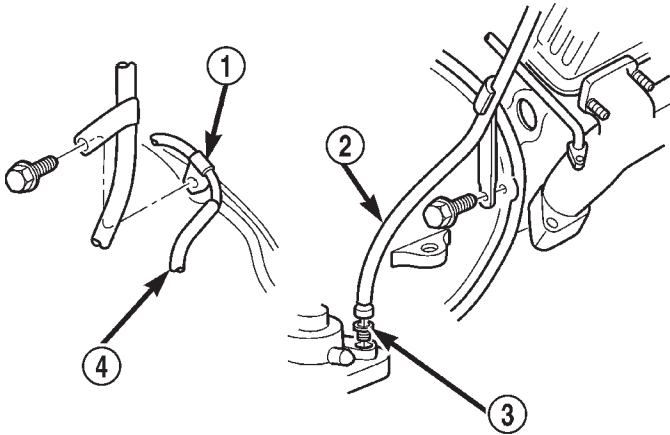
attaching transfer case vent tube to converter housing (Fig. 14).

(10) Rotate crankshaft in clockwise direction until converter bolts are accessible. Then remove bolts one at a time. Rotate crankshaft with socket wrench on dampener bolt.

(11) Mark propeller shaft and axle yokes for assembly alignment. Then disconnect and remove propeller shaft. On 4 x 4 models, remove both propeller shafts. (Refer to 3 - DIFFERENTIAL & DRIVELINE/PROPELLER SHAFT/PROPELLER SHAFT - REMOVAL)



## AUTOMATIC TRANSMISSION - 47RE (Continued)

**Fig. 14 Fill Tube Attachment**

80b170f3

- 1 - TRANSFER CASE VENT TUBE
- 2 - FILL TUBE (V8)
- 3 - TUBE SEAL
- 4 - FILL TUBE (V6)

(12) Disconnect wires from park/neutral position switch and transmission solenoid.

(13) Disconnect gearshift rod and torque shaft assembly from transmission.

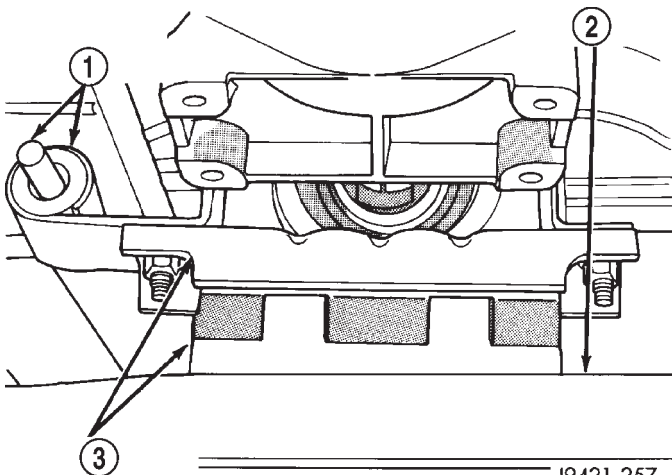
(14) Disconnect throttle valve cable from transmission bracket and throttle valve lever.

(15) On 4 x 4 models, disconnect shift rod from transfer case shift lever.

(16) Support rear of engine with safety stand or jack.

(17) Raise transmission slightly with service jack to relieve load on crossmember and supports.

(18) Remove bolts securing rear support and cushion to transmission and crossmember. Raise transmission slightly, slide exhaust hanger arm from bracket (Fig. 15) and remove rear support.

**Fig. 15 Rear Support Cushion**

J9421-257

- 1 - EXHAUST PIPE ARM AND BRACKET
- 2 - CROSSMEMBER
- 3 - REAR SUPPORT AND CUSHION

(19) Remove bolts attaching crossmember to frame and remove crossmember.

(20) On 4 x 4 models, remove transfer case with transmission jack or aid of helper.

(21) Remove all converter housing bolts.

(22) Carefully work transmission and torque converter assembly rearward off engine block dowels.

(23) Lower transmission and remove assembly from under the vehicle.

(24) To remove torque converter, remove C-clamp from edge of bell housing and carefully slide torque converter out of the transmission.

**DISASSEMBLY**

(1) Clean exterior of transmission with suitable solvent or pressure washer.

(2) Place transmission in vertical position.

(3) Measure the input shaft end play as follows (Fig. 16).

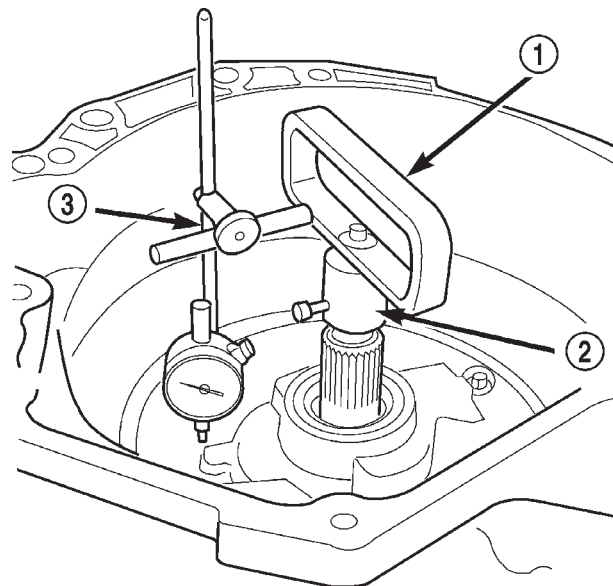
(a) Attach Adapter 8266-5 to Handle 8266-8.

(b) Attach dial indicator C-3339 to Handle 8266-8.

(c) Install the assembled tool onto the input shaft of the transmission and tighten the retaining screw on Adapter 8266-5 to secure it to the input shaft.

(d) Position the dial indicator plunger against a flat spot on the oil pump and zero the dial indicator.

(e) Move input shaft in and out and record reading. Record the maximum travel for assembly reference.

**Fig. 16 Checking Input Shaft End Play**

80c070b4

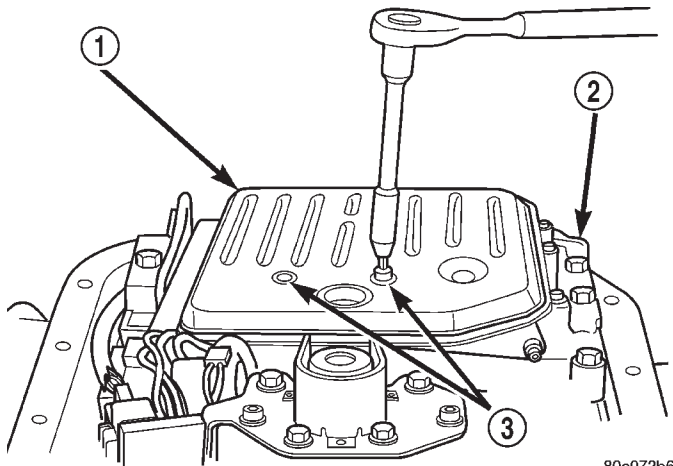
- 1 - TOOL 8266-8
- 2 - TOOL 8266-5
- 3 - TOOL C-3339

## AUTOMATIC TRANSMISSION - 47RE (Continued)

(4) Remove throttle and shift levers from valve body manual shaft and throttle lever shaft.

(5) Remove transmission oil pan and gasket.

(6) Remove filter from valve body (Fig. 17). Keep filter screws separate from other valve body screws. Filter screws are longer and should be kept with filter.



80c072b6

**Fig. 17 Oil Filter Removal**

- 1 - OIL FILTER
- 2 - VALVE BODY
- 3 - FILTER SCREWS (2)

(7) Remove park/neutral position switch and seal.

(8) Remove hex head bolts attaching valve body to transmission case (Fig. 18). A total of 10 bolts are used. Note different bolt lengths for assembly reference.

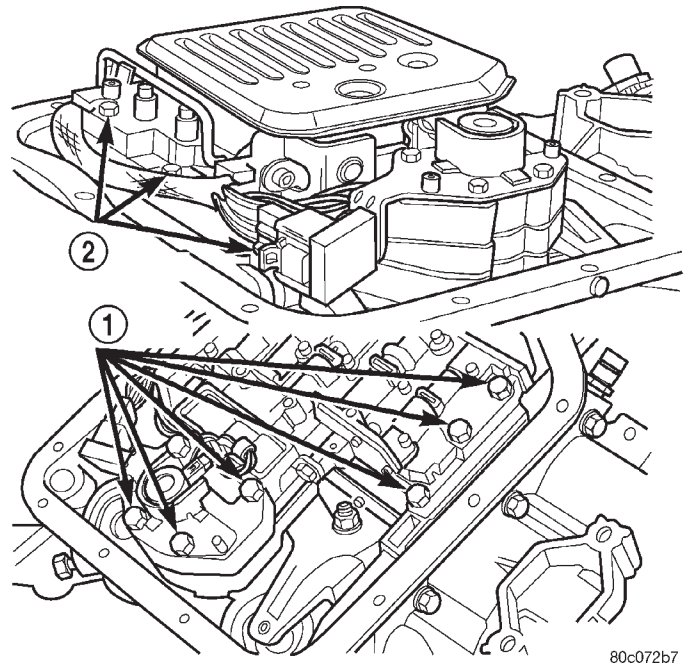
(9) Remove valve body assembly. Push valve body harness connector out of case. Then work park rod and valve body out of case (Fig. 19).

(10) Remove accumulator outer spring, piston and inner spring (Fig. 20). Note position of piston and springs for assembly reference. Remove and discard piston seals if worn or cut.

(11) Remove pump oil seal with suitable pry tool or slide-hammer mounted screw.

(12) Remove front band lever pin access plug (Fig. 21). Use square end of 1/4 in. drive extension to remove plug as shown.

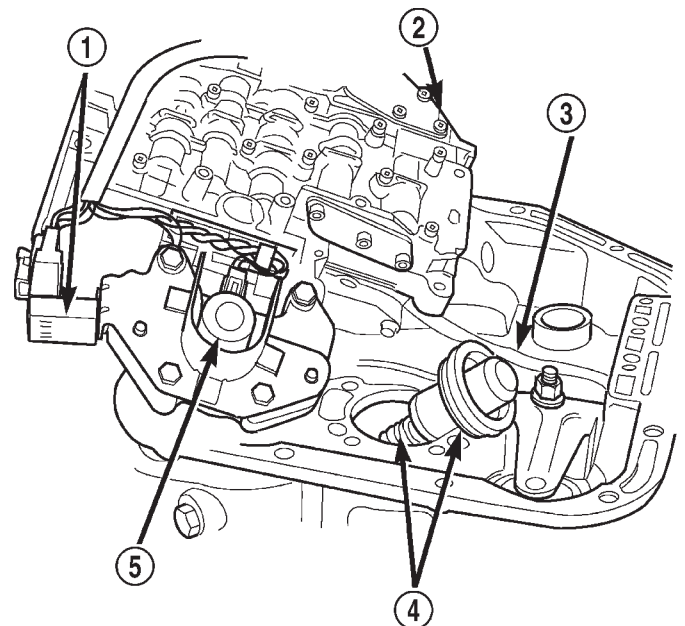
(13) Remove oil pump and reaction shaft support assembly as follows:



80c072b7

**Fig. 18 Valve Body Bolt Locations**

- 1 - VALVE BODY BOLTS
- 2 - VALVE BODY BOLTS

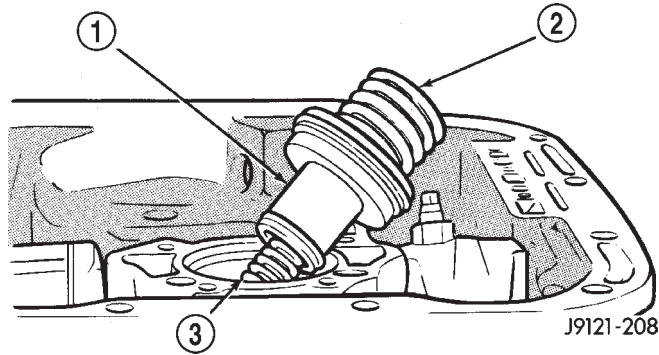


80c072b8

**Fig. 19 Valve Body Removal**

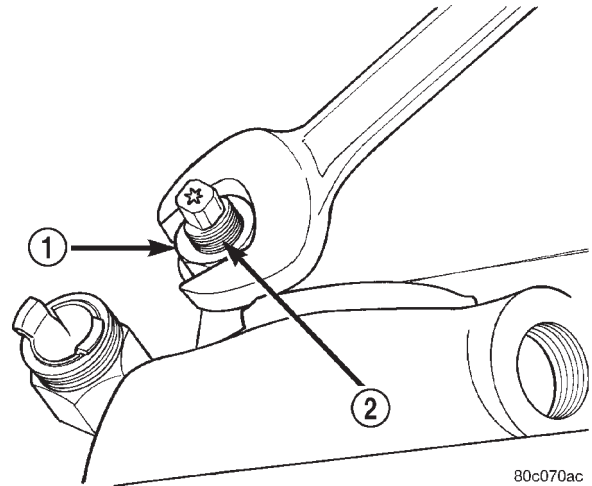
- 1 - GOVERNOR PRESSURE SENSOR
- 2 - VALVE BODY
- 3 - PARK ROD
- 4 - ACCUMULATOR PISTON
- 5 - GOVERNOR PRESSURE SOLENOID

AUTOMATIC TRANSMISSION - 47RE (Continued)



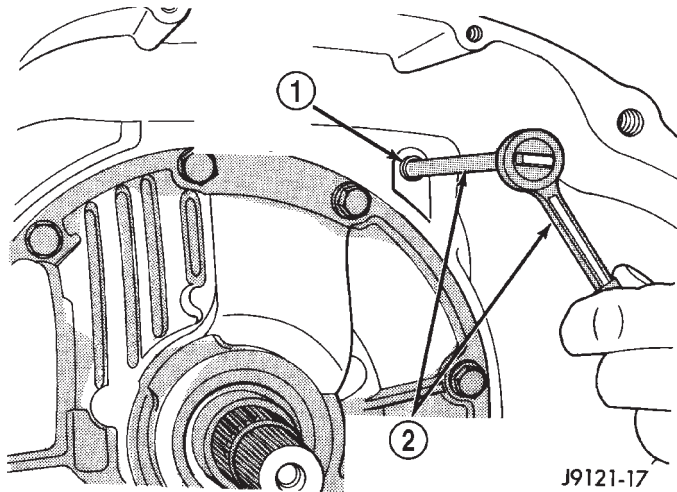
**Fig. 20 Accumulator Component Removal**

- 1 - ACCUMULATOR PISTON
- 2 - OUTER SPRING
- 3 - INNER SPRING



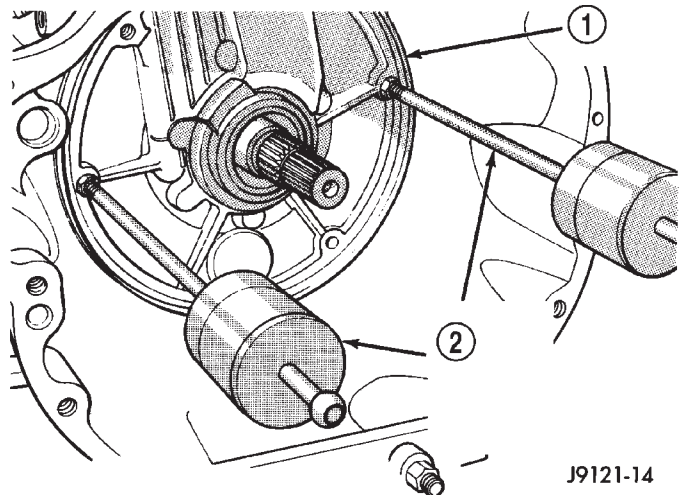
**Fig. 22 Tightening Front Band To Hold Front Clutch In Place**

- 1 - LOCK-NUT
- 2 - FRONT BAND ADJUSTER



**Fig. 21 Front Band Lever Pin Access Plug**

- 1 - FRONT BAND REACTION PIN ACCESS PLUG
- 2 - 1/4 DRIVE EXTENSION AND RATCHET



**Fig. 23 Oil Pump Removal Tools**

- 1 - PUMP HOUSING
- 2 - SLIDE HAMMER TOOLS (THREAD INTO PUMP HOUSING)

(a) Tighten front band adjusting screw until band is tight around front clutch retainer (Fig. 22). This will prevent retainer from coming out with pump and possibly damaging clutch or pump components.

(b) Remove oil pump bolts.

(c) Thread Slide Hammer Tools C-3752 into threaded holes in flange of oil pump housing (Fig. 23).



AUTOMATIC TRANSMISSION - 47RE (Continued)

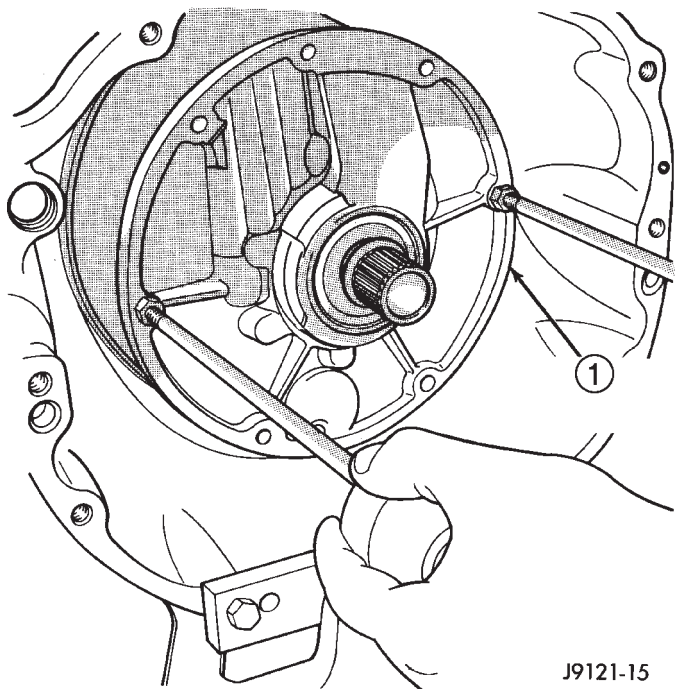
(d) Remove oil pump and reaction shaft support by bumping slide hammers outward alternately to pull pump from case (Fig. 24).

(14) Remove oil pump gasket (Fig. 25). Note gasket position in case for assembly reference.

(15) Loosen front band adjusting screw until band is completely loose.

(16) Remove front band strut and anchor (Fig. 26).

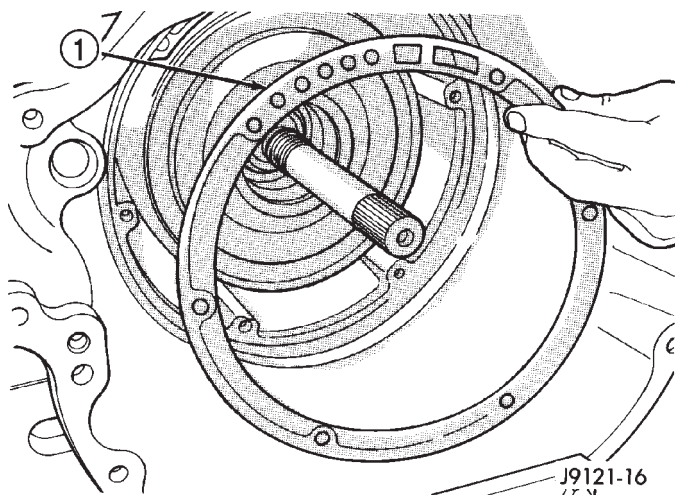
(17) Squeeze front band together slightly and slide band over front clutch retainer and out of case (Fig. 27).



J9121-15

**Fig. 24 Oil Pump Removal**

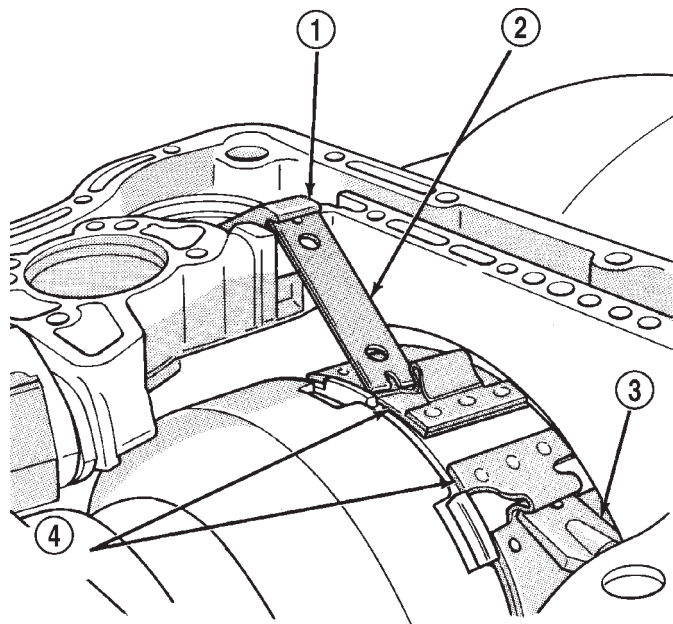
1 - OIL PUMP AND REACTION SHAFT SUPPORT



J9121-16

**Fig. 25 Oil Pump Gasket**

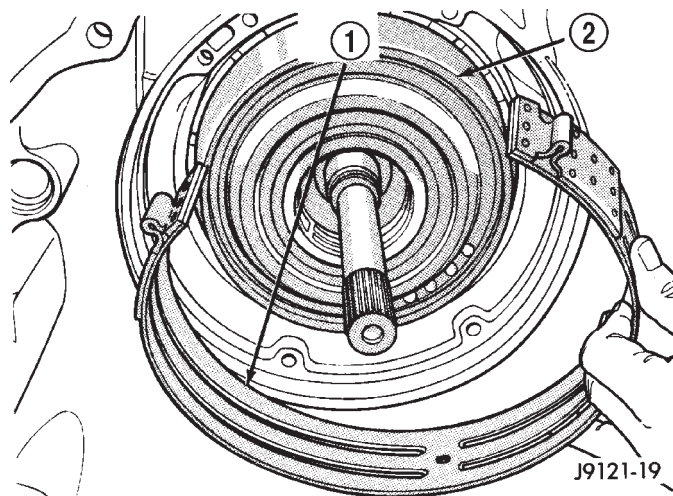
1 - OIL PUMP GASKET



J9121-18

**Fig. 26 Front Band Linkage**

1 - LEVER  
2 - STRUT  
3 - ANCHOR  
4 - FRONT BAND



J9121-19

**Fig. 27 Front Band Removal**

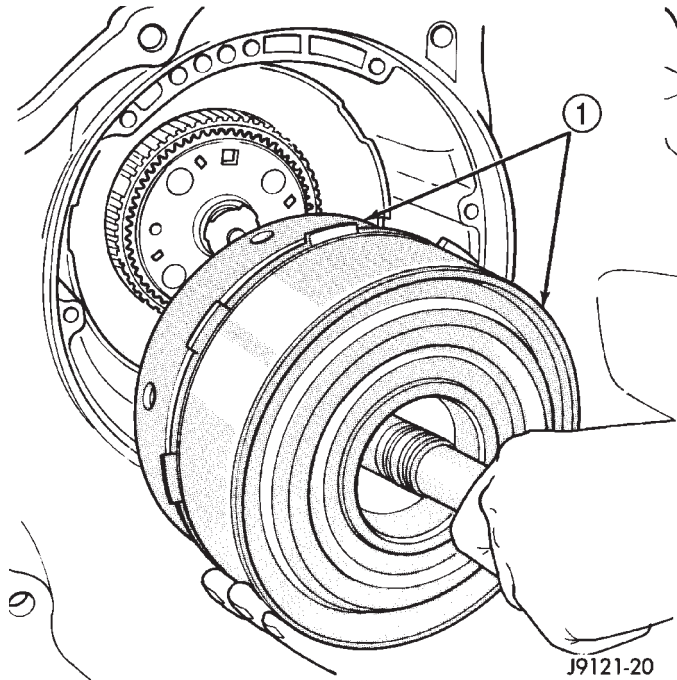
1 - FRONT BAND  
2 - FRONT CLUTCH RETAINER

AUTOMATIC TRANSMISSION - 47RE (Continued)

(18) Remove front and rear clutch assemblies as a unit (Fig. 28).

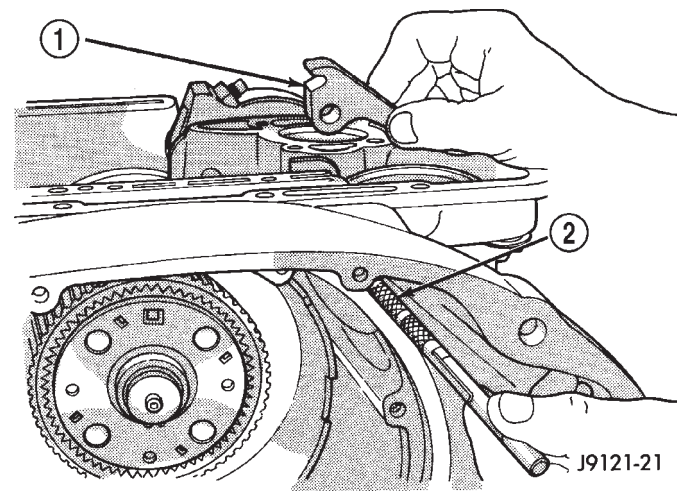
(19) Remove front band reaction pin and lever. Start pin through lever and out of case bore with drift or punch. Then use pencil magnet to withdraw pin completely (Fig. 29).

(20) Remove intermediate shaft thrust washer. Triangular shaped washer will either be on shaft pilot hub or in rear clutch retainer (Fig. 30).



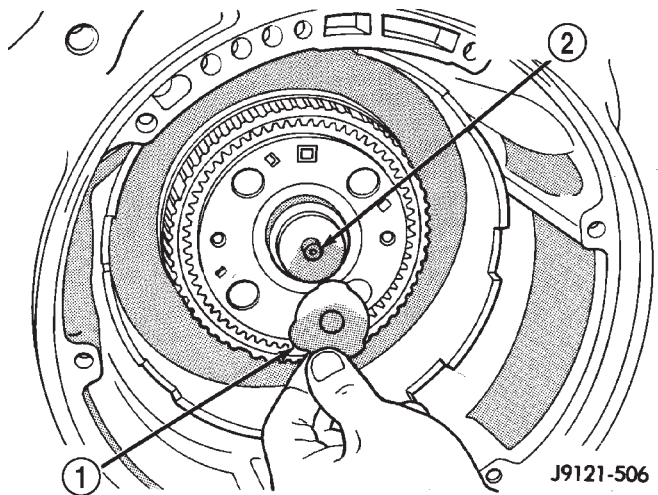
**Fig. 28 Removing Front/Rear Clutch Assemblies**

- 1 - FRONT AND REAR CLUTCH ASSEMBLIES



**Fig. 29 Front Band Lever And Pin**

- 1 - BAND LEVER
- 2 - USE PENCIL MAGNET TO REMOVE REACTION PIN



**Fig. 30 Intermediate Shaft Thrust Washer**

- 1 - THRUST WASHER
- 2 - INTERMEDIATE SHAFT PILOT HUB

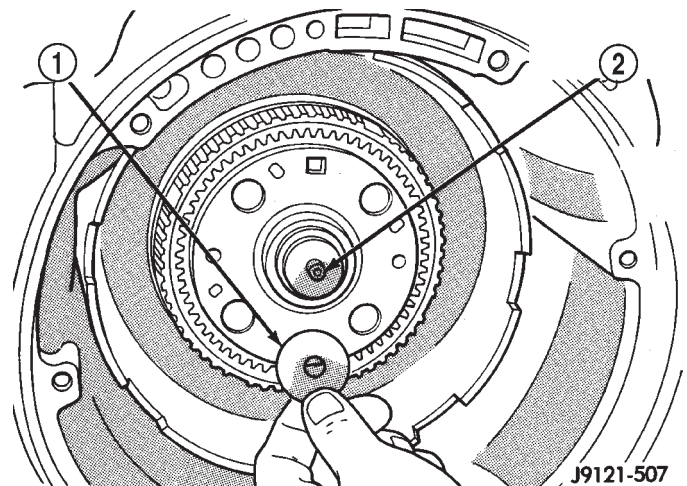
(21) Remove thrust plate from intermediate shaft hub (Fig. 31).

(22) Remove intermediate shaft-planetary geartrain assembly (Fig. 32).

(23) If overdrive unit is not to be serviced, install Alignment Shaft 6227-2 into the overdrive unit to prevent misalignment of the overdrive clutches during service of main transmission components.

(24) Loosen rear band locknut and loosen adjusting screw 3-4 turns.

(25) Remove snap-ring that retains low-reverse drum on overdrive piston retainer hub (Fig. 33).

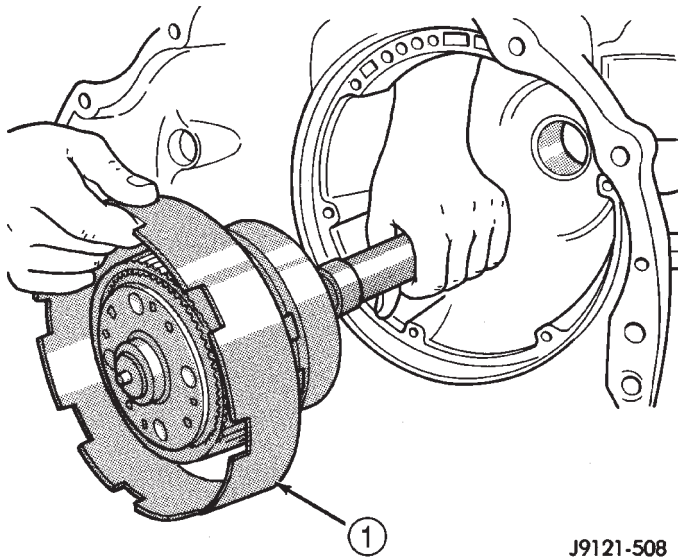


**Fig. 31 Intermediate Shaft Thrust Plate**

- 1 - SHAFT THRUST PLATE
- 2 - INTERMEDIATE SHAFT PILOT HUB



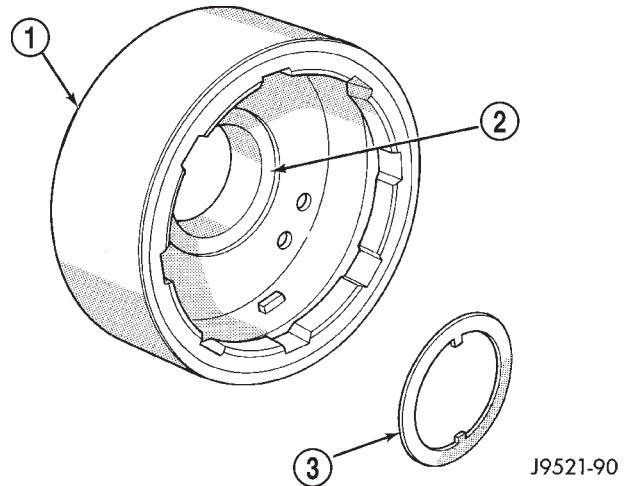
AUTOMATIC TRANSMISSION - 47RE (Continued)



J9121-508

**Fig. 32 Intermediate Shaft And Planetary Geartrain**

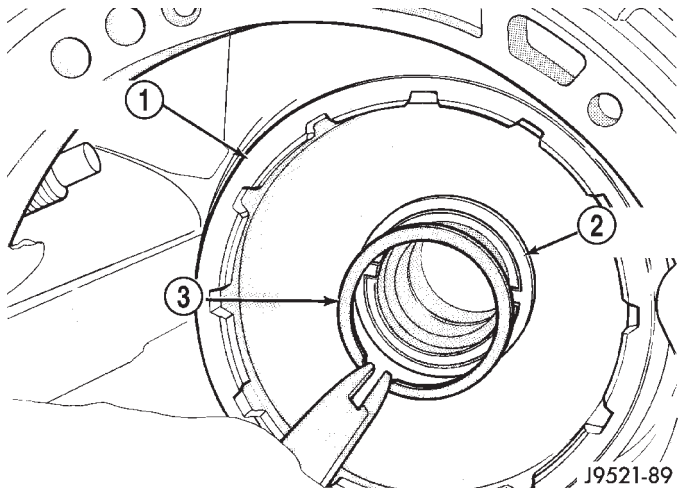
- 1 - INTERMEDIATE SHAFT AND PLANETARY GEAR TRAIN ASSEMBLY



J9521-90

**Fig. 34 Low-Reverse Drum And Thrust Washer**

- 1 - LOW-REVERSE DRUM
- 2 - SPOTFACE FOR WASHER
- 3 - THRUST WASHER



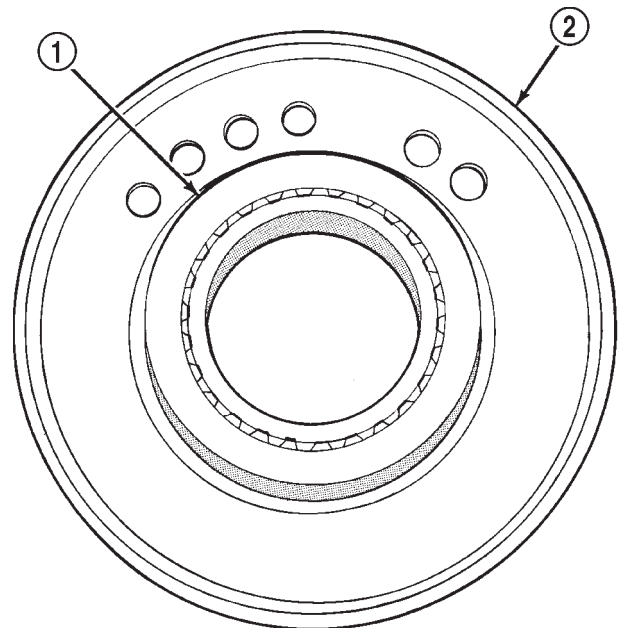
J9521-89

**Fig. 33 Low-Reverse Drum Snap-Ring**

- 1 - LOW-REVERSE DRUM
- 2 - TABBED WASHER
- 3 - SNAP-RING

(26) Slide low-reverse drum and thrust washer off piston retainer hub and out of rear band (Fig. 34).

(27) Note that overrunning clutch race will remain on splines of low-reverse drum after removal (Fig. 35). **The race is a permanent press fit on the hub splines. Do not attempt to remove the race.**



J9221-8

**Fig. 35 Overrunning Clutch Race Position On Low-Reverse Drum**

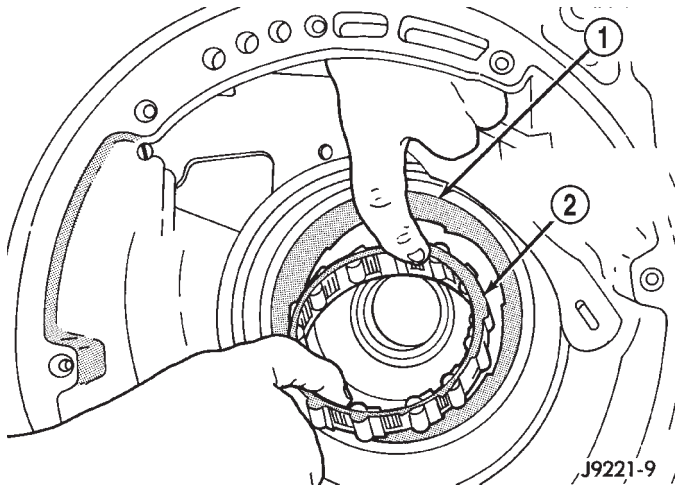
- 1 - OVERRUNNING CLUTCH RACE
- 2 - LOW-REVERSE DRUM

## AUTOMATIC TRANSMISSION - 47RE (Continued)

(28) Remove overrunning clutch assembly (Fig. 36). Assembly can be removed without displacing rollers and springs if care is exercised. Note position of rollers and springs for assembly reference.

(29) Remove rear band adjusting lever and reaction pin.

(30) Remove rear band.



**Fig. 36 Overrunning Clutch**

- 1 - CLUTCH CAM
- 2 - OVERRUNNING CLUTCH ASSEMBLY

(31) Compress front servo rod guide with large C-clamp and Tool C-4470, or Compressor Tool C-3422-B (Fig. 37). Compress guide only enough to permit snap-ring removal (about 1/8 in.).

(32) Remove servo piston snap-ring (Fig. 37). Unseat one end of ring. Then carefully work removal tool around back of ring until free of ring groove. **Exercise caution when removing snap-ring. Servo bore can be scratched or nicked if care is not exercised.**

(33) Remove tools and remove servo piston and spring.

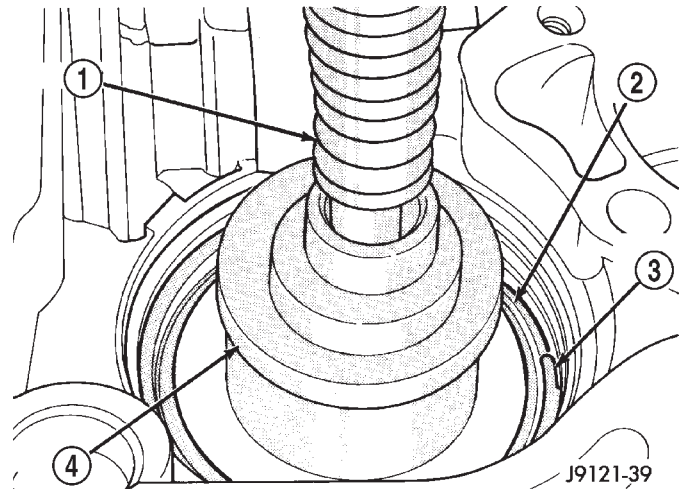
(34) Compress rear servo piston with C-clamp and Tool C-4470, or Valve Spring Compressor C-3422-B (Fig. 38). Compress servo spring retainer only enough to permit snap-ring removal.

(35) Remove servo piston snap-ring (Fig. 38). Start one end of ring out of bore. Then carefully work removal tool around back of snap-ring until free of ring groove. **Exercise caution when removing snap-ring. Servo bore can be scratched or nicked if care is not exercised.**

(36) Remove tools and remove rear servo retainer, spring and piston assembly.

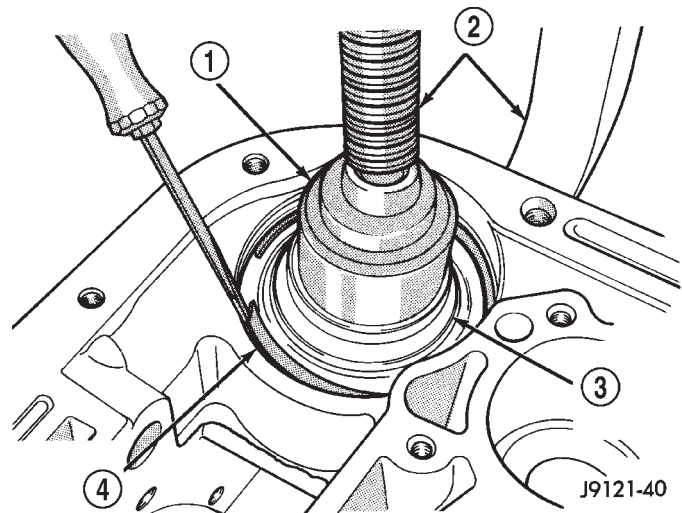
## CLEANING

Clean the case in a solvent tank. Flush the case bores and fluid passages thoroughly with solvent. Dry the case and all fluid passages with compressed



**Fig. 37 Front Servo Retaining Snap-Ring**

- 1 - C-CLAMP
- 2 - FRONT SERVO ROD GUIDE
- 3 - SNAP-RING
- 4 - TOOL C-4470



**Fig. 38 Rear Servo Retaining Snap-Ring**

- 1 - TOOL C-4470
- 2 - C-CLAMP
- 3 - REAR SERVO SPRING RETAINER
- 4 - RETAINER SNAP-RING

air. Be sure all solvent is removed from the case and that all fluid passages are clear.

**NOTE:** Do not use shop towels or rags to dry the case (or any other transmission component) unless they are made from lint-free materials. Lint will stick to case surfaces and transmission components and circulate throughout the transmission after assembly. A sufficient quantity of lint can block fluid passages and interfere with valve body operation.

## AUTOMATIC TRANSMISSION - 47RE (Continued)

Lubricate transmission parts with Mopar® ATF +4, type 9602, transmission fluid during overhaul and assembly. Use petroleum jelly, Mopar® Door Ease, or Ru-Glyde™ to prelubricate seals, O-rings, and thrust washers. Petroleum jelly can also be used to hold parts in place during reassembly.

**INSPECTION**

Inspect the case for cracks, porous spots, worn bores, or damaged threads. Damaged threads can be repaired with Helicoil thread inserts. However, the case will have to be replaced if it exhibits any type of damage or wear.

Lubricate the front band adjusting screw threads with petroleum jelly and thread the screw part-way into the case. Be sure the screw turns freely.

Inspect the transmission bushings during overhaul. Bushing condition is important as worn, scored bushings contribute to low pressures, clutch slip and accelerated wear of other components. However, do not replace bushings as a matter of course. Replace bushings only when they are actually worn, or scored.

Use recommended tools to replace bushings. The tools are sized and designed to remove, install, and seat bushings correctly. The bushing replacement tools are included in Bushing Tool Set C-3887-B.

Pre-sized service bushings are available for replacement purposes. Only the sun gear bushings are not serviced.

The use of crocus cloth is permissible where necessary, providing it is used carefully. When used on shafts, or valves, use extreme care to avoid rounding off sharp edges. Sharp edges are vital as they prevent foreign matter from getting between the valve and valve bore.

Do not reuse oil seals, gaskets, seal rings, or O-rings during overhaul. Replace these parts as a matter of course. Also do not reuse snap rings or E-clips that are bent or distorted. Replace these parts as well.

**ASSEMBLY**

Do not allow dirt, grease, or foreign material to enter the case or transmission components during assembly. Keep the transmission case and components clean. Also make sure the tools and workbench area used for reassembly operations are equally clean.

Shop towels used for wiping off tools and your hands must be made from **lint free** materials. Lint will stick to transmission parts and could interfere with valve operation or even restrict fluid passages.

Lubricate transmission clutch and gear components with Mopar® ATF +4, type 9602, during reassembly. Soak clutch discs in transmission fluid before installation.

Use Mopar® Door Ease, or Ru-Glyde™ on piston seals and o-rings to ease installation. Petroleum jelly can also be used to lubricate and hold thrust washers and plates in position during assembly.

**Do not use chassis grease, bearing grease, white grease, or similar lubricants on any part.** These types of lubricants can eventually block or restrict fluid passages and valve operation. Use petroleum jelly only.

Do not force parts into place. The transmission components and sub-assemblies are easily installed by hand when properly aligned. If a part seems difficult to install, it is either misaligned or incorrectly assembled. Verify that thrust washers, thrust plates and seal rings are correctly positioned.

The planetary geartrain, front/rear clutch assemblies and oil pump are all much easier to install when the transmission case is upright. Either tilt the case upward with wood blocks, or cut a hole in the bench large enough for the intermediate shaft and rear support. Then lower the shaft and support into the hole and support the rear of the case directly on the bench.

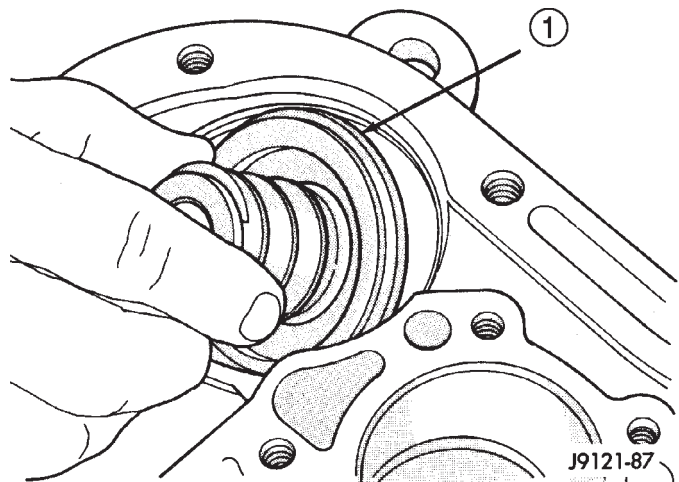
**FRONT/REAR SERVO**

(1) Lubricate rear servo piston seal with Mopar® Door Ease or ATF +4. Lubricate servo bore in case with ATF +4.

(2) Install rear servo piston in case. Position piston at slight angle to bore and insert piston with twisting motion (Fig. 39).

(3) Install rear servo spring and retainer in case bore (Fig. 40). Be sure spring is seated on piston.

(4) Compress rear servo piston with C-clamp or Valve Spring Compressor C-3422-B and install servo piston snap-ring (Fig. 41).



**Fig. 39 Rear Servo Piston**

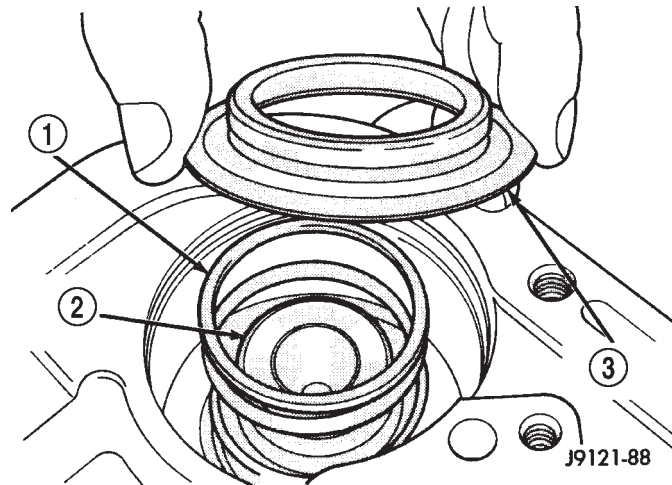
1 - REAR SERVO PISTON



AUTOMATIC TRANSMISSION - 47RE (Continued)

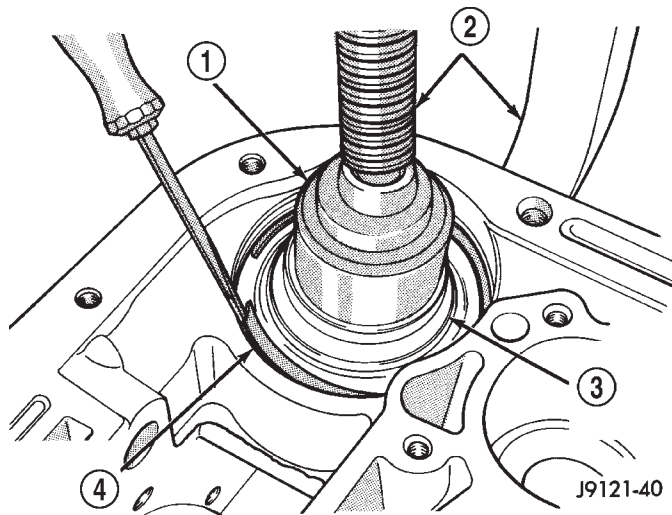
(5) Lubricate front servo piston components and servo bore in case with transmission fluid.

(6) Install front servo piston in bore. Carefully "run" small, suitable tool around piston ring to press it back into groove and ease installation (Fig. 42). Rotate piston into bore at same time. Rock piston slightly to ease piston ring past snap-ring groove and into bore.



**Fig. 40 Rear Servo Piston Spring And Retainer**

- 1 - PISTON SPRING
- 2 - REAR SERVO PISTON
- 3 - SPRING RETAINER

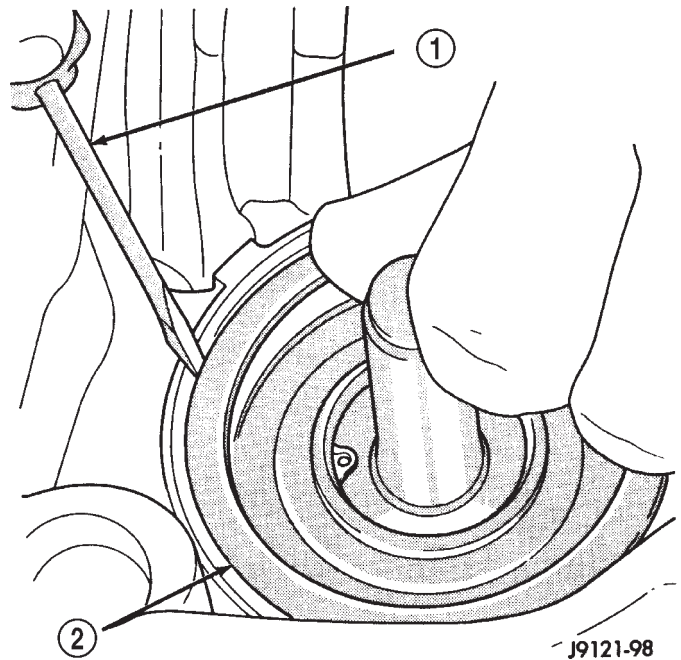


**Fig. 41 Rear Servo Snap-Ring**

- 1 - TOOL C-4470
- 2 - C-CLAMP
- 3 - REAR SERVO SPRING RETAINER
- 4 - RETAINER SNAP-RING

(7) Bottom front servo piston in bore and install servo spring.

(8) Install front servo piston rod guide as follows:



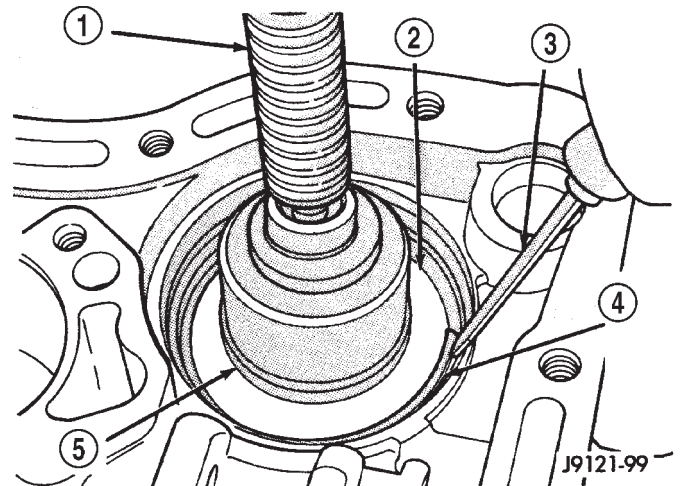
**Fig. 42 Front Servo Piston**

- 1 - USE SUITABLE TOOL TO HELP SEAT PISTON RING
- 2 - FRONT SERVO PISTON

(a) Place Tool SP-5560 (or similar size tool) on guide and position C-clamp on tool and case (Fig. 43).

(b) Slowly compress rod guide while simultaneously easing seal ring into bore with suitable tool.

(9) Install rod guide snap-ring (Fig. 43).



**Fig. 43 Front Servo Rod Guide And Snap-Ring**

- 1 - C-CLAMP
- 2 - ROD GUIDE
- 3 - SMALL SCREWDRIVER
- 4 - ROD GUIDE SNAP-RING
- 5 - TOOL SP-5560

## AUTOMATIC TRANSMISSION - 47RE (Continued)

**OVERRUNNING CLUTCH, REAR BAND, AND LOW-REVERSE DRUM**

(1) Install overrunning clutch components if not yet installed.

(2) Position rear band reaction pin and band in case. Be sure that the twin lugs on the band are seated against the reaction pin.

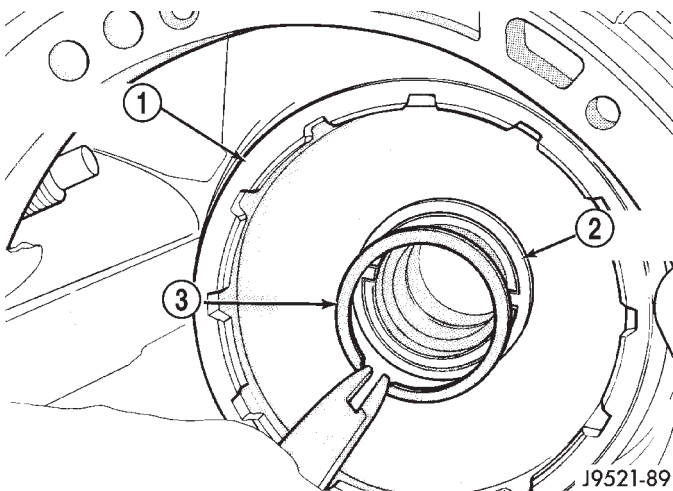
(3) Install low-reverse drum. Slide drum through rear band, onto piston retainer hub and into engagement with overrunning clutch and race.

(4) Install thrust washer in low-reverse drum spot-face (Fig. 44). Use petroleum jelly to hold washer in place.

(5) Install snap-ring that secures low-reverse drum to piston retainer hub (Fig. 44).

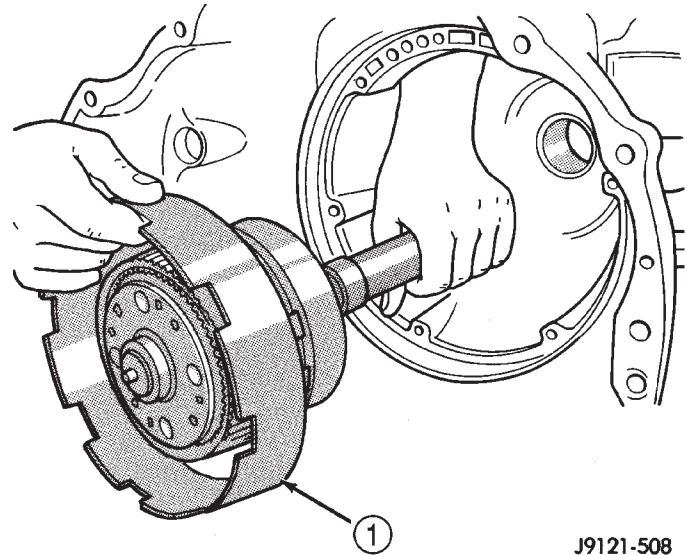
(6) Insert the rear band pivot pin part way into the case.

(7) Install rear band adjusting lever and pivot pin. Be sure lever and the single lug on the band are aligned and engaged before seating band pivot pin in case.



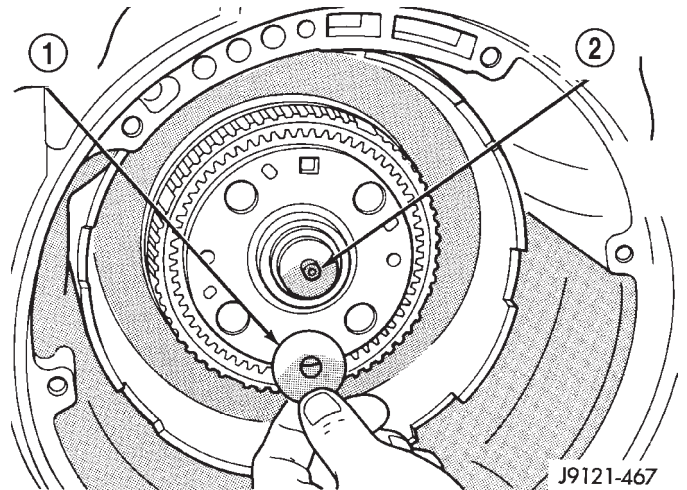
**Fig. 44 Low-Reverse Drum Snap-Ring**

- 1 - LOW-REVERSE DRUM
- 2 - TABBED WASHER
- 3 - SNAP-RING



**Fig. 45 Intermediate Shaft And Planetary Geartrain**

- 1 - INTERMEDIATE SHAFT AND PLANETARY GEAR TRAIN ASSEMBLY



**Fig. 46 Intermediate Shaft Thrust Plate**

- 1 - SHAFT THRUST PLATE
- 2 - INTERMEDIATE SHAFT PILOT HUB

**PLANETARY GEARTRAIN, FRONT/REAR CLUTCH, AND FRONT BAND**

(1) Remove Alignment Shaft 6227-2, if installed previously.

(2) Install assembled intermediate shaft and planetary geartrain (Fig. 45). **Support shaft carefully during installation. Do not allow shaft bearing/bushing surfaces to become nicked or scratched.**

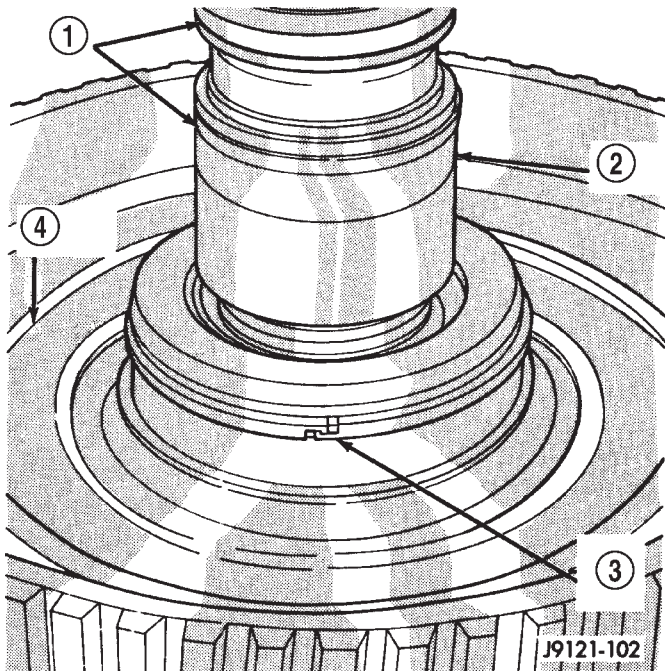
(3) Lubricate intermediate shaft thrust plate with petroleum jelly and install plate on shaft pilot hub (Fig. 46).



## AUTOMATIC TRANSMISSION - 47RE (Continued)

(4) Check input shaft front seal rings, fiber thrust washer and rear seal ring (Fig. 47). Be ends of rear seal ring are hooked together and diagonal cut ends of front seal rings are firmly seated against each other as shown. Lubricate seal rings with petroleum jelly after checking them.

(5) Assemble front and rear clutches (Fig. 48). Align lugs on front clutch discs. Mount front clutch on rear clutch. Turn front clutch retainer back and forth until front clutch discs are fully seated on rear clutch splined hub.

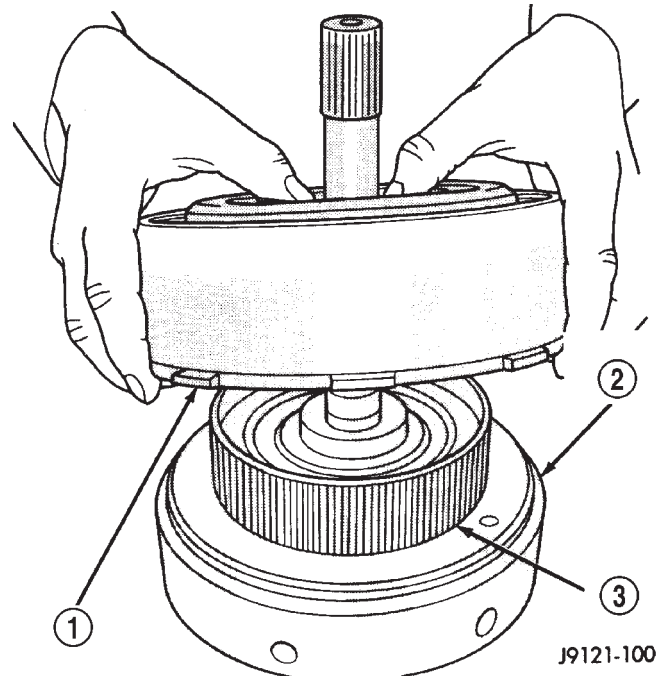


**Fig. 47 Input Shaft Seal Rings And Thrust Washer**

- 1 - TORLON® FRONT SEAL RINGS
- 2 - INPUT SHAFT
- 3 - REAR SEAL RING
- 4 - THRUST WASHER

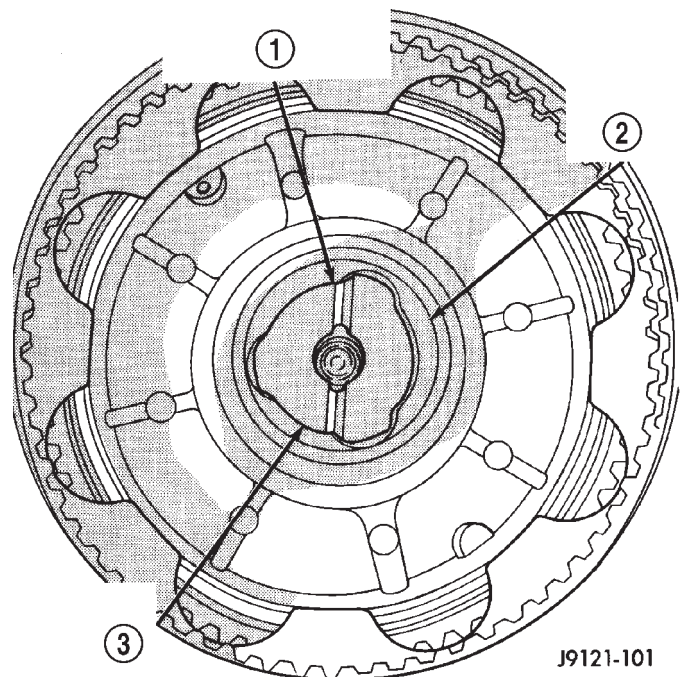
(6) Install intermediate shaft thrust washer in hub of rear clutch retainer (Fig. 49). Use petroleum jelly to hold washer in place. Position washer so grooves are facing outward. **Washer only fits one way in clutch retainer hub.**

(7) Place transmission case in upright position, or place blocks under front end of transmission repair stand to tilt case rearward. This makes it easier to install front/rear clutch assembly.



**Fig. 48 Assembling Front And Rear Clutches**

- 1 - FRONT CLUTCH ASSEMBLY
- 2 - REAR CLUTCH ASSEMBLY
- 3 - REAR CLUTCH SPLINED HUB



**Fig. 49 Intermediate Shaft Thrust Washer**

- 1 - BE SURE WASHER GROOVES FACE OUT AS SHOWN
- 2 - REAR CLUTCH RETAINER HUB
- 3 - OUTPUT SHAFT THRUST WASHER

## AUTOMATIC TRANSMISSION - 47RE (Continued)

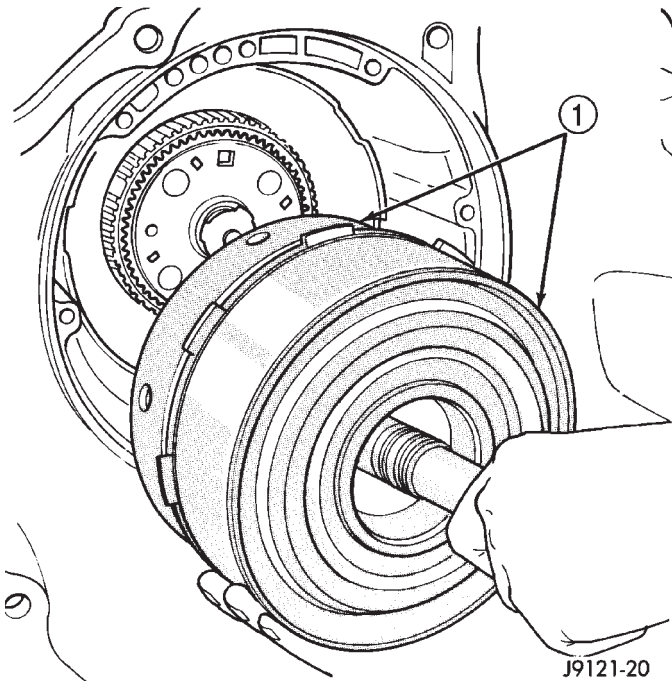
(8) Align discs in rear clutch. Then install and engage assembly in front planetary and driving shell (Fig. 50). Turn clutch retainers back and forth until both clutches are seated.

(9) Position front band lever in case and over servo rod guide. Then install front band lever pin in case and slide it through lever.

(10) Coat threads of front band pin access plug with sealer and install it in case. Tighten plug to 17 N·m (13 ft. lbs.) torque.

(11) Slide front band over front clutch retainer and install front band strut and anchor (Fig. 51).

(12) Tighten front band adjusting screw until band is tight on clutch retainer. This will hold clutches in place while oil pump is being installed. **Verify that front/rear clutch assembly is still properly seated before tightening band.**



J9121-20

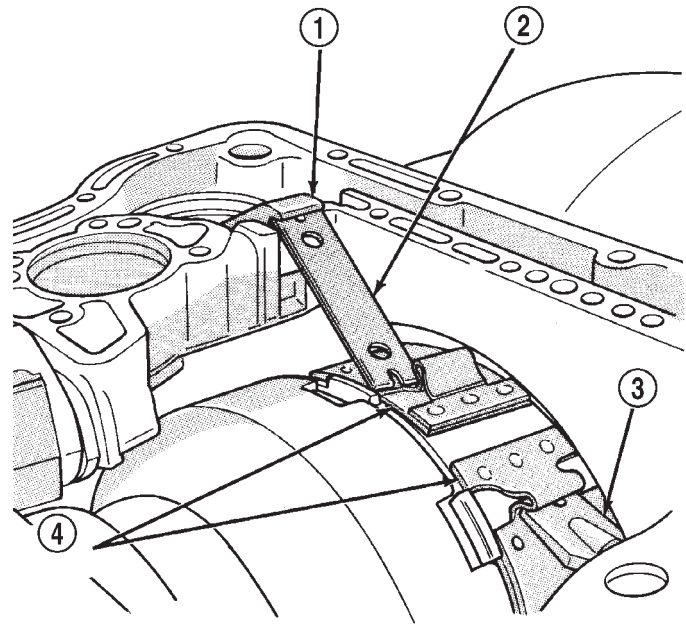
**Fig. 50 Front/Rear Clutch Assemblies**

1 - FRONT AND REAR CLUTCH ASSEMBLIES

## OIL PUMP

(1) Install oil pump Pilot Studs C-3288-B in case (Fig. 52).

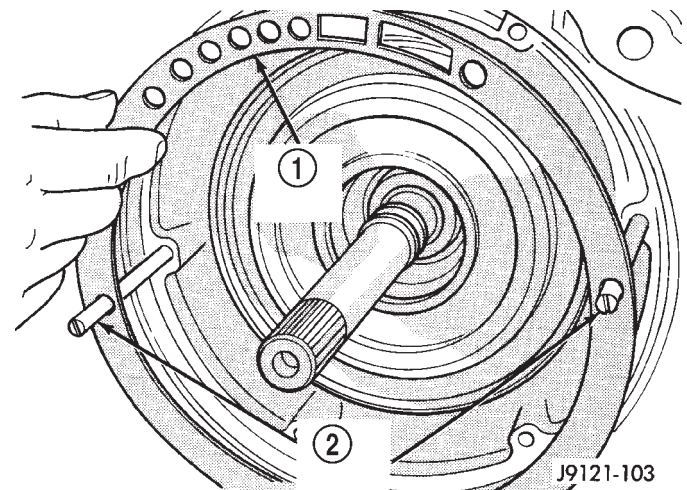
(2) Install new oil pump gasket on pilot studs and seat it in case. Be sure gasket is properly aligned with fluid passages in case (Fig. 52).



J9121-18

**Fig. 51 Front Band And Linkage**

1 - LEVER  
2 - STRUT  
3 - ANCHOR  
4 - FRONT BAND



J9121-103

**Fig. 52 Oil Pump Gasket And Pilot Studs**

1 - OIL PUMP GASKET  
2 - PILOT STUDS C-3288-B



## AUTOMATIC TRANSMISSION - 47RE (Continued)

(3) Coat front clutch thrust washer with petroleum jelly to hold it in place. Then install washer over reaction shaft hub and seat it on pump (Fig. 53).

**CAUTION:** The thrust washer bore (I.D.), is chamfered on one side. Make sure the chamfered side is installed so it faces the pump.

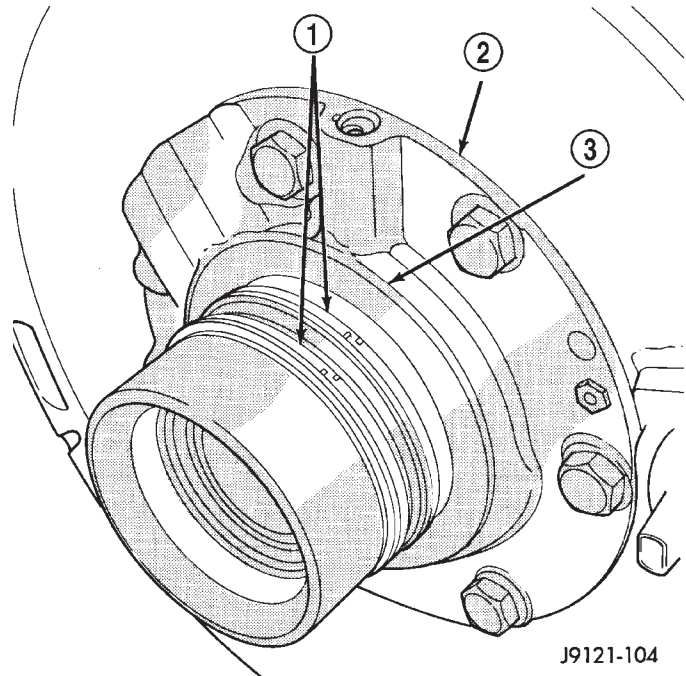
(4) Check seal rings on reaction shaft support. Be sure rings are hooked together correctly. Also be sure fiber thrust washer is in position (Fig. 54). Use extra petroleum jelly to hold washer in place if necessary.

(5) Lubricate oil pump seals with petroleum Mopar® ATF +4, type 9602.

(6) Mount oil pump on pilot studs and slide pump into case opening (Fig. 55). **Work pump into case by hand. Do not use a mallet or similar tools to seat pump.**

(7) Remove pilot studs and install oil pump bolts. Tighten pump bolts alternately and evenly to fully seat pump in case. Then final-tighten pump bolts to 20 N·m (15 ft. lbs.) torque.

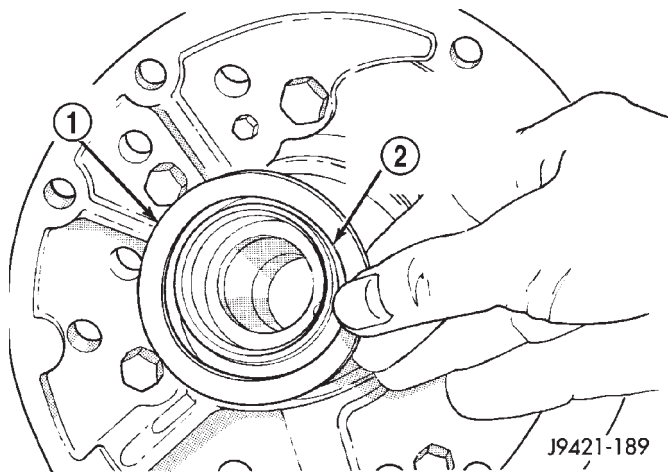
(8) Verify correct installation. Rotate input and intermediate shafts and check for bind. If bind exists, components are either mis-assembled, or not seated. Disassemble and correct as necessary before proceeding.



J9121-104

**Fig. 54 Reaction Shaft Seal Ring And Thrust Washer**

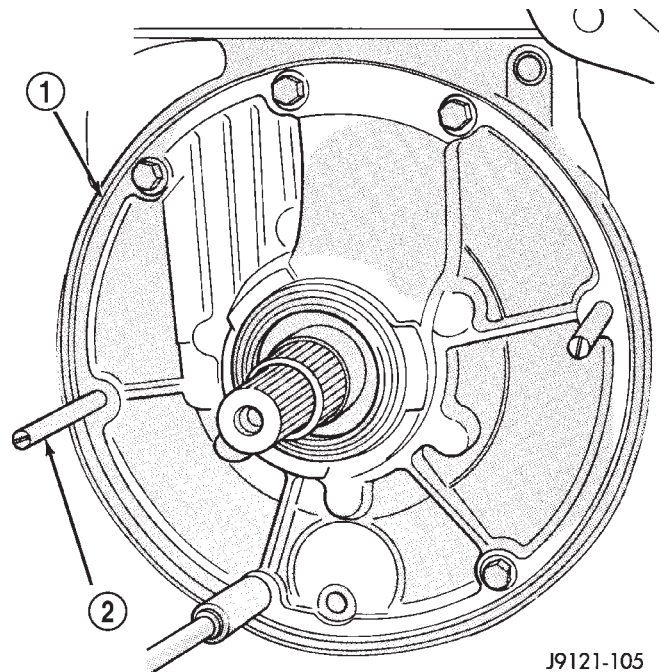
- 1 - SEAL RINGS
- 2 - REACTION SHAFT SUPPORT
- 3 - THRUST WASHER (FIBER)



J9421-189

**Fig. 53 Front Clutch Thrust Washer**

- 1 - THRUST WASHER
- 2 - CHAMFERED SIDE OF WASHER BORE GOES TOWARD PUMP



J9121-105

**Fig. 55 Oil Pump**

- 1 - SEAT OIL PUMP IN CASE BY HAND
- 2 - REMOVE PILOT STUDS WHEN PUMP IS SEATED

## AUTOMATIC TRANSMISSION - 47RE (Continued)

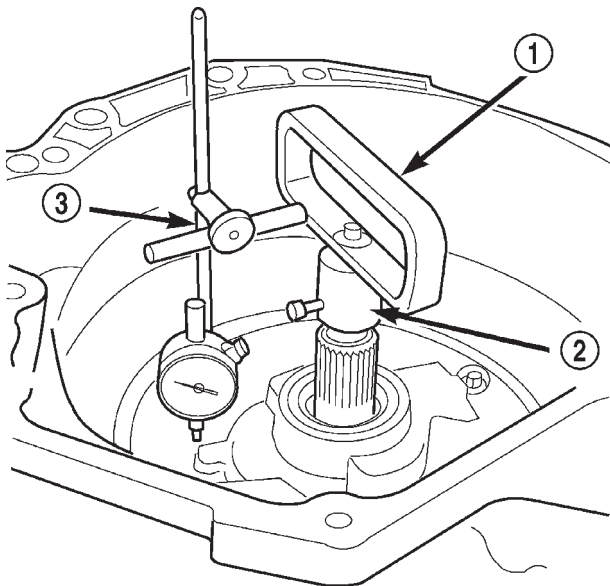
## INPUT SHAFT END PLAY CHECK

**NOTE:** Overdrive unit must be installed in order to correctly measure the input shaft end-play.

- (1) Measure input shaft end play (Fig. 56).

**NOTE:** If end play is incorrect, transmission is incorrectly assembled, or reaction shaft thrust washer is incorrect. The reaction shaft thrust washer is selective.

- (a) Attach Adapter 8266-5 to Handle 8266-8.
- (b) Attach dial indicator C-3339 to Handle 8266-8.
- (c) Install the assembled tool onto the input shaft of the transmission and tighten the retaining screw on Adapter 8266-5 to secure it to the input shaft.
- (d) Position the dial indicator plunger against a flat spot on the oil pump and zero the dial indicator.
- (e) Move input shaft in and out and record reading. End play should be 0.86 - 2.13 mm (0.034 - 0.084 in.). Adjust as necessary.



80c070b4

**Fig. 56 Checking Input Shaft End Play**

- 1 - TOOL 8266-8  
2 - TOOL 8266-5  
3 - TOOL C-3339

## ACCUMULATOR, VALVE BODY, OIL PAN, AND TORQUE CONVERTER

- (1) Install accumulator inner spring, piston and outer spring (Fig. 57).

- (2) Verify that park/neutral position switch has **not** been installed in case. Valve body can not be installed if switch is in position.

- (3) Install new valve body manual shaft seal in case (Fig. 58). Lubricate seal lip and manual shaft with petroleum jelly. Start seal over shaft and into case. Seat seal with 15/16 inch, deep well socket.

- (4) Install valve body as follows:

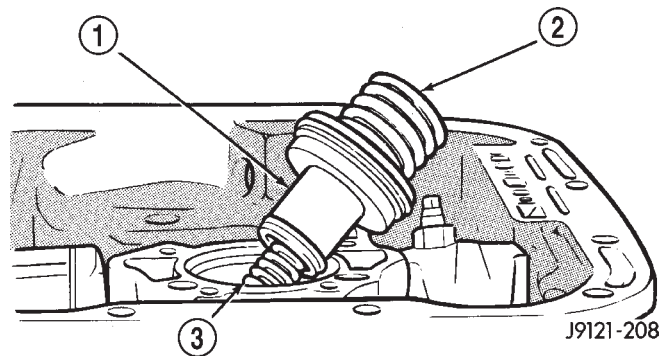
- (a) Start park rod into park pawl. If rod will not slide past park pawl, pawl is engaged in park gear. Rotate overdrive output shaft with suitable size 12 point socket; this will free pawl and allow rod to engage.

- (b) Align and seat valve body on case. Be sure manual lever shaft and overdrive connector are fully seated in case.

- (c) Install and start all valve body attaching bolts by hand. Then tighten bolts evenly, in a diagonal pattern to 12 N·m (105 in. lbs.) torque. **Do not overtighten valve body bolts. This could result in distortion and cross leakage after installation.**

- (5) Install new filter on valve body. Tighten filter screws to 4 N·m (35 in. lbs.).

- (6) Install seal on park/neutral position switch. Then install and tighten switch to 34 N·m (25 ft. lbs.).



J9121-208

**Fig. 57 Accumulator Piston And Springs**

- 1 - ACCUMULATOR PISTON  
2 - OUTER SPRING  
3 - INNER SPRING

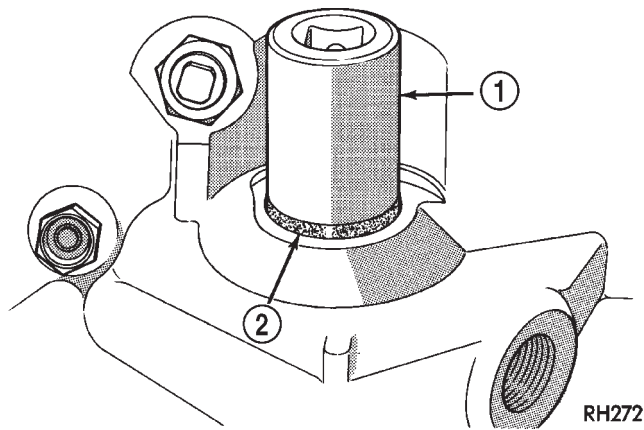
**CAUTION:** If the condition of the transmission before the overhaul procedure caused excessive metallic or fiber contamination in the fluid, replace the torque converter and reverse flush the cooler(s) and cooler lines. Fluid contamination and transmission failure can result if not done.

- (7) Install torque converter. Use C-clamp or metal strap to hold converter in place for installation.

## BAND ADJUSTMENT AND FINAL

- (1) Adjust front and rear bands as follows:

## AUTOMATIC TRANSMISSION - 47RE (Continued)



**Fig. 58 Manual Lever Shaft Seal**

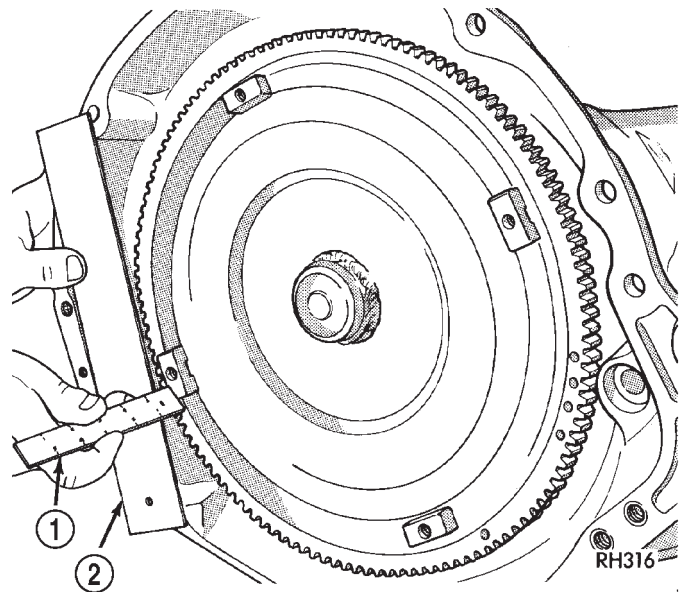
- 1 - 15/16" SOCKET  
2 - SEAL

- (a) Loosen locknut on each band adjusting screw 4-5 turns.
- (b) Tighten both adjusting screws to 8 N·m (72 in. lbs.).
- (c) Back off front band adjusting screw 1-7/8 turns.
- (d) Back off rear band adjusting screw 3 turns.
- (e) Hold each adjusting screw in position and tighten locknut to 34 N·m (25 ft. lbs.) torque.
- (2) Install magnet in oil pan. Magnet seats on small protrusion at corner of pan.
- (3) Position new oil pan gasket on case and install oil pan. Tighten pan bolts to 17 N·m (13 ft. lbs.).
- (4) Install throttle valve and shift selector levers on valve body manual lever shaft.
- (5) Apply small quantity of dielectric grease to terminal pins of solenoid case connector and neutral switch.
- (6) Fill transmission with recommended fluid.

## INSTALLATION

- (1) Check torque converter hub and hub drive notches for sharp edges burrs, scratches, or nicks. Polish the hub and notches with 320/400 grit paper and crocus cloth if necessary. The hub must be smooth to avoid damaging pump seal at installation.
- (2) Lubricate pocket in the rear oil pump seal lip with transmission fluid.
- (3) Lubricate converter pilot hub of the crankshaft with a light coating of Mopar® High Temp Grease.
- (4) Align and install converter in oil pump.
- (5) Carefully insert converter in oil pump. Then rotate converter back and forth until fully seated in pump gears.
- (6) Check converter seating with steel scale and straightedge (Fig. 59). Surface of converter lugs should be 19mm (0.75 in.) to the rear of straightedge when the converter is fully seated.

- (7) Temporarily secure converter with C-clamp.



**Fig. 59 Checking Converter Seating - Typical**

- 1 - SCALE  
2 - STRAIGHTEDGE

- (8) Position transmission on jack and secure it with chains.
- (9) Check condition of converter driveplate. Replace the plate if cracked, distorted or damaged. **Also be sure transmission dowel pins are seated in engine block and protrude far enough to hold transmission in alignment.**
- (10) Raise transmission and align converter with drive plate and converter housing with engine block.
- (11) Move transmission forward. Then raise, lower or tilt transmission to align converter housing with engine block dowels.
- (12) Carefully work transmission forward and over engine block dowels until converter hub is seated in crankshaft.
- (13) Install bolts attaching converter housing to engine.
- (14) Install rear support. Then lower transmission onto crossmember and install bolts attaching transmission mount to crossmember.
- (15) Remove engine support fixture.
- (16) Install crankshaft position sensor. (Refer to 14 - FUEL SYSTEM/FUEL INJECTION/CRANKSHAFT POSITION SENSOR - INSTALLATION)
- (17) Install new plastic retainer grommet on any shift linkage rod or lever that was disconnected. Grommets should not be reused. Use pry tool to remove rod from grommet and cut away old grommet. Use pliers to snap new grommet into lever and to snap rod into grommet at assembly.



## AUTOMATIC TRANSMISSION - 47RE (Continued)

(18) Connect gearshift and throttle cable to transmission.

(19) Connect wires to park/neutral position switch, transmission solenoid(s) and oxygen sensor. Be sure transmission harnesses are properly routed.

**CAUTION: It is essential that correct length bolts be used to attach the converter to the driveplate. Bolts that are too long will damage the clutch surface inside the converter.**

(20) Install torque converter-to-driveplate bolts. Tighten bolts to 47 N·m (35 ft. lbs.).

(21) Install converter housing access cover.

(22) Install starter motor and cooler line bracket. (Refer to 8 - ELECTRICAL/STARTING/STARTER MOTOR - INSTALLATION)

(23) Connect cooler lines to transmission.

(24) Install transmission fill tube. Install new seal on tube before installation.

(25) Install exhaust components.

(26) Align and connect propeller shaft. (Refer to 3 - DIFFERENTIAL & DRIVELINE/PROPELLER SHAFT/PROPELLER SHAFT - INSTALLATION)

(27) Adjust gearshift linkage and throttle valve cable if necessary.

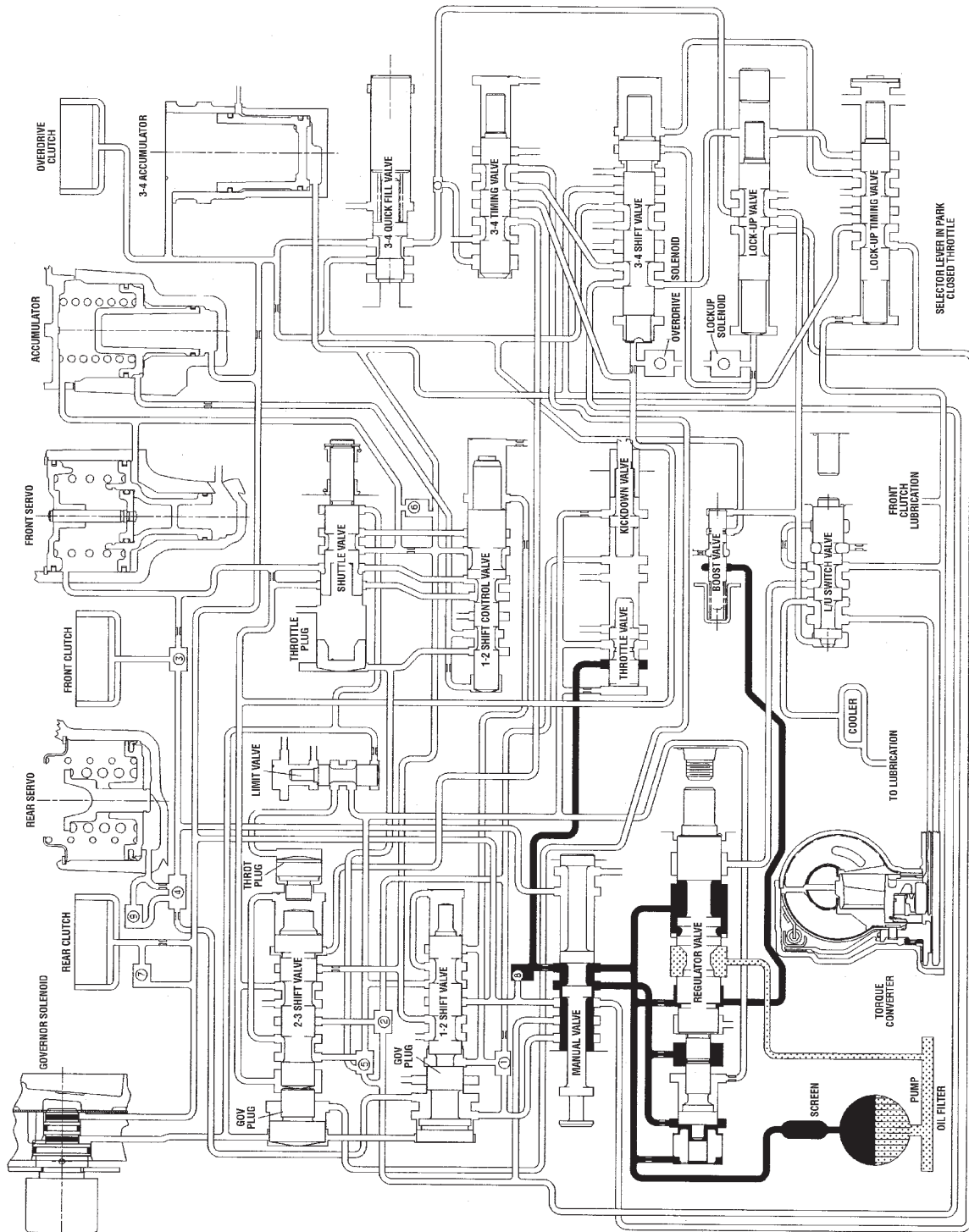
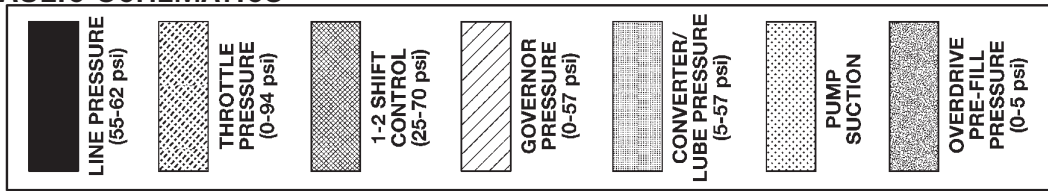
(28) Lower vehicle.

(29) Fill transmission with Mopar® ATF +4, type 9602, Automatic Transmission fluid.

AUTOMATIC TRANSMISSION - 47RE (Continued)

SCHEMATICS AND DIAGRAMS

HYDRAULIC SCHEMATICS

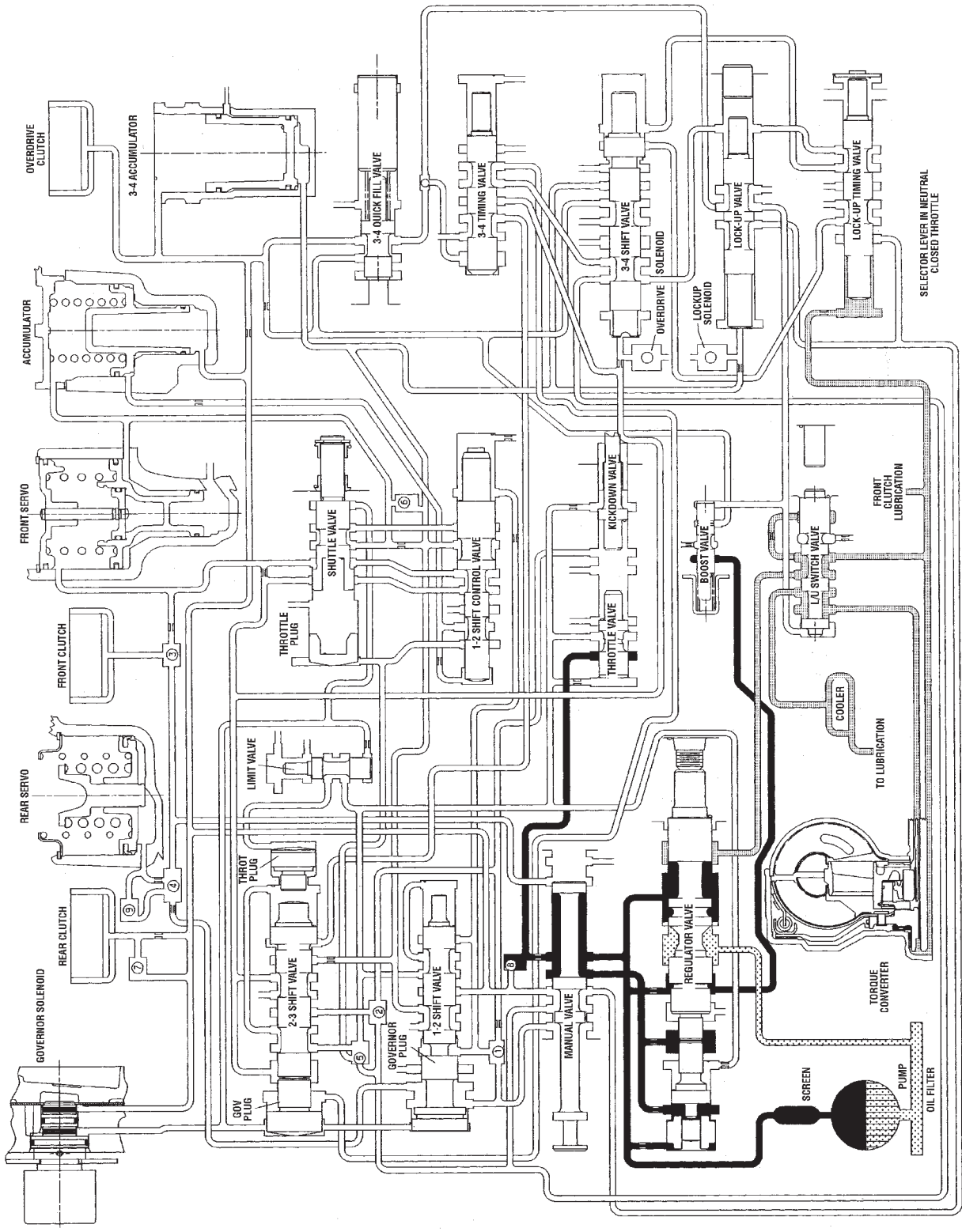
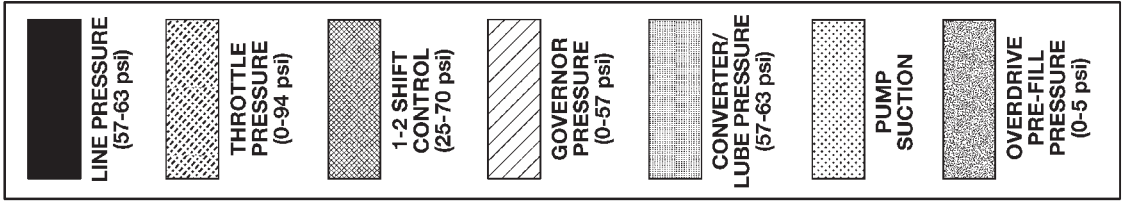


80860593

HYDRAULIC FLOW IN PARK

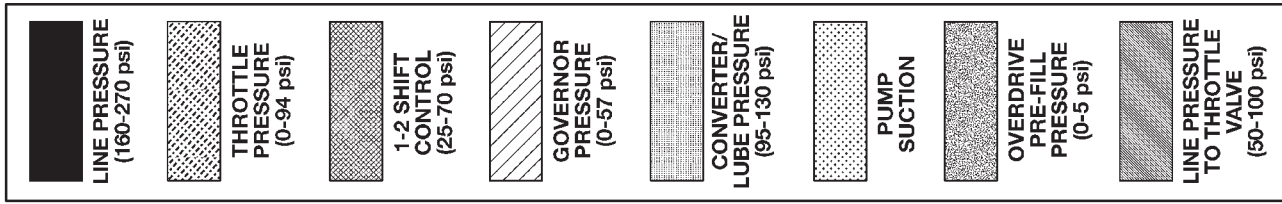
AUTOMATIC TRANSMISSION - 47RE (Continued)

80860594

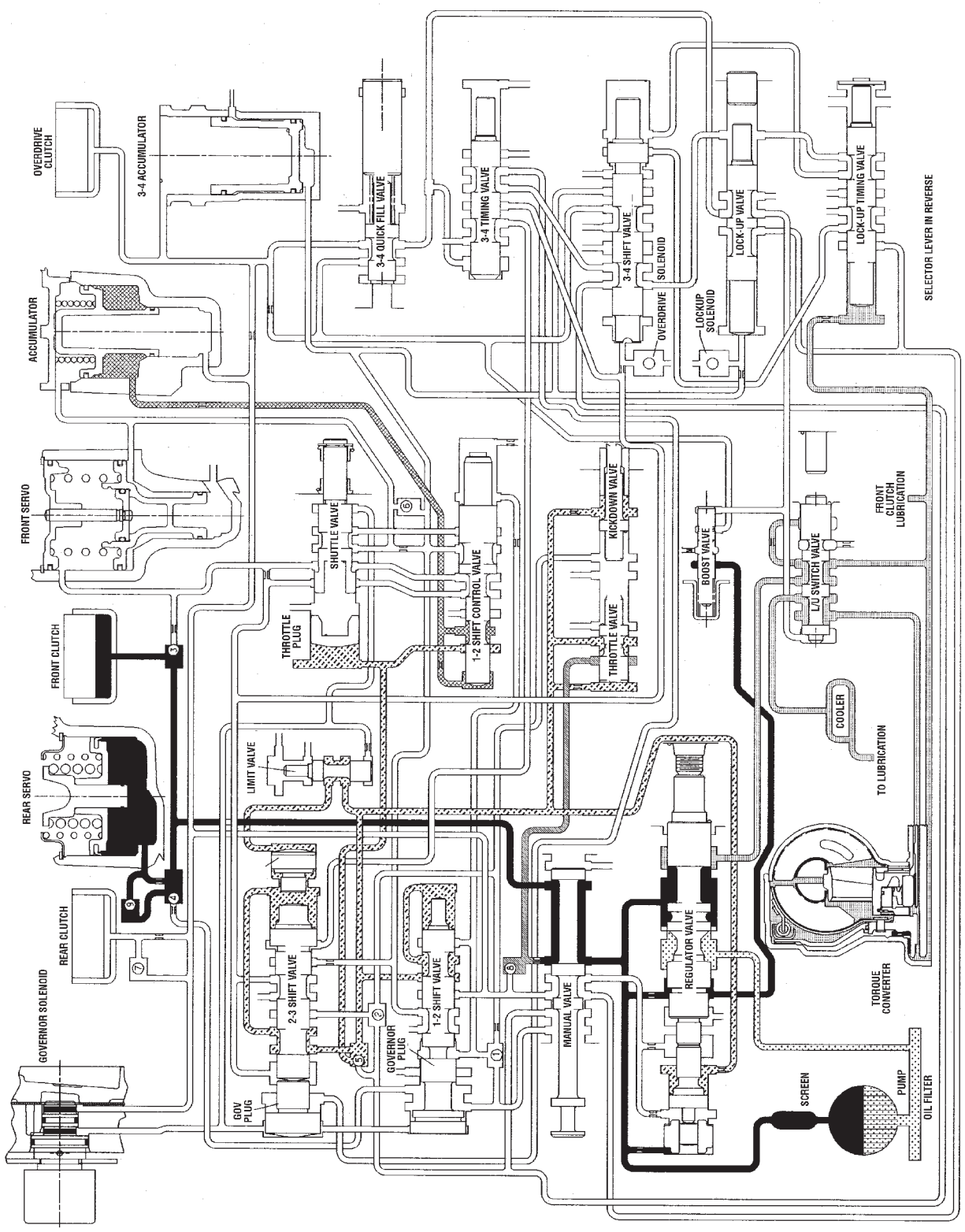


HYDRAULIC FLOW IN NEUTRAL

AUTOMATIC TRANSMISSION - 47RE (Continued)



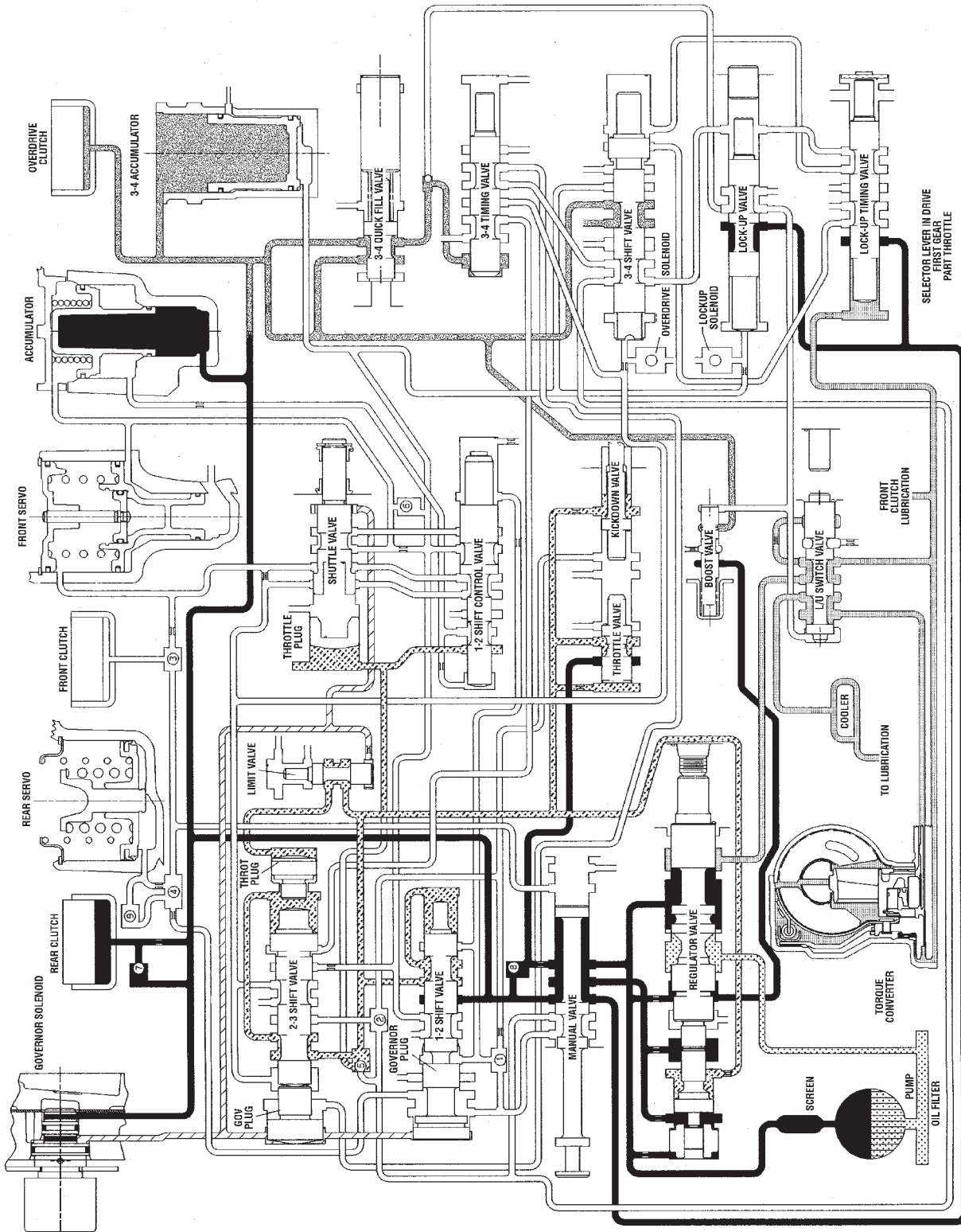
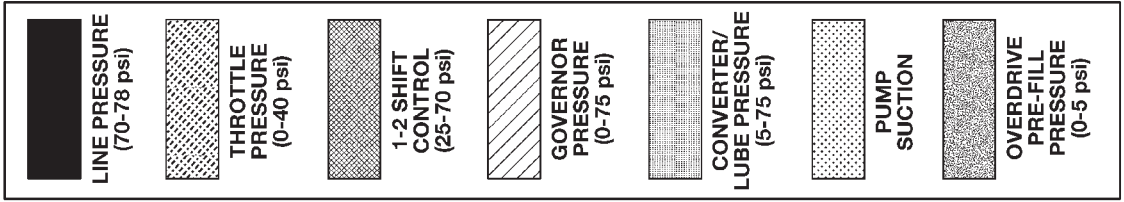
80880595



HYDRAULIC FLOW IN REVERSE

AUTOMATIC TRANSMISSION - 47RE (Continued)

80880596

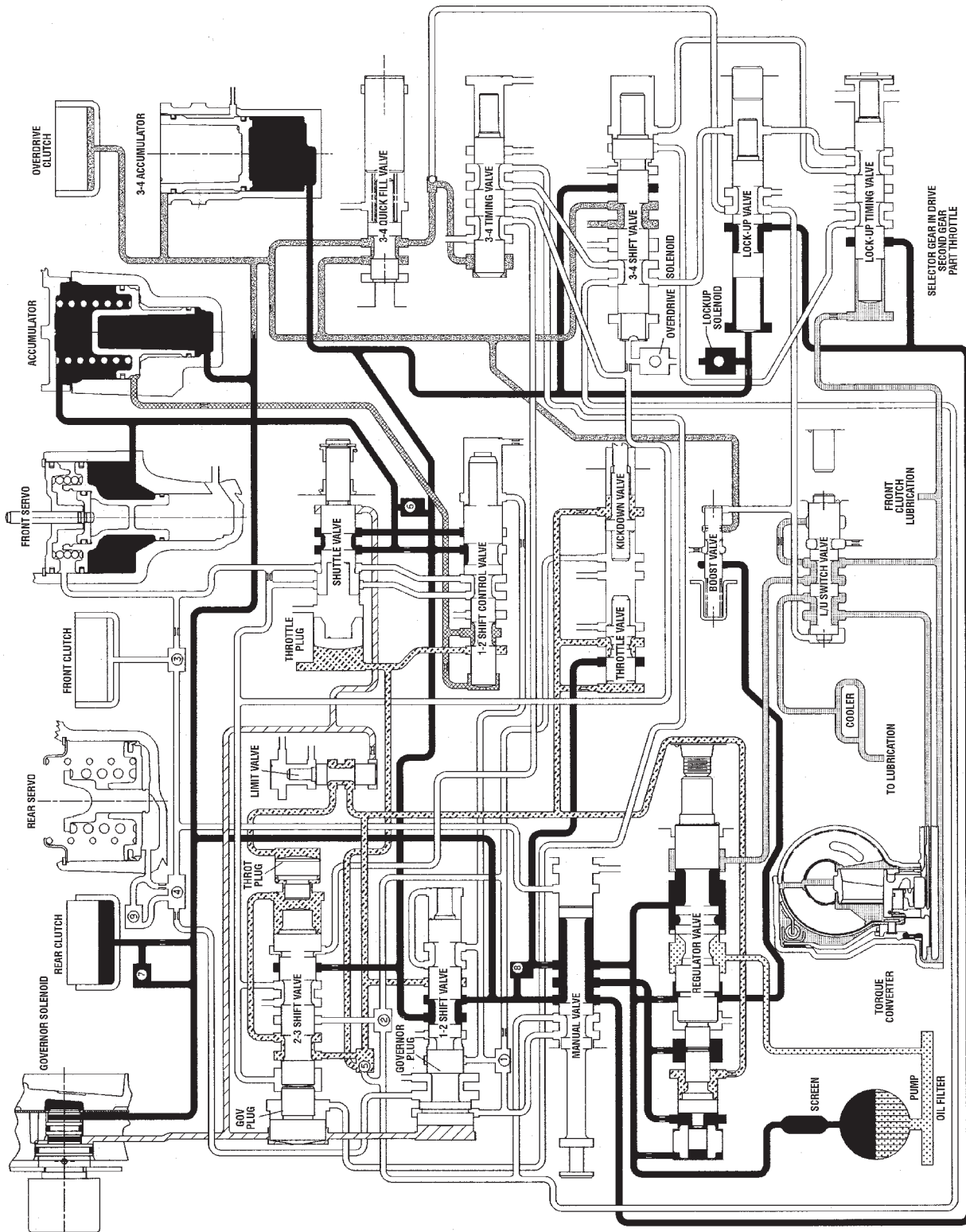
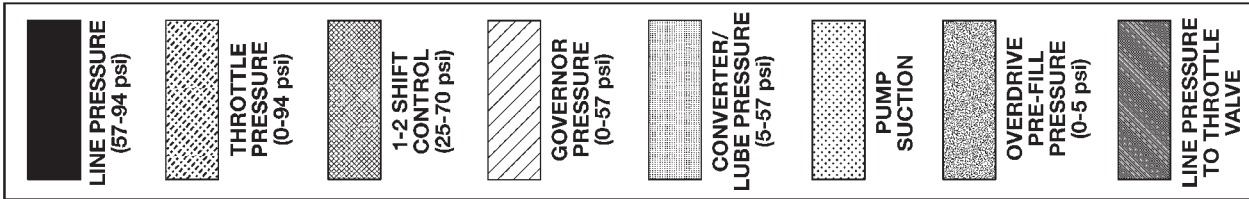


HYDRAULIC FLOW IN DRIVE FIRST GEAR



AUTOMATIC TRANSMISSION - 47RE (Continued)

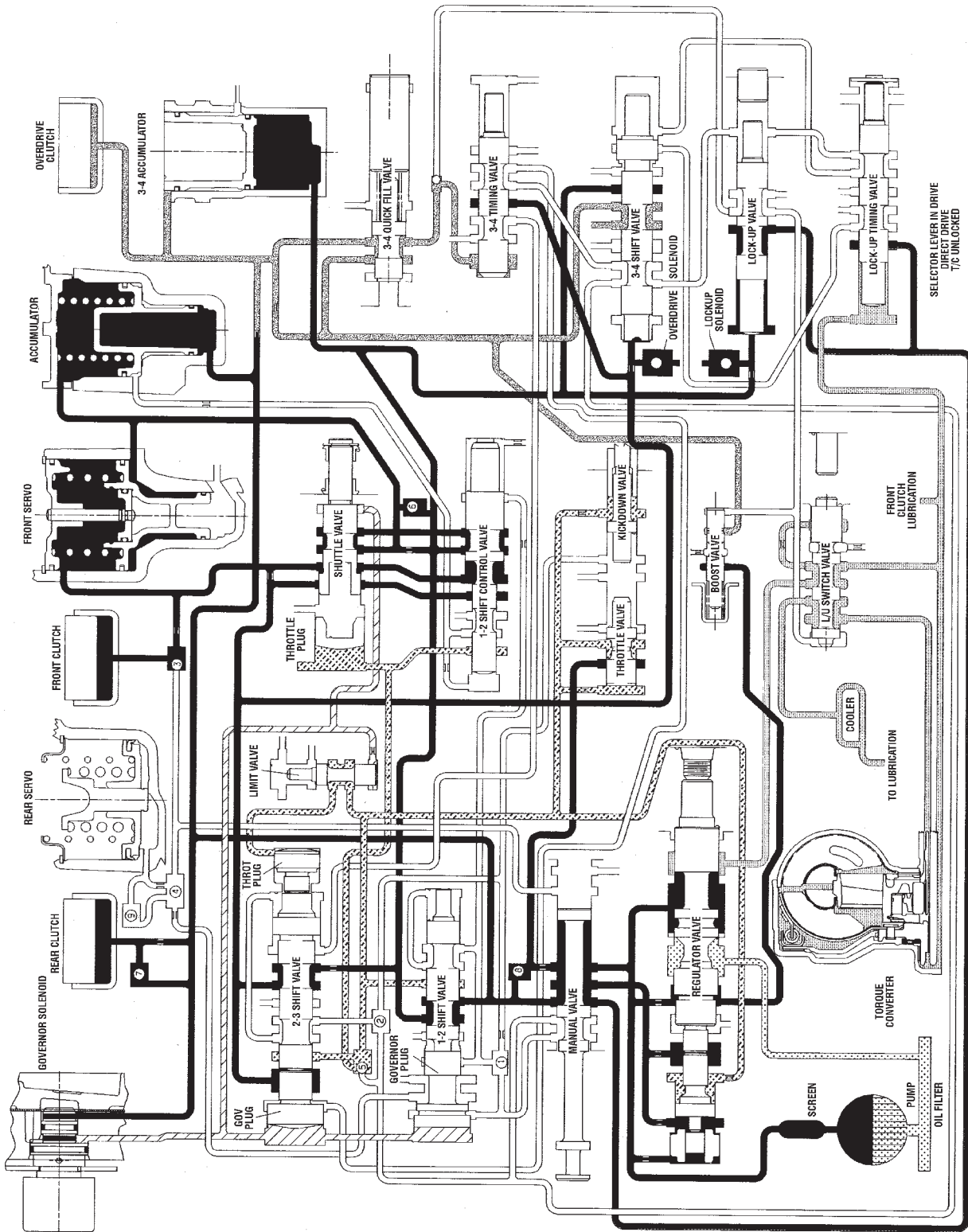
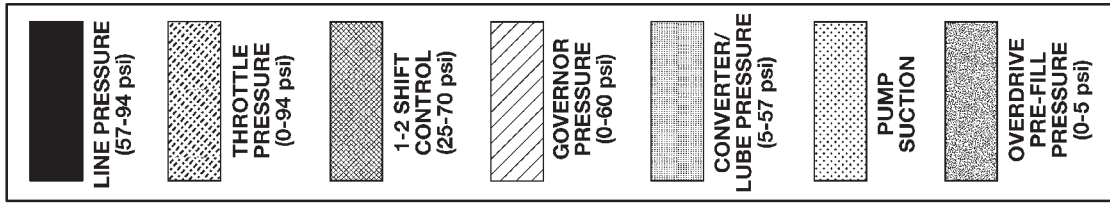
80880697



HYDRAULIC FLOW IN DRIVE SECOND GEAR

AUTOMATIC TRANSMISSION - 47RE (Continued)

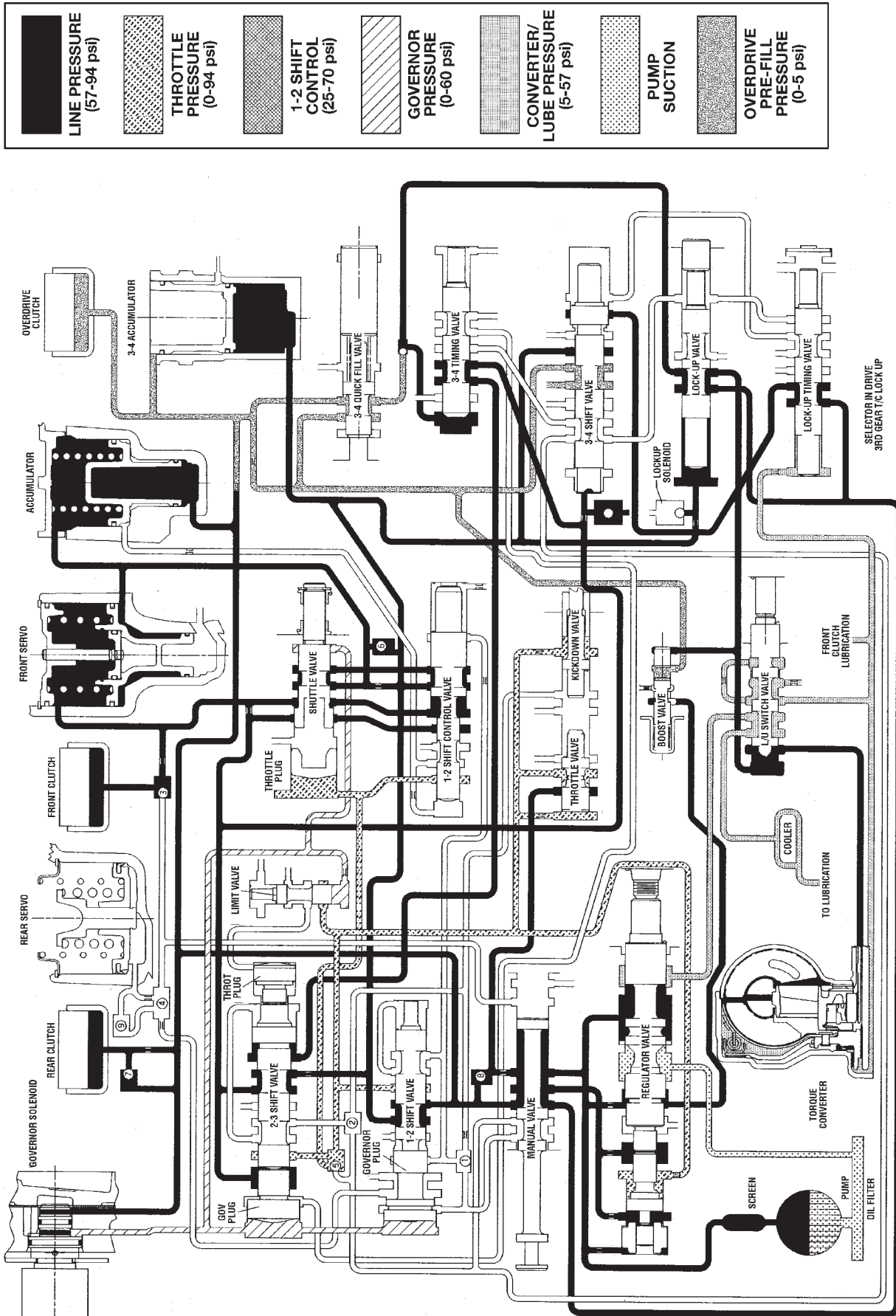
80860598



HYDRAULIC FLOW IN DRIVE THIRD GEAR (CONVERTER CLUTCH NOT APPLIED)

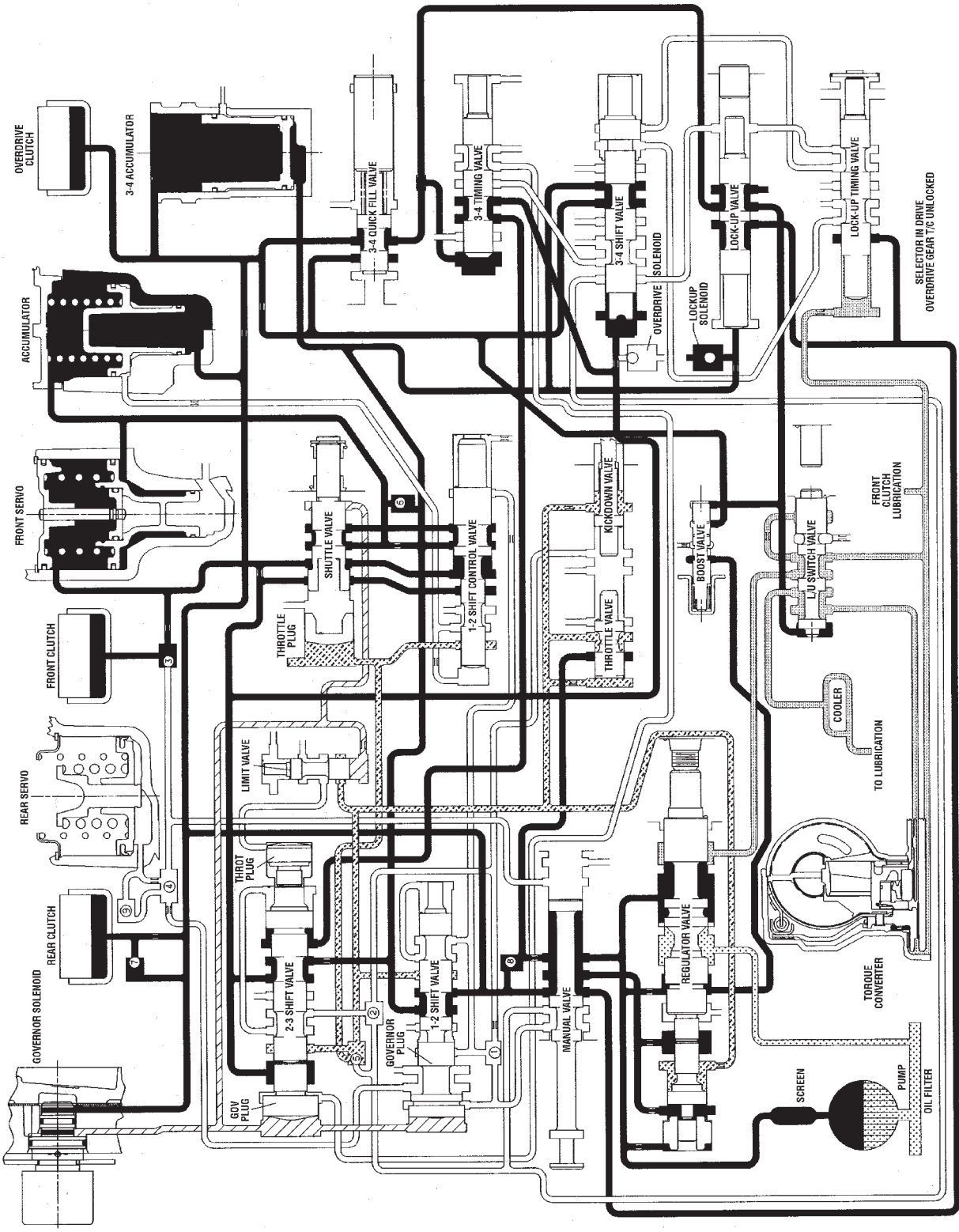
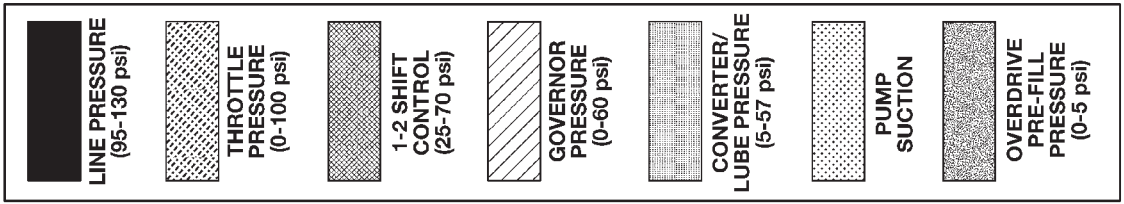
AUTOMATIC TRANSMISSION - 47RE (Continued)

80860599



AUTOMATIC TRANSMISSION - 47RE (Continued)

8088059b

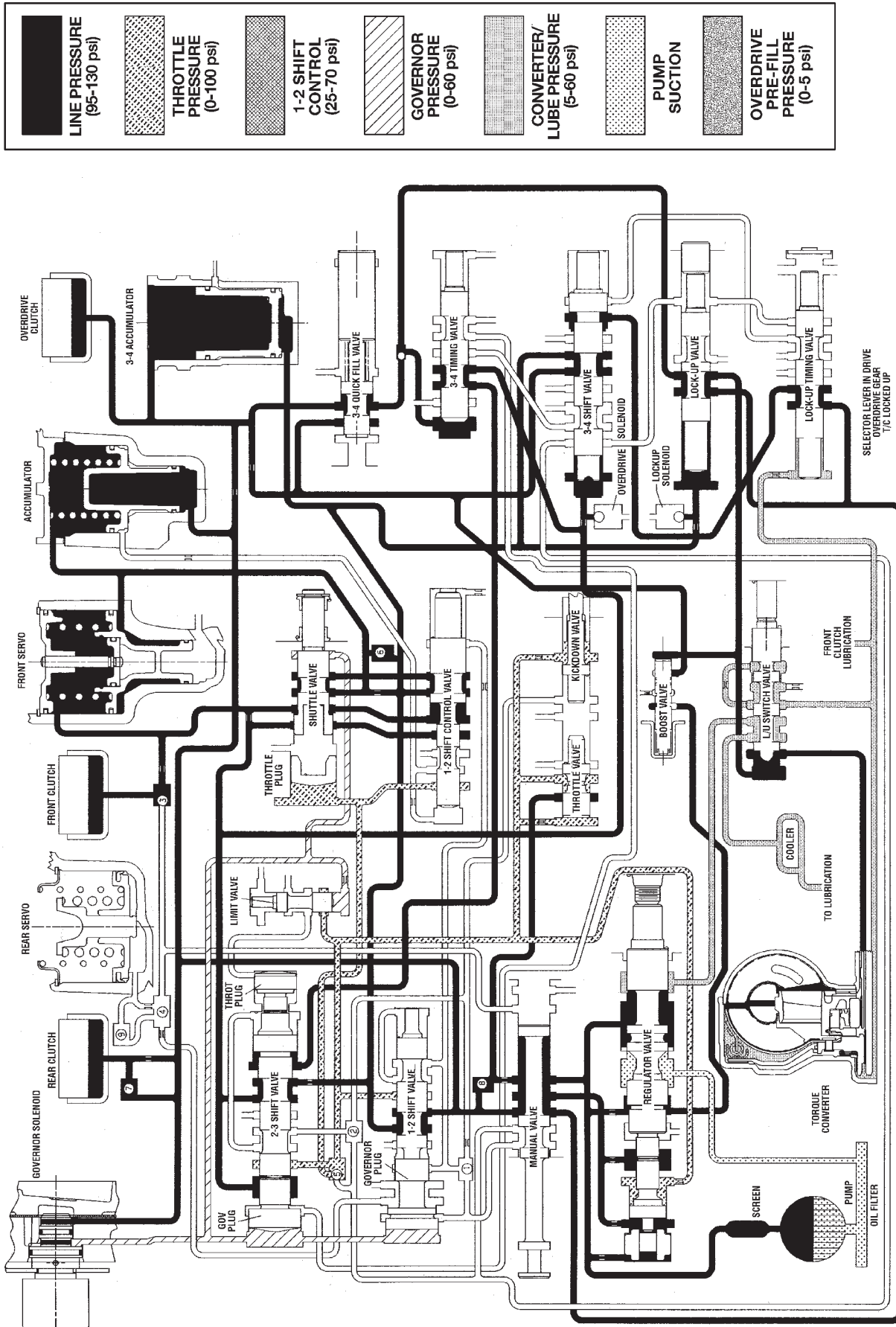


**HYDRAULIC FLOW IN DRIVE FOURTH GEAR (CONVERTER CLUTCH NOT APPLIED)**



AUTOMATIC TRANSMISSION - 47RE (Continued)

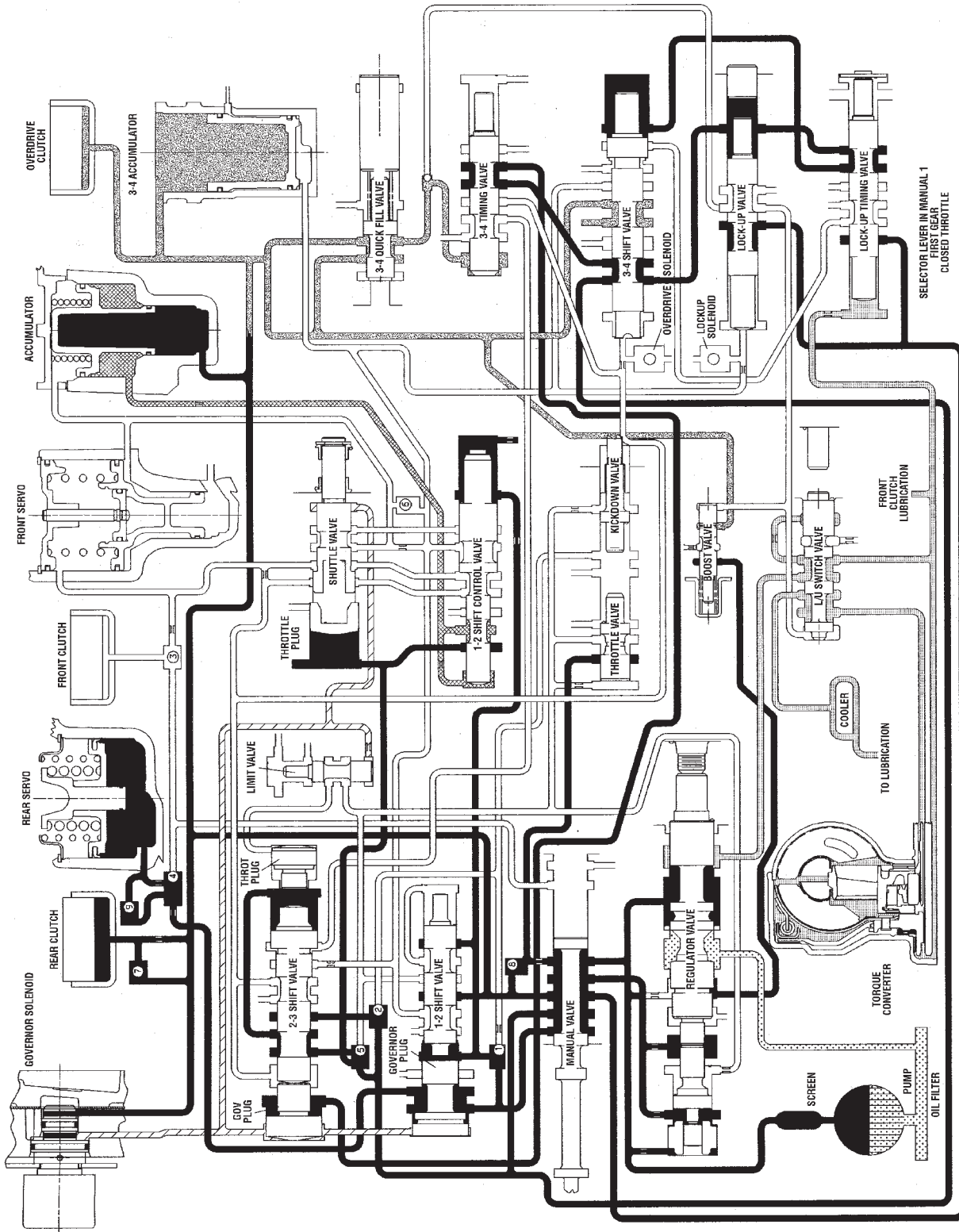
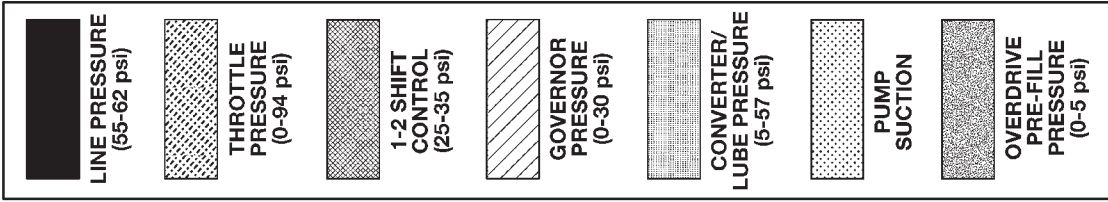
8086059c



HYDRAULIC FLOW IN DRIVE FOURTH GEAR (CONVERTER CLUTCH APPLIED)



AUTOMATIC TRANSMISSION - 47RE (Continued)

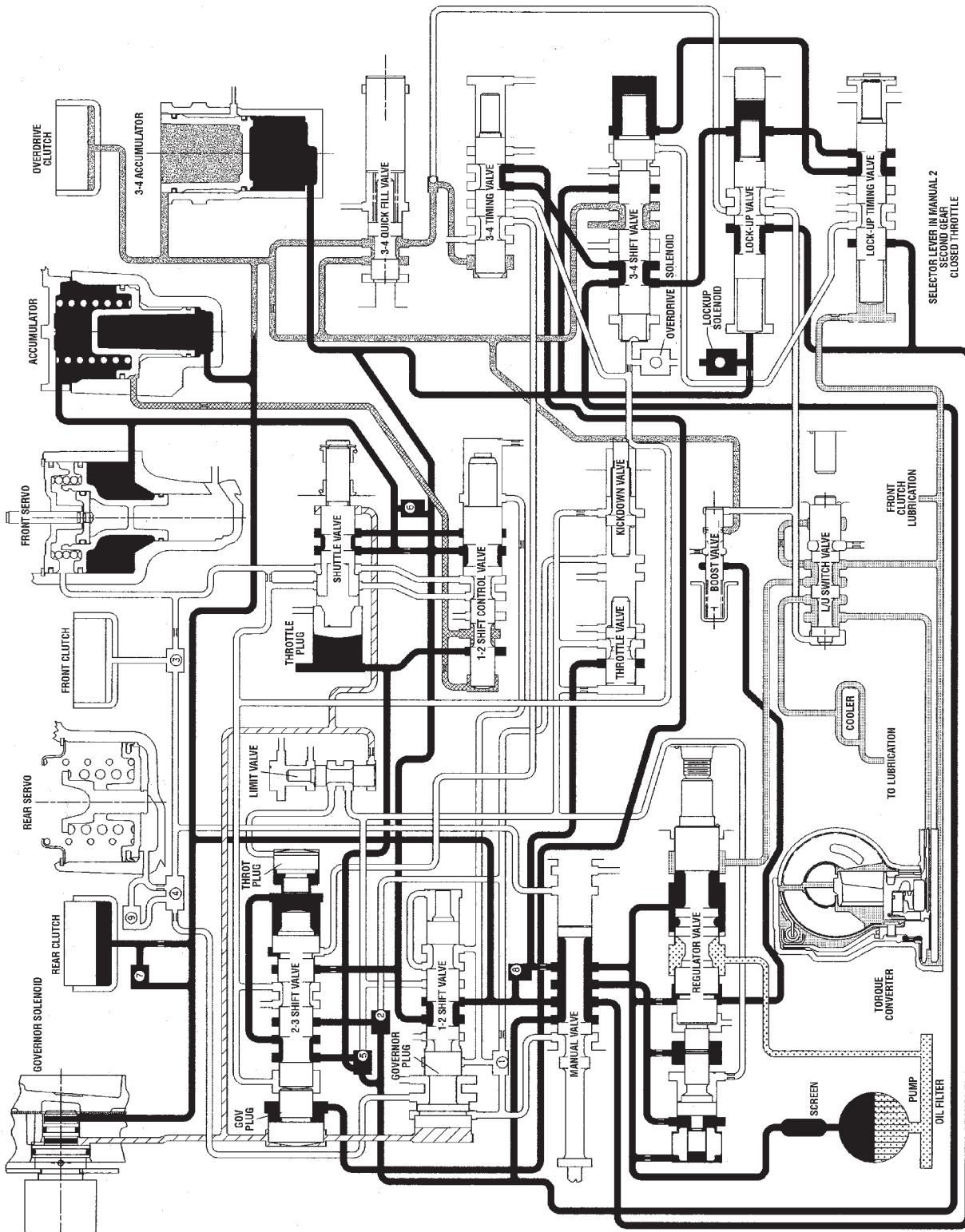
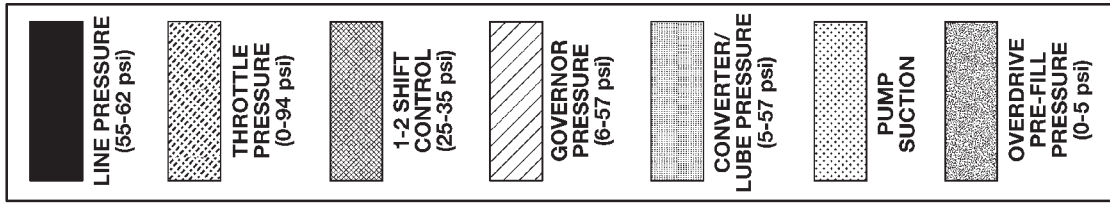


HYDRAULIC FLOW IN MANUAL LOW (1)

8088059c

AUTOMATIC TRANSMISSION - 47RE (Continued)

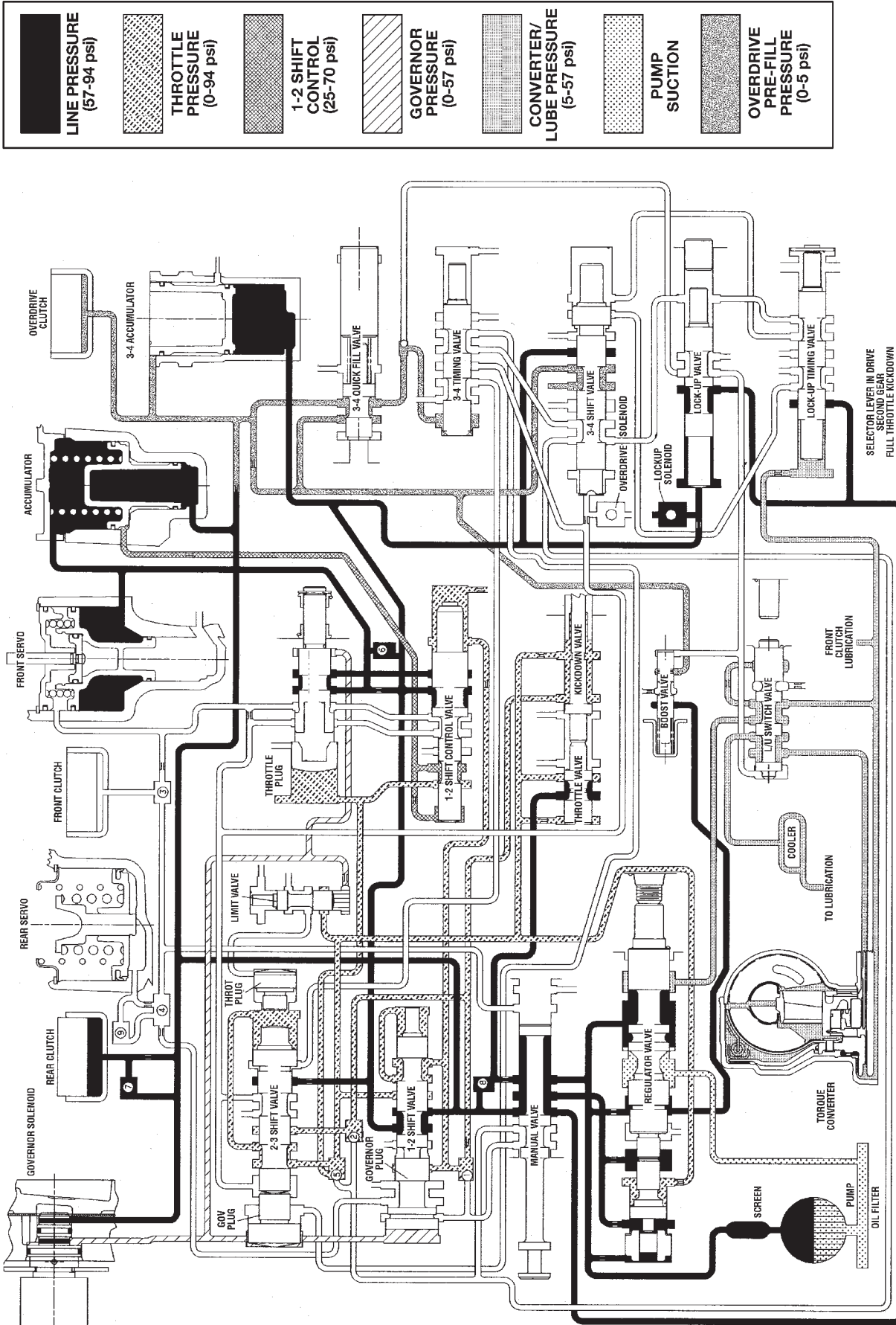
808805a1



HYDRAULIC FLOW IN MANUAL SECOND (2)

AUTOMATIC TRANSMISSION - 47RE (Continued)

808805e2



HYDRAULIC FLOW DURING FULL THROTTLE 3-2 DOWNSHIFT (PASSING)

AUTOMATIC TRANSMISSION - 47RE (Continued)

SPECIFICATIONS

TRANSMISSION

GENERAL

Component	Metric	Inch
Planetary end play	0.150-1.22 mm	0.006-0.048 in.
Input shaft end play	0.86-2.13 mm	0.034-0.084 in.
Clutch pack clearance/ Front.	1.78-3.28 mm	0.070-0.129 in.
Clutch pack clearance/ Rear.	0.635-0.914 mm	0.025-0.036 in.
Front clutch	4 discs	
Rear clutch	4 discs	
Overdrive clutch	5 discs	

Component	Metric	Inch
Direct clutch	10 discs	
Band adjustment from 72 in. lbs.	Back off 1 7/8 turns	
Front band	Back off 1 7/8 turns	
Rear band	Back off 3 turns	
Recommended fluid	Mopar® ATF +4, type 9602	

GEAR RATIOS

1ST GEAR	2.45:1
2ND GEAR	1.45:1
3RD GEAR	1.0:1
4TH GEAR	0.69:1
REVERSE	2.21:1

THRUST WASHER/SPACER/SNAP-RING DIMENSIONS

Component	Metric	Inch
Front clutch thrust washer (reaction shaft support hub)	1.55 mm	0.061 in.
	2.15 mm	0.084 in.
	2.59 mm	0.102 in.
Rear clutch thrust washer (clutch retainer)	1.55 mm	0.061 in.
Intermediate shaft thrust plate (shaft hub pilot)	1.5-1.6 mm	0.060-0.063 in.
Output shaft thrust washer (rear clutch hub)	1.3-1.4 mm	0.052-0.054 in.
	1.75-1.8 mm	0.068-0.070 in.
	2.1-2.2 mm	0.083-0.085 in.
Rear clutch pack snap-ring	1.5-1.6 mm	0.060-0.062 in.
	1.9-1.95 mm	0.074-0.076 in.
Planetary geartrain snap-ring (at front of output shaft)	1.4-1.5 mm	0.055-0.059 in.
	1.6-1.7 mm	0.062-0.066 in.
Overdrive piston thrust plate	Thrust plate and spacer are select fit. Refer to size charts and selection procedures in Overdrive Unit D&A procedures	
Intermediate shaft spacer		

## AUTOMATIC TRANSMISSION - 47RE (Continued)

**PRESSURE TEST**

Overdrive clutch	Fourth gear only	Pressure should be 469-496 kPa (68-72 psi) with closed throttle and increase to 620-896 kPa (90-130 psi) at 1/2 to 3/4 throttle.
Line pressure (at accumulator)	Closed throttle	372-414 kPa (54-60 psi).
Front servo	Third or Fourth gear only	No more than 21 kPa (3 psi) lower than line pressure.
Rear servo	1 range R range	No more than 21 kPa (3 psi) lower than line pressure. 1103 kPa (160 psi) at idle, builds to 1862 kPa (270 psi) at 1600 rpm.
Governor	D range closed throttle	Pressure should respond smoothly to changes in mph and return to 0-7 kPa (0-1.5 psi) when stopped with transmission in D, 1, 2. Pressure above 7 kPa (1.5 psi) at stand still will prevent transmission from downshifting.

*TORQUE SPECIFICATIONS*

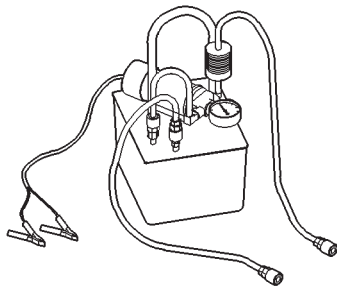
<b>DESCRIPTION</b>	<b>N-m</b>	<b>Ft. Lbs.</b>	<b>In. Lbs.</b>
Fitting, cooler line at trans	18	13	-
Bolt, torque convertor	47	35	-
Bolt, clevis bracket to crossmember	47	35	-
Bolt, clevis bracket to rear support	68	50	-
Bolt, driveplate to crankshaft	75	55	-
Plug, front band reaction	17	13	-
Locknut, front band adj.	34	25	-
Bolt, fluid pan	17	13	-
Screws, fluid filter	4	-	35
Bolt, oil pump	20	15	-
Bolt, overrunning clutch cam	17	13	-
Bolt, O/D to trans.	34	25	-
Bolt, O/D piston retainer	17	13	-
Plug, pressure test port	14	10	-
Bolt, reaction shaft support	20	15	-
Locknut, rear band	41	30	-
Bolt, valve body to case	12	-	100
Sensor, trans speed	27	20	-
Screw, solenoid wiring connector	4	-	35
Screw, solenoid to transfer plate	4	-	35
Switch, Park/Neutral	34	25	-



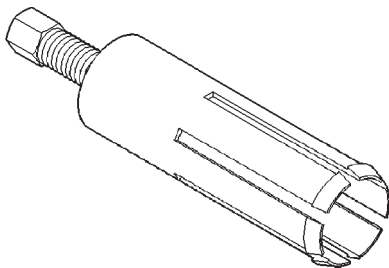
AUTOMATIC TRANSMISSION - 47RE (Continued)

SPECIAL TOOLS

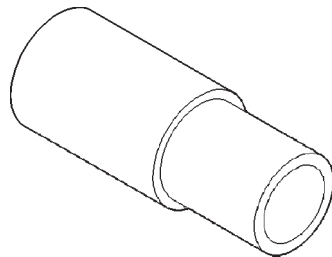
RE TRANSMISSION



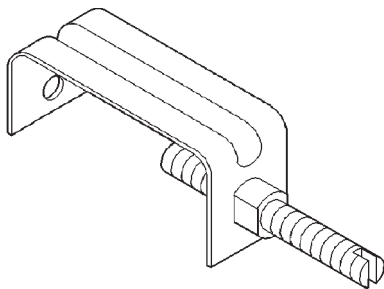
**Flusher, Oil Cooler - 6906**



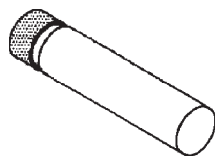
**Remover, Bushing - 6957**



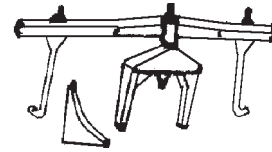
**Installer, Bushing - 6951**



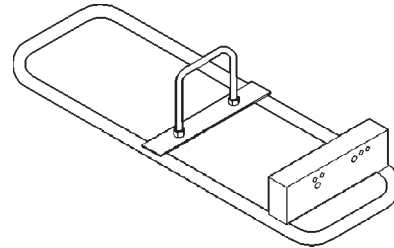
**Retainer, Detent Ball and Spring - 6583**



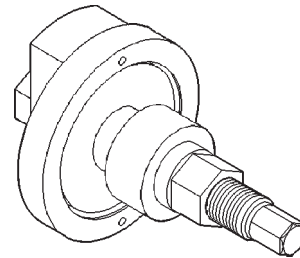
**Gauge, Block - 6312**



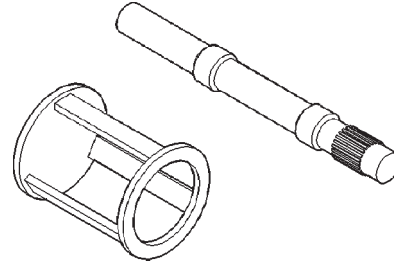
**Fixture, Engine Support - C-3487-A**



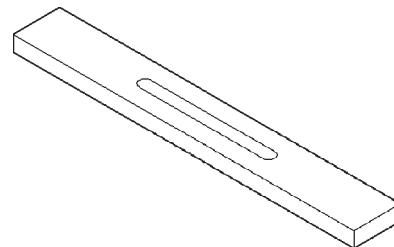
**Stand, Transmission Repair - C-3750-B**



**Compressor, Spring - C-3863-A**

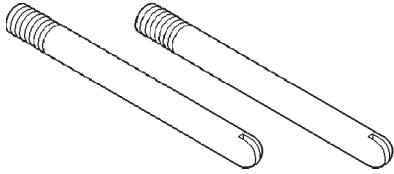


**Spring Compressor and Alignment Shaft - 6227**

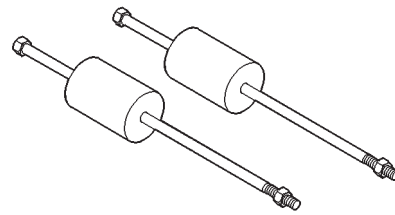


**Bar, Gauge - 6311**

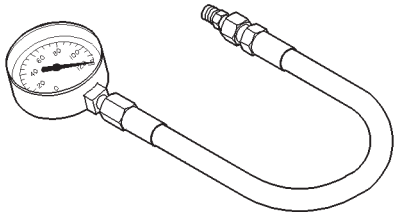
AUTOMATIC TRANSMISSION - 47RE (Continued)



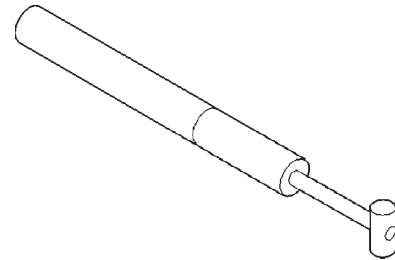
**Studs, Oil Pump Pilot - C-3288-B**



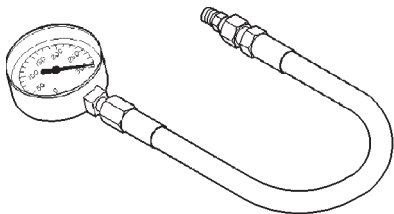
**Puller, Slide Hammer - C-3752**



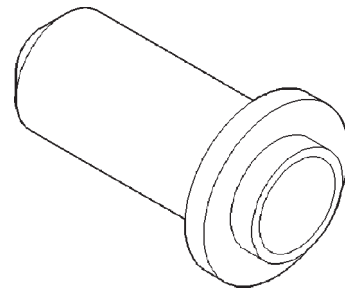
**Gauge, Pressure - C-3292**



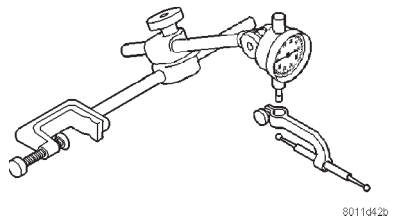
**Gauge, Throttle Setting - C-3763**



**Gauge, Pressure - C-3293SP**

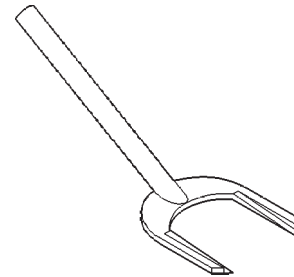


**Installer, Seal - C-3860-A**

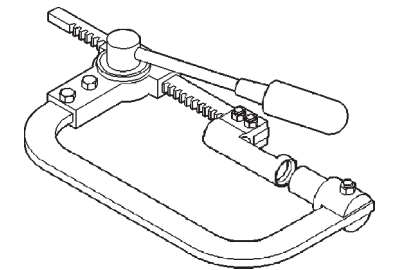


8011d42b

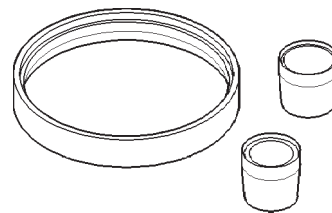
**Set, Dial Indicator - C-3339**



**Remover, Seal - C-3985-B**

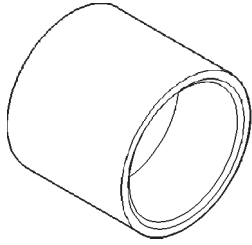


**Compressor, Spring - C-3422-B**

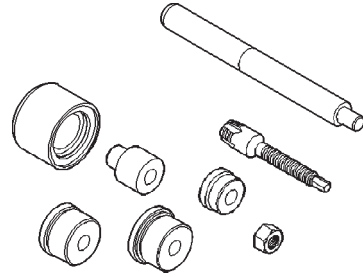


**Installer, Overdrive Piston Seal - 8114**

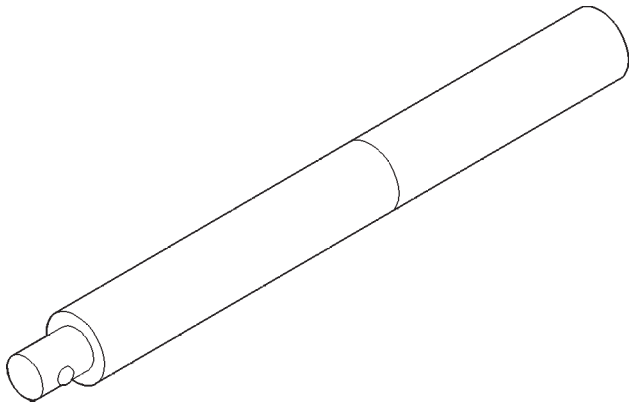
AUTOMATIC TRANSMISSION - 47RE (Continued)



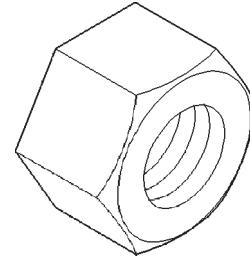
**Installer, Seal - C-3995-A**



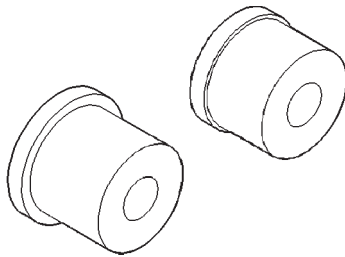
**Set, Bushing Remover/Installer - C-3887-J**



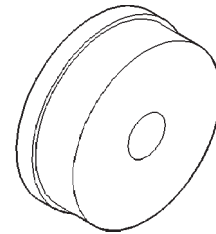
**Handle, Universal - C-4171**



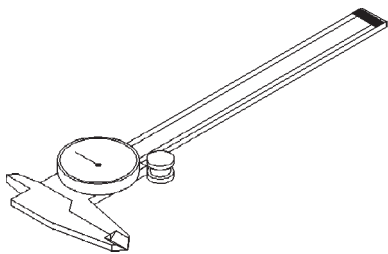
**Nut, Bushing Remover - SP-1191, From kit C-3887-J**



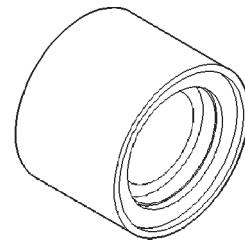
**Remover/Installer, Bushing - C-4470**



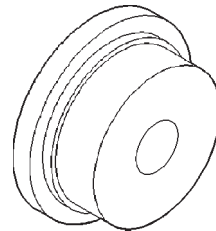
**Remover, Front Clutch Bushing - SP-3629, From kit C-3887-J**



**Dial Caliper - C-4962**

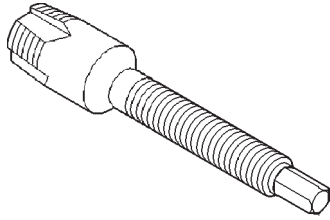


**Cup, Bushing Remover - SP-3633, From kit C-3887-J**

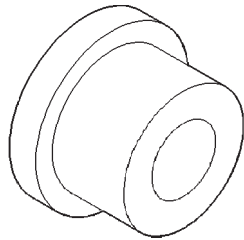


**Installer, Oil Pump Bushing - SP-5118, From kit C-3887-J**

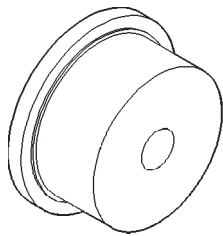
AUTOMATIC TRANSMISSION - 47RE (Continued)



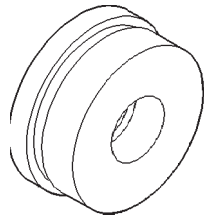
**Remover, Reaction Shaft Bushing - SP-5301, From Kit C-3887-J**



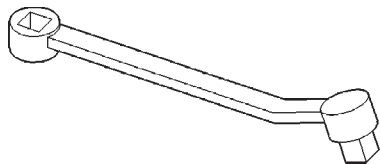
**Installer, Reaction Shaft Bushing - SP-5302, From kit C-3887-J**



**Installer, Front Clutch Bushing - SP-5511, From kit C-3887-J**



**Remover, Bushing - SP-3550, From kit C-3887-J**

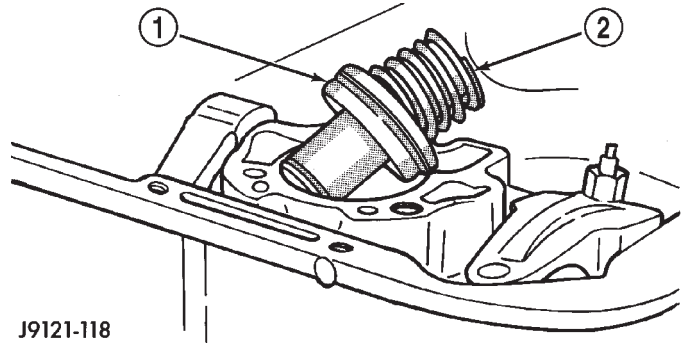


**Adapter, Band Adjuster - C-3705**

## ACCUMULATOR

### DESCRIPTION

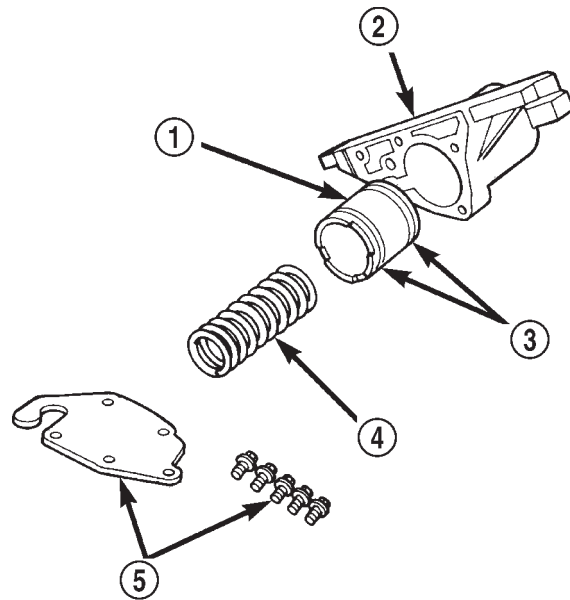
The accumulator (Fig. 60) is a hydraulic device that has the sole purpose of cushioning the application of a band or clutch. The accumulator consists of a dual-land piston and a spring located in a bore in the transmission case. The 3-4 accumulator is located in a housing attached to the side of the valve body (Fig. 61).



J9121-118

**Fig. 60 Accumulator**

- 1 - ACCUMULATOR PISTON
- 2 - PISTON SPRING



804d8eb9

**Fig. 61 3-4 Accumulator and Housing**

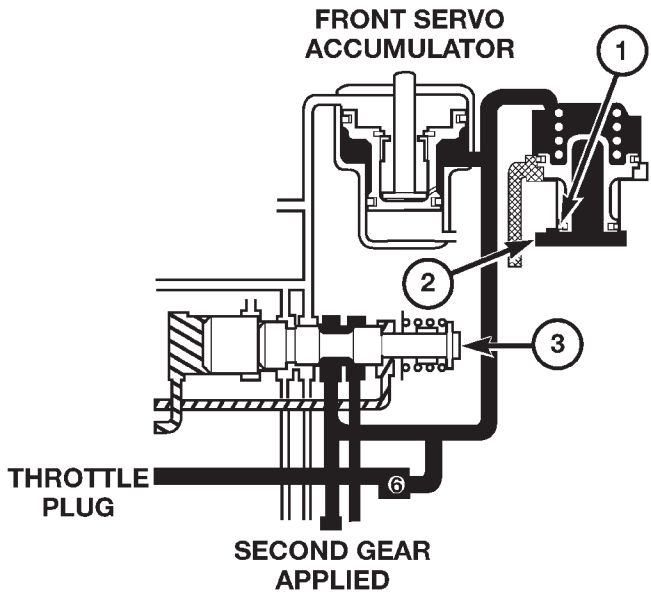
- 1 - ACCUMULATOR PISTON
- 2 - 3-4 ACCUMULATOR HOUSING
- 3 - TEFLON SEALS
- 4 - PISTON SPRING
- 5 - COVER PLATE AND SCREWS

ACCUMULATOR (Continued)

**OPERATION**

Both the accumulator and the 3-4 accumulator function the same. Line pressure is directed to the small end of the piston when the transmission is placed into a DRIVE position (Fig. 62), bottoming it against the accumulator plate. When the 1-2 upshift occurs (Fig. 63), line pressure is directed to the large end of the piston and then to the kickdown servo. As the line pressure reaches the accumulator, the combination of spring pressure and line pressure forces the piston away from the accumulator plate. This causes a balanced pressure situation, which results in a cushioned band application. After the kickdown servo has become immovable, line pressure will finish pushing the accumulator up into its bore. When the large end of the accumulator piston is seated in its bore, the band or clutch is fully applied.

**NOTE:** The accumulator is shown in the inverted position for illustrative purposes.

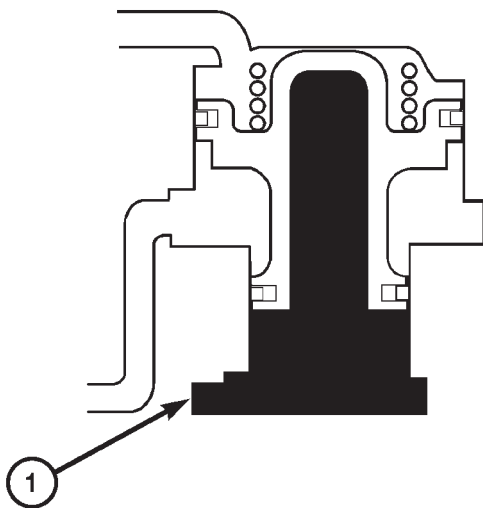


80a08a58

**Fig. 63 Accumulator in SECOND Gear Position**

- 1 - BOTTOM OF BORE
- 2 - LINE PRESSURE
- 3 - SHUTTLE VALVE

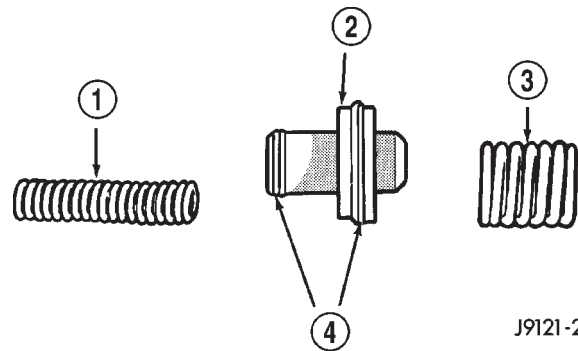
**BOTTOMED AGAINST ACCUMULATOR PLATE**



80a08a54

**Fig. 62 Accumulator in DRIVE - FIRST GEAR POSITION**

- 1 - LINE PRESSURE



J9121-230

**Fig. 64 Accumulator Components**

- 1 - INNER SPRING
- 2 - ACCUMULATOR PISTON
- 3 - OUTER SPRING
- 4 - SEAL RINGS

**INSPECTION**

Inspect the accumulator piston and seal rings (Fig. 64). Replace the seal rings if worn or cut. Replace the piston if chipped or cracked.

Check condition of the accumulator inner and outer springs (Fig. 64). Replace the springs if the coils are cracked, distorted or collapsed.

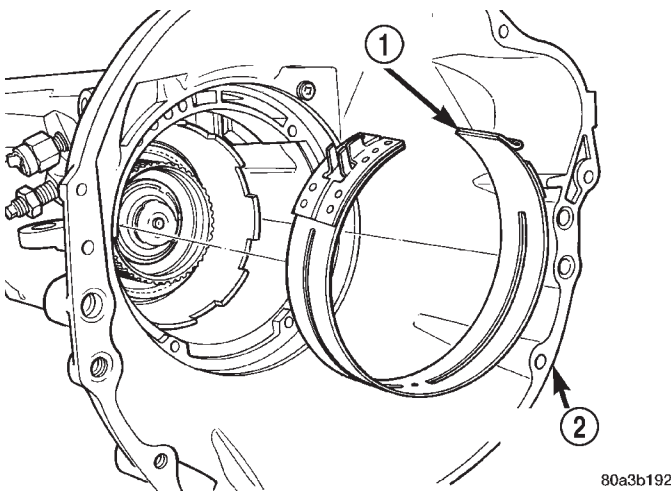


## BANDS

### DESCRIPTION

#### KICKDOWN (FRONT) BAND

The kickdown, or "front", band (Fig. 65) holds the common sun gear of the planetary gear sets. The front (kickdown) band is made of steel, and faced on its inner circumference with a friction-type lining. One end of the band is anchored to the transmission case, and the other is acted on with a pushing force by a servo piston. The front band is a single-wrap design (the band does not completely encompass/wrap the drum that it holds).



**Fig. 65 Front Band**

- 1 - FRONT BAND
- 2 - TRANSMISSION HOUSING

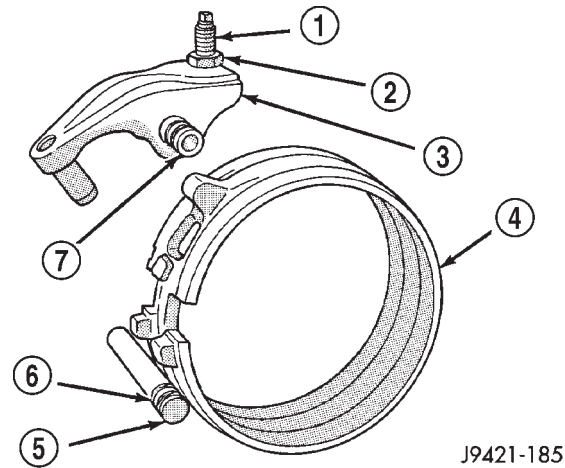
#### LOW/REVERSE (REAR) BAND

The low/reverse band, or "rear", band (Fig. 66) is similar in appearance and operation to the front band. The rear band is slightly different in that it does not use a link bar, but is acted directly on by the apply lever. This is referred to as a double-wrap band design (the drum is completely encompassed/wrapped by the band). The double-wrap band provides a greater holding power in comparison to the single-wrap design.

### OPERATION

#### KICKDOWN (FRONT) BAND

The kickdown band holds the common sun gear of the planetary gear sets by applying and holding the front clutch retainer, which is splined to the sun gear driving shell, and in turn splined directly to the sun gear. The application of the band by the servo is typically done by an apply lever and link bar.



J9421-185

**Fig. 66 Rear Band**

- 1 - ADJUSTING SCREW
- 2 - LOCKNUT
- 3 - LEVER
- 4 - REAR BAND
- 5 - REACTION PIN
- 6 - O-RINGS
- 7 - PIVOT PIN

#### LOW/REVERSE (REAR) BAND

The rear band holds the rear planet carrier stationary by being mounted around and applied to the low/reverse drum.

### ADJUSTMENT - BANDS

#### FRONT BAND

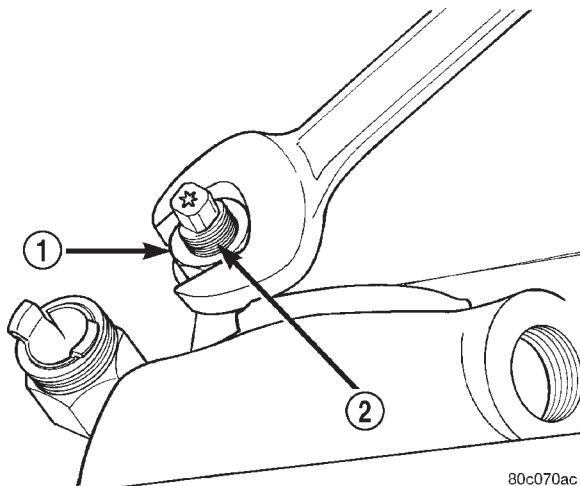
The front (kickdown) band adjusting screw is located on the left side of the transmission case above the manual valve and throttle valve levers.

- (1) Raise vehicle.
- (2) Loosen band adjusting screw locknut (Fig. 67). Then back locknut off 3-5 turns. Be sure adjusting screw turns freely in case. Apply lubricant to screw threads if necessary.
- (3) Tighten band adjusting screw to 8 N·m (72 in. lbs.) torque with Inch Pound Torque Wrench C-3380-A, a 3-in. extension and an appropriate Torx™ socket.

**CAUTION:** If Adapter C-3705 is needed to reach the adjusting screw, tighten the screw to only 5 N·m (47-50 in. lbs.) torque.

- (4) Back off front band adjusting screw 1-7/8 turns.
- (5) Hold adjuster screw in position and tighten locknut to 41 N·m (30 ft. lbs.) torque.
- (6) Lower vehicle.

## BANDS (Continued)



80c070ac

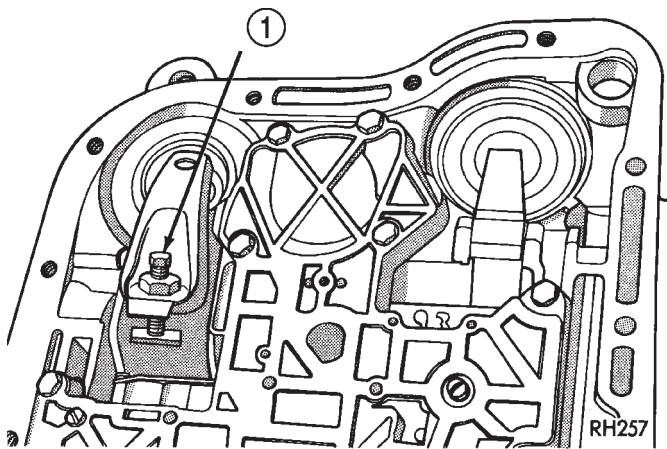
**Fig. 67 Front Band Adjustment Screw Location**

- 1 - LOCK-NUT  
2 - FRONT BAND ADJUSTER

**REAR BAND**

The transmission oil pan must be removed for access to the rear band adjusting screw.

- (1) Raise vehicle.
- (2) Remove transmission oil pan and drain fluid.
- (3) Loosen band adjusting screw locknut 5-6 turns. Be sure adjusting screw turns freely in lever.
- (4) Tighten adjusting screw to 8 N·m (72 in. lbs.) torque (Fig. 68).
- (5) Back off adjusting screw 3 turns.
- (6) Hold adjusting screw in place and tighten locknut to 34 N·m (25 ft. lbs.) torque.
- (7) Position new gasket on oil pan and install pan on transmission. Tighten pan bolts to 17 N·m (13 ft. lbs.) torque.
- (8) Lower vehicle and refill transmission with Mopar® ATF +4, Type 9602 fluid.



RH257

**Fig. 68 Rear Band Adjustment Screw Location**

- 1 - LOW-REVERSE BAND ADJUSTMENT

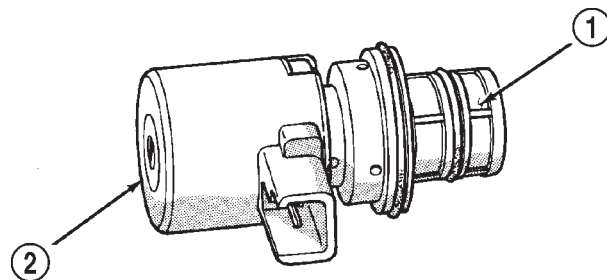
**ELECTRONIC GOVERNOR****DESCRIPTION**

Governor pressure is controlled electronically. Components used for governor pressure control include:

- Governor body
- Valve body transfer plate
- Governor pressure solenoid valve
- Governor pressure sensor
- Fluid temperature thermistor
- Throttle position sensor (TPS)
- Transmission speed sensor
- Powertrain control module (PCM)

**GOVERNOR PRESSURE SOLENOID VALVE**

The solenoid valve is a duty-cycle solenoid which regulates the governor pressure needed for upshifts and downshifts. It is an electro-hydraulic device located in the governor body on the valve body transfer plate (Fig. 69).



J9321-408A

**Fig. 69 Governor Pressure Solenoid Valve**

- 1 - SOLENOID FILTER  
2 - GOVERNOR PRESSURE SOLENOID

**GOVERNOR PRESSURE SENSOR**

The governor pressure sensor measures output pressure of the governor pressure solenoid valve (Fig. 70).

**GOVERNOR BODY AND TRANSFER PLATE**

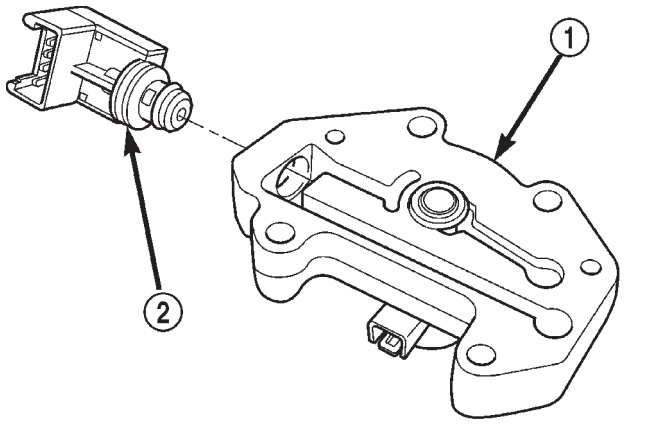
The transfer plate is designed to supply transmission line pressure to the governor pressure solenoid valve and to return governor pressure.

The governor pressure solenoid valve is mounted in the governor body. The body is bolted to the lower side of the transfer plate (Fig. 70).

**GOVERNOR PRESSURE CURVES**

There are four governor pressure curves programmed into the transmission control module. The different curves allow the control module to adjust governor pressure for varying conditions. One curve is used for operation when fluid temperature is at, or below,  $-1^{\circ}\text{C}$  ( $30^{\circ}\text{F}$ ). A second curve is used when fluid

## ELECTRONIC GOVERNOR (Continued)



80c072af

**Fig. 70 Governor Pressure Sensor**

- 1 - GOVERNOR BODY  
 2 - GOVERNOR PRESSURE SENSOR/TRANSMISSION FLUID TEMPERATURE THERMISTOR

temperature is at, or above, 10°C (50°F) during normal city or highway driving. A third curve is used during wide-open throttle operation. The fourth curve is used when driving with the transfer case in low range.

## OPERATION

Compensation is required for performance variations of two of the input devices. Though the slope of the transfer functions is tightly controlled, offset may vary due to various environmental factors or manufacturing tolerances.

The pressure transducer is affected by barometric pressure as well as temperature. Calibration of the zero pressure offset is required to compensate for shifting output due to these factors.

Normal calibration will be performed when sump temperature is above 50 degrees F, or in the absence of sump temperature data, after the first 10 minutes of vehicle operation. Calibration of the pressure transducer offset occurs each time the output shaft speed falls below 200 RPM. Calibration shall be repeated each 3 seconds the output shaft speed is below 200 RPM. A 0.5 second pulse of 95% duty cycle is applied to the governor pressure solenoid valve and the transducer output is read during this pulse. Averaging of the transducer signal is necessary to reject electrical noise.

Under cold conditions (below 50 degrees F sump), the governor pressure solenoid valve response may be too slow to guarantee 0 psi during the 0.5 second calibration pulse. Calibration pulses are continued during this period, however the transducer output valves are discarded. Transducer offset must be read at key-on, under conditions which promote a stable reading. This value is retained and becomes the offset during the "cold" period of operation.

## GOVERNOR PRESSURE SOLENOID VALVE

The inlet side of the solenoid valve is exposed to normal transmission line pressure. The outlet side of the valve leads to the valve body governor circuit.

The solenoid valve regulates line pressure to produce governor pressure. The average current supplied to the solenoid controls governor pressure. One amp current produces zero kPa/psi governor pressure. Zero amps sets the maximum governor pressure.

The powertrain control module (PCM) turns on the trans control relay which supplies electrical power to the solenoid valve. Operating voltage is 12 volts (DC). The PCM controls the ground side of the solenoid using the governor pressure solenoid control circuit.

## GOVERNOR PRESSURE SENSOR

The sensor output signal provides the necessary feedback to the PCM. This feedback is needed to adequately control governor pressure.

## GOVERNOR BODY AND TRANSFER PLATE

The transfer plate channels line pressure to the solenoid valve through the governor body. It also channels governor pressure from the solenoid valve to the governor circuit. It is the solenoid valve that develops the necessary governor pressure.

## GOVERNOR PRESSURE CURVES

### LOW TRANSMISSION FLUID TEMPERATURE

When the transmission fluid is cold the conventional governor can delay shifts, resulting in higher than normal shift speeds and harsh shifts. The electronically controlled low temperature governor pressure curve is higher than normal to make the transmission shift at normal speeds and sooner. The PCM uses a temperature sensor in the transmission oil sump to determine when low temperature governor pressure is needed.

### NORMAL OPERATION

Normal operation is refined through the increased computing power of the PCM and through access to data on engine operating conditions provided by the PCM that were not available with the previous stand-alone electronic module. This facilitated the development of a load adaptive shift strategy - the ability to alter the shift schedule in response to vehicle load condition. One manifestation of this capability is grade "hunting" prevention - the ability of the transmission logic to delay an upshift on a grade if the engine does not have sufficient power to maintain speed in the higher gear. The 3-2 downshift and the potential for hunting between gears occurs with a heavily loaded vehicle or on steep grades. When hunting occurs, it is very objectionable because shifts are frequent and accompanied by large changes in noise and acceleration.

## ELECTRONIC GOVERNOR (Continued)

## WIDE OPEN THROTTLE OPERATION

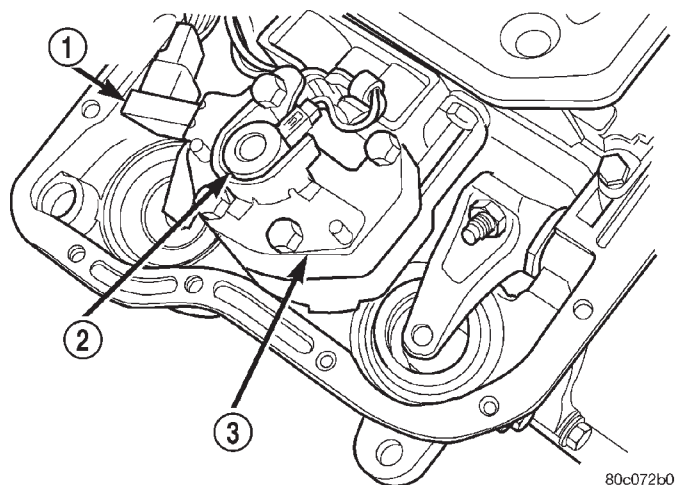
In wide-open throttle (WOT) mode, adaptive memory in the PCM assures that up-shifts occur at the pre-programmed optimum speed. WOT operation is determined from the throttle position sensor, which is also a part of the emission control system. The initial setting for the WOT upshift is below the optimum engine speed. As WOT shifts are repeated, the PCM learns the time required to complete the shifts by comparing the engine speed when the shifts occur to the optimum speed. After each shift, the PCM adjusts the shift point until the optimum speed is reached. The PCM also considers vehicle loading, grade and engine performance changes due to high altitude in determining when to make WOT shifts. It does this by measuring vehicle and engine acceleration and then factoring in the shift time.

## TRANSFER CASE LOW RANGE OPERATION

On four-wheel drive vehicles operating in low range, the engine can accelerate to its peak more rapidly than in Normal range, resulting in delayed shifts and undesirable engine "flare." The low range governor pressure curve is also higher than normal to initiate upshifts sooner. The PCM compares electronic vehicle speed signal used by the speedometer to the transmission output shaft speed signal to determine when the transfer case is in low range.

## REMOVAL

- (1) Hoist and support vehicle on safety stands.
- (2) Remove transmission fluid pan and filter.
- (3) Disengage wire connectors from pressure sensor and solenoid (Fig. 71).
- (4) Remove screws holding pressure solenoid retainer to governor body.

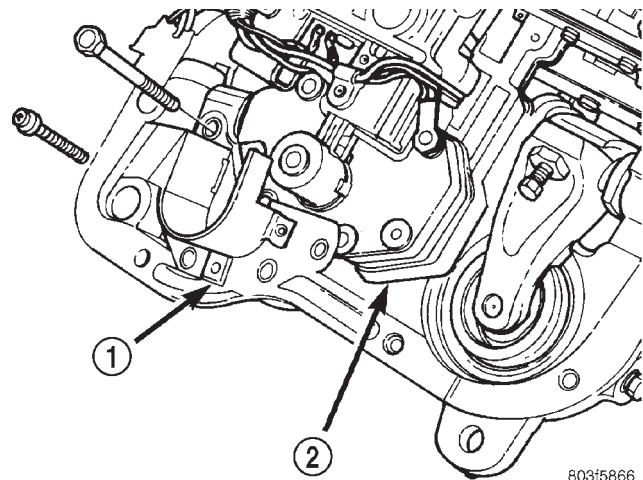


80c072b0

**Fig. 71 Governor Solenoid And Pressure Sensor**

- 1 - PRESSURE SENSOR
- 2 - PRESSURE SOLENOID
- 3 - GOVERNOR

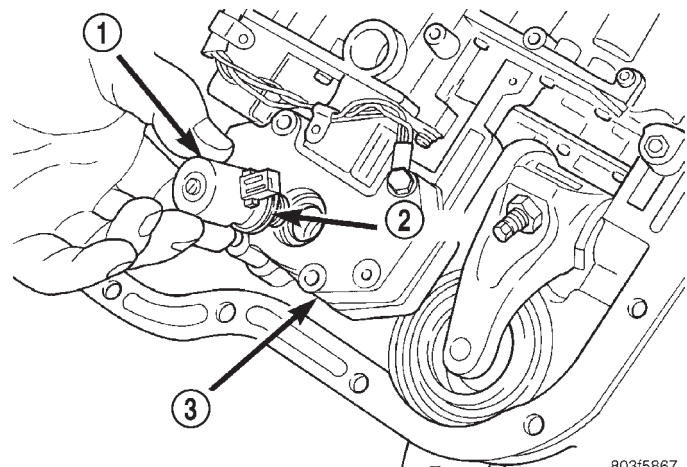
- (5) Separate solenoid retainer from governor (Fig. 72).
- (6) Pull solenoid from governor body (Fig. 73).
- (7) Pull pressure sensor from governor body.
- (8) Remove bolts holding governor body to valve body.



803f5866

**Fig. 72 Pressure Solenoid Retainer**

- 1 - PRESSURE SOLENOID RETAINER
- 2 - GOVERNOR



803f5867

**Fig. 73 Pressure Solenoid and O-ring**

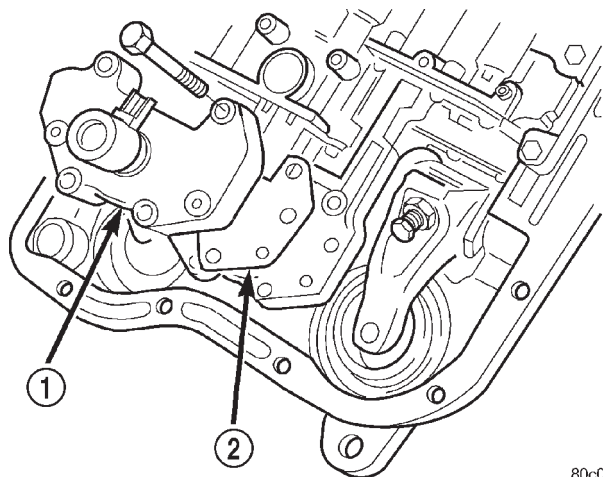
- 1 - PRESSURE SOLENOID
- 2 - O-RING
- 3 - GOVERNOR



## ELECTRONIC GOVERNOR (Continued)

(9) Separate governor body from valve body (Fig. 74).

(10) Remove governor body gasket.



80c072b1

**Fig. 74 Governor Body and Gasket**

- 1 - GOVERNOR BODY  
2 - GASKET

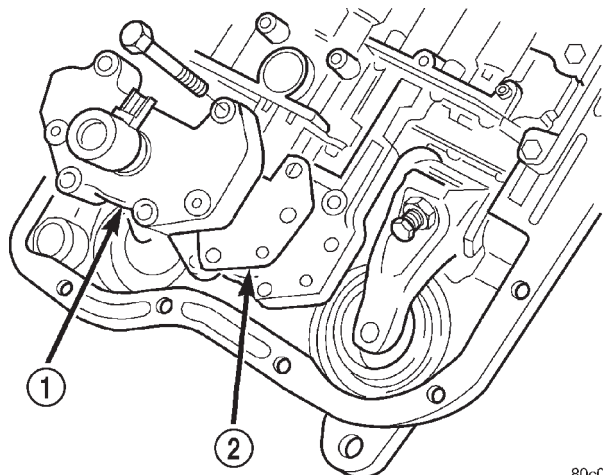
## INSTALLATION

Before installing the pressure sensor and solenoid in the governor body, replace o-ring seals, clean the gasket surfaces and replace gasket.

(1) Place gasket in position on back of governor body (Fig. 75).

(2) Place governor body in position on valve body.

(3) Install bolts to hold governor body to valve body.



80c072b1

**Fig. 75 Governor Body and Gasket**

- 1 - GOVERNOR BODY  
2 - GASKET

(4) Lubricate o-ring on pressure sensor with transmission fluid.

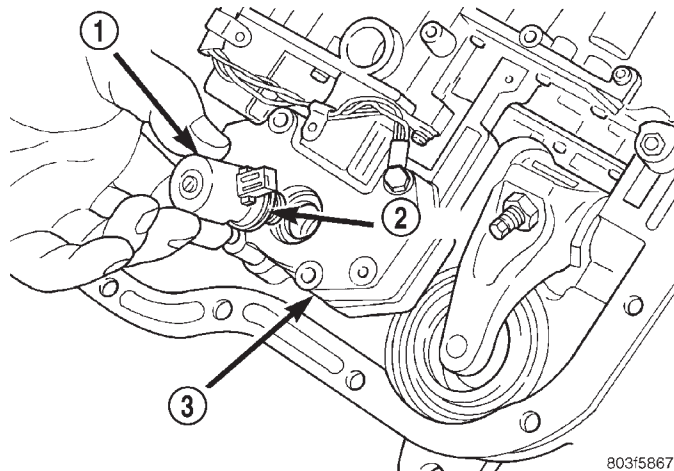
(5) Align pressure sensor to bore in governor body.

(6) Push pressure sensor into governor body.

(7) Lubricate o-ring, on pressure solenoid, with transmission fluid.

(8) Align pressure solenoid to bore in governor body (Fig. 76).

(9) Push solenoid into governor body.



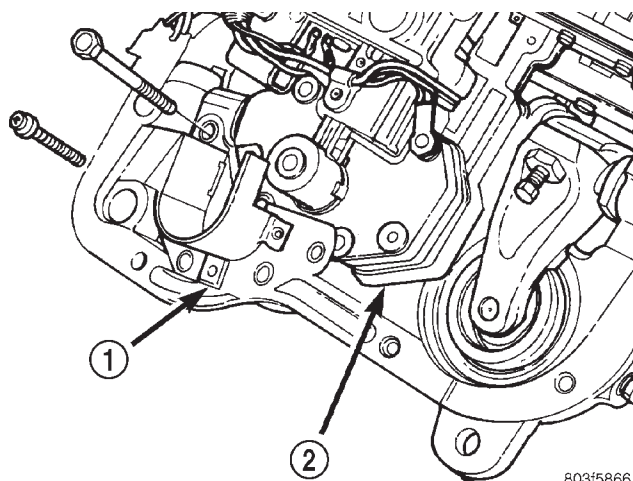
803f5867

**Fig. 76 Pressure Solenoid and O-ring**

- 1 - PRESSURE SOLENOID  
2 - O-RING  
3 - GOVERNOR

(10) Place solenoid retainer in position on governor (Fig. 77).

(11) Install screws to hold pressure solenoid retainer to governor body.



803f5866

**Fig. 77 Pressure Solenoid Retainer**

- 1 - PRESSURE SOLENOID RETAINER  
2 - GOVERNOR

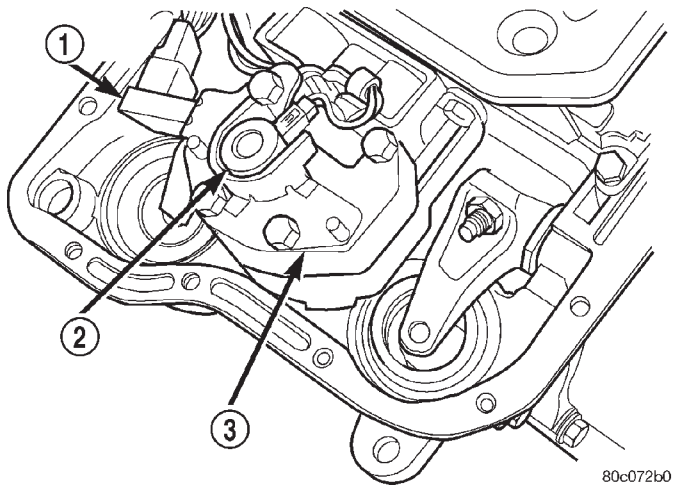
(4) Lubricate o-ring on pressure sensor with transmission fluid.

(5) Align pressure sensor to bore in governor body.



ELECTRONIC GOVERNOR (Continued)

- (12) Engage wire connectors into pressure sensor and solenoid (Fig. 78).
- (13) Install transmission fluid pan and (new) filter.
- (14) Lower vehicle and road test to verify repair.



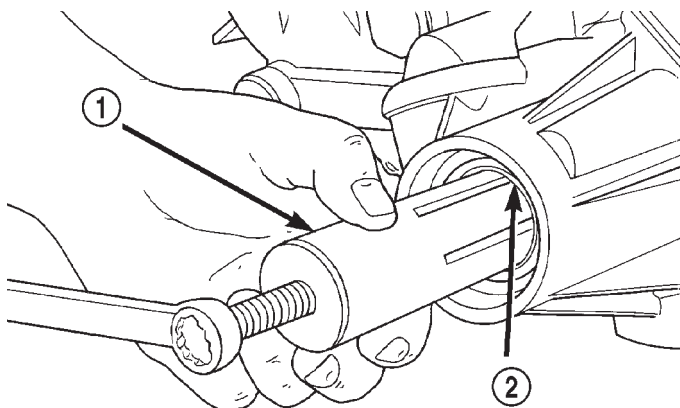
**Fig. 78 Governor Solenoid And Pressure Sensor**

- 1 - PRESSURE SENSOR
- 2 - PRESSURE SOLENOID
- 3 - GOVERNOR

EXTENSION HOUSING BUSHING

REMOVAL

- (1) Remove extension housing yoke seal.
- (2) Insert Remover 6957 into the extension housing. Tighten tool to bushing and remove bushing (Fig. 79).



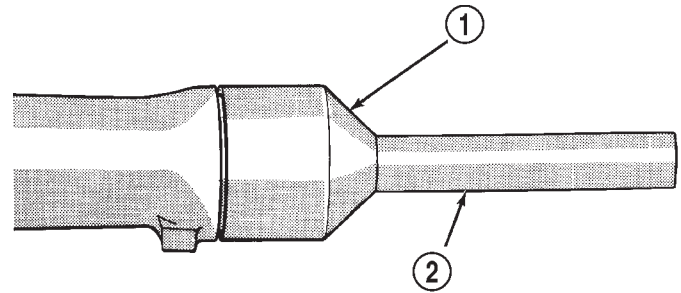
80a11095

**Fig. 79 Bushing Removal - Typical**

- 1 - REMOVER
- 2 - EXTENSION HOUSING BUSHING

INSTALLATION

- (1) Align bushing oil hole with oil slot in extension housing.
- (2) Tap bushing into place with Installer 6951 and Handle C-4171.
- (3) Install new oil seal in housing using Seal Installer C-3995-A (Fig. 80).



J9521-58

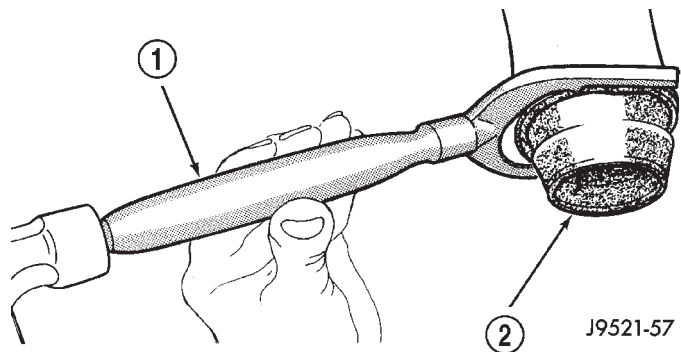
**Fig. 80 Extension Housing Seal Installation**

- 1 - SPECIAL TOOL C-3995-A OR C-3972-A
- 2 - SPECIAL TOOL C-4471

EXTENSION HOUSING SEAL

REMOVAL

- (1) Raise vehicle.
- (2) Mark propeller shaft and axle yoke for alignment reference.
- (3) Disconnect and remove propeller shaft.
- (4) Remove old seal with Seal Remover C-3985-B (Fig. 81) from overdrive housing.



J9521-57

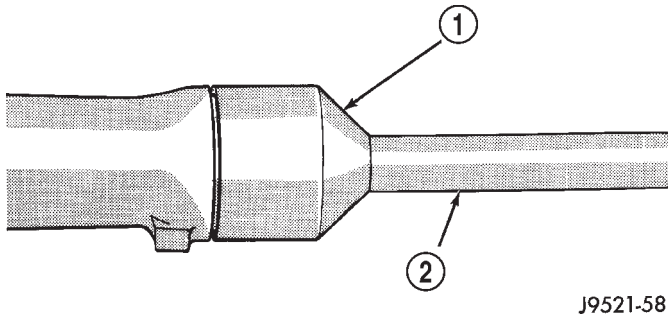
**Fig. 81 Removing Overdrive Housing Yoke Seal**

- 1 - SPECIAL TOOL C-3985-B
- 2 - SEAL

## EXTENSION HOUSING SEAL (Continued)

**INSTALLATION**

- (1) Place seal in position on overdrive housing.
- (2) Drive seal into overdrive housing with Seal Installer C-3995-A (Fig. 82).
- (3) Carefully guide propeller shaft slip yoke into housing and onto output shaft splines. Align marks made at removal and connect propeller shaft to rear axle pinion yoke.



**Fig. 82 Installing Overdrive Housing Seal**

- 1 - SPECIAL TOOL C-3995-A OR C-3972-A  
 2 - SPECIAL TOOL C-4471

**FLUID AND FILTER****DIAGNOSIS AND TESTING - EFFECTS OF INCORRECT FLUID LEVEL**

A low fluid level allows the pump to take in air along with the fluid. Air in the fluid will cause fluid pressures to be low and develop slower than normal. If the transmission is overfilled, the gears churn the fluid into foam. This aerates the fluid and causing the same conditions occurring with a low level. In either case, air bubbles cause fluid overheating, oxidation and varnish buildup which interferes with valve and clutch operation. Foaming also causes fluid expansion which can result in fluid overflow from the transmission vent or fill tube. Fluid overflow can easily be mistaken for a leak if inspection is not careful.

**DIAGNOSIS AND TESTING - CAUSES OF BURNT FLUID**

Burnt, discolored fluid is a result of overheating which has two primary causes.

- (1) A result of restricted fluid flow through the main and/or auxiliary cooler. This condition is usually the result of a faulty or improperly installed drainback valve, a damaged main cooler, or severe restrictions in the coolers and lines caused by debris or kinked lines.
- (2) Heavy duty operation with a vehicle not properly equipped for this type of operation. Trailer towing or similar high load operation will overheat the transmission fluid if the vehicle is improperly

equipped. Such vehicles should have an auxiliary transmission fluid cooler, a heavy duty cooling system, and the engine/axle ratio combination needed to handle heavy loads.

**DIAGNOSIS AND TESTING - FLUID CONTAMINATION**

Transmission fluid contamination is generally a result of:

- adding incorrect fluid
- failure to clean dipstick and fill tube when checking level
- engine coolant entering the fluid
- internal failure that generates debris
- overheat that generates sludge (fluid breakdown)
- failure to reverse flush cooler and lines after repair
- failure to replace contaminated converter after repair

The use of non-recommended fluids can result in transmission failure. The usual results are erratic shifts, slippage, abnormal wear and eventual failure due to fluid breakdown and sludge formation. Avoid this condition by using recommended fluids only.

The dipstick cap and fill tube should be wiped clean before checking fluid level. Dirt, grease and other foreign material on the cap and tube could fall into the tube if not removed beforehand. Take the time to wipe the cap and tube clean before withdrawing the dipstick.

Engine coolant in the transmission fluid is generally caused by a cooler malfunction. The only remedy is to replace the radiator as the cooler in the radiator is not a serviceable part. If coolant has circulated through the transmission, an overhaul is necessary.

The transmission cooler and lines should be reverse flushed whenever a malfunction generates sludge and/or debris. The torque converter should also be replaced at the same time.

Failure to flush the cooler and lines will result in recontamination. Flushing applies to auxiliary coolers as well. The torque converter should also be replaced whenever a failure generates sludge and debris. This is necessary because normal converter flushing procedures will not remove all contaminants.

**STANDARD PROCEDURE - FLUID LEVEL CHECK**

Low fluid level can cause a variety of conditions because it allows the pump to take in air along with the fluid. As in any hydraulic system, air bubbles make the fluid spongy, therefore, pressures will be low and build up slowly.

## FLUID AND FILTER (Continued)

Improper filling can also raise the fluid level too high. When the transmission has too much fluid, the geartrain churns up foam and cause the same conditions which occur with a low fluid level.

In either case, air bubbles can cause overheating and/or fluid oxidation, and varnishing. This can interfere with normal valve, clutch, and accumulator operation. Foaming can also result in fluid escaping from the transmission vent where it may be mistaken for a leak.

Along with fluid level, it is important to check the condition of the fluid. When the fluid smells burned, and is contaminated with metal or friction material particles, a complete transmission recondition is needed. Be sure to examine the fluid on the dipstick closely. If there is any doubt about its condition, drain out a sample for a double check.

After the fluid has been checked, seat the dipstick fully to seal out water and dirt.

The transmission has a dipstick to check oil level. It is located on the right side of the engine. Be sure to wipe all dirt from dipstick handle before removing.

Fluid level is checked with the engine running at curb idle speed, the transmission in NEUTRAL and the transmission fluid at normal operating temperature. **The engine should be running at idle speed for at least one minute, with the vehicle on level ground.**

The transmission fluid level can be checked two ways.

#### PROCEDURE ONE

(1) Transmission fluid must be at normal operating temperature for accurate fluid level check. Drive vehicle if necessary to bring fluid temperature up to normal hot operating temperature of 82°C (180°F).

(2) Position vehicle on level surface.

(3) Start and run engine at curb idle speed.

(4) Apply parking brakes.

(5) Shift transmission momentarily into all gear ranges. Then shift transmission back to NEUTRAL.

(6) Clean top of filler tube and dipstick to keep dirt from entering tube.

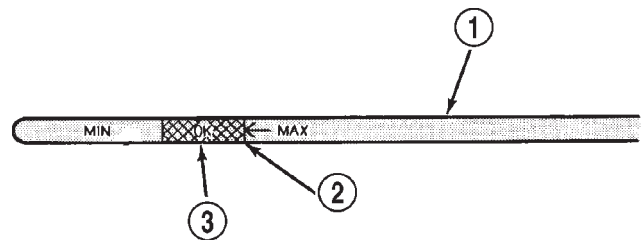
(7) Remove dipstick (Fig. 83) and check fluid level as follows:

(a) Correct acceptable level is in crosshatch area.

(b) Correct maximum level is to MAX arrow mark.

(c) Incorrect level is at or below MIN line.

(d) If fluid is low, add only enough Mopar® ATF +4, type 9602, to restore correct level. Do not over-fill.



804d8eee

**Fig. 83 Dipstick Fluid Level Marks—Typical**

- 1 - DIPSTICK
- 2 - MAXIMUM CORRECT FLUID LEVEL
- 3 - ACCEPTABLE FLUID LEVEL

#### PROCEDURE TWO

(1) Start engine and apply parking brake.

(2) Shift the transmission into DRIVE for approximately 2 seconds.

(3) Shift the transmission into REVERSE for approximately 2 seconds.

(4) Shift the transmission into PARK.

(5) Hook up DRB® scan tool and select engine.

(6) Select sensors.

(7) Read the transmission temperature value.

(8) Compare the fluid temperature value with the chart.

(9) Adjust transmission fluid level shown on the dipstick according to the chart (Fig. 84).

**NOTE:** After adding any fluid to the transmission, wait a minimum of 2 minutes for the oil to fully drain from the fill tube into the transmission before rechecking the fluid level.

(10) Check transmission for leaks.

## FLUID AND FILTER (Continued)

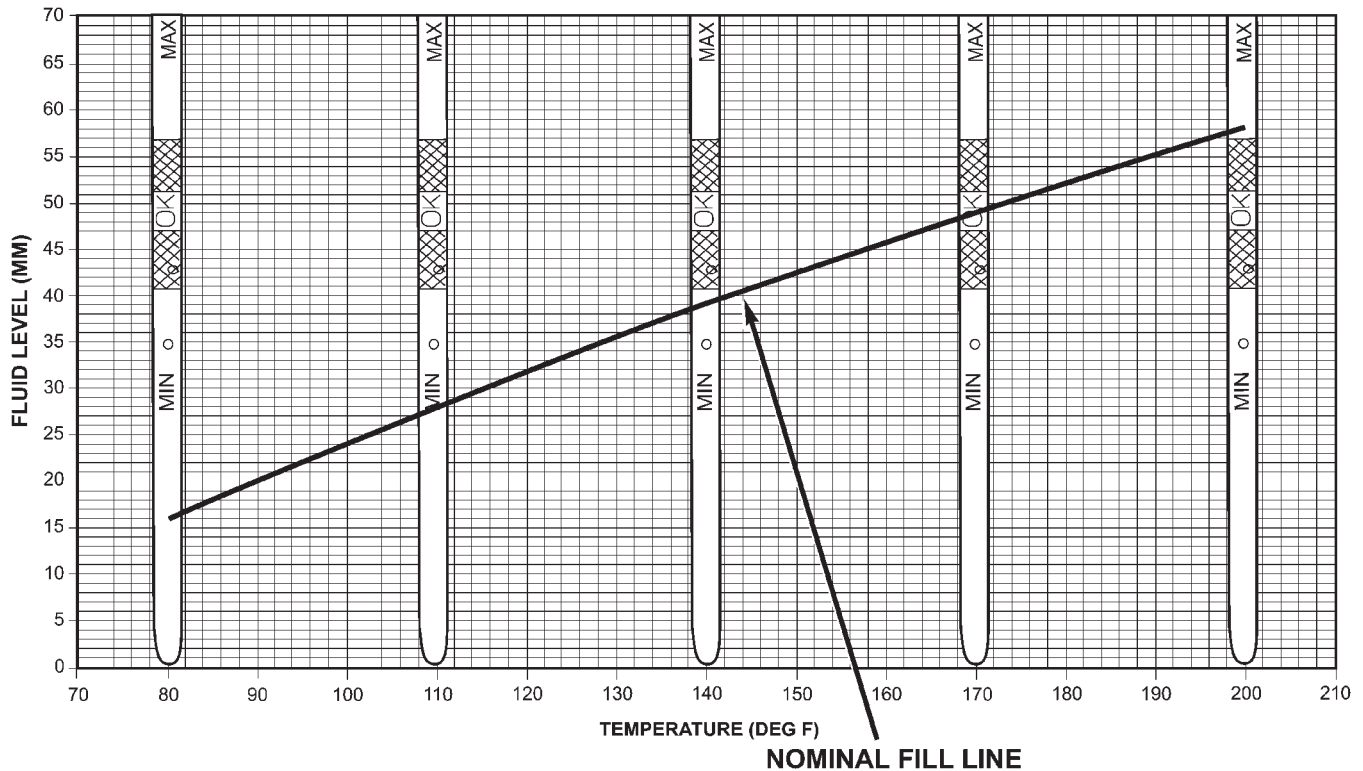


Fig. 84 47RE Fluid Fill Graph

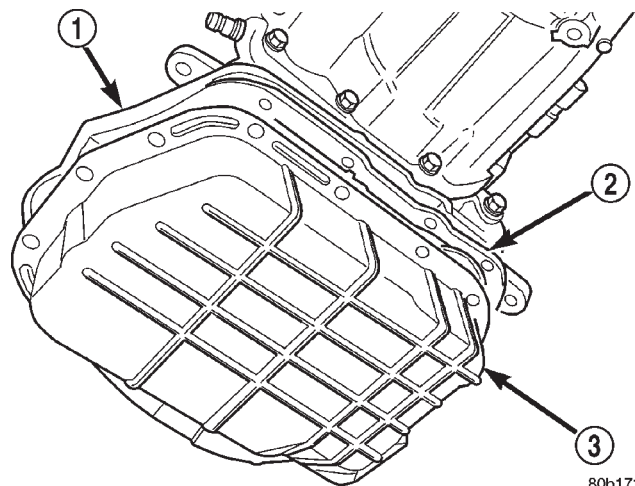
80a3d16f

## STANDARD PROCEDURE - FLUID AND FILTER REPLACEMENT

For proper service intervals (Refer to LUBRICATION & MAINTENANCE/MAINTENANCE SCHEDULES - DESCRIPTION). The service fluid fill after a filter change is approximately 3.8 liters (4.0 quarts).

- (1) Hoist and support vehicle on safety stands.
- (2) Place a large diameter shallow drain pan beneath the transmission pan.
- (3) Remove bolts holding front and sides of pan to transmission (Fig. 85).
- (4) Loosen bolts holding rear of pan to transmission.
- (5) Slowly separate front of pan away from transmission allowing the fluid to drain into drain pan.
- (6) Hold up pan and remove remaining bolt holding pan to transmission.
- (7) While holding pan level, lower pan away from transmission.
- (8) Pour remaining fluid in pan into drain pan.

- (9) Remove screws holding filter to valve body (Fig. 86).
- (10) Separate filter from valve body and pour fluid in filter into drain pan.
- (11) Dispose of used trans fluid and filter properly.



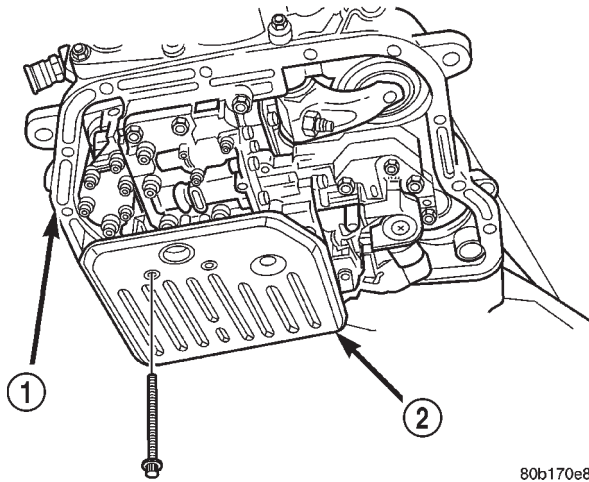
80b17180

Fig. 85 Transmission Pan

- 1 - TRANSMISSION
- 2 - GASKET
- 3 - PAN



## FLUID AND FILTER (Continued)



80b170e8

Fig. 86 Transmission Filter

- 1 - TRANSMISSION  
2 - FILTER

## STANDARD PROCEDURE - TRANSMISSION FILL

To avoid overfilling transmission after a fluid change or overhaul, perform the following procedure:

- (1) Remove dipstick and insert clean funnel in transmission fill tube.
- (2) Add following initial quantity of Mopar® ATF +4, type 9602, to transmission:
  - (a) If only fluid and filter were changed, add **3 pints (1-1/2 quarts)** of ATF +4 to transmission.
  - (b) If transmission was completely overhauled, torque converter was replaced or drained, and cooler was flushed, add **12 pints (6 quarts)** of ATF +4 to transmission.
- (3) Apply parking brakes.
- (4) Start and run engine at normal curb idle speed.
- (5) Apply service brakes, shift transmission through all gear ranges then back to NEUTRAL, set parking brake, and leave engine running at curb idle speed.
- (6) Remove funnel, insert dipstick and check fluid level. If level is low, **add fluid to bring level to MIN mark on dipstick.** Check to see if the oil level is equal on both sides of the dipstick. If one side is noticeably higher than the other, the dipstick has picked up some oil from the dipstick tube. Allow the oil to drain down the dipstick tube and re-check.
- (7) Drive vehicle until transmission fluid is at normal operating temperature.

(8) With the engine running at curb idle speed, the gear selector in NEUTRAL, and the parking brake applied, check the transmission fluid level.

**CAUTION: Do not overfill transmission, fluid foaming and shifting problems can result.**

(9) Add fluid to bring level up to MAX arrow mark.

When fluid level is correct, shut engine off, release park brake, remove funnel, and install dipstick in fill tube.

## FRONT CLUTCH

### DESCRIPTION

The front clutch assembly (Fig. 87) is composed of the front clutch retainer, pressure plate, clutch plates, driving discs, piston, piston return spring, return spring retainer, and snap-rings. The front clutch is the forward-most component in the transmission geartrain and is directly behind the oil pump and is considered a driving component.

**NOTE: The number of discs and plates may vary with each engine and vehicle combination.**

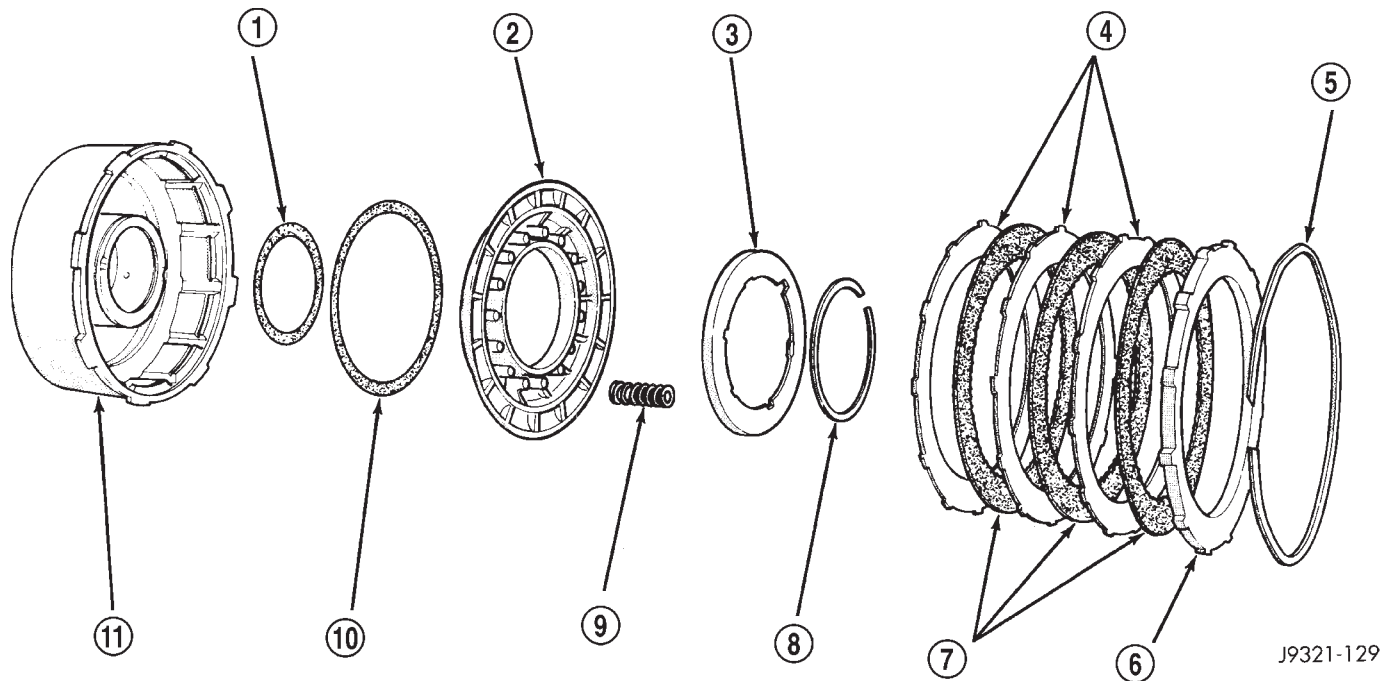
### OPERATION

To apply the clutch, pressure is applied between the clutch retainer and piston. The fluid pressure is provided by the oil pump, transferred through the control valves and passageways, and enters the clutch through the hub of the reaction shaft support. With pressure applied between the clutch retainer and piston, the piston moves away from the clutch retainer and compresses the clutch pack. This action applies the clutch pack, allowing torque to flow through the input shaft into the driving discs, and into the clutch plates and pressure plate that are lugged to the clutch retainer. The waved snap-ring is used to cushion the application of the clutch pack.

When pressure is released from the piston, the spring returns the piston to its fully released position and disengages the clutch. The release spring also helps to cushion the application of the clutch assembly. When the clutch is in the process of being released by the release spring, fluid flows through a vent and one-way ball-check-valve located in the clutch retainer. The check-valve is needed to eliminate the possibility of plate drag caused by centrifugal force acting on the residual fluid trapped in the clutch piston retainer.



## FRONT CLUTCH (Continued)



J9321-129

**Fig. 87 Front Clutch Components**

- |                                   |                               |
|-----------------------------------|-------------------------------|
| 1 - INNER PISTON SEAL             | 7 - CLUTCH DISCS              |
| 2 - CLUTCH PISTON                 | 8 - RETAINER SNAP-RING        |
| 3 - CLUTCH PISTON SPRING RETAINER | 9 - CLUTCH PISTON SPRINGS (9) |
| 4 - CLUTCH PLATES                 | 10 - OUTER PISTON SEAL        |
| 5 - CLUTCH PACK SNAP-RING (WAVED) | 11 - FRONT CLUTCH RETAINER    |
| 6 - REACTION PLATE                |                               |

**DISASSEMBLY**

(1) Remove the waved snap-ring, reaction plate, clutch plates, and clutch discs.

(2) Compress clutch piston retainer and piston springs with Compressor Tool C-3863-A (Fig. 88).

(3) Remove retainer snap-ring and remove compressor tool.

(4) Remove clutch piston springs (Fig. 89). Note position of piston springs for assembly reference.

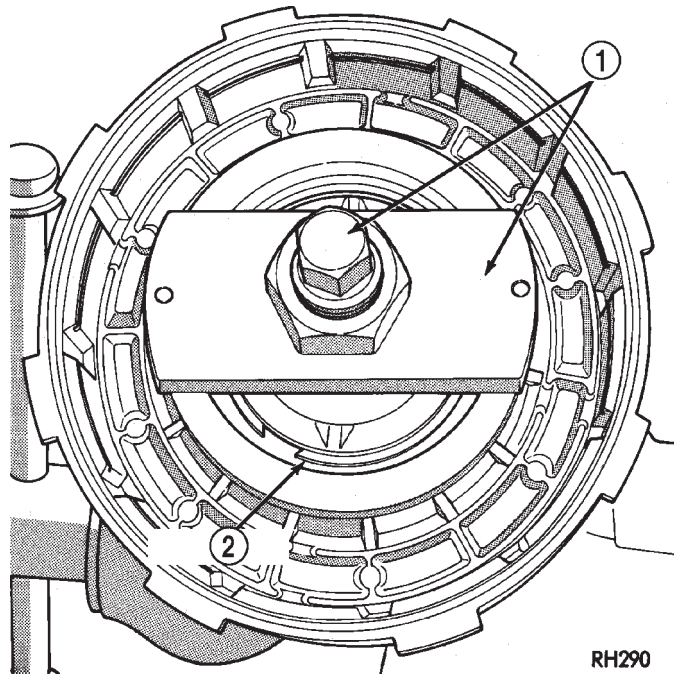
(5) Remove clutch piston from retainer with a twisting motion.

(6) Remove and discard clutch piston inner and outer seals.

(7) Assemble Tool Handle C-4171 and Bushing Remover SP-3629 (Fig. 90).

(8) Insert remover tool in bushing and drive bushing straight out of clutch retainer.

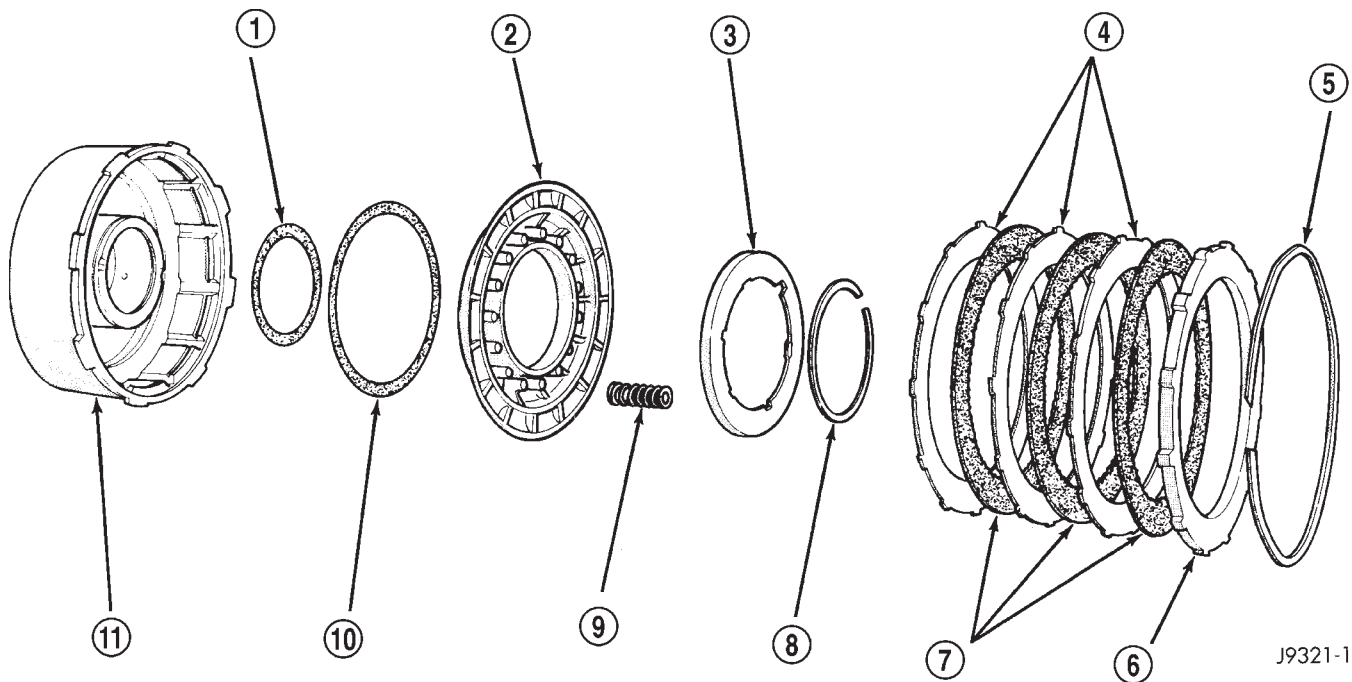
FRONT CLUTCH (Continued)



RH290

**Fig. 88 Removing Front Clutch Spring Retainer Snap-Ring**

- 1 - SPECIAL TOOL C-3863-A
- 2 - SNAP-RING

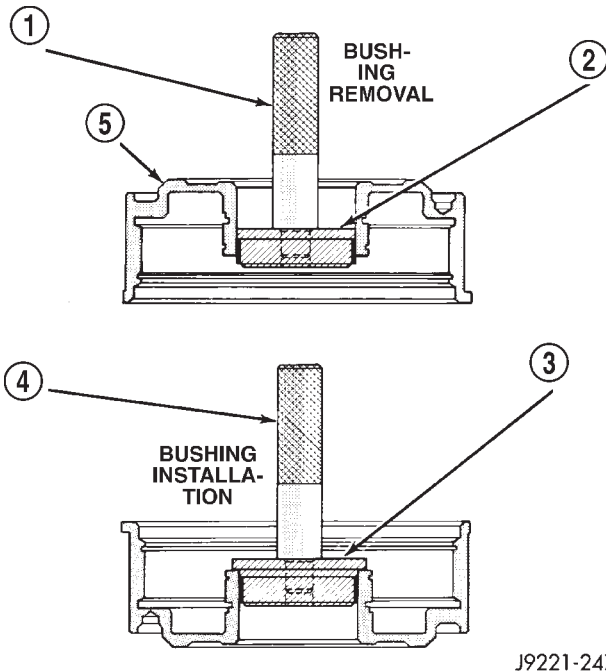


J9321-129

**Fig. 89 Front Clutch Components**

- 1 - INNER PISTON SEAL
- 2 - CLUTCH PISTON
- 3 - CLUTCH PISTON SPRING RETAINER
- 4 - CLUTCH PLATES
- 5 - CLUTCH PACK SNAP-RING (WAVED)
- 6 - REACTION PLATE
- 7 - CLUTCH DISCS
- 8 - RETAINER SNAP-RING
- 9 - CLUTCH PISTON SPRINGS (9)
- 10 - OUTER PISTON SEAL
- 11 - FRONT CLUTCH RETAINER

## FRONT CLUTCH (Continued)



J9221-247

**Fig. 90 Front Clutch Retainer Bushing Replacement Tools**

- 1 - SPECIAL TOOL C-4171
- 2 - SPECIAL TOOL SP-3629
- 3 - SPECIAL TOOL SP-5511
- 4 - SPECIAL TOOL C-4171
- 5 - FRONT CLUTCH RETAINER

## INSPECTION

Inspect the front clutch components. Replace the clutch discs if warped, worn, scored, burned or charred, the lugs are damaged, or if the facing is flaking off. Replace the steel plates and reaction plate if heavily scored, warped, or broken. Be sure the driving lugs on the discs and plate are also in good condition. The lugs must not be bent, cracked or damaged in any way.

Replace the piston springs and spring retainer if either are distorted, warped or broken.

Check the lug grooves in the clutch piston retainer. The steel plates should slide freely in the slots. Replace the piston retainer if the grooves are worn or damaged. Also check action of the check ball in the piston retainer. The ball must move freely and not stick.

Replace the retainer bushing if worn, scored, or there is any doubt about bushing condition.

Inspect the piston and retainer seal surfaces for nicks or scratches. Minor scratches can be removed with crocus cloth. However, replace the piston and/or retainer if the seal surfaces are seriously scored.

Check the clutch piston check ball. The ball should be securely in place. Replace the piston if the ball is missing, or seized in place.

## ASSEMBLY

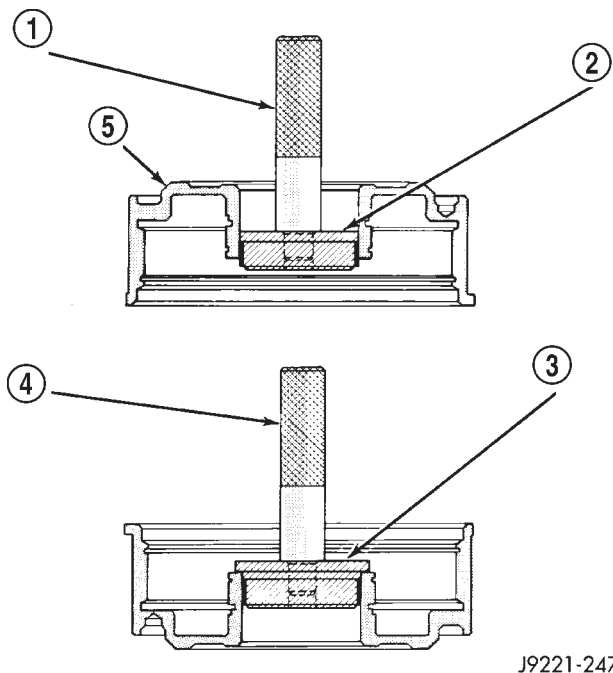
**NOTE:** The 47RE transmission uses four plates and discs for the front clutch.

(1) Mount Bushing Installer SP-5511 on tool handle (Fig. 91).

(2) Slide new bushing onto installer tool and start bushing into retainer.

(3) Tap new bushing into place until installer tool bottoms against clutch retainer.

(4) Remove installer tools and clean retainer thoroughly.



J9221-247

**Fig. 91 Front Clutch Retainer Bushing Replacement Tools**

- 1 - SPECIAL TOOL C-4171
- 2 - SPECIAL TOOL SP-3629
- 3 - SPECIAL TOOL SP-5511
- 4 - SPECIAL TOOL C-4171
- 5 - FRONT CLUTCH RETAINER

(5) Soak clutch discs in transmission fluid.

(6) Install new inner piston seal onto the outer diameter of the clutch retainer inner hub.

(7) Install new outer seal onto the clutch piston. Be sure seal lips of both seals face the interior of the retainer.

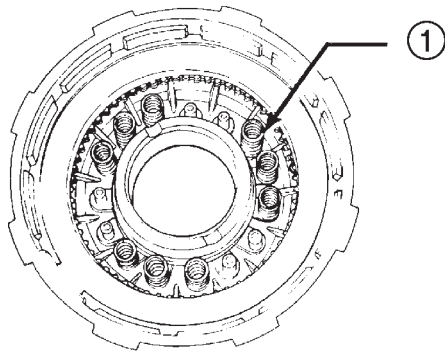
(8) Lubricate new inner and outer piston seals with Ru-Glyde™, or Mopar® Door Ease.

(9) Install clutch piston in retainer. Use twisting motion to seat piston in bottom of retainer. A thin strip of plastic (about 0.015 - 0.020 in. thick), can be used to guide seals into place if necessary.

FRONT CLUTCH (Continued)

**CAUTION:** Never push the clutch piston straight in. This will fold the seals over causing leakage and clutch slip. In addition, never use any type of metal tool to help ease the piston seals into place. Metal tools will cut, shave, or score the seals.

(10) Install and position nine clutch piston springs (Fig. 92).



J9521-75

**Fig. 92 Front Clutch Spring Position**

1 - 9 SPRING CLUTCH

(11) Install spring retainer on top of piston springs.

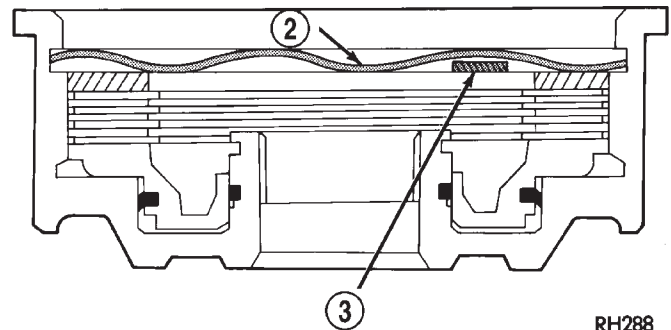
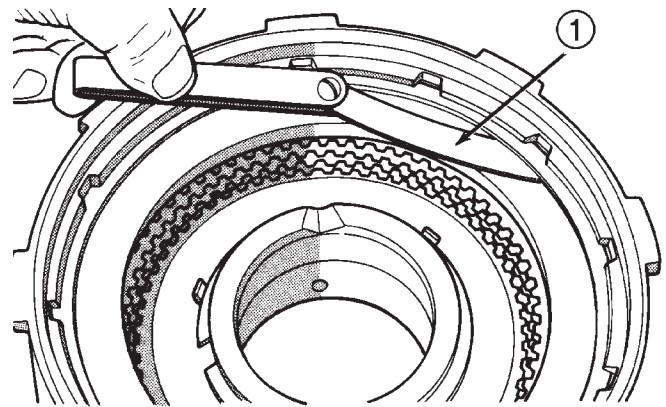
(12) Compress spring retainer and piston springs with Tool C-3863-A.

(13) Install spring retainer snap-ring and remove compressor tool.

(14) Install clutch plates and discs (Fig. 95). Four clutch discs, four steel plates and one reaction plate are required.

(15) Install reaction plate followed by waved snap-ring.

(16) Check clutch pack clearance with feeler gauge (Fig. 93). Clearance between waved spring and pressure plate should 1.78-3.28 mm (0.070-0.129 in.). If clearance is incorrect, clutch plates, clutch discs, snap-ring, or pressure plate may have to be changed.



RH288

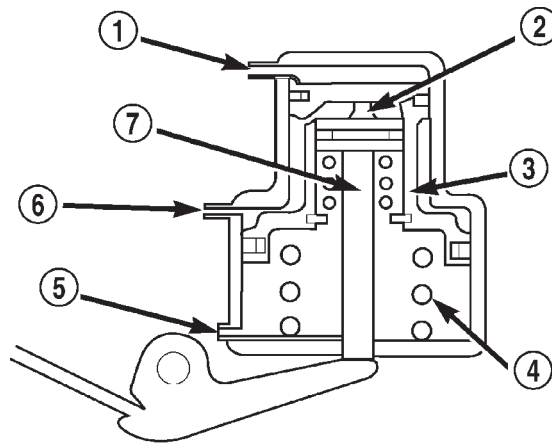
**Fig. 93 Typical Method Of Measuring Front Clutch Pack Clearance**

- 1 - FEELER GAUGE
- 2 - WAVED SNAP-RING
- 3 - FEELER GAUGE

FRONT SERVO

DESCRIPTION

The kickdown servo (Fig. 94) consists of a two-land piston with an inner piston, a piston rod and guide, and a return spring. The dual-land piston uses seal rings on its outer diameters and an O-ring for the inner piston.



80be45fa

**Fig. 94 Front Servo**

- 1 - VENT
- 2 - INNER PISTON
- 3 - PISTON
- 4 - SPRING
- 5 - RELEASE PRESSURE
- 6 - APPLY PRESSURE
- 7 - PISTON ROD

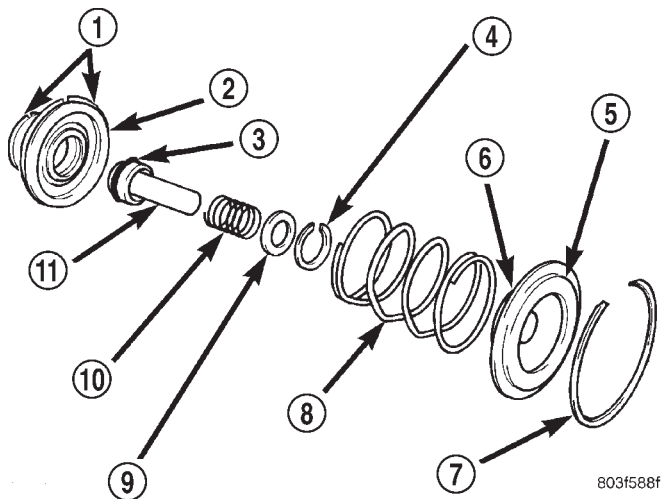
## FRONT SERVO (Continued)

**OPERATION**

The application of the piston is accomplished by applying pressure between the two lands of the piston. The pressure acts against the larger lower land to push the piston downward, allowing the piston rod to extend through its guide against the apply lever. Release of the servo at the 2-3 upshift is accomplished by a combination of spring and line pressure, acting on the bottom of the larger land of the piston. The small piston is used to cushion the application of the band by bleeding oil through a small orifice in the larger piston. The release timing of the kickdown servo is very important to obtain a smooth but firm shift. The release has to be very quick, just as the front clutch application is taking place. Otherwise, engine runaway or a shift hesitation will occur. To accomplish this, the band retains its holding capacity until the front clutch is applied, giving a small amount of overlap between them.

**DISASSEMBLY**

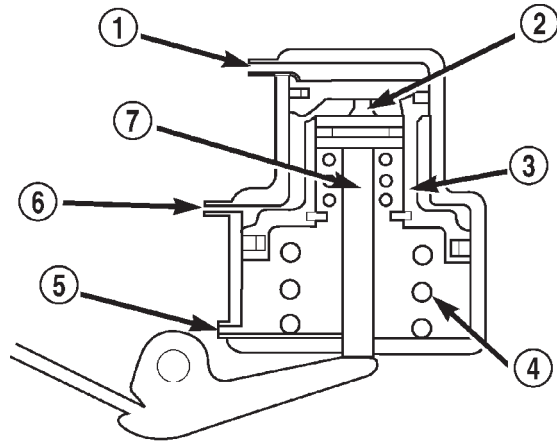
- (1) Remove seal ring from rod guide (Fig. 95).
- (2) Remove small snap-ring from servo piston rod. Then remove piston rod, spring and washer from piston.
- (3) Remove and discard servo component O-ring and seal rings.

**Fig. 95 Front Servo**

- 1 - PISTON RINGS
- 2 - SERVO PISTON
- 3 - O-RING
- 4 - SNAP-RING
- 5 - PISTON ROD GUIDE
- 6 - SEAL RING
- 7 - SNAP-RING
- 8 - SERVO SPRING
- 9 - WASHER
- 10 - SPRING
- 11 - PISTON ROD

**CLEANING**

Clean the servo piston components (Fig. 96) with solvent and dry them with compressed air.



80be45fa

**Fig. 96 Front Servo**

- 1 - VENT
- 2 - INNER PISTON
- 3 - PISTON
- 4 - SPRING
- 5 - RELEASE PRESSURE
- 6 - APPLY PRESSURE
- 7 - PISTON ROD

**INSPECTION**

Inspect the servo components (Fig. 97). Replace the springs if collapsed, distorted or broken. Replace the guide, rod and piston if cracked, bent, or worn. Discard the servo snap-ring if distorted or warped.

Check the servo piston bore for wear. If the bore is severely scored, or damaged, it will be necessary to replace the case.

Replace any servo component if doubt exists about condition. Do not reuse suspect parts.

**ASSEMBLY**

Clean and inspect front servo components.

- (1) Lubricate new o-ring and seal rings with petroleum jelly and install them on piston, guide and rod.
- (2) Install rod in piston. Install spring and washer on rod. Compress spring and install snap-ring (Fig. 98).



## FRONT SERVO (Continued)

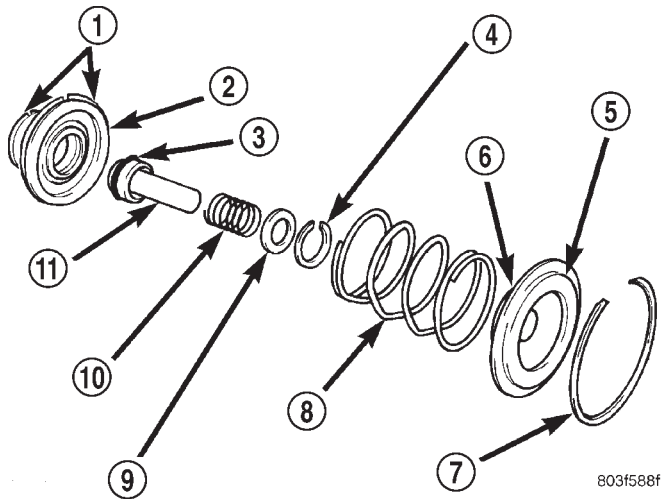


Fig. 97 Front Servo

- 1 - PISTON RINGS
- 2 - SERVO PISTON
- 3 - O-RING
- 4 - SNAP-RING
- 5 - PISTON ROD GUIDE
- 6 - SEAL RING
- 7 - SNAP-RING
- 8 - SERVO SPRING
- 9 - WASHER
- 10 - SPRING
- 11 - PISTON ROD

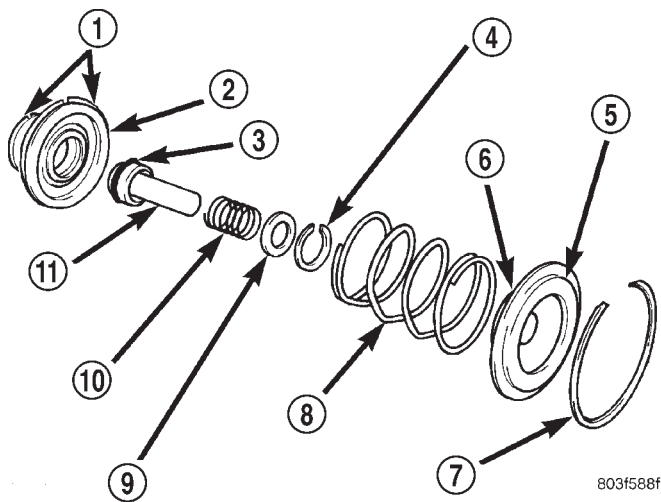


Fig. 98 Front Servo

- 1 - PISTON RINGS
- 2 - SERVO PISTON
- 3 - O-RING
- 4 - SNAP-RING
- 5 - PISTON ROD GUIDE
- 6 - SEAL RING
- 7 - SNAP-RING
- 8 - SERVO SPRING
- 9 - WASHER
- 10 - SPRING
- 11 - PISTON ROD

## OIL PUMP

## DESCRIPTION

The oil pump (Fig. 99) is located in the pump housing inside the bell housing of the transmission case. The oil pump consists of an inner and outer gear, a housing, and a reaction shaft support.

## OPERATION

As the torque converter rotates, the converter hub rotates the inner and outer gears. As the gears rotate, the clearance between the gear teeth increases in the crescent area, and creates a suction at the inlet side of the pump. This suction draws fluid through the pump inlet from the oil pan. As the clearance between the gear teeth in the crescent area decreases, it forces pressurized fluid into the pump outlet and to the valve body.

## STANDARD PROCEDURE - OIL PUMP VOLUME CHECK

Measuring the oil pump output volume will determine if sufficient oil flow to the transmission oil cooler exists, and whether or not an internal transmission failure is present.

Verify that the transmission fluid is at the proper level. Refer to the Fluid Level Check procedure in this section. If necessary, fill the transmission to the proper level with Mopar® ATF +4, type 9602, Automatic Transmission Fluid.

(1) Disconnect the **To cooler** line at the cooler inlet and place a collecting container under the disconnected line.

**CAUTION:** With the fluid set at the proper level, fluid collection should not exceed (1) quart or internal damage to the transmission may occur.

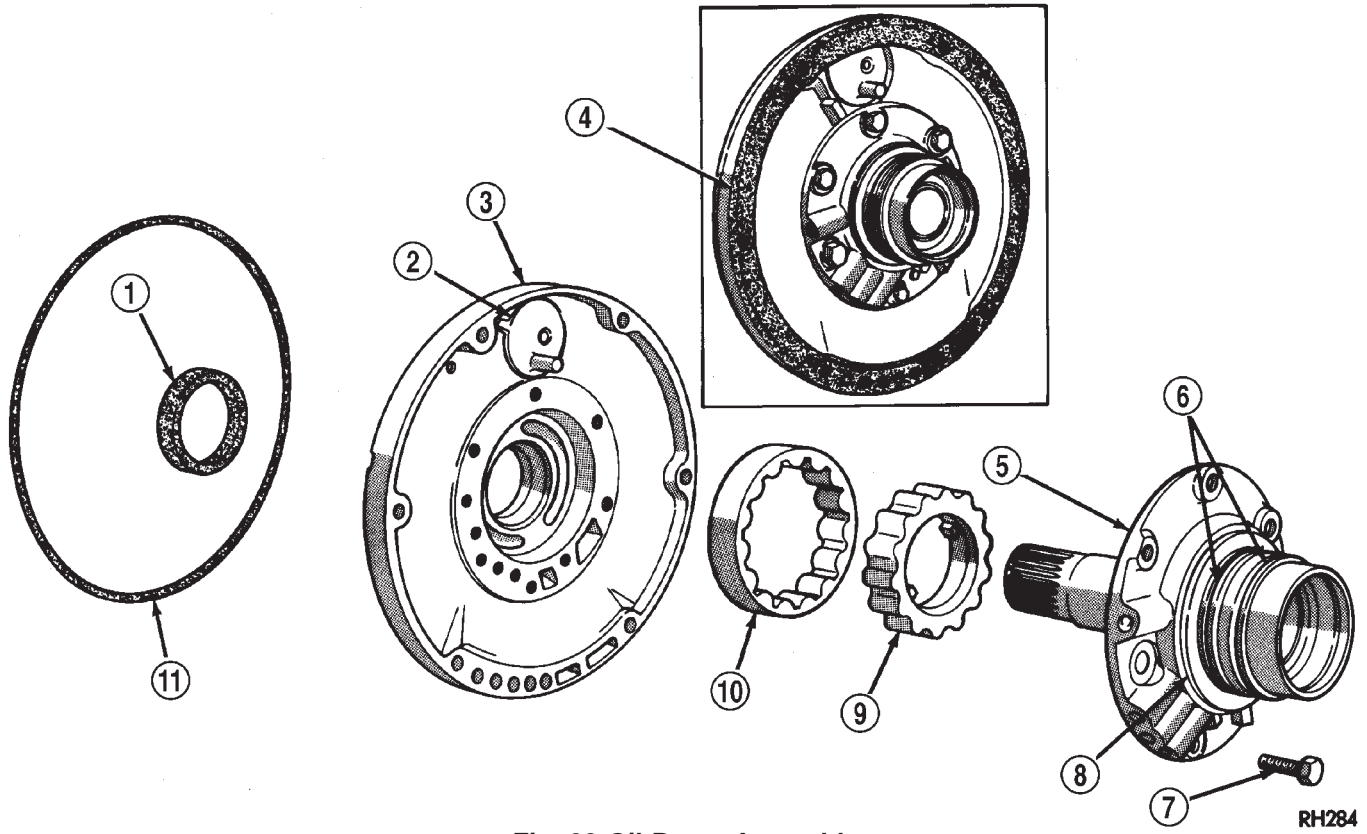
(2) Run the engine **at curb idle speed**, with the shift selector in neutral.

(3) If one quart of transmission fluid is collected in the container in 20 seconds or less, oil pump flow volume is within acceptable limits. If fluid flow is intermittent, or it takes more than 20 seconds to collect one quart of fluid, refer to the Hydraulic Pressure tests in this section for further diagnosis.

(4) Re-connect the **To cooler** line to the transmission cooler inlet.

(5) Refill the transmission to proper level.

OIL PUMP (Continued)



**Fig. 99 Oil Pump Assembly**

- 1 - OIL SEAL
- 2 - VENT BAFFLE
- 3 - OIL PUMP BODY
- 4 - GASKET
- 5 - REACTION SHAFT SUPPORT
- 6 - SEAL RINGS

- 7 - BOLTS (6)
- 8 - #1 THRUST WASHER (SELECTIVE)
- 9 - INNER GEAR
- 10 - OUTER GEAR
- 11 - "O" RING

RH284

## OIL PUMP (Continued)

**DISASSEMBLY**

(1) Mark position of support in oil pump body for assembly alignment reference. Use scribe or paint to make alignment marks.

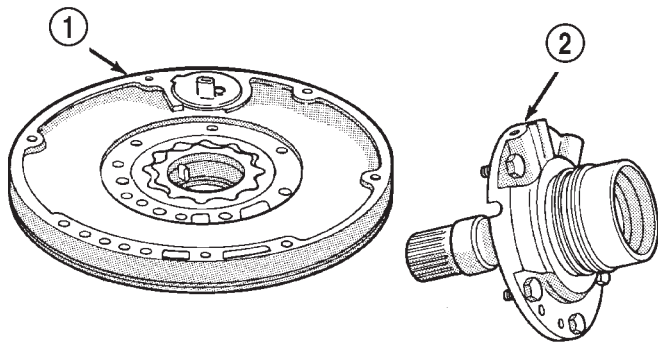
(2) Place pump body on two wood blocks.

(3) Remove reaction shaft support bolts and separate support from pump body (Fig. 100).

(4) Remove pump inner and outer gears (Fig. 101).

(5) Remove o-ring seal from pump body (Fig. 102). Discard seal after removal.

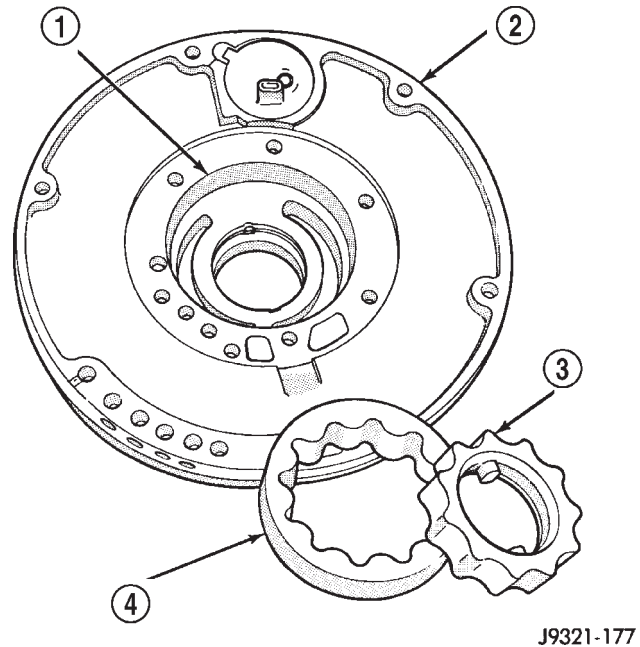
(6) Remove oil pump seal with Remover Tool C-3981. Discard seal after removal.



J9321-176

**Fig. 100 Reaction Shaft Support**

- 1 - OIL PUMP
- 2 - REACTION SHAFT SUPPORT

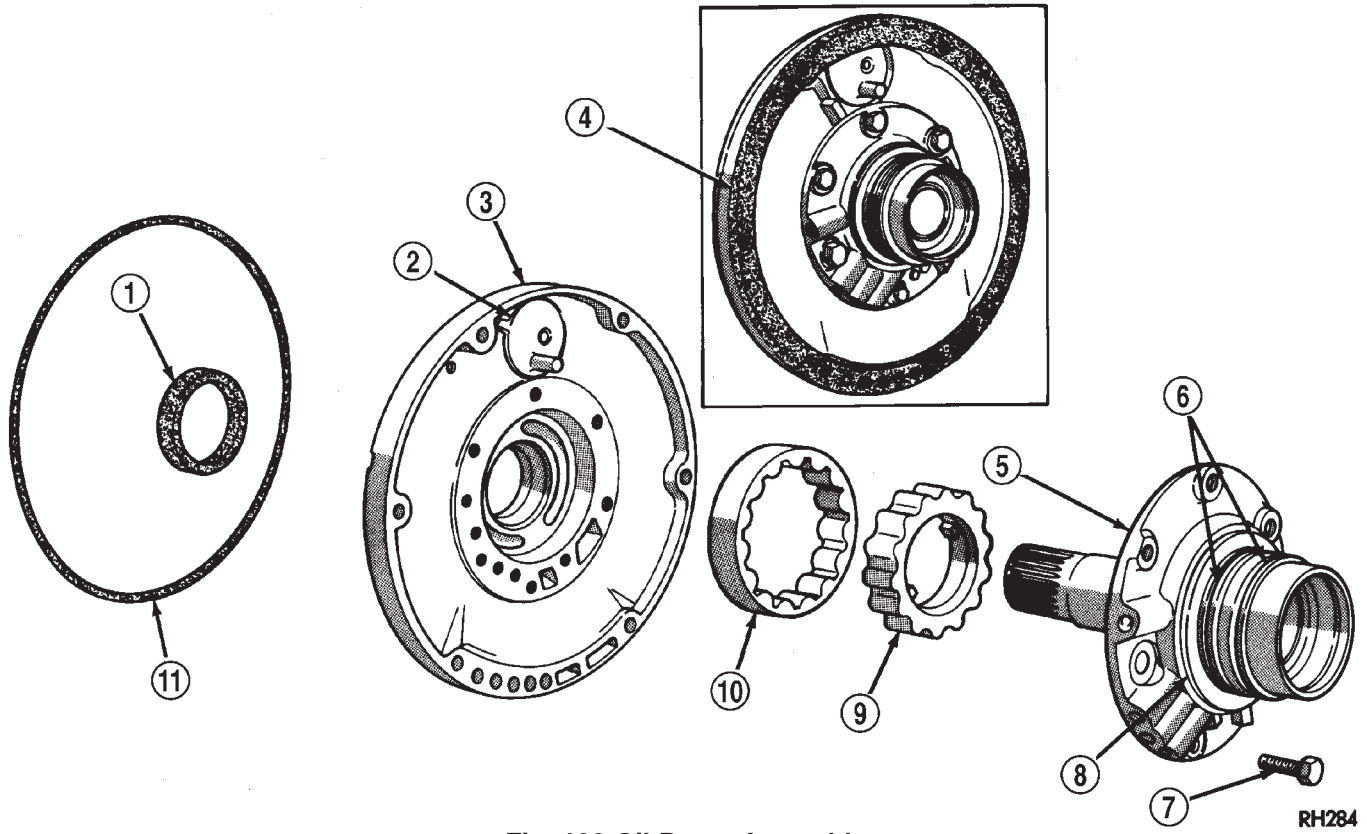


J9321-177

**Fig. 101 Pump Gears**

- 1 - GEAR BORE
- 2 - PUMP BODY
- 3 - INNER GEAR
- 4 - OUTER GEAR

OIL PUMP (Continued)



**Fig. 102 Oil Pump Assembly**

- 1 - OIL SEAL
- 2 - VENT BAFFLE
- 3 - OIL PUMP BODY
- 4 - GASKET
- 5 - REACTION SHAFT SUPPORT
- 6 - SEAL RINGS

- 7 - BOLTS (6)
- 8 - #1 THRUST WASHER (SELECTIVE)
- 9 - INNER GEAR
- 10 - OUTER GEAR
- 11 - "O" RING

RH284

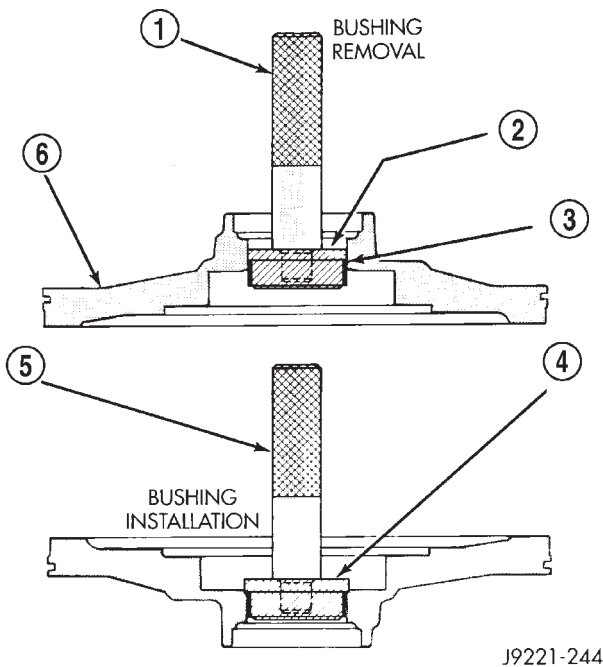
OIL PUMP (Continued)

**OIL PUMP BUSHING REMOVAL**

- (1) Position pump housing on clean, smooth surface with gear cavity facing down.
- (2) Remove bushing with Tool Handle C-4171 and Bushing Remover SP-3550 (Fig. 103).

**REACTION SHAFT SUPPORT BUSHING REMOVAL**

- (1) Assemble Cup Tool SP-3633, Nut SP-1191 and Bushing Remover SP-5301 (Fig. 104).
- (2) Hold cup tool firmly against reaction shaft. Thread remover tool into bushing as far as possible by hand.
- (3) Using wrench, thread remover tool an additional 3-4 turns into bushing to firmly engage tool.
- (4) Tighten tool hex nut against cup tool to pull bushing from shaft. Clean all chips from shaft and support after bushing removal.



**Fig. 103 Oil Pump Bushing**

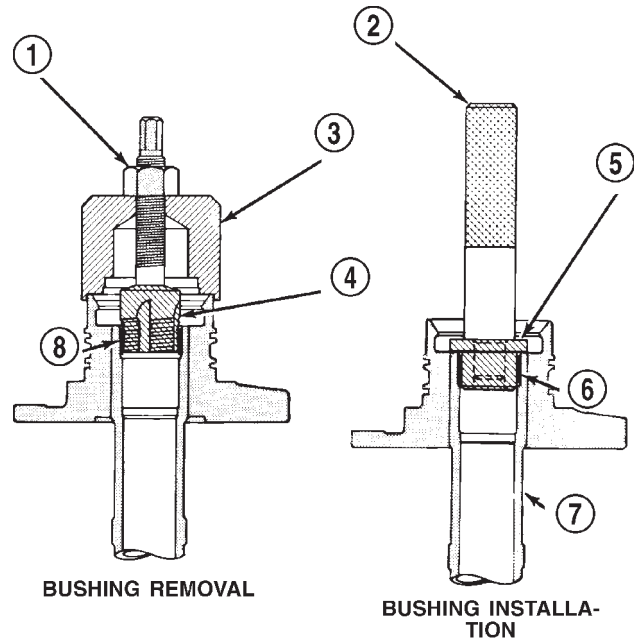
- 1 - SPECIAL TOOL C-4171
- 2 - SPECIAL TOOL SP-3550
- 3 - BUSHING
- 4 - SPECIAL TOOL SP-5118
- 5 - SPECIAL TOOL C-4171
- 6 - PUMP HOUSING

**CLEANING**

Clean pump and support components with solvent and dry them with compressed air.

**INSPECTION**

Check condition of the seal rings and thrust washer on the reaction shaft support. The seal rings do not need to be replaced unless cracked, broken, or severely worn.



**Fig. 104 Reaction Shaft Bushing**

- 1 - SPECIAL TOOL SP-1191
- 2 - SPECIAL TOOL C-4171
- 3 - SPECIAL TOOL SP-3633
- 4 - SPECIAL TOOL SP-5301
- 5 - SPECIAL TOOL SP-5302
- 6 - BUSHING
- 7 - REACTION SHAFT
- 8 - BUSHING

Inspect the pump and support components. Replace the pump or support if the seal ring grooves or machined surfaces are worn, scored, pitted, or damaged. Replace the pump gears if pitted, worn chipped, or damaged.

Inspect the pump bushing. Then check the reaction shaft support bushing. Replace either bushing only if heavily worn, scored or damaged. It is not necessary to replace the bushings unless they are actually damaged.

Clearance between outer gear and reaction shaft housing should be 0.010 to 0.063 mm (0.0004 to 0.0025 in.). Clearance between inner gear and reaction shaft housing should be 0.010 to 0.063 mm (0.0004 to 0.0025 in.). Both clearances can be measured at the same time by installing the gears in the pump body and measure pump component clearances as follows:

- (1) Position an appropriate piece of Plastigage™ across both gears.
- (2) Align the plastigage to a flat area on the reaction shaft housing.
- (3) Install the reaction shaft to the pump housing.

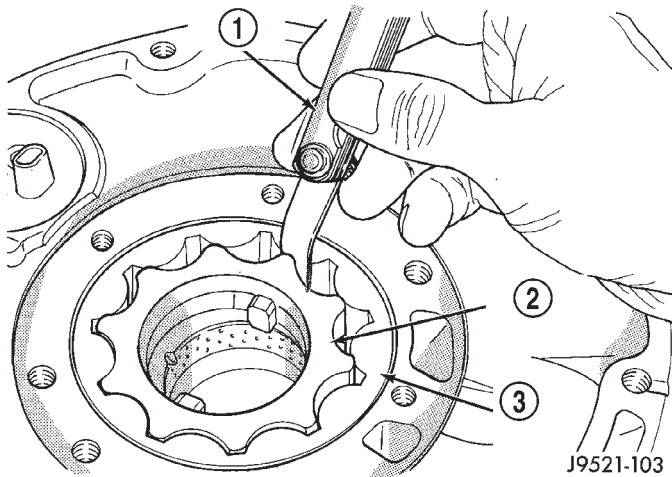


## OIL PUMP (Continued)

(4) Separate the reaction shaft housing from the pump housing and measure the Plastigage™ following the instructions supplied with it.

Clearance between inner gear tooth and outer gear should be 0.08 to 0.19 mm (0.0035 to 0.0075 in.). Measure clearance with an appropriate feeler gauge (Fig. 105).

Clearance between outer gear and pump housing should be 0.10 to 0.19 mm (0.004 to 0.0075 in.). Measure clearance with an appropriate feeler gauge.



**Fig. 105 Checking Pump Gear Tip Clearance**

- 1 - FEELER GAUGE
- 2 - INNER GEAR
- 3 - OUTER GEAR

## ASSEMBLY

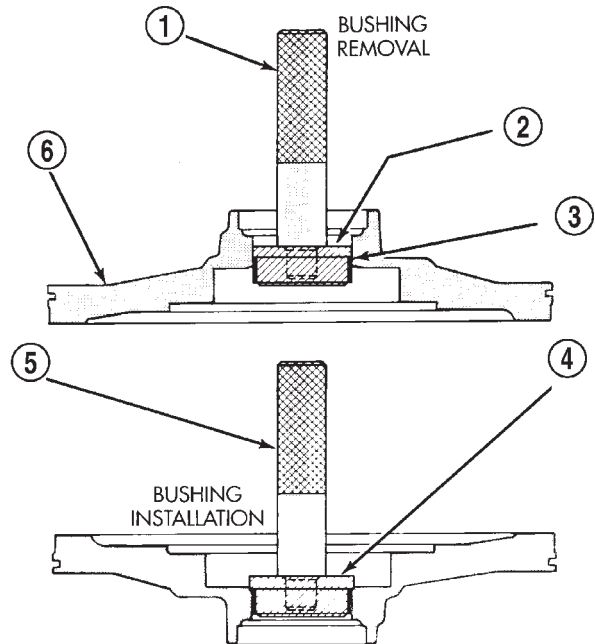
## OIL PUMP BUSHING

(1) Assemble Tool Handle C-4171 and Bushing Installer SP-5118 (Fig. 106).

(2) Place bushing on installer tool and start bushing into shaft.

(3) Tap bushing into place until Installer Tool SP-5118 bottoms in pump cavity. Keep tool and bushing square with bore. Do not allow bushing to become cocked during installation.

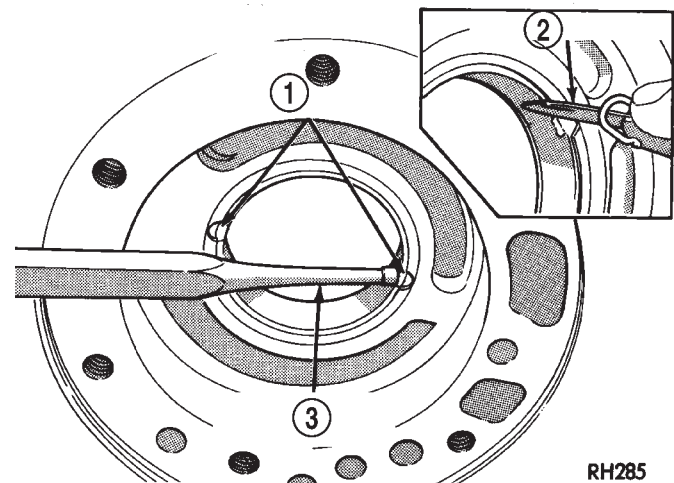
(4) Stake pump bushing in two places with blunt punch. Remove burrs from stake points with knife blade (Fig. 107).



J9221-244

**Fig. 106 Oil Pump Bushing**

- 1 - SPECIAL TOOL C-4171
- 2 - SPECIAL TOOL SP-3550
- 3 - BUSHING
- 4 - SPECIAL TOOL SP-5118
- 5 - SPECIAL TOOL C-4171
- 6 - PUMP HOUSING



RH285

**Fig. 107 Staking-Deburring Oil Pump Bushing**

- 1 - TWO STAKES
- 2 - NARROW BLADE
- 3 - BLUNT PUNCH

## OIL PUMP (Continued)

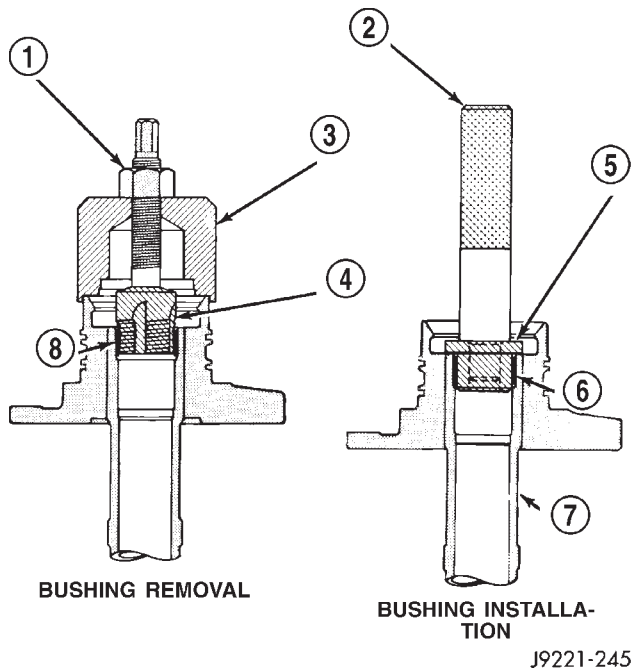
**REACTION SHAFT SUPPORT BUSHING**

(1) Place reaction shaft support upright on a clean, smooth surface.

(2) Assemble Bushing Installer Tools C-4171 and SP-5302. Then slide new bushing onto installer tool (Fig. 108).

(3) Start bushing in shaft. Tap bushing into shaft until installer tool bottoms against support flange.

(4) Clean reaction shaft support thoroughly after bushing replacement (to remove any chips).



**Fig. 108 Reaction Shaft Bushing**

- 1 - SPECIAL TOOL SP-1191
- 2 - SPECIAL TOOL C-4171
- 3 - SPECIAL TOOL SP-3633
- 4 - SPECIAL TOOL SP-5301
- 5 - SPECIAL TOOL SP-5302
- 6 - BUSHING
- 7 - REACTION SHAFT
- 8 - BUSHING

**OIL PUMP BODY**

(1) Lubricate pump gears with transmission fluid and install them in pump body.

(2) Install thrust washer on reaction shaft support hub. Lubricate washer with petroleum jelly or transmission fluid before installation.

(3) If reaction shaft seal rings are being replaced, install new seal rings on support hub. Lubricate seal rings with transmission fluid or petroleum jelly after installation. Squeeze each ring until ring ends are securely hooked together.

**CAUTION:** The reaction shaft support seal rings will break if overspread, or twisted. If new rings are

being installed, spread them only enough for installation. Also be very sure the ring ends are securely hooked together after installation. Otherwise, the rings will either prevent pump installation, or break during installation.

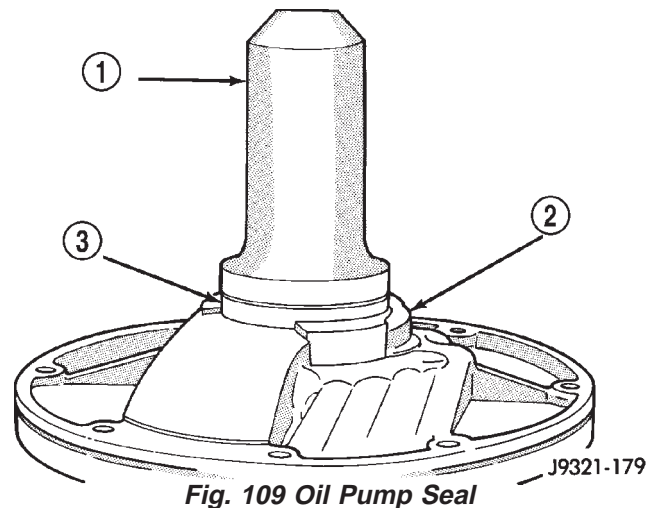
(4) Align and install reaction shaft support on pump body.

(5) Install bolts attaching reaction shaft support to pump. Tighten bolts to 20 N·m (175 in. lbs.) torque.

(6) Install new pump seal with Installer Tool C-3860-A (Fig. 109). Use hammer or mallet to tap seal into place.

(7) Install new o-ring on pump body. Lubricate oil seal and o-ring with petroleum jelly.

(8) Cover pump assembly to prevent dust entry and set aside for assembly installation.



**Fig. 109 Oil Pump Seal**

- 1 - SPECIAL TOOL C-3860-A
- 2 - PUMP BODY
- 3 - PUMP SEAL

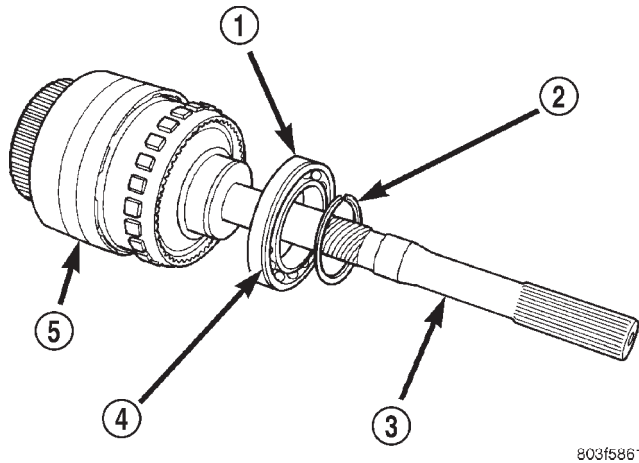
**OUTPUT SHAFT FRONT BEARING****REMOVAL**

- (1) Remove overdrive unit from the vehicle.
- (2) Remove overdrive geartrain from housing.
- (3) Remove snap-ring holding output shaft front bearing to overdrive geartrain. (Fig. 110).
- (4) Pull bearing from output shaft.

**INSTALLATION**

- (1) Place replacement bearing in position on geartrain with locating retainer groove toward the rear.
- (2) Push bearing onto shaft until the snap-ring groove is visible.
- (3) Install snap-ring to hold bearing onto output shaft.

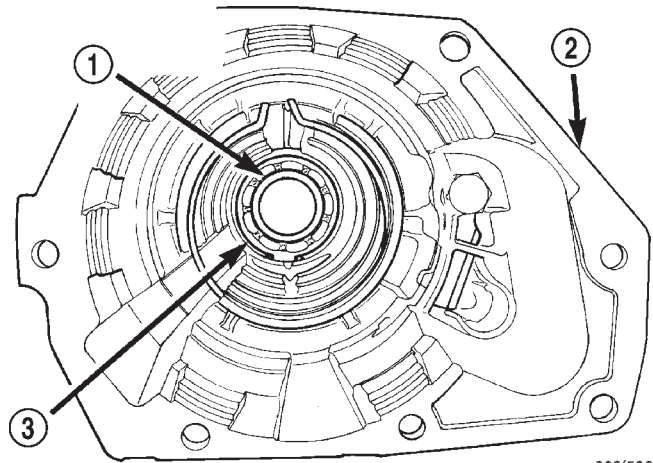
## OUTPUT SHAFT FRONT BEARING (Continued)



803f5861

**Fig. 110 Output Shaft Front Bearing**

- 1 - OUTPUT SHAFT FRONT BEARING
- 2 - SNAP-RING
- 3 - OUTPUT SHAFT
- 4 - GROOVE TO REAR
- 5 - OVERDRIVE GEARTRAIN



803f5860

**Fig. 111 Output Shaft Rear Bearing**

- 1 - OUTPUT SHAFT REAR BEARING
- 2 - OVERDRIVE HOUSING
- 3 - SNAP-RING

- (4) Install overdrive geartrain into housing.
- (5) Install overdrive unit in vehicle.

## OUTPUT SHAFT REAR BEARING

## REMOVAL

- (1) Remove overdrive unit from the vehicle. (Refer to 21 - TRANSMISSION/TRANSAXLE/AUTOMATIC/OVERDRIVE - REMOVAL)
- (2) Remove overdrive geartrain from housing.
- (3) Remove snap-ring holding output shaft rear bearing into overdrive housing (Fig. 111).
- (4) Using a suitable driver inserted through the rear end of housing, drive bearing from housing.

## INSTALLATION

- (1) Place replacement bearing in position in housing.
- (2) Using a suitable driver, drive bearing into housing until the snap-ring groove is visible.
- (3) Install snap-ring to hold bearing into housing (Fig. 112).
- (4) Install overdrive geartrain into housing.
- (5) Install overdrive unit in vehicle.

## OVERDRIVE CLUTCH

## DESCRIPTION

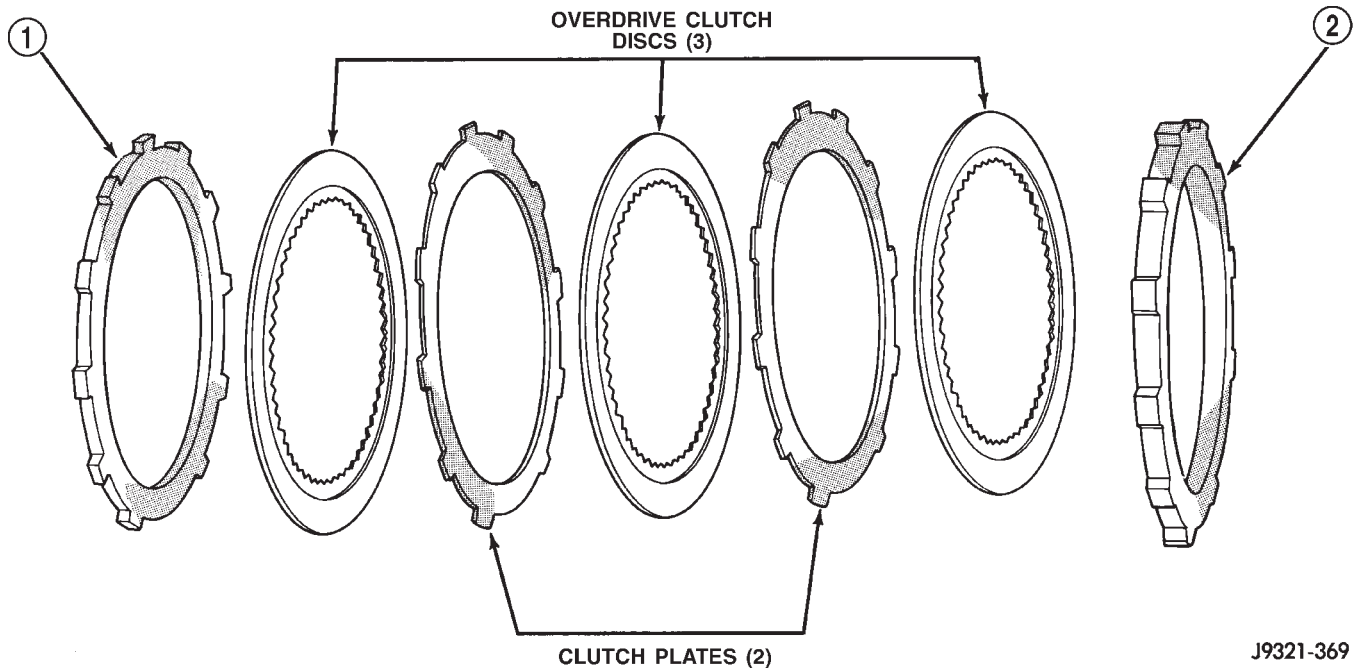
The overdrive clutch (Fig. 112) is composed of the pressure plate, clutch plates, holding discs, overdrive piston retainer, piston, piston spacer, and snap-rings. The overdrive clutch is the forwardmost component in the transmission overdrive unit and is considered a holding component. The overdrive piston retainer, piston, and piston spacer are located on the rear of the main transmission case.

**NOTE:** The number of discs and plates may vary with each engine and vehicle combination.

## OPERATION

To apply the clutch, pressure is applied between the piston retainer and piston. The fluid pressure is provided by the oil pump, transferred through the control valves and passageways, and enters the clutch through passages at the lower rear portion of the valve body area. With pressure applied between the piston retainer and piston, the piston moves away from the piston retainer and compresses the clutch pack. This action applies the clutch pack, allowing torque to flow through the intermediate shaft into the overdrive planetary gear set. The overdrive clutch discs are attached to the overdrive clutch hub while the overdrive clutch plates, reaction plate, and pressure plate are lugged to the overdrive housing. This allows the intermediate shaft to transfer the engine torque to the planetary gear and overrunning clutch. This drives the planetary gear inside the annulus, which is attached to the overdrive clutch

## OVERDRIVE CLUTCH (Continued)



J9321-369

**Fig. 112 Overdrive Clutch**

1 - REACTION PLATE

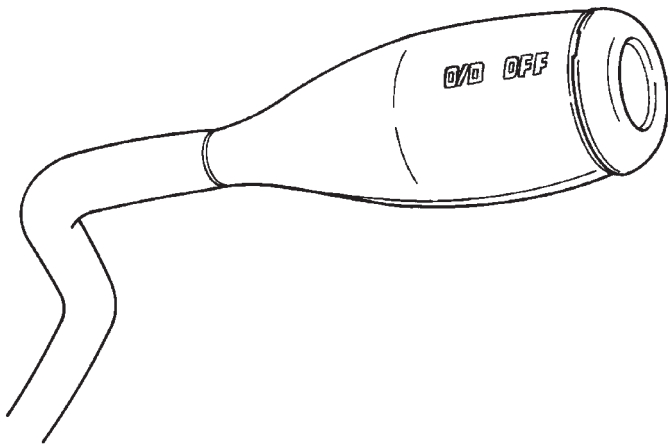
2 - PRESSURE PLATE

drum and output shaft, creating the desired gear ratio. The waved snap-ring is used to cushion the application of the clutch pack.

## OVERDRIVE SWITCH

### DESCRIPTION

The overdrive OFF (control) switch is located in the shift lever arm (Fig. 113). The switch is a momentary contact device that signals the PCM to toggle current status of the overdrive function.



80a8e1c1

**Fig. 113 Overdrive Off Switch**

### OPERATION

At key-on, overdrive operation is allowed. Pressing the switch once causes the overdrive OFF mode to be entered and the overdrive OFF switch lamp to be illuminated. Pressing the switch a second time causes normal overdrive operation to be restored and the overdrive lamp to be turned off. The overdrive OFF mode defaults to ON after the ignition switch is cycled OFF and ON. The normal position for the control switch is the ON position. The switch must be in this position to energize the solenoid and allow a 3-4 upshift. The control switch indicator light illuminates only when the overdrive switch is turned to the OFF position, or when illuminated by the transmission control module.

### DIAGNOSIS AND TESTING - OVERDRIVE ELECTRICAL CONTROLS

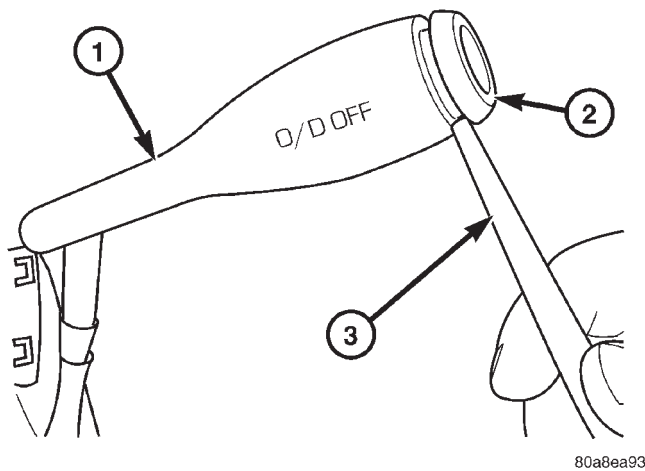
The overdrive off switch, valve body solenoid, case connectors and related wiring can all be tested with a 12 volt test lamp or a volt/ohmmeter. Check continuity of each component when diagnosis indicates this is necessary.

Switch and solenoid continuity should be checked whenever the transmission fails to shift into fourth gear range.

## OVERDRIVE SWITCH (Continued)

## REMOVAL

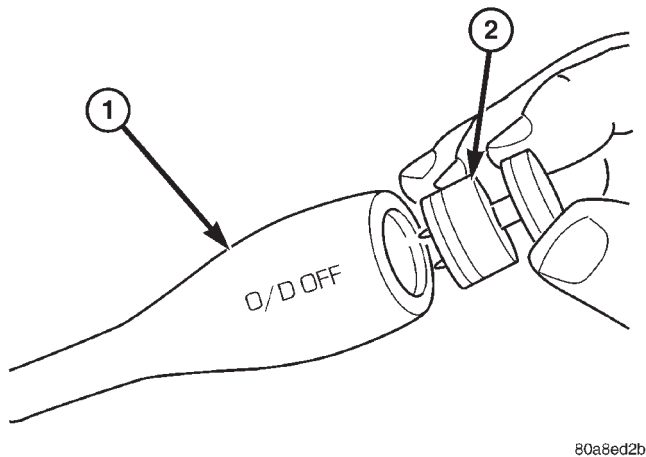
(1) Using a plastic trim tool, remove the overdrive off switch retainer from the shift lever (Fig. 114).



**Fig. 114 Overdrive Off Switch Retainer**

- 1 - GEAR SHIFT LEVER
- 2 - OVERDRIVE OFF SWITCH RETAINER
- 3 - PLASTIC TRIM TOOL

(2) Pull the switch outwards to release it from the connector in the lever (Fig. 115)



**Fig. 115 Remove the Overdrive Off Switch**

- 1 - GEAR SHIFT LEVER
- 2 - OVERDRIVE OFF SWITCH

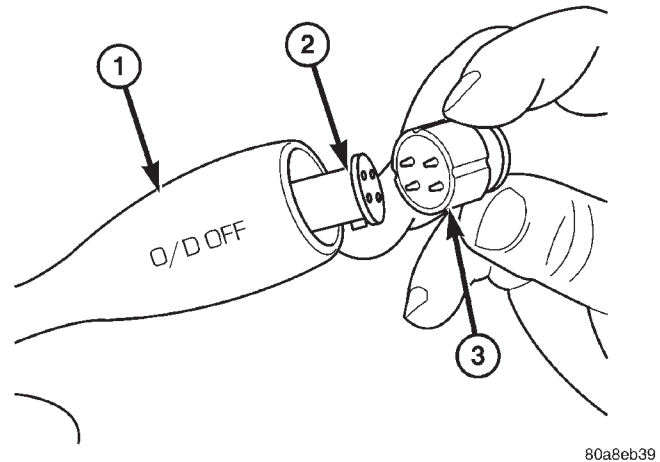
## INSTALLATION

**NOTE:** There is enough slack in the wire to pull out the connector from the lever.

(1) Pull the connector out of the lever just enough to grasp it.

**CAUTION:** Be careful not to bend the pins on the overdrive off switch. Use care when installing the switch, as it is not indexed, and can be accidentally installed incorrectly.

(2) Install the overdrive off switch into the connector (Fig. 116)



**Fig. 116 Install the Overdrive Off Switch**

- 1 - GEAR SHIFT LEVER
- 2 - OVERDRIVE OFF SWITCH WIRING CONNECTOR
- 3 - OVERDRIVE OFF SWITCH

(3) Push the overdrive off switch and wiring into the shift lever.

(4) Install the overdrive off switch retainer onto the shift lever.

## OVERDRIVE UNIT

## REMOVAL

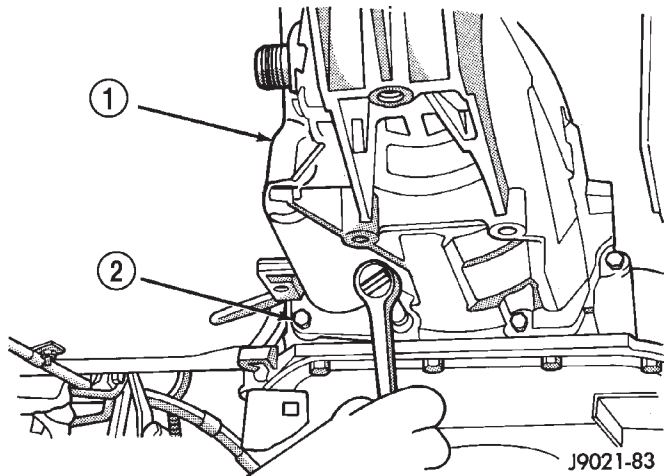
- (1) Shift transmission into PARK.
- (2) Raise vehicle.
- (3) Remove transfer case, if equipped.
- (4) Mark propeller shaft universal joint(s) and axle pinion yoke, or the companion flange and flange yoke, for alignment reference at installation, if necessary.
- (5) Disconnect and remove the rear propeller shaft, if necessary. (Refer to 3 - DIFFERENTIAL & DRIVELINE/PROPELLER SHAFT/PROPELLER SHAFT - REMOVAL)
- (6) Remove transmission oil pan, remove gasket, drain oil and reinstall pan.
- (7) If overdrive unit had malfunctioned, or if fluid is contaminated, remove entire transmission. If diagnosis indicated overdrive problems only, remove just the overdrive unit.
- (8) Support transmission with transmission jack.



## OVERDRIVE UNIT (Continued)

(9) Remove bolts attaching overdrive unit to transmission (Fig. 117).

**CAUTION:** Support the overdrive unit with a jack before moving it rearward. This is necessary to prevent damaging the intermediate shaft. Do not allow the shaft to support the entire weight of the overdrive unit.



**Fig. 117 Overdrive Unit Bolts**

- 1 - OVERDRIVE UNIT
- 2 - ATTACHING BOLTS (7)

(10) Carefully work overdrive unit off intermediate shaft. Do not tilt unit during removal. Keep it as level as possible.

(11) If overdrive unit does not require service, immediately insert Alignment Tool 6227-2 in splines of planetary gear and overrunning clutch to prevent splines from rotating out of alignment. If misalignment occurs, overdrive unit will have to be disassembled in order to realign splines.

(12) Remove and retain overdrive piston thrust bearing. Bearing may remain on piston or in clutch hub during removal.

(13) Position drain pan on workbench.

(14) Place overdrive unit over drain pan. Tilt unit to drain residual fluid from case.

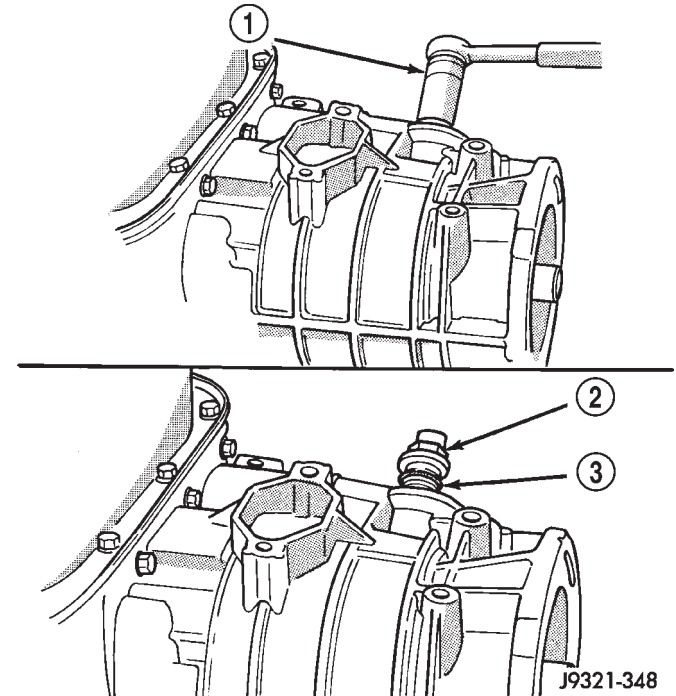
(15) Examine fluid for clutch material or metal fragments. If fluid contains these items, overhaul will be necessary.

(16) If overdrive unit does not require any service, leave alignment tool in position. Tool will prevent accidental misalignment of planetary gear and overrunning clutch splines.

## DISASSEMBLY

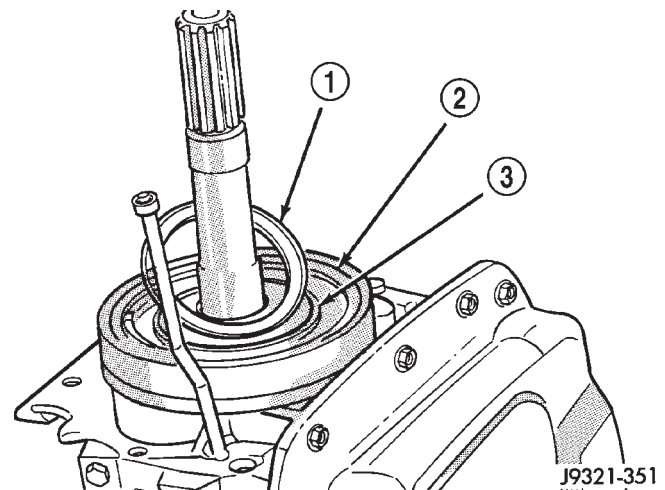
(1) Remove transmission speed sensor and o-ring seal from overdrive case (Fig. 118).

(2) Remove overdrive piston thrust bearing (Fig. 119).



**Fig. 118 Transmission Speed Sensor**

- 1 - SOCKET AND WRENCH
- 2 - SPEED SENSOR
- 3 - O-RING



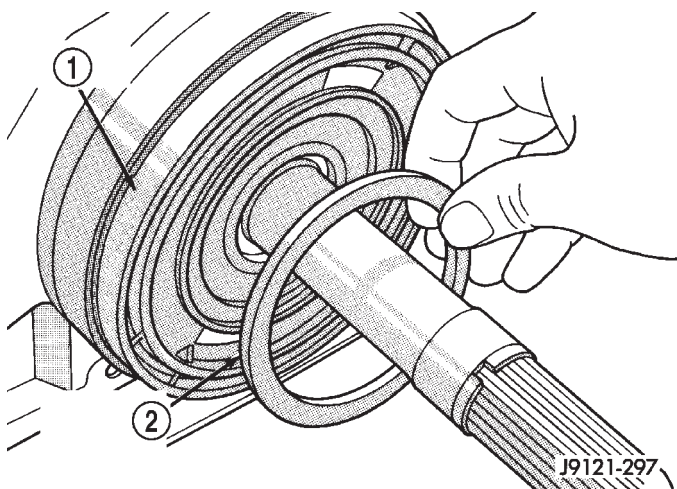
**Fig. 119 Overdrive Piston Thrust Bearing Removal/Installation**

- 1 - THRUST BEARING
- 2 - OVERDRIVE PISTON
- 3 - THRUST PLATE

## OVERDRIVE UNIT (Continued)

**OVERDRIVE PISTON**

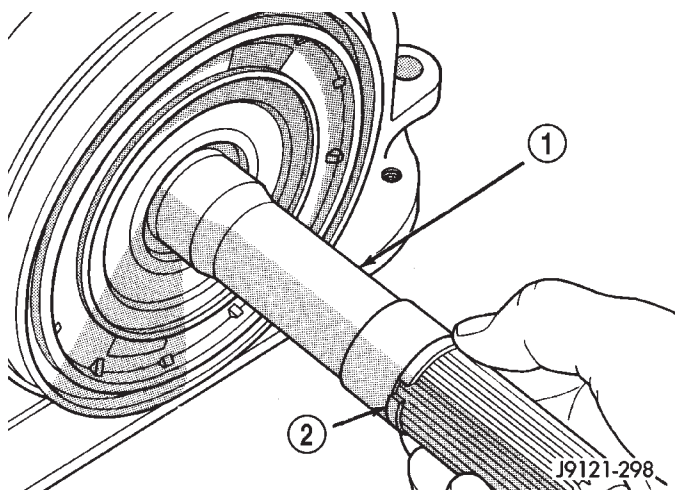
(1) Remove overdrive piston thrust plate (Fig. 120). Retain thrust plate. It is a select fit part and may possibly be reused.



**Fig. 120 Overdrive Piston Thrust Plate Removal/Installation**

- 1 - OVERDRIVE PISTON  
2 - OVERDRIVE PISTON SPACER (SELECT FIT)

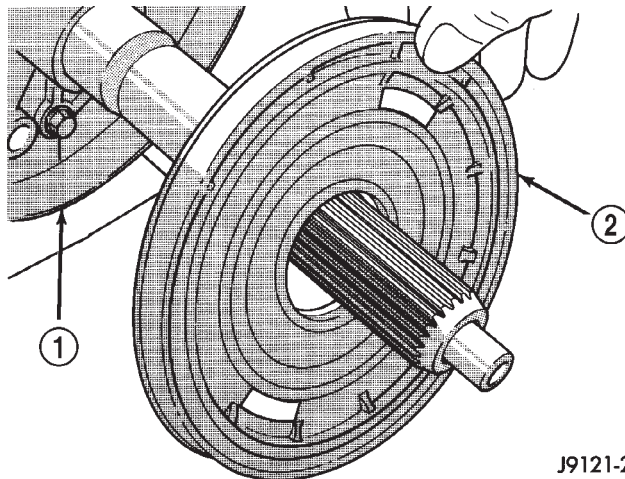
(2) Remove intermediate shaft spacer (Fig. 121). Retain spacer. It is a select fit part and may possibly be reused.



**Fig. 121 Intermediate Shaft Spacer Location**

- 1 - INTERMEDIATE SHAFT  
2 - INTERMEDIATE SHAFT SPACER (SELECT FIT)

(3) Remove overdrive piston from retainer (Fig. 122).



**Fig. 122 Overdrive Piston Removal**

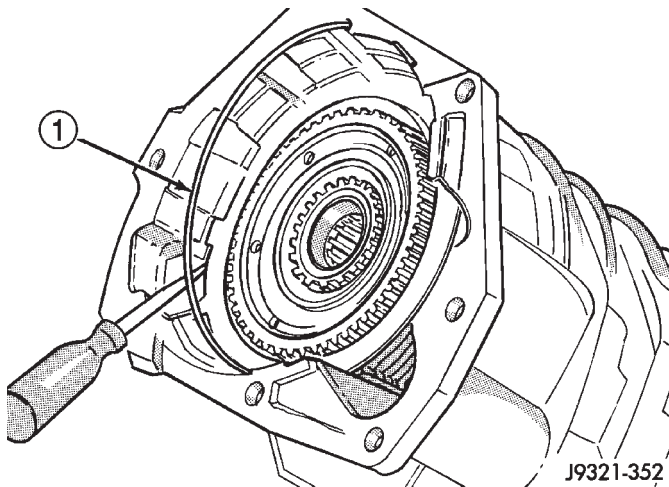
- 1 - PISTON RETAINER  
2 - OVERDRIVE PISTON

**OVERDRIVE CLUTCH PACK**

(1) Remove overdrive clutch pack wire retaining ring (Fig. 123).

(2) Remove overdrive clutch pack (Fig. 124).

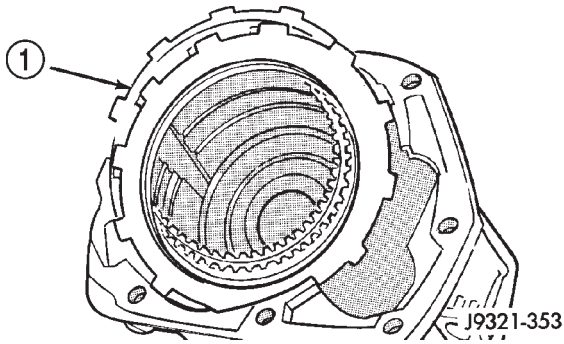
(3) Note position of clutch pack components for assembly reference (Fig. 125).



**Fig. 123 Removing Overdrive Clutch Pack Retaining Ring**

- 1 - OVERDRIVE CLUTCH PACK RETAINING RING

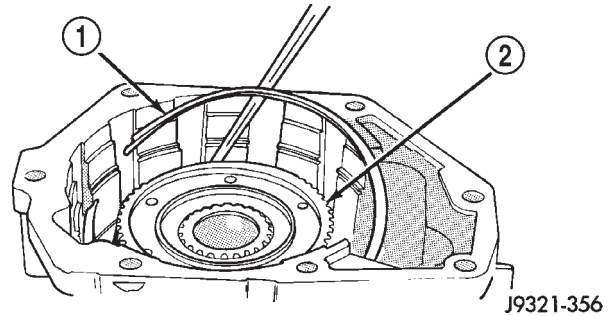
OVERDRIVE UNIT (Continued)



**Fig. 124 Overdrive Clutch Pack Removal**

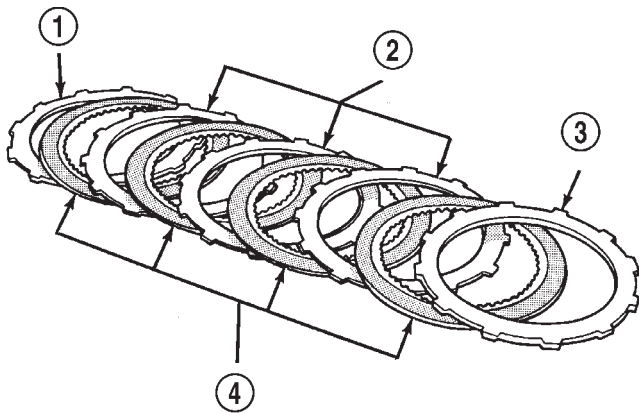
1 - OVERDRIVE CLUTCH PACK

(2) Remove overdrive clutch reaction snap-ring (Fig. 127). Note that snap-ring is located in same groove as wave spring.



**Fig. 127 Overdrive Clutch Reaction Snap-Ring Removal**

1 - REACTION RING  
2 - CLUTCH HUB

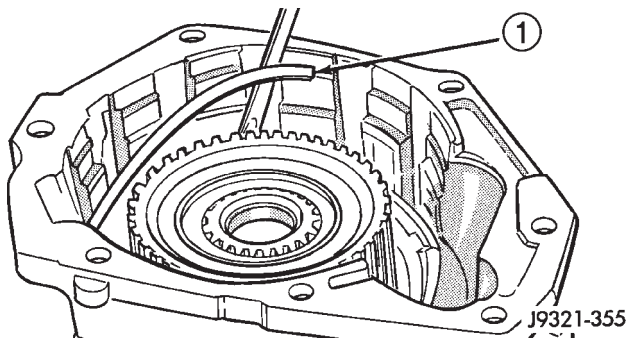


**Fig. 125 Overdrive Clutch Component Position - Typical**

1 - REACTION PLATE                      3 - PRESSURE PLATE  
2 - CLUTCH PLATES (3)                4 - CLUTCH DISCS (4)

**OVERDRIVE GEARTRAIN**

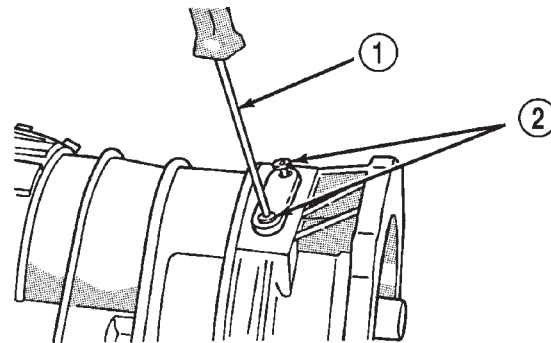
(1) Remove overdrive clutch wave spring (Fig. 126).



**Fig. 126 Overdrive Clutch Wave Spring Removal**

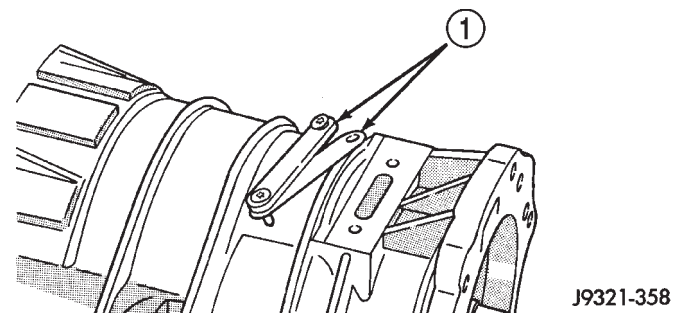
1 - WAVE SPRING

(3) Remove Torx™ head screws that attach access cover and gasket to overdrive case (Fig. 128).  
(4) Remove access cover and gasket (Fig. 129).



**Fig. 128 Access Cover Screw Removal**

1 - TORX SCREWDRIVER (T25)  
2 - ACCESS COVER SCREWS



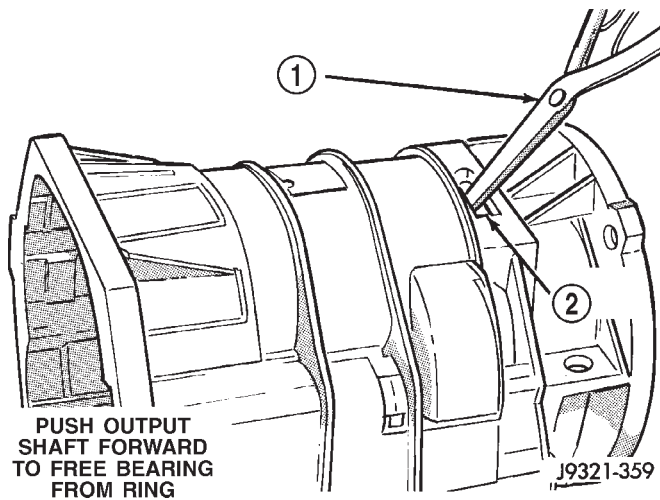
**Fig. 129 Access Cover And Gasket Removal**

1 - ACCESS COVER AND GASKET



## OVERDRIVE UNIT (Continued)

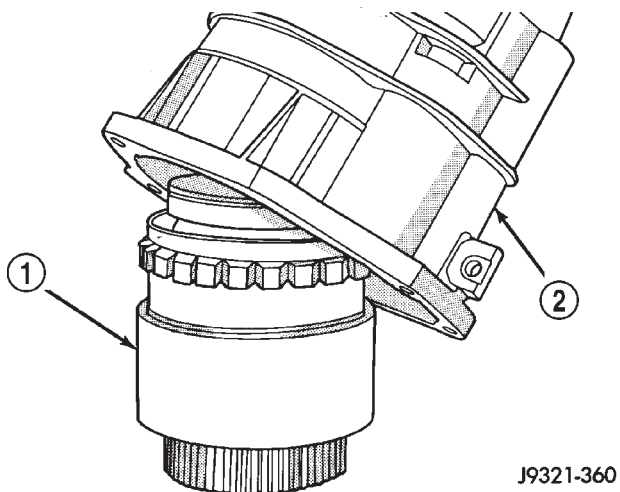
(5) Expand output shaft bearing snap-ring with expanding-type snap-ring pliers. Then push output shaft forward to release shaft bearing from locating ring (Fig. 130).



**Fig. 130 Releasing Bearing From Locating Ring**

- 1 - EXPAND BEARING LOCATING RING WITH SNAP-RING PLIERS  
2 - ACCESS HOLE

(6) Lift gear case up and off geartrain assembly (Fig. 131).

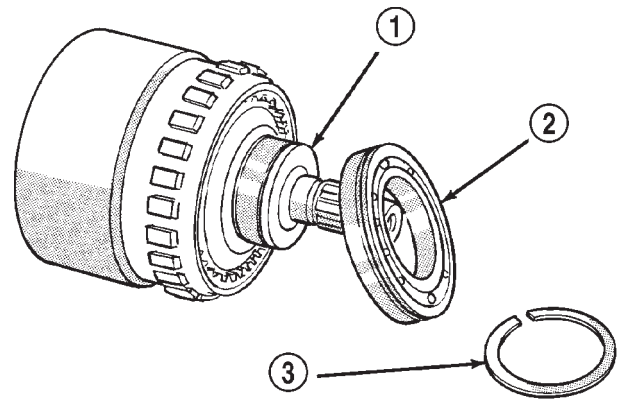


**Fig. 131 Removing Geartrain**

- 1 - GEARTRAIN ASSEMBLY  
2 - GEAR CASE

(7) Remove snap-ring that retains rear bearing on output shaft.

(8) Remove rear bearing from output shaft (Fig. 132).



**Fig. 132 Rear Bearing Removal**

- 1 - OUTPUT SHAFT  
2 - REAR BEARING  
3 - SNAP-RING

## DIRECT CLUTCH, HUB AND SPRING

**WARNING: THE NEXT STEP IN DISASSEMBLY INVOLVES COMPRESSING THE DIRECT CLUTCH SPRING. IT IS EXTREMELY IMPORTANT THAT PROPER EQUIPMENT BE USED TO COMPRESS THE SPRING AS SPRING FORCE IS APPROXIMATELY 830 POUNDS. USE SPRING COMPRESSOR TOOL 6227-1 AND A HYDRAULIC SHOP PRESS WITH A MINIMUM RAM TRAVEL OF 5-6 INCHES. THE PRESS MUST ALSO HAVE A BED THAT CAN BE ADJUSTED UP OR DOWN AS REQUIRED. RELEASE CLUTCH SPRING TENSION SLOWLY AND COMPLETELY TO AVOID PERSONAL INJURY.**

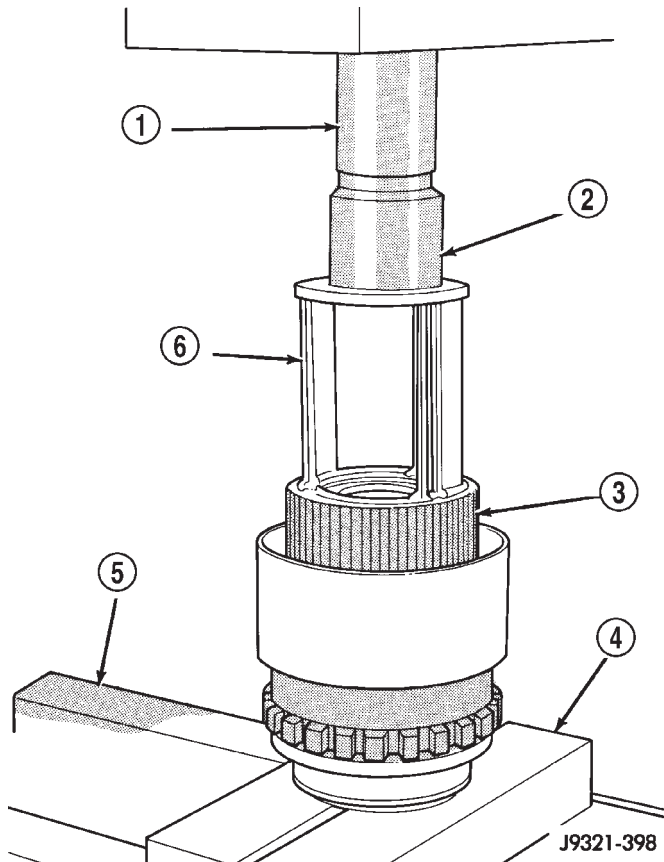
(1) Mount geartrain assembly in shop press (Fig. 133).

(2) Position Compressor Tool 6227-1 on clutch hub (Fig. 133). Support output shaft flange with steel press plates as shown and center assembly under press ram.

(3) Apply press pressure slowly. Compress hub and spring far enough to expose clutch hub retaining ring and relieve spring pressure on clutch pack snap-ring (Fig. 133).

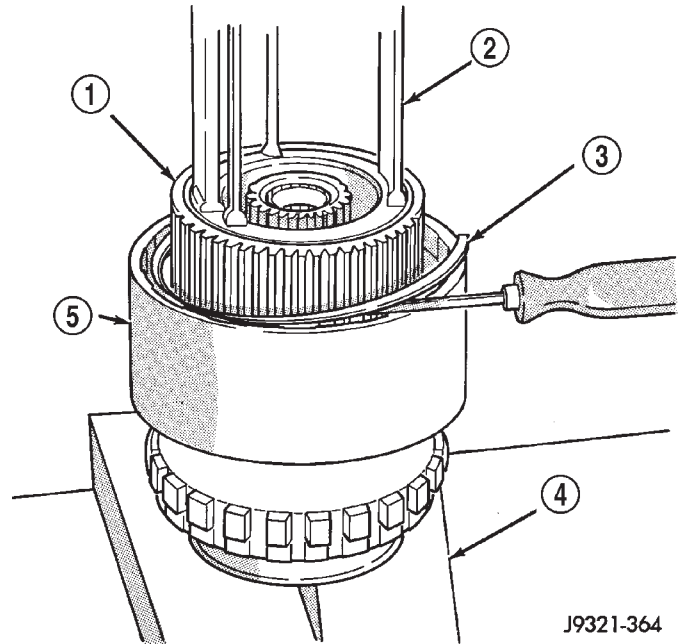
OVERDRIVE UNIT (Continued)

- (4) Remove direct clutch pack snap-ring (Fig. 134).
- (5) Remove direct clutch hub retaining ring (Fig. 135).
- (6) Release press load slowly and completely (Fig. 136).
- (7) Remove Special Tool 6227-1. Then remove clutch pack from hub (Fig. 136).



**Fig. 133 Geartrain Mounted In Shop Press**

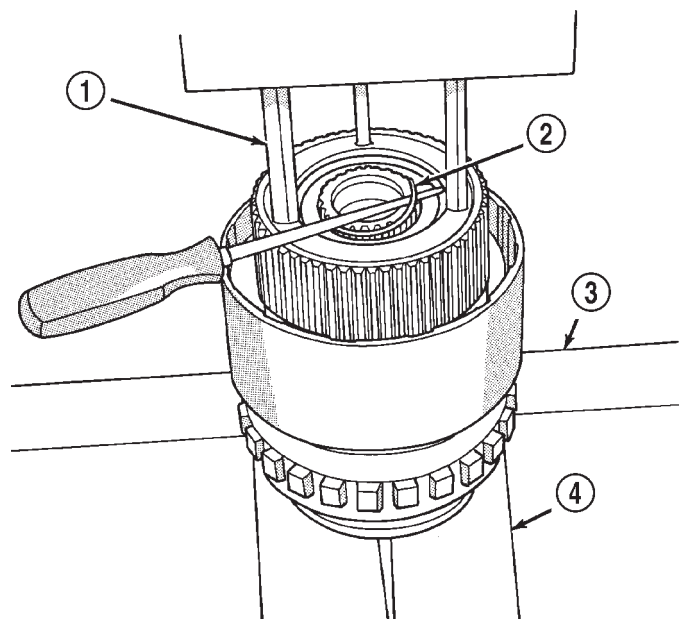
- 1 - PRESS RAM
- 2 - SPECIAL TOOL C-3995-A (OR SIMILAR TOOL)
- 3 - CLUTCH HUB
- 4 - PLATES
- 5 - PRESS BED
- 6 - SPECIAL TOOL 6227-1



J9321-364

**Fig. 134 Direct Clutch Pack Snap-Ring Removal**

- 1 - CLUTCH HUB
- 2 - SPECIAL TOOL 6227-1
- 3 - DIRECT CLUTCH PACK SNAP-RING
- 4 - PRESS PLATES
- 5 - CLUTCH DRUM



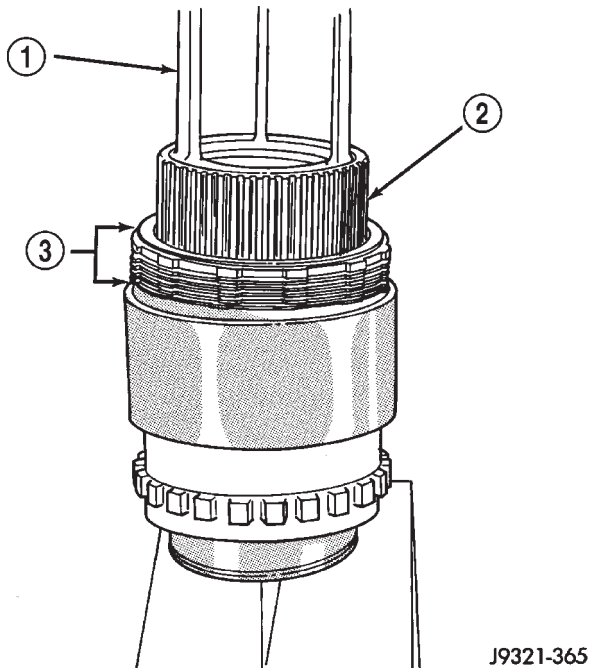
J9321-363

**Fig. 135 Direct Clutch Hub Retaining Ring Removal**

- 1 - SPECIAL TOOL 6227-1
- 2 - CLUTCH HUB RETAINING RING
- 3 - PRESS BED
- 4 - PRESS PLATES



## OVERDRIVE UNIT (Continued)

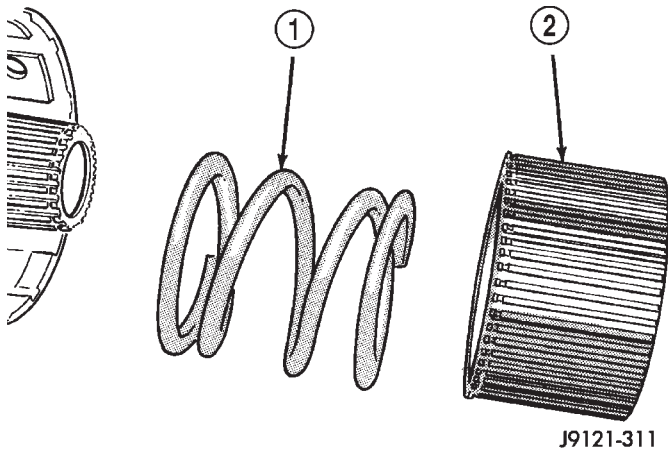


**Fig. 136 Direct Clutch Pack Removal**

- 1 - SPECIAL TOOL 6227-1
- 2 - DIRECT CLUTCH HUB
- 3 - DIRECT CLUTCH PACK

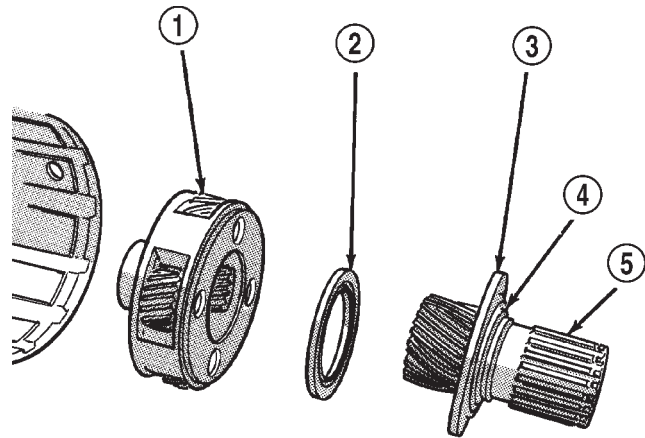
## GEARTRAIN

- (1) Remove direct clutch hub and spring (Fig. 137).
- (2) Remove sun gear and spring plate. Then remove planetary thrust bearing and planetary gear (Fig. 138).



**Fig. 137 Direct Clutch Hub And Spring Removal**

- 1 - DIRECT CLUTCH SPRING
- 2 - DIRECT CLUTCH HUB



**Fig. 138 Removing Sun Gear, Thrust Bearing And Planetary Gear**

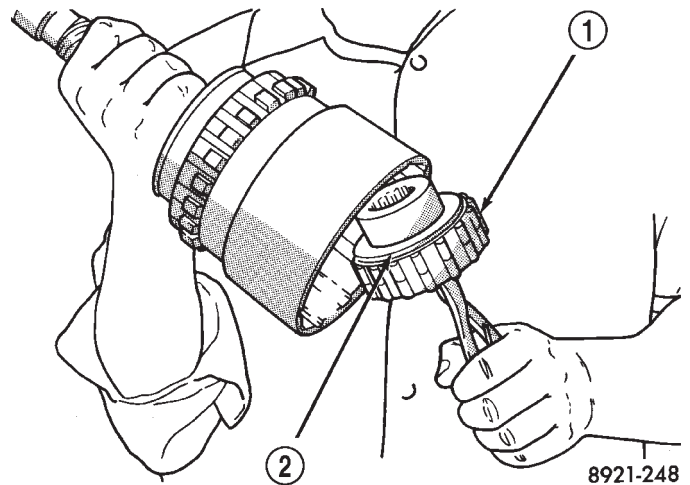
- 1 - PLANETARY GEAR
- 2 - PLANETARY THRUST BEARING
- 3 - CLUTCH SPRING PLATE
- 4 - SPRING PLATE SNAP-RING
- 5 - SUN GEAR

(3) Remove overrunning clutch assembly with expanding type snap-ring pliers (Fig. 139). Insert pliers into clutch hub. Expand pliers to grip hub splines and remove clutch with counterclockwise, twisting motion.

(4) Remove thrust bearing from overrunning clutch hub.

(5) Remove overrunning clutch from hub.

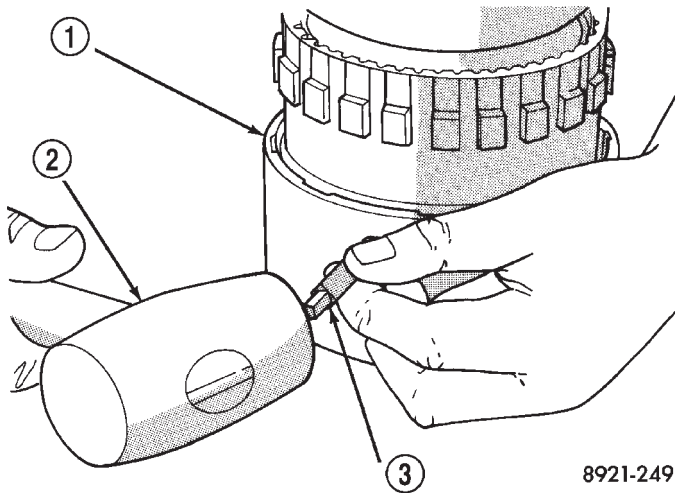
(6) Mark position of annulus gear and direct clutch drum for assembly alignment reference (Fig. 140). Use small center punch or scribe to make alignment marks.



**Fig. 139 Overrunning Clutch Assembly Removal/Installation**

- 1 - OVERRUNNING CLUTCH
- 2 - NEEDLE BEARING

OVERDRIVE UNIT (Continued)



8921-249

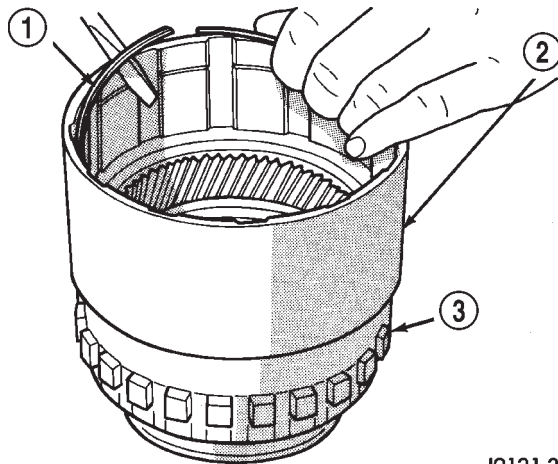
**Fig. 140 Marking Direct Clutch Drum And Annulus Gear For Assembly Alignment**

- 1 - DIRECT CLUTCH DRUM
- 2 - HAMMER
- 3 - PUNCH

(7) Remove direct clutch drum rear retaining ring (Fig. 141).

(8) Remove direct clutch drum outer retaining ring (Fig. 142).

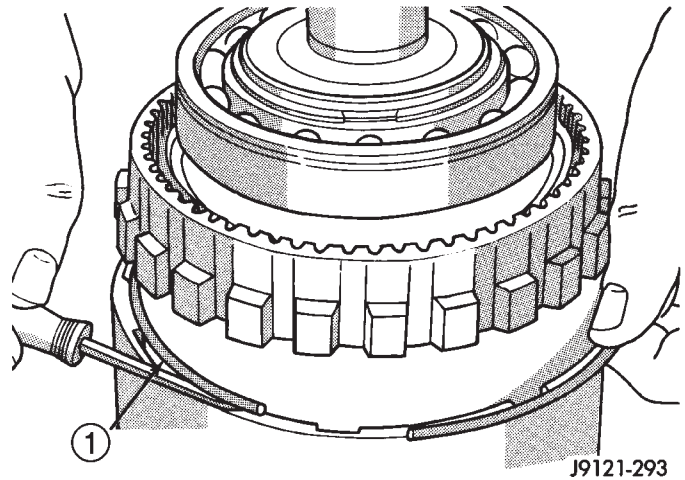
(9) Mark annulus gear and output shaft for assembly alignment reference (Fig. 143). Use punch or scriber to mark gear and shaft.



J9121-292

**Fig. 141 Clutch Drum Inner Retaining Ring Removal**

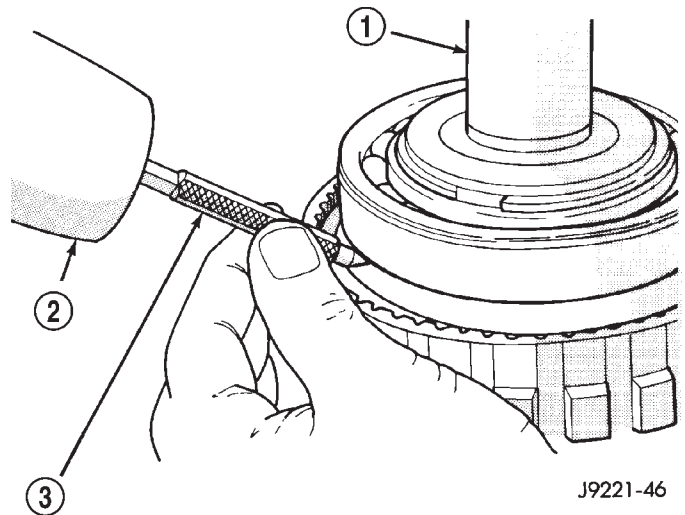
- 1 - INNER RETAINING RING
- 2 - DIRECT CLUTCH DRUM
- 3 - ANNULUS GEAR



J9121-293

**Fig. 142 Clutch Drum Outer Retaining Ring Removal**

- 1 - OUTER RETAINING RING



J9221-46

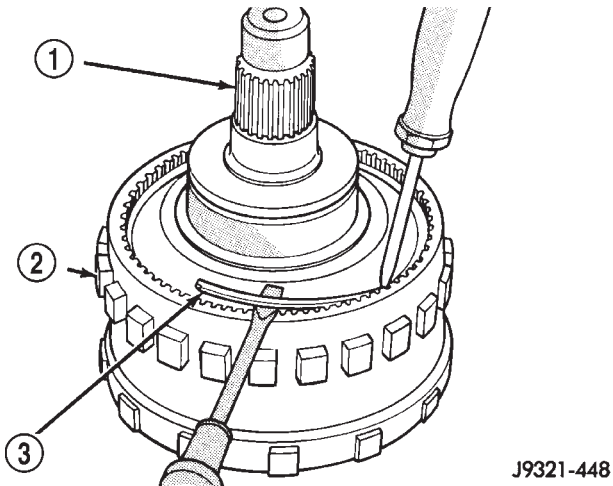
**Fig. 143 Marking Annulus Gear And Output Shaft For Assembly Alignment**

- 1 - OUTPUT SHAFT
- 2 - HAMMER
- 3 - PUNCH

## OVERDRIVE UNIT (Continued)

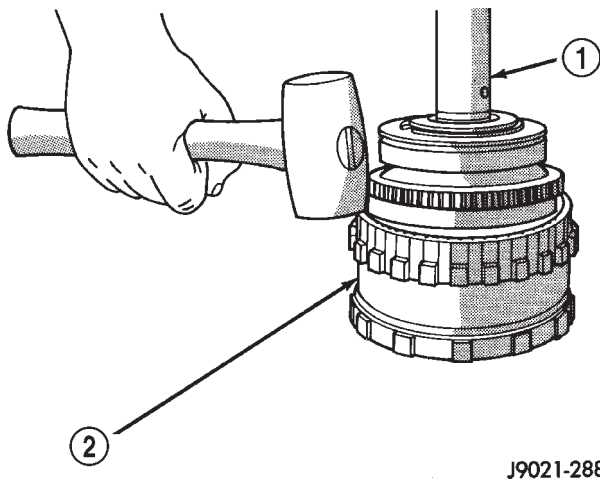
(10) Remove snap-ring that secures annulus gear on output shaft (Fig. 144). Use two screwdrivers to unseat and work snap-ring out of groove as shown.

(11) Remove annulus gear from output shaft (Fig. 145). Use rawhide or plastic mallet to tap gear off shaft.



**Fig. 144 Annulus Gear Snap-Ring Removal**

- 1 - OUTPUT SHAFT
- 2 - ANNULUS GEAR
- 3 - SNAP-RING



**Fig. 145 Annulus Gear Removal**

- 1 - OUTPUT SHAFT
- 2 - ANNULUS GEAR

## GEAR CASE AND PARK LOCK

- (1) Remove locating ring from gear case.
- (2) Remove park pawl shaft retaining bolt and remove shaft, pawl and spring.
- (3) Remove reaction plug snap-ring and remove reaction plug.
- (4) Remove output shaft seal.

## CLEANING

Clean the geartrain and case components with solvent. Dry all parts except the bearings with compressed air. Allow bearings to air dry.

Do not use shop towels for wiping parts dry unless the towels are made from a lint-free material. A sufficient quantity of lint (from shop towels, cloths, rags, etc.) could plug the transmission filter and fluid passages.

Discard the old case gasket and seals. Do not attempt to salvage these parts. They are not reusable. Replace any of the overdrive unit snap-rings if distorted or damaged.

Minor nicks or scratches on components can be smoothed with crocus cloth. However, do not attempt to reduce severe scoring on any components with abrasive materials. Replace severely scored components; do not try to salvage them.

## INSPECTION

Check condition of the park lock components and the overdrive case.

Check the bushings in the overdrive case. Replace the bushings if severely scored or worn. Also replace the case seal if loose, distorted, or damaged.

Examine the overdrive and direct clutch discs and plates. Replace the discs if the facing is worn, severely scored, or burned and flaking off. Replace the clutch plates if worn, heavily scored, or cracked. Check the lugs on the clutch plates for wear. The plates should slide freely in the drum. Replace the plates or drum if binding occurs.

Check condition of the annulus gear, direct clutch hub, clutch drum and clutch spring. Replace the gear, hub and drum if worn or damaged. Replace the spring if collapsed, distorted, or cracked.

Be sure the splines and lugs on the gear, drum and hub are in good condition. The clutch plates and discs should slide freely in these components.

Inspect the thrust bearings and spring plate. Replace the plate if worn or scored. Replace the bearings if rough, noisy, brinnelled, or worn.

Inspect the planetary gear assembly and the sun gear and bushings. If either the sun gear or the bushings are damaged, replace the gear and bushings as an assembly. The gear and bushings are not serviced separately.

## OVERDRIVE UNIT (Continued)

The planetary carrier and pinions must be in good condition. Also be sure the pinion pins are secure and in good condition. Replace the carrier if worn or damaged.

Inspect the overrunning clutch and race. The race surface should be smooth and free of scores. Replace the overrunning clutch assembly or the race if either assembly is worn or damaged in any way.

Replace the shaft pilot bushing and inner bushing if damaged. Replace either shaft bearing if rough or noisy. Replace the bearing snap-rings if distorted or cracked.

Check the machined surfaces on the output shaft. These surfaces should be clean and smooth. Very minor nicks or scratches can be smoothed with crocus cloth. Replace the shaft if worn, scored or damaged in any way.

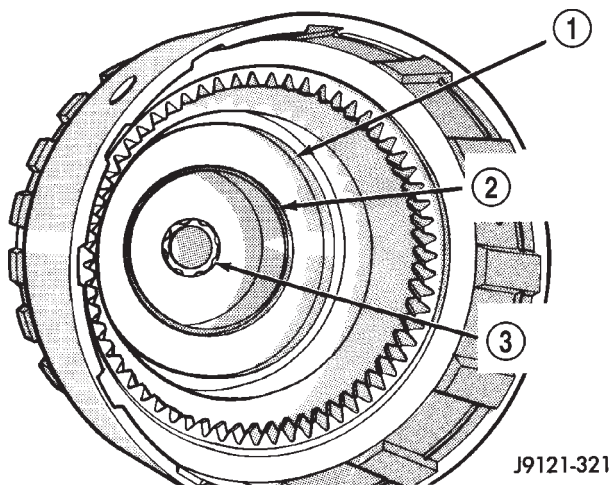
Inspect the output shaft bushings. The small bushing is the intermediate shaft pilot bushing. The large bushing is the overrunning clutch hub bushing. Replace either bushing if scored, pitted, cracked, or worn.

## ASSEMBLY

## GEARTRAIN AND DIRECT CLUTCH

(1) Soak direct clutch and overdrive clutch discs in Mopar® ATF +4, type 9602, transmission fluid. Allow discs to soak for 10-20 minutes.

(2) Install new pilot bushing and clutch hub bushing in output shaft if necessary (Fig. 146). Lubricate bushings with petroleum jelly, or transmission fluid.



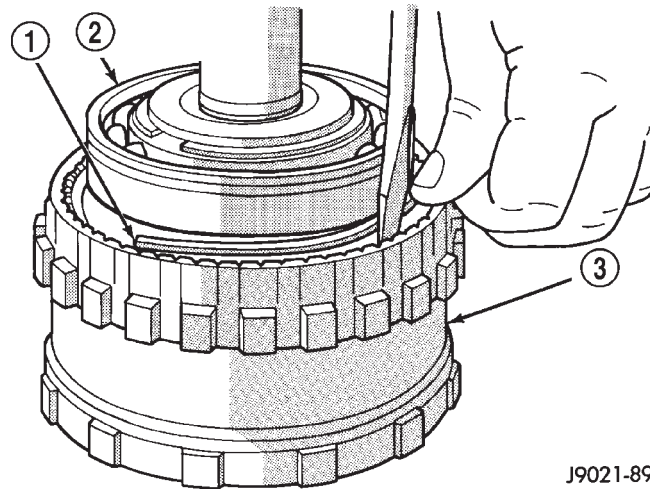
**Fig. 146 Output Shaft Pilot Bushing**

- 1 - OUTPUT SHAFT HUB
- 2 - OVERRUNNING CLUTCH HUB BUSHING
- 3 - INTERMEDIATE SHAFT PILOT BUSHING

(3) Install annulus gear on output shaft, if removed. Then install annulus gear retaining snap-ring (Fig. 147).

(4) Align and install clutch drum on annulus gear (Fig. 148). Be sure drum is engaged in annulus gear lugs.

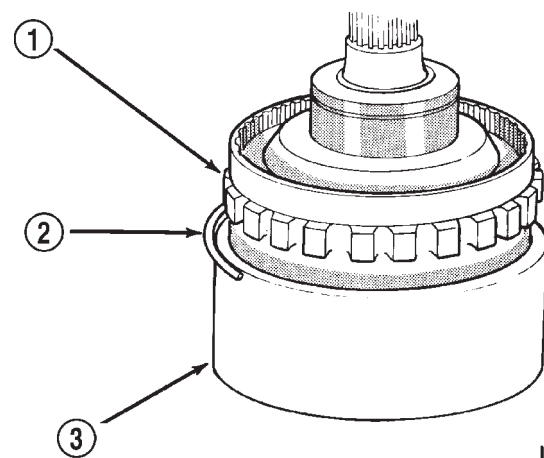
(5) Install clutch drum outer retaining ring (Fig. 148).



J9021-89

**Fig. 147 Annulus Gear Installation**

- 1 - SNAP-RING
- 2 - OUTPUT SHAFT FRONT BEARING
- 3 - ANNULUS GEAR



J9321-393

**Fig. 148 Clutch Drum And Outer Retaining Ring Installation**

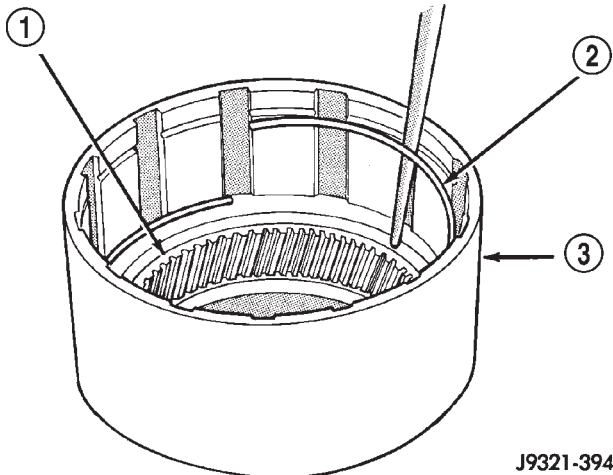
- 1 - ANNULUS GEAR
- 2 - OUTER SNAP-RING
- 3 - CLUTCH DRUM



## OVERDRIVE UNIT (Continued)

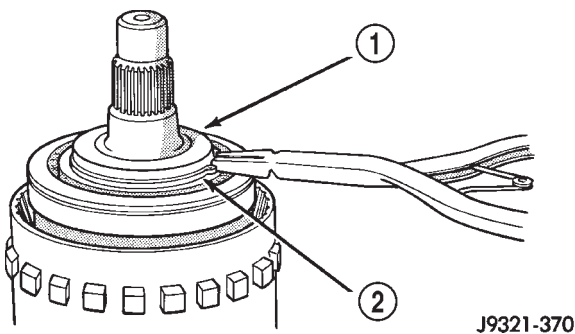
(6) Slide clutch drum forward and install inner retaining ring (Fig. 149).

(7) Install rear bearing and snap-ring on output shaft (Fig. 150). Be sure locating ring groove in bearing is toward rear.



**Fig. 149 Clutch Drum Inner Retaining Ring Installation**

- 1 - ANNULUS GEAR
- 2 - INNER SNAP-RING
- 3 - CLUTCH DRUM

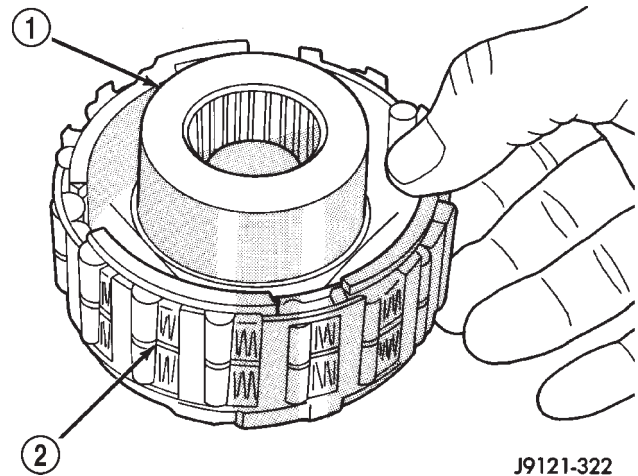


**Fig. 150 Rear Bearing And Snap-Ring Installation**

- 1 - REAR BEARING
- 2 - SNAP-RING

(8) Install overrunning clutch on hub (Fig. 151). Note that clutch only fits one way. Shoulder on clutch should seat in small recess at edge of hub.

(9) Install thrust bearing on overrunning clutch hub. Use generous amount of petroleum jelly to hold bearing in place for installation. Bearing fits one way only. Be sure bearing is seated squarely against hub. Reinstall bearing if it does not seat squarely.



**Fig. 151 Assembling Overrunning Clutch And Hub**

- 1 - CLUTCH HUB
- 2 - OVERRUNNING CLUTCH

(10) Install overrunning clutch in output shaft (Fig. 152). Insert snap-ring pliers in hub splines. Expand pliers to grip hub. Then install assembly with counterclockwise, twisting motion.

(11) Install planetary gear in annulus gear (Fig. 153). Be sure planetary pinions are fully seated in annulus gear before proceeding.

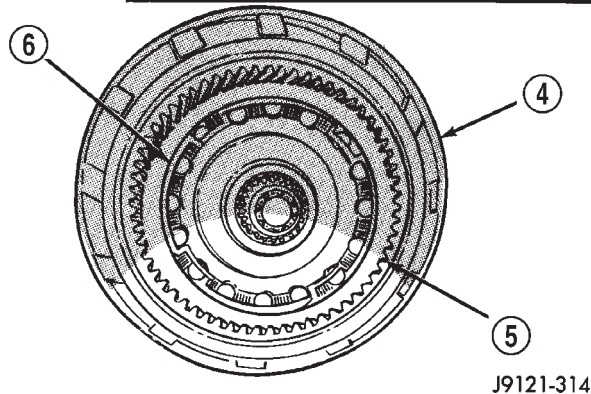
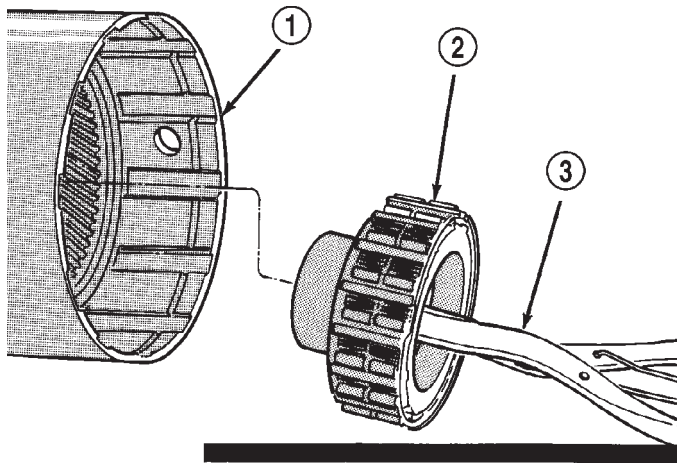
(12) Coat planetary thrust bearing and bearing contact surface of spring plate with generous amount of petroleum jelly. This will help hold bearing in place during installation.

(13) Install planetary thrust bearing on sun gear (Fig. 154). Slide bearing onto gear and seat it against spring plate as shown. Bearing fits one way only. If it does not seat squarely against spring plate, remove and reposition bearing.

(14) Install assembled sun gear, spring plate and thrust bearing (Fig. 155). Be sure sun gear and thrust bearing are fully seated before proceeding.

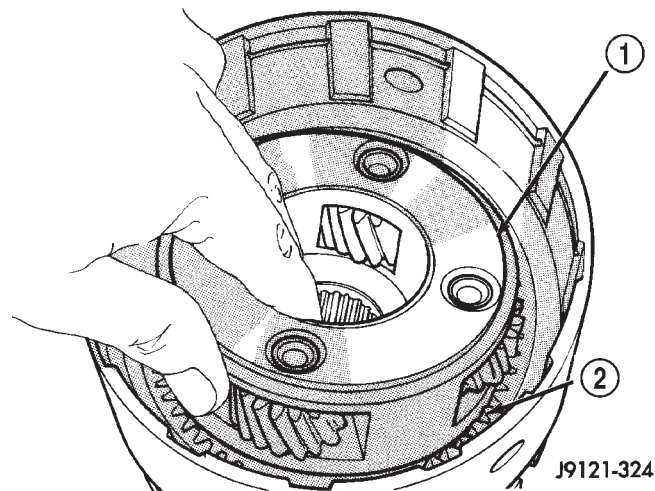


OVERDRIVE UNIT (Continued)



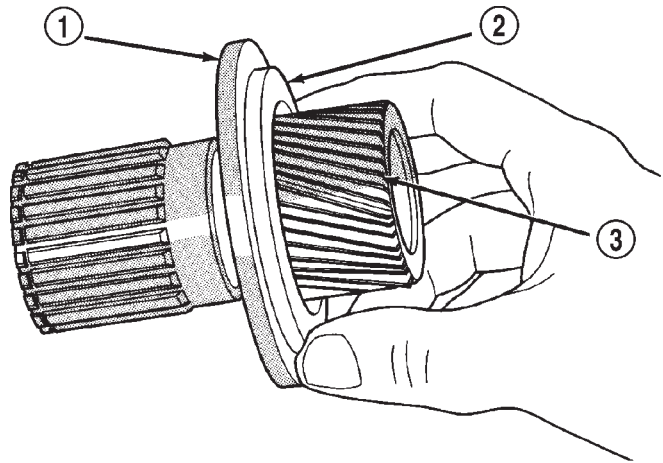
**Fig. 152 Overrunning Clutch Installation**

- 1 - CLUTCH DRUM
- 2 - OVERRUNNING CLUTCH ASSEMBLY
- 3 - EXPANDING-TYPE SNAP-RING PLIERS
- 4 - CLUTCH DRUM
- 5 - ANNULUS GEAR
- 6 - OVERRUNNING CLUTCH ASSEMBLY SEATED IN OUTPUT SHAFT



**Fig. 153 Planetary Gear Installation**

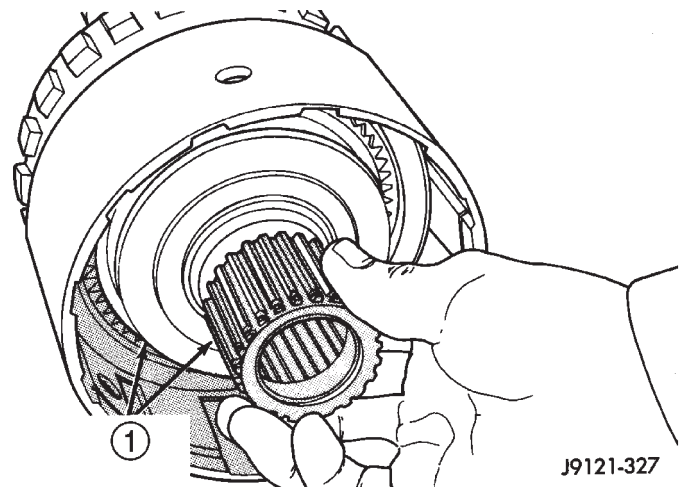
- 1 - PLANETARY GEAR
- 2 - ANNULUS GEAR



J9121-326

**Fig. 154 Planetary Thrust Bearing Installation**

- 1 - SPRING PLATE
- 2 - PLANETARY THRUST BEARING
- 3 - SUN GEAR



J9121-327

**Fig. 155 Sun Gear Installation**

- 1 - SUN GEAR AND SPRING PLATE ASSEMBLY

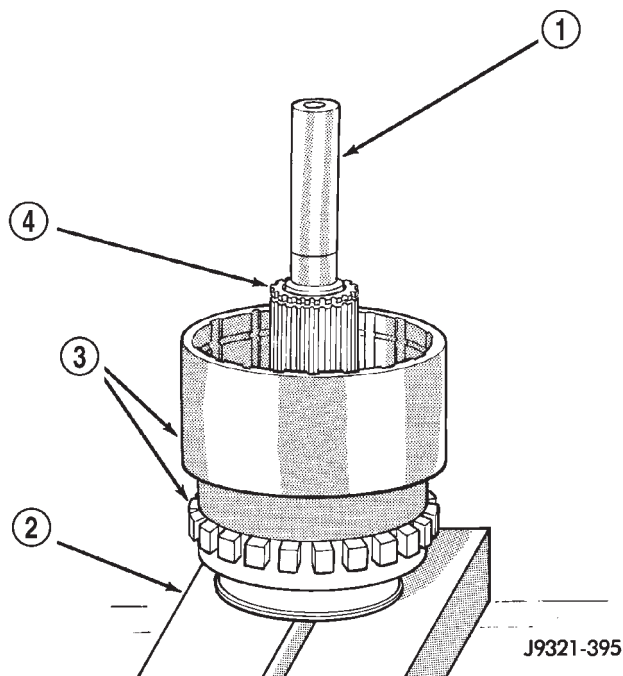
(15) Mount assembled output shaft, annulus gear, and clutch drum in shop press. Direct clutch spring, hub and clutch pack are easier to install with assembly mounted in press.

(16) Align splines in hubs of planetary gear and overrunning clutch with Alignment tool 6227-2 (Fig. 156). Insert tool through sun gear and into splines of both hubs. Be sure alignment tool is fully seated before proceeding.

(17) Install direct clutch spring (Fig. 157). Be sure spring is properly seated on spring plate.

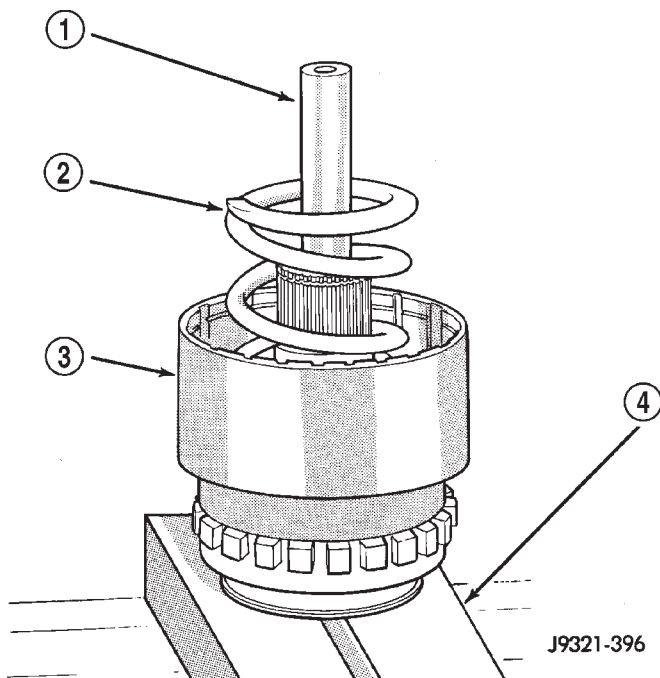
**NOTE:** The direct clutch in a 47RE transmission uses 10 clutch discs.

## OVERDRIVE UNIT (Continued)



**Fig. 156 Alignment Tool Installation**

- 1 - SPECIAL TOOL 6227-2
- 2 - PRESS PLATES
- 3 - ASSEMBLED DRUM AND ANNULUS GEAR
- 4 - SUN GEAR



**Fig. 157 Direct Clutch Spring Installation**

- 1 - SPECIAL TOOL 6227-2
- 2 - DIRECT CLUTCH SPRING
- 3 - CLUTCH HUB
- 4 - PRESS PLATES

(18) Assemble and install direct clutch pack on hub as follows:

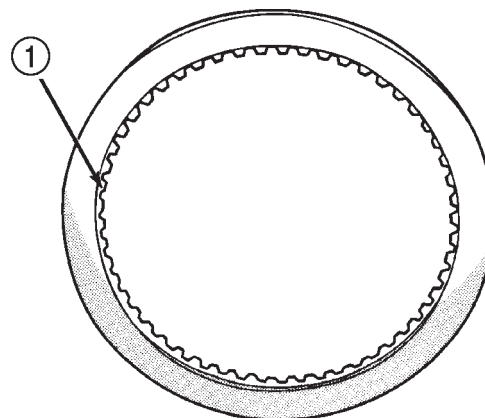
(a) Assemble clutch pack components.

(b) Install direct clutch reaction plate on clutch hub first. Note that one side of reaction plate is counterbored. Be sure this side faces rearward. Splines at rear of hub are raised slightly. Counterbore in plate fits over raised splines. Plate should be flush with this end of hub (Fig. 158).

(c) Install first clutch disc followed by a steel plate until all discs and plates have been installed.

(d) Install pressure plate. This is last clutch pack item to be installed. Be sure plate is installed with shoulder side facing upward (Fig. 159).

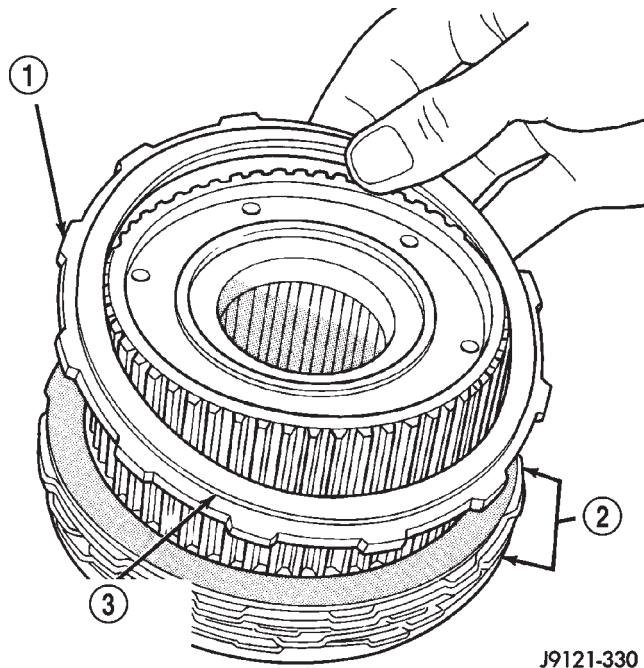
(19) Install clutch hub and clutch pack on direct clutch spring (Fig. 160). Be sure hub is started on sun gear splines before proceeding.



**Fig. 158 Correct Position Of Direct Clutch Reaction Plate**

- 1 - REACTION PLATE COUNTERBORE
- 2 - DIRECT CLUTCH REACTION PLATE (FLUSH WITH END OF HUB)
- 3 - CLUTCH HUB

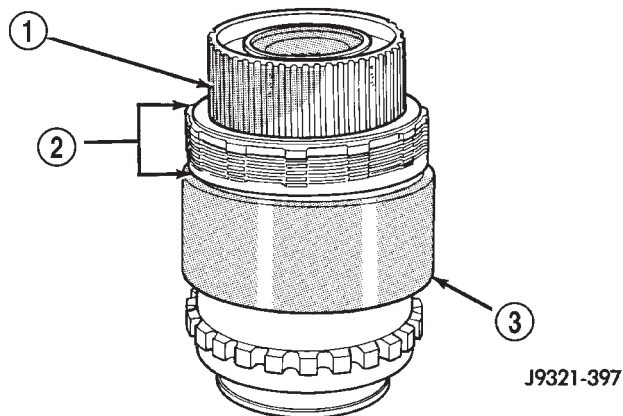
## OVERDRIVE UNIT (Continued)



J9121-330

**Fig. 159 Correct Position Of Direct Clutch**

- 1 - DIRECT CLUTCH PRESSURE PLATE
- 2 - CLUTCH PACK
- 3 - BE SURE SHOULDER SIDE OF PLATE FACES UPWARD



J9321-397

**Fig. 160 Direct Clutch Pack And Clutch Hub Installation**

- 1 - CLUTCH HUB
- 2 - DIRECT CLUTCH PACK
- 3 - CLUTCH DRUM

**WARNING: THE NEXT STEP IN GEARTRAIN ASSEMBLY INVOLVES COMPRESSING THE DIRECT CLUTCH HUB AND SPRING. IT IS EXTREMELY IMPORTANT THAT PROPER EQUIPMENT BE USED TO COMPRESS THE SPRING AS SPRING FORCE IS APPROXIMATELY 830 POUNDS. USE COMPRESSOR TOOL C-6227-1 AND A HYDRAULIC-TYPE SHOP PRESS WITH A MINIMUM RAM TRAVEL OF 6 INCHES. THE PRESS MUST ALSO HAVE A BED THAT CAN BE ADJUSTED UP OR DOWN AS REQUIRED. RELEASE CLUTCH SPRING TENSION SLOWLY AND COMPLETELY TO AVOID PERSONAL INJURY.**

(20) Position Compressor Tool 6227-1 on clutch hub.

(21) Compress clutch hub and spring just enough to place tension on hub and hold it in place.

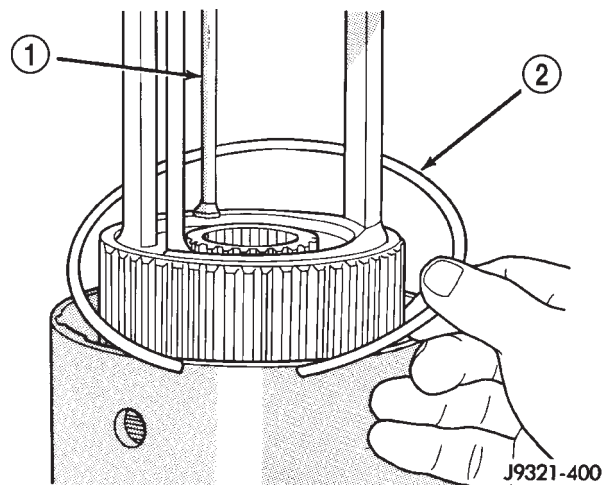
(22) Slowly compress clutch hub and spring. Compress spring and hub only enough to expose ring grooves for clutch pack snap-ring and clutch hub retaining ring.

(23) Realign clutch pack on hub and seat clutch discs and plates in clutch drum.

(24) Install direct clutch pack snap-ring (Fig. 161). Be very sure snap-ring is fully seated in clutch drum ring groove.

(25) Install clutch hub retaining ring (Fig. 162). Be very sure retaining ring is fully seated in sun gear ring groove.

(26) Slowly release press ram, remove compressor tools and remove geartrain assembly.



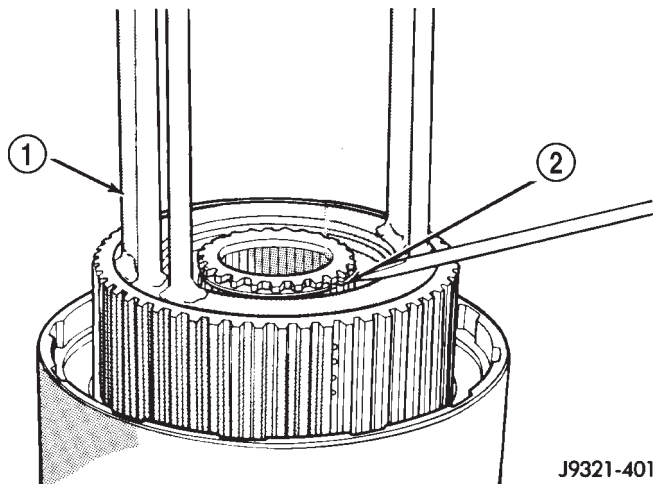
J9321-400

**Fig. 161 Direct Clutch Pack Snap-Ring Installation**

- 1 - SPECIAL TOOL 6227-1
- 2 - DIRECT CLUTCH PACK SNAP-RING



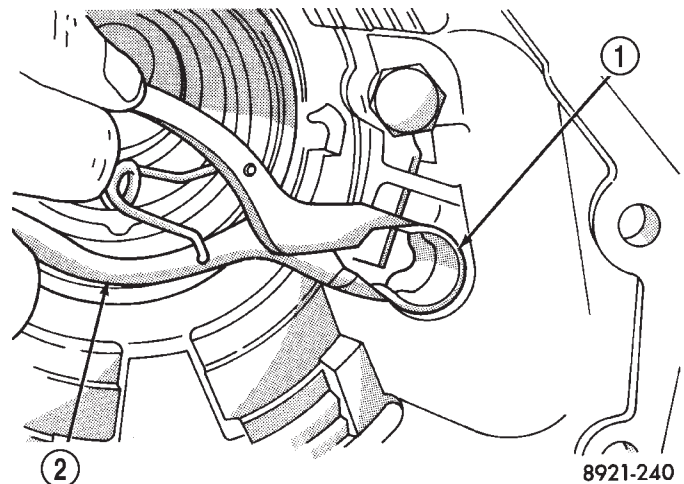
## OVERDRIVE UNIT (Continued)



J9321-401

**Fig. 162 Clutch Hub Retaining Ring Installation**

- 1 - SPECIAL TOOL 6227-1
- 2 - CLUTCH HUB RETAINING RING



8921-240

**Fig. 164 Reaction Plug And Snap-Ring Installation**

- 1 - REACTION PLUG SNAP-RING
- 2 - SNAP-RING PLIERS

**GEAR CASE**

(1) Position park pawl and spring in case and install park pawl shaft. Verify that end of spring with 90° bend is hooked to pawl and straight end of spring is seated against case.

(2) Install pawl shaft retaining bolt. Tighten bolt to 27 N·m (20 ft. lbs.) torque.

(3) Install park lock reaction plug. Note that plug has locating pin at rear (Fig. 163). Be sure pin is seated in hole in case before installing snap-ring.

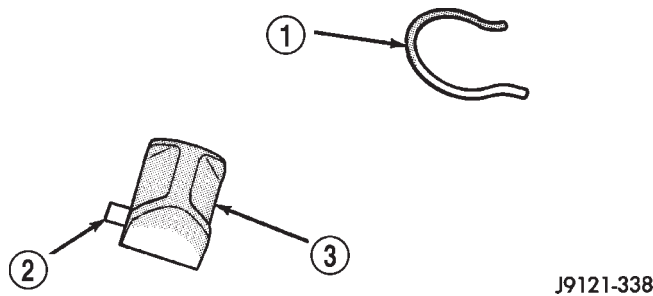
(4) Install reaction plug snap-ring (Fig. 164). Compress snap-ring only enough for installation; do not distort it.

(5) Install new seal in gear case. Use Handle C-4171 and Installer C-3995-A to seat seal in case.

(6) Verify that tab ends of rear bearing locating ring extend into access hole in gear case (Fig. 165).

(7) Support geartrain on Tool 6227-1 (Fig. 166). Be sure tool is securely seated in clutch hub.

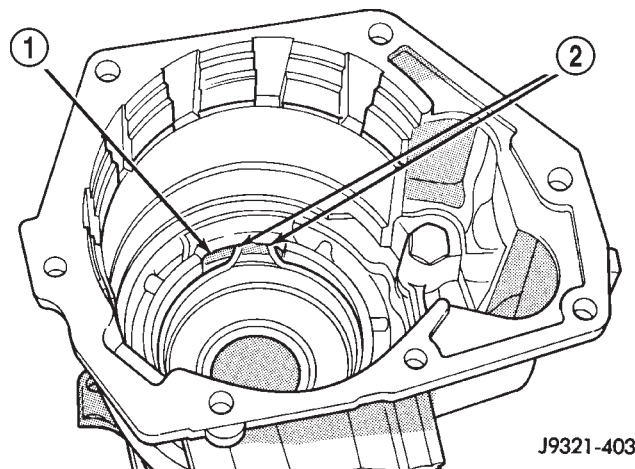
(8) Install overdrive gear case on geartrain (Fig. 166).



J9121-338

**Fig. 163 Reaction Plug Locating Pin And Snap-Ring**

- 1 - REACTION PLUG SNAP-RING (DO NOT OVERCOMPRESS TO INSTALL)
- 2 - LOCATING PIN
- 3 - PARK LOCK REACTION PLUG

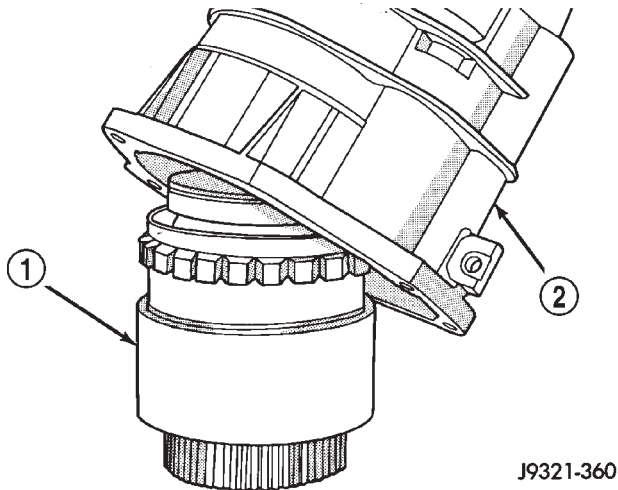


J9321-403

**Fig. 165 Correct Rear Bearing Locating Ring Position**

- 1 - CASE ACCESS HOLE
- 2 - TAB ENDS OF LOCATING RING

OVERDRIVE UNIT (Continued)



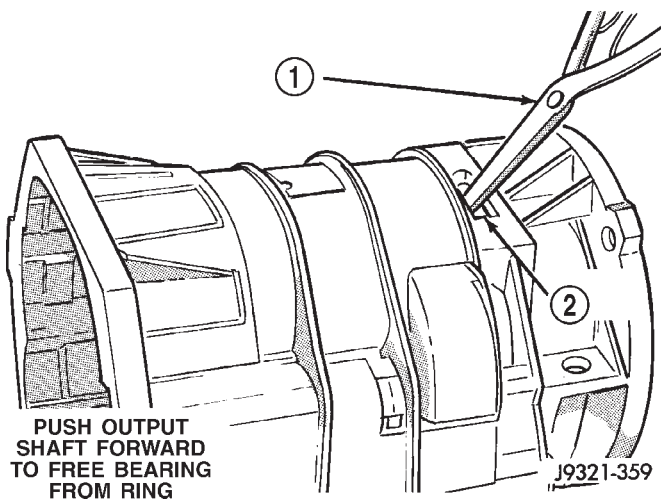
J9321-360

**Fig. 166 Overdrive Gear Case Installation**

- 1 - GEARTRAIN ASSEMBLY
- 2 - GEAR CASE

(9) Expand front bearing locating ring with snap-ring pliers (Fig. 167). Then slide case downward until locating ring locks in bearing groove and release snap-ring.

(10) Install locating ring access cover and gasket in overdrive unit case (Fig. 168).



J9321-359

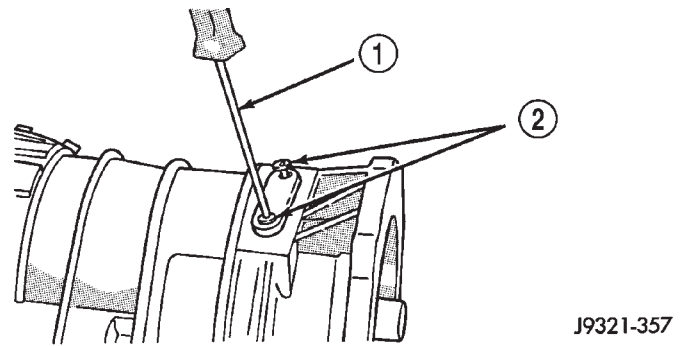
**Fig. 167 Seating Locating Ring In Rear Bearing**

- 1 - EXPAND BEARING LOCATING RING WITH SNAP-RING PLIERS
- 2 - ACCESS HOLE

**OVERDRIVE CLUTCH**

**NOTE:** The overdrive clutch in a 47RE transmission uses 5 clutch discs.

(1) Install overdrive clutch reaction ring first. Reaction ring is flat with notched ends (Fig. 169).



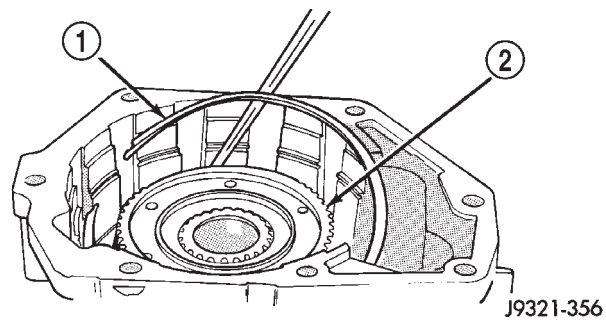
J9321-357

**Fig. 168 Locating Ring Access Cover And Gasket Installation**

- 1 - TORX SCREWDRIVER (T25)
- 2 - ACCESS COVER SCREWS

(2) Install wave spring on top of reaction ring (Fig. 170). Reaction ring and wave ring both fit in same ring groove. Use screwdriver to seat each ring securely in groove. Also ensure that the ends of the two rings are offset from each other.

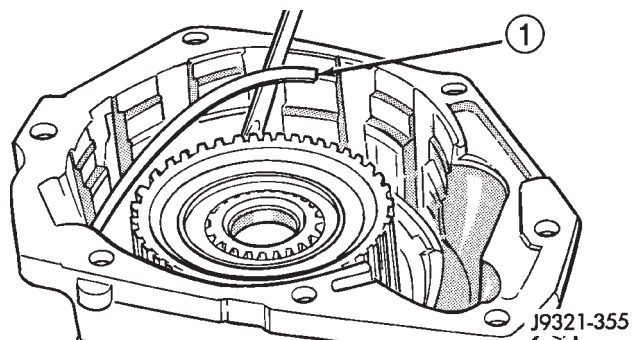
(3) Assemble overdrive clutch pack.



J9321-356

**Fig. 169 Overdrive Clutch Reaction Ring Installation**

- 1 - REACTION RING
- 2 - CLUTCH HUB



J9321-355

**Fig. 170 Overdrive Clutch Wave Spring Installation**

- 1 - WAVE SPRING

(4) Install overdrive clutch reaction plate first.



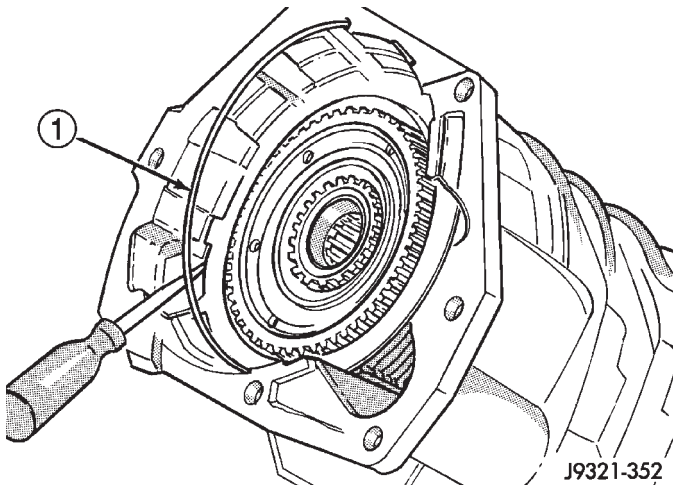
## OVERDRIVE UNIT (Continued)

**NOTE:** The reaction plate is thicker than the pressure plate in a 47RE transmission.

(5) Install first clutch disc followed by first clutch plate. Then install remaining clutch discs and plates in same order.

(6) Install clutch pack pressure plate.

(7) Install clutch pack wire-type retaining ring (Fig. 171).



**Fig. 171 Overdrive Clutch Pack Retaining Ring Installation**

1 - OVERDRIVE CLUTCH PACK RETAINING RING

## INTERMEDIATE SHAFT SPACER SELECTION

(1) Place overdrive unit in vertical position. Mount it on blocks, or in workbench with appropriate size mounting hole cut into it. Be sure unit is facing upward for access to direct clutch hub. Also be sure output shaft is not loaded and internal components are moved rearward for accurate measurement.

(2) Determine correct thickness intermediate shaft spacer as follows:

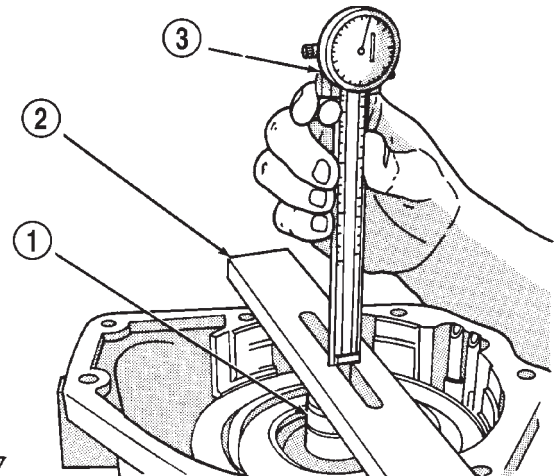
(a) Insert Special Tool 6312 through sun gear, planetary gear and into pilot bushing in output shaft. Be sure tool bottoms against planetary shoulder.

(b) Position Gauge Tool 6311 across face of overdrive case (Fig. 172). Then position Dial Caliper C-4962 over gauge tool.

(c) Extend sliding scale of dial caliper downward through gauge tool slot until scale contacts end of Gauge Alignment Tool 6312. Lock scale in place. Remove dial caliper tool and note distance measured (Fig. 172).

(d) Select proper thickness end play spacer from spacer chart based on distance measured (Fig. 173).

(e) Remove Gauge Alignment Tool 6312.



**Fig. 172 Shaft End Play Measurement**

1 - SPECIAL TOOL 6312  
2 - SPECIAL TOOL 6311  
3 - SPECIAL TOOL C-4962

End Play Measurement (Inches)	Spacer Thickness (Inches)
.7336 - .7505	.158 - .159
.7506 - .7675	.175 - .176
.7676 - .7855	.193 - .194
.7856 - .8011	.211 - .212

J9121-341

**Fig. 173 Intermediate Shaft End Play Spacer Selection**

## OD THRUST PLATE SELECTION

(1) Place overdrive unit in vertical position. Mount it on blocks, or in workbench with appropriate size mounting hole cut into it. Be sure unit is facing upward for access to direct clutch hub. Also be sure output shaft is not loaded and internal components are moved rearward for accurate measurement.

(2) Determine correct thickness overdrive piston thrust plate as follows:

(a) Position Gauge Tool 6311 across face of overdrive case. Then position Dial Caliper C-4962 over gauge tool (Fig. 174).

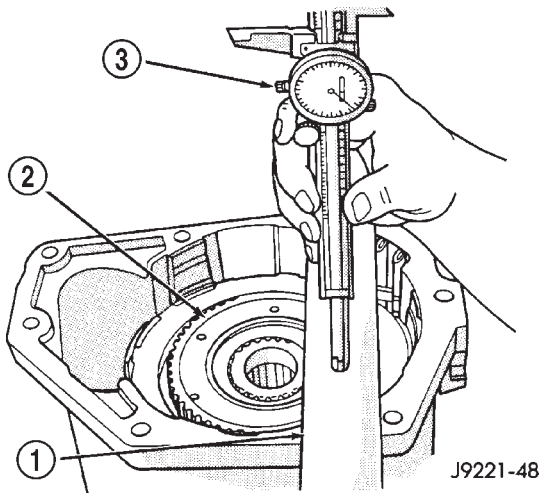
(b) Measure distance to clutch hub thrust bearing seat at four points 90° apart. Then average measurements by adding them and dividing by 4.

(c) Select and install required thrust plate from information in thrust plate chart (Fig. 175).

(3) Leave Alignment Tool 6227-2 in place. Tool will keep planetary and clutch hub splines in alignment until overdrive unit is ready for installation on transmission.

OVERDRIVE UNIT (Continued)

(4) Transmission speed sensor can be installed at this time if desired. However, it is recommended that sensor not be installed until after overdrive unit is secured to transmission.



**Fig. 174 Overdrive Piston Thrust Plate Measurement**

- 1 - SPECIAL TOOL 6311
- 2 - DIRECT CLUTCH HUB THRUST BEARING SEAT
- 3 - SPECIAL TOOL C-4962

End Play Measurement (Inches)	Spacer Thickness (Inches)
1.7500 - 1.7649	.108 - .110
1.7650 - 1.7799	.123 - .125
1.7800 - 1.7949	.138 - .140
1.7950 - 1.8099	.153 - .155
1.8100 - 1.8249	.168 - .170
1.8250 - 1.8399	.183 - .185
1.8400 - 1.8549	.198 - .200
1.8550 - 1.8699	.213 - .215
1.8700 - 1.8849	.228 - .230
1.8850 - 1.8999	.243 - .245

J9121-342

**Fig. 175 Overdrive Piston Thrust Plate Selection**

**OVERDRIVE PISTON**

- (1) Install new seals on overdrive piston.
- (2) Stand transmission case upright on bellhousing.
- (3) Position Guide Ring 8114-1 on outer edge of overdrive piston retainer.
- (4) Position Seal Guide 8114-3 on inner edge of overdrive piston retainer.
- (5) Install overdrive piston in overdrive piston retainer by:
  - (a) Aligning locating lugs on overdrive piston to the two mating holes in retainer.

(b) Lubricate overdrive piston seals with Mopar® Door Ease, or equivalent.

(c) Install piston over Seal Guide 8114-3 and inside Guide Ring 8114-1.

(d) Push overdrive piston into position in retainer.

(e) Verify that the locating lugs entered the lug bores in the retainer.

(6) Install intermediate shaft spacer on intermediate shaft.

(7) Install overdrive piston thrust plate on overdrive piston.

(8) Install overdrive piston thrust bearing on overdrive piston.

(9) Install transmission speed sensor and o-ring seal in overdrive case.

**INSTALLATION**

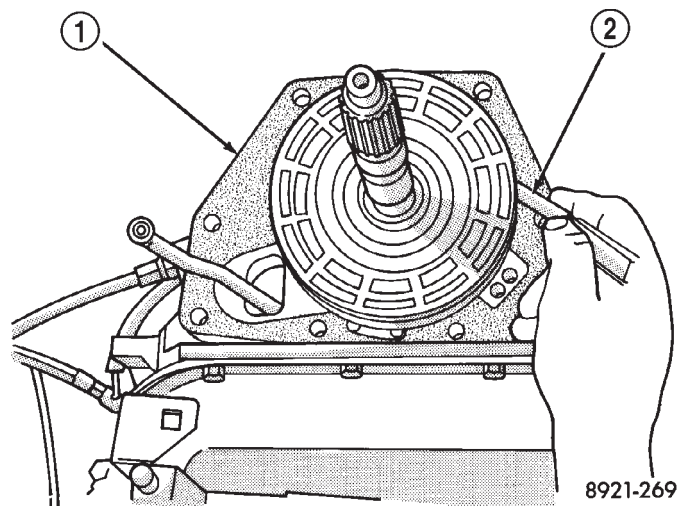
(1) Be sure overdrive unit Alignment Tool 6227-2 is fully seated before moving unit. If tool is not seated and gear splines rotate out of alignment, overdrive unit will have to be disassembled in order to realign splines.

(2) If overdrive piston retainer was not removed during service and original case gasket is no longer reusable, prepare new gasket by trimming it.

(3) Cut out old case gasket around piston retainer with razor knife (Fig. 176).

(4) Use old gasket as template and trim new gasket to fit.

(5) Position new gasket over piston retainer and on transmission case. Use petroleum jelly to hold gasket in place if necessary. Do not use any type of sealer to secure gasket. Use petroleum jelly only.

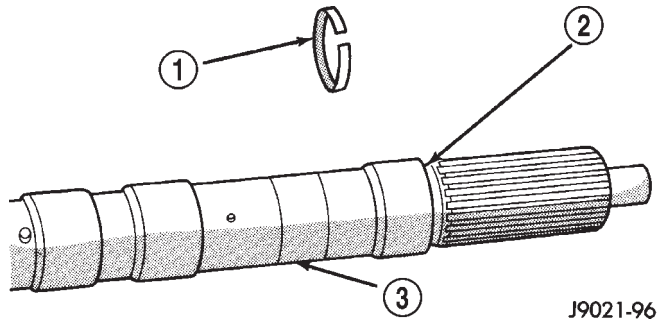


**Fig. 176 Trimming Overdrive Case Gasket**

- 1 - GASKET
- 2 - SHARP KNIFE

## OVERDRIVE UNIT (Continued)

(6) Install selective spacer on intermediate shaft, if removed. Spacer goes in groove just rearward of shaft rear splines (Fig. 177).



**Fig. 177 Intermediate Shaft Selective Spacer Location**

- 1 - SELECTIVE SPACER
- 2 - SPACER GROOVE
- 3 - INTERMEDIATE SHAFT

(7) Install thrust bearing in overdrive unit sliding hub. Use petroleum jelly to hold bearing in position.

**CAUTION:** Be sure the shoulder on the inside diameter of the bearing is facing forward.

(8) Verify that splines in overdrive planetary gear and overrunning clutch hub are aligned with Alignment Tool 6227-2. Overdrive unit cannot be installed if splines are not aligned. If splines have rotated out of alignment, unit will have to be disassembled to realign splines.

(9) Carefully slide Alignment Tool 6227-2 out of overdrive planetary gear and overrunning clutch splines.

(10) Raise overdrive unit and carefully slide it straight onto intermediate shaft. Insert park rod into park lock reaction plug at same time. Avoid tilting overdrive during installation as this could cause planetary gear and overrunning clutch splines to rotate out of alignment. If this occurs, it will be necessary to remove and disassemble overdrive unit to realign splines.

(11) Work overdrive unit forward on intermediate shaft until seated against transmission case.

(12) Install bolts attaching overdrive unit to transmission unit. Tighten bolts in diagonal pattern to 34 N·m (25 ft-lbs).

(13) Connect the transmission speed sensor and overdrive wiring connectors.

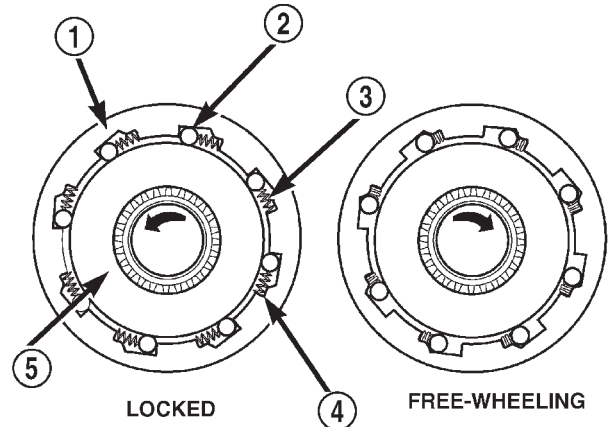
(14) Install the transfer case, if equipped.

(15) Align and install rear propeller shaft, if necessary. (Refer to 3 - DIFFERENTIAL & DRIVELINE/ PROPELLER SHAFT/PROPELLER SHAFT - INSTALLATION)

## OVERRUNNING CLUTCH CAM/OVERDRIVE PISTON RETAINER

### DESCRIPTION

The overrunning clutch (Fig. 178) consists of an inner race, an outer race (or cam), rollers and springs, and the spring retainer. The number of rollers and springs depends on what transmission and which overrunning clutch is being dealt with.



**Fig. 178 Overrunning Clutch**

- 1 - OUTER RACE (CAM)
- 2 - ROLLER
- 3 - SPRING
- 4 - SPRING RETAINER
- 5 - INNER RACE (HUB)

80be45f8

### OPERATION

As the inner race is rotated in a clockwise direction (as viewed from the front of the transmission), the race causes the rollers to roll toward the springs, causing them to compress against their retainer. The compression of the springs increases the clearance between the rollers and cam. This increased clearance between the rollers and cam results in a free-wheeling condition. When the inner race attempts to rotate counterclockwise, the action causes the rollers to roll in the same direction as the race, aided by the pushing of the springs. As the rollers try to move in the same direction as the inner race, they are wedged between the inner and outer races due to the design of the cam. In this condition, the clutch is locked and acts as one unit.

### DISASSEMBLY

- (1) Remove the overdrive piston (Fig. 179).
- (2) Remove the overdrive piston retainer bolts.
- (3) Remove overdrive piston retainer.

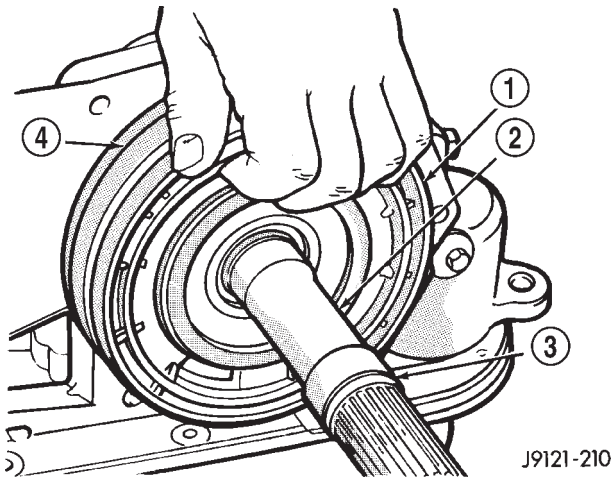


## OVERRUNNING CLUTCH CAM/OVERDRIVE PISTON RETAINER (Continued)

(4) Remove case gasket.

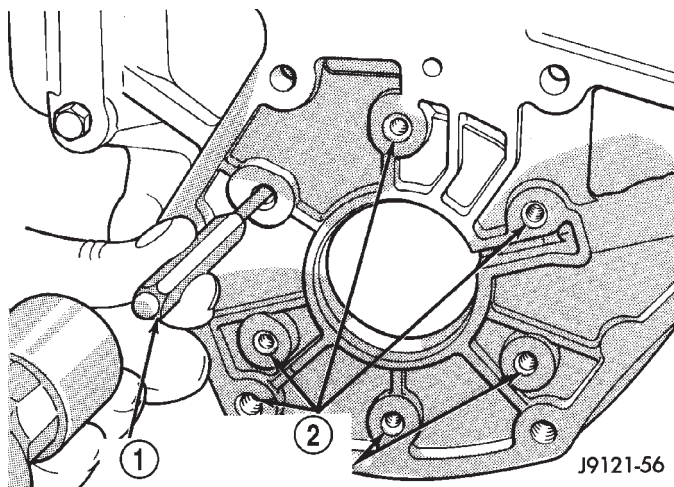
(5) Tap old cam out of case with pin punch. Insert punch through bolt holes at rear of case (Fig. 180). Alternate position of punch to avoid cocking cam during removal.

(6) Clean clutch cam bore and case. Be sure to remove all chips/shavings generated during cam removal.



**Fig. 179 Overdrive Piston Removal**

- 1 - OVERDRIVE CLUTCH PISTON
- 2 - INTERMEDIATE SHAFT
- 3 - SELECTIVE SPACER
- 4 - PISTON RETAINER



**Fig. 180 Overrunning Clutch Cam**

- 1 - PIN PUNCH
- 2 - REAR SUPPORT BOLT HOLES

## CLEANING

Clean the overrunning clutch assembly, clutch cam, low-reverse drum, and overdrive piston retainer in solvent. Dry them with compressed air after cleaning.

## INSPECTION

Inspect condition of each clutch part after cleaning. Replace the overrunning clutch roller and spring assembly if any rollers or springs are worn or damaged, or if the roller cage is distorted, or damaged. Replace the cam if worn, cracked or damaged.

Replace the low-reverse drum if the clutch race, roller surface or inside diameter is scored, worn or damaged. **Do not remove the clutch race from the low-reverse drum under any circumstances. Replace the drum and race as an assembly if either component is damaged.**

Examine the overdrive piston retainer carefully for wear, cracks, scoring or other damage. Be sure the retainer hub is a snug fit in the case and drum. Replace the retainer if worn or damaged.

## ASSEMBLY

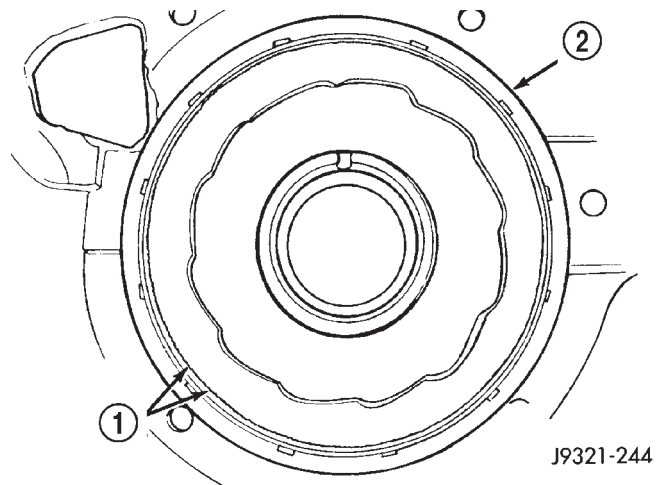
(1) Temporarily install overdrive piston retainer in case. Use 3-4 bolts to secure retainer.

(2) Align and start new clutch cam in the transmission case. Be sure serrations on cam and in case are aligned (Fig. 181). Then tap cam into case just enough to hold it in place.

(3) Verify that cam is correctly positioned before proceeding any further. Narrow ends of cam ramps should be to left when cam is viewed from front end of case (Fig. 181).

(4) Insert Adapter Tool SP-5124 into piston retainer (Fig. 182).

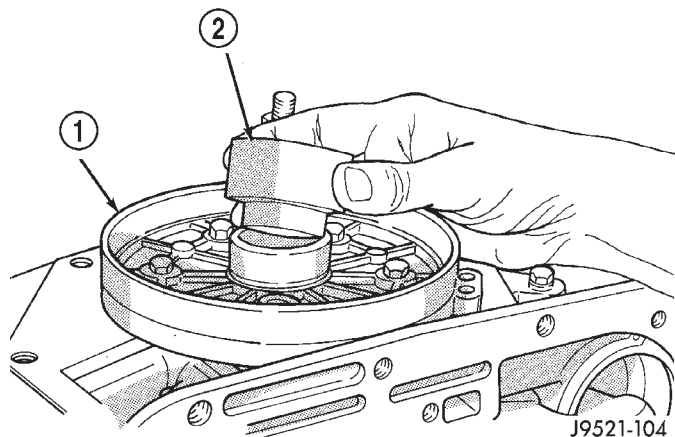
(5) Assemble Puller Bolt SP-3701 and Press Plate SP-3583-A (Fig. 183).



**Fig. 181 Positioning Replacement Clutch Cam In Case**

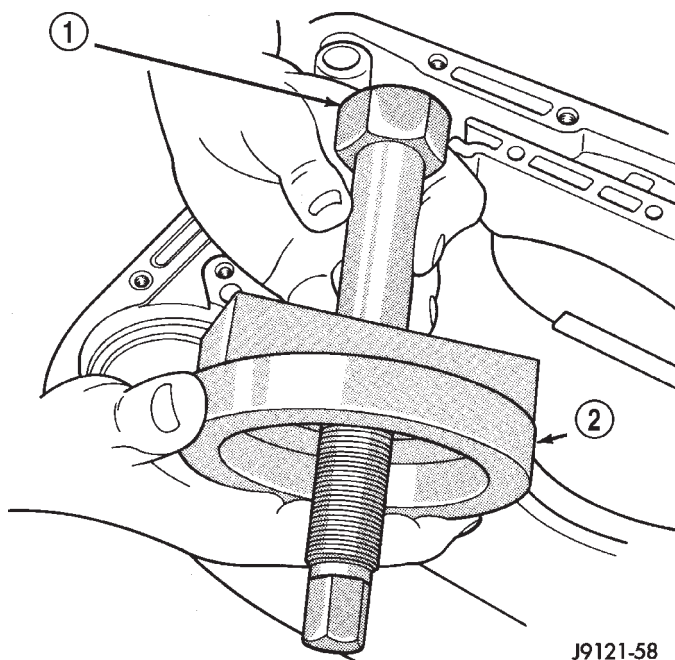
- 1 - ALIGN SERRATIONS ON CAM AND IN CASE
- 2 - CLUTCH CAM

## OVERRUNNING CLUTCH CAM/OVERDRIVE PISTON RETAINER (Continued)



**Fig. 182 Positioning Adapter Tool In Overdrive Piston Retainer**

- 1 - PISTON RETAINER  
2 - SPECIAL TOOL SP-5124



**Fig. 183 Assembling Clutch Cam Puller Bolt And Press Plate**

- 1 - PULLER BOLT SP-3701  
2 - PRESS PLATE SP-3583-A

(6) Install assembled puller plate and bolt (Fig. 184). Insert bolt through cam, case and adapter tool. Be sure plate is seated squarely on cam.

(7) Hold puller plate and bolt in place and install puller nut SP-3701 on puller bolt (Fig. 185).

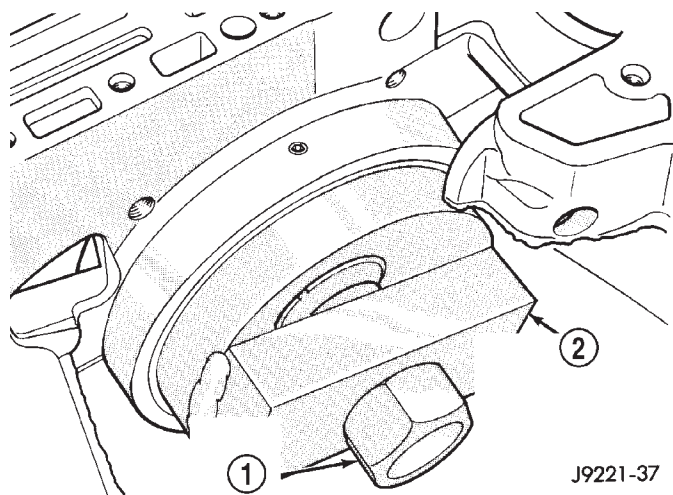
(8) Tighten puller nut to press clutch cam into case (Fig. 185). Be sure cam is pressed into case evenly and does not become cocked.

(9) Remove clutch cam installer tools.

(10) Stake case in 14 places around clutch cam to help secure cam in case. Use blunt punch or chisel to stake case.

(11) Remove piston retainer from case. Cover retainer with plastic sheeting, or paper to keep it dust free.

(12) Clean case and cam thoroughly. Be sure any chips/shavings generated during cam installation are removed from case.



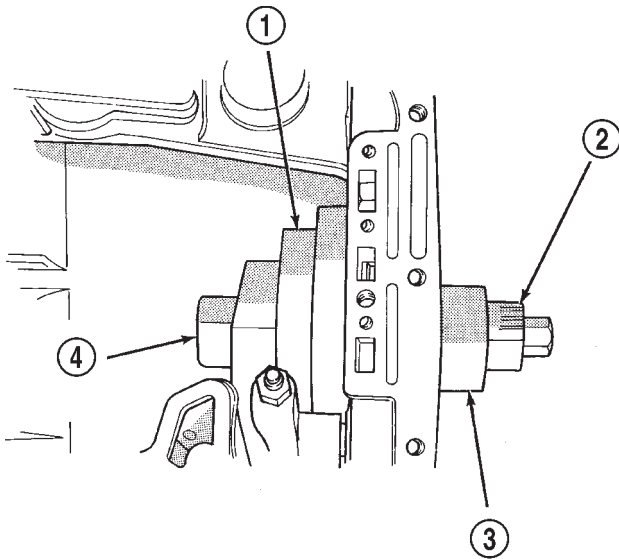
**Fig. 184 Positioning Puller Plate On Clutch Cam**

- 1 - SPECIAL TOOL SP-3701  
2 - BE SURE PLATE SP-3583-A IS SEATED SQUARELY ON CAM

(13) Install new gasket at rear of transmission case. Use petroleum jelly to hold gasket in place. Be sure to align governor feed holes in gasket with feed passages in case (Fig. 186). Also install gasket before overdrive piston retainer. Center hole in gasket is smaller than retainer and cannot be installed over retainer.



## OVERRUNNING CLUTCH CAM/OVERDRIVE PISTON RETAINER (Continued)



J9521-105

**Fig. 185 Pressing Overrunning Clutch Cam Into Case**

- 1 - SPECIAL TOOL SP-3583-A
- 2 - TIGHTEN NUT TO DRAW CAM INTO CASE (NUT IS PART OF BOLT SP-3701)
- 3 - SPECIAL TOOL SP-5124
- 4 - SPECIAL TOOL SP-3701

(14) Position overdrive piston retainer on transmission case and align bolt holes in retainer, gasket and case (Fig. 187). Then install and tighten retainer bolts to 17 N·m (13 ft. lbs.) torque.

(15) Install new seals on overdrive piston.

(16) Stand transmission case upright on bellhousing.

(17) Position Guide Ring 8114-1 on outer edge of overdrive piston retainer.

(18) Position Seal Guide 8114-3 on inner edge of overdrive piston retainer.

(19) Install overdrive piston in overdrive piston retainer by: aligning locating lugs on overdrive piston to the two mating holes in retainer.

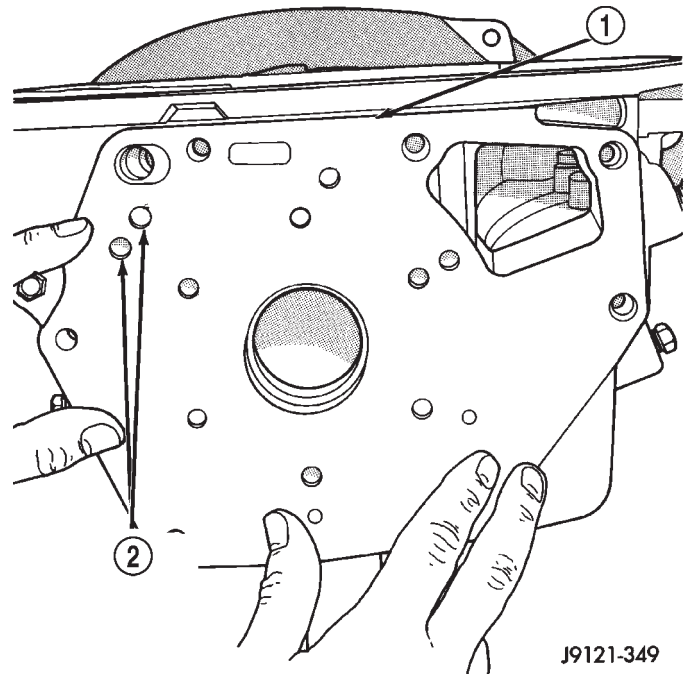
(a) Aligning locating lugs on overdrive piston to the two mating holes in retainer.

(b) Lubricate overdrive piston seals with Mopar® Door Ease, or equivalent.

(c) Install piston over Seal Guide 8114-3 and inside Guide Ring 8114-1.

(d) Push overdrive piston into position in retainer.

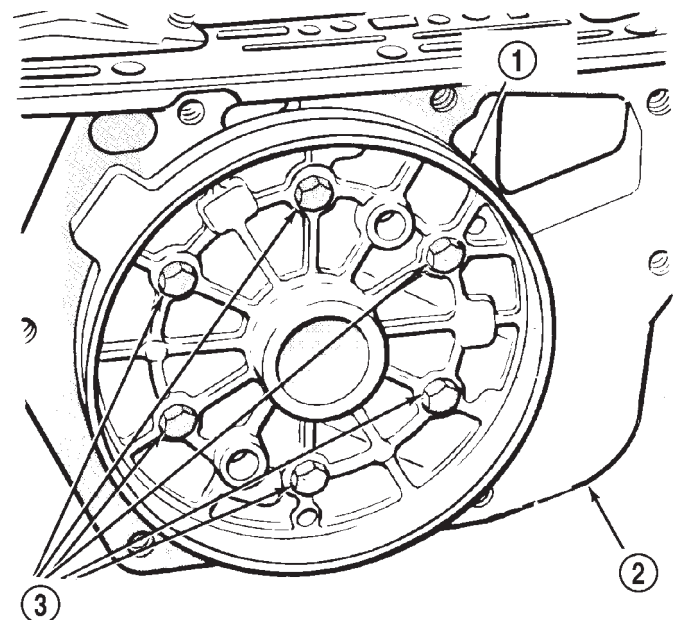
(e) Verify that the locating lugs entered the lug bores in the retainer.



J9121-349

**Fig. 186 Installing/Aligning Case Gasket**

- 1 - CASE GASKET
- 2 - BE SURE GOVERNOR TUBE FEED HOLES IN CASE AND GASKET ARE ALIGNED



J9321-464

**Fig. 187 Aligning Overdrive Piston Retainer**

- 1 - PISTON RETAINER
- 2 - GASKET
- 3 - RETAINER BOLTS

## PARK/NEUTRAL POSITION SWITCH

### DIAGNOSIS AND TESTING - PARK/NEUTRAL POSITION SWITCH

The center terminal of the park/neutral position switch is the starter-circuit terminal. It provides the ground for the starter solenoid circuit through the selector lever in PARK and NEUTRAL positions only. The outer terminals on the switch are for the backup lamp circuit.

### SWITCH TEST

To test the switch, remove the wiring connector. Test for continuity between the center terminal and the transmission case. Continuity should exist only when the transmission is in PARK or NEUTRAL.

Shift the transmission into REVERSE and test continuity at the switch outer terminals. Continuity should exist only when the transmission is in REVERSE. Continuity should not exist between the outer terminals and the case.

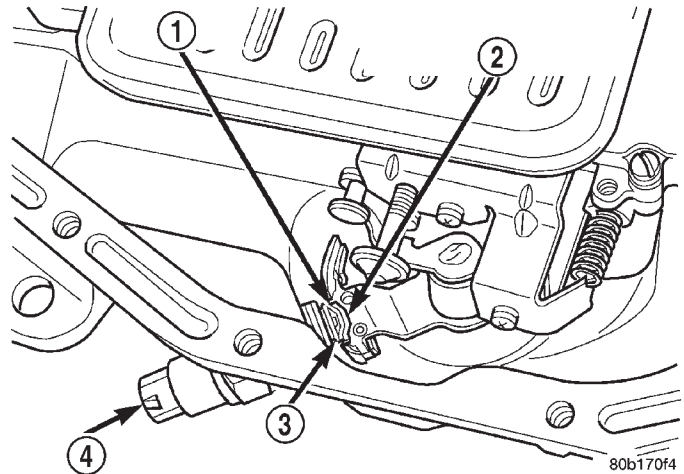
Check gearshift linkage adjustment before replacing a switch that tests faulty.

### REMOVAL

- (1) Raise vehicle and position drain pan under switch.
- (2) Disconnect switch wires.
- (3) Remove switch from case.

### INSTALLATION

- (1) Move shift lever to PARK and NEUTRAL positions. Verify that switch operating lever fingers are centered in switch opening in case (Fig. 188).
- (2) Install new seal on switch and install switch in case. Tighten switch to 34 N·m (25 ft. lbs.) torque.
- (3) Test continuity of new switch with 12V test lamp.
- (4) Connect switch wires and lower vehicle.
- (5) Top off transmission fluid level.



**Fig. 188 Park/Neutral Position Switch**

- 1 - NEUTRAL CONTACT
- 2 - MANUAL LEVER AND SWITCH PLUNGER IN REVERSE POSITION
- 3 - PARK CONTACT
- 4 - SWITCH

## PISTONS

### DESCRIPTION

There are several sizes and types of pistons used in an automatic transmission. Some pistons are used to apply clutches, while others are used to apply bands. They all have in common the fact that they are round or circular in shape, located within a smooth walled cylinder, which is closed at one end and converts fluid pressure into mechanical movement. The fluid pressure exerted on the piston is contained within the system through the use of piston rings or seals.

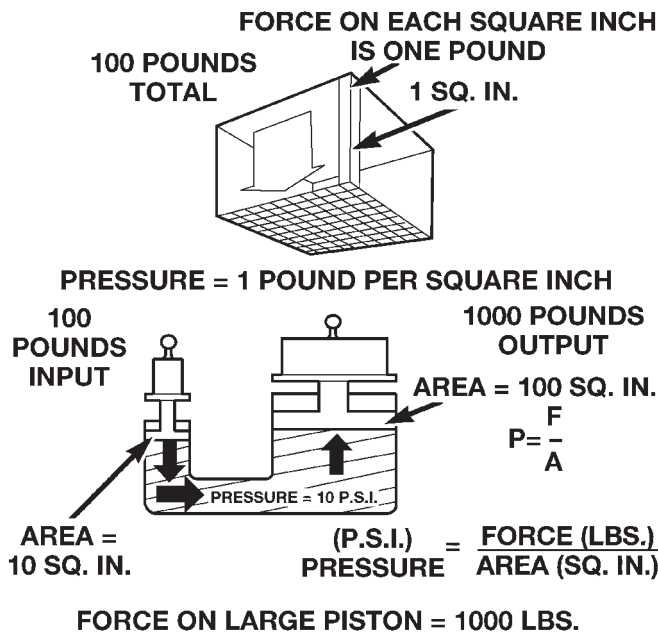
### OPERATION

The principal which makes this operation possible is known as Pascal's Law. Pascal's Law can be stated as: "Pressure on a confined fluid is transmitted equally in all directions and acts with equal force on equal areas."

PISTONS (Continued)

**PRESSURE**

Pressure (Fig. 189) is nothing more than force (lbs.) divided by area (in or ft.), or force per unit area. Given a 100 lb. block and an area of 100 sq. in. on the floor, the pressure exerted by the block is: 100 lbs. 100 in or 1 pound per square inch, or PSI as it is commonly referred to.

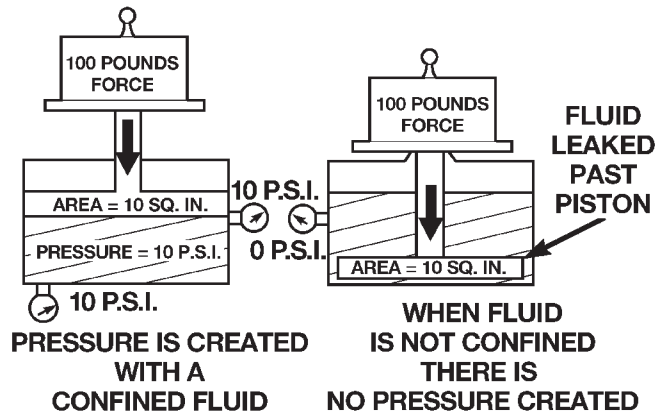


**Fig. 189 Force and Pressure Relationship**

**PRESSURE ON A CONFINED FLUID**

Pressure is exerted on a confined fluid (Fig. 190) by applying a force to some given area in contact with the fluid. A good example of this is a cylinder filled with fluid and equipped with a piston that is closely fitted to the cylinder wall. If a force is applied to the piston, pressure will be developed in the fluid. Of course, no pressure will be created if the fluid is not confined. It will simply "leak" past the piston. There must be a resistance to flow in order to create pressure. Piston sealing is extremely important in hydraulic operation. Several kinds of seals are used to accomplish this within a transmission. These include but are not limited to O-rings, D-rings, lip seals, sealing rings, or extremely close tolerances between the piston and the cylinder wall. The force exerted is downward (gravity), however, the principle remains the same no matter which direction is taken. The pressure created in the fluid is equal to the force applied, divided by the piston area. If the force is 100 lbs., and the piston area is 10 sq. in., then the pressure created equals 10 PSI. Another interpretation of Pascal's Law is that regardless of container shape or size, the pressure will be maintained throughout, as long as the fluid is confined. In other words, the

pressure in the fluid is the same everywhere within the container.



80bfe273

**Fig. 190 Pressure on a Confined Fluid**

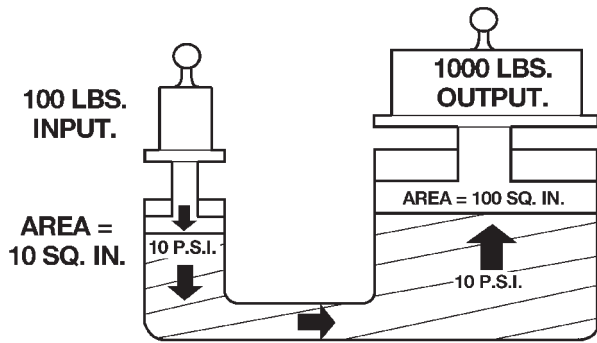
**FORCE MULTIPLICATION**

Using the 10 PSI example used in the illustration (Fig. 191), a force of 1000 lbs. can be moved with a force of only 100 lbs. The secret of force multiplication in hydraulic systems is the total fluid contact area employed. The illustration, (Fig. 191), shows an area that is ten times larger than the original area. The pressure created with the smaller 100 lb. input is 10 PSI. The concept "pressure is the same everywhere" means that the pressure underneath the larger piston is also 10 PSI. Pressure is equal to the force applied divided by the contact area. Therefore, by means of simple algebra, the output force may be found. This concept is extremely important, as it is also used in the design and operation of all shift valves and limiting valves in the valve body, as well as the pistons, of the transmission, which activate the clutches and bands. It is nothing more than using a difference of area to create a difference in pressure to move an object.

**PISTON TRAVEL**

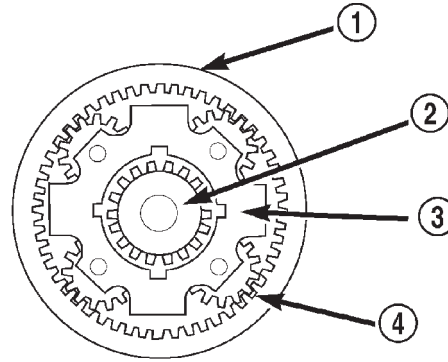
The relationship between hydraulic lever and a mechanical lever is the same. With a mechanical lever it's a weight-to-distance output rather than a pressure-to-area output. Using the same forces and areas as in the previous example, the smaller piston (Fig. 192) has to move ten times the distance required to move the larger piston one inch. Therefore, for every inch the larger piston moves, the smaller piston moves ten inches. This principle is true in other instances also. A common garage floor jack is a good example. To raise a car weighing 2000 lbs., an effort of only 100 lbs. may be required. For every inch the car moves upward, the input piston at the jack handle must move 20 inches downward.

PISTONS (Continued)



80bfe274

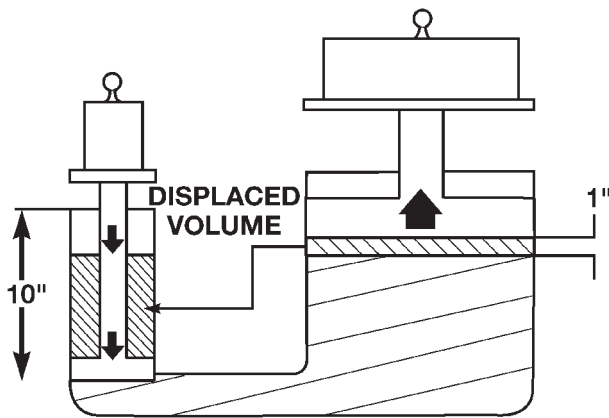
**Fig. 191 Force Multiplication**



80be45fc

**Fig. 193 Planetary Gearset**

- 1 - ANNULUS GEAR
- 2 - SUN GEAR
- 3 - PLANET CARRIER
- 4 - PLANET PINIONS (4)



80bfe275

**Fig. 192 Piston Travel**

**PLANETARY GEARTRAIN/  
OUTPUT SHAFT**

**DESCRIPTION**

The planetary gearsets (Fig. 193) are designated as the front, rear, and overdrive planetary gear assemblies and located in such order. A simple planetary gearset consists of three main members:

- The sun gear which is at the center of the system.
- The planet carrier with planet pinion gears which are free to rotate on their own shafts and are in mesh with the sun gear.

- The annulus gear, which rotates around and is in mesh with the planet pinion gears.

**NOTE:** The number of pinion gears does not affect the gear ratio, only the duty rating.

**OPERATION**

With any given planetary gearset, several conditions must be met for power to be able to flow:

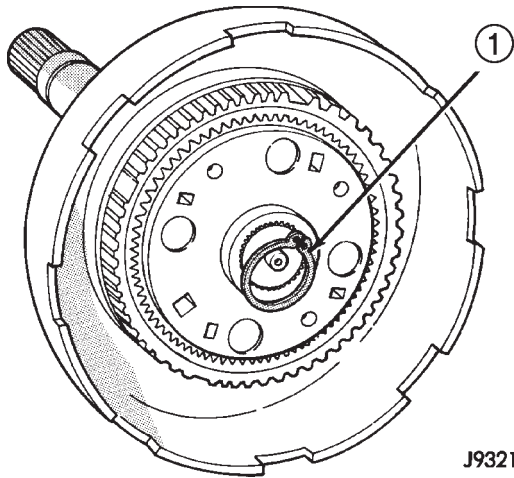
- One member must be held.
- Another member must be driven or used as an input.
- The third member may be used as an output for power flow.
- For direct drive to occur, two gear members in the front planetary gearset must be driven.

**NOTE:** Gear ratios are dependent on the number of teeth on the annulus and sun gears.

**DISASSEMBLY**

- (1) Remove planetary snap-ring from intermediate shaft (Fig. 194). Discard snap-ring as it is not reusable.
- (2) Remove front planetary gear and front annulus gear as assembly (Fig. 195).
- (3) Remove front planetary gear and thrust washer from front annulus gear (Fig. 196). Note thrust washer position for assembly reference.
- (4) Remove tabbed thrust washer from driving shell (Fig. 197). Note washer position for assembly reference.
- (5) Remove sun gear and driving shell as assembly (Fig. 198).

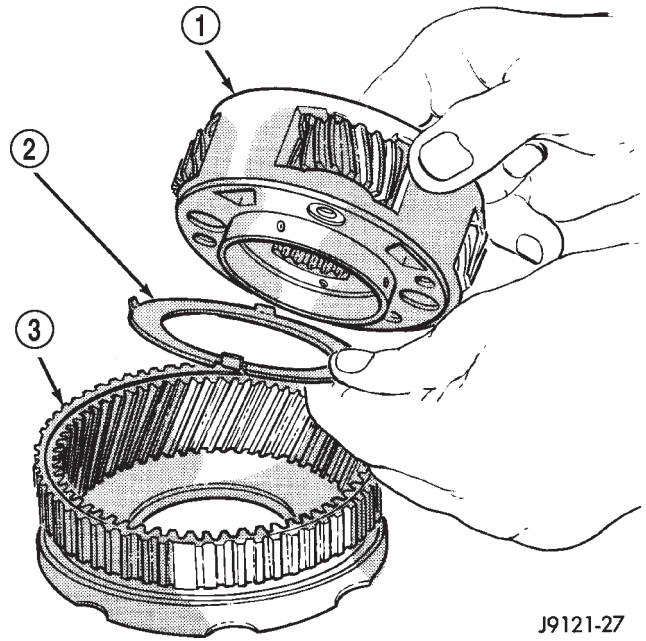
PLANETARY GEARTRAIN/OUTPUT SHAFT (Continued)



J9321-168

**Fig. 194 Removing Planetary Snap-Ring**

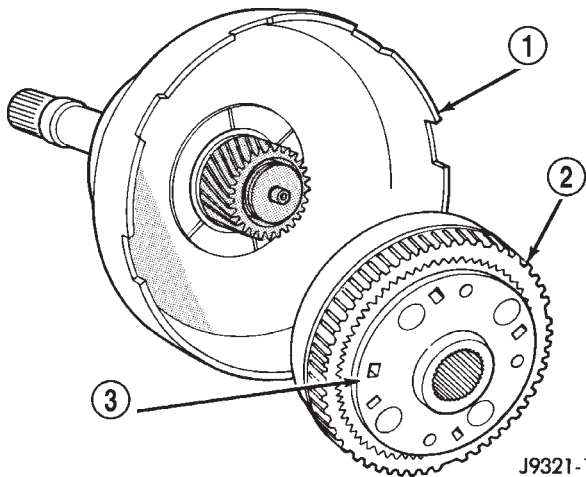
- 1 - PLANETARY SNAP-RING



J9121-27

**Fig. 196 Disassembling Front Planetary And Annulus Gears**

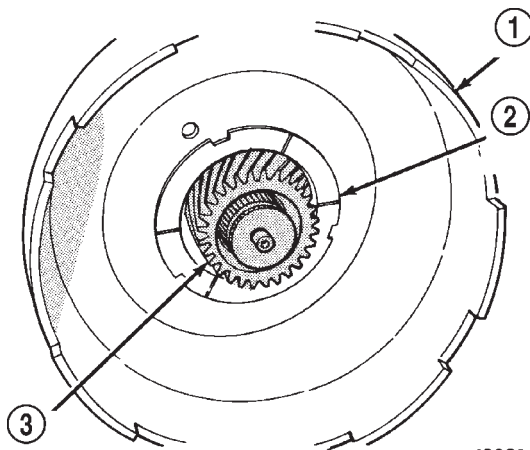
- 1 - FRONT PLANETARY GEAR
- 2 - TABBED THRUST WASHER
- 3 - FRONT ANNULUS GEAR



J9321-169

**Fig. 195 Removing Front Planetary And Annulus Gears**

- 1 - DRIVING SHELL
- 2 - FRONT ANNULUS GEAR
- 3 - FRONT PLANETARY GEAR



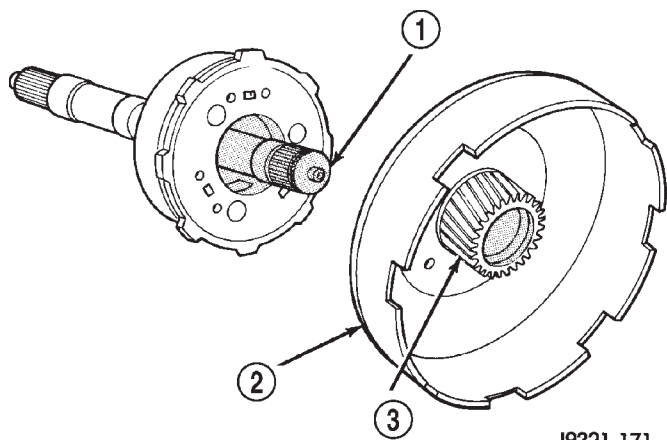
J9321-170

**Fig. 197 Driving Shell Thrust Washer Removal**

- 1 - DRIVING SHELL
- 2 - TABBED THRUST WASHER
- 3 - SUN GEAR



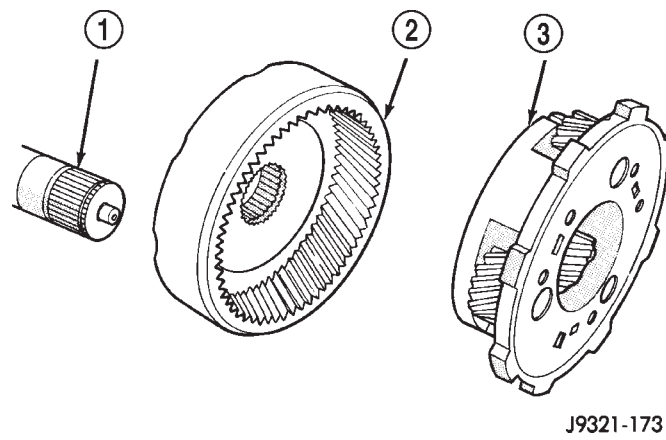
PLANETARY GEARTRAIN/OUTPUT SHAFT (Continued)



J9321-171

**Fig. 198 Sun Gear And Driving Shell Removal**

- 1 - INTERMEDIATE SHAFT
- 2 - DRIVING SHELL
- 3 - SUN GEAR



J9321-173

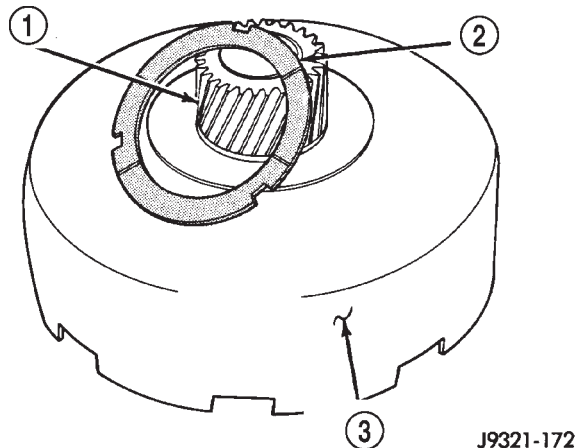
**Fig. 200 Rear Planetary And Annulus Gear Removal**

- 1 - INTERMEDIATE SHAFT
- 2 - REAR ANNULUS GEAR
- 3 - REAR PLANETARY GEAR

(6) Remove tabbed thrust washer from rear planetary gear (Fig. 199). Note washer position on gear for assembly reference.

(7) Remove rear planetary gear and rear annulus gear from intermediate shaft (Fig. 200).

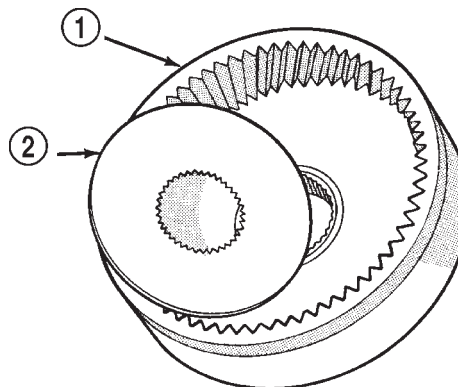
(8) Remove thrust plate from rear annulus gear (Fig. 201).



J9321-172

**Fig. 199 Rear Planetary Thrust Washer Removal**

- 1 - SUN GEAR
- 2 - REAR PLANETARY THRUST WASHER
- 3 - DRIVING SHELL



J9321-174

**Fig. 201 Rear Annulus Thrust Plate Removal**

- 1 - REAR ANNULUS GEAR
- 2 - THRUST PLATE

## PLANETARY GEARTRAIN/OUTPUT SHAFT (Continued)

**INSPECTION**

Inspect the planetary gear sets and annulus gears. The planetary pinions, shafts, washers, and retaining pins are serviceable. However, if a pinion carrier is damaged, the entire planetary gear set must be replaced as an assembly.

Replace the annulus gears if the teeth are chipped, broken, or worn, or the gear is cracked. Replace the planetary thrust plates and the tabbed thrust washers if cracked, scored or worn.

Inspect the machined surfaces of the intermediate shaft. Be sure the oil passages are open and clear. Replace the shaft if scored, pitted, or damaged.

Inspect the sun gear and driving shell. If either component is worn or damaged, remove the sun gear rear retaining ring and separate the sun gear and thrust plate from the driving shell. Then replace the necessary component.

Replace the sun gear as an assembly if the gear teeth are chipped or worn. Also replace the gear as an assembly if the bushings are scored or worn. The sun gear bushings are not serviceable. Replace the thrust plate if worn, or severely scored. Replace the driving shell if distorted, cracked, or damaged in any way.

Replace all snap-rings during geartrain assembly. Reusing snap-rings is not recommended.

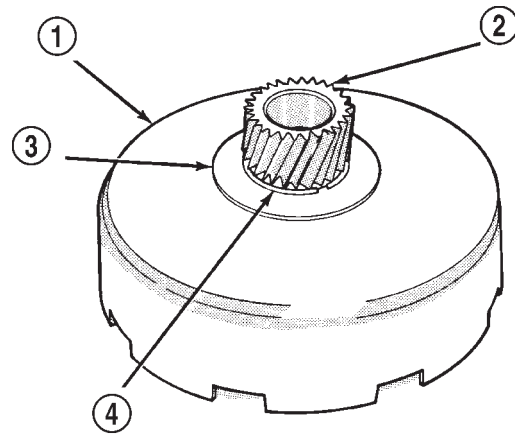
**ASSEMBLY**

(1) Lubricate sun gear and planetary gears with transmission fluid during assembly. Use petroleum jelly to lubricate intermediate shaft bushing surfaces, thrust washers and thrust plates and to hold these parts in place during assembly.

(2) Install front snap-ring on sun gear and install gear in driving shell. Then install thrust plate over sun gear and against rear side of driving shell (Fig. 202). Install rear snap-ring to secure sun gear and thrust plate in driving shell.

(3) Install rear annulus gear on intermediate shaft (Fig. 203).

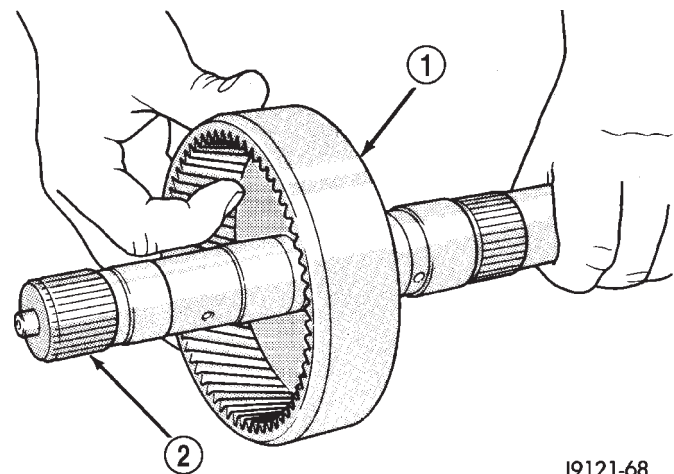
(4) Install thrust plate in annulus gear (Fig. 204). Be sure plate is seated on shaft splines and against gear.



J9321-175

**Fig. 202 Sun Gear Installation**

- 1 - DRIVING SHELL
- 2 - SUN GEAR
- 3 - THRUST PLATE
- 4 - SUN GEAR REAR RETAINING RING

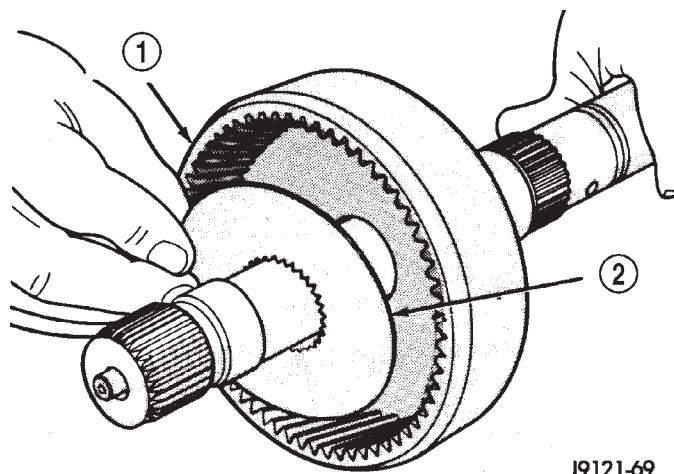


J9121-68

**Fig. 203 Installing Rear Annulus Gear On Intermediate Shaft**

- 1 - REAR ANNULUS GEAR
- 2 - OUTPUT SHAFT

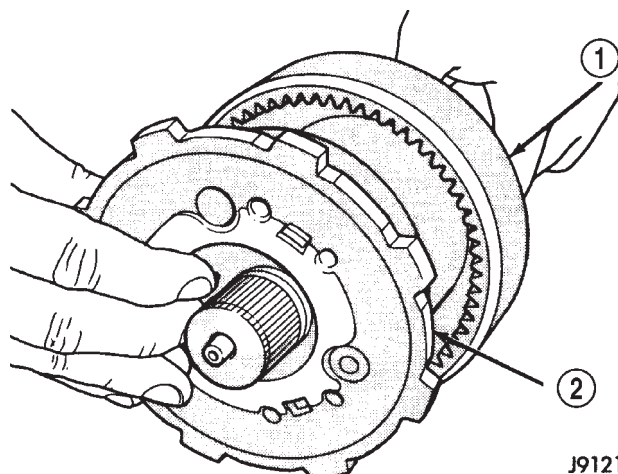
## PLANETARY GEARTRAIN/OUTPUT SHAFT (Continued)



J9121-69

**Fig. 204 Installing Rear Annulus Thrust Plate**

- 1 - REAR ANNULUS GEAR
- 2 - THRUST PLATE



J9121-70

**Fig. 205 Installing Rear Planetary Gear**

- 1 - REAR ANNULUS GEAR
- 2 - REAR PLANETARY GEAR

(5) Install rear planetary gear in rear annulus gear (Fig. 205). Be sure planetary carrier is seated against annulus gear.

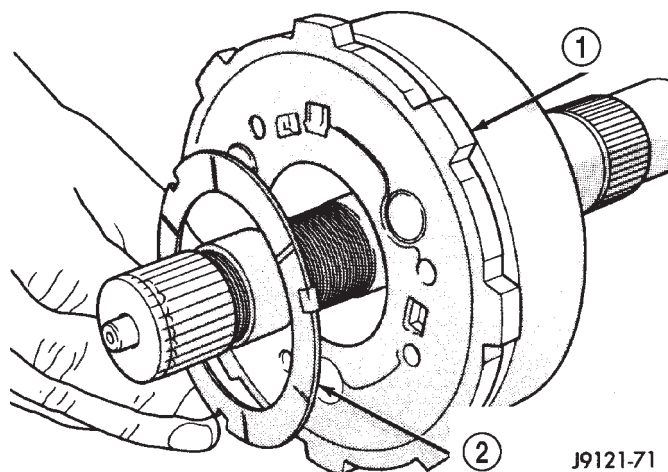
(6) Install tabbed thrust washer on front face of rear planetary gear (Fig. 206). Seat washer tabs in matching slots in face of gear carrier. Use extra petroleum jelly to hold washer in place if desired.

(7) Lubricate sun gear bushings with petroleum jelly or transmission fluid.

(8) Install sun gear and driving shell on intermediate shaft (Fig. 207). Seat shell against rear planetary gear. Verify that thrust washer on planetary gear was not displaced during installation.

(9) Install tabbed thrust washer in driving shell (Fig. 208), be sure washer tabs are seated in tab slots of driving shell. Use extra petroleum jelly to hold washer in place if desired.

(10) Install tabbed thrust washer on front planetary gear (Fig. 209). Seat washer tabs in matching slots in face of gear carrier. Use extra petroleum jelly to hold washer in place if desired.

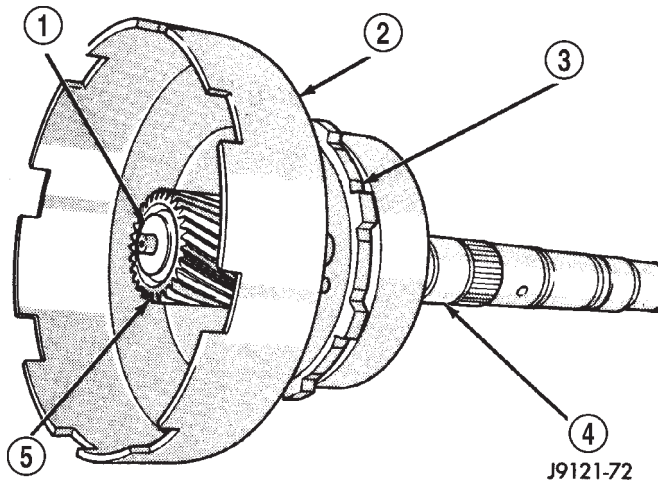


J9121-71

**Fig. 206 Installing Rear Planetary Thrust Washer**

- 1 - REAR PLANETARY GEAR
- 2 - TABBED THRUST WASHER

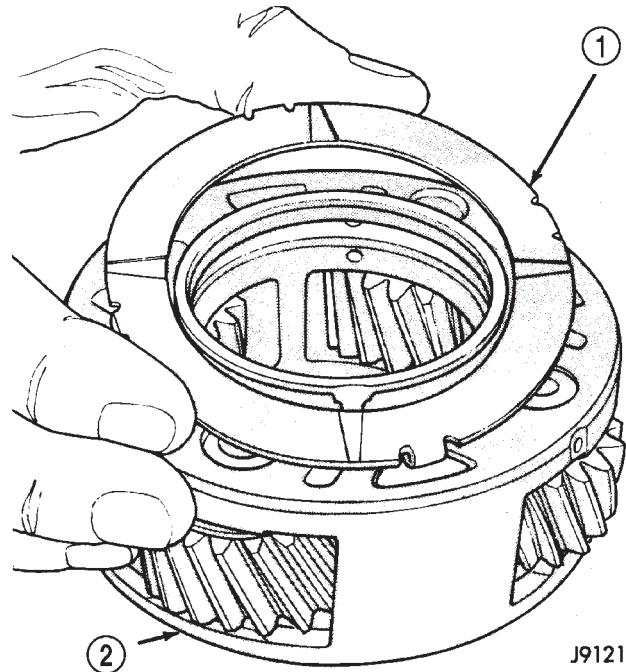
## PLANETARY GEARTRAIN/OUTPUT SHAFT (Continued)



J9121-72

**Fig. 207 Installing Sun Gear And Driving Shell**

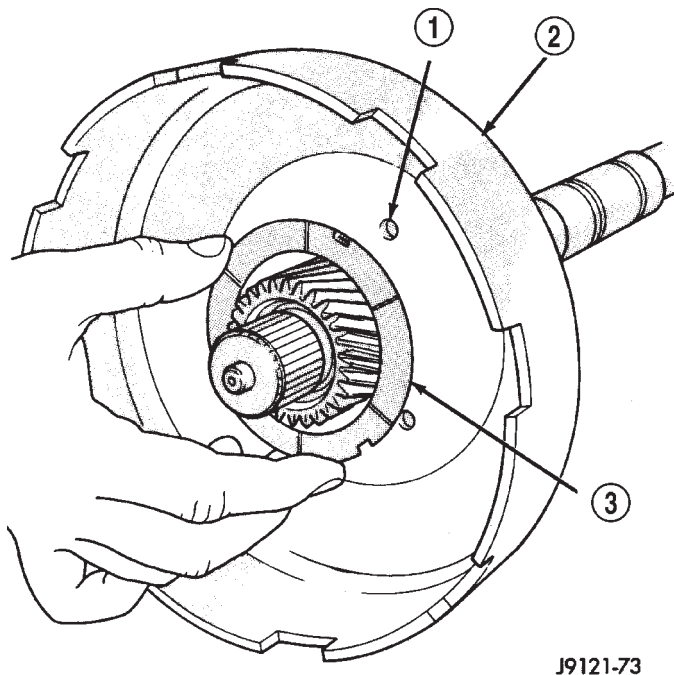
- 1 - OUTPUT SHAFT
- 2 - DRIVING SHELL
- 3 - REAR PLANETARY GEAR
- 4 - OUTPUT SHAFT
- 5 - SUN GEAR



J9121-74

**Fig. 209 Installing Thrust Washer On Front Planetary Gear**

- 1 - TABBED THRUST WASHER
- 2 - FRONT PLANETARY GEAR



J9121-73

**Fig. 208 Installing Driving Shell Thrust Washer**

- 1 - TAB SLOTS (3)
- 2 - DRIVING SHELL
- 3 - TABBED THRUST WASHER

(11) Install front annulus gear over and onto front planetary gear (Fig. 210). Be sure gears are fully meshed and seated.

(12) Install front planetary and annulus gear assembly (Fig. 211). Hold gears together and slide them onto shaft. Be sure planetary pinions are seated on sun gear and that planetary carrier is seated on intermediate shaft.

(13) Place geartrain in upright position. Rotate gears to be sure all components are seated and properly assembled. Snap-ring groove at forward end of intermediate shaft will be completely exposed when components are assembled correctly.

(14) Install new planetary snap-ring in groove at end of intermediate shaft (Fig. 212).

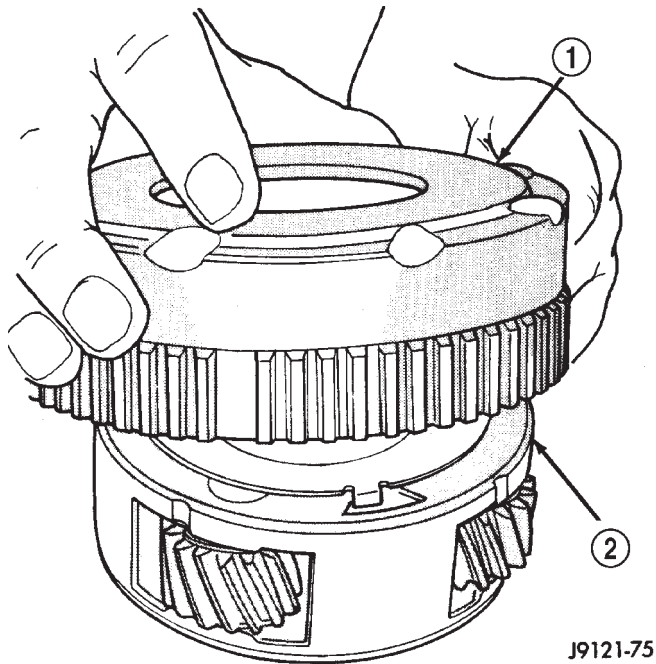
(15) Turn planetary geartrain over. Position wood block under front end of intermediate shaft and support geartrain on shaft. Be sure all geartrain parts have moved forward against planetary snap-ring. This is important for accurate end play check.

(16) Check planetary geartrain end play with feeler gauge (Fig. 213). Insert gauge between rear annulus gear and shoulder on intermediate shaft as shown. End play should be 0.15 to 1.22 mm (0.006 to 0.048 in.).

(17) If end play is incorrect, install thinner/thicker planetary snap-ring as needed.

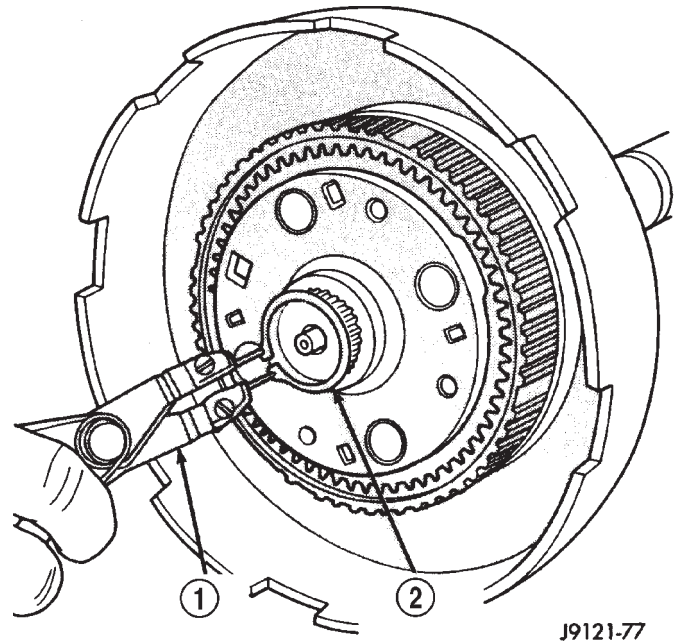


PLANETARY GEARTRAIN/OUTPUT SHAFT (Continued)



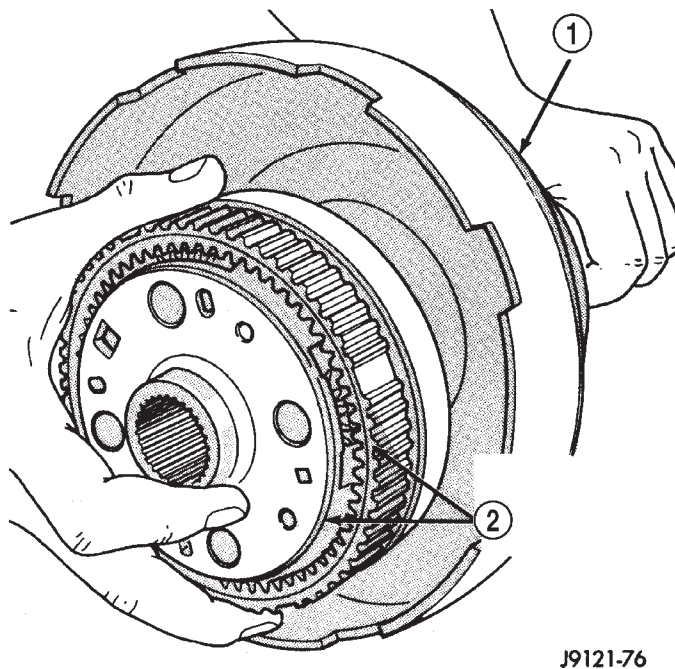
**Fig. 210 Assembling Front Planetary And Annulus Gears**

- 1 - FRONT ANNULUS GEAR
- 2 - FRONT PLANETARY GEAR



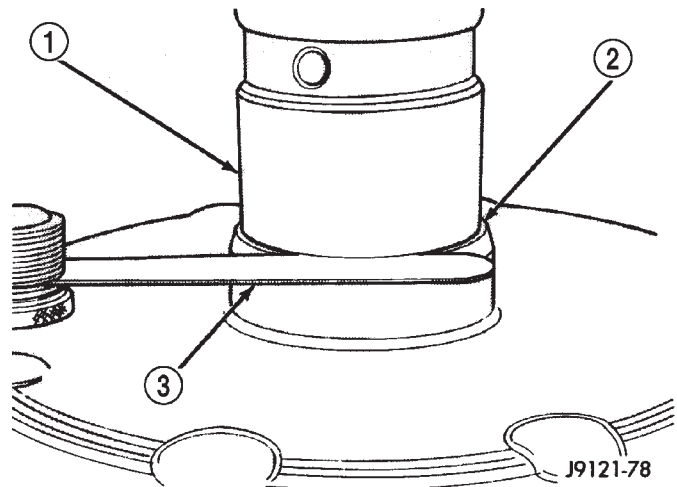
**Fig. 212 Installing Planetary Snap-Ring**

- 1 - SNAP-RING PLIERS
- 2 - PLANETARY SNAP-RING



**Fig. 211 Installing Front Planetary And Annulus Gear Assembly**

- 1 - DRIVING SHELL
- 2 - ASSEMBLED FRONT PLANETARY AND ANNULUS GEARS



**Fig. 213 Checking Planetary Geartrain End Play**

- 1 - OUTPUT SHAFT
- 2 - REAR ANNULUS GEAR
- 3 - FEELER GAUGE



## REAR CLUTCH

### DESCRIPTION

The rear clutch assembly (Fig. 214) is composed of the rear clutch retainer, pressure plate, clutch plates, driving discs, piston, Belleville spring, and snap-rings. The Belleville spring acts as a lever to multiply the force applied on to it by the apply piston. The increased apply force on the rear clutch pack, in comparison to the front clutch pack, is needed to hold against the greater torque load imposed onto the rear pack. The rear clutch is directly behind the front clutch and is considered a driving component.

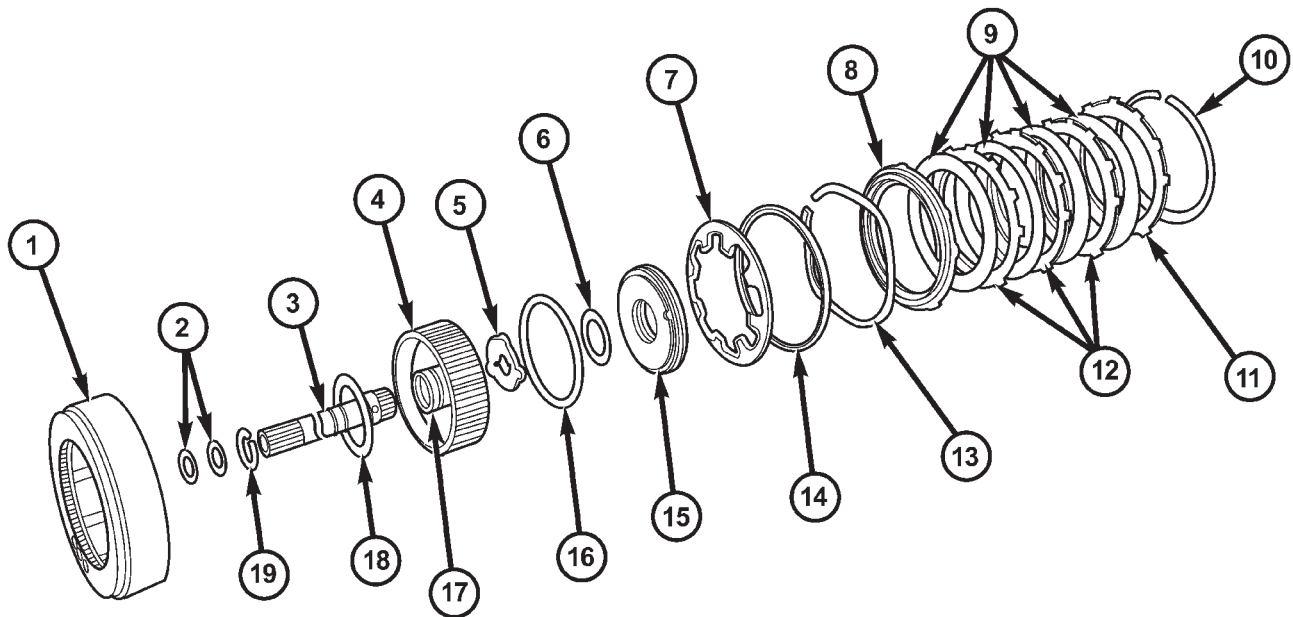
**NOTE: The number of discs and plates may vary with each engine and vehicle combination.**

### OPERATION

To apply the clutch, pressure is applied between the clutch retainer and piston. The fluid pressure is provided by the oil pump, transferred through the control valves and passageways, and enters the

clutch through the hub of the reaction shaft support. With pressure applied between the clutch retainer and piston, the piston moves away from the clutch retainer and compresses the clutch pack. This action applies the clutch pack, allowing torque to flow through the input shaft into the driving discs, and into the clutch plates and pressure plate that are lugged to the clutch retainer. The waved spring is used to cushion the application of the clutch pack. The snap-ring is selective and used to adjust clutch pack clearance.

When pressure is released from the piston, the spring returns the piston to its fully released position and disengages the clutch. The release spring also helps to cushion the application of the clutch assembly. When the clutch is in the process of being released by the release spring, fluid flows through a vent and one-way ball-check-valve located in the piston. The check-valve is needed to eliminate the possibility of plate drag caused by centrifugal force acting on the residual fluid trapped in the clutch piston retainer.



**Fig. 214 Rear Clutch Components**

- |                                |                          |
|--------------------------------|--------------------------|
| 1 - REAR CLUTCH RETAINER       | 11 - REACTION PLATE      |
| 2 - TORLON™ SEAL RINGS         | 12 - CLUTCH PLATES       |
| 3 - INPUT SHAFT                | 13 - WAVE SPRING         |
| 4 - PISTON RETAINER            | 14 - SPACER RING         |
| 5 - OUTPUT SHAFT THRUST WASHER | 15 - PISTON              |
| 6 - INNER PISTON SEAL          | 16 - OUTER PISTON SEAL   |
| 7 - PISTON SPRING              | 17 - REAR SEAL RING      |
| 8 - PRESSURE PLATE             | 18 - FIBER THRUST WASHER |
| 9 - CLUTCH DISCS               | 19 - RETAINING RING      |
| 10 - SNAP-RING (SELECTIVE)     |                          |

## REAR CLUTCH (Continued)

**DISASSEMBLY**

- (1) Remove fiber thrust washer from forward side of clutch retainer.
- (2) Remove input shaft front and rear seal rings.
- (3) Remove selective clutch pack snap-ring (Fig. 215).
- (4) Remove the reaction plate, clutch discs, steel plates, pressure plate, wave spring, spacer ring, and piston spring (Fig. 215).
- (5) Remove clutch piston with rotating motion.
- (6) Remove and discard piston seals.
- (7) Remove input shaft retaining ring. It may be necessary to press the input shaft in slightly to relieve tension on the retaining ring
- (8) Press input shaft out of retainer with shop press and suitable size press tool. Use a suitably sized press tool to support the retainer as close to the input shaft as possible.

**CLEANING**

Clean the clutch components with solvent and dry them with compressed air. Do not use rags or shop

towels to dry any of the clutch parts. Lint from such materials will adhere to component surfaces and could restrict or block fluid passages after assembly.

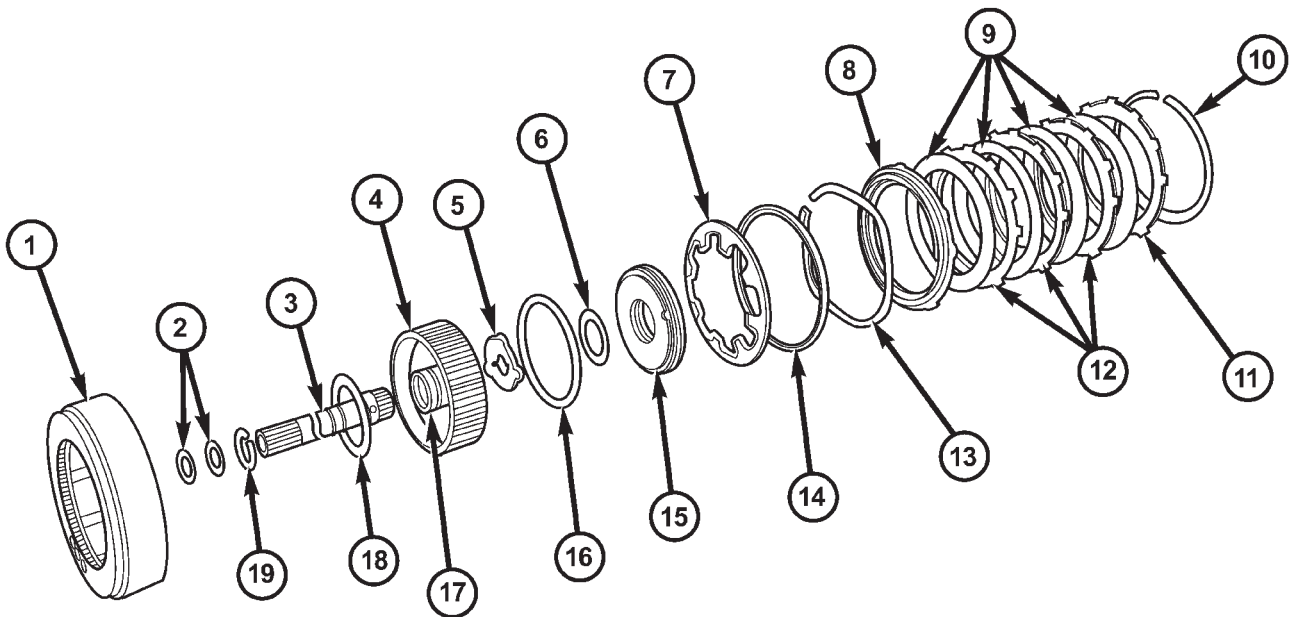
**INSPECTION**

Replace the clutch discs if warped, worn, scored, burned/charred, the lugs are damaged, or if the facing is flaking off. Replace the top and bottom pressure plates if scored, warped, or cracked. Be sure the driving lugs on the pressure and clutch plates are also in good condition. The lugs must not be bent, cracked or damaged in any way.

Replace the piston spring and wave spring if either part is distorted, warped or broken.

Check the lug grooves in the clutch retainer. The clutch and pressure plates should slide freely in the slots. Replace the retainer if the grooves are worn or damaged. Also check action of the check balls in the retainer and piston. Each check ball must move freely and not stick.

Replace the retainer bushing if worn, scored, or doubt exists about bushing condition.



**Fig. 215 Rear Clutch Components**

- |                                |                          |
|--------------------------------|--------------------------|
| 1 - REAR CLUTCH RETAINER       | 11 - REACTION PLATE      |
| 2 - TORLON™ SEAL RINGS         | 12 - CLUTCH PLATES       |
| 3 - INPUT SHAFT                | 13 - WAVE SPRING         |
| 4 - PISTON RETAINER            | 14 - SPACER RING         |
| 5 - OUTPUT SHAFT THRUST WASHER | 15 - PISTON              |
| 6 - INNER PISTON SEAL          | 16 - OUTER PISTON SEAL   |
| 7 - PISTON SPRING              | 17 - REAR SEAL RING      |
| 8 - PRESSURE PLATE             | 18 - FIBER THRUST WASHER |
| 9 - CLUTCH DISCS               | 19 - RETAINING RING      |
| 10 - SNAP-RING (SELECTIVE)     |                          |

## REAR CLUTCH (Continued)

Inspect the piston and retainer seal surfaces for nicks or scratches. Minor scratches can be removed with crocus cloth. However, replace the piston and/or retainer if the seal surfaces are seriously scored.

Check condition of the fiber thrust washer and metal output shaft thrust washer. Replace either washer if worn or damaged.

Check condition of the seal rings on the input shaft and clutch retainer hub. Replace the seal rings only if worn, distorted, or damaged. The input shaft front seal ring is teflon with chamfered ends. The rear ring is metal with interlocking ends.

Check the input shaft for wear, or damage. Replace the shaft if worn, scored or damaged in any way.

**ASSEMBLY**

(1) Soak clutch discs in transmission fluid while assembling other clutch parts.

(2) Install new seal rings on clutch retainer hub and input shaft if necessary.

(a) Be sure clutch hub seal ring is fully seated in groove and is not twisted.

(3) Lubricate splined end of input shaft and clutch retainer with transmission fluid. Then partially press input shaft into retainer (Fig. 216). Use a suitably sized press tool to support retainer as close to input shaft as possible.

(4) Install input shaft retaining ring.

(5) Press the input shaft the remainder of the way into the clutch retainer.

(6) Install new seals on clutch piston. Be sure lip of each seal faces interior of clutch retainer.

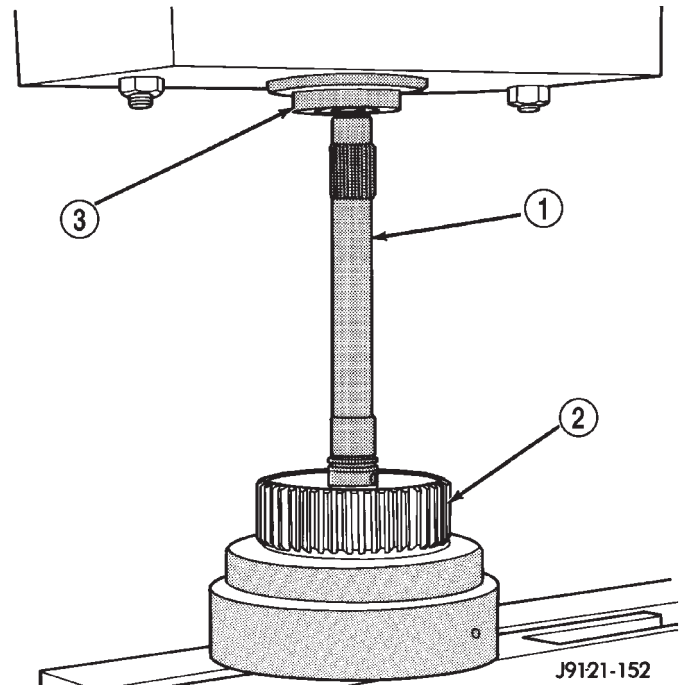
(7) Lubricate lip of piston seals with generous quantity of Mopar® Door Ease. Then lubricate retainer hub and bore with light coat of transmission fluid.

(8) Install clutch piston in retainer. Use twisting motion to seat piston in bottom of retainer. A thin strip of plastic (about 0.020" thick), can be used to guide seals into place if necessary.

**CAUTION: Never push the clutch piston straight in. This will fold the seals over causing leakage and clutch slip. In addition, never use any type of metal tool to help ease the piston seals into place. Metal tools will cut, shave, or score the seals.**

(9) Install piston spring in retainer and on top of piston. Concave side of spring faces downward (toward piston).

(10) Install the spacer ring and wave spring into the retainer. Be sure spring is completely seated in retainer groove.



**Fig. 216 Pressing Input Shaft Into Rear Clutch Retainer**

- 1 - INPUT SHAFT  
2 - REAR CLUTCH RETAINER  
3 - PRESS RAM

(11) Install pressure plate (Fig. 223). Ridged side of plate faces downward (toward piston) and flat side toward clutch pack.

(12) Install first clutch disc in retainer on top of pressure plate. Then install a clutch plate followed by a clutch disc until entire clutch pack is installed (4 discs and 3 plates are required) (Fig. 223).

(13) Install the reaction plate.

(14) Install selective snap-ring. Be sure snap-ring is fully seated in retainer groove.

(15) Using a suitable gauge bar and dial indicator, measure clutch pack clearance (Fig. 217).

(a) Position gauge bar across the clutch drum with the dial indicator pointer on the pressure plate (Fig. 217).

(b) Using two small screw drivers, lift the pressure plate and release it.

(c) Zero the dial indicator.

(d) Lift the pressure plate until it contacts the snap-ring and record the dial indicator reading.

Clearance should be 0.635 - 0.914 mm (0.025 - 0.036 in.). If clearance is incorrect, steel plates, discs, selective snap ring and pressure plates may have to be changed.

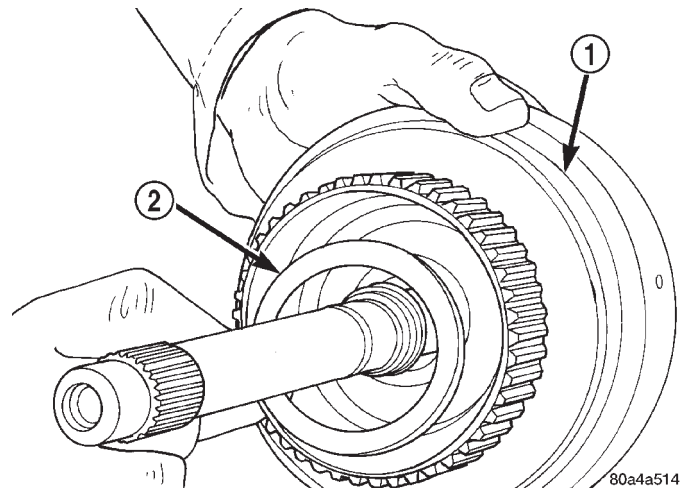
## REAR CLUTCH (Continued)

The selective snap ring thicknesses are:

- 0.107 - 0.109 in.
- 0.098 - 0.100 in.
- 0.095 - 0.097 in.
- 0.083 - 0.085 in.
- 0.076 - 0.078 in.
- 0.071 - 0.073 in.
- 0.060 - 0.062 in.

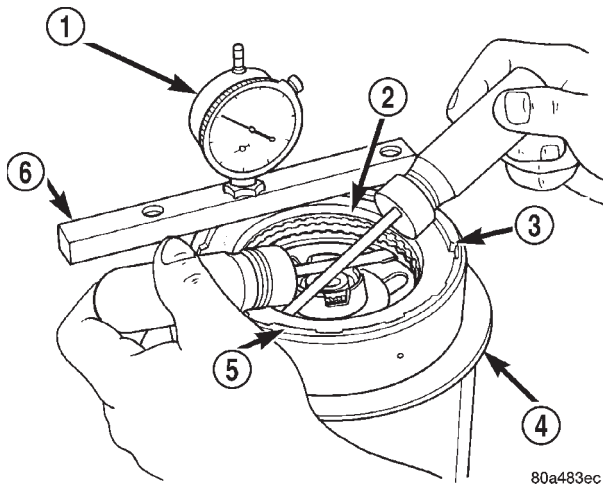
(16) Coat rear clutch thrust washer with petroleum jelly and install washer over input shaft and into clutch retainer (Fig. 218). Use enough petroleum jelly to hold washer in place.

(17) Set rear clutch aside for installation during final assembly.



**Fig. 218 Installing Rear Clutch Thrust Washer**

- 1 - REAR CLUTCH RETAINER  
2 - REAR CLUTCH THRUST WASHER



**Fig. 217 Checking Rear Clutch Pack Clearance**

- 1 - DIAL INDICATOR  
2 - PRESSURE PLATE  
3 - SNAP-RING  
4 - STAND  
5 - REAR CLUTCH  
6 - GAUGE BAR

## REAR SERVO

## DESCRIPTION

The rear (low/reverse) servo consists of a single stage or diameter piston and a spring loaded plug. The spring is used to cushion the application of the rear (low/reverse) band.

## OPERATION

While in the de-energized state (no pressure applied), the piston is held up in its bore by the piston spring. The plug is held down in its bore, in the piston, by the plug spring. When pressure is applied to the top of the piston, the plug is forced down in its bore, taking up any clearance. As the piston moves, it causes the plug spring to compress, and the piston moves down over the plug. The piston continues to move down until it hits the shoulder of the plug and fully applies the band. The period of time from the initial application, until the piston is against the shoulder of the plug, represents a reduced shocking of the band that cushions the shift.

## REAR SERVO (Continued)

## DISASSEMBLY

- (1) Remove small snap-ring and remove plug and spring from servo piston (Fig. 219).
- (2) Remove and discard servo piston seal ring.

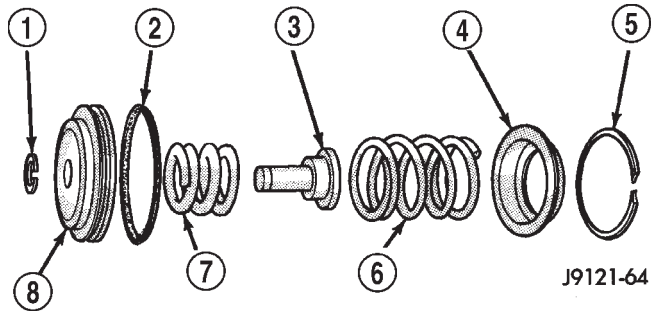


Fig. 219 Rear Servo Components

- 1 - SNAP-RING
- 2 - PISTON SEAL
- 3 - PISTON PLUG
- 4 - SPRING RETAINER
- 5 - SNAP-RING
- 6 - PISTON SPRING
- 7 - CUSHION SPRING
- 8 - PISTON

## CLEANING

Remove and discard the servo piston seal ring (Fig. 220). Then clean the servo components with solvent and dry with compressed air. Replace either spring if collapsed, distorted or broken. Replace the plug and piston if cracked, bent, or worn. Discard the servo snap-rings and use new ones at assembly.

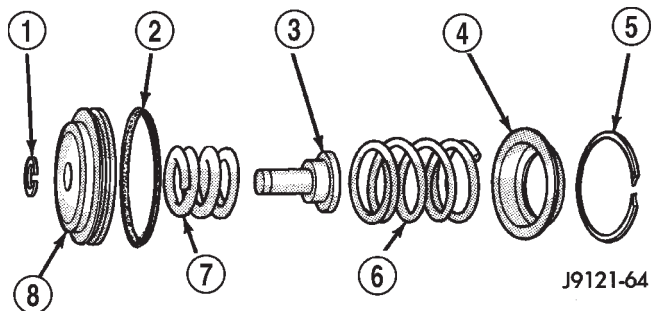


Fig. 220 Rear Servo Components

- 1 - SNAP-RING
- 2 - PISTON SEAL
- 3 - PISTON PLUG
- 4 - SPRING RETAINER
- 5 - SNAP-RING
- 6 - PISTON SPRING
- 7 - CUSHION SPRING
- 8 - PISTON

## ASSEMBLY

- (1) Lubricate piston and guide seals (Fig. 221) with petroleum jelly. Lubricate other servo parts with Mopar® ATF +4, type 9602, transmission fluid.
- (2) Install new seal ring on servo piston.
- (3) Assemble piston, plug, spring and new snap-ring.
- (4) Lubricate piston seal lip with petroleum jelly.

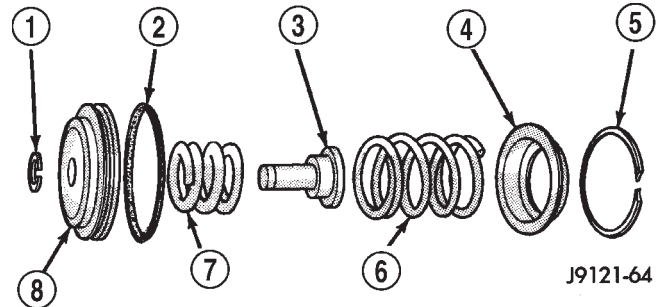


Fig. 221 Rear Servo Components

- 1 - SNAP-RING
- 2 - PISTON SEAL
- 3 - PISTON PLUG
- 4 - SPRING RETAINER
- 5 - SNAP-RING
- 6 - PISTON SPRING
- 7 - CUSHION SPRING
- 8 - PISTON

## SHIFT MECHANISM

## DESCRIPTION

The gear shift mechanism provides six shift positions which are:

- PARK (P)
- REVERSE (R)
- NEUTRAL (N)
- DRIVE (D)
- Manual SECOND (2)
- Manual LOW (1)

## OPERATION

Manual LOW (1) range provides first gear only. Overrun braking is also provided in this range. Manual SECOND (2) range provides first and second gear only.

DRIVE range provides first, second third and overdrive fourth gear ranges. The shift into overdrive fourth gear range occurs only after the transmission has completed the shift into D third gear range. No further movement of the shift mechanism is required to complete the 3-4 shift.

The fourth gear upshift occurs automatically when the overdrive selector switch is in the ON position.



## SHIFT MECHANISM (Continued)

No upshift to fourth gear will occur if any of the following are true:

- The transmission fluid temperature is below 10° C (50° F) or above 121° C (250° F).
- The shift to third is not yet complete.
- Vehicle speed is too low for the 3-4 shift to occur.
- Battery temperature is below -5° C (23° F).

## ADJUSTMENT

Check linkage adjustment by starting engine in PARK and NEUTRAL. Adjustment is acceptable if the engine starts in only these two positions. Adjustment is incorrect if the engine starts in one position but not both positions.

If the engine starts in any other position, or if the engine will not start in any position, the park/neutral switch is probably faulty.

## LINKAGE ADJUSTMENT

Check condition of the shift linkage (Fig. 222). Do not attempt adjustment if any component is loose, worn, or bent. Replace any suspect components.

Replace the grommet securing the shift rod or torque rod in place if either rod was removed from the grommet. Remove the old grommet as necessary and use suitable pliers to install the new grommet.

- (1) Shift transmission into PARK.
- (2) Raise and support vehicle.
- (3) Loosen lock bolt in front shift rod adjusting swivel (Fig. 222).
- (4) Ensure that the shift rod slides freely in the swivel. Lube rod and swivel as necessary.
- (5) Move transmission shift lever fully rearward to the Park detent.
- (6) Center adjusting swivel on shift rod.
- (7) Tighten swivel lock bolt to 10 N·m (90 in. lbs.).
- (8) Lower vehicle and verify proper adjustment.

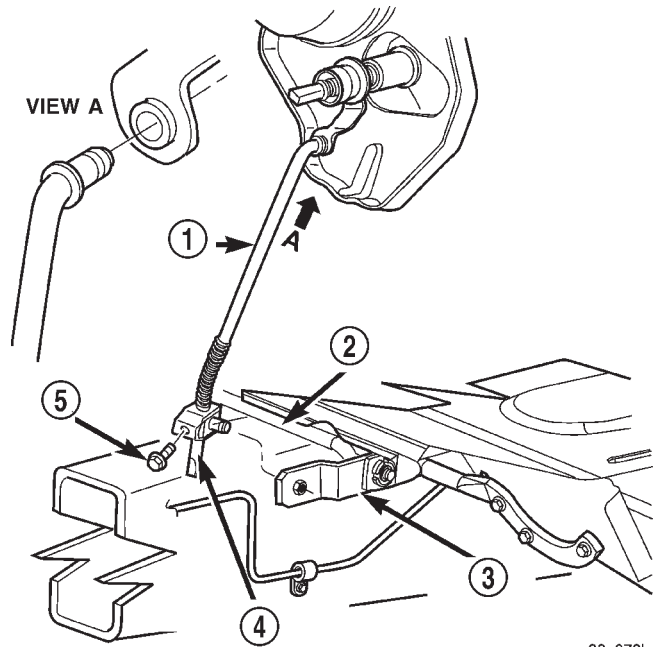
## SOLENOID

## DESCRIPTION

The typical electrical solenoid used in automotive applications is a linear actuator. It is a device that produces motion in a straight line. This straight line motion can be either forward or backward in direction, and short or long distance.

A solenoid is an electromechanical device that uses a magnetic force to perform work. It consists of a coil of wire, wrapped around a magnetic core made from steel or iron, and a spring loaded, movable plunger, which performs the work, or straight line motion.

The solenoids used in transmission applications are attached to valves which can be classified as **normally open** or **normally closed**. The **normally open** solenoid valve is defined as a valve which



**Fig. 222 Linkage Adjustment Components**

- 1 - FRONT SHIFT ROD
- 2 - TORQUE SHAFT ASSEMBLY
- 3 - TORQUE SHAFT ARM
- 4 - ADJUSTING SWIVEL
- 5 - LOCK BOLT

allows hydraulic flow when no current or voltage is applied to the solenoid. The **normally closed** solenoid valve is defined as a valve which does not allow hydraulic flow when no current or voltage is applied to the solenoid. These valves perform hydraulic control functions for the transmission and must therefore be durable and tolerant of dirt particles. For these reasons, the valves have hardened steel poppets and ball valves. The solenoids operate the valves directly, which means that the solenoids must have very high outputs to close the valves against the sizable flow areas and line pressures found in current transmissions. Fast response time is also necessary to ensure accurate control of the transmission.

The strength of the magnetic field is the primary force that determines the speed of operation in a particular solenoid design. A stronger magnetic field will cause the plunger to move at a greater speed than a weaker one. There are basically two ways to increase the force of the magnetic field:

- Increase the amount of current applied to the coil or
- Increase the number of turns of wire in the coil.

The most common practice is to increase the number of turns by using thin wire that can completely fill the available space within the solenoid housing. The strength of the spring and the length of the

## SOLENOID (Continued)

plunger also contribute to the response speed possible by a particular solenoid design.

A solenoid can also be described by the method by which it is controlled. Some of the possibilities include variable force, pulse-width modulated, constant ON, or duty cycle. The variable force and pulse-width modulated versions utilize similar methods to control the current flow through the solenoid to position the solenoid plunger at a desired position somewhere between full ON and full OFF. The constant ON and duty cycled versions control the voltage across the solenoid to allow either full flow or no flow through the solenoid's valve.

## OPERATION

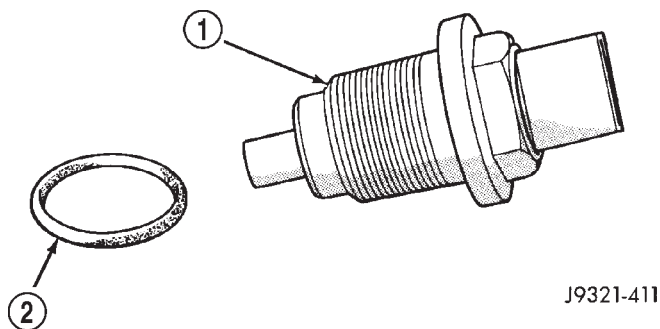
When an electrical current is applied to the solenoid coil, a magnetic field is created which produces an attraction to the plunger, causing the plunger to move and work against the spring pressure and the load applied by the fluid the valve is controlling. The plunger is normally directly attached to the valve which it is to operate. When the current is removed from the coil, the attraction is removed and the plunger will return to its original position due to spring pressure.

The plunger is made of a conductive material and accomplishes this movement by providing a path for the magnetic field to flow. By keeping the air gap between the plunger and the coil to the minimum necessary to allow free movement of the plunger, the magnetic field is maximized.

## SPEED SENSOR

## DESCRIPTION

The speed sensor (Fig. 223) is located in the over-drive gear case. The sensor is positioned over the park gear and monitors transmission output shaft rotating speed.



J9321-411

**Fig. 223 Transmission Output Speed Sensor**

- 1 - TRANSMISSION OUTPUT SHAFT SPEED SENSOR
- 2 - SEAL

## OPERATION

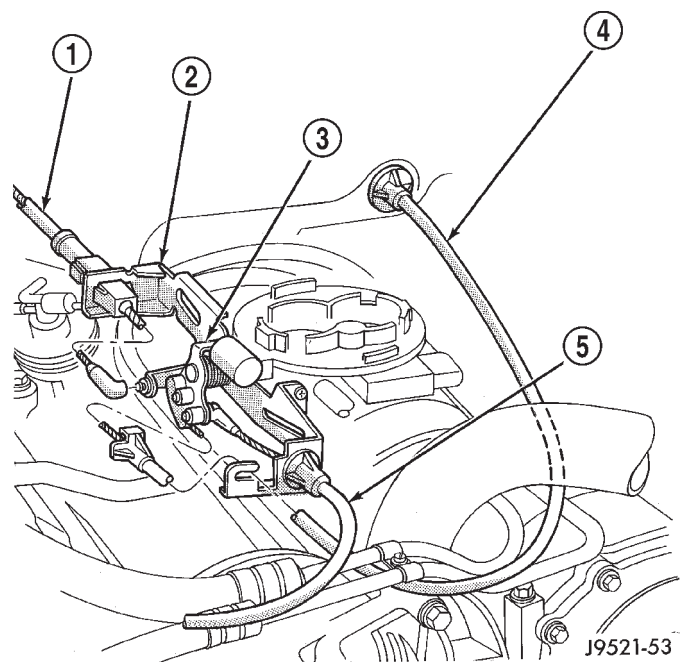
Speed sensor signals are triggered by the park gear lugs as they rotate past the sensor pickup face. Input signals from the sensor are sent to the transmission control module for processing. Signals from this sensor are shared with the powertrain control module.

## THROTTLE VALVE CABLE

## DESCRIPTION

Transmission throttle valve cable (Fig. 224) adjustment is extremely important to proper operation. This adjustment positions the throttle valve, which controls shift speed, quality, and part-throttle downshift sensitivity.

If cable setting is too loose, early shifts and slippage between shifts may occur. If the setting is too tight, shifts may be delayed and part throttle downshifts may be very sensitive.



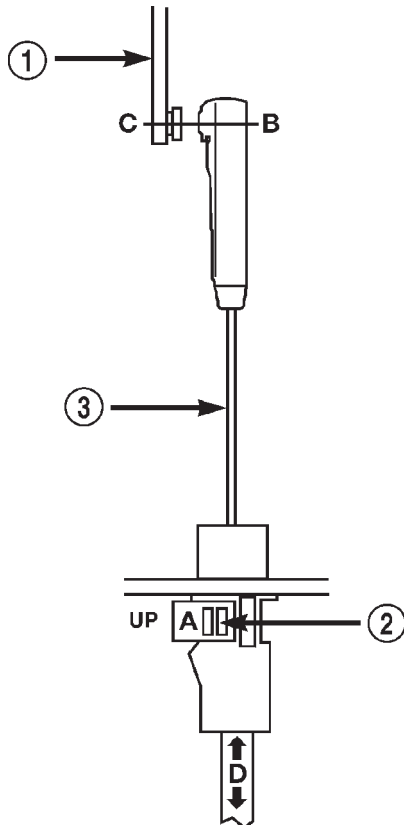
J9521-53

**Fig. 224 Throttle Valve Cable Attachment - At Engine**

- 1 - THROTTLE VALVE CABLE
- 2 - CABLE BRACKET
- 3 - THROTTLE BODY LEVER
- 4 - ACCELERATOR CABLE
- 5 - SPEED CONTROL CABLE

## THROTTLE VALVE CABLE (Continued)

The transmission throttle valve is operated by a cam on the throttle lever. The throttle lever is operated by an adjustable cable (Fig. 225). The cable is attached to an arm mounted on the throttle lever shaft. A retaining clip at the engine-end of the cable is removed to provide for cable adjustment. The retaining clip is then installed back onto the throttle valve cable to lock in the adjustment.



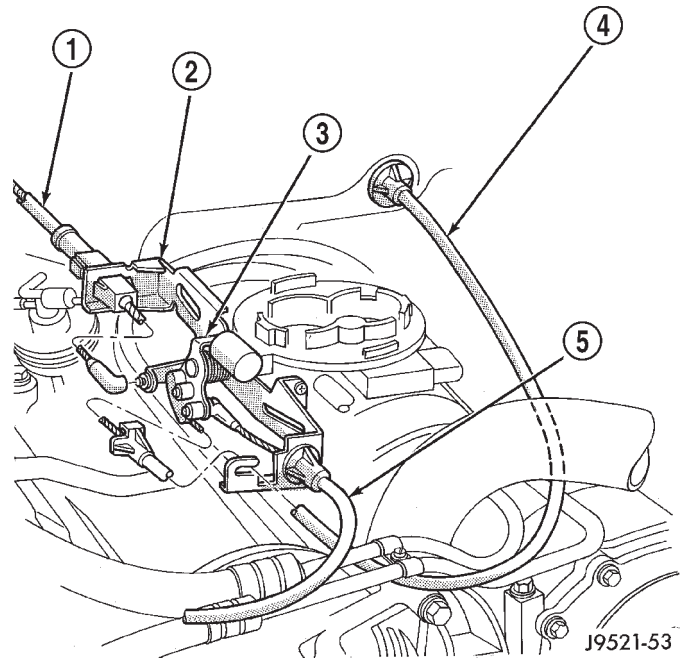
80bce9fb

**Fig. 225 Throttle Valve Cable at Throttle Linkage**

- 1 - THROTTLE LINKAGE
- 2 - THROTTLE VALVE CABLE LOCKING CLIP
- 3 - THROTTLE VALVE CABLE

## ADJUSTMENTS - TRANSMISSION THROTTLE VALVE CABLE

A correctly adjusted throttle valve cable will cause the throttle lever on the transmission to move simultaneously with the throttle body lever from the idle position. Proper adjustment will allow simultaneous movement without causing the transmission throttle lever to either move ahead of, or lag behind the lever on the throttle body.



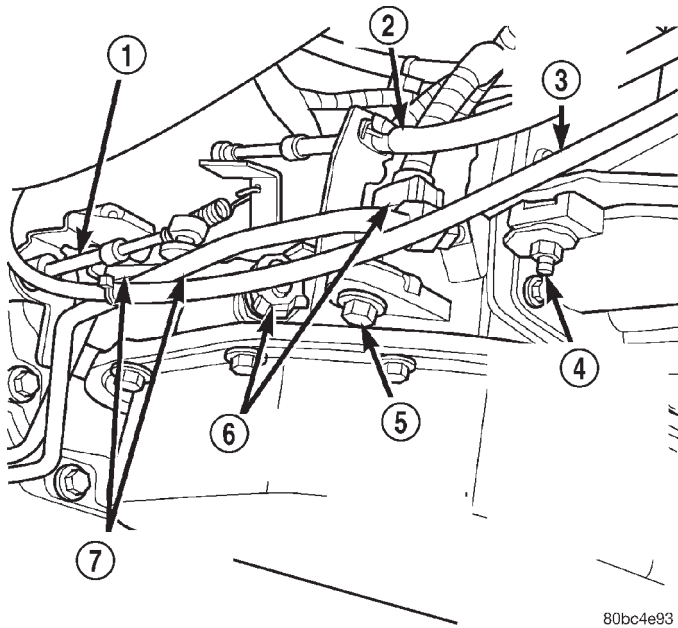
**Fig. 226 Throttle Valve Cable Attachment - At Engine**

- 1 - THROTTLE VALVE CABLE
- 2 - CABLE BRACKET
- 3 - THROTTLE BODY LEVER
- 4 - ACCELERATOR CABLE
- 5 - SPEED CONTROL CABLE

## ADJUSTMENT VERIFICATION

- (1) Turn ignition key to OFF position.
- (2) Remove air cleaner.
- (3) Verify that lever on throttle body is at curb idle position (Fig. 226). Then verify that the transmission throttle lever (Fig. 227) is also at idle (fully forward) position.
  - (4) Slide cable off attachment stud on throttle body lever.
  - (5) Compare position of cable end to attachment stud on throttle body lever:
    - Cable end and attachment stud should be aligned (or centered on one another) to within 1 mm (0.039 in.) in either direction (Fig. 228).
    - If cable end and attachment stud are misaligned (off center), cable will have to be adjusted as described in Throttle Valve Cable Adjustment procedure.

## THROTTLE VALVE CABLE (Continued)



**Fig. 227 Throttle Valve Cable at Transmission**

- 1 - TRANSMISSION SHIFTER CABLE
- 2 - THROTTLE VALVE CABLE
- 3 - TRANSFER CASE SHIFTER CABLE
- 4 - TRANSFER CASE SHIFTER CABLE BRACKET RETAINING BOLT (1 OR 2)
- 5 - THROTTLE VALVE CABLE BRACKET RETAINING BOLT
- 6 - ELECTRICAL CONNECTORS
- 7 - TRANSMISSION FLUID LINES

(6) Reconnect cable end to attachment stud. Then with aid of a helper, observe movement of transmission throttle lever and lever on throttle body.

- If both levers move simultaneously from idle to half-throttle and back to idle position, adjustment is correct.

- If transmission throttle lever moves ahead of, or lags behind throttle body lever, cable adjustment will be necessary. Or, if throttle body lever prevents transmission lever from returning to closed position, cable adjustment will be necessary.

#### ADJUSTMENT PROCEDURE

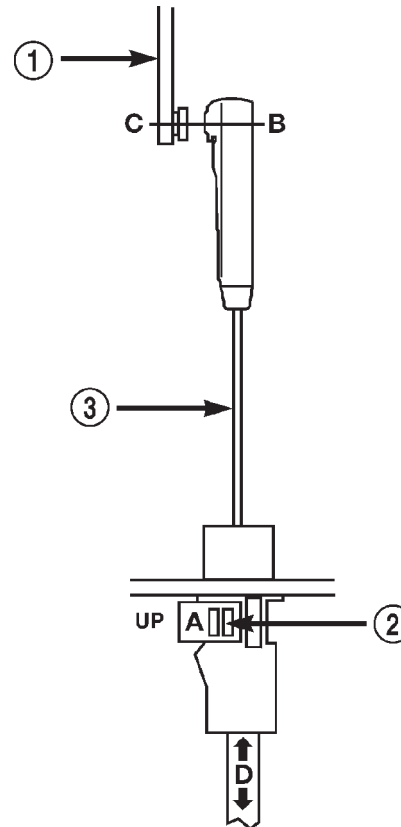
- (1) Turn ignition switch to OFF position.
- (2) Remove air cleaner if necessary.
- (3) Disconnect cable end from attachment stud.

**Carefully slide cable off stud. Do not pry or pull cable off.**

(4) Verify that transmission throttle lever is in fully closed position. Then be sure lever on throttle body is at curb idle position.

(5) Pry the T.V. cable lock (A) into the UP position (Fig. 228). This will unlock the cable and allow for readjustment.

(6) Apply just enough tension on the T.V. cable (B) to remove any slack in the cable. **Pulling too tight**



**Fig. 228 Throttle Valve Cable at Throttle Linkage**

- 1 - THROTTLE LINKAGE
- 2 - THROTTLE VALVE CABLE LOCKING CLIP
- 3 - THROTTLE VALVE CABLE

**will cause the T.V. lever on the transmission to move out of its idle position, which will result in an incorrect T.V. cable adjustment.** Slide the sheath of the T.V. cable (D) back and forth until the centerlines of the T.V. cable end (B) and the throttle bell crank lever (C) are aligned within one millimeter (1mm) (Fig. 228).

(7) While holding the T.V. cable in the set position push the T.V. cable lock (A) into the down position (Fig. 228). This will lock the present T.V. cable adjustment.

**NOTE:** Be sure that as the cable is pulled forward and centered on the throttle lever stud, the cable housing moves smoothly with the cable. Due to the angle at which the cable housing enters the spring housing, the cable housing may bind slightly and create an incorrect adjustment.

(8) Reconnect the T.V. cable (B) to the throttle bellcrank lever (C).

(9) Check cable adjustment. Verify transmission throttle lever and lever on throttle body move simultaneously.

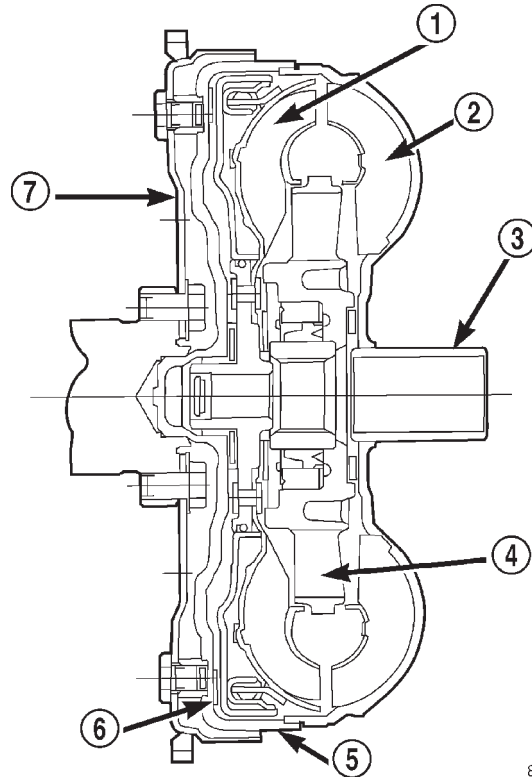
## TORQUE CONVERTER

### DESCRIPTION

The torque converter (Fig. 229) is a hydraulic device that couples the engine crankshaft to the transmission. The torque converter consists of an outer shell with an internal turbine, a stator, an overrunning clutch, an impeller and an electronically applied converter clutch. The converter clutch provides reduced engine speed and greater fuel economy when engaged. Clutch engagement also provides reduced transmission fluid temperatures. The torque converter hub drives the transmission oil (fluid) pump.

The torque converter is a sealed, welded unit that is not repairable and is serviced as an assembly.

**CAUTION:** The torque converter must be replaced if a transmission failure resulted in large amounts of metal or fiber contamination in the fluid. If the fluid is contaminated, flush the all transmission fluid cooler(s) and lines.



80c07135

**Fig. 229 Torque Converter Assembly**

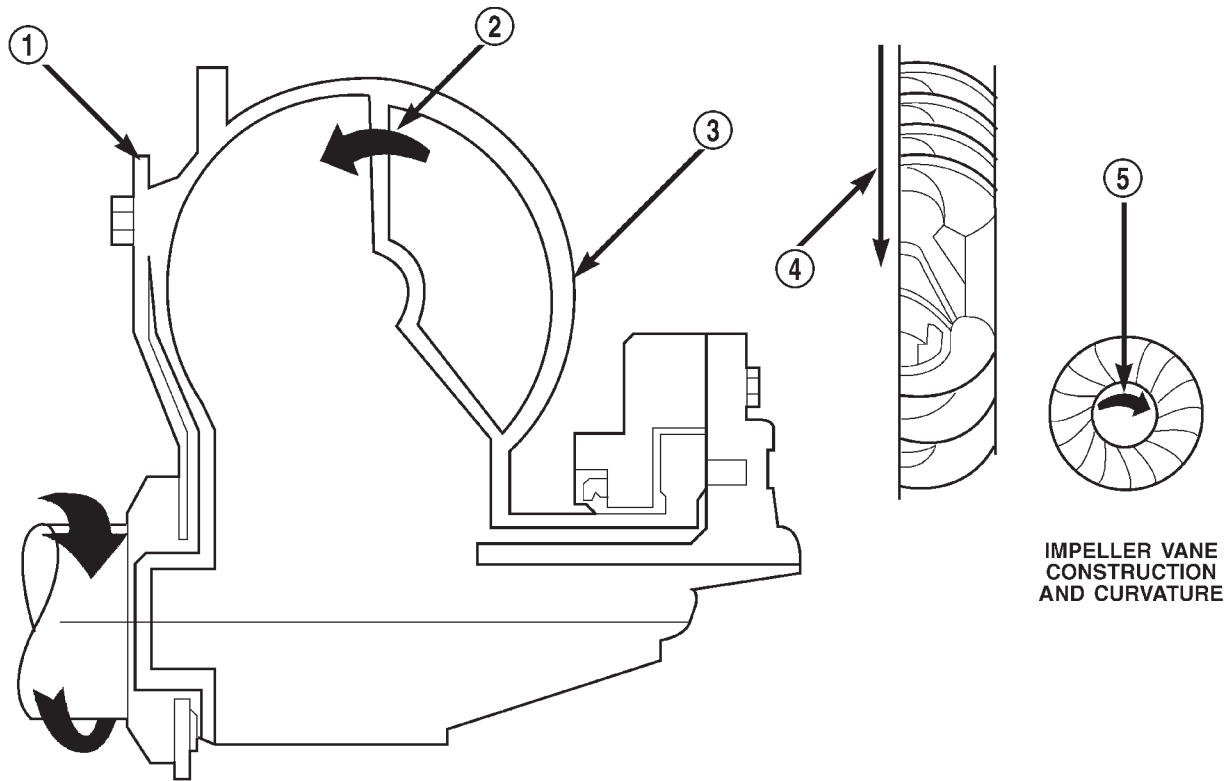
- 1 - TURBINE
- 2 - IMPELLER
- 3 - HUB
- 4 - STATOR
- 5 - FRONT COVER
- 6 - CONVERTER CLUTCH DISC
- 7 - DRIVE PLATE



TORQUE CONVERTER (Continued)

**IMPELLER**

The impeller (Fig. 230) is an integral part of the converter housing. The impeller consists of curved blades placed radially along the inside of the housing on the transmission side of the converter. As the converter housing is rotated by the engine, so is the impeller, because they are one and the same and are the driving members of the system.



**IMPELLER VANE  
CONSTRUCTION  
AND CURVATURE**

**Fig. 230 Impeller**

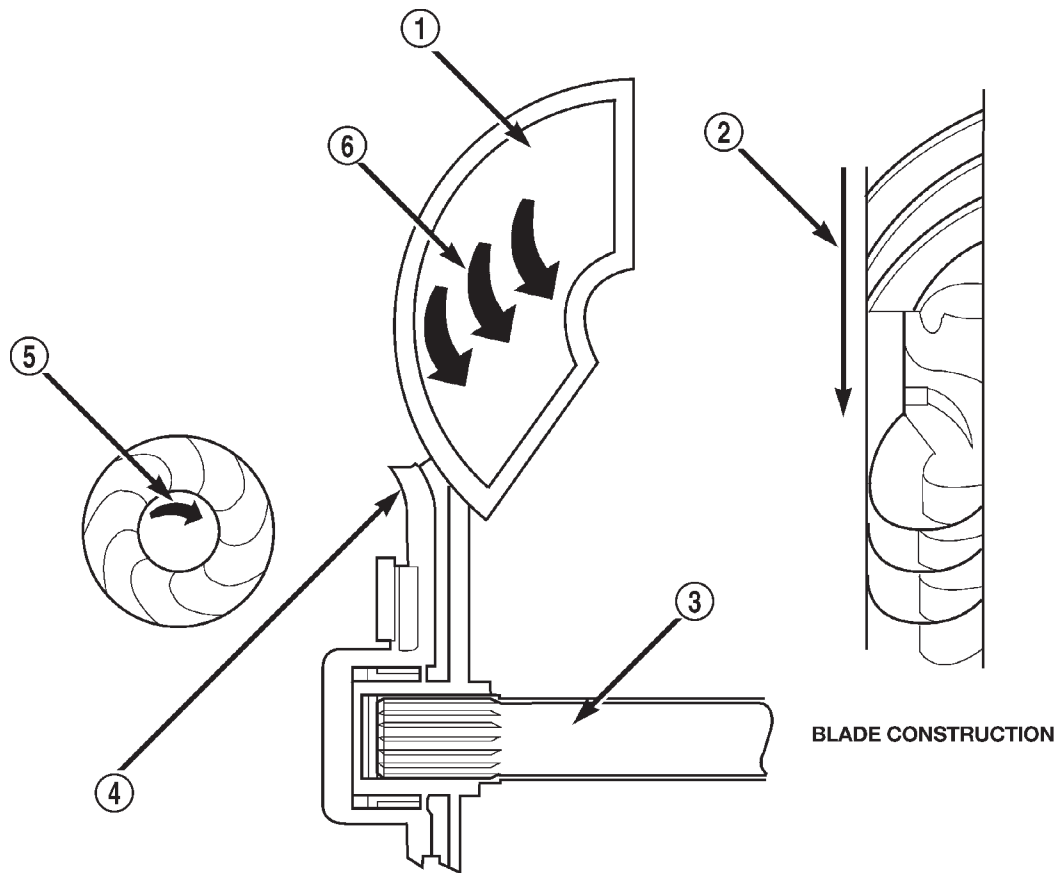
80bfe26a

- 1 - ENGINE FLEXPLATE
- 2 - OIL FLOW FROM IMPELLER SECTION INTO TURBINE SECTION
- 3 - IMPELLER VANES AND COVER ARE INTEGRAL
- 4 - ENGINE ROTATION
- 5 - ENGINE ROTATION

TORQUE CONVERTER (Continued)

**TURBINE**

The turbine (Fig. 231) is the output, or driven, member of the converter. The turbine is mounted within the housing opposite the impeller, but is not attached to the housing. The input shaft is inserted through the center of the impeller and splined into the turbine. The design of the turbine is similar to the impeller, except the blades of the turbine are curved in the opposite direction.



**Fig. 231 Turbine**

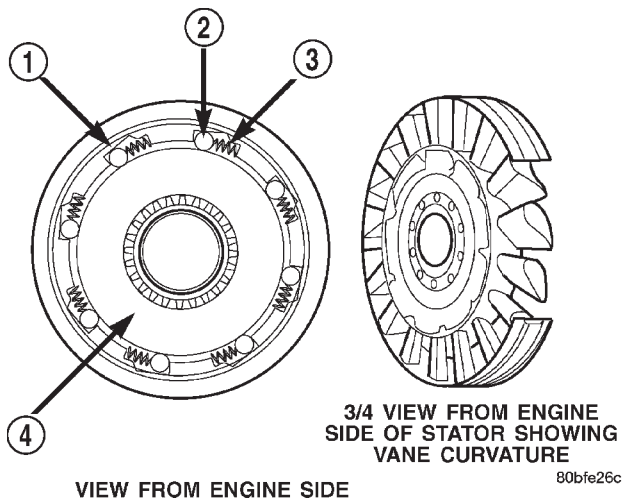
80bfe26b

- 1 - TURBINE VANE
- 2 - ENGINE ROTATION
- 3 - INPUT SHAFT
- 4 - PORTION OF TORQUE CONVERTER COVER
- 5 - ENGINE ROTATION
- 6 - OIL FLOW WITHIN TURBINE SECTION

TORQUE CONVERTER (Continued)

**STATOR**

The stator assembly (Fig. 232) is mounted on a stationary shaft which is an integral part of the oil pump. The stator is located between the impeller and turbine within the torque converter case (Fig. 233). The stator contains an over-running clutch, which allows the stator to rotate only in a clockwise direction. When the stator is locked against the over-running clutch, the torque multiplication feature of the torque converter is operational.

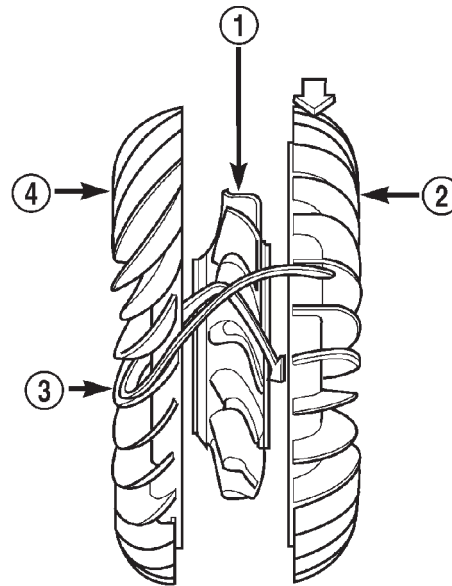


**Fig. 232 Stator Components**

- 1 - CAM (OUTER RACE)
- 2 - ROLLER
- 3 - SPRING
- 4 - INNER RACE

**TORQUE CONVERTER CLUTCH (TCC)**

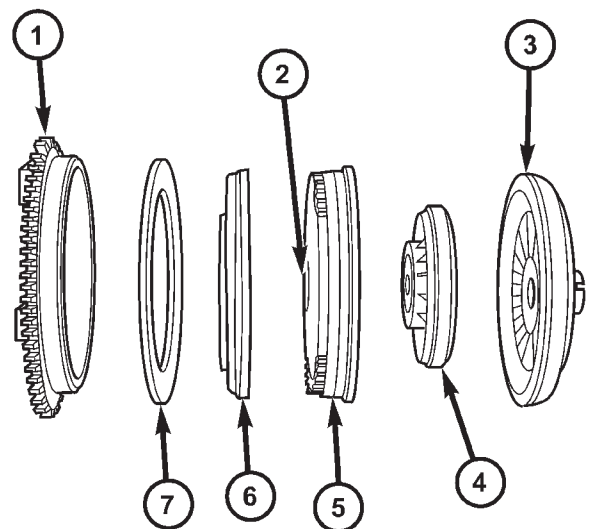
The TCC (Fig. 234) was installed to improve the efficiency of the torque converter that is lost to the slippage of the fluid coupling. Although the fluid coupling provides smooth, shock-free power transfer, it is natural for all fluid couplings to slip. If the impeller and turbine were mechanically locked together, a zero slippage condition could be obtained. A hydraulic piston was added to the turbine, and a friction material was added to the inside of the front cover to provide this mechanical lock-up.



80bfe26d

**Fig. 233 Stator Location**

- 1 - STATOR
- 2 - IMPELLER
- 3 - FLUID FLOW
- 4 - TURBINE

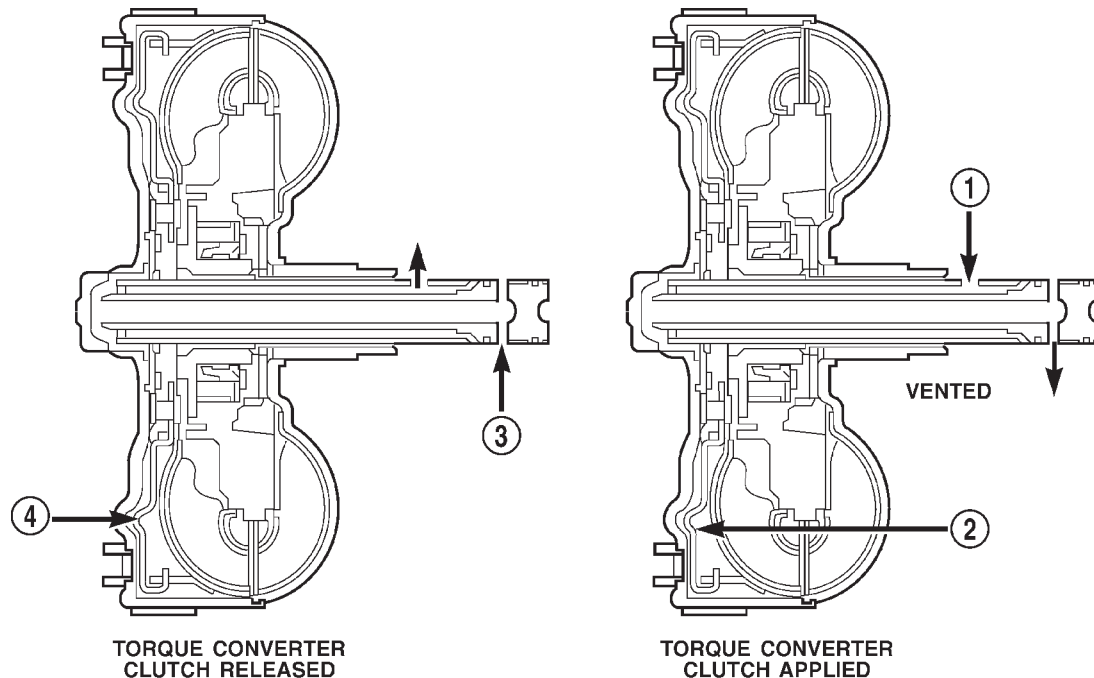


80870b2f

**Fig. 234 Torque Converter Clutch (TCC)**

- 1 - IMPELLER FRONT COVER
- 2 - THRUST WASHER ASSEMBLY
- 3 - IMPELLER
- 4 - STATOR
- 5 - TURBINE
- 6 - PISTON
- 7 - FRICTION DISC

## TORQUE CONVERTER (Continued)

**Fig. 235 Torque Converter Fluid Operation**

80bfe276

1 - APPLY PRESSURE

2 - THE PISTON MOVES SLIGHTLY FORWARD

3 - RELEASE PRESSURE

4 - THE PISTON MOVES SLIGHTLY REARWARD

**OPERATION**

The converter impeller (Fig. 235) (driving member), which is integral to the converter housing and bolted to the engine drive plate, rotates at engine speed. The converter turbine (driven member), which reacts from fluid pressure generated by the impeller, rotates and turns the transmission input shaft.

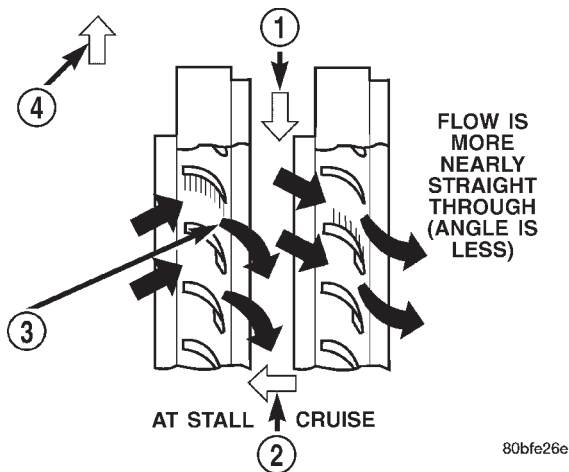
**TURBINE**

As the fluid that was put into motion by the impeller blades strikes the blades of the turbine, some of the energy and rotational force is transferred into the turbine and the input shaft. This causes both of them (turbine and input shaft) to rotate in a clockwise direction following the impeller. As the fluid is leaving the trailing edges of the turbine's blades it continues in a "hindering" direction back toward the impeller. If the fluid is not redirected before it strikes the impeller, it will strike the impeller in such a direction that it would tend to slow it down.

**STATOR**

Torque multiplication is achieved by locking the stator's over-running clutch to its shaft (Fig. 236). Under stall conditions (the turbine is stationary), the oil leaving the turbine blades strikes the face of the stator blades and tries to rotate them in a counter-clockwise direction. When this happens the overrunning clutch of the stator locks and holds the stator from rotating. With the stator locked, the oil strikes the stator blades and is redirected into a "helping" direction before it enters the impeller. This circulation of oil from impeller to turbine, turbine to stator, and stator to impeller, can produce a maximum torque multiplication of about 2.4:1. As the turbine begins to match the speed of the impeller, the fluid that was hitting the stator in such a way as to cause it to lock-up is no longer doing so. In this condition of operation, the stator begins to free wheel and the converter acts as a fluid coupling.

## TORQUE CONVERTER (Continued)



**Fig. 236 Stator Operation**

- 1 - DIRECTION STATOR WILL FREE WHEEL DUE TO OIL PUSHING ON BACKSIDE OF VANES
- 2 - FRONT OF ENGINE
- 3 - INCREASED ANGLE AS OIL STRIKES VANES
- 4 - DIRECTION STATOR IS LOCKED UP DUE TO OIL PUSHING AGAINST STATOR VANES

### TORQUE CONVERTER CLUTCH (TCC)

The torque converter clutch is hydraulically applied and is released when fluid is vented from the hydraulic circuit by the torque converter control (TCC) solenoid on the valve body. The torque converter clutch is controlled by the Powertrain Control Module (PCM). The torque converter clutch engages in fourth gear, and in third gear under various conditions, such as when the O/D switch is OFF, when the vehicle is cruising on a level surface after the vehicle has warmed up. The torque converter clutch will disengage momentarily when an increase in engine load is sensed by the PCM, such as when the vehicle begins to go uphill or the throttle pressure is increased.

### REMOVAL

- (1) Remove transmission and torque converter from vehicle.
- (2) Place a suitable drain pan under the converter housing end of the transmission.

**CAUTION:** Verify that transmission is secure on the lifting device or work surface, the center of gravity of the transmission will shift when the torque converter is removed creating an unstable condition. The torque converter is a heavy unit. Use caution when separating the torque converter from the transmission.

- (3) Pull the torque converter forward until the center hub clears the oil pump seal.

- (4) Separate the torque converter from the transmission.

### INSTALLATION

Check converter hub and drive notches for sharp edges, burrs, scratches, or nicks. Polish the hub and notches with 320/400 grit paper or crocus cloth if necessary. The hub must be smooth to avoid damaging the pump seal at installation.

- (1) Lubricate oil pump seal lip with transmission fluid.
- (2) Place torque converter in position on transmission.

**CAUTION:** Do not damage oil pump seal or bushing while inserting torque converter into the front of the transmission.

- (3) Align torque converter to oil pump seal opening.
- (4) Insert torque converter hub into oil pump.
- (5) While pushing torque converter inward, rotate converter until converter is fully seated in the oil pump gears.
- (6) Check converter seating with a scale and straightedge (Fig. 237). Surface of converter lugs should be 19mm (0.75 in.) to the rear of the straightedge when converter is fully seated.
- (7) If necessary, temporarily secure converter with C-clamp attached to the converter housing.
- (8) Install the transmission in the vehicle.
- (9) Fill the transmission with the recommended fluid.

## TORQUE CONVERTER DRAINBACK VALVE

### DESCRIPTION

The drainback valve is located in the transmission cooler outlet (pressure) line.

### OPERATION

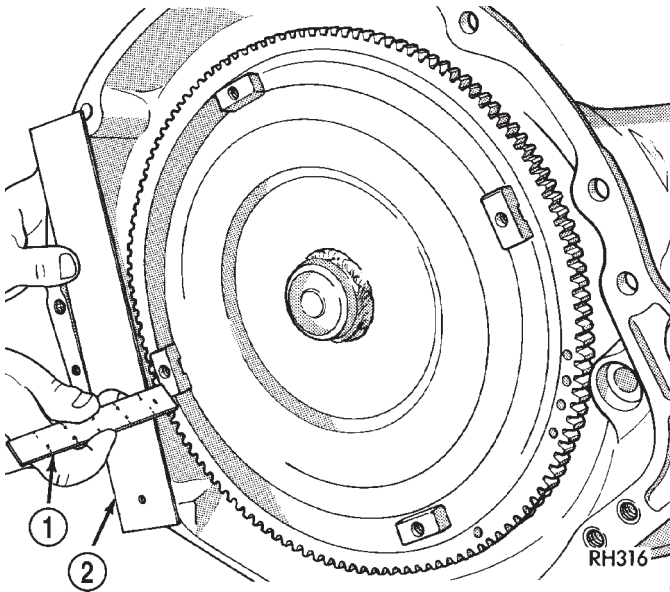
The valve prevents fluid from draining from the converter into the cooler and lines when the vehicle is shut down for lengthy periods. Production valves have a hose nipple at one end, while the opposite end is threaded for a flare fitting. All valves have an arrow (or similar mark) to indicate direction of flow through the valve.

### STANDARD PROCEDURE - TORQUE CONVERTER DRAINBACK VALVE

The converter drainback check valve is located in the cooler outlet (pressure) line near the radiator tank. The valve prevents fluid drainback when the



## TORQUE CONVERTER DRAINBACK VALVE (Continued)



**Fig. 237 Typical Method Of Checking Converter Seating**

- 1 - SCALE  
2 - STRAIGHTEDGE

vehicle is parked for lengthy periods. The valve check ball is spring loaded and has an opening pressure of approximately 2 psi.

The valve is serviced as an assembly; it is not repairable. Do not clean the valve if restricted, or contaminated by sludge, or debris. If the valve fails, or if a transmission malfunction occurs that generates significant amounts of sludge and/or clutch particles and metal shavings, the valve must be replaced.

The valve must be removed whenever the cooler and lines are reverse flushed. The valve can be flow tested when necessary. The procedure is exactly the same as for flow testing a cooler.

If the valve is restricted, installed backwards, or in the wrong line, it will cause an overheating condition and possible transmission failure.

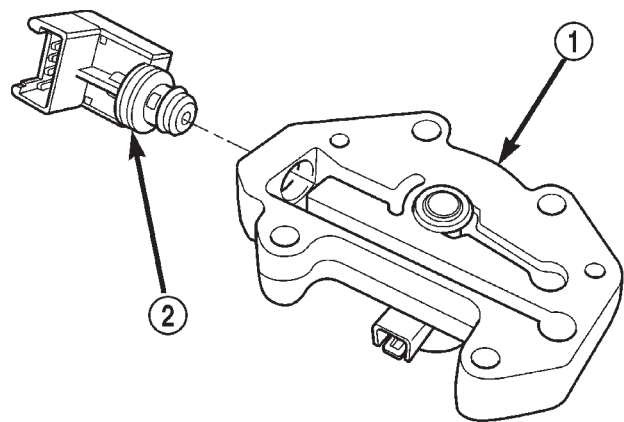
**CAUTION:** The drainback valve is a one-way flow device. It must be properly oriented in terms of flow direction for the cooler to function properly. The valve must be installed in the pressure line. Otherwise flow will be blocked and would cause an overheating condition and eventual transmission failure.

## TRANSMISSION TEMPERATURE SENSOR

## DESCRIPTION

Transmission fluid temperature readings are supplied to the transmission control module by the thermistor (Fig. 238). The temperature readings are used to control engagement of the fourth gear overdrive clutch, the converter clutch, and governor pressure. Normal resistance value for the thermistor at room temperature is approximately 1000 ohms.

The thermistor is part of the governor pressure sensor assembly and is immersed in transmission fluid at all times.



**Fig. 238 Governor Pressure Sensor**

- 1 - GOVERNOR BODY  
2 - GOVERNOR PRESSURE SENSOR/TRANSMISSION FLUID TEMPERATURE THERMISTOR

## OPERATION

The PCM prevents engagement of the converter clutch and overdrive clutch, when fluid temperature is below approximately 10°C (50°F).

If fluid temperature exceeds 126°C (260°F), the PCM causes a 4-3 downshift and engage the converter clutch. Engagement is according to the third gear converter clutch engagement schedule.

The overdrive OFF lamp in the instrument panel illuminates when the shift back to third occurs. The transmission will not allow fourth gear operation until fluid temperature decreases to approximately 110°C (230°F).

# VALVE BODY

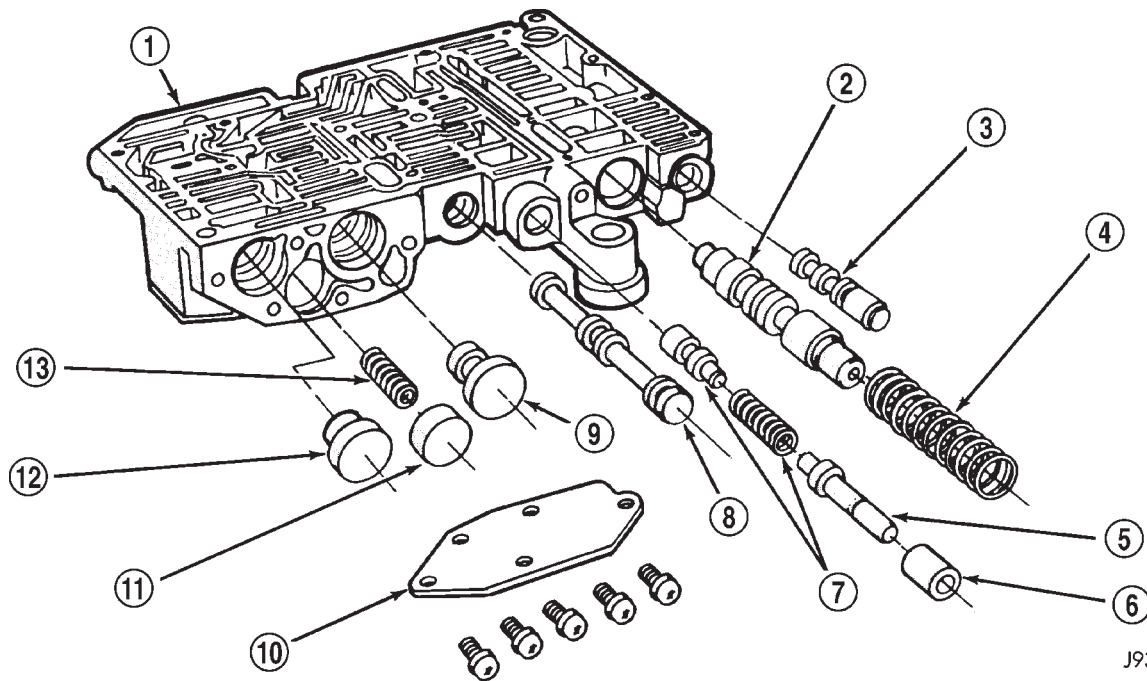
## DESCRIPTION

The valve body consists of a cast aluminum valve body, a separator plate, and transfer plate. The valve body contains valves and check balls that control fluid delivery to the torque converter clutch, bands, and frictional clutches. The valve body contains the following components (Fig. 239), (Fig. 240), (Fig. 241), and (Fig. 242):

- Regulator valve
- Regulator valve throttle pressure plug
- Line pressure plug and sleeve
- Kickdown valve
- Kickdown limit valve
- 1-2 shift valve
- 1-2 control valve
- 2-3 shift valve

- 2-3 governor plug
- 3-4 shift valve
- 3-4 timing valve
- 3-4 quick fill valve
- 3-4 accumulator
- Throttle valve
- Throttle pressure plug
- Switch valve
- Manual valve
- Converter clutch lock-up valve
- Converter clutch lock-up timing Valve
- Shuttle valve
- Shuttle valve throttle plug
- Boost Valve
- 10 check balls

By adjusting the spring pressure acting on the regulator valve, transmission line pressure can be adjusted.

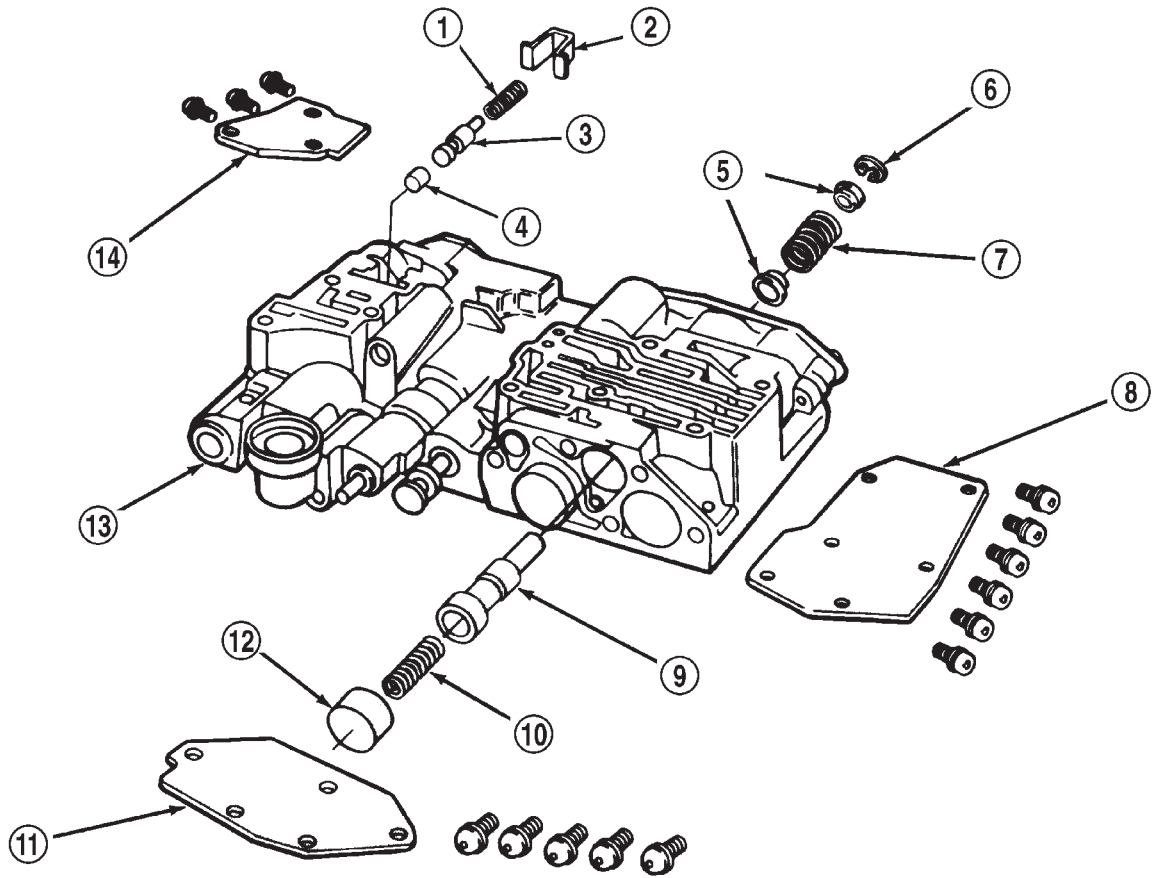


J9321-155

**Fig. 239 Upper Housing Control Valve Locations**

- |                               |                                   |
|-------------------------------|-----------------------------------|
| 1 - UPPER HOUSING             | 8 - MANUAL VALVE                  |
| 2 - REGULATOR VALVE           | 9 - 1-2 GOVERNOR PLUG             |
| 3 - SWITCH VALVE              | 10 - GOVERNOR PLUG COVER          |
| 4 - REGULATOR VALVE SPRING    | 11 - THROTTLE PLUG                |
| 5 - KICKDOWN VALVE            | 12 - 2-3 GOVERNOR PLUG            |
| 6 - KICKDOWN DETENT           | 13 - SHUTTLE VALVE PRIMARY SPRING |
| 7 - THROTTLE VALVE AND SPRING |                                   |

VALVE BODY (Continued)

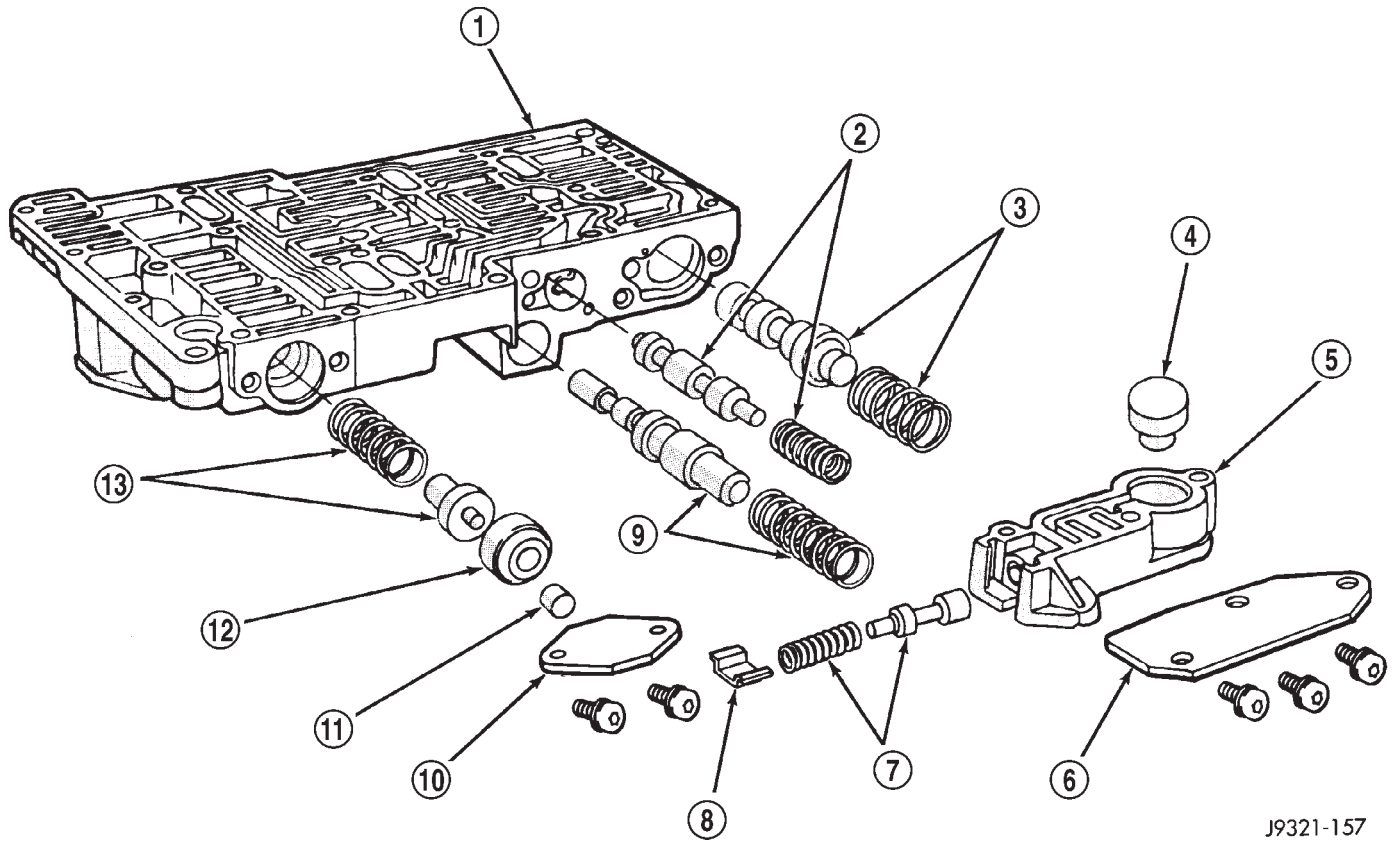


J9421-217

**Fig. 240 Shuttle and Boost Valve Locations**

- |                                    |                                   |
|------------------------------------|-----------------------------------|
| 1 - SPRING                         | 8 - SHUTTLE VALVE COVER           |
| 2 - RETAINER                       | 9 - SHUTTLE VALVE                 |
| 3 - BOOST VALVE                    | 10 - SHUTTLE VALVE PRIMARY SPRING |
| 4 - BOOST VALVE PLUG               | 11 - GOVERNOR PLUG COVER          |
| 5 - SPRING GUIDES                  | 12 - THROTTLE PLUG                |
| 6 - E-CLIP                         | 13 - UPPER HOUSING                |
| 7 - SHUTTLE VALVE SECONDARY SPRING | 14 - BOOST VALVE COVER            |

VALVE BODY (Continued)

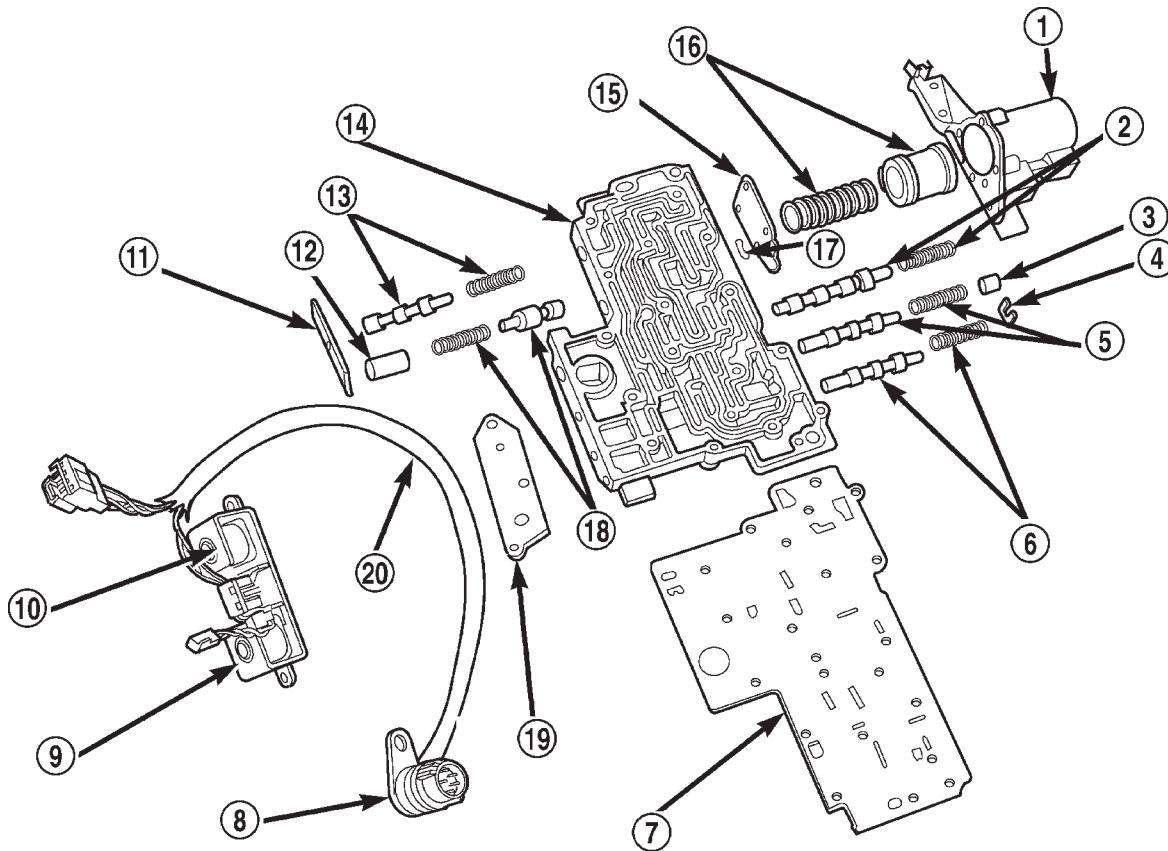


J9321-157

**Fig. 241 Upper Housing Shift Valve and Pressure Plug Locations**

- |                                |  |
|--------------------------------|--|
| 1 - UPPER HOUSING              | 8 - RETAINER                           |
| 2 - 1-2 SHIFT VALVE AND SPRING | 9 - 1-2 SHIFT CONTROL VALVE AND SPRING |
| 3 - 2-3 SHIFT VALVE AND SPRING | 10 - PRESSURE PLUG COVER               |
| 4 - 2-3 THROTTLE PLUG          | 11 - LINE PRESSURE PLUG                |
| 5 - LIMIT VALVE HOUSING        | 12 - PLUG SLEEVE                       |
| 6 - LIMIT VALVE COVER          | 13 - THROTTLE PRESSURE SPRING AND PLUG |
| 7 - LIMIT VALVE AND SPRING     |  |

## VALVE BODY (Continued)



80c072b5

**Fig. 242 Lower Housing Shift Valves and Springs**

- |  |  |
|--|--|
| 1 - 3-4 ACCUMULATOR HOUSING                  | 11 - TIMING VALVE COVER                |
| 2 - 3-4 SHIFT VALVE AND SPRING               | 12 - PLUG                              |
| 3 - PLUG                                     | 13 - 3-4 TIMING VALVE AND SPRING       |
| 4 - SPRING RETAINER                          | 14 - LOWER HOUSING                     |
| 5 - CONVERTER CLUTCH VALVE AND SPRING        | 15 - ACCUMULATOR END PLATE             |
| 6 - CONVERTER CLUTCH TIMING VALVE AND SPRING | 16 - 3-4 ACCUMULATOR PISTON AND SPRING |
| 7 - OVERDRIVE SEPARATOR PLATE                | 17 - E-CLIP                            |
| 8 - CASE CONNECTOR                           | 18 - 3-4 QUICK FILL SPRING AND VALVE   |
| 9 - CONVERTER CLUTCH SOLENOID                | 19 - SOLENOID GASKET                   |
| 10 - OVERDRIVE SOLENOID                      | 20 - HARNESS                           |

**OPERATION**

**NOTE:** Refer to the Hydraulic Schematics for a visual aid in determining valve location, operation and design.



## VALVE BODY (Continued)

## CHECK BALLS

CHECK BALL NUMBER	DESCRIPTION
1	Allows either the manual valve to put line pressure on the 1-2 governor plug or the KD Valve to put WOT line pressure on the 1-2 governor plug.
2	Allows either the manual valve to put line pressure on the 2-3 governor plug or the KD Valve to put WOT line pressure on the 2-3 governor plug.
3	Allows either the Reverse circuit or the 3rd gear circuit to pressurize the front clutch.
4	Allows either the Manual Low circuit from the Manual Valve or the Reverse from the Manual Valve circuit to pressurize the rear servo.
5	Directs line pressure to the spring end of the 2-3 shift valve in either Manual Low or Manual 2nd, forcing the downshift to 2nd gear regardless of governor pressure.
6	Provides a by-pass around the front servo orifice so that the servo can release quickly.
7	Provides a by-pass around the rear clutch orifice so that the clutch can release quickly.
8	Directs reverse line pressure through an orifice to the throttle valve eliminating the extra leakage and insuring that Reverse line pressure pressure will be sufficient.
9	Provides a by-pass around the rear servo orifice so that the servo can release quickly.
ECE (10)	Allows the lockup clutch to used at WOT in 3rd gear by putting line pressure from the 3-4 Timing Valve on the interlock area of the 2-3 shift valve, thereby preventing a 3rd gear Lock-up to 2nd gear kickdown.

## REGULATOR VALVE

The pressure regulator valve is needed to control the hydraulic pressure within the system and reduce the amount of heat produced in the fluid. The pressure regulator valve is located in the valve body near the manual valve. The pressure regulator valve train controls the maximum pressure in the lines by metering the dumping of fluid back into the sump. Regulated pressure is referred to as "line pressure."

The regulator valve (Fig. 243) has a spring on one end that pushes the valve to the left. This closes a dump (vent) that is used to lower pressure. The closing of the dump will cause the oil pressure to increase. Oil pressure on the opposite end of the valve pushes the valve to the right, opening the dump and lowering oil pressure. The result is spring pressure working against oil pressure to maintain the oil at specific pressures. With the engine running, fluid flows from the pump to the pressure regulator valve, manual valve, and the interconnected circuits. As fluid is sent through passages to the regulator valve, the pressure pushes the valve to the right against the large spring. It is also sent to the reaction areas on the left side of the throttle pressure plug and the line pressure plug. With the gear selec-

tor in the PARK position, fluid recirculates through the regulator and manual valves back to the sump.

Meanwhile, the torque converter is filled slowly. In all other gear positions (Fig. 244), fluid flows between two right side lands to the switch valve and torque converter. At low pump speeds, the flow is controlled by the pressure valve groove to reduce pressure to the torque converter. After the torque converter and switch valve fill with fluid, the switch valve becomes the controlling metering device for torque converter pressure. The regulator valve then begins to control the line pressure for the other transmission circuits. The balance of the fluid pressure pushing the valve to the right and the spring pressure pushing to the left determines the size of the metering passage at land #2 (land #1 being at the far right of the valve in the diagram). As fluid leaks past the land, it moves into a groove connected to the filter or sump. As the land meters the fluid to the sump, it causes the pressure to reduce and the spring decreases the size of the metering passage. When the size of the metering passage is reduced, the pressure rises again and the size of the land is increased again. Pressure is regulated by this constant balance of hydraulic and spring pressure.

VALVE BODY (Continued)

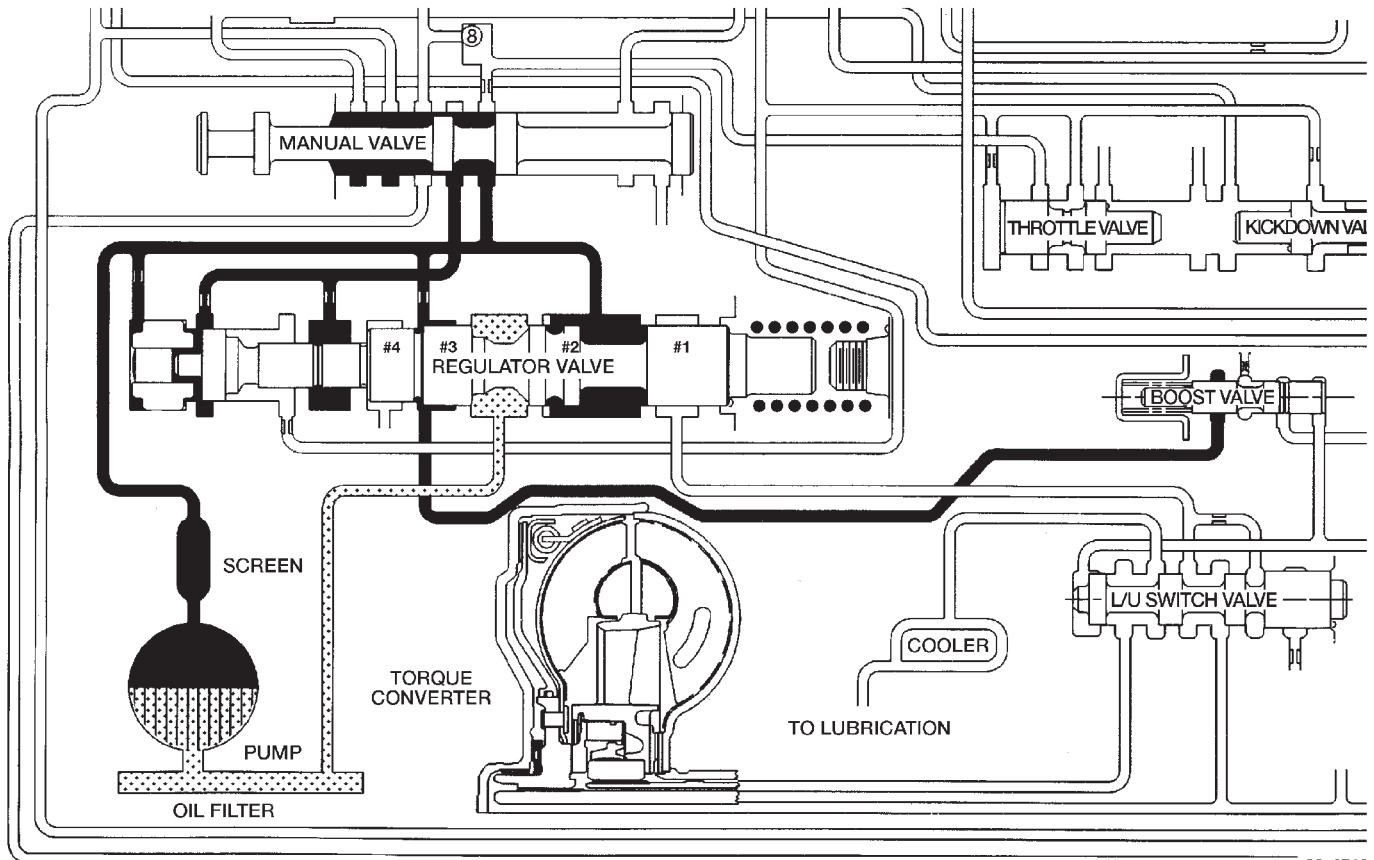


Fig. 243 Regulator Valve in PARK Position

80c0713c

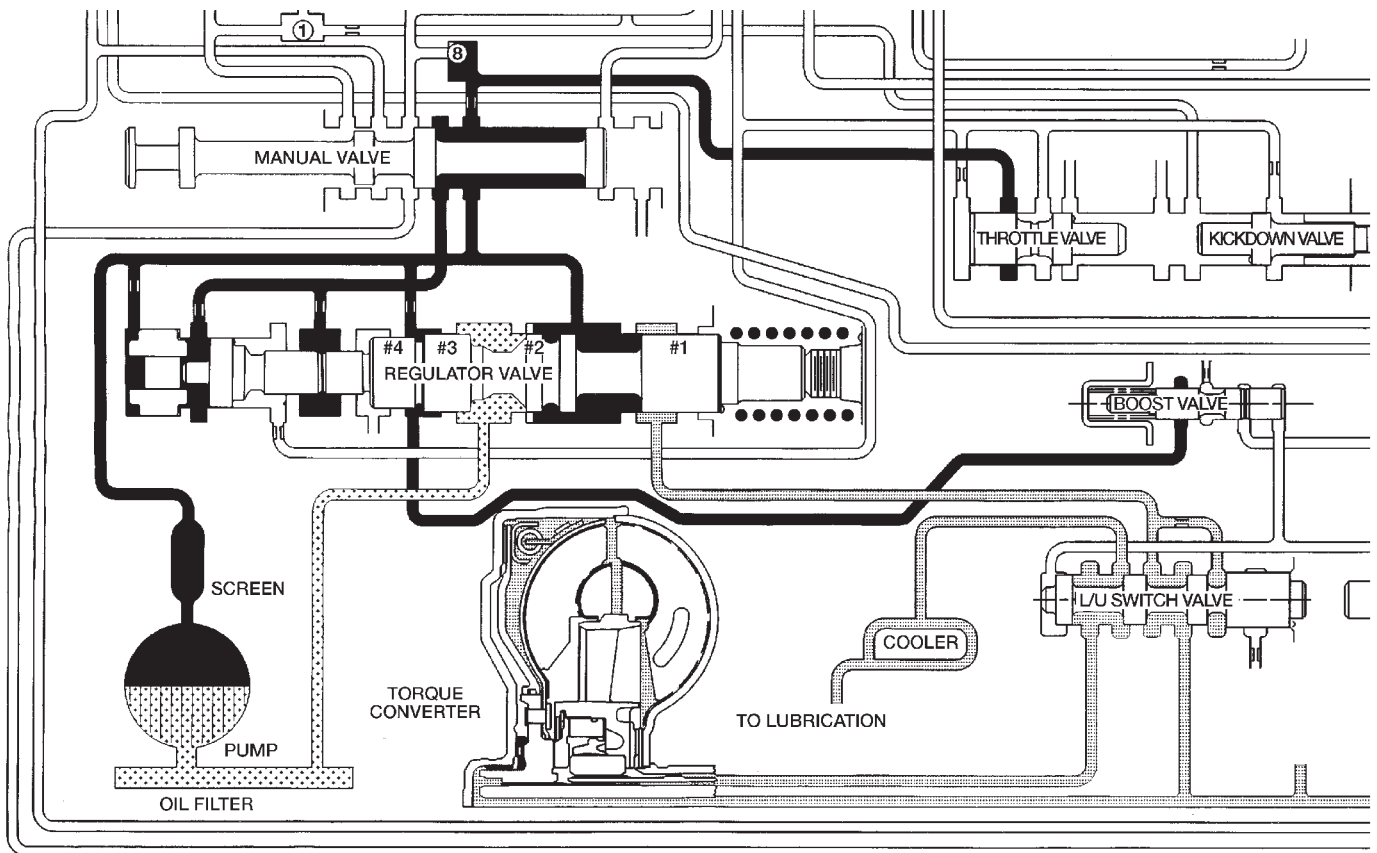
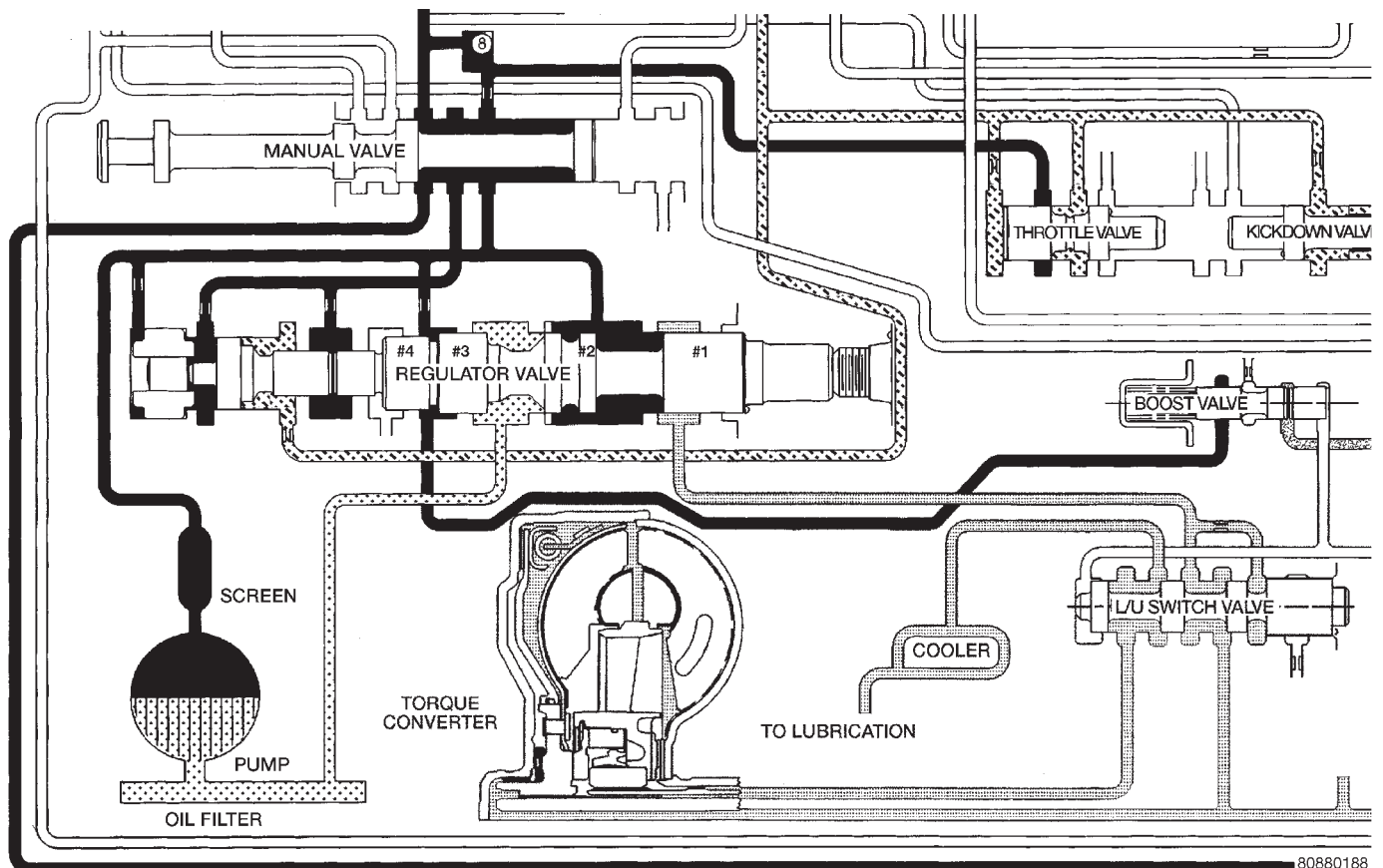


Fig. 244 Regulator Valve in NEUTRAL Position

80880187

## VALVE BODY (Continued)

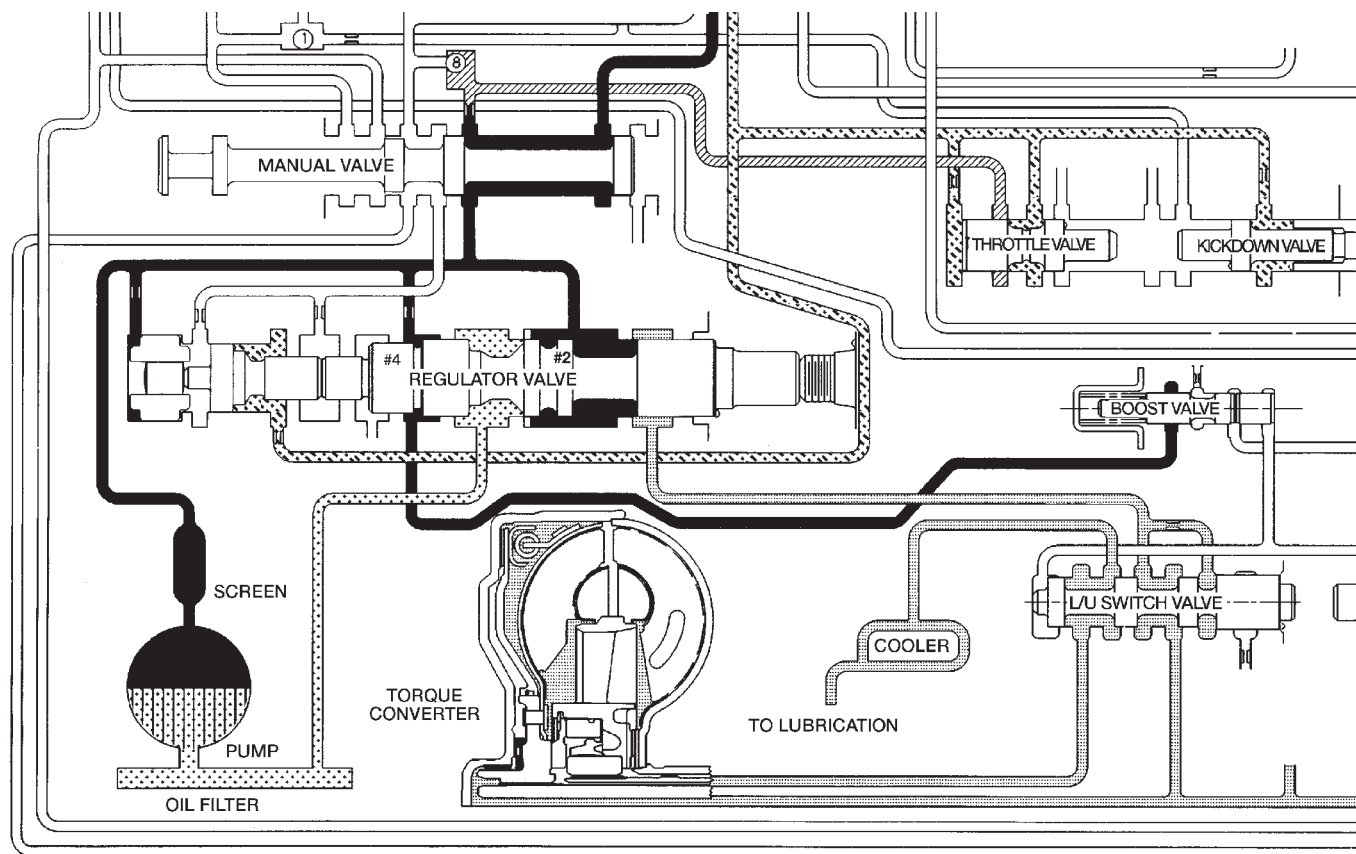
The metering at land #2 establishes the line pressure throughout the transmission. It is varied according to changes in throttle position and the transmission's internal condition within a range of 57-94 psi (except in REVERSE) (Fig. 245). The regulated line pressure in REVERSE (Fig. 246) is held at much higher pressures than in the other gear positions: 145-280 psi. The higher pressure for REVERSE is achieved by the manual valve blocking the supply of line pressure to the reaction area left of land #4. With this pressure blocked, there is less area for pressure to act on to balance the force of the spring on the right. This allows line pressure to push the valve train to the right, reducing the amount of fluid returned to the pump's inlet, increasing line pressure.



80880188

**Fig. 245 Regulator Valve in DRIVE Position**

## VALVE BODY (Continued)



**Fig. 246 Regulator Valve in REVERSE Position**

### KICKDOWN VALVE

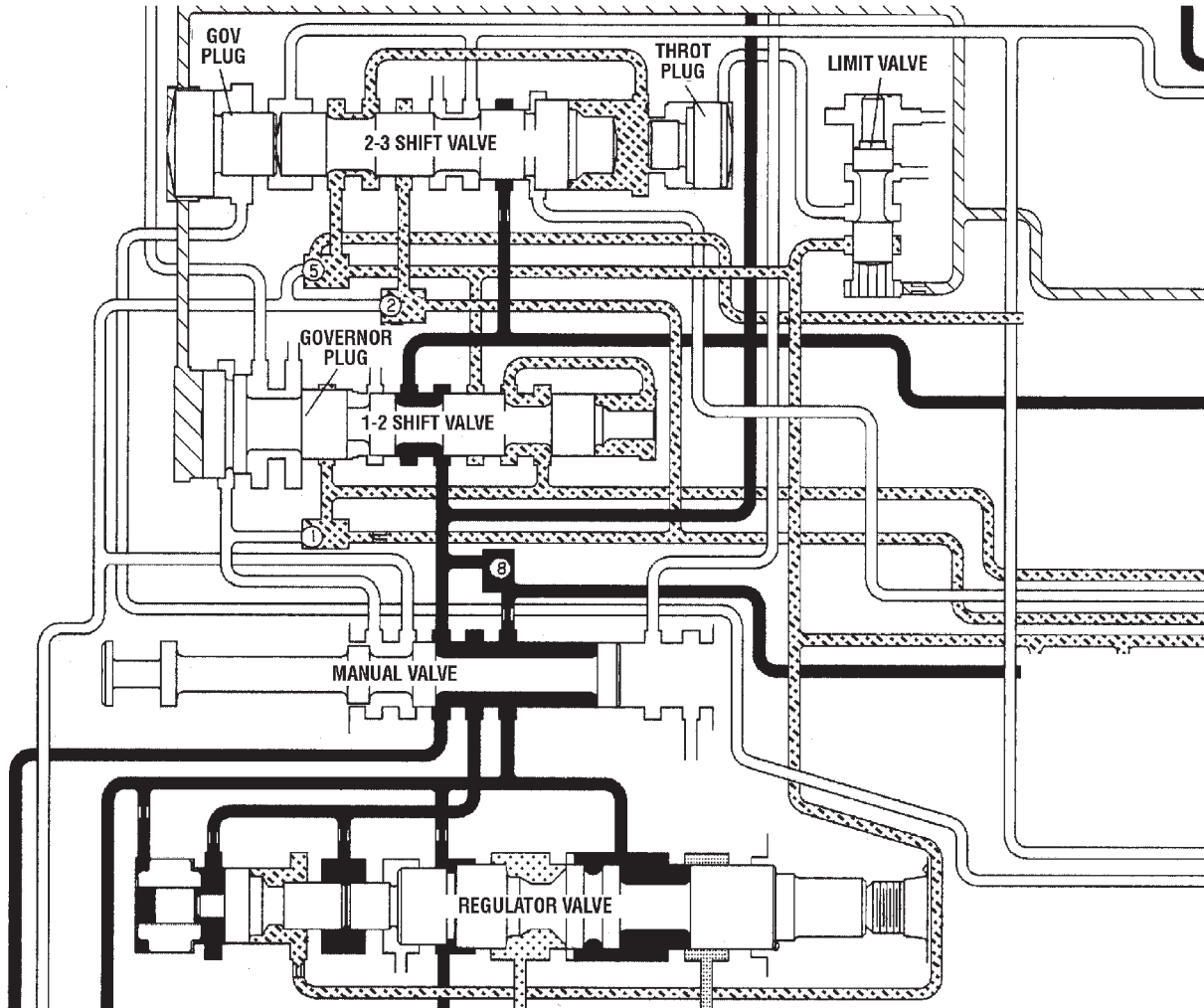
When the throttle valve is as far over to the left as it can go, the maximum line pressure possible will enter the throttle pressure circuit. In this case, throttle pressure will equal line pressure. With the kickdown valve (Fig. 247) pushed into the bore as far as it will go, fluid initially flows through the annular groove of the 2-3 shift valve (which will be in the direct drive position to the right).

After passing the annular groove, the fluid is routed to the spring end of the 2-3 shift valve. Fluid pressure reacting on the area of land #1 overcomes governor pressure, downshifting the 2-3 shift valve into the kickdown, or second gear stage of operation. The valve is held in the kickdown position by throttle pressure routed from a seated check ball (#2). Again, if vehicle speed is low enough, throttle pressure will also push the 1-2 shift valve left to seat its governor plug, and downshift to drive breakaway.

### KICKDOWN LIMIT VALVE

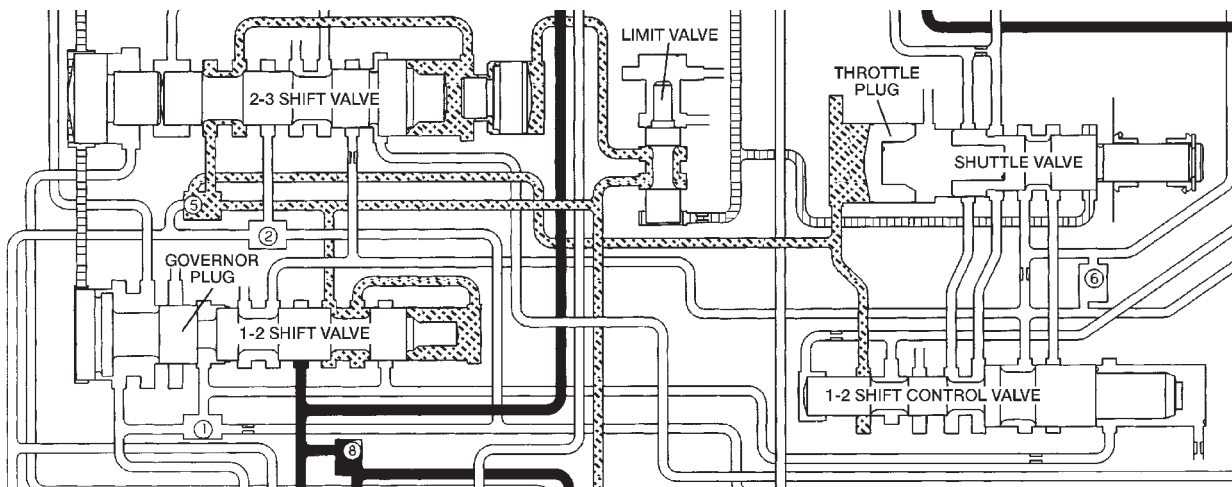
The purpose of the limit valve is to prevent a 3-2 downshift at higher speeds when a part-throttle downshift is not desirable. At these higher speeds only a full throttle 3-2 downshift will occur. At low road speeds (Fig. 248) the limit valve does not come into play and does not affect the downshifts. As the vehicle's speed increases (Fig. 249), the governor pressure also increases. The increased governor pressure acts on the reaction area of the bottom land of the limit valve overcoming the spring force trying to push the valve toward the bottom of its bore. This pushes the valve upward against the spring and bottoms the valve against the top of the housing. With the valve bottomed against the housing, the throttle pressure supplied to the valve will be closed off by the bottom land of the limit valve. When the supply of throttle pressure has been shut off, the 3-2 part throttle downshift plug becomes inoperative, because no pressure is acting on its reaction area.

VALVE BODY (Continued)



8088018a

**Fig. 247 Kickdown Valve-Wide Open Throttle**

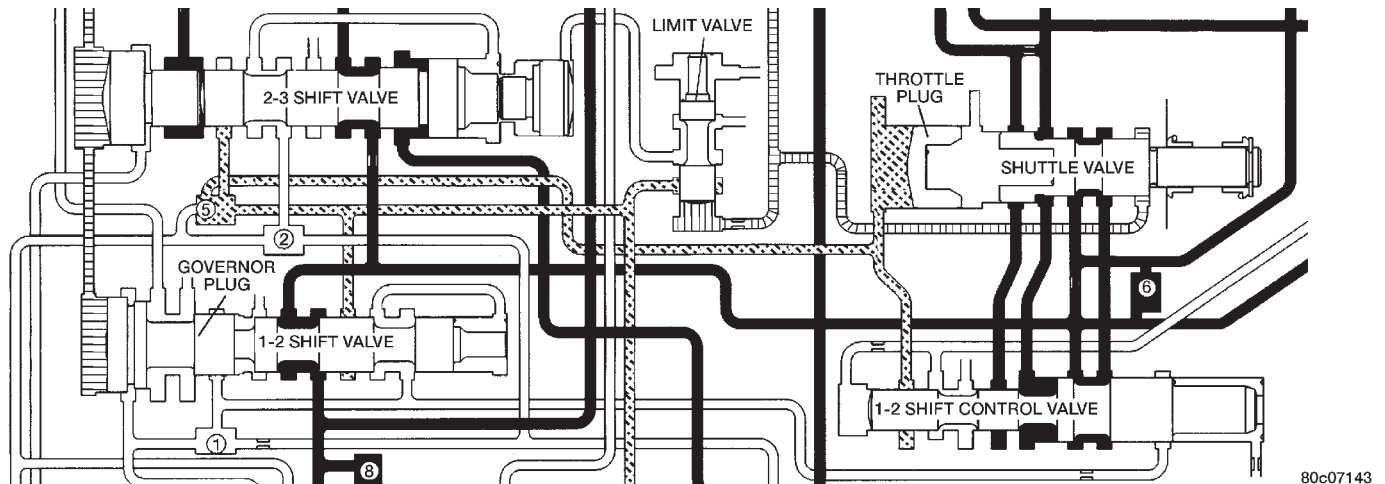


80c07142

**Fig. 248 Kickdown Limit Valve-Low Speeds**



## VALVE BODY (Continued)



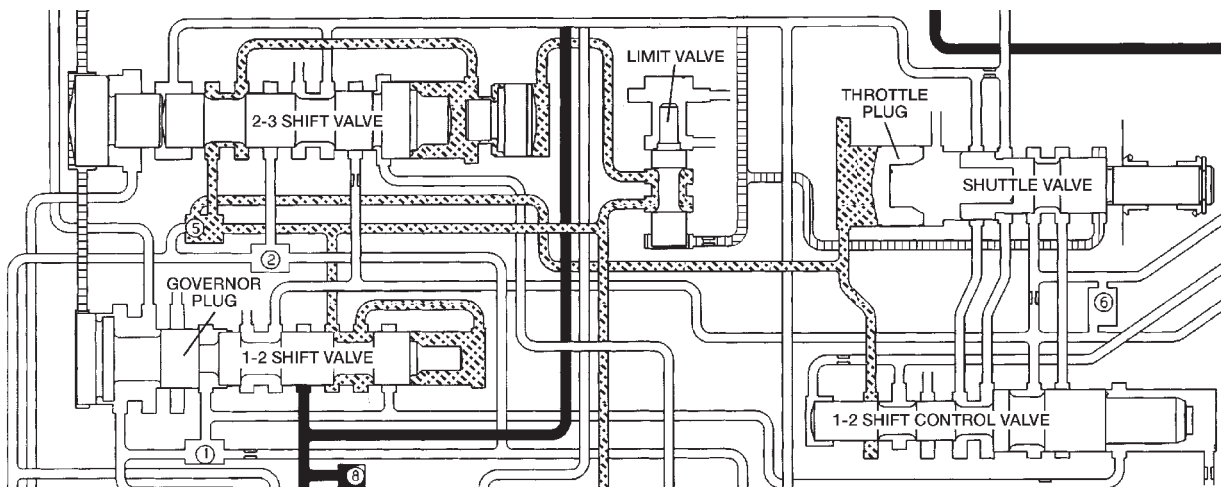
80c07143

**Fig. 249 Kickdown Limit Valve-High Speeds**

### 1-2 SHIFT VALVE

The 1-2 shift valve assembly (Fig. 250), or mechanism, consists of: the 1-2 shift valve, governor plug, and a spring on the end of the valve. After the manual valve has been placed into a forward gear range, line pressure is directed to the 1-2 shift valve. As the throttle is depressed, throttle pressure is applied to the right side of the 1-2 shift valve assembly. With throttle pressure applied to the right side of the valve, there is now both spring pressure and throttle pressure acting on the valve, holding it against the governor plug. As the vehicle begins to move and build speed, governor pressure is created and is applied to the left of the valve at the governor plug.

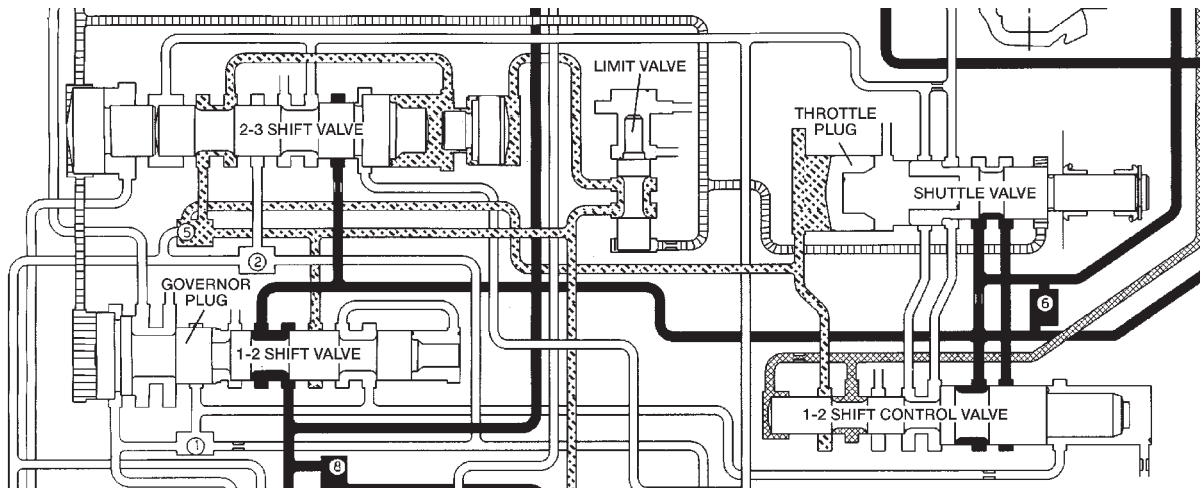
When governor pressure builds to a point where it can overcome the combined force of the spring and throttle pressure on the other side of the valve, the valve will begin to move over to the right. As the valve moves to the right, the middle land of the valve will close off the circuit supplying the throttle pressure to the right side of the valve. When the throttle pressure is closed off, the valve will move even farther to the right, allowing line pressure to enter another circuit and energize the front servo, applying the front band (Fig. 251).



80c07144

**Fig. 250 1-2 Shift Valve-Before Shift**

## VALVE BODY (Continued)



80c07145

**Fig. 251 1-2 Shift Valve-After Shift**

The governor plug serves a dual purpose:

- It allows the shift valves to move either left or right, allowing both upshifts and downshifts.
- When in a manual selection position, it will be hydraulically “blocked” into position so no upshift can occur.

The physical blocking of the upshift while in the manual “1” position is accomplished by the directing of line pressure between both lands of the governor plug. The line pressure reacts against the larger land of the plug, pushing the plug back against the end plate overcoming governor pressure. With the combination of the line pressure and spring pressure, the valve cannot move, preventing any upshift.

### 1-2 SHIFT CONTROL VALVE

It contains a valve with four lands and a spring. It is used as both a “relay” and “balanced” valve.

The valve has two specific operations (Fig. 252):

- Aid in quality of the 1-2 upshift.
- Aid in the quality and timing of the 3-2 kick-down ranges.

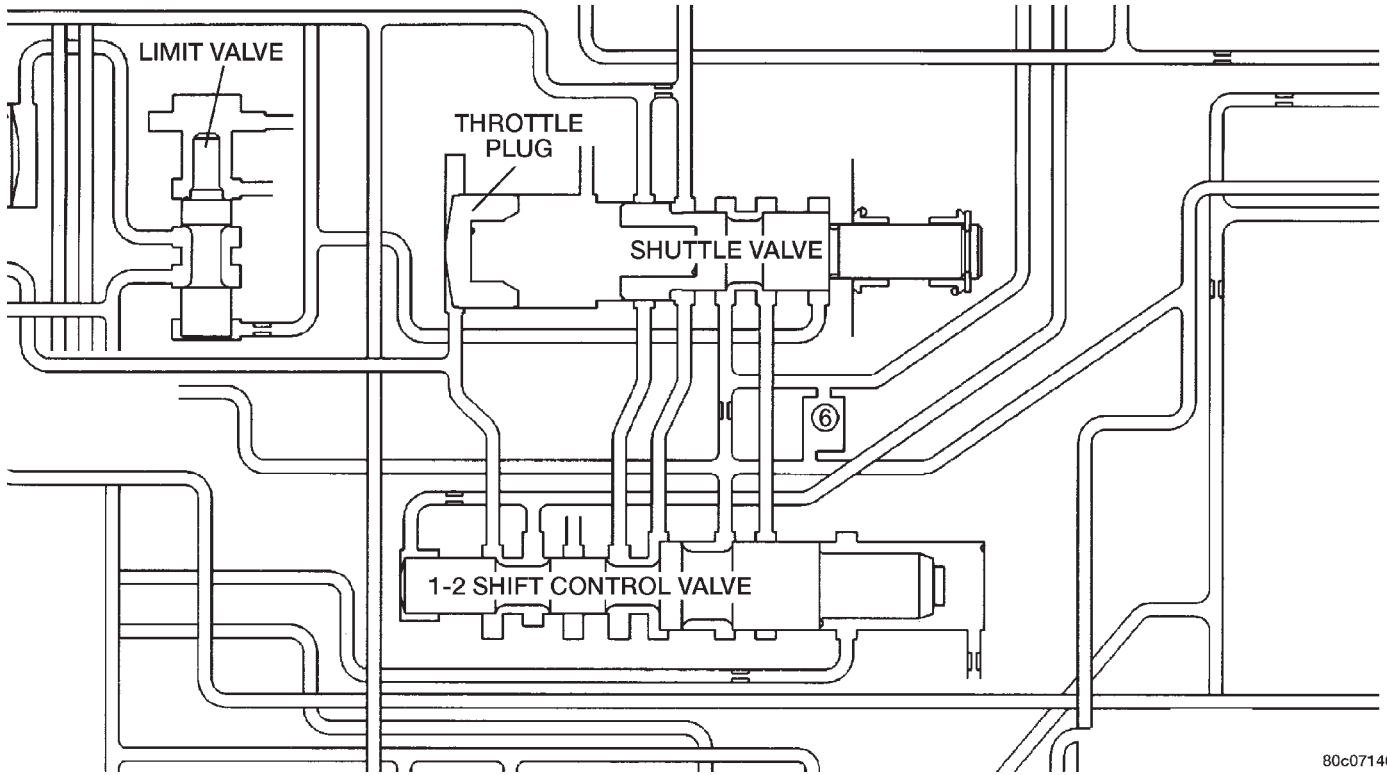
When the manual valve is set to the DRIVE position and the transmission is in the first or second gear range, 1-2 shift control or “modulated throttle pressure” is supplied to the middle of the accumulator piston by the 1-2 shift control valve. During the 1-2 upshift, this pressure is used to control the kick-down servo apply pressure that is needed to apply the kickdown and accumulator pistons. Thus, the 1-2 shift point is “cushioned” and the quality is improved. During a WOT kickdown, kickdown pressure is applied between the kickdown valve and the 1-2 shift control valve. This additional pressure is directed to the 1-2 shift control’s spring cavity, adding to the spring load on the valve. The result of this increased “modulated” throttle pressure is a firmer WOT upshift.

### 2-3 SHIFT VALVE

The 2-3 shift valve mechanism (Fig. 253) consists of the 2-3 shift valve, governor plug and spring, and a throttle plug. After the 1-2 shift valve has completed its operation and applied the front band, line pressure is directed to the 2-3 shift valve through the connecting passages from the 1-2 shift valve. The line pressure will then dead-end at land #2 until the 2-3 valve is ready to make its shift. Now that the vehicle is in motion and under acceleration, there is throttle pressure being applied to the spring side of the valve and between lands #3 and #4.

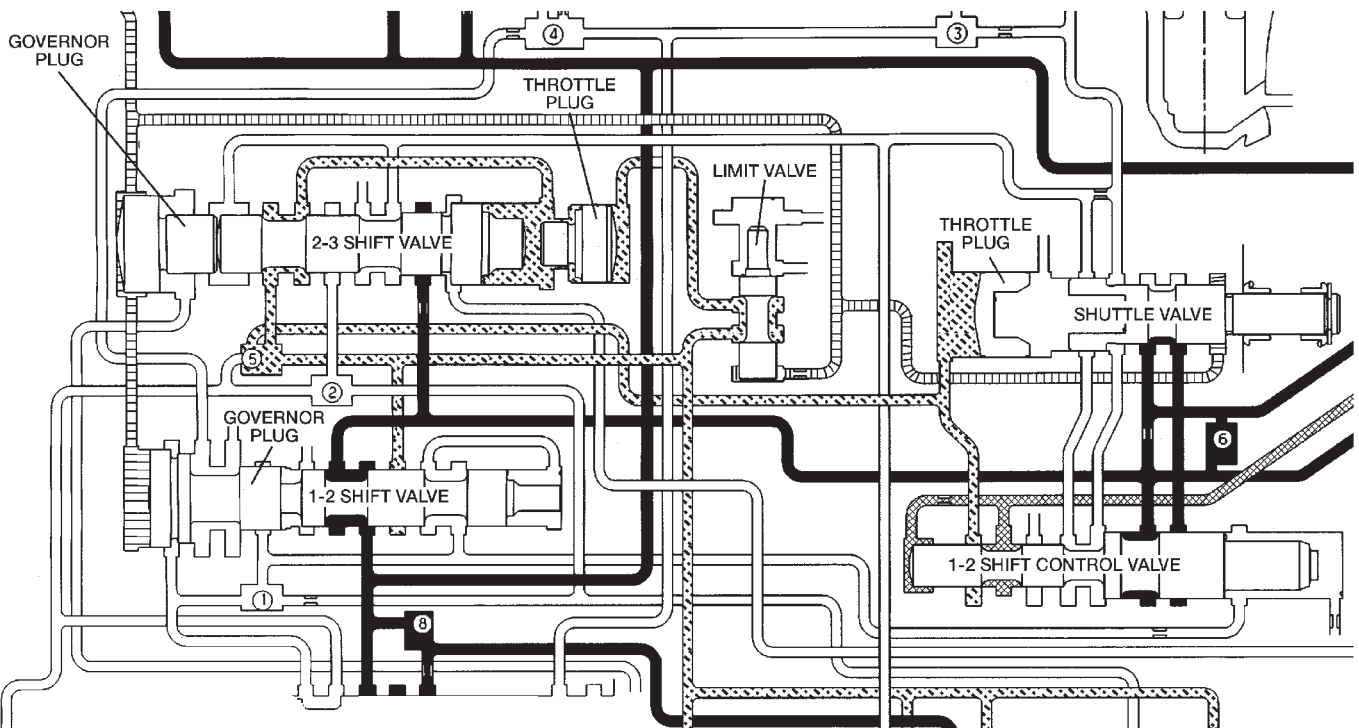
As vehicle speed increases, governor pressure increases proportionately, until it becomes great enough to overcome the combined throttle and spring pressure on the right side of the valve. Since the throttle pressure end of the 2-3 shift valve is larger in diameter than the 1-2 shift valve, the 2-3 shift will always happen at a greater speed than the 1-2 shift. When this happens, the governor plug is forced against the shift valve moving it to the right. The shift valve causes land #4 to close the passage supplying throttle pressure to the 2-3 shift valve. Without throttle pressure present in the circuit now, the governor plug will push the valve over far enough to bottom the valve in its bore. This allows land #2 to direct line pressure to the front clutch.

VALVE BODY (Continued)



80c07146

**Fig. 252 1-2 Shift Control Valve**



80c07147

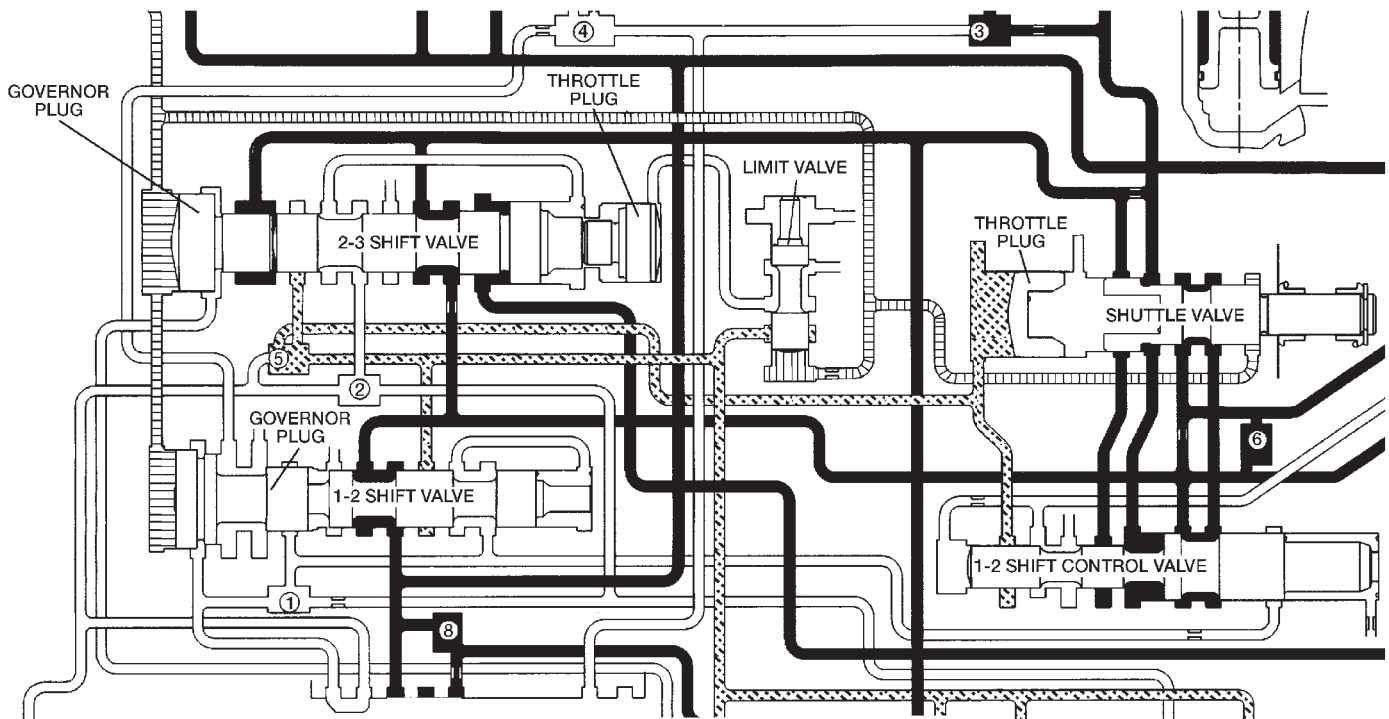
**Fig. 253 2-3 Shift Valve-Before Shift**

## VALVE BODY (Continued)

After the shift (Fig. 254), line pressure is directed to the land between the shift valve and the governor plug, and to the release side of the kickdown servo. This releases the front band and applies the front clutch, shifting into third gear or direct drive. The rear clutch remains applied, as it has been in the other gears. During a manual "1" or manual "2" gear selection, line pressure is sent between the two lands of the 2-3 governor plug. This line pressure at the governor plug locks the shift valve into the second gear position, preventing an upshift into direct drive. The theory for the blocking of the valve is the same as that of the 1-2 shift valve.

## 3-4 SHIFT VALVE

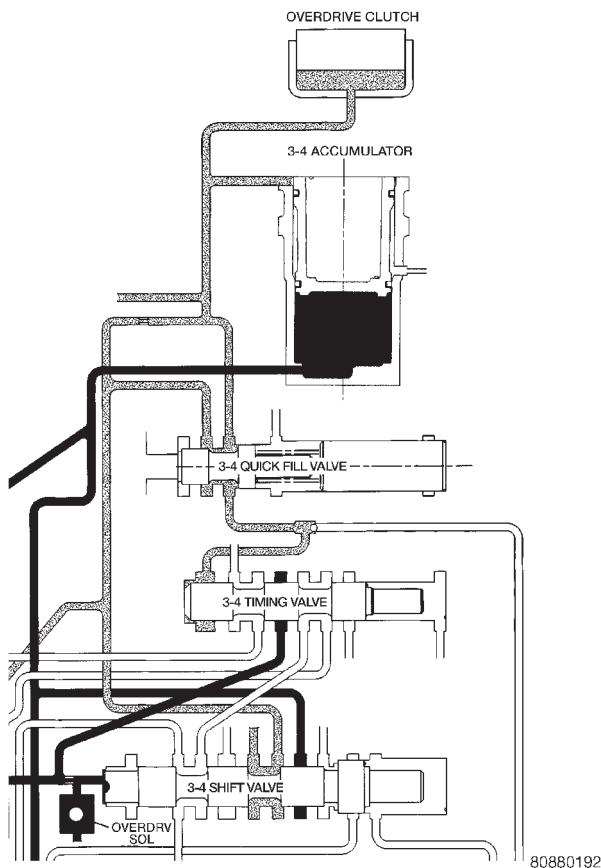
The PCM energizes the overdrive solenoid during the 3-4 upshift (Fig. 255). This causes the solenoid check ball to close the vent port allowing line pressure from the 2-3 shift valve to act directly on the 3-4 upshift valve. Line pressure on the 3-4 shift valve overcomes valve spring pressure moving the valve to the upshift position (Fig. 256). This action exposes the feed passages to the 3-4 timing valve, 3-4 quick fill valve, 3-4 accumulator, and ultimately to the overdrive piston.



80c07148

Fig. 254 2-3 Shift Valve-After Shift

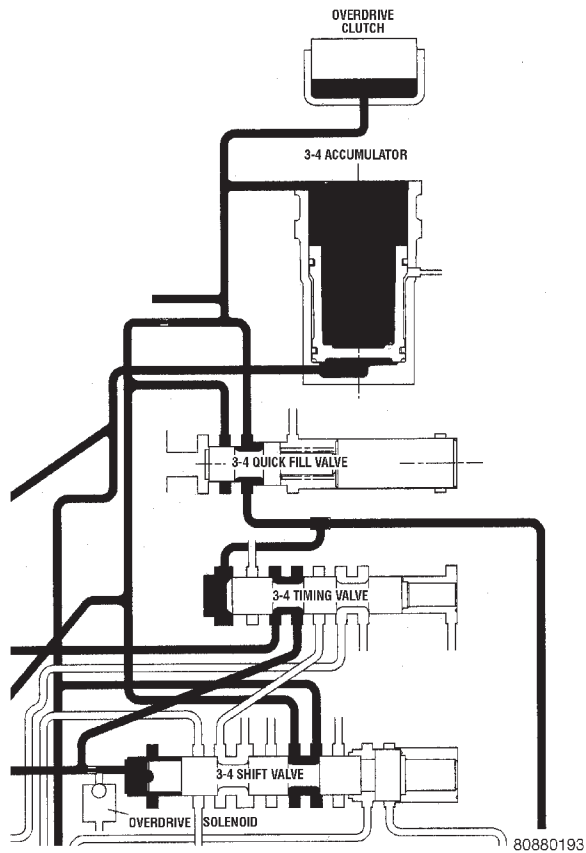
## VALVE BODY (Continued)



**Fig. 255 3-4 Shift Valve Before Shift**

### 3-4 TIMING VALVE

The 3-4 timing valve is moved by line pressure coming through the 3-4 shift valve (Fig. 256). After the shift, the timing valve holds the 2-3 shift valve in an upshift position. The purpose is to prevent the 2-3 valve from downshifting before the 3-4 valve (Fig. 255).



**Fig. 256 3-4 Shift Valve After Shift**

### 3-4 QUICK FILL VALVE

The 3-4 quick fill valve provides faster engagement of the overdrive clutch during 3-4 upshifts. The valve temporarily bypasses the clutch piston feed orifice at the start of a 3-4 upshift (Fig. 255). This exposes a larger passage into the piston retainer resulting in a much faster clutch fill and apply sequence. The quick fill valve does not bypass the regular clutch feed orifice throughout the 3-4 upshift. Instead, once a pre-determined pressure develops within the clutch, the valve closes the bypass (Fig. 256). Clutch fill is then completed through the regular feed orifice.



## VALVE BODY (Continued)

## THROTTLE VALVE

In all gear positions the throttle valve (Fig. 257) is being supplied with line pressure. The throttle valve meters and reduces the line pressure that now becomes throttle pressure. The throttle valve is moved by a spring and the kickdown valve, which is mechanically connected to the throttle. The larger the throttle opening, the higher the throttle pressure (to a maximum of line pressure). The smaller the throttle opening, the lower the throttle pressure (to a minimum of zero at idle). As engine speed increases, the increase in pump speed increases pump output. The increase in pressure and volume must be regulated to maintain the balance within the transmission. To do this, throttle pressure is routed to the reaction area on the right side of the throttle pressure plug (in the regulator valve).

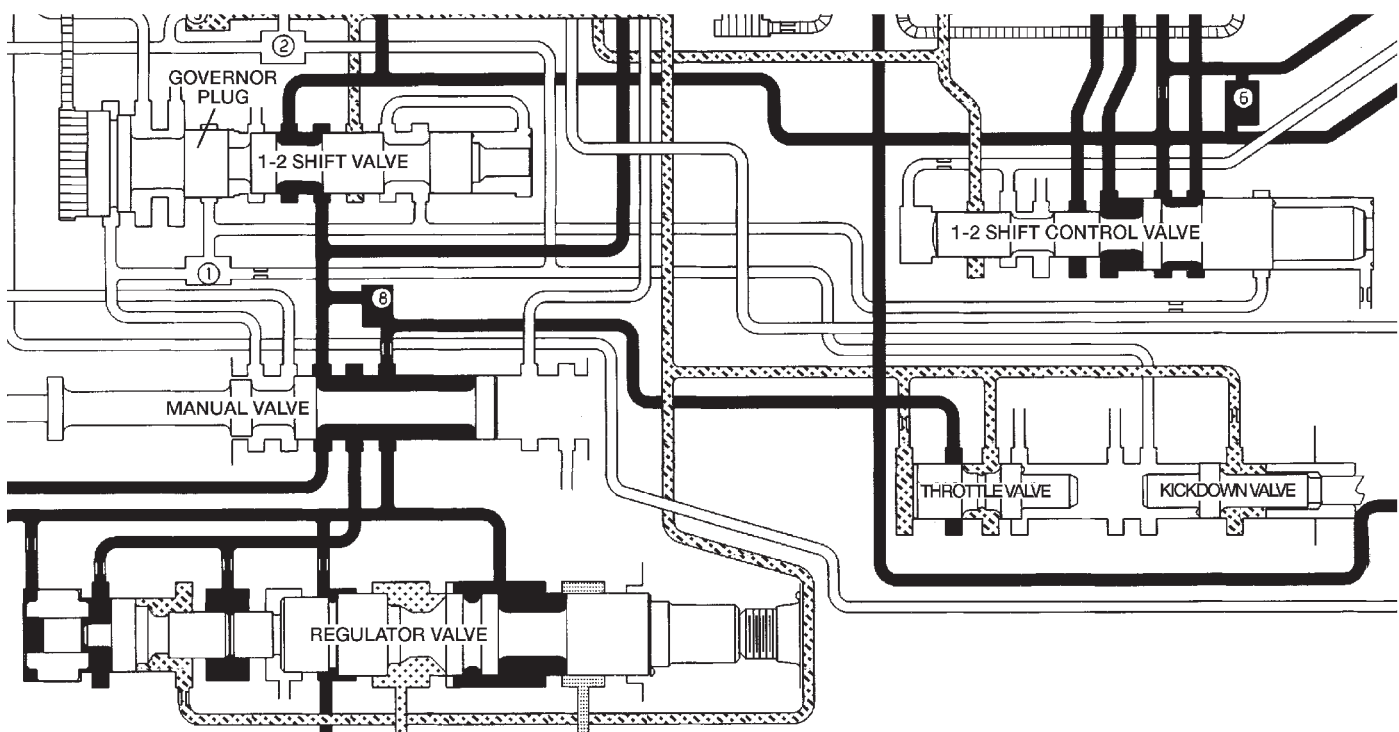
The higher engine speed and line pressure would open the vent too far and reduce line pressure too much. Throttle pressure, which increases with engine speed (throttle opening), is used to oppose the movement of the pressure valve to help control the metering passage at the vent. The throttle pressure is combined with spring pressure to reduce the force of the throttle pressure plug on the pressure valve. The larger spring at the right closes the regulator valve passage and maintains or increases line pressure. The increased line pressure works against the reaction area of the line pressure plug and the reaction area left of land #3 simultaneously moves the regu-

lator valve train to the right and controls the metering passage.

The kickdown valve, along with the throttle valve, serve to delay upshifts until the correct vehicle speed has been reached. It also controls downshifts upon driver demand, or increased engine load. If these valves were not in place, the shift points would be at the same speed for all throttle positions. The kickdown valve is actuated by a cam connected to the throttle. This is accomplished through either a linkage or a cable. The cam forces the kickdown valve toward the throttle valve compressing the spring between them and moving the throttle valve. As the throttle valve land starts to uncover its port, line pressure is "metered" out into the circuits and viewed as throttle pressure. This increased throttle pressure is metered out into the circuits it is applied to: the 1-2 and 2-3 shift valves. When the throttle pressure is high enough, a 3-2 downshift will occur. If the vehicle speed is low enough, a 2-1 downshift will occur.

## SWITCH VALVE

When the transmission is in Drive Second before the TCC application occurs (Fig. 258), the pressure regulator valve is supplying torque converter pressure to the switch valve. The switch valve directs this pressure through the transmission input shaft, into the converter, through the converter, back out between the input shaft and the reaction shaft, and



80c07149

Fig. 257 Throttle Valve

## VALVE BODY (Continued)

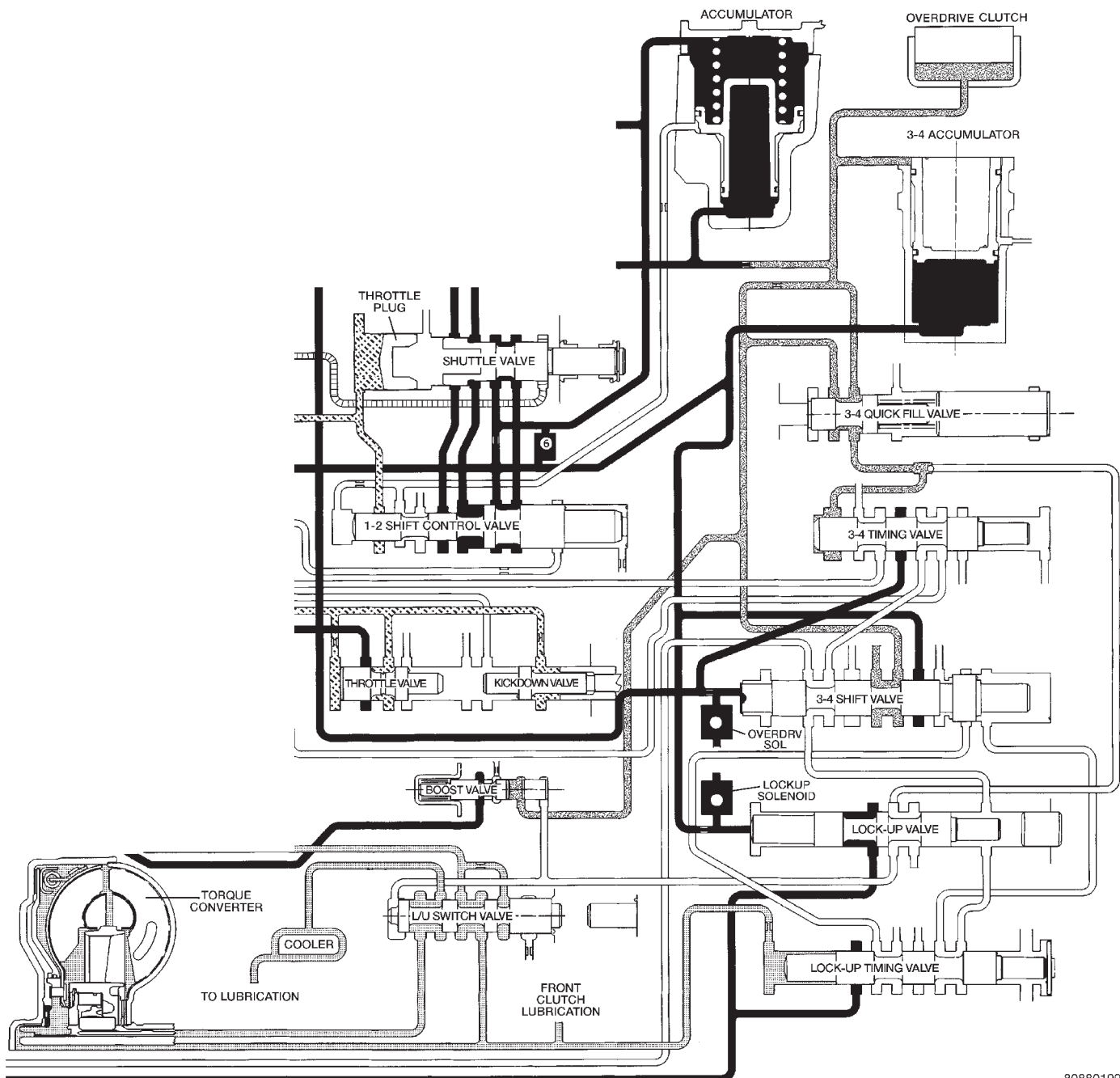
back up to the switch valve. From the switch valve, the fluid pressure is directed to the transmission cooler, and lubrication pressure returns from the cooler to lubricate different portions of the transmission.

Once the TCC control valve has moved to the right (Fig. 259), line pressure is directed to the tip of the switch valve, forcing the valve to the right. The switch valve now vents oil from the front of the piston in the torque converter, and supplies line pressure to the (rear) apply side of the torque converter piston. This pressure differential causes the piston to

apply against the friction material, cutting off any further flow of line pressure oil. After the switch valve is shuttled right allowing line pressure to engage the TCC, torque converter pressure is directed past the switch valve into the transmission cooler and lubrication circuits.

## MANUAL VALVE

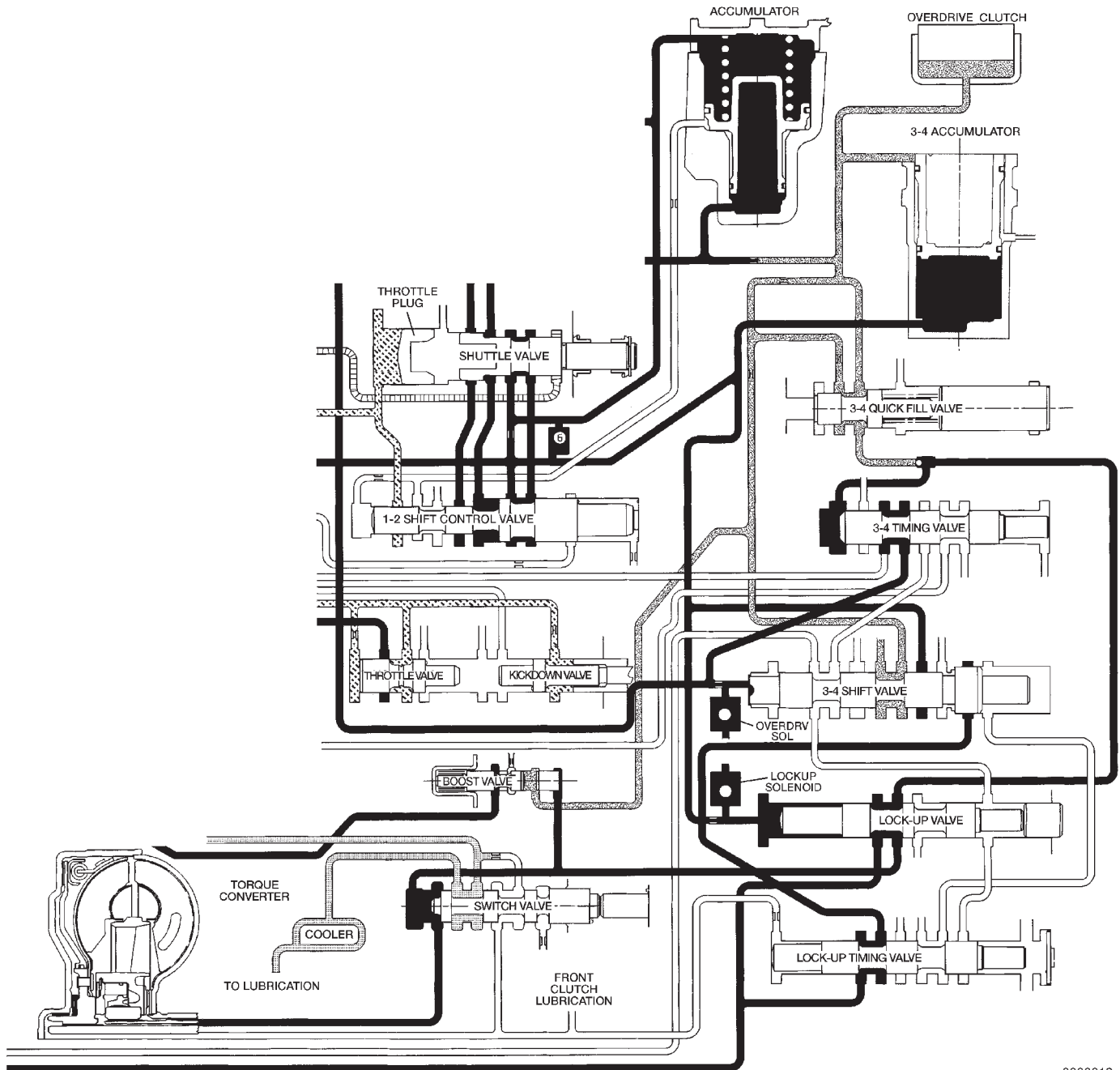
The manual valve (Fig. 260) is a relay valve. The purpose of the manual valve is to direct fluid to the correct circuit needed for a specific gear or driving range. The manual valve, as the name implies, is



80880199

Fig. 258 Switch Valve-Torque Converter Unlocked

## VALVE BODY (Continued)



8088019a

**Fig. 259 Switch Valve-Torque Converter Locked**

manually operated by the driver with a lever located on the side of the valve body. The valve is connected mechanically by either a cable or linkage to the gear-shift mechanism. The valve is held in each of its positions by a spring-loaded roller or ball that engages the "roostercomb" of the manual valve lever.

#### CONVERTER CLUTCH LOCK-UP VALVE

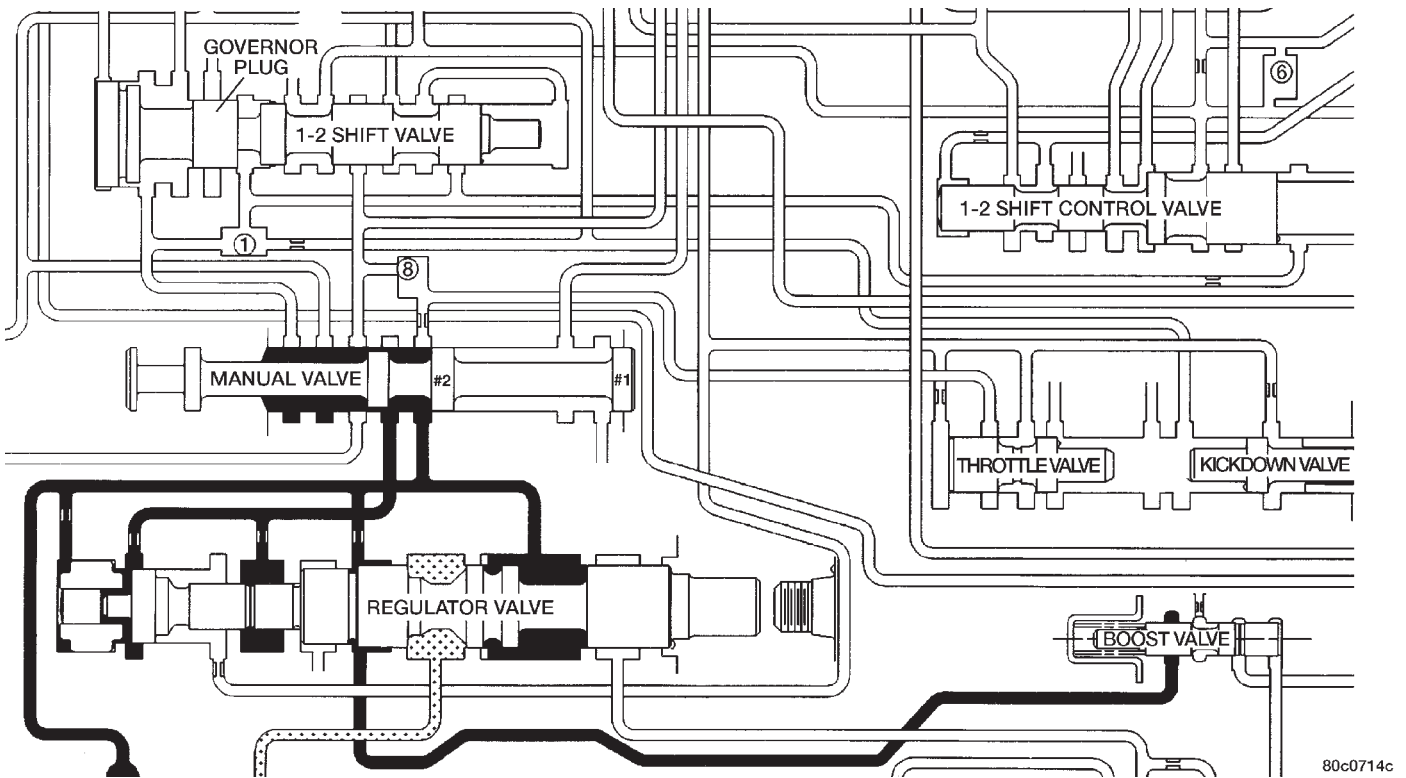
The torque converter clutch (TCC) lock-up valve controls the back (ON) side of the torque converter clutch. When the PCM energizes the TCC solenoid to engage the converter clutch piston, pressure is

applied to the TCC lock-up valve which moves to the right and applies pressure to the torque converter clutch.

#### CONVERTER CLUTCH LOCK-UP TIMING VALVE

The torque converter clutch (TCC) lock-up timing valve is there to block any 4-3 downshift until the TCC is completely unlocked and the clutch is disengaged.

## VALVE BODY (Continued)



80c0714c

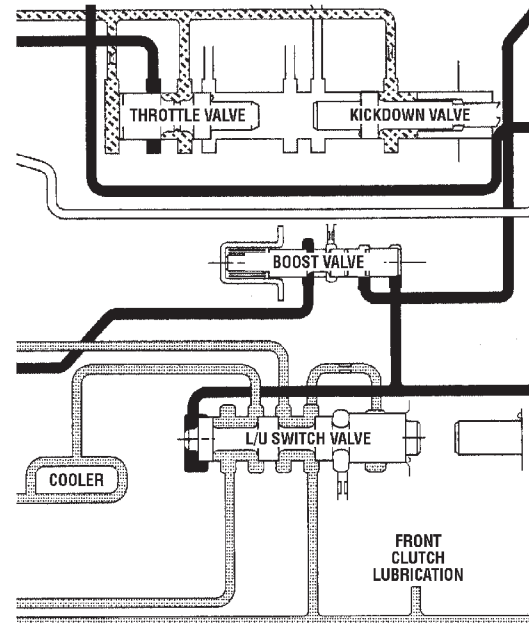
Fig. 260 Manual Valve

## SHUTTLE VALVE

The assembly is contained in a bore in the valve body above the shift valves. When the manual valve is positioned in the Drive range, throttle pressure acts on the throttle plug of the shuttle valve (Fig. 252) to move it against a spring, increasing the spring force on the shuttle valve. During a part or full throttle 1-2 upshift, the throttle plug is bottomed by throttle pressure, holding the shuttle valve to the right against governor pressure, and opening a by-pass circuit. The shuttle valve controls the quality of the kickdown shift by restricting the rate of fluid discharge from the front clutch and servo release circuits. During a 3-2 kickdown, fluid discharges through the shuttle by-pass circuit. When the shuttle valve closes the by-pass circuit, fluid discharge is restricted and controlled for the application of the front band. During a 2-3 "lift foot" upshift, the shuttle valve by-passes the restriction to allow full fluid flow through the by-pass groove for a faster release of the band.

## BOOST VALVE

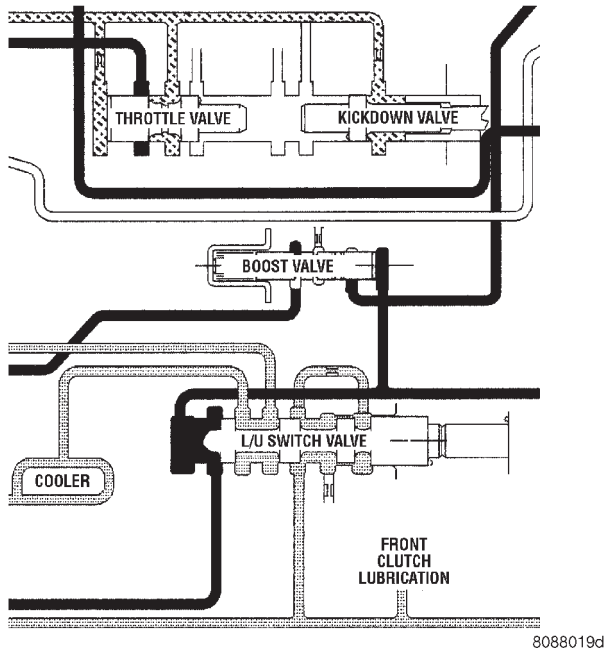
The boost valve (Fig. 261) provides increased fluid apply pressure to the overdrive clutch during 3-4 upshifts (Fig. 262), and when accelerating in fourth gear. The boost valve also serves to increase line pressure during torque converter lock-up.



8088019c

Fig. 261 Boost Valve Before Lock-up

## VALVE BODY (Continued)



**Fig. 262 Boost Valve After Lock-up**

## REMOVAL

The valve body can be removed for service without having to remove the transmission assembly.

The valve body can be disassembled for cleaning and inspection of the individual components.

The only replaceable valve body components are:

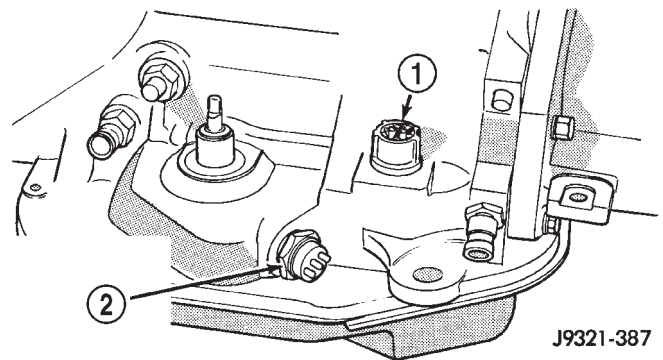
- Manual lever.
  - Manual lever washer, seal, E-clip, and shaft seal.
  - Manual lever detent ball.
  - Throttle lever.
  - Fluid filter.
  - Pressure adjusting screw bracket.
  - Governor pressure solenoid.
  - Governor pressure sensor (includes transmission temperature thermistor).
  - Converter clutch/overdrive solenoid assembly and harness .
  - Governor housing gasket.
  - Solenoid case connector O-rings.
- (1) Shift transmission into NEUTRAL.
  - (2) Raise vehicle.
  - (3) Remove gearshift and throttle levers from shaft of valve body manual lever.
  - (4) Disconnect wires at solenoid case connector (Fig. 263).
  - (5) Position drain pan under transmission oil pan.
  - (6) Remove transmission oil pan and gasket.
  - (7) Remove fluid filter from valve body.

(8) Remove bolts attaching valve body to transmission case.

(9) Lower valve body enough to remove accumulator piston and springs.

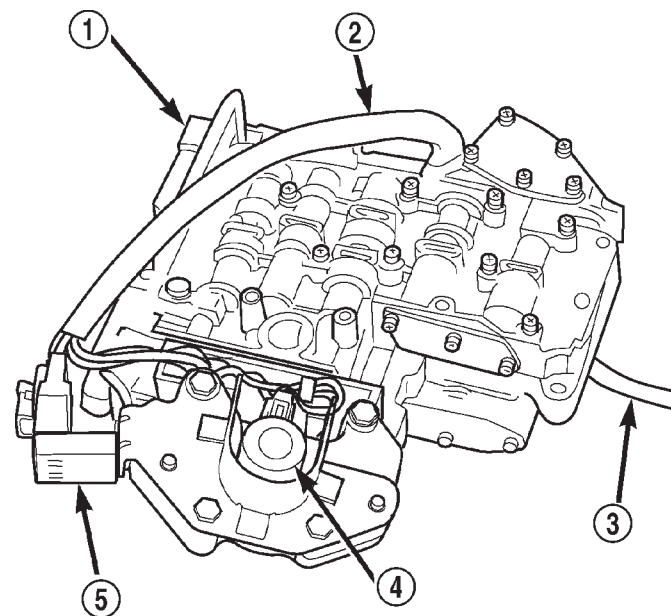
(10) Work manual lever shaft and electrical connector out of transmission case.

(11) Lower valve body, rotate valve body away from case, pull park rod out of sprag, and remove valve body (Fig. 264).



**Fig. 263 Transmission Case Connector**

- 1 - SOLENOID CASE CONNECTOR
- 2 - PARK/NEUTRAL POSITION SWITCH



**Fig. 264 Valve Body**

- 1 - VALVE BODY
- 2 - WIRE HARNESS
- 3 - PARK ROD
- 4 - GOVERNOR PRESSURE SOLENOID
- 5 - GOVERNOR PRESSURE SENSOR

80c072b2



## VALVE BODY (Continued)

## DISASSEMBLY

**CAUTION:** Do not clamp any valve body component in a vise. This practice can damage the component resulting in unsatisfactory operation after assembly and installation. Do not use pliers to remove any of the valves, plugs or springs and do not force any of the components out or into place. The valves and valve body housings will be damaged if force is used. Tag or mark the valve body springs for reference as they are removed. Do not allow them to become intermixed.

(1) Disconnect wires from governor pressure sensor and solenoid.

(2) Remove screws attaching governor body and retainer plate to transfer plate.

(3) Remove retainer plate, governor body and gasket from transfer plate.

(4) Remove governor pressure sensor from governor body.

(5) Remove governor pressure solenoid by pulling it straight out of bore in governor body. Remove and discard solenoid O-rings if worn, cut, or torn.

(6) Remove small shoulder bolt that secures solenoid harness case connector to 3-4 accumulator housing (Fig. 265). Retain shoulder bolt. Either tape it to harness or thread it back into accumulator housing after connector removal.

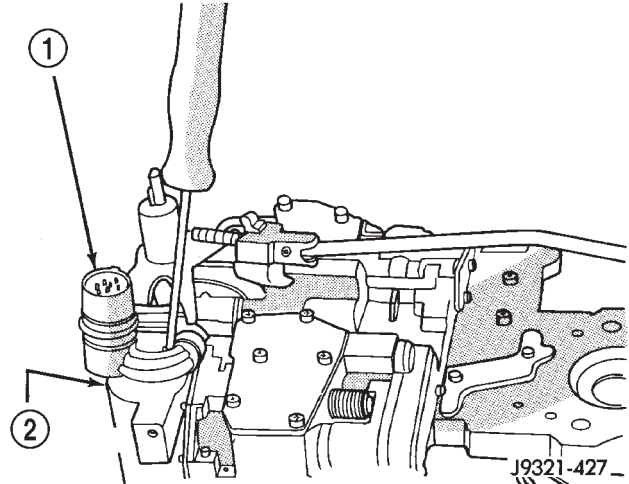
(7) Unhook overdrive/converter solenoid harness from 3-4 accumulator cover plate (Fig. 266).

(8) Turn valve body over and remove screws that attach overdrive/converter solenoid assembly to valve body (Fig. 267).

(9) Remove solenoid and harness assembly from valve body (Fig. 268).

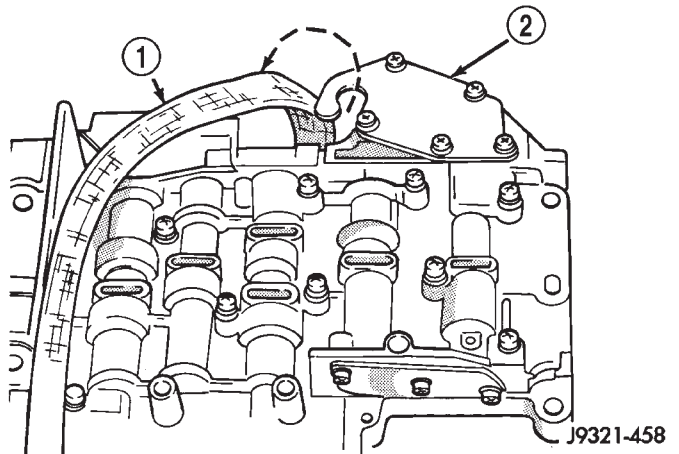
(10) Remove boost valve cover (Fig. 269).

(11) Remove boost valve retainer, valve spring and boost valve (Fig. 270).



**Fig. 265 Solenoid Harness Case Connector Shoulder Bolt**

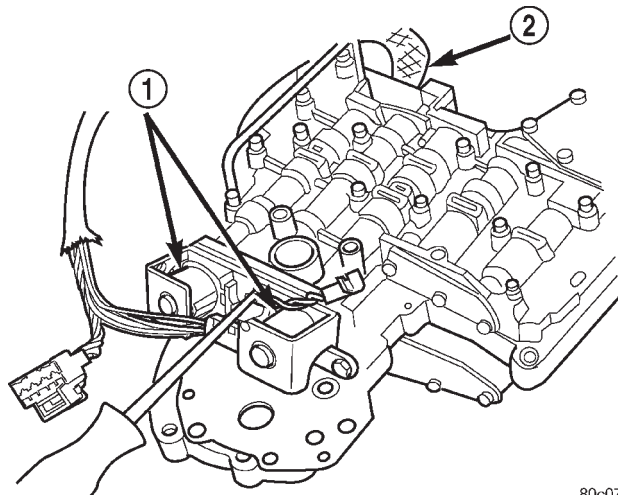
- 1 - SOLENOID HARNESS CASE CONNECTOR  
2 - 3-4 ACCUMULATOR HOUSING



**Fig. 266 Solenoid Harness Routing**

- 1 - OVERDRIVE/CONVERTER SOLENOID WIRE HARNESS  
2 - 3-4 ACCUMULATOR COVER PLATE

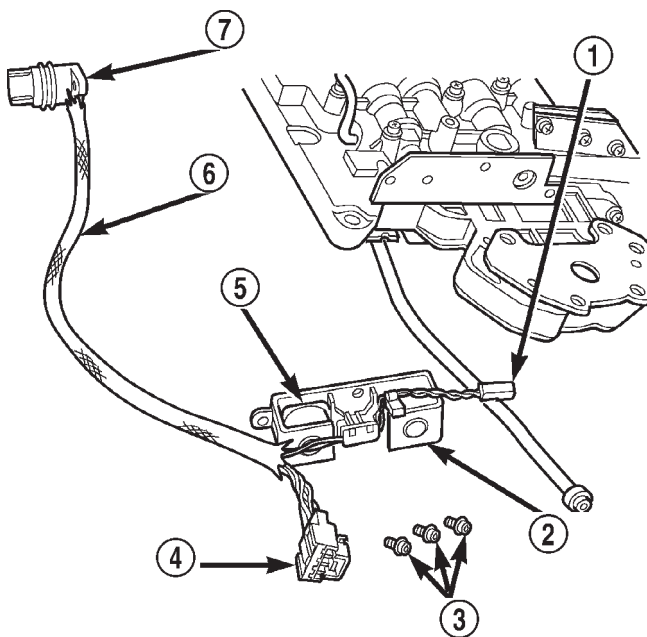
VALVE BODY (Continued)



80c072b3

**Fig. 267 Solenoid Assembly Screws**

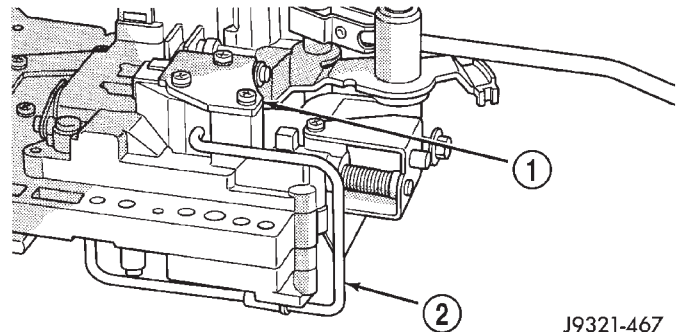
- 1 - OVERDRIVE/CONVERTER CLUTCH SOLENOID ASSEMBLY
- 2 - HARNESS



80c072b4

**Fig. 268 Solenoid Assembly**

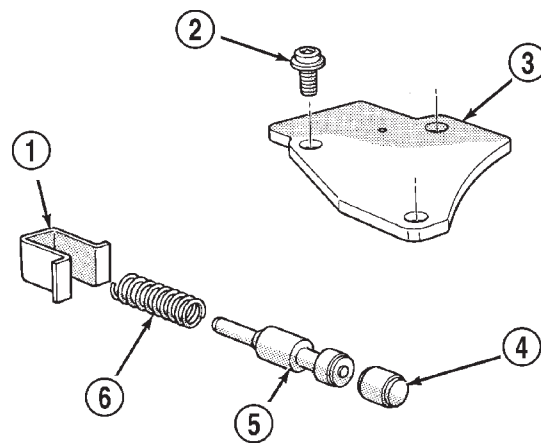
- 1 - GOVERNOR SOLENOID WIRES
- 2 - CONVERTER CLUTCH SOLENOID
- 3 - SOLENOID SCREWS
- 4 - GOVERNOR SENSOR WIRES
- 5 - OVERDRIVE SOLENOID
- 6 - HARNESS
- 7 - CASE CONNECTOR



J9321-467

**Fig. 269 Boost Valve Cover Location**

- 1 - BOOST VALVE HOUSING AND COVER
- 2 - BOOST VALVE TUBE



J9321-468

**Fig. 270 Boost Valve Components**

- 1 - SPRING AND VALVE RETAINER
- 2 - COVER SCREWS
- 3 - BOOST VALVE COVER
- 4 - BOOST VALVE PLUG
- 5 - BOOST VALVE
- 6 - BOOST VALVE SPRING

(12) Secure detent ball and spring with Retainer Tool 6583 (Fig. 271).

(13) Remove park rod E-clip and separate rod from manual lever (Fig. 272).

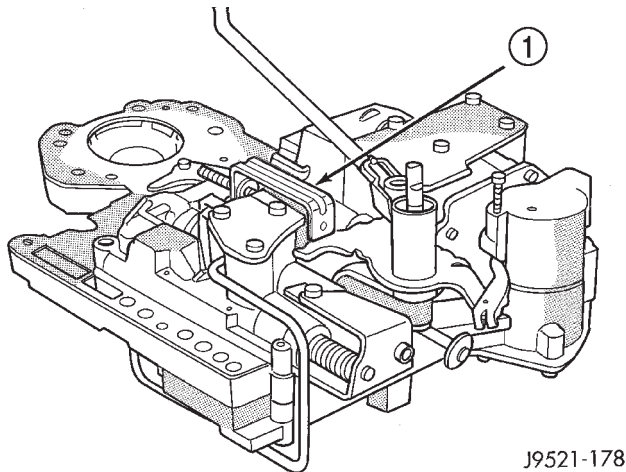
(14) Remove E-clip and washer that retains throttle lever shaft in manual lever (Fig. 273).

(15) Remove manual lever and throttle lever (Fig. 274). Rotate and lift manual lever off valve body and throttle lever shaft. Then slide throttle lever out of valve body.

(16) Position pencil magnet next to detent housing to catch detent ball and spring. Then carefully remove Retainer Tool 6583 and remove detent ball and spring (Fig. 275).

## VALVE BODY (Continued)

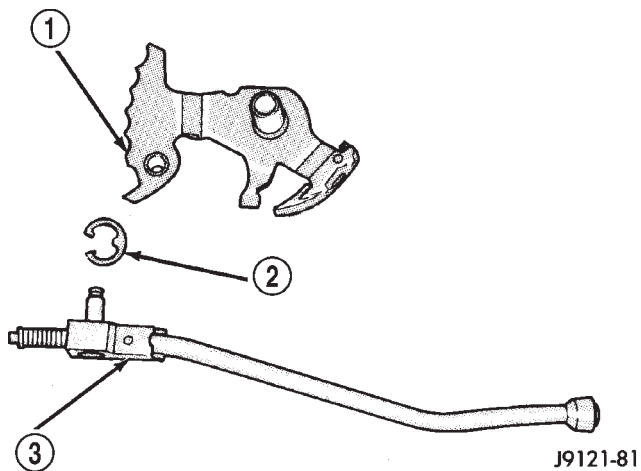
(17) Remove screws attaching pressure adjusting screw bracket to valve body and transfer plate (Fig. 276). Hold bracket firmly against spring tension while removing last screw.



J9521-178

**Fig. 271 Detent Ball Spring**

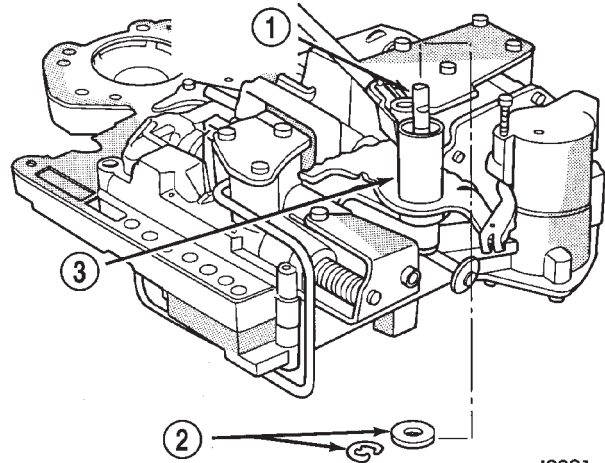
1 - SPECIAL TOOL 6583 POSITIONED ON DETENT HOUSING



J9121-81

**Fig. 272 Park Rod**

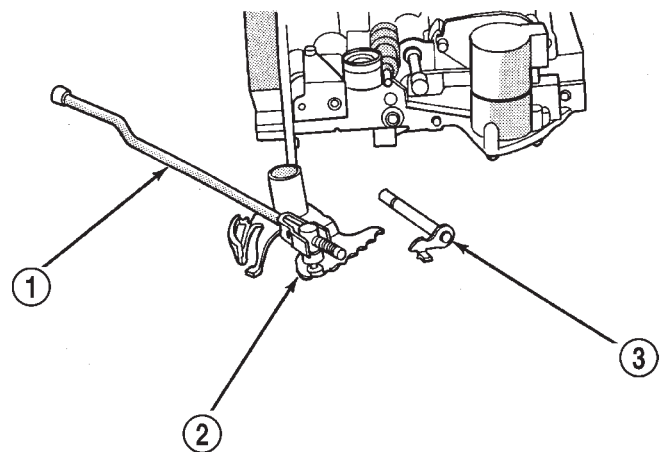
1 - MANUAL LEVER  
2 - E-CLIP  
3 - PARK ROD



J9321-424

**Fig. 273 Throttle Lever E-Clip And Washer**

1 - THROTTLE LEVER SHAFT  
2 - E-CLIP AND WASHER  
3 - MANUAL SHAFT

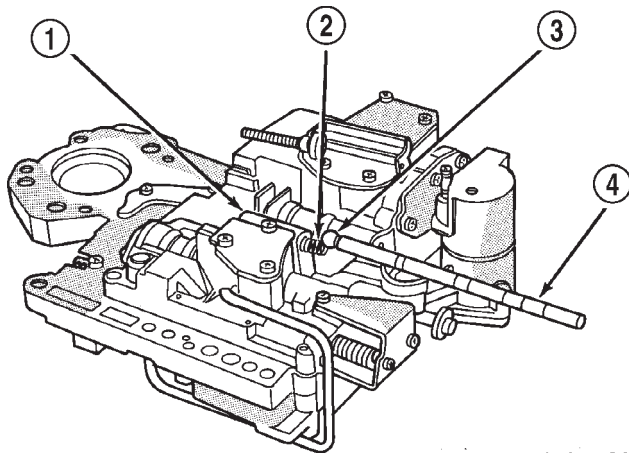


J9321-425

**Fig. 274 Manual And Throttle Lever**

1 - PARK ROD  
2 - MANUAL LEVER ASSEMBLY  
3 - THROTTLE LEVER

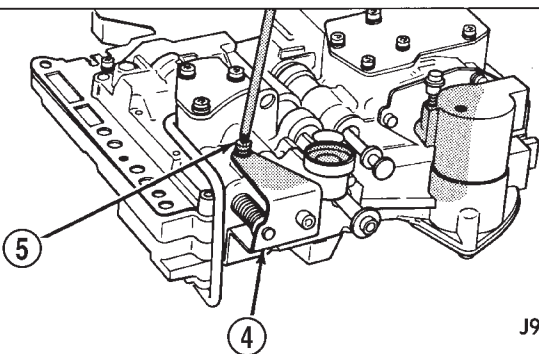
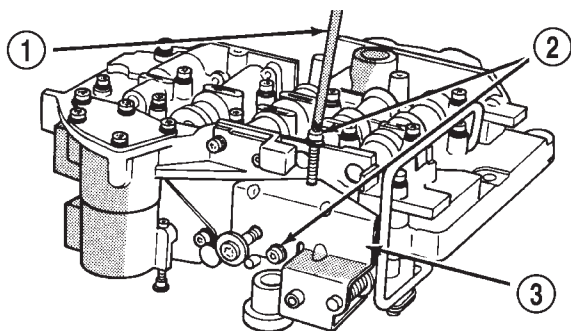
VALVE BODY (Continued)



J9321-426

**Fig. 275 Detent Ball And Spring**

- 1 - DETENT HOUSING
- 2 - DETENT SPRING
- 3 - DETENT BALL
- 4 - PENCIL MAGNET



J9321-430

**Fig. 276 Adjusting Screw Bracket Fastener**

- 1 - T25 TORX™ BIT
- 2 - REMOVE THESE SCREWS FIRST
- 3 - BRACKET
- 4 - BRACKET
- 5 - REMOVE THIS SCREW LAST

(18) Remove adjusting screw bracket, line pressure adjusting screw, pressure regulator valve spring and switch valve spring (Fig. 277). Do not remove throttle pressure adjusting screw from bracket and do not disturb setting of either adjusting screw during removal.

(19) Turn upper housing over and remove switch valve, regulator valve and spring, and manual valve (Fig. 278).

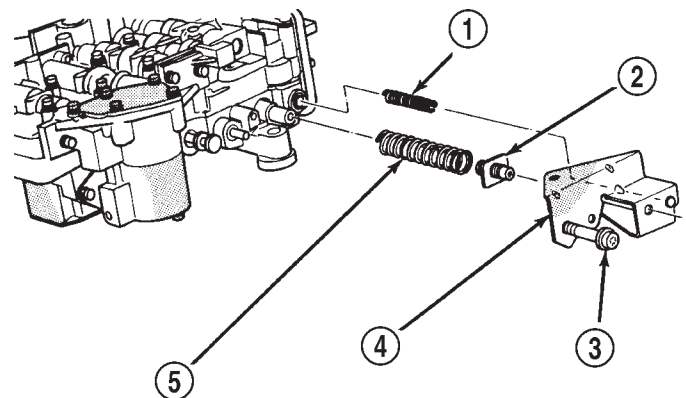
(20) Remove kickdown detent, kickdown valve, and throttle valve and spring (Fig. 278).

(21) Loosen left-side 3-4 accumulator housing attaching screw about 2-3 threads. Then remove center and right-side housing attaching screws (Fig. 279).

(22) Carefully rotate 3-4 accumulator housing upward and remove 3-4 shift valve spring and converter clutch valve plug and spring (Fig. 280).

(23) Remove left-side screw and remove 3-4 accumulator housing from valve body (Fig. 281).

(24) Bend back tabs on boost valve tube brace (Fig. 282).

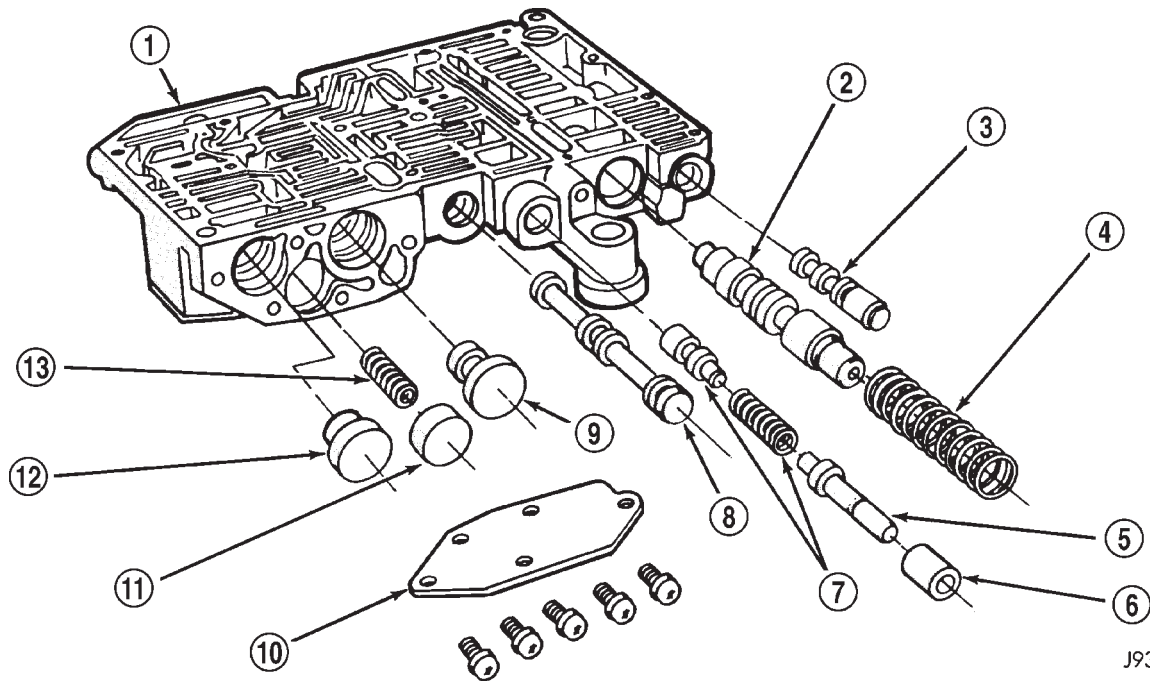


J9321-431

**Fig. 277 Adjusting Screw Bracket**

- 1 - SWITCH VALVE SPRING
- 2 - LINE PRESSURE SCREW
- 3 - THROTTLE PRESSURE ADJUSTING SCREW
- 4 - ADJUSTING SCREW BRACKET
- 5 - PRESSURE REGULATOR VALVE SPRING

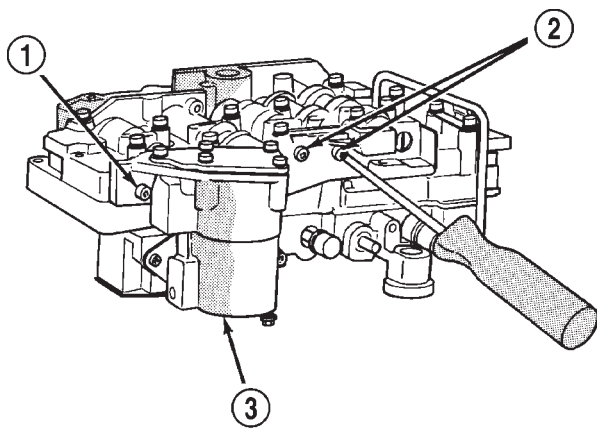
VALVE BODY (Continued)



J9321-155

**Fig. 278 Upper Housing Control Valve Locations**

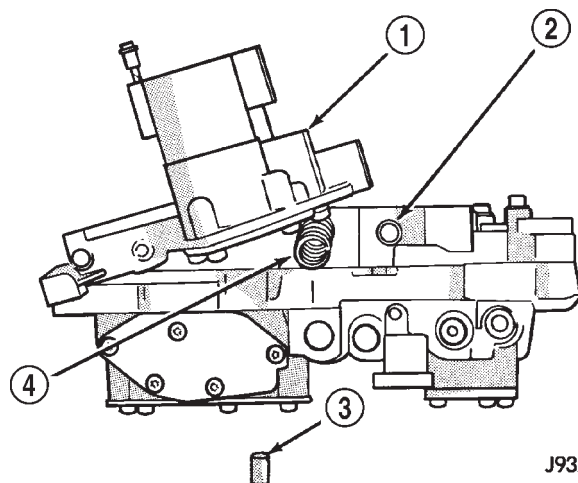
- |                               |                                   |
|-------------------------------|-----------------------------------|
| 1 - UPPER HOUSING             | 8 - MANUAL VALVE                  |
| 2 - REGULATOR VALVE           | 9 - 1-2 GOVERNOR PLUG             |
| 3 - SWITCH VALVE              | 10 - GOVERNOR PLUG COVER          |
| 4 - REGULATOR VALVE SPRING    | 11 - THROTTLE PLUG                |
| 5 - KICKDOWN VALVE            | 12 - 2-3 GOVERNOR PLUG            |
| 6 - KICKDOWN DETENT           | 13 - SHUTTLE VALVE PRIMARY SPRING |
| 7 - THROTTLE VALVE AND SPRING |                                   |



J9321-432

**Fig. 279 Accumulator Housing Screw Locations**

- 1 - LOOSEN THIS SCREW
- 2 - REMOVE THESE SCREWS
- 3 - 3-4 ACCUMULATOR HOUSING



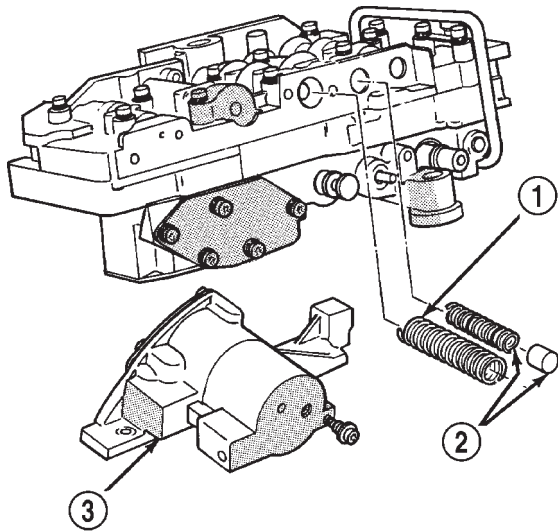
J9321-433

**Fig. 280 3-4 Shift And Converter Clutch Valve Springs and Plug**

- 1 - ACCUMULATOR HOUSING
- 2 - CONVERTER CLUTCH VALVE SPRING
- 3 - CLUTCH VALVE PLUG
- 4 - 3-4 SHIFT VALVE SPRING



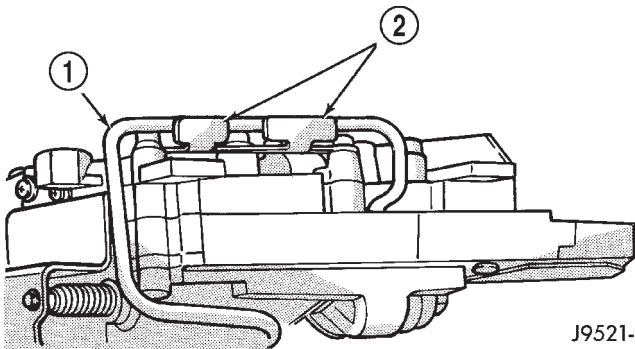
VALVE BODY (Continued)



J9321-434

**Fig. 281 Accumulator Housing, Valve Springs, and Plug**

- 1 - 3-4 SHIFT VALVE SPRING
- 2 - CONVERTER CLUTCH VALVE SPRING AND PLUG
- 3 - 3-4 ACCUMULATOR HOUSING



J9521-101

**Fig. 282 Boost Valve Tube Brace**

- 1 - BOOST VALVE TUBE
- 2 - TUBE BRACE (DOUBLE TAB)

(25) Remove boost valve connecting tube (Fig. 283). Disengage tube from upper housing port first. Then rock opposite end of tube back and forth to work it out of lower housing.

**CAUTION:** Do not use tools to loosen or pry the connecting tube out of the valve body housings. Loosen and remove the tube by hand only.

(26) Turn valve body over so lower housing is facing upward (Fig. 284). In this position, the two check balls in upper housing will remain in place and not fall out when lower housing and separator plate are removed.

(27) Remove screws attaching valve body lower housing to upper housing and transfer plate (Fig.

284). Note position of boost valve tube brace for assembly reference.

(28) Remove lower housing and overdrive separator plate from transfer plate (Fig. 284).

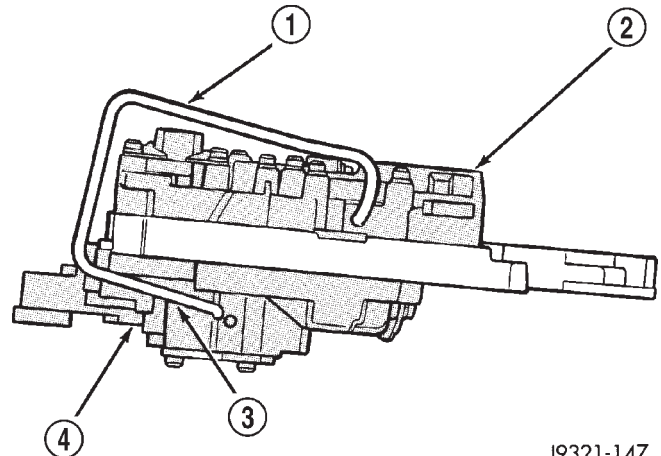
(29) Remove the ECE check ball from the transfer plate (Fig. 285). The ECE check ball is approximately 4.8 mm (3/16 in.) in diameter.

(30) Remove transfer plate from upper housing (Fig. 286).

(31) Turn transfer plate over so upper housing separator plate is facing upward.

(32) Remove upper housing separator plate from transfer plate (Fig. 287). Note position of filter in separator plate for assembly reference.

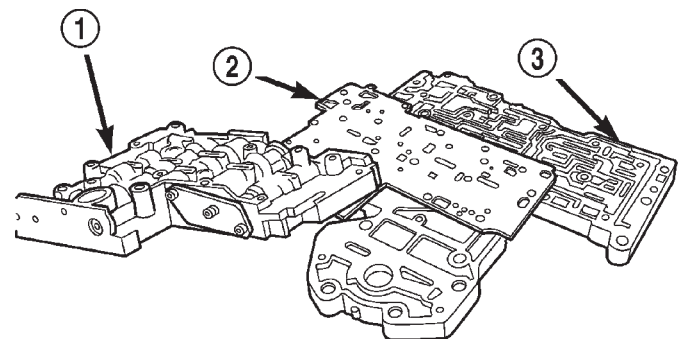
(33) Remove rear clutch and rear servo check balls from transfer plate. Note check ball location for assembly reference (Fig. 288).



J9321-147

**Fig. 283 Boost Valve Tube**

- 1 - BOOST VALVE TUBE
- 2 - LOWER HOUSING
- 3 - DISENGAGE THIS END OF TUBE FIRST
- 4 - UPPER HOUSING

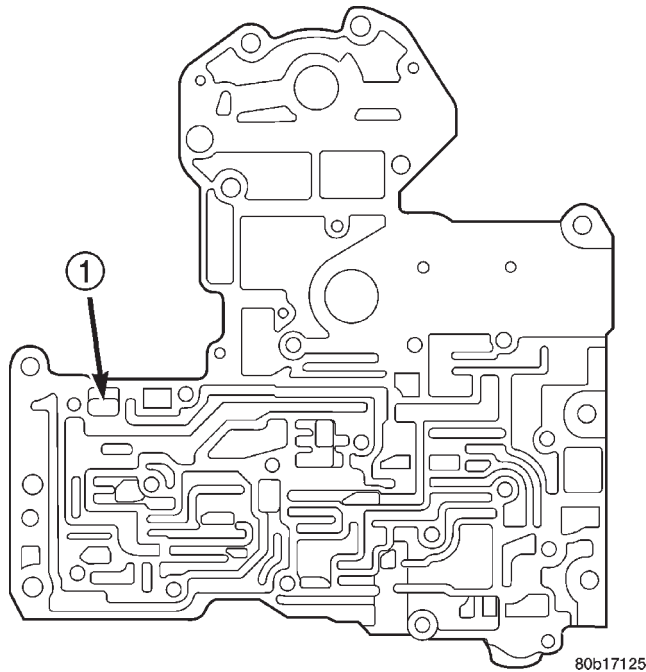


80b170f8

**Fig. 284 Lower Housing**

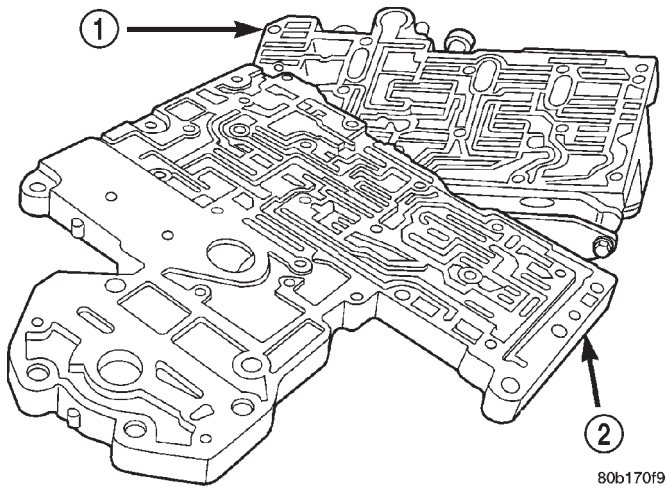
- 1 - LOWER HOUSING
- 2 - OVERDRIVE SEPARATOR PLATE
- 3 - TRANSFER PLATE AND UPPER HOUSING

VALVE BODY (Continued)



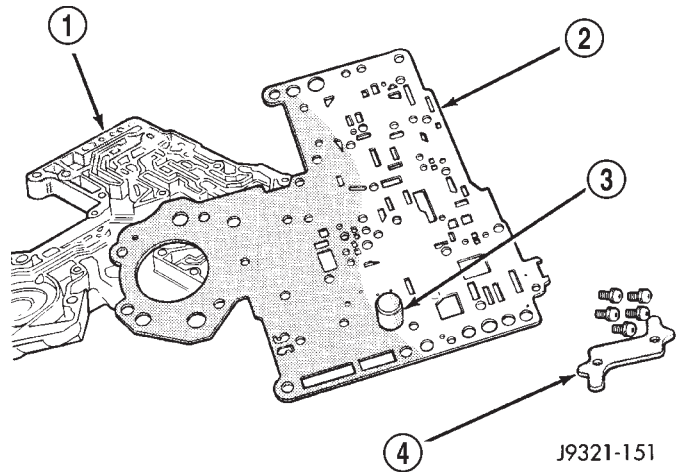
**Fig. 285 ECE Check Ball**

- 1 - ECE CHECK BALL (3/16")



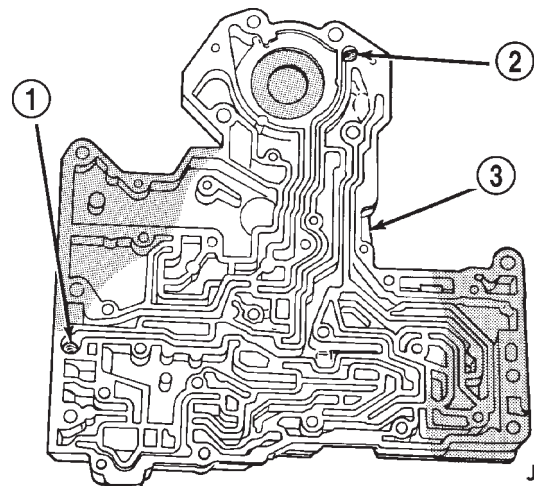
**Fig. 286 Transfer Plate**

- 1 - UPPER HOUSING
- 2 - TRANSFER PLATE



**Fig. 287 Upper Housing Separator Plate**

- 1 - TRANSFER PLATE
- 2 - UPPER HOUSING SEPARATOR PLATE
- 3 - FILTER SCREEN
- 4 - BRACE



**Fig. 288 Rear Clutch and Rear Servo Check Ball Locations**

- 1 - REAR CLUTCH CHECK BALL
- 2 - REAR SERVO CHECK BALL
- 3 - TRANSFER PLATE

## VALVE BODY (Continued)

## VALVE BODY UPPER HOUSING

(1) Note location of check balls in valve body upper housing (Fig. 289). Then remove the one large diameter and the six smaller diameter check balls.

(2) Remove governor plug and shuttle valve covers (Fig. 291).

(3) Remove E-clip that secures shuttle valve secondary spring on valve stem (Fig. 290).

(4) Remove throttle plug, primary spring, shuttle valve, secondary spring, and spring guides (Fig. 291).

(5) Remove boost valve retainer, spring and valve if not previously removed.

(6) Remove throttle plug and 1-2 and 2-3 governor plugs (Fig. 278).

(7) Turn upper housing around and remove limit valve and shift valve covers (Fig. 292).

(8) Remove limit valve housing. Then remove retainer, spring, limit valve, and 2-3 throttle plug from limit valve housing (Fig. 292).

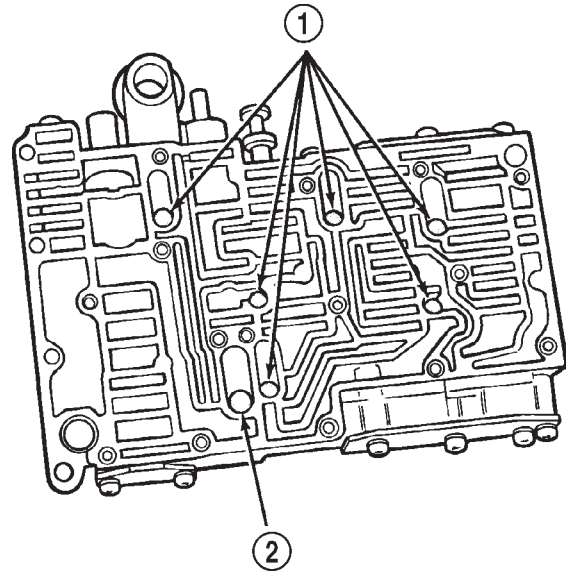
(9) Remove 1-2 shift control valve and spring (Fig. 292).

(10) Remove 1-2 shift valve and spring (Fig. 292).

(11) Remove 2-3 shift valve and spring from valve body (Fig. 292).

(12) Remove pressure plug cover (Fig. 292).

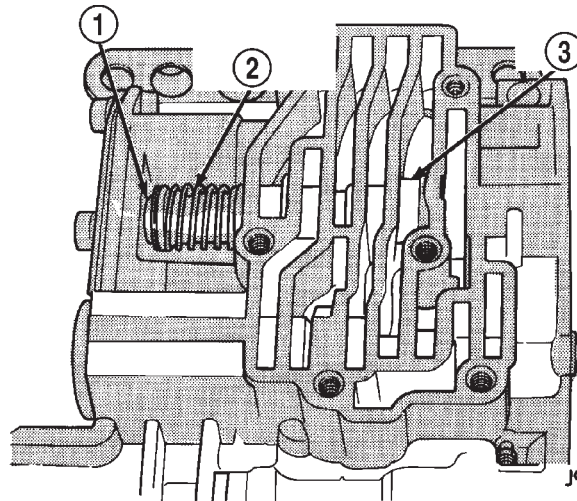
(13) Remove line pressure plug, sleeve, throttle pressure plug and spring (Fig. 292).



J9321-154

**Fig. 289 Check Ball Locations In Upper Housing**

- 1 - SMALL DIAMETER CHECK BALLS (6)  
2 - LARGE DIAMETER CHECK BALL (1)

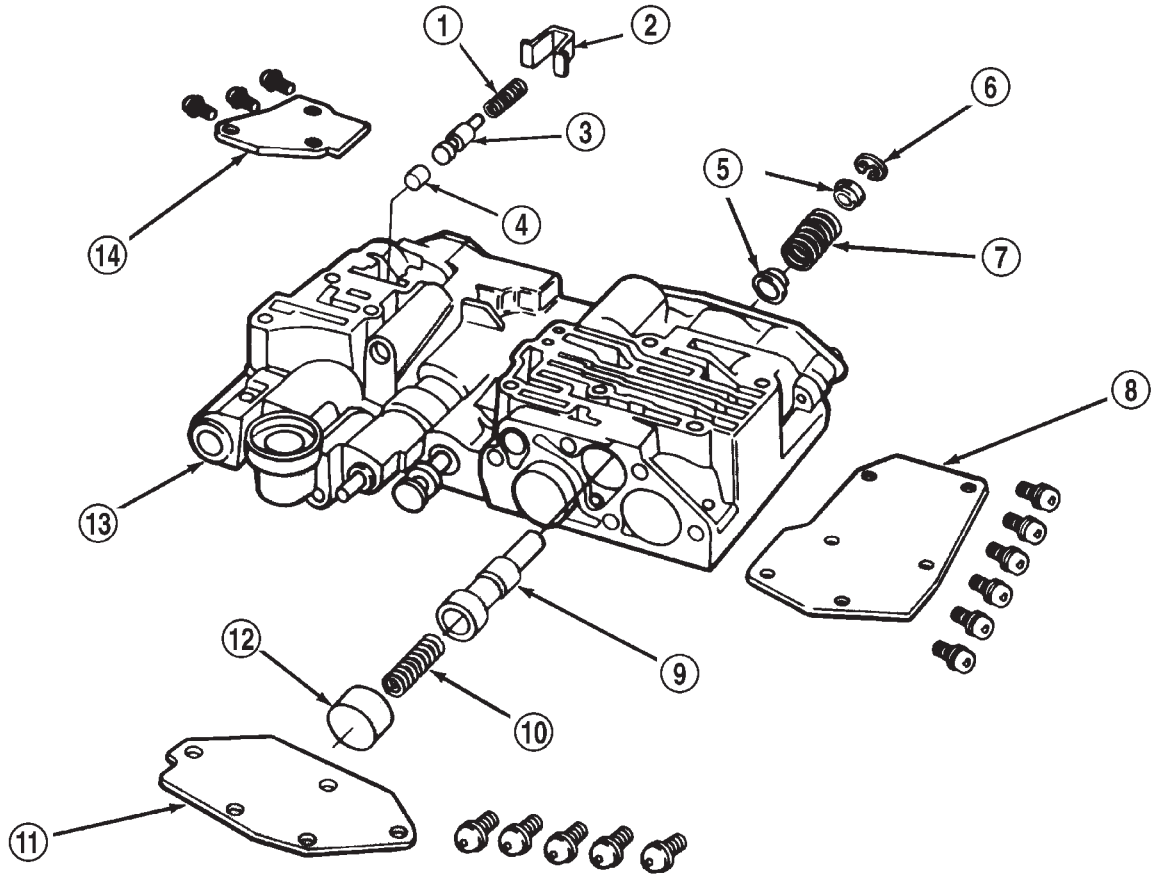


J9121-179

**Fig. 290 Shuttle Valve E-Clip And Secondary Spring**

- 1 - E-CLIP  
2 - SECONDARY SPRING AND GUIDES  
3 - SHUTTLE VALVE

VALVE BODY (Continued)



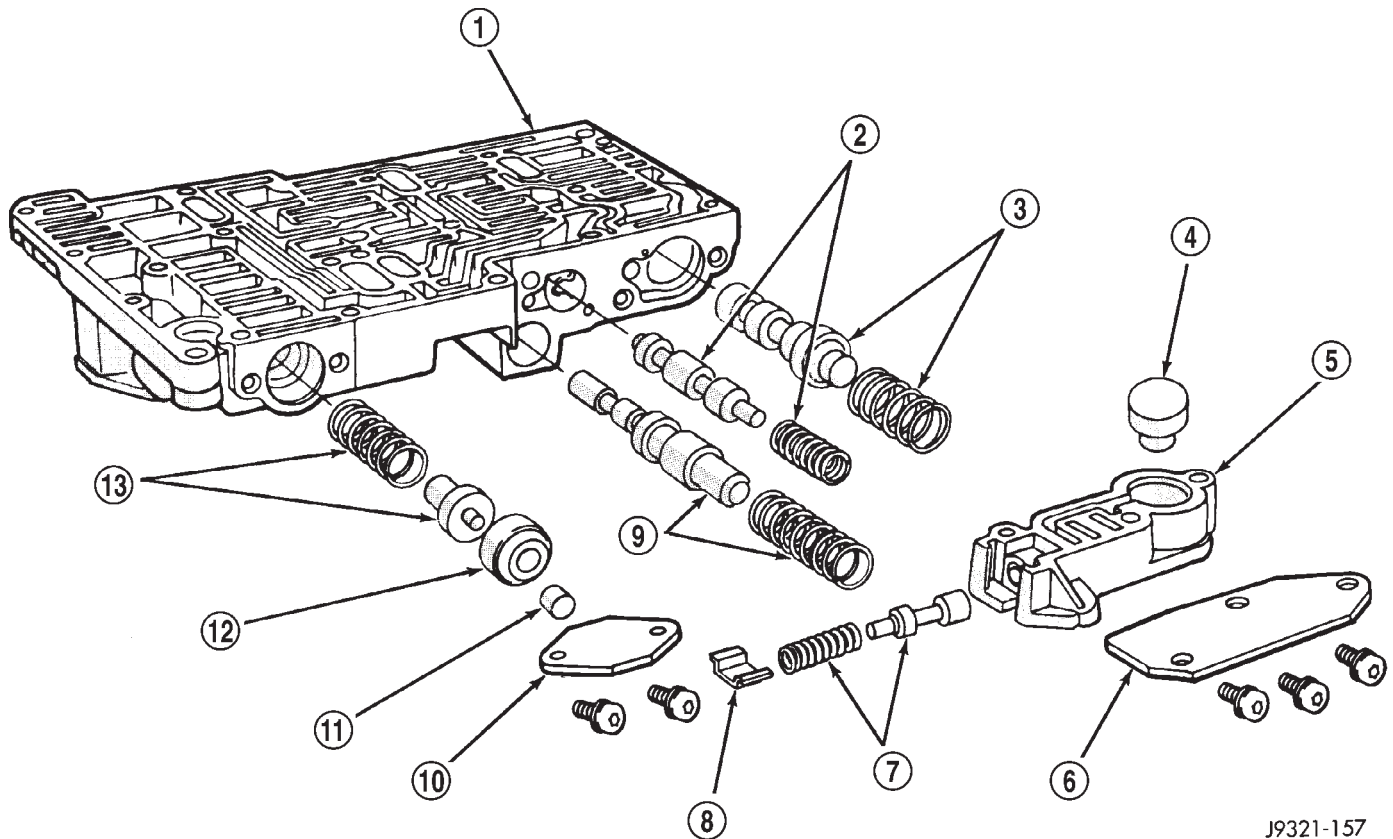
J9421-217

**Fig. 291 Shuttle and Boost Valve Location**

- |                                    |                                   |
|------------------------------------|-----------------------------------|
| 1 - SPRING                         | 8 - SHUTTLE VALVE COVER           |
| 2 - RETAINER                       | 9 - SHUTTLE VALVE                 |
| 3 - BOOST VALVE                    | 10 - SHUTTLE VALVE PRIMARY SPRING |
| 4 - BOOST VALVE PLUG               | 11 - GOVERNOR PLUG COVER          |
| 5 - SPRING GUIDES                  | 12 - THROTTLE PLUG                |
| 6 - E-CLIP                         | 13 - UPPER HOUSING                |
| 7 - SHUTTLE VALVE SECONDARY SPRING | 14 - BOOST VALVE COVER            |



## VALVE BODY (Continued)



J9321-157

**Fig. 292 Upper Housing Shift Valve and Pressure Plug Locations**

- |                                |  |
|--------------------------------|--|
| 1 - UPPER HOUSING              | 8 - RETAINER                           |
| 2 - 1-2 SHIFT VALVE AND SPRING | 9 - 1-2 SHIFT CONTROL VALVE AND SPRING |
| 3 - 2-3 SHIFT VALVE AND SPRING | 10 - PRESSURE PLUG COVER               |
| 4 - 2-3 THROTTLE PLUG          | 11 - LINE PRESSURE PLUG                |
| 5 - LIMIT VALVE HOUSING        | 12 - PLUG SLEEVE                       |
| 6 - LIMIT VALVE COVER          | 13 - THROTTLE PRESSURE SPRING AND PLUG |
| 7 - LIMIT VALVE AND SPRING     |  |

### VALVE BODY LOWER HOUSING

- (1) Remove timing valve cover.
- (2) Remove 3-4 timing valve and spring.
- (3) Remove 3-4 quick fill valve, spring and plug.
- (4) Remove 3-4 shift valve and spring.
- (5) Remove converter clutch valve, spring and plug (Fig. 293).
- (6) Remove converter clutch timing valve, retainer and valve spring.

### 3-4 ACCUMULATOR HOUSING

- (1) Remove end plate from housing.
- (2) Remove piston spring.
- (3) Remove piston. Remove and discard piston seals (Fig. 294).

### CLEANING

Clean the valve housings, valves, plugs, springs, and separator plates with a standard parts cleaning

solution only. Do not use gasoline, kerosene, or any type of caustic solution.

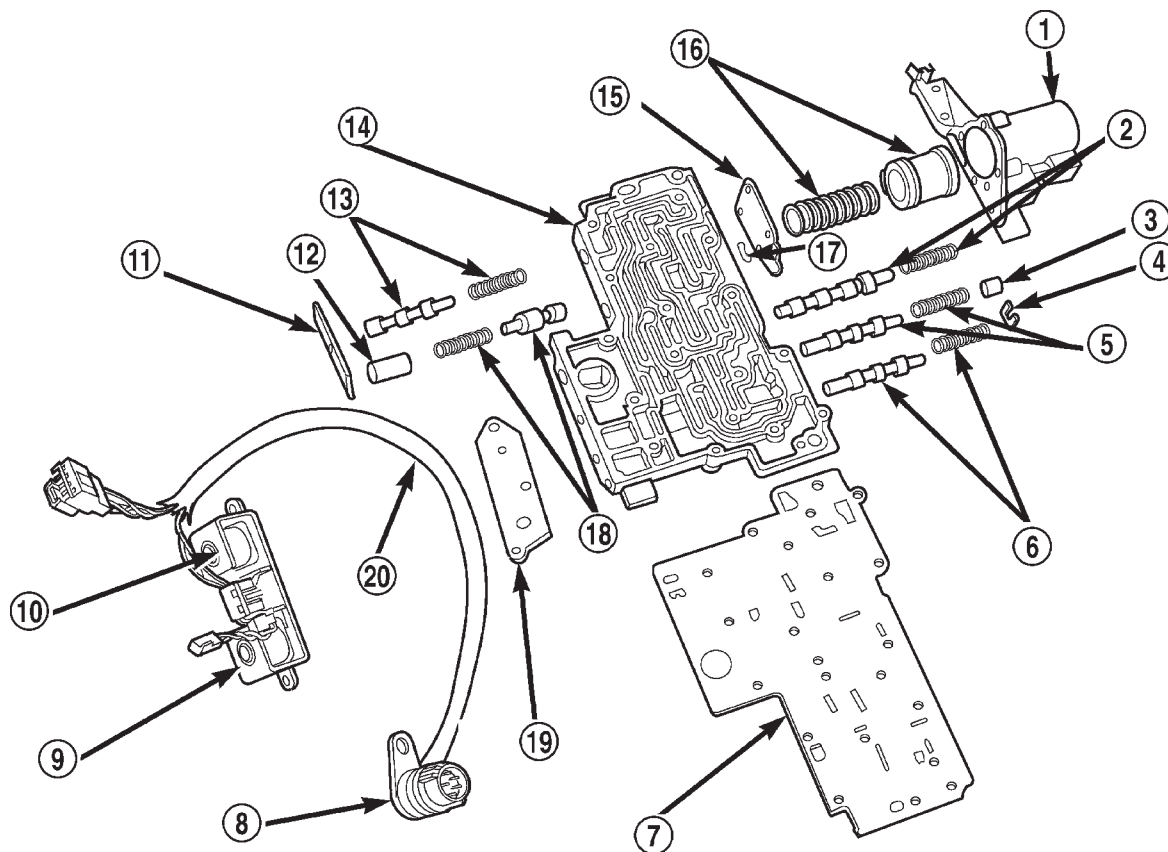
Do not immerse any of the electrical components in cleaning solution. Clean the governor solenoid and sensor and the dual solenoid and harness assembly by wiping them off with dry shop towels only.

Dry all except the electrical parts with compressed air. Make sure all passages are clean and free from obstructions. **Do not use rags or shop towels to dry or wipe off valve body components. Lint from these materials can stick to valve body parts, interfere with valve operation, and clog filters and fluid passages.**

Wipe the governor pressure sensor and solenoid valve with dry, lint free shop towels only. The O-rings on the sensor and solenoid valve are the only serviceable components. Be sure the vent ports in the solenoid valve are open and not blocked by dirt or debris. Replace the valve and/or sensor only when DRB scan tool diagnosis indicates this is necessary. Or, if either



## VALVE BODY (Continued)



80c072b5

**Fig. 293 Lower Housing Shift Valves and Springs**

- |  |  |
|--|--|
| 1 - 3-4 ACCUMULATOR HOUSING                  | 11 - TIMING VALVE COVER                |
| 2 - 3-4 SHIFT VALVE AND SPRING               | 12 - PLUG                              |
| 3 - PLUG                                     | 13 - 3-4 TIMING VALVE AND SPRING       |
| 4 - SPRING RETAINER                          | 14 - LOWER HOUSING                     |
| 5 - CONVERTER CLUTCH VALVE AND SPRING        | 15 - ACCUMULATOR END PLATE             |
| 6 - CONVERTER CLUTCH TIMING VALVE AND SPRING | 16 - 3-4 ACCUMULATOR PISTON AND SPRING |
| 7 - OVERDRIVE SEPARATOR PLATE                | 17 - E-CLIP                            |
| 8 - CASE CONNECTOR                           | 18 - 3-4 QUICK FILL SPRING AND VALVE   |
| 9 - CONVERTER CLUTCH SOLENOID                | 19 - SOLENOID GASKET                   |
| 10 - OVERDRIVE SOLENOID                      | 20 - HARNESS                           |

part has sustained physical damage (dented, deformed, broken, etc.).

**CAUTION:** Do not turn the small screw at the end of the solenoid valve for any reason. Turning the screw in either direction will ruin solenoid calibration and result in solenoid failure. In addition, the filter on the solenoid valve is NOT serviceable. Do not try to remove the filter as this will damage the valve housing.

**INSPECTION**

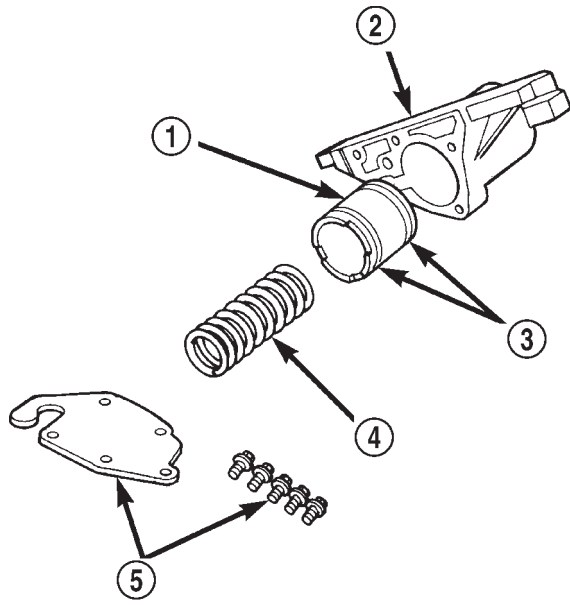
Inspect the throttle and manual valve levers and shafts. Do not attempt to straighten a bent shaft or

correct a loose lever. Replace these components if worn, bent, loose or damaged in any way.

Inspect all of the valve body mating surfaces for scratches, nicks, burrs, or distortion. Use a straight-edge to check surface flatness. Minor scratches may be removed with crocus cloth using only very light pressure.

Minor distortion of a valve body mating surface may be corrected by smoothing the surface with a sheet of crocus cloth. Position the crocus cloth on a surface plate, sheet of plate glass or equally flat surface. If distortion is severe or any surfaces are heavily scored, the valve body will have to be replaced.

## VALVE BODY (Continued)



804d8eb9

**Fig. 294 3-4 Accumulator and Housing**

- 1 - ACCUMULATOR PISTON
- 2 - 3-4 ACCUMULATOR HOUSING
- 3 - TEFLON SEALS
- 4 - PISTON SPRING
- 5 - COVER PLATE AND SCREWS

**CAUTION:** Many of the valves and plugs, such as the throttle valve, shuttle valve plug, 1-2 shift valve and 1-2 governor plug, are made of coated aluminum. Aluminum components are identified by the dark color of the special coating applied to the surface (or by testing with a magnet). Do not sand aluminum valves or plugs under any circumstances. This practice could damage the special coating causing the valves/plugs to stick and bind.

Inspect the valves and plugs for scratches, burrs, nicks, or scores. Minor surface scratches on steel valves and plugs can be removed with crocus cloth but **do not round off the edges of the valve or plug lands**. Maintaining sharpness of these edges is vitally important. The edges prevent foreign matter from lodging between the valves and plugs and the bore.

Inspect all the valve and plug bores in the valve body. Use a penlight to view the bore interiors. Replace the valve body if any bores are distorted or scored. Inspect all of the valve body springs. The springs must be free of distortion, warpage or broken coils.

Check the two separator plates for distortion or damage of any kind. Inspect the upper housing, lower housing, 3-4 accumulator housing, and transfer plate carefully. Be sure all fluid passages are clean and clear. Check condition of the upper housing and

transfer plate check balls as well. The check balls and ball seats must not be worn or damaged.

Trial fit each valve and plug in its bore to check freedom of operation. When clean and dry, the valves and plugs should drop freely into the bores.

Valve body bores do not change dimensionally with use. If the valve body functioned correctly when new, it will continue to operate properly after cleaning and inspection. It should not be necessary to replace a valve body assembly unless it is damaged in handling.

The only serviceable valve body components are listed below. The remaining valve body components are serviced only as part of a complete valve body assembly. Serviceable parts are:

- dual solenoid and harness assembly
- solenoid gasket
- solenoid case connector O-rings and shoulder bolt
- switch valve and spring
- pressure adjusting screw and bracket assembly
- throttle lever
- manual lever and shaft seal
- throttle lever shaft seal, washer, and E-clip
- fluid filter and screws
- detent ball and spring
- valve body screws
- governor pressure solenoid
- governor pressure sensor and retaining clip
- park lock rod and E-clip

## ASSEMBLY

**CAUTION:** Do not force valves or plugs into place during reassembly. If the valve body bores, valves and plugs are free of distortion or burrs, the valve body components should all slide into place easily. In addition, do not overtighten the transfer plate and valve body screws during reassembly. Overtightening can distort the housings resulting in valve sticking, cross leakage and unsatisfactory operation. Tighten valve body screws to recommended torque only.

## LOWER HOUSING

(1) Lubricate valves, springs, and the housing valve and plug bores with clean transmission fluid (Fig. 298).

(2) Install 3-4 timing valve spring and valve in lower housing.

(3) Install 3-4 quick fill valve in lower housing.

(4) Install 3-4 quick fill valve spring and plug in housing.

(5) Install timing valve end plate. Tighten end plate screws to 4 N·m (35 in. lbs.) torque.

## VALVE BODY (Continued)

**3-4 ACCUMULATOR**

(1) Lubricate accumulator piston, seals and housing piston bore with clean transmission fluid (Fig. 299).

(2) Install new seal rings on accumulator piston.

(3) Install piston and spring in housing.

(4) Install end plate on housing.

**TRANSFER PLATE**

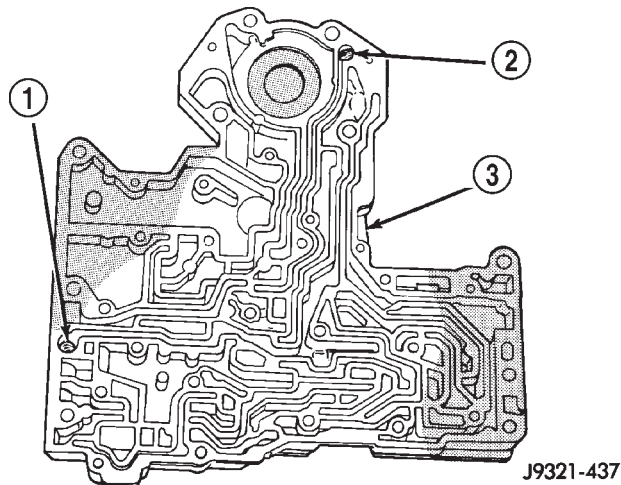
(1) Install rear clutch and rear servo check balls in transfer plate (Fig. 295).

(2) Install filter screen in upper housing separator plate (Fig. 296).

(3) Align and position upper housing separator plate on transfer plate (Fig. 297).

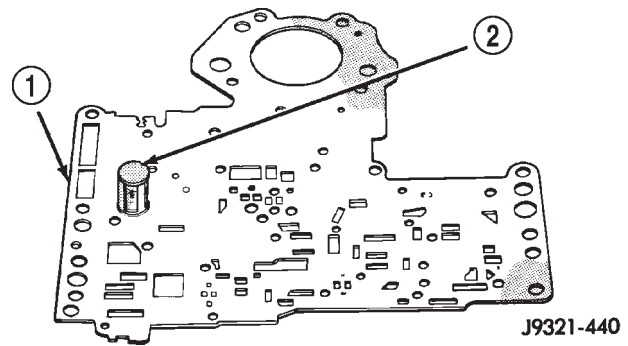
(4) Install brace plate (Fig. 297). Tighten brace attaching screws to 4 N·m (35 in. lbs.) torque.

(5) Install remaining separator plate attaching screws. Tighten screws to 4 N·m (35 in. lbs.) torque.



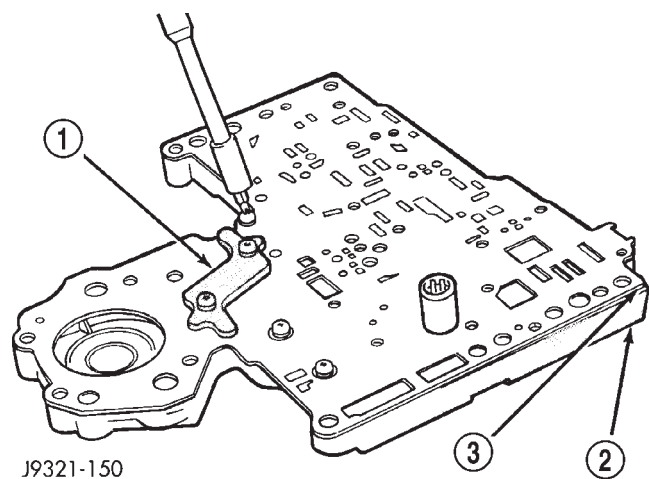
**Fig. 295 Rear Clutch And Rear Servo Check Ball Locations**

- 1 - REAR CLUTCH CHECK BALL
- 2 - REAR SERVO CHECK BALL
- 3 - TRANSFER PLATE



**Fig. 296 Separator Plate Filter Screen Installation**

- 1 - UPPER HOUSING SEPARATOR PLATE
- 2 - FILTER SCREEN



**Fig. 297 Brace Plate**

- 1 - BRACE
- 2 - TRANSFER PLATE
- 3 - SEPARATOR PLATE

## VALVE BODY (Continued)

## UPPER AND LOWER HOUSING

(1) Position upper housing so internal passages and check ball seats are facing upward. Then install check balls in housing (Fig. 298). Eight check balls are used. The single large check ball is approximately 8.7 mm (11/32 in.) diameter. The single small check ball is approximately 4.8 mm (3/16 in.) in diameter. The remaining 6 check balls are approximately 6.3 mm (1/4 in.) in diameter.

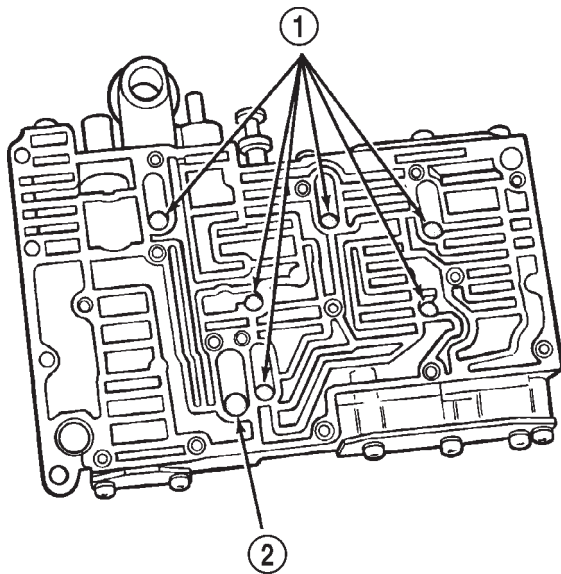
(2) Position assembled transfer plate and upper housing separator plate on upper housing (Fig. 299). Be sure filter screen is seated in proper housing recess.

(3) Install the ECE check ball into the transfer plate (Fig. 290). The ECE check ball is approximately 4.8 mm (3/16 in.) in diameter.

(4) Position lower housing separator plate on transfer plate (Fig. 300).

(5) Install lower housing on assembled transfer plate and upper housing (Fig. 301).

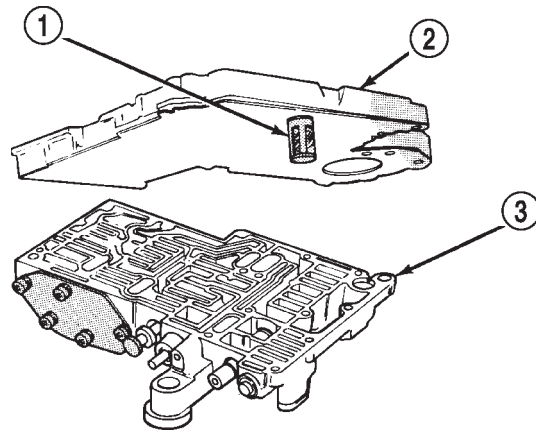
(6) Install and start all valve body screws by hand except for the screws to hold the boost valve tube brace. Save those screws for later installation. Then tighten screws evenly to 4 N·m (35 in. lbs.) torque. Start at center and work out to sides when tightening screws (Fig. 301).



J9321-154

**Fig. 298 Check Ball Locations In Upper Housing**

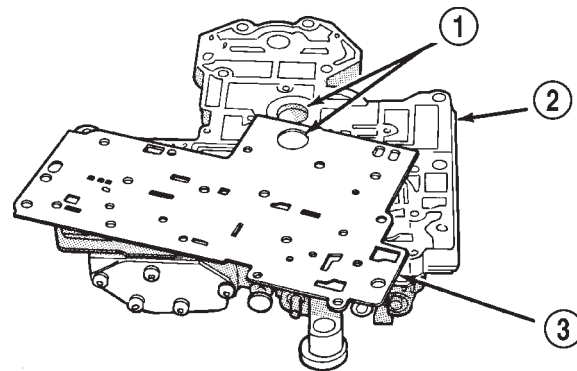
- 1 - SMALL DIAMETER CHECK BALLS (6)  
2 - LARGE DIAMETER CHECK BALL (1)



J9321-439

**Fig. 299 Installing Transfer Plate On Upper Housing**

- 1 - FILTER SCREEN  
2 - TRANSFER PLATE/SEPARATOR PLATE ASSEMBLY  
3 - UPPER HOUSING



J9321-441

**Fig. 300 Lower Housing Separator Plate**

- 1 - BE SURE TO ALIGN BORES  
2 - TRANSFER PLATE  
3 - LOWER HOUSING (OVERDRIVE) SEPARATOR PLATE

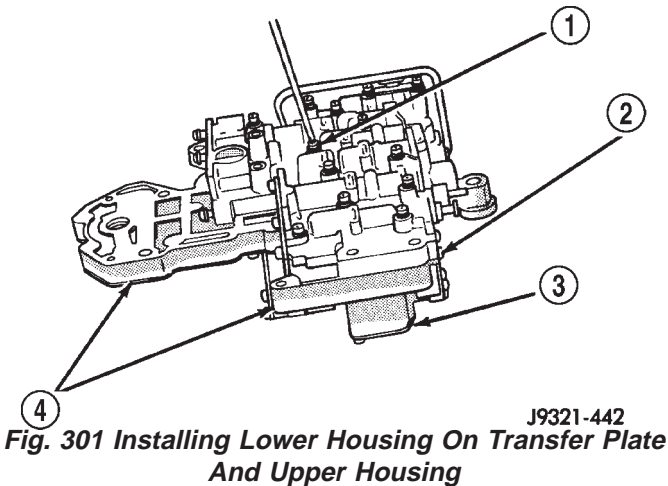
## UPPER HOUSING VALVE AND PLUG

Refer to (Fig. 302), (Fig. 303) and (Fig. 304) to perform the following steps.

(1) Lubricate valves, plugs, springs with clean transmission fluid.

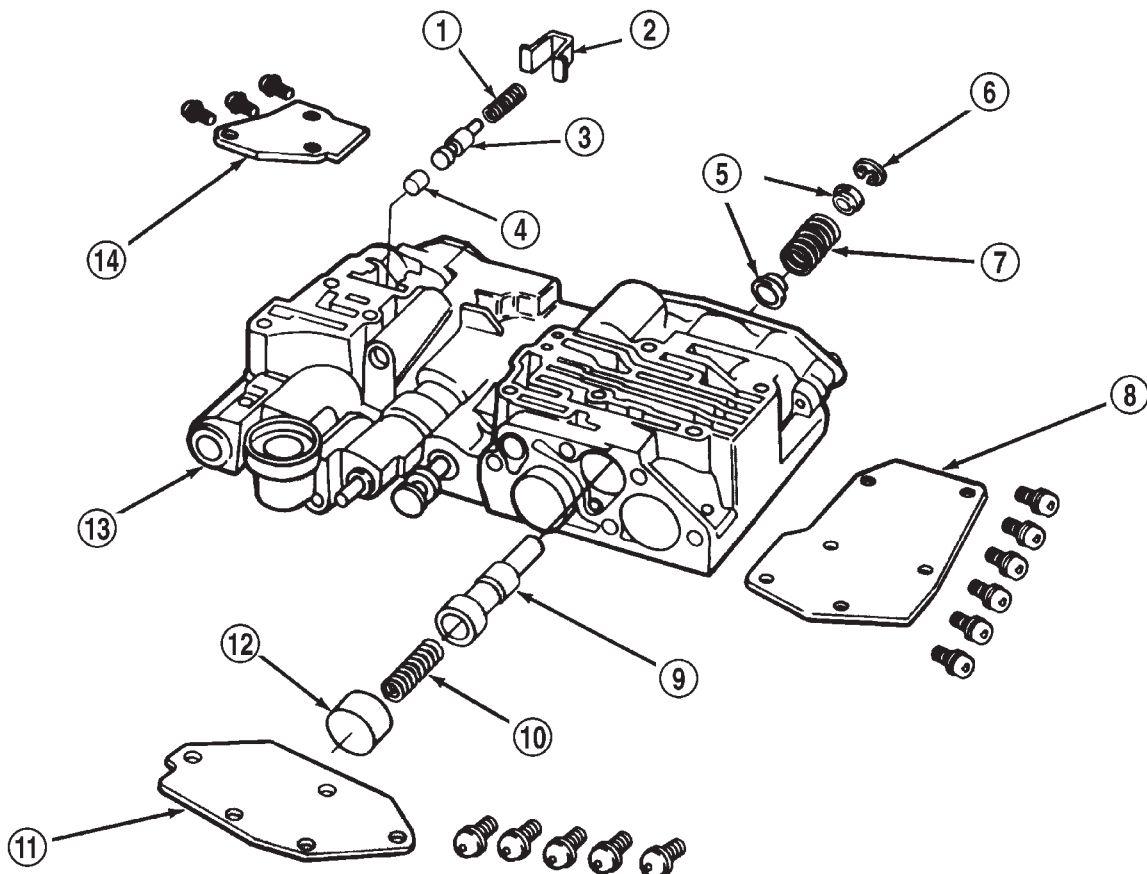
(2) Assemble regulator valve line pressure plug, sleeve, throttle plug and spring. Insert assembly in upper housing and install cover plate. Tighten cover plate screws to 4 N·m (35 in. lbs.) torque.

## VALVE BODY (Continued)



- 1 - VALVE BODY SCREWS (13)
- 2 - LOWER HOUSING
- 3 - UPPER HOUSING
- 4 - TRANSFER PLATE

- (3) Install 1-2 and 2-3 shift valves and springs.
- (4) Install 1-2 shift control valve and spring.
- (5) Install retainer, spring, limit valve, and 2-3 throttle plug from limit valve housing.
- (6) Install limit valve housing and cover plate. Tighten screws to 4 N·m (35 in. lbs.).
- (7) Install shuttle valve as follows:
  - (a) Insert plastic guides in shuttle valve secondary spring and install spring on end of valve.
  - (b) Install shuttle valve into housing.
  - (c) Hold shuttle valve in place.
  - (d) Compress secondary spring and install E-clip in groove at end of shuttle valve.
  - (e) Verify that spring and E-clip are properly seated before proceeding.
- (8) Install shuttle valve cover plate. Tighten cover plate screws to 4 N·m (35 in. lbs.) torque.
- (9) Install 1-2 and 2-3 valve governor plugs in valve body.



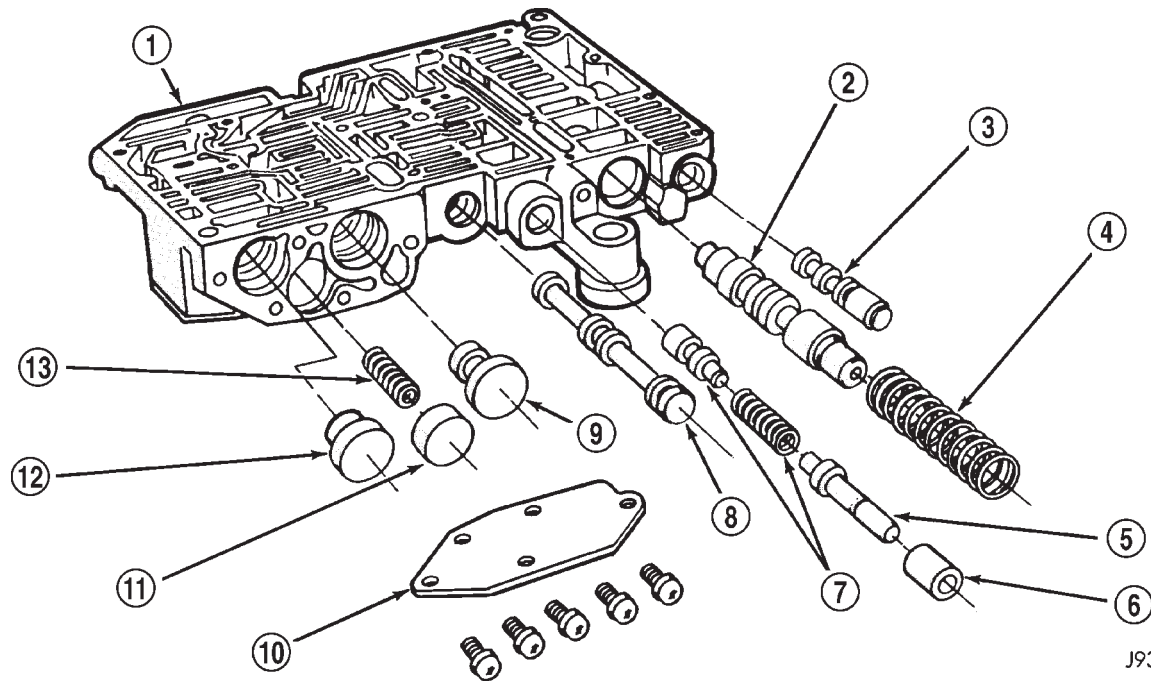
**Fig. 302 Shuttle and Boost Valve Locations**

- |  |   |
|--|---|
| <ul style="list-style-type: none"> <li>1 - SPRING</li> <li>2 - RETAINER</li> <li>3 - BOOST VALVE</li> <li>4 - BOOST VALVE PLUG</li> <li>5 - SPRING GUIDES</li> <li>6 - E-CLIP</li> <li>7 - SHUTTLE VALVE SECONDARY SPRING</li> </ul> | <ul style="list-style-type: none"> <li>8 - SHUTTLE VALVE COVER</li> <li>9 - SHUTTLE VALVE</li> <li>10 - SHUTTLE VALVE PRIMARY SPRING</li> <li>11 - GOVERNOR PLUG COVER</li> <li>12 - THROTTLE PLUG</li> <li>13 - UPPER HOUSING</li> <li>14 - BOOST VALVE COVER</li> </ul> |
|--|---|

J9421-217



## VALVE BODY (Continued)



J9321-155

**Fig. 303 Upper Housing Control Valve Locations**

- |                               |                                   |
|-------------------------------|-----------------------------------|
| 1 - UPPER HOUSING             | 8 - MANUAL VALVE                  |
| 2 - REGULATOR VALVE           | 9 - 1-2 GOVERNOR PLUG             |
| 3 - SWITCH VALVE              | 10 - GOVERNOR PLUG COVER          |
| 4 - REGULATOR VALVE SPRING    | 11 - THROTTLE PLUG                |
| 5 - KICKDOWN VALVE            | 12 - 2-3 GOVERNOR PLUG            |
| 6 - KICKDOWN DETENT           | 13 - SHUTTLE VALVE PRIMARY SPRING |
| 7 - THROTTLE VALVE AND SPRING |                                   |

(10) Install shuttle valve primary spring and throttle plug.

(11) Align and install governor plug cover. Tighten cover screws to 4 N·m (35 in. lbs.) torque.

**BOOST VALVE TUBE AND BRACE**

(1) Position valve body assembly so lower housing is facing upward (Fig. 305).

(2) Lubricate tube ends and housing ports with transmission fluid or petroleum jelly.

(3) Start tube in lower housing port first. Then swing tube downward and work opposite end of tube into upper housing port (Fig. 305).

(4) Insert and seat each end of tube in housings.

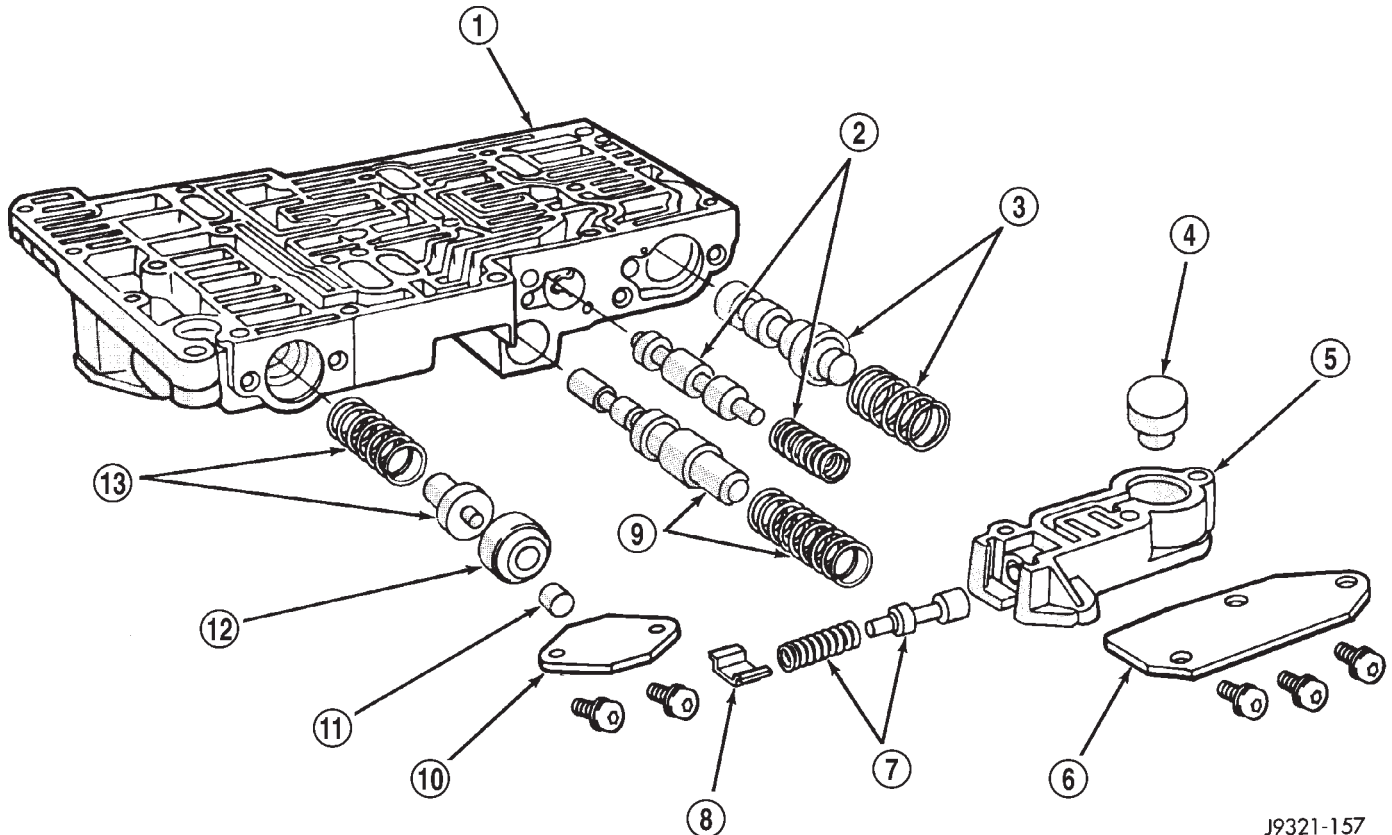
(5) Slide tube brace under tube and into alignment with valve body screw holes (Fig. 306).

(6) Install and finger tighten three screws that secure tube brace to valve body housings (Fig. 306).

(7) Bend tube brace tabs up and against tube to hold it in position (Fig. 307).

(8) Tighten all valve body housing screws to 4 N·m (35 in. lbs.) torque after tube and brace are installed. Tighten screws in diagonal pattern starting at center and working outward.

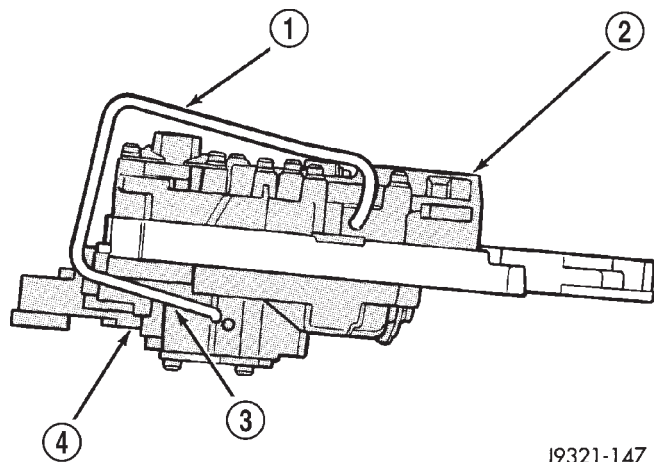
VALVE BODY (Continued)



**Fig. 304 Upper Housing Shift Valve and Pressure Plug Locations**

J9321-157

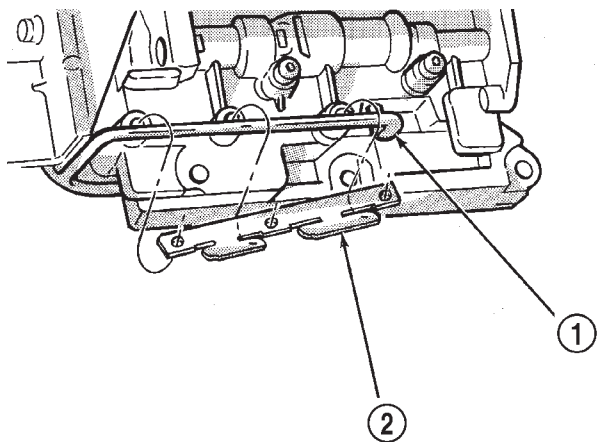
- |                                |  |
|--------------------------------|--|
| 1 - UPPER HOUSING              | 8 - RETAINER                           |
| 2 - 1-2 SHIFT VALVE AND SPRING | 9 - 1-2 SHIFT CONTROL VALVE AND SPRING |
| 3 - 2-3 SHIFT VALVE AND SPRING | 10 - PRESSURE PLUG COVER               |
| 4 - 2-3 THROTTLE PLUG          | 11 - LINE PRESSURE PLUG                |
| 5 - LIMIT VALVE HOUSING        | 12 - PLUG SLEEVE                       |
| 6 - LIMIT VALVE COVER          | 13 - THROTTLE PRESSURE SPRING AND PLUG |
| 7 - LIMIT VALVE AND SPRING     |  |



**Fig. 305 Boost Valve Tube**

J9321-147

- 1 - BOOST VALVE TUBE
- 2 - LOWER HOUSING
- 3 - DISENGAGE THIS END OF TUBE FIRST
- 4 - UPPER HOUSING

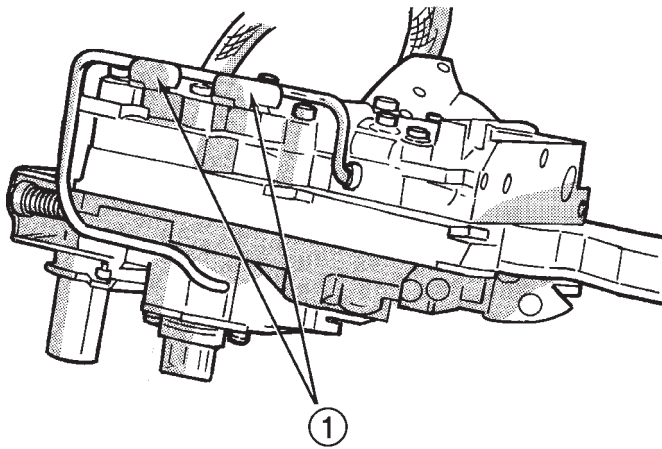


**Fig. 306 Boost Valve Tube And Brace**

J9521-107

- 1 - BOOST VALVE TUBE
- 2 - TUBE BRACE

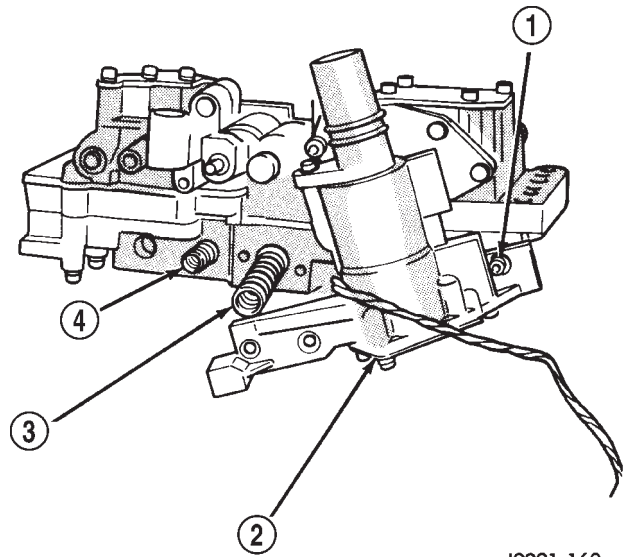
## VALVE BODY (Continued)



J9521-108

**Fig. 307 Securing Boost Valve Tube With Brace Tabs**

1 - BEND TABS UP AGAINST TUBE AS SHOWN



J9321-160

**Fig. 308 Converter Clutch And 3-4 Shift Valve Springs**

- 1 - RIGHT-SIDE SCREW
- 2 - 3-4 ACCUMULATOR
- 3 - 3-4 SHIFT VALVE SPRING
- 4 - CONVERTER CLUTCH VALVE SPRING

### 3-4 ACCUMULATOR

(1) Position converter clutch valve and 3-4 shift valve springs in housing (Fig. 308).

(2) Loosely attach accumulator housing with right-side screw (Fig. 308). Install only one screw at this time as accumulator must be free to pivot upward for ease of installation.

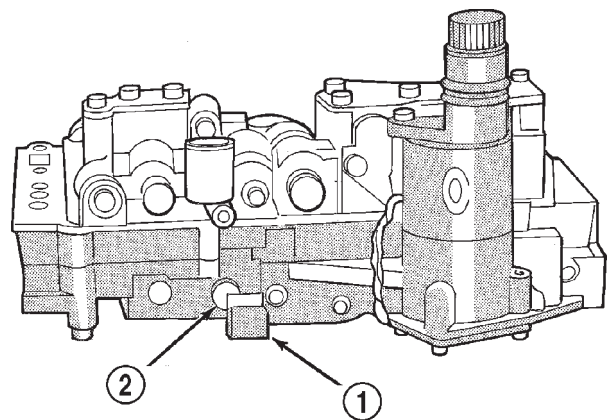
(3) Install 3-4 shift valve and spring.

(4) Install converter clutch timing valve and spring.

(5) Position plug on end of converter clutch valve spring. Then compress and hold springs and plug in place with fingers of one hand.

(6) Swing accumulator housing upward over valve springs and plug.

(7) Hold accumulator housing firmly in place and install remaining two attaching screws. Be sure springs and clutch valve plug are properly seated (Fig. 309). Tighten screws to 4 N·m (35 in. lbs.).



J9521-180

**Fig. 309 Seating 3-4 Accumulator On Lower Housing**

- 1 - ACCUMULATOR BOX
- 2 - CONVERTER CLUTCH VALVE PLUG

### VALVE BODY FINAL

(1) Install boost valve, valve spring, retainer and cover plate. Tighten cover plate screws to 4 N·m (35 in. lbs.) torque.

(2) Insert manual lever detent spring in upper housing.

(3) Position detent ball on end of spring. Then hold detent ball and spring in detent housing with Retainer Tool 6583 (Fig. 310).

(4) Install throttle lever in upper housing. Then install manual lever over throttle lever and start manual lever into housing.

(5) Align manual lever with detent ball and manual valve. Hold throttle lever upward. Then press down on manual lever until fully seated. Remove detent ball retainer tool after lever is seated.

(6) Then install manual lever seal, washer and E-clip.

(7) Verify that throttle lever is aligned with end of kickdown valve stem and that manual lever arm is engaged in manual valve (Fig. 311).

(8) Position line pressure adjusting screw in adjusting screw bracket.

(9) Install spring on end of line pressure regulator valve.

(10) Install switch valve spring on tang at end of adjusting screw bracket.

## VALVE BODY (Continued)

- (11) Install manual valve.
- (12) Install throttle valve and spring.
- (13) Install kickdown valve and detent.
- (14) Install pressure regulator valve.
- (15) Install switch valve.
- (16) Position adjusting screw bracket on valve body. Align valve springs and press bracket into place. Install short, upper bracket screws first and long bottom screw last. Verify that valve springs and bracket are properly aligned. Then tighten all three bracket screws to 4 N·m (35 in. lbs.) torque.

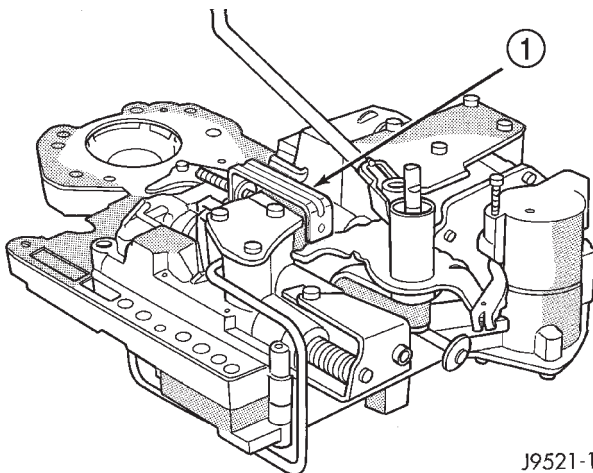
(17) Perform Line Pressure and Throttle Pressure adjustments. (Refer to 21 - TRANSMISSION/TRAN-SAXLE/AUTOMATIC/VALVE BODY - ADJUSTMENTS)

(18) Lubricate solenoid case connector O-rings and shaft of manual lever with light coat of petroleum jelly.

(19) Attach solenoid case connector to 3-4 accumulator with shoulder-type screw. Connector has small locating tang that fits in dimple at top of accumulator housing (Fig. 312). Seat tang in dimple before tightening connector screw.

(20) Install solenoid assembly and gasket. Tighten solenoid attaching screws to 8 N·m (72 in. lbs.) torque.

(21) Verify that solenoid wire harness is properly routed (Fig. 313). Solenoid harness must be clear of manual lever and park rod and not be pinched between accumulator housing and cover.



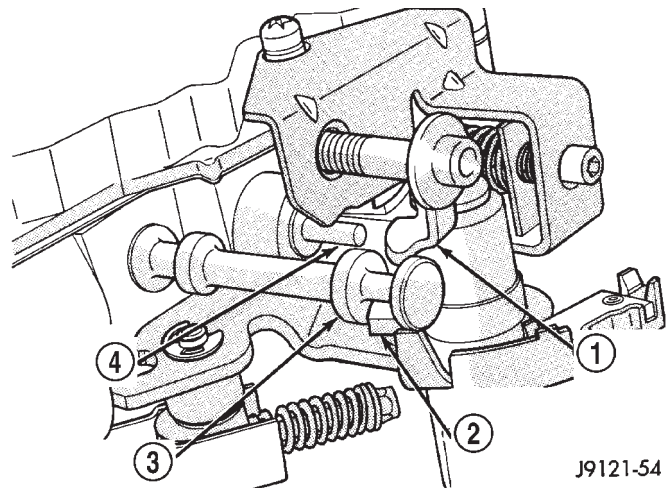
J9521-178

**Fig. 310 Detent Ball Spring**

1 - SPECIAL TOOL 6583 POSITIONED ON DETENT HOUSING

## GOVERNOR BODY, SENSOR AND SOLENOID

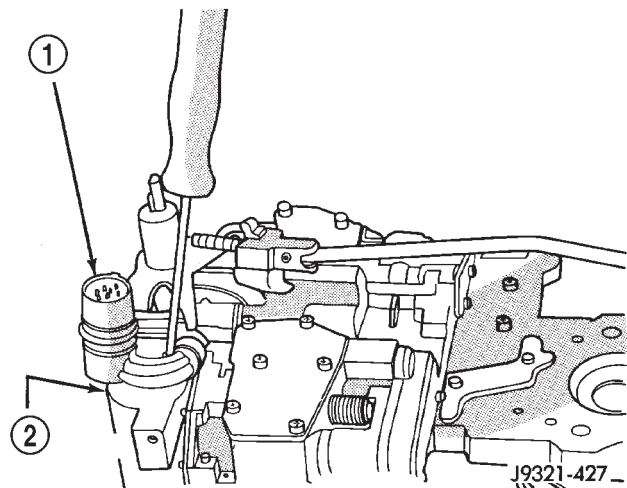
- (1) Turn valve body assembly over so accumulator side of transfer plate is facing down.
- (2) Install new O-rings on governor pressure solenoid and sensor.
- (3) Lubricate solenoid and sensor O-rings with clean transmission fluid.



J9121-54

**Fig. 311 Manual And Throttle Lever Alignment**

- 1 - THROTTLE LEVER
- 2 - MANUAL LEVER VALVE ARM
- 3 - MANUAL VALVE
- 4 - KICKDOWN VALVE



J9321-427

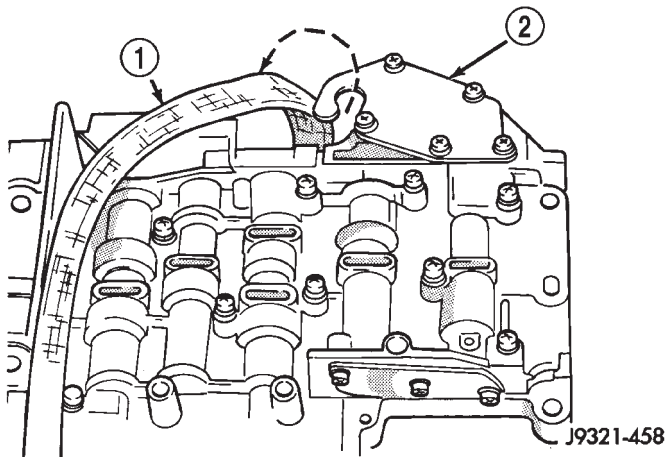
**Fig. 312 Solenoid Harness Case Connector Shoulder Bolt**

- 1 - SOLENOID HARNESS CASE CONNECTOR
- 2 - 3-4 ACCUMULATOR HOUSING

- (4) Install governor pressure sensor in governor body.
- (5) Install governor pressure solenoid in governor body. Push solenoid in until it snaps into place in body.
- (6) Position governor body gasket on transfer plate.
- (7) Install retainer plate on governor body and around solenoid. Be sure solenoid connector is positioned in retainer cutout.
- (8) Align screw holes in governor body and transfer plate. Then install and tighten governor body screws to 4 N·m (35 in. lbs.) torque.



## VALVE BODY (Continued)



**Fig. 313 Solenoid Harness Routing**

- 1 - OVERDRIVE/CONVERTER SOLENOID WIRE HARNESS  
2 - 3-4 ACCUMULATOR COVER PLATE

(9) Connect harness wires to governor pressure solenoid and governor pressure sensor.

(10) Install fluid filter and pan.

(11) Lower vehicle.

(12) Fill transmission with recommended fluid and road test vehicle to verify repair.

## INSTALLATION

(1) Check condition of O-ring seals on valve body harness connector (Fig. 314). Replace seals on connector body if cut or worn.

(2) Check condition of manual lever shaft seal in transmission case. Replace seal if lip is cut or worn. Install new seal with 15/16 deep well socket (Fig. 315).

(3) Check condition of seals on accumulator piston (Fig. 316). Install new piston seals, if necessary.

(4) Place valve body manual lever in low (1 position) so ball on park lock rod will be easier to install in sprag.

(5) Lubricate shaft of manual lever with petroleum jelly. This will ease inserting shaft through seal in case.

(6) Lubricate seal rings on valve body harness connector with petroleum jelly.

(7) Position valve body in case and work end of park lock rod into and through pawl sprag. Turn propeller shaft to align sprag and park lock teeth if necessary. The rod will click as it enters pawl. Move rod to check engagement.

**CAUTION:** It is possible for the park rod to displace into a cavity just above the pawl sprag during installation. Make sure the rod is actually engaged in the pawl and has not displaced into this cavity.

(8) Install accumulator springs and piston into case. Then swing valve body over piston and outer spring to hold it in place.

(9) Align accumulator piston and outer spring, manual lever shaft and electrical connector in case.

(10) Then seat valve body in case and install one or two bolts to hold valve body in place.

(11) Tighten valve body bolts alternately and evenly to 11 N·m (100 in. lbs.) torque.

(12) Install new fluid filter on valve body. Tighten filter screws to 4 N·m (35 in. lbs.) torque.

(13) Install throttle and gearshift levers on valve body manual lever shaft.

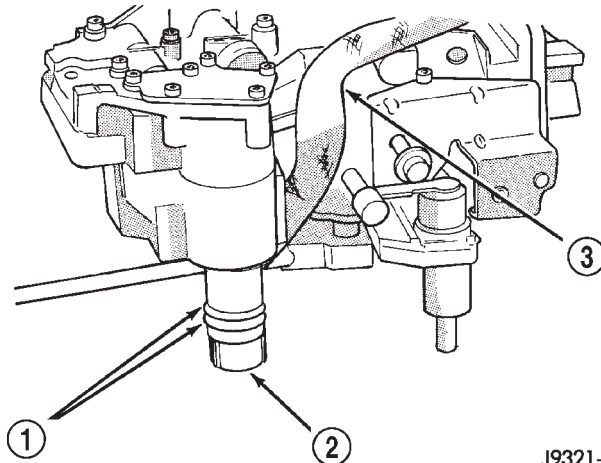
(14) Check and adjust front and rear bands if necessary.

(15) Connect solenoid case connector wires.

(16) Install oil pan and new gasket. Tighten pan bolts to 17 N·m (13 ft. lbs.) torque.

(17) Lower vehicle and fill transmission with Mopar® ATF +4, type 9602, fluid.

(18) Check and adjust gearshift and throttle valve cables, if necessary.



**Fig. 314 Valve Body Harness Connector O-Ring Seal**

- 1 - CONNECTOR O-RINGS  
2 - VALVE BODY HARNESS CONNECTOR  
3 - HARNESS

## ADJUSTMENTS - VALVE BODY

### CONTROL PRESSURE ADJUSTMENTS

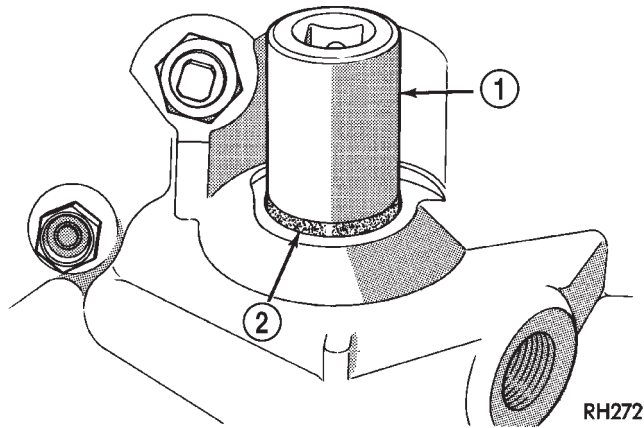
There are two control pressure adjustments on the valve body;

- Line Pressure
- Throttle Pressure

Line and throttle pressures are interdependent because each affects shift quality and timing. As a result, both adjustments must be performed properly and in the correct sequence. Adjust line pressure first and throttle pressure last.

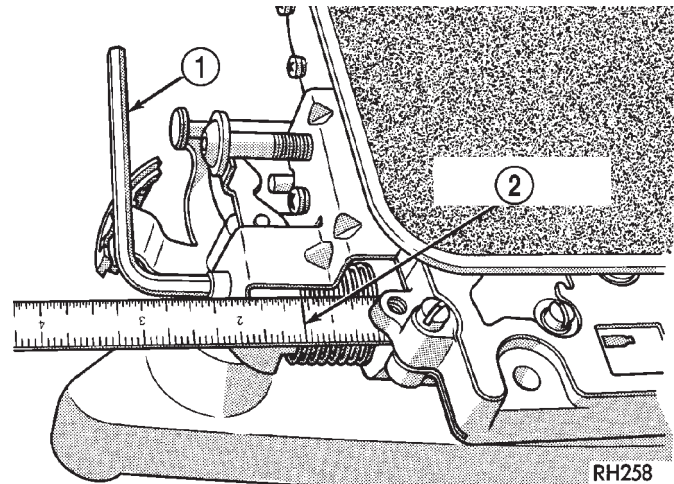


## VALVE BODY (Continued)



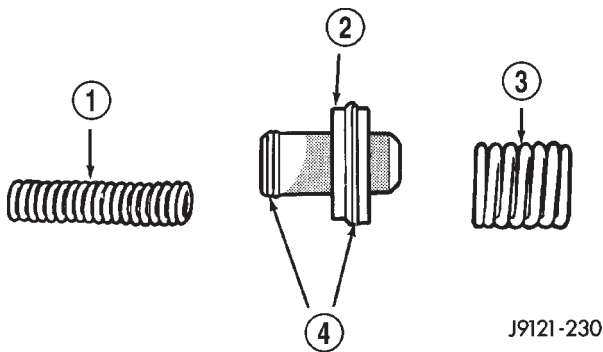
**Fig. 315 Manual Lever Shaft Seal**

- 1 - 15/16" SOCKET  
2 - SEAL



**Fig. 317 Line Pressure Adjustment**

- 1 - WRENCH  
2 - 1-5/16 INCH



**Fig. 316 Accumulator Piston Components**

- 1 - INNER SPRING  
2 - ACCUMULATOR PISTON  
3 - OUTER SPRING  
4 - SEAL RINGS

## LINE PRESSURE ADJUSTMENT

Measure distance from the valve body to the inner edge of the adjusting screw with an accurate steel scale (Fig. 317).

Distance should be 33.4 mm (1-5/16 in.).

If adjustment is required, turn the adjusting screw in, or out, to obtain required distance setting.

**NOTE:** The 33.4 mm (1-5/16 in.) setting is an approximate setting. Manufacturing tolerances may make it necessary to vary from this dimension to obtain desired pressure.

One complete turn of the adjusting screw changes line pressure approximately 1-2/3 psi (9 kPa).

Turning the adjusting screw counterclockwise increases pressure while turning the screw clockwise decreases pressure.

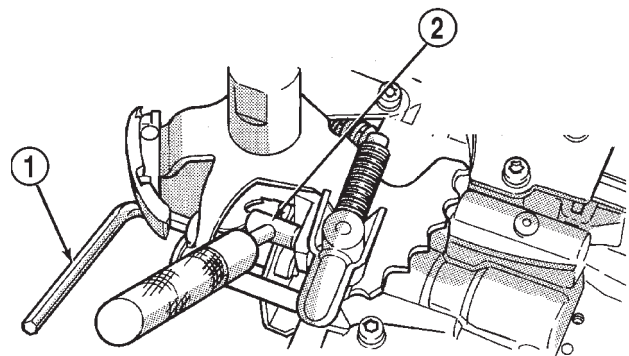
## THROTTLE PRESSURE ADJUSTMENT

Insert Gauge Tool C-3763 between the throttle lever cam and the kickdown valve stem (Fig. 318).

Push the gauge tool inward to compress the kickdown valve against the spring and bottom the throttle valve.

Maintain pressure against kickdown valve spring. Turn throttle lever stop screw until the screw head touches throttle lever tang and the throttle lever cam touches gauge tool.

**NOTE:** The kickdown valve spring must be fully compressed and the kickdown valve completely bottomed to obtain correct adjustment.



J9521-109

**Fig. 318 Throttle Pressure Adjustment**

- 1 - HEX WRENCH (IN THROTTLE LEVER ADJUSTING SCREW)  
2 - SPECIAL TOOL C-3763 (POSITIONED BETWEEN THROTTLE LEVER AND KICKDOWN VALVE)

# TRANSFER CASE - NV231HD

## TABLE OF CONTENTS

	page		page
<b>TRANSFER CASE - NV231HD</b>			
DESCRIPTION .....	820	<b>EXTENSION HOUSING BUSHING AND SEAL</b>	
OPERATION .....	820	REMOVAL .....	850
DIAGNOSIS AND TESTING .....	821	INSTALLATION .....	850
TRANSFER CASE .....	821	<b>FLUID</b>	
REMOVAL .....	822	STANDARD PROCEDURE .....	851
DISASSEMBLY .....	822	FLUID DRAIN AND REFILL .....	851
CLEANING .....	831	<b>FRONT OUTPUT SHAFT SEAL</b>	
INSPECTION .....	832	REMOVAL .....	851
ASSEMBLY .....	834	INSTALLATION .....	852
INSTALLATION .....	847	<b>SHIFT LEVER</b>	
SPECIFICATIONS .....	848	REMOVAL .....	852
SPECIAL TOOLS .....	849	INSTALLATION .....	853
		ADJUSTMENTS .....	853

## TRANSFER CASE - NV231HD

### DESCRIPTION

The NV231HD transfer case is a part-time transfer case with a low-range gear system. It provides three operating ranges plus a NEUTRAL position. The low range position provides a gear reduction ratio of 2.72:1 for increased low speed torque capability.

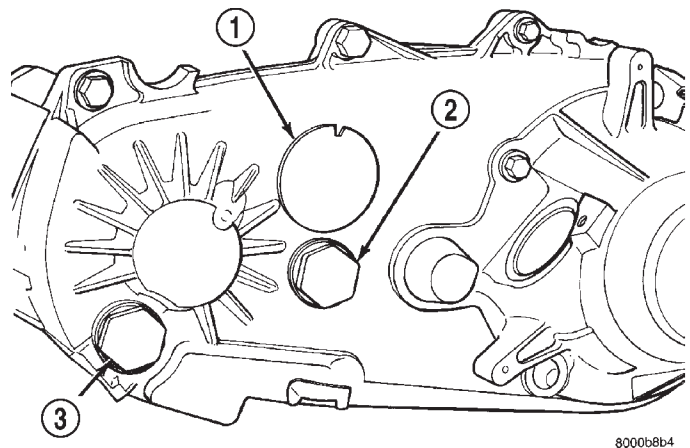
The synchronizer mechanism consists of a brass stop ring, synchro hub, and the sliding clutch. The synchronizer components allow the transfer case to be shifted between the 2H and 4H operating ranges while the vehicle is in motion.

The gear cases, retainer and extension are all of aluminum. Drive sprockets and an interconnecting drive chain are used to transmit engine torque to the front/rear propeller shafts. The mainshaft, input gear and front output shaft are supported by ball and needle bearings.

### IDENTIFICATION

An identification tag (Fig. 1) is attached to the rear case of every transfer case. The tag provides the transfer case model number, assembly number, serial number, and low range ratio.

The transfer case serial number also represents the date of build.



8000b8b4

**Fig. 1 Transfer Case Identification Tag - Typical**

- 1 - I.D. TAG
- 2 - FILL PLUG
- 3 - DRAIN PLUG

### OPERATION

#### OPERATING RANGES

Transfer case operating ranges are:

- 4x2 (2-wheel drive)
- 4x4 (4-wheel drive)
- 4 Lo (4-wheel drive low range)

## TRANSFER CASE - NV231HD (Continued)

The 4x2 range is for use on any road surface at any time.

The 4x4 and 4 Lo ranges are for off road use only. They are not for use on hard surface roads. The only exception being when the road surface is covered by ice and snow.

The low range reduction gear system is operative in 4 Lo range only. This range is for extra pulling power in off road situations. Low range reduction ratio is 2.72:1.

A front axle disconnect system is used to achieve two-wheel drive mode. The axle disconnect vacuum motor is actuated by a vacuum switch on the transfer case. The switch is operated by the transfer case range rod.

**SHIFT MECHANISM**

The transfer case is operated by an adjustable floor mounted shift linkage. The transfer case shift lever is directly attached to the shift sector. The sector operates the range and mode forks within the transfer case.

A straight line shift pattern is used with a NEUTRAL detent. Lever range positions are imprinted in the shift knob.

**SHIFTING**

The synchronizer components allow the transfer case to be shifted between the 2H and 4H operating ranges while the vehicle is in motion. The vehicle must have the transmission placed in NEUTRAL, or the clutch depressed in the case of a manual transmission, and be moving less than 2-3 MPH when shifting into the 4L operating range.

**DIAGNOSIS AND TESTING - TRANSFER CASE**

Before beginning repair on a suspected transfer case malfunction, check all other driveline components beforehand.

The actual cause of a problem may be related to such items as: front hubs, axles, propeller shafts, wheels and tires, transmission, or clutch instead. If all other driveline components are in good condition and operating properly, refer to the Diagnosis Chart for further information.

**DIAGNOSIS CHART**

Condition	Possible Cause	Correction
Transfer Case difficult to shift or will not shift into desired range.	1) Vehicle speed too great to permit shifting.  2) If vehicle was operated for an extended period in 4H on a dry paved surface, the driveline torque load may be causing a bind.  3) Transfer case external shift linkage binding.  4) Insufficient or incorrect lubricant.  5) Internal components binding, worn, or damaged.	1) Stop vehicle and shift into desired range. Or, reduce speed to below 3-4 km/h (2-3 mph) before attempting the shift.  2) Stop vehicle and shift the transmission into neutral. Shift the transfer case to 2H and operate vehicle in 2H on dry paved surfaces.  3) Lubricate, repair, or replace linkage bushings, or tighten loose components as necessary.  4) Drain and refill to edge of fill hole with Mopar® ATF +4, type 9602, Automatic Transmission fluid.  5) Disassemble the transfer case and replace worn or damaged components as necessary.
Transfer Case noisy in all operating ranges.	1) Insufficient or incorrect lubricant.	1) Drain and refill to edge of fill hole with Mopar® ATF +4, type 9602, Automatic Transmission fluid.

## TRANSFER CASE - NV231HD (Continued)

Condition	Possible Cause	Correction
Noisy in, or jumps out of, four wheel drive low range.	1) Transfer case not completely engaged in 4L position.  2) Shift linkage out of adjustment. 3) Shift linkage loose or binding.  4) Range fork damaged, inserts worn, or fork is binding on the shift rail.  5) Low range gear worn or damaged.	1) With the transmission in NEUTRAL, or the clutch depressed in the case of a manual transmission and the vehicle moving under 3-4 km/h (2-3 mph), shift the transfer case to NEUTRAL and then shift into the 4L position.  2) Adjust linkage. 3) Tighten, lubricate, or repair linkage as necessary. 4) Disassemble unit and repair as necessary.  5) Disassemble unit and repair as necessary.
Lubricant leaking from output shaft seal or vent.	1) Transfer case overfilled.  2) Vent closed or restricted.  3) Output shaft seals damaged or installed incorrectly.	1) Drain lubricant to the correct level.  2) Clear or replace vent as necessary. 3) Replace seal as necessary. Check to ensure that another component, the propeller shaft slip yoke for example, is not causing damage to seal.
Abnormal tire wear.	1) Extended operation on hard, dry surfaces in the 4H position.	1) Operate vehicle in the 2H position on hard, dry surfaces.

**REMOVAL**

- (1) Raise and support vehicle.
- (2) Remove skid plate, if equipped. (Refer to 13 - FRAMES & BUMPERS/FRAME/TRANSFER CASE SKID PLATE - REMOVAL)
- (3) Position drain oil container under transfer case.
- (4) Remove transfer case drain plug and drain lubricant into container.
- (5) Disconnect vent hose and vacuum harness at transfer case switch.
- (6) Disconnect shift rod from grommet in transfer case shift lever, or from floor shift arm whichever provides easy access. Use channel lock style pliers to press rod out of lever grommet.
- (7) Support transmission with jack stand.
- (8) Remove rear crossmember.
- (9) Mark front and rear propeller shafts for assembly reference.

(10) Remove front and rear propeller shafts. (Refer to 3 - DIFFERENTIAL & DRIVELINE/PROPELLER SHAFT/PROPELLER SHAFT - REMOVAL)

(11) Support transfer case with suitable jack. Secure transfer case to jack with safety chains.

(12) Remove nuts attaching transfer case to transmission.

(13) Move transfer case assembly rearward until free of transmission output shaft.

(14) Lower jack and move transfer case from under vehicle.

**DISASSEMBLY**

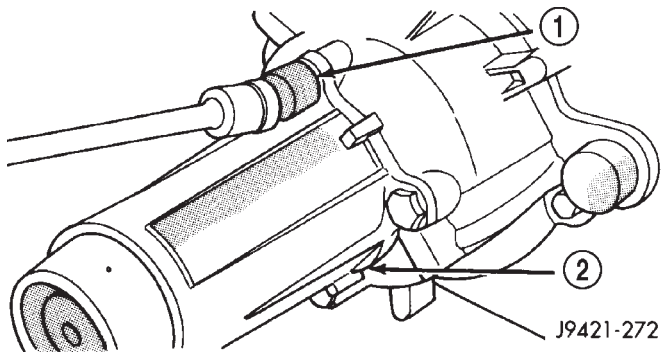
Position transfer case in a shallow drain pan. Remove drain plug and drain any remaining lubricant remaining in case.



## TRANSFER CASE - NV231HD (Continued)

**REAR EXTENSION, RETAINER, AND REAR CASE**

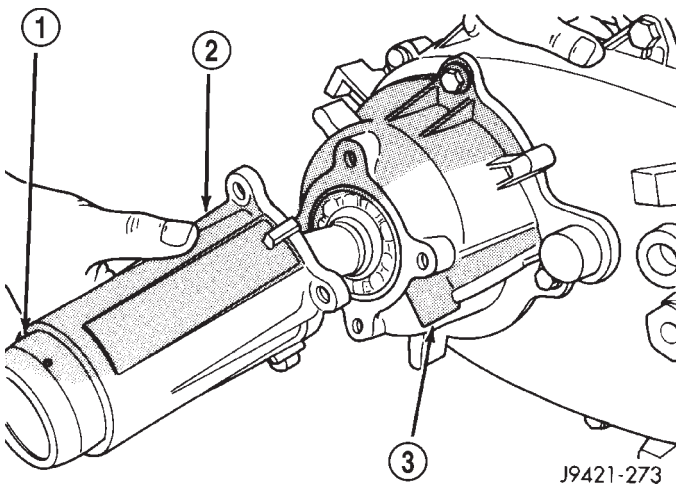
(1) Remove rear extension bolts (Fig. 2).



**Fig. 2 Rear Extension Bolt Removal**

- 1 - SOCKET  
2 - REAR EXTENSION

(2) Remove rear extension housing (Fig. 3). Tap extension once or twice with a plastic mallet to break sealer bead and loosen it.



**Fig. 3 Rear Extension Housing Removal**

- 1 - SEAL  
2 - REAR EXTENSION HOUSING  
3 - REAR RETAINER

(3) Remove output bearing retaining ring with heavy duty snap-ring pliers (Fig. 4).

(4) Remove rear retainer bolts (Fig. 5).

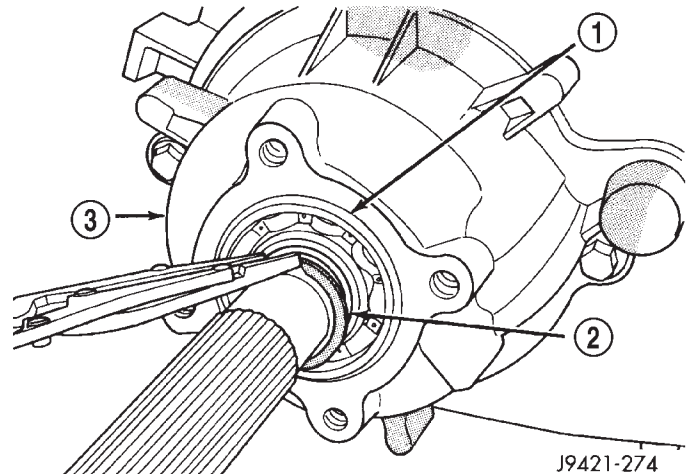
(5) Loosen rear retainer with pry bar placed under flange (Fig. 6).

(6) Remove rear retainer and output bearing assembly (Fig. 7).

**COMPANION FLANGE AND SHIFT LEVER**

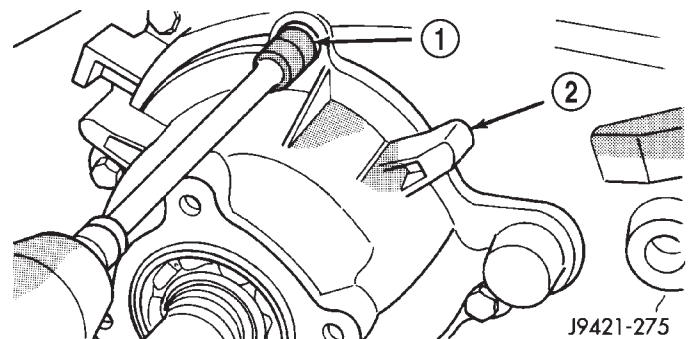
(1) Shift transfer case into NEUTRAL.

(2) Remove companion flange nut (Fig. 8). Discard nut after removal. It is not reusable.



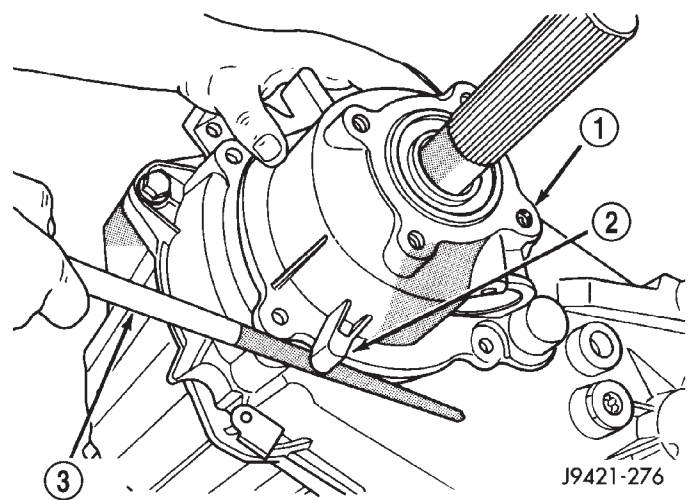
**Fig. 4 Removing Output Bearing Retaining Ring**

- 1 - OUTPUT BEARING  
2 - RETAINING RING  
3 - REAR RETAINER



**Fig. 5 Removing Rear Extension Bolts**

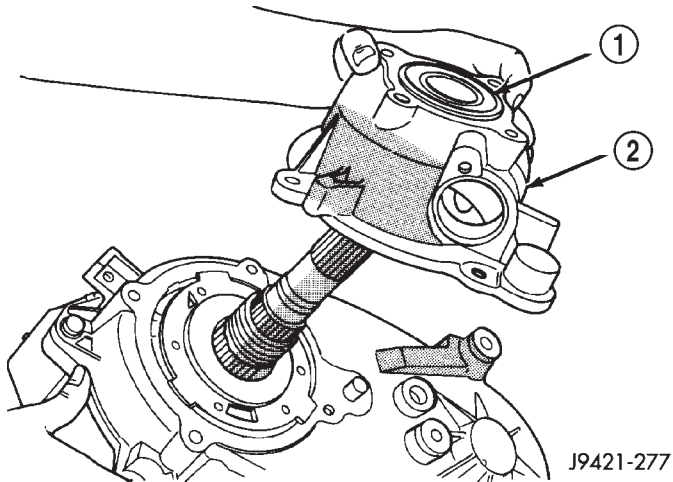
- 1 - SOCKET  
2 - REAR RETAINER



**Fig. 6 Loosening Rear Retainer**

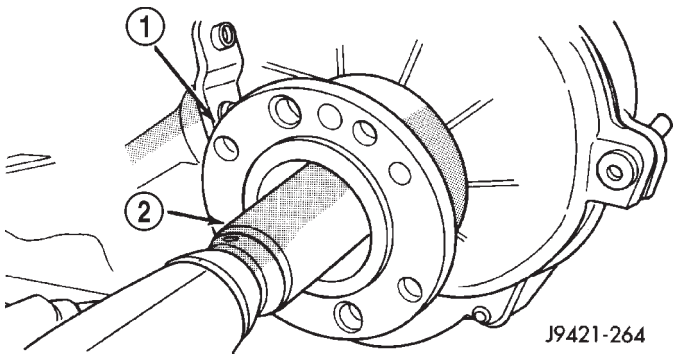
- 1 - REAR RETAINER  
2 - FLANGE  
3 - PRY TOOL





**Fig. 7 Rear Retainer Removal**

- 1 - OUTPUT BEARING
- 2 - REAR RETAINER

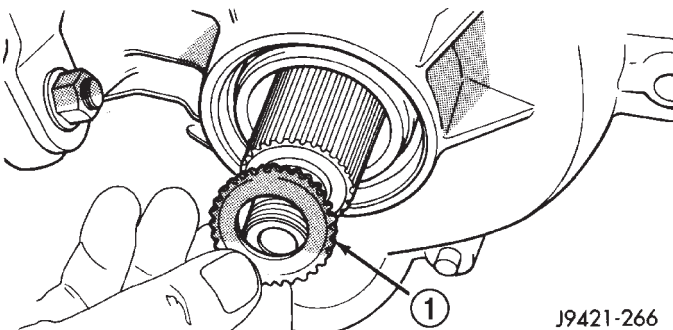


**Fig. 8 Removing Companion Flange Nut**

- 1 - COMPANION FLANGE
- 2 - SOCKET

(3) Remove companion flange from front output shaft. Use a suitable puller if flange can not be removed by hand.

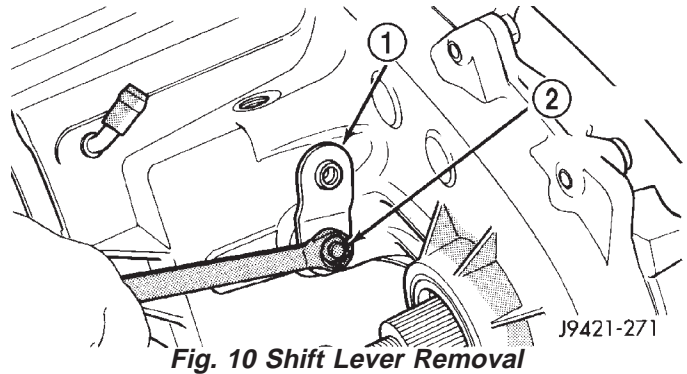
(4) Remove companion flange rubber seal from front output shaft (Fig. 9).



**Fig. 9 Companion Flange Seal Removal**

- 1 - FLANGE SEAL

(5) Remove nut and washer that retain shift lever to sector shaft. Then remove shift lever from shaft (Fig. 10).



**Fig. 10 Shift Lever Removal**

- 1 - SHIFT LEVER
- 2 - NUT/WASHER

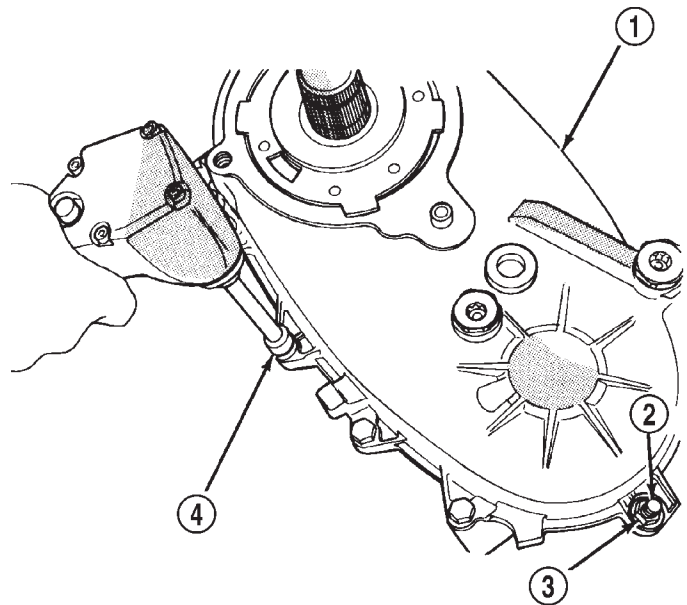
**FRONT OUTPUT SHAFT AND DRIVE CHAIN**

(1) Remove output bearing retaining ring with heavy duty snap-ring pliers.

(2) Remove output shaft bearing.

(3) Note position of bolts that attach rear case to front case (Fig. 11). Some bolts/studs at ends of case require flat washers. Mark position of these bolts with paint or scribe.

(4) Remove rear case-to-front case bolts.

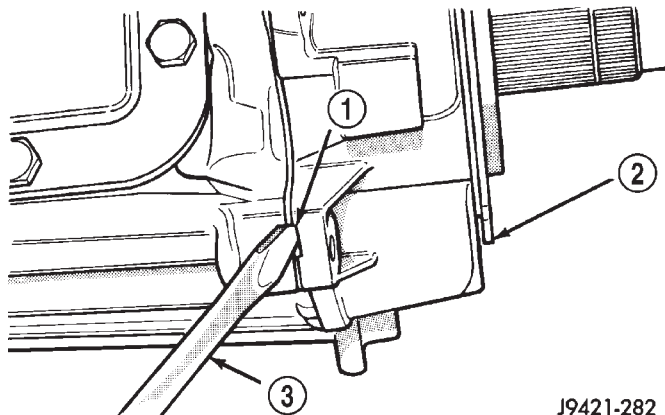


**Fig. 11 Removing Case Attaching Bolts**

- 1 - REAR CASE
- 2 - STUD
- 3 - NUT AND WASHER
- 4 - SOCKET

## TRANSFER CASE - NV231HD (Continued)

(5) Loosen rear case with pry tool to break sealer bead. Insert tool in slot at each end of case (Fig. 12).

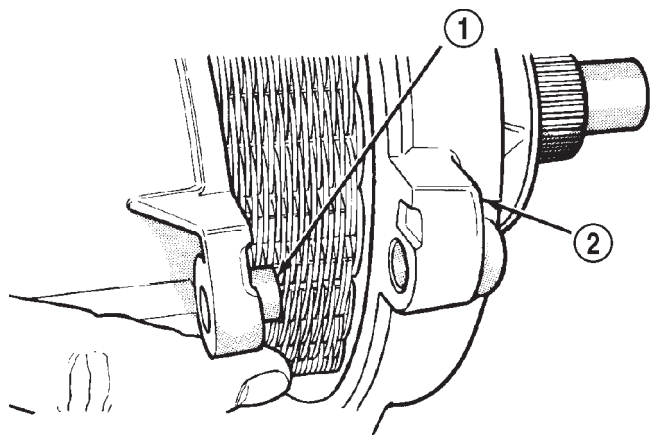


J9421-282

**Fig. 12 Loosening Rear Case (Breaking Sealer Bead)**

- 1 - SLOT
- 2 - REAR CASE
- 3 - PRY TOOL

(6) Unseat rear case from alignment dowels (Fig. 13).



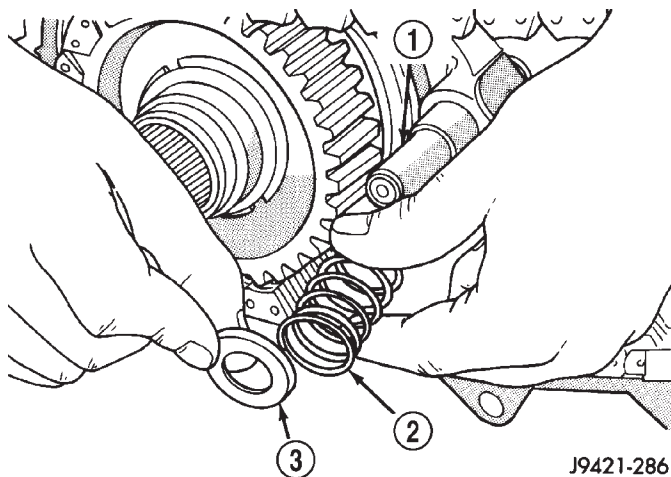
J9421-283

**Fig. 13 Removing Rear Case From Alignment Dowels**

- 1 - CASE DOWELS (2)
- 2 - REAR CASE

(7) Remove rear case and oil pump assembly from front case.

(8) Remove shift rail cup and spring (Fig. 14).

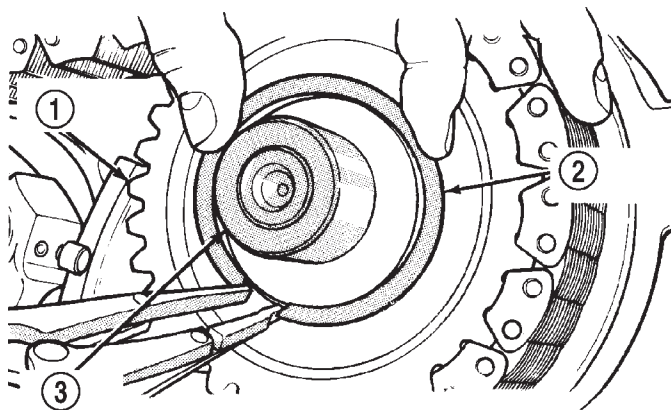


J9421-286

**Fig. 14 Shift Rail Cup And Spring Removal**

- 1 - SHIFT RAIL
- 2 - SPRING
- 3 - CUP

(9) Remove front sprocket retaining ring (Fig. 15).



J9421-287

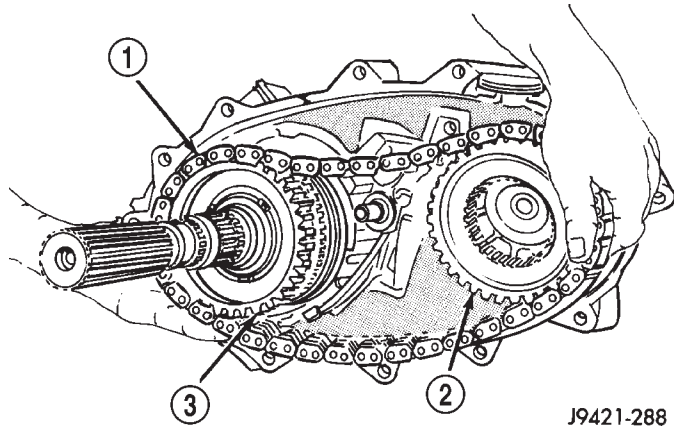
**Fig. 15 Removing Front Sprocket Retaining Ring**

- 1 - FRONT SPROCKET
- 2 - RETAINING RING
- 3 - FRONT OUTPUT SHAFT

TRANSFER CASE - NV231HD (Continued)

(10) Pull mainshaft, front sprocket and chain outward about 25.4 mm (1-inch) simultaneously (Fig. 16).

(11) Remove chain from mainshaft drive sprocket and remove front sprocket and chain as assembly.



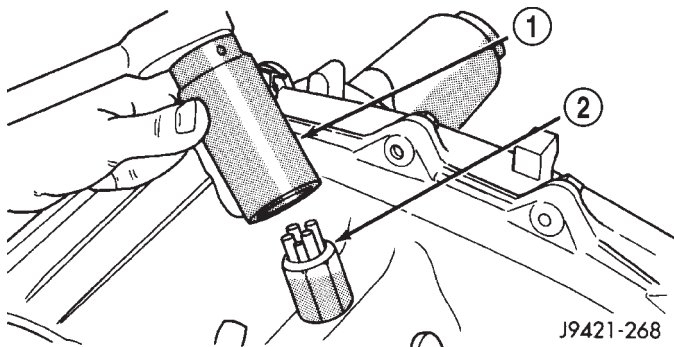
J9421-288

**Fig. 16 Removing Drive Chain And Front Sprocket**

- 1 - CHAIN
- 2 - DRIVE SPROCKET
- 3 - FRONT SPROCKET

**SHIFT FORKS AND MAINSHAFT**

(1) Remove vacuum/indicator switch (Fig. 17).

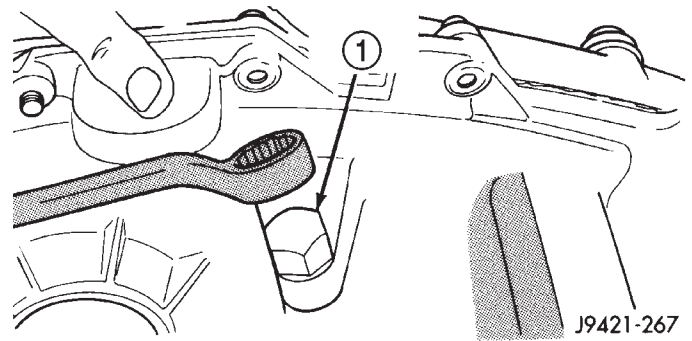


J9421-268

**Fig. 17 Vacuum/Indicator Switch Removal**

- 1 - 1-1/16" SOCKET
- 2 - INDICATOR SWITCH

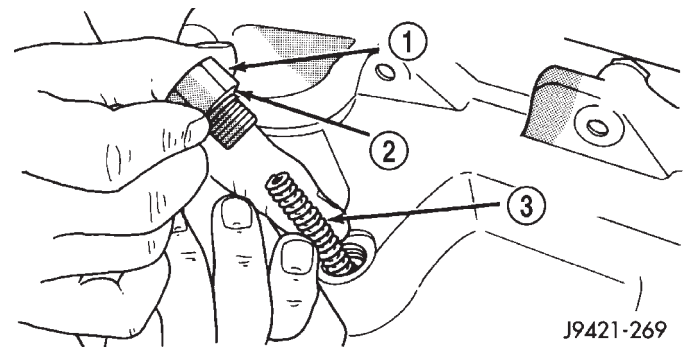
- (2) Loosen poppet plunger screw (Fig. 18).
- (3) Remove poppet plunger screw and spring (Fig. 19). Note that screw has O-ring seal. Remove and discard seal this seal.
- (4) Remove poppet plunger with magnet (Fig. 20).



J9421-267

**Fig. 18 Loosening Poppet Plunger Screw**

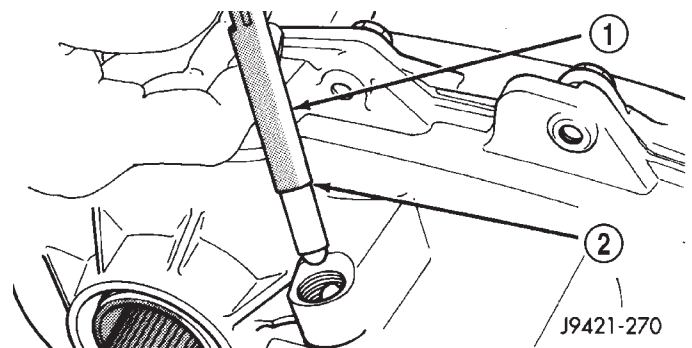
- 1 - POPPET PLUNGER SCREW



J9421-269

**Fig. 19 Poppet Plunger Screw And Spring Removal**

- 1 - POPPET PLUNGER SCREW
- 2 - O-RING
- 3 - PLUNGER SPRING



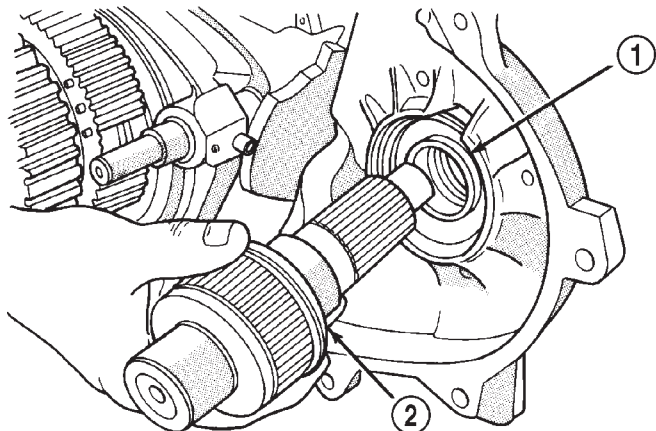
J9421-270

**Fig. 20 Poppet Plunger Removal**

- 1 - MAGNET
- 2 - POPPET PLUNGER

## TRANSFER CASE - NV231HD (Continued)

(5) Remove front output shaft from bearing in case (Fig. 21).

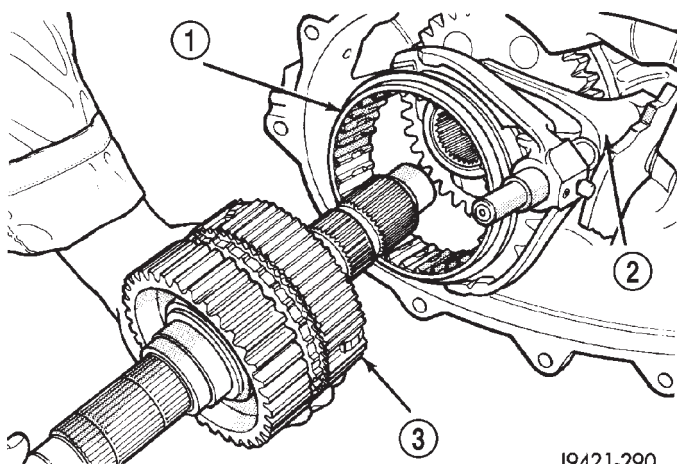


J9421-289

**Fig. 21 Front Output Shaft Removal**

- 1 - BALL BEARING
- 2 - FRONT OUTPUT SHAFT

(6) Pull mainshaft assembly out of input gear, sliding clutch and case (Fig. 22).

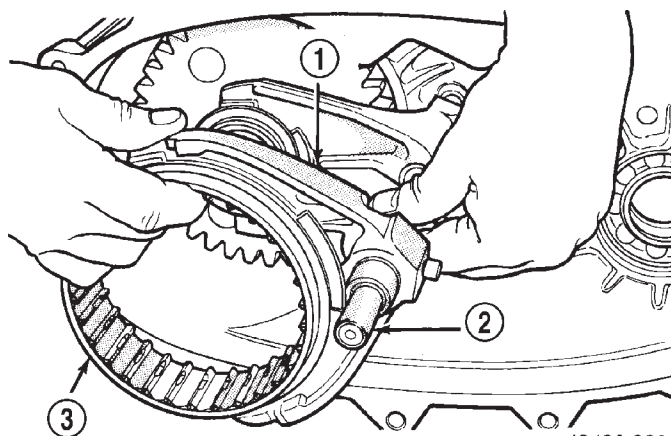


J9421-290

**Fig. 22 Mainshaft Assembly Removal**

- 1 - SLIDING CLUTCH
- 2 - MODE FORK
- 3 - MAINSHAFT ASSEMBLY

(7) Remove mode fork, sliding clutch and shift rail as assembly (Fig. 23). Note which way clutch fits in fork (long side of clutch goes to front).

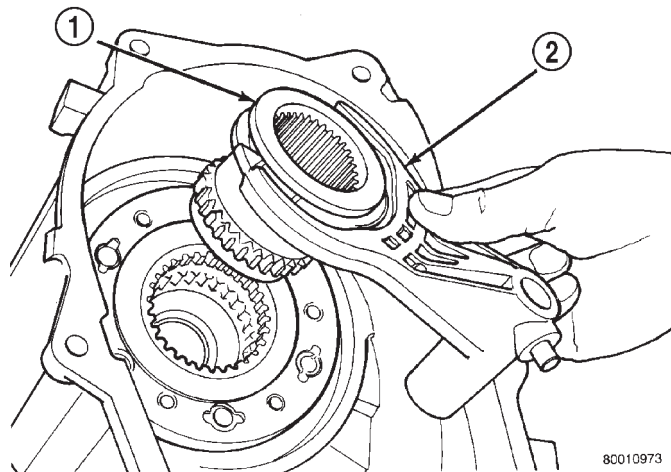


J9421-291

**Fig. 23 Mode Fork, Shift Rail And Sliding Clutch Removal**

- 1 - MODE FORK
- 2 - SHIFT RAIL
- 3 - SLIDING CLUTCH

(8) Remove range fork retaining ring.  
 (9) Remove range fork and hub as an assembly (Fig. 24). Note fork position for installation reference.  
 (10) Remove shift sector (Fig. 25).

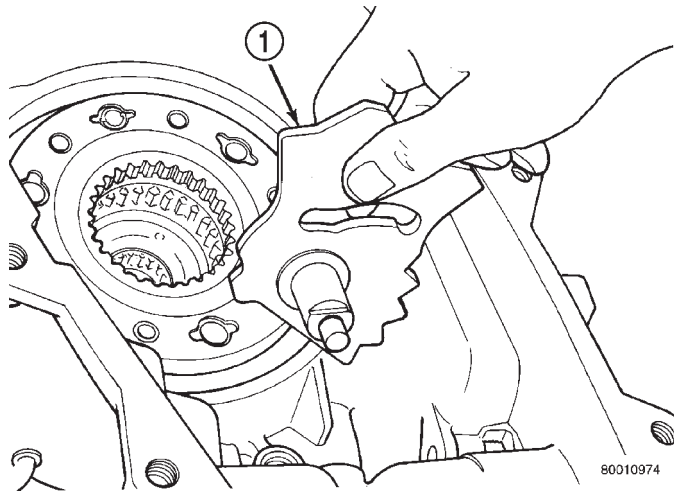


8C010973

**Fig. 24 Range Fork And Hub Removal**

- 1 - RANGE HUB
- 2 - RANGE FORK

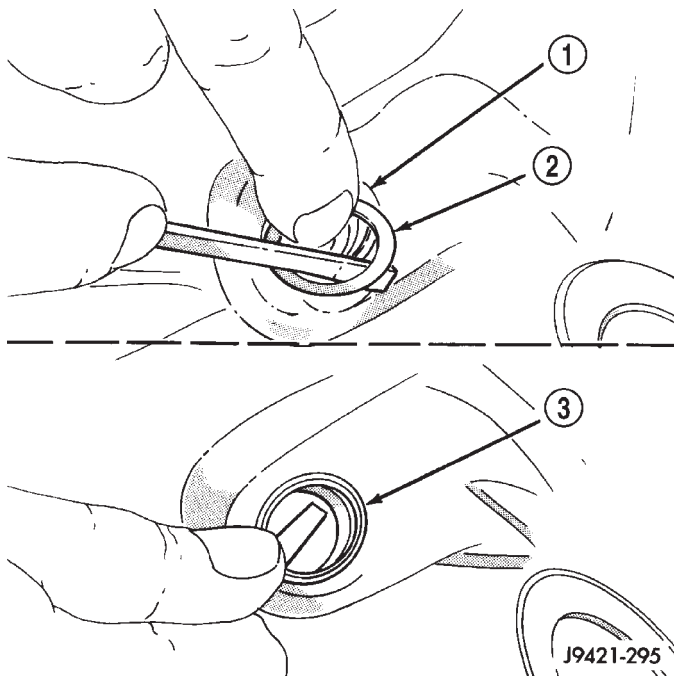




**Fig. 25 Shift Sector Removal**

1 - SHIFT SECTOR

(11) Remove shift sector shaft nylon retainer and O-ring from shaft bore in front case (Fig. 26).

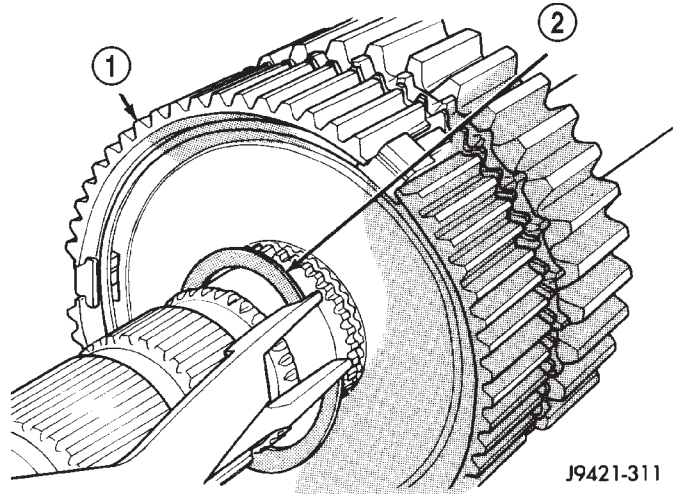


**Fig. 26 Removing Sector Shaft O-Ring And Retainer**

1 - SHAFT BORE  
2 - NYLON RETAINING RING  
3 - SECTOR SHAFT O-RING

### MAINSHAFT

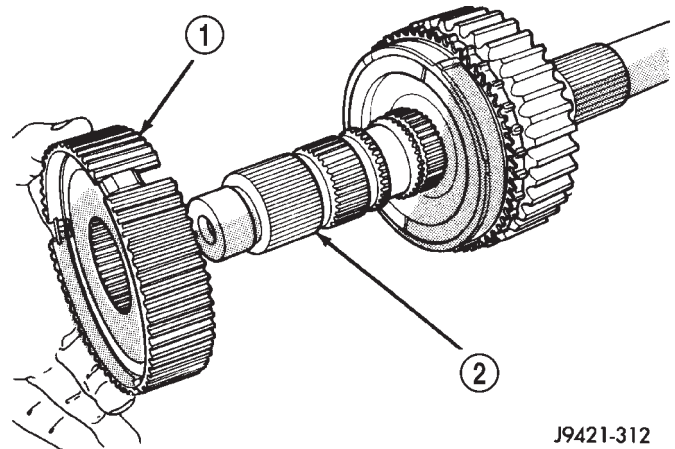
(1) Remove retaining ring that secures synchronizer hub onto mainshaft (Fig. 27). Use standard (instead of parallel jaw) snap-ring pliers to remove this retaining ring.



**Fig. 27 Synchronizer Hub Retaining Ring Removal**

1 - SYNCHRONIZER HUB  
2 - RETAINING RING

(2) Remove synchronizer hub (Fig. 28).



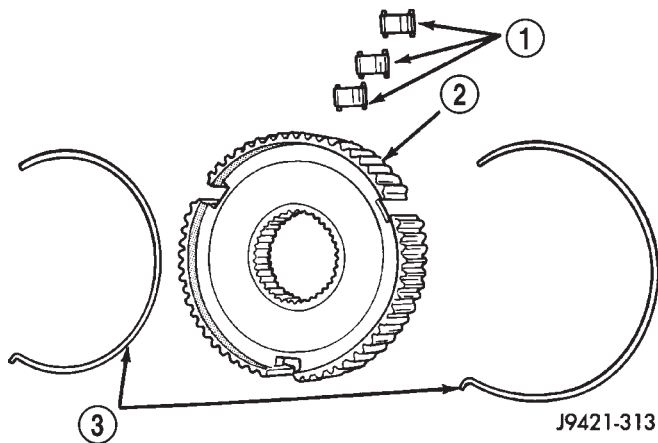
**Fig. 28 Synchronizer Hub Removal**

1 - SYNCHRONIZER HUB  
2 - MAINSHAFT



## TRANSFER CASE - NV231HD (Continued)

(3) Inspect synchronizer hub struts and springs. If struts appear worn, remove struts and springs from hub. Note position of springs for installation reference (Fig. 29).

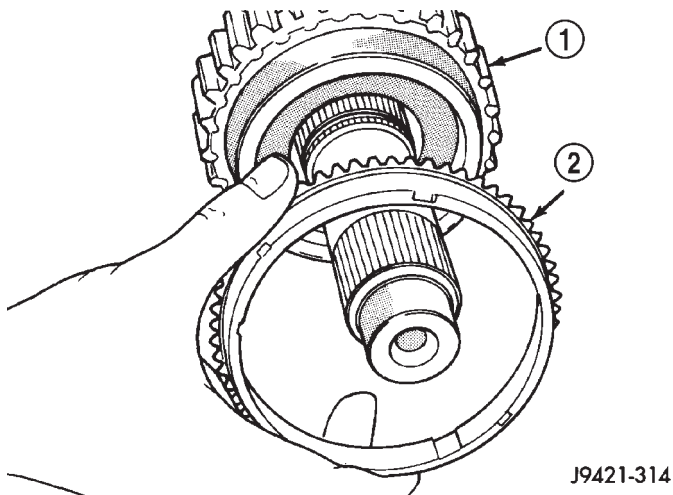


J9421-313

**Fig. 29 Synchronizer Strut And Spring Removal**

- 1 - SYNCHRONIZER STRUTS
- 2 - SYNCHRONIZER HUB
- 3 - SYNCHRONIZER SPRINGS

(4) Remove brass stop ring (Fig. 30). Discard stop ring if worn, cracked, or any teeth are missing.

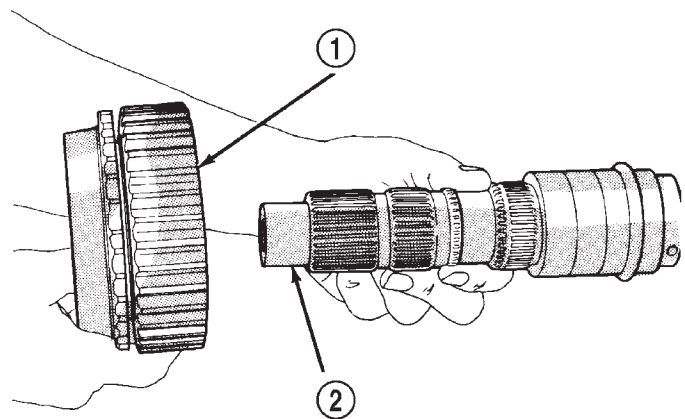


J9421-314

**Fig. 30 Synchronizer Stop Ring Removal**

- 1 - DRIVE SPROCKET
- 2 - STOP RING

(5) Remove drive sprocket (Fig. 31).



J9421-315

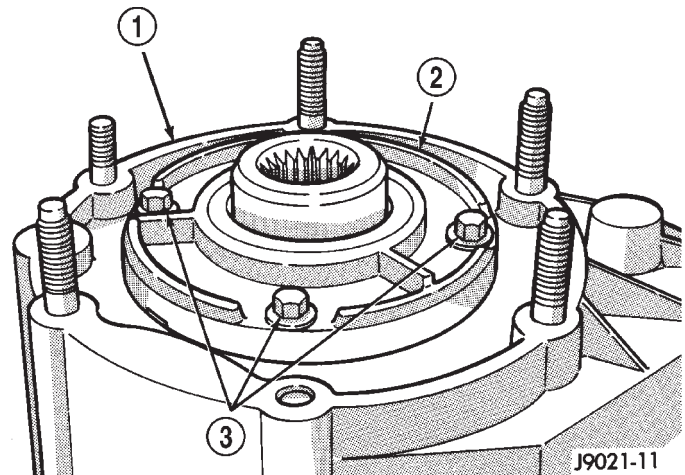
**Fig. 31 Drive Sprocket Removal**

- 1 - DRIVE SPROCKET
- 2 - MAINSHAFT

### INPUT AND PLANETARY GEAR

(1) Remove front bearing retainer attaching bolts (Fig. 32).

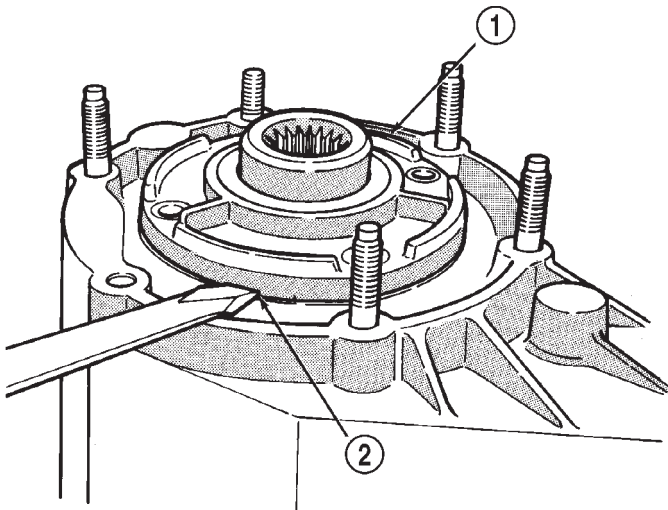
(2) Remove front bearing retainer. Pry retainer loose with pry tool positioned in slots at each end of retainer (Fig. 33).



J9021-11

**Fig. 32 Front Bearing Retainer Bolts**

- 1 - FRONT CASE
- 2 - FRONT BEARING RETAINER
- 3 - RETAINER BOLTS



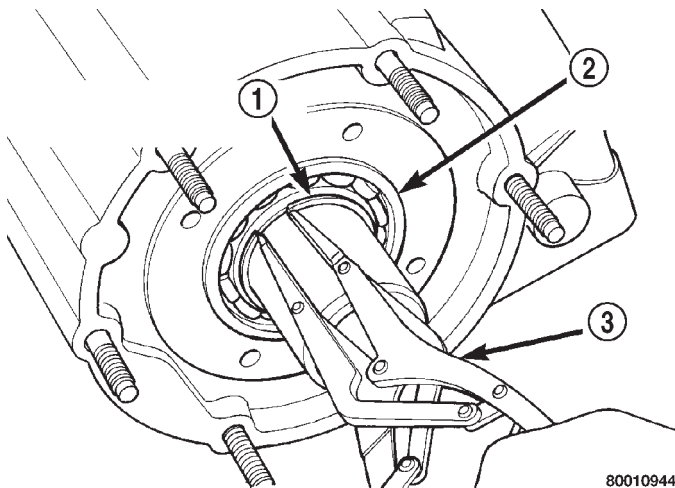
J8921-266

**Fig. 33 Front Bearing Retainer Removal**

- 1 - FRONT BEARING RETAINER
- 2 - RETAINER SLOT

(3) Remove front bearing retainer seal. Tap seal out with drift and hammer.

(4) Remove input gear retaining ring with heavy duty snap-ring pliers (Fig. 34).

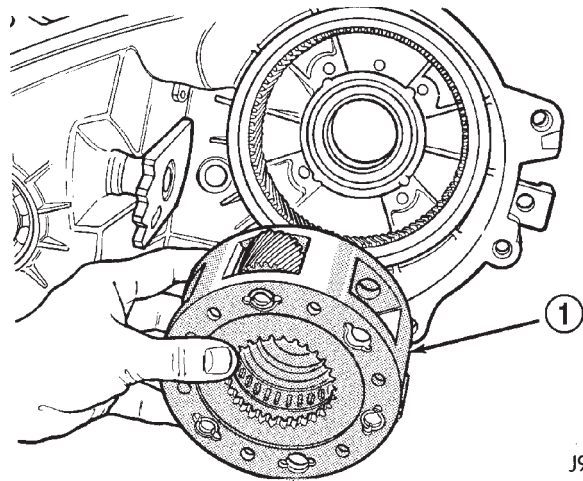


80010944

**Fig. 34 Removing Input Gear Retaining Ring**

- 1 - INPUT GEAR BEARING RETAINING RING
- 2 - INPUT GEAR BEARING
- 3 - SNAP-RING PLIERS

(5) Place front case in horizontal position. Then remove input gear and low range gear as an assembly (Fig. 35). Tap gear out of bearing with plastic mallet, if necessary.



J9321-29

**Fig. 35 Input Gear And Planetary Carrier Removal**

- 1 - INPUT AND LOW RANGE GEAR ASSEMBLY

**INPUT AND PLANETARY GEAR**

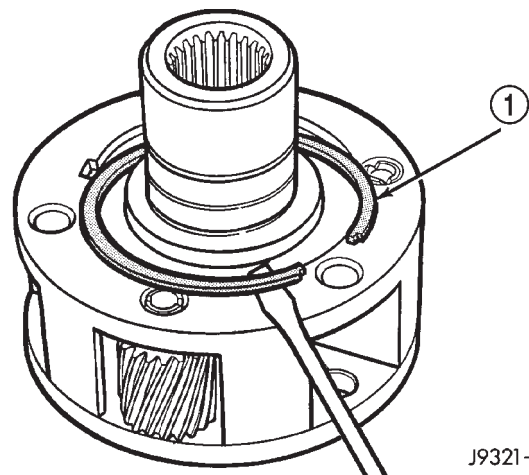
(1) Remove snap-ring that retains input gear in low range gear (Fig. 36).

(2) Remove retainer (Fig. 37).

(3) Remove front tabbed thrust washer (Fig. 38).

(4) Remove input gear (Fig. 39).

(5) Remove rear tabbed thrust washer from low range gear (Fig. 40).

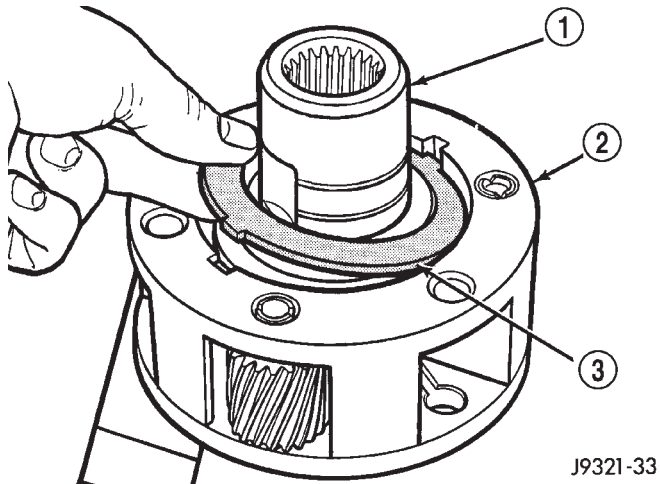


J9321-32

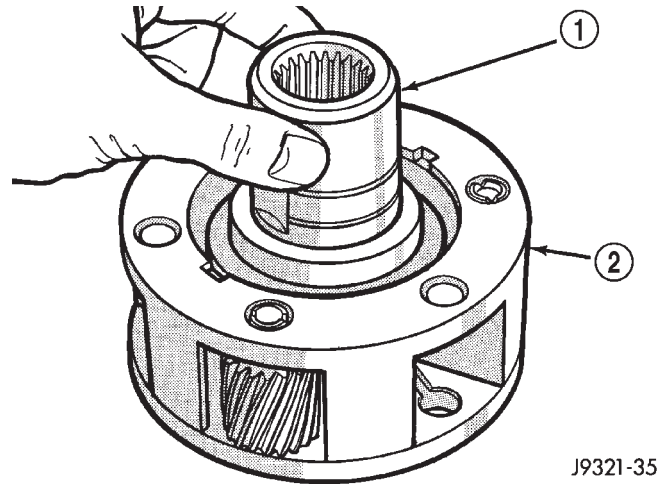
**Fig. 36 Input Gear Snap-Ring Removal**

- 1 - INPUT GEAR SNAP-RING

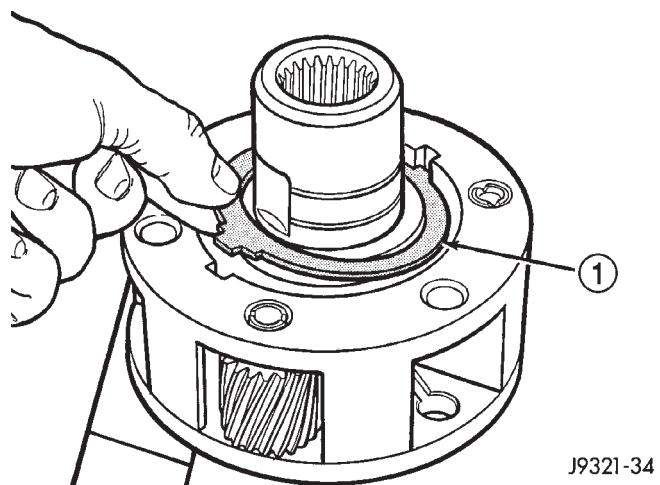
## TRANSFER CASE - NV231HD (Continued)

**Fig. 37 Input Gear Retainer Removal**

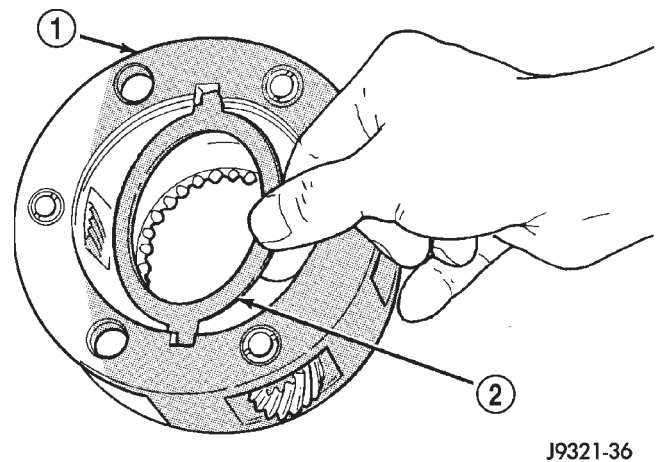
- 1 - INPUT GEAR
- 2 - LOW RANGE GEAR
- 3 - RETAINER

**Fig. 39 Input Gear Removal**

- 1 - INPUT GEAR
- 2 - LOW RANGE GEAR

**Fig. 38 Front Tabbed Thrust Washer Removal**

- 1 - FRONT TABBED THRUST WASHER

**Fig. 40 Rear Tabbed Thrust Washer Removal**

- 1 - LOW RANGE GEAR
- 2 - REAR TABBED THRUST WASHER

**CLEANING**

Clean the transfer case parts with a standard parts cleaning solvent. Remove all traces of sealer from the cases and retainers with a scraper and 3M™ all purpose cleaner. Use compressed air to remove solvent residue from oil feed passages in the case halves, retainers, gears, and shafts.

## TRANSFER CASE - NV231HD (Continued)

**INSPECTION****MAINSHAFT/SPROCKET/HUB**

Inspect the splines on the hub and shaft and the teeth on the sprocket (Fig. 41). Minor nicks and scratches can be smoothed with an oilstone, however, replace any part that is damaged.

Check the contact surfaces in the sprocket bore and on the mainshaft. Minor nicks and scratches can be smoothed with 320-400 grit emery cloth but do not try to salvage the shaft if nicks or wear is severe.

Inspect the spline teeth on the synchronizer hub. If evidence of chipping or excessive wear is apparent, replace the hub. The hooked end of each synchronizer spring should be inserted in one of the struts. In addition, the springs should not interfere with the polished gear cone or inside diameters of the hub.

Inspect the stop ring for cracks and wear. Replace the ring if necessary or if doubt exists over condition. Check a replacement synchronizer ring for proper fit on the cone with a minimum of wobble. Also check the synchronizer struts for wear or damage.

**INPUT GEAR AND PLANETARY CARRIER**

Check the teeth on the gear (Fig. 42). Minor nicks can be dressed off with an oilstone but replace the gear if any teeth are broken, cracked, or chipped. The bearing surface on the gear can be smoothed with 300-400 grit emery cloth if necessary.

Examine the carrier body and pinion gears for wear or damage. The carrier will have to be replaced as an assembly if the body, pinion pins, or pinion gears are damaged.

Check the lock ring and both thrust washers for wear or cracks. Replace them if necessary. Also replace the lock retaining ring if bent, distorted, or broken.

**SHIFT FORKS/HUBS/SLEEVES**

Check condition of the shift forks and mode fork shift rail (Fig. 43). Minor nicks on the shift rail can be smoothed with 320-400 grit emery cloth.

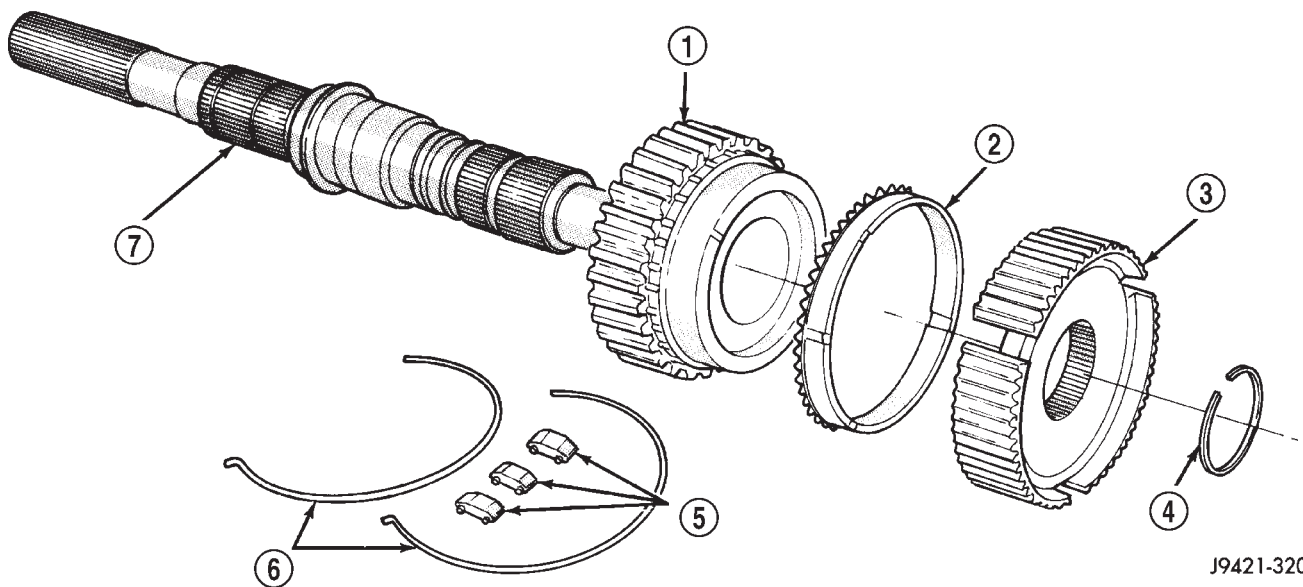
Inspect the shift fork wear pads (Fig. 44). The mode fork pads are serviceable and can be replaced if necessary. The range fork pads are not serviceable. The fork must be replaced as an assembly if the pads are worn or damaged.

Check both of the sleeves for wear or damage, especially on the interior teeth. Replace the sleeves if wear or damage is evident.

**REAR RETAINER COMPONENTS**

Inspect the retainer components. Replace the bearing if rough or noisy. Check the retainer for cracks or wear in the bearing bore.

Inspect the retaining rings and washers. Replace any part if distorted, bent, or broken. Reuse is not recommended.



J9421-320

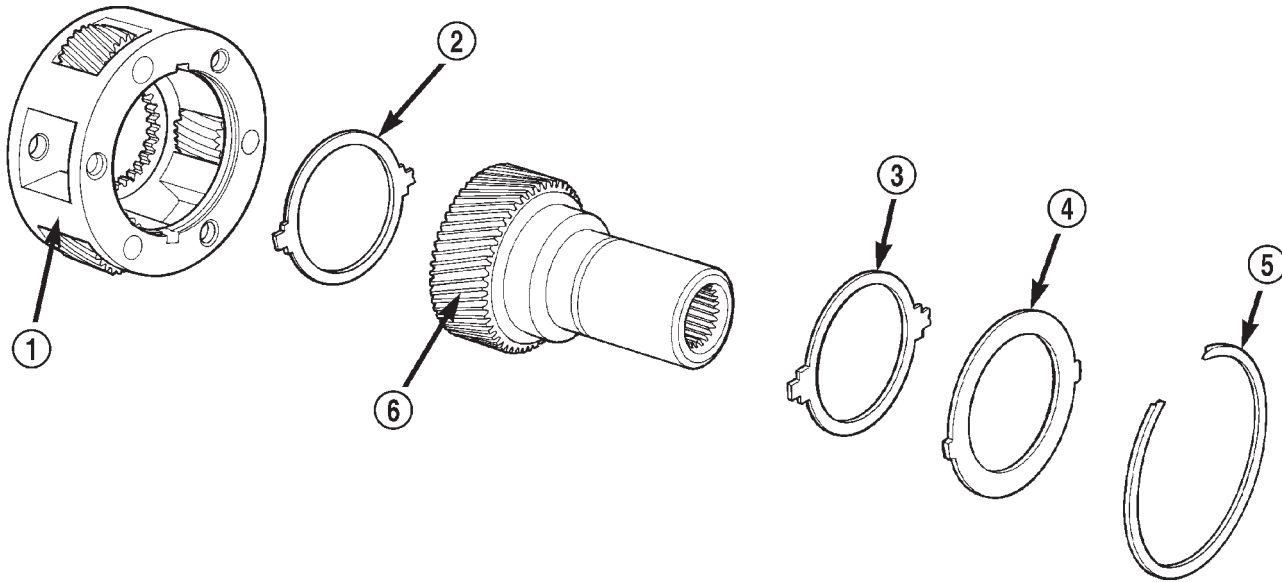
**Fig. 41 Mainshaft Components**

- 1 - DRIVE SPROCKET
- 2 - STOP RING
- 3 - SYNCHRONIZER HUB
- 4 - RETAINING RING

- 5 - STRUTS
- 6 - SYNCHRONIZER SPRINGS
- 7 - MAINSHAFT



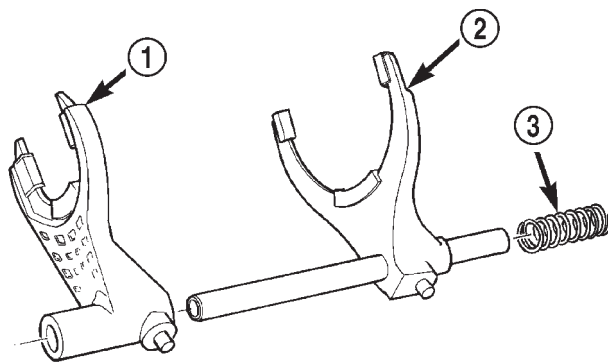
TRANSFER CASE - NV231HD (Continued)



8001b75f

**Fig. 42 Input Gear And Carrier Components**

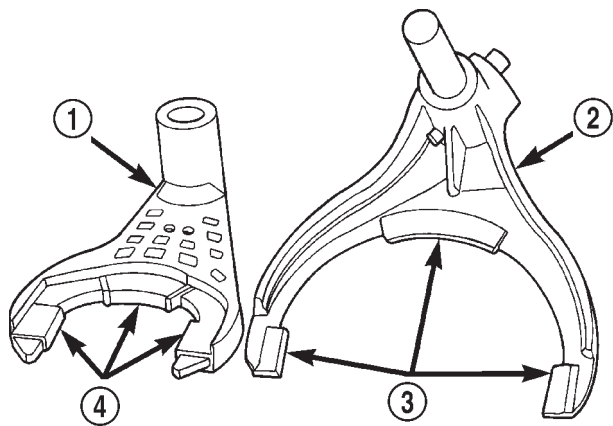
- |                         |                                 |
|-------------------------|---------------------------------|
| 1 - PLANETARY CARRIER   | 4 - CARRIER LOCK RING           |
| 2 - REAR THRUST WASHER  | 5 - CARRIER LOCK RETAINING RING |
| 3 - FRONT THRUST WASHER | 6 - INPUT GEAR                  |



80010948

**Fig. 43 Shift Forks**

- 1 - RANGE FORK
- 2 - MODE FORK AND RAIL
- 3 - MODE SPRING



8001097c

**Fig. 44 Shift Fork And Wear Pad Locations**

- 1 - RANGE FORK
- 2 - MODE FORK
- 3 - WEAR PADS (SERVICEABLE)
- 4 - WEAR PADS (NON-SERVICEABLE)

Inspect rear extension bushing. Replace if worn or scored.

**DRIVE CHAIN**

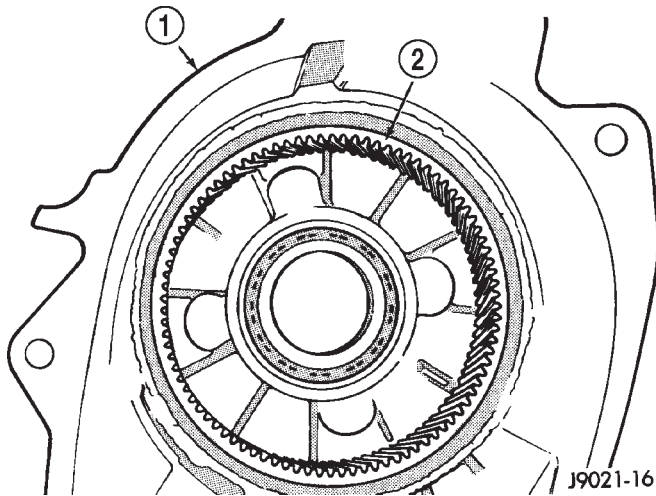
Examine the drive chain and shaft bearings. replace the chain if stretched, distorted, or if any of the links bind. Replace the bearings if rough, or noisy.



## TRANSFER CASE - NV231HD (Continued)

**LOW RANGE ANNULUS GEAR**

Inspect annulus gear condition carefully. The gear is only serviced as part of the front case. If the gear is damaged, it will be necessary to replace the gear and front case as an assembly. Do not attempt to remove the gear (Fig. 45)



**Fig. 45 Low Range Annulus Gear**

- 1 - FRONT CASE  
2 - LOW RANGE ANNULUS GEAR

**FRONT-REAR CASES AND FRONT RETAINER**

Inspect the cases and retainer for wear and damage. Replace the input retainer seal, do not reuse it.

Check case condition. If leaks were a problem, look for gouges and severe scoring of case sealing surfaces. Also make sure the front case mounting studs are in good condition.

Check the front case mounting studs and vent tube. The tube can be secured with Loctite™ 271 or 680 if loose. The stud threads can be cleaned up with a die if necessary. Also check condition of the fill/drain plug threads in the rear case. The threads can be repaired with a thread chaser or tap if necessary. Or the threads can be repaired with Helicoil™ stainless steel inserts if required.

**OIL PUMP/OIL PICKUP**

Examine the oil pump pickup parts. Replace the pump if any part appears to be worn or damaged. Do not disassemble the pump as individual parts are not available. The pump is only available as a complete assembly. The pickup screen, hose, and tube are the only serviceable parts and are available separately.

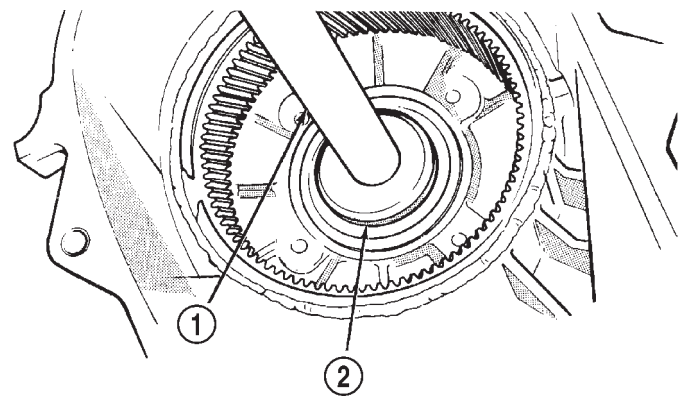
**ASSEMBLY****BEARINGS AND SEALS**

(1) Using Remover C-4210 and Handle C-4171, drive input shaft bearing from case from inside annulus gear opening (Fig. 46).

(2) Install locating ring on new bearing.

(3) Position case so that the forward end is facing upward.

(4) Using Remover C-4210 and Handle C-4171, drive input shaft bearing into case. The bearing locating ring must be fully seated on case (Fig. 47).



**Fig. 46 Input Shaft Bearing Removal**

- 1 - SPECIAL TOOL C-4171  
2 - SPECIAL TOOL C-4210

(5) Using Installer 6953, remove front output shaft bearing.

(6) Start front shaft output bearing in case (Fig. 48). Then seat bearing with Handle C-4171 and Installer 6953.

(7) Install front output bearing retaining ring.

(8) Install new front output seal front case with Installer Tool 8143-A as follows:

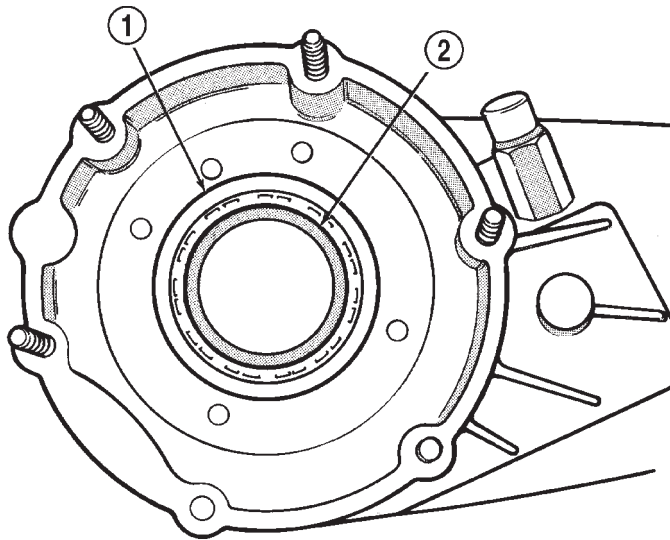
(a) Place new seal on tool. Garter spring on seal goes toward interior of case.

(b) Start seal in bore with light taps from hammer (Fig. 49). Once seal is started, continue tapping seal into bore until installer tool seats against case.

(9) Remove seal from front bearing retainer with suitable pry tool.

(10) Install new oil seal in front bearing retainer with Installer 7884 (Fig. 50).

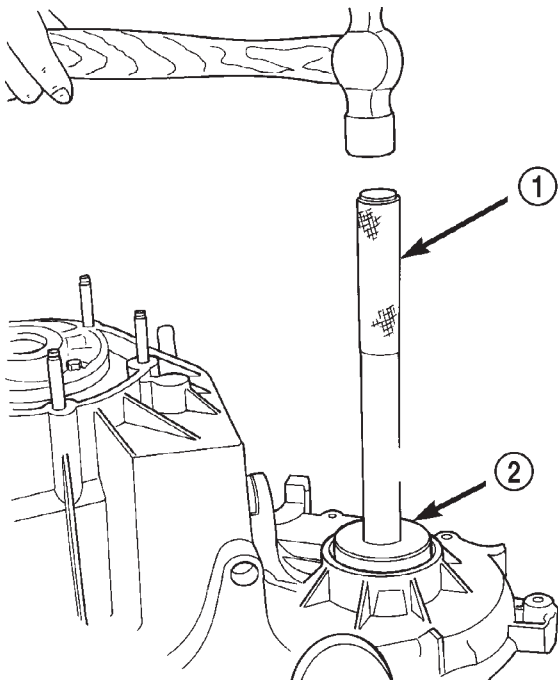
## TRANSFER CASE - NV231HD (Continued)



J8921-219

**Fig. 47 Seating Input Shaft Bearing**

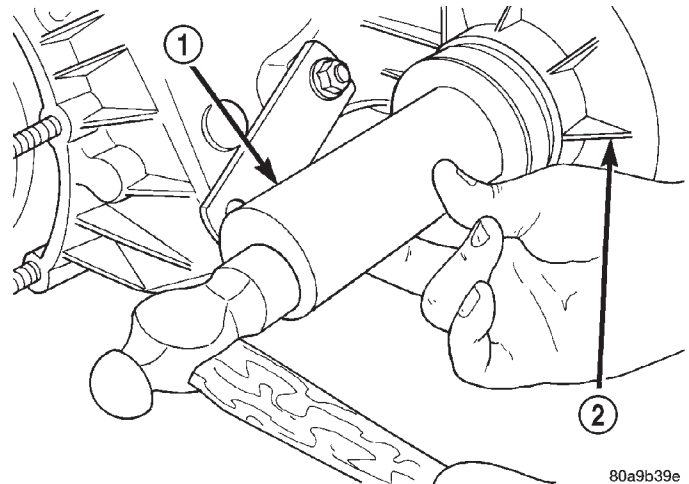
- 1 - SNAP-RING
- 2 - INPUT SHAFT BEARING



80a1108e

**Fig. 48 Front Output Bearing Installation**

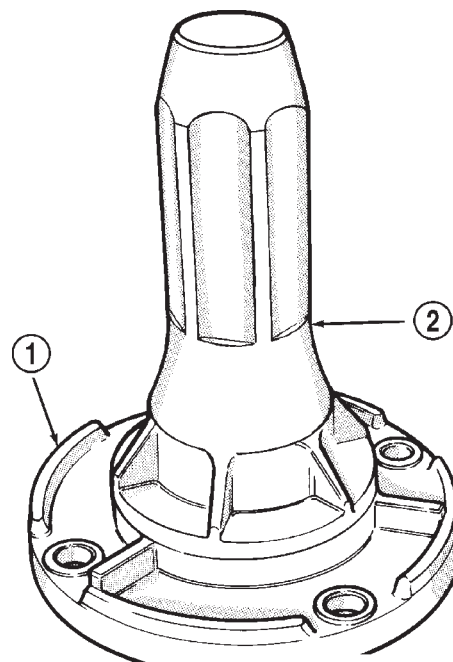
- 1 - HANDLE C-4171
- 2 - REMOVER/INSTALLER 6953



80a9b39e

**Fig. 49 Front Output Seal Installation**

- 1 - INSTALLER 8143-A
- 2 - TRANSFER CASE



J9521-41

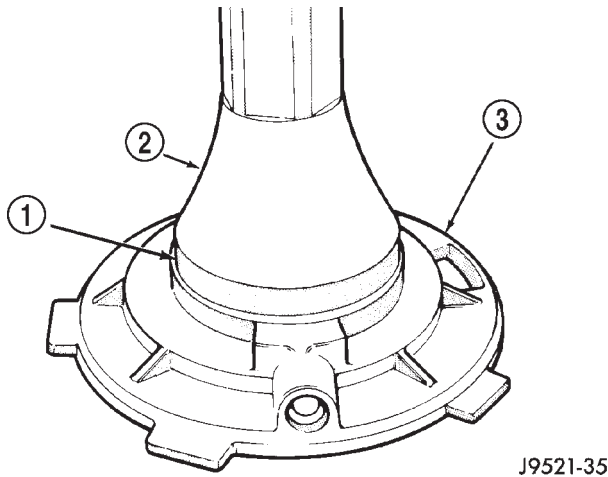
**Fig. 50 Install Front Bearing Retainer Seal**

- 1 - FRONT BEARING RETAINER
- 2 - SPECIAL TOOL 7884

## TRANSFER CASE - NV231HD (Continued)

(11) Remove seal from oil pump with suitable pry tool.

(12) Install new seal in oil pump with Installer 7888 (Fig. 51).

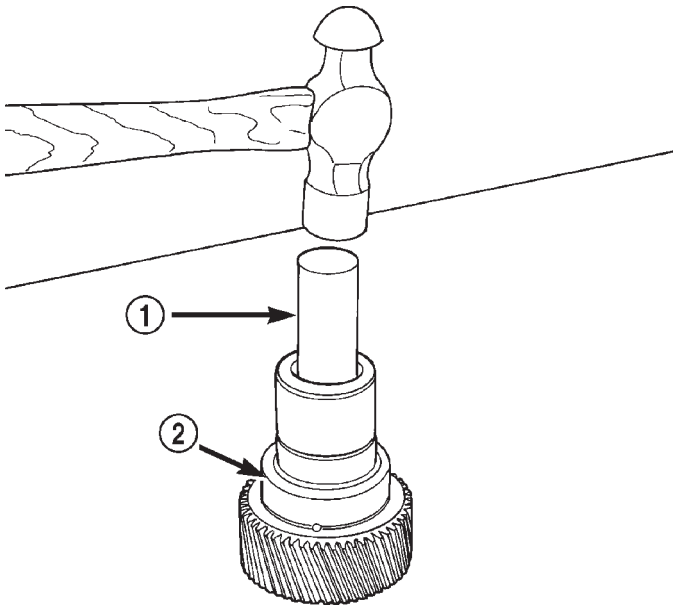


**Fig. 51 Install Oil Pump Seal**

- 1 - HOUSING SEAL
- 2 - SPECIAL TOOL 7888
- 3 - OIL PUMP FEED HOUSING

(13) Remove input gear pilot bearing by inserting a suitably sized drift into the splined end of the input gear and driving the bearing out with the drift and a hammer (Fig. 52).

(14) Install new pilot bearing with Plug C-293-3.

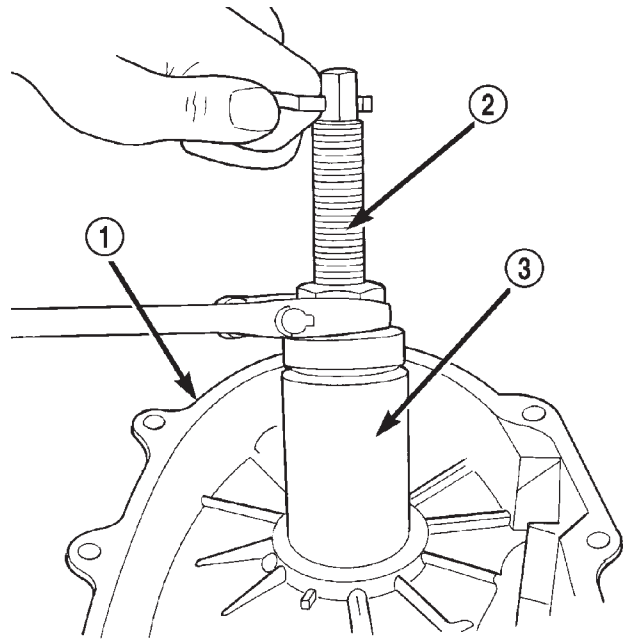


**Fig. 52 Remove Input Gear Pilot Bearing**

- 1 - DRIFT
- 2 - INPUT GEAR

(15) Remove the output shaft rear bearing with the screw and jaws from Remover L-4454 and Cup 8148 (Fig. 53).

(16) Install new bearing with Tool Handle C-4171 and Installer 5066 (Fig. 54). The bearing bore is chamfered at the top. Install the bearing so it is flush with the lower edge of this chamfer (Fig. 55).



**Fig. 53 Output Shaft Rear Bearing Removal**

- 1 - REAR CASE
- 2 - SPECIAL TOOL L-4454-1 AND L-4454-3
- 3 - SPECIAL TOOL 8148

## INPUT AND PLANETARY GEAR

(1) Lubricate gears and thrust washers (Fig. 56) with recommended transmission fluid.

(2) Install first thrust washer in low range gear (Fig. 56). Be sure washer tabs are properly aligned in gear notches.

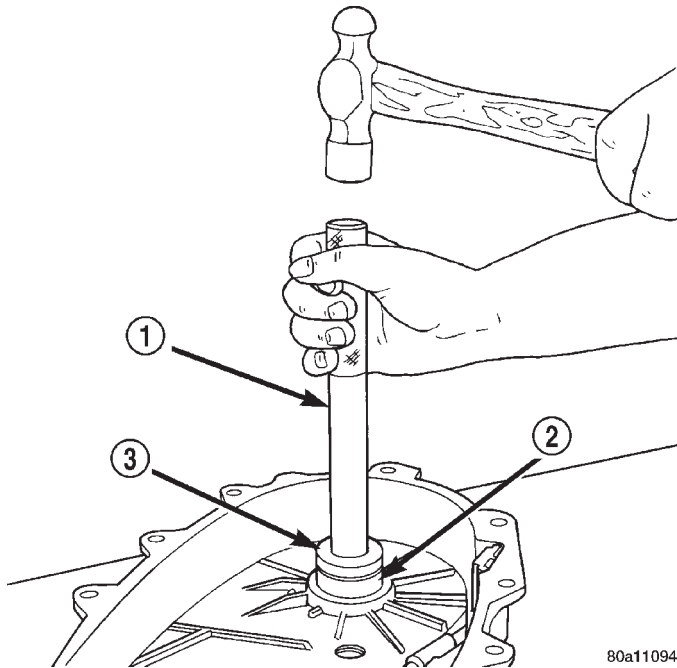
(3) Install input gear in low range gear. Be sure input gear is fully seated.

(4) Install remaining thrust washer in low range gear and on top of input gear. Be sure washer tabs are properly aligned in gear notches.

(5) Install retainer on input gear and install snapping.

(6) Align and install low range/input gear assembly in front case (Fig. 57). Be sure low range gear pinions are engaged in annulus gear and that input gear shaft is fully seated in front bearing.

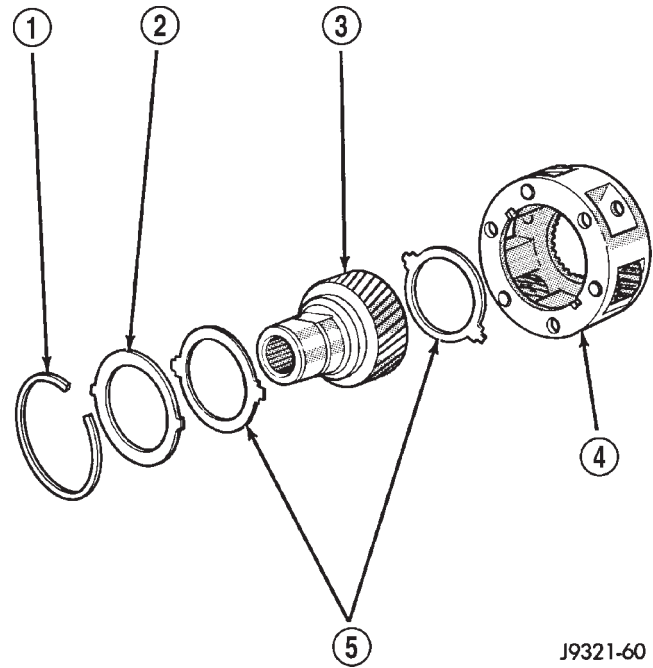
## TRANSFER CASE - NV231HD (Continued)



80a11094

**Fig. 54 Output Shaft Rear Bearing Installation**

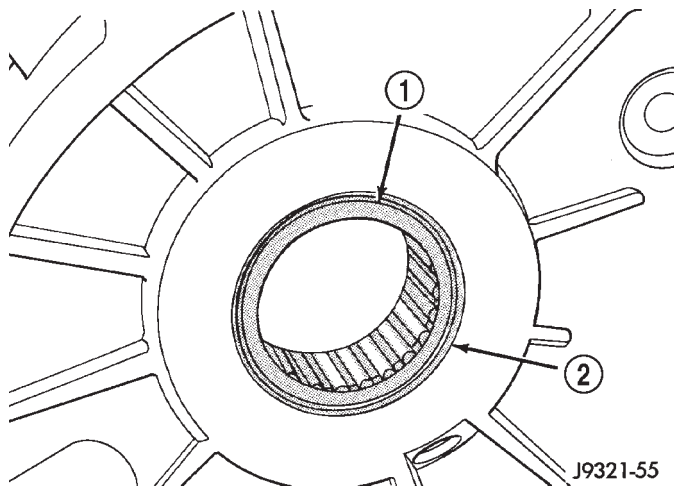
- 1 - HANDLE C-4171
- 2 - OUTPUT SHAFT INNER BEARING
- 3 - INSTALLER 5066



J9321-60

**Fig. 56 Input/Low Range Gear Components**

- 1 - SNAP-RING
- 2 - RETAINER PLATE
- 3 - INPUT GEAR
- 4 - LOW RANGE GEAR
- 5 - THRUST WASHERS

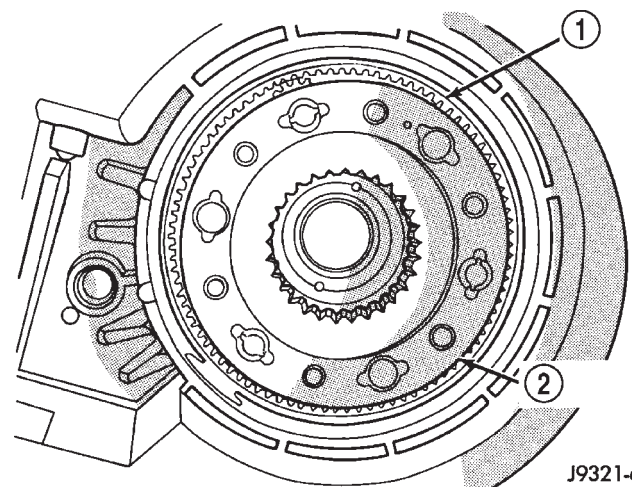


J9321-55

**Fig. 55 Output Shaft Rear Bearing Installation Depth**

- 1 - BEARING (SEATED) AT LOWER EDGE OF CHAMFER
- 2 - CHAMFER

(7) Install snap-ring to hold input/low range gear into front bearing (Fig. 58).

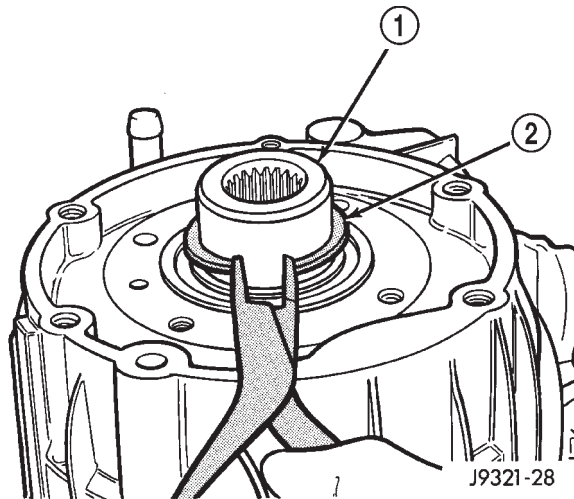


J9321-61

**Fig. 57 Input/Low Range Gear Installation**

- 1 - ANNULUS GEAR
- 2 - INPUT/LOW RANGE GEAR

## TRANSFER CASE - NV231HD (Continued)



**Fig. 58 Install Input Gear Snap-Ring**

- 1 - INPUT GEAR  
2 - SNAP-RING

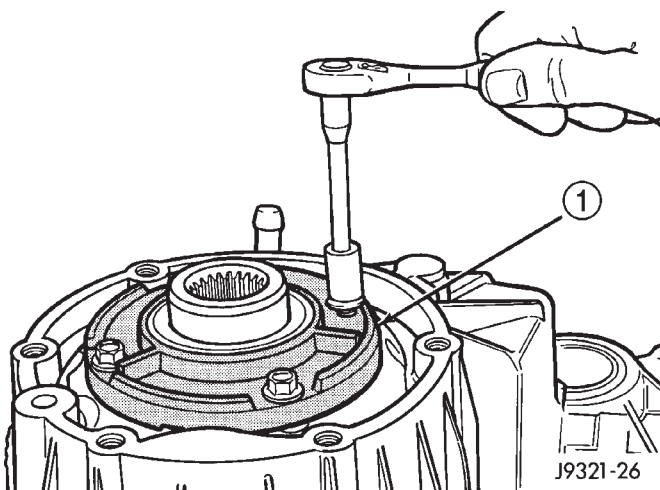
(8) Clean gasket sealer residue from retainer and inspect retainer for cracks or other damage.

(9) Apply a 3 mm (1/8 in.) bead of Mopar® Gasket Maker, or equivalent silicone adhesive, to sealing surface of retainer.

(10) Align cavity in seal retainer with fluid return hole in front of case.

**CAUTION:** Do not block fluid return cavity on sealing surface of retainer when applying Mopar® Gasket Maker, or equivalent silicone adhesive sealer. Seal failure and fluid leak can result.

(11) Install bolts to hold retainer to transfer case (Fig. 59). Tighten to 21 N·m (16 ft. lbs.) of torque.



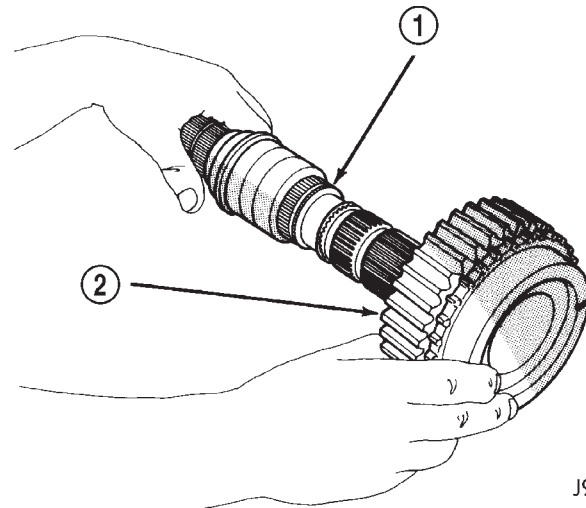
**Fig. 59 Install Front Bearing Retainer**

- 1 - FRONT BEARING RETAINER

## SHIFT FORKS AND MAINSHAFT

(1) Lubricate mainshaft splines with recommended transmission fluid.

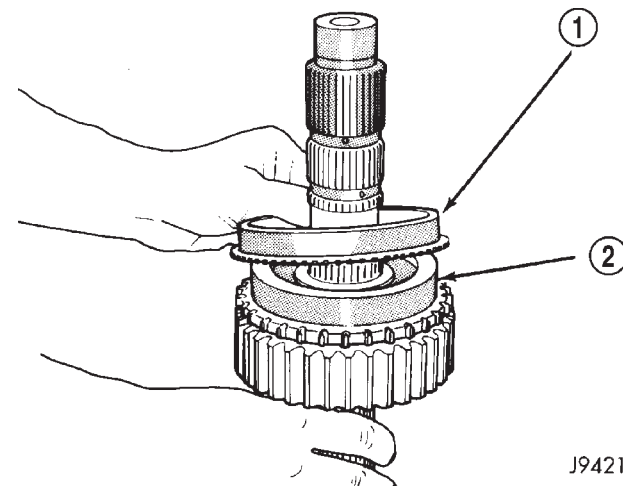
(2) Install drive sprocket on mainshaft (Fig. 60).



**Fig. 60 Drive Sprocket Installation**

- 1 - MAINSHAFT  
2 - DRIVE SPROCKET

(3) Install brass stop ring on drive sprocket (Fig. 61).



**Fig. 61 Synchro Stop Ring Installation**

- 1 - BRASS STOP RING  
2 - DRIVE SPROCKET

(4) Install 3 synchro struts and 2 springs in hub as follows:

(a) Insert first strut in hub (Fig. 62). Strut shoulders rest (and slide) on sides hub slot as shown.

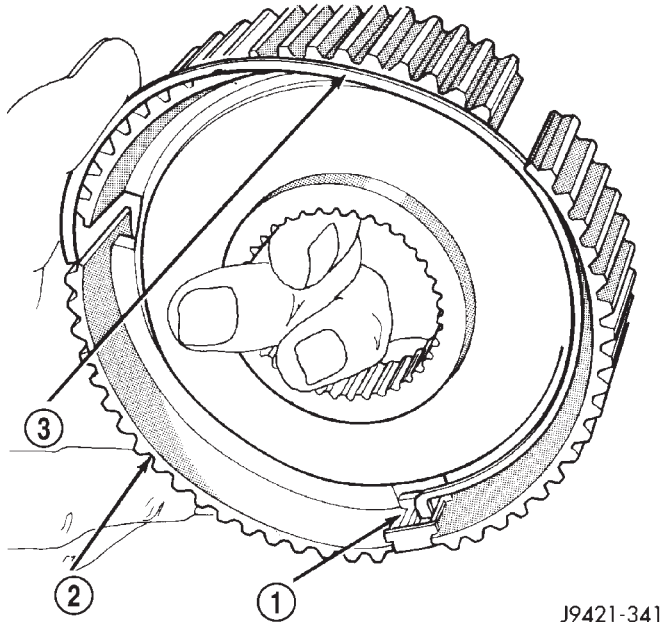
(b) Insert hooked end of first spring in center of strut to secure it. Then work spring into hub (Fig. 63).



## TRANSFER CASE - NV231HD (Continued)

(c) Press spring inward and insert last two struts in hub slots. Be sure spring is positioned under struts to properly secure them (Fig. 64).

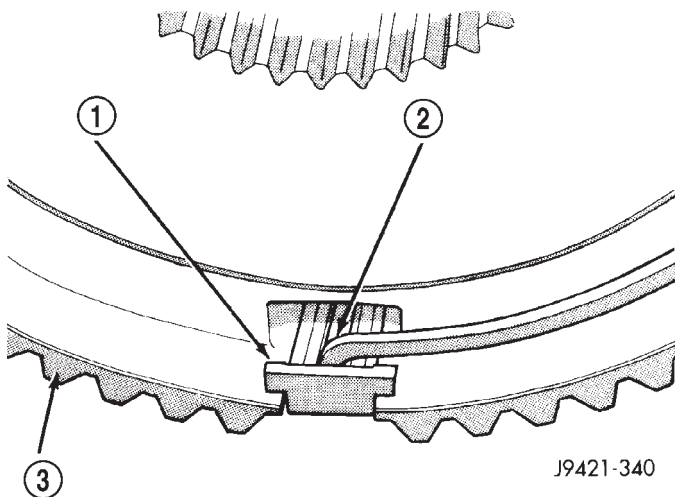
(d) Turn hub over and install remaining spring in hub. Position hooked end of second spring 180° away from first spring end.



J9421-341

**Fig. 62 Installing First Synchro Strut And Spring**

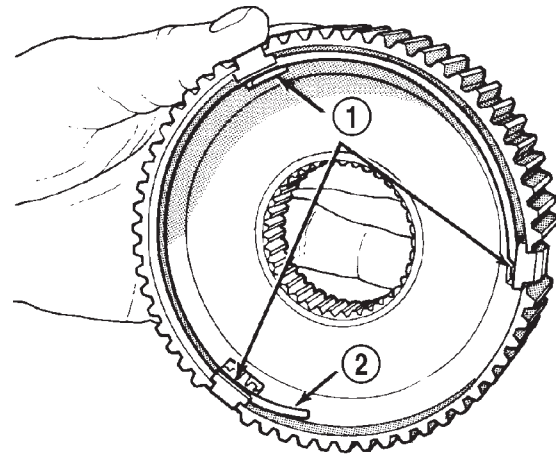
- 1 - FIRST STRUT
- 2 - SYNCHRONIZER HUB
- 3 - SPRING



J9421-340

**Fig. 63 Synchro Spring Installation**

- 1 - STRUT SHOULDER
- 2 - SPRING (SEATED IN STRUT)
- 3 - HUB

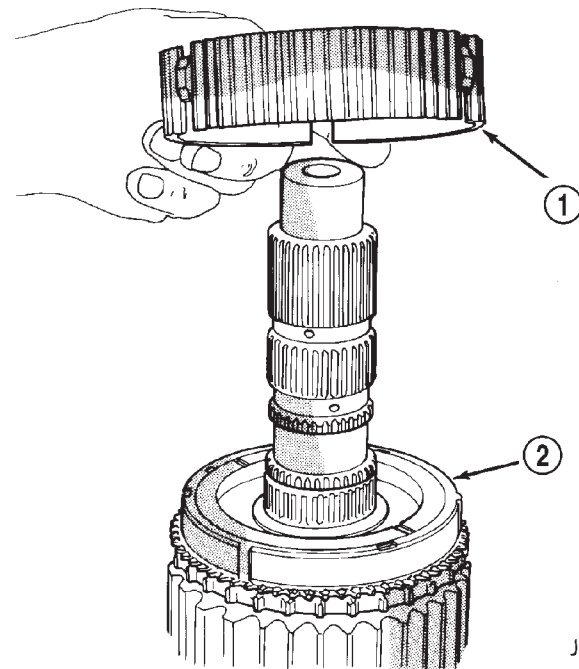


J9421-342

**Fig. 64 Correct Position Of Struts And Springs**

- 1 - STRUTS
- 2 - SPRING

(5) Install assembled synchro hub on mainshaft (Fig. 65). Hub has shoulder on one side which goes toward sprocket (rear of shaft). Flat side of hub faces front of shaft.



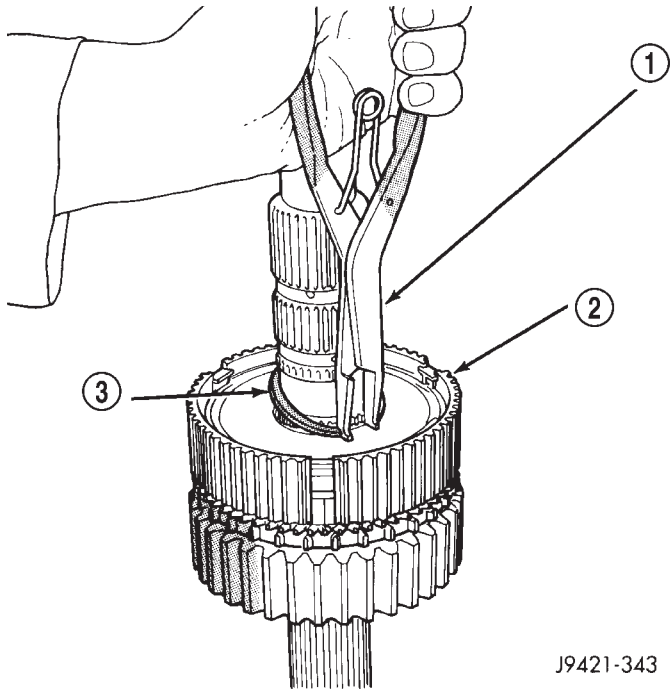
J9421-345

**Fig. 65 Synchro Hub Installation**

- 1 - SYNCHRONIZER HUB (SHOULDER SIDE DOWN)
- 2 - STOP RING AND SPROCKET

TRANSFER CASE - NV231HD (Continued)

(6) Install synchro hub retaining ring (Fig. 66). Be sure ring is fully seated before proceeding.

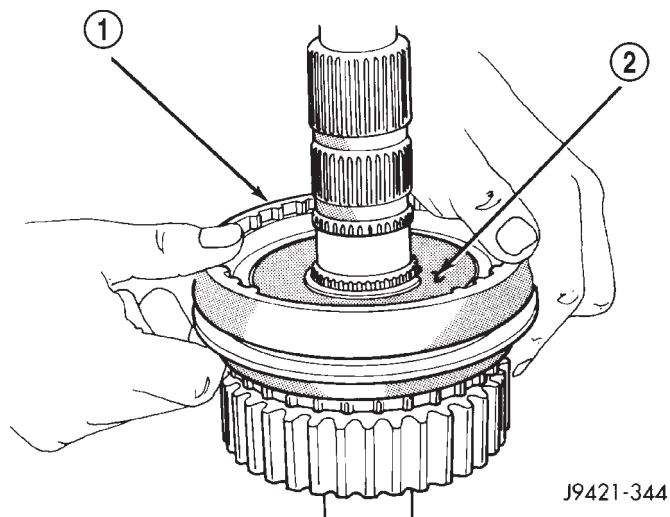


J9421-343

**Fig. 66 Synchro Hub Retaining Ring Installation**

- 1 - SNAP-RING PLIERS
- 2 - SYNCHRONIZER HUB
- 3 - HUB RETAINING RING

(7) Install sliding clutch (sleeve) on synchro hub (Fig. 67).



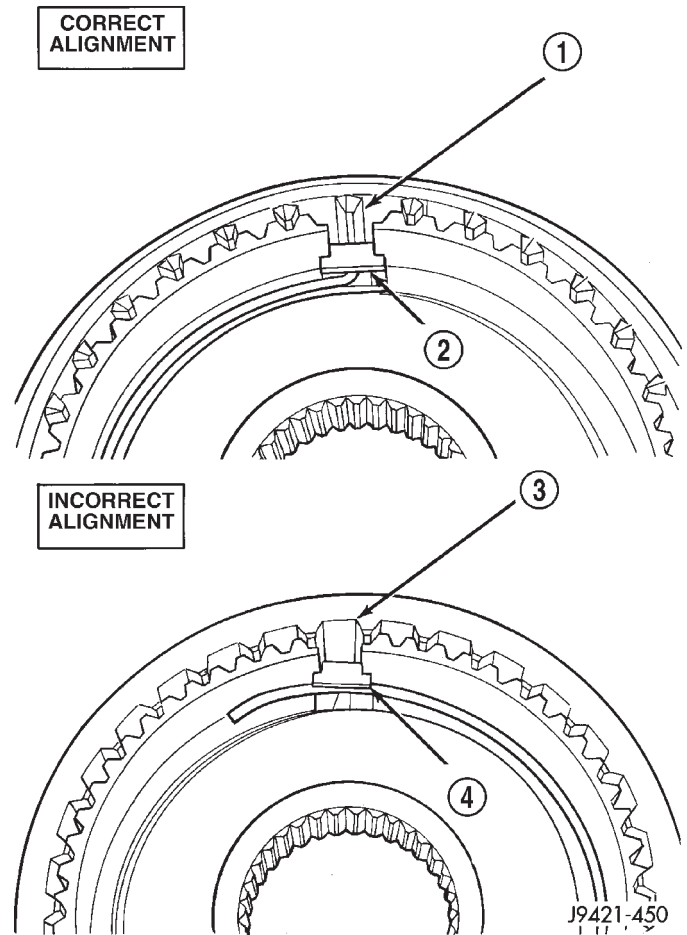
J9421-344

**Fig. 67 Sliding Clutch Installation**

- 1 - SLIDING CLUTCH
- 2 - SYNCHRONIZER HUB

**CAUTION:** The sliding clutch must be correctly positioned to ensure proper shifting. Position the clutch on the hub so a clutch spline is centered

over each strut as shown (Fig. 68). If the clutch is installed so a gap between splines is aligned with one or more struts, gear clash will result.



**Fig. 68 Correct Alignment Of Struts And Sliding Clutch**

- 1 - SLEEVE TOOTH ALIGNED WITH STRUT
- 2 - STRUT
- 3 - SLEEVE TOOTH NOT ALIGNED WITH STRUT
- 4 - STRUT

(8) Support front case on wood blocks so case interior is facing up. Place blocks between mounting studs on forward surface of case. Be sure blocks will not interfere with input gear installation.

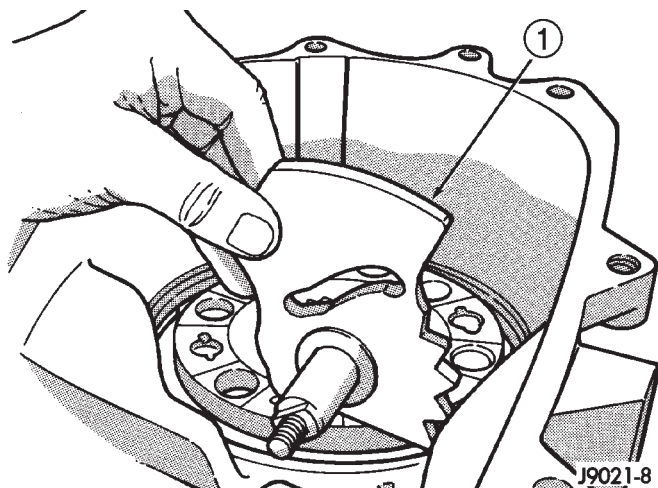
(9) Lubricate mainshaft components with transmission fluid.

(10) Lubricate sector shaft with transmission fluid and install shift sector in case (Fig. 69). Position slot in sector so it will be aligned with shift fork pin when shift forks are installed.

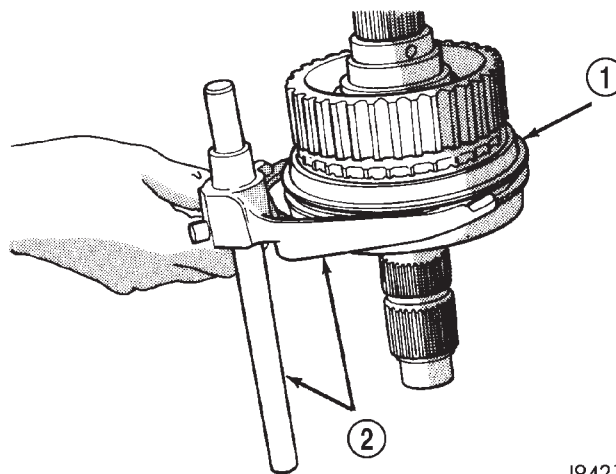
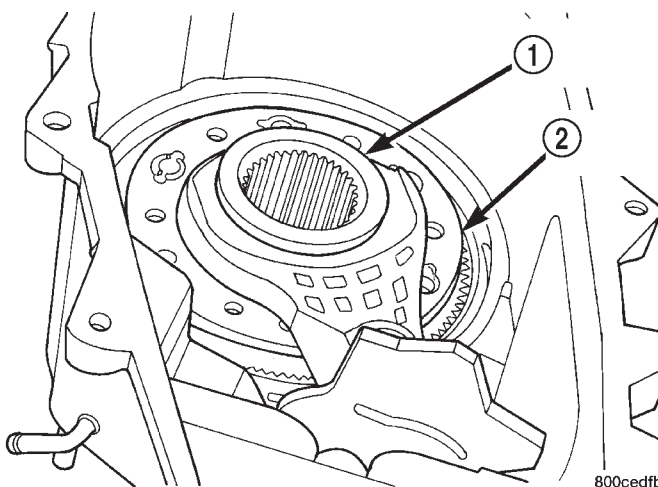
(11) Assemble and install range fork and hub (Fig. 70). Be sure hub is properly seated in low range gear and engaged to the input gear.

(12) Align and insert range fork pin in shift sector slot.

## TRANSFER CASE - NV231HD (Continued)

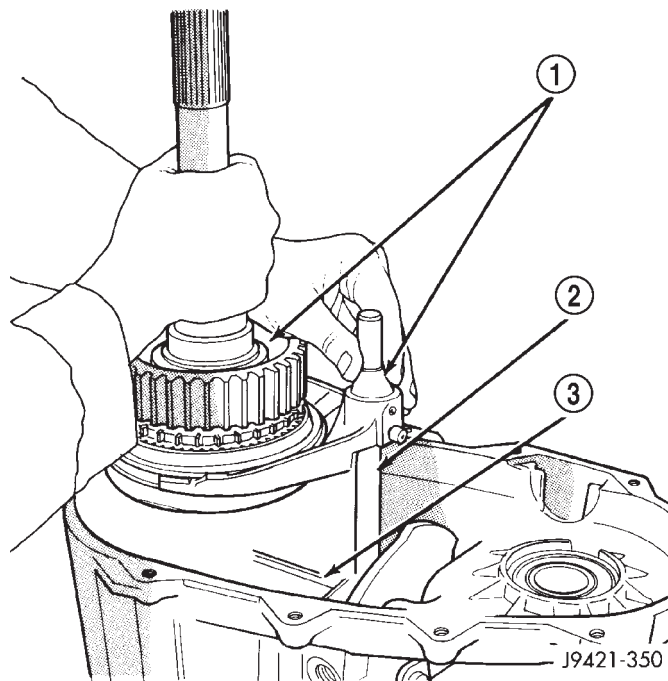
**Fig. 69 Shift Sector Installation**

1 - SHIFT SECTOR

**Fig. 71 Assembling Mode Fork And Mainshaft**1 - SLIDING CLUTCH  
2 - MODE FORK AND SHIFT RAIL**Fig. 70 Install Range Fork And Hub Assembly**1 - RANGE HUB  
2 - RANGE FORK

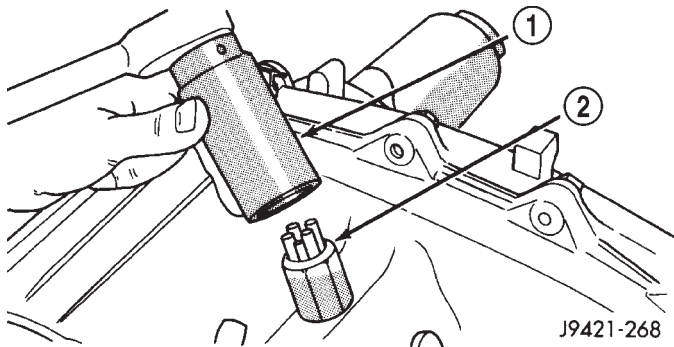
(13) Install mode fork and shift rail in sliding clutch (Fig. 71).

(14) Install mainshaft/mode fork assembly (Fig. 72). Guide mainshaft through hub and into input gear and shift rail through range fork and into case bore.

**Fig. 72 Installing Mainshaft And Mode Fork Assembly**1 - MAINSHAFT AND MODE FORK ASSEMBLY  
2 - SHIFT RAIL  
3 - RANGE FORK

## TRANSFER CASE - NV231HD (Continued)

(15) Install vacuum/indicator switch (Fig. 73). Tighten switch to 20-34 N·m (15-25 ft. lbs.) torque. Install new O-ring on switch beforehand, if necessary.

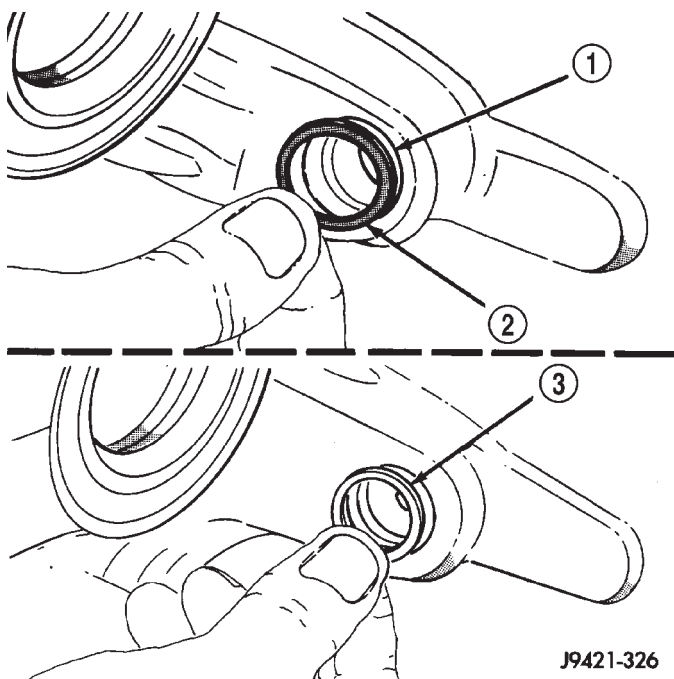


J9421-268

**Fig. 73 Vacuum/Indicator Switch Installation**

- 1 - 1-1/16" SOCKET  
2 - INDICATOR SWITCH

(16) Install new sector shaft O-ring and O-ring retainer in sector shaft bore (Fig. 74). Lubricate O-ring with transmission fluid or petroleum jelly after installation.

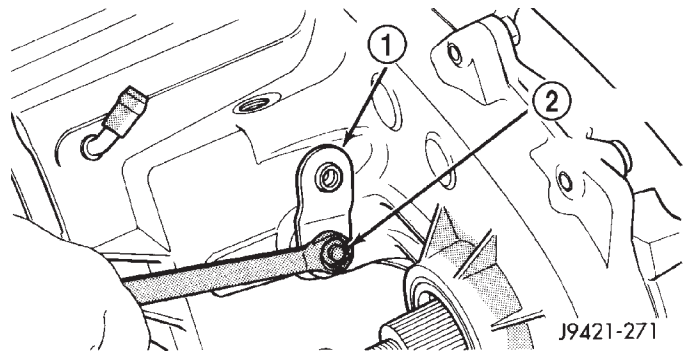


J9421-326

**Fig. 74 Sector Shaft O-Ring And Retainer Installation**

- 1 - SECTOR SHAFT BORE  
2 - O-RING  
3 - O-RING RETAINER

(17) Install shift lever on sector shaft (Fig. 75).  
(18) Install washer and nut on sector shaft to secure shift lever. Apply 1-2 drops Mopar® Lock N' Seal, or equivalent, to nut threads before installation. Then tighten nut to 27-34 N·m (20-25 ft. lbs.) torque.

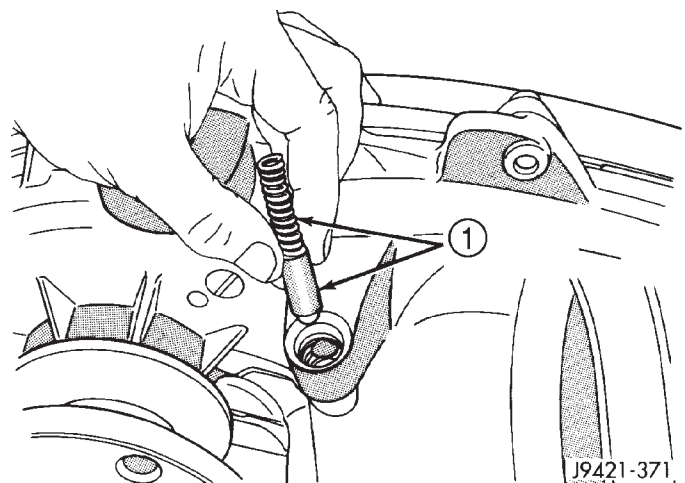


J9421-271

**Fig. 75 Shift Lever Installation**

- 1 - SHIFT LEVER  
2 - NUT/WASHER

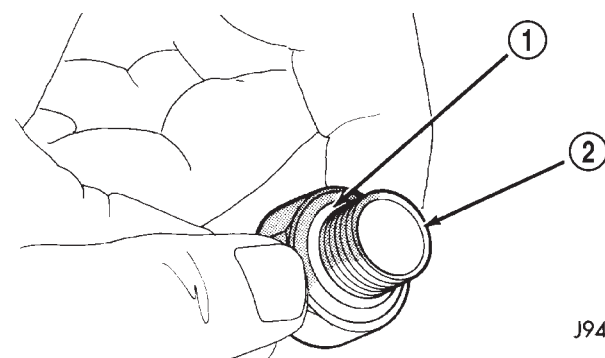
(19) Install poppet plunger and spring (Fig. 76).  
(20) Install new O-ring on poppet screw and install screw in front case (Fig. 77). Tighten screw to 16-24 N·m (12-18 ft. lbs.).



J9421-371

**Fig. 76 Poppet Plunger And Spring Installation**

- 1 - POPPET PLUNGER AND SPRING



J9421-372

**Fig. 77 O-Ring Installation On Poppet Plunger Screw**

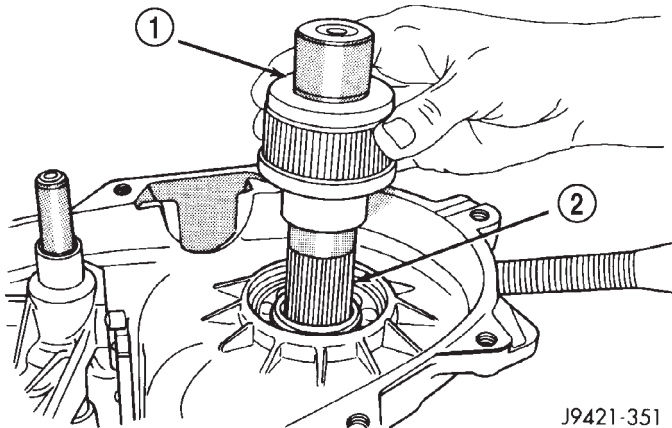
- 1 - O-RING  
2 - PLUNGER SCREW



## TRANSFER CASE - NV231HD (Continued)

**FRONT OUTPUT SHAFT AND DRIVE CHAIN**

(1) Install front output shaft in bearing (Fig. 78).

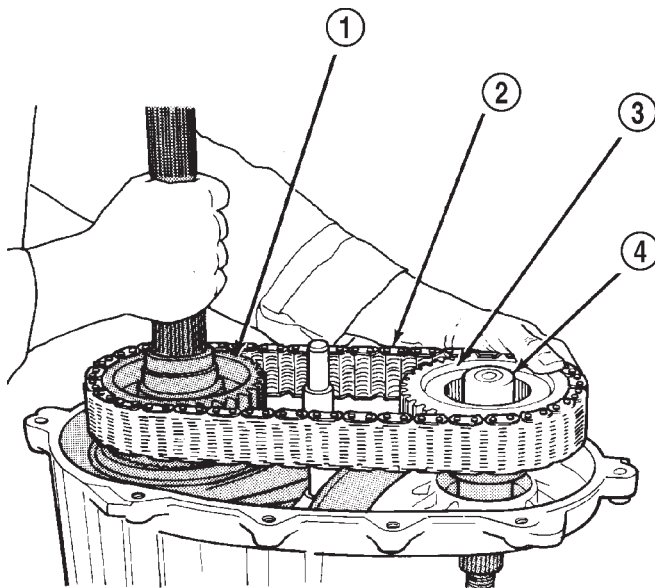


J9421-351

**Fig. 78 Front Output Shaft Installation**

- 1 - FRONT OUTPUT SHAFT  
2 - BEARING

(2) Insert front sprocket in drive chain (Fig. 79).  
(3) Install drive chain around mainshaft sprocket (Fig. 79). Then position front sprocket over front shaft.  
(4) Raise mainshaft about 2.54 cm (one inch) and seat front sprocket on front output shaft.



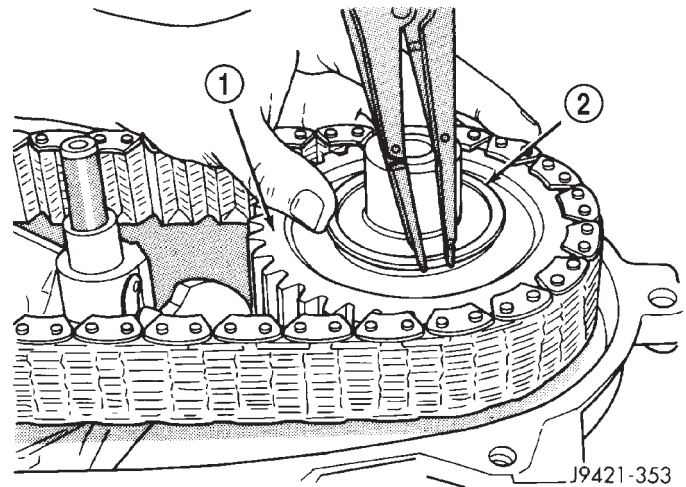
J9421-352

**Fig. 79 Drive Chain And Front Sprocket Installation**

- 1 - DRIVE SPROCKET  
2 - DRIVE CHAIN  
3 - FRONT SPROCKET  
4 - FRONT SHAFT

(5) If mainshaft and mode sleeve were unseated during chain installation, align and reseat mainshaft in input gear and hub.

(6) Install front sprocket retaining ring (Fig. 80).

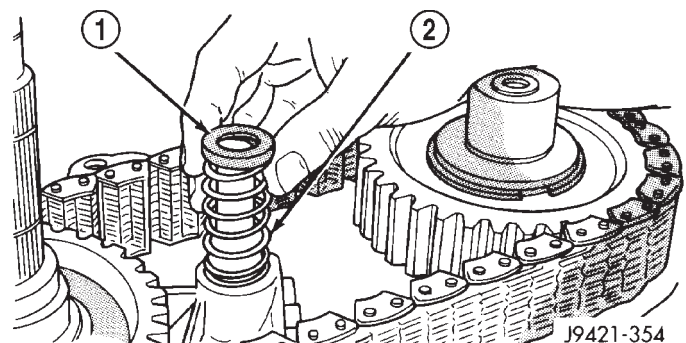


J9421-353

**Fig. 80 Front Sprocket Retaining Ring Installation**

- 1 - FRONT SPROCKET  
2 - RETAINING RING

(7) Install spring and cup on shift rail (Fig. 81).



J9421-354

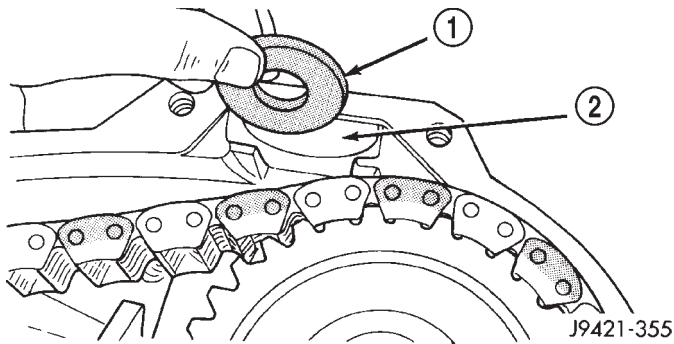
**Fig. 81 Shift Rail Spring And Cup Installation**

- 1 - CUP  
2 - SPRING



## TRANSFER CASE - NV231HD (Continued)

(8) Insert magnet in front case pocket (Fig. 82).



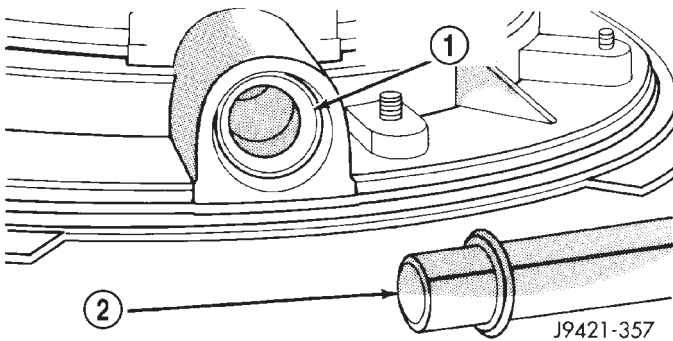
**Fig. 82 Case Magnet Installation**

- 1 - MAGNET
- 2 - CASE POCKET

### OIL PUMP AND REAR CASE

Lubricate the oil pump components with before installation. Prime the oil pickup tube by pouring a little oil into the tube before installation.

(1) Install new O-ring in pickup tube inlet of oil pump (Fig. 83).



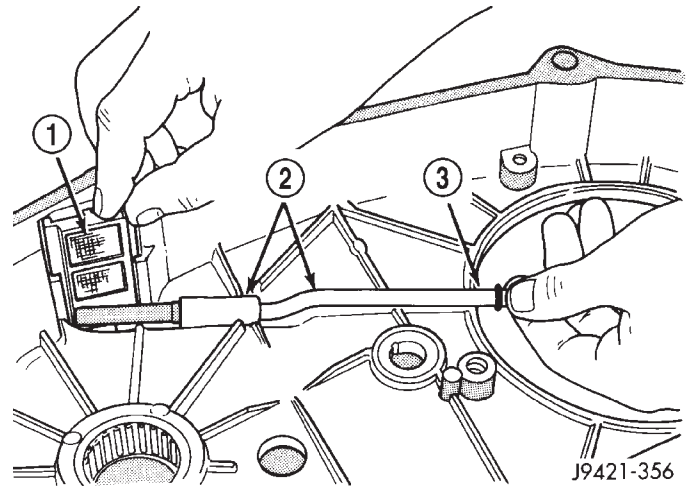
**Fig. 83 Pickup Tube O-Ring Installation**

- 1 - O-RING (PUMP PICKUP)
- 2 - PICKUP TUBE

(2) Position oil pickup tube and filter in rear case. Be sure pickup filter is seated in case pocket and that pickup tube is aligned in case notches (Fig. 84). Be sure hose that connects tube to filter is securely positioned.

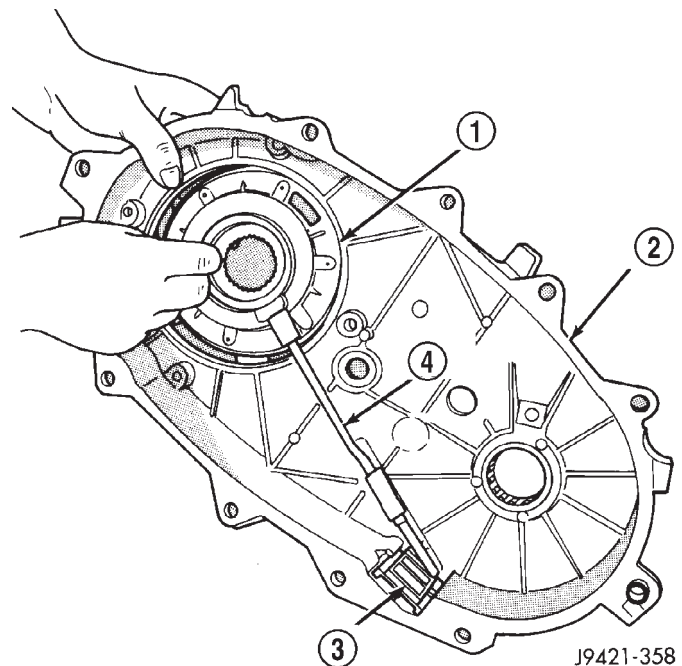
(3) Insert oil pickup tube in oil pump and position pump in rear case (Fig. 85).

(4) Apply bead of Mopar® Gasket Maker, or equivalent, to mating surface of front case. Keep sealer bead width to maximum of 3/16 inch. Do not use excessive amount of sealer as excess will be displaced into case interior.



**Fig. 84 Oil Pickup Tube And Filter Position In Rear Case**

- 1 - FILTER
- 2 - TUBE AND HOSE
- 3 - TUBE IN NOTCH

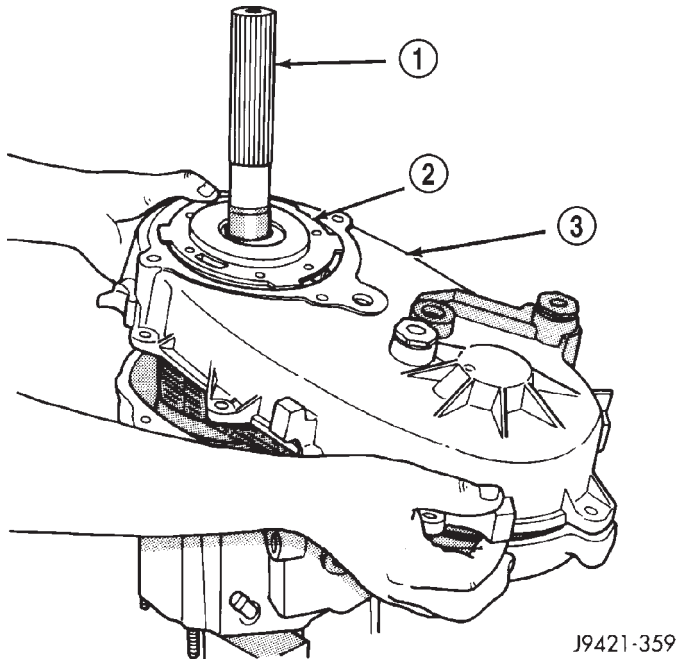


**Fig. 85 Positioning Oil Pump In Rear Case**

- 1 - OIL PUMP
- 2 - REAR CASE
- 3 - FILTER
- 4 - PICKUP TUBE

## TRANSFER CASE - NV231HD (Continued)

(5) Align oil pump with mainshaft and align shift rail with bore in rear case. Then install rear case and oil pump assembly (Fig. 86). Be sure oil pump and pickup tube remain in position during case installation.

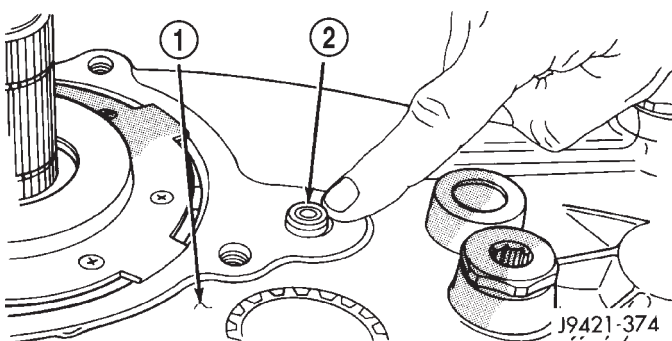


**Fig. 86 Rear Case And Oil Pump Installation**

- 1 - MAINSHAFT
- 2 - OIL PUMP
- 3 - REAR CASE

(6) Install 4-5 rear case-to front case bolts to hold rear case in position. Tighten bolts snug but not to specified torque at this time.

**CAUTION:** Verify that shift rail (Fig. 87), and case alignment dowels are seated before installing any bolts. Case could be cracked if shaft rail or dowels are misaligned.



**Fig. 87 Shift Rail Seated In Rear Case Bore**

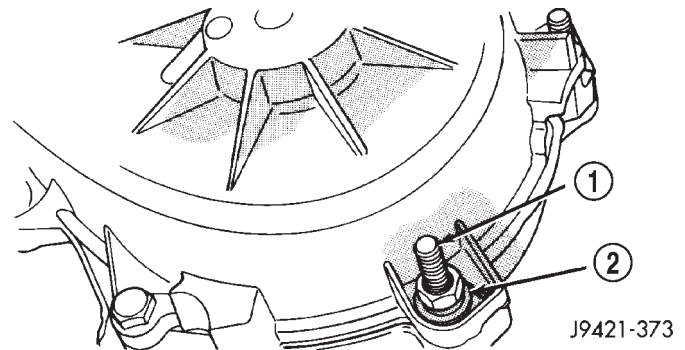
- 1 - REAR CASE
- 2 - SHIFT RAIL

(7) Verify that oil pump is aligned and seated on rear case. Reposition pump if necessary.

(8) Check stud at end of case halves (Fig. 88). If stud was loosened or came out during disassembly, apply Loctite™ 242 to stud threads and reseal stud in case.

(9) Apply Loctite™ 242 to remainder of rear case-to-front case bolt threads and install bolts. Be sure lock washers are used on studs/bolts at case ends. Tighten bolts, or stud nuts as follows:

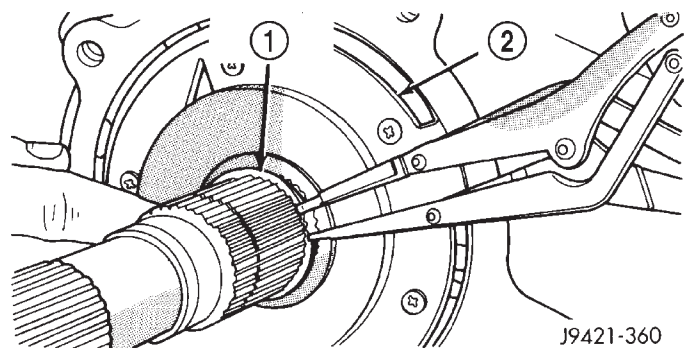
- flange head bolts to 47-61 N-m (35-45 ft. lbs.)
- all other bolts/nuts to 27-34 N-m (20-25 ft. lbs.)



**Fig. 88 Washer Installation On Case Stud And Dowel Bolts**

- 1 - CASE STUD/BOLT
- 2 - WASHER

(10) Install oil pump retaining ring on mainshaft (Fig. 89).



**Fig. 89 Oil Pump Retaining Ring Installation**

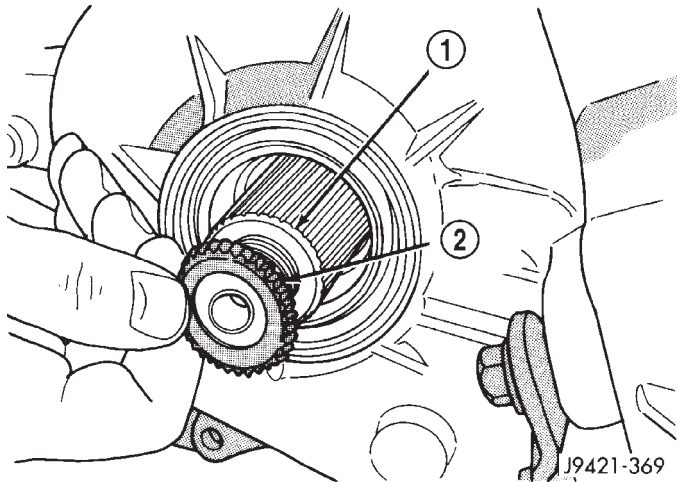
- 1 - RETAINING RING
- 2 - OIL PUMP

## TRANSFER CASE - NV231HD (Continued)

(11) Install rear output bearing and snap-ring to output shaft.

**COMPANION FLANGE**

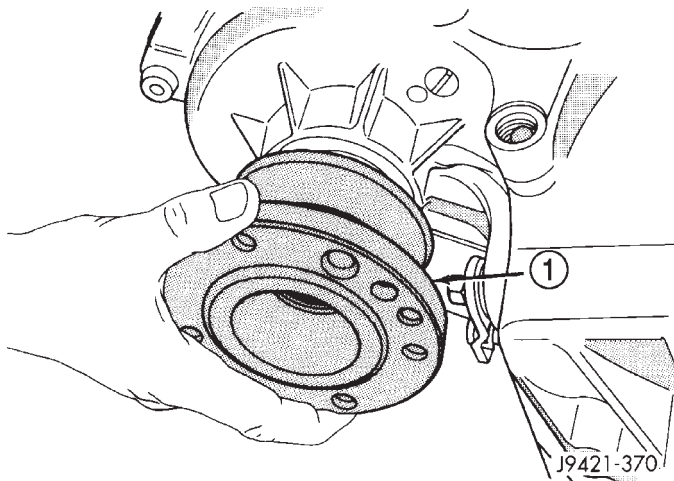
(1) Install companion flange seal on front shaft (Fig. 90).



**Fig. 90 Installing Flange Seal On Front Shaft**

- 1 - FRONT OUTPUT SHAFT  
2 - FLANGE SEAL

(2) Install companion flange on front shaft (Fig. 91). Then install and tighten flange nut to 176-271 N·m (130-200 ft. lbs.) torque.



**Fig. 91 Installing Companion Flange On Front Shaft**

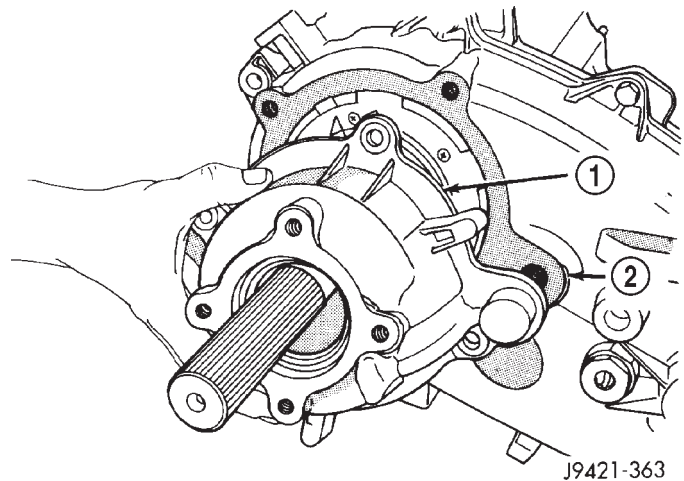
- 1 - COMPANION FLANGE

**REAR RETAINER AND EXTENSION**

(1) Clean mating surfaces of transfer case housing and the rear retainer of any original gasket material.

(2) Install new rear retainer gasket onto the transfer case housing or rear retainer.

(3) Align and install rear retainer on rear case (Fig. 92).

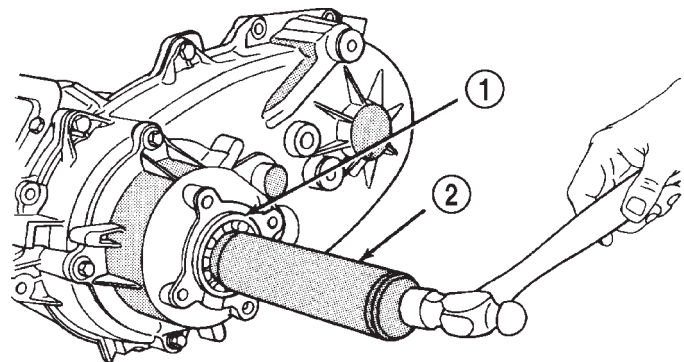


**Fig. 92 Rear Retainer Installation**

- 1 - REAR RETAINER  
2 - SHIFT RAIL

(4) Apply Mopar® Silicone Sealer to threads of rear retainer bolts. Then install retainer bolts finger tight.

(5) Install output bearing on mainshaft and seat it in rear retainer with suitable size pipe tool (Fig. 93).

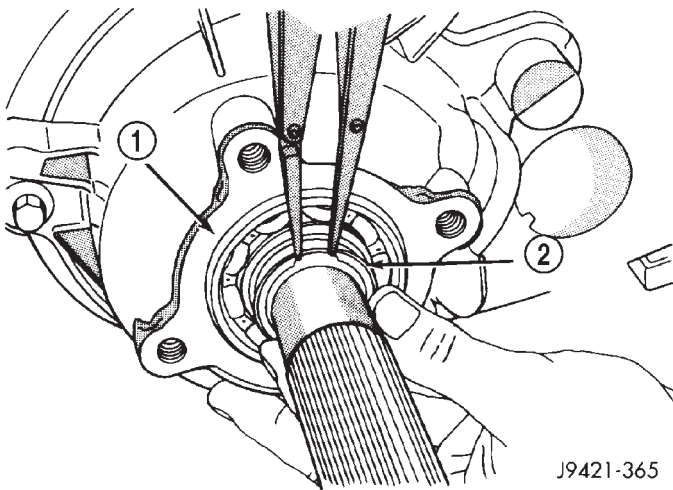


**Fig. 93 Output Bearing Installation**

- 1 - OUTPUT BEARING  
2 - PIPE TOOL

## TRANSFER CASE - NV231HD (Continued)

(6) Install output bearing retaining ring (Fig. 94).



**Fig. 94 Output Bearing Retaining Ring Installation**

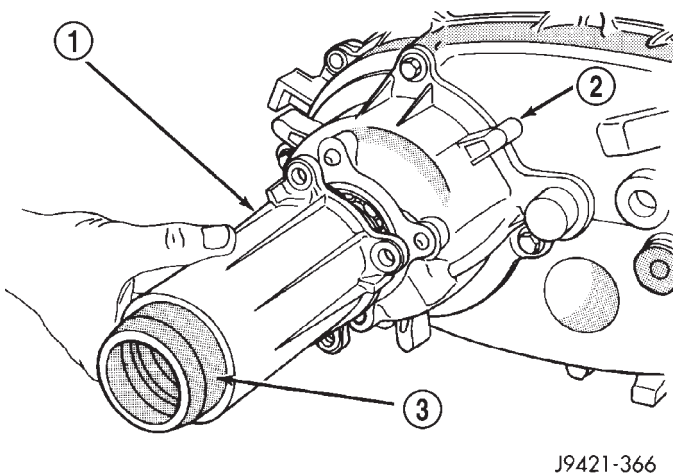
- 1 - OUTPUT BEARING  
2 - RETAINING RING

(7) Tighten rear retainer bolts to 27-34 N·m (20-25 ft. lbs.) torque.

(8) Install new seal in rear extension housing seal with suitable size installer tool.

(9) Apply bead of Mopar® Gasket Maker, or equivalent, to mating surface of rear extension housing. Keep sealer bead width to maximum of 3/16 inch. Do not use excessive amount of sealer as excess could be displaced into output bearing.

(10) Align and install rear extension on retainer (Fig. 95).



**Fig. 95 Rear Extension Housing Installation**

- 1 - REAR EXTENSION  
2 - RETAINER  
3 - EXTENSION SEAL

(11) Apply Mopar® Silicone Sealer to threads of rear extension housing bolts. Then install and tighten bolts to 27-34 N·m (20-25 ft. lbs.) torque.

## INSTALLATION

(1) Align and seat transfer case on transmission. Be sure transfer case input gear splines are aligned with transmission output shaft. Align splines by rotating transfer case rear output shaft yoke if necessary. Do not install any transfer case attaching nuts until the transfer case is completely seated against the transmission.

(2) Install and tighten transfer case attaching nuts. Tighten nuts to 30-41 N·m (20-30 ft.lbs.).

(3) Install rear crossmember.

(4) Remove jack stand from under transmission.

(5) Align and connect propeller shafts. (Refer to 3 - DIFFERENTIAL & DRIVELINE/PROPELLER SHAFT/PROPELLER SHAFT - INSTALLATION)

(6) Connect vacuum harness and vent hose.

(7) Connect shift rod to transfer case lever or floor shift arm. Use channel lock style pliers to press rod back into lever grommet.

(8) Adjust shift linkage, if necessary.

(9) Fill transfer case with recommended transmission fluid and install fill plug.

(10) Install skid plate, if equipped. (Refer to 13 - FRAMES & BUMPERS/FRAME/TRANSFER CASE SKID PLATE - INSTALLATION)

(11) Lower vehicle

TRANSFER CASE - NV231HD (Continued)

## SPECIFICATIONS

## TRANSFER CASE

## TORQUE SPECIFICATIONS

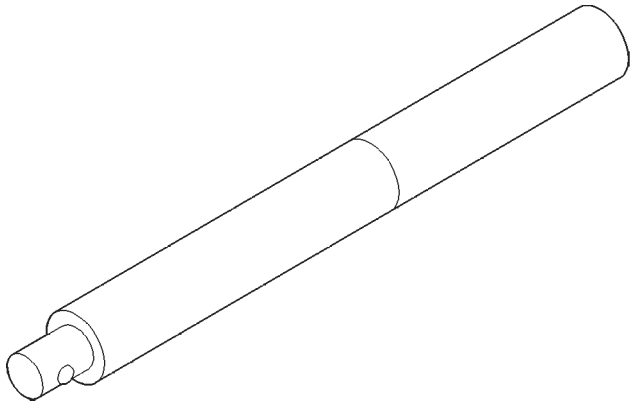
DESCRIPTION	N-m	Ft. Lbs.	In. Lbs.
Plug, Detent	16-24	12-18	-
Bolt, Diff. Case	17-27	15-24	-
Plug, Drain/Fill	40-45	30-40	-
Bolt, Extension Housing	35-46	26-34	-
Bolt, Front Brg. Retainer	16-27	12-24	-
Bolt, Case Half	35-46	26-34	-
Nut, Front Yoke	122-176	90-130	-
Screw, Oil Pump	1.2-1.8	-	12-15
Nut, Range Lever	27-34	20-25	-
Bolt, Rear Retainer	35-46	26-34	-
Nuts, Mounting	30-41	20-30	-
Bolts, U-Joint	19	17	-
Vacuum Switch	20-34	15-25	-



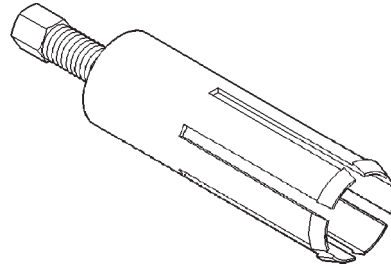
TRANSFER CASE - NV231HD (Continued)

SPECIAL TOOLS

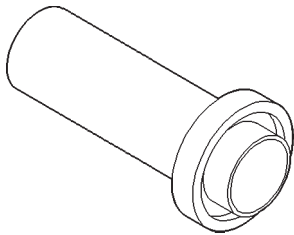
TRANSFER CASE - NV231HD



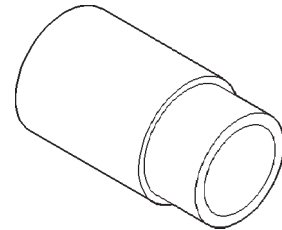
**Handle, Universal - C-4171**



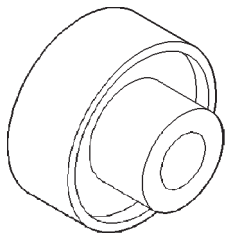
**Remover, Bushing - 6957**



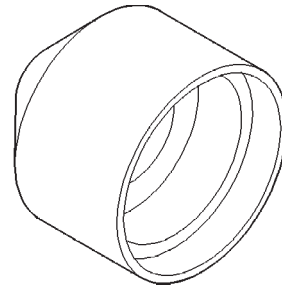
**Installer, Seal - 8143-A**



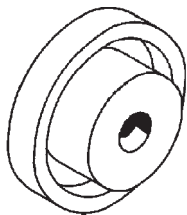
**Installer, Bushing - 8157**



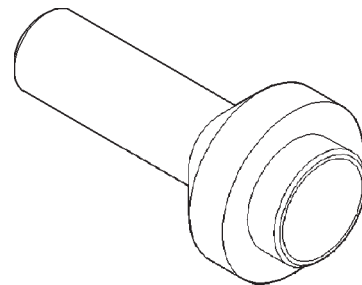
**Installer, Bearing - 6953**



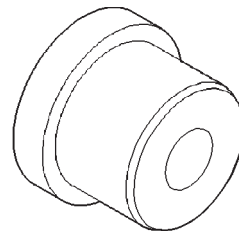
**Installer, Seal - D-163**



**Installer, Seal - C-4210**

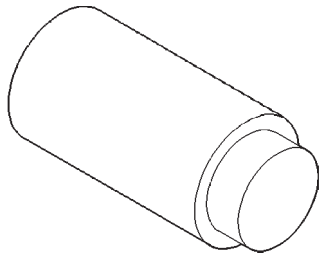
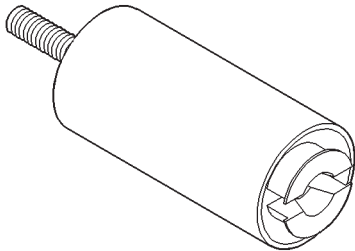
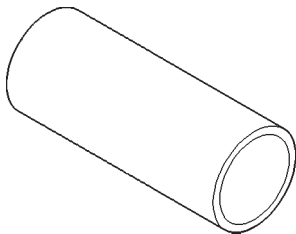
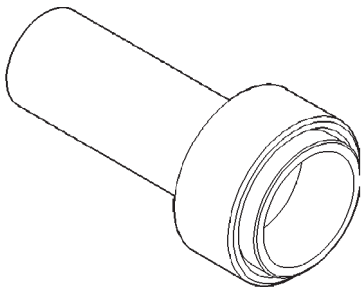


**Installer, Seal - 7884**



**Installer, Bushing - 5066**

## EXTENSION HOUSING BUSHING AND SEAL (Continued)

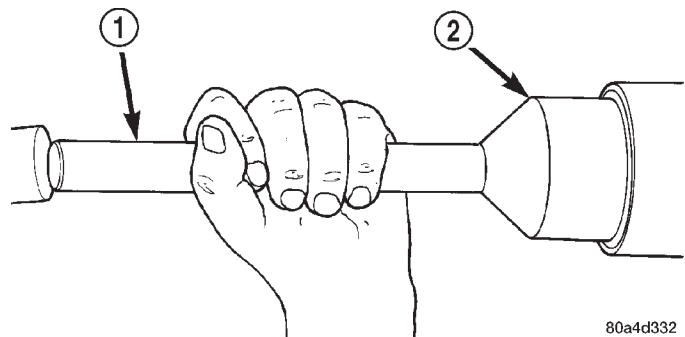
**Plug, Extension - C-293-3****Tool Set - L-4518****Cup - 8148****Installer, Pump Housing Seal - 7888**EXTENSION HOUSING  
BUSHING AND SEAL

## REMOVAL

- (1) Raise and support vehicle.
- (2) Remove rear propeller shaft. (Refer to 3 - DIFFERENTIAL & DRIVELINE/PROPELLER SHAFT/PROPELLER SHAFT - REMOVAL)
- (3) Using a suitable pry tool or slide-hammer mounted screw, remove the extension housing seal.
- (4) Using Remover 8158, remove bushing from extension housing.

## INSTALLATION

- (1) Clean fluid residue from sealing surface and inspect for defects.
- (2) Position replacement bushing in extension housing with fluid port in bushing aligned with slot in housing.
- (3) Using Installer 8157, drive bushing into housing until installer seats against case.
- (4) Using Installer D-163, install seal in extension housing (Fig. 96).



80a4d332

**Fig. 96 Install Rear Seal in Extension Housing**

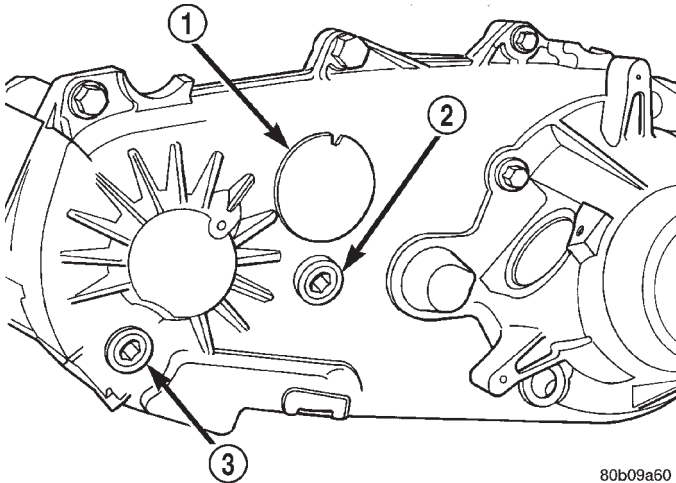
- 1 - SPECIAL TOOL C-4171
- 2 - SPECIAL TOOL D-163

- (5) Install propeller shaft. (Refer to 3 - DIFFERENTIAL & DRIVELINE/PROPELLER SHAFT/PROPELLER SHAFT - INSTALLATION)
- (6) Verify proper transfer case fluid level.
- (7) Lower vehicle.

## FLUID

### STANDARD PROCEDURE - FLUID DRAIN AND REFILL

The fill and drain plugs are both in the rear case (Fig. 97).



80b09a60

**Fig. 97 Fill/Drain Plug and I.D. Tag Location - Typical**

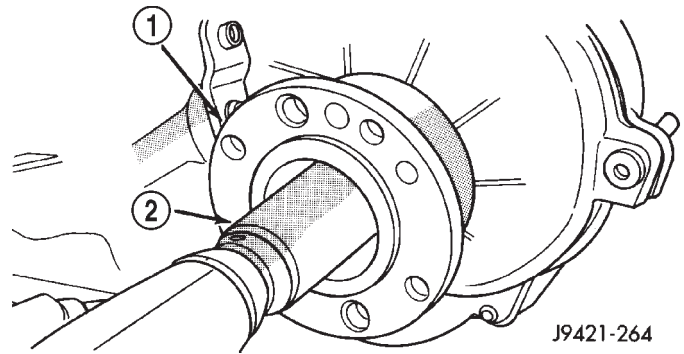
- 1 - I.D. TAG
- 2 - FILL PLUG
- 3 - DRAIN PLUG

- (1) Raise vehicle.
- (2) Position drain pan under transfer case.
- (3) Remove drain and fill plugs and drain lubricant completely.
- (4) Install drain plug. Tighten plug to 41-54 N·m (30-40 ft. lbs.).
- (5) Remove drain pan.
- (6) Fill transfer case to bottom edge of fill plug opening with Mopar® ATF +4, type 9602, Automatic Transmission fluid.
- (7) Install and tighten fill plug to 41-54 N·m (30-40 ft. lbs.).
- (8) Lower vehicle.

## FRONT OUTPUT SHAFT SEAL

### REMOVAL

- (1) Shift transfer case into NEUTRAL.
- (2) Raise vehicle.
- (3) Remove front propeller shaft. (Refer to 3 - DIFFERENTIAL & DRIVELINE/PROPELLER SHAFT/PROPELLER SHAFT - REMOVAL)
- (4) Remove companion flange nut (Fig. 98).
- (5) Remove companion flange from output shaft. Use a suitable puller if flange can not be removed by hand.

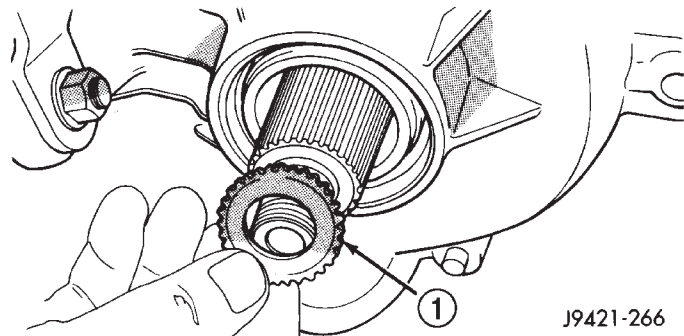


J9421-264

**Fig. 98 Removing Companion Flange Nut**

- 1 - COMPANION FLANGE
- 2 - SOCKET

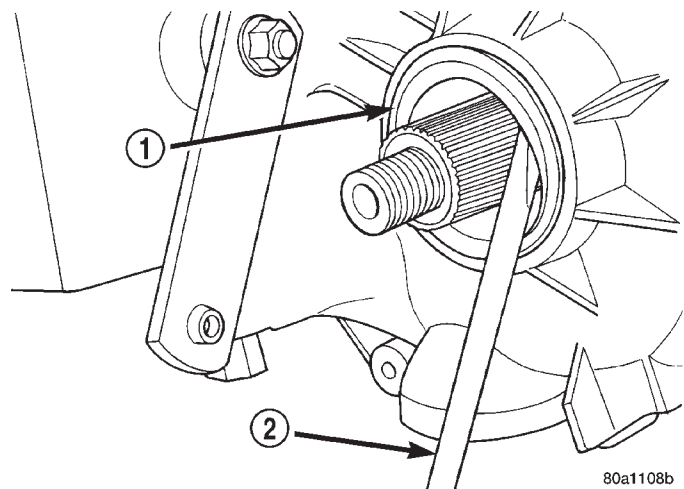
- (6) Remove companion flange rubber seal from front output shaft (Fig. 99).
- (7) Remove seal from front case with pry tool (Fig. 100).



J9421-266

**Fig. 99 Companion Flange Seal Removal**

- 1 - FLANGE SEAL



80a1108b

**Fig. 100 Remove Front Output Shaft Seal**

- 1 - OUTPUT SHAFT SEAL
- 2 - PRYBAR

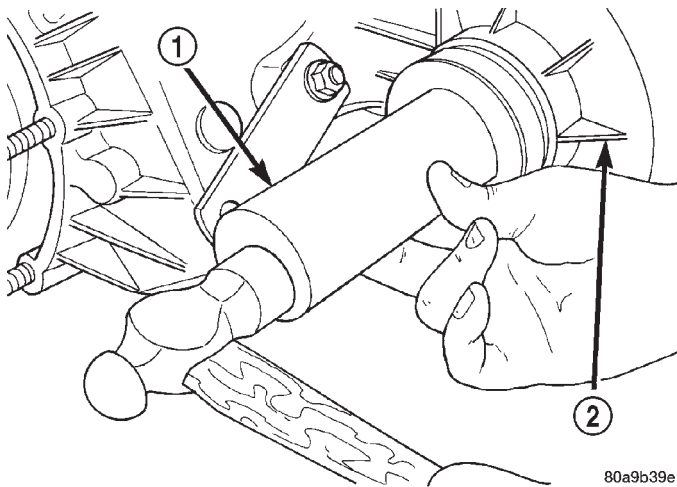
## FRONT OUTPUT SHAFT SEAL (Continued)

**INSTALLATION**

(1) Install new front output seal in front case with Installer Tool 8143-A as follows:

(a) Place new seal on tool. Garter spring on seal goes toward interior of case.

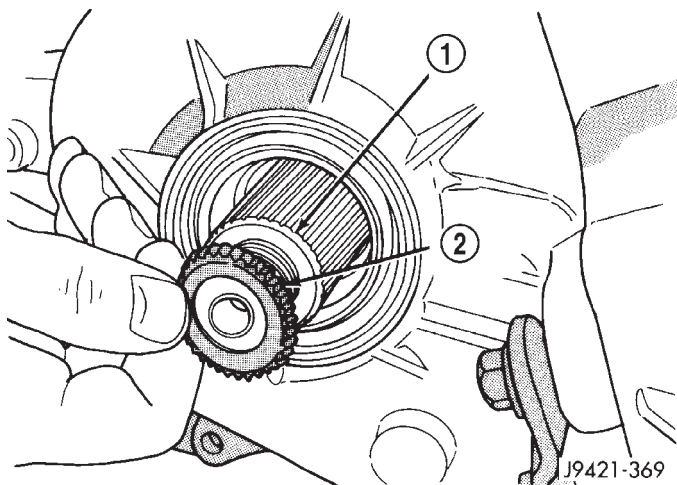
(b) Start seal in bore with light taps from hammer (Fig. 101). Once seal is started, continue tapping seal into bore until installer tool seats against case.



**Fig. 101 Front Output Seal Installation**

- 1 - INSTALLER 8143-A  
2 - TRANSFER CASE

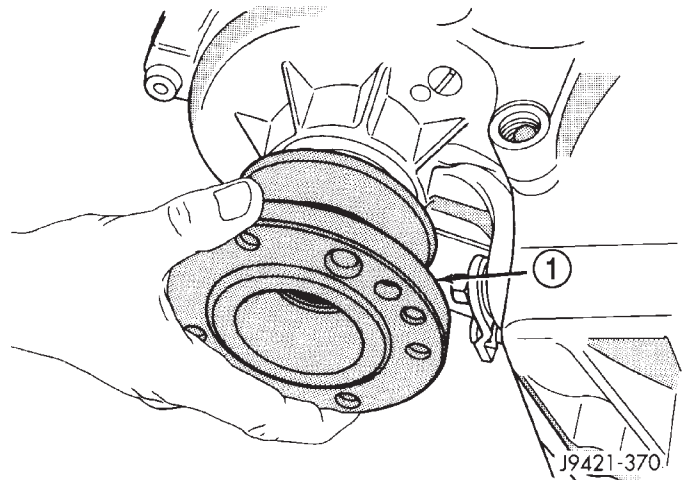
(2) Install companion flange seal on front shaft (Fig. 102).



**Fig. 102 Installing Flange Seal On Front Shaft**

- 1 - FRONT OUTPUT SHAFT  
2 - FLANGE SEAL

(3) Install companion flange on front shaft (Fig. 103). Then install and tighten flange nut to 176-271 N·m (130-200 ft. lbs.) torque.



**Fig. 103 Installing Companion Flange On Front Shaft**

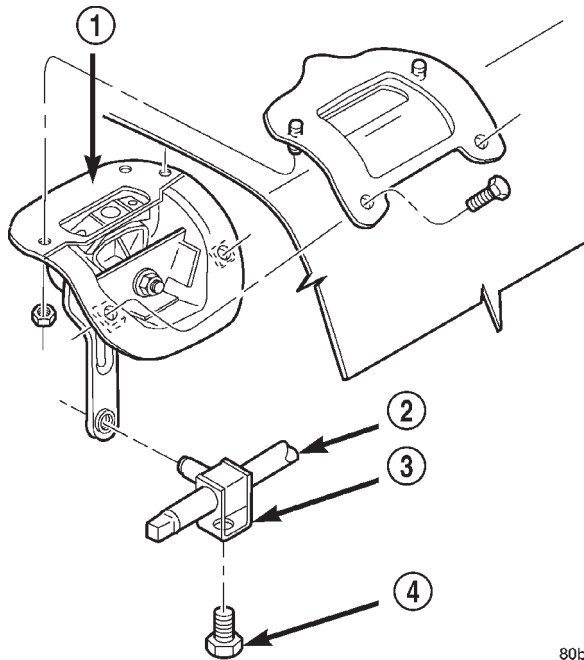
- 1 - COMPANION FLANGE

(4) Install propeller shaft. (Refer to 3 - DIFFERENTIAL & DRIVELINE/PROPELLER SHAFT/PROPELLER SHAFT - INSTALLATION)

**SHIFT LEVER****REMOVAL**

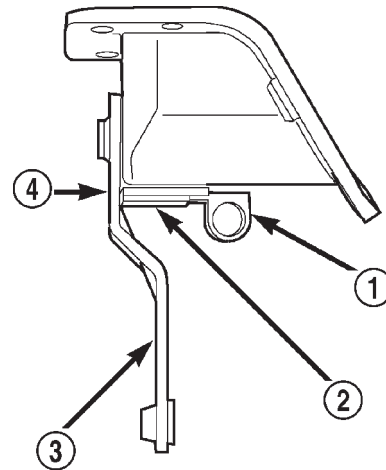
- (1) Shift transfer case into 2H.
- (2) Remove transfer case shifter knob cap.
- (3) Remove nut holding shifter knob to shift lever.
- (4) Remove shifter knob.
- (5) Remove the shift boot from the shifter bezel.
- (6) Remove the bolts securing the shifter mechanism to the floor pan along the driver's side of the transmission tunnel (Fig. 104).
- (7) Raise and support the vehicle.
- (8) Loosen adjusting trunnion lock bolt and slide shift rod out of trunnion. If rod lacks enough travel to come out of trunnion, push trunnion out of shift lever.
- (9) Remove the nuts holding the shifter mechanism to the underside of the floor pan.
- (10) Separate shift lever mechanism from the vehicle.

## SHIFT LEVER (Continued)

**Fig. 104 Transfer Case Shifter**

- 1 - TRANSFER CASE SHIFTER ASSEMBLY
- 2 - SHIFT ROD
- 3 - TRUNNION
- 4 - LOCK BOLT

80be45f5

**Fig. 105 Shifter Adjustment**

- 1 - LOCATING PIN
- 2 - ADJUSTMENT CHANNEL
- 3 - LOWER SHIFTER LEVER
- 4 - LOCATING HOLE

80be45f6

(3) Loosen shift rod lock bolt at trunnion (Fig. 106).

**INSTALLATION**

(1) If the shifter mechanism does not have a adjustment locating pin installed, align the adjustment channel on the shifter assembly to the locating hole in the lower shift lever and install an appropriately sized pin to retain the position (Fig. 105).

(2) Position shift lever on vehicle.

(3) Install nuts to hold shift lever to the underside of the body.

(4) Install trunnion to shift lever, if necessary.

(5) Install shift rod to trunnion, if necessary.

(6) Tighten the shift rod lock bolt to 10 N·m (90 in.lbs.).

(7) Remove the shifter adjustment locating pin from the adjustment channel and the locating hole.

(8) Lower vehicle.

(9) Install the bolts to hold the shifter mechanism to the floor pan.

(10) Install the transfer case shifter bezel.

(11) Install the shifter boot and the shifter knob onto the shifter lever.

(12) Install nut to hold shifter knob to shift lever.

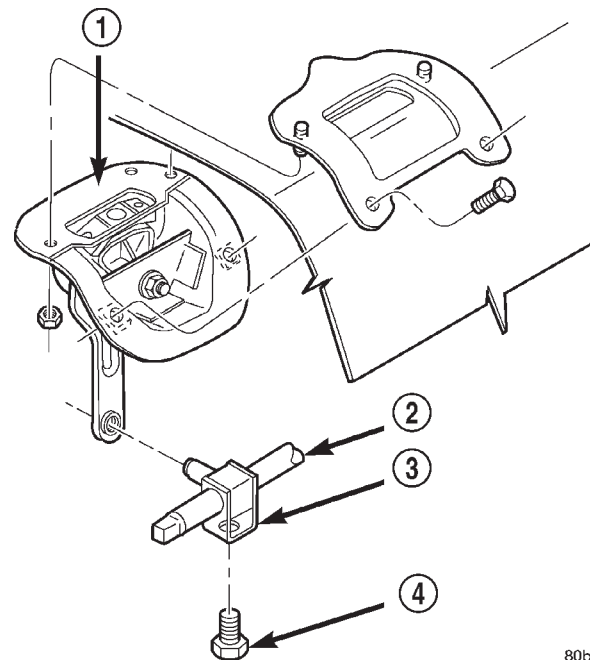
(13) Install shifter knob cap.

(14) Verify transfer case operation.

**ADJUSTMENT - SHIFT LEVER**

(1) Move shift lever into 2H position.

(2) Raise vehicle.

**Fig. 106 Shift Rod Lock Bolt Location**

- 1 - TRANSFER CASE SHIFTER ASSEMBLY
- 2 - SHIFT ROD
- 3 - TRUNNION
- 4 - LOCK BOLT

80be45f5



## SHIFT LEVER (Continued)

(4) Check shift rod fit in trunnion. Be sure rod does not bind in trunnion. Lubricate the shift rod and trunnion if necessary.

(5) Verify that transfer case shift lever is in 2H detent position. The 2H detent position on the transfer case shift arm is the second position from full forward.

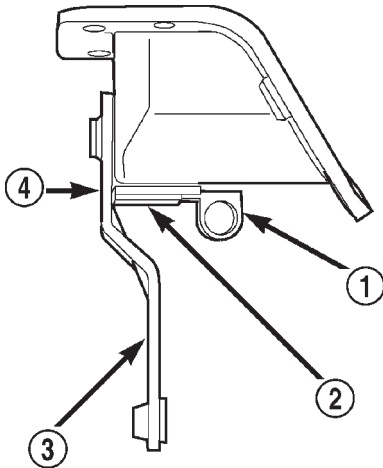
(6) Align the adjustment locating hole on the lower shifter lever with the adjustment channel on the shifter bracket assembly (Fig. 107).

(7) Insert an appropriately sized pin through into the adjustment channel and through the locating hole to hold the shifter in the correct position.

(8) Tighten shift rod lock bolt to 10 N·m (90 in. lbs.) torque.

(9) Remove the locating pin from the adjustment channel and locating hole.

(10) Check shift linkage operation. Be sure transfer case shifts into and operates properly in all ranges.



80be45f6

**Fig. 107 Shifter Adjustment Location**

- 1 - LOCATING PIN
  - 2 - ADJUSTMENT CHANNEL
  - 3 - LOWER SHIFTER LEVER
  - 4 - LOCATING HOLE
-

## TRANSFER CASE - NV241LD

### TABLE OF CONTENTS

	page		page
<b>TRANSFER CASE - NV241LD</b>		<b>EXTENSION HOUSING BUSHING AND SEAL</b>	
DESCRIPTION .....	855	REMOVAL .....	885
OPERATION .....	855	INSTALLATION .....	885
DIAGNOSIS AND TESTING .....	856	<b>FLUID</b>	
TRANSFER CASE .....	856	STANDARD PROCEDURE .....	885
REMOVAL .....	858	FLUID DRAIN AND REFILL .....	885
DISASSEMBLY .....	858	<b>FRONT OUTPUT SHAFT SEAL</b>	
CLEANING .....	866	REMOVAL .....	886
INSPECTION .....	867	INSTALLATION .....	886
ASSEMBLY .....	869	<b>SHIFT LEVER</b>	
INSTALLATION .....	882	REMOVAL .....	887
SPECIFICATIONS .....	883	INSTALLATION .....	888
SPECIAL TOOLS .....	884	ADJUSTMENTS .....	888

## TRANSFER CASE - NV241LD

### DESCRIPTION

The NV241LD transfer case is a part-time transfer case with a low-range gear system. It provides three operating ranges plus a NEUTRAL position. The low range position provides a gear reduction ratio of 2.72:1 for increased low speed torque capability.

The synchronizer mechanism consists of a brass stop ring, synchro hub, and the sliding clutch. The synchronizer components allow the transfer case to be shifted between the 2H and 4H operating ranges while the vehicle is in motion.

The gear cases, retainer and extension are all of aluminum. Drive sprockets and an interconnecting drive chain are used to transmit engine torque to the front/rear propeller shafts. The mainshaft, input gear and front output shaft are supported by ball and needle bearings.

### IDENTIFICATION

An identification tag (Fig. 1) is attached to the rear case of every transfer case. The tag provides the transfer case model number, assembly number, serial number, and low range ratio.

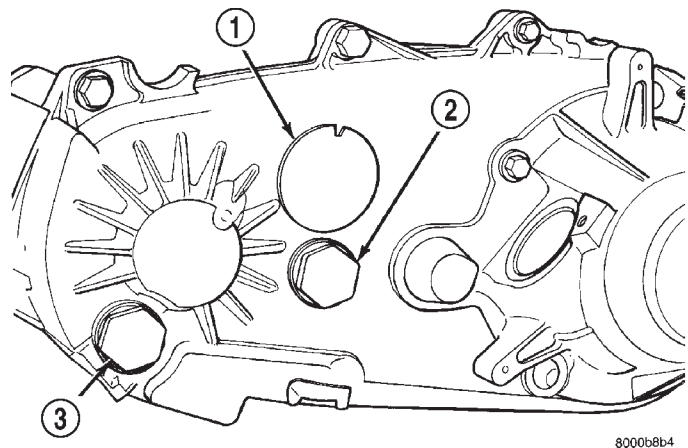
The transfer case serial number also represents the date of build.

### OPERATION

#### OPERATING RANGES

Transfer case operating ranges are:

- 2H (2-wheel drive)
- 4H (4-wheel drive)



**Fig. 1 Transfer Case Identification Tag - Typical**

- 1 - I.D. TAG
- 2 - FILL PLUG
- 3 - DRAIN PLUG

- 4LO (4-wheel drive low range)

The 2H range is for use on any road surface at any time.

The 4H and 4LO ranges are for off road use only. They are not for use on hard surface roads. The only exception being when the road surface is covered by ice and snow.

The low range reduction gear system is operative in 4LO range only. This range is for extra pulling power in off road situations. Low range reduction ratio is 2.72:1.

A front axle disconnect system is used to achieve two-wheel drive mode. The axle disconnect vacuum motor is actuated by a vacuum switch on the transfer

## TRANSFER CASE - NV241LD (Continued)

case. The switch is operated by the transfer case range rod.

**SHIFT MECHANISM**

The transfer case is operated by an adjustable floor mounted shift linkage. The transfer case shift lever is directly attached to the shift sector. The sector operates the range and mode forks within the transfer case.

A straight line shift pattern is used with a NEUTRAL detent. Lever range positions are imprinted in the shift knob.

**SHIFTING**

The synchronizer components allow the transfer case to be shifted between the 2H and 4H operating ranges while the vehicle is in motion. The vehicle

must have the transmission placed in NEUTRAL, or the clutch depressed in the case of a manual transmission, and be moving less than 2-3 MPH when shifting into the 4L operating range.

**DIAGNOSIS AND TESTING - TRANSFER CASE**

Before beginning repair on a suspected transfer case malfunction, check all other driveline components beforehand.

The actual cause of a problem may be related to such items as: front hubs, axles, propeller shafts, wheels and tires, transmission, or clutch instead. If all other driveline components are in good condition and operating properly, refer to the Diagnosis Chart for further information.

## TRANSFER CASE - NV241LD (Continued)

**DIAGNOSIS CHART**

Condition	Possible Cause	Correction
Transfer Case difficult to shift or will not shift into desired range.	<ol style="list-style-type: none"> <li>1) Vehicle speed too great to permit shifting.</li> <li>2) If vehicle was operated for an extended period in 4H on a dry paved surface, the driveline torque load may be causing a bind.</li> <li>3) Transfer case external shift linkage binding.</li> <li>4) Insufficient or incorrect lubricant.</li> <li>5) Internal components binding, worn, or damaged.</li> </ol>	<ol style="list-style-type: none"> <li>1) Stop vehicle and shift into desired range. Or, reduce speed to below 3-4 km/h (2-3 mph) before attempting the shift.</li> <li>2) Stop vehicle and shift the transmission into neutral. Shift the transfer case to 2H and operate vehicle in 2H on dry paved surfaces.</li> <li>3) Lubricate, repair, or replace linkage bushings, or tighten loose components as necessary.</li> <li>4) Drain and refill to edge of fill hole with Mopar® ATF +4, type 9602, Automatic Transmission fluid.</li> <li>5) Disassemble the transfer case and replace worn or damaged components as necessary.</li> </ol>
Transfer Case noisy in all operating ranges.	<ol style="list-style-type: none"> <li>1) Insufficient or incorrect lubricant.</li> </ol>	<ol style="list-style-type: none"> <li>1) Drain and refill to edge of fill hole with Mopar® ATF +4, type 9602, Automatic Transmission fluid.</li> </ol>
Noisy in, or jumps out of, four wheel drive low range.	<ol style="list-style-type: none"> <li>1) Transfer case not completely engaged in 4L position.</li> <li>2) Shift linkage out of adjustment.</li> <li>3) Shift linkage loose or binding.</li> <li>4) Range fork damaged, inserts worn, or fork is binding on the shift rail.</li> <li>5) Low range gear worn or damaged.</li> </ol>	<ol style="list-style-type: none"> <li>1) With the transmission in NEUTRAL, or the clutch depressed in the case of a manual transmission and the vehicle moving under 3-4 km/h (2-3 mph), shift the transfer case to NEUTRAL and then shift into the 4L position.</li> <li>2) Adjust linkage.</li> <li>3) Tighten, lubricate, or repair linkage as necessary.</li> <li>4) Disassemble unit and repair as necessary.</li> <li>5) Disassemble unit and repair as necessary.</li> </ol>
Lubricant leaking from output shaft seal or vent.	<ol style="list-style-type: none"> <li>1) Transfer case overfilled.</li> <li>2) Vent closed or restricted.</li> <li>3) Output shaft seals damaged or installed incorrectly.</li> </ol>	<ol style="list-style-type: none"> <li>1) Drain lubricant to the correct level.</li> <li>2) Clear or replace vent as necessary.</li> <li>3) Replace seal as necessary. Check to ensure that another component, the propeller shaft slip yoke for example, is not causing damage to seal.</li> </ol>
Abnormal tire wear.	<ol style="list-style-type: none"> <li>1) Extended operation on hard, dry surfaces in the 4H position.</li> </ol>	<ol style="list-style-type: none"> <li>1) Operate vehicle in the 2H position on hard, dry surfaces.</li> </ol>

## TRANSFER CASE - NV241LD (Continued)

**REMOVAL**

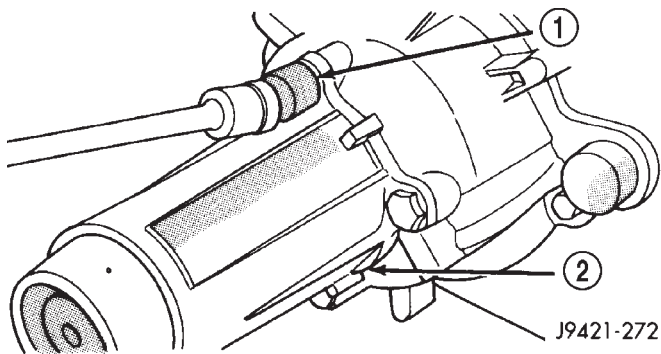
- (1) Raise and support vehicle.
- (2) Remove skid plate, if equipped. (Refer to 13 - FRAMES & BUMPERS/FRAME/TRANSFER CASE SKID PLATE - REMOVAL)
- (3) Position drain oil container under transfer case.
- (4) Remove transfer case drain plug and drain lubricant into container.
- (5) Disconnect vent hose and vacuum harness at transfer case switch.
- (6) Disconnect shift rod from grommet in transfer case shift lever, or from floor shift arm whichever provides easy access. Use channel lock style pliers to press rod out of lever grommet.
- (7) Support transmission with jack stand.
- (8) Remove rear crossmember.
- (9) Mark front and rear propeller shafts for assembly reference.
- (10) Remove front and rear propeller shafts. (Refer to 3 - DIFFERENTIAL & DRIVELINE/PROPELLER SHAFT/PROPELLER SHAFT - REMOVAL)
- (11) Support transfer case with suitable jack. Secure transfer case to jack with safety chains.
- (12) Remove nuts attaching transfer case to transmission.
- (13) Move transfer case assembly rearward until free of transmission output shaft.
- (14) Lower jack and move transfer case from under vehicle.

**DISASSEMBLY**

Position transfer case in a shallow drain pan. Remove drain plug and drain any remaining lubricant remaining in case.

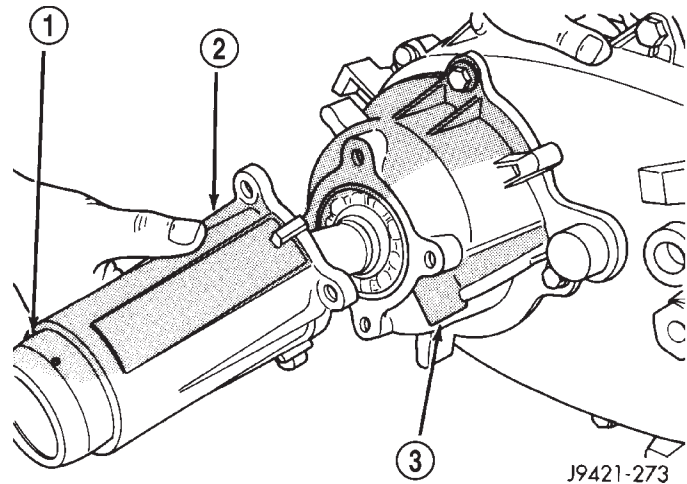
**REAR EXTENSION, RETAINER, AND REAR CASE**

- (1) Remove rear extension bolts (Fig. 2).

**Fig. 2 Rear Extension Bolt Removal**

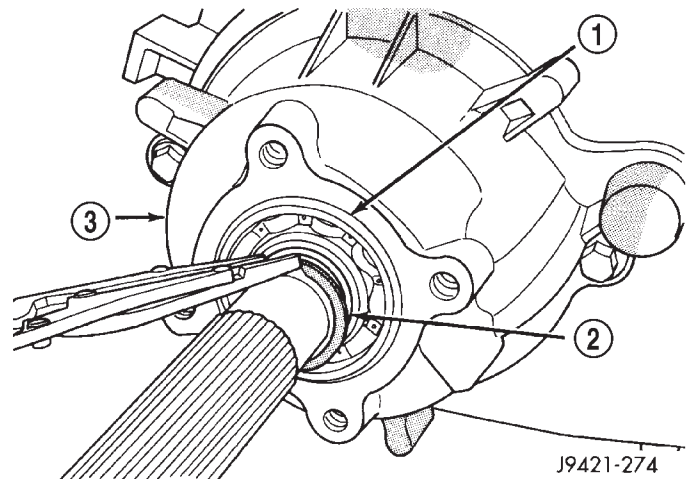
- 1 - SOCKET
- 2 - REAR EXTENSION

- (2) Remove rear extension housing (Fig. 3). Tap extension once or twice with a plastic mallet to break sealer bead and loosen it.

**Fig. 3 Rear Extension Housing Removal**

- 1 - SEAL
- 2 - REAR EXTENSION HOUSING
- 3 - REAR RETAINER

- (3) Remove output bearing retaining ring with heavy duty snap-ring pliers (Fig. 4).

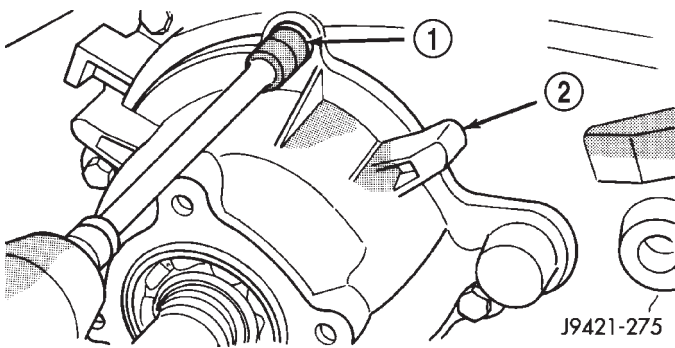
**Fig. 4 Removing Output Bearing Retaining Ring**

- 1 - OUTPUT BEARING
- 2 - RETAINING RING
- 3 - REAR RETAINER



## TRANSFER CASE - NV241LD (Continued)

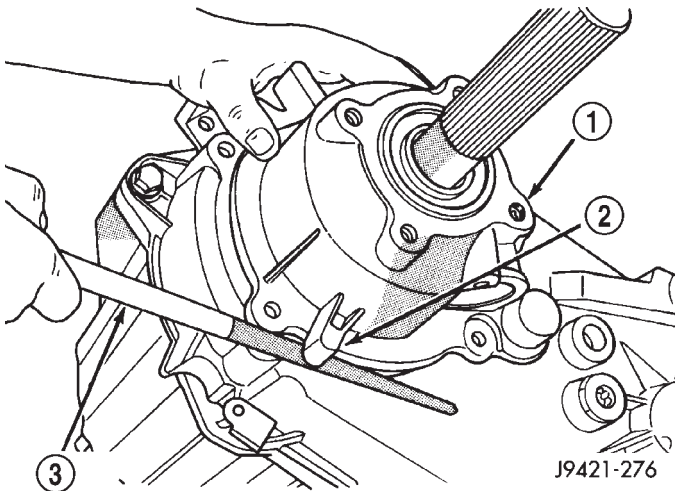
(4) Remove rear retainer bolts (Fig. 5).



**Fig. 5 Removing Rear Extension Bolts**

- 1 - SOCKET  
2 - REAR RETAINER

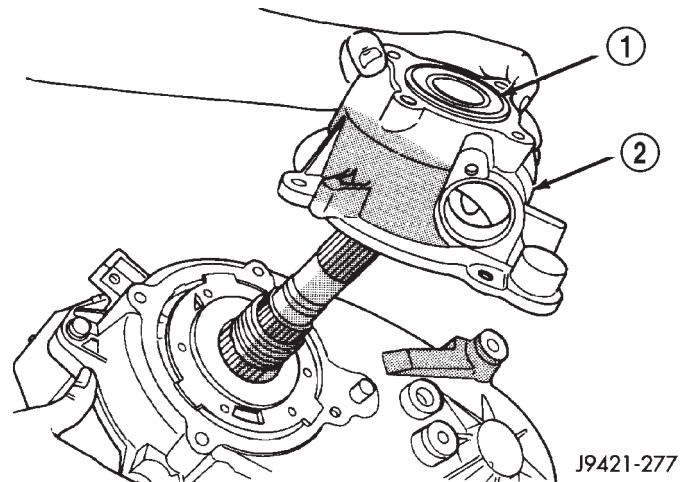
(5) Loosen rear retainer with pry bar placed under flange (Fig. 6).



**Fig. 6 Loosening Rear Retainer**

- 1 - REAR RETAINER  
2 - FLANGE  
3 - PRY TOOL

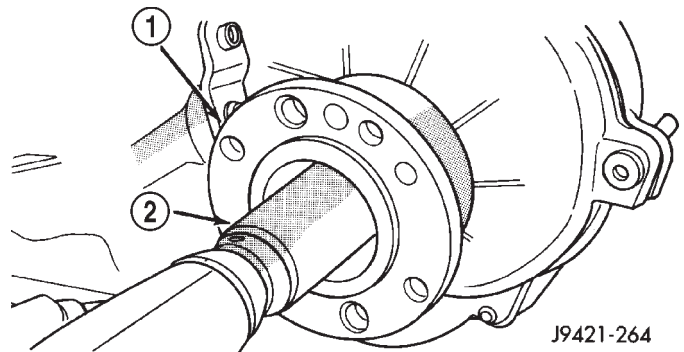
(6) Remove rear retainer and output bearing as assembly (Fig. 7).



**Fig. 7 Rear Retainer Removal**

- 1 - OUTPUT BEARING  
2 - REAR RETAINER

(5) Loosen rear retainer with pry bar placed under flange (Fig. 6).



**Fig. 8 Removing Companion Flange Nut**

- 1 - COMPANION FLANGE  
2 - SOCKET

### COMPANION FLANGE AND SHIFT LEVER

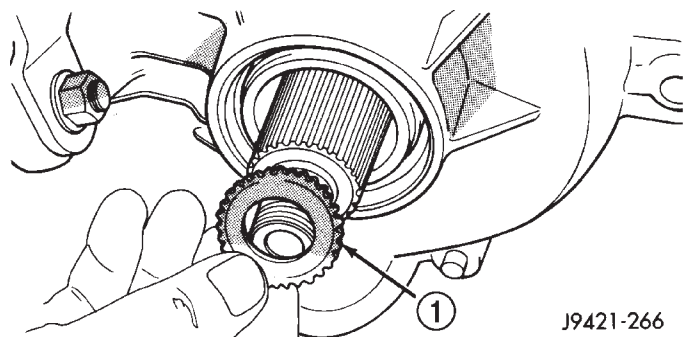
(1) Shift transfer case into NEUTRAL.

(2) Remove companion flange nut (Fig. 8). Discard nut after removal. It is not reusable.

(3) Remove companion flange from front output shaft. Use a suitable puller if flange can not be removed by hand.

(4) Remove companion flange rubber seal from front output shaft (Fig. 9).

(5) Remove nut and washer that retain shift lever to sector shaft. Then remove shift lever from shaft (Fig. 10).



**Fig. 9 Companion Flange Seal Removal**

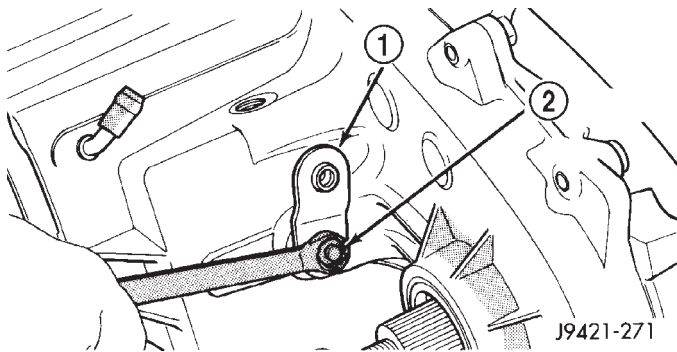
- 1 - FLANGE SEAL

### FRONT OUTPUT SHAFT AND DRIVE CHAIN

(1) Remove output bearing retaining ring with heavy duty snap-ring pliers.

(2) Remove output shaft bearing.

TRANSFER CASE - NV241LD (Continued)



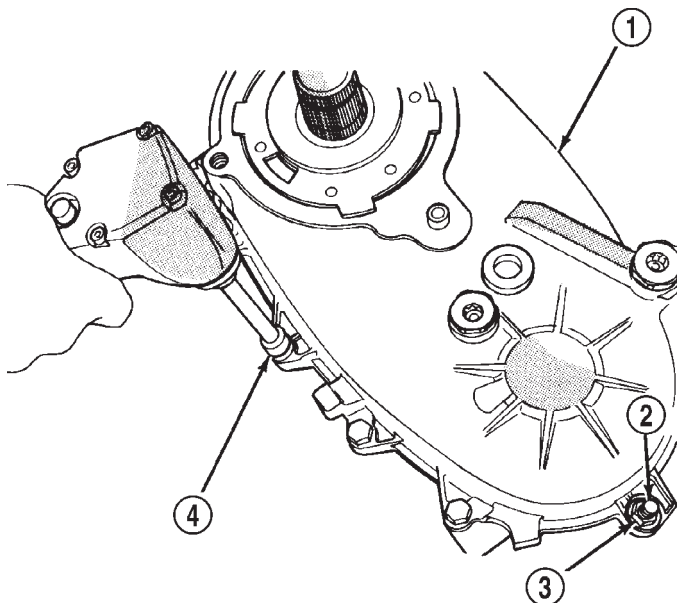
J9421-271

**Fig. 10 Shift Lever Removal**

- 1 - SHIFT LEVER
- 2 - NUT/WASHER

(3) Note position of bolts that attach rear case to front case (Fig. 11). Some bolts/studs at ends of case require flat washers. Mark position of these bolts with paint or scribe.

(4) Remove rear case-to-front case bolts.



J9421-278

**Fig. 11 Removing Case Attaching Bolts**

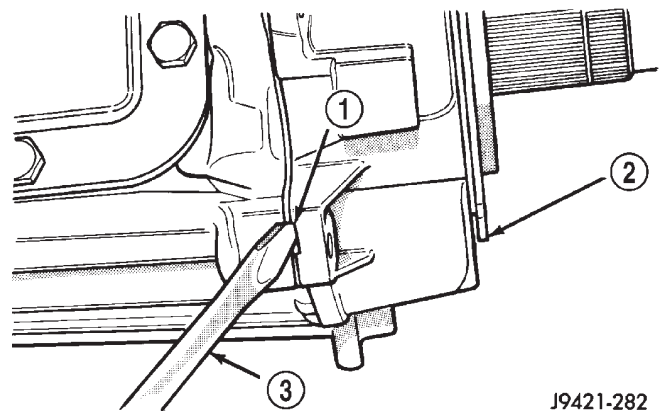
- 1 - REAR CASE
- 2 - STUD
- 3 - NUT AND WASHER
- 4 - SOCKET

(5) Loosen rear case with pry tool to break sealer bead. Insert tool in slot at each end of case (Fig. 12).

(6) Unseat rear case from alignment dowels (Fig. 13).

(7) Remove rear case and oil pump assembly from front case.

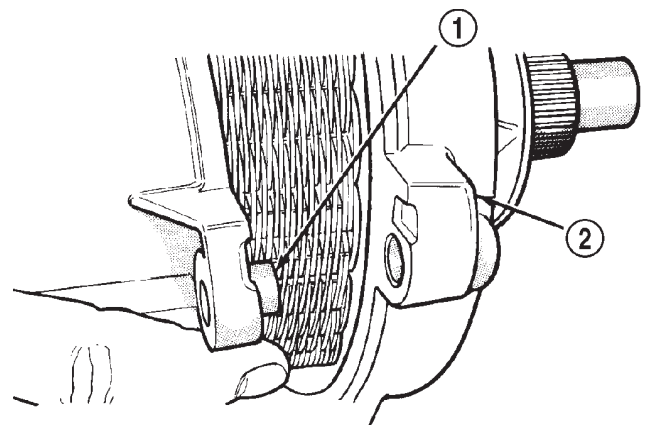
(8) Remove shift rail cup and spring (Fig. 14).



J9421-282

**Fig. 12 Loosening Rear Case (Breaking Sealer Bead)**

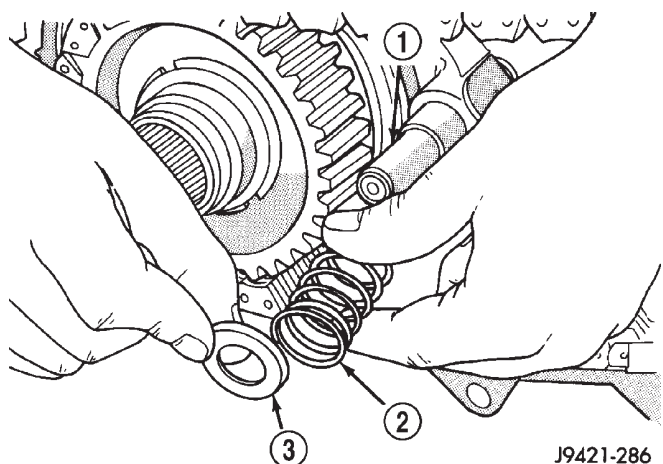
- 1 - SLOT
- 2 - REAR CASE
- 3 - PRY TOOL



J9421-283

**Fig. 13 Removing Rear Case From Alignment Dowels**

- 1 - CASE DOWELS (2)
- 2 - REAR CASE



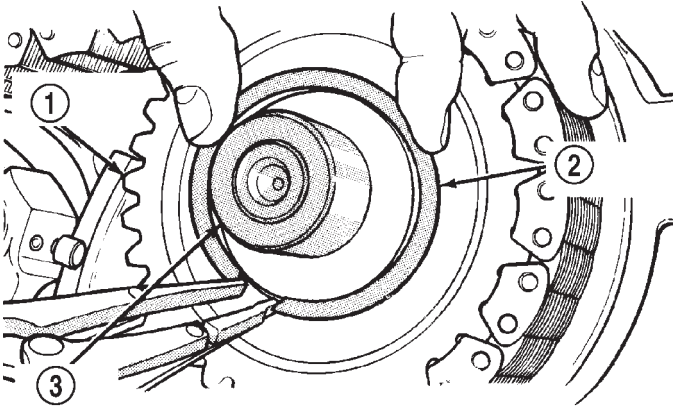
J9421-286

**Fig. 14 Shift Rail Cup And Spring Removal**

- 1 - SHIFT RAIL
- 2 - SPRING
- 3 - CUP

## TRANSFER CASE - NV241LD (Continued)

(9) Remove front sprocket retaining ring (Fig. 15).



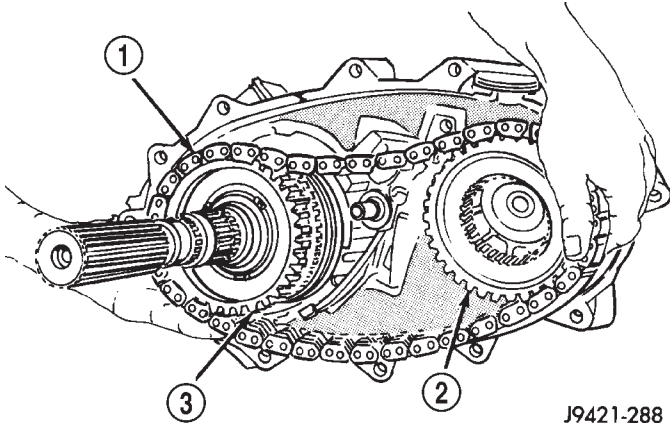
J9421-287

**Fig. 15 Removing Front Sprocket Retaining Ring**

- 1 - FRONT SPROCKET
- 2 - RETAINING RING
- 3 - FRONT OUTPUT SHAFT

(10) Pull mainshaft, front sprocket and chain outward about 25.4 mm (1-inch) simultaneously (Fig. 16).

(11) Remove chain from mainshaft drive sprocket and remove front sprocket and chain as assembly.



J9421-288

**Fig. 16 Removing Drive Chain And Front Sprocket**

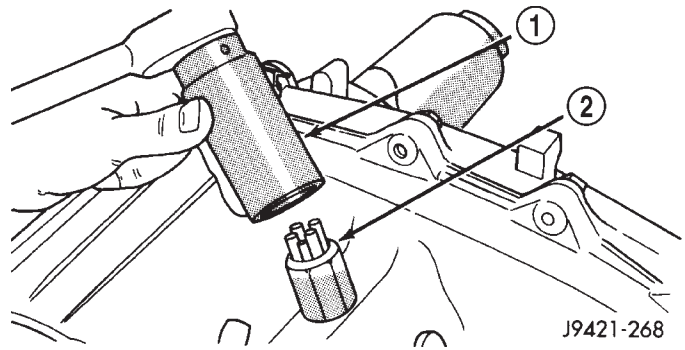
- 1 - CHAIN
- 2 - DRIVE SPROCKET
- 3 - FRONT SPROCKET

## SHIFT FORKS AND MAINSHAFT

(1) Remove vacuum/indicator switch (Fig. 17).

(2) Loosen poppet plunger screw (Fig. 18).

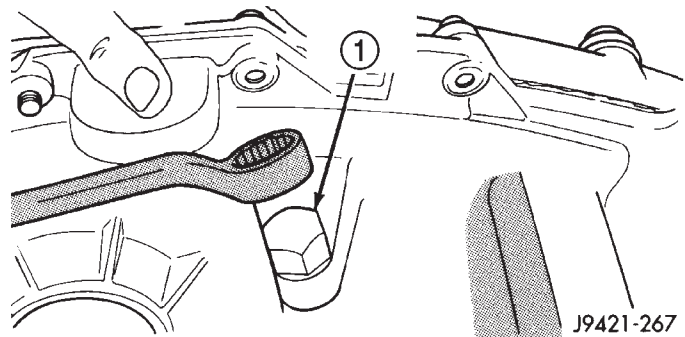
(3) Remove poppet plunger screw and spring (Fig. 19). Note that screw has O-ring seal. Remove and discard seal this seal.



J9421-268

**Fig. 17 Vacuum/Indicator Switch Removal**

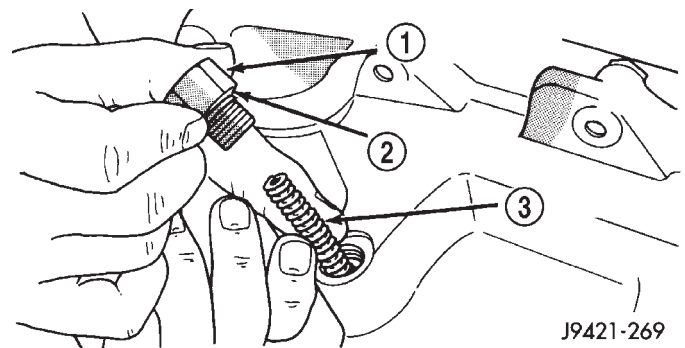
- 1 - 1-1/16" SOCKET
- 2 - INDICATOR SWITCH



J9421-267

**Fig. 18 Loosening Poppet Plunger Screw**

- 1 - POPPET PLUNGER SCREW



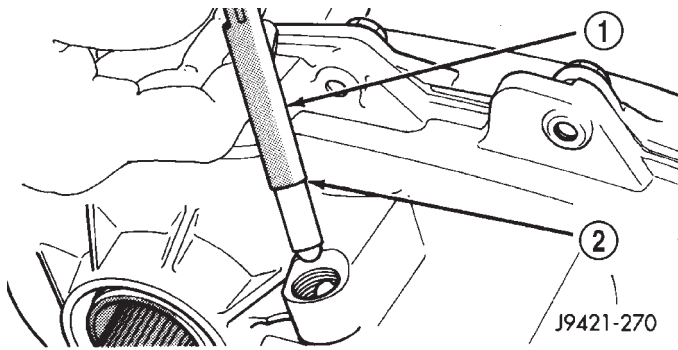
J9421-269

**Fig. 19 Poppet Plunger Screw And Spring Removal**

- 1 - POPPET PLUNGER SCREW
- 2 - O-RING
- 3 - PLUNGER SPRING

TRANSFER CASE - NV241LD (Continued)

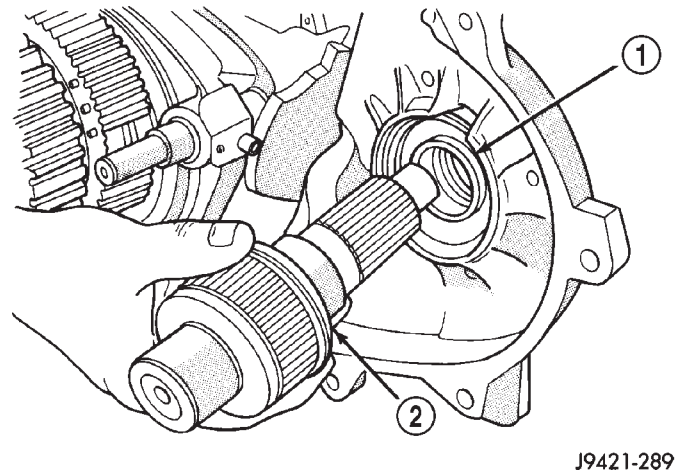
(4) Remove poppet plunger with magnet (Fig. 20).



**Fig. 20 Poppet Plunger Removal**

- 1 - MAGNET
- 2 - POPPET PLUNGER

(5) Remove front output shaft from bearing in case (Fig. 21).



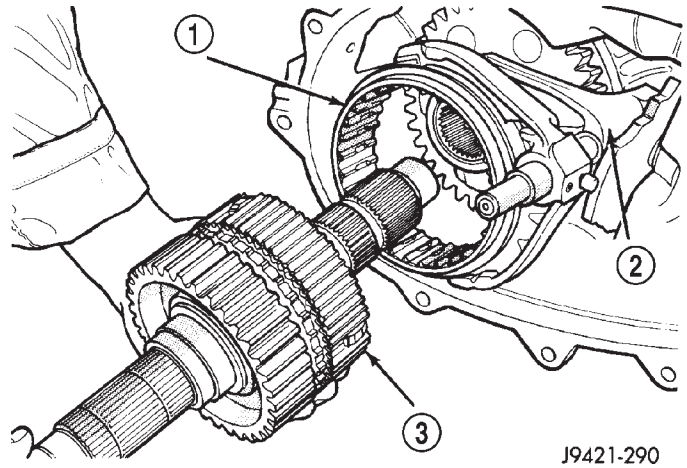
**Fig. 21 Front Output Shaft Removal**

- 1 - BALL BEARING
- 2 - FRONT OUTPUT SHAFT

(6) Pull mainshaft assembly out of input gear, sliding clutch and case (Fig. 22).

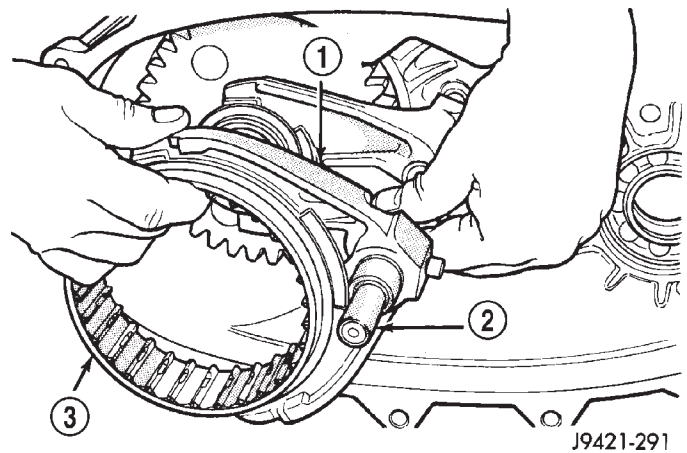
(7) Remove mode fork, sliding clutch and shift rail as assembly (Fig. 23). Note which way clutch fits in fork (long side of clutch goes to front).

(8) Remove range fork retaining ring.



**Fig. 22 Mainshaft Assembly Removal**

- 1 - SLIDING CLUTCH
- 2 - MODE FORK
- 3 - MAINSHAFT ASSEMBLY



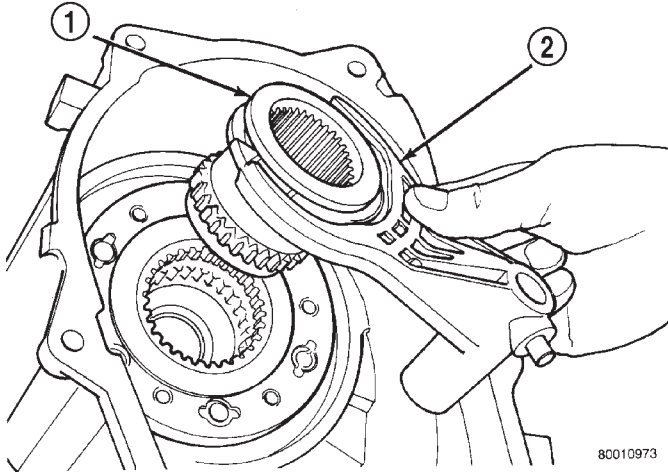
**Fig. 23 Mode Fork, Shift Rail And Sliding Clutch Removal**

- 1 - MODE FORK
- 2 - SHIFT RAIL
- 3 - SLIDING CLUTCH



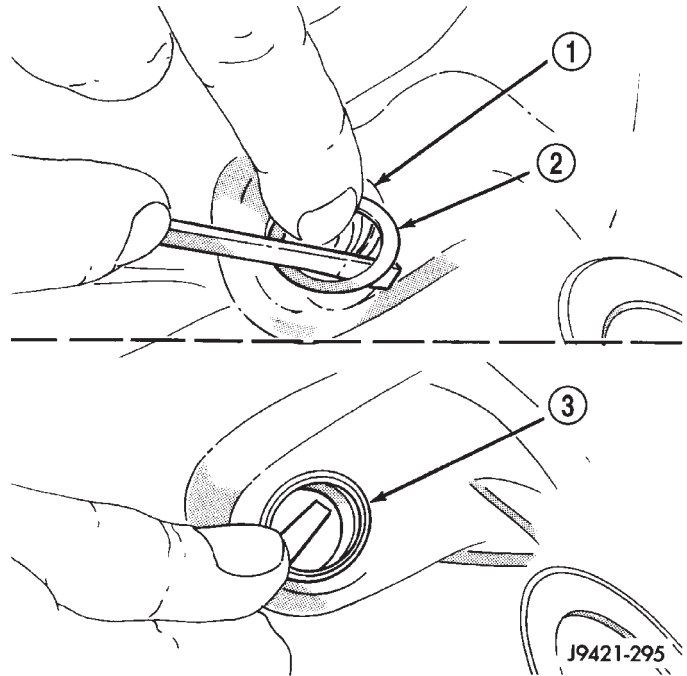
## TRANSFER CASE - NV241LD (Continued)

- (9) Remove range fork and hub as an assembly (Fig. 24). Note fork position for installation reference.  
 (10) Remove shift sector (Fig. 25).



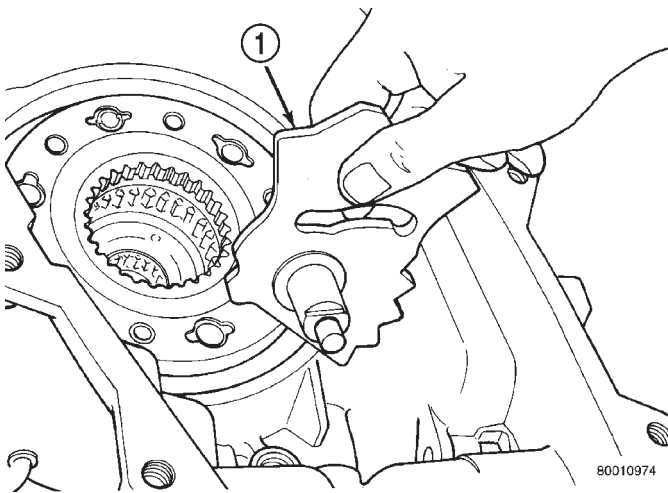
**Fig. 24 Range Fork And Hub Removal**

- 1 - RANGE HUB  
 2 - RANGE FORK



**Fig. 26 Removing Sector Shaft O-Ring And Retainer**

- 1 - SHAFT BORE  
 2 - NYLON RETAINING RING  
 3 - SECTOR SHAFT O-RING



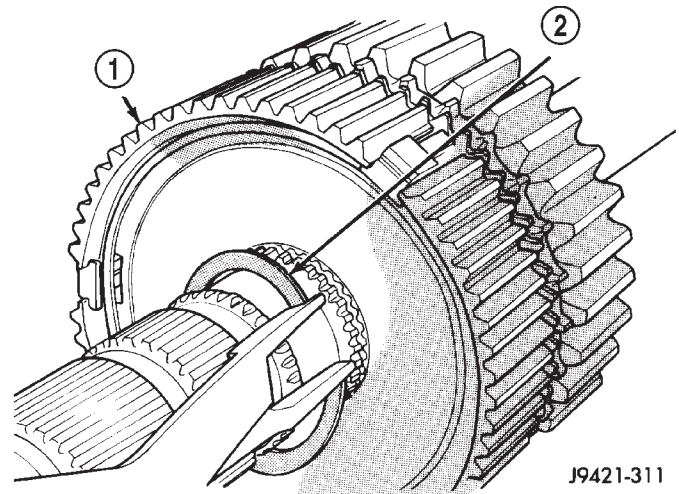
**Fig. 25 Shift Sector Removal**

- 1 - SHIFT SECTOR

- (11) Remove shift sector shaft nylon retainer and O-ring from shaft bore in front case (Fig. 26).

## MAINSHAFT

- (1) Remove retaining ring that secures synchronizer hub onto mainshaft (Fig. 27). Use standard (instead of parallel jaw) snap-ring pliers to remove this retaining ring.



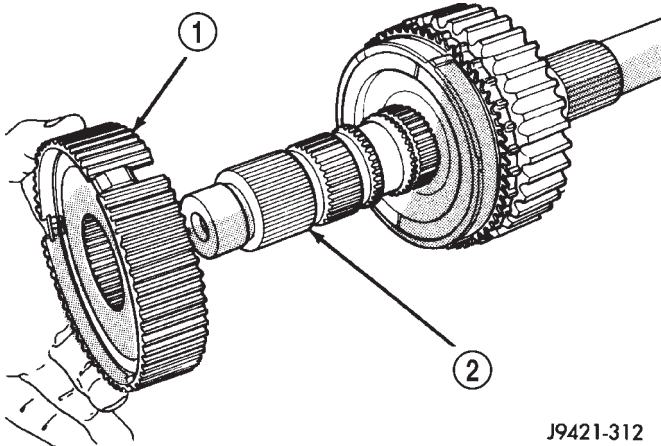
**Fig. 27 Synchronizer Hub Retaining Ring Removal**

- 1 - SYNCHRONIZER HUB  
 2 - RETAINING RING



TRANSFER CASE - NV241LD (Continued)

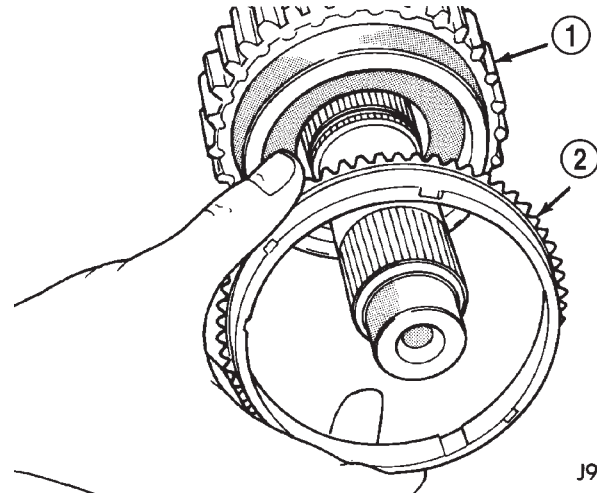
(2) Remove synchronizer hub (Fig. 28).



J9421-312

**Fig. 28 Synchronizer Hub Removal**

- 1 - SYNCHRONIZER HUB
- 2 - MAINSHAFT

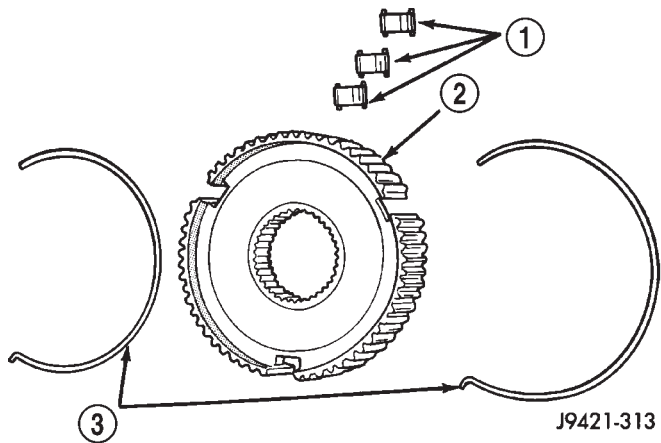


J9421-314

**Fig. 30 Synchronizer Stop Ring Removal**

- 1 - DRIVE SPROCKET
- 2 - STOP RING

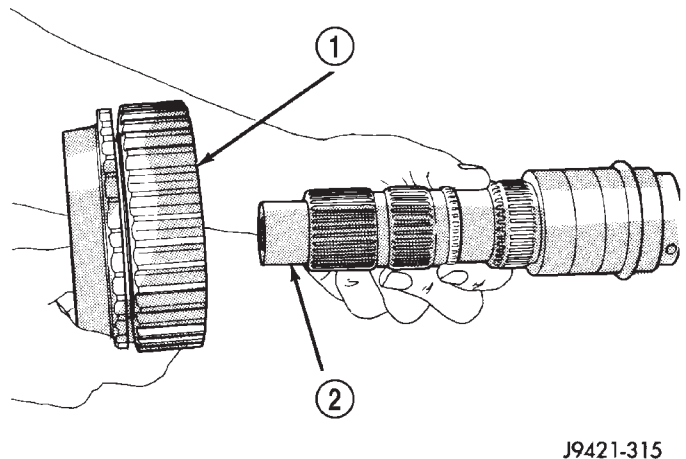
(3) Inspect synchronizer hub struts and springs. If struts appear worn, remove struts and springs from hub. Note position of springs for installation reference (Fig. 29).



J9421-313

**Fig. 29 Synchronizer Strut And Spring Removal**

- 1 - SYNCHRONIZER STRUTS
- 2 - SYNCHRONIZER HUB
- 3 - SYNCHRONIZER SPRINGS



J9421-315

**Fig. 31 Drive Sprocket Removal**

- 1 - DRIVE SPROCKET
- 2 - MAINSHAFT

(4) Remove brass stop ring (Fig. 30). Discard stop ring if worn, cracked, or any teeth are missing.

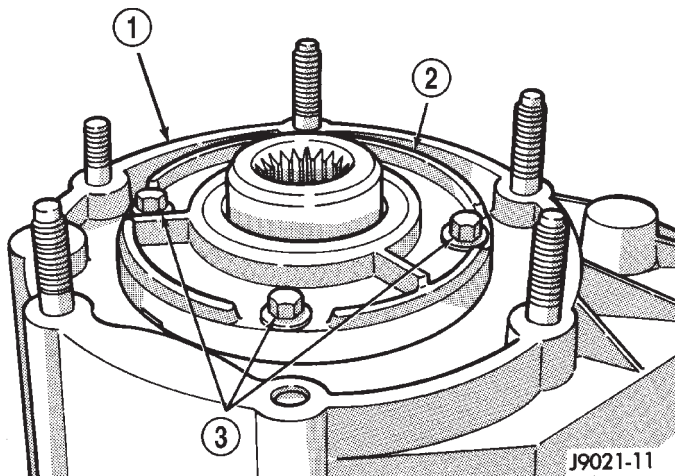
(5) Remove drive sprocket (Fig. 31).

## TRANSFER CASE - NV241LD (Continued)

## INPUT AND PLANETARY GEAR

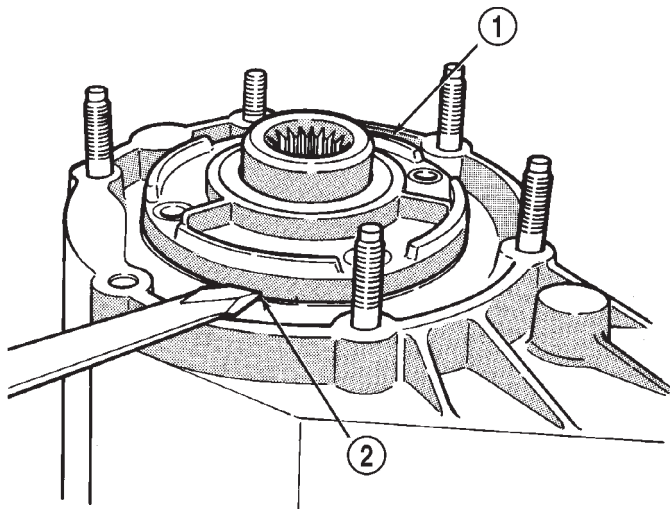
(1) Remove front bearing retainer attaching bolts (Fig. 32).

(2) Remove front bearing retainer. Pry retainer loose with pry tool positioned in slots at each end of retainer (Fig. 33).



**Fig. 32 Front Bearing Retainer Bolts**

- 1 - FRONT CASE
- 2 - FRONT BEARING RETAINER
- 3 - RETAINER BOLTS

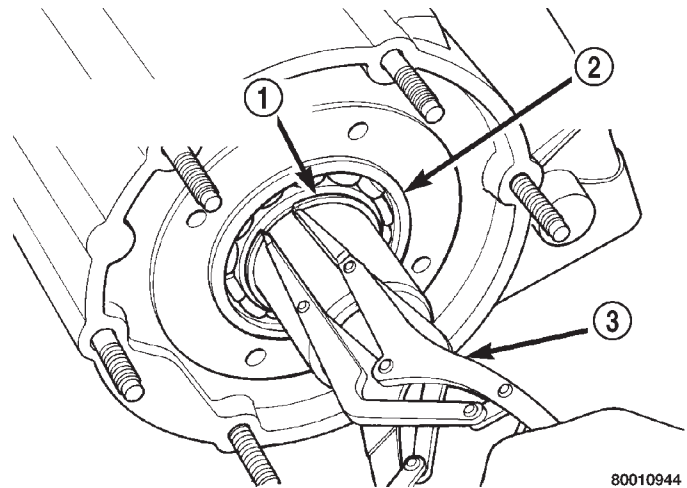


**Fig. 33 Front Bearing Retainer Removal**

- 1 - FRONT BEARING RETAINER
- 2 - RETAINER SLOT

(3) Remove front bearing retainer seal. Tap seal out with drift and hammer.

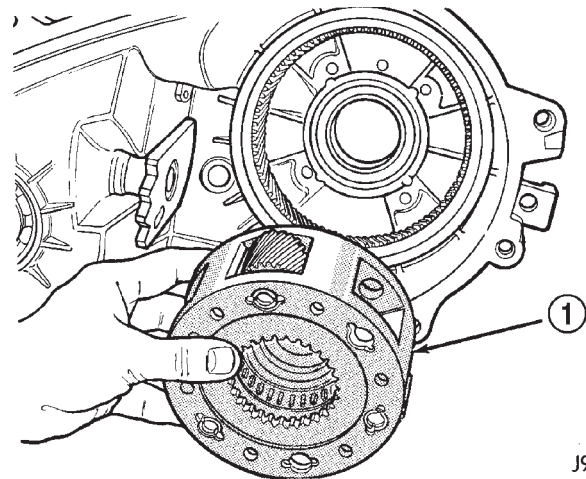
(4) Remove input gear retaining ring with heavy duty snap-ring pliers (Fig. 34).



**Fig. 34 Removing Input Gear Retaining Ring**

- 1 - INPUT GEAR BEARING RETAINING RING
- 2 - INPUT GEAR BEARING
- 3 - SNAP-RING PLIERS

(5) Place front case in horizontal position. Then remove input gear and low range gear as an assembly (Fig. 35). Tap gear out of bearing with plastic mallet, if necessary.



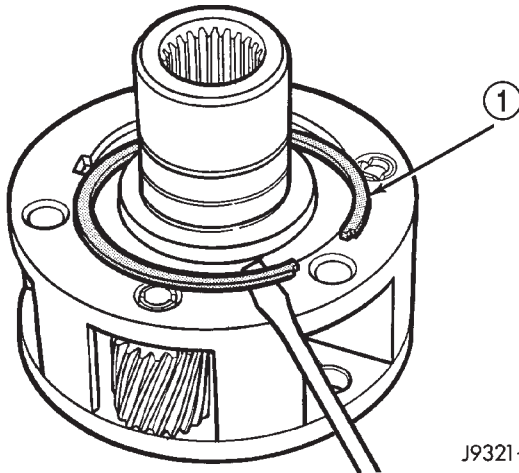
**Fig. 35 Input Gear And Planetary Carrier Removal**

- 1 - INPUT AND LOW RANGE GEAR ASSEMBLY

## TRANSFER CASE - NV241LD (Continued)

## INPUT AND PLANETARY GEAR

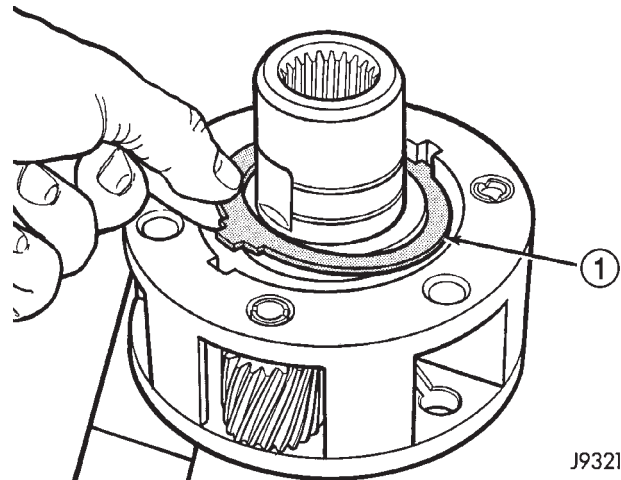
- (1) Remove snap-ring that retains input gear in low range gear (Fig. 36).
- (2) Remove retainer (Fig. 37).
- (3) Remove front tabbed thrust washer (Fig. 38).
- (4) Remove input gear (Fig. 39).
- (5) Remove rear tabbed thrust washer from low range gear (Fig. 40).



J9321-32

**Fig. 36 Input Gear Snap-Ring Removal**

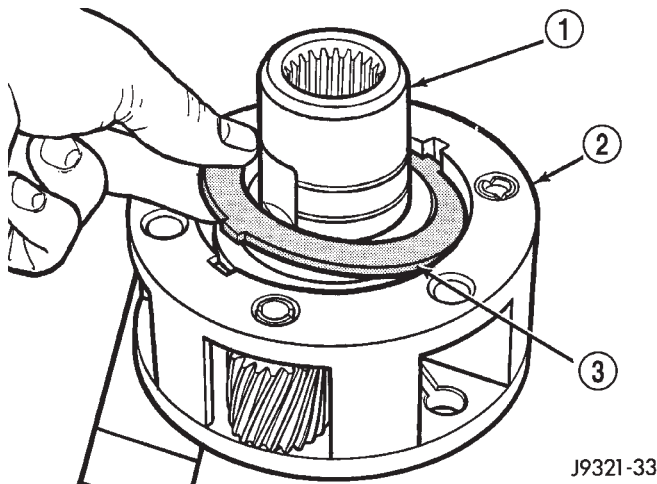
1 - INPUT GEAR SNAP-RING



J9321-34

**Fig. 38 Front Tabbed Thrust Washer Removal**

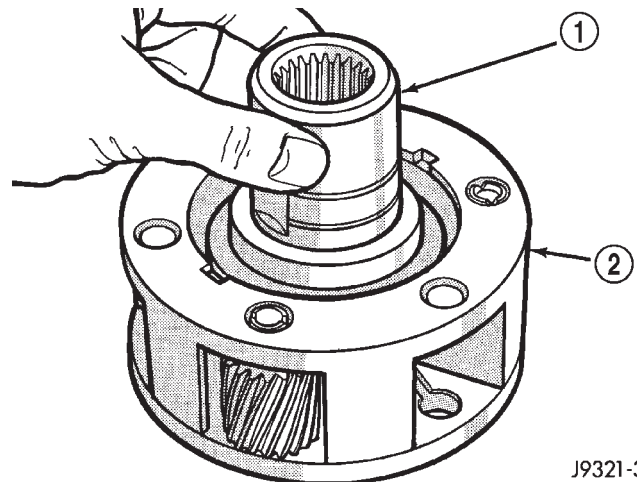
1 - FRONT TABBED THRUST WASHER



J9321-33

**Fig. 37 Input Gear Retainer Removal**

1 - INPUT GEAR  
2 - LOW RANGE GEAR  
3 - RETAINER



J9321-35

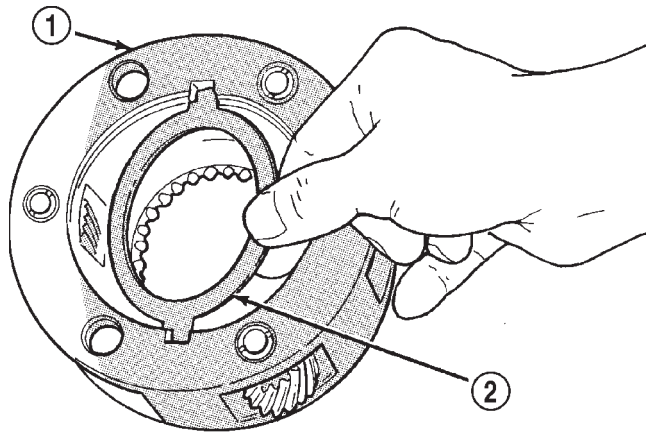
**Fig. 39 Input Gear Removal**

1 - INPUT GEAR  
2 - LOW RANGE GEAR

## CLEANING

Clean the transfer case parts with a standard parts cleaning solvent. Remove all traces of sealer from the cases and retainers with a scraper and 3M™ all purpose cleaner. Use compressed air to remove solvent residue from oil feed passages in the case halves, retainers, gears, and shafts.

## TRANSFER CASE - NV241LD (Continued)



J9321-36

**Fig. 40 Rear Tabbed Thrust Washer Removal**

- 1 - LOW RANGE GEAR  
2 - REAR TABBED THRUST WASHER

**INSPECTION****MAINSHAFT/SPROCKET/HUB**

Inspect the splines on the hub and shaft and the teeth on the sprocket (Fig. 41). Minor nicks and scratches can be smoothed with an oilstone, however, replace any part that is damaged.

Check the contact surfaces in the sprocket bore and on the mainshaft. Minor nicks and scratches can

be smoothed with 320-400 grit emery cloth but do not try to salvage the shaft if nicks or wear is severe.

Inspect the spline teeth on the synchronizer hub. If evidence of chipping or excessive wear is apparent, replace the hub. The hooked end of each synchronizer spring should be inserted in one of the struts. In addition, the springs should not interfere with the polished gear cone or inside diameters of the hub.

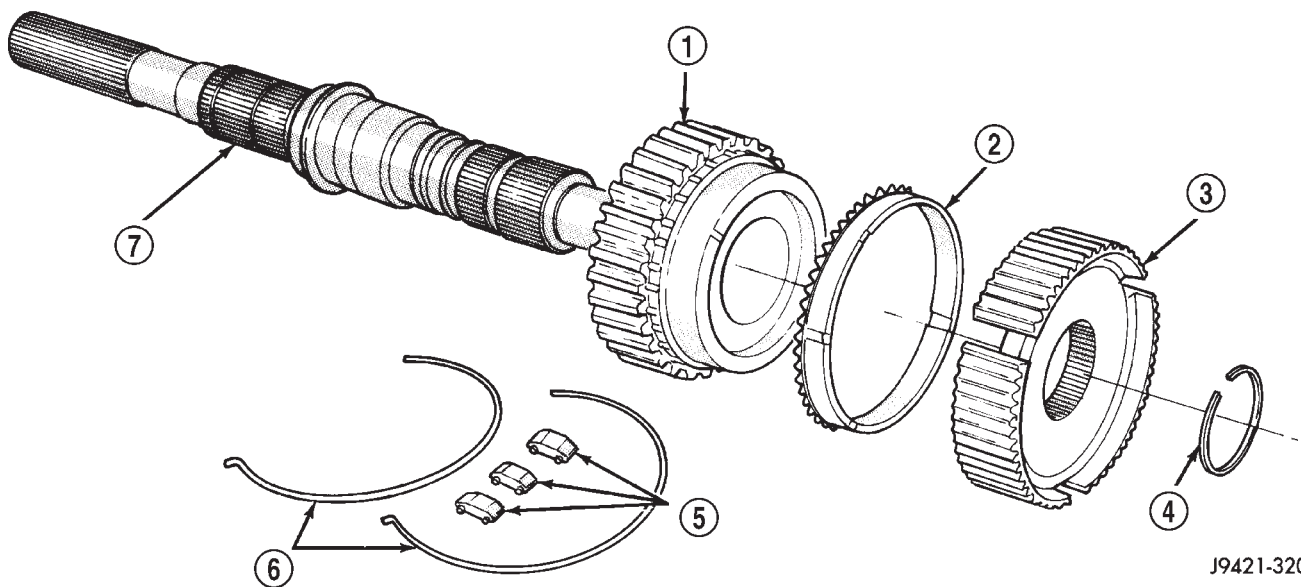
Inspect the stop ring for cracks and wear. Replace the ring if necessary or if doubt exists over condition. Check a replacement synchronizer ring for proper fit on the cone with a minimum of wobble. Also check the synchronizer struts for wear or damage.

**INPUT GEAR AND PLANETARY CARRIER**

Check the teeth on the gear (Fig. 42). Minor nicks can be dressed off with an oilstone but replace the gear if any teeth are broken, cracked, or chipped. The bearing surface on the gear can be smoothed with 300-400 grit emery cloth if necessary.

Examine the carrier body and pinion gears for wear or damage. The carrier will have to be replaced as an assembly if the body, pinion pins, or pinion gears are damaged.

Check the lock ring and both thrust washers for wear or cracks. Replace them if necessary. Also replace the lock retaining ring if bent, distorted, or broken.



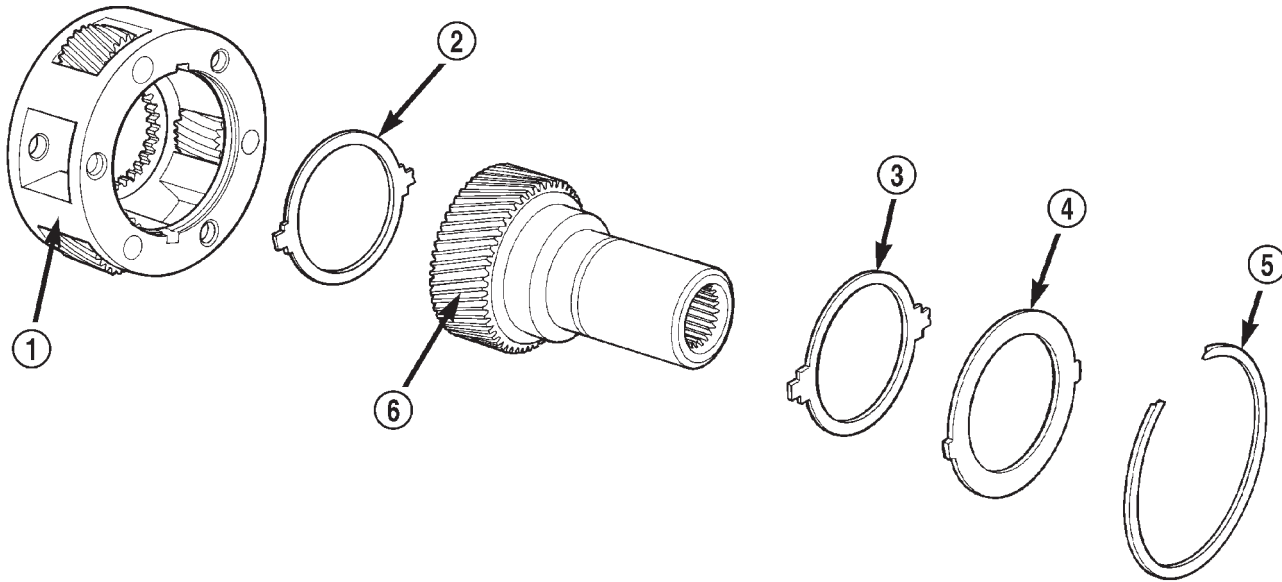
J9421-320

**Fig. 41 Mainshaft Components**

- |                      |                          |
|----------------------|--------------------------|
| 1 - DRIVE SPROCKET   | 5 - STRUTS               |
| 2 - STOP RING        | 6 - SYNCHRONIZER SPRINGS |
| 3 - SYNCHRONIZER HUB | 7 - MAINSHAFT            |
| 4 - RETAINING RING   |                          |



TRANSFER CASE - NV241LD (Continued)



8001b75f

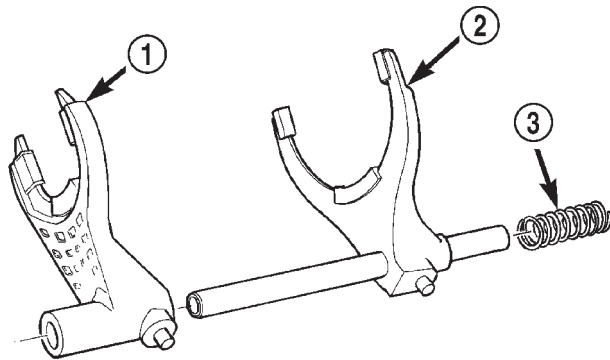
**Fig. 42 Input Gear And Carrier Components**

- 1 - PLANETARY CARRIER
- 2 - REAR THRUST WASHER
- 3 - FRONT THRUST WASHER

- 4 - CARRIER LOCK RING
- 5 - CARRIER LOCK RETAINING RING
- 6 - INPUT GEAR

**SHIFT FORKS/HUBS/SLEEVES**

Check condition of the shift forks and mode fork shift rail (Fig. 43). Minor nicks on the shift rail can be smoothed with 320-400 grit emery cloth.

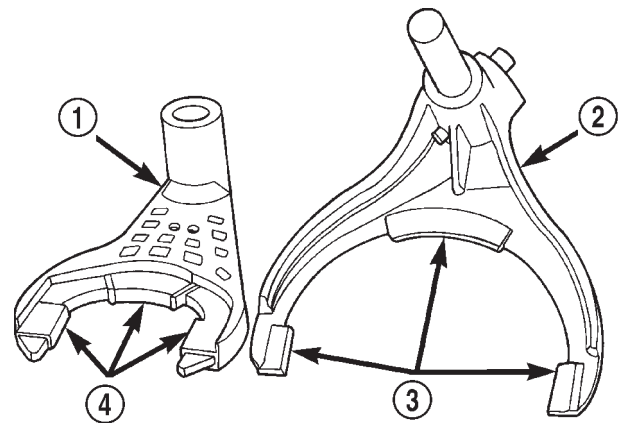


80010948

**Fig. 43 Shift Forks**

- 1 - RANGE FORK
- 2 - MODE FORK AND RAIL
- 3 - MODE SPRING

The fork must be replaced as an assembly if the pads are worn or damaged.



8001097c

**Fig. 44 Shift Fork And Wear Pad Locations**

- 1 - RANGE FORK
- 2 - MODE FORK
- 3 - WEAR PADS (SERVICEABLE)
- 4 - WEAR PADS (NON-SERVICEABLE)

Inspect the shift fork wear pads (Fig. 44). The mode fork pads are serviceable and can be replaced if necessary. The range fork pads are not serviceable.

Check both of the sleeves for wear or damage, especially on the interior teeth. Replace the sleeves if wear or damage is evident.



## TRANSFER CASE - NV241LD (Continued)

**REAR RETAINER COMPONENTS**

Inspect the retainer components. Replace the bearing if rough or noisy. Check the retainer for cracks or wear in the bearing bore.

Inspect the retaining rings and washers. Replace any part if distorted, bent, or broken. Reuse is not recommended.

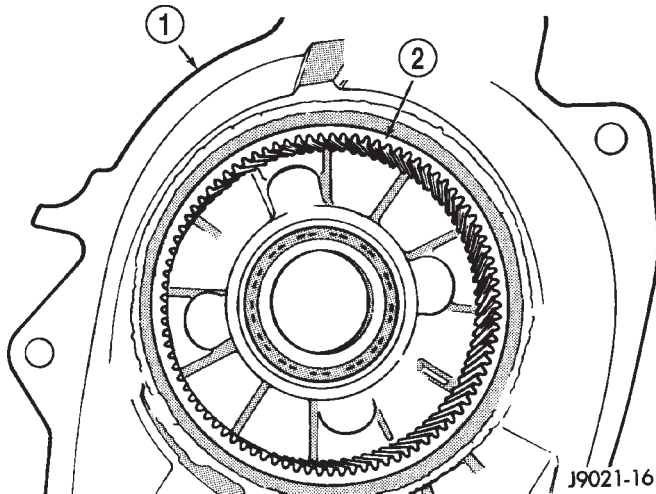
Inspect rear extension bushing. Replace if worn or scored.

**DRIVE CHAIN**

Examine the drive chain and shaft bearings. replace the chain if stretched, distorted, or if any of the links bind. Replace the bearings if rough, or noisy.

**LOW RANGE ANNULUS GEAR**

Inspect annulus gear condition carefully. The gear is only serviced as part of the front case. If the gear is damaged, it will be necessary to replace the gear and front case as an assembly. Do not attempt to remove the gear (Fig. 45)



**Fig. 45 Low Range Annulus Gear**

- 1 - FRONT CASE  
2 - LOW RANGE ANNULUS GEAR

**FRONT-REAR CASES AND FRONT RETAINER**

Inspect the cases and retainer for wear and damage. Replace the input retainer seal, do not reuse it.

Check case condition. If leaks were a problem, look for gouges and severe scoring of case sealing surfaces. Also make sure the front case mounting studs are in good condition.

Check the front case mounting studs and vent tube. The tube can be secured with Loctite™ 271 or 680 if loose. The stud threads can be cleaned up with a die if necessary. Also check condition of the fill/drain plug threads in the rear case. The threads can be repaired with a thread chaser or tap if necessary.

Or the threads can be repaired with Helicoil™ stainless steel inserts if required.

**OIL PUMP/OIL PICKUP**

Examine the oil pump pickup parts. Replace the pump if any part appears to be worn or damaged. Do not disassemble the pump as individual parts are not available. The pump is only available as a complete assembly. The pickup screen, hose, and tube are the only serviceable parts and are available separately.

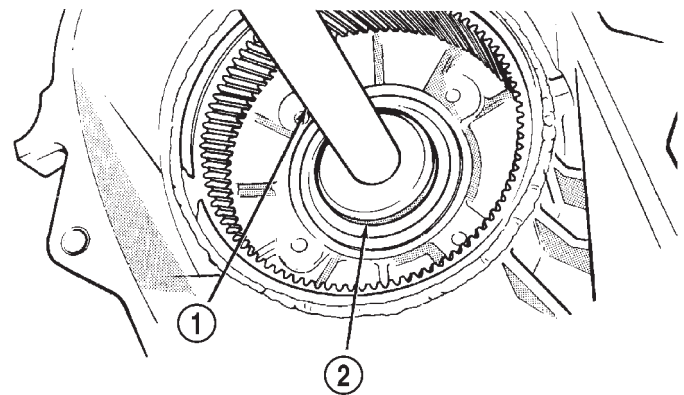
**ASSEMBLY****BEARINGS AND SEALS**

(1) Using Remover C-4210 and Handle C-4171, drive input shaft bearing from case from inside annulus gear opening (Fig. 46).

(2) Install locating ring on new bearing.

(3) Position case so that the forward end is facing upward.

(4) Using Remover C-4210 and Handle C-4171, drive input shaft bearing into case. The bearing locating ring must be fully seated on case (Fig. 47).



**Fig. 46 Input Shaft Bearing Removal**

- 1 - SPECIAL TOOL C-4171  
2 - SPECIAL TOOL C-4210

(5) Using Installer 6953, remove front output shaft bearing.

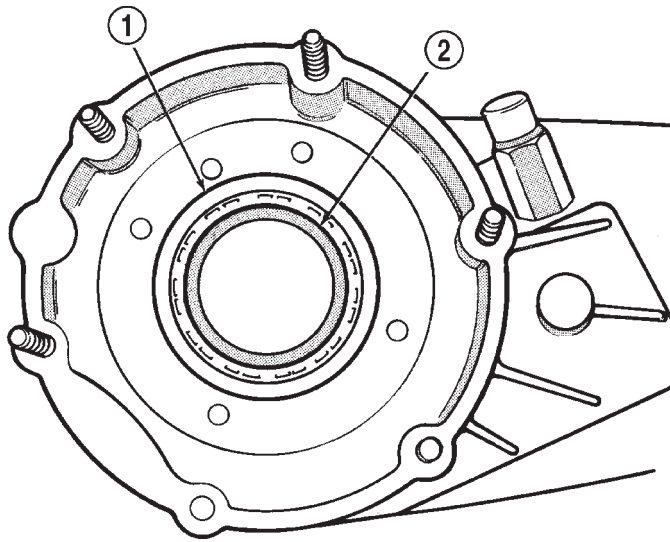
(6) Start front output shaft bearing in case (Fig. 48). Then seat bearing with Handle C-4171 and Installer 6953.

(7) Install front output shaft bearing retaining ring.

(8) Install new front output seal in front case with Installer Tool 6888 and Tool Handle C-4171 as follows:

- (a) Place new seal on tool. **Garner spring on seal goes toward interior of case.**

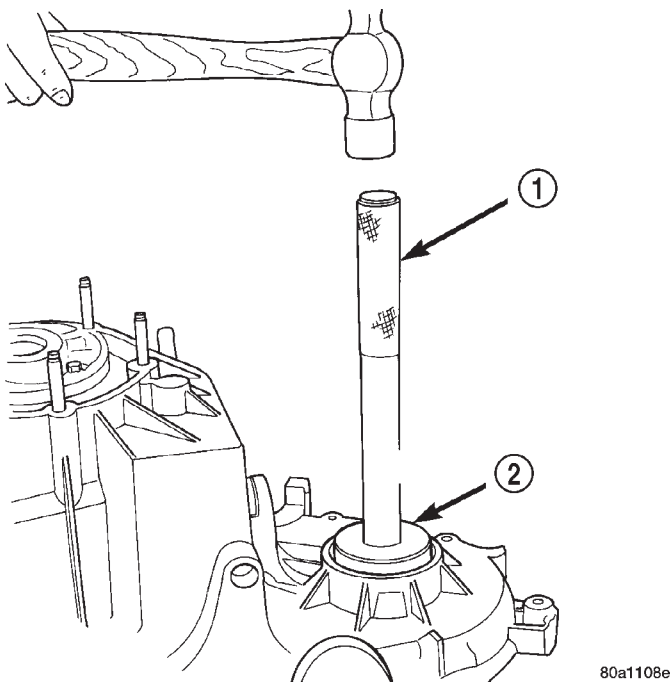
TRANSFER CASE - NV241LD (Continued)



J8921-219

**Fig. 47 Seating Input Shaft Bearing**

- 1 - SNAP-RING
- 2 - INPUT SHAFT BEARING



80a1108e

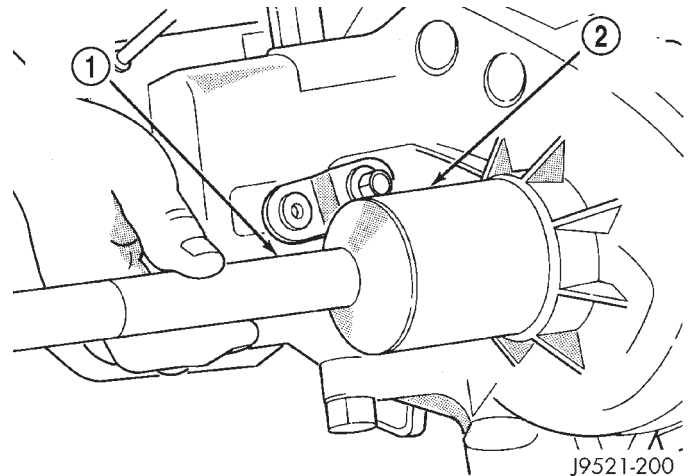
**Fig. 48 Front Output Shaft Bearing Installation**

- 1 - HANDLE C-4171
- 2 - REMOVER/INSTALLER 6953

(b) Start seal in bore with light taps from hammer (Fig. 49). Once seal is started, continue tapping seal into bore until installer tool bottoms against case.

(c) Remove installer and verify that seal is recessed the proper amount (Fig. 50). Seal should be 2.03 to 2.5 mm (0.080 to 0.100 in.) below top edge of seal bore in front case. This is correct final seal position.

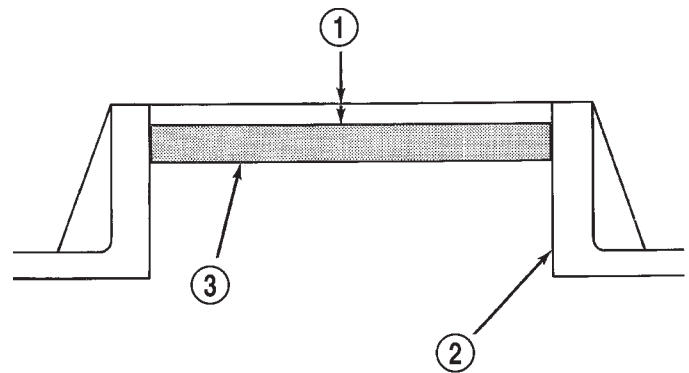
**CAUTION:** Be sure the front output seal is seated below the top edge of the case bore as shown. The seal could loosen, or become cocked if not seated to recommended depth.



J9521-200

**Fig. 49 Front Output Seal Installation**

- 1 - SPECIAL TOOL C-4171
- 2 - SPECIAL TOOL 6888



J9521-190

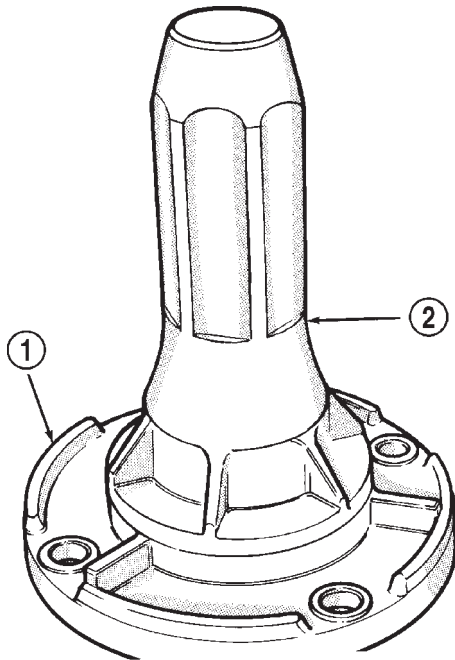
**Fig. 50 Checking Front Output Seal Installation Depth**

- 1 - CORRECT SEAL DEPTH IS 2.03-2.5 mm (0.080-0.100 in.) BELOW TOP EDGE OF BORE
- 2 - FRONT CASE SHAFT BORE
- 3 - FRONT OUTPUT SEAL

(9) Remove seal from front bearing retainer with suitable pry tool.

## TRANSFER CASE - NV241LD (Continued)

(10) Install new oil seal in front bearing retainer with Installer 7884 (Fig. 51).

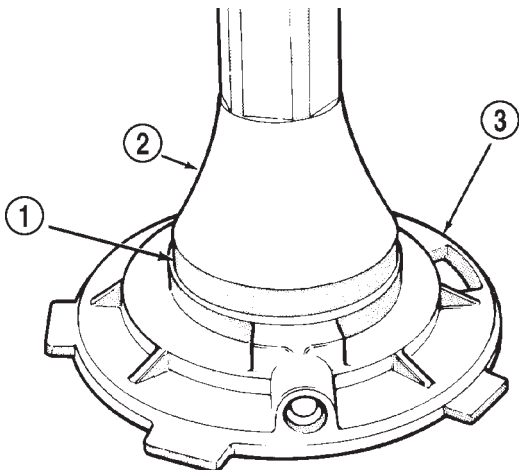


J9521-41

**Fig. 51 Install Front Bearing Retainer Seal**

- 1 - FRONT BEARING RETAINER  
2 - SPECIAL TOOL 7884

(11) Remove seal from oil pump with suitable pry tool.  
(12) Install new seal in oil pump with Installer 7888 (Fig. 52).



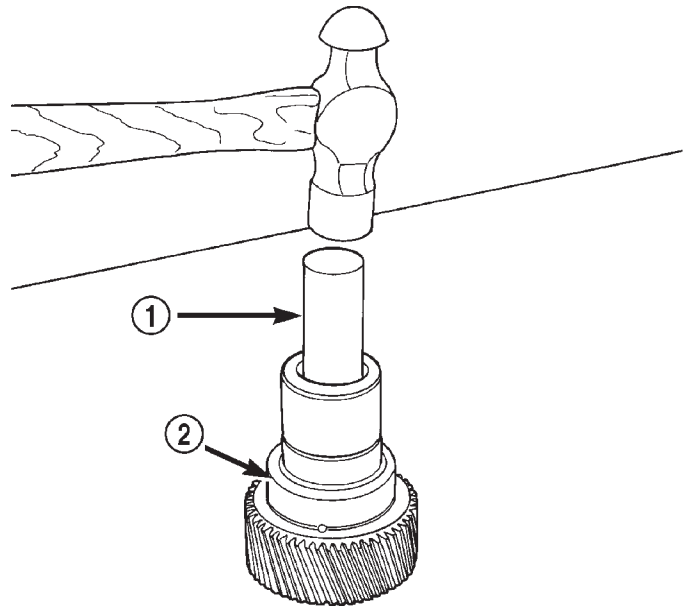
J9521-35

**Fig. 52 Oil Pump Seal Installation**

- 1 - HOUSING SEAL  
2 - SPECIAL TOOL 7888  
3 - OIL PUMP FEED HOUSING

(13) Remove input gear pilot bearing by inserting a suitably sized drift into the splined end of the input gear and driving the bearing out with the drift and a hammer (Fig. 53).

(14) Install new pilot bearing with Plug C-293-3.

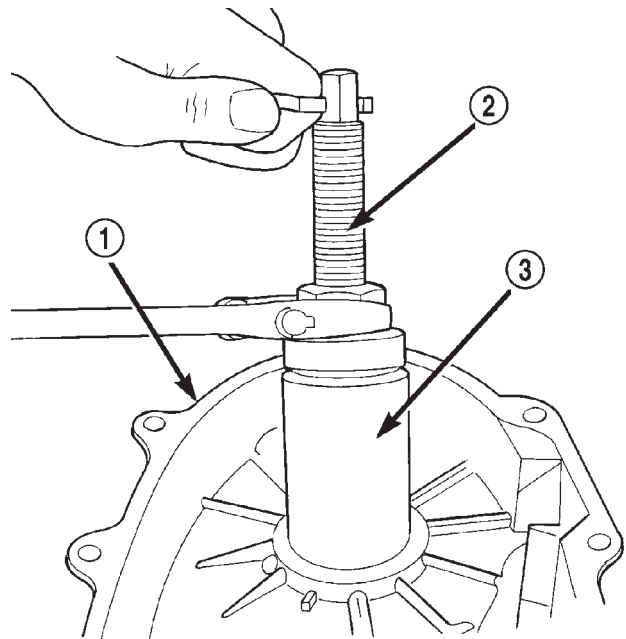


80a11090

**Fig. 53 Remove Input Gear Pilot Bearing**

- 1 - DRIFT  
2 - INPUT GEAR

(15) Remove the front output shaft rear bearing with the screw and jaws from Remover L-4454 and Cup 8148 (Fig. 54).



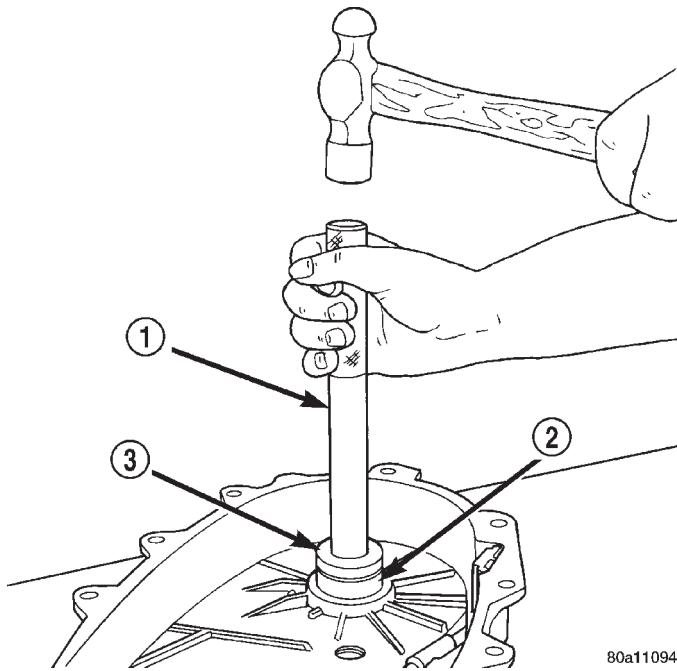
80a98366

**Fig. 54 Front Output Shaft Rear Bearing Removal**

- 1 - REAR CASE  
2 - SPECIAL TOOL L-4454-1 AND L-4454-3  
3 - SPECIAL TOOL 8148

TRANSFER CASE - NV241LD (Continued)

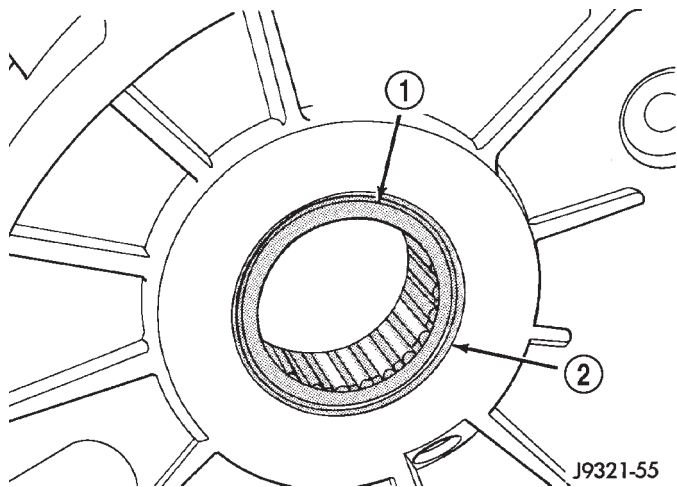
(16) Install new bearing with Tool Handle C-4171 and Installer 5066 (Fig. 55). The bearing bore is chamfered at the top. Install the bearing so it is flush with the lower edge of this chamfer (Fig. 56).



80a11094

**Fig. 55 Output Shaft Rear Bearing Installation**

- 1 - HANDLE C-4171
- 2 - OUTPUT SHAFT INNER BEARING
- 3 - INSTALLER 5066



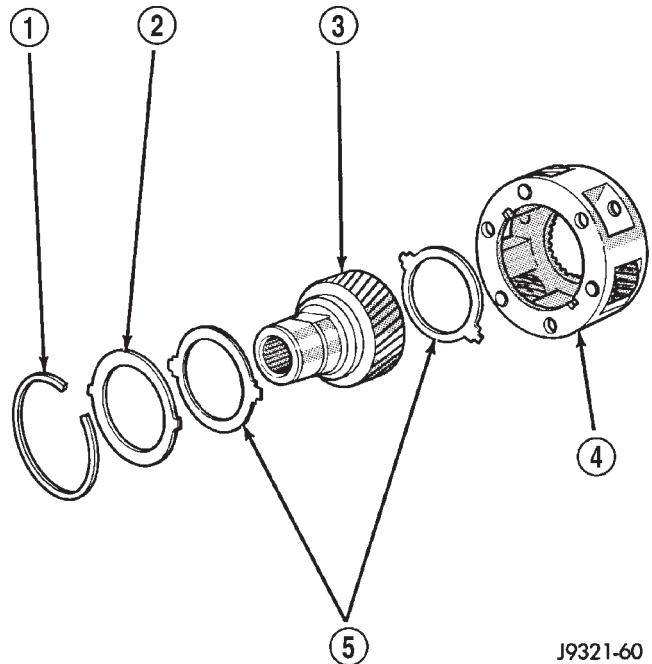
J9321-55

**Fig. 56 Output Shaft Rear Bearing Installation Depth**

- 1 - BEARING (SEATED) AT LOWER EDGE OF CHAMFER
- 2 - CHAMFER

**INPUT AND PLANETARY GEAR**

- (1) Lubricate gears and thrust washers (Fig. 57) with recommended transmission fluid.
- (2) Install first thrust washer in low range gear (Fig. 57). Be sure washer tabs are properly aligned in gear notches.
- (3) Install input gear in low range gear. Be sure input gear is fully seated.
- (4) Install remaining thrust washer in low range gear and on top of input gear. Be sure washer tabs are properly aligned in gear notches.
- (5) Install retainer on input gear and install snap-ring.



J9321-60

**Fig. 57 Input/Low Range Gear Components**

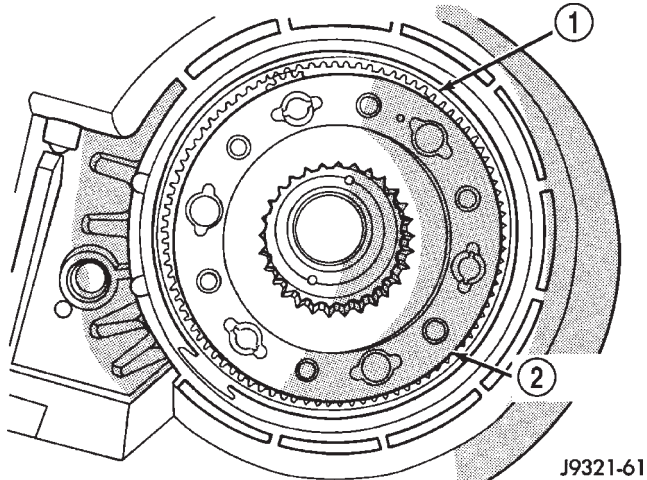
- 1 - SNAP-RING
- 2 - RETAINER PLATE
- 3 - INPUT GEAR
- 4 - LOW RANGE GEAR
- 5 - THRUST WASHERS



## TRANSFER CASE - NV241LD (Continued)

(6) Align and install low range/input gear assembly in front case (Fig. 58). Be sure low range gear pinions are engaged in annulus gear and that input gear shaft is fully seated in front bearing.

(7) Install snap-ring to hold input/low range gear into front bearing (Fig. 59).



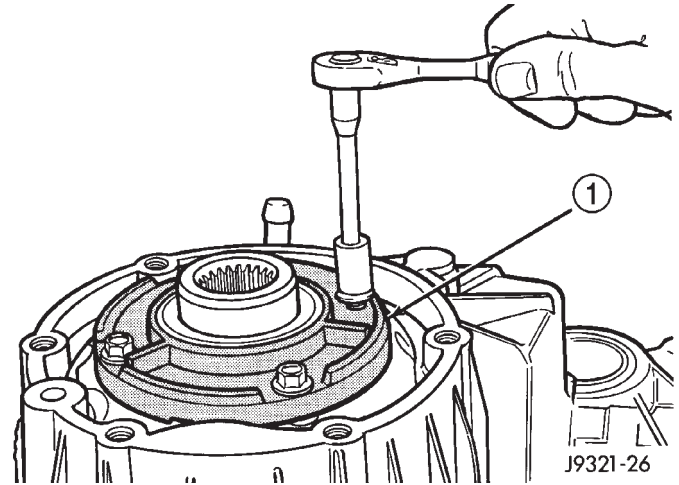
J9321-61

**Fig. 58 Input/Low Range Gear Installation**

- 1 - ANNULUS GEAR  
2 - INPUT/LOW RANGE GEAR

**CAUTION: Do not block fluid return cavity on sealing surface of retainer when applying Mopar® Gasket Maker, or equivalent silicone adhesive sealer. Seal failure and fluid leak can result.**

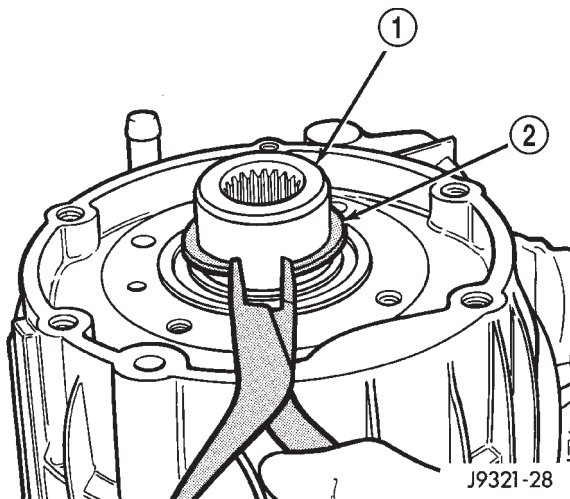
(11) Install bolts to hold retainer to transfer case (Fig. 60). Tighten to 21 N·m (16 ft. lbs.) of torque.



J9321-26

**Fig. 60 Install Front Bearing Retainer**

- 1 - FRONT BEARING RETAINER



J9321-28

**Fig. 59 Install Input Gear Snap-Ring**

- 1 - INPUT GEAR  
2 - SNAP-RING

(8) Clean gasket sealer residue from retainer and inspect retainer for cracks or other damage.

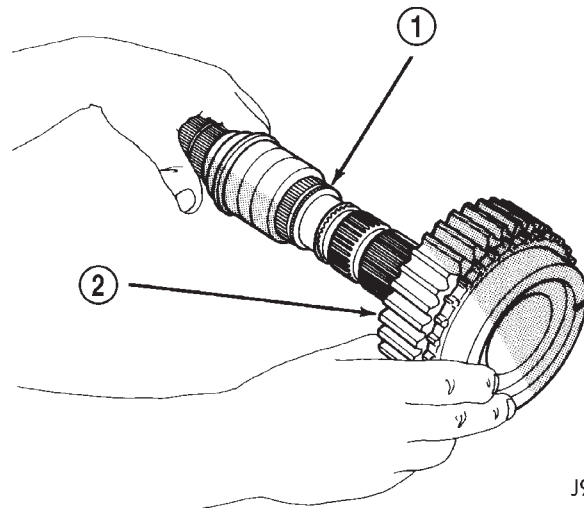
(9) Apply a 3 mm (1/8 in.) bead of Mopar® Gasket Maker, or equivalent silicone adhesive, to sealing surface of retainer.

(10) Align cavity in seal retainer with fluid return hole in front of case.

## SHIFT FORKS AND MAINSHAFT

(1) Lubricate mainshaft splines with recommended transmission fluid.

(2) Install drive sprocket on mainshaft (Fig. 61).



J9421-338

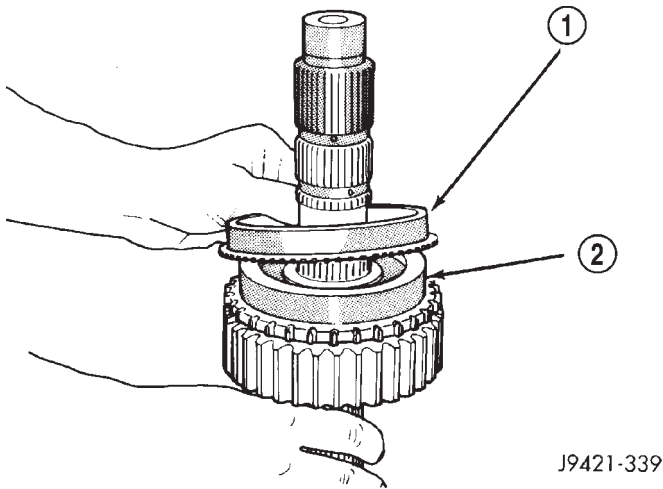
**Fig. 61 Drive Sprocket Installation**

- 1 - MAINSHAFT  
2 - DRIVE SPROCKET



TRANSFER CASE - NV241LD (Continued)

(3) Install brass stop ring on drive sprocket (Fig. 62).

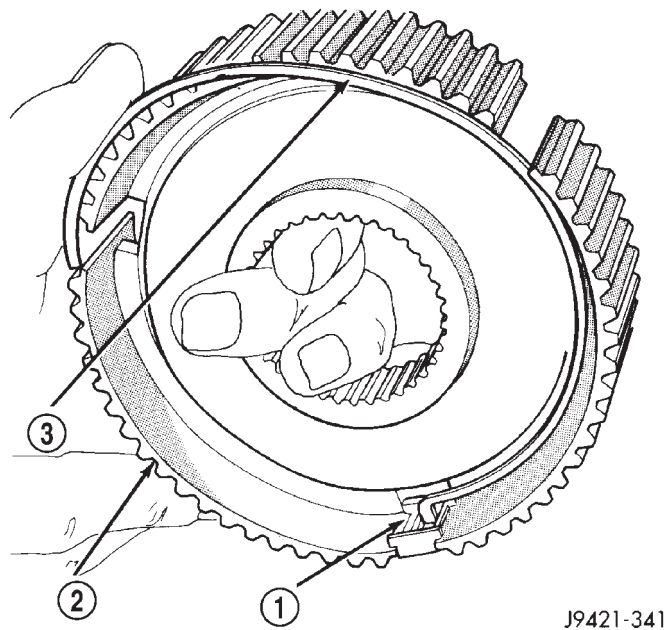


**Fig. 62 Synchronizer Stop Ring Installation**

- 1 - BRASS STOP RING
- 2 - DRIVE SPROCKET

(4) Install 3 synchronizer struts and 2 springs in hub as follows:

(a) Insert first strut in hub (Fig. 63). Strut shoulders rest (and slide) on sides hub slot as shown.



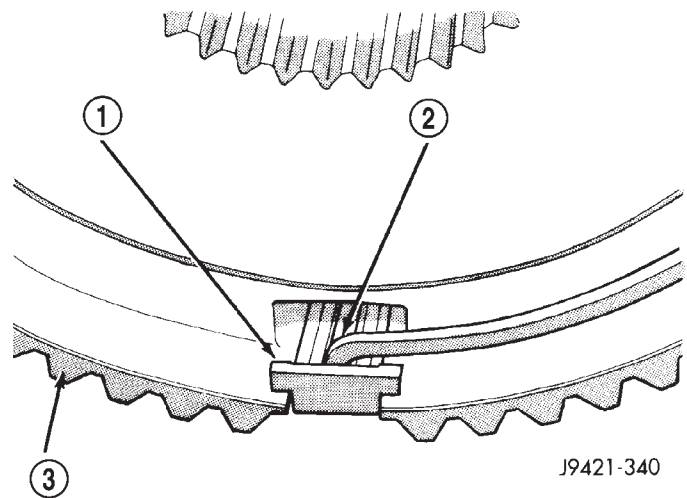
**Fig. 63 Installing First Synchronizer Strut And Spring**

- 1 - FIRST STRUT
- 2 - SYNCHRONIZER HUB
- 3 - SPRING

(b) Insert hooked end of first spring in center of strut to secure it. Then work spring into hub (Fig. 64).

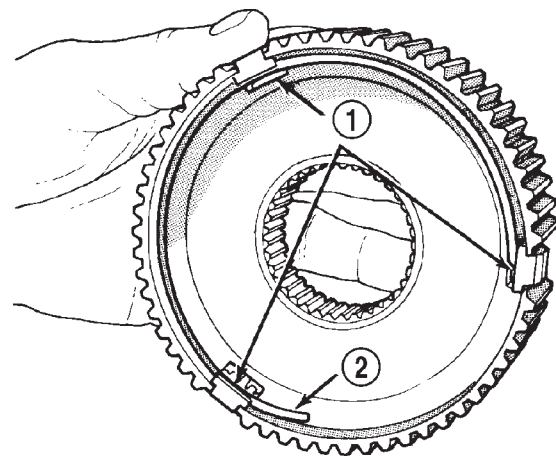
(c) Press spring inward and insert last two struts in hub slots. Be sure spring is positioned under struts to properly secure them (Fig. 65).

(d) Turn hub over and install remaining spring in hub. Position hooked end of second spring opposite the first spring's hooked end.



**Fig. 64 Synchronizer Spring Installation**

- 1 - STRUT SHOULDER
- 2 - SPRING (SEATED IN STRUT)
- 3 - HUB

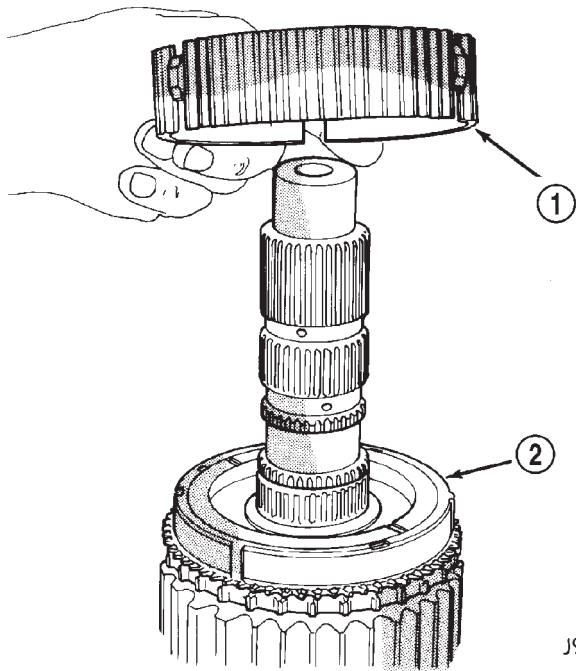


**Fig. 65 Correct Position Of Struts And Springs**

- 1 - STRUTS
- 2 - SPRING

## TRANSFER CASE - NV241LD (Continued)

(5) Install assembled synchronizer hub on mainshaft (Fig. 66). Hub has shoulder on one side which goes toward sprocket (rear of shaft). Flat side of hub faces front of shaft.



J9421-345

**Fig. 66 Synchronizer Hub Installation**

- 1 - SYNCHRONIZER HUB (SHOULDER SIDE DOWN)
- 2 - STOP RING AND SPROCKET

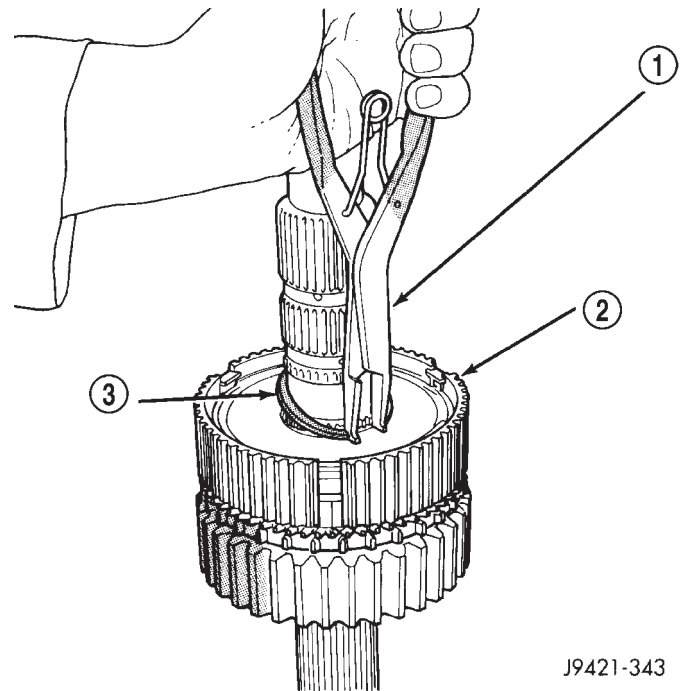
(6) Install synchronizer hub retaining ring (Fig. 67). Be sure ring is fully seated before proceeding.

(7) Install sliding clutch (sleeve) on synchronizer hub (Fig. 68).

**CAUTION:** The sliding clutch must be correctly positioned to ensure proper shifting. Position the clutch on the hub so a clutch spline is centered over each strut as shown (Fig. 69). If the clutch is installed so a gap between splines is aligned with one or more struts, gear clash will result.

(8) Support front case on wood blocks so case interior is facing up. Place blocks between mounting studs on forward surface of case. Be sure blocks will not interfere with input gear installation.

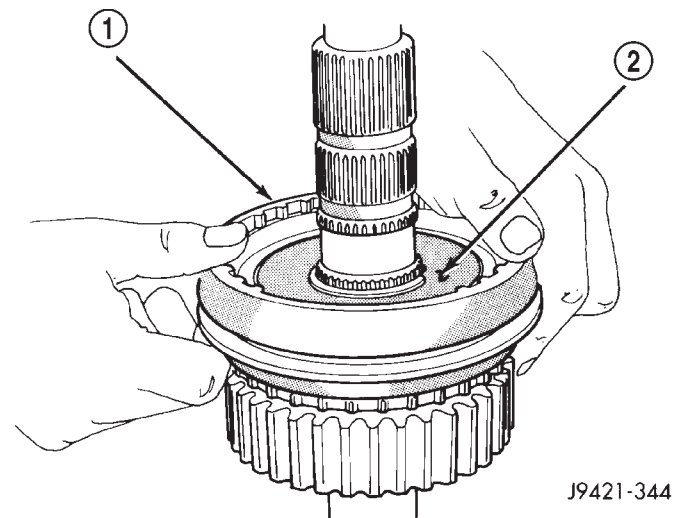
(9) Lubricate mainshaft components with transmission fluid.



J9421-343

**Fig. 67 Synchronizer Hub Retaining Ring Installation**

- 1 - SNAP-RING PLIERS
- 2 - SYNCHRONIZER HUB
- 3 - HUB RETAINING RING

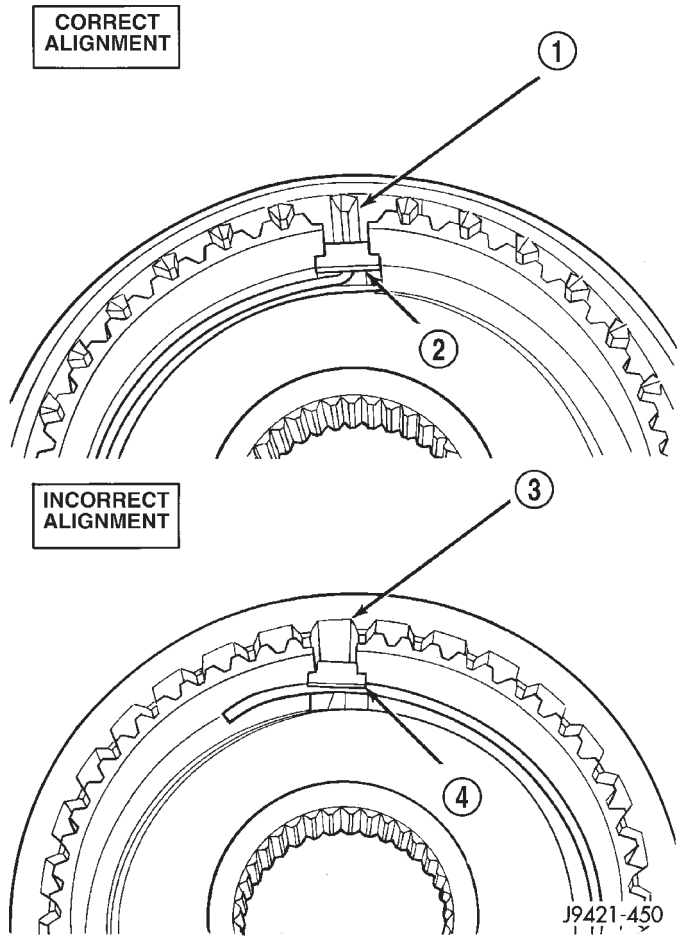


J9421-344

**Fig. 68 Sliding Clutch Installation**

- 1 - SLIDING CLUTCH
- 2 - SYNCHRONIZER HUB

TRANSFER CASE - NV241LD (Continued)



**Fig. 69 Correct Alignment Of Struts And Sliding Clutch**

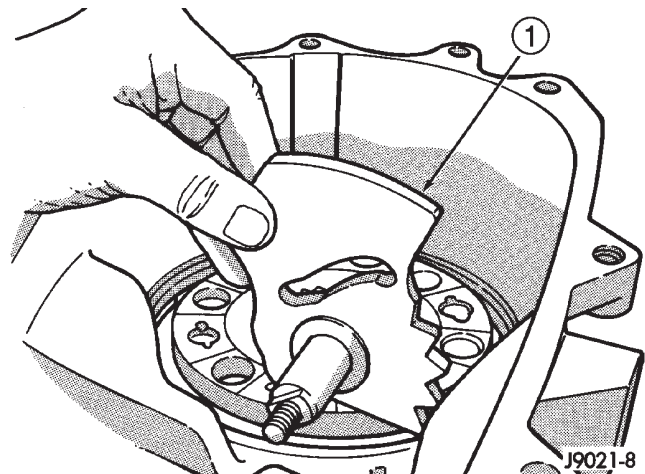
- 1 - SLEEVE TOOTH ALIGNED WITH STRUT
- 2 - STRUT
- 3 - SLEEVE TOOTH NOTALIGNED WITH STRUT
- 4 - STRUT

(10) Lubricate sector shaft with transmission fluid and install shift sector in case (Fig. 70). Position slot in sector so it will be aligned with shift fork pin when shift forks are installed.

(11) Assemble and install range fork and hub (Fig. 71). Be sure hub is properly seated in low range gear and engaged to the input gear.

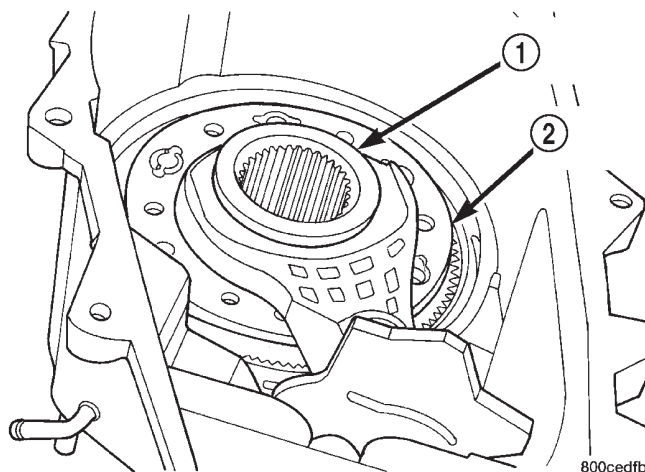
(12) Align and insert range fork pin in shift sector slot.

(13) Install mode fork and shift rail in sliding clutch (Fig. 72).



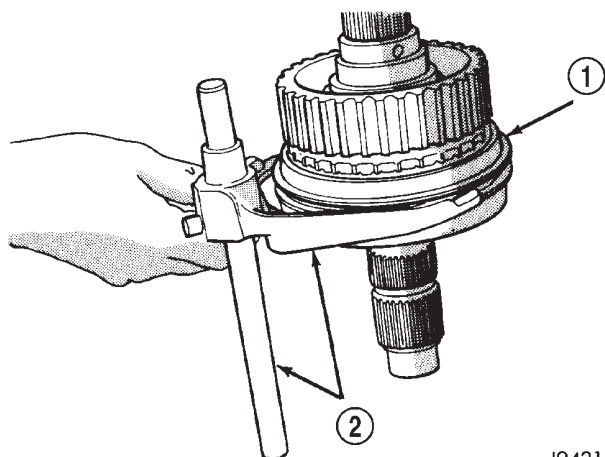
**Fig. 70 Shift Sector Installation**

- 1 - SHIFT SECTOR



**Fig. 71 Install Range Fork And Hub Assembly**

- 1 - RANGE HUB
- 2 - RANGE FORK

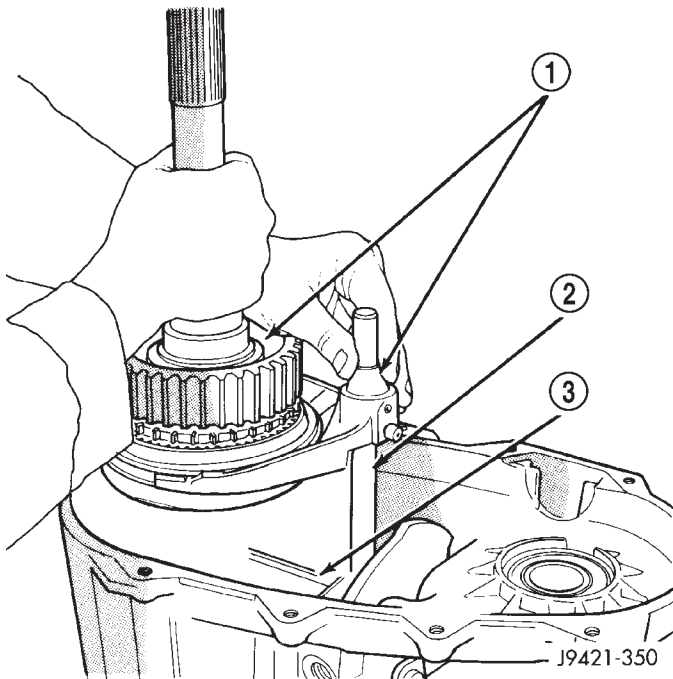


**Fig. 72 Assembling Mode Fork And Mainshaft**

- 1 - SLIDING CLUTCH
- 2 - MODE FORK AND SHIFT RAIL

## TRANSFER CASE - NV241LD (Continued)

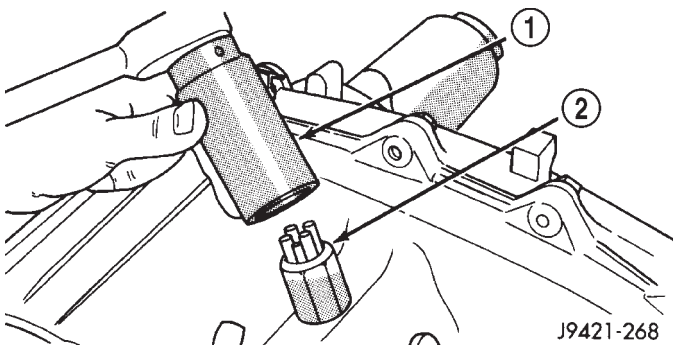
(14) Install mainshaft/mode fork assembly (Fig. 73). Guide mainshaft through hub and into input gear and shift rail through range fork and into case bore.



**Fig. 73 Installing Mainshaft And Mode Fork Assembly**

- 1 - MAINSHAFT AND MODE FORK ASSEMBLY
- 2 - SHIFT RAIL
- 3 - RANGE FORK

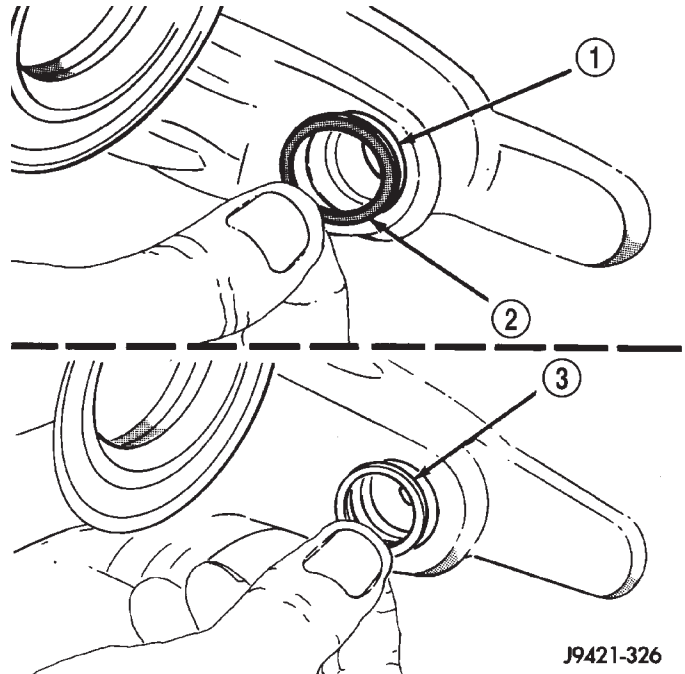
(15) Install new o-ring on vacuum/indicator switch, if necessary. Install vacuum/indicator switch (Fig. 74). Tighten switch to 20-34 N·m (15-25 ft. lbs.) torque.



**Fig. 74 Vacuum/Indicator Switch Installation**

- 1 - 1-1/16" SOCKET
- 2 - INDICATOR SWITCH

(16) Install new sector shaft o-ring and o-ring retainer in sector shaft bore (Fig. 75). Lubricate o-ring with transmission fluid or petroleum jelly after installation.

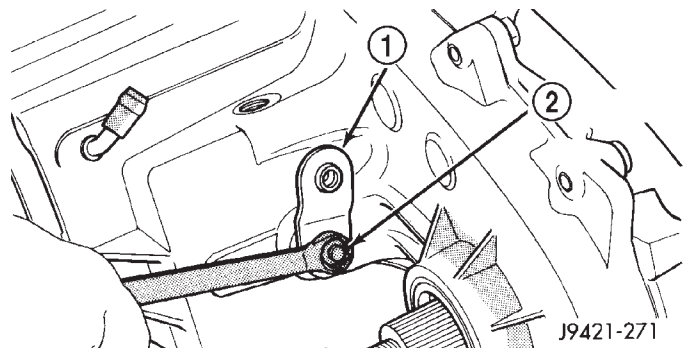


**Fig. 75 Sector Shaft O-Ring And Retainer Installation**

- 1 - SECTOR SHAFT BORE
- 2 - O-RING
- 3 - O-RING RETAINER

(17) Install shift lever on sector shaft (Fig. 76).

(18) Install washer and nut on sector shaft to secure shift lever. Apply 1-2 drops Mopar® Lock N' Seal, or equivalent, to nut threads before installation. Then tighten nut to 27-34 N·m (20-25 ft. lbs.) torque.



**Fig. 76 Shift Lever Installation**

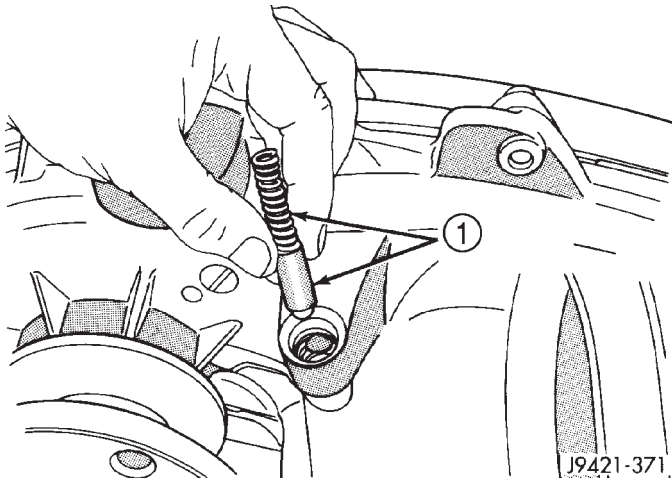
- 1 - SHIFT LEVER
- 2 - NUT/WASHER



## TRANSFER CASE - NV241LD (Continued)

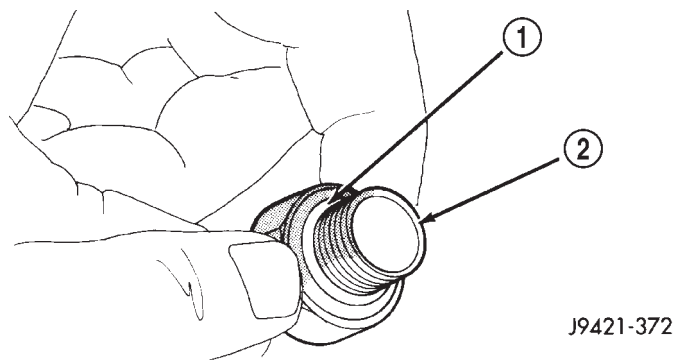
(19) Install poppet plunger and spring (Fig. 77).

(20) Install new o-ring on poppet screw and install screw in front case (Fig. 78). Tighten screw to 16-24 N·m (12-18 ft. lbs.).



**Fig. 77 Poppet Plunger And Spring Installation**

1 - POPPET PLUNGER AND SPRING



**Fig. 78 O-Ring Installation On Poppet Plunger Screw**

1 - O-RING  
2 - PLUNGER SCREW

### FRONT OUTPUT SHAFT AND DRIVE CHAIN

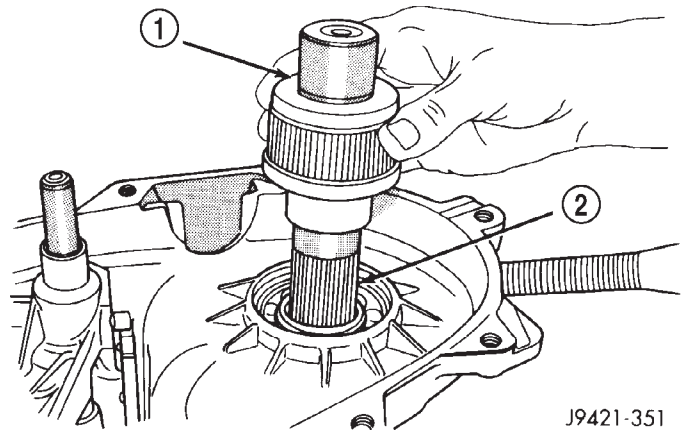
(1) Install front output shaft in bearing (Fig. 79).

(2) Insert front sprocket in drive chain (Fig. 80).

(3) Install drive chain around mainshaft sprocket (Fig. 80). Then position front sprocket over front shaft.

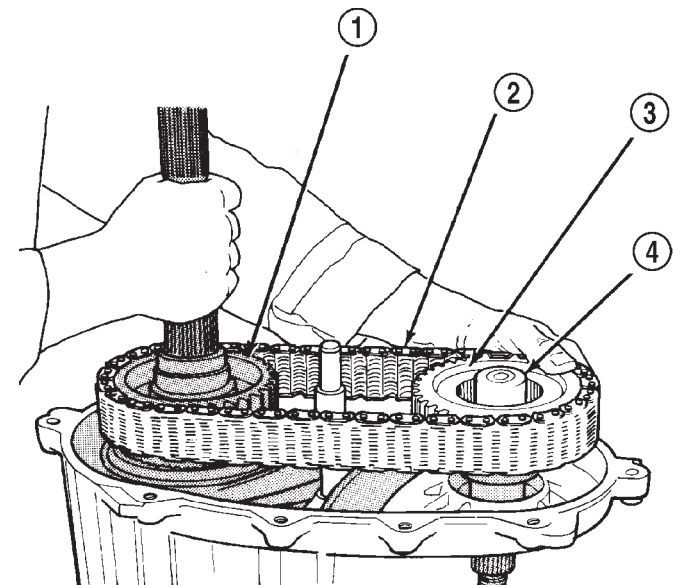
(4) Raise mainshaft about 2.54 cm (one inch) and seat front sprocket on front output shaft.

(5) If mainshaft and mode sleeve were unseated during chain installation, align and reseat mainshaft in input gear and hub.



**Fig. 79 Front Output Shaft Installation**

1 - FRONT OUTPUT SHAFT  
2 - BEARING



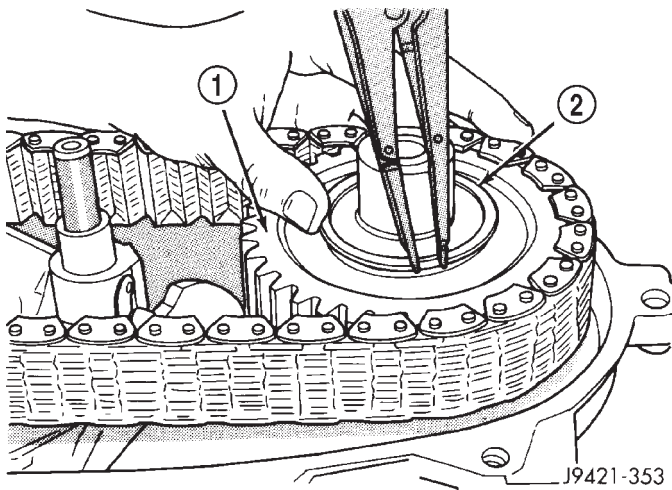
**Fig. 80 Drive Chain And Front Sprocket Installation**

1 - DRIVE SPROCKET  
2 - DRIVE CHAIN  
3 - FRONT SPROCKET  
4 - FRONT SHAFT



## TRANSFER CASE - NV241LD (Continued)

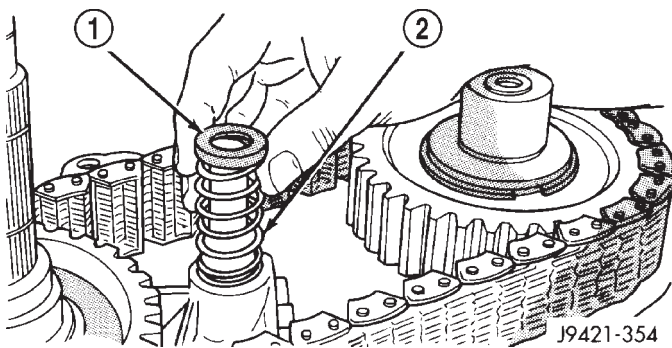
(6) Install front sprocket retaining ring (Fig. 81).



**Fig. 81 Front Sprocket Retaining Ring Installation**

- 1 - FRONT SPROCKET
- 2 - RETAINING RING

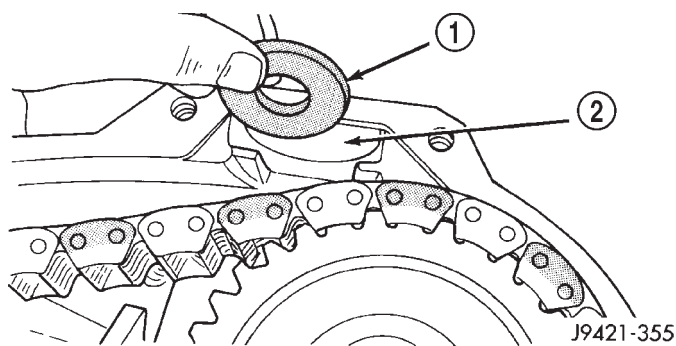
(7) Install spring and cup on shift rail (Fig. 82).



**Fig. 82 Shift Rail Spring And Cup Installation**

- 1 - CUP
- 2 - SPRING

(8) Insert magnet in front case pocket (Fig. 83).



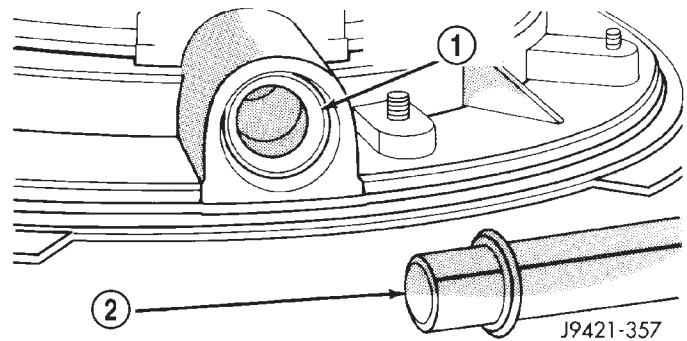
**Fig. 83 Case Magnet Installation**

- 1 - MAGNET
- 2 - CASE POCKET

## OIL PUMP AND REAR CASE

Lubricate the oil pump components with before installation. Prime the oil pickup tube by pouring a little oil into the tube before installation.

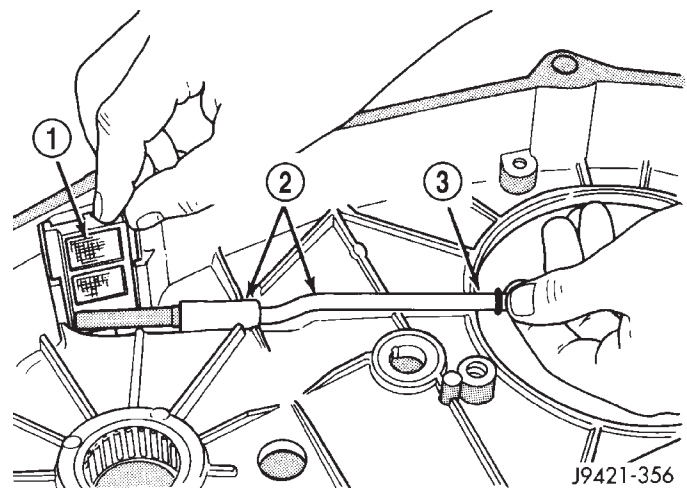
(1) Install new o-ring in pickup tube inlet of oil pump (Fig. 84).



**Fig. 84 Pickup Tube O-Ring Installation**

- 1 - O-RING (PUMP PICKUP)
- 2 - PICKUP TUBE

(2) Position oil pickup tube and filter in rear case. Be sure pickup filter is seated in case pocket and that pickup tube is aligned in case notches (Fig. 85). Be sure hose that connects tube to filter is securely positioned.

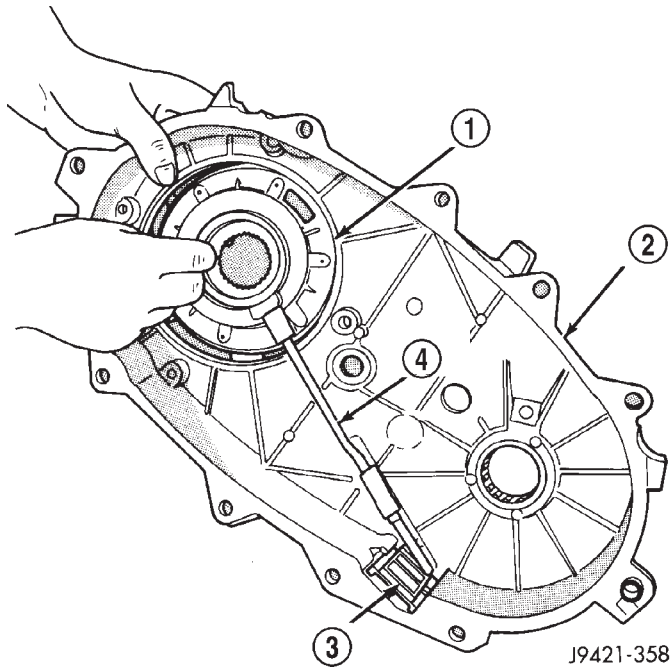


**Fig. 85 Oil Pickup Tube And Filter Position In Rear Case**

- 1 - FILTER
- 2 - TUBE AND HOSE
- 3 - TUBE IN NOTCH

## TRANSFER CASE - NV241LD (Continued)

(3) Insert oil pickup tube in oil pump and position pump in rear case (Fig. 86).



**Fig. 86 Positioning Oil Pump In Rear Case**

- 1 - OIL PUMP
- 2 - REAR CASE
- 3 - FILTER
- 4 - PICKUP TUBE

(4) Apply bead of Mopar® Gasket Maker, or equivalent, to mating surface of front case. Keep sealer bead width to maximum of 3/16 inch. Do not use excessive amount of sealer as excess will be displaced into case interior.

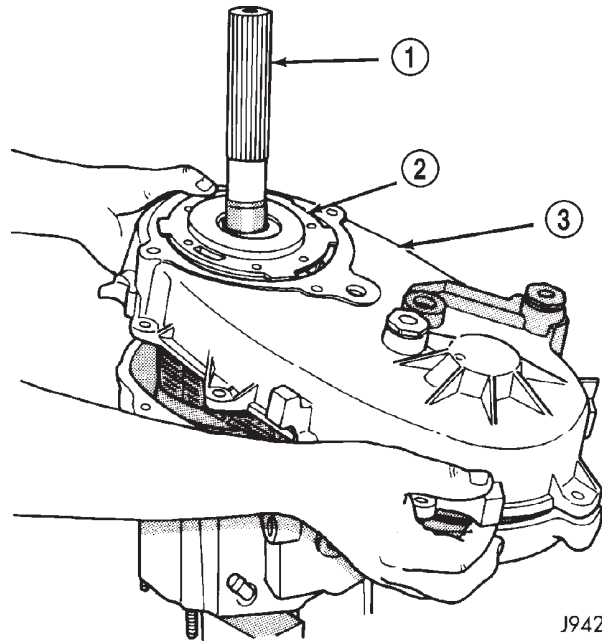
(5) Align oil pump with mainshaft and align shift rail with bore in rear case. Then install rear case and oil pump assembly (Fig. 87). Be sure oil pump and pickup tube remain in position during case installation.

(6) Install 4-5 rear case-to front case bolts to hold rear case in position. Tighten bolts snug but not to specified torque at this time.

**CAUTION:** Verify that shift rail (Fig. 88), and case alignment dowels are seated before installing any bolts. Case could be cracked if shaft rail or dowels are misaligned.

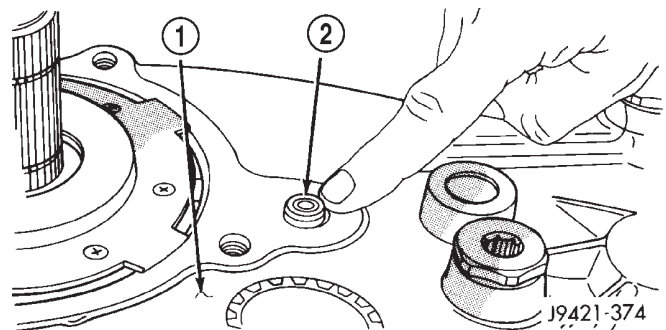
(7) Verify that oil pump is aligned and seated on rear case. Reposition pump if necessary.

(8) Check stud at end of case halves (Fig. 89). If stud was loosened or came out during disassembly, apply Loctite™ 242 to stud threads and reseal stud in case.



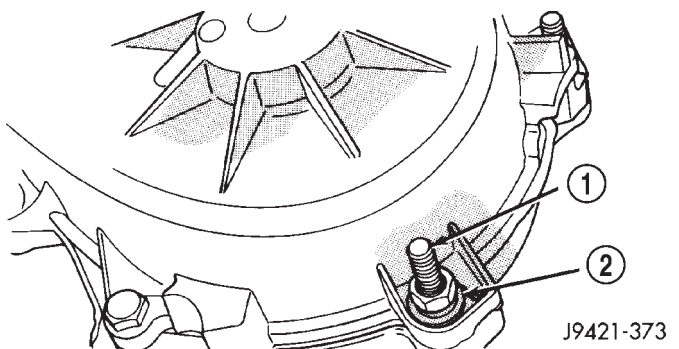
**Fig. 87 Rear Case And Oil Pump Installation**

- 1 - MAINSHAFT
- 2 - OIL PUMP
- 3 - REAR CASE



**Fig. 88 Shift Rail Seated In Rear Case Bore**

- 1 - REAR CASE
- 2 - SHIFT RAIL



**Fig. 89 Washer Installation On Case Stud And Dowel Bolts**

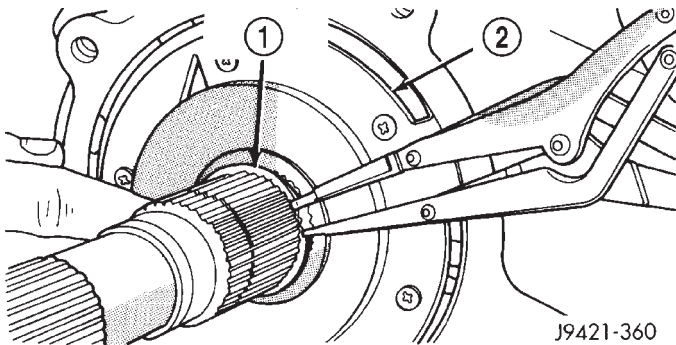
- 1 - CASE STUD/BOLT
- 2 - WASHER

## TRANSFER CASE - NV241LD (Continued)

(9) Apply Loctite™ 242 to remainder of rear case-to-front case bolt threads and install bolts. Be sure lock washers are used on studs/bolts at case ends. Tighten bolts, or stud nuts as follows:

- flange head bolts to 47-61 N-m (35-45 ft. lbs.)
- all other bolts/nuts to 27-34 N-m (20-25 ft. lbs.)

(10) Install oil pump retaining ring on mainshaft (Fig. 90).



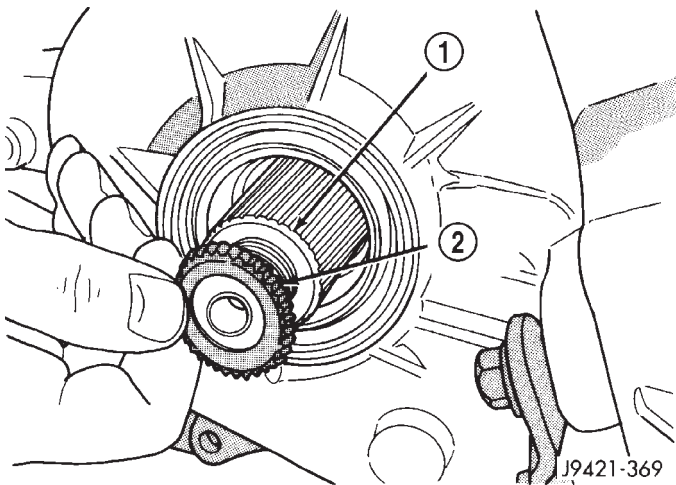
**Fig. 90 Oil Pump Retaining Ring Installation**

- 1 - RETAINING RING  
2 - OIL PUMP

(11) Install rear output bearing and snap-ring to output shaft.

### COMPANION FLANGE

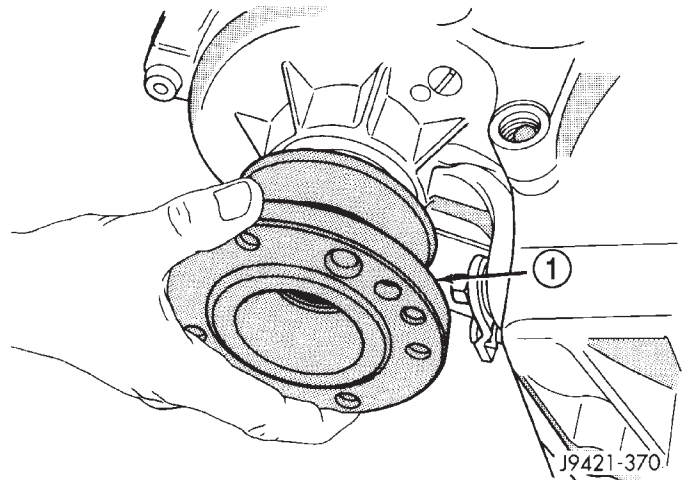
(1) Install companion flange seal on front shaft (Fig. 91).



**Fig. 91 Installing Flange Seal On Front Shaft**

- 1 - FRONT OUTPUT SHAFT  
2 - FLANGE SEAL

(2) Install companion flange on front shaft (Fig. 92). Then install and tighten flange nut to 176-271 N-m (130-200 ft. lbs.) torque.



**Fig. 92 Installing Companion Flange On Front Shaft**

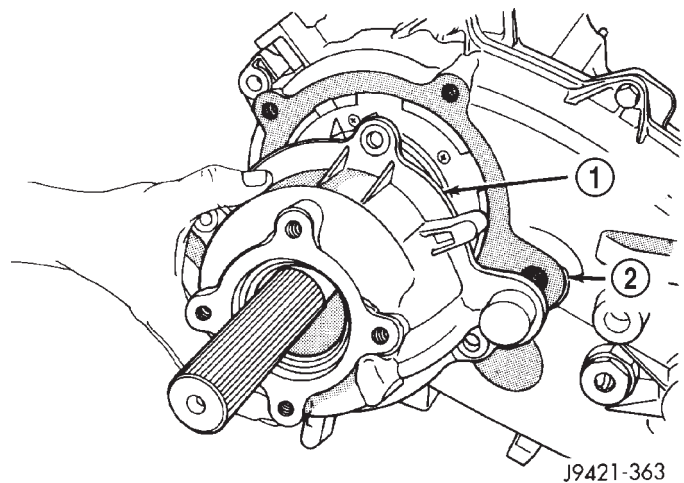
- 1 - COMPANION FLANGE

### REAR RETAINER AND EXTENSION

(1) Clean mating surfaces of transfer case housing and the rear retainer of any original gasket material.

(2) Install new rear retainer gasket onto the transfer case housing or rear retainer.

(3) Align and install rear retainer on rear case (Fig. 93).



**Fig. 93 Rear Retainer Installation**

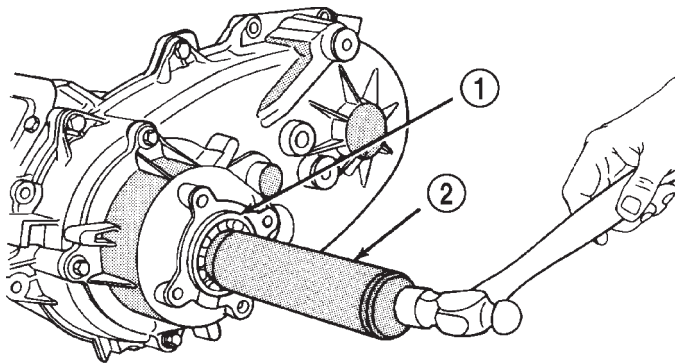
- 1 - REAR RETAINER  
2 - SHIFT RAIL



## TRANSFER CASE - NV241LD (Continued)

(4) Apply Mopar® Silicone Sealer to threads of rear retainer bolts. Then install retainer bolts finger tight.

(5) Install output bearing on mainshaft and seat it in rear retainer with suitable size pipe tool (Fig. 94).

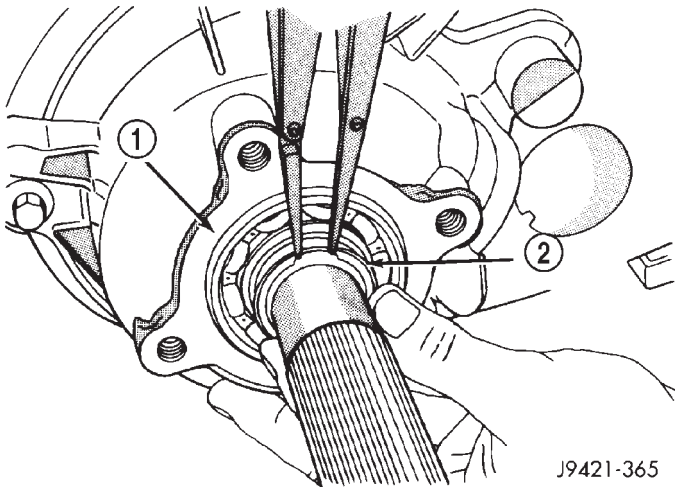


J9421-364

**Fig. 94 Output Bearing Installation**

- 1 - OUTPUT BEARING
- 2 - PIPE TOOL

(6) Install output bearing retaining ring (Fig. 95).



J9421-365

**Fig. 95 Output Bearing Retaining Ring Installation**

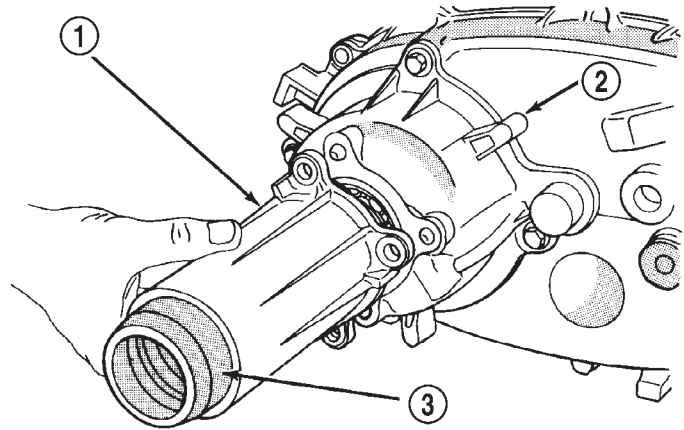
- 1 - OUTPUT BEARING
- 2 - RETAINING RING

(7) Tighten rear retainer bolts to 27-34 N·m (20-25 ft. lbs.) torque.

(8) Install new seal in rear extension housing seal with suitable size installer tool.

(9) Apply bead of Mopar® Gasket Maker, or equivalent, to mating surface of rear extension housing. Keep sealer bead width to maximum of 3/16 inch. Do not use excessive amount of sealer as excess could be displaced into output bearing.

(10) Align and install rear extension on retainer (Fig. 96).



J9421-366

**Fig. 96 Rear Extension Installation**

- 1 - REAR EXTENSION
- 2 - RETAINER
- 3 - EXTENSION SEAL

(11) Apply Mopar® Silicone Sealer to threads of rear extension housing bolts. Then install and tighten bolts to 27-34 N·m (20-25 ft. lbs.) torque.

## INSTALLATION

(1) Align and seat transfer case on transmission. Be sure transfer case input gear splines are aligned with transmission output shaft. Align splines by rotating transfer case rear output shaft yoke if necessary. Do not install any transfer case attaching nuts until the transfer case is completely seated against the transmission.

(2) Install and tighten transfer case attaching nuts. Tighten nuts to 30-41 N·m (20-30 ft.lbs.).

(3) Install rear crossmember.

(4) Remove jack stand from under transmission.

(5) Align and connect propeller shafts. (Refer to 3 - DIFFERENTIAL & DRIVELINE/PROPELLER SHAFT/PROPELLER SHAFT - INSTALLATION)

(6) Connect vacuum harness and vent hose.

(7) Connect shift rod to transfer case lever or floor shift arm. Use channel lock style pliers to press rod back into lever grommet.

(8) Adjust shift linkage, if necessary.

(9) Fill transfer case with recommended transmission fluid and install fill plug.

(10) Install skid plate, if equipped. (Refer to 13 - FRAMES & BUMPERS/FRAME/TRANSFER CASE SKID PLATE - INSTALLATION)

(11) Lower vehicle

TRANSFER CASE - NV241LD (Continued)

## SPECIFICATIONS

## TRANSFER CASE

## TORQUE SPECIFICATIONS

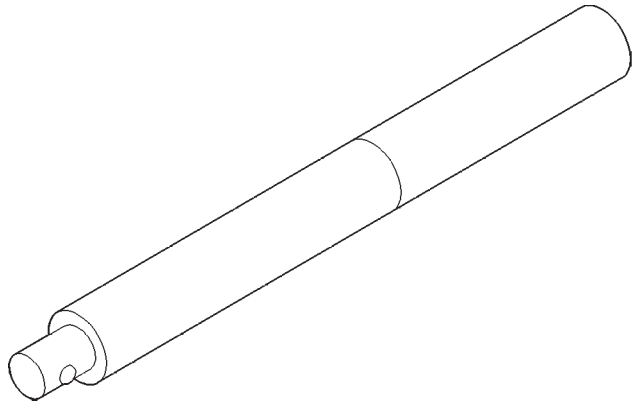
DESCRIPTION	N-m	Ft. Lbs.	In. Lbs.
Plug, Detent	16-24	12-18	-
Bolt, Diff. Case	17-27	15-24	-
Plug, Drain/Fill	40-45	30-40	-
Bolt, Extension Housing	35-46	26-34	-
Bolt, Front Brg. Retainer	16-27	12-24	-
Bolt, Case Half	35-46	26-34	-
Nut, Front Yoke	122-176	90-130	-
Screw, Oil Pump	1.2-1.8	-	12-15
Nut, Range Lever	27-34	20-25	-
Bolt, Rear Retainer	35-46	26-34	-
Nuts, Mounting	30-41	20-30	-
Bolts, U-Joint	19	17	-
Vacuum Switch	20-34	15-25	-



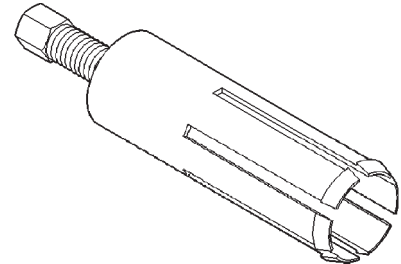
TRANSFER CASE - NV241LD (Continued)

SPECIAL TOOLS

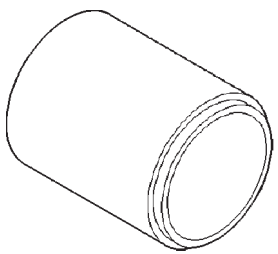
TRANSFER CASE - NV241LD



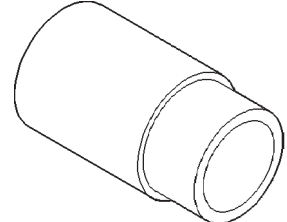
*Handle, Universal - C-4171*



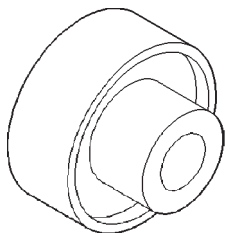
*Remover, Bushing - 6957*



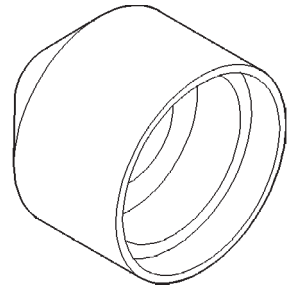
*Installer, Seal - 6888*



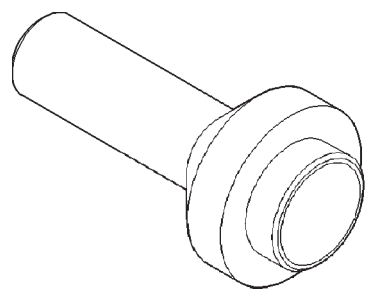
*Installer, Bushing - 8157*



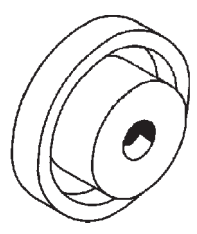
*Installer, Bearing - 6953*



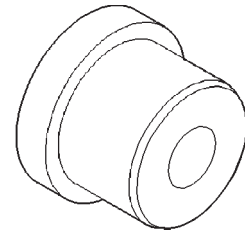
*Installer, Seal - D-163*



*Installer, Seal - 7884*

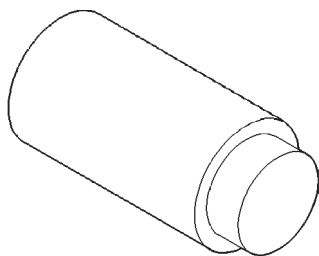
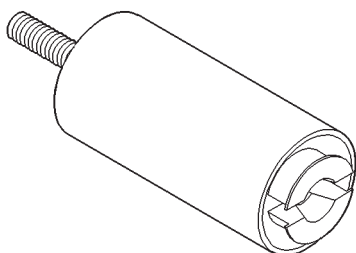
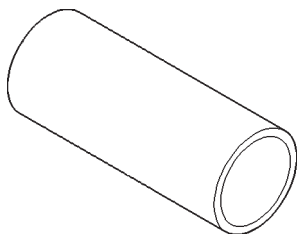
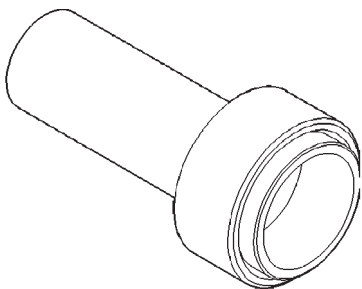


*Installer, Seal - C-4210*



*Installer, Bushing - 5066*

## TRANSFER CASE - NV241LD (Continued)

**Plug, Extension - C-293-3****Tool Set - L-4518****Cup - 8148****Installer, Pump Housing Seal - 7888**

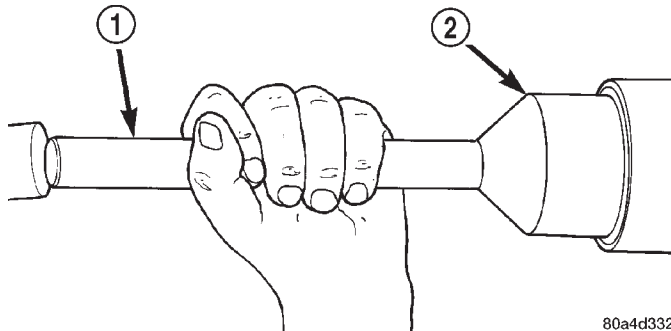
## EXTENSION HOUSING BUSHING AND SEAL

### REMOVAL

- (1) Raise and support vehicle.
- (2) Remove rear propeller shaft. (Refer to 3 - DIFFERENTIAL & DRIVELINE/PROPELLER SHAFT/PROPELLER SHAFT - REMOVAL)
- (3) Using a suitable pry tool or slide-hammer mounted screw, remove the extension housing seal.
- (4) Using Remover 8158, remove bushing from extension housing.

### INSTALLATION

- (1) Clean fluid residue from sealing surface and inspect for defects.
- (2) Position replacement bushing in extension housing with fluid port in bushing aligned with slot in housing.
- (3) Using Installer 8157, drive bushing into housing until installer seats against case.
- (4) Using Installer D-163, install seal in extension housing (Fig. 97).



80a4d332

**Fig. 97 Install Rear Seal in Extension Housing**

- 1 - SPECIAL TOOL C-4171
- 2 - SPECIAL TOOL D-163

- (5) Install propeller shaft. (Refer to 3 - DIFFERENTIAL & DRIVELINE/PROPELLER SHAFT/PROPELLER SHAFT - INSTALLATION)
- (6) Verify proper transfer case fluid level.
- (7) Lower vehicle.

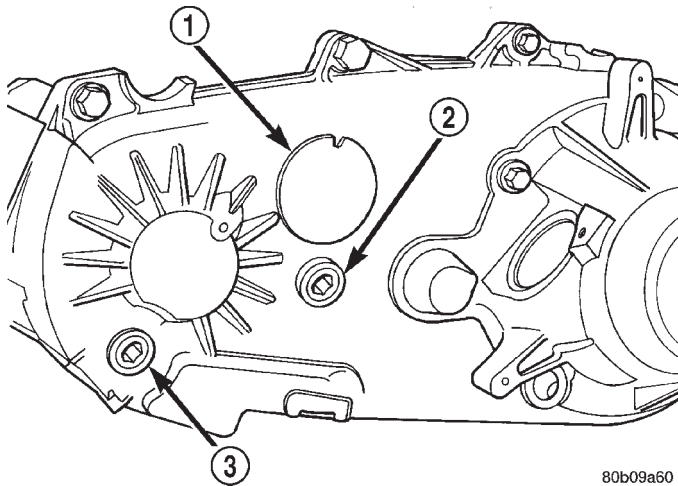
## FLUID

### STANDARD PROCEDURE - FLUID DRAIN AND REFILL

The fill and drain plugs are both in the rear case (Fig. 98).

- (1) Raise vehicle.
- (2) Position drain pan under transfer case.
- (3) Remove drain and fill plugs and drain lubricant completely.
- (4) Install drain plug. Tighten plug to 41-54 N·m (30-40 ft. lbs.).
- (5) Remove drain pan.
- (6) Fill transfer case to bottom edge of fill plug opening with Mopar® ATF +4, type 9602, Automatic Transmission fluid.
- (7) Install and tighten fill plug to 41-54 N·m (30-40 ft. lbs.).
- (8) Lower vehicle.

FLUID (Continued)



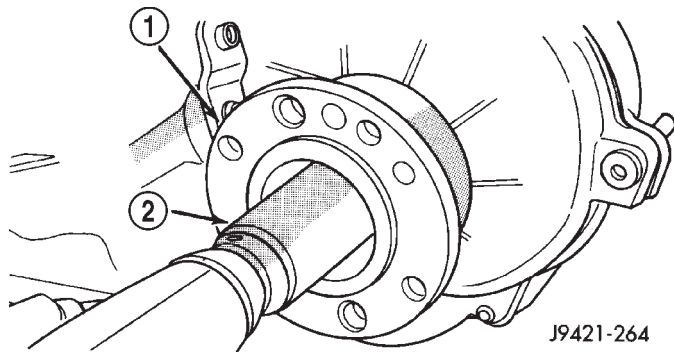
**Fig. 98 Fill/Drain Plug and I.D. Tag Location - Typical**

- 1 - I.D. TAG
- 2 - FILL PLUG
- 3 - DRAIN PLUG

**FRONT OUTPUT SHAFT SEAL**

**REMOVAL**

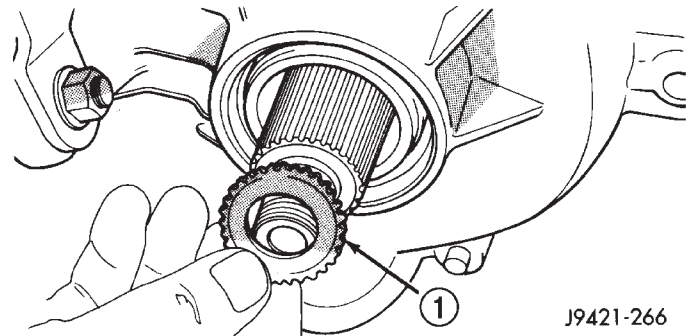
- (1) Shift transfer case into NEUTRAL.
- (2) Raise vehicle.
- (3) Remove front propeller shaft. (Refer to 3 - DIFFERENTIAL & DRIVELINE/PROPELLER SHAFT/PROPELLER SHAFT - REMOVAL)
- (4) Remove companion flange nut (Fig. 99). Discard nut after removal. It is not reusable.



**Fig. 99 Removing Companion Flange Nut**

- 1 - COMPANION FLANGE
- 2 - SOCKET

- (5) Remove companion flange from output shaft. Use a suitable puller if flange can not be removed by hand.
- (6) Remove companion flange rubber seal from front output shaft (Fig. 100).
- (7) Remove front output shaft seal with suitable pry tool, or a slide hammer mounted screw.



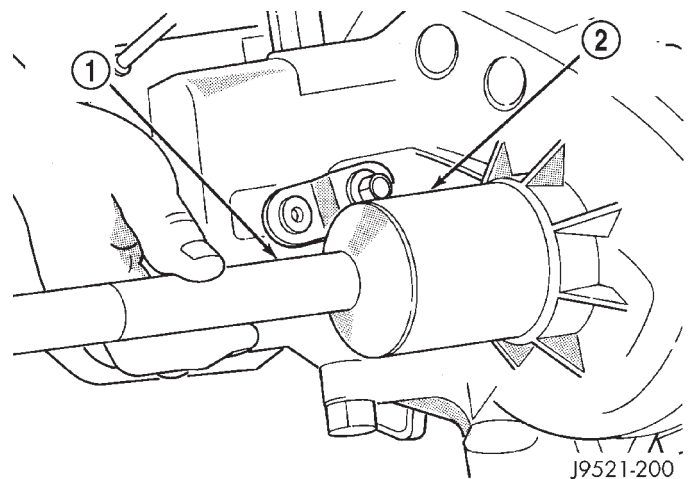
**Fig. 100 Companion Flange Seal Removal**

- 1 - FLANGE SEAL

**INSTALLATION**

- (1) Install new front output seal in front case with Installer Tool 6888 and Tool Handle C-4171 (Fig. 101) as follows:
  - (a) Place new seal on tool. Garter spring on seal goes toward interior of case.
  - (b) Start seal in bore. Once seal is started, continue tapping seal into bore until installer tool bottoms against case.
  - (c) Remove installer and verify that seal is recessed the proper amount. Seal should be 2.03 to 2.5 mm (0.080 to 0.100 in.) below top edge of seal bore in front case (Fig. 102). This is correct final seal position.

**CAUTION:** Be sure the front output seal is seated below the top edge of the case bore as shown. The seal could loosen, or become cocked if not seated to recommended depth.

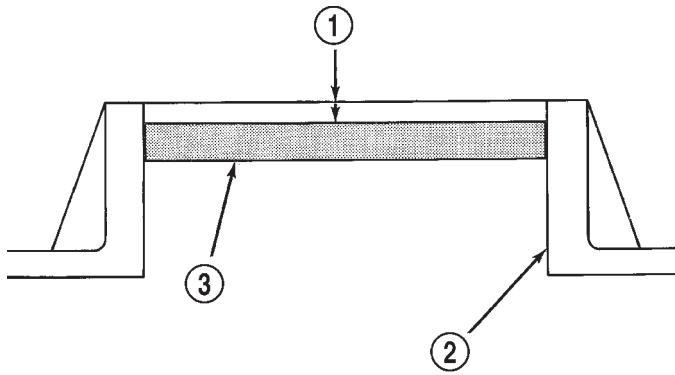


**Fig. 101 Front Output Seal Installation**

- 1 - SPECIAL TOOL C-4171
- 2 - SPECIAL TOOL 6888

- (2) Install companion flange seal on front shaft (Fig. 103).

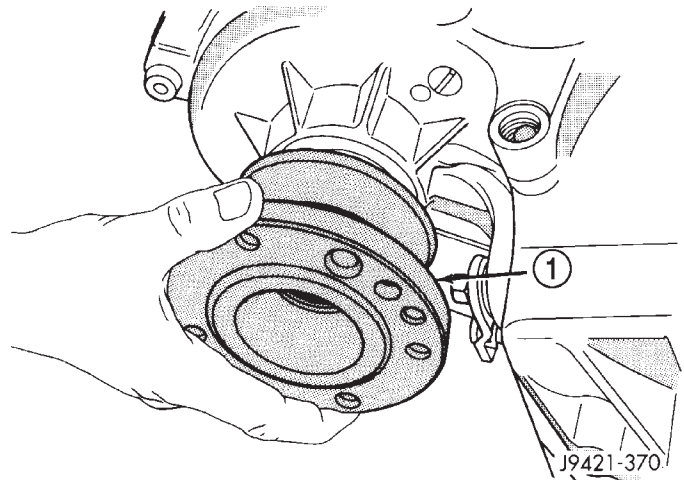
## FRONT OUTPUT SHAFT SEAL (Continued)



J9521-190

**Fig. 102 Checking Front Output Seal Installation Depth**

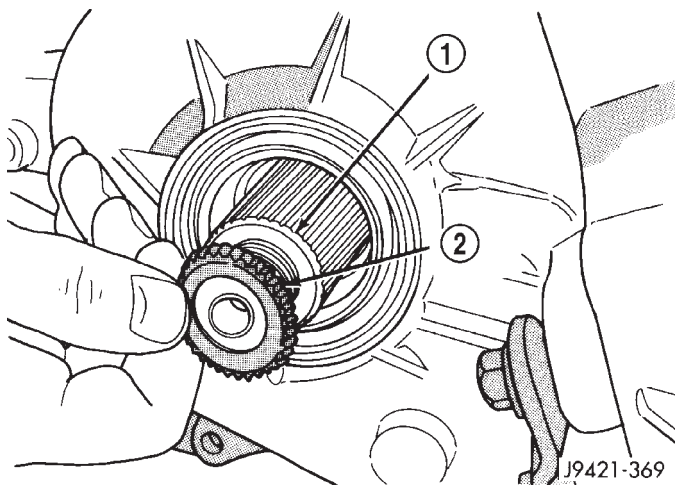
- 1 - CORRECT SEAL DEPTH IS 2.03-2.5 mm (0.080-0.100 in.) BELOW TOP EDGE OF BORE  
 2 - FRONT CASE SHAFT BORE  
 3 - FRONT OUTPUT SEAL



J9421-370

**Fig. 104 Installing Companion Flange On Front Shaft**

- 1 - COMPANION FLANGE



J9421-369

**Fig. 103 Installing Flange Seal On Front Shaft**

- 1 - FRONT OUTPUT SHAFT  
 2 - FLANGE SEAL

(3) Install companion flange on front shaft (Fig. 104). Then install and tighten flange nut to 176-271 N·m (130-200 ft. lbs.) torque.

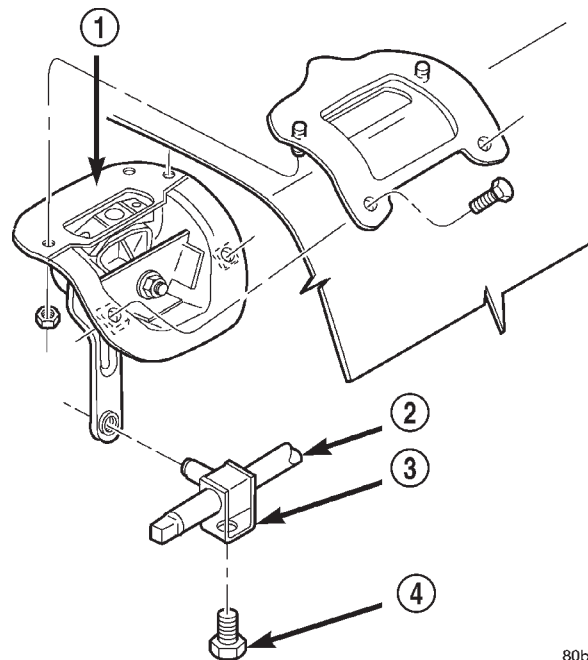
(4) Install propeller shaft. (Refer to 3 - DIFFERENTIAL & DRIVELINE/PROPELLER SHAFT/PROPELLER SHAFT - INSTALLATION)

## SHIFT LEVER

## REMOVAL

- (1) Shift transfer case into 2H.
- (2) Remove transfer case shifter knob cap.
- (3) Remove nut holding shifter knob to shift lever.
- (4) Remove shifter knob.

- (5) Remove the shift boot from the shifter bezel.
- (6) Remove the bolts securing the shifter mechanism to the floor pan along the driver's side of the transmission tunnel (Fig. 105).



80be45f5

**Fig. 105 Transfer Case Shifter**

- 1 - TRANSFER CASE SHIFTER ASSEMBLY  
 2 - SHIFT ROD  
 3 - TRUNNION  
 4 - LOCK BOLT

- (7) Raise and support the vehicle.
- (8) Loosen adjusting trunnion lock bolt and slide shift rod out of trunnion. If rod lacks enough travel

## SHIFT LEVER (Continued)

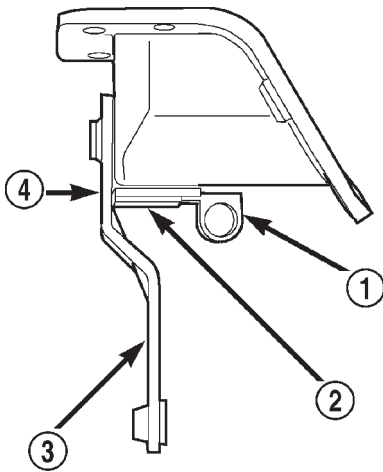
to come out of trunnion, push trunnion out of shift lever.

(9) Remove the nuts holding the shifter mechanism to the underside of the floor pan.

(10) Separate shift lever mechanism from the vehicle.

**INSTALLATION**

(1) If the shifter mechanism does not have a adjustment locating pin installed, align the adjustment channel on the shifter assembly to the locating hole in the lower shift lever and install an appropriately sized pin to retain the position (Fig. 106).



80be45f6

**Fig. 106 Shifter Adjustment**

- 1 - LOCATING PIN
- 2 - ADJUSTMENT CHANNEL
- 3 - LOWER SHIFTER LEVER
- 4 - LOCATING HOLE

(2) Position shift lever on vehicle.  
 (3) Install nuts to hold shift lever to the underside of the body.

(4) Install trunnion to shift lever, if necessary.

(5) Install shift rod to trunnion, if necessary.

(6) Tighten the shift rod lock bolt to 10 N·m (90 in.lbs.).

(7) Remove the shifter adjustment locating pin from the adjustment channel and the locating hole.

(8) Lower vehicle.

(9) Install the bolts to hold the shifter mechanism to the floor pan.

(10) Install the transfer case shifter bezel.

(11) Install the shifter boot and the shifter knob onto the shifter lever.

(12) Install nut to hold shifter knob to shift lever.

(13) Install shifter knob cap.

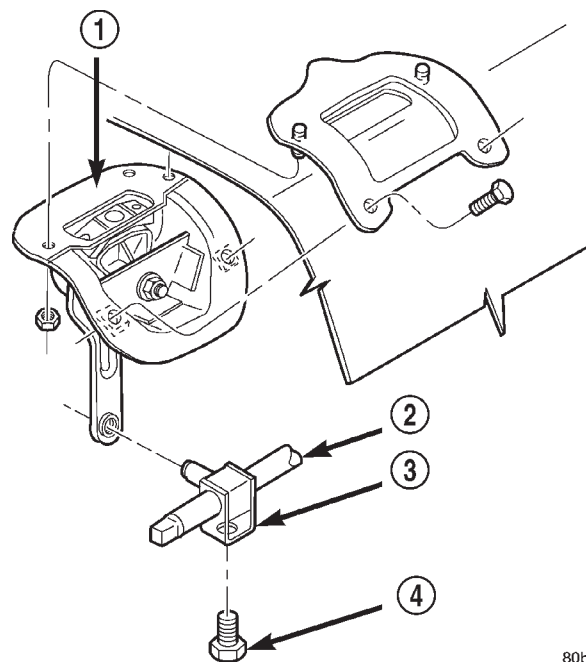
(14) Verify transfer case operation.

**ADJUSTMENT - SHIFT LEVER**

(1) Move shift lever into 2H position.

(2) Raise vehicle.

(3) Loosen shift rod lock bolt at trunnion (Fig. 107).



80be45f5

**Fig. 107 Shift Rod Lock Bolt Location**

- 1 - TRANSFER CASE SHIFTER ASSEMBLY
- 2 - SHIFT ROD
- 3 - TRUNNION
- 4 - LOCK BOLT



## SHIFT LEVER (Continued)

(4) Check shift rod fit in trunnion. Be sure rod does not bind in trunnion. Lubricate the shift rod and trunnion if necessary.

(5) Verify that transfer case shift lever is in 2H detent position. The 2H detent position on the transfer case shift arm is the second position from full forward.

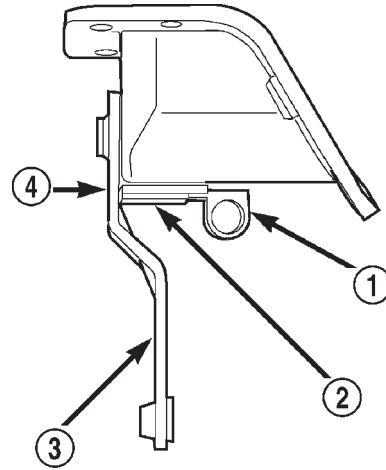
(6) Align the adjustment locating hole on the lower shifter lever with the adjustment channel on the shifter bracket assembly (Fig. 108).

(7) Insert an appropriately sized pin through into the adjustment channel and through the locating hole to hold the shifter in the correct position.

(8) Tighten shift rod lock bolt to 10 N·m (90 in. lbs.) torque.

(9) Remove the locating pin from the adjustment channel and locating hole.

(10) Check shift linkage operation. Be sure transfer case shifts into and operates properly in all ranges.



80be45f6

**Fig. 108 Shifter Adjustment Location**

- 1 - LOCATING PIN
- 2 - ADJUSTMENT CHANNEL
- 3 - LOWER SHIFTER LEVER
- 4 - LOCATING HOLE

# TRANSFER CASE - NV241HD

## TABLE OF CONTENTS

	page		page
<b>TRANSFER CASE - NV241HD</b>		<b>EXTENSION HOUSING BUSHING AND SEAL</b>	
DESCRIPTION .....	890	REMOVAL .....	921
OPERATION .....	892	INSTALLATION .....	921
DIAGNOSIS AND TESTING .....	892	<b>FLUID</b>	
TRANSFER CASE .....	892	STANDARD PROCEDURE .....	922
REMOVAL .....	894	FLUID DRAIN AND REFILL .....	922
DISASSEMBLY .....	894	<b>FRONT OUTPUT SHAFT SEAL</b>	
CLEANING .....	902	REMOVAL .....	922
INSPECTION .....	902	INSTALLATION .....	922
ASSEMBLY .....	904	<b>SHIFT LEVER</b>	
INSTALLATION .....	919	REMOVAL .....	924
SPECIFICATIONS .....	919	INSTALLATION .....	924
SPECIAL TOOLS .....	920	ADJUSTMENTS .....	925

## TRANSFER CASE - NV241HD

### DESCRIPTION

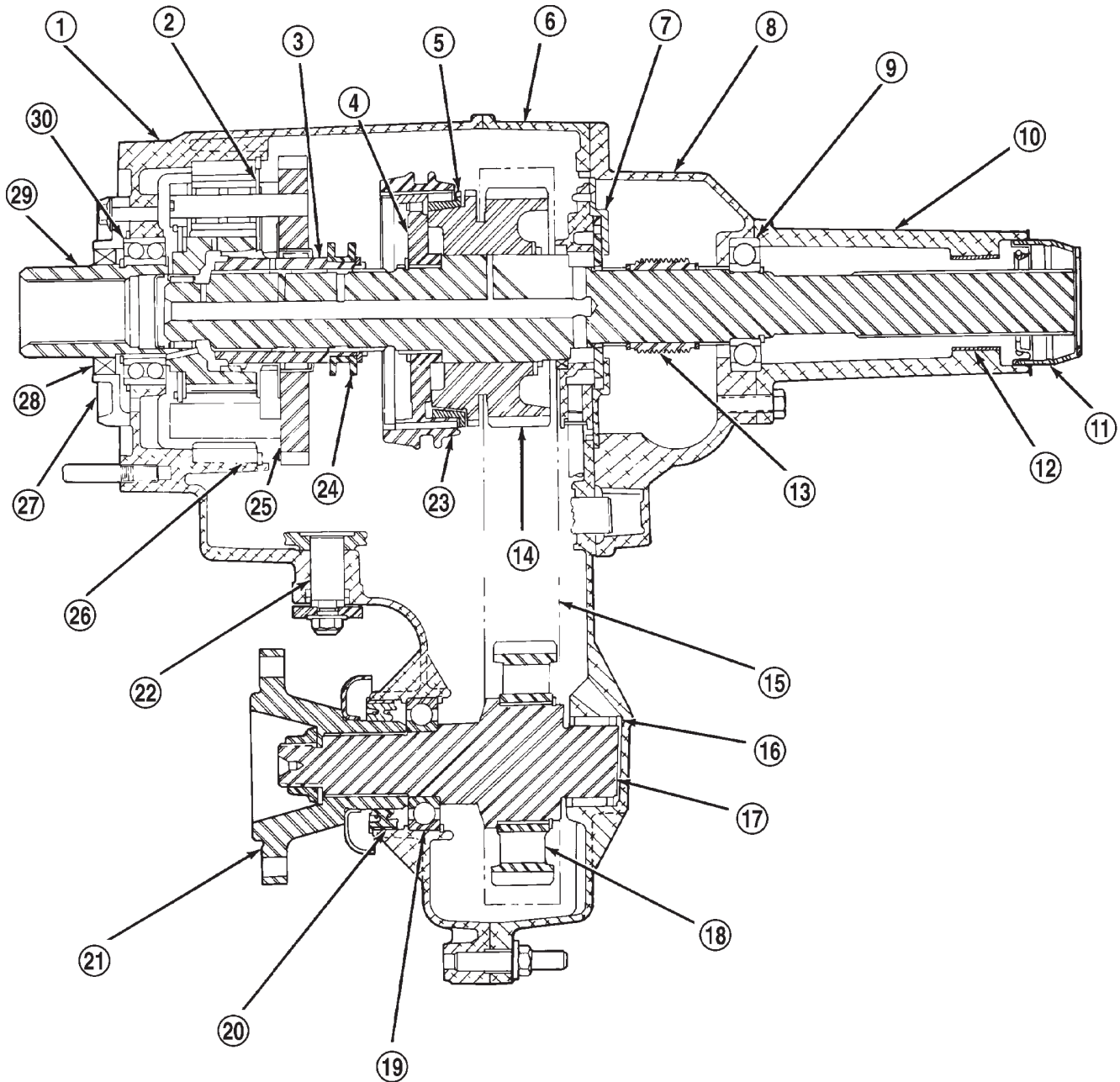
The NV241HD is a part-time transfer case with a low-range gear system. The transfer case provides three operating ranges plus a NEUTRAL position. The low range position provides a gear reduction ratio of 2.72:1 for increased low speed torque capability. Operating ranges are: 2H, 4H, and 4LO.

The synchronizer mechanism consists of a brass stop ring, synchronizer hub, and the sliding clutch

(Fig. 1). The synchronizer components allow the transfer case to be shifted between the 2H and 4H operating ranges while the vehicle is in motion.

The gear cases, retainer and extension are all of aluminum. Drive sprockets and an interconnecting drive chain are used to transmit engine torque to the front/rear propeller shafts. The mainshaft, input gear and front output shaft are supported by ball and needle bearings.

TRANSFER CASE - NV241HD (Continued)



**Fig. 1 NV241HD Transfer Case**

- |                        |                             |
|------------------------|-----------------------------|
| 1 - FRONT CASE         | 16 - NEEDLE BEARING         |
| 2 - PLANETARY ASSEMBLY | 17 - FRONT OUTPUT SHAFT     |
| 3 - SUPPORT SLEEVE     | 18 - SPROCKET               |
| 4 - SYNCHRO HUB        | 19 - ROLLER BEARING         |
| 5 - STOP RING          | 20 - SEAL                   |
| 6 - REAR CASE          | 21 - COMPANION FLANGE       |
| 7 - OIL PUMP           | 22 - SECTOR SHAFT           |
| 8 - REAR RETAINER      | 23 - SLIDING CLUTCH         |
| 9 - OUTPUT BEARING     | 24 - SLIDING HUB            |
| 10 - REAR EXTENSION    | 25 - PTO GEAR               |
| 11 - SEAL              | 26 - ANNULUS GEAR           |
| 12 - BUSHING           | 27 - INPUT BEARING RETAINER |
| 13 - SPEEDOMETER GEAR  | 28 - SEAL                   |
| 14 - DRIVE SPROCKET    | 29 - INPUT GEAR             |
| 15 - CHAIN             | 30 - INPUT BEARING          |

J9421-230

## TRANSFER CASE - NV241HD (Continued)

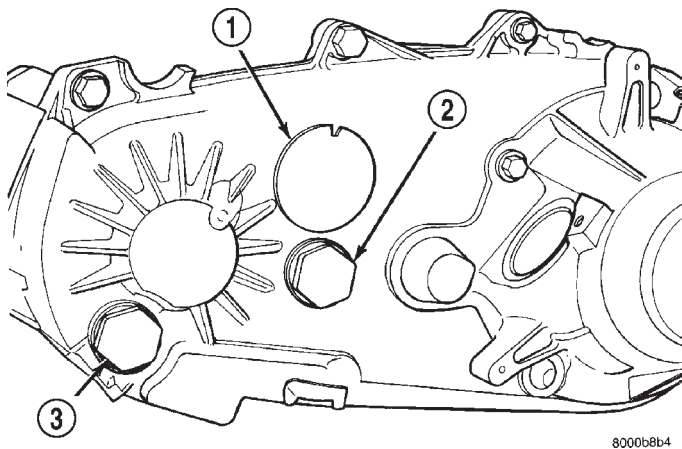
**PTO CAPABILITY**

The NV241HD transfer case has power take-off capability. A PTO gear permanently attached to the planetary carrier, and a removable PTO cover are provided for this purpose.

**IDENTIFICATION**

An identification tag (Fig. 2) is attached to the rear case of every transfer case. The tag provides the transfer case model number, assembly number, serial number, and low range ratio.

The transfer case serial number also represents the date of build.



800068b4

**Fig. 2 Transfer Case Identification Tag - Typical**

- 1 - I.D. TAG
- 2 - FILL PLUG
- 3 - DRAIN PLUG

**OPERATION****OPERATING RANGES**

Transfer case operating ranges are:

- 2H (2-wheel drive)
- 4H (4-wheel drive)
- 4LO (4-wheel drive low range)

The 2H range is for use on any road surface at any time.

The 4H and 4LO ranges are for off road use only. They are not for use on hard surface roads. The only exception being when the road surface is covered by ice and snow or other loose, slippery material.

The low range reduction gear system is operative in 4LO range only. This range is for extra pulling power in off road situations. Low range reduction ratio is 2.72:1.

A front axle disconnect system is used to achieve two-wheel drive mode. The axle disconnect vacuum motor is actuated by a vacuum switch on the transfer case. The switch is operated by the transfer case range rod.

**SHIFT MECHANISM**

The transfer case is operated by an adjustable floor mounted shift linkage. The transfer case shift lever is directly attached to the shift sector. The sector operates the range and mode forks within the transfer case.

A straight line shift pattern is used with a NEUTRAL detent. Lever range positions are imprinted in the shift knob.

**SHIFTING**

The synchronizer components allow the transfer case to be shifted between the 2H and 4H operating ranges while the vehicle is in motion. The vehicle must have the transmission placed in NEUTRAL, or the clutch depressed in the case of a manual transmission, and be moving less than 2-3 MPH when shifting into the 4L operating range.

**DIAGNOSIS AND TESTING - TRANSFER CASE**

Before beginning repair on a suspected transfer case malfunction, check all other driveline components beforehand.

The actual cause of a problem may be related to such items as: front hubs, axles, propeller shafts, wheels and tires, transmission, or clutch instead. If all other driveline components are in good condition and operating properly, refer to the Diagnosis Chart for further information.

## TRANSFER CASE - NV241HD (Continued)

**DIAGNOSIS CHART**

Condition	Possible Cause	Correction
Transfer Case difficult to shift or will not shift into desired range.	<ol style="list-style-type: none"> <li>1) Vehicle speed too great to permit shifting.</li> <li>2) If vehicle was operated for an extended period in 4H on a dry paved surface, the driveline torque load may be causing a bind.</li> <li>3) Transfer case external shift linkage binding.</li> <li>4) Insufficient or incorrect lubricant.</li> <li>5) Internal components binding, worn, or damaged.</li> </ol>	<ol style="list-style-type: none"> <li>1) Stop vehicle and shift into desired range. Or, reduce speed to below 3-4 km/h (2-3 mph) before attempting the shift.</li> <li>2) Stop vehicle and shift the transmission into neutral. Shift the transfer case to 2H and operate vehicle in 2H on dry paved surfaces.</li> <li>3) Lubricate, repair, or replace linkage bushings, or tighten loose components as necessary.</li> <li>4) Drain and refill to edge of fill hole with Mopar® ATF +4, type 9602, Automatic Transmission fluid.</li> <li>5) Disassemble the transfer case and replace worn or damaged components as necessary.</li> </ol>
Transfer Case noisy in all operating ranges.	<ol style="list-style-type: none"> <li>1) Insufficient or incorrect lubricant.</li> </ol>	<ol style="list-style-type: none"> <li>1) Drain and refill to edge of fill hole with Mopar® ATF +4, type 9602, Automatic Transmission fluid.</li> </ol>
Noisy in, or jumps out of, four wheel drive low range.	<ol style="list-style-type: none"> <li>1) Transfer case not completely engaged in 4L position.</li> <li>2) Shift linkage out of adjustment.</li> <li>3) Shift linkage loose or binding.</li> <li>4) Range fork damaged, inserts worn, or fork is binding on the shift rail.</li> <li>5) Low range gear worn or damaged.</li> </ol>	<ol style="list-style-type: none"> <li>1) With the transmission in NEUTRAL, or the clutch depressed in the case of a manual transmission and the vehicle moving under 3-4 km/h (2-3 mph), shift the transfer case to NEUTRAL and then shift into the 4L position.</li> <li>2) Adjust linkage.</li> <li>3) Tighten, lubricate, or repair linkage as necessary.</li> <li>4) Disassemble unit and repair as necessary.</li> <li>5) Disassemble unit and repair as necessary.</li> </ol>
Lubricant leaking from output shaft seal or vent.	<ol style="list-style-type: none"> <li>1) Transfer case overfilled.</li> <li>2) Vent closed or restricted.</li> <li>3) Output shaft seals damaged or installed incorrectly.</li> </ol>	<ol style="list-style-type: none"> <li>1) Drain lubricant to the correct level.</li> <li>2) Clear or replace vent as necessary.</li> <li>3) Replace seal as necessary. Check to ensure that another component, the propeller shaft slip yoke for example, is not causing damage to seal.</li> </ol>
Abnormal tire wear.	<ol style="list-style-type: none"> <li>1) Extended operation on hard, dry surfaces in the 4H position.</li> </ol>	<ol style="list-style-type: none"> <li>1) Operate vehicle in the 2H position on hard, dry surfaces.</li> </ol>



## TRANSFER CASE - NV241HD (Continued)

**REMOVAL**

- (1) Raise and support vehicle.
- (2) Remove skid plate, if equipped. (Refer to 13 - FRAMES & BUMPERS/FRAME/TRANSFER CASE SKID PLATE - REMOVAL)
- (3) Position drain oil container under transfer case.
- (4) Remove transfer case drain plug and drain lubricant into container.
- (5) Disconnect vent hose and vacuum harness at transfer case switch.
- (6) Disconnect shift rod from grommet in transfer case shift lever, or from floor shift arm whichever provides easy access. Use channel lock style pliers to press rod out of lever grommet.
- (7) Support transmission with jack stand.
- (8) Remove rear crossmember.
- (9) Mark front and rear propeller shafts for assembly reference.
- (10) Remove front and rear propeller shafts. (Refer to 3 - DIFFERENTIAL & DRIVELINE/PROPELLER SHAFT/PROPELLER SHAFT - REMOVAL)
- (11) Support transfer case with suitable jack. Secure transfer case to jack with safety chains.
- (12) Remove nuts attaching transfer case to transmission.
- (13) Move transfer case assembly rearward until free of transmission output shaft.
- (14) Lower jack and move transfer case from under vehicle.

**DISASSEMBLY**

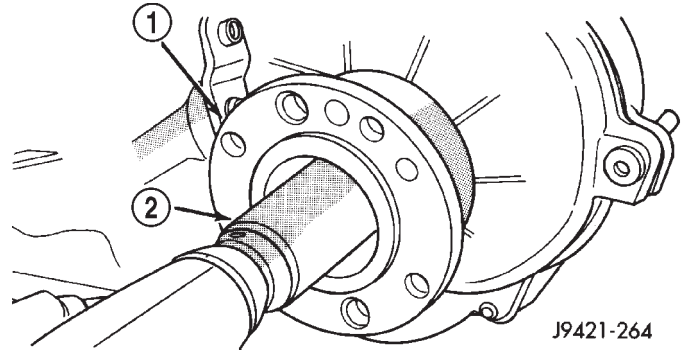
Position transfer case in a shallow drain pan. Remove drain plug and drain any remaining lubricant remaining in case.

**EXTENSION HOUSING**

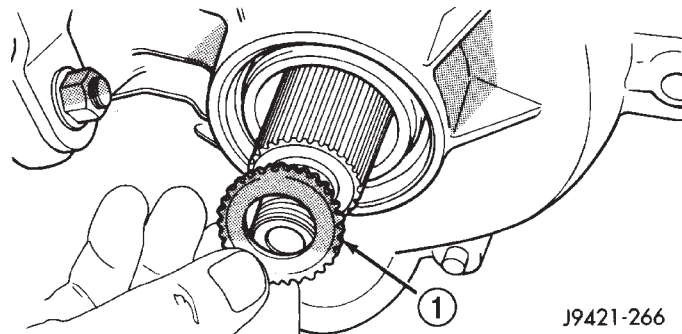
- (1) Remove extension housing snap-ring access cover.
- (2) Remove bolts holding extension housing to rear case half.
- (3) Tap extension housing with plastic or rawhide hammer to loosen sealant.
- (4) Disengage extension housing snap-ring from rear output shaft bearing.
- (5) Separate extension housing from transfer case.

**COMPANION FLANGE AND SHIFT LEVER**

- (1) Shift transfer case into NEUTRAL.
- (2) Remove companion flange nut (Fig. 3). Discard nut after removal. It is not reusable.
- (3) Remove companion flange from front output shaft. Use a suitable puller if flange can not be removed by hand.
- (4) Remove companion flange rubber seal from front output shaft (Fig. 4).

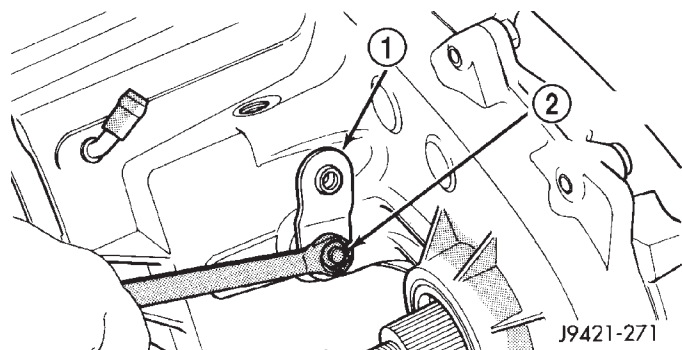
**Fig. 3 Removing Companion Flange Nut**

- 1 - COMPANION FLANGE  
2 - SOCKET

**Fig. 4 Companion Flange Seal Removal**

- 1 - FLANGE SEAL

- (5) Remove nut and washer that retain shift lever to sector shaft. Then remove shift lever from shaft (Fig. 5).

**Fig. 5 Shift Lever Removal**

- 1 - SHIFT LEVER  
2 - NUT/WASHER

## TRANSFER CASE - NV241HD (Continued)

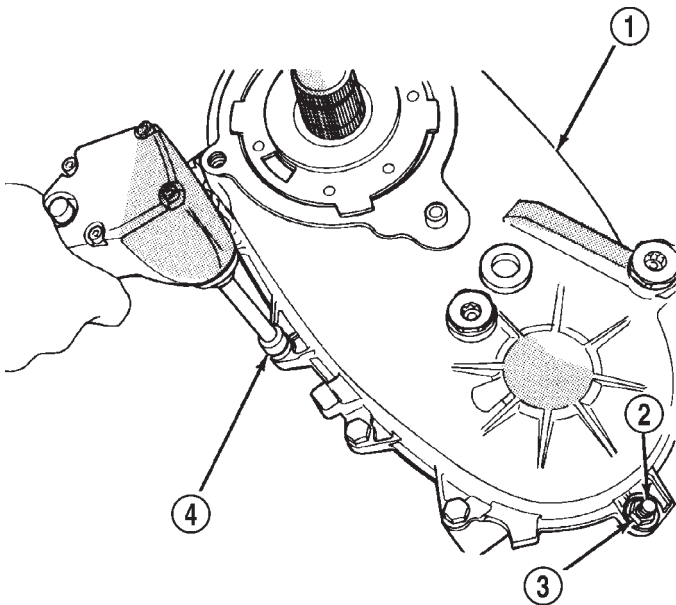
**FRONT OUTPUT SHAFT AND DRIVE CHAIN**

(1) Remove output bearing retaining ring with heavy duty snap-ring pliers.

(2) Remove output shaft bearing.

(3) Note position of bolts that attach rear case to front case (Fig. 6). Some bolts/studs at ends of case require flat washers. Mark position of these bolts with paint or scribe.

(4) Remove rear case-to-front case bolts.

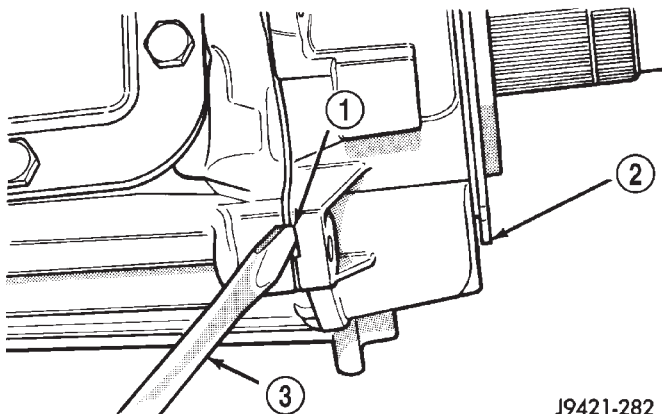


J9421-278

**Fig. 6 Removing Case Attaching Bolts**

- 1 - REAR CASE
- 2 - STUD
- 3 - NUT AND WASHER
- 4 - SOCKET

(5) Loosen rear case with pry tool to break sealer bead. Insert tool in slot at each end of case (Fig. 7).

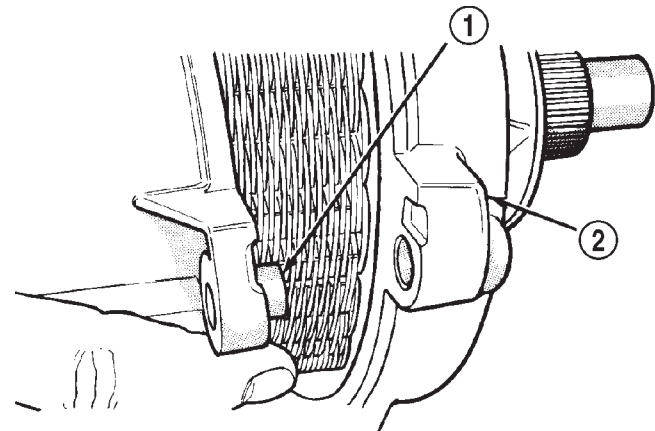


J9421-282

**Fig. 7 Loosening Rear Case (Breaking Sealer Bead)**

- 1 - SLOT
- 2 - REAR CASE
- 3 - PRY TOOL

(6) Unseat rear case from alignment dowels (Fig. 8).



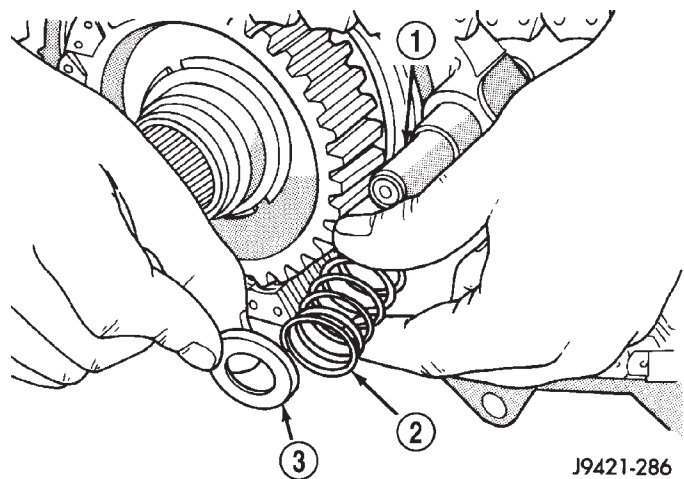
J9421-283

**Fig. 8 Removing Rear Case From Alignment Dowels**

- 1 - CASE DOWELS (2)
- 2 - REAR CASE

(7) Remove rear case and oil pump assembly from front case.

(8) Remove shift rail cup and spring (Fig. 9).



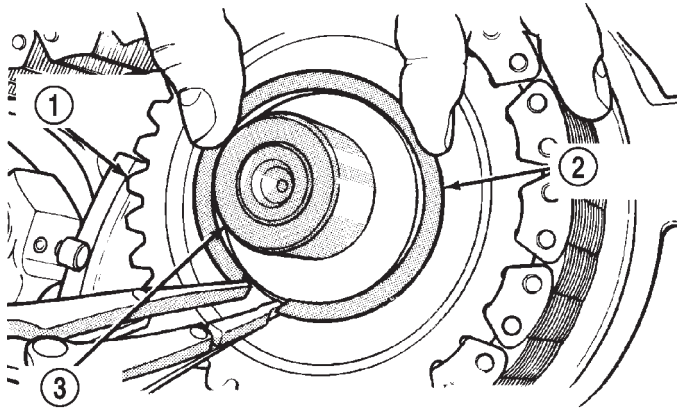
J9421-286

**Fig. 9 Shift Rail Cup And Spring Removal**

- 1 - SHIFT RAIL
- 2 - SPRING
- 3 - CUP

TRANSFER CASE - NV241HD (Continued)

(9) Remove front sprocket retaining ring (Fig. 10).



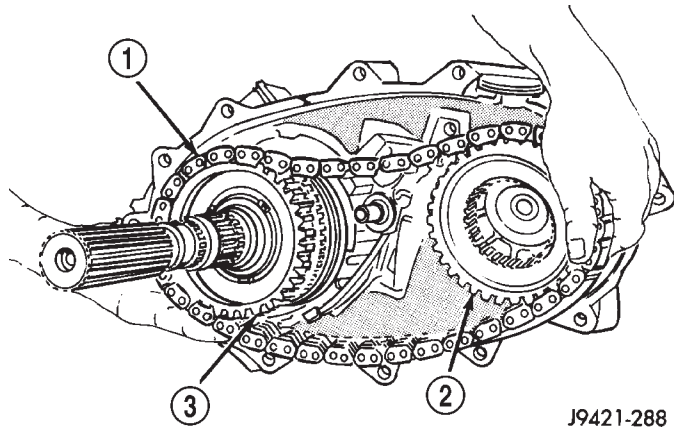
J9421-287

**Fig. 10 Removing Front Drive Sprocket Retaining Ring**

- 1 - FRONT SPROCKET
- 2 - RETAINING RING
- 3 - FRONT OUTPUT SHAFT

(10) Pull mainshaft, front sprocket, and chain outward about 25.4 mm (1-inch) simultaneously (Fig. 11).

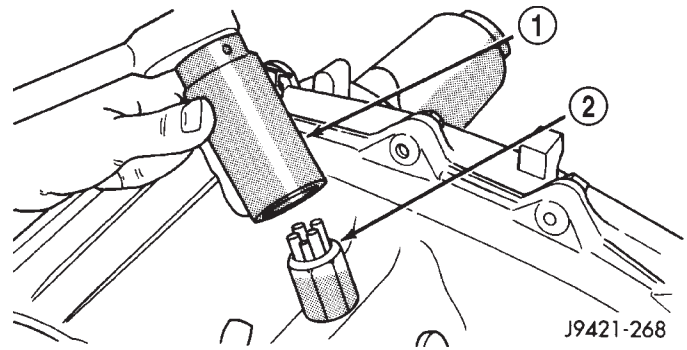
(11) Remove chain from mainshaft drive sprocket and remove front sprocket and chain as an assembly.



J9421-288

**Fig. 11 Removing Drive Chain And Front Sprocket**

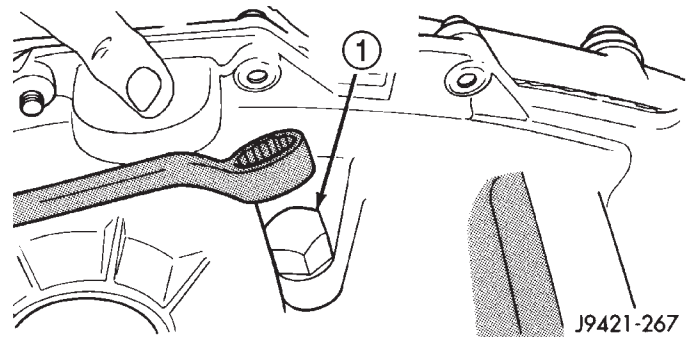
- 1 - CHAIN
- 2 - DRIVE SPROCKET
- 3 - FRONT SPROCKET



J9421-268

**Fig. 12 Vacuum/Indicator Switch Removal**

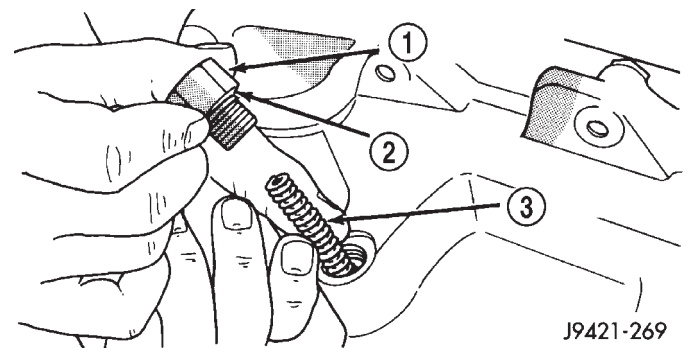
- 1 - 1-1/16" SOCKET
- 2 - INDICATOR SWITCH



J9421-267

**Fig. 13 Loosening Poppet Plunger Screw**

- 1 - POPPET PLUNGER SCREW



J9421-269

**Fig. 14 Poppet Plunger Screw And Spring Removal**

- 1 - POPPET PLUNGER SCREW
- 2 - O-RING
- 3 - PLUNGER SPRING

**SHIFT FORK AND MAINSHAFT**

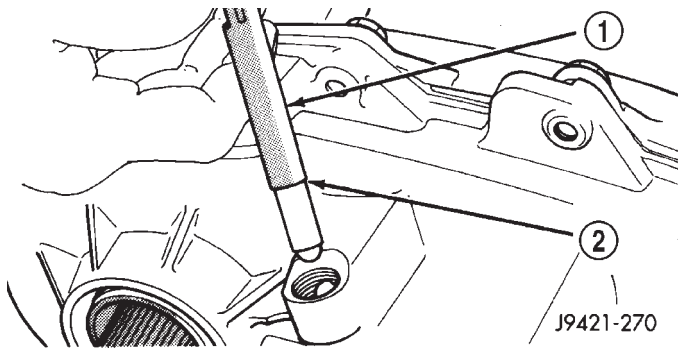
(1) Remove vacuum/indicator switch (Fig. 12).

(2) Loosen poppet plunger screw (Fig. 13).

(3) Remove poppet plunger screw and spring (Fig. 14). Note that screw has o-ring seal. Remove and discard seal this seal.

## TRANSFER CASE - NV241HD (Continued)

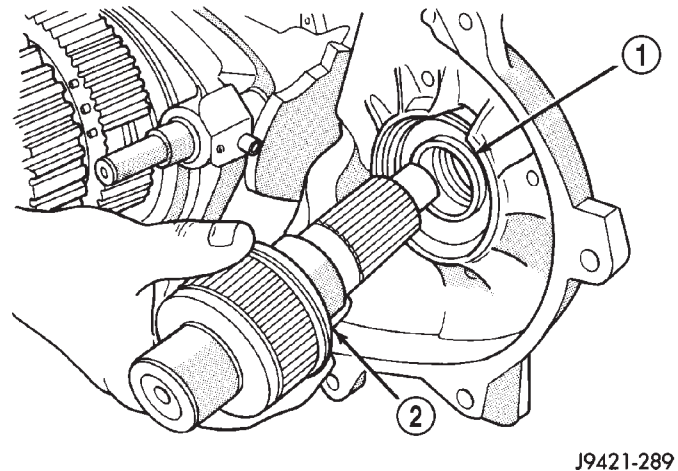
(4) Remove poppet plunger with magnet (Fig. 15).



**Fig. 15 Poppet Plunger Removal**

- 1 - MAGNET  
2 - POPPET PLUNGER

(5) Remove front output shaft from bearing in case (Fig. 16).

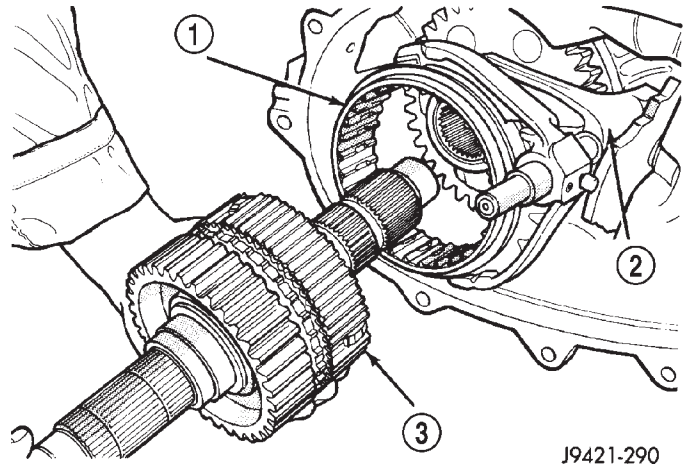


**Fig. 16 Front Output Shaft Removal**

- 1 - BALL BEARING  
2 - FRONT OUTPUT SHAFT

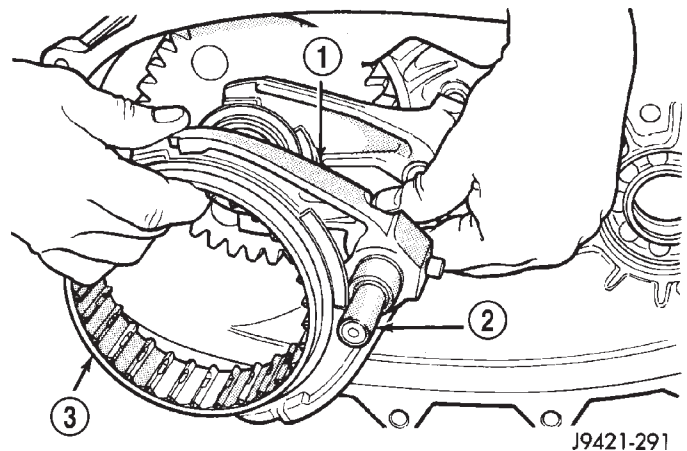
(6) Pull mainshaft assembly out of input gear, sliding clutch and case (Fig. 17).

(7) Remove mode fork, sliding clutch and shift rail as assembly (Fig. 18). Note which way clutch fits in fork (long side of clutch goes to front).



**Fig. 17 Mainshaft Assembly Removal**

- 1 - SLIDING CLUTCH  
2 - MODE FORK  
3 - MAINSHAFT ASSEMBLY



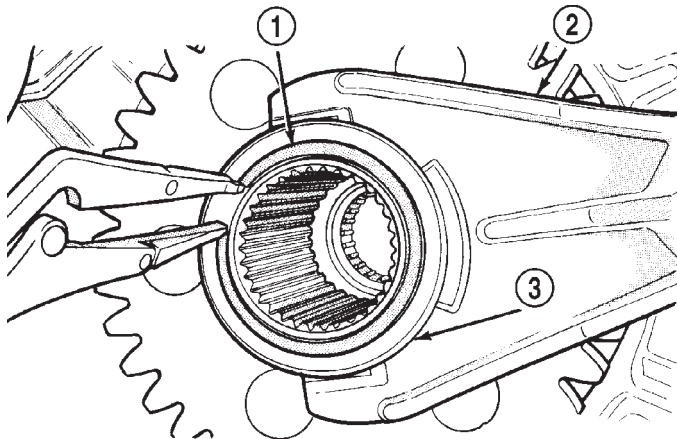
**Fig. 18 Mode Fork, Shift Rail And Sliding Clutch Removal**

- 1 - MODE FORK  
2 - SHIFT RAIL  
3 - SLIDING CLUTCH



TRANSFER CASE - NV241HD (Continued)

(8) Remove sliding hub retaining ring (Fig. 19).

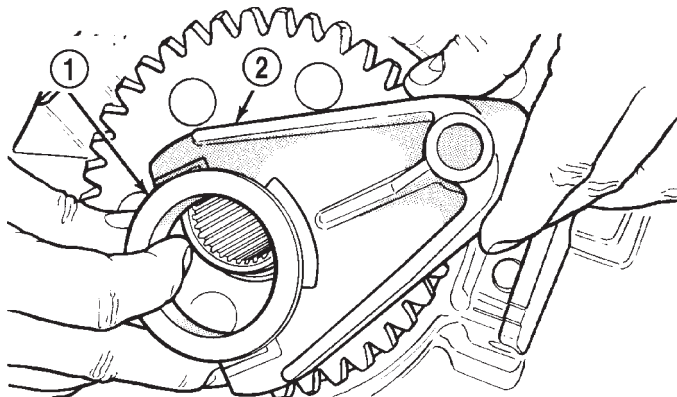


J9421-292

**Fig. 19 Sliding Hub Retaining Ring Removal**

- 1 - RETAINING RING
- 2 - RANGE FORK
- 3 - SLIDING HUB

(9) Remove range fork and sliding hub as an assembly (Fig. 20).



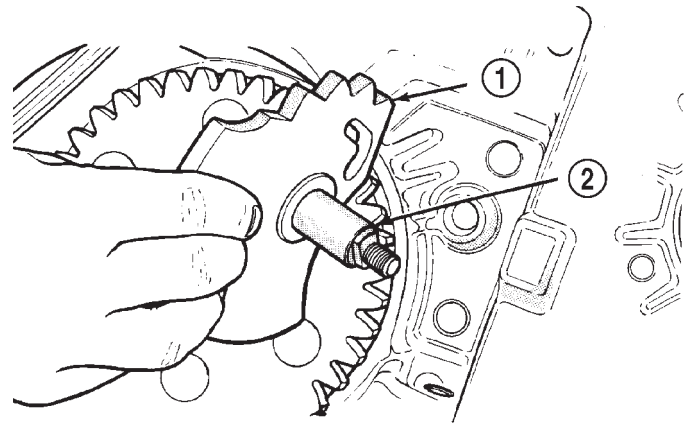
J9421-293

**Fig. 20 Range Fork And Sliding Hub Removal**

- 1 - SUPPORT SLEEVE
- 2 - RANGE FORK

(10) Remove shift sector (Fig. 21).

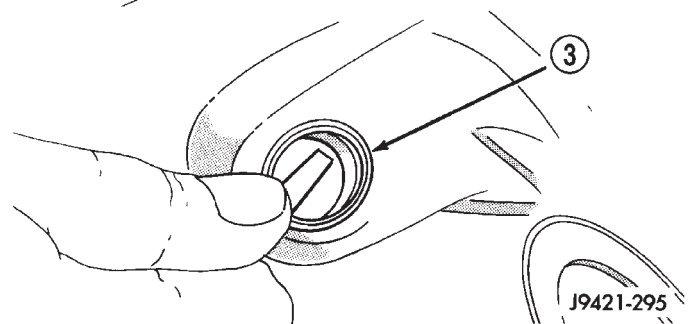
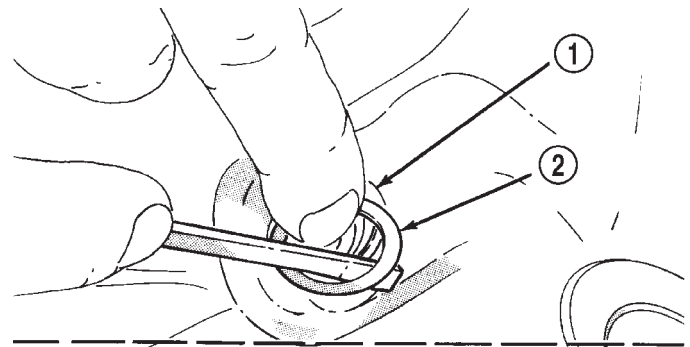
(11) Remove shift sector shaft nylon retainer and o-ring from shaft bore in front case (Fig. 22).



J9421-294

**Fig. 21 Shift Sector Removal**

- 1 - SHIFT SECTOR
- 2 - SECTOR SHAFT



J9421-295

**Fig. 22 Removing Sector Shaft O-Ring And Retainer**

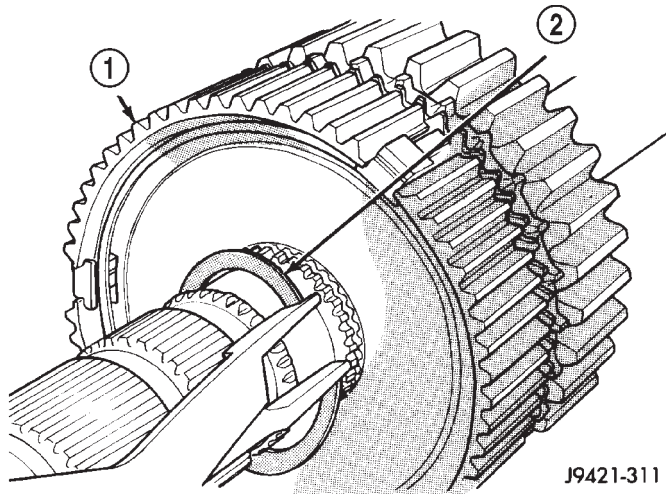
- 1 - SHAFT BORE
- 2 - NYLON RETAINING RING
- 3 - SECTOR SHAFT O-RING



## TRANSFER CASE - NV241HD (Continued)

## MAINSHAFT

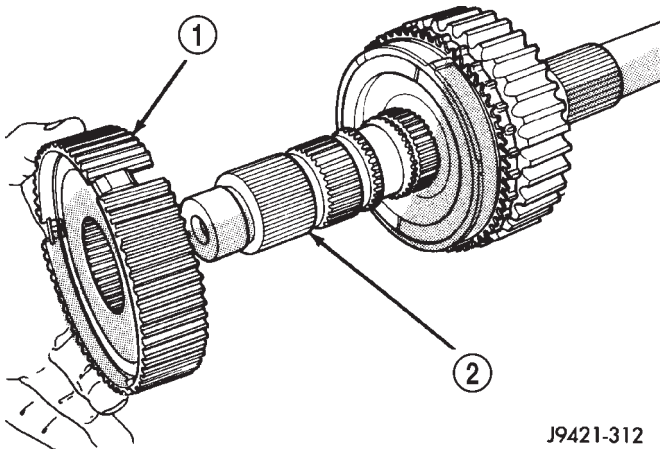
(1) Remove retaining ring that secures synchronizer hub on mainshaft (Fig. 23). Use standard (instead of parallel jaw) snap-ring pliers to remove this retaining ring.



**Fig. 23 Synchronizer Hub Retaining Ring Removal**

- 1 - SYNCHRONIZER HUB
- 2 - RETAINING RING

(2) Remove synchronizer hub (Fig. 24).



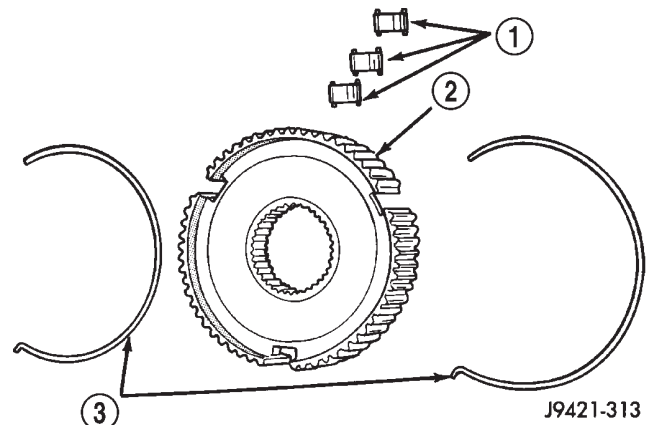
**Fig. 24 Synchronizer Hub Removal**

- 1 - SYNCHRONIZER HUB
- 2 - MAINSHAFT

(3) Inspect synchronizer hub struts and springs. If struts appear worn, remove struts and springs from hub. Note position of springs for installation reference (Fig. 25).

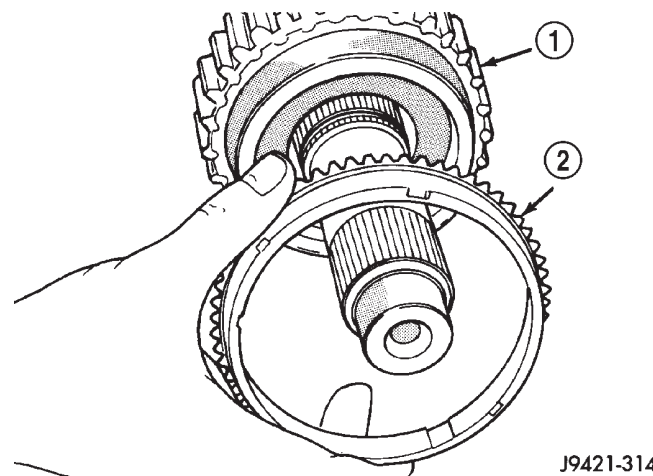
(4) Remove brass stop ring (Fig. 26). Discard stop ring if worn, cracked, or any teeth are missing.

(5) Remove drive sprocket (Fig. 27).



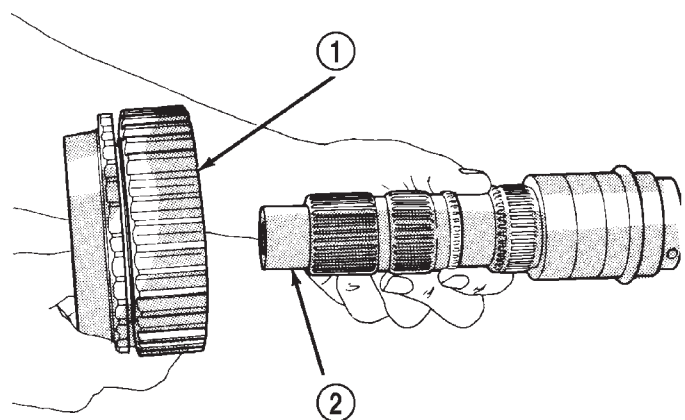
**Fig. 25 Synchronizer Strut And Spring Removal**

- 1 - SYNCHRONIZER STRUTS
- 2 - SYNCHRONIZER HUB
- 3 - SYNCHRONIZER SPRINGS



**Fig. 26 Synchronizer Stop Ring Removal**

- 1 - DRIVE SPROCKET
- 2 - STOP RING



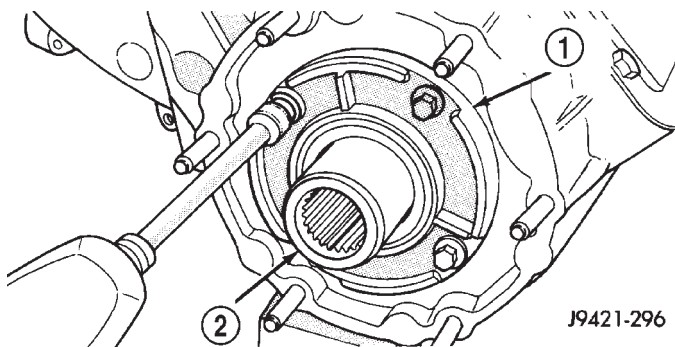
**Fig. 27 Drive Sprocket Removal**

- 1 - DRIVE SPROCKET
- 2 - MAINSHAFT

## TRANSFER CASE - NV241HD (Continued)

**INPUT AND PLANETARY GEAR**

(1) Remove input bearing retainer bolts (Fig. 28).

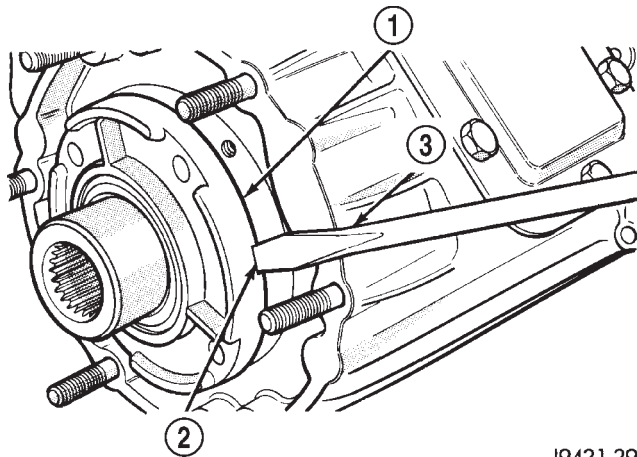


J9421-296

**Fig. 28 Removing Input Bearing Retainer Bolts**

- 1 - BEARING RETAINER  
2 - INPUT GEAR

(2) Loosen bearing retainer with pry tool. Insert tool in retainer slot as shown (Fig. 29). Then remove retainer.



J9421-298

**Fig. 29 Loosening/Removing Input Bearing Retainer**

- 1 - BEARING RETAINER  
2 - SLOT  
3 - PRY TOOL

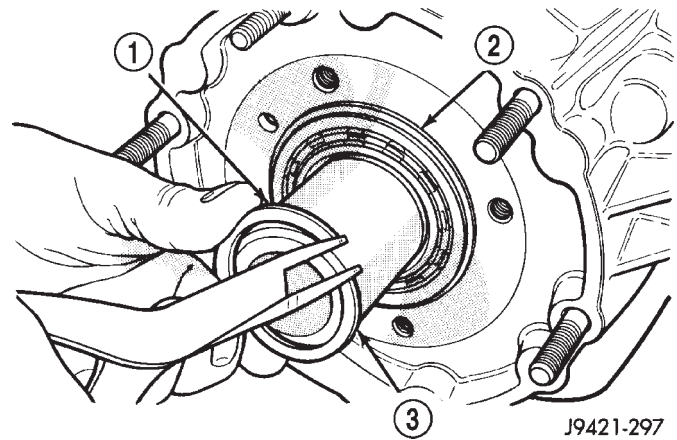
(3) Remove input gear retaining ring with heavy duty parallel jaw snap-ring pliers (Fig. 30).

(4) Tap input gear out of bearing with plastic mallet (Fig. 31).

(5) Remove input gear and planetary/PTO gear as assembly (Fig. 32).

**INPUT AND PLANETARY GEAR**

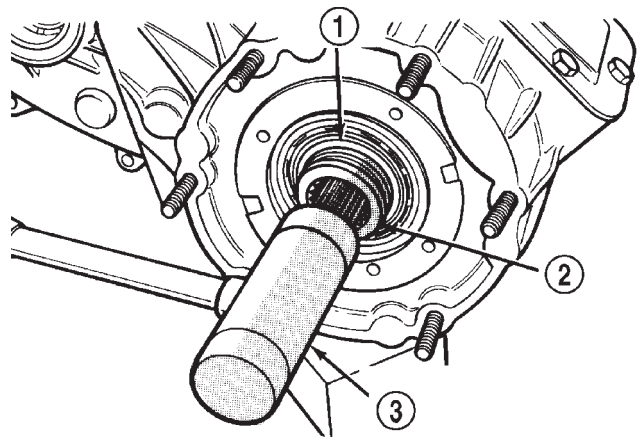
The only removable parts in the planetary assembly are the snap-rings, needle bearing, thrust washers, lock ring, input gear, and support sleeve. **The planetary carrier, PTO gear, planetary pinions, and remaining planetary components are fixed parts and are serviced as an assembly.**



J9421-297

**Fig. 30 Removing Input Gear Retaining Ring**

- 1 - RETAINING RING  
2 - INPUT BEARING  
3 - INPUT GEAR



J9421-299

**Fig. 31 Removing Input Gear**

- 1 - BEARING  
2 - INPUT GEAR  
3 - PLASTIC MALLETT

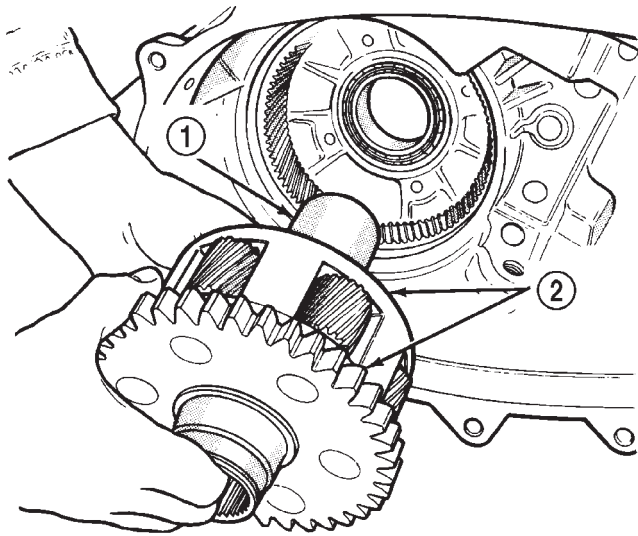
(1) Position planetary assembly so PTO gear is on bench (Fig. 33).

(2) Remove retaining ring that secures input gear and lock ring in planetary assembly.

(3) Remove lock ring and front thrust washer from carrier (Fig. 34). Note that lock ring and thrust washer are both tabbed.

(4) Remove input gear from planetary carrier (Fig. 35). Lift gear straight up and out of carrier.

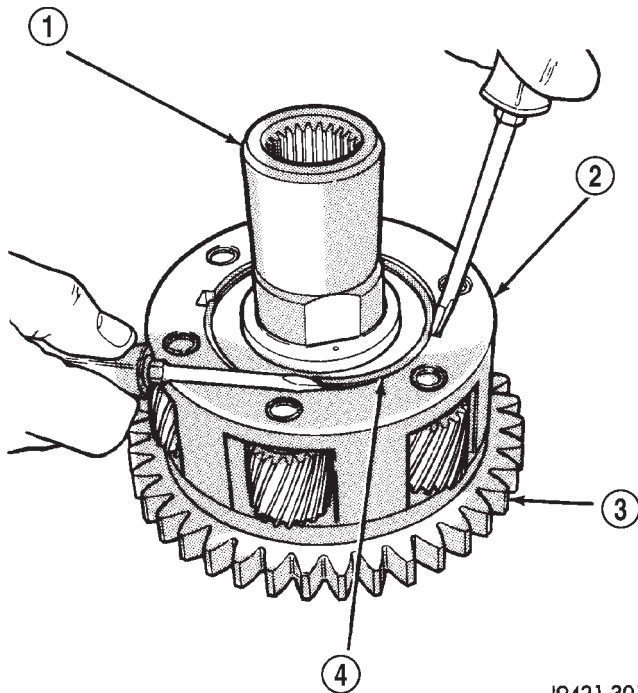
## TRANSFER CASE - NV241HD (Continued)



J9421-300

**Fig. 32 Input Gear And Planetary Assembly Removal**

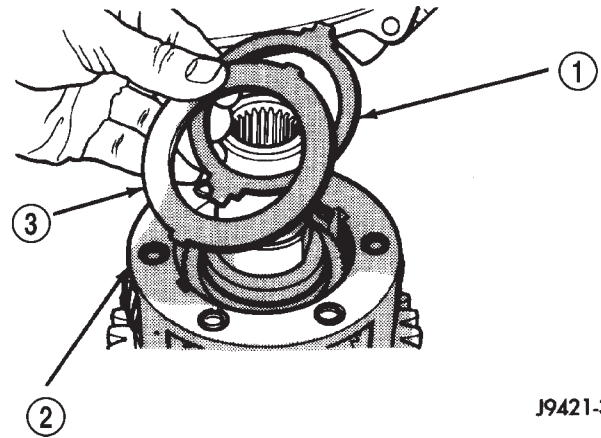
- 1 - INPUT GEAR
- 2 - PLANETARY AND PTO GEAR ASSEMBLY



J9421-301

**Fig. 33 Removing Lock Ring/Input Gear Retaining Ring**

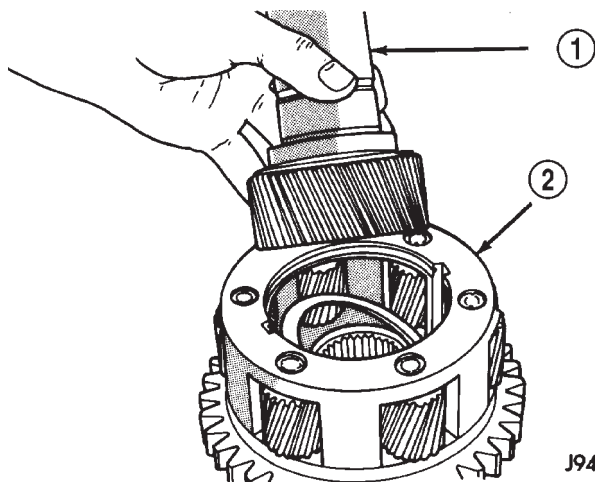
- 1 - INPUT GEAR
- 2 - PLANETARY ASSEMBLY
- 3 - PTO GEAR
- 4 - RETAINING RING



J9421-302

**Fig. 34 Planetary Lock Ring And Front Thrust Washer Removal**

- 1 - THRUST WASHER
- 2 - PLANETARY
- 3 - LOCK RING



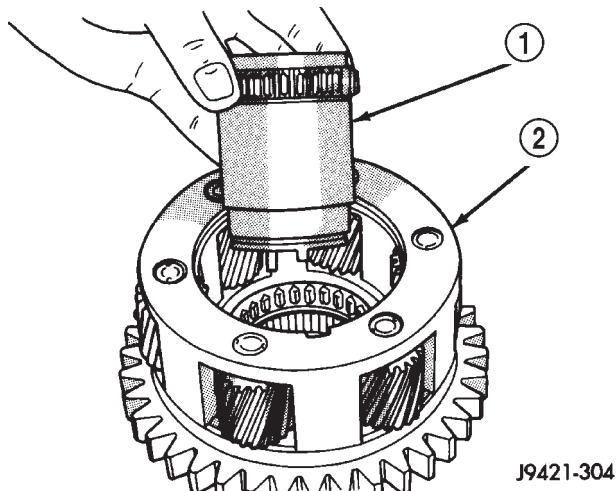
J9421-303

**Fig. 35 Removing Input Gear From Planetary Carrier**

- 1 - INPUT GEAR
- 2 - PLANETARY CARRIER



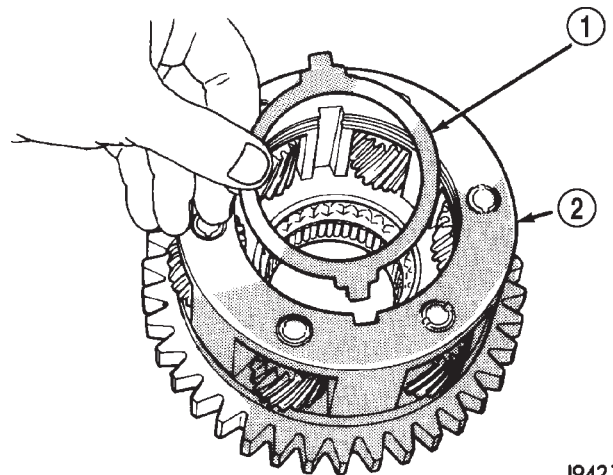
TRANSFER CASE - NV241HD (Continued)



J9421-304

**Fig. 36 Support Sleeve Removal**

- 1 - SUPPORT SLEEVE
- 2 - PLANETARY CARRIER



J9421-305

**Fig. 37 Rear Thrust Washer Removal**

- 1 - REAR THRUST WASHER
- 2 - PLANETARY CARRIER

- (5) Remove support sleeve from carrier (Fig. 36).
- (6) Remove rear thrust washer (Fig. 37).

**CLEANING**

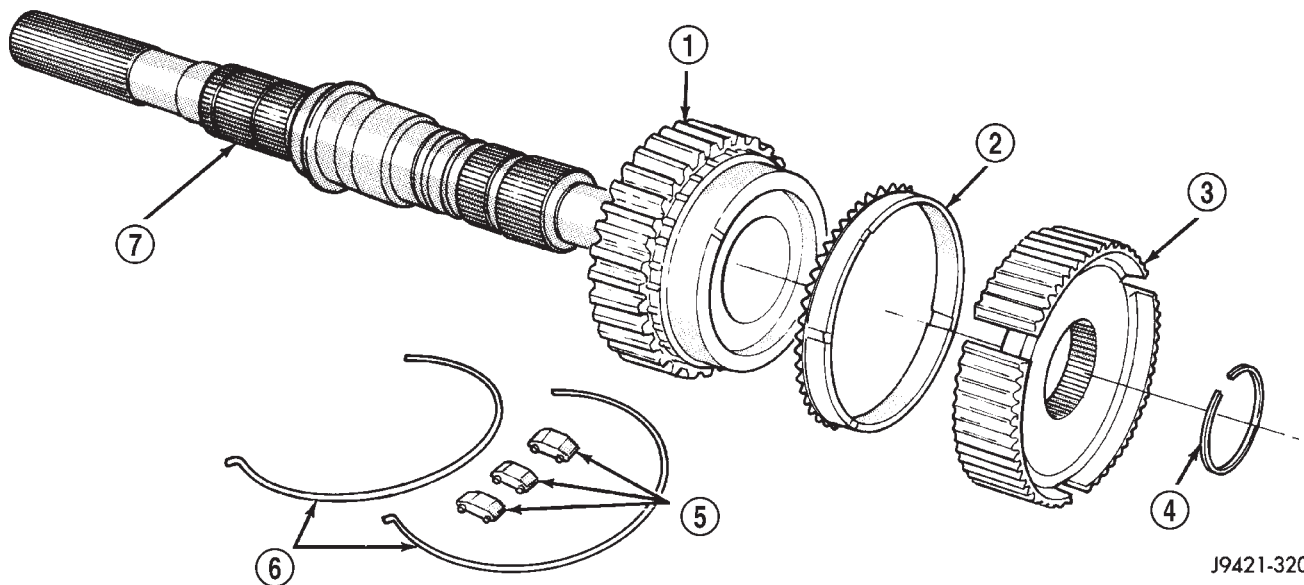
Clean the transfer case parts with a standard parts cleaning solvent. Remove all traces of sealer from the cases and retainers with a scraper and 3M™ all purpose cleaner. Use compressed air to remove solvent residue from oil feed passages in the case halves, retainers, gears, and shafts.

**INSPECTION**

If any pump component is worn, or damaged, the pump must be replaced as an assembly.

Inspect the spline teeth on the synchronizer hub (Fig. 38). If evidence of chipping or excessive wear is apparent, replace the hub. The hooked end of each synchronizer spring should be inserted in one of the struts. In addition, the springs should not interfere with the polished gear cone or inside diameters of the hub.

Inspect the stop ring for cracks and wear. Replace the ring if necessary or if doubt exists over condition.



J9421-320

**Fig. 38 Mainshaft Components**

- 1 - DRIVE SPROCKET
- 2 - STOP RING
- 3 - SYNCHRONIZER HUB
- 4 - RETAINING RING
- 5 - STRUTS
- 6 - SYNCHRONIZER SPRINGS
- 7 - MAINSHAFT

## TRANSFER CASE - NV241HD (Continued)

Check a replacement synchronizer ring for proper fit on the cone with a minimum of wobble. Also check the synchronizer struts for wear or damage.

Inspect all gear teeth and splines for wear or damage. Also check splines for burrs, or nicks. Remove minor nicks and scratches with an oil stone. Replace any part with damaged splines.

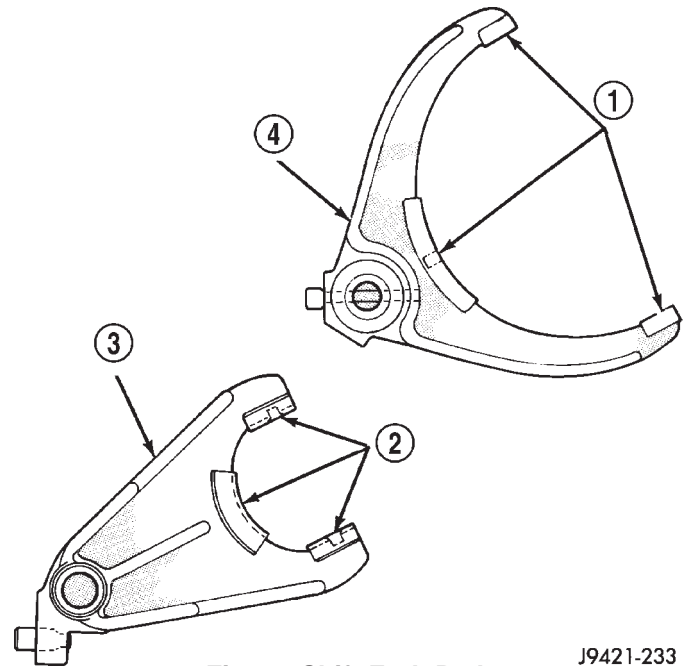
It is recommended that all retaining rings be replaced during overhaul. Most of the retaining rings can be distorted during removal and should not be reused.

Inspect the two case halves, for cracks, porosity, damaged mating surfaces, stripped bolt threads, or distortion. Replace either case half if necessary. However, stripped threads can be repaired with Heli-Coil™ stainless steel thread inserts. The case vent tube can be resecured with Loctite™ 680 if necessary.

Inspect the annulus gear. Be sure the gear teeth are in good condition. Replace the front case and annulus as an assembly if the gear is damaged.

Check condition of the shift fork pads (Fig. 39). The pads should be replaced if cracked, worn, or loose (won't stay on fork).

The shift forks, clutch and sleeve should all be checked for wear, cracks, or any type of damage (Fig. 40). The shift sector shaft and detents should be inspected for wear. The mode fork and shift rail are a one-piece unit. If either part is damaged, replace the fork and rail as an assembly. Replace the shift rail cup and spring if they exhibit wear.

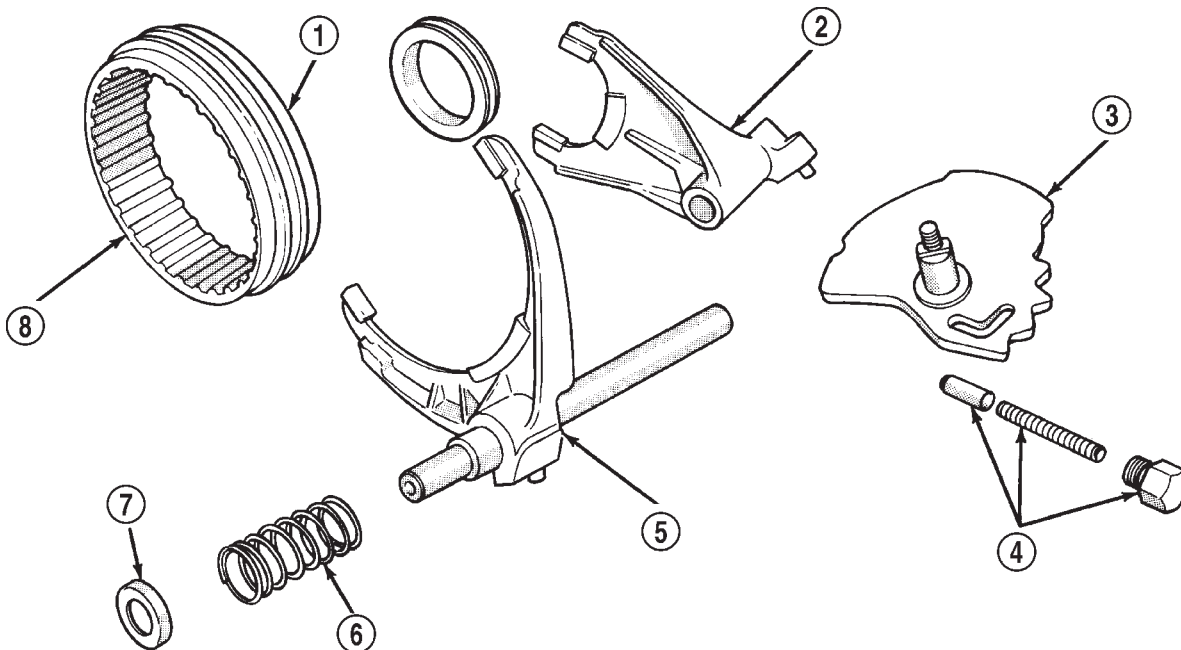


**Fig. 39 Shift Fork Pads**

J9421-233

- 1 - PADS
- 2 - PADS
- 3 - RANGE FORK
- 4 - MODE FORK

Inspect the planetary thrust washers (Fig. 41) carefully for wear or damage. Replace both washers if necessary.



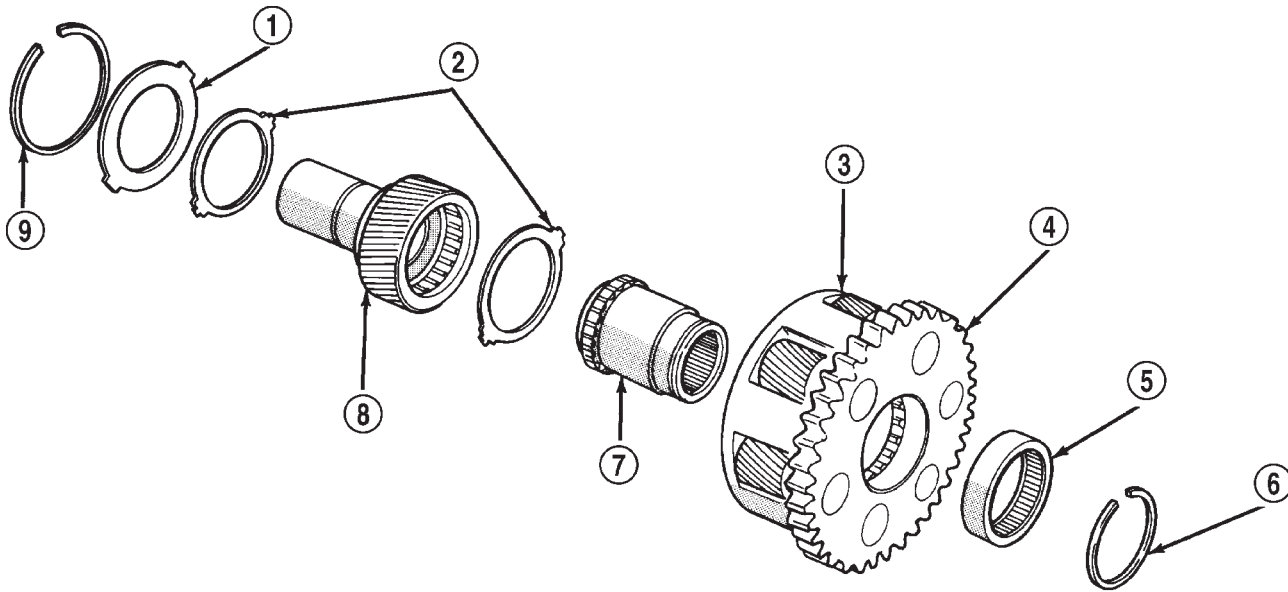
**Fig. 40 Shift Fork Components**

J9421-323

- 1 - SUPPORT SLEEVE
- 2 - RANGE FORK
- 3 - SHIFT SECTOR
- 4 - POPPET PLUNGER, SPRING, SCREW

- 5 - MODE FORK AND SHIFT RAIL
- 6 - SPRING
- 7 - CUP
- 8 - SLIDING CLUTCH





J9421-322

**Fig. 41 Planetary And Input Gear Components**

- |                       |                    |
|-----------------------|--------------------|
| 1 - LOCK RING         | 6 - RETAINING RING |
| 2 - THRUST WASHERS    | 7 - SUPPORT SLEEVE |
| 3 - PLANETARY CARRIER | 8 - INPUT GEAR     |
| 4 - PTO GEAR          | 9 - RETAINING RING |
| 5 - BEARING           |                    |

The planetary carrier cannot be disassembled. It must be serviced as an assembly if damaged. Check condition of the pinion teeth and PTO gear teeth. If pinion tooth wear is evident, it will also be necessary to check condition of the annulus gear teeth.

## ASSEMBLY

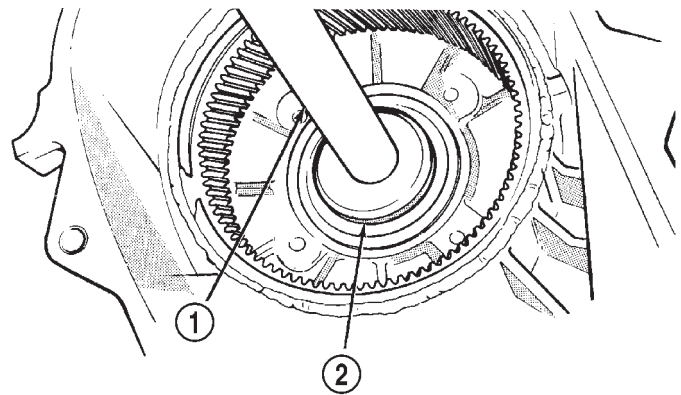
### BEARINGS AND SEALS

(1) Using Remover C-4210 and Handle C-4171, drive input shaft bearing from case from inside annulus gear opening (Fig. 42).

(2) Install locating ring on new bearing.

(3) Position case so that the forward end is facing upward.

(4) Using Remover C-4210 and Handle C-4171, drive input shaft bearing into case. The bearing locating ring must be fully seated on case (Fig. 43).

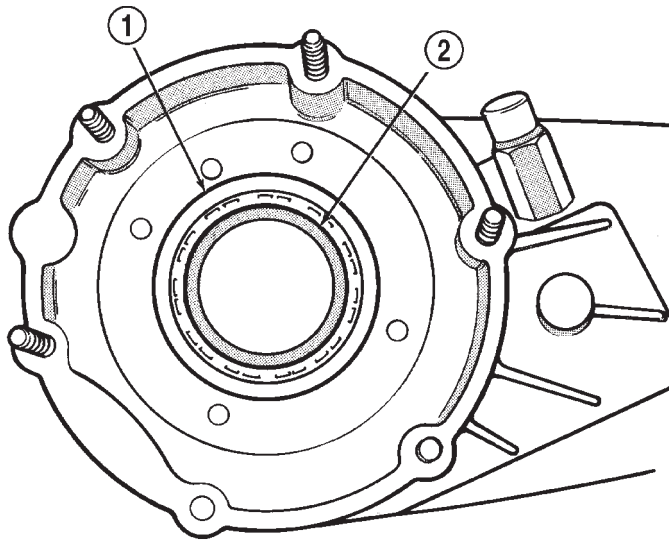


J9521-43

**Fig. 42 Input Shaft Bearing Removal**

- |                         |
|-------------------------|
| 1 - SPECIAL TOOL C-4171 |
| 2 - SPECIAL TOOL C-4210 |

## TRANSFER CASE - NV241HD (Continued)

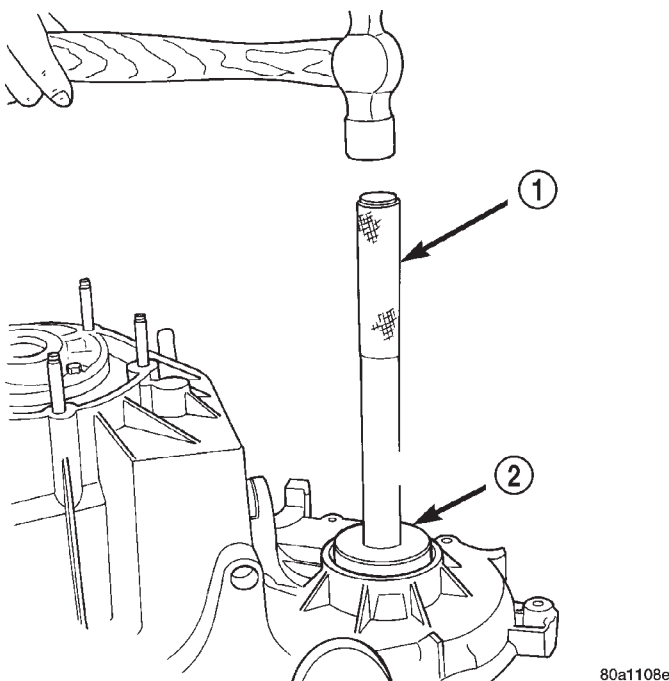


**Fig. 43 Seating Input Shaft Bearing** J8921-219

- 1 - SNAP-RING  
2 - INPUT SHAFT BEARING

(5) Using Installer 6953, remove front output shaft bearing.

(6) Start front shaft output bearing in case (Fig. 44). Then seat bearing with Handle C-4171 and Installer 6953.



**Fig. 44 Front Output Bearing Installation** 80a1108e

- 1 - HANDLE C-4171  
2 - REMOVER/INSTALLER 6953

(7) Install front output bearing retaining ring.

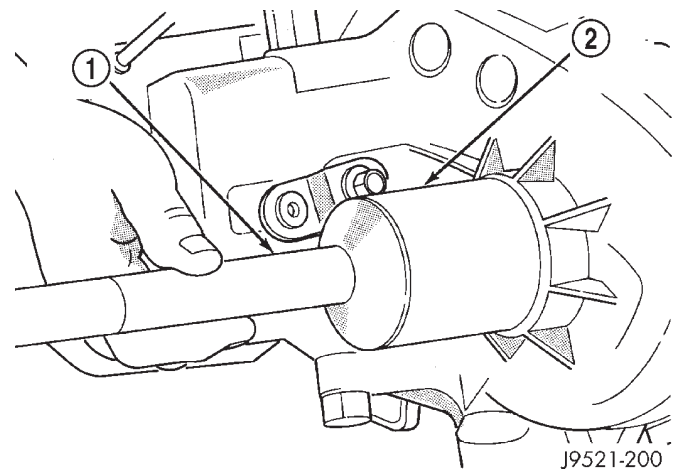
(8) Install new front output seal in front case with Installer Tool 6888 (Fig. 45) and Tool Handle C-4171 as follows:

(a) Place new seal on tool. **Garner spring on seal goes toward interior of case.**

(b) Start seal in bore with light taps from hammer (Fig. 46). Once seal is started, continue tapping seal into bore until installer tool bottoms against case.

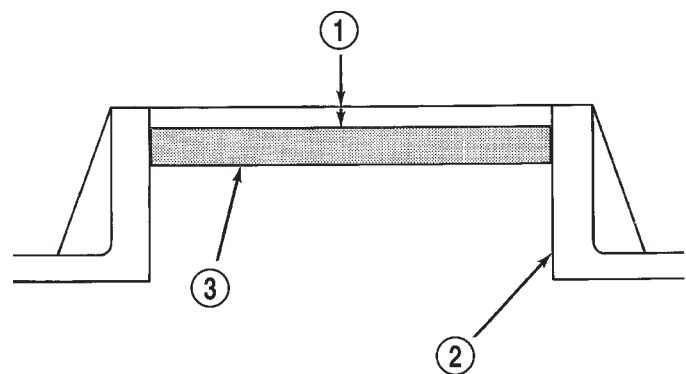
(c) Remove installer and verify that seal is recessed the proper amount. Seal should be 2.03 to 2.5 mm (0.080 to 0.100 in.) below top edge of seal bore in front case. This is correct final seal position.

**CAUTION:** Be sure the front output seal is seated below the top edge of the case bore as shown. The seal could loosen, or become cocked if not seated to recommended depth.



**Fig. 45 Front Output Seal Installation** J9521-200

- 1 - SPECIAL TOOL C-4171  
2 - SPECIAL TOOL 6888



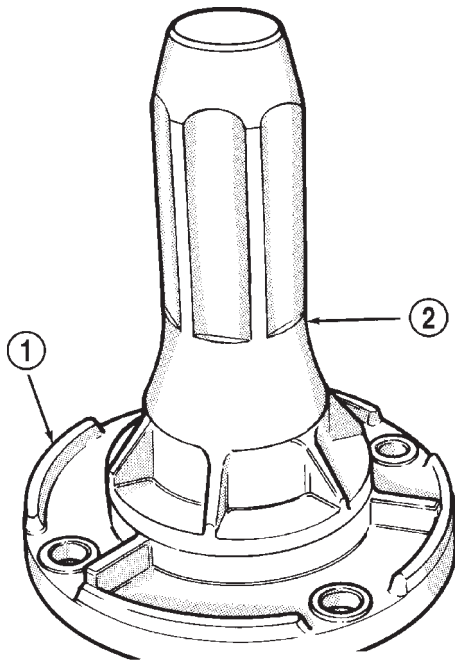
**Fig. 46 Checking Front Output Seal Installation Depth** J9521-190

- 1 - CORRECT SEAL DEPTH IS 2.03-2.5 mm (0.080-0.100 in.) BELOW TOP EDGE OF BORE  
2 - FRONT CASE SHAFT BORE  
3 - FRONT OUTPUT SEAL

TRANSFER CASE - NV241HD (Continued)

(9) Remove seal from front bearing retainer with suitable pry tool.

(10) Install new oil seal in front bearing retainer with Installer 7884 (Fig. 47).



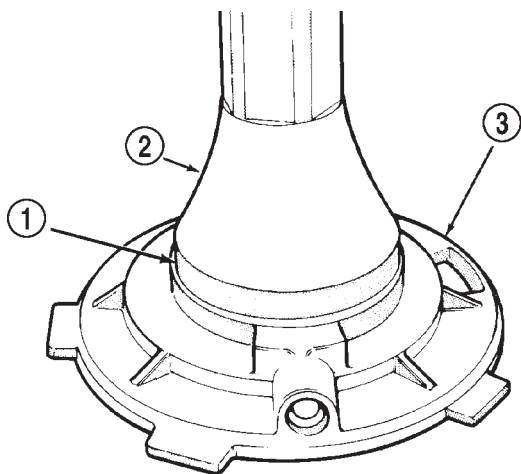
J9521-41

**Fig. 47 Install Front Bearing Retainer Seal**

- 1 - FRONT BEARING RETAINER
- 2 - SPECIAL TOOL 7884

(11) Remove seal from oil pump with suitable pry tool.

(12) Install new seal in oil pump with Installer 7888 (Fig. 48).

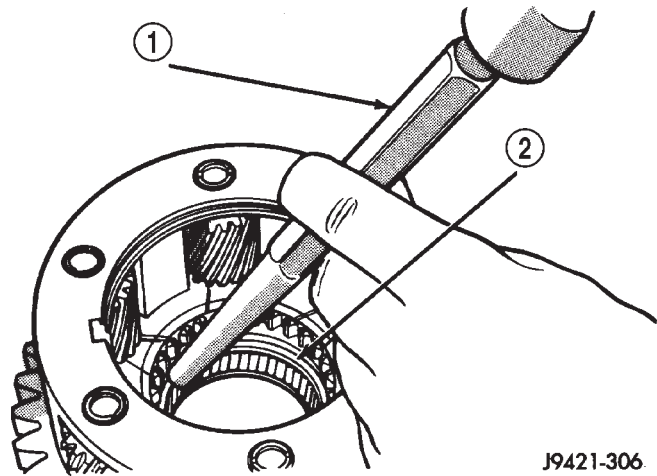


J9521-35

**Fig. 48 Install Oil Pump Seal**

- 1 - HOUSING SEAL
- 2 - SPECIAL TOOL 7888
- 3 - OIL PUMP FEED HOUSING

(13) Inspect carrier needle bearing. If bearing is worn, rough, or damaged in any way, remove it with a brass punch and hammer (Fig. 49).

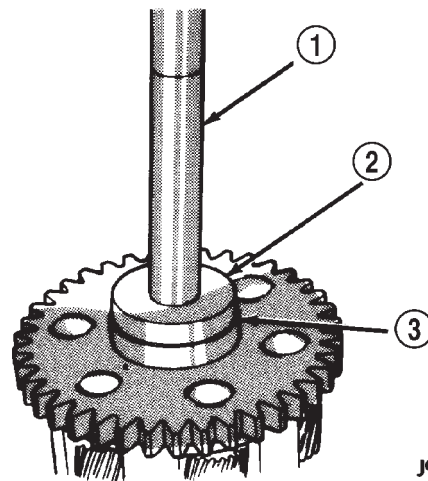


J9421-306

**Fig. 49 Carrier Needle Bearing Removal**

- 1 - BRASS PUNCH
- 2 - CARRIER NEEDLE BEARING

(14) Install new needle bearing in planetary carrier (Fig. 50). Use Handle C-4171 and Installer 5062 to install bearing.



J9421-329

**Fig. 50 Planetary Carrier Needle Bearing Installation**

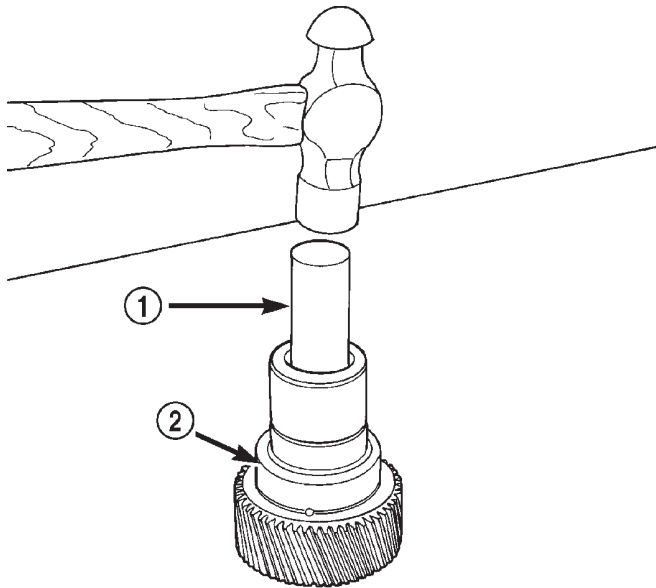
- 1 - SPECIAL TOOL C-4171
- 2 - SPECIAL TOOL 5062
- 3 - CARRIER BEARING

(15) Remove input gear pilot bearing by inserting a suitably sized drift into the splined end of the input gear and driving the bearing out with the drift and a hammer (Fig. 51).

(16) Install new pilot bearing with Plug C-293-3.

(17) Remove the output shaft rear bearing with the screw and jaws from Remover L-4454 and Cup 8148 (Fig. 52).

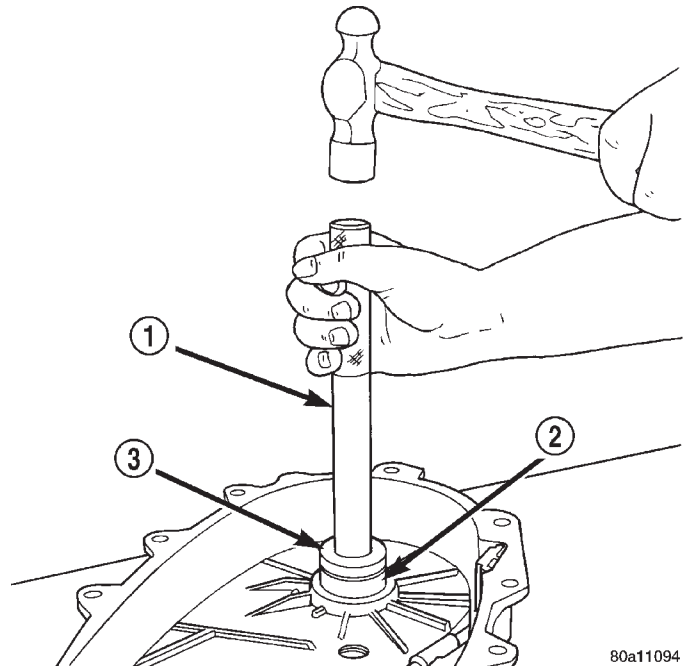
## TRANSFER CASE - NV241HD (Continued)



80a11090

**Fig. 51 Remove Input Gear Pilot Bearing**

- 1 - DRIFT
- 2 - INPUT GEAR

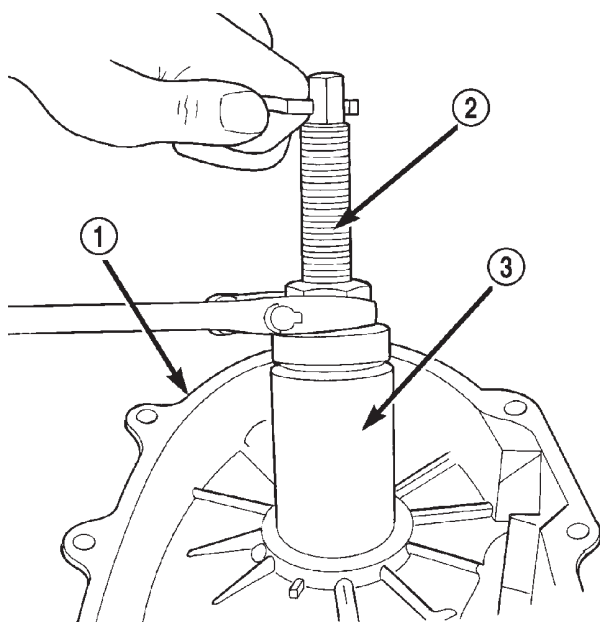


80a11094

**Fig. 53 Output Shaft Rear Bearing Installation**

- 1 - HANDLE C-4171
- 2 - OUTPUT SHAFT INNER BEARING
- 3 - INSTALLER 5066

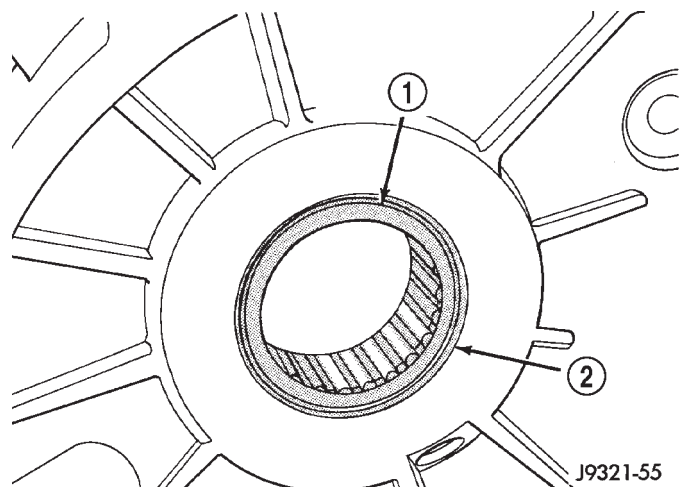
(18) Install new bearing with Tool Handle C-4171 and Installer 5066 (Fig. 53). The bearing bore is chamfered at the top. Install the bearing so it is flush with the lower edge of this chamfer (Fig. 54).



80a98366

**Fig. 52 Output Shaft Rear Bearing Removal**

- 1 - REAR CASE
- 2 - SPECIAL TOOL L-4454-1 AND L-4454-3
- 3 - SPECIAL TOOL 8148



J9321-55

**Fig. 54 Output Shaft Rear Bearing Installation Depth**

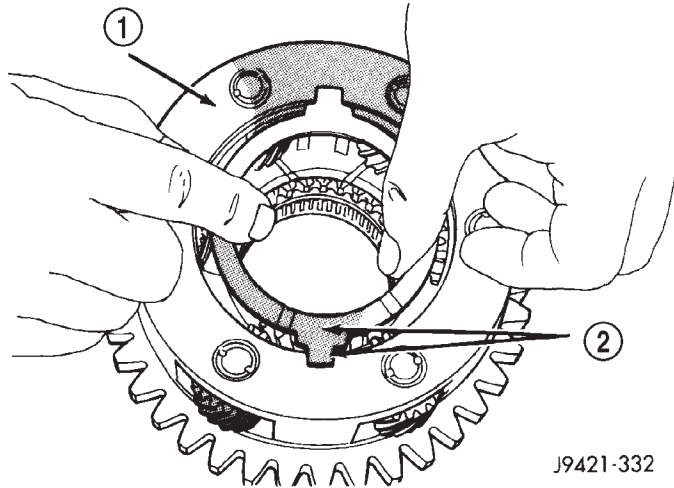
- 1 - BEARING (SEATED) AT LOWER EDGE OF CHAMFER
- 2 - CHAMFER

TRANSFER CASE - NV241HD (Continued)

**INPUT AND PLANETARY GEAR**

(1) Lubricate planetary components with transmission fluid.

(2) Install first thrust washer in carrier (Fig. 55). Lube washer with petroleum jelly before installation.



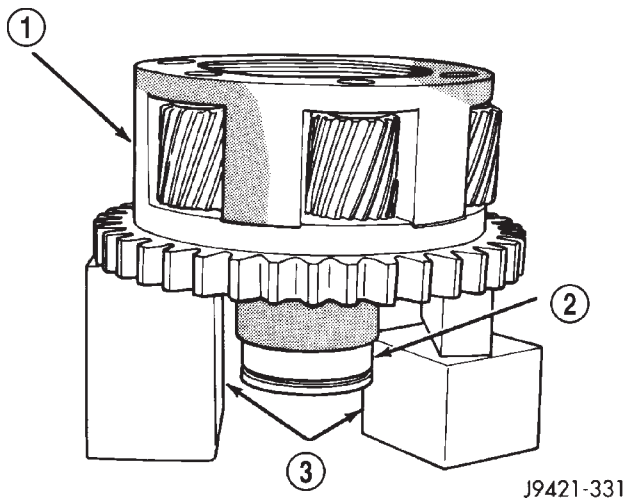
J9421-332

**Fig. 55 Thrust Washer Installation**

- 1 - THRUST WASHER
- 2 - TABS IN SLOTS

(3) Support carrier with wood blocks under PTO gear (Fig. 56).

(4) Install support sleeve in planetary carrier. Be sure sleeve is seated.



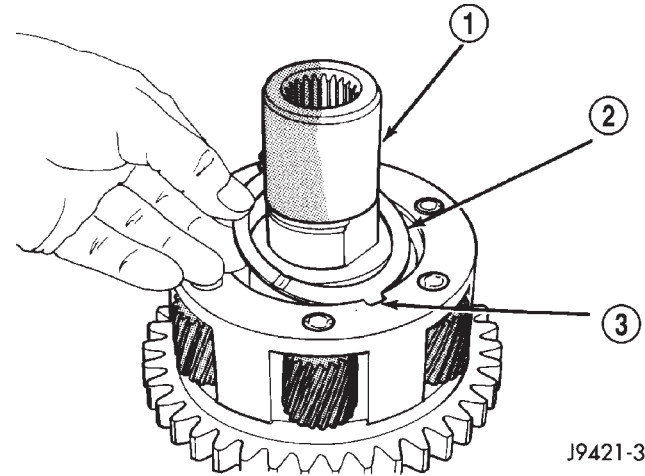
J9421-331

**Fig. 56 Support Sleeve Installation**

- 1 - PLANETARY
- 2 - SUPPORT SLEEVE
- 3 - WOOD BLOCKS

(5) Install input gear in planetary carrier (Fig. 57).

(6) Install second thrust washer in planetary carrier. Be sure washer tabs are seated in carrier slots.

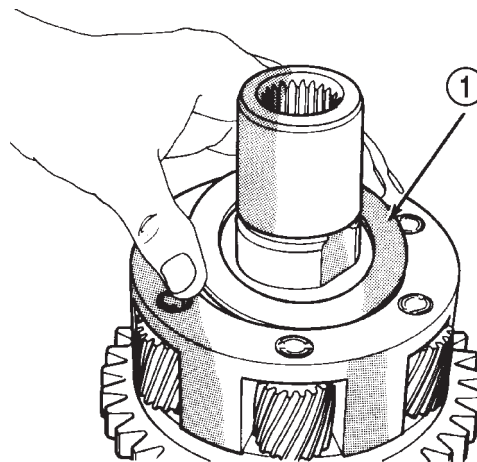


J9421-333

**Fig. 57 Input Gear And Thrust Washer Installation**

- 1 - INPUT GEAR
- 2 - THRUST WASHER
- 3 - TABS IN SLOTS

(7) Install lock ring (Fig. 58).



J9421-334

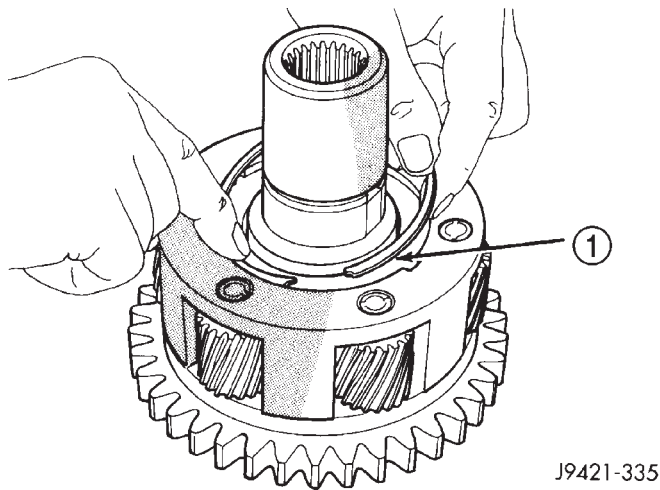
**Fig. 58 Lock Ring Installation**

- 1 - LOCK RING (BE SURE TABS ARE SEATED IN SLOTS)



## TRANSFER CASE - NV241HD (Continued)

- (8) Install retaining ring (Fig. 59).

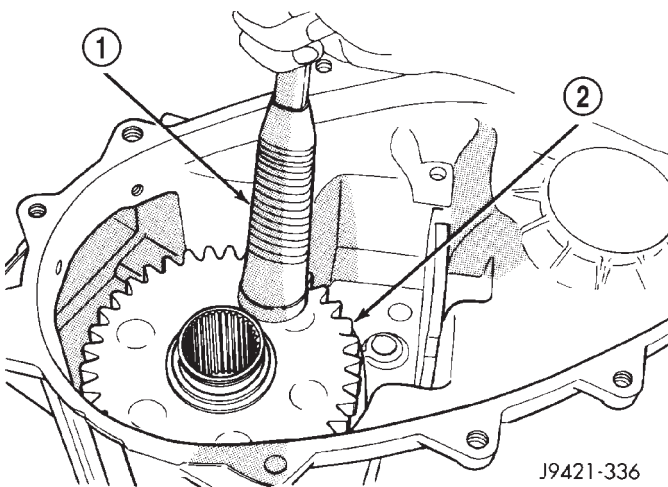


**Fig. 59 Retaining Ring Installation**

1 - RETAINING RING

### INPUT AND PLANETARY GEAR

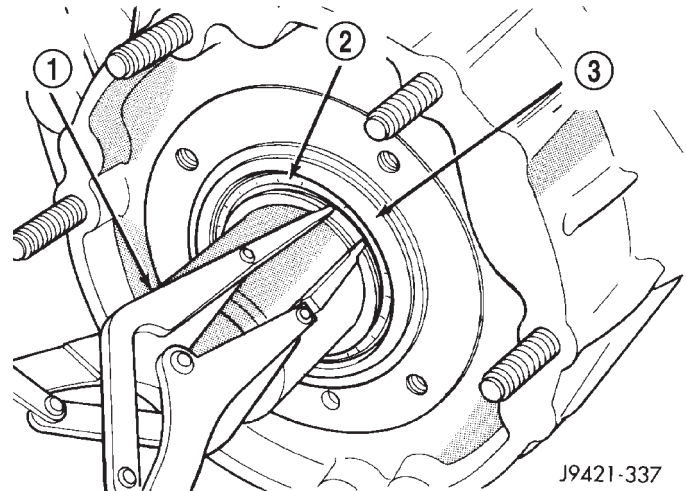
- (1) Lubricate planetary pinions and annulus gear with transmission fluid.  
 (2) Install planetary/input gear assembly in case (Fig. 60).  
 (3) Start planetary pinions in low range annulus gear. Then tap PTO gear, with hammer handle to seat planetary pinions in annulus gear.



**Fig. 60 Planetary/Input Gear Assembly Installation**

1 - WOOD/RUBBER HAMMER HANDLE  
 2 - PLANETARY ASSEMBLY

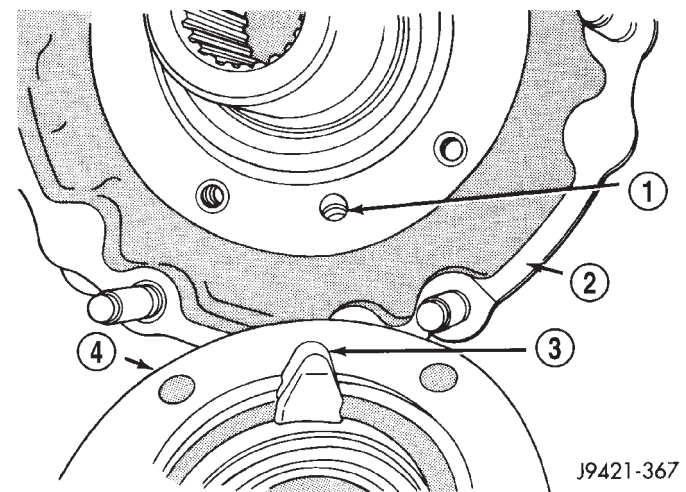
- (4) Install retaining ring on input gear (Fig. 61).  
 (5) Apply bead of Mopar® Gasket Maker, or equivalent, to mating surface of input retainer. Keep sealer bead width to maximum of 3/16 inch. Do not use excessive amount of sealer as excess could be displaced into oil channel and feed hole in case.



**Fig. 61 Installing Input Gear Retaining Ring**

1 - INPUT BEARING RETAINING RING  
 2 - SNAP-RING PLIERS  
 3 - INPUT GEAR

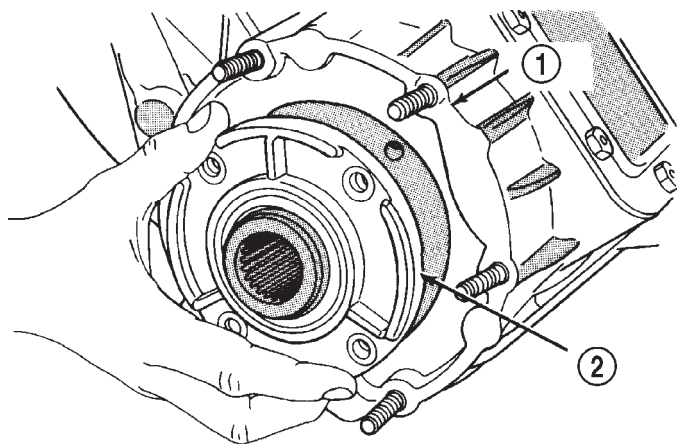
- (6) Align oil channel in retainer with oil feed hole in front case (Fig. 62).  
 (7) Install retainer on input gear shaft and front case (Fig. 63).



**Fig. 62 Aligning Retainer Oil Channel and Case Feed Holes**

1 - FEED HOLE  
 2 - FRONT CASE  
 3 - FEED CHANNEL  
 4 - BEARING RETAINER

## TRANSFER CASE - NV241HD (Continued)



J9421-368

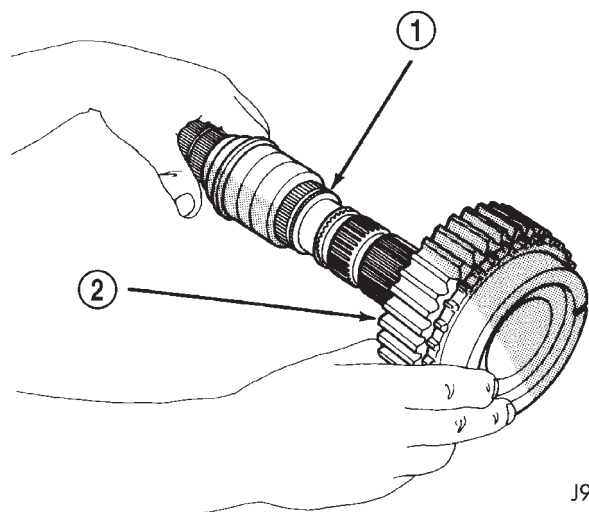
**Fig. 63 Input Bearing Retainer Installation**

- 1 - FRONT CASE
- 2 - INPUT BEARING RETAINER

(8) Apply Mopar® Silicone Sealer to threads of input retainer bolts. Then install and tighten bolts to 27-34 N·m (20-25 ft. lbs.) torque.

**MAINSHAFT**

- (1) Install drive sprocket on mainshaft (Fig. 64).



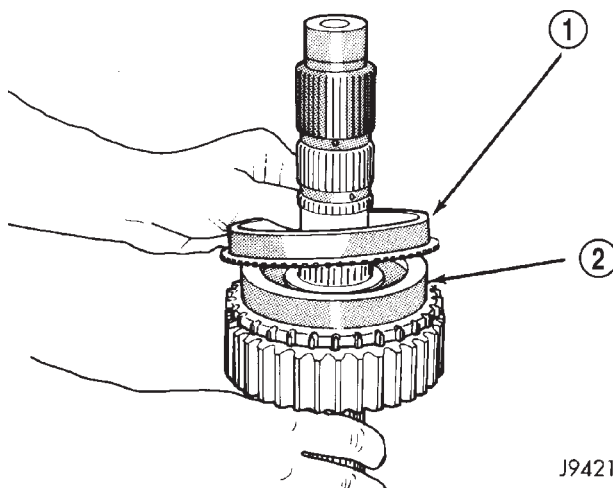
J9421-338

**Fig. 64 Drive Sprocket Installation**

- 1 - MAINSHAFT
- 2 - DRIVE SPROCKET

(2) Install brass stop ring on drive sprocket (Fig. 65).  
 (3) Install 3 synchronizer struts and 2 springs in hub as follows:

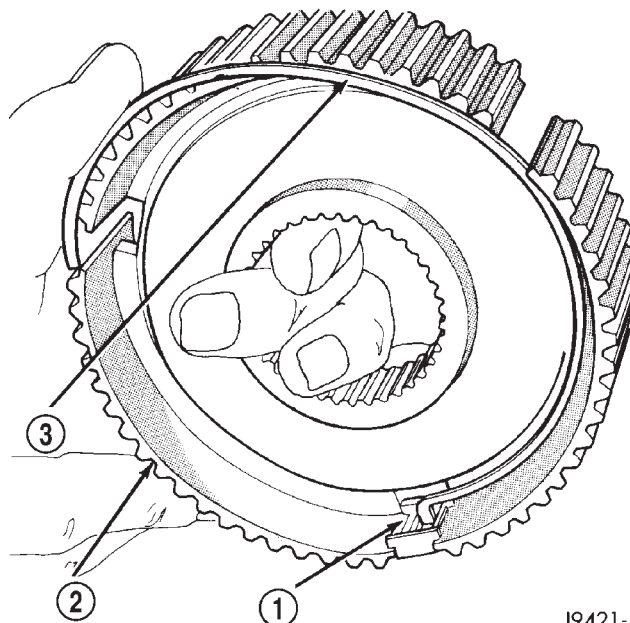
(a) Insert first strut in hub (Fig. 66). Strut shoulders rest (and slide) on sides hub slot as shown.



J9421-339

**Fig. 65 Synchronizer Stop Ring Installation**

- 1 - BRASS STOP RING
- 2 - DRIVE SPROCKET



J9421-341

**Fig. 66 Installing First Synchronizer Strut And Spring**

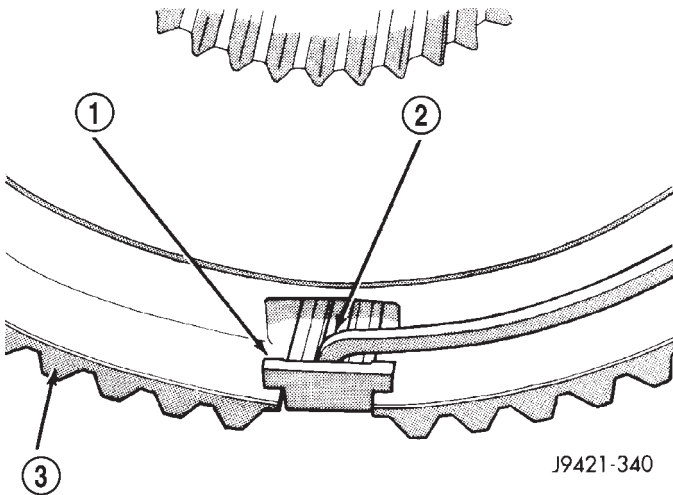
- 1 - FIRST STRUT
- 2 - SYNCHRONIZER HUB
- 3 - SPRING

## TRANSFER CASE - NV241HD (Continued)

(b) Insert hooked end of first spring in center of strut to secure it. Then work spring into hub (Fig. 67).

(c) Press spring inward and insert last two struts in hub slots. Be sure spring is positioned under struts to properly secure them (Fig. 68).

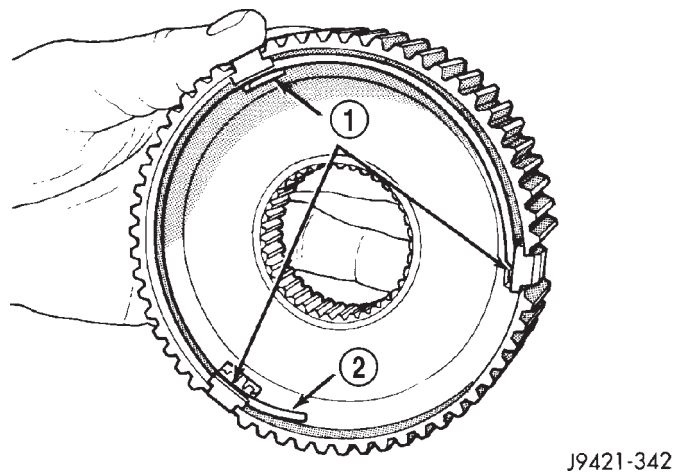
(d) Turn hub over and install remaining spring in hub. Position hooked end of second spring opposite the first spring's hooked end.



J9421-340

**Fig. 67 Synchronizer Spring Installation**

- 1 - STRUT SHOULDER
- 2 - SPRING (SEATED IN STRUT)
- 3 - HUB



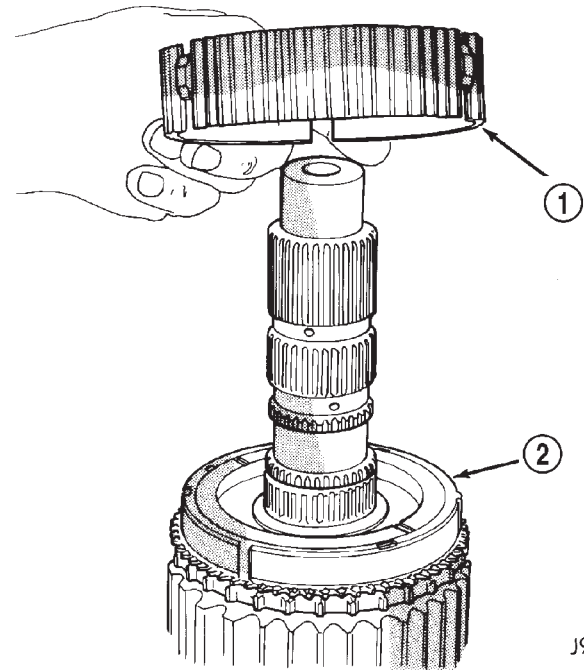
J9421-342

**Fig. 68 Correct Position Of Struts And Springs**

- 1 - STRUTS
- 2 - SPRING

(4) Install assembled synchronizer hub on main-shaft (Fig. 69). Hub has shoulder on one side which goes toward sprocket (rear of shaft). Flat side of hub faces front of shaft.

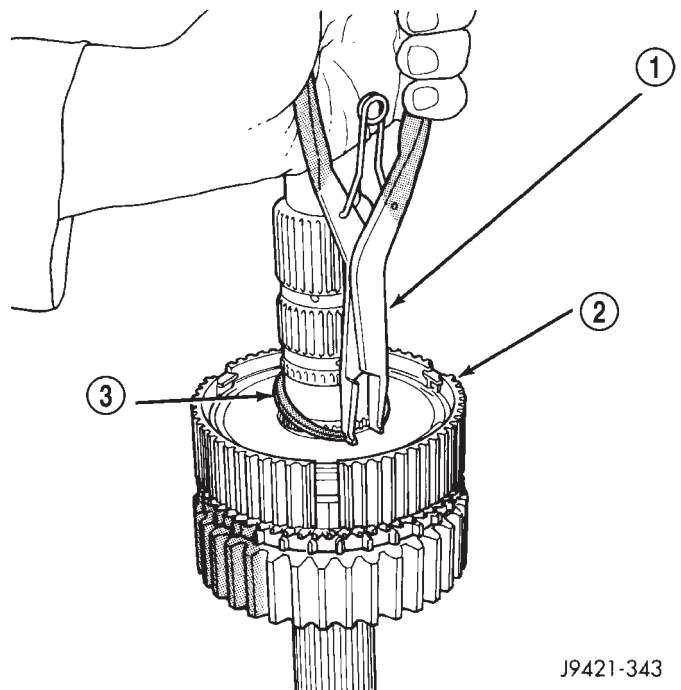
(5) Install synchronizer hub retaining ring (Fig. 70). Be sure ring is fully seated before proceeding.



J9421-345

**Fig. 69 Synchronizer Hub Installation**

- 1 - SYNCHRONIZER HUB (SHOULDER SIDE DOWN)
- 2 - STOP RING AND SPROCKET



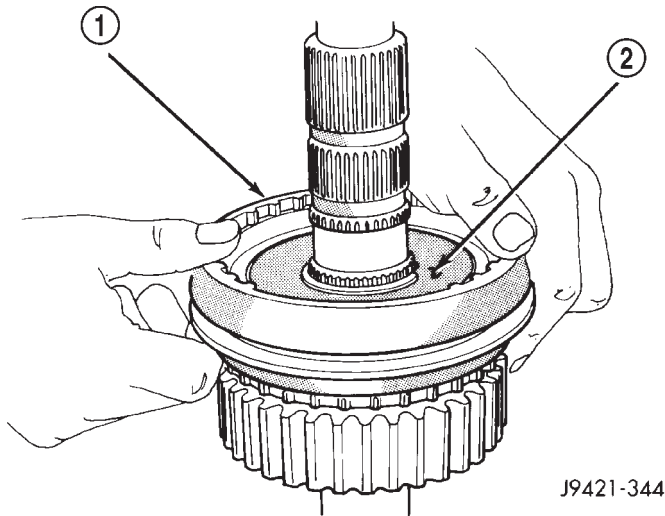
J9421-343

**Fig. 70 Synchronizer Hub Retaining Ring Installation**

- 1 - SNAP-RING PLIERS
- 2 - SYNCHRONIZER HUB
- 3 - HUB RETAINING RING

TRANSFER CASE - NV241HD (Continued)

(6) Install sliding clutch (sleeve) on synchronizer hub (Fig. 71).



J9421-344

**Fig. 71 Sliding Clutch Installation**

- 1 - SLIDING CLUTCH
- 2 - SYNCHRONIZER HUB

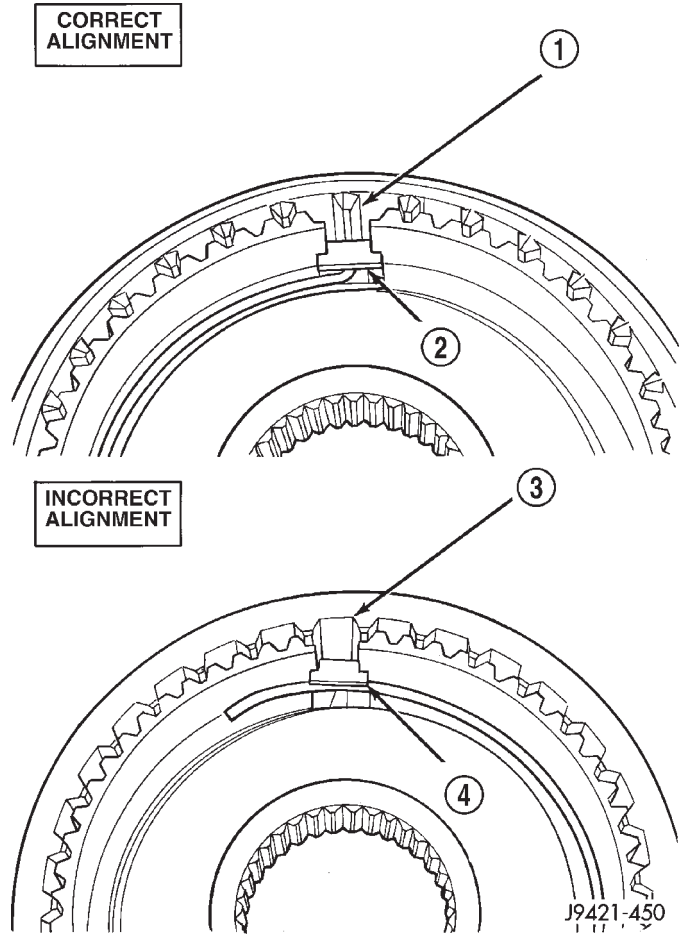
**CAUTION:** The sliding clutch must be correctly positioned to ensure proper shifting. Position the clutch on the hub so a clutch spline is centered over each strut as shown (Fig. 72). If the clutch is installed so a gap between splines is aligned with one or more struts, gear clash will result.

**SHIFT FORKS AND MAINSHAFT**

(1) Support front case on wood blocks so case interior is facing up. Place blocks between mounting studs on forward surface of case. Be sure blocks will not interfere with input gear installation.

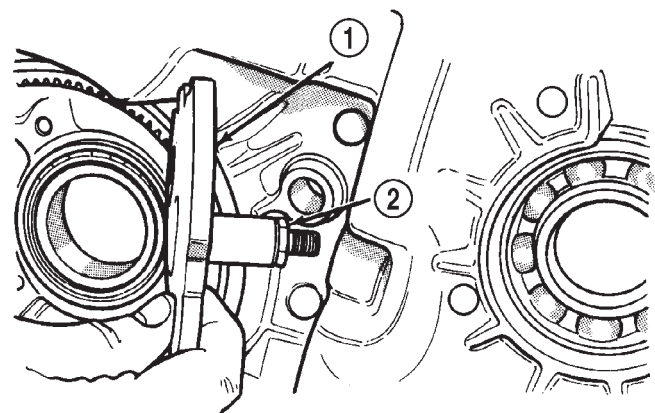
(2) Lubricate mainshaft components with transmission fluid.

(3) Lubricate sector shaft with transmission fluid and install shift sector in case (Fig. 73). Position slot in sector so it will be aligned with shift fork pin when shift forks are installed.



**Fig. 72 Correct Alignment Of Struts And Sliding Clutch**

- 1 - SLEEVE TOOTH ALIGNED WITH STRUT
- 2 - STRUT
- 3 - SLEEVE TOOTH NOT ALIGNED WITH STRUT
- 4 - STRUT



J9421-328

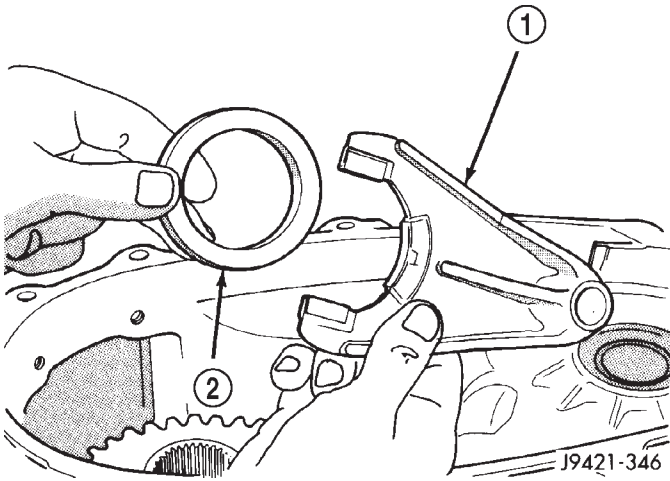
**Fig. 73 Shift Sector Installation**

- 1 - SHIFT SECTOR
- 2 - SECTOR SHAFT



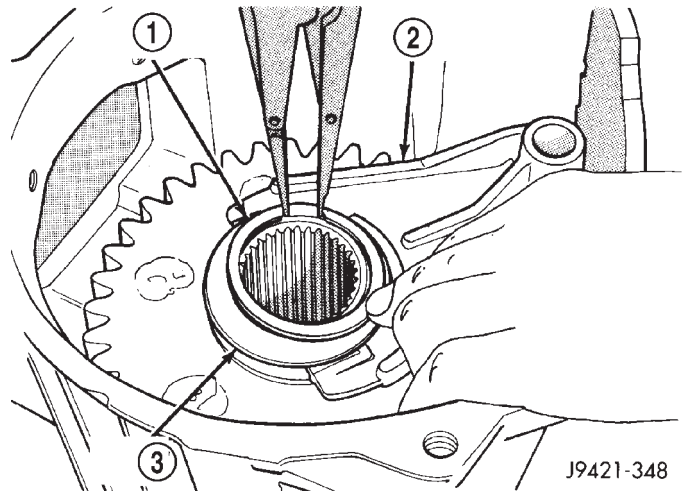
## TRANSFER CASE - NV241HD (Continued)

(4) Assemble range fork and sliding hub (Fig. 74). Then install fork and hub in case. Seat hub on support sleeve and seat range fork pin in shift sector slot (Fig. 75).



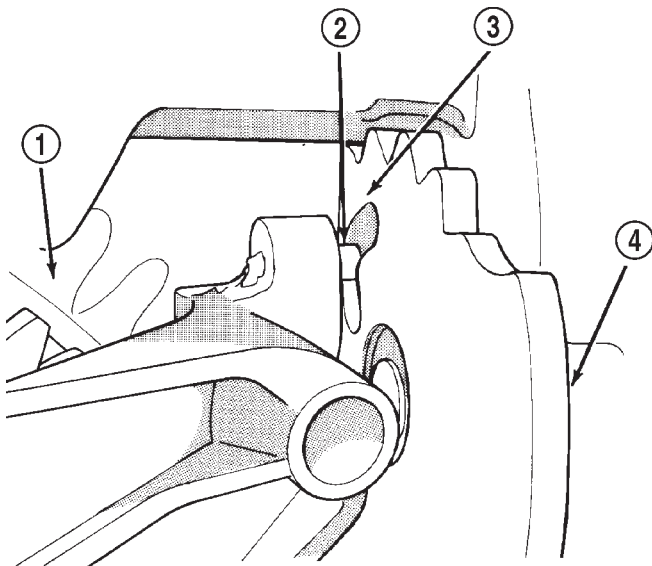
**Fig. 74 Assembling Range Fork And Sliding Hub**

- 1 - RANGE FORK
- 2 - SLIDING HUB



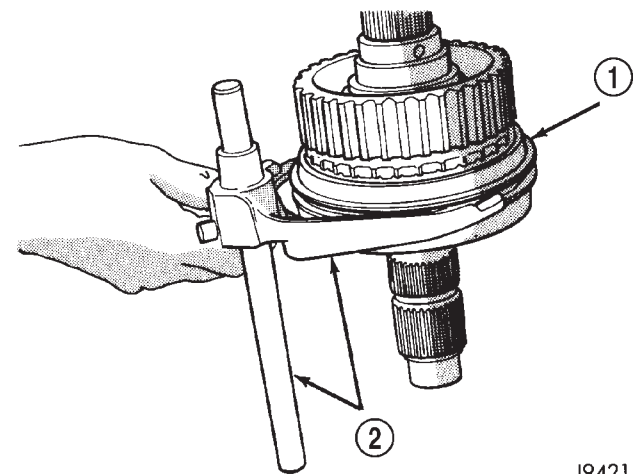
**Fig. 76 Sliding Hub Retaining Ring Installation**

- 1 - RETAINING RING
- 2 - RANGE FORK
- 3 - SLIDING HUB



**Fig. 75 Seating Range Fork And Hub**

- 1 - RANGE FORK
- 2 - RANGE FORK PIN
- 3 - SECTOR SLOT
- 4 - SHIFT SECTOR



**Fig. 77 Assembling Mode Fork And Mainshaft**

- 1 - SLIDING CLUTCH
- 2 - MODE FORK AND SHIFT RAIL

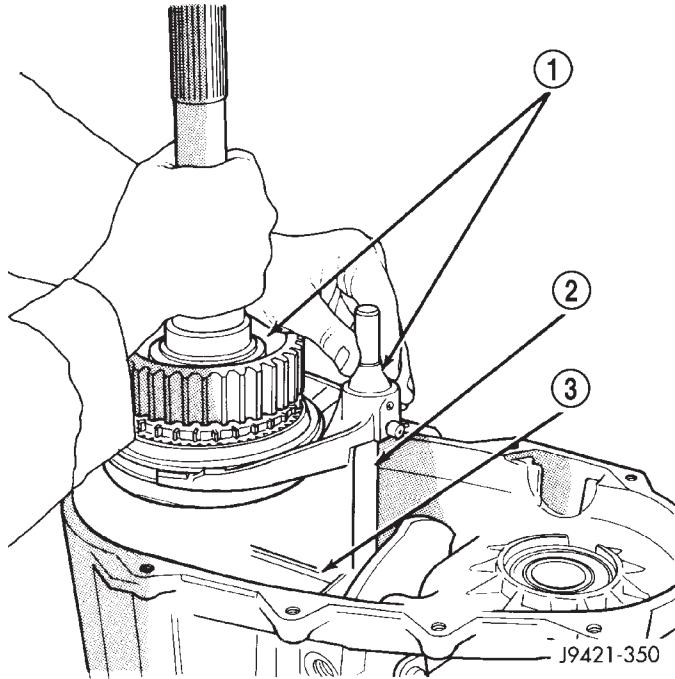
(5) Install sliding hub retaining ring (Fig. 76). Be sure ring is fully seated before proceeding.

(6) Install mode fork and shift rail in sliding clutch (Fig. 77).



TRANSFER CASE - NV241HD (Continued)

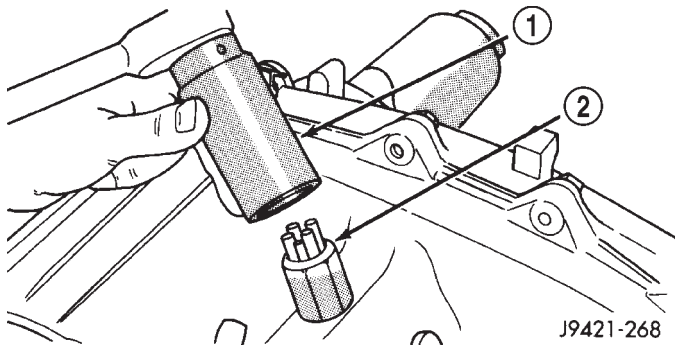
(7) Install mainshaft/mode fork assembly (Fig. 78). Guide mainshaft through hub and into input gear and shift rail through range fork and into case bore.



**Fig. 78 Installing Mainshaft And Mode Fork Assembly**

- 1 - MAINSHAFT AND MODE FORK ASSEMBLY
- 2 - SHIFT RAIL
- 3 - RANGE FORK

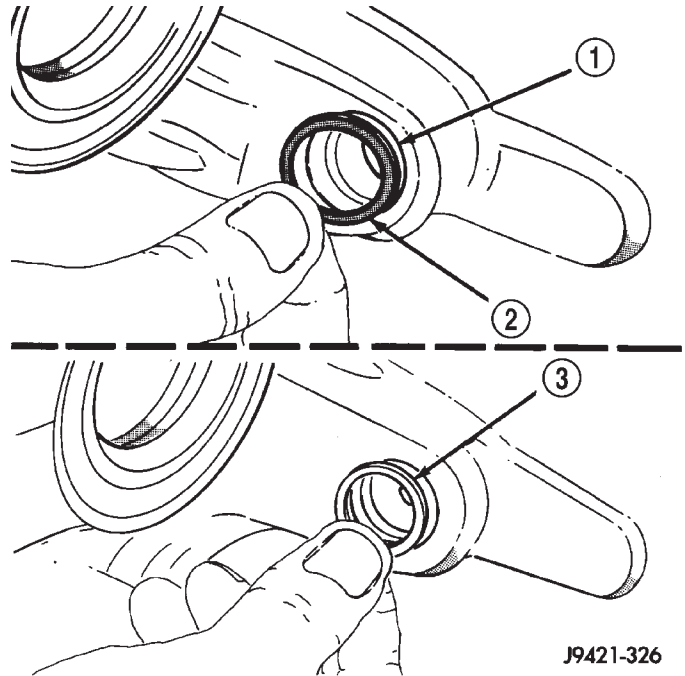
(8) Install new o-ring on vacuum/indicator switch, if necessary. Install vacuum/indicator switch (Fig. 79). Tighten switch to 20-34 N·m (15-25 ft. lbs.) torque.



**Fig. 79 Vacuum/Indicator Switch Installation**

- 1 - 1-1/16" SOCKET
- 2 - INDICATOR SWITCH

(9) Install new sector shaft o-ring and o-ring retainer in sector shaft bore (Fig. 80). Lubricate o-ring with transmission fluid or petroleum jelly after installation.

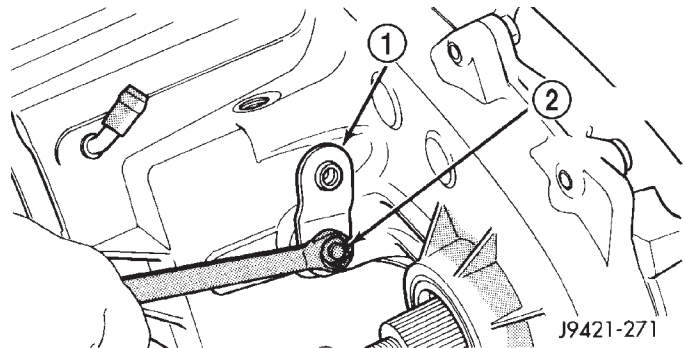


**Fig. 80 Sector Shaft O-Ring And Retainer Installation**

- 1 - SECTOR SHAFT BORE
- 2 - O-RING
- 3 - O-RING RETAINER

(10) Install shift lever on sector shaft (Fig. 81).

(11) Install washer and nut on sector shaft to secure shift lever. Apply 1-2 drops Mopar® Lock N' Seal, or equivalent, to nut threads before installation. Then tighten nut to 27-34 N·m (20-25 ft. lbs.) torque.



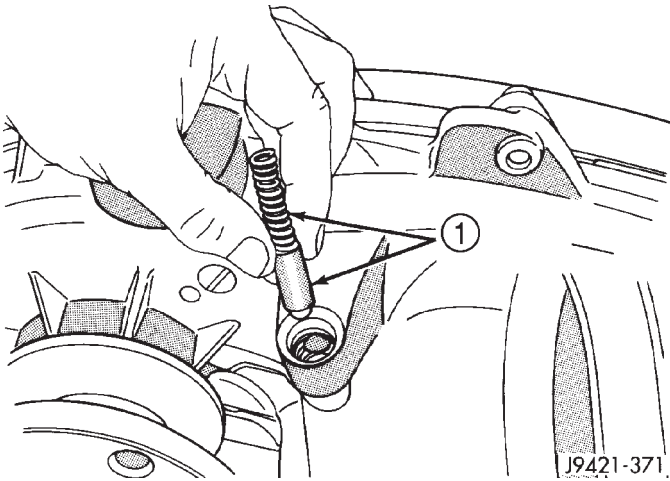
**Fig. 81 Shift Lever Installation**

- 1 - SHIFT LEVER
- 2 - NUT/WASHER

## TRANSFER CASE - NV241HD (Continued)

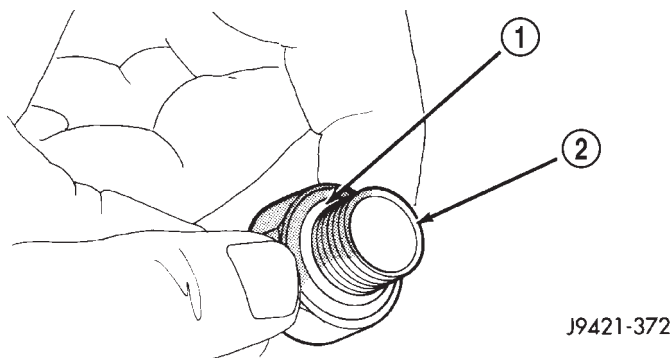
(12) Install poppet plunger and spring (Fig. 82).

(13) Install new o-ring on poppet screw and install screw in front case (Fig. 83). Tighten screw to 16-24 N·m (12-18 ft. lbs.).



**Fig. 82 Poppet Plunger And Spring Installation**

1 - POPPET PLUNGER AND SPRING



**Fig. 83 O-Ring Installation On Poppet Plunger Screw**

1 - O-RING  
2 - PLUNGER SCREW

### FRONT OUTPUT SHAFT AND DRIVE CHAIN

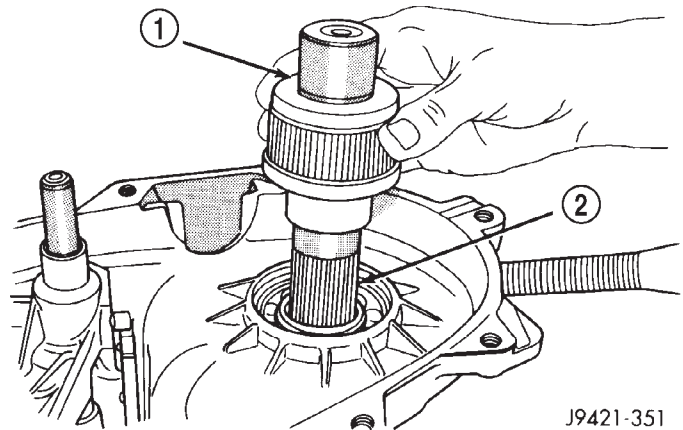
(1) Install front output shaft in bearing (Fig. 84).

(2) Insert front sprocket in drive chain (Fig. 85).

(3) Install drive chain around mainshaft sprocket (Fig. 85). Then position front sprocket over front shaft.

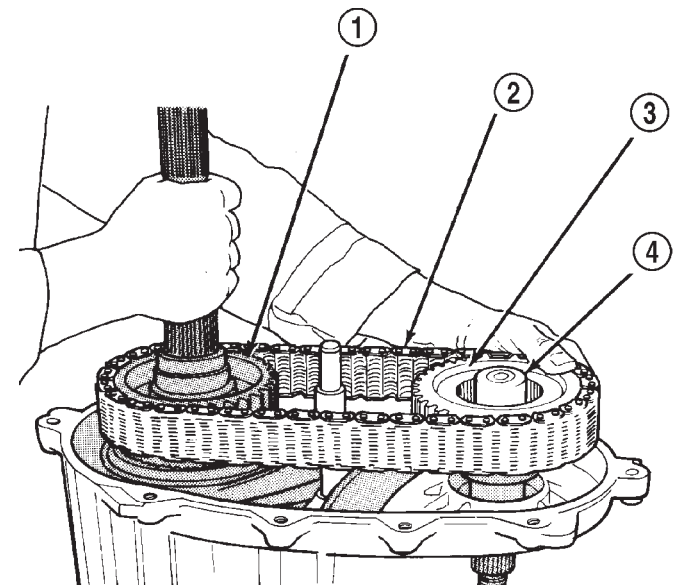
(4) Raise mainshaft about 2.54 cm (one inch) and seat front sprocket on front output shaft.

(5) If mainshaft and sliding clutch were unseated during chain installation, align and reseat mainshaft in input gear and hub. Then reseat synchronizer hub in sliding clutch. Press synchronizer struts inward to ease clutch back onto hub.



**Fig. 84 Front Output Shaft Installation**

1 - FRONT OUTPUT SHAFT  
2 - BEARING

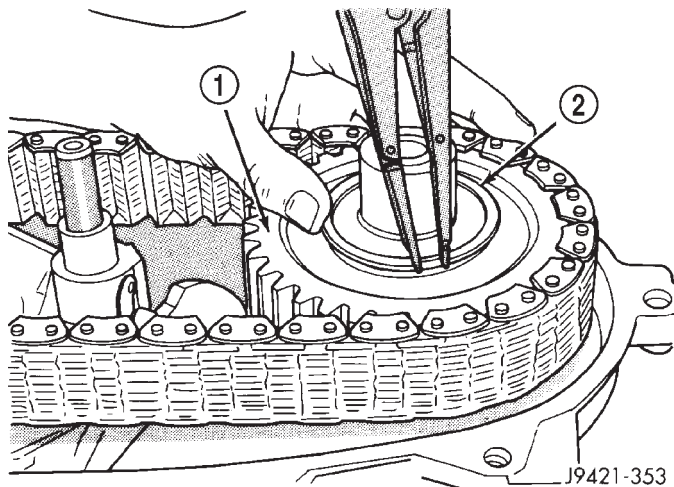


**Fig. 85 Drive Chain And Front Sprocket Installation**

1 - DRIVE SPROCKET  
2 - DRIVE CHAIN  
3 - FRONT SPROCKET  
4 - FRONT SHAFT

TRANSFER CASE - NV241HD (Continued)

(6) Install front sprocket retaining ring (Fig. 86).

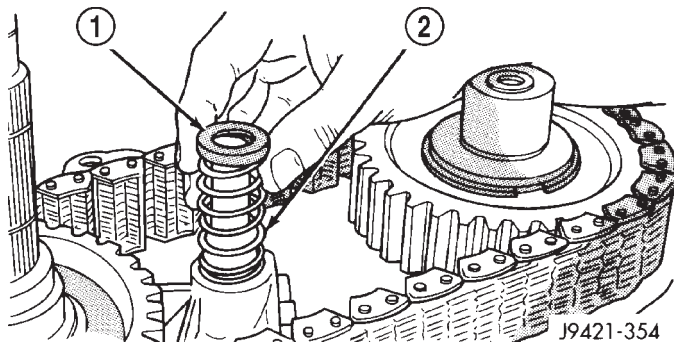


**Fig. 86 Front Sprocket Retaining Ring Installation**

- 1 - FRONT SPROCKET
- 2 - RETAINING RING

(7) Realign sliding clutch on synchronizer hub if necessary. Press synchronizer struts inward to ease realignment. Be sure mainshaft is fully seated before proceeding.

(8) Install spring and cup on shift rail (Fig. 87).



**Fig. 87 Shift Rail Spring And Cup Installation**

- 1 - CUP
- 2 - SPRING

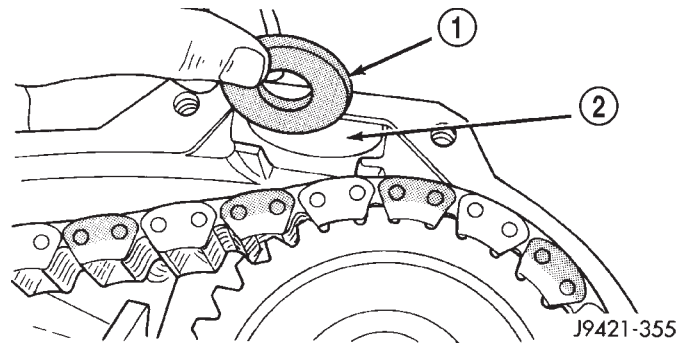
(9) Insert magnet in front case pocket (Fig. 88).

**OIL PUMP AND REAR CASE**

Lubricate the oil pump components before installation. Prime the oil pickup tube by pouring a little oil into the tube before installation.

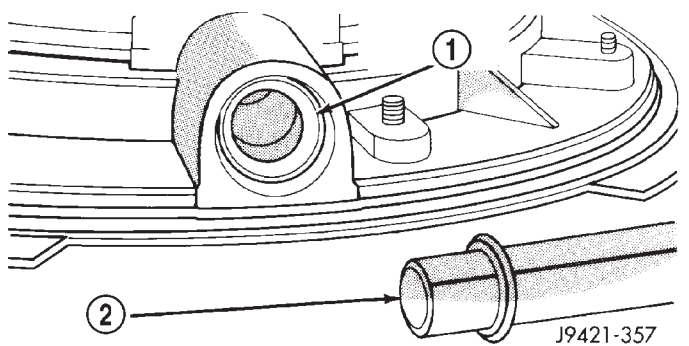
(1) Install new o-ring in pickup tube inlet of oil pump (Fig. 89).

(2) Position oil pickup tube and filter in rear case. Be sure pickup filter is seated in case pocket and that pickup tube is aligned in case notches (Fig. 90). Be sure hose that connects tube to filter is securely positioned.



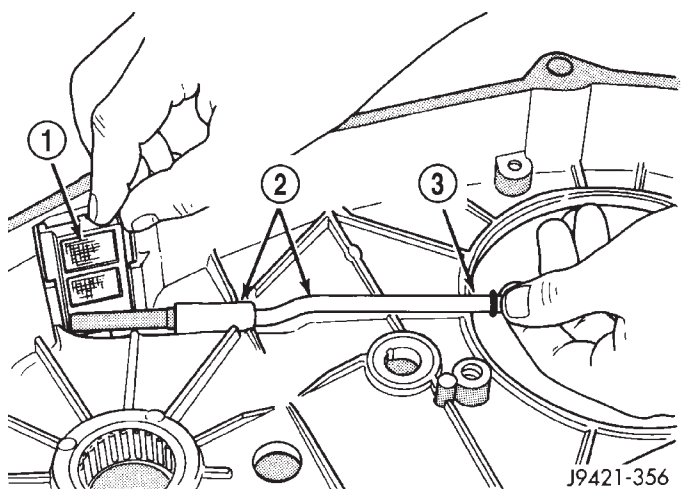
**Fig. 88 Case Magnet Installation**

- 1 - MAGNET
- 2 - CASE POCKET



**Fig. 89 Pickup Tube O-Ring Installation**

- 1 - O-RING (PUMP PICKUP)
- 2 - PICKUP TUBE

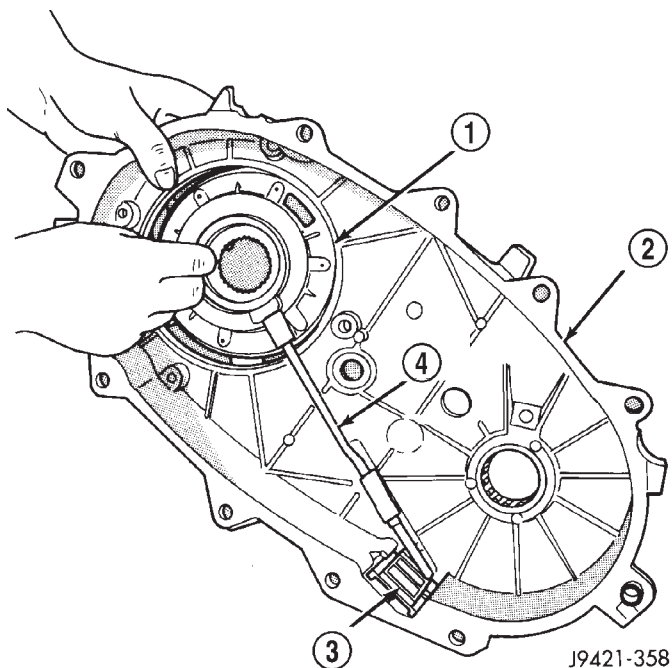


**Fig. 90 Oil Pickup Tube And Filter Position In Rear Case**

- 1 - FILTER
- 2 - TUBE AND HOSE
- 3 - TUBE IN NOTCH

(3) Insert oil pickup tube in oil pump and position pump in rear case (Fig. 91).

## TRANSFER CASE - NV241HD (Continued)



**Fig. 91 Positioning Oil Pump In Rear Case**

- 1 - OIL PUMP
- 2 - REAR CASE
- 3 - FILTER
- 4 - PICKUP TUBE

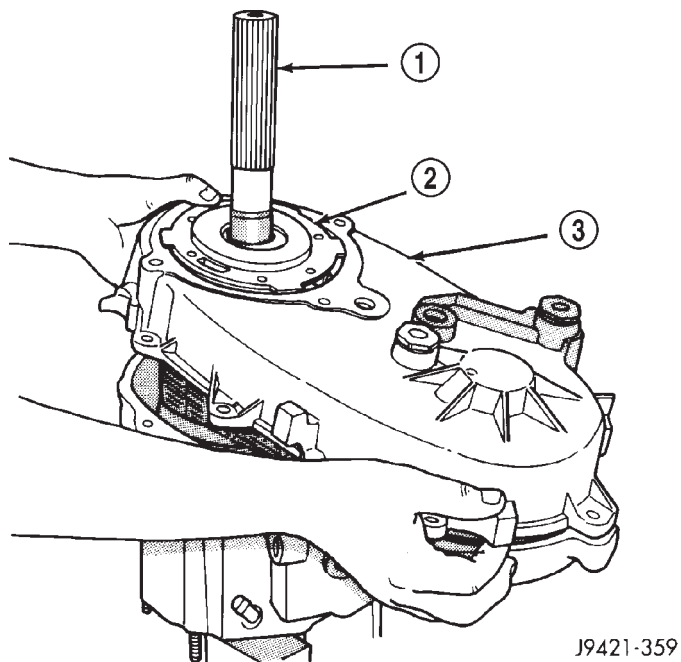
(4) Apply bead of Mopar® Gasket Maker, or equivalent, to mating surface of front case. Keep sealer bead width to maximum of 3/16 inch. Do not use excessive amount of sealer as excess will be displaced into case interior.

(5) Align oil pump with mainshaft and align shift rail with bore in rear case. Then install rear case and oil pump assembly (Fig. 92). Be sure oil pump and pickup tube remain in position during case installation.

(6) Install 4-5 rear case-to front case bolts to hold rear case in position. Tighten bolts snug but not to specified torque at this time.

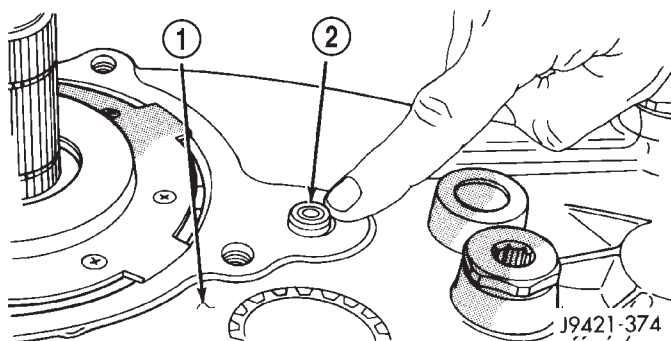
**CAUTION:** Verify that shift rail (Fig. 93), and case alignment dowels are seated before installing any bolts. Case could be cracked if shaft rail or dowels are misaligned.

(7) Verify that oil pump is aligned and seated on rear case. Reposition pump if necessary.



**Fig. 92 Rear Case And Oil Pump Installation**

- 1 - MAINSHAFT
- 2 - OIL PUMP
- 3 - REAR CASE



**Fig. 93 Shift Rail Seated In Rear Case Bore**

- 1 - REAR CASE
- 2 - SHIFT RAIL

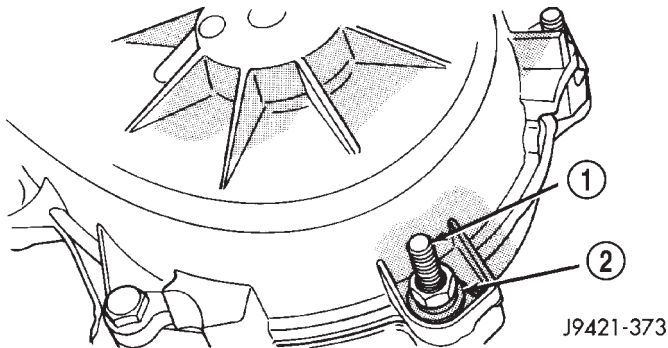


## TRANSFER CASE - NV241HD (Continued)

(8) Check stud at end of case halves (Fig. 94). If stud was loosened or came out during disassembly, apply Loctite™ 242 to stud threads and reseal stud in case.

(9) Apply Loctite™ 242 to remainder of rear case-to-front case bolt threads and install bolts. Be sure lock washers are used on studs/bolts at case ends. Tighten bolts, or stud nuts as follows:

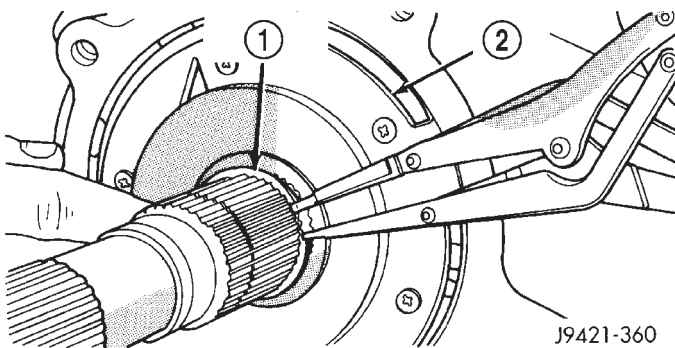
- flange head bolts to 47-61 N·m (35-45 ft. lbs.)
- all other bolts/nuts to 27-34 N·m (20-25 ft. lbs.)



**Fig. 94 Washer Installation On Case Stud And Dowel Bolts**

- 1 - CASE STUD/BOLT  
2 - WASHER

(10) Install oil pump retaining ring on mainshaft (Fig. 95).



**Fig. 95 Oil Pump Retaining Ring Installation**

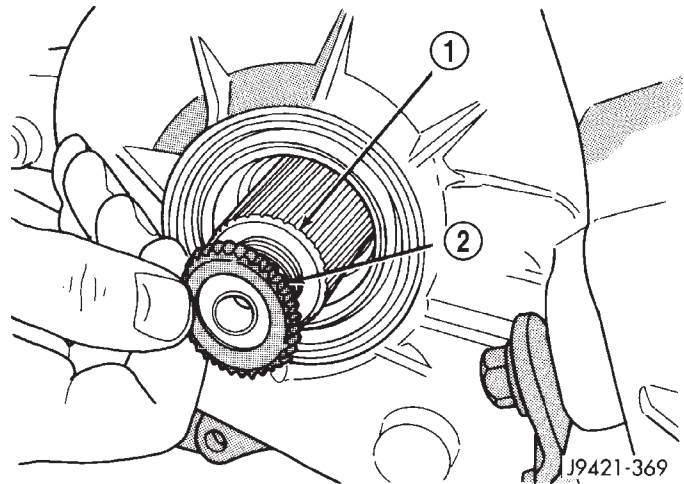
- 1 - RETAINING RING  
2 - OIL PUMP

(11) Install rear output bearing and snap-ring to output shaft.

### COMPANION FLANGE

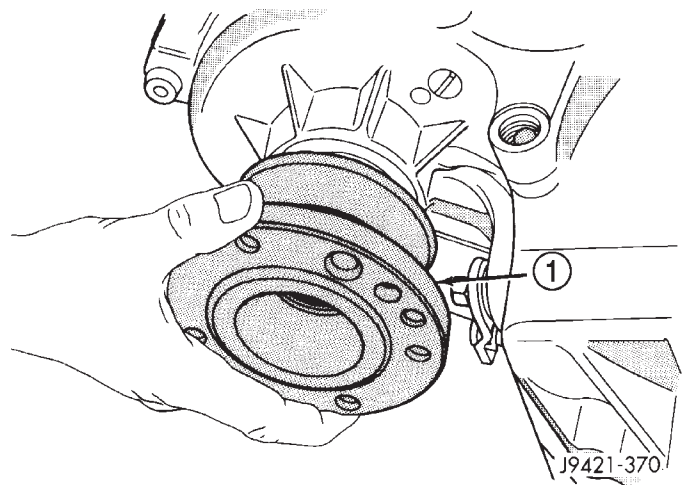
(1) Install companion flange seal on front shaft (Fig. 96).

(2) Install companion flange on front shaft (Fig. 97). Then install and tighten flange nut to 176-271 N·m (130-200 ft. lbs.) torque.



**Fig. 96 Installing Flange Seal On Front Shaft**

- 1 - FRONT OUTPUT SHAFT  
2 - FLANGE SEAL



**Fig. 97 Installing Companion Flange On Front Shaft**

- 1 - COMPANION FLANGE

### EXTENSION HOUSING AND PTO COVER

(1) Apply bead of Mopar® Gasket Maker, or equivalent, to mating surface of extension housing. Keep sealer bead width to maximum of 3/16 inch. Do not use excessive amount of sealer as excess could be displaced into oil pump.

(2) Position extension housing over output shaft.

(3) Spread extension housing retaining ring and seat extension housing on rear case. Verify that the retaining ring is seated in output shaft rear bearing.

(4) Install retaining ring access cover.

(5) Apply Mopar® Silicone Sealer, or equivalent, to threads of extension housing bolts. Then install bolts finger tight.

(6) Tighten extension housing bolts to 27-34 N·m (20-25 ft. lbs.) torque.



## TRANSFER CASE - NV241HD (Continued)

(7) Apply Mopar® Silicone Sealer to mating surface of PTO cover and to cover bolt shanks and underside of bolt heads. Then install and tighten bolts to 27-34 N·m (20-25 ft. lbs.) torque.

**INSTALLATION**

(1) Align and seat transfer case on transmission. Be sure transfer case input gear splines are aligned with transmission output shaft. Align splines by rotating transfer case rear output shaft yoke if necessary. Do not install any transfer case attaching nuts until the transfer case is completely seated against the transmission.

(2) Install and tighten transfer case attaching nuts. Tighten nuts to 30-41 N·m (20-30 ft.lbs.).

(3) Install rear crossmember.

(4) Remove jack stand from under transmission.

(5) Align and connect propeller shafts. (Refer to 3 - DIFFERENTIAL & DRIVELINE/PROPELLER SHAFT/PROPELLER SHAFT - INSTALLATION)

(6) Connect vacuum harness and vent hose.

(7) Connect shift rod to transfer case lever or floor shift arm. Use channel lock style pliers to press rod back into lever grommet.

(8) Adjust shift linkage, if necessary.

(9) Fill transfer case with recommended transmission fluid and install fill plug.

(10) Install skid plate, if equipped. (Refer to 13 - FRAMES & BUMPERS/FRAME/TRANSFER CASE SKID PLATE - INSTALLATION)

(11) Lower vehicle

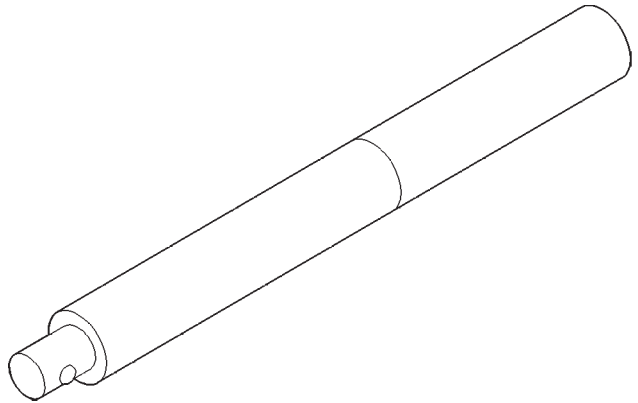
**SPECIFICATIONS****TRANSFER CASE****TORQUE SPECIFICATIONS**

DESCRIPTION	N-m	Ft. Lbs.	In. Lbs.
Plug, Detent	16-24	12-18	-
Bolt, Diff. Case	17-27	15-24	-
Plug, Drain/Fill	40-45	30-40	-
Bolt, Extension Housing	35-46	26-34	-
Bolt, Front Brg. Retainer	16-27	12-24	-
Bolt, Case Half	35-46	26-34	-
Nut, Front Yoke	122-176	90-130	-
Screw, Oil Pump	1.2-1.8	-	12-15
Nut, Range Lever	27-34	20-25	-
Bolt, Rear Retainer	35-46	26-34	-
Nuts, Mounting	30-41	20-30	-
Bolts, U-Joint	19	17	-
Vacuum Switch	20-34	15-25	-

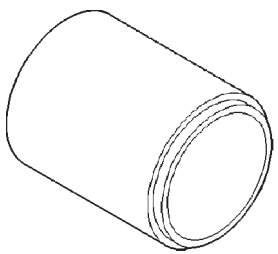
TRANSFER CASE - NV241HD (Continued)

SPECIAL TOOLS

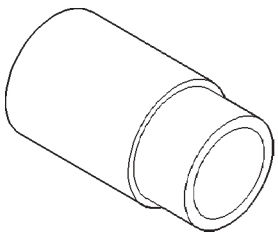
TRANSFER CASE - NV241HD



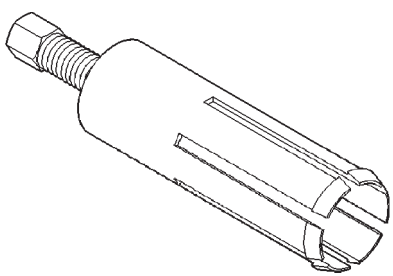
**Handle, Universal - C-4171**



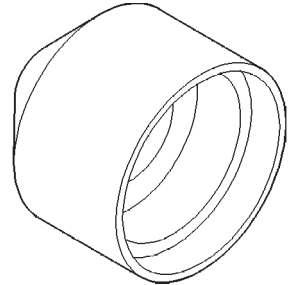
**Installer, Seal - 6888**



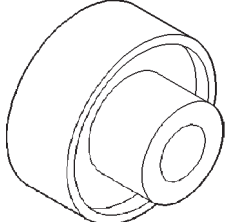
**Installer, Bushing - 8156**



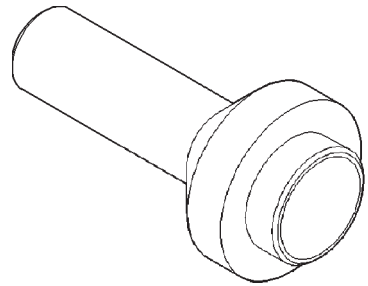
**Remover, Bushing - 8155**



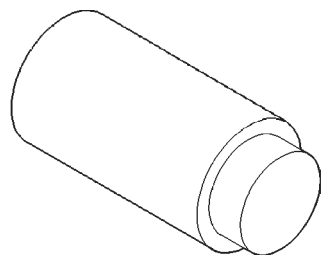
**Installer, Seal - 8154**



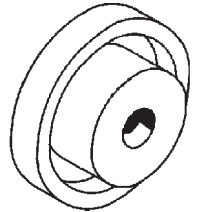
**Installer, Bearing - 6953**



**Installer, Seal - 7884**

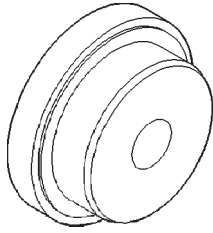
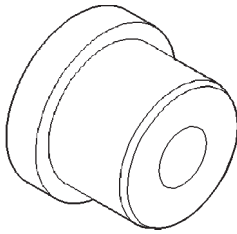
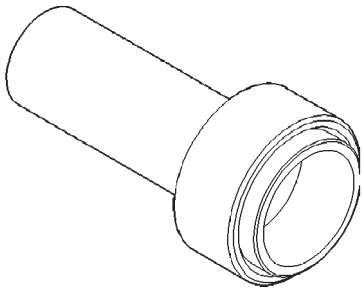
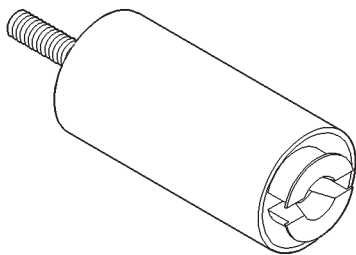
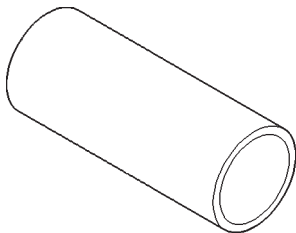


**Plug, Extension - C-293-3**



**Installer, Seal - C-4210**

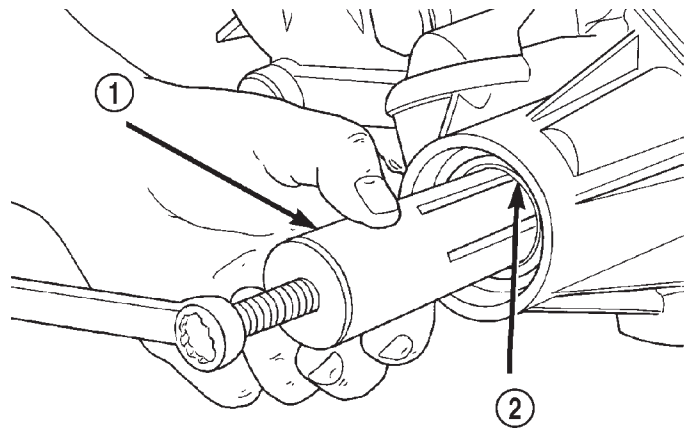
## TRANSFER CASE - NV241HD (Continued)

**Installer, Bearing - 5062****Installer, Bushing - 5066****Installer, Pump Housing Seal - 7888****Remover, Bearing - L-4454****Cup - 8148**

## EXTENSION HOUSING BUSHING AND SEAL

### REMOVAL

- (1) Raise and support vehicle.
- (2) Remove rear propeller shaft. (Refer to 3 - DIFFERENTIAL & DRIVELINE/PROPELLER SHAFT/PROPELLER SHAFT - REMOVAL)
- (3) Using a suitable pry tool or slide-hammer mounted screw, remove the extension housing seal.
- (4) Using Remover 8155, remove bushing from extension housing (Fig. 98).



80aa0fdc

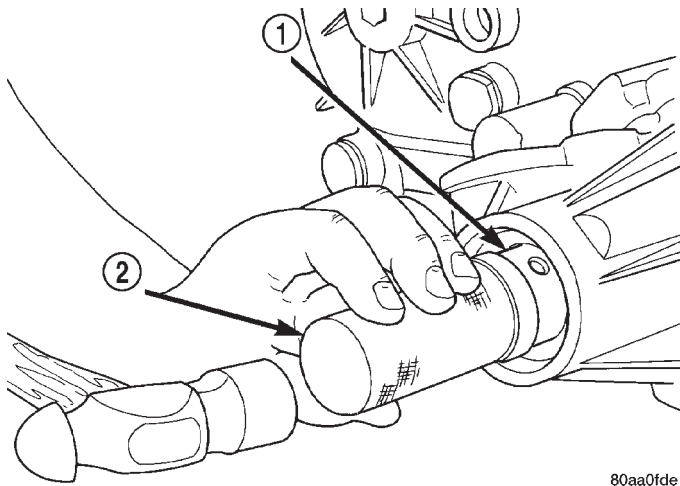
**Fig. 98 Extension Housing Bushing Removal**

- 1 - REMOVER 8155
- 2 - EXTENSION HOUSING BUSHING

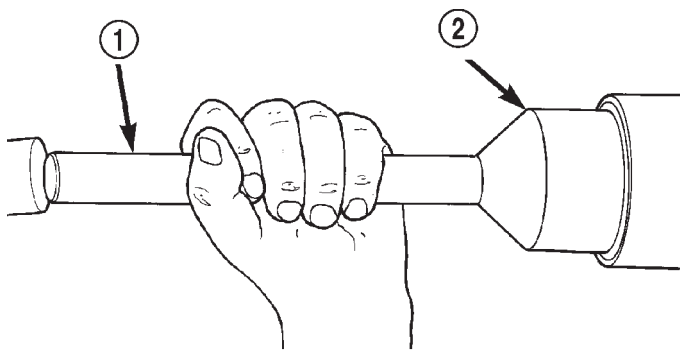
### INSTALLATION

- (1) Clean fluid residue from sealing surface and inspect for defects.
- (2) Position replacement bushing in extension housing with fluid port in bushing aligned with slot in housing.
- (3) Using Installer 8156, drive bushing into housing until installer seats against case (Fig. 99).
- (4) Using Installer 8154, install seal in extension housing (Fig. 100).
- (5) Install propeller shaft. (Refer to 3 - DIFFERENTIAL & DRIVELINE/PROPELLER SHAFT/PROPELLER SHAFT - INSTALLATION)
- (6) Verify proper transfer case fluid level.
- (7) Lower vehicle.

## EXTENSION HOUSING BUSHING AND SEAL (Continued)

**Fig. 99 Extension Housing Bushing Installation**

- 1 - EXTENSION HOUSING BUSHING  
2 - INSTALLER 8156

**Fig. 100 Install Extension Housing Seal**

- 1 - SPECIAL TOOL C-4171  
2 - SPECIAL TOOL 8154

## FLUID

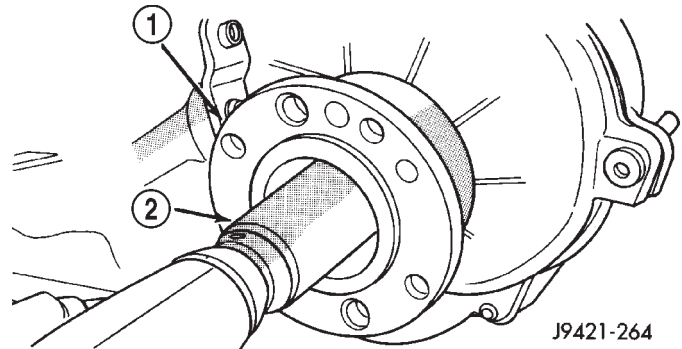
## STANDARD PROCEDURE - FLUID DRAIN AND REFILL

- (1) Raise vehicle.
- (2) Position drain pan under transfer case.
- (3) Remove drain and fill plugs and drain lubricant completely.
- (4) Install drain plug. Tighten plug to 41-54 N-m (30-40 ft. lbs.).
- (5) Remove drain pan.
- (6) Fill transfer case to bottom edge of fill plug opening with Mopar® ATF +4, type 9602, Automatic Transmission fluid.
- (7) Install and tighten fill plug to 41-54 N-m (30-40 ft. lbs.).
- (8) Lower vehicle.

## FRONT OUTPUT SHAFT SEAL

## REMOVAL

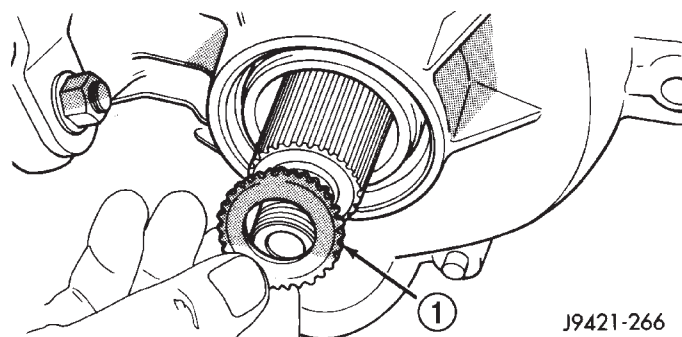
- (1) Shift transfer case into NEUTRAL.
- (2) Raise vehicle.
- (3) Remove front propeller shaft. (Refer to 3 - DIFFERENTIAL & DRIVELINE/PROPELLER SHAFT/PROPELLER SHAFT - REMOVAL)
- (4) Remove companion flange nut (Fig. 101). Discard nut after removal. It is not reusable.

**Fig. 101 Removing Companion Flange Nut**

- 1 - COMPANION FLANGE  
2 - SOCKET

(5) Remove companion flange from output shaft. Use a suitable puller if flange can not be removed by hand.

(6) Remove companion flange rubber seal from front output shaft (Fig. 102).

**Fig. 102 Companion Flange Seal Removal**

- 1 - FLANGE SEAL

(7) Remove front output shaft seal with suitable pry tool, or a slide hammer mounted screw.

## INSTALLATION

(1) Install new front output seal in front case with Installer Tool 6888 and Tool Handle C-4171 (Fig. 103) as follows:

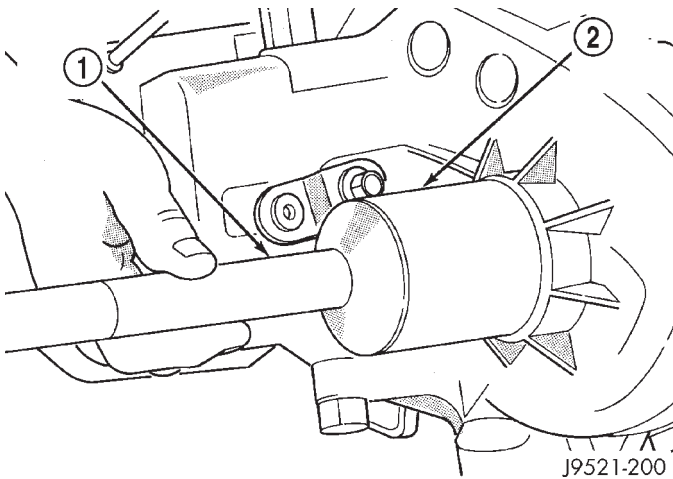
- (a) Place new seal on tool. Garter spring on seal goes toward interior of case.

## FRONT OUTPUT SHAFT SEAL (Continued)

(b) Start seal in bore. Once seal is started, continue tapping seal into bore until installer tool bottoms against case.

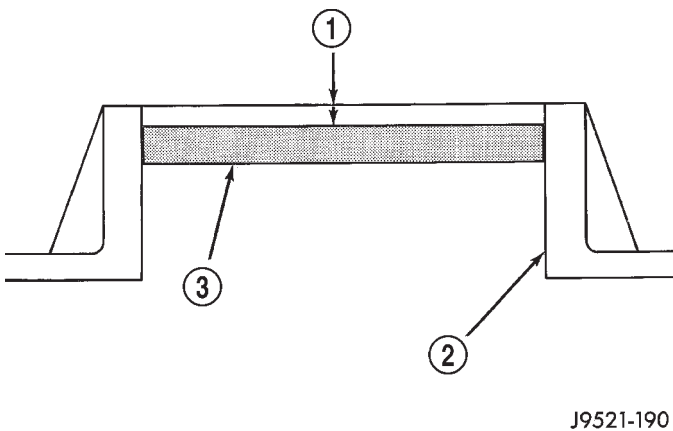
(c) Remove installer and verify that seal is recessed the proper amount. Seal should be 2.03 to 2.5 mm (0.080 to 0.100 in.) below top edge of seal bore in front case (Fig. 104). This is correct final seal position.

**CAUTION:** Be sure the front output seal is seated below the top edge of the case bore as shown. The seal could loosen, or become cocked if not seated to recommended depth.



**Fig. 103 Front Output Seal Installation**

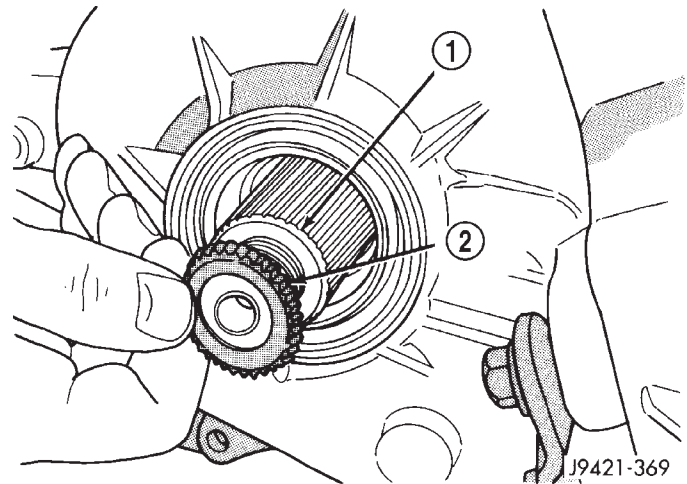
- 1 - SPECIAL TOOL C-4171  
2 - SPECIAL TOOL 6888



**Fig. 104 Checking Front Output Seal Installation Depth**

- 1 - CORRECT SEAL DEPTH IS 2.03-2.5 mm (0.080-0.100 in.) BELOW TOP EDGE OF BORE  
2 - FRONT CASE SHAFT BORE  
3 - FRONT OUTPUT SEAL

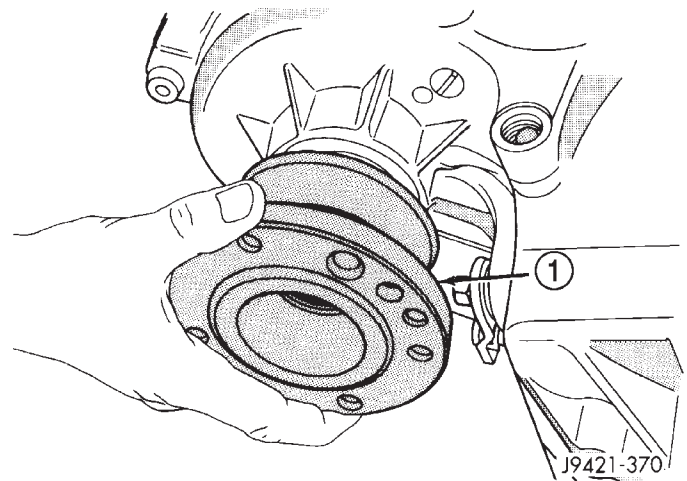
(2) Install companion flange seal on front shaft (Fig. 105).



**Fig. 105 Installing Flange Seal On Front Shaft**

- 1 - FRONT OUTPUT SHAFT  
2 - FLANGE SEAL

(3) Install companion flange on front shaft (Fig. 106). Then install and tighten flange nut to 176-271 N·m (130-200 ft. lbs.) torque.



**Fig. 106 Installing Companion Flange On Front Shaft**

- 1 - COMPANION FLANGE

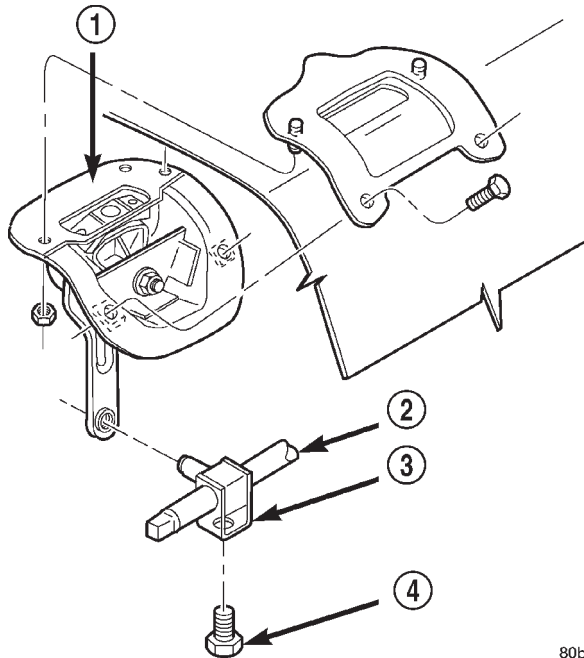
(4) Install propeller shaft. (Refer to 3 - DIFFERENTIAL & DRIVELINE/PROPELLER SHAFT/PROPELLER SHAFT - INSTALLATION)



## SHIFT LEVER

### REMOVAL

- (1) Shift transfer case into 2H.
- (2) Remove transfer case shifter knob cap.
- (3) Remove nut holding shifter knob to shift lever.
- (4) Remove shifter knob.
- (5) Remove the shift boot from the shifter bezel.
- (6) Remove the bolts securing the shifter mechanism to the floor pan along the driver's side of the transmission tunnel (Fig. 107).



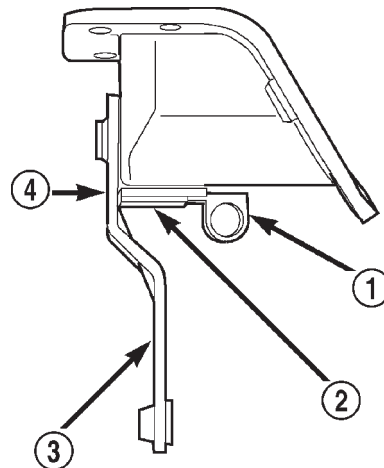
**Fig. 107 Transfer Case Shifter**

- 1 - TRANSFER CASE SHIFTER ASSEMBLY
- 2 - SHIFT ROD
- 3 - TRUNNION
- 4 - LOCK BOLT

- (7) Raise and support the vehicle.
- (8) Loosen adjusting trunnion lock bolt and slide shift rod out of trunnion. If rod lacks enough travel to come out of trunnion, push trunnion out of shift lever.
- (9) Remove the nuts holding the shifter mechanism to the underside of the floor pan.
- (10) Separate shift lever mechanism from the vehicle.

### INSTALLATION

- (1) If the shifter mechanism does not have an adjustment locating pin installed, align the adjustment channel on the shifter assembly to the locating hole in the lower shift lever and install an appropriately sized pin to retain the position (Fig. 108).



80be45f6

**Fig. 108 Shifter Adjustment**

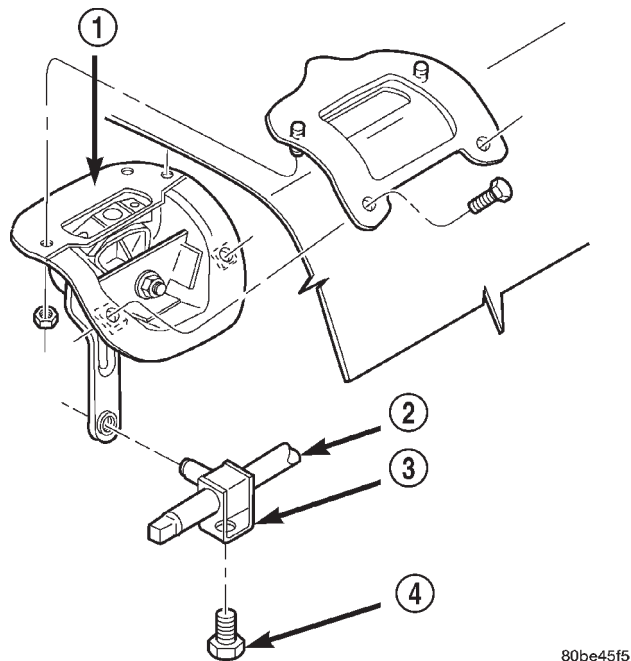
- 1 - LOCATING PIN
- 2 - ADJUSTMENT CHANNEL
- 3 - LOWER SHIFTER LEVER
- 4 - LOCATING HOLE

- (2) Position shift lever on vehicle.
- (3) Install nuts to hold shift lever to the underside of the body.
- (4) Install trunnion to shift lever, if necessary.
- (5) Install shift rod to trunnion, if necessary.
- (6) Tighten the shift rod lock bolt to 10 N·m (90 in.lbs.).
- (7) Remove the shifter adjustment locating pin from the adjustment channel and the locating hole.
- (8) Lower vehicle.
- (9) Install the bolts to hold the shifter mechanism to the floor pan.
- (10) Install the transfer case shifter bezel.
- (11) Install the shifter boot and the shifter knob onto the shifter lever.
- (12) Install nut to hold shifter knob to shift lever.
- (13) Install shifter knob cap.
- (14) Verify transfer case operation.

## SHIFT LEVER (Continued)

**ADJUSTMENT - SHIFT LEVER**

- (1) Move shift lever into 2H position.
- (2) Raise vehicle.
- (3) Loosen shift rod lock bolt at trunnion (Fig. 109).



80be45f5

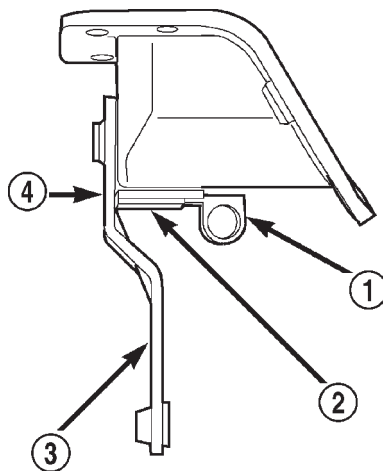
**Fig. 109 Shift Rod Lock Bolt Location**

- 1 - TRANSFER CASE SHIFTER ASSEMBLY
- 2 - SHIFT ROD
- 3 - TRUNNION
- 4 - LOCK BOLT

(4) Check shift rod fit in trunnion. Be sure rod does not bind in trunnion. Lubricate the shift rod and trunnion if necessary.

(5) Verify that transfer case shift lever is in 2H detent position. The 2H detent position on the transfer case shift arm is the second position from full forward.

- (6) Align the adjustment locating hole on the lower shifter lever with the adjustment channel on the shifter bracket assembly (Fig. 110).



80be45f6

**Fig. 110 Shifter Adjustment Location**

- 1 - LOCATING PIN
- 2 - ADJUSTMENT CHANNEL
- 3 - LOWER SHIFTER LEVER
- 4 - LOCATING HOLE

(7) Insert an appropriately sized pin through into the adjustment channel and through the locating hole to hold the shifter in the correct position.

(8) Tighten shift rod lock bolt to 10 N·m (90 in. lbs.) torque.

(9) Remove the locating pin from the adjustment channel and locating hole.

(10) Check shift linkage operation. Be sure transfer case shifts into and operates properly in all ranges.



# TIRES/WHEELS

## TABLE OF CONTENTS

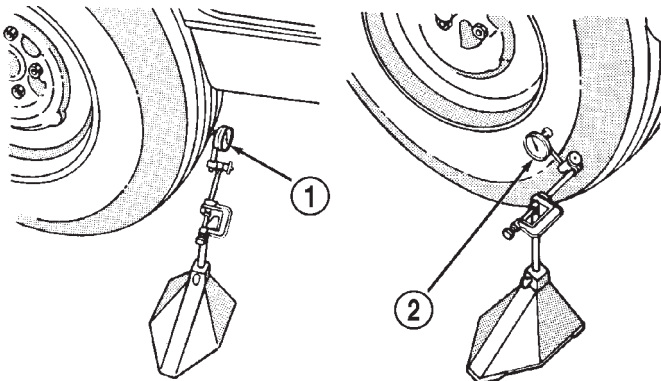
	page		page
<b>TIRES/WHEELS</b>		<b>SPARE TIRE</b>	
DIAGNOSIS AND TESTING . . . . .	1	DESCRIPTION . . . . .	9
TIRE AND WHEEL RUNOUT . . . . .	1	<b>WHEELS</b>	
STANDARD PROCEDURE . . . . .	2	DESCRIPTION . . . . .	9
TIRE ROTATION . . . . .	2	OPERATION . . . . .	10
MATCH MOUNTING . . . . .	2	DIAGNOSIS AND TESTING . . . . .	10
TIRE AND WHEEL BALANCE . . . . .	4	WHEEL INSPECTION . . . . .	10
<b>TIRES</b>		STANDARD PROCEDURE . . . . .	10
DESCRIPTION . . . . .	5	DUAL WHEEL INSTALLATION . . . . .	10
DIAGNOSIS AND TESTING . . . . .	7	SPECIFICATIONS . . . . .	11
PRESSURE GAUGES . . . . .	7	<b>STUDS</b>	
TREAD WEAR INDICATORS . . . . .	7	REMOVAL . . . . .	12
TIRE WEAR PATTERNS . . . . .	7	INSTALLATION . . . . .	12
TIRE NOISE OR VIBRATION . . . . .	8	<b>WHEEL COVER</b>	
STANDARD PROCEDURE . . . . .	8	REMOVAL . . . . .	12
REPAIRING LEAKS . . . . .	8	INSTALLATION . . . . .	12
SPECIFICATIONS . . . . .	9		

## TIRES/WHEELS

### DIAGNOSIS AND TESTING - TIRE AND WHEEL RUNOUT

Radial runout is the difference between the high and low points on the tire or wheel (Fig. 1).

Lateral runout is the **wobble** of the tire or wheel.



J9022-4

**Fig. 1 Checking Tire/Wheel/Hub Runout**

- 1 - RADIAL RUNOUT
- 2 - LATERAL RUNOUT

Radial runout of more than 1.5 mm (.060 inch) measured at the center line of the tread may cause the vehicle to shake.

Lateral runout of more than 2.0 mm (.080 inch) measured near the shoulder of the tire may cause the vehicle to shake.

Sometimes radial runout can be reduced. Relocate the wheel and tire assembly on the mounting studs (See Method 1). If this does not reduce runout to an acceptable level, the tire can be rotated on the wheel. (See Method 2).

#### METHOD 1 (RELOCATE WHEEL ON HUB)

(1) Drive vehicle a short distance to eliminate tire flat spotting from a parked position.

(2) Check wheel bearings and adjust if adjustable or replace if necessary.

(3) Check the wheel mounting surface.

(4) Relocate wheel on the mounting, two studs over from the original position.

(5) Tighten wheel nuts until all are properly torqued, to eliminate brake distortion.

(6) Check radial runout. If still excessive, mark tire sidewall, wheel, and stud at point of maximum runout and proceed to Method 2.

TIRES/WHEELS (Continued)

METHOD 2 (RELOCATE TIRE ON WHEEL)

**NOTE:** Rotating the tire on wheel is particularly effective when there is runout in both tire and wheel.

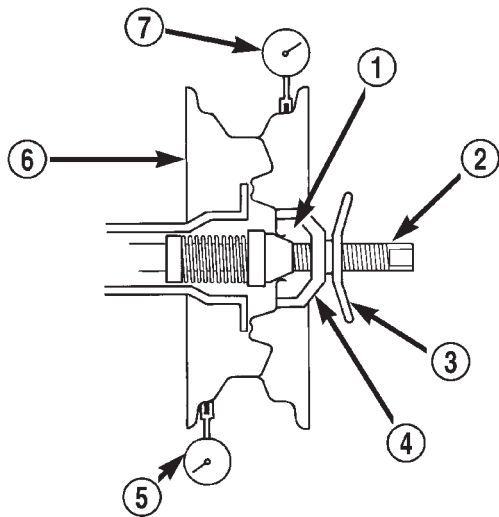
(1) Remove tire from wheel and mount wheel on service dynamic balance machine.

(2) Check wheel radial runout (Fig. 2) and lateral runout (Fig. 3).

- STEEL WHEELS: Radial runout 0.040 in., Lateral runout 0.045 in. (maximum)

- ALUMINUM WHEELS: Radial runout 0.030 in., Lateral runout 0.035 in. (maximum)

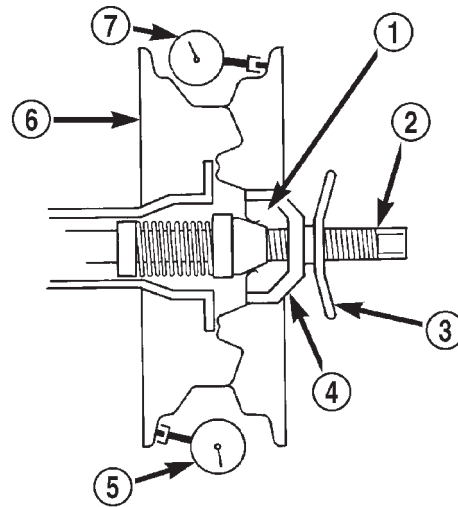
(3) If point of greatest wheel lateral runout is near original chalk mark, remount tire 180 degrees. Recheck runout, Refer to match mounting procedure.



**Fig. 2 Radial Runout**

- 1 - MOUNTING CONE
- 2 - SPINDLE SHAFT
- 3 - WING NUT
- 4 - PLASTIC CUP
- 5 - DIAL INDICATOR
- 6 - WHEEL
- 7 - DIAL INDICATOR

80a611da

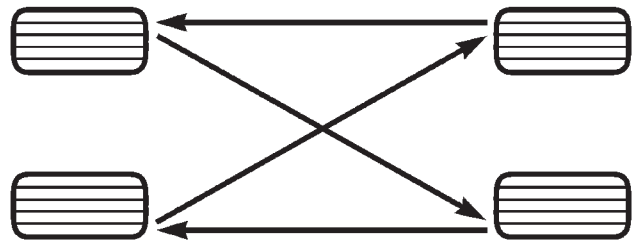


80a611db

**Fig. 3 Lateral Runout**

- 1 - MOUNTING CONE
- 2 - SPINDLE SHAFT
- 3 - WING NUT
- 4 - PLASTIC CUP
- 5 - DIAL INDICATOR
- 6 - WHEEL
- 7 - DIAL INDICATOR

Dual wheel vehicles require a different tire rotation pattern. Refer to (Fig. 5) for the proper tire rotation with dual wheels.



8031e864

**Fig. 4 Tire Rotation Pattern**

**STANDARD PROCEDURES - TIRE ROTATION**

Tires on the front and rear axles operate at different loads and perform different steering, driving, and braking functions. For these reasons, the tires wear at unequal rates. They may also develop irregular wear patterns. These effects can be reduced by rotating the tires according to the maintenance schedule in the Owners Manual. This will improve tread life, traction and maintain a smooth quiet ride.

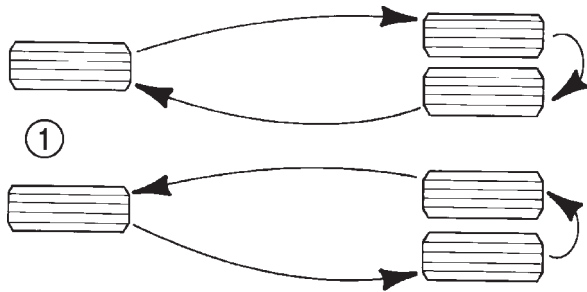
The recommended method of tire rotation is (Fig. 4). Other methods can be used, but may not provide the same tire longevity benefits.

**STANDARD PROCEDURES - MATCH MOUNTING**

Wheels and tires are match mounted at the factory. This means that the high spot of the tire is matched to the low spot on the wheel rim. Each are marked with a bright colored temporary label on the out-board surface for alignment. The wheel is also marked permanently on the inside of the rim in the tire well. This permanent mark may be a paint dot or line, a permanent label or a stamped impression such as an X. An optional location mark is a small spherical indentation on the vertical face of the out-



## TIRES/WHEELS (Continued)



803f5899

**Fig. 5 Dual Wheel Tire Rotation Pattern**

1 - FRONT

board flange on some non styled base steel wheels. The tire must be removed to locate the permanent mark on the inside of the wheel.

Before dismounting a tire from its wheel, a reference mark should be placed on the tire at the valve stem location. This reference will ensure that it is remounted in the original position on the wheel.

(1) Remove the tire and wheel assembly from the vehicle and mount on a service dynamic balance machine.

(2) Measure the total runout on the center of the tire tread rib with a dial indicator. Record the indicator reading. Mark the tire to indicate the high spot. Place a mark on the tire at the valve stem location (Fig. 6).

(3) Break down the tire and remount it 180 degrees on the rim (Fig. 7).

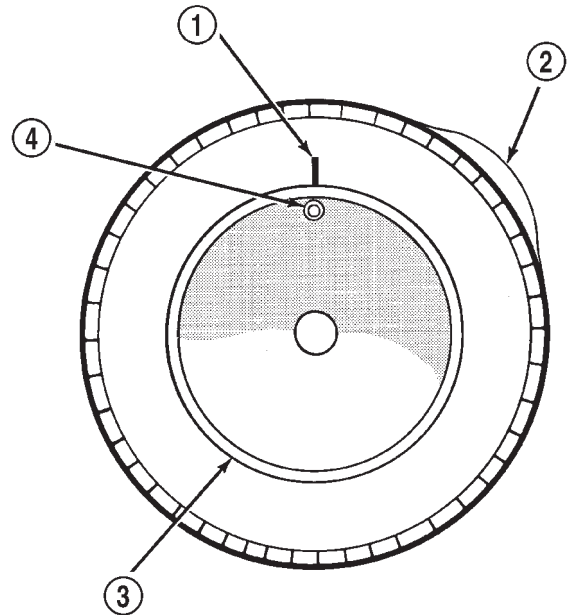
(4) Measure the total indicator runout again. Mark the tire to indicate the high spot.

(5) If runout is still excessive, the following procedures must be done.

- If the high spot is within 101.6 mm (4.0 in.) of the first spot and is still excessive, replace the tire.

- If the high spot is within 101.6 mm (4.0 in.) of the first spot on the wheel, the wheel may be out of specifications. Refer to Wheel and Tire Runout.

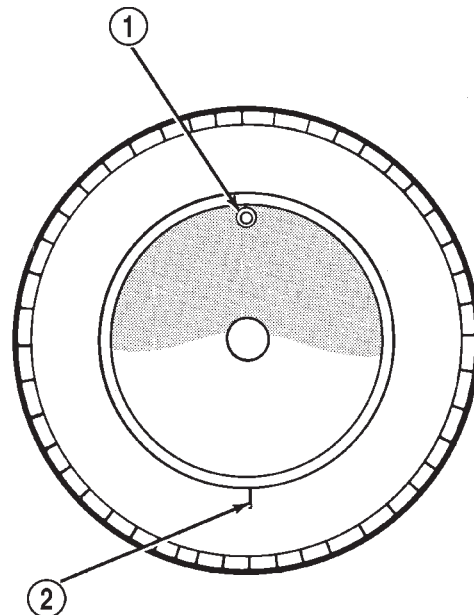
- If the high spot is NOT within 101.6 mm (4.0 in.) of either high spot, draw an arrow on the tread from second high spot to first. Break down the tire and remount it 90 degrees on rim in that direction (Fig. 8). This procedure will normally reduce the runout to an acceptable amount, if not replace the rim.



J9322-3

**Fig. 6 First Measurement On Tire**

- 1 - REFERENCE MARK
- 2 - 1ST MEASUREMENT HIGH SPOT MARK TIRE AND RIM
- 3 - WHEEL
- 4 - VALVE STEM

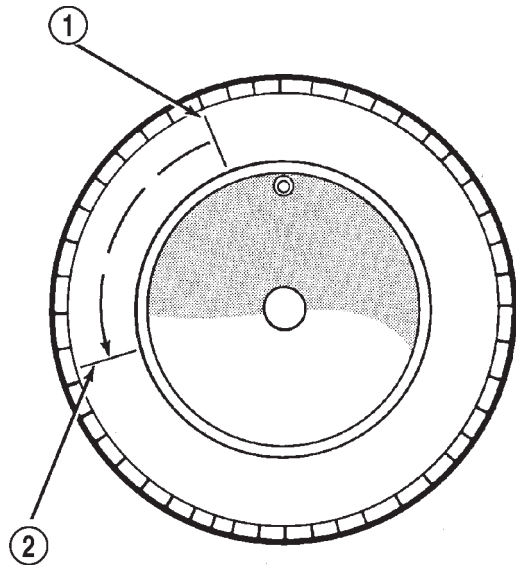


J9322-4

**Fig. 7 Remount Tire 180 Degrees**

- 1 - VALVE STEM
- 2 - REFERENCE MARK

TIRES/WHEELS (Continued)



J9322-5

**Fig. 8 Remount Tire 90 Degrees In Direction of Arrow**

- 1 - 2ND HIGH SPOT ON TIRE
- 2 - 1ST HIGH SPOT ON TIRE

**STANDARD PROCEDURES - TIRE AND WHEEL BALANCE**

It is recommended that a two plane service dynamic balancer be used when a tire and wheel assembly require balancing. Refer to balancer operation instructions for proper cone mounting procedures. Typically use front cone mounting method for steel wheels. For aluminum wheel use back cone mounting method without cone spring.

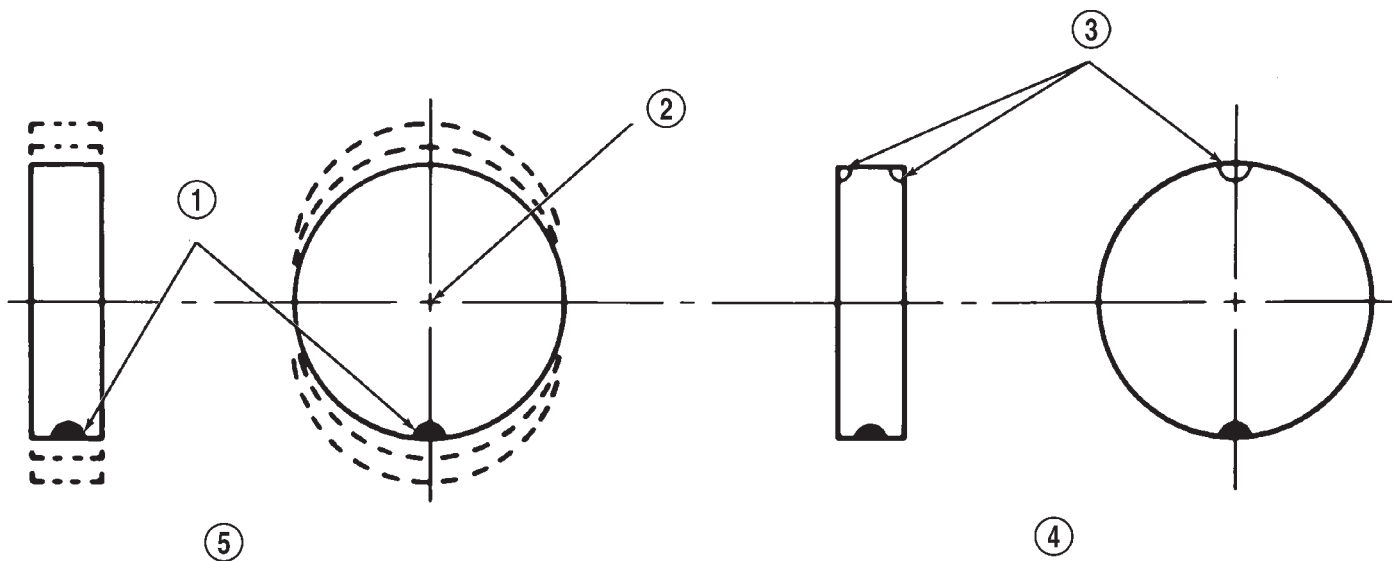
**NOTE:** Static should be used only when a two plane balancer is not available.

**NOTE:** Cast aluminum and forged aluminum wheels require coated balance weights and special alignment equipment.

Wheel balancing can be accomplished with either on or off vehicle equipment. When using on-vehicle balancing equipment, remove the opposite wheel/tire. Off-vehicle balancing is recommended.

For static balancing, find the location of the heavy spot causing the imbalance. Counter balance wheel directly opposite the heavy spot. Determine weight required to counter balance the area of imbalance. Place half of this weight on the **inner** rim flange and the other half on the **outer** rim flange (Fig. 9).

For dynamic balancing, the balancing equipment is designed to locate the amount of weight to be applied to both the inner and outer rim flange (Fig. 10).

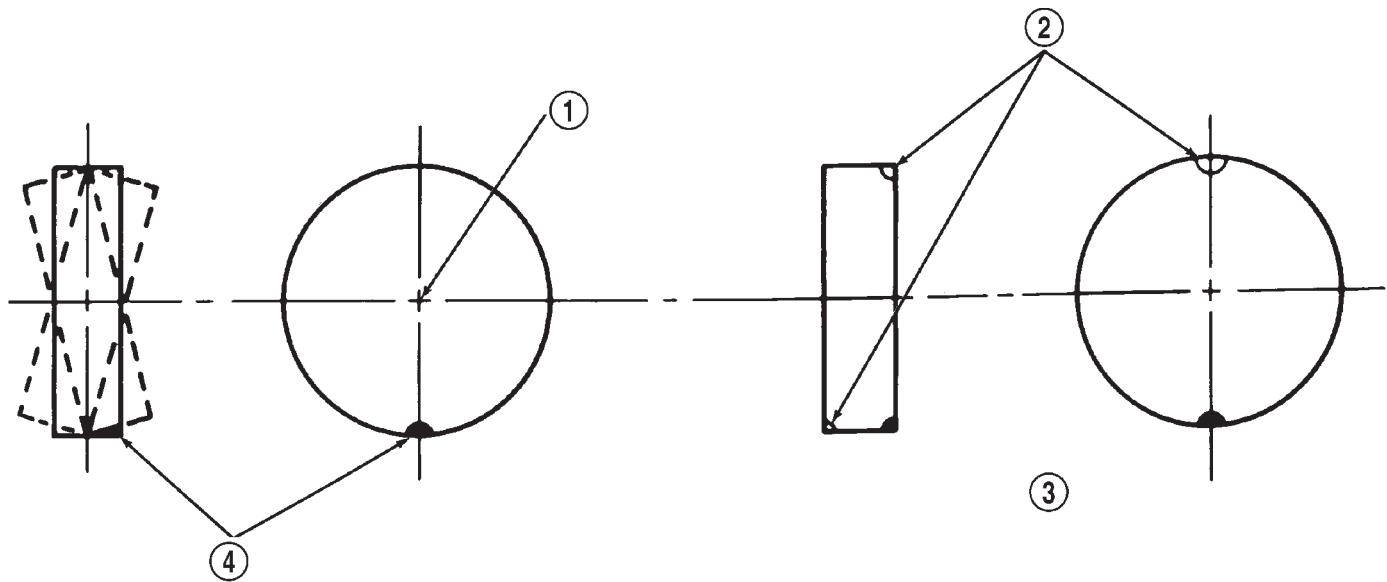


**Fig. 9 Static Unbalance & Balance**

J8922-8

- 1 - HEAVY SPOT
- 2 - CENTER LINE OF SPINDLE
- 3 - ADD BALANCE WEIGHTS HERE
- 4 - CORRECTIVE WEIGHT LOCATION
- 5 - TIRE OR WHEEL TRAMP, OR WHEEL HOP

## TIRES/WHEELS (Continued)



J8922-9

**Fig. 10 Dynamic Unbalance & Balance**

1 - CENTER LINE OF SPINDLE  
2 - ADD BALANCE WEIGHTS HERE

3 - CORRECTIVE WEIGHT LOCATION  
4 - HEAVY SPOT WHEEL SHIMMY AND VIBRATION

## TIRES

### DESCRIPTION

The temporary spare tire is designed for emergency use only. The original tire should be repaired or replaced at the first opportunity, then reinstalled. Do not exceed speeds of 50 M.P.H. when using the temporary spare tire. Refer to Owner's Manual for complete details.

### DESCRIPTION

Tires are designed and engineered for each specific vehicle. They provide the best overall performance for normal operation. The ride and handling characteristics match the vehicle's requirements. With proper care they will give excellent reliability, traction, skid resistance, and tread life.

Driving habits have more effect on tire life than any other factor. Careful drivers will obtain in most cases, much greater mileage than severe use or careless drivers. A few of the driving habits which will shorten the life of any tire are:

- Rapid acceleration
- Severe brake applications
- High speed driving
- Excessive speeds on turns
- Striking curbs and other obstacles

Radial-ply tires are more prone to irregular tread wear. It is important to follow the tire rotation inter-

val shown in the section on Tire Rotation, (Refer to 22 - TIRES/WHEELS - STANDARD PROCEDURE). This will help to achieve a greater tread life.

### TIRE IDENTIFICATION

Tire type, size, aspect ratio and speed rating are encoded in the letters and numbers imprinted on the side wall of the tire. Refer to the chart to decipher the tire identification code (Fig. 11).

Performance tires have a speed rating letter after the aspect ratio number. The speed rating is not always printed on the tire sidewall. These ratings are:

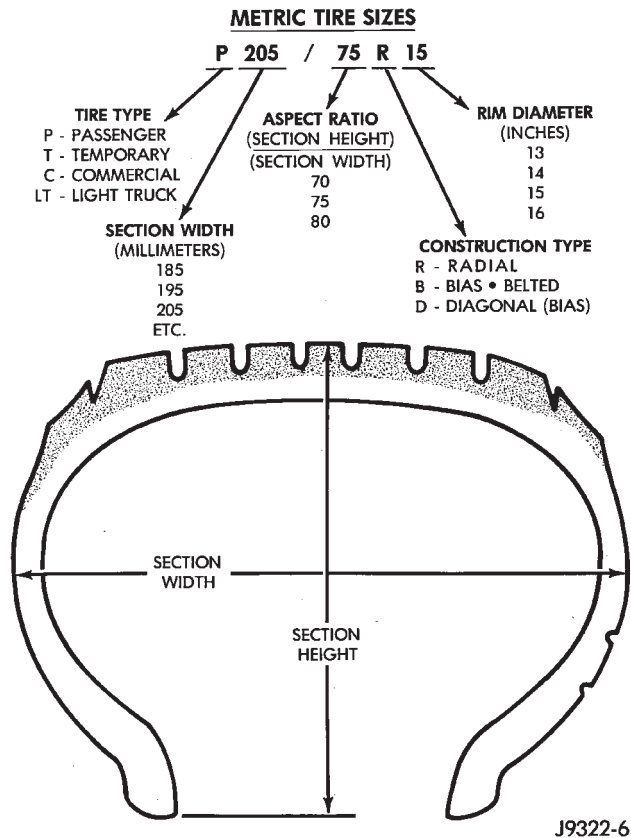
- **Q** up to 100 mph
- **R** up to 106 mph
- **S** up to 112 mph
- **T** up to 118 mph
- **U** up to 124 mph
- **H** up to 130 mph
- **V** up to 149 mph
- **Z** more than 149 mph (consult the tire manufacturer for the specific speed rating)

An All Season type tire will have either **M + S**, **M & S** or **M-S** (indicating mud and snow traction) imprinted on the side wall.

### TIRE CHAINS

Tire snow chains may be used on **certain** models. Refer to the Owner's Manual for more information.

## TIRES (Continued)



**Fig. 11 Tire Identification**

### DESCRIPTION

Radial-ply tires improve handling, tread life and ride quality, and decrease rolling resistance.

Radial-ply tires must always be used in sets of four. Under no circumstances should they be used on the front only. They may be mixed with temporary spare tires when necessary. A maximum speed of 50 MPH is recommended while a temporary spare is in use.

Radial-ply tires have the same load-carrying capacity as other types of tires of the same size. They also use the same recommended inflation pressures.

The use of oversized tires, either in the front or rear of the vehicle, can cause vehicle drive train failure. This could also cause inaccurate wheel speed signals when the vehicle is equipped with Anti-Lock Brakes.

The use of tires from different manufactures on the same vehicle is NOT recommended. The proper tire pressure should be maintained on all four tires.

### DESCRIPTION

Where speed limits allow the vehicle to be driven at high speeds, correct tire inflation pressure is very important. For speeds up to and including 120 km/h (75 mph), tires must be inflated to the pressures shown on the tire placard. For continuous speeds in

excess of 120 km/h (75 mph), tires must be inflated to the maximum pressure specified on the tire sidewall.

Vehicles loaded to the maximum capacity should not be driven at continuous speeds above 75 mph (120 km/h).

For emergency vehicles that are driven at speeds over 90 mph (144 km/h), special high speed tires must be used. Consult tire manufacturer for correct inflation pressure recommendations.

### DESCRIPTION

The original equipment tires provide a proper balance of many characteristics such as:

- Ride
- Noise
- Handling
- Durability
- Tread life
- Traction
- Rolling resistance
- Speed capability

It is recommended that tires equivalent to the original equipment tires be used when replacement is needed.

Failure to use equivalent replacement tires may adversely affect the safety and handling of the vehicle.

The use of oversize tires may cause interference with vehicle components. Under extremes of suspension and steering travel, interference with vehicle components may cause tire damage.

**WARNING: FAILURE TO EQUIP THE VEHICLE WITH TIRES HAVING ADEQUATE SPEED CAPABILITY CAN RESULT IN SUDDEN TIRE FAILURE.**

### DESCRIPTION

Under inflation will cause rapid shoulder wear, tire flexing, and possible tire failure (Fig. 12) .

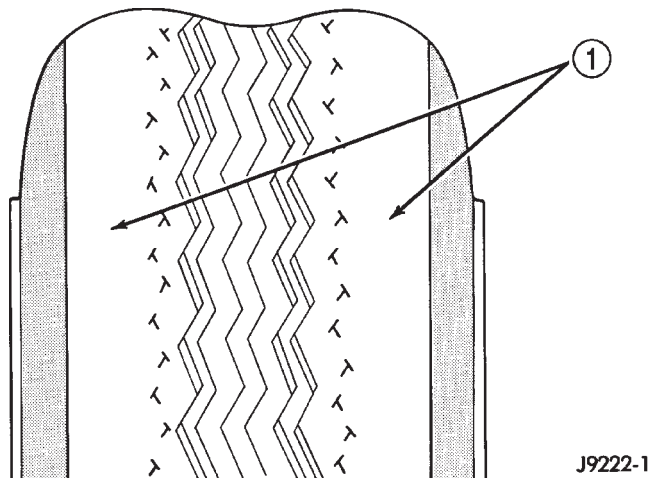
Over inflation will cause rapid center wear and loss of the tire's ability to cushion shocks (Fig. 13) .

Improper inflation can cause:

- Uneven wear patterns
- Reduced tread life
- Reduced fuel economy
- Unsatisfactory ride
- Vehicle drift

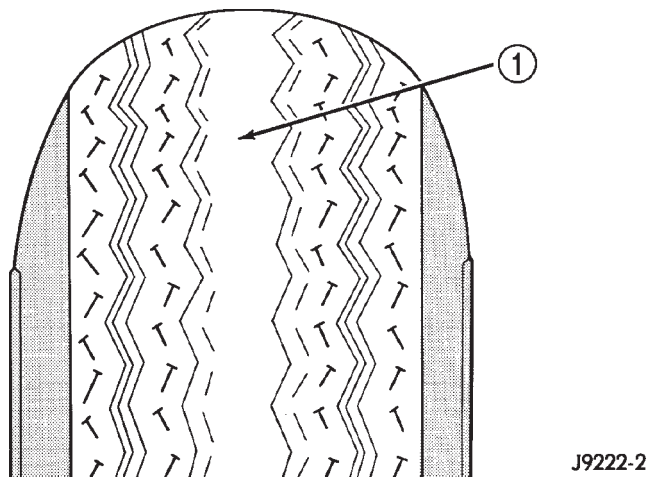
For proper tire pressure specification refer to the Tire Inflation Pressure Chart provided with the vehicles Owners Manual. A Certification Label on the drivers side door pillar provides the minimum tire and rim size for the vehicle. The label also list the cold inflation pressure for these tires at full load operation

## TIRES (Continued)



**Fig. 12 Under Inflation Wear**

1 - THIN TIRE THREAD AREAS



**Fig. 13 Over Inflation Wear**

1 - THIN TIRE THREAD AREA

Tire pressures have been chosen to provide safe operation, vehicle stability, and a smooth ride. Tire pressure should be checked cold once a month. Tire pressure decreases as the ambient temperature drops. Check tire pressure frequently when ambient temperature varies widely.

Tire inflation pressures are cold inflation pressure. The vehicle must sit for at least 3 hours to obtain the correct cold inflation pressure reading. Or be driven less than one mile after sitting for 3 hours. Tire inflation pressures may increase from 2 to 6 pounds per square inch (psi) during operation. Do not reduce this normal pressure build-up.

**WARNING: OVER OR UNDER INFLATED TIRES CAN AFFECT VEHICLE HANDLING AND TREAD WEAR. THIS MAY CAUSE THE TIRE TO FAIL SUDDENLY, RESULTING IN LOSS OF VEHICLE CONTROL.**

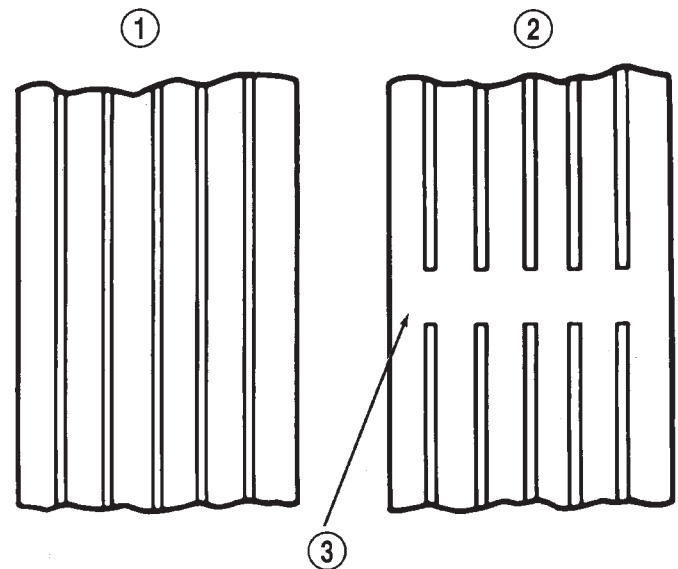
## DIAGNOSIS AND TESTING - PRESSURE GAUGES

A quality air pressure gauge is recommended to check tire pressure. After checking the air pressure, replace valve cap finger tight.

## DIAGNOSIS AND TESTING - TREAD WEAR INDICATORS

Tread wear indicators are molded into the bottom of the tread grooves. When tread depth is 1.6 mm (1/16 in.), the tread wear indicators will appear as a 13 mm (1/2 in.) band (Fig. 14).

Tire replacement is necessary when indicators appear in two or more grooves or if localized balding occurs.



**Fig. 14 Tread Wear Indicators**

- 1 - TREAD ACCEPTABLE  
2 - TREAD UNACCEPTABLE  
3 - WEAR INDICATOR

## DIAGNOSIS AND TESTING - TIRE WEAR PATTERNS



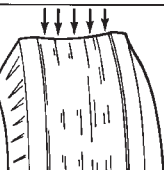

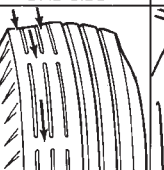
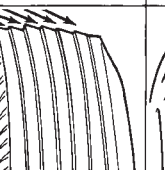


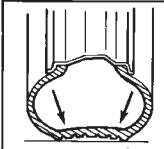
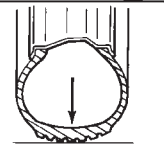
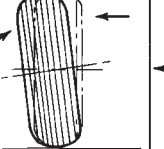
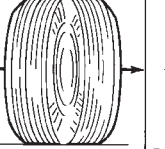
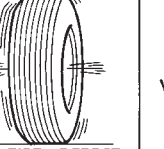
Under inflation will cause wear on the shoulders of tire. Over inflation will cause wear at the center of tire.

Excessive camber causes the tire to run at an angle to the road. One side of tread is then worn more than the other (Fig. 15).

Excessive toe-in or toe-out causes wear on the tread edges and a feathered effect across the tread (Fig. 15).



TIRES (Continued)

CONDITION	RAPID WEAR AT SHOULDERS	RAPID WEAR AT CENTER	CRACKED TREADS	WEAR ON ONE SIDE	FEATHERED EDGE	BALD SPOTS	SCALLOPED WEAR
EFFECT	 						
CAUSE	UNDER-INFLATION OR LACK OF ROTATION	OVER-INFLATION OR LACK OF ROTATION	UNDER-INFLATION OR EXCESSIVE SPEED*	EXCESSIVE CAMBER	INCORRECT TOE	UNBALANCED WHEEL	LACK OF ROTATION OF TIRES OR WORN OR OUT-OF-ALIGNMENT SUSPENSION.
							
CORRECTION	ADJUST PRESSURE TO SPECIFICATIONS WHEN TIRES ARE COOL ROTATE TIRES			ADJUST CAMBER TO SPECIFICATIONS	ADJUST TOE-IN TO SPECIFICATIONS	DYNAMIC OR STATIC BALANCE WHEELS	ROTATE TIRES AND INSPECT SUSPENSION SEE GROUP 2

\*HAVE TIRE INSPECTED FOR FURTHER USE.

RN797

Fig. 15 Tire Wear Patterns

DIAGNOSIS AND TESTING - TIRE NOISE OR VIBRATION

Radial-ply tires are sensitive to force impulses caused by improper mounting, vibration, wheel defects, or possibly tire imbalance.

To find out if tires are causing the noise or vibration, drive the vehicle over a smooth road at varying speeds. Note the noise level during acceleration and deceleration. The engine, differential and exhaust noises will change as speed varies, while the tire noise will usually remain constant.

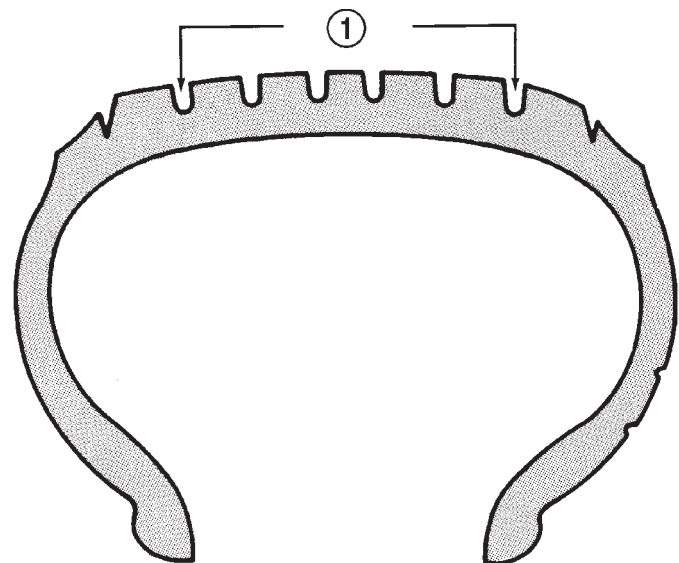
STANDARD PROCEDURES - REPAIRING LEAKS

For proper repairing, a radial tire must be removed from the wheel. Repairs should only be made if the defect, or puncture, is in the tread area (Fig. 16). The tire should be replaced if the puncture is located in the sidewall.

Deflate tire completely before removing the tire from the wheel. Use lubrication such as a mild soap solution when dismounting or mounting tire. Use tools free of burrs or sharp edges which could damage the tire or wheel rim.

Before mounting tire on wheel, make sure all rust is removed from the rim bead and repaint if necessary.

Install wheel on vehicle, and tighten to proper torque specification, (Refer to 22 - TIRES/WHEELS/WHEELS - SPECIFICATIONS).



J8922-6

Fig. 16 Tire Repair Area

1 - REPAIRABLE AREA

TIRES (Continued)

SPECIFICATIONS

TIRE REVOLUTIONS PER MILE

TIRE SIZE	SUPPLIER	REVOLUTIONS PER MILE
P225/75/R16 XL	GOODYEAR	716
P245/75R16 WRT/S	GOODYEAR	692
P245/75R16 LTX A/S	MICHELIN	691
P265/75R16 WRT/S	GOODYEAR	668
LT245/75R16 LTX A/S	MICHELIN	679
LT245/75R16 LTX M/S	MICHELIN	678
LT265/75R16 LTX A/S	MICHELIN	648
LT265/75R16 LTX M/S	MICHELIN	652
LT275/70R17 WGS A	GOODYEAR	650
LT235/85R16 WAP	GOODYEAR	650
LT235/85R16 LTX M/S	MICHELIN	650

SPARE TIRE

DESCRIPTION

The temporary spare tire is designed for emergency use only. The original tire should be repaired or replaced at the first opportunity, then reinstalled. Do not exceed speeds of 50 M.P.H. when using the temporary spare tire. Refer to Owner's Manual for complete details.

WHEELS

DESCRIPTION

Original equipment wheels are designed for the specified Maximum Vehicle Capacity.

All models use steel or cast aluminum drop center wheels.

Cast aluminum wheels require special balance weights and alignment equipment.

Ram Truck Models equipped with dual rear wheels have eight-stud hole rear wheels. The wheels have a flat mounting surface (Fig. 17). The slots in the wheel must be aligned to provide access to the valve stem (Fig. 18).

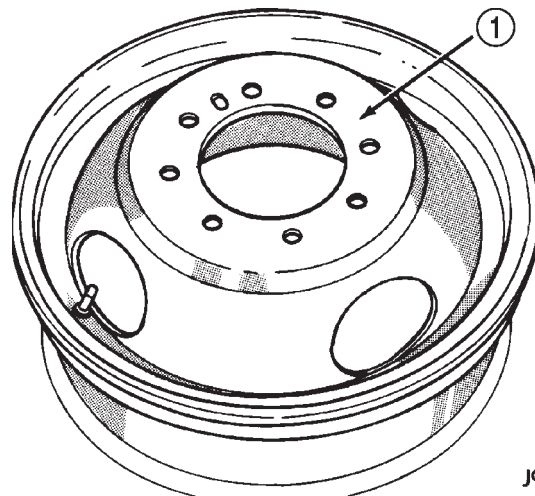
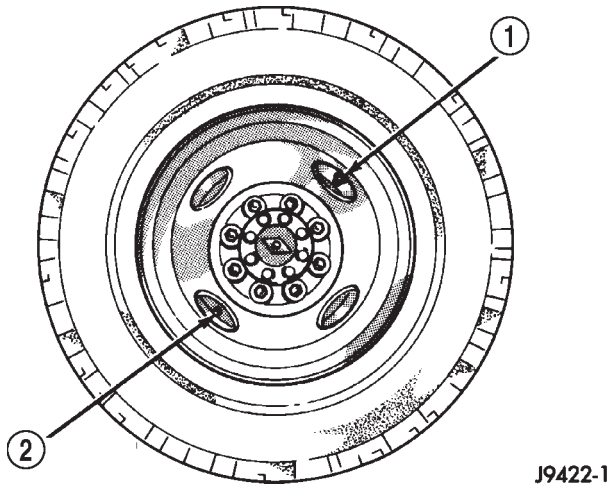


Fig. 17 Flat Face Wheel

1 - FLAT FACE

## WHEELS (Continued)



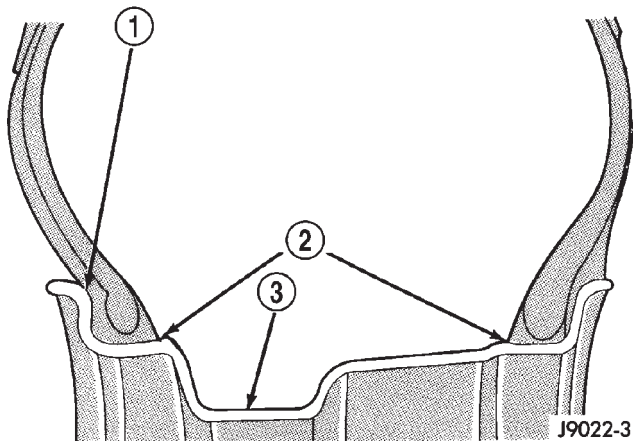
J9422-1

**Fig. 18 Dual Rear Wheels**

- 1 - INBOARD WHEEL VALVE STEM  
2 - OUTBOARD WHEEL VALVE STEM

**OPERATION**

The wheel (Fig. 19) has raised sections between the rim flanges and the rim well. Initial inflation of the tire forces the bead over these raised sections. In case of tire failure, the raised sections hold the tire in position on the wheel until the vehicle can be brought to a safe stop.



J9022-3

**Fig. 19 Safety Rim**

- 1 - FLANGE  
2 - RIDGE  
3 - WELL

**DIAGNOSIS AND TESTING - WHEEL INSPECTION**

Inspect wheels for:

- Excessive run out
- Dents or cracks
- Damaged wheel lug nut holes
- Air Leaks from any area or surface of the rim

**NOTE:** Do not attempt to repair a wheel by hammering, heating or welding.

If a wheel is damaged an original equipment replacement wheel should be used. When obtaining replacement wheels, they should be equivalent in load carrying capacity. The diameter, width, offset, pilot hole and bolt circle of the wheel should be the same as the original wheel.

**WARNING:** FAILURE TO USE EQUIVALENT REPLACEMENT WHEELS MAY ADVERSELY AFFECT THE SAFETY AND HANDLING OF THE VEHICLE. USED WHEELS ARE NOT RECOMMENDED. THE SERVICE HISTORY OF THE WHEEL MAY HAVE INCLUDED SEVERE TREATMENT OR VERY HIGH MILEAGE. THE RIM COULD FAIL WITHOUT WARNING.

**STANDARD PROCEDURE - DUAL REAR WHEEL INSTALLATION**

Dual rear wheels use a special heavy duty lug nut wrench. It is recommended to remove and install dual rear wheels only when the proper wrench is available. The wrench is also use to remove wheel center caps for more information refer to Owner's Manual.

The tires on both wheels must be completely raised off the ground when tightening the lug nuts. This will ensure correct wheel centering and maximum wheel clamping.

A two piece flat face lug nut with right-hand threads is used for retaining the wheels on the hubs (Fig. 20).

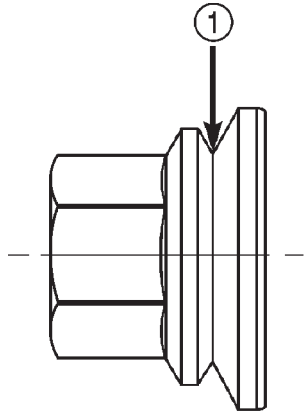
The dual rear wheel lug nuts should be tightened according to the following procedure:

- Place two drops of oil to the interface of the nut/washer (Fig. 20) before installing on the wheel stud.

**NOTE:** Do not use more then two drops of oil on the nut/washer, since the center caps attach in this area.

- Tighten the wheel lug nuts in the numbered sequential pattern until they are snug tight. Then tighten lug nut to specified torque following same number sequence, (Refer to 22 - TIRES/WHEELS/WHEELS - SPECIFICATIONS).

WHEELS (Continued)



80a410f9

**Fig. 20 Oil Location**

1 - PLACE TWO DROPS OF OIL HERE

- Tighten lug nuts in same numbered sequence a second time to the specified torque. This will ensure that the wheels are thoroughly mated.

SPECIFICATIONS

TORQUE CHART

TORQUE SPECIFICATIONS

DESCRIPTION	N-m	Ft. Lbs.	In. Lbs.
Lug Nut BR1500 (5 Stud Wheel)	130	95	—
Lug Nut BR2500 (8 Stud Wheel)	180	135	—
Lug Nut BR3500 (8 Stud Dual Wheel)	195	145	—

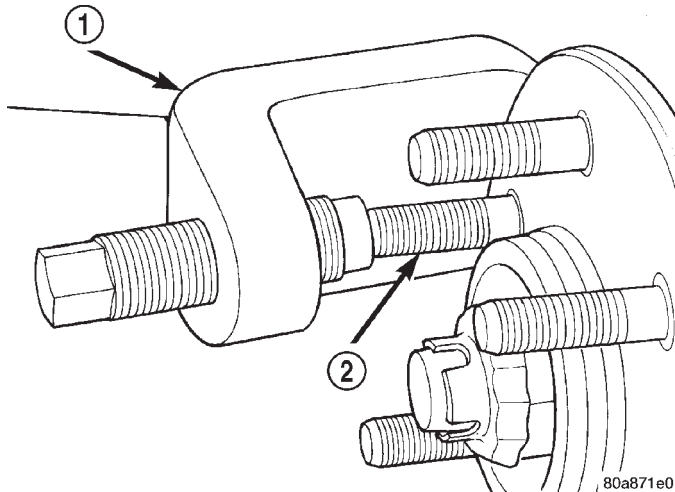
- Check lug nut specified torque after 100 miles (160 kilometers). Also after 500 miles (800 kilometers) of vehicle operation.

**NOTE:** Wheel lug nuts should be tightened to specified torque at every maintenance interval thereafter.

## STUDS

### REMOVAL

- (1) Raise and support the vehicle.
- (2) Remove the wheel and tire assembly.
- (3) Remove the brake caliper, caliper adapter and rotor, (Refer to 5 - BRAKES/HYDRAULIC/MECHANICAL/ROTORS - REMOVAL).
- (4) Remove the stud from the hub with Remover C-4150A (Fig. 21).



**Fig. 21 Wheel Stud Removal**

- 1 - REMOVER  
2 - WHEEL STUD

### INSTALLATION

- (1) Install the new stud into the hub flange.
- (2) Install the three washers onto the stud, then install the lug nut with the flat side of the nut against the washers.
- (3) Tighten the lug nut until the stud is pulled into the hub flange. Verify that the stud is properly seated into the flange.
- (4) Remove the lug nut and washers.
- (5) Install the brake rotor, caliper adapter, and caliper, (Refer to 5 - BRAKES/HYDRAULIC/MECHANICAL/ROTORS - INSTALLATION).
- (6) Install the wheel and tire assembly, (Refer to 22 - TIRES/WHEELS/WHEELS - STANDARD PROCEDURE), use new the lug nut on stud or studs that were replaced.
- (7) Remove the support and lower vehicle.

## WHEEL COVER

### REMOVAL

- (1) Insert a hub/cap remover/installer combination tool around the circumference of the wheel between the wheel and wheel trim cover.
- (2) Twist the tool to remove wheel trim cover.

### INSTALLATION - REAR

- (1) Install one 1 1/2 in. valve stem extension on each rear inner wheel.

**NOTE:** A 3/8 in. drive 10mm deep wheel socket with a 10 in. or greater extension can be used to remove the existing valve stem cap and install the extension.

- (2) Install one 1 in. valve stem extension on each outer wheel.

(3) Align the cooling windows of the wheel skin with the cooling windows of the wheel. Seat one side of the wheel skin's retainer onto the wheel. Using a rubber mallet, strike the wheel skin on the outer circumference. Strike at several locations around the circumference until the skin is fully seated.

**NOTE:** The wheel skin and the hub cap are fully seated when there is a consistent gap between the skin/cap and the wheel.

- (4) Tug on the hub/cap wheel skin to ensure that they are properly installed.

### INSTALLATION - FRONT

- (1) Align the valve stem with the notch in the wheel skin.
- (2) Seat on side of the wheel skin's wire retainer on to the wheel.
- (3) Using a rubber mallet, strike the opposite side of the wheel skin until the skin is properly seated.

**NOTE:** The wheel skin and the hub cap are fully seated when there is a consistent gap between the skin/ cap and the wheel.

- (4) Tug on the hub cap/wheel skin to ensure that they are properly installed.



# BODY

## TABLE OF CONTENTS

	page		page
<b>BODY</b>		<b>DOOR - CARGO</b>	77
DESCRIPTION	1	<b>EXTERIOR</b>	86
WARNING	1	<b>HOOD</b>	99
DIAGNOSIS AND TESTING	2	<b>INSTRUMENT PANEL SYSTEM</b>	104
WATER LEAKS	2	<b>INTERIOR</b>	118
WIND NOISE	3	<b>PAINT</b>	129
SPECIFICATIONS	4	<b>SEATS</b>	131
<b>DECKLID/HATCH/LIFTGATE/TAILGATE</b>	62	<b>STATIONARY GLASS</b>	145
<b>DOOR - FRONT</b>	67	<b>WEATHERSTRIP/SEALS</b>	152

## BODY

### DESCRIPTION – PUSH-IN FASTENERS

DaimlerChrysler Corporation uses many different types of push-in fasteners to secure the interior and exterior trim to the body. Most of these fasteners can be reused to assemble the trim during various repair procedures. At times, a push-in fastener cannot be removed without damaging the fastener or the component it is holding. If it is not possible to remove a fastener without damaging a component or body, cut or break the fastener and use a new one when installing the component. Never pry or pound on a plastic or pressed-board trim component. Using a suitable fork-type prying device, pry the fastener from the retaining hole behind the component being removed. When installing, verify fastener alignment with the retaining hole by hand. Push directly on or over the fastener until it seats. Apply a low-force pull to the panel to verify that it is secure.

When it is necessary to remove components to service another, it should not be necessary to apply excessive force or bend a component to remove it. Before damaging a trim component, verify hidden fasteners or captured edges holding the component in place.

### DESCRIPTION – LOCK CYLINDERS

Ignition, door, deck lid, and rear hatch lock cylinders are all codable to the key. Lock barrels, tumblers, and tumbler springs are available to allow the technician to change replacement locks cylinders to match the customer's original key set. See the appropriate section in this manual for lock cylinder removal. See the Mopar® catalogue for part numbers and lock coding procedures.

## SAFETY PRECAUTIONS AND WARNINGS

**WARNING: USE A OSHA APPROVED BREATHING FILTER WHEN SPRAYING PAINT OR SOLVENTS IN A CONFINED AREA. PERSONAL INJURY CAN RESULT.**

**AVOID PROLONGED SKIN CONTACT WITH PETROLEUM OR ALCOHOL – BASED CLEANING SOLVENTS. PERSONAL INJURY CAN RESULT.**

**DO NOT STAND UNDER A HOISTED VEHICLE THAT IS NOT PROPERLY SUPPORTED ON SAFETY STANDS. PERSONAL INJURY CAN RESULT.**

**CAUTION: When holes must be drilled or punched in an inner body panel, verify depth of space to the outer body panel, electrical wiring, or other components. Damage to vehicle can result.**

**Do not weld exterior panels unless combustible material on the interior of vehicle is removed from the repair area. Fire or hazardous conditions, can result.**

**Always have a fire extinguisher ready for use when welding.**

**Disconnect the negative (-) cable clamp from the battery when servicing electrical components that are live when the ignition is OFF. Damage to electrical system can result.**

**Do not use abrasive chemicals or compounds on painted surfaces. Damage to finish can result.**

**Do not use harsh alkaline based cleaning solvents on painted or upholstered surfaces. Damage to finish or color can result.**

**Do not hammer or pound on plastic trim panel when servicing interior trim. Plastic panels can break.**

## BODY (Continued)

**DIAGNOSIS AND TESTING – WATER LEAKS**

Water leaks can be caused by poor sealing, improper body component alignment, body seam porosity, missing plugs, or blocked drain holes. Centrifugal and gravitational force can cause water to drip from a location away from the actual leak point, making leak detection difficult. All body sealing points should be water tight in normal wet-driving conditions. Water flowing downward from the front of the vehicle should not enter the passenger or luggage compartment. Moving sealing surfaces will not always seal water tight under all conditions. At times, side glass or door seals will allow water to enter the passenger compartment during high pressure washing or hard driving rain (severe) conditions. Overcompensating on door or glass adjustments to stop a water leak that occurs under severe conditions can cause premature seal wear and excessive closing or latching effort. After completing a repair, water test vehicle to verify leak has stopped before returning vehicle to use.

**VISUAL INSPECTION BEFORE WATER LEAK TESTS**

Verify that floor and body plugs are in place, body drains are clear, and body components are properly aligned and sealed. If component alignment or sealing is necessary, refer to the appropriate section of this group for proper procedures.

**WATER LEAK TESTS**

**WARNING: DO NOT USE ELECTRIC SHOP LIGHTS OR TOOLS IN WATER TEST AREA. PERSONAL INJURY CAN RESULT.**

When the conditions causing a water leak have been determined, simulate the conditions as closely as possible.

- If a leak occurs with the vehicle parked in a steady light rain, flood the leak area with an open-ended garden hose.
- If a leak occurs while driving at highway speeds in a steady rain, test the leak area with a reasonable velocity stream or fan spray of water. Direct the spray in a direction comparable to actual conditions.
- If a leak occurs when the vehicle is parked on an incline, hoist the end or side of the vehicle to simulate this condition. This method can be used when the leak occurs when the vehicle accelerates, stops or turns. If the leak occurs on acceleration, hoist the front of the vehicle. If the leak occurs when braking, hoist the back of the vehicle. If the leak occurs on left turns, hoist the left side of the vehicle. If the leak occurs on right turns, hoist the right side of the vehicle. For hoisting recommendations refer to Group 0, Lubrication and Maintenance, General Information section.

**WATER LEAK DETECTION**

To detect a water leak point-of-entry, do a water test and watch for water tracks or droplets forming on the inside of the vehicle. If necessary, remove interior trim covers or panels to gain visual access to the leak area. If the hose cannot be positioned without being held, have someone help do the water test.

Some water leaks must be tested for a considerable length of time to become apparent. When a leak appears, find the highest point of the water track or drop. The highest point usually will show the point of entry. After leak point has been found, repair the leak and water test to verify that the leak has stopped.

Locating the entry point of water that is leaking into a cavity between panels can be difficult. The trapped water may splash or run from the cavity, often at a distance from the entry point. Most water leaks of this type become apparent after accelerating, stopping, turning, or when on an incline.

**MIRROR INSPECTION METHOD**

When a leak point area is visually obstructed, use a suitable mirror to gain visual access. A mirror can also be used to deflect light to a limited-access area to assist in locating a leak point.

**BRIGHT LIGHT LEAK TEST METHOD**

Some water leaks in the luggage compartment can be detected without water testing. Position the vehicle in a brightly lit area. From inside the darkened luggage compartment inspect around seals and body seams. If necessary, have a helper direct a drop light over the suspected leak areas around the luggage compartment. If light is visible through a normally sealed location, water could enter through the opening.

**PRESSURIZED LEAK TEST METHOD**

When a water leak into the passenger compartment cannot be detected by water testing, pressurize the passenger compartment and soap test exterior of the vehicle. To pressurize the passenger compartment, close all doors and windows, start engine, and set heater control to high blower in HEAT position. If engine can not be started, connect a charger to the battery to ensure adequate voltage to the blower. With interior pressurized, apply dish detergent solution to suspected leak area on the exterior of the vehicle. Apply detergent solution with spray device or soft bristle brush. If soap bubbles occur at a body seam, joint, seal or gasket, the leak entry point could be at that location.

## BODY (Continued)

**DIAGNOSIS AND TESTING – WIND NOISE**

Wind noise is the result of most air leaks. Air leaks can be caused by poor sealing, improper body component alignment, body seam porosity, or missing plugs in the engine compartment or door hinge pillar areas. All body sealing points should be airtight in normal driving conditions. Moving sealing surfaces will not always seal airtight under all conditions. At times, side glass or door seals will allow wind noise to be noticed in the passenger compartment during high cross winds. Over compensating on door or glass adjustments to stop wind noise that occurs under severe conditions can cause premature seal wear and excessive closing or latching effort. After a repair procedure has been performed, test vehicle to verify noise has stopped before returning vehicle to use.

Wind noise can also be caused by improperly fitted exterior moldings or body ornamentation. Loose moldings can flutter, creating a buzzing or chattering noise. An open cavity or protruding edge can create a whistling or howling noise. Inspect the exterior of the vehicle to verify that these conditions do not exist.

**VISUAL INSPECTION BEFORE TESTS**

Verify that floor and body plugs are in place and body components are aligned and sealed. If compo-

nent alignment or sealing is necessary, refer to the appropriate section of this group for proper procedures.

**ROAD TESTING WIND NOISE**

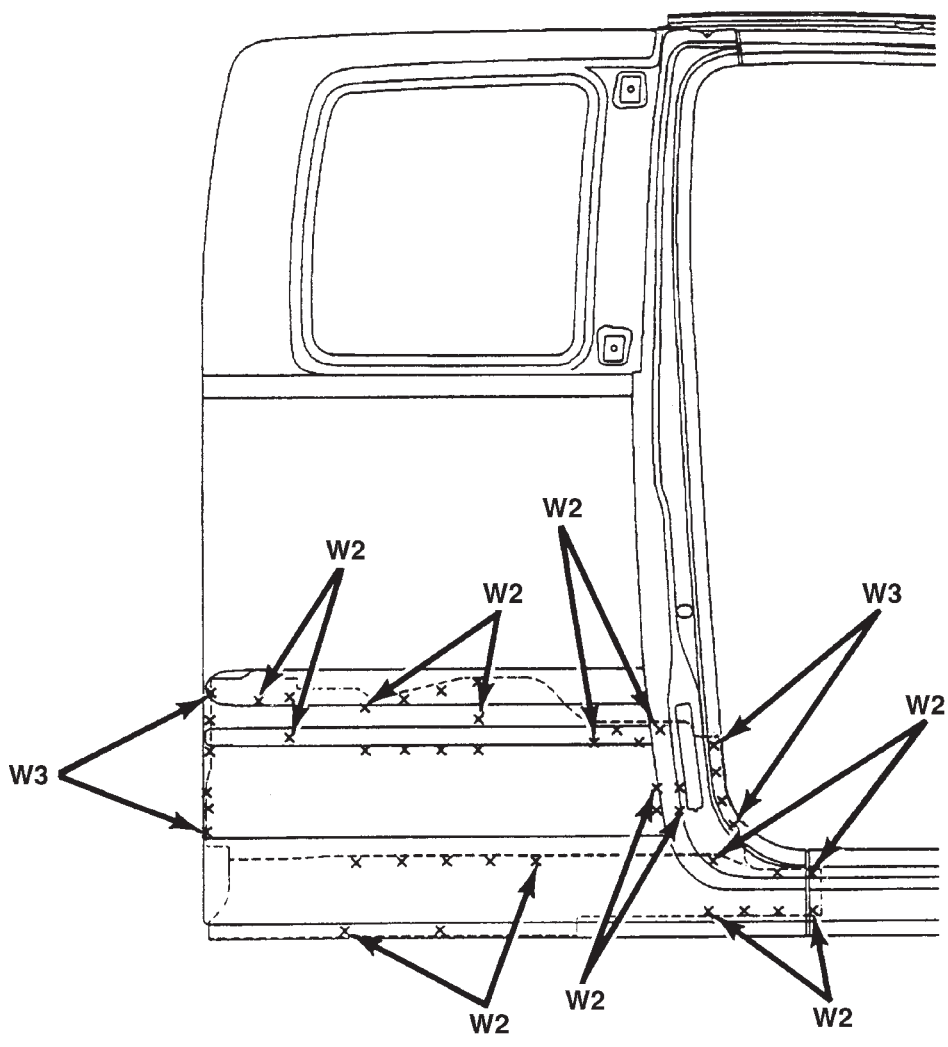
(1) Drive the vehicle to verify the general location of the wind noise.

(2) Apply 50 mm (2 in.) masking tape in 150 mm (6 in.) lengths along weatherstrips, weld seams or moldings. After each length is applied, drive the vehicle. If noise goes away after a piece of tape is applied, remove tape, locate, and repair defect.

**POSSIBLE CAUSE OF WIND NOISE**

- Moldings standing away from body surface can catch wind and whistle.
- Gaps in sealed areas behind overhanging body flanges can cause wind-rushing sounds.
- Misaligned movable components.
- Missing or improperly installed plugs in pillars.
- Weld burn through holes.

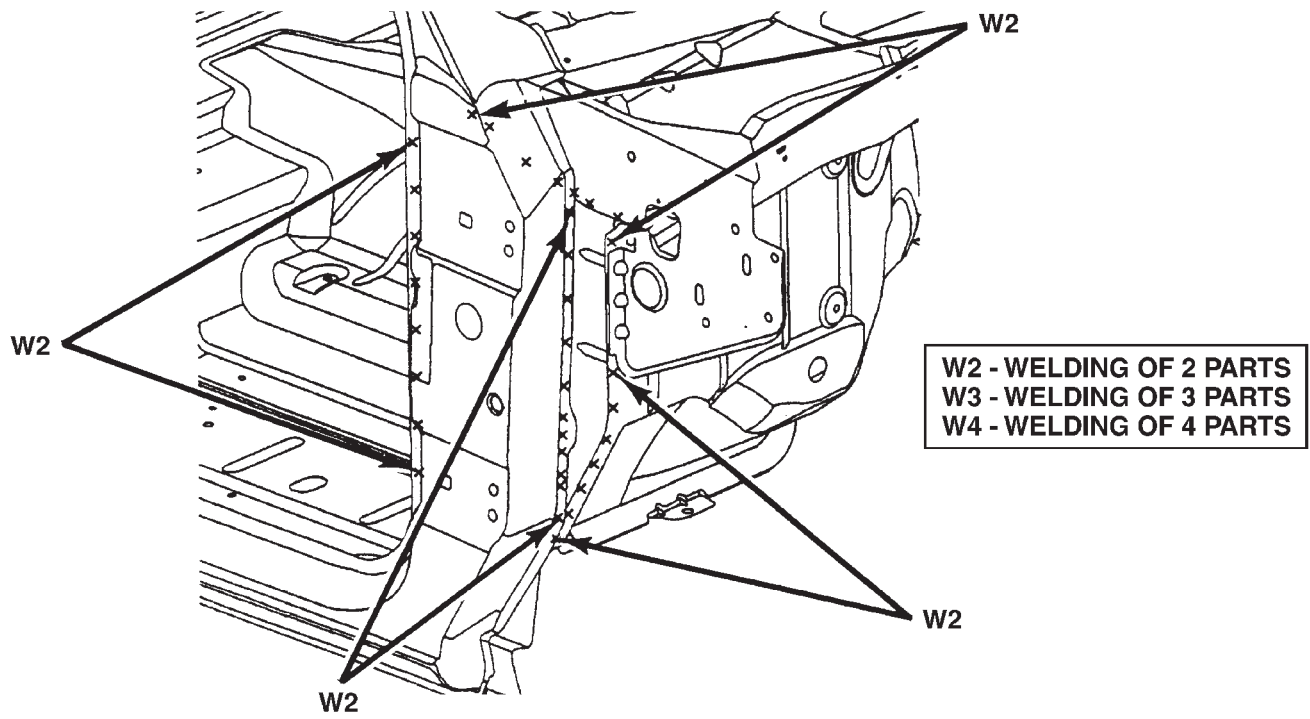
BODY (Continued)  
SPECIFICATIONS  
WELD LOCATIONS



W2 - WELDING OF 2 PARTS  
W3 - WELDING OF 3 PARTS  
W4 - WELDING OF 4 PARTS

**BODY SIDE APERTURE — CLUB CAB**

BODY (Continued)

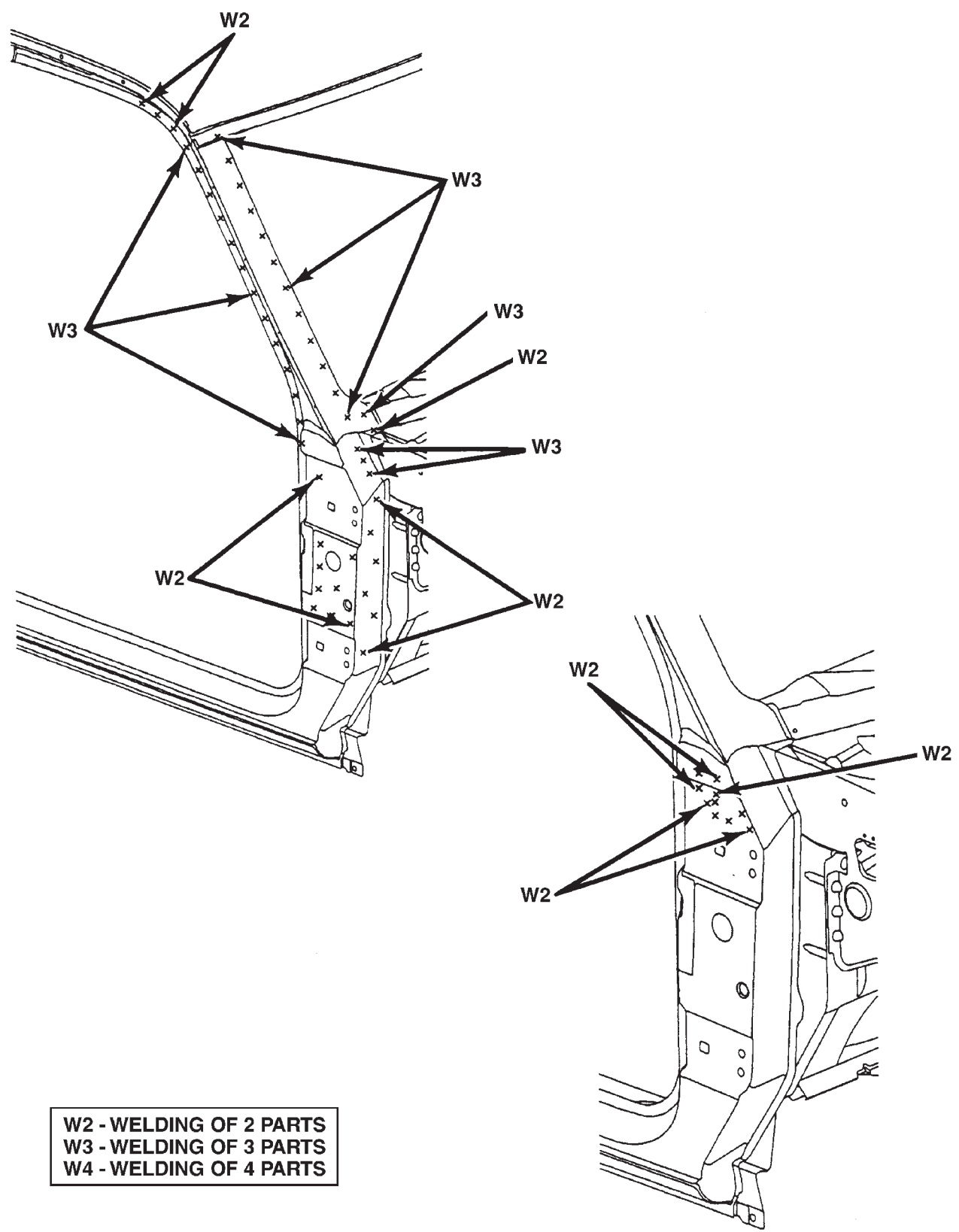


80b62af3

**BODY SIDE APERTURE — QUAD CAB**



BODY (Continued)

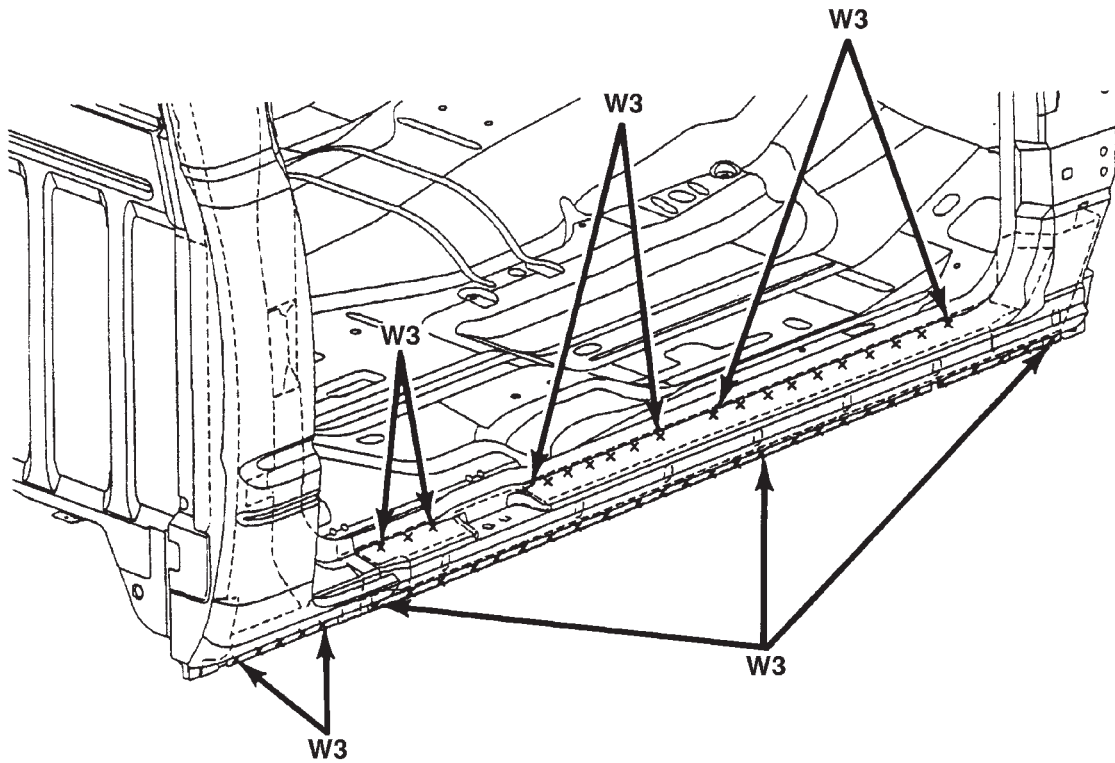
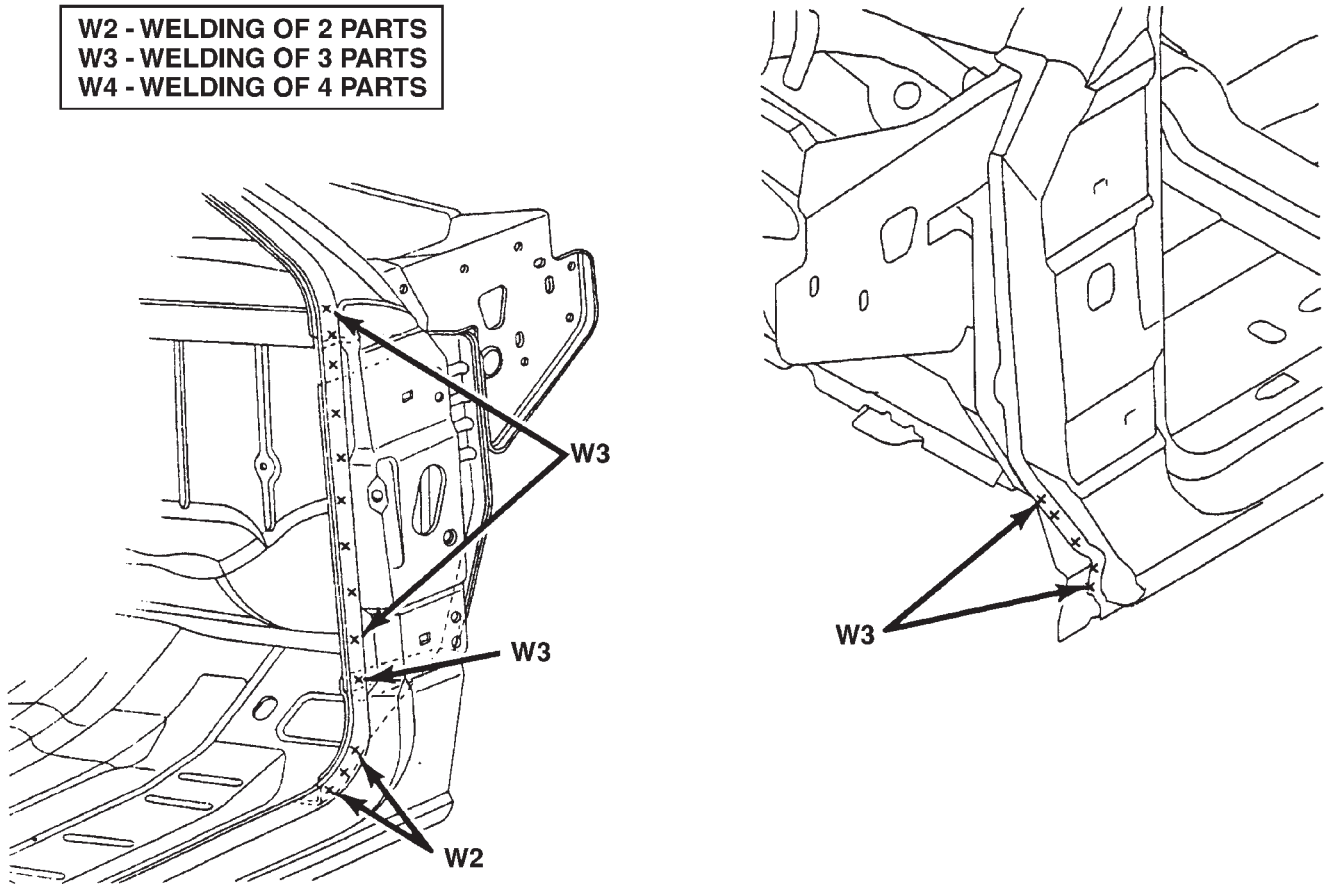


W2 - WELDING OF 2 PARTS  
W3 - WELDING OF 3 PARTS  
W4 - WELDING OF 4 PARTS

BODY SIDE APERTURE — QUAD CAB

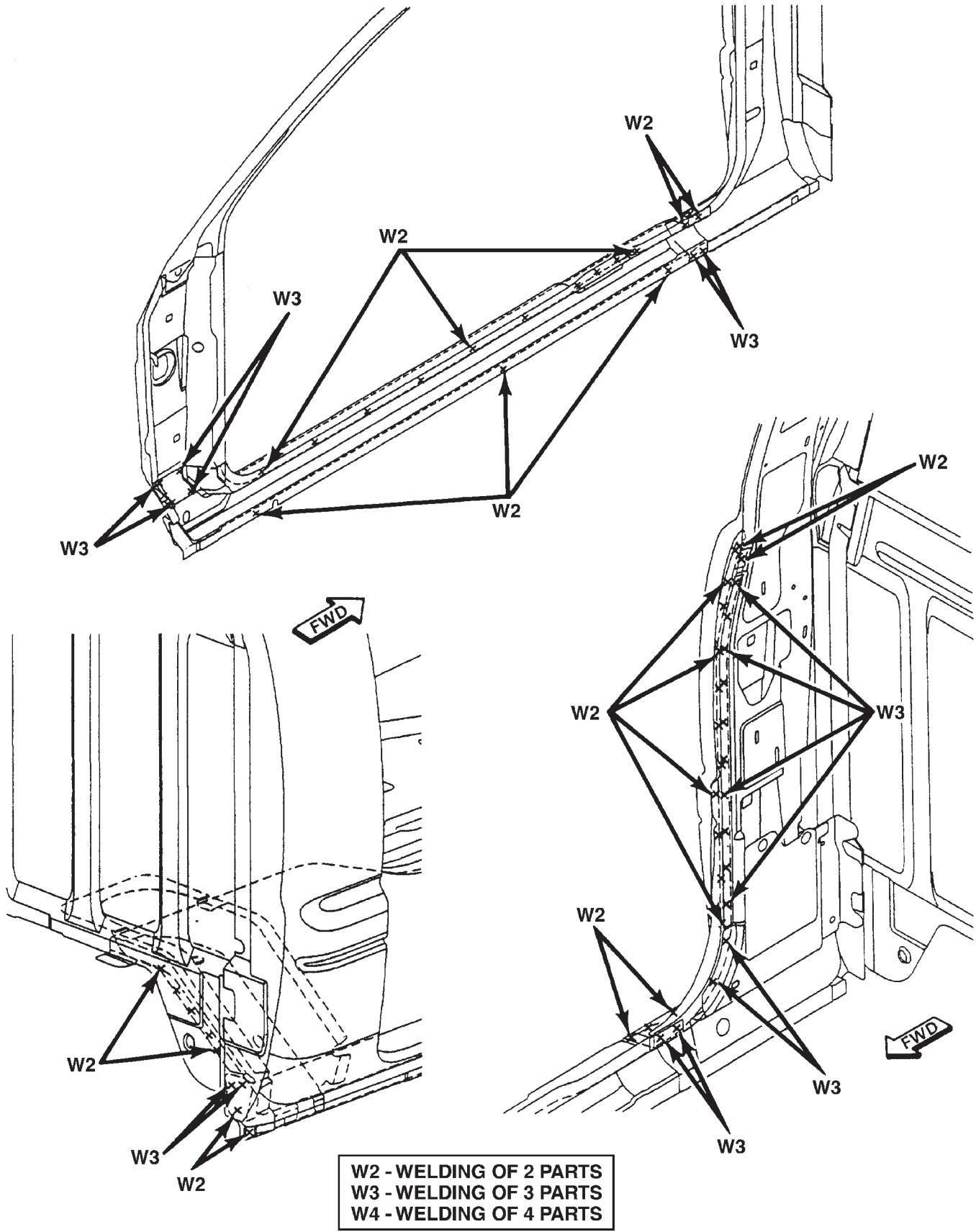
BODY (Continued)

W2 - WELDING OF 2 PARTS  
W3 - WELDING OF 3 PARTS  
W4 - WELDING OF 4 PARTS



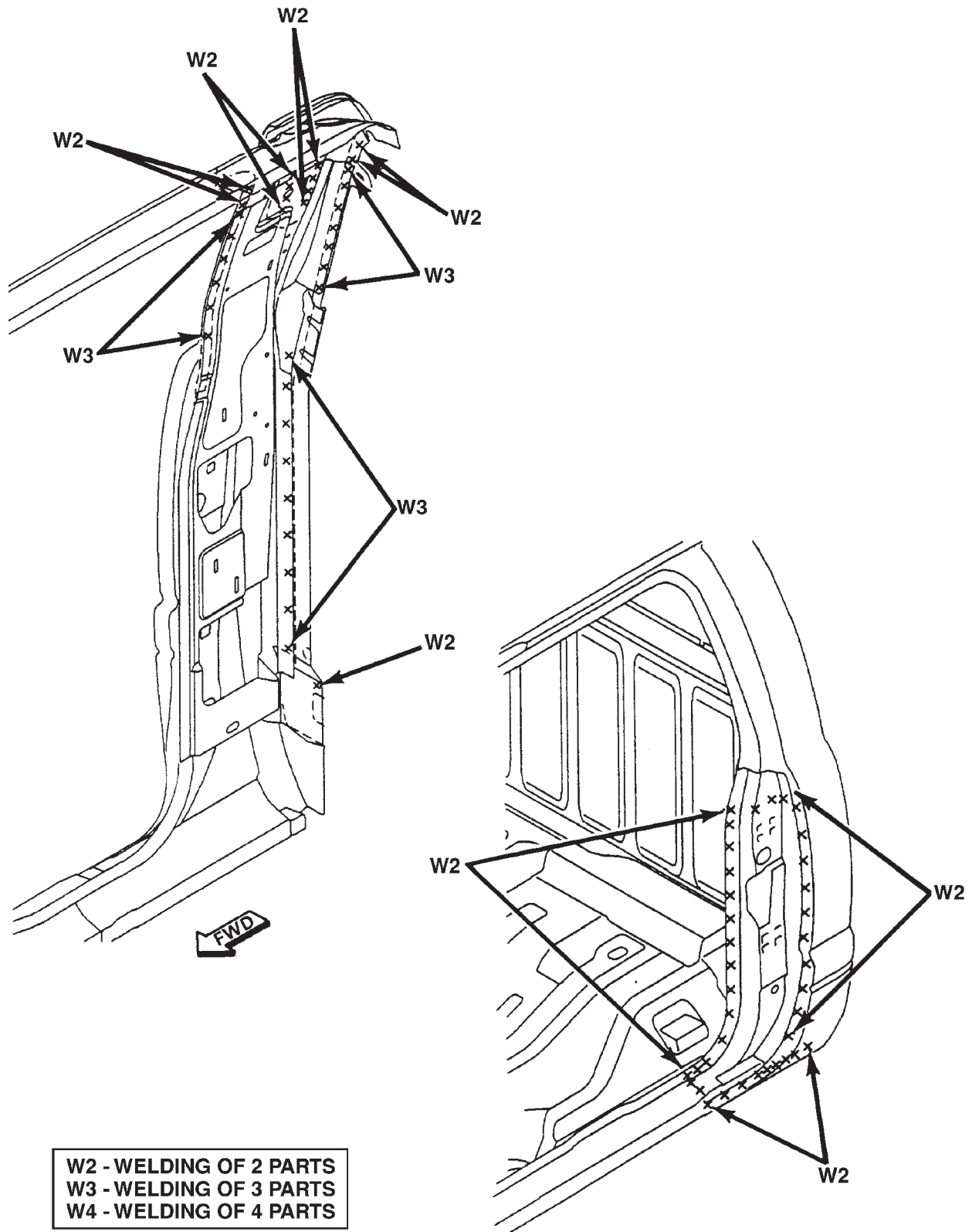
BODY SIDE APERTURE — QUAD CAB

BODY (Continued)



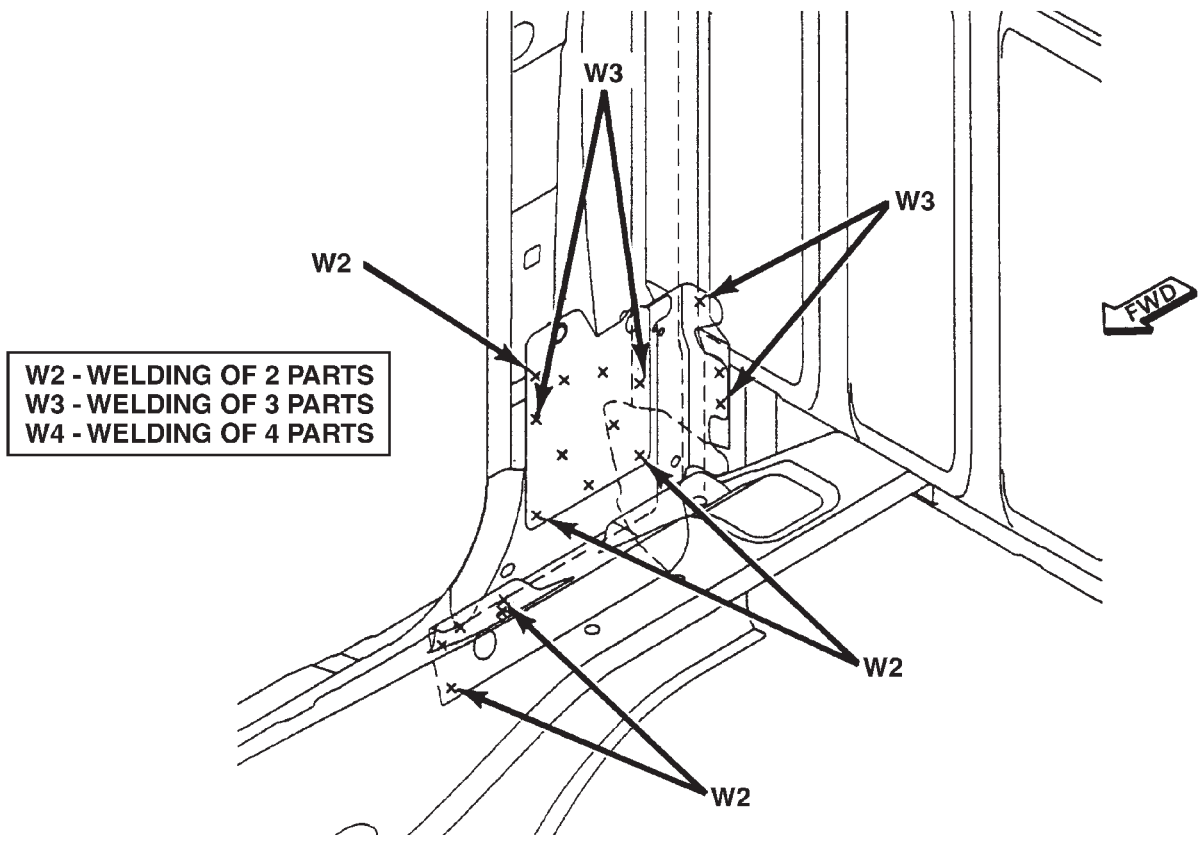
BODY SIDE APERTURE — QUAD CAB

BODY (Continued)



BODY SIDE APERTURE — QUAD CAB

BODY (Continued)

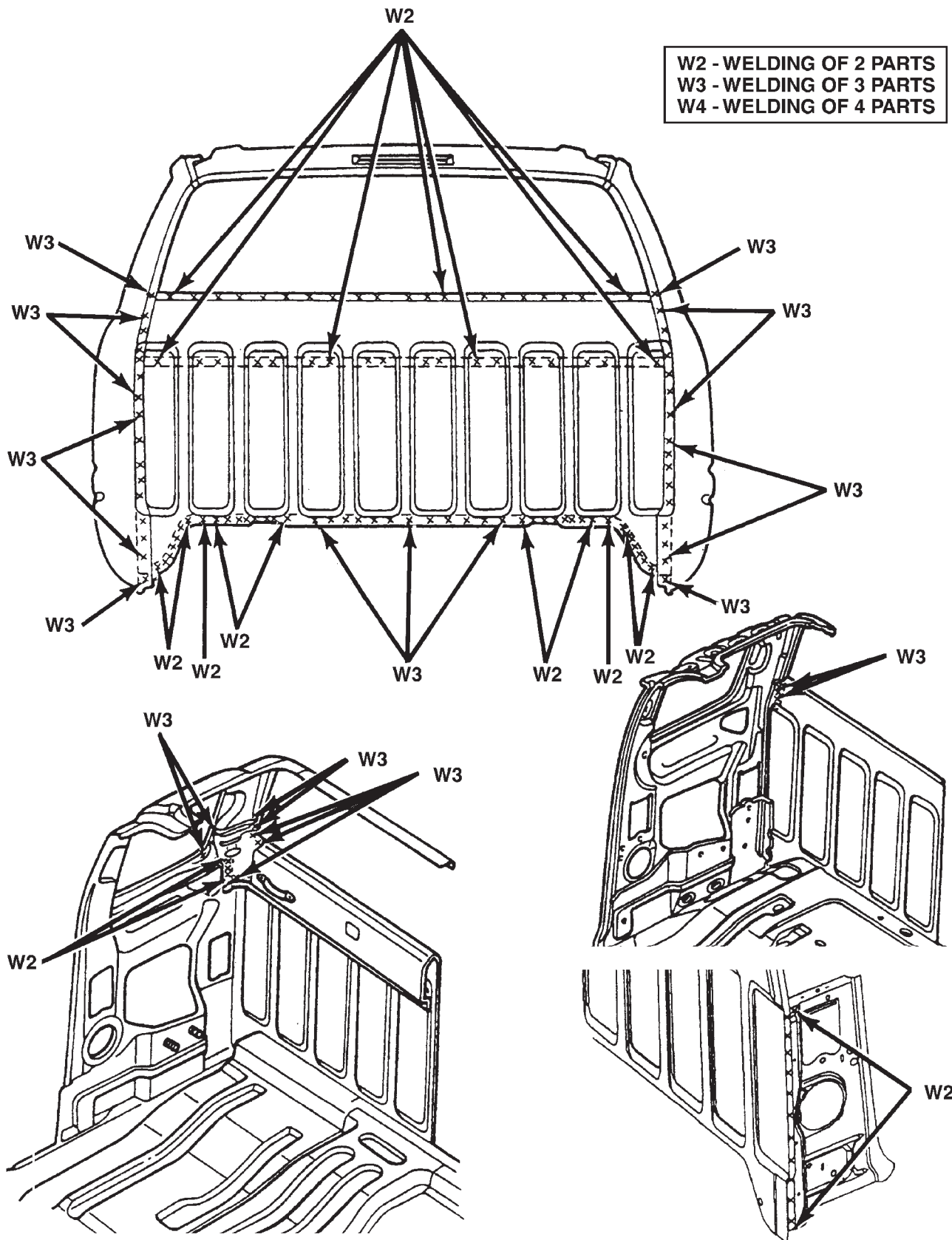


**BODY SIDE APERTURE — QUAD CAB**

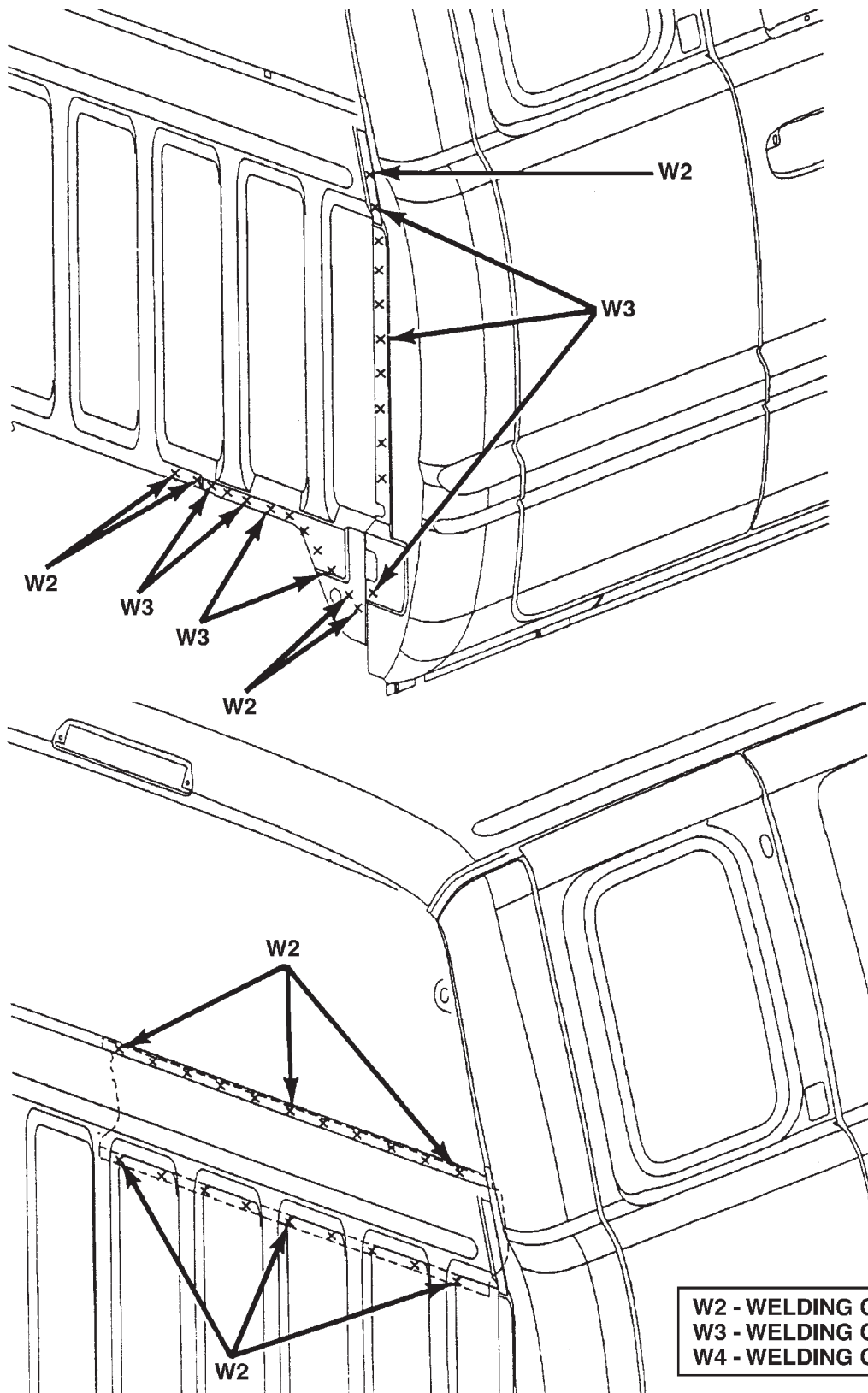
80b62af8



BODY (Continued)

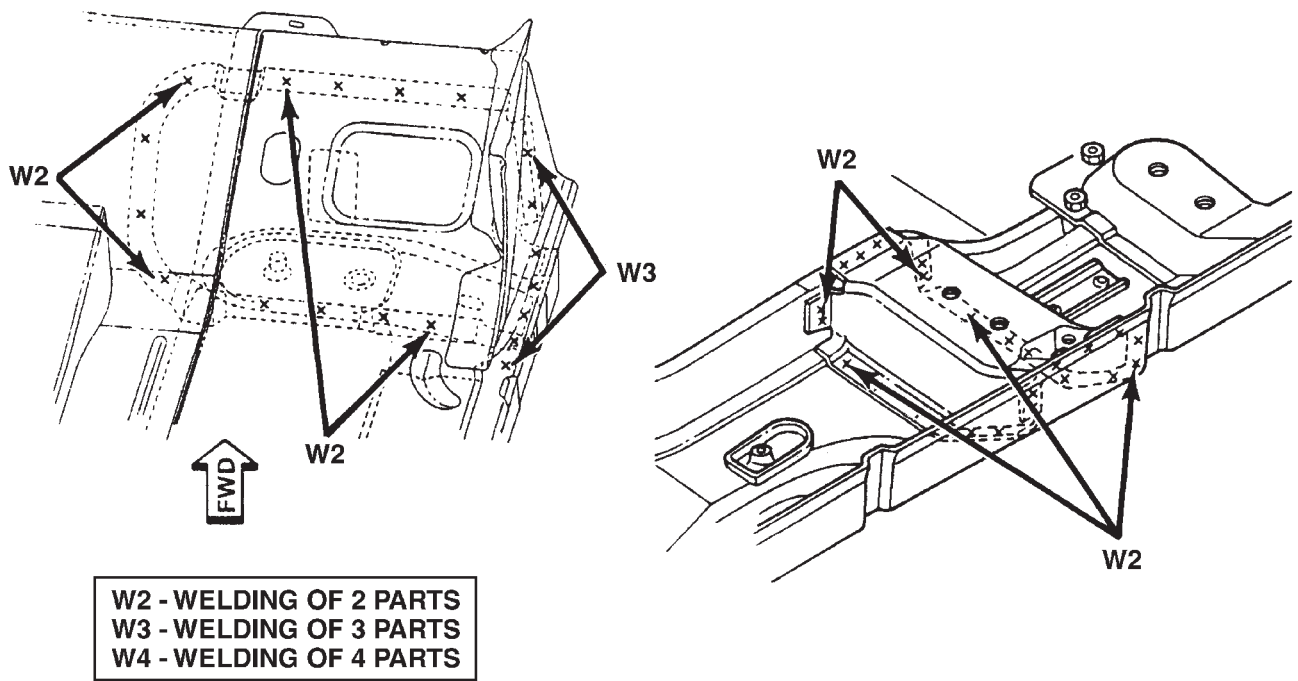


CAB BACK PANEL — CLUB CAB



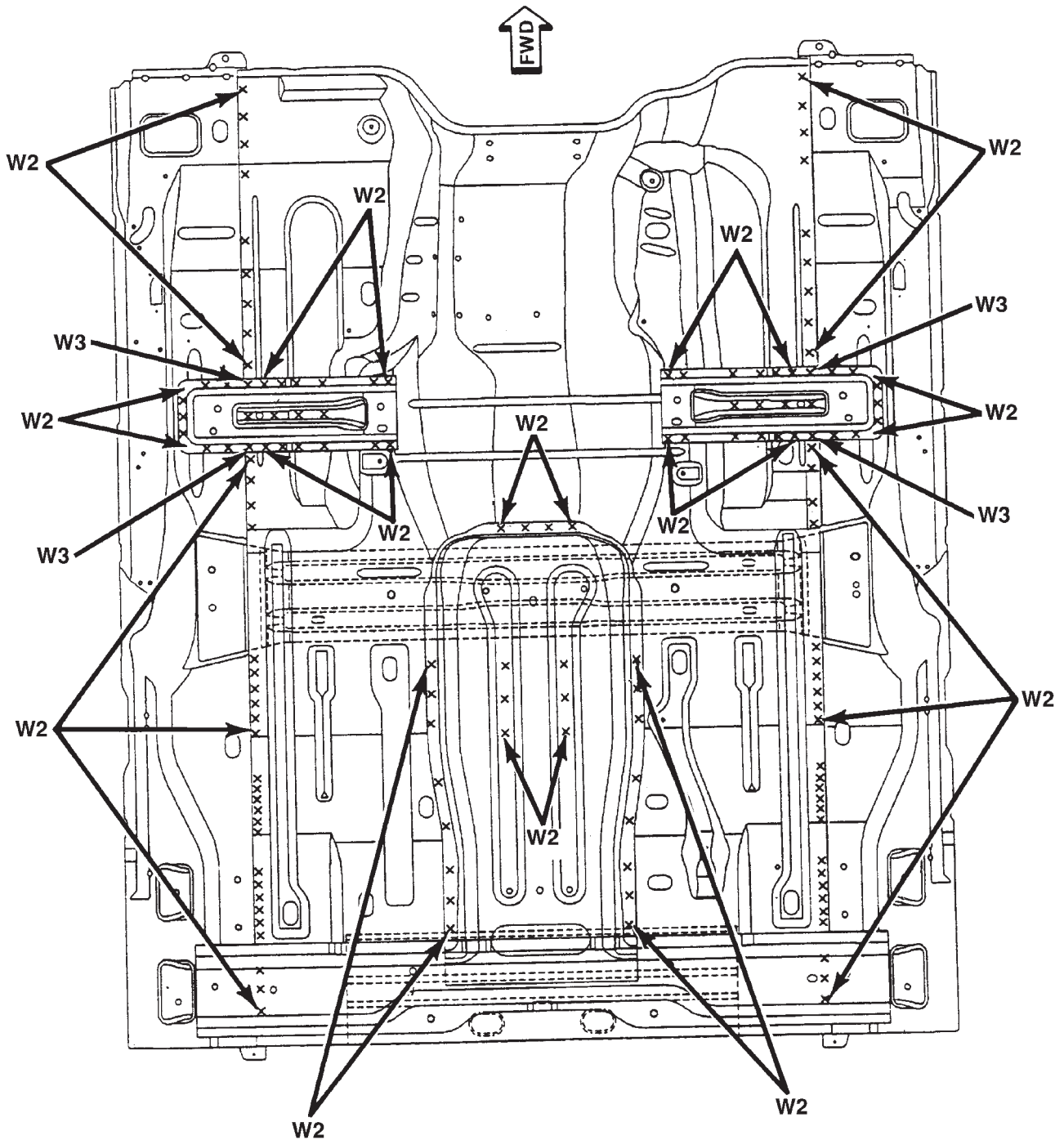
**CAB BACK PANEL — QUAD CAB**

BODY (Continued)



80b62b02

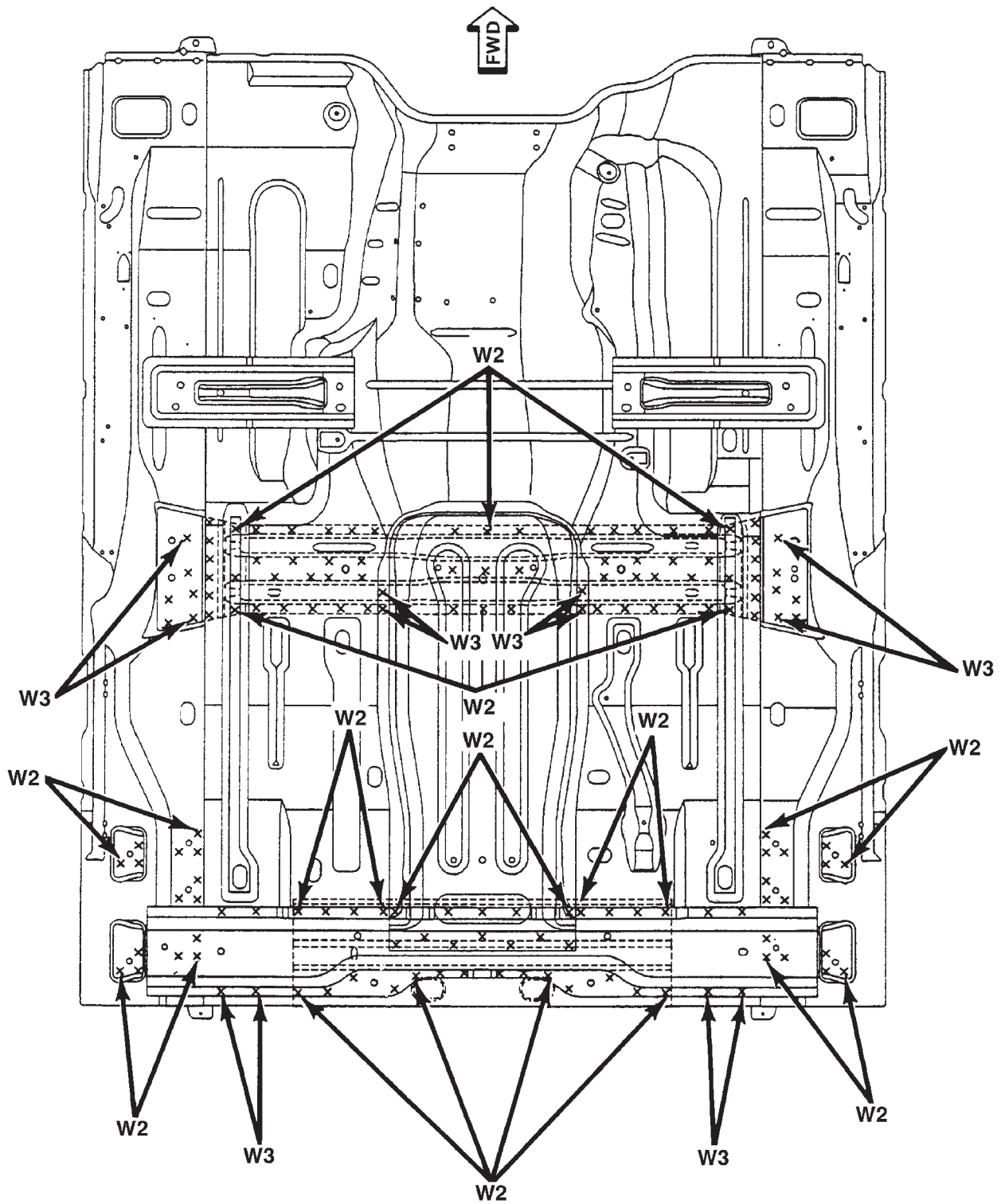
**FLOOR PAN — CLUB CAB**



W2 - WELDING OF 2 PARTS  
W3 - WELDING OF 3 PARTS  
W4 - WELDING OF 4 PARTS

FLOOR PAN — CLUB CAB

BODY (Continued)

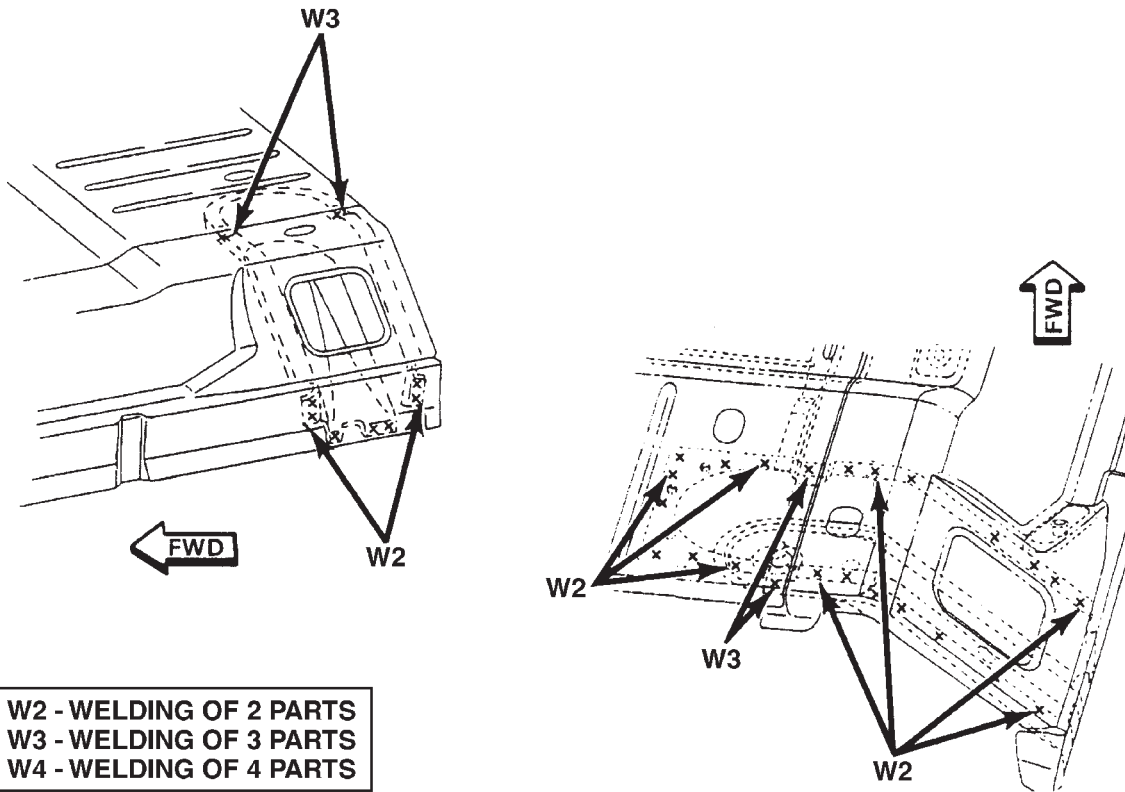


W2 - WELDING OF 2 PARTS  
W3 - WELDING OF 3 PARTS  
W4 - WELDING OF 4 PARTS

FLOOR PAN — CLUB CAB



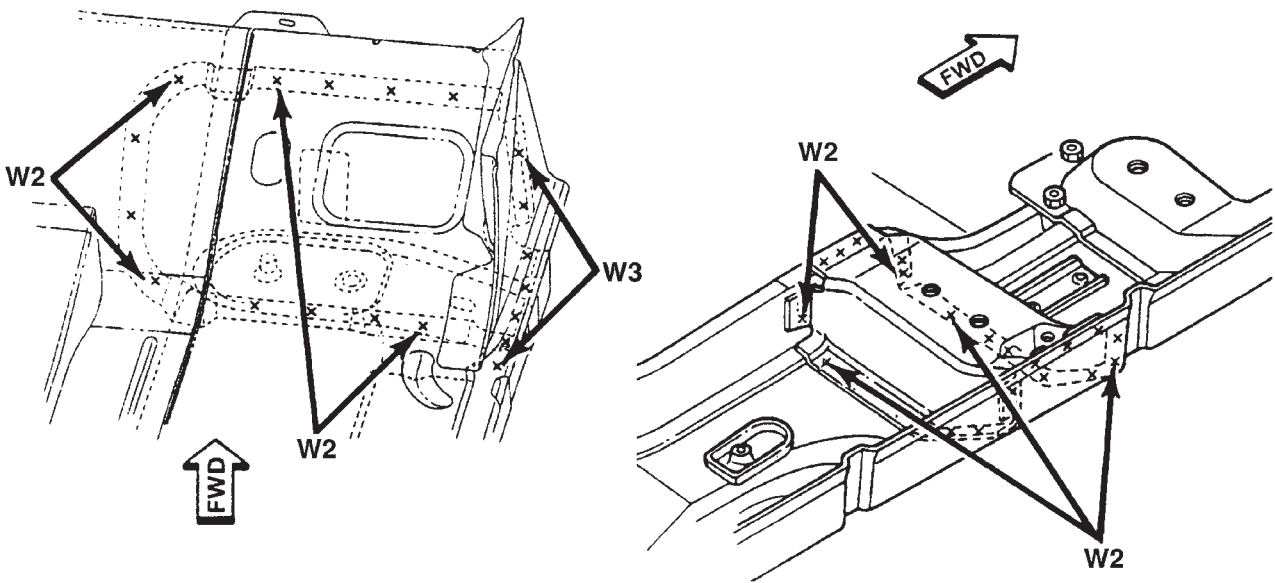
BODY (Continued)



W2 - WELDING OF 2 PARTS  
 W3 - WELDING OF 3 PARTS  
 W4 - WELDING OF 4 PARTS

80b62b05

FLOOR PAN — CLUB CAB

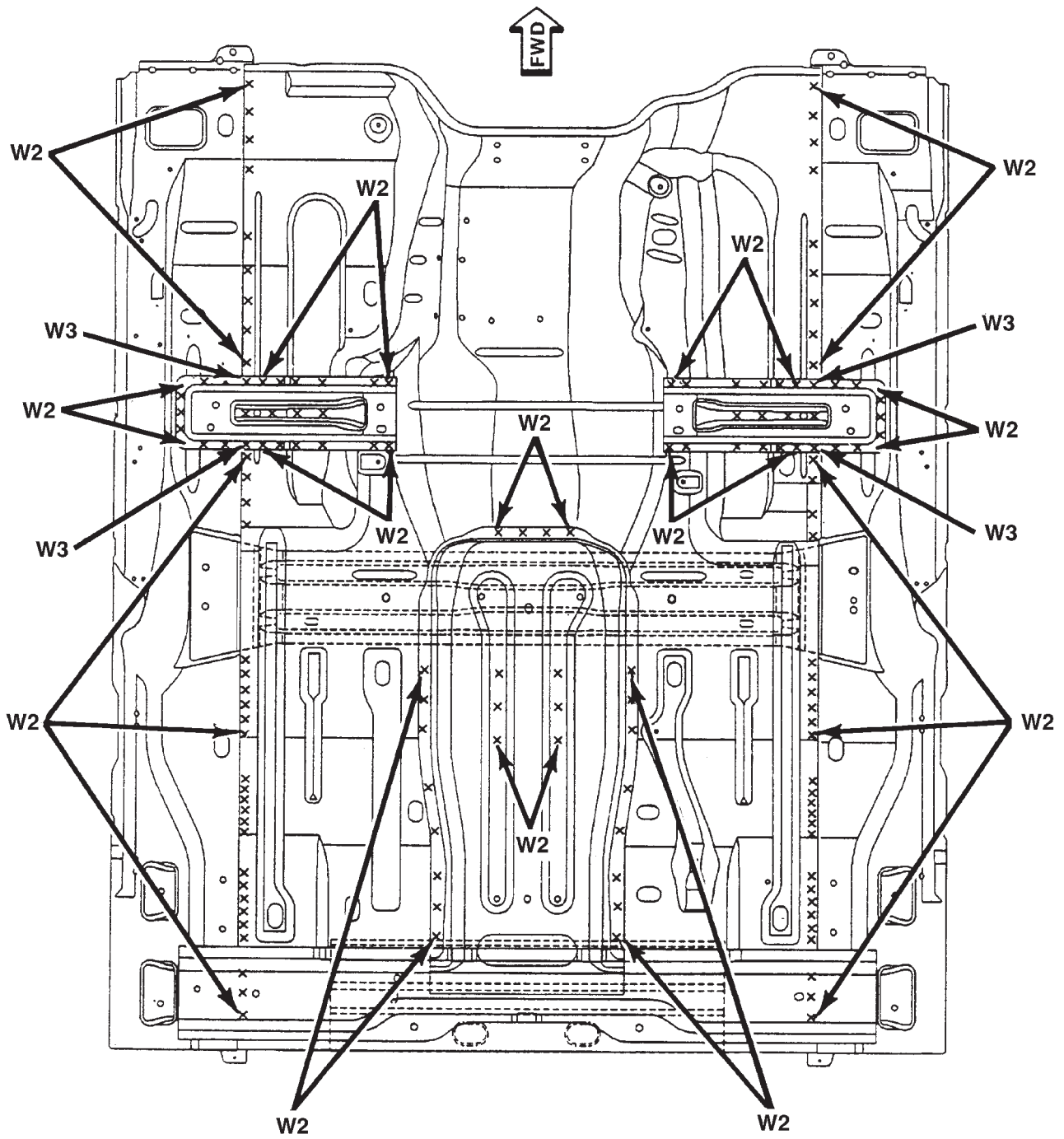


W2 - WELDING OF 2 PARTS  
 W3 - WELDING OF 3 PARTS  
 W4 - WELDING OF 4 PARTS

80b62b06

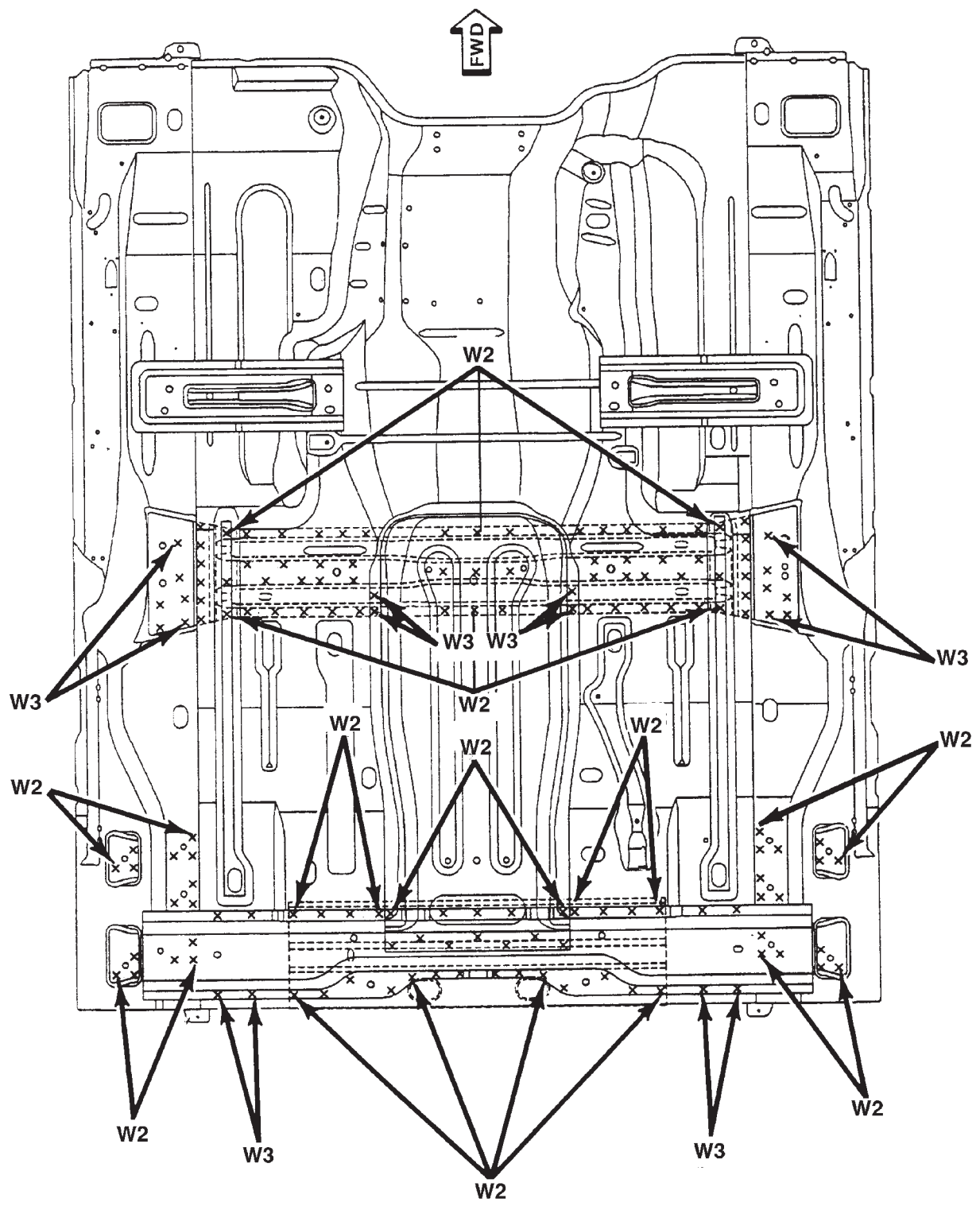
FLOOR PAN — QUAD CAB

BODY (Continued)



W2 - WELDING OF 2 PARTS  
W3 - WELDING OF 3 PARTS  
W4 - WELDING OF 4 PARTS

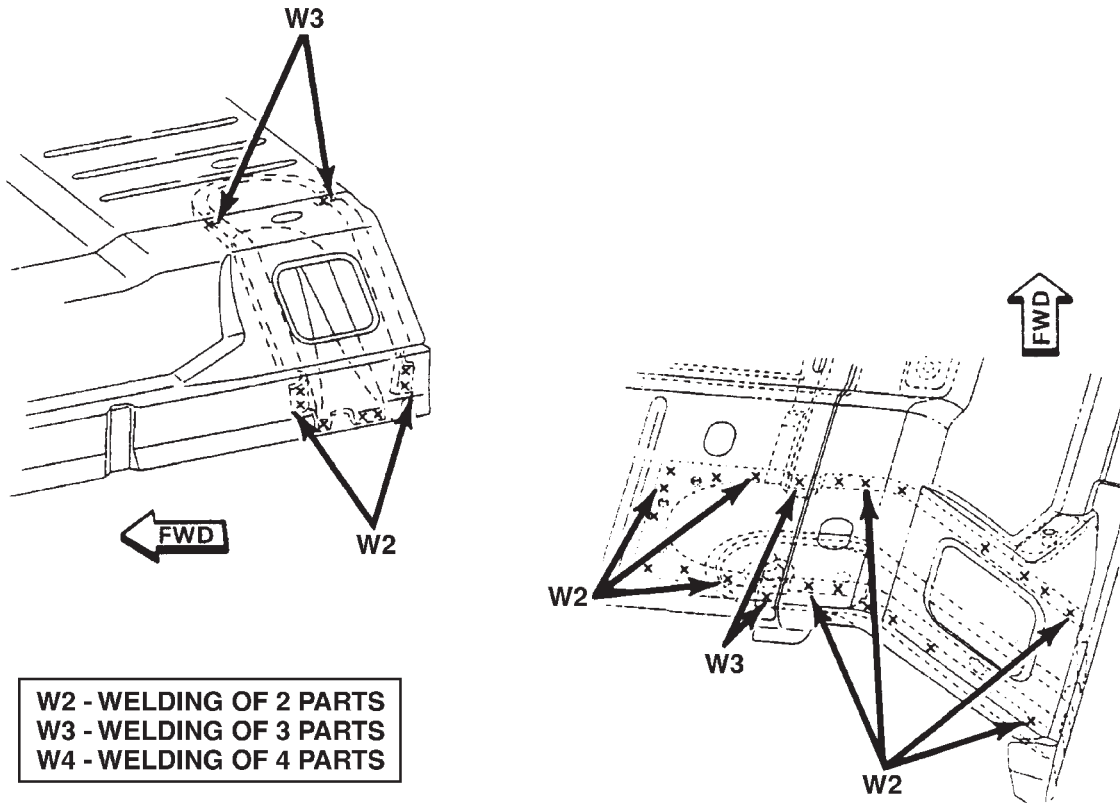
BODY (Continued)



W2 - WELDING OF 2 PARTS  
W3 - WELDING OF 3 PARTS  
W4 - WELDING OF 4 PARTS

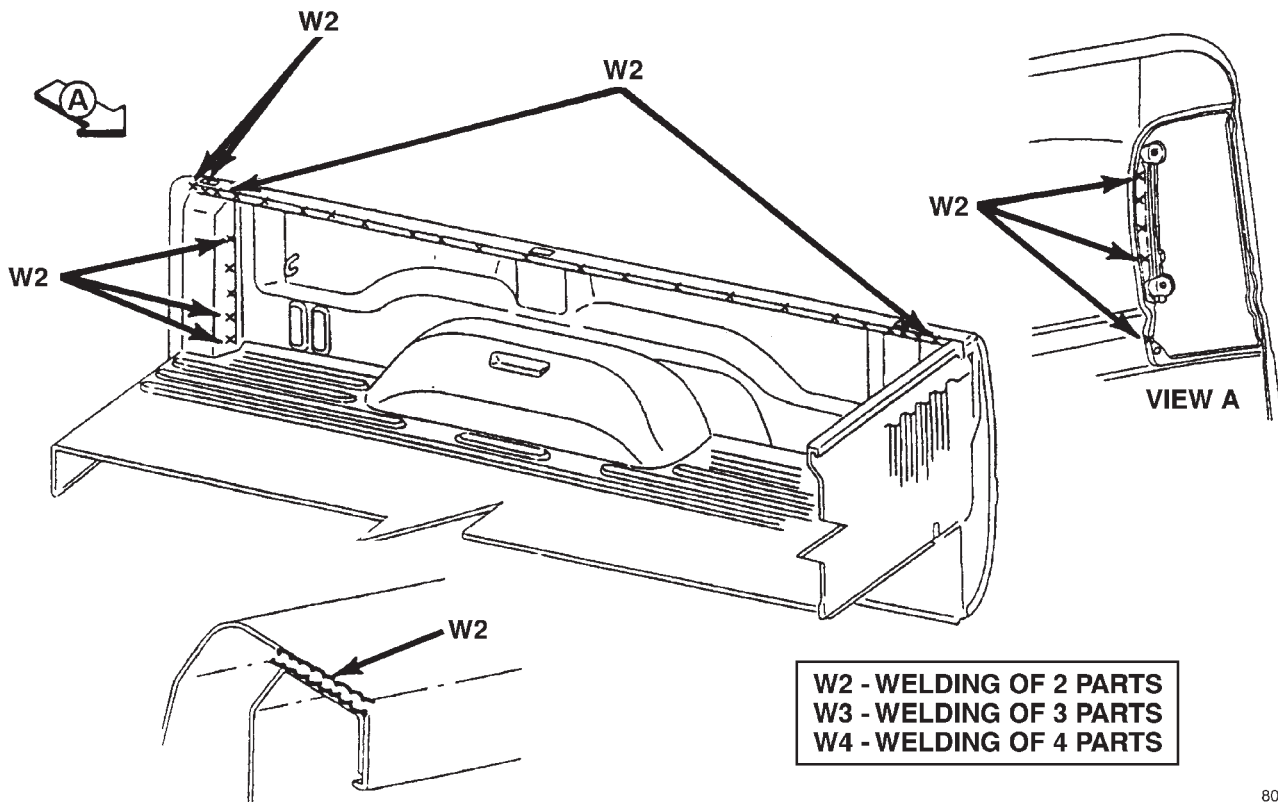
FLOOR PAN — QUAD CAB

BODY (Continued)



80b62b09

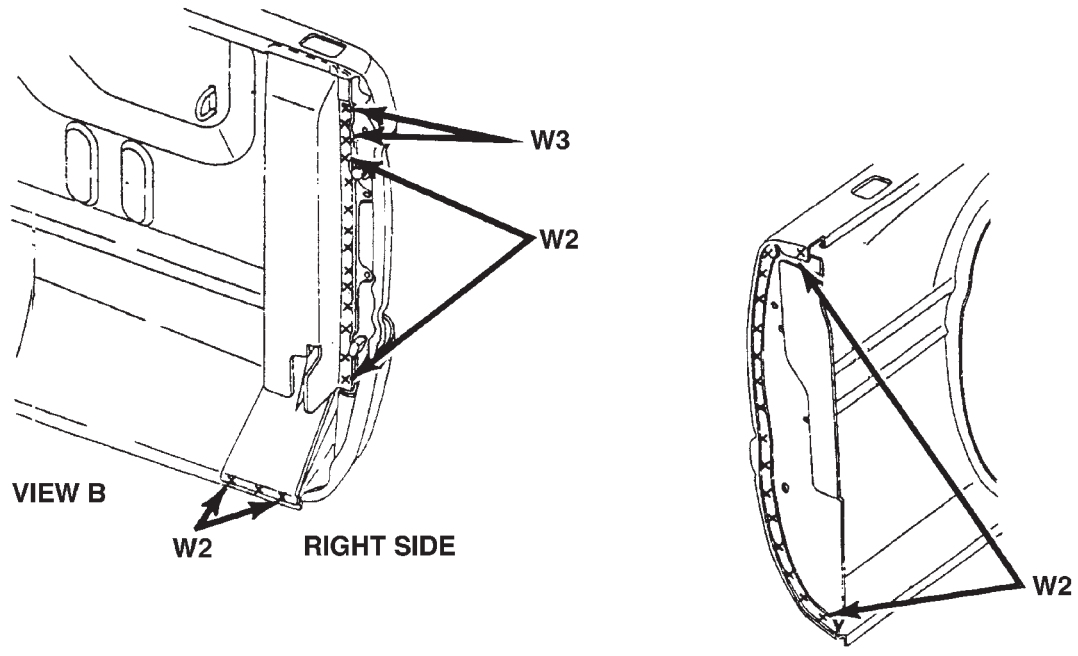
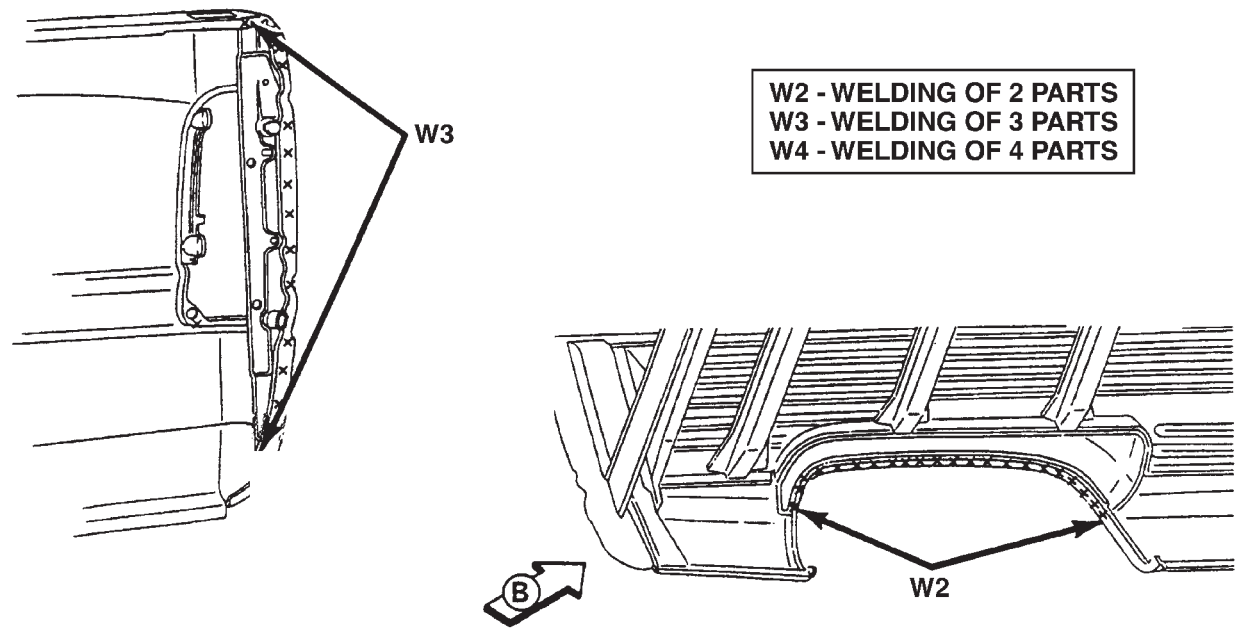
FLOOR PAN — QUAD CAB



80b62b0a

CARGO BOX OUTER SIDE PANEL

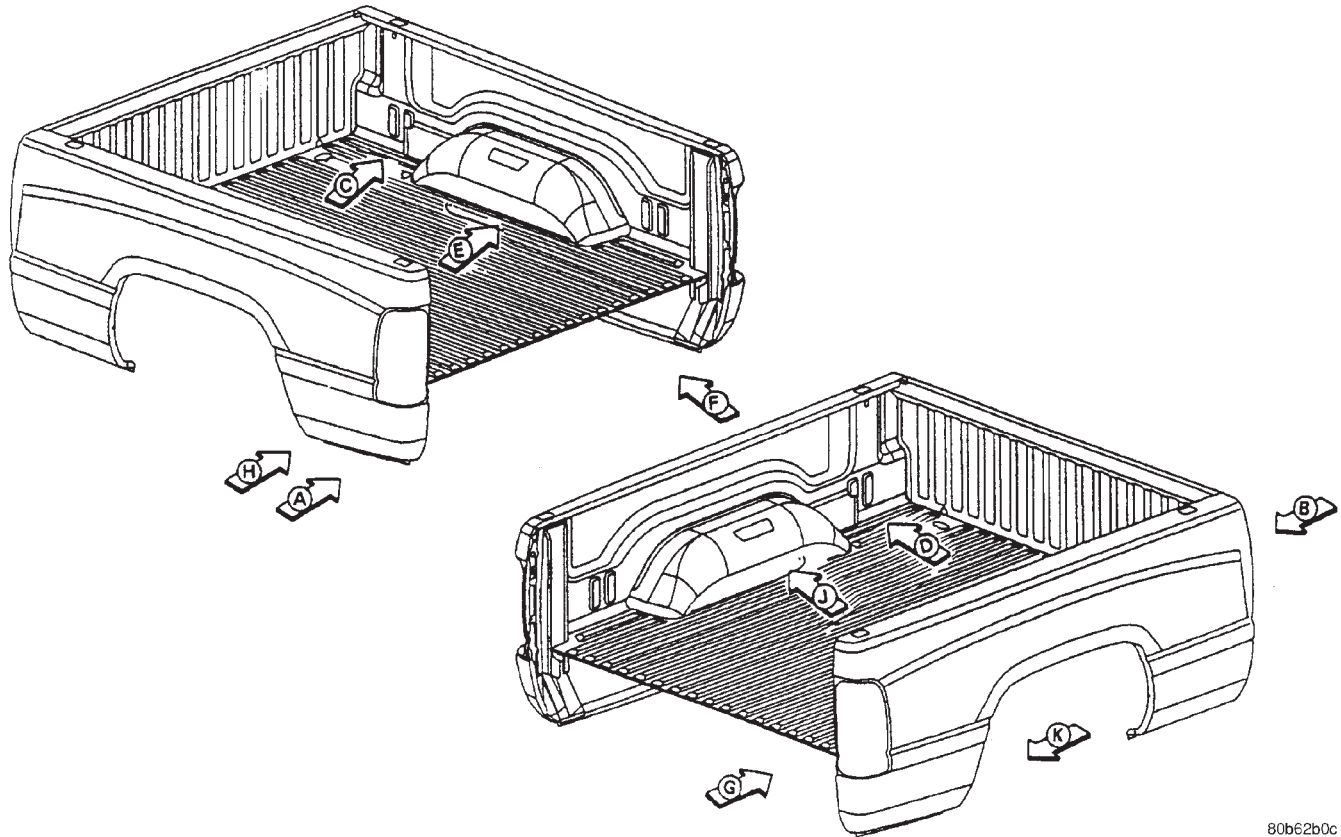
BODY (Continued)



CARGO BOX OUTER SIDE PANEL

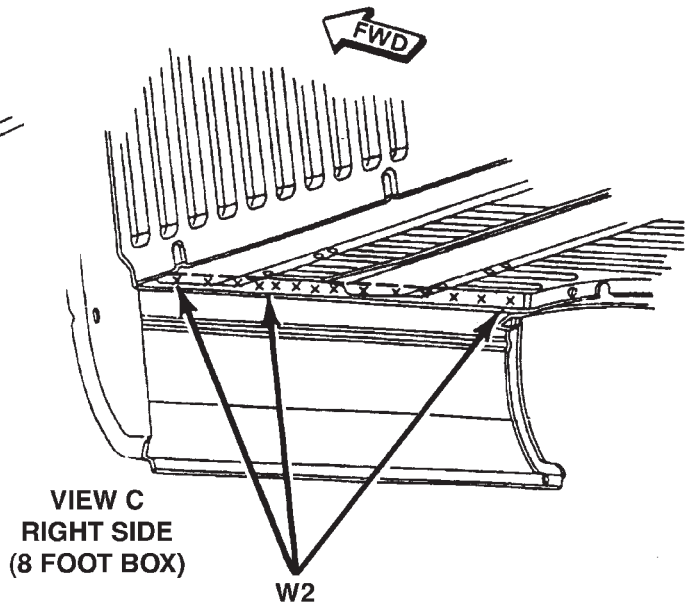
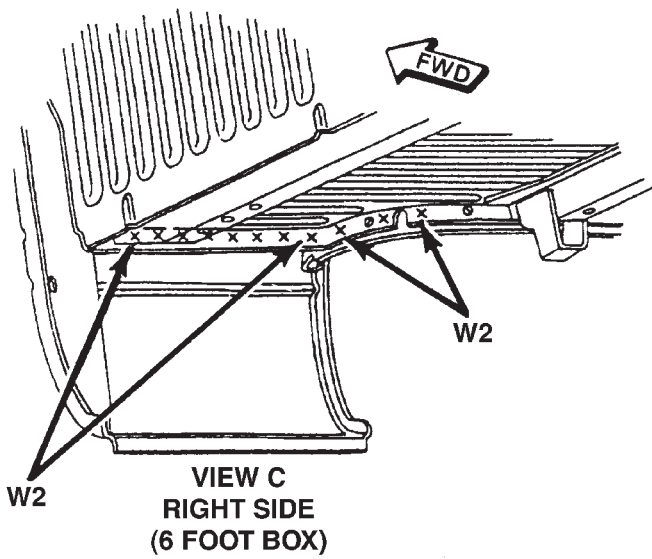
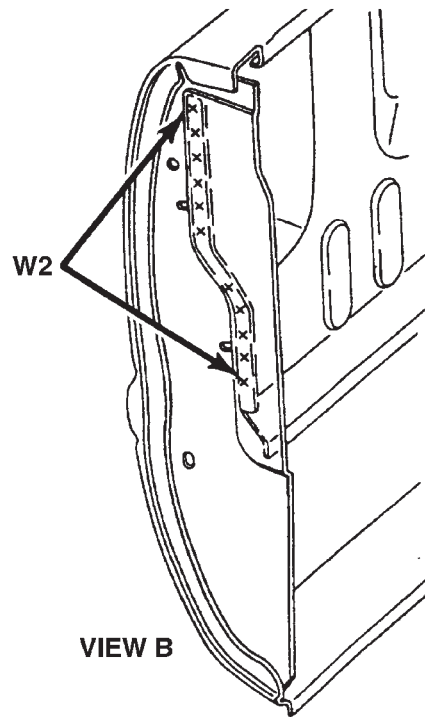
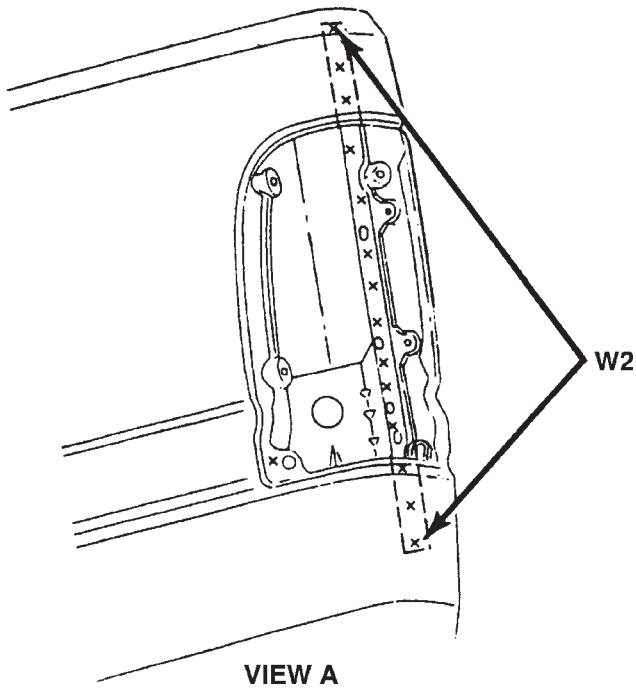


BODY (Continued)



80b62b0c

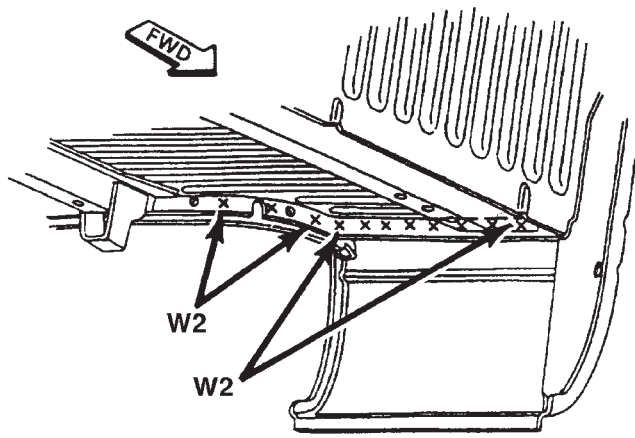
**CARGO BOX INNER SIDE PANEL**



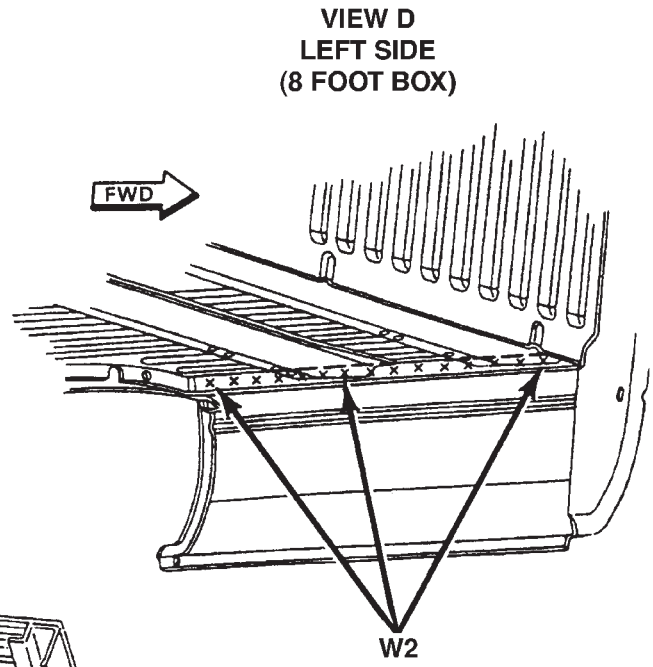
W2 - WELDING OF 2 PARTS  
W3 - WELDING OF 3 PARTS  
W4 - WELDING OF 4 PARTS

CARGO BOX INNER SIDE PANEL

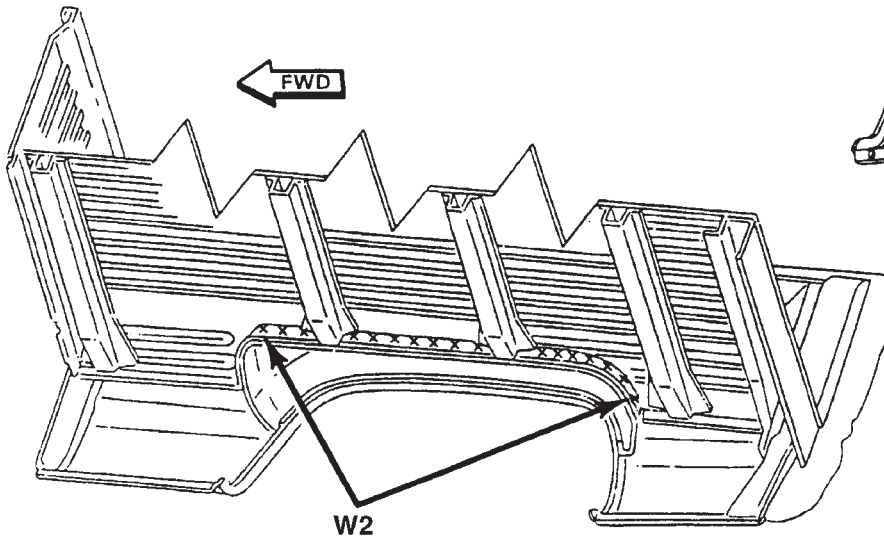
BODY (Continued)



**VIEW D  
LEFT SIDE  
(6 FOOT BOX)**

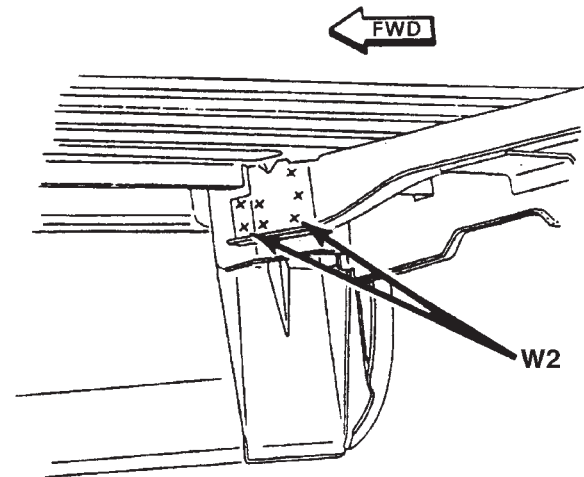


**VIEW D  
LEFT SIDE  
(8 FOOT BOX)**



W2

**VIEW E**



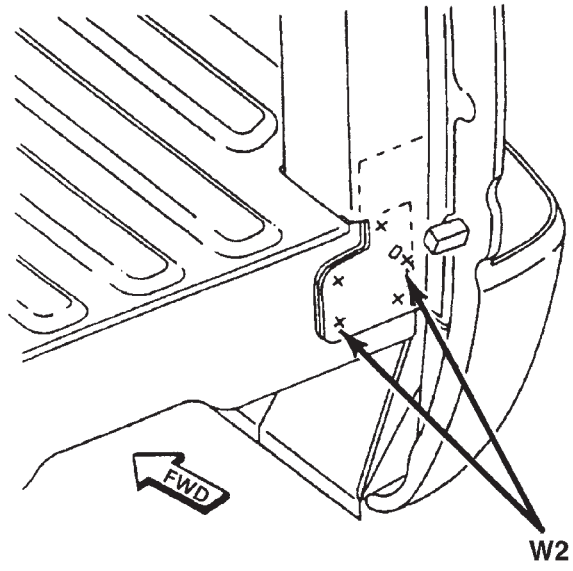
W2

**VIEW F**

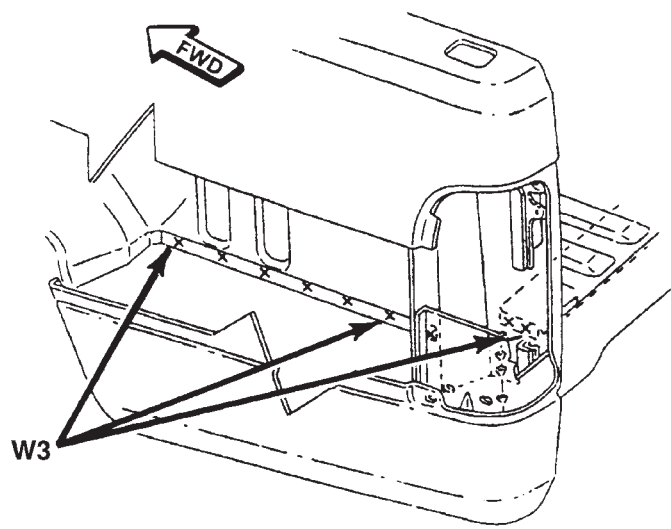
W2 - WELDING OF 2 PARTS  
W3 - WELDING OF 3 PARTS  
W4 - WELDING OF 4 PARTS

**CARGO BOX INNER SIDE PANEL**

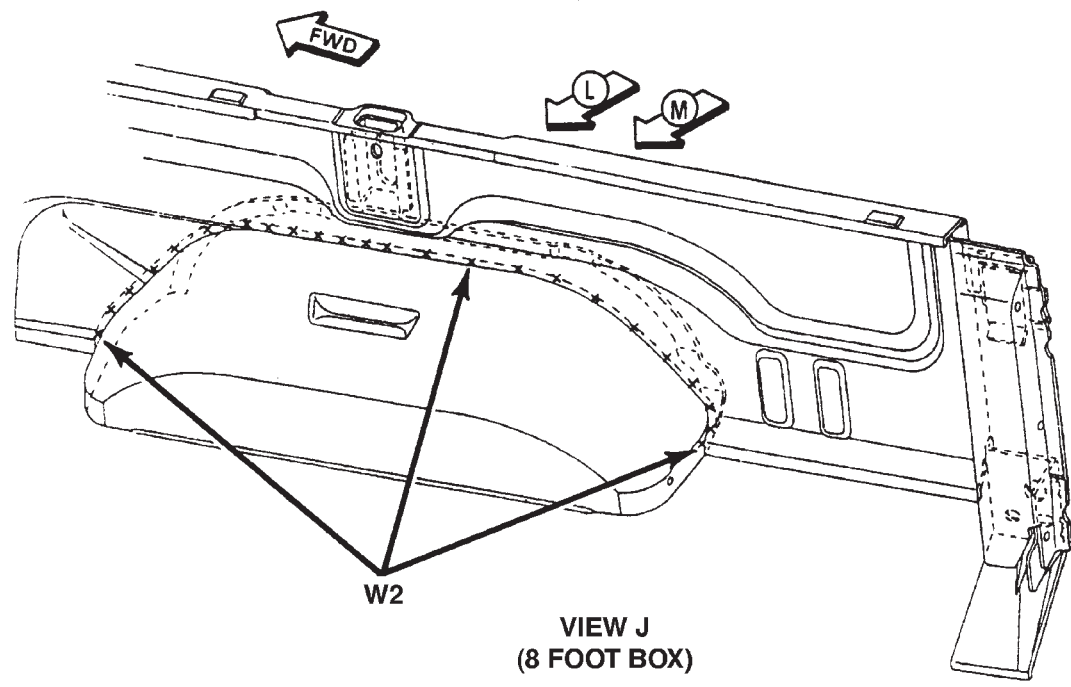
BODY (Continued)



VIEW G



VIEW H

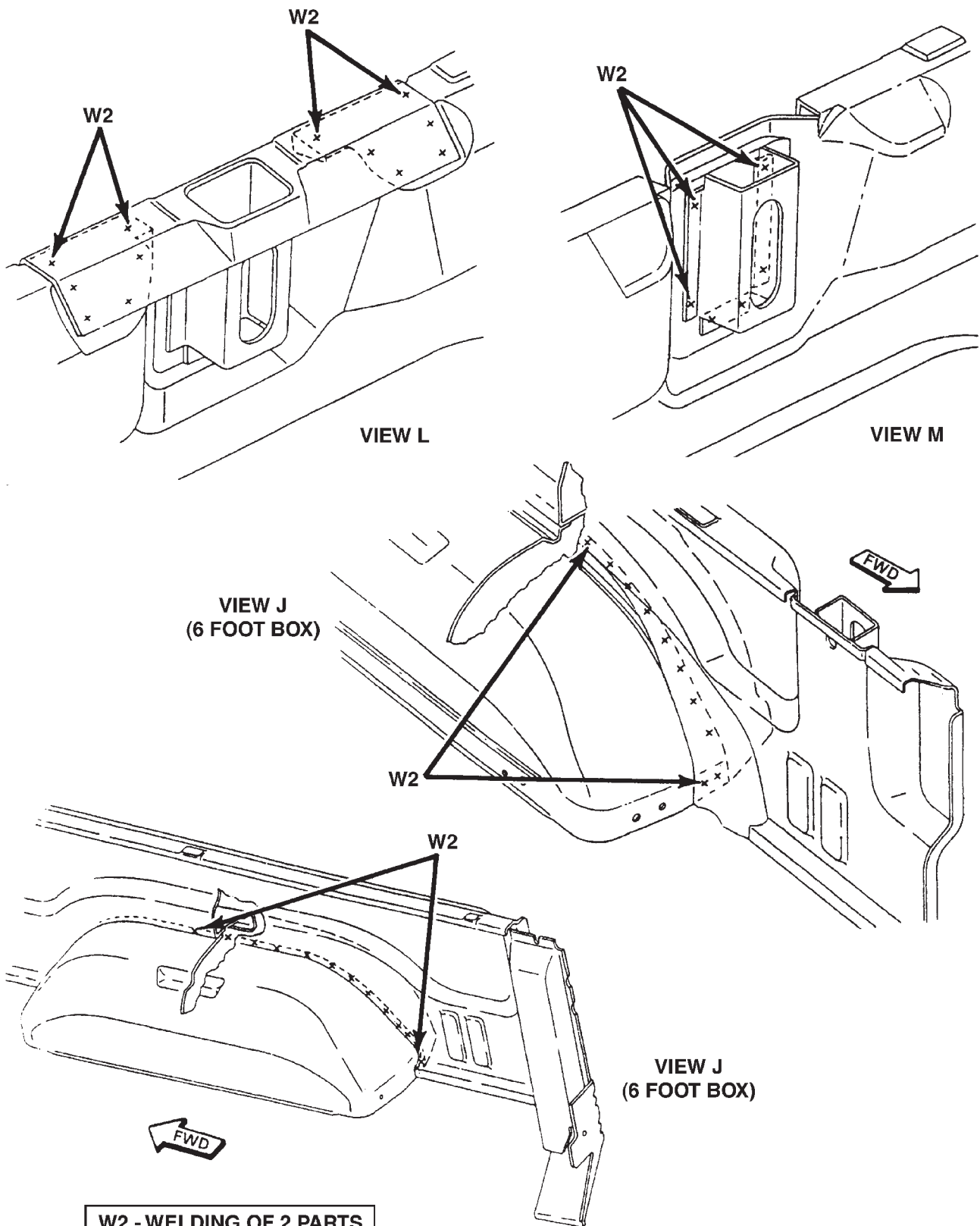


VIEW J  
(8 FOOT BOX)

W2 - WELDING OF 2 PARTS  
W3 - WELDING OF 3 PARTS  
W4 - WELDING OF 4 PARTS

CARGO BOX INNER SIDE PANEL

BODY (Continued)

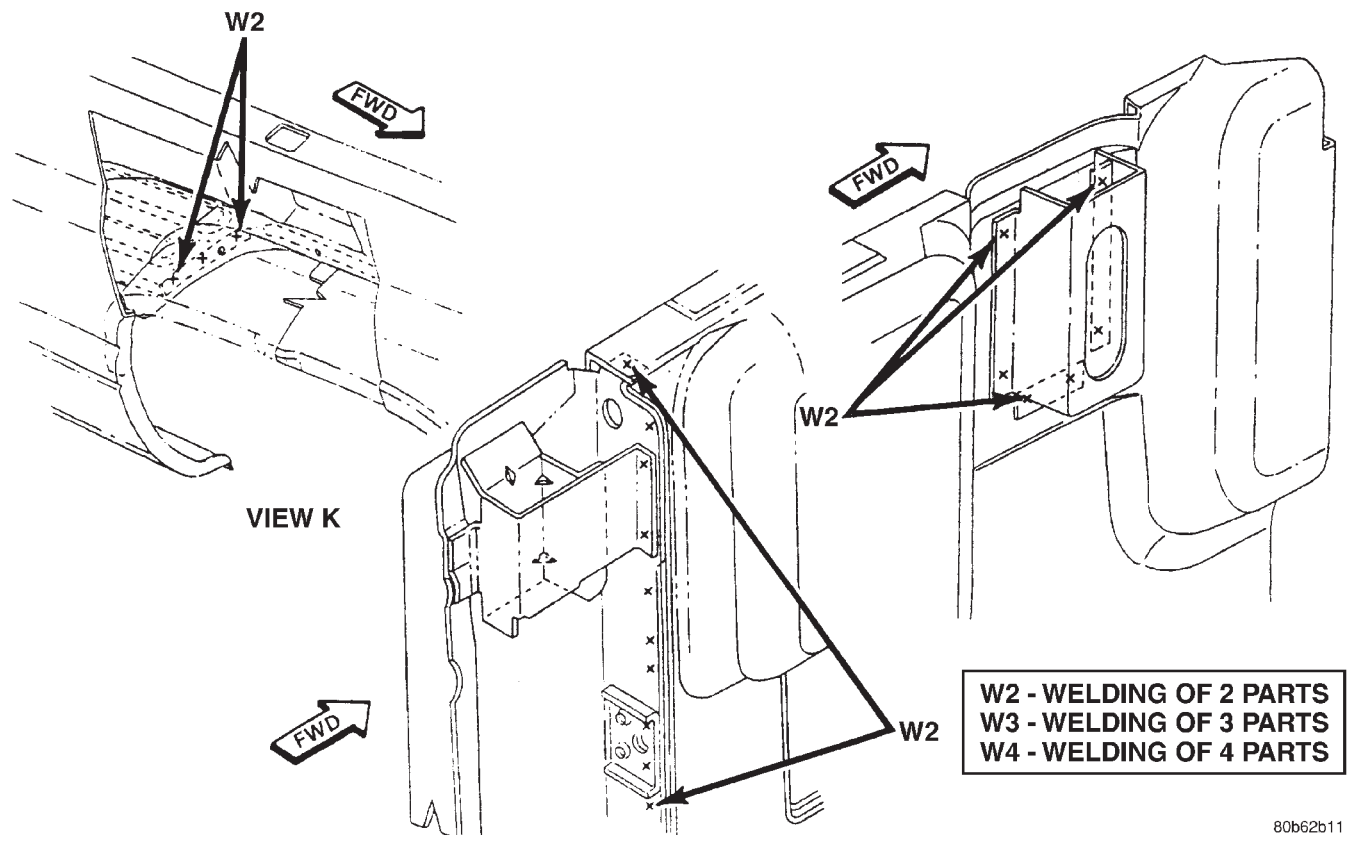


W2 - WELDING OF 2 PARTS  
W3 - WELDING OF 3 PARTS  
W4 - WELDING OF 4 PARTS

CARGO BOX INNER SIDE PANEL



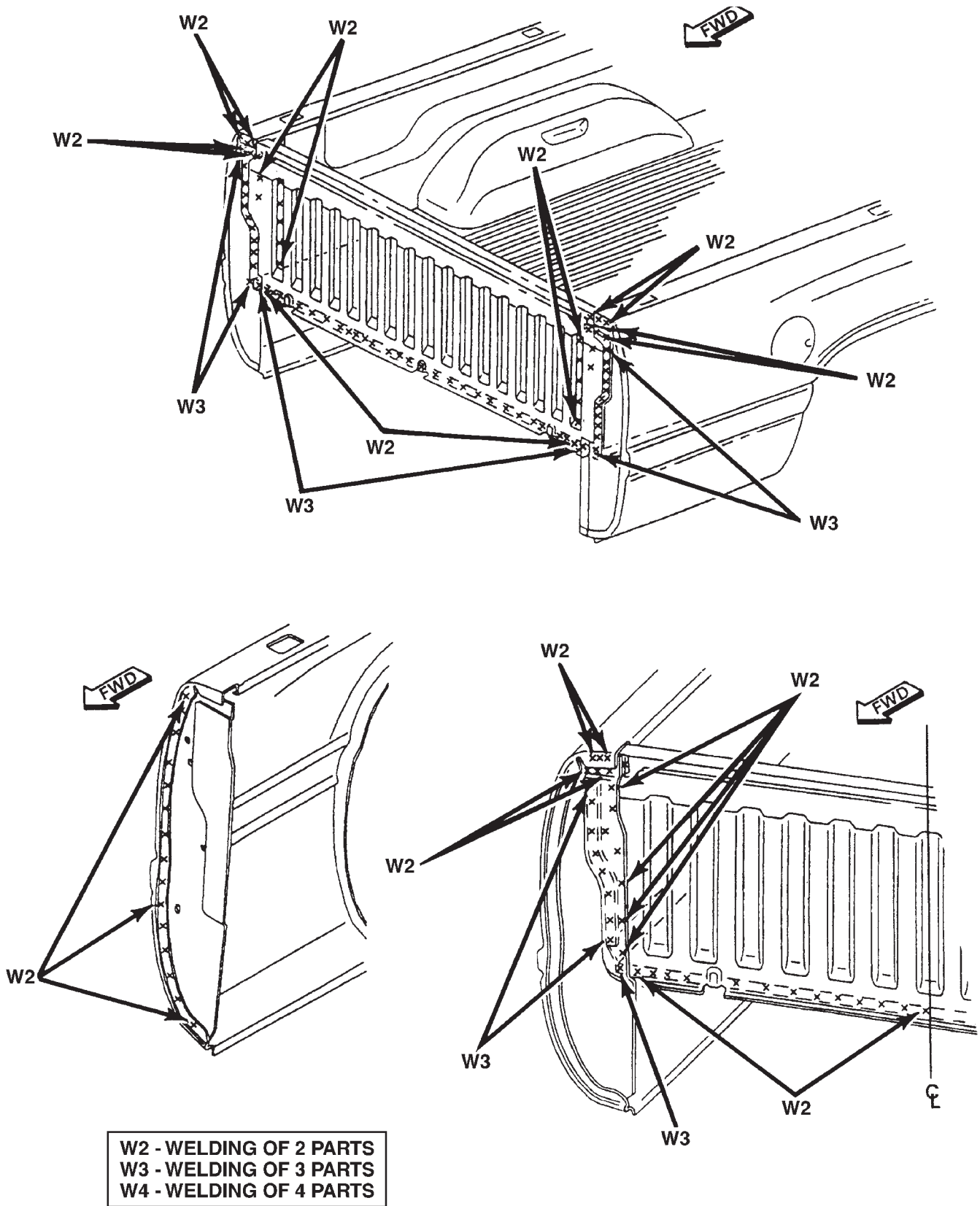
BODY (Continued)



**CARGO BOX INNER SIDE PANEL**

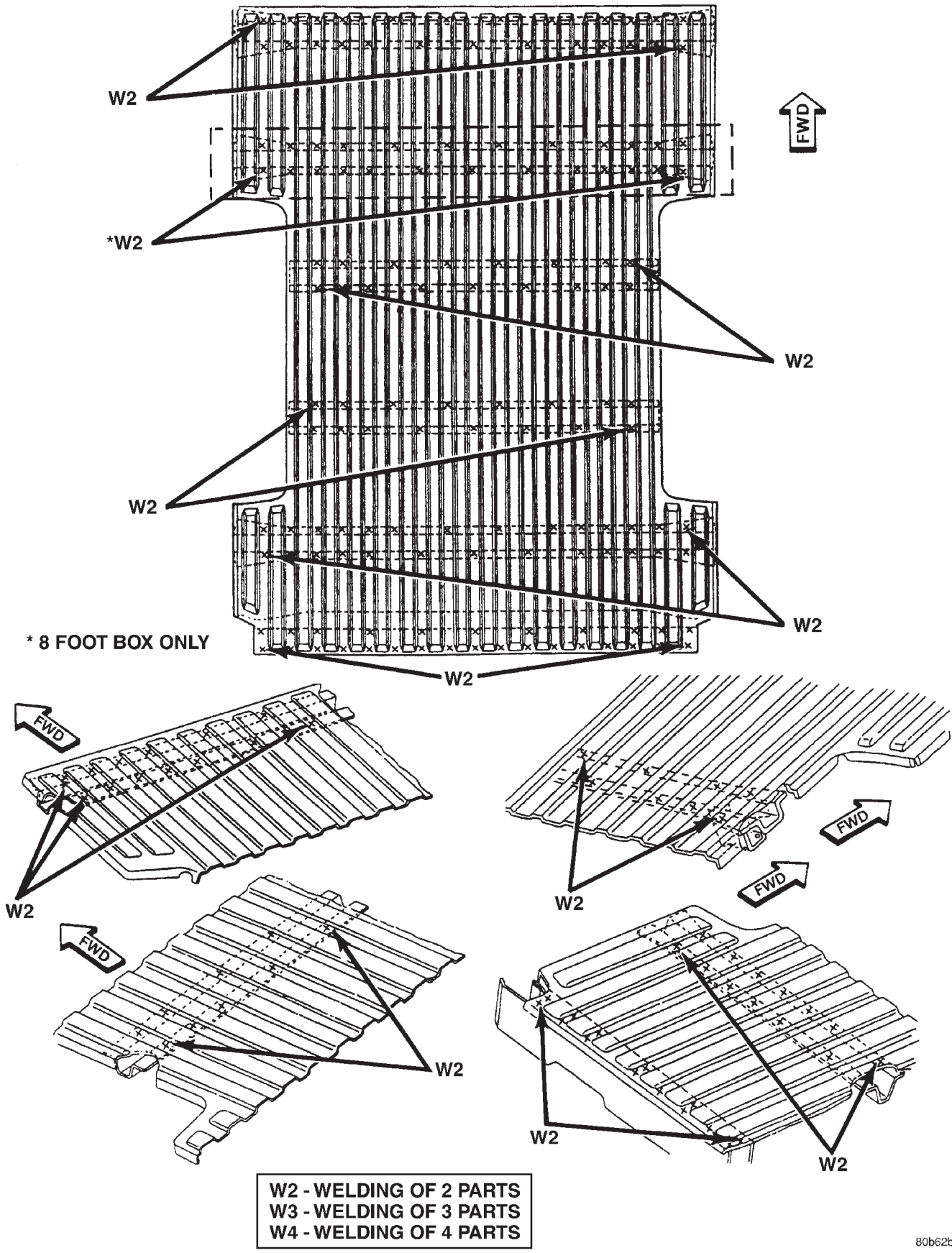
80b62b11

BODY (Continued)



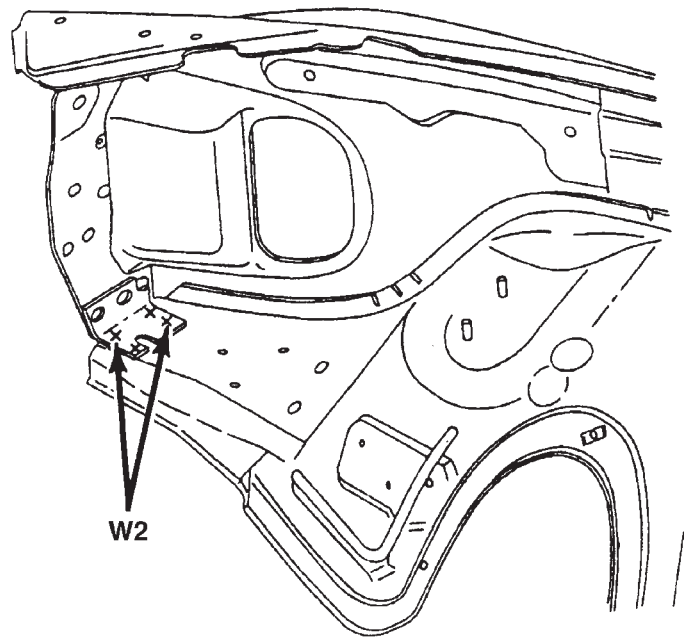
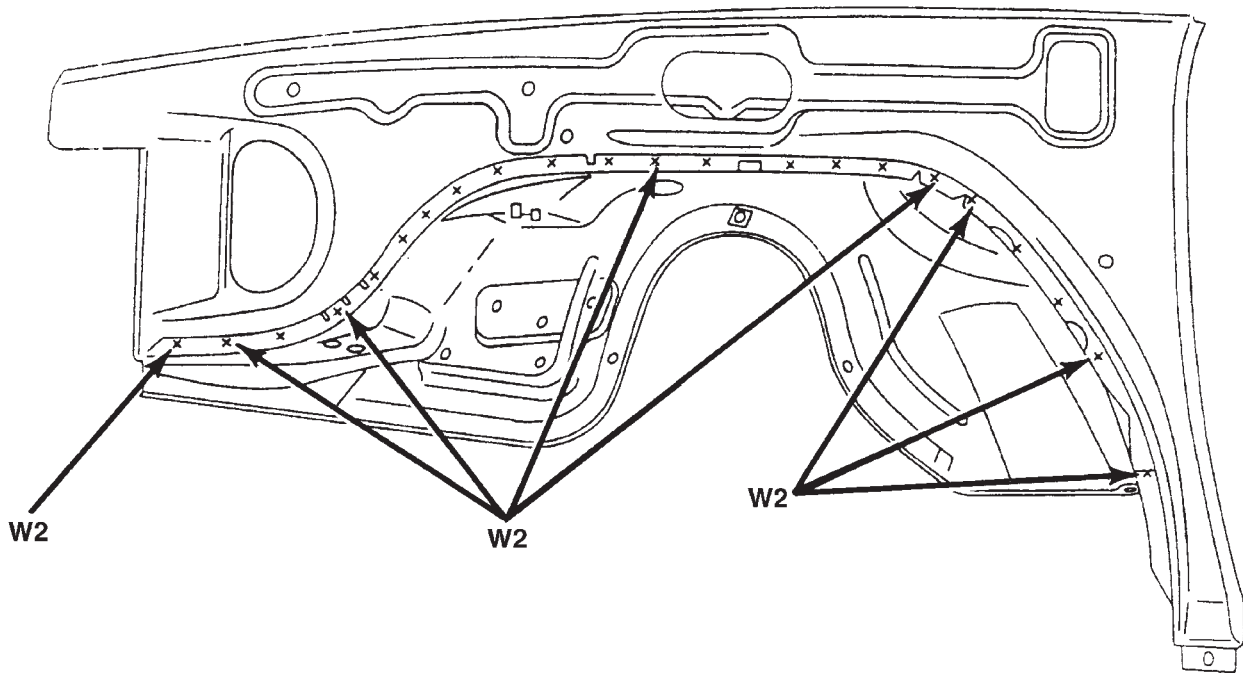
CARGO BOX FRONT PANELS

BODY (Continued)



CARGO BOX FLOOR

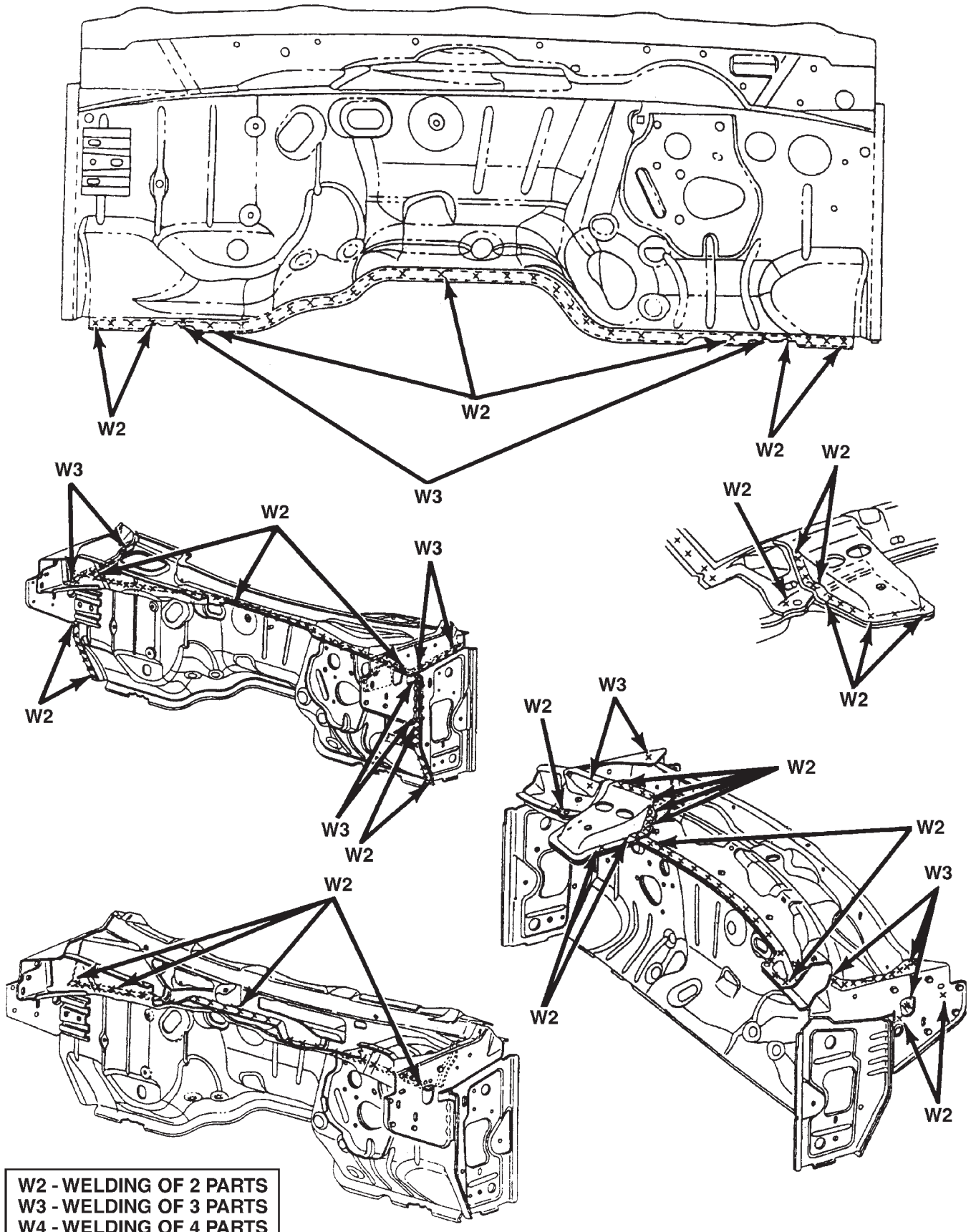
BODY (Continued)



W2 - WELDING OF 2 PARTS  
W3 - WELDING OF 3 PARTS  
W4 - WELDING OF 4 PARTS

**FRONT FENDER AND INNER WHEELHOUSE**

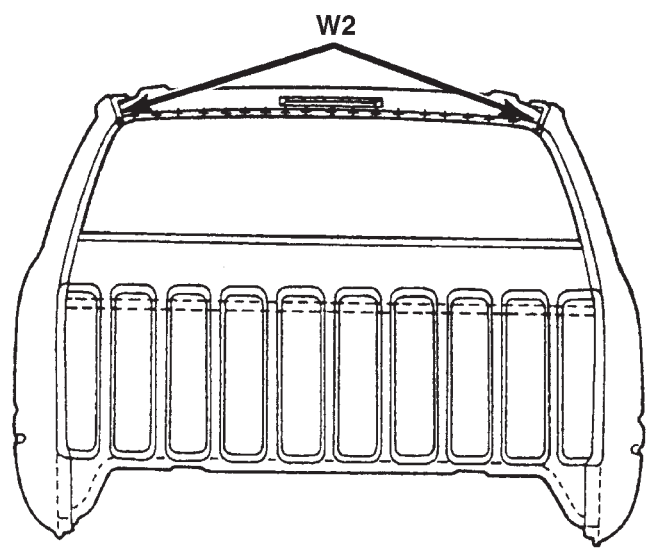
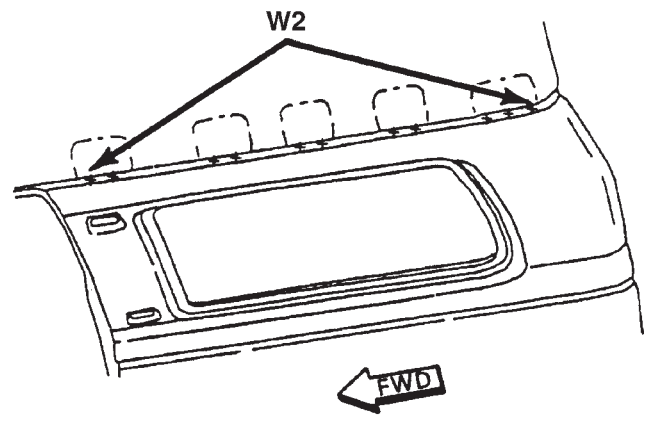
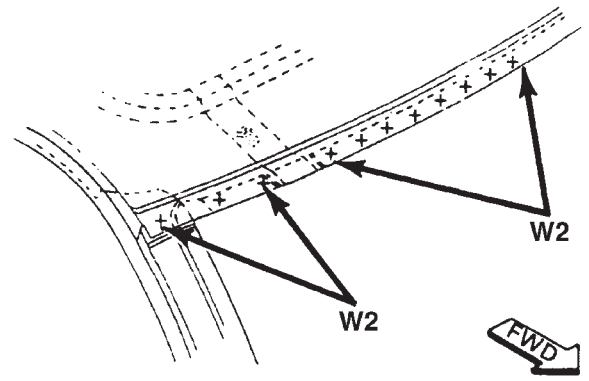
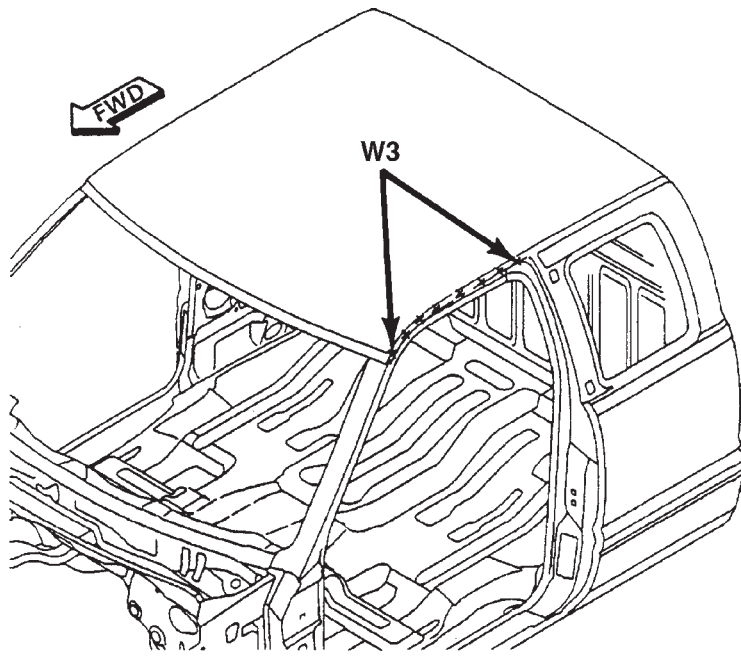
BODY (Continued)



COWL AND DASH PANEL



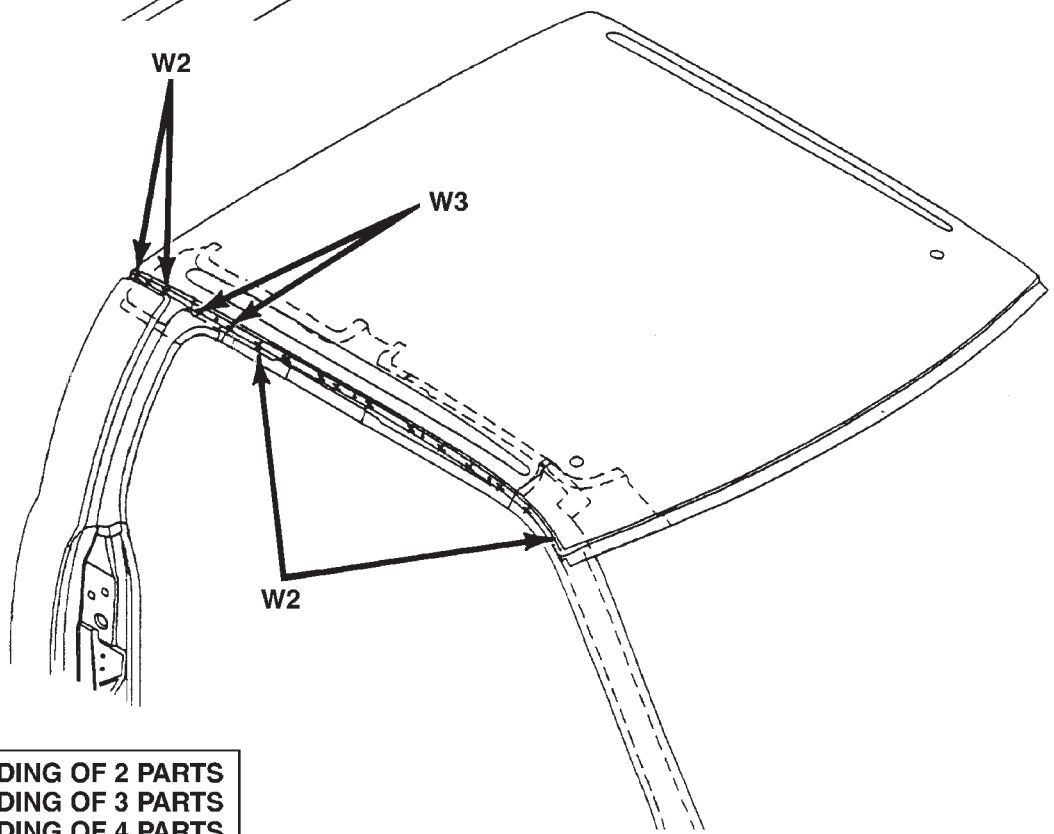
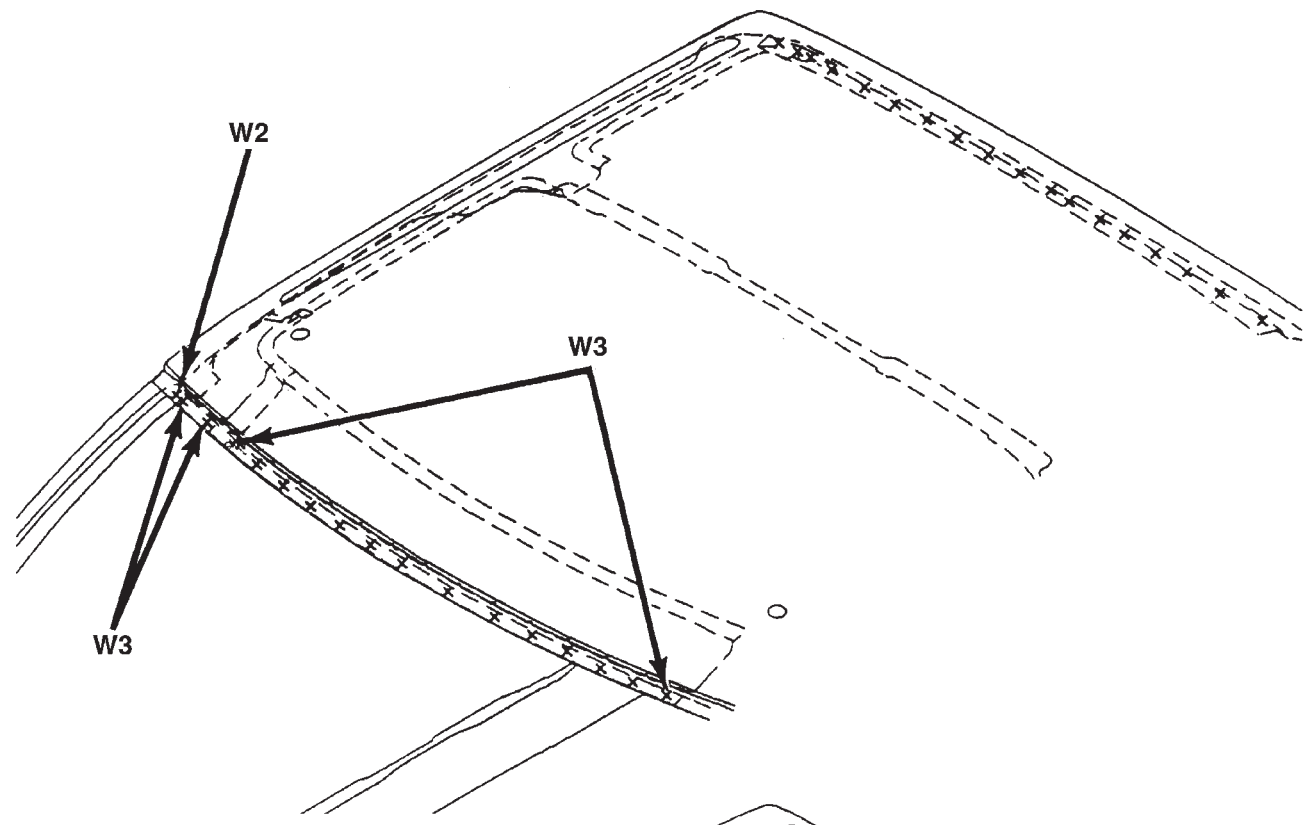
BODY (Continued)



W2 - WELDING OF 2 PARTS  
W3 - WELDING OF 3 PARTS  
W4 - WELDING OF 4 PARTS

ROOF PANEL — CLUB CAB

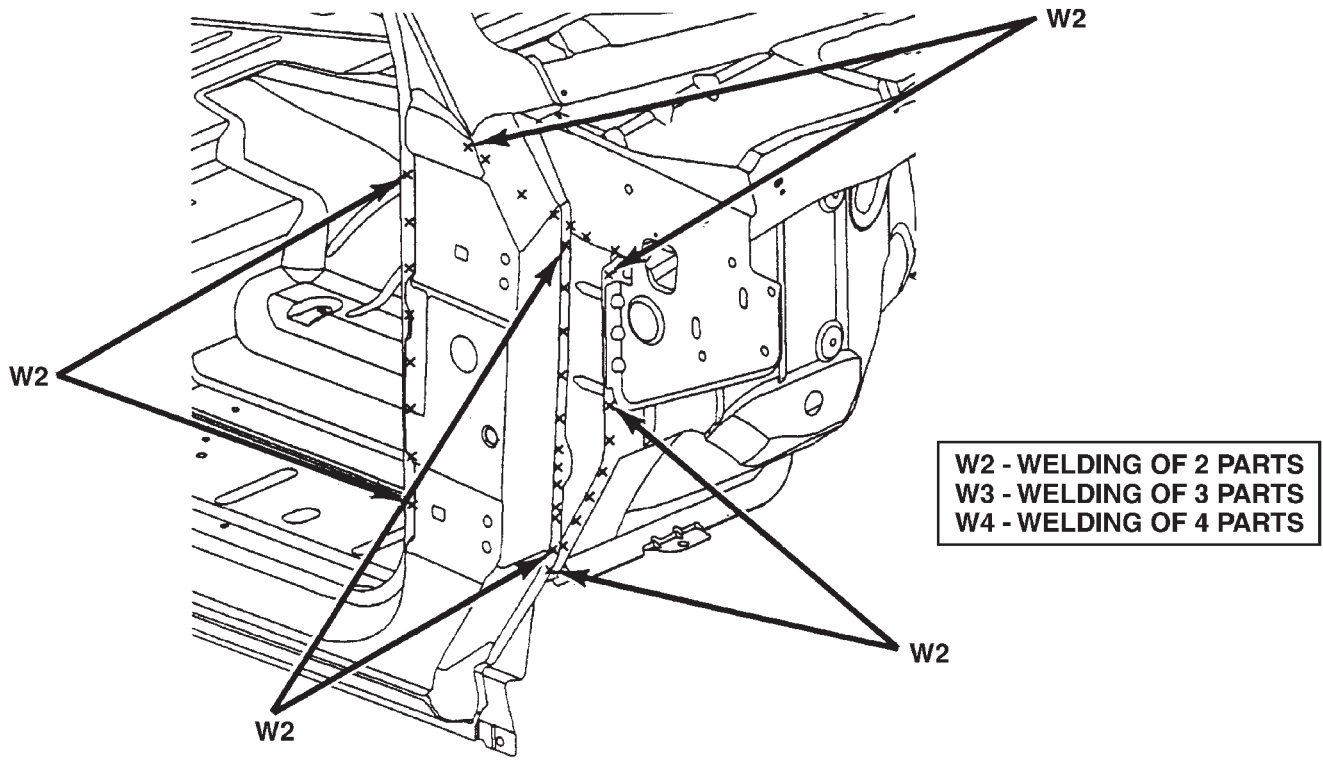
BODY (Continued)



W2 - WELDING OF 2 PARTS  
W3 - WELDING OF 3 PARTS  
W4 - WELDING OF 4 PARTS

ROOF PANEL — QUAD CAB

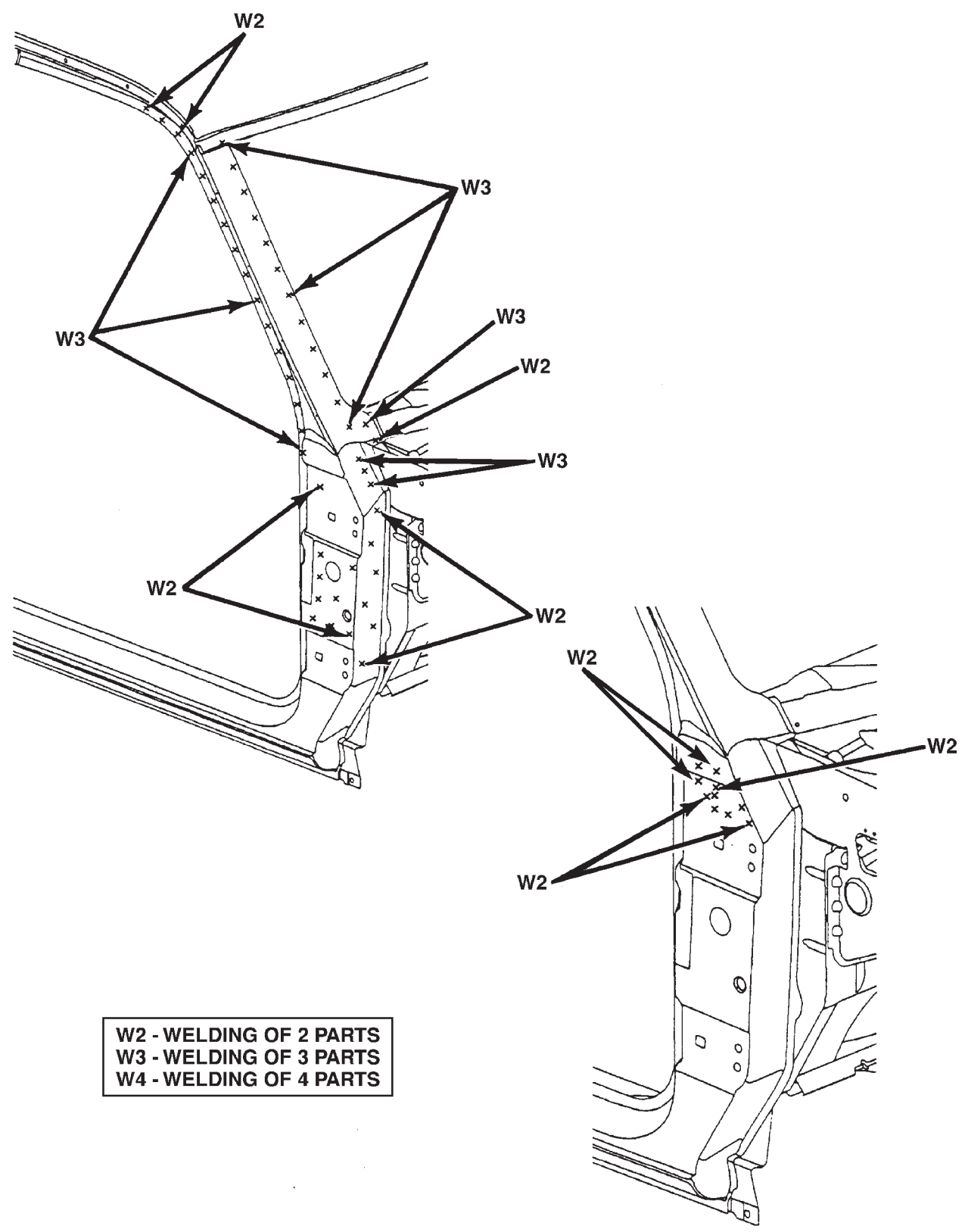
BODY (Continued)



80b62aed

**BODY SIDE APERTURE — CLUB CAB**

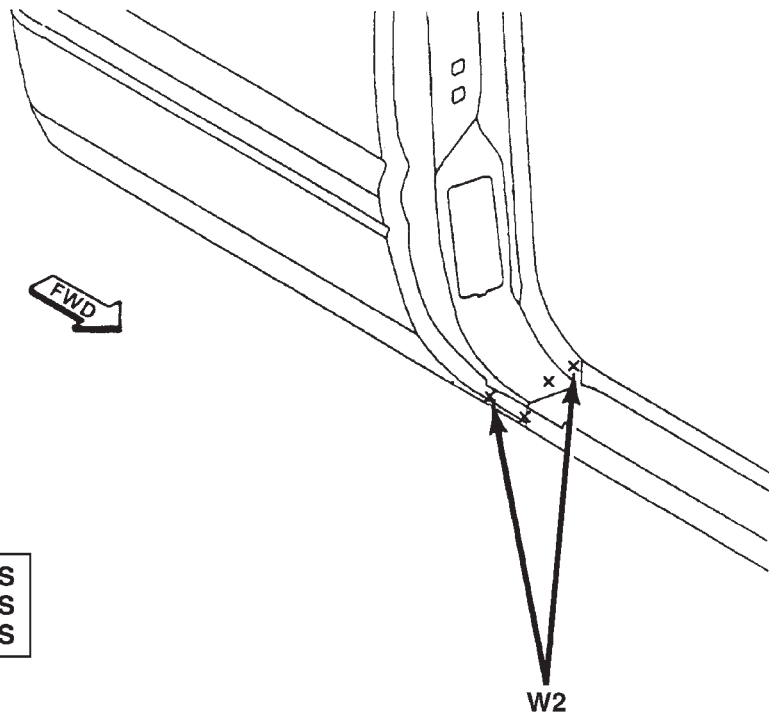
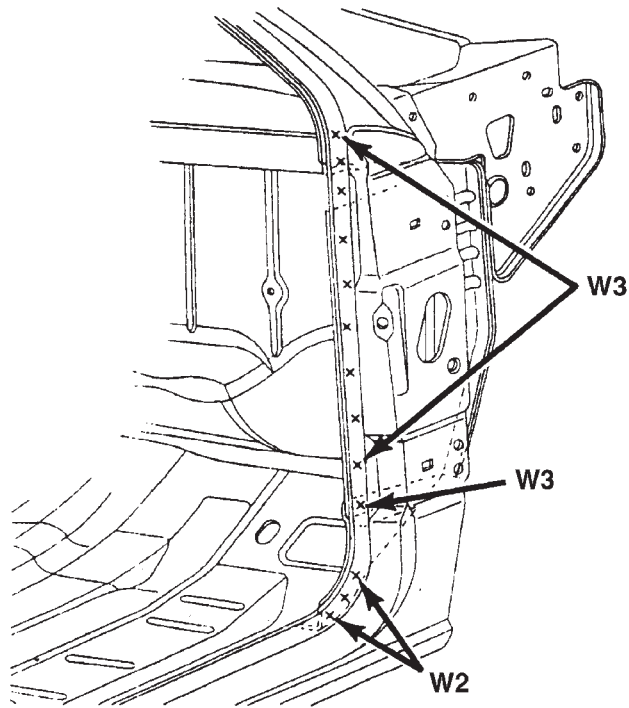
BODY (Continued)



W2 - WELDING OF 2 PARTS  
W3 - WELDING OF 3 PARTS  
W4 - WELDING OF 4 PARTS

BODY SIDE APERTURE — CLUB CAB

BODY (Continued)

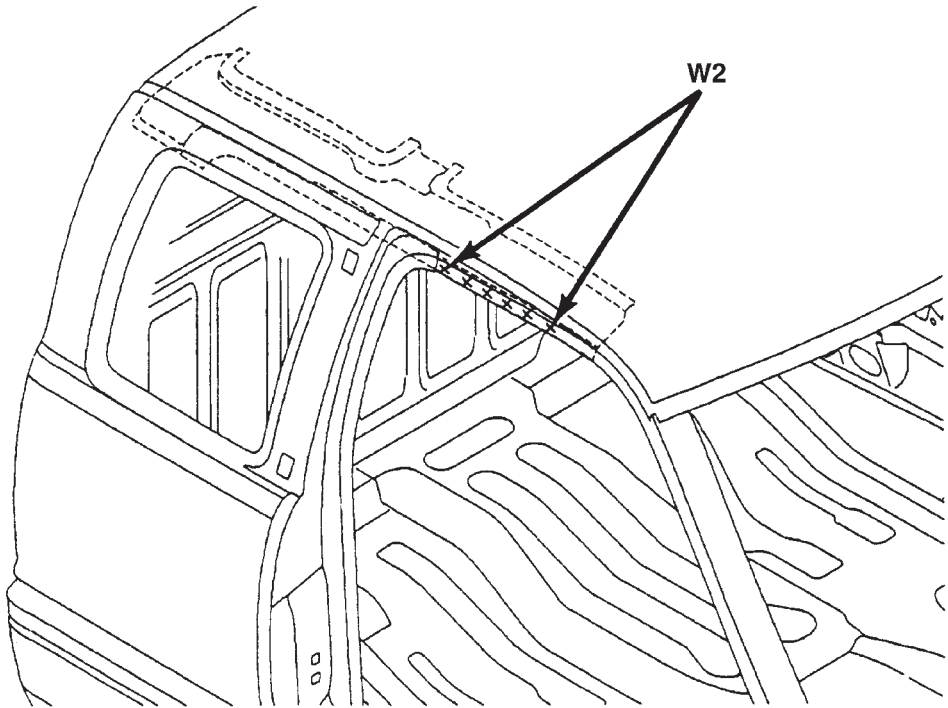


**W2 - WELDING OF 2 PARTS**  
**W3 - WELDING OF 3 PARTS**  
**W4 - WELDING OF 4 PARTS**

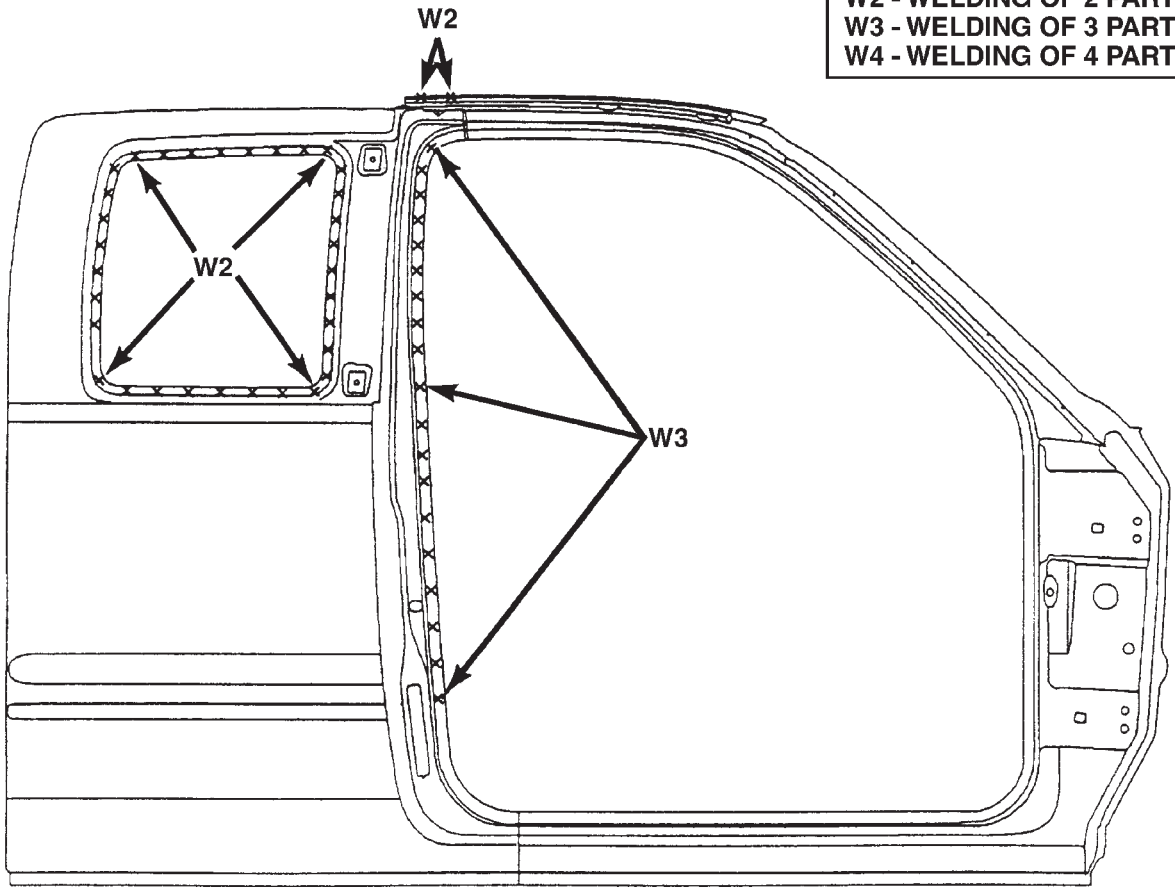
**BODY SIDE APERTURE — CLUB CAB**



BODY (Continued)

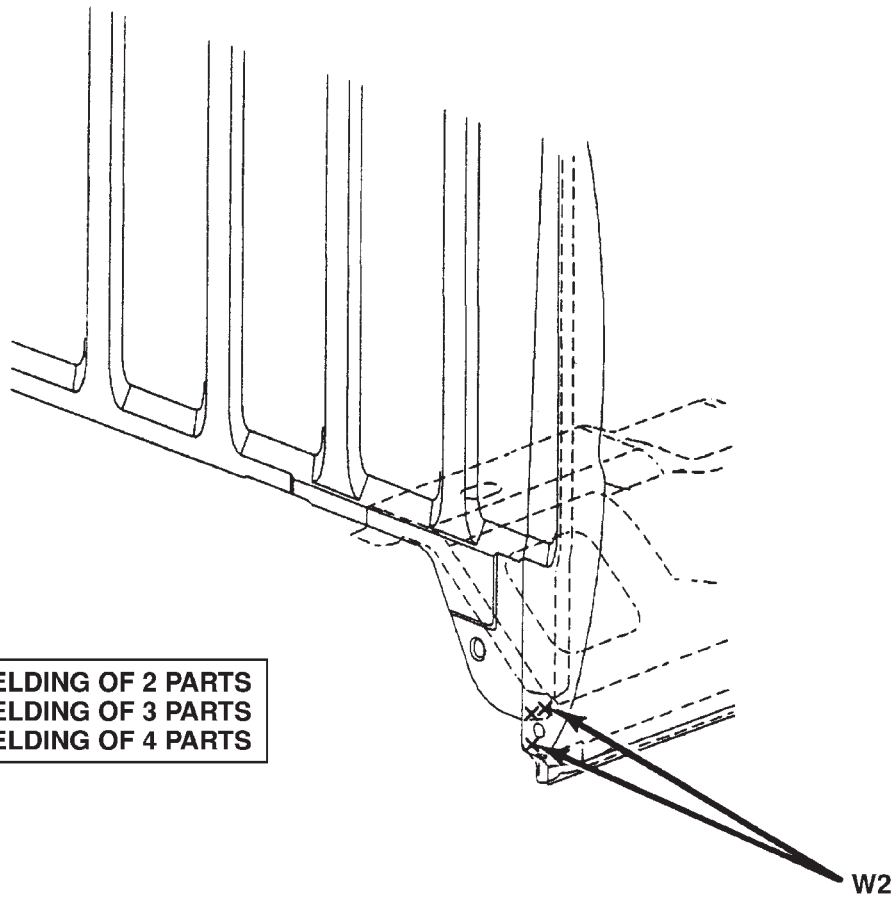
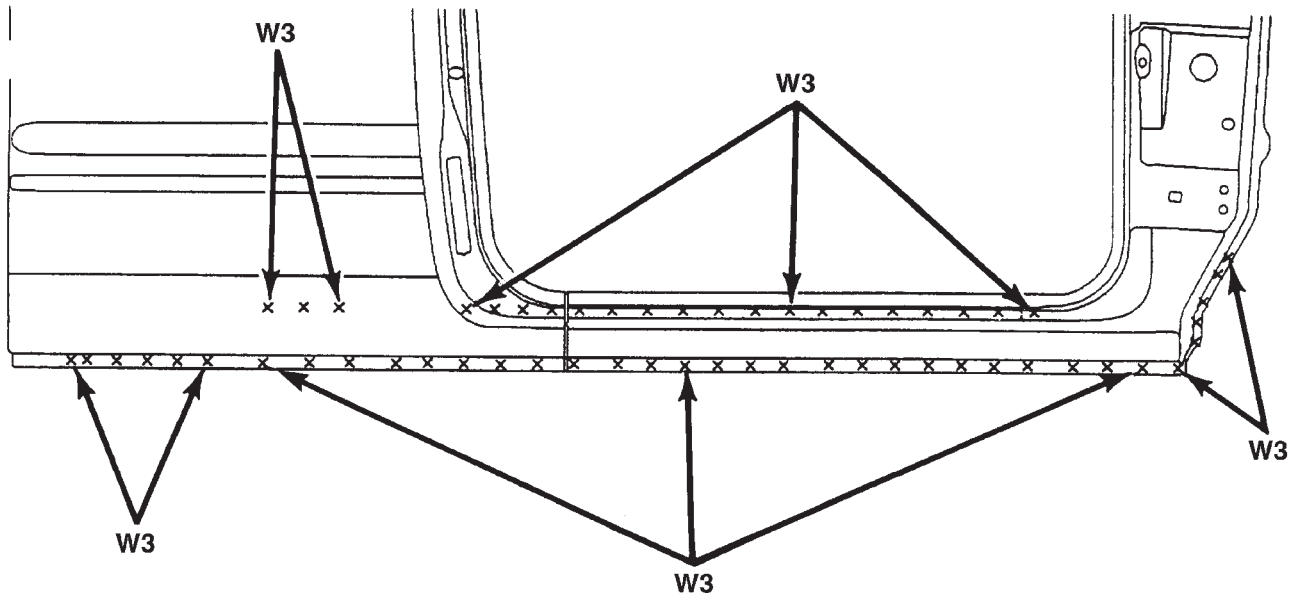


W2 - WELDING OF 2 PARTS  
W3 - WELDING OF 3 PARTS  
W4 - WELDING OF 4 PARTS



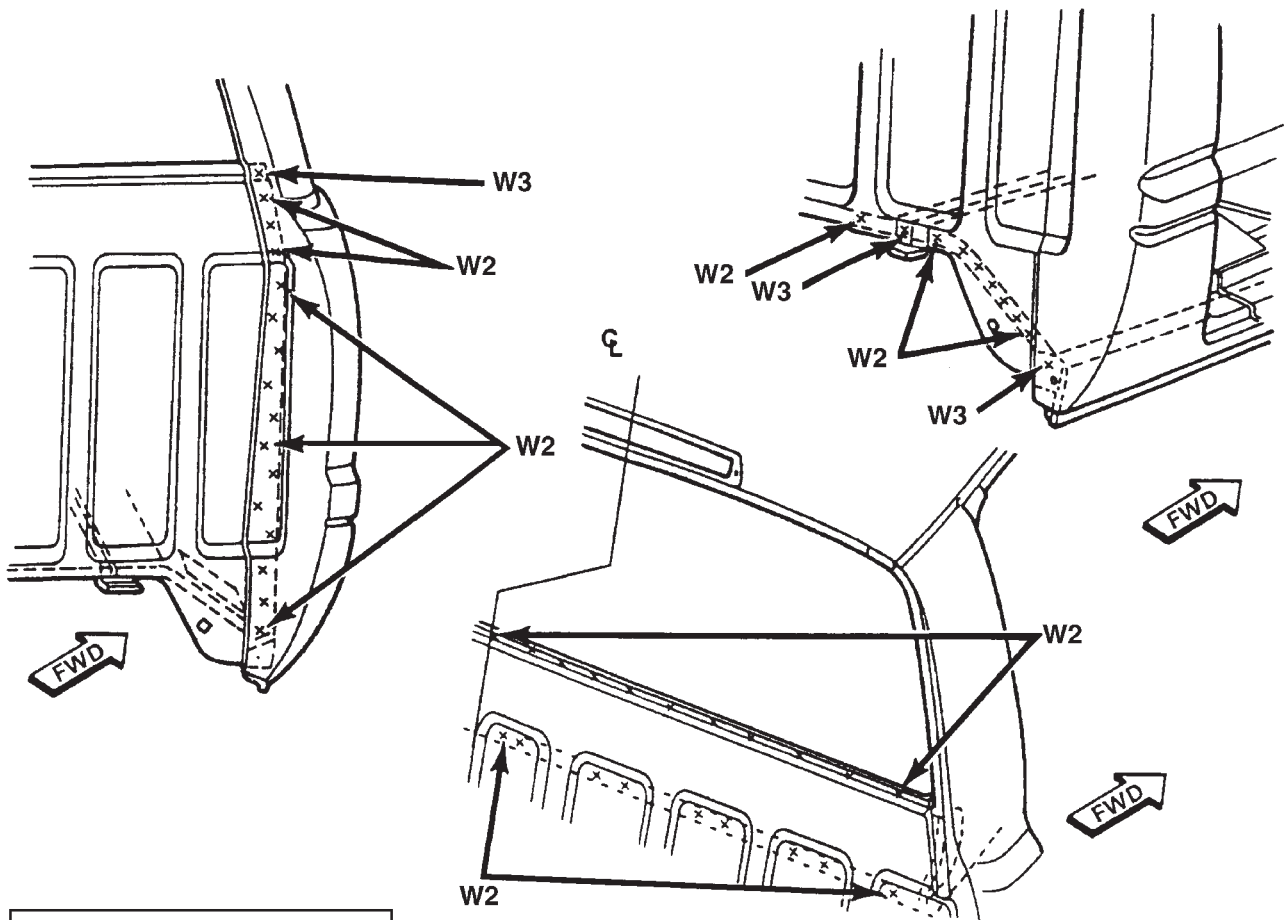
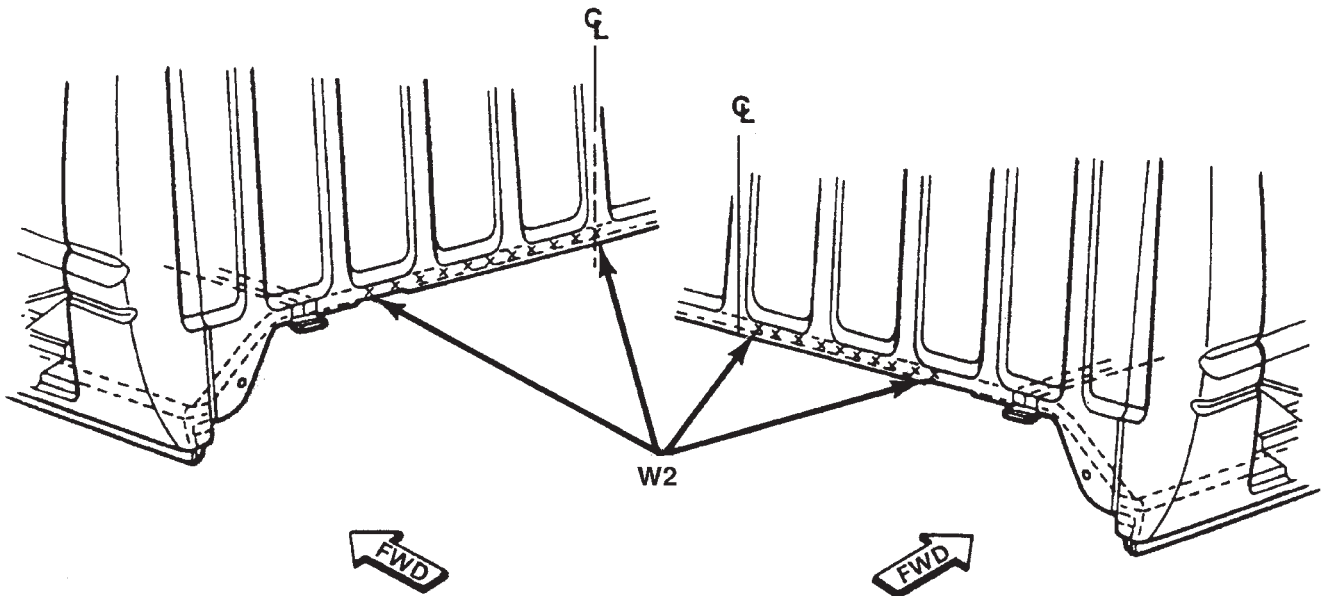
**BODY SIDE APERTURE — CLUB CAB**

BODY (Continued)



W2 - WELDING OF 2 PARTS  
W3 - WELDING OF 3 PARTS  
W4 - WELDING OF 4 PARTS

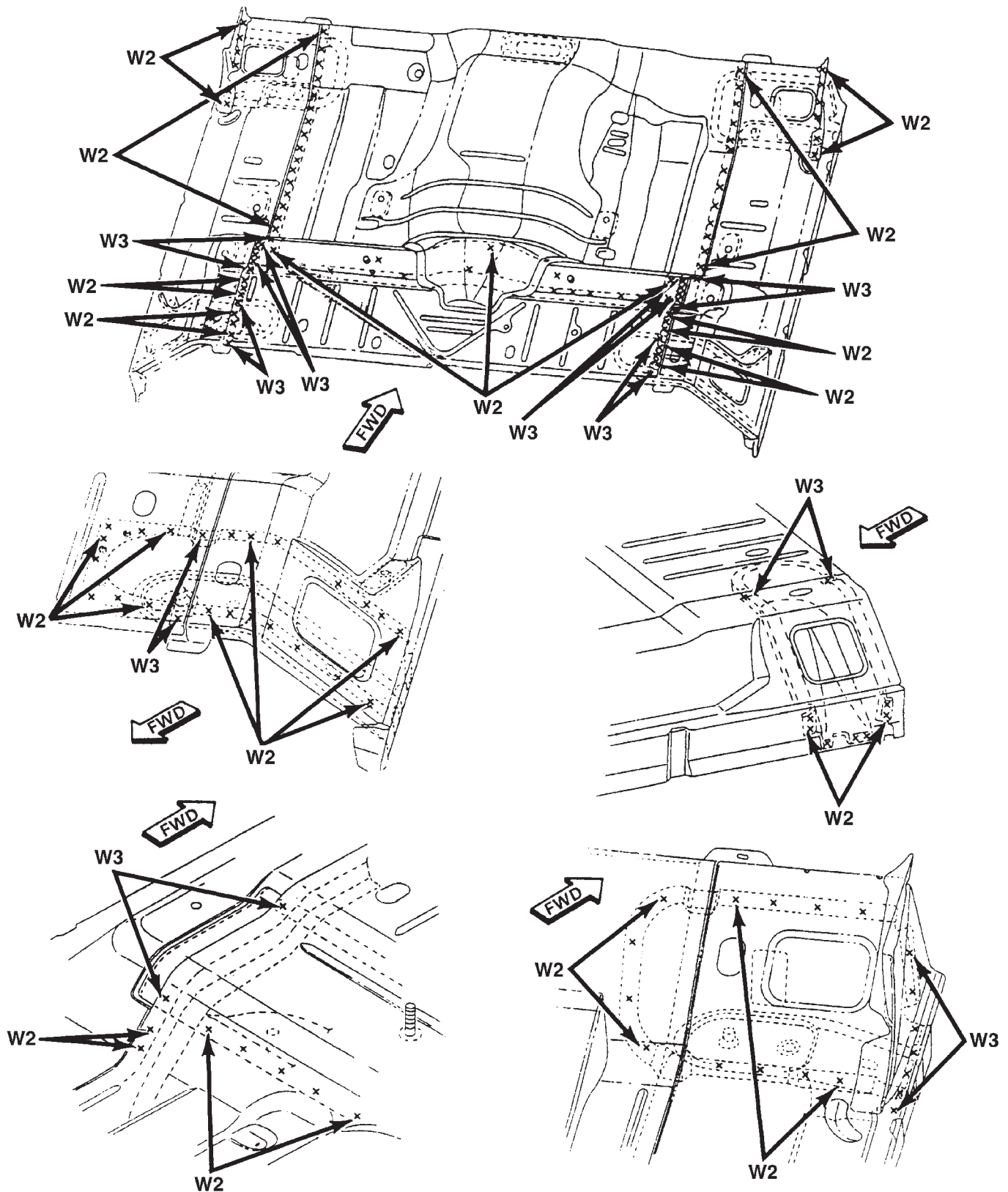
**BODY SIDE APERTURE — CLUB CAB**



W2 - WELDING OF 2 PARTS  
W3 - WELDING OF 3 PARTS  
W4 - WELDING OF 4 PARTS

CAB BACK PANEL REG CAB

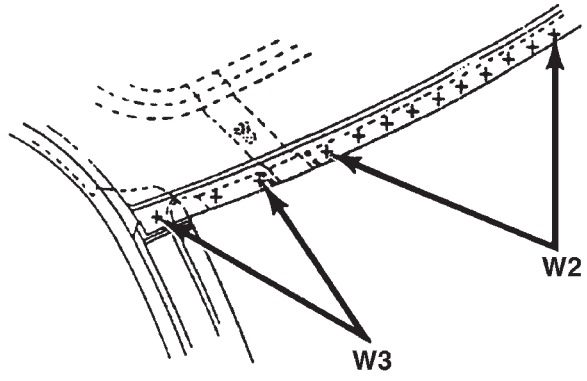
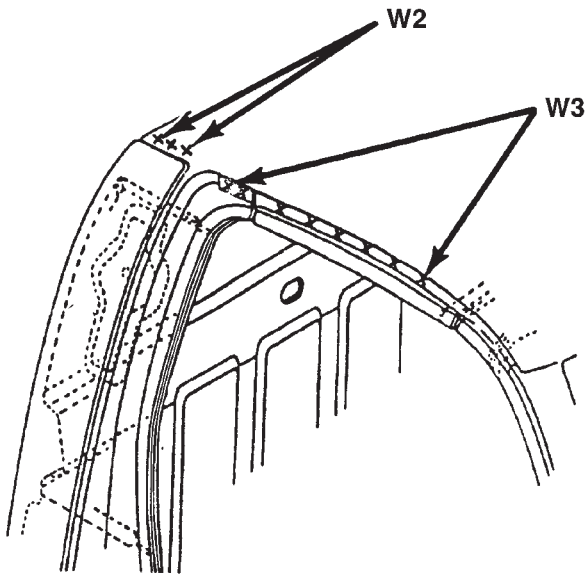
BODY (Continued)



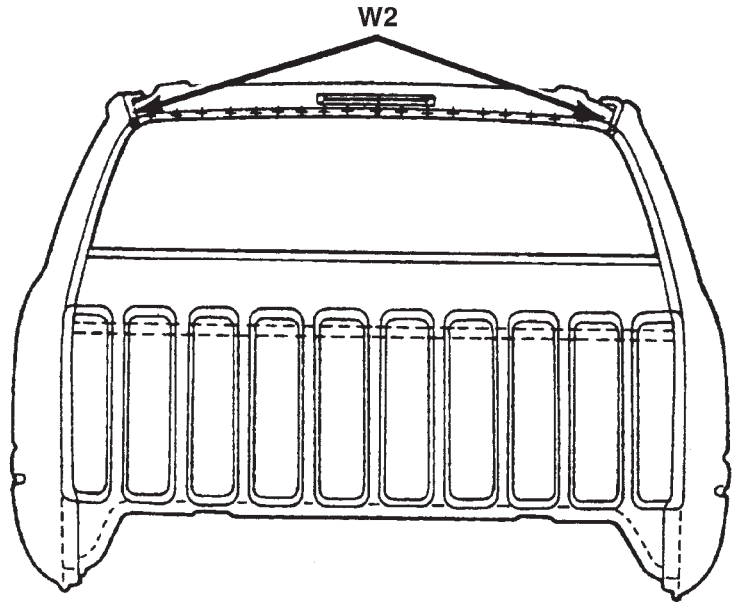
W2 - WELDING OF 2 PARTS  
W3 - WELDING OF 3 PARTS  
W4 - WELDING OF 4 PARTS

FLOOR PAN REG CAB

BODY (Continued)



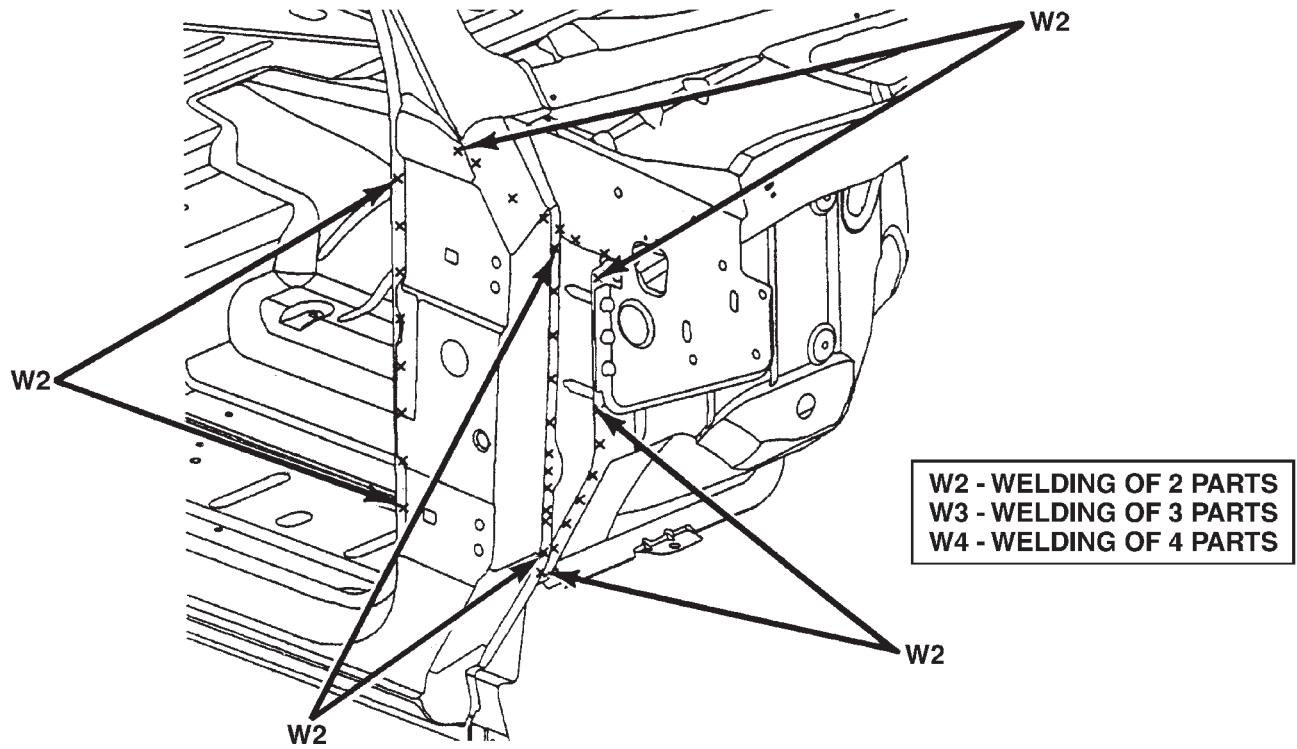
W2 - WELDING OF 2 PARTS  
W3 - WELDING OF 3 PARTS  
W4 - WELDING OF 4 PARTS



ROOF PANEL - REG CAB



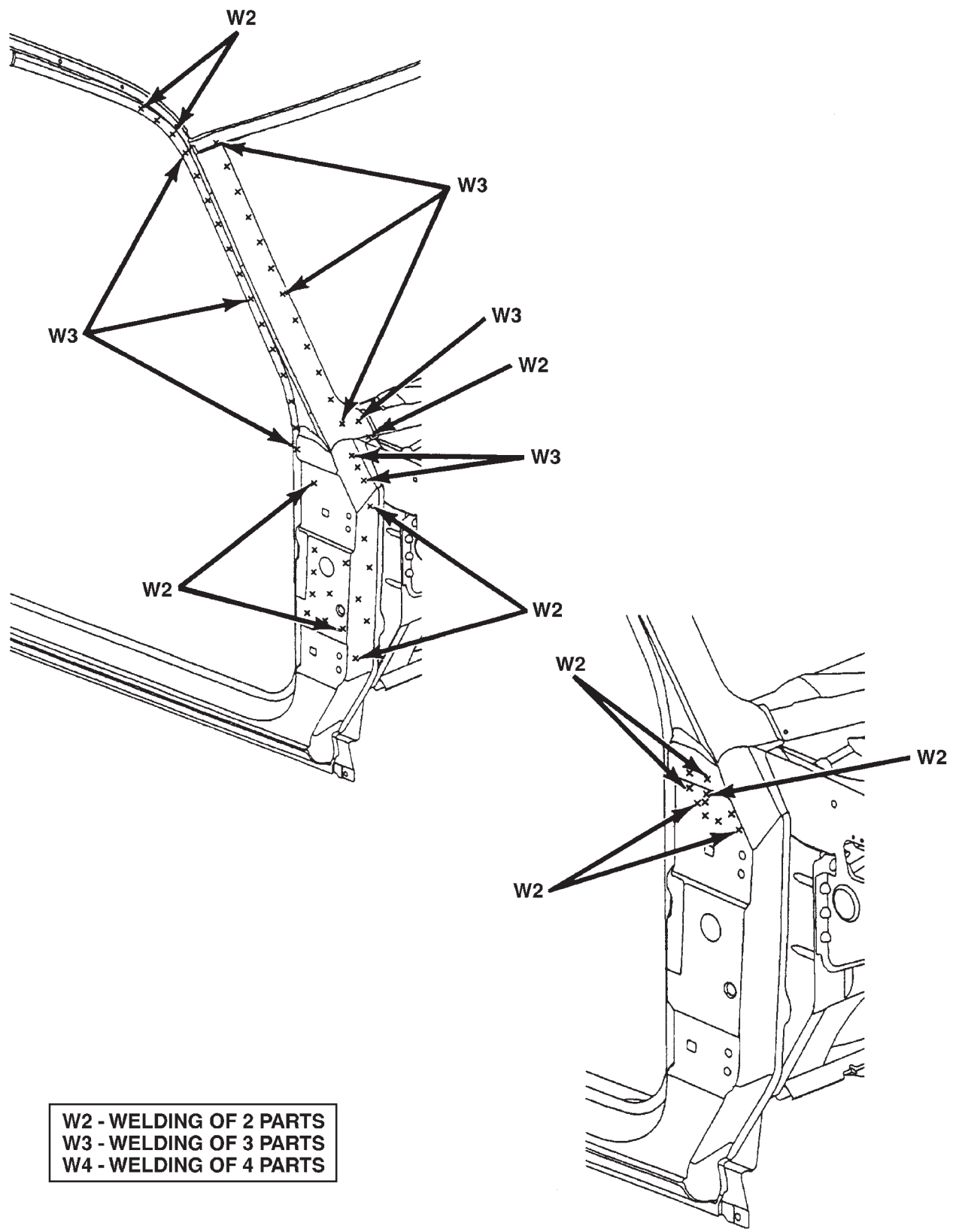
BODY (Continued)



80b62aea

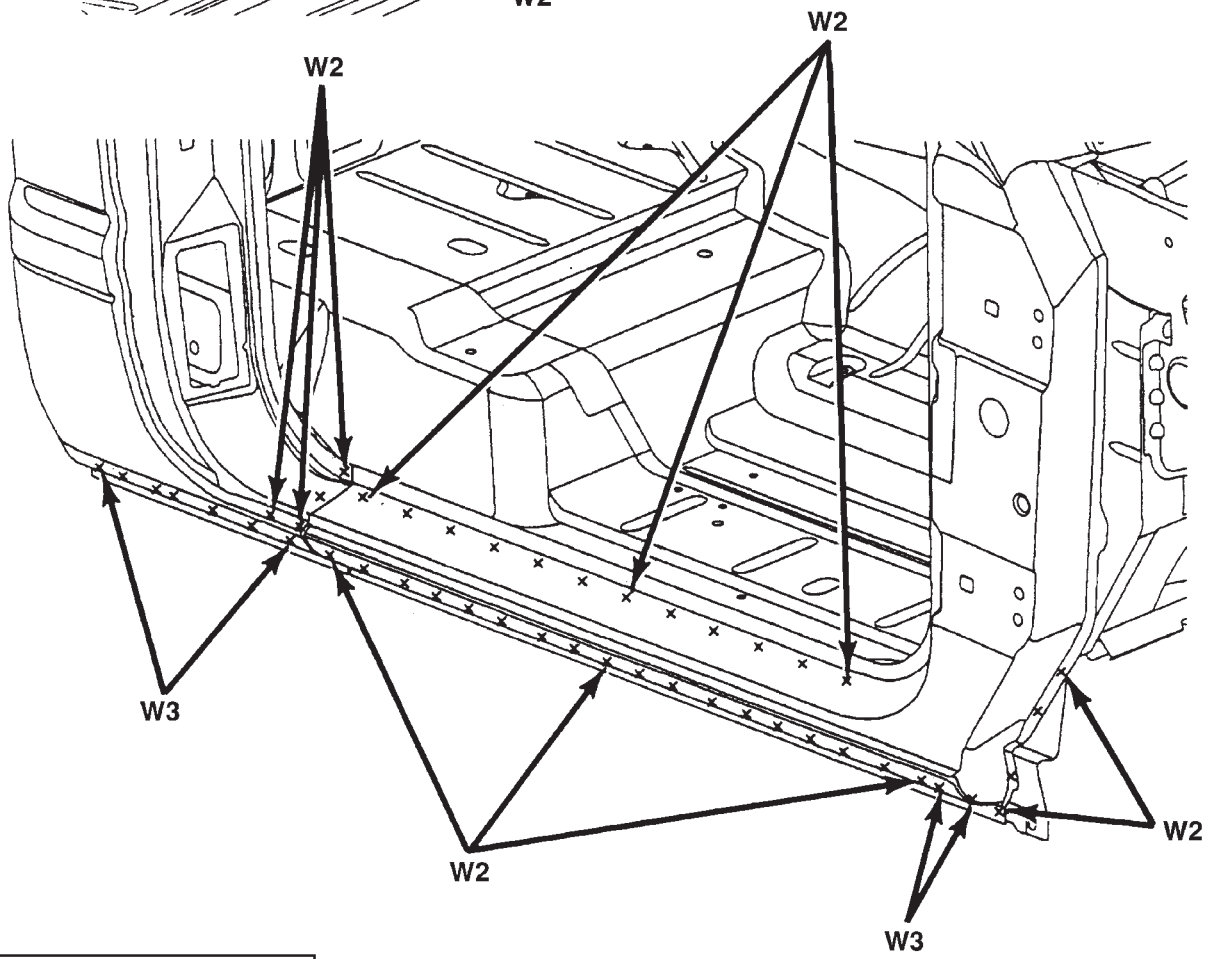
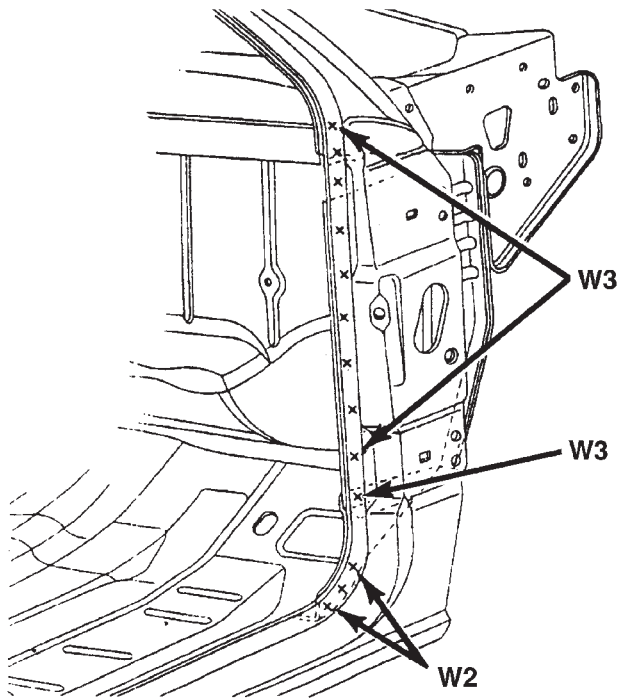
**BODY SIDE APERTURE - REG CAB**

BODY (Continued)



BODY SIDE APERTURE - REG CAB

BODY (Continued)

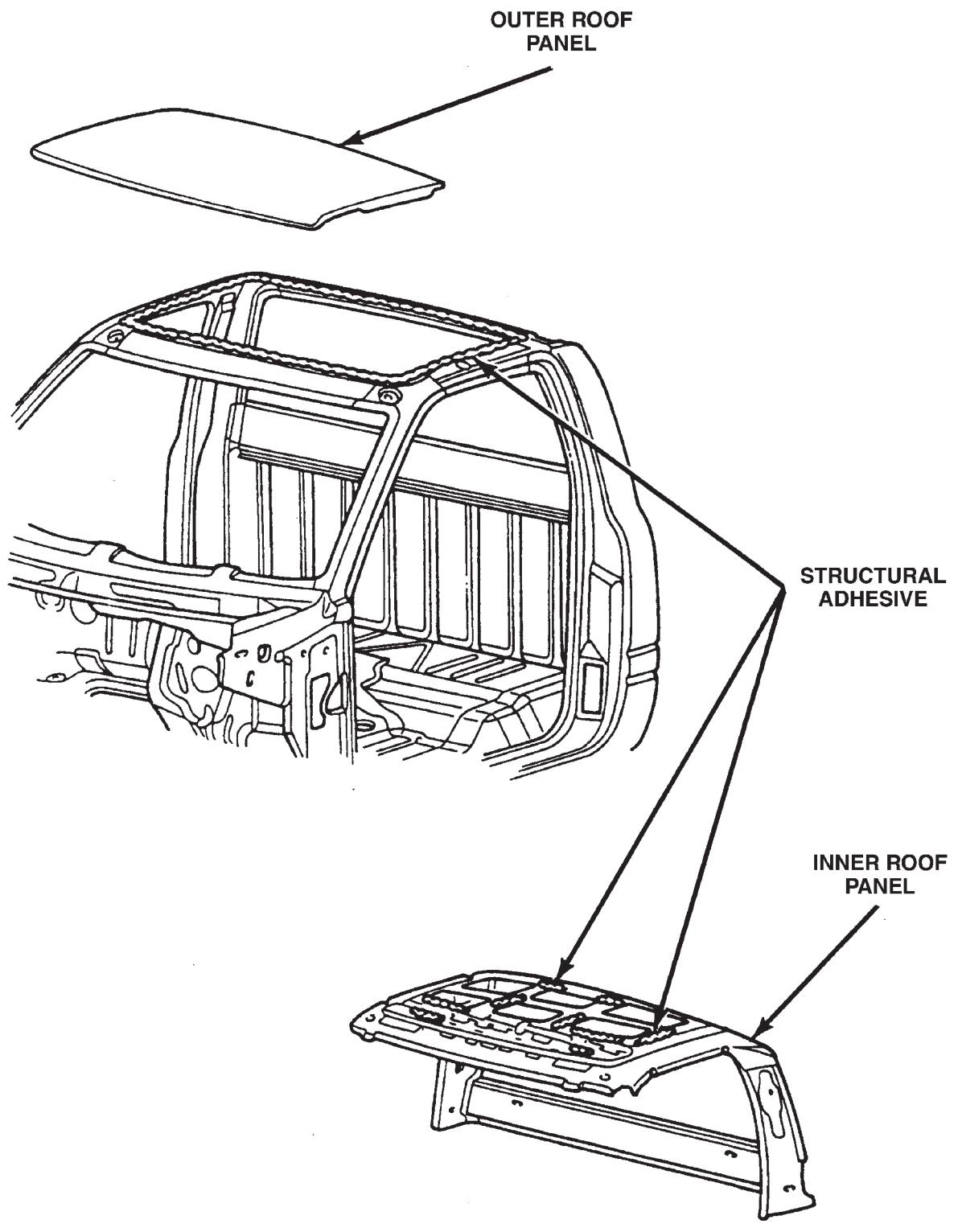


W2 - WELDING OF 2 PARTS  
W3 - WELDING OF 3 PARTS  
W4 - WELDING OF 4 PARTS

BODY SIDE APERTURE - REG CAB

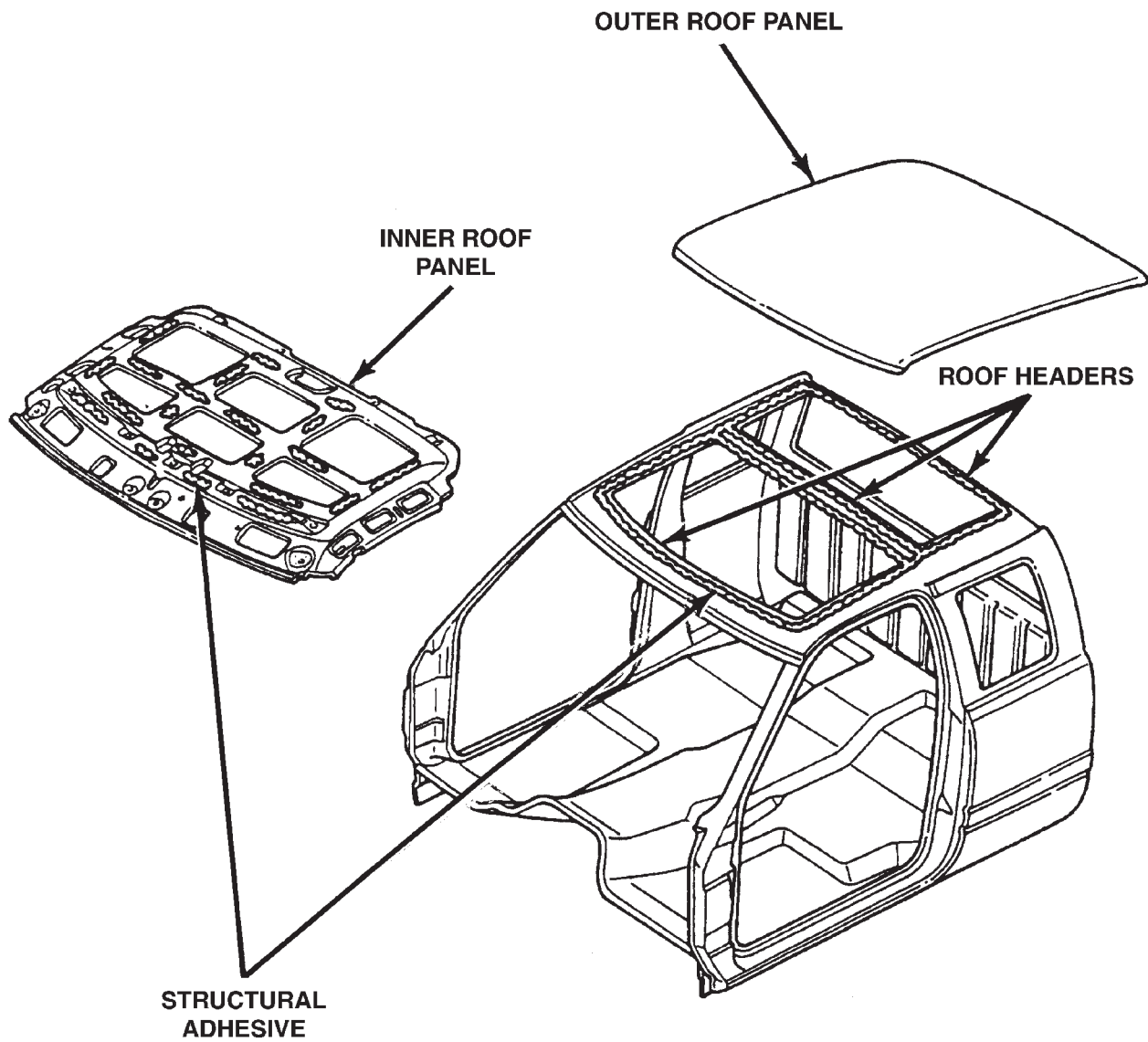
BODY (Continued)

STRUCTURAL ADHESIVE LOCATIONS



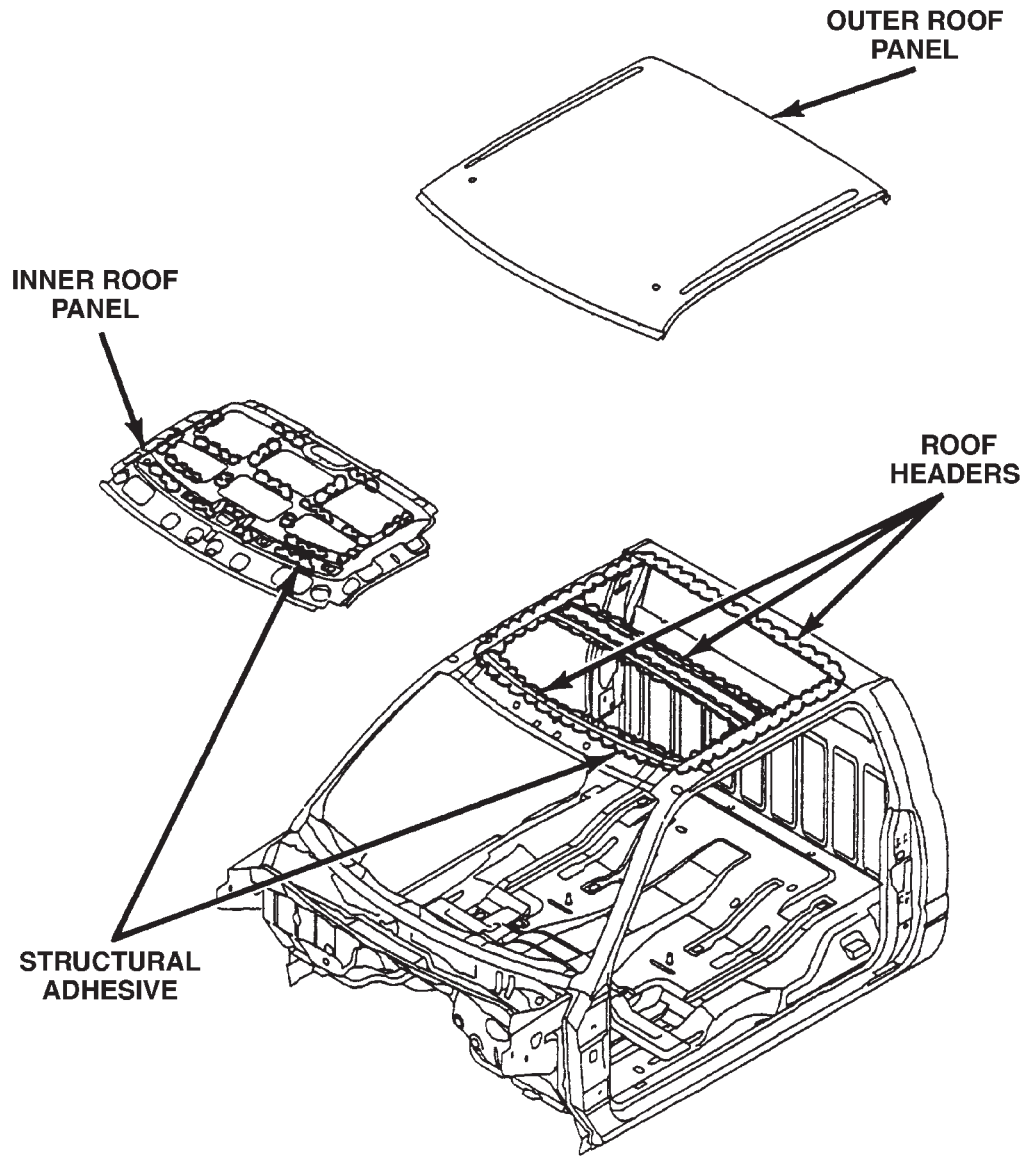
ROOF PANELS — REGULAR CAB

BODY (Continued)



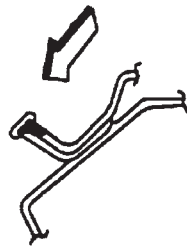


BODY (Continued)

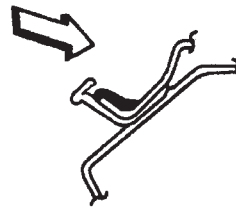


BODY (Continued)

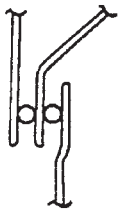
**BODY SEALER LOCATIONS**



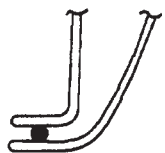
**HOLD GUN NOZZLE IN DIRECTION OF ARROW IN ORDER TO EFFECTIVELY SEAL METAL JOINTS.**



**DO NOT HOLD GUN NOZZLE IN DIRECTION OF ARROW. SEALER APPLIED AS SHOWN IN INEFFECTIVE.**



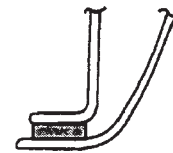
**3 METAL THICKNESS**



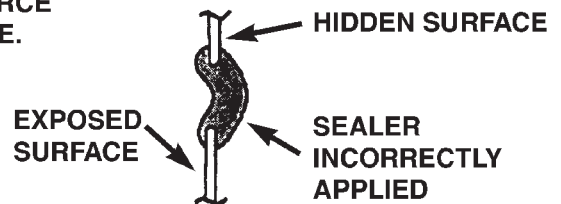
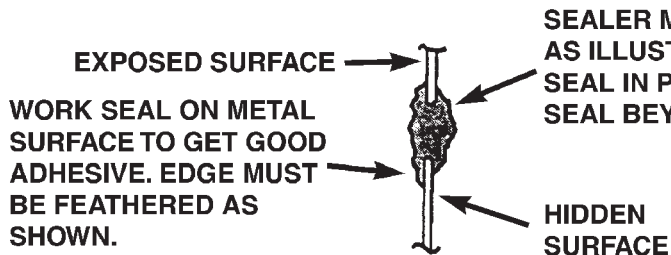
**2 METAL THICKNESS**



**3 METAL THICKNESS**



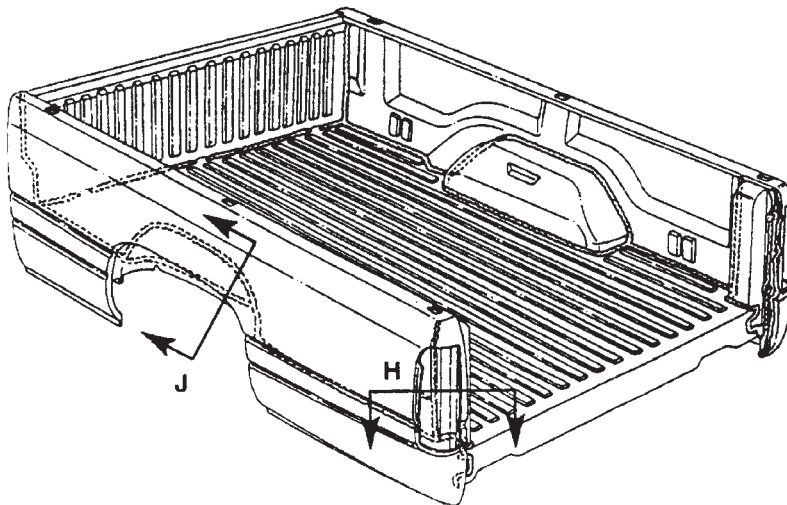
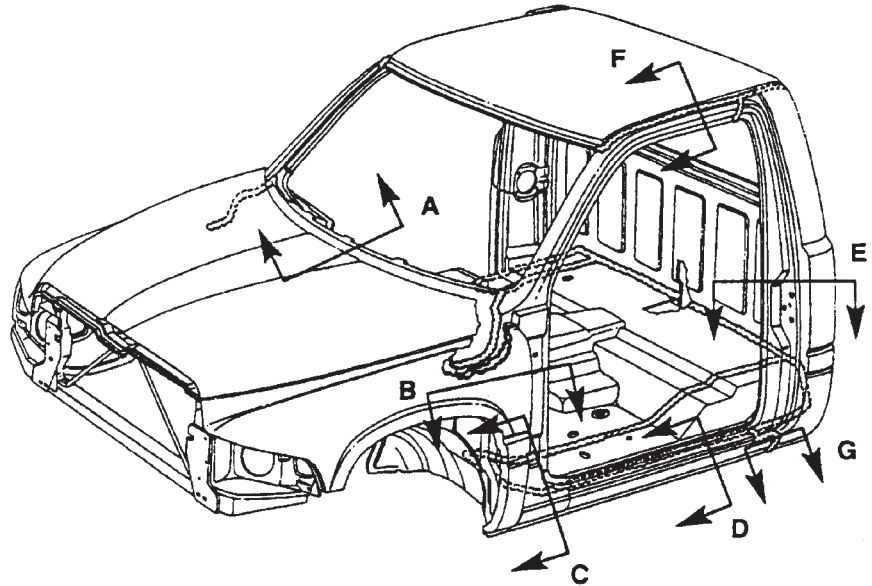
**2 METAL THICKNESS**



SYMBOLS	
	THUMBGRADEABLE SEALER
	EXTRUDABLE THERMOPLASTIC
	EXPOSED THERMOPLASTIC SEALANT
	HIDDEN SEALANT

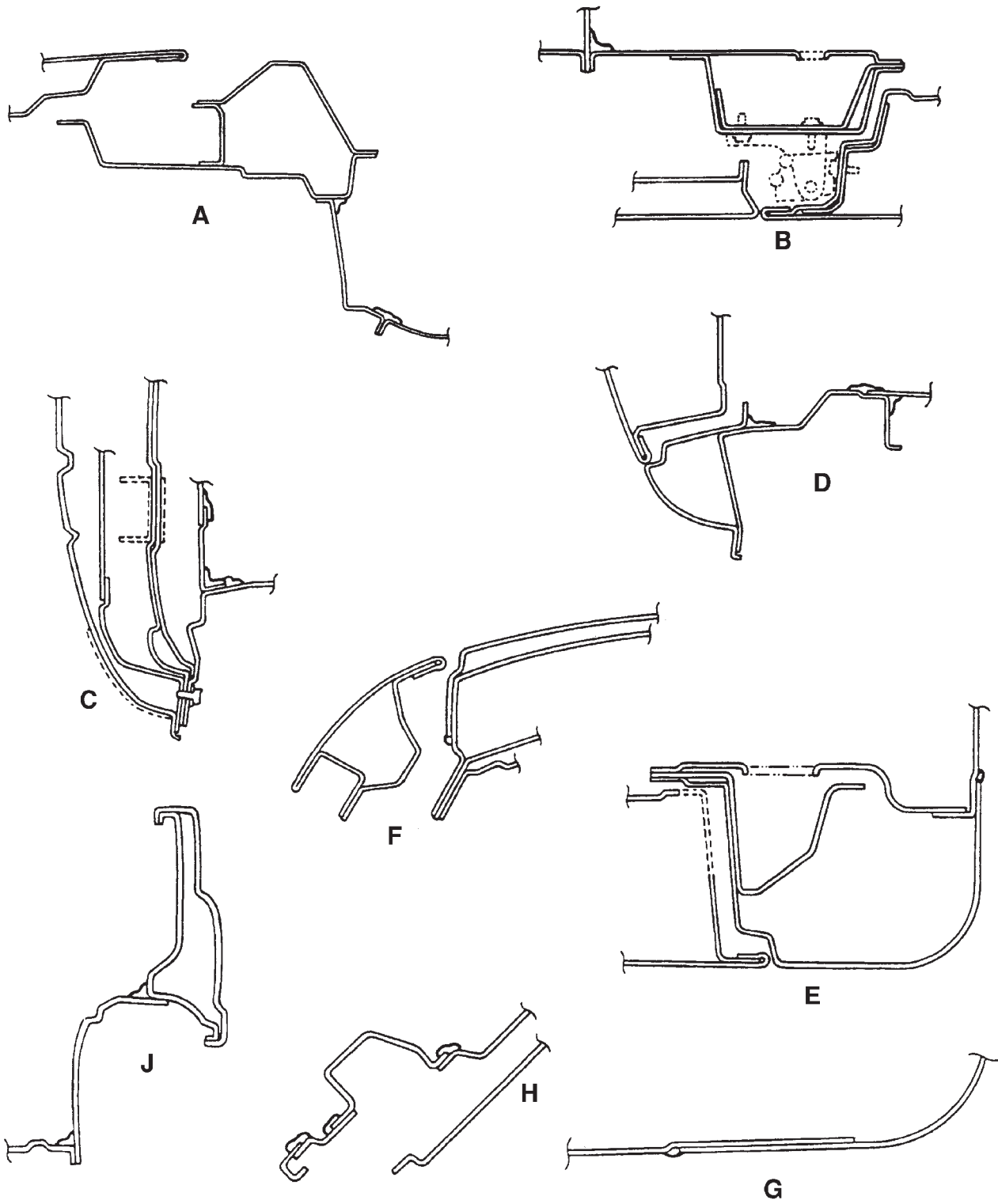
BODY (Continued)

- A - COWL AND PLENUM
- B - HINGE PILLAR TOP VIEW
- C - HINGE PILLAR END VIEW
- D - FLOOR AND SIDE SILL
- E - B-PILLAR
- F - ROOF SIDE RAIL
- G - SIDE SILL TO QUARTER PANEL
- H - BOX REAR CORNER
- J - BOX WHEEL WELL



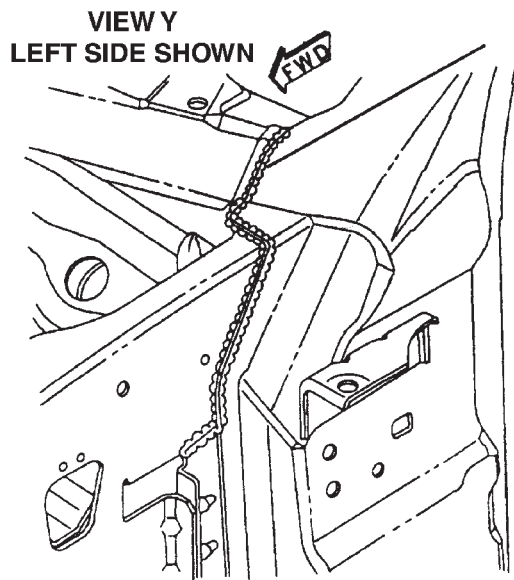
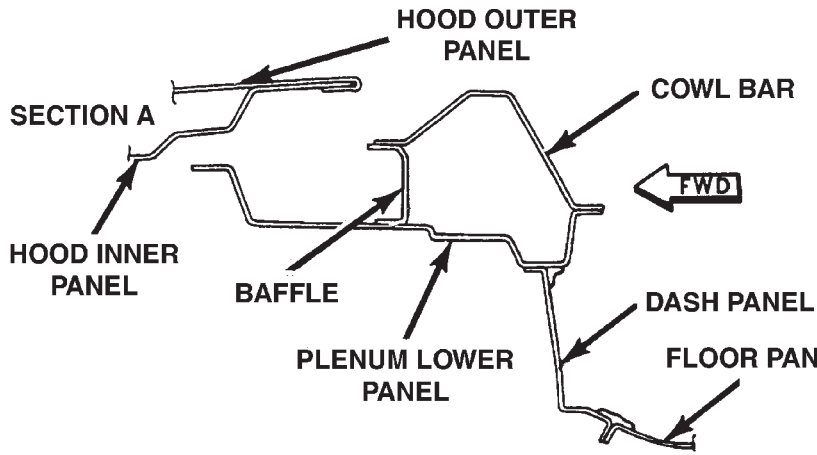
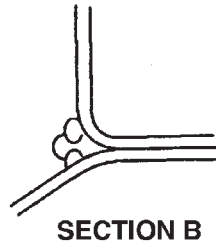
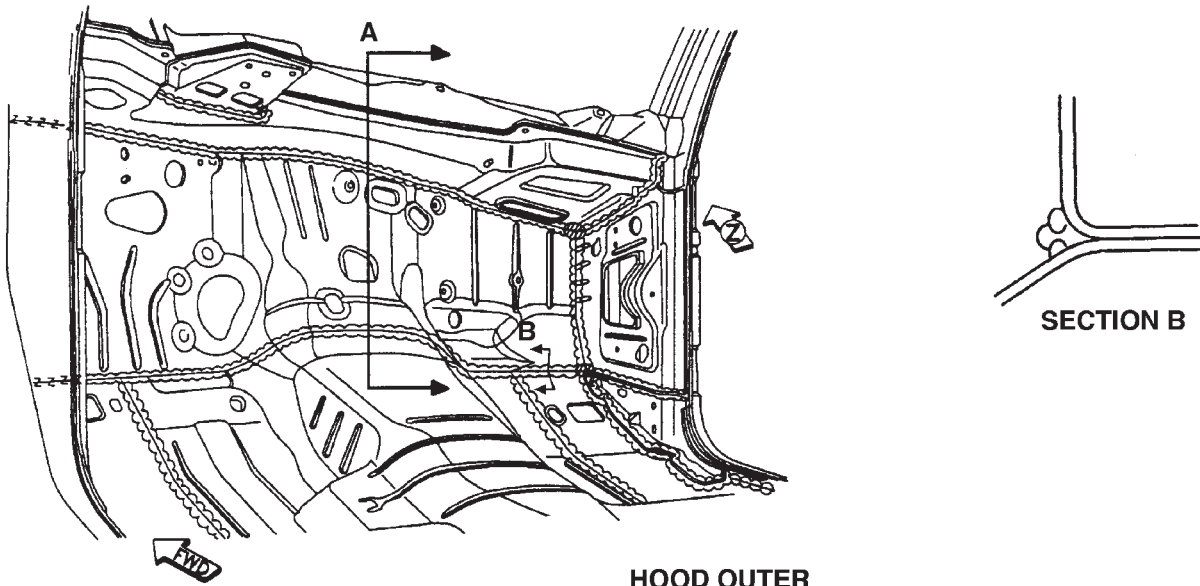
**SEALER LOCATION**

BODY (Continued)



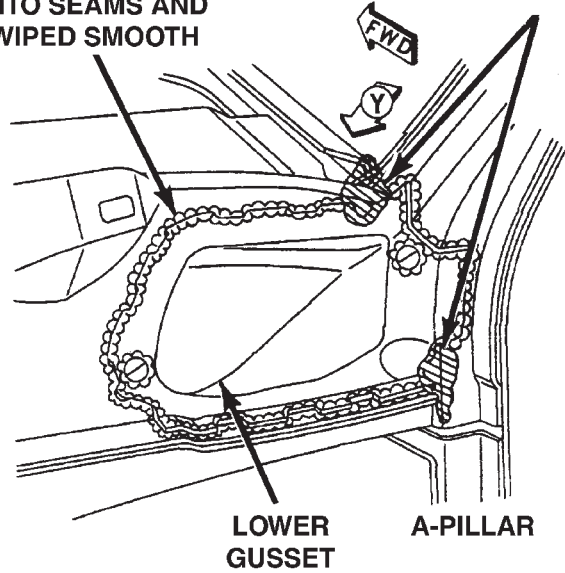
CUT-AWAY VIEW

BODY (Continued)



THUMBGRADABLE SEALER PRESSED INTO THESE LOCATIONS

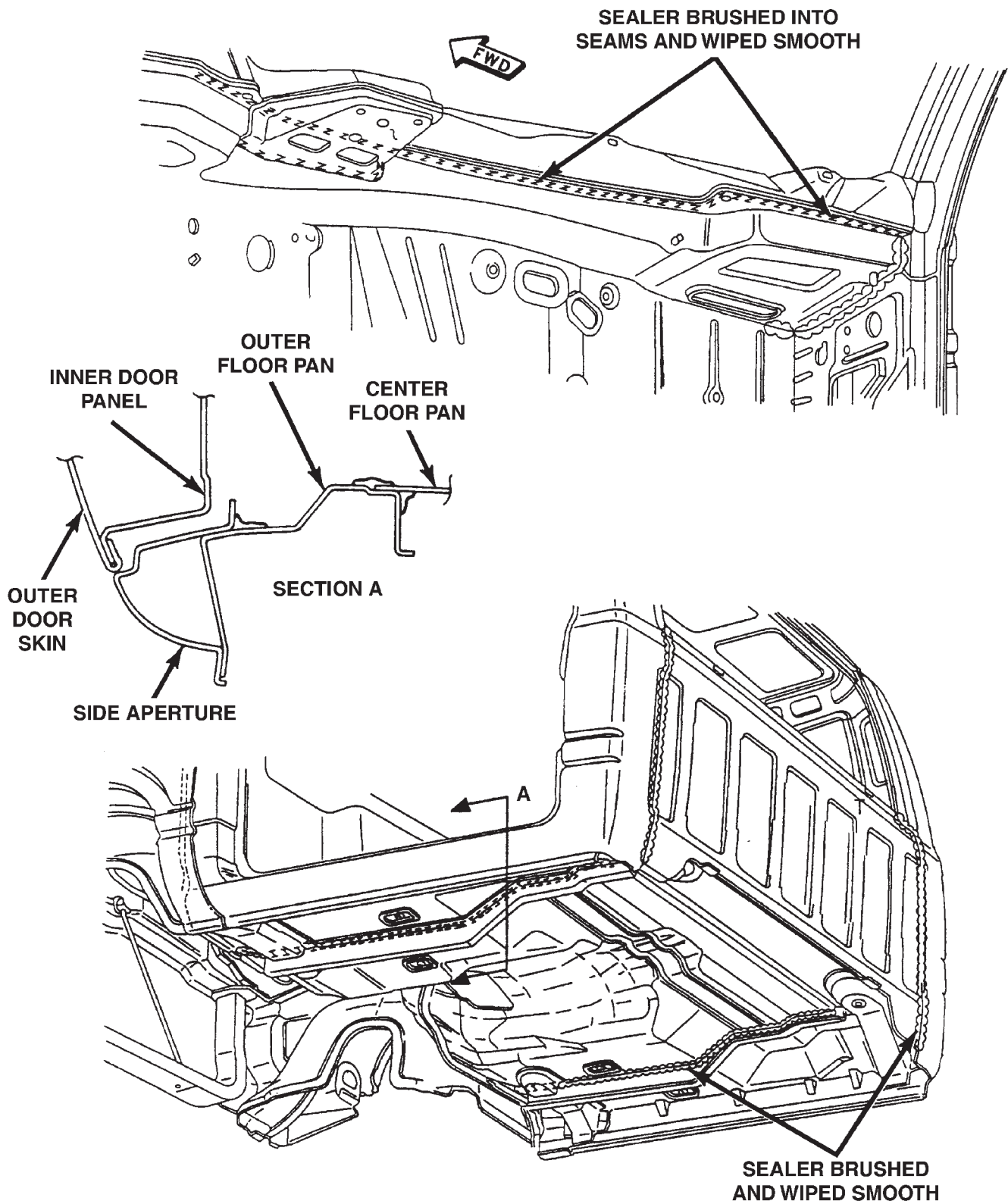
SEALER BRUSHED INTO SEAMS AND WIPED SMOOTH



COWL AND DASH PANEL



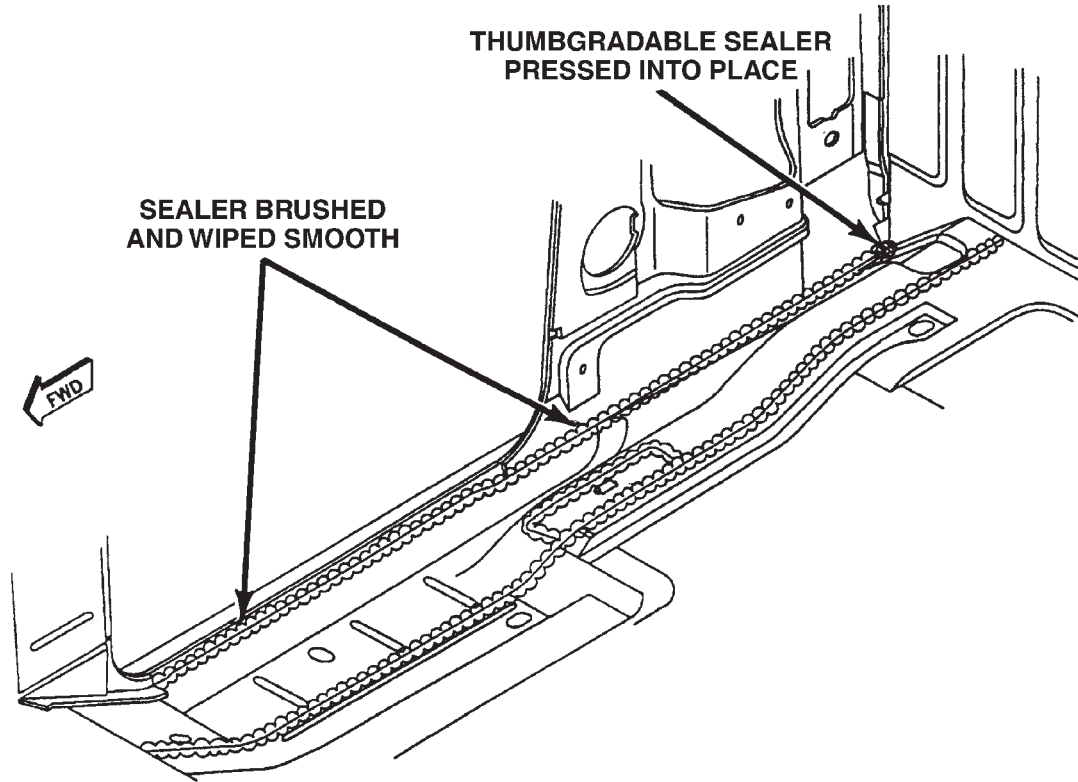
BODY (Continued)



**NOTE: SEALER ON UNDERSIDE OF FLOOR PAN IS USED ONLY ON VEHICLES BUILT IN MEXICO.**

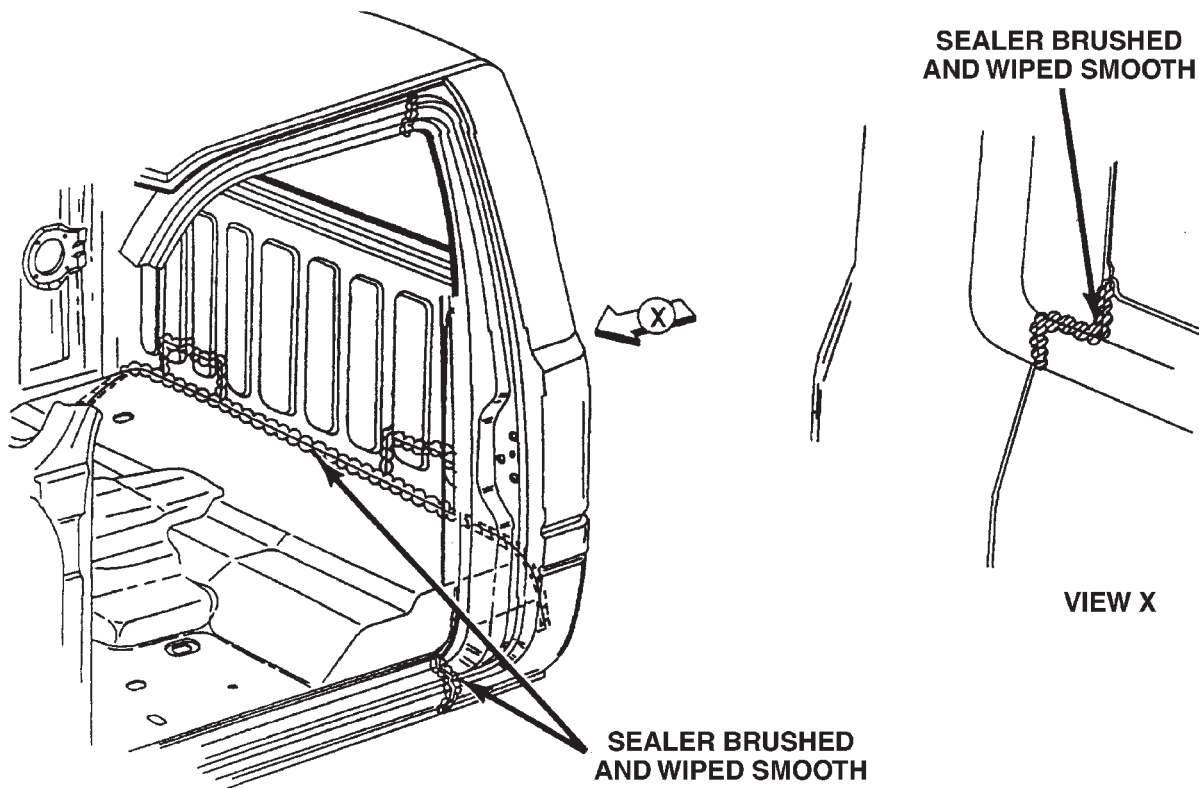
80b62b1e

**COWL AND DASH PANEL**



FLOOR PAN

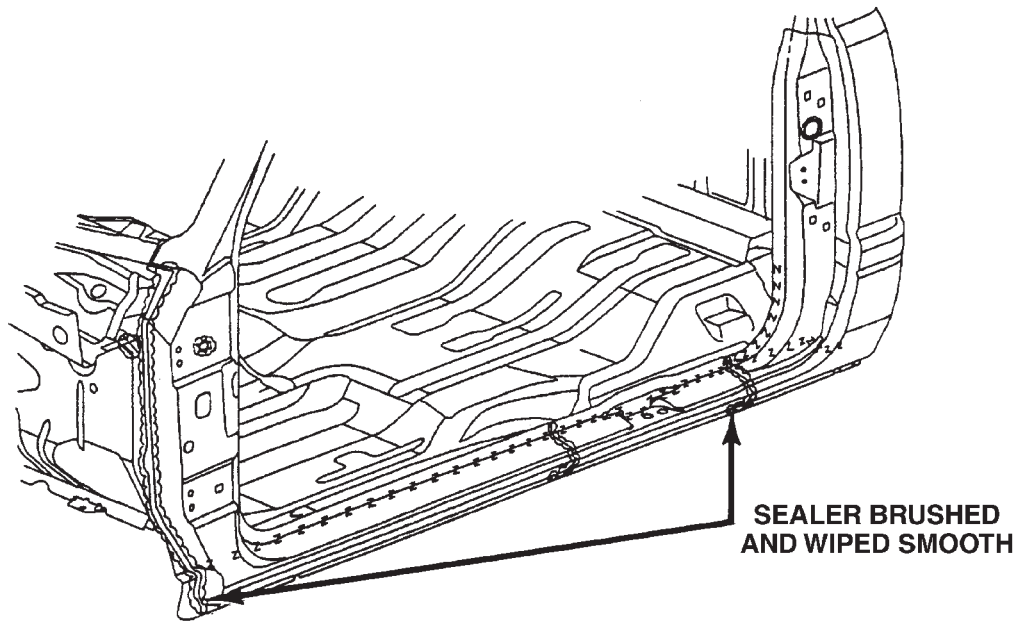
80b62bdb



CAB BACK PANEL

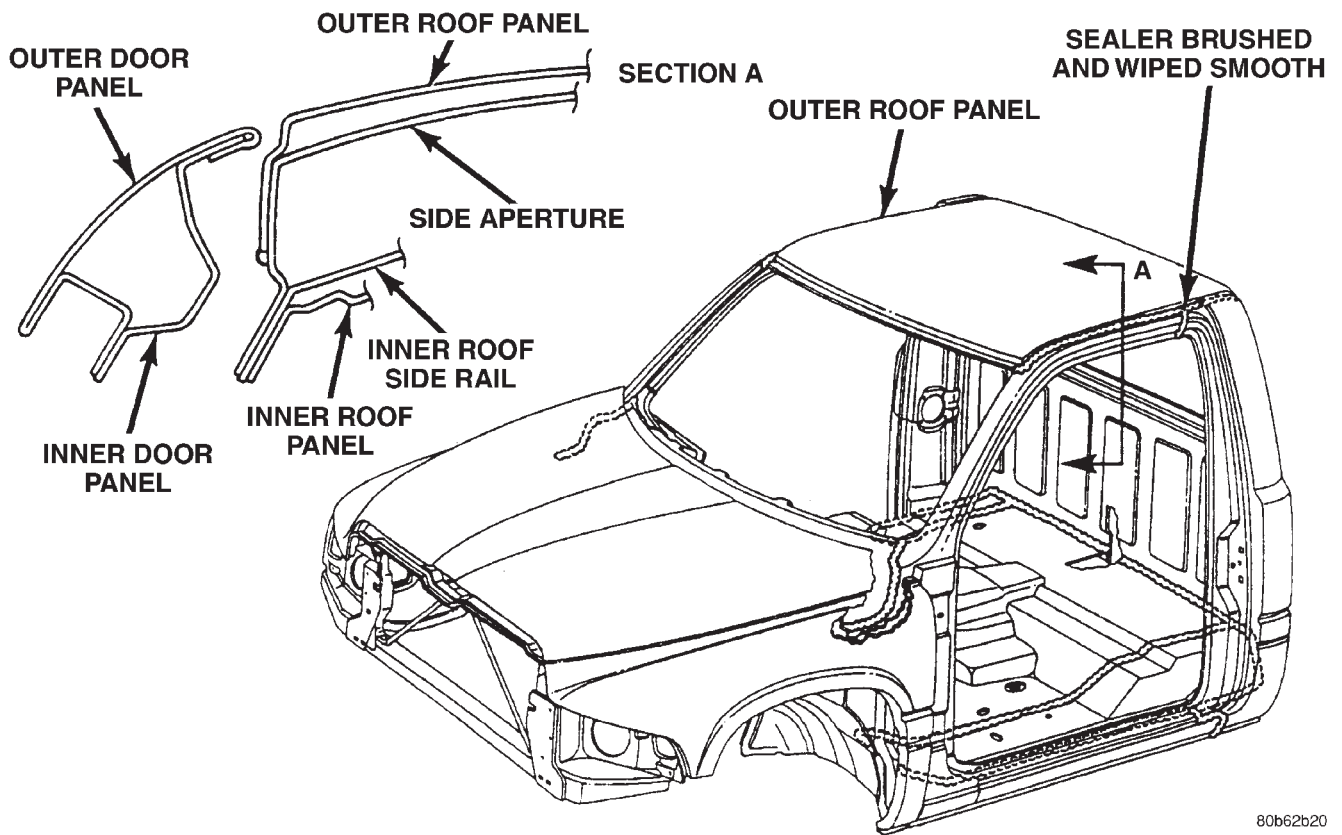
80b62b1f

BODY (Continued)



80b62bdc

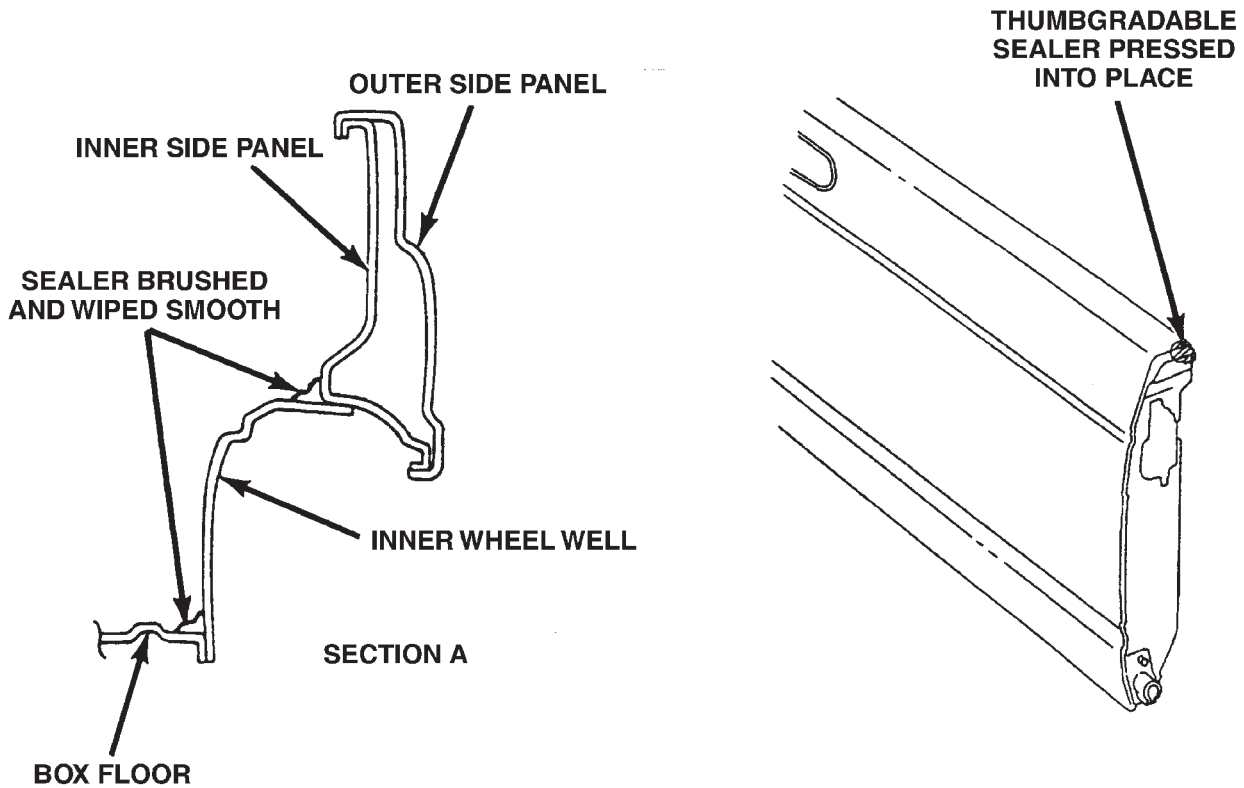
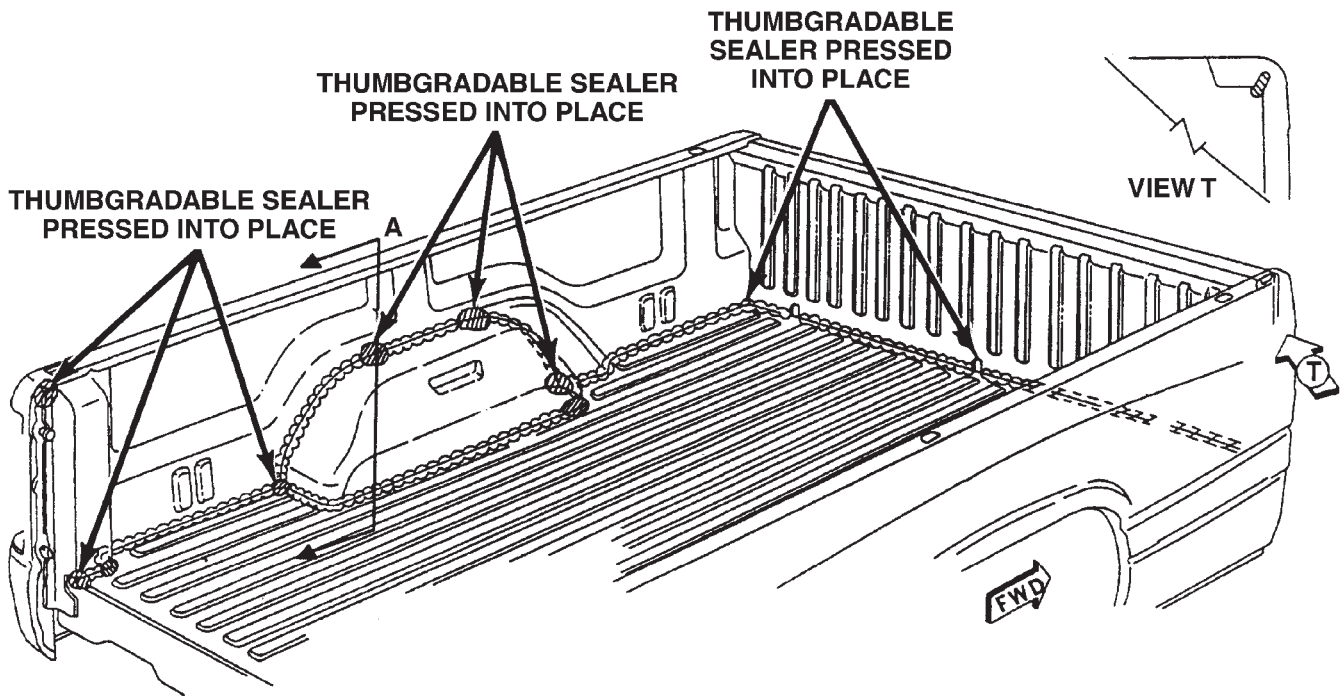
CAB REAR PANEL



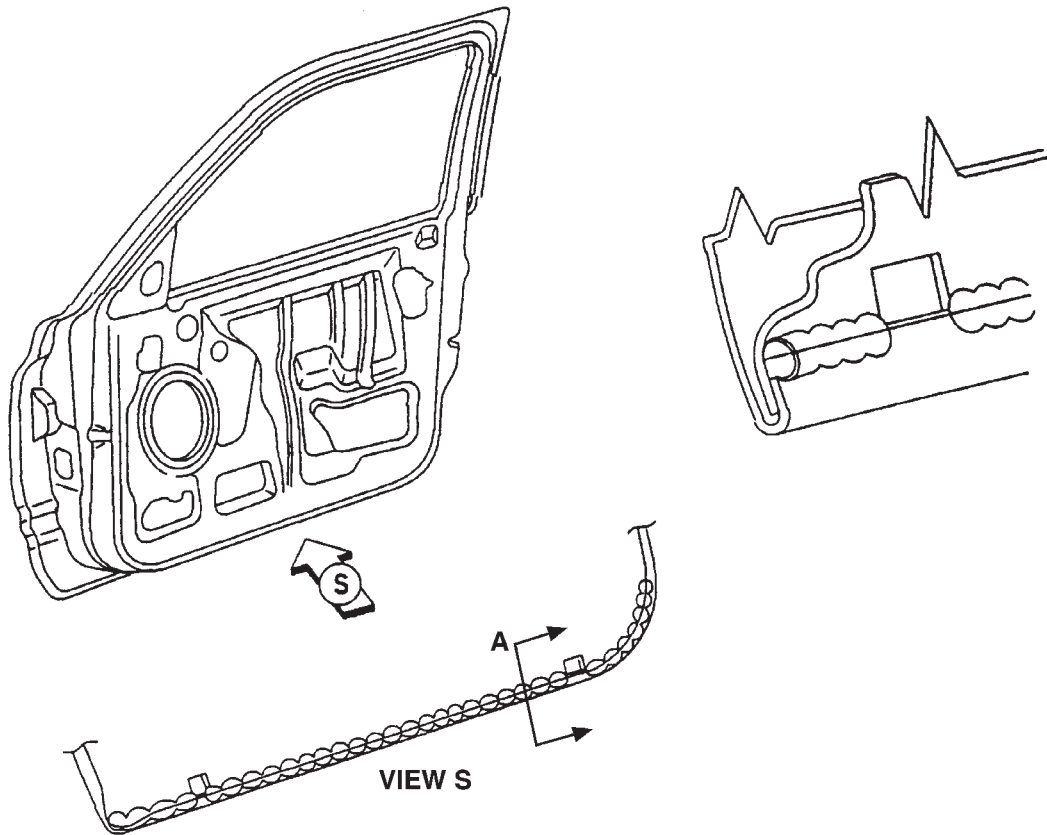
80b62b20

ROOF PANEL

BODY (Continued)



BODY (Continued)



**DOORS**

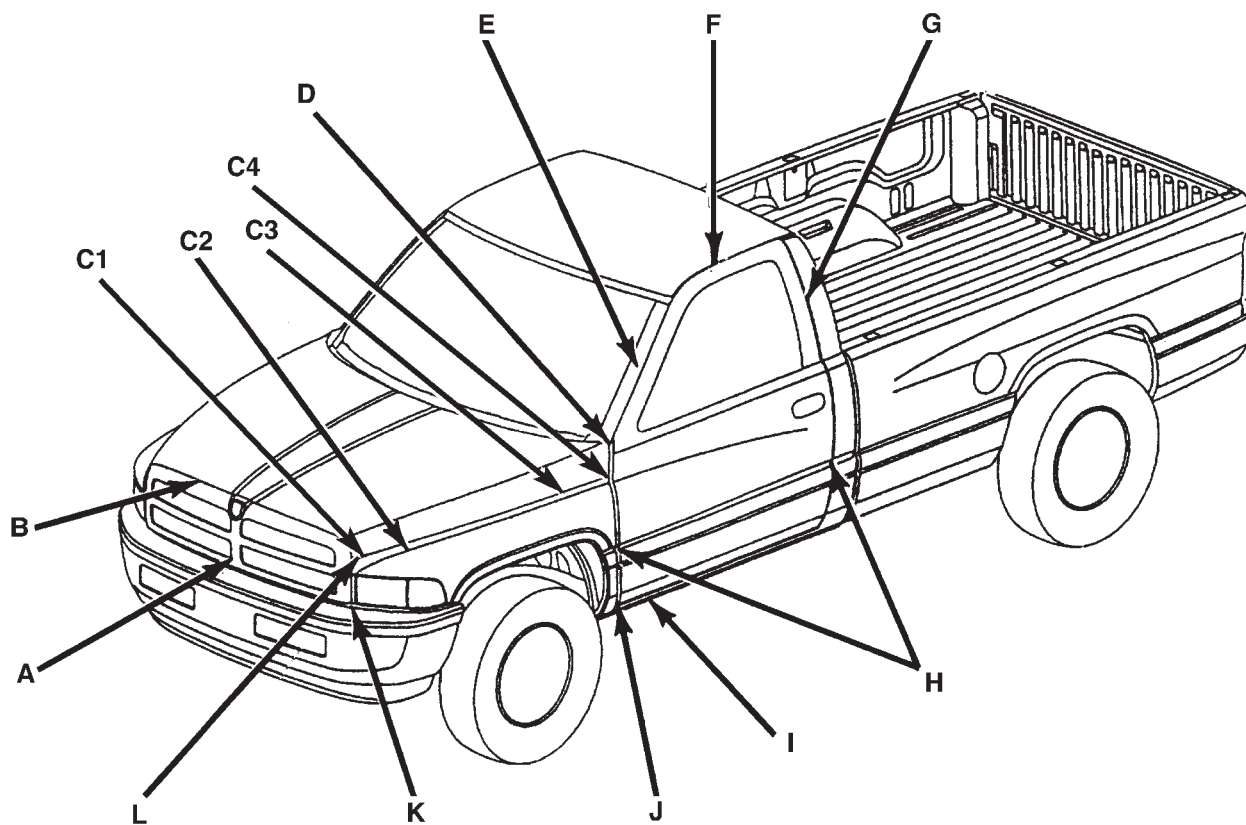
809db9e6



BODY (Continued)

## BODY GAP AND FLUSH MEASUREMENTS

## REGULAR CAB



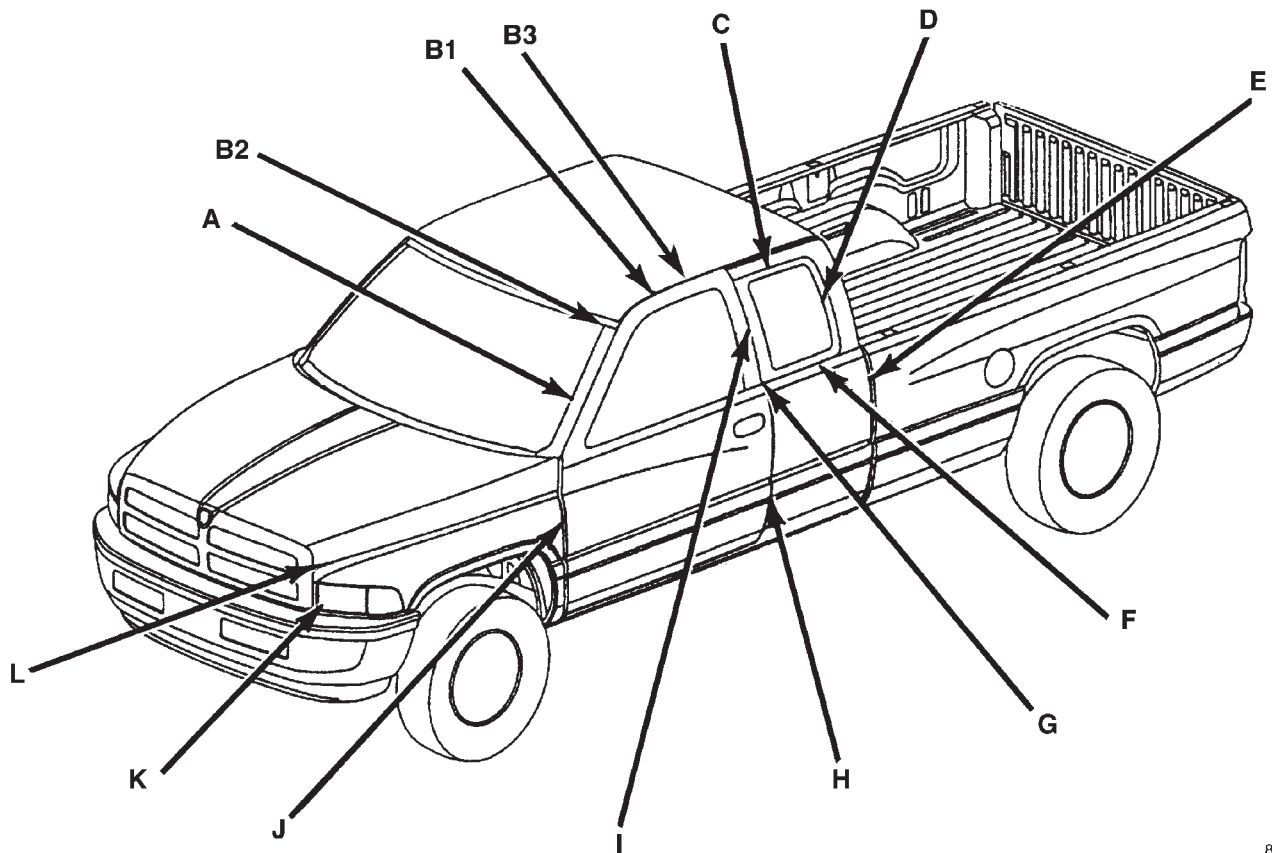
809db663

**REGULAR CAB**

	<b>DESCRIPTION</b>	<b>GAP</b>	<b>FLUSH</b>
A	Grille to Fascia	19.0 +/- 3.0	N/A
B	Hood to Grille	1.0 +/- 0.75	0.0 + 0.0/- 1.0
C1	Hood to Fender	6.0 +/- 1.0	1.5 +/- 1.0
C2	Hood to Fender	6.0 +/- 1.0	3.5 +/- 1.0
C3	Hood to Fender	6.0 +/- 1.0	1.5 +/- 1.0
C4	Hood to Fender	6.0 +/- 1.0	1.5 +/- 1.0
D	Door to Hood/Fender	5.0 +/- 1.0	0.0 +/- 1.0
E	Door to Windshield Molding	N/A	2.0 +/- 2.0
F	Door to Roof	6.0 +/- 1.5	2.0 +/- 1.0
G	Door to Quarter	5.0 +/- 1.0	0.0 +/- 1.0
H	Fender/Door/Quarter Char Line U/D	N/A	0.0 +/- 1.0
I	Door to Sill	7.7 +/- 2.0	0.0 +/- 1.5
J	Fender to Aperture	5.0 +/- 1.0	0.0 +/- 1.0
K	Grille to Headlamp	6.0 +/- 3.0	N/A
L	Grille to Fender	5.0 +/- 0.75	1.0 +/- 0.5

BODY (Continued)

CLUB CAB



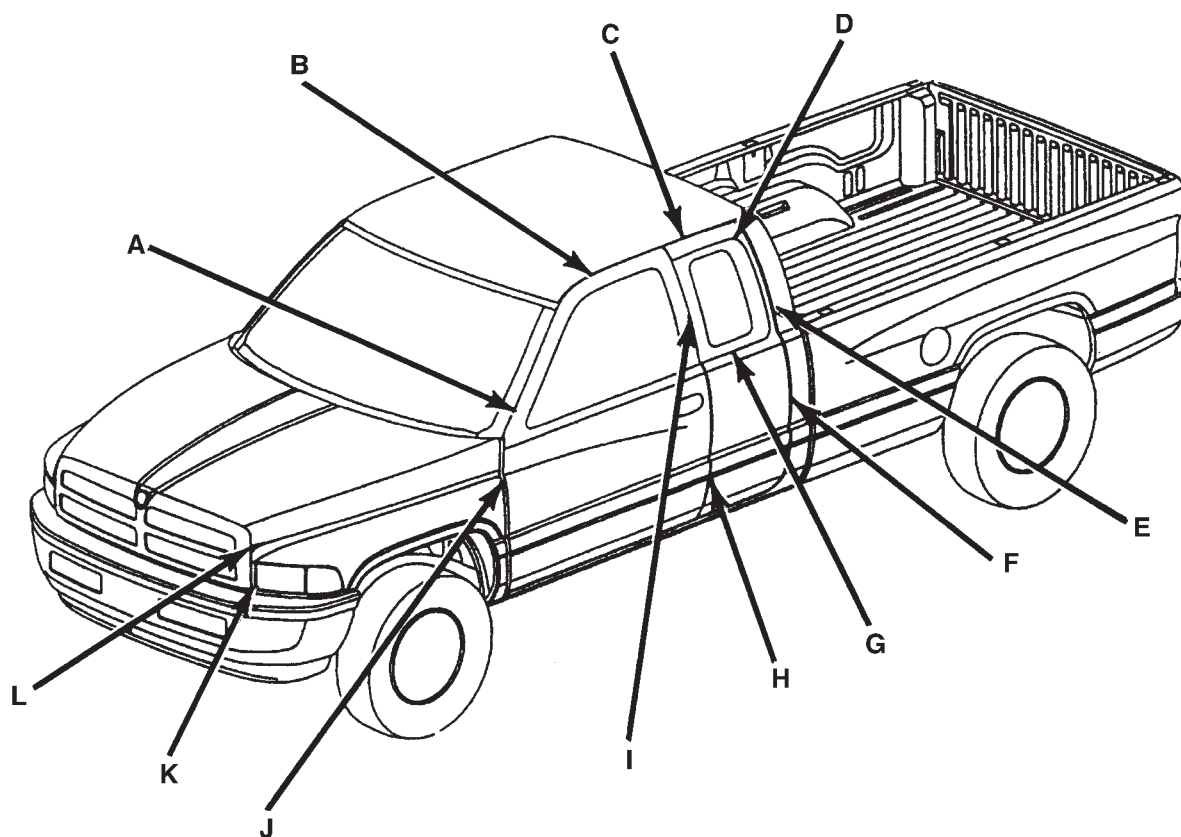
809dbeab

**CLUB CAB**

	<b>DESCRIPTION</b>	<b>GAP</b>	<b>FLUSH</b>
A	Door to Windshield Molding	N/A	2.0 +/- 2.0
B1	Door to Roof	5.0 +/- 1.5	0.0 +/- 1.0
B2	Door to Roof	5.0 +/- 1.5	1.4 ± 1.0 CONS. W/IN 1.5
B3	Door to Roof	5.0 +/- 1.5	4.1 ± 1.0 CONS. W/IN 1.5
C	Quarter Glass to Quarter (top)	5.0 +/- 1.0	3.5 +/- 1.5
D	Quarter Glass to Quarter (rear)	5.0 +/- 2.0	3.25 +/- 1.5
E	Cab to Box (side view)	31.0 +/- 3.0	3.25 +/- 2.5
F	Quarter Glass to Quarter (bottom)	5.0 +/- 1.5	N/A
G	Quarter Glass to Quarter (front)	in-line within +/- 1.0	
H	Door to Quarter	5.0 +/- 1.0	0.0 +/- 1.0
I	Quarter Glass to Door	N/A	2.0 +/- 1.5
J	Door to Hood/Fender	5.0 +/- 1.0	0.0 +/- 1.0
K	Grille to Headlamp	6.0 +/- 3.0	N/A
L	Grille to Fender	5.0 +/- 0.75	1.0 +/- 0.5

## BODY (Continued)

## QUAD CAB



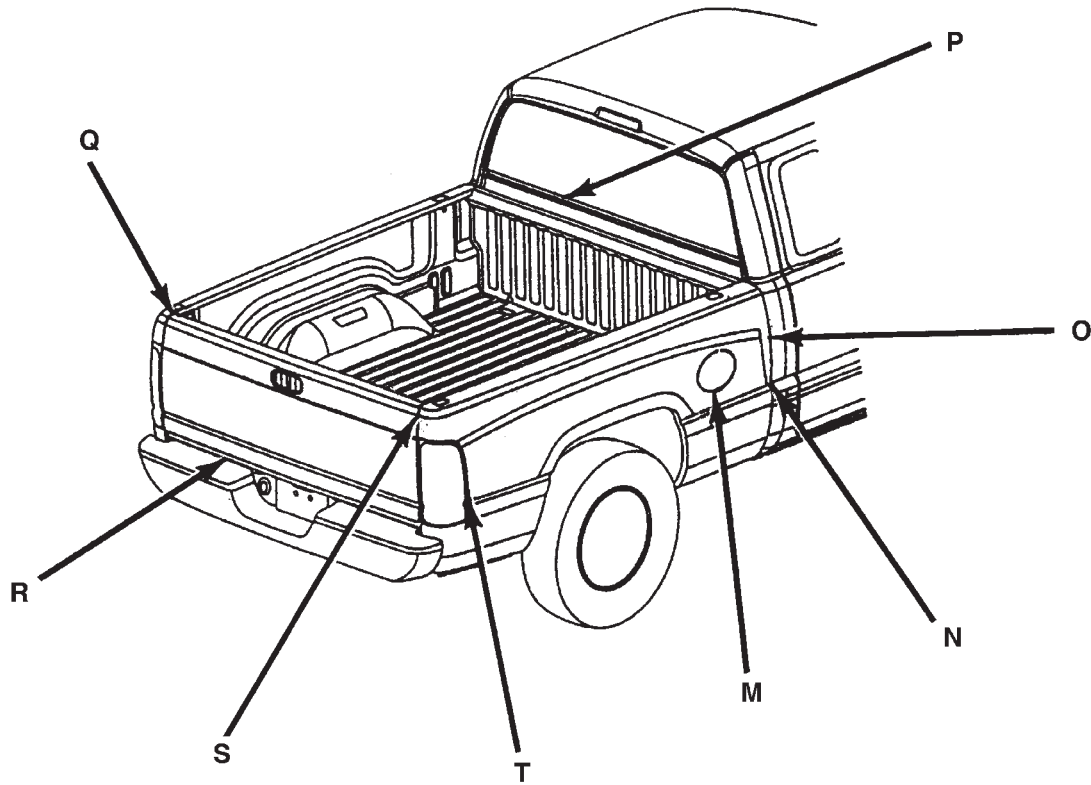
809db9c

**QUAD CAB**

	<b>DESCRIPTION</b>	<b>GAP</b>	<b>FLUSH</b>
A	Door to Windshield Molding	N/A	2.0 +/- 2.0
B	Front Door to Roof	5.0 +/- 1.5	0.0 +/- 1.0
C	Rear Door to Roof	5.0 +/- 1.0	0.0 +/- 1.0
D	Rear Door Glass to Rear Door (top)	5.0 +/- 1.0	3.25 +/- 1.5
E	Rear Door Glass to Rear Door (rear)	5.0 +/- 2.0	3.25 +/- 1.5
F	Rear Door to Quarter	5.5 +/- 1.0	0.0 +/- 1.0
G	Rear Door Glass to Rear Door (bottom)	5.0 +/- 1.5	N/A
H	Front Door to Rear Door	5.0 +/- 1.0	0.0 +/- 1.0
I	Rear Door Glass to Rear Door (front)	in-line within +/- 1.0	
	Rear Door Glass to Front Door	N/A	3.25 +/- 1.5
J	Door to Hood/Fender	5.0 +/- 1.0	0.0 +/- 1.0
K	Grille to Headlamp	6.0 +/- 3.0	N/A
L	Grille to Fender	5.0 +/- 0.75	1.0 +/- 0.5

BODY (Continued)

CARGO BOX



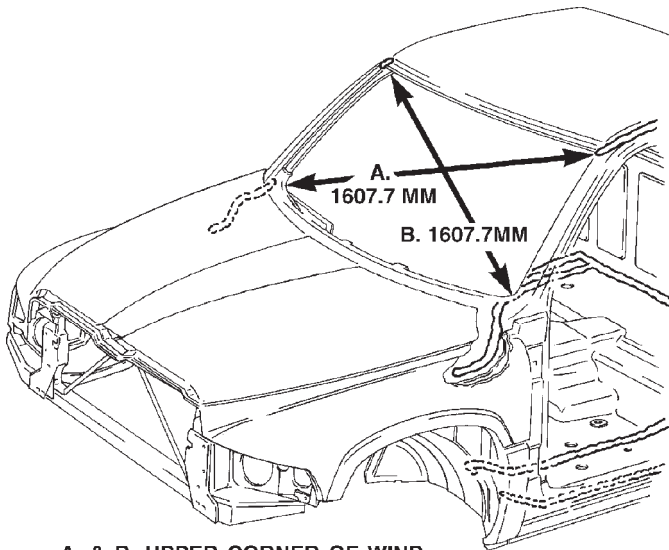
809db91e

**CARGO BOX**

	<b>DESCRIPTION</b>	<b>GAP</b>	<b>FLUSH</b>
M	Fuel Filler Door to Box	3.0 +/- 0.75	0.0 +/- 3.0
N	Cab to Box Character Line U/D	N/A	0.0 +/- 3.0
O	Cargo to Box (side)	31.0 +/- 3.0	5.0 +/- 2.5
P	Cab to Box at Centerline	34.0 +/- 3.0	N/A
Q	Box to Tailgate U/D	N/A	1.0 +/- 1.5
R	Tailgate to Bumper	43.0 +/- 3.0	N/A
S	Box to Tailgate	6.0 +/- 1.5	1.0 +/- 1.5
T	Box to Tailgate	1.0 +/- 1.0	4.0 +/- 1.5

BODY (Continued)

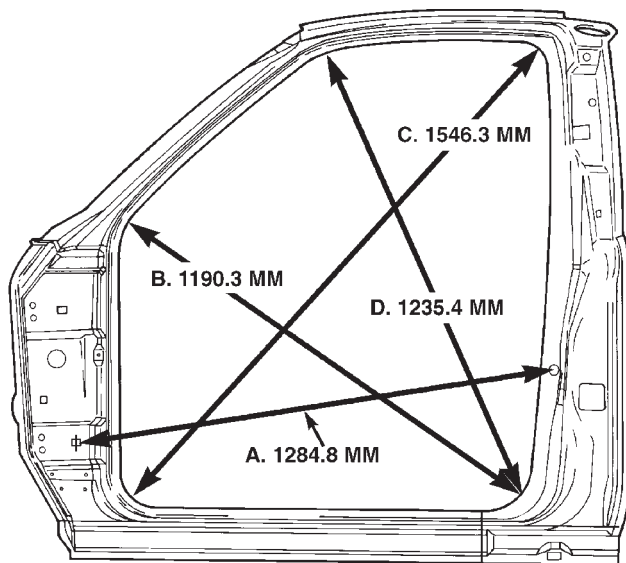
BODY OPENING DIMENSIONS



A. & B. UPPER CORNER OF WINDSHIELD OPENING TO TOP OF RADIUS AT LOWER CORNER OF OPENING.

803f586c

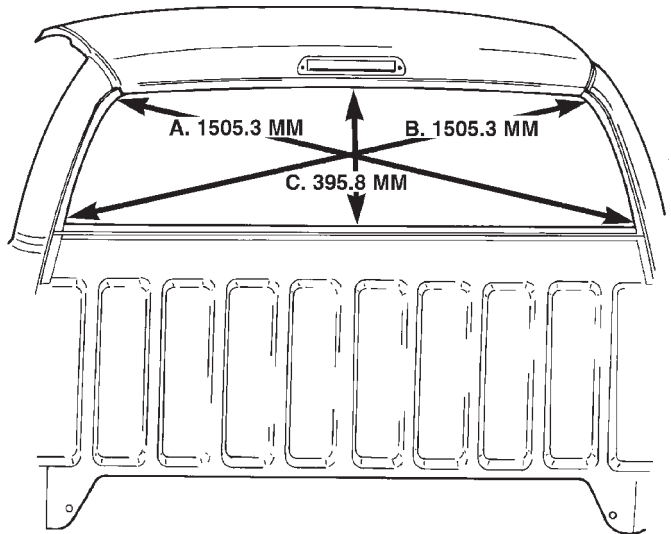
WINDSHIELD OPENING



- A. Centerline of A—Pillar gaging hole to centerline of seat belt retractor hole at B—Pillar.
- B. Centerline of radius at rear lower door opening flange inner edge to center of radius at cowl flange edge.
- C. Centerline of radius at front lower door opening flange inner edge to center of radius at upper opening rear flange inner edge.
- D. Centerline of radius at rear lower door opening flange inner edge to center of radius at upper front flange inner edge.

803f586f

DOOR OPENING — REGULAR CAB

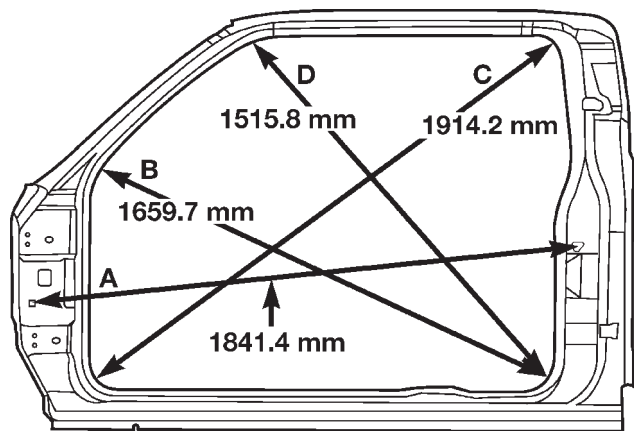


REAR VIEW

- A & B. Center of radius at top corner to center of radius at lower corner of glass mounting flange.
- C. Lower edge of upper back glass mounting flange to upper edge of lower back glass mounting flange measurement taken at centerline of rear glass opening.

803f586d

BACKLITE OPENING

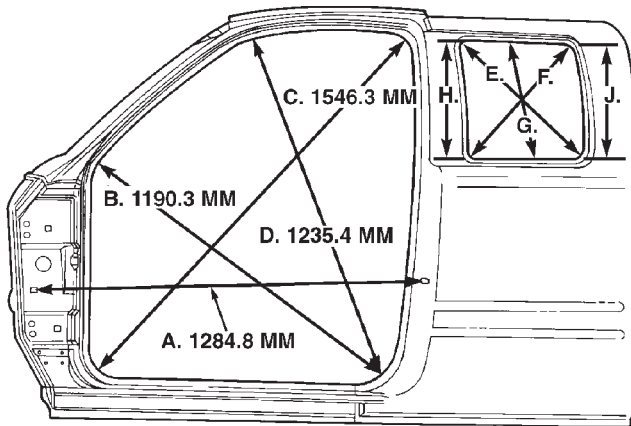


80af60f6

DOOR OPENING — QUAD CAB



## BODY (Continued)

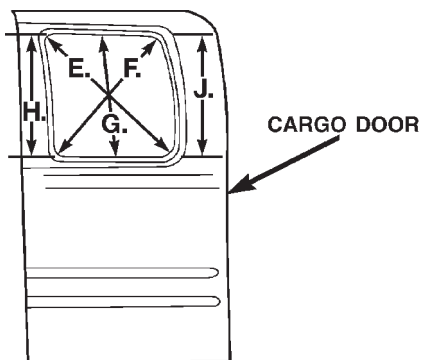
**LH SIDE VIEW**

- A. Centerline of A—Pillar gaging hole to centerline of seat belt retractor hole at B—Pillar.
- B. Center of radius at rear lower door opening flange inner edge to center of radius at cowl flange edge.
- C. Center of radius at front lower door opening flange inner edge to center of radius at upper opening rear flange inner edge.
- D. Center of radius at rear lower door opening flange inner edge to center of radius at upper front flange inner edge.
- E. Lower rear corner inner flange edge to upper front corner inner flange edge of quarter glass opening.
- F. Lower front corner inner flange edge to upper rear corner inner flange edge of quarter glass opening.
- G. Upper inner flange lower edge to lower flange upper edge of quarter glass opening.

803f586e

**DOOR OPENING AND QUARTER GLASS OPENING  
— CLUB CAB**

A. 1284.8 MM	D. 1235.4 MM	G. 436.2 MM
B. 1190.3 MM	E. 582.6 MM	H. 440.5 MM
C. 1546.3 MM	F. 538.8 MM	J. 426.8 MM



80af618e

**CARGO DOOR QUARTER GLASS OPENING**

E. 484.14	H. 427.28
F. 456.83	J. 418.38
G. 424.97	

**TORQUE SPECIFICATIONS****BODY COMPONENTS**

Description	N-m	Ft. lbs.	In. lbs.
Bench seat front anchor bolt	54	40	—
Bench seat rear inboard anchor nut	40	30	—
Bench seat rear outboard anchor nut	54	40	—
Bench seat, rear seat track to frame bolt	25	18	—
Bench seat, front seat track to frame bolt	25	18	—
Bench seat, inboard belt/buckle anchor bolt	40	30	—
Bench seat back to cushion pivot bolt	25	18	—
Bench seat slider bolts	10	7	—
Cab mounting bolt	81	60	—
Front shoulder belt upper anchor bolt	39	28	—
Front belt buckle inboard anchor nut	45	33	—
Front belt retractor anchor bolt	39	28	—
Front shoulder belt lower anchor bolt	39	28	—
Front shoulder belt lower anchor bolt	45	33	—
Door hinge to A-pillar bolt	28	21	—
Door latch screw	11	8	—
Door latch striker screw	28	21	—
Door glass to lift plate screw	9	7	—
Sliding backlite latch/keeper screws	1.5	—	15
Split bench seat front anchor bolt	54	40	—
Split bench seat rear inboard anchor nut	40	30	—
Split bench seat rear outboard anchor nut	54	40	—
Split bench seat track to frame bolt	25	18	—
Split bench seat back to cushion pivot bolt	25	18	—

# DECKLID/HATCH/LIFTGATE/TAILGATE

## TABLE OF CONTENTS

	page		page
<b>APPLIQUE</b>		INSTALLATION.....	64
REMOVAL.....	62	<b>LATCH HANDLE</b>	
INSTALLATION.....	62	REMOVAL.....	65
<b>CHECK CABLE</b>		INSTALLATION.....	65
REMOVAL.....	62	<b>LATCH STRIKER</b>	
INSTALLATION.....	63	REMOVAL.....	65
<b>DECALS</b>		INSTALLATION.....	65
REMOVAL.....	63	<b>SLAM BUMPER</b>	
INSTALLATION.....	63	REMOVAL.....	66
<b>HANDLE ESCUTCHEON</b>		INSTALLATION.....	66
REMOVAL.....	63	<b>TAILGATE</b>	
INSTALLATION.....	63	REMOVAL.....	66
<b>LATCH</b>		INSTALLATION.....	66
REMOVAL.....	64		

## APPLIQUE

### REMOVAL

- (1) Apply a length of masking tape on the body, parallel to the top edge of the applique to use as a guide, if necessary.
- (2) Warm the tailgate applique and tailgate metal to approximately 38°C (100°F) using a suitable heat lamp or heat gun.
- (3) Pull applique from tailgate (Fig. 1).

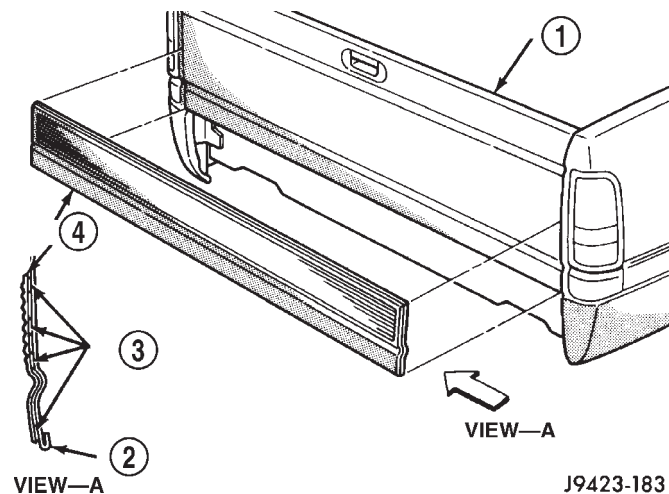


Fig. 1 Tailgate Applique

- 1 - TAILGATE
- 2 - TAILGATE
- 3 - ADHESIVE TAPE
- 4 - APPLIQUE

## INSTALLATION

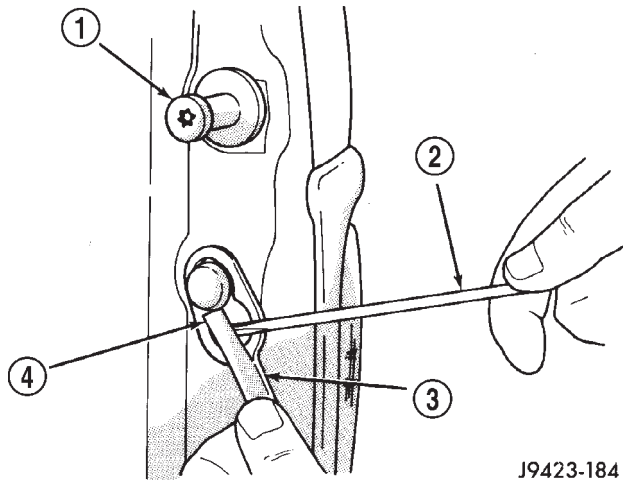
- (1) Remove adhesive tape residue from painted surface of tailgate.
- (2) If applique is to be reused, remove tape residue from applique. Clean back of applique with MOPAR®, Super Kleen solvent or equivalent. Wipe molding dry with lint free cloth. Apply new body side molding (two sided adhesive) tape to back of applique.
- (3) Clean tailgate surface with MOPAR®, Super Kleen solvent or equivalent. Wipe surface dry with lint free cloth. An adhesion promoter must be applied to ensure proper applique adhesion.
- (4) Remove protective cover from tape on back of applique. Apply applique to body below the masking tape guide (Fig. 1).
- (5) Remove masking tape guide and heat tailgate and applique, see step one. Firmly press applique to tailgate to assure adhesion.

## CHECK CABLE

### REMOVAL

- (1) Open tailgate.
- (2) Pry lock tab outward to clear stud head on cargo box (Fig. 2).
- (3) Push cable end forward until stud head is in clearance hole portion of cable end.
- (4) Separate cable end from stud.
- (5) Remove screw attaching cable to tailgate.
- (6) Separate check cable from tailgate.

## CHECK CABLE (Continued)



J9423-184

**Fig. 2 Tailgate Check**

- 1 - TAILGATE STRIKER
- 2 - SCREW DRIVER
- 3 - TAILGATE CHECK CABLE
- 4 - LOCK TAB

**INSTALLATION**

- (1) Position check cable on tailgate.
- (2) Install screw attaching small end of cable to tailgate.
- (3) Position large end of cable onto stud head and slide downward to secure lock tab.

**DECALS****REMOVAL**

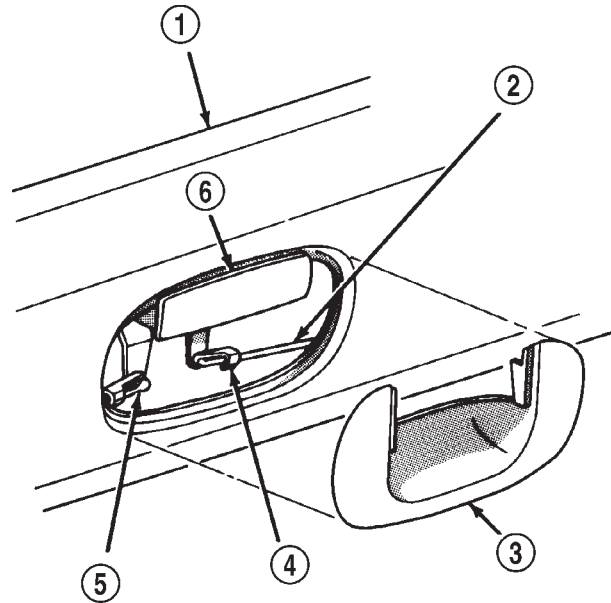
- (1) Warm the panel to approximately 38°C (100°F) using a suitable heat lamp or heat gun.
- (2) Peel tape stripe from body panel using an even pressure pull.
- (3) Remove adhesive residue from body panel using a suitable adhesive removing solvent.

**INSTALLATION**

- (1) Clean painted body surface with Mopar® Super Clean solvent or equivalent and a lint free cloth.
- (2) Remove protective cover from back side of decal.
- (3) Position decal properly on body.
- (4) Press decal firmly to body with palm of hand.
- (5) If temperature is below 21°C (70°F) warm decal with a heat lamp or gun to assure adhesion. Do not exceed 65°C (150°F) when heating emblem.

**HANDLE ESCUTCHEON****REMOVAL**

- (1) Lift and hold tailgate latch release handle.
- (2) Using a trim stick (C-4755), pry bottom of escutcheon outward to disengage clips.
- (3) Rotate escutcheon upward to disengage clip above release handle.
- (4) Push escutcheon downward from behind to clear handle.
- (5) Separate escutcheon from tailgate (Fig. 3).



J9423-31

**Fig. 3 Tailgate Handle Escutcheon**

- 1 - TAILGATE
- 2 - HANDLE—TO—RIGHT LATCH CONTROL ROD
- 3 - ESCUTCHEON
- 4 - LATCH ROD RETAINER
- 5 - HANDLE—TO—LATCH CONTROL ROD AND RETAINER
- 6 - HANDLE

**INSTALLATION**

- (1) Insert upper ends of escutcheon into handle opening.
- (2) Lift escutcheon upward from behind release handle.
- (3) Press bottom of escutcheon inward to engage clips.

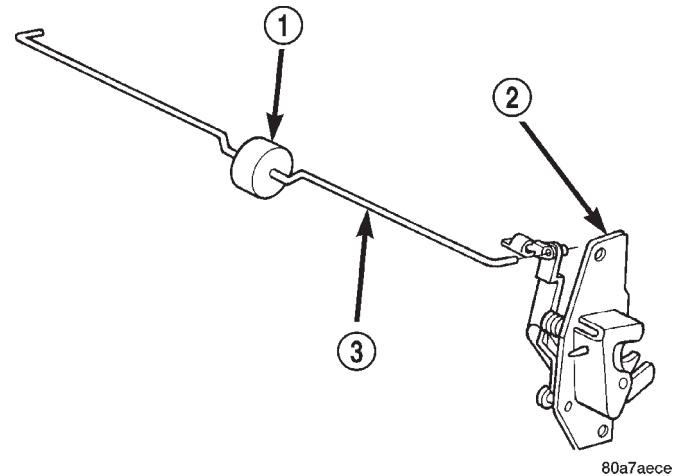
## LATCH

### REMOVAL

- (1) Remove tailgate latch handle escutcheon (Refer to 23 - BODY/DECKLID/HATCH/LIFTGATE/TAILGATE/HANDLE ESCUTCHEON - REMOVAL).
- (2) Open tailgate.
- (3) Disengage linkage rod from latch handle.
- (4) Remove screws attaching latch to tailgate (Fig. 4).
- (5) Separate latch from tailgate.
- (6) Pull latch and linkage rod from tailgate (Fig. 5).

### INSTALLATION

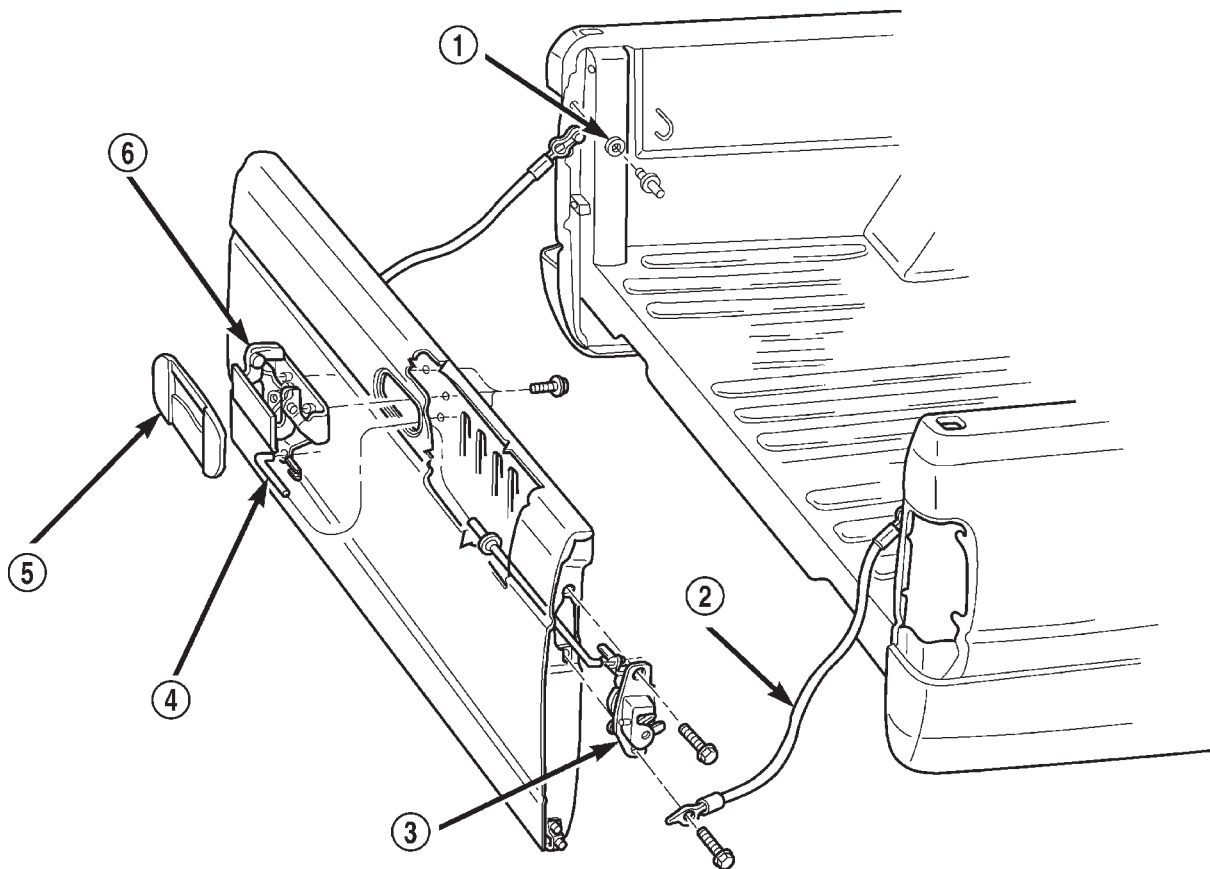
- (1) Position latch and linkage rod in tailgate.
- (2) Install upper screw attaching latch to tailgate.
- (3) Install lower screw attaching check cable and latch to tailgate.
- (4) Engage linkage rod to latch handle.



80a7aece

**Fig. 5 Tailgate Latch and Linkage Rod**

- 1 - SILENCER
- 2 - LATCH ASSEMBLY
- 3 - LINKAGE ROD



80b3b1da

**Fig. 4 Tailgate Latch**

- 1 - SPACER
- 2 - CHECK CABLE
- 3 - LATCH
- 4 - LINKAGE ROD
- 5 - HANDLE ESCUTCHEON
- 6 - LATCH HANDLE

## LATCH (Continued)

(5) Install tailgate latch handle escutcheon (Refer to 23 - BODY/DECKLID/HATCH/LIFTGATE/TAILGATE/HANDLE ESCUTCHEON - INSTALLATION).

## LATCH HANDLE

## REMOVAL

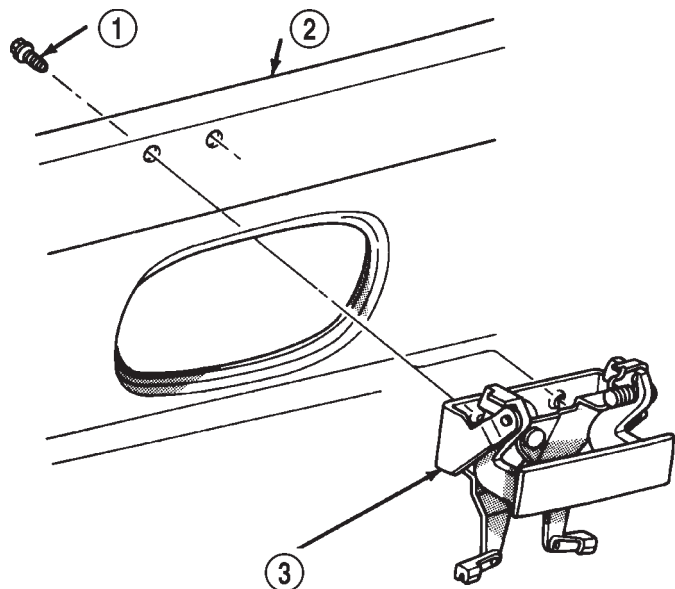
(1) Remove tailgate latch handle escutcheon (Refer to 23 - BODY/DECKLID/HATCH/LIFTGATE/TAILGATE/HANDLE ESCUTCHEON - REMOVAL).

(2) Disengage clips holding linkage rods to latch handle.

(3) Separate linkage rods from handle.

(4) Remove screws attaching latch handle to tailgate (Fig. 6).

(5) Separate latch handle from tailgate.



J9423-32

**Fig. 6 Tailgate Latch Handle**

- 1 - SCREW  
2 - TAILGATE  
3 - HANDLE ASSEMBLY

## INSTALLATION

(1) Position latch handle in tailgate.  
(2) Install screws attaching latch handle to tailgate.

(3) Install linkage rods to latch handle.

(4) Engage clips to linkage rods.

(5) Install tailgate latch handle escutcheon.

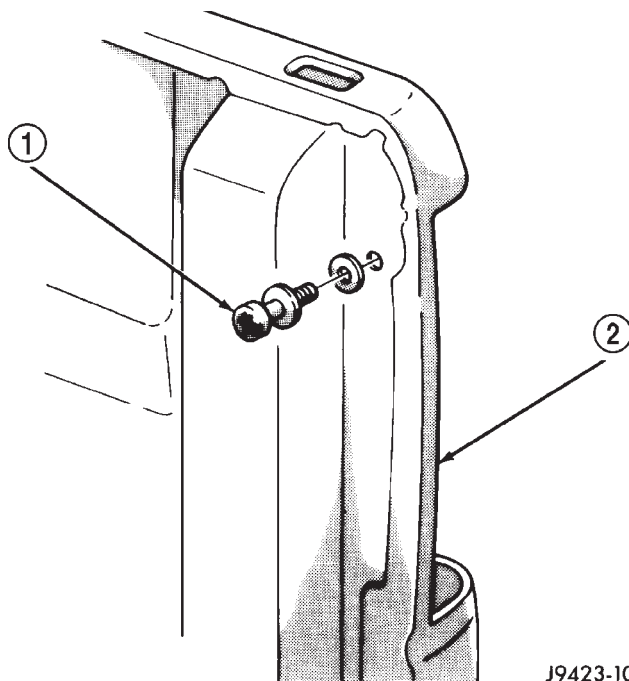
## LATCH STRIKER

## REMOVAL

(1) Open tailgate.

(2) Mark outline of striker on cargo box jamb to aid installation.

(3) Using a Torx drive wrench, remove striker and washer from cargo box (Fig. 7).



J9423-102

**Fig. 7 Tailgate Striker**

- 1 - TAILGATE STRIKER  
2 - CARGO BOX

## INSTALLATION

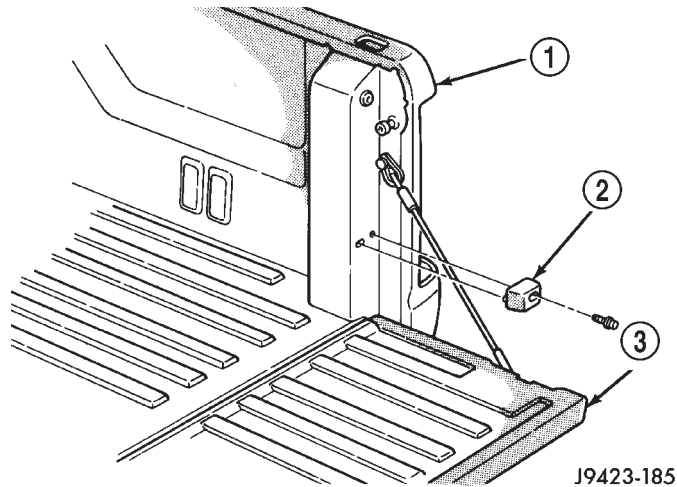
(1) Position striker and washer on jamb using alignment outline as reference and install with Torx drive wrench.



## SLAM BUMPER

### REMOVAL

- (1) Open tailgate.
- (2) Remove screw holding slam bumper to cargo box (Fig. 8).
- (3) Separate slam bumper from vehicle.



**Fig. 8 Tailgate Slam Bumper**

- 1 - CARGO BOX  
2 - SLAM BUMPER  
3 - TAILGATE

### INSTALLATION

- (1) Position slam bumper on vehicle.
- (2) Install screw holding slam bumper to cargo box.
- (3) Close tailgate and verify operation.

## TAILGATE

### REMOVAL

- (1) Open tailgate.
- (2) Disconnect tailgate marker light harness, if equipped.
- (3) Remove tailgate check cables (Refer to 23 - BODY/DECKLID/HATCH/LIFTGATE/TAILGATE/CHECK CABLE - REMOVAL).
- (4) Close tailgate until the notch in the right hand collar aligns with the pivot pin.
- (5) Slip tailgate hinge collar from pivot pins.
- (6) Slide tailgate to the right and separate left hand collar from the pivot pin.
- (7) Separate tailgate from vehicle.

### INSTALLATION

- (1) Position tailgate collar on left hand pivot pin and slide tailgate to the left.
- (2) Raise tailgate until the notch in the right hand collar aligns with the pivot pin.
- (3) Install tailgate check cables (Refer to 23 - BODY/DECKLID/HATCH/LIFTGATE/TAILGATE/CHECK CABLE - INSTALLATION).
- (4) Connect tailgate marker light harness, if equipped.

## DOOR - FRONT

## TABLE OF CONTENTS

	page		page
<b>APPLIQUE</b>		<b>LATCH</b>	
REMOVAL . . . . .	67	REMOVAL . . . . .	72
INSTALLATION . . . . .	67	INSTALLATION . . . . .	72
<b>DOOR</b>		ADJUSTMENTS . . . . .	72
REMOVAL . . . . .	68	<b>LATCH STRIKER</b>	
INSTALLATION . . . . .	68	REMOVAL . . . . .	73
ADJUSTMENTS . . . . .	68	INSTALLATION . . . . .	73
<b>DOOR GLASS</b>		<b>LOCK CYLINDER</b>	
REMOVAL . . . . .	69	REMOVAL . . . . .	73
INSTALLATION . . . . .	69	INSTALLATION . . . . .	73
<b>EXTERIOR HANDLE</b>		<b>SIDE VIEW MIRROR FLAG</b>	
REMOVAL . . . . .	70	REMOVAL . . . . .	74
INSTALLATION . . . . .	70	INSTALLATION . . . . .	74
<b>GLASS RUN CHANNEL</b>		<b>TRIM PANEL</b>	
REMOVAL . . . . .	70	REMOVAL . . . . .	74
INSTALLATION . . . . .	70	INSTALLATION . . . . .	74
<b>HINGE</b>		<b>WATERDAM</b>	
REMOVAL . . . . .	70	REMOVAL . . . . .	75
INSTALLATION . . . . .	71	INSTALLATION . . . . .	75
<b>INSIDE HANDLE ACTUATOR</b>		<b>WINDOW REGULATOR</b>	
REMOVAL . . . . .	71	REMOVAL . . . . .	75
INSTALLATION . . . . .	71	INSTALLATION . . . . .	76

## APPLIQUE

## REMOVAL

(1) Using a heat lamp, warm B-pillar to 38° C (100° F).

(2) Remove glass run weatherstrip (Refer to 23 - BODY/WEATHERSTRIP/SEALS/FDR GLASS RUN WEATHERSTRIP - REMOVAL).

(3) Remove outer belt weatherstrip (Refer to 23 - BODY/WEATHERSTRIP/SEALS/FDR OUTER BELT WEATHERSTRIP - REMOVAL).

(4) Using an even pressure pull, peel B-pillar applique away from the B-pillar.

## INSTALLATION

Installation equipment needed:

- Lint free applicator cloth
- six inch applicator squeegee
- Piercing pin

(1) Clean B-pillar using Mopar Super Kleen or equivalent.

(2) Wipe surface with a lint free cloth.

(3) Using a heat gun, warm surface to 22° C (70° F).

(4) Fold down, up/down locator tab (1a or 1b) (Fig. 1) along crease.

(5) Remove carrier from adhesion strip (2).

(6) Using up/down locator tab (1a or 1b) and fore/aft locator tab (3a or 3b), position the applique on the upper portion of the B-pillar.

(7) Using the lower edge locator (4), position the applique on the lower portion of the B-pillar.

(8) Verify the applique is positioned correctly and press the adhesion strip (2) to the door to temporarily secure it in place.

(9) Remove the carrier for the applique.

(10) Holding the applique from the surface, apply firm downward pressure with a six inch applicator squeegee. Ensure the lower rear edge (4) is aligned correctly.

(11) Wrap edges around door to at least a 90° angle.

(12) Remove premask by pulling in a firm continuous manner from top down at 180°.

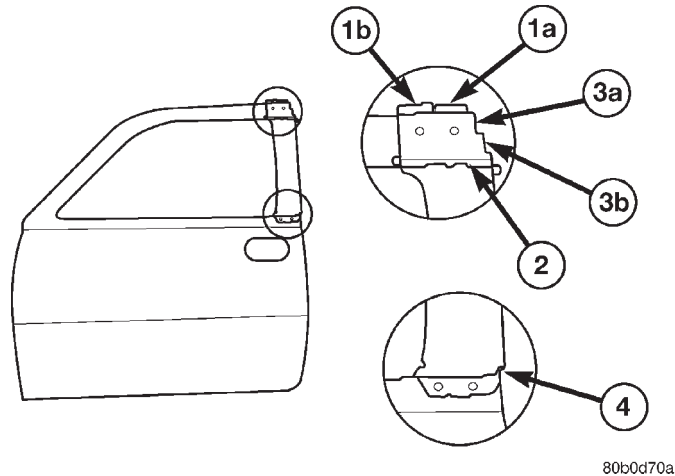
(13) Complete wrapping applique around the door edges.

(14) Inspect for air bubbles. Small bubbles can be pierced with a sharp pin and smoothed out.

## APPLIQUE (Continued)

(15) Install outer belt weatherstrip (Refer to 23 - BODY/WEATHERSTRIP/SEALS/FDR OUTER BELT WEATHERSTRIP - INSTALLATION).

(16) Install glass run weatherstrip (Refer to 23 - BODY/WEATHERSTRIP/SEALS/FDR GLASS RUN WEATHERSTRIP - INSTALLATION).



**Fig. 1 B-Pillar Applique**

- 1A = Club Cab - Up/Down
- 1B = Quad Cab - Up/Down
- 2 = Adhesion Strip
- 3A = Club Cab - For/Aft
- 3B = Quad Cab - For/Aft
- 4 = Rear Edge Locator

## DOOR

## REMOVAL

(1) Remove cowl trim panel (Refer to 23 - BODY/INTERIOR/COWL TRIM COVER - REMOVAL).

(2) Disengage door wire harness connector of instrument panel harness and push door harness through access hole in pillar.

(3) Remove hidden bolts attaching door hinge to hinge pillar from behind cowl panel (Fig. 2).

(4) Using a grease pencil or equivalent, mark the outline of the door hinges on the hinge pillar to aid installation.

(5) Support door on a suitable lifting device.

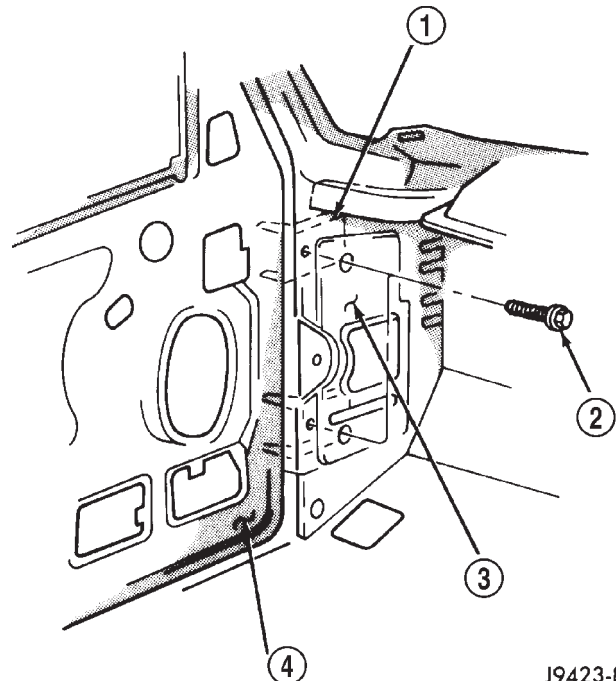
(6) Remove bolts attaching lower door hinge to hinge pillar (Fig. 3).

(7) While holding door steady on lift, remove bolts attaching upper door hinge to hinge pillar.

(8) Separate door from vehicle.

## INSTALLATION

(1) While holding door steady on lift, position door at A-pillar.



**Fig. 2 Door Hinge Hidden Bolt**

- 1 - HINGE
- 2 - DOOR HINGE SCREW
- 3 - A-PILLER
- 4 - DOOR

(2) Align hinges using reference marks.

(3) Install bolts attaching upper door hinge to hinge pillar.

(4) Install bolts attaching lower door hinge to hinge pillar (Fig. 3).

(5) Install hidden bolts attaching door hinge to hinge pillar from behind cowl panel (Fig. 2).

(6) Align door to achieve equal spacing on all sides and flush across the gaps.

(7) Tighten hinge bolts to 28 N-m (21 ft. lbs.) torque.

(8) Route harness through door and engage door wire harness connector.

(9) Install cowl trim panel (Refer to 23 - BODY/INTERIOR/COWL TRIM COVER - INSTALLATION).

## ADJUSTMENT - FRONT DOOR FORE/AFT

Fore/aft (lateral) door adjustment is done by loosening the hinge to cowl screws one hinge at a time. Then move the door to the correct position.

(1) Support the door with a padded floor jack.

(2) Loosen the hinge to cowl screws, if necessary, refer to the front door hinge removal/installation procedure for hinge fastener location. Move the door to the correct fore/aft position.

(3) Tighten the hinge to cowl screws.

(4) Remove the floor jack from the door.

## DOOR (Continued)

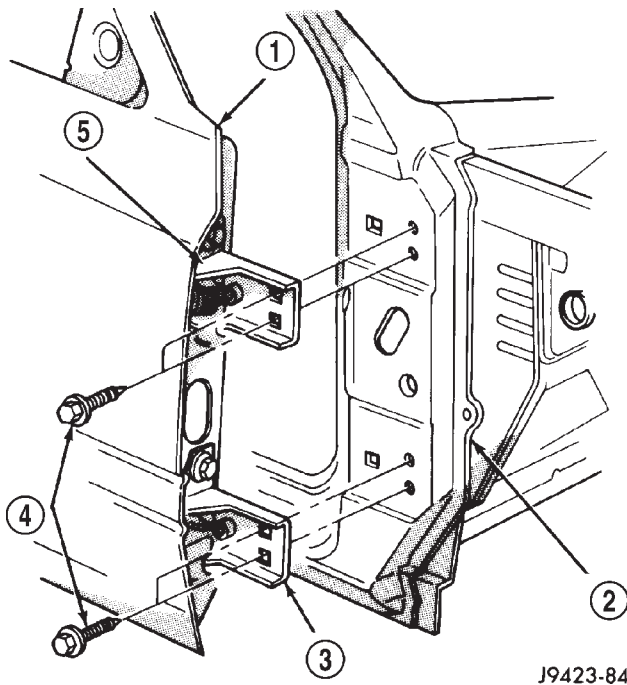


Fig. 3 Door

- 1 - DOOR
- 2 - A—PILLER
- 3 - LOWER DOOR HINGE
- 4 - SCREW
- 5 - UPPER DOOR HINGE

## ADJUSTMENT – FRONT DOOR UP/DOWN

Up/down door adjustment is done by loosening the hinge to cowl fasteners at both hinges. Then move the door to the correct position.

- (1) Support the door with a padded floor jack.
  - (2) Loosen hinge to cowl fasteners at both hinges.
- Move the door to the correct up/down position.
- (3) Tighten the hinge to cowl fasteners.
  - (4) Remove the floor jack from the door.

## ADJUSTMENT – FRONT DOOR IN/OUT

In/out door adjustment is done by loosening the hinge to door fasteners. Then move the door to the correct position.

- (1) Support the door with a padded floor jack.
  - (2) Loosen the applicable hinge to door fasteners.
- Move the door to the correct in/out position.
- (3) If necessary, loosen the other hinge to door fasteners and move the door to the correct in/out position.
  - (4) Tighten the hinge to door fasteners.
  - (5) Remove the floor jack from the door.

## DOOR GLASS

## REMOVAL

- (1) Remove the door waterdam (Refer to 23 - BODY/DOOR - FRONT/WATERDAM - REMOVAL).
- (2) Remove inner door belt weatherstrip (Refer to 23 - BODY/WEATHERSTRIP/SEALS/FDR INNER BELT WEATHERSTRIP - REMOVAL).
- (3) Align door glass lift plate to access holes in inner door panel.
- (4) Loosen bolts attaching front lower run channel to inner door panel.
- (5) Remove nuts attaching door glass to lift plate (Fig. 4).
- (6) Separate glass from lift plate.
- (7) Lift glass upward and out of opening at top of door.

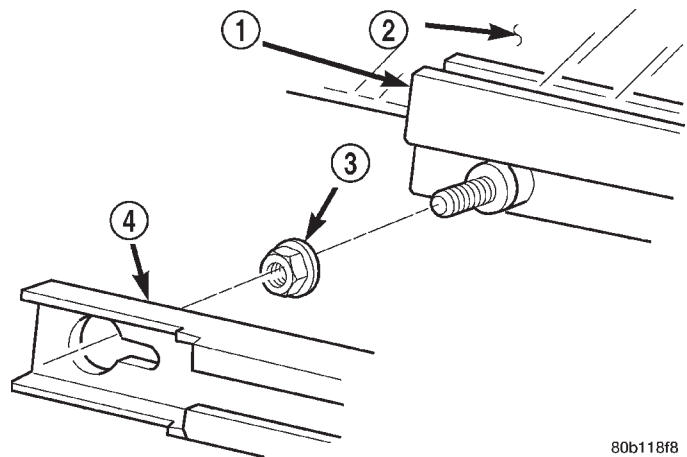


Fig. 4 Door Glass

- 1 - GLASS LIFT PLATE
- 2 - GLASS
- 3 - NUT
- 4 - REGULATOR ARM LOWER CHANNEL

## INSTALLATION

- (1) Position in door.
- (2) Insert glass in lift plate.

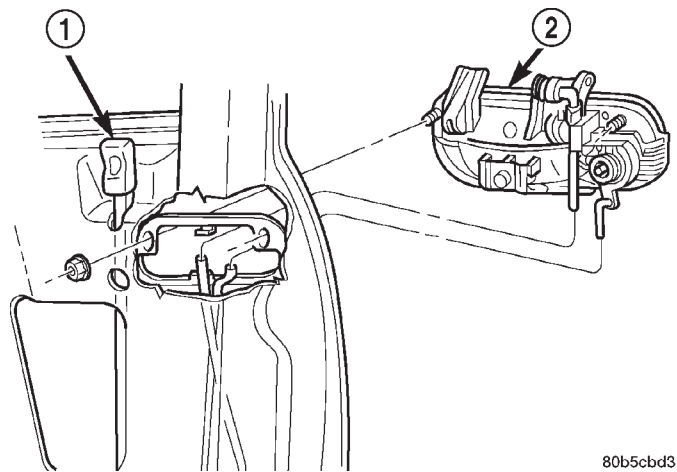
**CAUTION: Do not exceed 11 N·m (8 ft. lbs.) torque when tightening the nuts that attach the glass to the lift plate.**

- (3) Install nuts attaching glass to lift plate (Fig. 4). Tighten nuts to 9 N·m (7 ft. lbs.) torque.
- (4) Tighten bolts attaching front lower run channel to inner door panel.
- (5) Install inner door belt weatherstrip (Refer to 23 - BODY/WEATHERSTRIP/SEALS/FDR INNER BELT WEATHERSTRIP - INSTALLATION).
- (6) Install the door waterdam (Refer to 23 - BODY/DOOR - FRONT/WATERDAM - INSTALLATION).

## EXTERIOR HANDLE

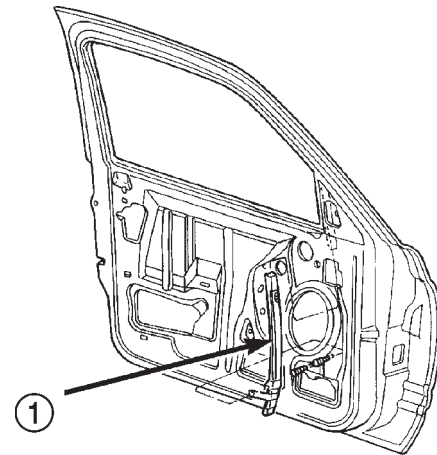
### REMOVAL

- (1) Remove the waterdam (Refer to 23 - BODY/DOOR - FRONT/WATERDAM - REMOVAL).
- (2) Raise the window to the closed position.
- (3) Remove fastener access plug from door end panel.
- (4) Disengage clips holding latch and lock rods to door latch.
- (5) Separate latch and lock rods from door latch.
- (6) Remove nuts attaching outside door handle to door (Fig. 5).
- (7) Separate outside door handle from door.



**Fig. 5 Outside Door Handle**

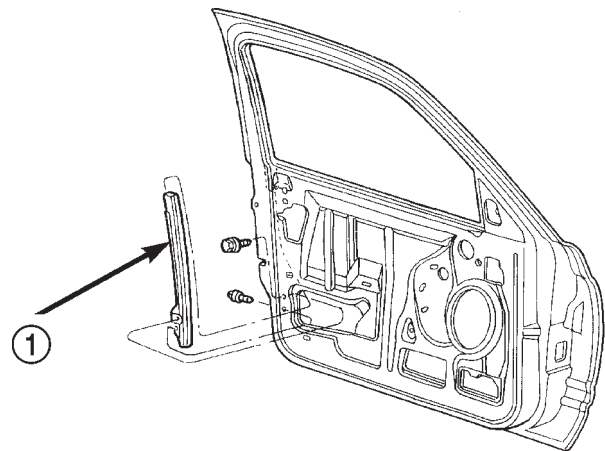
- 1 - LOCK KNOB
- 2 - OUTSIDE HANDLE



80ae843e

**Fig. 6 Front Glass Run Lower Channel**

- 1 - FRONT GLASS RUN CHANNEL



80ae83fc

**Fig. 7 Rear Glass Run Lower Channel**

- 1 - REAR GLASS RUN CHANNEL

### INSTALLATION

- (1) Position outside door handle in door.
- (2) Install nuts attaching outside door handle to door.
- (3) Engage latch and lock rods to door latch.
- (4) install access plug to door end panel.
- (5) Install the door waterdam (Refer to 23 - BODY/DOOR - FRONT/WATERDAM - INSTALLATION).

## GLASS RUN CHANNEL

### REMOVAL

- (1) Remove the door waterdam (Refer to 23 - BODY/DOOR - FRONT/WATERDAM - REMOVAL).
- (2) Raise the window to the closed position..
- (3) Remove bolts holding run channel to inner door panel (Fig. 6) and (Fig. 7).
- (4) Slide channel downward to disengage it from the upper glass frame.
- (5) Separate door glass run channel from door.

### INSTALLATION

- (1) Position door glass run channels on inner door panel.
- (2) Slide channel upward to engage it in the upper glass frame.
- (3) Install bolts attaching run channels to inner door panel (Fig. 6) and (Fig. 7).
- (4) Install the door waterdam (Refer to 23 - BODY/DOOR - FRONT/WATERDAM - INSTALLATION).

## HINGE

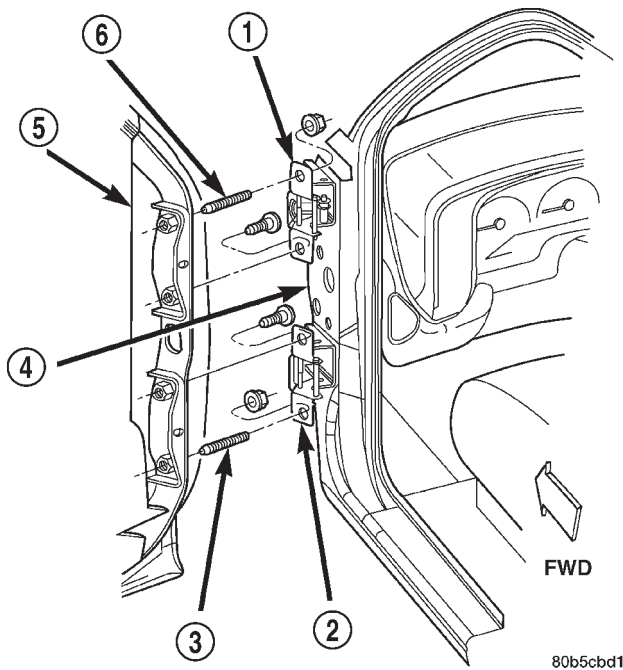
### REMOVAL

- (1) Remove cowl trim panel (Refer to 23 - BODY/INTERIOR/COWL TRIM COVER - REMOVAL).
- (2) Remove hidden bolt attaching door hinge to hinge pillar (Fig. 2).



## HINGE (Continued)

- (3) Support door on a suitable lifting device.
- (4) Using a grease pencil or equivalent, mark the outline of the door hinge on the hinge pillar to aid installation.
- (5) Remove bolts attaching door hinge to hinge pillar (Fig. 3).
- (6) Remove nut and bolt attaching door hinge to door end frame (Fig. 8).
- (7) Separate door hinge from vehicle.

**Fig. 8 Door Hinge**

- 1 - UPPER HINGE
- 2 - LOWER HINGE
- 3 - STUD
- 4 - HINGE PILLAR
- 5 - DOOR
- 6 - STUD

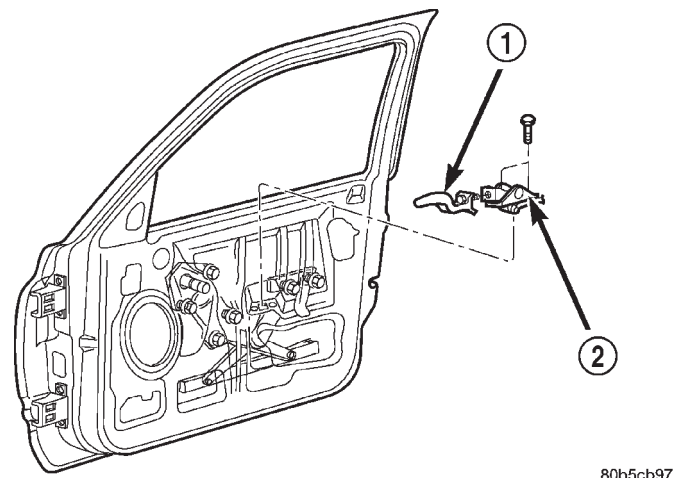
**INSTALLATION**

- (1) If necessary, paint replacement door hinge before installation.
- (2) Position hinge on door end frame.
- (3) Align hinge using reference marks.

- (4) Install nuts and bolts attaching door hinge to door end frame. Tighten nuts and bolts to 28 N-m (21 ft. lbs.) torque.
- (5) Install bolts attaching door hinge to hinge pillar. Tighten bolts to 28 N-m (21 ft. lbs.) torque.
- (6) Install hidden bolt attaching door hinge to hinge pillar. Tighten bolt to 28 N-m (21 ft. lbs.) torque.
- (7) Remove support.
- (8) Install cowl trim panel (Refer to 23 - BODY/INTERIOR/COWL TRIM COVER - INSTALLATION).

**INSIDE HANDLE ACTUATOR****REMOVAL**

- (1) Remove the door waterdam (Refer to 23 - BODY/DOOR - FRONT/WATERDAM - REMOVAL).
- (2) Raise the window to the closed position.
- (3) Remove the screws attaching the actuator to the door (Fig. 9).

**Fig. 9 Front Door Inside Handle Actuator**

- 1 - INSIDE HANDLE
- 2 - ACTUATOR

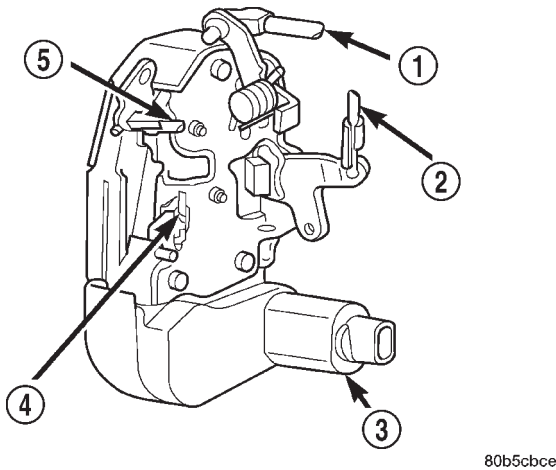
**INSTALLATION**

- (1) Install the screws attaching the actuator to the door.
- (2) Test handle for proper operation.
- (3) Install the door waterdam (Refer to 23 - BODY/DOOR - FRONT/WATERDAM - INSTALLATION).

## LATCH

### REMOVAL

- (1) Remove the door waterdam (Refer to 23 - BODY/DOOR - FRONT/WATERDAM - REMOVAL).
- (2) Disengage clips attaching lock and latch rods to door latch.
- (3) Disconnect power door lock/latch connector, if equipped (Fig. 10).
- (4) Remove screws attaching door latch to door end panel (Fig. 11).
- (5) Separate door latch/lock from door.



**Fig. 10 Power Lock/Latch Connector**

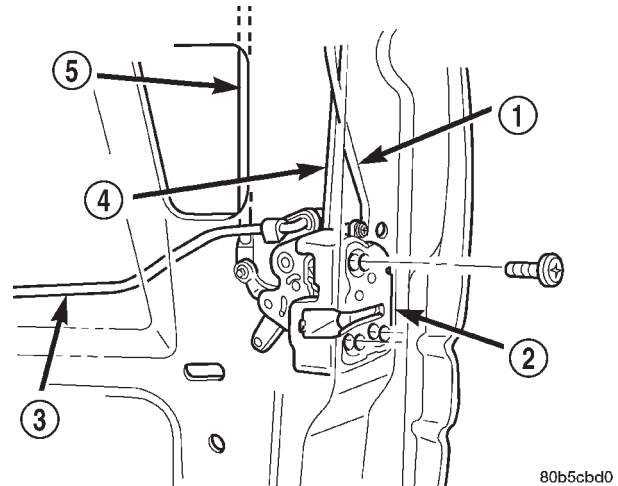
- 1 - INSIDE HANDLE—TO—LATCH ROD
- 2 - LOCK KNOB—TO—LATCH ROD
- 3 - POWER LATCH CONNECTOR
- 4 - LOCK CYLINDER—TO—LATCH ROD
- 5 - OUTSIDE HANDLE—TO—LATCH ROD

### INSTALLATION

- (1) Position door latch/lock in door.
- (2) Install screws attaching door latch to door end panel. Tighten screws to 10 N·m (7 ft. lbs.) torque.
- (3) Connect power door lock/latch connector, if equipped.
- (4) Engage clips attaching lock and latch rods to door latch.
- (5) Install the door waterdam (Refer to 23 - BODY/DOOR - FRONT/WATERDAM - INSTALLATION).

### ADJUSTMENT – FRONT DOOR LATCH

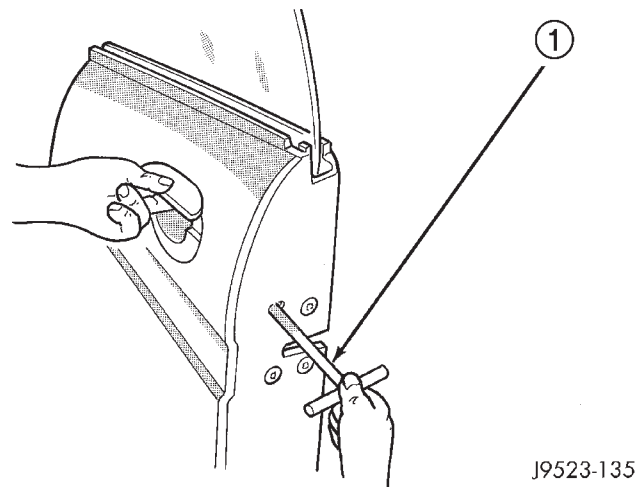
- (1) Insert a hex-wrench through the elongated hole in the door end frame near the latch striker opening (Fig. 12).



**Fig. 11 Front Door Latch**

- 1 - OUTSIDE HANDLE—TO—LATCH ROD
- 2 - LATCH
- 3 - INSIDE HANDLE—TO—LATCH ROD
- 4 - LOCK CYLINDER—TO—LATCH ROD
- 5 - LOCK KNOB—TO—LATCH ROD

- (2) Loosen torx head screw on the side of the latch linkage.
- (3) Lift upward on outside door handle and release it.
- (4) Tighten torx head screw on latch.
- (5) Verify latch operation.



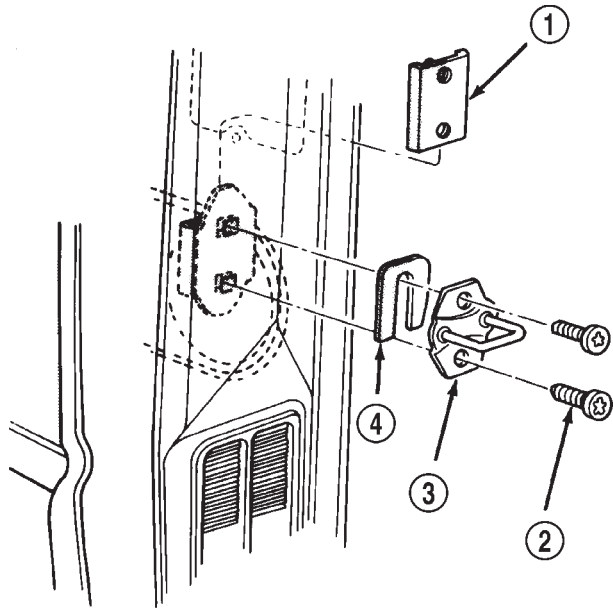
**Fig. 12 DOOR LATCH ADJUSTMENT**

- 1 - HEX WRENCH

## LATCH STRIKER

### REMOVAL

- (1) Mark outline of striker base on B-pillar with a grease pencil or equivalent to aid installation.
- (2) Remove screws attaching striker to B-pillar (Fig. 13).
- (3) Separate striker from vehicle.



J9423-49

**Fig. 13 Front Door Latch Striker**

- 1 - RETAINING PLATE
- 2 - SCREW
- 3 - STRIKER
- 4 - SPACER

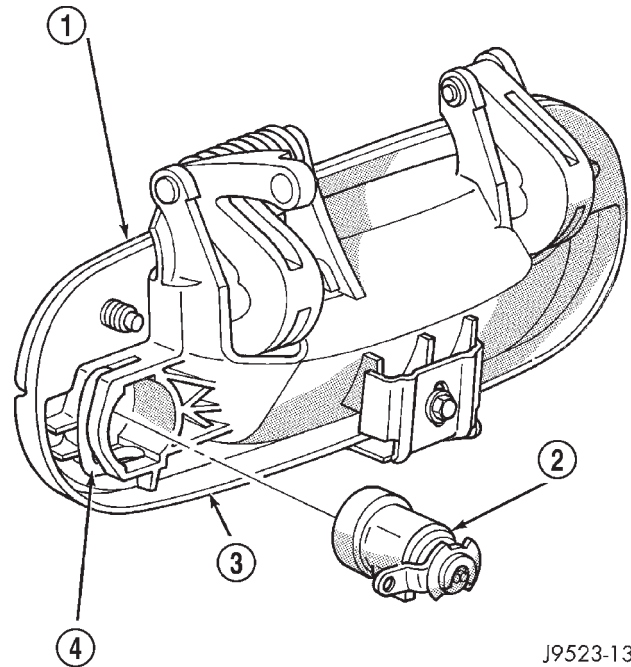
### INSTALLATION

- (1) Position striker on vehicle and align with reference marks.
- (2) Install screws attaching striker to B-pillar. Tighten screws to 28 N·m (21 ft. lbs.) torque. (Fig. 13).

## LOCK CYLINDER

### REMOVAL

- (1) Remove outside door handle (Refer to 23 - BODY/DOOR - FRONT/EXTERIOR HANDLE - REMOVAL).
- (2) Remove clip securing lock cylinder to outside door handle (Fig. 14).
- (3) Pull lock cylinder from door handle.



J9523-134

**Fig. 14 Door Lock Cylinder**

- 1 - DOOR HANDLE
- 2 - LOCK CYLINDER
- 3 - LOCK CYLINDER RETAINER
- 4 - LOCK RETAINING CLIP

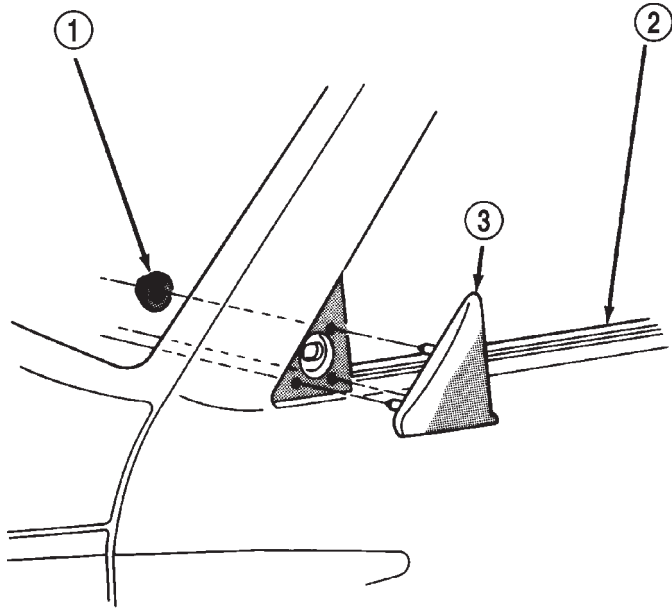
### INSTALLATION

- (1) Position lock cylinder in door handle.
- (2) Install clip securing lock cylinder to outside door handle.
- (3) Install outside door handle (Refer to 23 - BODY/DOOR - FRONT/EXTERIOR HANDLE - INSTALLATION).

## SIDE VIEW MIRROR FLAG

### REMOVAL

- (1) Remove door trim panel.
- (2) Remove flag door seal.
- (3) Remove nuts attaching mirror flag cover to door frame (Fig. 15).
- (4) Separate flag cover from door.



J9423-60

**Fig. 15 Mirror Flag Cover**

- 1 - NUT
- 2 - DOOR
- 3 - FLAG COVER ASSEMBLY

### INSTALLATION

- (1) Position flag cover on door.
- (2) Install nuts attaching mirror flag cover to door frame.
- (3) Install flag door seal.
- (4) Install door trim panel.

## TRIM PANEL

### REMOVAL

- (1) Roll window down.
- (2) Remove window crank (Fig. 16), if equipped.
- (3) Remove screw attaching trim panel to outside mirror frame.

(4) Remove screws attaching pull cup to door (Fig. 17).

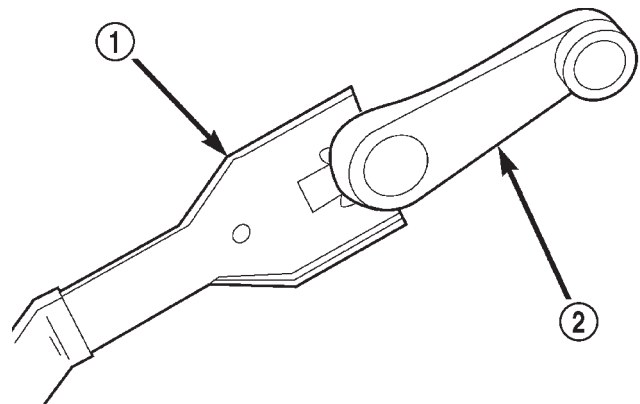
(5) Using a trim panel removal tool, disengage clips around perimeter of trim panel, attaching trim panel to door.

(6) While holding bottom of trim panel away from door, simultaneously lift upward and inboard.

(7) Disengage power mirror switch connector, if equipped.

(8) Disengage power window/lock switch connectors from switch panel, if equipped (Fig. 18).

(9) Separate trim panel from door.



80ad2f28

**Fig. 16 Window Crank—Typical**

- 1 - WINDOW CRANK REMOVAL TOOL
- 2 - WINDOW CRANK

### INSTALLATION

**NOTE:** When replacing door trim panel, installer must replace the X-mas tree style pin 6506878aa.

(1) Engage power mirror switch connector, if equipped.

(2) Engage power window/lock switch connectors to switch panel, if equipped.

(3) Position trim panel on door.

(4) Engage clips around perimeter of trim panel, attaching trim panel to door.

(5) Install screws attaching pull cup to door.

(6) Install screw attaching trim panel to outside mirror frame.

(7) Install window crank, if equipped.

## TRIM PANEL (Continued)

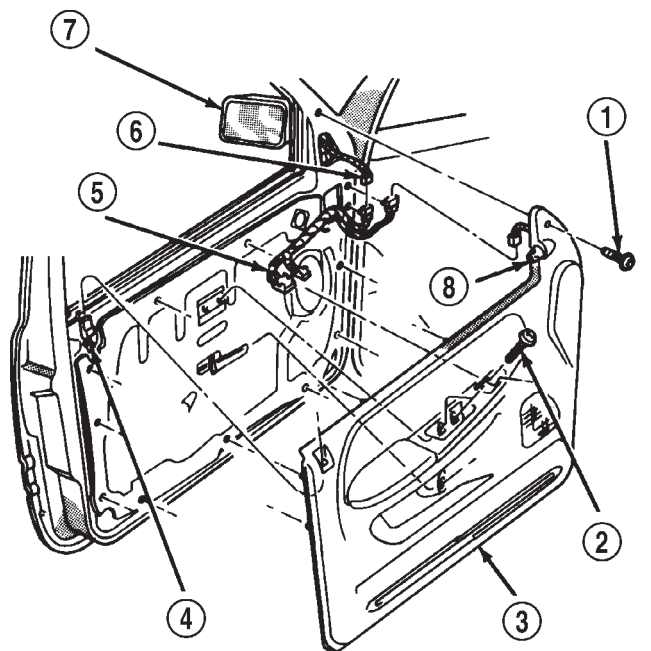


Fig. 17 Door Trim Panel

J9423-34

- 1 - SCREW
- 2 - SCREW
- 3 - TRIM PANEL
- 4 - DOOR LOCK BUTTON
- 5 - POWER WINDOW HARNESS
- 6 - POWER MIRROR HARNESS
- 7 - POWER MIRROR
- 8 - POWER MIRROR CONTROL

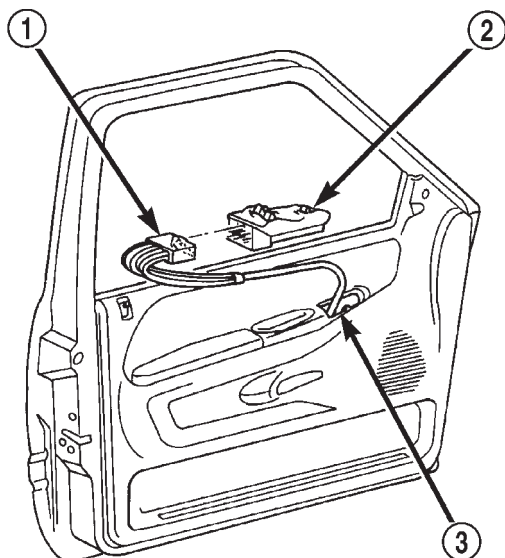


Fig. 18 Power Window/Lock Switch Panel

80b1b30e

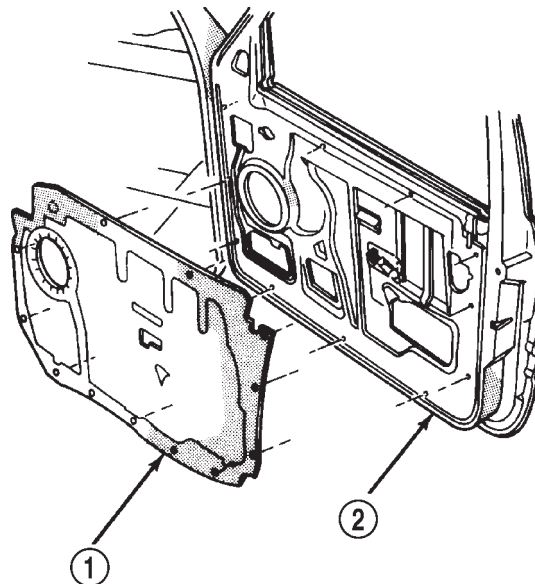
- 1 - ELECTRICAL CONNECTOR
- 2 - POWER WINDOW/LOCK SWITCH PANEL
- 3 - WIRE HARNESS

## WATERDAM

## REMOVAL

(1) Remove door trim panel (Refer to 23 - BODY/DOOR - FRONT/TRIM PANEL - REMOVAL).

(2) Peel waterdam away from adhesive around perimeter of inner door panel (Fig. 19).



J9423-37

Fig. 19 Door Water Dam

- 1 - WATER DAM
- 2 - DOOR

## INSTALLATION

(1) Position and align water dam with adhesive around perimeter of inner door panel.

(2) Press water dam onto inner door panel to secure.

(3) Install door trim panel (Refer to 23 - BODY/DOOR - FRONT/TRIM PANEL - INSTALLATION).

## WINDOW REGULATOR

## REMOVAL

(1) Remove the door waterdam (Refer to 23 - BODY/DOOR - FRONT/WATERDAM - REMOVAL).

(2) Remove nuts attaching door glass to window regulator.

(3) Remove glass from door or move glass to full up position and secure glass to door with tape.

(4) Disengage power window motor wire connector from door harness, if equipped.

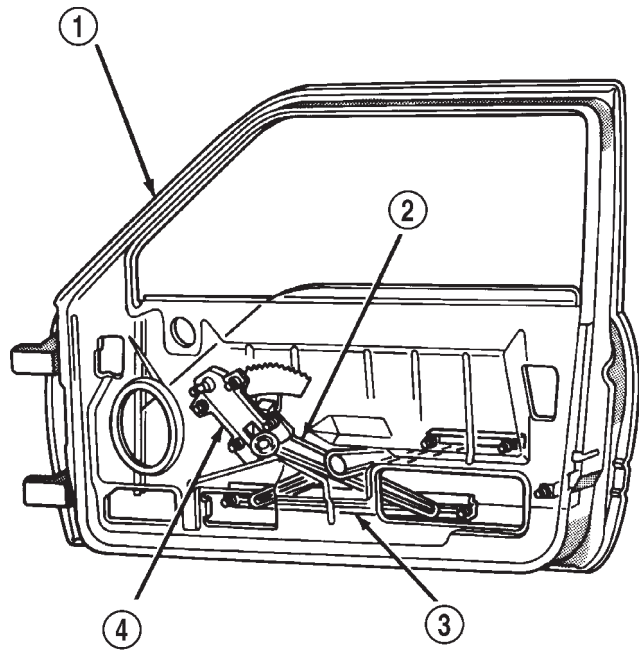
(5) Remove bolts attaching window regulator to inner door panel.



## WINDOW REGULATOR (Continued)

(6) Separate window regulator from door panel (Fig. 20).

(7) Extract window regulator through access hole in inner door panel.



J9423-38

**Fig. 20 Door Glass Window Regulator**

- 1 - DOOR ASSEMBLY
- 2 - WINDOW REGULATOR ASSEMBLY
- 3 - DOOR GLASS ASSEMBLY
- 4 - WINDOW REGULATOR

**INSTALLATION**

(1) Position window regulator in door through access hole.

(2) Install bolts attaching window regulator to inner door panel.

(3) Engage power window motor wire connector to door harness, if equipped.

(4) Install glass in lift plate.

(5) Install the door waterdam (Refer to 23 - BODY/DOOR - FRONT/WATERDAM - INSTALLATION).

## DOOR - CARGO

## TABLE OF CONTENTS

	page		page
<b>AIR EXHAUSTER</b>		INSTALLATION.....	81
REMOVAL.....	77	<b>LATCH STRIKER - LOWER</b>	
INSTALLATION.....	77	REMOVAL.....	82
<b>CHECK</b>		INSTALLATION.....	82
REMOVAL.....	78	<b>LATCH STRIKER - UPPER</b>	
INSTALLATION.....	78	REMOVAL.....	82
<b>DOOR</b>		INSTALLATION.....	82
REMOVAL.....	78	<b>RELEASE CABLE</b>	
INSTALLATION.....	78	REMOVAL.....	82
ADJUSTMENTS.....	78	INSTALLATION.....	83
<b>EXHAUST VENT</b>		<b>SHUTFACE HANDLE</b>	
REMOVAL.....	79	REMOVAL.....	83
INSTALLATION.....	79	INSTALLATION.....	83
<b>HINGE</b>		<b>TRIM PANEL</b>	
REMOVAL.....	79	REMOVAL.....	84
INSTALLATION.....	79	INSTALLATION.....	84
<b>INSIDE HANDLE ACTUATOR</b>		<b>VENT WINDOW</b>	
REMOVAL.....	80	REMOVAL.....	85
INSTALLATION.....	80	INSTALLATION.....	85
<b>LATCH - LOWER</b>		<b>WATERDAM</b>	
REMOVAL.....	80	REMOVAL.....	85
INSTALLATION.....	80	INSTALLATION.....	85
<b>LATCH - UPPER</b>			
REMOVAL.....	81		

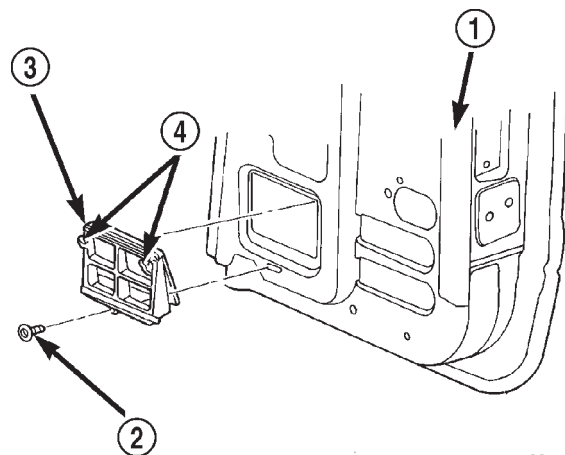
## AIR EXHAUSTER

## REMOVAL

- (1) Remove cargo door trim panel (Refer to 23 - BODY/DOOR - CARGO/TRIM PANEL - REMOVAL).
- (2) Peel back waterdam.
- (3) Remove push-in fastener attaching air exhauster to cargo door inner panel (Fig. 1).
- (4) Separate air exhauster from cargo door.

## INSTALLATION

- (1) Position air exhauster in cargo door.
- (2) Engage air exhauster upper tabs with cargo door inner panel.
- (3) Install push-in fastener attaching air exhauster to cargo door inner panel (Fig. 1).
- (4) Reposition waterdam.
- (5) Install cargo door trim panel (Refer to 23 - BODY/DOOR - CARGO/TRIM PANEL - INSTALLATION).



80ae8470

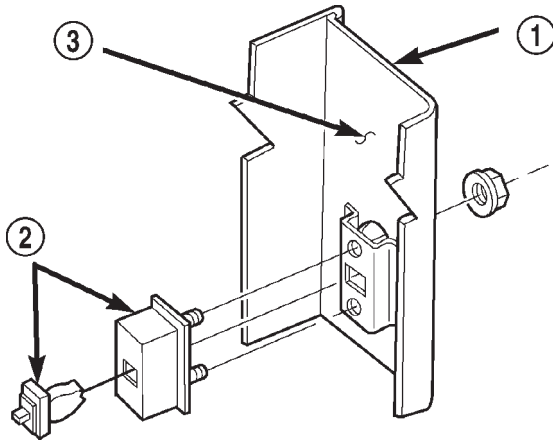
Fig. 1 Cargo Door Air Exhauster

- 1 - CARGO DOOR
- 2 - PUSH-IN FASTENER
- 3 - DOOR EXHAUSTER
- 4 - TAB

## CHECK

### REMOVAL

- (1) Remove cargo door trim panel (Refer to 23 - BODY/DOOR - CARGO/TRIM PANEL - REMOVAL).
- (2) Remove the bolts attaching the door check to the cab C-pillar.
- (3) Remove the nuts attaching the door check to the cargo door (Fig. 2).
- (4) Remove the door check through the access hole in the cargo door.



80ace4bb

**Fig. 2 Door Check**

- 1 - CARGO DOOR
- 2 - DOOR CHECK
- 3 - CARGO DOOR INNER PANEL

### INSTALLATION

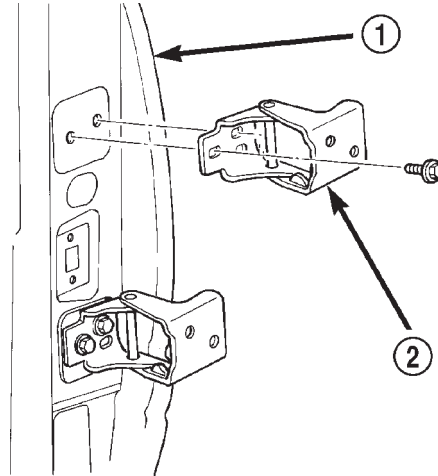
- (1) Position the door check in the cargo door through the access hole.
- (2) Install the nuts attaching the door check to the cargo door (Fig. 2).
- (3) Install the bolts attaching the door check to the cab C-pillar.
- (4) Install cargo door trim panel (Refer to 23 - BODY/DOOR - CARGO/TRIM PANEL - INSTALLATION).

## DOOR

### REMOVAL

- (1) Using a grease pencil or equivalent, mark the position of the hinge on the door.
- (2) Remove the cargo door trim panel (Refer to 23 - BODY/DOOR - CARGO/TRIM PANEL - REMOVAL).
- (3) Remove the cargo door check strap from the cab C-pillar (Refer to 23 - BODY/DOOR - CARGO/CHECK - REMOVAL).

- (4) Using the access hole in the cargo door inner panel, disengage the speaker wire from the speaker and route the wire through the door.
- (5) Support the cargo door on a suitable device.
- (6) Remove the bolts attaching the hinges to the cargo door (Fig. 3).



80ace4ba

**Fig. 3 Cargo Door**

- 1 - CARGO DOOR
- 2 - CARGO DOOR HINGE

### INSTALLATION

- (1) Support the cargo door on a suitable device.
- (2) Using the alignment marks, position the door at the hinge.
- (3) Install the bolts attaching the hinges to the cargo door (Fig. 3). Tighten the bolts to 28 N·m (21 ft. lbs.) torque.
- (4) Route the speaker wire through the door and using the access hole in the cargo door inner panel, engage the speaker wire at the speaker.
- (5) Install the cargo door check strap at the cab C-pillar (Refer to 23 - BODY/DOOR - CARGO/CHECK - INSTALLATION).
- (6) Install the cargo door trim panel (Refer to 23 - BODY/DOOR - CARGO/TRIM PANEL - INSTALLATION).

### ADJUSTMENT – CARGO DOOR

#### CARGO DOOR FORE/AFT AND UP/DOWN

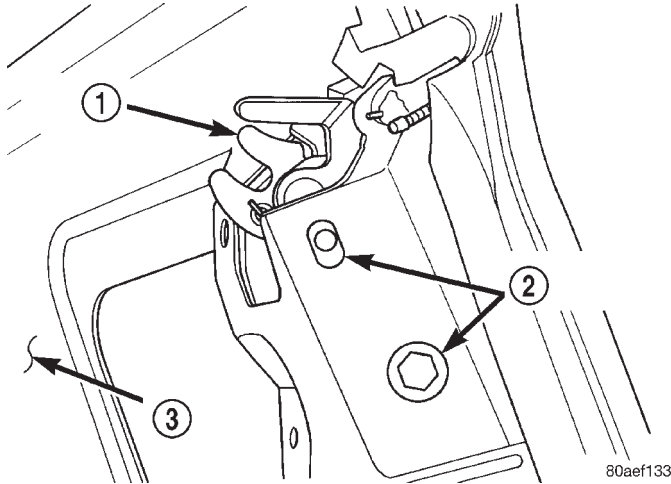
- (1) As applicable, remove the C-pillar trim to access the bolts attaching the cargo door to the C-pillar.
- (2) Support the door with a padded floor jack.
- (3) Loosen the applicable C-pillar to hinge bolts and move the door to the correct position. If necessary, loosen the other C-pillar to hinge bolts and move the door to the correct position.
- (4) Tighten the bolts to 28 N·m (21 ft. lbs.) torque.

## DOOR (Continued)

(5) If necessary, loosen the bolts attaching the lower striker and move striker to the correct position.

(6)

If necessary, loosen the bolts attaching the upper latch to the cargo door and move to the correct position. (Fig. 4)



**Fig. 4 CARGO DOOR UPPER LATCH**

- 1 - UPPER LATCH
- 2 - ADJUSTMENT SLOTS
- 3 - CARGO DOOR

## CARGO DOOR IN/OUT

(1) Loosen the applicable hinge to door fasteners and move the door to the correct position.

(2) Tighten the bolts to 28 N·m (21 ft. lbs.) torque.

## EXHAUST VENT

## REMOVAL

(1) Using a trim stick, carefully pry bottom of vent to disengage from door (Fig. 5).

(2) Separate vent from door.

## INSTALLATION

(1) Position upper side of vent in door opening.

(2) Slide upward until tabs on top edge are in place.

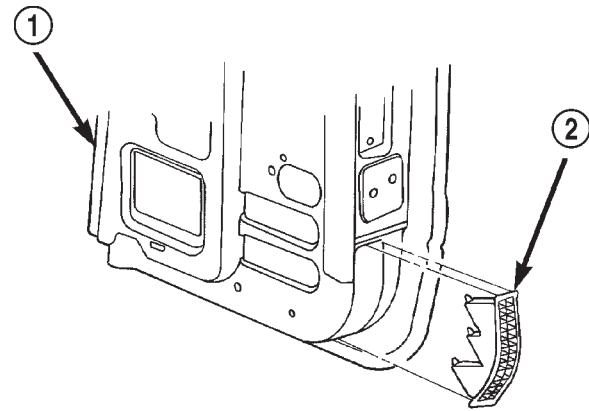
(3) Push the lower side of the vent towards the door until the tabs snap into place.

(4) Ensure vent is fully seated.

## HINGE

## REMOVAL

(1) Remove cargo door (Refer to 23 - BODY/DOOR - CARGO/DOOR - REMOVAL).



80ae8471

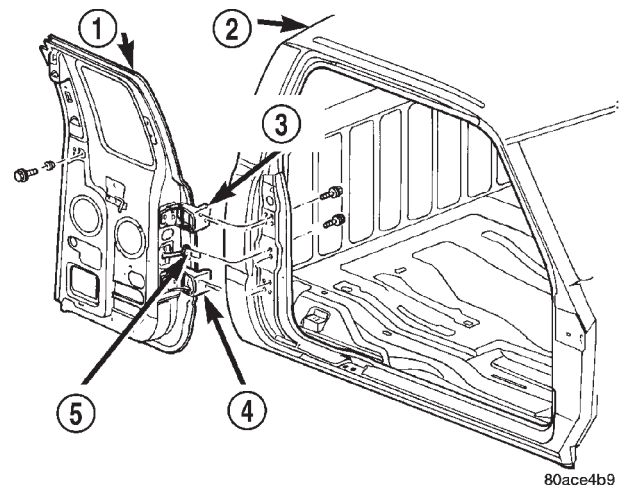
**Fig. 5 Cargo Door Exhaust Vent**

- 1 - CARGO DOOR
- 2 - EXHAUST VENT

(2) Remove quarter trim panel (Refer to 23 - BODY/INTERIOR/QUARTER TRIM PANEL - REMOVAL).

(3) Remove bolts attaching hinge to C-pillar (Fig. 6).

(4) Separate hinge from vehicle.



80ace4b9

**Fig. 6 Cargo Door Hinge**

- 1 - CARGO DOOR
- 2 - CAB
- 3 - UPPER HINGE
- 4 - LOWER HINGE
- 5 - DOOR CHECK

## INSTALLATION

(1) Position hinge on vehicle.

(2) Install bolts attaching hinge to C-pillar (Fig. 6). Tighten bolts to 28 N·m (21 ft. lbs.) torque.

(3) Install quarter trim panel (Refer to 23 - BODY/INTERIOR/QUARTER TRIM PANEL - INSTALLATION).

## HINGE (Continued)

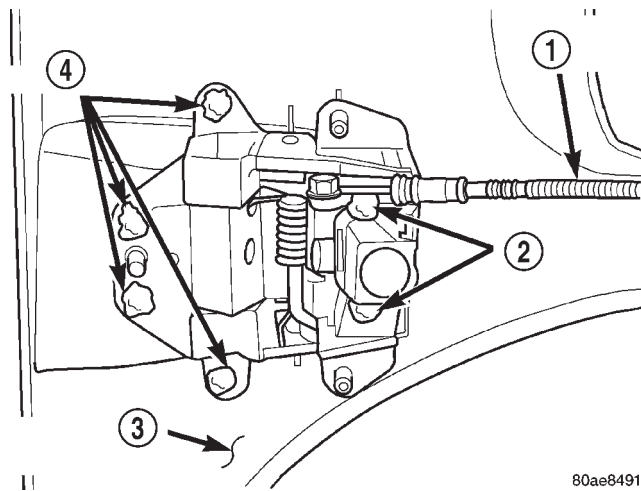
(4) Install cargo door (Refer to 23 - BODY/DOOR - CARGO/DOOR - INSTALLATION).

## INSIDE HANDLE ACTUATOR

## REMOVAL

**NOTE:** The cargo door inside handle actuator is heat staked to the trim panel (Fig. 7).

- (1) Remove cargo door trim panel (Refer to 23 - BODY/DOOR - CARGO/TRIM PANEL - REMOVAL).
- (2) Disengage release cable from inside handle.
- (3) Using a small file, drummel tool or die grinder, remove the melted material securing the handle to the trim panel.
- (4) Separate the handle from the trim panel.



**Fig. 7 Heat Staked Locations**

- 1 - RELEASE CABLE
- 2 - HEAT STAKED LOCATIONS
- 3 - CARGO DOOR TRIM PANEL
- 4 - HEAT STAKED LOCATIONS

## INSTALLATION

- (1) Position the handle in the trim panel.
- (2) Using a soldering gun, and using the additional studs, heat stake the handle to the trim panel.
- (3) Engage release cable to inside handle.
- (4) Install cargo door trim panel (Refer to 23 - BODY/DOOR - CARGO/TRIM PANEL - INSTALLATION).

## LATCH - LOWER

## REMOVAL

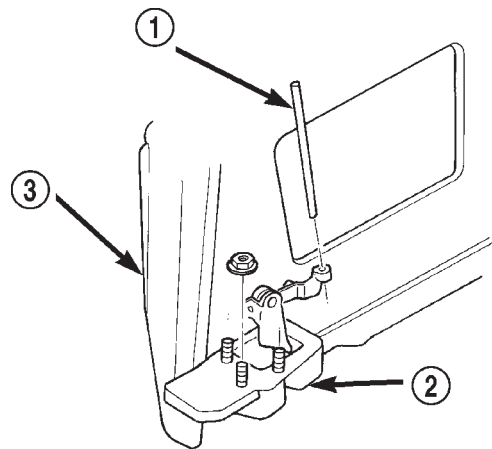
- (1) Remove cargo door trim panel (Refer to 23 - BODY/DOOR - CARGO/TRIM PANEL - REMOVAL).
- (2) Peel back waterdam to access air exhauster.

(3) Remove cargo door air exhauster (Refer to 23 - BODY/DOOR - CARGO/AIR EXHAUSTER - REMOVAL).

(4) Disengage lower latch to shutface handle rod at shutface handle (Fig. 8).

(5) Remove nuts attaching lower latch to cargo door.

(6) Separate lower latch and latch rod from cargo door.



80acd01c

**Fig. 8 Cargo Door Lower Latch**

- 1 - LOWER LATCH TO HANDLE ROD
- 2 - LOWER CARGO DOOR LATCH
- 3 - CARGO DOOR

## INSTALLATION

- (1) If installing a new replacement latch:
  - (a) Engage latch rod to latch rod retaining clip in lower latch. Ensure "white" latch installation pin is in the position closest to the latch release lever (Fig. 9).
- (2) If the latch was not replaced and the existing latch is to be installed:
  - (a) Slide "white" latch installation pin to the position closest to the latch release lever.
- (3) Position lower latch and latch rod in cargo door.
- (4) Install nuts attaching lower latch to cargo door. Tighten nuts to 12 N·m (9 ft. lbs.) torque (Fig. 8).
- (5) Engage latch rod to latch rod retaining clip in lower latch.

**CAUTION:** When engaging lower latch release rod to shutface handle, ensure lower latch rod is pushed all the way down before engaging to the handle.

- (6) Engage lower latch rod to shutface handle
- (7) Cycle the shutface handle and verify latch operation.

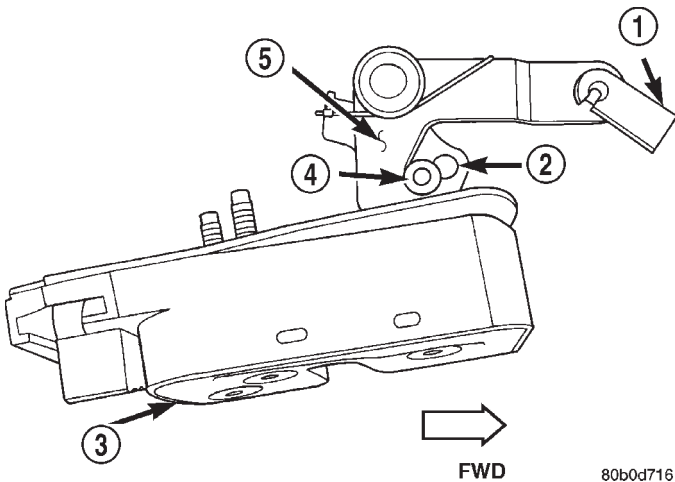


## LATCH - LOWER (Continued)

(8) Install cargo door air exhauster (Refer to 23 - BODY/DOOR - CARGO/AIR EXHAUSTER - INSTALLATION).

(9) Reposition waterdam.

(10) Install cargo door trim panel (Refer to 23 - BODY/DOOR - CARGO/TRIM PANEL - INSTALLATION).



**Fig. 9 Cargo Door Lower Latch Installation Pin**

- 1 - LATCH ROD RETAINING CLIP
- 2 - SLOT
- 3 - CARGO DOOR LOWER LATCH
- 4 - INSTALLATION PIN
- 5 - LATCH RELEASE LEVER

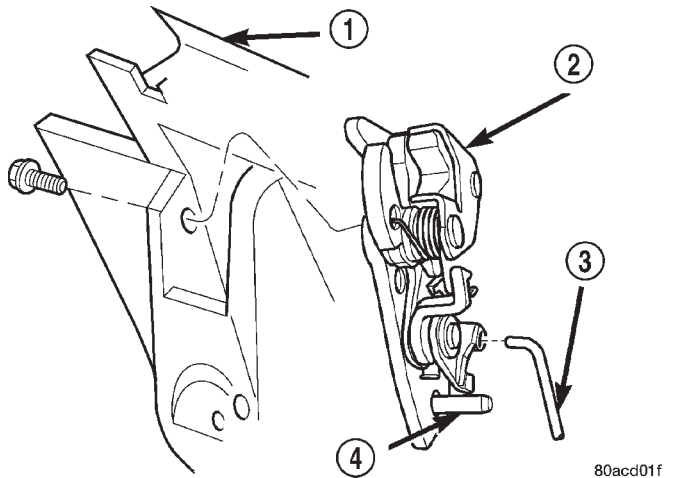
## LATCH - UPPER

## REMOVAL

- (1) Remove cargo door trim panel (Refer to 23 - BODY/DOOR - CARGO/TRIM PANEL - REMOVAL).
- (2) Using a grease pencil or equivalent, mark the position of the bolts.
- (3) Disengage upper latch release rod from shutface handle.
- (4) Remove the bolts attaching upper latch to cargo door (Fig. 10).
- (5) Separate upper latch and latch rod from cargo door.

## INSTALLATION

- (1) The new replacement latch is supplied with an alignment set screw located in the lower mounting hole of the upper cargo door latch. If a new latch is being installed, use the following procedure:
  - (a) Verify alignment set screw is fully seated in latch.
  - (b) Engage latch rod to latch.
  - (c) Position latch in cargo door with alignment set screw located in the lower hole.
  - (d) Align bolt with reference mark.



**Fig. 10 Cargo Door Upper Latch**

- 1 - CARGO DOOR
- 2 - UPPER CARGO DOOR LATCH
- 3 - UPPER LATCH TO HANDLE ROD
- 4 - ALIGNMENT SET SCREW

- (e) Install upper bolt. Tighten bolt to 23 N·m (17 ft. lbs.) torque.
- (f) Engage latch rod to shutface handle.
- (g) Remove alignment set screw from lower hole.
- (h) Align lower bolt with reference mark.
- (i) Install bolt in lower hole. Tighten bolt to 23 N·m (17 ft. lbs.) torque.

**CAUTION:** When engaging upper latch release rod to shutface handle, ensure the latch rod is pushed all the way up before engaging into the shutface handle.

- (2) If the latch was not replaced and the existing latch is to be installed:
  - (a) Engage latch rod to latch.
  - (b) Position upper latch and latch rod in cargo door.
  - (c) Align bolts with reference marks.
  - (d) Install the bolts attaching upper latch to cargo door (Fig. 10). Tighten the bolts to 23 N·m (17 ft. lbs.) torque.
  - (e) Engage upper latch release rod to shutface handle.
- (3) Cycle the shutface handle and verify latch operation.
- (4) Install cargo door trim panel (Refer to 23 - BODY/DOOR - CARGO/TRIM PANEL - INSTALLATION).

## LATCH STRIKER - LOWER

### REMOVAL

- (1) Using a grease pencil or equivalent, mark the position of the lower striker on the sill.
- (2) Remove the torx screws attaching the striker to the sill (Fig. 11).
- (3) Separate striker from sill.

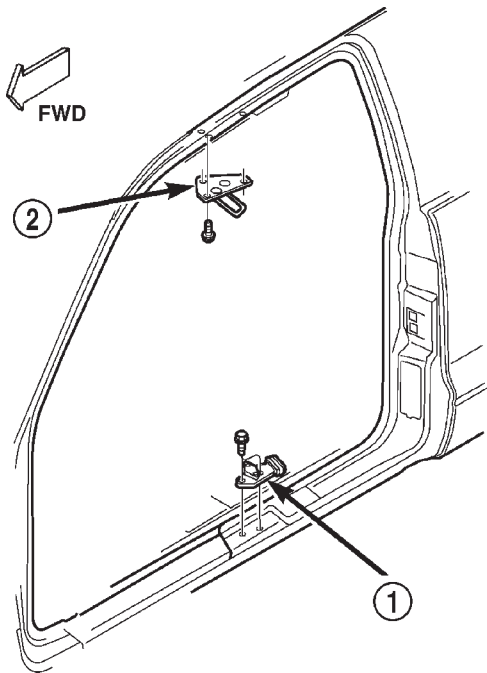
### INSTALLATION

- (1) Using the alignment marks, position striker on sill.
- (2) Install the torx screws attaching the striker to the sill (Fig. 11). Tighten screws to 28 N·m (21 ft. lbs.) torque.

## LATCH STRIKER - UPPER

### REMOVAL

- (1) Remove screws attaching striker trim cover to roof.
- (2) Remove bolts attaching striker to roof (Fig. 11).
- (3) Separate upper striker from roof.



80acd01b

**Fig. 11 Cargo Door Strikers**

- 1 - UPPER STRIKER
- 2 - LOWER STRIKER

### INSTALLATION

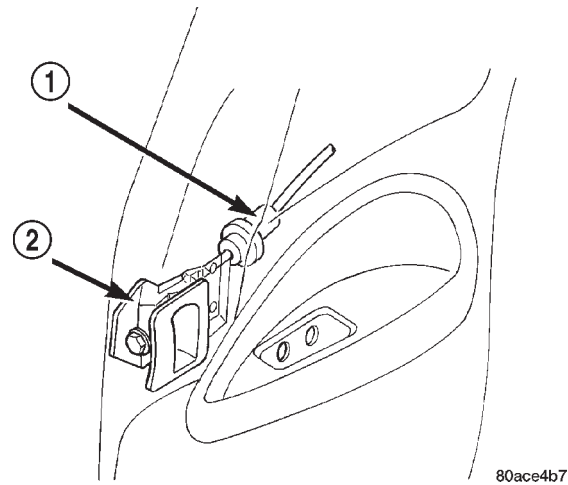
- (1) Position upper striker on roof.
- (2) Install bolts attaching striker to roof (Fig. 11). Tighten bolts to 23 N·m (17 ft. lbs.) torque.

- (3) Install the screws attaching striker trim cover to roof.

## RELEASE CABLE

### REMOVAL

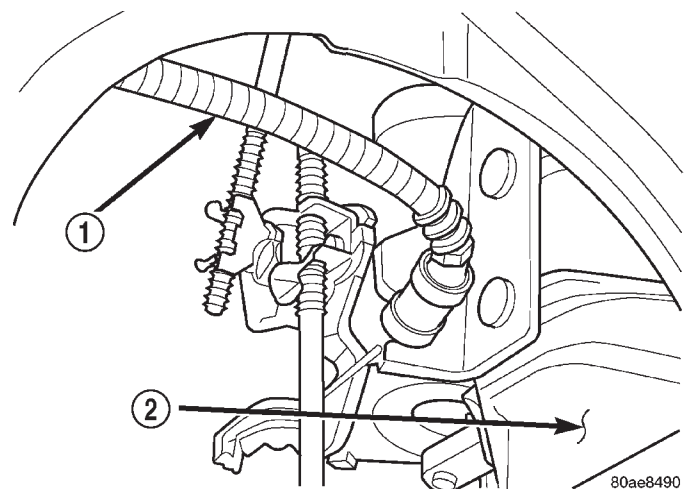
- (1) Remove cargo door trim panel (Refer to 23 - BODY/DOOR - CARGO/TRIM PANEL - REMOVAL).
- (2) Disengage release cable from inside release handle (Fig. 12).
- (3) Peel back waterdam
- (4) Disengage release cable from shutface door handle (Fig. 13).
- (5) Separate release cable from cargo door.



80ace4b7

**Fig. 12 Cargo Door Release Handle**

- 1 - CARGO DOOR RELEASE CABLE
- 2 - CARGO DOOR RELEASE HANDLE



80ae8490

**Fig. 13 Shutface Door Handle**

- 1 - RELEASE CABLE
- 2 - SHUTFACE DOOR HANDLE

## RELEASE CABLE (Continued)

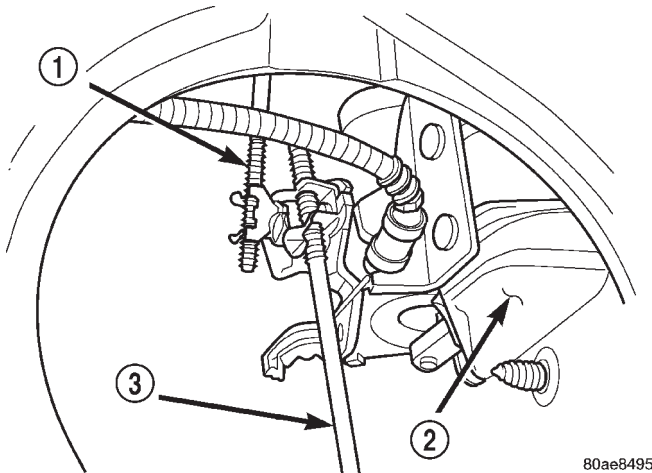
## INSTALLATION

- (1) Position release cable in cargo door.
- (2) Engage release cable to shutface door handle.
- (3) Reposition waterdam
- (4) Engage release cable to inside release handle.
- (5) Install cargo door trim panel (Refer to 23 - BODY/DOOR - CARGO/TRIM PANEL - INSTALLATION).

## SHUTFACE HANDLE

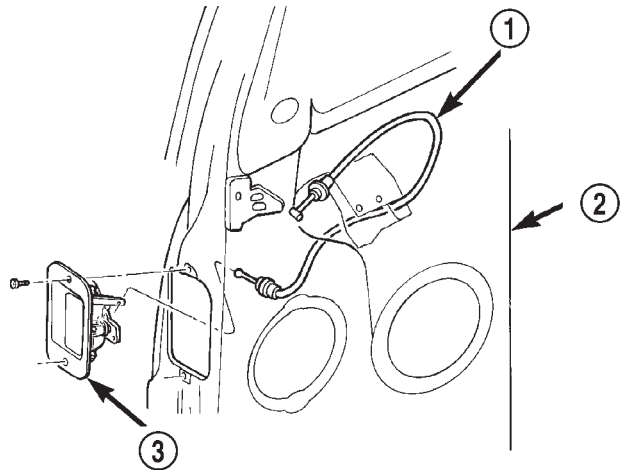
## REMOVAL

- (1) Remove cargo door trim panel (Refer to 23 - BODY/DOOR - CARGO/TRIM PANEL - REMOVAL).
- (2) Peel back waterdam.
- (3) Disengage upper and lower latch release rods from shutface handle (Fig. 14).
- (4) Disengage cargo door release cable.
- (5) Remove screws attaching shutface handle to cargo door (Fig. 15).
- (6) Separate handle from cargo door.



**Fig. 14 Cargo Door Latch Rods**

- 1 - UPPER LATCH ROD
- 2 - SHUTFACE HANDLE
- 3 - LOWER LATCH ROD



80ace5ff

**Fig. 15 Shutface Handle**

- 1 - CARGO DOOR RELEASE CABLE
- 2 - CARGO DOOR
- 3 - SHUTFACE DOOR HANDLE

## INSTALLATION

- (1) Position handle in cargo door.
- (2) Install screws attaching shutface handle to cargo door (Fig. 15).
- (3) Engage cargo door release cable.

**CAUTION:** When engaging upper and lower latch release rods to shutface handle, ensure the upper latch rod is pushed all the way up and the lower latch rod is pushed all the way down before engaging into the shutface handle.

- (4) Engage upper and lower latch release rods to shutface handle.
- (5) Cycle the shutface handle and verify operation.
- (6) Reposition waterdam.
- (7) Install cargo door trim panel (Refer to 23 - BODY/DOOR - CARGO/TRIM PANEL - INSTALLATION).

## TRIM PANEL

### REMOVAL

(1) Remove the screws attaching the cargo door pull cup to the cargo door (Fig. 16).

(2) Remove the screw attaching the inside release handle to the cargo door.

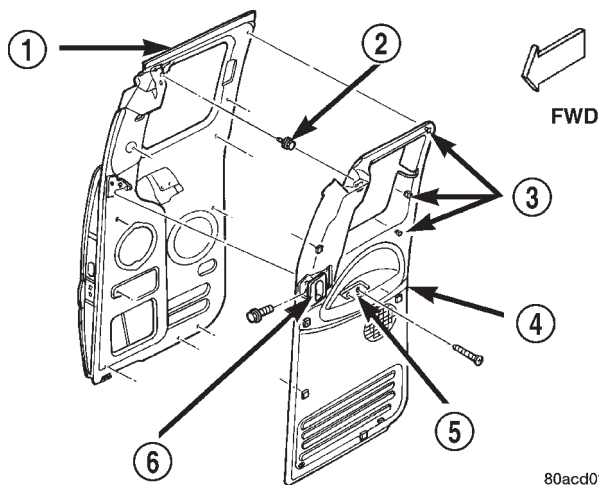
**NOTE:** The cargo door trim panel is secured to the cargo door with spring clips and push-in fasteners (Fig. 17).

(3) Using a trim panel removal tool, remove the push-in fasteners attaching the trim panel to the cargo door.

(4) Pull the trim panel outward to disengage the spring clips.

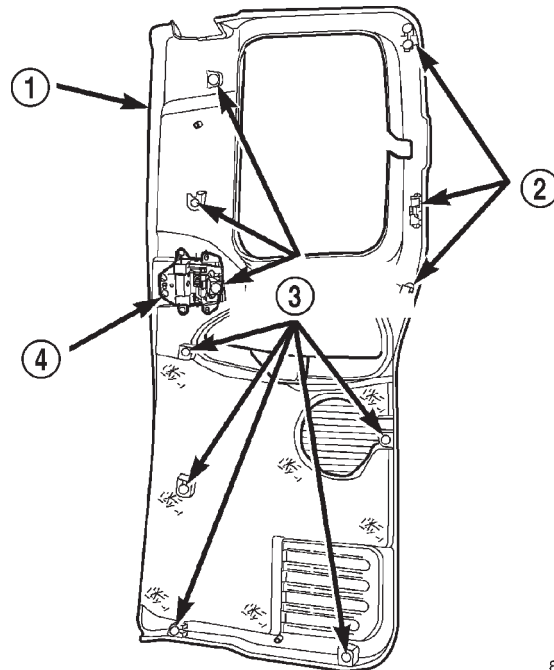
(5) Separate the trim panel from the cargo door.

(6) Disengage the cargo door release cable from the inside release handle (Fig. 18).



**Fig. 16 Cargo Door Trim Panel**

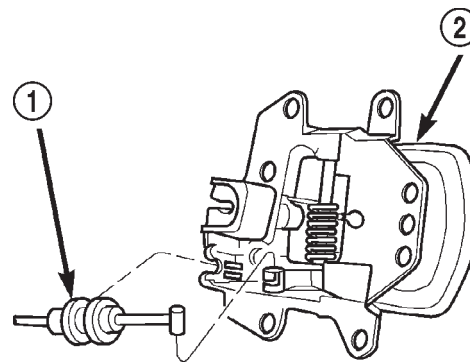
- 1 - CARGO DOOR
- 2 - PUSH-IN FASTENER
- 3 - SPRING CLIP
- 4 - CARGO DOOR TRIM
- 5 - PULL CUP
- 6 - INSIDE HANDLE



80ae848f

**Fig. 17 Cargo Door Trim Panel Fasteners**

- 1 - CARGO DOOR TRIM PANEL
- 2 - SPRING CLIPS
- 3 - PUSH-IN FASTENERS
- 4 - INSIDE RELEASE HANDLE



80ace4b8

**Fig. 18 Cargo Door Release Cable**

- 1 - CARGO DOOR RELEASE CABLE
- 2 - CARGO DOOR RELEASE HANDLE

### INSTALLATION

**NOTE:** When replacing door trim panel, installer must replace the X-mas tree style pin 6506878aa.

(1) Engage the cargo door release cable to the inside release handle (Fig. 18).

(2) Position the trim panel on the cargo door.

(3) Align all fasteners and starting at the top of the panel, push into place to secure.

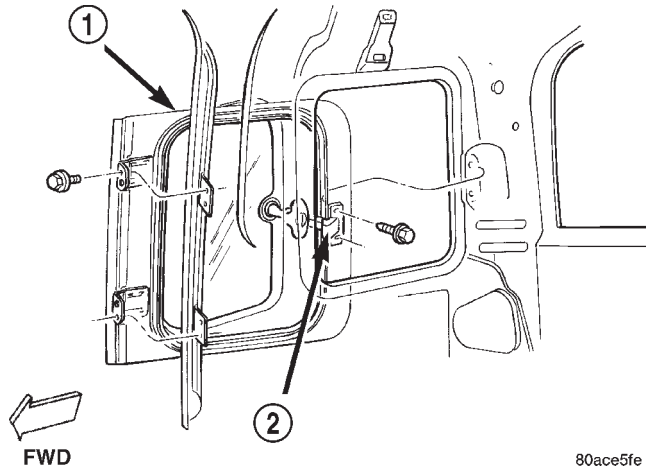
(4) Install the screw attaching the inside release handle to the cargo door.

(5) Install the screws attaching the cargo door pull cup to the cargo door (Fig. 16).

## VENT WINDOW

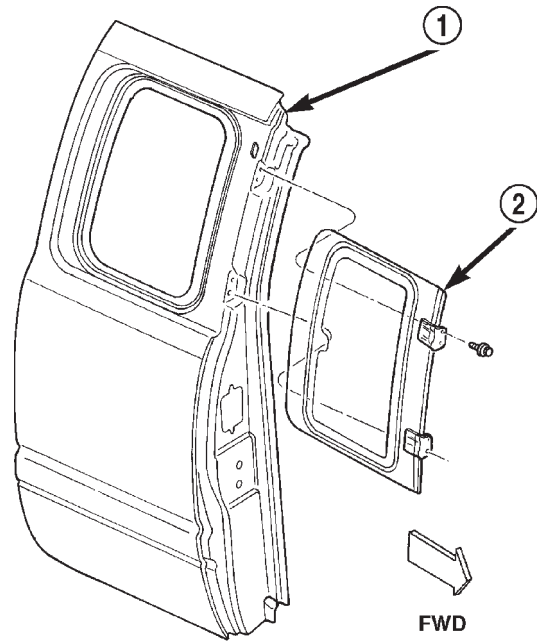
### REMOVAL

- (1) Remove cargo door trim panel (Refer to 23 - BODY/DOOR - CARGO/TRIM PANEL - REMOVAL).
- (2) Remove the screws attaching the latch to the cargo door (Fig. 19).
- (3) Remove the bolts attaching the vent glass to the cargo door (Fig. 20).
- (4) Remove the glass from the door.
- (5) If necessary, remove the latch from the glass.



**Fig. 19 Cargo Door Quarter Glass Vent Window Latch**

- 1 - CARGO DOOR QUARTER GLASS
- 2 - LATCH



80ace4bc

**Fig. 20 Cargo Door Quarter Glass Vent Window**

- 1 - CARGO DOOR
- 2 - CARGO DOOR QUARTER GLASS

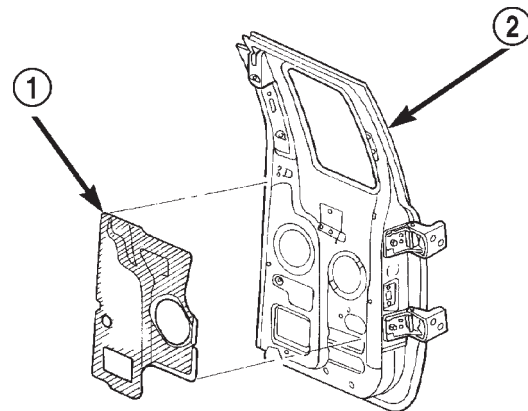
### INSTALLATION

- (1) If removed, install the latch to the glass. Tighten the screw with 5 N-m (45 in. lbs.) torque.
- (2) Center the glass in the cargo door opening.
- (3) Install the bolts attaching the vent glass to the cargo door.
- (4) Install the screws attaching the latch to the cargo door.
- (5) Install cargo door trim panel (Refer to 23 - BODY/DOOR - CARGO/TRIM PANEL - INSTALLATION).

## WATERDAM

### REMOVAL

- (1) Remove cargo door trim panel (Refer to 23 - BODY/DOOR - CARGO/TRIM PANEL - REMOVAL).
- (2) Carefully peel waterdam from door (Fig. 21).



80ae845f

**Fig. 21 Cargo Door Waterdam**

- 1 - WATER DAM
- 2 - CARGO DOOR

### INSTALLATION

If a replacement waterdam is being applied, clean cargo door inner panel with Mopar Super Clean or equivalent.

- (1) Position waterdam on cargo door and press into place.
- (2) install cargo door trim panel (Refer to 23 - BODY/DOOR - CARGO/TRIM PANEL - INSTALLATION).



# EXTERIOR

## TABLE OF CONTENTS

	page		page
<b>EXTERIOR</b>		<b>LEFT FRONT FENDER</b>	
DESCRIPTION . . . . .	86	REMOVAL . . . . .	92
OPERATION . . . . .	86	INSTALLATION . . . . .	93
<b>BODY SIDE MOLDINGS</b>		<b>RIGHT FRONT FENDER</b>	
REMOVAL . . . . .	87	REMOVAL . . . . .	94
INSTALLATION . . . . .	87	INSTALLATION . . . . .	94
<b>BODY STRIPES AND DECALS</b>		<b>FUEL FILL DOOR</b>	
REMOVAL . . . . .	87	REMOVAL . . . . .	95
INSTALLATION . . . . .	87	INSTALLATION . . . . .	95
<b>TAPE STRIPE</b>		<b>REAR FENDER</b>	
REMOVAL . . . . .	88	REMOVAL . . . . .	95
INSTALLATION . . . . .	88	INSTALLATION . . . . .	95
<b>EXTERIOR NAME PLATES</b>		<b>REAR SPLASH SHIELD</b>	
REMOVAL . . . . .	89	REMOVAL . . . . .	96
INSTALLATION . . . . .	89	INSTALLATION . . . . .	96
<b>COWL GRILLE</b>		<b>REAR WHEELHOUSE LINER</b>	
REMOVAL . . . . .	90	REMOVAL . . . . .	96
INSTALLATION . . . . .	90	INSTALLATION . . . . .	96
<b>ROOF JOINT MOLDING</b>		<b>CARGO BOX</b>	
REMOVAL . . . . .	91	REMOVAL . . . . .	96
INSTALLATION . . . . .	91	INSTALLATION . . . . .	97
<b>GRILLE</b>		<b>SIDE VIEW MIRROR</b>	
REMOVAL . . . . .	91	REMOVAL . . . . .	97
INSTALLATION . . . . .	91	INSTALLATION . . . . .	97
<b>GRILLE FRAME</b>		<b>SIDE VIEW MIRROR - LOW MOUNTED</b>	
REMOVAL . . . . .	91	REMOVAL . . . . .	98
INSTALLATION . . . . .	92	INSTALLATION . . . . .	98
<b>FRONT END SPLASH SHIELDS</b>		<b>SIDE VIEW MIRROR GLASS</b>	
REMOVAL . . . . .	92	REMOVAL . . . . .	98
INSTALLATION . . . . .	92	INSTALLATION . . . . .	98

## EXTERIOR

### DESCRIPTION

Exterior sheet metal components make up the exterior of the vehicle. Some exterior metal systems are welded assemblies, such as doors and hoods. Some exterior trim items are made of composite.

### OPERATION

The exterior is finished in various metal stampings and composite moldings. These assemblies give the vehicle a finished appearance and protect the occupants from the elements. Some components are part

of the energy absorbing system used to protect the occupants in collisions. The exterior sheet metal is repairable and adjustable for fit and finish. Welded and bonded component systems are adjustable as a system. Trim components made of composite are stamped with the type of material used. Daimler-Chrysler uses various fasteners to retain trim items. At times, it is not possible to remove trim items without damaging the fastener. If it is not possible to remove an item without damaging a component, cut or break the fasteners and use new ones when installing the component.

## BODY SIDE MOLDINGS

### REMOVAL

(1) Warm the effected stick-on molding and body metal to approximately 38°C (100°F) using a suitable heat lamp or heat gun.

(2) Pull stick-on molding from painted surface (Fig. 1) and (Fig. 2).

### INSTALLATION

(1) Clean body surface with MOPAR® Super Kleen solvent or equivalent. Wipe surface dry with lint free cloth.

(2) Apply a length of masking tape on the body, parallel to the top edge of the molding to use as a guide, if necessary.

(3) Remove protective cover from tape on back of molding. Apply molding to body below the masking tape guide (Fig. 1) and (Fig. 2).

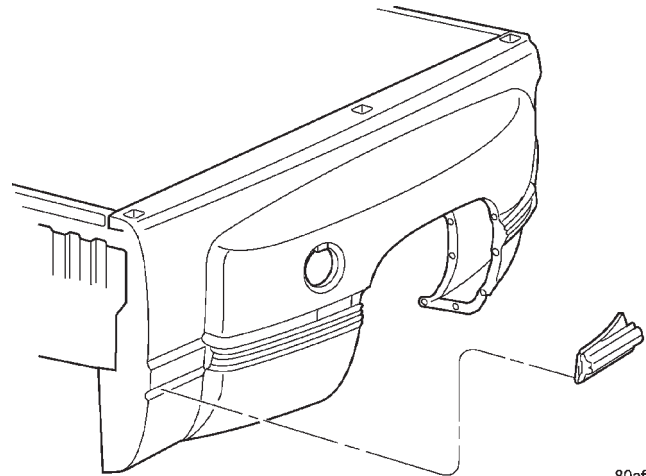
(4) Remove masking tape guide and heat body and molding, see step one. Firmly press molding to body surface to assure adhesion.

## BODY STRIPES AND DECALS

### REMOVAL

(1) Warm the panel to approximately 38°C (100°F) using a suitable heat lamp or heat gun.

(2) Peel decal from body panel using an even pressure pull.



80af619e

**Fig. 2 Body Side Moldings—Dual Wheel**

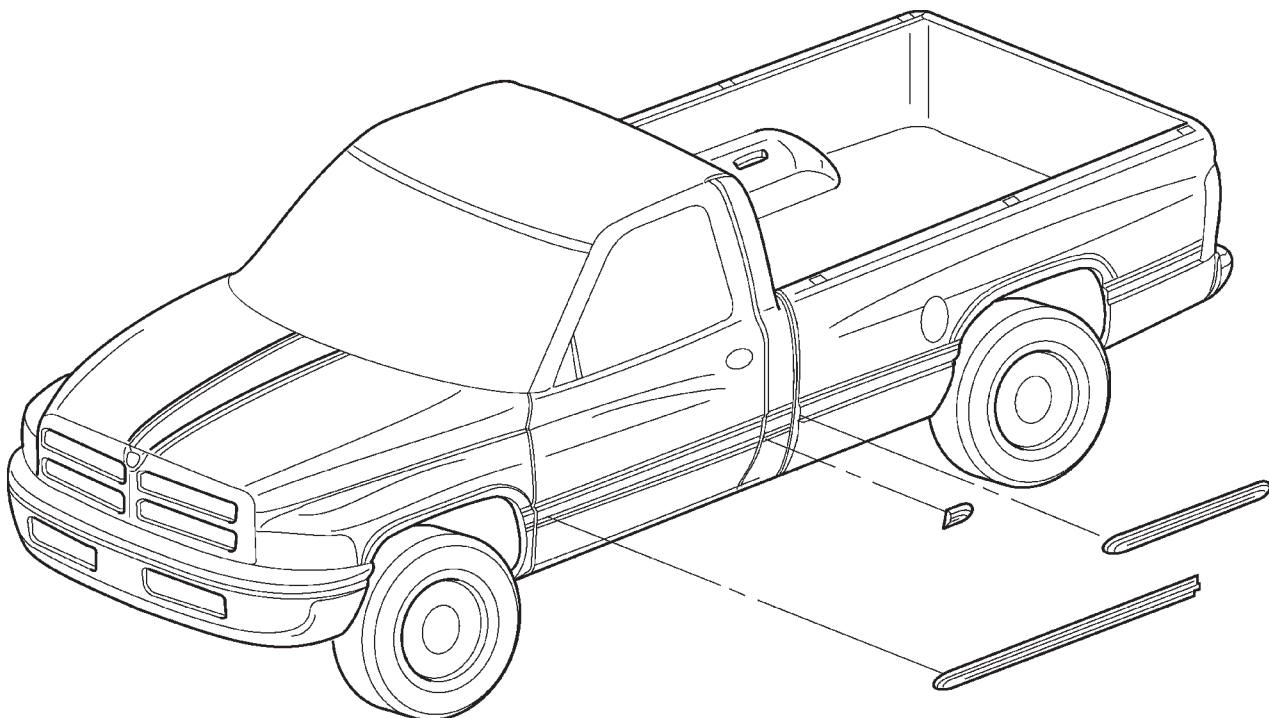
(3) Remove adhesive residue from body panel using a suitable adhesive removing solvent.

### INSTALLATION

The painted surface of the body panel to be covered by a decal must be smooth and completely cured before decal can be applied. Ripples and feather edging will read through if surface is not properly prepared. Clean all residue from surface.

(1) Peel paper backing away from decal exposing adhesive back of decal.

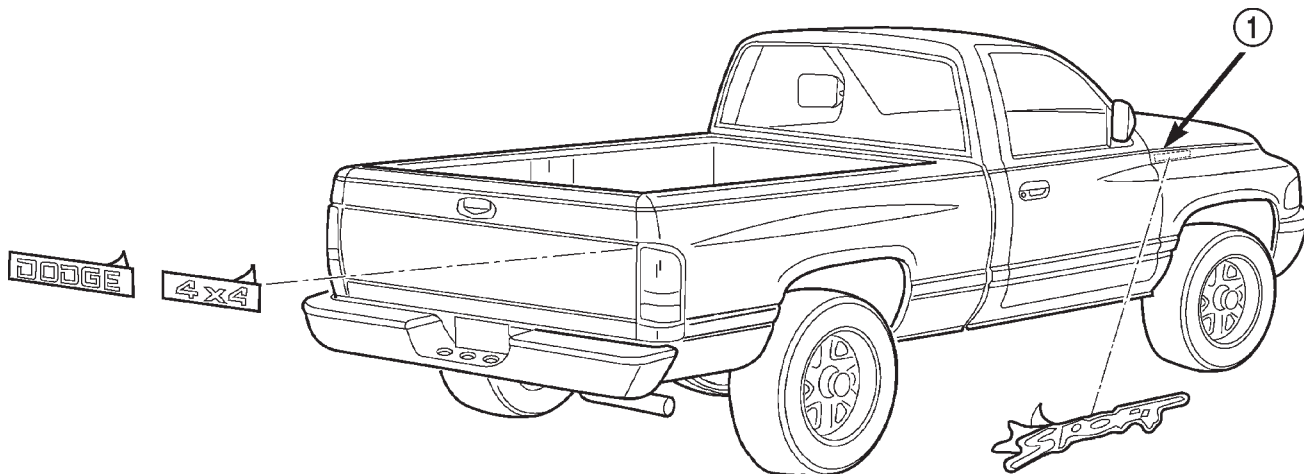
(2) Apply soap solution liberally to adhesive back of decal.



**Fig. 1 Body Side Moldings**

80ae8333

## BODY STRIPES AND DECALS (Continued)



80b5cb9e

Fig. 3 Decals

1 - TAPE STRIPE

(3) Apply soap solution liberally to body panel surface.

(4) Place decal into position on body panel (Fig. 3). Smooth out wrinkles by pulling lightly on edges of decal until it lays flat on painted surface.

(5) Push air pockets from under decal to the perimeter of the panel from the center of the decal out.

(6) Squeegee soap solution and air bubbles from behind decal from the center of the panel out using a body putty applicator squeegee.

(7) Apply heat to decal to evaporate residual moisture from edges of decal.

(8) Small air or water bubbles under decal can be pierced with a pin and smoothed out.

## TAPE STRIPE

## REMOVAL

(1) If the panel that is being serviced is not going to be refinished, apply a length of masking tape parallel to the edge of the original tape stripe to aid installation.

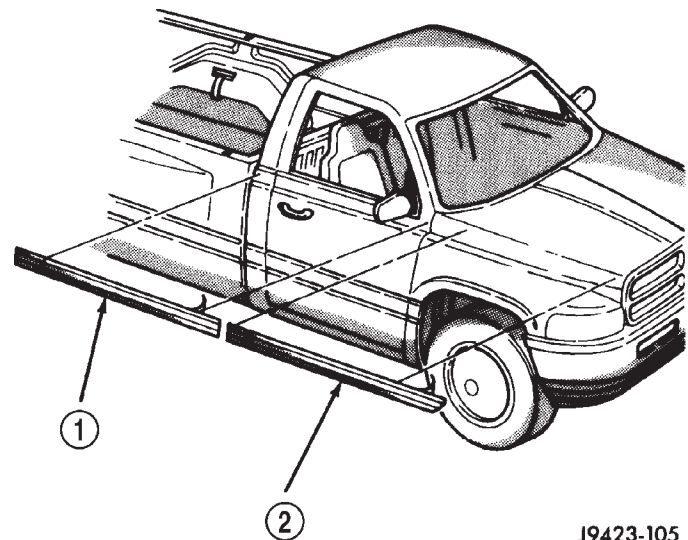
(2) Warm the panel to approximately 38°C (100°F) using a suitable heat lamp or heat gun.

(3) Peel tape stripe (Fig. 4) from body panel using an even pressure pull.

(4) Remove adhesive residue from body panel using a suitable adhesive removing solvent.

## INSTALLATION

The painted surface of the body panel to be covered by a tape stripe overlay must be smooth and com-



J9423-105

Fig. 4 Tape Stripe Overlay

1 - CAB/DOOR TAPE STRIPE

2 - HOOD TAPE STRIPE

pletely cured before overlay can be applied. If painted surface is not smooth, wet sand with 600 grit wet/dry sand paper until surface is smooth. Ripples and feather edging will read through overlay if surface is not properly prepared. Clean all residue from surface.

Installation equipment:

- Pail filled with mild dish soap solution.
- Lint free applicator cloth or sponge.
- Body putty applicator squeegee.
- Heat gun or sun lamp.
- Razor knife.

## TAPE STRIPE (Continued)

(1) Spread replacement tape stripe overlay across a smooth flat work surface, finish side down.

(2) Peel paper backing away from overlay exposing adhesive back of overlay.

(3) Apply soap solution liberally to adhesive back of overlay.

(4) Apply soap solution liberally to body panel surface.

(5) Place overlay into position on body panel. Smooth out wrinkles by pulling lightly on edges of overlay until it lays flat on painted surface.

(6) Push air pockets from under overlay to the perimeter of the panel from the center of the overlay out.

(7) Squeegee soap solution and air bubbles from behind overlay from the center of the panel out using a body putty applicator squeegee (Fig. 5).

**CAUTION: Do not cut into painted surface of body panel when trimming overlay to size.**

(8) Trim overlay to size using a razor knife. Leave at least 13 mm (0.5 in.) for edges of doors and openings.

**CAUTION: Do not overheat overlay when performing step 9.**

(9) Apply heat to overlay to evaporate residual moisture from edges of overlay and to allow overlay to be stretched into concave surfaces.

(10) Edge turn overlay around doors or fenders.

(11) Install exterior trim if necessary.

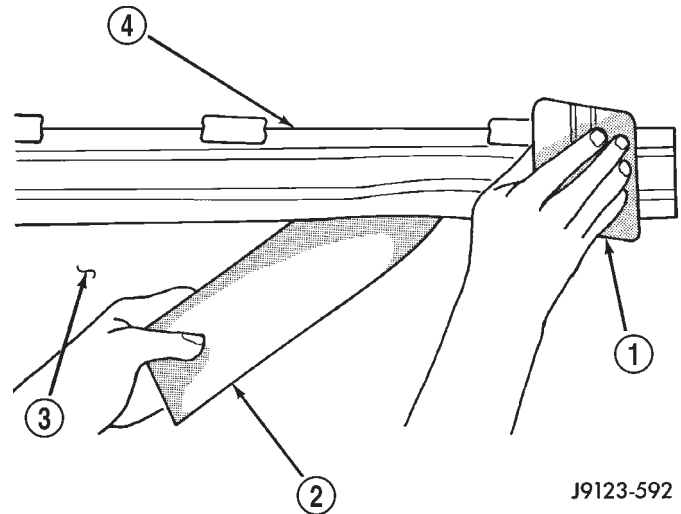
(12) Small air or water bubbles under overlay can be pierced with a pin and smoothed out.

## EXTERIOR NAME PLATES

## REMOVAL

**NOTE: Exterior nameplates are attached to body panels with adhesive tape.**

(1) Apply a length of masking tape on the body, parallel to the top edge of the nameplate to use as a guide, if necessary.



J9123-592

**Fig. 5 Tape Stripe Application**

- 1 - SQUEEGEE
- 2 - CARRIER
- 3 - BODY PANEL
- 4 - TAPE STRIPE

(2) If temperature is below 21°C (70°F) warm emblem with a heat lamp or gun. Do not exceed 52°C (120°F) when heating emblem.

(3) Insert a plastic trim stick or a hard wood wedge behind the emblem to separate the adhesive backing from the body.

(4) Clean adhesive residue from body with MOPAR® Super Clean solvent or equivalent.

## INSTALLATION

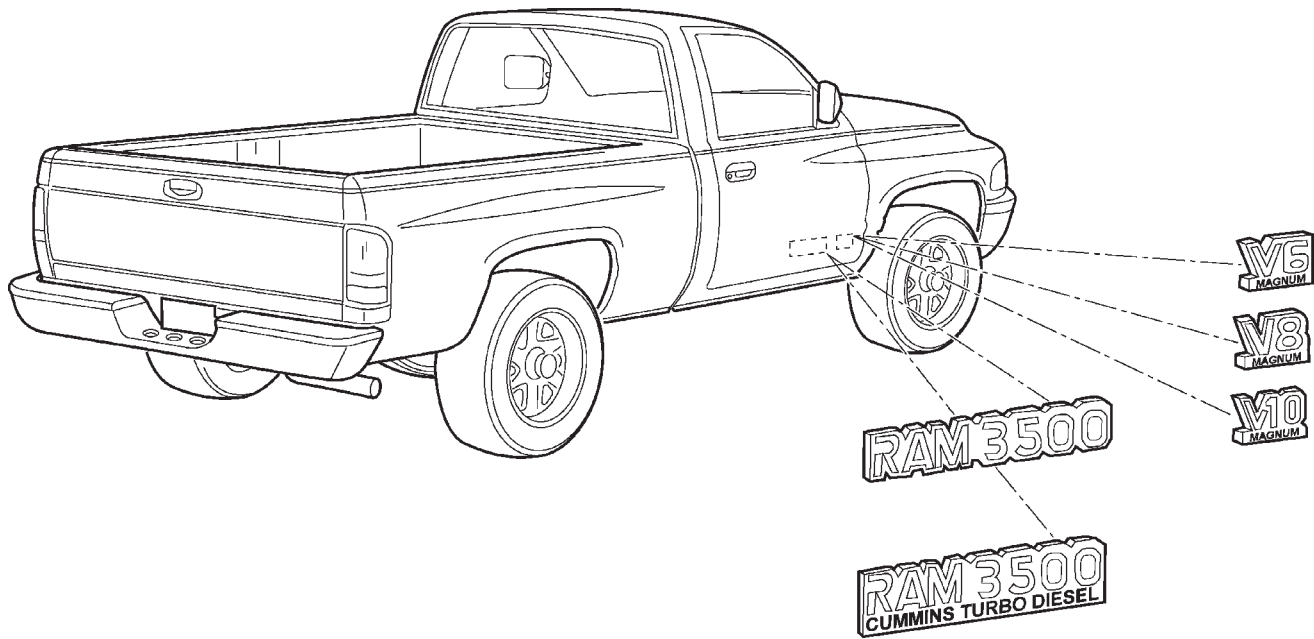
(1) Remove protective cover from adhesive tape on back of emblem.

(2) Position emblem properly on body (Fig. 6).

(3) Press emblem firmly to body with palm of hand.

(4) If temperature is below 21°C (70°F) warm emblem with a heat lamp or gun to assure adhesion. Do not exceed 52°C (120°F) when heating emblem.

## EXTERIOR NAME PLATES (Continued)



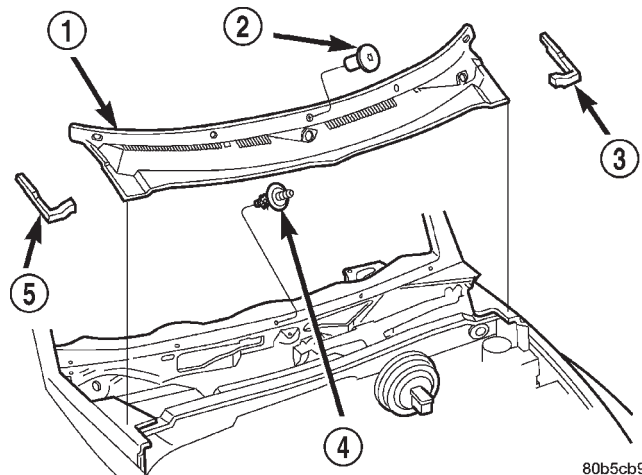
80b3b1d9

**Fig. 6 Exterior Nameplates**

## COWL GRILLE

**REMOVAL**

- (1) Open hood.
- (2) Remove wiper arms (Refer to 8 - ELECTRICAL/WIPERS/WASHERS/WIPER ARMS - REMOVAL AND INSTALLATION).
- (3) Disconnect windshield washer tubing from coupling near left hood hinge.
- (4) Remove plastic nuts attaching cowl cover to cowl (Fig. 7).
- (5) Pull cowl seal from flange on front of cowl.
- (6) Separate cowl cover from vehicle.



80b5cb95

**Fig. 7 Cowl Cover****INSTALLATION**

- (1) Position cowl cover on vehicle. Ensure end seals are positioned correctly and in good condition.
- (2) Install cowl seal.
- (3) Install plastic nuts attaching cowl cover to cow.
- (4) Connect windshield washer tubing to coupling near left hood hinge.
- (5) Install wiper arms.

- 1 - COWL COVER
- 2 - PLASTIC NUT
- 3 - END SEAL
- 4 - PUSH-IN STUD
- 5 - END SEAL

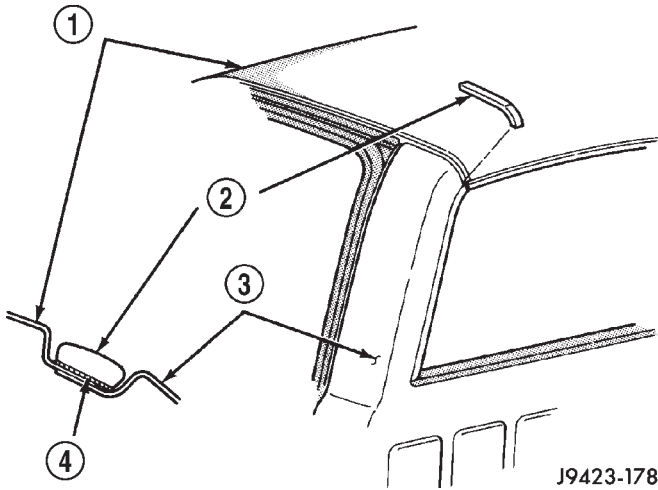


## ROOF JOINT MOLDING

### REMOVAL

(1) Warm the roof joint molding and roof panel to approximately 38°C (100°F) using a suitable heat lamp or heat gun.

(2) Pull molding from roof joint (Fig. 8).



**Fig. 8 Roof Joint Molding**

- 1 - ROOF
- 2 - JOINT MOLDING
- 3 - B-PILLAR
- 4 - ADHESIVE TAPE

### INSTALLATION

(1) Remove adhesive tape residue from roof joint.

(2) If molding is to be reused, remove tape residue from back of molding. Clean molding with MOPAR® Super Kleen solvent or equivalent. Wipe molding dry with lint free cloth. Apply new body side molding (two sided adhesive) tape to back of molding.

(3) Clean roof joint with MOPAR® Super Kleen solvent or equivalent. Wipe dry with lint free cloth.

(4) Remove protective cover from tape on back of molding and apply molding to roof joint.

(5) Heat roof and molding, see step one. Firmly press molding into roof joint to assure adhesion.

## GRILLE

### REMOVAL

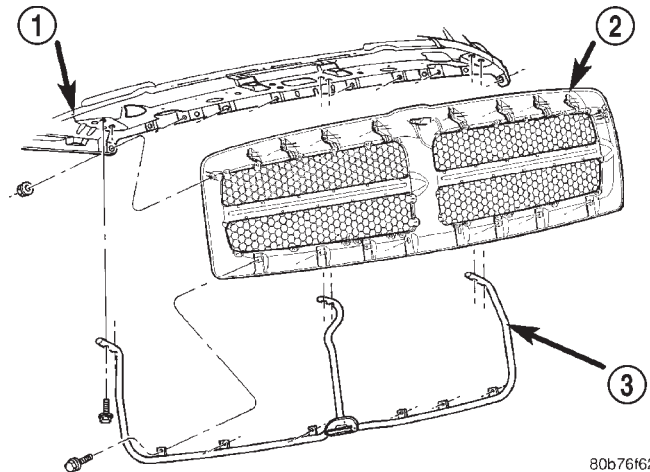
(1) Open hood.

(2) Remove bolts attaching bottom of grille to frame (Fig. 9).

(3) Remove bolts attaching sides of grille to frame.

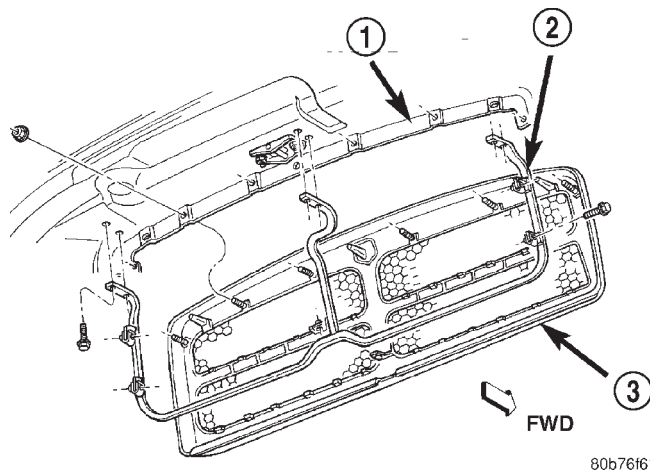
(4) Remove nuts attaching grille to hood (Fig. 10).

(5) Separate grille from vehicle.



**Fig. 9 Grille — Sport**

- 1 - HOOD
- 2 - GRILLE
- 3 - GRILLE FRAME



**Fig. 10 Grille — SLT**

- 1 - HOOD
- 2 - GRILLE FRAME
- 3 - GRILLE

### INSTALLATION

(1) Position grille on vehicle.

(2) Install nuts attaching grille to hood.

(3) Install bolts attaching sides of grille to frame.

(4) Install bolts attaching bottom of grille to frame.

## GRILLE FRAME

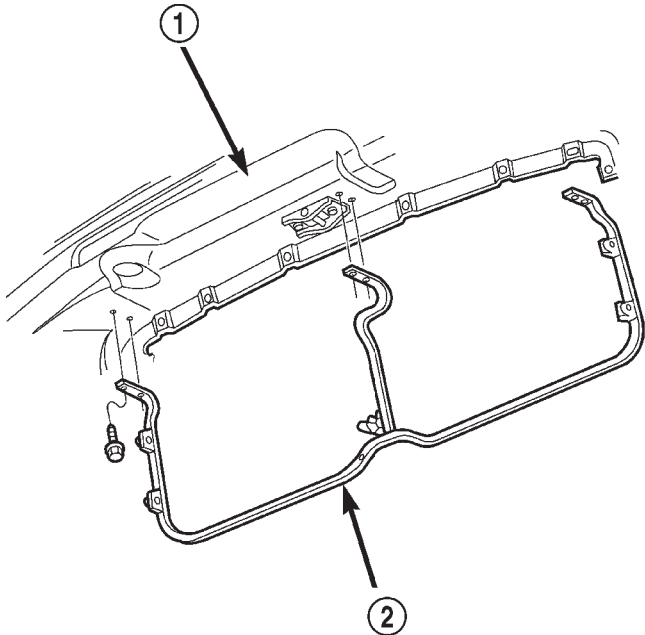
### REMOVAL

(1) Remove bolts attaching guide loop for hood safety catch release rod to grille frame.

(2) Remove grille.

## GRILLE FRAME (Continued)

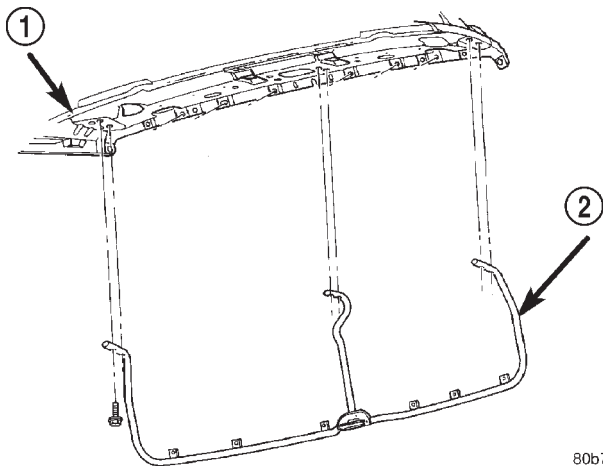
- (3) Remove screws attaching grille frame to hood (Fig. 11) and (Fig. 12).
- (4) Separate grille frame from hood.



80b5cb9c

**Fig. 11 Grille Frame — SLT**

- 1 - HOOD  
2 - GRILLE FRAME



80b76f63

**Fig. 12 Grille Frame — Sport**

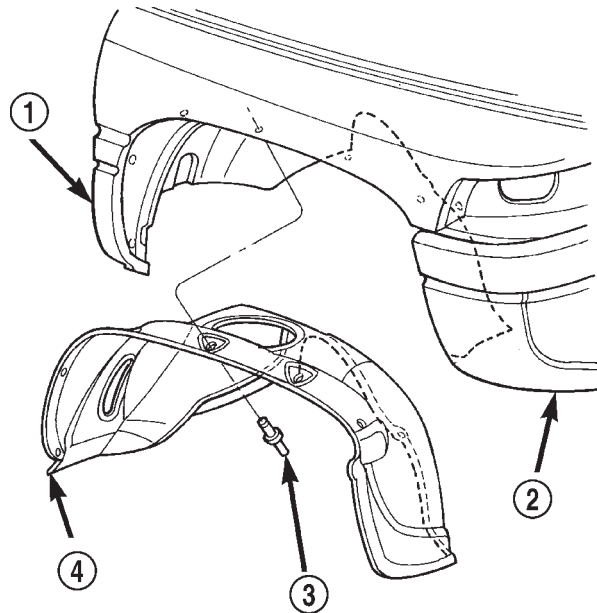
- 1 - HOOD  
2 - GRILLE FRAME

**INSTALLATION**

- (1) Position grille frame on hood.
- (2) Install screws attaching grille frame to hood.
- (3) Install grille.
- (4) Install bolts attaching guide loop for hood safety catch release rod to grille frame.

**FRONT END SPLASH SHIELDS****REMOVAL**

- (1) Hoist and support vehicle on safety stands.
- (2) Remove front wheel.
- (3) Remove plastic rivets attaching wheelhouse liner to fender at the edge of wheel opening.
- (4) Remove plastic rivets attaching liner to the wheelhouse (Fig. 13).
- (5) Separate front wheelhouse liner from wheelhouse.



80a7e231

**Fig. 13 Front Wheelhouse Liner**

- 1 - FENDER  
2 - BUMPER ASSEMBLY  
3 - PLASTIC RIVET  
4 - WHEELHOUSE LINER

**INSTALLATION**

- (1) Position front wheelhouse liner in wheelhouse.
- (2) Install plastic rivets attaching liner to the wheelhouse.
- (3) Install plastic rivets attaching wheelhouse liner to fender at the edge of wheel opening.
- (4) Install front wheel.
- (5) Remove safety stands and lower vehicle.

**LEFT FRONT FENDER****REMOVAL**

- (1) Remove front bumper (Refer to 13 - FRAMES & BUMPERS/BUMPERS/FRONT BUMPER - REMOVAL).

## LEFT FRONT FENDER (Continued)

(2) Remove air cleaner from wheelhouse (DIESEL ONLY).

(3) Remove coolant overflow bottle (V-10 ONLY).

(4) Remove battery tray (Refer to 8 - ELECTRICAL/BATTERY SYSTEM/TRAY - REMOVAL).

(5) Remove screws attaching power distribution center to left wheelhouse (Fig. 14).

(6) Disengage wire harness tie-downs from wheelhouse.

(7) Disconnect wiring harness to headlamp connector.

(8) Disconnect wiring harness to airbag sensor and remove airbag sensor from wheelhouse.

(9) Remove bolts attaching anti-lock brake controller to wheelhouse (Fig. 14), if equipped.

(10) Disengage windshield washer tubing tie-downs from wheelhouse (Fig. 14).

(11) Remove bolts attaching front fender to cowl reinforcement (Fig. 15).

(12) Remove bolts attaching front fender to radiator closure panel (Fig. 16).

(13) Remove bolts attaching bottom of front fender to rocker panel lower flange.

(14) Open left door.

(15) Remove bolt attaching front fender to hinge pillar mounting bracket.

(16) Remove bolts attaching top of fender to radiator closure panel.

(17) Separate left front fender from vehicle.

## INSTALLATION

(1) Position left front fender on vehicle.

(2) Install bolts attaching top of fender to radiator closure panel.

(3) Install bolt attaching front fender to hinge pillar mounting bracket.

(4) Install bolts attaching bottom of front fender to rocker panel lower flange.

(5) Install bolts attaching front fender to radiator closure panel.

(6) Install bolts attaching front fender to cowl reinforcement.

(7) Secure windshield washer tubing tie-downs to wheelhouse.

(8) Install anti-lock brake controller to wheelhouse, if equipped.

(9) Install airbag sensor to wheelhouse and connect wiring harness to airbag sensor.

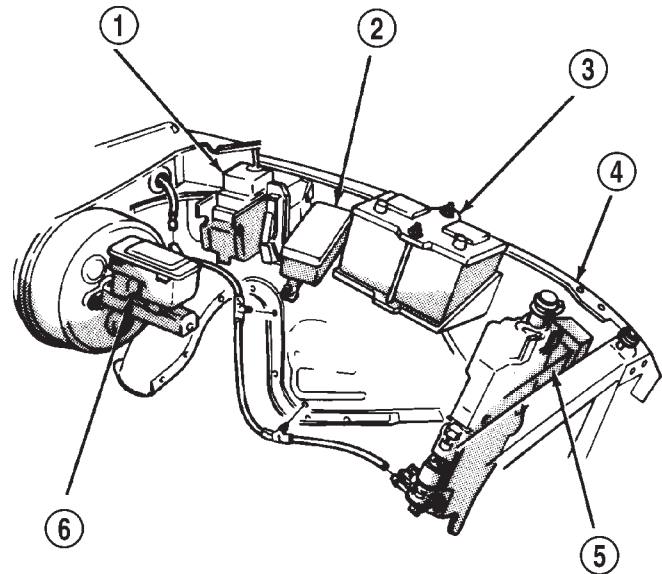
(10) Connect wiring harness to headlamp connector.

(11) Secure wire harness tie-downs to wheelhouse.

(12) Install power distribution center to wheelhouse.

(13) Install battery tray (Refer to 8 - ELECTRICAL/BATTERY SYSTEM/TRAY - INSTALLATION).

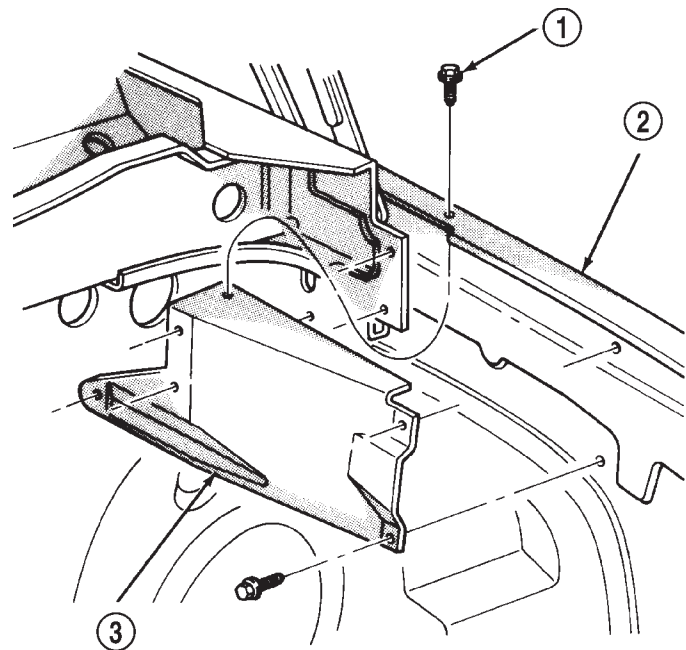
(14) Install coolant overflow bottle (V-10 ONLY).



J9423-90

**Fig. 14 Left Front Fender Access Components**

- 1 - ABS CONTROLLER
- 2 - POWER DISTRIBUTION CENTER
- 3 - BATTERY
- 4 - FENDER
- 5 - WINDSHIELD WASHER RESERVOIR
- 6 - BRAKE MASTER CYLINDER

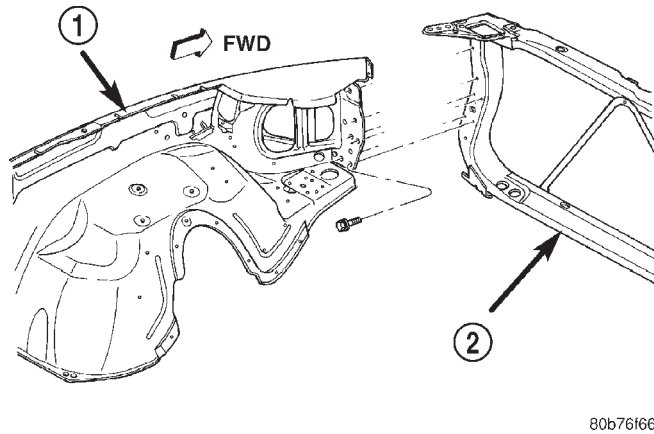


J9423-96

**Fig. 15 Fender to Cowl Reinforcement—Typical**

- 1 - BOLT
- 2 - FENDER
- 3 - FENDER—TO—COWL REINFORCEMENT

## LEFT FRONT FENDER (Continued)



**Fig. 16 Left Fender to Radiator Closure Panel Fasteners**

- 1 - LEFT FENDER  
2 - RADIATOR CLOSURE PANEL

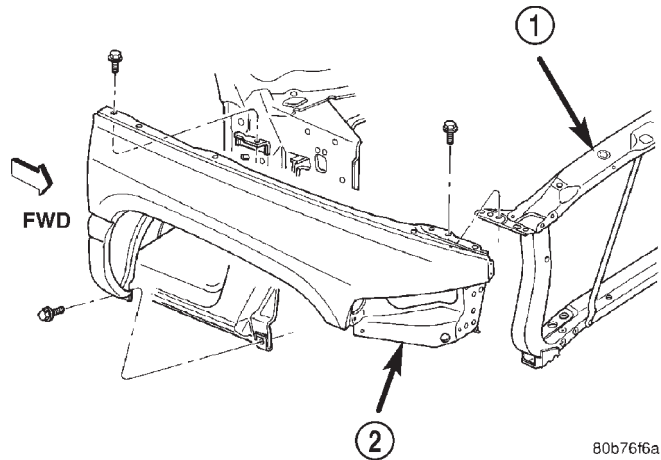
- (15) Install air cleaner (DIESEL ONLY).  
(16) Install front bumper (Refer to 13 - FRAMES & BUMPERS/BUMPERS/FRONT BUMPER - INSTALLATION).

## RIGHT FRONT FENDER

## REMOVAL

- (1) Remove front bumper (Refer to 13 - FRAMES & BUMPERS/BUMPERS/FRONT BUMPER - REMOVAL).
- (2) Disconnect and isolate battery negative cable.
- (3) Remove auxiliary battery and tray on right side, if equipped.
- (4) Disengage wire harness tie-downs from wheelhouse.
- (5) Disconnect wiring harness to headlamp connector.
- (6) Disconnect wiring harness to airbag sensor and remove airbag sensor from wheelhouse.
- (7) Remove front wheelhouse liner (Fig. 13) (Refer to 23 - BODY/EXTERIOR/FRONT END SPLASH SHIELDS - REMOVAL).
- (8) Disengage air conditioning tubing from inner fender clips.
- (9) Remove bolts attaching front fender to cowl reinforcement (Fig. 15).
- (10) Remove bolts attaching front fender to radiator closure panel.
- (11) Remove bolts attaching bottom of front fender to rocker panel lower flange (Fig. 17).
- (12) Open right door.

- (13) Remove bolt attaching front fender to hinge pillar mounting bracket (Fig. 17).
- (14) Remove bolts attaching top of fender to radiator closure panel (Fig. 17).
- (15) Separate right front fender from vehicle.



**Fig. 17 Right Front Fender**

- 1 - RADIATOR CLOSURE PANEL  
2 - RIGHT FENDER

## INSTALLATION

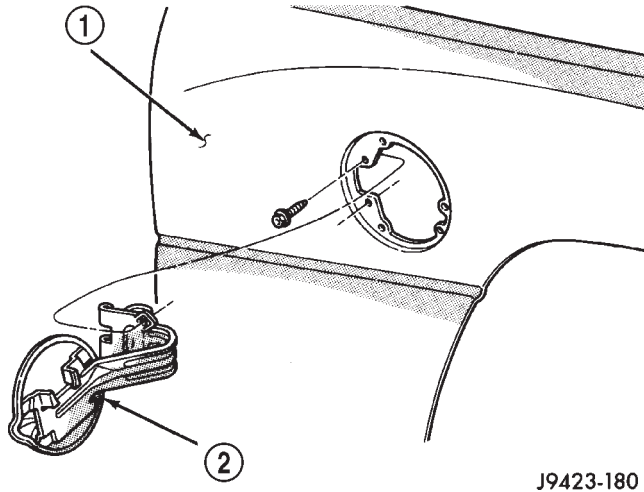
- (1) Position fender on vehicle.
- (2) Install bolts attaching top of fender to radiator closure panel.
- (3) Install bolt attaching front fender to hinge pillar mounting bracket.
- (4) Install bolts attaching bottom of front fender to rocker panel lower flange.
- (5) Install bolts attaching front fender to radiator closure panel.
- (6) Install bolts attaching front fender to cowl reinforcement.
- (7) Secure air conditioning tubing to inner fender clips.
- (8) Install front wheelhouse liner (Refer to 23 - BODY/EXTERIOR/FRONT END SPLASH SHIELDS - INSTALLATION).
- (9) Install airbag sensor and connect wiring harness to airbag sensor.
- (10) Connect wiring harness to headlamp connector.
- (11) Secure wire harness tie-downs to wheelhouse.
- (12) Install auxiliary battery tray and battery on right side, if equipped.
- (13) Connect battery negative cable.
- (14) Install front bumper (Refer to 13 - FRAMES & BUMPERS/BUMPERS/FRONT BUMPER - INSTALLATION).



## FUEL FILL DOOR

### REMOVAL

- (1) Open fuel fill door.
- (2) Remove bolts attaching fuel fill door to cargo box quarter panel (Fig. 18).
- (3) Separate fuel fill door from vehicle.



J9423-180

**Fig. 18 Fuel Fill Door**

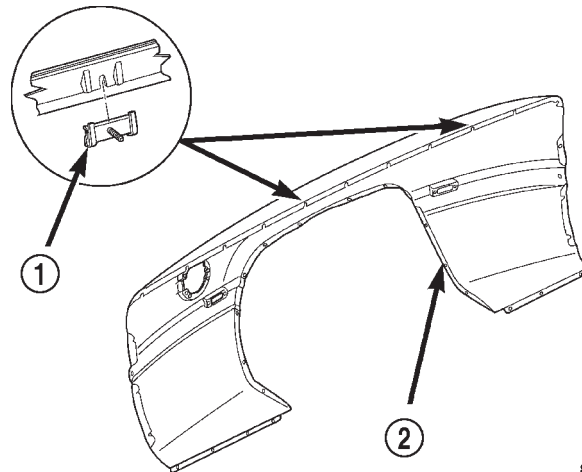
- 1 - CARGO BOX  
2 - FUEL FILL DOOR

- (11) Remove nuts attaching front of rear fender to cargo box from behind side panel forward of wheelhouse.

- (12) Remove screws attaching access panel to top of wheelhouse.

- (13) Remove nuts attaching rear fender to cargo box through access hole in top of wheelhouse.

- (14) Separate rear fender from cargo box side panel (Fig. 19).



80af619f

**Fig. 19 Rear Fender—Dual Wheels**

- 1 - RETAINER  
2 - FENDER (DUAL WHEEL)

### INSTALLATION

- (1) Separate fuel fill door on cargo box.
- (2) Install bolts attaching fuel fill door to cargo box quarter panel.

## REAR FENDER

### REMOVAL

- (1) Open fuel fill door, left side only.
- (2) Remove screws attaching fuel fill neck to rear fender opening.
- (3) Remove tail lamp.
- (4) Remove nuts attaching rear fender to cargo box side panel through tail lamp opening.
- (5) Remove clearance lamps.
- (6) Remove sockets from clearance lamps.
- (7) Remove bolts attaching bottom of fender to cargo box forward of rear wheel.
- (8) Remove bolts attaching bottom of fender to cargo box rearward of rear wheel.
- (9) Remove rear wheelhouse splash shields (Refer to 23 - BODY/EXTERIOR/REAR WHEELHOUSE SPLASH SHIELD - REMOVAL).
- (10) Remove rear wheelhouse liner, if equipped (Refer to 23 - BODY/EXTERIOR/REAR WHEELHOUSE SPLASH SHIELD - REMOVAL).

### INSTALLATION

Ensure the retainers are in good condition.

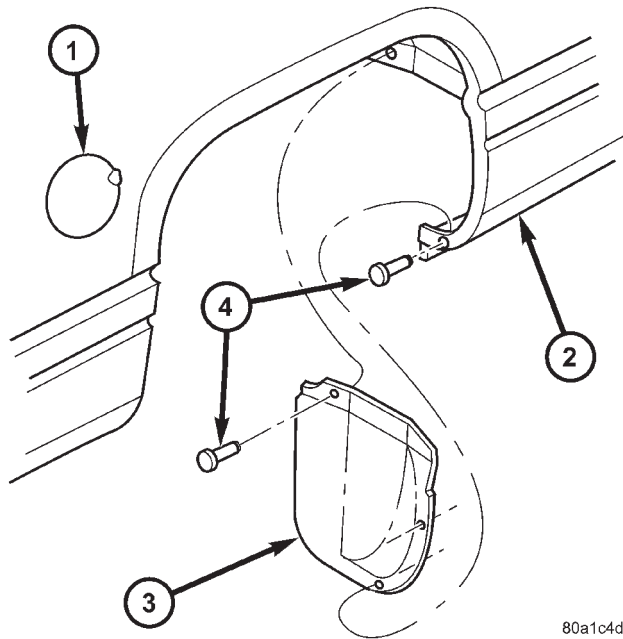
- (1) Position rear fender on cargo box side panel.
- (2) Using access hole in top of wheelhouse, install nuts attaching rear fender to cargo box.
- (3) Install screws attaching access panel to top of wheelhouse.
- (4) From behind side panel forward of wheelhouse, install nuts attaching front of rear fender to cargo box.
- (5) Install rear wheelhouse liners if equipped, (Refer to 23 - BODY/EXTERIOR/REAR WHEELHOUSE SPLASH SHIELD - INSTALLATION).
- (6) Install rear wheelhouse splash shields (Refer to 23 - BODY/EXTERIOR/REAR WHEELHOUSE SPLASH SHIELD - INSTALLATION).
- (7) Install bolts attaching bottom of fender to cargo box rearward of rear wheel.
- (8) Install bolts attaching bottom of fender to cargo box forward of rear wheel.
- (9) Install sockets into clearance lamps.
- (10) Install clearance lamps.
- (11) Using tail lamp opening, install nuts attaching rear fender to cargo box side panel.
- (12) Install tail lamp.
- (13) Install screws attaching fuel fill neck to rear fender opening.



## REAR SPLASH SHIELD

### REMOVAL

- (1) Remove screws holding rear splash shield to rear wheel opening lip (Fig. 20).
- (2) Remove push in fasteners holding rear splash shield to rear wheelhouse.
- (3) Separate splash shield from vehicle.



**Fig. 20 REAR SPLASH SHIELDS**

- 1 - FUEL FILLER DOOR
- 2 - REAR FENDER
- 3 - REAR SECTION REAR WHEEL HOUSE LINER
- 4 - PUSH IN FASTENERS

80a1c4d7

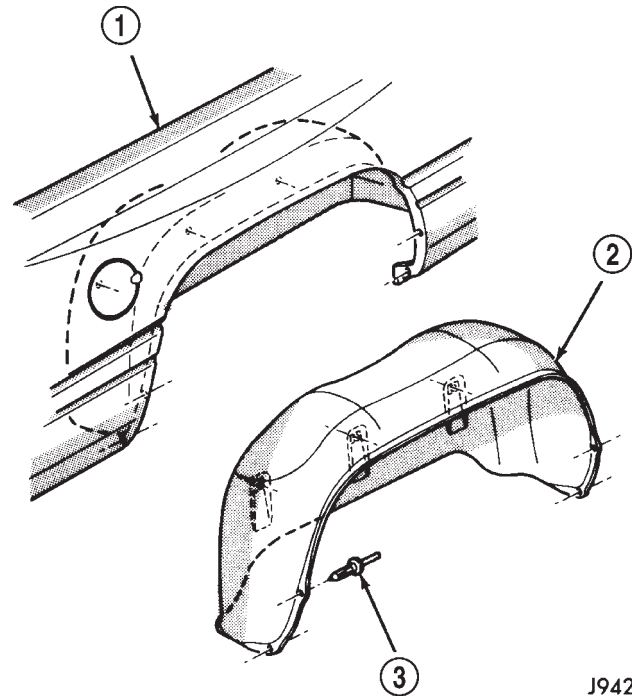
### INSTALLATION

- (1) Position splash shield in wheelhouse opening.
- (2) Install plastic rivets holding rear splash shield to rear wheelhouse.
- (3) Install plastic rivets holding rear splash shield to rear wheel opening lip.

## REAR WHEELHOUSE LINER

### REMOVAL

- (1) Remove plastic rivets attaching rear wheelhouse liner to rear wheel opening lip (Fig. 21).
- (2) Remove plastic rivets attaching rear wheelhouse liner to rear wheelhouse.
- (3) Separate rear wheelhouse liner from vehicle.



J9423-19

**Fig. 21 Rear Wheelhouse Liner**

- 1 - FENDER
- 2 - WHEEL HOUSELINER
- 3 - PLASTIC RIVET

### INSTALLATION

- (1) Position rear wheelhouse liner in wheelhouse opening.
- (2) Install plastic rivets attaching rear wheelhouse liner to rear wheelhouse.
- (3) Working front to rear, install plastic rivets attaching rear wheelhouse liner to rear wheel opening lip.

## CARGO BOX

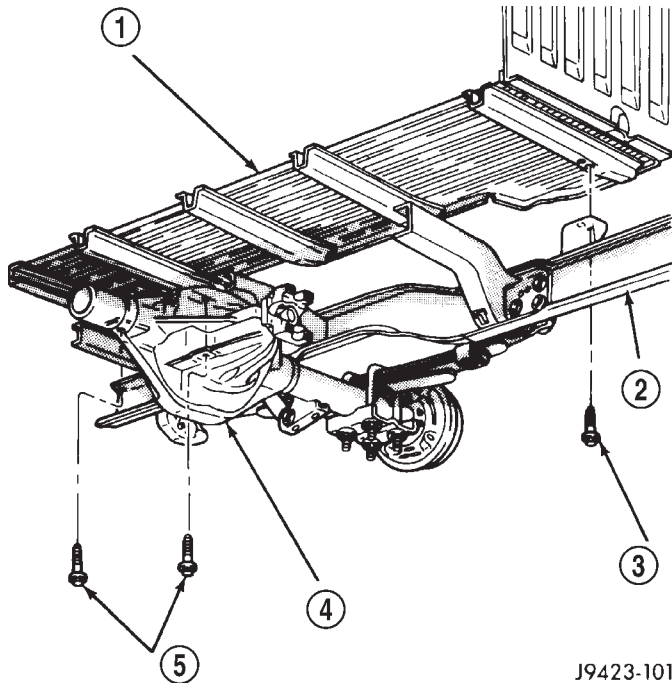
### REMOVAL

**CAUTION:** The bolts attaching the cargo box to the frame are specially coated to provide a locking action. These bolts are not reusable and must be replaced each time the cargo box is removed or replaced.

- (1) Open fuel fill door.
- (2) Remove screws attaching fuel fill neck adaptor to cargo box side wall.
- (3) Separate fuel fill neck from cargo box.
- (4) Disengage tail lamp wire connector from main body harness at left rear frame rail.
- (5) Remove bolts attaching cargo box to frame rails (Fig. 22).

## CARGO BOX (Continued)

(6) Using a suitable lifting device, separate cargo box from vehicle.



**Fig. 22 Cargo Box**

- 1 - CARGO BOX
- 2 - FRAME
- 3 - BOLT
- 4 - AXLE
- 5 - BOLT

J9423-101

## INSTALLATION

(1) Using a suitable lifting device, position cargo box on vehicle.

(2) Install **new** bolts attaching cargo box to frame rails. Tighten bolts to 54 N-m (40 ft. lbs.) torque.

(3) Engage tail lamp wire connector to main body harness at left rear frame rail.

(4) Install fuel fill neck.

## SIDE VIEW MIRROR

### REMOVAL

(1) Remove door trim panel (Refer to 23 - BODY/DOOR - FRONT/TRIM PANEL - REMOVAL).

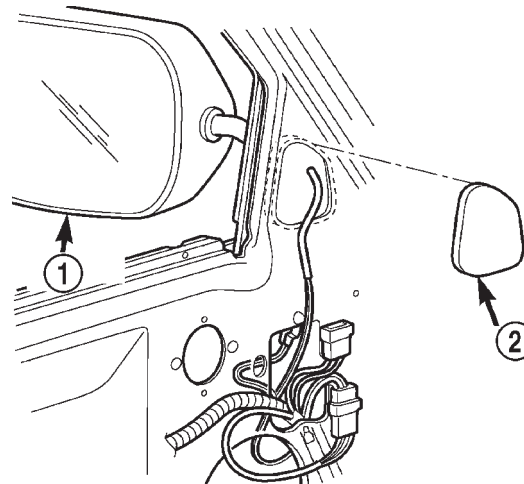
(2) Remove mirror flag door seal (Fig. 23).

(3) Disengage power mirror wire connector from door harness, if equipped (Fig. 24).

(4) Remove nuts attaching sideview mirror to door frame (Fig. 25).

(5) Separate harness grommet from door frame, if equipped.

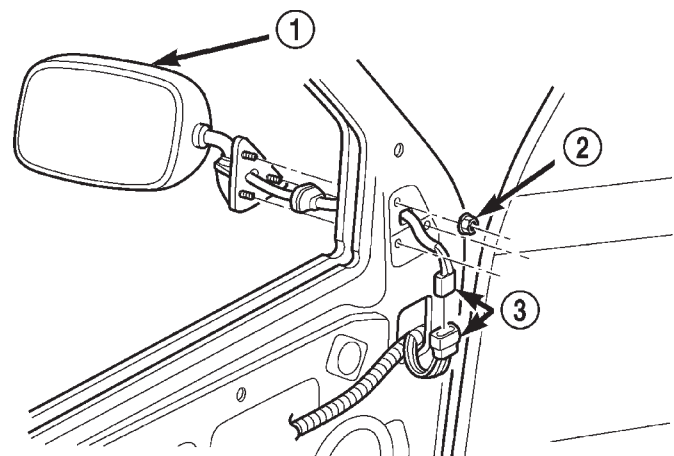
(6) Separate sideview mirror from vehicle.



**Fig. 23 Mirror Flag Door Seal**

- 1 - MIRROR
- 2 - MIRROR FLAG SEAL

80b118f9



**Fig. 24 Sideview Mirror—Power**

- 1 - POWER MIRROR
- 2 - NUT
- 3 - CONNECTOR

80b11930

### INSTALLATION

(1) Position sideview mirror on door.

(2) Install harness grommet in door frame, if equipped.

(3) Install nuts attaching sideview mirror to door (Fig. 25).

(4) Engage power mirror wire connector to harness, if equipped (Fig. 24).

(5) Install mirror flag door seal (Fig. 23).

(6) Install door trim panel (Refer to 23 - BODY/DOOR - FRONT/TRIM PANEL - INSTALLATION).

## SIDE VIEW MIRROR (Continued)

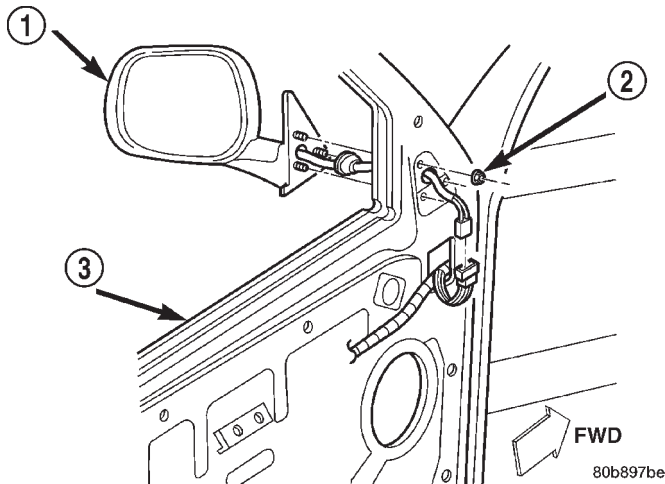


Fig. 25 Sideview Mirror

- 1 - MIRROR
- 2 - NUT
- 3 - DOOR

## SIDE VIEW MIRROR - LOW MOUNTED

## REMOVAL

- (1) Remove bolts attaching lower support legs to outer door panel.
- (2) Remove bolts attaching upper support arms to outer door panel (Fig. 26).
- (3) Separate mirror from door.

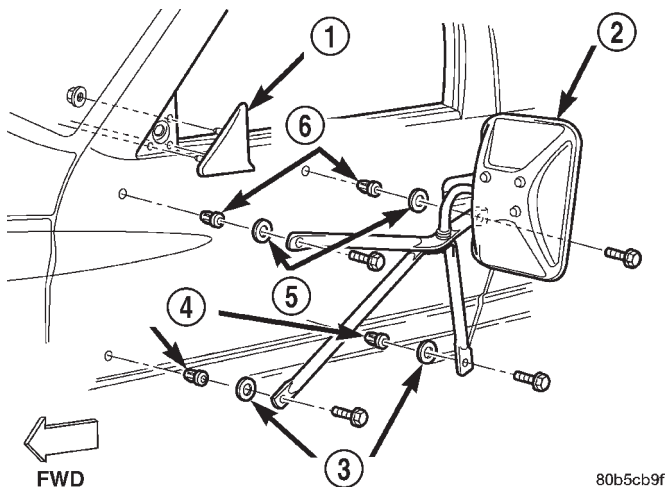


Fig. 26 Low Mounted Side View Mirror

- 1 - FLAG COVER
- 2 - MIRROR
- 3 - WASHER
- 4 - NUTSERT
- 5 - WASHER
- 6 - NUTSERT

## INSTALLATION

- (1) Position mirror on door.
- (2) Place insulation washers between support frame and door panel
- (3) Install bolts attaching upper support arms to outer door panel.
- (4) Install bolts attaching lower support legs to outer door panel.

## SIDE VIEW MIRROR GLASS

## REMOVAL

**WARNING: ALWAYS WEAR EYE AND HAND PROTECTION WHEN SERVICING THE MIRROR ASSEMBLY. FAILURE TO OBSERVE THESE WARNINGS MAY RESULT IN PERSONAL INJURY FROM BROKEN GLASS.**

- (1) Carefully pull/pry the broken glass holder from the mirror assembly.
- (2) Disconnect the heated mirror electrical connectors from the terminals on the mirror glass holder, if equipped.

## INSTALLATION

- (1) Position the new mirror glass holder to the mirror assembly.
- (2) Align the mirror glass holder's attaching fingers to the mirror motor housing.

**NOTE: ENSURE THAT THE MOISTURE DRAIN HOLE ON THE MIRROR GLASS HOLDER ASSEMBLY IS FACING DOWNWARD.**

- (3) Using one hand, firmly press the mirror glass holder assembly into place while at the same time supporting the housing assembly from the backside with the other hand.

**NOTE: PRESSURE MUST BE APPLIED EQUALLY OVER THE CENTER PORTION OF THE MIRROR TO ENGAGE THE MIRROR GLASS HOLDER'S ATTACHING FINGERS TO THE CORRESPONDING FINGERS ON THE HOUSING ASSEMBLY. ONE OR MORE CLICKS MAY BE HEARD WHEN FINGER ENGAGEMENT TAKES PLACE.**

- (4) Verify retention of the mirror glass holder assembly by gently pulling outward on the mirror glass holder.

## HOOD

## TABLE OF CONTENTS

	page		page
<b>HINGE</b>		<b>INSTALLATION</b> .....	101
REMOVAL.....	99	<b>LATCH STRIKER</b>	
INSTALLATION.....	99	REMOVAL.....	102
<b>HOOD</b>		INSTALLATION.....	102
REMOVAL.....	100	ADJUSTMENTS.....	102
INSTALLATION.....	100	<b>SAFETY LATCH</b>	
ADJUSTMENTS.....	100	REMOVAL.....	102
<b>LATCH</b>		INSTALLATION.....	102
REMOVAL.....	100	<b>SILENCER PAD</b>	
INSTALLATION.....	100	REMOVAL.....	103
ADJUSTMENTS.....	100	INSTALLATION.....	103
<b>LATCH RELEASE CABLE</b>			
REMOVAL.....	101		

## HINGE

## REMOVAL

- (1) Open hood and support the side that requires hinge replacement.
- (2) Mark all bolt and hinge attachment locations with a grease pencil or equivalent to provide reference marks for installation.
- (3) Remove nuts attaching hood to hinge (Fig. 1).
- (4) Remove bolts attaching hood hinge to cowl.
- (5) Separate hinge from vehicle.

## INSTALLATION

- (1) If necessary, paint new hinge before installation.
- (2) Position hinge on vehicle.
- (3) Align all marks
- (4) Install bolts attaching hood hinge to cowl.
- (5) Install nuts attaching hood to hinge.

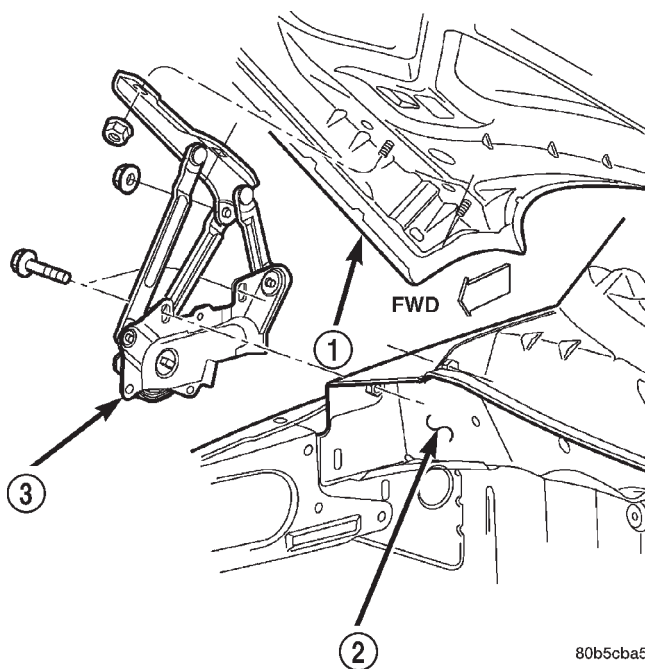


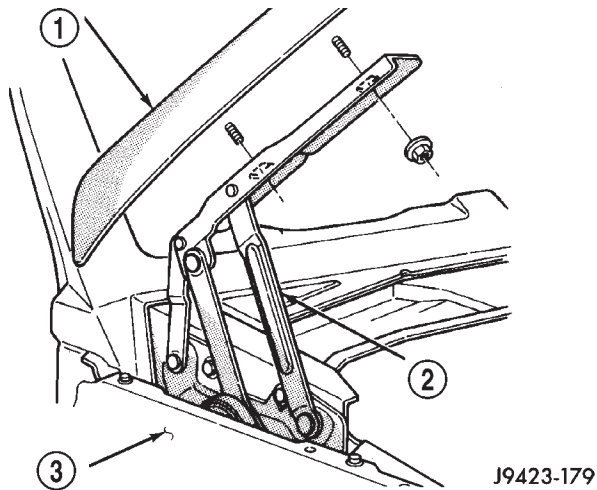
Fig. 1 Hood Hinge

- 1 - HOOD
- 2 - COWL
- 3 - HINGE

## HOOD

### REMOVAL

- (1) Disconnect the under hood lamp wire connector.
- (2) Disconnect the air temperature sensor wire connector, if equipped.
- (3) Mark all bolt and hinge attachment locations with a grease pencil or equivalent to provide reference marks for installation.
- (4) Remove top nuts attaching hood to hinge and loosen bottom nuts until they can be removed by hand (Fig. 2).
- (5) With assistance of a helper at the opposite side of the vehicle to support the hood, remove the bottom nuts. Separate the hood from the vehicle.



**Fig. 2 Hood**

- 1 - HOOD  
2 - HOOD HINGE  
3 - FENDER

### INSTALLATION

- (1) With assistance of a helper, position hood on vehicle loosely install bottom nuts.

Align all marks, install top nuts and tighten bottom nuts. The hood should be aligned to 5 mm (0.2 in.) gap to the front fenders and flush across the top surfaces along fenders.

- (2) Connect the air temperature sensor wire connector, if equipped.
- (3) Connect the under hood lamp wire connector.

### ADJUSTMENT

- (1) Loosen the hinge arm-to-hood panel bolts at each side of the vehicle.
- (2) Loosen the hood latch screws.
- (3) Close the hood. Adjust the fore/aft position.
- (4) Raise the hood. Tighten the hinge arm-to-hood panel bolts.
- (5) Tighten the latch screws.
- (6) Lower the hood. Inspect clearance between the hood and the cowl cover.

## LATCH

### REMOVAL

- (1) Remove bolts attaching hood latch to radiator closure panel crossmember (Fig. 3).
- (2) Separate hood latch from crossmember.
- (3) Disconnect release cable from hood latch.

### INSTALLATION

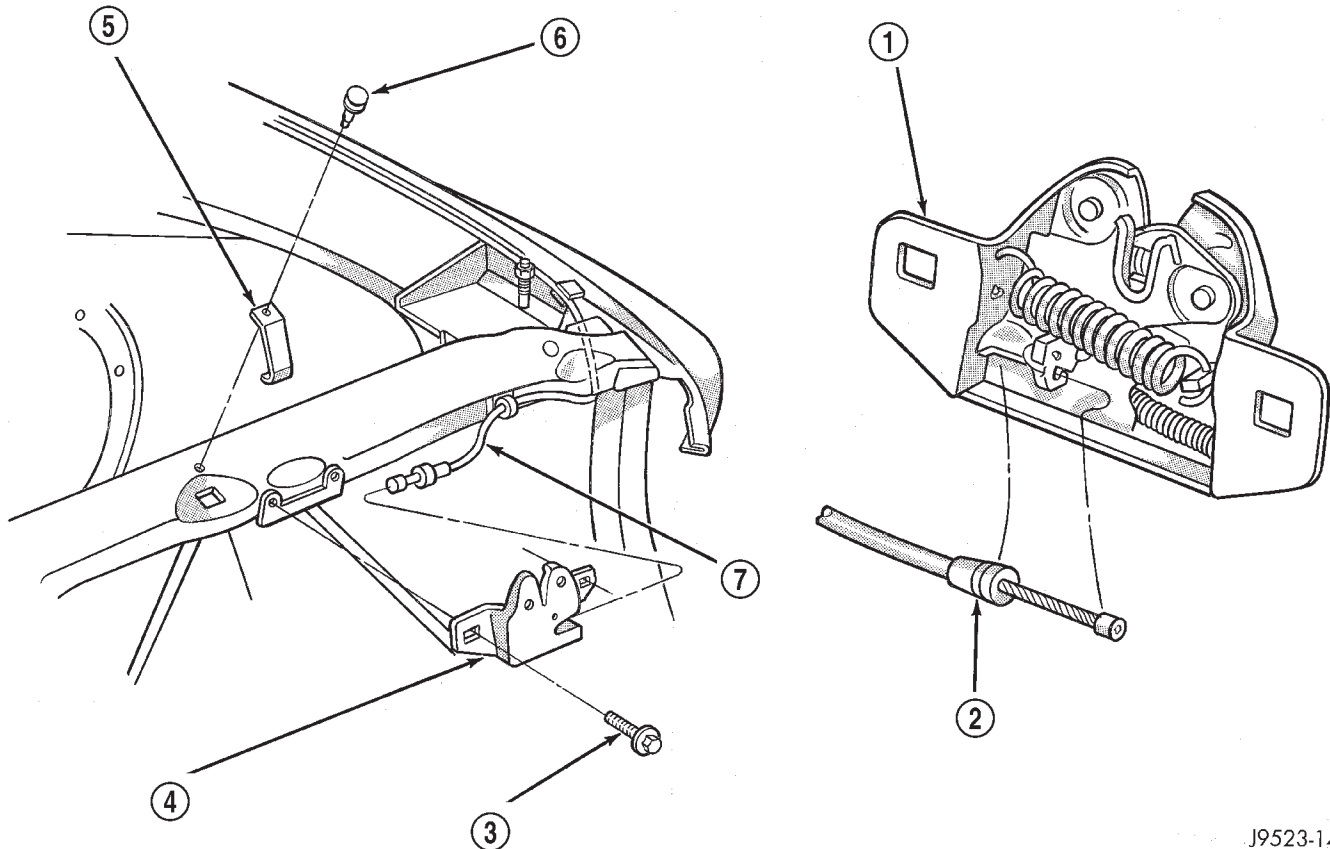
- (1) Connect release cable to hood latch.
- (2) Position hood latch on crossmember.
- (3) Install bolts attaching hood latch to radiator closure panel crossmember.

### ADJUSTMENT

- (1) Loosen the hood latch screws.
- (2) Move the latch to the correct location and lightly tighten the screws.
- (3) Close the hood slowly and observe the latching operation.
- (4) As necessary, re-adjust the latch position and tighten the screws.



## LATCH (Continued)



J9523-145

**Fig. 3 Hood Latch**

1 - LATCH ASSEMBLY  
 2 - CABLE  
 3 - SCREW  
 4 - LATCH ASSEMBLY

5 - HOOD SECONDARY SKID PLATE  
 6 - PUSH-IN FASTENER  
 7 - CABLE

## LATCH RELEASE CABLE

**REMOVAL**

(1) Remove hood latch (Refer to 23 - BODY/HOOD/LATCH - REMOVAL).

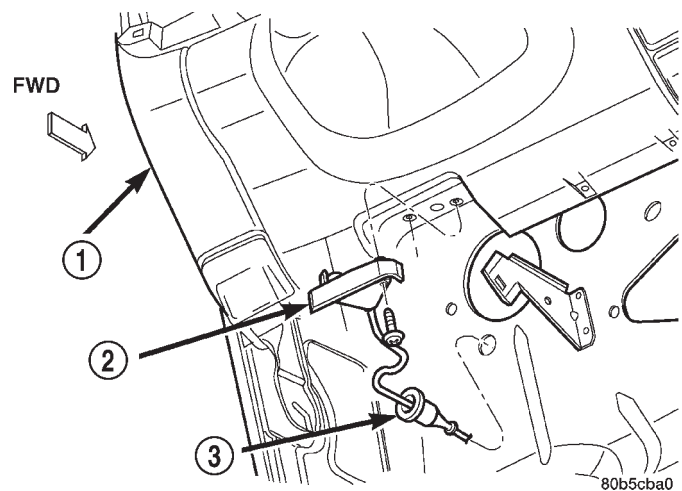
(2) Disconnect release cable from hood latch.

(3) Detach the release cable from the retainer clips in the engine compartment.

(4) Separate the release cable grommet from the dash panel hole.

(5) From the inside of the vehicle, remove the screws attaching the hood release handle to the bottom of the instrument panel (Fig. 4).

(6) Pull/route the hood release cable through the dash panel hole and remove it via the inside of the vehicle.

**Fig. 4 Hood Release Handle**

1 - INSTRUMENT PANEL  
 2 - HOOD RELEASE HANDLE  
 3 - HOOD RELEASE CABLE

**INSTALLATION**

**NOTE:** If replacement hood latch is also being installed, ensure that it is thoroughly lubricated.

## LATCH RELEASE CABLE (Continued)

- (1) From inside the vehicle, pull/route the hood release cable through the dash panel hole and into the engine compartment.
- (2) Install the hood release handle.
- (3) Install the cable grommet in the dash panel hole.
- (4) Attach the release cable to the retainer clips in the engine compartment.
- (5) Attach release cable to hood latch.
- (6) Install hood latch (Refer to 23 - BODY/HOOD/LATCH - INSTALLATION).
- (7) Test the hood latch release cable for proper operation.

## LATCH STRIKER

## REMOVAL

- (1) Open hood.
- (2) Remove bolts attaching hood latch striker to hood (Fig. 5).
- (3) Separate hood latch striker from hood.

## INSTALLATION

- (1) Position hood latch striker on hood.
- (2) Install bolts attaching hood latch striker to hood.

## ADJUSTMENT

- (1) Open the hood.
- (2) Loosen the latch striker screws.
- (3) Slowly close the hood and observe the latching operation. As necessary, re-adjust the striker position. Tighten the screws.

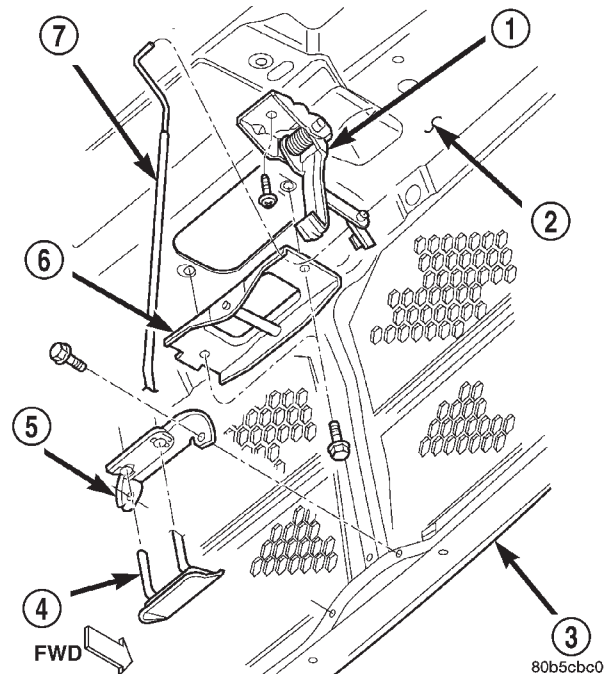
## SAFETY LATCH

## REMOVAL

- (1) Open hood.
- (2) Remove bolts attaching hood safety catch to hood (Fig. 5) and (Fig. 6).
- (3) Separate safety catch from hood.

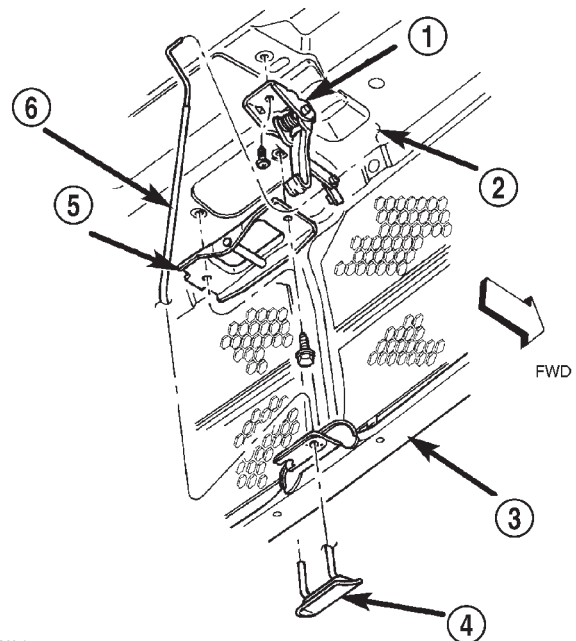
## INSTALLATION

- (1) Position safety catch on hood.
- (2) Engage catch rod to catch.
- (3) Install bolts attaching hood safety catch to hood.



**Fig. 5 Hood Safety Catch and Latch Striker — SLT**

- 1 - SAFETY CATCH
- 2 - HOOD
- 3 - GRILLE
- 4 - SAFETY CATCH RELEASE HANDLE
- 5 - GUIDE
- 6 - STRIKER
- 7 - HANDLE-TO-CATCH ROD



**Fig. 6 Hood Safety Catch and Latch Striker — Sport**

- 1 - SAFETY LATCH
- 2 - HOOD
- 3 - GRILLE FRAME
- 4 - RELEASE HANDLE
- 5 - STRIKER
- 6 - HANDLE—TO—LATCH ROD

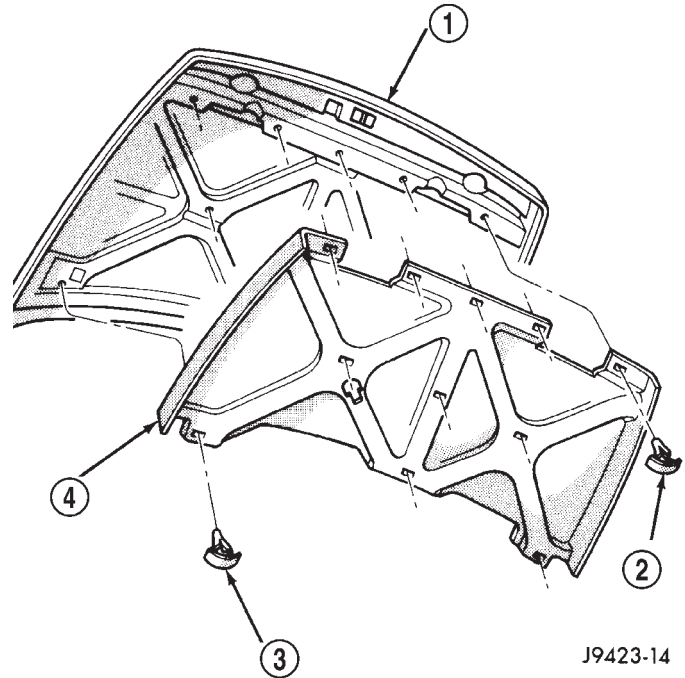
## SILENCER PAD

### REMOVAL

- (1) Disconnect underhood lamp wire connector.
- (2) Disconnect air temperature sensor connector, if equipped.
- (3) Remove push-in fasteners holding silencer to hood (Fig. 7).
- (4) Separate hood silencer from hood.

### INSTALLATION

- (1) Position hood silencer on hood.
- (2) Install push-in fasteners holding silencer to hood.
- (3) Connect air temperature sensor connector, if equipped.
- (4) Connect underhood lamp wire connector.



**Fig. 7 Hood Silencer**

- 1 - HOOD
- 2 - CLIP
- 3 - CLIP
- 4 - INSULATOR PAD

## INSTRUMENT PANEL SYSTEM

## TABLE OF CONTENTS

	page		page
<b>INSTRUMENT PANEL SYSTEM</b>		<b>DISASSEMBLY</b> . . . . .	112
DESCRIPTION . . . . .	104	<b>ASSEMBLY</b> . . . . .	112
OPERATION . . . . .	105	<b>INSTALLATION</b> . . . . .	113
REMOVAL . . . . .	106	<b>GLOVE BOX LATCH STRIKER</b>	
INSTALLATION . . . . .	107	REMOVAL . . . . .	113
<b>ASH RECEIVER</b>		INSTALLATION . . . . .	113
REMOVAL . . . . .	108	<b>GLOVE BOX OPENING UPPER TRIM</b>	
INSTALLATION . . . . .	109	REMOVAL . . . . .	114
<b>CLUSTER BEZEL</b>		INSTALLATION . . . . .	114
REMOVAL . . . . .	109	<b>INSTRUMENT PANEL TOP COVER</b>	
INSTALLATION . . . . .	110	REMOVAL . . . . .	114
<b>CUBBY BIN</b>		INSTALLATION . . . . .	115
REMOVAL . . . . .	110	<b>STEERING COLUMN OPENING COVER</b>	
INSTALLATION . . . . .	110	REMOVAL . . . . .	115
<b>CUP HOLDER</b>		INSTALLATION . . . . .	116
REMOVAL . . . . .	110	<b>STORAGE BIN</b>	
INSTALLATION . . . . .	111	REMOVAL . . . . .	116
<b>GLOVE BOX</b>		INSTALLATION . . . . .	116
REMOVAL . . . . .	112		

## INSTRUMENT PANEL SYSTEM

## DESCRIPTION

The instrument panel is located at the front of the passenger compartment. This instrument panel is molded from a blend of various plastics that are mechanically attached to the vehicle. Colors are molded into the plastic components to minimize appearance degradation from scratches or abrasions. The panel components are internally ribbed and riveted to steel reinforcements for additional structural integrity and dimensional stability. The instrument panel surface components are designed to deform upon impact without breaking. This type of construction provides improved energy absorption which, in conjunction with the dual airbags and seat belts, helps to improve occupant protection.

The top of the instrument panel is secured to the top of the dash panel near the base of the windshield using screws. An end bracket integral to each end of the instrument panel structure is secured to each cowl side inner panel with a screw. A stamped metal bracket supports the center of the instrument panel by securing it to the top of the floor panel transmission tunnel below the instrument panel with screws. The instrument cluster, radio, heater-air conditioner control, passenger airbag, glove box, electrical junction block, Central Timer Module (CTM), accessory

switches, ash receiver, cigar lighter, accessory power outlet, park brake release handle, inside hood release handle, as well as numerous other components are secured to and supported by this unit.

The instrument panel for this vehicle includes the following major features:

- **Cluster Bezel** - This molded plastic bezel is secured with snap clips to the instrument panel supporting structure. It trims out the edges of the headlamp switch, instrument cluster, radio, heater-air conditioner controls, passenger airbag on-off switch, and the heated seat switches on vehicles so equipped. On vehicles without the heated seat option, a small storage cubby bin is provided in the cluster bezel. This bezel also incorporates three completely adjustable panel outlets for the climate control system, and fills the opening between the instrument cluster and the top of the steering column where it passes through the instrument panel.

- **Cup Holder/Storage Bin** - Vehicles equipped with an automatic transmission feature a latching fold-down, adjustable cup holder located on the lower instrument panel between the glove box and the ash receiver. Vehicles equipped with a manual transmission have a lighted storage bin on the instrument panel in place of the cup holder.

- **Glove Box** - The hinged bin-type glove box in the passenger side of the instrument panel features a recessed paddle-operated latch handle. Three molded

## INSTRUMENT PANEL SYSTEM (Continued)

hook formations on the lower edge of the glove box door are engaged with and pivot on three hinge pins integral to the lower edge of the instrument panel support structure. The glove box door also serves as the passenger side knee blocker. A honeycomb structure between the inner and outer glove box door panels helps to absorb the impact load and distribute it to the instrument panel structure.

- **Steering Column Opening Cover** - The steering column opening cover serves as the driver side knee blocker. This molded plastic cover has an integral ribbed plastic liner concealed behind it, for increased strength and integrity. The steering column opening cover transfers impact loads to the instrument panel structural support.

- **Top Cover** - The instrument panel top cover or base trim is the molded, grained, and color impregnated plastic outer skin of the instrument panel structural support.

Hard wired circuitry connects the electrical components on the instrument panel to each other through the electrical system of the vehicle. These hard wired circuits are integral to several wire harnesses, which are routed throughout the vehicle and retained by many different methods. These circuits may be connected to each other, to the vehicle electrical system and to the instrument panel components through the use of a combination of soldered splices, splice block connectors and many different types of wire harness terminal connectors and insulators. Refer to the appropriate wiring information. The wiring information includes complete circuit diagrams, proper wire and connector repair procedures, further details on wire harness routing and retention, as well as pin-out and location views for the various wire harness connectors, splices, and grounds.

## OPERATION

The instrument panel serves as the command center of the vehicle, which necessarily makes it a very complex unit. The instrument panel is designed to house the controls and monitors for standard and optional powertrains, climate control systems, audio systems, safety systems, and many other comfort or convenience items. When the components of the instrument panel structural support are properly assembled and secured in the vehicle they provide superior instrument panel stiffness and integrity to help reduce buzzes, squeaks, and rattles. This type of construction also provides improved energy absorption which, in conjunction with the dual airbags and seat belts, helps to improve occupant protection.

The instrument panel is also designed so that all of the various controls can be safely reached and the monitors can be easily viewed by the vehicle operator when driving, while still allowing relative ease of

access to each of these items for service. Modular instrument panel construction allows all of the gauges and controls to be serviced from the front of the panel. In addition, most of the instrument panel electrical components can be accessed without complete instrument panel removal. However, if necessary, the instrument panel can be removed from the vehicle as an assembly.

The steering column opening cover with its integral knee blocker located on the driver side of the instrument panel works in conjunction with the airbag system in a frontal vehicle impact to keep the driver properly positioned for an airbag deployment. In addition, removal of this component provides access to the steering column mounts, the steering column wiring, the Junction Block (JB) (removal of a snap-fit fuse access panel on the left end of the instrument panel allows access to the fuses and circuit breakers), the Central Timer Module (CTM), the Infinity speaker filter choke and relay unit, much of the instrument panel wiring, and the gear selector indicator cable (automatic transmission).

In a frontal collision, the glove box door on the passenger side of the instrument panel provides the same function for the front seat passenger as the knee blocker does for the driver. The glove box door also incorporates a recessed latch handle. Removal of the glove box provides access to the passenger airbag, the glove box lamp and switch, the radio antenna coaxial cable, the heating and air conditioning vacuum harness connector, and additional instrument panel wiring.

Removal of the instrument panel cluster bezel allows access to the headlamp switch, instrument cluster, radio, passenger airbag on-off switch, heated seat switches (if equipped), and the heating and air conditioning control. Removal of the instrument cluster allows access to the cluster illumination and indicator bulbs, and more of the instrument panel wiring. Complete instrument panel removal is required for service of most components internal to the heating and air conditioning system housing, including the heater core and the evaporator.

See the owner's manual in the vehicle glove box for more information on the features, use and operation of all of the components and systems mounted on or in the instrument panel.



## INSTRUMENT PANEL SYSTEM (Continued)

**REMOVAL**

**WARNING: ON VEHICLES EQUIPPED WITH AIRBAGS, DISABLE THE AIRBAG SYSTEM BEFORE ATTEMPTING ANY STEERING WHEEL, STEERING COLUMN, OR INSTRUMENT PANEL COMPONENT DIAGNOSIS OR SERVICE. DISCONNECT AND ISOLATE THE BATTERY NEGATIVE (GROUND) CABLE, THEN WAIT TWO MINUTES FOR THE AIRBAG SYSTEM CAPACITOR TO DISCHARGE BEFORE PERFORMING FURTHER DIAGNOSIS OR SERVICE. THIS IS THE ONLY SURE WAY TO DISABLE THE AIRBAG SYSTEM. FAILURE TO TAKE THE PROPER PRECAUTIONS COULD RESULT IN ACCIDENTAL AIRBAG DEPLOYMENT AND POSSIBLE PERSONAL INJURY.**

**NOTE: Before starting this procedure, be certain to turn the steering wheel until the front wheels are in the straight-ahead position.**

(1) Disconnect and isolate the battery negative cable.

(2) Remove the Airbag Control Module (ACM) and bracket from the floor panel transmission tunnel. (Refer to 8 - ELECTRICAL/RESTRAINTS/AIRBAG CONTROL MODULE - REMOVAL).

(3) Remove the trim from the left and right cowl side inner panels. (Refer to 23 - BODY/INTERIOR/COWL TRIM COVER - REMOVAL).

(4) Remove the steering column opening cover from the instrument panel. (Refer to 23 - BODY/INSTRUMENT PANEL/STEERING COLUMN OPENING COVER - REMOVAL).

(5) Remove the two screws that secure the inside hood latch release handle to the instrument panel lower reinforcement and lower the release handle to the floor.

(6) Disconnect the clockspring pigtail wire connector from the instrument panel wire harness connector located on the instrument panel lower reinforcement.

(7) If the vehicle is so equipped, disconnect the overdrive lockout switch pigtail wire connector from the instrument panel wire harness connector near the instrument panel lower reinforcement.

(8) Remove the steering column from the vehicle, but do not remove the driver airbag, the steering wheel, or the switches from the column. Be certain that the steering wheel is locked and secured from rotation to prevent the loss of clockspring centering. (Refer to 19 - STEERING/COLUMN - REMOVAL).

(9) From under the driver side of the instrument panel, perform the following:

(a) Disengage the park brake release handle linkage rod from the park brake mechanism on the

left cowl side inner panel. (Refer to 5 - BRAKES/PARKING BRAKE/RELEASE - REMOVAL).

(b) Disconnect the instrument panel wire harness connector from the park brake switch on the park brake mechanism.

(c) Disconnect the three connectors (one from the body wire harness, and two from the headlamp and dash wire harness) from the three connector receptacles located closest to the dash panel on the back of the Junction Block (JB).

(d) Remove the screw from the center of the headlamp and dash wire harness to instrument panel wire harness bulkhead connector and disconnect the connector.

(e) Disconnect the instrument panel wire harness to door wire harness connector located directly below the instrument panel wire harness to headlamp and dash wire harness bulkhead connector.

(f) If the vehicle is equipped with the Infinity sound system option, disconnect the Infinity wire harness connector from the instrument panel wire harness connector that is secured to the outboard side of the instrument panel wire harness to headlamp and dash wire harness bulkhead connector.

(g) Disconnect the instrument panel wire harness connector from the stop lamp switch.

(h) Disconnect the heater-A/C housing vacuum harness connector from the heater-A/C control vacuum harness connector located near the left end of the heater-A/C housing.

(10) From under the passenger side of the instrument panel, disconnect the two halves of the radio antenna coaxial cable connector.

(11) Loosen the right and left instrument panel cowl side roll-down bracket screws about 13 mm (0.50 inch) (Fig. 1).

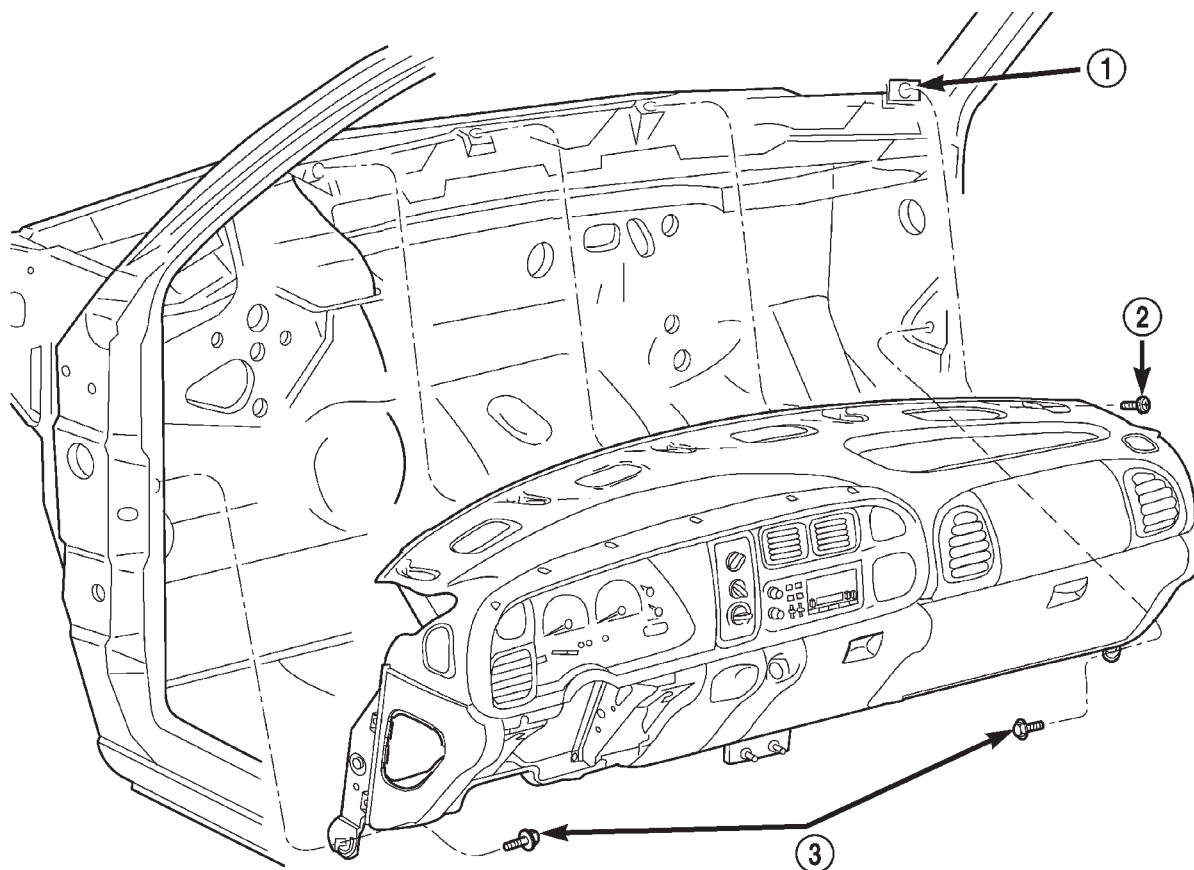
(12) Remove the five screws that secure the top of the instrument panel to the top of the dash panel, removing the center screw last.

(13) Roll down the instrument panel and install a temporary hook in the center hole on top of the instrument panel. Secure the other end of the hook to the center hole in the top of the dash panel. The hook should support the instrument panel in its rolled down position about 46 cm (18 inches) from the dash panel.

(14) With the instrument panel supported in the roll-down position, disconnect the instrument panel wire harness connectors from the heater-A/C housing wire harness connectors.

(15) With the aid of an assistant, remove the temporary hook and lift the instrument panel assembly off of the roll-down bracket screws and remove it from the vehicle.

## INSTRUMENT PANEL SYSTEM (Continued)



80ae83ba

**Fig. 1 Instrument Panel Assembly Remove/Install**

1 - PLASTIC NUT  
2 - SCREWS

3 - SCREWS

## INSTALLATION

**WARNING: ON VEHICLES EQUIPPED WITH AIRBAGS, DISABLE THE AIRBAG SYSTEM BEFORE ATTEMPTING ANY STEERING WHEEL, STEERING COLUMN, OR INSTRUMENT PANEL COMPONENT DIAGNOSIS OR SERVICE. DISCONNECT AND ISOLATE THE BATTERY NEGATIVE (GROUND) CABLE, THEN WAIT TWO MINUTES FOR THE AIRBAG SYSTEM CAPACITOR TO DISCHARGE BEFORE PERFORMING FURTHER DIAGNOSIS OR SERVICE. THIS IS THE ONLY SURE WAY TO DISABLE THE AIRBAG SYSTEM. FAILURE TO TAKE THE PROPER PRECAUTIONS COULD RESULT IN ACCIDENTAL AIRBAG DEPLOYMENT AND POSSIBLE PERSONAL INJURY.**

(1) With the aid of an assistant, load the instrument panel assembly onto the roll-down bracket screws on the cowl side inner panels in the vehicle (Fig. 1). Install a temporary hook in the center hole on top of the instrument panel. Secure the other end of the hook to the center hole in the top of the dash

panel. The hook should support the instrument panel in its rolled down position about 46 cm (18 inches) from the dash panel.

(2) With the instrument panel supported in the roll-down position, reconnect the instrument panel wire harness connectors to the heater-A/C housing wire harness connectors.

(3) Remove the temporary hook from the instrument panel and roll the instrument panel up to its installed position against the dash panel.

(4) Install and tighten the five screws that secure the top of the instrument panel to the top of the dash panel. Tighten the screws to 3.2 N·m (28 in. lbs.).

(5) Tighten the right and left instrument panel cowl side roll-down bracket screws. Tighten the screws to 11.9 N·m (105 in. lbs.).

(6) From under the passenger side of the instrument panel, reconnect the two halves of the radio antenna coaxial cable connector.

(7) From under the driver side of the instrument panel, perform the following:

(a) Engage the park brake release handle linkage rod with the park brake mechanism on the left

## INSTRUMENT PANEL SYSTEM (Continued)

cowl side inner panel. (Refer to 5 - BRAKES/PARKING BRAKE/RELEASE - INSTALLATION).

(b) Reconnect the instrument panel wire harness connector to the park brake switch on the park brake mechanism.

(c) Reconnect the three connectors (one from the body wire harness, and two from the headlamp and dash wire harness) to the three connector receptacles located closest to the dash panel on the back of the Junction Block (JB).

(d) Reconnect the headlamp and dash wire harness to instrument panel wire harness bulkhead connector and tighten the screw in the center of the connector. Tighten the screw to 3.5 N·m (31 in. lbs.).

(e) Reconnect the instrument panel wire harness to door wire harness connector located directly below the instrument panel wire harness to headlamp and dash wire harness bulkhead connector.

(f) If the vehicle is equipped with the Infinity sound system option, reconnect the Infinity wire harness connector to the instrument panel wire harness connector that is secured to the outboard side of the instrument panel wire harness to headlamp and dash wire harness bulkhead connector.

(g) Reconnect the instrument panel wire harness connector to the stop lamp switch.

(h) Reconnect the heater-A/C housing vacuum harness connector to the heater-A/C control vacuum harness connector located near the left end of the heater-A/C housing.

(8) Reinstall the steering column into the vehicle. Be certain that the steering wheel was locked and secured from rotation to prevent the loss of clockspring centering. (Refer to 19 - STEERING/COLUMN - INSTALLATION).

(9) If the vehicle is so equipped, reconnect the overdrive lockout switch pigtail wire connector to the instrument panel wire harness connector near the instrument panel lower reinforcement.

(10) Reconnect the clockspring pigtail wire connector to the instrument panel wire harness connector at the instrument panel lower reinforcement.

(11) Position the inside hood latch release handle to the instrument panel lower reinforcement.

(12) Install and tighten the two screws that secure the inside hood latch release handle to the instrument panel lower reinforcement. Tighten the screws to 2.8 N·m (25 in. lbs.).

(13) Reinstall the steering column opening cover onto the instrument panel. (Refer to 23 - BODY/INSTRUMENT PANEL/STEERING COLUMN OPENING COVER - INSTALLATION).

(14) Reinstall the trim onto the left and right cowl side inner panels. (Refer to 23 - BODY/INTERIOR/COWL TRIM COVER - INSTALLATION).

(15) Reinstall the Airbag Control Module (ACM) and bracket onto the floor panel transmission tunnel. (Refer to 8 - ELECTRICAL/RESTRAINTS/AIRBAG CONTROL MODULE - INSTALLATION).

(16) Reconnect the battery negative cable.

## ASH RECEIVER

## REMOVAL

**WARNING: ON VEHICLES EQUIPPED WITH AIRBAGS, DISABLE THE AIRBAG SYSTEM BEFORE ATTEMPTING ANY STEERING WHEEL, STEERING COLUMN, OR INSTRUMENT PANEL COMPONENT DIAGNOSIS OR SERVICE. DISCONNECT AND ISOLATE THE BATTERY NEGATIVE (GROUND) CABLE, THEN WAIT TWO MINUTES FOR THE AIRBAG SYSTEM CAPACITOR TO DISCHARGE BEFORE PERFORMING FURTHER DIAGNOSIS OR SERVICE. THIS IS THE ONLY SURE WAY TO DISABLE THE AIRBAG SYSTEM. FAILURE TO TAKE THE PROPER PRECAUTIONS COULD RESULT IN ACCIDENTAL AIRBAG DEPLOYMENT AND POSSIBLE PERSONAL INJURY.**

(1) Disconnect and isolate the battery negative cable.

(2) Open the instrument panel ash receiver.

(3) From the open position, close the ash receiver slightly and pull it straight back far enough to disengage it from the pivot pins in the lower instrument panel.

(4) Remove the three screws that secure the ash receiver flame shield to the lower instrument panel (Fig. 2).

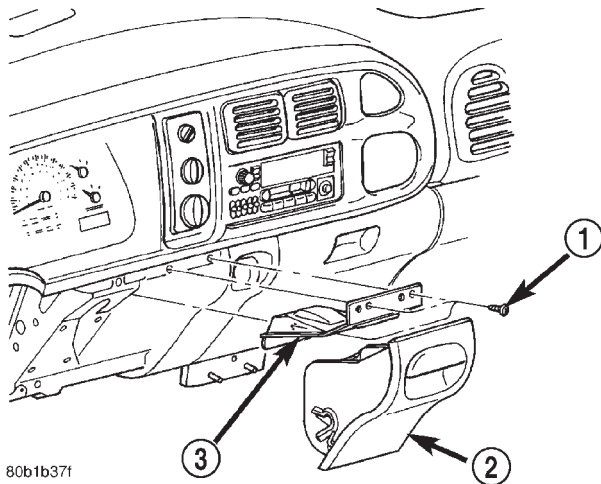
(5) Pull the ash receiver flame shield out from the instrument panel far enough to disengage the two retaining tabs on the top of the shield from the mounting holes in the instrument panel.

(6) Lower the flame shield from the instrument panel far enough to access the ash receiver lamp and hood.

(7) Squeeze the ash receiver lamp and hood bracket to disengage the unit from the mounting hole in the flame shield.

(8) Remove the ash receiver flame shield from the instrument panel.

## ASH RECEIVER (Continued)



80b1b371

**Fig. 2 Instrument Panel Ash Receiver Remove/Install**

- 1 - SCREW
- 2 - ASH RECEIVER
- 3 - FLAME SHIELD

## INSTALLATION

**WARNING: ON VEHICLES EQUIPPED WITH AIRBAGS, DISABLE THE AIRBAG SYSTEM BEFORE ATTEMPTING ANY STEERING WHEEL, STEERING COLUMN, OR INSTRUMENT PANEL COMPONENT DIAGNOSIS OR SERVICE. DISCONNECT AND ISOLATE THE BATTERY NEGATIVE (GROUND) CABLE, THEN WAIT TWO MINUTES FOR THE AIRBAG SYSTEM CAPACITOR TO DISCHARGE BEFORE PERFORMING FURTHER DIAGNOSIS OR SERVICE. THIS IS THE ONLY SURE WAY TO DISABLE THE AIRBAG SYSTEM. FAILURE TO TAKE THE PROPER PRECAUTIONS COULD RESULT IN ACCIDENTAL AIRBAG DEPLOYMENT AND POSSIBLE PERSONAL INJURY.**

(1) Position the ash receiver flame shield to the instrument panel (Fig. 2).

(2) Squeeze the ash receiver lamp and hood bracket and engage the unit to the mounting hole in the flame shield.

(3) Insert the two retaining tabs on the top of the ash receiver flame shield into the mounting holes in the instrument panel, then push the shield forward to engage the tabs with the instrument panel.

(4) Install and tighten the three screws that secure the ash receiver flame shield to the instrument panel. Tighten the screws to 2.2 N·m (20 in. lbs.).

(5) Align the pivot receptacles on each side of the ash receiver with the pivot pins in the lower instrument panel.

(6) Push the ash receiver forward onto the pivot pins in the instrument panel until the open ash receiver snaps into place.

(7) Reconnect the battery negative cable.

## CLUSTER BEZEL

## REMOVAL

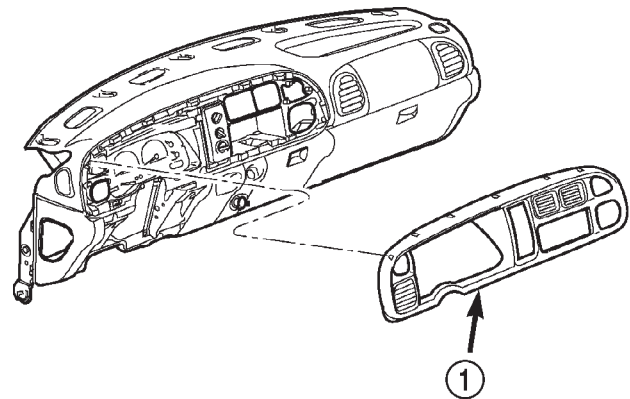
**WARNING: ON VEHICLES EQUIPPED WITH AIRBAGS, DISABLE THE AIRBAG SYSTEM BEFORE ATTEMPTING ANY STEERING WHEEL, STEERING COLUMN, OR INSTRUMENT PANEL COMPONENT DIAGNOSIS OR SERVICE. DISCONNECT AND ISOLATE THE BATTERY NEGATIVE (GROUND) CABLE, THEN WAIT TWO MINUTES FOR THE AIRBAG SYSTEM CAPACITOR TO DISCHARGE BEFORE PERFORMING FURTHER DIAGNOSIS OR SERVICE. THIS IS THE ONLY SURE WAY TO DISABLE THE AIRBAG SYSTEM. FAILURE TO TAKE THE PROPER PRECAUTIONS COULD RESULT IN ACCIDENTAL AIRBAG DEPLOYMENT AND POSSIBLE PERSONAL INJURY.**

(1) Disconnect and isolate the battery negative cable.

(2) If the vehicle is equipped with an automatic transmission, turn the ignition switch to the Off position (not Lock), set the parking brake, and place the automatic transmission gear selector lever in the Low position.

(3) If the vehicle is so equipped, set the tilt steering column in its lowest position.

(4) Using a trim stick or another suitable wide flat-bladed tool, gently pry around the perimeter of the cluster bezel to disengage the snap clips from their receptacles in the instrument panel (Fig. 3).



80b89824

**Fig. 3 Cluster Bezel Remove/Install**

- 1 - CLUSTER BEZEL



## CLUSTER BEZEL (Continued)

(5) Remove the cluster bezel from the instrument panel.

## INSTALLATION

**WARNING: ON VEHICLES EQUIPPED WITH AIRBAGS, DISABLE THE AIRBAG SYSTEM BEFORE ATTEMPTING ANY STEERING WHEEL, STEERING COLUMN, OR INSTRUMENT PANEL COMPONENT DIAGNOSIS OR SERVICE. DISCONNECT AND ISOLATE THE BATTERY NEGATIVE (GROUND) CABLE, THEN WAIT TWO MINUTES FOR THE AIRBAG SYSTEM CAPACITOR TO DISCHARGE BEFORE PERFORMING FURTHER DIAGNOSIS OR SERVICE. THIS IS THE ONLY SURE WAY TO DISABLE THE AIRBAG SYSTEM. FAILURE TO TAKE THE PROPER PRECAUTIONS COULD RESULT IN ACCIDENTAL AIRBAG DEPLOYMENT AND POSSIBLE PERSONAL INJURY.**

(1) Position the cluster bezel to the instrument panel (Fig. 3).

(2) Align the snap clips on the cluster bezel with the receptacles in the instrument panel.

(3) Press firmly on the cluster bezel over each of the snap clip locations until each of the snap clips is fully engaged in its receptacle.

(4) Reconnect the battery negative cable.

## CUBBY BIN

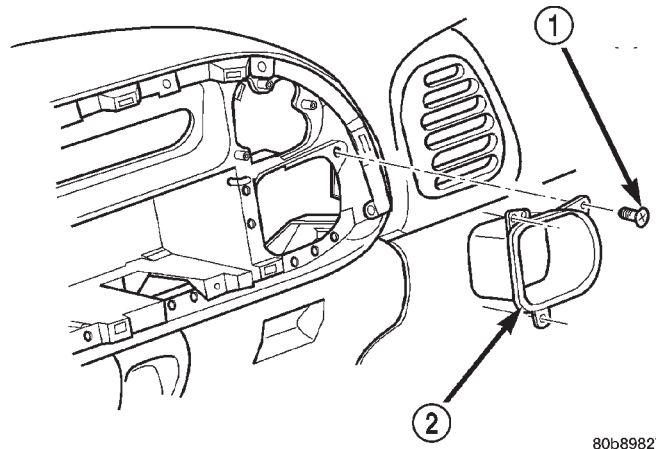
## REMOVAL

**WARNING: ON VEHICLES EQUIPPED WITH AIRBAGS, DISABLE THE AIRBAG SYSTEM BEFORE ATTEMPTING ANY STEERING WHEEL, STEERING COLUMN, OR INSTRUMENT PANEL COMPONENT DIAGNOSIS OR SERVICE. DISCONNECT AND ISOLATE THE BATTERY NEGATIVE (GROUND) CABLE, THEN WAIT TWO MINUTES FOR THE AIRBAG SYSTEM CAPACITOR TO DISCHARGE BEFORE PERFORMING FURTHER DIAGNOSIS OR SERVICE. THIS IS THE ONLY SURE WAY TO DISABLE THE AIRBAG SYSTEM. FAILURE TO TAKE THE PROPER PRECAUTIONS COULD RESULT IN ACCIDENTAL AIRBAG DEPLOYMENT AND POSSIBLE PERSONAL INJURY.**

(1) Disconnect and isolate the battery negative cable.

(2) Remove the cluster bezel from the instrument panel. (Refer to 23 - BODY/INSTRUMENT PANEL/CLUSTER BEZEL - REMOVAL).

(3) Remove the three screws that secure the cubby bin to the instrument panel (Fig. 4).



80b89827

**Fig. 4 Instrument Panel Cubby Bin Remove/Install**

1 - SCREW (3)

2 - CUBBY BIN

(4) Remove the cubby bin from the instrument panel.

## INSTALLATION

**WARNING: ON VEHICLES EQUIPPED WITH AIRBAGS, DISABLE THE AIRBAG SYSTEM BEFORE ATTEMPTING ANY STEERING WHEEL, STEERING COLUMN, OR INSTRUMENT PANEL COMPONENT DIAGNOSIS OR SERVICE. DISCONNECT AND ISOLATE THE BATTERY NEGATIVE (GROUND) CABLE, THEN WAIT TWO MINUTES FOR THE AIRBAG SYSTEM CAPACITOR TO DISCHARGE BEFORE PERFORMING FURTHER DIAGNOSIS OR SERVICE. THIS IS THE ONLY SURE WAY TO DISABLE THE AIRBAG SYSTEM. FAILURE TO TAKE THE PROPER PRECAUTIONS COULD RESULT IN ACCIDENTAL AIRBAG DEPLOYMENT AND POSSIBLE PERSONAL INJURY.**

(1) Position the cubby bin to the instrument panel (Fig. 4).

(2) Install and tighten the three screws that secure the cubby bin to the instrument panel. Tighten the screws to 2.2 N-m (20 in. lbs.).

(3) Install the cluster bezel onto the instrument panel. (Refer to 23 - BODY/INSTRUMENT PANEL/CLUSTER BEZEL - INSTALLATION).

(4) Reconnect the battery negative cable.

## CUP HOLDER

## REMOVAL

Vehicles equipped with an automatic transmission have a lighted fold-down cup holder installed on the instrument panel just inboard of the glove box. Vehi-

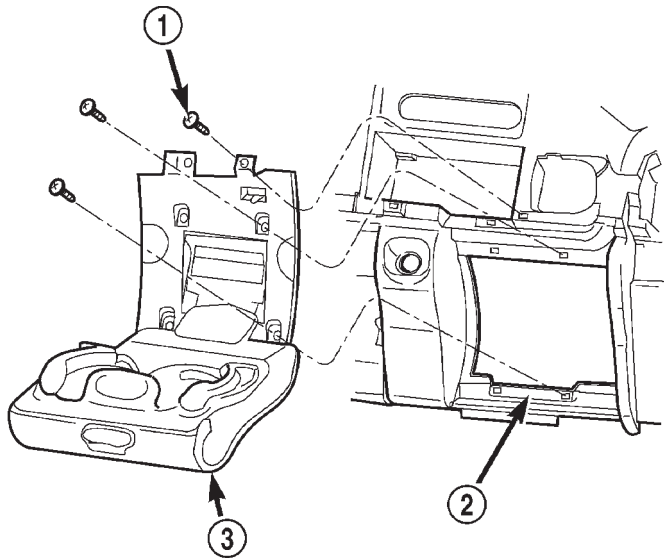


## CUP HOLDER (Continued)

cles equipped with a manual transmission have a lighted storage bin installed on the instrument panel in place of the fold-down cup holder.

**WARNING: ON VEHICLES EQUIPPED WITH AIRBAGS, DISABLE THE AIRBAG SYSTEM BEFORE ATTEMPTING ANY STEERING WHEEL, STEERING COLUMN, OR INSTRUMENT PANEL COMPONENT DIAGNOSIS OR SERVICE. DISCONNECT AND ISOLATE THE BATTERY NEGATIVE (GROUND) CABLE, THEN WAIT TWO MINUTES FOR THE AIRBAG SYSTEM CAPACITOR TO DISCHARGE BEFORE PERFORMING FURTHER DIAGNOSIS OR SERVICE. THIS IS THE ONLY SURE WAY TO DISABLE THE AIRBAG SYSTEM. FAILURE TO TAKE THE PROPER PRECAUTIONS COULD RESULT IN ACCIDENTAL AIRBAG DEPLOYMENT AND POSSIBLE PERSONAL INJURY.**

- (1) Disconnect and isolate the battery negative cable.
- (2) Remove the cluster bezel from the instrument panel. (Refer to 23 - BODY/INSTRUMENT PANEL/CLUSTER BEZEL - REMOVAL).
- (3) Unlatch and fold the cup holder down from the instrument panel to its open position.
- (4) Remove the six screws that secure the cup holder to the instrument panel (Fig. 5).



80b170eb

**Fig. 5 Instrument Panel Cup Holder**

- 1 - SCREW
- 2 - INSTRUMENT PANEL
- 3 - CUP HOLDER

(5) Pull the cup holder away from the instrument panel far enough to access the illumination lamp and hood unit.

(6) Disengage the illumination lamp and hood retainer clip from the back of the instrument panel cup holder unit.

(7) Remove the cup holder unit from the instrument panel.

## INSTALLATION

Vehicles equipped with an automatic transmission have a lighted fold-down cup holder installed on the instrument panel just inboard of the glove box. Vehicles equipped with a manual transmission have a lighted storage bin installed on the instrument panel in place of the fold-down cup holder.

**WARNING: ON VEHICLES EQUIPPED WITH AIRBAGS, DISABLE THE AIRBAG SYSTEM BEFORE ATTEMPTING ANY STEERING WHEEL, STEERING COLUMN, OR INSTRUMENT PANEL COMPONENT DIAGNOSIS OR SERVICE. DISCONNECT AND ISOLATE THE BATTERY NEGATIVE (GROUND) CABLE, THEN WAIT TWO MINUTES FOR THE AIRBAG SYSTEM CAPACITOR TO DISCHARGE BEFORE PERFORMING FURTHER DIAGNOSIS OR SERVICE. THIS IS THE ONLY SURE WAY TO DISABLE THE AIRBAG SYSTEM. FAILURE TO TAKE THE PROPER PRECAUTIONS COULD RESULT IN ACCIDENTAL AIRBAG DEPLOYMENT AND POSSIBLE PERSONAL INJURY.**

- (1) Position the cup holder unit near the instrument panel.
- (2) Engage the illumination lamp and hood retainer clip to the back of the instrument panel cup holder unit.
- (3) Position the cup holder unit onto the instrument panel (Fig. 5).
- (4) Install and tighten the six screws that secure the cup holder to the instrument panel. Tighten the screws to 2.2 N·m (20 in. lbs.).
- (5) Reinstall the cluster bezel onto the instrument panel. (Refer to 23 - BODY/INSTRUMENT PANEL/CLUSTER BEZEL - INSTALLATION).
- (6) Reconnect the battery negative cable.

## GLOVE BOX

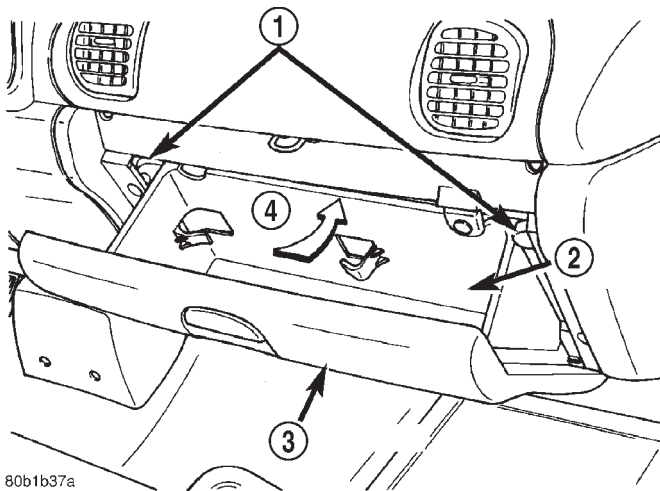
### REMOVAL

**WARNING: ON VEHICLES EQUIPPED WITH AIRBAGS, DISABLE THE AIRBAG SYSTEM BEFORE ATTEMPTING ANY STEERING WHEEL, STEERING COLUMN, OR INSTRUMENT PANEL COMPONENT DIAGNOSIS OR SERVICE. DISCONNECT AND ISOLATE THE BATTERY NEGATIVE (GROUND) CABLE, THEN WAIT TWO MINUTES FOR THE AIRBAG SYSTEM CAPACITOR TO DISCHARGE BEFORE PERFORMING FURTHER DIAGNOSIS OR SERVICE. THIS IS THE ONLY SURE WAY TO DISABLE THE AIRBAG SYSTEM. FAILURE TO TAKE THE PROPER PRECAUTIONS COULD RESULT IN ACCIDENTAL AIRBAG DEPLOYMENT AND POSSIBLE PERSONAL INJURY.**

(1) Disconnect and isolate the battery negative cable.

(2) Open the glove box.

(3) While holding the glove box door securely with one hand, push the center of the glove box bin towards the front of the vehicle (Fig. 6). Flex the center of the glove box bin far enough so that the glove box stops on each side of the bin will clear the sides of the instrument panel glove box opening.



80b1b37a

**Fig. 6 Glove Box**

- 1 - GLOVE BOX STOPS
- 2 - GLOVE BOX BIN
- 3 - GLOVE BOX DOOR
- 4 - PUSH

(4) Roll the glove box downward until the stop bumpers are beyond the sides of the instrument panel glove box opening, then release the bin.

(5) Lift the bottom of the glove box upward to disengage the three glove box hinge hooks from the three hinge pins on the instrument panel.

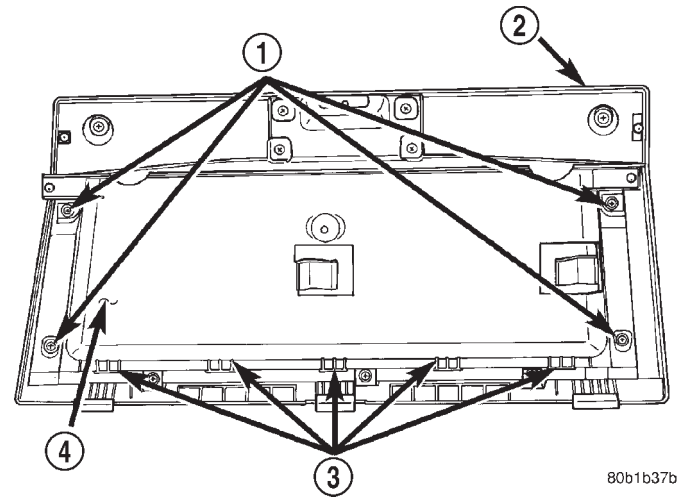
### DISASSEMBLY - GLOVE BOX

The only serviced component of the glove box is the glove box bin. If any other component of the glove box is faulty or damaged, the entire glove box assembly must be replaced.

(1) Disconnect and isolate the battery negative cable.

(2) Remove the glove box from the instrument panel. (Refer to 23 - BODY/INSTRUMENT PANEL/GLOVE BOX - REMOVAL).

(3) Remove the two screws that secure each out-board flange of the glove box bin to the glove box door (Fig. 7).



80b1b37b

**Fig. 7 Glove Box Disassemble/Assemble**

- 1 - SCREWS
- 2 - GLOVE BOX DOOR
- 3 - HOOKS
- 4 - GLOVE BOX BIN

(4) Pull the top of the bin away from the top of the glove box door.

(5) Disengage the five hook formations on the bottom of the glove box bin from the slots near the bottom of the inner glove box door.

(6) Remove the glove box bin from the glove box door.

### ASSEMBLY - GLOVE BOX

(1) Position the glove box bin onto the glove box door.

(2) Engage the five hook formations on the bottom of the glove box bin with the slots near the bottom of the inner glove box door (Fig. 7).

(3) Position the top of the bin to the top of the glove box door.

## GLOVE BOX (Continued)

(4) Install and tighten the two screws that secure each outboard flange of the glove box bin to the glove box door. Tighten the screws to 2.2 N·m (20 in. lbs.).

(5) Reinstall the glove box onto the instrument panel. (Refer to 23 - BODY/INSTRUMENT PANEL/GLOVE BOX - INSTALLATION).

(6) Reconnect the battery negative cable.

## INSTALLATION

**WARNING: ON VEHICLES EQUIPPED WITH AIRBAGS, DISABLE THE AIRBAG SYSTEM BEFORE ATTEMPTING ANY STEERING WHEEL, STEERING COLUMN, OR INSTRUMENT PANEL COMPONENT DIAGNOSIS OR SERVICE. DISCONNECT AND ISOLATE THE BATTERY NEGATIVE (GROUND) CABLE, THEN WAIT TWO MINUTES FOR THE AIRBAG SYSTEM CAPACITOR TO DISCHARGE BEFORE PERFORMING FURTHER DIAGNOSIS OR SERVICE. THIS IS THE ONLY SURE WAY TO DISABLE THE AIRBAG SYSTEM. FAILURE TO TAKE THE PROPER PRECAUTIONS COULD RESULT IN ACCIDENTAL AIRBAG DEPLOYMENT AND POSSIBLE PERSONAL INJURY.**

- (1) Position the glove box to the instrument panel.
- (2) Engage the three hinge hooks near the bottom of the glove box door with the three hinge pins on the instrument panel.
- (3) While holding the glove box door securely with one hand, push the center of the glove box bin towards the front of the vehicle (Fig. 6). Flex the center of the glove box bin far enough so that the glove box stops on each side of the bin will clear the sides of the instrument panel glove box opening.
- (4) Roll the glove box upward until the stop bumpers are beyond the sides of the instrument panel glove box opening, then release the bin.
- (5) Close the glove box.
- (6) Reconnect the battery negative cable.

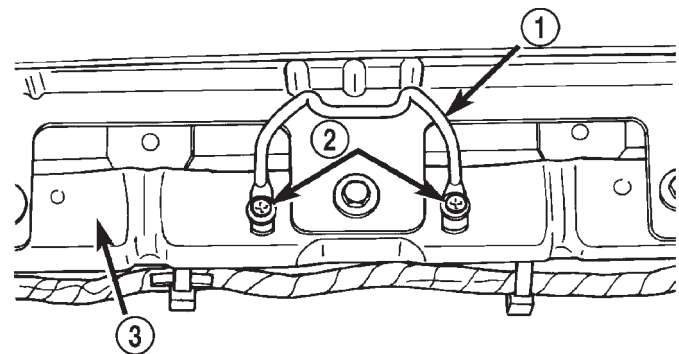
## GLOVE BOX LATCH STRIKER

## REMOVAL

**WARNING: ON VEHICLES EQUIPPED WITH AIRBAGS, DISABLE THE AIRBAG SYSTEM BEFORE ATTEMPTING ANY STEERING WHEEL, STEERING COLUMN, OR INSTRUMENT PANEL COMPONENT DIAGNOSIS OR SERVICE. DISCONNECT AND ISOLATE THE BATTERY NEGATIVE (GROUND) CABLE, THEN WAIT TWO MINUTES FOR THE AIRBAG SYSTEM CAPACITOR TO DISCHARGE BEFORE PERFORMING FURTHER DIAGNOSIS OR SERVICE. THIS IS THE ONLY SURE WAY TO DISABLE THE AIRBAG SYSTEM. FAILURE TO TAKE THE PROPER PRECAUTIONS COULD RESULT IN ACCIDENTAL AIRBAG DEPLOYMENT AND POSSIBLE PERSONAL INJURY.**

**CAUTIONS COULD RESULT IN ACCIDENTAL AIRBAG DEPLOYMENT AND POSSIBLE PERSONAL INJURY.**

- (1) Disconnect and isolate the battery negative cable.
- (2) Remove the trim from the upper glove box opening. (Refer to 23 - BODY/INSTRUMENT PANEL/GLOVE BOX OPENING UPPER TRIM - REMOVAL).
- (3) Remove the two screws that secure the latch striker to the instrument panel glove box opening upper reinforcement (Fig. 8).



80b1b381

**Fig. 8 Glove Box Latch Striker Remove/Install**

- 1 - LATCH STRIKER
- 2 - SCREWS
- 3 - GLOVE BOX OPENING UPPER REINFORCEMENT

- (4) Remove the latch striker from the instrument panel glove box opening upper reinforcement.

## INSTALLATION

**WARNING: ON VEHICLES EQUIPPED WITH AIRBAGS, DISABLE THE AIRBAG SYSTEM BEFORE ATTEMPTING ANY STEERING WHEEL, STEERING COLUMN, OR INSTRUMENT PANEL COMPONENT DIAGNOSIS OR SERVICE. DISCONNECT AND ISOLATE THE BATTERY NEGATIVE (GROUND) CABLE, THEN WAIT TWO MINUTES FOR THE AIRBAG SYSTEM CAPACITOR TO DISCHARGE BEFORE PERFORMING FURTHER DIAGNOSIS OR SERVICE. THIS IS THE ONLY SURE WAY TO DISABLE THE AIRBAG SYSTEM. FAILURE TO TAKE THE PROPER PRECAUTIONS COULD RESULT IN ACCIDENTAL AIRBAG DEPLOYMENT AND POSSIBLE PERSONAL INJURY.**

- (1) Position the latch striker onto the instrument panel glove box opening upper reinforcement (Fig. 8).
- (2) Install and tighten the two screws that secure the latch striker to the instrument panel glove box

## GLOVE BOX LATCH STRIKER (Continued)

opening upper reinforcement. Tighten the screws to 2.2 N·m (20 in. lbs.).

(3) Reinstall the trim onto the upper glove box opening. (Refer to 23 - BODY/INSTRUMENT PANEL/GLOVE BOX OPENING UPPER TRIM - INSTALLATION).

(4) Reconnect the battery negative cable.

## GLOVE BOX OPENING UPPER TRIM

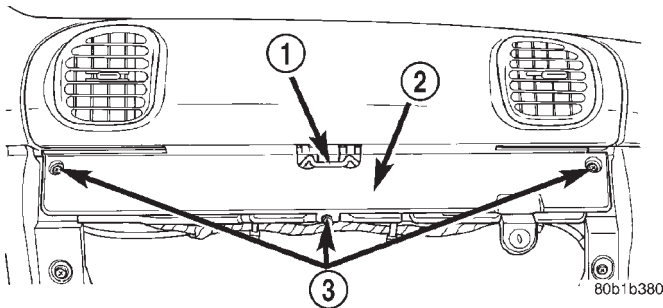
## REMOVAL

**WARNING: ON VEHICLES EQUIPPED WITH AIRBAGS, DISABLE THE AIRBAG SYSTEM BEFORE ATTEMPTING ANY STEERING WHEEL, STEERING COLUMN, OR INSTRUMENT PANEL COMPONENT DIAGNOSIS OR SERVICE. DISCONNECT AND ISOLATE THE BATTERY NEGATIVE (GROUND) CABLE, THEN WAIT TWO MINUTES FOR THE AIRBAG SYSTEM CAPACITOR TO DISCHARGE BEFORE PERFORMING FURTHER DIAGNOSIS OR SERVICE. THIS IS THE ONLY SURE WAY TO DISABLE THE AIRBAG SYSTEM. FAILURE TO TAKE THE PROPER PRECAUTIONS COULD RESULT IN ACCIDENTAL AIRBAG DEPLOYMENT AND POSSIBLE PERSONAL INJURY.**

(1) Disconnect and isolate the battery negative cable.

(2) Open the glove box.

(3) Remove the three screws that secure the trim to the instrument panel glove box opening upper reinforcement (Fig. 9).



**Fig. 9 Glove Box Opening Upper Trim Remove/Install**

- 1 - LATCH STRIKER
- 2 - TRIM
- 3 - SCREWS

(4) Remove the trim from the instrument panel glove box opening upper reinforcement.

## INSTALLATION

**WARNING: ON VEHICLES EQUIPPED WITH AIRBAGS, DISABLE THE AIRBAG SYSTEM BEFORE ATTEMPTING ANY STEERING WHEEL, STEERING COLUMN, OR INSTRUMENT PANEL COMPONENT DIAGNOSIS OR SERVICE. DISCONNECT AND ISOLATE THE BATTERY NEGATIVE (GROUND) CABLE, THEN WAIT TWO MINUTES FOR THE AIRBAG SYSTEM CAPACITOR TO DISCHARGE BEFORE PERFORMING FURTHER DIAGNOSIS OR SERVICE. THIS IS THE ONLY SURE WAY TO DISABLE THE AIRBAG SYSTEM. FAILURE TO TAKE THE PROPER PRECAUTIONS COULD RESULT IN ACCIDENTAL AIRBAG DEPLOYMENT AND POSSIBLE PERSONAL INJURY.**

(1) Position the trim onto the instrument panel glove box opening upper reinforcement (Fig. 9).

(2) Install and tighten the three screws that secure the trim to the instrument panel glove box opening upper reinforcement. Tighten the mounting screws to 2.2 N·m (20 in. lbs.).

(3) Close the glove box.

(4) Reconnect the battery negative cable.

## INSTRUMENT PANEL TOP COVER

## REMOVAL

**WARNING: ON VEHICLES EQUIPPED WITH AIRBAGS, DISABLE THE AIRBAG SYSTEM BEFORE ATTEMPTING ANY STEERING WHEEL, STEERING COLUMN, OR INSTRUMENT PANEL COMPONENT DIAGNOSIS OR SERVICE. DISCONNECT AND ISOLATE THE BATTERY NEGATIVE (GROUND) CABLE, THEN WAIT TWO MINUTES FOR THE AIRBAG SYSTEM CAPACITOR TO DISCHARGE BEFORE PERFORMING FURTHER DIAGNOSIS OR SERVICE. THIS IS THE ONLY SURE WAY TO DISABLE THE AIRBAG SYSTEM. FAILURE TO TAKE THE PROPER PRECAUTIONS COULD RESULT IN ACCIDENTAL AIRBAG DEPLOYMENT AND POSSIBLE PERSONAL INJURY.**

(1) Disconnect and isolate the battery negative cable.

(2) Remove the cluster bezel from the instrument panel. (Refer to 23 - BODY/INSTRUMENT PANEL/CLUSTER BEZEL - REMOVAL).

(3) Remove the passenger airbag from the instrument panel. (Refer to 8 - ELECTRICAL/RESTRAINTS/PASSENGER AIRBAG - REMOVAL).



## INSTRUMENT PANEL TOP COVER (Continued)

(4) Remove the instrument panel from the vehicle. (Refer to 23 - BODY/INSTRUMENT PANEL - REMOVAL).

(5) Place the instrument panel on a suitable work surface. Be certain to take the proper precautions to protect the instrument panel from any possible cosmetic damage.

(6) Remove the screws around the perimeter of the top cover that secure it to the instrument panel structural support, the defroster duct, and the demister ducts.

(7) Lift the top cover off of the instrument panel.

## INSTALLATION

**WARNING: ON VEHICLES EQUIPPED WITH AIRBAGS, DISABLE THE AIRBAG SYSTEM BEFORE ATTEMPTING ANY STEERING WHEEL, STEERING COLUMN, OR INSTRUMENT PANEL COMPONENT DIAGNOSIS OR SERVICE. DISCONNECT AND ISOLATE THE BATTERY NEGATIVE (GROUND) CABLE, THEN WAIT TWO MINUTES FOR THE AIRBAG SYSTEM CAPACITOR TO DISCHARGE BEFORE PERFORMING FURTHER DIAGNOSIS OR SERVICE. THIS IS THE ONLY SURE WAY TO DISABLE THE AIRBAG SYSTEM. FAILURE TO TAKE THE PROPER PRECAUTIONS COULD RESULT IN ACCIDENTAL AIRBAG DEPLOYMENT AND POSSIBLE PERSONAL INJURY.**

(1) Position the top cover onto the instrument panel.

(2) Install and tighten the screws around the perimeter of the top cover that secure it to the instrument panel structural support, the defroster duct, and the demister ducts. Tighten the screws to 2.2 N·m (20 in. lbs.).

(3) Reinstall the instrument panel into the vehicle. (Refer to 23 - BODY/INSTRUMENT PANEL - INSTALLATION).

(4) Reinstall the passenger airbag into the instrument panel. (Refer to 8 - ELECTRICAL/RESTRAINTS/PASSENGER AIRBAG - INSTALLATION).

(5) Reinstall the cluster bezel onto the instrument panel. (Refer to 23 - BODY/INSTRUMENT PANEL/CLUSTER BEZEL - INSTALLATION).

(6) Reconnect the battery negative cable.

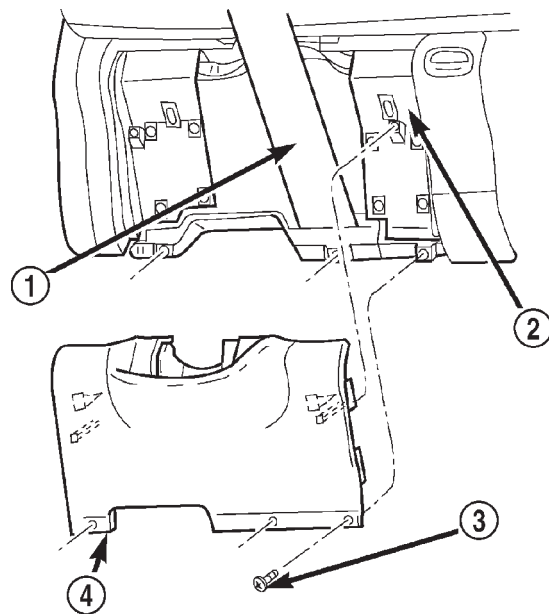
## STEERING COLUMN OPENING COVER

## REMOVAL

**WARNING: ON VEHICLES EQUIPPED WITH AIRBAGS, DISABLE THE AIRBAG SYSTEM BEFORE ATTEMPTING ANY STEERING WHEEL, STEERING COLUMN, OR INSTRUMENT PANEL COMPONENT DIAGNOSIS OR SERVICE. DISCONNECT AND ISOLATE THE BATTERY NEGATIVE (GROUND) CABLE, THEN WAIT TWO MINUTES FOR THE AIRBAG SYSTEM CAPACITOR TO DISCHARGE BEFORE PERFORMING FURTHER DIAGNOSIS OR SERVICE. THIS IS THE ONLY SURE WAY TO DISABLE THE AIRBAG SYSTEM. FAILURE TO TAKE THE PROPER PRECAUTIONS COULD RESULT IN ACCIDENTAL AIRBAG DEPLOYMENT AND POSSIBLE PERSONAL INJURY.**

(1) Disconnect and isolate the battery negative cable.

(2) Remove the three screws that secure the lower edge of the steering column opening cover to the lower instrument panel reinforcement (Fig. 10).



80b170ee

**Fig. 10 Steering Column Opening Cover Remove/Install**

- 1 - STEERING COLUMN
- 2 - INSTRUMENT PANEL
- 3 - SCREW
- 4 - STEERING COLUMN OPENING COVER

(3) Using a trim stick or another suitable wide flat-bladed tool, gently pry the upper edge of the steering column opening cover just below the cluster



## STEERING COLUMN OPENING COVER (Continued)

bezel on each side of the steering column away from the instrument panel far enough to disengage the snap clip retainers from their receptacles in the instrument panel.

(4) Remove the steering column opening cover from the instrument panel.

## INSTALLATION

**WARNING: ON VEHICLES EQUIPPED WITH AIRBAGS, DISABLE THE AIRBAG SYSTEM BEFORE ATTEMPTING ANY STEERING WHEEL, STEERING COLUMN, OR INSTRUMENT PANEL COMPONENT DIAGNOSIS OR SERVICE. DISCONNECT AND ISOLATE THE BATTERY NEGATIVE (GROUND) CABLE, THEN WAIT TWO MINUTES FOR THE AIRBAG SYSTEM CAPACITOR TO DISCHARGE BEFORE PERFORMING FURTHER DIAGNOSIS OR SERVICE. THIS IS THE ONLY SURE WAY TO DISABLE THE AIRBAG SYSTEM. FAILURE TO TAKE THE PROPER PRECAUTIONS COULD RESULT IN ACCIDENTAL AIRBAG DEPLOYMENT AND POSSIBLE PERSONAL INJURY.**

(1) Position the steering column opening cover to the instrument panel (Fig. 10).

(2) Align the snap clip retainers on the steering column opening cover with their receptacles in the instrument panel.

(3) Press firmly and evenly on the steering column opening cover over the snap clip locations until each of the snap clips is fully engaged in its receptacle.

(4) Install and tighten the three screws that secure the lower edge of the steering column opening cover to the lower instrument panel reinforcement. Tighten the screws to 2.2 N·m (20 in. lbs.).

(5) Reconnect the battery negative cable.

## STORAGE BIN

## REMOVAL

Vehicles equipped with an automatic transmission have a lighted fold-down cup holder installed on the instrument panel just inboard of the glove box. Vehicles equipped with a manual transmission have a lighted storage bin installed on the instrument panel in place of the fold-down cup holder.

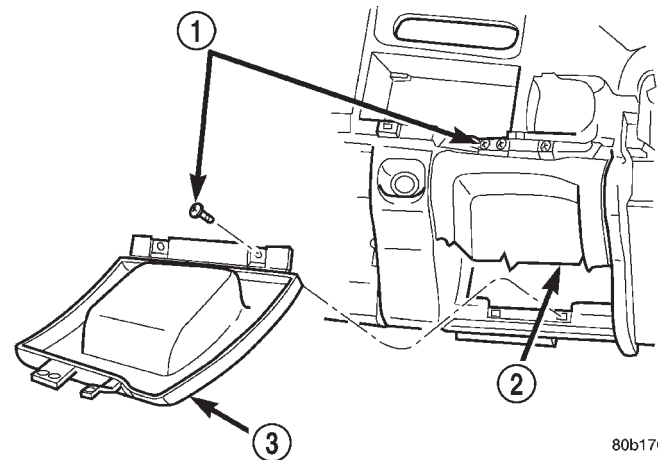
**WARNING: ON VEHICLES EQUIPPED WITH AIRBAGS, DISABLE THE AIRBAG SYSTEM BEFORE ATTEMPTING ANY STEERING WHEEL, STEERING COLUMN, OR INSTRUMENT PANEL COMPONENT DIAGNOSIS OR SERVICE. DISCONNECT AND ISOLATE THE BATTERY NEGATIVE (GROUND) CABLE, THEN WAIT TWO MINUTES FOR THE AIRBAG SYSTEM CAPACITOR TO DISCHARGE BEFORE PER-**

**FORMING FURTHER DIAGNOSIS OR SERVICE. THIS IS THE ONLY SURE WAY TO DISABLE THE AIRBAG SYSTEM. FAILURE TO TAKE THE PROPER PRECAUTIONS COULD RESULT IN ACCIDENTAL AIRBAG DEPLOYMENT AND POSSIBLE PERSONAL INJURY.**

(1) Disconnect and isolate the battery negative cable.

(2) Remove the cluster bezel from the instrument panel. (Refer to 23 - BODY/INSTRUMENT PANEL/CLUSTER BEZEL - REMOVAL).

(3) Remove the two screws that secure the top of the storage bin to the instrument panel (Fig. 11).



80b170ed

**Fig. 11 Instrument Panel Storage Bin Remove/Install**

- 1 - SCREWS
- 2 - STORAGE BIN (RAISED)
- 3 - STORAGE BIN (LOWERED)

(4) Lower the top of the storage bin away from the instrument panel far enough to access the illumination lamp and hood unit.

(5) Disengage the illumination lamp and hood retainer clip from the back of the instrument panel storage bin unit.

(6) Remove the storage bin unit from the instrument panel.

## INSTALLATION

Vehicles equipped with an automatic transmission have a lighted fold-down cup holder installed on the instrument panel just inboard of the glove box. Vehicles equipped with a manual transmission have a lighted storage bin installed on the instrument panel in place of the fold-down cup holder.

## STORAGE BIN (Continued)

**WARNING: ON VEHICLES EQUIPPED WITH AIRBAGS, DISABLE THE AIRBAG SYSTEM BEFORE ATTEMPTING ANY STEERING WHEEL, STEERING COLUMN, OR INSTRUMENT PANEL COMPONENT DIAGNOSIS OR SERVICE. DISCONNECT AND ISOLATE THE BATTERY NEGATIVE (GROUND) CABLE, THEN WAIT TWO MINUTES FOR THE AIRBAG SYSTEM CAPACITOR TO DISCHARGE BEFORE PERFORMING FURTHER DIAGNOSIS OR SERVICE. THIS IS THE ONLY SURE WAY TO DISABLE THE AIRBAG SYSTEM. FAILURE TO TAKE THE PROPER PRECAUTIONS COULD RESULT IN ACCIDENTAL AIRBAG DEPLOYMENT AND POSSIBLE PERSONAL INJURY.**

- (1) Position the storage bin unit onto the instrument panel (Fig. 11).
- (2) Engage the illumination lamp and hood retainer clip to the back of the instrument panel storage bin unit.
- (3) Raise and position the top of the storage bin to the instrument panel.
- (4) Install and tighten the two screws that secure the top of the storage bin unit to the instrument panel. Tighten the screws to 2.2 N·m (20 in. lbs.).
- (5) Reinstall the cluster bezel onto the instrument panel. (Refer to 23 - BODY/INSTRUMENT PANEL/CLUSTER BEZEL - INSTALLATION).
- (6) Reconnect the battery negative cable.

# INTERIOR

## TABLE OF CONTENTS

	page		page
<b>INTERIOR</b>		<b>INSTALLATION</b> . . . . .	122
CAUTION . . . . .	118	<b>CARPETS AND FLOOR MATS</b>	
<b>A-PILLAR GRAB HANDLE</b>		REMOVAL . . . . .	123
REMOVAL . . . . .	119	INSTALLATION . . . . .	123
INSTALLATION . . . . .	119	<b>ASSIST HANDLE</b>	
<b>A-PILLAR TRIM</b>		REMOVAL . . . . .	124
REMOVAL . . . . .	119	INSTALLATION . . . . .	124
INSTALLATION . . . . .	119	<b>COAT HOOK</b>	
<b>COWL TRIM COVER</b>		REMOVAL . . . . .	124
REMOVAL . . . . .	119	INSTALLATION . . . . .	125
INSTALLATION . . . . .	120	<b>HEADLINER</b>	
<b>B-PILLAR TRIM</b>		REMOVAL . . . . .	125
REMOVAL . . . . .	120	INSTALLATION . . . . .	125
INSTALLATION . . . . .	120	<b>BODY VENT</b>	
<b>REAR CLOSURE PANEL TRIM</b>		REMOVAL . . . . .	126
REMOVAL . . . . .	120	INSTALLATION . . . . .	126
INSTALLATION . . . . .	121	<b>REAR VIEW MIRROR</b>	
<b>REAR FLOOR STOWAGE TRAY</b>		REMOVAL . . . . .	126
REMOVAL . . . . .	121	INSTALLATION . . . . .	126
INSTALLATION . . . . .	121	<b>SUN VISOR</b>	
<b>DOOR SILL TRIM</b>		REMOVAL . . . . .	127
REMOVAL . . . . .	121	INSTALLATION . . . . .	127
INSTALLATION . . . . .	121	<b>QUARTER TRIM PANEL</b>	
<b>SHIFT BOOT - MANUAL TRANSMISSION</b>		REMOVAL . . . . .	127
REMOVAL . . . . .	122	INSTALLATION . . . . .	128
INSTALLATION . . . . .	122	<b>C-PILLAR TRIM</b>	
<b>4WD FLOOR SHIFT BOOT</b>		REMOVAL . . . . .	128
REMOVAL . . . . .	122	INSTALLATION . . . . .	128
INSTALLATION . . . . .	122		
<b>CENTER CONSOLE</b>			
REMOVAL . . . . .	122		

## INTERIOR

### CAUTION

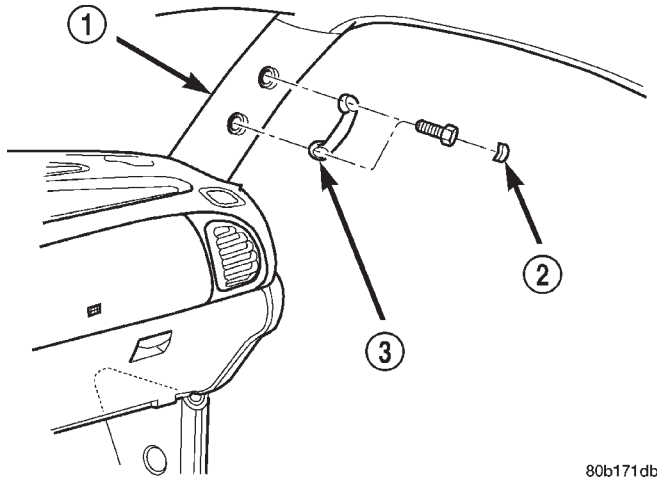
**CAUTION:** Do not attempt to remove interior trim panels/moldings without first removing the neces-

sary adjacent panels. To avoid damaging the panels, ensure that all the screws and clips are removed before attempting to remove an interior trim panel/molding. Trim panels are somewhat flexible but can be damaged if handled improperly.

## A-PILLAR GRAB HANDLE

### REMOVAL

- (1) Using a small flat blade screw driver, pry trim plugs from A-pillar grab handle.
- (2) Remove screws attaching grab handle to A-pillar (Fig. 1).
- (3) Separate A-pillar grab handle from vehicle.



80b171db

**Fig. 1 A-pillar Grab Handle (4X4)**

- 1 - A-PILLAR TRIM
- 2 - TRIM PLUG
- 3 - GRAB HANDLE

### INSTALLATION

- (1) Position grab handle on A-pillar.
- (2) Install screws attaching grab handle to A-pillar (Fig. 1).
- (3) Install trim plugs in A-pillar grab handle.

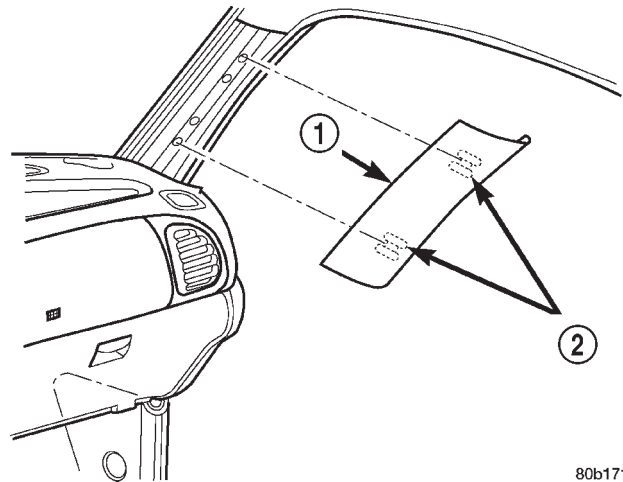
## A-PILLAR TRIM

### REMOVAL

- (1) Remove A-pillar grab handle, if equipped (Refer to 23 - BODY/INTERIOR/A-PILLAR GRAB HANDLE - REMOVAL).
- (2) Grasp A-pillar trim at top and pull outward/downward to disengage upper spring clip (Fig. 2).
- (3) Carefully pull bottom of A-pillar trim outward to disengage lower spring clip.
- (4) Disengage speaker harness connector, if equipped.
- (5) Separate A-pillar trim from vehicle.

### INSTALLATION

- (1) Position A-pillar trim in vehicle.
- (2) Engage speaker harness connector, if equipped.
- (3) Align spring clips and press into place.



80b171dc

**Fig. 2 A-pillar Trim**

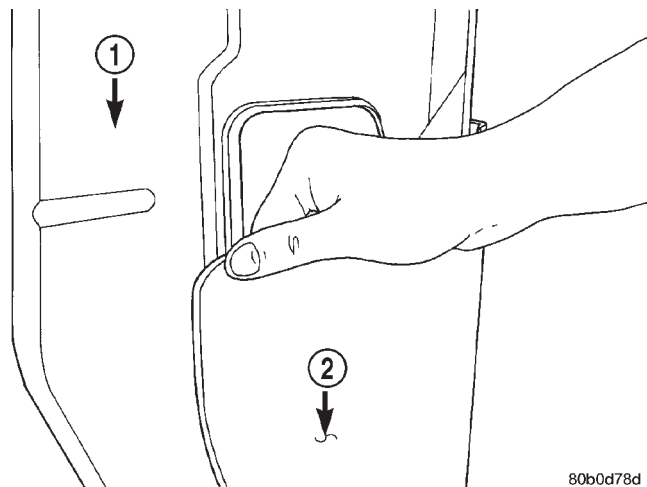
- 1 - A-PILLAR TRIM
- 2 - SPRING CLIPS

- (4) Install A-pillar grab handle, if equipped (Refer to 23 - BODY/INTERIOR/A-PILLAR GRAB HANDLE - INSTALLATION).

## COWL TRIM COVER

### REMOVAL

- (1) Remove front door sill trim cover (Refer to 23 - BODY/INTERIOR/DOOR SILL TRIM - REMOVAL).
- (2) Grasp center upper edge of cowl trim cover (Fig. 3) and pull outward allowing cowl trim cover to bow in the center releasing trim cover retaining tab (Fig. 4).
- (3) Separate cowl trim cover from lower cowl.

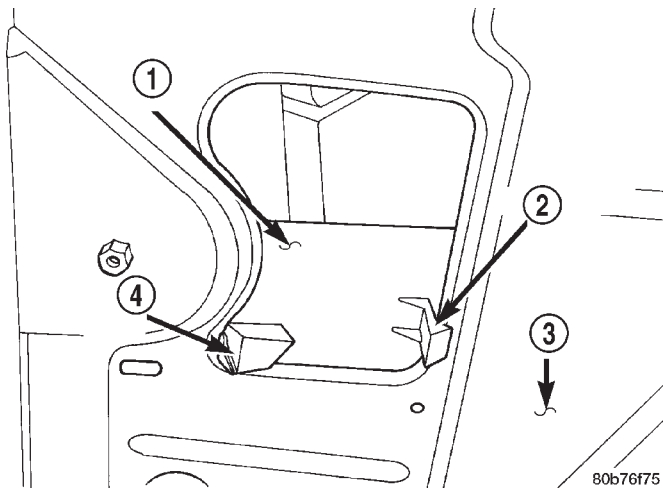


80b0d78d

**Fig. 3 Lower Cowl Trim Cover**

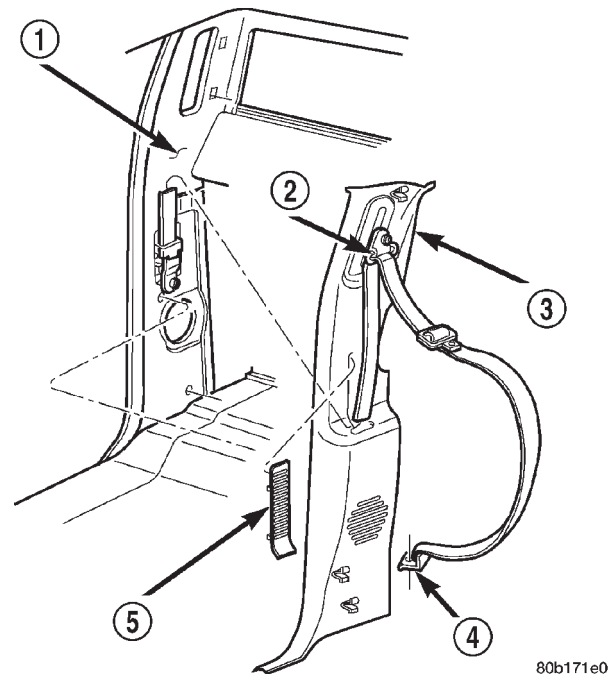
- 1 - LOWER COWL
- 2 - LOWER COWL TRIM

## COWL TRIM COVER (Continued)



**Fig. 4 Lower Cowl Trim Cover Retaining Tab**

- 1 - LOWER COWL TRIM
- 2 - RETAINING TAB
- 3 - LOWER COWL
- 4 - LOCATOR TAB



**Fig. 5 B-Pillar Trim**

- 1 - B-PILLAR
- 2 - TURNING LOOP
- 3 - B-PILLAR TRIM
- 4 - SEAT BELT ANCHOR
- 5 - EXIT PLUG

## INSTALLATION

- (1) Position cowl trim cover on lower cowl.
- (2) Press into place.
- (3) Install front door sill trim cover (Refer to 23 - BODY/INTERIOR/DOOR SILL TRIM - INSTALLATION).

## B-PILLAR TRIM

### REMOVAL

- (1) Remove rear floor stowage tray, If equipped. (Refer to 23 - BODY/INTERIOR/REAR FLOOR STOWAGE TRAY - REMOVAL).
- (2) Remove door sill cover (Refer to 23 - BODY/INTERIOR/DOOR SILL TRIM - REMOVAL).
- (3) Remove bolt attaching seat belt anchor to floor.
- (4) Snap turning loop cover up and remove bolt attaching turning loop to B-pillar.
- (5) Remove seat belt exit plug (Fig. 5).
- (6) Disengage clips attaching B-pillar trim to upper B-pillar.
- (7) Separate B-pillar trim from B-pillar.
- (8) Route seat belt webbing through opening in B-pillar trim.

### INSTALLATION

- (1) Route seat belt webbing through opening in B-pillar trim.
- (2) Position B-pillar trim at B-pillar.
- (3) Starting at the top, engage clips attaching B-pillar trim to upper B-pillar.
- (4) Install seat belt exit plug.

- (5) Install bolt attaching turning loop to B-pillar and reposition turning loop cover.
- (6) Install bolt attaching seat belt anchor to floor.
- (7) Install door sill cover (Refer to 23 - BODY/INTERIOR/DOOR SILL TRIM - INSTALLATION).
- (8) Install rear floor stowage tray (Refer to 23 - BODY/INTERIOR/REAR FLOOR STOWAGE TRAY - INSTALLATION).

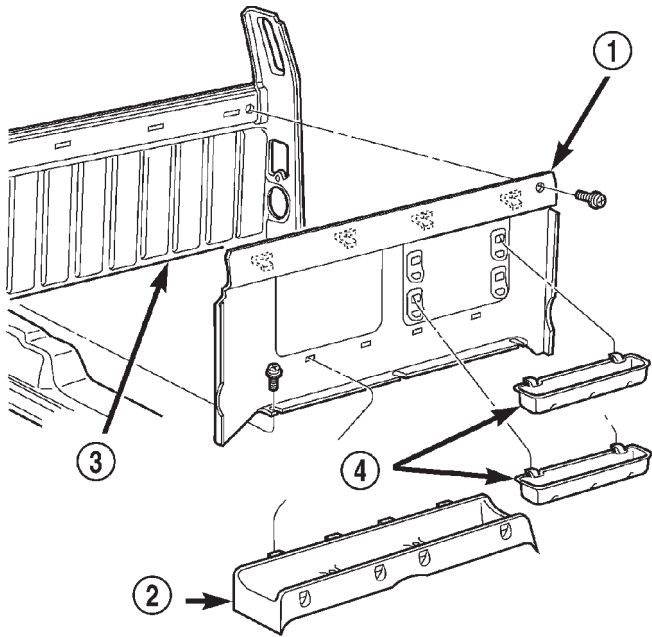
## REAR CLOSURE PANEL TRIM

### REMOVAL

- (1) Remove B-pillar trim panels (Refer to 23 - BODY/INTERIOR/B-PILLAR TRIM - REMOVAL).
- (2) Remove rear floor stowage tray, if equipped. (Refer to 23 - BODY/INTERIOR/REAR FLOOR STOWAGE TRAY - REMOVAL).
- (3) Remove screws attaching bottom of rear closure panel trim to floor pan (Fig. 6).
- (4) Remove screws attaching rear closure panel trim to cab back panel.
- (5) Disengage clips attaching top of rear closure panel trim to cab back panel.
- (6) Separate rear closure panel trim from vehicle.



## REAR CLOSURE PANEL TRIM (Continued)



80b171e5

**Fig. 6 Rear Closure Panel Trim**

- 1 - REAR TRIM PANEL
- 2 - REAR FLOOR STORAGE TRAY
- 3 - CAB BACK PANEL
- 4 - STOWAGE BINS

**INSTALLATION**

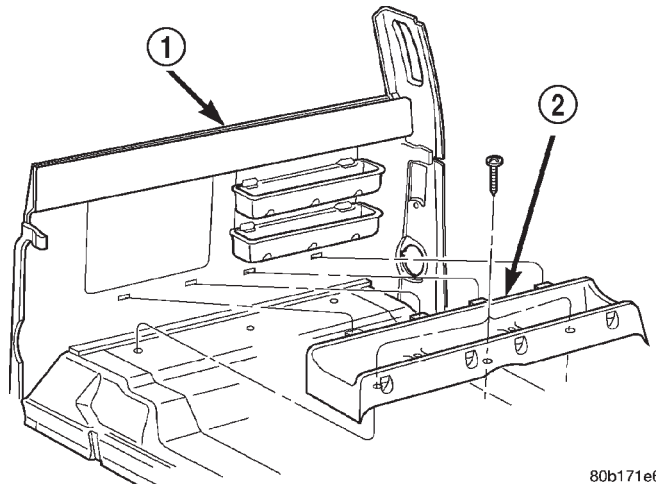
- (1) Position rear closure panel trim in vehicle.
- (2) Align and engage clips attaching top of rear closure panel trim to cab back panel.
- (3) Install screws attaching rear closure panel trim to cab back panel.
- (4) Install screws attaching bottom of rear closure panel trim to floor pan (Fig. 6).
- (5) Install rear floor stowage tray, if equipped. (Refer to 23 - BODY/INTERIOR/REAR FLOOR STOWAGE TRAY - INSTALLATION).
- (6) Install B-pillar trim panels (Refer to 23 - BODY/INTERIOR/B-PILLAR TRIM - INSTALLATION).

**REAR FLOOR STOWAGE TRAY****REMOVAL**

- (1) Move seat tracks to forward position.
- (2) Remove screws attaching rear floor stowage tray to floor (Fig. 7).
- (3) Disengage hooks on stowage tray from slots in rear closure panel trim.
- (4) Separate rear floor stowage tray from vehicle.

**INSTALLATION**

- (1) Position rear floor stowage tray in vehicle.



80b171e6

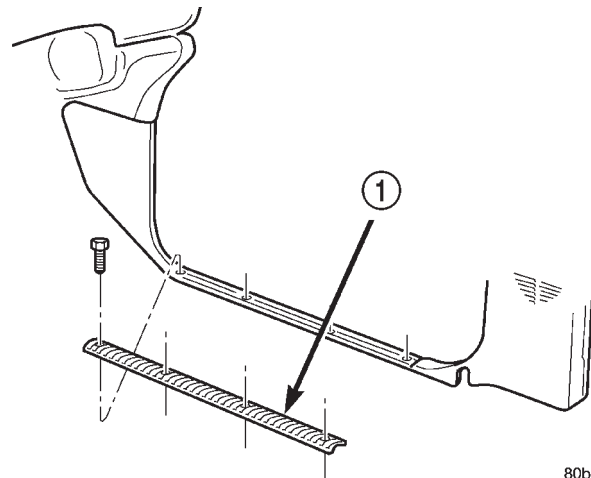
**Fig. 7 Rear Floor Stowage Tray**

- 1 - REAR CLOSURE PANEL TRIM
- 2 - REAR FLOOR STORAGE TRAY

- (2) Engage hooks on stowage tray into slots in rear closure panel trim.
- (3) Install screws attaching rear floor stowage tray to floor.

**DOOR SILL TRIM****REMOVAL**

- (1) Remove screws attaching door sill trim cover to door sill (Fig. 8).
- (2) Separate door sill trim cover from door sill.



80b171e9

**Fig. 8 Door Sill Trim Cover**

- 1 - DOOR SILL TRIM

**INSTALLATION**

- (1) Position door sill trim cover on door sill.
- (2) Install screws attaching door sill trim cover to door sill.

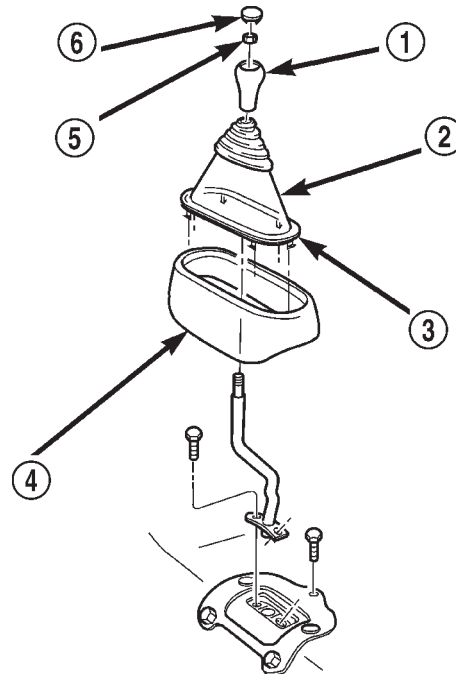
## SHIFT BOOT - MANUAL TRANSMISSION

### REMOVAL

- (1) Using a trim stick, pry the corner of the shift boot up to expose the fasteners.
- (2) Remove the screws attaching the shift boot to the console.
- (3) Remove the insert from the shift knob, remove nut attaching knob to the lever, and remove the shift knob.
- (4) Lift floor shift boot off shifter.

### INSTALLATION

- (1) Install shift boot over the shift lever, position boot on console and install the fasteners attaching boot to console.
- (2) Install the shift knob, shift knob nut, and tighten to 27.1 N·m (20 ft.lbs) torque.
- (3) Install the shift knob insert.



80b897c0

**Fig. 9 4WD Transfer Case Shift Boot—Automatic Transmission**

- 1 - KNOB
- 2 - BOOT
- 3 - RETAINER
- 4 - BASE
- 5 - NUT
- 6 - INSERT

## 4WD FLOOR SHIFT BOOT

### REMOVAL

- (1) Remove insert from shift knob.
- (2) Remove nut attaching shift knob to shift lever.
- (3) Remove shift knob.
- (4) Using a trim stick, disengage retainers attaching boot to shifter base (Fig. 9). Automatic transmission vehicle shown, manual transmission similar.
- (5) Lift floor shift boot off shift lever.

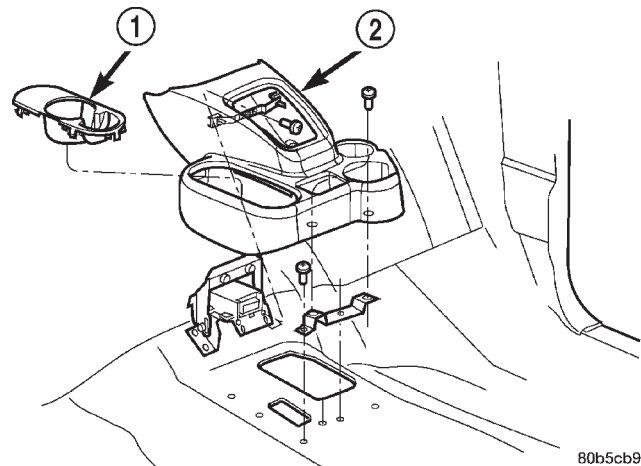
### INSTALLATION

- (1) Place shift boot over shifter.
- (2) Engage retainers attaching boot to shifter base.
- (3) Position shift knob on shift lever.
- (4) Install nut attaching shift knob to shift lever.
- (5) Install insert on shift knob.

## CENTER CONSOLE

### REMOVAL

- (1) Remove the transfer case shift boot, if equipped. (Refer to 23 - BODY/INTERIOR/SHIFT BOOT/TRANSFER CASE - REMOVAL).
- (2) Remove the transmission shifter boot. (Refer to 23 - BODY/INTERIOR/SHIFT BOOT - REMOVAL).
- (3) Remove the screws attaching the console to mounting brackets (Fig. 10).
- (4) Lift the console upward.
- (5) Disengage wire harness connector, if equipped.
- (6) Separate console from vehicle.



80b5cb96

**Fig. 10 Floor Console W/Cup Holder**

- 1 - CUP HOLDER
- 2 - FLOOR CONSOLE

### INSTALLATION

- (1) Position console in vehicle.
- (2) Engage wire harness connector, if equipped.
- (3) Position the console on the floor.

## CENTER CONSOLE (Continued)

(4) Install the screws attaching the console to mounting brackets.

(5) Install the transmission shifter boot, (Refer to 23 - BODY/INTERIOR/SHIFT BOOT - INSTALLATION).

(6) Install the transfer case shifter boot, if equipped. (Refer to 23 - BODY/INTERIOR/SHIFT BOOT - INSTALLATION).

(7) Install cup holder in console, if equipped.

## CARPETS AND FLOOR MATS

### REMOVAL

#### STANDARD CAB

(1) Remove seat (Refer to 23 - BODY/SEATS/SEAT - BENCH SEAT - REMOVAL) or(Refer to 23 - BODY/SEATS/SEAT - SPLIT BENCH - REMOVAL).

(2) Remove door sill covers (Refer to 23 - BODY/INTERIOR/DOOR SILL TRIM - REMOVAL).

(3) Remove cowl trim covers (Refer to 23 - BODY/INTERIOR/COWL TRIM COVER - REMOVAL).

(4) Remove center console, if equipped.(Refer to 23 - BODY/INTERIOR/CENTER CONSOLE - REMOVAL)

(5) If not equipped with a center console remove the transfer case shifter boot (Refer to 23 - BODY/INTERIOR/SHIFT BOOT/TRANSFER CASE - REMOVAL).

(6) Remove rear stowage tray (Refer to 23 - BODY/INTERIOR/REAR FLOOR STOWAGE TRAY - REMOVAL).

(7) Remove rear closure panel trim (Refer to 23 - BODY/INTERIOR/REAR CLOSURE PANEL TRIM - REMOVAL).

(8) Fold carpet or mat toward center of cab.

(9) Remove carpet or mat through door opening (Fig. 11).

#### QUAD/CLUB CABS

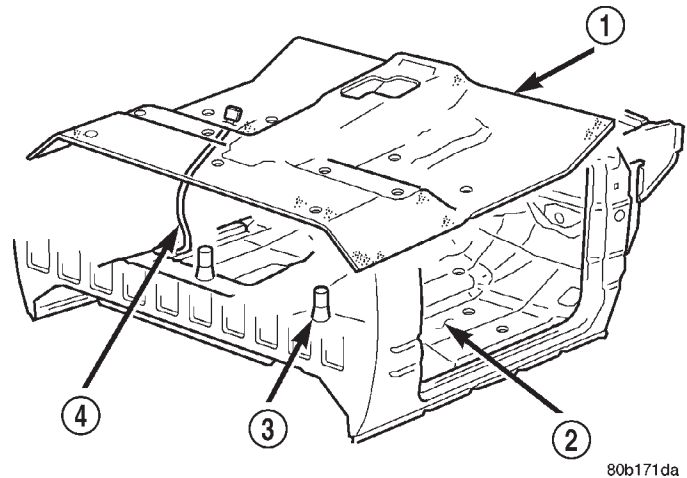
(1) Remove front and rear seats. (Refer to 23 - BODY/SEATS/SEAT - BENCH SEAT - REMOVAL) or(Refer to 23 - BODY/SEATS/SEAT - SPLIT BENCH - REMOVAL) and (Refer to 23 - BODY/SEATS/REAR SEAT - REMOVAL)

(2) Remove door sill covers (Refer to 23 - BODY/INTERIOR/DOOR SILL TRIM - REMOVAL).

(3) Remove center console, if equipped.(Refer to 23 - BODY/INTERIOR/CENTER CONSOLE - REMOVAL)

(4) If not equipped with a center console remove the transfer case shifter boot (Refer to 23 - BODY/INTERIOR/SHIFT BOOT/TRANSFER CASE - REMOVAL).

(5) Remove emergency jack tool kit.



**Fig. 11 Floor Carpet or Mat**

- 1 - CARPET OR MAT
- 2 - FLOOR PAN
- 3 - REAR/INNER SEAT MOUNT
- 4 - POWER SEAT HARNESS

(6) Remove rear seat belt buckles. (Refer to 8 - ELECTRICAL/RESTRAINTS/SEAT BELT BUCKLE - REMOVAL)

(7) Remove rear closure panel trim (Refer to 23 - BODY/INTERIOR/REAR CLOSURE PANEL TRIM - REMOVAL).

(8) Remove C-pillar trim panels. (Refer to 23 - BODY/INTERIOR/C-PILLAR TRIM - REMOVAL)

(9) Remove the quarter trim panels. (Refer to 23 - BODY/INTERIOR/QUARTER TRIM PANEL - REMOVAL)

(10) Fold carpet or mat toward center of cab.

(11) Remove carpet or mat through door opening.

### INSTALLATION

#### STANDARD CAB

(1) Position carpet or mat in vehicle and align all holes (Fig. 11).

(2) Install rear closure panel trim (Refer to 23 - BODY/INTERIOR/REAR CLOSURE PANEL TRIM - INSTALLATION).

(3) Install rear stowage tray (Refer to 23 - BODY/INTERIOR/REAR FLOOR STOWAGE TRAY - INSTALLATION).

(4) Install the transfer case shifter boot if not equipped with a center console. (Refer to 23 - BODY/INTERIOR/SHIFT BOOT/TRANSFER CASE - INSTALLATION)

(5) Install the center console, if equipped. (Refer to 23 - BODY/INTERIOR/CENTER CONSOLE - INSTALLATION)

(6) Install cowl trim covers (Refer to 23 - BODY/INTERIOR/COWL TRIM COVER - INSTALLATION).

## CARPETS AND FLOOR MATS (Continued)

(7) Install door sill covers (Refer to 23 - BODY/INTERIOR/DOOR SILL TRIM - INSTALLATION).

(8) Install seat, (Refer to 23 - BODY/SEATS/SEAT - INSTALLATION) or (Refer to 23 - BODY/SEATS/SEAT/SPLIT BENCH - INSTALLATION).

## QUAD/CLUB CABS

(1) Position carpet or mat in vehicle.

(2) Install quarter trim panels. (Refer to 23 - BODY/INTERIOR/QUARTER TRIM PANEL - INSTALLATION)

(3) Install rear seat belt buckles.

(4) Install the C-pillar trim panels, if equipped. (Refer to 23 - BODY/INTERIOR/C-PILLAR TRIM - INSTALLATION)

(5) Install rear closure panel trim (Refer to 23 - BODY/INTERIOR/REAR CLOSURE PANEL TRIM - INSTALLATION).

(6) Install the rear seat belt buckles. (Refer to 8 - ELECTRICAL/RESTRAINTS/SEAT BELT BUCKLE - INSTALLATION)

(7) Install emergency jack tool kit.

(8) Install the transfer case shifter boot if not equipped with a center console. (Refer to 23 - BODY/INTERIOR/SHIFT BOOT/TRANSFER CASE - INSTALLATION)

(9) Install the center console, if equipped. (Refer to 23 - BODY/INTERIOR/CENTER CONSOLE - INSTALLATION)

(10) Install floor shift boot, if equipped.

(11) Install cowl trim covers (Refer to 23 - BODY/INTERIOR/COWL TRIM COVER - INSTALLATION).

(12) Install door sill covers (Refer to 23 - BODY/INTERIOR/DOOR SILL TRIM - INSTALLATION).

(13) Install front and rear seats. (Refer to 23 - BODY/SEATS/SEAT - BENCH SEAT - INSTALLATION) or (Refer to 23 - BODY/SEATS/SEAT - SPLIT BENCH - INSTALLATION) and (Refer to 23 - BODY/SEATS/REAR SEAT - INSTALLATION)

## ASSIST HANDLE

## REMOVAL

(1) Disengage tabs attaching assist handle end covers to assist handle.

(2) Remove screws attaching overhead assist handle to roof rail (Fig. 12).

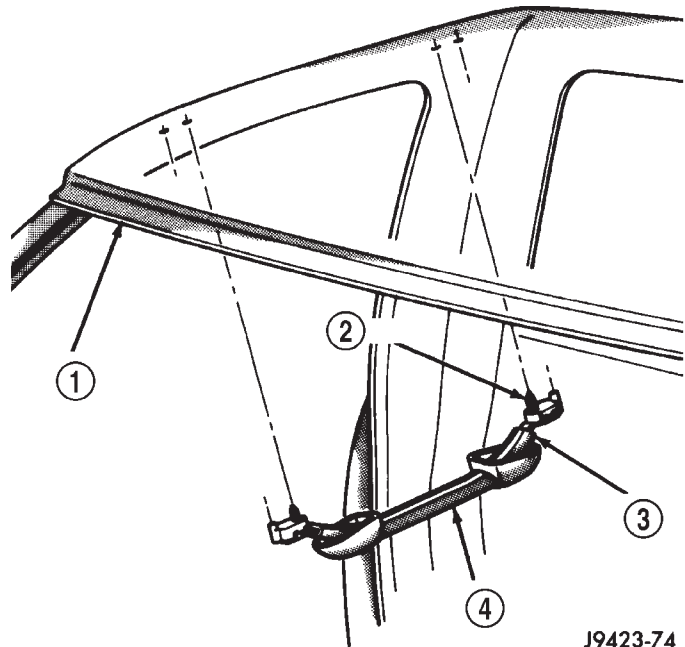
(3) Separate overhead assist handle from vehicle.

## INSTALLATION

(1) Position assist handle on vehicle.

(2) Install screws attaching overhead assist handle to roof rail (Fig. 12).

(3) Install tabs attaching assist handle end covers to assist handle.



J9423-74

**Fig. 12 Overhead Assist Handle**

- 1 - CAB ASSEMBLY
- 2 - SCREW
- 3 - ASSIST HANDLE
- 4 - TRIM COVER

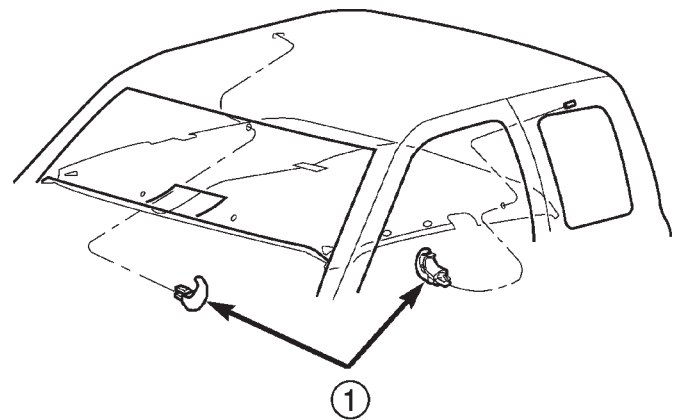
## COAT HOOK

## REMOVAL

(1) Insert a small flat blade into the tip of the hook.

(2) Carefully pry outward to separate the coat hook from coat hook base.

(3) Pull coat hook out of roof panel (Fig. 13). Extended cab shown, standard cab similar.



80ae848d

**Fig. 13 Coat Hook—Club/Quad Cab**

- 1 - COAT HOOK

## COAT HOOK (Continued)

## INSTALLATION

- (1) Position coat hook in roof panel.
- (2) Push the coat hook cover inward and secure the coat hook to roof panel.

## HEADLINER

## REMOVAL

- (1) Remove sun visors and visor hooks. (Refer to 23 - BODY/INTERIOR/SUN VISOR - REMOVAL).
- (2) Remove overhead assist handle. (Refer to 23 - BODY/INTERIOR/ASSIST HANDLE - REMOVAL).
- (3) Remove coat hook(s). (Refer to 23 - BODY/INTERIOR/COAT HOOK - REMOVAL)
- (4) Remove overhead console, if equipped. (Refer to 8 - ELECTRICAL/OVERHEAD CONSOLE - REMOVAL).
- (5) Remove A-pillar trim. (Refer to 23 - BODY/INTERIOR/A-PILLAR TRIM - REMOVAL).
- (6) Remove B-pillar trim panels. (Refer to 23 - BODY/INTERIOR/B-PILLAR TRIM - REMOVAL).
- (7) Remove the C-pillar trim panels, if equipped. (Refer to 23 - BODY/INTERIOR/C-PILLAR TRIM - REMOVAL)
- (8) Remove the quarter trim panels, if equipped. (Refer to 23 - BODY/INTERIOR/QUARTER TRIM PANEL - REMOVAL)
- (9) Remove dome lamp. (Refer to 8 - ELECTRICAL/LAMPS/LIGHTING - INTERIOR/DOME LAMP - REMOVAL).
- (10) If equipped, disengage push-in fasteners attaching headliner to roof panel (Fig. 15). Extended cab shown, standard cab similar.
- (11) Separate headliner from roof panel (Fig. 14).
- (12) Extract headliner through door opening.

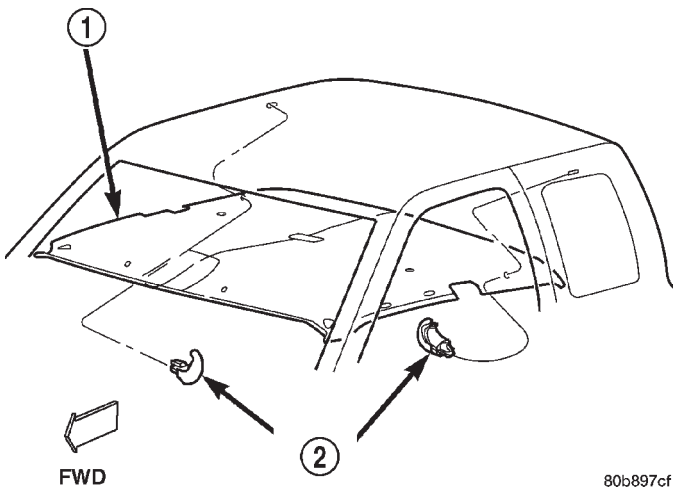


Fig. 14 Headliner

- 1 - HEADLINER
- 2 - COAT HOOK

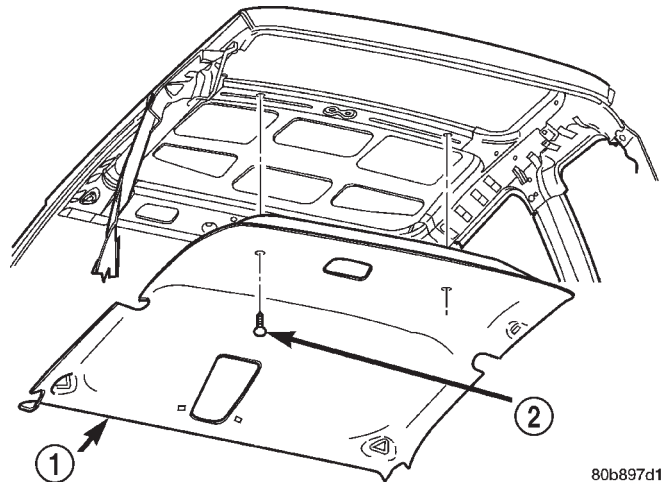


Fig. 15 Headliner Push-In Fasteners

- 1 - HEADLINER
- 2 - PUSH-IN FASTENER

## INSTALLATION

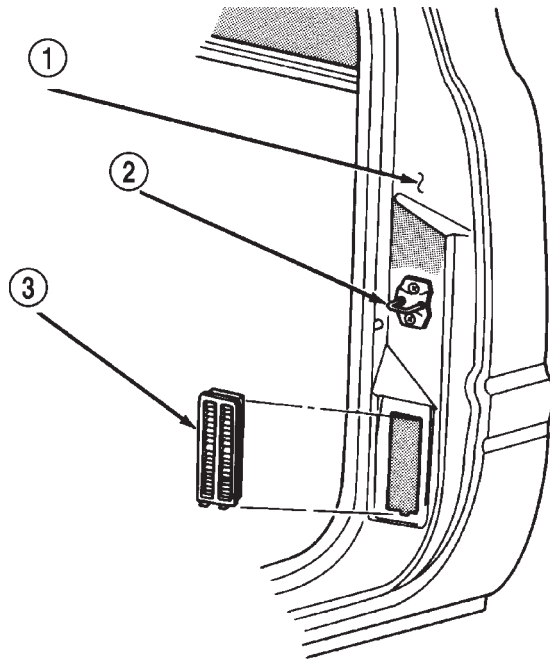
- (1) Position headliner on roof panel (Fig. 14). Extended cab shown, standard cab similar.
- (2) Install passenger side sun visor hook. (Refer to 23 - BODY/INTERIOR/SUN VISOR - INSTALLATION).
- (3) Install driver's side coat hook. (Refer to 23 - BODY/INTERIOR/COAT HOOK - INSTALLATION).
- (4) Install driver side sun visor hook.
- (5) Install dome lamp. (Refer to 8 - ELECTRICAL/LAMPS/LIGHTING - INTERIOR/DOME LAMP - INSTALLATION).
- (6) Install the C-pillar trim panels, if equipped. (Refer to 23 - BODY/INTERIOR/C-PILLAR TRIM - INSTALLATION)
- (7) Install the quarter trim panels, if equipped. (Refer to 23 - BODY/INTERIOR/QUARTER TRIM PANEL - INSTALLATION)
- (8) Install B-pillar trim panels. (Refer to 23 - BODY/INTERIOR/B-PILLAR TRIM - INSTALLATION).
- (9) Install A-pillar trim. (Refer to 23 - BODY/INTERIOR/A-PILLAR TRIM - INSTALLATION).
- (10) Install overhead console, if equipped. (Refer to 8 - ELECTRICAL/OVERHEAD CONSOLE - INSTALLATION).
- (11) Install overhead assist handle. (Refer to 23 - BODY/INTERIOR/ASSIST HANDLE - INSTALLATION).
- (12) Install sun visors.



## BODY VENT

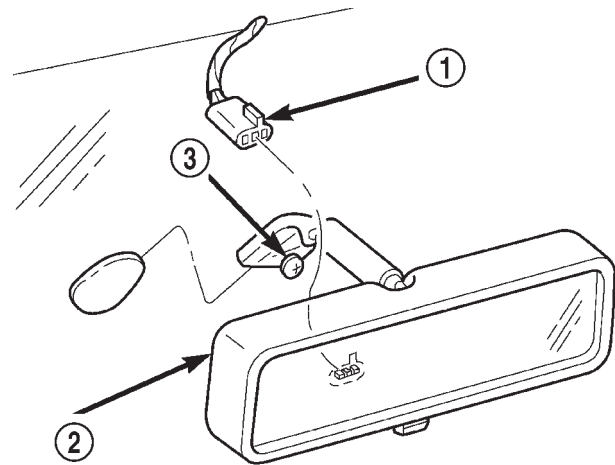
### REMOVAL

- (1) Open door.
- (2) Pull outward at top of vent to disengage clips attaching vent to door jamb (Fig. 16).
- (3) Separate vent from door jamb.



**Fig. 16 Body Vent**

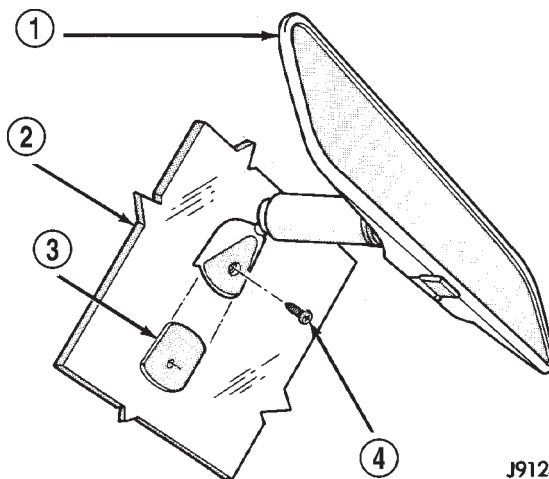
- 1 - B-PILLAR  
2 - DOOR STRIKER  
3 - BODY VENT



80b5cbcf

**Fig. 17 Rearview Mirror Connector**

- 1 - CONNECTOR  
2 - MIRROR  
3 - SCREW



J9123-463

**Fig. 18 Rearview Mirror**

- 1 - REARVIEW MIRROR  
2 - WINDSHIELD GLASS  
3 - SUPPORT BRACKET  
4 - SCREW

### INSTALLATION

- (1) Position vent from in jamb.
- (2) Press vent inward to engage clips.

## REAR VIEW MIRROR

### REMOVAL

- (1) If equipped, disconnect mirror harness wire connector (Fig. 17).
- (2) Loosen the mirror base setscrew (Fig. 18).
- (3) Slide the mirror base upward and off the bracket.

### INSTALLATION

- (1) Position the mirror base at the bracket and slide it downward onto the support bracket.
- (2) Tighten the setscrew 1 N·m (15 in. lbs.) torque.
- (3) If equipped, connect mirror harness wire connector.

### INSTALLATION - REARVIEW MIRROR SUPPORT BRACKET

- (1) Mark the position for the mirror bracket on the outside of the windshield glass with a wax pencil.
- (2) Clean the bracket contact area on the glass. Use a mild powdered cleanser on a cloth saturated with isopropyl (rubbing) alcohol. Finally, clean the glass with a paper towel dampened with alcohol.
- (3) Sand the surface on the support bracket with fine grit-sandpaper. Wipe the bracket surface clean with a paper towel.

## REAR VIEW MIRROR (Continued)

(4) Apply accelerator to the surface on the bracket according to the following instructions:

- (a) Crush the vial to saturate the felt applicator.
- (b) Remove the paper sleeve.
- (c) Apply accelerator to the contact surface on the bracket.
- (d) Allow the accelerator to dry for five minutes.
- (e) Do not touch the bracket contact surface after the accelerator has been applied.

(5) Apply adhesive accelerator to the bracket contact surface on the windshield glass. Allow the accelerator to dry for one minute. Do not touch the glass contact surface after the accelerator has been applied.

(6) Install the bracket according to the following instructions:

- (a) Apply one drop of adhesive at the center of the bracket contact-surface on the windshield glass.
- (b) Apply an even coat of adhesive to the contact surface on the bracket.
- (c) Align the bracket with the marked position on the windshield glass.
- (d) Press and hold the bracket in place for at least one minute.

**NOTE: Verify that the mirror support bracket is correctly aligned, because the adhesive will cure rapidly.**

(7) Allow the adhesive to cure for 8-10 minutes. Remove any excess adhesive with an alcohol-dampened cloth.

(8) Allow the adhesive to cure for an additional 8-10 minutes before installing the mirror.

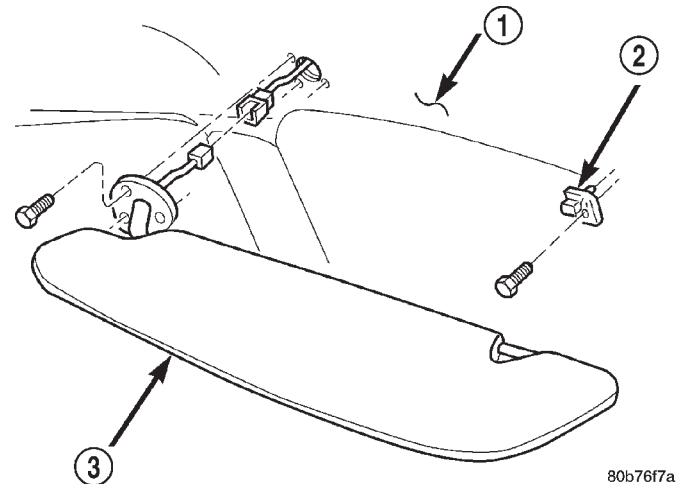
## SUN VISOR

## REMOVAL

- (1) Remove screws attaching sunvisor to roof (Fig. 19).
- (2) If equipped, disengage lighted vanity mirror connector.
- (3) Separate sunvisor from roof.
- (4) Remove screw attaching sun visor hook to roof.
- (5) Separate sunvisor hook from roof.

## INSTALLATION

- (1) Position sunvisor hook on roof.
- (2) Install screw attaching sunvisor hook to roof.
- (3) Position sunvisor on roof.
- (4) If equipped, engage lighted vanity mirror connector.
- (5) Install screws attaching sunvisor to roof (Fig. 19).



80b76f7a

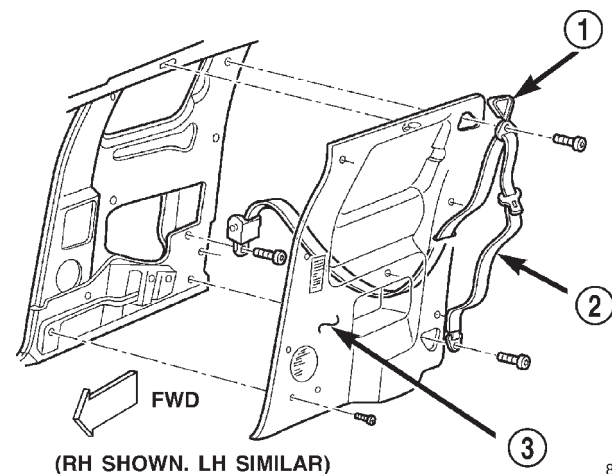
Fig. 19 Sunvisor

- 1 - BODY
- 2 - CLIP
- 3 - SUNVISOR

## QUARTER TRIM PANEL

## REMOVAL

- (1) Remove rear seat. (Refer to 23 - BODY/SEATS/ REAR SEAT - REMOVAL)
- (2) Remove door sill cover as necessary to clear quarter trim.
- (3) Remove lower seat belt anchor bolt (Fig. 20).
- (4) Remove seat belt tuning loop anchor bolt.
- (5) Disengage clips attaching quarter trim panel from quarter panel.
- (6) Route seat belt webbing through opening in quarter trim panel and remove panel from vehicle.



80c070e3

Fig. 20 Quarter Trim Panel — Club Cab

- 1 - TURNING LOOP COVER
- 2 - BELT ASSEMBLY
- 3 - TRIM PANEL

## QUARTER TRIM PANEL (Continued)

**INSTALLATION**

- (1) Position trim panel in vehicle and route seat belt webbing through opening in quarter trim panel.
- (2) Open quarter vent window.
- (3) Position trim panel on quarter panel and engage clips on upper portion of panel.
- (4) Engage clips attaching lower portion of quarter trim panel to quarter panel.
- (5) Install lower seat belt anchor bolt.
- (6) Install door sill cover as necessary.
- (7) Install rear seat. (Refer to 23 - BODY/SEATS/REAR SEAT - INSTALLATION)

**C-PILLAR TRIM****REMOVAL**

- (1) Remove rear floor stowage tray. (Refer to 23 - BODY/INTERIOR/REAR FLOOR STOWAGE TRAY - REMOVAL)
- (2) Remove door sill cover as necessary to clear C-pillar trim.
- (3) Remove bolt attaching seat belt anchor to floor.
- (4) Unsnap turning loop, push cover up and remove bolt attaching turning loop to C-pillar.

- (5) Remove seat belt exit plug.
- (6) Disengage clips attaching C-pillar trim to upper C-pillar.
- (7) Separate C-pillar trim from C-pillar.
- (8) Route seat belt webbing through opening in C-pillar trim.

**INSTALLATION**

- (1) Route seat belt webbing through opening in C-pillar trim.
- (2) Position C-pillar trim at C-pillar.
- (3) Starting at the top, engage clips attaching C-pillar trim to upper C-pillar.
- (4) Install seat belt exit plug.
- (5) Install bolt attaching turning loop to C-pillar and position turning loop cover. Snap turning loop cover into place.
- (6) Install bolt attaching seat belt anchor to floor.
- (7) Install door sill cover.
- (8) Install rear floor stowage tray. (Refer to 23 - BODY/INTERIOR/REAR FLOOR STOWAGE TRAY - INSTALLATION)

# PAINT

## TABLE OF CONTENTS

	page		page
<b>PAINT</b>		<b>PAINT TOUCH-UP</b>	
SPECIFICATIONS.....	129	DESCRIPTION.....	129
<b>BASE COAT/CLEAR COAT FINISH</b>		<b>WET SANDING/BUFFING &amp; POLISHING</b>	
DESCRIPTION.....	129	DESCRIPTION.....	130
OPERATION.....	129		
<b>PAINT CODE</b>			
DESCRIPTION.....	129		

## PAINT

### SPECIFICATIONS

#### 2001 BR PAINT COLOR CODES

##### EXTERIOR COLORS

DC CODE	EXTERIOR COLOR	DC CODE	EXTERIOR COLOR
DX8	Black Clear Coat	GW7	Bright White Clear Coat
PR4	Flame Red Clear Coat	VB3	Intense Blue Pearl Coat
WBT/ WB7	Patriot Blue Pearl Coat	SG8	Forest Green Pearl Coat
XV3/XVL	Amber Fire Pearl Coat	WSB/ WS2	Bright Silver Metallic Clear Coat
XTL	Sierra Bronze	XRV	Dark Garnet Red

##### INTERIOR COLORS

DC CODE	INTERIOR COLOR	DC CODE	INTERIOR COLOR
A	Agate	M	Mist Gray
C	Camel		

### BASE COAT/CLEAR COAT FINISH

#### DESCRIPTION

The original equipment finish is a multi-step process that involves cleaning, electrodeposition (e-coat), base coat, and clear coat steps. Additionally, selected

areas of the vehicle may be coated with an anti-chip finish.

#### OPERATION

On most vehicles a two-part paint application (base coat/clear coat) is used. Color paint that is applied to primer is called base coat. The clear coat protects the base coat from ultraviolet light and provides a durable high-gloss finish.

**CAUTION: Do not use abrasive chemicals or compounds on painted surfaces. Damage to finish can result.**

**Do not use harsh alkaline based cleaning solvents on painted surfaces. Damage to finish or color can result.**

### PAINT CODE

#### DESCRIPTION

Exterior vehicle body colors are identified on the Body Code plate. The plate is located on the floor pan under the passenger seat or attached to the front face of the radiator closure panel. Refer to the Introduction section at the front of this manual for body code plate description. The paint code is also identified on the Vehicle Safety Certification Label which is located on the drivers door shut face. The color names provided in the Paint and Trim Code Description chart are the color names used on most repair product containers.

### PAINT TOUCH-UP

#### DESCRIPTION

When a painted metal surface has been scratched or chipped, it should be touched-up as soon as possible to avoid corrosion. For best results, use Mopar®

## PAINT TOUCH-UP (Continued)

Scratch Filler/Primer, Touch-Up Paints and Clear Top Coat. Refer to Introduction group of this manual for Body Code Plate information.

**WARNING: USE A OSHA APPROVED BREATHING FILTER WHEN SPRAYING PAINT OR SOLVENTS IN A CONFINED AREA. PERSONAL INJURY CAN RESULT.**

**OPERATION**

(1) Scrape loose paint and corrosion from inside scratch or chip.

(2) Clean affected area with Mopar® Tar/Road Oil Remover, and allow to dry.

(3) Fill the inside of the scratch or chip with a coat of filler/primer. Do not overlap primer onto good surface finish. The applicator brush should be wet enough to puddle-fill the defect without running. Do not stroke brush applicator on body surface. Allow the filler/primer to dry hard.

(4) Cover the filler/primer with color touch-up paint. Do not overlap touch-up color onto the original color coat around the scratch or chip. Butt the new color to the original color, if possible. Do not stroke applicator brush on body surface. Allow touch-up paint to dry hard.

(5) On vehicles without clear coat, the touch-up color can be lightly finesse sanded (1500 grit) and polished with rubbing compound.

(6) On vehicles with clear coat, apply clear top coat to touch-up paint with the same technique as described in Step 4. Allow clear top coat to dry hard. If desired, Step 5 can be performed on clear top coat.

**WARNING: AVOID PROLONGED SKIN CONTACT WITH PETROLEUM OR ALCOHOL – BASED CLEANING SOLVENTS. PERSONAL INJURY CAN RESULT. AVOID PROLONGED SKIN CONTACT WITH PETROLEUM OR ALCOHOL – BASED CLEANING SOLVENTS. PERSONAL INJURY CAN RESULT.**

**WET SANDING/BUFFING & POLISHING****DESCRIPTION**

Minor acid etching, orange peel, or smudging in clear coat or single-stage finishes can be reduced with light finesse sanding, hand buffing, and polishing. **If the finish has been finesse sanded in the past, it cannot be repeated. Finesse sanding operation should be performed by a trained automotive paint technician.**

**CAUTION: Do not remove clear coat finish, if equipped. Base coat paint must retain clear coat for durability.**



# SEATS

## TABLE OF CONTENTS

	page		page
<b>SEATS</b>		<b>SEAT BACK RECLINER</b>	
DESCRIPTION . . . . .	131	REMOVAL . . . . .	138
OPERATION . . . . .	131	INSTALLATION . . . . .	138
<b>CENTER CONSOLE LID</b>		<b>SEAT CUSHION</b>	
REMOVAL . . . . .	131	REMOVAL . . . . .	138
INSTALLATION . . . . .	132	INSTALLATION . . . . .	138
<b>CENTER SEAT ARMREST/CONSOLE</b>		<b>SEAT CUSHION COVER</b>	
REMOVAL . . . . .	132	REMOVAL . . . . .	139
INSTALLATION . . . . .	132	INSTALLATION . . . . .	139
<b>CENTER SEAT ARMREST/LATCH COVER</b>		<b>SEAT CUSHION COVER - SPLIT BENCH</b>	
REMOVAL . . . . .	132	REMOVAL . . . . .	139
INSTALLATION . . . . .	132	INSTALLATION . . . . .	140
<b>LUMBAR SUPPORT</b>		<b>SEAT RISER</b>	
REMOVAL . . . . .	133	REMOVAL . . . . .	141
INSTALLATION . . . . .	133	INSTALLATION . . . . .	141
<b>SEAT - BENCH SEAT</b>		<b>SEAT TRACK</b>	
REMOVAL . . . . .	133	REMOVAL . . . . .	141
INSTALLATION . . . . .	133	INSTALLATION . . . . .	141
<b>SEAT - SPLIT BENCH</b>		<b>SEAT TRACK - SPLIT BENCH</b>	
REMOVAL . . . . .	134	REMOVAL . . . . .	142
INSTALLATION . . . . .	134	INSTALLATION . . . . .	142
<b>SEAT BACK - BENCH SEAT</b>		<b>EASY ENTRY SEAT TRACK</b>	
REMOVAL . . . . .	135	REMOVAL . . . . .	142
INSTALLATION . . . . .	135	INSTALLATION . . . . .	142
<b>SEAT BACK - SPLIT BENCH</b>		<b>SEAT TRACK ADJUSTER</b>	
REMOVAL . . . . .	135	REMOVAL . . . . .	143
INSTALLATION . . . . .	136	INSTALLATION . . . . .	143
<b>SEAT BACK COVER</b>		<b>STANCHION COVER</b>	
REMOVAL . . . . .	137	REMOVAL . . . . .	143
INSTALLATION . . . . .	137	INSTALLATION . . . . .	143
<b>SEAT BACK COVER - SPLIT BENCH</b>		<b>REAR SEAT</b>	
REMOVAL . . . . .	137	REMOVAL . . . . .	144
INSTALLATION . . . . .	138	INSTALLATION . . . . .	144

## SEATS

### DESCRIPTION

Seat modules are made up of a seat frame, seat cushion, seat back cushion, a covering material, and the electrical components used for power operation, if equipped. Some seat systems also contain seat belt components and supplemental restraint systems.

### OPERATION

Seat assemblies transport the occupants in comfort and safety. Seat assemblies also help position occupants correctly in the event of airbag deployment. Seat cushions, coverings, and electrical components are serviceable. Refer to the appropriate group in this manual.

## CENTER CONSOLE LID

### REMOVAL

- (1) Open console lid.
- (2) Using a small flat blade screwdriver, disengage locking tabs located under the console lid trim bezel.
- (3) Separate bezel from lid.
- (4) Move driver and passenger seat to full forward position.
- (5) Using a small drift and hammer, tap out console lid hinge pin.
- (6) Separate lid from console.

## CENTER CONSOLE LID (Continued)

**INSTALLATION**

- (1) Align console lid with console. Verify lid tension spring is in position.
- (2) Install hinge pin.
- (3) Position trim bezel on lid and snap into place.

**CENTER SEAT ARMREST/  
CONSOLE****REMOVAL**

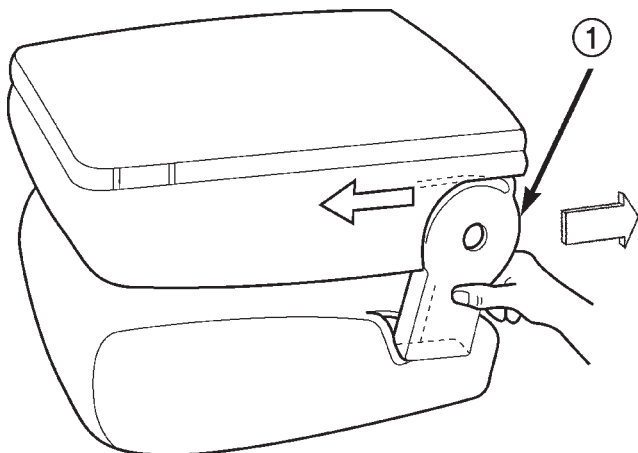
- (1) Remove bolts on driver and passenger seat inboard seat tracks.
- (2) Separate center section.

**INSTALLATION**

- (1) Position and align center section on driver and passenger seat inboard seat tracks.
- (2) Install bolts. Tighten to 19.5 N·m (14 ft. lbs.) torque.

**CENTER SEAT ARMREST/  
LATCH COVER****REMOVAL**

- (1) With the seat back fully forward, move the driver's seat to a full forward position.
- (2) Place the center arm rest in a full up position.
- (3) Remove the fastener securing the cover to the inertia latch.
- (4) Disengage the front edge of the cover, then lower the arm rest.
- (5) Remove the inertia latch cover by pulling the cover rearwards (Fig. 1).



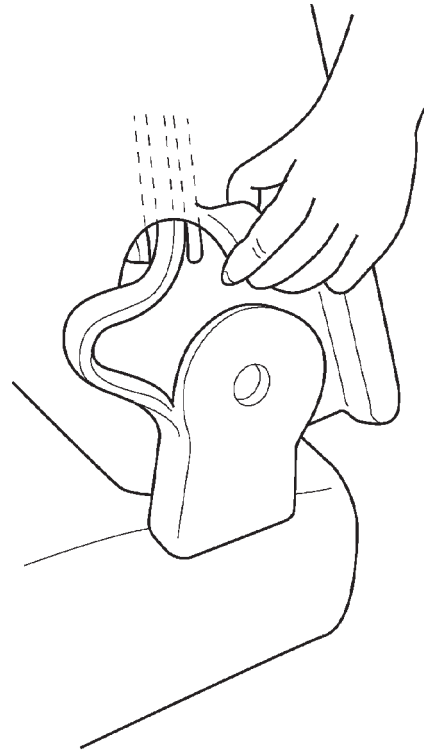
80b76fab

**Fig. 1 Armrest Inertia Latch Cover**

1 - INERTIA LATCH COVER

**INSTALLATION**

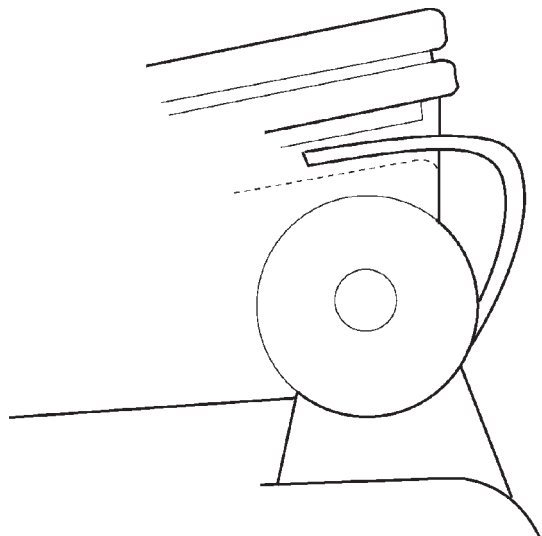
- (1) Slide the inertia latch cover onto the latch arm.
- (2) Raise the armrest, then engage the front edge of the cover.
- (3) Install the lower strap into the center armrest's lower track (Fig. 2).
- (4) Slide back the armrest trim to visually ensure the lower strap is properly installed.
- (5) Slowly cycle the armrest to ensure the strap moves freely in the track.
- (6) Install the upper strap into the center armrest's upper track (Fig. 3).
- (7) Slowly cycle the armrest to ensure the strap moves freely in the track.
- (8) Secure the armrest inertia latch cover and tighten the fastener to 4N·m (35 in. lbs.).



80b76fad

**Fig. 2 Inertia Latch Cover Lower Strap Installation**

## CENTER SEAT ARMREST/LATCH COVER (Continued)



80b76fae

**Fig. 3 Inertia Latch Cover Upper Strap**

## LUMBAR SUPPORT

## REMOVAL

- (1) Remove the seat back cover. (Refer to 23 - BODY/SEATS/SEAT BACK COVER - REMOVAL).
- (2) Disengage the heated seat connectors.
- (3) Partially separate the seat back foam to access the lumbar frame clips.
- (4) Separate the lumbar assembly from the seat frame.

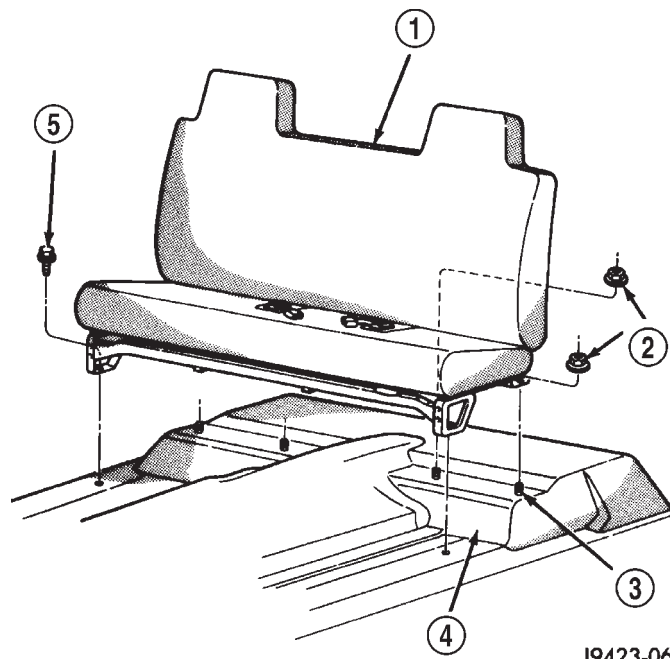
## INSTALLATION

- (1) Position the lumbar assembly on the seat back frame.
- (2) Engage the retaining clips on the seat frame.
- (3) Route the lumbar wire harness through seat assembly.
- (4) Engage the heated seat wire connectors.
- (5) Install the seat back cover. (Refer to 23 - BODY/SEATS/SEAT BACK COVER - INSTALLATION).
- (6) Perform a function check on the seat operations.

## SEAT - BENCH SEAT

## REMOVAL

- (1) Move seat track to forward position.
- (2) Hinge seat backs forward.
- (3) Remove nuts attaching rear of seat tracks to floor (Fig. 4).
- (4) Move seat track to rearward position.
- (5) Remove bolts attaching front of seat tracks to floor.
- (6) Separate seat from vehicle.



J9423-06

**Fig. 4 Bench Seat**

- 1 - BENCH SEAT
- 2 - NUT
- 3 - STUD
- 4 - FLOOR PAN
- 5 - SCREW

## INSTALLATION

**NOTE:** Seat adjustment latch must be engaged and in equal positions prior to seat installation. Verify inboard and outboard seat latch operation.

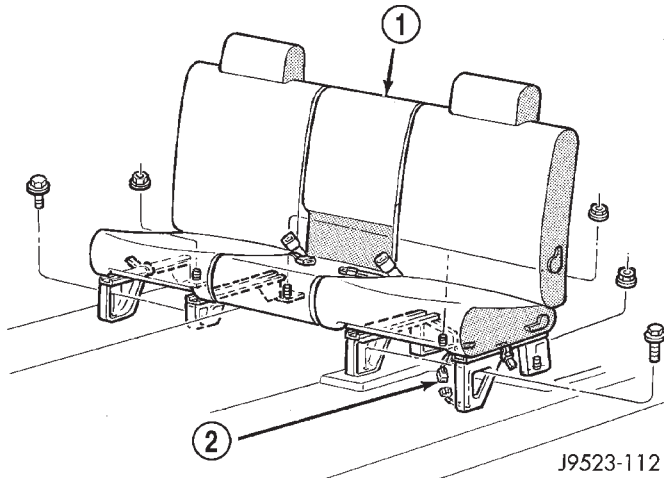
- (1) Position seat in vehicle.
- (2) Install bolts attaching front of seat tracks to floor. Tighten bolts to 54 N·m (40 ft. lbs.) torque.
- (3) Move seat track to forward position.
- (4) Hinge seat backs forward.
- (5) Install nuts attaching rear of seat tracks to floor. Tighten inboard nuts to 40 N·m (30 ft. lbs.) torque. Tighten outboard nuts to 54 N·m (40 ft. lbs.) torque.

## SEAT - SPLIT BENCH

### REMOVAL

#### STANDARD CAB

- (1) Move seat track to forward position.
- (2) Hinge seat back forward.
- (3) Remove nuts holding outboard and inboard tracks to floor (Fig. 5).
- (4) Move seat track to forward position.
- (5) Remove bolt holding inboard seat track to bottom of center occupant seat.
- (6) Remove bolts holding front of seat tracks to floor.
- (7) Disengage power seat wire connector from body harness, if equipped (Fig. 5).
- (8) Lift center occupant seat upward to clear rear attachment stud.
- (9) Separate seat from vehicle.



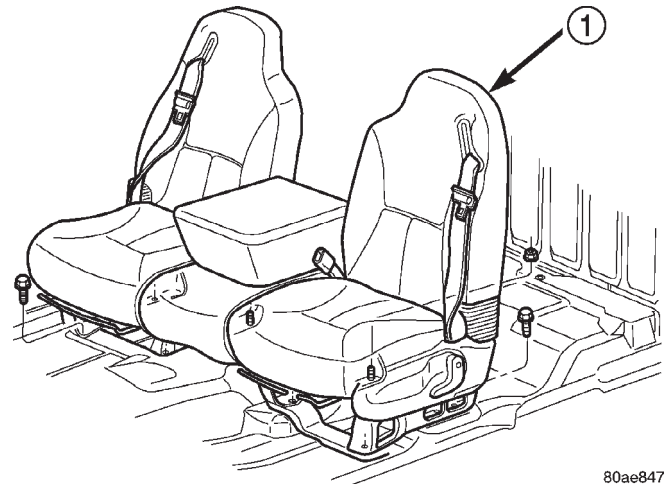
**Fig. 5 Split Bench Seat**

1 - SEAT

2 - POWER SEAT HARNESS CONNECTOR

#### QUAD CAB

- (1) Clamp seat belt to prevent belt from retracting.
- (2) Move seats to full rearward position.
- (3) Remove bolts attaching front of seat tracks to floor.
- (4) Move seats to full forward position.
- (5) Remove bolts attaching rear of outboard seat tracks to floor (Fig. 6).
- (6) Remove nuts attaching inboard seat tracks to floor.
- (7) Disengage wire connectors from body harness.
- (8) Lift seats upward to clear rear studs.
- (9) With the aid of a helper, separate seat from vehicle.



80ae8474

**Fig. 6 Split Bench Seat—Club/Quad Cab**

1 - SEAT

### INSTALLATION

#### STANDARD CAB

- (1) Position seat in vehicle.
- (2) Connect power seat wire connector to body harness, if equipped.
- (3) Install bolts holding front of seat tracks to floor. Tighten the bolts to 40 N·m (30 ft. lbs.) torque.
- (4) Install bolt holding inboard seat track to bottom of center occupant seat. Tighten the bolt to 28 N·m (25 in- lbs) torque.
- (5) Install nuts holding outboard and inboard tracks to floor. Tighten the inboard nuts to 40 N·m (30 ft. lbs.) torque. Tighten the outer nuts to 54 N·m (40 ft. lbs. torque).

#### QUAD CAB

- (1) Position seat in vehicle.

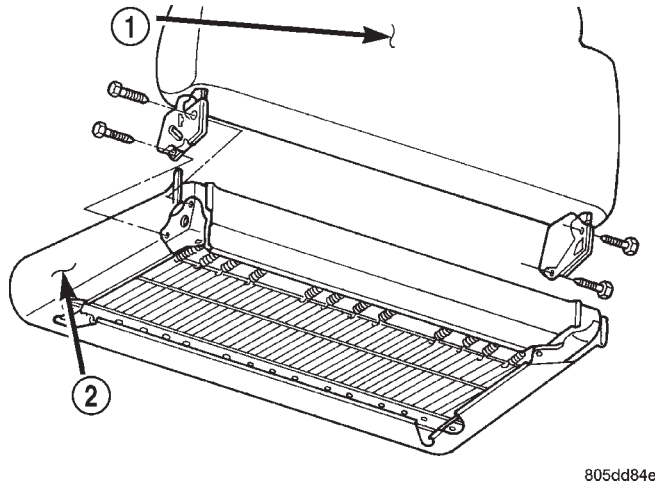
**CAUTION:** Verify that power is not being supplied when engaging connector.

- (2) Engage driver's seat belt buckle wire connector. Engage power seat wire connector to body harness, if equipped.
- (3) Ensure seats are in full forward position.
- (4) Install outboard bolts attaching rear of seat tracks to floor (Fig. 6). Tighten the bolts to 54 N·m (40 ft. lbs.) torque.
- (5) Install nuts attaching inboard seat tracks to floor. Tighten the nuts to 40 N·m (30 ft. lbs.) torque.
- (6) Move seats to full forward position.
- (7) Install bolts attaching front of seat tracks to floor. Tighten the bolts to 54 N·m (40 ft. lbs.) torque.

## SEAT BACK - BENCH SEAT

### REMOVAL

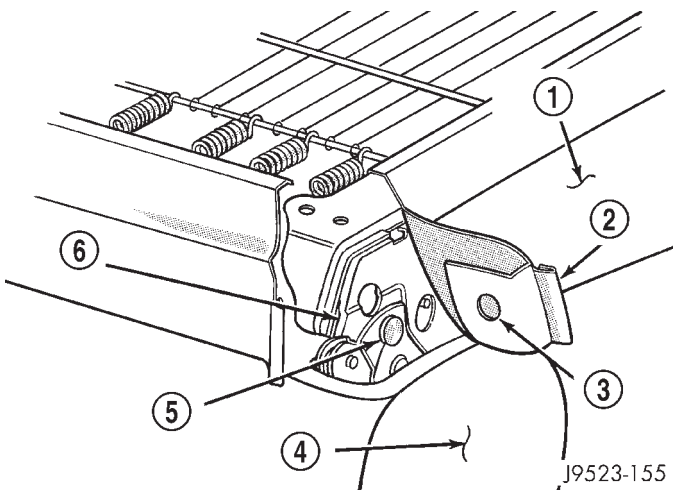
- (1) Move seat to the full forward position.
- (2) Release J-Strap and peel back side of cover (corner flap) (Fig. 8).
- (3) Remove bolts attaching seat back to seat cushion and separate seat back from seat cushion (Fig. 7).



805dd84e

**Fig. 7 Seat Back Removal/Installation**

- 1 - SEAT BACK  
2 - SEAT CUSHION



J9523-155

**Fig. 8 J-Strap Corner Removal/Installation**

- 1 - SEAT CUSHION  
2 - J—STRAP  
3 - PLASTIC COVER  
4 - SEAT BACK  
5 - PIN  
6 - LATCH

### INSTALLATION

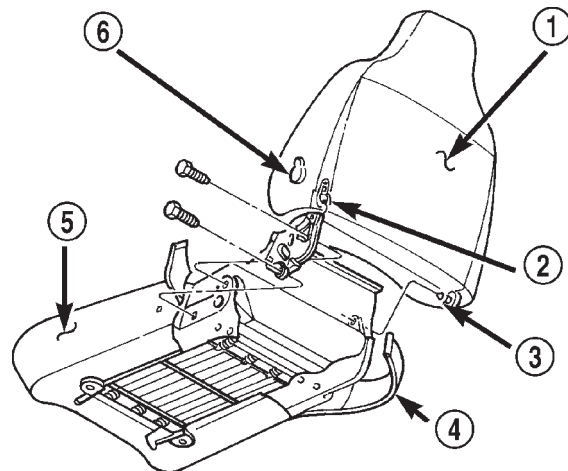
- (1) Align seat cushion with seat back.
- (2) Install bolts through seat back latch into seat cushion frame. Tighten bolts to 25 N-m (18 ft.lbs.) torque.
- (3) Pull side of cover (corner flap) facing rear of the cushion over and secure J-Strap (Fig. 8).
- (4) Plastic cover on side cover (corner flap) at rear of cushion must be over the pin on the inertia latches.

## SEAT BACK - SPLIT BENCH

### REMOVAL

#### STANDARD CAB

- (1) Disconnect power seat switch connector, if equipped.
- (2) Remove center seat/console armrest. (Refer to 23 - BODY/SEATS/CENTER SEAT ARMREST / CONSOLE - REMOVAL).
- (3) Disconnect rear end flap J-Straps and peel back rear J-Strap.
- (4) Remove bolts attaching seat back to seat cushion frame.
- (5) Separate seat back from seat cushion (Fig. 9).



805dd848

**Fig. 9 Seat Back Removal**

- 1 - SEAT BACK  
2 - RELEASE LATCH KNOB  
3 - SHOULDER BOLT  
4 - END FLAP J—STRAP  
5 - SEAT CUSHION  
6 - LUMBAR HANDLE

#### QUAD CAB

- (1) Remove screw attaching recliner handle and pull handle to remove.
- (2) Remove seat dump handle, 2-door "BE" vehicles only.



## SEAT BACK - SPLIT BENCH (Continued)

(3) Remove screws attaching side shield to seat track adjuster.

(4) Remove seat dump handle.

(5) Pull shoulder belt out completely and clamp shoulder belt to prevent shoulder belt from retracting (Fig. 10).

(6) Remove shoulder belt anchor bolt.

(7) From the underside of the seat, remove the inboard pivot bolt (Fig. 11).

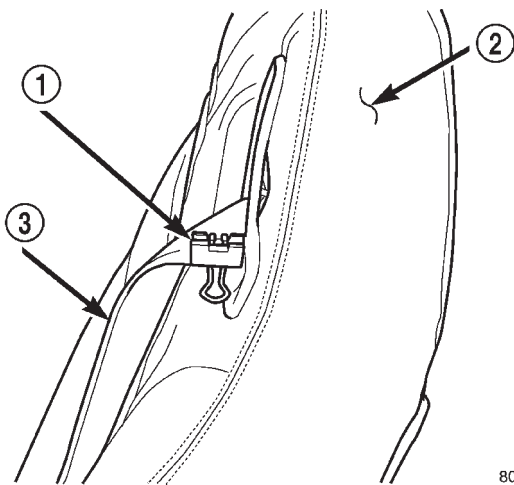
**WARNING: DO NOT REMOVE UPPER RECLINER HANDLE, PULL ON UPPER RECLINER HANDLE OR RECLINER CABLE END. THE RECLINER LEAD SCREW IS SPRING LOADED AND WILL EJECT IF EITHER THE HANDLE OR CABLE IS PULLED BEFORE THE LEAD SCREW IS REMOVED.**

(8) Remove clip attaching recliner cable (Fig. 12) to seat track adjuster and separate the cable from the seat track adjuster.

(9) Remove the inboard and outboard pivot bolts attaching the frame to the seat track adjuster (Fig. 13).

(10) Remove recliner lower bolt.

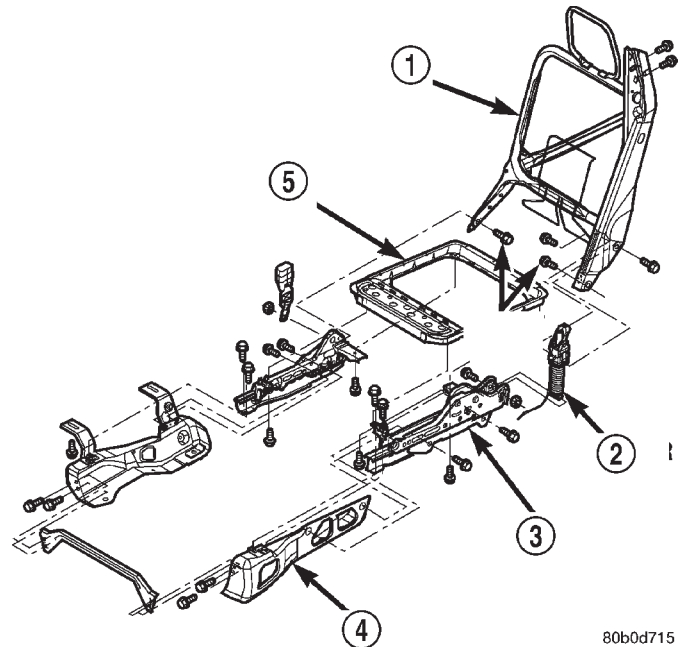
(11) Separate seat back from seat track adjuster.



**Fig. 10 Shoulder Belt Clamp**

- 1 - CLAMP
- 2 - SEAT BACK
- 3 - SHOULDER BELT

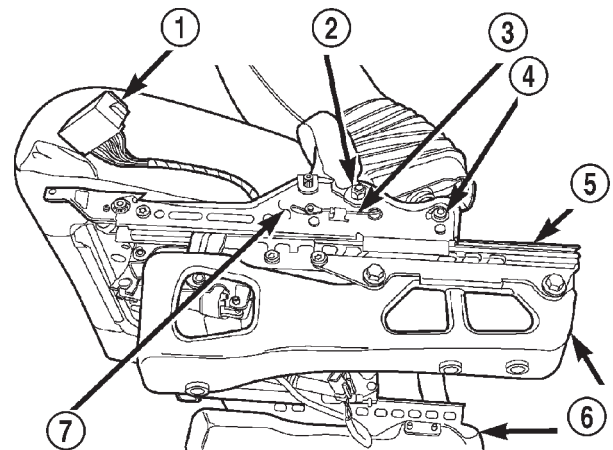
80aef286



80b0d715

**Fig. 11 Pivot Bolt**

- 1 - SEAT BACK FRAME
- 2 - RECLINER
- 3 - SEAT TRACK ADJUSTER
- 4 - RISER
- 5 - SEAT CUSHION FRAME



**Fig. 12 Recliner Cable**

80aef285

- 1 - POWER SEAT SWITCH
- 2 - PIVOT BOLT
- 3 - RECLINER CABLE
- 4 - LOWER RECLINER BOLT
- 5 - SEAT TRACK
- 6 - SEAT RISER
- 7 - SEAT TRACK ADJUSTER

## INSTALLATION

### STANDARD CAB

(1) Align seat cushion with seat back and install shoulder bolt through seat back into seat cushion frame on inboard side. Tighten bolt to 49 N·m (36 ft.lbs.) torque.

(2) Install bolts through seat back latch into seat cushion frame. Tighten bolts to 25 N·m (18 ft.lbs.) torque.

(3) Connect rear end flap J-Straps and pull rear J-Strap up and secure to frame.

(4) Install seat in vehicle.

(5) Connect power seat switch connector, if equipped.

## SEAT BACK - SPLIT BENCH (Continued)

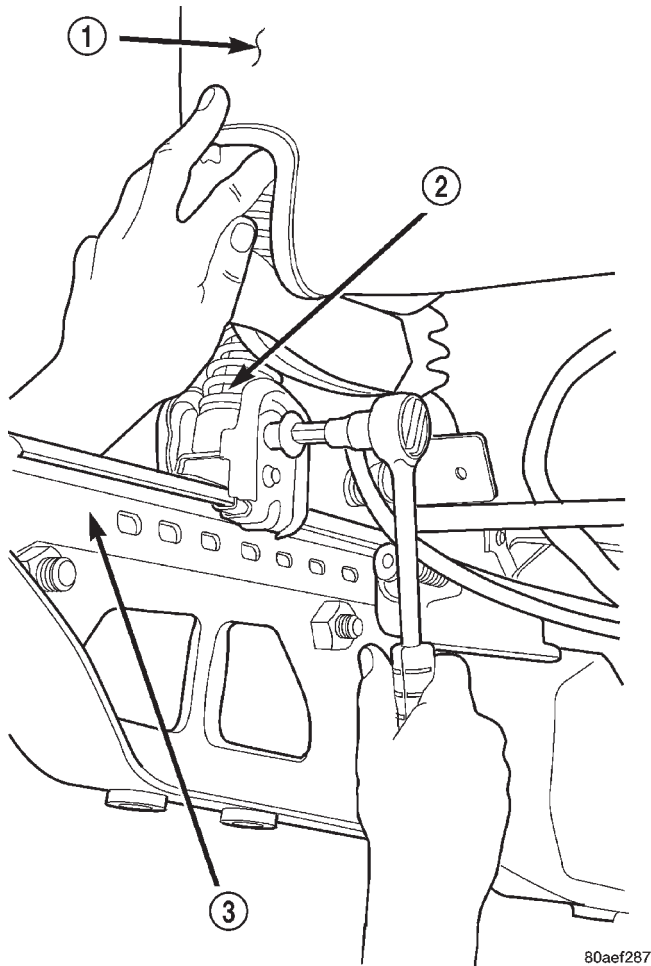


Fig. 13 Recliner

- 1 - SEAT BACK  
2 - RECLINER  
3 - SEAT TRACK

## QUAD CAB

- (1) Position seat back on seat track adjuster.
- (2) Install the inboard and outboard pivot bolts attaching the frame to the seat track adjuster (Fig. 11).
- (3) Install the bolt attaching the lower recliner to the seat track adjuster.
- (4) Position the recliner cable on seat track adjuster and install **new** clip.
- (5) Install shoulder belt anchor bolt. Tighten bolt to 45 N·m (33 ft. lbs.) torque.
- (6) Remove clamp (Fig. 10).
- (7) Install side shield.
- (8) Install recliner handle.
- (9) Install seat dump handle, if removed.

## SEAT BACK COVER

## REMOVAL

- (1) Remove seat back from vehicle. (Refer to 23 - BODY/SEATS/SEAT BACK - BENCH SEAT - REMOVAL)
- (2) Disengage J-Straps from base of seat back.
- (3) Remove hogrings, if equipped.
- (4) With seat back in a normal vertical position, roll cover upwards and remove.

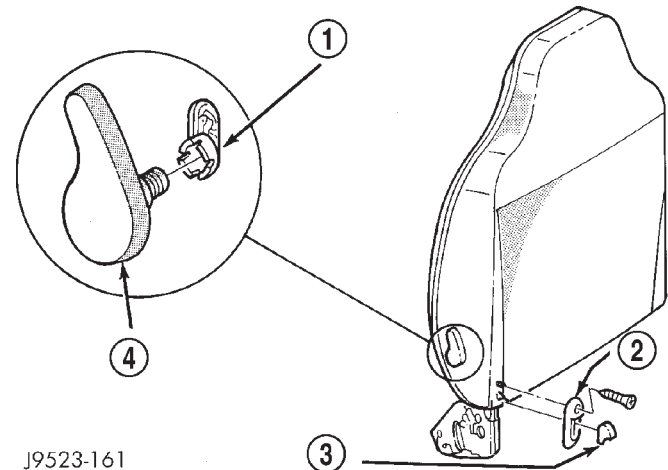
## INSTALLATION

- (1) With seat back in a normal vertical position, roll cover downwards over seat back.
- (2) Install hogrings, if equipped.
- (3) Secure J-Straps at base of seat back.
- (4) Install seat back. (Refer to 23 - BODY/SEATS/SEAT BACK - BENCH SEAT - INSTALLATION)

## SEAT BACK COVER - SPLIT BENCH

## REMOVAL

- (1) Remove the seat back. (Refer to 23 - BODY/SEATS/SEAT BACK - SPLIT BENCH - REMOVAL)
- (2) Using a trim stick or equivalent tool, pry off lumbar handle, if equipped (Fig. 14). (Damage to lumbar handle may occur during removal, verify availability of replacement handle before removing.)
- (3) Remove latch release knob (Fig. 14).
- (4) Remove latch release bezel.
- (5) Disengage J-Straps from base of seat back.
- (6) Remove hog rings, if equipped.



J9523-161

Fig. 14 Lumbar Handle Removal

- 1 - LUMBAR CAM  
2 - BEZEL  
3 - RELEASE LATCH KNOB  
4 - LUMBAR HANDLE

## SEAT BACK COVER - SPLIT BENCH (Continued)

(7) With seat back in a normal vertical position, roll cover upwards and remove.

## INSTALLATION

- (1) With seat back in a normal vertical position, roll cover downwards over seat back.
- (2) Install hog rings, if equipped.
- (3) Engage J-Straps at base of seat back.
- (4) Align lumbar handle with lumbar cam and tap on with rubber mallet until seated.
- (5) Install latch release bezel.
- (6) Install latch release knob.
- (7) Install seat back. (Refer to 23 - BODY/SEATS/SEAT BACK - SPLIT BENCH - INSTALLATION)

## SEAT BACK RECLINER

## REMOVAL

- (1) Remove seat back. (Refer to 23 - BODY/SEATS/SEAT BACK - SPLIT BENCH - REMOVAL)
- (2) Disengage J-straps at base of seat back and roll seat back cover upward to access rubber bellows push-in fasteners.

**NOTE:** Notice the routing of the recliner cable for installation.

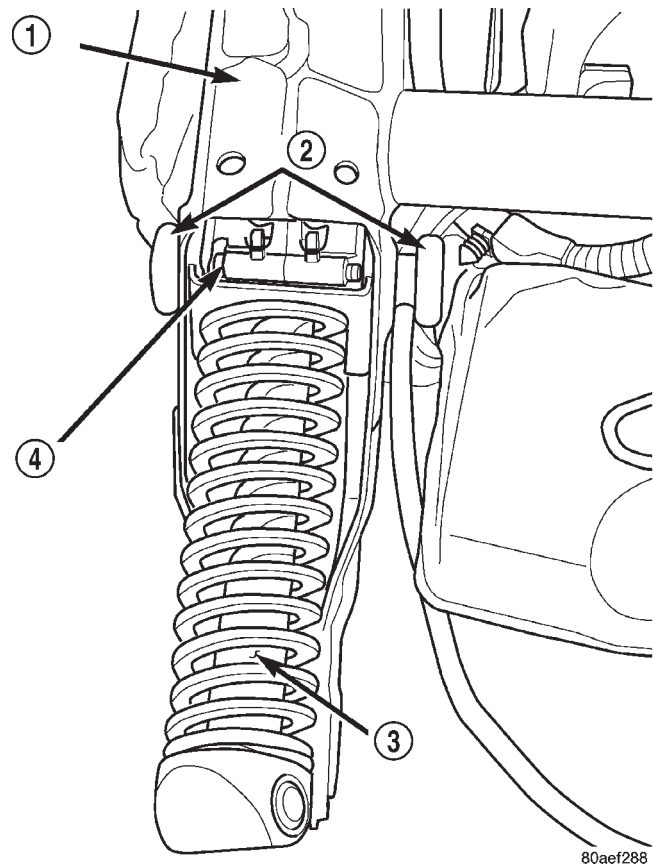
- (3) Remove the push-in fasteners attaching upper rubber bellows to the seat back frame.
- (4) Remove rubber bellows.
- (5) Remove seat dump handle, 2-door "BE" vehicles only.

**WARNING:** Do not pull on upper recliner handle or recliner cable end. The recliner lead screw is spring loaded and will eject if either the handle or cable is pulled before the lead screw is removed.

- (6) Remove the bolts attaching upper recliner to seat back frame (Fig. 15).
- (7) Separate the recliner from the seat back.

## INSTALLATION

- (1) Install seat dump handle, if removed.
- (2) Position the recliner in the seat back.
- (3) Install the bolts attaching upper recliner to seat back frame (Fig. 15).
- (4) Install rubber bellows.
- (5) Roll seat back cover upward and engage J-straps at base of seat back.
- (6) Ensure recliner cable is correctly routed.
- (7) Install seat back. (Refer to 23 - BODY/SEATS/SEAT BACK - SPLIT BENCH - INSTALLATION)



**Fig. 15 Seat Back Recliner**

- 1 - SEAT BACK FRAME
- 2 - BOLT
- 3 - LEAD SCREW
- 4 - SEAT BACK RECLINER

## SEAT CUSHION

## REMOVAL

- (1) Remove the seat. (Refer to 23 - BODY/SEATS/SEAT - BENCH SEAT - REMOVAL) or (Refer to 23 - BODY/SEATS/SEAT - SPLIT BENCH - REMOVAL)
- (2) Remove the seat back. (Refer to 23 - BODY/SEATS/SEAT BACK - BENCH SEAT - REMOVAL) or (Refer to 23 - BODY/SEATS/SEAT BACK - SPLIT BENCH - REMOVAL)
- (3) From the underside of the seat, remove the bolts attaching the cushion frame to the mounting brackets.
- (4) Disengage wire harness connector, if equipped.
- (5) Remove the cushion from the seat tracks.

## INSTALLATION

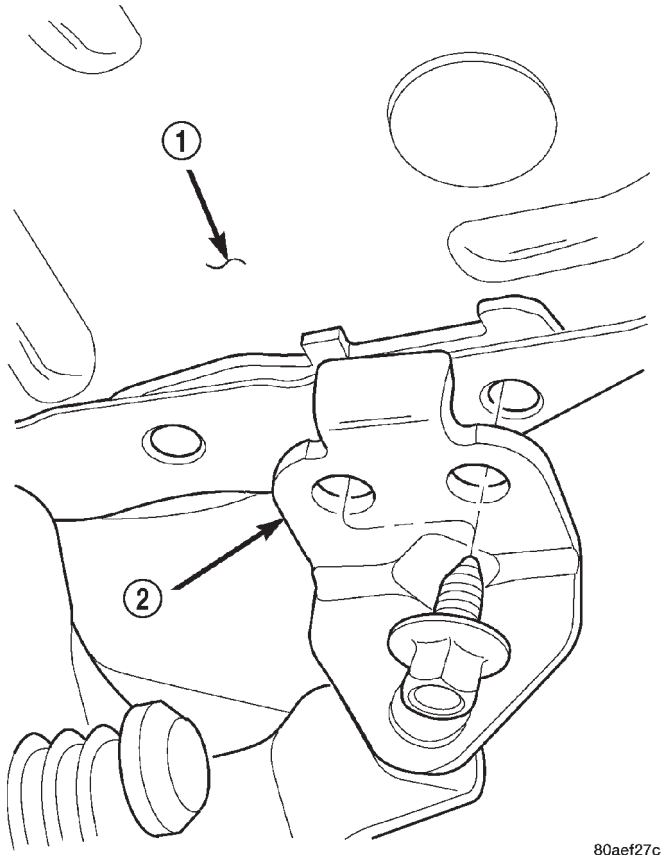
- (1) Position the cushion frame on the seat tracks.
- (2) Ensure that the cushion frame is aligned with the mounting brackets (Fig. 16).
- (3) Engage wire harness connector, if equipped.

## SEAT CUSHION (Continued)

(4) Install the bolts attaching the seat cushion frame to the mounting brackets. Tighten bolts to 25 N·m (18 ft. lbs.) torque.

(5) Install the seat back. (Refer to 23 - BODY/SEATS/SEAT BACK - BENCH SEAT - INSTALLATION) or (Refer to 23 - BODY/SEATS/SEAT BACK - SPLIT BENCH - INSTALLATION)

(6) Install the seat. (Refer to 23 - BODY/SEATS/SEAT - BENCH SEAT - INSTALLATION) or (Refer to 23 - BODY/SEATS/SEAT - SPLIT BENCH - INSTALLATION)



80aef27c

**Fig. 16 Seat Cushion Mounting Frame**

- 1 - SEAT CUSHION FRAME  
2 - MOUNTING BRACKET

## SEAT CUSHION COVER

## REMOVAL

(1) Remove seat cushion. (Refer to 23 - BODY/SEATS/SEAT CUSHION - REMOVAL)

(2) Position seat cushion on a suitable work surface with frame side up.

(3) Remove seat track. (Refer to 23 - BODY/SEATS/SEAT TRACK - REMOVAL)

(4) Remove left and right side J-Straps.

(5) Remove rear J-Strap.

(6) Remove front J-Strap.

(7) Roll trim cover off of front and rear corners and separate from foam cushion.

## INSTALLATION

(1) Position cushion cover on cushion and roll cover over front and rear corners.

(2) Secure front J-Strap (Fig. 17).

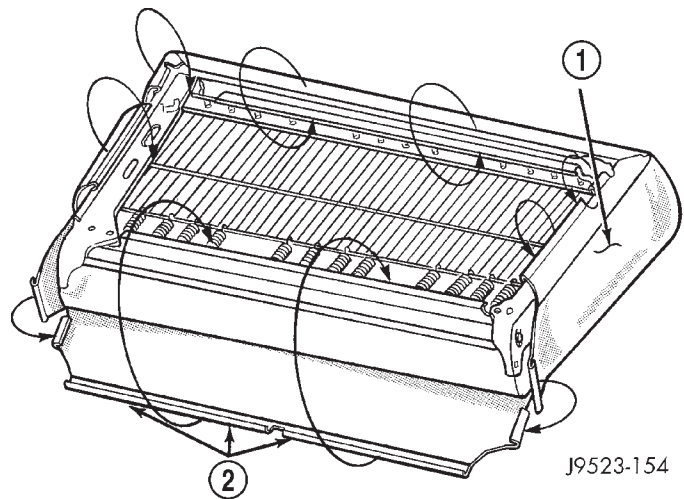
(3) Secure rear J-Strap.

(4) Secure left and right side J-Straps.

(5) Verify stitching lines are straight, correct as necessary.

(6) Install the seat track. (Refer to 23 - BODY/SEATS/SEAT TRACK - INSTALLATION)

(7) Install seat cushion. (Refer to 23 - BODY/SEATS/SEAT CUSHION - INSTALLATION)



J9523-154

**Fig. 17 J-Strap Installation**

- 1 - SEAT CUSHION  
2 - J-STRAPS

## SEAT CUSHION COVER - SPLIT BENCH

## REMOVAL

## STANDARD CAB

(1) Remove seat tracks. (Refer to 23 - BODY/SEATS/SEAT TRACK - SPLIT BENCH - REMOVAL)

(2) Remove seat back. (Refer to 23 - BODY/SEATS/SEAT BACK - SPLIT BENCH - REMOVAL)

(3) Remove left and right J-straps.

(4) Position seat cushion on a suitable work surface with frame side up.

(5) Remove rear J-strap.

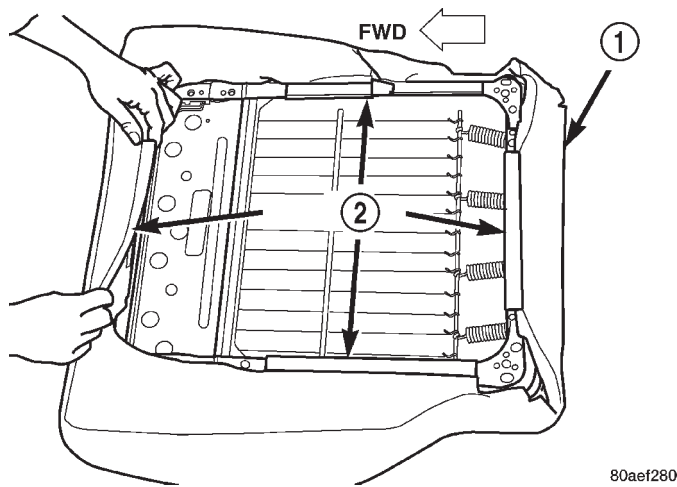
(6) Remove front J-strap.

(7) Roll cushion cover off of foam cushion.

SEAT CUSHION COVER - SPLIT BENCH (Continued)

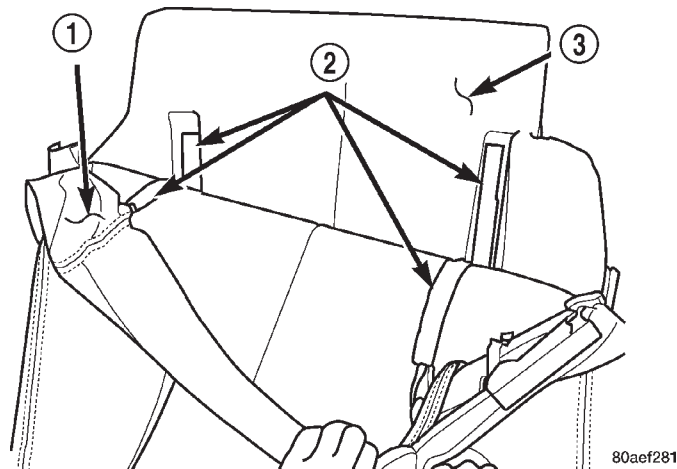
**QUAD CAB**

- (1) Remove seat cushion. (Refer to 23 - BODY/SEATS/SEAT CUSHION - REMOVAL)
- (2) Disengage the J-straps attaching the cushion cover to the cushion frame (Fig. 18).
- (3) Peel the cushion cover and disengage the hook and loop fasteners (Fig. 19).
- (4) Disengage the electrical connectors for the heated seat grid, if equipped.
- (5) Disengage the hog rings attaching the cushion cover to the cushion frame (Fig. 20).
- (6) Separate the cover from the cushion.



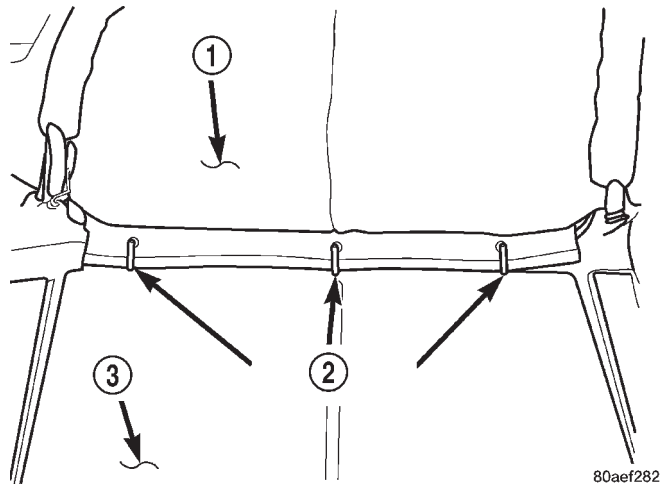
**Fig. 18 Seat Cushion J-Straps**

- 1 - SEAT CUSHION
- 2 - J—STRAPS



**Fig. 19 Seat Cushion Cover Hook and Loop**

- 1 - CUSHION COVER
- 2 - HOOK AND LOOP FASTENERS
- 3 - SEAT CUSHION



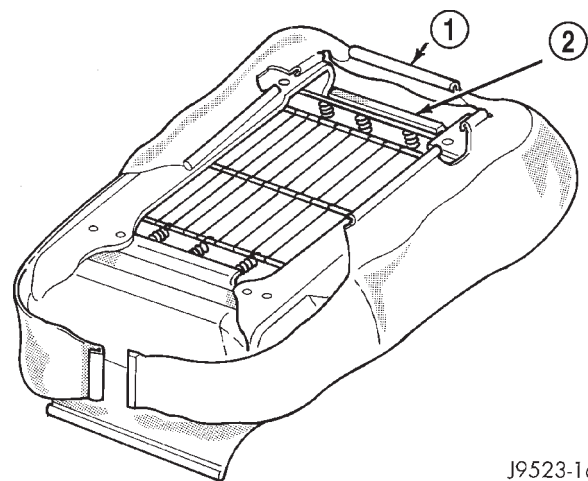
**Fig. 20 Seat Cushion Cover Hog Rings**

- 1 - CUSHION COVER
- 2 - HOG RINGS
- 3 - CUSHION

**INSTALLATION**

**STANDARD CAB**

- (1) Position cushion cover on cushion and roll cover over front and rear corners. Verify stitching lines are straight, correct as necessary.
- (2) Pull front J-strap up, align cover to foam notches and secure front J-strap to frame (Fig. 21).
- (3) Install seat backs. (Refer to 23 - BODY/SEATS/SEAT BACK - SPLIT BENCH - INSTALLATION)
- (4) Pull the left J-strap up and secure to frame. Verify cover is straight.
- (5) Pull the right side J-strap up and secure to frame.



**Fig. 21 J-Strap Installation**

- 1 - J—STRAP
- 2 - FRAME

J9523-162



## SEAT CUSHION COVER - SPLIT BENCH (Continued)

(6) Install seat tracks. (Refer to 23 - BODY/SEATS/SEAT TRACK - SPLIT BENCH - INSTALLATION)

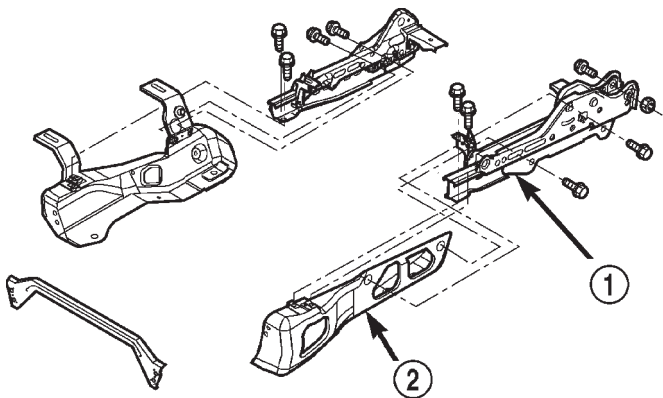
## QUAD CAB

- (1) Position the cover on the cushion.
- (2) Engage the hog rings attaching the cushion cover to the cushion frame.
- (3) Engage the hook and loop fasteners.
- (4) Engage the electrical connectors for the heated seat grid, if equipped.
- (5) Engage the J-straps attaching the cushion cover to the cushion frame.
- (6) Install seat cushion. (Refer to 23 - BODY/SEATS/SEAT CUSHION - INSTALLATION)

## SEAT RISER

## REMOVAL

- (1) Disconnect seat harness connector.
- (2) Remove the seat from the vehicle. (Refer to 23 - BODY/SEATS/SEAT - BENCH SEAT - REMOVAL) or (Refer to 23 - BODY/SEATS/SEAT - SPLIT BENCH - REMOVAL)
- (3) Remove the bolts attaching the seat track adjuster to the seat riser (Fig. 22).
- (4) Separate the seat track adjuster from the riser.



80b0d736

Fig. 22 Seat Riser

- 1 - SEAT TRACK ADJUSTER
- 2 - RISER

## INSTALLATION

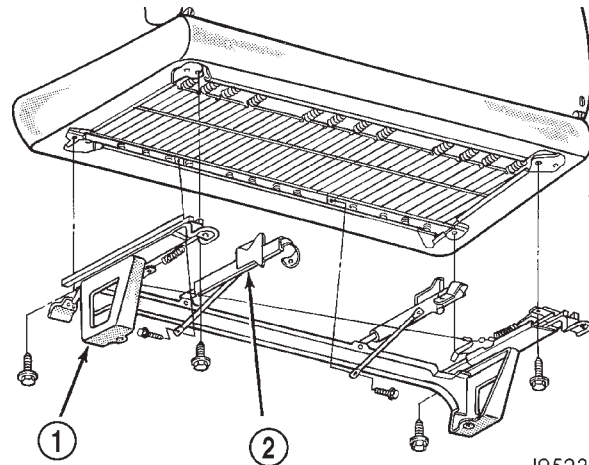
- (1) Position the seat track adjuster on the riser.
- (2) Install the bolts attaching the seat track adjuster to the seat riser. Tighten front bolts to 17 N·m (12 ft. lbs.) torque. Tighten rear inboard bolt to 22 N·m (16 ft. lbs.) torque. Tighten rear outboard bolt to 45 N·m (33 ft. lbs.) torque.
- (3) Install the seat in the vehicle. (Refer to 23 - BODY/SEATS/SEAT - BENCH SEAT - INSTALLATION)

(4) Connect seat harness connector.

## SEAT TRACK

## REMOVAL

- (1) Remove seat from vehicle. (Refer to 23 - BODY/SEATS/SEAT - BENCH SEAT - REMOVAL)
- (2) Remove inboard seat belt buckles. (Refer to 8 - ELECTRICAL/RESTRAINTS/SEAT BELT BUCKLE - REMOVAL)
- (3) Remove bolts attaching seat track to seat cushion frame (Fig. 23).
- (4) Separate seat track from seat cushion frame.



J9523-152

Fig. 23 Seat Track Removal

- 1 - SEAT TRACK
- 2 - SLIDER BAR

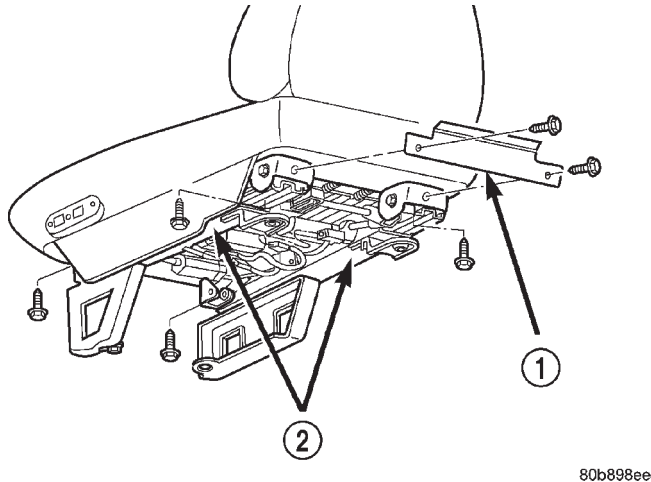
## INSTALLATION

- (1) Position seat track on seat cushion frame.
- (2) Ensure seat track and slider bar are aligned.
- (3) Install rear seat track bolts. Tighten seat track bolts to 25 N·m (18 ft.lbs.) torque.
- (4) Install inboard seat belt buckles. (Refer to 8 - ELECTRICAL/RESTRAINTS/SEAT BELT BUCKLE - INSTALLATION)
- (5) Pull seat release and move track rearward.
- (6) Install front seat track bolts. Tighten seat track bolts to 25 N·m (18 ft.lbs.) torque.
- (7) Align slider bars and install bolts. Tighten slider bar bolts to 10.0 N·m (7 ft.lbs.) torque.
- (8) Install seat. (Refer to 23 - BODY/SEATS/SEAT - BENCH SEAT - INSTALLATION)

## SEAT TRACK - SPLIT BENCH

### REMOVAL

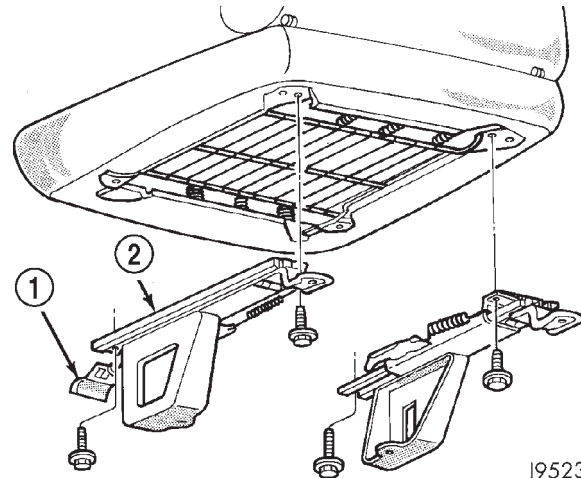
- (1) Remove seat from vehicle. (Refer to 23 - BODY/SEATS/SEAT - SPLIT BENCH - REMOVAL)
- (2) Remove bolts from crossbrace to seat cushion frame and power track (Fig. 24).
- (3) Remove bolts attaching center seat to seat frame and remove center seat.
- (4) Remove bolts attaching seat track to seat frame (Fig. 25) and (Fig. 26).



**Fig. 24 Cross Brace**

- 1 - CROSS BRACE
- 2 - SEAT TRACK

80b898ee



J9523-158

**Fig. 26 Seat Track Removal/Installation**

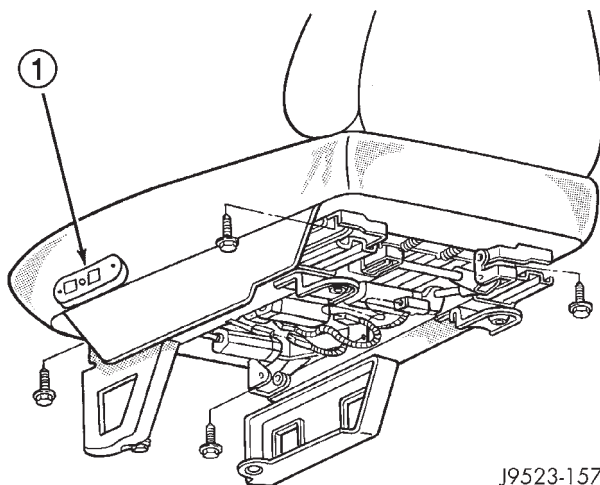
- 1 - RELEASE HANDLE
- 2 - SEAT TRACK

(2) Install bolts into crossbrace and seat cushion frame to power track and torque to 10N·m (8.5–11.5 ft. lbs.).

(3) Install bolts attaching center seat to seat frame. Tighten bolts to 25 N·m (18 ft. lbs.) torque.

(4) Install seat. (Refer to 23 - BODY/SEATS/SEAT - SPLIT BENCH - INSTALLATION)

(5) Power adjuster on power seat must be cycled in all 6 functions to ensure the adjuster is working properly.



**Fig. 25 Power Seat Track**

- 1 - SEAT SWITCH

J9523-157

## EASY ENTRY SEAT TRACK

### REMOVAL

- (1) Remove front passenger seat. (Refer to 23 - BODY/SEATS/SEAT - SPLIT BENCH - REMOVAL)
- (2) Remove recliner handle.
- (3) Remove side shield.
- (4) Disengage seat track latch release cables.
- (5) Remove bolts attaching seat adjuster track to easy entry seat track. (Fig. 27).
- (6) Remove inboard seat back pivot bolt.
- (7) Disengage latch release cable from pulley.
- (8) Separate seat adjuster track from seat back.

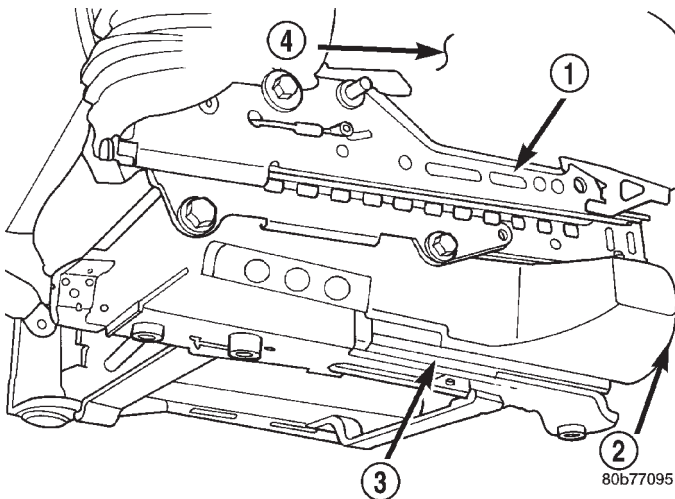
### INSTALLATION

- (1) Position inboard easy entry seat track at seat back.
- (2) Engage latch release cable around pulley.
- (3) Install inboard seat back pivot bolt. Tighten bolt to 50 N·m (36 ft. lbs.) torque.
- (4) Install screws attaching seat adjuster track to seat cushion frame. Tighten screws to 25 N·m (18 ft. lbs.) torque.

### INSTALLATION

- (1) Install bolts attaching seat track to seat frame. Tighten bolts to 25 N·m (18 ft. lbs.) torque.

## EASY ENTRY SEAT TRACK (Continued)



**Fig. 27 EASY ENTRY SEAT TRACK**

- 1 - SEAT ADJUSTER TRACK
- 2 - RISER
- 3 - EASY ENTRY SEAT TRACK
- 4 - SEAT CUSHION

(5) Install bolts attaching easy entry seat track to seat adjuster track. Tighten front bolts to 17 N·m (12 ft. lbs.) torque. Tighten rear inboard bolts to 21 N·m (16 ft. lbs.) torque. Tighten rear outboard bolts to 45 N·m (33 ft. lbs.) torque.

(6) Engage seat track latch release cables.

(7) Install front passenger seat. (Refer to 23 - BODY/SEATS/SEAT - SPLIT BENCH - INSTALLATION)

(8) Install side shield.

(9) Install recliner handle.

## SEAT TRACK ADJUSTER

## REMOVAL

(1) Remove the seat cushion. (Refer to 23 - BODY/SEATS/SEAT CUSHION - REMOVAL)

(2) Unwind recliner spring from seat back. Use care not to lose upper spring seat.

**WARNING: DO NOT PULL THE RECLINER CABLE OR THE RECLINER HANDLE. THE RECLINER LEAD SCREW IS SPRING LOADED AND WILL EJECT IF**

**EITHER THE HANDLE , CABLE, OR TOWEL BAR IS PULLED BEFORE THE LEAD SCREW IS REMOVED.**

(3) Remove right and left risers.

## INSTALLATION

(1) Install the left and right risers.

(2) Install the recliner lead screw and spring in the seat back.

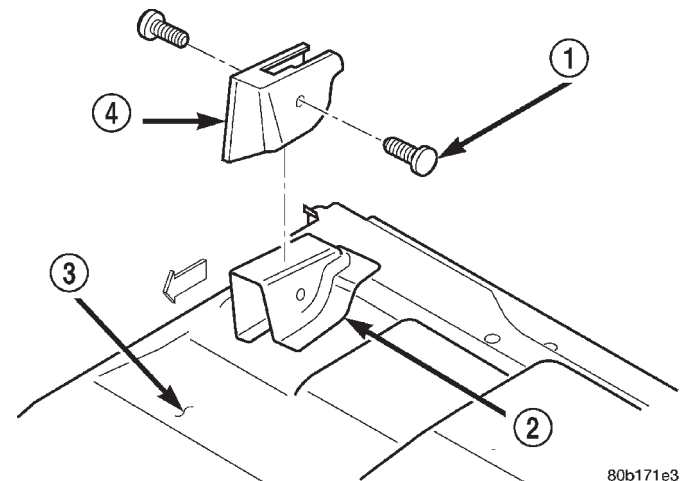
(3) Install seat cushion. (Refer to 23 - BODY/SEATS/SEAT CUSHION - INSTALLATION)

## STANCHION COVER

## REMOVAL

(1) Remove push-in fasteners attaching stanchion cover to seat stanchion (Fig. 28).

(2) Separate cover from seat stanchion.



**Fig. 28 Stanchion Cover**

- 1 - PUSH-IN FASTENER
- 2 - SEAT STANCHION
- 3 - FLOOR PAN
- 4 - STANCHION COVER

## INSTALLATION

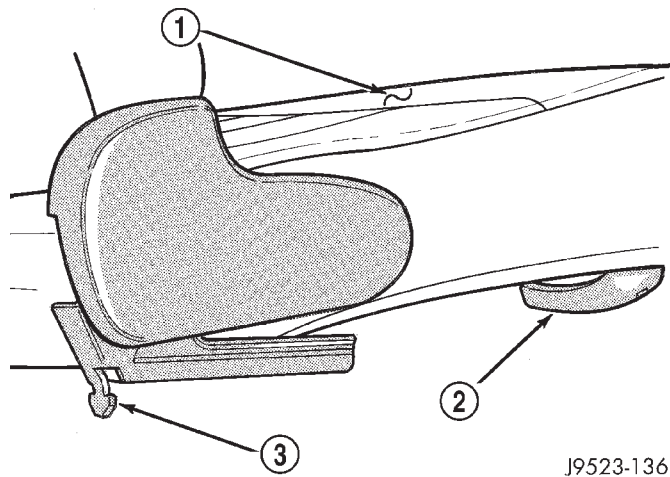
(1) Position cover on seat stanchion.

(2) Install push-in fasteners attaching stanchion cover to seat stanchion (Fig. 28).

## REAR SEAT

### REMOVAL

- (1) Move front seat track to full forward position.
- (2) Turn release handle on underside of rear seat (Fig. 29) to disengage seat cushion and move seat to the stowed position.
- (3) Remove side support bracket screws and lift seat to disengage from cab (Fig. 30).



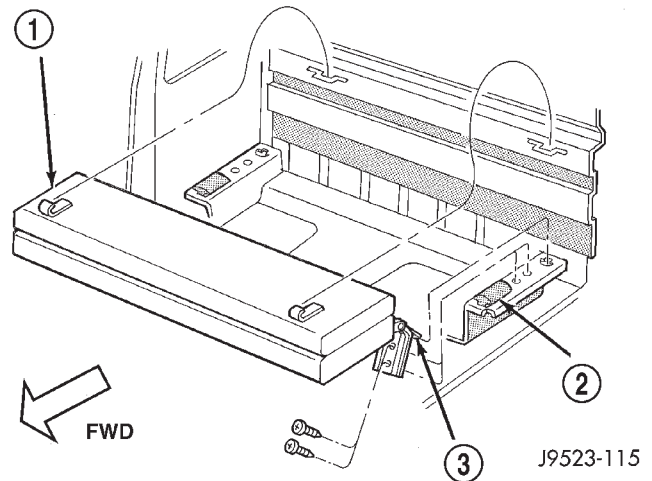
J9523-136

**Fig. 29 Rear Seat Release Handle**

- 1 - SEAT CUSHION
- 2 - RELEASE HANDLE
- 3 - ALIGNMENT TAB

### INSTALLATION

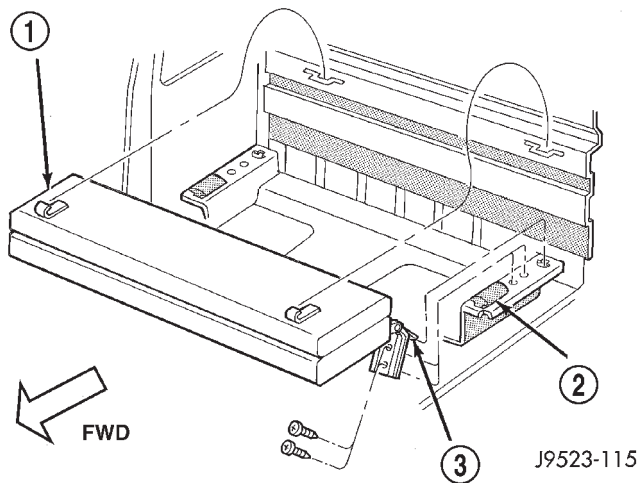
- (1) Position seat in vehicle.
- (2) Align seatback hooks with loops on cab rear panel (Fig. 31).
- (3) Align side support alignment tabs, and lower seat into place.
- (4) Install side support bracket screws. Tighten the screws to 28 N·m (250 in-lbs) torque.
- (5) Turn release handle to disengage seat from stowed position and push seat cushion downward to lock into place.



J9523-115

**Fig. 31 Rear Seat Removal/Installation**

- 1 - REAR SEAT
- 2 - BUMPER
- 3 - TAB



J9523-115

**Fig. 30 Rear Seat Removal/Installation**

- 1 - REAR SEAT
- 2 - BUMPER
- 3 - TAB

# STATIONARY GLASS

## TABLE OF CONTENTS

	page		page
<b>STATIONARY GLASS</b>		INSTALLATION.....	147
DESCRIPTION.....	145	<b>WINDSHIELD</b>	
OPERATION.....	145	DESCRIPTION.....	148
<b>BACKLITE</b>		REMOVAL.....	148
REMOVAL.....	145	INSTALLATION.....	148
INSTALLATION.....	145	<b>QUARTER WINDOW</b>	
<b>BACKLITE LATCH AND KEEPER</b>		REMOVAL.....	151
REMOVAL.....	146	INSTALLATION.....	151
INSTALLATION.....	146		
<b>BACKLITE VENT GLASS</b>			
REMOVAL.....	147		

## STATIONARY GLASS

### DESCRIPTION

Windshields are made of two pieces of glass with a plastic inner layer. Windshields and selected stationary glass are structural members of the vehicle. The windshield glass is bonded to the windshield frame with urethane adhesive.

### OPERATION

Windshields and other stationary glass protect the occupants from the effects of the elements. Windshields are also used to retain some airbags in position during deployment. Urethane bonded glass is difficult to salvage during removal. The urethane bonding is difficult to cut or clean from any surface. Before removing the glass, check the availability of replacement components.

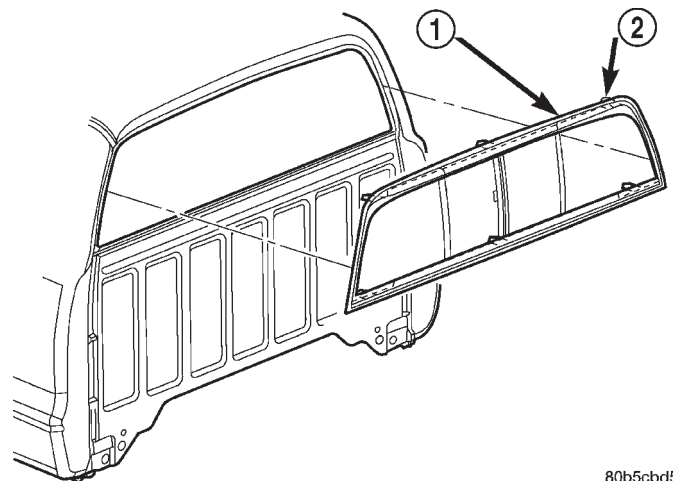
## BACKLITE

### REMOVAL

It is difficult to salvage the backlite during the removal operation. The backlite is part of the structural support for the roof. The urethane bonding used to secure the glass to the fence is difficult to cut or clean from any surface. Since the molding is set in urethane, it is unlikely it would be salvaged. Before removing the backlite, check the availability from the parts supplier.

The backlite is attached to the window frame with urethane adhesive. The urethane adhesive is applied cold and seals the surface area between the window opening and the glass. The primer adheres the urethane adhesive to the backlite.

- (1) Roll down door glass.
- (2) Remove headliner. (Refer to 23 - BODY/INTERIOR/HEADLINER - REMOVAL).
- (3) Remove rear closer panel trim. (Refer to 23 - BODY/INTERIOR/REAR CLOSURE PANEL TRIM - REMOVAL).
- (4) Bend backlite retaining tabs (Fig. 1) inward against glass.
- (5) Using a suitable pneumatic knife from inside the vehicle, cut urethane holding backlite frame to opening fence.
- (6) Separate glass from vehicle.



80b5cbd5

**Fig. 1 Backlite Tabs**

- 1 - BACKLITE  
2 - TAB

### INSTALLATION

- (1) Clean urethane adhesive from around backlite opening fence.



## BACKLITE (Continued)

(2) If necessary, apply black-out primer to outer edge of replacement backlite frame.

(3) If black-out primer was pre-applied on backlite, clean bonding surface with Isopropyl alcohol and clean lint free cloth. Allow 3 minutes for drying time.

(4) Apply black-out primer to backlite opening fence.

(5) Apply a 13 mm (0.5 in.) bead of urethane around the perimeter of the window frame bonding surface (Fig. 2).

(6) Set glass on lower fence and move glass forward into opening (Fig. 3).

(7) Firmly push glass against rear window glass opening fence.

(8) Bend tabs around edges of backlite opening fence to retain glass.

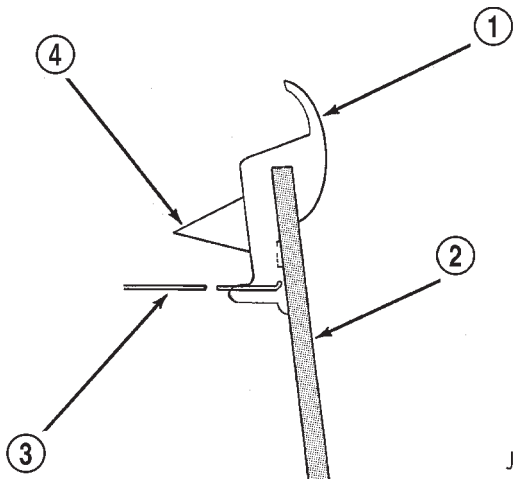
(9) Clean excess urethane from exterior with MOPAR, Super Clean or equivalent.

(10) Allow urethane to cure at least 24 hours (full cure is 72 hours).

(11) Water test to verify repair before returning vehicle to service.

(12) Install rear closer panel trim. (Refer to 23 - BODY/INTERIOR/REAR CLOSURE PANEL TRIM - INSTALLATION).

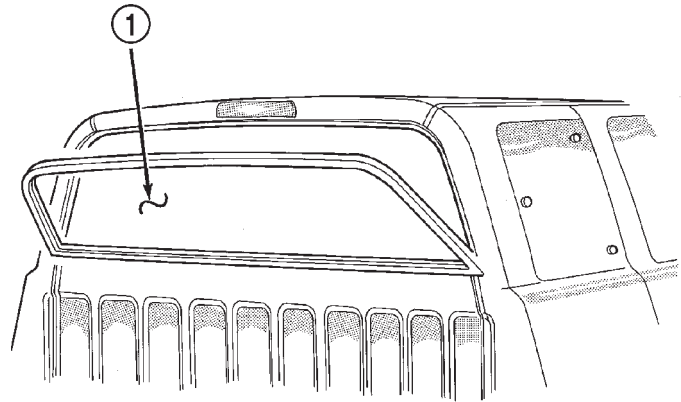
(13) Install the headliner. (Refer to 23 - BODY/INTERIOR/HEADLINER - INSTALLATION).



J9523-143

**Fig. 2 Urethane Adhesive Application**

- 1 - WINDOW FRAME
- 2 - GLASS
- 3 - RETAINER TAB
- 4 - URETHANE ADHESIVE



J9523-133

**Fig. 3 Backlite Installation**

1 - BACKLITE

## BACKLITE LATCH AND KEEPER

### REMOVAL

- (1) Disengage latch and keeper.
- (2) Remove latch/keeper screws.
- (3) Separate Latch/keeper from glass panel.

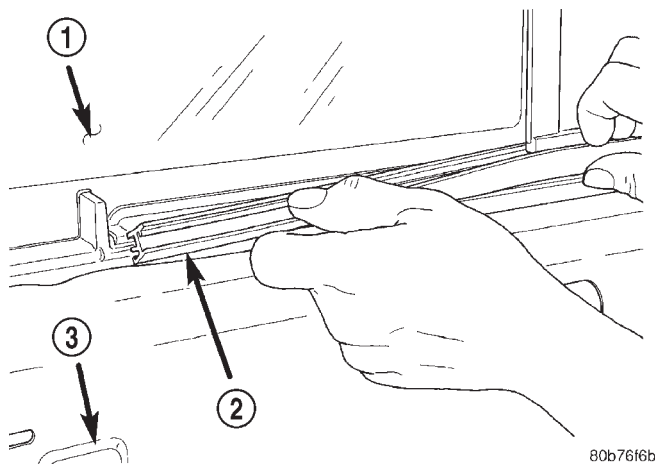
### INSTALLATION

- (1) Position Latch/keeper on glass panel.
- (2) Install screws. Tighten the screws with 1.5 N·m (15 in. lbs.) torque.
- (3) Engage latch and keeper to verify operation.

## BACKLITE VENT GLASS

### REMOVAL

- (1) Close and latch sliding vent glass.
- (2) Remove rear closure panel trim, if necessary. (Refer to 23 - BODY/INTERIOR/REAR CLOSURE PANEL TRIM - REMOVAL).
- (3) Grasp end of lower run channel.
- (4) Roll corners of lower run channel outward (Fig. 4).
- (5) Disengage enough of the lower run channel from the backlite frame lower rail and firmly pull/slide lower run channel outward (Fig. 5).
- (6) Disengage vent glass from upper run channel.
- (7) Separate vent glass from backlite frame.



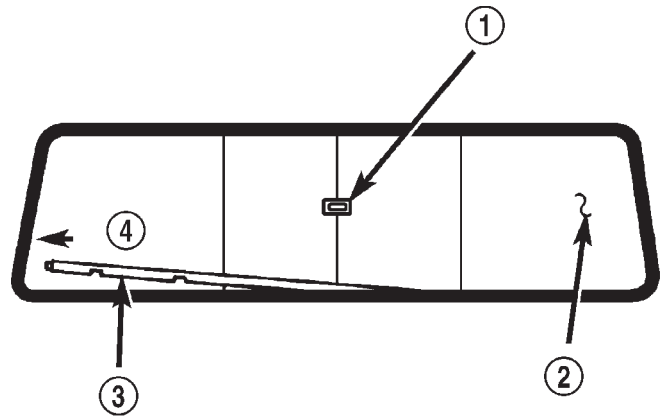
**Fig. 4 Lower Run Channel**

- 1 - SLIDING BACKLITE
- 2 - LOWER RUN CHANNEL
- 3 - CAB BACK PANEL

### INSTALLATION

- (1) Remove excess sealer from backlite frame lower rail.
- (2) Clean bond area with hand scuff pad.
- (3) Clean bond area with Mopar® Tar and Oil Remover or equivalent.
- (4) Using a lint free cloth, clean bond area with 50/50 mixture of Isopropyl alcohol and water.
- (5) Apply a 0.5 mm bead of pumpable grade butyl along entire length of the lip retainer in lower run channel (Fig. 6).
- (6) Slide vent glass panels into lower run channel.
- (7) Latch vent glass panels
- (8) Insert upper ends of vent glass panels into upper run channel.

**NOTE: Aggressive clamp pressure is required to lock lower run channel into place.**



80b6f10e

**Fig. 5 Lower Run Channel Removal**

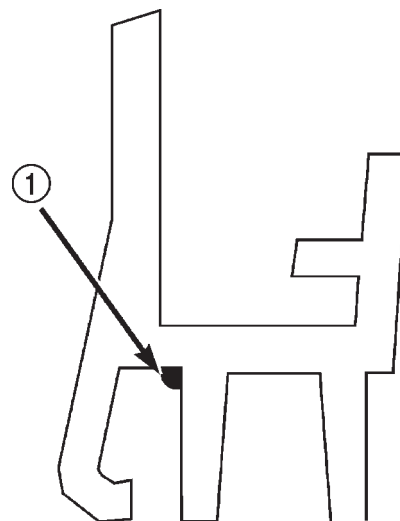
- 1 - LATCH/KEEPER
- 2 - BACK LITE
- 3 - LOWER RUN CHANNEL
- 4 - SLIDE OUTWARD

(9) Position lower run channel on backlite frame lower rail and roll lower run channel onto backlite frame rail.

(10) Fill the ends of the run channel with Mopar GEN II Silicone Rubber Adhesive Sealant or equivalent.

(11) Verify window and latch/keeper operation.

(12) Install rear closure panel trim. (Refer to 23 - BODY/INTERIOR/REAR CLOSURE PANEL TRIM - INSTALLATION).



80b6f0be

**Fig. 6 Glass Panel Installation**

- 1 - INSERT A 0.5mm DIA. BEAD OF PUMPABLE GRADE BUTYL ALONG THE ENTIRE LENGTH OF THE LOWER RUN WINDOW CHANNEL

## WINDSHIELD

### DESCRIPTION

**WARNING: DO NOT OPERATE THE VEHICLE WITHIN 24 HOURS OF WINDSHIELD INSTALLATION. IT TAKES AT LEAST 24 HOURS FOR URETHANE ADHESIVE TO CURE. IF IT IS NOT CURED, THE WINDSHIELD MAY NOT PERFORM PROPERLY IN AN ACCIDENT.**

**URETHANE ADHESIVES ARE APPLIED AS A SYSTEM. USE GLASS CLEANER, GLASS PREP SOLVENT, GLASS PRIMER, PVC (VINYL) PRIMER AND PINCH WELD (FENCE) PRIMER PROVIDED BY THE ADHESIVE MANUFACTURER. IF NOT, STRUCTURAL INTEGRITY COULD BE COMPROMISED.**

**DAIMLERCHRYSLER DOES NOT RECOMMEND GLASS ADHESIVE BY BRAND. TECHNICIANS SHOULD REVIEW PRODUCT LABELS AND TECHNICAL DATA SHEETS, AND USE ONLY ADHESIVES THAT THEIR MANUFACTURERS WARRANT WILL RESTORE A VEHICLE TO THE REQUIREMENTS OF FMVSS 212. TECHNICIANS SHOULD ALSO INSURE THAT PRIMERS AND CLEANERS ARE COMPATIBLE WITH THE PARTICULAR ADHESIVE USED.**

**BE SURE TO REFER TO THE URETHANE MANUFACTURER'S DIRECTIONS FOR CURING TIME SPECIFICATIONS, AND DO NOT USE ADHESIVE AFTER ITS EXPIRATION DATE.**

**VAPORS THAT ARE EMITTED FROM THE URETHANE ADHESIVE OR PRIMER COULD CAUSE PERSONAL INJURY. USE THEM IN A WELL-VENTILATED AREA.**

**SKIN CONTACT WITH URETHANE ADHESIVE SHOULD BE AVOIDED. PERSONAL INJURY MAY RESULT.**

**ALWAYS WEAR EYE AND HAND PROTECTION WHEN WORKING WITH GLASS.**

**CAUTION: Protect all painted and trimmed surfaces from coming in contact with urethane or primers. Be careful not to damage painted surfaces when removing moldings or cutting urethane around windshield.**

### OPERATION

The windshield is attached to the window frame with urethane adhesive. The urethane adhesive is applied cold and seals the surface area between the window opening and the glass. The primer adheres the urethane adhesive to the windshield.

It is difficult to salvage a windshield during the removal operation. The windshield is part of the structural support for the roof. The urethane bonding used to secure the windshield to the fence is difficult

to cut or clean from any surface. If the moldings are set in urethane, it would also be unlikely they could be salvaged. Before removing the windshield, check the availability of the windshield and moldings from the parts supplier.

### REMOVAL

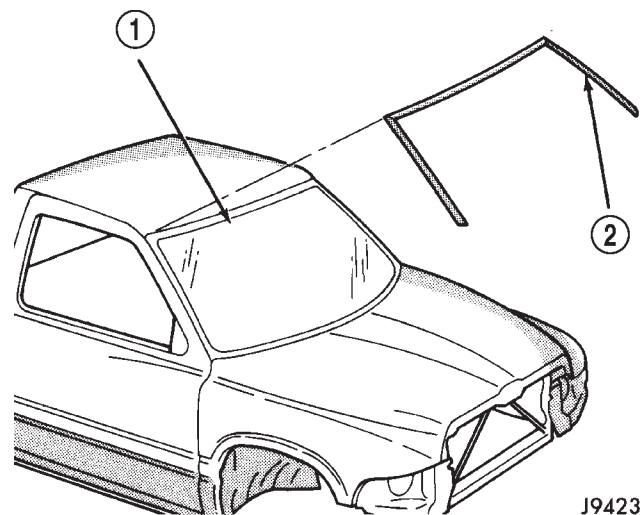
(1) Remove inside rear view mirror. (Refer to 23 - BODY/INTERIOR/REAR VIEW MIRROR - REMOVAL).

(2) Remove cowl grill. (Refer to 23 - BODY/EXTERIOR/COWL GRILLE - REMOVAL).

(3) With doors open, remove windshield molding (Fig. 7). Pull outward on molding beginning at the bottom of A-pillars using pliers.

(4) Cut urethane bonding from around windshield using a suitable sharp cold knife (C-4849). A pneumatic cutting device can be used but is not recommended (Fig. 8).

(5) Separate windshield from vehicle.



J9423-188

**Fig. 7 Windshield Moldings**

- 1 - WINDSHIELD  
2 - WINDSHIELD MOLDING

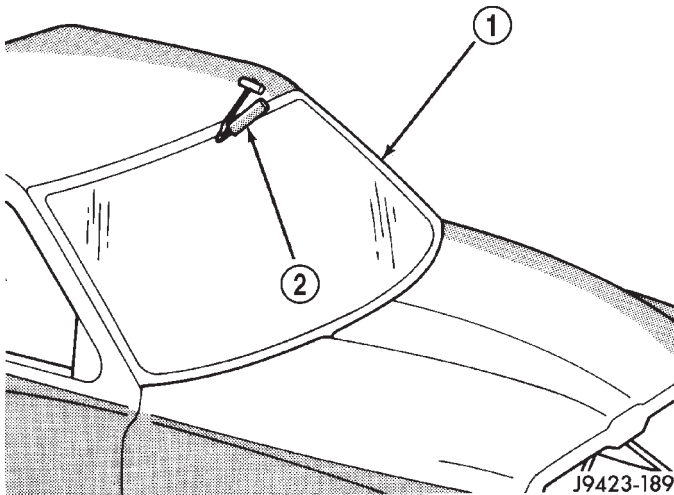
### INSTALLATION

**WARNING: Allow the urethane at least 24 hours to cure before returning the vehicle to use.**

**CAUTION: Roll down the left and right front door glass and open the rear glass slider (if available) before installing windshield to avoid pressurizing the passenger compartment if a door is slammed before urethane is cured. Water leaks can result.**

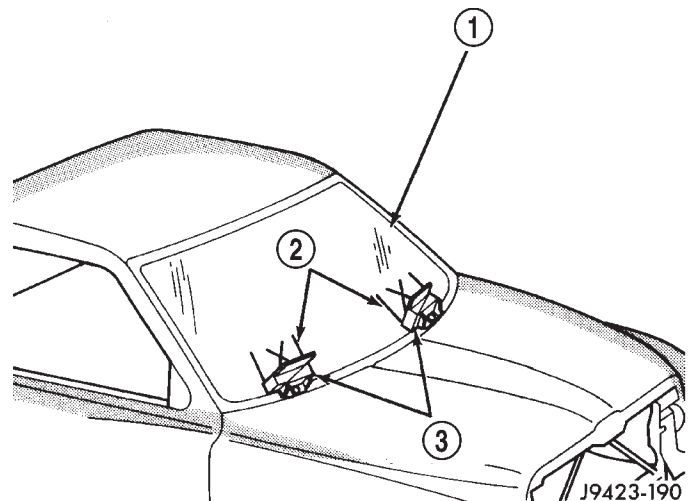
The windshield fence should be cleaned of most of its old urethane bonding material. A small amount of old urethane, approximately 1-2 mm in height,

## WINDSHIELD (Continued)



**Fig. 8 Cut Urethane Around Windshield**

- 1 - WINDSHIELD  
2 - COLD KNIFE



**Fig. 9 Center Windshield and Mark at Support**

- 1 - WINDSHIELD  
2 - INDEX MARKS  
3 - SUPPORT SPACERS

should remain on the fence. Do not grind off or completely remove all old urethane from the fence, the paint finish and bonding strength will be adversely affected.

(1) Place replacement windshield into windshield opening and position glass in the center of the opening against the support spacers. Mark the outside surface of the glass at the support spacers with a grease pencil or pieces of masking tape and ink pen to use as a reference for installation. Remove replacement windshield from windshield opening (Fig. 9).

(2) Position the windshield inside up on a suitable work surface with two padded, wood 10 cm by 10 cm by 50 cm (4 in. by 4 in. by 20 in.) blocks, placed parallel 75 cm (2.5 ft.) apart (Fig. 10).

(3) Clean inside of windshield with MOPAR Glass Cleaner and lint-free cloth.

(4) Apply clear glass primer 25 mm (1 in.) wide around perimeter of windshield and wipe with a new clean and dry lint-free cloth.

(5) Apply the molding to the windshield:

(a) Press the upper corners of the molding onto the windshield.

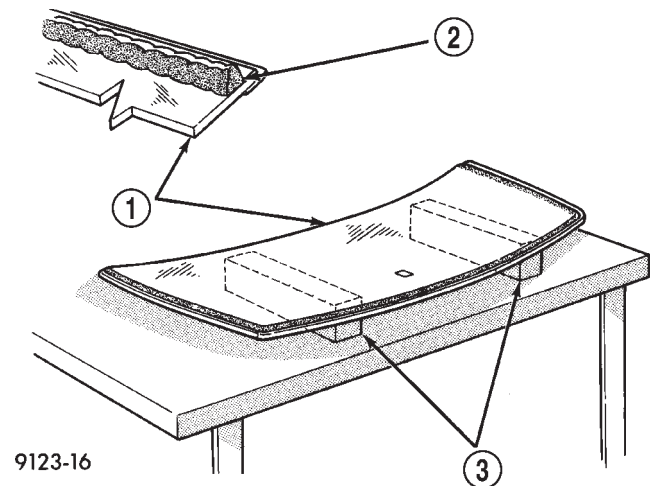
(b) Press the header section onto the windshield.

(c) Press the A-Pillar sections onto the windshield.

(6) Apply black-out primer onto the glass using the windshield molding as a guide. The primer should be 15 mm (5/8 in.) wide on the top and sides of the glass and 25 mm (1 in.) on the bottom of windshield. Allow at least three minutes drying time.

(7) Locate **new** support spacers on support brackets and adjust to lowest height.

(8) Position one 5 mm (3/16 in.) soft spacer (p/n 55028214) at the bottom of the windshield fence (Fig. 11).



**Fig. 10 Work Surface Set up**

- 1 - WINDSHIELD AND MOULDINGS  
2 - URETHANE BEAD AROUND GLASS 7mm (.3 in.) FROM EDGE  
3 - BLOCKS

(9) Apply a 13mm (1/2 in.) high and 10mm (3/8 in.) wide bead of urethane around the perimeter of windshield. At the bottom, apply the bead 7 mm (1/4 in.) inboard from the glass edge. On the three sides where the molding is on the glass, follow the edge of molding. The urethane bead should be shaped in a triangular cross-section, this can be achieved by notching the tip of the applicator (Fig. 12).

(10) With the aid of a helper, position the windshield over the windshield opening. Align the reference marks at the bottom of the windshield to the support spacers.

WINDSHIELD (Continued)

(11) Slowly lower windshield glass to the fence opening guiding the lower corners into proper position. Beginning at the bottom and continuing to the top, push glass onto fence along the A-Pillars. Push windshield inward to the fence at the bottom corners (Fig. 13).

(12) Push windshield upward, snug with roof and ratchet up the adjustable support brackets. Discard tab from support spacer.

(13) Using clean water, lightly mist the support spacers.

(14) Clean excess urethane from exterior with MOPAR® Super Clean or equivalent.

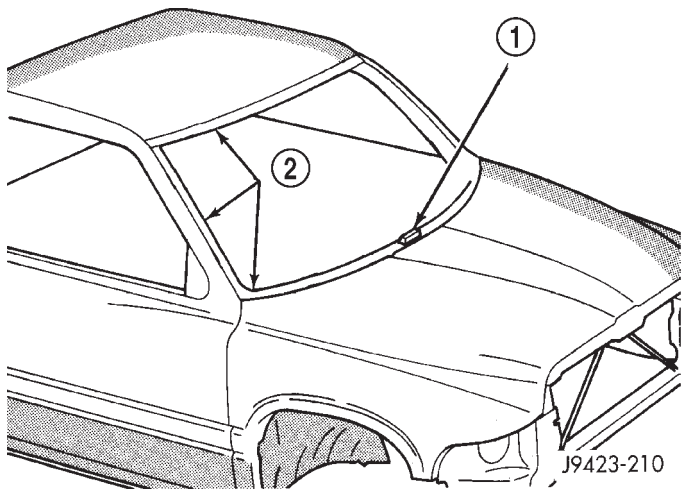
(15) Apply 150 mm (6 in.) lengths of 50 mm (2 in.) masking tape spaced 250 mm (10 in.) apart to hold molding in place until urethane cures.

(16) Install cowl grill. (Refer to 23 - BODY/EXTE-RIOR/COWL GRILLE - INSTALLATION).

(17) Install rear view mirror support bracket. (Refer to 23 - BODY/INTERIOR/REAR VIEW MIR-ROR - INSTALLATION).

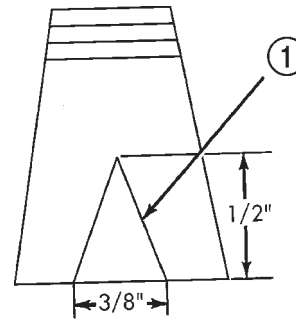
(18) Install rear view mirror. (Refer to 23 - BODY/INTERIOR/REAR VIEW MIRROR - INSTALLA-TION).

(19) After urethane has cured, remove tape strips and water test windshield to verify repair.



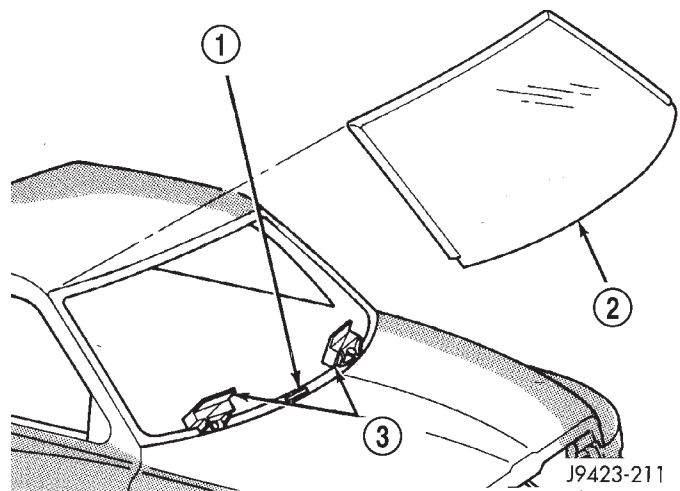
**Fig. 11 Position Urethane Compression Spacer**

- 1 - URETHANE COMPRESSION SPACER
- 2 - FENCE



**Fig. 12 Applicator Tip**

- 1 - APPLICATOR TIP



**Fig. 13 Lower Windshield Into Position**

- 1 - COMPRESSION SPACER
- 2 - WINDSHIELD
- 3 - ADJUSTABLE SUPPORT SPACERS



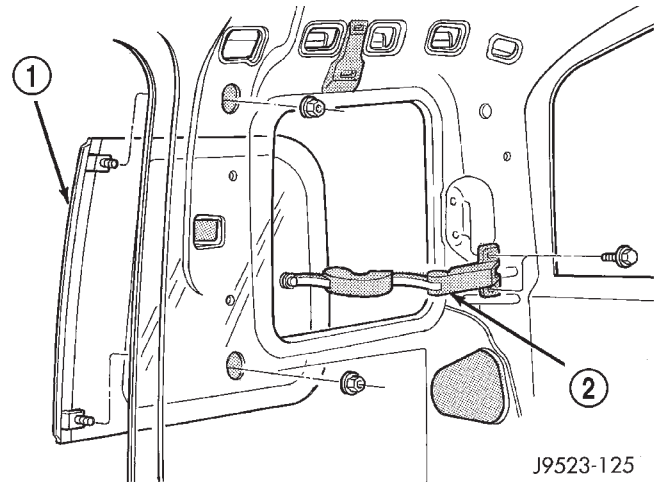
## QUARTER WINDOW

### REMOVAL

- (1) Remove quarter trim panel.
- (2) Remove the latch retaining screws from the cab rear side panel (Fig. 14).
- (3) Remove the frame/hinge retaining nuts from the B-pillar.
- (4) Remove the window glass from the cab.
- (5) If necessary, remove the latch from the glass.

### INSTALLATION

- (1) If removed, install the latch to the glass. Tighten the screw to 6 N·m (60 in. lbs.) torque.
- (2) Center the window glass at the opening, insert the hinge studs in the B-pillar holes, and install the retaining nuts. Tighten the nuts to 11 N·m (95 in. lbs.) torque.
- (3) Attach the latch to the rear side panel with the screws. Tighten the screws with the latch in the lock position and pushing rearward on the latch. Tighten the screws to 11 N·m (95 in. lbs.) torque.



**Fig. 14 Vent Window—Club Cab**

- 1 - QUARTER GLASS  
2 - LATCH

- (4) Test the vent window for water leaks.
- (5) Install quarter trim panel.

# WEATHERSTRIP/SEALS

## TABLE OF CONTENTS

	page		page
<b>B-PILLAR DOOR SEAL</b>		<b>FRONT DOOR INNER BELT WEATHERSTRIP</b>	
REMOVAL .....	152	REMOVAL .....	154
INSTALLATION .....	152	INSTALLATION .....	154
<b>COWL WEATHERSTRIP</b>		<b>FRONT DOOR OUTER BELT WEATHERSTRIP</b>	
REMOVAL .....	153	REMOVAL .....	154
INSTALLATION .....	153	INSTALLATION .....	154
<b>DOOR OPENING SEAL</b>		<b>FRONT DOOR UPPER CORNER SEAL</b>	
REMOVAL .....	153	REMOVAL .....	154
INSTALLATION .....	153	INSTALLATION .....	155
<b>FRONT DOOR GLASS RUN WEATHERSTRIP</b>		<b>FRONT DOOR SECOND WEATHERSTRIP</b>	
REMOVAL .....	153	REMOVAL .....	155
INSTALLATION .....	154	INSTALLATION .....	155

## B-PILLAR DOOR SEAL

### REMOVAL

(1) Warm the seal and body metal to approximately 38°C (100°F) using a suitable heat lamp or heat gun.

(2) Pull seal from painted surface (Fig. 1).

### INSTALLATION

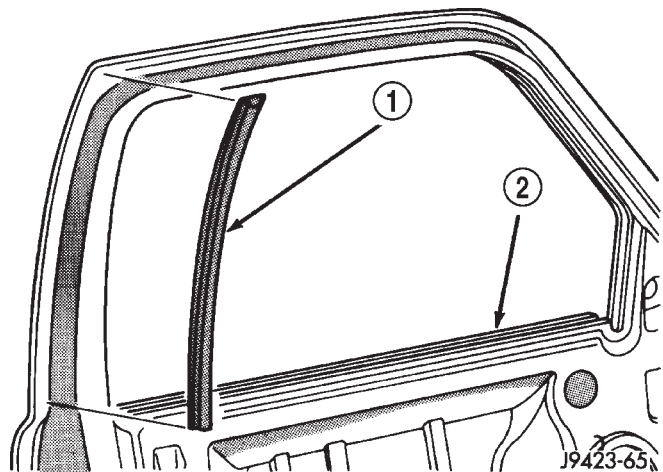
(1) Remove adhesive tape residue from painted surface of vehicle.

(2) If seal is to be reused, remove tape residue from seal. Clean back of seal with MOPAR®, Super Kleen solvent or equivalent. Wipe seal dry with lint free cloth. Apply new body side molding (two sided adhesive) tape to back of seal.

(3) Clean body surface with MOPAR®, Super Kleen solvent or equivalent. Wipe surface dry with lint free cloth.

(4) Remove protective cover from tape on back of seal and apply seal to body.

(5) Heat body and seal, see step one. Firmly press seal to body surface to assure adhesion (Fig. 1).



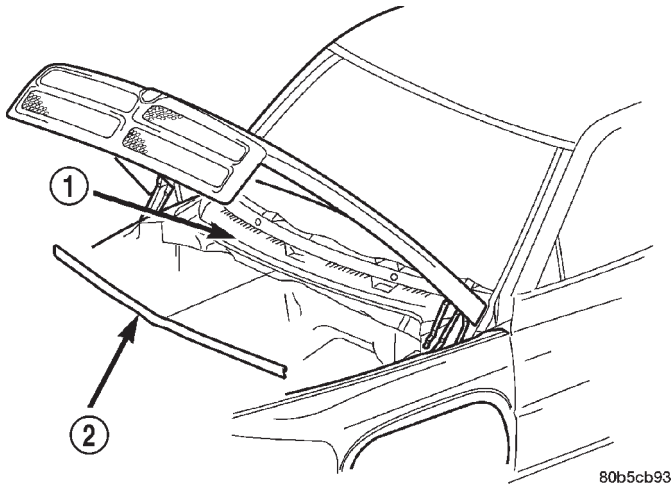
**Fig. 1 B-Pillar Secondary Seal**

- 1 - B—PILLAR SECONDARY SEAL
- 2 - DOOR

## COWL WEATHERSTRIP

### REMOVAL

- (1) Grasp cowl seal and pull from cowl flange.
- (2) Separate cowl seal from vehicle (Fig. 2).



**Fig. 2 Cowl Seal**

- 1 - COWL  
2 - COWL SEAL

### INSTALLATION

- (1) Position cowl seal on flange and press into place.

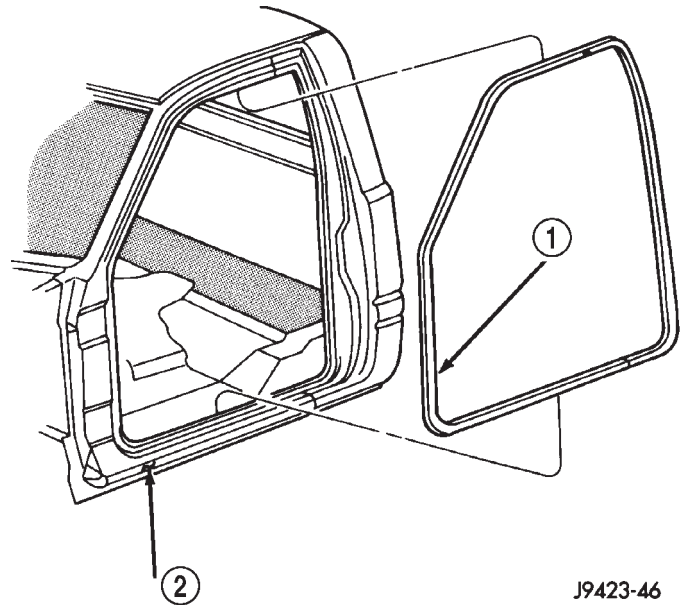
## DOOR OPENING SEAL

### REMOVAL

- (1) Remove A-pillar molding. (Refer to 23 - BODY/INTERIOR/A-PILLAR TRIM - REMOVAL)
- (2) Remove cowl pane. (Refer to 23 - BODY/INTERIOR/COWL TRIM COVER - REMOVAL)
- (3) Remove sill cover. (Refer to 23 - BODY/INTERIOR/DOOR SILL TRIM - REMOVAL)
- (4) Remove B-pillar trim. (Refer to 23 - BODY/INTERIOR/B-PILLAR TRIM - REMOVAL)
- (5) Pull seal from pinch flange around door opening (Fig. 3).

### INSTALLATION

- (1) Press seal onto pinch flange around door opening (Fig. 3).
- (2) Install B-pillar trim panel. (Refer to 23 - BODY/INTERIOR/B-PILLAR TRIM - INSTALLATION)
- (3) Install cowl panel. (Refer to 23 - BODY/INTERIOR/COWL TRIM COVER - INSTALLATION)
- (4) Install sill cover. (Refer to 23 - BODY/INTERIOR/DOOR SILL TRIM - INSTALLATION)



**Fig. 3 Door Opening Seal—Club Cab**

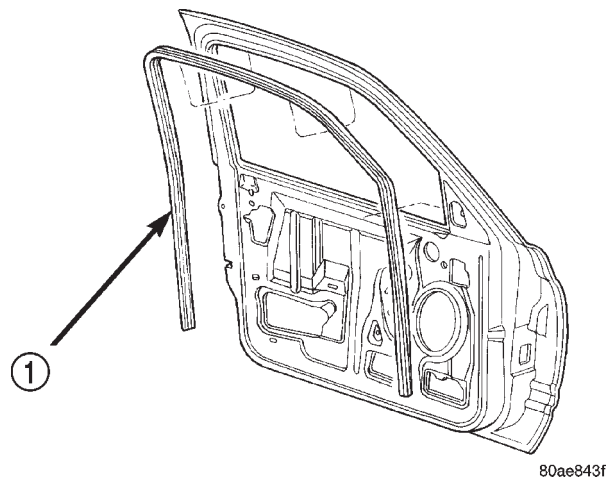
- 1 - DOOR SEAL  
2 - BODY

- (5) Install A-pillar molding. (Refer to 23 - BODY/INTERIOR/A-PILLAR TRIM - INSTALLATION)

## FRONT DOOR GLASS RUN WEATHERSTRIP

### REMOVAL

- (1) Remove inner door belt weatherstrip. (Refer to 23 - BODY/WEATHERSTRIP/SEALS/FRONT DOOR INNER BELT WEATHERSTRIP - REMOVAL)
- (2) Pull door glass run weatherstrip from channel around window opening (Fig. 4).



**Fig. 4 Door Glass Run Weatherstrip**

- 1 - GLASS RUN WEATHERSTRIP

## FRONT DOOR GLASS RUN WEATHERSTRIP (Continued)

**INSTALLATION**

(1) Press door glass run weatherstrip into channel around window opening (Fig. 4).

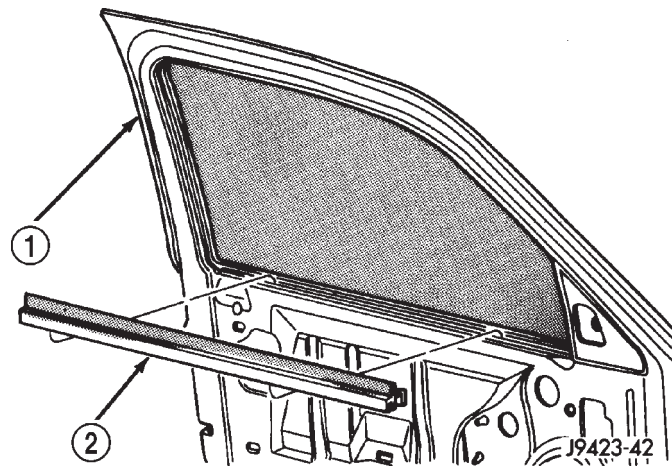
(2) Install inner door belt weatherstrip. (Refer to 23 - BODY/WEATHERSTRIP/SEALS/FRONT DOOR INNER BELT WEATHERSTRIP - INSTALLATION)

**FRONT DOOR INNER BELT WEATHERSTRIP****REMOVAL**

(1) Remove door trim panel. (Refer to 23 - BODY/DOOR - FRONT/TRIM PANEL - REMOVAL)

(2) Lift inner door belt weatherstrip upward (Fig. 5).

(3) Separate inner door belt weatherstrip from door.

**Fig. 5 Inner Door Belt Weatherstrip**

- 1 - DOOR  
2 - INNER BELTLINE WEATHERSEAL

**INSTALLATION**

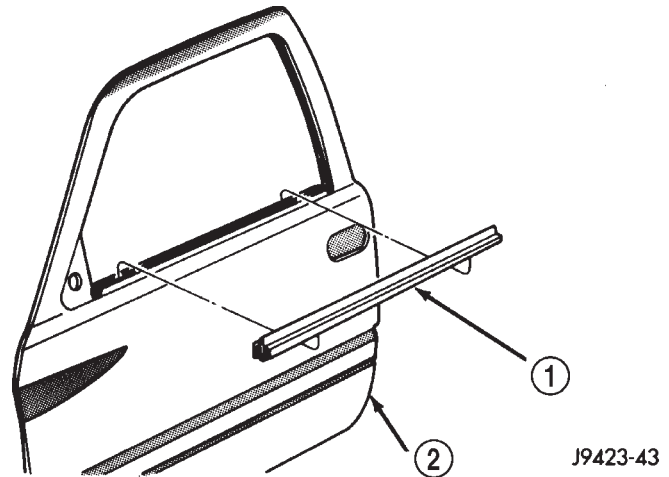
(1) Position inner door belt weatherstrip on door.  
(2) Press inner door belt weatherstrip downward to seat.

(3) Install door trim panel. (Refer to 23 - BODY/DOOR - FRONT/TRIM PANEL - INSTALLATION)

**FRONT DOOR OUTER BELT WEATHERSTRIP****REMOVAL**

- (1) Roll door glass down.  
(2) Remove mirror. (Refer to 23 - BODY/EXTERIOR/SIDE VIEW MIRROR - REMOVAL)  
(3) Using a hook tool inserted into the end of the belt weatherstrip, lift upward.

(4) Separate outer door belt weatherstrip from door (Fig. 6).

**Fig. 6 Outer Door Belt Weatherstrip**

- 1 - OUTER BELTLINE WATHERSTRIP  
2 - DOOR

**INSTALLATION**

- (1) Position outer door belt weatherstrip on door.  
(2) Press weatherstrip downward to seat.  
(3) Install mirror. (Refer to 23 - BODY/EXTERIOR/SIDE VIEW MIRROR - INSTALLATION)

**FRONT DOOR UPPER CORNER SEAL****REMOVAL**

- (1) Remove the push-in fasteners attaching the upper corner seal to the front door (Fig. 7).  
(2) Separate the upper corner seal from the door.

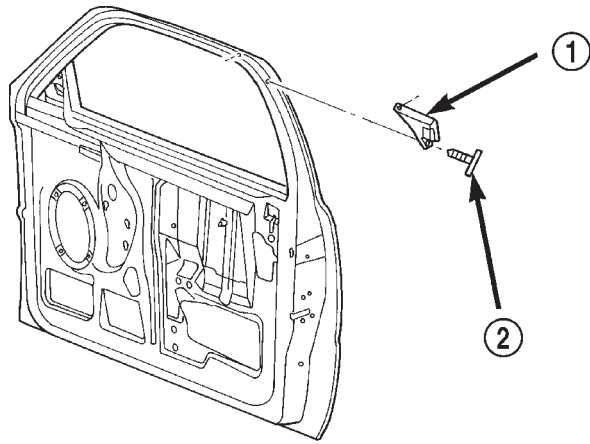
**INSTALLATION**

- (1) Position the upper corner seal on the door.  
(2) Install the push-in fasteners attaching the upper corner seal to the front door (Fig. 7).

**FRONT DOOR SECOND WEATHERSTRIP****REMOVAL**

- (1) Remove the push-in fasteners attaching the secondary seal to the inner door panel.  
(2) Separate the secondary seal from the inner door panel (Fig. 8).

FRONT DOOR 2ND WEATHERSTRIP (Continued)

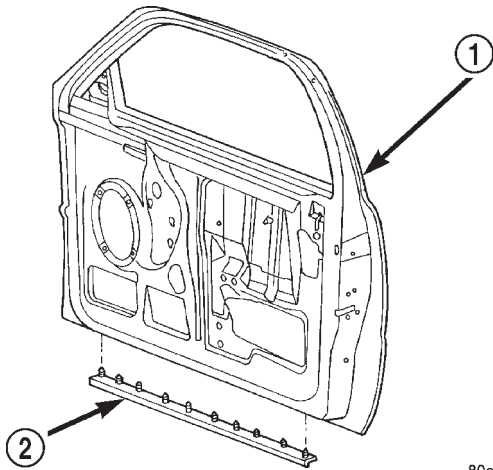


(2) Install the push-in fasteners attaching the secondary seal to the inner door panel.

80ae8472

**Fig. 7 Upper Corner Seal—Quad Cab**

- 1 - UPPER CORNER SEAL
- 2 - PUSH-IN FASTENER



80ae8441

**Fig. 8 Front Door Secondary Seal—Quad Cab**

- 1 - FRONT DOOR
- 2 - SECONDARY SEAL

**INSTALLATION**

(1) Position the secondary seal on the inner door panel.





# HEATING & AIR CONDITIONING

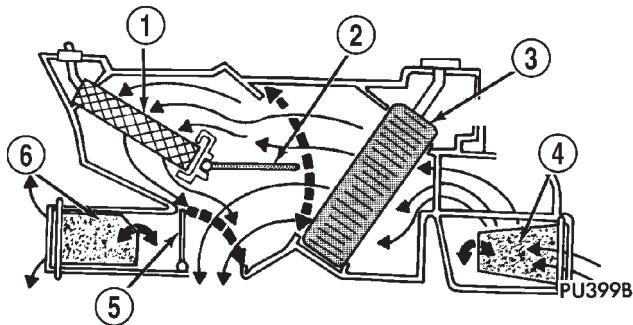
## TABLE OF CONTENTS

	page		page
<b>HEATING &amp; AIR CONDITIONING</b>		<b>STANDARD PROCEDURE</b> .....	7
DESCRIPTION .....	1	DIODE REPLACEMENT .....	7
OPERATION .....	1	SPECIFICATIONS .....	8
DIAGNOSIS AND TESTING .....	2	<b>CONTROLS</b> .....	9
A/C PERFORMANCE .....	2	<b>DISTRIBUTION</b> .....	31
HEATER PERFORMANCE .....	6	<b>PLUMBING</b> .....	40

## HEATING & AIR CONDITIONING

### DESCRIPTION - HEATER AND AIR CONDITIONER

All vehicles are equipped with a common HVAC housing assembly (Fig. 1). The system combines air conditioning, heating, and ventilating capabilities in a single unit housing mounted under the instrument panel. On heater-only systems, the evaporator coil and recirculation door are omitted from the housing.



**Fig. 1 COMMON BLEND-AIR HEATER-AIR**

- 1 - HEATER CORE
- 2 - BLEND DOOR
- 3 - EVAPORATOR (A/C ONLY)
- 4 - RECIRCULATION DOOR (A/C ONLY)
- 5 - FLOOR/PANEL DOOR
- 6 - FLOOR/DEFROST DOOR

### DESCRIPTION - COOLING SYSTEM REQUIREMENTS

To maintain the performance level of the HVAC system, the engine cooling system must be properly maintained. The use of a bug screen is not recommended. Any obstructions in front of the radiator or condenser will reduce the performance of the air conditioning and engine cooling systems.

The engine cooling system includes the heater core and the heater hoses. Refer to Cooling for more information before the opening of, or attempting any service to the engine cooling system.

### DESCRIPTION - REFRIGERANT SYSTEM SERVICE PORT

The two refrigerant system service ports are used to charge, recover/recycle, evacuate, and test the air conditioning refrigerant system. Unique service port coupler sizes are used on the R-134a system, to ensure that the refrigerant system is not accidentally contaminated by the use of the wrong refrigerant (R-12), or refrigerant system service equipment.

### OPERATION - HEATER AND AIR CONDITIONER

The heater and optional air conditioner are blend-air type systems. In a blend-air system, a blend door controls the amount of unconditioned air (or cooled air from the evaporator on models with air conditioning) that is allowed to flow through, or around, the heater core. A temperature control knob on the A/C Heater control panel determines the discharge air temperature by controlling an electric actuator, which moves the blend door. This allows an almost immediate control of the output air temperature of the system.

The mode control knob on the heater-only or A/C Heater control panel is used to direct the conditioned air to the selected system outlets. Both mode control switches use engine vacuum to control the mode doors, which are operated by vacuum actuators.

On air conditioned vehicles, the outside air intake can be shut off by selecting the Recirculation Mode with the mode control knob. This will operate a vacuum actuated recirculation door that closes off the outside fresh air intake and recirculates the air that is already inside the vehicle.

The optional air conditioner for all models is designed for the use of non-CFC, R-134a refrigerant. The air conditioning system has an evaporator to cool and dehumidify the incoming air prior to blending it with the

## HEATING &amp; AIR CONDITIONING (Continued)

heated air. This air conditioning system uses a fixed orifice tube in the middle of the liquid line to meter refrigerant flow to the evaporator coil. To maintain minimum evaporator temperature and prevent evaporator freezing, the a/c low pressure switch on the accumulator cycles the compressor clutch.

### OPERATION - REFRIGERANT SYSTEM SERVICE PORT

The high pressure service port is located on the liquid line between the condenser and the evaporator, near the front of the engine compartment. The low pressure service port is located on the suction line, near the accumulator outlet.

Each of the service ports has a threaded plastic protective cap installed over it from the factory. After servicing the refrigerant system, always reinstall both of the service port caps.

### DIAGNOSIS AND TESTING - A/C PERFORMANCE

The air conditioning system is designed to provide the passenger compartment with low temperature and low humidity air. The evaporator, located in the HVAC housing on the dash panel below the instrument panel, is cooled to temperatures near the freezing point. As warm damp air passes through the cooled evaporator, the air transfers its heat to the refrigerant in the evaporator tubes and the moisture in the air condenses on the evaporator fins. During periods of high heat and humidity, an air conditioning system will be more effective in the recirculation mode (Max-A/C). With the system in the recirculation mode, only air from the passenger compartment passes through the evaporator. As the passenger compartment air dehumidifies, the air conditioning system performance levels improve.

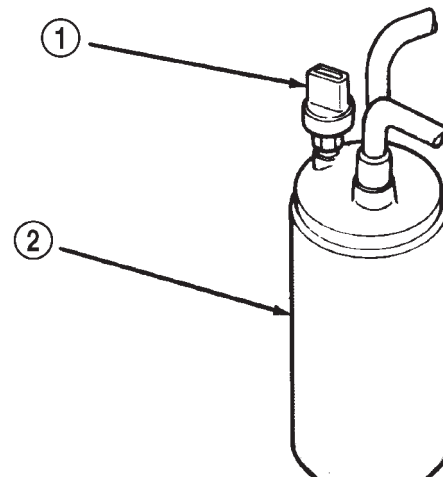
Humidity has an important bearing on the temperature of the air delivered to the interior of the vehicle. It is important to understand the effect that humidity has on the performance of the air conditioning system. When humidity is high, the evaporator has to perform a double duty. It must lower the air temperature, and it must lower the temperature of the moisture in the air that condenses on the evaporator fins. Condensing the moisture in the air transfers heat energy into the evaporator fins and tubing. This reduces the amount of heat the evaporator can absorb from the air. High humidity greatly reduces the ability of the evaporator to lower the temperature of the air.

However, evaporator capacity used to reduce the amount of moisture in the air is not wasted. Wringing some of the moisture out of the air entering the vehicle adds to the comfort of the passengers. Although, an owner may expect too much from their

air conditioning system on humid days. A performance test is the best way to determine whether the system is performing up to standard. This test also provides valuable clues as to the possible cause of trouble with the air conditioning system.

Before proceeding, (Refer to 24 - HEATING & AIR CONDITIONING/PLUMBING - WARNING) and (Refer to 24 - HEATING & AIR CONDITIONING/PLUMBING - CAUTION). The air temperature in the test room and in the vehicle must be a minimum of 21° C (70° F) for this test.

- (1) Connect a tachometer and a manifold gauge set.
- (2) Set the a/c heater mode control switch knob to the recirculation mode (Max-A/C) position, the temperature control knob to the full cool position, and the blower motor switch to the highest speed position.
- (3) Start the engine and hold the idle speed at 1,000 rpm with the compressor clutch engaged. If the compressor clutch does not engage, (Refer to 24 - HEATING & AIR CONDITIONING/CONTROLS/A/C COMPRESSOR CLUTCH COIL - DIAGNOSIS AND TESTING).
- (4) The engine should be at operating temperature. The doors and windows must be closed and the hood must be mostly closed.
- (5) Insert a thermometer in the driver side center A/C (panel) outlet. Operate the engine for five minutes.
- (6) The compressor clutch may cycle, depending upon the ambient temperature and humidity. If the clutch cycles, unplug the a/c low pressure switch wire harness connector from the switch located on the accumulator (Fig. 2). Place a jumper wire between the two cavities of the a/c low pressure switch wire harness connector.



J9424-26

**Fig. 2 A/C LOW PRESSURE SWITCH**

- 1 - A/C LOW PRESSURE SWITCH  
2 - ACCUMULATOR

HEATING & AIR CONDITIONING (Continued)

(7) With the compressor clutch engaged, record the panel outlet discharge air temperature, the discharge pressure (high side), and the suction pressure (low side).

(8) Compare the panel outlet discharge air temperature reading to the Performance Temperature and Pressure chart. If the temperature reading is high, clamp off both heater hoses (inlet and outlet), wait five minutes and record the temperature again. Compare the second reading to the Performance Temperature and Pressure chart.

If the temperature reading is now OK, see Temperature Control Cable in the Removal and Installation section and in the Adjustments section of this group. If the temperature reading is still too high, (Refer to 24 - HEATING & AIR CONDITIONING/PLUMBING - DIAGNOSIS AND TESTING), and (Refer to 24 - HEATING & AIR CONDITIONING/PLUMBING - STANDARD PROCEDURE) in this group.

Performance Temperature and Pressure						
Ambient Temperature	21° C (70° F)	27° C (80° F)	32° C (90° F)	38° C (100° F)	43° C (110° F)	49° C (120° F)
Center Panel Outlet Discharge Air Temperature	5 to 7° C (40 to 45° F)	13 to 16° C (55 to 60° F)	16 to 21° C (60 to 70° F)	21 to 24° C (70 to 75° F)	27 to 29° C (80 to 85° F)	29 to 32° C (85 to 90° F)
*Suction Pressure (Low Side)	241 to 276 kPa (35 to 40 psi)	276 to 345 kPa (40 to 50 psi)	345 to 414 kPa (50 to 60 psi)	414 to 483 kPa (60 to 70 psi)	483 to 552 kPa (70 to 80 psi)	552 to 586 kPa (85 to 90 psi)
*Discharge Pressure (High Side)	931 to 1000 kPa (135 to 145 psi)	1207 to 1482 kPa (175 to 215 psi)	1482 to 1862 kPa (215 to 270 psi)	1862 to 2275 kPa (270 to 330 psi)	2344 to 2551 kPa (340 to 370 psi)	2758 to 2965 kPa (400 to 430 psi)
*Note: If pressures are lower than shown, but center panel outlet discharge air temperatures are OK, then the A/C system is OK.						

(9) Compare the discharge (high side) and suction (low side) pressure readings to the Performance Temperature and Pressure chart.

If the pressures are abnormal, see the A/C Diagnosis chart.

A/C Diagnosis		
Condition	Possible Causes	Correction
RAPID COMPRESSOR CLUTCH CYCLING (TEN OR MORE CYCLES PER MINUTE).	1. Low refrigerant system charge.  2. Faulty a/c low pressure switch.  3. Faulty Powertrain Control Module (PCM).	1. (Refer to Plumbing/Diagnosis and Testing - Refrigerant System Leaks) in this group. Test the refrigerant system for leaks. Repair, evacuate and charge the refrigerant system, if required.  2. (Refer to Controls/A/C Low Pressure Switch/Diagnosis and Testing) in this group. Test the a/c low pressure switch and replace, if required.  3. (Refer to Appropriate Diagnostic Information) for testing the PCM. Test the PCM and replace, if required.
EQUAL PRESSURES, BUT THE COMPRESSOR CLUTCH DOES NOT ENGAGE.	1. No refrigerant in the refrigerant system.  2. Faulty fuse.	1. (Refer to Plumbing/Diagnosis and Testing - Refrigerant System Leaks) in this group. Test the refrigerant system for leaks. Repair, evacuate and charge the refrigerant system, if required.  2. Check the fuses in the Power Distribution Center and the junction block. Repair the shorted circuit or component and replace the fuses, if required.

## HEATING &amp; AIR CONDITIONING (Continued)

A/C Diagnosis		
Condition	Possible Causes	Correction
	3. Faulty a/c compressor clutch coil. 4. Faulty a/c compressor clutch relay. 5. Improperly installed or faulty a/c low pressure switch. 6. Faulty a/c high pressure switch. 7. Faulty Powertrain Control Module (PCM). 8. Faulty a/c heater control.	3. (Refer to Controls/A/C Compressor Clutch Coil/ Diagnosis and Testing) in this group. Test the compressor clutch coil and replace, if required. 4. (Refer to Controls/A/C Compressor Clutch Relay/ Diagnosis and Testing) in this group. Test the compressor clutch relay and relay circuits. Repair the circuits or replace the relay, if required. 5. (Refer to Controls/A/C Low Pressure Switch/Diagnosis and Testing) in this group. Test the a/c low pressure switch and tighten or replace, if required. 6. (Refer to Controls/A/C High Pressure Switch/Diagnosis and Testing) in this group. Test the a/c high pressure switch and replace, if required. 7. (Refer to Appropriate Diagnostic Information) for testing the PCM. Test the PCM and replace, if required. 8. (Refer to Controls/A/C Heater Control/Diagnosis and Testing) in this group. Test the a/c heater control and replace, if required.
NORMAL PRESSURES, BUT A/C PERFORMANCE TEST AIR TEMPERATURES AT CENTER PANEL OUTLET ARE TOO HIGH.	1. Excessive refrigerant oil in system. 2. Blend door actuator inoperative or faulty. 3. Blend door inoperative, obstructed or sealing improperly.	1. (Refer to Plumbing/Refrigerant Oil/Standard Procedure - Refrigerant Oil Level) in this group. Recover the refrigerant from the refrigerant system and inspect the refrigerant oil content. Restore the refrigerant oil to the proper level, if required. 2. Check the Blend Door Actuator operation. Replace as required. 3. (Refer to Distribution/Blend Door/Removal/Installation) in this group. Inspect the blend door for proper operation and sealing and correct, if required.
LOW SIDE PRESSURE IS NORMAL OR SLIGHTLY LOW, AND HIGH SIDE PRESSURE IS TOO LOW.	1. Low refrigerant system charge. 2. Refrigerant flow through the accumulator is restricted. 3. Refrigerant flow through the a/c evaporator is restricted. 4. Faulty compressor.	1. (Refer to Plumbing/Diagnosis and Testing - Refrigerant System Leaks) in this group. Test the refrigerant system for leaks. Repair, evacuate and charge the refrigerant system, if required. 2. (Refer to Plumbing/Accumulator/ Removal/Installation) in this group. Replace the restricted accumulator, if required. 3. (Refer to Plumbing/A/C Evaporator/ Removal/ Installation) in this group. Replace the restricted evaporator, if required. 4. (Refer to Plumbing/A/C Compressor/ Removal/ Installation) in this group. Replace the compressor, if required.



## HEATING &amp; AIR CONDITIONING (Continued)

A/C Diagnosis		
Condition	Possible Causes	Correction
LOW SIDE PRESSURE IS NORMAL OR SLIGHTLY HIGH, AND HIGH SIDE PRESSURE IS TOO HIGH.	<ol style="list-style-type: none"> <li>1. Condenser air flow restricted.</li> <li>2. Inoperative cooling fan.</li> <li>3. Refrigerant system overcharged.</li> <li>4. Air in the refrigerant system.</li> <li>5. Engine overheating.</li> </ol>	<ol style="list-style-type: none"> <li>1. Check the condenser for damaged fins, foreign objects obstructing air flow through the condenser fins, and missing or improperly installed air seals. Refer to Cooling for more information on air seals. Clean, repair, or replace components as required.</li> <li>2. Refer to Cooling for more information. Test the cooling fan and replace, if required.</li> <li>3. (Refer to Plumbing/Standard Procedure - Refrigerant System Charge) in this group. Recover the refrigerant from the refrigerant system. Charge the refrigerant system to the proper level, if required.</li> <li>4. (Refer to Plumbing/Diagnosis and Testing - Refrigerant System Leaks) in this group. Test the refrigerant system for leaks. Repair, evacuate and charge the refrigerant system, if required.</li> <li>5. Refer to Cooling for more information. Test the cooling system and repair, if required.</li> </ol>
LOW SIDE PRESSURE IS TOO HIGH, AND HIGH SIDE PRESSURE IS TOO LOW.	<ol style="list-style-type: none"> <li>1. Accessory drive belt slipping.</li> <li>2. A/C orifice tube not installed.</li> <li>3. Faulty a/c compressor.</li> </ol>	<ol style="list-style-type: none"> <li>1. Refer to Cooling for more information. Inspect the accessory drive belt condition and tension. Tighten or replace the accessory drive belt, if required.</li> <li>2. (Refer to Plumbing/A/C Orifice Tube/Diagnosis and Testing) in this group. Replace the liquid line, if required.</li> <li>3. (Refer to Plumbing/A/C Compressor/ Removal/ Installation) in this group. Replace the compressor, if required.</li> </ol>
LOW SIDE PRESSURE IS TOO LOW, AND HIGH SIDE PRESSURE IS TOO HIGH.	<ol style="list-style-type: none"> <li>1. Restricted refrigerant flow through the refrigerant lines.</li> <li>2. Restricted refrigerant flow through the a/c orifice tube.</li> <li>3. Restricted refrigerant flow through the a/c condenser.</li> </ol>	<ol style="list-style-type: none"> <li>1. (Refer to Plumbing/Caution - Refrigerant Hoses/Lines/ Tubes Precautions) in this group. Inspect the refrigerant lines for kinks, tight bends or improper routing. Correct the routing or replace the refrigerant line, if required.</li> <li>2. (Refer to Plumbing/A/C Orifice Tube/Diagnosis and Testing) in this group. Replace the liquid line, if required.</li> <li>3. (Refer to Plumbing/A/C Condenser/ Removal/ Installation) in this group. Replace the restricted a/c condenser, if required.</li> </ol>

HEATING & AIR CONDITIONING (Continued)

**DIAGNOSIS AND TESTING - HEATER PERFORMANCE**

Before performing the following tests, refer to Cooling for the procedures to check the engine coolant level and flow, engine coolant reserve/recovery system operation, accessory drive belt condition and tension, radiator air flow and the fan drive operation. Also be certain that the accessory vacuum supply line is connected at the engine vacuum source.

**MAXIMUM HEATER OUTPUT**

Engine coolant is delivered to the heater core through two heater hoses. With the engine idling at

normal operating temperature, set the temperature control knob in the full hot position, the mode control switch knob in the floor position, and the blower motor switch knob in the highest speed position. Using a test thermometer, check the temperature of the air being discharged at the HVAC housing floor outlets. Compare the test thermometer reading to the Temperature Reference chart.

Temperature Reference				
Ambient Air Temperature	15.5° C (60° F)	21.1° C (70° F)	26.6° C (80° F)	32.2° C (90° F)
Minimum Air Temperature at Floor Outlet	62.2° C (144° F)	63.8° C (147° F)	65.5° C (150° F)	67.2° C (153° F)

If the floor outlet air temperature is too low, refer to Cooling to check the engine coolant temperature specifications. Both of the heater hoses should be hot to the touch. The coolant return heater hose should be slightly cooler than the coolant supply heater hose. If the return hose is much cooler than the supply hose, locate and repair the engine coolant flow obstruction in the cooling system. Refer to Cooling for the procedures.

An alternate method of checking heater performance is to use a DRBIII® scan tool to monitor the engine coolant temperature. The floor outlet air temperature reading should be no more than 4.5° C (40° F) lower than the engine coolant temperature reading.

**OBSTRUCTED COOLANT FLOW** Possible locations or causes of obstructed coolant flow:

- Faulty water pump.
- Faulty thermostat.
- Pinched or kinked heater hoses.
- Improper heater hose routing.
- Plugged heater hoses or supply and return ports at the cooling system connections.
- A plugged heater core.

If proper coolant flow through the cooling system is verified, and heater outlet air temperature is still low, a mechanical problem may exist.

**MECHANICAL PROBLEMS** Possible locations or causes of insufficient heat:

- An obstructed cowl air intake.
- Obstructed heater system outlets.
- A faulty, obstructed or improperly installed blend door.
- A faulty blower system.
- A faulty a/c heater control.

**TEMPERATURE CONTROL**

If the heater outlet air temperature cannot be adjusted with the temperature control knob on the a/c heater control panel, the following could require service:

- A faulty a/c heater control.
- A faulty blend door actuator.
- A faulty, obstructed or improperly installed blend door.
- An obstructed cowl air intake.
- The engine cooling system.

HEATING & AIR CONDITIONING (Continued)

Heater Diagnosis		
CONDITION	POSSIBLE CAUSE	CORRECTION
INSUFFICIENT HEATER OUTPUT.	1. Incorrect engine coolant level. 2. Air trapped in engine cooling system. 3. Incorrect engine coolant temperature.  4. Blend door actuator inoperative or defective. 5. Blend door not operating properly.  6. Insufficient air flow through heater housing. 7. Improper blower motor operation.	1. Check the engine coolant level. Refer to Cooling for the procedures. 2. Check the operation of the coolant reserve/recovery system. Refer to Cooling for the procedures. 3. Check the performance and operation of the engine cooling system including: thermostat, water pump, fan drive, accessory drive belt, coolant flow (plugged radiator or heater core, plugged or kinked coolant hoses), air flow (missing or improperly installed radiator air seals or fan shroud). Refer to Cooling for the procedures. 4. (Refer to Controls/Blend Door Actuator) in this group.  5. Check for a damaged, obstructed or improperly installed blend door or seals. (Refer to Controls/Blend Door Actuator) in this group. 6. Remove foreign material or obstructions from cowl air intake. 7. (Refer to Distribution/Blower Motor/ Diagnosis and Testing) in this group.

**STANDARD PROCEDURE - DIODE REPLACEMENT**

- (1) Disconnect the battery.
- (2) Locate the diode in the harness, and remove the protective covering.
- (3) Remove the diode from the harness, pay attention to the current flow direction (Fig. 3).

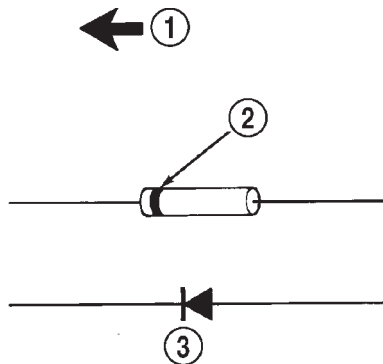
(4) Remove the insulation from the wires in the harness. Only remove enough insulation to solder in the new diode.

(5) Install the new diode in the harness, making sure current flow is correct. If necessary refer to the appropriate wiring diagram for current flow.

(6) Solder the connection together using rosin core type solder only. **Do not use acid core solder.**

(7) Tape the diode to the harness using electrical tape making, sure the diode is completely sealed from the elements.

(8) Re-connect the battery, and test affected systems.



948W-197

**Fig. 3 DIODE IDENTIFICATION**

- 1 - CURRENT FLOW
- 2 - BAND AROUND DIODE INDICATES CURRENT FLOW
- 3 - DIODE AS SHOWN IN THE DIAGRAMS

## HEATING &amp; AIR CONDITIONING (Continued)

## SPECIFICATIONS

## A/C APPLICATION TABLE

Item	Description	Notes
Vehicle	BR/BE - Ram Pickup	
System	R134a w/orifice tube	
Compressor	Sanden SD7H15	SP-20 PAG oil
Freeze-up Control	A/C Low Pressure Switch	accumulator mounted
Low psi Control	opens < 22-24 psi resets > 37-43 psi	
High psi Control	switch - opens > 450 - 490 psi, resets < 270 - 330 psi	mounted on discharge line, near compressor
A/C Heater Control Head	manual type	
Mode Door	vacuum actuator	

Item	Description	Notes
Blend Door	electric actuator	
Recirculation Door	vacuum actuator	
Blower Motor	hardwired to control head	resistor block
Cooling Fan	viscous fan	
Clutch		
Control	relay	PCM
Draw	2 - 3.9 amps @ 12V	± 0.5V @ 70° F
Gap	0.016" - 0.031"	
DRB III®		
Reads	TPS, RPM, A/C switch test	
Actuators	clutch relay	

## TORQUE SPECIFICATIONS

## TORQUE SPECIFICATIONS

DESCRIPTION	N-m	Ft. Lbs.	In. Lbs.
A/C COMPRESSOR CLUTCH PLATE NUT	14.4	10.5	-
A/C COMPRESOR LINE MANIFOLD FASTENER	22	-	200
A/C COMPRESSOR TO MOUNTING BRACKET BOLTS	24	-	210
ACCUMULATOR RETAINING BAND	4.5	-	40
BLOWER MOTOR SCREWS	2.2	-	20
CHECK VALVE AND NIPPLE UNIT (DIESEL)	24	18	-
CONDENSER MOUNTING SCREWS/NUTS	10.5	-	95
DISCHARGE LINE TO CONDENSER FASTENER	20	-	180
DOOR ACTUATOR SCREWS	2.2	-	20
HVAC HOUSING SCREWS	2.2	-	20
HVAC HOUSING TO DASH PANEL NUTS (ENGINE SIDE)	7	-	60
HVAC HOUSING TO DASH PANEL NUTS (PASSENGER COMPARTMENT SIDE)	4.5	-	40

# CONTROLS

## TABLE OF CONTENTS

	page		page
<b>CONTROLS</b>		<b>INSTALLATION</b> . . . . .	22
DIAGNOSIS AND TESTING . . . . .	10	<b>BLOWER MOTOR RELAY</b>	
VACUUM SYSTEM . . . . .	10	DESCRIPTION . . . . .	22
<b>A/C COMPRESSOR CLUTCH</b>		OPERATION . . . . .	22
DESCRIPTION . . . . .	13	DIAGNOSIS AND TESTING . . . . .	22
OPERATION . . . . .	13	BLOWER MOTOR RELAY . . . . .	22
DIAGNOSIS AND TESTING . . . . .	13	REMOVAL . . . . .	23
A/C COMPRESSOR CLUTCH COIL . . . . .	13	INSTALLATION . . . . .	23
STANDARD PROCEDURE . . . . .	13	<b>BLOWER MOTOR RESISTOR BLOCK</b>	
A/C COMPRESSOR CLUTCH BREAK-IN . . . . .	13	DESCRIPTION . . . . .	23
REMOVAL . . . . .	14	OPERATION . . . . .	23
INSPECTION . . . . .	16	DIAGNOSIS AND TESTING . . . . .	24
INSTALLATION . . . . .	16	BLOWER MOTOR RESISTOR BLOCK . . . . .	24
<b>A/C COMPRESSOR CLUTCH RELAY</b>		REMOVAL . . . . .	24
DESCRIPTION . . . . .	17	INSTALLATION . . . . .	24
OPERATION . . . . .	17	<b>BLOWER MOTOR SWITCH</b>	
DIAGNOSIS AND TESTING . . . . .	17	DESCRIPTION . . . . .	24
A/C COMPRESSOR CLUTCH RELAY . . . . .	17	OPERATION . . . . .	25
REMOVAL . . . . .	18	DIAGNOSIS AND TESTING . . . . .	25
INSTALLATION . . . . .	18	BLOWER MOTOR SWITCH . . . . .	25
<b>A/C HEATER CONTROL</b>		REMOVAL . . . . .	25
DESCRIPTION . . . . .	18	<b>BLEND DOOR ACTUATOR</b>	
OPERATION . . . . .	18	REMOVAL . . . . .	25
DIAGNOSIS AND TESTING . . . . .	19	INSTALLATION . . . . .	26
A/C HEATER CONTROL . . . . .	19	<b>MODE DOOR ACTUATOR</b>	
REMOVAL . . . . .	19	REMOVAL . . . . .	26
INSTALLATION . . . . .	20	INSTALLATION . . . . .	27
<b>A/C HIGH PRESSURE SWITCH</b>		<b>RECIRCULATION DOOR ACTUATOR</b>	
DESCRIPTION . . . . .	20	REMOVAL . . . . .	27
OPERATION . . . . .	20	INSTALLATION . . . . .	28
DIAGNOSIS AND TESTING . . . . .	20	<b>VACUUM CHECK VALVE</b>	
A/C HIGH PRESSURE SWITCH . . . . .	20	DESCRIPTION . . . . .	28
REMOVAL . . . . .	21	OPERATION . . . . .	28
INSTALLATION . . . . .	21	REMOVAL . . . . .	29
<b>A/C LOW PRESSURE SWITCH</b>		INSTALLATION . . . . .	29
DESCRIPTION . . . . .	21	<b>VACUUM RESERVOIR</b>	
OPERATION . . . . .	21	DESCRIPTION . . . . .	29
DIAGNOSIS AND TESTING . . . . .	21	OPERATION . . . . .	29
A/C LOW PRESSURE SWITCH . . . . .	21	REMOVAL . . . . .	30
REMOVAL . . . . .	21	INSTALLATION . . . . .	30



## CONTROLS

### DIAGNOSIS AND TESTING - VACUUM SYSTEM

Vacuum control is used to operate the mode doors in the heater-only and HVAC housings. Testing of the heater-only and a/c heater mode control switch operation will determine if the vacuum, electrical, and mechanical controls are functioning. However, it is possible that a vacuum control system that operates perfectly at engine idle (high engine vacuum) may not function properly at high engine speeds or loads (low engine vacuum). This can be caused by leaks in the vacuum system, or by a faulty or improperly installed vacuum check valve.

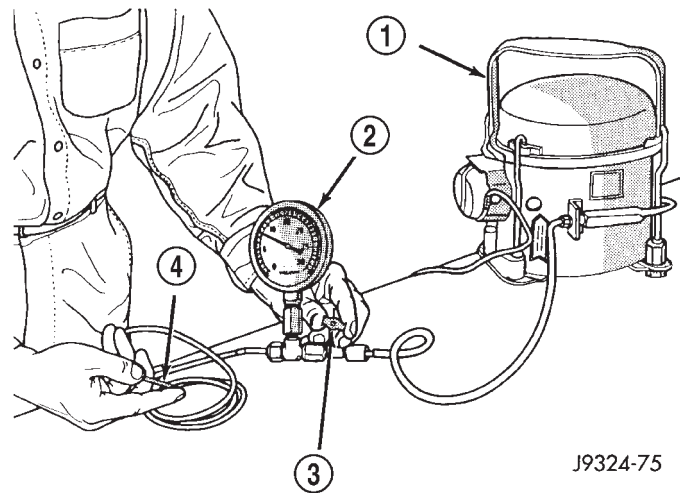
A vacuum system test will help to identify the source of poor vacuum system performance or vacuum system leaks. Before starting this test, stop the engine and make certain that the problem is not a disconnected vacuum supply tube at the engine vacuum source or the vacuum reservoir.

Use an adjustable vacuum test set (Special Tool C-3707) and a suitable vacuum pump to test the HVAC vacuum control system. With a finger placed over the end of the vacuum test hose probe (Fig. 1), adjust the bleed valve on the test set gauge to obtain a vacuum of exactly 27 kPa (8 in. Hg.). Release and block the end of the probe several times to verify that the vacuum reading returns to the exact 27 kPa (8 in. Hg.) setting. Otherwise, a false reading will be obtained during testing.

### VACUUM CHECK VALVE

(1) Remove the vacuum check valve. On gasoline engines, one valve is located in the vacuum supply tube (black) at the intake manifold tap on the right side of the engine. A second check valve is located next to the tee fitting in the vacuum supply tube (black) near the dash panel in the engine compartment. On diesel engines, the vacuum check valve is integral to the engine vacuum pump nipple and is threaded into the vacuum pump. The vacuum check valve must be removed in order to perform the following tests. (Refer to 24 - HEATING & AIR CONDITIONING/CONTROLS/VACUUM CHECK VALVE - REMOVAL)

(2) Connect the test set vacuum supply hose to the a/c heater control side of the valve. When connected to this side of the check valve, no vacuum should pass and the test set gauge should return to the 27



J9324-75

**Fig. 1 ADJUST VACUUM TEST BLEED VALVE**

- 1 - VACUUM PUMP TOOL C-4289
- 2 - VACUUM TEST SET C-3707
- 3 - BLEED VALVE
- 4 - PROBE

kPa (8 in. Hg.) setting. If OK, go to step Step 3. If not OK, replace the faulty valve.

(3) Connect the test set vacuum supply hose to the engine vacuum side of the valve. When connected to this side of the check valve, vacuum should flow through the valve without restriction. If not OK, replace the faulty valve.

### A/C HEATER CONTROLS

(1) Connect the test set vacuum probe to the HVAC vacuum supply (black) tube in the engine compartment. Position the test set gauge so that it can be viewed from the passenger compartment.

(2) Place the a/c heater mode control switch knob to each mode position, one position at a time, and pause after each selection. The test set gauge should return to the 27 kPa (8 in. Hg.) setting shortly after each selection is made. If not OK, a component or vacuum line in the vacuum circuit of the selected mode has a leak. See Locating Vacuum Leaks below.

**CAUTION: Do not use lubricant on the switch ports or in the holes in the plug, as lubricant will ruin the vacuum valve in the switch. A drop of clean water in the connector plug holes will help the connector slide onto the switch ports.**

## CONTROLS (Continued)

## LOCATING VACUUM LEAKS

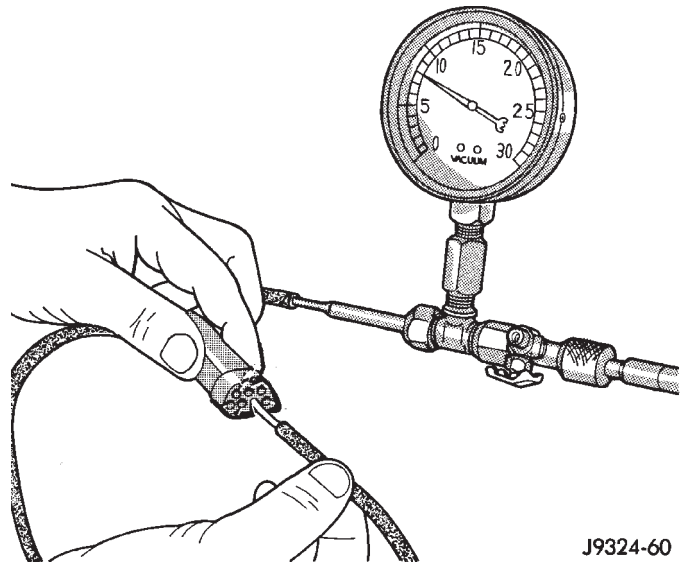
**WARNING: ON VEHICLES EQUIPPED WITH AIRBAGS, DISABLE THE AIRBAG SYSTEM BEFORE ATTEMPTING ANY STEERING WHEEL, STEERING COLUMN, OR INSTRUMENT PANEL COMPONENT DIAGNOSIS OR SERVICE. DISCONNECT AND ISOLATE THE BATTERY NEGATIVE (GROUND) CABLE, THEN WAIT TWO MINUTES FOR THE AIRBAG SYSTEM CAPACITOR TO DISCHARGE BEFORE PERFORMING FURTHER DIAGNOSIS OR SERVICE. THIS IS THE ONLY SURE WAY TO DISABLE THE AIRBAG SYSTEM. FAILURE TO TAKE THE PROPER PRECAUTIONS COULD RESULT IN AN ACCIDENTAL AIRBAG DEPLOYMENT AND POSSIBLE PERSONAL INJURY.**

(1) Disconnect the vacuum harness connector located between the a/c heater control and the HVAC housing under the instrument panel.

(2) Connect the test set vacuum hose probe to each port in the HVAC housing half of the vacuum harness connector, one port at a time, and pause after each connection (Fig. 2). The test set gauge should return to the 27 kPa (8 in. Hg.) setting shortly after each connection is made. If OK, replace the faulty a/c heater control. If not OK, go to step Step 3.

(3) Determine the vacuum line color of the vacuum circuit that is leaking. To determine the vacuum line colors, see the Vacuum Circuits chart (Fig. 3).

(4) Disconnect and plug the vacuum line from the component (fitting, actuator, valve, switch, or reservoir) on the other end of the leaking circuit. Instrument panel disassembly or removal may be necessary to gain access to some components. Refer to Instrument Panel System for the procedures.



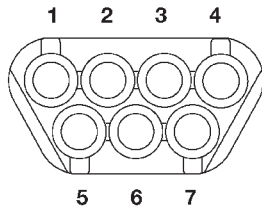
J9324-60

**Fig. 2 VACUUM CIRCUIT TEST**

(5) Connect the test set hose or probe to the open end of the leaking circuit. The test set gauge should return to the 27 kPa (8 in. Hg.) setting shortly after each connection is made. If OK, replace the faulty disconnected component. If not OK, go to Step 6.

(6) To locate a leak in a vacuum line, leave one end of the line plugged and connect the test set hose or probe to the other end of the line. Run your fingers slowly along the line while watching the test set gauge. The vacuum reading will fluctuate when your fingers contact the source of the leak. To repair the vacuum line, cut out the leaking section of the line. Then, insert the loose ends of the line into a suitable length of 3 millimeter (0.125 inch) inside diameter rubber hose.

CONTROLS (Continued)



HEATER-A/C VACUUM HARNESS CONNECTOR – HOUSING HALF (VIEWED FROM ENGAGEMENT END)

VACUUM CIRCUIT LEGEND		
ID	FUNCTION	COLOR
1	RECIRCULATION ACTUATOR	GREEN
2	DEFROST/FLOOR ACTUATOR	RED
3	VACUUM RESERVOIR	BLACK
4	NOT USED	N/A
5	DEFROST/FLOOR ACTUATOR	BROWN
6	PANEL/DEFROST ACTUATOR	YELLOW
7	NOT USED	N/A

HEATER ONLY

MODE KNOB POSITION	PORTS/TUBE COLOR						
	DK GRN	RED	BLK	LT BLU	BRN	YEL	LT GRN
	1	2	3	4	5	6	7
OFF	●	○	●	N	○	●	N
				O			O
				T			T
BI-LEVEL	○	●	●	/	○	●	/
PANEL	○	○	●	U	○	●	U
FLOOR	○	●	●	S	●	○	S
FLOOR/DEFROST	○	●	●	E	○	○	E
DEFROST	○	○	●	D	○	○	D

● = VACUUM  
○ = VENTED

HEATER - A/C

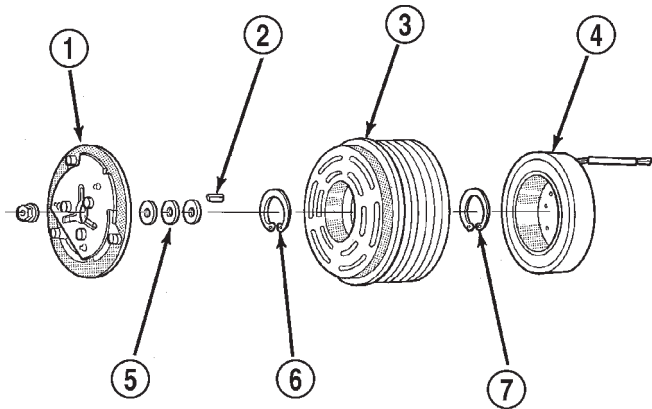
MODE KNOB POSITION	PORTS/TUBE COLOR							CLUTCH RELAY
	DK GRN	RED	BLK	LT BLU	BRN	YEL	LT GRN	
	1	2	3	4	5	6	7	
OFF	●	○	●	N	○	●	N	OFF
MAX A/C	●	○	●	O	○	●	O	ON
PANEL A/C	○	○	●	T	○	●	T	ON
BI-LEVEL A/C	○	●	●	/	○	●	/	ON
PANEL	○	○	●	U	○	●	U	OFF
FLOOR	○	●	●	S	●	○	S	OFF
FLOOR/DEFROST	○	●	●	E	○	○	E	ON
DEFROST	○	○	●	D	○	○	D	ON

Fig. 3 VACUUM CIRCUITS

## A/C COMPRESSOR CLUTCH

### DESCRIPTION

The compressor clutch assembly consists of a stationary electromagnetic coil, a hub bearing and pulley assembly, and a clutch plate (Fig. 4). The electromagnetic coil unit and the hub bearing and pulley assembly are each retained on the nose of the compressor front housing with snap rings. The clutch plate is mounted to the compressor shaft and secured with a nut.



J9524-33

**Fig. 4 COMPRESSOR CLUTCH - TYPICAL**

- 1 - CLUTCH PLATE
- 2 - SHAFT KEY
- 3 - PULLEY
- 4 - COIL
- 5 - CLUTCH SHIMS
- 6 - SNAP RING
- 7 - SNAP RING

### OPERATION

The compressor clutch assembly provides the means to engage and disengage the compressor from the engine serpentine accessory drive belt. When the clutch coil is energized, it magnetically draws the clutch into contact with the pulley and drives the compressor shaft. When the coil is not energized, the pulley freewheels on the clutch hub bearing, which is part of the pulley. The compressor clutch and coil are the only serviced parts on the compressor.

The compressor clutch engagement is controlled by several components: the a/c heater mode control switch, the a/c low pressure switch, the a/c high pressure switch, the compressor clutch relay, and the Powertrain Control Module (PCM). The PCM may delay compressor clutch engagement for up to thirty seconds. Refer to Electronic Control Modules for more information on the PCM controls.

### DIAGNOSIS AND TESTING - A/C COMPRESSOR CLUTCH COIL

For circuit descriptions and diagrams, (Refer to Appropriate Wiring Information). The battery must be fully-charged before performing the following tests. Refer to Battery for more information.

(1) Connect an ammeter (0 to 10 ampere scale) in series with the clutch coil terminal. Use a voltmeter (0 to 20 volt scale) with clip-type leads for measuring the voltage across the battery and the compressor clutch coil.

(2) With the a/c heater mode control switch in any A/C mode, and the blower motor switch in the lowest speed position, start the engine and run it at normal idle.

(3) The compressor clutch coil voltage should read within 0.2 volts of the battery voltage. If there is voltage at the clutch coil, but the reading is not within 0.2 volts of the battery voltage, test the clutch coil feed circuit for excessive voltage drop and repair as required. If there is no voltage reading at the clutch coil, use a DRB III® scan tool and (Refer to Appropriate Diagnostic Information) for testing of the compressor clutch circuit. The following components must be checked and repaired as required before you can complete testing of the clutch coil:

- Fuses in the junction block and the Power Distribution Center (PDC)
- A/C Heater mode control switch
- Compressor clutch relay
- A/C High Pressure Switch
- A/C Low Pressure Switch
- Powertrain Control Module (PCM).

(4) The compressor clutch coil is acceptable if the current draw measured at the clutch coil is 2.0 to 3.9 amperes with the electrical system voltage at 11.5 to 12.5 volts. This should only be checked with the work area temperature at 21° C (70° F). If system voltage is more than 12.5 volts, add electrical loads by turning on electrical accessories until the system voltage drops below 12.5 volts.

(a) If the clutch coil current reading is four amperes or more, the coil is shorted and should be replaced.

(b) If the clutch coil current reading is zero, the coil is open and should be replaced.

### STANDARD PROCEDURE - A/C COMPRESSOR CLUTCH BREAK-IN

After a new compressor clutch has been installed, cycle the compressor clutch approximately twenty times (five seconds on, then five seconds off). During this procedure, set the A/C Heater control to the Recirculation Mode, the blower motor switch in the highest speed position, and the engine speed at 1500 to 2000 rpm. This procedure (burnishing) will seat

## A/C COMPRESSOR CLUTCH (Continued)

the opposing friction surfaces and provide a higher compressor clutch torque capability.

**REMOVAL**

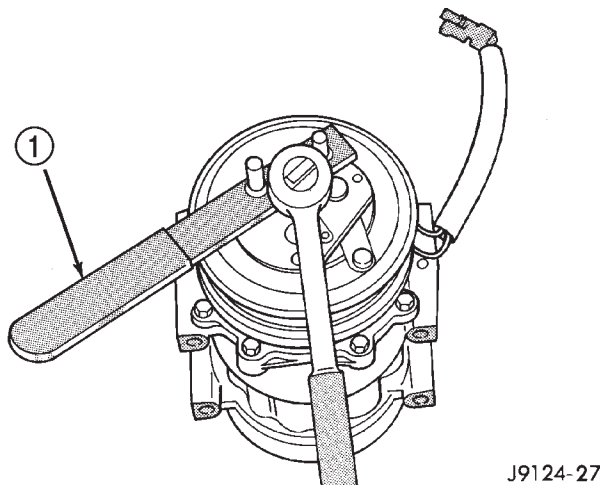
The refrigerant system can remain fully-charged during compressor clutch, pulley, or coil replacement. The compressor clutch can be serviced in the vehicle.

(1) Disconnect and isolate the battery negative cable.

(2) On models with the diesel engine option, remove the compressor from the engine. Do not remove the refrigerant lines or fittings. (Refer to 24 - HEATING & AIR CONDITIONING/PLUMBING/A/C COMPRESSOR - REMOVAL)

(3) Unplug the compressor clutch coil wire harness connector.

(4) Insert the two pins of the spanner wrench (Special Tool 6462 in Kit 6460) into the holes of the clutch plate. Hold the clutch plate stationary and remove the hex nut (Fig. 5).



J9124-27

**Fig. 5 CLUTCH NUT REMOVE**

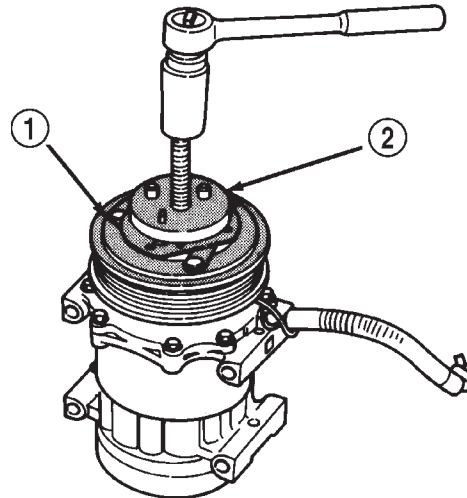
1 - FRONT PLATE SPANNER

(5) Remove the clutch plate and clutch shims. On models with the diesel engine option, a puller (Special Tool 6461 in Kit 6460) is used to remove the clutch plate (Fig. 6). This compressor also uses a shaft key, which must be removed.

(6) Remove the external front housing snap ring with snap ring pliers (Fig. 7).

(7) Install the lip of the rotor puller (Special Tool C-6141-1 in Kit 6460) into the snap ring groove exposed in Step 6, and install the shaft protector (Special Tool C-6141-2 in Kit 6460) (Fig. 8).

(8) Install the puller through-bolts (Special Tool C-6461) through the puller flange and into the jaws of the rotor puller and tighten (Fig. 9). Turn the puller center bolt clockwise until the rotor pulley is free.

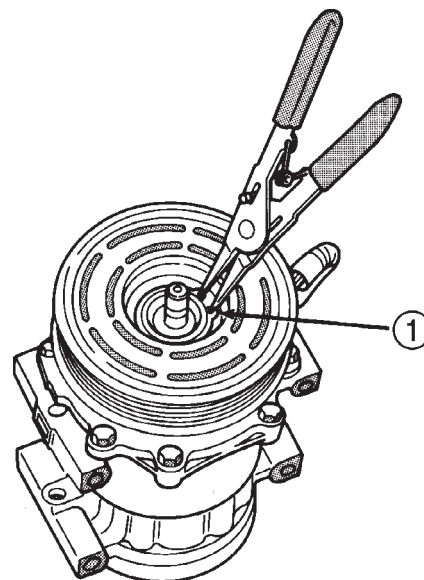


J8924-18

**Fig. 6 CLUTCH PULLER - DIESEL MODELS**

1 - FRONT PLATE

2 - PULLER



J8924-20

**Fig. 7 EXTERNAL SNAP RING REMOVE**

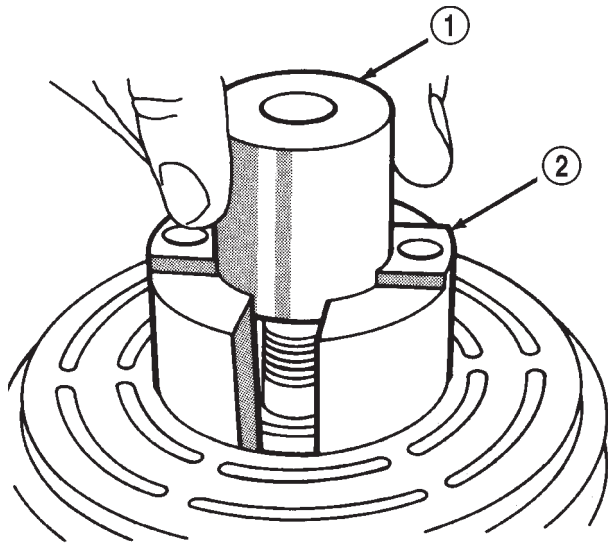
1 - EXTERNAL SNAP RING

(9) Remove the screw and retainer from the clutch coil lead wire harness on the compressor front housing (Fig. 10).

(10) Remove the snap ring from the compressor hub and remove the clutch field coil (Fig. 11). Slide the clutch field coil off of the compressor hub.



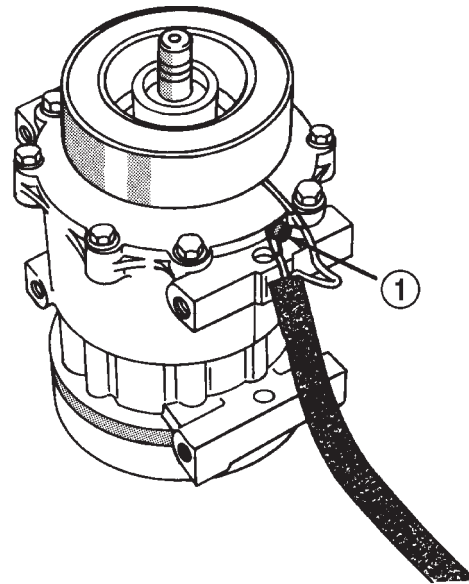
## A/C COMPRESSOR CLUTCH (Continued)



J8924-21

**Fig. 8 SHAFT PROTECTOR AND PULLER**

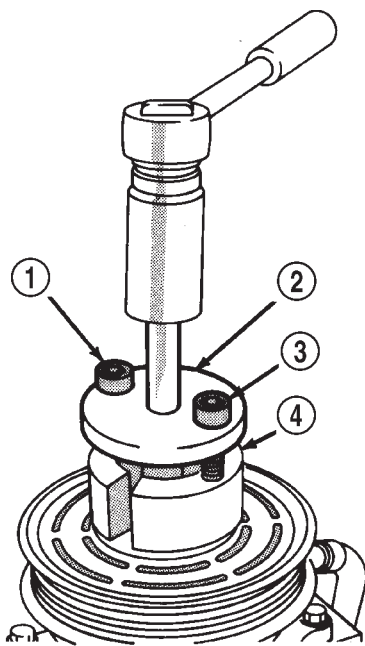
- 1 - PULLER SHAFT PROTECTOR
- 2 - JAWS



J8924-23

**Fig. 10 CLUTCH COIL LEAD WIRE HARNESS**

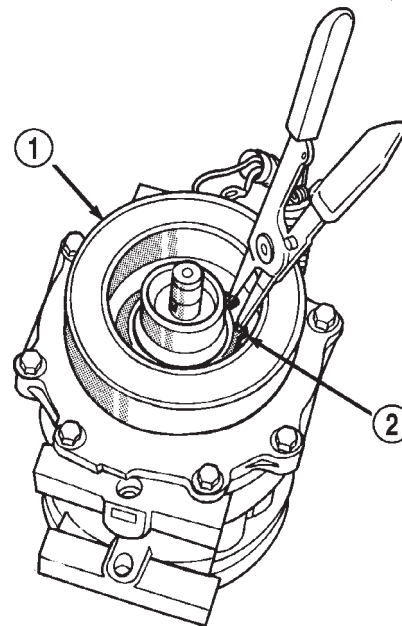
- 1 - CLIP



J8924-22

**Fig. 9 INSTALL PULLER PLATE**

- 1 - BOLT
- 2 - PULLER PLATE AND BOLT
- 3 - BOLT
- 4 - JAWS



J8924-24

**Fig. 11 CLUTCH FIELD COIL SNAP RING REMOVE**

- 1 - FIELD COIL
- 2 - SNAP RING

## A/C COMPRESSOR CLUTCH (Continued)

**INSPECTION**

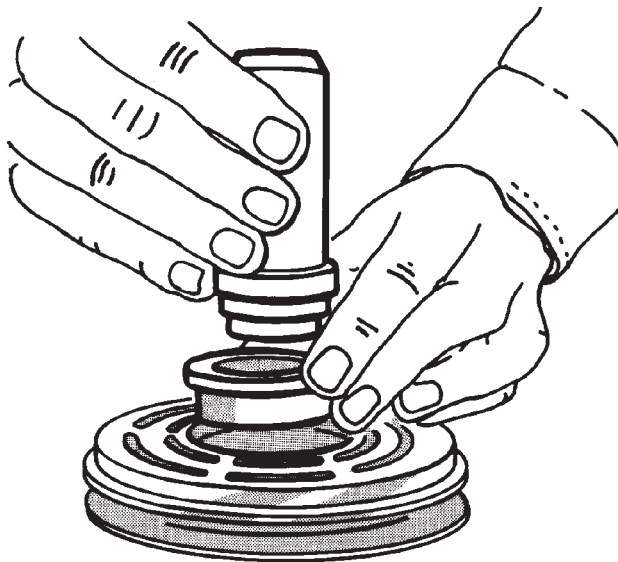
Examine the friction surfaces of the clutch pulley and the front plate for wear. The pulley and front plate should be replaced if there is excessive wear or scoring.

If the friction surfaces are oily, inspect the shaft and nose area of the compressor for oil. Remove the felt from the front cover. If the felt is saturated with oil, the shaft seal is leaking and the compressor must be replaced.

Check the clutch pulley bearing for roughness or excessive leakage of grease. Replace the bearing, if required.

**INSTALLATION**

- (1) Install the clutch field coil and snap ring.
- (2) Install the clutch coil lead wire harness retaining clip on the compressor front housing and tighten the retaining screw.
- (3) Align the rotor assembly squarely on the front compressor housing hub.
- (4) Thread the handle (Special Tool 6464 in Kit 6460) into the driver (Special Tool 6143 in Kit 6460) (Fig. 12).

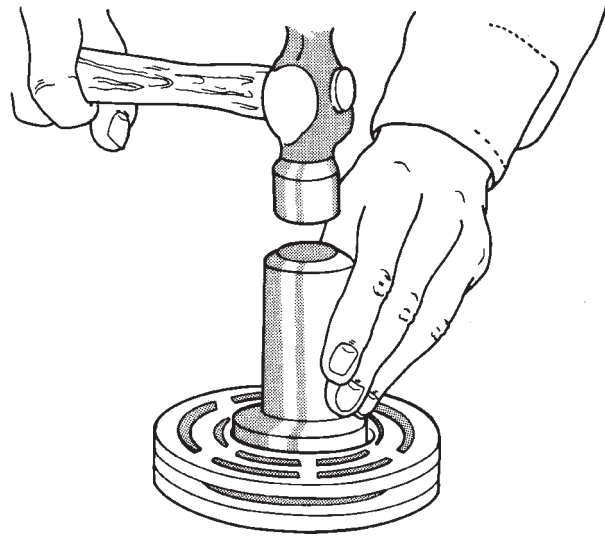


J8924-25

**Fig. 12 ROTOR INSTALLER SET**

(5) Place the driver tool assembly into the bearing cavity on the rotor. Make certain the outer edge of the tool rests firmly on the rotor bearing inner race (Fig. 13).

(6) Tap the end of the driver while guiding the rotor to prevent binding. Tap until the rotor bottoms against the compressor front housing hub. Listen for a distinct change of sound during the tapping process, to indicate the bottoming of the rotor.



J8924-26

**Fig. 13 ROTOR INSTALL**

(7) Install the external front rotor snap ring with snap ring pliers. The bevel side of the snap ring must be facing outward. Press the snap ring to make sure it is properly seated in the groove.

**CAUTION:** If the snap ring is not fully seated in the groove it will vibrate out, resulting in a clutch failure and severe damage to the front housing of the compressor.

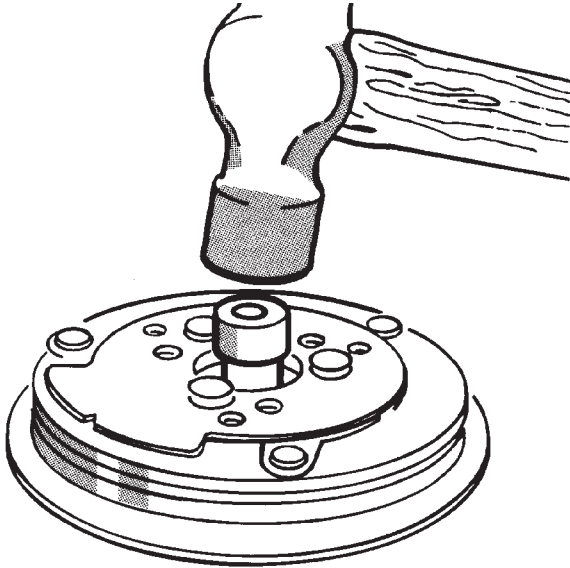
(8) Install the original clutch shims on the compressor shaft.

(9) Install the clutch plate. On models with the diesel engine option, install the shaft key. Use the shaft protector (Special Tool 6141-2 in Kit 6460) to install the clutch plate on the compressor shaft (Fig. 14). Tap the clutch plate over the compressor shaft until it has bottomed against the clutch shims. Listen for a distinct change of sound during the tapping process, to indicate the bottoming of the clutch plate.

(10) Install the compressor shaft hex nut. Tighten the nut to 14.4 N·m (10.5 ft. lbs.).

(11) Check the clutch air gap with a feeler gauge (Fig. 15). If the air gap does not meet the specification, add or subtract shims as required. The air gap specification is 0.41 to 0.79 millimeter (0.016 to 0.031 inch). If the air gap is not consistent around the circumference of the clutch, lightly pry up at the minimum variations. Lightly tap down at the points of maximum variation.

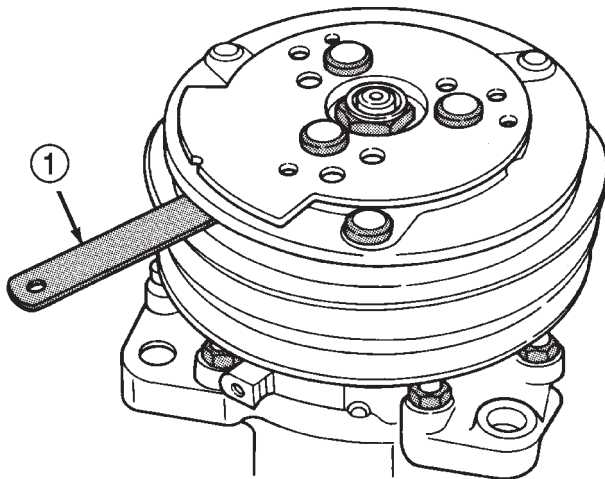
## A/C COMPRESSOR CLUTCH (Continued)



J8924-27

**Fig. 14 CLUTCH PLATE INSTALL**

**NOTE:** The air gap is determined by the spacer shims. When installing an original, or a new clutch assembly, try the original shims first. When installing a new clutch onto a compressor that previously did not have a clutch, use 1.0, 0.50, and 0.13 millimeter (0.040, 0.020, and 0.005 inch) shims from the clutch hardware package that is provided with the new clutch.



J8924-28

**Fig. 15 CHECK CLUTCH AIR GAP**

1 - FEELER GAUGE

(12) On models with the diesel engine option, install the compressor on the engine. (Refer to 24 - HEATING & AIR CONDITIONING/PLUMBING/A/C COMPRESSOR - INSTALLATION)

(13) Connect the battery negative cable.

## A/C COMPRESSOR CLUTCH RELAY

### DESCRIPTION

The a/c compressor clutch relay is a International Standards Organization (ISO) micro-relay. The terminal designations and functions are the same as a conventional ISO relay. However, the micro-relay terminal orientation (footprint) is different, the current capacity is lower, and the relay case dimensions are smaller than those of the conventional ISO relay.

### OPERATION

The compressor clutch relay is a electromechanical device that switches battery current to the compressor clutch coil when the Powertrain Control Module (PCM) grounds the coil side of the relay. The PCM responds to inputs from the a/c heater control, the a/c low pressure switch, and the a/c high pressure switch.

The compressor clutch relay is located in the Power Distribution Center (PDC) in the engine compartment. Refer to the PDC label for relay identification and location.

The compressor clutch relay cannot be repaired and, if faulty or damaged, it must be replaced.

## DIAGNOSIS AND TESTING - A/C COMPRESSOR CLUTCH RELAY

### RELAY TEST

The compressor clutch relay (Fig. 16) is located in the Power Distribution Center (PDC). Refer to the PDC label for relay identification and location. Remove the relay from the PDC to perform the following tests:

(1) A relay in the de-energized position should have continuity between terminals 87A and 30, and no continuity between terminals 87 and 30. If OK, go to Step 2. If not OK, replace the faulty relay.

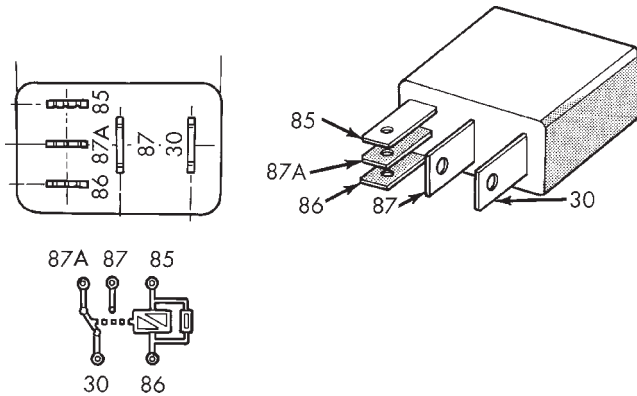
(2) Resistance between terminals 85 and 86 (electromagnet) should be  $75 \pm 5$  ohms. If OK, go to Step 3. If not OK, replace the faulty relay.

(3) Connect a battery to terminals 85 and 86. There should now be continuity between terminals 30 and 87, and no continuity between terminals 87A and 30. If OK, see the Relay Circuit Test below. If not OK, replace the faulty relay.

### RELAY CIRCUIT TEST

For circuit descriptions and diagrams, (Refer to Appropriate Wiring Information).

## A/C COMPRESSOR CLUTCH RELAY (Continued)

**Fig. 16 COMPRESSOR CLUTCH RELAY**

## TERMINAL LEGEND

NUMBER	IDENTIFICATION
30	COMMON FEED
85	COIL GROUND
86	COIL BATTERY
87	NORMALLY OPEN
87A	NORMALLY CLOSED

(1) The relay common feed terminal cavity (30) is connected to fused battery feed. There should be battery voltage at the cavity for relay terminal 30 at all times. If OK, go to Step 2. If not OK, repair the open circuit to the fuse in the PDC as required.

(2) The relay normally closed terminal (87A) is not used in this application. Go to Step 3.

(3) The relay normally open terminal cavity (87) is connected to the compressor clutch coil. There should be continuity between this cavity and the A/C compressor clutch relay output circuit cavity of the compressor clutch coil wire harness connector. If OK, go to Step 4. If not OK, repair the open circuit as required.

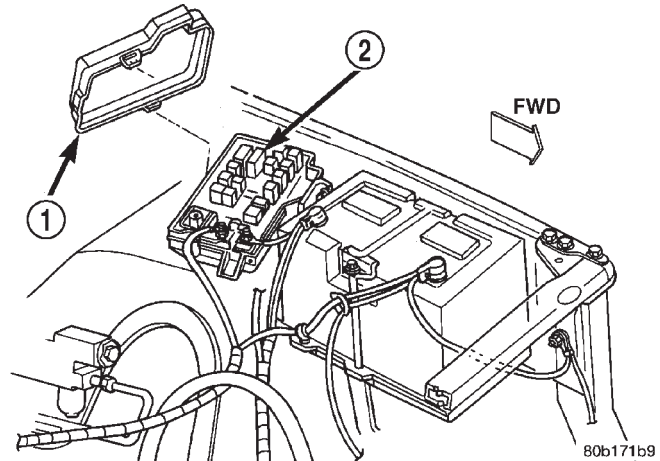
(4) The relay coil battery terminal (86) is connected to the fused ignition switch output (run/start) circuit. There should be battery voltage at the cavity for relay terminal 86 with the ignition switch in the On position. If OK, go to Step 5. If not OK, repair the open circuit to the fuse in the junction block as required.

(5) The coil ground terminal cavity (85) is switched to ground through the Powertrain Control Module (PCM). There should be continuity between this cavity and the A/C compressor clutch relay control circuit cavity of the PCM wire harness connector C (gray) at all times. If not OK, repair the open circuit as required.

**REMOVAL**

(1) Disconnect and isolate the battery negative cable.

(2) Remove the cover from the Power Distribution Center (PDC) (Fig. 17).

**Fig. 17 POWER DISTRIBUTION CENTER**

- 1 - COVER
- 2 - POWER DISTRIBUTION CENTER

(3) Refer to the label on the PDC for compressor clutch relay identification and location.

(4) Unplug the compressor clutch relay from the PDC.

**INSTALLATION**

(1) Install the compressor clutch relay by aligning the relay terminals with the cavities in the PDC and pushing the relay firmly into place.

(2) Install the PDC cover.

(3) Connect the battery negative cable.

(4) Test the relay operation.

**A/C HEATER CONTROL****DESCRIPTION**

Both the heater-only and a/c heater systems use a combination of electrical and vacuum controls. These controls provide the vehicle operator with a number of setting options to help control the climate and comfort within the vehicle. Refer to the owner's manual in the vehicle glove box for more information on the features, use, and suggested operation of these controls.

**OPERATION**

The heater-only or a/c heater control panel is located to the right of the instrument cluster on the instrument panel. The control panel contains a rotary-type temperature control knob, a rotary-type mode control switch knob, and a rotary-type blower motor speed switch knob. On models with the optional heated mirror system, a momentary push button switch and indicator lamp are located near the bot-



## A/C HEATER CONTROL (Continued)

tom of the a/c heater control panel. Refer to Heated Mirrors for more information on this feature.

The heater-only or a/c heater control panel cannot be repaired. If faulty or damaged, the entire unit must be replaced. The control knobs and the illumination lamps are available for service replacement.

## DIAGNOSIS AND TESTING - A/C HEATER CONTROL

Satisfactory heater and air conditioner performance depends upon proper operation and adjustment of all operating controls and refrigeration system components. For circuit descriptions and diagrams, (Refer to Appropriate Wiring Information). These inspections, tests, and adjustments should be used to locate the cause of a malfunction.

Operation must be tested as described in the following sequence:

(1) Inspect and adjust the serpentine drive belt. Refer to Cooling for the procedures.

(2) Start the engine and hold the idle speed at 1,300 rpm.

(3) On vehicles with air conditioning, turn the temperature control knob to the extreme counterclockwise (Cool) position, and set the mode control switch knob to the Bi-Level (A/C) position. The outside (recirculation) air door should be open to outside air. If not OK, (Refer to 24 - HEATING & AIR CONDITIONING/CONTROLS - DIAGNOSIS AND TESTING - VACUUM SYSTEM).

(4) Open the vehicle windows. Test the blower motor operation in all speeds. If not OK, (Refer to 24 - HEATING & AIR CONDITIONING/DISTRIBUTION/BLOWER MOTOR - DIAGNOSIS AND TESTING).

(5) On vehicles with air conditioning, the compressor should be running and the air conditioning system in operation unless the ambient air temperature is below about  $-1^{\circ}\text{C}$  ( $30^{\circ}\text{F}$ ). If not OK, (Refer to 24 - HEATING & AIR CONDITIONING - DIAGNOSIS AND TESTING - A/C PERFORMANCE).

(6) Check the mode control switch operation. The heater and air conditioner systems should respond as described in the owner's manual in the vehicle glove box to each mode selected. Reduce the engine speed to normal idle. The vacuum will be high at low idle and the vacuum actuators should respond quickly. If not OK, (Refer to 24 - HEATING & AIR CONDITIONING/CONTROLS - DIAGNOSIS AND TESTING - VACUUM SYSTEM).

(7) If the vacuum tests, and the electrical component and circuit tests reveal no problems, disassemble the HVAC housing to inspect for mechanical misalignment or binding of the mode doors. (Refer to 24 - HEATING & AIR CONDITIONING/DISTRIBUTION/HVAC HOUSING - DISASSEMBLY)

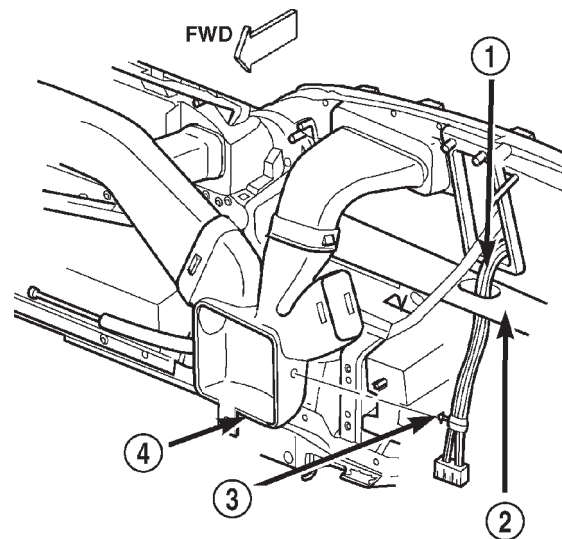
## REMOVAL

**WARNING: ON VEHICLES EQUIPPED WITH AIRBAGS, DISABLE THE AIRBAG SYSTEM BEFORE ATTEMPTING ANY STEERING WHEEL, STEERING COLUMN, OR INSTRUMENT PANEL COMPONENT DIAGNOSIS OR SERVICE. DISCONNECT AND ISOLATE THE BATTERY NEGATIVE (GROUND) CABLE, THEN WAIT TWO MINUTES FOR THE AIRBAG SYSTEM CAPACITOR TO DISCHARGE BEFORE PERFORMING FURTHER DIAGNOSIS OR SERVICE. THIS IS THE ONLY SURE WAY TO DISABLE THE AIRBAG SYSTEM. FAILURE TO TAKE THE PROPER PRECAUTIONS COULD RESULT IN AN ACCIDENTAL AIRBAG DEPLOYMENT AND POSSIBLE PERSONAL INJURY.**

(1) Disconnect and isolate the battery negative cable.

(2) Reach under the instrument panel near the driver side of the floor panel transmission tunnel and unplug the a/c heater control to HVAC housing vacuum harness connector.

(3) While still reaching under the instrument panel, disengage the retainer on the a/c heater control half of the vacuum harness from the hole in the center distribution duct (Fig. 18).



80b1b35f

**Fig. 18 A/C HEATER CONTROL VACUUM HARNESS ROUTING**

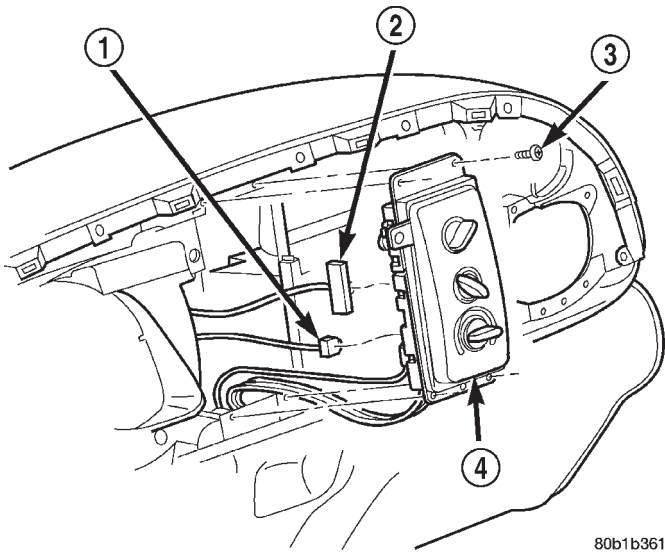
- 1 - A/C HEATER CONTROL VACUUM HARNESS
- 2 - REINFORCEMENT
- 3 - RETAINER
- 4 - CENTER DISTRIBUTION DUCT

(4) Remove the cluster bezel from the instrument panel. Refer to Instrument Panel System for the procedures.



## A/C HEATER CONTROL (Continued)

(5) Remove the four screws that secure the a/c heater control to the instrument panel (Fig. 19).



**Fig. 19 A/C HEATER CONTROL REMOVE/INSTALL**

- 1 - HEATED MIRROR WIRE HARNESS CONNECTOR
- 2 - WIRE HARNESS CONNECTOR
- 3 - SCREW
- 4 - HEATER-A/C CONTROL

(6) Pull the a/c heater control assembly away from the instrument panel far enough to access the connections on the back of the control.

(7) Unplug the wire harness connector from the back of the a/c heater control.

(8) On vehicles with heated mirrors, unplug the heated mirror wire harness connector from the back of the a/c heater control.

(9) Remove the a/c heater control from the instrument panel.

### INSTALLATION

(1) Plug the wire harness connector(s) into the receptacle(s) on the back of the a/c heater control.

(2) Route the HVAC vacuum harness through the hole in the reinforcement below the a/c heater control opening of the instrument panel.

(3) Position the a/c heater control in the instrument panel and secure it with four screws. Tighten the screws to 2.2 N·m (20 in. lbs.).

(4) Reinstall the cluster bezel to the instrument panel. Refer to Instrument Panel System for the procedures.

(5) Reach under the instrument panel to reinstall the a/c heater control vacuum harness retainer to the side of the center distribution duct.

(6) Plug in the two halves of the a/c heater control to HVAC housing vacuum harness connector.

(7) Connect the battery negative cable.

## A/C HIGH PRESSURE SWITCH

### DESCRIPTION

The a/c high pressure switch is located on the discharge line near the compressor. The switch is screwed onto a fitting that contains a Schrader-type valve, which allows the switch to be serviced without discharging the refrigerant system. The discharge line fitting is equipped with an O-ring to seal the switch connection.

### OPERATION

The a/c high pressure switch is connected in series electrically with the a/c low pressure switch between ground and the Powertrain Control Module (PCM). The switch contacts open and close causing the PCM to turn the compressor clutch on and off. This prevents compressor operation when the discharge line pressure approaches high levels.

The a/c high pressure switch contacts are open when the discharge line pressure rises above about 3100 to 3375 kPa (450 to 490 psi). The switch contacts will close when the discharge line pressure drops to about 1860 to 2275 kPa (270 to 330 psi). When checking refrigerant system pressures with a manifold gauge set, keep in mind that the indicated pressures will be about 172 kPa (25 psi) below the actual switch pressure values due to the pressure drop that occurs in the refrigerant system between the switch and the high pressure service port.

The a/c high pressure switch is a factory-calibrated unit. The switch cannot be adjusted or repaired and, if faulty or damaged, it must be replaced.

### DIAGNOSIS AND TESTING - A/C HIGH PRESSURE SWITCH

Before performing diagnosis of the a/c high pressure switch, verify that the refrigerant system has the correct refrigerant charge. (Refer to 24 - HEATING & AIR CONDITIONING - DIAGNOSIS AND TESTING)

For circuit descriptions and diagrams, (Refer to Appropriate Wiring Information).

(1) Disconnect and isolate the battery negative cable.

(2) Unplug the a/c high pressure switch wire harness connector from the switch on the refrigerant system fitting.

(3) On the four terminal high pressure switch, check for continuity between terminals C and D. On the two terminal switch, check for continuity between both terminals of the a/c high pressure switch. There should be continuity. If OK, test and repair the A/C switch sense circuit as required. If not OK, replace the faulty switch.

## A/C HIGH PRESSURE SWITCH (Continued)

**REMOVAL**

- (1) Disconnect and isolate the battery negative cable.
- (2) Unplug the wire harness connector from the a/c high pressure switch, which is mounted to a fitting on the discharge line between the compressor and the condenser inlet.
- (3) Unscrew the a/c high pressure switch from the discharge line fitting.
- (4) Remove the a/c high pressure switch from the vehicle.
- (5) Remove the O-ring seal from the discharge line fitting and discard.

**INSTALLATION**

- (1) Lubricate a new O-ring seal with clean refrigerant oil and install it on the discharge line fitting. Use only the specified O-rings as they are made of a special material for the R-134a system. Use only refrigerant oil of the type recommended for the compressor in the vehicle. (Refer to 24 - HEATING & AIR CONDITIONING/PLUMBING/REFRIGERANT OIL - DESCRIPTION)
- (2) Install and tighten the high pressure cut-off switch on the discharge line fitting. The switch should be hand-tightened onto the discharge line fitting.
- (3) Plug the wire harness connector into the high pressure cut-off switch.
- (4) Connect the battery negative cable.

## A/C LOW PRESSURE SWITCH

**DESCRIPTION**

The a/c low pressure switch is located on the top of the accumulator. The switch is screwed onto an accumulator fitting that contains a Schrader-type valve, which allows the switch to be serviced without discharging the refrigerant system. The accumulator fitting is equipped with an O-ring to seal the switch connection.

**OPERATION**

The a/c low pressure switch is connected in series electrically with the a/c high pressure switch and the a/c heater control, between ground and the Powertrain Control Module (PCM). The switch contacts open and close causing the PCM to turn the compressor clutch on and off. This regulates the refrigerant system pressure and controls evaporator temperature. Controlling evaporator temperature prevents condensate water on the evaporator fins from freezing and obstructing air conditioning system air flow.

The a/c low pressure switch contacts are open when the suction pressure is about 152-165 kPa

(22-24 psi) or lower. The switch contacts will close when the suction pressure rises to about 255-296 kPa (37-43 psi) or above. Lower ambient temperatures, below about -1° C (30° F), will also cause the switch contacts to open. This is due to the pressure/temperature relationship of the refrigerant in the system.

The a/c low pressure switch is a factory-calibrated unit. It cannot be adjusted or repaired and, if faulty or damaged, it must be replaced.

**DIAGNOSIS AND TESTING - A/C LOW PRESSURE SWITCH**

Before performing diagnosis of the a/c low pressure switch, be certain that the switch is properly installed on the accumulator fitting. If the switch is too loose it may not open the Schrader-type valve in the accumulator fitting, which will prevent the switch from correctly monitoring the refrigerant system pressure. Also verify that the refrigerant system has the correct refrigerant charge. (Refer to 24 - HEATING & AIR CONDITIONING - DIAGNOSIS AND TESTING - A/C PERFORMANCE)

Remember that lower ambient temperatures, below about -1° C (30° F), during cold weather will open the switch contacts and prevent compressor operation due to the pressure/temperature relationship of the refrigerant. For circuit descriptions and diagrams, (Refer to Appropriate Wiring Information).

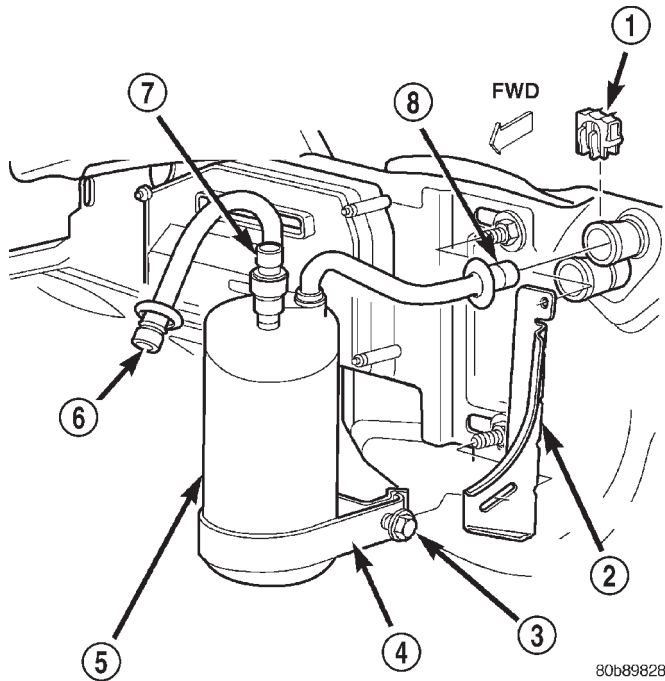
- (1) Disconnect and isolate the battery negative cable.
- (2) Unplug the a/c low pressure switch wire harness connector from the switch on the accumulator fitting.
- (3) Install a jumper wire between the two cavities of the a/c low pressure switch wire harness connector.
- (4) Connect a manifold gauge set to the refrigerant system service ports. (Refer to 24 - HEATING & AIR CONDITIONING/PLUMBING - STANDARD PROCEDURE - REFRIGERANT SYSTEM SERVICE EQUIPMENT)
- (5) Connect the battery negative cable.
- (6) Place the a/c heater mode control switch knob in any A/C position and start the engine.
- (7) Check for continuity between the two terminals of the low pressure cycling clutch switch. There should be continuity with a suction pressure reading of 296 kPa (43 psi) or above, and no continuity with a suction pressure reading of 172 kPa (25 psi) or below. If OK, test and repair the A/C switch sense circuit as required. If not OK, replace the faulty switch.

**REMOVAL**

- (1) Disconnect and isolate the battery negative cable.

## A/C LOW PRESSURE SWITCH (Continued)

(2) Unplug the wire harness connector from the a/c low pressure switch on the top of the accumulator (Fig. 20).



**Fig. 20 ACCUMULATOR AND A/C LOW PRESSURE SWITCH**

- 1 - CLIP
- 2 - BRACKET
- 3 - SCREW
- 4 - BAND
- 5 - ACCUMULATOR
- 6 - TO SUCTION LINE
- 7 - A/C LOW PRESSURE SWITCH
- 8 - FROM EVAPORATOR OUTLET

(3) Unscrew the a/c low pressure switch from the fitting on the top of the accumulator.

(4) Remove the O-ring seal from the accumulator fitting and discard.

### INSTALLATION

(1) Lubricate a new O-ring seal with clean refrigerant oil and install it on the accumulator fitting. Use only the specified O-rings as they are made of a special material for the R-134a system. Use only refrigerant oil of the type recommended for the compressor in the vehicle. (Refer to 24 - HEATING & AIR CONDITIONING/PLUMBING/REFRIGERANT OIL - DESCRIPTION)

(2) Install and tighten the a/c low pressure switch on the accumulator fitting. The switch should be hand-tightened onto the accumulator fitting.

(3) Plug the wire harness connector into the a/c low pressure switch.

(4) Connect the battery negative cable.

## BLOWER MOTOR RELAY

### DESCRIPTION

The blower motor relay is an International Standards Organization (ISO)-type relay. The relay is an electromechanical device that switches battery current from a fuse in the Power Distribution Center (PDC) directly to the blower motor. The relay is energized when the relay coil is provided a voltage signal by the ignition switch. This arrangement reduces the amount of battery current that must flow through the ignition switch.

### OPERATION

The blower motor relay control circuit is protected by a fuse located in the junction block. When the relay is de-energized, the blower motor receives no battery current.

The blower motor relay is located in the PDC in the engine compartment. Refer to the PDC label for blower motor relay identification and location.

The blower motor relay cannot be repaired and, if faulty or damaged, it must be replaced.

### DIAGNOSIS AND TESTING - BLOWER MOTOR RELAY

#### RELAY TEST

The blower motor relay (Fig. 21) is located in the Power Distribution Center (PDC). Remove the blower motor relay from the PDC to perform the following tests:

(1) A relay in the de-energized position should have continuity between terminals 87A and 30, and no continuity between terminals 87 and 30. If OK, go to Step 2. If not OK, replace the faulty relay.

(2) Resistance between terminals 85 and 86 (electromagnet) should be  $75 \pm 5$  ohms. If OK, go to Step 3. If not OK, replace the faulty relay.

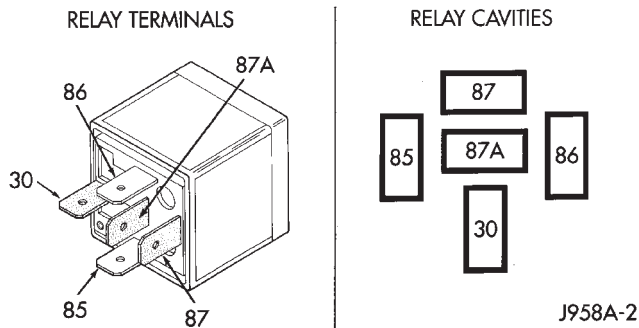
(3) Connect a battery to terminals 85 and 86. There should now be continuity between terminals 30 and 87, and no continuity between terminals 87A and 30. If OK, see Relay Circuit Test below. If not OK, replace the faulty relay.

#### RELAY CIRCUIT TEST

For circuit descriptions and diagrams, (Refer to Appropriate Wiring Information).

(1) The relay common feed terminal cavity (30) is connected to fused battery feed directly from a fuse in the Power Distribution Center (PDC), and should be hot at all times. Check for battery voltage at the PDC cavity for relay terminal 30. If OK, go to Step 2. If not OK, repair the open circuit to the PDC fuse as required.

## BLOWER MOTOR RELAY (Continued)

**Fig. 21 BLOWER MOTOR RELAY**

TERMINAL LEGEND	
NUMBER	IDENTIFICATION
30	COMMON FEED
85	COIL GROUND
86	COIL BATTERY
87	NORMALLY OPEN
87A	NORMALLY CLOSED

(2) The relay normally closed terminal cavity (87A) is not used for this application. Go to Step 3.

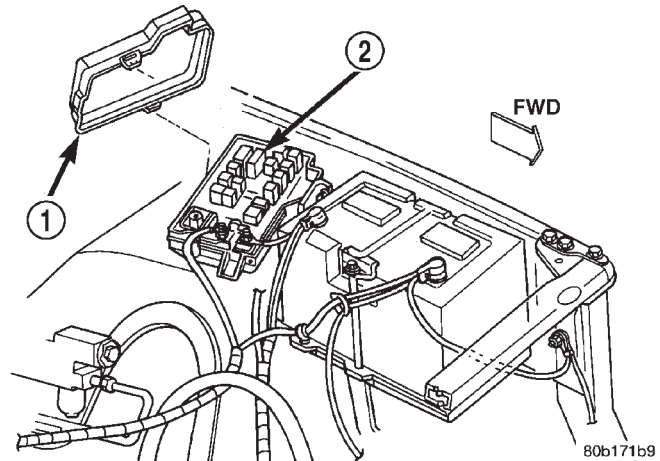
(3) The relay normally open terminal cavity (87) is connected to the blower motor. When the relay is energized, terminal 87 is connected to terminal 30 and provides full battery current to the blower motor feed circuit. There should be continuity between the PDC cavity for terminal 87 and the blower motor relay output circuit cavity of the blower motor wire harness connector at all times. If OK, go to Step 4. If not OK, repair the open circuit to the blower motor as required.

(4) The coil battery terminal cavity (86) is connected to the ignition switch. When the ignition switch is placed in the On position, fused ignition switch output is directed from a fuse in the junction block to the relay electromagnetic coil to energize the relay. There should be battery voltage at the PDC cavity for relay terminal 86 with the ignition switch in the On position. If OK, go to Step 5. If not OK, repair the open circuit to the junction block fuse as required.

(5) The coil ground terminal cavity (85) is connected to ground. This terminal supplies the ground for the relay electromagnetic coil. There should be continuity between the PDC cavity for relay terminal 85 and a good ground at all times. If not OK, repair the open circuit as required.

**REMOVAL**

- (1) Disconnect and isolate the battery negative cable.
- (2) Remove the cover from the Power Distribution Center (PDC) (Fig. 22).

**Fig. 22 POWER DISTRIBUTION CENTER**

- 1 - COVER
- 2 - POWER DISTRIBUTION CENTER

- (3) Refer to the label on the PDC for blower motor relay identification and location.
- (4) Unplug the blower motor relay from the PDC.

**INSTALLATION**

- (1) Install the blower motor relay by aligning the relay terminals with the cavities in the PDC and pushing the relay firmly into place.
- (2) Install the PDC cover.
- (3) Connect the battery negative cable.
- (4) Test the relay operation.

**BLOWER MOTOR RESISTOR BLOCK****DESCRIPTION**

The blower motor resistor is mounted to the bottom of the HVAC housing, under the instrument panel and just inboard of the blower motor. It can be accessed without removing any other components.

**OPERATION**

The resistor has multiple resistor wires, each of which will change the resistance in the blower motor ground path to change the blower motor speed. The blower motor switch directs the ground path through the correct resistor wire to obtain the selected blower motor speed.



## BLOWER MOTOR RESISTOR BLOCK (Continued)

With the blower motor switch in the lowest speed position, the ground path for the motor is applied through all of the resistor wires. Each higher speed selected with the blower motor switch applies the blower motor ground path through fewer of the resistor wires, increasing the blower motor speed. When the blower motor switch is in the highest speed position, the blower motor resistor is bypassed and the blower motor receives a direct path to ground.

The blower motor resistor cannot be repaired and, if faulty or damaged, it must be replaced.

## DIAGNOSIS AND TESTING - BLOWER MOTOR RESISTOR BLOCK

For circuit descriptions and diagrams, (Refer to Appropriate Wiring Information).

**WARNING: ON VEHICLES EQUIPPED WITH AIRBAGS, DISABLE THE AIRBAG SYSTEM BEFORE ATTEMPTING ANY STEERING WHEEL, STEERING COLUMN, OR INSTRUMENT PANEL COMPONENT DIAGNOSIS OR SERVICE. DISCONNECT AND ISOLATE THE BATTERY NEGATIVE (GROUND) CABLE, THEN WAIT TWO MINUTES FOR THE AIRBAG SYSTEM CAPACITOR TO DISCHARGE BEFORE PERFORMING FURTHER DIAGNOSIS OR SERVICE. THIS IS THE ONLY SURE WAY TO DISABLE THE AIRBAG SYSTEM. FAILURE TO TAKE THE PROPER PRECAUTIONS COULD RESULT IN AN ACCIDENTAL AIRBAG DEPLOYMENT AND POSSIBLE PERSONAL INJURY.**

(1) Disconnect and isolate the battery negative cable.

(2) Unplug the wire harness connector from the blower motor resistor.

(3) Check for continuity between each of the blower motor switch input terminals of the resistor and the resistor output terminal. In each case there should be continuity. If OK, repair the wire harness circuits between the blower motor switch and the blower motor resistor or blower motor as required. If not OK, replace the faulty blower motor resistor.

## REMOVAL

**WARNING: ON VEHICLES EQUIPPED WITH AIRBAGS, DISABLE THE AIRBAG SYSTEM BEFORE ATTEMPTING ANY STEERING WHEEL, STEERING COLUMN, OR INSTRUMENT PANEL COMPONENT DIAGNOSIS OR SERVICE. DISCONNECT AND ISOLATE THE BATTERY NEGATIVE (GROUND) CABLE, THEN WAIT TWO MINUTES FOR THE AIRBAG SYSTEM CAPACITOR TO DISCHARGE BEFORE PERFORMING FURTHER DIAGNOSIS OR SERVICE. THIS IS THE ONLY SURE WAY TO DISABLE THE AIRBAG**

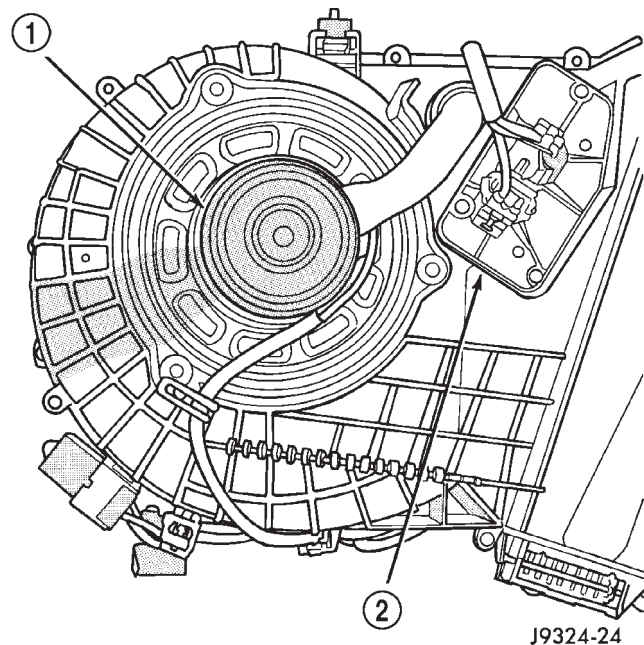
**SYSTEM. FAILURE TO TAKE THE PROPER PRECAUTIONS COULD RESULT IN AN ACCIDENTAL AIRBAG DEPLOYMENT AND POSSIBLE PERSONAL INJURY.**

(1) Disconnect and isolate the battery negative cable.

(2) Reach under the passenger side end of the HVAC housing and unplug the wire harness connector from the blower motor resistor.

(3) Remove the screws that secure the blower motor resistor to the HVAC housing.

(4) Remove the blower motor resistor from the HVAC housing (Fig. 23).



**Fig. 23 BLOWER MOTOR/RESISTOR**

- 1 - BLOWER MOTOR  
2 - BLOWER MOTOR RESISTOR

## INSTALLATION

(1) Install the blower motor resistor into the HVAC housing and secure it with the mounting screws. Tighten the mounting screws to 2.2 N·m (20 in. lbs.).

(2) Plug the wire harness connector into the blower motor resistor.

(3) Connect the battery negative cable.

## BLOWER MOTOR SWITCH

### DESCRIPTION

The heater-only or a/c heater blower motor is controlled by a four position rotary-type blower motor switch, mounted in the HVAC control panel. The switch allows the selection of one of four blower



## BLOWER MOTOR SWITCH (Continued)

motor speeds, but can only be turned off by selecting the Off position with the heater-only or a/c heater control switch knob.

### OPERATION

The blower motor switch directs the blower motor ground path through the mode control switch to the blower motor resistor, or directly to ground, as required to achieve the selected blower motor speed.

The blower motor switch cannot be repaired and, if faulty or damaged, the entire heater-only or a/c heater control unit must be replaced. The blower motor switch knob is serviced separately.

### DIAGNOSIS AND TESTING - BLOWER MOTOR SWITCH

For circuit descriptions and diagrams, (Refer to Appropriate Wiring Information).

**WARNING: ON VEHICLES EQUIPPED WITH AIRBAGS, DISABLE THE AIRBAG SYSTEM BEFORE ATTEMPTING ANY STEERING WHEEL, STEERING COLUMN, OR INSTRUMENT PANEL COMPONENT DIAGNOSIS OR SERVICE. DISCONNECT AND ISOLATE THE BATTERY NEGATIVE (GROUND) CABLE, THEN WAIT TWO MINUTES FOR THE AIRBAG SYSTEM CAPACITOR TO DISCHARGE BEFORE PERFORMING FURTHER DIAGNOSIS OR SERVICE. THIS IS THE ONLY SURE WAY TO DISABLE THE AIRBAG SYSTEM. FAILURE TO TAKE THE PROPER PRECAUTIONS COULD RESULT IN AN ACCIDENTAL AIRBAG DEPLOYMENT AND POSSIBLE PERSONAL INJURY.**

(1) Check for battery voltage at the fuse in the Power Distribution Center (PDC). If OK, go to Step 2. If not OK, repair the shorted circuit or component as required and replace the faulty fuse.

(2) Turn the ignition switch to the Off position. Disconnect and isolate the battery negative cable. Remove the a/c heater control from the instrument panel. (Refer to 24 - HEATING & AIR CONDITIONING/CONTROLS/A/C HEATER CONTROL - REMOVAL) Check for continuity between the ground circuit cavity of the a/c heater control wire harness connector and a good ground. There should be continuity. If OK, go to Step 3. If not OK, repair the open circuit to ground as required.

(3) With the a/c heater control wire harness connector unplugged, place the a/c heater mode control switch knob in any position except the Off position. Check for continuity between the ground circuit terminal and each of the blower motor driver circuit terminals of the a/c heater control as you move the blower motor switch knob to each of the four speed positions. There should be continuity at each driver

circuit terminal in only one blower motor switch speed position. If OK, test and repair the blower driver circuits between the a/c heater control connector and the blower motor resistor as required. If not OK, replace the faulty a/c heater control unit.

### REMOVAL

The blower motor switch cannot be repaired and, if faulty or damaged, the entire heater-only or a/c heater control unit must be replaced. (Refer to 24 - HEATING & AIR CONDITIONING/CONTROLS/A/C HEATER CONTROL - REMOVAL) The blower motor switch knob is serviced separately.

## BLEND DOOR ACTUATOR

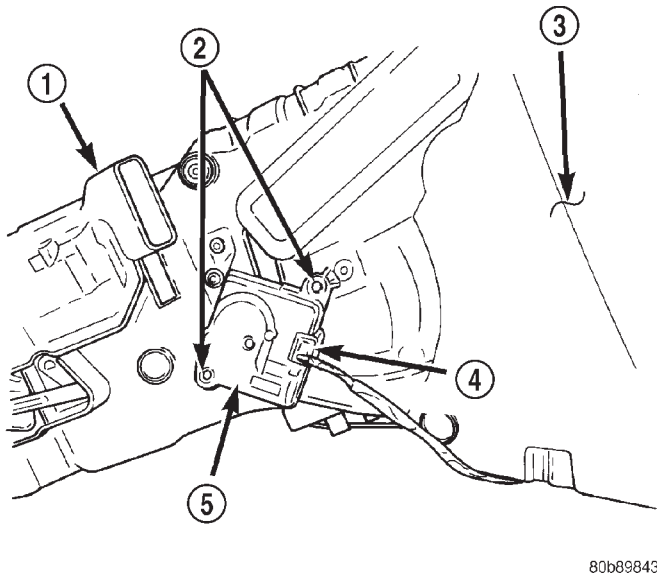
### REMOVAL

**WARNING: ON VEHICLES EQUIPPED WITH AIRBAGS, DISABLE THE AIRBAG SYSTEM BEFORE ATTEMPTING ANY STEERING WHEEL, STEERING COLUMN, OR INSTRUMENT PANEL COMPONENT DIAGNOSIS OR SERVICE. DISCONNECT AND ISOLATE THE BATTERY NEGATIVE (GROUND) CABLE, THEN WAIT TWO MINUTES FOR THE AIRBAG SYSTEM CAPACITOR TO DISCHARGE BEFORE PERFORMING FURTHER DIAGNOSIS OR SERVICE. THIS IS THE ONLY SURE WAY TO DISABLE THE AIRBAG SYSTEM. FAILURE TO TAKE THE PROPER PRECAUTIONS COULD RESULT IN AN ACCIDENTAL AIRBAG DEPLOYMENT AND POSSIBLE PERSONAL INJURY.**

- (1) Turn the ignition switch to the run position.
- (2) Locate the temperature control knob in the mid (12 o'clock) position.
- (3) Turn the ignition switch to the off position.
- (4) Disconnect and isolate the battery negative cable.
- (5) Remove the instrument panel from the vehicle. Refer to Instrument Panel System for the procedures.
- (6) Remove the HVAC housing from the vehicle. (Refer to 24 - HEATING & AIR CONDITIONING/DISTRIBUTION/HVAC HOUSING - REMOVAL)
- (7) Unplug the wire harness connector from the blend door actuator (Fig. 24).
- (8) Remove the two mounting screws which secure the actuator to the housing.
- (9) Slide the blend door actuator off the blend door shaft.

**NOTE: A black plastic coupler may be attached to the blend door shaft. Remove the coupler and inspect for damage. Reinstall if there is no damage found.**

## BLEND DOOR ACTUATOR (Continued)



**Fig. 24 BLEND DOOR ACTUATOR REMOVE/INSTALL**

- 1 - DUCT
- 2 - MOUNTING SCREWS
- 3 - UNIT HOUSING
- 4 - HARNESS AND CONNECTOR
- 5 - BLEND DOOR ACTUATOR

## INSTALLATION

**NOTE:** Before installing the blend door actuator, be certain that the blend door is not binding and is capable of full travel in both directions.

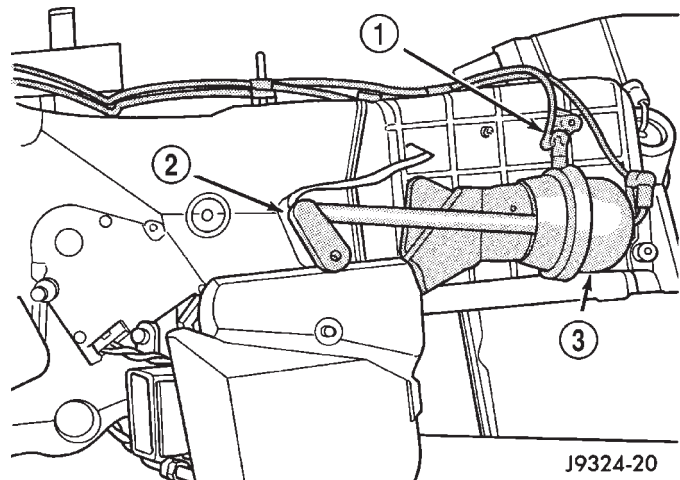
- (1) Align the actuator with the blend door shaft and rotate the actuator to align it to the mounting bosses on the HVAC housing.
- (2) Align and install the actuator screws. Tighten the mounting screws to 2.2 N·m (20 in. lbs.).
- (3) Plug in the wire harness connector to the blend door actuator.
- (4) Install the HVAC housing in the vehicle. (Refer to 24 - HEATING & AIR CONDITIONING/DISTRIBUTION/HVAC HOUSING - INSTALLATION)
- (5) Install the instrument panel in the vehicle. Refer to Instrument Panel System for the procedures.
- (6) Make sure the Temperature Control Knob is in the mid (12 o'clock) position to allow the actuator to automatically position itself in the mid position and come to a complete stop when powered up.
- (7) Connect the battery negative cable.

## MODE DOOR ACTUATOR

## REMOVAL - HEAT/DEFROST DOOR ACTUATOR

**WARNING:** ON VEHICLES EQUIPPED WITH AIRBAGS, DISABLE THE AIRBAG SYSTEM BEFORE ATTEMPTING ANY STEERING WHEEL, STEERING COLUMN, OR INSTRUMENT PANEL COMPONENT DIAGNOSIS OR SERVICE. DISCONNECT AND ISOLATE THE BATTERY NEGATIVE (GROUND) CABLE, THEN WAIT TWO MINUTES FOR THE AIRBAG SYSTEM CAPACITOR TO DISCHARGE BEFORE PERFORMING FURTHER DIAGNOSIS OR SERVICE. THIS IS THE ONLY SURE WAY TO DISABLE THE AIRBAG SYSTEM. FAILURE TO TAKE THE PROPER PRECAUTIONS COULD RESULT IN AN ACCIDENTAL AIRBAG DEPLOYMENT AND POSSIBLE PERSONAL INJURY.

- (1) Disconnect and isolate the battery negative cable.
- (2) Remove the HVAC housing from the vehicle and place it on a work bench. (Refer to 24 - HEATING & AIR CONDITIONING/DISTRIBUTION/HVAC HOUSING - REMOVAL)
- (3) Unplug the two vacuum harness connectors from the heat/defrost door actuator (Fig. 25).



**Fig. 25 HEAT/DEFROST DOOR ACTUATOR**

- 1 - VACUUM LINE
- 2 - DOOR PIVOT CONNECTION
- 3 - HEAT/DEFROST DOOR ACTUATOR

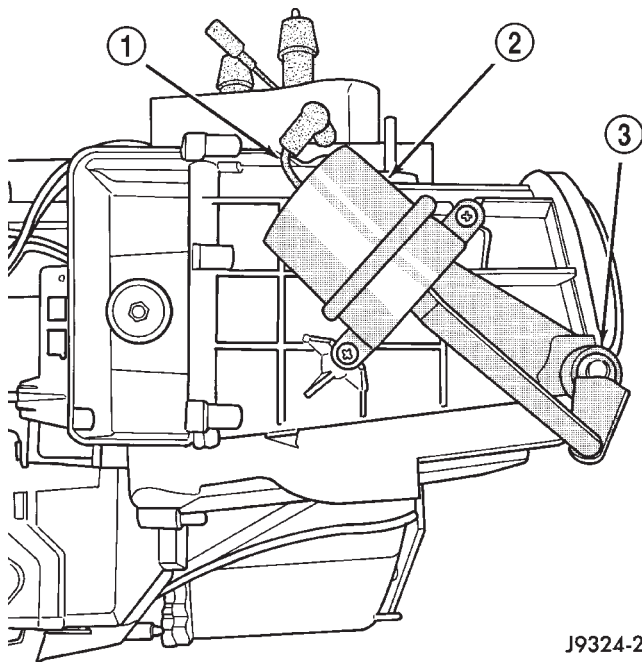
- (4) Using a trim stick or another suitable wide flat-bladed tool, gently pry the heat/defrost door crank arm off the heat/defrost door pivot.
- (5) Remove the two screws that secure the heat/defrost door actuator to the HVAC housing.
- (6) Remove the heat/defrost door actuator from the HVAC housing.

## MODE DOOR ACTUATOR (Continued)

## REMOVAL - PANEL/DEFROST DOOR ACTUATOR

**WARNING: ON VEHICLES EQUIPPED WITH AIRBAGS, DISABLE THE AIRBAG SYSTEM BEFORE ATTEMPTING ANY STEERING WHEEL, STEERING COLUMN, OR INSTRUMENT PANEL COMPONENT DIAGNOSIS OR SERVICE. DISCONNECT AND ISOLATE THE BATTERY NEGATIVE (GROUND) CABLE, THEN WAIT TWO MINUTES FOR THE AIRBAG SYSTEM CAPACITOR TO DISCHARGE BEFORE PERFORMING FURTHER DIAGNOSIS OR SERVICE. THIS IS THE ONLY SURE WAY TO DISABLE THE AIRBAG SYSTEM. FAILURE TO TAKE THE PROPER PRECAUTIONS COULD RESULT IN AN ACCIDENTAL AIRBAG DEPLOYMENT AND POSSIBLE PERSONAL INJURY.**

- (1) Disconnect and isolate the battery negative cable.
- (2) Remove the instrument panel assembly from the vehicle. Refer to Instrument Panel System for the procedures.
- (3) Unplug the vacuum harness connector from the panel/defrost door actuator (Fig. 26).



**Fig. 26 PANEL/DEFROST DOOR ACTUATOR**

- 1 - VACUUM LINE
- 2 - PANEL/DEFROST ACTUATOR
- 3 - SHAFT RETAINER

- (4) Using a trim stick or another suitable wide flat-bladed tool, gently pry the panel/defrost door crank arm off the panel/defrost door pivot.
- (5) Remove the two screws that secure the panel/defrost door actuator to the HVAC housing.
- (6) Remove the panel/defrost door actuator from the HVAC housing.

## INSTALLATION - HEAT/DEFROST DOOR ACTUATOR

**NOTE: Before installing the heat/defrost door actuator, be certain that the heat/defrost door is not binding.**

- (1) Install the heat/defrost door actuator from the HVAC housing. Tighten the actuator mounting screws to 2.2 N·m (20 in. lbs.).
- (2) Carefully snap the heat/defrost door crank arm on the heat/defrost door pivot.
- (3) Plug in the two vacuum harness connectors to the heat/defrost door actuator.
- (4) Install the HVAC housing in the vehicle. (Refer to 24 - HEATING & AIR CONDITIONING/DISTRIBUTION/HVAC HOUSING - INSTALLATION)
- (5) Connect the battery negative cable.

## INSTALLATION - PANEL/DEFROST DOOR ACTUATOR

**NOTE: Before installing the panel/defrost door actuator, be certain that the panel/defrost door is not binding.**

- (1) Install the panel/defrost door actuator on the HVAC housing. Tighten the mounting screws to 2.2 N·m (20 in. lbs.).
- (2) Carefully snap the panel/defrost door crank arm on the panel/defrost door pivot.
- (3) Plug the vacuum harness connector to the panel/defrost door actuator.
- (4) Install the instrument panel assembly in the vehicle. Refer to Instrument Panel System for the procedures.
- (5) Connect the battery negative cable.

## RECIRCULATION DOOR ACTUATOR

## REMOVAL

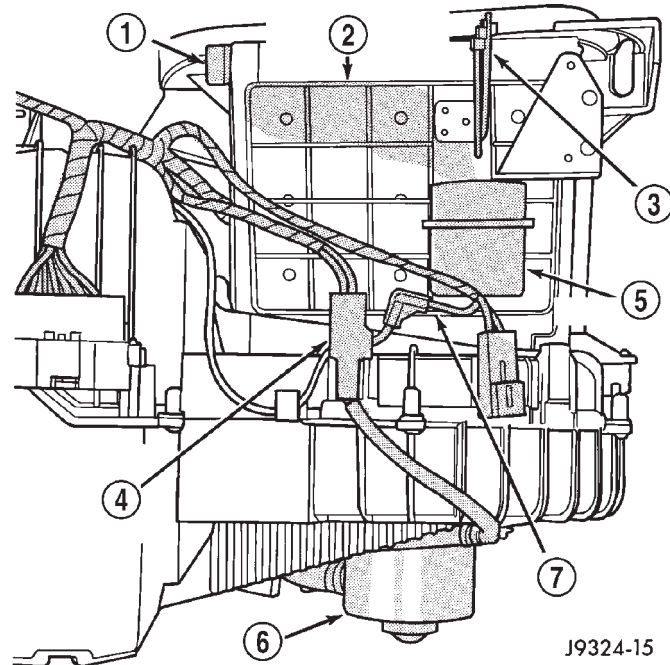
**WARNING: ON VEHICLES EQUIPPED WITH AIRBAGS, DISABLE THE AIRBAG SYSTEM BEFORE ATTEMPTING ANY STEERING WHEEL, STEERING COLUMN, OR INSTRUMENT PANEL COMPONENT DIAGNOSIS OR SERVICE. DISCONNECT AND ISOLATE THE BATTERY NEGATIVE (GROUND) CABLE, THEN WAIT TWO MINUTES FOR THE AIRBAG SYSTEM CAPACITOR TO DISCHARGE BEFORE PERFORMING FURTHER DIAGNOSIS OR SERVICE. THIS IS THE ONLY SURE WAY TO DISABLE THE AIRBAG SYSTEM. FAILURE TO TAKE THE PROPER PRECAUTIONS COULD RESULT IN AN ACCIDENTAL AIRBAG DEPLOYMENT AND POSSIBLE PERSONAL INJURY.**

## RECIRCULATION DOOR ACTUATOR (Continued)

(1) Disconnect and isolate the battery negative cable.

(2) Remove the glove box from the instrument panel. Refer to Glove Box in Instrument Panel System for the procedures.

(3) Reach through the glove box opening to access and unplug the vacuum harness connector from the recirculation door actuator (Fig. 27).



J9324-15

**Fig. 27 RECIRCULATION DOOR ACTUATOR**

- 1 - DOOR SHAFT RETAINER
- 2 - RECIRCULATION DOOR
- 3 - ROD CLIP
- 4 - BLOWER MOTOR ELECTRICAL CONNECTOR
- 5 - RECIRCULATION DOOR ACTUATOR
- 6 - BLOWER MOTOR
- 7 - VACUUM LINE

(4) Loosen the two nuts that secure the recirculation door actuator to the mounting bracket on the HVAC housing.

(5) Slide the two actuator mounting studs out of the slots in the actuator mounting bracket.

(6) Pull the recirculation door actuator downward far enough to access the clip that retains the actuator link to the recirculation door lever.

(7) Unsnap the clip from the recirculation door actuator link and disengage the link from the recirculation door lever.

(8) Remove the recirculation door actuator from the HVAC housing.

## INSTALLATION

**NOTE:** When reinstalling the recirculation door actuator, insert a screwdriver or another suitable tool through the recirculation air intake grille to prop the recirculation air door up in the open position far enough to access the recirculation air door lever through the instrument panel glove box opening.

**NOTE:** Before installing the blend door actuator, be certain that the blend door is not binding.

(1) Snap the clip on the recirculation door actuator link to engage the link to the recirculation door lever.

(2) Slide the two actuator mounting studs into the slots in the actuator mounting bracket.

(3) Install the two nuts that secure the recirculation door actuator to the mounting bracket on the HVAC housing. Tighten the mounting nuts until the recirculation air door actuator is seated to the mounting bracket.

(4) Plug in the vacuum harness connector to the recirculation door actuator.

(5) Install the glove box in the instrument panel. Refer to Glove Box in Instrument Panel System for the procedures.

(6) Connect the battery negative cable.

## VACUUM CHECK VALVE

## DESCRIPTION

On models with a gasoline engine, a vacuum check valve is installed in the accessory vacuum supply line near the vacuum tap on the right side of the engine intake manifold. On models with a diesel engine, a vacuum check valve is installed on the engine vacuum pump. The vacuum check valve is designed to allow vacuum to flow in only one direction through the accessory vacuum supply circuits.

## OPERATION

The use of a vacuum check valve helps to maintain the system vacuum needed to retain the selected HVAC mode and vehicle speed control settings. On gasoline engine models, it prevents the engine from bleeding down system vacuum through the intake manifold during extended heavy engine load (low engine vacuum) operation. On diesel engine models, it prevents oil from contaminating the vacuum supply system by maintaining vacuum in the pump after the engine is shut-off.

On gasoline engine models, a second vacuum check valve is installed in the accessory vacuum supply line at the tee fitting near the dash panel in the engine



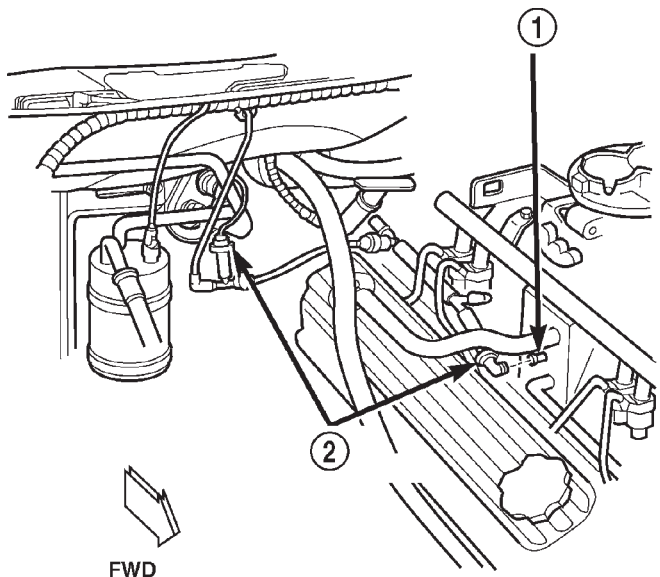
## VACUUM CHECK VALVE (Continued)

compartment. This check valve also helps to maintain the system vacuum needed to retain the selected HVAC mode settings, but isolates the HVAC vacuum circuit from the vehicle speed control vacuum circuit. It prevents the vehicle speed control servo from bleeding down the HVAC system vacuum during extended heavy engine load operation.

The vacuum check valve cannot be repaired and, if faulty or damaged, it must be replaced.

## REMOVAL

(1) On models with a gasoline engine, unplug the vacuum supply line connector at the vacuum check valve (Fig. 28). On models with a diesel engine, remove the clamp from the vacuum supply line connector and unplug the connector from the vacuum check valve (Fig. 29).



80b1b34f

**Fig. 28 VACUUM CHECK VALVES - GASOLINE ENGINE**

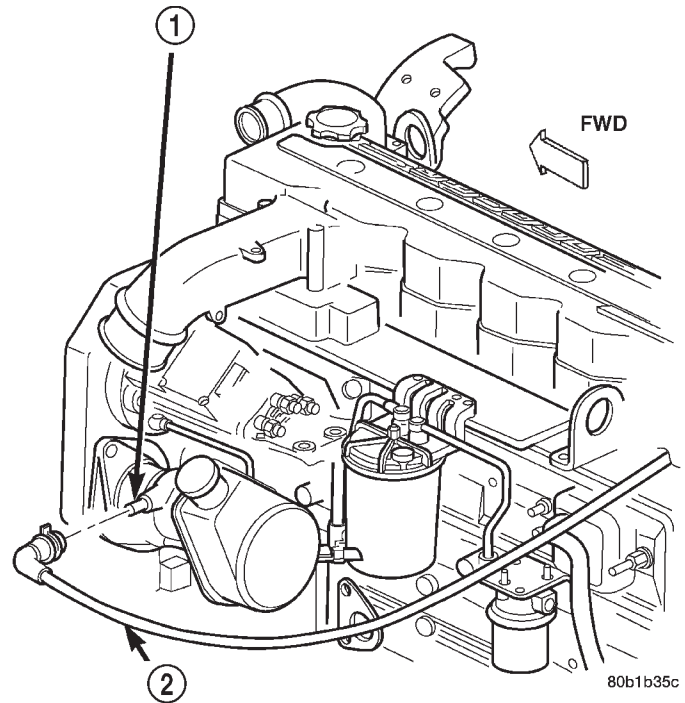
- 1 - INTAKE MANIFOLD VACUUM TAP  
2 - VACUUM CHECK VALVES

(2) On models with a gasoline engine, note the orientation of the check valve in the vacuum supply line for correct reinstallation.

(3) On models with a gasoline engine, unplug the remaining line on the vacuum check valve from the vacuum supply line fitting. On models with a diesel engine, unscrew the check valve and nipple unit from the engine vacuum pump.

## INSTALLATION

(1) On models with a gasoline engine, plug in the vacuum check valve to the vacuum line fittings, not-



80b1b35c

**Fig. 29 VACUUM CHECK VALVE - DIESEL ENGINE**

- 1 - VACUUM CHECK VALVE  
2 - VACUUM SUPPLY LINE

ing the proper orientation of the check valve in the line. On models with a diesel engine, screw the check valve and nipple unit into the engine vacuum pump. Tighten the check valve and nipple unit to 24 N·m (18 ft. lbs.).

(2) On models with a diesel engine, plug in the connector to the vacuum check valve and install the clamp from the vacuum supply line connector.

## VACUUM RESERVOIR

## DESCRIPTION

Models equipped with a gasoline engine have a vacuum reservoir. The vacuum reservoir is mounted in the passenger side cowl plenum area, under the cowl plenum cover/grille panel. The cowl plenum cover/grille panel must be removed from the vehicle to access the vacuum reservoir for service.

## OPERATION

Engine vacuum is stored in the vacuum reservoir. The stored vacuum is used to operate the vacuum-controlled vehicle accessories during periods of low engine vacuum such as when the vehicle is climbing a steep grade, or under other high engine load operating conditions.

The vacuum reservoir cannot be repaired and, if faulty or damaged, it must be replaced.



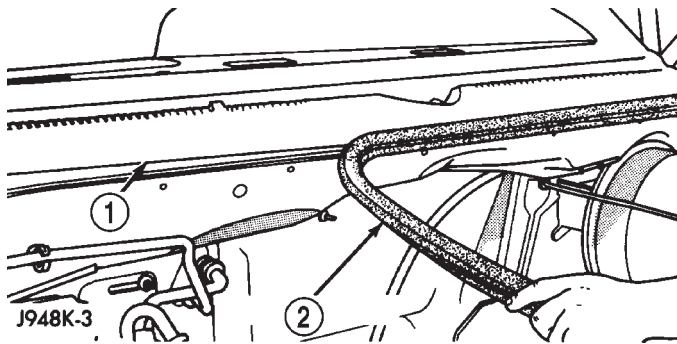
## VACUUM RESERVOIR (Continued)

**REMOVAL**

(1) Disconnect and isolate the battery negative cable.

(2) Remove the wiper arms from the wiper pivots. Refer to Wipers/Washers for the procedures.

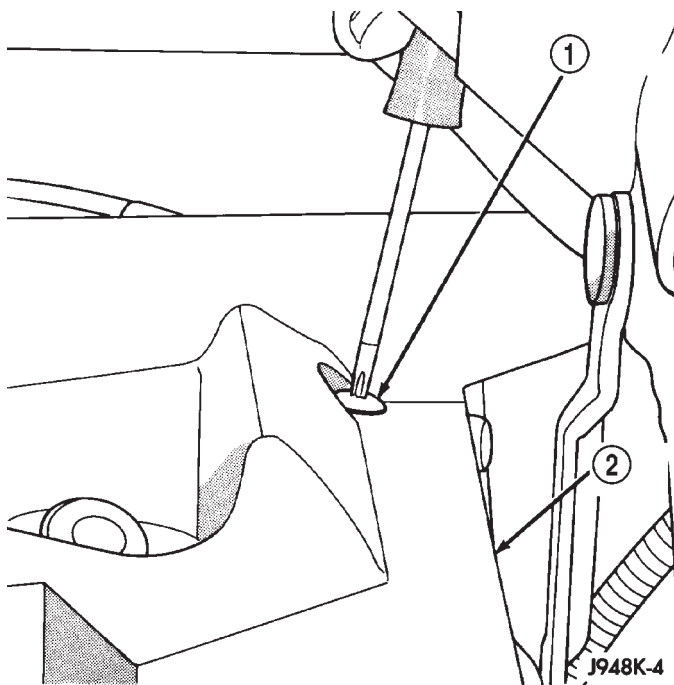
(3) Remove the weatherstrip along the front edge of the cowl plenum cover/grille panel and the cowl plenum panel (Fig. 30).



**Fig. 30 COWL PLENUM COVER/GRILLE PANEL WEATHERSTRIP**

- 1 - COWL GRILLE  
2 - WEATHERSTRIP

(4) Remove the plastic screws that secure the cowl plenum cover/grille panel to the studs on the cowl top panel near the base of the windshield (Fig. 31).

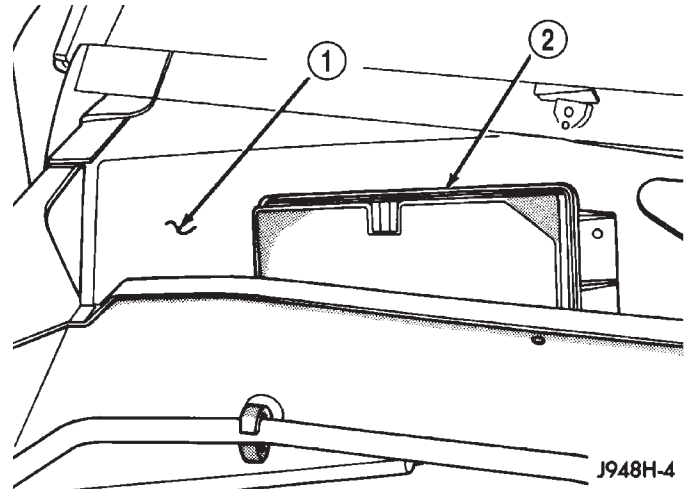


**Fig. 31 COWL PLENUM PLASTIC SCREWS REMOVAL**

- 1 - PLASTIC SCREW ANCHOR  
2 - COWL GRILLE

(5) Lift the cowl plenum cover/grille panel from the cowl top far enough to access the vacuum reservoir near the right end of the cowl plenum.

(6) Disconnect the vacuum supply hose from the vacuum reservoir, which is secured to the dash panel near the right end of the cowl plenum (Fig. 32).



**Fig. 32 VACUUM RESERVOIR REMOVE/INSTALL**

- 1 - COWL PLENUM  
2 - VACUUM RESERVOIR

(7) Remove the two nuts that secure the reservoir to the studs on the dash panel near the right end of the cowl plenum.

(8) Remove the vacuum reservoir from the dash panel studs.

**INSTALLATION**

(1) Install the vacuum reservoir on the dash panel studs. Tighten the mounting nuts to 2.8 N·m (25 in. lbs.).

(2) Connect the vacuum supply hose to the vacuum reservoir.

(3) Install the plastic screws that secure the cowl plenum cover/grille panel to the studs on the cowl top panel.

(4) Install the weatherstrip along the front edge of the cowl plenum cover/grille panel and the cowl plenum panel.

(5) Install the wiper arms on the wiper pivots. Refer to Wipers/Washers for the procedures.

(6) Connect the battery negative cable.

# DISTRIBUTION

## TABLE OF CONTENTS

	page		page
<b>DISTRIBUTION</b>		<b>DISASSEMBLY</b> .....	36
DESCRIPTION.....	31	<b>ASSEMBLY</b> .....	36
<b>AIR OUTLETS</b>		<b>INSTALLATION</b> .....	37
REMOVAL.....	31	<b>INSTRUMENT PANEL DEMISTER DUCTS</b>	
INSTALLATION.....	32	REMOVAL.....	37
<b>BLOWER MOTOR</b>		<b>INSTRUMENT PANEL DUCTS</b>	
DESCRIPTION.....	32	REMOVAL.....	37
OPERATION.....	32	<b>BLEND DOOR</b>	
DIAGNOSIS AND TESTING.....	33	REMOVAL.....	38
BLOWER MOTOR.....	33	INSTALLATION.....	38
REMOVAL.....	33	<b>MODE DOOR</b>	
INSTALLATION.....	33	REMOVAL.....	38
<b>DEFROSTER DUCTS</b>		INSTALLATION.....	39
REMOVAL.....	34	<b>RECIRCULATION DOOR</b>	
INSTALLATION.....	35	REMOVAL.....	39
<b>HVAC HOUSING</b>		INSTALLATION.....	39
REMOVAL.....	35		

## DISTRIBUTION

### DESCRIPTION - HVAC SYSTEM AIRFLOW

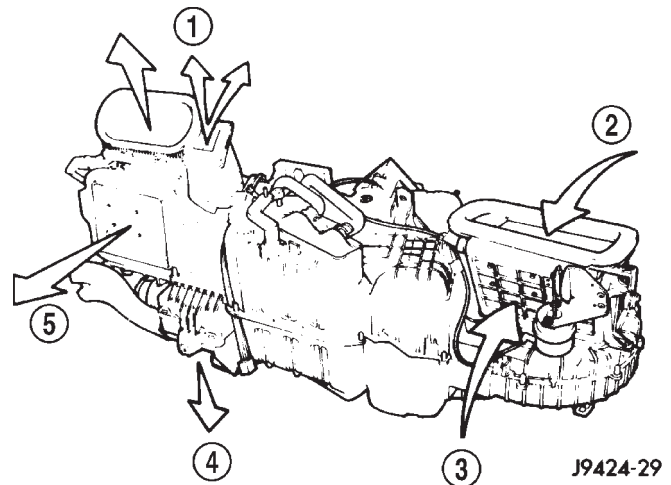
Outside air enters the vehicle through the cowl top opening at the base of the windshield, and passes through a plenum chamber to the HVAC system blower housing (Fig. 1). Air flow velocity can then be adjusted with the blower motor switch on the a/c heater control panel. The air intake openings must be kept free of snow, ice, leaves, and other obstructions for the HVAC system to receive a sufficient volume of outside air.

It is also important to keep the air intake openings clear of debris because leaf particles and other debris that is small enough to pass through the cowl plenum screen can accumulate within the HVAC housing. The closed, warm, damp and dark environment created within the HVAC housing is ideal for the growth of certain molds, mildews and other fungi. Any accumulation of decaying plant matter provides an additional food source for fungal spores, which enter the housing with the fresh air. Excess debris, as well as objectionable odors created by decaying plant matter and growing fungi can be discharged into the passenger compartment during HVAC system operation.

## AIR OUTLETS

### REMOVAL - DEMISTER GRILLES

(1) Using a trim stick or another suitable wide flat-bladed tool, gently pry at the perimeter edges of



**Fig. 1 HVAC SYSTEM AIRFLOW**

- 1 - DEFROST OUTLET
- 2 - OUTSIDE AIR INLET
- 3 - RECIRCULATION INLET
- 4 - FLOOR OUTLET
- 5 - PANEL OUTLET

the demister grille to release the snap features from the instrument panel top cover.

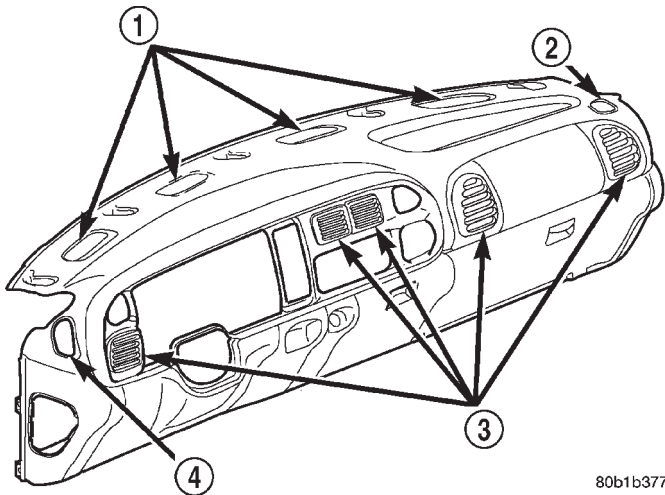
(2) Remove the demister grille from the instrument panel.

## AIR OUTLETS (Continued)

## REMOVAL - PANEL OUTLET BARRELS

**WARNING: THE PANEL OUTLET BARRELS INSTALLED IN THE PASSENGER SIDE AIRBAG DOOR PANEL OUTLET HOUSINGS MUST NEVER BE REINSTALLED FOLLOWING REMOVAL FOR ANY REASON. THEY MUST BE REPLACED WITH NEW BARRELS. FAILURE TO OBSERVE THIS WARNING COULD RESULT IN OCCUPANT INJURIES UPON AIRBAG DEPLOYMENT.**

(1) Using a trim stick or another suitable wide flat-bladed tool, gently pry near the center of either side of the panel outlet barrel to release the snap-fit pivots on the barrel from the pivot pins in the outlet housing of the passenger side airbag module or the instrument cluster bezel (Fig. 2).



**Fig. 2 PANEL OUTLET BARRELS**

- 1 - DEFROSTER OUTLETS
- 2 - DEMISTER OUTLET GRILLE
- 3 - PANEL OUTLET BARRELS
- 4 - DEMISTER OUTLET GRILLE

(2) Remove the barrel from the panel outlet housing.

## INSTALLATION - DEMISTER GRILLES

(1) To install the demister grille, position the grille in the opening of the instrument panel top cover and press inwards firmly and evenly near the center of both sides of the grille until it snaps into place.

## INSTALLATION - PANEL OUTLET BARRELS

**WARNING: THE PANEL OUTLET BARRELS INSTALLED IN THE PASSENGER SIDE AIRBAG DOOR PANEL OUTLET HOUSINGS MUST NEVER BE REINSTALLED FOLLOWING REMOVAL FOR ANY REASON. THEY MUST BE REPLACED WITH NEW BARRELS. FAILURE TO OBSERVE THIS WARNING COULD RESULT IN OCCUPANT INJURIES UPON AIRBAG DEPLOYMENT.**

(1) To install a new panel outlet barrel, position the barrel in the outlet housing and press inwards firmly and evenly near the center of both sides of the panel outlet barrel until the pivots snap into place.

## BLOWER MOTOR

## DESCRIPTION

The blower motor and blower wheel are located in the passenger side end of the HVAC housing, below the glove box. The blower motor controls the velocity of the air flowing through the HVAC housing by spinning a squirrel cage-type blower wheel within the housing at the selected speed. The blower motor and blower wheel can be serviced from the passenger compartment side of the housing.

## OPERATION

The blower motor will only operate when the ignition switch is in the On position, and the a/c heater mode control switch knob is in any position, except Off. The blower motor receives a fused battery feed through the blower motor relay whenever the ignition switch is in the On position.

The blower motor battery feed circuit is protected by a fuse in the Power Distribution Center (PDC). The blower motor relay control circuit is protected by a fuse in the junction block. Blower motor speed is controlled by regulating the ground path through the a/c heater mode control switch, the blower motor switch, and the blower motor resistor.

The blower motor and blower wheel cannot be repaired and, if faulty or damaged, they must be replaced. The blower motor and blower wheel may be serviced separately, although if the motor is to be replaced, a blower wheel will come as part of a pre-balanced assembly.

## BLOWER MOTOR (Continued)

## DIAGNOSIS AND TESTING - BLOWER MOTOR

**WARNING: ON VEHICLES EQUIPPED WITH AIRBAGS, DISABLE THE AIRBAG SYSTEM BEFORE ATTEMPTING ANY STEERING WHEEL, STEERING COLUMN, OR INSTRUMENT PANEL COMPONENT DIAGNOSIS OR SERVICE. DISCONNECT AND ISOLATE THE BATTERY NEGATIVE (GROUND) CABLE, THEN WAIT TWO MINUTES FOR THE AIRBAG SYSTEM CAPACITOR TO DISCHARGE BEFORE PERFORMING FURTHER DIAGNOSIS OR SERVICE. THIS IS THE ONLY SURE WAY TO DISABLE THE AIRBAG SYSTEM. FAILURE TO TAKE THE PROPER PRECAUTIONS COULD RESULT IN AN ACCIDENTAL AIRBAG DEPLOYMENT AND POSSIBLE PERSONAL INJURY.**

For circuit descriptions and diagrams, (Refer to Appropriate Wiring Information). Possible causes of an inoperative blower motor include:

- Faulty fuse
- Faulty blower motor circuit wiring or wire harness connectors
- Faulty blower motor resistor
- Faulty blower motor relay
- Faulty blower motor switch
- Faulty a/c heater mode control switch
- Faulty blower motor.

Possible causes of the blower motor not operating in all speeds include:

- Faulty fuse
- Faulty blower motor switch
- Faulty blower motor resistor
- Faulty blower motor relay
- Faulty blower motor circuit wiring or wire harness connectors.

## VIBRATION

Possible causes of blower motor vibration include:

- Improper blower motor mounting
- Improper blower wheel mounting
- Blower wheel out of balance or deformed
- Blower motor faulty.

## NOISE

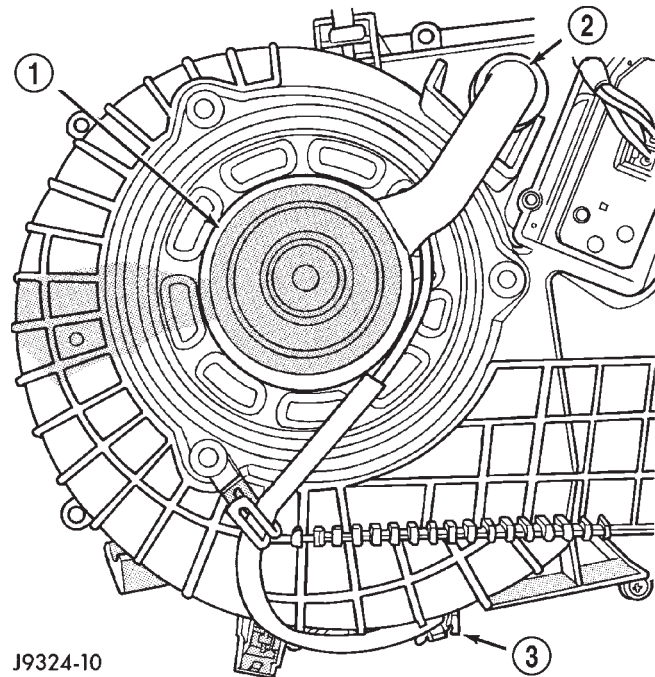
To verify that the blower is the source of the noise, unplug the blower motor wire harness connector and operate the HVAC system. If the noise goes away, possible causes include:

- Foreign material in the HVAC housing
- Improper blower motor mounting
- Improper blower wheel mounting
- Blower motor faulty.

## REMOVAL

(1) Disconnect and isolate the battery negative cable.

(2) Disconnect the blower motor cooling tube from the nipple on the blower motor housing (Fig. 3).



J9324-10

**Fig. 3 BLOWER MOTOR REMOVE/INSTALL**

- 1 - BLOWER MOTOR HOUSING  
2 - COOLING TUBE  
3 - ELECTRICAL CONNECTOR

(3) Disengage the blower motor wire harness from the wire harness retainer.

(4) Unplug the blower motor wire harness connector from the HVAC housing wire harness.

(5) Remove the three screws that secure the blower motor and blower wheel assembly to the HVAC housing.

(6) Lower the blower motor and wheel assembly, and cover, from the HVAC housing.

(7) Remove the blower wheel retainer clip and remove the wheel from the blower motor shaft (Fig. 4).

## INSTALLATION

(1) If installing the blower motor wheel only, press the blower wheel hub onto the blower motor shaft. Be sure the flat on the blower motor shaft is indexed to the flat on the inside of the blower wheel hub.

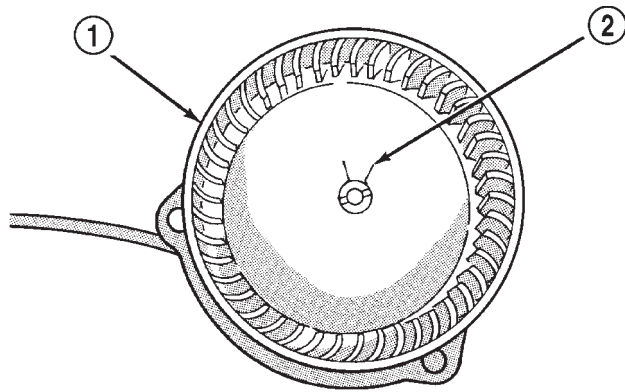
(2) Install the retainer clip over the blower wheel hub. The ears of the retainer clip must be indexed over the flats on the blower motor shaft and blower wheel hub.

(3) Be certain that the blower motor seal is installed on the blower motor housing (Fig. 5).

(4) Install the blower motor and wheel assembly, and cover in the HVAC housing with three mounting screws. Tighten the mounting screws to 2.2 N-m (20 in. lbs.).



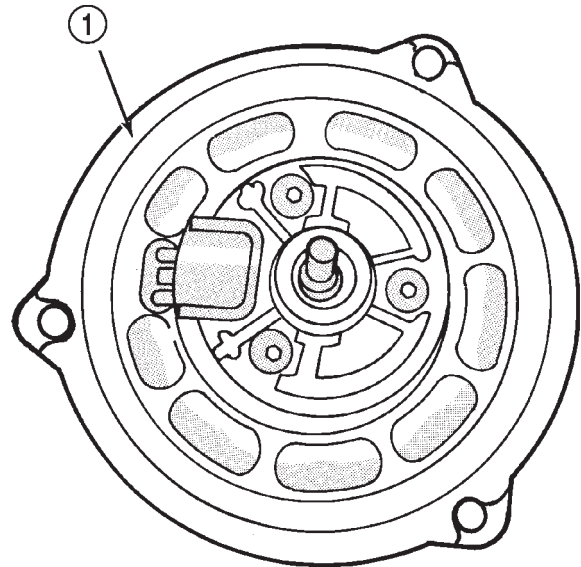
BLOWER MOTOR (Continued)



J9324-92

**Fig. 4 BLOWER MOTOR WHEEL REMOVE/INSTALL**

- 1 - BLOWER MOTOR WHEEL
- 2 - RETAINER CLIP



J9324-33

**Fig. 5 BLOWER MOTOR SEAL**

- 1 - BLOWER MOTOR SEAL

(5) Plug the blower motor wire harness connector into the HVAC housing wire harness.

(6) Install the blower motor wire harness into the wire harness retainer.

(7) Connect the blower motor cooling tube to the nipple on the blower motor housing.

(8) Connect the battery negative cable.

DEFROSTER DUCTS

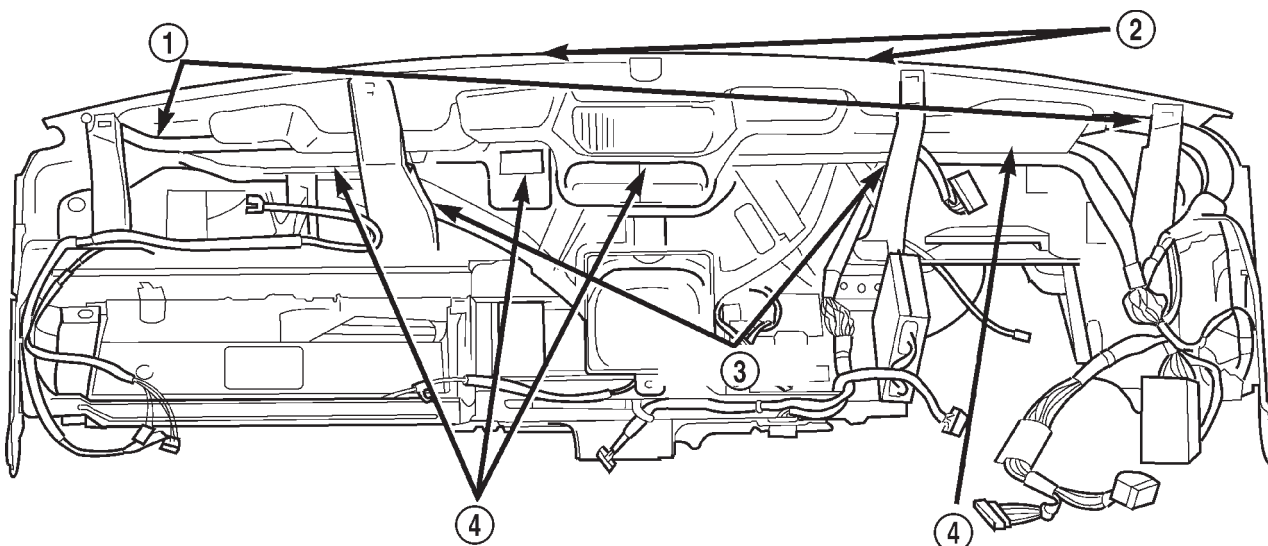
REMOVAL - DEFROSTER AND DEMISTER DUCTS

The defroster duct and the main demister duct are a single molded plastic unit. The defroster outlet

grilles are heat-staked to the defroster outlets and cannot be serviced separately. The demister tubes on each end of the main demister duct are only serviced in the instrument panel assembly.

(1) Remove the instrument panel top cover from the instrument panel. Refer to Instrument System for the procedures.

(2) Remove the screws that secure the defroster and demister ducts to the instrument panel brackets (Fig. 6).



80ae83cf

**Fig. 6 DEFROSTER AND DEMISTER DUCT**

- 1 - DEMISTER TUBE
- 2 - INSTRUMENT PANEL TOP COVER

- 3 - BRACKETS
- 4 - DEFROSTER AND DEMISTER DUCT



## DEFROSTER DUCTS (Continued)

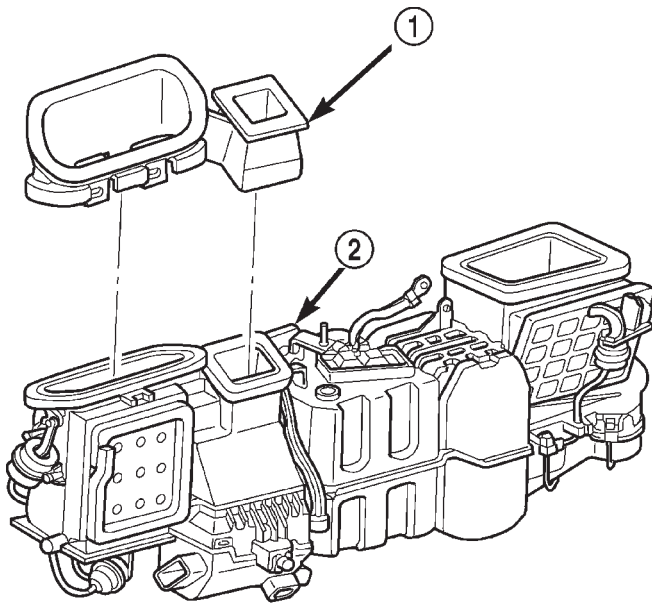
(3) Disengage the demister tubes from each end of the main demister duct.

(4) Remove the defroster and demister duct unit from the instrument panel.

## REMOVAL - DEFROSTER AND DEMISTER DUCT ADAPTER

(1) Roll the instrument panel assembly down, but do not remove it from the vehicle. Refer to Instrument Panel System for the procedures.

(2) Using a trim stick or another suitable wide flat-bladed tool, gently pry at the perimeter edges of the defroster and demister duct adapter to release the snap features from the top of the HVAC housing (Fig. 7).



80b1b378

**Fig. 7 DEFROSTER AND DEMISTER DUCT ADAPTER REMOVE/INSTALL**

- 1 - DEFROSTER AND DEMISTER DUCT ADAPTER  
2 - HVAC HOUSING

(3) Remove the defroster and demister duct adapter from the top of the HVAC housing.

## INSTALLATION - DEFROSTER AND DEMISTER DUCTS

(1) Place the defroster and demister duct unit in position.

(2) Engage the demister tubes with each end of the main demister duct.

(3) Install the screws that secure the defroster and demister ducts to the instrument panel brackets. Tighten the mounting screws to 2.2 N·m (20 in. lbs.).

(4) Install the instrument panel top cover on the instrument panel. Refer to Instrument System for the procedures.

## INSTALLATION - DEFROSTER AND DEMISTER DUCT ADAPTER

(1) Snap the defroster and demister duct adapter from the top of the HVAC housing.

(2) Roll the instrument panel assembly up, and fasten it properly to the vehicle. Refer to Instrument Panel System for the procedures.

## HVAC HOUSING

## REMOVAL

**WARNING: ON VEHICLES EQUIPPED WITH AIRBAGS, DISABLE THE AIRBAG SYSTEM BEFORE ATTEMPTING ANY STEERING WHEEL, STEERING COLUMN, OR INSTRUMENT PANEL COMPONENT DIAGNOSIS OR SERVICE. DISCONNECT AND ISOLATE THE BATTERY NEGATIVE (GROUND) CABLE, THEN WAIT TWO MINUTES FOR THE AIRBAG SYSTEM CAPACITOR TO DISCHARGE BEFORE PERFORMING FURTHER DIAGNOSIS OR SERVICE. THIS IS THE ONLY SURE WAY TO DISABLE THE AIRBAG SYSTEM. FAILURE TO TAKE THE PROPER PRECAUTIONS COULD RESULT IN AN ACCIDENTAL AIRBAG DEPLOYMENT AND POSSIBLE PERSONAL INJURY.**

**WARNING: IF THE VEHICLE IS EQUIPPED WITH AIR CONDITIONING, REVIEW THE WARNINGS AND CAUTIONS IN PLUMBING BEFORE PERFORMING THE FOLLOWING OPERATION. (Refer to 24 - HEATING & AIR CONDITIONING/PLUMBING - WARNING) (Refer to 24 - HEATING & AIR CONDITIONING/PLUMBING - CAUTION)**

The HVAC housing assembly must be removed from the vehicle and disassembled for service access of the heater core, a/c evaporator, and each of the various mode control doors.

(1) Disconnect and isolate the battery negative cable.

(2) Remove the instrument panel from the vehicle. Refer to Instrument Panel System for the procedures.

(3) If the vehicle is not equipped with air conditioning, go to Step 6. If the vehicle is equipped with air conditioning, recover the refrigerant from the system. (Refer to 24 - HEATING & AIR CONDITIONING/PLUMBING - STANDARD PROCEDURE - REFRIGERANT RECOVERY)

(4) Disconnect the liquid line refrigerant line fitting from the evaporator inlet tube. (Refer to 24 - HEATING & AIR CONDITIONING/PLUMBING - STANDARD PROCEDURE - A/C LINE COUPLERS) Install plugs in, or tape over all of the opened refrigerant line fittings.

## HVAC HOUSING (Continued)

(5) Remove the accumulator. (Refer to 24 - HEATING & AIR CONDITIONING/PLUMBING/ACCUMULATOR - REMOVAL) Install plugs in, or tape over all of the opened refrigerant line fittings.

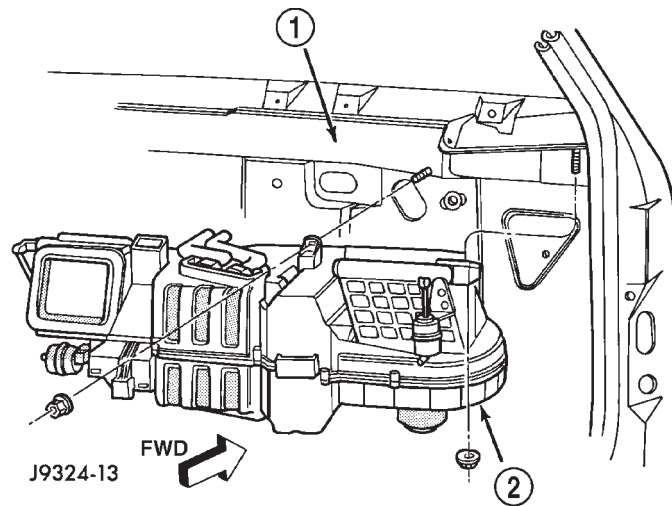
(6) Drain the engine cooling system. Refer to Cooling for the procedures.

(7) Disconnect the heater hoses from the heater core tubes. Refer to Cooling for the procedures. Install plugs in, or tape over the opened heater core tubes.

(8) Remove the Powertrain Control Module (PCM) from the dash panel and set it aside, but do not unplug the PCM wire harness connectors. Refer to Electronic Control Modules for the procedures.

(9) Remove the nuts from the HVAC housing mounting studs on the engine compartment side of the dash panel.

(10) Remove the nuts that secure the HVAC housing to the mounting studs on the passenger compartment side of the dash panel (Fig. 8).



**Fig. 8 HVAC HOUSING REMOVE/INSTALL**

- 1 - BODY ASSEMBLY  
2 - HVAC HOUSING

(11) Pull the HVAC housing rearward far enough for the mounting studs and the evaporator condensate drain tube to clear the dash panel holes.

(12) Remove the HVAC housing from the vehicle.

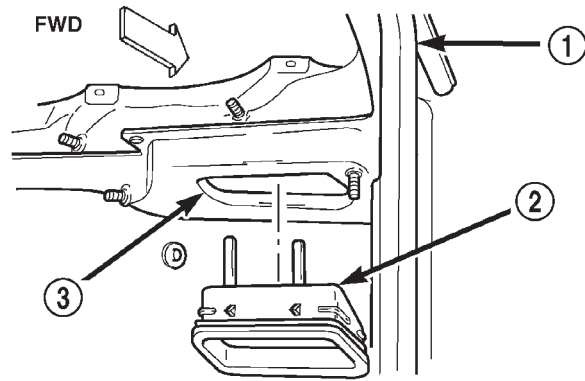
### REMOVAL - HVAC HOUSING INLET BAFFLE

(1) Remove the HVAC housing from the vehicle. (Refer to 24 - HEATING & AIR CONDITIONING/DISTRIBUTION/HVAC HOUSING - REMOVAL)

(2) Slide the HVAC housing inlet baffle (Fig. 9) all the way to one side of the cowl plenum opening.

(3) Pull downwards sharply and firmly on the opposite side of the HVAC housing inlet baffle to disengage the snap features from the cowl plenum opening.

(4) Remove the HVAC housing inlet baffle from the cowl plenum panel.



80b1b379

**Fig. 9 HVAC HOUSING INLET BAFFLE REMOVE/INSTALL**

- 1 - RIGHT A-PILLAR  
2 - INLET BAFFLE  
3 - COWL PLENUM OPENING

### DISASSEMBLY

(1) Place the HVAC housing upside down on a work bench.

(2) Remove the screw that secures the floor duct to the bottom of the HVAC housing and slide the floor duct off of the center heat duct adaptor.

(3) Unsnap the center heat duct adaptor from the bottom of the HVAC housing and remove the screw that was hidden by the adaptor.

(4) Remove the remaining screws on the bottom of the HVAC housing that secure the two housing halves together.

(5) Place the HVAC housing right side up on the work bench.

(6) Separate the top half of the HVAC housing from the bottom half and set it aside.

### ASSEMBLY

(1) Position the top half of the HVAC housing over the bottom half. Be certain that the mode door pivot pins are properly inserted in their pivot holes.

(2) Place the HVAC housing upside down on the work bench.

(3) Install and tighten the screws on the bottom of the HVAC housing that secure the two housing halves together. Tighten the screws to 2.2 N·m (20 in. lbs.).

(4) Snap the center heat duct adaptor onto the bottom of the HVAC housing.

(5) Slide the floor duct onto the center heat duct adaptor and secure it with a screw to the bottom of the HVAC housing. Tighten the mounting screw to 2.2 N·m (20 in. lbs.).

## HVAC HOUSING (Continued)

**INSTALLATION**

(1) Position the HVAC housing to the dash panel. Be certain that the evaporator condensate drain tube and the housing mounting studs are inserted into their correct mounting holes.

(2) Install the nuts that secure the HVAC housing to the mounting studs on the passenger compartment side of the dash panel. Tighten the nuts to 4.5 N·m (40 in. lbs.).

(3) Install and tighten the nuts onto the HVAC housing mounting studs on the engine compartment side of the dash panel. Tighten the nuts to 7 N·m (60 in. lbs.).

(4) Unplug or remove the tape from the heater core tubes. Connect the heater hoses to the heater core tubes and fill the engine cooling system. Refer Cooling for the procedures.

(5) If the vehicle is not equipped with air conditioning, go to Step 10. If the vehicle is equipped with air conditioning, install the accumulator. (Refer to 24 - HEATING & AIR CONDITIONING/PLUMBING/ACCUMULATOR - INSTALLATION) Connect the accumulator inlet tube coupler to the evaporator outlet tube. (Refer to 24 - HEATING & AIR CONDITIONING/PLUMBING - STANDARD PROCEDURE - A/C LINE COUPLERS)

(6) Unplug or remove the tape from the liquid line and the evaporator inlet tube fittings. Connect the liquid line coupler to the evaporator inlet tube. (Refer to 24 - HEATING & AIR CONDITIONING/PLUMBING - STANDARD PROCEDURE - A/C LINE COUPLERS)

(7) Evacuate the refrigerant system. (Refer to 24 - HEATING & AIR CONDITIONING/PLUMBING - STANDARD PROCEDURE - REFRIGERANT SYSTEM EVACUATE)

(8) Charge the refrigerant system. (Refer to 24 - HEATING & AIR CONDITIONING/PLUMBING - STANDARD PROCEDURE - REFRIGERANT SYSTEM CHARGE)

(9) Reinstall the PCM to the dash panel. Refer to Electronic Control Modules for the procedures.

(10) Reinstall the instrument panel in the vehicle. Refer to Instrument Panel System for the procedures.

(11) Connect the battery negative cable.

(12) Start the engine and check for proper operation of the heating and air conditioning systems.

**INSTALLATION - HVAC HOUSING INLET Baffle**

(1) Install the HVAC housing inlet baffle in the cowl plenum panel.

(2) Slide the HVAC housing inlet baffle to engage the snap features.

(3) Make certain that the snap features on each side of the adapter are fully engaged with the sides of the plenum panel opening. This must be a water tight connection to prevent leaks.

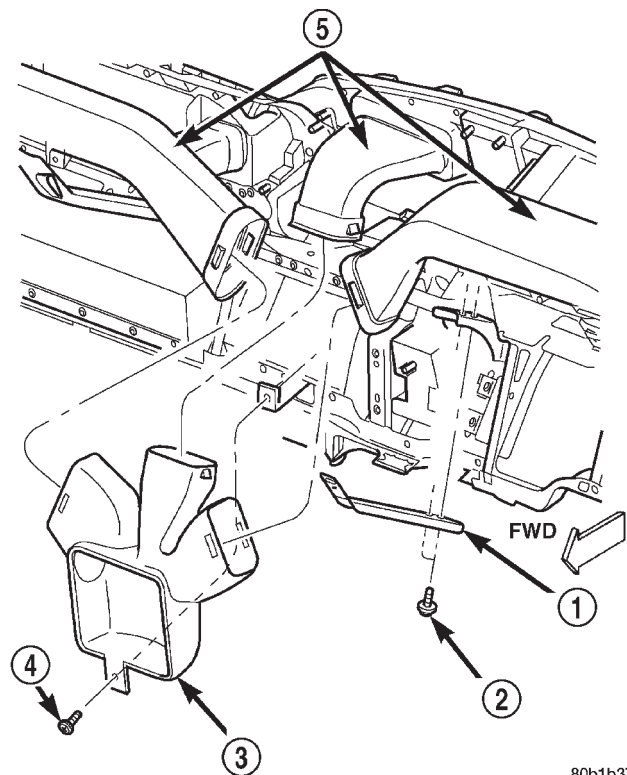
(4) Install the HVAC housing in the vehicle. (Refer to 24 - HEATING & AIR CONDITIONING/DISTRIBUTION/HVAC HOUSING - INSTALLATION)

**INSTRUMENT PANEL DEMISTER DUCTS****REMOVAL**

The defroster duct and the main demister duct are a single molded plastic unit. The defroster outlet grilles are heat-staked to the defroster outlets and cannot be serviced separately. The demister tubes on each end of the main demister duct are only serviced in the instrument panel assembly. (Refer to 24 - HEATING & AIR CONDITIONING/DISTRIBUTION/DEFROSTER DUCTS - REMOVAL)

**INSTRUMENT PANEL DUCTS****REMOVAL**

The panel and center distribution ducts (Fig. 10) are only serviced as part of the instrument panel assembly. Refer to Instrument Panel System for the service procedures.



80b1b376

**Fig. 10 PANEL AND CENTER DISTRIBUTION DUCTS**

- 1 - BRACKET
- 2 - SCREW
- 3 - CENTER DISTRIBUTION DUCT
- 4 - SCREW
- 5 - PANEL DUCTS

## BLEND DOOR

### REMOVAL

(1) Remove the HVAC housing from the vehicle, and disassemble the housing halves. (Refer to 24 - HEATING & AIR CONDITIONING/DISTRIBUTION/HVAC HOUSING - REMOVAL) (Refer to 24 - HEATING & AIR CONDITIONING/DISTRIBUTION/HVAC HOUSING - DISASSEMBLY)

(2) Lift the blend door pivot shaft out of the pivot hole in the bottom of the HVAC housing (Fig. 11).

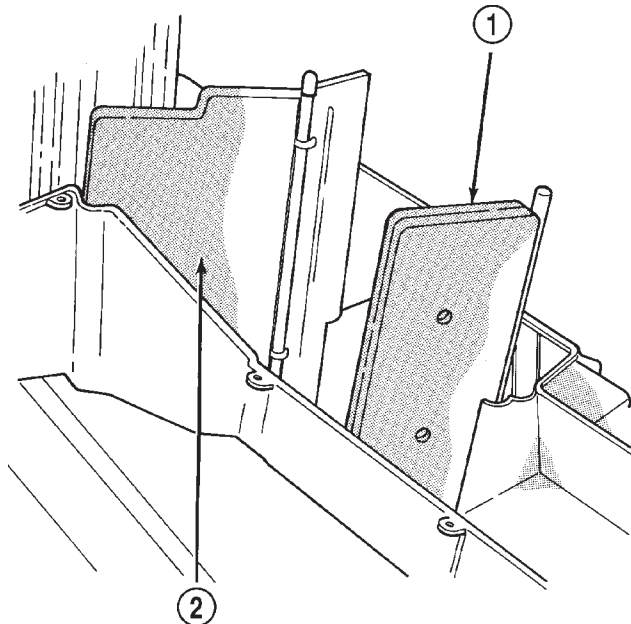


Fig. 11 BLEND DOOR

J9324-18

1 - HEAT/DEFROST DOOR  
2 - BLEND DOOR

### INSTALLATION

(1) Install the blend door pivot shaft in the bottom of the HVAC housing.

(2) Assemble the HVAC housing. (Refer to 24 - HEATING & AIR CONDITIONING/DISTRIBUTION/HVAC HOUSING - ASSEMBLY)

(3) Install the HVAC housing in the vehicle. (Refer to 24 - HEATING & AIR CONDITIONING/DISTRIBUTION/HVAC HOUSING - INSTALLATION)

## MODE DOOR

### REMOVAL - HEAT/DEFROST DOOR

**WARNING: ON VEHICLES EQUIPPED WITH AIRBAGS, DISABLE THE AIRBAG SYSTEM BEFORE ATTEMPTING ANY STEERING WHEEL, STEERING COLUMN, OR INSTRUMENT PANEL COMPONENT DIAGNOSIS OR SERVICE. DISCONNECT AND ISOLATE THE BATTERY**

**NEGATIVE (GROUND) CABLE, THEN WAIT TWO MINUTES FOR THE AIRBAG SYSTEM CAPACITOR TO DISCHARGE BEFORE PERFORMING FURTHER DIAGNOSIS OR SERVICE. THIS IS THE ONLY SURE WAY TO DISABLE THE AIRBAG SYSTEM. FAILURE TO TAKE THE PROPER PRECAUTIONS COULD RESULT IN AN ACCIDENTAL AIRBAG DEPLOYMENT AND POSSIBLE PERSONAL INJURY.**

**WARNING: IF THE VEHICLE IS EQUIPPED WITH AIR CONDITIONING, REVIEW THE WARNINGS AND CAUTIONS IN PLUMBING BEFORE PERFORMING THE FOLLOWING OPERATION. (Refer to 24 - HEATING & AIR CONDITIONING/PLUMBING - WARNING) (Refer to 24 - HEATING & AIR CONDITIONING/PLUMBING - CAUTION)**

(1) Remove and disassemble the HVAC housing. (Refer to 24 - HEATING & AIR CONDITIONING/DISTRIBUTION/HVAC HOUSING - REMOVAL) (Refer to 24 - HEATING & AIR CONDITIONING/DISTRIBUTION/HVAC HOUSING - DISASSEMBLY)

(2) Remove the heat/defrost door actuator from the HVAC housing. (Refer to 24 - HEATING & AIR CONDITIONING/CONTROLS/MODE DOOR ACTUATOR - REMOVAL)

(3) Remove the heat/defrost door from the HVAC housing.

### REMOVAL - PANEL/DEFROST DOOR

**WARNING: ON VEHICLES EQUIPPED WITH AIRBAGS, DISABLE THE AIRBAG SYSTEM BEFORE ATTEMPTING ANY STEERING WHEEL, STEERING COLUMN, OR INSTRUMENT PANEL COMPONENT DIAGNOSIS OR SERVICE. DISCONNECT AND ISOLATE THE BATTERY NEGATIVE (GROUND) CABLE, THEN WAIT TWO MINUTES FOR THE AIRBAG SYSTEM CAPACITOR TO DISCHARGE BEFORE PERFORMING FURTHER DIAGNOSIS OR SERVICE. THIS IS THE ONLY SURE WAY TO DISABLE THE AIRBAG SYSTEM. FAILURE TO TAKE THE PROPER PRECAUTIONS COULD RESULT IN AN ACCIDENTAL AIRBAG DEPLOYMENT AND POSSIBLE PERSONAL INJURY.**

(1) Disconnect and isolate the battery negative cable.

(2) Remove the instrument panel assembly from the vehicle. Refer to Instrument Panel System for the procedures.

(3) Remove the panel/defrost door actuator from the HVAC housing. (Refer to 24 - HEATING & AIR CONDITIONING/CONTROLS/MODE DOOR ACTUATOR - REMOVAL)

(4) Remove the defroster and demister duct adapter from the HVAC housing. \*\*\*L\*\*\*



## MODE DOOR (Continued)

(5) Lift the panel/defrost door out of the top opening of the HVAC housing.

### INSTALLATION - HEAT/DEFROST DOOR

(1) Install the heat/defrost door in the HVAC housing.

(2) Assemble the HVAC housing. (Refer to 24 - HEATING & AIR CONDITIONING/DISTRIBUTION/HVAC HOUSING - ASSEMBLY)

(3) Install the heat/defrost door actuator on the HVAC housing. (Refer to 24 - HEATING & AIR CONDITIONING/CONTROLS/MODE DOOR ACTUATOR - INSTALLATION)

(4) Install the HVAC housing in the vehicle. (Refer to 24 - HEATING & AIR CONDITIONING/DISTRIBUTION/HVAC HOUSING - INSTALLATION)

### INSTALLATION - PANEL/DEFROST DOOR

(1) Install the panel/defrost door through the top opening of the HVAC housing.

(2) Install the defroster and demister duct adapter on the HVAC housing. (Refer to 24 - HEATING & AIR CONDITIONING/DISTRIBUTION/DEFROSTER DUCTS - INSTALLATION)

(3) Install the panel/defrost door actuator on the HVAC housing. (Refer to 24 - HEATING & AIR CONDITIONING/CONTROLS/MODE DOOR ACTUATOR - REMOVAL)

(4) Install the instrument panel assembly in the vehicle. Refer to Instrument Panel System for the procedures.

(5) Connect the battery negative cable.

## RECIRCULATION DOOR

### REMOVAL

**WARNING: ON VEHICLES EQUIPPED WITH AIRBAGS, DISABLE THE AIRBAG SYSTEM BEFORE ATTEMPTING ANY STEERING WHEEL, STEERING COLUMN, OR INSTRUMENT PANEL COMPONENT DIAGNOSIS OR SERVICE. DISCONNECT AND ISOLATE THE BATTERY NEGATIVE (GROUND) CABLE, THEN WAIT TWO MINUTES FOR THE AIRBAG SYSTEM CAPACITOR TO DISCHARGE BEFORE PER-**

**FORMING FURTHER DIAGNOSIS OR SERVICE. THIS IS THE ONLY SURE WAY TO DISABLE THE AIRBAG SYSTEM. FAILURE TO TAKE THE PROPER PRECAUTIONS COULD RESULT IN AN ACCIDENTAL AIRBAG DEPLOYMENT AND POSSIBLE PERSONAL INJURY.**

**WARNING: IF THE VEHICLE IS EQUIPPED WITH AIR CONDITIONING, REVIEW THE WARNINGS AND CAUTIONS IN PLUMBING BEFORE PERFORMING THE FOLLOWING OPERATION. (Refer to 24 - HEATING & AIR CONDITIONING/PLUMBING - WARNING) (Refer to 24 - HEATING & AIR CONDITIONING/PLUMBING - CAUTION)**

(1) Remove the HVAC housing from the vehicle. (Refer to 24 - HEATING & AIR CONDITIONING/DISTRIBUTION/HVAC HOUSING - REMOVAL)

(2) Unsnap the recirculation door vacuum actuator link clip and disengage the link from the recirculation door lever. (Refer to 24 - HEATING & AIR CONDITIONING/CONTROLS/RECIRCULATION DOOR ACTUATOR - REMOVAL)

(3) Using a trim stick or another suitable wide flat-bladed tool, gently pry the retainer off of the recirculation door pivot shaft.

(4) Remove the recirculation door through the outside air intake opening on the top of the HVAC housing.

### INSTALLATION

(1) Install the recirculation door through the outside air intake opening on the top of the HVAC housing.

(2) Install the retainer on the recirculation door pivot shaft.

(3) Engage the recirculation door vacuum actuator link clip with the recirculation door lever. (Refer to 24 - HEATING & AIR CONDITIONING/CONTROLS/RECIRCULATION DOOR ACTUATOR - INSTALLATION)

(4) Install the HVAC housing in the vehicle. (Refer to 24 - HEATING & AIR CONDITIONING/DISTRIBUTION/HVAC HOUSING - INSTALLATION)



# PLUMBING

## TABLE OF CONTENTS

	page		page
<b>PLUMBING</b>		<b>INSTALLATION</b> . . . . .	52
DESCRIPTION . . . . .	40	<b>A/C EVAPORATOR</b>	
OPERATION . . . . .	41	DESCRIPTION . . . . .	52
WARNING . . . . .	41	OPERATION . . . . .	53
CAUTION . . . . .	41	REMOVAL . . . . .	53
DIAGNOSIS AND TESTING	43	INSTALLATION . . . . .	53
REFRIGERANT SYSTEM LEAKS . . . . .	43	<b>A/C ORIFICE TUBE</b>	
STANDARD PROCEDURE . . . . .	43	DESCRIPTION . . . . .	53
A/C LINE COUPLERS . . . . .	43	OPERATION . . . . .	53
REFRIGERANT SYSTEM SERVICE		DIAGNOSIS AND TESTING . . . . .	54
EQUIPMENT . . . . .	44	FIXED ORIFICE TUBE . . . . .	54
REFRIGERANT RECOVERY . . . . .	45	REMOVAL . . . . .	54
REFRIGERANT SYSTEM EVACUATE . . . . .	45	<b>ACCUMULATOR</b>	
REFRIGERANT SYSTEM CHARGE . . . . .	46	DESCRIPTION . . . . .	54
SPECIFICATIONS . . . . .	46	OPERATION . . . . .	54
<b>A/C COMPRESSOR</b>		REMOVAL . . . . .	54
DESCRIPTION . . . . .	46	INSTALLATION . . . . .	55
OPERATION . . . . .	46	<b>HEATER CORE</b>	
DIAGNOSIS AND TESTING . . . . .	46	DESCRIPTION . . . . .	55
A/C COMPRESSOR . . . . .	46	OPERATION . . . . .	55
REMOVAL . . . . .	47	REMOVAL . . . . .	56
INSTALLATION . . . . .	47	INSTALLATION . . . . .	56
<b>A/C CONDENSER</b>		<b>REFRIGERANT</b>	
DESCRIPTION . . . . .	48	DESCRIPTION . . . . .	56
OPERATION . . . . .	48	OPERATION . . . . .	56
REMOVAL . . . . .	49	<b>REFRIGERANT OIL</b>	
INSTALLATION . . . . .	49	DESCRIPTION . . . . .	56
<b>SUCTION AND DISCHARGE LINE</b>		OPERATION . . . . .	56
REMOVAL . . . . .	50	STANDARD PROCEDURE . . . . .	57
INSTALLATION . . . . .	51	REFRIGERANT OIL LEVEL . . . . .	57
<b>LIQUID LINE</b>			
REMOVAL . . . . .	52		

## PLUMBING

### DESCRIPTION - A/C LINE COUPLERS

Spring-lock type refrigerant line couplers are used to connect many of the refrigerant lines and other components to the refrigerant system. These couplers require a special tool for disengaging the two coupler halves.

### DESCRIPTION

The refrigerant lines and hoses are used to carry the refrigerant between the various air conditioning system components. A barrier hose design with a nylon tube, which is sandwiched between rubber layers, is used for the R-134a air conditioning system on

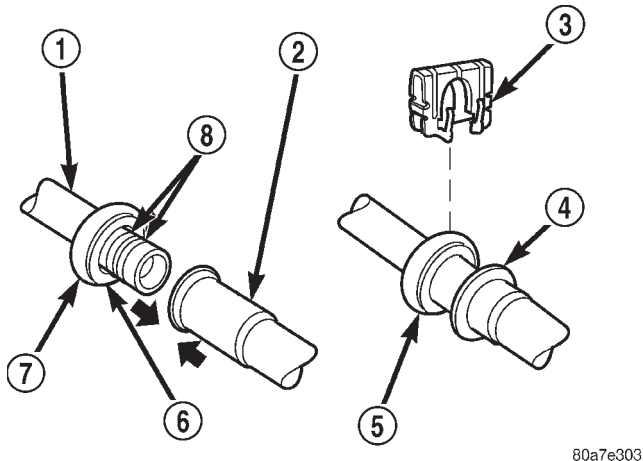
this vehicle. This nylon tube helps to further contain the R-134a refrigerant, which has a smaller molecular structure than R-12 refrigerant. The ends of the refrigerant hoses are made from lightweight aluminum or steel, and commonly use braze-less fittings.

Any kinks or sharp bends in the refrigerant plumbing will reduce the capacity of the entire air conditioning system. Kinks and sharp bends reduce the flow of refrigerant in the system. A good rule for the flexible hose refrigerant lines is to keep the radius of all bends at least ten times the diameter of the hose. In addition, the flexible hose refrigerant lines should be routed so they are at least 80 millimeters (3 inches) from the exhaust manifold.

## PLUMBING (Continued)

**OPERATION - A/C LINE COUPLERS**

The spring-lock coupler is held together by a garter spring inside a circular cage on the male half of the fitting (Fig. 1). When the two coupler halves are connected, the flared end of the female fitting slips behind the garter spring inside the cage on the male fitting. The garter spring and cage prevent the flared end of the female fitting from pulling out of the cage.



**Fig. 1 SPRING-LOCK COUPLER - TYPICAL**

- 1 - MALE HALF SPRING-LOCK COUPLER
- 2 - FEMALE HALF SPRING-LOCK COUPLER
- 3 - SECONDARY CLIP
- 4 - CONNECTION INDICATOR RING
- 5 - COUPLER CAGE
- 6 - GARTER SPRING
- 7 - COUPLER CAGE
- 8 - "O" RINGS

Two O-rings on the male half of the fitting are used to seal the connection. These O-rings are compatible with R-134a refrigerant and must be replaced with O-rings made of the same material.

Secondary clips are installed over the two connected coupler halves at the factory for added blowoff protection. In addition, some models have a plastic ring that is used at the factory as a visual indicator to confirm that these couplers are connected. After the coupler is connected, the plastic indicator ring is no longer needed; however, it will remain on the refrigerant line near the coupler cage.

**OPERATION**

High pressures are produced in the refrigerant system when the air conditioning compressor is operating. Extreme care must be exercised to make sure that each of the refrigerant system connections is pressure-tight and leak free. It is a good practice to inspect all flexible hose refrigerant lines at least once a year to make sure they are in good condition and properly routed.

The refrigerant lines and hoses are coupled with other components of the HVAC system with peanut-block style fittings. A stat-O seal type flat steel gasket with a captured compressible O-ring, is used to mate plumbing lines with A/C components to ensure the integrity of the refrigerant system.

The refrigerant lines and hoses cannot be repaired and, if faulty or damaged, they must be replaced.

**WARNING:**

**THE AIR CONDITIONING SYSTEM CONTAINS REFRIGERANT UNDER HIGH PRESSURE. SEVERE PERSONAL INJURY MAY RESULT FROM IMPROPER SERVICE PROCEDURES. REPAIRS SHOULD ONLY BE PERFORMED BY QUALIFIED SERVICE PERSONNEL.**

**AVOID BREATHING THE REFRIGERANT AND REFRIGERANT OIL VAPOR OR MIST. EXPOSURE MAY IRRITATE THE EYES, NOSE, AND/OR THROAT. WEAR EYE PROTECTION WHEN SERVICING THE AIR CONDITIONING REFRIGERANT SYSTEM. SERIOUS EYE INJURY CAN RESULT FROM DIRECT CONTACT WITH THE REFRIGERANT. IF EYE CONTACT OCCURS, SEEK MEDICAL ATTENTION IMMEDIATELY.**

**DO NOT EXPOSE THE REFRIGERANT TO OPEN FLAME. POISONOUS GAS IS CREATED WHEN REFRIGERANT IS BURNED. AN ELECTRONIC LEAK DETECTOR IS RECOMMENDED.**

**IF ACCIDENTAL SYSTEM DISCHARGE OCCURS, VENTILATE THE WORK AREA BEFORE RESUMING SERVICE. LARGE AMOUNTS OF REFRIGERANT RELEASED IN A CLOSED WORK AREA WILL DISPLACE THE OXYGEN AND CAUSE SUFFOCATION. THE EVAPORATION RATE OF R-134a REFRIGERANT AT AVERAGE TEMPERATURE AND ALTITUDE IS EXTREMELY HIGH. AS A RESULT, ANYTHING THAT COMES IN CONTACT WITH THE REFRIGERANT WILL FREEZE. ALWAYS PROTECT THE SKIN OR DELICATE OBJECTS FROM DIRECT CONTACT WITH THE REFRIGERANT.**

**THE R-134a SERVICE EQUIPMENT OR THE VEHICLE REFRIGERANT SYSTEM SHOULD NOT BE PRESSURE TESTED OR LEAK TESTED WITH COMPRESSED AIR. SOME MIXTURES OF AIR AND R-134a HAVE BEEN SHOWN TO BE COMBUSTIBLE AT ELEVATED PRESSURES. THESE MIXTURES ARE POTENTIALLY DANGEROUS, AND MAY RESULT IN FIRE OR EXPLOSION CAUSING INJURY OR PROPERTY DAMAGE.**

## PLUMBING (Continued)

**CAUTION:**

Liquid refrigerant is corrosive to metal surfaces. Follow the operating instructions supplied with the service equipment being used.

Never add R-12 to a refrigerant system designed to use R-134a. Damage to the system will result.

R-12 refrigerant oil must not be mixed with R-134a refrigerant oil. They are not compatible.

Do not use R-12 equipment or parts on the R-134a system. Damage to the system will result.

Do not overcharge the refrigerant system. This will cause excessive compressor head pressure and can cause noise and system failure.

Recover the refrigerant before opening any fitting or connection. Open the fittings with caution, even after the system has been discharged. Never open or loosen a connection before recovering the refrigerant.

Do not remove the secondary retention clip from any spring-lock coupler connection while the refrigerant system is under pressure. Recover the refrigerant before removing the secondary retention clip. Open the fittings with caution, even after the system has been discharged. Never open or loosen a connection before recovering the refrigerant.

The refrigerant system must always be evacuated before charging.

Do not open the refrigerant system or uncap a replacement component until you are ready to service the system. This will prevent contamination in the system.

Before disconnecting a component, clean the outside of the fittings thoroughly to prevent contamination from entering the refrigerant system.

Immediately after disconnecting a component from the refrigerant system, seal the open fittings with a cap or plug.

Before connecting an open refrigerant fitting, always install a new seal or gasket. Coat the fitting and seal with clean refrigerant oil before connecting.

Do not remove the sealing caps from a replacement component until it is to be installed.

When installing a refrigerant line, avoid sharp bends that may restrict refrigerant flow. Position the refrigerant lines away from exhaust system components or any sharp edges, which may damage the line.

Tighten refrigerant fittings only to the specified torque. The aluminum fittings used in the refrigerant system will not tolerate overtightening.

When disconnecting a refrigerant fitting, use a wrench on both halves of the fitting. This will prevent twisting of the refrigerant lines or tubes.

Refrigerant oil will absorb moisture from the atmosphere if left uncapped. Do not open a container of

refrigerant oil until you are ready to use it. Replace the cap on the oil container immediately after using. Store refrigerant oil only in a clean, airtight, and moisture-free container.

Keep service tools and the work area clean. Contamination of the refrigerant system through careless work habits must be avoided.

**CAUTION - REFRIGERANT HOSES/LINES/  
TUBES PRECAUTIONS**

Kinks or sharp bends in the refrigerant plumbing will reduce the capacity of the entire system. High pressures are produced in the system when it is operating. Extreme care must be exercised to make sure that all refrigerant system connections are pressure tight.

A good rule for the flexible hose refrigerant lines is to keep the radius of all bends at least ten times the diameter of the hose. Sharp bends will reduce the flow of refrigerant. The flexible hose lines should be routed so they are at least 80 millimeters (3 inches) from the exhaust manifold. It is a good practice to inspect all flexible refrigerant system hose lines at least once a year to make sure they are in good condition and properly routed.

There are two types of refrigerant fittings:

- All fittings with O-rings need to be coated with refrigerant oil before installation. Use only O-rings that are the correct size and approved for use with R-134a refrigerant. Failure to do so may result in a leak.

- Unified plumbing connections with gaskets cannot be serviced with O-rings. The gaskets are not reusable and new gaskets do not require lubrication before installing.

Using the proper tools when making a refrigerant plumbing connection is very important. Improper tools or improper use of the tools can damage the refrigerant fittings. Always use two wrenches when loosening or tightening tube fittings. Use one wrench to hold one side of the connection stationary, while loosening or tightening the other side of the connection with a second wrench.

The refrigerant must be recovered completely from the system before opening any fitting or connection. Open the fittings with caution, even after the refrigerant has been recovered. If any pressure is noticed as a fitting is loosened, tighten the fitting and recover the refrigerant from the system again.

Do not discharge refrigerant into the atmosphere. Use an R-134a refrigerant recovery/recycling device that meets SAE Standard J2210.

## PLUMBING (Continued)

The refrigerant system will remain chemically stable as long as pure, moisture-free R-134a refrigerant and refrigerant oil is used. Dirt, moisture, or air can upset this chemical stability. Operational troubles or serious damage can occur if foreign material is present in the refrigerant system.

When it is necessary to open the refrigerant system, have everything needed to service the system ready. The refrigerant system should not be left open to the atmosphere any longer than necessary. Cap or plug all lines and fittings as soon as they are opened to prevent the entrance of dirt and moisture. All lines and components in parts stock should be capped or sealed until they are to be installed.

All tools, including the refrigerant recycling equipment, the manifold gauge set, and test hoses should be kept clean and dry. All tools and equipment must be designed for R-134a refrigerant.

## DIAGNOSIS AND TESTING - REFRIGERANT SYSTEM LEAKS

**WARNING: REVIEW THE WARNINGS AND CAUTIONS IN THE FRONT OF THIS SECTION BEFORE PERFORMING THE FOLLOWING OPERATION. (Refer to 24 - HEATING & AIR CONDITIONING/PLUMBING - WARNING) (Refer to 24 - HEATING & AIR CONDITIONING/PLUMBING - CAUTION)**

If the air conditioning system is not cooling properly, determine if the refrigerant system is fully-charged. (Refer to 24 - HEATING & AIR CONDITIONING - DIAGNOSIS AND TESTING - A/C PERFORMANCE) If the refrigerant system is low or empty; a leak at a refrigerant line, connector fitting, component, or component seal is likely.

An electronic leak detector designed for R-134a refrigerant, or a fluorescent R-134a leak detection dye and a black light are recommended for locating and confirming refrigerant system leaks. Refer to the operating instructions supplied by the equipment manufacturer for proper care and use of this equipment.

An oily residue on or near refrigerant system lines, connector fittings, components, or component seals can indicate the general location of a possible refrigerant leak. However, the exact leak location should be confirmed with an electronic leak detector prior to component repair or replacement.

To detect a leak in the refrigerant system with an electronic leak detector, perform one of the following procedures:

### SYSTEM EMPTY

(1) Evacuate the refrigerant system. (Refer to 24 - HEATING & AIR CONDITIONING/PLUMBING -

### STANDARD PROCEDURE - REFRIGERANT SYSTEM EVACUATE)

(2) Connect and dispense 0.283 kilograms (0.625 pounds or 10 ounces) of R-134a refrigerant into the evacuated refrigerant system. (Refer to 24 - HEATING & AIR CONDITIONING/PLUMBING - STANDARD PROCEDURE - REFRIGERANT SYSTEM CHARGE)

(3) Position the vehicle in a wind-free work area. This will aid in detecting small leaks.

(4) With the engine not running, use an electronic R-134a leak detector and search for leaks. Because R-134a refrigerant is heavier than air, the leak detector probe should be moved slowly along the bottom side of all refrigerant lines, connector fittings and components.

(5) To inspect the evaporator coil for leaks, insert the electronic leak detector probe into the center instrument panel outlet. Set the blower motor switch to the lowest speed position, and the mode control switch in the recirculation mode.

### SYSTEM LOW

(1) Position the vehicle in a wind-free work area. This will aid in detecting small leaks.

(2) Bring the refrigerant system up to operating temperature and pressure. This is done by allowing the engine to run with the air conditioning system turned on for five minutes.

(3) With the engine not running, use an electronic R-134a leak detector and search for leaks. Because R-134a refrigerant is heavier than air, the leak detector probe should be moved slowly along the bottom side of all refrigerant lines, connector fittings and components.

(4) To inspect the evaporator coil for leaks, insert the electronic leak detector probe into the center instrument panel outlet. Set the blower motor switch to the lowest speed position, and the mode control switch in the recirculation mode.

## STANDARD PROCEDURE - A/C LINE COUPLERS

**WARNING: REVIEW THE WARNINGS AND CAUTIONS IN THE FRONT OF THIS SECTION BEFORE PERFORMING THE FOLLOWING OPERATION. (Refer to 24 - HEATING & AIR CONDITIONING/PLUMBING - WARNING) (Refer to 24 - HEATING & AIR CONDITIONING/PLUMBING - CAUTION)**

### REMOVAL

(1) Recover the refrigerant from the refrigerant system. (Refer to 24 - HEATING & AIR CONDI-

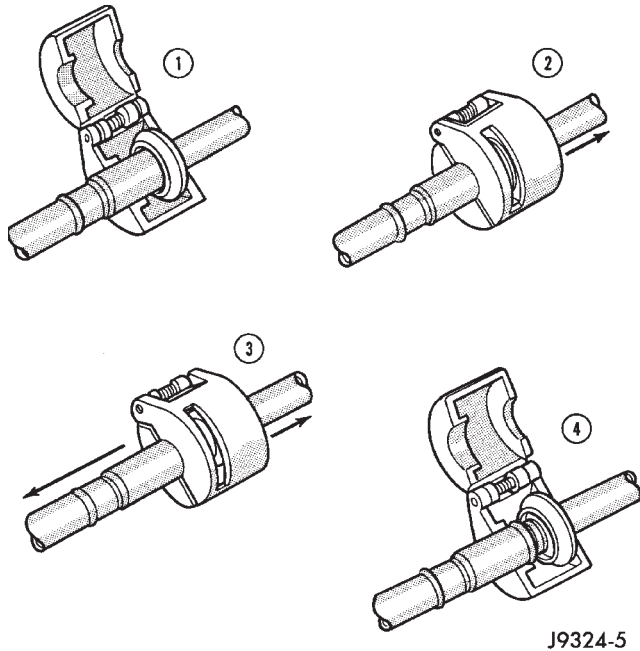


## PLUMBING (Continued)

## TIONING/PLUMBING - STANDARD PROCEDURE - REFRIGERANT RECOVERY)

(2) Remove the secondary clip from the spring-lock coupler.

(3) Fit the proper size A/C line disconnect tool (Special Tool Kit 7193) over the spring-lock coupler cage (Fig. 2).



**Fig. 2 REFRIGERANT LINE SPRING-LOCK COUPLER DISCONNECT**

(4) Close the two halves of the A/C line disconnect tool around the spring-lock coupler.

(5) Push the A/C line disconnect tool into the open side of the coupler cage to expand the garter spring. Once the garter spring is expanded and while still pushing the disconnect tool into the open side of the coupler cage, pull on the refrigerant line attached to the female half of the coupler fitting until the flange on the female fitting is separated from the garter spring and cage on the male fitting within the disconnect tool.

## INSTALLATION

(1) Check to ensure that the garter spring is located within the cage of the male coupler fitting, and that the garter spring is not damaged.

(a) If the garter spring is missing, install a new spring by pushing it into the coupler cage opening.

(b) If the garter spring is damaged, remove it from the coupler cage with a small wire hook (DO NOT use a screwdriver) and install a new garter spring.

(2) Clean any dirt or foreign material from both halves of the coupler fitting.

(3) Install new O-rings on the male half of the coupler fitting.

**CAUTION:** Use only the specified O-rings as they are made of a special material for the R-134a system. The use of any other O-rings may allow the connection to leak intermittently during vehicle operation.

(4) Lubricate the male fitting and O-rings, and the inside of the female fitting with clean R-134a refrigerant oil. Use only refrigerant oil of the type recommended for the compressor in the vehicle.

(5) Fit the female half of the coupler fitting over the male half of the fitting.

(6) Push together firmly on the two halves of the coupler fitting until the garter spring in the cage on the male half of the fitting snaps over the flanged end on the female half of the fitting.

(7) Ensure that the spring-lock coupler is fully engaged by trying to separate the two coupler halves. This is done by pulling the refrigerant lines on either side of the coupler away from each other.

(8) Reinstall the secondary clip over the spring-lock coupler cage.

## STANDARD PROCEDURE - REFRIGERANT SYSTEM SERVICE EQUIPMENT

**WARNING:** REVIEW THE WARNINGS AND CAUTIONS IN THE FRONT OF THIS SECTION BEFORE PERFORMING THE FOLLOWING OPERATION. (Refer to 24 - HEATING & AIR CONDITIONING/PLUMBING - WARNING) (Refer to 24 - HEATING & AIR CONDITIONING/PLUMBING - CAUTION)

When servicing the air conditioning system, a R-134a refrigerant recovery/recycling/charging station that meets SAE Standard J2210 must be used. Contact an automotive service equipment supplier for refrigerant recovery/recycling/charging equipment. Refer to the operating instructions supplied by the equipment manufacturer for proper care and use of this equipment.

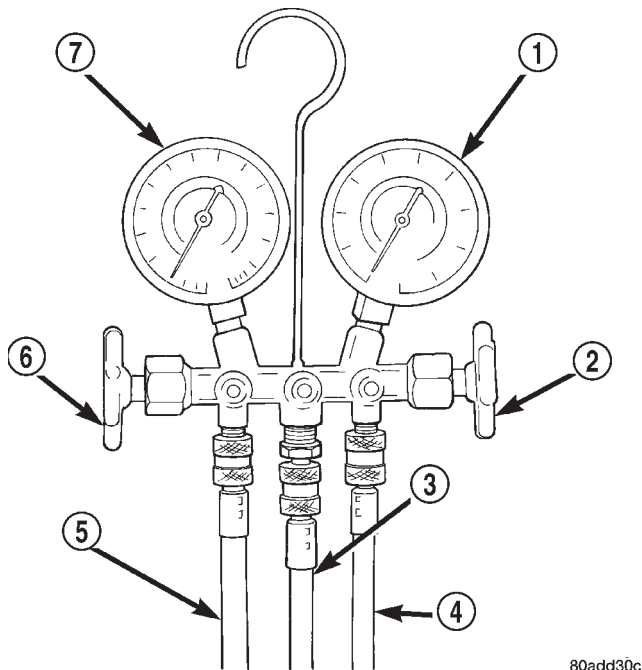
A manifold gauge set may be needed with some recovery/recycling/charging equipment (Fig. 3). The service hoses on the gauge set being used should have manual (turn wheel), or automatic back-flow valves at the service port connector ends. This will prevent refrigerant from being released into the atmosphere.

## MANIFOLD GAUGE SET CONNECTIONS

**CAUTION:** Do not use an R-12 manifold gauge set on an R-134a system. The refrigerants are not compatible and system damage will result.



## PLUMBING (Continued)



80acd30c

**Fig. 3 MANIFOLD GAUGE SET - TYPICAL**

- 1 - HIGH PRESSURE GAUGE
- 2 - VALVE
- 3 - VACUUM/REFRIGERANT HOSE (YELLOW W/ BLACK STRIPE)
- 4 - HIGH PRESSURE HOSE (RED W/ BLACK STRIPE)
- 5 - LOW PRESSURE HOSE (BLUE W/ BLACK STRIPE)
- 6 - VALVE
- 7 - LOW PRESSURE GAUGE

**LOW PRESSURE GAUGE HOSE** The low pressure hose (Blue with Black stripe) attaches to the suction service port. This port is located on the suction line between the accumulator outlet and the compressor.

**HIGH PRESSURE GAUGE HOSE** The high pressure hose (Red with Black stripe) attaches to the discharge service port. This port is located on the discharge line between the compressor and the condenser inlet.

**RECOVERY/RECYCLING/EVACUATION/CHARGING HOSE** The center manifold hose (Yellow, or White, with Black stripe) is used to recover, evacuate, and charge the refrigerant system. When the low or high pressure valves on the manifold gauge set are opened, the refrigerant in the system will escape through this hose.

### STANDARD PROCEDURE - REFRIGERANT RECOVERY

**WARNING: REVIEW THE WARNINGS AND CAUTIONS IN THE FRONT OF THIS SECTION BEFORE PERFORMING THE FOLLOWING OPERATION.** (Refer to 24 - HEATING & AIR CONDITIONING/

### PLUMBING - WARNING) (Refer to 24 - HEATING & AIR CONDITIONING/PLUMBING - CAUTION)

A R-134a refrigerant recovery/recycling/charging station that meets SAE Standard J2210 must be used to recover the refrigerant from an R-134a refrigerant system. Refer to the operating instructions supplied by the equipment manufacturer for the proper care and use of this equipment.

### STANDARD PROCEDURE - REFRIGERANT SYSTEM EVACUATE

**WARNING: REVIEW THE WARNINGS AND CAUTIONS IN THE FRONT OF THIS SECTION BEFORE PERFORMING THE FOLLOWING OPERATION.** (Refer to 24 - HEATING & AIR CONDITIONING/PLUMBING - WARNING) (Refer to 24 - HEATING & AIR CONDITIONING/PLUMBING - CAUTION)

If the refrigerant system has been open to the atmosphere, it must be evacuated before the system can be charged. If moisture and air enters the system and becomes mixed with the refrigerant, the compressor head pressure will rise above acceptable operating levels. This will reduce the performance of the air conditioner and damage the compressor. Evacuating the refrigerant system will remove the air and boil the moisture out of the system at near room temperature. To evacuate the refrigerant system, use the following procedure:

(1) Connect a R-134a refrigerant recovery/recycling/charging station that meets SAE Standard J2210 and a manifold gauge set to the refrigerant system of the vehicle.

(2) Open the low and high side valves and start the charging station vacuum pump. When the suction gauge reads 88 kPa (26 in. Hg.) vacuum or greater, close all of the valves and turn off the vacuum pump.

(a) If the refrigerant system fails to reach the specified vacuum, the system has a leak that must be corrected. (Refer to 24 - HEATING & AIR CONDITIONING/PLUMBING - DIAGNOSIS AND TESTING - REFRIGERANT SYSTEM LEAKS)

(b) If the refrigerant system maintains the specified vacuum for five minutes, restart the vacuum pump, open the suction and discharge valves and evacuate the system for an additional ten minutes.

(3) Close all of the valves, and turn off the charging station vacuum pump.

(4) The refrigerant system is now ready to be charged with R-134a refrigerant. (Refer to 24 - HEATING & AIR CONDITIONING/PLUMBING - STANDARD PROCEDURE - REFRIGERANT SYSTEM CHARGE)

## PLUMBING (Continued)

**STANDARD PROCEDURE - REFRIGERANT SYSTEM CHARGE**

**WARNING: REVIEW THE WARNINGS AND CAUTIONS IN THE FRONT OF THIS SECTION BEFORE PERFORMING THE FOLLOWING OPERATION. (Refer to 24 - HEATING & AIR CONDITIONING/PLUMBING - WARNING) (Refer to 24 - HEATING & AIR CONDITIONING/PLUMBING - CAUTION)**

After the refrigerant system has been tested for leaks and evacuated, a refrigerant charge can be injected into the system. (Refer to 24 - HEATING & AIR CONDITIONING/PLUMBING - SPECIFICATIONS - CHARGE CAPACITY)

A R-134a refrigerant recovery/recycling/charging station that meets SAE Standard J2210 must be used to charge the refrigerant system with R-134a refrigerant. Refer to the operating instructions supplied by the equipment manufacturer for proper care and use of this equipment.

**SPECIFICATIONS****SPECIFICATIONS**

The R-134a refrigerant system charge capacity for this vehicle is: 0.907 kilograms (32 ounces).

**A/C COMPRESSOR****DESCRIPTION - A/C COMPRESSOR**

The air conditioning system uses a Sanden SD7H15 seven cylinder, reciprocating wobble plate-type compressor on all models. This compressor has a fixed displacement of 150 cubic centimeters (9.375 cubic inches), and has both the suction and discharge ports located on the cylinder head. A label identifying the use of R-134a refrigerant is located on the compressor.

**DESCRIPTION - HIGH PRESSURE RELIEF VALVE**

A high pressure relief valve is located on the compressor cylinder head, which is at the rear of the compressor. This mechanical valve is designed to vent refrigerant from the system to protect against damage to the compressor and other system components, caused by condenser air flow restriction or an overcharge of refrigerant.

**OPERATION - A/C COMPRESSOR**

The compressor is driven by the engine through an electric clutch, drive pulley and belt arrangement. The compressor is lubricated by refrigerant oil that is

circulated throughout the refrigerant system with the refrigerant.

The compressor draws in low-pressure refrigerant vapor from the evaporator through its suction port. It then compresses the refrigerant into a high-pressure, high-temperature refrigerant vapor, which is then pumped to the condenser through the compressor discharge port.

The compressor cannot be repaired. If faulty or damaged, the entire compressor assembly must be replaced. The compressor clutch, pulley and clutch coil are available for service.

**OPERATION - HIGH PRESSURE RELIEF VALVE**

The high pressure relief valve vents the system when a discharge pressure of 3445 to 4135 kPa (500 to 600 psi) or above is reached. The valve closes with a minimum discharge pressure of 2756 kPa (400 psi) is reached.

The high pressure relief valve vents only enough refrigerant to reduce the system pressure, and then re-seats itself. The majority of the refrigerant is conserved in the system. If the valve vents refrigerant, it does not mean the valve is faulty.

The high pressure relief valve is a factory-calibrated unit. The valve cannot be adjusted or repaired, and must not be removed or otherwise disturbed. The valve is only serviced as a part of the compressor assembly.

**DIAGNOSIS AND TESTING - A/C COMPRESSOR**

When investigating an air conditioning related noise, you must first know the conditions under which the noise occurs. These conditions include: weather, vehicle speed, transmission in gear or neutral, engine speed, engine temperature, and any other special conditions. Noises that develop during air conditioning operation can often be misleading. For example: What sounds like a failed front bearing or connecting rod, may be caused by loose bolts, nuts, mounting brackets, or a loose compressor clutch assembly.

Drive belts are speed sensitive. At different engine speeds and depending upon belt tension, belts can develop noises that are mistaken for a compressor noise. Improper belt tension can cause a misleading noise when the compressor clutch is engaged, which may not occur when the compressor clutch is disengaged. Check the serpentine drive belt condition and tension as described in Cooling before beginning this procedure.

(1) Select a quiet area for testing. Duplicate the complaint conditions as much as possible. Switch the compressor on and off several times to clearly identify the compressor noise. Listen to the compressor while the clutch is engaged and disengaged. Probe

## A/C COMPRESSOR (Continued)

the compressor with an engine stethoscope or a long screwdriver with the handle held to your ear to better localize the source of the noise.

(2) Loosen all of the compressor mounting hardware and retighten. Tighten the compressor clutch mounting nut. Be certain that the clutch coil is mounted securely to the compressor, and that the clutch plate and pulley are properly aligned and have the correct air gap. (Refer to 24 - HEATING & AIR CONDITIONING/CONTROLS/A/C COMPRESSOR CLUTCH - INSTALLATION)

(3) To duplicate a high-ambient temperature condition (high head pressure), restrict the air flow through the condenser. Install a manifold gauge set to be certain that the discharge pressure does not exceed 2760 kPa (400 psi).

(4) Check the refrigerant system plumbing for incorrect routing, rubbing or interference, which can cause unusual noises. Also check the refrigerant lines for kinks or sharp bends that will restrict refrigerant flow, which can cause noises. (Refer to 24 - HEATING & AIR CONDITIONING/PLUMBING - CAUTION)

(5) If the noise is from opening and closing of the high pressure relief valve, recover, evacuate, and recharge the refrigerant system. (Refer to 24 - HEATING & AIR CONDITIONING/PLUMBING - STANDARD PROCEDURE - REFRIGERANT RECOVERY) (Refer to 24 - HEATING & AIR CONDITIONING/PLUMBING - STANDARD PROCEDURE - REFRIGERANT SYSTEM EVACUATE) (Refer to 24 - HEATING & AIR CONDITIONING/PLUMBING - STANDARD PROCEDURE - REFRIGERANT SYSTEM CHARGE) If the high pressure relief valve still does not seat properly, replace the compressor.

(6) If the noise is from liquid slugging on the suction line, replace the accumulator. (Refer to 24 - HEATING & AIR CONDITIONING/PLUMBING/ACCUMULATOR - REMOVAL) Check the refrigerant oil level and the refrigerant system charge. (Refer to 24 - HEATING & AIR CONDITIONING/PLUMBING/REFRIGERANT OIL - STANDARD PROCEDURE - REFRIGERANT OIL LEVEL) (Refer to 24 - HEATING & AIR CONDITIONING/PLUMBING - SPECIFICATIONS - CHARGE CAPACITY) If the liquid slugging condition continues following accumulator replacement, replace the compressor.

(7) If the noise continues, replace the compressor and repeat Step 1.

## REMOVAL

**WARNING: REVIEW THE WARNINGS AND CAUTIONS IN THE FRONT OF THIS SECTION BEFORE PERFORMING THE FOLLOWING OPERATION.** (Refer to 24 - HEATING & AIR CONDITIONING/

**PLUMBING - WARNING) (Refer to 24 - HEATING & AIR CONDITIONING/PLUMBING - CAUTION)**

The compressor may be removed and repositioned without disconnecting the refrigerant lines or discharging the refrigerant system. Discharging is not necessary if servicing the compressor clutch or clutch coil, the engine, the cylinder head, or the generator.

(1) Recover the refrigerant from the refrigerant system. (Refer to 24 - HEATING & AIR CONDITIONING/PLUMBING - STANDARD PROCEDURE - REFRIGERANT RECOVERY)

(2) Disconnect and isolate the battery negative cable.

(3) Remove the serpentine drive belt. Refer to Cooling for the procedures.

(4) Unplug the compressor clutch coil wire harness connector.

(5) Remove the bolt that secures the refrigerant line manifold to the compressor. Install plugs in, or tape over all of the opened refrigerant line fittings.

(6) Remove the four bolts that secure the compressor to the mounting bracket (Fig. 4) or (Fig. 5).

(7) Remove the a/c compressor from the mounting bracket.

## INSTALLATION

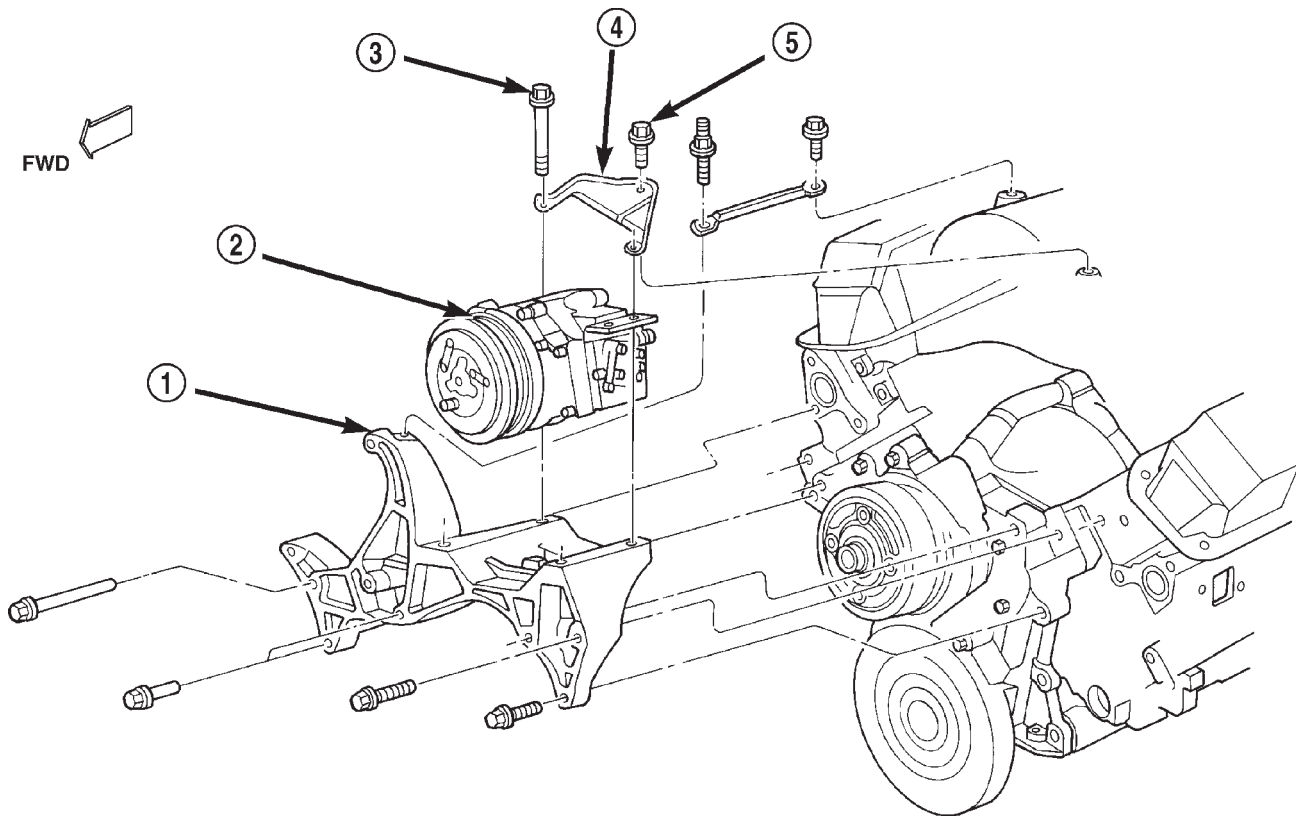
**WARNING: REVIEW THE WARNINGS AND CAUTIONS IN THE FRONT OF THIS SECTION BEFORE PERFORMING THE FOLLOWING OPERATION.** (Refer to 24 - HEATING & AIR CONDITIONING/PLUMBING - WARNING) (Refer to 24 - HEATING & AIR CONDITIONING/PLUMBING - CAUTION) (Refer to 24 - HEATING & AIR CONDITIONING/PLUMBING - CAUTION - REFRIGERANT HOSES/LINES/TUBES PRECAUTIONS)

**NOTE: If a replacement compressor is being installed, be certain to check the refrigerant oil level.** (Refer to 24 - HEATING & AIR CONDITIONING/PLUMBING/REFRIGERANT OIL - STANDARD PROCEDURE) Use only refrigerant oil of the type recommended for the compressor in the vehicle. (Refer to 24 - HEATING & AIR CONDITIONING/PLUMBING/REFRIGERANT OIL - DESCRIPTION)

(1) Install the compressor to the mounting bracket. Tighten the four mounting bolts to 24 N·m (210 in. lbs.).

(2) Remove the tape or plugs from all of the opened refrigerant line fittings. Install the suction and discharge line manifold to the compressor. (Refer to 24 - HEATING & AIR CONDITIONING/PLUMBING/A/C SUCTION AND DISCHARGE LINE - INSTALLATION)

## A/C COMPRESSOR (Continued)



80a89405

**Fig. 4 COMPRESSOR REMOVE/INSTALL - GASOLINE ENGINE**

- 1 - BRACKET  
 2 - A/C COMPRESSOR  
 3 - BOLT AND WASHER

- 4 - BRACE  
 5 - BOLT

(3) Install the serpentine drive belt. Refer to Cooling for the procedures.

(4) Plug in the compressor clutch coil wire harness connector.

(5) Connect the battery negative cable.

(6) Evacuate the refrigerant system. (Refer to 24 - HEATING & AIR CONDITIONING/PLUMBING - STANDARD PROCEDURE - REFRIGERANT SYSTEM EVACUATE)

(7) Charge the refrigerant system. (Refer to 24 - HEATING & AIR CONDITIONING/PLUMBING - STANDARD PROCEDURE - REFRIGERANT SYSTEM CHARGE)

## A/C CONDENSER

### DESCRIPTION

The condenser is located in the air flow in front of the engine cooling radiator. The condenser is a heat exchanger that allows the high-pressure refrigerant gas being discharged by the compressor to give up its

heat to the air passing over the condenser fins, thus causing the refrigerant to change to a liquid state.

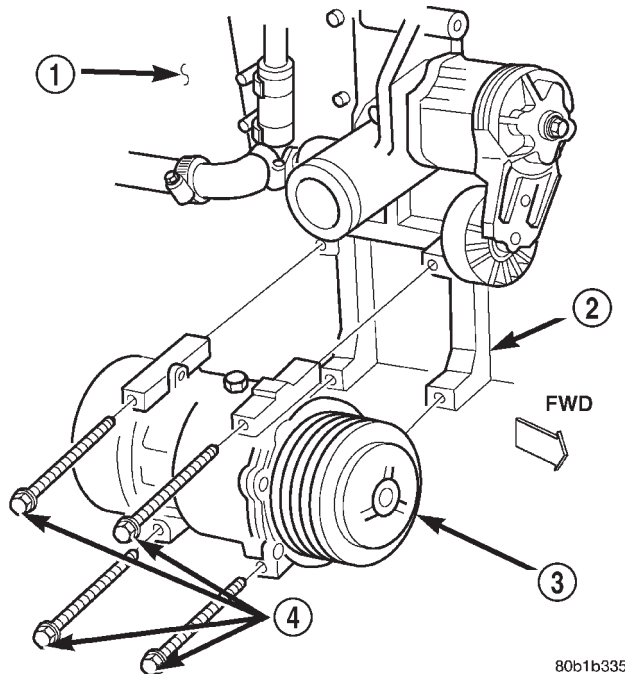
### OPERATION

When the refrigerant gas gives up its heat, it condenses. When the refrigerant leaves the condenser, it has become a high-pressure liquid refrigerant. The volume of air flowing over the condenser fins is critical to the proper cooling performance of the air conditioning system. Therefore, it is important that there are no objects placed in front of the radiator grille openings in the front of the vehicle or foreign material on the condenser fins that might obstruct proper air flow. Also, any factory-installed air seals or shrouds must be properly reinstalled following radiator or condenser service.

The condenser cannot be repaired and, if faulty or damaged, it must be replaced.



## A/C CONDENSER (Continued)



**Fig. 5 COMPRESSOR REMOVE/INSTALL - DIESEL ENGINE**

- 1 - ENGINE
- 2 - BRACKET
- 3 - A/C COMPRESSOR
- 4 - BOLTS

## REMOVAL

**WARNING: REVIEW THE WARNINGS AND CAUTIONS IN THE FRONT OF THIS SECTION BEFORE PERFORMING THE FOLLOWING OPERATION. (Refer to 24 - HEATING & AIR CONDITIONING/PLUMBING - WARNING) (Refer to 24 - HEATING & AIR CONDITIONING/PLUMBING - CAUTION)**

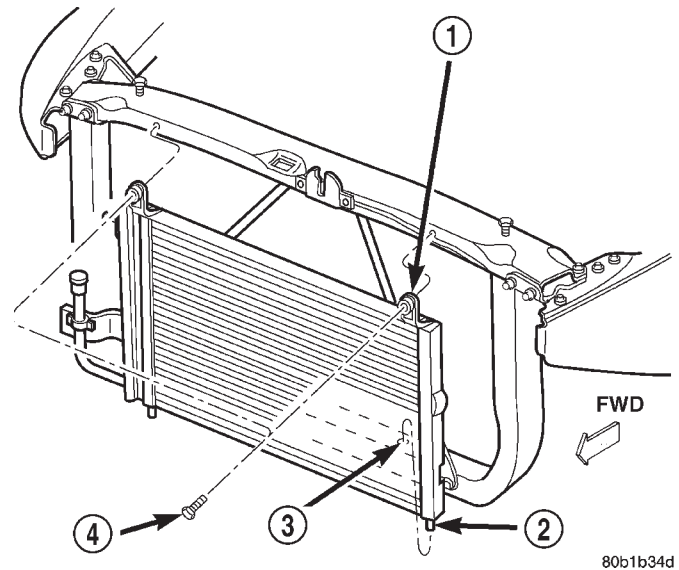
- (1) Disconnect and isolate the battery negative cable.
- (2) Recover the refrigerant from the refrigerant system. (Refer to 24 - HEATING & AIR CONDITIONING/PLUMBING - STANDARD PROCEDURE - REFRIGERANT RECOVERY)
- (3) Remove the nut that secures the block fitting to the stud on the condenser inlet, and disconnect the discharge line from the condenser. Install plugs in, or tape over all of the opened refrigerant line fittings.
- (4) Disconnect the refrigerant line fitting that secures the liquid line to the condenser outlet. (Refer to 24 - HEATING & AIR CONDITIONING/PLUMBING - STANDARD PROCEDURE - A/C LINE COUPLER) Install plugs in, or tape over all of the opened refrigerant line fittings.
- (5) On gasoline engine models:

(a) Remove the two screws that secure the condenser upper mounting brackets to the outside of the upper radiator crossmember (Fig. 6).

(b) Tilt the condenser away from the engine compartment far enough to grasp the top of the condenser with both hands.

(c) Lift the condenser far enough to remove the two lower condenser locators from the isolators in the holes of the lower crossmember.

(d) Remove the condenser from the vehicle.



**Fig. 6 CONDENSER REMOVE/INSTALL - GASOLINE ENGINE**

- 1 - CONDENSER
- 2 - LOCATOR
- 3 - ISOLATOR
- 4 - SCREW

(6) On diesel engine models:

(a) Remove the two screws that secure the brackets on the passenger side end of the condenser to the charge air cooler (Fig. 7).

(b) Remove the two nuts that secure the driver side end of the condenser to the studs on the charge air cooler.

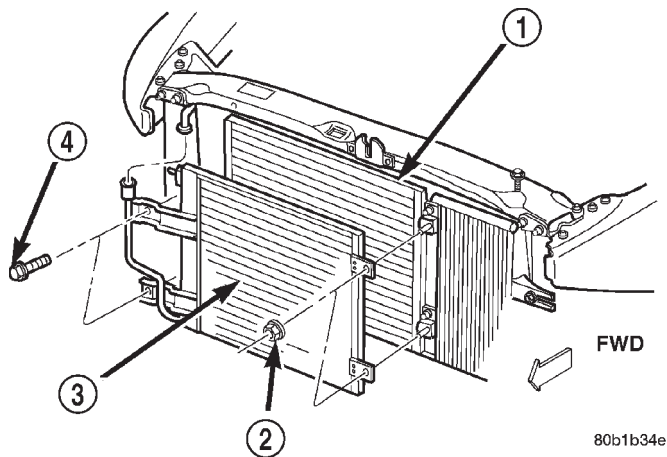
(c) Remove the condenser from the vehicle.

## INSTALLATION

**WARNING: REVIEW THE WARNINGS AND CAUTIONS IN THE FRONT OF THIS SECTION BEFORE PERFORMING THE FOLLOWING OPERATION. (Refer to 24 - HEATING & AIR CONDITIONING/PLUMBING - WARNING) (Refer to 24 - HEATING & AIR CONDITIONING/PLUMBING - CAUTION)(Refer to 24 - HEATING & AIR CONDITIONING/PLUMBING - CAUTION - REFRIGERANT HOSES/LINES/TUBES PRECAUTIONS)**



## A/C CONDENSER (Continued)



**Fig. 7 CONDENSER REMOVE/INSTALL - DIESEL ENGINE**

- 1 - CHARGE AIR COOLER
- 2 - NUT
- 3 - CONDENSER
- 4 - SCREW

(1) On gasoline engine models:

(a) Insert the two lower condenser locators into the isolators in the holes of the lower crossmember.

(b) Tilt the condenser up towards the engine compartment far enough to align the upper mounting bracket holes with the holes in the upper radiator crossmember.

(c) Install the two screws that secure the condenser upper mounting brackets to the outside of the upper radiator crossmember. Tighten the mounting screws to 10.5 N·m (95 in. lbs.).

(2) On diesel engine models:

(a) Install the driver side condenser mounting brackets over the two studs on the charge air cooler.

(b) Install the two screws that secure the brackets on the passenger side end of the condenser to the charge air cooler. Tighten the mounting screws to 10.5 N·m (95 in. lbs.).

(c) Install the two nuts that secure the driver side end of the condenser to the studs on the charge air cooler. Tighten the mounting nuts to 10.5 N·m (95 in. lbs.).

(3) Remove the plugs or tape from the refrigerant line fittings on the liquid line and the condenser outlet. Connect the liquid line to the condenser outlet. (Refer to 24 - HEATING & AIR CONDITIONING/PLUMBING - STANDARD PROCEDURE - A/C LINE COUPLERS)

(4) Install a new gasket and the discharge line block fitting over the stud on the condenser inlet. Tighten the mounting nut to 20 N·m (180 in. lbs.).

(5) Check that all of the condenser and radiator air seals are in their proper locations.

(6) Connect the battery negative cable.

(7) Evacuate the refrigerant system. (Refer to 24 - HEATING & AIR CONDITIONING/PLUMBING - STANDARD PROCEDURE - REFRIGERANT SYSTEM EVACUATE)

(8) Charge the refrigerant system. (Refer to 24 - HEATING & AIR CONDITIONING/PLUMBING - STANDARD PROCEDURE - REFRIGERANT SYSTEM CHARGE)

**NOTE:** If the condenser is replaced, add 30 milliliters (1 fluid ounce) of refrigerant oil to the refrigerant system. Use only refrigerant oil of the type recommended for the compressor in the vehicle. (Refer to 24 - HEATING & AIR CONDITIONING/PLUMBING/REFRIGERANT OIL - DESCRIPTION)

## SUCTION AND DISCHARGE LINE

### REMOVAL

**WARNING: REVIEW THE WARNINGS AND CAUTIONS IN THE FRONT OF THIS SECTION BEFORE PERFORMING THE FOLLOWING OPERATION.** (Refer to 24 - HEATING & AIR CONDITIONING/PLUMBING - WARNING) (Refer to 24 - HEATING & AIR CONDITIONING/PLUMBING - CAUTION)

(1) Disconnect and isolate the battery negative cable.

(2) Recover the refrigerant from the refrigerant system. (Refer to 24 - HEATING & AIR CONDITIONING/PLUMBING - STANDARD PROCEDURE - REFRIGERANT RECOVERY)

(3) Unplug the wire harness connector from the a/c high pressure switch.

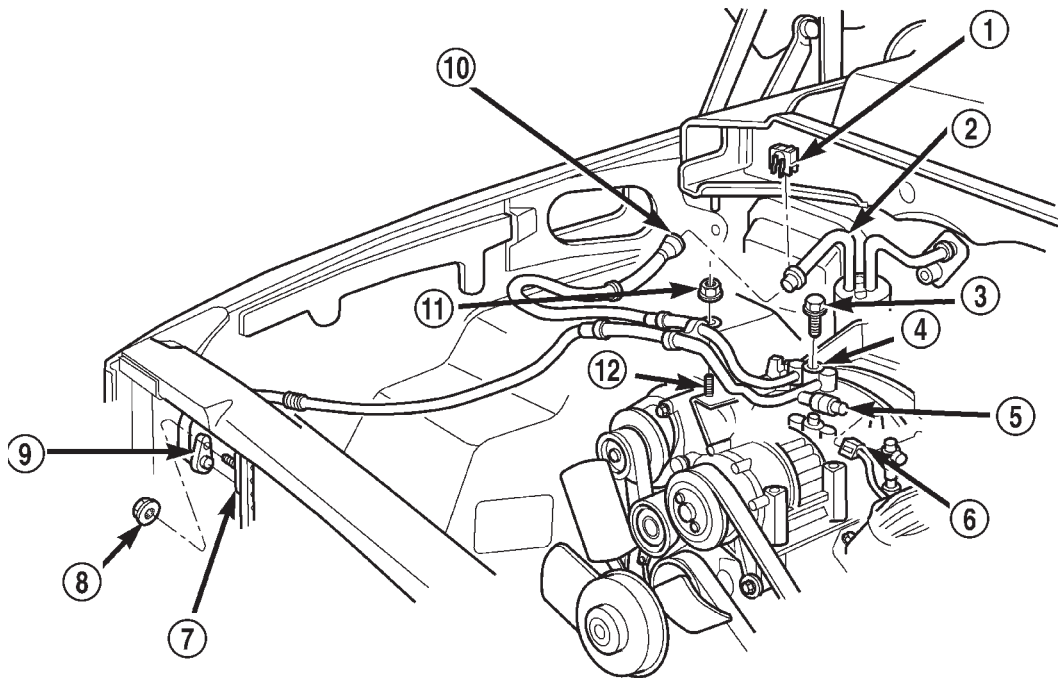
(4) Disconnect the suction line refrigerant line coupler at the accumulator. (Refer to 24 - HEATING & AIR CONDITIONING/PLUMBING - STANDARD PROCEDURE - A/C LINE COUPLER) Install plugs in, or tape over all of the opened refrigerant line fittings.

(5) Remove the nut that secures the block fitting to the stud on the condenser inlet and disconnect the discharge line from the condenser. Install plugs in, or tape over all of the opened refrigerant line fittings.

(6) On models with a gasoline engine, remove the nut that secures the refrigerant line support bracket to the stud on the compressor mounting bracket.

(7) Remove the bolt that secures the refrigerant line manifold to the compressor (Fig. 8) or (Fig. 9). Install plugs in, or tape over all of the opened refrigerant line fittings.

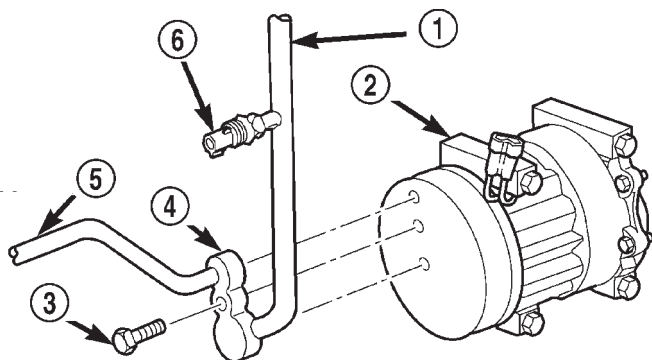
## SUCTION AND DISCHARGE LINE (Continued)



80ae83c9

**Fig. 8 SUCTION AND DISCHARGE LINE REMOVE/INSTALL - GASOLINE ENGINE**

- |                              |                    |
|------------------------------|--------------------|
| 1 - CLIP                     | 8 - NUT            |
| 2 - ACCUMULATOR              | 9 - DISCHARGE LINE |
| 3 - BOLT                     | 10 - SUCTION LINE  |
| 4 - MANIFOLD                 | 11 - NUT           |
| 5 - A/C HIGH PRESSURE SWITCH | 12 - STUD          |
| 6 - WIRE HARNESS CONNECTOR   |                    |
| 7 - CONDENSER                |                    |



80b1b333

**Fig. 9 SUCTION AND DISCHARGE LINE REMOVE/INSTALL - DIESEL ENGINE**

- |                                     |
|-------------------------------------|
| 1 - DISCHARGE LINE (TO CONDENSER)   |
| 2 - COMPRESSOR                      |
| 3 - BOLT                            |
| 4 - MANIFOLD                        |
| 5 - SUCTION LINE (FROM ACCUMULATOR) |
| 6 - A/C HIGH PRESSURE SWITCH        |

## INSTALLATION

**WARNING: REVIEW THE WARNINGS AND CAUTIONS IN THE FRONT OF THIS SECTION BEFORE PERFORMING THE FOLLOWING OPERATION. (Refer to 24 - HEATING & AIR CONDITIONING/PLUMBING - WARNING) (Refer to 24 - HEATING & AIR CONDITIONING/PLUMBING - CAUTION)(Refer to 24 - HEATING & AIR CONDITIONING/PLUMBING - CAUTION - REFRIGERANT HOSES/LINES/TUBES PRECAUTIONS)**

- (1) Remove the tape or plugs from all of the refrigerant line fittings. Connect the suction line refrigerant line coupler to the accumulator. (Refer to 24 - HEATING & AIR CONDITIONING/PLUMBING - STANDARD PROCEDURE - A/C LINE COUPLERS)
- (2) Install a new gasket and the discharge line block fitting over the stud on the condenser inlet. Tighten the mounting nut to 20 N·m (180 in. lbs.).

**(8) Remove the suction and discharge line assembly from the vehicle.**

## SUCTION AND DISCHARGE LINE (Continued)

(3) Install the refrigerant line manifold to the compressor. Tighten the mounting bolt to 22 N·m (200 in. lbs.).

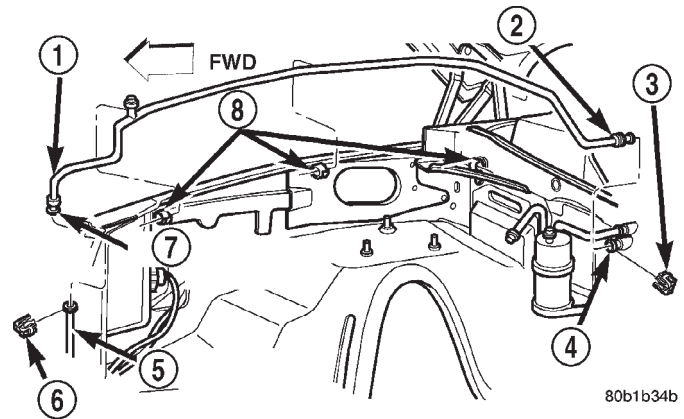
(4) On models with a gasoline engine, install the nut that secures the refrigerant line support bracket to the stud on the compressor mounting bracket. Tighten the mounting nut to 22 N·m (200 in. lbs.).

(5) Plug in the wire harness connector to the a/c high pressure switch.

(6) Connect the battery negative cable.

(7) Evacuate the refrigerant system. (Refer to 24 - HEATING & AIR CONDITIONING/PLUMBING - STANDARD PROCEDURE - REFRIGERANT SYSTEM EVACUATE)

(8) Charge the refrigerant system. (Refer to 24 - HEATING & AIR CONDITIONING/PLUMBING - STANDARD PROCEDURE - REFRIGERANT SYSTEM CHARGE)



**Fig. 10 LIQUID LINE REMOVE/INSTALL**

- 1 - TO EVAPORATOR INLET
- 2 - CLIP
- 3 - EVAPORATOR INLET
- 4 - CONDENSER OUTLET
- 5 - CLIP
- 6 - TO CONDENSER OUTLET
- 7 - LIQUID LINE
- 8 - CLIPS

## LIQUID LINE

## REMOVAL

**WARNING: REVIEW THE WARNINGS AND CAUTIONS IN THE FRONT OF THIS SECTION BEFORE PERFORMING THE FOLLOWING OPERATION. (Refer to 24 - HEATING & AIR CONDITIONING/PLUMBING - WARNING) (Refer to 24 - HEATING & AIR CONDITIONING/PLUMBING - CAUTION)**

(1) Disconnect and isolate the battery negative cable.

(2) Recover the refrigerant from the refrigerant system. (Refer to 24 - HEATING & AIR CONDITIONING/PLUMBING - STANDARD PROCEDURE - REFRIGERANT RECOVERY)

(3) Disconnect the liquid line refrigerant line couplers at the condenser outlet and the evaporator inlet. (Refer to 24 - HEATING & AIR CONDITIONING/PLUMBING - STANDARD PROCEDURE - A/C LINE COUPLERS) Install plugs in, or tape over all of the opened refrigerant line fittings.

(4) Disengage any clips that secure the liquid line to the inner fender shield and the dash panel (Fig. 10).

(5) Remove the liquid line from the vehicle.

## INSTALLATION

**WARNING: REVIEW THE WARNINGS AND CAUTIONS IN THE FRONT OF THIS SECTION BEFORE PERFORMING THE FOLLOWING OPERATION. (Refer to 24 - HEATING & AIR CONDITIONING/PLUMBING - WARNING) (Refer to 24 - HEATING & AIR CONDITIONING/PLUMBING - CAUTION)(Refer to 24 - HEATING & AIR CONDITIONING/PLUMBING -**

**CAUTION - REFRIGERANT HOSES/LINES/TUBES PRECAUTIONS)**

(1) Install the liquid line into any clips on the inner fender shield and the dash panel.

(2) Remove the tape or plugs from the refrigerant line fittings on the liquid line, the condenser outlet, and the evaporator inlet. Connect the liquid line to the condenser and the evaporator. (Refer to 24 - HEATING & AIR CONDITIONING/PLUMBING - STANDARD PROCEDURE - A/C LINE COUPLERS)

(3) Connect the battery negative cable.

(4) Evacuate the refrigerant system. (Refer to 24 - HEATING & AIR CONDITIONING/PLUMBING - STANDARD PROCEDURE - REFRIGERANT SYSTEM EVACUATE)

(5) Charge the refrigerant system. (Refer to 24 - HEATING & AIR CONDITIONING/PLUMBING - STANDARD PROCEDURE - REFRIGERANT SYSTEM CHARGE)

## A/C EVAPORATOR

## DESCRIPTION

The a/c evaporator is located in the HVAC housing, under the instrument panel. The evaporator coil is positioned in the HVAC housing so that all air that enters the housing must pass over the fins of the evaporator before it is distributed through the system ducts and outlets. However, air passing over the evaporator coil fins will only be conditioned when the

## A/C EVAPORATOR (Continued)

compressor is engaged and circulating refrigerant through the evaporator coil tubes.

## OPERATION

Refrigerant enters the evaporator from the fixed orifice tube as a low-temperature, low-pressure liquid. As air flows over the fins of the evaporator, the humidity in the air condenses on the fins, and the heat from the air is absorbed by the refrigerant. Heat absorption causes the refrigerant to boil and vaporize. The refrigerant becomes a low-pressure gas when it leaves the evaporator.

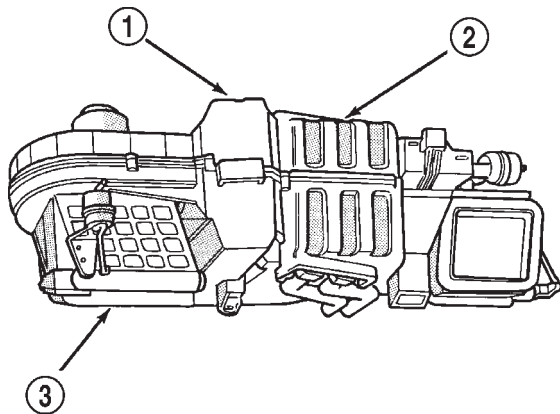
The evaporator coil cannot be repaired and, if faulty or damaged, it must be replaced.

## REMOVAL

**WARNING: REVIEW THE WARNINGS AND CAUTIONS IN THE FRONT OF THIS SECTION BEFORE PERFORMING THE FOLLOWING OPERATION. (Refer to 24 - HEATING & AIR CONDITIONING/PLUMBING - WARNING) (Refer to 24 - HEATING & AIR CONDITIONING/PLUMBING - CAUTION)**

(1) Remove the HVAC housing from the vehicle, and disassemble the housing halves. (Refer to 24 - HEATING & AIR CONDITIONING/DISTRIBUTION/HVAC HOUSING - REMOVAL) (Refer to 24 - HEATING & AIR CONDITIONING/DISTRIBUTION/HVAC HOUSING - DISASSEMBLY)

(2) Lift the a/c evaporator out of the HVAC housing (Fig. 11).



J9324-14

**Fig. 11 A/C EVAPORATOR LOCATION IN HVAC HOUSING (UPSIDE DOWN)**

- 1 - EVAPORATOR LOCATION  
2 - BOTTOM HALF OF HVAC HOUSING  
3 - TOP HALF OF HVAC HOUSING

## INSTALLATION

**WARNING: REVIEW THE WARNINGS AND CAUTIONS IN THE FRONT OF THIS SECTION BEFORE PERFORMING THE FOLLOWING OPERATION. (Refer to 24 - HEATING & AIR CONDITIONING/PLUMBING - WARNING) (Refer to 24 - HEATING & AIR CONDITIONING/PLUMBING - CAUTION)(Refer to 24 - HEATING & AIR CONDITIONING/PLUMBING - CAUTION - REFRIGERANT HOSES/LINES/TUBES PRECAUTIONS)**

(1) Insert the evaporator coil into the bottom of the HVAC housing.

(2) Reassemble and reinstall the HVAC housing in the vehicle. (Refer to 24 - HEATING & AIR CONDITIONING/DISTRIBUTION/HVAC HOUSING - ASSEMBLY) (Refer to 24 - HEATING & AIR CONDITIONING/DISTRIBUTION/HVAC HOUSING - INSTALLATION)

**NOTE: If the evaporator is replaced, add 60 milliliters (2 fluid ounces) of refrigerant oil to the refrigerant system.**

## A/C ORIFICE TUBE

## DESCRIPTION

The fixed orifice tube is installed in the liquid line between the outlet of the condenser and the inlet of the evaporator. The fixed orifice tube is only serviced as an integral part of the liquid line.

## OPERATION

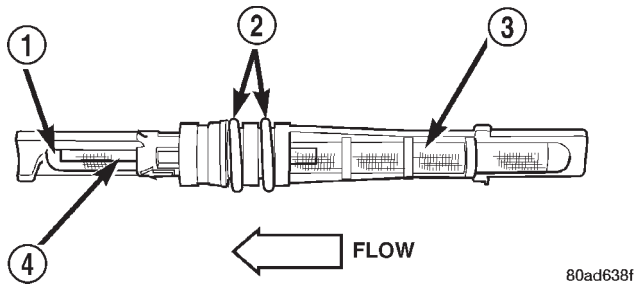
The inlet end of the fixed orifice tube has a nylon mesh filter screen, which filters the refrigerant and helps to reduce the potential for blockage of the metering orifice by refrigerant system contaminants (Fig. 12). The outlet end of the tube has a nylon mesh diffuser screen. The O-rings on the plastic body of the fixed orifice tube seal the tube to the inside of the liquid line and prevent the refrigerant from bypassing the fixed metering orifice.

The fixed orifice tube is used to meter the flow of liquid refrigerant into the evaporator coil. The high-pressure liquid refrigerant from the condenser expands into a low-pressure liquid as it passes through the metering orifice and diffuser screen of the fixed orifice tube.

The fixed orifice tube cannot be repaired and, if faulty or plugged, the liquid line assembly must be replaced.



## A/C ORIFICE TUBE (Continued)



80ad638f

**Fig. 12 FIXED ORIFICE TUBE - TYPICAL**

- 1 - DIFFUSER SCREEN
- 2 - "O" RINGS
- 3 - INLET FILTER SCREEN
- 4 - ORIFICE

## DIAGNOSIS AND TESTING - FIXED ORIFICE TUBE

The fixed orifice tube can be checked for proper operation using the following procedure. However, the fixed orifice tube is only serviced as a part of the liquid line unit. If the results of this test indicate that the fixed orifice tube is obstructed or missing, the entire liquid line unit must be replaced.

**WARNING: THE LIQUID LINE BETWEEN THE CONDENSER OUTLET AND THE FIXED ORIFICE TUBE CAN BECOME HOT ENOUGH TO BURN THE SKIN. USE EXTREME CAUTION WHEN PERFORMING THE FOLLOWING TEST.**

- (1) Confirm that the refrigerant system is properly charged. (Refer to 24 - HEATING & AIR CONDITIONING - DIAGNOSIS AND TESTING - A/C PERFORMANCE)
- (2) Start the engine. Turn on the air conditioning system and confirm that the compressor clutch is engaged.
- (3) Allow the air conditioning system to operate for five minutes.
- (4) Lightly and cautiously touch the liquid line near the condenser outlet at the front of the engine compartment. The liquid line should be hot to the touch.
- (5) Touch the liquid line near the evaporator inlet at the rear of the engine compartment. The liquid line should be cold to the touch.
- (6) If there is a distinct temperature differential between the two ends of the liquid line, the orifice tube is in good condition. If there is little or no detectable temperature differential between the two ends of the liquid line, the orifice tube is obstructed or missing and the liquid line must be replaced.

## REMOVAL

The fixed orifice tube is located in the liquid line, between the condenser and the evaporator coil. If the fixed orifice tube is faulty or plugged, the liquid line assembly must be replaced. (Refer to 24 - HEATING & AIR CONDITIONING/PLUMBING/LIQUID LINE - REMOVAL)

## ACCUMULATOR

### DESCRIPTION

The accumulator is mounted in the engine compartment between the a/c evaporator outlet tube and the compressor inlet.

### OPERATION

Refrigerant enters the accumulator canister as a low pressure vapor through the inlet tube. Any liquid, oil-laden refrigerant falls to the bottom of the canister, which acts as a separator. A desiccant bag is mounted inside the accumulator canister to absorb any moisture which may have entered and become trapped within the refrigerant system (Fig. 13).

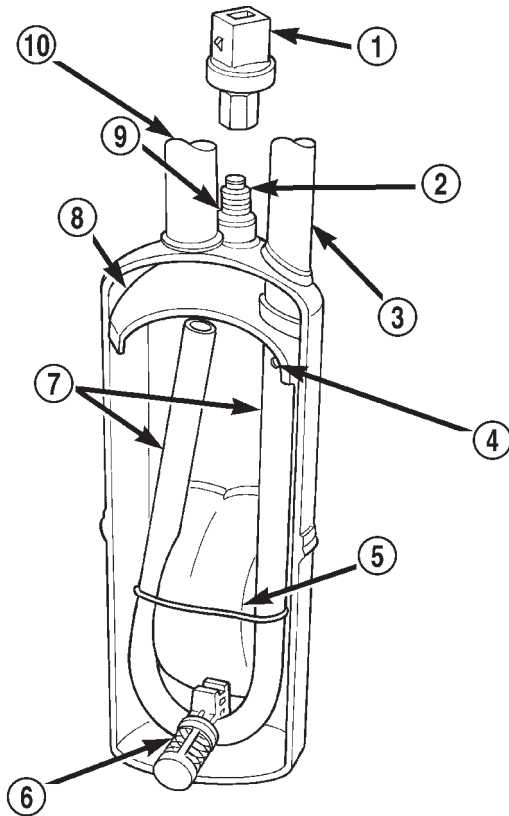
### REMOVAL

**WARNING: REVIEW THE WARNINGS AND CAUTIONS IN THE FRONT OF THIS SECTION BEFORE PERFORMING THE FOLLOWING OPERATION. (Refer to 24 - HEATING & AIR CONDITIONING/PLUMBING - WARNING) (Refer to 24 - HEATING & AIR CONDITIONING/PLUMBING - CAUTION)**

- (1) Disconnect and isolate the battery negative cable.
- (2) Recover the refrigerant from the refrigerant system. (Refer to 24 - HEATING & AIR CONDITIONING/PLUMBING - STANDARD PROCEDURE - REFRIGERANT RECOVERY)
- (3) Remove the a/c low pressure switch from the accumulator. (Refer to 24 - HEATING & AIR CONDITIONING/CONTROLS/A/C LOW PRESSURE SWITCH - REMOVAL)
- (4) Loosen the screw that secures the accumulator retaining band to the support bracket on the dash panel (Fig. 20).
- (5) Disconnect the suction line refrigerant line fitting from the accumulator outlet. (Refer to 24 - HEATING & AIR CONDITIONING/PLUMBING - STANDARD PROCEDURE - A/C LINE COUPLERS) Install plugs in, or tape over all of the opened refrigerant line fittings.
- (6) Disconnect the accumulator inlet refrigerant line fitting from the evaporator outlet. (Refer to 24 - HEATING & AIR CONDITIONING/PLUMBING -



## ACCUMULATOR (Continued)



80add30t

**Fig. 13 ACCUMULATOR - TYPICAL**

- 1 - A/C LOW PRESSURE SWITCH FITTING
- 2 - PRESSURE SWITCH FITTING
- 3 - OUTLET TO COMPRESSOR
- 4 - ANTI-SIPHON HOLE
- 5 - DESICCANT BAG
- 6 - OIL RETURN ORIFICE FILTER
- 7 - VAPOR RETURN TUBE
- 8 - ACCUMULATOR DOME
- 9 - O-RING SEAL
- 10 - INLET FROM EVAPORATOR

STANDARD PROCEDURE) Install plugs in, or tape over all of the opened refrigerant line fittings.

(7) Pull the accumulator out of the retaining band.

(8) Remove the accumulator from the engine compartment.

**INSTALLATION**

**WARNING: REVIEW THE WARNINGS AND CAUTIONS IN THE FRONT OF THIS SECTION BEFORE PERFORMING THE FOLLOWING OPERATION. (Refer to 24 - HEATING & AIR CONDITIONING/PLUMBING - WARNING) (Refer to 24 - HEATING & AIR CONDITIONING/PLUMBING - CAUTION)(Refer to 24 - HEATING & AIR CONDITIONING/PLUMBING - CAUTION - REFRIGERANT HOSES/LINES/TUBES PRECAUTIONS)**

(1) Install the accumulator in the retaining band.

(2) Remove the tape or plugs from the refrigerant line fittings on the accumulator inlet and the evaporator outlet. Connect the accumulator inlet refrigerant line coupler to the evaporator outlet. (Refer to 24 - HEATING & AIR CONDITIONING/PLUMBING - STANDARD PROCEDURE - A/C LINE COUPLERS)

(3) Tighten the accumulator retaining band screw to 4.5 N·m (40 in. lbs.).

(4) Remove the tape or plugs from the refrigerant line fittings on the suction line and the accumulator outlet. Connect the suction line refrigerant line coupler to the accumulator outlet. (Refer to 24 - HEATING & AIR CONDITIONING/PLUMBING - STANDARD PROCEDURE - A/C LINE COUPLERS)

(5) Reinstall the a/c low pressure switch on the accumulator. (Refer to 24 - HEATING & AIR CONDITIONING/CONTROLS/A/C LOW PRESSURE SWITCH - INSTALLATION)

(6) Connect the battery negative cable.

(7) Evacuate the refrigerant system. (Refer to 24 - HEATING & AIR CONDITIONING/PLUMBING - STANDARD PROCEDURE - REFRIGERANT SYSTEM EVACUATE)

(8) Charge the refrigerant system. (Refer to 24 - HEATING & AIR CONDITIONING/PLUMBING - STANDARD PROCEDURE - REFRIGERANT SYSTEM CHARGE)

**NOTE: If the accumulator is replaced, add 60 milliliters (2 fluid ounces) of refrigerant oil to the refrigerant system. Use only refrigerant oil of the type recommended for the compressor in the vehicle.**

**HEATER CORE****DESCRIPTION**

The heater core is located in the HVAC housing, under the instrument panel. It is a heat exchanger made of rows of tubes and fins.

**OPERATION**

Engine coolant is circulated through heater hoses to the heater core at all times. As the coolant flows through the heater core, heat removed from the engine is transferred to the heater core fins and tubes. Air directed through the heater core picks up the heat from the heater core fins. The blend door allows control of the heater output air temperature by controlling how much of the air flowing through the HVAC housing is directed through the heater core. The blower motor speed controls the volume of air flowing through the HVAC housing.

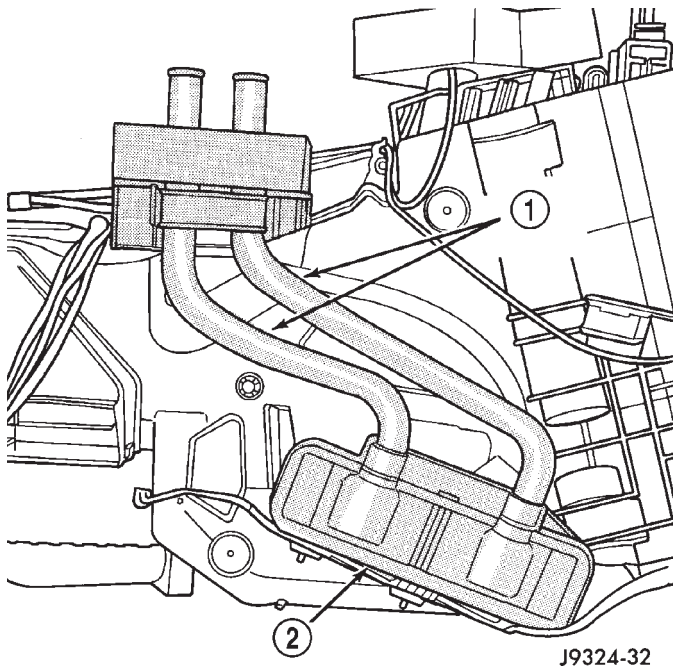
The heater core cannot be repaired and, if faulty or damaged, it must be replaced. Refer to Cooling for

## HEATER CORE (Continued)

more information on the engine cooling system, the engine coolant and the heater hoses.

**REMOVAL**

- (1) Remove the HVAC housing from the vehicle. (Refer to 24 - HEATING & AIR CONDITIONING/DISTRIBUTION/HVAC HOUSING - REMOVAL)
- (2) Remove the screws and retainers that secure the heater core to the HVAC housing.
- (3) Lift the heater core straight up and out of the heater-A/C housing (Fig. 14).



**Fig. 14 HEATER CORE REMOVE/INSTALL**

- 1 - HEATER CORE LINES  
2 - HEATER CORE

**INSTALLATION**

- (1) Lower the heater core into the HVAC housing.
- (2) Position the retainers over the heater core tubes. Install and tighten the screws that secure the heater core and retainers to the HVAC housing. Tighten the screws to 2.2 N·m (20 in. lbs.).
- (3) Reinstall the HVAC housing in the vehicle. (Refer to 24 - HEATING & AIR CONDITIONING/DISTRIBUTION/HVAC HOUSING - INSTALLATION)

**REFRIGERANT****DESCRIPTION**

The refrigerant used in this air conditioning system is a HydroFluoroCarbon (HFC), type R-134a. Unlike R-12, which is a ChloroFluoroCarbon (CFC),

R-134a refrigerant does not contain ozone-depleting chlorine. R-134a refrigerant is a non-toxic, non-flammable, clear, and colorless liquefied gas.

Even though R-134a does not contain chlorine, it must be reclaimed and recycled just like CFC-type refrigerants. This is because R-134a is a greenhouse gas and can contribute to global warming.

**OPERATION**

R-134a refrigerant is not compatible with R-12 refrigerant in an air conditioning system. Even a small amount of R-12 added to an R-134a refrigerant system will cause compressor failure, refrigerant oil sludge or poor air conditioning system performance. In addition, the PolyAlkylene Glycol (PAG) synthetic refrigerant oils used in an R-134a refrigerant system are not compatible with the mineral-based refrigerant oils used in an R-12 refrigerant system.

R-134a refrigerant system service ports, service tool couplers and refrigerant dispensing bottles have all been designed with unique fittings to ensure that an R-134a system is not accidentally contaminated with the wrong refrigerant (R-12). There are also labels posted in the engine compartment of the vehicle and on the compressor identifying to service technicians that the air conditioning system is equipped with R-134a.

**REFRIGERANT OIL****DESCRIPTION**

The refrigerant oil used in R-134a refrigerant systems is a synthetic-based, PolyAlkylene Glycol (PAG), wax-free lubricant. Mineral-based R-12 refrigerant oils are not compatible with PAG oils, and should never be introduced to an R-134a refrigerant system.

There are different PAG oils available, and each contains a different additive package. The SD7H15 compressor used in this vehicle is designed to use an SP-20 PAG refrigerant oil. Use only refrigerant oil of this same type to service the refrigerant system.

**OPERATION**

After performing any refrigerant recovery or recycling operation, always replenish the refrigerant system with the same amount of the recommended refrigerant oil as was removed. Too little refrigerant oil can cause compressor damage, and too much can reduce air conditioning system performance.

PAG refrigerant oil is much more hygroscopic than mineral oil, and will absorb any moisture it comes into contact with, even moisture in the air. The PAG oil container should always be kept tightly capped until it is ready to be used. After use, recap the oil

## REFRIGERANT OIL (Continued)

container immediately to prevent moisture contamination.

### STANDARD PROCEDURE - REFRIGERANT OIL LEVEL

When an air conditioning system is assembled at the factory, all components except the compressor are refrigerant oil free. After the refrigerant system has been charged and operated, the refrigerant oil in the compressor is dispersed throughout the refrigerant system. The accumulator, evaporator, condenser, and compressor will each retain a significant amount of the needed refrigerant oil.

It is important to have the correct amount of oil in the refrigerant system. This ensures proper lubrication of the compressor. Too little oil will result in damage to the compressor. Too much oil will reduce the cooling capacity of the air conditioning system.

It will not be necessary to check the oil level in the compressor or to add oil, unless there has been an oil loss. An oil loss may occur due to a rupture or leak from a refrigerant line, a connector fitting, a component, or a component seal. If a leak occurs, add 30 milliliters (1 fluid ounce) of refrigerant oil to the refrigerant system after the repair has been made.

Refrigerant oil loss will be evident at the leak point by the presence of a wet, shiny surface around the leak.

Refrigerant oil must be added when an accumulator, evaporator coil, or condenser are replaced. See the Refrigerant Oil Capacities chart. When a compressor is replaced, the refrigerant oil must be drained from the old compressor and measured. Drain all of the refrigerant oil from the new compressor, then fill the new compressor with the same amount of refrigerant oil that was drained out of the old compressor.

Refrigerant Oil Capacities		
Component	ml	fl oz
A/C System	210	6.2
Accumulator	60	2
Condenser	30	1
Evaporator	60	2
Compressor	drain and measure the oil from the old compressor - see text.	



# EMISSIONS CONTROL

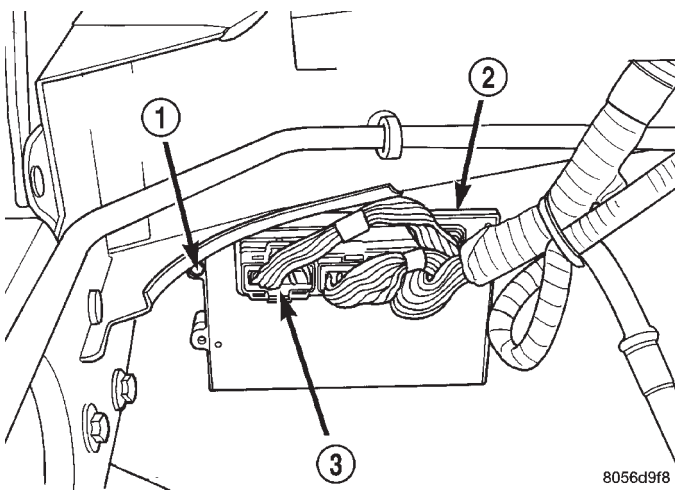
## TABLE OF CONTENTS

	page		page
<b>EMISSIONS CONTROL</b>		<b>AIR INJECTION</b> .....	25
DESCRIPTION .....	1	<b>EVAPORATIVE EMISSIONS</b> .....	31
OPERATION .....	18		

## EMISSIONS CONTROL

### DESCRIPTION - DIESEL

Two different modules are used for powertrain control with the diesel engine. The Powertrain Control Module (PCM) is used primarily for charging system, transmission, A/C compressor clutch operation and speed control functions. The Engine Control Module (ECM) is used to control the **fuel and emissions systems**. The PCM is located in the right/rear of engine compartment (Fig. 1). The ECM is bolted to the left side of the engine cylinder block (Fig. 2).

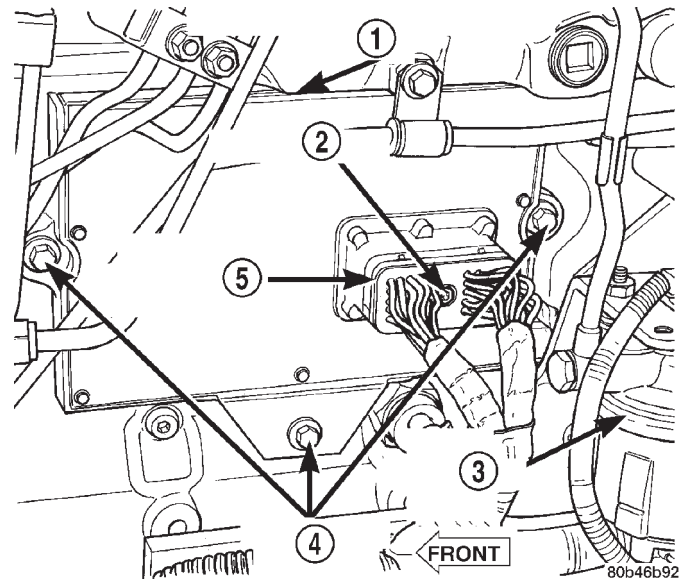


**Fig. 1 Powertrain Control Module (PCM) Location**

- 1 - PCM MOUNTING BOLTS (3)
- 2 - POWERTRAIN CONTROL MODULE (PCM)
- 3 - (3) 32-WAY CONNECTORS

### DESCRIPTION - STATE DISPLAY TEST MODE

The switch inputs to the Powertrain Control Module (PCM) have two recognized states; HIGH and LOW. For this reason, the PCM cannot recognize the difference between a selected switch position versus an open circuit, a short circuit, or a defective switch. If the State Display screen shows the change from HIGH to LOW or LOW to HIGH, assume the entire switch circuit to the PCM functions properly. Connect



**Fig. 2 Engine Control Module (ECM) Location**

- 1 - ENGINE CONTROL MODULE (ECM)
- 2 - HEX HEADED BOLT
- 3 - FUEL TRANSFER PUMP
- 4 - MOUNTING BOLTS (3)
- 5 - 50-WAY CONNECTOR

the DRB scan tool to the data link connector and access the state display screen. Then access either State Display Inputs and Outputs or State Display Sensors.

### DESCRIPTION - CIRCUIT ACTUATION TEST MODE

The Circuit Actuation Test Mode checks for proper operation of output circuits or devices the Powertrain Control Module (PCM) may not internally recognize. The PCM attempts to activate these outputs and allow an observer to verify proper operation. Most of the tests provide an audible or visual indication of device operation (click of relay contacts, fuel spray, etc.). Except for intermittent conditions, if a device functions properly during testing, assume the device, its associated wiring, and driver circuit work correctly. Connect the DRB scan tool to the data link connector and access the Actuators screen.



EMISSIONS CONTROL (Continued)

**DESCRIPTION - DIAGNOSTIC TROUBLE CODES**

A Diagnostic Trouble Code (DTC) indicates the PCM has recognized an abnormal condition in the system.

**Remember that DTC's are the results of a system or circuit failure, but do not directly identify the failed component or components.**

**NOTE: For a list of DTC's, refer to the charts in this section.**

**BULB CHECK**

Each time the ignition key is turned to the ON position, the malfunction indicator (check engine) lamp on the instrument panel should illuminate for approximately 2 seconds then go out. This is done for a bulb check.

**OBTAINING DTC'S USING DRB SCAN TOOL**

(1) Connect the DRB scan tool to the data link (diagnostic) connector. This connector is located in the passenger compartment; at the lower edge of instrument panel; near the steering column.

(2) Turn the ignition switch on and access the "Read Fault" screen.

(3) Record all the DTC's and "freeze frame" information shown on the DRB scan tool.

(4) To erase DTC's, use the "Erase Trouble Code" data screen on the DRB scan tool. **Do not erase any DTC's until problems have been investigated and repairs have been performed.**

<b>(M)</b> Malfunction Indicator Lamp (MIL) illuminated during engine operation if this DTC was recorded (depending if required by CARB and/or EPA). MIL is displayed as an engine icon on instrument panel.		
<b>(G)</b> Generator lamp illuminated		
Generic Scan Tool P-Code	DRB Scan Tool Display	Brief Description of DTC
P0030 (M)	1/1 O2 Sensor Heater Relay Circuit	Problem detected in oxygen sensor heater relay circuit.
P0036 (M)	1/2 O2 Sensor Heater Relay Circuit	Problem detected in oxygen sensor heater relay circuit.
P0106	Barometric Pressure Out of Range	MAP sensor input voltage out of an acceptable range detected during reading of barometric pressure at key-on.
P0107 (M)	Map Sensor Voltage Too Low	MAP sensor input below minimum acceptable voltage.
P0108 (M)	Map Sensor Voltage Too High	MAP sensor input above maximum acceptable voltage.
P0112 (M)	Intake Air Temp Sensor Voltage Low	Intake air (charge) temperature sensor input below the minimum acceptable voltage.
P0113 (M)	Intake Air Temp Sensor Voltage High	Intake air (charge) temperature sensor input above the maximum acceptable voltage.
P0116		A rationality error has been detected in the coolant temp sensor.
P0117 (M)	ECT Sensor Voltage Too Low	Engine coolant temperature sensor input below the minimum acceptable voltage.
P0118 (M)	ECT Sensor Voltage Too High	Engine coolant temperature sensor input above the maximum acceptable voltage.
P0121 (M)	TPS Voltage Does Not Agree With MAP	TPS signal does not correlate to MAP sensor signal.
P0121 (M)	Accelerator Position Sensor (APPS) Signal Voltage Too Low	APPS voltage input below the minimum acceptable voltage.
P0122 (M)	Throttle Position Sensor Voltage Low	Throttle position sensor input below the acceptable voltage range.
P0122 (M)	Accelerator Position Sensor (APPS) Signal Voltage Too Low	APPS voltage input below the minimum acceptable voltage.
P0123 (M)	Throttle Position Sensor Voltage High	Throttle position sensor input above the maximum acceptable voltage.

## EMISSIONS CONTROL (Continued)

<b>(M) Malfunction Indicator Lamp (MIL) illuminated during engine operation if this DTC was recorded (depending if required by CARB and/or EPA). MIL is displayed as an engine icon on instrument panel.</b>		
<b>(G) Generator lamp illuminated</b>		
Generic Scan Tool P-Code	DRB Scan Tool Display	Brief Description of DTC
P0123 (M)	Accelerator Position Sensor (APPS) Signal Voltage Too High	APPS voltage input above the maximum acceptable voltage.
P0125 (M)	Closed Loop Temp Not Reached	Time to enter Closed Loop Operation (Fuel Control) is excessive.
P0125 (M)	Engine is Cold Too Long	Engine does not reach operating temperature.
P0130 (M)	1/1 O2 Sensor Heater Circuit Malfunction	Oxygen sensor heater element malfunction.
P0131 (M)	1/1 O2 Sensor Shorted To Ground	Oxygen sensor input voltage maintained below normal operating range.
P0132 (M)	1/1 O2 Sensor Shorted To Voltage	Oxygen sensor input voltage maintained above normal operating range.
P0133 (M)	1/1 O2 Sensor Slow Response	Oxygen sensor response slower than minimum required switching frequency.
P0134 (M)	1/1 O2 Sensor Stays at Center	Neither rich or lean condition is detected from the oxygen sensor input.
P0135 (M)	1/1 O2 Sensor Heater Failure	Oxygen sensor heater element malfunction.
P0136 (M)	1/2 O2 Sensor Heater Circuit Malfunction	Oxygen sensor heater element malfunction.
P0137 (M)	1/2 O2 Sensor Shorted To Ground	Oxygen sensor input voltage maintained below normal operating range.
P0138 (M)	1/2 O2 Sensor Shorted To Voltage	Oxygen sensor input voltage maintained above normal operating range.
P0139 (M)	1/2 O2 Sensor Slow Response	Oxygen sensor response not as expected.
P0140 (M)	1/2 O2 Sensor Stays at Center	Neither rich or lean condition is detected from the oxygen sensor.
P0141 (M)	1/2 O2 Sensor Heater Failure	Oxygen sensor heater element malfunction.
P0143 (M)	1/3 O2 Sensor Shorted To Ground	Oxygen sensor input voltage maintained below normal operating range.
P0144 (M)	1/3 O2 Sensor Shorted To Voltage	Oxygen sensor input voltage maintained above normal operating range.
P0145 (M)	1/3 O2 Sensor Slow Response	Oxygen sensor response slower than minimum required switching frequency.
P0146 (M)	1/3 O2 Sensor Stays at Center	Neither rich or lean condition is detected from the oxygen sensor.
P0147 (M)	1/3 O2 Sensor Heater Failure	Oxygen sensor heater element malfunction.
P0151 (M)	2/1 O2 Sensor Shorted To Ground	Oxygen sensor input voltage maintained below normal operating range.
P0152 (M)	2/1 O2 Sensor Shorted To Voltage	Oxygen sensor input voltage sustained above normal operating range.
P0153 (M)	2/1 O2 Sensor Slow Response	Oxygen sensor response slower than minimum required switching frequency.
P0154 (M)	2/1 O2 Sensor Stays at Center	Neither rich or lean condition is detected from the oxygen sensor.

## EMISSIONS CONTROL (Continued)

<b>(M)</b> Malfunction Indicator Lamp (MIL) illuminated during engine operation if this DTC was recorded (depending if required by CARB and/or EPA). MIL is displayed as an engine icon on instrument panel.		
<b>(G)</b> Generator lamp illuminated		
Generic Scan Tool P-Code	DRB Scan Tool Display	Brief Description of DTC
P0155 (M)	2/1 O2 Sensor Heater Failure	Oxygen sensor heater element malfunction.
P0157 (M)	2/2 O2 Sensor Shorted To Ground	Oxygen sensor input voltage maintained below normal operating range.
P0158 (M)	2/2 O2 Sensor Shorted To Voltage	Oxygen sensor input voltage maintained above normal operating range.
P0159	2/2 O2 Sensor Slow Response	Oxygen sensor response slower than minimum required switching frequency.
P0160 (M)	2/2 O2 Sensor Stays at Center	Neither rich or lean condition is detected from the oxygen sensor.
P0161 (M)	2/2 O2 Sensor Heater Failure	Oxygen sensor heater element malfunction.
P0168	Decreased Engine Performance Due To High Injection Pump Fuel Temp	Fuel temperature is above the engine protection limit. Engine power will be derated.
P0171 (M)	1/1 Fuel System Lean	A lean air/fuel mixture has been indicated by an abnormally rich correction factor.
P0172 (M)	1/1 Fuel System Rich	A rich air/fuel mixture has been indicated by an abnormally lean correction factor.
P0174 (M)	2/1 Fuel System Lean	A lean air/fuel mixture has been indicated by an abnormally rich correction factor.
P0175 (M)	2/1 Fuel System Rich	A rich air/fuel mixture has been indicated by an abnormally lean correction factor.
P0176	Loss of Flex Fuel Calibration Signal	No calibration voltage present from flex fuel sensor.
P0177	Water In Fuel	Excess water found in fuel by water-in-fuel sensor.
P0178	Flex Fuel Sensor Volts Too Low	Flex fuel sensor input below minimum acceptable voltage.
P0178	Water In Fuel Sensor Voltage Too Low	Loss of water-in-fuel circuit or sensor.
P0179	Flex Fuel Sensor Volts Too High	Flex fuel sensor input above maximum acceptable voltage.
P0181	Fuel Injection Pump Failure	Low power, engine derated, or engine stops.
P0182 (M)	CNG Temp Sensor Voltage Too Low	Compressed natural gas temperature sensor voltage below acceptable voltage.
P0183 (M)	CNG Temp Sensor Voltage Too High	Compressed natural gas temperature sensor voltage above acceptable voltage.
P0201 (M)	Injector #1 Control Circuit	An open or shorted condition detected in control circuit for injector #1 or the INJ 1 injector bank.
P0202 (M)	Injector #2 Control Circuit	An open or shorted condition detected in control circuit for injector #2 or the INJ 2 injector bank.
P0203 (M)	Injector #3 Control Circuit	An open or shorted condition detected in control circuit for injector #3 or the INJ 3 injector bank.
P0204 (M)	Injector #4 Control Circuit	Injector #4 or INJ 4 injector bank output driver stage does not respond properly to the control signal.
P0205 (M)	Injector #5 Control Circuit	Injector #5 output driver stage does not respond properly to the control signal.

## EMISSIONS CONTROL (Continued)

<b>(M) Malfunction Indicator Lamp (MIL) illuminated during engine operation if this DTC was recorded (depending if required by CARB and/or EPA). MIL is displayed as an engine icon on instrument panel.</b>		
<b>(G) Generator lamp illuminated</b>		
Generic Scan Tool P-Code	DRB Scan Tool Display	Brief Description of DTC
P0206 (M)	Injector #6 Control Circuit	Injector #6 output driver stage does not respond properly to the control signal.
P0207 (M)	Injector #7 Control Circuit	Injector #7 output driver stage does not respond properly to the control signal.
P0208 (M)	Injector #8 Control Circuit	Injector #8 output driver stage does not respond properly to the control signal.
P0209 (M)	Injector #9 Control Circuit	Injector #9 output driver stage does not respond properly to the control signal.
P0210 (M)	Injector #10 Control Circuit	Injector #10 output driver stage does not respond properly to the control signal.
P0215	Fuel Injection Pump Control Circuit	Failure in fuel pump relay control circuit.
P0216 (M)	Fuel Injection Pump Timing Failure	High fuel supply restriction, low fuel pressure or possible wrong or incorrectly installed pump keyway.
P0217	Decreased Engine Performance Due To Engine Overheat Condition	Engine overheating. ECM will derate engine performance.
P0219	Crankshaft Position Sensor Overspeed Signal	Engine has exceeded rpm limits.
P0222 (M)	Idle Validation Signals Both Low	Problem detected with idle validation circuits within APPS.
P0223 (M)	Idle Validation Signals Both High (Above 5 Volts)	Problem detected with idle validation circuits within APPS.
P0230	Transfer Pump (Lift Pump) Circuit Out of Range	Problem detected in fuel transfer pump circuits.
P0232	Fuel Shutoff Signal Voltage Too High	Fuel shut-off signal voltage too high from ECM to fuel injection pump.
P0234 (M)	Turbo Boost Limit Exceeded	Problem detected in turbocharger wastegate.
P0236 (M)	Map Sensor Too High Too Long	Problem detected in turbocharger wastegate.
P0237 (M)	Map Sensor Voltage Too Low	MAP sensor voltage input below the minimum acceptable voltage.
P0238 (M)	Map Sensor Voltage Too High	MAP sensor voltage input above the maximum acceptable voltage.
P0251 (M)	Fuel Inj. Pump Mech. Failure Fuel Valve Feedback Circuit	Problem sensed with fuel circuit internal to fuel injection pump.
P0253 (M)	Fuel Injection Pump Fuel Valve Open Circuit	Problem sensed with fuel circuit internal to fuel injection pump.
P0254	Fuel Injection Pump Fuel Valve Current Too High	Problem caused by internal fuel injection pump failure.
P0300 (M)	Multiple Cylinder Mis-fire	Misfire detected in multiple cylinders.
P0301 (M)	CYLINDER #1 MISFIRE	Misfire detected in cylinder #1.
P0302 (M)	CYLINDER #2 MISFIRE	Misfire detected in cylinder #2.
P0303 (M)	CYLINDER #3 MISFIRE	Misfire detected in cylinder #3.
P0304 (M)	CYLINDER #4 MISFIRE	Misfire detected in cylinder #4.
P0305 (M)	CYLINDER #5 MISFIRE	Misfire detected in cylinder #5.

## EMISSIONS CONTROL (Continued)

<b>(M)</b> Malfunction Indicator Lamp (MIL) illuminated during engine operation if this DTC was recorded (depending if required by CARB and/or EPA). MIL is displayed as an engine icon on instrument panel.		
<b>(G)</b> Generator lamp illuminated		
Generic Scan Tool P-Code	DRB Scan Tool Display	Brief Description of DTC
P0306 (M)	CYLINDER #6 MISFIRE	Misfire detected in cylinder #6.
P0307 (M)	CYLINDER #7 MISFIRE	Misfire detected in cylinder #7
P0308 (M)	CYLINDER #8 MISFIRE	Misfire detected in cylinder #8.
P0309 (M)	CYLINDER #9 MISFIRE	Misfire detected in cylinder #9.
P0310 (M)	CYLINDER #10 MISFIRE	Misfire detected in cylinder #10.
P0320 (M)	No Crank Referance Signal at PCM	No reference signal (crankshaft position sensor) detected during engine cranking.
P0320 (M)	No RPM Signal to PCM (Crankshaft Position Sensor Signal to JTEC)	A CKP signal has not been detected at the PCM.
P0325	Knock Sensor #1 Circuit	Knock sensor (#1) signal above or below minimum acceptable threshold voltage at particular engine speeds.
P0330	Knock Sensor #2 Circuit	Knock sensor (#2) signal above or below minimum acceptable threshold voltage at particular engine speeds.
P0336 (M)	Crankshaft Position (CKP) Sensor Signal	Problem with voltage signal from CKP.
P0340 (M)	No Cam Signal At PCM	No fuel sync
P0341 (M)	Camshaft Position (CMP) Sensor Signal	Problem with voltage signal from CMP.
P0350	Ignition Coil Draws Too Much Current	A coil (1-5) is drawing too much current.
P0351 (M)	Ignition Coil # 1 Primary Circuit	Peak primary circuit current not achieved with maximum dwell time.
P0352 (M)	Ignition Coil # 2 Primary Circuit	Peak primary circuit current not achieved with maximum dwell time.
P0353 (M)	Ignition Coil # 3 Primary Circuit	Peak primary circuit current not achieved with maximum dwell time.
P0354 (M)	Ignition Coil # 4 Primary Circuit	Peak primary circuit current not achieved with maximum dwell time (High Impedance).
P0355 (M)	Ignition Coil # 5 Primary Circuit	Peak primary circuit current not achieved with maximum dwell time (High Impedance).
P0356 (M)	Ignition Coil # 6 Primary Circuit	Peak primary circuit current not achieved with maximum dwell time (high impedance).
P0357 (M)	Ignition Coil # 7 Primary Circuit	Peak primary circuit current not achieved with maximum dwell time (high impedance).
P0358 (M)	Ignition Coil # 8 Primary Circuit	Peak primary circuit current not achieved with maximum dwell time (high impedance).
P0370	Fuel Injection Pump Speed/Position Sensor Sig Lost	Problem caused by internal fuel injection pump failure.
P0380 (M)	Intake Air Heater Relay #1 Control Circuit	Problem detected in #1 air heater solenoid/relay circuit (not heater element)
P0381 (M)	Wait To Start Lamp Inoperative	Problem detected in wait-to-start bulb circuit.
P0382 (M)	Intake Air Heater Relay #2 Control Circuit	Problem detected in #2 air heater solenoid/relay circuit (not heater element)



## EMISSIONS CONTROL (Continued)

<b>(M) Malfunction Indicator Lamp (MIL) illuminated during engine operation if this DTC was recorded (depending if required by CARB and/or EPA). MIL is displayed as an engine icon on instrument panel.</b>		
<b>(G) Generator lamp illuminated</b>		
Generic Scan Tool P-Code	DRB Scan Tool Display	Brief Description of DTC
P0387	Crankshaft Position Sensor Supply Voltage Too Low	CKP sensor voltage input below the minimum acceptable voltage.
P0388	Crankshaft Position Sensor Supply Voltage Too High	CKP sensor voltage input above the maximum acceptable voltage.
P0401	EGR System Failure	Required change in air/fuel ration not detected during diagnostic test.
P0403	EGR Solenoid Circuit	An open or shorted condition detected in the EGR solenoid control circuit.
P0404	EGR Position Sensor Rationality	EGR position sensor signal does not correlate to EGR duty cycle.
P0405	EGR Position Sensor Volts Too Low	EGR position sensor input below the acceptable voltage range.
P0406	EGR Position Sensor Volts Too High	EGR position sensor input above the acceptable voltage range.
P0412	Secondary Air Solenoid Circuit	An open or shorted condition detected in the secondary air (air switching/aspirator) solenoid control circuit.
P0420 (M)	1/1 Catalytic Converter Efficiency	Catalyst 1/1 efficiency below required level.
P0432 (M)	1/2 Catalytic Converter Efficiency	Catalyst 2/1 efficiency below required level.
P0441 (M)	Evap Purge Flow Monitor	Insufficient or excessive vapor flow detected during evaporative emission system operation.
P0442 (M)	Evap Leak Monitor Medium Leak Detected	A small leak has been detected in the evaporative system.
P0443 (M)	Evap Purge Solenoid Circuit	An open or shorted condition detected in the EVAP purge solenoid control circuit.
P0455 (M)	Evap Leak Monitor Large Leak Detected	A large leak has been detected in the evaporative system.
P0456 (M)	Evap Leak Monitor Small Leak Detected	Leak has been detected in the evaporative system.
P0460	Fuel Level Unit No Change Over Miles	During low fuel
P0460	Fuel Level Unit No Change Over Miles	Fuel level sending unit voltage does not change for more than 40 miles.
P0462	Fuel Level Sending Unit Volts Too Low	Fuel level sensor input below acceptable voltage.
P0462 (M)	Fuel Level Sending Unit Volts Too Low	Open circuit between PCM and fuel gauge sending unit.
P0463	Fuel Level Sending Unit Volts Too High	Fuel level sensor input above acceptable voltage.
P0463 (M)	Fuel Level Sending Unit Volts Too High	Circuit shorted to voltage between PCM and fuel gauge sending unit.
P0500 (M)	No Vehicle Speed Sensor Signal	No vehicle speed sensor signal detected during road load conditions.
P0500 (M)	No Vehicle Speed Sensor Signal	A vehicle speed signal was not detected.

## EMISSIONS CONTROL (Continued)

<b>(M)</b> Malfunction Indicator Lamp (MIL) illuminated during engine operation if this DTC was recorded (depending if required by CARB and/or EPA). MIL is displayed as an engine icon on instrument panel.		
<b>(G)</b> Generator lamp illuminated		
Generic Scan Tool P-Code	DRB Scan Tool Display	Brief Description of DTC
P0505 (M)	Idle Air Control Motor Circuits	SBEC II
P0522	Oil Pressure Voltage Too Low	Oil pressure sending unit (sensor) voltage input below the minimum acceptable voltage.
P0523	Oil Pressure Voltage Too High	Oil pressure sending unit (sensor) voltage input above the maximum acceptable voltage.
P0524	Oil Pressure Too Low	Engine oil pressure is low. Engine power derated.
P0545	A/C Clutch Relay Circuit	Problem detected in air conditioning clutch relay control circuit.
P0551	Power Steering Switch Failure	Incorrect input state detected for the power steering switch circuit. PL: High pressure seen at high speed.
P0562	Charging System Voltage Too Low	Supply voltage sensed at ECM too low.
P0563	Charging System Voltage Too High	Supply voltage sensed at ECM too high.
P0600	PCM Failure SPI Communications	No communication detected between co-processors in the control module.
P0601 (M)	Internal Controller Failure	Internal control module fault condition (check sum) detected.
P0602 (M)	ECM Fueling Calibration Error	ECM Internal fault condition detected.
P0604	RAM Check Failure	Transmission control module RAM self test fault detected. -Aisin transmission
P0605	ROM Check Failure	Transmission control module ROM self test fault detected -Aisin transmission
P0606 (M)	ECM Failure	ECM Internal fault condition detected.
P0615	Starter Relay Control Circuit	An open or shorted condition detected in the starter relay control circuit.
P0622 (G)	Generator Field Not Switching Properly	An open or shorted condition detected in the generator field control circuit.
P0645	A/C Clutch Relay Circuit	An open or shorted condition detected in the A/C clutch relay control circuit.
P0700	EATX Controller DTC Present	This SBEC III or JTEC DTC indicates that the EATX or Aisin controller has an active fault and has illuminated the MIL via a CCD (EATX) or SCI (Aisin) message. The specific fault must be acquired from the EATX via CCD or from the Aisin via ISO-9141.
P0703	Brake Switch Stuck Pressed or Released	Incorrect input state detected in the brake switch circuit. (Changed from P1595)
P0711 (M)	Trans Temp Sensor, No Temp Rise After Start	Relationship between the transmission temperature and overdrive operation and/or TCC operation indicates a failure of the Transmission Temperature Sensor. OBD II Rationality. Was MIL code 37.
P0712	Trans Temp Sensor Voltage Too Low	Transmission fluid temperature sensor input below acceptable voltage. Was MIL code 37.
P0712 (M)	Trans Temp Sensor Voltage Too Low	Voltage less than 1.55 volts (4-speed auto. trans. only).

## EMISSIONS CONTROL (Continued)

<b>(M) Malfunction Indicator Lamp (MIL) illuminated during engine operation if this DTC was recorded (depending if required by CARB and/or EPA). MIL is displayed as an engine icon on instrument panel.</b>		
<b>(G) Generator lamp illuminated</b>		
Generic Scan Tool P-Code	DRB Scan Tool Display	Brief Description of DTC
P0713	Trans Temp Sensor Voltage Too High	Transmission fluid temperature sensor input above acceptable voltage. Was MIL code 37.
P0713 (M)	Trans Temp Sensor Voltage Too High	Voltage greater than 3.76 volts (4-speed auto. trans. only).
P0720 (M)	Low Output SPD Sensor RPM, Above 15 MPH	The relationship between the Output Shaft Speed Sensor and vehicle speed is not within acceptable limits.
P0720 (M)	Low Output Spd Sensor RPM Above 15 mph	Output shaft speed is less than 60 rpm with vehicle speed above 15 mph (4-speed auto. trans. only).
P0740 (M)	Torq Con Clu, No RPM Drop at Lockup	Relationship between engine and vehicle speeds indicated failure of torque converter clutch lock-up system (TCC/PTU solenoid)
P0743 (M)	Torque Converter Clutch Solenoid/ Trans Relay Circuits	An open or shorted condition detected in the torque converter clutch (part throttle unlock) solenoid control circuit. Shift solenoid C electrical fault - Aisin transmission
P0743 (M)	Torque Converter Clutch Solenoid/ Trans Relay Circuits	An open or shorted condition detected in the torque converter part throttle unlock solenoid control circuit (3 or 4-speed auto. trans. only).
P0748 (M)	Governor Pressur Sol Control/Trans Relay Circuits	An open or shorted condition detected in the Governor Pressure Solenoid circuit or Trans Relay Circuit in JTEC RE transmissions.
P0748 (M)	Governor Pressure Sol Control/Trans Relay Circuits	An open or shorted condition detected in the governor pressure solenoid or relay circuits (4-speed auto. trans. only).
P0751 (M)	O/D Switch Pressed (Lo) More Than 5 Minutes	Overdrive override switch input is in a prolonged depressed state.
P0751 (M)	O/D Switch Pressed (LO) More Than 5 Min	Overdrive Off switch input too low for more than 5 minutes (4-speed auto. trans. only).
P0753 (M)	Trans 3-4 Shift Sol/Trans Relay Circuits	An open or shorted condition detected in the overdrive solenoid control circuit or Trans Relay Circuit in JTEC RE transmissions. Was MIL code 45.
P0753 (M)	Trans 3-4 Shift Sol/Trans Relay Circuits	An open or shorted condition detected in the transmission 2-4 shift solenoid circuit (4-speed auto. trans. only).
P0756	AW4 Shift Sol B (2-3) Functional Failure	Shift solenoid B (2-3) functional fault - Aisin transmission
P0783 (M)	3-4 Shift Sol, No RPM Drop at Lockup	The overdrive solenoid is unable to engage the gear change from 3rd gear to the overdrive gear.
P0801	Reverse Gear Lockout Circuit Open or Short	An open or shorted condition detected in the transmission reverse gear lock-out solenoid control circuit.
P0830	Clutch Depressed Switch Circuit	Problem detected in clutch switch circuit.
P0833	Clutch Released Switch Circuit	Problem detected in clutch switch circuit.
P1110	Decrease Engine Performance Due To High Intake Air Temperature	Intake manifold air temperature is above the engine protection limit. Engine power will be derated.
P1180	Decreased Engine Performance Due To High Injection Pump Fuel Temp	Fuel temperature is above the engine protection limit. Engine power will be derated.

## EMISSIONS CONTROL (Continued)

<b>(M) Malfunction Indicator Lamp (MIL) illuminated during engine operation if this DTC was recorded (depending if required by CARB and/or EPA). MIL is displayed as an engine icon on instrument panel.</b>		
<b>(G) Generator lamp illuminated</b>		
Generic Scan Tool P-Code	DRB Scan Tool Display	Brief Description of DTC
P1195 (M)	1/1 O2 Sensor Slow During Catalyst Monitor	A slow switching oxygen sensor has been detected in bank 1/1 during catalyst monitor test. (Also see SCI DTC \$66) (was P0133)
P1196 (M)	2/1 O2 Sensor Slow During Catalyst Monitor	A slow switching oxygen sensor has been detected in bank 2/1 during catalyst monitor test. (Also see SCI DTC \$7A) (was P0153)
P1197	1/2 O2 Sensor Slow During Catalyst Monitor	A slow switching oxygen sensor has been detected in bank 1/2 during catalyst monitor test. (Also see SCI DTC \$68) (was P0139)
P1198	Radiator Temperature Sensor Volts Too High	Radiator coolant temperature sensor input above the maximum acceptable voltage.
P1199	Radiator Temperature Sensor Volts Too Low	Radiator coolant temperature sensor input below the minimum acceptable voltage.
P1281	Engine is Cold Too Long	Engine coolant temperature remains below normal operating temperatures during vehicle travel (Thermostat).
P1282	Fuel Pump Relay Control Circuit	An open or shorted condition detected in the fuel pump relay control circuit.
P1283	Idle Select Signal Invalid	ECM or fuel injection pump module internal fault condition detected.
P1284 (M)	Fuel Injection Pump Battery Voltage Out-Of-Range	Fuel injection pump module internal fault condition detected. Engine power will be derated.
P1285 (M)	Fuel Injection Pump Controller Always On	Fuel injection pump module relay circuit failure detected. Engine power will be derated.
P1286	Accelerator Position Sensor (APPS) Supply Voltage Too High	High voltage detected at APPS.
P1287	Fuel Injection Pump Controller Supply Voltage Low	ECM or fuel injection pump module internal fault condition detected. Engine power will be derated.
P1288	Intake Manifold Short Runner Solenoid Circuit	An open or shorted condition detected in the short runner tuning valve circuit.
P1289	Manifold Tune Valve Solenoid Circuit	An open or shorted condition detected in the manifold tuning valve solenoid control circuit.
P1290	CNG Fuel System Pressure Too High	Compressed natural gas system pressure above normal operating range.
P1291	No Temp Rise Seen From Intake Heaters	Energizing Heated Air Intake does not change intake air temperature sensor an acceptable amount.
P1291 (M)	No Temperature Rise Seen From Intake Air Heaters	Problem detected in intake manifold air heating system.
P1292	CNG Pressure Sensor Voltage Too High	Compressed natural gas pressure sensor reading above acceptable voltage.
P1293	CNG Pressure Sensor Voltage Too Low	Compressed natural gas pressure sensor reading below acceptable voltage.
P1294 (M)	Target Idle Not Reached	Target RPM not achieved during drive idle condition. Possible vacuum leak or IAC (AIS) lost steps.

## EMISSIONS CONTROL (Continued)

<b>(M) Malfunction Indicator Lamp (MIL) illuminated during engine operation if this DTC was recorded (depending if required by CARB and/or EPA). MIL is displayed as an engine icon on instrument panel.</b>		
<b>(G) Generator lamp illuminated</b>		
Generic Scan Tool P-Code	DRB Scan Tool Display	Brief Description of DTC
P1295 (M)	No 5 Volts to TP Sensor	Loss of a 5 volt feed to the Throttle Position Sensor has been detected.
P1295 (M)	Accelerator Position Sensor (APPS) Supply Voltage Too Low	APPS supply voltage input below the minimum acceptable voltage.
P1296	No 5 Volts to MAP Sensor	Loss of a 5 volt feed to the MAP Sensor has been detected.
P1297 (M)	No Change in MAP From Start To Run	No difference is recognized between the MAP reading at engine idle and the stored barometric pressure reading.
P1298	Lean Operation at Wide Open Throttle	A prolonged lean condition is detected during Wide Open Throttle
P1299	Vacuum Leak Found (IAC Fully Seated)	MAP Sensor signal does not correlate to Throttle Position Sensor signal. Possible vacuum leak.
P1388	Auto Shutdown Relay Control Circuit	An open or shorted condition detected in the ASD or CNG shutoff relay control ckt.
P1388	Auto Shutdown Relay Control Circuit	An open or shorted condition detected in the auto shutdown relay circuit.
P1389	No ASD Relay Output Voltage At PCM	No Z1 or Z2 voltage sensed when the auto shutdown relay is energized.
P1389 (M)	No ASD Relay Output Voltage at PCM	An open condition detected In the ASD relay output circuit.
P1390	Timing Belt Skipped 1 Tooth or More	Relationship between Cam and Crank signals not correct
P1391 (M)	Intermittent Loss of CMP or CKP	Loss of the Cam Position Sensor or Crank Position sensor has occurred. For PL 2.0L
P1398 (M)	Mis-Fire Adaptive Numerator at Limit	PCM is unable to learn the Crank Sensor's signal in preparation for Misfire Diagnostics. Probable defective Crank Sensor
P1399	Wait To Start Lamp Cicuit	An open or shorted condition detected in the Wait to Start Lamp circuit.
P1403	No 5V to EGR Sens	Loss of 5v feed to the EGR position sensor.
P01475	Aux 5 Volt Supply Voltage High	Sensor supply voltage for ECM sensors is too high.
P1476	Too Little Secondary Air	Insufficient flow of secondary air injection detected during aspirator test (was P0411)
P1477	Too Much Secondary Air	Excessive flow of secondary air injection detected during aspirator test (was P0411).
P1478	Battery Temp Sensor Volts Out of Limit	Internal temperature sensor input voltage out of an acceptable range.
P1479	Transmission Fan Relay Circuit	An open or shorted condition detected in the transmission fan relay circuit.
P1480	PCV Solenoid Circuit	An open or shorted condition detected in the PCV solenoid circuit.
P1481	EATX RPM Pulse Perf	EATX RPM pulse generator signal for misfire detection does not correlate with expected value.



## EMISSIONS CONTROL (Continued)

<b>(M)</b> Malfunction Indicator Lamp (MIL) illuminated during engine operation if this DTC was recorded (depending if required by CARB and/or EPA). MIL is displayed as an engine icon on instrument panel.		
<b>(G)</b> Generator lamp illuminated		
Generic Scan Tool P-Code	DRB Scan Tool Display	Brief Description of DTC
P1482	Catalyst Temperature Sensor Circuit Shorted Low	Catalyst temperature sensor circuit shorted low.
P1483	Catalyst Temperature Sensor Circuit Shorted High.	Catalyst temperature sensor circuit shorted high.
P1484	Catalytic Converter Overheat Detected	A catalyst overheat condition has been detected by the catalyst temperature sensor.
P1485	Air Injection Solenoid Circuit	An open or shorted condition detected in the air assist solenoid circuit.
P1486	Evap Leak Monitor Pinched Hose Found	LDP has detected a pinched hose in the evaporative hose system.
P1487	Hi Speed Rad Fan CTRL Relay Circuit	An open or shorted condition detected in the control circuit of the #2 high speed radiator fan control relay.
P1488	Auxiliary 5 Volt Supply Output Too Low	Auxiliary 5 volt sensor feed is sensed to be below an acceptable limit.
P1488	5 Volt Supply Voltage Low	Sensor supply voltage for ECM sensors is too low.
P1489	High Speed Fan CTRL Relay Circuit	An open or shorted condition detected in the control circuit of the high speed radiator fan control relay.
P1490	Low Speed Fan CTRL Relay Circuit	An open or shorted condition detected in control circuit of the low speed radiator fan control relay.
P1491	Rad Fan Control Relay Circuit	An open or shorted condition detected in the radiator fan control relay control circuit. This includes PWM solid state relays.
P1492	Ambient/Batt Temp Sen Volts Too High	External temperature sensor input above acceptable voltage.
P1492 (M)	Ambient/Batt Temp Sensor Volts Too High	Battery temperature sensor input voltage above an acceptable range.
P1493 (M)	Ambient/Batt Temp Sen Volts Too Low	External temperature sensor input below acceptable voltage.
P1493 (M)	Ambient/Batt Temp Sen Volts Too Low	Battery temperature sensor input voltage below an acceptable range.
P1494 (M)	Leak Detection Pump Sw or Mechanical Fault	Incorrect input state detected for the Leak Detection Pump (LDP) pressure switch.
P1495	Leak Detection Pump Solenoid Circuit	An open or shorted condition detected in the Leak Detection Pump (LDP) solenoid circuit.
P1496	5 Volt Supply, Output Too Low	5 volt sensor feed is sensed to be below an acceptable limit. ( less than 4v for 4 sec )
P1498	High Speed Rad Fan Ground CTRL Rly Circuit	An open or shorted condition detected in the control circuit of the #3 high speed radiator fan control relay.
P1499	Hydraulic cooling fan solenoid circuit	An open or shorted condition detected in the cooling fan control solenoid circuit.
P1594 (G)	Charging System Voltage Too High	Battery voltage sense input above target charging voltage during engine operation.
P1594	Charging System Voltage Too High	Battery voltage sense input above target charging voltage during engine operation.

## EMISSIONS CONTROL (Continued)

<b>(M) Malfunction Indicator Lamp (MIL) illuminated during engine operation if this DTC was recorded (depending if required by CARB and/or EPA). MIL is displayed as an engine icon on instrument panel.</b>		
<b>(G) Generator lamp illuminated</b>		
Generic Scan Tool P-Code	DRB Scan Tool Display	Brief Description of DTC
P1595	Speed Control Solenoid Circuits	An open or shorted condition detected in either of the speed control vacuum or vent solenoid control circuits.
P1595	Speed Control Solenoid Circuits	An open or shorted condition detected in the speed control vacuum or vent solenoid circuits.
P1596	Speed Control Switch Always High	Speed control switch input above maximum acceptable voltage.
P1597	Speed Control Switch Always Low	Speed control switch input below minimum acceptable voltage.
P1597	Speed Control Switch Always Low	Speed control switch input below the minimum acceptable voltage.
P1598	A/C Pressure Sensor Volts Too High	A/C pressure sensor input above maximum acceptable voltage.
P1598	A/C Sensor Input Hi	Problem detected in air conditioning electrical circuit.
P1599	A/C Pressure Sensor Volts Too Low	A/C pressure sensor input below minimum acceptable voltage.
P1599	A/C Sensor Input Lo	Problem detected in air conditioning electrical circuit.
P1680	Clutch Released Switch Circuit	Problem detected in clutch switch electrical circuit.
P1681	No I/P Cluster CCD/J1850 Messages Received	No CCD/J1850 messages received from the cluster control module.
P1682 (G)	Charging System Voltage Too Low	Battery voltage sense input below target charging voltage during engine operation and no significant change in voltage detected during active test of generator output circuit.
P1682	Charging System Voltage Too Low	Charging system output voltage low.
P1683	SPD CTRL PWR Relay; or S/C 12v Driver CKT	An open or shorted condition detected in the speed control servo power control circuit.
P1683	Spd ctrl pwr rly, or s/c 12v driver circuit	An open or shorted condition detected in the speed control servo power control circuit.
P1684	Batt Loss in 50 Star	The battery has been disconnected within the last 50 starts
P1685	SKIM Invalid Key	The engine controller has received an invalid key from the SKIM.
P1686	No SKIM BUS Messages Received	No CCD/J1850 messages received from the Smart Key Immobilizer Module (SKIM).
P1687	No MIC BUS Message	No CCD/J1850 messages received from the Mechanical Instrument Cluster (MIC) module.
P1688 (M)	Internal Fuel Injection Pump Controller Failure	Internal problem within the fuel injection pump. Low power, engine derated, or engine stops.
P1689 (M)	No Communication Between ECM and Injection Pump Module	Data link circuit failure between ECM and fuel injection pump. Low power, engine derated, or engine stops.
P1690 (M)	Fuel Injection Pump CKP Sensor Does Not Agree With ECM CKP Sensor	Problem in fuel sync signal. Possible injection pump timing problem. Low power, engine derated, or engine stops.

## EMISSIONS CONTROL (Continued)

<b>(M)</b> Malfunction Indicator Lamp (MIL) illuminated during engine operation if this DTC was recorded (depending if required by CARB and/or EPA). MIL is displayed as an engine icon on instrument panel.		
<b>(G)</b> Generator lamp illuminated		
Generic Scan Tool P-Code	DRB Scan Tool Display	Brief Description of DTC
P1691	Fuel Injection Pump Controller Calibration Error	Internal fuel injection pump failure. Low power, engine derated, or engine stops.
P1692	DTC Set In ECM	A "Companion DTC" was set in both the ECM and PCM.
P1693 (M)	DTC Detected in Companion Module	A fault has been generated in the companion engine control module.
P1693 (M)	DTC Detected in PCM/ECM or DTC Detected in ECM	A "Companion DTC" was set in both the ECM and PCM.
P1694	Fault In Companion Module	No CCD/J1850 messages received from the powertrain control module-Aisin transmission
P1694 (M)	No CCD Messages received from ECM	Bus communication failure to PCM.
P1695	No CCD/J1850 Message From Body Control Module	No CCD/J1850 messages received from the body control module.
P1696	PCM Failure EEPROM Write Denied	Unsuccessful attempt to write to an EEPROM location by the control module.
P1697	PCM Failure SRI Mile Not Stored	Unsuccessful attempt to update Service Reminder Indicator (SRI or EMR) mileage in the control module EEPROM.
P1698	No CCD/J1850 Message From TCM	No CCD/J1850 messages received from the electronic transmission control module (EATX) or the Aisin transmission controller.
P1698	No CCD Messages received from PCM	Bus communication failure to PCM. A "Companion DTC" was set in both the ECM and PCM.
P1719	Skip Shift Solenoid Circuit	An open or shorted condition detected in the transmission 2-3 gear lock-out solenoid control circuit.
P1740	TCC or OD Sol Perf	A rationality error has been detected in either the TCC solenoid or overdrive solenoid systems.
P1740 (M)	TCC OR O/D Solenoid Performance	Problem detected in transmission convertor clutch and/or overdrive circuits (diesel engine with 4-speed auto. trans. only).
P1756 (M)	GOV Press Not Equal to Target @ 15-20 PSI	The requested pressure and the actual pressure are not within a tolerance band for the Governor Control System which is used to regulate governor pressure to control shifts for 1st, 2nd, and 3rd gear. (Mid Pressure Malfunction)
P1756 (M)	Governor Pressure Not Equal to Target @ 15-20 PSI	Governor sensor input not between 10 and 25 psi when requested (4-speed auto. trans. only).
P1757	GOV Press Not Equal to Target @ 15-20 PSI	The requested pressure and the actual pressure are not within a tolerance band for the Governor Control System which is used to regulate governor pressure to control shifts for 1st, 2nd, and 3rd gear (Zero Pressure Malfunction)
P1757 (M)	Governor Pressure Above 3 PSI In Gear With 0 MPH	Governor pressure greater than 3 psi when requested to be 0 psi (4-speed auto. trans. only).

## EMISSIONS CONTROL (Continued)

<b>(M)</b> Malfunction Indicator Lamp (MIL) illuminated during engine operation if this DTC was recorded (depending if required by CARB and/or EPA). MIL is displayed as an engine icon on instrument panel.		
<b>(G)</b> Generator lamp illuminated		
Generic Scan Tool P-Code	DRB Scan Tool Display	Brief Description of DTC
P1762 (M)	Gov Press Sen Offset Volts Too Low or High	The Governor Pressure Sensor input is greater than a calibration limit or is less than a calibration limit for 3 consecutive park/neutral calibrations.
P1762 (M)	Governor Press Sen Offset Volts Too Low or High	Sensor input greater or less than calibration for 3 consecutive Neutral/Park occurrences (4-speed auto. trans. only).
P1763	Governor Pressure Sensor Volts Too Hi	The Governor Pressure Sensor input is above an acceptable voltage level.
P1763 (M)	Governor Pressure Sensor Volts Too HI	Voltage greater than 4.89 volts (4-speed auto. trans. only).
P1764 (M)	Governor Pressure Sensor Volts Too Low	The Governor Pressure Sensor input is below an acceptable voltage level.
P1764 (M)	Governor Pressure Sensor Volts Too Low	Voltage less than .10 volts (4-speed auto. trans. only).
P1765 (M)	Trans 12 Volt Supply Relay CTRL Circuit	An open or shorted condition is detected in the Transmission Relay control circuit. This relay supplies power to the TCC
P1765 (M)	Trans 12 Volt Supply Relay Ctrl Circuit	Current state of solenoid output port is different than expected (4-speed auto. trans. only).
P1899 (M)	P/N Switch Stuck in Park or in Gear	Incorrect input state detected for the Park/Neutral switch.
P1899 (M)	P/N Switch Stuck in Park or in Gear	Incorrect input state detected for the Park/Neutral switch (3 or 4-speed auto. trans. only).

**DESCRIPTION - TASK MANAGER**

The PCM is responsible for efficiently coordinating the operation of all the emissions-related components. The PCM is also responsible for determining if the diagnostic systems are operating properly. The software designed to carry out these responsibilities is called the 'Task Manager'.

**DESCRIPTION - MONITORED SYSTEMS**

There are new electronic circuit monitors that check fuel, emission, engine and ignition performance. These monitors use information from various sensor circuits to indicate the overall operation of the fuel, engine, ignition and emission systems and thus the emissions performance of the vehicle.

The fuel, engine, ignition and emission systems monitors do not indicate a specific component problem. They do indicate that there is an implied problem within one of the systems and that a specific problem must be diagnosed.

If any of these monitors detect a problem affecting vehicle emissions, the Malfunction Indicator Lamp (MIL) will be illuminated. These monitors generate

Diagnostic Trouble Codes that can be displayed with the MIL or a scan tool.

The following is a list of the system monitors:

- Misfire Monitor
- Fuel System Monitor
- Oxygen Sensor Monitor
- Oxygen Sensor Heater Monitor
- Catalyst Monitor
- Leak Detection Pump Monitor (if equipped)

All these system monitors require two consecutive trips with the malfunction present to set a fault.

**Refer to the appropriate Powertrain Diagnostics Procedures manual for diagnostic procedures.**

The following is an operation and description of each system monitor:

**OXYGEN SENSOR (O2S) MONITOR**

Effective control of exhaust emissions is achieved by an oxygen feedback system. The most important element of the feedback system is the O2S. The O2S is located in the exhaust path. Once it reaches operating temperature 300° to 350°C (572° to 662°F), the sensor generates a voltage that is inversely propor-

## EMISSIONS CONTROL (Continued)

tional to the amount of oxygen in the exhaust. The information obtained by the sensor is used to calculate the fuel injector pulse width. This maintains a 14.7 to 1 Air Fuel (A/F) ratio. At this mixture ratio, the catalyst works best to remove hydrocarbons (HC), carbon monoxide (CO) and nitrogen oxide (NOx) from the exhaust.

The O<sub>2</sub>S is also the main sensing element for the Catalyst and Fuel Monitors.

The O<sub>2</sub>S can fail in any or all of the following manners:

- slow response rate
- reduced output voltage
- dynamic shift
- shorted or open circuits

Response rate is the time required for the sensor to switch from lean to rich once it is exposed to a richer than optimum A/F mixture or vice versa. As the sensor starts malfunctioning, it could take longer to detect the changes in the oxygen content of the exhaust gas.

The output voltage of the O<sub>2</sub>S ranges from 0 to 1 volt. A good sensor can easily generate any output voltage in this range as it is exposed to different concentrations of oxygen. To detect a shift in the A/F mixture (lean or rich), the output voltage has to change beyond a threshold value. A malfunctioning sensor could have difficulty changing beyond the threshold value.

### OXYGEN SENSOR HEATER MONITOR

If there is an oxygen sensor (O<sub>2</sub>S) shorted to voltage DTC, as well as a O<sub>2</sub>S heater DTC, the O<sub>2</sub>S fault MUST be repaired first. Before checking the O<sub>2</sub>S fault, verify that the heater circuit is operating correctly.

Effective control of exhaust emissions is achieved by an oxygen feedback system. The most important element of the feedback system is the O<sub>2</sub>S. The O<sub>2</sub>S is located in the exhaust path. Once it reaches operating temperature 300° to 350°C (572 ° to 662°F), the sensor generates a voltage that is inversely proportional to the amount of oxygen in the exhaust. The information obtained by the sensor is used to calculate the fuel injector pulse width. This maintains a 14.7 to 1 Air Fuel (A/F) ratio. At this mixture ratio, the catalyst works best to remove hydrocarbons (HC), carbon monoxide (CO) and nitrogen oxide (NOx) from the exhaust.

The voltage readings taken from the O<sub>2</sub>S sensor are very temperature sensitive. The readings are not accurate below 300°C. Heating of the O<sub>2</sub>S sensor is done to allow the engine controller to shift to closed loop control as soon as possible. The heating element used to heat the O<sub>2</sub>S sensor must be tested to ensure that it is heating the sensor properly.

The O<sub>2</sub>S sensor circuit is monitored for a drop in voltage. The sensor output is used to test the heater by isolating the effect of the heater element on the O<sub>2</sub>S sensor output voltage from the other effects.

### LEAK DETECTION PUMP MONITOR (IF EQUIPPED)

The leak detection assembly incorporates two primary functions: it must detect a leak in the evaporative system and seal the evaporative system so the leak detection test can be run.

The primary components within the assembly are: A three port solenoid that activates both of the functions listed above; a pump which contains a switch, two check valves and a spring/diaphragm, a canister vent valve (CVV) seal which contains a spring loaded vent seal valve.

Immediately after a cold start, between predetermined temperature thresholds limits, the three port solenoid is briefly energized. This initializes the pump by drawing air into the pump cavity and also closes the vent seal. During non test conditions the vent seal is held open by the pump diaphragm assembly which pushes it open at the full travel position. The vent seal will remain closed while the pump is cycling due to the reed switch triggering of the three port solenoid that prevents the diaphragm assembly from reaching full travel. After the brief initialization period, the solenoid is de-energized allowing atmospheric pressure to enter the pump cavity, thus permitting the spring to drive the diaphragm which forces air out of the pump cavity and into the vent system. When the solenoid is energized and de energized, the cycle is repeated creating flow in typical diaphragm pump fashion. The pump is controlled in 2 modes:

**Pump Mode:** The pump is cycled at a fixed rate to achieve a rapid pressure build in order to shorten the overall test length.

**Test Mode:** The solenoid is energized with a fixed duration pulse. Subsequent fixed pulses occur when the diaphragm reaches the Switch closure point.

The spring in the pump is set so that the system will achieve an equalized pressure of about 7.5" H<sub>2</sub>O. The cycle rate of pump strokes is quite rapid as the system begins to pump up to this pressure. As the pressure increases, the cycle rate starts to drop off. If there is no leak in the system, the pump would eventually stop pumping at the equalized pressure. If there is a leak, it will continue to pump at a rate representative of the flow characteristic of the size of the leak. From this information we can determine if the leak is larger than the required detection limit (currently set at .040" orifice by CARB). If a leak is revealed during the leak test portion of the test, the test is terminated at the end of the test mode and no further system checks will be performed.



## EMISSIONS CONTROL (Continued)

After passing the leak detection phase of the test, system pressure is maintained by turning on the LDP's solenoid until the purge system is activated. Purge activation in effect creates a leak. The cycle rate is again interrogated and when it increases due to the flow through the purge system, the leak check portion of the diagnostic is complete.

The canister vent valve will unseal the system after completion of the test sequence as the pump diaphragm assembly moves to the full travel position.

Evaporative system functionality will be verified by using the stricter evap purge flow monitor. At an appropriate warm idle the LDP will be energized to seal the canister vent. The purge flow will be clocked up from some small value in an attempt to see a shift in the O<sub>2</sub> control system. If fuel vapor, indicated by a shift in the O<sub>2</sub> control, is present the test is passed. If not, it is assumed that the purge system is not functioning in some respect. The LDP is again turned off and the test is ended.

### MISFIRE MONITOR

Excessive engine misfire results in increased catalyst temperature and causes an increase in HC emissions. Severe misfires could cause catalyst damage. To prevent catalytic convertor damage, the PCM monitors engine misfire.

The Powertrain Control Module (PCM) monitors for misfire during most engine operating conditions (positive torque) by looking at changes in the crankshaft speed. If a misfire occurs the speed of the crankshaft will vary more than normal.

### FUEL SYSTEM MONITOR

To comply with clean air regulations, vehicles are equipped with catalytic converters. These converters reduce the emission of hydrocarbons, oxides of nitrogen and carbon monoxide. The catalyst works best when the Air Fuel (A/F) ratio is at or near the optimum of 14.7 to 1.

The PCM is programmed to maintain the optimum air/fuel ratio of 14.7 to 1. This is done by making short term corrections in the fuel injector pulse width based on the O<sub>2</sub>S sensor output. The programmed memory acts as a self calibration tool that the engine controller uses to compensate for variations in engine specifications, sensor tolerances and engine fatigue over the life span of the engine. By monitoring the actual fuel-air ratio with the O<sub>2</sub>S sensor (short term) and multiplying that with the program long-term (adaptive) memory and comparing that to the limit, it can be determined whether it will pass an emissions test. If a malfunction occurs such that the PCM cannot maintain the optimum A/F ratio, then the MIL will be illuminated.

### CATALYST MONITOR

To comply with clean air regulations, vehicles are equipped with catalytic converters. These converters reduce the emission of hydrocarbons, oxides of nitrogen and carbon monoxide.

Normal vehicle miles or engine misfire can cause a catalyst to decay. A meltdown of the ceramic core can cause a reduction of the exhaust passage. This can increase vehicle emissions and deteriorate engine performance, driveability and fuel economy.

The catalyst monitor uses dual oxygen sensors (O<sub>2</sub>S's) to monitor the efficiency of the converter. The dual O<sub>2</sub>S's sensor strategy is based on the fact that as a catalyst deteriorates, its oxygen storage capacity and its efficiency are both reduced. By monitoring the oxygen storage capacity of a catalyst, its efficiency can be indirectly calculated. The upstream O<sub>2</sub>S is used to detect the amount of oxygen in the exhaust gas before the gas enters the catalytic converter. The PCM calculates the A/F mixture from the output of the O<sub>2</sub>S. A low voltage indicates high oxygen content (lean mixture). A high voltage indicates a low content of oxygen (rich mixture).

When the upstream O<sub>2</sub>S detects a lean condition, there is an abundance of oxygen in the exhaust gas. A functioning converter would store this oxygen so it can use it for the oxidation of HC and CO. As the converter absorbs the oxygen, there will be a lack of oxygen downstream of the converter. The output of the downstream O<sub>2</sub>S will indicate limited activity in this condition.

As the converter loses the ability to store oxygen, the condition can be detected from the behavior of the downstream O<sub>2</sub>S. When the efficiency drops, no chemical reaction takes place. This means the concentration of oxygen will be the same downstream as upstream. The output voltage of the downstream O<sub>2</sub>S copies the voltage of the upstream sensor. The only difference is a time lag (seen by the PCM) between the switching of the O<sub>2</sub>S's.

To monitor the system, the number of lean-to-rich switches of upstream and downstream O<sub>2</sub>S's is counted. The ratio of downstream switches to upstream switches is used to determine whether the catalyst is operating properly. An effective catalyst will have fewer downstream switches than it has upstream switches i.e., a ratio closer to zero. For a totally ineffective catalyst, this ratio will be one-to-one, indicating that no oxidation occurs in the device.

The system must be monitored so that when catalyst efficiency deteriorates and exhaust emissions increase to over the legal limit, the MIL will be illuminated.

## EMISSIONS CONTROL (Continued)

**DESCRIPTION - TRIP DEFINITION**

The term "Trip" has different meanings depending on what the circumstances are. If the MIL (Malfunction Indicator Lamp) is OFF, a Trip is defined as when the Oxygen Sensor Monitor and the Catalyst Monitor have been completed in the same drive cycle.

When any Emission DTC is set, the MIL on the dash is turned ON. When the MIL is ON, it takes 3 good trips to turn the MIL OFF. In this case, it depends on what type of DTC is set to know what a "Trip" is.

For the Fuel Monitor or Mis-Fire Monitor (continuous monitor), the vehicle must be operated in the "Similar Condition Window" for a specified amount of time to be considered a Good Trip.

If a Non-Continuous OBDII Monitor fails twice in a row and turns ON the MIL, re-running that monitor which previously failed, on the next start-up and passing the monitor, is considered to be a Good Trip. These will include the following:

- Oxygen Sensor
- Catalyst Monitor
- Purge Flow Monitor
- Leak Detection Pump Monitor (if equipped)
- EGR Monitor (if equipped)
- Oxygen Sensor Heater Monitor

If any other Emission DTC is set (not an OBDII Monitor), a Good Trip is considered to be when the Oxygen Sensor Monitor and Catalyst Monitor have been completed; or 2 Minutes of engine run time if the Oxygen Sensor Monitor or Catalyst Monitor have been stopped from running.

It can take up to 2 Failures in a row to turn on the MIL. After the MIL is ON, it takes 3 Good Trips to turn the MIL OFF. After the MIL is OFF, the PCM will self-erase the DTC after 40 Warm-up cycles. A Warm-up cycle is counted when the ECT (Engine Coolant Temperature Sensor) has crossed 160°F and has risen by at least 40°F since the engine has been started.

**DESCRIPTION - COMPONENT MONITORS - GAS ENGINES**

There are several components that will affect vehicle emissions if they malfunction. If one of these components malfunctions the Malfunction Indicator Lamp (MIL) will illuminate.

Some of the component monitors are checking for proper operation of the part. Electrically operated components now have input (rationality) and output (functionality) checks. Previously, a component like the Throttle Position sensor (TPS) was checked by the PCM for an open or shorted circuit. If one of these conditions occurred, a DTC was set. Now there is a check to ensure that the component is working. This is done by watching for a TPS indication of a

greater or lesser throttle opening than MAP and engine rpm indicate. In the case of the TPS, if engine vacuum is high and engine rpm is 1600 or greater, and the TPS indicates a large throttle opening, a DTC will be set. The same applies to low vacuum if the TPS indicates a small throttle opening.

All open/short circuit checks, or any component that has an associated limp-in, will set a fault after 1 trip with the malfunction present. Components without an associated limp-in will take two trips to illuminate the MIL.

**DESCRIPTION - COMPONENT MONITORS - DIESEL ENGINES**

There are several electrical components that will affect vehicle emissions if they malfunction. If one of these components is malfunctioning, a Diagnostic Trouble Code (DTC) will be set by either the Powertrain Control Module (PCM) or the Engine Control Module (ECM). The Malfunction Indicator Lamp (MIL) will then be illuminated when the engine is running.

These electrically operated components have input (rationality) and output (functionality) checks. A check is done by one or more components to check the operation of another component.

**Example:** The Intake Manifold Air Temperature (IAT) sensor is used to monitor intake manifold air temperature over a period of time after a cold start. If the temperature has not risen to a certain specification during a specified time, a Diagnostic Trouble Code (DTC) will be set for a problem in the manifold air heater system.

All open/short circuit checks, or any component that has an associated limp-in will set a DTC and trigger the MIL after 1 trip with the malfunction present. Components without an associated limp-in will take two trips to illuminate the MIL.

**OPERATION - GAS ENGINES**

The Powertrain Control Module (PCM) monitors many different circuits in the fuel injection, ignition, emission and engine systems. If the PCM senses a problem with a monitored circuit often enough to indicate an actual problem, it stores a Diagnostic Trouble Code (DTC) in the PCM's memory. If the problem is repaired or ceases to exist, the PCM cancels the code after 40 warm-up cycles. Diagnostic trouble codes that affect vehicle emissions illuminate the Malfunction Indicator Lamp (MIL). The MIL is displayed as an engine icon (graphic) on the instrument panel. Refer to Malfunction Indicator Lamp in this section.

Certain criteria must be met before the PCM stores a DTC in memory. The criteria may be a spe-

## EMISSIONS CONTROL (Continued)

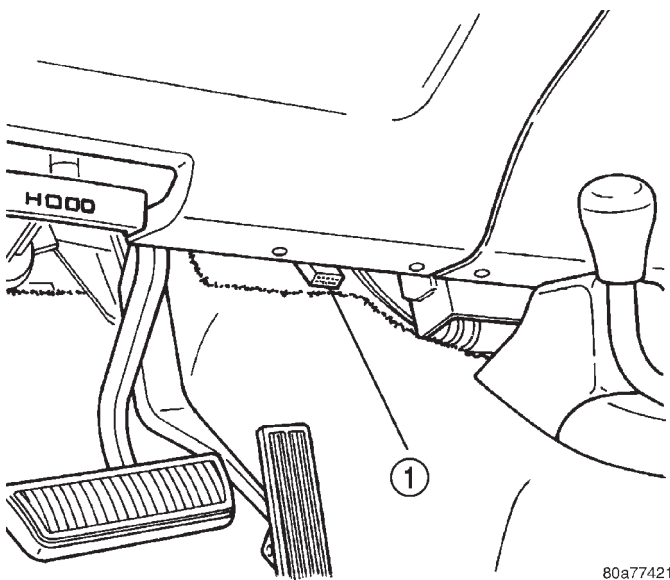
cific range of engine RPM, engine temperature, and/or input voltage to the PCM.

The PCM might not store a DTC for a monitored circuit even though a malfunction has occurred. This may happen because one of the DTC criteria for the circuit has not been met. **For example**, assume the diagnostic trouble code criteria requires the PCM to monitor the circuit only when the engine operates between 750 and 2000 RPM. Suppose the sensor's output circuit shorts to ground when engine operates above 2400 RPM (resulting in 0 volt input to the PCM). Because the condition happens at an engine speed above the maximum threshold (2000 rpm), the PCM will not store a DTC.

There are several operating conditions for which the PCM monitors and sets DTC's. Refer to Monitored Systems, Components, and Non-Monitored Circuits in this section.

Technicians must retrieve stored DTC's by connecting the DRB scan tool (or an equivalent scan tool) to the 16-way data link connector (Fig. 3).

**NOTE: Various diagnostic procedures may actually cause a diagnostic monitor to set a DTC. For instance, pulling a spark plug wire to perform a spark test may set the misfire code. When a repair is completed and verified, connect the DRB scan tool to the 16-way data link connector to erase all DTC's and extinguish the MIL.**



**Fig. 3 16-WAY DATA LINK CONNECTOR**

1 - DATA LINK CONNECTOR

## OPERATION - DIESEL

The PCM and ECM monitor many different circuits in the powertrain system. If the ECM or PCM senses a problem with a monitored circuit often

enough to indicate an actual problem, it stores a Diagnostic Trouble Code (DTC) in the ECM's or PCM's memory. With certain DTC's, if the problem is repaired or ceases to exist, the ECM or PCM cancels the code after 40 warm-up cycles. Certain other DTC's may be cancelled after 1 or 2 good "trips". Refer to Trip Definition. DTC's that affect vehicle emissions illuminate the Malfunction Indicator Lamp (MIL). The MIL is displayed as an engine icon (graphic) on the instrument panel. Refer to Malfunction Indicator Lamp.

Certain DTC's will set a "companion DTC" in the opposite control module. This means that after repair, the DTC must be erased from **both** modules.

Certain criteria must be met before the ECM or PCM will store a DTC in memory. The criteria may be a specific range of engine RPM, throttle opening, engine temperature or input voltage.

The ECM or PCM might not store a DTC for a monitored circuit even though a malfunction has occurred. This may happen because one of the DTC criteria for the circuit has not been met. **For example**, assume the DTC criteria requires the ECM to monitor the circuit only when the engine operates between 750 and 2000 RPM. Suppose the sensor's output circuit shorts to ground when engine operates above 2400 RPM (resulting in 0 volt input to the ECM). Because the condition happens at an engine speed above the maximum threshold (2000 rpm), the ECM will not store a DTC.

There are several operating conditions for which the ECM and PCM monitors and sets DTC's. Refer to Monitored Systems, Components, and Non-Monitored Circuits.

Technicians must retrieve stored DTC's by connecting the DRB scan tool (or an equivalent scan tool) to the 16-way data link connector (Fig. 3). Refer to the Diagnostic Trouble Code chart (list). **Remember that DTC's are the results of a system or circuit failure, but do not directly identify the failed component or components.**

Various diagnostic procedures may actually cause a diagnostic monitor to set a DTC. For instance, disconnecting a relay or removing an electrical connector while the engine is running. When a repair is completed and verified, connect the DRB scan tool to the 16-way data link connector to erase all ECM and PCM DTC's and extinguish the MIL.

## OPERATION - TASK MANAGER

The Task Manager determines which tests happen when and which functions occur when. Many of the diagnostic steps required by OBD II must be performed under specific operating conditions. The Task Manager software organizes and prioritizes the diagnostic procedures. The job of the Task Manager is to



## EMISSIONS CONTROL (Continued)

determine if conditions are appropriate for tests to be run, monitor the parameters for a trip for each test, and record the results of the test. Following are the responsibilities of the Task Manager software:

- Test Sequence
- MIL Illumination
- Diagnostic Trouble Codes (DTCs)
- Trip Indicator
- Freeze Frame Data Storage
- Similar Conditions Window

### Test Sequence

In many instances, emissions systems must fail diagnostic tests more than once before the PCM illuminates the MIL. These tests are known as 'two trip monitors.' Other tests that turn the MIL lamp on after a single failure are known as 'one trip monitors.' A trip is defined as 'start the vehicle and operate it to meet the criteria necessary to run the given monitor.'

Many of the diagnostic tests must be performed under certain operating conditions. However, there are times when tests cannot be run because another test is in progress (conflict), another test has failed (pending) or the Task Manager has set a fault that may cause a failure of the test (suspend).

- Pending

Under some situations the Task Manager will not run a monitor if the MIL is illuminated and a fault is stored from another monitor. In these situations, the Task Manager postpones monitors **pending** resolution of the original fault. The Task Manager does not run the test until the problem is remedied.

For example, when the MIL is illuminated for an Oxygen Sensor fault, the Task Manager does not run the Catalyst Monitor until the Oxygen Sensor fault is remedied. Since the Catalyst Monitor is based on signals from the Oxygen Sensor, running the test would produce inaccurate results.

- Conflict

There are situations when the Task Manager does not run a test if another monitor is in progress. In these situations, the effects of another monitor running could result in an erroneous failure. If this **conflict** is present, the monitor is not run until the conflicting condition passes. Most likely the monitor will run later after the conflicting monitor has passed.

For example, if the Fuel System Monitor is in progress, the Task Manager does not run the EGR Monitor. Since both tests monitor changes in air/fuel ratio and adaptive fuel compensation, the monitors will conflict with each other.

- Suspend

Occasionally the Task Manager may not allow a two trip fault to mature. The Task Manager will **sus-**

**pend** the maturing of a fault if a condition exists that may induce an erroneous failure. This prevents illuminating the MIL for the wrong fault and allows more precise diagnosis.

For example, if the PCM is storing a one trip fault for the Oxygen Sensor and the EGR monitor, the Task Manager may still run the EGR Monitor but will suspend the results until the Oxygen Sensor Monitor either passes or fails. At that point the Task Manager can determine if the EGR system is actually failing or if an Oxygen Sensor is failing.

### MIL Illumination

The PCM Task Manager carries out the illumination of the MIL. The Task Manager triggers MIL illumination upon test failure, depending on monitor failure criteria.

The Task Manager Screen shows both a Requested MIL state and an Actual MIL state. When the MIL is illuminated upon completion of a test for a third trip, the Requested MIL state changes to OFF. However, the MIL remains illuminated until the next key cycle. (On some vehicles, the MIL will actually turn OFF during the third key cycle) During the key cycle for the third good trip, the Requested MIL state is OFF, while the Actual MIL state is ON. After the next key cycle, the MIL is not illuminated and both MIL states read OFF.

### Diagnostic Trouble Codes (DTCs)

With OBD II, different DTC faults have different priorities according to regulations. As a result, the priorities determine MIL illumination and DTC erasure. DTCs are entered according to individual priority. DTCs with a higher priority overwrite lower priority DTCs.

#### Priorities

- Priority 0 — Non-emissions related trouble codes
- Priority 1 — One trip failure of a two trip fault for non-fuel system and non-misfire.
- Priority 2 — One trip failure of a two trip fault for fuel system (rich/lean) or misfire.
- Priority 3 — Two trip failure for a non-fuel system and non-misfire or matured one trip comprehensive component fault.
- Priority 4 — Two trip failure or matured fault for fuel system (rich/lean) and misfire or one trip catalyst damaging misfire.

Non-emissions related failures have no priority. One trip failures of two trip faults have low priority. Two trip failures or matured faults have higher priority. One and two trip failures of fuel system and misfire monitor take precedence over non-fuel system and non-misfire failures.

## EMISSIONS CONTROL (Continued)

**DTC Self Erasure**

With one trip components or systems, the MIL is illuminated upon test failure and DTCs are stored.

Two trip monitors are components requiring failure in two consecutive trips for MIL illumination. Upon failure of the first test, the Task Manager enters a maturing code. If the component fails the test for a second time the code matures and a DTC is set.

After three good trips the MIL is extinguished and the Task Manager automatically switches the trip counter to a warm-up cycle counter. DTCs are automatically erased following 40 warm-up cycles if the component does not fail again.

For misfire and fuel system monitors, the component must pass the test under a Similar Conditions Window in order to record a good trip. A Similar Conditions Window is when engine RPM is within  $\pm 375$  RPM and load is within  $\pm 10\%$  of when the fault occurred.

**NOTE:** It is important to understand that a component does not have to fail under a similar window of operation to mature. It must pass the test under a Similar Conditions Window when it failed to record a Good Trip for DTC erasure for misfire and fuel system monitors.

DTCs can be erased anytime with a DRB III. Erasing the DTC with the DRB III erases all OBD II information. The DRB III automatically displays a warning that erasing the DTC will also erase all OBD II monitor data. This includes all counter information for warm-up cycles, trips and Freeze Frame.

**Trip Indicator**

The **Trip** is essential for running monitors and extinguishing the MIL. In OBD II terms, a trip is a set of vehicle operating conditions that must be met for a specific monitor to run. All trips begin with a key cycle.

**Good Trip**

The Good Trip counters are as follows:

- Specific Good Trip
- Fuel System Good Trip
- Misfire Good Trip
- Alternate Good Trip (appears as a Global Good Trip on DRB III)
  - Comprehensive Components
  - Major Monitor
  - Warm-Up Cycles

**Specific Good Trip**

The term Good Trip has different meanings depending on the circumstances:

- If the MIL is OFF, a trip is defined as when the Oxygen Sensor Monitor and the Catalyst Monitor have been completed in the same drive cycle.

- If the MIL is ON and a DTC was set by the Fuel Monitor or Misfire Monitor (both continuous monitors), the vehicle must be operated in the Similar Condition Window for a specified amount of time.

- If the MIL is ON and a DTC was set by a Task Manager commanded once-per-trip monitor (such as the Oxygen Sensor Monitor, Catalyst Monitor, Purge Flow Monitor, Leak Detection Pump Monitor, EGR Monitor or Oxygen Sensor Heater Monitor), a good trip is when the monitor is passed on the next start-up.

- If the MIL is ON and any other emissions DTC was set (not an OBD II monitor), a good trip occurs when the Oxygen Sensor Monitor and Catalyst Monitor have been completed, or two minutes of engine run time if the Oxygen Sensor Monitor and Catalyst Monitor have been stopped from running.

**Fuel System Good Trip**

To count a good trip (three required) and turn off the MIL, the following conditions must occur:

- Engine in closed loop
- Operating in Similar Conditions Window
- Short Term multiplied by Long Term less than threshold

- Less than threshold for a predetermined time

If all of the previous criteria are met, the PCM will count a good trip (three required) and turn off the MIL.

**Misfire Good Trip**

If the following conditions are met the PCM will count one good trip (three required) in order to turn off the MIL:

- Operating in Similar Condition Window
- 1000 engine revolutions with no misfire

**Warm-Up Cycles**

Once the MIL has been extinguished by the Good Trip Counter, the PCM automatically switches to a Warm-Up Cycle Counter that can be viewed on the DRB III. Warm-Up Cycles are used to erase DTCs and Freeze Frames. Forty Warm-Up cycles must occur in order for the PCM to self-erase a DTC and Freeze Frame. A Warm-Up Cycle is defined as follows:

- Engine coolant temperature must start below and rise above 160° F
- Engine coolant temperature must rise by 40° F
- No further faults occur

**Freeze Frame Data Storage**

Once a failure occurs, the Task Manager records several engine operating conditions and stores it in a Freeze Frame. The Freeze Frame is considered one frame of information taken by an on-board data recorder. When a fault occurs, the PCM stores the input data from various sensors so that technicians



## EMISSIONS CONTROL (Continued)

can determine under what vehicle operating conditions the failure occurred.

The data stored in Freeze Frame is usually recorded when a system fails the first time for two trip faults. Freeze Frame data will only be overwritten by a different fault with a higher priority.

**CAUTION:** Erasing DTCs, either with the DRB III or by disconnecting the battery, also clears all Freeze Frame data.

### Similar Conditions Window

The Similar Conditions Window displays information about engine operation during a monitor. Absolute MAP (engine load) and Engine RPM are stored in this window when a failure occurs. There are two different Similar conditions Windows: Fuel System and Misfire.

#### FUEL SYSTEM

- **Fuel System Similar Conditions Window** — An indicator that 'Absolute MAP When Fuel Sys Fail' and 'RPM When Fuel Sys Failed' are all in the same range when the failure occurred. Indicated by switching from 'NO' to 'YES'.

- **Absolute MAP When Fuel Sys Fail** — The stored MAP reading at the time of failure. Informs the user at what engine load the failure occurred.

- **Absolute MAP** — A live reading of engine load to aid the user in accessing the Similar Conditions Window.

- **RPM When Fuel Sys Fail** — The stored RPM reading at the time of failure. Informs the user at what engine RPM the failure occurred.

- **Engine RPM** — A live reading of engine RPM to aid the user in accessing the Similar Conditions Window.

- **Adaptive Memory Factor** — The PCM utilizes both Short Term Compensation and Long Term Adaptive to calculate the Adaptive Memory Factor for total fuel correction.

- **Upstream O<sub>2</sub>S Volts** — A live reading of the Oxygen Sensor to indicate its performance. For example, stuck lean, stuck rich, etc.

- **SCW Time in Window (Similar Conditions Window Time in Window)** — A timer used by the PCM that indicates that, after all Similar Conditions have been met, if there has been enough good engine running time in the SCW without failure detected. This timer is used to increment a Good Trip.

- **Fuel System Good Trip Counter** — A Trip Counter used to turn OFF the MIL for Fuel System DTCs. To increment a Fuel System Good Trip, the engine must be in the Similar Conditions Window, Adaptive Memory Factor must be less than calibrated threshold and the Adaptive Memory Factor

must stay below that threshold for a calibrated amount of time.

- **Test Done This Trip** — Indicates that the monitor has already been run and completed during the current trip.

#### MISFIRE

- **Same Misfire Warm-Up State** — Indicates if the misfire occurred when the engine was warmed up (above 160° F).

- **In Similar Misfire Window** — An indicator that 'Absolute MAP When Misfire Occurred' and 'RPM When Misfire Occurred' are all in the same range when the failure occurred. Indicated by switching from 'NO' to 'YES'.

- **Absolute MAP When Misfire Occurred** — The stored MAP reading at the time of failure. Informs the user at what engine load the failure occurred.

- **Absolute MAP** — A live reading of engine load to aid the user in accessing the Similar Conditions Window.

- **RPM When Misfire Occurred** — The stored RPM reading at the time of failure. Informs the user at what engine RPM the failure occurred.

- **Engine RPM** — A live reading of engine RPM to aid the user in accessing the Similar Conditions Window.

- **Adaptive Memory Factor** — The PCM utilizes both Short Term Compensation and Long Term Adaptive to calculate the Adaptive Memory Factor for total fuel correction.

- **200 Rev Counter** — Counts 0–100 720 degree cycles.

- **SCW Cat 200 Rev Counter** — Counts when in similar conditions.

- **SCW FTP 1000 Rev Counter** — Counts 0–4 when in similar conditions.

- **Misfire Good Trip Counter** — Counts up to three to turn OFF the MIL.

- **Misfire Data**— Data collected during test.

- **Test Done This Trip**— Indicates YES when the test is done.

### OPERATION - NON-MONITORED CIRCUITS - GAS ENGINES

The PCM does not monitor the following circuits, systems and conditions that could have malfunctions causing driveability problems. The PCM might not store diagnostic trouble codes for these conditions. However, problems with these systems may cause the PCM to store diagnostic trouble codes for other systems or components. **EXAMPLE:** a fuel pressure problem will not register a fault directly, but could cause a rich/lean condition or misfire. This could cause the PCM to store an oxygen sensor or misfire diagnostic trouble code

## EMISSIONS CONTROL (Continued)

**FUEL PRESSURE**

The fuel pressure regulator controls fuel system pressure. The PCM cannot detect a clogged fuel pump inlet filter, clogged in-line fuel filter, or a pinched fuel supply or return line. However, these could result in a rich or lean condition causing the PCM to store an oxygen sensor or fuel system diagnostic trouble code.

**SECONDARY IGNITION CIRCUIT**

The PCM cannot detect an inoperative ignition coil, fouled or worn spark plugs, ignition cross firing, or open spark plug cables.

**CYLINDER COMPRESSION**

The PCM cannot detect uneven, low, or high engine cylinder compression.

**EXHAUST SYSTEM**

The PCM cannot detect a plugged, restricted or leaking exhaust system, although it may set a fuel system fault.

**FUEL INJECTOR MECHANICAL MALFUNCTIONS**

The PCM cannot determine if a fuel injector is clogged, the needle is sticking or if the wrong injector is installed. However, these could result in a rich or lean condition causing the PCM to store a diagnostic trouble code for either misfire, an oxygen sensor, or the fuel system.

**EXCESSIVE OIL CONSUMPTION**

Although the PCM monitors engine exhaust oxygen content when the system is in closed loop, it cannot determine excessive oil consumption.

**THROTTLE BODY AIR FLOW**

The PCM cannot detect a clogged or restricted air cleaner inlet or filter element.

**VACUUM ASSIST**

The PCM cannot detect leaks or restrictions in the vacuum circuits of vacuum assisted engine control system devices. However, these could cause the PCM to store a MAP sensor diagnostic trouble code and cause a high idle condition.

**PCM SYSTEM GROUND**

The PCM cannot determine a poor system ground. However, one or more diagnostic trouble codes may be generated as a result of this condition. The module should be mounted to the body at all times, also during diagnostic.

**PCM CONNECTOR ENGAGEMENT**

The PCM may not be able to determine spread or damaged connector pins. However, it might store

diagnostic trouble codes as a result of spread connector pins.

**OPERATION - NON-MONITORED CIRCUITS - DIESEL**

The PCM and/or the ECM will not monitor certain malfunctioning circuits or components that could cause driveability problems. Also, a Diagnostic Trouble Code (DTC) might not be stored for these malfunctions. However, problems with these circuits or components may cause the PCM/ECM to store DTC's for other circuits or components. **EXAMPLES:** A cylinder with low compression will not set a DTC directly, but may cause an engine misfire. This in turn may cause the ECM to set a DTC for an engine misfire. Or, a dirty or plugged air filter will not set a DTC directly, but may cause lack of turbocharger boost. This in turn may cause the ECM to set a DTC for a boost pressure malfunction.

**FUEL PRESSURE**

Primary fuel pressure from the fuel tank to the fuel injection pump is supplied by the low-pressure fuel transfer pump. High-pressure to the fuel injectors is supplied by the fuel injection pump. The ECM cannot detect actual fuel pressure, a clogged fuel filter, clogged fuel screen, or a pinched fuel supply or return line. However, a DTC may be set due to an engine misfire.

**CYLINDER COMPRESSION**

The ECM cannot detect uneven, low, or high engine cylinder compression. However, these could result in a possible misfire which may set a DTC.

**EXHAUST SYSTEM**

The ECM cannot detect a plugged, restricted or leaking exhaust system. However, DTC's may be set for engine misfire, high intake manifold temperature, high engine coolant temperature, turbocharger overboost or turbocharger underboost.

**FUEL INJECTOR MECHANICAL MALFUNCTIONS**

The ECM cannot determine if a fuel injector is clogged, the needle is sticking or if the wrong injector is installed. However, these could result in a possible misfire which may set a DTC.

**EXCESSIVE OIL CONSUMPTION**

The ECM cannot determine excessive oil consumption. However, if excess oil consumption is high enough, it could result in a possible engine misfire which may set a DTC.

## EMISSIONS CONTROL (Continued)

**AIR FLOW**

The ECM cannot detect a clogged, restricted or dirty air filter element, or a restriction in the air inlet system. However, these could result in a possible misfire which may set a DTC.

**AIR PRESSURE LEAKS**

The ECM cannot detect leaks or restrictions in the air intake system. However, these could cause the ECM to store a Manifold Air Pressure (MAP) sensor DTC (boost pressure problem detected).

**PCM/ECM SYSTEM GROUNDS**

The PCM/ECM cannot directly determine poor system grounds. However, one or more DTC's may be generated as a result of poor grounds.

**PCM/ECM CONNECTOR ENGAGEMENT**

The PCM/ECM may not be able to determine spread, damaged or corroded connector pins. However, it might store DTC's as a result of spread connector pins (circuits that are open).

# AIR INJECTION

## TABLE OF CONTENTS

	page		page
<b>AIR INJECTION</b>		<b>AIR PUMP FILTER</b>	
DESCRIPTION.....	25	REMOVAL.....	29
OPERATION.....	27	INSTALLATION.....	29
SPECIFICATIONS.....	28	<b>ONE WAY CHECK VALVE</b>	
<b>AIR INJECTION PUMP</b>		DESCRIPTION.....	30
DESCRIPTION.....	28	OPERATION.....	30
OPERATION.....	28	DIAGNOSIS AND TESTING.....	30
DIAGNOSIS AND TESTING.....	28	TESTING ONE-WAY CHECK VALVE.....	30
AIR INJECTION PUMP.....	28	REMOVAL.....	30
REMOVAL.....	29	INSTALLATION.....	30
INSTALLATION.....	29		

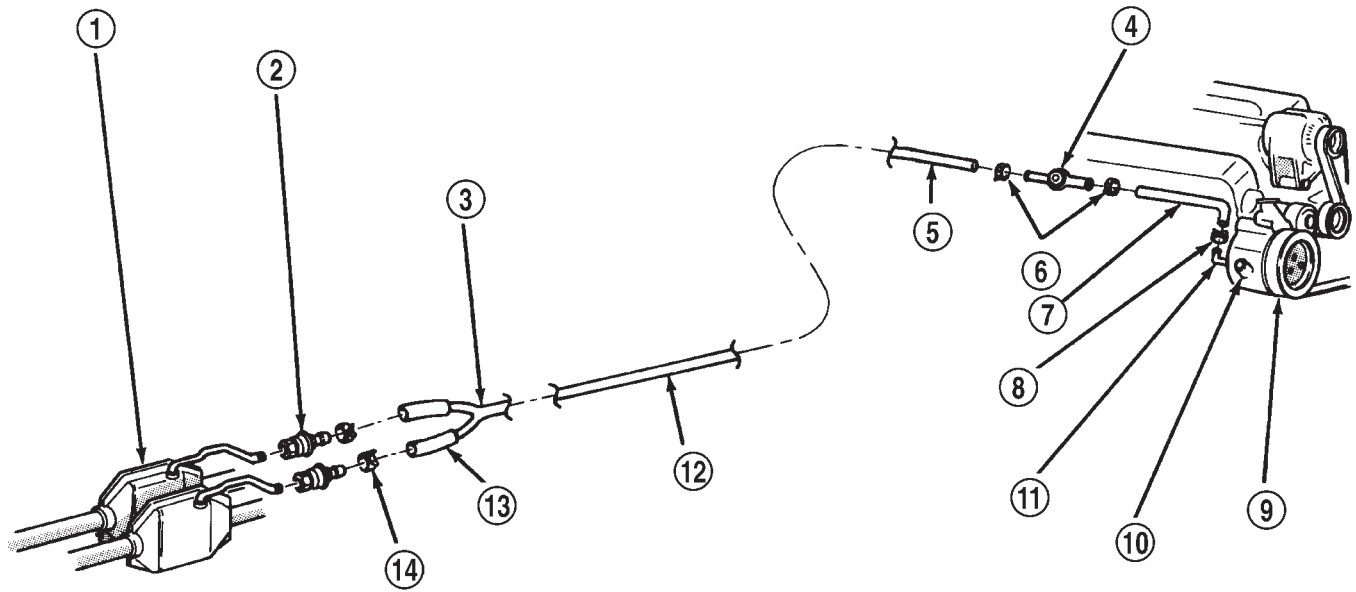
## AIR INJECTION

### DESCRIPTION - AIR INJECTION SYSTEM

The air injection system (Fig. 1), (Fig. 2) or (Fig. 3) is used on 5.9L V-8 and 8.0L V-10 heavy duty cycle (HDC) gas powered engines only. The air injection system consists of:

- A belt-driven air injection (AIR) pump
- Two air pressure relief valves
- Rubber connecting air injection hoses with clamps
- Metal connecting air tubes
- Two one-way check valves
- A replaceable injection pump air filter (8.0L V-10 engine only)

AIR INJECTION (Continued)



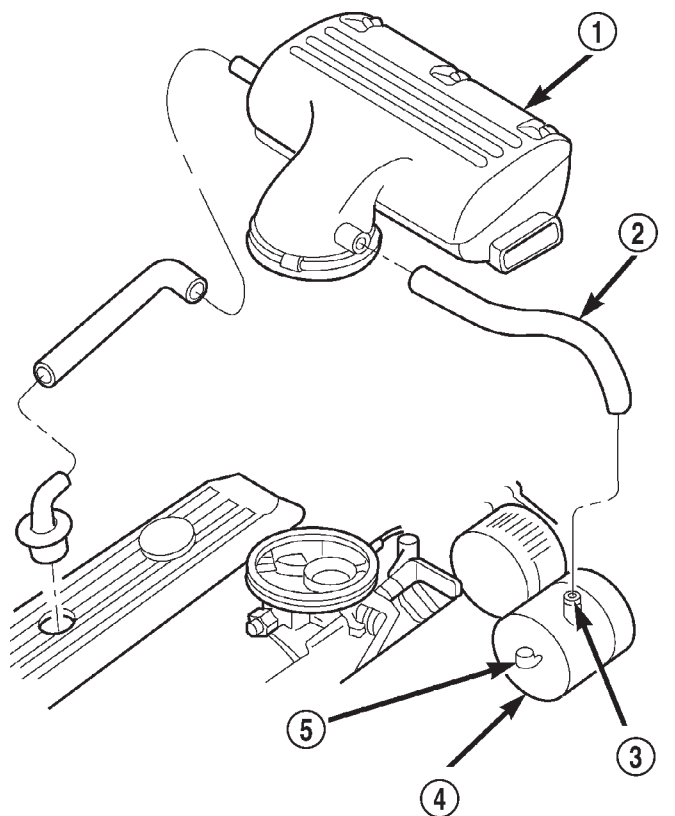
J9425-17

**Fig. 1 Air Injection System Components—Typical**

- |                              |                            |
|------------------------------|----------------------------|
| 1 - CATALYTIC CONVERTORS (2) | 9 - AIR INJECTION PUMP     |
| 2 - ONE-WAY CHECK VALVES (2) | 10 - INLET AIR FITTING     |
| 3 - "Y" CONNECTOR            | 11 - OUTLET AIR FITTING    |
| 4 - PRESSURE RELIEF VALVE    | 12 - METAL CONNECTING TUBE |
| 5 - HOSE                     | 13 - HOSE                  |
| 6 - CLAMPS                   | 14 - CLAMPS                |
| 7 - HOSE                     |                            |
| 8 - CLAMP                    |                            |



## AIR INJECTION (Continued)



**Fig. 2 Air Inlet for Air Pump—5.9L HDC Engine**

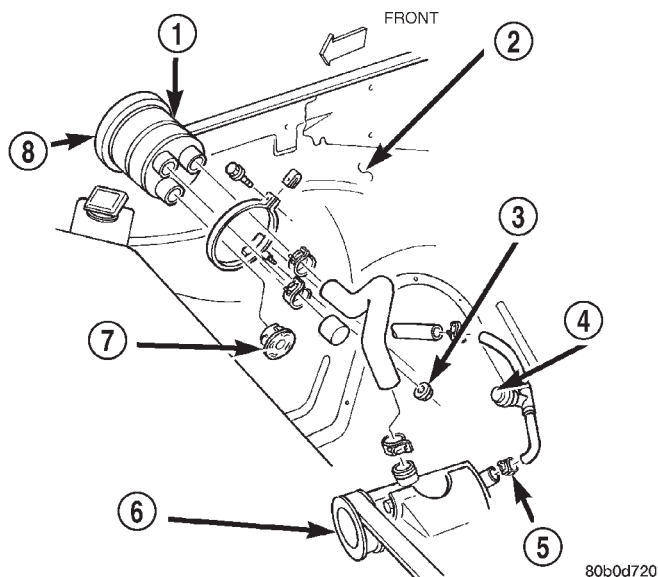
- 1 - AIR FILTER HOUSING
- 2 - AIR INLET TUBE
- 3 - INLET AIR FITTING
- 4 - AIR INJECTION PUMP
- 5 - OUTLET AIR FITTING

## OPERATION - AIR INJECTION SYSTEM

The air injection system adds a controlled amount of air to the exhaust gases aiding oxidation of hydrocarbons and carbon monoxide in the exhaust stream. The system does not interfere with the ability of the EGR system (if used) to control nitrous oxide (NO<sub>x</sub>) emissions.

**5.9L HDC ENGINE:** Air is drawn into the pump through a rubber tube that is connected to a fitting on the air cleaner housing (Fig. 2).

**8.0L V-10 ENGINE:** Air is drawn into the pump through a rubber tube that is connected to a fitting on the air injection pump filter housing (Fig. 3). Air is drawn into the filter housing from the front of the vehicle with rubber tube. This tube is used as a



**Fig. 3 Air Inlet and Air Pump Air**

- 1 - INJECTION PUMP AIR FILTER HOUSING
- 2 - R. F. INNER FENDER
- 3 - FILTER HOUSING MOUNTING NUT
- 4 - PRESSURE RELIEF VALVE
- 5 - HOSE CLAMPS
- 6 - AIR INJECTION PUMP
- 7 - AIR INLET REDUCER
- 8 - LID

silencer to help prevent air intake noise at the opening to the pump filter housing. An air filter is located within the air pump filter housing (Fig. 3).

Air is then compressed by the air injector pump. It is expelled from the pump and routed into a rubber tube where it reaches the air pressure relief valve (Fig. 1). Pressure relief holes in the relief valve will prevent excess downstream pressure. If excess downstream pressure occurs at the relief valve, it will be vented into the atmosphere.

Air is then routed (Fig. 1) from the relief valve, through a tube, down to a "Y" connector, through the two one-way check valves and injected at both of the catalytic convertors (referred to as downstream).

The two one-way check valves (Fig. 1) protect the hoses, air pump and injection tubes from hot exhaust gases backing up into the system. Air is allowed to flow through these valves in one direction only (towards the catalytic convertors).

Downstream air flow assists the oxidation process in the catalyst, but does not interfere with EGR operation (if EGR system is used).

## AIR INJECTION (Continued)

## SPECIFICATIONS

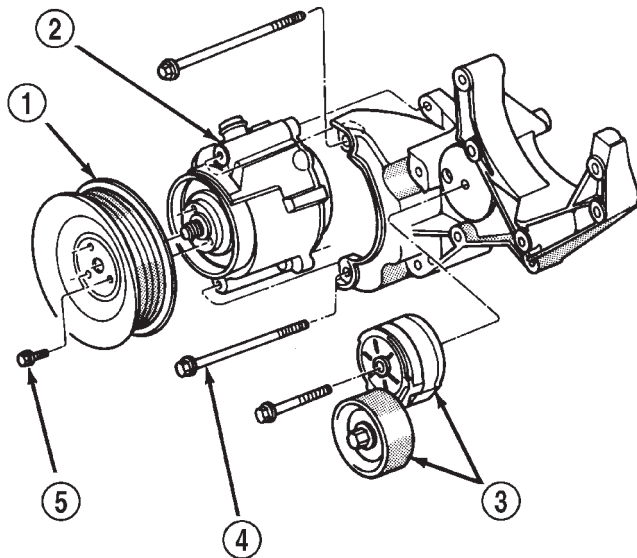
## TORQUE - AIR INJECTION SYSTEM

DESCRIPTION	N-m	Ft. Lbs.	In. Lbs.
Air Pump Filter Housing Nut	1	8	
Air Pump Mounting Bolts	40	30	
Air Pump Pulley Mounting Bolts	11		105
One-Way Check Valve to Catalyst Tube	33	25	

## AIR INJECTION PUMP

## DESCRIPTION

The air pump is mounted on the front of the engine and driven by a belt connected to the crankshaft pulley (Fig. 4).



J9425-15

**Fig. 4 Air Injection Pump Mounting—Typical**

- 1 - PUMP PULLEY
- 2 - AIR PUMP
- 3 - AUTOMATIC BELT TENSIONER
- 4 - PUMP MOUNTING BOLTS (2)
- 5 - PULLEY BOLTS

## DIAGNOSIS AND TESTING - AIR INJECTION PUMP

**The air injection system and air injection pump is not completely noiseless.** Under normal conditions, noise rises in pitch as engine speed increases. To determine if excessive noise is fault of air injection system, disconnect accessory drive belt and temporarily operate engine. **Do not allow engine to overheat when operating without drive belt.**

**CAUTION:** Do not attempt to lubricate the air injection pump. Oil in the pump will cause rapid deterioration and failure.

## OPERATION

Refer to Air Injection System Description and Operation for information.

## AIR INJECTION PUMP (Continued)

EXCESSIVE BELT NOISE	1. Loose belt or defective automatic belt tensioner. 2. Seized pump.	1. Refer to Cooling System. 2. Replace pump.
EXCESSIVE PUMP NOISE CHIRPING	1. Insufficient break-in.	1. Recheck for noise after 1600 km (1,000 miles) of operation.
EXCESSIVE PUMP NOISE CHIRPING, RUMBLING, OR KNOCKING	1. Leak in hose. 2. Loose hose. 3. Hose touching other engine parts. 4. Relief valve inoperative. 5. Check valve inoperative. 6. Pump mounting fasteners loose. 7. Pump failure.	1. Locate source of leak using soap solution and correct. 2. Reassemble and replace or tighten hose clamp. 3. Adjust hose position. 4. Replace relief valve. 5. Replace check valve. 6. Tighten mounting screws as specified. 7. Replace pump.
NO AIR SUPPLY. ACCELERATE ENGINE TO 1500 RPM AND OBSERVE AIR FLOW FROM HOSES. IF FLOW INCREASES AS RPM'S INCREASE, PUMP IS FUNCTIONING NORMALLY. IF NOT, CHECK POSSIBLE CAUSE.	1. Loose drive belt. 2. Leaks in supply hose. 3. Leak at fitting(s). 4. Check valve inoperative. 5. Plugged inlet air filter (8.0L).	1. Refer to Cooling System. 2. Locate leak and repair or replace as required. 3. Tighten and replace clamps. 4. Replace check valve. 5. Replace filter

**REMOVAL**

The air injection pump does not have any internal serviceable parts.

(1) Disconnect both of the hoses (tubes) at the air injection pump.

(2) Loosen, but do not remove at this time, the three air pump pulley mounting bolts (Fig. 4).

(3) Relax the automatic belt tensioner and remove the engine accessory drive belt. Refer to Cooling System. See Belt Removal/Installation.

(4) Remove the three air pump pulley bolts and remove pulley from pump.

(5) Remove the two air pump mounting bolts (Fig. 4) and remove pump from mounting bracket.

**INSTALLATION**

(1) Position air injection pump to mounting bracket.

(2) Install two pump mounting bolts to mounting bracket. Tighten bolts to 40 N·m (30 ft. lbs.) torque.

(3) Install pump pulley and three mounting bolts. Tighten bolts finger tight.

(4) Relax tension from automatic belt tensioner and install drive belt. Refer to Cooling System. See Belt Removal/Installation.

(5) Tighten pump pulley bolts to 11 N·m (105 in. lbs.) torque.

(6) Install hoses and hose clamps at pump.

**AIR PUMP FILTER****REMOVAL**

The air filter for the air injection pump is located inside a housing located in right-front side of engine compartment (Fig. 3). A rubber hose connects the filter housing to air injection pump. The filter is used with 8.0L V-10 engines only.

(1) Remove rubber tubes at filter housing.

(2) Remove filter housing mounting nut and remove housing.

(3) Remove lid from filter housing (snaps off).

(4) Remove filter from housing.

**INSTALLATION**

The air filter for the air injection pump is located inside a housing located in right-front side of engine compartment (Fig. 3). A rubber hose connects the filter housing to air injection pump. The filter is used with 8.0L V-10 engines only.

## AIR PUMP FILTER (Continued)

- (1) Clean inside of housing and lid before installing new filter.
- (2) Install filter into housing.
- (3) Install lid to filter housing (snaps on).
- (4) Position filter housing to fender.
- (5) Install mounting nut and tighten to 11 N·m (8 ft. lbs.) torque.
- (6) Install rubber tubes and cap at filter housing.

## ONE WAY CHECK VALVE

## DESCRIPTION

**For air injection systems:** A pair of one-way check valves is used with the air injection system. The check valves (Fig. 1) are located on each of the air injection downstream tubes.

## OPERATION

Each one-way check valve has a one-way diaphragm which prevents hot exhaust gases from backing up into the air injection hose and air injection pump. The check valve will protect the system if the air injection pump belt fails, an air hose ruptures or exhaust system pressure becomes abnormally high.

## DIAGNOSIS AND TESTING - ONE-WAY CHECK VALVE

The one-way check valves are not repairable. To determine condition of valve, remove the rubber air tube from the inlet side of each check valve. Start the engine. If exhaust gas is escaping through the inlet side of check valve, it must be replaced.

## REMOVAL

- (1) Remove the hose clamp at inlet side of valve.
- (2) Remove hose from valve.
- (3) Remove valve from catalyst tube (unscrew). **To prevent damage to catalyst tube, a backup wrench must be used on the tube.**

## INSTALLATION

- (1) Install valve to catalyst tube. Tighten to 33 N·m (25 ft. lbs.) torque.
- (2) Install hose and hose clamp to valve.

# EVAPORATIVE EMISSIONS

## TABLE OF CONTENTS

	page		page
<b>EVAPORATIVE EMISSIONS</b>		<b>REMOVAL</b> . . . . .	34
DESCRIPTION . . . . .	31	<b>INSTALLATION</b> . . . . .	34
SPECIFICATIONS . . . . .	31	<b>PCV FILTER</b>	
<b>CCV HOSE</b>		DESCRIPTION . . . . .	35
DESCRIPTION . . . . .	32	<b>PCV VALVE</b>	
OPERATION . . . . .	32	DESCRIPTION . . . . .	35
<b>CRANKCASE VENT HOSE</b>		OPERATION . . . . .	35
DESCRIPTION . . . . .	32	DIAGNOSIS AND TESTING . . . . .	36
<b>EVAP/PURGE SOLENOID</b>		PCV VALVE TEST - 3.9/5.2/5.9L ENGINE . . . . .	36
DESCRIPTION . . . . .	32	<b>VACUUM LINES</b>	
REMOVAL . . . . .	32	DIAGNOSIS AND TESTING . . . . .	37
INSTALLATION . . . . .	32	VACUUM SCHEMATICS . . . . .	37
<b>FUEL FILLER CAP</b>		<b>VAPOR CANISTER</b>	
DESCRIPTION . . . . .	33	DESCRIPTION . . . . .	37
OPERATION . . . . .	33	OPERATION . . . . .	37
REMOVAL . . . . .	33	REMOVAL . . . . .	37
<b>LEAK DETECTION PUMP</b>		INSTALLATION . . . . .	38
DESCRIPTION . . . . .	33		

## EVAPORATIVE EMISSIONS

### DESCRIPTION - EVAP SYSTEM

The evaporation control system prevents the emission of fuel tank vapors into the atmosphere. When fuel evaporates in the fuel tank, the vapors pass through vent hoses or tubes into the two charcoal filled evaporative canisters. The canisters temporarily hold the vapors. The Powertrain Control Module (PCM) allows intake manifold vacuum to draw vapors into the combustion chambers during certain operating conditions.

All 3.9L/5.2L/5.9L/8.0L gasoline powered engines use a duty cycle purge system. The PCM controls

vapor flow by operating the duty cycle EVAP purge solenoid. Refer to Duty Cycle EVAP Canister Purge Solenoid for additional information.

When equipped with certain emissions packages, a Leak Detection Pump (LDP) will be used as part of the evaporative system. This pump is used as part of OBD II requirements. Refer to Leak Detection Pump in this group for additional information.

**NOTE: The hoses used in this system are specially manufactured. If replacement becomes necessary, it is important to use only fuel resistant hose.**

## SPECIFICATIONS

### TORQUE - EVAP SYSTEM

DESCRIPTION	N-m	Ft. Lbs.	In. Lbs.
EVAP Canister Mounting Nuts	9		80
Leak Detection Pump Mounting Screws	1		11
Leak Detection Pump Filter Mounting Bolt	7		65

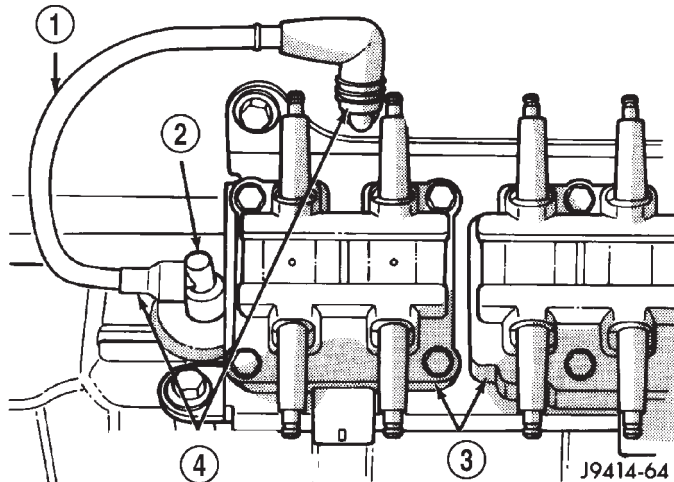


## CCV HOSE

### DESCRIPTION - 8.0L

The 8.0L V-10 engine is equipped with a Crankcase Ventilation (CCV) system. The CCV system performs the same function as a conventional PCV system, but does not use a vacuum controlled valve (PCV valve).

A molded vacuum tube connects manifold vacuum to the top of the right cylinder head (valve) cover. The vacuum tube connects to a fixed orifice fitting (Fig. 1) of a calibrated size 2.6 mm (0.10 inches).



**Fig. 1 Fixed Orifice Fitting—8.0L V-10 Engine—  
Typical**

- 1 - VACUUM TUBE
- 2 - FIXED ORIFICE FITTING
- 3 - COIL PACKS
- 4 - ORIFICE FITTING HOSE CONNECTIONS

### OPERATION - 8.0L

A molded vacuum tube connects manifold vacuum to the top of the right cylinder head (valve) cover. The vacuum tube connects to a fixed orifice fitting (Fig. 1) of a calibrated size 2.6 mm (0.10 inches). The fitting meters the amount of crankcase vapors drawn out of the engine. **The fixed orifice fitting is grey in color.** A similar fitting (but does not contain a fixed orifice) is used on the left cylinder head (valve) cover. This fitting is black in color. Do not interchange these two fittings.

When the engine is operating, fresh air enters the engine and mixes with crankcase vapors. Manifold vacuum draws the vapor/air mixture through the fixed orifice and into the intake manifold. The vapors are then consumed during engine combustion.

## CRANKCASE VENT HOSE

### OPERATION

The crankcase breather/filter is no longer used with the 3.9L, 5.2L or 5.9L engine.

## EVAP/PURGE SOLENOID

### DESCRIPTION

All 3.9L/5.2L/5.9L/8.0L gasoline powered engines use a duty cycle EVAP canister purge solenoid. The solenoid regulates the rate of vapor flow from the EVAP canister to the throttle body. The Powertrain Control Module (PCM) operates the solenoid.

During the cold start warm-up period and the hot start time delay, the PCM does not energize the solenoid. When de-energized, no vapors are purged. The PCM de-energizes the solenoid during open loop operation.

The engine enters closed loop operation after it reaches a specified temperature and the time delay ends. During closed loop operation, the PCM energizes and de-energizes the solenoid 5 or 10 times per second, depending upon operating conditions. The PCM varies the vapor flow rate by changing solenoid pulse width. Pulse width is the amount of time the solenoid energizes. The PCM adjusts solenoid pulse width based on engine operating condition.

### REMOVAL

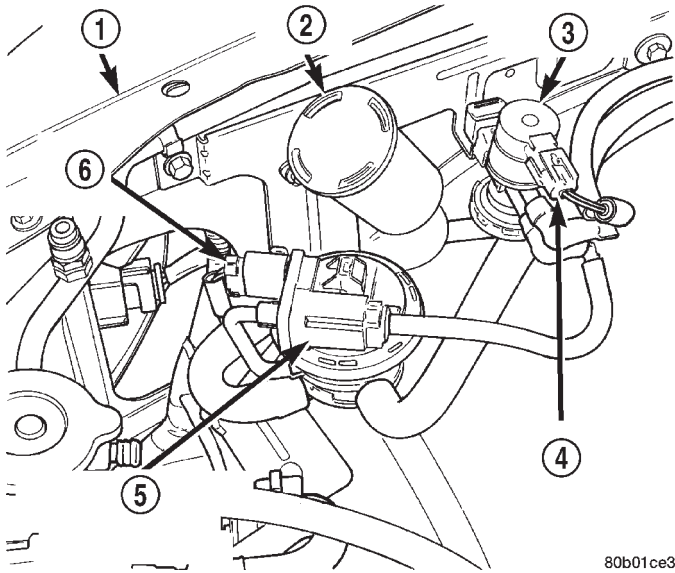
The duty cycle solenoid is attached to a bracket mounted to the right inner fender (Fig. 2).

- (1) Disconnect electrical wiring connector at solenoid (Fig. 2).
- (2) Disconnect vacuum harness at solenoid.
- (3) Remove solenoid from support bracket.

### INSTALLATION

- (1) Install solenoid assembly to support bracket.
- (2) Connect vacuum harness.
- (3) Connect wiring connector.

## EVAP/PURGE SOLENOID (Continued)



**Fig. 2 Duty Cycle EVAP Canister Purge Solenoid Location**

- 1 - RIGHT-FRONT FENDER
- 2 - LDP FILTER
- 3 - DUTY CYCLE SOLENOID
- 4 - ELEC. CONNec.
- 5 - LEAK DETECTION PUMP (LDP) (IF EQUIPPED)
- 6 - LDP ELEC. CONNec.

## FUEL FILLER CAP

### DESCRIPTION

The plastic fuel tank filler tube cap is threaded onto the end of the fuel fill tube. Certain models are equipped with a 1/4 turn cap.

### OPERATION

The loss of any fuel or vapor out of fuel filler tube is prevented by the use of a pressure-vacuum fuel fill cap. Relief valves inside the cap will release fuel tank pressure at predetermined pressures. Fuel tank vacuum will also be released at predetermined values. This cap must be replaced by a similar unit if replacement is necessary. This is in order for the system to remain effective.

**CAUTION:** Remove fill cap before servicing any fuel system component to relieve tank pressure. If equipped with a Leak Detection Pump (LDP), the cap must be tightened securely. If cap is left loose, a Diagnostic Trouble Code (DTC) may be set.

### REMOVAL/INSTALLATION

If replacement of the 1/4 turn fuel tank filler tube cap is necessary, it must be replaced with an identical cap to be sure of correct system operation.

**CAUTION:** Remove the fuel tank filler tube cap to relieve fuel tank pressure. The cap must be removed prior to disconnecting any fuel system component or before draining the fuel tank.

## LEAK DETECTION PUMP

### DESCRIPTION

The Leak Detection Pump (LDP) is used only with certain emission packages.

The LDP is a device used to detect a leak in the evaporative system.

The pump contains a 3 port solenoid, a pump that contains a switch, a spring loaded canister vent valve seal, 2 check valves and a spring/diaphragm.

Immediately after a cold start, engine temperature between 40°F and 86°F, the 3 port solenoid is briefly energized. This initializes the pump by drawing air into the pump cavity and also closes the vent seal. During non-test conditions, the vent seal is held open by the pump diaphragm assembly which pushes it open at the full travel position. The vent seal will remain closed while the pump is cycling. This is due to the operation of the 3 port solenoid which prevents the diaphragm assembly from reaching full travel. After the brief initialization period, the solenoid is de-energized, allowing atmospheric pressure to enter the pump cavity. This permits the spring to drive the diaphragm which forces air out of the pump cavity and into the vent system. When the solenoid is energized and de-energized, the cycle is repeated creating flow in typical diaphragm pump fashion. The pump is controlled in 2 modes:

**PUMP MODE:** The pump is cycled at a fixed rate to achieve a rapid pressure build in order to shorten the overall test time.

**TEST MODE:** The solenoid is energized with a fixed duration pulse. Subsequent fixed pulses occur when the diaphragm reaches the switch closure point.

The spring in the pump is set so that the system will achieve an equalized pressure of about 7.5 inches of water.

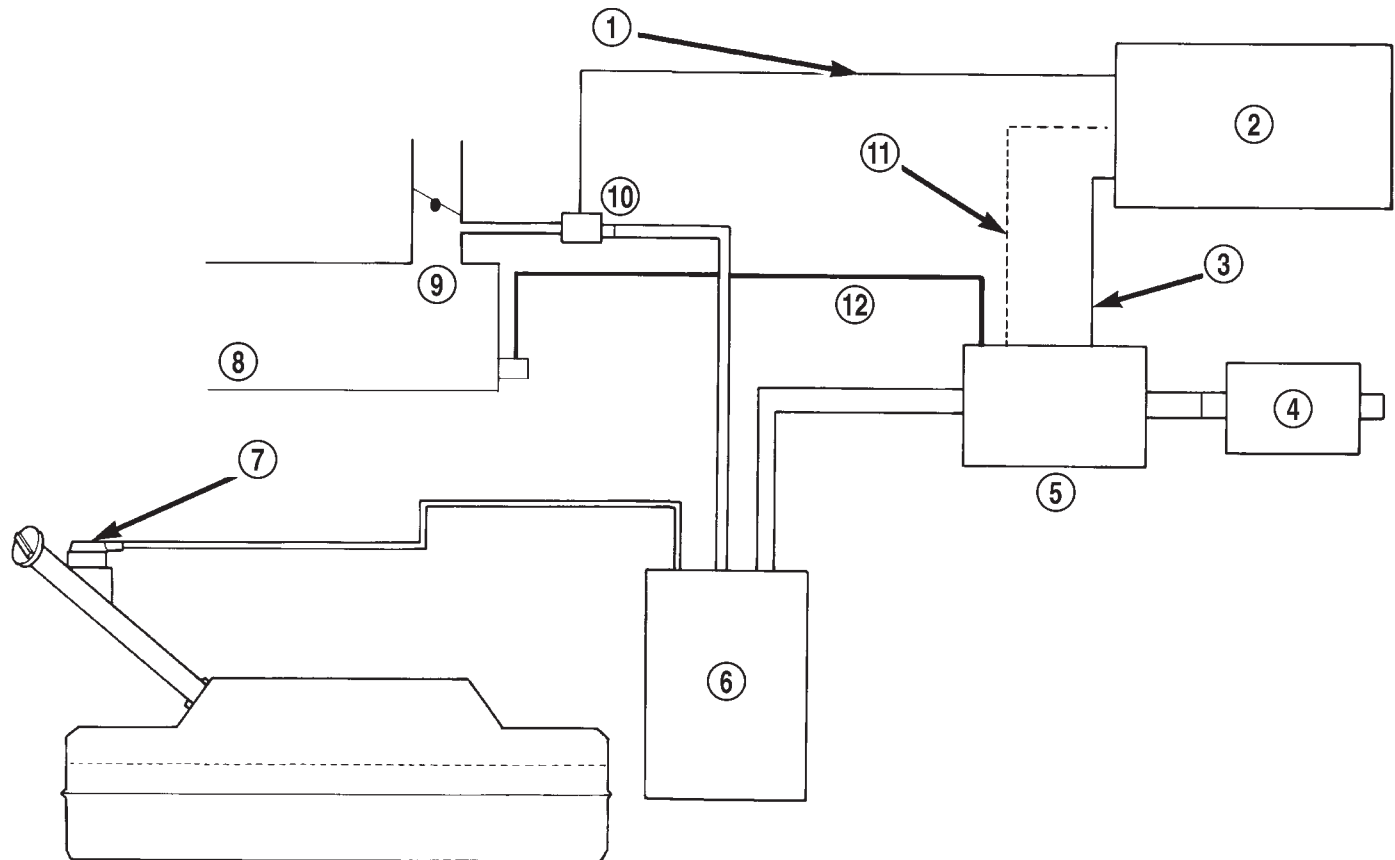
When the pump starts, the cycle rate is quite high. As the system becomes pressurized pump rate drops. If there is no leak the pump will quit. If there is a leak, the test is terminated at the end of the test mode.

If there is no leak, the purge monitor is run. If the cycle rate increases due to the flow through the purge system, the test is passed and the diagnostic is complete.

The canister vent valve will unseal the system after completion of the test sequence as the pump diaphragm assembly moves to the full travel position.

A typical system schematic is shown in (Fig. 3).

## LEAK DETECTION PUMP (Continued)



80004293

**Fig. 3 Evaporative System Monitor Schematic—Typical**

- |  |  |
|--|--|
| 1 - DUTY CYCLE PURGE SOLENOID (DCPS) DRIVER            | 7 - TANK ROLLOVER VALVE & VAPOR FLOW CONTROL ORIFICE |
| 2 - POWERTRAIN CONTROL MODULE (PCM)                    | 8 - INTAKE MANIFOLD                                  |
| 3 - 3-PORT SOLENOID DRIVER                             | 9 - THROTTLE BODY                                    |
| 4 - REMOTE FILTER                                      | 10 - DCPS  |
| 5 - COMBINED CANISTER VENT VALVE & LEAK DETECTION PUMP | 11 - SWITCH SIGNAL INPUT TO THE PCM                  |
| 6 - CANISTER   | 12 - ENGINE VACUUM LINE                              |

## REMOVAL

The LDP and LDP filter are attached to a bracket mounted to the right-inner fender (Fig. 2). The LDP and LDP filter are replaced (serviced) as one unit.

- (1) Carefully remove hose at LDP filter.
- (2) Remove LDP filter mounting bolt and remove from vehicle.
- (3) Carefully remove vapor/vacuum lines at LDP.
- (4) Disconnect electrical connector at LDP (Fig. 2).
- (5) Remove LDP mounting screws and remove LDP from vehicle.

## INSTALLATION

The LDP and LDP filter are attached to a bracket mounted to the right-inner fender (Fig. 2). The LDP and LDP filter are replaced (serviced) as one unit.

- (1) Install LDP to mounting bracket. Tighten screws to 1 N·m (11 in. lbs.) torque.

- (2) Install LDP filter to mounting bracket. Tighten bolt to 7 N·m (65 in. lbs.) torque.

- (3) Carefully install vapor/vacuum lines to LDP, and install hose to LDP filter. **The vapor/vacuum lines and hoses must be firmly connected. Check the vapor/vacuum lines at the LDP, LDP filter and EVAP canister purge solenoid for damage or leaks. If a leak is present, a Diagnostic Trouble Code (DTC) may be set.**

- (4) Connect electrical connector to LDP.

## PCV FILTER

### DESCRIPTION

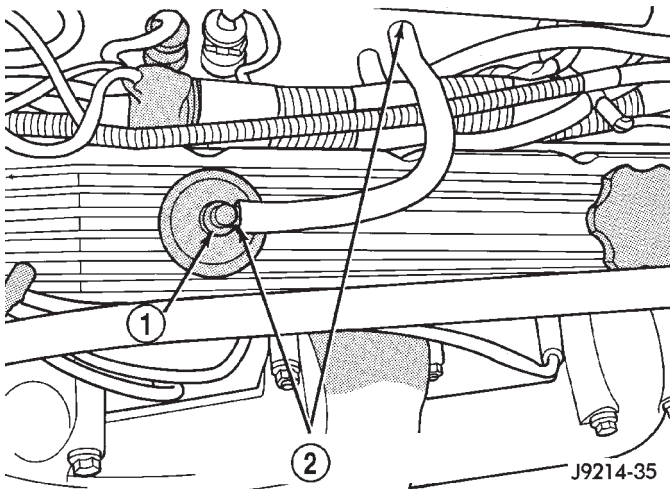
The crankcase breather/filter is no longer used with the 3.9L, 5.2L or 5.9L engine.

## PCV VALVE

### DESCRIPTION - V-6/V-8 ENGINES

All 3.9L V-6 and 5.2L/5.9L V-8 gas powered engines are equipped with a closed crankcase ventilation system and a positive crankcase ventilation (PCV) valve. The 8.0L V-10 engine is not equipped with a PCV valve. Refer to Crankcase Ventilation System—8.0L V-10 Engine for information.

This system consists of a PCV valve mounted on the cylinder head (valve) cover with a hose extending from the valve to the intake manifold (Fig. 4). Another hose connects the opposite cylinder head (valve) cover to the air cleaner housing to provide a source of clean air for the system. A separate crankcase breather/filter is not used.

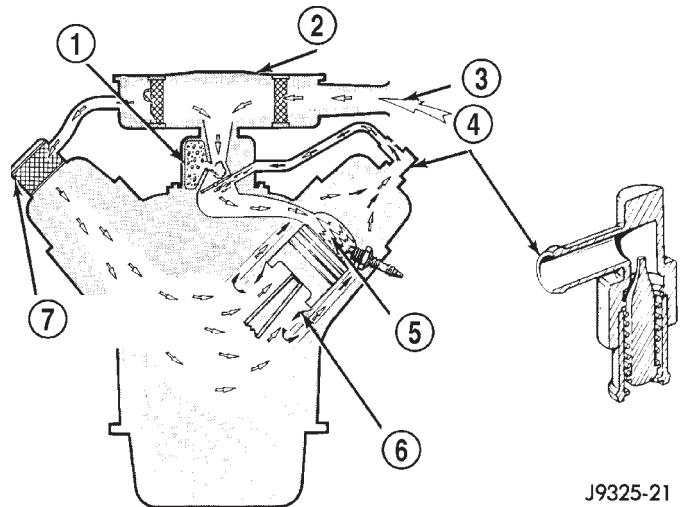


**Fig. 4 Typical PCV Valve/Hose (Non-California Shown)**

- 1 - PCV VALVE
- 2 - PCV VALVE HOSE CONNECTIONS

### OPERATION - V-6/V-8 ENGINES

The PCV system operates by engine intake manifold vacuum (Fig. 5). Filtered air is routed into the crankcase through the air cleaner hose. The metered air, along with crankcase vapors, are drawn through the PCV valve and into a passage in the intake manifold. The PCV system manages crankcase pressure and meters blow by gases to the intake system, reducing engine sludge formation.

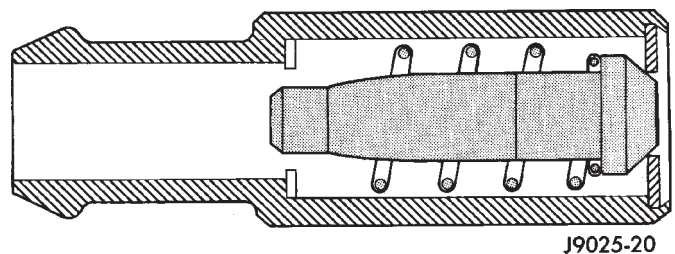


**Fig. 5 Typical Closed Crankcase Ventilation System**

- 1 - THROTTLE BODY
- 2 - AIR CLEANER
- 3 - AIR INTAKE
- 4 - PCV VALVE
- 5 - COMBUSTION CHAMBER
- 6 - BLOW-BY GASES
- 7 - CRANKCASE BREATHER/FILTER

The PCV valve contains a spring loaded plunger. This plunger meters the amount of crankcase vapors routed into the combustion chamber based on intake manifold vacuum.

When the engine is not operating or during an engine pop-back, the spring forces the plunger back against the seat (Fig 6). This will prevent vapors from flowing through the valve.



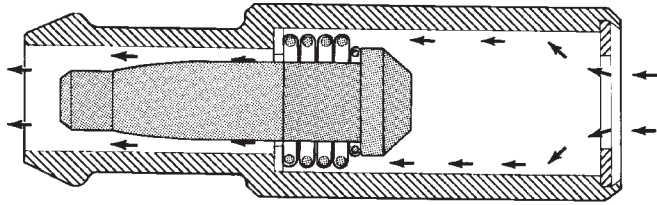
**Fig. 6 Engine Off or Engine Pop-Back—No Vapor Flow**

During periods of high manifold vacuum, such as idle or cruising speeds, vacuum is sufficient to completely compress spring. It will then pull the plunger to the top of the valve (Fig. 7). In this position there is minimal vapor flow through the valve.

During periods of moderate manifold vacuum, the plunger is only pulled part way back from inlet. This results in maximum vapor flow through the valve (Fig. 8).

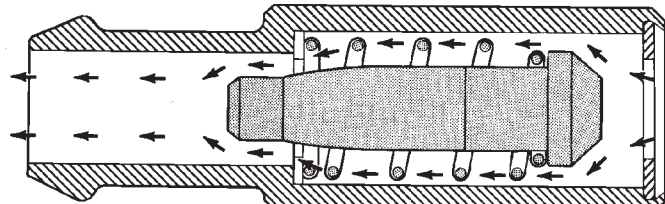


PCV VALVE (Continued)



J8925-14

**Fig. 7 High Intake Manifold Vacuum—Minimal Vapor Flow**

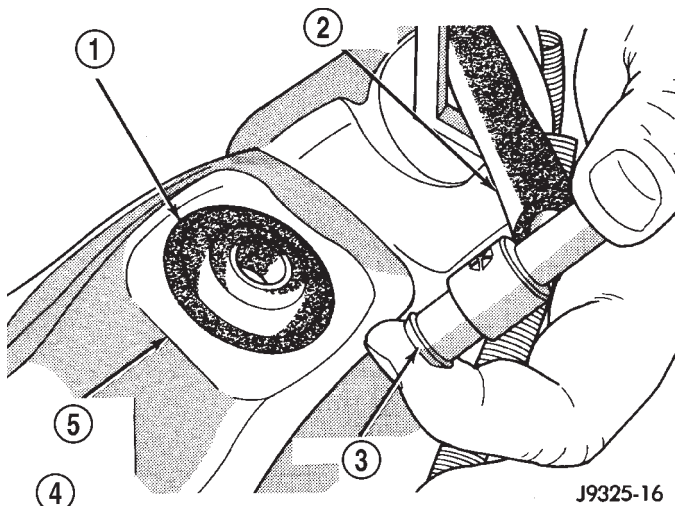


J8925-15

**Fig. 8 Moderate Intake Manifold Vacuum—Maximum Vapor Flow**

**DIAGNOSIS AND TESTING - PCV VALVE - V-6/V-8 ENGINES**

(1) With engine idling, remove the PCV valve from cylinder head (valve) cover. If the valve is not plugged, a hissing noise will be heard as air passes through the valve. Also, a strong vacuum should be felt at the valve inlet (Fig. 9).



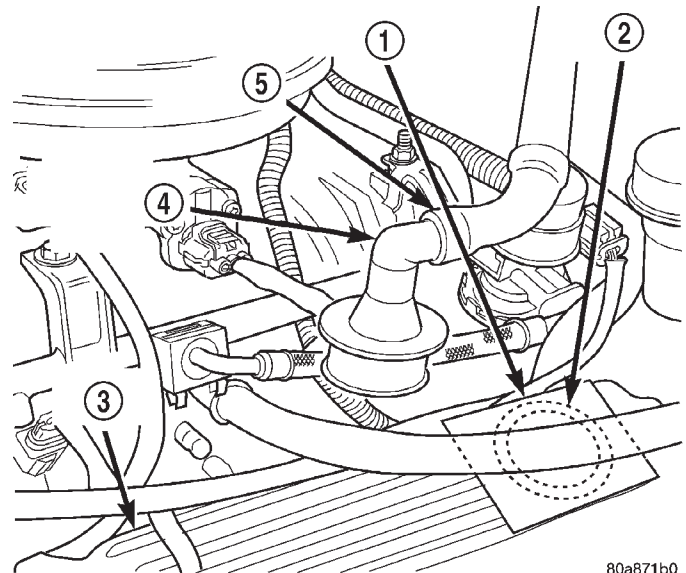
J9325-16

**Fig. 9 Vacuum Check at PCV**

- 1 - PCV VALVE GROMMET
- 2 - PCV HOSE
- 3 - PCV VALVE
- 4 - VACUUM MUST BE FELT AGAINST FINGER
- 5 - ENGINE VALVE COVER

(2) Return the PCV valve into the valve cover. Remove the fitting and air hose at the opposite valve cover. Loosely hold a piece of stiff paper, such as a

parts tag, over the opening (rubber grommet) at the valve cover (Fig. 10).



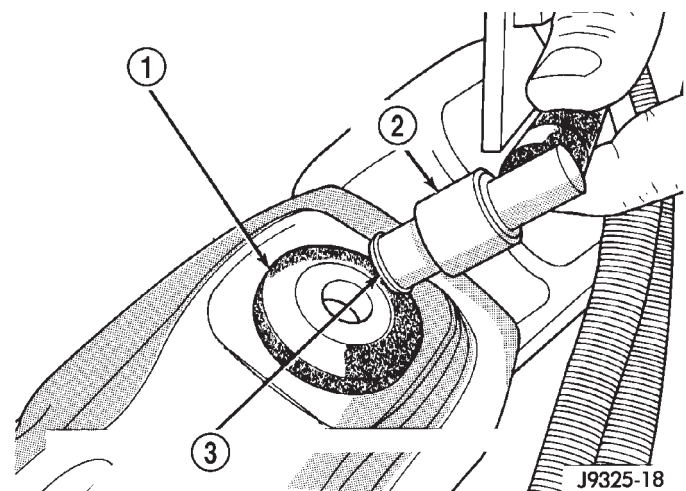
80a871b0

**Fig. 10 Vacuum Check at Valve Cover Opening**

- 1 - STIFF PAPER PLACED OVER RUBBER GROMMET
- 2 - RUBBER GROMMET
- 3 - VALVE COVER
- 4 - FITTING REMOVED FROM VALVE COVER
- 5 - AIR TUBE

(3) The paper should be drawn against the opening in the valve cover with noticeable force. This will be after allowing approximately one minute for crank-case pressure to reduce.

(4) Turn engine off and remove PCV valve from valve cover. The valve should rattle when shaken (Fig. 11).



J9325-18

**Fig. 11 Shake PCV**

- 1 - PCV VALVE GROMMET
- 2 - PCV VALVE
- 3 - PCV VALVE MUST RATTLE WHEN SHAKEN



## PCV VALVE (Continued)

(5) Replace the PCV valve and retest the system if it does not operate as described in the preceding tests. **Do not attempt to clean the old PCV valve.**

(6) If the paper is not held against the opening in valve cover after new valve is installed, the PCV valve hose may be restricted and must be replaced. The passage in the intake manifold must also be checked and cleaned.

(7) To clean the intake manifold fitting, turn a 1/4 inch drill (by hand) through the fitting to dislodge any solid particles. Blow out the fitting with shop air. If necessary, use a smaller drill to avoid removing any metal from the fitting.

## VACUUM LINES

## DIAGNOSIS AND TESTING - VACUUM SCHEMATICS

A vacuum schematic for emission related items can be found on the VECI label. Refer to Vehicle Emission Control Information (VECI) Label in this group for label location.

## VAPOR CANISTER

## DESCRIPTION

Two, maintenance free, EVAP canisters are used with all 3.9L/5.2L/5.9L/8.0L gasoline powered engines. Both canisters are mounted to a bracket located below rear of vehicle cab on outside of right frame rail (Fig. 12).

## OPERATION

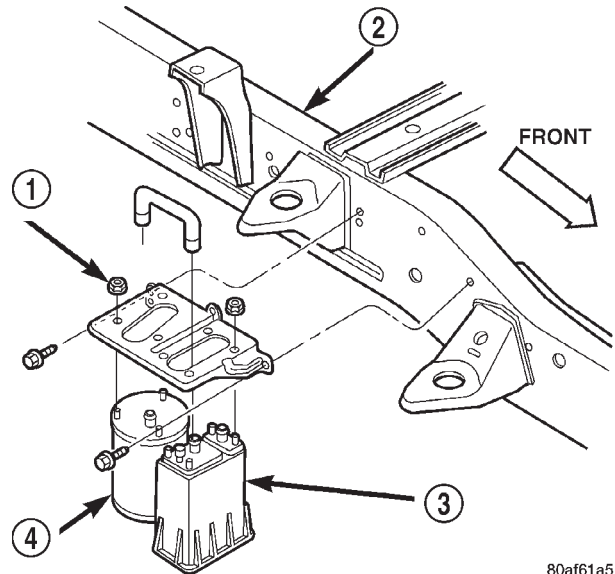
Two, maintenance free, EVAP canisters are used with all 3.9L/5.2L/5.9L/8.0L gasoline powered engines. The EVAP canisters are filled with granules of an activated carbon mixture. Fuel vapors entering the EVAP canisters are absorbed by the charcoal granules.

Fuel tank pressure vents into the EVAP canisters. Fuel vapors are temporarily held in the canisters until they can be drawn into the intake manifold. The duty cycle EVAP canister purge solenoid allows the EVAP canisters to be purged at predetermined times and at certain engine operating conditions.

## REMOVAL

Two EVAP canisters are used. Both canisters are mounted to a bracket located below rear of vehicle cab on outside of right frame rail (Fig. 13).

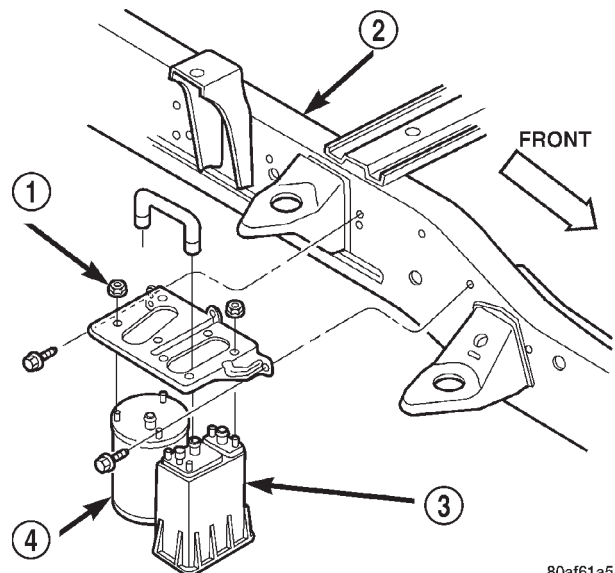
(1) Remove fuel tubes/lines at each EVAP canister. Note location of tubes/lines before removal for easier installation.



80af61a5

Fig. 12 Location of EVAP Canisters

- 1 - MOUNTING NUTS
- 2 - FRAME RAIL (RIGHT)
- 3 - FRONT EVAP CANISTER
- 4 - REAR EVAP CANISTER



80af61a5

Fig. 13 EVAP Canister Location

- 1 - MOUNTING NUTS
- 2 - FRAME RAIL (RIGHT)
- 3 - FRONT EVAP CANISTER
- 4 - REAR EVAP CANISTER

- (2) Remove mounting nuts at each canister (Fig. 13).
- (3) Remove each canister from mounting bracket.

## VAPOR CANISTER (Continued)

**INSTALLATION**

Two EVAP canisters are used. Both canisters are mounted to a bracket located below rear of vehicle cab on outside of right frame rail (Fig. 13).

- (1) Place each canister to mounting bracket (Fig. 13).
- (2) Install nuts and tighten to 9 N·m (80 in. lbs.) torque.
- (3) Install fuel tubes/lines to each canister.

# NEW VEHICLE PREPARATION

## TABLE OF CONTENTS

	page		page
<b>INTRODUCTION</b>		<b>INSPECTION</b> . . . . .	15
DESCRIPTION . . . . .	1	<b>PRE DELIVERY STORAGE</b>	
<b>RECEIVING</b>		DESCRIPTION . . . . .	19
INSPECTION . . . . .	3	STANDARD PROCEDURE . . . . .	20
<b>UNDER HOOD</b>		PRE DELIVERY STORAGE . . . . .	20
INSPECTION . . . . .	4	<b>PROGRAMMABLE ELECTRONIC FEATURES</b>	
<b>UNDER VEHICLE</b>		DESCRIPTION . . . . .	20
INSPECTION . . . . .	8	OPERATION . . . . .	20
INSTALLATION . . . . .	10	<b>APPEARANCE TIPS</b>	
<b>EXTERIOR</b>		CLEANING . . . . .	21
INSPECTION . . . . .	10	<b>FINAL STEPS</b>	
<b>BODY INTERIOR</b>		STANDARD PROCEDURE . . . . .	22
INSPECTION . . . . .	12	NEW VEHICLE PREPARATION FORM . . . . .	22
INSTALLATION . . . . .	14	OWNER CHECK OUT . . . . .	22
<b>ROAD TEST</b>		INSPECTION . . . . .	22
DESCRIPTION . . . . .	15		

## INTRODUCTION

### DESCRIPTION - THE IMPORTANCE OF CAREFUL NEW VEHICLE PREPARATION

Today, the automobile industry is more competitive than it has been for decades. Automakers around the world, including DaimlerChrysler, have made tremendous improvements in the quality of their vehicles.

As a result, customer expectations have also risen. Today's customers are more particular about their vehicles than ever before. The result is that problems once regarded as insignificant (such as a squeak or rattle) can now make the difference between a repeat customer and one who never purchases another vehicle from you dealership or another DaimlerChrysler Corporation product.

As a technician preparing a new car or truck for delivery, you are the final step in the entire quality process. Your inspection is the final opportunity to detect any flaws that would disappoint the customer. Your efforts will reflect upon the thousands of men and women who design, engineer and build DaimlerChrysler products as well as upon your dealership and on yourself as a competent, conscientious technician.

As manufacturing quality has improved, prep procedures have come to serve as additional quality checks. However, there are several compelling reasons for careful new vehicle preparation.

- **Safety**-You assure the customer that his or her new vehicle meets all federal safety standards.

- **Emissions Controls**-When your customers are assured that their new cars meet emissions standards, they will know that they are contributing to cleaner air and helping control pollution.

- **Customer Satisfaction**-First impressions are very important on a new vehicle. Careful new vehicle preparation will impress your customer.

- **Competition**-It is common knowledge in the industry that the availability of efficient service is one of the decisive factors in determining which cars will sell. A vehicle delivered to your customers in first class condition, inside and out, will bring them back to the dealership for the kind of service you have led them to expect and for their next new car.

This information outlines service procedures which will ensure that DaimlerChrysler Corporation vehicles are ready for delivery to the customer when they are complete. These procedures follow a logical order, from a careful underhood inspection, to the moment when you complete the warranty certificate and turn the keys over to your customer.

When you have completed the procedures described in this information, both you and your customer will be assured that his or her new vehicle will perform as expected.

### USING THE MANUAL

This guide to new vehicle preparation covers all items on the New Vehicle Preparation Form (Fig. 1).

INTRODUCTION (Continued)

DAIMLERCHRYSLER

NEW VEHICLE PREPARATION
Inspection and Road Test - Passenger Cars and Trucks

REPAIR ORDER NUMBER, DEALER STOCK NUMBER, KEY CODES, MAKE & YEAR, MODEL, DATE PERFORMED, TECHNICIAN NUMBER

VEHICLE IDENTIFICATION NUMBER, MILEAGE (EXCLUDING 10TH), CUSTOMER NAME, XXXXX

PERFORM THE INSPECTION AND ADJUSTMENTS AS LISTED BELOW
NOTE: Refer To The New Vehicle Preparation Manual For Proper Preparation Procedures...

Main inspection checklist including sections: A. UNDER HOOD, B. UNDER VEHICLE, C. BODY - EXTERIOR, D. BODY - INTERIOR, E. ROAD TEST, F. PREDELIVERY STORAGE, G. PROGRAMMABLE ELECTRONIC FEATURES. Includes items like Hood Latch/Safety Catch, Fluid Levels, Tie-Down Brackets, Operation Of Doors & Locks, etc.

EPA CERTIFICATION OF CONFORMITY
The selling Dealer hereby certifies that (1) this vehicle is covered by an EPA Certificate of Conformity...

DEALER CERTIFICATION
I CERTIFY THAT THIS VEHICLE HAS BEEN INSPECTED AND ROAD TESTED, AND THAT ADJUSTMENTS WERE PERFORMED...

Fig. 1 NEW VEHICLE PREPARATION FORM

## INTRODUCTION (Continued)

Items found requiring adjustment and/or repair should be corrected before delivery of the vehicle.

**NOTE: It is the dealer's responsibility to protect new vehicles from damage and deterioration prior to retail delivery both before and after new vehicle preparation.**

The information includes the following features:

Inspection points are cross-referenced to the New Vehicle Preparation Form as follows:

- Titles indicate the general area being inspected or the types of checks being made (i.e., underhood, body-exterior, road test, etc.).

- Sub-Titles identify the types of items to be inspected in that area (i.e., lines/hoses, wiring, etc.).

Procedures follow a logical order to prevent duplication and wasted effort.

Tips to help you do a better job are found as **NOTES**.

## RECEIVING

### INSPECTION

The following procedures are recommended for your own protection upon receipt of new vehicles. When a new car is delivered by the carrier, it should be inspected to ensure that it is in good condition and to determine if there is any shortage or transportation damage.

### EXTERIOR

Upon receipt of a new vehicle, check immediately for:

- Under carriage damage
- Chipped or cracked windshield, broken windows, and loose or missing moldings and name-plates
- Dents, scrapes, scratches, chips, dirt in paints or other damage to the body exterior
- Damaged or missing side view mirror(s)
- Missing wheel nuts
- Broken or missing lenses
- Chafing, bruises, cuts, or scrapes on tire side-walls or tread
- Missing underhood items
- Missing fuel filler cap
- Shipped loose items-license plate bracket, spare tire, jack and tire wrench, radio antenna, floor mats, wheel covers, cargo nets, fuses and other items

- Ensure that IOD fuse is removed
- Check battery test indicator when easily visible, or use voltmeter (battery must be at 12.4 volts or greater). Charge to ensure green dot-visibility, permanent damage may occur if battery remains in a discharged state for any length of time.

### INTERIOR

Check interior items such as:

- Rearview mirror
- Accessory control knobs
- Smokers package items
- Keys
- Radio
- Special equipment items listed on shipper
- Owner's Manual and Consumer information Brochures (normally stored in the glove box).
- Cuts, abrasions or stains on interior trim.

**NOTE: Remember a careful look at new vehicles when they are received may prevent problems when preparing vehicles for delivery to your customers.**

### MAJOR INSPECTION POINTS

- (1) Check operation of hood latch and safety catch-adjust as required.
- (2) Check all fluids for proper level and top off with the proper fluid as required-engine oil, automatic transmission fluid, brake master cylinder, clutch master cylinder, power steering, windshield washer, and cooling system. (Vehicle must be at normal operating temperature for some of these checks.)
- (3) Check brake, clutch, fuel, and power steering lines and hoses for leaks and clearance from moving and hot objects-reroute to the proper location and tighten as required.
- (4) Check battery state of charge-recharge if necessary, to ensure green dot is visible or instrument panel voltmeter indicates 12.4 volts or greater.
- (5) Check routing and connections of underhood wiring, vacuum hoses, refrigerant lines and coolant hoses for leaks, loose connections and clearance from moving objects reroute and tighten connections as required. Install IOD fuse on applicable vehicles.

**NOTE: Reset radio, clock, compass, etc., after installing, if vehicle is being delivered.**

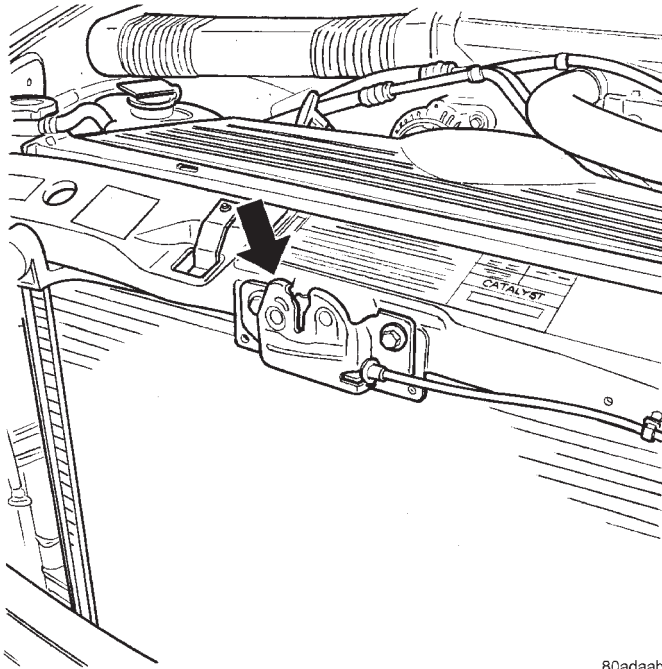


## UNDER HOOD

### INSPECTION - HOOD LATCH/SAFETY CATCH

(1) Check operation of hood latch (Fig. 2) and safety catch (Fig. 3) adjust as required.

**NOTE:** The safety catch prevents the hood from going to full open position until it is manually released. To test the safety catch, unlock the hood with the interior release, then try to raise the hood without operating the safety catch.



80adaab7

**Fig. 2 HOOD LATCH**

### INSPECTION - FLUID LEVELS

#### ENGINE OIL

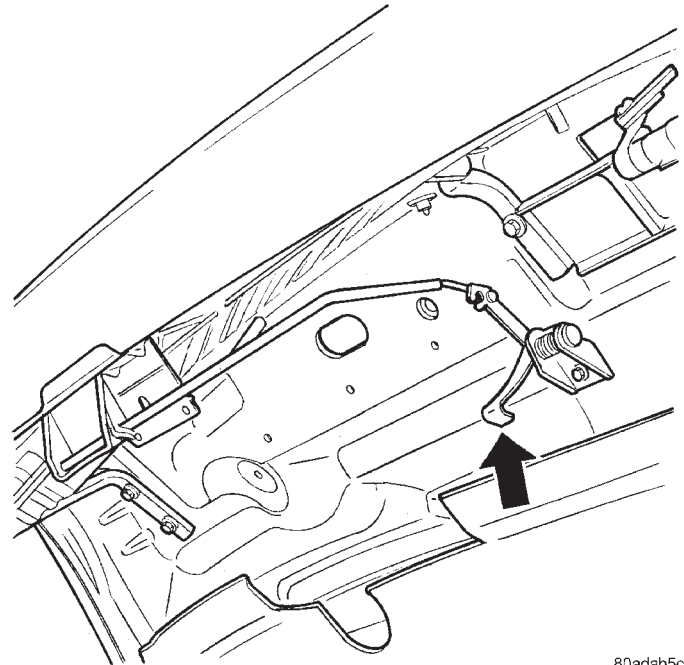
**CAUTION:** Use only oil that meets the specified requirements.

**NOTE:** If oil level is low, inspect for oil leaks.

(1) Check engine oil level. The oil should be in the safe range or between the minimum and maximum marks.

- If the oil level is at the minimum mark, add oil that meets specifications, (Refer to LUBRICATION & MAINTENANCE/FLUID TYPES - DESCRIPTION).

- The best time to check the oil is about 5 minutes after a fully warmed-up engine is turned off, or before starting the engine after it has been off overnight.



80adab5c

**Fig. 3 HOOD SAFETY CATCH**

- For the most accurate readings, the vehicle should be on level ground.
- Wipe up any excess oil that may have spilled, or the customer could mistakenly perceive this as the result of a leak.

#### AUTOMATIC TRANSMISSION

**CAUTION:** Only use fluid that meets the vehicle's specific requirement.

**NOTE:** Mopar ATF Plus contains special additives not found in Mercon and Dexron II fLuids. Use of fluid other than Mopar Plus (when specified) could result in an upshift shudder in some applications.

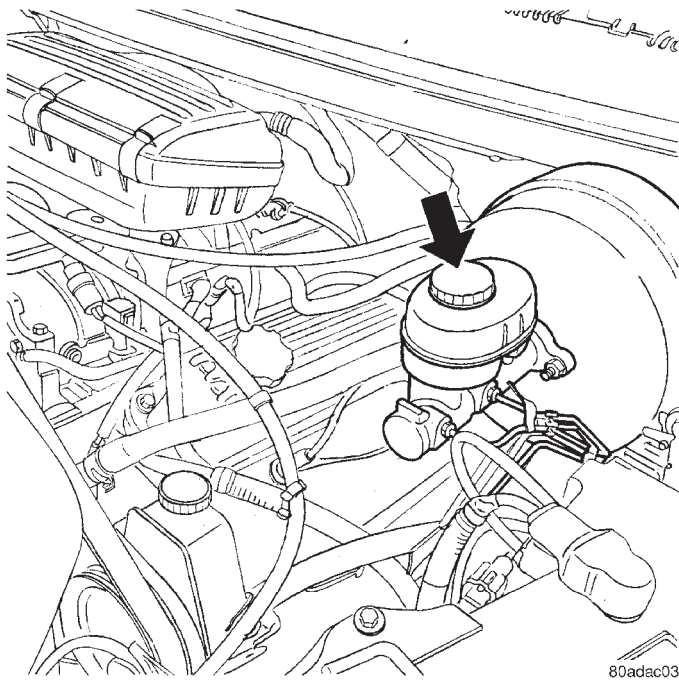
Transmission fluid check procedures are specific to each vehicle line. Refer to the appropriate service information for correct procedure.

#### CLUTCH MASTER CYLINDER

**CAUTION:** only use brake fluid that meets specified requirements (DOT 3 and MVSS 116).

Check the clutch master cylinder fluid level. Add fluid to the proper level if necessary.

UNDER HOOD (Continued)

**BRAKE MASTER CYLINDER****Fig. 4 BRAKE MASTER CYLINDER FLUID RESERVOIR**

**CAUTION:** Only use fluid that meets specified requirements (DOT 3).

**NOTE:** Wipe the master cylinder cover to remove any dirt.

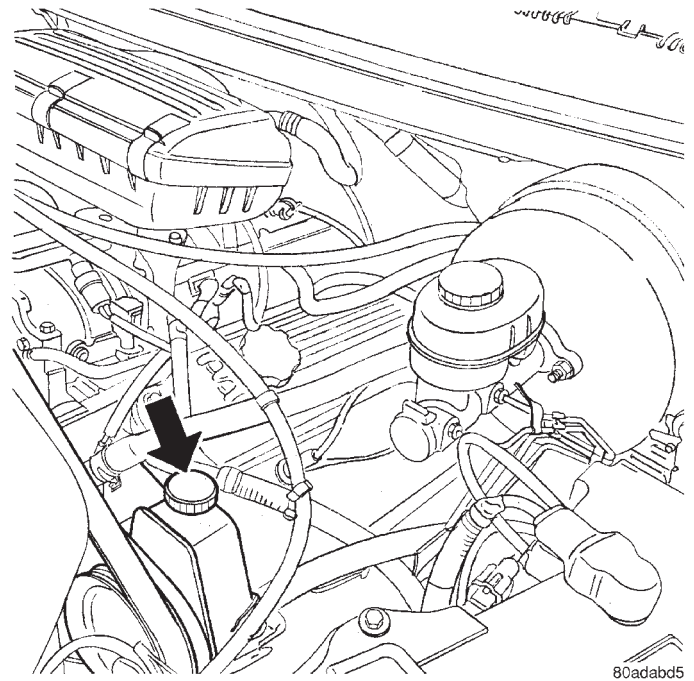
**NOTE:** On vehicles equipped with remote antilock brakes, the fluid level check is the same as for a normal system.

Check the brake master cylinder fluid level (Fig. 4). Add fluid to bring the level to the full line on the side of the reservoir (or above the bottom of the split ring in the primary filler hole). Be sure both primary and secondary cavities are full to the maximum level as indicated.

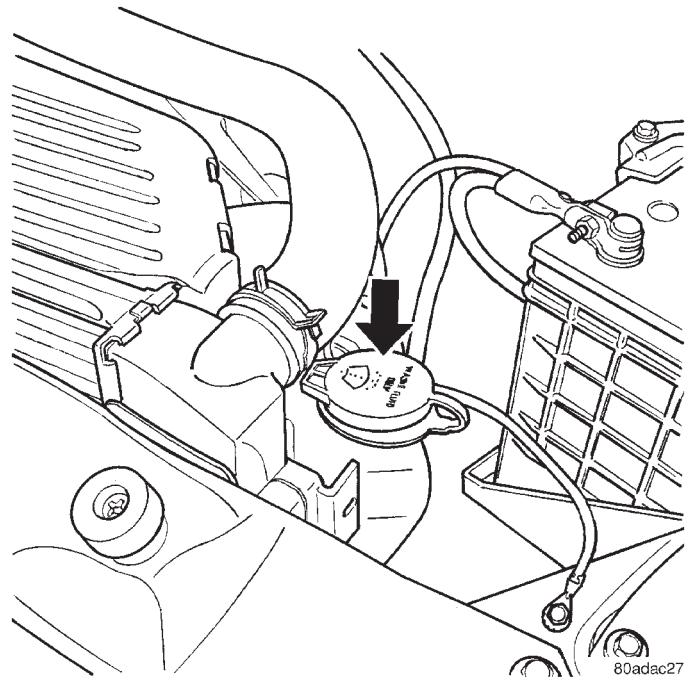
**POWER STEERING RESERVOIR**

**CAUTION:** Only use fluid that meets specified requirements. Petroleum fluids, such as Mopar Power Steering Fluid, are specially formulated for use with power steering hoses and seals.

Check the fluid level; it should be maintained at the proper level indicated on the dipstick, or as viewed through the translucent reservoir. If fluid is required, fill to the proper level. With the engine running at normal operating temperature, turn the steering wheel from stop to stop to expel air from

**Fig. 5 POWER STEERING RESERVOIR**

within the system. Stop the engine, remove the cap, and recheck the fluid level, making sure that foaming is not present (Fig. 5).

**WINDSHIELD WASHER RESERVOIR****Fig. 6 WINDSHIELD WASHER FLUID RESERVOIR**

**CAUTION:** Do not add engine coolant (antifreeze) to this reservoir.

**CAUTION:** Avoid spilling washer solvent on the vehicles paint; it could harm the finish.

## UNDER HOOD (Continued)

Check windshield washer solvent reservoir and fill as necessary (Fig. 6).

**NOTE:** When using concentrated solvent such as Mopar® All-Weather Windshield Washer Solution, dilute per container directions.

## COOLING SYSTEM RESERVOIR

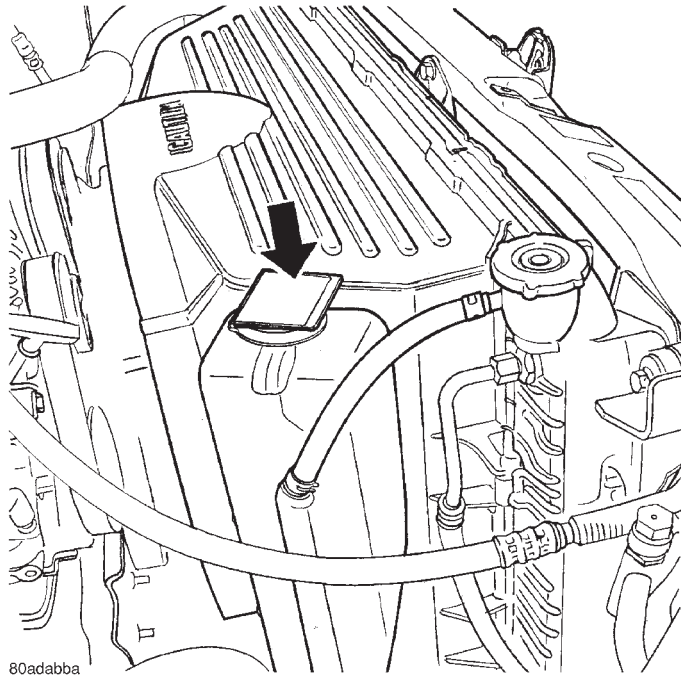


Fig. 7 ENGINE COOLANT RESERVOIR

**WARNING:** DO NOT REMOVE RADIATOR CAP WHILE COOLING SYSTEM IS UNDER PRESSURE.

**NOTE:** Add coolant only to plastic reserve tank if it is required. Engine must be at normal operating temperature before adding coolant to reserve tank. In cold climates, coolant in reserve tank may appear low; do not add coolant until normal temperature is reached.

Check coolant level with engine idling at normal operating temperature. Coolant level in plastic reserve tank must be between the minimum and maximum marks (Fig. 7).

If coolant is added, use a 50/50 (-30°F protection) concentration of the recommended (Refer to the Service Information for specific Mopar® antifreeze recommendation ) antifreeze and distilled water. Use a higher concentration (up to 65%) if a lower freeze point is required. Do not use recycled coolant in new vehicles.

## INSPECTION - LINES/HOSES

Inspect the following for line and hose leaks. Also inspect routing and connections and reroute and tighten as required.

- Brake Lines (Fig. 8)
- Fuel Lines (Fig. 9)
- Power Steering Hoses
- Vacuum Hoses
- Heating/Coolant Hoses
- Clutch Lines
- Refrigerant Lines
- Transmission oil cooler lines (Fig. 10)

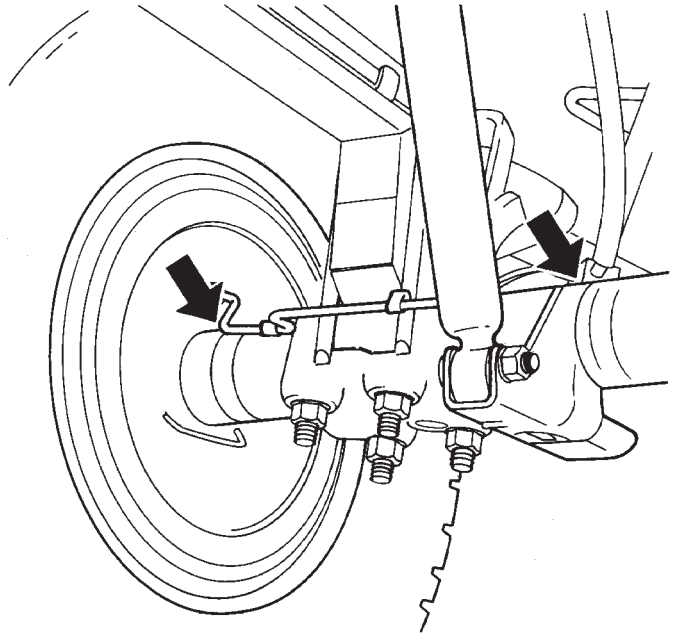


Fig. 8 PARKING BRAKE CABLE AND BRAKE LINE

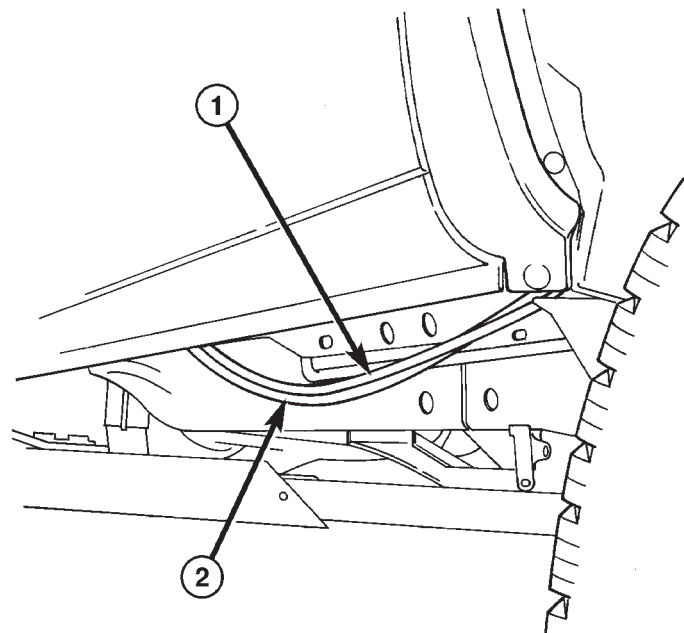
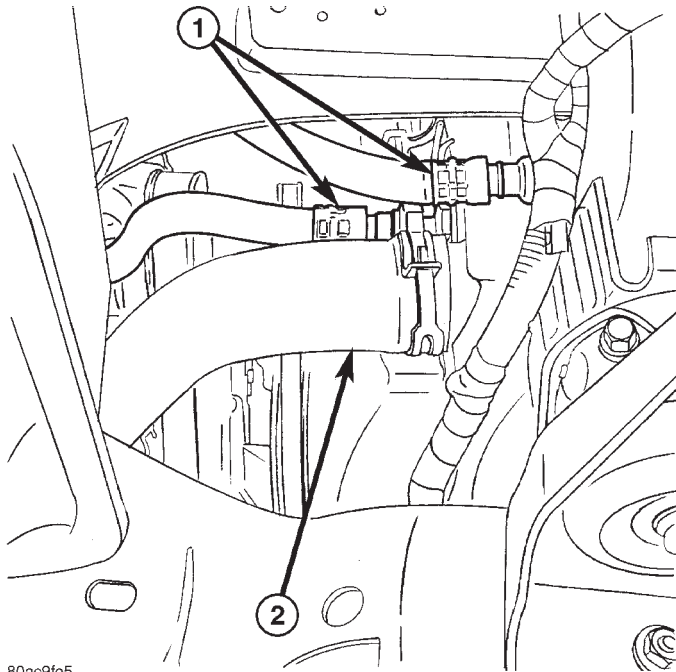


Fig. 9 BRAKE LINES AND FUEL LINES

- 1 - FUEL LINE
- 2 - BRAKE LINE

## UNDER HOOD (Continued)



**Fig. 10 TRANSMISSION COOLER LINES AND RADIATOR HOSE**

- 1 - TRANSMISSION OIL COOLER LINES  
2 - RADIATOR LOWER HOSE

## INSPECTION - BATTERY

When battery is easily accessible, check the test indicator (green dot), terminal tightness and felt (grease) washer on battery posts. Recharge battery as required to assure that the green dot is visible.

When battery is not easily accessible check battery condition with a voltmeter at the jump start locations, or check the voltmeter on the instrument panel (Fig. 11) or (Fig. 12). The reading should be at least 12.4 volts. Recharge battery as required.

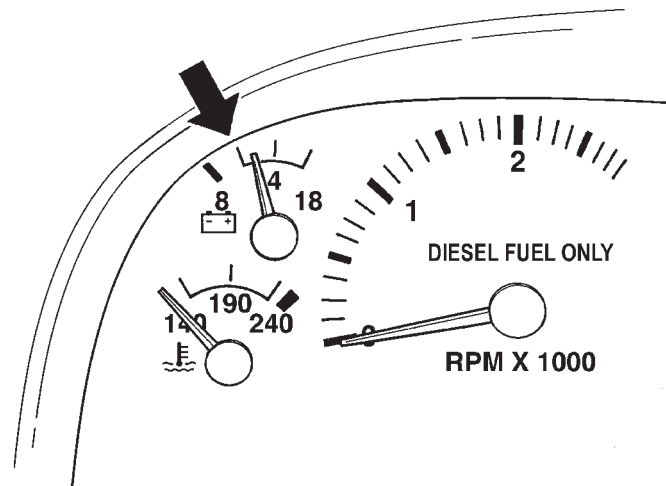
**NOTE:** Refer to service information for proper battery charging rates and times.

## INSPECTION - WIRING

The assembly plant has shipped all vehicles with the interior lights and most electronic memories non-functional by way of an Ignition Off Draw (IOD) fuse removed. The purpose is to reduce the possibility of battery run-down during shipping and storage.

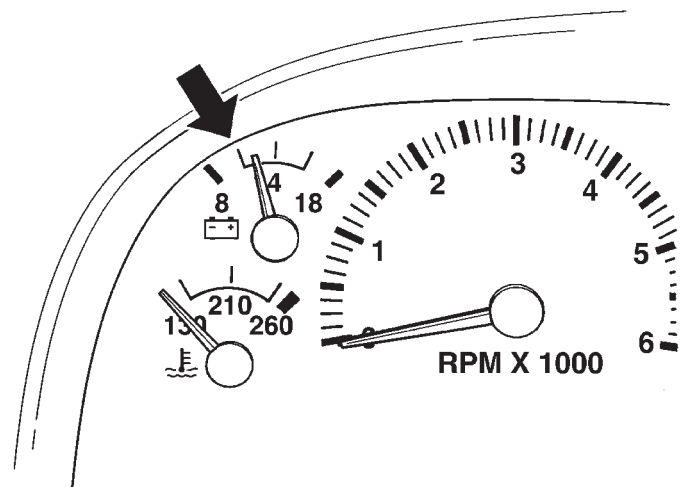
Vehicles stored after prep should have the IOD fuse that activates the accessories pulled to prevent battery drain.

**NOTE:** Ensure that the IOD fuse is removed to prevent battery drain and possible damage. Vehicles stored for extended periods after prep should be washed frequently, to prevent environmental dam-



**Fig. 11 BATTERY VOLTAGE GAUGE DIESEL ENGINE**

80aca02e



**Fig. 12 BATTERY VOLTAGE GAUGE GAS ENGINE**

80adade5

age, and reinspected for storage-related problems before delivery.

(1) Install the IOD fuse as equipped. (ON vehicles being delivered, remember to reset radio, clock, compass, etc., as required.)

(2) Check routing and connections of all underhood wiring-reroute and connect as required.

(3) Make sure the starter, generator and air conditioning clutch wiring are correctly installed, routed, and in the clips where provided.

(4) For predelivery storage, always pull the IOD fuse that activates accessories.



## UNDER VEHICLE

### INSPECTION - TIRE PRESSURES

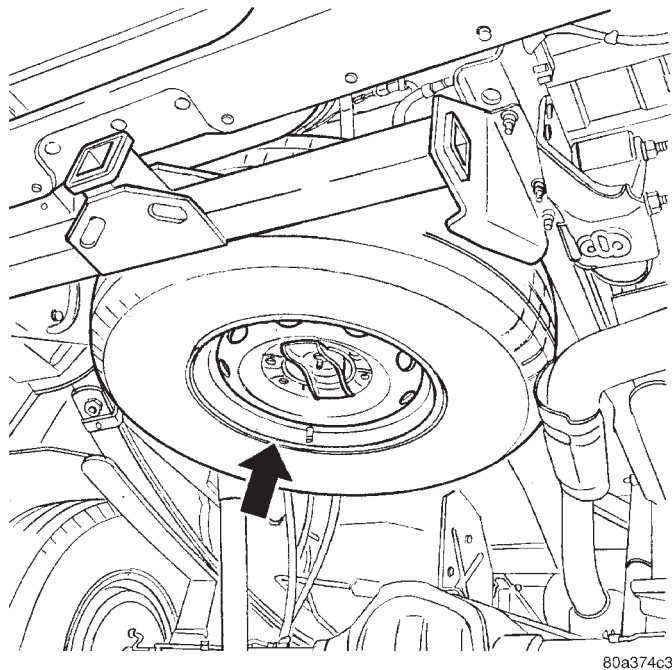
(1) Using the tire placard or the Safety Certification Label, check that the correct tires are mounted on the vehicle.

(2) Install valve stem extensions as required.

(3) Using the tire placard or the Safety Certification Label, check tire pressure (including spare) and adjust as required to recommended pressure.

(4) Inspect the spare tire for correct pressure and proper mounting (Fig. 13).

**NOTE:** Tire pressure may have been set above normal during manufacturing in order to properly seat the tire bead. Be sure to adjust to proper specification.



80a374c3

**Fig. 13 SPARE TIRE INSPECTION**

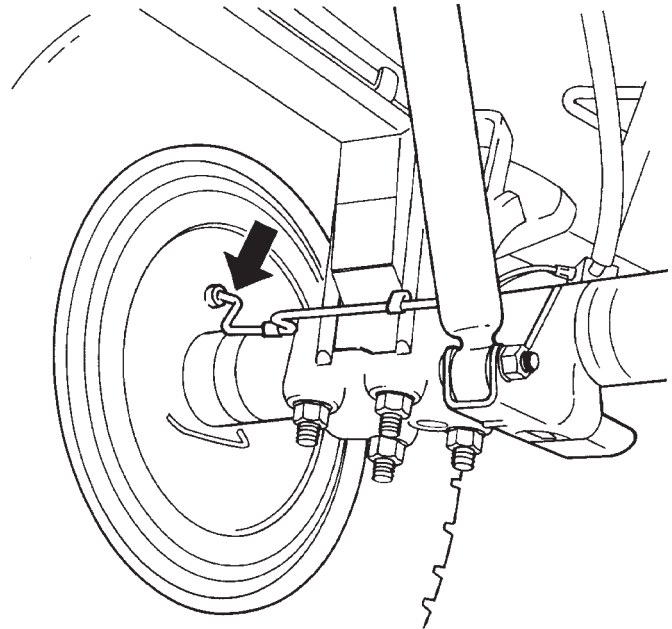
### INSPECTION - VISUAL

**CAUTION:** Before raising the vehicle on a hoist, (Refer to LUBRICATION & MAINTENANCE/HOISTING - STANDARD PROCEDURE) for the proper lifting points.

(1) Visually inspect the following for loose attachment, leakage, clearance and routing, and tighten connections and clamps as required:

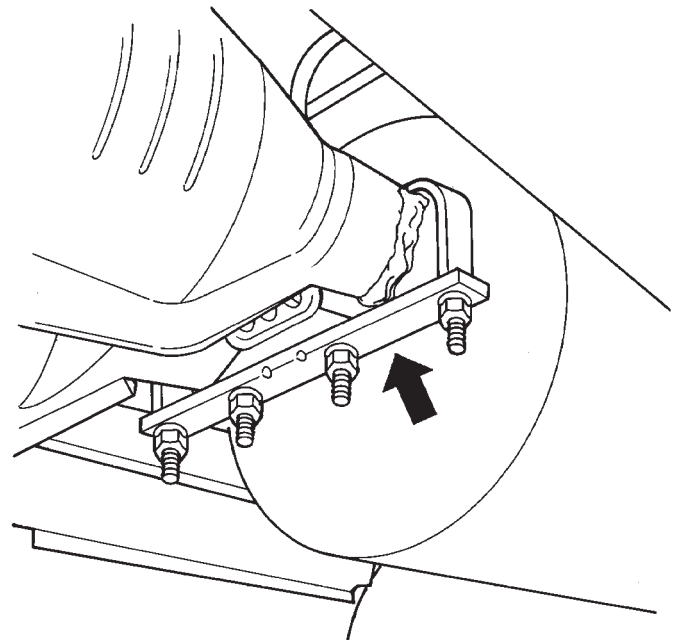
- Engine
- Oil Cooler
- Cooling System
- Transmission
- Driveshaft Boots

- Differential
- Transfer Case (Fig. 19)
- Transmission Cooler and Lines (Fig. 18)
- Brake System and Lines (Fig. 14)
- Fuel System
- Exhaust System (Fig. 15), (Fig. 16) and (Fig. 17)
- Steering and Suspension Components



80a373fe

**Fig. 14 BRAKE LINES TO CALIPERS (REAR)**

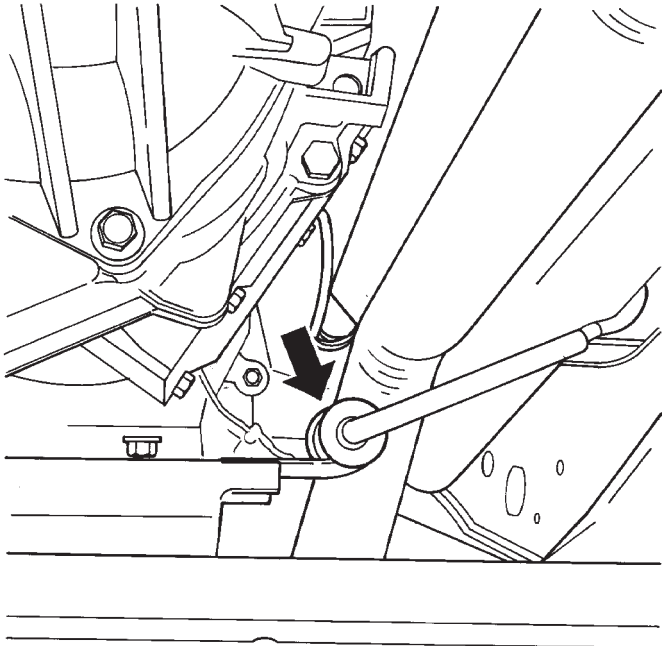


80a37361

**Fig. 15 EXHAUST CLAMPS**

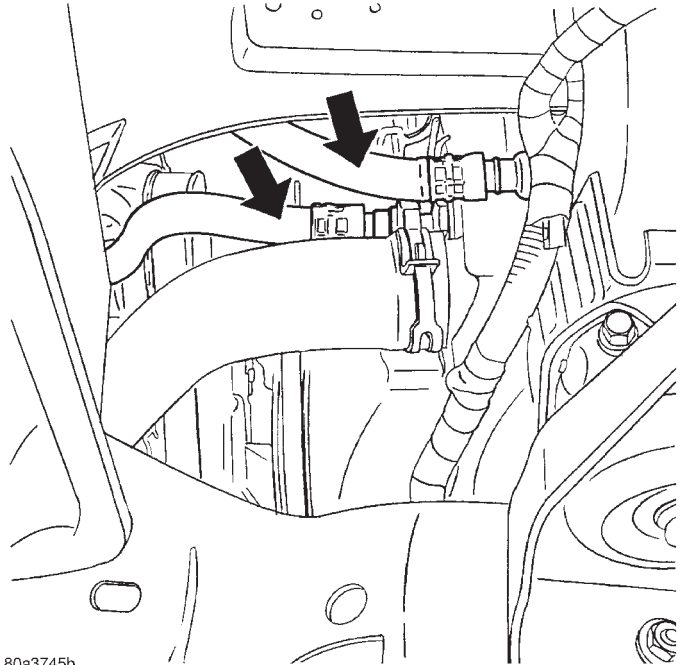


UNDER VEHICLE (Continued)



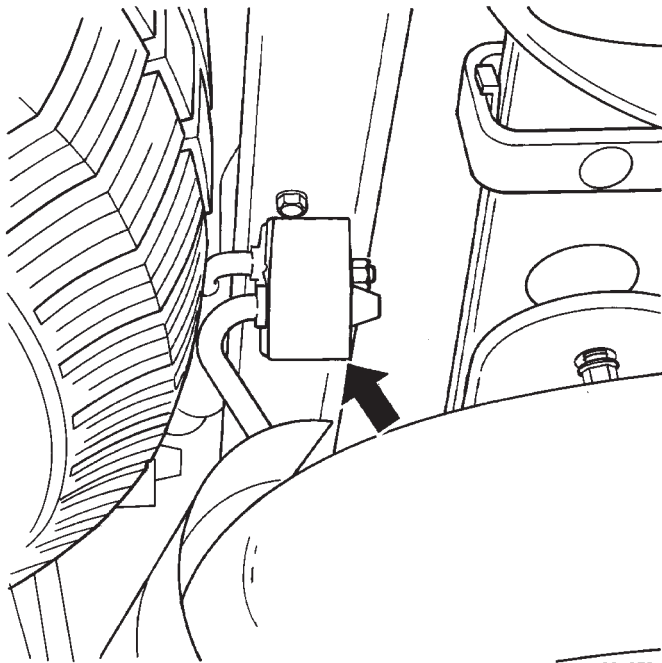
80a37373

**Fig. 16 EXHAUST HANGERS**



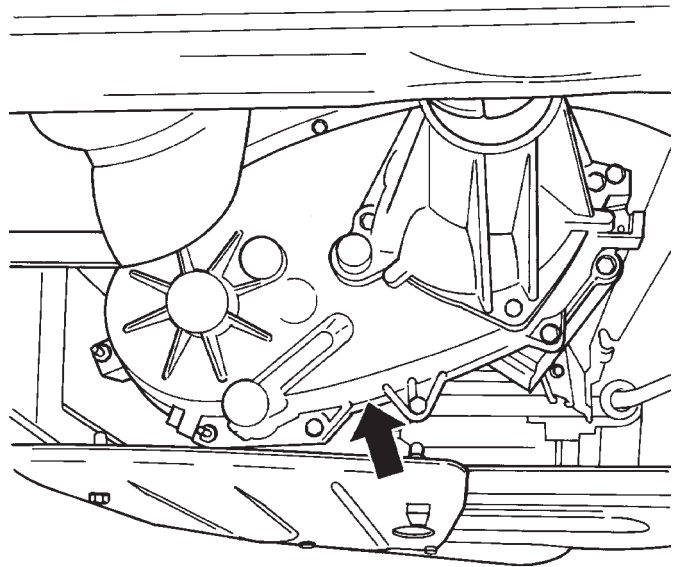
80a3745b

**Fig. 18 TRANSMISSION COOLER LINES**



80a373cd

**Fig. 17 TAILPIPE HANGERS**



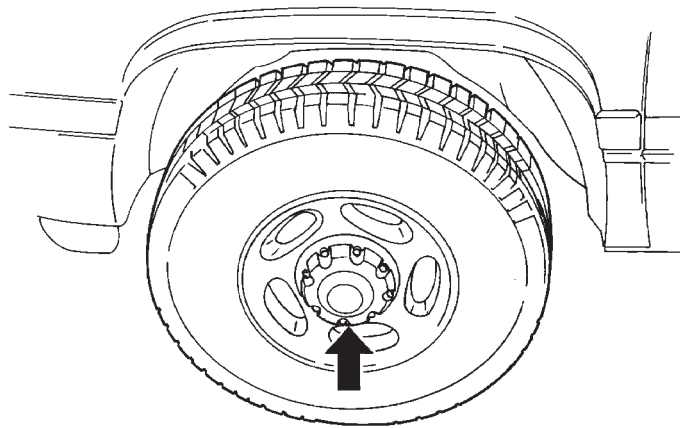
80a374a2

**Fig. 19 TRANSFER CASE INSPECTION**

## UNDER VEHICLE (Continued)

**INSTALLATION - WHEEL COVERS**

- (1) Install cover on wheel by hand only (Fig. 20).
- (2) Install and torque wheel nuts to 135 N·m (100 lb. ft.).
- (3) Install nut caps, if equipped using lug wrench, do not over tighten.
- (4) Remove release liner from removal instructions label and install label next to jacking instructions label. Surface must be clean and flat for proper adhesion of label.

**Fig. 20 WHEEL COVER**

80aca25d

**EXTERIOR****INSPECTION—BODY SEALING**

Visually inspect the following seals during the normal recommended wash. Look for areas where water may have entered the vehicle.

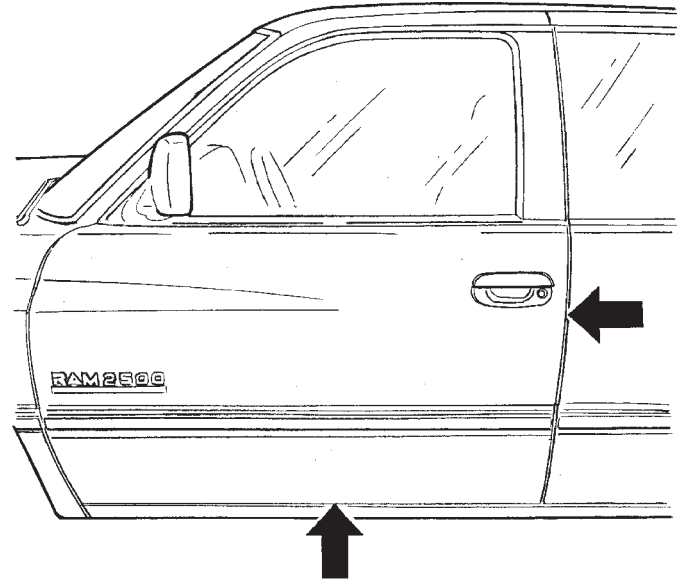
- Door and window seals
- Windshield
- Backlight

**INSPECTION - FIT AND FINISH**

- (1) Remove all protective coatings/covers.
  - Remove protective film from body moldings.
- (2) Make sure body is free from paint chips, scratches, sags, run, dirt or corrosion. Touch up any minor paint chips and scratches as required.
- (3) Ensure that moldings and stripes are aligned properly.
  - Ensure that moldings and stripes are present and securely fastened to the body.

**NOTE:** Painted-on accent strips require a unique paint for touch-ups.

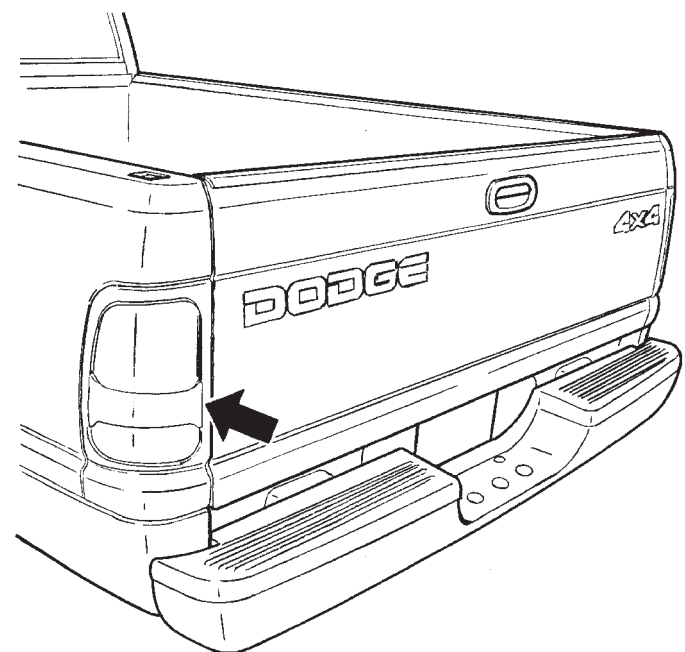
- (4) Check that the door panels have even gaps and fit well with adjacent body panels (Fig. 21).



80aca274

**Fig. 21 DOOR ALIGNMENT**

- (5) Check that the tailgate has even gaps and fits well with adjacent panels (Fig. 22).

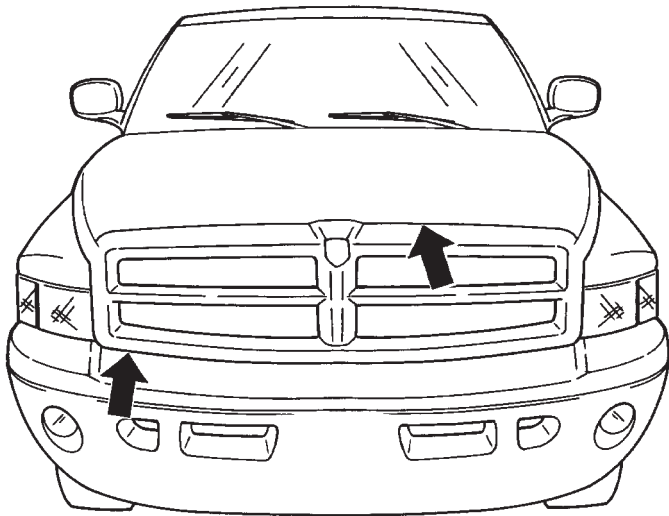


80adae40

**Fig. 22 TAILGATE ALIGNMENT**

## EXTERIOR (Continued)

(6) Check that the hood panel has even gaps and fits well with adjacent panels (Fig. 23).



80adae94

**Fig. 23 HOOD ALIGNMENT**

(7) Ensure that the body is free from dents and dings.

### INSPECTION - KEYLESS ENTRY

Check operation of keyless entry system and program the transmitter/receiver if necessary.

### INSPECTION - DOORS AND DOOR LOCKS

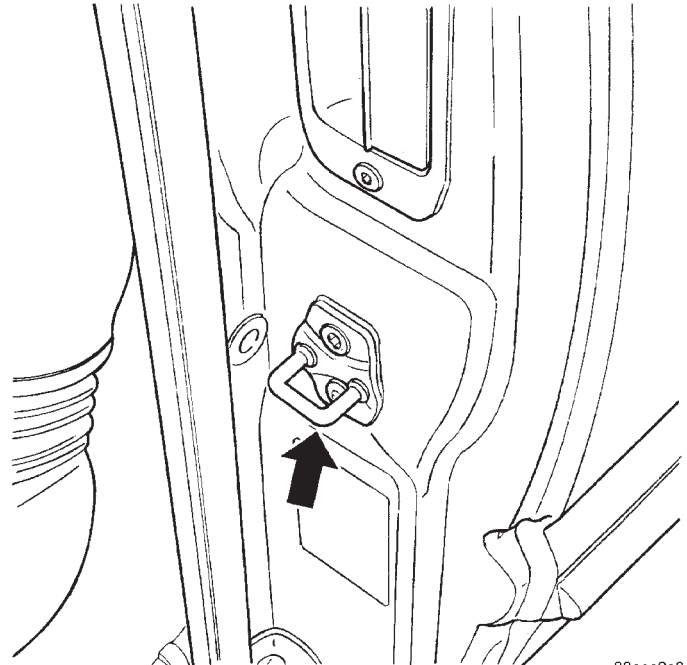
(1) Check operation of doors and locks, keyless entry, security alarm, and tailgate. Adjust strikers (Fig. 24) and latches (Fig. 25) as required.

(2) Remove any protective covers from the door sills.

**NOTE:** Windows should be in the full up position during these tests (except for the lock tests).

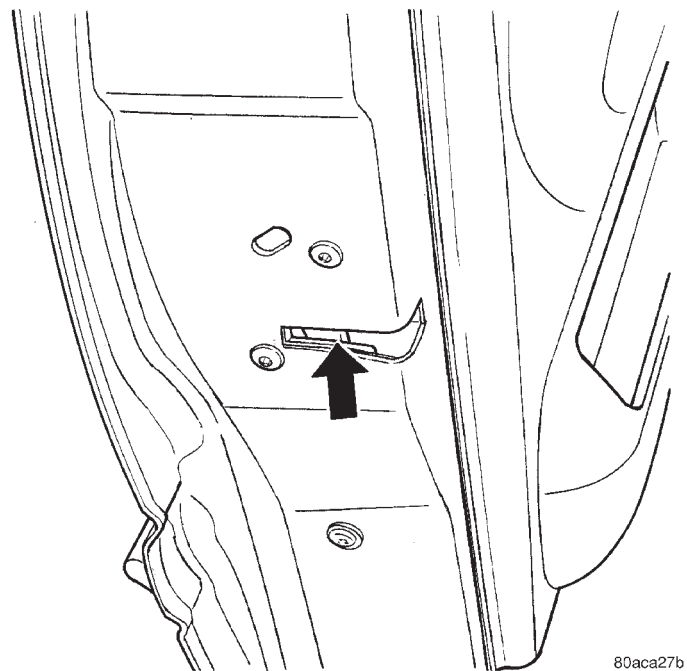
- Open each door (inside and out) to check the release mechanism and ease of operation.
- Partially close the door to check the open-door detent.
- Close the door to check the latches and striker.
- Open the door, lower the window depress the lock plunger and close the door to check the lock.
- Unlock each door (using both keys) to check lock and key operation.

**NOTE:** Child proof door locks should be disabled when delivered to the customer.



80aca2a0

**Fig. 24 DOOR STRIKER**



80aca27b

**Fig. 25 DOOR LATCH**

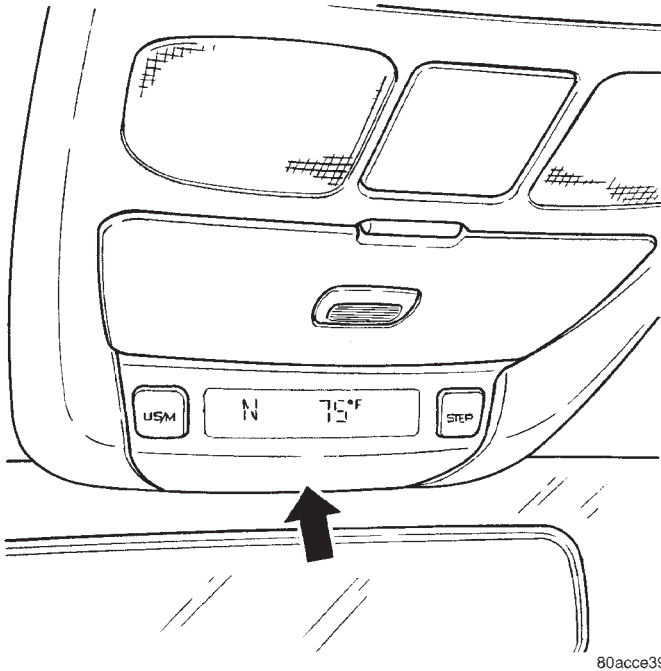
## BODY INTERIOR

### INSPECTION - COMPASS

**NOTE:** Set variance after calibration.

(1) Calibrate and set compass variance (Fig. 26), if so equipped (use appropriate procedures in service information).

(2) Remove protective film from overhead console, if equipped.



80acce39

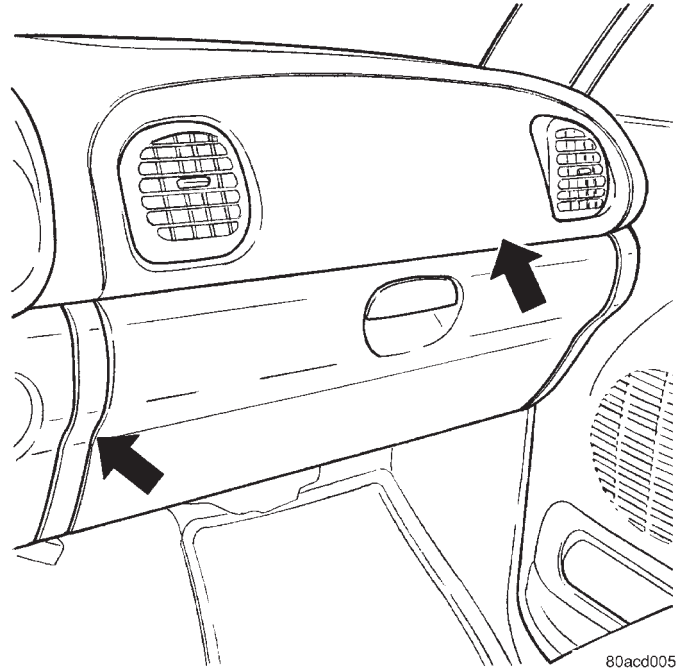
**Fig. 26 COMPASS OPERATION**

### INSPECTION - FIT AND FINISH

- (1) Remove any interior covers.
- (2) Inspect the instrument panel, glove box door (Fig. 27) and interior moldings for even gaps and alignments.
- (3) Check that the door panel material is clean, free from wrinkles and installed correctly.
- (4) Check that the seat material is clean, secure and free of wrinkles.
- (5) Check that the carpet is clean, secure and free of wrinkles.
- (6) Check that the headliner is clean, free of lint and dirt smudges.

### INSPECTION - LIGHTS AND SWITCHES

- (1) Remove protective film from all switch bezels.
- (2) Operate and visually inspect all interior lights and switches, including:
  - Dome/map lamps
  - Vanity mirror lamps
  - Glove box light



80acd005

**Fig. 27 GLOVE BOX DOOR**

- Ashtray light
  - Cigar lighter light
  - All gauge lights
  - Radio display
  - Door-mounted lights, if equipped
  - Illuminated entry system, if equipped
- (3) Visually inspect and operate all exterior lights and their switches, including:

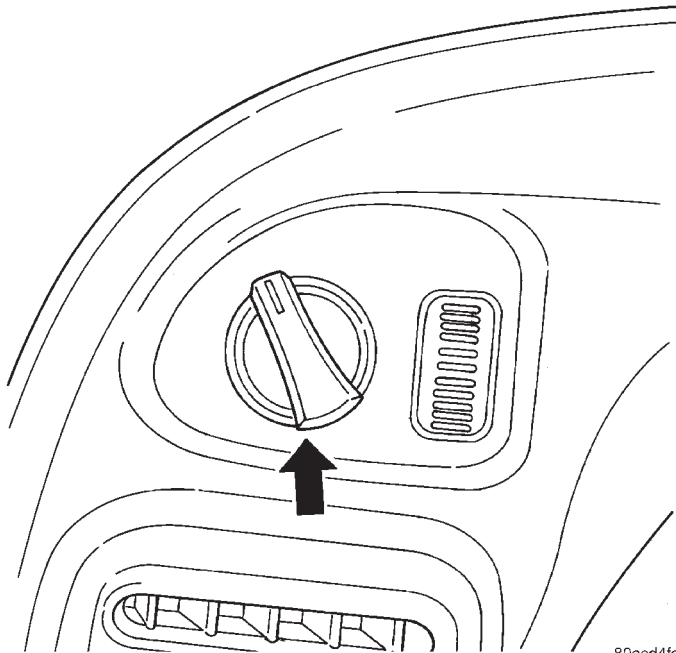
**NOTE:** Headlamp aim is preset during vehicle assembly.

- Headlights, including high beam, optical horn ("flash to pass") and daylight running lamps (DRL's) (Fig. 28)
    - Tail/stop lamps (including center high-mounted stop lamp)
    - Parking lights Turn signals Brake lights (including center high mounted stop lamp)
    - Emergency flashers (Fig. 29)
    - Fog/driving lights, if equipped
    - Off-road or other lights, if equipped
    - Cargo bed lights, if equipped
- (4) Check ignition switch for proper operation in all positions (accessory, lock, on, start and off).

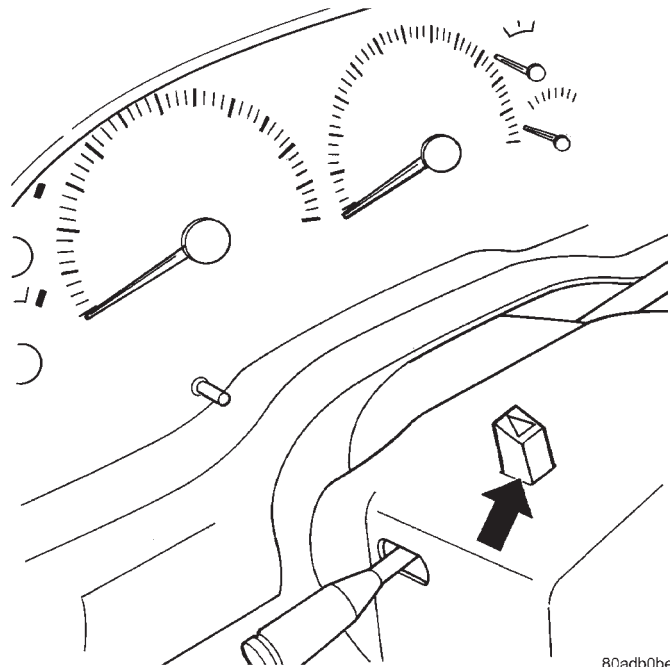
### INSPECTION - SEAT BELTS, SHOULDER BELTS, RETRACTORS AND HEAD RESTRAINTS

- (1) Inspect all seat belts and harnesses to ensure that they connect and hold properly.
- (2) Inspect the condition of the belts and anchors.
- (3) Inspect for proper seat belt retraction.

## BODY INTERIOR (Continued)

**Fig. 28 HEADLAMP SWITCH**

80acc4fe

**Fig. 29 EMERGENCY FLASHER SWITCH**

80adb0be

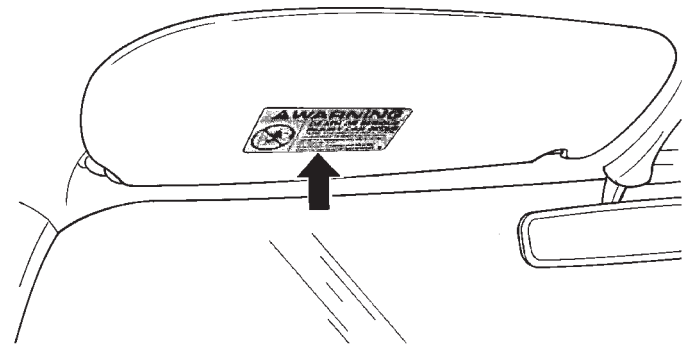
(4) Check that safety labels regarding the use of seat belts and air bags are in place (such as on the sun visors) (Fig. 30).

(5) Ensure head restraints are properly installed. Inspect the height adjustment for ease of operation.

**INSPECTION - SEATS**

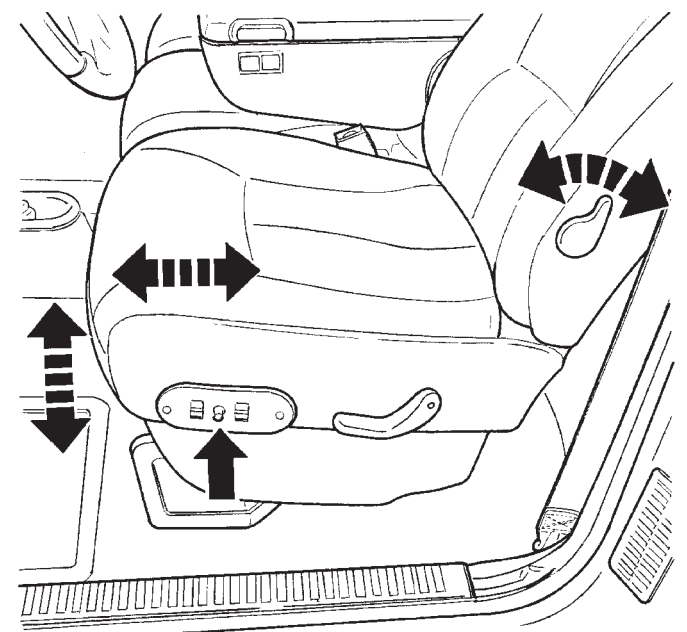
(1) Remove protective seat, carpet and door covers (if being delivered) where applicable.

(2) Check that manual/power seat adjustments work properly for all seats (Fig. 31).

**Fig. 30 SEAT BELT LABELS**

80adb271

- Inspect the operation of front seat mechanical slides and power adjusters (Fig. 31)
  - Check the seatback recliner for ease of release and operation
  - Check the rear seatback latches for ease of release
  - On fold-down rear seats, latch the rear seats and pull forward on the seats to check that the latches hold
- (3) Check the seat heaters on vehicles equipped with heated seats.
- (4) Check that all seats are securely located in their adjustable tracks (Fig. 31).

**Fig. 31 SEAT CONTROLS**

80adb781



## BODY INTERIOR (Continued)

**INSPECTION - WINDOWS, DOORS AND LOCKS**

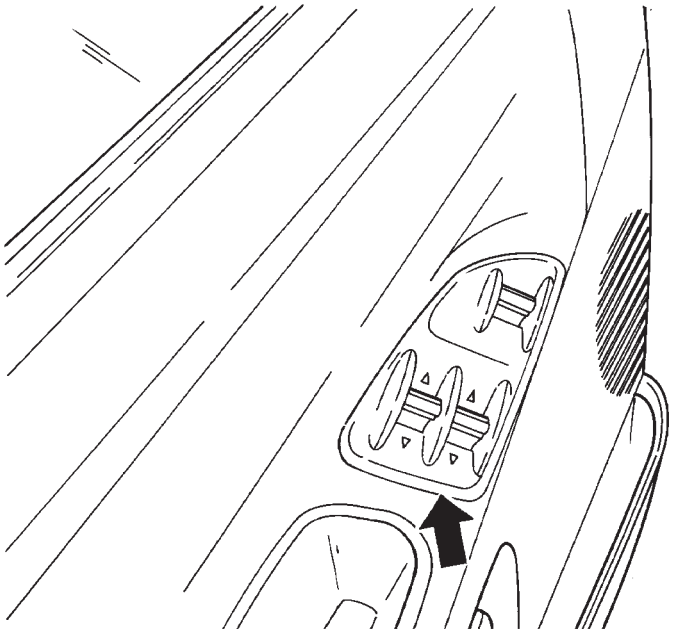
(1) Check all power window switches for proper operation (Fig. 32).

(2) Run all power or manually operated door, quarter and vent windows to the fully closed position to check operation and sealing.

(3)

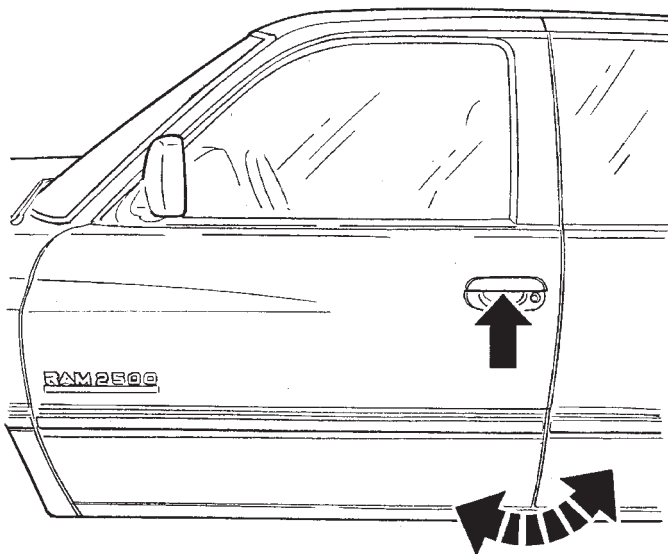
(4) Check all power/manual door locks for correct operation (Fig. 32).

(5) Ensure that all doors open/close easily (Fig. 33).



80adc4fa

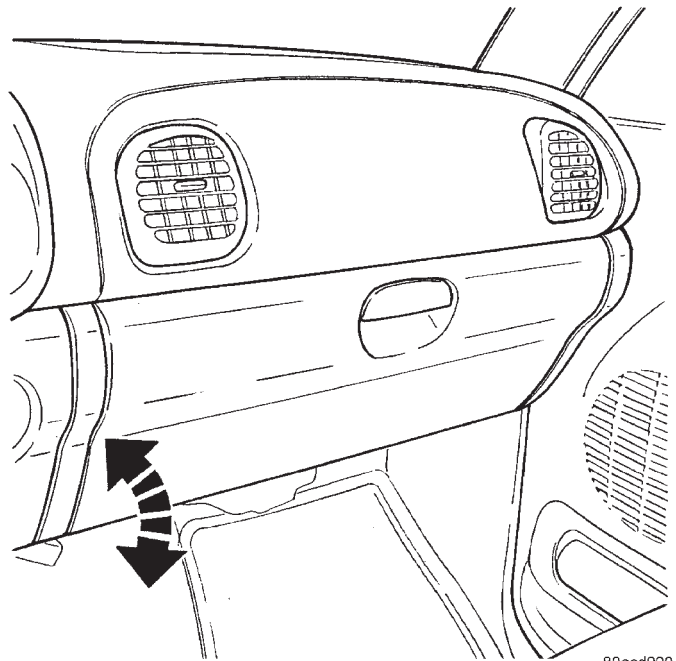
**Fig. 32 POWER WINDOW AND LOCK SWITCHES**



80adc9ef

**Fig. 33 DOOR OPERATION**

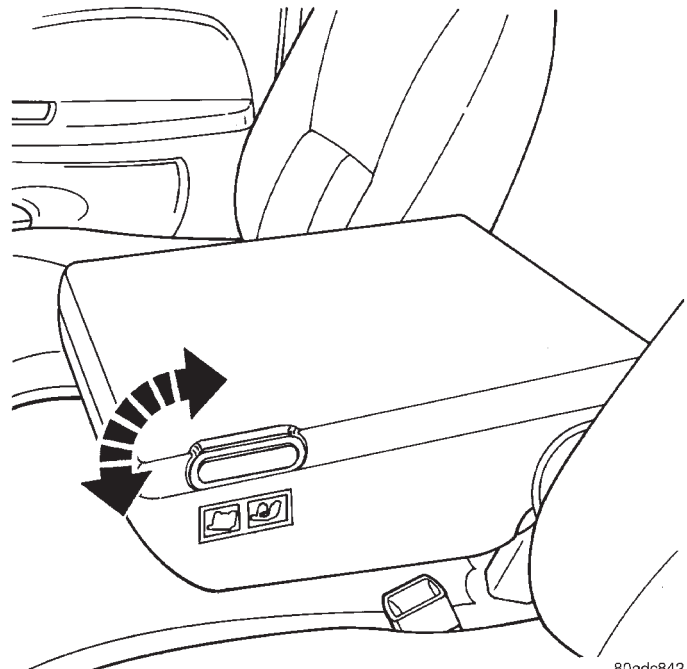
(6) Check that the glove box door opens/closes easily (Fig. 34).



80acd990

**Fig. 34 GLOVE BOX DOOR**

(7) Check that the console door opens/closes easily (Fig. 35).



80adc842

**Fig. 35 CENTER CONSOLE**

**INSTALLATION - SHIPPED LOOSE ITEMS**

- (1) Install the antenna mast.
- (2) Install rear license plate holder and front license plate holder (if required).
- (3) Install wheel covers (if required).

## ROAD TEST

### DESCRIPTION - ROAD TEST INSPECTION

The following items must be inspected during the road test portion of the new vehicle inspection.

- Check neutral safety switch operation
- Check operation of shift/clutch interlock system
- Check operation of gauges and warning lights
- Check horn operation
- Check operation of turn signals and emergency flashers
- Check all mirror adjustments, including day/night function
- Check windshield wipers for proper wipe pattern and intermittent mode (if equipped)
- Check washer spray pattern
- Check heater, defroster and air conditioning for proper operation
- Check that the fan operates quietly
- Check the rear window defroster (if equipped)
- Leave air selection lever in the fresh air position
- Check the rear heater and air conditioning for proper operation
- Check the rear air register locations
- Check that the indicator lamps operate properly
- Check the operation of the radio, cassette and/or compact disc player, and that sound quality is good
- Ensure that the clock displays the correct time
- Check that the trip computer/maintenance reminder operates in all modes
- Check all speed control functions
- Check the service brakes to ensure that they stop the vehicle in a straight line, without noise, shudder or vibration
- Check the brake warning light
- Check the parking brake operation
- Check the engine's performance
- Check the transmission's performance for smooth, quiet operation. If the vehicle is a 4x4, check that the transfer case shifts easily among all ranges
- Check Autostick function (if equipped)
- Check the vehicle's steering and handling
- The steering wheel should be centered when traveling in a straight line
- The vehicle should not pull or vibrate
- Check for squeaks, rattles and wind noise
- Check any other vehicle aspects you believe are important, but that may not be included on the New Vehicle Preparation Form
- Fill fuel tank with specified grade of fuel

### INSPECTION - FUEL

Fill fuel tank with specified grade of gasoline (regular, midgrade or premium).

### INSPECTION - OTHER

As part of DaimlerChrysler's Customer One philosophy, the "Other" blank is provided on the New Vehicle Preparation Form. This is designed to encourage you to check any aspects of vehicle operation that you believe are important to your customers, but that do not appear elsewhere on the form.

### INSPECTION - SQUEAKS, RATTLES AND WIND NOISE

(1) Make sure that the instrument panel, glove box, seats, steering wheel and column are free from squeaks and rattles. Tighten any obvious loose fasteners.

(2) Check that the windows and doors are free from squeaks, rattles and wind noise.

(3) Check that the vehicle exterior is free from squeaks, rattles and noise, front and rear.

(4) Make sure that all interior panels are free from squeaks and rattles.

### INSPECTION - STEERING AND HANDLING

(1) Check that the power assist works properly (if equipped). Steering should not require excessive effort.

(2) Make sure the steering wheel does not vibrate at idle or road speed.

(3) Ensure that the steering wheel is centered when traveling straight ahead.

(4) Check that the vehicle does not drift to one side.

(5) Make sure that the vehicle does not vibrate/shake.

### INSPECTION - TRANSMISSION/TRANSFER CASE

#### AUTOMATIC TRANSMISSION

(1) Make sure that the park lock holds the vehicle. With the vehicle on a grade, put automatic transmission in PARK and slowly release the service brake to see if park lock holds. If it does not hold, the transmission requires further service.

(2) Make sure shift lever operates easily/ smoothly (Fig. 36).

Check for smooth shifting. Check for proper upshifting and downshifting.

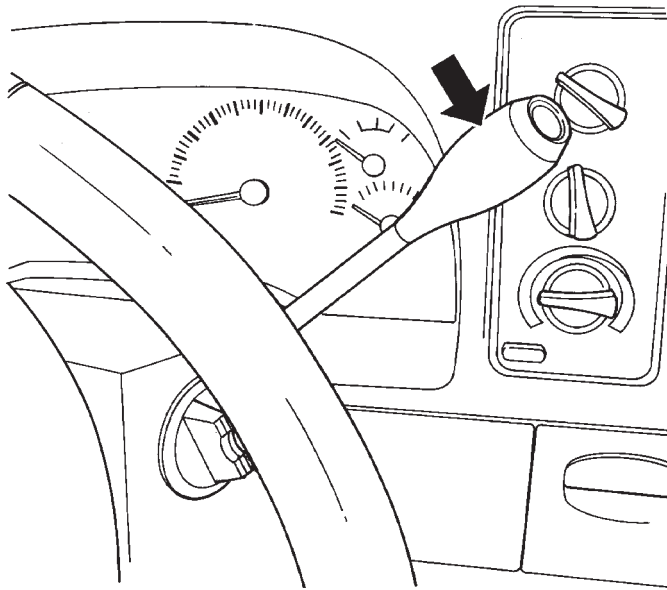
#### MANUAL TRANSMISSION

(1) Check that the shifter operates easily (Fig. 38).

(2) Make sure that the clutch operates smoothly (Fig. 37).

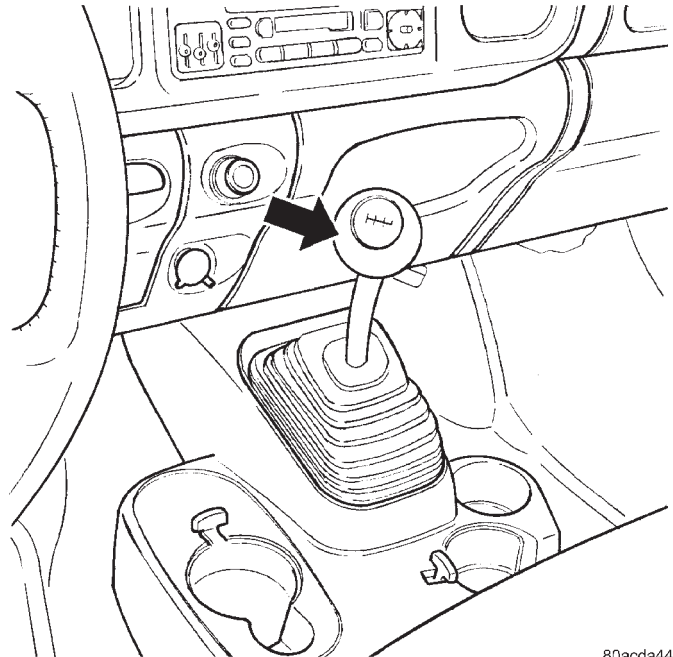
(3) Look for proper synchronization. The gears should not grind.

## ROAD TEST (Continued)



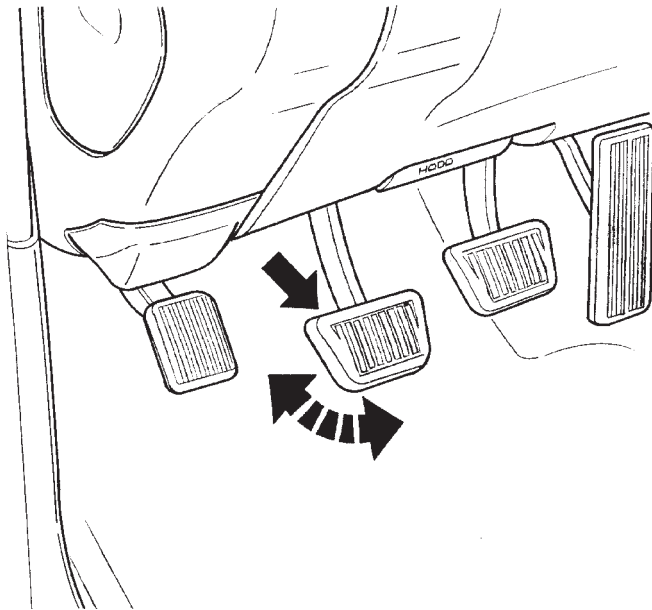
80adc84c

**Fig. 36 AUTOMATIC TRANSMISSION RANGE SELECTOR**



80acda44

**Fig. 38 MANUAL TRANSMISSION RANGE SELECTOR**



80acda81

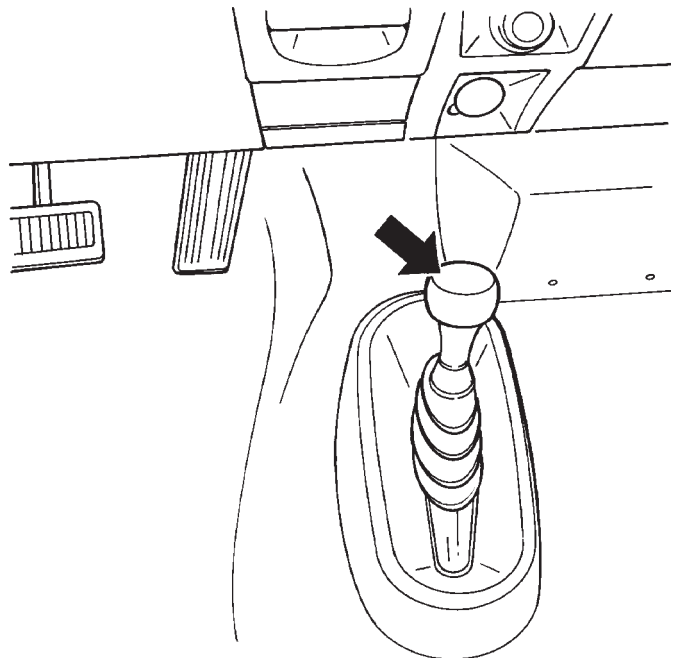
**Fig. 37 CLUTCH PEDAL OPERATION**

#### 4X4 TRANSFER CASE

(1) Shift the transfer case through all ranges to make sure shifting is smooth and all gear positions respond accordingly (Fig. 39).

#### INSPECTION - ENGINE PERFORMANCE

Check the engine for proper performance. It should:



80adc850

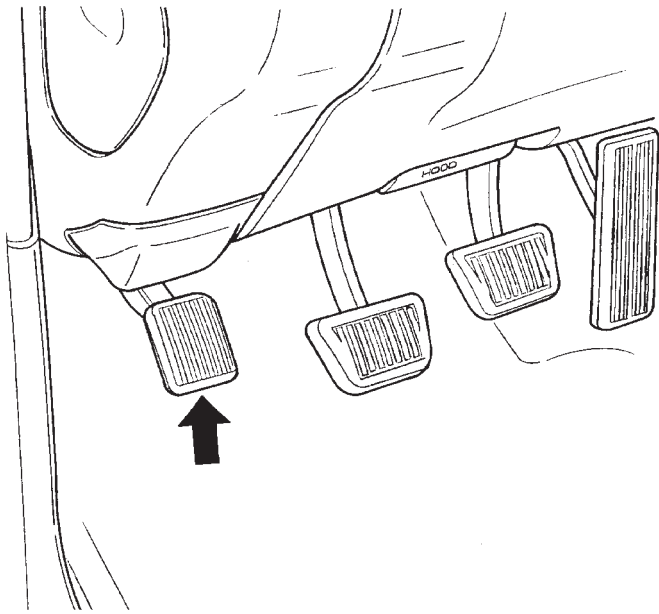
**Fig. 39 TRANSFER CASE SELECTOR**

- Start promptly
- Be free from stalling
- Idle smoothly and at proper speed
- Be free from stumbling or hesitation
- Produce sufficient power
- Be free from unusual noises
- Operate within the proper temperature range
- Stop when the ignition key is shut off

## ROAD TEST (Continued)

**INSPECTION - PARKING BRAKE**

- (1) Ensure that the parking brake is easy to operate (Fig. 40).
- (2) Make sure the parking brake does not drag.
- (3) With the vehicle stopped on a grade, firmly apply the service brakes, place the transmission in NEUTRAL and set the parking brake. Slowly release the service brakes to see if the parking brake will hold.
- (4) Check that the parking brake warning light comes on when the parking brake is applied, and is off when the brake is released.



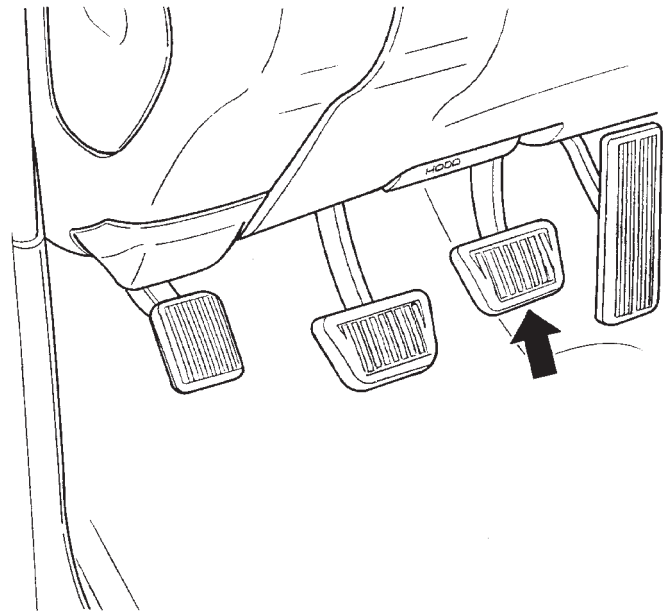
80acdadb

**Fig. 40 PARKING BRAKE OPERATION****INSPECTION - SERVICE BRAKES**

- (1) Check brake warning light operation at vehicle startup.
- (2) Check ABS warning light operation at vehicle startup.
- (3) Inspect service brake pedal travel and feel (Fig. 41).
- (4) Put the vehicle in gear and apply the brakes while the car is in motion. Be sure brake operation is smooth and positive.
- (5) Make sure that the vehicle stops in a straight line, without pulling to one side.
- (6) Check that the brakes operate quietly, without noise.
- (7) Ensure there is no shudder or vibration when braking.

**INSPECTION - SPEED CONTROL**

Check the following speed control functions (Fig. 42):



80acdb21

**Fig. 41 SERVICE BRAKE PEDAL**

- Check on/off switch
- Check "set" operation
- Check "resume" function
- Check "accelerate" and "decelerate" functions
- Check brake release function
- Check "cancel" function

**INSPECTION - TRIP COMPUTER/ MAINTENANCE REMINDER**

**NOTE:** Reset the average fuel economy when the road test is complete.

Check that all modes operate correctly (Fig. 43).

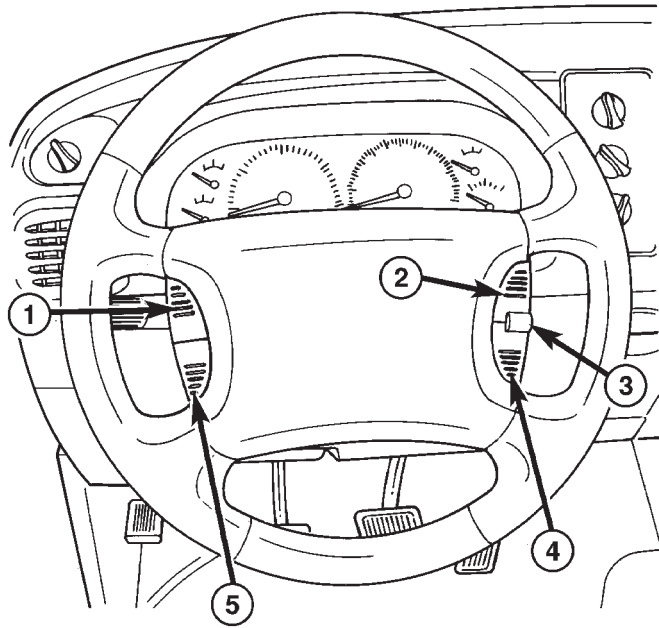
**INSPECTION - RADIO**

- (1) Check for good AM/FM reception, ensure that the cassette and/or compact disc (CD) player works properly (Fig. 44).
- (2) Check for good sound quality from all speakers.
- (3) Ensure that the radio displays the correct time.
- (4) Check the steering wheel controls (if equipped).

**INSPECTION - HEATER/AIR CONDITIONER**

- (1) Check that heater/defroster works properly (Fig. 45).
- (2) Turn on the heater when the engine reaches operating temperature.
- (3) Operate the blower motor in all speeds.
- (4) Operate system in all modes (heat, defrost, etc.).
- (5) Operate the rear heater (if equipped).
- (6) Check for hot air output at all outlets.

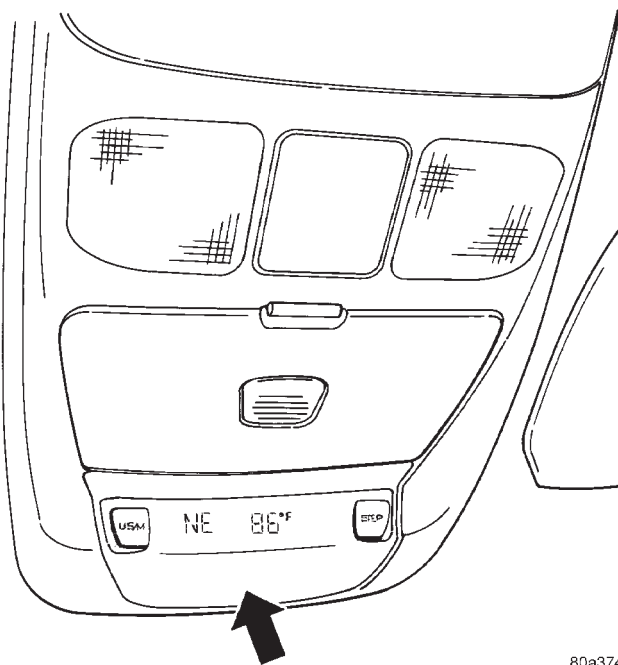
ROAD TEST (Continued)



80acdb37

**Fig. 42 SPEED CONTROL SWITCHES**

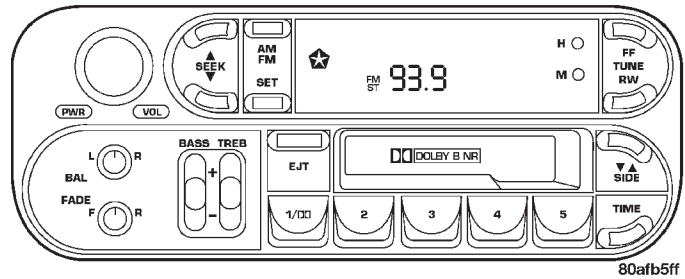
- 1 - ON/OFF SWITCH
- 2 - ACCELERATE/RESUME SWITCH
- 3 - CANCEL SWITCH
- 4 - COAST SWITCH
- 5 - SET SWITCH



80a374ca

**Fig. 43 TRIP COMPUTER**

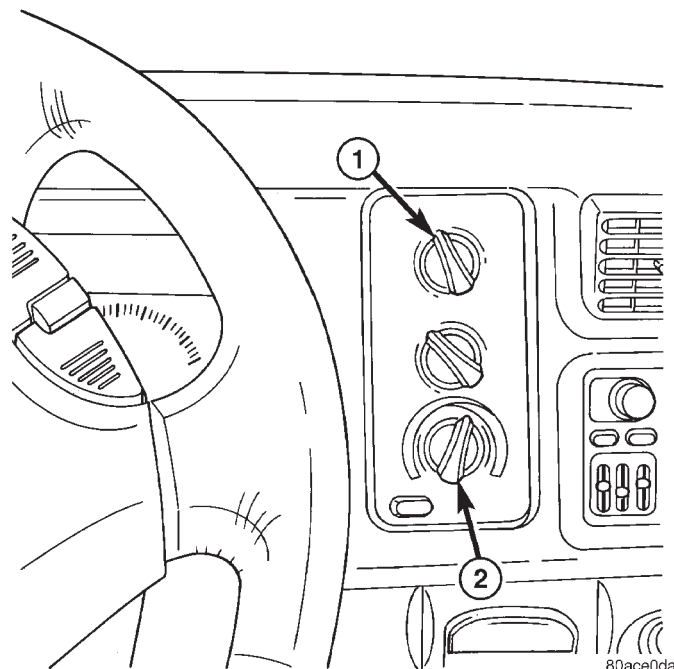
- (7) Operate temperature levers.
- (8) Ensure that rear defroster works.



80afb5ff

**Fig. 44 RADIO OPERATION**

- (9) Turn on rear defroster during drive, then feel window for warmth after drive.
- (10) Check that the air conditioner cools properly.
- (11) Turn on air conditioning system.
- (12) Activate the A/C in all modes. (Make sure all modes work properly including rear unit if equipped.).
- (13) Operate blower motor switch at all speeds.
- (14) Check for cold output at outlets.
- (15) Check that fan operation is quiet.



80ace0da

**Fig. 45 HEATER AND A/C CONTROLS**

- 1 - MODE CONTROL SWITCH
- 2 - TEMPERATURE SWITCH

**INSPECTION WINDSHIELD WIPERS/WASHERS**

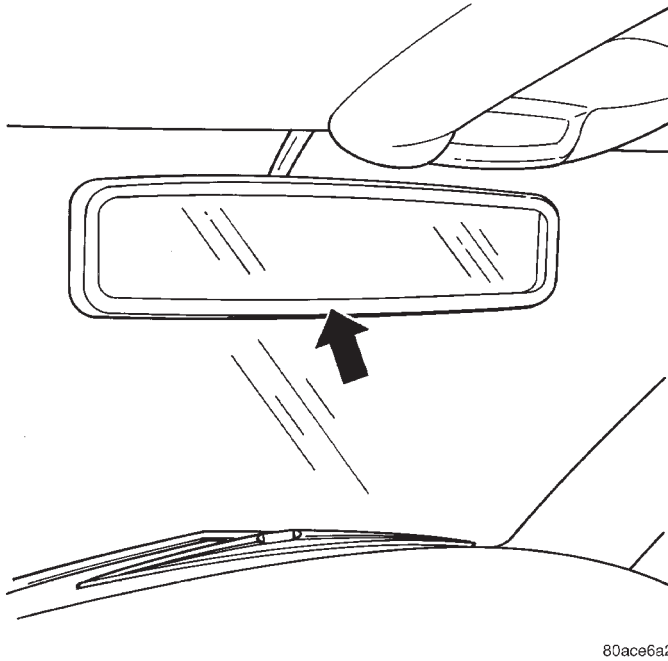
- (1) Check washer spray pattern for proper operation and aim.
- (2) Check intermittent wipe feature for proper operation.
- (3) Inspect wiper blades, check for proper wiping pattern-no streaking or missed areas.



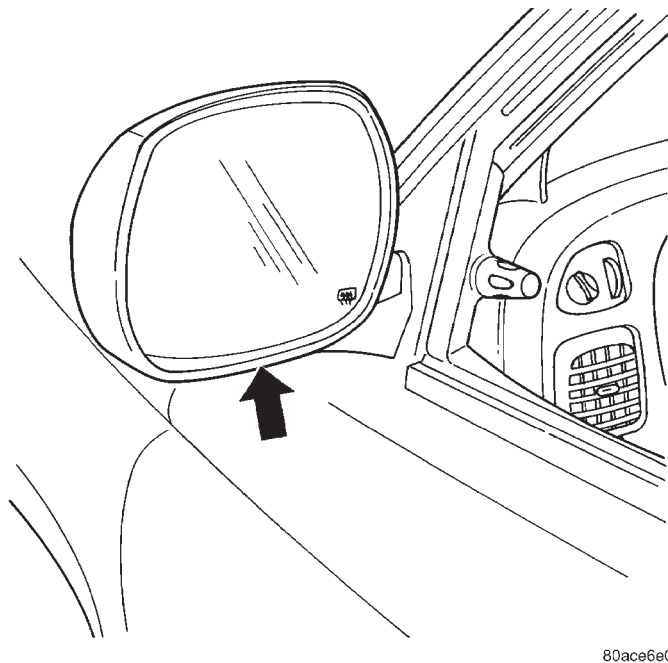
## ROAD TEST (Continued)

**INSPECTION - MIRROR**

- (1) Check operation of rearview mirror's day/night function (if equipped).
- (2) Check ease of adjustment for all mirrors (power or manual) (Fig. 46) and (Fig. 47).



80ace6a2

**Fig. 46 INSIDE REAR VIEW MIRROR**

80ace6e0

**Fig. 47 OUTSIDE REAR VIEW MIRROR****INSPECTION - TURN AND EMERGENCY SIGNALS**

- (1) Ensure that the turn signals work properly (including canceling after completing a turn).
- (2) Ensure that the emergency flashers work properly.

**INSPECTION - HORN**

Ensure that the horn works properly.

**INSPECTION - GAUGES/WARNING LIGHTS**

- (1) Ensure that all gauges, instrument indicator lights, warning lights and instrument panel lights are functioning properly.
- (2) Inspect operation of message center (if equipped).

**INSPECTION - SHIFT/CLUTCH INTERLOCK SYSTEM**

- (1) On vehicles with a manual transmission or transaxle, be sure engine starts only when clutch is depressed.
- (2) Some vehicles equipped with an automatic transmission also have a brake interlock system. On these vehicles, be sure that you cannot shift out of PARK without pressing the brake pedal.

**INSPECTION - NEUTRAL SAFETY SWITCH**

- (1) On vehicles with an automatic transmission or transaxle, check shift indicator alignment in all ranges.
- (2) Be sure the engine starts in both PARK and NEUTRAL.
- (3) Verify that the engine does not start in any REVERSE/DRIVE positions.

**PRE DELIVERY STORAGE****DESCRIPTION**

Pre Delivery Storage information is provided to recommend practices to use when storing new vehicles prior to delivery to the customer.

If you have prepared a vehicle that will not be immediately delivered to the customer, store the vehicle according to guidelines outlined in (Refer to 30 - NEW VEHICLE PREP/PREDELIVERY STORAGE - STANDARD PROCEDURE) to prevent unnecessary wear and tear on the vehicles electrical systems, paint and finish and damage due to pilferage and vandalism.

## PRE DELIVERY STORAGE (Continued)

**STANDARD PROCEDURE - PRE DELIVERY STORAGE**

(1) If possible, store vehicles indoors, in clean, dry places. If vehicles must be stored outdoors:

- Try to avoid storage locations that are near any obvious sources of industrial or environmental contamination (e.g., trees, factories, steam or vapor vents, railroad tracks, etc.)

- Maintain tight security to help prevent pilferage and vandalism, and inspect each vehicle regularly to check for such damage

- If the vehicle must be parked on an incline, park it with the front end higher than the rear; this will prevent “hydrostatic lock” caused by fuel draining into the engine

- Rinse the vehicle at least once a week. Snow should be washed away more often, since it can trap harmful contaminants. Dry all horizontal surfaces

(2) The IOD fuse should be removed in order to prevent battery drain and possible damage.

(3) Check the vehicle’s coolant and anti-freeze protection.

(4) Check the vehicle’s battery at least once a month for a proper charge (at least 12.4 volts). Charge the battery if necessary. This will help prevent freezing and deterioration.

(5) Check the vehicle’s tires and inflate them to their maximum recommended levels. Move the vehicles periodically to avoid “flatspotting” the tires.

(6) Do not engage the parking brake; keep it in the OFF position.

(7) Keep all windows closed, all doors locked, and all trim covers intact and in place.

(8) Do not use chalks, crayons or any marker containing abrasives on painted, plated or glass surfaces.

(9) Always use seat covers when moving a vehicle.

**PROGRAMMABLE ELECTRONIC FEATURES****DESCRIPTION**

The programming of electronic features applies to specific DaimlerChrysler Corporation vehicles. Not all vehicles are equipped with these electronic features, and not all vehicles equipped with electronic features have all the available features. Programmable electronic features are subject to change and may be added or deleted from specific vehicle models.

(1) The programmable electronic features that may be provided on the vehicle are:

- Rolling Power Door Locks
- Horn Chirp (When Doors Locked With Remote Keyless Entry)

- Headlamp Flash (When Doors Locked or Unlocked With Remote Keyless Entry)

- Low Fuel Chime
- Remote Keyless Entry Door Unlock Sequence
- Headlights On Automatically With Wipers
- Turn Signal Chime
- 12V Power Outlet
- Remote Unlock
- Remote Linked To Memory
- Headlamp Delay
- Service Interval
- Easy Exit Seat

(2) Programming any of the above features is to be performed prior to vehicle delivery to the customer, depending on customer preference.

**NOTE:** For all vehicles except Caravan/Town and Country, the programming must be performed using the DRB III® scan tool. On Caravan/Town and Country vehicles the features can be programmed using the DRB III® scan tool or by button pushing sequences. The customer can perform programming, if desired, by following the instructions outlined in the owner manual.

**OPERATION**

**NOTE:** The programmable features provided on vehicles need to be explained to the customer at the time of sale. The customer’s preferences concerning the features should be noted and programmed accordingly during predelivery.

**NOTE:** When using the DRB III® scan tool to enable/disable any programmable electronic features, go to the main menu item #9 on the DRB III® scan tool. This is “Customer Preferences”. You must choose “Customer Preferences” on the main menu to program the desired features.

**ROLLING POWER DOOR LOCKS**

With this feature enabled, the vehicle’s door locking mechanisms automatically lock when the vehicle reaches approximately 24 Km/h (15 mph).

**HORN CHIRP**

**NOTE:** This feature can be enabled with or without the headlamp flash feature.

The horn chirp function is a feature that can be enabled or disabled on vehicles equipped with

## PROGRAMMABLE ELECTRONIC FEATURES (Continued)

Remote Keyless Entry (RKE). The horn chirps when the vehicle is locked with the RKE transmitter.

**HEADLAMP FLASH**

**NOTE: This feature can be enabled with or without the horn chirp feature.**

The headlamp flash function is a feature that can be enabled or disabled on vehicles equipped with Remote Keyless Entry (RKE). The headlamps flash once when the vehicle is locked with the RKE transmitter, and flash twice when the vehicle is unlocked with the RKE transmitter.

**LOW FUEL CHIME**

All vehicles equipped with the audible low fuel chime are shipped with this feature enabled.

**REMOTE KEYLESS ENTRY (RKE) DOOR UNLOCK SEQUENCE**

Two door unlock sequences are provided on vehicles equipped with this feature. When using the RKE transmitter to unlock the doors, pressing the unlock button once when the feature is enabled unlocks only the driver's door. Pushing the RKE transmitter unlock button a second time unlocks the remaining doors. When the RKE door unlock feature is disabled, all doors unlock with one press of the RKE transmitter unlock button.

**HEADLIGHTS ON AUTOMATICALLY WITH WIPERS**

This feature appears on vehicles that have, as an option, automatic headlights. When the windshield wipers are turned on, the headlights automatically turn on.

**12V POWER OUTLET**

This feature currently appears on Caravan/Voyager/Town and Country vehicles. The vehicles are shipped with the 12V power outlets turned off with the ignition key. The relay can be changed to make the outlets powered at all times. This feature may be of interest to customers with cell phones.

**TURN SIGNAL CHIME**

This feature is an audible turn signal warning chime. The chime sounds if the turn signal is on, the vehicle has traveled one mile and vehicle speed has exceeded 40 Km/h (25 mph).

**REMOTE UNLOCK**

The remote unlock function is a feature that can be enabled or disabled on vehicles equipped with Remote Keyless Entry (RKE). With the first press of the RKE transmitter to unlock the doors, the driver's door only unlocks. With the second press of the RKE

transmitter, the remaining doors and the liftgate unlock. With the remote unlock feature enabled, the first press of the RKE transmitter unlocks all doors.

**REMOTE LINKED TO MEMORY**

The remote linked to memory function is currently only available only on Jeep Grand Cherokee Limited vehicles. When enabled, this feature recalls a memory of seats, mirror and radio presets and positions when unlocking the vehicle with the RKE transmitter.

**HEADLAMP DELAY**

Currently available only on Jeep Grand Cherokee vehicles, the headlamp delay timeout can be set to 30, 60 or 90 seconds. This timeout only occurs when the ignition is turned off prior to turning the headlamps off, or when leaving the headlamps in AUTO mode.

**SERVICE INTERVAL**

Currently available only on Jeep Grand Cherokee vehicles, the interval for the service reminder message can be set from 3,219 kilometers to 12,070 kilometers (2,000 miles to 7,500 miles).

**EASY EXIT SEAT**

Currently available only on Jeep Grand Cherokee Limited vehicles, the driver's seat will reposition 55mm (2.1 inches) rearward, or the end of travel if less than 55mm (2.1 inches) and full downward when the key is removed from the ignition. This feature allows ease of exiting the vehicle. The seat will reposition itself to the memory location when the vehicle is unlocked using the RKE transmitter or by pressing the memory buttons on the door panel.

**APPEARANCE TIPS****CLEANING**

(1) Before delivering the new vehicle to the customer, the following checks on appearance details are recommended:

- Wash the vehicle to remove all traces of road grime and other dirt on the car from new vehicle preparation operations
- Clean the tire sidewalls
- Clean exterior and interior glass surfaces
- Remove all protective covers
- Remove undercoat overspray, excess window sealer, and excess weatherstrip adhesive
- Inspect interior trim, seats, carpeting, and moldings. Clean as necessary
- Remove shipping and inspection stickers

**APPEARANCE TIPS (Continued)**

- After the vehicle is clean, inspect the paint again

(2) Mopar® offers a wide variety of car care products, developed to meet your dealership's requirements. All are specifically formulated for DaimlerChrysler vehicles

**FINAL STEPS****STANDARD PROCEDURE - OWNER CHECK OUT**

The last step in the new vehicle preparation procedure is to help the customer become familiar with the features on their new vehicle. Show the new owner where the controls and gauges are and explain how they operate.

**STANDARD PROCEDURE - INSPECTION - INFORMATION LABELS**

Verify that the following labels are installed and legible.

- Emission control labels
- Monroney label
- Tire pressure label
- Vehicle certification label

**NEW VEHICLE PREPARATION FORM**

Complete the Emission Certification Of Conformity Statement on the bottom of the New Vehicle Preparation Form (Fig. 1) in the glove box or storage box after it has been completed and signed by the designated individual.

Description	Group-Page	Description	Group-Page	Description	Group-Page
ABS INDICATOR - DESCRIPTION	8J-14	ACCUMULATOR - DESCRIPTION	24-54	ADJUSTMENT, FRONT DOOR LATCH	23-72
ABS INDICATOR - OPERATION	8J-14	ACCUMULATOR - DESCRIPTION	21-191,21-362, 21-537,21-707	ADJUSTMENT, FRONT DOOR UP/DOWN	23-69
A/C APPLICATION TABLE, SPECIFICATIONS	24-8	ACCUMULATOR - INSPECTION	21-192,21-363, 21-538,21-708	ADJUSTMENT, FRONT FASCIA	13-2
A/C COMPRESSOR - DESCRIPTION	24-46	ACCUMULATOR - INSTALLATION	24-55	ADJUSTMENT, HOOD	23-100
A/C COMPRESSOR - DIAGNOSIS AND TESTING	24-46	ACCUMULATOR - OPERATION	24-54	ADJUSTMENT, LATCH	23-100
A/C COMPRESSOR - INSTALLATION	24-47	ACCUMULATOR - OPERATION	21-191,21-362, 21-537,21-708	ADJUSTMENT, LATCH STRIKER	23-102
A/C COMPRESSOR - OPERATION	24-46	ACCUMULATOR - REMOVAL	24-54	ADJUSTMENT, REAR BRAKE DRUM	5-34
A/C COMPRESSOR - REMOVAL	24-47	ACTUATION TEST MODE - DESCRIPTION, CIRCUIT	25-1	ADJUSTMENT, SHIFT LEVER	21-853,21-888, 21-925
A/C COMPRESSOR CLUTCH - DESCRIPTION	24-13	ACTUATOR - INSTALLATION, BLEND DOOR	24-26	ADJUSTMENT, SHIFT MECHANISM	21-252, 21-423,21-596,21-769
A/C COMPRESSOR CLUTCH - INSPECTION	24-16	ACTUATOR - INSTALLATION, HEAT/ DEFROST DOOR	24-27	ADJUSTMENTS, FOG LAMP UNIT	8L-12
A/C COMPRESSOR CLUTCH - INSTALLATION	24-16	ACTUATOR - INSTALLATION, INSIDE HANDLE	23-71,23-80	ADJUSTMENTS, FRONT AXLE - 216FBI	3-17
A/C COMPRESSOR CLUTCH - OPERATION	24-13	ACTUATOR - INSTALLATION, PANEL/ DEFROST DOOR	24-27	ADJUSTMENTS, FRONT AXLE - 248FBI	3-50
A/C COMPRESSOR CLUTCH - REMOVAL	24-14	ACTUATOR - INSTALLATION, RECIRCULATION DOOR	24-28	ADJUSTMENTS, GEAR	19-16
A/C COMPRESSOR CLUTCH BREAK-IN - STANDARD PROCEDURE	24-13	ACTUATOR - REMOVAL, BLEND DOOR	24-25	ADJUSTMENTS, HEADLAMP UNIT	8L-21
A/C COMPRESSOR CLUTCH COIL - DIAGNOSIS AND TESTING	24-13	ACTUATOR - REMOVAL, HEAT/DEFROST DOOR	24-26	ADJUSTMENTS, REAR AXLE - 248RBI	3-114
A/C COMPRESSOR CLUTCH RELAY - DESCRIPTION	24-17	ACTUATOR - REMOVAL, INSIDE HANDLE	23-71, 23-80	ADJUSTMENTS, REAR AXLE - 267RBI	3-145
A/C COMPRESSOR CLUTCH RELAY - DIAGNOSIS AND TESTING	24-17	ADAPTER - INSTALLATION, DEFROSTER AND DEMISTER DUCT	24-35	ADJUSTMENTS, REAR AXLE - 286RBI	3-174
A/C COMPRESSOR CLUTCH RELAY - INSTALLATION	24-18	ADAPTER - REMOVAL, DEFROSTER AND DEMISTER DUCT	24-35	ADJUSTMENTS, REAR AXLE - 9 1/4	3-84
A/C COMPRESSOR CLUTCH RELAY - OPERATION	24-17	ADAPTER BRACKET - INSTALLATION, CAB CHASSIS	13-9	ADJUSTMENTS, TRANSMISSION THROTTLE VALVE CABLE	21-254,21-425,21-598, 21-771
A/C COMPRESSOR CLUTCH RELAY - REMOVAL	24-18	ADAPTER BRACKET - REMOVAL, CAB CHASSIS	13-9	ADJUSTMENTS, VALVE BODY	21-304,21-476, 21-646,21-818
A/C CONDENSER - DESCRIPTION	24-48	ADAPTER HOUSING SEAL - INSTALLATION	21-132,21-87	AFTER AN AIRBAG DEPLOYMENT - STANDARD PROCEDURE, SERVICE	80-4
A/C CONDENSER - INSTALLATION	24-49	ADAPTER HOUSING SEAL - REMOVAL	21-132, 21-87	AIR BLEED - STANDARD PROCEDURE	14-57
A/C CONDENSER - OPERATION	24-48	ADDING ADDITIONAL COOLANT - STANDARD PROCEDURE	7-16	AIR CHECKING TRANSMISSION CLUTCH AND BAND OPERATION - DIAGNOSIS AND TESTING	21-147,21-318
A/C CONDENSER - REMOVAL	24-49	ADDITIONAL COOLANT - STANDARD PROCEDURE, ADDING	7-16	AIR CLEANER ELEMENT - INSTALLATION	9-245
A/C EVAPORATOR - DESCRIPTION	24-52	ADHESIVE LOCATIONS, SPECIFICATIONS - STRUCTURAL	23-44	AIR CLEANER ELEMENT - REMOVAL	9-244
A/C EVAPORATOR - INSTALLATION	24-53	ADJUSTER - DIAGNOSIS & TESTING, POWER LUMBAR	8N-18	AIR CONDITIONER - DESCRIPTION, HEATER	24-1
A/C EVAPORATOR - OPERATION	24-53	ADJUSTER - INSTALLATION, SEAT BELT TURNING LOOP	80-29	AIR CONDITIONER - OPERATION, HEATER	24-1
A/C EVAPORATOR - REMOVAL	24-53	ADJUSTER - INSTALLATION, SEAT TRACK	23-143	AIR CONDITIONING - INSTALLATION, WATER PUMP BYPASS HOSE WITH	7-77
A/C HEATER CONTROL - DESCRIPTION	24-18	ADJUSTER - REMOVAL, SEAT BELT TURNING LOOP	80-29	AIR CONDITIONING - INSTALLATION, WATER PUMP BYPASS HOSE WITHOUT	7-78
A/C HEATER CONTROL - DIAGNOSIS AND TESTING	24-19	ADJUSTER - REMOVAL, SEAT TRACK	23-143	AIR CONDITIONING - REMOVAL, WATER PUMP BYPASS HOSE WITH	7-74
A/C HEATER CONTROL - INSTALLATION	24-20	ADJUSTER ASSEMBLY - INSTALLATION, ROCKER ARM	9-85	AIR CONDITIONING - REMOVAL, WATER PUMP BYPASS HOSE WITHOUT	7-77
A/C HEATER CONTROL - OPERATION	24-18	ADJUSTER ASSEMBLY - REMOVAL, ROCKER ARM	9-85	AIR CONTROL MOTOR - DESCRIPTION, IDLE	14-41
A/C HEATER CONTROL - REMOVAL	24-19	ADJUSTER ASSY - CLEANING, ROCKER ARM	9-262	AIR CONTROL MOTOR - OPERATION, IDLE	14-41
A/C HIGH PRESSURE SWITCH - DESCRIPTION	24-20	ADJUSTER ASSY - DESCRIPTION, ROCKER ARM	9-261	AIR COOLER AND PLUMBING - CLEANING, CHARGE	11-18
A/C HIGH PRESSURE SWITCH - DIAGNOSIS AND TESTING	24-20	ADJUSTER ASSY - INSPECTION, ROCKER ARM	9-262	AIR COOLER AND PLUMBING - DESCRIPTION, CHARGE	11-17
A/C HIGH PRESSURE SWITCH - INSTALLATION	24-21	ADJUSTER ASSY - INSTALLATION, ROCKER ARM	9-142,9-200,9-263	AIR COOLER AND PLUMBING - INSPECTION, CHARGE	11-18
A/C HIGH PRESSURE SWITCH - OPERATION	24-20	ADJUSTER ASSY - REMOVAL, ROCKER ARM	9-142,9-200,9-261	AIR COOLER AND PLUMBING - INSTALLATION, CHARGE	11-18
A/C HIGH PRESSURE SWITCH - REMOVAL	24-21	ADJUSTER KNOB - INSTALLATION, TURNING LOOP HEIGHT	80-30	AIR COOLER AND PLUMBING - OPERATION, CHARGE	11-17
A/C LINE COUPLERS - DESCRIPTION	24-40	ADJUSTER KNOB - REMOVAL, TURNING LOOP HEIGHT	80-30	AIR COOLER AND PLUMBING - REMOVAL, CHARGE	11-17
A/C LINE COUPLERS - OPERATION	24-41	ADJUSTMENT - STANDARD PROCEDURE, COMPASS VARIATION	8M-4	AIR DAM - INSTALLATION, FRONT	13-2
A/C LINE COUPLERS - STANDARD PROCEDURE	24-43	ADJUSTMENT AND VERIFICATION - STANDARD PROCEDURE, VALVE LASH	9-256	AIR DAM - REMOVAL, FRONT	13-1
A/C LOW PRESSURE SWITCH - DESCRIPTION	24-21	ADJUSTMENT, BANDS	21-193,21-364,21-539, 21-709	AIR EXHAUSTER - INSTALLATION	23-77
A/C LOW PRESSURE SWITCH - DIAGNOSIS AND TESTING	24-21	ADJUSTMENT, CABLE TENSIONER	5-40	AIR EXHAUSTER - REMOVAL	23-77
A/C LOW PRESSURE SWITCH - INSTALLATION	24-22	ADJUSTMENT, CARGO DOOR	23-78	AIR HEATER - DESCRIPTION, INTAKE	14-100
A/C LOW PRESSURE SWITCH - OPERATION	24-21	ADJUSTMENT, CENTER BEARING - CENTER BEARING	3-10	AIR HEATER - INSTALLATION, INTAKE	14-101
A/C LOW PRESSURE SWITCH - REMOVAL	24-21	ADJUSTMENT, FRONT DOOR FORE/AFT	23-68	AIR HEATER - OPERATION, INTAKE	14-100
A/C ORIFICE TUBE - DESCRIPTION	24-53	ADJUSTMENT, FRONT DOOR IN/OUT	23-69	AIR HEATER - REMOVAL, INTAKE	14-100
A/C ORIFICE TUBE - OPERATION	24-53			AIR HEATER RELAY - DESCRIPTION, INTAKE	14-101
A/C ORIFICE TUBE - REMOVAL	24-54			AIR HEATER RELAY - INSTALLATION, INTAKE	14-102
A/C PERFORMANCE - DIAGNOSIS AND TESTING	24-2			AIR HEATER RELAY - OPERATION, INTAKE	14-102
ACCELERATOR PEDAL - INSTALLATION	14-37			AIR HEATER RELAY - REMOVAL, INTAKE	14-102
ACCELERATOR PEDAL - REMOVAL	14-37			AIR IN FUEL SYSTEM - DIAGNOSIS AND TESTING	14-56
ACCELERATOR PEDAL POSITION SENSOR - DESCRIPTION	14-91			AIR INJECTION PUMP - DESCRIPTION	25-28
ACCELERATOR PEDAL POSITION SENSOR - INSTALLATION	14-93			AIR INJECTION PUMP - DIAGNOSIS AND TESTING	25-28
ACCELERATOR PEDAL POSITION SENSOR - OPERATION	14-91			AIR INJECTION PUMP - INSTALLATION	25-29
ACCELERATOR PEDAL POSITION SENSOR - REMOVAL	14-91			AIR INJECTION PUMP - OPERATION	25-28
ACCESSORY DRIVE BELT - DIAGNOSIS AND TESTING	7-24,7-27,7-31			AIR INJECTION PUMP - REMOVAL	25-29
				AIR INJECTION SYSTEM - DESCRIPTION	25-25
				AIR INJECTION SYSTEM - OPERATION	25-27
				AIR INJECTION SYSTEM - TORQUE	25-28



Description	Group-Page	Description	Group-Page	Description	Group-Page
AIR PUMP FILTER - INSTALLATION	25-29	A-PILLAR GRAB HANDLE - INSTALLATION	23-119	ASSEMBLY, OVERDRIVE UNIT	21-225,21-395, 21-569,21-742
AIR PUMP FILTER - REMOVAL	25-29	A-PILLAR GRAB HANDLE - REMOVAL	23-119	ASSEMBLY, OVERHEAD CONSOLE - OVERHEAD CONSOLE	8M-7
AIR TESTING TRANSMISSION CLUTCH AND BAND OPERATION - DIAGNOSIS AND TESTING	21-490,21-661	A-PILLAR TRIM - INSTALLATION	23-119	ASSEMBLY, OVERRUNNING CLUTCH CAM/OVERDRIVE PISTON RETAINER	21-236,21-406,21-581,21-752
AIR TO OIL COOLER - INSTALLATION	7-88	A-PILLAR TRIM - REMOVAL	23-119	ASSEMBLY, PLANETARY GEARTRAIN/ OUTPUT SHAFT	21-241,21-412,21-588,21-760
AIR TO OIL COOLER - REMOVAL	7-87	A-PILLAR TWEETER SPEAKER - INSTALLATION	8A-19	ASSEMBLY, REAR CLUTCH	21-248,21-419, 21-593,21-766
AIRBAG - ASSEMBLY, DRIVER	80-17	A-PILLAR TWEETER SPEAKER - REMOVAL	8A-19	ASSEMBLY, REAR SERVO	21-251,21-422, 21-595,21-768
AIRBAG - DESCRIPTION, DRIVER	80-14	APPEARANCE TIPS - CLEANING	30-21	ASSEMBLY, TRANS COOLER - 3.9L/5.2L/5.9L	7-82
AIRBAG - DESCRIPTION, PASSENGER	80-21	APPLICATION TABLE, SPECIFICATIONS - A/C	24-8	ASSEMBLY, TRANSFER CASE - NV231HD	21-834
AIRBAG - DISASSEMBLY, DRIVER	80-15	APPLIQUE - INSTALLATION	23-62,23-67	ASSEMBLY, TRANSFER CASE - NV241HD	21-904
AIRBAG - INSTALLATION, DRIVER	80-18	APPLIQUE - REMOVAL	23-62,23-67	ASSEMBLY, TRANSFER CASE - NV241LD	21-869
AIRBAG - INSTALLATION, PASSENGER	80-23	AREA LEAKS - DIAGNOSIS AND TESTING, REAR SEAL	9-10	ASSEMBLY, VALVE BODY	21-294,21-466,21-638, 21-810
AIRBAG - OPERATION, DRIVER	80-14	ARM / ADJUSTER ASSEMBLY - INSTALLATION, ROCKER	9-85	ASSEMBLY, WHEEL CYLINDERS	5-31
AIRBAG - OPERATION, PASSENGER	80-21	ARM / ADJUSTER ASSEMBLY - REMOVAL, ROCKER	9-85	ASSIST HANDLE - INSTALLATION	23-124
AIRBAG - REMOVAL, DRIVER	80-14	ARM / ADJUSTER ASSY - CLEANING, ROCKER	9-262	ASSIST HANDLE - REMOVAL	23-124
AIRBAG - REMOVAL, PASSENGER	80-21	ARM / ADJUSTER ASSY - DESCRIPTION, ROCKER	9-261	ASSY - CLEANING, ROCKER ARM / ADJUSTER	9-262
AIRBAG CONTROL MODULE - DESCRIPTION	80-6	ARM / ADJUSTER ASSY - INSPECTION, ROCKER	9-262	ASSY - DESCRIPTION, ROCKER ARM / ADJUSTER	9-261
AIRBAG CONTROL MODULE - INSTALLATION	80-8	ARM / ADJUSTER ASSY - REMOVAL, ROCKER	9-142,9-200,9-263	ASSY - INSPECTION, ROCKER ARM / ADJUSTER	9-262
AIRBAG CONTROL MODULE - OPERATION	80-6	ARM / ADJUSTER ASSY - REMOVAL, ROCKER	9-142,9-200,9-261	ASSY - INSTALLATION, ROCKER ARM / ADJUSTER	9-142,9-200,9-263
AIRBAG CONTROL MODULE - REMOVAL	80-7	ARM - DESCRIPTION, WIPER	8R-11	ASSY - REMOVAL, ROCKER ARM / ADJUSTER	9-142,9-200,9-261
AIRBAG DEPLOYMENT - STANDARD PROCEDURE, SERVICE AFTER AN	80-4	ARM - INSTALLATION, LOWER CONTROL	2-10,2-20	AUDIO - DESCRIPTION	8A-1
AIRBAG INDICATOR - DESCRIPTION	8J-15	ARM - INSTALLATION, UPPER CONTROL	2-13,2-24	AUDIO - DIAGNOSIS AND TESTING	8A-2
AIRBAG INDICATOR - OPERATION	8J-15	ARM - OPERATION, WIPER	8R-12	AUDIO - OPERATION	8A-2
AIRBAG ON/OFF SWITCH - DESCRIPTION, PASSENGER	80-23	ARM - REMOVAL, LOWER CONTROL	2-10,2-20	AUDIO SYSTEMS, SPECIAL TOOLS	8A-4
AIRBAG ON/OFF SWITCH - INSTALLATION, PASSENGER	80-25	ARM - REMOVAL, UPPER CONTROL	2-13,2-23	AUGAT - INSTALLATION, CONNECTOR	8W-01-8
AIRBAG ON/OFF SWITCH - OPERATION, PASSENGER	80-24	ARM - REMOVAL, WIPER	8R-12	AUGAT - REMOVAL, CONNECTOR	8W-01-8
AIRBAG ON/OFF SWITCH - REMOVAL, PASSENGER	80-24	ARMREST/CONSOLE - INSTALLATION, CENTER SEAT	23-132	AUTO. TRANS. - INSTALLATION, DIESEL WITH	8P-11,8P-4
AIRBAG SYSTEM - DIAGNOSIS AND TESTING	80-4	ARMREST/CONSOLE - REMOVAL, CENTER SEAT	23-132	AUTO. TRANS. - REMOVAL, DIESEL WITH	8P-4,8P-8
AIRBAG SYSTEM - SPECIAL TOOLS	80-6	ARMREST/LATCH COVER - INSTALLATION, CENTER SEAT	23-132	AUTOMATIC DAY / NIGHT MIRROR - DESCRIPTION	8N-10
AIRBAGS - STANDARD PROCEDURE, HANDLING NON-DEPLOYED	80-4	ARMREST/LATCH COVER - REMOVAL, CENTER SEAT	23-132	AUTOMATIC DAY / NIGHT MIRROR - INSTALLATION	8N-12
AIRFLOW - DESCRIPTION, HVAC SYSTEM	24-31	ASD AND FUEL PUMP RELAYS - DIAGNOSIS AND TESTING	8I-3	AUTOMATIC DAY / NIGHT MIRROR - OPERATION	8N-11
AJAR SWITCH - DESCRIPTION, DOOR	8L-34	ASD SENSE - PCM INPUT - OPERATION	8I-3	AUTOMATIC DAY / NIGHT MIRROR - REMOVAL	8N-12
AJAR SWITCH - DIAGNOSIS AND TESTING, DOOR	8L-34	ASH RECEIVER - INSTALLATION	23-109	AUTOMATIC DAY/NIGHT MIRROR - DIAGNOSIS AND TESTING	8N-11
AJAR SWITCH - INSTALLATION, DOOR	8L-35	ASH RECEIVER - REMOVAL	23-108	AUTOMATIC SHUT DOWN RELAY - INSTALLATION	8I-5
AJAR SWITCH - REMOVAL, DOOR	8L-35	ASSEMBLE, OIL PUMP	9-109,9-165	AUTOMATIC SHUT DOWN RELAY - REMOVAL	8I-4
ALIGNMENT - DESCRIPTION, WHEEL	2-1	ASSEMBLY - INSTALLATION, ROCKER ARM / ADJUSTER	9-85	AUTOMATIC TRANSMISSION - 42RE - ASSEMBLY	21-166
ALIGNMENT - OPERATION, WHEEL	2-2	ASSEMBLY, AUTOMATIC TRANSMISSION - 42RE	21-166	AUTOMATIC TRANSMISSION - 42RE - CLEANING	21-165
ALIGNMENT I.F.S. - STANDARD PROCEDURES	2-2	ASSEMBLY, AUTOMATIC TRANSMISSION - 44RE	21-337	AUTOMATIC TRANSMISSION - 42RE - DESCRIPTION	21-135
ALIGNMENT LINK/COIL SUSPENSION - STANDARD PROCEDURES	2-5	ASSEMBLY, AUTOMATIC TRANSMISSION - 46RE	21-510	AUTOMATIC TRANSMISSION - 42RE - DISASSEMBLY	21-160
ALIGNMENT, SPECIAL TOOLS - HEADLAMP	8L-4	ASSEMBLY, AUTOMATIC TRANSMISSION - 47RE	21-681	AUTOMATIC TRANSMISSION - 42RE - INSPECTION	21-165
ALIGNMENT, SPECIFICATIONS	2-6	ASSEMBLY, AXLE VACUUM MOTOR	3-33,3-65	AUTOMATIC TRANSMISSION - 42RE - INSTALLATION	21-173
ALUMINUM THREAD REPAIR - STANDARD PROCEDURE	21-159,21-330,21-502,21-673	ASSEMBLY, DIFFERENTIAL	3-128,3-159,3-188, 3-37,3-69,3-98	AUTOMATIC TRANSMISSION - 42RE - OPERATION	21-137
AMBIENT TEMP SENSOR - DESCRIPTION	8M-11	ASSEMBLY, DIFFERENTIAL - POWR-LOK	3-163	AUTOMATIC TRANSMISSION - 42RE - REMOVAL	21-159
AMBIENT TEMP SENSOR - INSTALLATION	8M-13	ASSEMBLY, DIFFERENTIAL - TRAC-LOK	3-101, 3-132,3-190	AUTOMATIC TRANSMISSION - 44RE - ASSEMBLY	21-337
AMBIENT TEMP SENSOR - OPERATION	8M-11	ASSEMBLY, DISC BRAKE CALIPERS	5-12	AUTOMATIC TRANSMISSION - 44RE - CLEANING	21-336
AMBIENT TEMP SENSOR - REMOVAL	8M-12	ASSEMBLY, DRIVER AIRBAG	80-17	AUTOMATIC TRANSMISSION - 44RE - DESCRIPTION	21-306
AMBIENT TEMPERATURE SENSOR - DIAGNOSIS & TESTING	8M-12	ASSEMBLY, FLYWHEEL	6-17	AUTOMATIC TRANSMISSION - 44RE - DISASSEMBLY	21-331
AMPERAGE TEST - DIAGNOSIS AND TESTING, FUEL PUMP	14-10	ASSEMBLY, FRONT CLUTCH	21-206,21-376, 21-550,21-721	AUTOMATIC TRANSMISSION - 44RE - INSPECTION	21-337
AN AIRBAG DEPLOYMENT - STANDARD PROCEDURE, SERVICE AFTER	80-4	ASSEMBLY, FRONT SERVO	21-208,21-379, 21-553,21-723	AUTOMATIC TRANSMISSION - 44RE - INSTALLATION	21-344
ANTENNA - DIAGNOSIS AND TESTING	8A-5	ASSEMBLY, GLOVE BOX	23-112	AUTOMATIC TRANSMISSION - 44RE - OPERATION	21-308
ANTENNA BODY & CABLE - DESCRIPTION	8A-4	ASSEMBLY, HVAC HOUSING	24-36		
ANTENNA BODY & CABLE - OPERATION	8A-4	ASSEMBLY, INSTRUMENT CLUSTER	8J-13		
ANTENNA CABLE - INSTALLATION, INSTRUMENT PANEL	8A-10	ASSEMBLY, MANUAL - NV3500	21-17		
ANTENNA CABLE - REMOVAL, INSTRUMENT PANEL	8A-9	ASSEMBLY, MANUAL - NV4500	21-65		
ANTILOCK BRAKE - DESCRIPTION, CONTROLLER	8E-11	ASSEMBLY, MANUAL - NV5600	21-110		
ANTILOCK BRAKE - INSTALLATION, CONTROLLER	8E-12	ASSEMBLY, OIL PUMP	9-51		
ANTILOCK BRAKE - OPERATION, CONTROLLER	8E-11	ASSEMBLY, OIL PUMP	21-212,21-382,21-558, 21-729		
ANTILOCK BRAKE - REMOVAL, CONTROLLER	8E-12				

Description	Group-Page	Description	Group-Page	Description	Group-Page
AUTOMATIC TRANSMISSION - 44RE - REMOVAL	21-330	AXLE SHAFT SEALS - REMOVAL	3-29,3-61,3-94	BATTERIES - STANDARD PROCEDURE, RKE TRANSMITTER	8N-8
AUTOMATIC TRANSMISSION - 46RE - ASSEMBLY	21-510	AXLE SHAFTS - INSTALLATION	3-125,3-156,3-185,3-28,3-60,3-93	BATTERY - DESCRIPTION	8F-6
AUTOMATIC TRANSMISSION - 46RE - CLEANING	21-509	AXLE SHAFTS - INTERMEDIATE - INSTALLATION	3-28	BATTERY - DIAGNOSIS AND TESTING	8F-7
AUTOMATIC TRANSMISSION - 46RE - DESCRIPTION	21-478	AXLE SHAFTS - INTERMEDIATE - REMOVAL	3-28	BATTERY - INSPECTION	30-7
AUTOMATIC TRANSMISSION - 46RE - DISASSEMBLY	21-503	AXLE SHAFTS - REMOVAL	3-125,3-156,3-185,3-28,3-60,3-93	BATTERY - INSTALLATION	8F-17
AUTOMATIC TRANSMISSION - 46RE - INSPECTION	21-510	AXLE, SPECIAL TOOLS - FRONT	3-58	BATTERY - OPERATION	8F-7
AUTOMATIC TRANSMISSION - 46RE - INSTALLATION	21-518	AXLE VACUUM MOTOR - ASSEMBLY	3-33,3-65	BATTERY - REMOVAL	8F-17
AUTOMATIC TRANSMISSION - 46RE - OPERATION	21-480	AXLE VACUUM MOTOR - DESCRIPTION	3-29,3-62	BATTERY CABLE - DESCRIPTION	8F-19
AUTOMATIC TRANSMISSION - 46RE - REMOVAL	21-502	AXLE VACUUM MOTOR - DISASSEMBLY	3-33,3-65	BATTERY CABLE - OPERATION	8F-20
AUTOMATIC TRANSMISSION - 47RE - ASSEMBLY	21-681	AXLE VACUUM MOTOR - INSTALLATION	3-33,3-65	BATTERY CABLES - DIAGNOSIS & TESTING	8F-20
AUTOMATIC TRANSMISSION - 47RE - CLEANING	21-680	AXLE VACUUM MOTOR - OPERATION	3-30,3-62	BATTERY CHARGING - STANDARD PROCEDURE	8F-9
AUTOMATIC TRANSMISSION - 47RE - DESCRIPTION	21-649	AXLE VACUUM MOTOR - REMOVAL	3-33,3-65	BATTERY ELECTROLYTE LEVEL - STANDARD PROCEDURE, CHECKING	8F-8
AUTOMATIC TRANSMISSION - 47RE - DISASSEMBLY	21-674	AXLES, SPECIAL TOOLS - FRONT	3-25	BATTERY HOLDDOWN - DESCRIPTION	8F-18
AUTOMATIC TRANSMISSION - 47RE - INSPECTION	21-681	BACK - BENCH SEAT - INSTALLATION, SEAT	23-135	BATTERY HOLDDOWN - INSTALLATION	8F-18
AUTOMATIC TRANSMISSION - 47RE - INSTALLATION	21-688	BACK - BENCH SEAT - REMOVAL, SEAT	23-135	BATTERY HOLDDOWN - OPERATION	8F-18
AUTOMATIC TRANSMISSION - 47RE - OPERATION	21-651	BACK - SPLIT BENCH - INSTALLATION, SEAT	23-136	BATTERY HOLDDOWN - REMOVAL	8F-18
AUTOMATIC TRANSMISSION - 47RE - REMOVAL	21-673	BACK - SPLIT BENCH - REMOVAL, SEAT	23-135	BATTERY SPECIFICATIONS	8F-6
AUTOMATIC TRANSMISSION - DIAGNOSIS AND TESTING	21-143,21-314,21-486,21-657	BACK COVER - INSTALLATION, SEAT	23-137	BATTERY SYSTEM - CLEANING	8F-5
AUTOMATIC TRANSMISSION FLUID - DESCRIPTION	0-5	BACK COVER - SPLIT BENCH - INSTALLATION, SEAT	23-138	BATTERY SYSTEM - DESCRIPTION	8F-1
AUTOMATIC TRANSMISSION FLUID - OPERATION	0-5	BACK COVER - SPLIT BENCH - REMOVAL, SEAT	23-137	BATTERY SYSTEM - DIAGNOSIS AND TESTING	8F-2
AXLE - 216FBI - ADJUSTMENTS, FRONT	3-17	BACK RECLINER - INSTALLATION, SEAT	23-138	BATTERY SYSTEM - INSPECTION	8F-5
AXLE - 216FBI - DESCRIPTION, FRONT	3-12	BACK RECLINER - REMOVAL, SEAT	23-138	BATTERY SYSTEM - OPERATION	8F-2
AXLE - 216FBI - INSTALLATION, FRONT	3-17	BACKLITE - INSTALLATION	23-145	BATTERY TEMPERATURE SENSOR - DESCRIPTION	8F-29
AXLE - 216FBI - OPERATION, FRONT	3-12	BACKLITE - REMOVAL	23-145	BATTERY TEMPERATURE SENSOR - INSTALLATION	8F-29
AXLE - 216FBI - REMOVAL, FRONT	3-16	BACKLITE LATCH AND KEEPER - INSTALLATION	23-146	BATTERY TEMPERATURE SENSOR - OPERATION	8F-29
AXLE - 248FBI - ADJUSTMENTS, FRONT	3-50	BACKLITE LATCH AND KEEPER - REMOVAL	23-146	BATTERY TEMPERATURE SENSOR - REMOVAL	8F-29
AXLE - 248FBI - DESCRIPTION, FRONT	3-45	BACKLITE VENT GLASS - INSTALLATION	23-147	BATTERY TRAY - DESCRIPTION	8F-24
AXLE - 248FBI - INSTALLATION, FRONT	3-50	BACKLITE VENT GLASS - REMOVAL	23-147	BATTERY TRAY - INSTALLATION	8F-25
AXLE - 248FBI - OPERATION, FRONT	3-45	BAFFLE - INSTALLATION, HVAC HOUSING INLET	24-37	BATTERY TRAY - OPERATION	8F-25
AXLE - 248FBI - REMOVAL, FRONT	3-50	BAFFLE - REMOVAL, HVAC HOUSING INLET	24-36	BATTERY TRAY - REMOVAL	8F-25
AXLE - 248RBI - ADJUSTMENTS, REAR	3-114	BALANCE - STANDARD PROCEDURES, TIRE AND WHEEL	22-4	BEAM INDICATOR - DESCRIPTION, HIGH	8J-21
AXLE - 248RBI - DESCRIPTION, REAR	3-109	BALL JOINT - DIAGNOSIS AND TESTING, LOWER	2-10	BEAM INDICATOR - DIAGNOSIS AND TESTING, HIGH	8J-22
AXLE - 248RBI - INSTALLATION, REAR	3-114	BALL JOINT - DIAGNOSIS AND TESTING, UPPER	2-12	BEAM INDICATOR - OPERATION, HIGH	8J-22
AXLE - 248RBI - OPERATION, REAR	3-109	BALL JOINT - INSTALLATION, LOWER	2-25	BEARING - CENTER BEARING ADJUSTMENT, CENTER	3-10
AXLE - 248RBI - REMOVAL, REAR	3-113	BALL JOINT - INSTALLATION, UPPER	2-25	BEARING - DESCRIPTION, CENTER	3-10
AXLE - 267RBI - ADJUSTMENTS, REAR	3-145	BAND OPERATION - DIAGNOSIS AND TESTING, AIR CHECKING	21-147,21-318	BEARING - DESCRIPTION, CLUTCH RELEASE	6-14
AXLE - 267RBI - DESCRIPTION, REAR	3-140	BAND OPERATION - DIAGNOSIS AND TESTING, AIR TESTING	21-490,21-661	BEARING - DESCRIPTION, PILOT	6-17
AXLE - 267RBI - INSTALLATION, REAR	3-145	BANDS - ADJUSTMENT	21-193,21-364,21-539,21-709	BEARING - INSTALLATION, CENTER	3-10
AXLE - 267RBI - OPERATION, REAR	3-140	BANDS - DESCRIPTION	21-192,21-363,21-538,21-709	BEARING - INSTALLATION, CLUTCH RELEASE	6-15
AXLE - 267RBI - REMOVAL, REAR	3-144	BANDS - OPERATION	21-192,21-364,21-539,21-709	BEARING - INSTALLATION, HUB	2-9
AXLE - 286RBI - ADJUSTMENTS, REAR	3-174	BAR - DESCRIPTION, STABILIZER	2-12,2-22,2-30	BEARING - INSTALLATION, OUTPUT SHAFT FRONT	21-213,21-384,21-560,21-730
AXLE - 286RBI - DESCRIPTION, REAR	3-169	BAR - DESCRIPTION, TRACK	2-23	BEARING - INSTALLATION, OUTPUT SHAFT REAR	21-213,21-384,21-560,21-731
AXLE - 286RBI - INSTALLATION, REAR	3-174	BAR - DIAGNOSIS AND TESTING, TRACK	2-23	BEARING - INSTALLATION, PILOT	6-18
AXLE - 286RBI - OPERATION, REAR	3-169	BAR - INSTALLATION, STABILIZER	2-12,2-23,2-30	BEARING - INSTALLATION, PITMAN	19-21
AXLE - 286RBI - REMOVAL, REAR	3-173	BAR - INSTALLATION, TRACK	2-23	BEARING - OPERATION, CENTER	3-10
AXLE - 9 1/4 - ADJUSTMENTS, REAR	3-84	BAR - OPERATION, STABILIZER	2-12,2-22,2-30	BEARING - OPERATION, CLUTCH RELEASE	6-14
AXLE - 9 1/4 - DESCRIPTION, REAR	3-77	BAR - OPERATION, TRACK	2-23	BEARING - OPERATION, PILOT	6-18
AXLE - 9 1/4 - INSTALLATION, REAR	3-84	BAR - REMOVAL, STABILIZER	2-12,2-22,2-30	BEARING - REMOVAL, CENTER	3-10
AXLE - 9 1/4 - OPERATION, REAR	3-77	BAR - REMOVAL, TRACK	2-12,2-22,2-30	BEARING - REMOVAL, CLUTCH RELEASE	6-15
AXLE - 9 1/4 - REMOVAL, REAR	3-83	BARRELS - INSTALLATION, PANEL OUTLET	24-32	BEARING - REMOVAL, HUB	2-9
AXLE - DIAGNOSIS AND TESTING	3-111,3-13,3-142,3-171,3-46,3-80	BARRELS - REMOVAL, PANEL OUTLET	24-32	BEARING - REMOVAL, OUTPUT SHAFT FRONT	21-213,21-384,21-559,21-730
AXLE - INSTALLATION, INTERMEDIATE	3-61	BASE BRAKE, SPECIFICATIONS	5-2	BEARING - REMOVAL, OUTPUT SHAFT REAR	21-213,21-384,21-560,21-731
AXLE - REMOVAL, INTERMEDIATE	3-60	BASE BRAKE SYSTEM - DIAGNOSIS AND TESTING	5-5	BEARING - REMOVAL, PILOT	6-18
AXLE, 216FBI - FRONT	3-25	BASE BRAKES, SPECIAL TOOLS	5-4	BEARING - REMOVAL, PITMAN	19-20
AXLE, 248FBI - FRONT	3-58	BASE COAT/CLEAR COAT FINISH - DESCRIPTION	23-129	BEARING ADJUSTMENT, CENTER	3-10
AXLE, 248RBI - REAR	3-122	BASE COAT/CLEAR COAT FINISH - OPERATION	23-129	BEARING AND CRANKSHAFT JOURNAL CLEARANCE - STANDARD PROCEDURE, CONNECTING ROD	9-274
AXLE, 267RBI - REAR	3-153			BEARING CLEARANCE - STANDARD PROCEDURE, MAIN	9-275
AXLE, 286RBI - REAR	3-182			BEARING FITTING - STANDARD PROCEDURE, CONNECTING ROD	9-144,9-202,9-88
AXLE, 286RBI - REAR	3-182			BEARING FITTING - STANDARD PROCEDURE, CRANKSHAFT MAIN	9-146,9-90
AXLE, 9 1/4 - REAR	3-90			BEARING FITTING - STANDARD PROCEDURE, MAIN	9-203,9-33
AXLE BEARINGS - INSTALLATION	3-125,3-156,3-185,3-94				
AXLE BEARINGS - REMOVAL	3-125,3-156,3-185,3-94				
AXLE SHAFT SEALS - INSTALLATION	3-29,3-61,3-94				

Description	Group-Page	Description	Group-Page	Description	Group-Page
BEARING FITTING, CONNECTING ROD		BELT/CHAIN AND SPROCKETS -		BLOCK - REMOVAL, BLOWER MOTOR	
BEARINGS - STANDARD PROCEDURE-		INSTALLATION, TIMING . . . . .	9-115,9-170,9-227,9-58	RESISTOR . . . . .	24-24
CONNECTING ROD . . . . .	9-31	BELT/CHAIN AND SPROCKETS -		BLOCK - REMOVAL, JUNCTION . . . . .	8W-97-6
BEARINGS - DESCRIPTION,		REMOVAL, TIMING . . . . .	9-114,9-170,9-226,9-57	BLOCK - STANDARD PROCEDURE-	
CRANKSHAFT MAIN . . . . .	9-146,9-32,9-90	BELT/CHAIN TENSIONER - DESCRIPTION,		CYLINDER BLOCK REFACING, ENGINE . . . . .	9-263
BEARINGS - INSTALLATION, AXLE . . . . .	3-125,3-156, 3-185,3-95	TIMING . . . . .	9-57	BLOCK HEATER - 3.9L/5.2L/5.9L -	
BEARINGS - INSTALLATION, CAMSHAFT . . . . .	9-144, 9-201,9-273,9-29,9-87	BELT/CHAIN TENSIONER - OPERATION,		DESCRIPTION, ENGINE . . . . .	7-45
BEARINGS - INSTALLATION,		TIMING . . . . .	9-57	BLOCK HEATER - 3.9L/5.2L/5.9L -	
CRANKSHAFT MAIN . . . . .	9-147,9-204,9-34,9-90	BELTS - 3.9L/5.2L/5.9L - INSTALLATION,		INSTALLATION, ENGINE . . . . .	7-45
BEARINGS - INSTALLATION,		DRIVE . . . . .	7-27	BLOCK HEATER - 3.9L/5.2L/5.9L -	
DIFFERENTIAL CASE . . . . .	3-103,3-134,3-164,3-192, 3-39,3-71	BELTS - 3.9L/5.2L/5.9L - REMOVAL,		OPERATION, ENGINE . . . . .	7-45
BEARINGS - OPERATION, CRANKSHAFT		DRIVE . . . . .	7-26	BLOCK HEATER - 3.9L/5.2L/5.9L -	
MAIN . . . . .	9-146,9-32,9-90	BELTS - 5.9L DIESEL - INSTALLATION,		REMOVAL, ENGINE . . . . .	7-45
BEARINGS - REMOVAL, AXLE . . . . .	3-125,3-156, 3-185,3-94	DRIVE . . . . .	7-34	BLOCK HEATER - 5.9L DIESEL -	
BEARINGS - REMOVAL, CAMSHAFT . . . . .	9-143, 9-200,9-268,9-29,9-86	BELTS - 5.9L DIESEL - REMOVAL, DRIVE . . . . .	7-33	DESCRIPTION, ENGINE . . . . .	7-47
BEARINGS - REMOVAL, CRANKSHAFT		BELTS - 8.0L - INSTALLATION, DRIVE . . . . .	7-30	BLOCK HEATER - 5.9L DIESEL -	
MAIN . . . . .	9-147,9-204,9-33,9-90	BELTS - 8.0L - REMOVAL, DRIVE . . . . .	7-30	INSTALLATION, ENGINE . . . . .	7-47
BEARINGS - REMOVAL, DIFFERENTIAL		BELTS, RETRACTORS AND HEAD		BLOCK HEATER - 5.9L DIESEL -	
CASE . . . . .	3-103,3-134,3-164,3-192,3-39,3-71	RESTRAINTS - INSPECTION, SEAT		OPERATION, ENGINE . . . . .	7-47
BEARINGS - STANDARD PROCEDURE-		BELTS, SHOULDER . . . . .	30-12	BLOCK HEATER - 5.9L DIESEL -	
CONNECTING ROD BEARING FITTING,		BELTS, SHOULDER BELTS, RETRACTORS		REMOVAL, ENGINE . . . . .	7-47
CONNECTING ROD . . . . .	9-31	AND HEAD RESTRAINTS -		BLOCK HEATER - 8.0L - DESCRIPTION,	
BEARINGS (IN BLOCK) - INSPECTION,		INSPECTION, SEAT . . . . .	30-12	ENGINE . . . . .	7-46
CAMSHAFT . . . . .	9-272	BENCH - INSTALLATION, SEAT - SPLIT . . . . .	23-134	BLOCK HEATER - 8.0L - INSTALLATION,	
BED GROUND STRAP - INSTALLATION,		BENCH - INSTALLATION, SEAT BACK -		ENGINE . . . . .	7-46
CAB-TO . . . . .	8A-14	SPLIT . . . . .	23-136	BLOCK HEATER - 8.0L - OPERATION,	
BED GROUND STRAP - REMOVAL,		BENCH - INSTALLATION, SEAT BACK		ENGINE . . . . .	7-46
CAB-TO . . . . .	8A-14	COVER - SPLIT . . . . .	23-138	BLOCK HEATER - 8.0L - REMOVAL,	
BELT / CHAIN COVER(S) -		BENCH - INSTALLATION, SEAT CUSHION		ENGINE . . . . .	7-46
INSTALLATION, TIMING . . . . .	9-113,9-169,9-226,9-56	COVER - SPLIT . . . . .	23-140	BLOCK REFACING, ENGINE BLOCK -	
BELT / CHAIN COVER(S) - REMOVAL,		BENCH - INSTALLATION, SEAT TRACK -		STANDARD PROCEDURE-CYLINDER . . . . .	9-263
TIMING . . . . .	9-113,9-169,9-225,9-56	SPLIT . . . . .	23-142	BLOWER MOTOR - DESCRIPTION . . . . .	24-32
BELT - DIAGNOSIS AND TESTING,		BENCH - REMOVAL, SEAT - SPLIT . . . . .	23-134	BLOWER MOTOR - DIAGNOSIS AND	
ACCESSORY DRIVE . . . . .	7-24,7-27,7-31	BENCH - REMOVAL, SEAT BACK - SPLIT . . . . .	23-135	TESTING . . . . .	24-33
BELT & RETRACTOR - INSTALLATION,		BENCH - REMOVAL, SEAT BACK COVER		BLOWER MOTOR - INSTALLATION . . . . .	24-33
REAR SEAT . . . . .	80-26	- SPLIT . . . . .	23-137	BLOWER MOTOR - OPERATION . . . . .	24-32
BELT & RETRACTOR - REMOVAL, REAR		BENCH - REMOVAL, SEAT CUSHION		BLOWER MOTOR - REMOVAL . . . . .	24-33
SEAT . . . . .	80-26	COVER - SPLIT . . . . .	23-139	BLOWER MOTOR RELAY - DESCRIPTION . . . . .	24-22
BELT BUCKLE - INSTALLATION, FRONT		BENCH - REMOVAL, SEAT TRACK -		AND TESTING . . . . .	24-22
SEAT . . . . .	80-20	SPLIT . . . . .	23-142	BLOWER MOTOR RELAY -	
BELT BUCKLE - INSTALLATION, REAR		BENCH SEAT - INSTALLATION, SEAT . . . . .	23-133	INSTALLATION . . . . .	24-23
SEAT . . . . .	80-27	BACK . . . . .	23-135	BLOWER MOTOR RELAY - OPERATION . . . . .	24-22
BELT BUCKLE - REMOVAL, FRONT SEAT . . . . .	80-20	BENCH SEAT - REMOVAL, SEAT . . . . .	23-133	BLOWER MOTOR RELAY - REMOVAL . . . . .	24-23
BELT BUCKLE - REMOVAL, REAR SEAT . . . . .	80-27	BENCH SEAT - REMOVAL, SEAT BACK . . . . .	23-135	BLOWER MOTOR RESISTOR BLOCK -	
BELT SWITCH - DESCRIPTION, SEAT . . . . .	80-28	BETTS - INSTALLATION, CONNECTOR -		DESCRIPTION . . . . .	24-23
BELT SWITCH - DIAGNOSIS AND		THOMAS . . . . .	8W-01-10	BLOWER MOTOR RESISTOR BLOCK -	
TESTING, SEAT . . . . .	80-28	BETTS - REMOVAL, CONNECTOR -		DIAGNOSIS AND TESTING . . . . .	24-24
BELT SWITCH - OPERATION, SEAT . . . . .	80-28	THOMAS . . . . .	8W-01-9	BLOWER MOTOR RESISTOR BLOCK -	
BELT TENSIONERS - 3.9L/5.2L/5.9L -		BEZEL - INSTALLATION, CLUSTER . . . . .	23-110	INSTALLATION . . . . .	24-24
DESCRIPTION . . . . .	7-19	BEZEL - REMOVAL, CLUSTER . . . . .	23-109	BLOWER MOTOR RESISTOR BLOCK -	
BELT TENSIONERS - 3.9L/5.2L/5.9L -		BIN - INSTALLATION, CUBBY . . . . .	23-110	OPERATION . . . . .	24-23
INSTALLATION . . . . .	7-20	BIN - INSTALLATION, STORAGE . . . . .	23-116	BLOWER MOTOR RESISTOR BLOCK -	
BELT TENSIONERS - 3.9L/5.2L/5.9L -		BIN - REMOVAL, CUBBY . . . . .	23-110	REMOVAL . . . . .	24-24
OPERATION . . . . .	7-19	BIN - REMOVAL, STORAGE . . . . .	23-116	BLOWER MOTOR SWITCH -	
BELT TENSIONERS - 3.9L/5.2L/5.9L -		BLADE - DESCRIPTION, WIPER . . . . .	8R-12	DESCRIPTION . . . . .	24-24
REMOVAL . . . . .	7-20	BLADE - INSTALLATION, WIPER . . . . .	8R-13	BLOWER MOTOR SWITCH - DIAGNOSIS	
BELT TENSIONERS - 5.9L DIESEL -		BLADE - OPERATION, WIPER . . . . .	8R-13	AND TESTING . . . . .	24-25
DESCRIPTION . . . . .	7-23	BLADE - REMOVAL, WIPER . . . . .	8R-13	BLOWER MOTOR SWITCH - OPERATION . . . . .	24-25
BELT TENSIONERS - 5.9L DIESEL -		BLEED - STANDARD PROCEDURE, AIR . . . . .	14-57	BLOWER MOTOR SWITCH - REMOVAL . . . . .	24-25
INSTALLATION . . . . .	7-23	BLEEDING - STANDARD PROCEDURE . . . . .	5-19	BODY - ADJUSTMENTS, VALVE . . . . .	21-304,21-476, 21-646,21-818
BELT TENSIONERS - 5.9L DIESEL -		BLEEDING - STANDARD PROCEDURE,		BODY - ASSEMBLY, VALVE . . . . .	21-294,21-466, 21-638,21-810
OPERATION . . . . .	7-23	MANUAL . . . . .	5-7	BODY & CABLE - DESCRIPTION,	
BELT TENSIONERS - 5.9L DIESEL -		BLEEDING - STANDARD PROCEDURE,		ANTENNA . . . . .	8A-4
REMOVAL . . . . .	7-23	MASTER CYLINDER . . . . .	5-30	BODY & CABLE - OPERATION, ANTENNA . . . . .	8A-4
BELT TENSIONERS - 8.0L -		BLEEDING - STANDARD PROCEDURE,		BODY - CLEANING, VALVE . . . . .	21-293,21-465, 21-637,21-808
DESCRIPTION . . . . .	7-20	PRESSURE . . . . .	5-8	BODY - DESCRIPTION, THROTTLE . . . . .	14-48
BELT TENSIONERS - 8.0L -		BLEND DOOR - INSTALLATION . . . . .	24-38	BODY - DESCRIPTION, VALVE . . . . .	21-263,21-433, 21-607,21-780
INSTALLATION . . . . .	7-22	BLEND DOOR - REMOVAL . . . . .	24-38	BODY - DISASSEMBLY, VALVE . . . . .	21-282,21-453, 21-626,21-799
BELT TENSIONERS - 8.0L - OPERATION . . . . .	7-20	BLEND DOOR ACTUATOR -		BODY - INSPECTION, VALVE . . . . .	21-293,21-465, 21-637,21-809
INSTALLATION . . . . .	7-21	INSTALLATION . . . . .	24-26	BODY - INSTALLATION, VALVE . . . . .	21-303,21-475, 21-645,21-818
BELT TENSIONERS - 8.0L - REMOVAL . . . . .	7-21	BLEND DOOR ACTUATOR - REMOVAL . . . . .	24-25	BODY - OPERATION, THROTTLE . . . . .	14-48
BELT TURNING LOOP ADJUSTER -		BLOCK - CLEANING, ENGINE . . . . .	9-142,9-200,9-28, 9-86	BODY - OPERATION, VALVE . . . . .	21-267,21-438, 21-611,21-783
INSTALLATION, SEAT . . . . .	80-29	BLOCK - DESCRIPTION, BLOWER		BODY - REMOVAL, VALVE . . . . .	21-281,21-452, 21-625,21-798
BELT TURNING LOOP ADJUSTER -		MOTOR RESISTOR . . . . .	24-23	BODY - SAFETY PRECAUTIONS AND	
REMOVAL, SEAT . . . . .	80-29	BLOCK - DESCRIPTION, JUNCTION . . . . .	8W-97-6	WARNINGS . . . . .	23-1
BELT WEATHERSTRIP - INSTALLATION,		BLOCK - DIAGNOSIS AND TESTING,		BODY CODE PLATE - DESCRIPTION . . . . .	Intro.-1
FRONT DOOR INNER . . . . .	23-154	BLOWER MOTOR RESISTOR . . . . .	24-24	BODY CONTROL/CENTRAL TIMER	
BELT WEATHERSTRIP - INSTALLATION,		BLOCK - INSPECTION, ENGINE . . . . .	9-142,9-200, 9-267,9-28,9-86	MODULE - DESCRIPTION . . . . .	8E-1
FRONT DOOR OUTER . . . . .	23-154	BLOCK - INSTALLATION, BLOWER			
BELT WEATHERSTRIP - REMOVAL,		MOTOR RESISTOR . . . . .	24-24		
FRONT DOOR INNER . . . . .	23-154	BLOCK - INSTALLATION, JUNCTION . . . . .	8W-97-7		
BELT WEATHERSTRIP - REMOVAL,		BLOCK - OPERATION, BLOWER MOTOR			
FRONT DOOR OUTER . . . . .	23-154	RESISTOR . . . . .	24-23		
		BLOCK - OPERATION, JUNCTION . . . . .	8W-97-6		



Description	Group-Page	Description	Group-Page	Description	Group-Page
BODY CONTROL/CENTRAL TIMER MODULE - INSTALLATION	8E-6	BRAKE CABLE - 2500/3500 WITH REAR DISC BRAKES - INSTALLATION, REAR PARK	5-38	BREATHER VAPOR CANISTER - INSTALLATION, CRANKCASE	9-242
BODY CONTROL/CENTRAL TIMER MODULE - OPERATION	8E-3	BRAKE CABLE - 2500/3500 WITH REAR DISC BRAKES - REMOVAL, REAR PARK	5-37	BREATHER VAPOR CANISTER - REMOVAL, CRANKCASE	9-241
BODY CONTROL/CENTRAL TIMER MODULE - REMOVAL	8E-5	BRAKE CABLE - INSTALLATION, FRONT PARKING	5-39	BUCKLE - INSTALLATION, FRONT SEAT BELT	80-20
BODY GAP AND FLUSH MEASUREMENTS, SPECIFICATIONS	23-56	BRAKE CABLE - REMOVAL, FRONT PARKING	5-37	BUCKLE - INSTALLATION, REAR SEAT BELT	80-27
BODY OPENING DIMENSIONS, SPECIFICATIONS	23-60	BRAKE CABLE 2500/3500 SERIES WITH DRUM BRAKES - INSTALLATION, REAR PARK	5-39	BUCKLE - REMOVAL, FRONT SEAT BELT	80-20
BODY SEALER LOCATIONS, SPECIFICATIONS	23-47	BRAKE CALIPERS - ASSEMBLY, DISC	5-12	BUCKLE - REMOVAL, REAR SEAT BELT	80-27
BODY SEALING - INSPECTION	30-10	BRAKE CALIPERS - CLEANING, DISC	5-12	BUILT-IN INDICATOR TEST - STANDARD PROCEDURE	8F-11
BODY SIDE MOLDINGS - INSTALLATION	23-87	BRAKE CALIPERS - DISASSEMBLY, DISC	5-11	BUMPER - DESCRIPTION, JOUNCE	2-28,2-9
BODY SIDE MOLDINGS - REMOVAL	23-87	BRAKE CALIPERS - INSPECTION, DISC	5-12	BUMPER - INSTALLATION, FRONT	13-4
BODY STRIPES AND DECALS - INSTALLATION	23-87	BRAKE DRUM - ADJUSTMENT, REAR	5-34	BUMPER - INSTALLATION, REAR	13-5
BODY STRIPES AND DECALS - REMOVAL	23-87	BRAKE DRUM - DIAGNOSIS AND TESTING	5-33	BUMPER - INSTALLATION, SLAM	23-66
BODY VENT - INSTALLATION	23-126	BRAKE DRUM MACHINING - STANDARD PROCEDURE	5-33	BUMPER - OPERATION, JOUNCE	2-28,2-9
BODY VENT - REMOVAL	23-126	BRAKE FLUID CONTAMINATION - DIAGNOSIS AND TESTING	5-14	BUMPER - REMOVAL, FRONT	13-3
BOOST PRESSURE - DIAGNOSIS AND TESTING	14-89	BRAKE FLUID LEVEL - STANDARD PROCEDURE	5-14	BUMPER - REMOVAL, REAR	13-5
BOOSTER - DIAGNOSIS AND TESTING, HYDRAULIC	5-17	BRAKE FLUID, SPECIFICATIONS	5-15	BUMPER - REMOVAL, SLAM	23-66
BOOSTER - DIAGNOSIS AND TESTING, MASTER CYLINDER/POWER	5-29	BRAKE INDICATOR - DESCRIPTION, BRAKE/PARK	8J-16	BUMPERS - DESCRIPTION	13-1
BOOSTER - INSTALLATION, POWER BRAKE	5-20	BRAKE INDICATOR - DIAGNOSIS AND TESTING	8J-16	BUMPER-SPORT - INSTALLATION, FRONT	13-4
BOOSTER - REMOVAL, POWER BRAKE	5-19	BRAKE INDICATOR - OPERATION, BRAKE/PARK	8J-16	BUMPER-SPORT - REMOVAL, FRONT	13-4
BOOT - INSTALLATION, 4WD FLOOR SHIFT	23-122	BRAKE LAMP SWITCH - DESCRIPTION	8L-4	BURNT FLUID - DIAGNOSIS AND TESTING, CAUSES OF	21-199,21-370,21-545, 21-715
BOOT - MANUAL TRANSMISSION - INSTALLATION, SHIFT	23-122	BRAKE LAMP SWITCH - DIAGNOSIS AND TESTING	8L-5	BUS - DESCRIPTION, CCD DATA	8E-6
BOOT - MANUAL TRANSMISSION - REMOVAL, SHIFT	23-122	BRAKE LAMP SWITCH - INSTALLATION	8L-5	BUS - DIAGNOSIS AND TESTING, CCD DATA	8E-11
BOOT - REMOVAL, 4WD FLOOR SHIFT	23-122	BRAKE LAMP SWITCH - OPERATION	8L-4	BUS - OPERATION, CCD DATA	8E-7
BORE, DE-GLAZE - STANDARD PROCEDURE-CYLINDER	9-264	BRAKE LAMP SWITCH - REMOVAL	8L-5	BUSHING - INSTALLATION, DISTRIBUTOR	9-150,9-37,9-94
BORE HONING - STANDARD PROCEDURE, CYLINDER	9-10,9-126,9-180,9-69	BRAKE LAMP SWITCH - DIAGNOSIS AND TESTING	8L-5	BUSHING - INSTALLATION, EXTENSION HOUSING	21-198,21-369,21-544,21-714
BORE REPAIR - STANDARD PROCEDURE, CAM	9-267	BRAKE LAMP SWITCH - INSTALLATION	8L-5	BUSHING - REMOVAL, DISTRIBUTOR	9-150, 9-37,9-94
BORE REPAIR - STANDARD PROCEDURE, CYLINDER	9-265	BRAKE LAMP SWITCH - OPERATION	8L-4	BUSHING - REMOVAL, EXTENSION HOUSING	21-198,21-369,21-544,21-714
BOX - ASSEMBLY, GLOVE	23-112	BRAKE LAMP SWITCH - REMOVAL	8L-5	BUSHING AND SEAL - INSTALLATION, EXTENSION HOUSING	21-850,21-885,21-921
BOX - DISASSEMBLY, GLOVE	23-112	BRAKE ROTOR - DIAGNOSIS AND TESTING, DISC	5-20	BUSHING AND SEAL - REMOVAL, EXTENSION HOUSING	21-850,21-885,21-921
BOX - INSTALLATION, CARGO	23-97	BRAKE SHOES - 2500/3500 - INSTALLATION, REAR DRUM IN HAT PARK	5-42	BUSHINGS - INSTALLATION	2-28
BOX - INSTALLATION, GLOVE	23-113	BRAKE SHOES - 2500/3500 - REMOVAL, REAR DRUM IN HAT PARK	5-41	BUSHINGS - REMOVAL	2-28
BOX - REMOVAL, CARGO	23-96	BRAKE SHOES-11 INCH - INSTALLATION, REAR	5-27	BYPASS HOSE WITH AIR CONDITIONING - INSTALLATION, WATER PUMP	7-77
BOX - REMOVAL, GLOVE	23-112	BRAKE SHOES-11 INCH - REMOVAL, REAR	5-25	BYPASS HOSE WITH AIR CONDITIONING - REMOVAL, WATER PUMP	7-74
BOX LAMP AND SWITCH - INSTALLATION, GLOVE	8L-35	BRAKE, SPECIFICATIONS - BASE	5-2	BYPASS HOSE WITHOUT AIR CONDITIONING - INSTALLATION, WATER PUMP	7-78
BOX LAMP AND SWITCH - REMOVAL, GLOVE	8L-35	BRAKE SYSTEM - DIAGNOSIS AND TESTING, BASE	5-5	BYPASS HOSE WITHOUT AIR CONDITIONING - REMOVAL, WATER PUMP	7-77
BOX LATCH STRIKER - INSTALLATION, GLOVE	23-113	BRAKE/PARK BRAKE INDICATOR - DESCRIPTION	8J-16	CAB - INSTALLATION, CLUB/QUAD	80-20
BOX LATCH STRIKER - REMOVAL, GLOVE	23-113	BRAKE/PARK BRAKE INDICATOR - OPERATION	8J-16	CAB - INSTALLATION, STANDARD	80-19
BOX OPENING UPPER TRIM - INSTALLATION, GLOVE	23-114	BRAKES - DESCRIPTION, 2500/3500 WITH REAR DISC	5-35	CAB - REMOVAL, CLUB/QUAD	80-19
BOX OPENING UPPER TRIM - REMOVAL, GLOVE	23-114	BRAKES - INSPECTION, SERVICE	30-17	CAB - REMOVAL, STANDARD	80-18
B-PILLAR DOOR SEAL - INSTALLATION	23-152	BRAKES - INSTALLATION, REAR PARK BRAKE CABLE - 2500/3500 WITH REAR DISC	5-38	CAB CHASSIS ADAPTER BRACKET - INSTALLATION	13-9
B-PILLAR DOOR SEAL - REMOVAL	23-152	BRAKES - INSTALLATION, REAR PARK BRAKE CABLE 2500/3500 SERIES WITH DRUM	5-39	CAB CHASSIS ADAPTER BRACKET - REMOVAL	13-9
B-PILLAR TRIM - INSTALLATION	23-120	BRAKES - OPERATION, 2500/3500 WITH REAR DISC	5-36	CAB SIDE PANEL SPEAKER - INSTALLATION, REAR	8A-21
B-PILLAR TRIM - REMOVAL	23-120	BRAKES - REMOVAL, REAR PARK BRAKE CABLE - 2500/3500 WITH REAR DISC	5-37	CAB SIDE PANEL SPEAKER - REMOVAL, REAR	8A-20
BR PAINT COLOR CODES, SPECIFICATIONS - 2001	23-129	BRAKES - REMOVAL, REAR PARK BRAKE CABLES 2500/3500 SERIES WITH DRUM	5-38	CABLE - 2500/3500 WITH REAR DISC BRAKES - INSTALLATION, REAR PARK BRAKE	5-38
BRACKET - INSTALLATION, CAB CHASSIS ADAPTER	13-9	BRAKES, SPECIAL TOOLS - BASE	5-4	CABLE - 2500/3500 WITH REAR DISC BRAKES - REMOVAL, REAR PARK BRAKE	5-37
BRACKET - INSTALLATION, REARVIEW MIRROR SUPPORT	23-126	BREAKER - DESCRIPTION, CIRCUIT	8W-97-4	CABLE - ADJUSTMENTS, TRANSMISSION THROTTLE VALVE	21-254, 21-425,21-598,21-771
BRACKET - REMOVAL, CAB CHASSIS ADAPTER	13-9	BREAKER - DIAGNOSIS & TESTING, CIRCUIT	8W-97-4	CABLE - DESCRIPTION	8P-4
BRAKE - DESCRIPTION, CONTROLLER ANTILOCK	8E-11	BREAK-IN - STANDARD PROCEDURE, A/C COMPRESSOR CLUTCH	24-13	CABLE - DESCRIPTION, ANTENNA BODY	8A-4
BRAKE - INSPECTION, PARKING	30-17			CABLE - DESCRIPTION, BATTERY	8F-19
BRAKE - INSTALLATION, CONTROLLER ANTILOCK	8E-12			CABLE - DESCRIPTION, SPARK PLUG	8I-19
BRAKE - OPERATION, CONTROLLER ANTILOCK	8E-11			CABLE - DESCRIPTION, THROTTLE VALVE	21-253,21-424,21-597,21-770
BRAKE - REMOVAL, CONTROLLER ANTILOCK	8E-12			CABLE - INSTALLATION, CHECK	23-63
BRAKE BOOSTER - INSTALLATION, POWER	5-20			CABLE - INSTALLATION, FRONT PARKING BRAKE	5-39
BRAKE BOOSTER - REMOVAL, POWER	5-19			CABLE - INSTALLATION, INSTRUMENT PANEL ANTENNA	8A-10
				CABLE - INSTALLATION, LATCH RELEASE	23-101

Description	Group-Page	Description	Group-Page	Description	Group-Page
CABLE - INSTALLATION, RELEASE	23-83	CANCEL CAM - DESCRIPTION, TURN SIGNAL	8L-30	CASE - NV241HD - REMOVAL, TRANSFER	21-894
CABLE - INSTALLATION, SPARK PLUG	8I-20	CANCEL CAM - OPERATION, TURN SIGNAL	8L-31	CASE - NV241LD - ASSEMBLY, TRANSFER	21-869
CABLE - INSTALLATION, THROTTLE CONTROL	14-105,14-50	CANISTER - DESCRIPTION, VAPOR	25-37	CASE - NV241LD - CLEANING, TRANSFER	21-866
CABLE - OPERATION	8P-4	CANISTER - INSTALLATION, CRANKCASE BREATHER VAPOR	9-242	CASE - NV241LD - DESCRIPTION, TRANSFER	21-855
CABLE - OPERATION, ANTENNA BODY	8A-4	CANISTER - INSTALLATION, VAPOR	25-38	CASE - NV241LD - DISASSEMBLY, TRANSFER	21-858
CABLE - OPERATION, BATTERY	8F-20	CANISTER - OPERATION, VAPOR	25-37	CASE - NV241LD - INSPECTION, TRANSFER	21-867
CABLE - OPERATION, SPARK PLUG	8I-19	CANISTER - REMOVAL, CRANKCASE BREATHER VAPOR	9-241	CASE - NV241LD - INSTALLATION, TRANSFER	21-882
CABLE - REMOVAL, CHECK	23-62	CANISTER - REMOVAL, VAPOR	25-37	CASE - NV241LD - OPERATION, TRANSFER	21-855
CABLE - REMOVAL, FRONT PARKING BRAKE	5-37	CAP - CLEANING, RADIATOR PRESSURE	7-66	CASE - NV241LD - REMOVAL, TRANSFER	21-858
CABLE - REMOVAL, INSTRUMENT PANEL ANTENNA	8A-9	CAP - DESCRIPTION, FUEL FILLER	25-33	CASE BEARINGS - INSTALLATION, DIFFERENTIAL	3-103,3-134,3-164,3-192,3-39,3-71
CABLE - REMOVAL, LATCH RELEASE	23-101	CAP - DESCRIPTION, RADIATOR PRESSURE	7-65	CASE BEARINGS - REMOVAL, DIFFERENTIAL	3-103,3-134,3-164,3-192,3-39,3-71
CABLE - REMOVAL, RELEASE	23-82	CAP - DIAGNOSIS AND TESTING, DISTRIBUTOR	8I-12	CASE FLUID - DESCRIPTION, TRANSFER	0-5
CABLE - REMOVAL, SPARK PLUG	8I-20	CAP - DIAGNOSIS AND TESTING, RADIATOR	7-66	CASE, NV231HD - TRANSFER	21-849
CABLE - REMOVAL, THROTTLE CONTROL	14-104,14-50	CAP - INSPECTION, RADIATOR PRESSURE	7-66	CASE, NV241HD - TRANSFER	21-920
CABLE 2500/3500 SERIES WITH DRUM BRAKES - INSTALLATION, REAR PARK BRAKE	5-39	CAP - OPERATION, FUEL FILLER	25-33	CASE, NV241LD - TRANSFER	21-884
CABLE INSTALLATION, GASOLINE - NEGATIVE	8F-24	CAP - OPERATION, RADIATOR PRESSURE	7-65	CASE SKID PLATE - INSTALLATION, TRANSFER	13-11
CABLE INSTALLATION, GASOLINE - POSITIVE	8F-23	CAP - REMOVAL/INSTALLATION, FUEL FILLER	25-33	CASE SKID PLATE - REMOVAL, TRANSFER	13-11
CABLE ORDER, 8.0L V-10 ENGINE - SPARK PLUG	8I-2	CAPACITIES, SPECIFICATIONS - FLUID	0-6	CASE, SPECIFICATIONS - TRANSFER	21-848,21-883,21-919
CABLE REMOVAL, GASOLINE - NEGATIVE	8F-23	CAPACITY TEST - DIAGNOSIS AND TESTING, FUEL PUMP	14-9	CASTER CORRECTION MEASUREMENT - STANDARD PROCEDURES	2-3
CABLE REMOVAL, GASOLINE - POSITIVE	8F-23	CAP-TO-FILLER NECK SEAL - DIAGNOSIS AND TESTING, RADIATOR	7-66	CATALYTIC CONVERTER - 3.9L/5.2L/5.9L - DESCRIPTION	11-5
CABLE RESISTANCE, SPECIFICATIONS - SPARK PLUG	8I-3	CARDAN UNIVERSAL JOINTS - DISASSEMBLY, SINGLE	3-11	CATALYTIC CONVERTER - 3.9L/5.2L/5.9L - INSPECTION	11-5
CABLE TENSIONER - ADJUSTMENT	5-40	CARDAN UNIVERSAL JOINTS - INSTALLATION, SINGLE	3-34,3-66	CATALYTIC CONVERTER - 3.9L/5.2L/5.9L - INSTALLATION	11-5
CABLES - 1500 SERIES - INSTALLATION, REAR PARK BRAKE	5-39	CARDAN UNIVERSAL JOINTS - REMOVAL, SINGLE	3-33,3-65	CATALYTIC CONVERTER - 3.9L/5.2L/5.9L - OPERATION	11-5
CABLES - 1500 SERIES - REMOVAL, REAR PARK BRAKE	5-37	CAREFUL NEW VEHICLE PREPARATION - DESCRIPTION, THE IMPORTANCE OF	30-1	CATALYTIC CONVERTER - 3.9L/5.2L/5.9L - REMOVAL	11-5
CABLES - DIAGNOSIS & TESTING, BATTERY	8F-20	CARGO BOX - INSTALLATION	23-97	CATALYTIC CONVERTER - 5.9L HEAVY DUTY/8.0L - DESCRIPTION	11-6
CABLES - DIAGNOSIS AND TESTING, SPARK PLUG	8I-19	CARGO BOX - REMOVAL	23-96	CATALYTIC CONVERTER - 5.9L HEAVY DUTY/8.0L - INSPECTION	11-7
CABLES 2500/3500 SERIES WITH DRUM BRAKES - REMOVAL, REAR PARK BRAKE	5-38	CARGO DOOR - ADJUSTMENT	23-78	CATALYTIC CONVERTER - 5.9L HEAVY DUTY/8.0L - INSTALLATION	11-7
CAB-TO- BED GROUND STRAP - INSTALLATION	8A-14	CARPETS AND FLOOR MATS - INSTALLATION	23-123	CATALYTIC CONVERTER - 5.9L HEAVY DUTY/8.0L - OPERATION	11-6
CAB-TO- BED GROUND STRAP - REMOVAL	8A-14	CARPETS AND FLOOR MATS - REMOVAL	23-123	CATALYTIC CONVERTER - 5.9L HEAVY DUTY/8.0L - REMOVAL	11-6
CALIBRATION - STANDARD PROCEDURE, COMPASS	8M-4	CARTRIDGE FUSE - DESCRIPTION, GENERATOR	8W-97-4	CATCH - INSPECTION, HOOD LATCH/ SAFETY	30-4
CALIPERS - ASSEMBLY, DISC BRAKE	5-12	CARTRIDGE FUSE - INSTALLATION, GENERATOR	8W-97-4	CAUSES OF BURNT FLUID - DIAGNOSIS AND TESTING	21-199,21-370,21-545,21-715
CALIPERS - CLEANING, DISC BRAKE	5-12	CARTRIDGE FUSE - OPERATION, GENERATOR	8W-97-4	CAUTION, INTERIOR	23-118
CALIPERS - DISASSEMBLY, DISC BRAKE	5-11	CARTRIDGE FUSE - REMOVAL, GENERATOR	8W-97-4	CAUTION, REFRIGERANT HOSES/LINES/ TUBES PRECAUTIONS	24-42
CALIPERS - INSPECTION, DISC BRAKE	5-12	CASE - DIAGNOSIS AND TESTING, TRANSFER	21-821,21-856,21-892	CCD DATA BUS - DESCRIPTION	8E-6
CAM - DESCRIPTION, TURN SIGNAL	8L-30	CASE - INSPECTION, TRANSMISSION/ TRANSFER	30-15	CCD DATA BUS - DIAGNOSIS AND TESTING	8E-11
CANCEL	8L-30	CASE - NV231HD - ASSEMBLY, TRANSFER	21-834	CCD DATA BUS - OPERATION	8E-7
CAM - OPERATION, TURN SIGNAL	8L-31	CASE - NV231HD - CLEANING, TRANSFER	21-831	CENTER - DESCRIPTION, POWER DISTRIBUTION	8W-97-7
CANCEL	8L-31	CASE - NV231HD - DESCRIPTION, TRANSFER	21-820	CENTER - INSTALLATION, POWER DISTRIBUTION	8W-97-8
CAM BORE REPAIR - STANDARD PROCEDURE	9-267	CASE - NV231HD - DISASSEMBLY, TRANSFER	21-822	CENTER - OPERATION, POWER DISTRIBUTION	8W-97-8
CAM/OVERDRIVE PISTON RETAINER - ASSEMBLY, OVERRUNNING CLUTCH	21-236,21-406,21-581,21-752	CASE - NV231HD - INSPECTION, TRANSFER	21-832	CENTER - REMOVAL, POWER DISTRIBUTION	8W-97-8
CAM/OVERDRIVE PISTON RETAINER - CLEANING, OVERRUNNING CLUTCH	21-236,21-406,21-580,21-752	CASE - NV231HD - INSTALLATION, TRANSFER	21-847	CENTER BEARING - CENTER BEARING ADJUSTMENT	3-10
CAM/OVERDRIVE PISTON RETAINER - DESCRIPTION, OVERRUNNING CLUTCH	21-235,21-405,21-580,21-751	CASE - NV231HD - OPERATION, TRANSFER	21-820	CENTER BEARING - DESCRIPTION	3-10
CAM/OVERDRIVE PISTON RETAINER - DISASSEMBLY, OVERRUNNING CLUTCH	21-235,21-405,21-580,21-751	CASE - NV231HD - REMOVAL, TRANSFER	21-822	CENTER BEARING - INSTALLATION	3-10
CAM/OVERDRIVE PISTON RETAINER - INSPECTION, OVERRUNNING CLUTCH	21-236,21-406,21-580,21-752	CASE - NV241HD - ASSEMBLY, TRANSFER	21-904	CENTER BEARING - OPERATION	3-10
CAM/OVERDRIVE PISTON RETAINER - OPERATION, OVERRUNNING CLUTCH	21-235,21-405,21-580,21-751	CASE - NV241HD - CLEANING, TRANSFER	21-902	CENTER BEARING - REMOVAL	3-10
CAMSHAFT & BEARINGS (IN BLOCK) - INSPECTION	9-272	CASE - NV241HD - DESCRIPTION, TRANSFER	21-890	CENTER BEARING ADJUSTMENT, CENTER BEARING	3-10
CAMSHAFT - INSTALLATION	9-144,9-201,9-273,9-29,9-87	CASE - NV241HD - DISASSEMBLY, TRANSFER	21-894	CENTER BEARING - INSTALLATION	23-122
CAMSHAFT - REMOVAL	9-143,9-201,9-268,9-29,9-86	CASE - NV241HD - INSPECTION, TRANSFER	21-902	CENTER BEARING - OPERATION	23-122
CAMSHAFT BEARINGS - INSTALLATION	9-144,9-201,9-273,9-29,9-87	CASE - NV241HD - INSTALLATION, TRANSFER	21-919	CENTER BEARING - REMOVAL	23-132
CAMSHAFT BEARINGS - REMOVAL	9-143,9-200,9-268,9-29,9-86	CASE - NV241HD - OPERATION, TRANSFER	21-892	CENTER BEARING ADJUSTMENT, CENTER BEARING	23-131



Description	Group-Page	Description	Group-Page	Description	Group-Page
CENTER HIGH MOUNTED STOP LAMP - INSTALLATION	8L-6	CHECK VALVE - OPERATION, VACUUM	24-28	CLUTCH - 5.9L DIESEL - DESCRIPTION, FAN DRIVE VISCOUS	7-57
CENTER HIGH MOUNTED STOP LAMP - REMOVAL	8L-6	CHECK VALVE - REMOVAL, ONE WAY	25-30	CLUTCH - 5.9L DIESEL - OPERATION, FAN DRIVE VISCOUS	7-57
CENTER HIGH MOUNTED STOP LAMP UNIT - INSTALLATION	8L-6	CHECK VALVE - REMOVAL, VACUUM	24-29	CLUTCH - ASSEMBLY, FRONT	21-206,21-376,21-550,21-721
CENTER HIGH MOUNTED STOP LAMP UNIT - REMOVAL	8L-6	CHECKING BATTERY ELECTROLYTE LEVEL - STANDARD PROCEDURE	8F-8	CLUTCH - ASSEMBLY, REAR	21-248,21-419,21-593,21-766
CENTER SEAT ARMREST/CONSOLE - INSTALLATION	23-132	CHECKING TRANSMISSION CLUTCH AND BAND OPERATION - DIAGNOSIS AND TESTING, AIR	21-147,21-318	CLUTCH - CLEANING, REAR	21-247,21-418,21-593,21-765
CENTER SEAT ARMREST/CONSOLE - REMOVAL	23-132	CHECKS - DIAGNOSIS AND TESTING, PRELIMINARY	7-4	CLUTCH - DESCRIPTION	6-1
CENTER SEAT ARMREST/LATCH COVER - INSTALLATION	23-132	CHILD TETHER - INSTALLATION	80-9	CLUTCH - DESCRIPTION, A/C COMPRESSOR	24-13
CENTER SEAT ARMREST/LATCH COVER - REMOVAL	23-132	CHILD TETHER - REMOVAL	80-9	CLUTCH - DESCRIPTION, FRONT	21-202,21-373,21-548,21-718
CENTERING - STANDARD PROCEDURE, CLOCKSPrING	80-11	CHIME WARNING SYSTEM - DESCRIPTION	8B-1	CLUTCH - DESCRIPTION, OVERDRIVE	21-214,21-385,21-560,21-731
CENTRAL TIMER MODULE - DIAGNOSIS AND TESTING	8E-4	CHIME WARNING SYSTEM - DIAGNOSIS AND TESTING	8B-2	CLUTCH - DESCRIPTION, REAR	21-246,21-417,21-591,21-764
CERTIFICATION LABEL - DESCRIPTION, VEHICLE SAFETY	Intro-12	CHIME WARNING SYSTEM - OPERATION	8B-1	CLUTCH - DIAGNOSTIC AND TESTING	6-2
CHAIN COVER(S) - INSTALLATION, TIMING BELT	9-113,9-169,9-226,9-56	CHOKER RELAY - DESCRIPTION, RADIO	8A-8	CLUTCH - DISASSEMBLY, FRONT	21-202,21-373,21-549,21-719
CHAIN COVER(S) - REMOVAL, TIMING BELT	9-113,9-169,9-225,9-56	CHOKER RELAY - DIAGNOSIS AND TESTING, RADIO	8A-8	CLUTCH - DISASSEMBLY, REAR	21-247,21-418,21-592,21-765
CHAIN STRETCH - INSPECTION, MEASURING TIMING	9-114,9-170,9-227,9-58	CHOKER RELAY - INSTALLATION, RADIO	8A-9	CLUTCH - INSPECTION, A/C COMPRESSOR	24-16
CHANNEL - INSTALLATION, GLASS RUN	23-70	CHOKER RELAY - OPERATION, RADIO	8A-8	CLUTCH - INSPECTION, FRONT	21-205,21-376,21-550,21-721
CHANNEL - REMOVAL, GLASS RUN	23-70	CHOKER RELAY - REMOVAL, RADIO	8A-9	CLUTCH - INSPECTION, REAR	21-248,21-419,21-593,21-765
CHARGE - STANDARD PROCEDURE, REFRIGERANT SYSTEM	24-46	CIGAR LIGHTER - DIAGNOSIS & TESTING	8W-97-2	CLUTCH - INSTALLATION, A/C COMPRESSOR	24-16
CHARGE AIR COOLER AND PLUMBING - CLEANING	11-18	CIGAR LIGHTER OUTLET - DESCRIPTION	8W-97-2	CLUTCH - OPERATION	6-1
CHARGE AIR COOLER AND PLUMBING - DESCRIPTION	11-17	CIGAR LIGHTER OUTLET - INSTALLATION	8W-97-3	CLUTCH - OPERATION, A/C COMPRESSOR	24-13
CHARGE AIR COOLER AND PLUMBING - INSPECTION	11-18	CIGAR LIGHTER OUTLET - OPERATION	8W-97-2	CLUTCH - OPERATION, FRONT	21-202,21-373,21-548,21-718
CHARGE AIR COOLER AND PLUMBING - INSTALLATION	11-18	CIGAR LIGHTER OUTLET - REMOVAL	8W-97-3	CLUTCH - OPERATION, OVERDRIVE	21-214,21-385,21-560,21-731
CHARGE AIR COOLER AND PLUMBING - OPERATION	11-17	CIRCUIT ACTUATION TEST MODE - DESCRIPTION	25-1	CLUTCH - OPERATION, REAR	21-246,21-417,21-592,21-764
CHARGE AIR COOLER AND PLUMBING - REMOVAL	11-17	CIRCUIT BREAKER - DESCRIPTION	8W-97-4	CLUTCH - REMOVAL, A/C COMPRESSOR	24-14
CHARGING - DESCRIPTION	8F-27	CIRCUIT BREAKER - DIAGNOSIS & TESTING	8W-97-4	CLUTCH - SPECIFICATIONS	6-7
CHARGING - OPERATION	8F-27	CIRCUIT SENSE - DESCRIPTION, IGNITION	8E-17	CLUTCH - WARNING	6-2
CHARGING - STANDARD PROCEDURE, BATTERY	8F-9	CIRCUITS - DIESEL - OPERATION, NON-MONITORED	25-23	CLUTCH AND BAND OPERATION - DIAGNOSIS AND TESTING, AIR CHECKING TRANSMISSION	21-147,21-318
CHARGING SYSTEM - DIAGNOSIS AND TESTING	8F-27	CIRCUITS - GAS ENGINES - OPERATION, NON-MONITORED	25-22	CLUTCH AND BAND OPERATION - DIAGNOSIS AND TESTING, AIR TESTING TRANSMISSION	21-490,21-661
CHART, SPECIFICATIONS - TORQUE	5-3	CLAMPS - DESCRIPTION, HOSE	7-2	CLUTCH BREAK-IN - STANDARD PROCEDURE, A/C COMPRESSOR	24-13
CHART, SPECIFICATIONS - TORQUE	19-19,19-39,19-41,19-9	CLAMPS - OPERATION, HOSE	7-2	CLUTCH CAM/OVERDRIVE PISTON RETAINER - ASSEMBLY, OVERRUNNING	21-236,21-406,21-581,21-752
CHART, SPECIFICATIONS - TORQUE	2-15,2-27,2-8	CLASSIFICATION OF LUBRICANTS - STANDARD PROCEDURE	0-3	CLUTCH CAM/OVERDRIVE PISTON RETAINER - CLEANING, OVERRUNNING	21-236,21-406,21-580,21-752
CHART, SPECIFICATIONS - TORQUE	22-11	CLEANER ELEMENT - INSTALLATION, AIR	9-245	CLUTCH CAM/OVERDRIVE PISTON RETAINER - DESCRIPTION, OVERRUNNING	21-235,21-405,21-580,21-751
CHARTS - DIAGNOSIS AND TESTING, DIAGNOSIS	21-149,21-320,21-492,21-663	CLEANER ELEMENT - REMOVAL, AIR	9-244	CLUTCH CAM/OVERDRIVE PISTON RETAINER - DISASSEMBLY, OVERRUNNING	21-235,21-405,21-580,21-751
CHARTS - DIAGNOSIS AND TESTING, SMOKE DIAGNOSIS	9-234	CLEANING AND INSPECTION, OIL COOLER & LINES	9-296	CLUTCH CAM/OVERDRIVE PISTON RETAINER - INSPECTION, OVERRUNNING	21-236,21-406,21-580,21-752
CHASSIS ADAPTER BRACKET - INSTALLATION, CAB	13-9	CLEANING, APPEARANCE TIPS	30-21	CLUTCH CAM/OVERDRIVE PISTON RETAINER - OPERATION, OVERRUNNING	21-235,21-405,21-580,21-751
CHASSIS ADAPTER BRACKET - REMOVAL, CAB	13-9	CLEANING/REVERSE FLUSHING - STANDARD PROCEDURE, COOLING SYSTEM	7-16	CLUTCH COIL - DIAGNOSIS AND TESTING, A/C COMPRESSOR	24-13
CHECK - INSTALLATION	23-78	CLEARANCE - STANDARD PROCEDURE, CONNECTING ROD BEARING AND CRANKSHAFT JOURNAL	9-274	CLUTCH DISC - DESCRIPTION	6-7
CHECK - REMOVAL	23-78	CLEARANCE - STANDARD PROCEDURE, MAIN BEARING	9-275	CLUTCH DISC - INSTALLATION	6-9
CHECK - STANDARD PROCEDURE, COOLANT LEVEL	7-16	CLEARANCE LAMP - INSTALLATION	8L-6	CLUTCH DISC - OPERATION	6-8
CHECK - STANDARD PROCEDURE, FLUID LEVEL	21-199,21-370,21-545,21-715	CLEARANCE LAMP - REMOVAL	8L-6	CLUTCH DISC - REMOVAL	6-8
CHECK - STANDARD PROCEDURE, OIL PUMP VOLUME	21-209,21-379,21-554,21-724	CLOCKSPrING - DESCRIPTION	80-10	CLUTCH HOUSING - DIAGNOSIS AND TESTING	6-11
CHECK CABLE - INSTALLATION	23-63	CLOCKSPrING - INSTALLATION	80-13	CLUTCH HOUSING - INSTALLATION	6-13
CHECK CABLE - REMOVAL	23-62	CLOCKSPrING - OPERATION	80-10	CLUTCH HOUSING - REMOVAL	6-13
CHECK GAUGES INDICATOR - DESCRIPTION	8J-17	CLOCKSPrING - REMOVAL	80-11	CLUTCH PEDAL - INSTALLATION	6-19
CHECK GAUGES INDICATOR - OPERATION	8J-17	CLOCKSPrING CENTERING - STANDARD PROCEDURE	80-11	CLUTCH PEDAL - REMOVAL	6-18
CHECK OUT - STANDARD PROCEDURE, OWNER	30-22	CLOSURE PANEL TRIM - INSTALLATION, REAR	23-121	CLUTCH PEDAL POSITION SWITCH - DESCRIPTION	6-22
CHECK VALVE - DESCRIPTION, ONE WAY	25-30	CLOSURE PANEL TRIM - REMOVAL, REAR	23-120	CLUTCH PEDAL POSITION SWITCH - OPERATION	6-22
CHECK VALVE - DESCRIPTION, VACUUM	24-28	CLUB/QUAD CAB - INSTALLATION	80-20	CLUTCH RELAY - DESCRIPTION, A/C COMPRESSOR	24-17
CHECK VALVE - DIAGNOSIS AND TESTING, ONE-WAY	25-30	CLUB/QUAD CAB - REMOVAL	80-19		
CHECK VALVE - INSTALLATION, ONE WAY	25-30	CLUSTER - ASSEMBLY, INSTRUMENT	8J-13		
CHECK VALVE - INSTALLATION, VACUUM	24-29	CLUSTER - DESCRIPTION, INSTRUMENT	8J-2		
CHECK VALVE - OPERATION, ONE WAY	25-30	CLUSTER - DIAGNOSIS AND TESTING, INSTRUMENT	8J-6		
		CLUSTER - DISASSEMBLY, INSTRUMENT	8J-11		
		CLUSTER - INSTALLATION, INSTRUMENT	8J-14		
		CLUSTER - OPERATION, INSTRUMENT	8J-3		
		CLUSTER - REMOVAL, INSTRUMENT	8J-10		
		CLUSTER BEZEL - INSTALLATION	23-110		
		CLUSTER BEZEL - REMOVAL	23-109		
		CLUTCH - 3.9L/5.2L/5.9L/8.0L - DESCRIPTION, FAN DRIVE VISCOUS	7-56		
		CLUTCH - 3.9L/5.2L/5.9L/8.0L - OPERATION, FAN DRIVE VISCOUS	7-56		

Description	Group-Page	Description	Group-Page	Description	Group-Page
CLUTCH RELAY - DIAGNOSIS AND TESTING, A/C COMPRESSOR	24-17	COMPRESSOR CLUTCH - INSPECTION, A/C	24-16	CONSOLE - INSTALLATION, CENTER	23-122
CLUTCH RELAY - INSTALLATION, A/C COMPRESSOR	24-18	COMPRESSOR CLUTCH - INSTALLATION, A/C	24-16	CONSOLE - INSTALLATION, OVERHEAD	8M-8
CLUTCH RELAY - OPERATION, A/C COMPRESSOR	24-17	COMPRESSOR CLUTCH - OPERATION, A/C	24-13	CONSOLE - OVERHEAD CONSOLE ASSEMBLY, OVERHEAD	8M-7
CLUTCH RELAY - REMOVAL, A/C COMPRESSOR	24-18	COMPRESSOR CLUTCH - REMOVAL, A/C	24-14	CONSOLE - OVERHEAD CONSOLE DISASSEMBLY, OVERHEAD	8M-7
CLUTCH RELEASE BEARING - DESCRIPTION	6-14	COMPRESSOR CLUTCH BREAK-IN - STANDARD PROCEDURE, A/C	24-13	CONSOLE - REMOVAL, CENTER	23-122
CLUTCH RELEASE BEARING - INSTALLATION	6-15	COMPRESSOR CLUTCH COIL - DIAGNOSIS AND TESTING, A/C	24-13	CONSOLE - REMOVAL, OVERHEAD	8M-6
CLUTCH RELEASE BEARING - OPERATION	6-14	COMPRESSOR CLUTCH RELAY - DESCRIPTION, A/C	24-17	CONSOLE ASSEMBLY, OVERHEAD CONSOLE - OVERHEAD	8M-7
CLUTCH RELEASE BEARING - REMOVAL	6-15	COMPRESSOR CLUTCH RELAY - DIAGNOSIS AND TESTING, A/C	24-17	CONSOLE DISASSEMBLY, OVERHEAD CONSOLE - OVERHEAD	8M-7
COAT FINISH - DESCRIPTION, BASE COAT/CLEAR	23-129	COMPRESSOR CLUTCH RELAY - INSTALLATION, A/C	24-18	CONSOLE LID - INSTALLATION, CENTER	23-132
COAT FINISH - OPERATION, BASE COAT/CLEAR	23-129	COMPRESSOR CLUTCH RELAY - OPERATION, A/C	24-17	CONSOLE LID - REMOVAL, CENTER	23-131
COAT HOOK - INSTALLATION	23-125	COMPRESSOR CLUTCH RELAY - REMOVAL, A/C	24-18	CONSOLE SYSTEMS, SPECIAL TOOLS - OVERHEAD	8M-8
COAT HOOK - REMOVAL	23-124	COMPUTER - DESCRIPTION, COMPASS/ MINI-TRIP	8M-8	CONTAINER - 3.9L/5.2L/5.9L/5.9L DIESEL - DESCRIPTION, COOLANT RECOVERY	7-41
COAT/CLEAR COAT FINISH - DESCRIPTION, BASE	23-129	COMPUTER - DIAGNOSIS & TESTING, COMPASS MINI-TRIP	8M-10	CONTAINER - 3.9L/5.2L/5.9L/5.9L DIESEL - INSTALLATION, COOLANT RECOVERY	7-41
COAT/CLEAR COAT FINISH - OPERATION, BASE	23-129	COMPUTER - INSTALLATION, COMPASS/ MINI-TRIP	8M-11	CONTAINER - 3.9L/5.2L/5.9L/5.9L DIESEL - OPERATION, COOLANT RECOVERY	7-41
CODE - DESCRIPTION, PAINT	23-129	COMPUTER - OPERATION, COMPASS/ MINI-TRIP	8M-9	CONTAINER - 3.9L/5.2L/5.9L/5.9L DIESEL - REMOVAL, COOLANT RECOVERY	7-41
CODE PLATE - DESCRIPTION, BODY	Intro-1	COMPUTER - REMOVAL, COMPASS/ MINI-TRIP	8M-11	CONTAINER - 8.0L - DESCRIPTION, COOLANT RECOVERY	7-42
CODES - DESCRIPTION, DIAGNOSTIC TROUBLE	25-2	COMPUTER/MAINTENANCE REMINDER - INSPECTION, TRIP	30-17	CONTAINER - 8.0L - OPERATION, COOLANT RECOVERY	7-42
CODES, SPECIFICATIONS - 2001 BR PAINT COLOR	23-129	CONDENSER - DESCRIPTION, A/C	24-48	CONTAMINATION - DIAGNOSIS AND TESTING, BRAKE FLUID	5-14
COIL - DIAGNOSIS AND TESTING, A/C COMPRESSOR CLUTCH	24-13	CONDENSER - INSTALLATION, A/C	24-49	CONTAMINATION - DIAGNOSIS AND TESTING, FLUID	21-199,21-370,21-545,21-715
COIL RESISTANCE, 3.9L/5.2L/5.9L ENGINES - IGNITION	8I-3	CONDENSER - OPERATION, A/C	24-48	CONTINUITY - STANDARD PROCEDURE, TESTING	8W-01-6
COIL RESISTANCE, 8.0L V-10 ENGINE - IGNITION	8I-3	CONDENSER - REMOVAL, A/C	24-49	CONTROL - DESCRIPTION, A/C HEATER	24-18
COLOR CODES, SPECIFICATIONS - 2001 BR PAINT	23-129	CONDITIONER - DESCRIPTION, HEATER AND AIR	24-1	CONTROL - DIAGNOSIS AND TESTING, A/C HEATER	24-19
COLUMN - DESCRIPTION	19-6	CONDITIONER - INSPECTION, HEATER/AIR	30-17	CONTROL - INSPECTION, SPEED	30-17
COLUMN - INSTALLATION	19-8	CONDITIONER - OPERATION, HEATER AND AIR	24-1	CONTROL - INSTALLATION, A/C HEATER	24-20
COLUMN - REMOVAL	19-7	CONDITIONING - INSTALLATION, WATER PUMP BYPASS HOSE WITH AIR	7-77	CONTROL - OPERATION, A/C HEATER	24-18
COLUMN - SERVICE PRECAUTIONS	19-6	CONDITIONING - INSTALLATION, WATER PUMP BYPASS HOSE WITHOUT AIR	7-78	CONTROL - REMOVAL, A/C HEATER	24-19
COLUMN OPENING COVER - INSTALLATION, STEERING	23-116	CONDITIONING - REMOVAL, WATER PUMP BYPASS HOSE WITH AIR	7-74	CONTROL ARM - INSTALLATION, LOWER	2-10, 2-20
COLUMN OPENING COVER - REMOVAL, STEERING	23-115	CONDITIONING - REMOVAL, WATER PUMP BYPASS HOSE WITHOUT AIR	7-77	CONTROL ARM - INSTALLATION, UPPER	2-13, 2-24
COMBINATION FLASHER - DESCRIPTION	8L-7	CONDITIONS - DIAGNOSIS AND TESTING, SPARK PLUG	8I-16	CONTROL ARM - REMOVAL, LOWER	2-10, 2-20
COMBINATION FLASHER - INSTALLATION	8L-8	CONNECT FITTING - DESCRIPTION, QUICK	14-22	CONTROL ARM - REMOVAL, UPPER	2-13, 2-23
COMBINATION FLASHER - OPERATION	8L-7	CONNECTING ROD - CLEANING, PISTON	9-154, 9-209, 9-285, 9-41, 9-98	CONTROL CABLE - INSTALLATION, THROTTLE	14-105, 14-50
COMBINATION FLASHER - REMOVAL	8L-8	CONNECTING ROD - CONNECTING RODS, PISTON	9-286	CONTROL CABLE - REMOVAL, THROTTLE	14-104, 14-50
COMBINATION VALVE - DESCRIPTION	5-9	CONNECTING ROD - DESCRIPTION, PISTON	9-153, 9-208, 9-282, 9-40, 9-97	CONTROL MODULE - DESCRIPTION, AIRBAG	80-6
COMBINATION VALVE - DIAGNOSIS AND TESTING	5-9	CONNECTING ROD - INSPECTION, PISTON	9-154, 9-209, 9-285, 9-41, 9-98	CONTROL MODULE - INSTALLATION, AIRBAG	80-8
COMBINATION VALVE - INSTALLATION	5-10	CONNECTING ROD - INSTALLATION, PISTON	9-154, 9-210, 9-287, 9-41, 9-98	CONTROL MODULE - INSTALLATION, ENGINE	8E-14
COMBINATION VALVE - OPERATION	5-9	CONNECTING ROD - REMOVAL, PISTON	9-154, 9-209, 9-285, 9-40, 9-97	CONTROL MODULE - INSTALLATION, POWERTRAIN	8E-20
COMBINATION VALVE - REMOVAL	5-10	CONNECTOR - AUGAT - INSTALLATION	8W-01-8	CONTROL MODULE - OPERATION, AIRBAG	80-6
COMBUSTION PRESSURE LEAKAGE - DIAGNOSIS AND TESTING, CYLINDER	9-124, 9-179, 9-67, 9-9	CONNECTOR - AUGAT - REMOVAL	8W-01-8	CONTROL MODULE - REMOVAL, AIRBAG	80-7
COMPASS - INSPECTION	30-12	CONNECTOR - DESCRIPTION, DATA LINK	8E-12	CONTROL MODULE - REMOVAL, ENGINE	8E-14
COMPASS CALIBRATION - STANDARD PROCEDURE	8M-4	CONNECTOR - MOLEX - INSTALLATION	8W-01-9	CONTROL MODULE - REMOVAL, POWERTRAIN	8E-19
COMPASS DEMAGNETIZING - STANDARD PROCEDURE	8M-5	CONNECTOR - MOLEX - REMOVAL	8W-01-9	CONTROL MOTOR - DESCRIPTION, IDLE AIR	14-41
COMPASS MINI-TRIP COMPUTER - DIAGNOSIS & TESTING	8M-10	CONNECTOR - OPERATION, DATA LINK	8E-12	CONTROL MOTOR - OPERATION, IDLE AIR	14-41
COMPASS VARIATION ADJUSTMENT - STANDARD PROCEDURE	8M-4	CONNECTOR - THOMAS AND BETTS - INSTALLATION	8W-01-10	CONTROL SERVO - DESCRIPTION, SPEED	8P-5
COMPASS/MINI-TRIP COMPUTER - DESCRIPTION	8M-8	CONNECTOR - THOMAS AND BETTS - REMOVAL	8W-01-9	CONTROL SERVO - INSTALLATION, SPEED	8P-10
COMPASS/MINI-TRIP COMPUTER - INSTALLATION	8M-11	CONSOLE - DESCRIPTION, OVERHEAD	8M-1	CONTROL SERVO - OPERATION, SPEED	8P-5
COMPASS/MINI-TRIP COMPUTER - OPERATION	8M-9			CONTROL SERVO - REMOVAL, SPEED	8P-6
COMPASS/MINI-TRIP COMPUTER - REMOVAL	8M-11			CONTROL SWITCH - DESCRIPTION, LUMBAR	8N-17
COMPRESSION PRESSURE - DIAGNOSIS AND TESTING, CYLINDER	9-124, 9-179, 9-67, 9-9			CONTROL SWITCH - OPERATION, LUMBAR	8N-18
COMPRESSOR - DESCRIPTION, A/C	24-46			CONTROL SWITCH - REMOVAL, LUMBAR	8N-18
COMPRESSOR - DIAGNOSIS AND TESTING, A/C	24-46			CONTROL SYSTEM - DESCRIPTION, SPEED	8P-1
COMPRESSOR - INSTALLATION, A/C	24-47			CONTROL SYSTEM - OPERATION, SPEED	8P-2
COMPRESSOR - OPERATION, A/C	24-46			CONTROL SYSTEM - TORQUE, SPEED	8P-4
COMPRESSOR - REMOVAL, A/C	24-47			CONTROL/CENTRAL TIMER MODULE - DESCRIPTION, BODY	8E-1
COMPRESSOR CLUTCH - DESCRIPTION, A/C	24-13				

Description	Group-Page	Description	Group-Page	Description	Group-Page
CONTROL/CENTRAL TIMER MODULE - INSTALLATION, BODY	8E-6	COOLANT TEMP SENSOR - 3.9L/5.2L/ 5.9L - OPERATION, ENGINE	7-48	COOLING SYSTEM 3.9L/5.2L/5.9L/8.0L ENGINES - STANDARD PROCEDURE, REFILLING	7-15
CONTROL/CENTRAL TIMER MODULE - OPERATION, BODY	8E-3	COOLANT TEMP SENSOR - 3.9L/5.2L/ 5.9L - REMOVAL, ENGINE	7-48	COOLING SYSTEM 5.9L DIESEL ENGINE - STANDARD PROCEDURE, DRAINING	7-15
CONTROL/CENTRAL TIMER MODULE - REMOVAL, BODY	8E-5	COOLANT THERMOSTAT - 3.9L/5.2L/ 5.9L - DESCRIPTION, ENGINE	7-49	COOLING SYSTEM 5.9L DIESEL ENGINE - STANDARD PROCEDURE, REFILLING	7-15
CONTROLLER ANTILOCK BRAKE - DESCRIPTION	8E-11	COOLANT THERMOSTAT - 3.9L/5.2L/ 5.9L - INSTALLATION, ENGINE	7-50	COOLING SYSTEM CLEANING/REVERSE FLUSHING - STANDARD PROCEDURE	7-16
CONTROLLER ANTILOCK BRAKE - INSTALLATION	8E-12	COOLANT THERMOSTAT - 3.9L/5.2L/ 5.9L - OPERATION, ENGINE	7-49	COOLING SYSTEM DIESEL ENGINE - DIAGNOSIS AND TESTING	7-12
CONTROLLER ANTILOCK BRAKE - OPERATION	8E-11	COOLANT THERMOSTAT - 3.9L/5.2L/ 5.9L - REMOVAL, ENGINE	7-49	COOLING SYSTEM FLOW - 3.9L/5.2L/ 5.9L ENGINE - DESCRIPTION	7-1
CONTROLLER ANTILOCK BRAKE - REMOVAL	8E-12	COOLANT THERMOSTAT - 5.9L DIESEL - DESCRIPTION, ENGINE	7-54	COOLING SYSTEM FLOW - 5.9L DIESEL - DESCRIPTION	7-1
CONTROLS - DIAGNOSIS AND TESTING, OVERDRIVE		COOLANT THERMOSTAT - 5.9L DIESEL - INSTALLATION, ENGINE	7-55	COOLING SYSTEM GAS ENGINE - DIAGNOSIS AND TESTING	7-7
ELECTRICAL	21-215,21-386,21-579,21-732	COOLANT THERMOSTAT - 5.9L DIESEL - OPERATION, ENGINE	7-54	COOLING SYSTEM LEAKS - DIAGNOSIS AND TESTING	7-5
CONVERTER - 3.9L/5.2L/5.9L - DESCRIPTION, CATALYTIC	11-5	COOLANT THERMOSTAT - 5.9L DIESEL - REMOVAL, ENGINE	7-55	COOLING SYSTEM REQUIREMENTS - DESCRIPTION	24-1
CONVERTER - 3.9L/5.2L/5.9L - INSPECTION, CATALYTIC	11-5	COOLANT THERMOSTAT - 8.0L - DESCRIPTION, ENGINE	7-52	CORE - DESCRIPTION, HEATER	24-55
CONVERTER - 3.9L/5.2L/5.9L - INSTALLATION, CATALYTIC	11-5	COOLANT THERMOSTAT - 8.0L - INSTALLATION, ENGINE	7-53	CORE - INSTALLATION, HEATER	24-56
CONVERTER - 3.9L/5.2L/5.9L - OPERATION, CATALYTIC	11-5	COOLANT THERMOSTAT - 8.0L - OPERATION, ENGINE	7-52	CORE - OPERATION, HEATER	24-55
CONVERTER - 3.9L/5.2L/5.9L - REMOVAL, CATALYTIC	11-5	COOLANT THERMOSTAT - 8.0L - REMOVAL, ENGINE	7-52	CORE - REMOVAL, HEATER	24-56
CONVERTER - 5.9L HEAVY DUTY/8.0L - DESCRIPTION, CATALYTIC	11-6	COOLER - 3.9L/5.2L/5.9L - ASSEMBLY, TRANS	7-82	CORE GROUND STRAP - INSTALLATION, HEATER	8A-15
CONVERTER - 5.9L HEAVY DUTY/8.0L - INSPECTION, CATALYTIC	11-7	COOLER - 3.9L/5.2L/5.9L - DESCRIPTION, TRANS	7-79	CORE GROUND STRAP - REMOVAL, HEATER	8A-14
CONVERTER - 5.9L HEAVY DUTY/8.0L - INSTALLATION, CATALYTIC	11-7	COOLER - 3.9L/5.2L/5.9L - DISASSEMBLY, TRANS	7-81	CORNER SEAL - INSTALLATION, FRONT DOOR UPPER	23-154
CONVERTER - 5.9L HEAVY DUTY/8.0L - OPERATION, CATALYTIC	11-6	COOLER - 3.9L/5.2L/5.9L - INSTALLATION, TRANS	7-82	CORNER SEAL - REMOVAL, FRONT DOOR UPPER	23-154
CONVERTER - 5.9L HEAVY DUTY/8.0L - REMOVAL, CATALYTIC	11-6	COOLER - 3.9L/5.2L/5.9L - OPERATION, TRANS	7-79	COUPLERS - DESCRIPTION, A/C LINE	24-40
CONVERTER - DESCRIPTION, TORQUE	21-256,21-427,21-600,21-773	COOLER - 3.9L/5.2L/5.9L - REMOVAL, TRANS	7-81	COUPLERS - OPERATION, A/C LINE	24-41
CONVERTER - INSTALLATION, TORQUE	21-261,21-432,21-605,21-778	COOLER - 5.9L DIESEL - DESCRIPTION, TRANS	7-85	COUPLERS - STANDARD PROCEDURE, A/C LINE	24-43
CONVERTER - OPERATION, TORQUE	21-260,21-430,21-604,21-777	COOLER - 5.9L DIESEL - INSTALLATION, TRANS	7-88	COVER - INSTALLATION, CENTER SEAT ARMREST/LATCH	23-132
CONVERTER - REMOVAL, TORQUE	21-261,21-432,21-605,21-778	COOLER - 5.9L DIESEL - OPERATION, TRANS	7-85	COVER - INSTALLATION, COWL TRIM	23-120
CONVERTER DRAINBACK VALVE - DESCRIPTION, TORQUE	21-262,21-432,21-605,21-778	COOLER - 8.0L - DESCRIPTION, TRANS	7-82	COVER - INSTALLATION, GEAR HOUSING	9-307
CONVERTER DRAINBACK VALVE - OPERATION, TORQUE	21-262,21-432,21-605,21-778	COOLER - 8.0L - INSTALLATION, TRANS	7-85	COVER - INSTALLATION, INSTRUMENT PANEL TOP	23-115
CONVERTER DRAINBACK VALVE - STANDARD PROCEDURE, TORQUE	21-262,21-432,21-606,21-778	COOLER - 8.0L - OPERATION, TRANS	7-82	COVER - INSTALLATION, SEAT BACK	23-137
CONVERTER HOUSING FLUID LEAK - DIAGNOSIS AND TESTING	21-148,21-319,21-491,21-662	COOLER - 8.0L - REMOVAL, TRANS	7-84	COVER - INSTALLATION, SEAT CUSHION	23-139
COOLANT - DESCRIPTION	7-40	COOLER - INSTALLATION, AIR TO OIL	7-88	COVER - INSTALLATION, SHIFT	21-133,21-90
COOLANT - OPERATION	7-40	COOLER & LINES - CLEANING AND INSPECTION, OIL	9-296	COVER - INSTALLATION, STANCHION	23-143
COOLANT - STANDARD PROCEDURE, ADDING ADDITIONAL	7-16	COOLER - REMOVAL, AIR TO OIL	7-87	COVER - INSTALLATION, STEERING COLUMN OPENING	23-116
COOLANT FLOW - DIAGNOSIS AND TESTING, RADIATOR	7-59,7-61,7-63	COOLER - REMOVAL, WATER TO OIL	7-87	COVER - REMOVAL, CENTER SEAT ARMREST/LATCH	23-132
COOLANT LEVEL CHECK - STANDARD PROCEDURE	7-16	COOLER - STANDARD PROCEDURE, FLUSHING COOLER AND TUBES - WITHOUT RADIATOR IN-TANK TRANSMISSION OIL	7-80,7-83,7-86	COVER - REMOVAL, COWL TRIM	23-119
COOLANT RECOVERY CONTAINER - 3.9L/5.2L/5.9L/5.9L DIESEL - DESCRIPTION	7-41	COOLER - STANDARD PROCEDURE, FLUSHING COOLERS AND TUBES - WITH RADIATOR IN-TANK TRANSMISSION OIL	7-79,7-83,7-85	COVER - REMOVAL, GEAR HOUSING	9-306
COOLANT RECOVERY CONTAINER - 3.9L/5.2L/5.9L/5.9L DIESEL - INSTALLATION	7-41	COOLER AND PLUMBING - CLEANING, CHARGE AIR	11-18	COVER - REMOVAL, INSTRUMENT PANEL TOP	23-114
COOLANT RECOVERY CONTAINER - 3.9L/5.2L/5.9L/5.9L DIESEL - OPERATION	7-41	COOLER AND PLUMBING - DESCRIPTION, CHARGE AIR	11-17	COVER - REMOVAL, SEAT BACK	23-137
COOLANT RECOVERY CONTAINER - 3.9L/5.2L/5.9L/5.9L DIESEL - REMOVAL	7-41	COOLER AND PLUMBING - INSPECTION, CHARGE AIR	11-18	COVER - REMOVAL, SEAT CUSHION	23-139
COOLANT RECOVERY CONTAINER - 8.0L - DESCRIPTION	7-42	COOLER AND PLUMBING - OPERATION, CHARGE AIR	11-17	COVER - REMOVAL, SHIFT	21-132,21-90
COOLANT RECOVERY CONTAINER - 8.0L - OPERATION	7-42	COOLER AND PLUMBING - REMOVAL, CHARGE AIR	11-17	COVER - REMOVAL, STANCHION	23-143
COOLANT SELECTION-ADDITIVES - STANDARD PROCEDURE	7-17	COOLER AND TUBES - WITHOUT RADIATOR IN-TANK TRANSMISSION OIL COOLER - STANDARD PROCEDURE, FLUSHING	7-80,7-83,7-86	COVER - REMOVAL, STEERING COLUMN OPENING	23-115
COOLANT TEMP SENSOR - 3.9L/5.2L/ 5.9L - DESCRIPTION, ENGINE	7-48	COOLERS AND TUBES - WITH RADIATOR IN-TANK TRANSMISSION OIL COOLER - STANDARD PROCEDURE, FLUSHING	7-79,7-83,7-85	COVER - REMOVAL, WHEEL	22-12
COOLANT TEMP SENSOR - 3.9L/5.2L/ 5.9L - INSTALLATION, ENGINE	7-48	COOLING, SPECIAL TOOLS	7-18	COVER - SPLIT BENCH - INSTALLATION, SEAT BACK	23-138
		COOLING SYSTEM - OPERATION	7-4	COVER - SPLIT BENCH - INSTALLATION, SEAT CUSHION	23-140
		COOLING SYSTEM 3.9L/5.2L/5.9L/8.0L ENGINES - STANDARD PROCEDURE, DRAINING	7-15	COVER - SPLIT BENCH - REMOVAL, SEAT BACK	23-137
				COVER - SPLIT BENCH - REMOVAL, SEAT CUSHION	23-139
				COVER GASKET - DESCRIPTION, CYLINDER	9-79
				COVER GASKET - DESCRIPTION, CYLINDER HEAD	9-22
				COVER GASKET - OPERATION, CYLINDER HEAD	9-22
				COVER INSTALLED - INSTALLATION, FRONT OIL SEAL - FRONT	9-205
				COVER INSTALLED - REMOVAL, FRONT OIL SEAL - FRONT	9-204
				COVER REMOVED - INSTALLATION, FRONT OIL SEAL - FRONT	9-205
				COVER REMOVED - REMOVAL, FRONT OIL SEAL - FRONT	9-204
				COVER(S) - CLEANING, CYLINDER HEAD	9-138, 9-194,9-24,9-253,9-81
				COVER(S) - DESCRIPTION, CYLINDER HEAD	9-194



Description	Group-Page	Description	Group-Page	Description	Group-Page
COVER(S) - INSPECTION, CYLINDER HEAD	9-138,9-194,9-24,9-253,9-81	CYLINDER - REMOVAL, LOCK	23-73	DAY / NIGHT MIRROR - OPERATION, AUTOMATIC	8N-11
COVER(S) - INSTALLATION, CYLINDER HEAD	9-138,9-194,9-24,9-253,9-81	CYLINDER - REMOVAL, MASTER	5-30	DAY / NIGHT MIRROR - REMOVAL, AUTOMATIC	8N-12
COVER(S) - INSTALLATION, TIMING BELT / CHAIN	9-113,9-169,9-226,9-56	CYLINDER BLEEDING - STANDARD PROCEDURE, MASTER	5-30	DAY/NIGHT MIRROR - DIAGNOSIS AND TESTING, AUTOMATIC	8N-11
COVERS - INSTALLATION, WHEEL	30-10	CYLINDER BORE HONING - STANDARD PROCEDURE	9-10,9-126,9-180,9-69	DAYTIME RUNNING LAMP MODULE - DESCRIPTION	8L-9
COVER(S) - REMOVAL, CYLINDER HEAD	9-138,9-194,9-24,9-253,9-81	CYLINDER BORE REPAIR - STANDARD PROCEDURE	9-265	DAYTIME RUNNING LAMP MODULE - INSTALLATION	8L-9
COVER(S) - REMOVAL, TIMING BELT / CHAIN	9-113,9-169,9-225,9-56	CYLINDER COMBUSTION PRESSURE LEAKAGE - DIAGNOSIS AND TESTING	9-124,9-179,9-67,9-9	DAYTIME RUNNING LAMP MODULE - OPERATION	8L-9
COWL GRILLE - INSTALLATION	23-90	CYLINDER COMPRESSION PRESSURE - DIAGNOSIS AND TESTING	9-124,9-179,9-67,9-9	DAYTIME RUNNING LAMP MODULE - REMOVAL	8L-9
COWL GRILLE - REMOVAL	23-90	CYLINDER COVER GASKET - DESCRIPTION	9-79	DECALS - INSTALLATION	23-63
COWL TRIM COVER - INSTALLATION	23-120	CYLINDER HEAD - CLEANING	9-137,9-193,9-23,9-248,9-80	DECALS - INSTALLATION, BODY STRIPES	23-87
COWL TRIM COVER - REMOVAL	23-119	CYLINDER HEAD - DESCRIPTION	9-136,9-191,9-22,9-246,9-79	DECALS - REMOVAL	23-63
COWL WEATHERSTRIP - INSTALLATION	23-153	CYLINDER HEAD - INSPECTION	9-137,9-193,9-23,9-250,9-80	DECALS - REMOVAL, BODY STRIPES	23-87
COWL WEATHERSTRIP - REMOVAL	23-153	CYLINDER HEAD - INSTALLATION	9-137,9-193,9-23,9-250,9-80	DEFINITION - DESCRIPTION, TRIP	25-18
C-PILLAR TRIM - INSTALLATION	23-128	CYLINDER HEAD - OPERATION	9-136,9-22,9-79	DEFROSTER AND DEMISTER DUCT ADAPTER - INSTALLATION	24-35
C-PILLAR TRIM - REMOVAL	23-128	CYLINDER HEAD - REMOVAL	9-137,9-192,9-23,9-246,9-80	DEFROSTER AND DEMISTER DUCT ADAPTER - REMOVAL	24-35
CRANKCASE BREATHER VAPOR CANISTER - INSTALLATION	9-242	CYLINDER HEAD COVER GASKET - DESCRIPTION	9-22	DEFROSTER AND DEMISTER DUCTS - INSTALLATION	24-35
CRANKCASE BREATHER VAPOR CANISTER - REMOVAL	9-241	CYLINDER HEAD COVER GASKET - OPERATION	9-22	DEFROSTER AND DEMISTER DUCTS - REMOVAL	24-34
CRANKCASE VENT HOSE - OPERATION	25-32	CYLINDER HEAD COVER(S) - CLEANING	9-138,9-194,9-24,9-253,9-81	DE-GLAZE - STANDARD PROCEDURE - CYLINDER BORE	9-264
CRANKSHAFT - DESCRIPTION	9-145,9-275,9-31,9-88	CYLINDER HEAD COVER(S) - DESCRIPTION	9-194	DELIVERY - DIESEL - OPERATION, FUEL	14-56
CRANKSHAFT - INSTALLATION	9-145,9-203,9-32,9-89	CYLINDER HEAD COVER(S) - INSPECTION	9-138,9-194,9-24,9-253,9-81	DELIVERY - SPECIFICATIONS, TORQUE - FUEL	14-4
CRANKSHAFT - OPERATION	9-145,9-31,9-88	CYLINDER HEAD COVER(S) - INSTALLATION	9-138,9-194,9-24,9-253,9-81	DELIVERY STORAGE - DESCRIPTION, PRE	30-19
CRANKSHAFT - REMOVAL	9-145,9-202,9-31,9-88	CYLINDER HEAD COVER(S) - REMOVAL	9-138,9-194,9-24,9-253,9-81	DELIVERY STORAGE - STANDARD PROCEDURE, PRE	30-20
CRANKSHAFT JOURNAL CLEARANCE - STANDARD PROCEDURE, CONNECTING ROD BEARING	9-274	CYLINDER HEAD GASKET FAILURE - DIAGNOSIS AND TESTING	9-136,9-191,9-22,9-79	DELIVERY SYSTEM - DESCRIPTION, DIESEL FUEL	14-54
CRANKSHAFT MAIN BEARING FITTING - STANDARD PROCEDURE	9-146,9-90	CYLINDER HOUSING - INSTALLATION, LOCK	19-11	DELIVERY SYSTEM - DESCRIPTION, FUEL	14-2
CRANKSHAFT MAIN BEARINGS - DESCRIPTION	9-146,9-32,9-90	CYLINDER HOUSING - REMOVAL, LOCK	19-10	DELIVERY SYSTEM - OPERATION, FUEL	14-2
CRANKSHAFT MAIN BEARINGS - INSTALLATION	9-147,9-204,9-34,9-90	CYLINDER LOCK SWITCH - DESCRIPTION, DOOR	8N-5	DEMAGNETIZING - STANDARD PROCEDURE, COMPASS	8M-5
CRANKSHAFT MAIN BEARINGS - OPERATION	9-146,9-32,9-90	CYLINDER LOCK SWITCH - DIAGNOSIS & TESTING, DOOR	8N-5	DEMISTER DUCT ADAPTER - INSTALLATION, DEFROSTER	24-35
CRANKSHAFT MAIN BEARINGS - REMOVAL	9-147,9-204,9-33,9-90	CYLINDER LOCK SWITCH - INSTALLATION, DOOR	8N-6	DEMISTER DUCT ADAPTER - REMOVAL, DEFROSTER	24-35
CRANKSHAFT OIL SEAL - FRONT - DESCRIPTION	9-147,9-34,9-91	CYLINDER LOCK SWITCH - OPERATION, DOOR	8N-5	DEMISTER DUCTS - INSTALLATION, DEFROSTER	24-35
CRANKSHAFT OIL SEAL - FRONT - INSTALLATION	9-148,9-277,9-34,9-91	CYLINDER LOCK SWITCH - REMOVAL, DOOR	8N-6	DEMISTER DUCTS - REMOVAL, DEFROSTER	24-34
CRANKSHAFT OIL SEAL - FRONT - OPERATION	9-147,9-34,9-91	CYLINDER/POWER BOOSTER - DIAGNOSIS AND TESTING, MASTER	5-29	DEMISTER DUCTS - REMOVAL, INSTRUMENT PANEL	24-37
CRANKSHAFT OIL SEAL - FRONT - REMOVAL	9-147,9-276,9-34,9-91	CYLINDERS - ASSEMBLY, WHEEL	5-31	DEMISTER GRILLES - INSTALLATION	24-32
CRANKSHAFT OIL SEAL - REAR - DESCRIPTION	9-148,9-34,9-91	CYLINDERS - CLEANING, WHEEL	5-31	DEMISTER GRILLES - REMOVAL	24-31
CRANKSHAFT OIL SEAL - REAR - INSTALLATION	9-149,9-206,9-278,9-35,9-92	CYLINDERS - DESCRIPTION, LOCK	23-1	DEPLOYMENT - STANDARD PROCEDURE, SERVICE AFTER AN AIRBAG	80-4
CRANKSHAFT OIL SEAL - REAR - OPERATION	9-148,9-34,9-92	CYLINDERS - DISASSEMBLY, WHEEL	5-31	DETECTION PUMP - DESCRIPTION, LEAK	25-33
CRANKSHAFT OIL SEAL - REAR - REMOVAL	9-149,9-206,9-278,9-35,9-92	CYLINDERS - INSPECTION, WHEEL	5-31	DETECTION PUMP - INSTALLATION, LEAK	25-34
CRANKSHAFT REAR OIL SEAL RETAINER - INSTALLATION	9-206,9-279	CYLINDERS - INSTALLATION, WHEEL	5-32	DETECTION PUMP - REMOVAL, LEAK	25-34
CRANKSHAFT REAR OIL SEAL RETAINER - REMOVAL	9-206,9-278	CYLINDERS - REMOVAL, WHEEL	5-31	DIAGNOSIS - INTRODUCTION - DIAGNOSIS AND TESTING, ENGINE	9-118,9-173,9-3
CROSSHEADS - CLEANING	9-249	DAM - INSTALLATION, FRONT AIR	13-2	DIAGNOSIS - MECHANICAL - DIAGNOSIS AND TESTING, ENGINE	9-232
CROSSHEADS - INSPECTION	9-250	DAM - REMOVAL, FRONT AIR	13-1	DIAGNOSIS CHARTS - DIAGNOSIS AND TESTING	21-149,21-320,21-492,21-663
CRUISE INDICATOR - DESCRIPTION	8J-18	DAMAGED OR WORN THREADS - STANDARD PROCEDURE, REPAIR	9-111,9-125,9-181,9-238,9-68	DIAGNOSIS CHARTS - DIAGNOSIS AND TESTING, SMOKE	9-234
CRUISE INDICATOR - OPERATION	8J-18	DAMPER - INSPECTION, VIBRATION	9-289	DIAGNOSIS, INTRODUCTION - DIAGNOSIS AND TESTING-ENGINE	9-61
CUBBY BIN - INSTALLATION	23-110	DAMPER - INSTALLATION, VIBRATION	9-156,9-212,9-289,9-42,9-99	DIAGNOSTIC AND TESTING, CLUTCH	6-2
CUBBY BIN - REMOVAL	23-110	DAMPER - REMOVAL, VIBRATION	9-155,9-212,9-289,9-42,9-99	DIAGNOSTIC TROUBLE CODES - DESCRIPTION	25-2
CUMMINS TURBO DIESEL - DESCRIPTION, MAINTENANCE SCHEDULES - 24-VALVE	0-22	DATA BUS - DESCRIPTION, CCD	8E-6	DIAGNOSTICS (OBD) - DIAGNOSIS AND TESTING, ON-BOARD	7-4
CUP HOLDER - INSTALLATION	23-111	DATA BUS - DIAGNOSIS AND TESTING, CCD	8E-11	DIAGRAMS - DESCRIPTION, HOW TO USE WIRING	8W-01-1
CUP HOLDER - REMOVAL	23-110	DATA BUS - OPERATION, CCD	8E-7	DIAGRAMS - HYDRAULIC SCHEMATICS, SCHEMATICS	21-174,21-345,21-520,21-690
CUSHION - INSTALLATION, SEAT	23-138	DATA LINK CONNECTOR - DESCRIPTION	8E-12	DIESEL - CLEANING, RADIATOR - 5.9L	7-65
CUSHION - REMOVAL, SEAT	23-138	DATA LINK CONNECTOR - OPERATION	8E-12	DIESEL - CLEANING, RADIATOR FAN - 5.9L	7-44
CUSHION COVER - INSTALLATION, SEAT	23-139	DATA PLATE - DESCRIPTION, ENGINE	9-244	DIESEL - CLEANING, WATER PUMP - 5.9L	7-73
CUSHION COVER - REMOVAL, SEAT	23-139	DATA PLATE, SPECIFICATIONS - FUEL INJECTION PUMP	14-73		
CUSHION COVER - SPLIT BENCH - INSTALLATION, SEAT	23-140	DAY / NIGHT MIRROR - DESCRIPTION, AUTOMATIC	8N-10		
CUSHION COVER - SPLIT BENCH - REMOVAL, SEAT	23-139	DAY / NIGHT MIRROR - INSTALLATION, AUTOMATIC	8N-12		
CYLINDER - DESCRIPTION, MASTER	5-29				
CYLINDER - DIAGNOSIS AND TESTING, IGNITION SWITCH AND KEY LOCK	19-10				
CYLINDER - INSTALLATION, LOCK	23-73				
CYLINDER - INSTALLATION, MASTER	5-30				
CYLINDER - OPERATION, MASTER	5-29				

Description	Group-Page	Description	Group-Page	Description	Group-Page
DIESEL - DESCRIPTION	25-1	DIESEL - OPERATION, VACUUM PUMP -		DISC - REMOVAL, CLUTCH	6-8
DIESEL - DESCRIPTION	14-102,14-103	5.9L	7-35	DISC BRAKE CALIPERS - ASSEMBLY	5-12
DIESEL - DESCRIPTION	81-5	DIESEL - OPERATION, WATER PUMP -		DISC BRAKE CALIPERS - CLEANING	5-12
DIESEL - DESCRIPTION, 5.9L	11-3	5.9L	7-73	DISC BRAKE CALIPERS - DISASSEMBLY	5-11
DIESEL - DESCRIPTION, BELT		DIESEL - REMOVAL	14-103,14-104	DISC BRAKE CALIPERS - INSPECTION	5-12
TENSIONERS - 5.9L	7-23	DIESEL - REMOVAL	81-7	DISC BRAKE ROTOR - DIAGNOSIS AND	
DIESEL - DESCRIPTION, COOLANT		DIESEL - REMOVAL, BELT TENSIONERS -		TESTING	5-20
RECOVERY CONTAINER - 3.9L/5.2L/		5.9L	7-23	DISC BRAKES - DESCRIPTION,	
5.9L/5.9L	7-41	DIESEL - REMOVAL, COOLANT		2500/3500 WITH REAR	5-35
DIESEL - DESCRIPTION, COOLING		RECOVERY CONTAINER - 3.9L/5.2L/		DISC BRAKES - INSTALLATION, REAR	
SYSTEM FLOW - 5.9L	7-1	5.9L/5.9L	7-41	PARK BRAKE CABLE - 2500/3500	
DIESEL - DESCRIPTION, ENGINE 5.9L	9-231	DIESEL - REMOVAL, DRIVE BELTS - 5.9L	7-33	WITH REAR	5-38
DIESEL - DESCRIPTION, ENGINE BLOCK		DIESEL - REMOVAL, ENGINE BLOCK		DISC BRAKES - OPERATION, 2500/3500	
HEATER - 5.9L	7-47	HEATER - 5.9L	7-47	WITH REAR	5-36
DIESEL - DESCRIPTION, ENGINE		DIESEL - REMOVAL, ENGINE COOLANT		DISC BRAKES - REMOVAL, REAR PARK	
COOLANT THERMOSTAT - 5.9L	7-54	THERMOSTAT - 5.9L	7-55	BRAKE CABLE - 2500/3500 WITH	
DIESEL - DESCRIPTION, FAN DRIVE		DIESEL - REMOVAL, EXHAUST PIPE -		REAR	5-37
VISCOUS CLUTCH - 5.9L	7-57	5.9L	11-9	DISCHARGE LINE - INSTALLATION,	
DIESEL - DESCRIPTION, MAINTENANCE		DIESEL - REMOVAL, MUFFLER - 5.9L	11-11	SUCTION	24-51
SCHEDULES - 24-VALVE CUMMINS		DIESEL - REMOVAL, RADIATOR - 5.9L	7-63	DISCHARGE LINE - REMOVAL, SUCTION	24-50
TURBO	0-22	DIESEL - REMOVAL, RADIATOR FAN -		DISPLAY TEST MODE - DESCRIPTION,	
DIESEL - DESCRIPTION, RADIATOR -		5.9L	7-44	STATE	25-1
5.9L	7-63	DIESEL - REMOVAL, TAILPIPE - 5.9L	11-12	DISTRIBUTION - DESCRIPTION, POWER	8W-97-1
DIESEL - DESCRIPTION, TRANS COOLER		DIESEL - REMOVAL, VACUUM PUMP -		DISTRIBUTION - OPERATION, POWER	8W-97-1
- 5.9L	7-85	5.9L	7-35	DISTRIBUTION CENTER - DESCRIPTION,	
DIESEL - DESCRIPTION, VACUUM PUMP		DIESEL - REMOVAL, WATER PUMP -		POWER	8W-97-7
- 5.9L	7-34	5.9L	7-73	DISTRIBUTION CENTER - INSTALLATION,	
DIESEL - DESCRIPTION, WATER PUMP -		DIESEL ENGINE - DESCRIPTION, FUEL		POWER	8W-97-8
5.9L	7-73	REQUIREMENTS	0-2	DISTRIBUTION CENTER - OPERATION,	
DIESEL - FUEL INJECTOR FIRING ORDER	14-58	DIESEL ENGINE - DIAGNOSIS AND		POWER	8W-97-8
DIESEL - INSPECTION, EXHAUST PIPE -		TESTING	11-4	DISTRIBUTION CENTER - REMOVAL,	
5.9L	11-9	DIESEL ENGINE - DIAGNOSIS AND		POWER	8W-97-8
DIESEL - INSPECTION, RADIATOR - 5.9L	7-65	TESTING, COOLING SYSTEM	7-12	DISTRIBUTION SYSTEMS, SPECIAL	
DIESEL - INSPECTION, RADIATOR FAN -		DIESEL ENGINE - INSTALLATION	19-35	TOOLS - POWER	8W-97-2
5.9L	7-44	DIESEL ENGINE - REMOVAL	19-33	DISTRIBUTOR - DESCRIPTION	81-10
DIESEL - INSPECTION, TAILPIPE - 5.9L	11-12	DIESEL ENGINE - STANDARD		DISTRIBUTOR - INSTALLATION	81-11
DIESEL - INSPECTION, WATER PUMP -		PROCEDURE, DRAINING COOLING		DISTRIBUTOR - OPERATION	81-11
5.9L	7-73	SYSTEM 5.9L	7-15	DISTRIBUTOR - REMOVAL	81-11
DIESEL - INSTALLATION	14-103	DIESEL ENGINE - STANDARD		DISTRIBUTOR BUSHING - INSTALLATION	9-150,
DIESEL - INSTALLATION	81-8	PROCEDURE, REFILLING COOLING		9-37,9-94	
DIESEL - INSTALLATION, BELT		SYSTEM 5.9L	7-15	DISTRIBUTOR BUSHING - REMOVAL	9-150,
TENSIONERS - 5.9L	7-23	DIESEL ENGINE - TORQUE	14-90	9-37,9-94	
DIESEL - INSTALLATION, COOLANT		DIESEL ENGINE, SPECIAL TOOLS - 5.9L	9-244	DISTRIBUTOR CAP - DIAGNOSIS AND	
RECOVERY CONTAINER - 3.9L/5.2L/		DIESEL ENGINES - DESCRIPTION,		TESTING	81-12
5.9L/5.9L	7-41	COMPONENT MONITORS	25-18	DISTRIBUTOR ROTOR - DIAGNOSIS AND	
DIESEL - INSTALLATION, DRIVE BELTS -		DIESEL ENGINES - FUEL SYSTEM		TESTING	81-13
5.9L	7-34	PRESSURES	14-58	DOME LAMP - INSTALLATION	8L-33
DIESEL - INSTALLATION, ENGINE BLOCK		DIESEL FUEL DELIVERY SYSTEM -		DOME LAMP - REMOVAL	8L-33
HEATER - 5.9L	7-47	DESCRIPTION	14-54	DOOR - ADJUSTMENT, CARGO	23-78
DIESEL - INSTALLATION, ENGINE		DIESEL FUEL INJECTION SYSTEM -		DOOR - INSTALLATION	23-68,23-78
COOLANT THERMOSTAT - 5.9L	7-55	DESCRIPTION	14-87	DOOR - INSTALLATION, BLEND	24-38
DIESEL - INSTALLATION, EXHAUST PIPE		DIESEL FUEL SYSTEM, SPECIAL TOOLS	14-59	DOOR - INSTALLATION, FUEL FILL	23-95
- 5.9L	11-10	DIESEL FUEL TANK - DESCRIPTION	14-78	DOOR - INSTALLATION, HEAT/DEFROST	24-39
DIESEL - INSTALLATION, MUFFLER -		DIESEL, SPECIFICATIONS - 5.9L	9-242	DOOR - INSTALLATION, PANEL/DEFROST	24-39
5.9L	11-11	DIESEL WITH AUTO. TRANS. -		DOOR - INSTALLATION, RECIRCULATION	24-39
DIESEL - INSTALLATION, RADIATOR -		INSTALLATION	8P-11,8P-4	DOOR - REMOVAL	23-68,23-78
5.9L	7-65	DIESEL WITH AUTO. TRANS. - REMOVAL	8P-4,	DOOR - REMOVAL, BLEND	24-38
DIESEL - INSTALLATION, RADIATOR FAN		8P-8		DOOR - REMOVAL, FUEL FILL	23-95
- 5.9L	7-45	DIFFERENTIAL - ASSEMBLY	3-128,3-159,3-188,	DOOR - REMOVAL, HEAT/DEFROST	24-38
DIESEL - INSTALLATION, TAILPIPE - 5.9L	11-12	3-37,3-69,3-98		DOOR - REMOVAL, PANEL/DEFROST	24-38
DIESEL - INSTALLATION, TRANS		DIFFERENTIAL - DISASSEMBLY	3-128,3-158,	DOOR - REMOVAL, RECIRCULATION	24-39
COOLER - 5.9L	7-88	3-188,3-36,3-68,3-97		DOOR ACTUATOR - INSTALLATION,	
DIESEL - INSTALLATION, VACUUM		DIFFERENTIAL - INSTALLATION	3-129,3-159,	BLEND	24-26
PUMP - 5.9L	7-37	3-188,3-37,3-69,3-98		DOOR ACTUATOR - INSTALLATION,	
DIESEL - INSTALLATION, WATER PUMP -		DIFFERENTIAL - POWR-LOK - ASSEMBLY	3-163	HEAT/DEFROST	24-27
5.9L	7-74	DISASSEMBLY	3-161	DOOR ACTUATOR - INSTALLATION,	
DIESEL - OPERATION	8E-18	DIFFERENTIAL - REMOVAL	3-127,3-158,3-187,	PANEL/DEFROST	24-27
DIESEL - OPERATION	25-19	3-36,3-68,3-96		DOOR ACTUATOR - INSTALLATION,	
DIESEL - OPERATION	14-102,14-103	DIFFERENTIAL - TRAC-LOK - ASSEMBLY	3-101,	RECIRCULATION	24-28
DIESEL - OPERATION	81-5	3-132,3-190		DOOR ACTUATOR - REMOVAL, BLEND	24-25
DIESEL - OPERATION, BELT		DIFFERENTIAL - TRAC-LOK -		DOOR ACTUATOR - REMOVAL,	
TENSIONERS - 5.9L	7-23	DISASSEMBLY	3-130,3-190,3-99	HEAT/DEFROST	24-26
DIESEL - OPERATION, COOLANT		DIFFERENTIAL CASE BEARINGS -		DOOR ACTUATOR - REMOVAL,	
RECOVERY CONTAINER - 3.9L/5.2L/		INSTALLATION	3-103,3-134,3-164,3-192,3-39,	PANEL/DEFROST	24-27
5.9L/5.9L	7-41	3-71		DOOR ACTUATOR - REMOVAL,	
DIESEL - OPERATION, ENGINE BLOCK		DIFFERENTIAL CASE BEARINGS -		RECIRCULATION	24-27
HEATER - 5.9L	7-47	REMOVAL	3-103,3-134,3-164,3-192,3-39,3-71	DOOR AJAR SWITCH - DESCRIPTION	8L-34
DIESEL - OPERATION, ENGINE COOLANT		DIMENSION, SPECIFICATIONS - FRAME	13-7	DOOR AJAR SWITCH - DIAGNOSIS AND	
THERMOSTAT - 5.9L	7-54	DIMENSIONS, SPECIFICATIONS - BODY		TESTING	8L-34
DIESEL - OPERATION, FAN DRIVE		OPENING	23-60	DOOR AJAR SWITCH - INSTALLATION	8L-35
VISCOUS CLUTCH - 5.9L	7-57	DIODE - INSTALLATION	8W-01-10	DOOR AJAR SWITCH - REMOVAL	8L-35
DIESEL - OPERATION, FUEL DELIVERY	14-56	DIODE - REMOVAL	8W-01-10	DOOR CYLINDER LOCK SWITCH -	
DIESEL - OPERATION, NON-MONITORED		DIODE REPLACEMENT - STANDARD		DESCRIPTION	8N-5
CIRCUITS	25-23	PROCEDURE	24-7	DOOR CYLINDER LOCK SWITCH -	
DIESEL - OPERATION, RADIATOR - 5.9L	7-63	DISC - DESCRIPTION, CLUTCH	6-7	DIAGNOSIS & TESTING	8N-5
DIESEL - OPERATION, TRANS COOLER -		DISC - INSTALLATION, CLUTCH	6-9	DOOR CYLINDER LOCK SWITCH -	
5.9L	7-85	DISC - OPERATION, CLUTCH	6-8	INSTALLATION	8N-6



Description	Group-Page	Description	Group-Page	Description	Group-Page
DOOR CYLINDER LOCK SWITCH - OPERATION	8N-5	DRIVE VISCOUS CLUTCH - 3.9L/5.2L/5.9L/8.0L - DESCRIPTION, FAN	7-56	DUTY/8.0L - INSTALLATION, CATALYTIC CONVERTER - 5.9L HEAVY	11-7
DOOR CYLINDER LOCK SWITCH - REMOVAL	8N-6	DRIVE VISCOUS CLUTCH - 3.9L/5.2L/5.9L/8.0L - OPERATION, FAN	7-56	DUTY/8.0L - INSTALLATION, EXHAUST PIPE - 5.9L HEAVY	11-9
DOOR FORE/AFT - ADJUSTMENT, FRONT	23-68	DRIVE VISCOUS CLUTCH - 5.9L DIESEL - DESCRIPTION, FAN	7-57	DUTY/8.0L - INSTALLATION, TAILPIPE - 5.9L HEAVY	11-12
DOOR GLASS - INSTALLATION	23-69	DRIVE VISCOUS CLUTCH - 5.9L DIESEL - OPERATION, FAN	7-57	DUTY/8.0L - OPERATION, CATALYTIC CONVERTER - 5.9L HEAVY	11-6
DOOR GLASS - REMOVAL	23-69	DRIVER AIRBAG - ASSEMBLY	80-17	DUTY/8.0L - REMOVAL, CATALYTIC CONVERTER - 5.9L HEAVY	11-6
DOOR GLASS RUN WEATHERSTRIP - INSTALLATION, FRONT	23-154	DRIVER AIRBAG - DESCRIPTION	80-14	DUTY/8.0L - REMOVAL, EXHAUST PIPE - 5.9L HEAVY	11-8
DOOR GLASS RUN WEATHERSTRIP - REMOVAL, FRONT	23-153	DRIVER AIRBAG - DISASSEMBLY	80-15	DUTY/8.0L - REMOVAL, TAILPIPE - 5.9L HEAVY	11-12
DOOR INNER BELT WEATHERSTRIP - INSTALLATION, FRONT	23-154	DRIVER AIRBAG - INSTALLATION	80-18	EASY ENTRY SEAT TRACK - INSTALLATION	23-142
DOOR INNER BELT WEATHERSTRIP - REMOVAL, FRONT	23-154	DRIVER AIRBAG - OPERATION	80-14	EASY ENTRY SEAT TRACK - REMOVAL	23-142
DOOR IN/OUT - ADJUSTMENT, FRONT	23-69	DRIVER AIRBAG - REMOVAL	80-14	ECM - DESCRIPTION	8E-13
DOOR LATCH - ADJUSTMENT, FRONT	23-72	DRIVER POWER SEAT SWITCH - DESCRIPTION	8N-16	ECM - OPERATION	8E-13
DOOR LOCKS - INSPECTION, DOORS	30-11	DRIVER POWER SEAT SWITCH - INSTALLATION	8N-17	EFFECTS OF INCORRECT FLUID LEVEL - DIAGNOSIS AND TESTING	21-199,21-370,21-545,21-715
DOOR OPENING SEAL - INSTALLATION	23-153	DRIVER POWER SEAT SWITCH - OPERATION	8N-16	ELECTRICAL CONTROLS - DIAGNOSIS AND TESTING, OVERDRIVE	21-215,21-386,21-579,21-732
DOOR OPENING SEAL - REMOVAL	23-153	DRIVER POWER SEAT SWITCH - REMOVAL	8N-17	ELECTROLYTE LEVEL - STANDARD PROCEDURE, CHECKING BATTERY	8F-8
DOOR OUTER BELT WEATHERSTRIP - INSTALLATION, FRONT	23-154	DRIVER SEAT HEATER SWITCH - DESCRIPTION	8G-7	ELECTRONIC FEATURES - DESCRIPTION, PROGRAMMABLE	30-20
DOOR OUTER BELT WEATHERSTRIP - REMOVAL, FRONT	23-154	DRIVER SEAT HEATER SWITCH - INSTALLATION	8G-9	ELECTRONIC FEATURES - OPERATION, PROGRAMMABLE	30-20
DOOR SEAL - INSTALLATION, B-PILLAR	23-152	DRIVER SEAT HEATER SWITCH - OPERATION	8G-7	ELECTRONIC GOVERNOR - DESCRIPTION	21-194,21-365,21-540,21-710
DOOR SEAL - REMOVAL, B-PILLAR	23-152	DRIVER SEAT HEATER SWITCH - REMOVAL	8G-9	ELECTRONIC GOVERNOR - INSTALLATION	21-197,21-367,21-543,21-713
DOOR SECOND WEATHERSTRIP - INSTALLATION, FRONT	23-155	DROP - STANDARD PROCEDURE, TESTING FOR A VOLTAGE	8W-01-7	ELECTRONIC GOVERNOR - OPERATION	21-194,21-365,21-541,21-711
DOOR SECOND WEATHERSTRIP - REMOVAL, FRONT	23-154	DRUM - ADJUSTMENT, REAR BRAKE	5-34	ELECTRONIC GOVERNOR - REMOVAL	21-196,21-367,21-542,21-712
DOOR SILL TRIM - INSTALLATION	23-121	DRUM - CLEANING	5-33	ELEMENT - DESCRIPTION, HEATED SEAT	8G-10
DOOR SILL TRIM - REMOVAL	23-121	DRUM - DESCRIPTION	5-32	ELEMENT - INSTALLATION, AIR CLEANER	9-245
DOOR SPEAKER - INSTALLATION, FRONT	8A-20	DRUM - DIAGNOSIS AND TESTING, BRAKE	5-33	ELEMENT - OPERATION, HEATED SEAT	8G-10
DOOR SPEAKER - INSTALLATION, REAR	8A-21	DRUM - INSPECTION	5-33	ELEMENT - REMOVAL, AIR CLEANER	9-244
DOOR SPEAKER - REMOVAL, FRONT	8A-20	DRUM - OPERATION	5-32	ELEMENT AND SENSOR - DIAGNOSIS & TESTING, HEATED SEAT	8G-11
DOOR SPEAKER - REMOVAL, REAR	8A-21	DRUM BRAKES - INSTALLATION, REAR PARK BRAKE CABLE 2500/3500 SERIES WITH	5-39	EMERGENCY SIGNALS - INSPECTION, TURN	30-19
DOOR UP/DOWN - ADJUSTMENT, FRONT	23-69	DRUM BRAKES - REMOVAL, REAR PARK BRAKE CABLES 2500/3500 SERIES WITH	5-38	END SPLASH SHIELDS - INSTALLATION, FRONT	23-92
DOOR UPPER CORNER SEAL - INSTALLATION, FRONT	23-154	DRUM IN HAT PARK BRAKE SHOES - 2500/3500 - INSTALLATION, REAR	5-42	END SPLASH SHIELDS - REMOVAL, FRONT	23-92
DOOR UPPER CORNER SEAL - REMOVAL, FRONT	23-154	DRUM IN HAT PARK BRAKE SHOES - 2500/3500 - REMOVAL, REAR	5-41	ENGINE - DESCRIPTION, COOLING SYSTEM FLOW - 3.9L/5.2L/5.9L	7-1
DOORS AND DOOR LOCKS - INSPECTION	30-11	DRUM MACHINING - STANDARD PROCEDURE, BRAKE	5-33	ENGINE - DESCRIPTION, FUEL REQUIREMENTS - DIESEL	0-2
DOORS AND LOCKS - INSPECTION, WINDOWS	30-14	DUAL REAR WHEEL INSTALLATION - STANDARD PROCEDURE	22-10	ENGINE - DIAGNOSIS AND TESTING, COOLING SYSTEM DIESEL	7-12
DOUBLE INVERTED FLARING - STANDARD PROCEDURE	5-8	DUCT ADAPTER - INSTALLATION, DEFROSTER AND DEMISTER	24-35	ENGINE - DIAGNOSIS AND TESTING, COOLING SYSTEM GAS	7-7
DRAIN AND REFILL - STANDARD PROCEDURE, FLUID	21-851,21-885,21-922	DUCT ADAPTER - REMOVAL, DEFROSTER AND DEMISTER	24-35	ENGINE - DIAGNOSIS AND TESTING, DIESEL	11-4
DRAIN MANIFOLD - DESCRIPTION, FUEL	14-86	DUCTS - INSTALLATION, DEFROSTER AND DEMISTER	24-35	ENGINE - DIAGNOSIS AND TESTING, GAS	11-4
DRAIN MANIFOLD - INSTALLATION, FUEL	14-86	DUCTS - REMOVAL, DEFROSTER AND DEMISTER	24-34	ENGINE - ENGINE FIRING ORDER, 3.9L V-6	8I-2
DRAIN MANIFOLD - OPERATION, FUEL	14-86	DUCTS - REMOVAL, INSTRUMENT PANEL	24-37	ENGINE - IGNITION COIL RESISTANCE, 8.0L V-10	8I-3
DRAIN MANIFOLD - REMOVAL, FUEL	14-86	DUCTS - REMOVAL, INSTRUMENT PANEL DEMISTER	24-37	ENGINE - INSTALLATION	9-241
DRAINBACK VALVE - DESCRIPTION, TORQUE CONVERTER	21-262,21-432,21-605,21-778	DUTY ENGINE (1500 AND 2500 MODELS EXCEPT 8.0L) MAINTENANCE SCHEDULES, MAINTENANCE SCHEDULES - LIGHT	0-7	ENGINE - INSTALLATION, DIESEL	19-35
DRAINBACK VALVE - OPERATION, TORQUE CONVERTER	21-262,21-432,21-605,21-778	DUTY ENGINE (FEDERAL ONLY - 2500 8.0L HD AND 3500 5.9L & 8.0L MODELS) MAINTENANCE SCHEDULES - DESCRIPTION, HEAVY	0-17	ENGINE - INSTALLATION, GASOLINE	19-35
DRAINBACK VALVE - STANDARD PROCEDURE, TORQUE CONVERTER	21-262,21-432,21-606,21-778	DUTY TRUCK MAINTENANCE SCHEDULE (8.0L 2500 & 3500 MODELS - CALIFORNIA ONLY) - DESCRIPTION, MEDIUM	0-13	ENGINE - REMOVAL	9-238
DRAINING AT FUEL FILTER - STANDARD PROCEDURES, WATER	14-56	DUTY/8.0L - DESCRIPTION, CATALYTIC CONVERTER - 5.9L HEAVY	11-6	ENGINE - REMOVAL, DIESEL	19-33
DRAINING COOLING SYSTEM 3.9L/5.2L/5.9L/8.0L ENGINES - STANDARD PROCEDURE	7-15	DUTY/8.0L - INSPECTION, CATALYTIC CONVERTER - 5.9L HEAVY	11-7	ENGINE - REMOVAL, GASOLINE	19-33
DRAINING COOLING SYSTEM 5.9L DIESEL ENGINE - STANDARD PROCEDURE	7-15	DUTY/8.0L - INSPECTION, EXHAUST PIPE - 5.9L HEAVY	11-9	ENGINE - SPARK PLUG CABLE ORDER, 8.0L V-10	8I-2
DRAW TEST - STANDARD PROCEDURE, IGNITION-OFF	8F-15	DUTY/8.0L - INSPECTION, TAILPIPE - 5.9L HEAVY	11-12	ENGINE - STANDARD PROCEDURE, DRAINING COOLING SYSTEM 5.9L DIESEL	7-15
DRIVE - DIAGNOSIS AND TESTING, VISCOUS FAN	7-56,7-58			ENGINE - STANDARD PROCEDURE, REFILLING COOLING SYSTEM 5.9L DIESEL	7-15
DRIVE BELT - DIAGNOSIS AND TESTING, ACCESSORY	7-24,7-27,7-31			ENGINE - TORQUE, DIESEL	14-90
DRIVE BELTS - 3.9L/5.2L/5.9L - INSTALLATION	7-27			ENGINE - VISUAL INSPECTION, 8.0L	14-32
DRIVE BELTS - 3.9L/5.2L/5.9L - REMOVAL	7-26				
DRIVE BELTS - 5.9L DIESEL - INSTALLATION	7-34				
DRIVE BELTS - 5.9L DIESEL - REMOVAL	7-33				
DRIVE BELTS - 8.0L - INSTALLATION	7-30				
DRIVE BELTS - 8.0L - REMOVAL	7-30				
DRIVE INDICATOR - DIAGNOSIS AND TESTING, FOUR-WHEEL	8J-29				

Description	Group-Page	Description	Group-Page	Description	Group-Page
ENGINE (1500 AND 2500 MODELS EXCEPT 8.0L) MAINTENANCE SCHEDULES, MAINTENANCE SCHEDULES - LIGHT DUTY	0-7	ENGINE DIAGNOSIS - MECHANICAL - DIAGNOSIS AND TESTING	9-232	ENTRY SYSTEM - DIAGNOSIS AND TESTING, POWER LOCK & REMOTE KEYLESS	8N-4
ENGINE, 3.9L	9-19	ENGINE (FEDERAL ONLY - 2500 8.0L HD AND 3500 5.9L& 8.0L MODELS) MAINTENANCE SCHEDULES - DESCRIPTION, HEAVY DUTY	0-17	ENTRY SYSTEM - OPERATION, REMOTE KEYLESS	8N-3
ENGINE 3.9L - DESCRIPTION	9-3	ENGINE FIRING ORDER, 3.9L V-6 ENGINE	8I-2	ENTRY TRANSMITTER - DESCRIPTION, REMOTE KEYLESS	8N-7
ENGINE 3.9L - INSTALLATION	9-13	ENGINE FIRING ORDER, 5.2L/5.9L V-8 ENGINES	8I-2	ENTRY TRANSMITTER - DIAGNOSIS AND TESTING, REMOTE KEYLESS	8N-7
ENGINE 3.9L - REMOVAL	9-12	ENGINE OIL - DESCRIPTION	0-3,0-4	ENTRY TRANSMITTER - OPERATION, REMOTE KEYLESS	8N-7
ENGINE 5.2L - DESCRIPTION	9-60	ENGINE OIL - STANDARD PROCEDURE	9-104, 9-160,9-217,9-47	EQUIPMENT - STANDARD PROCEDURE, REFRIGERANT SYSTEM SERVICE	24-44
ENGINE 5.2L - INSTALLATION	9-70	ENGINE OIL LEAKS - DIAGNOSIS AND TESTING	9-104,9-160,9-215,9-47	EQUIPMENT IDENTIFICATION PLATE - DESCRIPTION	Intro.-12
ENGINE 5.2L - REMOVAL	9-69	ENGINE OIL PRESSURE - DIAGNOSIS AND TESTING	9-104,9-160,9-215,9-295,9-47	ESCUTCHEON - INSTALLATION, HANDLE	23-63
ENGINE 5.9L - DESCRIPTION	9-117	ENGINE PERFORMANCE - INSPECTION	30-16	ESCUTCHEON - REMOVAL, HANDLE	23-63
ENGINE 5.9L - INSTALLATION	9-127	ENGINE, SPECIAL TOOLS - 5.2L	9-77	EVAQUATE - STANDARD PROCEDURE, REFRIGERANT SYSTEM	24-45
ENGINE 5.9L - REMOVAL	9-126	ENGINE, SPECIAL TOOLS - 5.9L	9-134	EVAP SYSTEM - DESCRIPTION	25-31
ENGINE 5.9L DIESEL - DESCRIPTION	9-231	ENGINE, SPECIAL TOOLS - 5.9L DIESEL	9-244	EVAP SYSTEM - TORQUE	25-31
ENGINE 8.0L - DESCRIPTION	9-172	ENGINE, SPECIAL TOOLS - 8.0L	9-188	EVAPORATOR - DESCRIPTION, A/C	24-52
ENGINE 8.0L - INSTALLATION	9-182	ENGINE, SPECIFICATIONS - 3.9L	9-14	EVAPORATOR - INSTALLATION, A/C	24-53
ENGINE 8.0L - REMOVAL	9-181	ENGINE, SPECIFICATIONS - 5.2L	9-72	EVAPORATOR - OPERATION, A/C	24-53
ENGINE BLOCK - CLEANING	9-142,9-200,9-28,9-86	ENGINE, SPECIFICATIONS - 5.9L	9-129	EVAPORATOR - REMOVAL, A/C	24-53
ENGINE BLOCK - INSPECTION	9-142,9-200,9-267,9-28,9-86	ENGINE, SPECIFICATIONS - 8.0L	9-184	EVAP/PURGE SOLENOID - DESCRIPTION	25-32
ENGINE BLOCK - STANDARD PROCEDURE-CYLINDER BLOCK REFACING	9-263	ENGINE STARTER MOTOR - DESCRIPTION	8F-39	EVAP/PURGE SOLENOID - INSTALLATION	25-32
ENGINE BLOCK HEATER - 3.9L/5.2L/5.9L - DESCRIPTION	7-45	ENGINE STARTER MOTOR - INSTALLATION	8F-41	EVAP/PURGE SOLENOID - REMOVAL	25-32
ENGINE BLOCK HEATER - 3.9L/5.2L/5.9L - INSTALLATION	7-45	ENGINE STARTER MOTOR - OPERATION	8F-39	EXHAUST MANIFOLD - CLEANING	9-112,9-168,9-225,9-304,9-55
ENGINE BLOCK HEATER - 3.9L/5.2L/5.9L - OPERATION	7-45	ENGINE STARTER MOTOR - REMOVAL	8F-40	EXHAUST MANIFOLD - DESCRIPTION	9-112, 9-168,9-224,9-55
ENGINE BLOCK HEATER - 3.9L/5.2L/5.9L - REMOVAL	7-45	ENGINE STARTER MOTOR RELAY - DESCRIPTION	8F-42	EXHAUST MANIFOLD - INSPECTION	9-112, 9-168,9-225,9-304,9-55
ENGINE BLOCK HEATER - 5.9L DIESEL - DESCRIPTION	7-47	ENGINE STARTER MOTOR RELAY - INSTALLATION	8F-43	EXHAUST MANIFOLD - INSTALLATION	9-113, 9-168,9-225,9-304,9-55
ENGINE BLOCK HEATER - 5.9L DIESEL - INSTALLATION	7-47	ENGINE STARTER MOTOR RELAY - OPERATION	8F-42	EXHAUST MANIFOLD - OPERATION	9-112,9-168,9-224,9-55
ENGINE BLOCK HEATER - 5.9L DIESEL - OPERATION	7-47	ENGINE STARTER MOTOR RELAY - REMOVAL	8F-43	EXHAUST MANIFOLD - REMOVAL	9-112,9-168,9-225,9-303,9-55
ENGINE BLOCK HEATER - 5.9L DIESEL - REMOVAL	7-47	ENGINE TEMPERATURE GAUGE - DESCRIPTION	8J-19	EXHAUST PIPE - 3.9L/5.2L/5.9L - INSPECTION	11-7
ENGINE BLOCK HEATER - 8.0L - DESCRIPTION	7-46	ENGINE TEMPERATURE GAUGE - OPERATION	8J-19	EXHAUST PIPE - 3.9L/5.2L/5.9L - INSTALLATION	11-7
ENGINE BLOCK HEATER - 8.0L - INSTALLATION	7-46	ENGINES - DESCRIPTION, COMPONENT MONITORS - DIESEL	25-18	EXHAUST PIPE - 3.9L/5.2L/5.9L - REMOVAL	11-7
ENGINE BLOCK HEATER - 8.0L - OPERATION	7-46	ENGINES - DESCRIPTION, COMPONENT MONITORS - GAS	25-18	EXHAUST PIPE - 5.9L DIESEL - INSPECTION	11-9
ENGINE BLOCK HEATER - 8.0L - REMOVAL	7-46	ENGINES - DESCRIPTION, FUEL REQUIREMENTS - GAS	0-1	EXHAUST PIPE - 5.9L DIESEL - INSTALLATION	11-10
ENGINE CONTROL MODULE - INSTALLATION	8E-14	ENGINES - DESCRIPTION, V-6/V-8	25-35	EXHAUST PIPE - 5.9L DIESEL - REMOVAL	11-9
ENGINE CONTROL MODULE - REMOVAL	8E-14	ENGINES - DIAGNOSIS AND TESTING, PCV VALVE - V-6/V-8	25-36	EXHAUST PIPE - 5.9L HEAVY DUTY/8.0L - INSPECTION	11-9
ENGINE COOLANT TEMP SENSOR - 3.9L/5.2L/5.9L - DESCRIPTION	7-48	ENGINES - ENGINE FIRING ORDER, 5.2L/5.9L V-8	8I-2	EXHAUST PIPE - 5.9L HEAVY DUTY/8.0L - INSTALLATION	11-9
ENGINE COOLANT TEMP SENSOR - 3.9L/5.2L/5.9L - INSTALLATION	7-48	ENGINES - FUEL SYSTEM PRESSURES, DIESEL	14-58	EXHAUST PIPE - 5.9L HEAVY DUTY/8.0L - REMOVAL	11-8
ENGINE COOLANT TEMP SENSOR - 3.9L/5.2L/5.9L - OPERATION	7-48	ENGINES - IGNITION COIL RESISTANCE, 3.9L/5.2L/5.9L	8I-3	EXHAUST VENT - INSTALLATION	23-79
ENGINE COOLANT TEMP SENSOR - 3.9L/5.2L/5.9L - REMOVAL	7-48	ENGINES - INSTALLATION, GAS	8P-4	EXHAUST VENT - REMOVAL	23-79
ENGINE COOLANT THERMOSTAT - 3.9L/5.2L/5.9L - DESCRIPTION	7-49	ENGINES - OPERATION, GAS	25-18	EXHAUSTER - INSTALLATION, AIR	23-77
ENGINE COOLANT THERMOSTAT - 3.9L/5.2L/5.9L - INSTALLATION	7-50	ENGINES - OPERATION, NON-MONITORED CIRCUITS - GAS	25-22	EXHAUSTER - REMOVAL, AIR	23-77
ENGINE COOLANT THERMOSTAT - 3.9L/5.2L/5.9L - OPERATION	7-49	ENGINES - OPERATION, PCM - GAS	8E-17	EXTENSION HOUSING BUSHING - INSTALLATION	21-198,21-369,21-544,21-714
ENGINE COOLANT THERMOSTAT - 3.9L/5.2L/5.9L - REMOVAL	7-49	ENGINES - OPERATION, V-6/V-8	25-35	EXTENSION HOUSING BUSHING - REMOVAL	21-198,21-369,21-544,21-714
ENGINE COOLANT THERMOSTAT - 5.9L DIESEL - DESCRIPTION	7-54	ENGINES - REMOVAL, GAS	8P-4	EXTENSION HOUSING BUSHING AND SEAL - INSTALLATION	21-850,21-885,21-921
ENGINE COOLANT THERMOSTAT - 5.9L DIESEL - INSTALLATION	7-55	ENGINES - SPECIFICATIONS, FUEL SYSTEM PRESSURE - GAS	14-4	EXTENSION HOUSING BUSHING AND SEAL - REMOVAL	21-850,21-885,21-921
ENGINE COOLANT THERMOSTAT - 5.9L DIESEL - OPERATION	7-54	ENGINES - STANDARD PROCEDURE, DRAINING COOLING SYSTEM 3.9L/5.2L/5.9L/8.0L	7-15	EXTENSION HOUSING SEAL - INSTALLATION	21-132,21-198,21-369,21-544,21-714,21-87
ENGINE COOLANT THERMOSTAT - 5.9L DIESEL - REMOVAL	7-55	ENGINES - STANDARD PROCEDURE, REFILLING COOLING SYSTEM 3.9L/5.2L/5.9L/8.0L	7-15	EXTENSION HOUSING SEAL - REMOVAL	21-132, 21-198,21-369,21-544,21-714,21-87
ENGINE COOLANT THERMOSTAT - 8.0L - DESCRIPTION	7-52	ENGINES - VISUAL INSPECTION, 3.9L/5.2L/5.9L	14-28	EXTERIOR - DESCRIPTION	23-86
ENGINE COOLANT THERMOSTAT - 8.0L - INSTALLATION	7-53	ENGINE-TO-BODY GROUND STRAP - INSTALLATION	8A-13	EXTERIOR - OPERATION	23-86
ENGINE COOLANT THERMOSTAT - 8.0L - OPERATION	7-52	ENGINE-TO-BODY GROUND STRAP - REMOVAL	8A-13	EXTERIOR HANDLE - INSTALLATION	23-70
ENGINE COOLANT THERMOSTAT - 8.0L - REMOVAL	7-52	ENTRY - INSPECTION, KEYLESS	30-11	EXTERIOR HANDLE - REMOVAL	23-70
ENGINE DATA PLATE - DESCRIPTION	9-244	ENTRY SEAT TRACK - INSTALLATION, EASY	23-142	EXTERIOR NAME PLATES - INSTALLATION	23-89
ENGINE DIAGNOSIS - INTRODUCTION - DIAGNOSIS AND TESTING	9-118,9-173,9-3	ENTRY SEAT TRACK - REMOVAL, EASY	23-142	EXTERIOR NAME PLATES - REMOVAL	23-89
		ENTRY SYSTEM - DESCRIPTION, REMOTE KEYLESS	8N-2	FAILURE - DIAGNOSIS AND TESTING, CYLINDER HEAD GASKET	9-136,9-191,9-22,9-79
				FAN - 3.9L/5.2L/5.9L/8.0L - CLEANING, RADIATOR	7-43
				FAN - 3.9L/5.2L/5.9L/8.0L - INSPECTION, RADIATOR	7-43

Description	Group-Page	Description	Group-Page	Description	Group-Page
FAN - 3.9L/5.2L/5.9L/8.0L - INSTALLATION, RADIATOR	7-43	FIRING ORDER, 3.9L V-6 ENGINE - ENGINE	81-2	FLUID LEVEL - STANDARD PROCEDURE, BRAKE	5-14
FAN - 3.9L/5.2L/5.9L/8.0L - REMOVAL, RADIATOR	7-42	FIRING ORDER, 5.2L/5.9L V-8 ENGINES - ENGINE	81-2	FLUID LEVEL CHECK - STANDARD PROCEDURE	21-199,21-370,21-545,21-715
FAN - 5.9L DIESEL - CLEANING, RADIATOR	7-44	FIRING ORDER, DIESEL - FUEL INJECTOR	14-58	FLUID LEVEL SWITCH - DESCRIPTION, WASHER	8R-7
FAN - 5.9L DIESEL - INSPECTION, RADIATOR	7-44	FIT AND FINISH - INSPECTION	30-10,30-12	FLUID LEVEL SWITCH - INSTALLATION, WASHER	8R-8
FAN - 5.9L DIESEL - INSTALLATION, RADIATOR	7-45	FITTING - DESCRIPTION, QUICK CONNECT	14-22	FLUID LEVEL SWITCH - OPERATION, WASHER	8R-7
FAN - 5.9L DIESEL - REMOVAL, RADIATOR	7-44	FITTING - STANDARD PROCEDURE, CONNECTING ROD BEARING	9-144,9-202,9-88	FLUID LEVEL SWITCH - REMOVAL, WASHER	8R-8
FAN DRIVE - DIAGNOSIS AND TESTING, VISCIOUS	7-56,7-58	FITTING - STANDARD PROCEDURE, CRANKSHAFT MAIN BEARING	9-146,9-90	FLUID LEVELS - INSPECTION	30-4
FAN DRIVE VISCIOUS CLUTCH - 3.9L/5.2L/5.9L/8.0L - DESCRIPTION	7-56	FITTING - STANDARD PROCEDURE, MAIN BEARING	9-203,9-33	FLUID RESERVOIR - INSTALLATION	5-15
FAN DRIVE VISCIOUS CLUTCH - 3.9L/5.2L/5.9L/8.0L - OPERATION	7-56	FITTING - STANDARD PROCEDURE, PISTON	9-153,9-208,9-40,9-97	FLUID RESERVOIR - REMOVAL	5-15
FAN DRIVE VISCIOUS CLUTCH - 5.9L DIESEL - DESCRIPTION	7-57	FITTING - STANDARD PROCEDURE, PISTON RING	9-154,9-41,9-98	FLUID, SPECIFICATIONS - BRAKE	5-15
FAN DRIVE VISCIOUS CLUTCH - 5.9L DIESEL - OPERATION	7-57	FITTING, CONNECTING ROD BEARINGS - STANDARD PROCEDURE-CONNECTING ROD BEARING	9-31	FLUID TYPES - DESCRIPTION	0-5
FASCIA - ADJUSTMENT, FRONT	13-2	FITTING PISTON RINGS - STANDARD PROCEDURE	9-211	FLUSH MEASUREMENTS, SPECIFICATIONS - BODY GAP	23-56
FASCIA - INSTALLATION, FRONT	13-2	FITTING, PISTON RINGS - STANDARD PROCEDURE-PISTON RING	9-288	FLUSHING - STANDARD PROCEDURE, COOLING SYSTEM CLEANING/ REVERSE	7-16
FASCIA - INSTALLATION, FRONT LOWER	13-3	FITTINGS - STANDARD PROCEDURES, QUICK-CONNECT	14-22	FLUSHING COOLER AND TUBES - WITHOUT RADIATOR IN-TANK TRANSMISSION OIL COOLER - STANDARD PROCEDURE	7-80,7-83,7-86
FASCIA - REMOVAL, FRONT	13-2	FIXED ORIFICE TUBE - DIAGNOSIS AND TESTING	24-54	FLUSHING COOLERS AND TUBES - WITH RADIATOR IN-TANK TRANSMISSION OIL COOLER - STANDARD PROCEDURE	7-79,7-83,7-85
FASCIA - REMOVAL, FRONT LOWER	13-3	FLAG - INSTALLATION, SIDE VIEW MIRROR	23-74	FLUSHING POWER STEERING SYSTEM - STANDARD PROCEDURE	19-32
FASCIA-SPORT - INSTALLATION, FRONT	13-3	FLAG - REMOVAL, SIDE VIEW MIRROR	23-74	FLYWHEEL - ASSEMBLY	6-17
FASCIA-SPORT - REMOVAL, FRONT	13-3	FLARING - STANDARD PROCEDURE, DOUBLE INVERTED	5-8	FLYWHEEL - DESCRIPTION	6-16
FASTENER IDENTIFICATION - DESCRIPTION	Intro.-3	FLARING - STANDARD PROCEDURE, ISO	5-8	FLYWHEEL - DIAGNOSIS AND TESTING	6-17
FASTENER USAGE - DESCRIPTION	Intro.-6	FLASHER - DESCRIPTION, COMBINATION	8L-7	FLYWHEEL - DISASSEMBLY	6-17
FASTENERS - DESCRIPTION, PUSH-IN	23-1	FLASHER - INSTALLATION, COMBINATION	8L-8	FLYWHEEL - OPERATION	6-16
FEATURES - DESCRIPTION, PROGRAMMABLE ELECTRONIC	30-20	FLASHER - OPERATION, COMBINATION	8L-7	FOG LAMP - DIAGNOSIS AND TESTING	8L-9
FEATURES - OPERATION, PROGRAMMABLE ELECTRONIC	30-20	FLASHER - REMOVAL, COMBINATION	8L-8	FOG LAMP - INSTALLATION	8L-11
FENDER - INSTALLATION, LEFT FRONT	23-93	FLOOR MATS - INSTALLATION, CARPETS	23-123	FOG LAMP - REMOVAL	8L-11
FENDER - INSTALLATION, REAR	23-95	FLOOR MATS - REMOVAL, CARPETS	23-123	FOG LAMP UNIT - ADJUSTMENTS	8L-12
FENDER - INSTALLATION, RIGHT FRONT	23-94	FLOOR SHIFT BOOT - INSTALLATION, 4WD	23-122	FOG LAMP UNIT - INSTALLATION	8L-12
FENDER - REMOVAL, LEFT FRONT	23-92	FLOOR SHIFT BOOT - REMOVAL, 4WD	23-122	FOG LAMP UNIT - REMOVAL	8L-11
FENDER - REMOVAL, REAR	23-95	FLOOR STOWAGE TRAY - INSTALLATION, REAR	23-121	FORE/AFT - ADJUSTMENT, FRONT DOOR	23-68
FENDER - REMOVAL, RIGHT FRONT	23-94	FLOOR STOWAGE TRAY - REMOVAL, REAR	23-121	FORM, FINAL STEPS - NEW VEHICLE PREPARATION	30-22
FILL - STANDARD PROCEDURE, TRANSMISSION	21-201,21-372,21-547,21-718	FLOW - 3.9L/5.2L/5.9L ENGINE - DESCRIPTION, COOLING SYSTEM	7-1	FORM-IN-PLACE GASKETS & SEALERS - STANDARD PROCEDURE	9-11,9-125,9-180, 9-237,9-68
FILL DOOR - INSTALLATION, FUEL	23-95	FLOW - 5.9L DIESEL - DESCRIPTION, COOLING SYSTEM	7-1	FOUR-WHEEL DRIVE INDICATOR - DIAGNOSIS AND TESTING	8J-29
FILL DOOR - REMOVAL, FUEL	23-95	FLOW - DIAGNOSIS AND TESTING, RADIATOR COOLANT	7-59,7-61,7-63	FRAME - DESCRIPTION	13-6
FILLER CAP - DESCRIPTION, FUEL	25-33	FLOW AND PRESSURE - DIAGNOSIS AND TESTING, POWER STEERING	19-4	FRAME - FRAME SERVICE	13-6
FILLER CAP - OPERATION, FUEL	25-33	FLUID - DESCRIPTION, AUTOMATIC TRANSMISSION	0-5	FRAME - INSTALLATION, GRILLE	23-92
FILLER CAP - REMOVAL/INSTALLATION, FUEL	25-33	FLUID - DESCRIPTION, TRANSFER CASE	0-5	FRAME - REMOVAL, GRILLE	23-91
FILTER - DESCRIPTION, PCV	25-35	FLUID - DIAGNOSIS AND TESTING, CAUSES OF BURNT	21-199,21-370,21-545, 21-715	FRAME DIMENSION, SPECIFICATIONS	13-7
FILTER - INSTALLATION, AIR PUMP	25-29	FLUID - OPERATION, AUTOMATIC TRANSMISSION	0-5	FRAME SERVICE, FRAME	13-6
FILTER - INSTALLATION, INLET	14-22	FLUID AND FILTER REPLACEMENT - STANDARD PROCEDURE	21-201,21-372,21-547, 21-717	FRONT - 2WD - DESCRIPTION	2-7,2-8
FILTER - INSTALLATION, OIL	9-105,9-161,9-218, 9-296,9-48	FLUID CAPACITIES, SPECIFICATIONS	0-6	FRONT - 4WD - DESCRIPTION	2-14
FILTER - REMOVAL, AIR PUMP	25-29	FLUID CONTAMINATION - DIAGNOSIS AND TESTING	21-199,21-370,21-545,21-715	FRONT - DESCRIPTION, CRANKSHAFT OIL SEAL	9-147,9-34,9-91
FILTER - REMOVAL, INLET	14-22	FLUID CONTAMINATION - DIAGNOSIS AND TESTING, BRAKE	5-14	FRONT - INSTALLATION	5-14,5-27
FILTER - REMOVAL, OIL	9-105,9-161,9-218, 9-296,9-48	FLUID DRAIN AND REFILL - STANDARD PROCEDURE	21-851,21-885,21-922	FRONT - INSTALLATION, 1500/2500	5-22
FILTER - STANDARD PROCEDURES, WATER DRAINING AT FUEL	14-56	FLUID INDICATOR - DESCRIPTION, WASHER	8J-35	FRONT - INSTALLATION, 3500	5-22
FILTER / WATER SEPARATOR - DESCRIPTION, FUEL	14-59	FLUID INDICATOR - DIAGNOSIS AND TESTING, WASHER	8J-36	FRONT - INSTALLATION, CRANKSHAFT OIL SEAL	9-148,9-277,9-34,9-91
FILTER / WATER SEPARATOR - INSTALLATION, FUEL	14-61	FLUID INDICATOR - OPERATION, WASHER	8J-35	FRONT - INSTALLATION, PROPELLER SHAFT	3-8
FILTER / WATER SEPARATOR - OPERATION, FUEL	14-59	FLUID LEAK - DIAGNOSIS AND TESTING, CONVERTER HOUSING	21-148,21-319,21-491, 21-662	FRONT - OPERATION, CRANKSHAFT OIL SEAL	9-147,9-34,9-91
FILTER / WATER SEPARATOR - REMOVAL, FUEL	14-60	FLUID LEVEL - DIAGNOSIS AND TESTING, EFFECTS OF INCORRECT	21-199, 21-370,21-545,21-715	FRONT - REMOVAL	5-10,5-24
FILTER REPLACEMENT - STANDARD PROCEDURE, FLUID	21-201,21-372,21-547, 21-717			FRONT - REMOVAL, 1500/2500	5-21
FILTER/PRESSURE REGULATOR - DESCRIPTION, FUEL	14-5			FRONT - REMOVAL, 3500	5-22
FILTER/PRESSURE REGULATOR - INSTALLATION, FUEL	14-6			FRONT - REMOVAL, CRANKSHAFT OIL SEAL	9-147,9-276,9-34,9-91
FILTER/PRESSURE REGULATOR - OPERATION, FUEL	14-5			FRONT - REMOVAL, PROPELLER SHAFT	3-8
FILTER/PRESSURE REGULATOR - REMOVAL, FUEL	14-5			FRONT AIR DAM - INSTALLATION	13-2
FINAL STEPS - NEW VEHICLE PREPARATION FORM	30-22			FRONT AIR DAM - REMOVAL	13-1
FINISH - DESCRIPTION, BASE COAT/CLEAR COAT	23-129			FRONT AXLE - 216FBI - ADJUSTMENTS	3-17
FINISH - INSPECTION, FIT	30-10,30-12			FRONT AXLE - 216FBI - DESCRIPTION	3-12
FINISH - OPERATION, BASE COAT/CLEAR COAT	23-129			FRONT AXLE - 216FBI - INSTALLATION	3-17
				FRONT AXLE - 216FBI - OPERATION	3-12
				FRONT AXLE - 216FBI - REMOVAL	3-16
				FRONT AXLE - 248FBI - ADJUSTMENTS	3-50
				FRONT AXLE - 248FBI - DESCRIPTION	3-45
				FRONT AXLE - 248FBI - INSTALLATION	3-50
				FRONT AXLE - 248FBI - OPERATION	3-45



Description	Group-Page	Description	Group-Page	Description	Group-Page
FRONT AXLE - 248FBI - REMOVAL	3-50	FRONT PARKING BRAKE CABLE - INSTALLATION	5-39	FUEL INJECTION PUMP TIMING - DIAGNOSIS AND TESTING	14-66
FRONT AXLE, 216FBI	3-25	FRONT PARKING BRAKE CABLE - REMOVAL	5-37	FUEL INJECTION SYSTEM - DESCRIPTION, DIESEL	14-87
FRONT AXLE, 248FBI	3-58	FRONT SEAT BELT BUCKLE - INSTALLATION	80-20	FUEL INJECTOR - DESCRIPTION	14-53,14-93
FRONT AXLE, SPECIAL TOOLS	3-58	FRONT SEAT BELT BUCKLE - REMOVAL	80-20	FUEL INJECTOR - INSTALLATION	14-53,14-98
FRONT AXLES, SPECIAL TOOLS	3-25	FRONT SERVO - ASSEMBLY	21-208,21-379, 21-553,21-723	FUEL INJECTOR - OPERATION	14-53,14-94
FRONT BEARING - INSTALLATION, OUTPUT SHAFT	21-213,21-384,21-560,21-730	FRONT SERVO - CLEANING	21-207,21-378, 21-552,21-723	FUEL INJECTOR - REMOVAL	14-53,14-96
FRONT BEARING - REMOVAL, OUTPUT SHAFT	21-213,21-384,21-559,21-730	FRONT SERVO - DESCRIPTION	21-206,21-377, 21-551,21-722	FUEL INJECTOR FIRING ORDER, DIESEL	14-58
FRONT BUMPER - INSTALLATION	13-4	FRONT SERVO - DISASSEMBLY	21-207,21-378, 21-552,21-723	FUEL INJECTOR TEST - DIAGNOSIS AND TESTING	14-53,14-95
FRONT BUMPER - REMOVAL	13-3	FRONT SERVO - INSPECTION	21-207,21-378, 21-553,21-723	FUEL LEVEL SENDING UNIT / SENSOR - DESCRIPTION	14-7,14-73
FRONT BUMPER-SPORT - INSTALLATION	13-4	FRONT SERVO - OPERATION	21-207,21-377, 21-552,21-723	FUEL LEVEL SENDING UNIT / SENSOR - INSTALLATION	14-9
FRONT BUMPER-SPORT - REMOVAL	13-4	FRONT SUSPENSION, SPECIAL TOOLS - INDEPENDENT	2-9	FUEL LEVEL SENDING UNIT / SENSOR - OPERATION	14-7,14-73
FRONT CLUTCH - ASSEMBLY	21-206,21-376, 21-550,21-721	FRONT TOW HOOK - INSTALLATION	13-10	FUEL LEVEL SENDING UNIT / SENSOR - REMOVAL	14-8
FRONT CLUTCH - DESCRIPTION	21-202,21-373, 21-548,21-718	FRONT TOW HOOK - REMOVAL	13-9	FUEL LINE LEAKS - DIAGNOSIS AND TESTING, HIGH-PRESSURE	14-74
FRONT CLUTCH - DISASSEMBLY	21-202,21-373, 21-549,21-719	FUEL - INSPECTION	30-15	FUEL LINES - DESCRIPTION	14-73,14-9
FRONT CLUTCH - INSPECTION	21-205,21-376, 21-550,21-721	FUEL DELIVERY - DIESEL - OPERATION	14-56	FUEL LINES - DESCRIPTION, HIGH PRESSURE	14-74
FRONT CLUTCH - OPERATION	21-202,21-373, 21-548,21-718	FUEL DELIVERY - SPECIFICATIONS, TORQUE	14-4	FUEL LINES - INSTALLATION	14-77
FRONT COVER INSTALLED - INSTALLATION, FRONT OIL SEAL	9-205	FUEL DELIVERY SYSTEM - DESCRIPTION	14-2	FUEL LINES - OPERATION, HIGH PRESSURE	14-74
FRONT COVER INSTALLED - REMOVAL, FRONT OIL SEAL	9-204	FUEL DELIVERY SYSTEM - DESCRIPTION, DIESEL	14-54	FUEL LINES - REMOVAL	14-75
FRONT COVER REMOVED - INSTALLATION, FRONT OIL SEAL	9-205	FUEL DELIVERY SYSTEM - OPERATION	14-2	FUEL PRESSURE LEAK DOWN TEST - DIAGNOSIS AND TESTING	14-2
FRONT COVER REMOVED - REMOVAL, FRONT OIL SEAL	9-204	FUEL DRAIN MANIFOLD - DESCRIPTION	14-86	FUEL PUMP - DESCRIPTION	14-9
FRONT DOOR FORE/AFT - ADJUSTMENT	23-68	FUEL DRAIN MANIFOLD - INSTALLATION	14-86	FUEL PUMP - OPERATION	14-9
FRONT DOOR GLASS RUN WEATHERSTRIP - INSTALLATION	23-154	FUEL DRAIN MANIFOLD - OPERATION	14-86	FUEL PUMP 235 H.P. - DESCRIPTION	14-66
FRONT DOOR GLASS RUN WEATHERSTRIP - REMOVAL	23-153	FUEL DRAIN MANIFOLD - REMOVAL	14-86	FUEL PUMP 245 H.P. - DESCRIPTION	14-65
FRONT DOOR INNER BELT WEATHERSTRIP - INSTALLATION	23-154	FUEL FILL DOOR - INSTALLATION	23-95	FUEL PUMP AMPERAGE TEST - DIAGNOSIS AND TESTING	14-10
FRONT DOOR INNER BELT WEATHERSTRIP - REMOVAL	23-154	FUEL FILL DOOR - REMOVAL	23-95	FUEL PUMP CAPACITY TEST - DIAGNOSIS AND TESTING	14-9
FRONT DOOR IN/OUT - ADJUSTMENT	23-69	FUEL FILLER CAP - DESCRIPTION	25-33	FUEL PUMP MODULE - DESCRIPTION	14-12
FRONT DOOR LATCH - ADJUSTMENT	23-72	FUEL FILLER CAP - OPERATION	25-33	FUEL PUMP MODULE - INSTALLATION	14-13
FRONT DOOR OUTER BELT WEATHERSTRIP - INSTALLATION	23-154	FUEL FILLER CAP - REMOVAL/ INSTALLATION	25-33	FUEL PUMP MODULE - OPERATION	14-13
FRONT DOOR OUTER BELT WEATHERSTRIP - REMOVAL	23-154	FUEL FILTER - STANDARD PROCEDURES, WATER DRAINING AT	14-56	FUEL PUMP MODULE - REMOVAL	14-13
FRONT DOOR SECOND WEATHERSTRIP - INSTALLATION	23-155	FUEL FILTER / WATER SEPARATOR - DESCRIPTION	14-59	FUEL PUMP PRESSURE TEST - DIAGNOSIS AND TESTING	14-10
FRONT DOOR SECOND WEATHERSTRIP - REMOVAL	23-154	FUEL FILTER / WATER SEPARATOR - INSTALLATION	14-61	FUEL PUMP RELAY - DESCRIPTION	14-41
FRONT DOOR SPEAKER - INSTALLATION	8A-20	FUEL FILTER / WATER SEPARATOR - OPERATION	14-59	FUEL PUMP RELAY - INSTALLATION	14-41
FRONT DOOR SPEAKER - REMOVAL	8A-20	FUEL FILTER / WATER SEPARATOR - REMOVAL	14-60	FUEL PUMP RELAY - OPERATION	14-41
FRONT DOOR UP/DOWN - ADJUSTMENT	23-69	FUEL FILTER/PRESSURE REGULATOR - DESCRIPTION	14-5	FUEL PUMP RELAY - REMOVAL	14-41
FRONT DOOR UPPER CORNER SEAL - INSTALLATION	23-154	FUEL FILTER/PRESSURE REGULATOR - INSTALLATION	14-6	FUEL PUMP RELAYS - DIAGNOSIS AND TESTING, ASD	8I-3
FRONT DOOR UPPER CORNER SEAL - REMOVAL	23-154	FUEL FILTER/PRESSURE REGULATOR - OPERATION	14-5	FUEL REQUIREMENTS - DIESEL ENGINE - DESCRIPTION	0-2
FRONT END SPLASH SHIELDS - INSTALLATION	23-92	FUEL FILTER/PRESSURE REGULATOR - REMOVAL	14-5	FUEL REQUIREMENTS - GAS ENGINES - DESCRIPTION	0-1
FRONT END SPLASH SHIELDS - REMOVAL	23-92	FUEL GAUGE - DESCRIPTION	8J-20	FUEL SENSOR - DESCRIPTION, WATER IN	14-85
FRONT FASCIA - ADJUSTMENT	13-2	FUEL GAUGE - OPERATION	8J-20	FUEL SENSOR - OPERATION, WATER IN	14-85
FRONT FASCIA - INSTALLATION	13-2	FUEL GAUGE SENDING UNIT - DIAGNOSIS AND TESTING	14-8	FUEL SENSOR - REMOVAL, WATER IN	14-85
FRONT FASCIA - REMOVAL	13-2	FUEL HEATER - DESCRIPTION	14-62	FUEL SUPPLY RESTRICTIONS - DIAGNOSIS AND TESTING	14-56
FRONT FASCIA-SPORT - INSTALLATION	13-3	FUEL HEATER - DIAGNOSIS AND TESTING	14-62	FUEL SYSTEM - DIAGNOSIS AND TESTING, AIR IN	14-56
FRONT FASCIA-SPORT - REMOVAL	13-3	FUEL HEATER - OPERATION	14-62	FUEL SYSTEM PARTS - STANDARD PROCEDURES, CLEANING	14-57
FRONT FENDER - INSTALLATION, LEFT	23-93	FUEL HEATER - REMOVAL/INSTALLATION	14-63	FUEL SYSTEM PRESSURE - GAS ENGINES - SPECIFICATIONS	14-4
FRONT FENDER - INSTALLATION, RIGHT	23-94	FUEL HEATER RELAY - DESCRIPTION	14-63	FUEL SYSTEM PRESSURE RELEASE - STANDARD PROCEDURE	14-3
FRONT FENDER - REMOVAL, LEFT	23-92	FUEL HEATER RELAY - DIAGNOSIS AND TESTING	14-64	FUEL SYSTEM PRESSURES, DIESEL ENGINES	14-58
FRONT FENDER - REMOVAL, RIGHT	23-94	FUEL HEATER RELAY - INSTALLATION	14-65	FUEL SYSTEM, SPECIAL TOOLS	14-36,14-4
FRONT LOWER FASCIA - INSTALLATION	13-3	FUEL HEATER RELAY - OPERATION	14-63	FUEL SYSTEM, SPECIAL TOOLS - DIESEL	14-59
FRONT LOWER FASCIA - REMOVAL	13-3	FUEL HEATER RELAY - REMOVAL	14-65	FUEL TANK - DESCRIPTION	14-19
FRONT MOUNT - INSTALLATION	9-100,9-156, 9-213,9-290,9-43	FUEL INDICATOR - DESCRIPTION, LOW	8J-23	FUEL TANK - DESCRIPTION, DIESEL	14-78
FRONT MOUNT - REMOVAL	9-100,9-156,9-213, 9-290,9-43	FUEL INDICATOR - OPERATION, LOW	8J-23	FUEL TANK - INSTALLATION	14-20
FRONT OIL SEAL - FRONT COVER INSTALLED - INSTALLATION	9-205	FUEL INJECTION - SPECIFICATIONS, TORQUE - GAS	14-35	FUEL TANK - OPERATION	14-19
FRONT OIL SEAL - FRONT COVER INSTALLED - REMOVAL	9-204	FUEL INJECTION PUMP - INSTALLATION	14-71	FUEL TANK - REMOVAL	14-19
FRONT OIL SEAL - FRONT COVER REMOVED - INSTALLATION	9-205	FUEL INJECTION PUMP - OPERATION	14-66	FUEL TANK MODULE - DESCRIPTION	14-78
FRONT OIL SEAL - FRONT COVER REMOVED - REMOVAL	9-204	FUEL INJECTION PUMP - REMOVAL	14-68	FUEL TANK MODULE - INSTALLATION	14-79
FRONT OUTPUT SHAFT SEAL - INSTALLATION	21-852,21-886,21-922	FUEL INJECTION PUMP DATA PLATE, SPECIFICATIONS	14-73	FUEL TANK MODULE - OPERATION	14-78
FRONT OUTPUT SHAFT SEAL - REMOVAL	21-851,21-886,21-922	FUEL INJECTION PUMP RELAY - DESCRIPTION	14-99	FUEL TANK MODULE - REMOVAL	14-78
		FUEL INJECTION PUMP RELAY - OPERATION	14-99	FUEL TEMPERATURE SENSOR - DESCRIPTION	14-99

Description	Group-Page	Description	Group-Page	Description	Group-Page
FUEL TRANSFER PUMP - OPERATION	14-79	GEAR HOUSING - REMOVAL	9-304	GLOVE BOX OPENING UPPER TRIM - INSTALLATION	23-114
FUEL TRANSFER PUMP - REMOVAL	14-83	GEAR HOUSING COVER - INSTALLATION	9-307	GLOVE BOX OPENING UPPER TRIM - REMOVAL	23-114
FUEL TRANSFER PUMP PRESSURE - DIAGNOSIS AND TESTING	14-80	GEAR HOUSING COVER - REMOVAL	9-306	GOVERNOR - DESCRIPTION, ELECTRONIC	21-194,21-365,21-540,21-710
FUSE - DESCRIPTION, GENERATOR CARTRIDGE	8W-97-4	GEAR HOUSING PLUG - INSTALLATION, STEERING	19-27	GOVERNOR - INSTALLATION, ELECTRONIC	21-197,21-367,21-543,21-713
FUSE - DESCRIPTION, IOD	8W-97-4	GEAR HOUSING PLUG - REMOVAL, STEERING	19-27	GOVERNOR - OPERATION, ELECTRONIC	21-194, 21-365,21-541,21-711
FUSE - INSTALLATION, GENERATOR CARTRIDGE	8W-97-4	GEAR LEAKAGE - DIAGNOSIS AND TESTING, POWER STEERING	19-14	GOVERNOR - REMOVAL, ELECTRONIC	21-196, 21-367,21-542,21-712
FUSE - INSTALLATION, IOD	8W-97-5	GEAR SELECTOR INDICATOR - DESCRIPTION	8J-21	GRAB HANDLE - INSTALLATION, A-PILLAR	23-119
FUSE - OPERATION, GENERATOR CARTRIDGE	8W-97-4	GEAR SELECTOR INDICATOR - OPERATION	8J-21	GRAB HANDLE - REMOVAL, A-PILLAR	23-119
FUSE - OPERATION, IOD	8W-97-5	GEAR SHIFT LEVER - INSTALLATION	19-13	GRADING - STANDARD PROCEDURE, PISTON	9-282
FUSE - REMOVAL, GENERATOR CARTRIDGE	8W-97-4	GEAR SHIFT LEVER - REMOVAL	19-13	GRID - DESCRIPTION, HEATED MIRROR	8G-4
FUSE - REMOVAL, IOD	8W-97-5	GEAR, SPECIAL TOOLS - POWER STEERING	19-20	GRID - DIAGNOSIS AND TESTING, HEATED MIRROR	8G-4
FUSES POWERING SEVERAL LOADS - STANDARD PROCEDURE, TESTING FOR SHORT TO GROUND ON	8W-01-7	GEAR, SPECIFICATIONS - POWER STEERING	19-19	GRID - OPERATION, HEATED MIRROR	8G-4
GAP AND FLUSH MEASUREMENTS, SPECIFICATIONS - BODY	23-56	GEAR/RING GEAR - INSTALLATION, PINION	3-42,3-74	GRILLE - INSTALLATION	23-91
GAS ENGINE - DIAGNOSIS AND TESTING	11-4	GEAR/RING GEAR - REMOVAL, PINION	3-40, 3-72	GRILLE - INSTALLATION, COWL	23-90
GAS ENGINE - DIAGNOSIS AND TESTING, COOLING SYSTEM	7-7	GEAR/RING GEAR/TONE RING - INSTALLATION, PINION	3-105,3-137,3-166,3-195	GRILLE - REMOVAL	23-91
GAS ENGINES - DESCRIPTION, COMPONENT MONITORS	25-18	GEAR/RING GEAR/TONE RING - REMOVAL, PINION	3-103,3-135,3-165,3-193	GRILLE - REMOVAL, COWL	23-90
GAS ENGINES - DESCRIPTION, FUEL REQUIREMENTS	0-1	GEAR/TONE RING - INSTALLATION, PINION GEAR/RING	3-105,3-137,3-166,3-195	GRILLE FRAME - INSTALLATION	23-92
GAS ENGINES - INSTALLATION	8P-4	GEAR/TONE RING - REMOVAL, PINION GEAR/RING	3-103,3-135,3-165,3-193	GRILLE FRAME - REMOVAL	23-91
GAS ENGINES - OPERATION	25-18	GEARTRAIN/OUTPUT SHAFT - ASSEMBLY, PLANETARY	21-241,21-412,21-588, 21-760	GRILLES - INSTALLATION, DEMISTER	24-32
GAS ENGINES - OPERATION, NON- MONITORED CIRCUITS	25-22	GEARTRAIN/OUTPUT SHAFT - DESCRIPTION, PLANETARY	21-240,21-410, 21-585,21-757	GRILLES - REMOVAL, DEMISTER	24-31
GAS ENGINES - OPERATION, PCM	8E-17	GEARTRAIN/OUTPUT SHAFT - DISASSEMBLY, PLANETARY	21-240,21-411, 21-586,21-757	GROUND - DESCRIPTION, SIGNAL	8E-17
GAS ENGINES - REMOVAL	8P-4	GEARTRAIN/OUTPUT SHAFT - INSPECTION, PLANETARY	21-241,21-411, 21-587,21-760	GROUND - STANDARD PROCEDURE, TESTING FOR A SHORT TO	8W-01-6
GAS ENGINES - SPECIFICATIONS, FUEL SYSTEM PRESSURE	14-4	GEARTRAIN/OUTPUT SHAFT - OPERATION, PLANETARY	21-240,21-410,21-585,21-757	GROUND ON FUSES POWERING SEVERAL LOADS - STANDARD PROCEDURE, TESTING FOR SHORT TO	8W-01-7
GAS FUEL INJECTION - SPECIFICATIONS, TORQUE	14-35	GENERAL - WARNINGS	8W-01-5	GROUND STRAP - INSTALLATION, CAB-TO- BED	8A-14
GASKET - DESCRIPTION, CYLINDER COVER	9-79	GENERATOR - DESCRIPTION	8F-29	GROUND STRAP - INSTALLATION, ENGINE-TO-BODY	8A-13
GASKET - DESCRIPTION, CYLINDER HEAD COVER	9-22	GENERATOR - INSTALLATION	8F-30	GROUND STRAP - INSTALLATION, HEATER CORE	8A-15
GASKET - OPERATION, CYLINDER HEAD COVER	9-22	GENERATOR - OPERATION	8F-29	GROUND STRAP - REMOVAL, CAB-TO- BED	8A-14
GASKET FAILURE - DIAGNOSIS AND TESTING, CYLINDER HEAD	9-136,9-191,9-22, 9-79	GENERATOR - REMOVAL	8F-30	GROUND STRAP - REMOVAL, ENGINE-TO-BODY	8A-13
GASKETS & SEALERS - STANDARD PROCEDURE, FORM-IN-PLACE	9-11,9-125, 9-180,9-237,9-68	GENERATOR CARTRIDGE FUSE - DESCRIPTION	8W-97-4	GROUND STRAP - REMOVAL, HEATER CORE	8A-14
GASOLINE - NEGATIVE CABLE INSTALLATION	8F-24	GENERATOR CARTRIDGE FUSE - INSTALLATION	8W-97-4	GROUNDS - DESCRIPTION, POWER	8E-17
GASOLINE - NEGATIVE CABLE REMOVAL	8F-23	GENERATOR CARTRIDGE FUSE - OPERATION	8W-97-4	GUIDES AND SPRINGS - STANDARD PROCEDURE, VALVES	9-138,9-25,9-82
GASOLINE - POSITIVE CABLE INSTALLATION	8F-23	GENERATOR CARTRIDGE FUSE - REMOVAL	8W-97-4	HANDLE - INSTALLATION, A-PILLAR GRAB	23-119
GASOLINE - POSITIVE CABLE REMOVAL	8F-23	GENERATOR RATINGS, SPECIFICATIONS	8F-28	HANDLE - INSTALLATION, ASSIST	23-124
GASOLINE ENGINE - INSTALLATION	19-35	GENERATOR/CHARGING SYSTEM - SPECIFICATIONS, TORQUE	8F-28	HANDLE - INSTALLATION, EXTERIOR	23-70
GASOLINE ENGINE - REMOVAL	19-33	GLASS - DESCRIPTION, STATIONARY	23-145	HANDLE - INSTALLATION, LATCH	23-65
GAUGE - DESCRIPTION, ENGINE TEMPERATURE	8J-19	GLASS - INSTALLATION, BACKLITE VENT	23-147	HANDLE - INSTALLATION, SHUTFACE	23-83
GAUGE - DESCRIPTION, FUEL	8J-20	GLASS - INSTALLATION, DOOR MIRROR	23-69	HANDLE - REMOVAL, A-PILLAR GRAB	23-119
GAUGE - DESCRIPTION, OIL PRESSURE	8J-25	GLASS - OPERATION, STATIONARY	23-145	HANDLE - REMOVAL, ASSIST	23-124
GAUGE - DESCRIPTION, VOLTAGE	8J-33	GLASS - REMOVAL, BACKLITE VENT	23-147	HANDLE - REMOVAL, EXTERIOR	23-70
GAUGE - OPERATION, ENGINE TEMPERATURE	8J-19	GLASS - REMOVAL, DOOR	23-69	HANDLE - REMOVAL, LATCH	23-65
GAUGE - OPERATION, FUEL	8J-20	GLASS - REMOVAL, SIDE VIEW MIRROR	23-98	HANDLE - REMOVAL, SHUTFACE	23-83
GAUGE - OPERATION, OIL PRESSURE	8J-26	GLASS RUN CHANNEL - INSTALLATION	23-70	HANDLE ACTUATOR - INSTALLATION, INSIDE	23-71,23-80
GAUGE - OPERATION, VOLTAGE	8J-34	GLASS RUN CHANNEL - REMOVAL	23-70	HANDLE ACTUATOR - REMOVAL, INSIDE	23-71,23-80
GAUGE SENDING UNIT - DIAGNOSIS AND TESTING, FUEL	14-8	GLASS RUN WEATHERSTRIP - INSTALLATION, FRONT DOOR	23-154	HANDLE ESCUTCHEON - INSTALLATION	23-63
GAUGES - DIAGNOSIS AND TESTING, PRESSURE	22-7	GLASS RUN WEATHERSTRIP - REMOVAL, FRONT DOOR	23-153	HANDLE ESCUTCHEON - REMOVAL	23-63
GAUGES INDICATOR - DESCRIPTION, CHECK	8J-17	GLOVE BOX - ASSEMBLY	23-112	HANDLING - INSPECTION, STEERING	30-15
GAUGES INDICATOR - OPERATION, CHECK	8J-17	GLOVE BOX - DISASSEMBLY	23-112	HANDLING NON-DEPLOYED AIRBAGS - STANDARD PROCEDURE	80-4
GAUGES/WARNING LIGHTS - INSPECTION	30-19	GLOVE BOX - INSTALLATION	23-113	HARNES - DIAGNOSIS AND TESTING, WIRING	8W-01-5
GEAR - ADJUSTMENTS	19-16	GLOVE BOX - REMOVAL	23-112	HAT PARK BRAKE SHOES - 2500/3500 - INSTALLATION, REAR DRUM IN	5-42
GEAR - DESCRIPTION	19-14	GLOVE BOX LAMP AND SWITCH - INSTALLATION	8L-35	HAT PARK BRAKE SHOES - 2500/3500 - REMOVAL, REAR DRUM IN	5-41
GEAR - INSTALLATION	19-16	GLOVE BOX LAMP AND SWITCH - REMOVAL	8L-35	HAZARD WARNING SYSTEM - DESCRIPTION, TURN SIGNAL	8L-2
GEAR - INSTALLATION, PINION GEAR/RING	3-42,3-74	GLOVE BOX LATCH STRIKER - INSTALLATION	23-113	HAZARD WARNING SYSTEM - DIAGNOSIS AND TESTING, TURN SIGNAL	8L-3
GEAR - OPERATION	19-14	GLOVE BOX LATCH STRIKER - REMOVAL	23-113	HAZARD WARNING SYSTEM - OPERATION, TURN SIGNAL	8L-2
GEAR - REMOVAL	19-16	GLOVE BOX LATCH STRIKER - REMOVAL	23-113	HEAD - CLEANING, CYLINDER	9-137,9-193,9-23, 9-248,9-80
GEAR - REMOVAL, PINION GEAR/RING	3-40, 3-72	GEAR HOUSING - INSTALLATION	9-305	HEAD - DESCRIPTION, CYLINDER	9-136,9-191, 9-22,9-246,9-79



Description	Group-Page	Description	Group-Page	Description	Group-Page
HEAD - INSPECTION, CYLINDER	9-137,9-193,9-23,9-250,9-80	HEATER - 3.9L/5.2L/5.9L - INSTALLATION, ENGINE BLOCK	7-45	HEAVY DUTY/8.0L - DESCRIPTION, CATALYTIC CONVERTER - 5.9L	11-6
HEAD - INSTALLATION, CYLINDER	9-137,9-193,9-23,9-250,9-80	HEATER - 3.9L/5.2L/5.9L - OPERATION, ENGINE BLOCK	7-45	HEAVY DUTY/8.0L - INSPECTION, CATALYTIC CONVERTER - 5.9L	11-7
HEAD - OPERATION, CYLINDER	9-136,9-22,9-79	HEATER - 3.9L/5.2L/5.9L - REMOVAL, ENGINE BLOCK	7-45	HEAVY DUTY/8.0L - INSPECTION, EXHAUST PIPE - 5.9L	11-9
HEAD - REMOVAL, CYLINDER	9-137,9-192,9-23,9-246,9-80	HEATER - 5.9L DIESEL - DESCRIPTION, ENGINE BLOCK	7-47	HEAVY DUTY/8.0L - INSPECTION, TAILPIPE - 5.9L	11-12
HEAD COVER GASKET - DESCRIPTION, CYLINDER	9-22	HEATER - 5.9L DIESEL - INSTALLATION, ENGINE BLOCK	7-47	HEAVY DUTY/8.0L - INSTALLATION, CATALYTIC CONVERTER - 5.9L	11-7
HEAD COVER GASKET - OPERATION, CYLINDER	9-22	HEATER - 5.9L DIESEL - OPERATION, ENGINE BLOCK	7-47	HEAVY DUTY/8.0L - INSTALLATION, EXHAUST PIPE - 5.9L	11-9
HEAD COVER(S) - CLEANING, CYLINDER	9-138,9-194,9-24,9-253,9-81	HEATER - 5.9L DIESEL - REMOVAL, ENGINE BLOCK	7-47	HEAVY DUTY/8.0L - INSTALLATION, TAILPIPE - 5.9L	11-12
HEAD COVER(S) - DESCRIPTION, CYLINDER	9-194	HEATER - 8.0L - DESCRIPTION, ENGINE BLOCK	7-46	HEAVY DUTY/8.0L - OPERATION, CATALYTIC CONVERTER - 5.9L	11-6
HEAD COVER(S) - INSPECTION, CYLINDER	9-138,9-194,9-24,9-253,9-81	HEATER - 8.0L - INSTALLATION, ENGINE BLOCK	7-46	HEAVY DUTY/8.0L - REMOVAL, CATALYTIC CONVERTER - 5.9L	11-6
HEAD COVER(S) - INSTALLATION, CYLINDER	9-138,9-194,9-24,9-253,9-81	HEATER - 8.0L - OPERATION, ENGINE BLOCK	7-46	HEAVY DUTY/8.0L - REMOVAL, EXHAUST PIPE - 5.9L	11-8
HEAD COVER(S) - REMOVAL, CYLINDER	9-138,9-194,9-24,9-253,9-81	HEATER - 8.0L - REMOVAL, ENGINE BLOCK	7-46	HEAVY DUTY/8.0L - REMOVAL, TAILPIPE - 5.9L	11-12
HEAD GASKET FAILURE - DIAGNOSIS AND TESTING, CYLINDER	9-136,9-191,9-22,9-79	HEATER - DESCRIPTION, FUEL	14-62	HEIGHT ADJUSTER KNOB - INSTALLATION, TURNING LOOP	80-30
HEAD RESTRAINTS - INSPECTION, SEAT BELTS, SHOULDER BELTS, RETRACTORS	30-12	HEATER - DESCRIPTION, INTAKE AIR	14-100	HEIGHT ADJUSTER KNOB - REMOVAL, TURNING LOOP	80-30
HEADLAMP - DESCRIPTION	8L-13	HEATER - DIAGNOSIS AND TESTING, FUEL	14-62	HIGH BEAM INDICATOR - DESCRIPTION	8J-21
HEADLAMP - DIAGNOSIS AND TESTING	8L-13	HEATER - INSTALLATION, INTAKE AIR	14-101	HIGH BEAM INDICATOR - DIAGNOSIS AND TESTING	8J-22
HEADLAMP - INSTALLATION	8L-16	HEATER - OPERATION, FUEL	14-62	HIGH BEAM INDICATOR - OPERATION	8J-22
HEADLAMP - OPERATION	8L-13	HEATER - OPERATION, INTAKE AIR	14-100	HIGH MOUNTED STOP LAMP - HIGH MOUNTED STOP LAMP UNIT - INSTALLATION, CENTER	8L-6
HEADLAMP - REMOVAL	8L-16	HEATER - REMOVAL, INTAKE AIR	14-100	HIGH MOUNTED STOP LAMP - REMOVAL, CENTER	8L-6
HEADLAMP ALIGNMENT, SPECIAL TOOLS	8L-4	HEATER - REMOVAL/INSTALLATION, FUEL	14-63	HIGH MOUNTED STOP LAMP UNIT - INSTALLATION, CENTER	8L-6
HEADLAMP RELAY - DESCRIPTION	8L-16	HEATER AND AIR CONDITIONER - DESCRIPTION	24-1	HIGH MOUNTED STOP LAMP UNIT - REMOVAL, CENTER	8L-6
HEADLAMP RELAY - DIAGNOSIS AND TESTING	8L-17	HEATER AND AIR CONDITIONER - OPERATION	24-1	HIGH MOUNTED STOP LAMP UNIT - INSTALLATION, CENTER	8L-6
HEADLAMP RELAY - INSTALLATION	8L-18	HEATER CONTROL - DESCRIPTION, A/C	24-18	HIGH MOUNTED STOP LAMP UNIT - REMOVAL, CENTER	8L-6
HEADLAMP RELAY - OPERATION	8L-17	HEATER CONTROL - DIAGNOSIS AND TESTING, A/C	24-19	HIGH PRESSURE FUEL LINES - DESCRIPTION	14-74
HEADLAMP RELAY - REMOVAL	8L-18	HEATER CONTROL - INSTALLATION, A/C	24-20	HIGH PRESSURE FUEL LINES - OPERATION	14-74
HEADLAMP SWITCH - DESCRIPTION	8L-18	HEATER CONTROL - OPERATION, A/C	24-18	HIGH PRESSURE RELIEF VALVE - DESCRIPTION	24-46
HEADLAMP SWITCH - DIAGNOSIS AND TESTING	8L-18	HEATER CONTROL - REMOVAL, A/C	24-19	HIGH PRESSURE RELIEF VALVE - OPERATION	24-46
HEADLAMP SWITCH - INSTALLATION	8L-20	HEATER CORE - DESCRIPTION	24-55	HIGH PRESSURE SWITCH - DESCRIPTION, A/C	24-20
HEADLAMP SWITCH - OPERATION	8L-18	HEATER CORE - INSTALLATION	24-56	HIGH PRESSURE SWITCH - DIAGNOSIS AND TESTING, A/C	24-20
HEADLAMP SWITCH - REMOVAL	8L-19	HEATER CORE - OPERATION	24-55	HIGH PRESSURE SWITCH - INSTALLATION, A/C	24-21
HEADLAMP UNIT - ADJUSTMENTS	8L-21	HEATER CORE - REMOVAL	24-56	HIGH PRESSURE SWITCH - OPERATION, A/C	24-20
HEADLAMP UNIT - INSTALLATION	8L-20	HEATER CORE GROUND STRAP - INSTALLATION	8A-15	HIGH PRESSURE SWITCH - REMOVAL, A/C	24-21
HEADLAMP UNIT - REMOVAL	8L-20	HEATER CORE GROUND STRAP - REMOVAL	8A-14	HIGH-PRESSURE FUEL LINE LEAKS - DIAGNOSIS AND TESTING	14-74
HEADLINER - INSTALLATION	23-125	HEATER PERFORMANCE - DIAGNOSIS AND TESTING	24-6	HINGE - INSTALLATION	23-71,23-79,23-99
HEADLINER - REMOVAL	23-125	HEATER RELAY - DESCRIPTION, FUEL	14-63	HINGE - REMOVAL	23-70,23-79,23-99
HEAT SHIELDS - DESCRIPTION	11-10	HEATER RELAY - DESCRIPTION, INTAKE AIR	14-101	HITCH - INSTALLATION, TRAILER	13-10
HEAT SHIELDS - INSTALLATION	11-10	HEATER RELAY - DIAGNOSIS AND TESTING, FUEL	14-64	HITCH - REMOVAL, TRAILER	13-10
HEAT SHIELDS - REMOVAL	11-10	HEATER RELAY - INSTALLATION, FUEL	14-65	HOISTING - STANDARD PROCEDURE	0-28
HEAT/DEFROST DOOR - INSTALLATION	24-39	HEATER RELAY - INSTALLATION, INTAKE AIR	14-102	HOLDDOWN - DESCRIPTION, BATTERY	8F-18
HEAT/DEFROST DOOR - REMOVAL	24-38	HEATER RELAY - OPERATION, FUEL	14-63	HOLDDOWN - INSTALLATION, BATTERY	8F-18
HEAT/DEFROST DOOR ACTUATOR - INSTALLATION	24-27	HEATER RELAY - OPERATION, INTAKE AIR	14-102	HOLDDOWN - OPERATION, BATTERY	8F-18
HEAT/DEFROST DOOR ACTUATOR - REMOVAL	24-26	HEATER RELAY - REMOVAL, FUEL	14-65	HOLDDOWN - REMOVAL, BATTERY	8F-18
HEATED MIRROR GRID - DESCRIPTION	8G-4	HEATER RELAY - REMOVAL, INTAKE AIR	14-102	HOLDER - INSTALLATION, CUP	23-111
HEATED MIRROR GRID - DIAGNOSIS AND TESTING	8G-4	HEATER SWITCH - DESCRIPTION, DRIVER SEAT	8G-7	HOLDER - REMOVAL, CUP	23-110
HEATED MIRROR GRID - OPERATION	8G-4	HEATER SWITCH - DESCRIPTION, PASSENGER SEAT	8G-13	HOLE REPAIR - DESCRIPTION, THREADED	Intro.-6
HEATED MIRROR SWITCH - DIAGNOSIS AND TESTING	8G-3	HEATER SWITCH - INSTALLATION, DRIVER SEAT	8G-9	HONING - STANDARD PROCEDURE, CYLINDER BORE	9-10,9-126,9-180,9-69
HEATED MIRROR SYSTEM - DESCRIPTION	8G-1	HEATER SWITCH - INSTALLATION, PASSENGER SEAT	8G-16	HOOD - ADJUSTMENT	23-100
HEATED MIRROR SYSTEM - DIAGNOSIS AND TESTING	8G-2	HEATER SWITCH - OPERATION, DRIVER SEAT	8G-7	HOOD - INSTALLATION	23-100
HEATED MIRROR SYSTEM - OPERATION	8G-2	HEATER SWITCH - OPERATION, PASSENGER SEAT	8G-14	HOOD - REMOVAL	23-100
HEATED SEAT ELEMENT - DESCRIPTION	8G-10	HEATER SWITCH - REMOVAL, DRIVER SEAT	8G-9	HOOD LATCH/SAFETY CATCH - INSPECTION	30-4
HEATED SEAT ELEMENT - OPERATION	8G-10	HEATER SWITCH - REMOVAL, PASSENGER SEAT	8G-15	HOOK - INSTALLATION, COAT	23-125
HEATED SEAT ELEMENT AND SENSOR - DIAGNOSIS & TESTING	8G-11	HEATER SWITCH - REMOVAL, PASSENGER SEAT	8G-15	HOOK - INSTALLATION, FRONT TOW	13-10
HEATED SEAT RELAY - DESCRIPTION	8G-11	HEATER SWITCH - REMOVAL, DRIVER SEAT	8G-9	HOOK - REMOVAL, COAT	23-124
HEATED SEAT RELAY - DIAGNOSIS & TESTING	8G-12	HEATER SWITCH - OPERATION, PASSENGER SEAT	8G-14	HOOK - REMOVAL, FRONT TOW	13-9
HEATED SEAT RELAY - INSTALLATION	8G-13	HEATER SWITCH - REMOVAL, PASSENGER SEAT	8G-15	HORN - DESCRIPTION	8H-1,8H-2
HEATED SEAT RELAY - OPERATION	8G-12	HEATER/AIR CONDITIONER - INSPECTION	30-17	HORN - DIAGNOSIS AND TESTING	8H-2
HEATED SEAT RELAY - REMOVAL	8G-13	HEAVY DUTY ENGINE (FEDERAL ONLY - 2500 8.0L HD AND 3500 5.9L& 8.0L MODELS) MAINTENANCE SCHEDULES - DESCRIPTION	0-17	HORN - INSPECTION	30-19
HEATED SEAT SWITCH - DIAGNOSIS & TESTING	8G-14,8G-8			HORN - OPERATION	8H-1,8H-2
HEATED SEAT SYSTEM - DESCRIPTION	8G-5			HORN RELAY - DESCRIPTION	8H-3
HEATED SEAT SYSTEM - DIAGNOSIS & TESTING	8G-6				
HEATED SEAT SYSTEM - OPERATION	8G-6				
HEATER - 3.9L/5.2L/5.9L - DESCRIPTION, ENGINE BLOCK	7-45				

Description	Group-Page	Description	Group-Page	Description	Group-Page
HORN RELAY - DIAGNOSIS AND TESTING	8H-3	HYDRAULIC LIFTERS - CLEANING	9-152,9-208	INDICATOR - DESCRIPTION, SEATBELT	8J-27
HORN RELAY - OPERATION	8H-3	HYDRAULIC LIFTERS - INSTALLATION	9-152, 9-208	INDICATOR - DESCRIPTION, SERVICE REMINDER	8J-28
HORN SWITCH - DESCRIPTION	8H-4	HYDRAULIC LIFTERS - REMOVAL	9-152,9-207	INDICATOR - DESCRIPTION, TRANSMISSION OVERTEMP	8J-31
HORN SWITCH - DIAGNOSIS AND TESTING	8H-5	HYDRAULIC LIFTERS (CAM IN BLOCK) - CLEANING	9-39,9-96	INDICATOR - DESCRIPTION, UPSHIFT	8J-33
HORN SWITCH - OPERATION	8H-5	HYDRAULIC LIFTERS (CAM IN BLOCK) - INSTALLATION	9-39,9-96	INDICATOR - DESCRIPTION, VTSS	8Q-3
HOSE - OPERATION, CRANKCASE VENT	25-32	HYDRAULIC LIFTERS (CAM IN BLOCK) - REMOVAL	9-39,9-96	INDICATOR - DESCRIPTION, WAIT-TO-START	8J-34
HOSE CLAMPS - DESCRIPTION	7-2	HYDRAULIC PRESSURE TEST - DIAGNOSIS AND TESTING	21-144,21-315, 21-487,21-658	INDICATOR - DESCRIPTION, WASHER FLUID	8J-35
HOSE CLAMPS - OPERATION	7-2	HYDRAULIC SCHEMATICS, SCHEMATICS AND DIAGRAMS	21-174,21-345,21-520,21-690	INDICATOR - DESCRIPTION, WATER-IN-FUEL	8J-36
HOSE WITH AIR CONDITIONING - INSTALLATION, WATER PUMP BYPASS	7-77	HYDRAULIC TAPPETS - DIAGNOSIS AND TESTING	9-151,9-206,9-38,9-95	INDICATOR - DIAGNOSIS AND TESTING, BRAKE	8J-16
HOSE WITH AIR CONDITIONING - REMOVAL, WATER PUMP BYPASS	7-74	HYDRAULIC/MECHANICAL - DESCRIPTION	5-4	INDICATOR - DIAGNOSIS AND TESTING, FOUR-WHEEL DRIVE	8J-29
HOSE WITHOUT AIR CONDITIONING - INSTALLATION, WATER PUMP BYPASS	7-78	HYDRAULIC/MECHANICAL - WARNING	5-5	INDICATOR - DIAGNOSIS AND TESTING, HIGH BEAM	8J-22
HOSE WITHOUT AIR CONDITIONING - REMOVAL, WATER PUMP BYPASS	7-77	HYDROMETER TEST - STANDARD PROCEDURE	8F-12	INDICATOR - DIAGNOSIS AND TESTING, VTSS	8Q-3
HOSES - PRESSURE - DESCRIPTION	19-37	HYDROSTATIC LOCK - STANDARD PROCEDURE	9-11,9-125,9-181,9-238,9-68	INDICATOR - DIAGNOSIS AND TESTING, WASHER FLUID	8J-36
HOSES - PRESSURE - OPERATION	19-37	IDENTIFICATION - DESCRIPTION, FASTENER	Intro.-3	INDICATOR - OPERATION, ABS	8J-14
HOSES - RETURN - DESCRIPTION	19-37	IDENTIFICATION LAMP - INSTALLATION, OUTBOARD	8L-29	INDICATOR - OPERATION, AIRBAG	8J-15
HOSES - RETURN - OPERATION	19-37	IDENTIFICATION LAMP - REMOVAL, OUTBOARD	8L-28	INDICATOR - OPERATION, BRAKE/PARK BRAKE	8J-16
HOSES/LINES/TUBES PRECAUTIONS - CAUTION, REFRIGERANT	24-42	IDENTIFICATION NUMBER - DESCRIPTION, VEHICLE	Intro.-10	INDICATOR - OPERATION, CHECK GAUGES	8J-17
HOSES/TUBES - DESCRIPTION, WASHER	8R-8	IDENTIFICATION PLATE - DESCRIPTION, EQUIPMENT	Intro.-12	INDICATOR - OPERATION, CRUISE	8J-18
HOSES/TUBES - OPERATION, WASHER	8R-8	IDLE AIR CONTROL MOTOR - DESCRIPTION	14-41	INDICATOR - OPERATION, GEAR SELECTOR	8J-21
HOUSING - ASSEMBLY, HVAC	24-36	IDLE AIR CONTROL MOTOR - OPERATION	14-41	INDICATOR - OPERATION, HIGH BEAM	8J-22
HOUSING - DIAGNOSIS AND TESTING, CLUTCH	6-11	I.F.S. - STANDARD PROCEDURES, ALIGNMENT	2-2	INDICATOR - OPERATION, LOW FUEL	8J-23
HOUSING - DISASSEMBLY, HVAC	24-36	IGNITION - SPECIFICATIONS, TORQUE	8I-2	INDICATOR - OPERATION, OVERDRIVE OFF	8J-27
HOUSING - INSTALLATION, CLUTCH	6-13	IGNITION CIRCUIT SENSE - DESCRIPTION	8E-17	INDICATOR - OPERATION, SEATBELT	8J-27
HOUSING - INSTALLATION, GEAR	9-305	IGNITION CIRCUIT SENSE - OPERATION	8E-19	INDICATOR - OPERATION, SERVICE REMINDER	8J-28
HOUSING - INSTALLATION, HVAC	24-37	IGNITION COIL RESISTANCE, 3.9L/5.2L/5.9L ENGINES	8I-3	INDICATOR - OPERATION, TRANSMISSION OVERTEMP	8J-31
HOUSING - INSTALLATION, LOCK CYLINDER	19-11	IGNITION COIL RESISTANCE, 8.0L V-10 ENGINE	8I-3	INDICATOR - OPERATION, UPSHIFT	8J-33
HOUSING - REMOVAL, CLUTCH	6-13	IGNITION SWITCH - DESCRIPTION	19-11	INDICATOR - OPERATION, VTSS	8Q-3
HOUSING - REMOVAL, GEAR	9-304	IGNITION SWITCH - DESCRIPTION, KEY-IN	19-9	INDICATOR - OPERATION, WAIT-TO-START	8J-35
HOUSING - REMOVAL, HVAC	24-35	IGNITION SWITCH - DIAGNOSIS AND TESTING	19-11	INDICATOR - OPERATION, WASHER FLUID	8J-35
HOUSING - REMOVAL, LOCK CYLINDER	19-10	IGNITION SWITCH - INSTALLATION	19-12	INDICATOR - OPERATION, WATER-IN-FUEL	8J-37
HOUSING BUSHING - INSTALLATION, EXTENSION	21-198,21-369,21-544,21-714	IGNITION SWITCH - OPERATION	19-11	INDICATOR LAMP (MIL) - DESCRIPTION, MALFUNCTION	8J-24
HOUSING BUSHING - REMOVAL, EXTENSION	21-198,21-369,21-544,21-714	IGNITION SWITCH - REMOVAL	19-12	INDICATOR LAMP (MIL) - OPERATION, MALFUNCTION	8J-24
HOUSING BUSHING AND SEAL - INSTALLATION, EXTENSION	21-850,21-885, 21-921	IGNITION SWITCH AND KEY LOCK CYLINDER - DIAGNOSIS AND TESTING	19-10	INDICATOR TEST - STANDARD PROCEDURE, BUILT-IN	8F-11
HOUSING BUSHING AND SEAL - REMOVAL, EXTENSION	21-850,21-885,21-921	IGNITION TIMING, SPECIFICATIONS	8I-3	INDICATOR (TRANSFER CASE) - DESCRIPTION, SHIFT	8J-29
HOUSING COVER - INSTALLATION, GEAR	9-307	IGNITION-OFF DRAW TEST - STANDARD PROCEDURE	8F-15	INDICATOR (TRANSFER CASE) - OPERATION, SHIFT	8J-29
HOUSING COVER - REMOVAL, GEAR	9-306	IMPORTANCE OF CAREFUL NEW VEHICLE PREPARATION - DESCRIPTION, THE	30-1	INDICATORS - DESCRIPTION, TURN SIGNAL	8J-32
HOUSING FLUID LEAK - DIAGNOSIS AND TESTING, CONVERTER	21-148,21-319,21-491, 21-662	INCH - INSTALLATION, 12 1/8 SHOES-11	5-27	INDICATORS - DIAGNOSIS AND TESTING, TREAD WEAR	22-7
HOUSING INLET BAFFLE - INSTALLATION, HVAC	24-37	INCH - REMOVAL, 12 1/8 SHOES-11	5-26	INDICATORS - DIAGNOSIS AND TESTING, TURN SIGNAL	8J-32
HOUSING INLET BAFFLE - REMOVAL, HVAC	24-36	INCH - REMOVAL, REAR BRAKE SHOES-11	5-25	INDICATORS - OPERATION, TURN SIGNAL	8J-32
HOUSING PLUG - INSTALLATION, STEERING GEAR	19-27	INCORRECT FLUID LEVEL - DIAGNOSIS AND TESTING, EFFECTS OF	21-199,21-370, 21-545,21-715	INITIAL OPERATION - STANDARD PROCEDURE, POWER STEERING PUMP	19-31
HOUSING PLUG - REMOVAL, STEERING GEAR	19-27	INDEPENDENT FRONT SUSPENSION, SPECIAL TOOLS	2-9	INJECTION - SPECIFICATIONS, TORQUE - GAS FUEL	14-35
HOUSING SEAL - INSTALLATION, ADAPTER	21-132,21-87	INDICATOR - DESCRIPTION, ABS	8J-9	INJECTION PUMP - DESCRIPTION, AIR	25-28
HOUSING SEAL - INSTALLATION, EXTENSION	21-132,21-198,21-369,21-544, 21-715,21-87	INDICATOR - DESCRIPTION, AIRBAG	8J-15	INJECTION PUMP - DIAGNOSIS AND TESTING, AIR	25-28
HOUSING SEAL - REMOVAL, ADAPTER	21-132, 21-87	INDICATOR - DESCRIPTION, BRAKE/PARK BRAKE	8J-16	INJECTION PUMP - INSTALLATION, AIR	25-29
HOUSING SEAL - REMOVAL, EXTENSION	21-132,21-198,21-369,21-544, 21-714,21-87	INDICATOR - DESCRIPTION, CHECK GAUGES	8J-17	INJECTION PUMP - INSTALLATION, FUEL	14-71
HOW TO USE WIRING DIAGRAMS - DESCRIPTION	8W-01-1	INDICATOR - DESCRIPTION, CRUISE	8J-18	INJECTION PUMP - OPERATION, AIR	25-28
H.P. - DESCRIPTION, FUEL PUMP 235	14-66	INDICATOR - DESCRIPTION, GEAR SELECTOR	8J-21	INJECTION PUMP - OPERATION, FUEL	14-66
H.P. - DESCRIPTION, FUEL PUMP 245	14-65	INDICATOR - DESCRIPTION, HIGH BEAM	8J-21	INJECTION PUMP - REMOVAL, AIR	25-29
HUB / BEARING - INSTALLATION	2-9	INDICATOR - DESCRIPTION, LOW FUEL	8J-23	INJECTION PUMP - REMOVAL, FUEL	14-68
HUB / BEARING - REMOVAL	2-9	INDICATOR - DESCRIPTION, OVERDRIVE OFF	8J-27	INJECTION PUMP DATA PLATE, SPECIFICATIONS - FUEL	14-73
HVAC HOUSING - ASSEMBLY	24-36			INJECTION PUMP RELAY - DESCRIPTION, FUEL	14-99
HVAC HOUSING - DISASSEMBLY	24-36			INJECTION PUMP RELAY - OPERATION, FUEL	14-99
HVAC HOUSING - INSTALLATION	24-37				
HVAC HOUSING - REMOVAL	24-35				
HVAC HOUSING INLET BAFFLE - INSTALLATION	24-37				
HVAC HOUSING INLET BAFFLE - REMOVAL	24-36				
HVAC SYSTEM AIRFLOW - DESCRIPTION	24-31				
HYDRAULIC BOOSTER - DIAGNOSIS AND TESTING	5-17				

Description	Group-Page	Description	Group-Page	Description	Group-Page
INJECTION PUMP TIMING - DIAGNOSIS AND TESTING, FUEL	14-66	INSPECTION, FRONT SERVO	21-207,21-378, 21-553,21-723	INSPECTION, VALVE BODY	21-293,21-465, 21-637,21-809
INJECTION SYSTEM - DESCRIPTION, AIR	25-25	INSPECTION, FUEL	30-15	INSPECTION, VIBRATION DAMPER	9-289
INJECTION SYSTEM - DESCRIPTION, DIESEL FUEL	14-87	INSPECTION, GAUGES/WARNING LIGHTS	30-19	INSPECTION, VISUAL	30-8
INJECTION SYSTEM - OPERATION, AIR	25-27	INSPECTION, HEATER/AIR CONDITIONER	30-17	INSPECTION, WATER PUMP - 3.9L/5.2L/5.9L	7-69
INJECTION SYSTEM - TORQUE, AIR	25-28	INSPECTION, HOOD LATCH/SAFETY CATCH	30-4	INSPECTION, WATER PUMP - 5.9L DIESEL	7-73
INJECTOR - DESCRIPTION, FUEL	14-53,14-93	INSPECTION, HORN	30-19	INSPECTION, WATER PUMP - 8.0L	7-72
INJECTOR - INSTALLATION, FUEL	14-53,14-98	INSPECTION, INTAKE MANIFOLD	9-110,9-166, 9-223,9-302,9-53	INSPECTION, WHEEL CYLINDERS	5-31
INJECTOR - OPERATION, FUEL	14-53,14-94	INSPECTION, INTAKE/EXHAUST VALVES & SEATS	9-141,9-198,9-27,9-84	INSPECTION, WINDOWS, DOORS AND LOCKS	30-14
INJECTOR - REMOVAL, FUEL	14-53,14-96	INSPECTION, KEYLESS ENTRY	30-11	INSPECTION WINDSHIELD WIPERS/WASHERS, ROAD TEST	30-18
INJECTOR FIRING ORDER, DIESEL - FUEL	14-58	INSPECTION, LIGHTS AND SWITCHES	30-12	INSPECTION, WIPER & WASHER SYSTEM	8R-6
INJECTOR TEST - DIAGNOSIS AND TESTING, FUEL	14-53,14-95	INSPECTION, LINES/HOSES	30-6	INSPECTION, WIRING	30-7
INLET BAFFLE - INSTALLATION, HVAC HOUSING	24-37	INSPECTION, MANUAL - NV3500	21-15	INSTALLED - INSTALLATION, FRONT OIL SEAL - FRONT COVER	9-205
INLET BAFFLE - REMOVAL, HVAC HOUSING	24-36	INSPECTION, MEASURING TIMING CHAIN STRETCH	9-114,9-170,9-227,9-58	INSTALLED - REMOVAL, FRONT OIL SEAL - FRONT COVER	9-204
INLET FILTER - INSTALLATION	14-22	INSPECTION, MIRROR	30-19	INSTRUMENT CLUSTER - ASSEMBLY	8J-13
INLET FILTER - REMOVAL	14-22	INSPECTION, NEUTRAL SAFETY SWITCH	30-19	INSTRUMENT CLUSTER - DESCRIPTION	8J-2
INNER BELT WEATHERSTRIP - INSTALLATION, FRONT DOOR	23-154	INSPECTION, OIL COOLER & LINES - CLEANING	9-296	INSTRUMENT CLUSTER - DIAGNOSIS AND TESTING	8J-6
INNER BELT WEATHERSTRIP - REMOVAL, FRONT DOOR	23-154	INSPECTION, OIL PAN	9-106,9-162,9-219,9-297, 9-49	INSTRUMENT CLUSTER - DISASSEMBLY	8J-11
IN/OUT - ADJUSTMENT, FRONT DOOR	23-69	INSPECTION, OIL PRESSURE RELIEF VALVE	9-297	INSTRUMENT CLUSTER - INSTALLATION	8J-14
INPUT - DESCRIPTION, VEHICLE SPEED	8P-1	INSPECTION, OIL PUMP	9-107,9-163,9-220, 9-299,9-50	INSTRUMENT CLUSTER - OPERATION	8J-3
INPUT - OPERATION, ASD SENSE - PCM	8I-3	INSPECTION, OIL PUMP	21-211,21-382,21-557, 21-728	INSTRUMENT CLUSTER - REMOVAL	8J-10
INSIDE HANDLE ACTUATOR - INSTALLATION	23-71,23-80	INSPECTION, OTHER	30-15	INSTRUMENT PANEL ANTENNA CABLE - INSTALLATION	8A-10
INSIDE HANDLE ACTUATOR - REMOVAL	23-71, 23-80	INSPECTION, OVERDRIVE UNIT	21-224,21-394, 21-569,21-741	INSTRUMENT PANEL ANTENNA CABLE - REMOVAL	8A-9
INSPECTION - DESCRIPTION, ROAD TEST	30-15	INSPECTION, OVERRUNNING CLUTCH CAM/OVERDRIVE PISTON RETAINER	21-236, 21-406,21-580,21-752	INSTRUMENT PANEL DEMISTER DUCTS - REMOVAL	24-37
INSPECTION - DIAGNOSIS AND TESTING, WHEEL	22-10	INSPECTION, PARKING BRAKE	30-17	INSTRUMENT PANEL DUCTS - REMOVAL	24-37
INSPECTION - INFORMATION LABELS - STANDARD PROCEDURE	30-22	INSPECTION, PISTON & CONNECTING ROD	9-154,9-209,9-285,9-41,9-98	INSTRUMENT PANEL SYSTEM - DESCRIPTION	23-104
INSPECTION, 3.9L/5.2L/5.9L ENGINES - VISUAL	14-28	INSPECTION, PLANETARY GEARTRAIN/ OUTPUT SHAFT	21-241,21-411,21-587,21-760	INSTRUMENT PANEL SYSTEM - INSTALLATION	23-107
INSPECTION, 8.0L ENGINE - VISUAL	14-32	INSPECTION, PUSHRODS	9-250	INSTRUMENT PANEL SYSTEM - OPERATION	23-105
INSPECTION, A/C COMPRESSOR CLUTCH	24-16	INSPECTION, RADIATOR - 3.9L/5.2L/5.9L	7-61	INSTRUMENT PANEL SYSTEM - REMOVAL	23-106
INSPECTION, ACCUMULATOR	21-192,21-363, 21-538,21-708	INSPECTION, RADIATOR - 5.9L DIESEL	7-65	INSTRUMENT PANEL TOP COVER - INSTALLATION	23-115
INSPECTION, AUTOMATIC TRANSMISSION - 42RE	21-165	INSPECTION, RADIATOR - 8.0L	7-62	INSTRUMENT PANEL TOP COVER - REMOVAL	23-114
INSPECTION, AUTOMATIC TRANSMISSION - 44RE	21-337	INSPECTION, RADIATOR FAN - 3.9L/5.2L/5.9L/8.0L	7-43	INTAKE AIR HEATER - DESCRIPTION	14-100
INSPECTION, AUTOMATIC TRANSMISSION - 46RE	21-510	INSPECTION, RADIATOR FAN - 5.9L DIESEL	7-44	INTAKE AIR HEATER - INSTALLATION	14-101
INSPECTION, AUTOMATIC TRANSMISSION - 47RE	21-681	INSPECTION, RADIATOR PRESSURE CAP	7-66	INTAKE AIR HEATER - OPERATION	14-100
INSPECTION, BATTERY	30-7	INSPECTION, RADIO	30-17	INTAKE AIR HEATER - REMOVAL	14-100
INSPECTION, BATTERY SYSTEM	8F-5	INSPECTION, REAR CLUTCH	21-248,21-419, 21-593,21-765	INTAKE AIR HEATER RELAY - DESCRIPTION	14-101
INSPECTION, BODY SEALING	30-10	INSPECTION, RECEIVING	30-3	INTAKE AIR HEATER RELAY - INSTALLATION	14-102
INSPECTION, CAMSHAFT & BEARINGS (IN BLOCK)	9-272	INSPECTION, ROCKER ARM / ADJUSTER ASSY	9-262	INTAKE AIR HEATER RELAY - OPERATION	14-102
INSPECTION, CATALYTIC CONVERTER - 3.9L/5.2L/5.9L	11-5	INSPECTION, SEAT BELTS, SHOULDER BELTS, RETRACTORS AND HEAD RESTRAINTS	30-12	INTAKE AIR HEATER RELAY - REMOVAL	14-102
INSPECTION, CATALYTIC CONVERTER - 5.9L HEAVY DUTY/8.0L	11-7	INSPECTION, SEATS	30-13	INTAKE MANIFOLD - CLEANING	9-110,9-166, 9-223,9-302,9-53
INSPECTION, CHARGE AIR COOLER AND PLUMBING	11-18	INSPECTION, SERVICE BRAKES	30-17	INTAKE MANIFOLD - DESCRIPTION	9-109,9-165, 9-222,9-52
INSPECTION, COMPASS	30-12	INSPECTION, SHIFT/CLUTCH INTERLOCK SYSTEM	30-19	INTAKE MANIFOLD - INSPECTION	9-110,9-166, 9-223,9-302,9-53
INSPECTION, CROSSHEADS	9-250	INSPECTION, SOLID LIFTERS/TAPPETS	9-281	INTAKE MANIFOLD - INSTALLATION	9-111, 9-166,9-223,9-302,9-53
INSPECTION, CYLINDER HEAD	9-137,9-193, 9-23,9-250,9-80	INSPECTION, SPEED CONTROL	30-17	INTAKE MANIFOLD - OPERATION	9-109,9-165, 9-52
INSPECTION, CYLINDER HEAD COVER(S)	9-138, 9-194,9-24,9-253,9-81	INSPECTION, SQUEAKS, RATTLES AND WIND NOISE	30-15	INTAKE MANIFOLD - REMOVAL	9-110,9-166, 9-222,9-301,9-53
INSPECTION, DISC BRAKE CALIPERS	5-12	INSPECTION, STEERING AND HANDLING	30-15	INTAKE MANIFOLD LEAKAGE - DIAGNOSIS AND TESTING	9-110,9-165,9-222, 9-53
INSPECTION, DOORS AND DOOR LOCKS	30-11	INSPECTION, TAILPIPE - 3.9L/5.2L/5.9L	11-11	INTAKE/EXHAUST VALVES & SEATS - CLEANING	9-140,9-198,9-27,9-84
INSPECTION, DRUM	5-33	INSPECTION, TAILPIPE - 5.9L DIESEL	11-12	INTAKE/EXHAUST VALVES & SEATS - DESCRIPTION	9-138,9-195,9-25,9-253,9-81
INSPECTION, ENGINE BLOCK	9-142,9-200,9-267, 9-28,9-86	INSPECTION, TAILPIPE - 5.9L HEAVY DUTY/8.0L	11-12	INTAKE/EXHAUST VALVES & SEATS - INSPECTION	9-141,9-198,9-27,9-84
INSPECTION, ENGINE PERFORMANCE	30-16	INSPECTION, TIRE PRESSURES	30-8	INTAKE/EXHAUST VALVES & SEATS - INSTALLATION	9-141,9-260,9-28,9-85
INSPECTION, EXHAUST MANIFOLD	9-112,9-168, 9-225,9-304,9-55	INSPECTION, TRANSFER CASE - NV231HD	21-832	INTAKE/EXHAUST VALVES & SEATS - REMOVAL	9-140,9-258,9-27,9-84
INSPECTION, EXHAUST PIPE - 3.9L/5.2L/5.9L	11-7	INSPECTION, TRANSFER CASE - NV241HD	21-902	INTAKE/EXHAUST VALVES & SEATS - STANDARD PROCEDURE- VALVES, GUIDES AND SPRINGS	9-253
INSPECTION, EXHAUST PIPE - 5.9L DIESEL	11-9	INSPECTION, TRANSFER CASE - NV241LD	21-867		
INSPECTION, EXHAUST PIPE - 5.9L HEAVY DUTY/8.0L	11-9	INSPECTION, TRANSMISSION	21-109,21-64		
INSPECTION, FIT AND FINISH	30-10,30-12	INSPECTION, TRANSMISSION/TRANSFER CASE	30-15		
INSPECTION, FLUID LEVELS	30-4	INSPECTION, TRIP COMPUTER/ MAINTENANCE REMINDER	30-17		
INSPECTION, FRONT CLUTCH	21-205,21-376, 21-550,21-721	INSPECTION, TURBOCHARGER	11-16		
		INSPECTION, TURN AND EMERGENCY SIGNALS	30-19		



Description	Group-Page	Description	Group-Page	Description	Group-Page
INTAKE/EXHAUST VALVES & SEATS - VALVE SERVICE	9-195	KNUCKLE - REMOVAL	2-10,2-20	LATCH - LOWER - INSTALLATION	23-80
IN-TANK TRANSMISSION OIL COOLER - STANDARD PROCEDURE, FLUSHING COOLER AND TUBES - WITHOUT RADIATOR	7-80,7-83,7-86	LABEL - DESCRIPTION, VECI	Intro.-10	LATCH - LOWER - REMOVAL	23-80
IN-TANK TRANSMISSION OIL COOLER - STANDARD PROCEDURE, FLUSHING COOLERS AND TUBES - WITH RADIATOR	7-79,7-83,7-85	LABEL - DESCRIPTION, VEHICLE SAFETY CERTIFICATION	Intro.-10	LATCH - REMOVAL	23-100,23-64,23-72
INTERIOR - CAUTION	23-118	LABEL - OPERATION, VECI	Intro.-12	LATCH - REMOVAL, SAFETY	23-102
INTERLOCK SYSTEM - INSPECTION, SHIFT/CLUTCH	30-19	LABELS - STANDARD PROCEDURE, INSPECTION - INFORMATION	30-22	LATCH - UPPER - INSTALLATION	23-81
INTERMEDIATE - INSTALLATION, AXLE SHAFTS	3-28	LAMP - DESCRIPTION, READING	8L-36	LATCH - UPPER - REMOVAL	23-81
INTERMEDIATE - REMOVAL, AXLE SHAFTS	3-28	LAMP - DESCRIPTION, TAIL	8L-29	LATCH AND KEEPER - INSTALLATION, BACKLITE	23-146
INTERMEDIATE AXLE - INSTALLATION	3-61	LAMP - DIAGNOSIS AND TESTING, FOG	8L-9	LATCH AND KEEPER - REMOVAL, BACKLITE	23-146
INTERMEDIATE AXLE - REMOVAL	3-60	LAMP - INSTALLATION, CENTER HIGH MOUNTED STOP	8L-6	LATCH HANDLE - INSTALLATION	23-65
INTERNATIONAL SYMBOLS - DESCRIPTION	Intro.-6	LAMP - INSTALLATION, CLEARANCE	8L-6	LATCH HANDLE - REMOVAL	23-65
INTERNATIONAL SYMBOLS - DESCRIPTION	0-3	LAMP - INSTALLATION, DOME	8L-33	LATCH RELEASE CABLE - INSTALLATION	23-101
INTRODUCTION - DIAGNOSIS AND TESTING, ENGINE DIAGNOSIS	9-118,9-173,9-3	LAMP - INSTALLATION, FOG	8L-11	LATCH RELEASE CABLE - REMOVAL	23-101
INTRODUCTION - DIAGNOSIS AND TESTING-ENGINE DIAGNOSIS	9-61	LAMP - INSTALLATION, LICENSE PLATE	8L-22	LATCH STRIKER - ADJUSTMENT	23-102
INVERTED FLARING - STANDARD PROCEDURE, DOUBLE	5-8	LAMP - INSTALLATION, MARKER	8L-23	LATCH STRIKER - INSTALLATION	23-102,23-65,23-73
IOD FUSE - DESCRIPTION	8W-97-4	LAMP - INSTALLATION, OUTBOARD IDENTIFICATION	8L-29	LATCH STRIKER - INSTALLATION, GLOVE BOX	23-113
IOD FUSE - INSTALLATION	8W-97-5	LAMP - INSTALLATION, PARK/TURN SIGNAL	8L-29	LATCH STRIKER - LOWER - INSTALLATION	23-82
IOD FUSE - OPERATION	8W-97-5	LAMP - INSTALLATION, READING	8L-36	LATCH STRIKER - LOWER - REMOVAL	23-82
IOD FUSE - REMOVAL	8W-97-5	LAMP - INSTALLATION, TAIL	8L-30	LATCH STRIKER - REMOVAL	23-102,23-65,23-73
ISO FLARING - STANDARD PROCEDURE	5-8	LAMP - INSTALLATION, UNDERHOOD	8L-32	LATCH STRIKER - REMOVAL, GLOVE BOX	23-113
ITEMS - INSTALLATION, SHIPPED LOOSE	30-14	LAMP - INSTALLATION, VANITY	8L-37	LATCH STRIKER - UPPER - INSTALLATION	23-82
JOINT - DIAGNOSIS AND TESTING, LOWER BALL	2-10	LAMP - OPERATION, READING	8L-36	LATCH STRIKER - UPPER - REMOVAL	23-82
JOINT - DIAGNOSIS AND TESTING, UPPER BALL	2-12	LAMP - OPERATION, TAIL	8L-29	LATCH/SAFETY CATCH - INSPECTION, HOOD	30-4
JOINT - INSTALLATION, LOWER BALL	2-25	LAMP - REMOVAL, CENTER HIGH MOUNTED STOP	8L-6	LEAK - DIAGNOSIS AND TESTING, CONVERTER HOUSING FLUID	21-148,21-319,21-491,21-662
JOINT - INSTALLATION, UPPER BALL	2-25	LAMP - REMOVAL, CLEARANCE	8L-6	LEAK DETECTION PUMP - DESCRIPTION	25-33
JOINT MOLDING - INSTALLATION, ROOF	23-91	LAMP - REMOVAL, DOME	8L-33	LEAK DETECTION PUMP - INSTALLATION	25-34
JOINT MOLDING - REMOVAL, ROOF	23-91	LAMP - REMOVAL, FOG	8L-11	LEAK DETECTION PUMP - REMOVAL	25-34
JOINTS - DISASSEMBLY, SINGLE CARDAN UNIVERSAL	3-11	LAMP - REMOVAL, LICENSE PLATE	8L-22	LEAK DOWN TEST - DIAGNOSIS AND TESTING, FUEL PRESSURE	14-2
JOINTS - INSTALLATION, SINGLE CARDAN UNIVERSAL	3-34,3-66	LAMP - REMOVAL, MARKER	8L-22	LEAKAGE - DIAGNOSIS AND TESTING, CYLINDER COMBUSTION PRESSURE	9-124,9-179,9-67,9-9
JOINTS - REMOVAL, SINGLE CARDAN UNIVERSAL	3-33,3-65	LAMP - REMOVAL, OUTBOARD IDENTIFICATION	8L-28	LEAKAGE - DIAGNOSIS AND TESTING, INTAKE MANIFOLD	9-110,9-165,9-222,9-53
JOUNCE BUMPER - DESCRIPTION	2-28,2-9	LAMP - REMOVAL, PARK/TURN SIGNAL	8L-29	LEAKAGE - DIAGNOSIS AND TESTING, POWER STEERING GEAR	19-14
JOUNCE BUMPER - OPERATION	2-28,2-9	LAMP - REMOVAL, READING	8L-36	LEAKAGE - DIAGNOSIS AND TESTING, PUMP	19-31
JOURNAL CLEARANCE - STANDARD PROCEDURE, CONNECTING ROD BEARING AND CRANKSHAFT	9-274	LAMP - REMOVAL, TAIL	8L-29	LEAKS - DIAGNOSIS AND TESTING, COOLING SYSTEM	7-5
JUMP STARTING - STANDARD PROCEDURE	0-27	LAMP - REMOVAL, UNDERHOOD	8L-31	LEAKS - DIAGNOSIS AND TESTING, ENGINE OIL	9-104,9-160,9-215,9-47
JUNCTION BLOCK - DESCRIPTION	8W-97-6	LAMP - REMOVAL, VANITY	8L-37	LEAKS - DIAGNOSIS AND TESTING, HIGH-PRESSURE FUEL LINE	14-74
JUNCTION BLOCK - INSTALLATION	8W-97-7	LAMP AND SWITCH - INSTALLATION, GLOVE BOX	8L-35	LEAKS - DIAGNOSIS AND TESTING, REAR SEAL AREA	9-10
JUNCTION BLOCK - OPERATION	8W-97-6	LAMP AND SWITCH - REMOVAL, GLOVE BOX	8L-35	LEAKS - DIAGNOSIS AND TESTING, REFRIGERANT SYSTEM	24-43
JUNCTION BLOCK - REMOVAL	8W-97-6	LAMP (MIL) - DESCRIPTION, MALFUNCTION INDICATOR	8J-24	LEAKS - DIAGNOSIS AND TESTING, WATER	23-2
KEEPER - INSTALLATION, BACKLITE LATCH	23-146	LAMP (MIL) - OPERATION, MALFUNCTION INDICATOR	8J-24	LEAKS - STANDARD PROCEDURES, REPAIRING	22-8
KEEPER - REMOVAL, BACKLITE LATCH	23-146	LAMP MODULE - DESCRIPTION, DAYTIME RUNNING	8L-9	LEFT FRONT FENDER - INSTALLATION	23-93
KEY LOCK CYLINDER - DIAGNOSIS AND TESTING, IGNITION SWITCH	19-10	LAMP MODULE - INSTALLATION, DAYTIME RUNNING	8L-9	LEFT FRONT FENDER - REMOVAL	23-92
KEY-IN IGNITION SWITCH - DESCRIPTION	19-9	LAMP MODULE - OPERATION, DAYTIME RUNNING	8L-9	LEVEL - DIAGNOSIS AND TESTING, EFFECTS OF INCORRECT FLUID	21-199,21-370,21-545,21-715
KEYLESS ENTRY - INSPECTION	30-11	LAMP MODULE - REMOVAL, DAYTIME RUNNING	8L-9	LEVEL - STANDARD PROCEDURE, BRAKE FLUID	5-14
KEYLESS ENTRY SYSTEM - DESCRIPTION, REMOTE	8N-2	LAMP SWITCH - DESCRIPTION, BRAKE TESTING, BRAKE	8L-5	LEVEL - STANDARD PROCEDURE, CHECKING BATTERY ELECTROLYTE	8F-8
KEYLESS ENTRY SYSTEM - DIAGNOSIS AND TESTING, POWER LOCK & REMOTE	8N-4	LAMP SWITCH - INSTALLATION, BRAKE	8L-5	LEVEL - STANDARD PROCEDURE, REFRIGERANT OIL	24-57
KEYLESS ENTRY SYSTEM - OPERATION, REMOTE	8N-3	LAMP SWITCH - OPERATION, BRAKE	8L-4	LEVEL CHECK - STANDARD PROCEDURE, COOLANT	7-16
KEYLESS ENTRY TRANSMITTER - DESCRIPTION, REMOTE	8N-7	LAMP SWITCH - REMOVAL, BRAKE	8L-5	LEVEL CHECK - STANDARD PROCEDURE, FLUID	21-199,21-370,21-545,21-715
KEYLESS ENTRY TRANSMITTER - DIAGNOSIS AND TESTING, REMOTE	8N-7	LAMP UNIT - ADJUSTMENTS, FOG	8L-12	LEVEL, OIL - STANDARD PROCEDURE-ENGINE OIL	9-295
KEYLESS ENTRY TRANSMITTER - OPERATION, REMOTE	8N-7	LAMP UNIT - INSTALLATION, CENTER HIGH MOUNTED STOP	8L-6	LEVEL SENDING UNIT / SENSOR - DESCRIPTION, FUEL	14-7,14-73
KNOB - INSTALLATION, TURNING LOOP HEIGHT ADJUSTER	80-30	LAMP UNIT - INSTALLATION, FOG	8L-12	LEVEL SENDING UNIT / SENSOR - INSTALLATION, FUEL	14-9
KNOB - REMOVAL, TURNING LOOP HEIGHT ADJUSTER	80-30	LAMP UNIT - INSTALLATION, LICENSE PLATE	8L-22	LEVEL SENDING UNIT / SENSOR - OPERATION, FUEL	14-7,14-73
KNUCKLE - DESCRIPTION	2-20,2-9	LAMP UNIT - INSTALLATION, PARK/TURN SIGNAL	8L-29	LEVEL SENDING UNIT / SENSOR - REMOVAL, FUEL	14-8
KNUCKLE - INSTALLATION	2-10,2-20	LAMP UNIT - INSTALLATION, TAIL	8L-30		
KNUCKLE - OPERATION	2-10,2-20	LAMP UNIT - INSTALLATION, UNDERHOOD	8L-32		
		LAMP UNIT - REMOVAL, CENTER HIGH MOUNTED STOP	8L-6		
		LAMP UNIT - REMOVAL, FOG	8L-11		
		LAMP UNIT - REMOVAL, LICENSE PLATE	8L-22		
		LAMP UNIT - REMOVAL, PARK/TURN SIGNAL	8L-29		
		LAMP UNIT - REMOVAL, TAIL	8L-30		
		LASH ADJUSTMENT AND VERIFICATION - STANDARD PROCEDURE, VALVE	9-256		
		LATCH - ADJUSTMENT	23-100		
		LATCH - ADJUSTMENT, FRONT DOOR	23-72		
		LATCH - INSTALLATION	23-100,23-64,23-72		
		LATCH - INSTALLATION, SAFETY	23-102		

Description	Group-Page	Description	Group-Page	Description	Group-Page
LEVEL SWITCH - DESCRIPTION, WASHER FLUID	8R-7	LINKAGE - INSTALLATION	6-20	LOWER - REMOVAL, LATCH	23-80
LEVEL SWITCH - INSTALLATION, WASHER FLUID	8R-8	LINKAGE - OPERATION	6-20	LOWER - REMOVAL, LATCH STRIKER	23-82
LEVEL SWITCH - OPERATION, WASHER FLUID	8R-7	LINKAGE - REMOVAL	6-20	LOWER BALL JOINT - DIAGNOSIS AND TESTING	2-10
LEVEL SWITCH - REMOVAL, WASHER FLUID	8R-8	LINKAGE, SPECIAL TOOLS - STEERING	19-39, 19-42	LOWER BALL JOINT - INSTALLATION	2-25
LEVELS - INSPECTION, FLUID	30-4	LINK/COIL SUSPENSION - STANDARD PROCEDURES, ALIGNMENT	2-5	LOWER CONTROL ARM - INSTALLATION	2-10, 2-20
LEVER - ADJUSTMENT, SHIFT	21-853,21-888, 21-925	LINK/COIL SUSPENSION, SPECIAL TOOLS	2-16	LOWER CONTROL ARM - REMOVAL	2-10,2-20
LEVER - INSTALLATION, GEAR SHIFT	19-13	LIQUID LINE - INSTALLATION	24-52	LOWER FASCIA - INSTALLATION, FRONT	13-3
LEVER - INSTALLATION, SHIFT	21-853,21-888, 21-924	LIQUID LINE - REMOVAL	24-52	LOWER FASCIA - REMOVAL, FRONT	13-3
LEVER - REMOVAL, GEAR SHIFT	19-13	LOAD TEST - STANDARD PROCEDURE	8F-14	LUBRICANTS - STANDARD PROCEDURE, CLASSIFICATION OF	0-3
LEVER - REMOVAL, SHIFT	21-852,21-887, 21-924	LOADS - STANDARD PROCEDURE, TESTING FOR SHORT TO GROUND ON FUSES POWERING SEVERAL	8W-01-7	LUBRICATION - DESCRIPTION	9-102,9-158, 9-214,9-292,9-45
LICENSE PLATE LAMP - INSTALLATION	8L-22	LOCATIONS - DESCRIPTION, SPLICE	8W-95-1	LUBRICATION - DIAGNOSIS AND TESTING	9-123,9-178,9-66,9-8
LICENSE PLATE LAMP - REMOVAL	8L-22	LOCATIONS, SPECIFICATIONS - BODY SEALER	23-47	LUBRICATION - OPERATION	9-102,9-158,9-214, 9-292,9-45
LICENSE PLATE LAMP UNIT - INSTALLATION	8L-22	LOCATIONS, SPECIFICATIONS - STRUCTURAL ADHESIVE	23-44	LUBRICATION - STANDARD PROCEDURE	19-38, 19-40
LICENSE PLATE LAMP UNIT - REMOVAL	8L-22	LOCATIONS, SPECIFICATIONS - WELD	23-4	LUMBAR ADJUSTER - DIAGNOSIS & TESTING, POWER	8N-18
LID - INSTALLATION, CENTER CONSOLE	23-132	LOCK & REMOTE KEYLESS ENTRY SYSTEM - DIAGNOSIS AND TESTING, POWER	8N-4	LUMBAR CONTROL SWITCH - DESCRIPTION	8N-17
LID - REMOVAL, CENTER CONSOLE	23-131	LOCK - STANDARD PROCEDURE, HYDROSTATIC	9-11,9-125,9-181,9-238,9-68	LUMBAR CONTROL SWITCH - OPERATION	8N-18
LIFTERS - CLEANING, HYDRAULIC	9-152,9-208	LOCK CYLINDER - DIAGNOSIS AND TESTING, IGNITION SWITCH AND KEY	19-10	LUMBAR CONTROL SWITCH - REMOVAL	8N-18
LIFTERS - INSTALLATION, HYDRAULIC	9-152, 9-208	LOCK CYLINDER - INSTALLATION	23-73	LUMBAR MOTOR - DESCRIPTION	8N-18
LIFTERS - REMOVAL, HYDRAULIC	9-152,9-207	LOCK CYLINDER - REMOVAL	23-73	LUMBAR MOTOR - OPERATION	8N-18
LIFTERS (CAM IN BLOCK) - CLEANING, HYDRAULIC	9-39,9-96	LOCK CYLINDER HOUSING - INSTALLATION	19-11	LUMBAR SUPPORT - INSTALLATION	23-133
LIFTERS (CAM IN BLOCK) - INSTALLATION, HYDRAULIC	9-39,9-96	LOCK CYLINDER HOUSING - REMOVAL	19-10	LUMBAR SUPPORT - REMOVAL	23-133
LIFTERS (CAM IN BLOCK) - REMOVAL, HYDRAULIC	9-39,9-96	LOCK CYLINDERS - DESCRIPTION	23-1	MACHINING - STANDARD PROCEDURE, BRAKE DRUM	5-33
LIFTERS/TAPPETS - CLEANING, SOLID	9-281	LOCK MOTOR - DESCRIPTION, POWER	8N-6	MAIN BEARING CLEARANCE - STANDARD PROCEDURE	9-275
LIFTERS/TAPPETS - INSPECTION, SOLID	9-281	LOCK MOTOR - DIAGNOSIS AND TESTING, POWER	8N-7	MAIN BEARING FITTING - STANDARD PROCEDURE	9-203,9-33
LIFTERS/TAPPETS - INSTALLATION, SOLID	9-281	LOCK MOTOR - OPERATION, POWER	8N-6	MAIN BEARING FITTING - STANDARD PROCEDURE, CRANKSHAFT	9-146,9-90
LIFTERS/TAPPETS - REMOVAL, SOLID	9-280	LOCK SWITCH - DESCRIPTION, DOOR CYLINDER	8N-5	MAIN BEARINGS - DESCRIPTION, CRANKSHAFT	9-146,9-32,9-90
LIGHT DUTY ENGINE (1500 AND 2500 MODELS EXCEPT 8.0L) MAINTENANCE SCHEDULES, MAINTENANCE SCHEDULES	0-7	LOCK SWITCH - DIAGNOSIS & TESTING, DOOR CYLINDER	8N-5	MAIN BEARINGS - INSTALLATION, CRANKSHAFT	9-147,9-204,9-34,9-90
LIGHTER - DIAGNOSIS & TESTING, CIGAR	8W-97-2	LOCK SWITCH - DIAGNOSIS AND TESTING, POWER	8N-8	MAIN BEARINGS - OPERATION, CRANKSHAFT	9-146,9-32,9-90
LIGHTER OUTLET - DESCRIPTION, CIGAR	8W-97-2	LOCK SWITCH - INSTALLATION, DOOR CYLINDER	8N-6	MAIN BEARINGS - REMOVAL, CRANKSHAFT	9-147,9-204,9-33,9-90
LIGHTER OUTLET - INSTALLATION, CIGAR	8W-97-3	LOCK SWITCH - OPERATION, DOOR CYLINDER	8N-5	MAINTENANCE SCHEDULE (8.0L 2500 & 3500 MODELS - CALIFORNIA ONLY) - DESCRIPTION, MEDIUM DUTY TRUCK	0-13
LIGHTER OUTLET - OPERATION, CIGAR	8W-97-2	LOCK SWITCH - OPERATION, POWER	8N-8	MAINTENANCE SCHEDULES - 24-VALVE CUMMINS TURBO DIESEL - DESCRIPTION	0-22
LIGHTER OUTLET - REMOVAL, CIGAR	8W-97-3	LOCK SWITCH - REMOVAL, DOOR CYLINDER	8N-6	MAINTENANCE SCHEDULES - DESCRIPTION, HEAVY DUTY ENGINE (FEDERAL ONLY - 2500 8.0L HD AND 3500 5.9L& 8.0L MODELS)	0-17
LIGHTS - INSPECTION, GAUGES/ WARNING	30-19	LOCK SYSTEM - DESCRIPTION, POWER	8N-1	MAINTENANCE SCHEDULES - LIGHT DUTY ENGINE (1500 AND 2500 MODELS EXCEPT 8.0L) MAINTENANCE SCHEDULES	0-7
LIGHTS AND SWITCHES - INSPECTION	30-12	LOCK SYSTEM - DIAGNOSIS AND TESTING, POWER	8N-4	MAINTENANCE SCHEDULES, LIGHT DUTY ENGINE (1500 AND 2500 MODELS EXCEPT 8.0L)	0-7
LINE - INSTALLATION, LIQUID	24-52	LOCK SYSTEM - OPERATION, POWER	8N-3	MALFUNCTION INDICATOR LAMP (MIL) - DESCRIPTION	8J-24
LINE - INSTALLATION, SUCTION AND DISCHARGE	24-51	LOCKS - INSPECTION, DOORS AND DOOR	30-11	MALFUNCTION INDICATOR LAMP (MIL) - OPERATION	8J-24
LINE - REMOVAL, LIQUID	24-52	LOCKS - INSPECTION, WINDOWS, DOORS	30-14	MANAGER - DESCRIPTION, TASK	25-15
LINE - REMOVAL, SUCTION AND DISCHARGE	24-50	LOOP ADJUSTER - INSTALLATION, SEAT BELT TURNING	80-29	MANAGER - OPERATION, TASK	25-19
LINE COUPLERS - DESCRIPTION, A/C	24-40	LOOP ADJUSTER - REMOVAL, SEAT BELT TURNING	80-29	MANIFOLD - CLEANING, EXHAUST	9-112,9-168, 9-225,9-304,9-55
LINE COUPLERS - OPERATION, A/C	24-41	LOOP HEIGHT ADJUSTER KNOB - INSTALLATION, TURNING	80-30	MANIFOLD - CLEANING, INTAKE	9-110,9-166, 9-223,9-302,9-53
LINE COUPLERS - STANDARD PROCEDURE, A/C	24-43	LOOP HEIGHT ADJUSTER KNOB - REMOVAL, TURNING	80-30	MANIFOLD - DESCRIPTION, EXHAUST	9-112, 9-168,9-224,9-55
LINE LEAKS - DIAGNOSIS AND TESTING, HIGH-PRESSURE FUEL	14-74	LOOSE ITEMS - INSTALLATION, SHIPPED	30-14	MANIFOLD - DESCRIPTION, FUEL DRAIN	14-86
LINER - INSTALLATION, REAR WHEELHOUSE	23-96	LOW FUEL INDICATOR - DESCRIPTION	8J-23	MANIFOLD - DESCRIPTION, INTAKE	9-109, 9-165,9-222,9-52
LINER - REMOVAL, REAR WHEELHOUSE	23-96	LOW FUEL INDICATOR - OPERATION	8J-23	MANIFOLD - INSPECTION, EXHAUST	9-112, 9-168,9-225,9-304,9-55
LINES - CLEANING AND INSPECTION, OIL COOLER	9-296	LOW MOUNTED - INSTALLATION, SIDE VIEW MIRROR	23-98	MANIFOLD - INSPECTION, INTAKE	9-110,9-166, 9-223,9-302,9-53
LINES - DESCRIPTION, FUEL	14-73,14-9	LOW MOUNTED - REMOVAL, SIDE VIEW MIRROR	23-98	MANIFOLD - INSTALLATION, EXHAUST	9-113, 9-168,9-225,9-304,9-55
LINES - DESCRIPTION, HIGH PRESSURE FUEL	14-74	LOW PRESSURE SWITCH - DESCRIPTION, A/C	24-21	MANIFOLD - INSTALLATION, FUEL DRAIN	14-86
LINES - INSTALLATION, FUEL	14-77	LOW PRESSURE SWITCH - DIAGNOSIS AND TESTING, A/C	24-21		
LINES - OPERATION, HIGH PRESSURE FUEL	14-74	LOW PRESSURE SWITCH - INSTALLATION, A/C	24-22		
LINES - REMOVAL, FUEL	14-75	LOW PRESSURE SWITCH - OPERATION, A/C	24-21		
LINES/HOSES - INSPECTION	30-6	LOW PRESSURE SWITCH - REMOVAL, A/C	24-21		
LINK CONNECTOR - DESCRIPTION, DATA	8E-12	LOWER - INSTALLATION, LATCH	23-80		
LINK CONNECTOR - OPERATION, DATA	8E-12	LOWER - INSTALLATION, LATCH STRIKER	23-82		
LINKAGE - 2WD - DESCRIPTION	19-38				
LINKAGE - 2WD - INSTALLATION	19-39				
LINKAGE - 2WD - REMOVAL	19-38				
LINKAGE - 4WD - DESCRIPTION	19-40				
LINKAGE - 4WD - INSTALLATION	19-41				
LINKAGE - 4WD - REMOVAL	19-40				
LINKAGE - DESCRIPTION	6-19				



Description	Group-Page	Description	Group-Page	Description	Group-Page
MANIFOLD - INSTALLATION, INTAKE	9-111, 9-166,9-223,9-302,9-53	MIRROR - OPERATION, SIDEVIEW	8N-13	MOLEX - INSTALLATION, CONNECTOR	8W-01-9
MANIFOLD - OPERATION, EXHAUST	9-112, 9-168,9-224,9-55	MIRROR - REMOVAL, AUTOMATIC DAY / NIGHT	8N-12	MOLEX - REMOVAL, CONNECTOR	8W-01-9
MANIFOLD - OPERATION, FUEL DRAIN	14-86	MIRROR - REMOVAL, REAR VIEW	23-126	MONITORED SYSTEMS - DESCRIPTION	25-15
MANIFOLD - OPERATION, INTAKE	9-109,9-165, 9-52	MIRROR - REMOVAL, SIDE VIEW	23-97	MONITORS - DIESEL ENGINES - DESCRIPTION, COMPONENT	25-18
MANIFOLD - REMOVAL, EXHAUST	9-112,9-168, 9-225,9-303,9-55	MIRROR - REMOVAL, SIDEVIEW	8N-14	MONITORS - GAS ENGINES - DESCRIPTION, COMPONENT	25-18
MANIFOLD - REMOVAL, FUEL DRAIN	14-86	MIRROR FLAG - INSTALLATION, SIDE VIEW	23-74	MOTOR - ASSEMBLY, AXLE VACUUM	3-33,3-65
MANIFOLD - REMOVAL, INTAKE	9-110,9-166, 9-222,9-301,9-53	MIRROR FLAG - REMOVAL, SIDE VIEW	23-74	MOTOR - DESCRIPTION, AXLE VACUUM	3-29, 3-62
MANIFOLD LEAKAGE - DIAGNOSIS AND TESTING, INTAKE	9-110,9-165,9-222,9-53	MIRROR GLASS - INSTALLATION, SIDE VIEW	23-98	MOTOR - DESCRIPTION, BLOWER	24-32
MANUAL BLEEDING - STANDARD PROCEDURE	5-7	MIRROR GLASS - REMOVAL, SIDE VIEW	23-98	MOTOR - DESCRIPTION, ENGINE STARTER	8F-39
MANUAL, NV3500	21-41	MIRROR GRID - DESCRIPTION, HEATED	8G-4	MOTOR - DESCRIPTION, IDLE AIR CONTROL	14-41
MANUAL, NV4500	21-83	MIRROR GRID - DIAGNOSIS AND TESTING, HEATED	8G-4	MOTOR - DESCRIPTION, LUMBAR	8N-18
MANUAL TRANSMISSION - DIAGNOSIS AND TESTING	21-3,21-46,21-93	MIRROR GRID - OPERATION, HEATED	8G-4	MOTOR - DESCRIPTION, POWER LOCK	8N-6
MANUAL TRANSMISSION - INSTALLATION, SHIFT BOOT	23-122	MIRROR SUPPORT BRACKET - INSTALLATION, REARVIEW	23-126	MOTOR - DESCRIPTION, RECLINER	8N-20
MANUAL TRANSMISSION - REMOVAL, SHIFT BOOT	23-122	MIRROR SWITCH - DESCRIPTION	8G-3	MOTOR - DESCRIPTION, WINDOW	8N-26
MANUAL TRANSMISSION, SPECIAL TOOLS - NV5600	21-127	MIRROR SWITCH - DESCRIPTION, POWER	8N-12	MOTOR - DIAGNOSIS AND TESTING, BLOWER	24-33
MAP SENSOR - INSTALLATION	14-104	MIRROR SWITCH - DIAGNOSIS AND TESTING, HEATED	8G-3	MOTOR - DIAGNOSIS AND TESTING, POWER LOCK	8N-7
MARKER LAMP - INSTALLATION	8L-23	MIRROR SWITCH - INSTALLATION, POWER	8N-13	MOTOR - DIAGNOSIS AND TESTING, STARTER	8F-39
MARKER LAMP - REMOVAL	8L-22	MIRROR SWITCH - OPERATION	8G-3	MOTOR - DIAGNOSIS AND TESTING, VACUUM	3-31,3-63
MASTER CYLINDER - DESCRIPTION	5-29	MIRROR SWITCH - OPERATION, POWER	8N-12	MOTOR - DIAGNOSIS AND TESTING, WINDOW	8N-26
MASTER CYLINDER - INSTALLATION	5-30	MIRROR SWITCH - REMOVAL, POWER	8N-12	MOTOR - DISASSEMBLY, AXLE VACUUM	3-33, 3-65
MASTER CYLINDER - OPERATION	5-29	MIRROR SYSTEM - DESCRIPTION, HEATED	8G-1	MOTOR - INSTALLATION, AXLE VACUUM	3-33, 3-65
MASTER CYLINDER - REMOVAL	5-30	MIRROR SYSTEM - DIAGNOSIS AND TESTING, HEATED	8G-2	MOTOR - INSTALLATION, BLOWER	24-33
MASTER CYLINDER BLEEDING - STANDARD PROCEDURE	5-30	MIRROR SYSTEM - OPERATION, HEATED	8G-2	MOTOR - INSTALLATION, ENGINE STARTER	8F-41
MASTER CYLINDER/POWER BOOSTER - DIAGNOSIS AND TESTING	5-29	MIRRORS - DESCRIPTION, POWER	8N-10	MOTOR - OPERATION, AXLE VACUUM	3-30,3-62
MATCH MOUNTING - STANDARD PROCEDURES	22-2	MIRRORS - OPERATION, POWER	8N-10	MOTOR - OPERATION, BLOWER	24-32
MATS - INSTALLATION, CARPETS AND FLOOR	23-123	MODE - DESCRIPTION, CIRCUIT ACTUATION TEST	25-1	MOTOR - OPERATION, ENGINE STARTER	8F-39
MATS - REMOVAL, CARPETS AND FLOOR	23-123	MODE - DESCRIPTION, STATE DISPLAY TEST	25-1	MOTOR - OPERATION, IDLE AIR CONTROL	14-41
MEASUREMENT - STANDARD PROCEDURES, CASTER CORRECTION	2-3	Modes of Operation - Description	8E-14	MOTOR - OPERATION, LUMBAR	8N-18
MEASUREMENTS, SPECIFICATIONS - BODY GAP AND FLUSH	23-56	MODULE - DESCRIPTION, AIRBAG CONTROL	80-6	MOTOR - OPERATION, POWER LOCK	8N-6
MEASURING TIMING CHAIN STRETCH - INSPECTION	9-114,9-170,9-227,9-58	MODULE - DESCRIPTION, BODY CONTROL/CENTRAL TIMER	8E-1	MOTOR - OPERATION, RECLINER	8N-21
MECHANICAL - DIAGNOSIS AND TESTING	9-120,9-175,9-6,9-63	MODULE - DESCRIPTION, DAYTIME RUNNING LAMP	8L-9	MOTOR - REMOVAL, AXLE VACUUM	3-33,3-65
MECHANICAL - DIAGNOSIS AND TESTING, ENGINE DIAGNOSIS	9-232	MODULE - DESCRIPTION, FUEL PUMP	14-12	MOTOR - REMOVAL, BLOWER	24-33
MECHANISM - ADJUSTMENT, SHIFT	21-252, 21-423,21-596,21-769	MODULE - DESCRIPTION, FUEL TANK	14-78	MOTOR - REMOVAL, ENGINE STARTER	8F-40
MECHANISM - DESCRIPTION, SHIFT	21-251, 21-422,21-595,21-768	MODULE - DESCRIPTION, WIPER	8R-14	MOTOR - REMOVAL, WINDOW	8N-26
MECHANISM - INSTALLATION, SHIFT	21-89	MODULE - DIAGNOSIS AND TESTING, CENTRAL TIMER	8E-4	MOTOR RELAY - DESCRIPTION, BLOWER	24-22
MECHANISM - OPERATION, SHIFT	21-251, 21-422,21-595,21-768	MODULE - INSTALLATION, AIRBAG CONTROL	80-8	MOTOR RELAY - DESCRIPTION, ENGINE STARTER	8F-42
MECHANISM - REMOVAL, SHIFT	21-88	MODULE - INSTALLATION, BODY CONTROL/CENTRAL TIMER	8E-6	MOTOR RELAY - DIAGNOSIS AND TESTING, BLOWER	24-22
MEDIUM DUTY TRUCK MAINTENANCE SCHEDULE (8.0L 2500 & 3500 MODELS - CALIFORNIA ONLY) - DESCRIPTION	0-13	MODULE - INSTALLATION, DAYTIME RUNNING LAMP	8L-9	MOTOR RELAY - INSTALLATION, BLOWER	24-23
METRIC SYSTEM - DESCRIPTION	Intro-6	MODULE - INSTALLATION, ENGINE CONTROL	8E-14	MOTOR RELAY - INSTALLATION, ENGINE STARTER	8F-43
MILE, SPECIFICATIONS - TIRE REVOLUTIONS PER	22-9	MODULE - INSTALLATION, FUEL PUMP	14-13	MOTOR RELAY - OPERATION, BLOWER	24-22
MINI-TRIP COMPUTER - DIAGNOSIS & TESTING, COMPASS	8M-10	MODULE - INSTALLATION, FUEL TANK	14-79	MOTOR RELAY - OPERATION, ENGINE STARTER	8F-42
MIRROR - DESCRIPTION, AUTOMATIC DAY / NIGHT	8N-10	MODULE - INSTALLATION, POWERTRAIN CONTROL	8E-20	MOTOR RELAY - REMOVAL, BLOWER	24-23
MIRROR - DESCRIPTION, SIDEVIEW	8N-13	MODULE - INSTALLATION, WIPER	8R-15	MOTOR RELAY - REMOVAL, ENGINE STARTER	8F-43
MIRROR - DIAGNOSIS AND TESTING, AUTOMATIC DAY/NIGHT	8N-11	MODULE - OPERATION, AIRBAG CONTROL	80-7	MOTOR RESISTOR BLOCK - DESCRIPTION, BLOWER	24-23
MIRROR - DIAGNOSIS AND TESTING, SIDEVIEW	8N-13	MODULE - OPERATION, AIRBAG CONTROL/ CENTRAL TIMER	8E-5	MOTOR RESISTOR BLOCK - DIAGNOSIS AND TESTING, BLOWER	24-24
MIRROR - INSPECTION	30-19	MODULE - REMOVAL, DAYTIME RUNNING LAMP	8L-9	MOTOR RESISTOR BLOCK - INSTALLATION, BLOWER	24-24
MIRROR - INSTALLATION, AUTOMATIC DAY / NIGHT	8N-12	MODULE - REMOVAL, DAYTIME RUNNING LAMP	8L-9	MOTOR RESISTOR BLOCK - OPERATION, BLOWER	24-23
MIRROR - INSTALLATION, REAR VIEW	23-126	MODULE - REMOVAL, ENGINE CONTROL	8E-14	MOTOR RESISTOR BLOCK - REMOVAL, BLOWER	24-24
MIRROR - INSTALLATION, SIDE VIEW	23-97	MODULE - REMOVAL, FUEL PUMP	14-13	MOTOR SWITCH - DESCRIPTION, BLOWER	24-24
MIRROR - LOW MOUNTED - INSTALLATION, SIDE VIEW	23-98	MODULE - REMOVAL, FUEL TANK	14-78	MOTOR SWITCH - DIAGNOSIS AND TESTING, BLOWER	24-25
MIRROR - LOW MOUNTED - REMOVAL, SIDE VIEW	23-98	MODULE - REMOVAL, FUEL TANK	14-78	MOTOR SWITCH - OPERATION, BLOWER	24-25
MIRROR - OPERATION, AUTOMATIC DAY / NIGHT	8N-11	MODULE - REMOVAL, POWERTRAIN CONTROL	8E-19	MOUNT - INSTALLATION, FRONT	9-100,9-156, 9-213,9-290,9-43
		MODULE - REMOVAL, WIPER	8R-14	MOUNT - INSTALLATION, REAR	9-101,9-158, 9-213,9-291,9-44
		MOLDING - INSTALLATION, ROOF JOINT	23-91	MOUNT - REMOVAL, FRONT	9-100,9-156,9-213, 9-290,9-43
		MOLDING - REMOVAL, ROOF JOINT	23-91	MOUNT - REMOVAL, REAR	9-101,9-157,9-213, 9-291,9-44
		MOLDINGS - INSTALLATION, BODY SIDE	23-87		
		MOLDINGS - REMOVAL, BODY SIDE	23-87		

Description	Group-Page	Description	Group-Page	Description	Group-Page
MOUNTED - INSTALLATION, SIDE VIEW		NV241HD - CLEANING, TRANSFER CASE	21-902	OIL COOLER - STANDARD PROCEDURE,	
MIRROR - LOW	23-98	NV241HD - DESCRIPTION, TRANSFER		FLUSHING COOLERS AND TUBES -	
MOUNTED - REMOVAL, SIDE VIEW		CASE	21-890	WITH RADIATOR IN-TANK	
MIRROR - LOW	23-98	NV241HD - DISASSEMBLY, TRANSFER		TRANSMISSION	7-79,7-83,7-85
MOUNTED STOP LAMP - INSTALLATION,		CASE	21-894	OIL FILTER - INSTALLATION	9-105,9-161,9-218,
CENTER HIGH	8L-6	NV241HD - INSPECTION, TRANSFER			9-296,9-48
MOUNTED STOP LAMP - REMOVAL,		CASE	21-902	OIL FILTER - REMOVAL	9-105,9-161,9-218,
CENTER HIGH	8L-6	NV241HD - INSTALLATION, TRANSFER			9-296,9-48
MOUNTED STOP LAMP UNIT -		CASE	21-919	OIL LEAKS - DIAGNOSIS AND TESTING,	
INSTALLATION, CENTER HIGH	8L-6	NV241HD - OPERATION, TRANSFER		ENGINE	9-104,9-160,9-215,9-47
MOUNTED STOP LAMP UNIT -		CASE	21-892	OIL LEVEL - STANDARD PROCEDURE,	
REMOVAL, CENTER HIGH	8L-6	NV241HD - REMOVAL, TRANSFER CASE	21-894	REFRIGERANT	24-57
MOUNTING - STANDARD PROCEDURES,		NV241HD - TRANSFER CASE	21-920	OIL LEVEL, OIL - STANDARD	
MATCH	22-2	NV241LD - ASSEMBLY, TRANSFER CASE	21-869	PROCEDURE-ENGINE	9-295
MUFFLER - 3.9L/5.2L/5.9L/8.0L -		NV241LD - CLEANING, TRANSFER CASE	21-866	OIL PAN - CLEANING	9-106,9-162,9-218,9-297,
INSTALLATION	11-11	NV241LD - DESCRIPTION, TRANSFER			9-49
MUFFLER - 3.9L/5.2L/5.9L/8.0L -		CASE	21-855	OIL PAN - INSPECTION	9-106,9-162,9-219,
REMOVAL	11-10	NV241LD - DISASSEMBLY, TRANSFER			9-297,9-49
MUFFLER - 5.9L DIESEL - INSTALLATION	11-11	CASE	21-858	OIL PAN - INSTALLATION	9-106,9-162,9-219,
MUFFLER - 5.9L DIESEL - REMOVAL	11-11	NV241LD - INSPECTION, TRANSFER			9-297,9-49
MULTI-FUNCTION SWITCH -		CASE	21-867	OIL PAN - REMOVAL	9-105,9-161,9-218,9-296,
DESCRIPTION	8L-23	NV241LD - INSTALLATION, TRANSFER			9-48
MULTI-FUNCTION SWITCH - DIAGNOSIS		CASE	21-882	OIL PRESSURE - DIAGNOSIS AND	
AND TESTING	8L-25	NV241LD - OPERATION, TRANSFER		TESTING, ENGINE	9-104,9-160,9-215,9-295,9-47
MULTI-FUNCTION SWITCH -		CASE	21-855	OIL PRESSURE GAUGE - DESCRIPTION	8J-25
INSTALLATION	8L-28	NV241LD - REMOVAL, TRANSFER CASE	21-858	OIL PRESSURE GAUGE - OPERATION	8J-26
MULTI-FUNCTION SWITCH - OPERATION	8L-24	NV241LD - TRANSFER CASE	21-884	OIL PRESSURE RELIEF VALVE -	
MULTI-FUNCTION SWITCH - REMOVAL	8L-27	NV3500 - MANUAL	21-17	CLEANING	9-297
NAME PLATES - INSTALLATION,		NV3500 - CLEANING, MANUAL	21-15	OIL PRESSURE RELIEF VALVE -	
EXTERIOR	23-89	NV3500 - DESCRIPTION, MANUAL	21-1	INSPECTION	9-297
NAME PLATES - REMOVAL, EXTERIOR	23-89	NV3500 - DISASSEMBLY, MANUAL	21-5	OIL PRESSURE RELIEF VALVE -	
NECK SEAL - DIAGNOSIS AND TESTING,		NV3500 - INSPECTION, MANUAL	21-15	INSTALLATION	9-298
RADIATOR CAP-TO-FILLER	7-66	NV3500 - INSTALLATION, MANUAL	21-40	OIL PRESSURE RELIEF VALVE -	
NEGATIVE CABLE INSTALLATION,		NV3500 - MANUAL	21-41	REMOVAL	9-297
GASOLINE	8F-24	NV3500 - OPERATION, MANUAL	21-1	OIL PRESSURE SENSOR/SWITCH -	
NEGATIVE CABLE REMOVAL, GASOLINE	8F-23	NV3500 - REMOVAL, MANUAL	21-3	DESCRIPTION	9-298,9-49
NEUTRAL SAFETY SWITCH -		NV4500 - ASSEMBLY, MANUAL	21-65	OIL PRESSURE SENSOR/SWITCH -	
INSPECTION	30-19	NV4500 - CLEANING, MANUAL	21-64	INSTALLATION	9-299
NEW VEHICLE PREPARATION -		NV4500 - DESCRIPTION, MANUAL	21-44	OIL PRESSURE SENSOR/SWITCH -	
DESCRIPTION, THE IMPORTANCE OF	30-1	NV4500 - DISASSEMBLY, MANUAL	21-48	OPERATION	9-298,9-49
CAREFUL		NV4500 - INSTALLATION, MANUAL	21-82	OIL PRESSURE SENSOR/SWITCH -	
NEW VEHICLE PREPARATION FORM,		NV4500 - MANUAL	21-83	REMOVAL	9-298
FINAL STEPS	30-22	NV4500 - OPERATION, MANUAL	21-46	OIL PUMP - ASSEMBLE	9-109,9-165
NIGHT MIRROR - DESCRIPTION,		NV4500 - REMOVAL, MANUAL	21-47	OIL PUMP - ASSEMBLY	9-51
AUTOMATIC DAY	8N-10	NV4500 - SPECIFICATIONS	21-83	OIL PUMP - ASSEMBLY	21-212,21-382,21-558,
NIGHT MIRROR - INSTALLATION,		NV5600 - ASSEMBLY, MANUAL	21-110		21-729
AUTOMATIC DAY	8N-12	NV5600 - DESCRIPTION, MANUAL	21-91	OIL PUMP - CLEANING	9-220,9-299,9-50
NIGHT MIRROR - OPERATION,		NV5600 - DISASSEMBLY, MANUAL	21-95	OIL PUMP - CLEANING	21-211,21-381,21-557,
AUTOMATIC DAY	8N-11	NV5600 - INSTALLATION, MANUAL	21-125		21-728
NIGHT MIRROR - REMOVAL,		NV5600 - OPERATION, MANUAL	21-93	OIL PUMP - DESCRIPTION	21-208,21-379,
AUTOMATIC DAY	8N-12	NV5600 - REMOVAL, MANUAL	21-94		21-554,21-724
NOISE - DIAGNOSIS AND TESTING,		NV5600 - SPECIFICATIONS	21-126	OIL PUMP - DISASSEMBLE	9-107,9-163,9-50
WIND	23-3	NV5600 MANUAL TRANSMISSION,		OIL PUMP - DISASSEMBLY	21-209,21-380,
NOISE - INSPECTION, SQUEAKS,		SPECIAL TOOLS	21-127		21-555,21-726
RATTLES AND WIND	30-15	O2 SENSOR - DESCRIPTION	14-46	OIL PUMP - INSPECTION	9-107,9-163,9-220,
NOISE OR VIBRATION - DIAGNOSIS AND		O2 SENSOR - INSTALLATION	14-48		9-299,9-50
TESTING, TIRE	22-8	O2 SENSOR - OPERATION	14-46	OIL PUMP - INSPECTION	21-211,21-382,21-557,
NOISE SUPPRESSION COMPONENTS -		O2 SENSOR - REMOVAL	14-47		21-728
DESCRIPTION, RADIO	8A-12	ODOMETER - DESCRIPTION	8J-24	OIL PUMP - INSTALLATION	9-109,9-165,9-221,
NOISE SUPPRESSION COMPONENTS -		ODOMETER - OPERATION	8J-25		9-300,9-52
DIAGNOSIS AND TESTING, RADIO	8A-12	OFF INDICATOR - DESCRIPTION,		OIL PUMP - OPERATION	21-208,21-379,21-554,
NON-DEPLOYED AIRBAGS - STANDARD		OVERDRIVE	8J-27		21-724
PROCEDURE, HANDLING	80-4	OFF INDICATOR - OPERATION,		OIL PUMP - REMOVAL	9-107,9-162,9-219,
NON-MONITORED CIRCUITS - DIESEL -		OVERDRIVE	8J-27		9-299,9-50
OPERATION	25-23	OFF SWITCH - DESCRIPTION,		OIL PUMP VOLUME CHECK - STANDARD	
NON-MONITORED CIRCUITS - GAS		OVERDRIVE	21-215	PROCEDURE	21-209,21-379,21-554,21-724
ENGINES - OPERATION	25-22	OFF SWITCH - INSTALLATION,		OIL SEAL - FRONT - DESCRIPTION,	
NOZZLE - DESCRIPTION, WASHER	8R-9	OVERDRIVE	21-215	CRANKSHAFT	9-147,9-34,9-91
NOZZLE - INSTALLATION, WASHER	8R-9	OFF SWITCH - OPERATION, OVERDRIVE	21-215	OIL SEAL - FRONT - INSTALLATION,	
NOZZLE - OPERATION, WASHER	8R-9	OFF SWITCH - REMOVAL, OVERDRIVE	21-215	CRANKSHAFT	9-148,9-277,9-34,9-91
NOZZLE - REMOVAL, WASHER	8R-9	OIL - DESCRIPTION, ENGINE	0-3,0-4	OIL SEAL - FRONT - OPERATION,	
NUMBER - DESCRIPTION, VEHICLE		OIL - DESCRIPTION, REFRIGERANT	24-56	CRANKSHAFT	9-147,9-34,9-91
IDENTIFICATION	Intro-10	OIL - OPERATION, REFRIGERANT	24-56	OIL SEAL - FRONT - REMOVAL,	
NV231HD - ASSEMBLY, TRANSFER CASE	21-834	OIL - STANDARD PROCEDURE, ENGINE	9-104,	CRANKSHAFT	9-147,9-276,9-34,9-91
NV231HD - CLEANING, TRANSFER CASE	21-831		9-160,9-217,9-47	OIL SEAL - FRONT COVER INSTALLED -	
NV231HD - DESCRIPTION, TRANSFER		OIL - STANDARD PROCEDURE-ENGINE		INSTALLATION, FRONT	9-205
CASE	21-820	OIL LEVEL	9-295	OIL SEAL - FRONT COVER INSTALLED -	
NV231HD - DISASSEMBLY, TRANSFER		OIL - STANDARD PROCEDURE-ENGINE		REMOVAL, FRONT	9-204
CASE	21-822	OIL SERVICE	9-295	OIL SEAL - FRONT COVER REMOVED -	
NV231HD - INSPECTION, TRANSFER		OIL COOLER - INSTALLATION, AIR TO	7-88	INSTALLATION, FRONT	9-205
CASE	21-832	OIL COOLER & LINES - CLEANING AND		OIL SEAL - FRONT COVER REMOVED -	
NV231HD - INSTALLATION, TRANSFER		INSPECTION	9-296	REMOVAL, FRONT	9-204
CASE	21-847	OIL COOLER - REMOVAL, AIR TO	7-87	OIL SEAL - REAR - DESCRIPTION,	
NV231HD - OPERATION, TRANSFER		OIL COOLER - REMOVAL, WATER TO	7-87	CRANKSHAFT	9-148,9-34,9-91
CASE	21-820	OIL COOLER - STANDARD PROCEDURE,		OIL SEAL - REAR - INSTALLATION,	
NV231HD - REMOVAL, TRANSFER CASE	21-822	FLUSHING COOLER AND TUBES -		CRANKSHAFT	9-149,9-206,9-278,9-35,9-92
NV231HD - TRANSFER CASE	21-849	WITHOUT RADIATOR IN-TANK		OIL SEAL - REAR - OPERATION,	
NV241HD - ASSEMBLY, TRANSFER CASE	21-904	TRANSMISSION	7-80,7-83,7-86	CRANKSHAFT	9-148,9-34,9-92

Description	Group-Page	Description	Group-Page	Description	Group-Page
OIL SEAL - REAR - REMOVAL, CRANKSHAFT . . . . .	9-149,9-206,9-278,9-35,9-92	OUTPUT SHAFT REAR BEARING - INSTALLATION . . . . .	21-213,21-384,21-560,21-731	PAD - INSTALLATION, SILENCER . . . . .	23-103
OIL SEAL RETAINER - INSTALLATION, CRANKSHAFT REAR . . . . .	9-206,9-279	OUTPUT SHAFT REAR BEARING - REMOVAL . . . . .	21-213,21-384,21-560,21-731	PAD - REMOVAL, SILENCER . . . . .	23-103
OIL SEAL RETAINER - REMOVAL, CRANKSHAFT REAR . . . . .	9-206,9-278	OUTPUT SHAFT SEAL - INSTALLATION, FRONT . . . . .	21-852,21-886,21-922	PAINT CODE - DESCRIPTION . . . . .	23-129
OIL SERVICE, OIL - STANDARD PROCEDURE-ENGINE . . . . .	9-295	OUTPUT SHAFT SEAL - REMOVAL, FRONT . . . . .	21-851,21-886,21-922	PAINT COLOR CODES, SPECIFICATIONS - 2001 BR . . . . .	23-129
ON-BOARD DIAGNOSTICS (OBD) - DIAGNOSIS AND TESTING . . . . .	7-4	OVERDRIVE CLUTCH - DESCRIPTION . . . . .	21-214,21-385,21-560,21-731	PAINT TOUCH-UP - DESCRIPTION . . . . .	23-129
ONE WAY CHECK VALVE - DESCRIPTION . . . . .	25-30	OVERDRIVE CLUTCH - OPERATION . . . . .	21-214,21-385,21-560,21-731	PAN - CLEANING, OIL . . . . .	9-106,9-162,9-218,9-297,9-49
ONE WAY CHECK VALVE - INSTALLATION . . . . .	25-30	OVERDRIVE ELECTRICAL CONTROLS - DIAGNOSIS AND TESTING . . . . .	21-215,21-386,21-579,21-732	PAN - INSPECTION, OIL . . . . .	9-106,9-162,9-219,9-297,9-49
ONE WAY CHECK VALVE - OPERATION . . . . .	25-30	OVERDRIVE OFF INDICATOR - DESCRIPTION . . . . .	8J-27	PAN - INSTALLATION, OIL . . . . .	9-106,9-162,9-219,9-297,9-49
ONE WAY CHECK VALVE - REMOVAL . . . . .	25-30	OVERDRIVE OFF INDICATOR - OPERATION . . . . .	8J-27	PAN - REMOVAL, OIL . . . . .	9-105,9-161,9-218,9-296,9-48
ONE-WAY CHECK VALVE - DIAGNOSIS AND TESTING . . . . .	25-30	OVERDRIVE OFF SWITCH - DESCRIPTION . . . . .	21-215	PANEL - INSTALLATION, QUARTER TRIM . . . . .	23-128
ON/OFF SWITCH - DESCRIPTION, PASSENGER AIRBAG . . . . .	80-23	OVERDRIVE OFF SWITCH - INSTALLATION . . . . .	21-215	PANEL - INSTALLATION, TRIM . . . . .	23-74,23-84
ON/OFF SWITCH - INSTALLATION, PASSENGER AIRBAG . . . . .	80-25	OVERDRIVE OFF SWITCH - OPERATION . . . . .	21-215	PANEL - REMOVAL, QUARTER TRIM . . . . .	23-127
ON/OFF SWITCH - OPERATION, PASSENGER AIRBAG . . . . .	80-24	OVERDRIVE OFF SWITCH - REMOVAL . . . . .	21-215	PANEL - REMOVAL, TRIM . . . . .	23-74,23-84
ON/OFF SWITCH - REMOVAL, PASSENGER AIRBAG . . . . .	80-24	OVERDRIVE SWITCH - DESCRIPTION . . . . .	21-385,21-578,21-732	PANEL ANTENNA CABLE - INSTALLATION, INSTRUMENT . . . . .	8A-10
OPEN-CIRCUIT VOLTAGE TEST - STANDARD PROCEDURE . . . . .	8F-13	OVERDRIVE SWITCH - INSTALLATION . . . . .	21-386,21-579,21-733	PANEL ANTENNA CABLE - REMOVAL, INSTRUMENT . . . . .	8A-9
OPENING COVER - INSTALLATION, STEERING COLUMN . . . . .	23-116	OVERDRIVE SWITCH - OPERATION . . . . .	21-385,21-579,21-732	PANEL DEMISTER DUCTS - REMOVAL, INSTRUMENT . . . . .	24-37
OPENING COVER - REMOVAL, STEERING COLUMN . . . . .	23-115	OVERDRIVE SWITCH - REMOVAL . . . . .	21-386,21-579,21-733	PANEL DUCTS - REMOVAL, INSTRUMENT . . . . .	24-37
OPENING DIMENSIONS, SPECIFICATIONS - BODY . . . . .	23-60	OVERDRIVE UNIT - ASSEMBLY . . . . .	21-225,21-395,21-569,21-742	PANEL OUTLET BARRELS - INSTALLATION . . . . .	24-32
OPENING SEAL - INSTALLATION, DOOR . . . . .	23-153	OVERDRIVE UNIT - CLEANING . . . . .	21-224,21-394,21-568,21-741	PANEL OUTLET BARRELS - REMOVAL . . . . .	24-32
OPENING SEAL - REMOVAL, DOOR . . . . .	23-153	OVERDRIVE UNIT - DISASSEMBLY . . . . .	21-217,21-387,21-562,21-734	PANEL SPEAKER - INSTALLATION, REAR CAB SIDE . . . . .	8A-21
OPENING UPPER TRIM - INSTALLATION, GLOVE BOX . . . . .	23-114	OVERDRIVE UNIT - INSPECTION . . . . .	21-224,21-394,21-569,21-741	PANEL SPEAKER - REMOVAL, REAR CAB SIDE . . . . .	8A-20
OPENING UPPER TRIM - REMOVAL, GLOVE BOX . . . . .	23-114	OVERDRIVE UNIT - INSTALLATION . . . . .	21-234,21-404,21-577,21-750	PANEL SYSTEM - DESCRIPTION, INSTRUMENT . . . . .	23-104
OPERATION, WIPERS/WASHERS . . . . .	8R-2	OVERDRIVE UNIT - REMOVAL . . . . .	21-216,21-387,21-560,21-733	PANEL SYSTEM - INSTALLATION, INSTRUMENT . . . . .	23-107
ORDER, 3.9L V-6 ENGINE - ENGINE FIRING . . . . .	8I-2	OVERFLOW VALVE - DESCRIPTION . . . . .	14-83	PANEL SYSTEM - OPERATION, INSTRUMENT . . . . .	23-105
ORDER, 5.2L/5.9L V-8 ENGINES - ENGINE FIRING . . . . .	8I-2	OVERFLOW VALVE - DIAGNOSIS AND TESTING . . . . .	14-84	PANEL SYSTEM - REMOVAL, INSTRUMENT . . . . .	23-106
ORDER, 8.0L V-10 ENGINE - SPARK PLUG CABLE . . . . .	8I-2	OVERFLOW VALVE - INSTALLATION . . . . .	14-85	PANEL TOP COVER - INSTALLATION, INSTRUMENT . . . . .	23-115
ORDER, DIESEL - FUEL INJECTOR FIRING . . . . .	14-58	OVERFLOW VALVE - OPERATION . . . . .	14-83	PANEL TOP COVER - REMOVAL, INSTRUMENT . . . . .	23-114
ORIFICE TUBE - DESCRIPTION, A/C . . . . .	24-53	OVERFLOW VALVE - REMOVAL . . . . .	14-84	PANEL TRIM - INSTALLATION, REAR CLOSURE . . . . .	23-121
ORIFICE TUBE - DIAGNOSIS AND TESTING, FIXED . . . . .	24-54	OVERHEAD CONSOLE - DESCRIPTION . . . . .	8M-1	PANEL TRIM - REMOVAL, REAR CLOSURE . . . . .	23-120
ORIFICE TUBE - OPERATION, A/C . . . . .	24-53	OVERHEAD CONSOLE - INSTALLATION . . . . .	8M-8	PANEL/DEFROST DOOR - INSTALLATION . . . . .	24-39
ORIFICE TUBE - REMOVAL, A/C . . . . .	24-54	OVERHEAD CONSOLE - OVERHEAD CONSOLE ASSEMBLY . . . . .	8M-7	PANEL/DEFROST DOOR - REMOVAL . . . . .	24-38
OTHER - INSPECTION . . . . .	30-15	OVERHEAD CONSOLE - OVERHEAD CONSOLE DISASSEMBLY . . . . .	8M-7	PANEL/DEFROST DOOR ACTUATOR - INSTALLATION . . . . .	24-27
OUT - STANDARD PROCEDURE, OWNER CHECK . . . . .	30-22	OVERHEAD CONSOLE - REMOVAL . . . . .	8M-6	PANEL/DEFROST DOOR ACTUATOR - REMOVAL . . . . .	24-27
OUTBOARD IDENTIFICATION LAMP - INSTALLATION . . . . .	8L-29	OVERHEAD CONSOLE ASSEMBLY, OVERHEAD CONSOLE . . . . .	8M-7	PARK BRAKE CABLE - 2500/3500 WITH REAR DISC BRAKES - INSTALLATION, REAR . . . . .	5-38
OUTBOARD IDENTIFICATION LAMP - REMOVAL . . . . .	8L-28	OVERHEAD CONSOLE DISASSEMBLY, OVERHEAD CONSOLE . . . . .	8M-7	PARK BRAKE CABLE - 2500/3500 WITH REAR DISC BRAKES - REMOVAL, REAR . . . . .	5-37
OUTER BELT WEATHERSTRIP - INSTALLATION, FRONT DOOR . . . . .	23-154	OVERHEAD CONSOLE SYSTEMS, SPECIAL TOOLS . . . . .	8M-8	PARK BRAKE CABLE 2500/3500 SERIES WITH DRUM BRAKES - INSTALLATION, REAR . . . . .	5-39
OUTER BELT WEATHERSTRIP - REMOVAL, FRONT DOOR . . . . .	23-154	OVERERRUNNING CLUTCH CAM/ OVERDRIVE PISTON RETAINER - ASSEMBLY . . . . .	21-236,21-406,21-581,21-752	PARK BRAKE CABLES - 1500 SERIES - INSTALLATION, REAR . . . . .	5-39
OUTLET - DESCRIPTION, CIGAR LIGHTER . . . . .	8W-97-2	OVERERRUNNING CLUTCH CAM/ OVERDRIVE PISTON RETAINER - CLEANING . . . . .	21-236,21-406,21-580,21-752	PARK BRAKE CABLES - 1500 SERIES - REMOVAL, REAR . . . . .	5-37
OUTLET - DESCRIPTION, POWER . . . . .	8W-97-9	OVERERRUNNING CLUTCH CAM/ OVERDRIVE PISTON RETAINER - DESCRIPTION . . . . .	21-235,21-405,21-580,21-751	PARK BRAKE CABLES 2500/3500 SERIES WITH DRUM BRAKES - REMOVAL, REAR . . . . .	5-38
OUTLET - DIAGNOSIS & TESTING, POWER . . . . .	8W-97-10	OVERERRUNNING CLUTCH CAM/ OVERDRIVE PISTON RETAINER - DISASSEMBLY . . . . .	21-235,21-405,21-580,21-751	PARK BRAKE SHOES - 2500/3500 - INSTALLATION, REAR DRUM IN HAT . . . . .	5-42
OUTLET - INSTALLATION, CIGAR LIGHTER . . . . .	8W-97-3	OVERERRUNNING CLUTCH CAM/ OVERDRIVE PISTON RETAINER - INSPECTION . . . . .	21-236,21-406,21-580,21-752	PARK BRAKE SHOES - 2500/3500 - REMOVAL, REAR DRUM IN HAT . . . . .	5-41
OUTLET - INSTALLATION, POWER . . . . .	8W-97-11	OVERERRUNNING CLUTCH CAM/ OVERDRIVE PISTON RETAINER - OPERATION . . . . .	21-235,21-405,21-580,21-751	PARKING BRAKE - INSPECTION . . . . .	30-17
OUTLET - OPERATION, CIGAR LIGHTER . . . . .	8W-97-2	OVERTEMP INDICATOR - DESCRIPTION, TRANSMISSION . . . . .	8J-31	PARKING BRAKE CABLE - INSTALLATION, FRONT . . . . .	5-39
OUTLET - OPERATION, POWER . . . . .	8W-97-10	OVERTEMP INDICATOR - OPERATION, TRANSMISSION . . . . .	8J-31	PARKING BRAKE CABLE - REMOVAL, FRONT . . . . .	5-37
OUTLET - REMOVAL, CIGAR LIGHTER . . . . .	8W-97-3	OWNER CHECK OUT - STANDARD PROCEDURE . . . . .	30-22	PARK/NEUTRAL POSITION SWITCH - DIAGNOSIS AND TESTING . . . . .	21-237,21-408,21-583,21-755
OUTLET BARRELS - INSTALLATION, PANEL . . . . .	24-32			PARK/NEUTRAL POSITION SWITCH - INSTALLATION . . . . .	21-238,21-408,21-583,21-755
OUTLET BARRELS - REMOVAL, PANEL . . . . .	24-32			PARK/NEUTRAL POSITION SWITCH - REMOVAL . . . . .	21-238,21-408,21-583,21-755
OUTPUT - DESCRIPTION, PCM . . . . .	8I-3				
OUTPUT - DIAGNOSIS AND TESTING, VACUUM PUMP . . . . .	7-35				
OUTPUT - OPERATION, PCM . . . . .	14-53				
OUTPUT - OPERATION, PCM . . . . .	8I-3				
OUTPUT SHAFT FRONT BEARING - INSTALLATION . . . . .	21-213,21-384,21-560,21-730				
OUTPUT SHAFT FRONT BEARING - REMOVAL . . . . .	21-213,21-384,21-559,21-730				



Description	Group-Page	Description	Group-Page	Description	Group-Page
PARK/TURN SIGNAL LAMP - INSTALLATION	8L-29	PINION GEAR/RING GEAR/TONE RING - REMOVAL	3-103,3-135,3-165,3-193	PLANETARY GEARTRAIN/OUTPUT SHAFT - OPERATION	21-240,21-410,21-585, 21-757
PARK/TURN SIGNAL LAMP - REMOVAL	8L-29	PINION SEAL - INSTALLATION	3-125,3-157, 3-185,3-34,3-66,3-95	PLATE - DESCRIPTION, BODY CODE	Intro.-1
PARK/TURN SIGNAL LAMP UNIT - INSTALLATION	8L-29	PINION SEAL - REMOVAL	3-125,3-156,3-185, 3-34,3-66,3-95	PLATE - DESCRIPTION, ENGINE DATA	9-244
PARK/TURN SIGNAL LAMP UNIT - REMOVAL	8L-29	PIPE - 3.9L/5.2L/5.9L - INSPECTION, EXHAUST	11-7	PLATE - DESCRIPTION, EQUIPMENT IDENTIFICATION	Intro.-12
PARTS - STANDARD PROCEDURES, CLEANING FUEL SYSTEM	14-57	PIPE - 3.9L/5.2L/5.9L - INSTALLATION, EXHAUST	11-7	PLATE - DESCRIPTION, PRESSURE	6-15
PASSENGER AIRBAG - DESCRIPTION	80-21	PIPE - 3.9L/5.2L/5.9L - REMOVAL, EXHAUST	11-7	PLATE - INSTALLATION, SUPPORT	5-32
PASSENGER AIRBAG - INSTALLATION	80-23	PIPE - 5.9L DIESEL - INSPECTION, EXHAUST	11-9	PLATE - INSTALLATION, TRANSFER CASE SKID	13-11
PASSENGER AIRBAG - OPERATION	80-21	PIPE - 5.9L DIESEL - INSTALLATION, EXHAUST	11-10	PLATE - OPERATION, PRESSURE	6-16
PASSENGER AIRBAG - REMOVAL	80-21	PIPE - 5.9L DIESEL - REMOVAL, EXHAUST	11-9	PLATE - REMOVAL, SUPPORT	5-32
PASSENGER AIRBAG ON/OFF SWITCH - DESCRIPTION	80-23	PIPE - 5.9L HEAVY DUTY/8.0L - INSPECTION, EXHAUST	11-9	PLATE - REMOVAL, TRANSFER CASE SKID	13-11
PASSENGER AIRBAG ON/OFF SWITCH - INSTALLATION	80-25	PIPE - 5.9L HEAVY DUTY/8.0L - INSTALLATION, EXHAUST	11-9	PLATE LAMP - INSTALLATION, LICENSE	8L-22
PASSENGER AIRBAG ON/OFF SWITCH - OPERATION	80-24	PIPE - 5.9L HEAVY DUTY/8.0L - REMOVAL, EXHAUST	11-8	PLATE LAMP - REMOVAL, LICENSE	8L-22
PASSENGER AIRBAG ON/OFF SWITCH - REMOVAL	80-24	PISTON & CONNECTING ROD - CLEANING	9-154,9-209,9-285,9-41,9-98	PLATE LAMP UNIT - INSTALLATION, LICENSE	8L-22
PASSENGER POWER SEAT SWITCH - DESCRIPTION	8N-19	PISTON & CONNECTING ROD - CONNECTING RODS	9-286	PLATE LAMP UNIT - REMOVAL, LICENSE	8L-22
PASSENGER POWER SEAT SWITCH - DIAGNOSIS & TESTING	8N-19	PISTON & CONNECTING ROD - DESCRIPTION	9-153,9-208,9-282,9-40,9-97	PLATE, SPECIFICATIONS - FUEL INJECTION PUMP DATA	14-73
PASSENGER POWER SEAT SWITCH - INSTALLATION	8N-20	PISTON & CONNECTING ROD - INSPECTION	9-154,9-209,9-285,9-41,9-98	PLATES - INSTALLATION, EXTERIOR NAME	23-89
PASSENGER POWER SEAT SWITCH - OPERATION	8N-19	PISTON & CONNECTING ROD - INSTALLATION	9-154,9-210,9-287,9-41,9-98	PLATES - REMOVAL, EXTERIOR NAME	23-89
PASSENGER POWER SEAT SWITCH - REMOVAL	8N-20	PISTON & CONNECTING ROD - REMOVAL, EXHAUST	11-8	PLUG - CLEANING, SPARK	8I-19
PASSENGER SEAT HEATER SWITCH - DESCRIPTION	8G-13	PISTON FITTING - STANDARD PROCEDURE	9-153,9-208,9-40,9-97	PLUG - DESCRIPTION, SPARK	8I-16
PASSENGER SEAT HEATER SWITCH - INSTALLATION	8G-16	PISTON GRADING - STANDARD PROCEDURE	9-282	PLUG - INSTALLATION, SPARK	8I-19
PASSENGER SEAT HEATER SWITCH - OPERATION	8G-14	PISTON RETAINER - ASSEMBLY, OVERRUNNING CLUTCH CAM/ OVERDRIVE	21-236,21-406,21-581,21-752	PLUG - INSTALLATION, STEERING GEAR HOUSING	19-27
PASSENGER SEAT HEATER SWITCH - REMOVAL	8G-15	PISTON RETAINER - CLEANING, OVERRUNNING CLUTCH CAM/ OVERDRIVE	21-236,21-406,21-580,21-752	PLUG - OPERATION, SPARK	8I-16
PATTERNS - DIAGNOSIS AND TESTING, TIRE WEAR	22-7	PISTON RETAINER - DESCRIPTION, OVERRUNNING CLUTCH CAM/ OVERDRIVE	21-235,21-405,21-580,21-751	PLUG - REMOVAL, SPARK	8I-18
PCM - DESCRIPTION	8E-14	PISTON RETAINER - DISASSEMBLY, OVERRUNNING CLUTCH CAM/ OVERDRIVE	21-235,21-405,21-580,21-751	PLUG - REMOVAL, STEERING GEAR HOUSING	19-27
PCM - GAS ENGINES - OPERATION	8E-17	PISTON RETAINER - INSPECTION, OVERRUNNING CLUTCH CAM/ OVERDRIVE	21-236,21-406,21-580,21-752	PLUG - OPERATION, SPARK	8I-16
PCM INPUT - OPERATION, ASD SENSE	8I-3	PISTON RINGS - STANDARD PROCEDURE, FITTING	9-211	PLUG - REMOVAL, SPARK	8I-18
PCM OUTPUT - DESCRIPTION	8I-3	PISTON RINGS - STANDARD PROCEDURE-PISTON RING FITTING	9-288	PLUG - REMOVAL, STEERING GEAR HOUSING	19-27
PCM OUTPUT - OPERATION	14-53	PISTONS - DESCRIPTION	21-238,21-408,21-584, 21-755	PLUG CABLE - DESCRIPTION, SPARK	8I-19
PCM OUTPUT - OPERATION	8I-3	PISTONS - OPERATION	21-238,21-409,21-584, 21-755	PLUG CABLE - INSTALLATION, SPARK	8I-20
PCV FILTER - DESCRIPTION	25-35	PITMAN BEARING - INSTALLATION	19-21	PLUG CABLE - OPERATION, SPARK	8I-19
PCV VALVE - V-6/V-8 ENGINES - DIAGNOSIS AND TESTING	25-36	PITMAN BEARING - REMOVAL	19-20	PLUG CABLE - REMOVAL, SPARK	8I-20
PEDAL - DESCRIPTION	5-16	PITMAN SHAFT - INSTALLATION	19-23	PLUG CABLE ORDER, 8.0L V-10 ENGINE - SPARK	8I-2
PEDAL - INSTALLATION	5-17,5-36	PITMAN SHAFT - REMOVAL	19-22	PLUG CABLE RESISTANCE, SPECIFICATIONS - SPARK	8I-3
PEDAL - INSTALLATION, ACCELERATOR	14-37	PITMAN SHAFT SEAL - INSTALLATION	19-24	PLUG CABLES - DIAGNOSIS AND TESTING, SPARK	8I-19
PEDAL - INSTALLATION, CLUTCH	6-19	PLANETARY GEARTRAIN/OUTPUT SHAFT - ASSEMBLY	21-241,21-412,21-588, 21-760	PLUG CONDITIONS - DIAGNOSIS AND TESTING, SPARK	8I-16
PEDAL - OPERATION	5-16	PLANETARY GEARTRAIN/OUTPUT SHAFT - DISASSEMBLY	21-240,21-411,21-586, 21-757	PLUGS, SPECIFICATIONS - SPARK	8I-3
PEDAL - REMOVAL	5-16,5-36	PLANETARY GEARTRAIN/OUTPUT SHAFT - DESCRIPTION	21-240,21-410,21-585, 21-757	PLUMBING - CLEANING, CHARGE AIR COOLER	11-18
PEDAL - REMOVAL, ACCELERATOR	14-37	PLANETARY GEARTRAIN/OUTPUT SHAFT - INSPECTION	21-241,21-411,21-587, 21-760	PLUMBING - DESCRIPTION	24-40
PEDAL - REMOVAL, CLUTCH	6-18	PLANETARY GEARTRAIN/OUTPUT SHAFT - OPERATION	21-238,21-408,21-584, 21-755	PLUMBING - DESCRIPTION, CHARGE AIR COOLER	11-17
PEDAL POSITION SENSOR - DESCRIPTION, ACCELERATOR	14-91	PITMAN SHAFT SEAL - REMOVAL	19-23	PLUMBING - INSPECTION, CHARGE AIR COOLER	11-18
PEDAL POSITION SENSOR - INSTALLATION, ACCELERATOR	14-93	PLANETARY GEARTRAIN/OUTPUT SHAFT - ASSEMBLY	21-241,21-412,21-588, 21-760	PLUMBING - INSTALLATION, CHARGE AIR COOLER	11-18
PEDAL POSITION SENSOR - OPERATION, ACCELERATOR	14-91	PLANETARY GEARTRAIN/OUTPUT SHAFT - DISASSEMBLY	21-240,21-411,21-586, 21-757	PLUMBING - OPERATION, CHARGE AIR COOLER	11-18
PEDAL POSITION SENSOR - REMOVAL, ACCELERATOR	14-91	PLANETARY GEARTRAIN/OUTPUT SHAFT - INSPECTION	21-241,21-411,21-587, 21-760	PLUMBING - OPERATION, CHARGE AIR COOLER	11-17
PEDAL POSITION SWITCH - DESCRIPTION, CLUTCH	6-22	PLANETARY GEARTRAIN/OUTPUT SHAFT - OPERATION	21-238,21-409,21-584, 21-755	PLUMBING - REMOVAL, CHARGE AIR COOLER	11-17
PEDAL POSITION SWITCH - OPERATION, CLUTCH	6-22	PITMAN BEARING - INSTALLATION	19-21	PLUMBING - REMOVAL, CHARGE AIR COOLER	11-17
PER MILE, SPECIFICATIONS - TIRE REVOLUTIONS	22-9	PITMAN BEARING - REMOVAL	19-20	POLISHING - DESCRIPTION, WET SANDING/BUFFING	23-130
PERFORMANCE - DIAGNOSIS AND TESTING	9-118,9-173,9-4,9-61	PITMAN SHAFT - INSTALLATION	19-23	PORT - DESCRIPTION, REFRIGERANT SYSTEM SERVICE	24-1
PERFORMANCE - DIAGNOSIS AND TESTING, A/C	24-2	PITMAN SHAFT - REMOVAL	19-22	PORT - OPERATION, REFRIGERANT SYSTEM SERVICE	24-2
PERFORMANCE - DIAGNOSIS AND TESTING, HEATER	24-6	PITMAN SHAFT SEAL - INSTALLATION	19-24	POSITION SENSOR - DESCRIPTION, ACCELERATOR PEDAL	14-91
PERFORMANCE - INSPECTION, ENGINE	30-16	PITMAN SHAFT SEAL - REMOVAL	19-23	POSITION SENSOR - DESCRIPTION, THROTTLE	14-51
PILOT BEARING - DESCRIPTION	6-17	PLANETARY GEARTRAIN/OUTPUT SHAFT - ASSEMBLY	21-241,21-412,21-588, 21-760	POSITION SENSOR - INSTALLATION, ACCELERATOR PEDAL	14-93
PILOT BEARING - INSTALLATION	6-18	PLANETARY GEARTRAIN/OUTPUT SHAFT - DISASSEMBLY	21-240,21-411,21-586, 21-757	POSITION SENSOR - OPERATION, ACCELERATOR PEDAL	14-91
PILOT BEARING - OPERATION	6-18	PLANETARY GEARTRAIN/OUTPUT SHAFT - DESCRIPTION	21-240,21-410,21-585, 21-757	POSITION SENSOR - OPERATION, THROTTLE	14-51
PILOT BEARING - REMOVAL	6-18	PLANETARY GEARTRAIN/OUTPUT SHAFT - INSPECTION	21-241,21-411,21-587, 21-760	POSITION SENSOR - OPERATION, THROTTLE	14-51
PINION GEAR/RING GEAR - INSTALLATION	3-42,3-74	PLANETARY GEARTRAIN/OUTPUT SHAFT - OPERATION	21-238,21-408,21-583,21-755	POSITION SENSOR - REMOVAL, ACCELERATOR PEDAL	14-91
PINION GEAR/RING GEAR - REMOVAL	3-40,3-72	PLANETARY GEARTRAIN/OUTPUT SHAFT - OPERATION	21-238,21-408,21-583,21-755	POSITION SWITCH - DESCRIPTION, CLUTCH PEDAL	6-22
PINION GEAR/RING GEAR/TONE RING - INSTALLATION	3-105,3-137,3-166,3-195	PLANETARY GEARTRAIN/OUTPUT SHAFT - OPERATION	21-238,21-408,21-583,21-755	POSITION SWITCH - DIAGNOSIS AND TESTING, PARK/NEUTRAL	21-237,21-408, 21-583,21-755
		PLANETARY GEARTRAIN/OUTPUT SHAFT - OPERATION	21-238,21-408,21-583,21-755	POSITION SWITCH - INSTALLATION, PARK/NEUTRAL	21-238,21-408,21-583,21-755
		PLANETARY GEARTRAIN/OUTPUT SHAFT - OPERATION	21-238,21-408,21-583,21-755	POSITION SWITCH - OPERATION, CLUTCH PEDAL	6-22

Description	Group-Page	Description	Group-Page	Description	Group-Page
POSITION SWITCH - REMOVAL, PARK/NEUTRAL . . . . .	21-238,21-408,21-583,21-755	POWER STEERING FLOW AND PRESSURE - DIAGNOSIS AND TESTING . . . . .	19-4	PRESSURE GAUGE - DESCRIPTION, OIL . . . . .	8J-25
POSITIVE CABLE INSTALLATION, GASOLINE . . . . .	8F-23	POWER STEERING GEAR LEAKAGE - DIAGNOSIS AND TESTING . . . . .	19-14	PRESSURE GAUGE - OPERATION, OIL . . . . .	8J-26
POSITIVE CABLE REMOVAL, GASOLINE . . . . .	8F-23	POWER STEERING GEAR, SPECIAL TOOLS . . . . .	19-20	PRESSURE GAUGES - DIAGNOSIS AND TESTING . . . . .	22-7
POTENTIAL - STANDARD PROCEDURE, TESTING FOR VOLTAGE . . . . .	8W-01-6	POWER STEERING PUMP - INITIAL OPERATION - STANDARD PROCEDURE . . . . .	19-31	PRESSURE LEAK DOWN TEST - DIAGNOSIS AND TESTING, FUEL . . . . .	14-2
POWER BRAKE BOOSTER - INSTALLATION . . . . .	5-20	POWER STEERING PUMP, SPECIAL TOOLS . . . . .	19-36	PRESSURE LEAKAGE - DIAGNOSIS AND TESTING, CYLINDER COMBUSTION . . . . .	9-124,9-179,9-67,9-9
POWER BRAKE BOOSTER - REMOVAL . . . . .	5-19	POWER STEERING SYSTEM - DIAGNOSIS AND TESTING . . . . .	19-2	PRESSURE PLATE - DESCRIPTION . . . . .	6-15
POWER DISTRIBUTION - DESCRIPTION . . . . .	8W-97-1	POWER STEERING SYSTEM - STANDARD PROCEDURE, FLUSHING . . . . .	19-32	PRESSURE PLATE - OPERATION . . . . .	6-16
POWER DISTRIBUTION - OPERATION . . . . .	8W-97-1	POWER WINDOW SWITCH - DESCRIPTION . . . . .	8N-24	PRESSURE RELEASE - STANDARD PROCEDURE, FUEL SYSTEM . . . . .	14-3
POWER DISTRIBUTION CENTER - DESCRIPTION . . . . .	8W-97-7	POWER WINDOW SWITCH - DIAGNOSIS AND TESTING . . . . .	8N-24	PRESSURE RELIEF VALVE - CLEANING, OIL . . . . .	9-297
POWER DISTRIBUTION CENTER - INSTALLATION . . . . .	8W-97-8	POWER WINDOW SWITCH - INSTALLATION . . . . .	8N-26	PRESSURE RELIEF VALVE - DESCRIPTION, HIGH . . . . .	24-46
POWER DISTRIBUTION CENTER - OPERATION . . . . .	8W-97-8	POWER WINDOW SWITCH - OPERATION . . . . .	8N-24	PRESSURE RELIEF VALVE - INSPECTION, OIL . . . . .	9-297
POWER DISTRIBUTION CENTER - REMOVAL . . . . .	8W-97-8	POWER WINDOW SWITCH - REMOVAL . . . . .	8N-25	PRESSURE RELIEF VALVE - INSTALLATION, OIL . . . . .	9-298
POWER DISTRIBUTION SYSTEMS, SPECIAL TOOLS . . . . .	8W-97-2	POWER WINDOWS - DESCRIPTION . . . . .	8N-23	PRESSURE RELIEF VALVE - OPERATION, HIGH . . . . .	24-46
POWER GROUNDS - DESCRIPTION . . . . .	8E-17	POWER WINDOWS - DIAGNOSIS AND TESTING . . . . .	8N-23	PRESSURE RELIEF VALVE - REMOVAL, OIL . . . . .	9-297
POWER LOCK & REMOTE KEYLESS ENTRY SYSTEM - DIAGNOSIS AND TESTING . . . . .	8N-4	POWER WINDOWS - OPERATION . . . . .	8N-23	PRESSURE SENSOR/SWITCH - DESCRIPTION, OIL . . . . .	9-298,9-49
POWER LOCK MOTOR - DESCRIPTION . . . . .	8N-6	POWERING SEVERAL LOADS - STANDARD PROCEDURE, TESTING FOR SHORT TO GROUND ON FUSES . . . . .	8W-01-7	PRESSURE SENSOR/SWITCH - INSTALLATION, OIL . . . . .	9-299
POWER LOCK MOTOR - DIAGNOSIS AND TESTING . . . . .	8N-7	POWERTRAIN CONTROL MODULE - INSTALLATION . . . . .	8E-20	PRESSURE SENSOR/SWITCH - OPERATION, OIL . . . . .	9-298,9-49
POWER LOCK MOTOR - OPERATION . . . . .	8N-6	POWERTRAIN CONTROL MODULE - REMOVAL . . . . .	8E-19	PRESSURE SENSOR/SWITCH - REMOVAL, OIL . . . . .	9-298
POWER LOCK SWITCH - DESCRIPTION . . . . .	8N-8	POWR-LOK - ASSEMBLY, DIFFERENTIAL . . . . .	3-163	PRESSURE SWITCH - DESCRIPTION, A/C HIGH . . . . .	24-20
POWER LOCK SWITCH - DIAGNOSIS AND TESTING . . . . .	8N-8	POWR-LOK - DISASSEMBLY, DIFFERENTIAL . . . . .	3-161	PRESSURE SWITCH - DESCRIPTION, A/C LOW . . . . .	24-21
POWER LOCK SWITCH - OPERATION . . . . .	8N-8	POWR-LOK <sup>TM</sup> TEST - DIAGNOSIS AND TESTING . . . . .	3-161	PRESSURE SWITCH - DIAGNOSIS AND TESTING, A/C HIGH . . . . .	24-20
POWER LOCK SYSTEM - DESCRIPTION . . . . .	8N-1	PRE DELIVERY STORAGE - DESCRIPTION . . . . .	30-19	PRESSURE SWITCH - DIAGNOSIS AND TESTING, A/C LOW . . . . .	24-21
POWER LOCK SYSTEM - DIAGNOSIS AND TESTING . . . . .	8N-4	PRE DELIVERY STORAGE - STANDARD PROCEDURE . . . . .	30-20	PRESSURE SWITCH - INSTALLATION, A/C HIGH . . . . .	24-21
POWER LOCK SYSTEM - OPERATION . . . . .	8N-3	PRE-ALIGNMENT - DIAGNOSIS AND TESTING . . . . .	2-2	PRESSURE SWITCH - INSTALLATION, A/C LOW . . . . .	24-22
POWER LUMBAR ADJUSTER - DIAGNOSIS & TESTING . . . . .	8N-18	PRECAUTIONS - CAUTION, REFRIGERANT HOSES/LINES/TUBES . . . . .	24-42	PRESSURE SWITCH - OPERATION, A/C HIGH . . . . .	24-20
POWER MIRROR SWITCH - DESCRIPTION . . . . .	8N-12	PRECAUTIONS AND WARNINGS, BODY - SAFETY . . . . .	23-1	PRESSURE SWITCH - OPERATION, A/C LOW . . . . .	24-21
POWER MIRROR SWITCH - INSTALLATION . . . . .	8N-13	PRECAUTIONS, COLUMN - SERVICE . . . . .	19-6	PRESSURE SWITCH - REMOVAL, A/C HIGH . . . . .	24-21
POWER MIRROR SWITCH - OPERATION . . . . .	8N-12	PRELIMINARY - DIAGNOSIS AND TESTING . . . . .	21-143,21-314,21-486,21-657	PRESSURE SWITCH - REMOVAL, A/C LOW . . . . .	24-21
POWER MIRROR SWITCH - REMOVAL . . . . .	8N-12	PRELIMINARY CHECKS - DIAGNOSIS AND TESTING . . . . .	7-4	PRESSURE TEST - DIAGNOSIS AND TESTING, FUEL PUMP . . . . .	14-10
POWER MIRRORS - DESCRIPTION . . . . .	8N-10	PREPARATION - DESCRIPTION, THE IMPORTANCE OF CAREFUL NEW VEHICLE . . . . .	30-1	PRESSURE TEST - DIAGNOSIS AND TESTING, HYDRAULIC . . . . .	21-144,21-315,21-487,21-658
POWER MIRRORS - OPERATION . . . . .	8N-10	PREPARATION FORM, FINAL STEPS - NEW VEHICLE . . . . .	30-22	PRESSURES - INSPECTION, TIRE . . . . .	30-8
POWER OUTLET - DESCRIPTION . . . . .	8W-97-9	PRESSURE - DESCRIPTION, HOSES . . . . .	19-37	PRESSURES, DIESEL ENGINES - FUEL SYSTEM . . . . .	14-58
POWER OUTLET - DIAGNOSIS & TESTING . . . . .	8W-97-10	PRESSURE - DIAGNOSIS AND TESTING, BOOST . . . . .	14-89	PROCEDURE-CONNECTING ROD BEARING FITTING, CONNECTING ROD BEARINGS - STANDARD . . . . .	9-31
POWER OUTLET - INSTALLATION . . . . .	8W-97-11	PRESSURE - DIAGNOSIS AND TESTING, CYLINDER COMPRESSION . . . . .	9-124,9-179,9-67,9-9	PROCEDURE-CYLINDER BLOCK REFACING, ENGINE BLOCK - STANDARD . . . . .	9-263
POWER OUTLET - OPERATION . . . . .	8W-97-10	PRESSURE - DIAGNOSIS AND TESTING, ENGINE OIL . . . . .	9-104,9-160,9-215,9-295,9-47	PROCEDURE-CYLINDER BORE, DE-GLAZE - STANDARD . . . . .	9-264
POWER OUTLET - REMOVAL . . . . .	8W-97-10	PRESSURE - DIAGNOSIS AND TESTING, FUEL TRANSFER PUMP . . . . .	14-80	PROCEDURE-ENGINE OIL LEVEL, OIL - STANDARD . . . . .	9-295
POWER SEAT RECLINER - DIAGNOSIS & TESTING . . . . .	8N-21	PRESSURE - DIAGNOSIS AND TESTING, POWER STEERING FLOW . . . . .	19-4	PROCEDURE-ENGINE OIL SERVICE, OIL - STANDARD . . . . .	9-295
POWER SEAT SWITCH - DESCRIPTION, DRIVER . . . . .	8N-16	PRESSURE - GAS ENGINES - SPECIFICATIONS, FUEL SYSTEM . . . . .	14-4	PROCEDURE-PISTON RING FITTING, PISTON RINGS - STANDARD . . . . .	9-288
POWER SEAT SWITCH - DESCRIPTION, PASSENGER . . . . .	8N-19	PRESSURE - OPERATION, HOSES . . . . .	19-37	PROCEDURE-VALVES, GUIDES AND SPRINGS, INTAKE/EXHAUST VALVES & SEATS - STANDARD . . . . .	9-253
POWER SEAT SWITCH - DIAGNOSIS & TESTING, DRIVER . . . . .	8N-16	PRESSURE BLEEDING - STANDARD PROCEDURE . . . . .	5-8	PROGRAMMABLE ELECTRONIC FEATURES - DESCRIPTION . . . . .	30-20
POWER SEAT SWITCH - DIAGNOSIS & TESTING, PASSENGER . . . . .	8N-19	PRESSURE CAP - CLEANING, RADIATOR . . . . .	7-66	PROGRAMMABLE ELECTRONIC FEATURES - OPERATION . . . . .	30-20
POWER SEAT SWITCH - INSTALLATION, DRIVER . . . . .	8N-17	PRESSURE CAP - DESCRIPTION, RADIATOR . . . . .	7-65	PROGRAMMING - STANDARD PROCEDURE, RKE TRANSMITTER . . . . .	8N-8
POWER SEAT SWITCH - INSTALLATION, PASSENGER . . . . .	8N-20	PRESSURE CAP - INSPECTION, RADIATOR . . . . .	7-66	PROPELLER SHAFT - DESCRIPTION . . . . .	3-1
POWER SEAT SWITCH - OPERATION, DRIVER . . . . .	8N-16	PRESSURE CAP - OPERATION, RADIATOR . . . . .	7-65	PROPELLER SHAFT - DIAGNOSIS AND TESTING . . . . .	3-3
POWER SEAT SWITCH - OPERATION, PASSENGER . . . . .	8N-19	PRESSURE FUEL LINES - DESCRIPTION, HIGH . . . . .	14-74		
POWER SEAT SWITCH - REMOVAL, DRIVER . . . . .	8N-17	PRESSURE FUEL LINES - OPERATION, HIGH . . . . .	14-74		
POWER SEAT SWITCH - REMOVAL, PASSENGER . . . . .	8N-20				
POWER SEAT SYSTEM - DESCRIPTION . . . . .	8N-15				
POWER SEAT SYSTEM - DIAGNOSIS & TESTING . . . . .	8N-15				
POWER SEAT SYSTEM - OPERATION . . . . .	8N-15				
POWER SEAT TRACK - DESCRIPTION . . . . .	8N-21				
POWER SEAT TRACK - DIAGNOSIS & TESTING . . . . .	8N-21				
POWER SEAT TRACK - INSTALLATION . . . . .	8N-22				
POWER SEAT TRACK - OPERATION . . . . .	8N-21				
POWER SEAT TRACK - REMOVAL . . . . .	8N-22				



Description	Group-Page	Description	Group-Page	Description	Group-Page
PROPELLER SHAFT - FRONT - INSTALLATION	3-8	PUMP - OPERATION, FUEL	14-9	RADIATOR - 5.9L DIESEL - INSTALLATION	7-65
PROPELLER SHAFT - FRONT - REMOVAL	3-8	PUMP - OPERATION, FUEL INJECTION	14-66	RADIATOR - 5.9L DIESEL - OPERATION	7-63
PROPELLER SHAFT - OPERATION	3-1	PUMP - OPERATION, FUEL TRANSFER	14-79	RADIATOR - 5.9L DIESEL - REMOVAL	7-63
PROPELLER SHAFT - REAR - INSTALLATION	3-9	PUMP - OPERATION, OIL	21-208,21-379,21-554,21-724	RADIATOR - 8.0L - CLEANING	7-62
PROPELLER SHAFT - REAR - REMOVAL	3-9	PUMP - REMOVAL, AIR INJECTION	25-29	RADIATOR - 8.0L - DESCRIPTION	7-61
PROPELLER SHAFT - STANDARD PROCEDURES	3-5	PUMP - REMOVAL, FUEL INJECTION	14-68	RADIATOR - 8.0L - INSPECTION	7-62
PROPELLER SHAFT, SPECIAL TOOLS	3-8	PUMP - REMOVAL, FUEL TRANSFER	14-83	RADIATOR - 8.0L - INSTALLATION	7-63
PROPELLER SHAFT, SPECIFICATIONS	3-8	PUMP - REMOVAL, LEAK DETECTION	25-34	RADIATOR - 8.0L - OPERATION	7-61
PTO SWITCH - DESCRIPTION	14-48	PUMP - REMOVAL, OIL	9-107,9-162,9-219,9-299,9-50	RADIATOR - 8.0L - REMOVAL	7-62
PTO SWITCH - OPERATION	14-104,14-48	PUMP 235 H.P. - DESCRIPTION, FUEL	14-66	RADIATOR CAP - DIAGNOSIS AND TESTING	7-66
PULLEY - INSTALLATION	19-36	PUMP 245 H.P. - DESCRIPTION, FUEL	14-65	RADIATOR CAP-TO-FILLER NECK SEAL - DIAGNOSIS AND TESTING	7-66
PULLEY - REMOVAL	19-36	PUMP AMPERAGE TEST - DIAGNOSIS AND TESTING, FUEL	14-10	RADIATOR COOLANT FLOW - DIAGNOSIS AND TESTING	7-59,7-61,7-63
PUMP - 3.9L/5.2L/5.9L - CLEANING, WATER	7-69	PUMP BYPASS HOSE WITH AIR CONDITIONING - INSTALLATION, WATER	7-77	RADIATOR FAN - 3.9L/5.2L/5.9L/8.0L - CLEANING	7-43
PUMP - 3.9L/5.2L/5.9L - DESCRIPTION, WATER	7-67	PUMP BYPASS HOSE WITH AIR CONDITIONING - REMOVAL, WATER	7-74	RADIATOR FAN - 3.9L/5.2L/5.9L/8.0L - INSPECTION	7-43
PUMP - 3.9L/5.2L/5.9L - INSPECTION, WATER	7-69	PUMP BYPASS HOSE WITHOUT AIR CONDITIONING - INSTALLATION, WATER	7-78	RADIATOR FAN - 3.9L/5.2L/5.9L/8.0L - INSTALLATION	7-43
PUMP - 3.9L/5.2L/5.9L - INSTALLATION, WATER	7-70	PUMP BYPASS HOSE WITHOUT AIR CONDITIONING - REMOVAL, WATER	7-77	RADIATOR FAN - 3.9L/5.2L/5.9L/8.0L - REMOVAL	7-42
PUMP - 3.9L/5.2L/5.9L - OPERATION, WATER	7-67	PUMP CAPACITY TEST - DIAGNOSIS AND TESTING, FUEL	14-9	RADIATOR FAN - 5.9L DIESEL - CLEANING	7-44
PUMP - 3.9L/5.2L/5.9L - REMOVAL, WATER	7-67	PUMP DATA PLATE, SPECIFICATIONS - FUEL INJECTION	14-73	RADIATOR FAN - 5.9L DIESEL - INSPECTION	7-44
PUMP - 5.9L DIESEL - CLEANING, WATER	7-73	PUMP FILTER - INSTALLATION, AIR	25-29	RADIATOR FAN - 5.9L DIESEL - INSTALLATION	7-45
PUMP - 5.9L DIESEL - DESCRIPTION, VACUUM	7-34	PUMP FILTER - REMOVAL, AIR	25-29	RADIATOR FAN - 5.9L DIESEL - REMOVAL	7-44
PUMP - 5.9L DIESEL - DESCRIPTION, WATER	7-73	PUMP LEAKAGE - DIAGNOSIS AND TESTING	19-31	RADIATOR IN-TANK TRANSMISSION OIL COOLER - STANDARD PROCEDURE, FLUSHING COOLER AND TUBES - WITHOUT	7-80,7-83,7-86
PUMP - 5.9L DIESEL - INSPECTION, WATER	7-73	PUMP MODULE - DESCRIPTION, FUEL	14-12	RADIATOR IN-TANK TRANSMISSION OIL COOLER - STANDARD PROCEDURE, FLUSHING COOLERS AND TUBES - WITH	7-79,7-83,7-85
PUMP - 5.9L DIESEL - INSTALLATION, VACUUM	7-37	PUMP MODULE - INSTALLATION, FUEL	14-13	RADIATOR PRESSURE CAP - CLEANING	7-66
PUMP - 5.9L DIESEL - INSTALLATION, WATER	7-74	PUMP MODULE - OPERATION, FUEL	14-13	RADIATOR PRESSURE CAP - DESCRIPTION	7-65
PUMP - 5.9L DIESEL - OPERATION, VACUUM	7-35	PUMP MODULE - REMOVAL, FUEL	14-13	RADIATOR PRESSURE CAP - INSPECTION	7-66
PUMP - 5.9L DIESEL - OPERATION, WATER	7-73	PUMP OUTPUT - DIAGNOSIS AND TESTING, VACUUM	7-35	RADIATOR PRESSURE CAP - OPERATION	7-65
PUMP - 5.9L DIESEL - OPERATION, VACUUM	7-35	PUMP PRESSURE - DIAGNOSIS AND TESTING, FUEL TRANSFER	14-80	RADIO - DESCRIPTION	8A-10
PUMP - 5.9L DIESEL - OPERATION, WATER	7-73	PUMP PRESSURE TEST - DIAGNOSIS AND TESTING, FUEL	14-10	RADIO - DIAGNOSIS AND TESTING	8A-10
PUMP - 5.9L DIESEL - REMOVAL, VACUUM	7-35	PUMP RELAY - DESCRIPTION, FUEL	14-41	RADIO - INSPECTION	30-17
PUMP - 5.9L DIESEL - REMOVAL, WATER	7-73	PUMP RELAY - DESCRIPTION, FUEL INJECTION	14-99	RADIO - OPERATION	8A-10
PUMP - 8.0L - CLEANING, WATER	7-72	PUMP RELAY - INSTALLATION, FUEL	14-41	RADIO CHOKE RELAY - DESCRIPTION	8A-8
PUMP - 8.0L - INSPECTION, WATER	7-72	PUMP RELAY - OPERATION, FUEL	14-41	RADIO CHOKE RELAY - DIAGNOSIS AND TESTING	8A-8
PUMP - 8.0L - INSTALLATION, WATER	7-72	PUMP RELAY - OPERATION, FUEL INJECTION	14-99	RADIO CHOKE RELAY - INSTALLATION	8A-9
PUMP - 8.0L - REMOVAL, WATER	7-70	PUMP RELAY - REMOVAL, FUEL	14-41	RADIO CHOKE RELAY - OPERATION	8A-8
PUMP - ASSEMBLY, OIL	9-109,9-165	PUMP RELAYS - DIAGNOSIS AND TESTING, ASD AND FUEL	81-3	RADIO CHOKE RELAY - REMOVAL	8A-9
PUMP - ASSEMBLY, OIL	9-51	PUMP, SPECIAL TOOLS - POWER STEERING	19-36	RADIO NOISE SUPPRESSION COMPONENTS - DESCRIPTION	8A-12
PUMP - ASSEMBLY, OIL	21-212,21-382,21-558,21-729	PUMP TIMING - DIAGNOSIS AND TESTING, FUEL INJECTION	14-66	RADIO NOISE SUPPRESSION COMPONENTS - DIAGNOSIS AND TESTING	8A-12
PUMP - CLEANING, OIL	9-220,9-299,9-50	PUMP VOLUME CHECK - STANDARD PROCEDURE, OIL	21-209,21-379,21-554,21-724	RATINGS, SPECIFICATIONS - GENERATOR	8F-28
PUMP - CLEANING, OIL	21-211,21-381,21-557,21-728	PUMP/MOTOR - DESCRIPTION, WASHER	8R-9	RATTLES AND WIND NOISE - INSPECTION, SOUEAKS	30-15
PUMP - DESCRIPTION	19-31	PUMP/MOTOR - INSTALLATION, WASHER	8R-10	RBI - REAR AXLE, 286	3-182
PUMP - DESCRIPTION, AIR INJECTION	25-28	PUMP/MOTOR - OPERATION, WASHER	8R-9	RE TRANSMISSION, SPECIAL TOOLS	21-534,21-704
PUMP - DESCRIPTION, FUEL	14-9	PUMP/MOTOR - REMOVAL, WASHER	8R-10	RE TRANSMISSIONS, SPECIAL TOOLS	21-188,21-359
PUMP - DESCRIPTION, FUEL TRANSFER	14-79	PUSH-IN FASTENERS - DESCRIPTION	23-1	READING LAMP - DESCRIPTION	8L-36
PUMP - DESCRIPTION, LEAK DETECTION	25-33	PUSHRODS - CLEANING	9-249	READING LAMP - INSTALLATION	8L-36
PUMP - DESCRIPTION, OIL	21-208,21-379,21-554,21-724	PUSHRODS - INSPECTION	9-250	READING LAMP - OPERATION	8L-36
PUMP - DIAGNOSIS AND TESTING, AIR INJECTION	25-28	QUARTER TRIM PANEL - INSTALLATION	23-128	READING LAMP - REMOVAL	8L-36
PUMP - DIAGNOSIS AND TESTING, WATER	7-67,7-70,7-73	QUARTER TRIM PANEL - REMOVAL	23-127	REAR - 2500/3500 - INSTALLATION	5-22
PUMP - DISASSEMBLE, OIL	9-107,9-163,9-50	QUARTER WINDOW - INSTALLATION	23-151	REAR - 2500/3500 - REMOVAL	5-21
PUMP - DISASSEMBLY, OIL	21-209,21-380,21-555,21-726	QUARTER WINDOW - REMOVAL	23-151	REAR - DESCRIPTION	2-26
PUMP - INITIAL OPERATION - STANDARD PROCEDURE, POWER STEERING	19-31	QUICK CONNECT FITTING - DESCRIPTION	14-22	REAR - DESCRIPTION, CRANKSHAFT OIL SEAL	9-148,9-34,9-91
PUMP - INSPECTION, OIL	9-107,9-163,9-220,9-299,9-50	QUICK-CONNECT FITTINGS - STANDARD PROCEDURES	14-22	REAR - INSTALLATION	5-13,5-26
PUMP - INSPECTION, OIL	21-211,21-382,21-557,21-728	RADIATOR - 3.9L/5.2L/5.9L - CLEANING	7-60	REAR - INSTALLATION	22-12
PUMP - INSTALLATION, AIR INJECTION	25-29	RADIATOR - 3.9L/5.2L/5.9L - DESCRIPTION	7-59	REAR - INSTALLATION, CRANKSHAFT OIL SEAL	9-149,9-206,9-278,9-35,9-92
PUMP - INSTALLATION, FUEL INJECTION	14-71	RADIATOR - 3.9L/5.2L/5.9L - INSPECTION	7-61	REAR - INSTALLATION, PROPELLER SHAFT	3-9
PUMP - INSTALLATION, FUEL TRANSFER	14-83	RADIATOR - 3.9L/5.2L/5.9L - INSTALLATION	7-61	REAR - OPERATION, CRANKSHAFT OIL SEAL	9-148,9-34,9-92
PUMP - INSTALLATION, LEAK DETECTION	25-34	RADIATOR - 3.9L/5.2L/5.9L - OPERATION	7-59	REAR - REMOVAL	5-10,5-23
PUMP - INSTALLATION, OIL	9-109,9-165,9-221,9-300,9-52	RADIATOR - 3.9L/5.2L/5.9L - REMOVAL	7-59		
PUMP - OPERATION	19-31	RADIATOR - 5.9L DIESEL - CLEANING	7-65		
PUMP - OPERATION, AIR INJECTION	25-28	RADIATOR - 5.9L DIESEL - DESCRIPTION	7-63		
		RADIATOR - 5.9L DIESEL - INSPECTION	7-65		

Description	Group-Page	Description	Group-Page	Description	Group-Page
REAR - REMOVAL, CRANKSHAFT OIL SEAL	9-149,9-206,9-278,9-35,9-92	REAR OIL SEAL RETAINER - REMOVAL, CRANKSHAFT	9-206,9-278	REFILLING COOLING SYSTEM 5.9L DIESEL ENGINE - STANDARD PROCEDURE	7-15
REAR - REMOVAL, PROPELLER SHAFT	3-9	REAR PARK BRAKE CABLE - 2500/3500 WITH REAR DISC BRAKES - INSTALLATION	5-38	REFRIGERANT - DESCRIPTION	24-56
REAR AXLE - 248RBI - ADJUSTMENTS	3-114	REAR PARK BRAKE CABLE - 2500/3500 WITH REAR DISC BRAKES - REMOVAL	5-37	REFRIGERANT - OPERATION	24-56
REAR AXLE - 248RBI - DESCRIPTION	3-109	REAR PARK BRAKE CABLES - 1500 SERIES - INSTALLATION	5-39	REFRIGERANT HOSES/LINES/TUBES PRECAUTIONS - CAUTION	24-42
REAR AXLE - 248RBI - INSTALLATION	3-114	REAR PARK BRAKE CABLES - 1500 SERIES - REMOVAL	5-37	REFRIGERANT OIL - DESCRIPTION	24-56
REAR AXLE - 248RBI - OPERATION	3-109	REAR PARK BRAKE CABLES 2500/3500 SERIES WITH DRUM BRAKES - REMOVAL	5-38	REFRIGERANT OIL - OPERATION	24-56
REAR AXLE - 248RBI - REMOVAL	3-113	REAR SEAL AREA LEAKS - DIAGNOSIS AND TESTING	9-10	REFRIGERANT OIL LEVEL - STANDARD PROCEDURE	24-57
REAR AXLE - 267RBI - ADJUSTMENTS	3-145	REAR SEAT - INSTALLATION	23-144	REFRIGERANT RECOVERY - STANDARD PROCEDURE	24-45
REAR AXLE - 267RBI - DESCRIPTION	3-140	REAR SEAT - REMOVAL	23-144	REFRIGERANT SYSTEM CHARGE - STANDARD PROCEDURE	24-46
REAR AXLE - 267RBI - INSTALLATION	3-145	REAR SEAT BELT & RETRACTOR - INSTALLATION	80-26	REFRIGERANT SYSTEM EVACUATE - STANDARD PROCEDURE	24-45
REAR AXLE - 267RBI - OPERATION	3-140	REAR SEAT BELT & RETRACTOR - REMOVAL	80-26	REFRIGERANT SYSTEM LEAKS - DIAGNOSIS AND TESTING	24-43
REAR AXLE - 267RBI - REMOVAL	3-144	REAR SEAT BELT BUCKLE - INSTALLATION	80-27	REFRIGERANT SYSTEM SERVICE EQUIPMENT - STANDARD PROCEDURE	24-44
REAR AXLE - 286RBI - ADJUSTMENTS	3-174	REAR SEAT BELT BUCKLE - REMOVAL	80-27	REFRIGERANT SYSTEM SERVICE PORT - DESCRIPTION	24-1
REAR AXLE - 286RBI - DESCRIPTION	3-169	REAR SERVO - ASSEMBLY	21-251,21-422,21-595,21-768	REFRIGERANT SYSTEM SERVICE PORT - OPERATION	24-2
REAR AXLE - 286RBI - INSTALLATION	3-174	REAR SERVO - CLEANING	21-251,21-422,21-594,21-768	REGULATOR - DESCRIPTION, FUEL FILTER/PRESSURE	14-5
REAR AXLE - 286RBI - OPERATION	3-169	REAR SERVO - DESCRIPTION	21-250,21-421,21-594,21-767	REGULATOR - DESCRIPTION, VOLTAGE	8F-31
REAR AXLE - 286RBI - REMOVAL	3-173	REAR SERVO - DISASSEMBLY	21-251,21-421,21-594,21-768	REGULATOR - INSTALLATION, FUEL FILTER/PRESSURE	14-6
REAR AXLE - 9 1/4 - ADJUSTMENTS	3-84	REAR SERVO - OPERATION	21-250,21-421,21-594,21-767	REGULATOR - INSTALLATION, WINDOW	23-76
REAR AXLE - 9 1/4 - DESCRIPTION	3-77	REAR SPLASH SHIELD - INSTALLATION	23-96	REGULATOR - OPERATION, FUEL FILTER/PRESSURE	14-5
REAR AXLE - 9 1/4 - INSTALLATION	3-84	REAR SPLASH SHIELD - REMOVAL	23-96	REGULATOR - OPERATION, VOLTAGE	8F-31
REAR AXLE - 9 1/4 - OPERATION	3-77	REAR VIEW MIRROR - INSTALLATION	23-126	REGULATOR - REMOVAL, FUEL FILTER/PRESSURE	14-5
REAR AXLE - 9 1/4 - REMOVAL	3-83	REAR VIEW MIRROR - REMOVAL	23-126	REGULATOR - REMOVAL, WINDOW	23-75
REAR AXLE, 248RBI	3-122	REAR WHEEL INSTALLATION - STANDARD PROCEDURE, DUAL	22-10	RELAY - DESCRIPTION, A/C COMPRESSOR CLUTCH	24-17
REAR AXLE, 267RBI	3-153	REAR WHEELHOUSE LINER - INSTALLATION	23-96	RELAY - DESCRIPTION, BLOWER MOTOR	24-22
REAR AXLE, 286 RBI	3-182	REAR WHEELHOUSE LINER - REMOVAL	23-96	RELAY - DESCRIPTION, ENGINE STARTER MOTOR	8F-42
REAR AXLE, 286RBI	3-182	REARVIEW MIRROR SUPPORT BRACKET - INSTALLATION	23-126	RELAY - DESCRIPTION, FUEL HEATER	14-63
REAR AXLE, 9 1/4	3-90	RECEIVER - INSTALLATION, ASH	23-109	RELAY - DESCRIPTION, FUEL INJECTION PUMP	14-99
REAR BEARING - INSTALLATION, OUTPUT SHAFT	21-213,21-384,21-560,21-731	RECEIVER - REMOVAL, ASH	23-108	RELAY - DESCRIPTION, FUEL PUMP	14-41
REAR BEARING - REMOVAL, OUTPUT SHAFT	21-213,21-384,21-560,21-731	RECEIVING - INSPECTION	30-3	RELAY - DESCRIPTION, HEADLAMP	8L-16
REAR BRAKE DRUM - ADJUSTMENT	5-34	RECIRCULATION DOOR - INSTALLATION	24-39	RELAY - DESCRIPTION, HEATED SEAT	8G-11
REAR BRAKE SHOES-11 INCH - INSTALLATION	5-27	RECIRCULATION DOOR - REMOVAL	24-39	RELAY - DESCRIPTION, HORN	8H-3
REAR BRAKE SHOES-11 INCH - REMOVAL	5-25	RECIRCULATION DOOR ACTUATOR - INSTALLATION	24-28	RELAY - DESCRIPTION, INTAKE AIR HEATER	14-101
REAR BUMPER - INSTALLATION	13-5	RECIRCULATION DOOR ACTUATOR - REMOVAL	24-27	RELAY - DESCRIPTION, RADIO CHOKE	8A-8
REAR BUMPER - REMOVAL	13-5	RECLINER - DIAGNOSIS & TESTING, POWER SEAT	8N-21	RELAY - DESCRIPTION, WIPER	8R-15
REAR CAB SIDE PANEL SPEAKER - INSTALLATION	8A-21	RECLINER - INSTALLATION, SEAT BACK	23-138	RELAY - DIAGNOSIS & TESTING, HEATED SEAT	8G-12
REAR CAB SIDE PANEL SPEAKER - REMOVAL	8A-20	RECLINER - REMOVAL, SEAT BACK	23-138	RELAY - DIAGNOSIS AND TESTING, A/C COMPRESSOR CLUTCH	24-17
REAR CLOSURE PANEL TRIM - INSTALLATION	23-121	RECLINER MOTOR - DESCRIPTION	8N-20	RELAY - DIAGNOSIS AND TESTING, BLOWER MOTOR	24-22
REAR CLOSURE PANEL TRIM - REMOVAL	23-120	RECLINER MOTOR - OPERATION	8N-21	RELAY - DIAGNOSIS AND TESTING, FUEL HEATER	14-64
REAR CLUTCH - ASSEMBLY	21-248,21-419,21-593,21-766	RECOVERY - STANDARD PROCEDURE, REFRIGERANT	24-45	RELAY - DIAGNOSIS AND TESTING, HEADLAMP	8L-17
REAR CLUTCH - CLEANING	21-247,21-418,21-593,21-765	RECOVERY CONTAINER - 3.9L/5.2L/5.9L/5.9L DIESEL - DESCRIPTION, COOLANT	7-41	RELAY - DIAGNOSIS AND TESTING, HORN	8H-3
REAR CLUTCH - DESCRIPTION	21-246,21-417,21-591,21-764	RECOVERY CONTAINER - 3.9L/5.2L/5.9L/5.9L DIESEL - INSTALLATION, COOLANT	7-41	RELAY - DIAGNOSIS AND TESTING, RADIO CHOKE	8A-8
REAR CLUTCH - DISASSEMBLY	21-247,21-418,21-592,21-765	RECOVERY CONTAINER - 3.9L/5.2L/5.9L/5.9L DIESEL - OPERATION, COOLANT	7-41	RELAY - DIAGNOSIS AND TESTING, STARTER	8F-42
REAR CLUTCH - INSPECTION	21-248,21-419,21-593,21-765	RECOVERY CONTAINER - 3.9L/5.2L/5.9L/5.9L DIESEL - REMOVAL, COOLANT	7-41	RELAY - DIAGNOSIS AND TESTING, WIPER	8R-16
REAR CLUTCH - OPERATION	21-246,21-417,21-592,21-764	RECOVERY CONTAINER - 8.0L - DESCRIPTION, COOLANT	7-42	RELAY - INSTALLATION, A/C COMPRESSOR CLUTCH	24-18
REAR DISC BRAKES - DESCRIPTION, 2500/3500 WITH	5-35	RECOVERY CONTAINER - 8.0L - OPERATION, COOLANT	7-42	RELAY - INSTALLATION, AUTOMATIC SHUT DOWN	8I-5
REAR DISC BRAKES - INSTALLATION, REAR PARK BRAKE CABLE - 2500/3500 WITH	5-38	REFACING, ENGINE BLOCK - STANDARD PROCEDURE-CYLINDER BLOCK	9-263	RELAY - INSTALLATION, BLOWER MOTOR	24-23
REAR DISC BRAKES - OPERATION, 2500/3500 WITH	5-36	REFERENCES - DESCRIPTION, TORQUE	Intro-9	RELAY - INSTALLATION, ENGINE STARTER MOTOR	8F-43
REAR DISC BRAKES - REMOVAL, REAR PARK BRAKE CABLE - 2500/3500 WITH	5-37	REFILL - STANDARD PROCEDURE, FLUID DRAIN	21-851,21-885,21-922	RELAY - INSTALLATION, FUEL HEATER	14-65
REAR DOOR SPEAKER - INSTALLATION	8A-21	REFILLING COOLING SYSTEM 3.9L/5.2L/5.9L/8.0L ENGINES - STANDARD PROCEDURE	7-15	RELAY - INSTALLATION, FUEL PUMP	14-41
REAR DOOR SPEAKER - REMOVAL	8A-21			RELAY - INSTALLATION, HEADLAMP	8L-18
REAR DRUM IN HAT PARK BRAKE SHOES - 2500/3500 - INSTALLATION	5-42			RELAY - INSTALLATION, HEATED SEAT	8G-13
REAR DRUM IN HAT PARK BRAKE SHOES - 2500/3500 - REMOVAL	5-41			RELAY - INSTALLATION, INTAKE AIR HEATER	14-102
REAR FENDER - INSTALLATION	23-95			RELAY - INSTALLATION, RADIO CHOKE	8A-9
REAR FENDER - REMOVAL	23-95			RELAY - INSTALLATION, WIPER	8R-17
REAR FLOOR STOWAGE TRAY - INSTALLATION	23-121				
REAR FLOOR STOWAGE TRAY - REMOVAL	23-121				
REAR MOUNT - INSTALLATION	9-101,9-158,9-213,9-291,9-44				
REAR MOUNT - REMOVAL	9-101,9-157,9-213,9-291,9-44				
REAR OIL SEAL RETAINER - INSTALLATION, CRANKSHAFT	9-206,9-279				

Description	Group-Page	Description	Group-Page	Description	Group-Page
RELAY - OPERATION, A/C COMPRESSOR CLUTCH	24-17	REPAIR - STANDARD PROCEDURE, ALUMINUM THREAD	21-159,21-330,21-502,21-673	RETRACTORS AND HEAD RESTRAINTS - INSPECTION, SEAT BELTS, SHOULDER BELTS	30-12
RELAY - OPERATION, BLOWER MOTOR	24-22	REPAIR - STANDARD PROCEDURE, CAM BORE	9-267	RETURN - DESCRIPTION, HOSES	19-37
RELAY - OPERATION, ENGINE STARTER MOTOR	8F-42	REPAIR - STANDARD PROCEDURE, CYLINDER BORE	9-265	RETURN - DESCRIPTION, SENSOR	8E-17
RELAY - OPERATION, FUEL HEATER	14-63	REPAIR DAMAGED OR WORN THREADS - STANDARD PROCEDURE	9-11,9-125,9-181,9-238,9-68	RETURN - OPERATION, HOSES	19-37
RELAY - OPERATION, FUEL INJECTION PUMP	14-99	REPAIRING LEAKS - STANDARD PROCEDURES	22-8	REVOLUTIONS PER MILE, SPECIFICATIONS - TIRE	22-9
RELAY - OPERATION, FUEL PUMP	14-41	REQUIREMENTS - DESCRIPTION, COOLING SYSTEM	24-1	RIGHT FRONT FENDER - INSTALLATION	23-94
RELAY - OPERATION, HEADLAMP	8L-17	REQUIREMENTS - DIESEL ENGINE - DESCRIPTION, FUEL	0-2	RIGHT FRONT FENDER - REMOVAL	23-94
RELAY - OPERATION, HEATED SEAT	8G-12	REQUIREMENTS - GAS ENGINES - DESCRIPTION, FUEL	0-1	RING - INSTALLATION, PINION GEAR/RING GEAR/TONE	3-105,3-137,3-166,3-195
RELAY - OPERATION, HORN	8H-3	RESERVOIR - DESCRIPTION, VACUUM	24-29	RING - REMOVAL, PINION GEAR/RING GEAR/TONE	3-103,3-135,3-165,3-193
RELAY - OPERATION, INTAKE AIR HEATER	14-102	RESERVOIR - DESCRIPTION, VACUUM	8P-13	RING FITTING - STANDARD PROCEDURE	9-154,9-41,9-98
RELAY - OPERATION, RADIO CHOKE	8A-8	RESERVOIR - DESCRIPTION, WASHER	8R-10	RING FITTING, PISTON RINGS - STANDARD PROCEDURE-PISTON	9-288
RELAY - OPERATION, WIPER	8R-15	RESERVOIR - INSTALLATION, FLUID	5-15	RINGS - STANDARD PROCEDURE, FITTING PISTON	9-211
RELAY - REMOVAL, A/C COMPRESSOR CLUTCH	24-18	RESERVOIR - INSTALLATION, VACUUM	24-30	RINGS - STANDARD PROCEDURE-PISTON RING FITTING, PISTON	9-288
RELAY - REMOVAL, AUTOMATIC SHUT DOWN	8I-4	RESERVOIR - INSTALLATION, VACUUM	8P-14	RISER - INSTALLATION, SEAT	23-141
RELAY - REMOVAL, BLOWER MOTOR	24-23	RESERVOIR - INSTALLATION, WASHER	8R-11	RISER - REMOVAL, SEAT	23-141
RELAY - REMOVAL, ENGINE STARTER MOTOR	8F-43	RESERVOIR - OPERATION, VACUUM	24-29	RKE TRANSMITTER BATTERIES - STANDARD PROCEDURE	8N-8
RELAY - REMOVAL, FUEL HEATER	14-65	RESERVOIR - OPERATION, WASHER	8R-10	RKE TRANSMITTER PROGRAMMING - STANDARD PROCEDURE	8N-8
RELAY - REMOVAL, FUEL PUMP	14-41	RESERVOIR - REMOVAL, FLUID	5-15	ROAD TEST - DIAGNOSIS AND TESTING	8P-3
RELAY - REMOVAL, HEADLAMP	8L-18	RESERVOIR - REMOVAL, VACUUM	24-30	ROAD TEST - INSPECTION WINDSHIELD WIPERS/WASHERS	30-18
RELAY - REMOVAL, HEATED SEAT	8G-13	RESERVOIR - REMOVAL, VACUUM	8P-13	ROAD TEST INSPECTION - DESCRIPTION	30-15
RELAY - REMOVAL, INTAKE AIR HEATER	14-102	RESERVOIR - REMOVAL, WASHER	8R-10	ROAD TESTING - DIAGNOSIS AND TESTING	21-143,21-314,21-486,21-657
RELAY - REMOVAL, RADIO CHOKE	8A-9	RESISTANCE, 3.9L/5.2L/5.9L ENGINES - IGNITION COIL	8I-3	ROCKER ARM / ADJUSTER ASSEMBLY - INSTALLATION	9-85
RELAY - REMOVAL, WIPER	8R-17	RESISTANCE, 8.0L V-10 ENGINE - IGNITION COIL	8I-3	ROCKER ARM / ADJUSTER ASSEMBLY - REMOVAL	9-85
RELAYS - DIAGNOSIS AND TESTING, ASD AND FUEL PUMP	8I-3	RESISTANCE, SPECIFICATIONS - SPARK PLUG CABLE	8I-3	ROCKER ARM / ADJUSTER ASSY - CLEANING	9-262
RELEASE - INSTALLATION	5-41	RESISTOR BLOCK - DESCRIPTION, BLOWER MOTOR	24-23	ROCKER ARM / ADJUSTER ASSY - DESCRIPTION	9-261
RELEASE - REMOVAL	5-40	RESISTOR BLOCK - DIAGNOSIS AND TESTING, BLOWER MOTOR	24-24	ROCKER ARM / ADJUSTER ASSY - INSPECTION	9-262
RELEASE - STANDARD PROCEDURE, FUEL SYSTEM PRESSURE	14-3	RESISTOR BLOCK - INSTALLATION, BLOWER MOTOR	24-24	ROCKER ARM / ADJUSTER ASSY - INSTALLATION	9-142,9-200,9-263
RELEASE BEARING - DESCRIPTION, CLUTCH	6-14	RESISTOR BLOCK - OPERATION, BLOWER MOTOR	24-23	ROCKER ARM / ADJUSTER ASSY - REMOVAL	9-142,9-200,9-261
RELEASE BEARING - INSTALLATION, CLUTCH	6-15	RESISTOR BLOCK - REMOVAL, BLOWER MOTOR	24-24	ROD - CLEANING, PISTON & CONNECTING	9-154,9-209,9-285,9-41,9-98
RELEASE BEARING - OPERATION, CLUTCH	6-14	RESONATOR - INSTALLATION	11-13	ROD - CONNECTING RODS, PISTON & CONNECTING	9-286
RELEASE BEARING - REMOVAL, CLUTCH	6-15	RESONATOR - REMOVAL	11-13	ROD - DESCRIPTION, PISTON & CONNECTING	9-153,9-208,9-282,9-40,9-97
RELEASE CABLE - INSTALLATION	23-83	RESTRAINTS - DESCRIPTION	80-1	ROD - INSPECTION, PISTON & CONNECTING	9-154,9-209,9-285,9-41,9-98
RELEASE CABLE - INSTALLATION, LATCH	23-101	RESTRAINTS - INSPECTION, SEAT BELTS, SHOULDER BELTS, RETRACTORS AND HEAD	30-12	ROD - INSTALLATION, PISTON & CONNECTING	9-154,9-210,9-287,9-41,9-98
RELEASE CABLE - REMOVAL	23-82	RESTRAINTS - OPERATION	80-2	ROD - REMOVAL, PISTON & CONNECTING	9-154,9-209,9-285,9-40,9-97
RELEASE CABLE - REMOVAL, LATCH	23-101	RESTRAINTS - WARNING	80-3	ROD BEARING AND CRANKSHAFT JOURNAL CLEARANCE - STANDARD PROCEDURE, CONNECTING	9-274
RELIEF VALVE - CLEANING, OIL PRESSURE	9-297	RESTRICTIONS - DIAGNOSIS AND TESTING, FUEL SUPPLY	14-56	ROD BEARING FITTING - STANDARD PROCEDURE, CONNECTING	9-144,9-202,9-88
RELIEF VALVE - DESCRIPTION, HIGH PRESSURE	24-46	RETAINER - ASSEMBLY, OVERRUNNING CLUTCH CAM/OVERDRIVE PISTON	21-236,21-406,21-581,21-752	ROD BEARING FITTING, CONNECTING	9-31
RELIEF VALVE - INSPECTION, OIL PRESSURE	9-297	RETAINER - CLEANING, OVERRUNNING CLUTCH CAM/OVERDRIVE PISTON	21-236,21-406,21-580,21-751	ROD BEARINGS - STANDARD PROCEDURE-CONNECTING	9-31
RELIEF VALVE - INSTALLATION, OIL PRESSURE	9-298	RETAINER - DESCRIPTION, OVERRUNNING CLUTCH CAM/OVERDRIVE PISTON	21-235,21-405,21-580,21-751	ROD BEARINGS - STANDARD PROCEDURE-CONNECTING ROD BEARING FITTING, CONNECTING	9-31
RELIEF VALVE - OPERATION, HIGH PRESSURE	24-46	RETAINER - DISASSEMBLY, OVERRUNNING CLUTCH CAM/OVERDRIVE PISTON	21-235,21-405,21-580,21-751	RODS, PISTON & CONNECTING ROD - CONNECTING	9-286
RELIEF VALVE - REMOVAL, OIL PRESSURE	9-297	RETAINER - INSPECTION, OVERRUNNING CLUTCH CAM/OVERDRIVE PISTON	21-236,21-406,21-580,21-752	ROLLOVER VALVE - DESCRIPTION	14-25
REMINDER - INSPECTION, TRIP COMPUTER/MAINTENANCE	30-17	RETAINER - INSTALLATION, CRANKSHAFT REAR OIL SEAL	9-206,9-279	ROLLOVER VALVE - INSTALLATION	14-27
REMINDER INDICATOR - DESCRIPTION, SERVICE	8J-28	RETAINER - OPERATION, OVERRUNNING CLUTCH CAM/OVERDRIVE PISTON	21-235,21-405,21-580,21-751	ROLLOVER VALVE - REMOVAL	14-26
REMINDER INDICATOR - OPERATION, SERVICE	8J-28	RETAINER - REMOVAL, CRANKSHAFT REAR OIL SEAL	9-206,9-278	ROOF JOINT MOLDING - INSTALLATION	23-91
REMOTE KEYLESS ENTRY SYSTEM - DESCRIPTION	8N-2	RETRACTOR - INSTALLATION, REAR SEAT BELT	80-26	ROOF JOINT MOLDING - REMOVAL	23-91
REMOTE KEYLESS ENTRY SYSTEM - DIAGNOSIS AND TESTING, POWER LOCK	8N-4	RETRACTOR - REMOVAL, REAR SEAT BELT	80-26	ROTATION - STANDARD PROCEDURES, TIRE	22-2
REMOTE KEYLESS ENTRY SYSTEM - OPERATION	8N-3			ROTOR - DIAGNOSIS AND TESTING, DISC BRAKE	5-20
REMOTE KEYLESS ENTRY TRANSMITTER - DESCRIPTION	8N-7			ROTOR - DIAGNOSIS AND TESTING, DISTRIBUTOR	8I-13
REMOTE KEYLESS ENTRY TRANSMITTER - DIAGNOSIS AND TESTING	8N-7			RUN CHANNEL - INSTALLATION, GLASS	23-70
REMOTE KEYLESS ENTRY TRANSMITTER - OPERATION	8N-7			RUN CHANNEL - REMOVAL, GLASS	23-70
REMOTE SWITCHES - DESCRIPTION	8A-15				
REMOTE SWITCHES - DIAGNOSIS AND TESTING	8A-16				
REMOTE SWITCHES - OPERATION	8A-15				
REMOVAL/INSTALLATION, FUEL FILLER CAP	25-33				
REMOVAL/INSTALLATION, FUEL HEATER	14-63				
REPAIR - DESCRIPTION, THREADED HOLE	Intro-6				



Description	Group-Page	Description	Group-Page	Description	Group-Page
RUN WEATHERSTRIP - INSTALLATION, FRONT DOOR GLASS	23-154	SEAL - REAR - INSTALLATION, CRANKSHAFT OIL	9-149,9-206,9-278,9-35,9-92	SEAT BELT TURNING LOOP ADJUSTER - REMOVAL	80-29
RUN WEATHERSTRIP - REMOVAL, FRONT DOOR GLASS	23-153	SEAL - REAR - OPERATION, CRANKSHAFT OIL	9-148,9-34,9-92	SEAT BELTS, SHOULDER BELTS, RETRACTORS AND HEAD RESTRAINTS - INSPECTION	30-12
RUNNING LAMP MODULE - DESCRIPTION, DAYTIME	8L-9	SEAL - REAR - REMOVAL, CRANKSHAFT OIL	9-149,9-206,9-278,9-35,9-92	SEAT CUSHION - INSTALLATION	23-138
RUNNING LAMP MODULE - INSTALLATION, DAYTIME	8L-9	SEAL - REMOVAL, ADAPTER HOUSING	21-132, 21-87	SEAT CUSHION - REMOVAL	23-138
RUNNING LAMP MODULE - OPERATION, DAYTIME	8L-9	SEAL - REMOVAL, B-PILLAR DOOR	23-152	SEAT CUSHION COVER - INSTALLATION	23-139
RUNNING LAMP MODULE - REMOVAL, DAYTIME	8L-9	SEAL - REMOVAL, DOOR OPENING	23-153	SEAT CUSHION COVER - REMOVAL	23-139
RUNOUT - DIAGNOSIS AND TESTING, TIRE AND WHEEL	22-1	SEAL - REMOVAL, EXTENSION HOUSING	21-132,21-198,21-369,21-544,21-714, 21-87	SEAT CUSHION COVER - SPLIT BENCH - INSTALLATION	23-140
SAFETY CERTIFICATION LABEL - DESCRIPTION, VEHICLE	Intro-12	SEAL - REMOVAL, EXTENSION HOUSING BUSHING	21-850,21-885,21-921	SEAT CUSHION COVER - SPLIT BENCH - REMOVAL	23-139
SAFETY LATCH - INSTALLATION	23-102	SEAL - REMOVAL, FRONT DOOR UPPER CORNER	23-154	SEAT ELEMENT - DESCRIPTION, HEATED	8G-10
SAFETY LATCH - REMOVAL	23-102	SEAL - REMOVAL, FRONT OUTPUT SHAFT	21-851,21-886,21-922	SEAT ELEMENT - OPERATION, HEATED	8G-10
SAFETY PRECAUTIONS AND WARNINGS, BODY	23-1	SEAL - REMOVAL, PINION	3-125,3-156,3-185, 3-34,3-66,3-95	SEAT ELEMENT AND SENSOR - DIAGNOSIS & TESTING, HEATED	8G-11
SAFETY SWITCH - INSPECTION, NEUTRAL	30-19	SEAL - REMOVAL, PITMAN SHAFT	19-23	SEAT HEATER SWITCH - DESCRIPTION, DRIVER	8G-7
SANDING/BUFFING & POLISHING - DESCRIPTION, WET	23-130	SEAL AREA LEAKS - DIAGNOSIS AND TESTING, REAR	9-10	SEAT HEATER SWITCH - DESCRIPTION, PASSENGER	8G-13
SCHEDULE (8.0L 2500 & 3500 MODELS - CALIFORNIA ONLY) - DESCRIPTION, MEDIUM DUTY TRUCK MAINTENANCE	0-13	SEAL RETAINER - INSTALLATION, CRANKSHAFT REAR OIL	9-206,9-279	SEAT HEATER SWITCH - INSTALLATION, DRIVER	8G-9
SCHEDULES - 24-VALVE CUMMINS TURBO DIESEL - DESCRIPTION, MAINTENANCE	0-22	SEAL RETAINER - REMOVAL, CRANKSHAFT REAR OIL	9-206,9-278	SEAT HEATER SWITCH - INSTALLATION, PASSENGER	8G-16
SCHEDULES - DESCRIPTION, HEAVY DUTY ENGINE (FEDERAL ONLY - 2500 8.0L HD AND 3500 5.9L & 8.0L MODELS) MAINTENANCE	0-17	SEALER LOCATIONS, SPECIFICATIONS - BODY	23-47	SEAT HEATER SWITCH - OPERATION, DRIVER	8G-7
SCHEDULES - LIGHT DUTY ENGINE (1500 AND 2500 MODELS EXCEPT 8.0L) MAINTENANCE SCHEDULES, MAINTENANCE	0-7	SEALERS - STANDARD PROCEDURE, FORM-IN-PLACE GASKETS	9-11,9-125,9-180, 9-237,9-68	SEAT HEATER SWITCH - OPERATION, PASSENGER	8G-14
SCHEDULES, MAINTENANCE SCHEDULES - LIGHT DUTY ENGINE (1500 AND 2500 MODELS EXCEPT 8.0L) MAINTENANCE	0-7	SEALING - INSPECTION, BODY	30-10	SEAT HEATER SWITCH - REMOVAL, DRIVER	8G-9
SCHEMATICS - DIAGNOSIS AND TESTING, VACUUM	25-37	SEALS - INSTALLATION, AXLE SHAFT	3-29,3-61, 3-94	SEAT HEATER SWITCH - REMOVAL, PASSENGER	8G-15
SCHEMATICS AND DIAGRAMS - HYDRAULIC SCHEMATICS	21-174,21-345, 21-520,21-690	SEALS - REMOVAL, AXLE SHAFT	3-29,3-61,3-94	SEAT RECLINER - DIAGNOSIS & TESTING, POWER	8N-21
SCHEMATICS, SCHEMATICS AND DIAGRAMS - HYDRAULIC	21-174,21-345, 21-520,21-690	SEALS - REMOVAL, VALVE STEM	9-197	SEAT RELAY - DESCRIPTION, HEATED	8G-11
SEAL - DIAGNOSIS AND TESTING, RADIATOR CAP-TO-FILLER NECK	7-66	SEAT - BENCH SEAT - INSTALLATION	23-133	SEAT RELAY - DIAGNOSIS & TESTING, HEATED	8G-12
SEAL - FRONT - DESCRIPTION, CRANKSHAFT OIL	9-147,9-34,9-91	SEAT - BENCH SEAT - REMOVAL	23-133	SEAT RELAY - INSTALLATION, HEATED	8G-13
SEAL - FRONT - INSTALLATION, CRANKSHAFT OIL	9-148,9-277,9-34,9-91	SEAT - INSTALLATION, REAR	23-144	SEAT RELAY - OPERATION, HEATED	8G-12
SEAL - FRONT - OPERATION, CRANKSHAFT OIL	9-147,9-34,9-91	SEAT - INSTALLATION, SEAT - BENCH	23-133	SEAT RELAY - REMOVAL, HEATED	8G-13
SEAL - FRONT - REMOVAL, CRANKSHAFT OIL	9-147,9-276,9-34,9-91	SEAT - INSTALLATION, SEAT BACK - BENCH	23-135	SEAT RISER - INSTALLATION	23-141
SEAL - FRONT COVER INSTALLED - INSTALLATION, FRONT OIL	9-205	SEAT - REMOVAL, REAR	23-144	SEAT RISER - REMOVAL	23-141
SEAL - FRONT COVER INSTALLED - REMOVAL, FRONT OIL	9-204	SEAT - REMOVAL, SEAT - BENCH	23-133	SEAT SWITCH - DESCRIPTION, DRIVER POWER	8N-16
SEAL - FRONT COVER REMOVED - INSTALLATION, FRONT OIL	9-205	SEAT - REMOVAL, SEAT BACK - BENCH	23-135	SEAT SWITCH - DESCRIPTION, PASSENGER POWER	8N-19
SEAL - FRONT COVER REMOVED - REMOVAL, FRONT OIL	9-204	SEAT - SPLIT BENCH - INSTALLATION	23-134	SEAT SWITCH - DIAGNOSIS & TESTING, DRIVER POWER	8N-16
SEAL - INSTALLATION, ADAPTER HOUSING	21-132,21-87	SEAT - SPLIT BENCH - REMOVAL	23-134	SEAT SWITCH - DIAGNOSIS & TESTING, HEATED	8G-14,8G-8
SEAL - INSTALLATION, B-PILLAR DOOR	23-152	SEAT ARMREST/CONSOLE - INSTALLATION, CENTER	23-132	SEAT SWITCH - DIAGNOSIS & TESTING, PASSENGER POWER	8N-19
SEAL - INSTALLATION, DOOR OPENING	23-153	SEAT ARMREST/CONSOLE - REMOVAL, CENTER	23-132	SEAT SWITCH - INSTALLATION, DRIVER POWER	8N-17
SEAL - INSTALLATION, EXTENSION HOUSING	21-132,21-198,21-369,21-544,21-715, 21-87	SEAT ARMREST/LATCH COVER - INSTALLATION, CENTER	23-132	SEAT SWITCH - INSTALLATION, PASSENGER POWER	8N-20
SEAL - INSTALLATION, EXTENSION HOUSING BUSHING	21-850,21-885,21-921	SEAT ARMREST/LATCH COVER - REMOVAL, CENTER	23-132	SEAT SWITCH - OPERATION, DRIVER POWER	8N-16
SEAL - INSTALLATION, FRONT DOOR UPPER CORNER	23-154	SEAT BACK - BENCH SEAT - INSTALLATION	23-135	SEAT SWITCH - OPERATION, PASSENGER POWER	8N-19
SEAL - INSTALLATION, FRONT OUTPUT SHAFT	21-852,21-886,21-922	SEAT BACK - BENCH SEAT - REMOVAL	23-135	SEAT SWITCH - REMOVAL, DRIVER POWER	8N-17
SEAL - INSTALLATION, PINION	3-125,3-157, 3-185,3-34,3-66,3-95	SEAT BACK - SPLIT BENCH - INSTALLATION	23-136	SEAT SWITCH - REMOVAL, PASSENGER POWER	8N-20
SEAL - INSTALLATION, PITMAN SHAFT	19-24	SEAT BACK COVER - INSTALLATION	23-137	SEAT SYSTEM - DESCRIPTION, HEATED	8G-5
SEAL - INSTALLATION, VALVE STEM	9-198	SEAT BACK COVER - REMOVAL	23-137	SEAT SYSTEM - DESCRIPTION, POWER	8N-15
SEAL - REAR - DESCRIPTION, CRANKSHAFT OIL	9-148,9-34,9-91	SEAT BACK COVER - SPLIT BENCH - INSTALLATION	23-138	SEAT SYSTEM - DIAGNOSIS & TESTING, HEATED	8G-6
		SEAT BACK COVER - SPLIT BENCH - REMOVAL	23-137	SEAT SYSTEM - DIAGNOSIS & TESTING, POWER	8N-15
		SEAT BACK RECLINER - INSTALLATION	23-138	SEAT SYSTEM - OPERATION, HEATED	8G-6
		SEAT BACK RECLINER - REMOVAL	23-138	SEAT SYSTEM - OPERATION, POWER	8N-15
		SEAT BELT & RETRACTOR - INSTALLATION, REAR	80-26	SEAT TRACK - DESCRIPTION, POWER	8N-21
		SEAT BELT & RETRACTOR - REMOVAL, REAR	80-26	SEAT TRACK - DIAGNOSIS & TESTING, POWER	8N-21
		SEAT BELT BUCKLE - INSTALLATION, FRONT	80-20	SEAT TRACK - INSTALLATION	23-141
		SEAT BELT BUCKLE - INSTALLATION, REAR	80-27	SEAT TRACK - INSTALLATION, EASY ENTRY	23-142
		SEAT BELT BUCKLE - REMOVAL, FRONT	80-20	SEAT TRACK - INSTALLATION, POWER	8N-22
		SEAT BELT BUCKLE - REMOVAL, REAR	80-27	SEAT TRACK - OPERATION, POWER	8N-21
		SEAT BELT SWITCH - DESCRIPTION	80-28	SEAT TRACK - REMOVAL	23-141
		SEAT BELT SWITCH - DIAGNOSIS AND TESTING	80-28	SEAT TRACK - REMOVAL, EASY ENTRY	23-142
		SEAT BELT SWITCH - OPERATION	80-28	SEAT TRACK - REMOVAL, POWER	8N-22
		SEAT BELT TURNING LOOP ADJUSTER - INSTALLATION	80-29	SEAT TRACK - SPLIT BENCH - INSTALLATION	23-142
				SEAT TRACK - SPLIT BENCH - REMOVAL	23-142
				SEAT TRACK ADJUSTER - INSTALLATION	23-143

Description	Group-Page	Description	Group-Page	Description	Group-Page
SEAT TRACK ADJUSTER - REMOVAL	23-143	SENSOR - INSTALLATION, BATTERY		SEVERAL LOADS - STANDARD	
SEATBELT INDICATOR - DESCRIPTION	8J-27	TEMPERATURE	8F-29	PROCEDURE, TESTING FOR SHORT TO	
SEATBELT INDICATOR - OPERATION	8J-27	SENSOR - INSTALLATION, FUEL LEVEL		GROUND ON FUSES POWERING	8W-01-7
SEATS - CLEANING, INTAKE/EXHAUST		SENDING UNIT	14-9	SHAFT - ASSEMBLY, PLANETARY	
VALVES	9-140,9-198,9-27,9-84	SENSOR - INSTALLATION, MAP	14-104	GEARTRAIN/OUTPUT	21-241,21-412,21-588, 21-760
SEATS - DESCRIPTION	23-131	SENSOR - INSTALLATION, O2	14-48	SHAFT - DESCRIPTION, PLANETARY	
SEATS - DESCRIPTION, INTAKE/		SENSOR - OPERATION, ACCELERATOR		GEARTRAIN/OUTPUT	21-240,21-410,21-585, 21-757
EXHAUST VALVES	9-138,9-195,9-25,9-253,9-81	PEDAL POSITION	14-91	SHAFT - DESCRIPTION, PROPELLER	3-1
SEATS - INSPECTION	30-13	SENSOR - OPERATION, AMBIENT TEMP	8M-11	SHAFT - DIAGNOSIS AND TESTING,	
SEATS - INSPECTION, INTAKE/EXHAUST		SENSOR - OPERATION, BATTERY		PROPELLER	3-3
VALVES	9-141,9-198,9-27,9-84	TEMPERATURE	8F-29	SHAFT - DISASSEMBLY, PLANETARY	
SEATS - INSTALLATION, INTAKE/		SENSOR - OPERATION, FUEL LEVEL		GEARTRAIN/OUTPUT	21-240,21-411,21-586, 21-757
EXHAUST VALVES	9-141,9-260,9-28,9-85	SENDING UNIT	14-7,14-73	SHAFT - FRONT - INSTALLATION,	
SEATS - OPERATION	23-131	SENSOR - OPERATION, FUEL		PROPELLER	3-8
SEATS - REMOVAL, INTAKE/EXHAUST		TEMPERATURE	14-100	SHAFT - FRONT - REMOVAL,	
VALVES	9-140,9-258,9-27,9-84	SENSOR - OPERATION, O2	14-46	PROPELLER	3-8
SEATS - STANDARD PROCEDURE-		SENSOR - OPERATION, SPEED	21-253,21-424, 21-597,21-770	SHAFT - INSPECTION, PLANETARY	
VALVES, GUIDES AND SPRINGS,		SENSOR - OPERATION, THROTTLE		GEARTRAIN/OUTPUT	21-241,21-411,21-587, 21-760
INTAKE/EXHAUST VALVES	9-253	POSITION	14-51	SHAFT - INSTALLATION, PITMAN	19-23
SEATS - VALVE SERVICE, INTAKE/		SENSOR - OPERATION, TRANSMISSION		SHAFT - INSTALLATION, WORM	19-29
EXHAUST VALVES	9-195	TEMPERATURE	21-262,21-433,21-606,21-779	SHAFT - OPERATION, PLANETARY	
SECOND WEATHERSTRIP -		SENSOR - OPERATION, WATER IN FUEL	14-85	GEARTRAIN/OUTPUT	21-240,21-410,21-585, 21-757
INSTALLATION, FRONT DOOR	23-155	SENSOR - REMOVAL, ACCELERATOR		SHAFT - OPERATION, PROPELLER	3-1
SECOND WEATHERSTRIP - REMOVAL,		PEDAL POSITION	14-91	SHAFT - REAR - INSTALLATION,	
FRONT DOOR	23-154	SENSOR - REMOVAL, AMBIENT TEMP	8M-12	PROPELLER	3-9
SECURITY - DESCRIPTION, VEHICLE		SENSOR - REMOVAL, BATTERY		SHAFT - REAR - REMOVAL, PROPELLER	3-9
THEFT	8Q-1	TEMPERATURE	8F-29	SHAFT - REMOVAL, PITMAN	19-22
SECURITY - OPERATION, VEHICLE THEFT	8Q-2	SENSOR - REMOVAL, FUEL LEVEL		SHAFT - REMOVAL, WORM	19-27
SECURITY SYSTEM - DIAGNOSIS AND		SENDING UNIT	14-8	SHAFT - STANDARD PROCEDURES,	
TESTING, VEHICLE THEFT	8Q-3	SENSOR - REMOVAL, O2	14-47	PROPELLER	3-5
SELECTION-ADDITIVES - STANDARD		SENSOR - REMOVAL, WATER IN FUEL	14-85	SHAFT FRONT BEARING -	
PROCEDURE, COOLANT	7-17	SENSOR RETURN - DESCRIPTION	8E-17	INSTALLATION, OUTPUT	21-213,21-384,21-560, 21-730
SELECTOR INDICATOR - DESCRIPTION,		SENSOR/SWITCH - DESCRIPTION, OIL		SHAFT FRONT BEARING - REMOVAL,	
GEAR	8J-21	PRESSURE	9-298,9-49	OUTPUT	21-213,21-384,21-559,21-730
SELECTOR INDICATOR - OPERATION,		SENSOR/SWITCH - INSTALLATION, OIL		SHAFT REAR BEARING - INSTALLATION,	
GEAR	8J-21	PRESSURE	9-298,9-49	OUTPUT	21-213,21-384,21-560,21-731
SENDING UNIT - DIAGNOSIS AND		SENSOR/SWITCH - OPERATION, OIL		SHAFT REAR BEARING - REMOVAL,	
TESTING, FUEL GAUGE	14-8	PRESSURE	9-298,9-49	OUTPUT	21-213,21-384,21-560,21-731
SENDING UNIT / SENSOR -		SEPARATOR - DESCRIPTION, FUEL		SHAFT SEAL - INSTALLATION, FRONT	
DESCRIPTION, FUEL LEVEL	14-7,14-73	FILTER / WATER	14-59	OUTPUT	21-852,21-886,21-922
SENDING UNIT / SENSOR -		SEPARATOR - INSTALLATION, FUEL		SHAFT SEAL - INSTALLATION, PITMAN	19-24
INSTALLATION, FUEL LEVEL	14-9	FILTER / WATER	14-61	SHAFT SEAL - REMOVAL, FRONT	
SENDING UNIT / SENSOR - OPERATION,		SEPARATOR - OPERATION, FUEL FILTER		OUTPUT	21-851,21-886,21-922
FUEL LEVEL	14-7,14-73	/ WATER	14-59	SHAFT SEAL - REMOVAL, PITMAN	19-23
SENDING UNIT / SENSOR - REMOVAL,		SEPARATOR - REMOVAL, FUEL FILTER /		SHAFT SEALS - INSTALLATION, AXLE	3-29,3-61, 3-94
FUEL LEVEL	14-8	WATER	14-60	SHAFT SEALS - REMOVAL, AXLE	3-29,3-61,3-94
SENSE - DESCRIPTION, IGNITION		SERIES - INSTALLATION, REAR PARK		SHAFT SPECIAL TOOLS - PROPELLER	3-8
CIRCUIT	8E-17	BRAKE CABLES - 1500	5-39	SHAFT, SPECIFICATIONS - PROPELLER	3-8
SENSE - OPERATION, IGNITION CIRCUIT	8E-19	SERIES - REMOVAL, REAR PARK BRAKE		SHAFTS - INSTALLATION, AXLE	3-125,3-156, 3-185,3-28,3-60,3-93
SENSE - PCM INPUT - OPERATION, ASD	8I-3	CABLES - 1500	5-37	SHAFTS - INTERMEDIATE -	
SENSOR - 3.9L/5.2L/5.9L -		SERIES WITH DRUM BRAKES -		INSTALLATION, AXLE	3-28
DESCRIPTION, ENGINE COOLANT		INSTALLATION, REAR PARK BRAKE		SHAFTS - INTERMEDIATE - REMOVAL,	
TEMP	7-48	CABLE 2500/3500	5-39	AXLE	3-28
SENSOR - 3.9L/5.2L/5.9L -		SERIES WITH DRUM BRAKES -		SHAFTS - REMOVAL, AXLE	3-125,3-156,3-185, 3-28,3-60,3-93
INSTALLATION, ENGINE COOLANT		REMOVAL, REAR PARK BRAKE		SHIELD - INSTALLATION, REAR SPLASH	23-96
TEMP	7-48	CABLE 2500/3500	5-38	SHIELD - REMOVAL, REAR SPLASH	23-96
SENSOR - 3.9L/5.2L/5.9L - OPERATION,		SERVO - ASSEMBLY, FRONT	21-208,21-379, 21-553,21-723	SHIELDS - DESCRIPTION, HEAT	11-10
ENGINE COOLANT TEMP	7-48	SERVO - ASSEMBLY, REAR	21-251,21-422, 21-595,21-768	SHIELDS - INSTALLATION, FRONT END	
SENSOR - 3.9L/5.2L/5.9L - REMOVAL,		SERVO - CLEANING, FRONT	21-207,21-378, 21-552,21-723	SPLASH	23-92
ENGINE COOLANT TEMP	7-48	SERVO - CLEANING, REAR	21-251,21-422, 21-594,21-768	SHIELDS - INSTALLATION, HEAT	11-10
SENSOR - DESCRIPTION, ACCELERATOR		SERVO - DESCRIPTION, FRONT	21-206,21-377, 21-551,21-722	SHIELDS - REMOVAL, FRONT END	
PEDAL POSITION	14-91	SERVO - DESCRIPTION, REAR	21-250,21-421, 21-594,21-767	SPLASH	23-92
SENSOR - DESCRIPTION, AMBIENT		SERVO - DESCRIPTION, SPEED		SHIELDS - REMOVAL, HEAT	11-10
TEMP	8M-11	CONTROL	8P-5	SHIFT BOOT - INSTALLATION, 4WD	
SENSOR - DESCRIPTION, BATTERY		SERVO - DISASSEMBLY, FRONT	21-207,21-378, 21-552,21-723	FLOOR	23-122
TEMPERATURE	8F-29	SERVO - DISASSEMBLY, REAR	21-251,21-421, 21-594,21-768	SHIFT BOOT - MANUAL TRANSMISSION	
SENSOR - DESCRIPTION, FUEL LEVEL		SERVO - INSPECTION, FRONT	21-207,21-378, 21-553,21-723	- INSTALLATION	23-122
SENDING UNIT	14-7,14-73	SERVO - INSTALLATION, SPEED		SHIFT BOOT - MANUAL TRANSMISSION	
SENSOR - DESCRIPTION, FUEL		CONTROL	8P-10	- REMOVAL	23-122
TEMPERATURE	14-99	SERVO - OPERATION, FRONT	21-207,21-377, 21-552,21-723	SHIFT BOOT - REMOVAL, 4WD FLOOR	23-122
SENSOR - DESCRIPTION, O2	14-46	SERVO - OPERATION, REAR	21-250,21-421, 21-594,21-767	SHIFT COVER - INSTALLATION	21-133,21-90
SENSOR - DESCRIPTION, SPEED	21-253,21-424, 21-597,21-770	SERVO - OPERATION, SPEED CONTROL	8P-5	SHIFT COVER - REMOVAL	21-132,21-90
SENSOR - DESCRIPTION, THROTTLE		CONTROL	8P-5	SHIFT INDICATOR (TRANSFER CASE) -	
POSITION	14-51	SERVO - REMOVAL, SPEED CONTROL	8P-6	DESCRIPTION	8J-29
SENSOR - DESCRIPTION,				SHIFT INDICATOR (TRANSFER CASE) -	
TRANSMISSION TEMPERATURE	21-262,21-433, 21-606,21-779			OPERATION	8J-29
SENSOR - DESCRIPTION, WATER IN				SHIFT LEVER - ADJUSTMENT	21-853,21-888, 21-925
FUEL	14-85				
SENSOR - DIAGNOSIS & TESTING,					
AMBIENT TEMPERATURE	8M-12				
SENSOR - DIAGNOSIS & TESTING,					
HEATED SEAT ELEMENT	8G-11				
SENSOR - INSTALLATION,					
ACCELERATOR PEDAL POSITION	14-93				
SENSOR - INSTALLATION, AMBIENT					
TEMP	8M-13				



Description	Group-Page	Description	Group-Page	Description	Group-Page
SHIFT LEVER - INSTALLATION	21-853,21-888,21-924	SIGNAL LAMP UNIT - INSTALLATION, PARK/TURN	8L-29	SPECIAL TOOLS - LINK/COIL SUSPENSION	2-16
SHIFT LEVER - INSTALLATION, GEAR	19-13	SIGNAL LAMP UNIT - REMOVAL, PARK/TURN	8L-29	SPECIAL TOOLS - NV5600 MANUAL TRANSMISSION	21-127
SHIFT LEVER - REMOVAL	21-852,21-887,21-924	SIGNALS - INSPECTION, TURN AND EMERGENCY	30-19	SPECIAL TOOLS - OVERHEAD CONSOLE SYSTEMS	8M-8
SHIFT LEVER - REMOVAL, GEAR	19-13	SILENCER PAD - INSTALLATION	23-103	SPECIAL TOOLS - POWER DISTRIBUTION SYSTEMS	8W-97-2
SHIFT MECHANISM - ADJUSTMENT	21-252,21-423,21-596,21-769	SILENCER PAD - REMOVAL	23-103	SPECIAL TOOLS - POWER STEERING GEAR	19-20
SHIFT MECHANISM - DESCRIPTION	21-251,21-422,21-595,21-768	SILL TRIM - INSTALLATION, DOOR	23-121	SPECIAL TOOLS - POWER STEERING PUMP	19-36
SHIFT MECHANISM - INSTALLATION	21-89	SILL TRIM - REMOVAL, DOOR	23-121	SPECIAL TOOLS - PROPELLER SHAFT	3-8
SHIFT MECHANISM - OPERATION	21-251,21-422,21-595,21-768	SINGLE CARDAN UNIVERSAL JOINTS - DISASSEMBLY	3-11	SPECIAL TOOLS - RE TRANSMISSION	21-534,21-704
SHIFT MECHANISM - REMOVAL	21-88	SINGLE CARDAN UNIVERSAL JOINTS - INSTALLATION	3-34,3-66	SPECIAL TOOLS - RE TRANSMISSIONS	21-188,21-359
SHIFT/CLUTCH INTERLOCK SYSTEM - INSPECTION	30-19	SINGLE CARDAN UNIVERSAL JOINTS - REMOVAL	3-33,3-65	SPECIAL TOOLS - STEERING LINKAGE	19-39,19-42
SHIPPED LOOSE ITEMS - INSTALLATION	30-14	SKID PLATE - INSTALLATION, TRANSFER CASE	13-11	SPECIAL TOOLS - SUSPENSION-REAR	2-28
SHOCK - DESCRIPTION	2-11,2-21,2-28	SKID PLATE - REMOVAL, TRANSFER CASE	13-11	SPECIAL TOOLS, AIRBAG SYSTEM	80-6
SHOCK - DIAGNOSIS AND TESTING	2-11,2-21	SLAM BUMPER - INSTALLATION	23-66	SPECIAL TOOLS, WIRING/TERMINAL	8W-01-8
SHOCK - DIAGNOSIS AND TESTING, SPRING	2-26	SLAM BUMPER - REMOVAL	23-66	SPECIFICATIONS - 2001 BR PAINT COLOR CODES	23-129
SHOCK - INSTALLATION	2-11,2-21,2-28	SMOKE DIAGNOSIS CHARTS - DIAGNOSIS AND TESTING	9-234	SPECIFICATIONS - 3.9L ENGINE	9-14
SHOCK - OPERATION	2-11,2-21,2-28	SOLENOID - DESCRIPTION	21-252,21-423,21-596,21-769	SPECIFICATIONS - 5.2L ENGINE	9-72
SHOCK - REMOVAL	2-11,2-21,2-28	SOLENOID - DESCRIPTION, EVAP/PURGE	25-32	SPECIFICATIONS - 5.9L DIESEL	9-242
SHOES - 2500/3500 - INSTALLATION, REAR DRUM IN HAT PARK BRAKE	5-42	SOLENOID - INSTALLATION, EVAP/PURGE	25-32	SPECIFICATIONS - 5.9L ENGINE	9-129
SHOES - 2500/3500 - REMOVAL, REAR DRUM IN HAT PARK BRAKE	5-41	SOLENOID - OPERATION	21-253,21-424,21-597,21-770	SPECIFICATIONS - 8.0L ENGINE	9-184
SHOES-11 INCH - INSTALLATION, REAR BRAKE	5-27	SOLENOID - REMOVAL, EVAP/PURGE	25-32	SPECIFICATIONS - A/C APPLICATION TABLE	24-8
SHOES-11 INCH - REMOVAL, REAR BRAKE	5-25	SOLID LIFTERS/TAPPETS - CLEANING	9-281	SPECIFICATIONS - ALIGNMENT	2-6
SHORT TO GROUND - STANDARD PROCEDURE, TESTING FOR A	8W-01-6	SOLID LIFTERS/TAPPETS - INSPECTION	9-281	SPECIFICATIONS - BASE BRAKE	5-2
SHORT TO GROUND ON FUSES POWERING SEVERAL LOADS - STANDARD PROCEDURE, TESTING	8W-01-7	SOLID LIFTERS/TAPPETS - INSTALLATION	9-281	SPECIFICATIONS - BATTERY	8F-6
SHOULDER BELTS, RETRACTORS AND HEAD RESTRAINTS - INSPECTION, SEAT BELTS	30-12	SOLID LIFTERS/TAPPETS - REMOVAL	9-280	SPECIFICATIONS - BODY GAP AND FLUSH MEASUREMENTS	23-56
SHUT DOWN RELAY - INSTALLATION, AUTOMATIC	8I-5	SPARE TIRE - DESCRIPTION	22-9	SPECIFICATIONS - BODY OPENING DIMENSIONS	23-60
SHUT DOWN RELAY - REMOVAL, AUTOMATIC	8I-4	SPARE TIRE WINCH - INSTALLATION	13-10	SPECIFICATIONS - BODY SEALER LOCATIONS	23-47
SHUTFACE HANDLE - INSTALLATION	23-83	SPARE TIRE WINCH - REMOVAL	13-10	SPECIFICATIONS - BRAKE FLUID	5-15
SHUTFACE HANDLE - REMOVAL	23-83	SPARK PLUG - CLEANING	8I-19	SPECIFICATIONS - FLUID CAPACITIES	0-6
SIDE MOLDINGS - INSTALLATION, BODY	23-87	SPARK PLUG - DESCRIPTION	8I-16	SPECIFICATIONS - FRAME DIMENSION	13-7
SIDE MOLDINGS - REMOVAL, BODY	23-87	SPARK PLUG - INSTALLATION	8I-19	SPECIFICATIONS - FUEL INJECTION PUMP DATA PLATE	14-73
SIDE PANEL SPEAKER - INSTALLATION, REAR CAB	8A-21	SPARK PLUG - OPERATION	8I-16	SPECIFICATIONS - GENERATOR RATINGS	8F-28
SIDE PANEL SPEAKER - REMOVAL, REAR CAB	8A-20	SPARK PLUG - REMOVAL	8I-18	SPECIFICATIONS - IGNITION TIMING	8I-3
SIDE VIEW MIRROR - INSTALLATION	23-97	SPARK PLUG CABLE - DESCRIPTION	8I-19	SPECIFICATIONS - POWER STEERING GEAR	19-19
SIDE VIEW MIRROR - LOW MOUNTED - INSTALLATION	23-98	SPARK PLUG CABLE - INSTALLATION	8I-20	SPECIFICATIONS - PROPELLER SHAFT	3-8
SIDE VIEW MIRROR - LOW MOUNTED - REMOVAL	23-98	SPARK PLUG CABLE - OPERATION	8I-19	SPECIFICATIONS - SPARK PLUG CABLE RESISTANCE	8I-3
SIDE VIEW MIRROR - REMOVAL	23-97	SPARK PLUG CABLE - REMOVAL	8I-20	SPECIFICATIONS - SPARK PLUGS	8I-3
SIDE VIEW MIRROR FLAG - INSTALLATION	23-74	SPARK PLUG CABLE ORDER, 8.0L V-10 ENGINE	8I-2	SPECIFICATIONS - SPECIFICATIONS	24-46
SIDE VIEW MIRROR FLAG - REMOVAL	23-74	SPARK PLUG CABLE RESISTANCE, SPECIFICATIONS	8I-3	SPECIFICATIONS - SPECIFICATIONS	21-357
SIDE VIEW MIRROR GLASS - INSTALLATION	23-98	SPARK PLUG CABLES - DIAGNOSIS AND TESTING	8I-19	SPECIFICATIONS - STARTING SYSTEM	8F-38
SIDE VIEW MIRROR GLASS - REMOVAL	23-98	SPARK PLUG CONDITIONS - DIAGNOSIS AND TESTING	8I-16	SPECIFICATIONS - STRUCTURAL ADHESIVE LOCATIONS	23-44
SIDEVIEW MIRROR - DESCRIPTION	8N-13	SPARK PLUGS, SPECIFICATIONS	8I-3	SPECIFICATIONS - TIRE REVOLUTIONS PER MILE	22-9
SIDEVIEW MIRROR - DIAGNOSIS AND TESTING	8N-13	SPEAKER - DESCRIPTION	8A-17	SPECIFICATIONS - TORQUE	7-17
SIDEVIEW MIRROR - OPERATION	8N-13	SPEAKER - DIAGNOSIS AND TESTING	8A-18	SPECIFICATIONS - TORQUE	9-133,9-18,9-187,9-243,9-76
SIDEVIEW MIRROR - REMOVAL	8N-14	SPEAKER - INSTALLATION, A-PILLAR TWEETER	8A-19	SPECIFICATIONS - TORQUE	11-5
SIGNAL & HAZARD WARNING SYSTEM - DESCRIPTION, TURN	8L-2	SPEAKER - INSTALLATION, FRONT DOOR	8A-20	SPECIFICATIONS - TORQUE CHART	5-3
SIGNAL & HAZARD WARNING SYSTEM - DIAGNOSIS AND TESTING, TURN	8L-3	SPEAKER - INSTALLATION, REAR CAB SIDE PANEL	8A-21	SPECIFICATIONS - TORQUE CHART	19-19,19-39,19-41,19-9
SIGNAL & HAZARD WARNING SYSTEM - OPERATION, TURN	8L-2	SPEAKER - INSTALLATION, REAR DOOR	8A-21	SPECIFICATIONS - TORQUE CHART	2-15,2-27,2-8
SIGNAL CANCEL CAM - DESCRIPTION, TURN	8L-30	SPEAKER - OPERATION	8A-17	SPECIFICATIONS - TORQUE CHART	22-11
SIGNAL CANCEL CAM - OPERATION, TURN	8L-31	SPEAKER - REMOVAL, A-PILLAR TWEETER	8A-19	SPECIFICATIONS - TORQUE	23-61
SIGNAL GROUND - DESCRIPTION	8E-17	SPEAKER - REMOVAL, FRONT DOOR	8A-20	SPECIFICATIONS - TORQUE	13-9
SIGNAL INDICATORS - DESCRIPTION, TURN	8J-32	SPEAKER - REMOVAL, REAR CAB SIDE PANEL	8A-20	SPECIFICATIONS - TORQUE	24-8
SIGNAL INDICATORS - DIAGNOSIS AND TESTING, TURN	8J-32	SPEAKER - REMOVAL, REAR DOOR	8A-21	SPECIFICATIONS - TRANSFER CASE	21-848,21-883,21-919
SIGNAL INDICATORS - OPERATION, TURN	8J-32	SPECIAL TOOLS - 5.2L ENGINE	9-77	SPECIFICATIONS - TRANSMISSION	21-186,21-532,21-702
SIGNAL LAMP - INSTALLATION, PARK/TURN	8L-29	SPECIAL TOOLS - 5.9L DIESEL ENGINE	9-244	SPECIFICATIONS - WELD LOCATIONS	23-4
SIGNAL LAMP - REMOVAL, PARK/TURN	8L-29	SPECIAL TOOLS - 5.9L ENGINE	9-134	SPECIFICATIONS, CLUTCH	6-7
		SPECIAL TOOLS - 8.0L ENGINE	9-188	SPECIFICATIONS, FUEL SYSTEM PRESSURE - GAS ENGINES	14-4
		SPECIAL TOOLS - AUDIO SYSTEMS	8A-4	SPECIFICATIONS, NV4500	21-83
		SPECIAL TOOLS - BASE BRAKES	5-4	SPECIFICATIONS, NV5600	21-126
		SPECIAL TOOLS - COOLING	7-18	SPECIFICATIONS, SPECIFICATIONS	24-46
		SPECIAL TOOLS - DIESEL FUEL SYSTEM	14-59	SPECIFICATIONS, SPECIFICATIONS	21-357
		SPECIAL TOOLS - FRONT AXLE	3-58		
		SPECIAL TOOLS - FRONT AXLES	3-25		
		SPECIAL TOOLS - FUEL SYSTEM	14-36,14-4		
		SPECIAL TOOLS - HEADLAMP ALIGNMENT	8L-4		
		SPECIAL TOOLS - INDEPENDENT FRONT SUSPENSION	2-9		

Description	Group-Page	Description	Group-Page	Description	Group-Page
SPECIFICATIONS, SPECIFICATIONS - TORQUE	23-61	STANDARD CAB - REMOVAL	80-18	STRAP - INSTALLATION, ENGINE-TO-BODY GROUND	8A-13
SPECIFICATIONS, SPECIFICATIONS - TORQUE	13-9	STARTER MOTOR - DESCRIPTION, ENGINE	8F-39	STRAP - INSTALLATION, HEATER CORE GROUND	8A-15
SPECIFICATIONS, SPECIFICATIONS - TORQUE	24-8	STARTER MOTOR - DIAGNOSIS AND TESTING	8F-39	STRAP - REMOVAL, CAB-TO- BED GROUND	8A-14
SPECIFICATIONS, TORQUE - FUEL DELIVERY	14-4	STARTER MOTOR - INSTALLATION, ENGINE	8F-41	STRAP - REMOVAL, ENGINE-TO-BODY GROUND	8A-13
SPECIFICATIONS, TORQUE - GAS FUEL INJECTION	14-35	STARTER MOTOR - OPERATION, ENGINE	8F-39	STRAP - REMOVAL, HEATER CORE GROUND	8A-14
SPECIFICATIONS, TORQUE - GENERATOR/CHARGING SYSTEM	8F-28	STARTER MOTOR - REMOVAL, ENGINE	8F-40	STRETCH - INSPECTION, MEASURING TIMING CHAIN	9-114,9-170,9-227,9-58
SPECIFICATIONS, TORQUE - IGNITION	8I-2	STARTER MOTOR RELAY - DESCRIPTION, ENGINE	8F-42	STRIKER - ADJUSTMENT, LATCH	23-102
SPECIFICATIONS, TORQUE - STARTING SYSTEM	8F-38	STARTER MOTOR RELAY - INSTALLATION, ENGINE	8F-43	STRIKER - INSTALLATION, GLOVE BOX LATCH	23-113
SPEED CONTROL - INSPECTION	30-17	STARTER MOTOR RELAY - OPERATION, ENGINE	8F-42	STRIKER - INSTALLATION, LATCH	23-102,23-65, 23-73
SPEED CONTROL SERVO - DESCRIPTION	8P-5	STARTER MOTOR RELAY - REMOVAL, ENGINE	8F-43	STRIKER - LOWER - INSTALLATION, LATCH	23-82
SPEED CONTROL SERVO - INSTALLATION	8P-10	STARTER RELAY - DIAGNOSIS AND TESTING	8F-42	STRIKER - LOWER - REMOVAL, LATCH	23-82
SPEED CONTROL SERVO - OPERATION	8P-5	STARTING - DESCRIPTION	8F-32	STRIKER - REMOVAL, GLOVE BOX LATCH	23-113
SPEED CONTROL SERVO - REMOVAL	8P-6	STARTING - OPERATION	8F-32	STRIKER - REMOVAL, LATCH	23-102,23-65, 23-73
SPEED CONTROL SYSTEM - DESCRIPTION	8P-1	STARTING - STANDARD PROCEDURE, JUMP	0-27	STRIKER - UPPER - INSTALLATION, LATCH	23-82
SPEED CONTROL SYSTEM - OPERATION	8P-2	STARTING SYSTEM - DIAGNOSIS AND TESTING	8F-33	STRIKER - UPPER - REMOVAL, LATCH	23-82
SPEED CONTROL SYSTEM - TORQUE	8P-4	STARTING SYSTEM - SPECIFICATIONS, TORQUE	8F-38	STRIPE - INSTALLATION, TAPE	23-88
SPEED INPUT - DESCRIPTION, VEHICLE	8P-1	STARTING SYSTEM, SPECIFICATIONS	8F-38	STRIPE - REMOVAL, TAPE	23-88
SPEED SENSOR - DESCRIPTION	21-253,21-424, 21-597,21-770	STATE DISPLAY TEST MODE - DESCRIPTION	25-1	STRIPES AND DECALS - INSTALLATION, BODY	23-87
SPEED SENSOR - OPERATION	21-253,21-424, 21-597,21-770	STATIONARY GLASS - DESCRIPTION	23-145	STRIPES AND DECALS - REMOVAL, BODY	23-87
SPEEDOMETER - DESCRIPTION	8J-30	STATIONARY GLASS - OPERATION	23-145	STRUCTURAL ADHESIVE LOCATIONS, SPECIFICATIONS	23-44
SPEEDOMETER - OPERATION	8J-30	STEERING - DESCRIPTION	19-1	STUDS - INSTALLATION	22-12
SPLASH SHIELD - INSTALLATION, REAR	23-96	STEERING - OPERATION	19-1	STUDS - REMOVAL	22-12
SPLASH SHIELD - REMOVAL, REAR	23-96	STEERING AND HANDLING - INSPECTION	30-15	SUCTION AND DISCHARGE LINE - INSTALLATION	24-51
SPLASH SHIELDS - INSTALLATION, FRONT END	23-92	STEERING COLUMN OPENING COVER - INSTALLATION	23-116	SUCTION AND DISCHARGE LINE - REMOVAL	24-50
SPLASH SHIELDS - REMOVAL, FRONT END	23-92	STEERING COLUMN OPENING COVER - REMOVAL	23-115	SUN VISOR - INSTALLATION	23-127
SPLICE LOCATIONS - DESCRIPTION	8W-95-1	STEERING FLOW AND PRESSURE - DIAGNOSIS AND TESTING, POWER	19-4	SUN VISOR - REMOVAL	23-127
SPLICING - STANDARD PROCEDURE, WIRE	8W-01-12	STEERING GEAR HOUSING PLUG - INSTALLATION	19-27	SUPPLIES - DESCRIPTION, 5 VOLT	8E-17
SPLIT BENCH - INSTALLATION, SEAT	23-134	STEERING GEAR HOUSING PLUG - REMOVAL	19-27	SUPPLIES - OPERATION, 5 VOLT	8E-19
SPLIT BENCH - INSTALLATION, SEAT BACK	23-136	STEERING GEAR LEAKAGE - DIAGNOSIS AND TESTING, POWER	19-14	SUPPLY - DIAGNOSIS AND TESTING, VACUUM	8P-2
SPLIT BENCH - INSTALLATION, SEAT BACK COVER	23-138	STEERING GEAR, SPECIAL TOOLS - POWER	19-20	SUPPLY RESTRICTIONS - DIAGNOSIS AND TESTING, FUEL	14-56
SPLIT BENCH - INSTALLATION, SEAT CUSHION COVER	23-140	STEERING GEAR, SPECIFICATIONS - POWER	19-19	SUPPORT - INSTALLATION, LUMBAR	23-133
SPLIT BENCH - INSTALLATION, SEAT TRACK	23-142	STEERING LINKAGE, SPECIAL TOOLS	19-39, 19-42	SUPPORT - REMOVAL, LUMBAR	23-133
SPLIT BENCH - REMOVAL, SEAT	23-134	STEERING PUMP - INITIAL OPERATION - STANDARD PROCEDURE, POWER	19-31	SUPPORT BRACKET - INSTALLATION, REARVIEW MIRROR	23-126
SPLIT BENCH - REMOVAL, SEAT BACK	23-135	STEERING PUMP, SPECIAL TOOLS - POWER	19-36	SUPPORT PLATE - INSTALLATION	5-32
SPLIT BENCH - REMOVAL, SEAT BACK COVER	23-137	STEERING SYSTEM - DIAGNOSIS AND TESTING, POWER	19-2	SUPPORT PLATE - REMOVAL	5-32
SPLIT BENCH - REMOVAL, SEAT CUSHION COVER	23-139	STEERING SYSTEM - STANDARD PROCEDURE, FLUSHING POWER	19-32	SUPPRESSION COMPONENTS - DESCRIPTION, RADIO NOISE	8A-12
SPLIT BENCH - REMOVAL, SEAT TRACK	23-142	STEERING WHEEL - INSTALLATION	19-13	SUPPRESSION COMPONENTS - DIAGNOSIS AND TESTING, RADIO NOISE	8A-12
SPOOL VALVE - INSTALLATION	19-26	STEERING WHEEL - REMOVAL	19-13	SUSPENSION - STANDARD PROCEDURES, ALIGNMENT LINK/COIL	2-5
SPOOL VALVE - REMOVAL	19-24	STEM SEAL - INSTALLATION, VALVE	9-198	SUSPENSION, SPECIAL TOOLS - INDEPENDENT FRONT	2-9
SPRING - DESCRIPTION	2-11,2-22,2-28	STEM SEALS - REMOVAL, VALVE	9-197	SUSPENSION, SPECIAL TOOLS - LINK/COIL	2-16
SPRING - INSTALLATION	2-12,2-22,2-29	STEPS - NEW VEHICLE PREPARATION FORM, FINAL	30-22	SUSPENSION-REAR, SPECIAL TOOLS	2-28
SPRING - OPERATION	2-11,2-22,2-28	STOP LAMP - INSTALLATION, CENTER HIGH MOUNTED	8L-6	SWITCH - DESCRIPTION	8P-12
SPRING - REMOVAL	2-11,2-22,2-28	STOP LAMP - REMOVAL, CENTER HIGH MOUNTED	8L-6	SWITCH - DESCRIPTION, A/C HIGH PRESSURE	24-20
SPRING AND SHOCK - DIAGNOSIS AND TESTING	2-26	STOP LAMP UNIT - INSTALLATION, CENTER HIGH MOUNTED	8L-6	SWITCH - DESCRIPTION, A/C LOW PRESSURE	24-21
SPRINGS - INSTALLATION, VALVES AND VALVE	9-199	STOP LAMP UNIT - REMOVAL, CENTER HIGH MOUNTED	8L-6	SWITCH - DESCRIPTION, BLOWER MOTOR	24-24
SPRINGS - REMOVAL, VALVES AND VALVE	9-197	STORAGE - DESCRIPTION, PRE DELIVERY	30-19	SWITCH - DESCRIPTION, BRAKE LAMP	8L-4
SPRINGS - STANDARD PROCEDURE, VALVES, GUIDES	9-138,9-25,9-82	STORAGE - STANDARD PROCEDURE, PRE DELIVERY	30-20	SWITCH - DESCRIPTION, CLUTCH PEDAL POSITION	6-22
SPRINGS, INTAKE/EXHAUST VALVES & SEATS - STANDARD PROCEDURE- VALVES, GUIDES	9-253	STORAGE BIN - INSTALLATION	23-116	SWITCH - DESCRIPTION, DOOR AJAR	8L-34
SPROCKETS - INSTALLATION, TIMING BELT/CHAIN	9-115,9-170,9-227,9-58	STORAGE BIN - REMOVAL	23-116	SWITCH - DESCRIPTION, DOOR CYLINDER LOCK	8N-5
SPROCKETS - REMOVAL, TIMING BELT/CHAIN	9-114,9-170,9-226,9-57	STOWAGE TRAY - INSTALLATION, REAR FLOOR	23-121	SWITCH - DESCRIPTION, DRIVER POWER SEAT	8N-16
SQUEAKS, RATTLES AND WIND NOISE - INSPECTION	30-15	STOWAGE TRAY - REMOVAL, REAR FLOOR	23-121	SWITCH - DESCRIPTION, DRIVER SEAT HEATER	8G-7
STABILIZER BAR - DESCRIPTION	2-12,2-22,2-30	STRAP - INSTALLATION, CAB-TO- BED GROUND	8A-14	SWITCH - DESCRIPTION, HEADLAMP	8L-18
STABILIZER BAR - INSTALLATION	2-12,2-23, 2-30			SWITCH - DESCRIPTION, HORN	8H-4
STABILIZER BAR - OPERATION	2-12,2-22,2-30			SWITCH - DESCRIPTION, IGNITION	19-11
STABILIZER BAR - REMOVAL	2-12,2-22,2-30				
STANCHION COVER - INSTALLATION	23-143				
STANCHION COVER - REMOVAL	23-143				
STANDARD CAB - INSTALLATION	80-19				

Description	Group-Page	Description	Group-Page	Description	Group-Page
SWITCH - DESCRIPTION, KEY-IN IGNITION	19-9	SWITCH - INSTALLATION, PARK/NEUTRAL POSITION	21-238,21-408,21-583,21-755	SWITCH AND KEY LOCK CYLINDER - DIAGNOSIS AND TESTING, IGNITION	19-10
SWITCH - DESCRIPTION, LUMBAR CONTROL	8N-17	SWITCH - INSTALLATION, PASSENGER AIRBAG ON/OFF	80-25	SWITCHES - DESCRIPTION, REMOTE	8A-15
SWITCH - DESCRIPTION, MIRROR	8G-3	SWITCH - INSTALLATION, PASSENGER POWER SEAT	8N-20	SWITCHES - DIAGNOSIS AND TESTING, REMOTE	8A-16
SWITCH - DESCRIPTION, MULTI-FUNCTION	8L-23	SWITCH - INSTALLATION, PASSENGER SEAT HEATER	8G-16	SWITCHES - INSPECTION, LIGHTS	30-12
SWITCH - DESCRIPTION, OVERDRIVE OFF	21-385,21-578,21-732	SWITCH - INSTALLATION, POWER MIRROR	8N-13	SWITCHES - OPERATION, REMOTE	8A-15
SWITCH - DESCRIPTION, OVERDRIVE OFF	21-215	SWITCH - INSTALLATION, POWER WINDOW	8N-26	SYMBOLS - DESCRIPTION, INTERNATIONAL	Intro-6
SWITCH - DESCRIPTION, PASSENGER AIRBAG ON/OFF	80-23	SWITCH - INSTALLATION, WASHER FLUID LEVEL	8R-8	SYMBOLS - DESCRIPTION, INTERNATIONAL	0-3
SWITCH - DESCRIPTION, PASSENGER POWER SEAT	8N-19	SWITCH - OPERATION	8P-12	SYSTEM AIRFLOW - DESCRIPTION, HVAC	24-31
SWITCH - DESCRIPTION, PASSENGER SEAT HEATER	8G-13	SWITCH - OPERATION, A/C HIGH PRESSURE	24-20	SYSTEM CHARGE - STANDARD PROCEDURE, REFRIGERANT	24-46
SWITCH - DESCRIPTION, POWER LOCK MIRROR	8N-8	SWITCH - OPERATION, A/C LOW PRESSURE	24-21	SYSTEM CLEANING/REVERSE FLUSHING - STANDARD PROCEDURE, COOLING	7-16
SWITCH - DESCRIPTION, POWER WINDOW	8N-24	SWITCH - OPERATION, BLOWER MOTOR	24-25	SYSTEM DIESEL ENGINE - DIAGNOSIS AND TESTING, COOLING	7-12
SWITCH - DESCRIPTION, PTO	14-48	SWITCH - OPERATION, BRAKE LAMP	8L-4	SYSTEM EVACUATE - STANDARD PROCEDURE, REFRIGERANT	24-45
SWITCH - DESCRIPTION, SEAT BELT FLUID LEVEL	80-28	SWITCH - OPERATION, CLUTCH PEDAL POSITION	6-22	SYSTEM FLOW - 3.9L/5.2L/5.9L ENGINE	7-1
SWITCH - DESCRIPTION, WASHER FLUID LEVEL	8R-7	SWITCH - OPERATION, DOOR CYLINDER LOCK	8N-5	SYSTEM FLOW - 5.9L DIESEL - DESCRIPTION, COOLING	7-1
SWITCH - DIAGNOSIS & TESTING, DOOR CYLINDER LOCK	8N-5	SWITCH - OPERATION, DRIVER POWER SEAT	8N-16	SYSTEM GAS ENGINE - DIAGNOSIS AND TESTING, COOLING	7-7
SWITCH - DIAGNOSIS & TESTING, DRIVER POWER SEAT	8N-16	SWITCH - OPERATION, DRIVER SEAT HEATER	8G-7	SYSTEM LEAKS - DIAGNOSIS AND TESTING, COOLING	7-5
SWITCH - DIAGNOSIS & TESTING, HEATED SEAT	8G-14,8G-8	SWITCH - OPERATION, HEADLAMP	8L-18	SYSTEM LEAKS - DIAGNOSIS AND TESTING, REFRIGERANT	24-43
SWITCH - DIAGNOSIS & TESTING, PASSENGER POWER SEAT	8N-19	SWITCH - OPERATION, HORN	8H-5	SYSTEM PARTS - STANDARD PROCEDURES, CLEANING FUEL	14-57
SWITCH - DIAGNOSIS AND TESTING, A/C HIGH PRESSURE	24-20	SWITCH - OPERATION, IGNITION	19-11	SYSTEM PRESSURE - GAS ENGINES - SPECIFICATIONS, FUEL	14-4
SWITCH - DIAGNOSIS AND TESTING, A/C LOW PRESSURE	24-21	SWITCH - OPERATION, LUMBAR CONTROL	8N-18	SYSTEM PRESSURE RELEASE - STANDARD PROCEDURE, FUEL	14-3
SWITCH - DIAGNOSIS AND TESTING, BLOWER MOTOR	24-25	SWITCH - OPERATION, MIRROR	8G-3	SYSTEM PRESSURES, DIESEL ENGINES - FUEL	14-58
SWITCH - DIAGNOSIS AND TESTING, BRAKE LAMP	8L-5	SWITCH - OPERATION, MULTI-FUNCTION	8L-24	SYSTEM REQUIREMENTS - DESCRIPTION, COOLING	24-1
SWITCH - DIAGNOSIS AND TESTING, DOOR AJAR	8L-34	SWITCH - OPERATION, OVERDRIVE	21-385,21-579,21-732	SYSTEM SERVICE EQUIPMENT - STANDARD PROCEDURE, REFRIGERANT	24-44
SWITCH - DIAGNOSIS AND TESTING, HEADLAMP	8L-18	SWITCH - OPERATION, OVERDRIVE OFF	21-215	SYSTEM SERVICE PORT - DESCRIPTION, REFRIGERANT	24-1
SWITCH - DIAGNOSIS AND TESTING, HEATED MIRROR	8G-3	SWITCH - OPERATION, PASSENGER AIRBAG ON/OFF	80-24	SYSTEM SERVICE PORT - OPERATION, REFRIGERANT	24-2
SWITCH - DIAGNOSIS AND TESTING, HORN	8H-5	SWITCH - OPERATION, PASSENGER POWER SEAT	8N-19	SYSTEM, SPECIAL TOOLS - DIESEL FUEL	14-59
SWITCH - DIAGNOSIS AND TESTING, IGNITION	19-11	SWITCH - OPERATION, PASSENGER SEAT HEATER	8G-14	SYSTEM, SPECIAL TOOLS - FUEL	14-36,14-4
SWITCH - DIAGNOSIS AND TESTING, MULTI-FUNCTION	8L-25	SWITCH - OPERATION, POWER LOCK	8N-8	SYSTEM, SPECIFICATIONS - STARTING	8F-38
SWITCH - DIAGNOSIS AND TESTING, PARK/NEUTRAL POSITION	21-237,21-408,21-583,21-755	SWITCH - OPERATION, POWER MIRROR	8N-12	SYSTEMS - DESCRIPTION, MONITORED	25-15
SWITCH - DIAGNOSIS AND TESTING, POWER LOCK	8N-8	SWITCH - OPERATION, POWER WINDOW	8N-24	SYSTEMS, SPECIAL TOOLS - AUDIO	8A-4
SWITCH - DIAGNOSIS AND TESTING, POWER WINDOW	8N-24	SWITCH - OPERATION, PTO	14-104,14-48	SYSTEMS, SPECIAL TOOLS - OVERHEAD CONSOLE	8M-8
SWITCH - DIAGNOSIS AND TESTING, SEAT BELT	80-28	SWITCH - OPERATION, SEAT BELT	80-28	SYSTEMS, SPECIAL TOOLS - POWER DISTRIBUTION	8W-97-2
SWITCH - INSPECTION, NEUTRAL SAFETY	30-19	SWITCH - OPERATION, WASHER FLUID LEVEL	8R-7	TABLE, SPECIFICATIONS - A/C APPLICATION	24-8
SWITCH - INSTALLATION	8P-13	SWITCH - REMOVAL	8P-13	TACHOMETER - DESCRIPTION	8J-30
SWITCH - INSTALLATION, A/C HIGH PRESSURE	24-21	SWITCH - REMOVAL, A/C HIGH PRESSURE	24-21	TACHOMETER - OPERATION	8J-31
SWITCH - INSTALLATION, A/C LOW PRESSURE	24-22	SWITCH - REMOVAL, BLOWER MOTOR	24-25	TAIL LAMP - DESCRIPTION	8L-29
SWITCH - INSTALLATION, BRAKE LAMP	8L-5	SWITCH - REMOVAL, BRAKE LAMP	8L-5	TAIL LAMP - INSTALLATION	8L-30
SWITCH - INSTALLATION, DOOR AJAR	8L-35	SWITCH - REMOVAL, DOOR AJAR	8L-35	TAIL LAMP - OPERATION	8L-29
SWITCH - INSTALLATION, DOOR CYLINDER LOCK	8N-6	SWITCH - REMOVAL, DOOR CYLINDER LOCK	8N-6	TAIL LAMP - REMOVAL	8L-29
SWITCH - INSTALLATION, DRIVER POWER SEAT	8N-17	SWITCH - REMOVAL, DRIVER POWER SEAT	8N-17	TAIL LAMP UNIT - INSTALLATION	8L-30
SWITCH - INSTALLATION, DRIVER SEAT HEATER	8G-9	SWITCH - REMOVAL, DRIVER SEAT HEATER	8G-9	TAIL LAMP UNIT - REMOVAL	8L-30
SWITCH - INSTALLATION, GLOVE BOX LAMP	8L-35	SWITCH - REMOVAL, GLOVE BOX LAMP	8L-35	TAILGATE - INSTALLATION	23-66
SWITCH - INSTALLATION, HEADLAMP	8L-20	SWITCH - REMOVAL, HEADLAMP	8L-19	TAILGATE - REMOVAL	23-66
SWITCH - INSTALLATION, IGNITION	19-12	SWITCH - REMOVAL, IGNITION	19-12	TAILPIPE - 3.9L/5.2L/5.9L - INSPECTION	11-11
SWITCH - INSTALLATION, MULTI-FUNCTION	8L-28	SWITCH - REMOVAL, LUMBAR CONTROL	8N-18	TAILPIPE - 3.9L/5.2L/5.9L - INSTALLATION	11-12
SWITCH - INSTALLATION, OVERDRIVE OFF	21-386,21-579,21-733	SWITCH - REMOVAL, MULTI-FUNCTION	8L-27	TAILPIPE - 3.9L/5.2L/5.9L - REMOVAL	11-11
SWITCH - INSTALLATION, OVERDRIVE OFF	21-215	SWITCH - REMOVAL, OVERDRIVE	21-386,21-579,21-733	TAILPIPE - 5.9L DIESEL - INSPECTION	11-12
		SWITCH - REMOVAL, OVERDRIVE OFF	21-215	TAILPIPE - 5.9L DIESEL - INSTALLATION	11-12
		SWITCH - REMOVAL, PARK/NEUTRAL POSITION	21-238,21-408,21-583,21-755	TAILPIPE - 5.9L DIESEL - REMOVAL	11-12
		SWITCH - REMOVAL, PASSENGER AIRBAG ON/OFF	80-24	TAILPIPE - 5.9L HEAVY DUTY/8.0L - INSPECTION	11-12
		SWITCH - REMOVAL, PASSENGER POWER SEAT	8N-20	TAILPIPE - 5.9L HEAVY DUTY/8.0L - INSTALLATION	11-12
		SWITCH - REMOVAL, PASSENGER SEAT HEATER	8G-15	TAILPIPE - 5.9L HEAVY DUTY/8.0L - REMOVAL	11-12
		SWITCH - REMOVAL, POWER MIRROR	8N-12	TANK - DESCRIPTION, DIESEL FUEL	14-78
		SWITCH - REMOVAL, POWER WINDOW	8N-25	TANK - DESCRIPTION, FUEL	14-19
		SWITCH - REMOVAL, WASHER FLUID LEVEL	8R-8	TANK - INSTALLATION, FUEL	14-20
				TANK - OPERATION, FUEL	14-19
				TANK - REMOVAL, FUEL	14-19



Description	Group-Page	Description	Group-Page	Description	Group-Page
TANK MODULE - DESCRIPTION, FUEL	14-78	TEST - DIAGNOSIS AND TESTING, POWR-LOG™	3-161	TIMER MODULE - OPERATION, BODY CONTROL/CENTRAL	8E-3
TANK MODULE - INSTALLATION, FUEL	14-79	TEST - DIAGNOSIS AND TESTING, ROAD	8P-3	TIMER MODULE - REMOVAL, BODY CONTROL/CENTRAL	8E-5
TANK MODULE - OPERATION, FUEL	14-78	TEST - INSPECTION WINDSHIELD WIPERS/WASHERS, ROAD	30-18	TIMING - DIAGNOSIS AND TESTING, FUEL INJECTION PUMP	14-66
TANK MODULE - REMOVAL, FUEL	14-78	TEST - STANDARD PROCEDURE, BUILT-IN INDICATOR	8F-11	TIMING BELT / CHAIN COVER(S) - INSTALLATION	9-113,9-169,9-226,9-56
TAPE STRIPE - INSTALLATION	23-88	TEST - STANDARD PROCEDURE, HYDROMETER	8F-12	TIMING BELT / CHAIN COVER(S) - REMOVAL	9-113,9-169,9-225,9-56
TAPE STRIPE - REMOVAL	23-88	TEST - STANDARD PROCEDURE, IGNITION-OFF DRAW	8F-15	TIMING BELT/CHAIN AND SPROCKETS - INSTALLATION	9-115,9-170,9-227,9-58
TAPPETS - DIAGNOSIS AND TESTING, HYDRAULIC	9-151,9-206,9-38,9-95	TEST - STANDARD PROCEDURE, LOAD	8F-14	TIMING BELT/CHAIN AND SPROCKETS - REMOVAL	9-114,9-170,9-226,9-57
TASK MANAGER - DESCRIPTION	25-15	TEST - STANDARD PROCEDURE, VERIFICATION	80-5	TIMING BELT/CHAIN TENSIONER - DESCRIPTION	9-57
TASK MANAGER - OPERATION	25-19	TEST INSPECTION - DESCRIPTION, ROAD	30-15	TIMING BELT/CHAIN TENSIONER - OPERATION	9-57
TEMP SENSOR - 3.9L/5.2L/5.9L - DESCRIPTION, ENGINE COOLANT	7-48	TEST MODE - DESCRIPTION, CIRCUIT ACTUATION	25-1	TIMING CHAIN STRETCH - INSPECTION, MEASURING	9-114,9-170,9-227,9-58
TEMP SENSOR - 3.9L/5.2L/5.9L - INSTALLATION, ENGINE COOLANT	7-48	TEST MODE - DESCRIPTION, STATE DISPLAY	25-1	TIMING, SPECIFICATIONS - IGNITION	8I-3
TEMP SENSOR - 3.9L/5.2L/5.9L - OPERATION, ENGINE COOLANT	7-48	TETHER - INSTALLATION, CHILD	80-9	TIPS - CLEANING, APPEARANCE	30-21
TEMP SENSOR - 3.9L/5.2L/5.9L - REMOVAL, ENGINE COOLANT	7-48	TETHER - REMOVAL, CHILD	80-9	TIRE - DESCRIPTION, SPARE	22-9
TEMP SENSOR - DESCRIPTION, AMBIENT	8M-11	THEFT SECURITY - DESCRIPTION, VEHICLE	80-1	TIRE AND WHEEL BALANCE - STANDARD PROCEDURES	22-4
TEMP SENSOR - INSTALLATION, AMBIENT	8M-13	THEFT SECURITY - OPERATION, VEHICLE	80-2	TIRE AND WHEEL RUNOUT - DIAGNOSIS AND TESTING	22-1
TEMP SENSOR - OPERATION, AMBIENT	8M-11	THEFT SECURITY SYSTEM - DIAGNOSIS AND TESTING, VEHICLE	80-3	TIRE NOISE OR VIBRATION - DIAGNOSIS AND TESTING	22-8
TEMP SENSOR - REMOVAL, AMBIENT	8M-12	THERMOSTAT - 3.9L/5.2L/5.9L - DESCRIPTION, ENGINE COOLANT	7-49	TIRE PRESSURES - INSPECTION	30-8
TEMPERATURE GAUGE - DESCRIPTION, ENGINE	8J-19	THERMOSTAT - 3.9L/5.2L/5.9L - INSTALLATION, ENGINE COOLANT	7-50	TIRE REVOLUTIONS PER MILE, SPECIFICATIONS	22-9
TEMPERATURE GAUGE - OPERATION, ENGINE	8J-19	THERMOSTAT - 3.9L/5.2L/5.9L - OPERATION, ENGINE COOLANT	7-49	TIRE ROTATION - STANDARD PROCEDURES	22-2
TEMPERATURE SENSOR - DESCRIPTION, BATTERY	8F-29	THERMOSTAT - 3.9L/5.2L/5.9L - REMOVAL, ENGINE COOLANT	7-49	TIRE WEAR PATTERNS - DIAGNOSIS AND TESTING	22-7
TEMPERATURE SENSOR - DESCRIPTION, FUEL	14-99	THERMOSTAT - 5.9L DIESEL - DESCRIPTION, ENGINE COOLANT	7-54	TIRE WINCH - INSTALLATION, SPARE	13-10
TEMPERATURE SENSOR - DESCRIPTION, TRANSMISSION	21-262,21-433,21-606,21-779	THERMOSTAT - 5.9L DIESEL - INSTALLATION, ENGINE COOLANT	7-55	TIRE WINCH - REMOVAL, SPARE	13-10
TEMPERATURE SENSOR - DIAGNOSIS & TESTING, AMBIENT	8M-12	THERMOSTAT - 5.9L DIESEL - OPERATION, ENGINE COOLANT	7-54	TIRES - DESCRIPTION	22-5,22-6
TEMPERATURE SENSOR - INSTALLATION, BATTERY	8F-29	THERMOSTAT - 5.9L DIESEL - REMOVAL, ENGINE COOLANT	7-55	TO GROUND - STANDARD PROCEDURE, TESTING FOR A SHORT	8W-01-6
TEMPERATURE SENSOR - OPERATION, BATTERY	8F-29	THERMOSTAT - 5.9L DIESEL - OPERATION, ENGINE COOLANT	7-54	TO GROUND ON FUSES POWERING SEVERAL LOADS - STANDARD PROCEDURE, TESTING FOR SHORT	8W-01-7
TEMPERATURE SENSOR - OPERATION, FUEL	14-100	THERMOSTAT - 5.9L DIESEL - REMOVAL, ENGINE COOLANT	7-55	TO OIL COOLER - INSTALLATION, AIR	7-88
TEMPERATURE SENSOR - OPERATION, TRANSMISSION	21-262,21-433,21-606,21-779	THERMOSTAT - 8.0L - DESCRIPTION, ENGINE COOLANT	7-52	TO OIL COOLER - REMOVAL, AIR	7-87
TEMPERATURE SENSOR - REMOVAL, BATTERY	8F-29	THERMOSTAT - 8.0L - INSTALLATION, ENGINE COOLANT	7-53	TO OIL COOLER - REMOVAL, WATER	7-87
TENSIONER - ADJUSTMENT, CABLE	5-40	THERMOSTAT - 8.0L - OPERATION, ENGINE COOLANT	7-52	TO USE WIRING DIAGRAMS - DESCRIPTION, HOW	8W-01-1
TENSIONER - DESCRIPTION, TIMING BELT/CHAIN	9-57	THERMOSTAT - 8.0L - REMOVAL, ENGINE COOLANT	7-52	TOOLS - 5.2L ENGINE, SPECIAL	9-77
TENSIONER - OPERATION, TIMING BELT/CHAIN	9-57	THERMOSTAT - DIAGNOSIS AND TESTING	7-49,7-52,7-54	TOOLS - 5.9L DIESEL ENGINE, SPECIAL	9-244
TENSIONERS - 3.9L/5.2L/5.9L - DESCRIPTION, BELT	7-19	THOMAS AND BETTS - INSTALLATION, CONNECTOR	8W-01-10	TOOLS - 5.9L ENGINE, SPECIAL	9-134
TENSIONERS - 3.9L/5.2L/5.9L - INSTALLATION, BELT	7-20	THOMAS AND BETTS - REMOVAL, CONNECTOR	8W-01-9	TOOLS - 8.0L ENGINE, SPECIAL	9-188
TENSIONERS - 3.9L/5.2L/5.9L - OPERATION, BELT	7-19	THREAD REPAIR - STANDARD PROCEDURE, ALUMINUM	21-159,21-330,21-502,21-673	TOOLS - AUDIO SYSTEMS, SPECIAL	8A-4
TENSIONERS - 3.9L/5.2L/5.9L - REMOVAL, BELT	7-20	THREADED HOLE REPAIR - DESCRIPTION	Intro-6	TOOLS - BASE BRAKES, SPECIAL	5-4
TENSIONERS - 5.9L DIESEL - DESCRIPTION, BELT	7-23	THREADS - STANDARD PROCEDURE, REPAIR DAMAGED OR WORN	9-111,9-125,9-181,9-238,9-68	TOOLS - COOLING, SPECIAL	7-18
TENSIONERS - 5.9L DIESEL - INSTALLATION, BELT	7-23	THROTTLE BODY - DESCRIPTION	14-48	TOOLS - DIESEL FUEL SYSTEM, SPECIAL	14-59
TENSIONERS - 5.9L DIESEL - OPERATION, BELT	7-23	THROTTLE BODY - OPERATION	14-48	TOOLS - FRONT AXLE, SPECIAL	3-58
TENSIONERS - 5.9L DIESEL - REMOVAL, BELT	7-23	THROTTLE CONTROL CABLE - INSTALLATION	14-105,14-50	TOOLS - FRONT AXLES, SPECIAL	3-25
TENSIONERS - 8.0L - DESCRIPTION, BELT	7-20	THROTTLE CONTROL CABLE - REMOVAL	14-104,14-50	TOOLS - FUEL SYSTEM, SPECIAL	14-36,14-4
TENSIONERS - 8.0L - INSTALLATION, BELT	7-22	THROTTLE POSITION SENSOR - DESCRIPTION	14-51	TOOLS - HEADLAMP ALIGNMENT, SPECIAL	8L-4
TENSIONERS - 8.0L - OPERATION, BELT	7-20	THROTTLE POSITION SENSOR - OPERATION	14-51	TOOLS - INDEPENDENT FRONT SUSPENSION, SPECIAL	2-9
TENSIONERS - 8.0L - REMOVAL, BELT	7-21	THROTTLE VALVE CABLE - ADJUSTMENTS, TRANSMISSION	21-254,21-425,21-598,21-771	TOOLS - LINK/COIL SUSPENSION, SPECIAL	2-16
TERMINAL - INSTALLATION	8W-01-11	THRUST - DESCRIPTION	Intro-6	TOOLS - NV5600 MANUAL TRANSMISSION, SPECIAL	21-127
TERMINAL - REMOVAL	8W-01-11	THRUST - STANDARD PROCEDURE, REPAIR DAMAGED OR WORN	9-111,9-125,9-181,9-238,9-68	TOOLS - OVERHEAD CONSOLE SYSTEMS, SPECIAL	8M-8
TEST - DIAGNOSIS AND TESTING, FUEL INJECTOR	14-53,14-95	THRUST BODY - DESCRIPTION	14-48	TOOLS - POWER DISTRIBUTION SYSTEMS, SPECIAL	8W-97-2
TEST - DIAGNOSIS AND TESTING, FUEL PRESSURE LEAK DOWN	14-2	THRUST BODY - OPERATION	14-48	TOOLS - POWER STEERING GEAR, SPECIAL	19-20
TEST - DIAGNOSIS AND TESTING, FUEL PUMP AMPERAGE	14-10	THRUST CONTROL CABLE - INSTALLATION	14-105,14-50	TOOLS - POWER STEERING PUMP, SPECIAL	19-36
TEST - DIAGNOSIS AND TESTING, FUEL PUMP CAPACITY	14-9	THRUST CONTROL CABLE - REMOVAL	14-104,14-50	TOOLS - PROPELLER SHAFT, SPECIAL	3-8
TEST - DIAGNOSIS AND TESTING, FUEL PUMP PRESSURE	14-10	THRUST POSITION SENSOR - DESCRIPTION	14-51	TOOLS - RE TRANSMISSION, SPECIAL	21-534,21-704
TEST - DIAGNOSIS AND TESTING, HYDRAULIC PRESSURE	21-144,21-315,21-487,21-658	THRUST POSITION SENSOR - OPERATION	14-51	TOOLS - RE TRANSMISSIONS, SPECIAL	21-188,21-359
		THRUST VALVE CABLE - DESCRIPTION	21-253,21-424,21-597,21-770	TOOLS - STEERING LINKAGE, SPECIAL	19-39,19-42
		TIMER MODULE - DESCRIPTION, BODY CONTROL/CENTRAL	8E-1	TOOLS - SUSPENSION-REAR, SPECIAL	2-28
		TIMER MODULE - DIAGNOSIS AND TESTING, CENTRAL	8E-4	TOOLS, AIRBAG SYSTEM - SPECIAL	80-6
		TIMER MODULE - INSTALLATION, BODY CONTROL/CENTRAL	8E-6	TOOLS, WIRING/TERMINAL - SPECIAL	8W-01-8

Description	Group-Page	Description	Group-Page	Description	Group-Page
TOP COVER - INSTALLATION, INSTRUMENT PANEL	23-115	TRANS. - REMOVAL, DIESEL WITH AUTO	8P-4, 8P-8	TRANSMISSION - 42RE - CLEANING, AUTOMATIC	21-165
TOP COVER - REMOVAL, INSTRUMENT PANEL	23-114	TRANS COOLER - 3.9L/5.2L/5.9L - ASSEMBLY	7-82	TRANSMISSION - 42RE - DESCRIPTION, AUTOMATIC	21-135
TORQUE - FUEL DELIVERY - SPECIFICATIONS	14-4	TRANS COOLER - 3.9L/5.2L/5.9L - DESCRIPTION	7-79	TRANSMISSION - 42RE - DISASSEMBLY, AUTOMATIC	21-160
TORQUE - GAS FUEL INJECTION - SPECIFICATIONS	14-35	TRANS COOLER - 3.9L/5.2L/5.9L - DISASSEMBLY	7-81	TRANSMISSION - 42RE - INSPECTION, AUTOMATIC	21-165
TORQUE - GENERATOR/CHARGING SYSTEM - SPECIFICATIONS	8F-28	TRANS COOLER - 3.9L/5.2L/5.9L - INSTALLATION	7-82	TRANSMISSION - 42RE - INSTALLATION, AUTOMATIC	21-173
TORQUE - IGNITION - SPECIFICATIONS	8I-2	TRANS COOLER - 3.9L/5.2L/5.9L - OPERATION	7-79	TRANSMISSION - 42RE - OPERATION, AUTOMATIC	21-137
TORQUE - STARTING SYSTEM - SPECIFICATIONS	8F-38	TRANS COOLER - 3.9L/5.2L/5.9L - REMOVAL	7-81	TRANSMISSION - 42RE - REMOVAL, AUTOMATIC	21-159
TORQUE, AIR INJECTION SYSTEM	25-28	TRANS COOLER - 5.9L DIESEL - DESCRIPTION	7-85	TRANSMISSION - 44RE - ASSEMBLY, AUTOMATIC	21-337
TORQUE CHART, SPECIFICATIONS	5-3	TRANS COOLER - 5.9L DIESEL - INSTALLATION	7-88	TRANSMISSION - 44RE - CLEANING, AUTOMATIC	21-336
TORQUE CHART, SPECIFICATIONS	19-19,19-39, 19-41,19-9	TRANS COOLER - 5.9L DIESEL - OPERATION	7-85	TRANSMISSION - 44RE - DESCRIPTION, AUTOMATIC	21-306
TORQUE CHART, SPECIFICATIONS	2-15,2-27,2-8	TRANS COOLER - 8.0L - DESCRIPTION	7-82	TRANSMISSION - 44RE - DISASSEMBLY, AUTOMATIC	21-331
TORQUE CHART, SPECIFICATIONS	22-11	TRANS COOLER - 8.0L - INSTALLATION	7-85	TRANSMISSION - 44RE - INSPECTION, AUTOMATIC	21-337
TORQUE CONVERTER - DESCRIPTION	21-256, 21-427,21-600,21-773	TRANS COOLER - 8.0L - OPERATION	7-82	TRANSMISSION - 44RE - INSTALLATION, AUTOMATIC	21-344
TORQUE CONVERTER - INSTALLATION	21-261, 21-432,21-605,21-778	TRANS COOLER - 8.0L - REMOVAL	7-84	TRANSMISSION - 44RE - OPERATION, AUTOMATIC	21-308
TORQUE CONVERTER - OPERATION	21-260, 21-430,21-604,21-777	TRANSFER CASE - DIAGNOSIS AND TESTING	21-821,21-856,21-892	TRANSMISSION - 44RE - REMOVAL, AUTOMATIC	21-330
TORQUE CONVERTER - REMOVAL	21-261, 21-432,21-605,21-778	TRANSFER CASE - NV231HD - ASSEMBLY	21-834	TRANSMISSION - 46RE - ASSEMBLY, AUTOMATIC	21-510
TORQUE CONVERTER DRAINBACK VALVE - DESCRIPTION	21-262,21-432,21-605, 21-778	TRANSFER CASE - NV231HD - CLEANING	21-831	TRANSMISSION - 46RE - CLEANING, AUTOMATIC	21-509
TORQUE CONVERTER DRAINBACK VALVE - OPERATION	21-262,21-432,21-605, 21-778	TRANSFER CASE - NV231HD - DESCRIPTION	21-820	TRANSMISSION - 46RE - DESCRIPTION, AUTOMATIC	21-478
TORQUE CONVERTER DRAINBACK VALVE - STANDARD PROCEDURE	21-262, 21-432,21-606,21-778	TRANSFER CASE - NV231HD - DISASSEMBLY	21-822	TRANSMISSION - 46RE - DISASSEMBLY, AUTOMATIC	21-503
TORQUE, DIESEL ENGINE	14-90	TRANSFER CASE - NV231HD - INSPECTION	21-832	TRANSMISSION - 46RE - INSPECTION, AUTOMATIC	21-510
TORQUE, EVAP SYSTEM	25-31	TRANSFER CASE - NV231HD - INSTALLATION	21-847	TRANSMISSION - 46RE - INSTALLATION, AUTOMATIC	21-518
TORQUE REFERENCES - DESCRIPTION	Intro-9	TRANSFER CASE - NV231HD - OPERATION	21-820	TRANSMISSION - 46RE - OPERATION, AUTOMATIC	21-480
TORQUE, SPECIFICATIONS	7-17	TRANSFER CASE - NV231HD - REMOVAL	21-822	TRANSMISSION - 46RE - REMOVAL, AUTOMATIC	21-502
TORQUE, SPECIFICATIONS	9-133,9-18,9-187, 9-243,9-76	TRANSFER CASE - NV241HD - ASSEMBLY	21-904	TRANSMISSION - 47RE - ASSEMBLY, AUTOMATIC	21-681
TORQUE, SPECIFICATIONS	11-5	TRANSFER CASE - NV241HD - CLEANING	21-902	TRANSMISSION - 47RE - CLEANING, AUTOMATIC	21-680
TORQUE SPECIFICATIONS, SPECIFICATIONS	23-61	TRANSFER CASE - NV241HD - DESCRIPTION	21-890	TRANSMISSION - 47RE - DESCRIPTION, AUTOMATIC	21-649
TORQUE SPECIFICATIONS, SPECIFICATIONS	13-9	TRANSFER CASE - NV241HD - DISASSEMBLY	21-894	TRANSMISSION - 47RE - DISASSEMBLY, AUTOMATIC	21-674
TORQUE SPECIFICATIONS, SPECIFICATIONS	24-8	TRANSFER CASE - NV241HD - INSPECTION	21-902	TRANSMISSION - 47RE - INSPECTION, AUTOMATIC	21-681
TORQUE, SPEED CONTROL SYSTEM	8P-4	TRANSFER CASE - NV241HD - INSTALLATION	21-919	TRANSMISSION - 47RE - INSTALLATION, AUTOMATIC	21-688
TOUCH-UP - DESCRIPTION, PAINT	23-129	TRANSFER CASE - NV241HD - OPERATION	21-892	TRANSMISSION - 47RE - OPERATION, AUTOMATIC	21-651
TOW HOOK - INSTALLATION, FRONT	13-10	TRANSFER CASE - NV241HD - REMOVAL	21-894	TRANSMISSION - 47RE - REMOVAL, AUTOMATIC	21-673
TOW HOOK - REMOVAL, FRONT	13-9	TRANSFER CASE - NV241LD - ASSEMBLY	21-869	TRANSMISSION - CLEANING	21-109
TOWING - STANDARD PROCEDURE	0-29	TRANSFER CASE - NV241LD - CLEANING	21-866	TRANSMISSION - DIAGNOSIS AND TESTING, AUTOMATIC	21-143,21-314,21-486, 21-657
TRACK - DESCRIPTION, POWER SEAT	8N-21	TRANSFER CASE - NV241LD - DESCRIPTION	21-855	TRANSMISSION - DIAGNOSIS AND TESTING, MANUAL	21-3,21-46,21-93
TRACK - DIAGNOSIS & TESTING, POWER SEAT	8N-21	TRANSFER CASE - NV241LD - DISASSEMBLY	21-858	TRANSMISSION - INSPECTION	21-109,21-64
TRACK - INSTALLATION, EASY ENTRY SEAT	23-142	TRANSFER CASE - NV241LD - INSPECTION	21-867	TRANSMISSION - INSTALLATION, SHIFT BOOT - MANUAL	23-122
TRACK - INSTALLATION, POWER SEAT	8N-22	TRANSFER CASE - NV241LD - INSTALLATION	21-882	TRANSMISSION - REMOVAL, SHIFT BOOT - MANUAL	23-122
TRACK - INSTALLATION, SEAT	23-141	TRANSFER CASE - NV241LD - OPERATION	21-855	TRANSMISSION CLUTCH AND BAND OPERATION - DIAGNOSIS AND TESTING, AIR CHECKING	21-147,21-318
TRACK - OPERATION, POWER SEAT	8N-21	TRANSFER CASE - NV241LD - REMOVAL	21-858	TRANSMISSION CLUTCH AND BAND OPERATION - DIAGNOSIS AND TESTING, AIR TESTING	21-490,21-661
TRACK - REMOVAL, EASY ENTRY SEAT	23-142	TRANSFER CASE FLUID - DESCRIPTION	0-5	TRANSMISSION FILL - STANDARD PROCEDURE	21-201,21-372,21-547,21-718
TRACK - REMOVAL, POWER SEAT	8N-22	TRANSFER CASE, NV231HD	21-849	TRANSMISSION FLUID - DESCRIPTION, AUTOMATIC	0-5
TRACK - REMOVAL, SEAT	23-141	TRANSFER CASE, NV241HD	21-920	TRANSMISSION FLUID - OPERATION, AUTOMATIC	0-5
TRACK - SPLIT BENCH - INSTALLATION, SEAT	23-142	TRANSFER CASE, NV241LD	21-884		
TRACK - SPLIT BENCH - REMOVAL, SEAT	23-142	TRANSFER CASE SKID PLATE - INSTALLATION	13-11		
TRACK ADJUSTER - INSTALLATION, SEAT	23-143	TRANSFER CASE SKID PLATE - REMOVAL	13-11		
TRACK ADJUSTER - REMOVAL, SEAT	23-143	TRANSFER CASE, SPECIFICATIONS	21-848, 21-883,21-919		
TRACK BAR - DESCRIPTION	2-23	TRANSFER PUMP - DESCRIPTION, FUEL	14-79		
TRACK BAR - DIAGNOSIS AND TESTING	2-23	TRANSFER PUMP - INSTALLATION, FUEL	14-83		
TRACK BAR - INSTALLATION	2-23	TRANSFER PUMP - OPERATION, FUEL	14-79		
TRACK BAR - OPERATION	2-23	TRANSFER PUMP - REMOVAL, FUEL	14-83		
TRACK BAR - REMOVAL	2-23	TRANSFER PUMP PRESSURE - DIAGNOSIS AND TESTING, FUEL	14-80		
TRAC-LOK - ASSEMBLY, DIFFERENTIAL	3-101, 3-132,3-190	TRANSMISSION - 42RE - ASSEMBLY, AUTOMATIC	21-166		
TRAC-LOK - DISASSEMBLY, DIFFERENTIAL	3-130,3-190,3-99				
TRAC-LOK™ - DIAGNOSIS AND TESTING	3-130, 3-190,3-98				
TRAILER HITCH - INSTALLATION	13-10				
TRAILER HITCH - REMOVAL	13-10				
TRANS. - INSTALLATION, DIESEL WITH AUTO	8P-11,8P-4				



Description	Group-Page	Description	Group-Page	Description	Group-Page
TRANSMISSION OIL COOLER - STANDARD PROCEDURE, FLUSHING COOLER AND TUBES - WITHOUT RADIATOR IN-TANK	7-80,7-83,7-86	TUBES - WITHOUT RADIATOR IN-TANK TRANSMISSION OIL COOLER - STANDARD PROCEDURE, FLUSHING COOLER	7-80,7-83,7-86	UNIT / SENSOR - OPERATION, FUEL LEVEL SENDING	14-7,14-73
TRANSMISSION OIL COOLER - STANDARD PROCEDURE, FLUSHING COOLERS AND TUBES - WITH RADIATOR IN-TANK	7-79,7-83,7-85	TURBO DIESEL - DESCRIPTION, MAINTENANCE SCHEDULES - 24-VALVE CUMMINS	0-22	UNIT / SENSOR - REMOVAL, FUEL LEVEL SENDING	14-8
TRANSMISSION OVERTEMP INDICATOR - DESCRIPTION	8J-31	TURBOCHARGER - CLEANING	11-16	UNIVERSAL JOINTS - DISASSEMBLY, SINGLE CARDAN	3-11
TRANSMISSION OVERTEMP INDICATOR - OPERATION	8J-31	TURBOCHARGER - DESCRIPTION	11-13	UNIVERSAL JOINTS - INSTALLATION, SINGLE CARDAN	3-34,3-66
TRANSMISSION, SPECIAL TOOLS - NV5600 MANUAL	21-127	TURBOCHARGER - INSPECTION	11-16	UNIVERSAL JOINTS - REMOVAL, SINGLE CARDAN	3-33,3-65
TRANSMISSION, SPECIAL TOOLS - RE	21-534, 21-704	TURBOCHARGER - INSTALLATION	11-16	UP/DOWN - ADJUSTMENT, FRONT DOOR	23-69
TRANSMISSION, SPECIFICATIONS	21-186, 21-532,21-702	TURBOCHARGER - OPERATION	11-13	UPPER - INSTALLATION, LATCH	23-81
TRANSMISSION TEMPERATURE SENSOR - DESCRIPTION	21-262,21-433,21-606,21-779	TURBOCHARGER - REMOVAL	11-15	UPPER - INSTALLATION, LATCH STRIKER	23-82
TRANSMISSION TEMPERATURE SENSOR - OPERATION	21-262,21-433,21-606,21-779	TURN AND EMERGENCY SIGNALS - INSPECTION	30-19	UPPER - REMOVAL, LATCH	23-81
TRANSMISSION THROTTLE VALVE CABLE - ADJUSTMENTS	21-254,21-425,21-598, 21-771	TURN SIGNAL & HAZARD WARNING SYSTEM - DESCRIPTION	8L-2	UPPER - REMOVAL, LATCH STRIKER	23-82
TRANSMISSIONS, SPECIAL TOOLS - RE	21-188, 21-359	TURN SIGNAL & HAZARD WARNING SYSTEM - DIAGNOSIS AND TESTING	8L-3	UPPER BALL JOINT - DIAGNOSIS AND TESTING	2-12
TRANSMISSION/TRANSFER CASE - INSPECTION	30-15	TURN SIGNAL & HAZARD WARNING SYSTEM - OPERATION	8L-2	UPPER BALL JOINT - INSTALLATION	2-25
TRANSMITTER - DESCRIPTION, REMOTE KEYLESS ENTRY	8N-7	TURN SIGNAL CANCEL CAM - DESCRIPTION	8L-30	UPPER CONTROL ARM - INSTALLATION	2-13, 2-24
TRANSMITTER - DIAGNOSIS AND TESTING, REMOTE KEYLESS ENTRY	8N-7	TURN SIGNAL CANCEL CAM - OPERATION	8L-31	UPPER CONTROL ARM - REMOVAL	2-13,2-23
TRANSMITTER - OPERATION, REMOTE KEYLESS ENTRY	8N-7	TURN SIGNAL INDICATORS - DESCRIPTION	8J-32	UPPER CORNER SEAL - INSTALLATION, FRONT DOOR	23-154
TRANSMITTER BATTERIES - STANDARD PROCEDURE, RKE	8N-8	TURN SIGNAL INDICATORS - DIAGNOSIS AND TESTING	8J-32	UPPER CORNER SEAL - REMOVAL, FRONT DOOR	23-154
TRANSMITTER PROGRAMMING - STANDARD PROCEDURE, RKE	8N-8	TURN SIGNAL INDICATORS - OPERATION	8J-32	UPPER TRIM - INSTALLATION, GLOVE BOX OPENING	23-114
TRAY - DESCRIPTION, BATTERY	8F-24	TURNING LOOP ADJUSTER - INSTALLATION, SEAT BELT	80-29	UPPER TRIM - REMOVAL, GLOVE BOX OPENING	23-114
TRAY - INSTALLATION, BATTERY	8F-25	TURNING LOOP ADJUSTER - REMOVAL, SEAT BELT	80-29	UPSHIFT INDICATOR - DESCRIPTION	8J-33
TRAY - INSTALLATION, REAR FLOOR STOWAGE	23-121	TURNING LOOP HEIGHT ADJUSTER KNOB - INSTALLATION	80-30	UPSHIFT INDICATOR - OPERATION	8J-33
TRAY - OPERATION, BATTERY	8F-25	TURNING LOOP HEIGHT ADJUSTER KNOB - REMOVAL	80-30	USAGE - DESCRIPTION, FASTENER	Intro.-6
TRAY - REMOVAL, BATTERY	8F-25	TWEETER SPEAKER - INSTALLATION, A-PILLAR	8A-19	USE WIRING DIAGRAMS - DESCRIPTION, HOW TO	8W-01-1
TRAY - REMOVAL, REAR FLOOR STOWAGE	23-121	TWEETER SPEAKER - REMOVAL, A-PILLAR	8A-19	V-10 - DESCRIPTION, 8.0L	8I-1
TREAD WEAR INDICATORS - DIAGNOSIS AND TESTING	22-7	UNDERHOOD LAMP - INSTALLATION	8L-32	V-10 - OPERATION, 8.0L	8I-1
TRIM - INSTALLATION, A-PILLAR	23-119	UNDERHOOD LAMP - REMOVAL	8L-31	V-10 ENGINE - IGNITION COIL RESISTANCE, 8.0L	8I-3
TRIM - INSTALLATION, B-PILLAR	23-120	UNIT - INSTALLATION	8L-32	V-10 ENGINE - SPARK PLUG CABLE ORDER, 8.0L	8I-2
TRIM - INSTALLATION, C-PILLAR	23-128	UNIT - ADJUSTMENTS, FOG LAMP	8L-12	V-6 ENGINE - ENGINE FIRING ORDER, 3.9L	8I-2
TRIM - INSTALLATION, DOOR SILL	23-121	UNIT - ADJUSTMENTS, HEADLAMP	8L-21	V-6/V-8 - DESCRIPTION	8I-1
TRIM - INSTALLATION, GLOVE BOX OPENING UPPER	23-114	UNIT - ASSEMBLY, OVERDRIVE	21-225,21-395, 21-569,21-742	V-6/V-8 OPERATION	8I-1
TRIM - INSTALLATION, REAR CLOSURE PANEL	23-121	UNIT - CLEANING, OVERDRIVE	21-224,21-394, 21-568,21-741	V-6/V-8 ENGINES - DESCRIPTION	25-35
TRIM - REMOVAL, A-PILLAR	23-119	UNIT - DIAGNOSIS AND TESTING, FUEL GAUGE SENDING	14-8	V-6/V-8 ENGINES - DIAGNOSIS AND TESTING, PCV VALVE	25-36
TRIM - REMOVAL, B-PILLAR	23-120	UNIT - DISASSEMBLY, OVERDRIVE	21-217, 21-387,21-562,21-734	V-6/V-8 ENGINES - OPERATION	25-35
TRIM - REMOVAL, C-PILLAR	23-128	UNIT - INSPECTION, OVERDRIVE	21-224, 21-394,21-569,21-741	V-8 ENGINES - ENGINE FIRING ORDER, 5.2L/5.9L	8I-2
TRIM - REMOVAL, DOOR SILL	23-121	UNIT - INSTALLATION, CENTER HIGH MOUNTED STOP LAMP	8L-6	VACUUM CHECK VALVE - DESCRIPTION	24-28
TRIM - REMOVAL, GLOVE BOX OPENING UPPER	23-114	UNIT - INSTALLATION, FOG LAMP	8L-12	VACUUM CHECK VALVE - INSTALLATION	24-29
TRIM - REMOVAL, REAR CLOSURE PANEL	23-120	UNIT - INSTALLATION, HEADLAMP	8L-20	VACUUM CHECK VALVE - OPERATION	24-28
TRIM COVER - INSTALLATION, COWL	23-120	UNIT - INSTALLATION, LICENSE PLATE LAMP	8L-22	VACUUM CHECK VALVE - REMOVAL	24-29
TRIM COVER - REMOVAL, COWL	23-119	UNIT - INSTALLATION, OVERDRIVE	21-234, 21-404,21-577,21-750	VACUUM MOTOR - ASSEMBLY, AXLE	3-33,3-65
TRIM PANEL - INSTALLATION	23-74,23-84	UNIT - INSTALLATION, PARK/TURN SIGNAL LAMP	8L-29	VACUUM MOTOR - DESCRIPTION, AXLE	3-29, 3-62
TRIM PANEL - INSTALLATION, QUARTER	23-128	UNIT - INSTALLATION, TAIL LAMP	8L-30	VACUUM MOTOR - DIAGNOSIS AND TESTING	3-31,3-63
TRIM PANEL - REMOVAL	23-74,23-84	UNIT - INSTALLATION, UNDERHOOD LAMP	8L-32	VACUUM MOTOR - DISASSEMBLY, AXLE	3-33, 3-65
TRIM PANEL - REMOVAL, QUARTER	23-127	UNIT - REMOVAL, CENTER HIGH MOUNTED STOP LAMP	8L-6	VACUUM MOTOR - INSTALLATION, AXLE	3-33, 3-65
TRIP COMPUTER/MAINTENANCE REMINDER - INSPECTION	30-17	UNIT - REMOVAL, FOG LAMP	8L-11	VACUUM MOTOR - OPERATION, AXLE	3-30,3-62
TRIP DEFINITION - DESCRIPTION	25-18	UNIT - REMOVAL, HEADLAMP	8L-20	VACUUM MOTOR - REMOVAL, AXLE	3-33,3-65
TROUBLE CODES - DESCRIPTION, DIAGNOSTIC	25-2	UNIT - REMOVAL, LICENSE PLATE LAMP	8L-22	VACUUM PUMP - 5.9L DIESEL - DESCRIPTION	7-34
TRUCK MAINTENANCE SCHEDULE (8.0L 2500 & 3500 MODELS - CALIFORNIA ONLY) - DESCRIPTION, MEDIUM DUTY	0-13	UNIT - REMOVAL, OVERDRIVE	21-216,21-387, 21-560,21-733	VACUUM PUMP - 5.9L DIESEL - INSTALLATION	7-37
TUBE - DESCRIPTION, A/C ORIFICE	24-53	UNIT - REMOVAL, PARK/TURN SIGNAL LAMP	8L-29	VACUUM PUMP - 5.9L DIESEL - OPERATION	7-35
TUBE - DIAGNOSIS AND TESTING, FIXED ORIFICE	24-54	UNIT - REMOVAL, CENTER HIGH MOUNTED STOP LAMP	8L-6	VACUUM PUMP - 5.9L DIESEL - REMOVAL	7-35
TUBE - OPERATION, A/C ORIFICE	24-53	UNIT - REMOVAL, FOG LAMP	8L-11	VACUUM PUMP OUTPUT - DIAGNOSIS AND TESTING	7-35
TUBE - REMOVAL, A/C ORIFICE	24-54	UNIT - REMOVAL, HEADLAMP	8L-20	VACUUM RESERVOIR - DESCRIPTION	24-29
TUBES - WITH RADIATOR IN-TANK TRANSMISSION OIL COOLER - STANDARD PROCEDURE, FLUSHING COOLERS	7-79,7-83,7-85	UNIT - REMOVAL, LICENSE PLATE LAMP	8L-22	VACUUM RESERVOIR - DESCRIPTION	8P-13
		UNIT - REMOVAL, OVERDRIVE	21-216,21-387, 21-560,21-733	VACUUM RESERVOIR - INSTALLATION	24-30
		UNIT - REMOVAL, PARK/TURN SIGNAL LAMP	8L-29	VACUUM RESERVOIR - INSTALLATION	8P-14
		UNIT - REMOVAL, TAIL LAMP	8L-30	VACUUM RESERVOIR - OPERATION	24-29
		UNIT - REMOVAL, UNDERHOOD LAMP	8L-32	VACUUM RESERVOIR - REMOVAL	24-30
		UNIT / SENSOR - DESCRIPTION, FUEL LEVEL SENDING	14-7,14-73	VACUUM RESERVOIR - REMOVAL	8P-13
		UNIT / SENSOR - INSTALLATION, FUEL LEVEL SENDING	14-9	VACUUM SCHEMATICS - DIAGNOSIS AND TESTING	25-37
				VACUUM SUPPLY - DIAGNOSIS AND TESTING	8P-2

Description	Group-Page	Description	Group-Page	Description	Group-Page
VACUUM SYSTEM - DIAGNOSIS AND TESTING	24-10	VALVES & SEATS - DESCRIPTION, INTAKE/EXHAUST	9-138,9-195,9-25,9-253,9-81	VISCOUS CLUTCH - 5.9L DIESEL - OPERATION, FAN DRIVE	7-57
VALVE - CLEANING, OIL PRESSURE RELIEF	9-297	VALVES & SEATS - INSPECTION, INTAKE/EXHAUST	9-141,9-198,9-27,9-84	VISCOUS FAN DRIVE - DIAGNOSIS AND TESTING	7-56,7-58
VALVE - DESCRIPTION, COMBINATION	5-9	VALVES & SEATS - INSTALLATION, INTAKE/EXHAUST	9-141,9-260,9-28,9-85	VISOR - INSTALLATION, SUN	23-127
VALVE - DESCRIPTION, HIGH PRESSURE RELIEF	24-46	VALVES & SEATS - REMOVAL, INTAKE/EXHAUST	9-140,9-258,9-27,9-84	VISOR - REMOVAL, SUN	23-127
VALVE - DESCRIPTION, ONE WAY CHECK	25-30	VALVES & SEATS - STANDARD PROCEDURE-VALVES, GUIDES AND SPRINGS, INTAKE/EXHAUST	9-253	VISUAL - INSPECTION	30-8
VALVE - DESCRIPTION, OVERFLOW	14-83	VALVES & SEATS - VALVE SERVICE, INTAKE/EXHAUST	9-195	VISUAL INSPECTION, 3.9L/5.2L/5.9L ENGINES	14-28
VALVE - DESCRIPTION, ROLLOVER	14-25	VALVES AND VALVE SPRINGS - INSTALLATION	9-199	VISUAL INSPECTION, 8.0L ENGINE	14-32
VALVE - DESCRIPTION, TORQUE CONVERTER DRAINBACK	21-262,21-432,21-605,21-778	VALVES AND VALVE SPRINGS - REMOVAL	9-197	VOLT SUPPLIES - DESCRIPTION, 5	8E-17
VALVE - DESCRIPTION, VACUUM CHECK	24-28	VALVES, GUIDES AND SPRINGS - STANDARD PROCEDURE	9-138,9-25,9-82	VOLT SUPPLIES - OPERATION, 5	8E-19
VALVE - DIAGNOSIS AND TESTING, COMBINATION	5-9	VANITY LAMP - INSTALLATION	8L-37	VOLTAGE DROP - STANDARD PROCEDURE, TESTING FOR A	8W-01-7
VALVE - DIAGNOSIS AND TESTING, ONE-WAY CHECK	25-30	VANITY LAMP - REMOVAL	8L-37	VOLTAGE GAUGE - DESCRIPTION	8J-33
VALVE - DIAGNOSIS AND TESTING, OVERFLOW	14-84	VAPOR CANISTER - DESCRIPTION	25-37	VOLTAGE GAUGE - OPERATION	8J-34
VALVE - INSPECTION, OIL PRESSURE RELIEF	9-297	VAPOR CANISTER - INSTALLATION	25-38	VOLTAGE POTENTIAL - STANDARD PROCEDURE, TESTING	8W-01-6
VALVE - INSTALLATION, COMBINATION	5-10	VAPOR CANISTER - INSTALLATION, CRANKCASE BREATHER	9-242	VOLTAGE REGULATOR - DESCRIPTION	8F-31
VALVE - INSTALLATION, OIL PRESSURE RELIEF	9-298	VAPOR CANISTER - OPERATION	25-37	VOLTAGE REGULATOR - OPERATION	8F-31
VALVE - INSTALLATION, ONE WAY CHECK	25-30	VAPOR CANISTER - REMOVAL	25-37	VOLTAGE TEST - STANDARD PROCEDURE, OPEN-CIRCUIT	8F-13
VALVE - INSTALLATION, OVERFLOW	14-85	VAPOR CANISTER - REMOVAL, CRANKCASE BREATHER	9-241	VOLUME CHECK - STANDARD PROCEDURE, OIL PUMP	21-209,21-379,21-554,21-724
VALVE - INSTALLATION, ROLLOVER	14-27	VARIATION ADJUSTMENT - STANDARD PROCEDURE, COMPASS	8M-4	VTSS INDICATOR - DESCRIPTION	8Q-3
VALVE - INSTALLATION, SPOOL	19-26	VECI LABEL - DESCRIPTION	Intro-10	VTSS INDICATOR - DIAGNOSIS AND TESTING	8Q-3
VALVE - INSTALLATION, VACUUM CHECK	24-29	VECI LABEL - OPERATION	Intro-10	VTSS INDICATOR - OPERATION	8Q-3
VALVE - OPERATION, COMBINATION	5-9	VEHICLE IDENTIFICATION NUMBER - DESCRIPTION	Intro-10	WAIT-TO-START INDICATOR - DESCRIPTION	8J-34
VALVE - OPERATION, HIGH PRESSURE RELIEF	24-46	VEHICLE IDENTIFICATION NUMBER - DESCRIPTION	Intro-10	WAIT-TO-START INDICATOR - OPERATION	8J-35
VALVE - OPERATION, ONE WAY CHECK	25-30	VEHICLE PREPARATION - DESCRIPTION, THE IMPORTANCE OF CAREFUL NEW STEPS - NEW	30-1	WARNING, CLUTCH	6-2
VALVE - OPERATION, OVERFLOW	14-83	VEHICLE PREPARATION FORM, FINAL STEPS - NEW	30-22	WARNING, HYDRAULIC/MECHANICAL	5-5
VALVE - OPERATION, TORQUE CONVERTER DRAINBACK	21-262,21-432,21-605,21-778	VEHICLE SAFETY CERTIFICATION LABEL - DESCRIPTION	Intro-12	WARNING, RESTRAINTS	80-3
VALVE - OPERATION, VACUUM CHECK	24-28	VEHICLE SPEED INPUT - DESCRIPTION	8P-1	WARNING SYSTEM - DESCRIPTION, CHIME	8B-1
VALVE - REMOVAL, COMBINATION	5-10	VEHICLE THEFT SECURITY - DESCRIPTION	8Q-1	WARNING SYSTEM - DESCRIPTION, TURN SIGNAL & HAZARD	8L-2
VALVE - REMOVAL, OIL PRESSURE RELIEF	9-297	VEHICLE THEFT SECURITY - OPERATION	8Q-2	WARNING SYSTEM - DIAGNOSIS AND TESTING, CHIME	8B-2
VALVE - REMOVAL, ONE WAY CHECK	25-30	VEHICLE THEFT SECURITY SYSTEM - DIAGNOSIS AND TESTING	8Q-3	WARNING SYSTEM - DIAGNOSIS AND TESTING, TURN SIGNAL & HAZARD	8L-3
VALVE - REMOVAL, OVERFLOW	14-84	VENT - INSTALLATION, BODY	23-126	WARNING SYSTEM - OPERATION, CHIME	8B-1
VALVE - REMOVAL, ROLLOVER	14-26	VENT - INSTALLATION, EXHAUST	23-79	WARNING SYSTEM - OPERATION, TURN SIGNAL & HAZARD	8L-2
VALVE - REMOVAL, SPOOL	19-24	VENT - REMOVAL, BODY	23-126	WARNINGS, BODY - SAFETY PRECAUTIONS	23-1
VALVE - REMOVAL, VACUUM CHECK	24-29	VENT - REMOVAL, EXHAUST	23-79	WARNINGS, GENERAL	8W-01-5
VALVE - STANDARD PROCEDURE, TORQUE CONVERTER DRAINBACK	21-262,21-432,21-606,21-778	VENT GLASS - INSTALLATION, BACKLITE	23-147	WASHER FLUID INDICATOR - DESCRIPTION	8J-35
VALVE - V-6/V-8 ENGINES - DIAGNOSIS AND TESTING, PCV	25-36	VENT GLASS - REMOVAL, BACKLITE	23-147	WASHER FLUID INDICATOR - DIAGNOSIS AND TESTING	8J-36
VALVE BODY - ADJUSTMENTS	21-304,21-476,21-646,21-818	VENT HOSE - OPERATION, CRANKCASE	25-32	WASHER FLUID INDICATOR - OPERATION	8J-35
VALVE BODY - ASSEMBLY	21-294,21-466,21-638,21-810	VENT WINDOW - INSTALLATION	23-85	WASHER FLUID LEVEL SWITCH - DESCRIPTION	8R-7
VALVE BODY - CLEANING	21-293,21-465,21-637,21-808	VENT WINDOW - REMOVAL	23-85	WASHER FLUID LEVEL SWITCH - INSTALLATION	8R-8
VALVE BODY - DESCRIPTION	21-263,21-433,21-607,21-780	VERIFICATION - STANDARD PROCEDURE, VALVE LASH ADJUSTMENT	9-256	WASHER FLUID LEVEL SWITCH - OPERATION	8R-7
VALVE BODY - DISASSEMBLY	21-282,21-453,21-626,21-799	VERIFICATION TEST - STANDARD PROCEDURE	80-5	WASHER FLUID LEVEL SWITCH - REMOVAL	8R-8
VALVE BODY - INSPECTION	21-293,21-465,21-637,21-809	VIBRATION - DIAGNOSIS AND TESTING, TIRE NOISE OR	22-8	WASHER HOSES/TUBES - DESCRIPTION	8R-8
VALVE BODY - INSTALLATION	21-303,21-475,21-645,21-818	VIBRATION DAMPER - INSPECTION	9-289	WASHER HOSES/TUBES - OPERATION	8R-8
VALVE BODY - OPERATION	21-267,21-438,21-611,21-783	VIBRATION DAMPER - INSTALLATION	9-156,9-212,9-289,9-42,9-99	WASHER NOZZLE - DESCRIPTION	8R-9
VALVE BODY - REMOVAL	21-281,21-452,21-625,21-798	VIBRATION DAMPER - REMOVAL	9-155,9-212,9-289,9-42,9-99	WASHER NOZZLE - INSTALLATION	8R-9
VALVE CABLE - ADJUSTMENTS, TRANSMISSION THROTTLE	21-254,21-425,21-598,21-771	VIEW MIRROR - INSTALLATION, REAR	23-126	WASHER NOZZLE - OPERATION	8R-9
VALVE CABLE - DESCRIPTION, THROTTLE	21-253,21-424,21-597,21-770	VIEW MIRROR - INSTALLATION, SIDE	23-97	WASHER NOZZLE - REMOVAL	8R-9
VALVE LASH ADJUSTMENT AND VERIFICATION - STANDARD PROCEDURE	9-256	VIEW MIRROR - LOW MOUNTED - INSTALLATION, SIDE	23-98	WASHER PUMP/MOTOR - DESCRIPTION	8R-9
VALVE SERVICE, INTAKE/EXHAUST VALVES & SEATS	9-195	VIEW MIRROR - LOW MOUNTED - REMOVAL, SIDE	23-98	WASHER PUMP/MOTOR - INSTALLATION	8R-10
VALVE SPRINGS - INSTALLATION, VALVES	9-199	VIEW MIRROR - REMOVAL, REAR	23-126	WASHER PUMP/MOTOR - OPERATION	8R-9
VALVE SPRINGS - REMOVAL, VALVES	9-197	VIEW MIRROR - REMOVAL, SIDE	23-97	WASHER PUMP/MOTOR - REMOVAL	8R-10
VALVE STEM SEAL - INSTALLATION	9-198	VIEW MIRROR FLAG - INSTALLATION, SIDE	23-74	WASHER RESERVOIR - DESCRIPTION	8R-10
VALVE STEM SEALS - REMOVAL	9-197	VIEW MIRROR FLAG - REMOVAL, SIDE	23-74	WASHER RESERVOIR - INSTALLATION	8R-11
VALVES & SEATS - CLEANING, INTAKE/EXHAUST	9-140,9-198,9-27,9-84	VIEW MIRROR GLASS - INSTALLATION, SIDE	23-98	WASHER RESERVOIR - OPERATION	8R-10
		VIEW MIRROR GLASS - REMOVAL, SIDE	23-98	WASHER RESERVOIR - REMOVAL	8R-10
		VISCOUS CLUTCH - 3.9L/5.2L/5.9L/8.0L - DESCRIPTION, FAN DRIVE	7-56	WASHER SYSTEM - CLEANING, WIPER	8R-6
		VISCOUS CLUTCH - 3.9L/5.2L/5.9L/8.0L - OPERATION, FAN DRIVE	7-56	WASHER SYSTEM - DIAGNOSIS AND TESTING, WIPER	8R-3
		VISCOUS CLUTCH - 5.9L DIESEL - DESCRIPTION, FAN DRIVE	7-57	WASHER SYSTEM - INSPECTION, WIPER	8R-6
				WATER DRAINING AT FUEL FILTER - STANDARD PROCEDURES	14-56
				WATER IN FUEL SENSOR - DESCRIPTION	14-85
				WATER IN FUEL SENSOR - OPERATION	14-85

Description	Group-Page	Description	Group-Page	Description	Group-Page
WATER IN FUEL SENSOR - REMOVAL	14-85	WEATHERSTRIP - INSTALLATION, FRONT		WINDOW SWITCH - OPERATION, POWER	8N-24
WATER LEAKS - DIAGNOSIS AND TESTING	23-2	DOOR INNER BELT	23-154	WINDOW SWITCH - REMOVAL, POWER	8N-25
WATER PUMP - 3.9L/5.2L/5.9L - CLEANING	7-69	WEATHERSTRIP - INSTALLATION, FRONT		WINDOWS - DESCRIPTION, POWER	8N-23
WATER PUMP - 3.9L/5.2L/5.9L - DESCRIPTION	7-67	DOOR OUTER BELT	23-154	WINDOWS - DIAGNOSIS AND TESTING, POWER	8N-23
WATER PUMP - 3.9L/5.2L/5.9L - INSPECTION	7-69	WEATHERSTRIP - INSTALLATION, FRONT		WINDOWS - OPERATION, POWER	8N-23
WATER PUMP - 3.9L/5.2L/5.9L - INSTALLATION	7-70	DOOR SECOND	23-155	WINDOWS, DOORS AND LOCKS - INSPECTION	30-14
WATER PUMP - 3.9L/5.2L/5.9L - OPERATION	7-67	WEATHERSTRIP - REMOVAL, COWL	23-153	WINDSHIELD - DESCRIPTION	23-148
WATER PUMP - 3.9L/5.2L/5.9L - REMOVAL	7-67	WEATHERSTRIP - REMOVAL, FRONT		WINDSHIELD - INSTALLATION	23-148
WATER PUMP - 5.9L DIESEL - CLEANING	7-73	DOOR GLASS RUN	23-153	WINDSHIELD - REMOVAL	23-148
WATER PUMP - 5.9L DIESEL - DESCRIPTION	7-73	WEATHERSTRIP - REMOVAL, FRONT		WINDSHIELD WIPERS/WASHERS, ROAD TEST - INSPECTION	30-18
WATER PUMP - 5.9L DIESEL - INSPECTION	7-73	DOOR INNER BELT	23-154	WIPER & WASHER SYSTEM - CLEANING	8R-6
WATER PUMP - 5.9L DIESEL - INSTALLATION	7-74	WEATHERSTRIP - REMOVAL, FRONT		WIPER & WASHER SYSTEM - DIAGNOSIS AND TESTING	8R-3
WATER PUMP - 5.9L DIESEL - OPERATION	7-73	DOOR OUTER BELT	23-154	WIPER & WASHER SYSTEM - INSPECTION	8R-6
WATER PUMP - 5.9L DIESEL - REMOVAL	7-73	WEATHERSTRIP - REMOVAL, FRONT		WIPER ARM - DESCRIPTION	8R-11
WATER PUMP - 8.0L - CLEANING	7-72	DOOR SECOND	23-154	WIPER ARM - INSTALLATION	8R-12
WATER PUMP - 8.0L - INSPECTION	7-72	WELD LOCATIONS, SPECIFICATIONS	23-4	WIPER ARM - OPERATION	8R-12
WATER PUMP - 8.0L - INSTALLATION	7-72	WET SANDING/BUFFING & POLISHING - DESCRIPTION	23-130	WIPER ARM - REMOVAL	8R-12
WATER PUMP - 8.0L - REMOVAL	7-70	WHEEL - INSTALLATION, STEERING	19-13	WIPER BLADE - DESCRIPTION	8R-12
WATER PUMP - DIAGNOSIS AND TESTING	7-67,7-70,7-73	WHEEL - REMOVAL, STEERING	19-13	WIPER BLADE - INSTALLATION	8R-13
WATER PUMP BYPASS HOSE WITH AIR CONDITIONING - INSTALLATION	7-77	WHEEL ALIGNMENT - DESCRIPTION	2-1	WIPER BLADE - OPERATION	8R-13
WATER PUMP BYPASS HOSE WITH AIR CONDITIONING - REMOVAL	7-74	WHEEL ALIGNMENT - OPERATION	2-2	WIPER BLADE - REMOVAL	8R-13
WATER PUMP BYPASS HOSE WITHOUT AIR CONDITIONING - INSTALLATION	7-78	WHEEL BALANCE - STANDARD PROCEDURES, TIRE	22-4	WIPER MODULE - DESCRIPTION	8R-14
WATER PUMP BYPASS HOSE WITHOUT AIR CONDITIONING - REMOVAL	7-77	WHEEL COVER - REMOVAL	22-12	WIPER MODULE - INSTALLATION	8R-15
WATER SEPARATOR - DESCRIPTION, FUEL FILTER	14-59	WHEEL COVERS - INSTALLATION	30-10	WIPER MODULE - OPERATION	8R-14
WATER SEPARATOR - INSTALLATION, FUEL FILTER	14-61	WHEEL CYLINDERS - ASSEMBLY	5-31	WIPER MODULE - REMOVAL	8R-14
WATER SEPARATOR - OPERATION, FUEL FILTER	14-59	WHEEL CYLINDERS - CLEANING	5-31	WIPER RELAY - DESCRIPTION	8R-15
WATER SEPARATOR - REMOVAL, FUEL FILTER	14-60	WHEEL CYLINDERS - DISASSEMBLY	5-31	WIPER RELAY - DIAGNOSIS AND TESTING	8R-16
WATER TO OIL COOLER - REMOVAL	7-87	WHEEL CYLINDERS - INSPECTION	5-31	WIPER RELAY - INSTALLATION	8R-17
WATERDAM - INSTALLATION	23-75,23-85	WHEEL CYLINDERS - INSTALLATION	5-32	WIPER RELAY - OPERATION	8R-15
WATERDAM - REMOVAL	23-75,23-85	WHEEL CYLINDERS - REMOVAL	5-31	WIPER RELAY - REMOVAL	8R-17
WATER-IN-FUEL INDICATOR - DESCRIPTION	8J-36	WHEEL INSPECTION - DIAGNOSIS AND TESTING	22-10	WIPERS/WASHERS - DESCRIPTION	8R-1
WATER-IN-FUEL INDICATOR - OPERATION	8J-37	WHEEL INSTALLATION - STANDARD PROCEDURE, DUAL REAR	22-10	WIPERS/WASHERS - OPERATION	8R-2
WAY CHECK VALVE - DESCRIPTION, ONE	25-30	WHEELHOUSE LINER - INSTALLATION, REAR	23-96	WIPERS/WASHERS, ROAD TEST - INSPECTION WINDSHIELD	30-18
WAY CHECK VALVE - INSTALLATION, ONE	25-30	WHEELHOUSE LINER - REMOVAL, REAR	23-96	WIRE SPLICING - STANDARD PROCEDURE	8W-01-12
WAY CHECK VALVE - OPERATION, ONE	25-30	WHEELS - DESCRIPTION	22-9	WIRING - INSPECTION	30-7
WAY CHECK VALVE - REMOVAL, ONE	25-30	WHEELS - OPERATION	22-10	WIRING DIAGRAMS - DESCRIPTION, HOW TO USE	8W-01-1
WEAR INDICATORS - DIAGNOSIS AND TESTING, TREAD	22-7	WINCH - INSTALLATION, SPARE TIRE	13-10	WIRING HARNESS - DIAGNOSIS AND TESTING	8W-01-5
WEAR PATTERNS - DIAGNOSIS AND TESTING, TIRE	22-7	WINCH - REMOVAL, SPARE TIRE	13-10	WIRING/TERMINAL - SPECIAL TOOLS	8W-01-8
WEATHERSTRIP - INSTALLATION, COWL	23-153	WIND NOISE - DIAGNOSIS AND TESTING	23-3	WITHOUT AIR CONDITIONING - INSTALLATION, WATER PUMP BYPASS HOSE	7-78
WEATHERSTRIP - INSTALLATION, FRONT		WIND NOISE - INSPECTION, SQUEAKS, RATTLES	30-15	WITHOUT AIR CONDITIONING - REMOVAL, WATER PUMP BYPASS HOSE	7-77
DOOR GLASS RUN	23-154	WINDOW - INSTALLATION, QUARTER	23-151	WITHOUT RADIATOR IN-TANK TRANSMISSION OIL COOLER - STANDARD PROCEDURE, FLUSHING COOLER AND TUBES	7-80,7-83,7-86
		WINDOW - INSTALLATION, VENT	23-85	WORM SHAFT - INSTALLATION	19-29
		WINDOW - REMOVAL, QUARTER	23-151	WORM SHAFT - REMOVAL	19-27
		WINDOW - REMOVAL, VENT	23-85	WORN THREADS - STANDARD PROCEDURE, REPAIR DAMAGED OR	9-11,9-125,9-181,9-238,9-68
		WINDOW MOTOR - DESCRIPTION	8N-26		
		WINDOW MOTOR - DIAGNOSIS AND TESTING	8N-26		
		WINDOW MOTOR - REMOVAL	8N-26		
		WINDOW REGULATOR - INSTALLATION	23-76		
		WINDOW REGULATOR - REMOVAL	23-75		
		WINDOW SWITCH - DESCRIPTION, POWER	8N-24		
		WINDOW SWITCH - DIAGNOSIS AND TESTING, POWER	8N-24		
		WINDOW SWITCH - INSTALLATION, POWER	8N-26		



# SERVICE MANUAL COMMENTS

What features do you find most useful? \_\_\_\_\_

---

---

---

---

What errors have you found? Please include page number. \_\_\_\_\_

---

---

---

---

What topics are hard to locate, confusing, or not covered completely? \_\_\_\_\_

---

---

---

---

What comments or suggestions do you have? \_\_\_\_\_

---

---

---

---

Your Name: \_\_\_\_\_ Dealership: \_\_\_\_\_

Address: \_\_\_\_\_

---

Manual Name, Year and Number: \_\_\_\_\_

All comments become property of DaimlerChrysler Corporation and may be used without compensation.



(FOLD HERE)

**BUSINESS REPLY MAIL**

FIRST CLASS MAIL PERMIT NO. 124 CENTER LINE, MI

POSTAGE WILL BE PAID BY ADDRESSEE

**DaimlerChrysler Corporation**  
**Dealer Technical Operations**  
**800 Chrysler Drive**  
**CIMS 486-02-76**  
**Auburn Hills, MI 48326-2757**

NO POSTAGE  
NECESSARY  
IF MAILED  
IN THE  
UNITED  
STATES



(FOLD HERE)